

DWG NO	SHT	PIPE-EXHAUST	CONDUIT LENGTH	DETAIL A	B	
146897-01	1	105958-28-000	800	YES	90°	NA
146897-02	1	105958-25-000	900	YES	90°	NA
146897-03	1	105958-27-000	800	YES	90°	NA
146897-04	1	105958-28-000	1200	YES	90°	NA
146897-05	2	105958-10-000	1300	YES	90°	NA
146897-06	1	105958-07-000	1400	NO	7	NOT USED
146897-07	1	105958-14-000	900	YES	90°	J35P,J35Z
146897-08	1	105958-27-000	900	YES	90°	NOT USED
146897-09	2	105958-17-000	900	YES	90°	NOT USED
146897-10	1	105958-30-000	900	NO	90°	NOT USED

DWG NO	SHT	PIPE-EXHAUST	CONDUIT LENGTH	DETAIL A	B	
146897-11	1	105958-07-000	900	NO	90°	J32H,J37F,J38N
146897-12	1	105958-30-000	1300	NO	90°	NOT USED
146897-13	1	105958-07-000	1400	NO	61°	E32K
146897-14	3	105958-11-000	2700	NO	90°	D31E(UP TO 11-09-09)
146897-15	1	105958-40-000	1400	NO	7	D33C,D35J,D37L
146897-16	3	105958-02-000	1800	NO	270°	NOT USED
146897-17	3	105958-41-000	2700	NO	90°	D31E (AFTER 11-10-09)

RELEASE	REV DATE	DWG NO	146897
REV ZONE	REVISION RECORD	DATE	DTR-ORIG

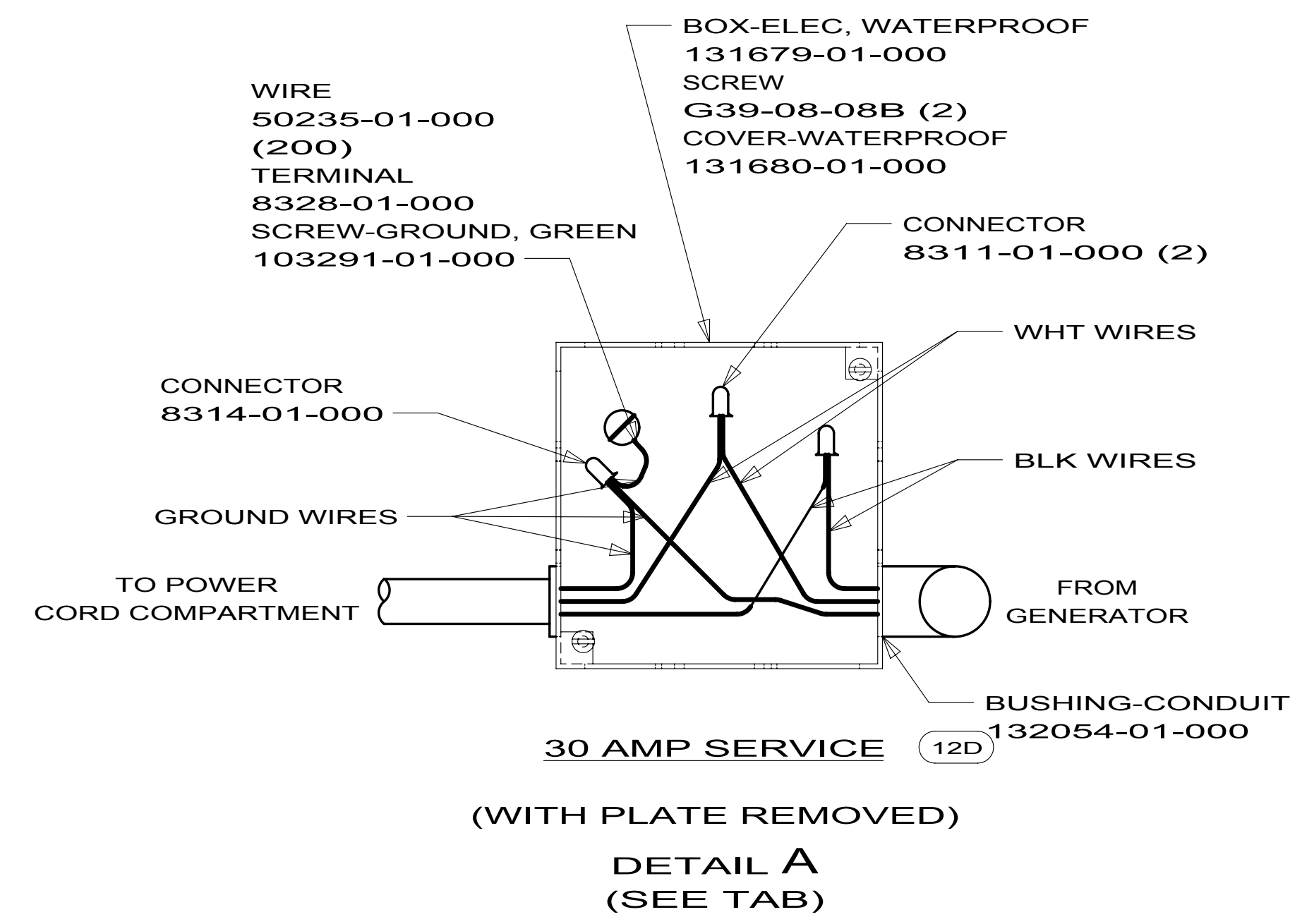
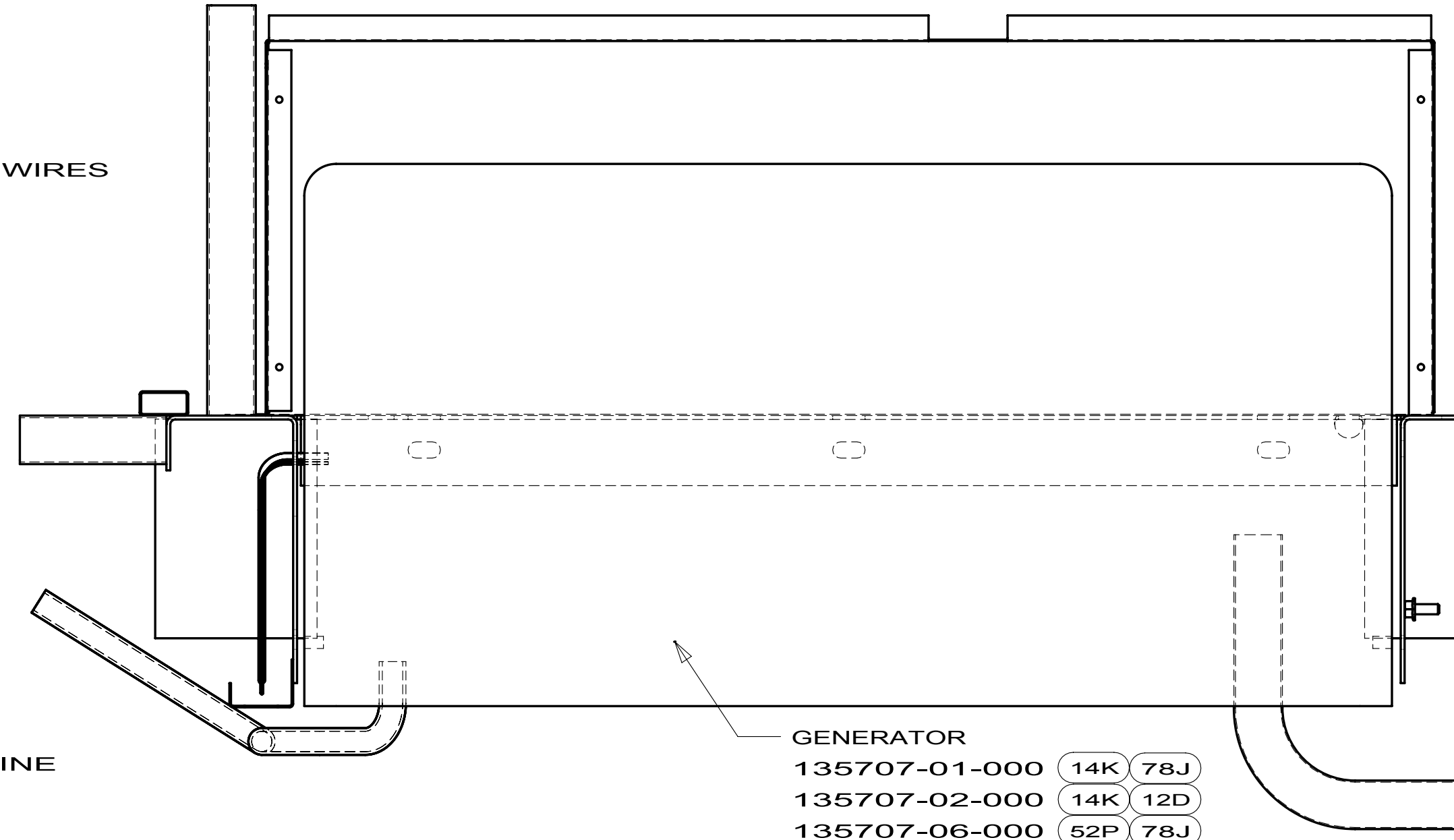
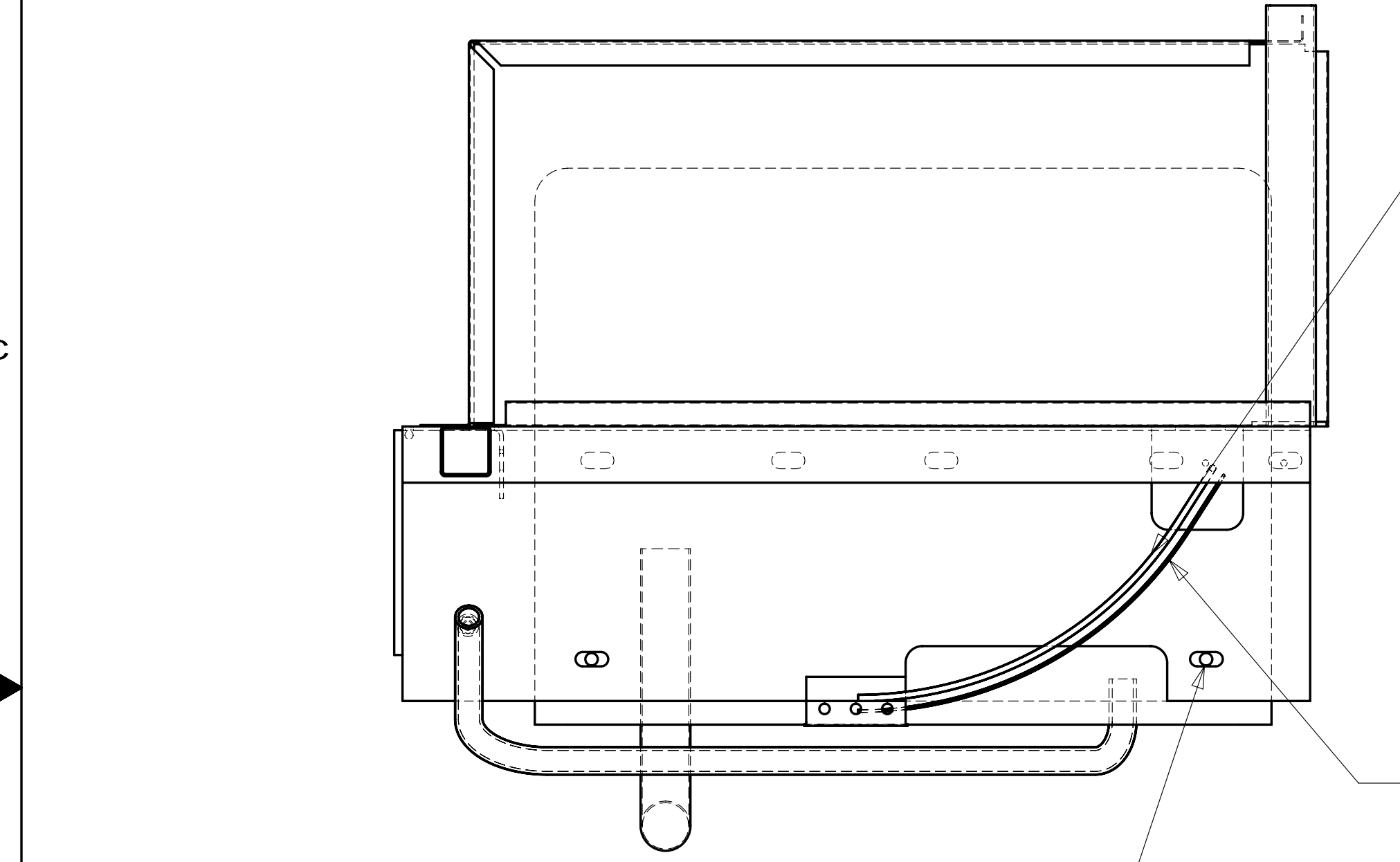

- 135707-01-000 (14K 78J)
- 135707-02-000 (14K 12D)
- 135707-06-000 (52P 78J)
- 135707-07-000 (52P 12D)
- 135707-08-000 (12D 51M)
- 135707-09-000 (39J 78J)
- 135707-12-000 (39N)
- 135707-13-000 (78J 51M)

- (51M) GEN-5.5KW ONAN-LP-MARQ GOLD
- (39N) GEN-7.0KW ONAN-CVGAS-MARQUIS
- (39U) GEN-6.5KW ONAN-CV-GAS
- (39J) GEN-7.0KW ONAN GAS MRQ PLTNM
- (265) CODES/STANDARDS-CSA/CMVSS
- (1B1) CODES/STANDARDS USA
- (78J) ELECTRICAL SYSTEM-50 AMP
- (52P) GEN-5.5KW ONAN-GAS-MARQ GOLD
- (14K) GEN-7.0KW ONAN-GAS-MARQ GOLD
- (12D) ELECTRICAL SYSTEM 30 AMP

7. DISTANCE FROM THE CENTERLINE OF THE FITCH RECEIVER TO THE CENTERLINE OF THE EXHAUST PIPE TO BE 525MM ±25MM.
6. TORQUE CLAMP TO 14 TO 20 FT-LBS.
5. SEE WIRING INSTL-BODY, 110 V FOR ADDITIONAL INFORMATION.
4. APPLY SEALANT INSIDE ELBOW ENCASING WIRE.
3. SEE WIRING INSTL-CHASSIS, WIRING INSTL-BODY, AND WIRING DIAGRAM-BODY FOR ADDITIONAL INFORMATION.
2. TORQUE TO 28 TO 42 FT-LBS.
1. SEE GENERATOR INSTALLATION INSTRUCTIONS.

CONDUIT-FLEXIBLE 91234-01-000 (LENGTH SEE TAB)

TO POWER CORD BOX

B° (SEE TAB)

PIPE-EXHAUST (SEE TAB)

CLAMP-PIPE 7125-03-000

SEE CHART FOR COLOR VARIATIONS OF THIS PART

		COPYRIGHT 2009 WINNEBAGO INDUSTRIES, INC.	
DTR	ORIG. DATE	ALL DIMENSIONS ARE IN MILLIMETERS	
CHKR		FIRST USED	
P.E.		GEN MH'S	
M.E.		UNSPECIFIED TOLERANCES ARE:	
DSNR		WHOLE DIM (X)	: 1.5
		ONE-PLACE (X.X)	:
		TWO-PLACE (X.XX)	:
		ANGLE	:
		THIRD ANGLE PROJECTION	
DO NOT SCALE DRAWING			
TITLE: GENERATOR INSTL			
SHEET 1 OF 3	PART NO	146897	REV
REF:	1		

CLAMP-CLOSED
10497-03-000(3)
SCREW
G67-10-08U(3)

CONDUIT
91234-01-000
(LENGTH SEE TAB)

5 THRU FLOOR
TO 4 X 4 BOX

GROMMET
23942-01-000

2 3/8" THD FORM SCREW (4)
(SUPPLIED WITH GENERATOR)

B°
(SEE TAB)

PIPE-EXHAUST, GENERATOR
(SEE TAB)
CLAMP
6 7125-03-000

GENERATOR-5.5, ONAN
135707-07-000 (52P) (12D)
135707-06-000 (52P) (78J)
135707-08-000 (51M) (12D)
135707-13-000 (51M) (78J)

HANGER
7131-01-000
BOLT
C26-05-12B
NUT
D29-05-00B
CLAMP
7125-03-000

FIRST USED		
09 D31E		
DO NOT SCALE DRAWING		
TITLE:		
GENERATOR INSTL		
SHEET 3	PART NO	REV
	146897	