

- 11 USE AS REQUIRED.
- 10 TORQUE TO 38± FT LBS.
9. THREAD ALL BLACK PIPE WITH STANDARD NATIONAL PIPE THREAD (NPT) ON BOTH ENDS.
- 8 GROMMET SUPPLIED WITH WATER HEATER.
7. MINIMUM BEND RADIUS ON COPPER TUBING TO BE 44 FOR 1/2" AND 28 FOR 3/8". HAND BENDS TO BE 76 RADIUS MINIMUM.
6. CUT CONVOLUTED TUBING BEFORE FLARE NUTS ARE ASSEMBLED.
5. GAS PIPING SYSTEM MATERIALS CONFORM WITH NFPA 1192.
- 4 REGULATOR TO BE POSITIONED WITH BENT POINTING DOWNWARD INSIDE OF 45° .
3. BLACK PIPE AND COPPER TUBING TO BE CLAMPED EVERY 1219 MAX WITH: SCREW 000G67-10-10B (WOOD SUPPORTS), SCREW 000G39-10-12T (METAL SUPPORTS).
2. STEEL PIPE AND FITTINGS TO BE ASSEMBLED WITH SEALANT 084456-01-000.
1. ALL COPPER TUBING BELOW FLOOR IS TO BE ENCASED IN CONDUIT 041953-05-000.

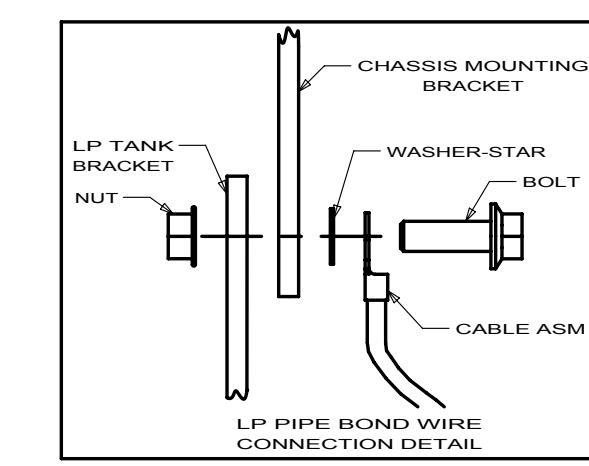
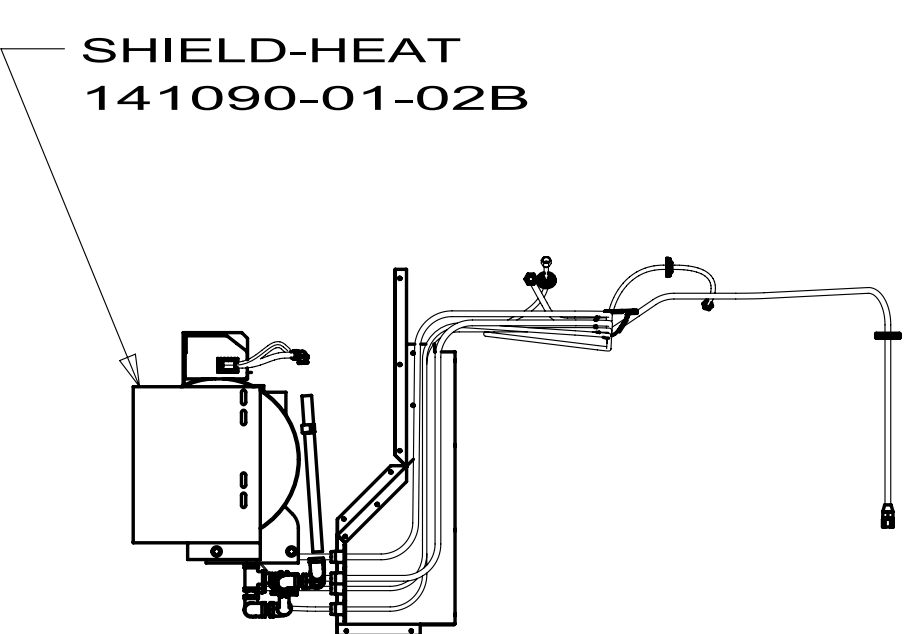

FOR LP CALLOUTS SEE DWG NO 116228-01-000

- IPU WORKHORSE 22K 230HP DIESEL
- 1B1 CODES/STANDARDS-USA
- 265 CODES/STANDARDS-CSA/CMVSS

		COPYRIGHT 2009 WINNEBAGO INDUSTRIES, INC.	
DFT-ORIG	ORIG. DATE	ALL DIMENSIONS ARE IN MILLIMETERS	
CHKR			
P.E.			
M.E.	FIRST USED	10 D35J	
DSNR			
UNSPECIFIED TOLERANCES ARE:		MATERIAL:	
WHOLE DIM (X)	: 3		
ONE-PLACE (X.X)	: 1.5		
TWO-PLACE (X.XX)	: 0.50		
ANGLE	: 1°		
THIRD ANGLE PROJECTION			
DO NOT SCALE DRAWING			
TITLE: LP SYSTEM INSTL			
SHEET 1 OF 2	PART NO	170408	REV
REF:	1		

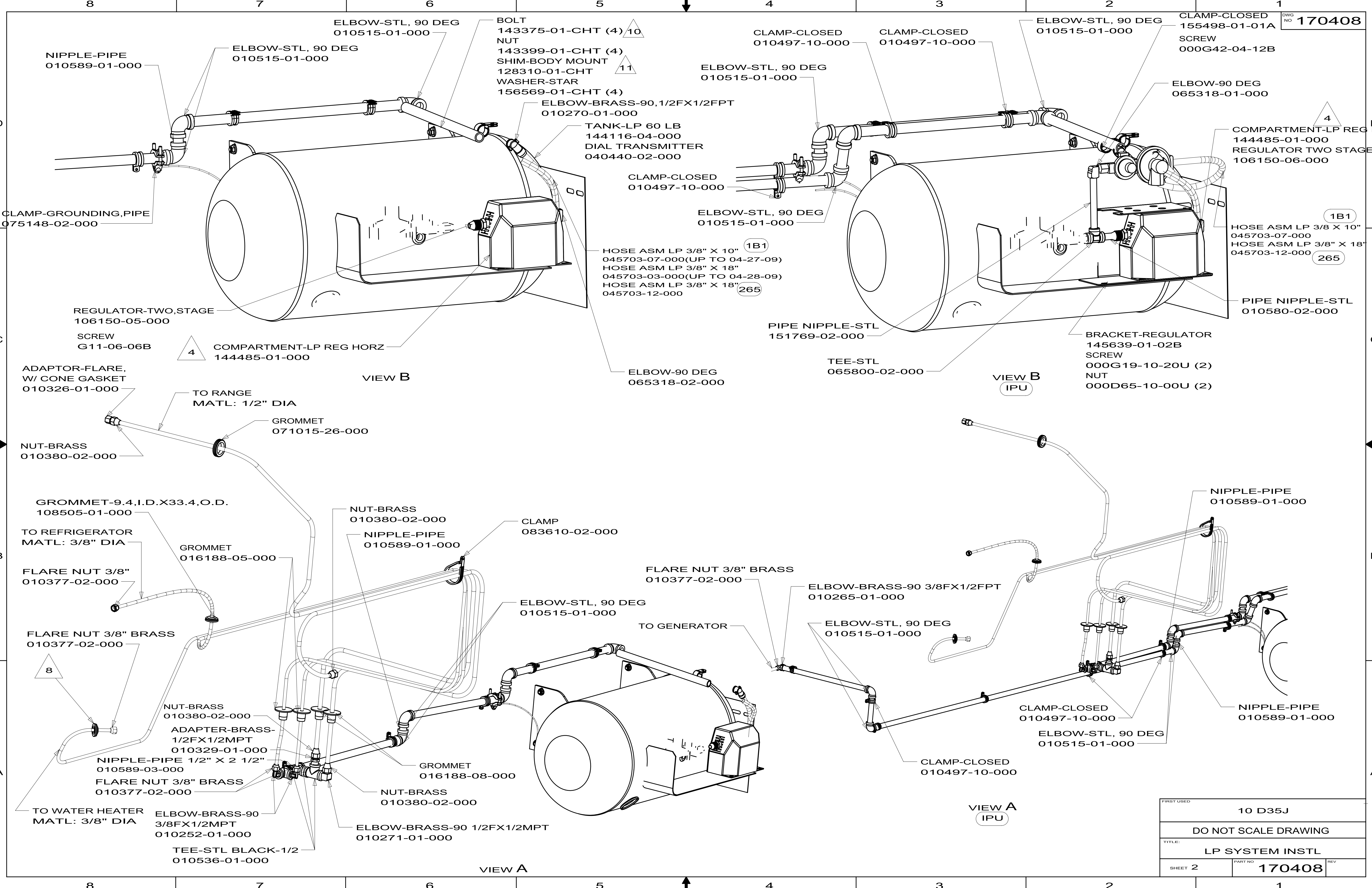

VIEW B

VIEW B

VIEW A

VIEW A

FIRST USED	10 D35J	
DO NOT SCALE DRAWING		
TITLE:	LP SYSTEM INSTL	
SHEET 2	PART NO	170408

**144116-01-000**

<b>KEY</b>	<b>PART NUMBER</b>	<b>U/M DESCRIPTION</b>	<b>VENDOR NO.</b>
	040421-01-712	EA VALVE-SERV. W/O VAPOR RELIEF	V20373/V21202
	040421-01-713	EA VALVE-RELIEF 1" W/SPRING 7"	V12560/V21207
	088253-09-700	EA SENDING UNIT-F/SNAP ON DIAL	G13062=SG14C0001466
	144116-01-700	EA VALVE-OUTAGE(NO STEM REMOVE)	V20058
	144116-01-701	EA VALVE/FILL 80 % W/YELLOW CAP	V13414

**144116-02-000, 144116-06-000, & 144116-07-000**

<b>KEY</b>	<b>PART NUMBER</b>	<b>U/M DESCRIPTION</b>	<b>VENDOR NO.</b>
	040421-01-712	EA VALVE-SERV. W/O VAPOR RELIEF	V20373/V21202
	040421-01-713	EA VALVE-RELIEF 1" W/SPRING 7"	V12560/V21207
	088253-01-702	EA FLOAT/SCREW IN-SNAP ON DIAL	G13063/SG16C0001442
	144116-01-700	EA VALVE-OUTAGE(NO STEM REMOVE)	V20058
	144116-01-701	EA VALVE/FILL 80 % W/YELLOW CAP	V13414

**144116-04-000**

<b>KEY</b>	<b>PART NUMBER</b>	<b>U/M DESCRIPTION</b>	<b>VENDOR NO.</b>
	040421-01-712	EA VALVE-SERV. W/O VAPOR RELIEF	V20373/V21202
	040421-01-713	EA VALVE-RELIEF 1" W/SPRING 7"	V12560/V21207
	144116-01-700	EA VALVE-OUTAGE(NO STEM REMOVE)	V20058
	144116-01-701	EA VALVE/FILL 80 % W/YELLOW CAP	V13414
	144116-04-700	EA FLOAT/SENDING UNIT W/O DIAL	G11530
	144116-04-701	EA DIAL - TRANSMITER	G12845

**144116-09-000**

<b>KEY</b>	<b>PART NUMBER</b>	<b>U/M DESCRIPTION</b>	<b>VENDOR NO.</b>
	040421-01-712	EA VALVE-SERV. W/O VAPOR RELIEF	V20373/V21202
	040421-01-713	EA VALVE-RELIEF 1" W/SPRING 7"	V12560/V21207
	144116-01-700	EA VALVE-OUTAGE(NO STEM REMOVE)	V20058
	144116-04-700	EA FLOAT/SENDING UNIT W/O DIAL	G11530
	144116-04-701	EA DIAL - TRANSMITER	G12845
	144116-09-700	EA VALVE/FILL 80%	V20150

5	010644-03-000	PIPE-STL BLK 1/2" (SCH 80)
4	010473-01-000	TUBING-COPPER 3/8" OD
3	010474-01-000	TUBING-COPPER 1/2" OD
1	010644-01-000	PIPE-STL BLK 1/2" (SCH 40)
E-15	140638-01-000	ELBOW-BLK,STREET 1/2" X 45° ,FPTXMPT
E-14	010515-03-000	ELBOW-BLK 1/2" X 90° STL (SCH 80)
E-13	010251-02-000	ELBOW-BRASS-90° 3/8"F X 1/4"MPT
E-12	010251-01-000	ELBOW-BRASS-90° 3/8"F X 3/8"MPT
E-10	010271-01-000	ELBOW-BRASS-90° 1/2"F X 1/2"MPT
E-9	010252-01-000	ELBOW-BRASS-90° 3/8"F X 1/2"MPT
E-8	010265-01-000	ELBOW-BRASS-90° 3/8"F X 1/2"FPT
E-6	010270-01-000	ELBOW-BRASS-90° 1/2"F X 1/2"FPT
E-5	065318-02-000	ELBOW-90° 3/8"MPT TO 3/8"FPT
E-4	065318-01-000	ELBOW-90° 1/4"MPT TO 1/4"FPT
E-3	166513-01-000	ELBOW STL 1/2"F X 1/2" FEM FL SWVL
E-2	010515-01-000	ELBOW-BLK 1/2" X 90° STL
E-1	039497-01-000	ELBOW-BLK-ST 1/2" X 90° STL
CR-2	144485-01-000	COMPARTMENT-LP REGULATOR
CR-1	105658-01-000	COMPARTMENT-LP REGULATOR
CA-2	036522-02-000	CAP-BRASS 1/2" FL
CA-1	036522-01-000	CAP-BRASS 3/8" FL
C-14	010497-12-000	CLAMP-CLOSED 1/2" ID
C-13	010497-10-000	CLAMP-CLOSED
C-12	075148-02-000	CLAMP-GROUNDING, BRZE SCREWS
C-11	075148-01-000	CLAMP-CLOSED
C-10	010497-09-000	CLAMP-CLOSED 5/16" ID
C-9	010497-08-000	CLAMP-CLOSED
C-8	010497-07-000	CLAMP-CLOSED 3/8" ID
C-7	010497-06-000	CLAMP-CLOSED 11/16" ID
C-6	155498-01-CHT	CLAMP-CLOSED 7/8" ID
C-5	010497-04-000	CLAMP-CLOSED 1 5/8" ID
C-4	010497-03-000	CLAMP-CLOSED
C-3	010497-02-000	CLAMP-CLOSED 1 1/2" ID
C-2	010497-01-000	CLAMP-CLOSED 5/8" ID
C-1	010495-01-000	CLAMP-CABLE 9/16"
A-8	010326-01-000	ADAPTER-FLARE 3/8"FEM FL X 1/2"MAL
A-7	010340-01-000	ADAPTER-BRASS 1/2"F X 1/2"FPT
A-6	010323-02-000	ADAPTER-BRASS 3/8"F X 3/8"MPT
A-5	010323-01-000	ADAPTER-BRASS 3/8"F X 1/2"MPT
A-4	024250-01-000	ADAPTER-BRASS 3/8"F X 1/2"FPT
A-3	010329-01-000	ADAPTER-BRASS 1/2"F X 1/2"MPT
A-1	057042-01-000	ADAPTER-CROSS 1/2" PIPE
NO.	PART NUMBER	DESCRIPTION

T-3	010536-02-000	TEE-STL BLK 1/2" (SCH 80)
T-1	010536-01-000	TEE-STL BLK 1/2"
R-3	106150-06-000	REGULATOR-TWO STAGE
R-2	106150-05-000	REGULATOR-TWO STAGE
R-1	106150-01-000	REGULATOR-TWO STAGE
NP-3	010589-03-000	NIPPLE-PIPE,STL BLK 1/2" X 2 1/2"
NP-2	010589-02-000	NIPPLE-PIPE,STL BLK 3/8" X 2"
NP-1	010589-01-000	NIPPLE-PIPE,STL BLK 1/2" X 1 1/2"
H-17	045703-19-000	HOSE-ASM-LP 3/8" ID X 102"
H-16	045703-16-000	HOSE-ASM-LP 3/8" ID X 109" US & CAN
H-15	045703-14-000	HOSE-ASM-LP 3/8" ID X 158" US & CAN
H-14	129467-01-000	HOSE-ASM-LP 3/8" ID X 158" CAN
H-13	045703-15-000	HOSE-ASM-LP 3/8" ID X 142" US & CAN
H-12	045703-13-000	HOSE-ASM-LP 3/8" ID X 120"
N-5	117835-01-000	NIPPLE-PIPE,STL BLK 1 1/4" X 5"
N-4	010377-02-000	NUT-BRASS 3/8"F, FORGED
N-3	010377-01-000	NUT-BRASS 3/8"F
N-2	010380-02-000	NUT-BRASS 1/2"F, FORGED
N-1	010380-01-000	NUT-BRASS 1/2"F
H-11	045703-12-000	HOSE-ASM-LP 3/8" ID X 18" CAN
H-10	045703-11-000	HOSE-ASM-LP 3/8" ID X 36" US
H-8	045703-07-000	HOSE-ASM-LP 3/8" ID X 10" US
H-7	045703-09-000	HOSE-ASM-LP 3/8" ID X 24" US & CAN
H-6	045703-06-000	HOSE-ASM-LP 3/8" ID X 28" CAN
H-5	045703-05-000	HOSE-ASM-LP 3/8" ID X 28" US
H-3	045703-03-000	HOSE-ASM-LP 3/8" ID X 18" US
H-2	045703-02-000	HOSE-ASM-LP 3/8" ID X 24" CAN
H-1	045703-01-000	HOSE-ASM-LP 3/8" ID X 24" US
G-14	016188-11-000	GROMMET-GAS LINE 11/16" X 3.25 LONG
G-13	108505-02-000	GROMMET 1/2" ID
G-12	071015-26-000	GROMMET 1-1/2" ID
G-11	016188-10-000	GROMMET-GAS LINE 11/16" X 2.50" LONG
G-10	016188-09-000	GROMMET-GAS LINE 11/16" X 1.25" LONG
G-9	016188-08-000	GROMMET-GAS LINE 1/2" X 1.25" LONG
G-8	071015-22-000	GROMMET 5/8" ID
G-7	016188-07-000	GROMMET-GAS LINE 1/2" X 3.25" LONG
G-6	016188-06-000	GROMMET-GAS LINE 3/8" X 3.25" LONG
G-5	016188-05-000	GROMMET-GAS LINE 3/8" X 1.25" LONG
G-4	016188-04-000	GROMMET-GAS LINE 1/2" X 2.50" LONG
G-3	016188-03-000	GROMMET-GAS LINE 3/8" X 2.50" LONG
G-2	016188-01-000	GROMMET-GAS LINE 3/8" X 2.00" LONG
G-1	108505-01-000	GROMMET-3/8" ID
NO.	PART NUMBER	DESCRIPTION

1. INACTIVE

		COPYRIGHT 2009 WINNEBAGO INDUSTRIES, INC.
DTR	ORIG. DATE	
CHKR	ALL DIMENSIONS ARE IN MILLIMETERS	
P.E.		
M.E.	FIRST USED	
DSNR	95 MH'S	
UNSPECIFIED TOLERANCES ARE:		MATERIAL:
WHOLE DIM (X)	: 3	
ONE-PLACE (X.X)	:	
TWO-PLACE (X.XX)	:	
ANGLE	:	
THIRD ANGLE PROJECTION		
DO NOT SCALE DRAWING		
TITLE: PART LISTING-LP SYSTEM		
SHEET 1 OF 1	PART NO 116228	REV
REF:	1	