

**2008**  
**SUNOVA**  
**IFD29R**  
**D-SERIES**  
**HONEY CHERRY**  
**W57 WINTER SURF**  
**W59 RAIN STORM**  
**W61 BOARDWALK**  
**WASHED MAPLE**  
**W58 WINTER SURF**  
**W60 RAIN STORM**  
**W62 BOARDWALK**  
**W57, W58, W61, W62 - CASHMERE**  
**W59, W60 - RIVERSTONE**

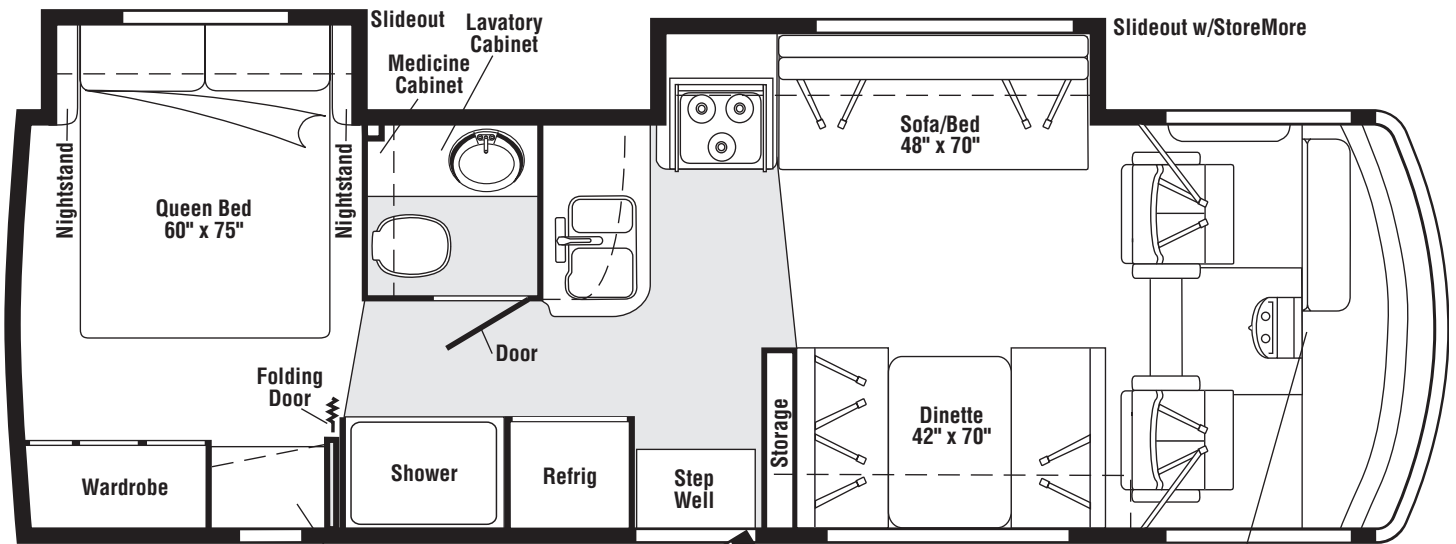

**FLOORPLAN**

# CONTENTS

<b>FLOORPLAN</b> .....	<b>1</b>
<b>ACCESSORIES GROUP</b> .....	<b>6</b>
OPERATORS MANUAL .....	6
<b>AUDIO VIDEO GROUP</b> .....	<b>7</b>
RADIO SYSTEM .....	7
REAR MONITOR .....	8
COMPONENT PARTS FOR REAR MONITOR .....	9
144677-10-01A .....	9
144677-10-02A, 144677-11-02A .....	9
144677-11-01A .....	9
<b>CABINET &amp; APPLIANCE GROUP</b> .....	<b>10</b>
CABINET & APPLIANCE LAYOUT .....	10
COMPONENT PARTS FOR CABINET & APPLIANCE LAYOUT .....	18
114030-04-01A .....	18
121568-06-01A, 121568-07-01A, 121568-08-01A .....	20
135065-03-01A, 135065-03-03A, 135065-04-01A .....	25
136354-01-01A, 136354-02-01A .....	27
136354-01-02A .....	28
136354-02-02A .....	28
136354-05-01A, 136354-05-02A .....	28
136354-06-01A, 136354-06-02A .....	28
150606-04-01A .....	28
151277-01-01A, 151277-02-01A .....	29
151277-03-01A, 151279-01-01A, 151279-02-01A/02A, 151279-03-01A .....	32
158686-01-01A .....	35
<b>CHASSIS GROUP</b> .....	<b>36</b>
FRAME .....	36
FRONT END .....	38
EXHAUST .....	40
FUEL .....	44
HYDRAULIC LEVELING .....	46
COMPONENT PARTS FOR HYDRAULIC LEVELING .....	48
139641-09-000 .....	48
139641-10-000 .....	48
139641-12-000 .....	48
139644-03-000 .....	48
156056-02-000 .....	48
164877-01-000 .....	49
165119-01-000 .....	49
165119-02-000 .....	49
165120-01-000 .....	49
165179-01-000 .....	49
SPARE TIRE .....	50
WHEEL, TIRE, COVERS &/OR LINERS .....	52
COMPONENT PARTS FOR WHEEL, TIRE, COVERS & LINERS .....	52
145580-06-000 .....	52
154672-01-000 .....	52
BRAKE .....	52
<b>CURTAIN &amp; CUSHION GROUP</b> .....	<b>53</b>
CURTAIN, CUSHION LAYOUT .....	53
BUCKET SEATS .....	57
SOFA .....	58
HARDWARE .....	59
FABRICS .....	61

# CONTENTS (CONTINUED)

<b>DRIVERS COMPARTMENT GROUP</b> .....	<b>63</b>
DASH .....	63
MOTOR COVER .....	64
BEVERAGE TRAY .....	65
FRONT INTERIOR .....	66
COMPONENT PARTS FOR FRONT INTERIOR .....	69
091990-04-01A .....	69
CABINETS .....	70
<b>ELECTRICAL GROUP</b> .....	<b>72</b>
110V BODY WIRING .....	72
12V BODY WIRING .....	74
EXTERIOR LAMPS .....	79
FRONT END .....	81
FRONT TV/DVD .....	83
SIDE TV/DVD .....	85
COMPONENT PARTS FOR WIRING .....	86
076319-23-000 .....	86
076319-25-000 .....	86
087694-01-000 .....	87
097917-01-06A .....	87
121935-01-01A .....	87
134940-06-01A .....	87
135420-20-000 .....	87
137135-02-000 .....	88
137135-05-000 .....	89
137417-01-01A, 137417-03-01A .....	89
137417-02-01A .....	89
137417-05-01A .....	89
137417-06-01A .....	89
149040-04-000 .....	89
158703-01-000 .....	89
159178-03-000 .....	89
160123-01-000 .....	89
163097-01-000 .....	89
164495-01-000 .....	89
165074-01-000 .....	89
166446-01-000 .....	89
CIRCUIT BREAKERS, FUSES & RELAYS .....	90
CONVERTER, INVERTER, LOAD CENTERS .....	91
COMPONENT PARTS FOR CONVERTOR, INVERTOR, LOAD CENTERS .....	91
083208-07-000 .....	91
BOXES & CORDS .....	92
WIRE ASSEMBLIES .....	92
CONNECTORS & CONDUIT .....	93
CHASSIS .....	96
<b>EXTERIOR BODY GROUP</b> .....	<b>99</b>
GRAPHICS & PAINT .....	99
PANELS & TRIMS .....	102
COMPONENT PARTS FOR PANELS & TRIMS .....	106
106015-12-01A .....	106
106015-13-01A .....	106
106015-14-01A .....	106
106015-15-01A .....	106
FRONT END .....	107
LADDER .....	108
STRUCTURAL COMPONENTS .....	108
AWNINGS .....	109

## CONTENTS (CONTINUED)

<b>EXTERIOR DOORS &amp; COMPARTMENTS GROUP</b> .....	<b>110</b>
DOOR & COMPARTMENT LAYOUT .....	110
COMPONENT PARTS FOR DOOR & COMPARTMENT LAYOUT .....	116
084103-08-000 .....	116
094707-04-01A .....	116
142226-02-01A .....	116
COMPARTMENT DOOR PIECE PARTS .....	117
ENTRY .....	120
SCREEN .....	122
LATCH .....	123
<b>EXTERIOR SLIDEOUT GROUP</b> .....	<b>124</b>
LEFT FRONT .....	124
COMPONENT PARTS FOR LEFT FRONT .....	128
162827-01-000, 162827-02-000 .....	128
LEFT REAR .....	129
COMPONENT PARTS FOR LEFT REAR .....	132
162834-01-000 .....	132
<b>GENERATOR GROUP</b> .....	<b>133</b>
GAS .....	133
<b>HEATING &amp; A/C GROUP</b> .....	<b>134</b>
AUTOMOTIVE .....	134
COMPONENT PARTS FOR AUTOMOTIVE .....	136
103930-44-000 .....	136
103930-45-000 .....	136
103930-46-000 .....	136
103930-47-000 .....	136
103930-55-000 .....	137
103930-63-000 .....	138
FURNACE .....	139
COMPONENT PARTS FOR FURNACE .....	140
139980-02-000 .....	140
143563-02-000 .....	142
REAR HEATER .....	144
COMPONENT PARTS FOR REAR HEATER .....	144
084405-01-000 .....	144
ROOF .....	145
COMPONENT PARTS FOR ROOF .....	146
131184-01-01A .....	146
131184-05-01A .....	147
131184-06-01A .....	148
131184-07-01A .....	149
131186-03-01A .....	150
131187-05-01A .....	151
131187-05-02A .....	152
131187-06-01A .....	153
131187-06-02A .....	154
131188-05-01A .....	155
131188-05-02A .....	156
131188-06-01A .....	157
131188-06-02A .....	158
<b>INTERIOR FINISH GROUP</b> .....	<b>159</b>
MOLDINGS & TRIMS .....	159
PANELING & LAMINATES .....	169
INTERIOR TRIM LAYOUT .....	170
COMPONENT PARTS FOR INTERIOR TRIM LAYOUT .....	172
115011-03-03A .....	172
131595-01-01A, 131595-05-01A, 131595-10-01A, 131595-13-01A .....	172
FLOOR COVERINGS .....	173
HARDWARE .....	174

## CONTENTS (CONTINUED)

<b>LABELS GROUP .....</b>	<b>180</b>
<b>LP GROUP .....</b>	<b>184</b>
LP SYSTEM .....	184
COMPONENT PARTS FOR LP SYSTEM .....	184
144116-04-000 .....	184
<b>SEALANTS &amp; FASTENERS GROUP .....</b>	<b>185</b>
SEALANTS & ADHESIVES .....	185
BOLTS, NUTS AND WASHERS .....	186
SCREWS .....	188
CLAMPS, CLIPS, GROMMETS, RIVETS & PLUGS .....	191
MISCELLANEOUS FASTENERS .....	192
<b>WATER &amp; SEWAGE GROUP .....</b>	<b>193</b>
DRAINAGE SYSTEM .....	193
COMPONENT PARTS FOR DRAINAGE SYSTEM .....	195
147421-03-01A .....	195
WATER SYSTEM .....	196
COMPONENT PARTS FOR WATER SYSTEM .....	201
051391-03-000 .....	201
145541-02-000 .....	202
151678-01-01A .....	202
<b>WINDOW &amp; VENTS GROUP .....</b>	<b>203</b>
WINDOW & VENT LAYOUT .....	203
COMPONENT PARTS FOR WINDOW & VENT LAYOUT .....	205
098644-01-01A .....	205
098647-23-02A .....	206
098647-47-02A .....	207
098647-63-01A .....	207
122882-01-01A .....	208
122882-02-01A, 122882-03-01A .....	208
123780-03-01A .....	209
123780-26-01A .....	210
125582-11-01A .....	211
125582-12-01A .....	211
150648-02-01A, 150648-03-01A/3A .....	212
150648-07-01A, 150648-22-01A .....	213
150648-12-01A .....	213
150649-15-01A .....	214
150651-01-01A/03A .....	215
151072-03-01A .....	215
151072-04-01A .....	215
<b>WINDSHIELD &amp; WIPER GROUP .....</b>	<b>216</b>
WINDSHIELD .....	216
WIPER .....	217
COMPONENT PARTS FOR WIPER .....	217
149401-01-000,149401-02-000 .....	217
149402-03-000 & 149402-04-000 .....	217

**ACCESSORIES GROUP**  
**OPERATORS MANUAL**

<b>KEY</b>	<b>PART NUMBER</b>	<b>U/M</b>	<b>DESCRIPTION</b>
	158603-08-005	EA	MANUAL/OWNER - SUPPLEMENT - D-SERIES - 2008
	159842-01-01A	EA	CASE - VINYL - F/MANUALS - W/SLEEVES - BLACK
	161500-08-010	EA	MANUAL/OWNER - SUNOVA - D SERIES - 2008
	162278-01-000	DW	TOP LEVEL-D,2008

## AUDIO VIDEO GROUP RADIO SYSTEM

KEY	PART NUMBER	U/M	DESCRIPTION
	163031-01-01A	EA	RADIO - WALL MOUNT - DVD/CD - W/ALARM - JENSEN AWM960
	165161-01-000	EA	FILTER - GROUND LOOP/VIDEO - <b>DC/AC INVERTOR</b>

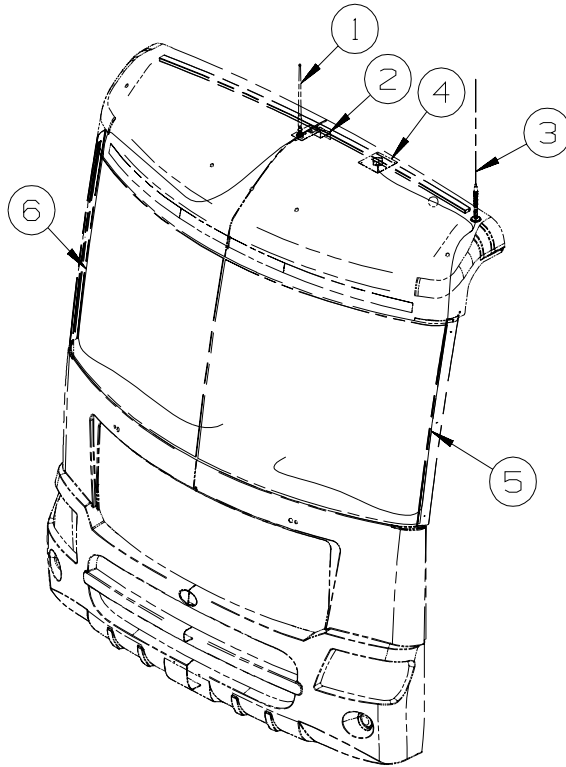

KEY	PART NUMBER	U/M	DESCRIPTION
1	090944-02-000	EA	ANTENNA - RADIO - 16" RUBBER - W/O LEAD WIRE
2	115916-01-01B	EA	BRACKET - ANTENNA MOUNT
3	NA	EA	ANTENNA - CB - W/O CABLE
4	158494-01-000	EA	ANTENNA/SATELLITE - RADIO/SIRIUS - <b>SATELLITE RADIO</b>
5	NA	EA	CABLE - CB - COAX
6	090944-03-000	EA	CABLE - ANTENNA

## AUDIO VIDEO GROUP (CONTINUED)

### REAR MONITOR

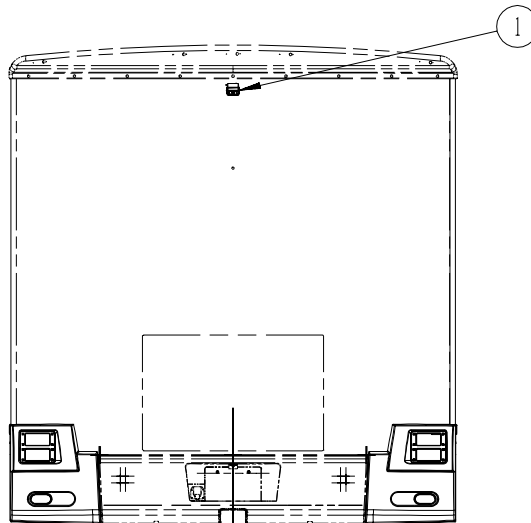

KEY	PART NUMBER	U/M	DESCRIPTION
1	144677-14-01A	EA	CAMERA - REAR VIEW W/BRACKET - WHITE - VBCS150
1	144677-14-02A	EA	CAMERA - REAR VIEW W/BRACKET - BLACK - VBCS150B

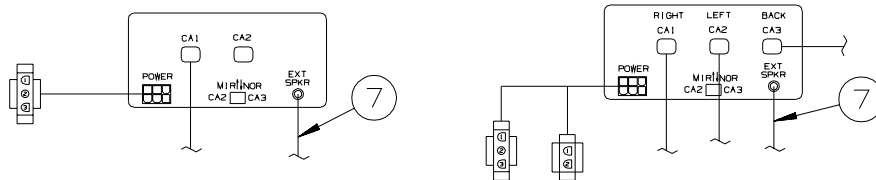
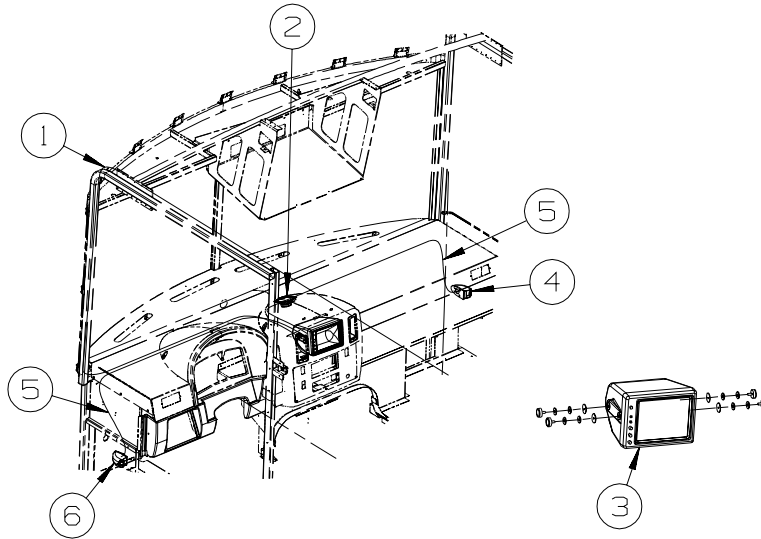

KEY	PART NUMBER	U/M	DESCRIPTION
1	136514-02-000	EA	CABLE - MONITOR/CAMERA
2	098819-01-000	EA	SPEAKER - 4" - 2 WATT - 8 OHM
2	093214-01-04A	EA	GRILLE - SPEAKER - 4" - RIVERSTONE
3	144677-06-000	EA	MONITOR/BLACK & WHITE-7"-3 PIN/MECH CONTROLS - <b>REARVIEW MONITOR SYSTEM W/AUDIO</b>
3	144677-08-000	EA	MONITOR/BLACK & WHITE- 7" -W/O SIDE CAMERAS/WIRE ASM/CABLE - <b>VIDEO CAMERA SYSTEM</b>
4*	144677-10-01A	EA	CAMERA - REAR VIEW - DASH MOUNT/RIGHT - WHITE - <b>VIDEO CAMERA SYSTEM</b>
4*	144677-10-02A	EA	CAMERA - REAR VIEW - DASH MOUNT/RIGHT - BLACK - <b>VIDEO CAMERA SYSTEM</b>
5	144677-12-000	EA	CABLE - MONITOR/CAMERA - 12'
6*	144677-11-01A	EA	CAMERA - REAR VIEW - DASH MOUNT/LEFT - WHITE - <b>VIDEO CAMERA SYSTEM</b>
6*	144677-11-02A	EA	CAMERA - REAR VIEW - DASH MOUNT/LEFT - BLACK - <b>VIDEO CAMERA SYSTEM</b>
7	114870-01-000	EA	PLUG - AUDIO W/LEADS - 48.5"

\*COMPONENT PARTS LISTED LATER IN THIS GROUP



**AUDIO VIDEO GROUP (CONTINUED)**  
**COMPONENT PARTS FOR REAR MONITOR**

**144677-10-01A**

<b>KEY</b>	<b>PART NUMBER</b>	<b>U/M</b>	<b>DESCRIPTION</b>	<b>VENDOR NO.</b>
	144677-10-700	EA	HOUSING/CAMERA-RT/LT-WHITE	SIDHSGWHT
	144677-10-702	EA	SERVICE PACK-SCREW COVER	PSVCSIDHSGWHT
	144677-10-703	EA	ERVICE PACK-SCREW COVER	PSVCSIDHSGGPR

**144677-10-02A, 144677-11-02A**

<b>KEY</b>	<b>PART NUMBER</b>	<b>U/M</b>	<b>DESCRIPTION</b>	<b>VENDOR NO.</b>
	144677-10-701	EA	HOUSING/CAMERA-RT/LT-PRIMED	SIDHSGGTR

**144677-11-01A**

<b>KEY</b>	<b>PART NUMBER</b>	<b>U/M</b>	<b>DESCRIPTION</b>	<b>VENDOR NO.</b>
	144677-10-700	EA	HOUSING/CAMERA-RT/LT-WHITE	SIDHSGWHT

# CABINET & APPLIANCE GROUP

## CABINET & APPLIANCE LAYOUT

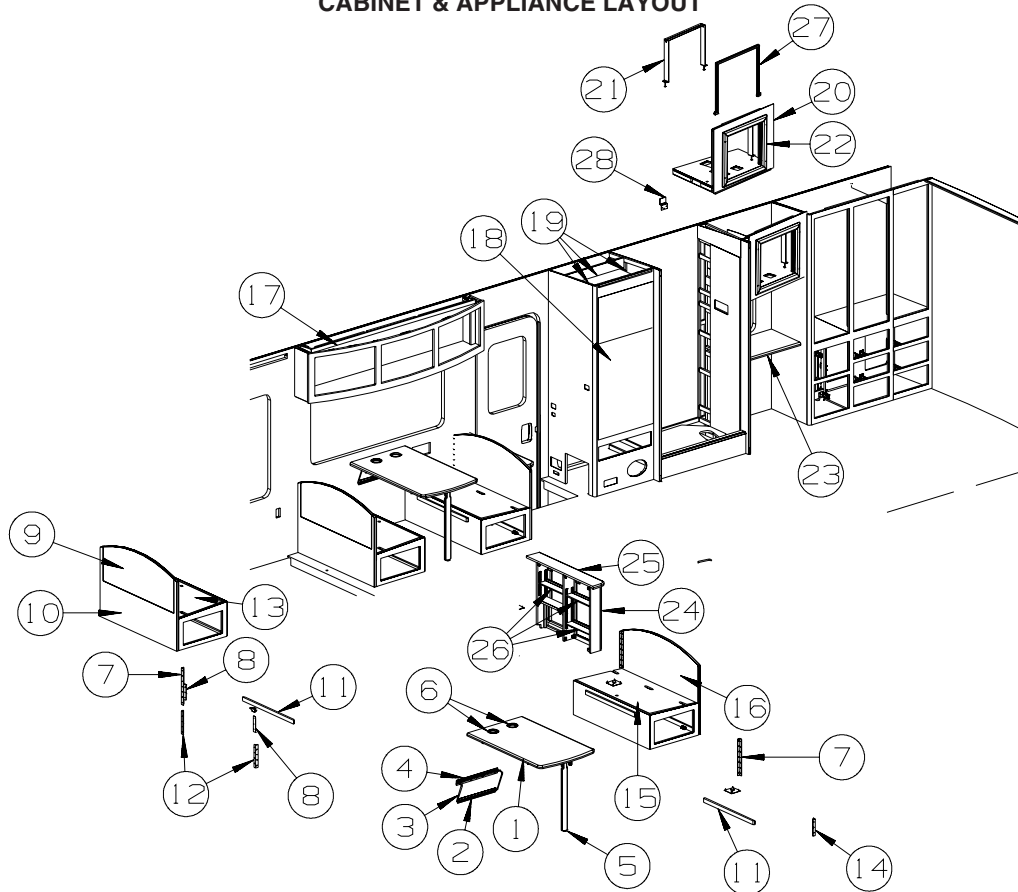

KEY	PART NUMBER	U/M	DESCRIPTION
1	159010-01-W21	EA	TABLE - DINETTE - W/HANGER (W57, W58, W61, W62)
1	159010-01-W51	EA	TABLE - DINETTE - W/HANGER (W59, W60)
	157828-05-05A	EA	COUNTERTOP - TABLE - W/O HDW (W57, W58, W61, W62)
	157828-05-04A	EA	COUNTERTOP - TABLE - W/O HDW (W59, W60)
2	024281-12-000	EA	BRACKET/WALL - TABLE LIFT - 17.1" - ALMOND
3	024275-16-000	EA	ROD - TABLE LIFT - W/ARMS 8" & BASE ROD 18.5" - ALMOND
4	140921-02-02A	EA	BRACKET/TABLE SUPPORT - 18.5" - ALMOND
5	143798-01-02A	EA	CATCH - FLOOR TO TABLE LEG - ALMOND
6	164128-02-01A	EA	HOLDER/CUP - TWO STEP - COLONIAL WHITE (W51, W52, W53, W54)
6	164128-02-02A	EA	HOLDER/CUP - TWO STEP - BLACK (W55, W56)
7	122021-02-02A	EA	ANGLE - W/HOLES - 13.7" LONG - OFF WHITE
8	111474-01-01A	EA	PLATE-STOP - OFF WHITE
9	137092-B2-W51	EA	PANEL/BACK - HINGED PORTION - HONEY CHERRY
9	137092-B2-W52	EA	PANEL/BACK - HINGED PORTION - WASHED MAPLE
10	137092-A8-W51	EA	PANEL/SEAT BACK - STATIONARY - W/O HINGED PORTION - HONEY CHERRY
10	137092-A8-W52	EA	PANEL/SEAT BACK - STATIONARY - W/O HINGED PORTION - WASHED MAPLE
10	137092-G1-W51	EA	PANEL - BACK - STATIONARY - W/O HINGED PORTION - HONEY CHERRY - INTERIOR UPGRADE PKG.
10	137092-G1-W52	EA	PANEL - BACK - STATIONARY - W/O HINGED PORTION - WASHED MAPLE - INTERIOR UPGRADE PKG.
11	081295-01-T02	EA	SUPPORT - BED/DINETTE - 28" LONG - HONEY CHERRY
11	081295-01-T01	EA	SUPPORT - BED/DINETTE - 28" LONG - WASHED MAPLE
12	122021-01-02A	EA	ANGLE - W/HOLES - 8.6" LONG - OFF WHITE
13	P37092-13-W51	EA	CABINET/SEAT BASE - W/O DOOR/DRAWER/HARDWARE - HONEY CHERRY
13	P37092-13-W52	EA	CABINET/SEAT BASE - W/O DOOR/DRAWER/HARDWARE - WASHED MAPLE
13	P37092-24-W51	EA	CABINET/SEAT BASE - LH - W/O DOOR/DRAWER/HDW - HONEY CHERRY - INTERIOR UPGRADE PKG.
13	P37092-24-W52	EA	CABINET/SEAT BASE - LH - W/O DOOR/DRAWER/HDW - WASHED MAPLE - INTERIOR UPGRADE PKG.
	096764-02-000	FT	SLIPNOT - ANTISLIP - 1'WIDE (180' ROLLS) - WHITE
14	122021-09-02A	EA	ANGLE - W/HOLES - OFF WHITE
15	P37092-19-W51	EA	CABINET/SEAT BASE - RIGHT HAND - W/O DOOR/DRAWER/HDW - HONEY CHERRY
15	P37092-19-W52	EA	CABINET/SEAT BASE - RIGHT HAND - W/O DOOR/DRAWER/HDW - WASHED MAPLE
15	P37092-23-W51	EA	CABINET/SEAT BASE - RH - W/O DOOR/DRAWER/HDW - HONEY CHERRY - INTERIOR UPGRADE PKG.
15	P37092-23-W52	EA	CABINET/SEAT BASE - RH - W/O DOOR/DRAWER/HDW - WASHED MAPLE - INTERIOR UPGRADE PKG.
	096764-02-000	FT	SLIPNOT - ANTISLIP - 1'WIDE (180' ROLLS) - WHITE

**CABINET & APPLIANCE GROUP (CONTINUED)**  
**CABINET & APPLIANCE LAYOUT (CONTINUED)**

KEY	PART NUMBER	U/M	DESCRIPTION
16	137092-E4-W51	EA	DINETTE SEAT BACK - W/O HARDWARE - HONEY CHERRY
16	137092-E4-W52	EA	DINETTE SEAT BACK - W/O HARDWARE - WASHED MAPLE
16	137092-F9-W51	EA	DINETTE SEAT BACK - W/O HARDWARE - HONEY CHERRY - INTERIOR UPGRADE PKG.
16	137092-F9-W52	EA	DINETTE SEAT BACK - W/O HARDWARE - WASHED MAPLE - INTERIOR UPGRADE PKG.
17	162266-01-W51	EA	CABINET - OVERHEAD/DINETTE - W/O DOORS/HDW - HONEY CHERRY
17	162266-01-W52	EA	CABINET - OVERHEAD/DINETTE - W/O DOORS/HDW - WASHED MAPLE
17	162266-02-W51	EA	CABINET - OVERHEAD/DINETTE - W/O DOORS/HDW - HONEY CHERRY - INTERIOR UPGRADE PKG.
17	162266-02-W52	EA	CABINET - OVERHEAD/DINETTE - W/O DOORS/HDW - WASHED MAPLE - INTERIOR UPGRADE PKG.
18*	121568-06-01A	EA	REFRIGERATOR - SMALL DBL DOOR-RH/2 WAY- 52.8"HX23.5"WX24"D
	158456-01-01A	EA	INSERT/REFRIGERATOR DOOR - 21.5"W X 14.5"H - TITANIUM SST - INTERIOR UPGRADE PKG.
	158456-02-01A	EA	INSERT/REFRIGERATOR DOOR - 21.5"W X 31.6"H - TITANIUM SST - INTERIOR UPGRADE PKG.
	054450-01-000	EA	LEVEL - REFRIGERATOR
	116751-02-01A	EA	TRAY - REFRIGERATOR - BLACK
19			REFRIGERATOR CABINET SEALS
	090329-01-000	FT	SEAL - "T" - REFRIGERATOR CABINET
	154585-02-01A	FT	SEAL - FOAM TAPE - ADHESIVE BACK - 3/4" X 1/2" - BLACK
20	162349-01-W51	EA	CABINET - OVERHEAD/TV - W/O HDW - HONEY CHERRY FROM: 00-00-00 THRU: 06-03-07
20	164712-02-W51	EA	CABINET - OVERHEAD/TV - W/O HDW - HONEY CHERRY FROM: 06-04-07 THRU: 99-99-99
20	162349-01-W52	EA	CABINET - OVERHEAD/TV - W/O HDW - WASHED MAPLE FROM: 00-00-00 THRU: 06-03-07
20	164712-02-W52	EA	CABINET - OVERHEAD/TV - W/O HDW - HONEY CHERRY FROM: 06-04-07 THRU: 99-99-99
20	162349-02-W51	EA	CABINET - OVERHEAD/TV - W/O HDW - HONEY CHERRY - TV (REAR)-19"COLOR, STEREO FROM: 00-00-00 THRU: 06-03-07
20	164712-01-W51	EA	CABINET - OVERHEAD/TV - W/O HDW - HONEY CHERRY - TV (REAR)-20"COLOR, STEREO FROM: 06-04-07 THRU: 99-99-99
20	162349-02-W52	EA	CABINET - OVERHEAD/TV - W/O HDW - WASHED MAPLE - TV (REAR)-19"COLOR, STEREO FROM: 00-00-00 THRU: 06-03-07
20	164712-01-W52	EA	CABINET - OVERHEAD/TV - W/O HDW - WASHED MAPLE - TV (REAR)-20"COLOR, STEREO FROM: 06-04-07 THRU: 99-99-99
21	148247-15-02B	EA	STRAP/TIEDOWN - TV - E-COATED FROM: 00-00-00 THRU: 06-04-07
21	159879-01-02B	EA	ANGLE/ZEE - W/HOLES - 2.6" X 4.1" X .8" BEND - E-COATED - NOT ILLUSTRATED FROM: 06-05-07 THRU: 99-99-99
22	144351-08-W51	EA	FRAME/TV CABINET - HONEY CHERRY - TV (REAR)-19"COLOR, STEREO FROM: 00-00-00 THRU: 06-03-07
22	144351-09-W51	EA	FRAME/TV CABINET - HONEY CHERRY - TV (REAR)-20"COLOR, STEREO FROM: 06-04-07 THRU: 99-99-99
22	144351-08-W52	EA	FRAME/TV CABINET - WASHED - TV (REAR)-19"COLOR, STEREO FROM: 00-00-00 THRU: 06-03-07
22	144351-09-W52	EA	FRAME/TV CABINET - WASHED - TV (REAR)-20"COLOR, STEREO FROM: 06-04-07 THRU: 99-99-99
23	157828-28-05A	EA	COUNTERTOP - VANITY - W/O FLIP LID (W57, W58, W61, W62)
23	157828-28-04A	EA	COUNTERTOP - VANITY - W/O FLIP LID (W59, W60)
24	156748-01-U21	EA	CABINET - STORAGE - W/O DOORS/HARDWARE - HONEY CHERRY
24	156748-01-U22	EA	CABINET - STORAGE - W/O DOORS/HARDWARE - WASHED MAPLE
25	157828-12-05A	EA	COUNTERTOP - STORAGE CABINET (W57, W58, W61, W62)
25	157828-12-04A	EA	COUNTERTOP - STORAGE CABINET (W59, W60)
26	156748-20-U21	EA	SHELF - W/PLASTIC MOLDING - HONEY CHERRY
26	156748-20-U22	EA	SHELF - W/PLASTIC MOLDING - WASHED MAPLE
27	151954-06-02B	EA	BRACKET/HOLD DOWN - TV - E-COATED FROM: 06-11-07 THRU: 99-99-99
28	159879-01-02B	EA	ANGLE/ZEE - W/HOLES - 2.6" X 4.1" X .8" BEND - E-COATED FROM: 06-11-07 THRU: 99-99-99

\*COMPONENT PARTS LISTED LATER IN THIS GROUP

**CABINET & APPLIANCE GROUP (CONTINUED)**  
**CABINET & APPLIANCE LAYOUT (CONTINUED)**

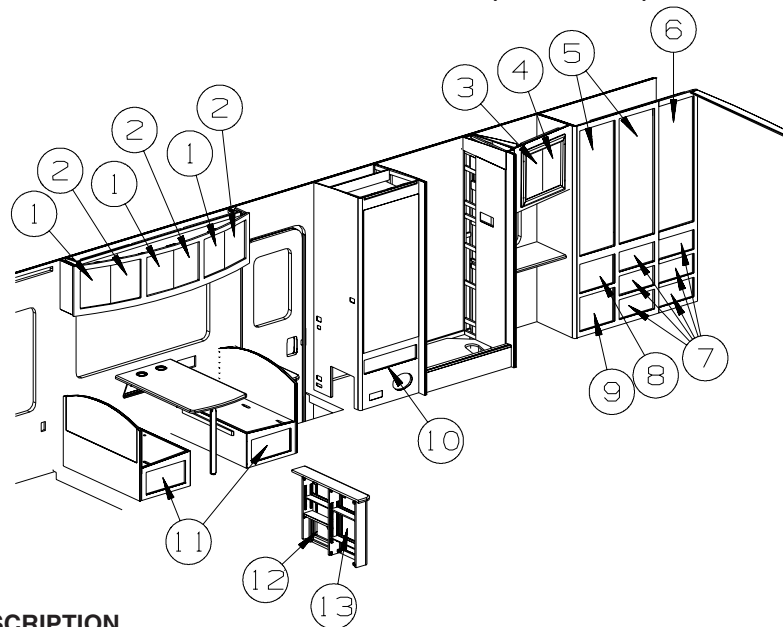

KEY	PART NUMBER	U/M	DESCRIPTION
1	160242-07-W51	EA	DOOR - CURVED - 15.7"H X 12.2"W - W/O HDW - HONEY CHERRY
1	160242-07-W52	EA	DOOR - CURVED - 15.7"H X 12.2"W - W/O HDW - WASHED MAPLE
2	160242-08-W51	EA	DOOR - CURVED - 15.7"H X 12.2"W - W/O HDW - HONEY CHERRY
2	160242-08-W52	EA	DOOR - CURVED - 15.7"H X 12.2"W - W/O HDW - WASHED MAPLE
3	160256-69-W51	EA	DOOR - FLAT/SQUARE EDGE - 19.1" X 10" - W/O HDW - HONEY CHERRY
3	160256-34-W51	EA	DOOR - FLAT/SQUARE EDGE - 21.8" X 10.8" - W/O HDW - HONEY CHERRY FROM: 00-00-00 THRU: 06-10-07
3	160256-69-W52	EA	DOOR - FLAT/SQUARE EDGE - 19.1" X 10" - W/O HDW - WASHED MAPLE FROM: 06-11-07 THRU: 99-99-99
3	160256-34-W52	EA	DOOR - FLAT/SQUARE EDGE - 21.8" X 10.8" - W/O HDW - WASHED MAPLE FROM: 00-00-00 THRU: 06-10-07 FROM: 06-11-07 THRU: 99-99-99
4	160256-70-W51	EA	DOOR - FLAT/SQUARE EDGE - 19.1" X 10" - W/O HDW - HONEY CHERRY FROM: 00-00-00 THRU: 06-10-07
4	160256-35-W51	EA	DOOR - FLAT/SQUARE EDGE - 21.8" X 10.8" - W/O HDW - HONEY CHERRY FROM: 06-11-07 THRU: 99-99-99
4	160256-70-W52	EA	DOOR - FLAT/SQUARE EDGE - 19.1" X 10" - W/O HDW - WASHED MAPLE FROM: 00-00-00 THRU: 06-10-07
4	160256-35-W52	EA	DOOR - FLAT/SQUARE EDGE - 21.8" X 10.8" - W/O HDW - WASHED MAPLE FROM: 06-11-07 THRU: 99-99-99
5	159204-02-U21	EA	DOOR - MIRRORED - 16.7" X 48" - W/O HDW - HONEY CHERRY
5	159204-02-U22	EA	DOOR - MIRRORED - 16.7" X 48" - W/O HDW - WASHED MAPLE
	140374-85-000	EA	MIRROR - SAFETY GLASS - 12.8" X 44"
6	160256-03-W51	EA	DOOR - FLAT/SQUARE EDGE - 48" X 16.7" - W/O HDW - HONEY CHERRY
6	160256-03-W52	EA	DOOR - FLAT/SQUARE EDGE - 48" X 16.7" - W/O HDW - WASHED MAPLE
7	161078-21-W51	EA	DRAWER - BROKEN EDGE - 14.7"W X 17.7"D - W/O SLIDES/HDW - HONEY CHERRY
7	161078-21-W52	EA	DRAWER - BROKEN EDGE - 14.7"W X 17.7"D - W/O SLIDES/HDW - WASHED MAPLE
8	161078-30-W51	EA	DRAWER - BROKEN EDGE - 14.7"W X 13.8"D - W/O SLIDES/HDW - HONEY CHERRY
8	161078-30-W52	EA	DRAWER - BROKEN EDGE - 14.7"W X 13.8"D - W/O SLIDES/HDW - WASHED MAPLE
9	161078-31-W51	EA	DRAWER - BROKEN EDGE - 14.7"W X 13.8"D - W/O SLIDES/HDW - HONEY CHERRY
9	161078-31-W52	EA	DRAWER - BROKEN EDGE - 14.7"W X 13.8"D - W/O SLIDES/HDW - WASHED MAPLE
10	161078-29-W51	EA	DRAWER - BROKEN EDGE - 22.6"W X 13.8"D - W/O SLIDES/HDW - HONEY CHERRY
10	161078-29-W52	EA	DRAWER - BROKEN EDGE - 22.6"W X 13.8"D - W/O SLIDES/HDW - WASHED MAPLE
11	160256-01-W21	EA	DOOR - FLAT/SQUARE EDGE - 19.1" X 10" - W/O HDW - HONEY CHERRY
11	160256-01-W22	EA	DOOR - FLAT/SQUARE EDGE - 19.1" X 10" - W/O HDW - WASHED MAPLE
11	160256-64-W51	EA	DOOR - FLAT/SQUARE EDGE - 14.5" X 9.8" - W/O HDW - HONEY CHERRY - INTERIOR UPGRADE PKG.
11	160256-64-W52	EA	DOOR - FLAT/SQUARE EDGE - 14.5" X 9.8" - W/O HDW - WASHED MAPLE - INTERIOR UPGRADE PKG.
12	160256-21-W51	EA	DOOR - FLAT/SQUARE EDGE - 21.8" X 12.8" - W/O HDW - HONEY CHERRY
12	160256-21-W52	EA	DOOR - FLAT/SQUARE EDGE - 21.8" X 12.8" - W/O HDW - WASHED MAPLE
13	160256-22-W51	EA	DOOR - FLAT/SQUARE EDGE - 21.8" X 12.8" - W/O HDW - HONEY CHERRY
13	160256-22-W52	EA	DOOR - FLAT/SQUARE EDGE - 21.8" X 12.8" - W/O HDW - WASHED MAPLE

**CABINET & APPLIANCE GROUP (CONTINUED)**  
**CABINET & APPLIANCE LAYOUT (CONTINUED)**

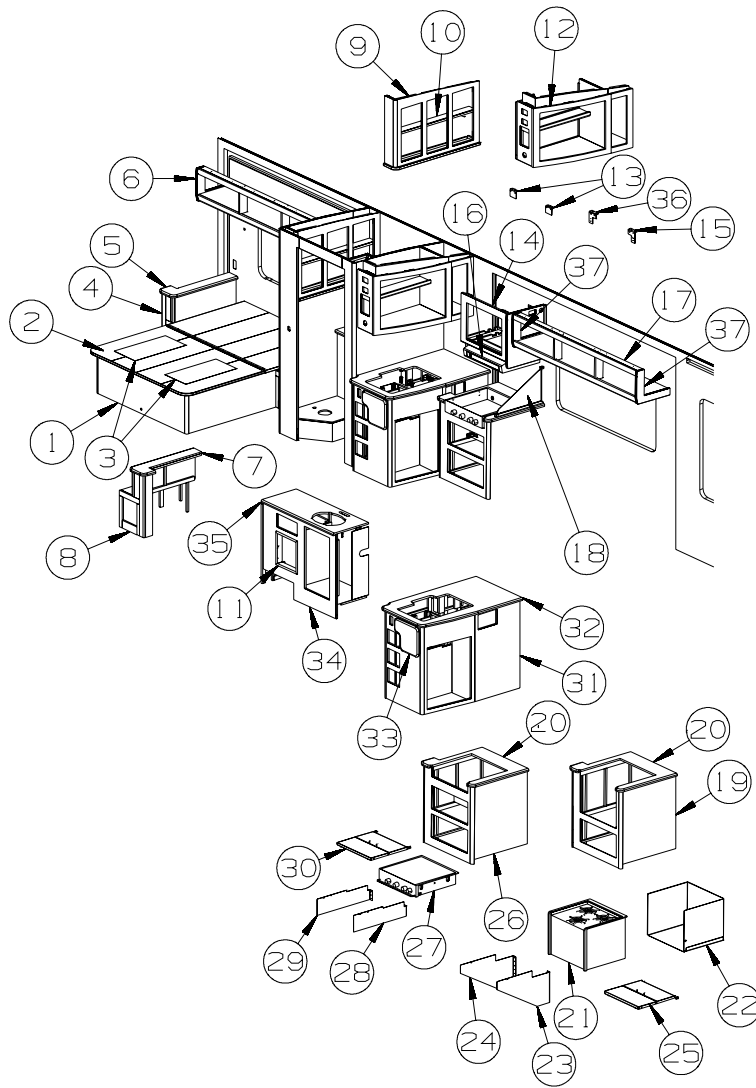

KEY	PART NUMBER	U/M	DESCRIPTION
1	162306-01-W51	EA	CABINET - BED BASE - QUEEN - W/O DOORS/DRAWERS/HDW - HONEY CHERRY
1	162306-01-W52	EA	CABINET - BED BASE - QUEEN - W/O DOORS/DRAWERS/HDW - WASHED MAPLE
2	137406-06-F32	EA	BEDBOARD - W/HINGE/T-MOLDING/SLIPNOT - FLIP-UP
	142569-15-000	EA	SPRING/GAS - 120 LB - 20" EXTENDED/12" COMPRESSED
	126263-06-02B	EA	BRACKET - GAS SPRING W/CENTERED BALL STUD - E-COATED
	126263-08-02B	EA	BRACKET - GAS SPRING W/CENTERED BALL STUD - E-COATED
3	096764-02-000	FT	SLIPNOT - ANTISLIP - 1'WIDE (180' ROLLS) - WHITE
4	136885-07-W51	EA	CABINET - NIGHTSTAND/LH - W/O CTRTP/DOOR/DWR/HDW - HONEY CHERRY
4	136885-07-RW1	EA	CABINET - NIGHTSTAND/LH - W/O CTRTP/DOOR/DWR/HDW - WASHED MAPLE
5	157828-58-05A	EA	COUNTERTOP - NIGHTSTAND (W57, W58, W61, W62)
5	157828-58-04A	EA	COUNTERTOP - NIGHTSTAND (W59, W60)
6	162284-01-W51	EA	CABINET - OVERHEAD/REAR - W/O DOORS/HDW - HONEY CHERRY
6	162284-01-W52	EA	CABINET - OVERHEAD/REAR - W/O DOORS/HDW - WASHED MAPLE
7	157828-59-05A	EA	COUNTERTOP - NIGHTSTAND (W57, W58, W61, W62)
7	157828-59-04A	EA	COUNTERTOP - NIGHTSTAND (W59, W60)
8	136885-08-W51	EA	CABINET - NIGHTSTAND/RH - W/O CTRTP/DOOR/DWR/HDW - HONEY CHERRY
8	136885-08-RW1	EA	CABINET - NIGHTSTAND/RH - W/O CTRTP/DOOR/DWR/HDW - WASHED MAPLE
9	162323-01-W51	EA	CABINET - OVERHEAD/MEDICINE - W/O DOORS/HDW - HONEY CHERRY
9	162323-01-W52	EA	CABINET - OVERHEAD/MEDICINE - W/O DOORS/HDW - WASHED MAPLE
10	162323-18-W51	EA	SHELF - W/PLASTIC MOLDING - HONEY CHERRY
10	162323-18-W52	EA	SHELF - W/PLASTIC MOLDING - WASHED MAPLE
11	137602-07-RE3	EA	POCKET - MAGAZINE - PEWTER - HONEY CHERRY
11	137602-07-RW5	EA	POCKET - MAGAZINE - PEWTER - WASHED MAPLE
12	162328-01-W51	EA	CABINET - GALLEY - W/O DOORS/HDW - HONEY CHERRY - WATER HEATER-ELEC. IGNITION
12	162328-01-W52	EA	CABINET - GALLEY - W/O DOORS/HDW - WASHED MAPLE - WATER HEATER-ELEC. IGNITION

## CABINET & APPLIANCE GROUP (CONTINUED)

### CABINET & APPLIANCE LAYOUT (CONTINUED)

KEY	PART NUMBER	U/M	DESCRIPTION
12	162328-02-W51	EA	CABINET - GALLEY - W/O DOORS/HDW - HONEY CHERRY - WTR HTR-6GAL/110/LP/MTR/AUTO
12	162328-02-W52	EA	CABINET - GALLEY - W/O DOORS/HDW - WASHED MAPLE - WTR HTR-6GAL/110/LP/MTR/AUTO
12	162328-03-W51	EA	CABINET-GALLEY - W/O D-RS/HDW - HONEY CHERRY - WTR HTR-ELEC. IGNTN/INT UPGRADE PKG.
12	162328-03-W52	EA	CABINET-GALLEY - W/O D-RS/HDW - WASHED MAPLE - WTR HTR-ELEC. IGNTN/INT UPGRADE PKG.
12	162328-04-W51	EA	CABINET-GALLEY - HONEY CHERRY - WTR HTR-6GAL/110/LP/MTR/AUTO/INT UPGRADE PKG.
12	162328-04-W52	EA	CABINET-GALLEY - WASHED MAPLE - WTR HTR-6GAL/110/LP/MTR/AUTO/INT UPGRADE PKG.
13	149420-07-02B	EA	BRACE - MICROWAVE - E-COATED- MICROWAVE/CONVECTION OVEN
13	098916-39-02B	EA	BRACE - MICROWAVE CABINET - E-COATED
14	162948-01-W51	EA	CABINET - OVERHEAD/MICROWAVE - W/O DOORS/HDW - HONEY CHERRY
14	162948-01-W52	EA	CABINET - OVERHEAD/MICROWAVE - W/O DOORS/HDW - WASHED MAPLE
14	162949-01-W51	EA	CABINET - MICROWAVE - W/O DOORS/HDW - HONEY CHERRY - MICROWAVE/CONVECTION OVEN
14	162949-01-W52	EA	CABINET - MICROWAVE - W/O DOORS/HDW - WASHED MAPLE - MICROWAVE/CONVECTION OVEN
15	149420-08-02B	EA	BRACE - MICROWAVE - E-COATED- MICROWAVE/CONVECTION OVEN
15	098916-39-02B	EA	BRACE - MICROWAVE CABINET - E-COATED
16*	136354-01-01A	EA	HOOD - RANGE - W/LITE/FAN - US/VENTED - TEXTURED BLK - MICROWAVE OVEN
16*	136354-02-02A	EA	HOOD - RANGE - W/LITE/FAN - BLACK TEXTURED - CSA - MICROWAVE OVEN - CANADIAN
16*	136354-05-01A	EA	HOOD - RANGE - W/LITE/FAN - BLACK TEXTURED - UL - MICROWAVE/CONVECTION OVEN
16*	136354-06-01A	EA	HOOD - RANGE - W/LITE/FAN - BLACK TEXTURED - MICROWAVE/CONVECTION OVEN - CANADIAN
	117806-01-000	EA	BULB - 12V - #912 - 1.0 AMP
17	162344-02-W51	EA	CABINET - OVERHEAD/FRONT - W/O DOORS/HDW - HONEY CHERRY
17	162344-02-W52	EA	CABINET - OVERHEAD/FRONT - W/O DOORS/HDW - WASHED MAPLE
18	145211-03-U21	EA	SPLASHGUARD - HONEY CHERRY
18	145211-03-U22	EA	SPLASHGUARD - WASHED MAPLE
19	162939-02-W51	EA	CABINET - GALLEY - W/O COUNTERTOP/DOORS/DRAWERS/HDW - HONEY CHERRY
19	162939-02-W52	EA	CABINET - GALLEY - W/O COUNTERTOP/DOORS/DRAWERS/HDW - WASHED MAPLE
19	162939-03-W51	EA	CABINET - GALLEY - W/O COUNTERTOP/DOORS/DRAWERS/HDW - HONEY CHERRY - CANADIAN
19	162939-03-W52	EA	CABINET - GALLEY - W/O COUNTERTOP/DOORS/DRAWERS/HDW - WASHED MAPLE - CANADIAN
20	162784-01-05A	EA	COUNTERTOP - GALLEY (W57, W58, W61, W62)
20	162784-01-04A	EA	COUNTERTOP - GALLEY (W59, W60)
21*	151277-01-01A	EA	RANGE-16"-3 BURNER - MERCURY FREE - BLACK DOOR/TEXTURED
21*	151279-03-01A	EA	RANGE-22"-3 BURNER/SEALED-MERCURY FREE-BLK DOOR/GLASS - CANADIAN
22	162694-01-01A	EA	ENCLOSURE - STOVE - 20.7"W X 16.1"H X 18.7"D
23	140176-15-02B	EA	BRACKET/TIEDOWN - STOVE - E-COATED
24	140176-16-02B	EA	BRACKET/TIEDOWN - STOVE - E-COATED
25	126022-04-01A	EA	COVER/RANGE - BI-FOLD - 16" - INTERIOR UPGRADE PKG.
25	151424-01-01A	EA	COVER/RANGE - BI-FOLD - 22" - F/SEALED BURNER - BLACK - INTERIOR UPGRADE PKG./CANADIAN
26	162939-01-W51	EA	CABINET - GALLEY - W/O DOORS/HDW - HONEY CHERRY - RANGE TOP/3 BURNER
26	162939-01-W52	EA	CABINET - GALLEY - W/O DOORS/HDW - WASHED MAPLE - RANGE TOP/3 BURNER
27*	114030-04-01A	EA	RANGE - 3 BRNR TOP/NEW STYLE KNOBS/GRATES-W/O OVEN-BLK
27*	135065-04-01A	EA	RANGE - 3 BURNER (SEALED) - W/O OVEN - CSA - BLACK TOP - CANADIAN
28	142139-20-02B	EA	BRACKET/TIEDOWN - STOVE - E-COATED
29	142139-21-02B	EA	BRACKET/TIEDOWN - STOVE - E-COATED
30	126022-05-01A	EA	COVER/RANGE - BI-FOLD - 22" - RANGE TOP/3 BURNER/INTERIOR UPGRADE PKG.
31	P62331-01-W51	EA	CABT-GALLEY-W/O CNTERTP/DRS/DRWRS/HDW-HONEY CHERRY-WATER HEATER-ELEC. IGNITION
31	P62331-01-W52	EA	CABT-GALLEY-W/O CNTERTP/DRS/DRWRS/HDW-WASHED MAPLE - WATER HEATER-ELEC. IGNITION
31	P62331-02-W51	EA	CABT-GAL-W/O CNTERTP/DRS/DRWRS/HDW-HONEY CHERRY - WTR HTR-6GAL/110/LP/MTR/AUTO
31	P62331-02-W52	EA	CABT-GAL-W/O CNTERTP/DRS/DRWRS/HDW-WASHED MAPLE - WTR HTR-6GAL/110/LP/MTR/AUTO
31	P62331-03-W51	EA	CABTT - GALLEY - HONEY CHERRY - WTR HTR - ELEC. IGN - INVERTER - AC/DC-300W
31	P62331-03-W52	EA	CABT - GALLEY - WASHED MAPLE - WTR HTR - ELEC. IGN - INVERTER - AC/DC-300W
31	P62331-04-W51	EA	CABT - GALLEY - HONEY CHERRY - WTR HTR-6GAL/110/LP/MTR/AUTO-INVERTER-AC/DC-300W
31	P62331-04-W52	EA	CABT - GALLEY - WASHED MAPLE - WTR HTR-6GAL/110/LP/MTR/AUTO-INVERTER-AC/DC-300W
32	157828-60-05A	EA	COUNTERTOP - GALLEY (W57, W58, W61, W62)
32	157828-60-04A	EA	COUNTERTOP - GALLEY (W59, W60)
33	157828-18-04A	EA	COUNTERTOP - EXTENSION/GALLEY (W57, W58, W61, W62)
33	157828-18-03A	EA	COUNTERTOP - EXTENSION/GALLEY (W59, W60)
34	P49171-01-W51	EA	CABINET - LAVATORY - W/O COUNTERTOP/DOORS/DRAWERS/HARDWARE - HONEY CHERRY
34	P49171-01-W52	EA	CABINET - LAVATORY - W/O COUNTERTOP/DOORS/DRAWERS/HARDWARE - WASHED MAPLE
35	157828-61-05A	EA	COUNTERTOP - LAVATORY (W57, W58, W61, W62)
35	157828-61-04A	EA	COUNTERTOP - LAVATORY (W59, W60)
36	149420-07-02B	EA	BRACE - MICROWAVE - E-COATED- MICROWAVE/CONVECTION OVEN
37	158629-16-U21	EA	PANEL - END CAP - HONEY CHERRY
37	158629-16-U22	EA	PANEL - END CAP - WASHED MAPLE

\*COMPONENT PARTS LISTED LATER IN THIS GROUP

**CABINET & APPLIANCE GROUP (CONTINUED)**  
**CABINET & APPLIANCE LAYOUT (CONTINUED)**

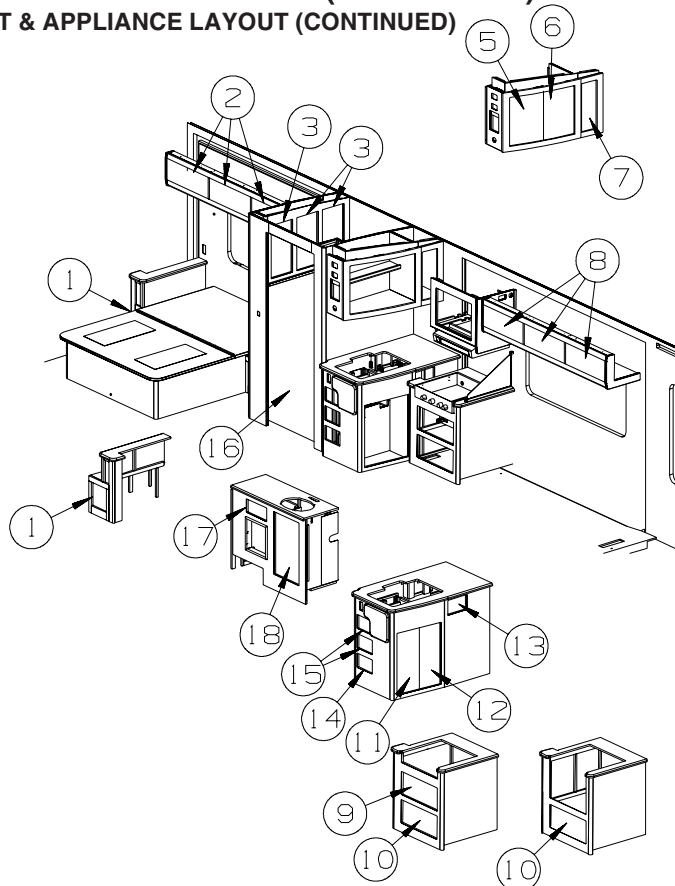

KEY	PART NUMBER	U/M	DESCRIPTION
1	161078-32-W51	EA	DRAWER - BROKEN EDGE - 7.6"W X 23.6"D - W/O SLIDES/HDW - HONEY CHERRY
1	161078-32-W52	EA	DRAWER - BROKEN EDGE - 7.6"W X 23.6"D - W/O SLIDES/HDW - WASHED MAPLE
2	160245-04-W51	EA	DOOR - CURVED - 11.8" X 24.4" - W/O HDW - HONEY CHERRY
2	160245-04-W52	EA	DOOR - CURVED - 11.8" X 24.4" - W/O HDW - WASHED MAPLE
3	160256-34-W51	EA	DOOR - FLAT/SQUARE EDGE - 21.8" X 10.8" - W/O HDW - HONEY CHERRY
3	160256-34-W52	EA	DOOR - FLAT/SQUARE EDGE - 21.8" X 10.8" - W/O HDW - WASHED MAPLE
4	160256-35-W51	EA	DOOR - FLAT/SQUARE EDGE - 21.8" X 10.8" - W/O HDW - HONEY CHERRY
4	160256-35-W52	EA	DOOR - FLAT/SQUARE EDGE - 21.8" X 10.8" - W/O HDW - WASHED MAPLE
5	160242-03-W51	EA	DOOR - CURVED - 19.9"H X 13.8"W - W/O HDW - HONEY CHERRY
5	160242-03-W52	EA	DOOR - CURVED - 19.9"H X 13.8"W - W/O HDW - WASHED MAPLE
6	160242-04-W51	EA	DOOR - CURVED - 19.9"H X 13.8"W - W/O HDW - HONEY CHERRY
6	160242-04-W52	EA	DOOR - CURVED - 19.9"H X 13.8"W - W/O HDW - WASHED MAPLE
7	160256-67-W51	EA	DOOR - FLAT/SQUARE EDGE - 19.9" X 7.9" - W/O HDW - HONEY CHERRY
7	160256-67-W52	EA	DOOR - FLAT/SQUARE EDGE - 19.9" X 7.9" - W/O HDW - WASHED MAPLE
8	160245-13-W51	EA	DOOR - CURVED - 11.8" X 23.6" - W/O HDW - HONEY CHERRY
8	160245-13-W52	EA	DOOR - CURVED - 11.8" X 23.6" - W/O HDW - WASHED MAPLE
9	161078-39-W51	EA	DRAWER - BROKEN EDGE - 19.8"W X 19.7"D - W/O SLIDES/HDW - HONEY CHERRY
9	161078-39-W52	EA	DRAWER - BROKEN EDGE - 19.8"W X 19.7"D - W/O SLIDES/HDW - WASHED MAPLE
10	161078-40-W51	EA	DRAWER - BROKEN EDGE - 19.8"W X 11.8"D - W/O SLIDES/HDW - HONEY CHERRY
10	161078-40-W52	EA	DRAWER - BROKEN EDGE - 19.8"W X 11.8"D - W/O SLIDES/HDW - WASHED MAPLE
11	160256-65-W51	EA	DOOR - FLAT/SQUARE EDGE - 25.2" X 10" - W/O HDW - HONEY CHERRY
11	160256-65-W52	EA	DOOR - FLAT/SQUARE EDGE - 25.2" X 10" - W/O HDW - WASHED MAPLE
12	160256-66-W51	EA	DOOR - FLAT/SQUARE EDGE - 25.2" X 10" - W/O HD - HONEY CHERRY
12	160256-66-W52	EA	DOOR - FLAT/SQUARE EDGE - 25.2" X 10" - W/O HD - WASHED MAPLE
13	161078-69-W51	EA	DRAWER - BROKEN EDGE - 8"W X 21.6"D - W/O SLIDES/HDW - HONEY CHERRY
13	161078-69-W52	EA	DRAWER - BROKEN EDGE - 8"W X 21.6"D - W/O SLIDES/HDW - WASHED MAPLE
14	161078-34-W51	EA	DRAWER - BROKEN EDGE - 7.6"W X 21.6"D - W/O SLIDES/HDW - HONEY CHERRY
14	161078-97-W51	EA	DRAWER - BROKEN EDGE - 6.1"W X 17.7"D - W/O SLIDES/HDW - HONEY CHERRY FROM: 00-00-00 THRU: 03-02-08
14	161078-34-W52	EA	DRAWER - BROKEN EDGE - 7.6"W X 21.6"D - W/O SLIDES/HDW - WASHED MAPLE FROM: 00-00-00 THRU: 03-02-08
14	161078-97-W52	EA	DRAWER - BROKEN EDGE - 6.1"W X 17.7"D - W/O SLIDES/HDW - WASHED MAPLE FROM: 03-03-08 THRU: 99-99-99

**CABINET & APPLIANCE GROUP (CONTINUED)**  
**CABINET & APPLIANCE LAYOUT (CONTINUED)**

KEY	PART NUMBER	U/M	DESCRIPTION
15	161078-36-W51	EA	DRAWER - BROKEN EDGE - 7.6"W X 17.7"D - W/O SLIDES/HDW - HONEY CHERRY FROM: 00-00-00 THRU: 03-02-08
15	161078-96-W51	EA	DRAWER - BROKEN EDGE - 6.1"W X 21.6"D - W/O SLIDES/HDW - WASHED MAPLE FROM: 03-03-08 THRU: 99-99-99
15	161078-36-W52	EA	DRAWER - BROKEN EDGE - 7.6"W X 17.7"D - W/O SLIDES/HDW - WASHED MAPLE FROM: 00-00-00 THRU: 03-02-08
15	161078-96-W52	EA	DRAWER - BROKEN EDGE - 6.1"W X 21.6"D - W/O SLIDES/HDW - WASHED MAPLE FROM: 03-03-08 THRU: 99-99-99
16	144645-04-U21	EA	DOOR - BATH - W/O FRAME (PICTURE)/TOWEL RACK/HDW - HONEY CHERRY
16	144645-04-RW1	EA	DOOR - BATH - W/O FRAME (PICTURE)/TOWEL RACK/HDW - WASHED MAPLE
17	161078-33-W51	EA	DRAWER - BROKEN EDGE - 10.8"W X 13.8"D - W/O SLIDES/HDW - HONEY CHERRY
17	161078-33-W52	EA	DRAWER - BROKEN EDGE - 10.8"W X 13.8"D - W/O SLIDES/HDW - WASHED MAPLE
18	160256-17-W51	EA	DOOR - FLAT/SQUARE EDGE - 25.6" X 15.13" - W/O HDW - HONEY CHERRY
18	160256-17-W52	EA	DOOR - FLAT/SQUARE EDGE - 25.6" X 15.13" - W/O HDW - WASHED MAPLE

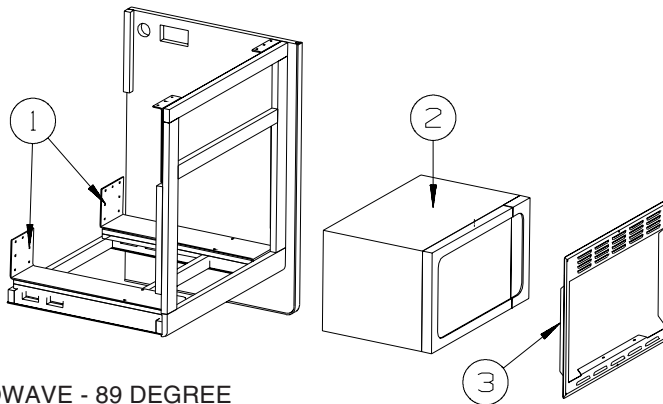

**MICROWAVE  
INSTL.**

KEY	PART NUMBER	U/M	DESCRIPTION
1	094750-10-000	EA	BRACKET - MICROWAVE - 89 DEGREE
2*	158686-01-01A	EA	OVEN/MICROWAVE - .9 CU FT - NON-CONV - BLACK FROM: 00-00-00 THRU: 04-08-07
2	158686-02-01A	EA	OVEN/MICROWAVE - .9 CU FT - NON-CONV - W/O TRIM/VENTS-BLK FROM: 04-09-07 THRU: 99-99-99
3	164197-01-01A	EA	TRIM KIT - MICROWAVE - BLACK FROM: 04-09-07 THRU: 99-99-99

**\*COMPONENT PARTS LISTED LATER IN THIS GROUP**

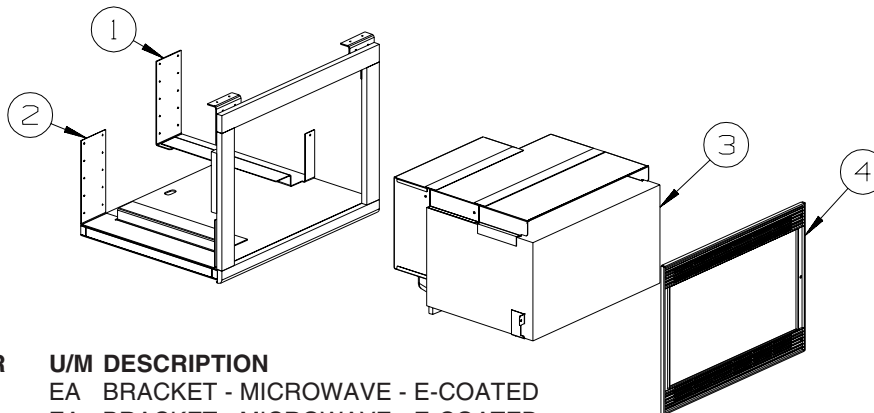

**CONVECTION  
MICROWAVE  
INSTL.**

KEY	PART NUMBER	U/M	DESCRIPTION
1	149418-11-02B	EA	BRACKET - MICROWAVE - E-COATED
2	149418-12-02B	EA	BRACKET - MICROWAVE - E-COATED
3*	150606-04-01A	EA	OVEN - MICROWAVE/CONVECTION/BLACK - .9 CU FT - #R-820BK - <b>U.S.</b>
3*	150606-06-01A	EA	OVEN - MICROWAVE/CONVECTION/BLACK - .9 CU FT - #R820BK- <b>CANADIAN</b>
4	150606-05-01A	EA	TRIM KIT - MICROWAVE .9 CU FT - BLACK - MAGNADYNE #R820

**\*COMPONENT PARTS LISTED LATER IN THIS GROUP**



**CABINET & APPLIANCE GROUP (CONTINUED)**  
**CABINET & APPLIANCE LAYOUT (CONTINUED)**

**D26P**

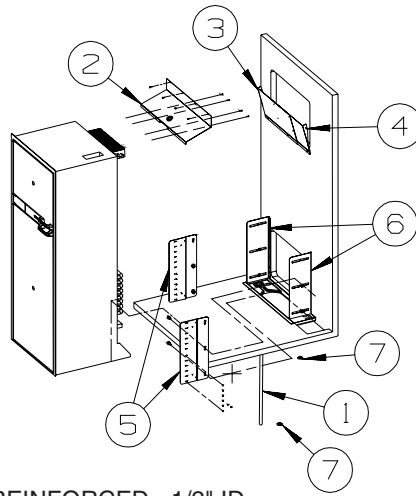

KEY	PART NUMBER	U/M	DESCRIPTION
1	112176-01-000	FT	TUBING - VINYL - REINFORCED - 1/2" ID
2	136966-04-02B	EA	BAFFLE - REFRIGERATOR - E-COATED
3	143195-03-02B	EA	BAFFLE - REFRIGERATOR - E-COATED
4	143195-04-02B	EA	BAFFLE - REFRIGERATOR - E-COATED
5	150740-01-02B	EA	BRACKET - REFRIGERATOR - E-COATED
6	150740-02-02B	EA	BRACKET - REFRIGERATOR - E-COATED
7	152417-01-01A	EA	CLAMP/RATCHET - F/REFRIDGERATOR DRIP TRAY HOSE - BLACK

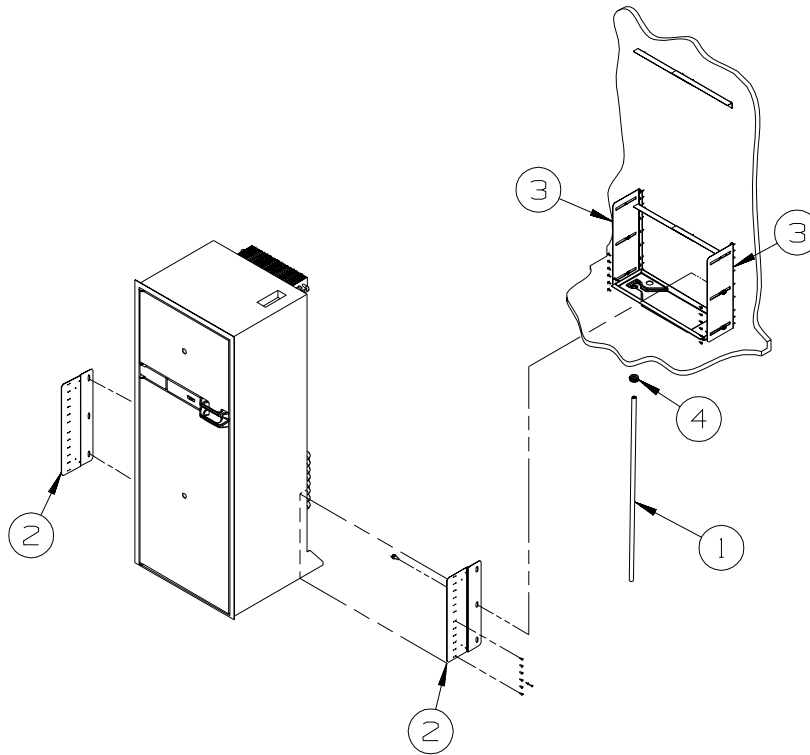

**D29R, D30B, D34M, D35J**

KEY	PART NUMBER	U/M	DESCRIPTION
1	112176-01-000	FT	TUBING - VINYL - REINFORCED - 1/2" ID
2	150740-01-02B	EA	BRACKET/TIEDOWN - REFRIGERATOR - E-COATED
3	150740-02-02B	EA	BRACKET/TIEDOWN - REFRIGERATOR - E-COATED
4	152417-01-01A	EA	CLAMP/RATCHET - F/REFRIDGERATOR DRIP TRAY HOSE - BLACK

**CABINET & APPLIANCE GROUP (CONTINUED)**  
**COMPONENT PARTS FOR CABINET & APPLIANCE LAYOUT**

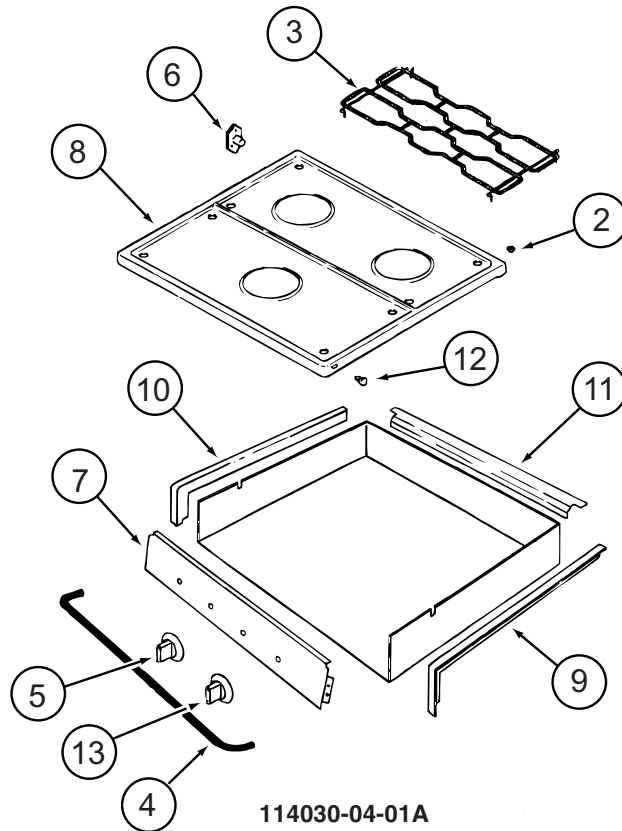

114030-04-01A

KEY	PART NUMBER	U/M	DESCRIPTION	VENDOR NO.
2	102020-01-709	EA	BUMPER-GRATE	8007P020-60
3	112881-04-702	EA	GRATE - BLACK	74007277
4	114030-02-700	EA	GUARD/FABRIC - TOWEL BAR	3609F006-70
5	128728-01-701	EA	KNOB - BURNER - REAR	74003941 (1 PER)
5	128728-01-702	EA	KNOB - BURNER - FRONT	74003942
6	128728-01-703	EA	PIN/T-NUT F/HINGE	7103P109-60
7	114030-04-700	EA	PANEL - MANIFOLD - BLACK	74007325
8	126023-01-728	EA	TOP - MAIN (BLACK)	74003323
9	114030-01-704	EA	TRIM - RIGHT/BLACK TEXTURED	74002839
10	114030-01-705	EA	TRIM - LEFT/BLACK TEXTURED	74002840
11	114030-01-706	EA	TRIM - REAR/BLACK TEXTURED	74002841
12	102020-01-724	EA	BUMPER - MAIN TOP	8003P008-60
13	128728-01-707	EA	KNOB - IGNITER	74003944

CONTACT WINNEBAGO PART SALES FOR UNLISTED COMPONENT(S)

**CABINET & APPLIANCE GROUP (CONTINUED)**  
**COMPONENT PARTS FOR CABINET & APPLIANCE LAYOUT (CONTINUED)**

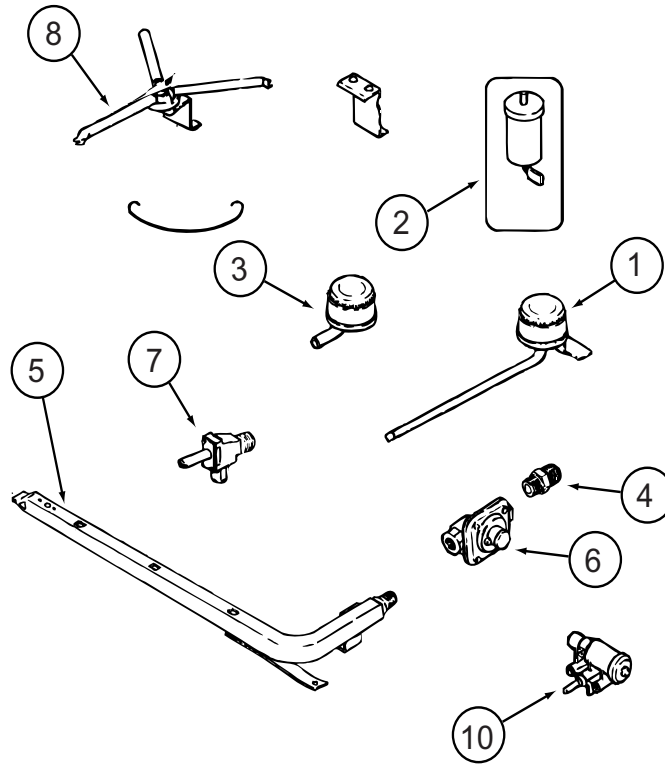

**114030-04-01A (CONTINUED)**

KEY	PART NUMBER	U/M	DESCRIPTION	VENDOR NO.
1	112881-04-700	EA	BURNER - TOP /LEFT REAR	74004584
1	126023-01-700	EA	BURNER - TOP (RT-REAR) 5100 BTU	74004583
2	112881-04-705	EA	PUSH RING (ELECTRODE MTG)	7104P002-60
2	126023-01-711	EA	ELECTRODE - IGNITER (ONLY)	7432P077-60
3	112881-04-701	EA	BURNER - TOP/FRONT	74004582
4	135065-03-700	EA	FITTING - HALF UNION	74004234
5	135065-01-702	EA	PIPE/MANIFOLD	74004642
6	126023-02-703	EA	REGULATOR - PRESSURE	74004235
7	126023-02-705	EA	VALVE - BURNER - REAR	74004362
7	126023-02-706	EA	VALVE - BURNER - FRONT	74004363
8	126023-01-736	EA	FLASH TUBE EXTENSION (REAR)	74003326
8	126023-01-737	EA	FLASH TUBE EXTENSION (FRONT)	74003327
10	126023-01-719	EA	IGNITER HEAD - TOP BURNER	74002413
	126023-02-702	EA	PIPE - MANIFOLD	74004360

CONTACT WINNEBAGO PART SALES FOR UNLISTED COMPONENT(S)

**CABINET & APPLIANCE GROUP (CONTINUED)**  
**COMPONENT PARTS FOR CABINET & APPLIANCE LAYOUT (CONTINUED)**

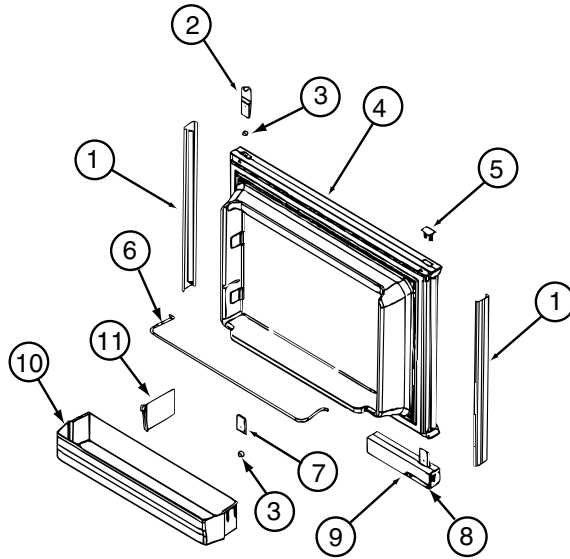

**121568-06-01A, 121568-07-01A, 121568-08-01A**

<b>KEY</b>	<b>PART NUMBER</b>	<b>U/M</b>	<b>DESCRIPTION</b>	<b>VENDOR NO.</b>
1	121568-03-700	EA	RETAINER-DOOR PNL/WAFFLE/BLK	619558-WDL-UPPER
2	120075-01-701	EA	HINGE-TOP RH/BOTTOM LH(DOOR)	618511
3	121568-03-701	EA	BUSHING - HINGE PIN/GRAY	619671
4	121568-03-702	EA	DOOR LINER-UPR/WAFFLED/BLACK	619627 - SMALL WDL
5	120075-01-702	EA	CAP, (HINGE PLUG)	618160
6	121568-01-700	EA	RAIL - DOOR UPPER	618618
7	120075-01-705	EA	HINGE-TOP LH/BOTTOM RH(DOOR)	618510
8	121568-03-705	EA	STORAGE LATCH - GRAY	619648
9	121568-03-721	EA	HANDLE/DOOR UPPER RH SWING	621465
9	121568-03-722	EA	HANDLE/DOOR LOWER RH SWING	621469
10	121568-01-701	EA	BIN - DOOR WHITE-WAFFLED LNR	618619 WDL

CONTACT WINNEBAGO PART SALES FOR UNLISTED COMPONENT(S)

**CABINET & APPLIANCE GROUP (CONTINUED)**  
**COMPONENT PARTS FOR CABINET & APPLIANCE LAYOUT (CONTINUED)**

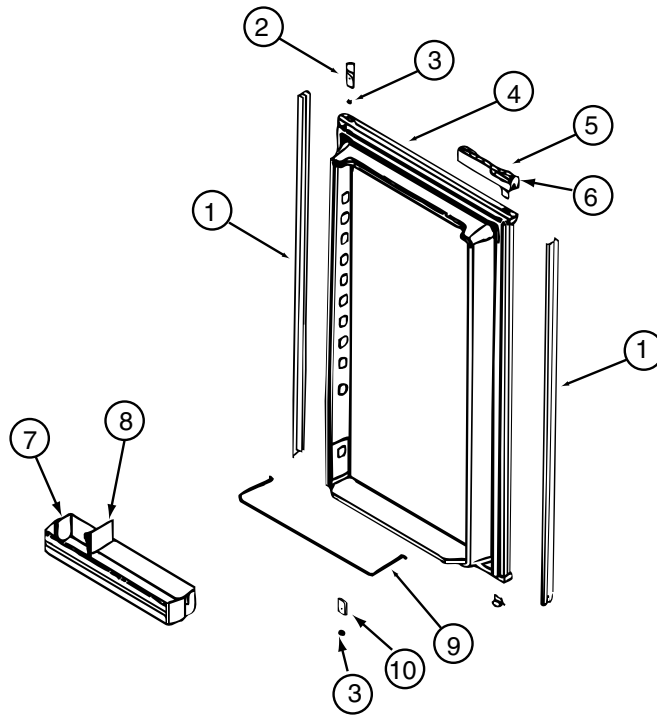

121568-06-01A, 121568-07-01A, 121568-08-01A (CONTINUED)

KEY	PART NUMBER	U/M	DESCRIPTION	VENDOR NO.
1	121568-03-706	EA	RETAINER-DOOR PNL/WAFFLE/BLK	619559-WDL-LOWER
2	120075-01-701	EA	HINGE-TOP RH/BOTTOM LH(DOOR)	618511
3	121568-03-701	EA	BUSHING - HINGE PIN/GRAY	619671
4	121568-03-707	EA	DOOR LINER-LWR/WAFFLED/B/TRM	619629
5	121568-03-722	EA	HANDLE/DOOR LOWER RH SWING	621469
6	121568-03-705	EA	STORAGE LATCH - GRAY	619648
7	121568-01-701	EA	BIN - DOOR WHITE-WAFFLED LNR	618619 WDL
9	121568-01-704	EA	RAIL - DOOR LOWER	618578
10	120075-01-705	EA	HINGE-TOP LH/BOTTOM RH(DOOR)	618510

CONTACT WINNEBAGO PART SALES FOR UNLISTED COMPONENT(S)

**CABINET & APPLIANCE GROUP (CONTINUED)**  
**COMPONENT PARTS FOR CABINET & APPLIANCE LAYOUT (CONTINUED)**

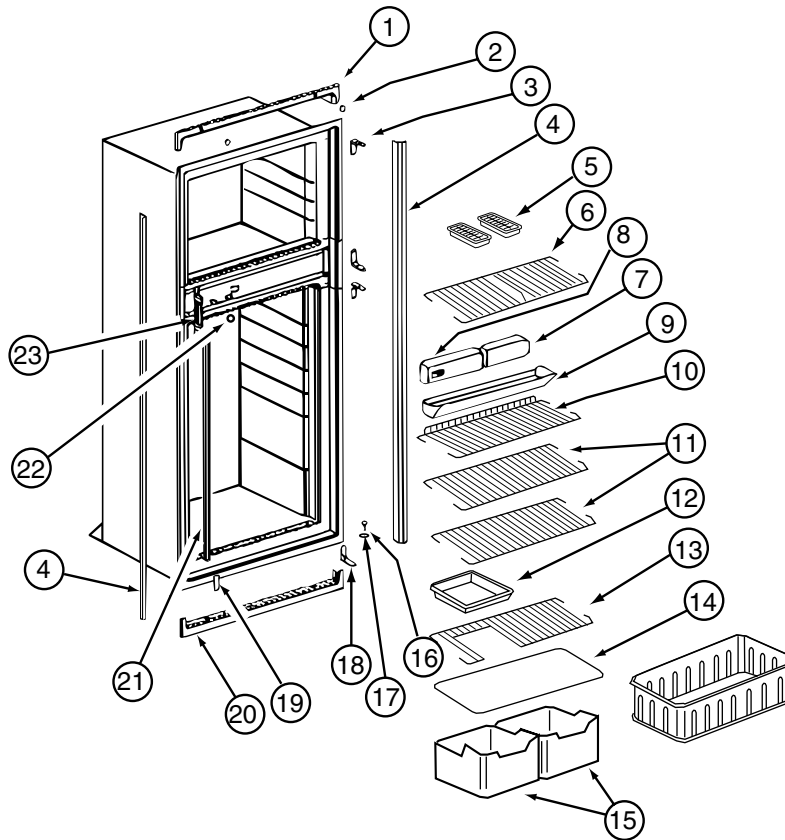

**121568-06-01A, 121568-07-01A, 121568-08-01A (CONTINUED)**

KEY	PART NUMBER	U/M	DESCRIPTION	VENDOR NO.
1	120075-01-713	EA	TRIM-TOP PIECE	619687
2	120075-01-714	EA	PLUG-HOLE (BLACK)	618170
3	121568-03-710	EA	HINGE/CABINET-TOP/RH-LWR/LH	619335 WAFFLED
4	121568-03-711	EA	TRIM - SIDE/BLACK	622295
6	121568-01-705	EA	SHELF - WIRE FREEZER	620250
7	121568-06-700	EA	FRONT BOX-N611	622002
8	121568-06-701	EA	CONTROL ASSY-OPTICAL/N611	621988 TO SN9056491
9	120075-01-720	EA	TRAY-DRIP	623250
9	120075-01-721	EA	LOUVER-DRIP TRAY	618176
11	121568-01-708	EA	SHELF - WIRE	620273
13	121568-01-707	EA	SHELF - WIRE - SHORT	620272
14	120075-01-725	EA	COVER-CRISPER - 18.5" WIDE	618158
15	121568-01-709	EA	CRISPER	618571
16	120075-01-727	EA	PIN-HINGE	618145
17	121568-03-701	EA	BUSHING - HINGE PIN/GRAY	619671
18	121568-03-715	EA	HINGE/CABINET-TOP/LH-LWR/RH	619336 WAFFLED
19	121568-03-716	EA	COVER - HINGE HOLES	619301
20	120075-01-729	EA	TRIM-BOTTOM PIECE	620958
21	121568-06-702	EA	CLIP - SHELF	61536522
22	121568-06-703	EA	HOLE PLUG - WHITE	620282
23	120075-01-732	EA	PLATE-STRIKE	618167

CONTACT WINNEBAGO PART SALES FOR UNLISTED COMPONENT(S)

**CABINET & APPLIANCE GROUP (CONTINUED)**  
**COMPONENT PARTS FOR CABINET & APPLIANCE LAYOUT (CONTINUED)**

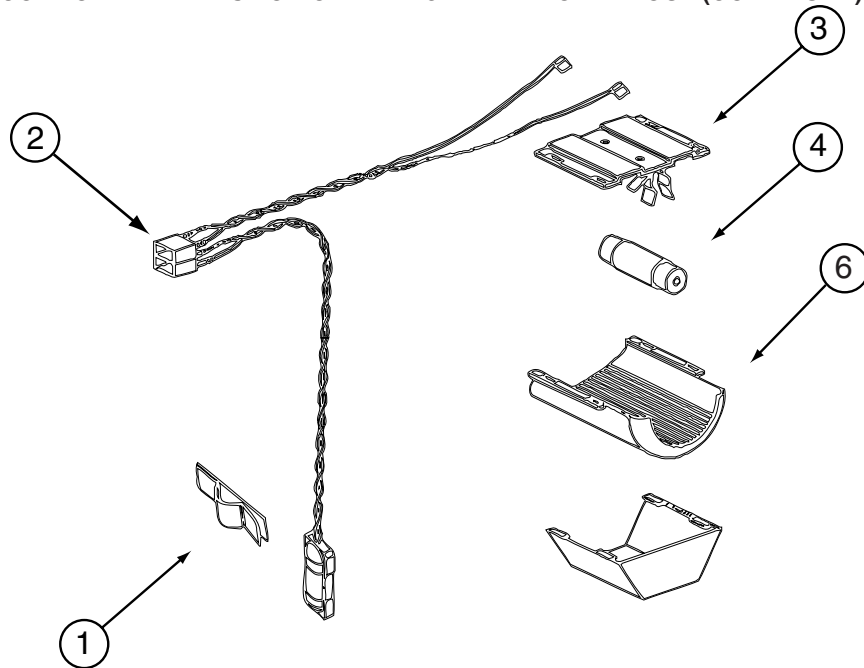

121568-03-01A, 121568-04-01A, 121568-05-01A, 121568-06-01A, 121568-07-01A, 121568-08-01A (CONTINUED)

KEY	PART NUMBER	U/M	DESCRIPTION	VENDOR NO.
1	084880-01-760	EA	CLIP (THERMISTER)	61689122
2	120075-01-735	EA	WIRE ASM - LAMP/THERMISTER	618548
3	084880-03-705	EA	BRACKET-LIGHT-INTERIOR	61629722
4	084880-03-706	EA	BULB-LAMP	61628922
6	084880-03-707	EA	COVER-LAMP, LENS	61627922

CONTACT WINNEBAGO PART SALES FOR UNLISTED COMPONENT(S)

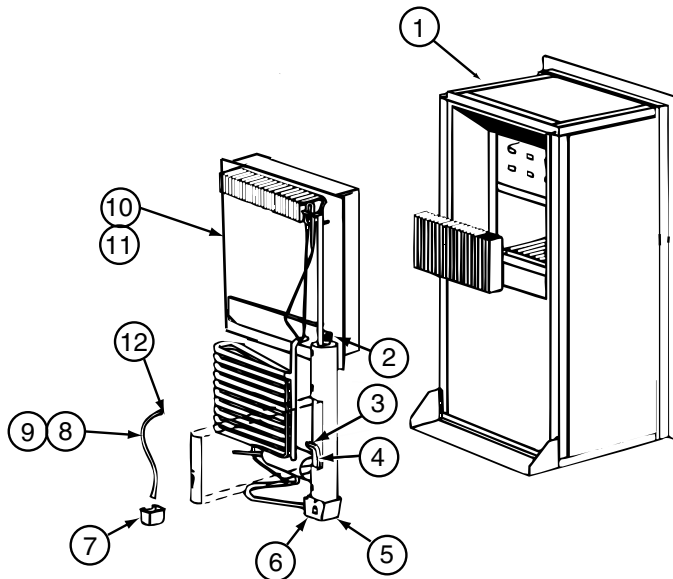

121568-06-01A, 121568-07-01A, 121568-08-01A (CONTINUED)

KEY	PART NUMBER	U/M	DESCRIPTION	VENDOR NO.
4	121568-06-704	EA	HEATER-AC/300W/120VAC	621702
10	120076-01-704	EA	COOLING UNIT, SERVICE PACK	618543

CONTACT WINNEBAGO PART SALES FOR UNLISTED COMPONENT(S)

**CABINET & APPLIANCE GROUP (CONTINUED)**  
**COMPONENT PARTS FOR CABINET & APPLIANCE LAYOUT (CONTINUED)**

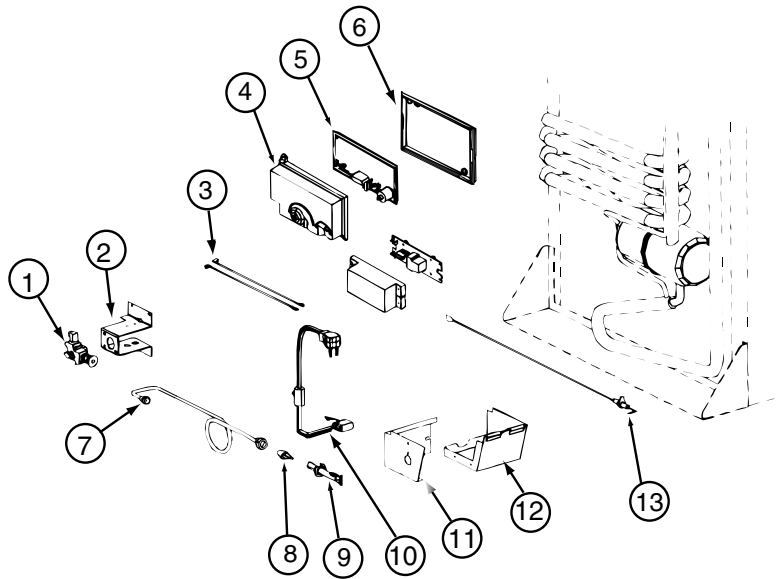

**121568-06-01A, 121568-07-01A, 121568-08-01A (CONTINUED)**

KEY	PART NUMBER	U/M	DESCRIPTION	VENDOR NO.
1	121568-06-705	EA	GAS VALVE/BRKT ASSY-COMBO	621439
1	121568-06-706	EA	GAS VALVE-COMBO/WRENCH FLAT	621329
4	120075-01-738	EA	COVER-POWER BOARD	618185
5	121568-06-707	EA	BOARD/POWER-N611	621991 = 621991001
6	120075-01-740	EA	BASE - POWER BOARD	618186
8	121568-06-708	EA	BURNER/ORFICE-ADAPTER KIT	621957
13	104137-06-715	EA	ELECTRODE-SPARK/SENSOR, SGL	61692222
	121569-08-704	EA	TUBE/BURNER - N8/N6	624682

CONTACT WINNEBAGO PART SALES FOR UNLISTED COMPONENT(S)



**CABINET & APPLIANCE GROUP (CONTINUED)**  
**COMPONENT PARTS FOR CABINET & APPLIANCE LAYOUT (CONTINUED)**

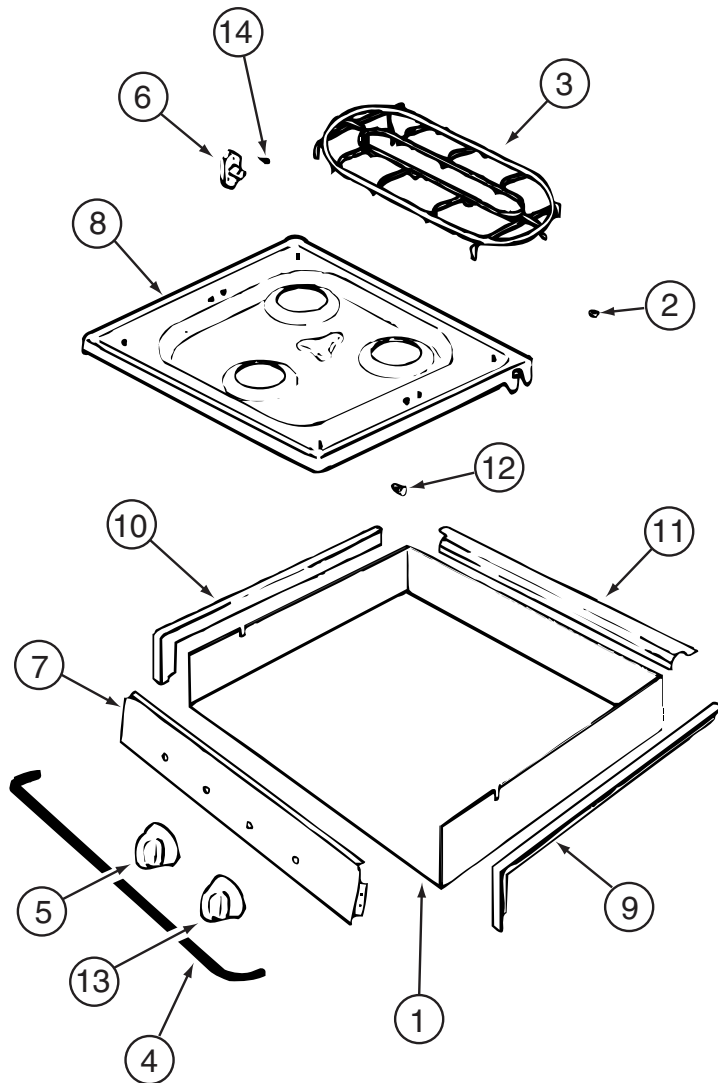

135065-03-01A, 135065-03-03A, 135065-04-01A

KEY	PART NUMBER	U/M	DESCRIPTION	VENDOR NO.
2	102020-01-709	EA	BUMPER-GRATE	8007-P020-60
3	135065-03-703	EA	GRATE - BLACK(SEALED BURNER)	74007304
4	114030-02-700	EA	GUARD/FABRIC - TOWEL BAR	3609F006-70
5	128728-01-701	EA	KNOB - BURNER - REAR	74003941
5	128728-01-702	EA	KNOB - BURNER - FRONT	74003942
6	128728-01-703	EA	PIN/T-NUT F/HINGE	7103P109-60
7	135065-03-704	EA	PANEL - MANIFOLD (BLACK)	74007330
8	128728-01-705	EA	TOP - MAIN - BLACK	74003928
8	135065-03-715	EA	TOP - MAIN - STAINLESS STEEL	74007299
9	114030-01-704	EA	TRIM - RIGHT/BLACK TEXTURED	74002839
10	114030-01-705	EA	TRIM - LEFT/BLACK TEXTURED	74002840
11	114030-01-706	EA	TRIM - REAR/BLACK TEXTURED	74002841
12	102020-01-724	EA	BUMPER-MAIN TOP	8003P008-60
13	128728-01-707	EA	KNOB - IGNITOR	74003944

CONTACT WINNEBAGO PART SALES FOR UNLISTED COMPONENT(S)

**CABINET & APPLIANCE GROUP (CONTINUED)**  
**COMPONENT PARTS FOR CABINET & APPLIANCE LAYOUT (CONTINUED)**

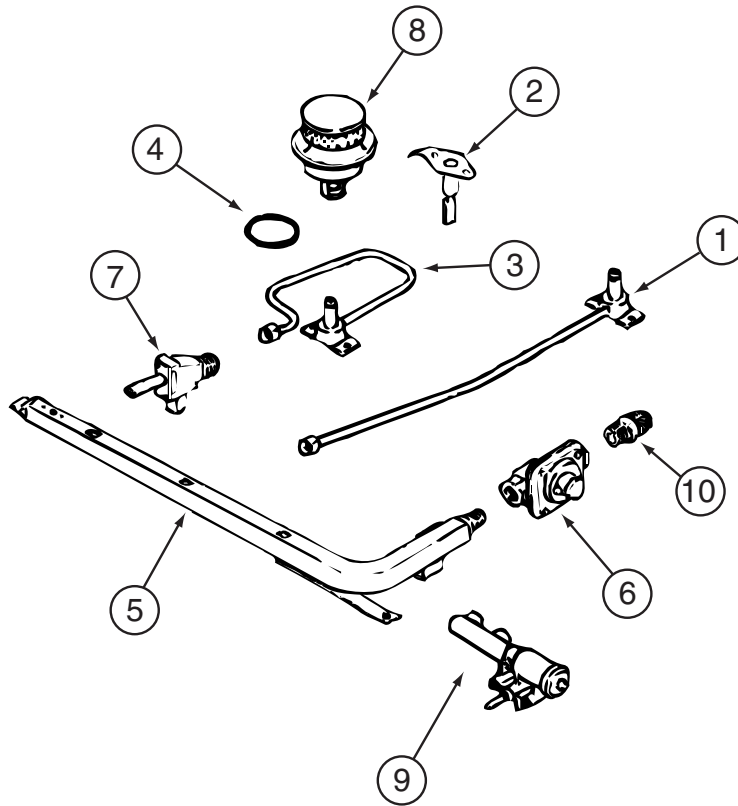

**135065-03-01A, 135065-03-03A, 135065-04-01A (CONTINUED)**

KEY	PART NUMBER	U/M	DESCRIPTION	VENDOR NO.
1	128728-01-708	EA	FITTING W/ORFICE/TUBE - REAR	74003931
2	135065-01-701	EA	IGNITOR/PORCELAIN-TOP BURNER	74004053
3	128728-01-710	EA	FITTING W/ORFICE/TUBE - FRT	74003930
4	135065-03-700	EA	FITTING - HALF UNION	74004234
5	135065-01-702	EA	PIPE/MANIFOLD	74004642
6	126023-02-703	EA	REGULATOR - PRESSURE	74004235
7	135065-01-703	EA	VALVE/BURNER - REAR	74004643
7	135065-01-704	EA	VALVE/BURNER-FRT-HI	74004644
7	135065-03-701	EA	SCREW - VALVE	71003231
8	135065-03-702	EA	SEALED BURNER ASM.(BLACK) RV	74003967
9	128728-01-716	EA	BURNER - IGNITOR	74003946
9	128728-01-717	EA	WIRES - IGNITOR	74003947

**CABINET & APPLIANCE GROUP (CONTINUED)**  
**COMPONENT PARTS FOR CABINET & APPLIANCE LAYOUT (CONTINUED)**

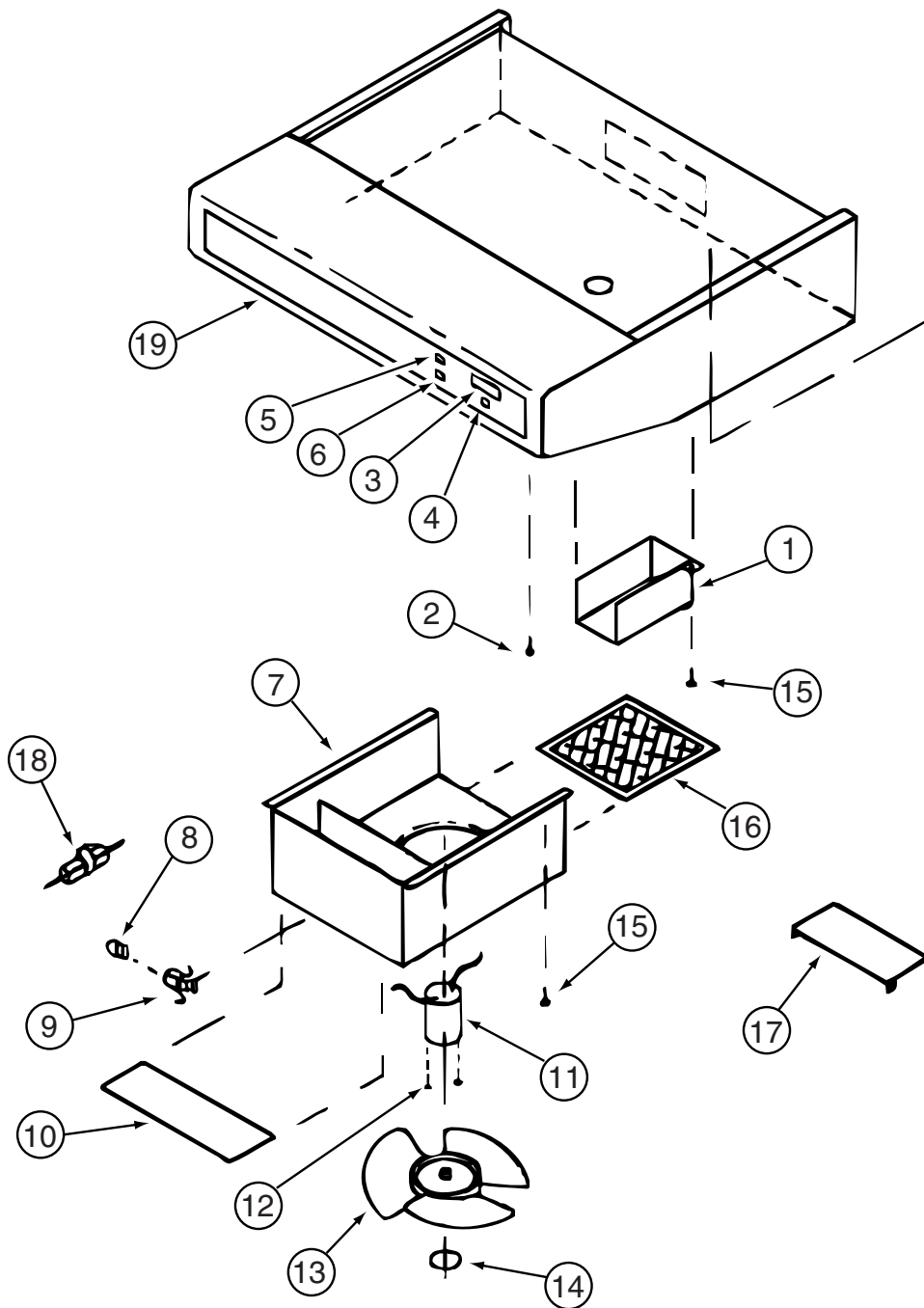

136354-01-01A, 136354-02-01A

KEY	PART NUMBER	U/M	DESCRIPTION	VENDOR NO.
3	100258-10-700	EA	GAUGE-HOUR METER, SCREW ON	L0150-00 WAS 150
4	096983-01-702	EA	SWITCH - MOM/OFF/MOM/3 TERM	L0112-00
6	096983-01-700	EA	SWITCH/1 SPEED -ON/OFF- BLK	00108-00
8	092696-01-709	EA	LAMP #912	VA415
9	092696-01-710	EA	HOLDER-LAMP	CB267-2
10	092696-02-701	EA	LENS-LAMP	CC179-2
11	090973-01-700	EA	MOTOR-12 VOLT, CSA & UL	CA508-1
13	090973-01-702	EA	BLADE-FAN	VA183-1
16	096983-01-707	EA	FILTER-MESH	CC246
17	100258-01-701	EA	DAMPER ASSEMBLY (METAL FLAP)	CAO-565-00
19	100258-01-700	EA	LABEL-HOOD NOSE	CC0428-00

CONTACT WINNEBAGO PART SALES FOR UNLISTED COMPONENT(S)

**CABINET & APPLIANCE GROUP (CONTINUED)**  
**COMPONENT PARTS FOR CABINET & APPLIANCE LAYOUT (CONTINUED)**

**136354-01-02A**

<b>KEY</b>	<b>PART NUMBER</b>	<b>U/M</b>	<b>DESCRIPTION</b>	<b>VENDOR NO.</b>
3	100258-10-700	EA	GAUGE-HOUR METER, SCREW ON	L0150-00 WAS 150
4	096983-01-702	EA	SWITCH - MOM/OFF/MOM/3 TERM	L0112-00
5	096983-01-700	EA	SWITCH/1 SPEED -ON/OFF- BLK	L0108-00
8	117806-01-000	EA	BULB - 12V NO.912 1.0 AMPS	
9	092696-01-710	EA	HOLDER-LAMP	CB267-02
10	096983-01-708	EA	LENS-LAMP	CC0179
11	136354-05-700	EA	MOTOR-12 VOLT	VC0536-02
13	136354-05-701	EA	BLADE-FAN 7" DIA	VD0216-00
16	096983-01-707	EA	FILTER-MESH	CC0246-00
17	100258-01-701	EA	DAMPER ASSEMBLY (METAL FLAP)	CA0565-00
19	100258-01-700	EA	LABEL-HOOD NOSE	CC0428-00
CONTACT WINNEBAGO PART SALES FOR UNLISTED COMPONENT(S)				

**136354-02-02A**

<b>KEY</b>	<b>PART NUMBER</b>	<b>U/M</b>	<b>DESCRIPTION</b>	<b>VENDOR NO.</b>
5	096983-01-700	EA	SWITCH/1 SPEED -ON/OFF- BLK	L0108-00
9	092696-01-710	EA	HOLDER-LAMP	CB267-02
10	096983-01-708	EA	LENS-LAMP	CC0179
11	136354-06-700	EA	MOTOR - FAN (CSA)	VC0535-02
13	136354-05-701	EA	BLADE-FAN 7" DIA	VD0216-00
16	096983-01-707	EA	FILTER-MESH	CC0246-00
17	100258-01-701	EA	DAMPER ASSEMBLY (METAL FLAP)	CA0565-00
19	100258-01-700	EA	LABEL-HOOD NOSE	CC0428-00
CONTACT WINNEBAGO PART SALES FOR UNLISTED COMPONENT(S)				

**136354-05-01A, 136354-05-02A**

<b>KEY</b>	<b>PART NUMBER</b>	<b>U/M</b>	<b>DESCRIPTION</b>	<b>VENDOR NO.</b>
3	100258-10-700	EA	GAUGE-HOUR METER, SCREW ON	L0150-00 WAS 150
4	096983-01-702	EA	SWITCH - MOM/OFF/MOM/3 TERM	L0112-00
5	096983-01-700	EA	SWITCH/1 SPEED -ON/OFF- BLK	L0108-00
8	117806-01-000	EA	BULB-12V NO.912 1.0 AMPS	GENERAL MOTOR HOMES
9	092696-01-710	EA	HOLDER-LAMP	CB0267-02
10	096983-01-708	EA	LENS-LAMP	CC0179
11	136354-05-700	EA	MOTOR-12 VOLT	VC0536-02
13	136354-05-701	EA	BLADE-FAN 7" DIA	VD0216-00
16	096983-01-707	EA	FILTER-MESH	CC0246-00
17	100258-01-701	EA	DAMPER ASSEMBLY (METAL FLAP)	CA0565-00
19	100258-01-700	EA	LABEL-HOOD NOSE	CC0428-00
CONTACT WINNEBAGO PART SALES FOR UNLISTED COMPONENT(S)				

**136354-06-01A, 136354-06-02A**

<b>KEY</b>	<b>PART NUMBER</b>	<b>U/M</b>	<b>DESCRIPTION</b>	<b>VENDOR NO.</b>
3	100258-10-700	EA	GAUGE-HOUR METER, SCREW ON	L0150-00 WAS 150
4	096983-01-702	EA	SWITCH - MOM/OFF/MOM/3 TERM	L0112-00
5	096983-01-700	EA	SWITCH/1 SPEED -ON/OFF- BLK	L0108-00
8	117806-01-000	EA	BULB-12V NO.912 1.0 AMPS	GENERAL MOTOR HOMES
9	092696-01-710	EA	HOLDER-LAMP	CB0267-02
10	096983-01-708	EA	LENS-LAMP	CC0179
11	136354-06-700	EA	MOTOR - FAN (CSA)	VC0535-02
13	136354-05-701	EA	BLADE-FAN 7" DIA	VD0216-00
16	096983-01-707	EA	FILTER-MESH	CC0246-00
17	100258-01-701	EA	DAMPER ASSEMBLY (METAL FLAP)	CA0565-00
19	100258-01-700	EA	LABEL-HOOD NOSE	CC0428-00
CONTACT WINNEBAGO PART SALES FOR UNLISTED COMPONENT(S)				

**150606-04-01A**

<b>KEY</b>	<b>PART NUMBER</b>	<b>U/M</b>	<b>DESCRIPTION</b>	<b>VENDOR NO.</b>
	150606-04-700	EA	RACK - BAKING	FAMI-A104WRM0
	150606-04-701	EA	PLATE/TURNTABLE	NTNT-A097WREO
	150606-04-703	EA	SUPPORT F/PLATE	FSRAHA063WRYZ

**CABINET & APPLIANCE GROUP (CONTINUED)**  
**COMPONENT PARTS FOR CABINET & APPLIANCE LAYOUT (CONTINUED)**

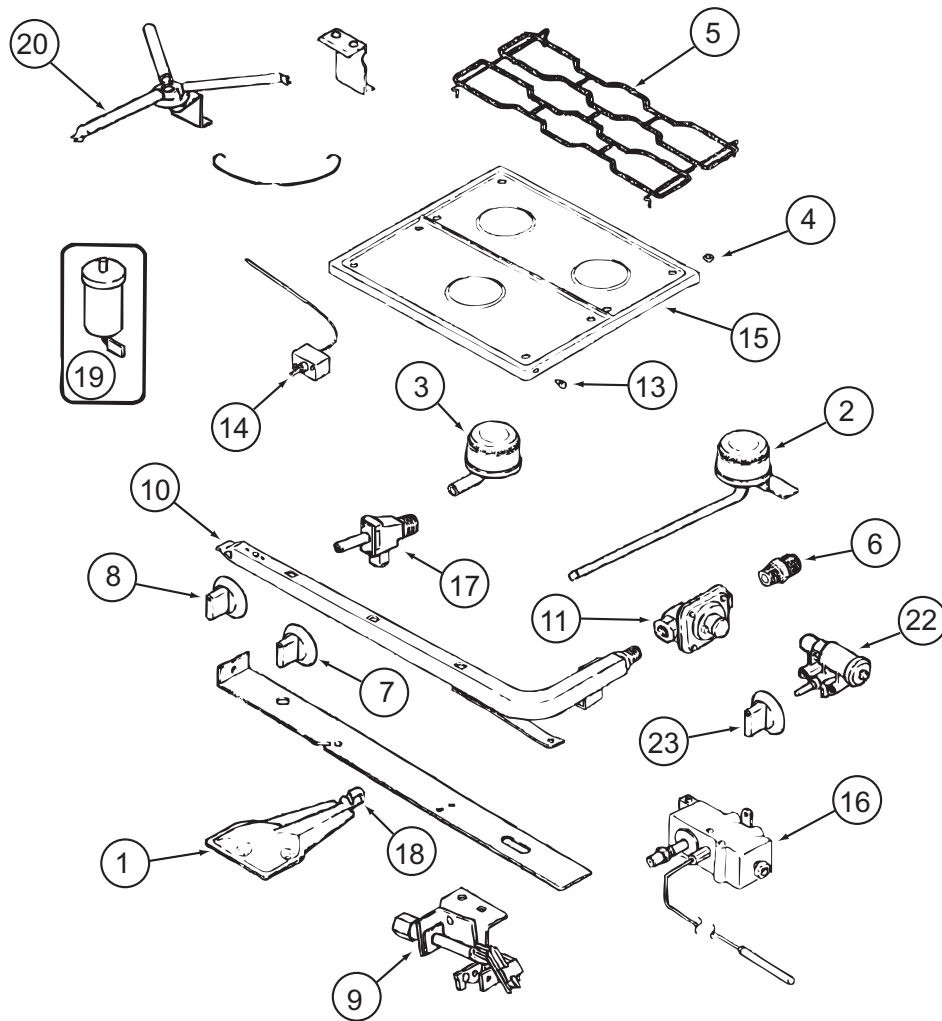

**151277-01-01A, 151277-02-01A**

KEY	PART NUMBER	U/M	DESCRIPTION	VENDOR NO.
1	151279-02-700	EA	BURNER - OVEN - W/SHUTTER	74009853
2	112881-04-700	EA	BURNER - TOP/LEFT REAR	74004584
2	126023-01-700	EA	BURNER-TOP (RT-REAR) 5100BTU	74004583
3	112881-04-701	EA	BURNER - TOP/FRONT	74004582
4	102020-01-709	EA	BUMPER-GRATE	8007P020-60
5	112881-04-702	EA	GRATE - BLACK	74007277
6	135065-03-700	EA	FITTING - HALF UNION	74004234
7	128728-01-701	EA	KNOB - BURNER - REAR	74003941 (1 PER)
7	128728-01-702	EA	KNOB - BURNER - FRONT	74003942
8	151279-02-701	EA	KNOB - THERMOSTAT - BLACK	74009858
9	151279-01-700	EA	PILOT - BURNER - 16" SERIES	74009852
10	151279-02-702	EA	PIPE - MANIFOLD	74009856
11	112881-03-701	EA	REGULATOR KIT W/FITTINGS	12001285
13	102020-01-724	EA	BUMPER-MAIN TOP	8003P008-60
14	151279-02-703	EA	THERMOSTAT	74009855
15	151277-01-700	EA	TOP - MAIN (BLACK)	74007287
16	151279-02-704	EA	ELBOW BLOCK ASM (VALVE-OVEN)	74009864
17	151277-01-701	EA	VALVE/REAR - W/SET SCREW	12002254
17	151277-01-702	EA	VALVE/FRONT - W/SET SCREW	12002246
19	112881-04-705	EA	PUSH RING (ELECTRODE MTG)	7104P002-60
19	126023-01-711	EA	ELECTRODE - IGNITER (ONLY)	7432P077-60
20	126023-01-736	EA	FLASH TUBE EXTENSION (REAR)	74003326
20	126023-01-737	EA	FLASH TUBE EXTENSION (FRONT)	74003327
21	112881-04-708	EA	CLIP-FLASH TUBE	7112P068-60
22	126023-01-735	EA	KIT - IGNITOR TOP BRNER & KNOB	12001296=74002413&4
23	128728-01-707	EA	KNOB - IGNITOR	74003944
26	112881-04-709	EA	SHIELD-SPARK	3604F211-45

CONTACT WINNEBAGO PART SALES FOR UNLISTED COMPONENT(S)

**CABINET & APPLIANCE GROUP (CONTINUED)**  
**COMPONENT PARTS FOR CABINET & APPLIANCE LAYOUT (CONTINUED)**

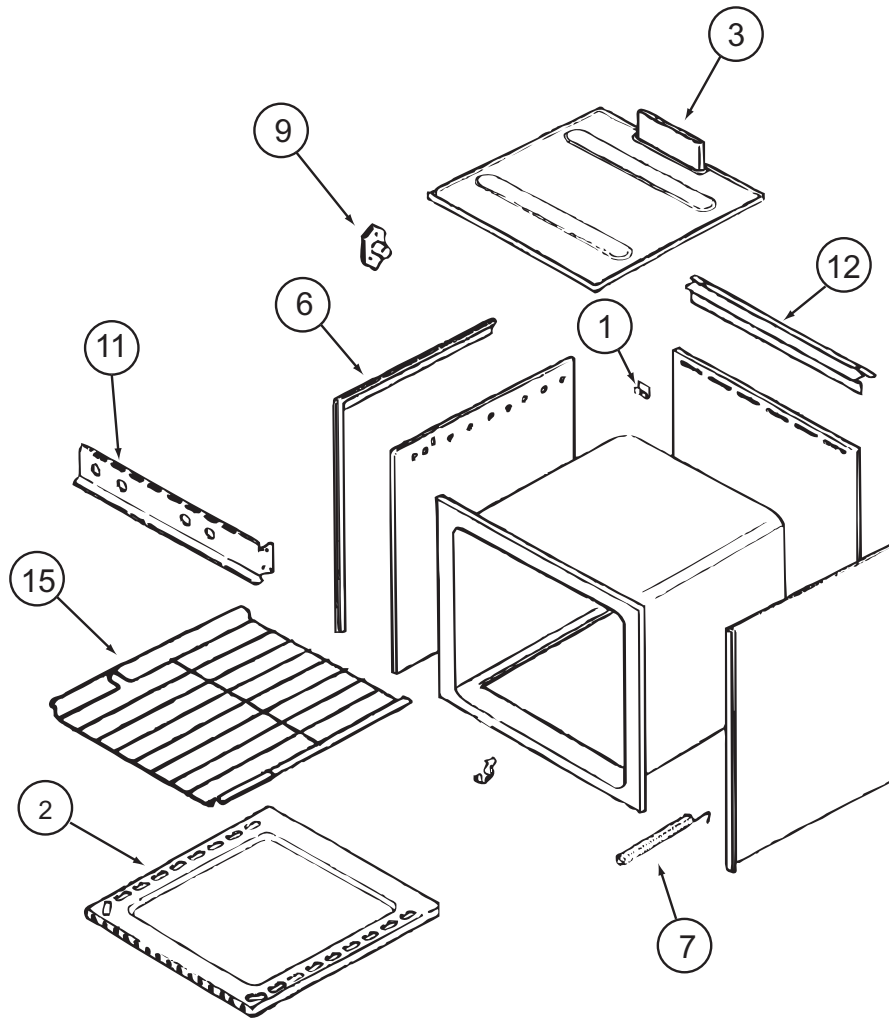

**151277-01-01A (CONTINUED)**

KEY	PART NUMBER	U/M	DESCRIPTION	VENDOR NO.
2	126023-01-731	EA	BOTTOM - OVEN	2205F016-19
3	126023-01-718	EA	FLUE BOX ASSEMBLY	4006W075-80
6	126023-01-713	EA	TRIM - SIDE (RIGHT) BLACK	74002827
6	126023-01-714	EA	TRIM - SIDE (LEFT) BLACK	74002828
7	135066-03-700	EA	SPRING - OVEN DOOR	74001835
9	128728-01-703	EA	PIN/T-NUT F/HINGE	7103P109-60
15	126023-01-716	EA	RACK - OVEN	74003106

CONTACT WINNEBAGO PART SALES FOR UNLISTED COMPONENT(S)

**CABINET & APPLIANCE GROUP (CONTINUED)**  
**COMPONENT PARTS FOR CABINET & APPLIANCE LAYOUT (CONTINUED)**

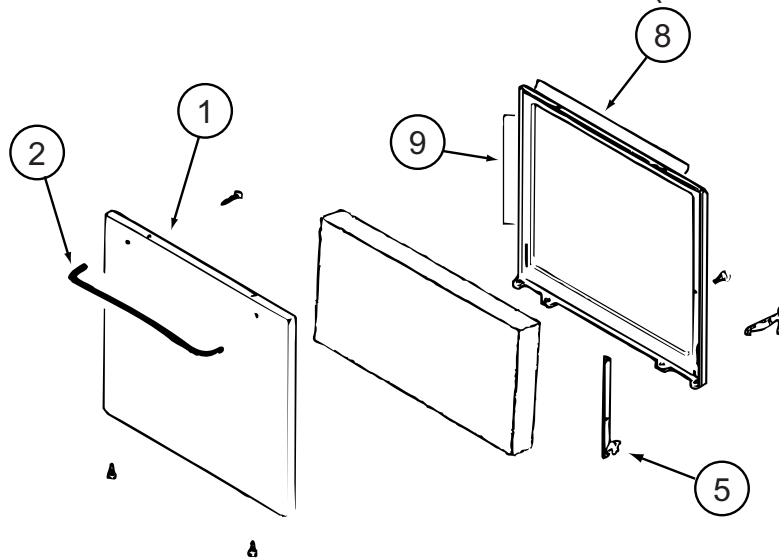

**151277-01-01A (CONTINUED)**

KEY	PART NUMBER	U/M	DESCRIPTION	VENDOR NO.
1	102022-01-704	EA	GLASS-OUTER	7902P261-60
1	112881-01-713	EA	DOOR/OVEN-TEXT/BLK NO WINDOW	2401F126-70
2	128727-01-701	EA	HANDLE - OVEN DOOR	74003929
5	151277-01-704	EA	HINGE KIT-OVEN DR/LT	12400028
5	151277-01-705	EA	HINGE KIT-OVEN DR/RT	12400029
8	126023-01-732	EA	SEAL/OVEN DR TOP	7212P014-60
9	135066-03-714	EA	SEAL - OVEN DOOR SIDES	7212P039-60

CONTACT WINNEBAGO PART SALES FOR UNLISTED COMPONENT(S)

**CABINET & APPLIANCE GROUP (CONTINUED)**  
**COMPONENT PARTS FOR CABINET & APPLIANCE LAYOUT (CONTINUED)**

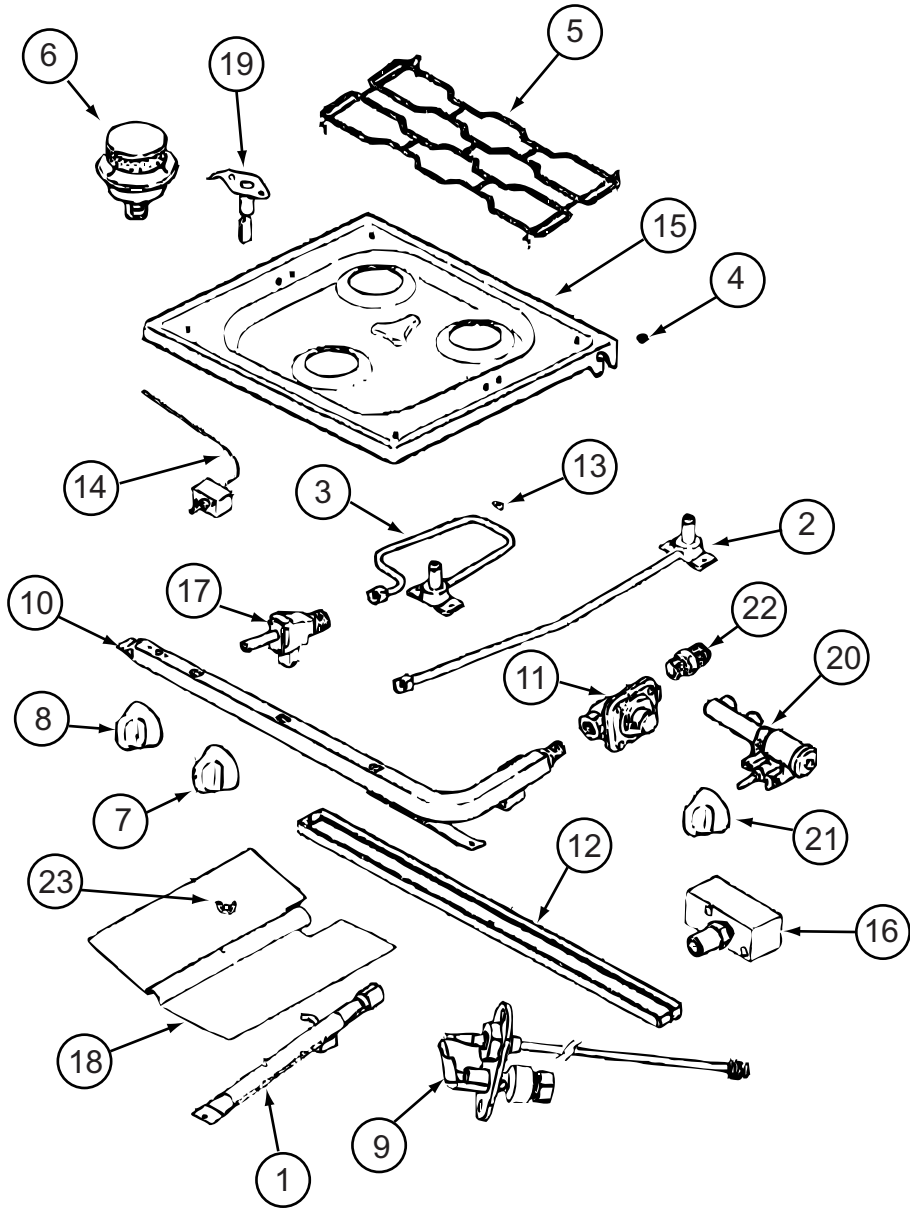

151277-03-01A, 151279-01-01A, 151279-02-01A/02A, 151279-03-01A



**CABINET & APPLIANCE GROUP (CONTINUED)**  
**COMPONENT PARTS FOR CABINET & APPLIANCE LAYOUT (CONTINUED)**

151277-03-01A, 151279-01-01A, 151279-02-01A/02A, 151279-03-01A (CONTINUED)

KEY	PART NUMBER	U/M DESCRIPTION	VENDOR NO.
1	151279-02-700	EA BURNER - OVEN - W/SHUTTER	74009853
2	128728-01-708	EA FITTING W/ORFICE/TUBE - REAR	74003931
3	128728-01-710	EA FITTING W/ORFICE/TUBE - FRT	74003930
4	102020-01-709	EA BUMPER-GRATE	8007P020-60
5	135065-03-703	EA GRATE - BLACK(SEALED BURNER)	74007304
6	135065-03-702	EA SEALED BURNER ASM.(BLACK) RV	74003967
7	128728-01-701	EA KNOB - BURNER - REAR	74003941 (1 PER)
7	128728-01-702	EA KNOB - BURNER - FRONT	74003942
8	151279-02-701	EA KNOB - THERMOSTAT - BLACK	74009858
9	112881-04-706	EA PILOT-OVEN (151279-01-01A ONLY)	74006334
9	151279-01-700	EA PILOT-BURNER-16" (151279-01-01A ONLY)	74009852
9	151279-02-705	EA PILOT - OVEN - 22" SERIES	74010544
10	151279-02-702	EA PIPE - MANIFOLD	74009856
11	112881-03-701	EA REGULATOR KIT W/FITTINGS	12001285
11	126023-02-703	EA REGULATOR - PRESSURE	74004235
13	102020-01-724	EA BUMPER-MAIN TOP	8003P008-60
14	151279-02-703	EA THERMOSTAT	74009855
15	128728-01-705	EA TOP - MAIN - BLACK	74003928
15	135065-03-715	EA TOP - MAIN - STAINLESS STEEL	74007299
15	151277-03-705	EA TOP-MAIN SNGL GRT/SEALED-BLK	2001F300-09
16	151279-02-704	EA ELBOW BLOCK ASM (VALVE-OVEN)	74009864
17	135065-01-703	EA VALVE/BURNER - REAR	74004643
17	135065-01-704	EA VALVE/BURNER-FRT-HI	74004644
18	135656-01-701	EA MIXER/AIR	3411F003-34
19	135065-01-701	EA IGNITOR/PORCELAIN-TOP BURNER	74004053
20	128728-01-716	EA IGNITOR - F/BURNERS	74003946
20	128728-01-717	EA WIRES - IGNITOR	74003947
21	128728-01-707	EA KNOB - IGNITOR	74003944
22	135065-03-700	EA FITTING - HALF UNION	74004234

CONTACT WINNEBAGO PART SALES FOR UNLISTED COMPONENT(S)

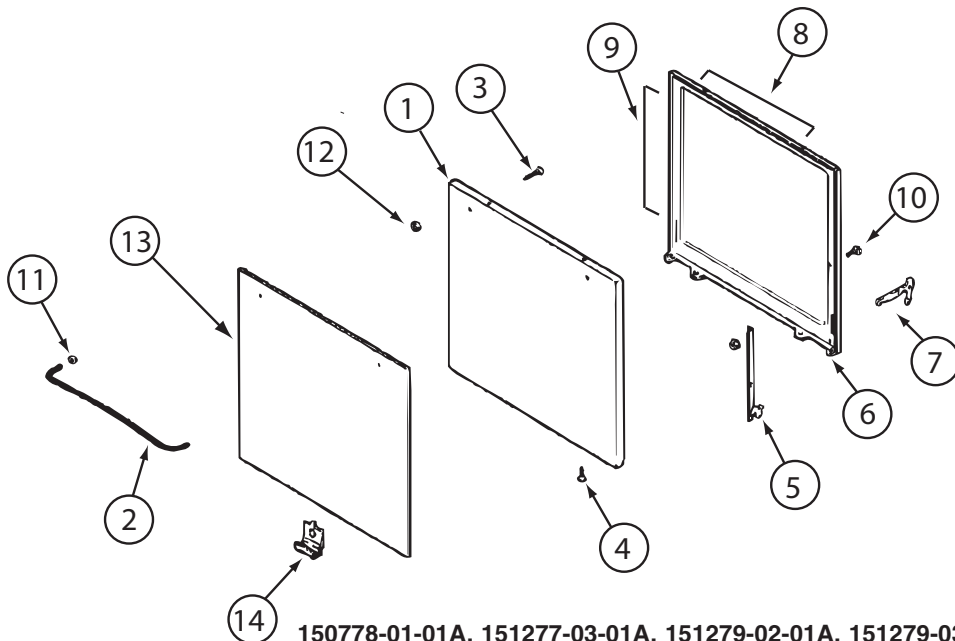

150778-01-01A, 151277-03-01A, 151279-02-01A, 151279-03-01A (CONTINUED)

KEY	PART NUMBER	U/M DESCRIPTION	VENDOR NO.
1	126023-01-712	EA PANEL - DOOR (BLACK)	74001190
2	128727-01-701	EA HANDLE - OVEN DOOR	74003929
5	151277-01-704	EA HINGE KIT-OVEN DR/LT	12400028
5	151277-01-705	EA HINGE KIT-OVEN DR/RT	12400029
8	126023-01-732	EA SEAL/OVEN DR TOP	7212P014-60
9	135066-03-714	EA SEAL - OVEN DOOR SIDES	7212P039-60
10	151277-03-707	EA DOOR LINING	74004228
13	102020-01-725	EA GLASS OUTER	7902P266-60
14	126023-01-738	EA CLIP - GLASS OVEN/BLACK	7112P093-60

CONTACT WINNEBAGO PART SALES FOR UNLISTED COMPONENT(S)

**CABINET & APPLIANCE GROUP (CONTINUED)**  
**COMPONENT PARTS FOR CABINET & APPLIANCE LAYOUT (CONTINUED)**

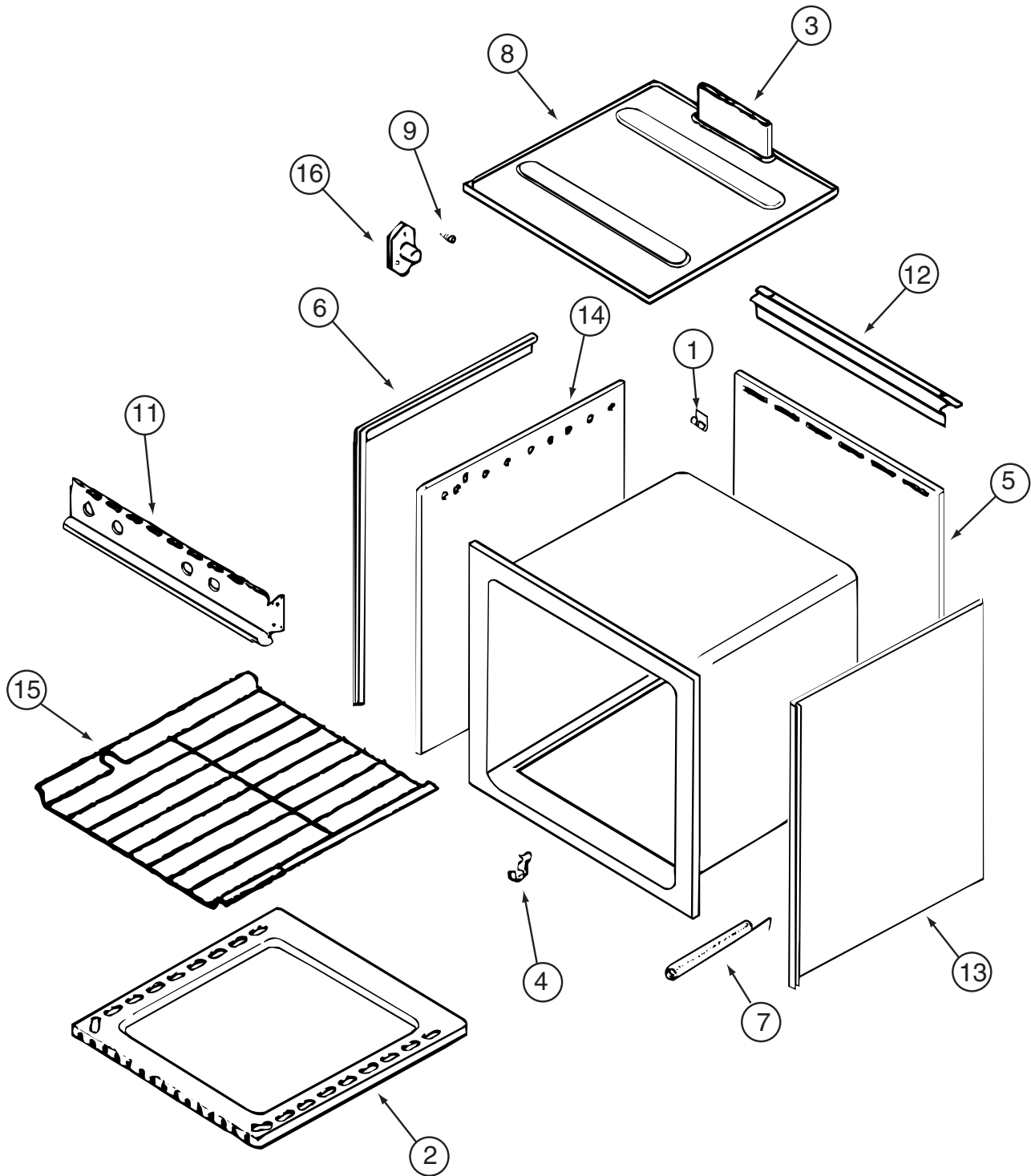

135066-03-01A/04A, 150778-01-01A, 151277-03-01A, 151279-02-01A/02A, 151279-03-01A (CONTINUED)

KEY	PART NUMBER	U/M	DESCRIPTION	VENDOR NO.
1	112881-03-702	EA	CLIP - MAIN TOP	74003998
2	126023-01-731	EA	BOTTOM - OVEN	2205F016-19
3	126023-01-718	EA	FLUE BOX ASSEMBLY	4006W075-80
6	126023-01-713	EA	TRIM - SIDE (RIGHT) BLACK	74002827
6	126023-01-714	EA	TRIM - SIDE (LEFT) BLACK	74002828
7	135066-03-708	EA	SPRING - OVEN DOOR	7803P053-60
9	128728-01-703	EA	PIN/T-NUT F/HINGE	7103P109-60
11	135066-03-701	EA	PANEL - MANIFOLD - BLACK	74007306
12	112881-01-721	EA	DEFLECTOR/FLUE-BLK-SEALED BR	74002829
15	126023-01-716	EA	RACK - OVEN	74003106

CONTACT WINNEBAGO PART SALES FOR UNLISTED COMPONENT(S)

**CABINET & APPLIANCE GROUP (CONTINUED)**  
**COMPONENT PARTS FOR CABINET & APPLIANCE LAYOUT (CONTINUED)**

158686-01-01A

<b>KEY</b>	<b>PART NUMBER</b>	<b>U/M</b>	<b>DESCRIPTION</b>	<b>VENDOR NO.</b>
	158686-01-700	EA	PLATE-GLASS	SR11092PLATE
	158686-01-701	EA	TRIM KIT - 2 PC.	ODY-2-92KIT

# CHASSIS GROUP FRAME

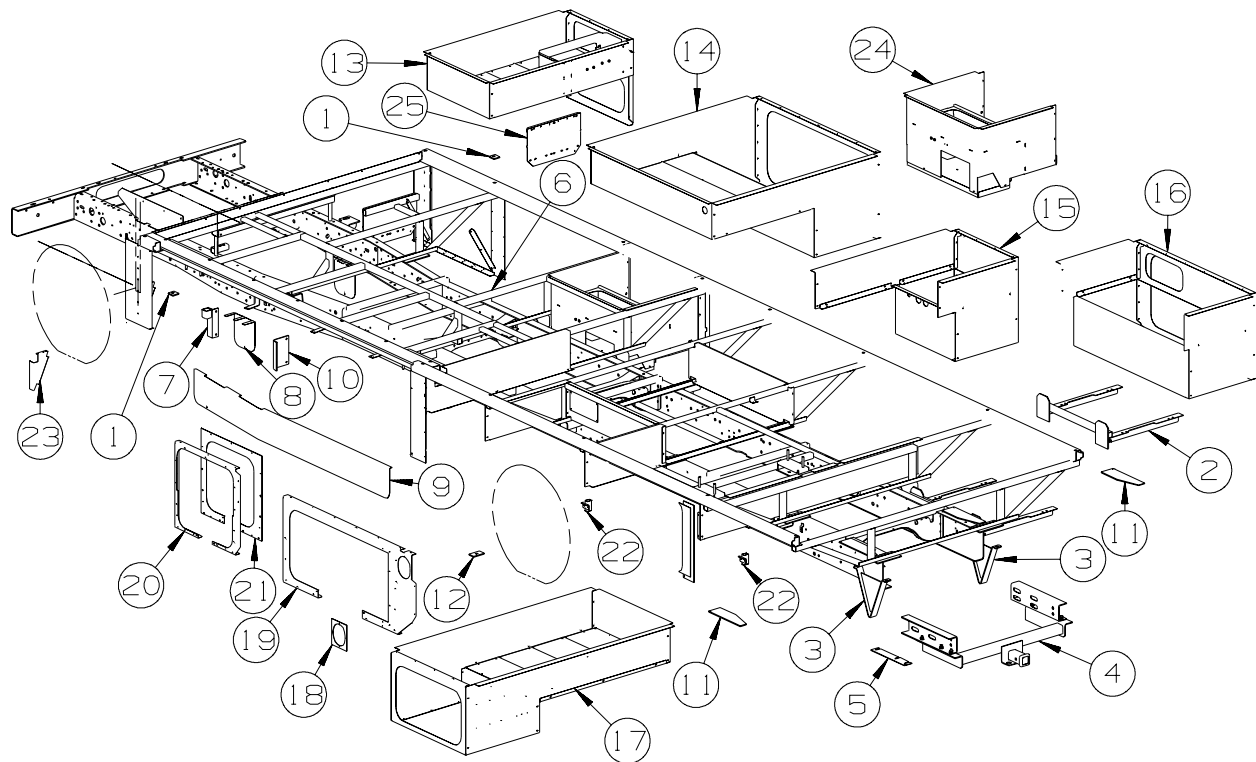

**FORD**

KEY	PART NUMBER	U/M	DESCRIPTION
1	135712-02-02B	EA	PLATE - BODY MOUNT - E-COATED
2	152901-01-02B	EA	OUTRIGGER - GENERATOR - E-COATED
3	140441-06-02B	EA	PLATE - SKID - E-COATED
4	154052-15-01A	EA	CLIP/REAR EXTENSION RAIL - W/HITCH - W/O TIRE CARRIER
5	136538-01-02B	EA	SHIM - HITCH - E-COATED
6	113452-01-000	FT	SEAL/TRIM - FRONT - VINYL W/WIRE CARRIER - .020"
7	139189-01-02B	EA	BRACKET - LP SUPPORT - E-COATED
8	134325-04-02B	EA	SHIELD - HEAT/EXHAUST - E-COATED
9	134325-01-02B	EA	SHIELD - HEAT/EXHAUST - E-COATED
10	139188-01-02B	EA	BRACKET - LP SUPPORT
11	133095-01-02B	EA	PLATE - CLIP - E-COATED
12	135712-01-02B	EA	PLATE - BODY MOUNT - E-COATED
13	137815-09-02B	EA	COMPARTMENT - RIGHT/FRONT - E-COATED
			FROM: 00-00-00 THRU: 10-07-07
13	137815-14-02B	EA	COMPARTMENT - RIGHT/FRONT - E-COATED
			FROM: 10-08-07 THRU: 99-99-99
14	137814-05-02B	EA	COMPARTMENT - RIGHT - E-COATED
15	138726-04-02B	EA	COMPARTMENT - MIDDLE - E-COATED
16	138044-04-02B	EA	COMPARTMENT - DRAINAGE - RIGHT HAND - E-COATED
17	153020-11-02B	EA	COMPARTMENT - REAR - E-COATED
18	154223-01-02B	EA	SPACER/PLATE - FUEL FILL - E-COATED
19	142221-03-02B	EA	PLATE/SEAL - E-COATED
20	142221-04-02B	EA	PLATE/SEAL - E-COATED
21	142221-05-02B	EA	PLATE/SEAL - E-COATED
22	136780-03-02B	EA	ADJUSTER - SLIDE - E-COATED
23	123440-14-02B	EA	SUPPORT - PANEL - 9.9"/7.6" X 4.8" - E-COATED
24	162351-01-02B	EA	BOX/ENTRANCE STEP - E-COATED
25	136391-01-02B	EA	GUARD/ROCK - STEEL - W/ANGLE - 18"W X 11"H - E-COATED

## CHASSIS GROUP (CONTINUED) FRAME (CONTINUED)

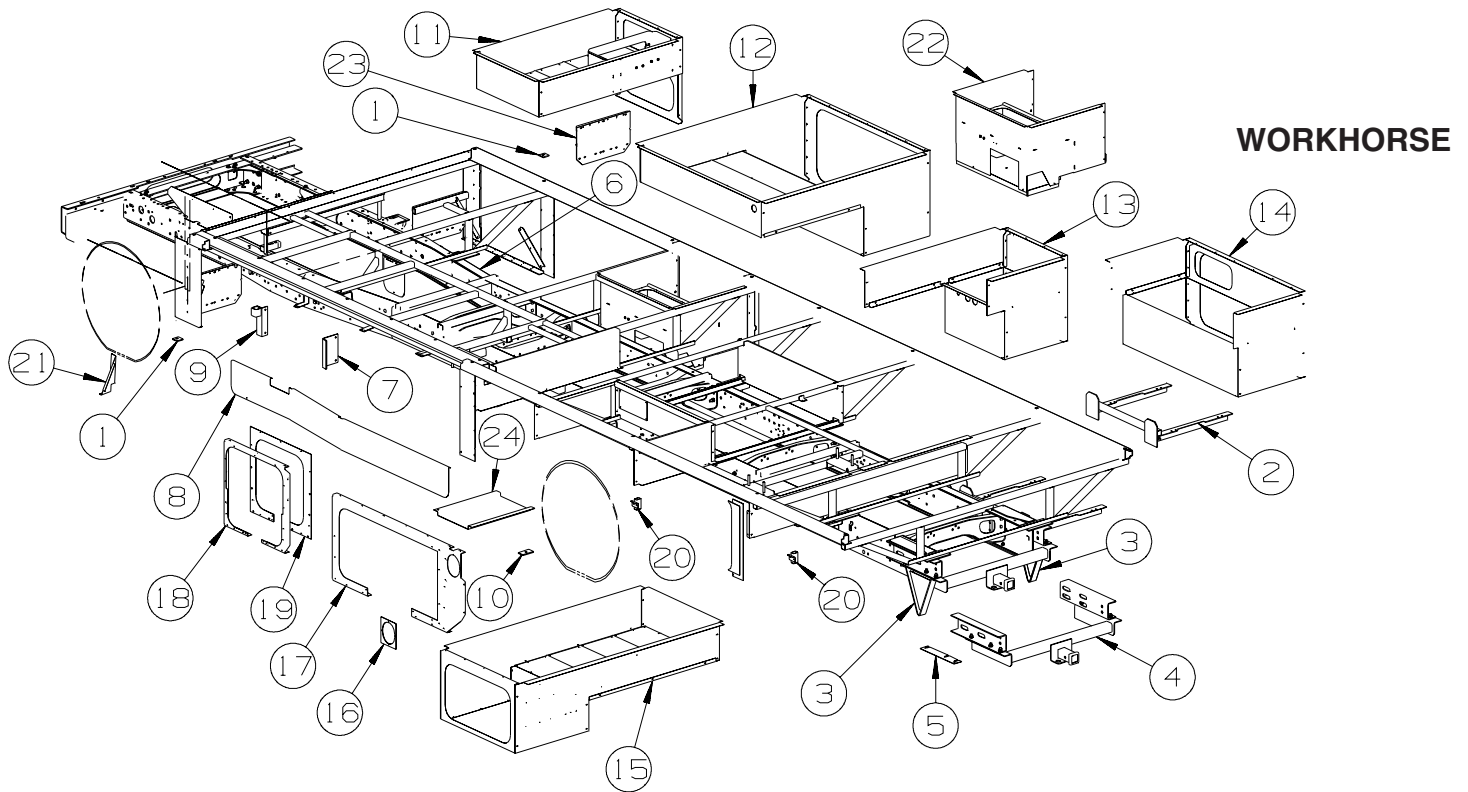

KEY	PART NUMBER	U/M	DESCRIPTION
1	135712-02-02B	EA	PLATE - BODY MOUNT - E-COATED
2	152901-01-02B	EA	OUTRIGGER - GENERATOR - E-COATED
3	140441-06-02B	EA	PLATE - SKID - E-COATED
4	154052-15-01A	EA	CLIP/REAR EXTENSION RAIL - W/HITCH - W/O TIRE CARRIER
5	136538-01-02B	EA	SHIM - HITCH - E-COATED
6	113452-01-000	FT	SEAL/TRIM - FRONT - VINYL W/WIRE CARRIER - .020"
7	139189-01-02B	EA	BRACKET - LP SUPPORT - E-COATED
8	134325-02-02B	EA	SHIELD - HEAT/EXHAUST - E-COATED
9	139188-02-02B	EA	BRACKET - LP SUPPORT
10	135712-01-02B	EA	PLATE - BODY MOUNT - E-COATED
11	137815-09-02B	EA	COMPARTMENT - RIGHT/FRONT - E-COATED
11	137815-14-02B	EA	COMPARTMENT - RIGHT/FRONT - E-COATED FROM: 00-00-00 THRU: 10-07-07 FROM: 10-08-07 THRU: 99-99-99
12	137814-05-02B	EA	COMPARTMENT - RIGHT - E-COATED
13	138726-04-02B	EA	COMPARTMENT - MIDDLE - E-COATED
14	138044-04-02B	EA	COMPARTMENT - DRAINAGE - RIGHT HAND - E-COATED
15	153020-11-02B	EA	COMPARTMENT - REAR - E-COATED
16	154223-01-02B	EA	SPACER/PLATE - FUEL FILL - E-COATED
17	142221-03-02B	EA	PLATE/SEAL - E-COATED
18	142221-04-02B	EA	PLATE/SEAL - E-COATED
19	142221-05-02B	EA	PLATE/SEAL - E-COATED
20	136780-03-02B	EA	ADJUSTER - SLIDE - E-COATED
21	123440-14-02B	EA	SUPPORT - PANEL - 9.9"/7.6" X 4.8" - E-COATED
22	162351-01-02B	EA	BOX/ENTRANCE STEP - E-COATED
23	136391-01-02B	EA	GUARD/ROCK - STEEL - W/ANGLE - 18"W X 11"H - E-COATED
24	140963-02-02B	EA	SHIELD - EXHAUST - E-COATED

## CHASSIS GROUP (CONTINUED) FRONT END

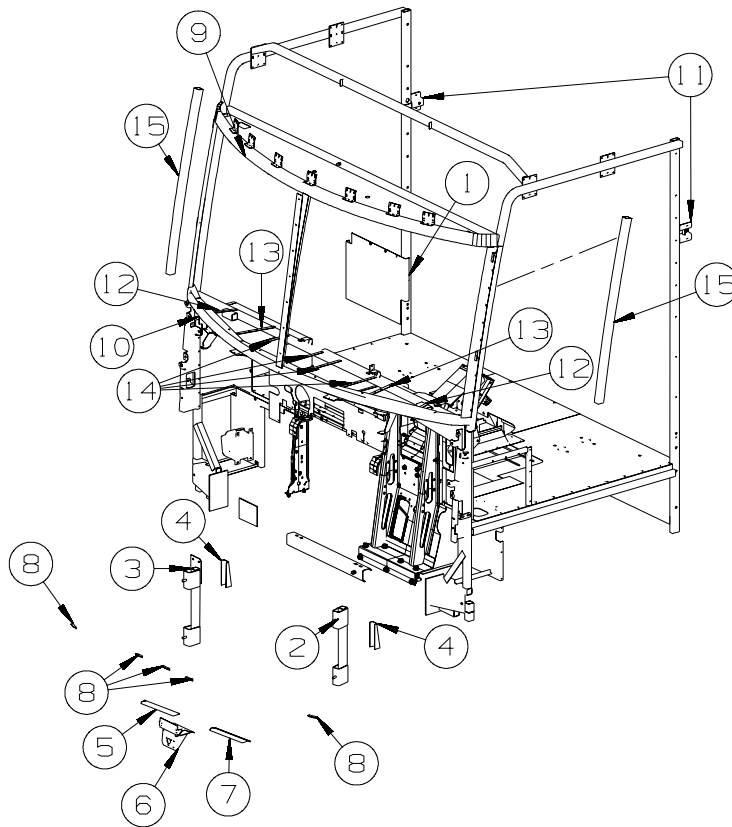

**FORD**

KEY	PART NUMBER	U/M	DESCRIPTION
1	144679-02-02B	EA	SHIELD/SPLASH - HEADLIGHT - E-COATED
2	152916-01-02B	EA	SUPPORT - FRONT - E-COATED
3	152916-05-02B	EA	SUPPORT - FRONT - E-COATED
4	117622-01-02B	EA	BRACE - TUBE/BUMPER - VERTICAL - E-COATED
5	134371-02-01B	EA	ANGLE/MOUNT - WIPER MOTOR
6	134506-04-01B	EA	BRACKET - WIPER MOTOR
7	134371-01-01B	EA	ANGLE/MOUNT - WIPER MOTOR
8	126289-65-01B	EA	ANGLE - FORMED
9	124975-01-01B	EA	SUPPORT-WINDSHIELD,UPPER,MLL
10	124974-01-01B	EA	SUPPORT-WINDSHIELD,LOWER,MLL
11	140387-02-01B	EA	MOUNT - SEATBELT/WALL - E-COATED
12	137047-06-01B	EA	STRAP - DEFROSTER PLENUM
13	137047-05-01B	EA	STRAP - DEFROSTER PLENUM
14	137047-04-01B	EA	STRAP - DEFROSTER PLENUM
15	117273-01-01A	EA	TUBE - SUPPORT - A-PILLAR

**CHASSIS GROUP (CONTINUED)**  
**FRONT END (CONTINUED)**

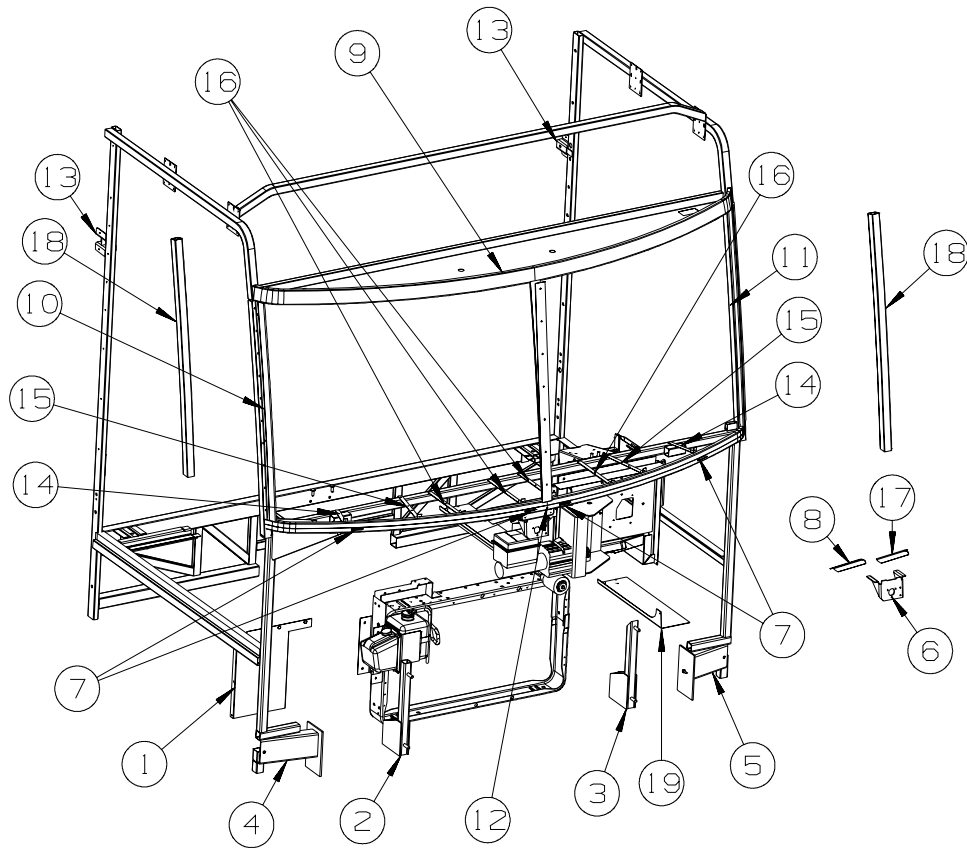

**WORKHORSE**

KEY	PART NUMBER	U/M	DESCRIPTION
1	121962-02-02B	EA	SHIELD/SPLASH - HEADLIGHT - E-COATED
2	134807-11-02B	EA	SUPPORT - FRONT - E-COATED
3	134807-12-02B	EA	SUPPORT - FRONT - E-COATED
4	137048-01-02B	EA	CHANNEL/SUPPORT - FRONT END - E-COATED
5	137048-02-02B	EA	CHANNEL/SUPPORT - FRONT END - E-COATED
6	134506-04-01B	EA	BRACKET - WIPER MOTOR
7	126289-65-01B	EA	ANGLE - FORMED
8	134371-01-01B	EA	ANGLE/MOUNT - WIPER MOTOR
9	124975-01-01B	EA	SUPPORT-WINDSHIELD,UPPER,MLL
10	156767-01-01B	EA	FRAME - WINDSHIELD - A-PILLAR - MILL
11	156767-02-01B	EA	FRAME - WINDSHIELD - A-PILLAR - MILL
12	124974-01-01B	EA	SUPPORT-WINDSHIELD,LOWER,MLL
13	140387-02-01B	EA	MOUNT - SEATBELT/WALL - E-COATED
14	137047-06-01B	EA	STRAP - DEFROSTER PLENUM
15	137047-05-01B	EA	STRAP - DEFROSTER PLENUM
16	137047-04-01B	EA	STRAP - DEFROSTER PLENUM
17	134371-02-01B	EA	ANGLE/MOUNT - WIPER MOTOR
18	117273-01-01A	EA	TUBE - SUPPORT - A-PILLAR
19	137041-01-02B	EA	ANGLE/FILLER - MOTOR COVER - E-COATED

FROM: 05-09-07 THRU: 99-99-00

## CHASSIS GROUP (CONTINUED)

### EXHAUST

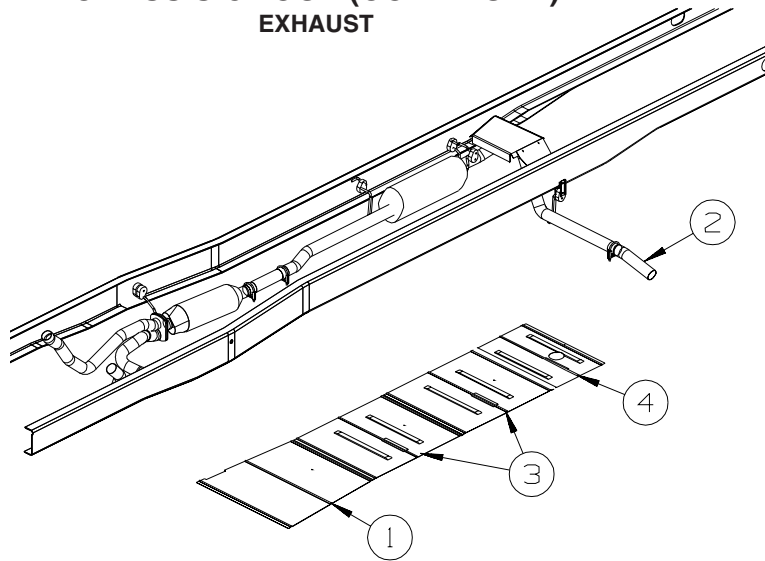

**FORD  
D29R**

190" WHEELBASE

KEY	PART NUMBER	U/M	DESCRIPTION
1	128756-01-02B	EA	SHIELD - HEAT/EXHAUST - 33.9" X 16.9" - E-COATED
2	142985-01-000	EA	PIPE - EXHAUST
3	143712-05-02B	EA	SHIELD/HEAT - EXHAUST - E-COATED - FRONT CENTER
3	143712-05-02B	EA	SHIELD/HEAT - EXHAUST - E-COATED - REAR CENTER
3	143712-02-02B	EA	SHIELD/HEAT - EXHAUST - E-COATED - REAR CENTER FROM: 00-00-00 THRU: 12-02-07
4	143712-07-02B	EA	SHIELD/HEAT - EXHAUST - E-COATED FROM: 12-03-07 THRU: 99-99-99
4	143712-02-02B	EA	SHIELD/HEAT - EXHAUST - E-COATED FROM: 00-00-00 THRU: 12-02-07
4	143712-02-02B	EA	SHIELD/HEAT - EXHAUST - E-COATED FROM: 12-03-07 THRU: 99-99-99

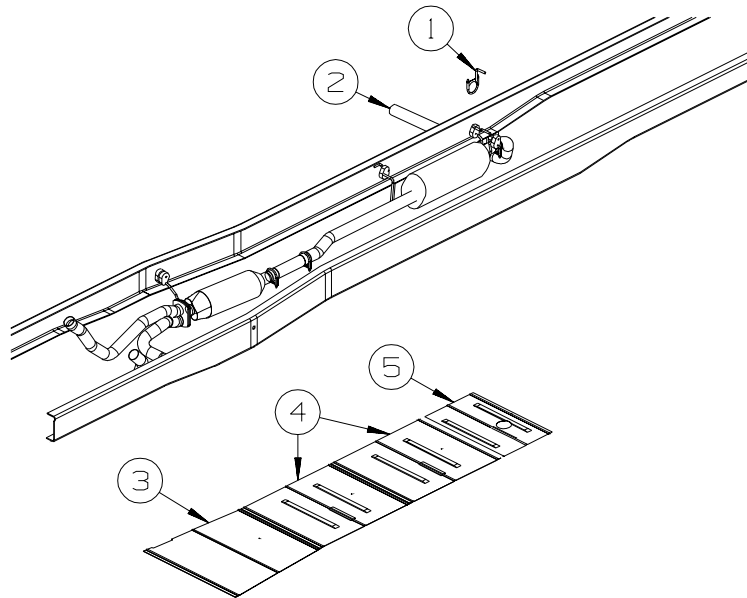

**FORD  
D30B**

190" WHEELBASE

KEY	PART NUMBER	U/M	DESCRIPTION
1	122392-16-02B	EA	HANGER - TAILPIPE - E-COATED
	094918-01-000	EA	CLAMP - EXHAUST - 3" - GUILLOTINE STYLE
2	122529-03-000	EA	PIPE - EXHAUST
3	128756-01-02B	EA	SHIELD - HEAT/EXHAUST - 33.9" X 16.9" - E-COATED
4	143712-05-02B	EA	SHIELD/HEAT - EXHAUST - E-COATED
4	143712-02-02B	EA	SHIELD/HEAT - EXHAUST - E-COATED FROM: 00-00-00 THRU: 12-02-07
4	143712-02-02B	EA	SHIELD/HEAT - EXHAUST - E-COATED FROM: 12-03-07 THRU: 99-99-99
5	143712-07-02B	EA	SHIELD/HEAT - EXHAUST - E-COATED



**CHASSIS GROUP (CONTINUED)**  
**EXHAUST (CONTINUED)**

**FORD**  
**D34M, D35J**

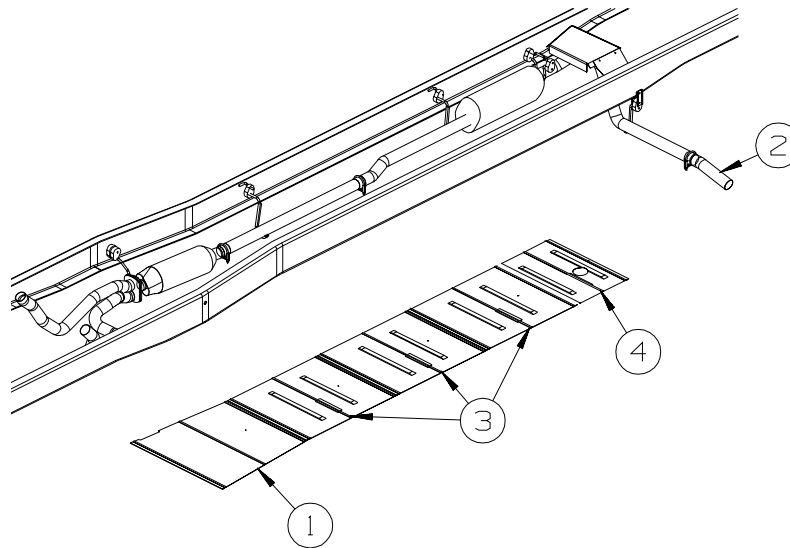

228" WHEELBASE

KEY	PART NUMBER	U/M	DESCRIPTION
1	128756-01-02B	EA	SHIELD - HEAT/EXHAUST - 33.9" X 16.9" - E-COATED
2	142985-01-000	EA	PIPE - EXHAUST
3	143712-05-02B	EA	SHIELD/HEAT - EXHAUST - E-COATED
4	143712-07-02B	EA	SHIELD/HEAT - EXHAUST - E-COATED
			FROM: 00-00-00 THRU: 12-02-07
4	143712-02-02B	EA	SHIELD/HEAT - EXHAUST - E-COATED
			FROM: 12-03-07 THRU: 99-99-99

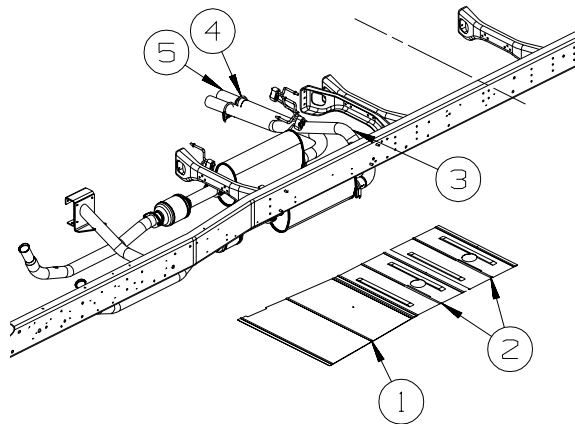

158.5" WHEELBASE

**WORKHORSE**  
**D26P**

KEY	PART NUMBER	U/M	DESCRIPTION
1	128756-01-02B	EA	SHIELD - HEAT/EXHAUST - 33.9" X 16.9" - E-COATED
2	143712-07-02B	EA	SHIELD/HEAT - EXHAUST - E-COATED
			FROM: 00-00-00 THRU: 12-02-07
2	143712-02-02B	EA	SHIELD/HEAT - EXHAUST - E-COATED
			FROM: 12-03-07 THRU: 99-99-99
3	141412-01-000	EA	PIPE - EXHAUST
4	098762-05-000	EA	EXTENSION - EXHAUST - STRAIGHT - 3" O.D X 7.9" LONG - SST
5	155919-01-02B	EA	HANGER - TAILPIPE - DOUBLE - E-COATED

**CHASSIS GROUP (CONTINUED)**  
**EXHAUST (CONTINUED)**

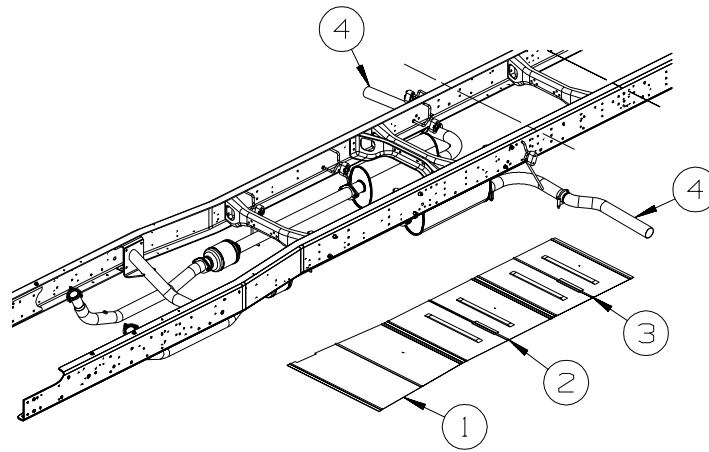

**WORKHORSE  
D29R**

190" WHEELBASE

KEY	PART NUMBER	U/M	DESCRIPTION
1	128756-01-02B	EA	SHIELD - HEAT/EXHAUST - 33.9" X 16.9" - E-COATED
2	143712-05-02B	EA	SHIELD - HEAT/EXHAUST - E-COATED
3	143712-02-02B	EA	SHIELD - HEAT/EXHAUST - E-COATED
4	129726-02-000	EA	PIPE - EXHAUST

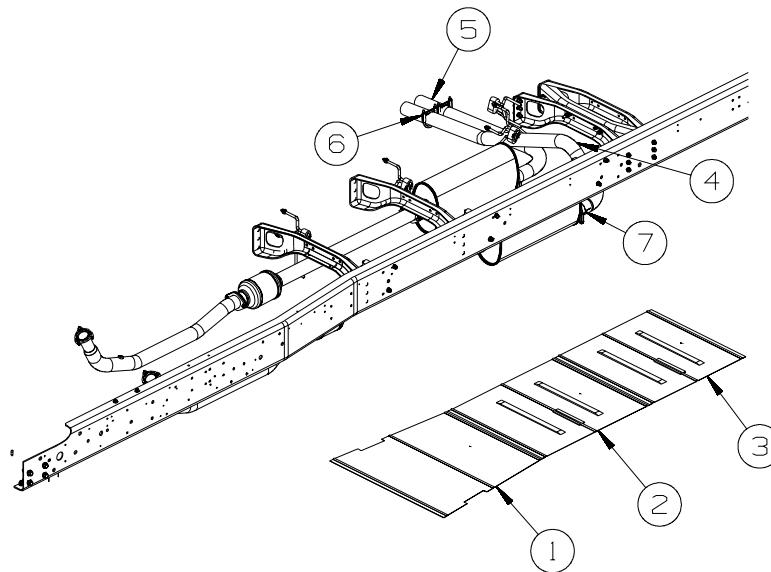

**WORKHORSE  
D30B**

KEY	PART NUMBER	U/M	DESCRIPTION
1	128756-01-02B	EA	SHIELD - HEAT/EXHAUST - 33.9" X 16.9" - E-COATED
2	143712-05-02B	EA	SHIELD - HEAT/EXHAUST - E-COATED
3	143712-02-02B	EA	SHIELD - HEAT/EXHAUST - E-COATED
4	141412-02-000	EA	PIPE - EXHAUST
5	098762-05-000	EA	EXTENSION - EXHAUST - STRAIGHT - 3" O.D X 7.9" LONG - SST
6	155919-01-02B	EA	HANGER - TAILPIPE - DOUBLE - E-COATED
7	094918-06-000	EA	CLAMP - EXHAUST - 3" - HEAVY DUTY

**CHASSIS GROUP (CONTINUED)**  
**EXHAUST (CONTINUED)**

**WORKHORSE  
D34M**

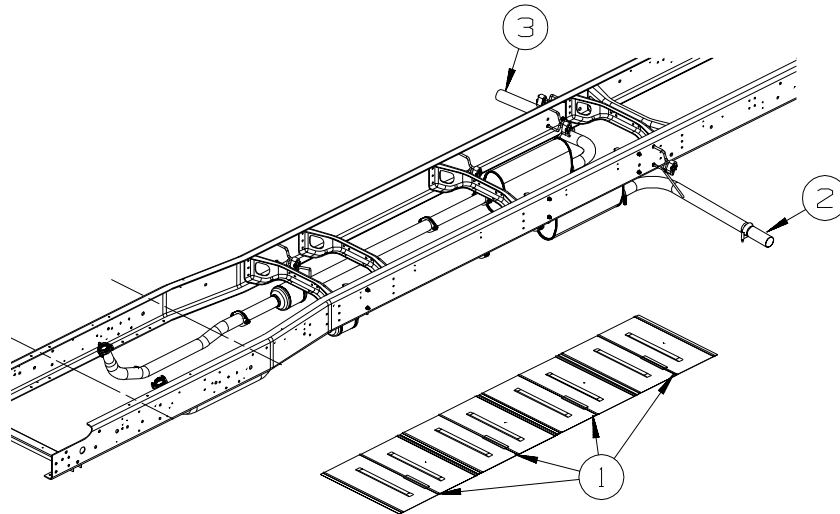

228" WHEELBASE

KEY	PART NUMBER	U/M	DESCRIPTION
1	143712-02-02B	EA	SHIELD - HEAT/EXHAUST - E-COATED
2	098762-05-000	EA	EXTENSION - EXHAUST - STRAIGHT - 3" O.D X 7.9" LONG - SST
	094918-01-000	EA	CLAMP - EXHAUST - 3" - GUILLOTINE STYLE
3	129726-02-000	EA	PIPE - EXHAUST

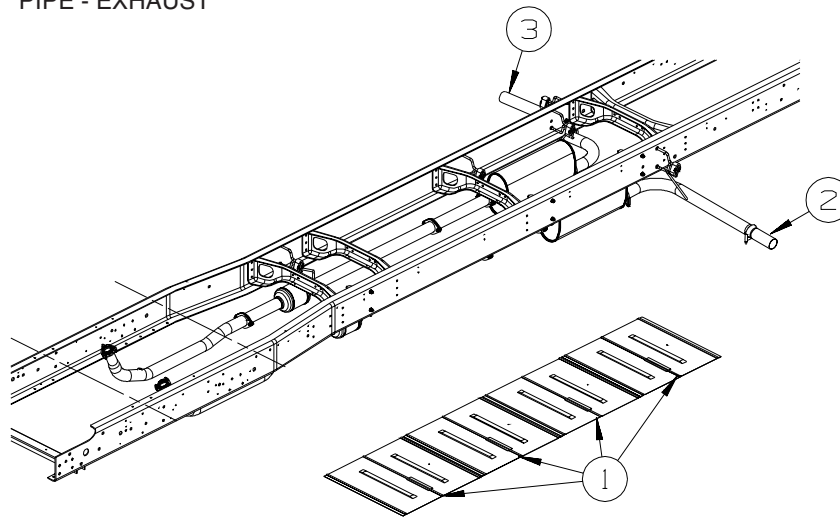

**WORKHORSE  
D35J**

228" WHEELBASE

KEY	PART NUMBER	U/M	DESCRIPTION
1	143712-02-02B	EA	SHIELD - HEAT/EXHAUST - E-COATED
2	098762-05-000	EA	EXTENSION - EXHAUST - STRAIGHT - 3" O.D X 7.9" LONG - SST
	094918-01-000	EA	CLAMP - EXHAUST - 3" - GUILLOTINE STYLE
3	129726-02-000	EA	PIPE - EXHAUST

## CHASSIS GROUP (CONTINUED)

### FUEL

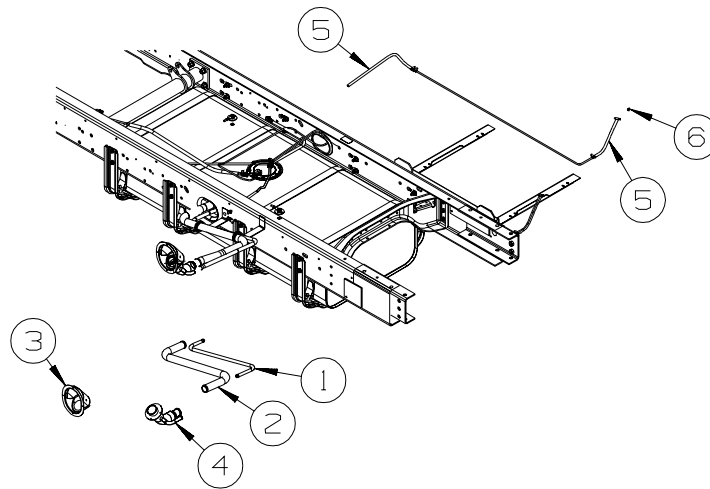

FORD

KEY	PART NUMBER	U/M	DESCRIPTION
1	129320-13-000	EA	PIPE - VENT - FILL - D29R
1	129320-06-000	EA	PIPE - VENT - FILL - D30B, D34M, D35J
2	129321-14-000	EA	TUBE - FUEL INLET - D29R
2	129321-06-000	EA	TUBE - FUEL INLET - D30B, D34M, D35J
3	128299-02-01A	EA	SHROUD - FUEL FILL
4	138884-02-000	EA	NECK - FUEL FILL - FORD
5	128139-03-000	FT	HOSE-FUEL - LOW PERMEABILITY - 1/4" DIAMETER
6	084884-01-000	EA	PLUG - BRASS - 3/8"
	068382-06-000	EA	BUSHING - 3/8"MPT X 1/8"FPT - BRASS

**CHASSIS GROUP (CONTINUED)**  
**FUEL (CONTINUED)**

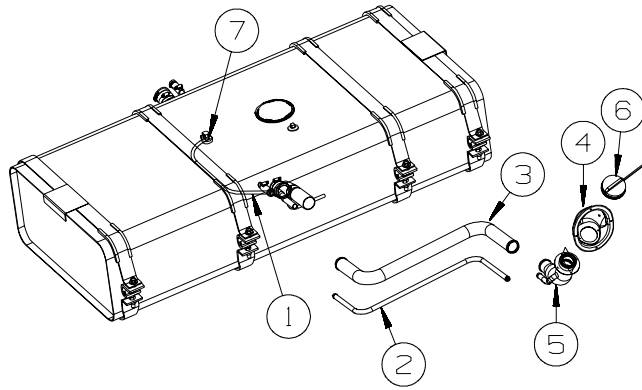

**WORKHORSE**

KEY	PART NUMBER	U/M DESCRIPTION
1	128139-03-000	FT HOSE - FUEL - LOW PERMEABILITY - 1/4" DIAMETER
2	128524-08-000	EA PIPE - VENT - FUEL FILL - <b>D26P</b>
2	128524-04-000	EA PIPE - VENT - FUEL FILL - <b>D29R</b>
2	128524-09-000	EA PIPE - VENT - FUEL FILL - <b>D30B</b>
2	128524-06-000	EA PIPE - VENT - FUEL FILL - <b>D34M, D35J</b>
3	124327-13-000	EA TUBE - FUEL INLET - <b>D26P</b>
3	124327-08-000	EA TUBE - FUEL INLET - <b>D29R</b>
3	124327-14-000	EA TUBE - FUEL INLET - <b>D30B</b>
3	124327-11-000	EA TUBE - FUEL INLET - <b>D34M, D35J</b>
4	128299-02-01A	EA SHROUD - FUEL FILL
5	127301-05-000	EA NECK - FUEL FILL - UNLEADED
6	163743-01-000	EA CAP - FUEL FILL - 1/4 TURN - WORKHORSE
7	068382-06-000	EA BUSHING - 3/8"MPT X 1/8"FPT - BRASS
7	114254-01-000	EA ADAPTER - 1/4"BARB X 1/8"MPT

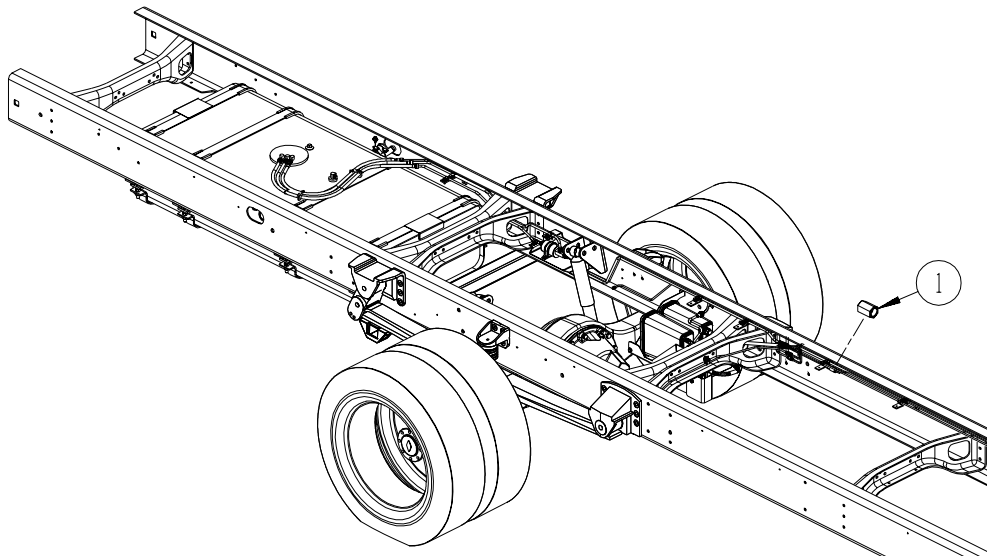

**WORKHORSE**

KEY	PART NUMBER	U/M DESCRIPTION
1	098779-02-000	EA COUPLER - FUEL LINE - 1.2" LONG X 16MM THREAD - <b>STRETCHED CHASSIS ONLY</b>

## CHASSIS GROUP (CONTINUED) HYDRAULIC LEVELING

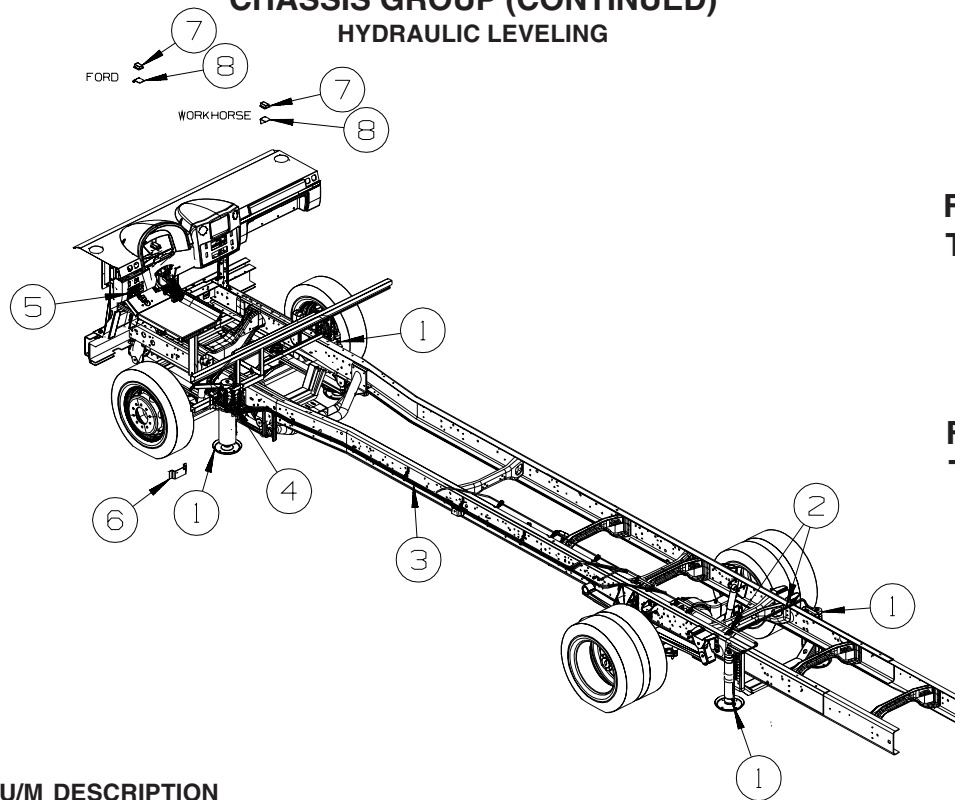

**FORD**  
**FROM: 00-00-00**  
**THRU: 06-15-07**

**WORKHORSE**  
**FROM: 00-00-00**  
**THRU: 08-03-07**

KEY	PART NUMBER	U/M	DESCRIPTION
1*	139641-09-000	EA	LEVELING SYSTEM-W/O PUMP-W/HARNESS/RMT SWITCH CAPABLE - <b>FORD</b> FROM: 00-00-00 THRU: 05-02-07
1*	139641-12-000	EA	LEVELING SYSTEM-W/O PUMP-W/HARNESS/RMT SWITCH CAPABLE - <b>FORD</b> FROM: 05-03-07 THRU: 99-99-00
1*	139641-10-000	EA	LEVELING SYSTEM-W/O PUMP-W/HARNESS/RMT SWITCH CAPABLE - <b>WORKHORSE</b>
2	126624-01-02B	EA	ANGLE - WIRE SUPPORT - E-COAT
3*	139644-03-000	EA	HOSE KIT - LEVELING JACKS
4*	156056-02-000	EA	PUMP - F/AUTOMATIC LEVELING SYSTEM
5	139643-08-000	EA	CONTROL-LEVEL - AUTO SYST-W/SENSOR HARNESS/RMT SW CAPABLE
6	154816-01-02B	EA	BRACKET - PUMP/LEVELING - E-COATED
7	156057-01-000	EA	SENSOR - F/AUTOMATIC LEVELING SYSTEM
8	153870-01-02B	EA	BRACKET - SENSOR/LEVEL - E-COATED - <b>WORKHORSE</b>
8	153870-02-02B	EA	BRACKET - SENSOR/LEVEL - E-COATED - <b>FORD</b>

**\*COMPONENT PARTS LISTED LATER IN THIS GROUP**

**CHASSIS GROUP (CONTINUED)**  
**HYDRAULIC LEVELING (CONTINUED)**

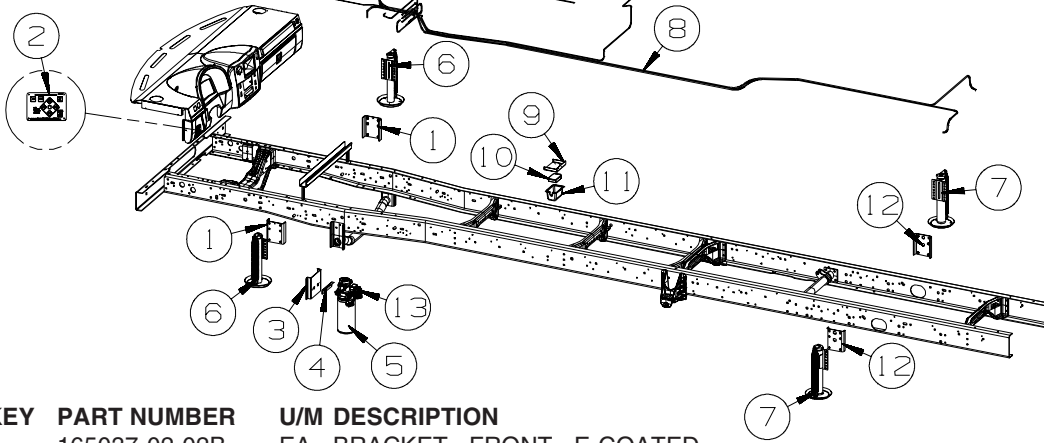

**FORD**  
**FROM: 06-16-07**  
**THRU: 99-99-99**

KEY	PART NUMBER	U/M	DESCRIPTION
1	165037-02-02B	EA	BRACKET - FRONT - E-COATED
2	164881-01-000	EA	TOUCH PAD/LEVEL CONTROL
3	165483-02-02B	EA	BRACKET - PUMP/LEVELING - E-COATED
4	165682-01-02B	EA	BRACKET - PUMP/LEVELING - E-COATED
5*	165120-01-000	EA	PUMP - LEVELING SYSTEM/VERTICAL MOUNT - FRT ENGINE/GAS
6*	165119-01-000	EA	JACK/LEVELING - 8000 LB/FRONT
7*	165119-02-000	EA	JACK/LEVELING - 13000 LB/REAR
8*	165179-01-000	EA	HOSE KIT - LEVELING JACKS
9	166322-01-02B	EA	BRACKET - CONTROL MODULE - E-COATED - <b>D29R</b>
9	164971-03-02B	EA	BRACKET - CONTROL MODULE/LEVELING SYSTEM - E-COATED - <b>D30B - D34M - D35J</b>
10	165121-01-000	EA	CONTROL MODULE - LEVELING SYSTEM
11	165075-01-01A	EA	COVER - ELECTRICAL BOX/LEVELING SYSTEM
12	165037-03-02B	EA	BRACKET - LEVELING JACK/REAR - FORD - E-COATED
12	165037-06-02B	EA	BRACKET - LEVELING JACK/REAR - FORD - E-COATED
			FROM: 00-00-00 THRU: 12-02-07
			FROM: 12-03-07 THRU: 99-99-99
13*	164877-01-000	EA	LEVELING SYSTEM - W/O PUMP/JACKS/CONTROL MODULE-W/HARNES

**\*COMPONENT PARTS LISTED LATER IN THIS GROUP**

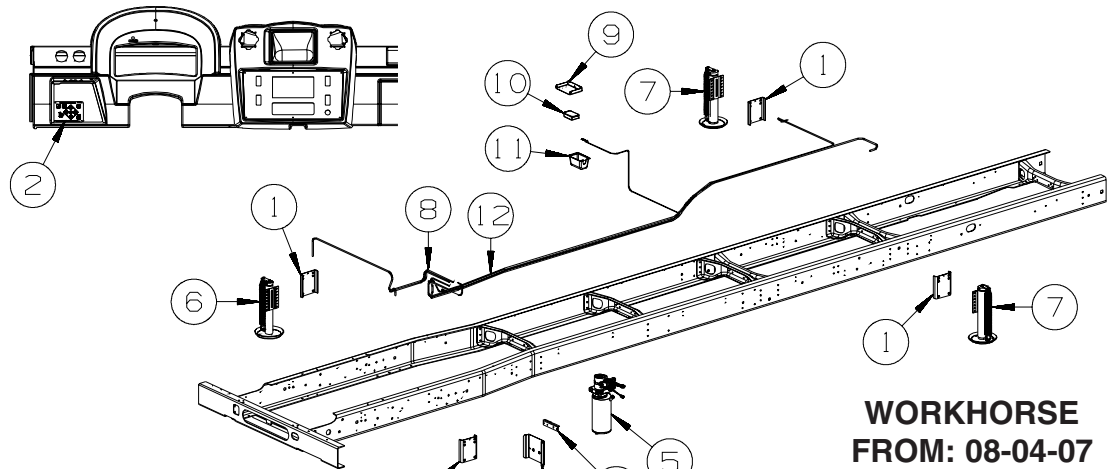

**WORKHORSE**  
**FROM: 08-04-07**  
**THRU: 99-99-99**

KEY	PART NUMBER	U/M	DESCRIPTION
1	165037-01-02B	EA	BRACKET - E-COATED
2	164881-01-000	EA	TOUCH PAD/LEVEL CONTROL
3	165483-02-02B	EA	BRACKET - PUMP/LEVELING - E-COATED
4	165682-01-02B	EA	BRACKET - PUMP/LEVELING - E-COATED
5*	165120-01-000	EA	PUMP - LEVELING SYSTEM/VERTICAL MOUNT - FRT ENGINE/GAS
6*	165119-01-000	EA	JACK/LEVELING - 8000 LB/FRONT
7*	165119-02-000	EA	JACK/LEVELING - 13000 LB/REAR
8*	164877-01-000	EA	LEVELING SYSTEM - W/O PUMP/JACKS/CONTROL MODULE-W/HARNES
9	166322-01-02B	EA	BRACKET - CONTROL MODULE - E-COATED - <b>D29R</b>
9	164971-03-02B	EA	BRACKET - CONTROL MODULE/LEVELING SYSTEM - E-COATED - <b>D26P - D30B - D34M - D35J</b>
10	165121-01-000	EA	CONTROL MODULE - LEVELING SYSTEM
11	165075-01-01A	EA	COVER - ELECTRICAL BOX/LEVELING SYSTEM
12*	165179-01-000	EA	HOSE KIT - LEVELING JACKS

**\*COMPONENT PARTS LISTED LATER IN THIS GROUP**

**CHASSIS GROUP (CONTINUED)**  
**COMPONENT PARTS FOR HYDRAULIC LEVELING**

**139641-09-000**

KEY	PART NUMBER	U/M	DESCRIPTION	VENDOR NO.
	139641-01-701	EA	HARNESSE -AIR PUMP/WARN LIGHT	1809891
	139641-01-704	EA	SWITCH/SENSOR-JACK (UP/DOWN)	1812992
	139641-01-705	EA	FITTING HYD (1/4"X90 DEGREE)	1904500
	139641-01-706	EA	FITTING HYD (1/4" STRAIGHT)	1904510
	139641-01-709	EA	JACK - REAR 15"/10K	3700701
	139641-01-710	EA	CYLINDER ONLY - 15"/10K	1905200
	139641-01-715	EA	BOLT KIT(CROSS MBR/JK/PUMP)	3717794
	139641-01-720	EA	JACK - FRONT 15"/10K	3700702
	139641-01-723	EA	FOOT PAD - JACK	3700367
	139641-01-724	EA	BOLT/FOOT - 3/4-10 X 1 1/2"	1204645
	139641-01-725	EA	HARNESSE - EMERGENCY RETRACT	1809908
	139641-02-700	EA	HARNESSE F/READ SWITCH (FORD)	1809911
	139641-02-701	EA	BRACKET MTG (F53/W22 REAR)	3717742
	139641-02-703	EA	CROSS MEMBER/REAR (F53/W22)	3717795
	139641-09-700	EA	BRACKET/MOUNTING (F53 FRONT)	3717809
	139641-09-701	EA	BRACKET/FRONT X-MEMBER	3717808

**139641-10-000**

KEY	PART NUMBER	U/M	DESCRIPTION	VENDOR NO.
	139641-01-701	EA	HARNESSE -AIR PUMP/WARN LIGHT	1809891
	139641-01-704	EA	SWITCH/SENSOR-JACK (UP/DOWN)	1812992
	139641-01-705	EA	FITTING HYD (1/4"X90 DEGREE)	1904500
	139641-01-706	EA	FITTING HYD (1/4" STRAIGHT)	1904510
	139641-01-709	EA	JACK - REAR 15"/10K	3700701
	139641-01-710	EA	CYLINDER ONLY - 15"/10K	1905200
	139641-01-711	EA	BRACKET MTG (WORKHORSE REAR)	3717740
	139641-01-715	EA	BOLT KIT(CROSS MBR/JK/PUMP)	3717794
	139641-01-720	EA	JACK - FRONT 15"/10K	3700702
	139641-01-723	EA	FOOT PAD - JACK	501-175/3700370/367
	139641-01-724	EA	BOLT/FOOT - 3/4-10 X 1 1/2"	1204645
	139641-01-725	EA	HARNESSE - EMERGENCY RETRACT	1809908
	139641-02-700	EA	HARNESSE F/READ SWITCH (FORD)	1809911
	139641-02-701	EA	BRACKET MTG (F53/W22 REAR)	3717742
	139641-02-703	EA	CROSS MEMBER/REAR (F53/W22)	3717795
	139641-03-700	EA	CROSSMEMBER/FRONT (W22)	3717804
	139641-09-702	EA	HARNESSE-CONTROL/PUMP	1809927

**139641-12-000**

KEY	PART NUMBER	U/M	DESCRIPTION	VENDOR NO.
	139641-12-700	EA	CYLINDER ONLY - 17K	1905210
	139641-12-701	EA	JACK/FRONT - 17K	1010000855
	139641-12-702	EA	JACK/REAR - 17K	1010000939

**139644-03-000**

KEY	PART NUMBER	U/M	DESCRIPTION	VENDOR NO.
	139644-03-700	EA	HOSE - 324" ROADSIDE REAR/T	080-AA324WSTRR
	139644-03-701	EA	HOSE - 324" CURBSIDE REAR/T	080-AA324WSTCR
	139644-03-702	EA	HOSE - 120" CURBSIDE FRONT/B	080-AA120WSBCF
	139644-03-703	EA	HOSE - 324" CURBSIDE REAR/B	080-AA324WSBCR
	139644-03-704	EA	HOSE - 324" ROADSIDE REAR/B	080-AA324WSBRR
	139644-03-705	EA	HOSE - 060" ROADSIDE FRONT/T	080-AA060WSTRF
	139644-03-706	EA	HOSE - 060" ROADSIDE FRONT/B	080-AA060WSBRF

**156056-02-000**

KEY	PART NUMBER	U/M	DESCRIPTION	VENDOR NO.
	139641-01-705	EA	FITTING HYD (1/4"X90 DEGREE)	1904500
	139641-01-718	EA	SOLENOID - 4 POST ELECTRICAL	906900250
	139641-01-719	EA	VALVE KIT (COIL W/PACKARD)	906963010
	139641-01-721	EA	SOLENOID VALVE - 2-WAY	906965000
	139641-01-722	EA	SOLENOID VALVE - 4-WAY	906964000
	139641-01-726	EA	COIL - FOR SOLENOID VALVE	1815312
	156056-02-700	EA	PRESSURE SWITCH - 1500 PSI	1812993



**CHASSIS GROUP (CONTINUED)**  
**COMPONENT PARTS FOR HYDRAULIC LEVELING (CONTINUED)**

**164877-01-000**

<b>KEY</b>	<b>PART NUMBER</b>	<b>U/M</b>	<b>DESCRIPTION</b>	<b>VENDOR NO.</b>
	164877-01-700	EA	PUMP HARNESS - 252"	1510000065
	164877-01-701	EA	INTERCONNECT HARNESS - 30"	1510000072
	164877-01-702	EA	SOLENOID	09-1141

**165119-01-000**

<b>KEY</b>	<b>PART NUMBER</b>	<b>U/M</b>	<b>DESCRIPTION</b>	<b>VENDOR NO.</b>
	165119-01-700	EA	SPRING - 8K/13K - 2.5" X 17"	31-1029
	165119-01-701	EA	CONE/THREADED - F/SPRING	500085
	165119-01-702	EA	REBUILD KIT (SEALS)	800138S

**165119-02-000**

<b>KEY</b>	<b>PART NUMBER</b>	<b>U/M</b>	<b>DESCRIPTION</b>	<b>VENDOR NO.</b>
	165119-01-700	EA	SPRING - 8K/13K - 2.5" X 17"	31-1029
	165119-01-701	EA	CONE/THREADED - F/SPRING	500085
	165119-02-700	EA	REBUILD KIT (SEALS)	800199S

**165120-01-000**

<b>KEY</b>	<b>PART NUMBER</b>	<b>U/M</b>	<b>DESCRIPTION</b>	<b>VENDOR NO.</b>
	165120-01-700	EA	BREATHING VENT	06-1018
	165120-01-701	EA	HARNESS - HYDRAULIC LEVEL	1510000064
	165120-01-702	EA	O-RING	01-1029
	165120-01-703	EA	SOLENOID KIT	500568
	165120-01-704	EA	FLUID SENSOR - VERTICLE SYST	14-1137
	165120-01-705	EA	MANIFOLD - VERTICLE SYSTEM	1010000992
	165120-01-706	EA	MOTOR/PUMP ASM. - VERTICLE	13-1100

**165179-01-000**

<b>KEY</b>	<b>PART NUMBER</b>	<b>U/M</b>	<b>DESCRIPTION</b>	<b>VENDOR NO.</b>
	165179-01-700	EA	HOSE - 288" - ROADSIDE REAR	080-AA288WSTRR
	165179-01-701	EA	HOSE - 288" - CURBSIDE REAR	080-AA228WSTCR
	165179-01-702	EA	HOSE - 88" - CURBSIDE FRONT	080-AA088WSTCF
	165179-01-703	EA	HOSE - 32" - ROADSIDE FRONT	080-AA032WSTRF

## CHASSIS GROUP (CONTINUED) SPARE TIRE

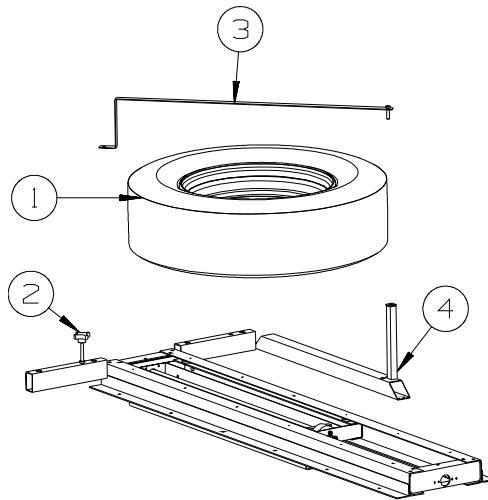

D26P

KEY	PART NUMBER	U/M	DESCRIPTION
1	102340-08-000	EA	TIRE - 245/70R X 19.5F - GOODYEAR
1	102340-09-000	EA	TIRE - 245/70R X 19.5G - GOODYEAR - W21 21200 GVWR WORKHORSE
1			WHEEL FORD CHASSIS SUPPLIED
1	118814-05-000	EA	WHEEL - STEEL - 19.5" X 6.75" - W/STEM - GRAY - W21 21200 GVWR WORKHORSE
2	134194-01-01A	EA	KNOB - HOLD DOWN/RECLINER - BLACK
3	148969-01-02B	EA	STRAP - SPARE TIRE - E-COATED
4	148982-02-02B	EA	BRACKET - SPARE TIRE - E-COATED

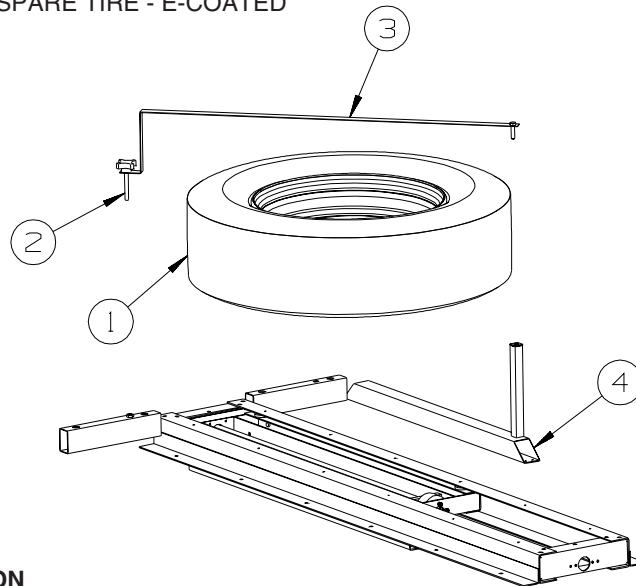

D29R, D34M

KEY	PART NUMBER	U/M	DESCRIPTION
1	102340-08-000	EA	TIRE - 245/70R X 19.5F - GOODYEAR - FORD
1	091673-07-000	EA	TIRE - 225/70R19.5 LRF - MICHELIN XRV - W16/W18 16000/18000 GVWR WORKHORSE
1	102340-09-000	EA	TIRE - 245/70R X 19.5G - GOODYEAR - W21 21200 GVWR WORKHORSE
1			WHEEL - FORD IS CHASSIS SUPPLIED
1	156482-01-000	EA	WHEEL - STEEL - 19.5" X 6" - 10 BOLT - W16/W18 16000/18000 GVWR WORKHORSE
1	118814-05-000	EA	WHEEL - STEEL - 19.5" X 6.75" - W/STEM - GRAY - W21 21200 GVWR WORKHORSE
2	134194-01-01A	EA	KNOB - HOLD DOWN/RECLINER - BLACK
3	148969-03-02B	EA	STRAP - SPARE TIRE - E-COATED
4	148982-02-02B	EA	BRACKET - SPARE TIRE - E-COATED
	155645-01-000	EA	VALVE STEM - 1.25" - 16/18,000 WORKHORSE W16/18
	051377-06-000	EA	VALVE STEM - .5" X 2 1/3" W/22 DEGREE BEND - 21,200 WORKHORSE W21

**CHASSIS GROUP (CONTINUED)**  
**SPARE TIRE (CONTINUED)**

**D30B**

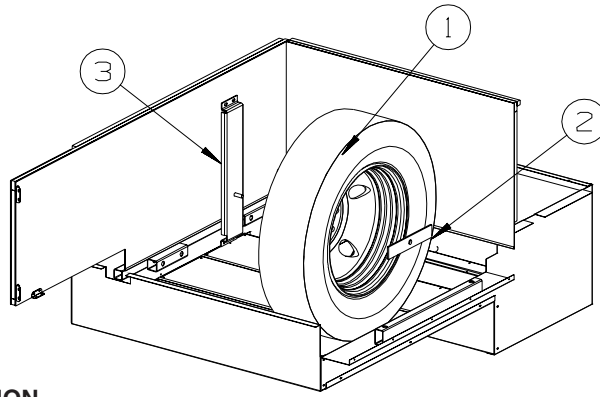

KEY	PART NUMBER	U/M	DESCRIPTION
1		EA	WHEEL ASM - CHASSIS SUPPLIED - FORD
1	091673-07-000	EA	TIRE - 225/70R19.5 LRF - MICHELIN XRV - WORKHORSE
1	156482-01-000	EA	WHEEL - STEEL - 19.5" X 6" - 10 BOLT - WORKHORSE
	155645-01-000	EA	VALVE STEM - 1.25" - WORKHORSE
2	143547-01-02B	EA	RETAINER - SPARE TIRE - E-COATED
			FROM: 00-00-00 THRU: 12-03-06
3	157324-04-02B	EA	BRACKET - SPARE TIRE - E-COATED

**D35J**

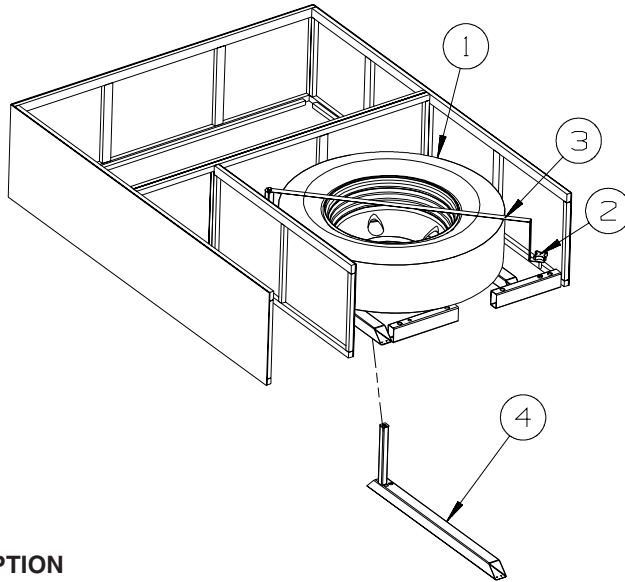

KEY	PART NUMBER	U/M	DESCRIPTION
1		EA	TIRE - FORD CHASSIS SUPPLIED
1	102340-09-000	EA	TIRE - 245/70R X 19.5G - GOODYEAR - WORKHORSE
1		EA	WHEEL - FORD CHASSIS SUPPLIED
1	118814-05-000	EA	WHEEL - STEEL - 19.5" X 6.75" - W/STEM - GRAY - WORKHORSE
2	134194-02-01A	EA	KNOB - HOLD DOWN/RECLINER - BLACK
3	148969-03-02B	EA	STRAP - SPARE TIRE - E-COATED
4	148982-02-02B	EA	BRACKET - SPARE TIRE - E-COATED

## CHASSIS GROUP (CONTINUED)

### WHEEL, TIRE, COVERS &/OR LINERS

KEY	PART NUMBER	U/M	DESCRIPTION
	077030-10-000	EA	EXTENSION - VALVE STEM - .50" - METAL - FORD
	095012-07-000	EA	STABILIZER/VALVE EXTENSION - LIVE - 4" - FORD
	095012-09-000	EA	EXTENSION/VALVE STEM - LIVE - 7.7" - FORD
*	154672-01-000	EA	LINER - WHEEL - SET/4 - 19.5 - 10 BOLT - FORD
*	145580-06-000	EA	LINER - WHEEL(SET OF 4) - 19.5"/10 BOLT - WORKHORSE

**\*COMPONENT PARTS LISTED LATER IN THIS GROUP**

#### COMPONENT PARTS FOR WHEEL, TIRE, COVERS & LINERS

145580-06-000				
KEY	PART NUMBER	U/M	DESCRIPTION	VENDOR NO.
	110435-04-705	EA	DECAL-CTR HUB 2 3/4"	2 3/4 DECAL DIAMOND
	110435-10-702	EA	JAMB NUT/JAMB NUT COVER COMBINATION	
	110435-10-705	EA	TOOL/JAMB NUT INSTALLATION	V195P7-TOL
	145580-06-700	EA	LINER - WHEEL/FRONT - 1EA=1	V195W18-FWC
	145580-06-701	EA	LINER - WHEEL/REAR - 1EA=1	V195W18-RWC

154672-01-000				
KEY	PART NUMBER	U/M	DESCRIPTION	VENDOR NO.
	154672-01-700	EA	LINER - WHEEL - FRONT	V195F6-FWC
	154672-01-701	EA	LINER - WHEEL - REAR	V195F6-RWC

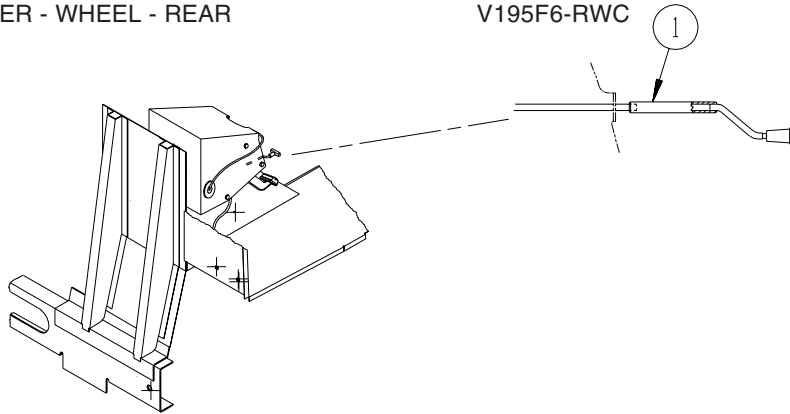

#### BRAKE

KEY	PART NUMBER	U/M	DESCRIPTION
1	113007-01-000	EA	PIN - SPRING - .375 X 3"

## CURTAIN & CUSHION GROUP

### CURTAIN, CUSHION LAYOUT

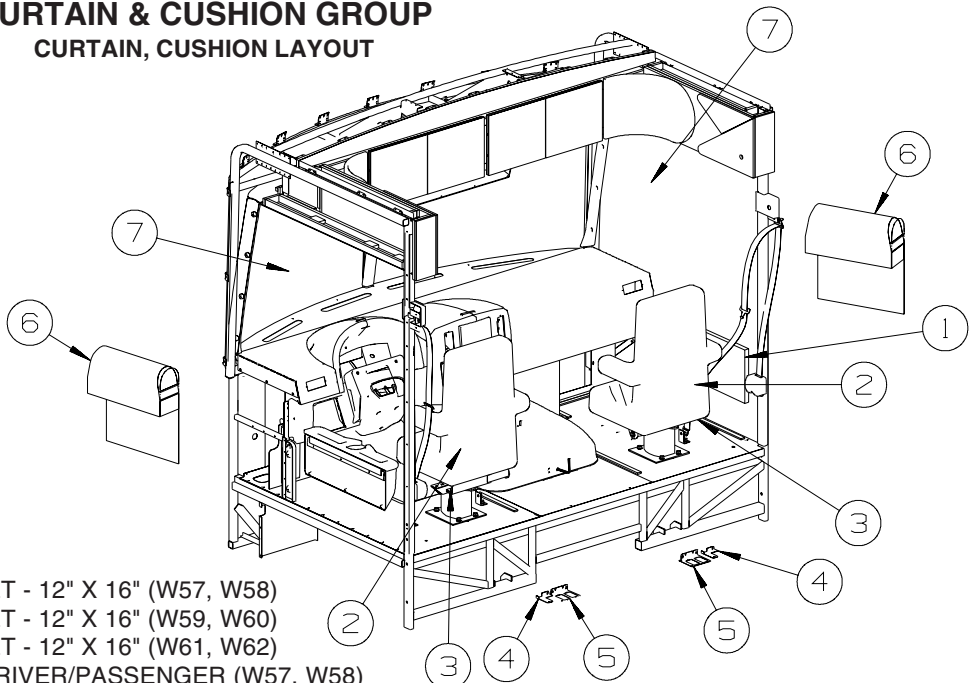

KEY	PART NUMBER	U/M	DESCRIPTION
1	086120-01-W53	EA	PAD - MAP POCKET - 12" X 16" (W57, W58)
1	086120-01-W59	EA	PAD - MAP POCKET - 12" X 16" (W59, W60)
1	086120-01-W61	EA	PAD - MAP POCKET - 12" X 16" (W61, W62)
2	135473-32-W53	EA	BUCKET SEAT - DRIVER/PASSENGER (W57, W58)
			FROM: 00-00-00 THRU: 09-16-07
2	135473-36-W53	EA	BUCKET SEAT - DRIVER/PASSENGER (W57, W58)
			FROM: 09-17-07 THRU: 99-99-99
2	135473-32-W59	EA	BUCKET SEAT - DRIVER/PASSENGER (W59, W60)
			FROM: 00-00-00 THRU: 09-16-07
2	135473-36-W59	EA	BUCKET SEAT - DRIVER/PASSENGER (W59, W60)
			FROM: 09-17-07 THRU: 99-99-99
2	135473-34-W61	EA	BUCKET SEAT - DRIVER/PASSENGER (W61, W62)
			FROM: 00-00-00 THRU: 09-16-07
2	135473-38-W61	EA	BUCKET SEAT - DRIVER/PASSENGER (W61, W62)
			FROM: 09-17-07 THRU: 99-99-99
2	135473-33-W51	EA	BUCKET SEAT - DRIVER/PASSENGER - LEATHER (W57, W58, W61, W62) - <b>ULTRALEATHER</b>
			FROM: 00-00-00 THRU: 09-16-07
2	135473-37-W51	EA	BUCKET SEAT - DRIVER/PASSENGER - LEATHER (W57, W58, W61, W62) - <b>ULTRALEATHER</b>
			FROM: 09-17-07 THRU: 99-99-99
2	135473-33-U59	EA	BUCKET SEAT - DRIVER/PASSENGER - LEATHER (W59, W60) - <b>ULTRALEATHER</b>
			FROM: 00-00-00 THRU: 09-16-07
2	135473-37-W59	EA	BUCKET SEAT - DRIVER/PASSENGER - LEATHER (W59, W60) - <b>ULTRALEATHER</b>
			FROM: 09-17-07 THRU: 99-99-99
3	148630-01-W57	EA	SKIRT - W/SEAT BELT SLOT (W57, W58)
3	148630-01-W59	EA	SKIRT - W/SEAT BELT SLOT (W59, W60)
3	148630-09-W61	EA	SKIRT - W/SEAT BELT SLOT (W61, W62)
3	148630-15-WB0	EA	SKIRT - W/SEAT BELT SLOT - LEATHER (W57, W58, W61, W62) - <b>ULTRALEATHER</b>
3	148630-15-TC4	EA	SKIRT - W/SEAT BELT SLOT - LEATHER (W59, W60) - <b>ULTRALEATHER</b>
	108049-02-000	EA	CLIP - CABLE/PEDESTAL
	108049-04-000	EA	CABLE - W/MINI LEVER ACTION SWITCH - 28" SHEATH/30" CABLE
4	117125-01-02B	EA	BRACKET - CABLE MOUNT - ADJUSTER W/LOCK
5	127159-02-02B	EA	BRACKET - SEAT RELEASE - DUAL REMOTE - E-COATED
6	152337-01-000	EA	PROTECTOR - SEAT - CLEAR VINYL
7	161724-16-W57	EA	CURTAIN - TAPE TOP - 41" X 110" (W57, W58)
7	161724-16-W59	EA	CURTAIN - TAPE TOP - 41" X 110" (W59, W60)
7	161724-16-W61	EA	CURTAIN - TAPE TOP - 41" X 110" (W61, W62)
	073260-42-W57	EA	TIEBACK - 6" X 18" (W57, W58)
			FROM: 00-00-00 THRU: 06-03-07
	165138-01-W57	EA	TIEBACK - 7" X 20" (W57, W58)
			FROM: 06-04-07 THRU: 99-99-99
	073260-42-W59	EA	TIEBACK - 6" X 18" (W59, W60)
			FROM: 00-00-00 THRU: 06-03-07
	165138-01-W59	EA	TIEBACK - 7" X 20" (W59, W60)
			FROM: 06-04-07 THRU: 99-99-99
	073260-42-W61	EA	TIEBACK - 6" X 18" (W61, W62)
			FROM: 00-00-00 THRU: 06-03-07
	165138-01-W61	EA	TIEBACK - 7" X 20" (W61, W62)
			FROM: 06-04-07 THRU: 99-99-99

**CURTAIN & CUSHION GROUP (CONTINUED)**  
**CUSHION LAYOUT (CONTINUED)**

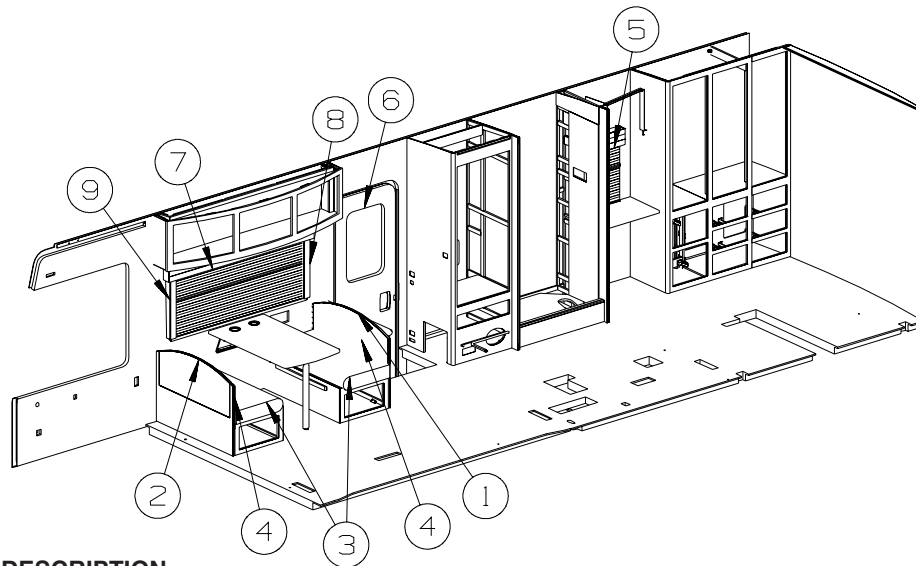

KEY	PART NUMBER	U/M	DESCRIPTION
1	153519-28-W57	EA	PAD - TOP/RH - F/DINETTE BACK - W/TAB - FABRIC COVERED (W57, W58)
1	153519-36-W59	EA	PAD - TOP/RH - F/DINETTE BACK - W/TAB FABRIC COVERED (W59, W60)
1	153519-14-W61	EA	PAD - TOP/RH - F/DINETTE BACK - W/TAB FABRIC COVERED (W61, W62)
2	153519-43-W57	EA	PAD - TOP/LH - F/DINETTE BACK - W/TAB - FABRIC COVERED (W57, W58)
2	153519-32-W59	EA	PAD - TOP/LH - F/DINETTE BACK - W/TAB FABRIC COVERED (W59, W60)
2	153519-45-W61	EA	PAD - TOP/LH - F/DINETTE BACK - W/TAB FABRIC COVERED (W61, W62)
3	153671-04-W57	EA	CUSHION - SEAT - 21" X 42" X 5" (W57, W58)
3	153671-01-W59	EA	CUSHION - SEAT - 21" X 42" X 5" (W59, W60)
3	153671-01-W61	EA	CUSHION - SEAT - 21" X 42" X 5" (W61, W62)
	153671-A4-W57	EA	COVER/CUSHION - SEAT - 21" X 42" X 5" (W57, W58)
	153671-A1-W59	EA	COVER/CUSHION - SEAT - 21" X 42" X 5" (W59, W60)
	153671-A1-W61	EA	COVER/CUSHION - SEAT - 21" X 42" X 5" (W61, W62)
4	153672-04-W57	EA	CUSHION - SEAT BACK - 13.5" X 42" X 5" (W57, W58)
4	153672-04-W59	EA	CUSHION - SEAT BACK - 13.5" X 42" X 5" (W59, W60)
4	153672-04-W61	EA	CUSHION - SEAT BACK - 13.5" X 42" X 5" (W61, W62)
	P53672-04-W57	EA	COVER/BACK - 13.5" X 42" X 5" (W57, W58)
	P53672-04-W59	EA	COVER/BACK - 13.5" X 42" X 5" (W59, W60)
	P53672-04-W61	EA	COVER/BACK - 13.5" X 42" X 5" (W61, W62)
5	161575-15-W57	EA	VALANCE - JAXSON - 19" X 6" (W57, W58)
5	161575-17-W59	EA	VALANCE - JAXSON - 19" X 6" (W59, W60)
5	161575-17-W61	EA	VALANCE - JAXSON - 19" X 6" (W61, W62)
5	157506-28-W53	EA	BLIND - PLEATED - 17.5" X 28" (W57, W58, W61, W62)
5	157506-28-W51	EA	BLIND - PLEATED - 17.5" X 28" (W59, W60)
5	140789-50-W57	EA	BLIND - DAY/NIGHTER - 17.5" X 28" (W57, W58, W61, W62) - WINDOW COVER EXCHANGE
5	140789-50-W51	EA	BLIND - DAY/NIGHTER - 17.5" X 28" (W59, W60) - WINDOW COVER EXCHANGE
	097565-01-000	EA	BRACKET - MOUNTING - PLEATED BLIND
6	153643-86-W57	EA	VALANCE - MODERATE - 12" X 32" (W57, W58)
6	153643-85-W59	EA	VALANCE - MODERATE - 12" X 32" (W59, W60)
6	153643-86-W61	EA	VALANCE - MODERATE - 12" X 32" (W61, W62)
	105648-01-02A	EA	BRACE - VALANCE - 14" - OFF WHITE
6	084755-57-P37	EA	SHADE - PULL - 27.25"
7	161575-14-W57	EA	VALANCE - JAXSON - 65" X 6" (W57, W58)
7	161575-12-W59	EA	VALANCE - JAXSON - 65" X 6" (W59, W60)
7	161575-14-W61	EA	VALANCE - JAXSON - 65" X 6" (W61, W62)
7	109041-53-05A	EA	BLIND - MINI - 61" X 28.5"
	162496-01-01A	EA	BRACKET/BLIND - LEFT SIDE WHEN FACING WINDOW - CLEAR
	162496-02-01A	EA	BRACKET/BLIND - RIGHT SIDE WHEN FACING WINDOW - CLEAR
	109441-01-000	EA	BRACKET/HOOK - BLIND HOLD DOWN - LARGE - CLEAR
	109353-04-000	EA	CLIP - VALANCE SLAT MOUNTING - CLEAR PLASTIC
	102555-03-000	EA	BRACKET - (CLEAT TYPE) - F/BLIND HOLDDOWN - MILKY WHITE
7	140789-14-W37	EA	BLIND - DAY/NIGHTER - 61" X 28.5" (W57, W58, W61, W62) - WINDOW COVER EXCHANGE
7	140789-14-W51	EA	BLIND - DAY/NIGHTER - 61" X 28.5" (W59, W60) - WINDOW COVER EXCHANGE
	097565-01-000	EA	BRACKET - MOUNTING - PLEATED BLIND

**CURTAIN & CUSHION GROUP (CONTINUED)**  
**CUSHION LAYOUT (CONTINUED)**

KEY	PART NUMBER	U/M	DESCRIPTION
8	152445-09-W53	EA	LEG - RIGHT - 27" (W57, W58)
8	152445-47-W59	EA	LEG - RIGHT - 27" (W59, W60)
8	152445-09-W61	EA	LEG - RIGHT - 27" (W61, W62)
	154316-01-01A	EA	BRACE/ANGLE - W/HOLE - CASHMERE
9	152445-10-W53	EA	LEG - LEFT - 27" (W57, W58)
9	152445-48-W59	EA	LEG - LEFT - 27" (W59, W60)
9	152445-10-W61	EA	LEG - LEFT - 27" (W61, W62)
	154316-01-01A	EA	BRACE/ANGLE - W/HOLE - CASHMERE

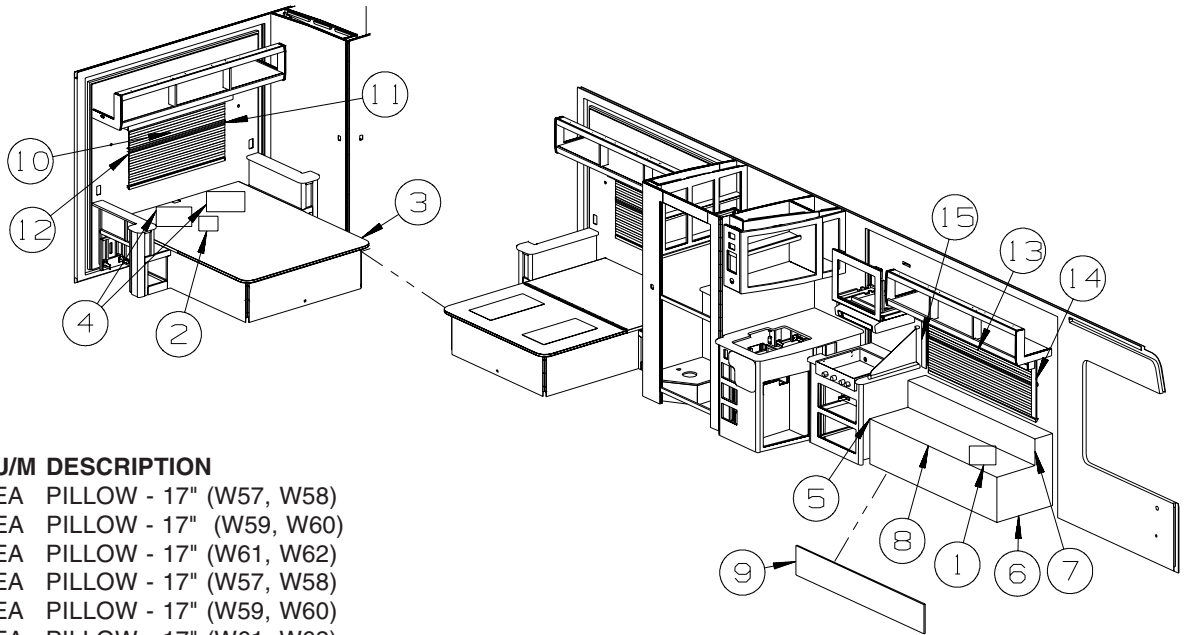

KEY	PART NUMBER	U/M	DESCRIPTION
1	163175-01-W57	EA	PILLOW - 17" (W57, W58)
1	163175-02-W59	EA	PILLOW - 17" (W59, W60)
1	163175-01-W61	EA	PILLOW - 17" (W61, W62)
2	163175-03-W57	EA	PILLOW - 17" (W57, W58)
2	163175-03-W59	EA	PILLOW - 17" (W59, W60)
2	163175-03-W61	EA	PILLOW - 17" (W61, W62)
3	132336-09-W57	EA	BEDSPREAD/CAP - 60" X 75" (W57, W58)
3	132336-09-W59	EA	BEDSPREAD/CAP - 60" X 75" (W59, W60)
3	132336-09-W61	EA	BEDSPREAD/CAP - 60" X 75" (W61, W62)
4	104176-04-W57	EA	PILLOW SHAM - 30" (W57, W58)
4	104176-04-W59	EA	PILLOW SHAM - 30" (W59, W60)
4	104176-04-W61	EA	PILLOW SHAM - 30" (W61, W62)
5	134282-01-W57	EA	PANEL - RIGHT END/SHORT - SOFA/BED - FABRIC COVERED (W57, W58)
5	134282-01-W59	EA	PANEL - RIGHT END/SHORT - SOFA/BED - FABRIC COVERED (W59, W60)
5	134282-01-W61	EA	PANEL - RIGHT END/SHORT - SOFA/BED - FABRIC COVERED (W61, W62)
5	134282-30-W51	EA	PANEL/RIGHT END/SHORT - SOFA/BED - LEATHER (W57, W58, W61, W62) - <b>ULTRALEATHER</b>
5	134282-30-U59	EA	PANEL/RIGHT END/SHORT - SOFA/BED - LEATHER (W59, W60) - <b>ULTRALEATHER</b>
	101926-01-02A	EA	BRACKET - ZEE - 2" - BLACK
	156732-01-02A	EA	BRACE - ANGLE - 2.5" - OFF WHITE
6	134282-02-W57	EA	PANEL - LEFT END/SHORT - SOFA/BED - FABRIC COVERED (W57, W58)
6	134282-02-W59	EA	PANEL - LEFT END/SHORT - SOFA/BED - FABRIC COVERED (W59, W60)
6	134282-02-W61	EA	PANEL - LEFT END/SHORT - SOFA/BED - FABRIC COVERED (W61, W62)
6	134282-31-W51	EA	PANEL/LEFT END/SHORT - SOFA/BED - LEATHER (W57, W58, W61, W62) - <b>ULTRALEATHER</b>
6	134282-31-U59	EA	PANEL/LEFT END/SHORT - SOFA/BED - LEATHER (W59, W60) - <b>ULTRALEATHER</b>
	101926-01-02A	EA	BRACKET - ZEE - 2" - BLACK
	156732-01-02A	EA	BRACE - ANGLE - 2.5" - OFF WHITE
7	153676-05-W57	EA	BACK - SOFA - 70" (W57, W58)
7	153676-05-W59	EA	BACK - SOFA - 70" (W59, W60)
7	153676-05-W61	EA	BACK - SOFA - 70" (W61, W62)
7	161040-01-W51	EA	BACK - SOFA/BED - 70" - LEATHER (W57, W58, W61, W62) - <b>ULTRALEATHER</b>
7	161040-01-U55	EA	BACK - SOFA/BED - 70" - LEATHER (W59, W60) - <b>ULTRALEATHER</b>
	P53676-05-W57	EA	COVER/BACK - SOFA - 70" (W57, W58)
	P53676-05-W59	EA	COVER/BACK - SOFA - 70" (W59, W60)
	P53676-05-W61	EA	COVER/BACK - SOFA - 70" (W61, W62)
	161040-A1-W51	EA	COVER - BACK - SOFA/BED - 70" - LEATHER (W57, W58, W61, W62) - <b>ULTRALEATHER</b>
	161040-A1-U55	EA	COVER - BACK - SOFA/BED - 70" - LEATHER (W59, W60) - <b>ULTRALEATHER</b>

**CURTAIN & CUSHION GROUP (CONTINUED)**  
**CUSHION LAYOUT (CONTINUED)**

KEY	PART NUMBER	U/M	DESCRIPTION
8	153676-06-W57	EA	SEAT - SOFA - 70" (W57, W58)
8	153676-06-W59	EA	SEAT - SOFA - 70" (W59, W60)
8	153676-06-W61	EA	SEAT - SOFA - 70" (W61, W62)
8	135138-31-W51	EA	SEAT - SOFA/BED - 70" - LEATHER (W57, W58, W61, W62) - <b>ULTRALEATHER</b>
8	135138-31-U55	EA	SEAT - SOFA/BED - 70" - LEATHER (W59, W60) - <b>ULTRALEATHER</b>
	P53676-06-W57	EA	COVER/SEAT - SOFA - 70" (W57, W58)
	P53676-06-W59	EA	COVER/SEAT - SOFA - 70" (W59, W60)
	P53676-06-W61	EA	COVER/SEAT - SOFA - 70" (W61, W62)
	P35138-31-W51	EA	COVER/SEAT - SOFA/BED - 70" - LEATHER (W57, W58, W61, W62) - <b>ULTRALEATHER</b>
	P35138-31-U55	EA	COVER/SEAT - SOFA/BED - 70" - LEATHER (W59, W60) - <b>ULTRALEATHER</b>
	127335-07-000	EA	LEG - SOFA/BED - 8"
9	155857-01-W57	EA	PANEL/FRONT KICK - SOFA/SLEEPER - 70" - FABRIC COVERED (W57, W58)
9	155857-01-W59	EA	PANEL/FRONT KICK - SOFA/SLEEPER - 70" - FABRIC COVERED (W59, W60)
9	155857-01-W61	EA	PANEL/FRONT KICK - SOFA/SLEEPER - 70" - FABRIC COVERED (W61, W62)
9	120992-39-W51	EA	PANEL/FRONT KICK - SOFA/BED - FABRIC COVERED - 70" (W57, W58, W61, W62) - <b>ULTRALEATHER</b>
9	120992-39-U59	EA	PANEL/FRONT KICK - SOFA/BED - FABRIC COVERED - 70" (W59, W60) - <b>ULTRALEATHER</b>
	121906-01-02B	EA	BRACKET - KICKBOARD - E-COATED
10	161575-34-W57	EA	VALANCE - JAXSON - 47" X 6" (W57, W58)
10	161575-35-W59	EA	VALANCE - JAXSON - 47" X 6" (W59, W60)
10	161575-35-W61	EA	VALANCE - JAXSON - 47" X 6" (W61, W62)
10	157506-04-W23	EA	BLIND - PLEATED - 43" X 28" (W57, W58, W61, W62)
10	157506-04-W21	EA	BLIND - PLEATED - 43" X 28" (W59, W60)
10	140789-02-W57	EA	BLIND - DAY/NIGHTER - 43" X 28" (W57, W58, W61, W62) - <b>WINDOW COVER EXCHANGE</b>
10	140789-02-W21	EA	BLIND - DAY/NIGHTER - 43" X 28" (W59, W60) - <b>WINDOW COVER EXCHANGE</b>
	097565-01-000	EA	BRACKET - MOUNTING - PLEATED BLIND
11	152664-23-W57	EA	LEG - RIGHT - 26" (W57, W58)
11	152664-29-W59	EA	LEG - RIGHT - 26" (W59, W60)
11	152664-29-W61	EA	LEG - RIGHT - 26" (W61, W62)
12	152664-24-W57	EA	LEG - LEFT - 26" (W57, W58)
12	152664-30-W59	EA	LEG - LEFT - 26" (W59, W60)
12	152664-30-W61	EA	LEG - LEFT - 26" (W61, W62)
13	161575-13-W57	EA	VALANCE - JAXSON - 63" X 6" (W57, W58)
13	161575-11-W59	EA	VALANCE - JAXSON - 63" X 6" (W59, W60)
13	161575-13-W61	EA	VALANCE - JAXSON - 63" X 6" (W61, W62)
13	109041-66-05A	EA	BLIND - MINI - 59" X 26"
	162496-01-01A	EA	BRACKET/BLIND - LEFT SIDE WHEN FACING WINDOW - CLEAR
	162496-02-01A	EA	BRACKET/BLIND - RIGHT SIDE WHEN FACING WINDOW - CLEAR
	109441-01-000	EA	BRACKET/HOOK - BLIND HOLD DOWN - LARGE - CLEAR
	109353-04-000	EA	CLIP - VALANCE SLAT MOUNTING - CLEAR PLASTIC
	102555-03-000	EA	BRACKET - (CLEAT TYPE) - F/BLIND HOLDOWN - MILKY WHITE
13	140789-08-W37	EA	BLIND - DAY/NIGHTER - 59" X 26.5" (W57, W58, W61, W62) - <b>WINDOW COVER EXCHANGE</b>
13	140789-08-W39	EA	BLIND - DAY/NIGHTER - 59" X 26.5" (W59, W60) - <b>WINDOW COVER EXCHANGE</b>
	097565-01-000	EA	BRACKET - MOUNTING - PLEATED BLIND
14	152445-13-W23	EA	LEG - RIGHT - 25" (W57, W58)
14	152445-05-W59	EA	LEG - RIGHT - 25" (W59, W60)
14	152445-13-W33	EA	LEG - RIGHT - 25" (W61, W62)
	154316-01-01A	EA	BRACE/ANGLE - W/HOLE - CASHMERE
15	152445-14-W23	EA	LEG - LEFT - 25" (W57, W58)
15	152445-06-W59	EA	LEG - LEFT - 25" (W59, W60)
15	152445-14-W33	EA	LEG - LEFT - 25" (W61, W62)
	154316-01-01A	EA	BRACE/ANGLE - W/HOLE - CASHMERE



# CURTAIN & CUSHION GROUP (CONTINUED)

## BUCKET SEATS

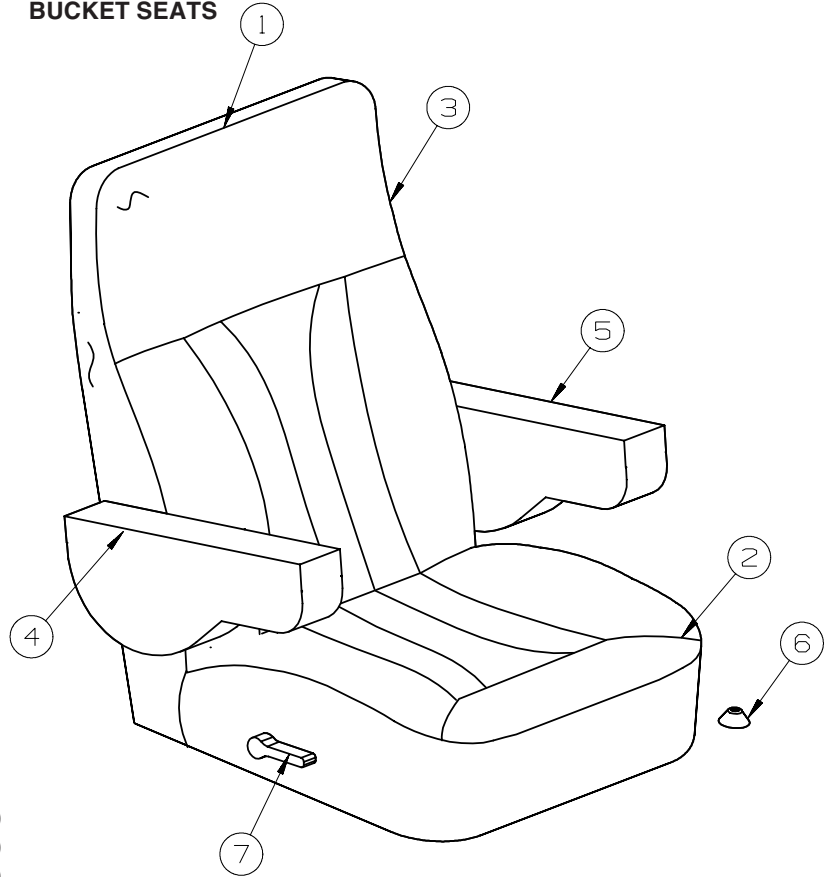

KEY	PART NUMBER	U/M	DESCRIPTION
1	M05962-X3-W53	EA	COVER/BACK (W57, W58)
1	M05962-X3-W59	EA	COVER/BACK (W59, W60)
1	M05962-V1-W61	EA	COVER/BACK (W61, W62)
1	M05962-X5-W51	EA	COVER/BACK - LEATHER (W57, W58, W61, W62) - <b>ULTRALEATHER</b>
1	M05962-X5-U59	EA	COVER/BACK - LEATHER (W59, W60) - <b>ULTRALEATHER</b>
2	M05962-X4-W53	EA	COVER/SEAT (W57, W58)
2	M05962-X4-W59	EA	COVER/SEAT (W59, W60)
2	M05962-V2-W61	EA	COVER/SEAT (W61, W62)
2	M05962-X6-W51	EA	COVER/SEAT - LEATHER (W57, W58, W61, W62) - <b>ULTRALEATHER</b>
2	M05962-X6-U59	EA	COVER/SEAT - LEATHER (W59, W60) - <b>ULTRALEATHER</b>
3	134532-01-000	EA	FRAME - SEAT/HIGH BACK
3	134532-06-000	EA	FRAME - SEAT/HIGH BACK
			FROM: 00-00-00 THRU: 09-16-07
			FROM: 09-17-07 THRU: 99-99-99
4	148652-01-W53	EA	ARMREST - RIGHT (W57, W58)
4	148652-01-W59	EA	ARMREST - RIGHT (W59, W60)
4	148652-05-W61	EA	ARMREST - RIGHT (W61, W62)
4	148652-03-W51	EA	ARMREST - RIGHT - LEATHER (W57, W58, W61, W62) - <b>ULTRALEATHER</b>
4	148652-03-S55	EA	ARMREST - RIGHT - LEATHER (W59, W60) - <b>ULTRALEATHER</b>
	P48652-01-W53	EA	COVER/ARMREST - RIGHT (W57, W58)
	P48652-01-W59	EA	COVER/ARMREST - RIGHT (W59, W60)
	P48652-05-W61	EA	COVER/ARMREST - RIGHT (W61, W62)
	P48652-03-W51	EA	COVER/ARMREST - RIGHT - LEATHER (W57, W58, W61, W62) - <b>ULTRALEATHER</b>
	P48652-03-S55	EA	COVER/ARMREST - RIGHT - LEATHER (W59, W60) - <b>ULTRALEATHER</b>
	130698-03-000	EA	ARMREST/MOLDED - RIGHT - W/O COVER
5	148652-02-W53	EA	ARMREST - LEFT (W57, W58)
5	148652-02-W59	EA	ARMREST - LEFT (W59, W60)
5	148652-06-W61	EA	ARMREST - LEFT (W61, W62)
5	148652-04-W51	EA	ARMREST - LEFT - LEATHER (W57, W58, W61, W62) - <b>ULTRALEATHER</b>
5	148652-04-S55	EA	ARMREST - LEFT - LEATHER (W59, W60) - <b>ULTRALEATHER</b>
	P48652-02-W53	EA	COVER/ARMREST - LEFT (W57, W58)
	P48652-02-W59	EA	COVER/ARMREST - LEFT (W59, W60)
	P48652-06-W61	EA	COVER/ARMREST - LEFT (W61, W62)
	P48652-04-W51	EA	COVER/ARMREST - LEFT - LEATHER (W57, W58, W61, W62) - <b>ULTRALEATHER</b>
	P48652-04-S55	EA	COVER/ARMREST - LEFT - LEATHER (W59, W60) - <b>ULTRALEATHER</b>
	130698-04-000	EA	ARMREST/MOLDED - LEFT - W/O COVER
6	148668-01-01A	EA	CUP/TRIM COVER - F/LEVER - BLACK
7	130802-02-000	EA	LEVER - RIGHT HAND
	130802-03-000	EA	SCREW F/LEVER

## CURTAIN & CUSHION GROUP (CONTINUED)

### SOFA

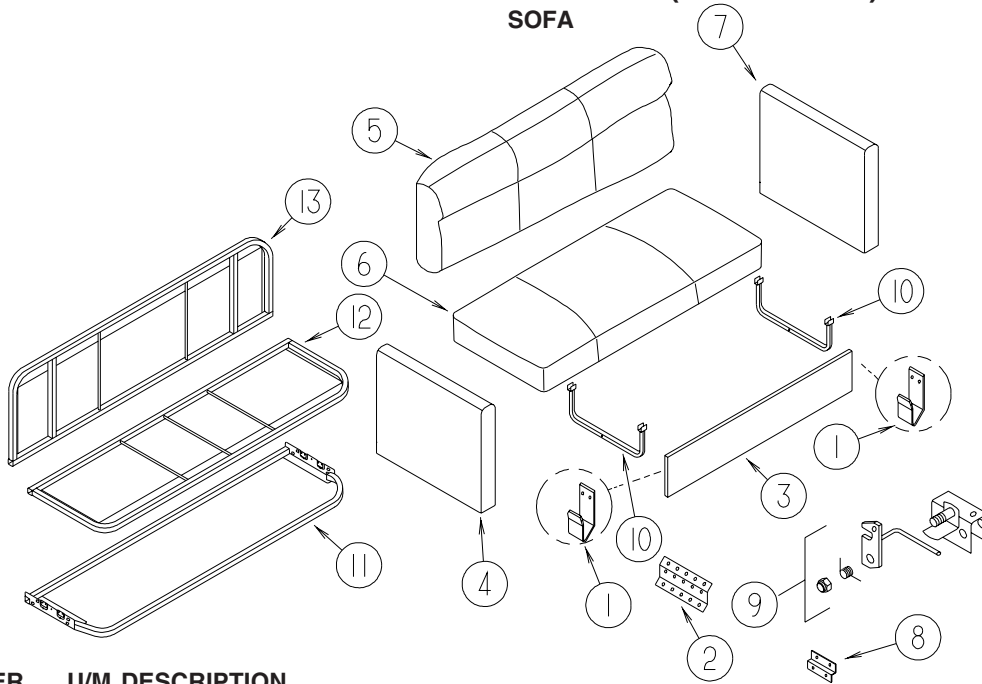

KEY	PART NUMBER	U/M	DESCRIPTION
1	121906-01-02B	EA	BRACKET - KICKBOARD - E-COATED
2	NOT USED		
3	155857-01-W57	EA	PANEL/FRONT KICK - SOFA/SLEEPER - 70" - FABRIC COVERED (W57, W58)
3	155857-01-W59	EA	PANEL/FRONT KICK - SOFA/SLEEPER - 70" - FABRIC COVERED (W59, W60)
3	155857-01-W61	EA	PANEL/FRONT KICK - SOFA/SLEEPER - 70" - FABRIC COVERED (W61, W62)
3	120992-39-W51	EA	PANEL/FRONT KICK - SOFA/BED - FABRIC COVERED - 70" (W57, W58, W61, W62) - <b>ULTRALEATHER</b>
3	120992-39-U59	EA	PANEL/FRONT KICK - SOFA/BED - FABRIC COVERED - 70" (W59, W60) - <b>ULTRALEATHER</b>
4	134282-01-W57	EA	PANEL - RIGHT END/SHORT - SOFA/BED - FABRIC COVERED (W57, W58)
4	134282-01-W59	EA	PANEL - RIGHT END/SHORT - SOFA/BED - FABRIC COVERED (W59, W60)
4	134282-01-W61	EA	PANEL - RIGHT END/SHORT - SOFA/BED - FABRIC COVERED (W61, W62)
4	134282-30-W51	EA	PANEL/RIGHT END/SHORT - SOFA/BED - LEATHER (W57, W58, W61, W62) - <b>ULTRALEATHER</b>
4	134282-30-U59	EA	PANEL/RIGHT END/SHORT - SOFA/BED - LEATHER (W59, W60) - <b>ULTRALEATHER</b>
5	153676-05-W57	EA	BACK - SOFA - 70" (W57, W58)
5	153676-05-W59	EA	BACK - SOFA - 70" (W59, W60)
5	153676-05-W61	EA	BACK - SOFA - 70" (W61, W62)
5	161040-01-W51	EA	BACK - SOFA/BED - 70" - LEATHER (W57, W58, W61, W62) - <b>ULTRALEATHER</b>
5	161040-01-U55	EA	BACK - SOFA/BED - 70" - LEATHER (W59, W60) - <b>ULTRALEATHER</b>
	P53676-05-W57	EA	COVER/BACK - SOFA - 70" (W57, W58)
	P53676-05-W59	EA	COVER/BACK - SOFA - 70" (W59, W60)
	P53676-05-W61	EA	COVER/BACK - SOFA - 70" (W61, W62)
	161040-A1-W51	EA	COVER - BACK - SOFA/BED - 70" - LEATHER (W57, W58, W61, W62) - <b>ULTRALEATHER</b>
	161040-A1-U55	EA	COVER - BACK - SOFA/BED - 70" - LEATHER (W59, W60) - <b>ULTRALEATHER</b>
6	153676-06-W57	EA	SEAT - SOFA - 70" (W57, W58)
6	153676-06-W59	EA	SEAT - SOFA - 70" (W59, W60)
6	153676-06-W61	EA	SEAT - SOFA - 70" (W61, W62)
6	135138-31-W51	EA	SEAT - SOFA/BED - 70" - LEATHER (W57, W58, W61, W62) - <b>ULTRALEATHER</b>
6	135138-31-U55	EA	SEAT - SOFA/BED - 70" - LEATHER (W59, W60) - <b>ULTRALEATHER</b>
	P53676-06-W57	EA	COVER/SEAT - SOFA - 70" (W57, W58)
	P53676-06-W59	EA	COVER/SEAT - SOFA - 70" (W59, W60)
	P53676-06-W61	EA	COVER/SEAT - SOFA - 70" (W61, W62)
	P35138-31-W51	EA	COVER/SEAT - SOFA/BED - 70" - LEATHER (W57, W58, W61, W62) - <b>ULTRALEATHER</b>
	P35138-31-U55	EA	COVER/SEAT - SOFA/BED - 70" - LEATHER (W59, W60) - <b>ULTRALEATHER</b>
7	134282-02-W57	EA	PANEL - LEFT END/SHORT - SOFA/BED - FABRIC COVERED (W57, W58)
7	134282-02-W59	EA	PANEL - LEFT END/SHORT - SOFA/BED - FABRIC COVERED (W59, W60)
7	134282-02-W61	EA	PANEL - LEFT END/SHORT - SOFA/BED - FABRIC COVERED (W61, W62)
7	134282-31-W51	EA	PANEL/LEFT END/SHORT - SOFA/BED - LEATHER (W57, W58, W61, W62) - <b>ULTRALEATHER</b>
7	134282-31-U59	EA	PANEL/LEFT END/SHORT - SOFA/BED - LEATHER (W59, W60) - <b>ULTRALEATHER</b>
8	NOT USED		
9	NOT USED		
10	127335-07-000	EA	LEG - SOFA/BED - 8"
11	151290-21-000	EA	FRAME - BASE - 27.25" X 70"
12	151290-06-000	EA	FRAME - SEAT - 70"
13	132870-01-000	EA	FRAME/BACK - 70" - CUSTOM LOUNGE

**CURTAIN & CUSHION GROUP (CONTINUED)**  
**HARDWARE**

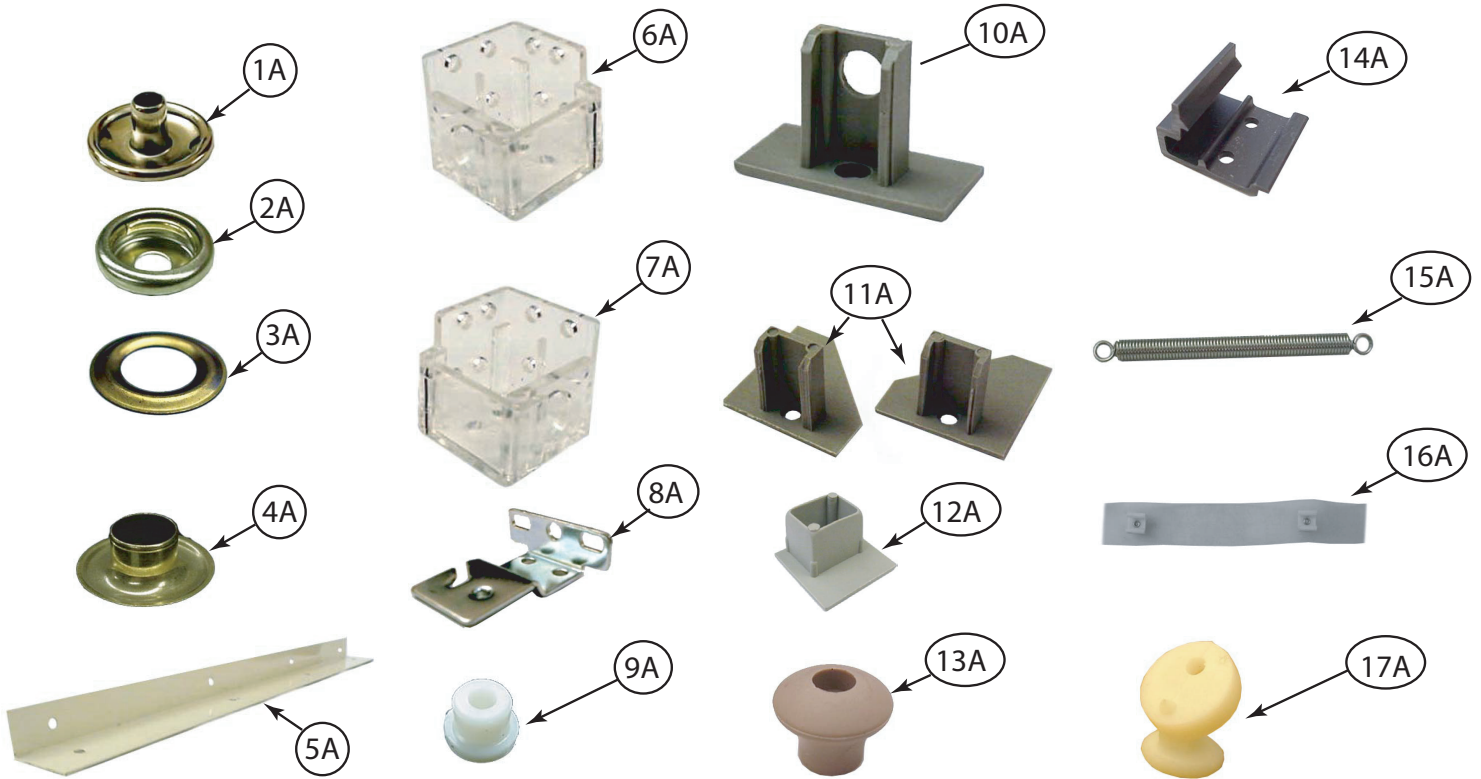

KEY	PART NUMBER	U/M	DESCRIPTION
1A	029155-01-000	EA	CAP - SNAP - 5/32" OUTSIDE DIAMETER OF PIN
2A	029156-01-000	EA	SOCKET - SNAP - 9/16" O.D.
3A	046867-05-000	EA	WASHER - #0
4A	046867-04-000	EA	GROMMET - #0
5A	160457-01-01A	EA	BRACE - VALANCE - L-SHAPED - 20" - OFF WHITE
6A	162496-01-01A	EA	BRACKET/BLIND - LEFT SIDE WHEN FACING WINDOW - CLEAR
7A	162496-02-01A	EA	BRACKET/BLIND - RIGHT SIDE WHEN FACING WINDOW - CLEAR
8A	084434-01-000	EA	BRACKET - MOUNTING - ROLLER SHADE - 1 3/8"
9A	094896-02-000	EA	GROMMET - CORD/PLEATED BLIND - NYLON - GRAY
10A	094907-02-000	EA	END CAP - PLEATED BLIND/TOP - RH/LH - GRAY PLASTIC
11A	094907-04-000	EA	END CAP - PLEATED BLIND/BOTTOM - RH/LH
12A	094907-09-000	EA	END CAP/BLIND - CENTER RAIL - RH/LH
13A	097564-03-000	EA	HANDLE - KNOB - E-Z LIFT SHADE - TAN
14A	097565-01-000	EA	BRACKET - MOUNTING - PLEATED BLIND
15A	155748-01-000	EA	SPRING - EXTENSION - DAY/NIGHTER BLIND
16A	101031-01-000	YD	TAPE/GLIDE - 4.25" SPACING
17A	102555-03-000	EA	BRACKET - (CLEAT TYPE) - F/BLIND HOLDOWN - MILKY WHITE

**CURTAIN & CUSHION GROUP (CONTINUED)**  
**HARDWARE (CONTINUED)**

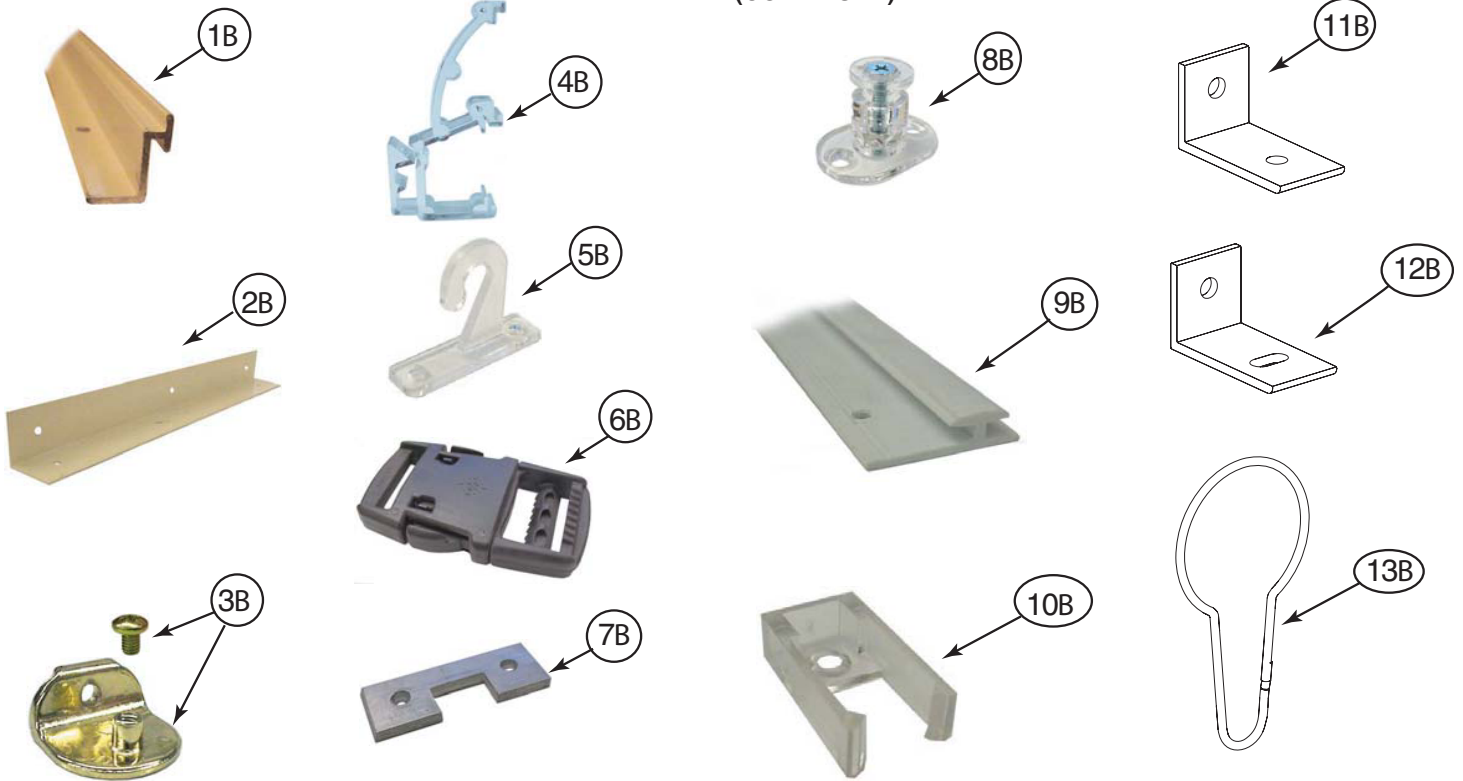

KEY	PART NUMBER	U/M	DESCRIPTION
1B	105450-14-01A	EA	TRACK - CURTAIN - 90" - OFF WHITE
2B	105648-01-02A	EA	BRACE - VALANCE - 14" - OFF WHITE
2B	105648-02-02A	EA	BRACE - VALANCE - 8.5" - OFF WHITE
3B	106544-01-000	EA	PULL - SHADE/BRASS
3B	106544-01-001	EA	SCREW - SHADE/BRASS
3B	106544-02-000	EA	PULL-SHADE - NICKEL
4B	109353-04-000	EA	CLIP - VALANCE SLAT MOUNTING - CLEAR PLASTIC
5B	109441-01-000	EA	BRACKET/HOOK - BLIND HOLD DOWN - LARGE - CLEAR
	109441-02-000	EA	SPACER/BRACKET - BLIND HOLD DOWN
6B	129491-01-000	EA	CATCH - SNAP HOOK - 1"
7B	130549-01-01A	EA	STOP - CURTAIN TRACK
8B	141634-01-000	EA	BRACKET-(BOBBIN TYPE) 7/8"H HOLDUPBASE(OVAL)-2 HOLE-CLEAR
9B	156172-02-01A	EA	TRACK/WALL - 32" - BONE
9B	156172-03-01A	EA	TRACK/WALL - 21" - BONE
10B	156172-04-01A	EA	END CAP - WALL TRACK - CLEAR
11B	154316-01-01A	EA	BRACE/ANGLE - W/HOLE - CASHMERE
12B	154316-02-01A	EA	BRACE/ANGLE - W/SLOT - CASHMERE
13B	159702-01-01A	EA	HOOK/RING - CURTAIN/SHOWER - NICKEL

## CURTAIN & CUSHION GROUP (CONTINUED)

### FABRICS

#### W57, W58

113979-09-01A CARPET-HEADLINER (SY) - CEILING  
FROM: 00-00-00 THRU: 01-13-08

113979-09-02A CARPET-HEADLINER (SY) - CEILING  
FROM: 01-14-08 THRU: 99-99-99

113979-10-01A CARPET-HEADLINER - SLDOUT (SY) - CEILING  
FROM: 00-00-00 THRU: 01-13-08

113979-10-02A CARPET-HEADLINER - SLDOUT (SY) - CEILING  
FROM: 01-14-08 THRU: 99-99-99

113979-11-01A CARPET-HEADLINER - SLDOUT (SY) - CEILING  
FROM: 00-00-00 THRU: 01-13-08

113979-11-02A CARPET-HEADLINER - SLDOUT (SY) - CEILING  
FROM: 01-14-08 THRU: 99-99-99

156773-40-000 FABRIC-DRAPERY, MAIN

156773-40-000 FABRIC-UPHOLSTRY, BEDSPREAD MAIN

156773-40-000 FABRIC-OVERHEAD CABINET, BEDROOM

148797-AP-000 FABRIC-UPHOLSTRY, MAIN

148797-AP-000 FABRIC-OVERHEAD CABINET, DINETTE/LOUNGE

148797-AL-000 FABRIC-UPHOLSTRY, PLAIN ACCENT

148797-AQ-000 FABRIC-UPHOLSTRY, ACCENT PATTERN

148797-AQ-000 FABRIC-UPHOLSTRY, BEDSPREAD PATTERN ACCENT

142523-19-000 FABRIC-UPHOLSTRY, ULTRALEATHER

072333-98-000 FABRIC-SPEAKER COVER

142523-03-000 VINYL-CABINET ENDS

142523-04-000 VINYL-SUNVISORS

103907-01-01A VINYL-DINETTE CUSHION

#### W59, W60

113979-09-01A CARPET-HEADLINER (SY) - CEILING  
FROM: 00-00-00 THRU: 01-13-08

113979-09-02A CARPET-HEADLINER (SY) - CEILING  
FROM: 01-14-08 THRU: 99-99-99

113979-10-01A CARPET-HEADLINER - SLDOUT (SY) - CEILING  
FROM: 00-00-00 THRU: 01-13-08

113979-10-02A CARPET-HEADLINER - SLDOUT (SY) - CEILING  
FROM: 01-14-08 THRU: 99-99-99

113979-11-01A CARPET-HEADLINER - SLDOUT (SY) - CEILING  
FROM: 00-00-00 THRU: 01-13-08

113979-11-02A CARPET-HEADLINER - SLDOUT (SY) - CEILING  
FROM: 01-14-08 THRU: 99-99-99

156773-78-000 FABRIC-DRAPERY - MAIN

156773-78-000 FABRIC-UPHOLSTERY, BEDSPREAD MAIN

156773-78-000 FABRIC-OVERHEAD CABINET, BEDROOM

148797-CN-000 FABRIC-UPHOLSTERY, MAIN

148797-CN-000 FABRIC-OVERHEAD CABINET, DINETTE/LOUNGE

148797-CT-000 FABRIC-UPHOLSTERY, PLAIN ACCENT

137813-N0-000 FABRIC-UPHOLSTERY, 2ND PATTERN ACCENT

148797-CP-000 FABRIC-UPHOLSTERY, ACCENT PATTERN

142523-02-000 FABRIC-UPHOLSTERY, ULTRALEATHER

156773-77-000 FABRIC-UPHOLSTERY, BEDSPREAD, PATTERN ACCENT

072333-98-000 FABRIC-SPEAKER COVER

142523-03-000 VINYL-CABINET ENDS

142523-04-000 VINYL-SUNVISORS

103907-01-01A VINYL-DINETTE CUSHION

**CURTAIN & CUSHION GROUP (CONTINUED)**  
**FABRICS (CONTINUED)**

**W61, W62**

113979-09-01A CARPET-HEADLINER (SY) - CEILING  
FROM: 00-00-00 THRU: 01-13-08

113979-09-02A CARPET-HEADLINER (SY) - CEILING  
FROM: 01-14-08 THRU: 99-99-99

113979-10-01A CARPET-HEADLINER - SLDOUT (SY) - CEILING  
FROM: 00-00-00 THRU: 01-13-08

113979-10-02A CARPET-HEADLINER - SLDOUT (SY) - CEILING  
FROM: 01-14-08 THRU: 99-99-99

113979-11-01A CARPET-HEADLINER - SLDOUT (SY) - CEILING  
FROM: 00-00-00 THRU: 01-13-08

113979-11-02A CARPET-HEADLINER - SLDOUT (SY) - CEILING  
FROM: 01-14-08 THRU: 99-99-99

156773-76-000 FABRIC-DRAPERY, MAIN

156773-76-000 FABRIC-UPHOLSTERY, BEDSPREAD MAIN

148797-JC-000 FABRIC-UPHOLSTERY MAIN ONE

148797-CR-000 FABRIC-UPHOLSTERY, PLAIN ACCENT

148797-CR-000 FABRIC-OVERHEAD CABINET, DINETTE/LOUNGE

148797-CK-000 FABRIC-UPHOLSTERY, ACCENT PATTERN

142523-19-000 FABRIC-UPHOLSTERY, ULTRALEATHER

156773-42-000 FABRIC-UPHOLSTERY-BEDSPREAD - PATTERN ACCENT

156773-42-000 FABRIC-OVERHEAD CABINET, BEDROOM

072333-98-000 FABRIC-SPEAKER COVER

142523-03-000 VINYL-CABINET ENDS

142523-04-000 VINYL-SUNVISORS

103907-01-01A VINYL-DINETTE CUSHION

# DRIVERS COMPARTMENT GROUP

## DASH

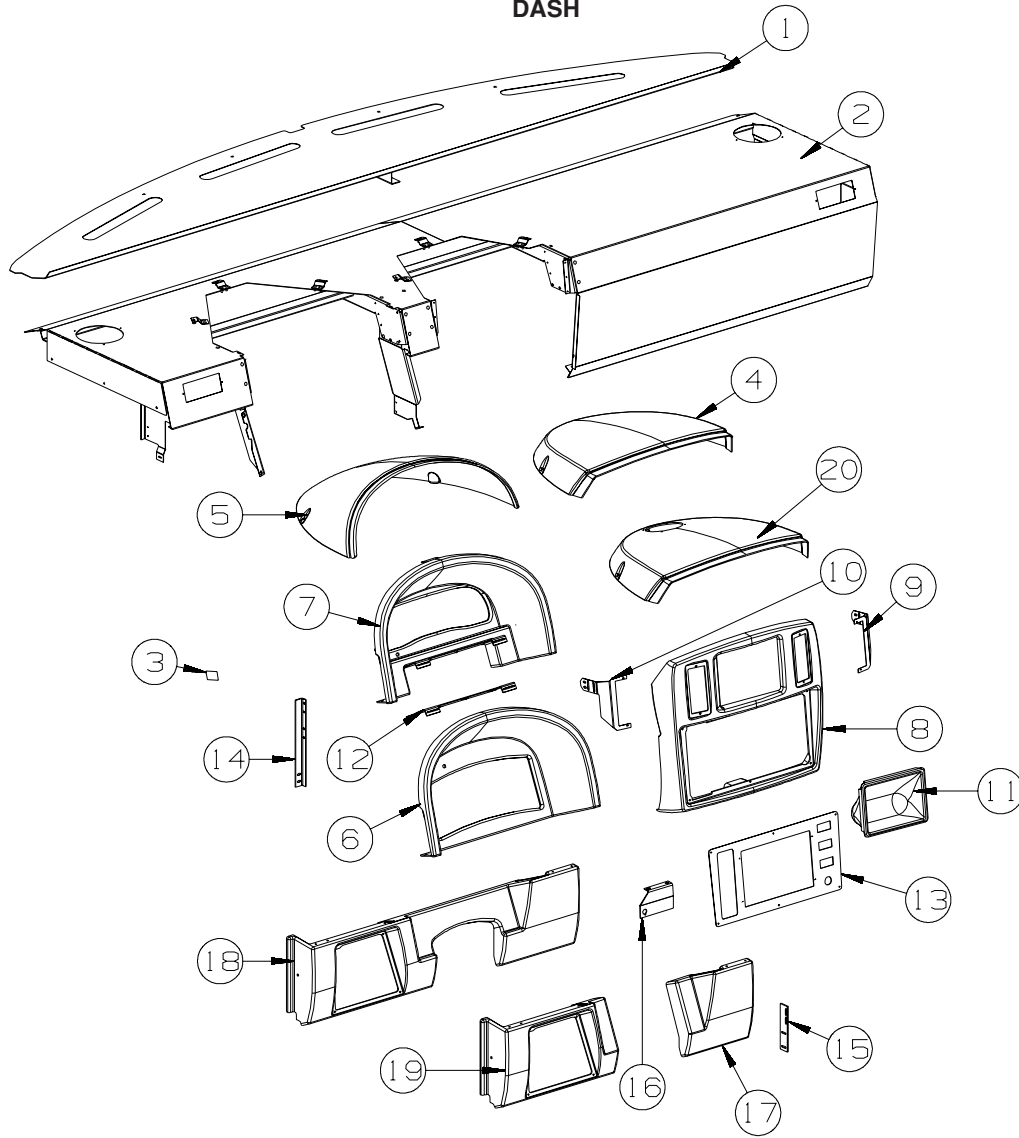

KEY	PART NUMBER	U/M	DESCRIPTION
1	154741-02-02B	EA	PANEL - DASH - FRONT/TOP - W/O VINYL
	106569-07-09A	EA	VINYL - LAMINATE - 1/4" X 17" X 100" - CASHMERE
	106569-07-08A	EA	VINYL - LAMINATE - 1/4" X 17" X 100" - RIVERSTONE
2	156677-02-02B	EA	DASH - W/O VINYL - E-COATED
	106569-17-09A	EA	VINYL - LAMINATE - 1/4" X 40" X 108" - CASHMERE
	106569-17-08A	EA	VINYL - LAMINATE - 1/4" X 40" X 108" - RIVERSTONE
3	110530-01-000	FT	SEAL - SPONGE - .31" X .62"
4	156682-01-20A	EA	DASH POD - CENTER - CASHMERE
4	156682-01-19A	EA	DASH POD - CENTER - RIVERSTONE
5	155700-01-20A	EA	POD - INSTRUMENT PANEL - CASHMERE
5	155700-01-19A	EA	POD - INSTRUMENT PANEL - RIVERSTONE
6	155698-06-U57	EA	BEZEL ASM - INST PANEL - WORKHORSE - CASHMERE
6	155698-06-U59	EA	BEZEL ASM - INST PANEL - WORKHORSE - RIVERSTONE
6	155698-04-U57	EA	BEZEL ASM - INSTRUMENT PANEL - WORKHORSE - CASHMERE - HYDRAULIC LEVEL JACKS-AUTO
6	155698-04-U59	EA	BEZEL ASM - INSTRUMENT PANEL - WORKHORSE - RIVERSTONE - HYDRAULIC LEVEL JACKS-AUTO
7	155699-10-W51	EA	BEZEL ASM - INSTRUMENT PANEL - FORD - CASHMERE
7	155699-10-UQ1	EA	BEZEL ASM - INSTRUMENT PANEL - FORD - RIVERSTONE
7	155699-08-W51	EA	BEZEL ASM - INSTRUMENT PANEL - FORD - CASHMERE - HYDRAULIC LEVEL JACKS-AUTO
7	155699-08-UQ1	EA	BEZEL ASM - INSTRUMENT PANEL - FORD - RIVERSTONE - HYDRAULIC LEVEL JACKS-AUTO

## DRIVERS COMPARTMENT GROUP (CONTINUED) DASH (CONTINUED)

KEY	PART NUMBER	U/M	DESCRIPTION
8	156681-01-20A	EA	BEZEL - DASH/CENTER - CASHMERE
8	156681-01-19A	EA	BEZEL - DASH/CENTER - RIVERSTONE
9	157043-01-02B	EA	RETAINER - LOUVER/RIGHT - E-COATED
10	157043-02-02B	EA	RETAINER - LOUVER/LEFT - E-COATED
11	111350-02-20A	EA	POCKET - INSTRUMENT PANEL-UPPER/RIGHT - CASHMERE
11	111350-02-19A	EA	POCKET-INSTRUMENT PNL-UPPER/RIGHT - RIVERSTONE
12	149106-02-02B	EA	SUPPORT - LOWER BEZEL/STEERING - FORD - E-COATED
13	156051-04-02B	EA	PANEL/BEZEL - DASH/CENTER - E-COATED
14	128692-01-02B	EA	ANGLE - FORMED - DASH SUPPORT - E-COATED
15	139603-01-02B	EA	STRAP - DASH SUPPORT - CENTER - E-COATEDS
16	155948-01-02B	EA	SUPPORT - PARK BRAKE SWITCH - E-COATED
17	156253-01-02A	EA	PANEL/TRIM - DASH/LOWER - DRIVER/RIGHT - CASHMERE - FORD
17	156253-01-01A	EA	PANEL/TRIM - DASH/LOWER-DRIVER/RIGHT- RIVERSTONE - FORD
18	155129-01-02A	EA	PANEL/TRIM - DASH/LOWER LEFT - CASHMERE - WORKHORSE
18	155129-01-01A	EA	PANEL/TRIM - DASH/LOWER LEFT - RIVERSTONE - WORKHORSE
19	156254-01-02A	EA	PANEL/TRIM - DASH/DRIVER/LOWER LEFT - CASHMERE - FORD
19	156254-01-01A	EA	PANEL/TRIM - DASH/DRIVER/LOWER LEFT - RIVERSTONE - FORD
20	156682-02-20A	EA	DASH POD - CENTER - CASHMERE - REARVIEW MONITOR SYSTEM W/AUDIO
20	156682-02-19A	EA	DASH POD - CENTER - RIVERSTONE - REARVIEW MONITOR SYSTEM W/AUDIO

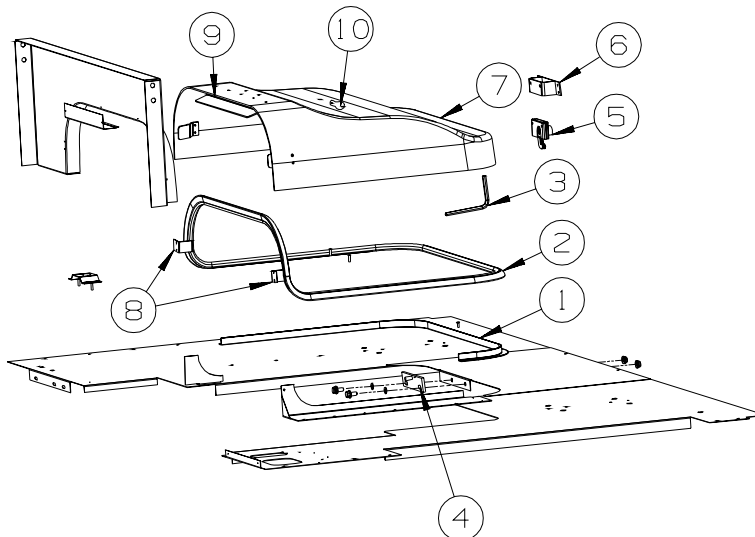

**MOTOR COVER**

**FORD**

KEY	PART NUMBER	U/M	DESCRIPTION
1	115860-06-01A	EA	TRIM - MOTOR COVER - FORD - MILL FINISH
2	039623-01-000	FT	SEAL - MOTOR COVER - RUBBER BULB TYPE
3	116833-01-02B	EA	WRENCH - HEX MOTOR COVER - E-COATED
4	115852-01-02B	EA	STRIKE - LATCH - MOTOR COVER - E-COATED
5	116581-01-000	EA	LATCH - W/O STRIKE - MOTOR COVER
6	115850-01-02B	EA	RETAINER - LATCH - MOTOR COVER - RIGHT HAND - E-COATED
7	156754-02-W53	EA	COVER - MOTOR - W/CARPET - FORD (W57, W58)
7	156754-02-W59	EA	COVER - MOTOR - W/CARPET - FORD (W59, W60)
7	156754-02-U57	EA	COVER - MOTOR - W/CARPET - FORD (W61, W62)
	153970-02-01A	EA	COVER - MOTOR - W/O CARPET
8	115855-04-02B	EA	RETAINER - MOTOR COVER/SIDE - E-COATED
9	115855-01-02B	EA	RETAINER - MOTOR COVER/TOP - E-COATED
10	134497-01-000	SF	FOIL/ALUMINUM - REINFORCED



**DRIVERS COMPARTMENT GROUP (CONTINUED)**  
**MOTOR COVER (CONTINUED)**

**WORKHORSE**

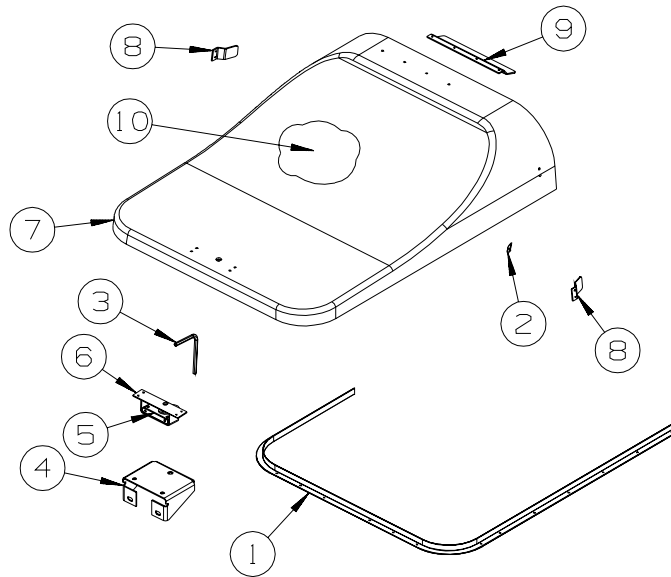

KEY	PART NUMBER	U/M	DESCRIPTION
1	137332-01-01A	EA	TRIM - MOTOR COVER
2	039623-01-000	FT	SEAL - MOTOR COVER - RUBBER BULB TYPE
3	116833-01-02B	EA	WRENCH - HEX MOTOR COVER - E-COATED
4	137305-02-02B	EA	BRACKET - STRIKE SUPPORT - E-COATED
5	116581-01-000	EA	LATCH - W/O STRIKE - MOTOR COVER
6	115850-01-02B	EA	RETAINER - LATCH - MOTOR COVER - RIGHT HAND - E-COATED
7	137097-01-W53	EA	COVER - MOTOR - W/CARPET (W57, W58)
7	137097-01-U57	EA	COVER - MOTOR - W/CARPET (W59, W60, W61, W62)
	137096-01-01A	EA	COVER - MOTOR - W/O CARPET
8	115855-04-02B	EA	RETAINER - MOTOR COVER/SIDE - E-COATED
9	115855-03-02B	EA	RETAINER - MOTOR COVER/TOP - E-COATED
10	NOT USED		

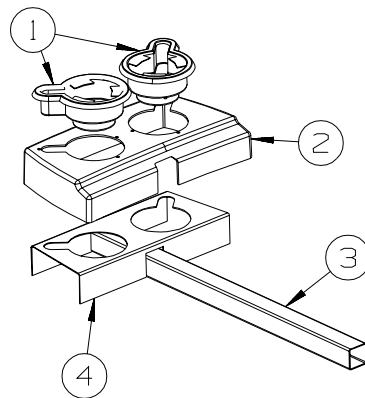

**BEVERAGE TRAY**

KEY	PART NUMBER	U/M	DESCRIPTION
1	133831-01-01A	EA	HOLDER - CUP W/THREE CENTERLINE RUBBER FINGERS
2	156018-01-20A	EA	TRAY - BEVERAGE - CASHMERE
2	156018-01-19A	EA	TRAY - BEVERAGE - RIVERSTONE
3	156047-01-02B	EA	SUPPORT - BEVERAGE TRAY - E-COATED
4	156016-01-01B	EA	BRACKET - BEVERAGE TRAY - E-COATED

## DRIVERS COMPARTMENT GROUP (CONTINUED)

### FRONT INTERIOR

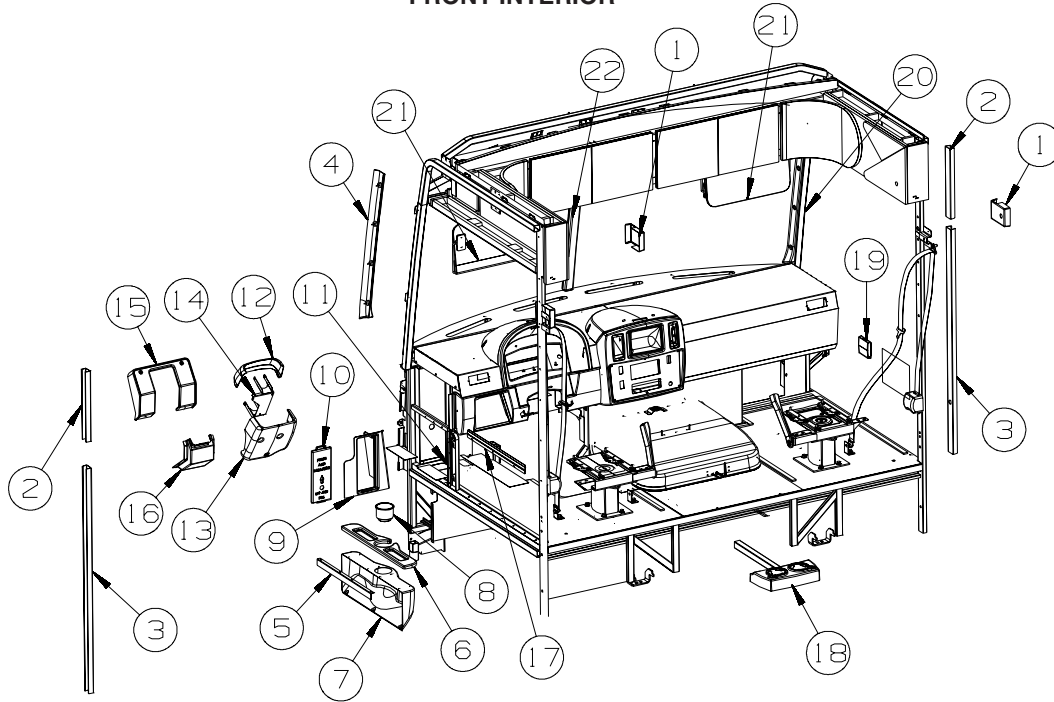

KEY	PART NUMBER	U/M	DESCRIPTION
1	103961-03-02A	EA	COVER - BRACKET - SEATBELT - BLACK
2	161808-04-01A	EA	COVER - ROLL BAR/U-CHANNEL - 16.5" PLASTIC - MED OAK
3	161808-03-01A	EA	COVER - ROLL BAR/U-CHANNEL - 52.9" PLASTIC - MED OAK
4	162541-02-05A	EA	TRIM - A-PILLAR/DRIVER - CASHMERE
4	162541-02-04A	EA	TRIM - A-PILLAR/DRIVER - RIVERSTONE
5	132595-02-02B	EA	BRACKET - BEVERAGE TRAY HOLDER - E-COATED
6	132297-03-06A	EA	PANEL/TRIM - W/BEVERAGE HOLDER - SANDSTONE
	122717-07-01A	EA	PAD - NON-SKID - PSA - 3.2" X 8.3"
7	132354-05-20A	EA	PANEL/TRIM - INNER - W/O BEVERAGE TRAY - CASHMERE
7	132354-05-19A	EA	PANEL/TRIM - INNER - W/O BEVERAGE TRAY - RIVERSTONE
7	132354-08-20A	EA	PANEL/TRIM - INNER - W/O BEVERAGE TRAY - CASHMERE - <b>ELECTRIC EXTERIOR MIRRORS</b>
7	132354-08-19A	EA	PANEL/TRIM - INNER - W/O BEVERAGE TRAY - RIVERSTONE - <b>ELECTRIC EXTERIOR MIRRORS</b>
8	134566-01-01A	EA	HOLDER - CUP - TWO STEP - BLACK
9	148824-01-20A	EA	PANEL/TRIM - FUSE PANEL/LEFT HAND - WORKHORSE - CASHMERE
9	148824-01-19A	EA	PANEL/TRIM - FUSE PANEL/LEFT HAND - WORKHORSE - RIVERSTONE
9	148824-02-20A	EA	PANEL/TRIM - FUSE PANEL/LEFT HAND - FORD - CASHMERE
9	148824-02-19A	EA	PANEL/TRIM - FUSE PANEL/LEFT HAND - FORD - RIVERSTONE
10	148826-01-20A	EA	PANEL/DOOR - FUSE PANEL/LEFT HAND - CASHMERE
10	148826-01-19A	EA	PANEL/DOOR - FUSE PANEL/LEFT HAND - RIVERSTONE
11	127901-01-20A	EA	PANEL - TOEKICK/LEFT HAND - CASHMERE
11	127901-01-19A	EA	PANEL - TOEKICK/LEFT HAND - RIVERSTONE
12	155934-01-20A	EA	COVER - STEERING COLUMN - UPPER - WORKHORSE - CASHMERE
12	155934-01-19A	EA	COVER - STEERING COLUMN - UPPER - WORKHORSE - RIVERSTONE
13	155935-01-20A	EA	COVER - STEERING COLUMN - LOWER - WORKHORSE - CASHMERE
13	155935-01-19A	EA	COVER - STEERING COLUMN - LOWER - WORKHORSE - RIVERSTONE
14	148806-01-02B	EA	MOUNT ASM-STEERING COVE - E-COAT - WORKHORSE
15	148815-02-20A	EA	COVER - STEERING COLUMN - UPPER - FORD - CASHMERE
15	148815-02-19A	EA	COVER - STEERING COLUMN - UPPER - FORD - RIVERSTONE
16	125795-01-20A	EA	COVER - STEERING COLUMN/LOWER - FORD - CASHMERE
16	125795-01-19A	EA	COVER - STEERING COLUMN/LOWER - FORD - RIVERSTONE
	110530-01-000	FT	SEAL - SPONGE - .31" X .62"
17	130034-11-02B	EA	CLIP - TRIM - E-COATED
18	156020-01-U57	EA	TRAY - BEVERAGE - CASHMERE
18	156020-01-U59	EA	TRAY - BEVERAGE - RIVERSTONE
19	118718-01-03A	EA	HOLDER/DRINK - COLLAPSIBLE MUG - ALMOND
20	162541-01-05A	EA	TRIM - A-PILLAR/PASSENGER - CASHMERE
20	162541-01-04A	EA	TRIM - A-PILLAR/PASSENGER - RIVERSTONE
21	123298-04-09A	EA	SUNVISOR - 10.5" X 21" - DRIVER/PASSENGER - CASHMERE
21	123298-04-08A	EA	SUNVISOR - 10.5" X 21" - DRIVER/PASSENGER - RIVERSTONE
22	118452-13-20A	EA	TRIM - WINDSHIELD/CENTER - CASHMERE
22	118452-13-19A	EA	TRIM - WINDSHIELD/CENTER - RIVERSTONE

**DRIVERS COMPARTMENT GROUP (CONTINUED)**  
**FRONT INTERIOR (CONTINUED)**

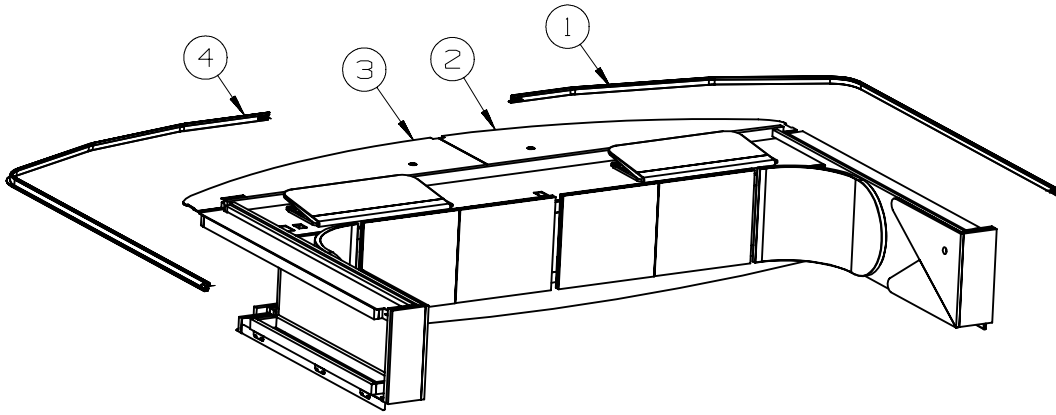

KEY	PART NUMBER	U/M	DESCRIPTION
1	127254-14-20A	EA	TRACK/WRAPAROUND - PASSENGER - CASHMERE
1	127254-14-19A	EA	TRACK/WRAPAROUND - PASSENGER - RIVERSTONE
2	134146-10-W51	EA	PANEL - OVERHEAD/FRONT - BOTTOM/LH HAND - CASHMERE
2	134146-10-W55	EA	PANEL - OVERHEAD/FRONT - BOTTOM/LH HAND - RIVERSTONE
3	134146-09-W51	EA	PANEL - OVERHEAD/FRONT - BOTTOM/RH HAND - CASHMERE
3	134146-09-W55	EA	PANEL - OVERHEAD/FRONT - BOTTOM/RH HAND - RIVERSTONE
4	127254-04-20A	EA	TRACK/WRAPAROUND - DRIVER - CASHMERE
4	127254-04-19A	EA	TRACK/WRAPAROUND - DRIVER - RIVERSTONE

**DRIVERS COMPARTMENT GROUP (CONTINUED)**  
**FRONT INTERIOR (CONTINUED)**

**DRIVER MANUAL**

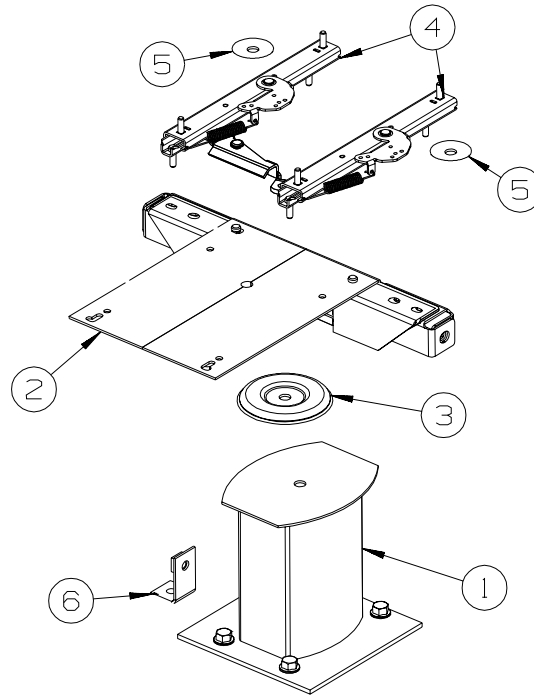

KEY	PART NUMBER	U/M	DESCRIPTION
1	133408-01-000	EA	PEDESTAL - SEAT/DRIVER - 9 3/4"
2	133408-19-000	EA	TOP PLATE - DRIVERS - W/ANCHOR
3	107921-06-000	EA	BEARING KIT - PEDESTAL
4	131566-04-000	EA	SLIDE/SEAT - HEAVY DUTY LOCKING - 5"
	119952-07-000	EA	WIRE - LATCH RELEASE/ROTARY
5	131566-05-000	EA	WASHER - SLIDE SPACER
6	133408-04-000	EA	BRACKET - ANCHOR/FLOOR

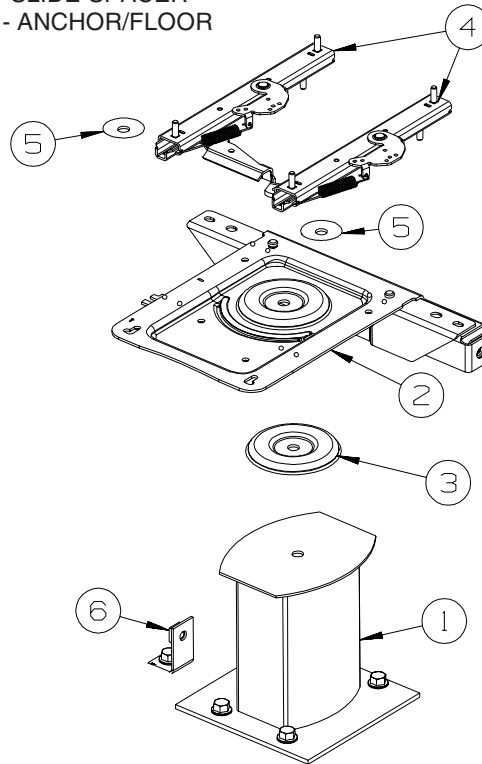

**PASSENGER MANUAL**

KEY	PART NUMBER	U/M	DESCRIPTION
1	133408-01-000	EA	PEDESTAL - SEAT - DRIVER/PASSENGER - 9 3/4"
2	133408-20-000	EA	TOP PLATE - PASSENGER - W/ANCHOR
3	107921-06-000	EA	BEARING KIT - PEDESTAL
4	131566-04-000	EA	SLIDE/SEAT - HEAVY DUTY LOCKING - 5"
	119952-07-000	EA	WIRE - LATCH RELEASE/ROTARY
5	131566-05-000	EA	WASHER - SLIDE SPACER
6	133408-04-000	EA	BRACKET - ANCHOR/FLOOR

**DRIVERS COMPARTMENT GROUP (CONTINUED)**  
**FRONT INTERIOR (CONTINUED)**

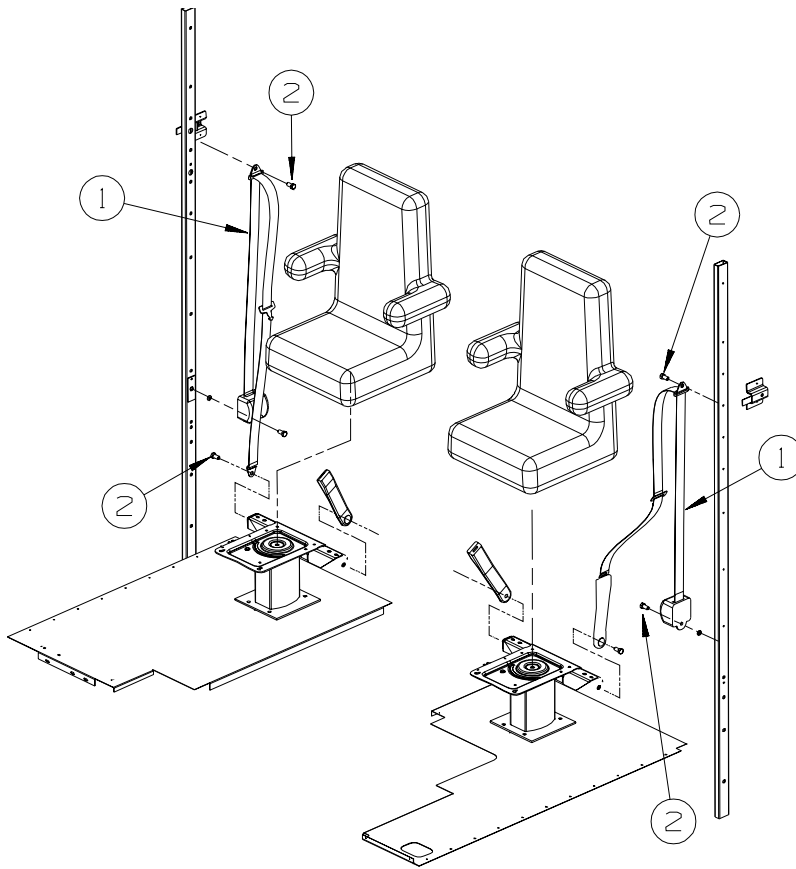

KEY	PART NUMBER	U/M	DESCRIPTION
1*	091990-04-01A	EA	SEAT BELT/SHOULDER HARNESS - DRIVERS/PASSENGER - BLACK
2	109146-01-000	EA	BOLT - SHOULDER/SEAT BELT

**\*COMPONENT PARTS LISTED LATER IN THIS GROUP**

**COMPONENT PARTS FOR FRONT INTERIOR**

**091990-04-01A**

KEY	PART NUMBER	U/M	DESCRIPTION	VENDOR NO.
	091990-01-701	EA	EXTENDER 9" FOR A8408 3 PT	I-1331-02
	091990-01-703	EA	RECEIVER/FEMALE END-SEATBELT	I-1159-02
	091990-05-700	EA	SLEEVE/BUCKLE COVER-PLASTIC	209S-2
	091990-05-701	EA	CAP/COVER - BOLT HOLE COVER	209SC-02
	091990-05-702	EA	SLEEVE/RETRACTABLE COVER	309C-02
	091990-05-703	EA	EXTENDER 12"	I-1442-02

## DRIVERS COMPARTMENT GROUP (CONTINUED) CABINETS

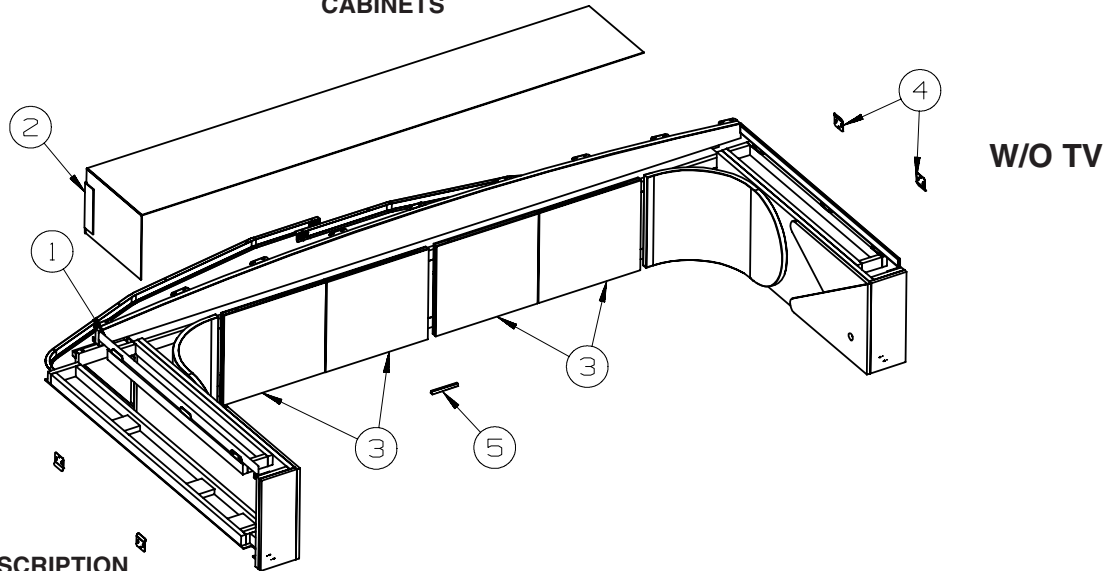

KEY	PART NUMBER	U/M	DESCRIPTION
1	163919-01-W51	EA	CABINET - OVERHEAD/FRONT - W/O DOORS/HDW - HONEY CHERRY
1	163919-01-W52	EA	CABINET - OVERHEAD/FRONT - W/O DOORS/HDW - WASHED MAPLE
1	163919-02-W51	EA	CABINET - OVERHEAD/FRONT - W/O DOORS/HDW - HONEY CHERRY - INTERIOR UPGRADE PKG.
1	163919-02-W51	EA	CABINET - OVERHEAD/FRONT - W/O DOORS/HDW - WASHED MAPLE - INTERIOR UPGRADE PKG.
2	163935-01-W51	EA	PANEL - CLOSEOUT
3	160256-91-W51	EA	DOOR - FLAT/SQUARE EDGE - 13.4" X 15.3" - W/O HDW - HONEY CHERRY
3	160256-91-W52	EA	DOOR - FLAT/SQUARE EDGE - 13.4" X 15.3" - W/O HDW - WASHED MAPLE
4	163936-01-02B	EA	BRACKET - CLIP/DOOR - E-COATED
5	146514-04-000	EA	CHANNEL/MOUNT - F/ROPE LIGHT

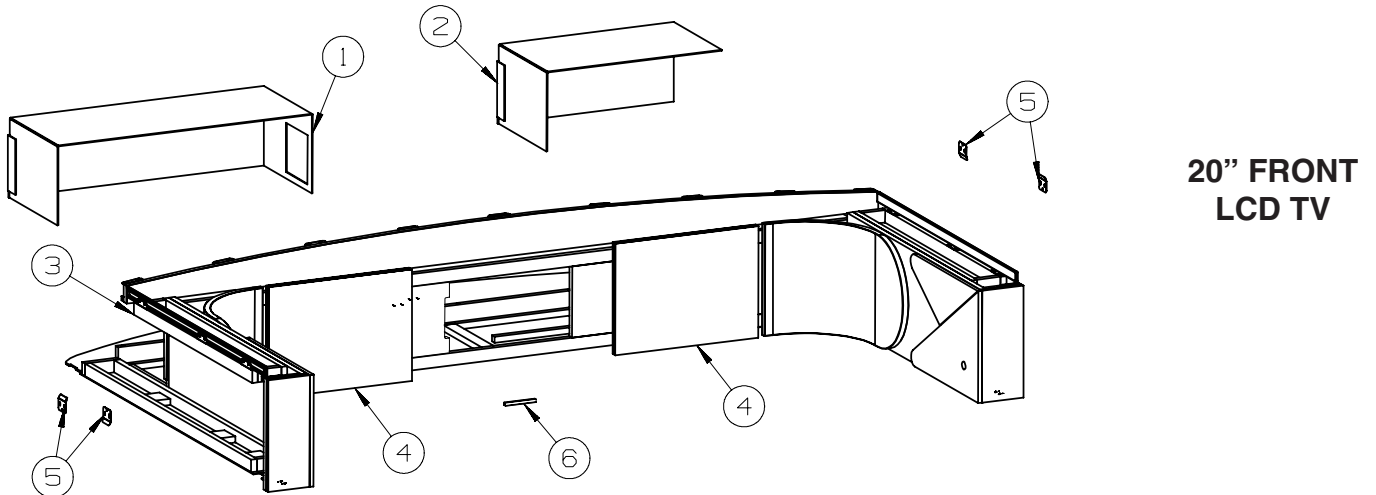

KEY	PART NUMBER	U/M	DESCRIPTION
1	163935-02-W51	EA	PANEL - CLOSEOUT
2	163935-03-W51	EA	PANEL - CLOSEOUT
3	163919-06-W51	EA	CABINET-W/O DOORS/HDW - HONEY CHERRY
3	163919-06-W52	EA	CABINET-W/O DOORS/HDW - WASHED MAPLE
4	160256-B4-W51	EA	DOOR - FLAT/SQUARE EDGE - 13.4" X 18.3" - W/O HDW - HONEY CHERRY
4	160256-B4-W52	EA	DOOR - FLAT/SQUARE EDGE - 13.4" X 18.3" - W/O HDW - WASHED MAPLE
5	163936-01-02B	EA	BRACKET - CLIP/DOOR - E-COATED
6	146514-04-000	EA	CHANNEL/MOUNT - F/ROPE LIGHT

**DRIVERS COMPARTMENT GROUP (CONTINUED)**  
**CABINETS (CONTINUED)**

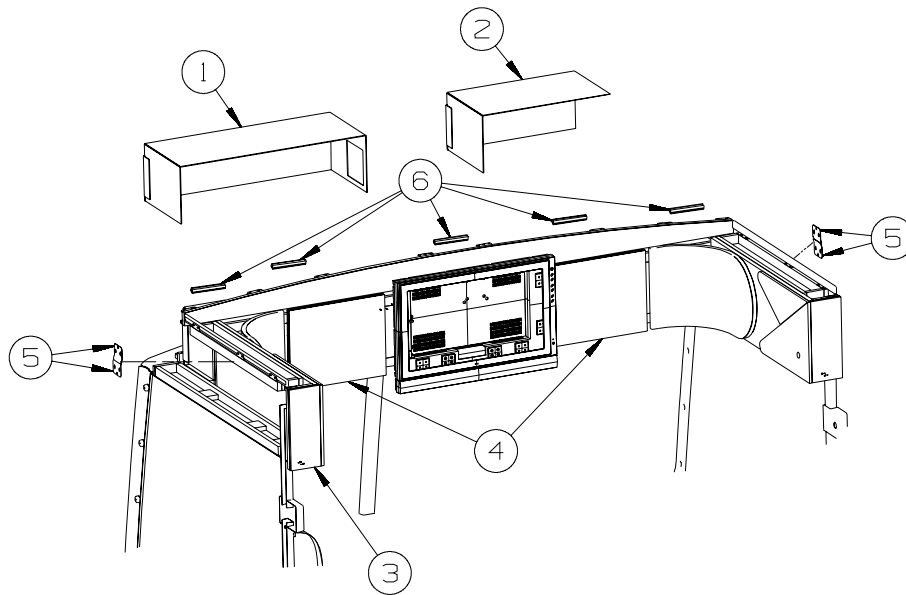

**W/26" OR /27"  
FRONT TV**

KEY	PART NUMBER	U/M	DESCRIPTION
1	163935-02-W51	EA	PANEL - CLOSEOUT
2	163935-03-W51	EA	PANEL - CLOSEOUT
3	163919-09-W51	EA	CABINET - W/O DOORS/HDW - HONEY CHERRY
3	163919-09-W52	EA	CABINET - W/O DOORS/HDW - WASHED MAPLE
4	160256-92-W51	EA	DOOR - FLAT/SQUARE EDGE - 13.4" X 16.7" - W/O HDW - HONEY CHERRY
4	160256-92-W52	EA	DOOR - FLAT/SQUARE EDGE - 13.4" X 16.7" - W/O HDW - WASHED MAPLE
5	163936-01-02B	EA	BRACKET - CLIP/DOOR - E-COATED
6	146514-04-000	EA	CHANNEL/MOUNT - F/ROPE LIGHT

## ELECTRICAL GROUP 110V BODY WIRING

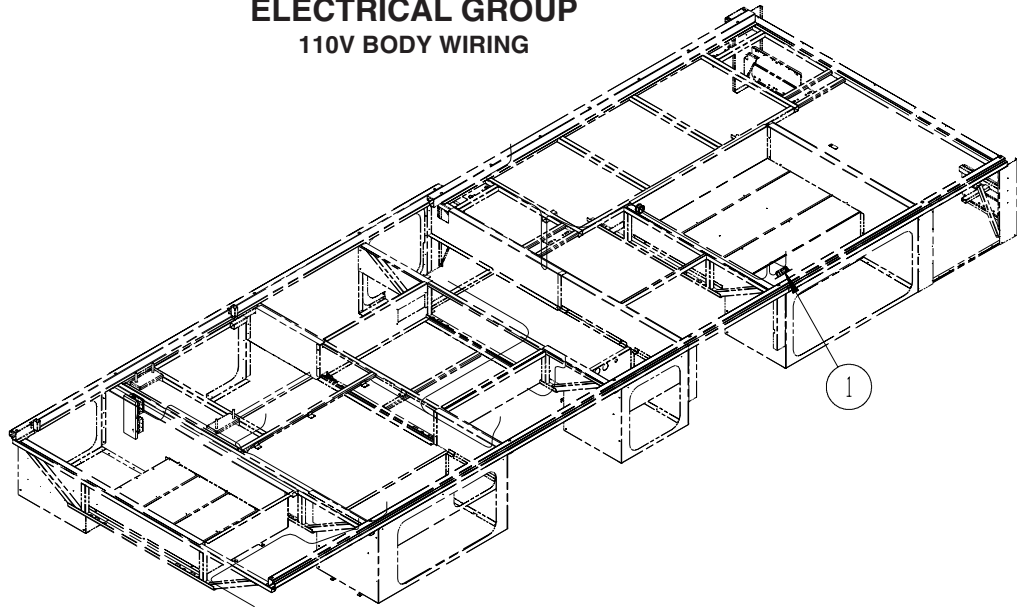

KEY	PART NUMBER	U/M	DESCRIPTION
1	058708-01-000	EA	RECEPTACLE - ELECTRIC - DOUBLE - BROWN

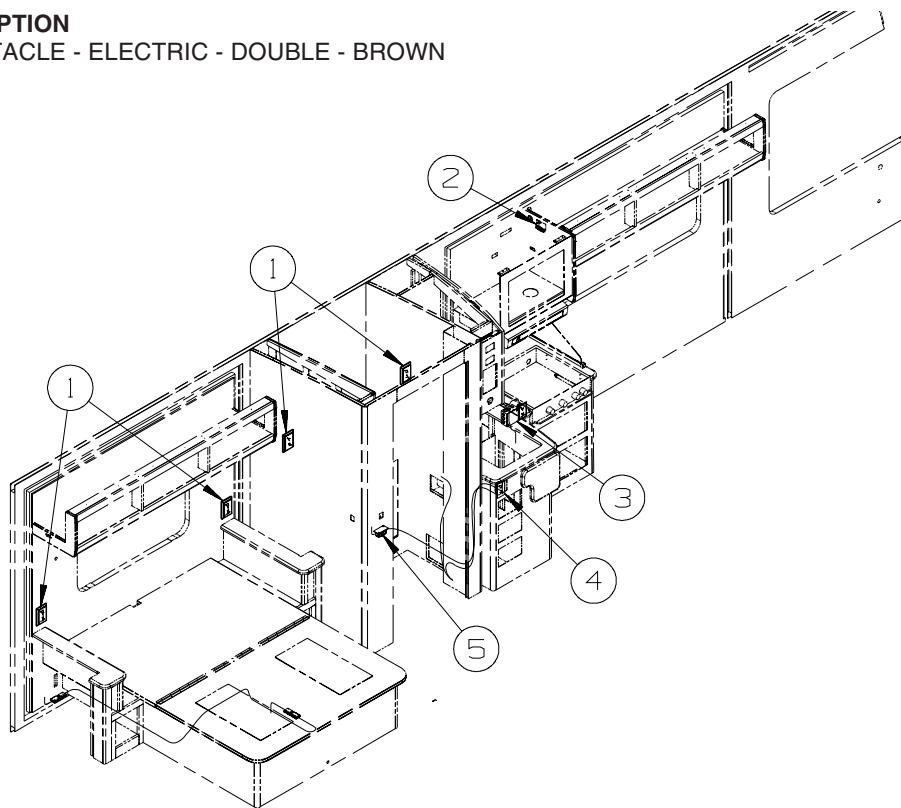

KEY	PART NUMBER	U/M	DESCRIPTION
1	058708-01-000	EA	RECEPTACLE - ELECTRIC - DOUBLE - BROWN
1	133713-01-23A	EA	SPACER/RECEPTACLE - VINYL - HONEY CHERRY
1	133713-01-21A	EA	SPACER/RECEPTACLE - VINYL - WASHED MAPLE
2	058708-01-000	EA	RECEPTACLE - ELECTRIC - DOUBLE - BROWN
2	160984-01-01A	EA	RECEPTACLE - ELECTRICAL - SINGLE/FLUSH - 20 AMP - BROWN - CANADIAN
3	008289-01-000	EA	BOX - ELECTRIC/STEEL - 4" X 4" - 1/2" & 3/4" KNOCKOUTS
3	008294-01-000	EA	COVER - ELECTRIC BOX - BLANK/STEEL - 4" X 4" - GRAY
4	058708-01-000	EA	RECEPTACLE - ELECTRIC - DOUBLE - BROWN
5	058707-02-000	EA	RECEPTACLE - BLANK - JUNCTION BOX



**ELECTRICAL GROUP (CONTINUED)**  
**110V BODY WIRING (CONTINUED)**

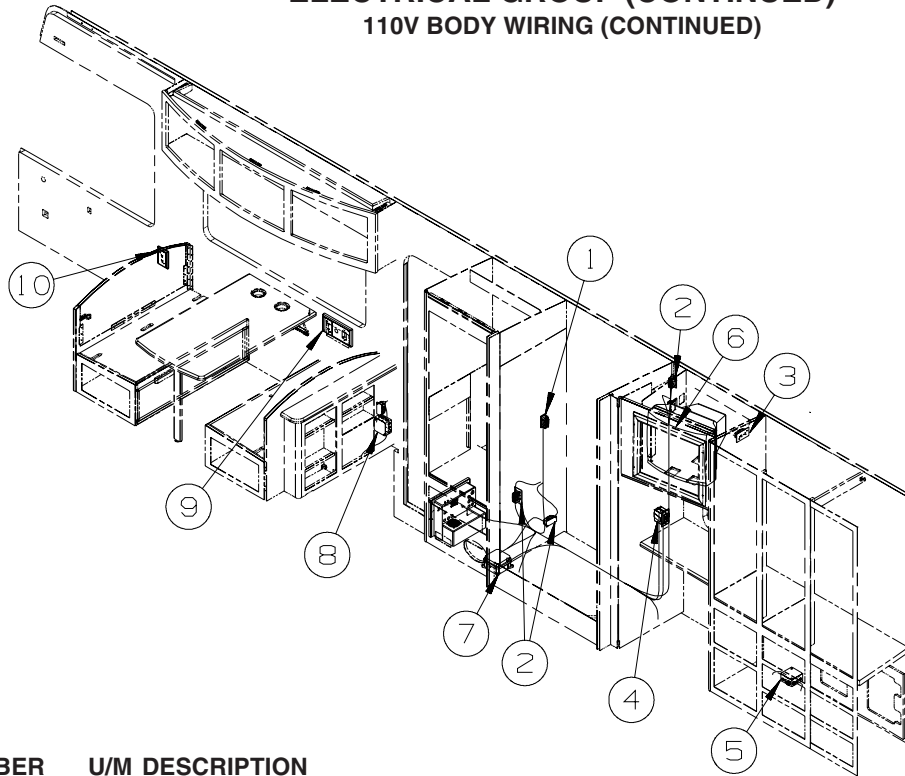

KEY	PART NUMBER	U/M	DESCRIPTION
1	058707-01-000	EA	RECEPTACLE - ELECTRIC - SINGLE - BROWN
2	058707-02-000	EA	RECEPTACLE - BLANK - JUNCTION BOX
3	058708-05-000	EA	RECEPTACLE - ELECTRICAL - SINGLE - BROWN
3	158542-02-01A	EA	LABEL - RECEPTACLE - ELECTRONICS - WHITE/BLACK - CANADIAN
4	163319-01-02A	EA	RECEPTACLE - GFCI - 15A 125V - BROWN
5	008289-01-000	EA	BOX - ELECTRIC/STEEL - 4" X 4" - 1/2" & 3/4" KNOCKOUTS - GEN-4.0KW-ONANGAS-MICROQUIET
5	008294-01-000	EA	COVER - ELECTRIC BOX - BLANK/STEEL - 4" X 4" - GRAY - GEN-4.0KW-ONANGAS-MICROQUIET
6*	159178-03-000	EA	TV - 19" - W/RCA INPUT - UL - TOSHIBA - TV (REAR)-19"COLOR, STEREO
			FROM: 00-00-00 THRU: 06-10-07
6*	149040-04-000	EA	TV - 20" FLAT SCREEN/STEREO - RCA 20F424T - TV (REAR)-20"COLOR, STEREO
			FROM: 06-11-07 THRU: 99-99-99
7	136481-01-000	EA	MODULE - AUTO ENERGY SELECTOR
8	008289-01-000	EA	BOX - ELECTRIC/STEEL - 4" X 4" - 1/2" & 3/4" KNOCKOUTS
8	008294-01-000	EA	COVER - ELECTRIC BOX - BLANK/STEEL - 4" X 4" - GRAY
9	058708-01-000	EA	RECEPTACLE - ELECTRIC - DOUBLE - BROWN
9	133713-06-23A	EA	SPACER/RECEPTACLE - PHONE - VINYL - HONEY CHERRY
9	133713-06-21A	EA	SPACER/RECEPTACLE - PHONE - VINYL - WASHED MAPLE
10	058708-01-000	EA	RECEPTACLE - ELECTRIC - DOUBLE - BROWN
10	133713-01-23A	EA	SPACER/RECEPTACLE - VINYL - HONEY CHERRY
10	133713-01-21A	EA	SPACER/RECEPTACLE - VINYL - WASHED MAPLE

\*COMPONENT PARTS LISTED LATER IN THIS GROUP

**ELECTRICAL GROUP (CONTINUED)**  
**12V BODY WIRING**

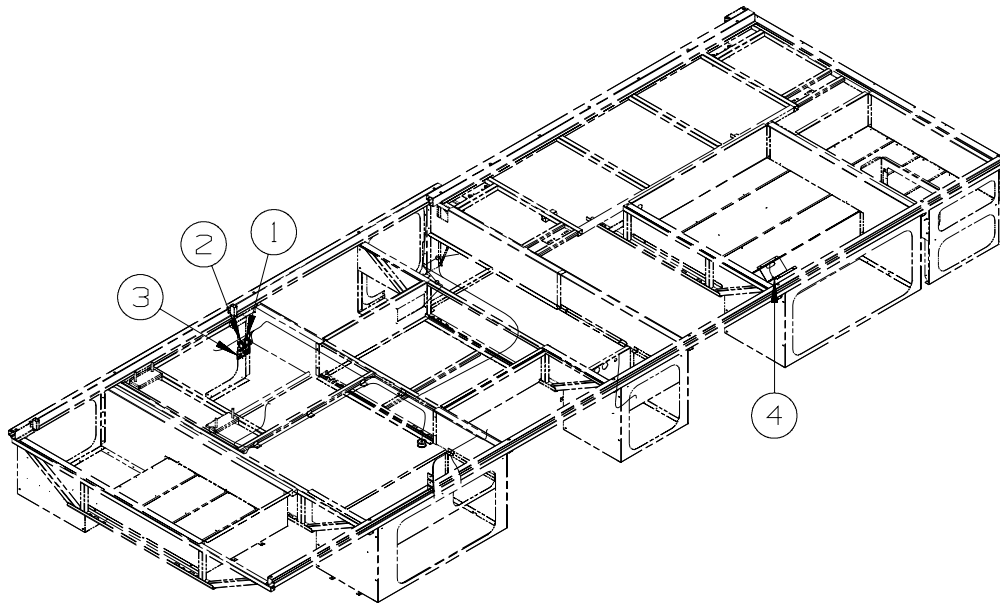

KEY	PART NUMBER	U/M	DESCRIPTION
1	108357-15-000	EA	SWITCH - ROCKER - DPDT - ON/NONE/ON - W/LIGHT W/O COVER
1	108356-03-01A	EA	COVER/ACTUATOR SWITCH - 3 GROOVES W/LENS - BLACK
1	108355-01-000	EA	HOUSING - SWITCH
2	108357-18-000	EA	SWITCH - ROCKER - DPDT - MOM/OFF/MOM - W/O COVER - HYDRAULIC LEVEL JACKS-AUTO
2	108356-03-01A	EA	COVER/ACTUATOR SWITCH - 3 GROOVES W/LENS - BLACK - HYDRAULIC LEVEL JACKS-AUTO
2	108355-01-000	EA	HOUSING - SWITCH - HYDRAULIC LEVEL JACKS-AUTO
2	096241-03-000	EA	SWITCH - BLANK - BLACK
3	149557-02-01A	EA	PLATE/WALL - PHONE/DUAL COAXIAL/HORIZONTAL - WHITE
4	082134-01-000	EA	ADAPTER - TV - CABLE TO CABLE
4	082136-01-000	EA	NUT - HEX JAM - 3/8-32
4	157486-01-02A	EA	LABEL - TV/EXTERIOR

**ELECTRICAL GROUP (CONTINUED)**  
**12V BODY WIRING (CONTINUED)**

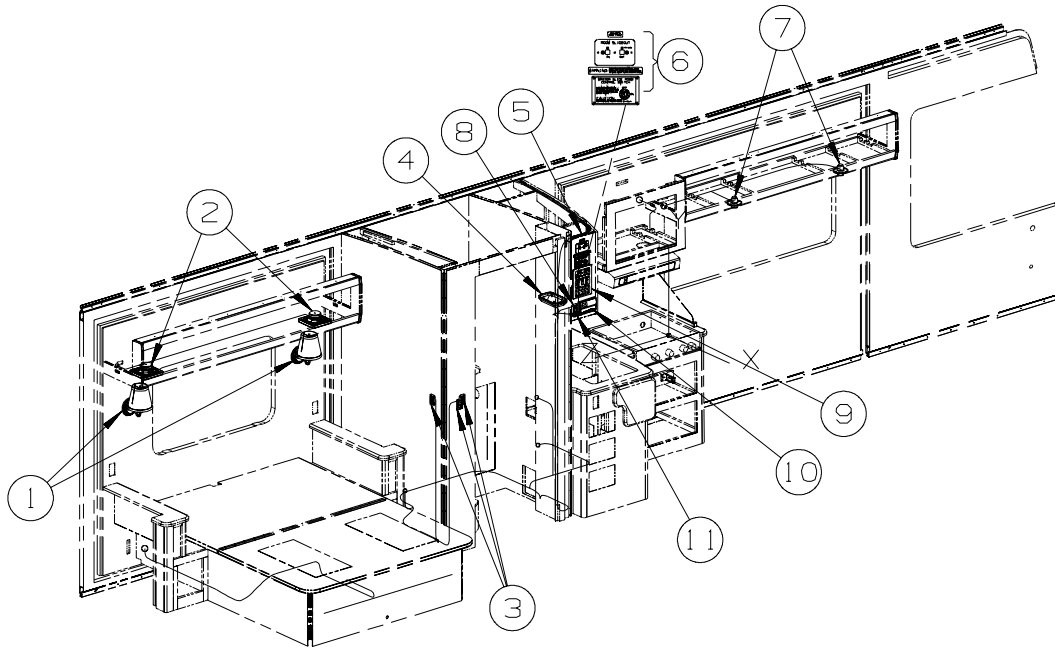

KEY	PART NUMBER	U/M	DESCRIPTION
1	119258-56-01A	EA	LAMP - WALL - UL/CSA - BRUSHED NICKEL
1	119257-28-01A	EA	SHADE - LAMP - ROUND - IVORY
2	094097-01-000	EA	SPEAKER - RADIO/TV - W/O GRILLE - 5.25" DIAMETER
2	089340-02-000	EA	GRILLE - SPEAKER - 6.5" SQUARE
3	135740-01-01A	EA	SWITCH - ROCKER - SPST - ON/OFF - BROWN
3	135741-01-01A	EA	SWITCH - BASE - SINGLE - BROWN
3	135742-07-02A	EA	BEZEL - SWITCH - CEILING - BROWN
4*	137417-02-01A	EA	LIGHT - DOME - SINGLE - W/SWITCH/OPTIC LENS - WHITE
5	146514-02-000	EA	CONNECTOR - LIGHT
5	146514-03-000	FT	LIGHT - FLEX - ROPE/ROUND - W/O MOUNT CHANNEL
5	146514-04-000	EA	CHANNEL/MOUNT - F/ROPE LIGHT
6	163992-01-01A	EA	LABEL - SLIDEOUT - DRIVER/Front - BLACK/WHITE
6	138173-04-000	EA	CONTROL PANEL (TOUCH PAD) - ELECTRIC SLIDEOUT - #1802931
6	163097-01-000	EA	SWITCH - SPST - KEY ACTIVATED - W/2 KEYS
6	163988-01-01A	EA	LABEL - SLIDEOUT CONTROL/MANUAL - BLACK/WHITE
7	132427-01-02A	EA	LIGHT - READING/SWIVEL - ROUND - NICKEL
8	135740-06-01A	EA	SWITCH - ROCKER - ON/OFF - LIGHTED - RED - <b>WTR HTR-6GAL/110/LP/MTR/AUTO</b>
8	135741-01-01A	EA	SWITCH - BASE - SINGLE - BROWN - <b>WTR HTR-6GAL/110/LP/MTR/AUTO</b>
8	135742-35-02A	EA	BEZEL - SWITCH - WATER HEATER/110 VOLT - BROWN - <b>WTR HTR-6GAL/110/LP/MTR/AUTO</b>
9*	134940-06-01A	EA	PANEL - MONITOR - 2 TANK - W/GENERATOR SWITCH
10	135618-03-01A	EA	THERMOSTAT - ROOF A/C & FURNACE - WHITE - <b>A/C ROOF AIR (1) 14,800 BTU</b>
10	135618-01-01A	EA	THERMOSTAT - HEAT PUMP/FURNACE - WHITE - <b>AC HEAT PUMP-1</b>
11	135740-01-01A	EA	SWITCH - ROCKER - SPST - ON/OFF - BROWN
11	135741-01-01A	EA	SWITCH - BASE - SINGLE - BROWN
11	135742-50-02A	EA	BEZEL - SWITCH - ACCENT - BROWN

\*COMPONENT PARTS LISTED LATER IN THIS GROUP

## ELECTRICAL GROUP (CONTINUED)

### 12V BODY WIRING (CONTINUED)

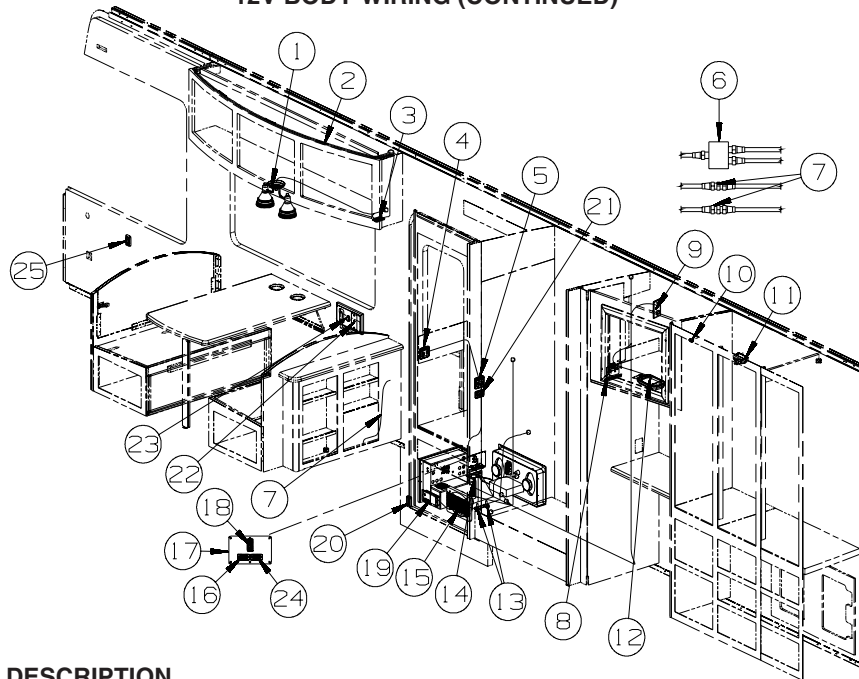

KEY	PART NUMBER	U/M	DESCRIPTION
1	093575-46-01A	EA	LIGHT - CEILING/DOUBLE - BRUSHED NICKEL
2	146514-02-000	EA	CONNECTOR - LIGHT
2	146514-03-000	FT	LIGHT - FLEX - ROPE/ROUND - W/O MOUNT CHANNEL
2	146514-04-000	EA	CHANNEL/MOUNT - F/ROPE LIGHT
3	135740-01-01A	EA	SWITCH - ROCKER - SPST - ON/OFF - BROWN - <b>INTERIOR UPGRADE PACKAGE</b>
3	135741-01-01A	EA	SWITCH - BASE - SINGLE - BROWN - <b>INTERIOR UPGRADE PACKAGE</b>
3	135742-50-02A	EA	BEZEL - SWITCH - ACCENT - BROWN - <b>INTERIOR UPGRADE PACKAGE</b>
4	135740-01-01A	EA	SWITCH - ROCKER - SPST - ON/OFF - BROWN
4	135740-02-01A	EA	SWITCH - ROCKER - SPDT - ON/ON - BROWN
4	135741-02-01A	EA	SWITCH - BASE - DOUBLE - BROWN
4	135742-16-02A	EA	BEZEL - SWITCH - CEILING/HALL - BROWN
5	135740-01-01A	EA	SWITCH - ROCKER - SPST - ON/OFF - BROWN
5	135741-02-01A	EA	SWITCH - BASE - DOUBLE - BROWN
5	135742-19-02A	EA	BEZEL - SWITCH - CEILING/PORCH - BROWN
6	082134-01-000	EA	ADAPTER - TV - CABLE TO CABLE
6	086756-01-000	EA	SPLITTER - TV/2 WAY - <b>ENTERTAINMENT CENTR/EXT W/CD</b>
7	082134-01-000	EA	ADAPTER - TV - CABLE TO CABLE
8	163992-02-01A	EA	LABEL - SLIDEOUT - DRIVER/REAR - BLACK/WHITE
8	138173-04-000	EA	CONTROL PANEL (TOUCH PAD) - ELECTRIC SLIDEOUT - #1802931
8	116549-01-000	EA	LABEL - WARNING - SLIDEOUT
9	076319-09-000	EA	WALLPLATE - TV CABLE RECEPTACLE - SINGLE - BROWN
10	056264-01-000	EA	SWITCH - LEAF ACTUATOR
11*	087694-01-000	EA	LIGHT - WARDROBE/CLOSET - W/SWITCH
12*	137417-02-01A	EA	LIGHT - DOME - SINGLE - W/SWITCH/OPTIC LENS - WHITE
13	086233-01-000	EA	STUD - ISOLATED - 3/8" X 7/8" LONG
14	061424-01-000	EA	LIGHT - AISLE - 12 VOLT - RECTANGULAR
15	124884-01-000	EA	SPEAKER - 6" X 9" - SUB-WOOFER - W/O GRILLE
15	151844-01-01A	EA	GRILLE - SPEAKER - 6" X 9" - SUB WOOFER - BLACK
16	108357-06-000	EA	SWITCH - ROCKER - DPDT - MOM/OFF/MOM - 6 TERM - W/O COVER - <b>AUXILIARY BATTERY</b> FROM: 00-00-00 THRU: 10-07-07
16	108357-17-000	EA	SWITCH - ROCKER - DPDT - MOM/OFF/MOM - W/LIGHT - W/O COVER - <b>COACH BATTERY</b> FROM: 10-08-07 THRU: 99-99-99
16	108356-11-01A	EA	COVER/ACTUATOR SWITCH - 3 GROOVES - <b>AUXILIARY BATTERY</b> FROM: 00-00-00 THRU: 10-07-07
16	108356-19-01A	EA	COVER/ACTUATOR SWITCH - 3 GROOVES-COACH BATT DISC - BLK - <b>COACH BATTERY</b> FROM: 10-08-07 THRU: 99-99-99
16	108355-01-000	EA	HOUSING - SWITCH
17	098351-22-02A	EA	PLATE/SWITCH - 2 GANG - CHROME FROM: 00-00-00 THRU: 10-07-07
17	158431-10-04B	EA	PLATE - SWITCH - BLACK FROM: 10-08-07 THRU: 99-99-99

## ELECTRICAL GROUP (CONTINUED)

### 12V BODY WIRING (CONTINUED)

KEY	PART NUMBER	U/M	DESCRIPTION
18	108357-18-000	EA	SWITCH - ROCKER - DPDT - MOM/OFF/MOM - W/O COVER - HYDRAULIC LEVEL JACKS-AUTO
18	108356-15-01A	EA	COVER/ACTUATOR SW.-3 GROOVES-LEVELING JACKS/REMOTE-HYDRAULIC LEVEL JACKS-AUTO
18	108355-01-000	EA	HOUSING - SWITCH - HYDRAULIC LEVEL JACKS-AUTO
18	096241-03-000	EA	SWITCH - BLANK - BLACK
19	150138-01-02A	EA	DETECTOR - LP GAS - BROWN
20	116995-02-000	EA	SWITCH/MAGNET - ELECTRIC STEP - BLACK/WHITE- NORMALLY OPEN
20	116995-03-000	EA	SWITCH/MAGNET - ELECTRIC STEP - FULL BODY PAINT
21	135740-01-01A	EA	SWITCH - ROCKER - SPST - ON/OFF - BROWN
21	135741-01-01A	EA	SWITCH - BASE - SINGLE - BROWN
21	135742-11-02A	EA	BEZEL - SWITCH - STEP - BROWN
22	093253-01-02A	EA	PLATE - WALL - TELEPHONE - BROWN
23	132958-01-000	EA	RECEPTACLE - 12 VOLT - MOUNTING FLANGE - BLACK
24	108357-17-000	EA	SWITCH - ROCKER - DPDT - MOM/OFF/MOM - W/LIGHT - W/O COVER - CHASSIS BATTERY FROM: 10-08-07 THRU: 99-99-99
24	108356-20-01A	EA	COVER/ACTUATOR SWITCH - 3 GROOVES-CHASSIS BATT DISC - BLK - CHASSIS BATTERY FROM: 10-08-07 THRU: 99-99-99
25	135740-01-01A	EA	SWITCH - ROCKER - SPST - ON/OFF - BROWN
25	135741-01-01A	EA	SWITCH - BASE - SINGLE - BROWN
25	135742-01-01A	EA	BEZEL - SWITCH - SINGLE - BROWN

**\*COMPONENT PARTS LISTED LATER IN THIS GROUP**

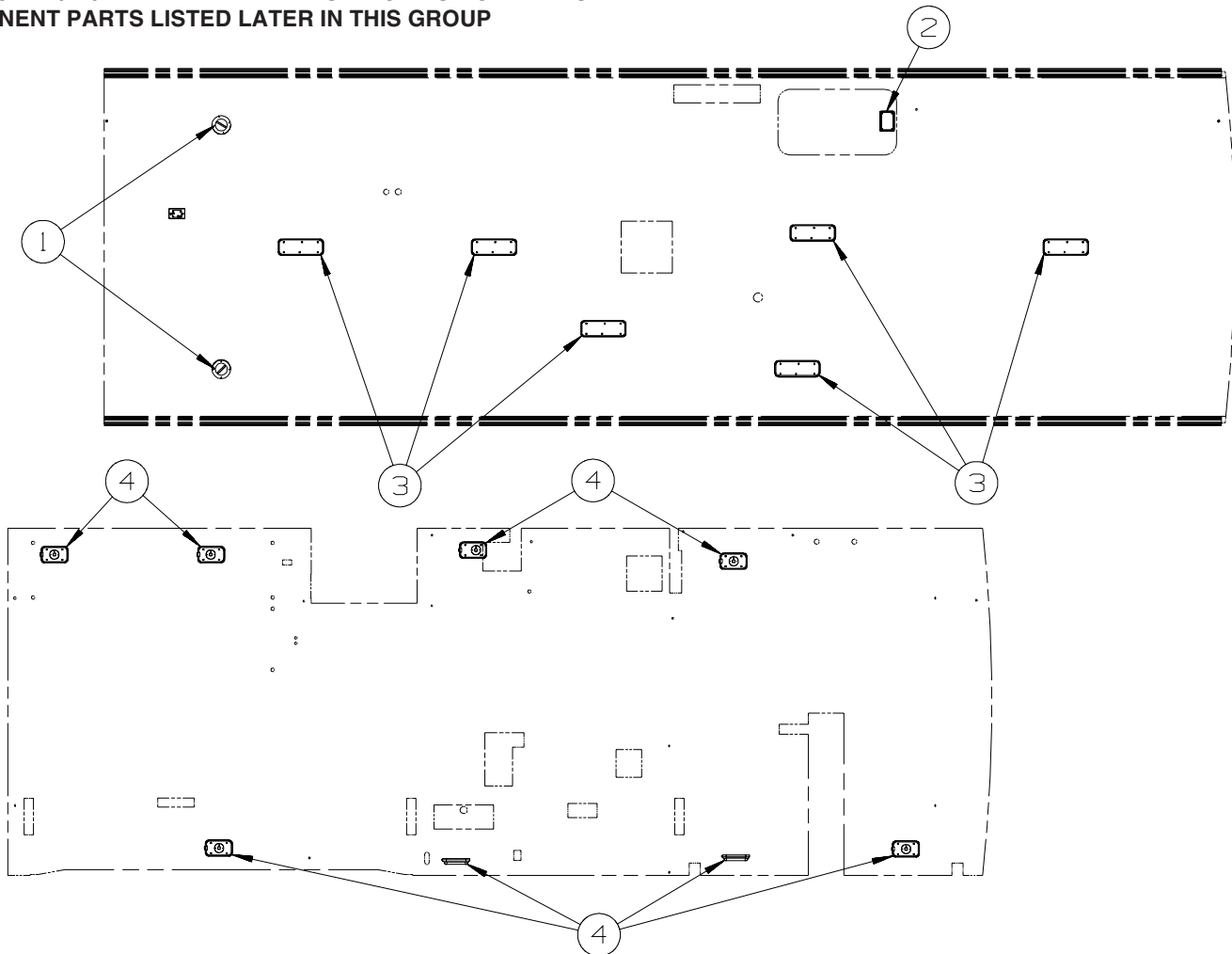

KEY	PART NUMBER	U/M	DESCRIPTION
1	160867-01-01A	EA	SPEAKER - ROUND/CEILING - CREAM - MAGNADYNE - LS3EYC-WN
2*	121935-01-01A	EA	LIGHT - DOME - SHOWER
3*	137417-06-01A	EA	LIGHT - DOME - DOUBLE - W/O SWITCH - W/FROSTED LENS-WHITE
4*	137417-01-01A	EA	LIGHT - DOME - SINGLE - W/SWITCH/FROSTED LENS - WHITE

**\*COMPONENT PARTS LISTED LATER IN THIS GROUP**

## ELECTRICAL GROUP (CONTINUED)

### 12V BODY WIRING (CONTINUED)

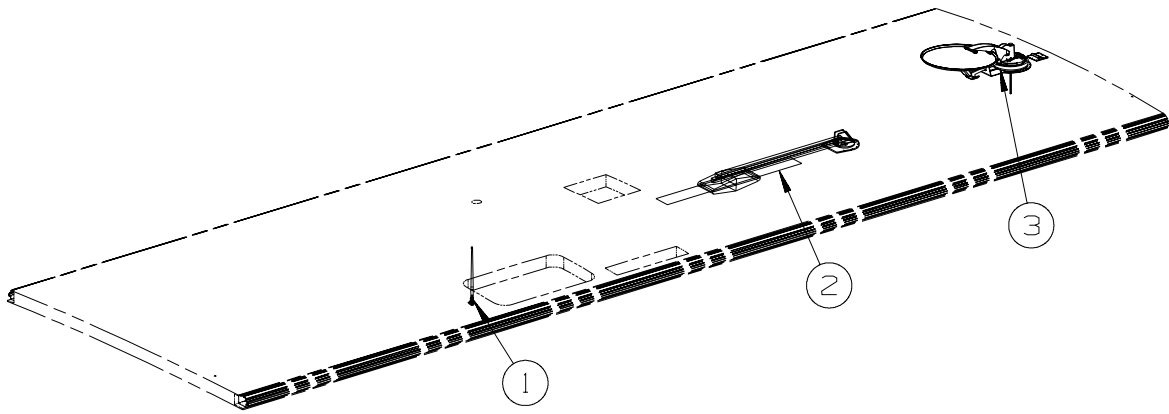

KEY	PART NUMBER	U/M	DESCRIPTION
1	090944-01-000	EA	ANTENNA - RADIO - 16" RUBBER - W/72" LEAD WIRE - ENTERTAINMENT CENTR/EXT W/CD
1	109889-04-000	EA	EXTENDER - ANTENNA SHAFT - 3.7" - ENTERTAINMENT CENTR/EXT W/CD
1	147741-01-09B	EA	BRACKET - ANTENNA GROUND - GALVANIZED - ENTERTAINMENT CENTR/EXT W/CD
2*	076319-23-000	EA	ANTENNA - TV ROOF MOUNT - 44.5" MAST
2*	076319-25-000	EA	KIT - HARDWARE INTERIOR
2	069726-02-000	EA	BUMPER - .88" OD X .40" THICK - BLACK
3*	137135-02-000	EA	ANTENNA - SATELLITE DSS - W/SENSOR - SATELLITE TV SYSTEM MANUAL FROM: 00-00-00 THRU: 01-30-07
3*	137135-05-000	EA	ANTENNA - SATELLITE DSS - W/SENSOR - SATELLITE TV SYSTEM MANUAL FROM: 01-31-07 THRU: 99-99-99

\*COMPONENT PARTS LISTED LATER IN THIS GROUP

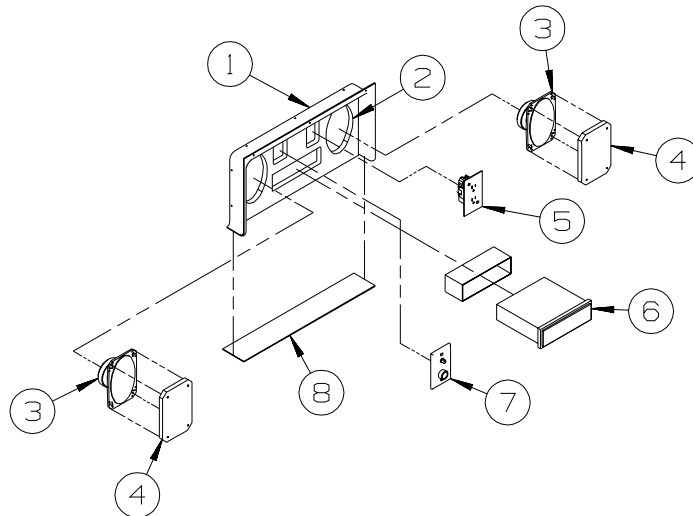

KEY	PART NUMBER	U/M	DESCRIPTION
1	124696-02-01A	EA	BOX-ENTERTAINMENT CTR/EXT-19.4"W X 10"H X 2.5"D - BRT WHT
	124696-01-01A	EA	BOX-ENTERTAINMENT CTR/EXT-19.4"W X 10"H X 10.2"D W/CUTOUTS
2	127409-03-U89	EA	PLATE - RADIO MOUNTING
3	110469-01-000	EA	SPEAKER - 4" X 6" OVAL - COAXIAL
4	110470-01-01A	EA	GRILLE - 4" X 6" - OVAL SPEAKER - BLACK
5	058708-01-000	EA	RECEPTACLE - ELECTRIC - DOUBLE - BROWN
6	155619-02-000	EA	RADIO - AM/FM CD-W/O REMOTE/WIRE HARNESS-MAGNADYNE M3200CD
	155619-03-000	EA	REMOTE - RADIO
7	132958-01-000	EA	RECEPTACLE - 12 VOLT - MOUNTING FLANGE - BLACK
8	104898-01-02A	EA	PLATE - PLASTIC BOTTOM - BRIGHT WHITE

**ELECTRICAL GROUP (CONTINUED)**  
**EXTERIOR LAMPS**

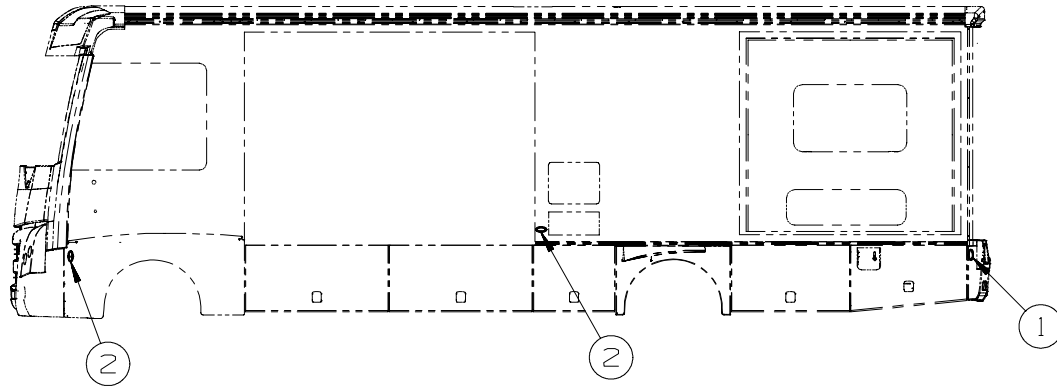
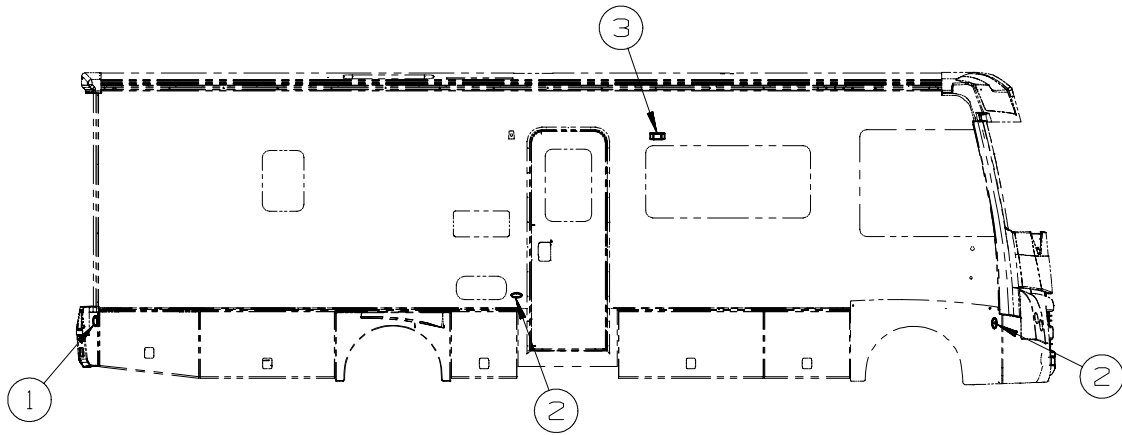

KEY	PART NUMBER	U/M	DESCRIPTION
1	147680-03-01A	EA	LAMP - MARKER - LENS - RED
1	147680-01-01A	EA	BASE - MARKER LAMP - WHITE
2	147680-02-01A	EA	LAMP - MARKER - LENS - AMBER
2	147680-01-01A	EA	BASE - MARKER LAMP - WHITE
3*	097917-01-06A	EA	LIGHT - PORCH - ENTRY DOOR - BRIGHT WHITE
			FROM: 00-00-00 THRU: 02-10-08
3	097917-01-09A	EA	LIGHT - PORCH - ENTRY DOOR - WHITE
			FROM: 02-11-08 THRU: 99-99-99
3	097917-01-08A	EA	LIGHT - PORCH - ENTRY DOOR - CHROME

**\*COMPONENT PARTS LISTED LATER IN THIS GROUP**

**ELECTRICAL GROUP (CONTINUED)**  
**EXTERIOR LAMPS (CONTINUED)**

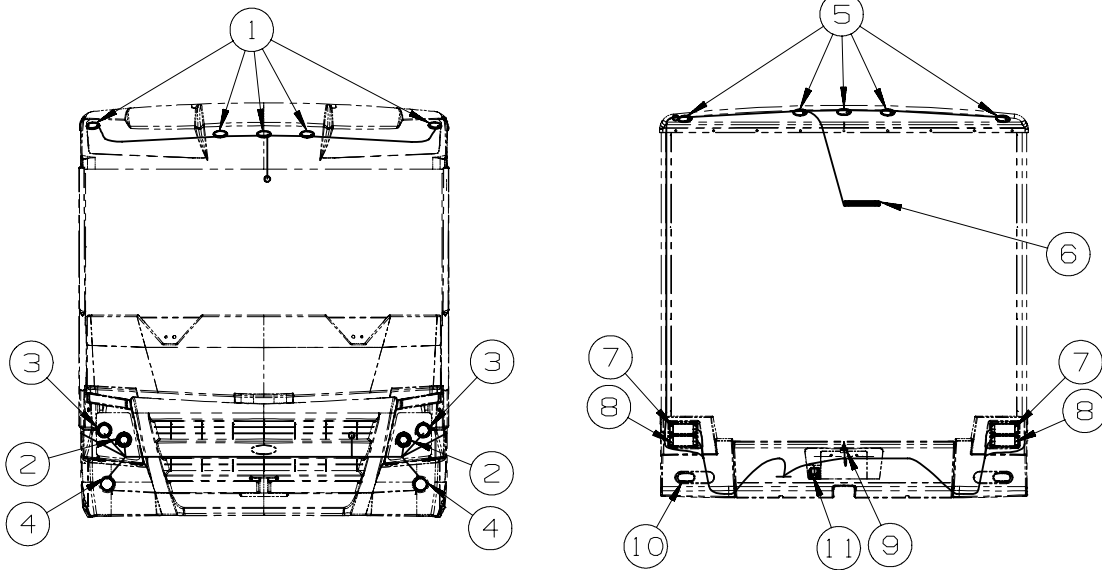

KEY	PART NUMBER	U/M	DESCRIPTION
1	147680-02-01A	EA	LAMP - MARKER - LENS - AMBER
1	147680-01-01A	EA	BASE - MARKER LAMP - WHITE
2	146527-02-000	EA	HEADLAMP - HIGH BEAM
2	147103-01-000	EA	HOUSING/CONNECTOR - HEADLAMP - W/PIGTAIL
2	146560-02-000	EA	SOCKET - LAMP - 3 WIRE
3	146527-01-000	EA	HEADLAMP - LOW BEAM
4	146560-03-000	EA	LAMP - PARK/TURN - AMBER
4	112708-01-000	EA	BULB - 12 VOLT - #3157 - .59/2.10 AMP
5	147680-03-01A	EA	LAMP - MARKER - LENS - RED
5	147680-01-01A	EA	BASE - MARKER LAMP - WHITE
6	136916-01-000	EA	LIGHT - BRAKE - CENTER MOUNT - RECTANGLE - 1.3" X 9.8"
7	152352-03-000	EA	LAMP - STOP/TURN/TAIL - RED
7	037935-01-000	EA	BULB - 12V - #1157 OR #2057 - 2.1 AMP - CLEAR GLASS
7	152352-04-000	EA	SOCKET - LAMP - 3 WIRE
8	152352-01-000	EA	LIGHT - BACKUP - CLEAR LENS - W/O SOCKET
8	037934-01-000	EA	BULB - 12V - #1156 - 2.1 AMP - CLEAR GLASS
8	152352-02-000	EA	SOCKET - BACK-UP LIGHT - 2 WIRE
9	087201-01-000	EA	LIGHT - HALF ROUND - 1" X 1.7" - PLASTIC - BLACK OR WHITE
10	157998-01-000	EA	REFLECTOR - OVAL/RED - 1.9" X 4.3"
11	157593-01-000	EA	CONNECTOR - PLUG - TRAILER - 7 SOCKET
11	146246-01-000	EA	CONNECTOR/PLUG - TRAILER - 7 PIN



## ELECTRICAL GROUP (CONTINUED) FRONT END

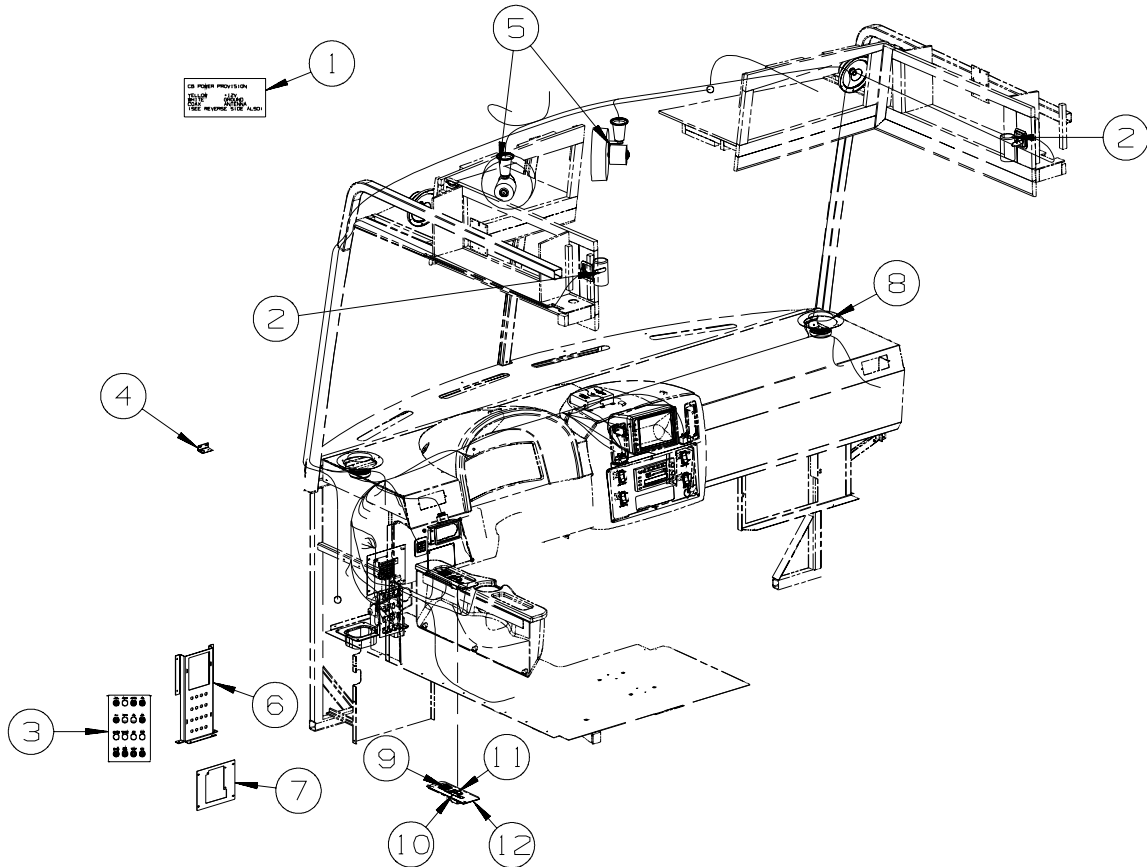

KEY	PART NUMBER	U/M	DESCRIPTION
1	104678-01-000	EA	LABEL - CB PREP
2	149590-01-02A	EA	LIGHT - READING/SWIVEL - W/O SWITCH - NICKEL
2	123917-01-000	EA	BULB - 12V - HALOGEN SPOT
3	093236-47-000	EA	LABEL - CIRCUIT BREAKER
4	147428-01-02B	EA	BRACKET/ZEE - F/TEMPERATURE SENSOR - E-COATED - WORKHORSE
5	122856-01-01A	EA	FAN-DEFROSTER-2 SPEED W/SWIVEL BASE/NON-OSCILLATING-CHROME
6	149689-01-02B	EA	BRACKET - CIRCUIT BREAKER, E-COAT
7	149690-01-02B	EA	BRACKET - FUSE PANEL, WH, E-COAT - WORKHORSE
7	149690-02-02B	EA	BRACKET - FUSE PANEL, FORD, E-COAT - FORD
8	094097-01-000	EA	SPEAKER - RADIO/TV - W/O GRILLE - 5.25" DIAMETER
8	159430-01-01A	EA	GRILLE - SPEAKER - 6" ROUND - CASHMERE
9	088246-01-000	EA	SWITCH/REMOTE MIRROR - W/2PIN & 6 PIN CONNECTORS/PIGTAIL
10	133533-04-01A	EA	LABEL - WINDOW/MIRROR HEAT - BLACK/CLEAR
11	145638-02-01A	EA	SWITCH/ROCKER - SPST (ON/OFF) - LIGHTED - BLACK
12	158280-01-02B	EA	PLATE - SWITCH - MIRROR/HEAT - E-COATED

## CANADIAN DAY RUN LAMPS

KEY	PART NUMBER	U/M	DESCRIPTION
	163912-01-000	EA	RESISITOR - DAYTIME RUNNING LIGHTS - FORD/CSA
	163913-01-000	EA	RELAY - DAYTIME RUNNING LIGHTS - FORD/CSA

## ELECTRICAL GROUP (CONTINUED) FRONT END (CONTINUED)

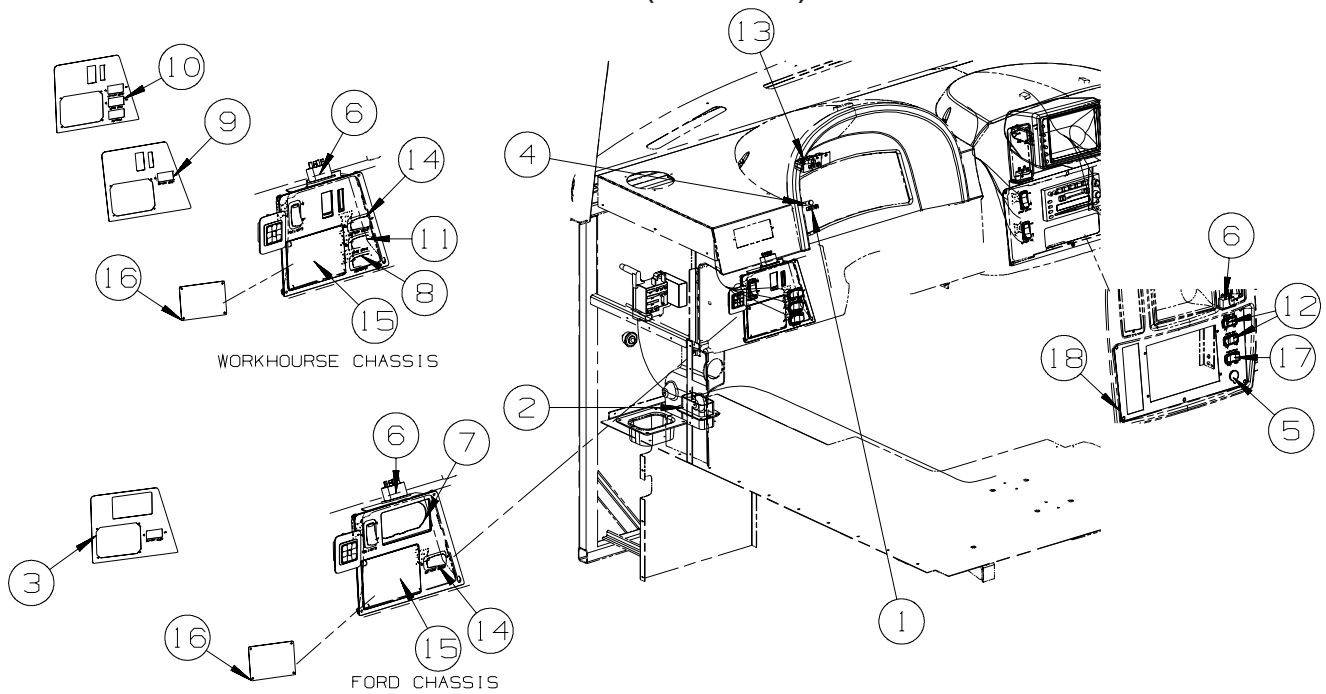

KEY	PART NUMBER	U/M	DESCRIPTION
1	133533-01-01A	EA	LABEL - JACKS DOWN - CLEAR W/WHITE LETTERING
2	118571-03-000	EA	BRACKET - MOUNTING
	118571-04-000	EA	GASKET
3	156292-10-01A	EA	APPLIQUE - DRIVERS/LEFT - DARK ANTELOPE - FORD
4	150237-01-000	EA	LIGHT - INDICATOR - RED
5	111414-01-000	EA	RECEPTACLE/SOCKET - 12 VOLT
6	157655-01-01A	EA	LIGHT - DASH/SWITCH - 2 LAMP INCANDESCENT - BLACK HOUSING
7	155516-01-02B	EA	MOUNT - HEADLAMP SWITCH - E-COATED
8	145638-14-01A	EA	SWITCH/ROCKER - DPDT (ON/OFF/ON) - BLACK
8	108355-02-000	EA	HOUSING - SWITCH - 12 POSITION
9	156292-09-01A	EA	APPLIQUE - DRIVERS/LEFT - DARK ANTELOPE - WORKHORSE
10	156292-08-01A	EA	APPLIQUE - DRIVERS/LEFT - DARK ANTELOPE - 20700 GVWR WORKHORSE
11	145638-01-01A	EA	SWITCH/ROCKER - SPST (ON/OFF) - BLACK
11	108355-02-000	EA	HOUSING - SWITCH - 12 POSITION
12	145638-03-01A	EA	SWITCH/ROCKER - SPDT (ON/OFF/ON) - FANS-DEFROSTER AUX/WATER HEATER W/MOTOR AID
12	145754-01-01A	EA	SWITCH - BLANK - BLACK - FANS-DEFROSTER AUX/WATER HEATER W/MOTOR AID
12	108355-02-000	EA	HOUSING - SWITCH - 12 POSITION - FANS-DEFROSTER AUX/WATER HEATER W/MOTOR AID
13	063912-02-000	EA	RELAY CANISTER, SPDT
14	145638-04-01A	EA	SWITCH/ROCKER - SPDT (ON/ON) - BLACK
14	108355-02-000	EA	HOUSING - SWITCH - 12 POSITION
15	134149-01-04B	EA	PLATE - COVER - LEVEL JACK CONTROL - BLACK
16	156292-11-01A	EA	APPLIQUE - COVER - LEVEL JACK - DARK ANTELOPE
17	145638-07-01A	EA	SWITCH/ROCKER - DPDT (ON/ON) - BLACK
17	108355-02-000	EA	HOUSING - SWITCH - 12 POSITION
18	156292-15-01A	EA	APPLIQUE - BEZEL - CENTER - DARK ANTELOPE/GLACIER

## ELECTRICAL GROUP (CONTINUED)

### FRONT TV/DVD

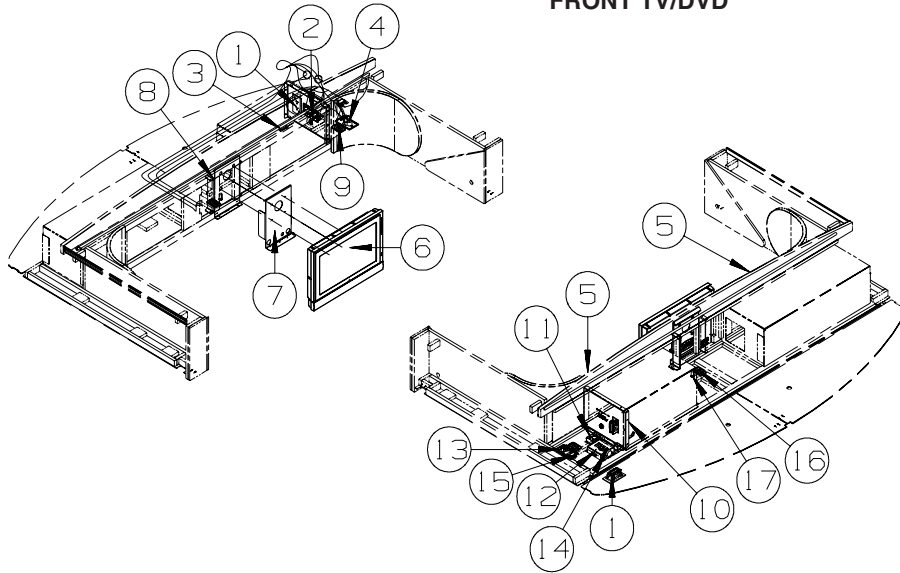

**W/19" OR 20"  
FRONT TV**

KEY	PART NUMBER	U/M	DESCRIPTION
1	058708-01-000	EA	RECEPTACLE - ELECTRIC - DOUBLE - BROWN
2	149557-04-01A	EA	PLATE/WALL - TRIPLE COAXIAL/HORIZONTAL - WHITE
3	149750-03-000	EA	TRANSMITTER - F/INFRA RED RECEIVER - <b>SATELLITE TV SYSTEM MANUAL</b>
4	086777-02-000	EA	WALLPLATE/TV CABLE W/ANTENNA SWITCH/BOOSTER - 2 TV - BLACK
5	146514-02-000	EA	CONNECTOR - LIGHT - <b>INTERIOR UPGRADE PACKAGE</b>
5	146514-03-000	EA	LIGHT - FLEX - ROPE/ROUND - W/O MOUNT CHANNEL - <b>INTERIOR UPGRADE PACKAGE</b>
6*	158703-01-000	EA	TV - 20" - LCD 4:3 - SIDE SPEAKER - JENSEN JE2043
			FROM: 00-00-00 THRU: 04-29-07
6*	164495-01-000	EA	TV - 19" - LCD 16:9 - BOTTOM SPEAKER - JENSEN JE1907DC
			FROM: 04-30-07 THRU: 99-99-99
7	162935-01-02B	EA	PLATE/MOUNTING - TV - E-COATED - <b>NOT ILLUSTRATED</b>
			FROM: 00-00-00 THRU: 04-29-07
7	162935-02-02B	EA	PLATE/MOUNTING - TV - E-COATED
			FROM: 04-30-07 THRU: 99-99-99
8	162934-01-02B	EA	SUPPORT/MOUNTING - TV - E-COATED
			FROM: 00-00-00 THRU: 04-29-07
8	162934-02-02B	EA	SUPPORT/MOUNTING - TV - E-COATED
			FROM: 04-30-07 THRU: 99-99-99
9	135740-01-01A	EA	SWITCH - ROCKER - SPST - ON/OFF - BROWN
9	135741-01-01A	EA	SWITCH - BASE - SINGLE - BROWN
9	135742-45-02A	EA	BEZEL - SWITCH - TV - BROWN
10	162936-01-02B	EA	PANEL - ELECTRICAL - E-COATED
11	149750-04-000	EA	MODULE/INTERFACE - INFRA RED (RECEIVER TO TRANSMITTER) - <b>SATELLITE TV SYSTEM MANUAL</b>
12	150140-01-000	EA	CROSSOVER BOX - STANDARD STEREO TO DELUXE SOUND
13	149750-02-000	EA	CABLE - (RECEIVER TO MODULE) - 45'
14	150140-02-000	EA	CROSSOVER COIL - F/SUBWOOFER SPEAKER/LOW FREQUENCY
15	086756-01-000	EA	SPLITTER - TV/2 WAY
16	135740-01-01A	EA	SWITCH - ROCKER - SPST - ON/OFF - BROWN - <b>INTERIOR UPGRADE PACKAGE</b>
16	135741-01-01A	EA	SWITCH - BASE - SINGLE - BROWN - <b>INTERIOR UPGRADE PACKAGE</b>
16	135742-50-02A	EA	BEZEL - SWITCH - ACCENT - BROWN - <b>INTERIOR UPGRADE PACKAGE</b>
17	149750-01-000	EA	RECEIVER - (INFRA RED SIGNAL) - W/6"LEAD/PLUG - <b>SATELLITE TV SYSTEM MANUAL</b>
18	136860-01-000	EA	CABLE - RCA - SHIELDED - 3 MALE TO MALE CONNECTORS - 12'
19	123324-01-000	EA	FILTER - GROUND LOOP - ISOLATION TRANSFORMER

**\*COMPONENT PARTS LISTED LATER IN THIS GROUP**

**ELECTRICAL GROUP (CONTINUED)**  
**FRONT TV/DVD (CONTINUED)**

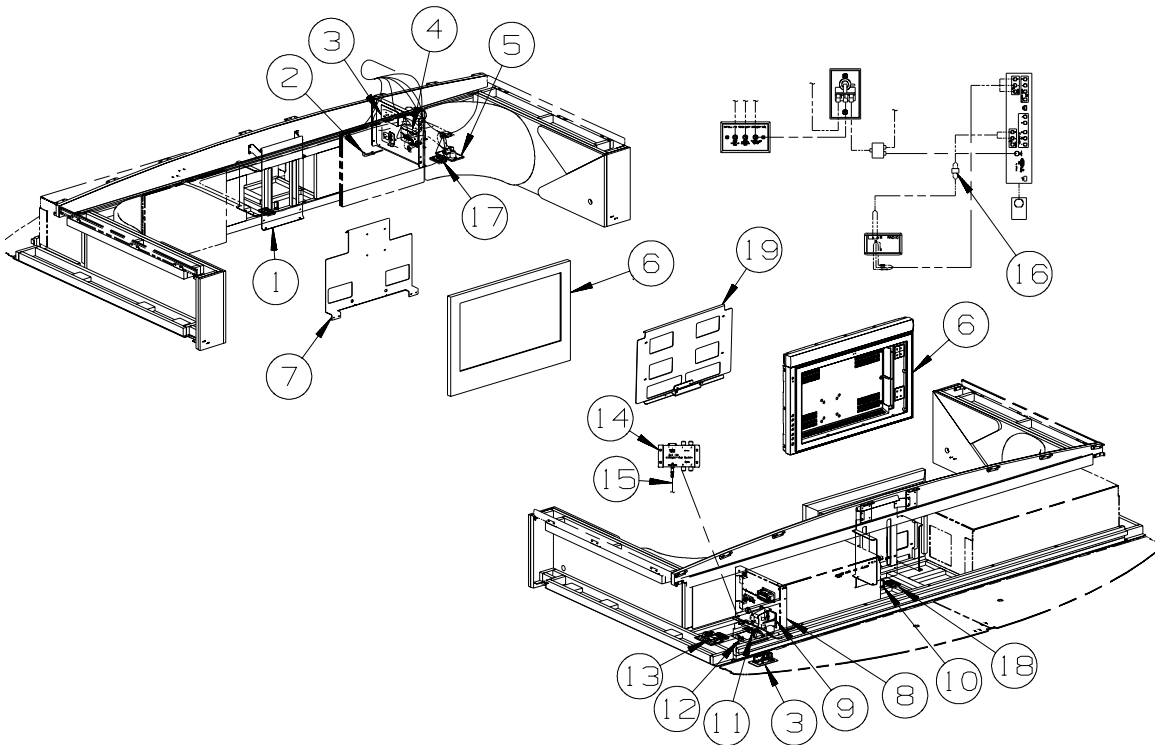

**W/26" OR 27"  
FRONT TV**

KEY	PART NUMBER	U/M	DESCRIPTION
1	165530-01-02B	EA	BRACKET - TV - E-COATED - <b>TV - 27" COLOR, STEREO W/REMOTE</b>
1	165530-02-02B	EA	BRACKET - TV - E-COATED - <b>TV (FRONT) - 26" COLOR, STEREO</b>
2	149750-03-000	EA	TRANSMITTER - F/INFRA RED RECEIVER - <b>SATELLITE TV SYSTEM MANUAL</b>
3	058708-01-000	EA	RECEPTACLE - ELECTRIC - DOUBLE - BROWN
4	149557-04-01A	EA	PLATE/WALL - TRIPLE COAXIAL/HORIZONTAL - WHITE
5	086777-02-000	EA	WALLPLATE/TV CABLE W/ANTENNA SWITCH/BOOSTER - 2 TV - BLACK
6*	165074-01-000	EA	TV - 27" - LCD 16:9 - BOTTOM SPEAKER - JENSEN JE2707 - <b>TV - 27" COLOR, STEREO W/REMOTE</b>
6*	166446-01-000	EA	TV - 26" - LCD 16:9 - BOTTOM SPEAKER - JENSEN JE2608 - <b>TV (FRONT) - 26" COLOR, STEREO</b>
7	165518-01-02B	EA	BRACKET - TV - 27" JENSON - E-COATED - <b>TV - 27" COLOR, STEREO W/REMOTE</b>
8	162936-01-02B	EA	PANEL - ELECTRICAL - E-COATED
8	162936-02-02B	EA	PANEL - ELECTRICAL - E-COATED
8	162936-03-02B	EA	PANEL - ELECTRICAL - E-COATED - <b>INTVERTER - DC/AC, 300 WATT</b>
9	156676-01-000	EA	CONTROLLER/OUTLET - POWER/TV - AUTO SHUTOFF W/IGNITION - POWERTEK RL-1003
10	149750-01-000	EA	RECEIVER - (INFRA RED SIGNAL) - W/6"LEAD/PLUG - <b>SATELLITE TV SYSTEM MANUAL</b>
11	150140-02-000	EA	CROSSOVER COIL - F/SUBWOOFER SPEAKER/LOW FREQUENCY
12	150140-01-000	EA	CROSSOVER BOX - STANDARD STEREO TO DELUXE SOUND
13	086756-01-000	EA	SPLITTER - TV/2 WAY
14	149750-04-000	EA	MODULE/INTERFACE - INFRA RED (RECEIVER TO TRANSMITTER) - <b>SATELLITE TV SYSTEM MANUAL</b>
15	149750-02-000	EA	CABLE - (RECEIVER TO MODULE) - 45'
16	123324-01-000	EA	FILTER - GROUND LOOP - ISOLATION TRANSFORMER
17	135740-01-01A	EA	SWITCH - ROCKER - SPST - ON/OFF - BROWN
17	135741-01-01A	EA	SWITCH - BASE - SINGLE - BROWN
17	135742-45-02A	EA	BEZEL - SWITCH - TV - BROWN
18	135740-01-01A	EA	SWITCH - ROCKER - SPST - ON/OFF - BROWN - <b>INTERIOR UPGRADE PACKAGE</b>
18	135741-01-01A	EA	SWITCH - BASE - SINGLE - BROWN - <b>INTERIOR UPGRADE PACKAGE</b>
18	135742-50-02A	EA	BEZEL - SWITCH - ACCENT - BROWN - <b>INTERIOR UPGRADE PACKAGE</b>
19	166789-01-02B	EA	BRACKET - TV - E-COATED - <b>TV (FRONT) - 26" COLOR, STEREO</b>

\*COMPONENT PARTS LISTED LATER IN THIS GROUP

## ELECTRICAL GROUP (CONTINUED)

### SIDE TV/DVD

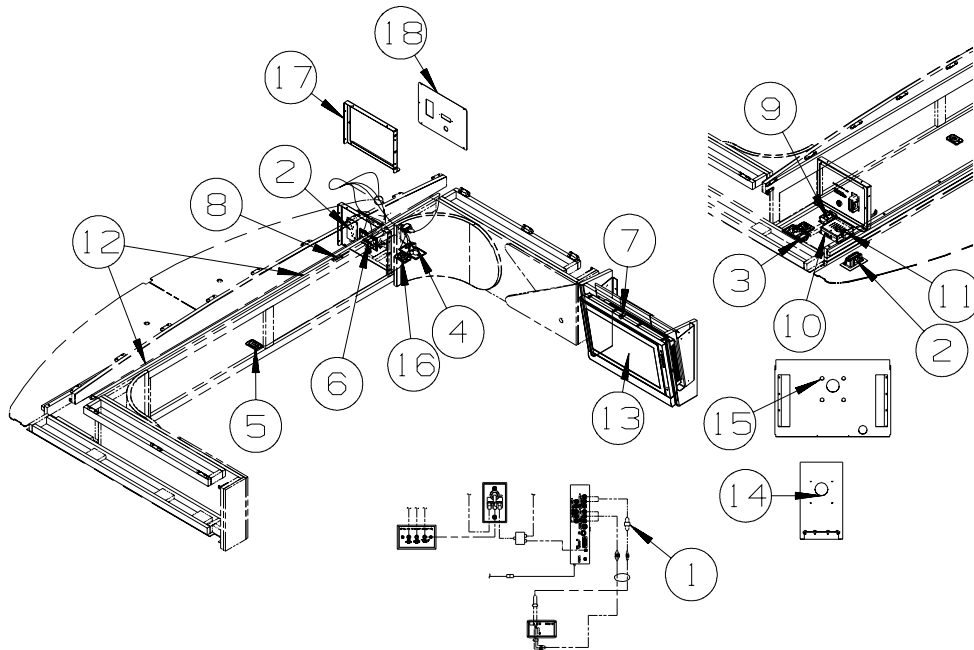

**W/19" OR 20"  
SIDE TV**

KEY	PART NUMBER	U/M	DESCRIPTION
1	123324-01-000	EA	FILTER - GROUND LOOP
2	058708-01-000	EA	RECEPTACLE - ELECTRIC - DOUBLE - BROWN
3	086756-01-000	EA	SPLITTER - TV/2 WAY
4	086777-02-000	EA	WALLPLATE/TV CABLE W/ANTENNA SWITCH/BOOSTER - 2 TV - BLACK
5	135740-01-01A	EA	SWITCH - ROCKER - SPST - ON/OFF - BROWN
5	135741-01-01A	EA	SWITCH - BASE - SINGLE - BROWN
5	135742-50-02A	EA	BEZEL - SWITCH - ACCENT - BROWN - <b>INTERIOR UPGRADE PACKAGE</b>
6	149557-04-01A	EA	PLATE/WALL - TRIPLE COAXIAL/HORIZONTAL - WHITE
7	149750-01-000	EA	RECEIVER - (INFRA RED SIGNAL) - W/6"LEAD/PLUG
8	149750-03-000	EA	TRANSMITTER - F/INFRA RED RECEIVER
9	149750-04-000	EA	MODULE/INTERFACE - INFRA RED (RECEIVER TO TRANSMITTER)
10	150140-01-000	EA	CROSSOVER BOX - STANDARD STEREO TO DELUXE SOUND
11	150140-02-000	EA	CROSSOVER COIL - F/SUBWOOFER SPEAKER/LOW FREQUENCY
12	146514-03-000	FT	LIGHT - FLEX - ROPE/ROUND - W/O MOUNT CHANNEL
12	146514-02-000	EA	CONNECTOR - LIGHT
13*	158703-01-000	EA	TV - 20" - LCD 4:3 - SIDE SPEAKER - JENSEN JE2043 FROM: 00-00-00 THRU: 04-29-07
13*	164495-01-000	EA	TV - 19" - LCD 16:9 - BOTTOM SPEAKER - JENSEN JE1907DC FROM: 04-30-07 THRU: 99-99-99
14	163323-01-02B	EA	PLATE/MOUNTING - TV - E-COATED - <b>NOT ILLUSTRATED</b> FROM: 00-00-00 THRU: 04-29-07
14	163323-02-02B	EA	PLATE/MOUNTING - TV - E-COATED FROM: 04-30-07 THRU: 99-99-99
15	163322-01-02B	EA	SUPPORT/MOUNT - TV - E-COATED - <b>NOT ILLUSTRATED</b> FROM: 00-00-00 THRU: 04-29-07
15	163322-02-02B	EA	SUPPORT/MOUNT - TV - E-COATED FROM: 04-30-07 THRU: 99-99-99
16	135740-01-01A	EA	SWITCH - ROCKER - SPST - ON/OFF - BROWN
16	135741-01-01A	EA	SWITCH - BASE - SINGLE - BROWN
16	135742-45-02A	EA	BEZEL - SWITCH - TV - BROWN
17	162936-01-02B	EA	PANEL - ELECTRICAL - E-COATED
18	162936-02-02B	EA	PANEL - ELECTRICAL - E-COATED

**\*COMPONENT PARTS LISTED LATER IN THIS GROUP**

**ELECTRICAL GROUP (CONTINUED)**  
**COMPONENT PARTS FOR WIRING**

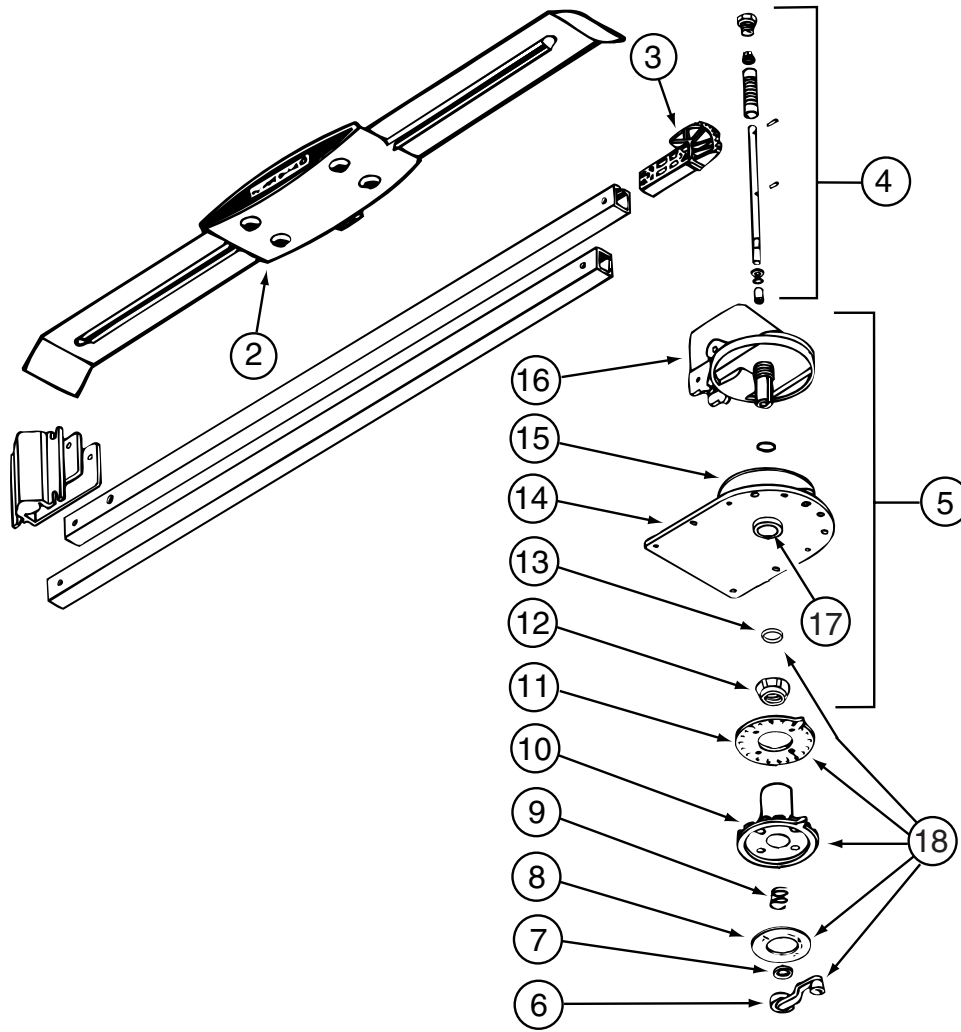

**076319-23-000**

KEY	PART NUMBER	U/M	DESCRIPTION	VENDOR NO.
2	076319-01-700	EA	HEAD-ANTENNA, AMPLIFIED	RVSA U/V
3	076319-01-701	EA	GEAR-ELEVATING, PLASTIC	2200046
4	076319-01-702	EA	SHAFT ASM-ELEVATING	RP-4000
5	076319-01-711	EA	BASE & LIFT ASM	2762802
7	076319-01-705	EA	GROMMET-NYLON, 7/8"ID	3200658
8	076319-01-708	EA	DECAL-CRANK	5413002
9	076319-01-707	EA	SPRING-HANDLE	2160822
11	076319-01-712	EA	PLATE - CEILING	3200608
12	076319-01-715	EA	NUT (GEAR HOUSING)	2200047
14	076319-01-713	EA	PLATE-BASE, STEEL	3100523
15	076319-01-703	EA	BEARING-NYLON, 5"OD	3200656
16	076319-01-714	EA	HOUSING, ROTATING GEAR	2200049
17	076319-01-704	EA	BEARING-NYLON, 1.25"OD	3200657
18	076319-01-709	EA	HANDLE-HEAD DIRECTIONAL	200644
	076319-01-716	EA	TUBING, ELEVATING	RP-2900

CONTACT WINNEBAGO PART SALES FOR UNLISTED COMPONENT(S)

**076319-25-000**

KEY	PART NUMBER	U/M	DESCRIPTION	VENDOR NO.
6	076319-01-706	EA	CRANK-W/SET SCREW UNIV/BEIGE	2750897
6	120233-01-710	EA	HANDLE-CRANK W/SCREW - WHITE	RP-6795
8	076319-01-708	EA	DECAL-CRANK	5413002
10	076319-25-700	EA	DIRECTIONAL HANDLE(WHITE)	3200612
11	076319-25-701	EA	PLATE - CEILING(WHITE)	3200609
13	120233-01-709	EA	WASHER-NYLON	RP-2658

CONTACT WINNEBAGO PART SALES FOR UNLISTED COMPONENT(S)

**ELECTRICAL GROUP (CONTINUED)**  
**COMPONENT PARTS FOR WIRING (CONTINUED)**

			<b>087694-01-000</b>	
<b>KEY</b>	<b>PART NUMBER</b>	<b>U/M DESCRIPTION</b>		<b>VENDOR NO.</b>
	087694-01-700	EA BULB		GE561
			<b>097917-01-06A</b>	
<b>KEY</b>	<b>PART NUMBER</b>	<b>U/M DESCRIPTION</b>		<b>VENDOR NO.</b>
	097917-01-700	EA LENS-LIGHT, CLEAR		30-78-021
			<b>121935-01-01A</b>	
<b>KEY</b>	<b>PART NUMBER</b>	<b>U/M DESCRIPTION</b>		<b>VENDOR NO.</b>
	121935-01-700	EA LENS ONLY - W/CENTER HOLE		809511

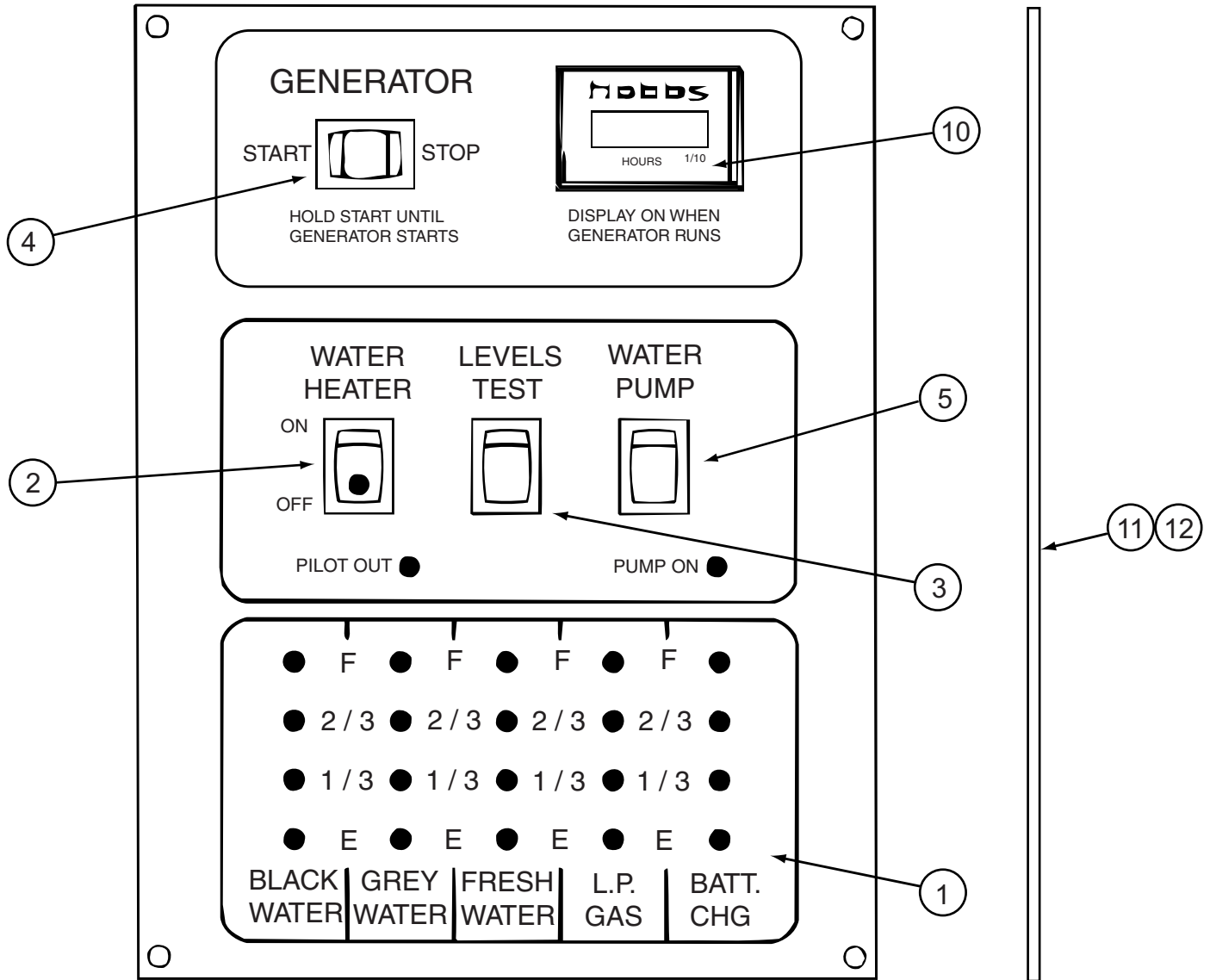

			<b>134940-06-01A</b>	
<b>KEY</b>	<b>PART NUMBER</b>	<b>U/M DESCRIPTION</b>		<b>VENDOR NO.</b>
1	134940-01-702	EA CHASSIS - SILKSCREENED		CC0558-00
2	134940-01-701	EA SWITCH-SPST/ON-OFF/BLK W/LGT		L0109
3	096983-01-701	EA SWITCH - SPST/MOM 2 TERMINAL		L0111-00
4	096983-01-702	EA SWITCH - MOM/OFF/MOM/3 TERM		L0112-00
5	096983-01-703	EA SWITCH - ON/ON		L0115-00
10	100258-10-701	EA GAUGE-HR METER ONLY (LCD)		L0775-00
11	134940-06-700	EA PC BOARD - SENSOR SYSTEM/RED		L5131-02
		CONTACT WINNEBAGO PART SALES FOR UNLISTED COMPONENT(S)		

			<b>135420-20-000</b>	
<b>KEY</b>	<b>PART NUMBER</b>	<b>U/M DESCRIPTION</b>		<b>VENDOR NO.</b>
	135420-20-700	EA CABLE-RECIEVER TO RADIO		M9CABLE

**ELECTRICAL GROUP (CONTINUED)**  
**COMPONENT PARTS FOR WIRING (CONTINUED)**

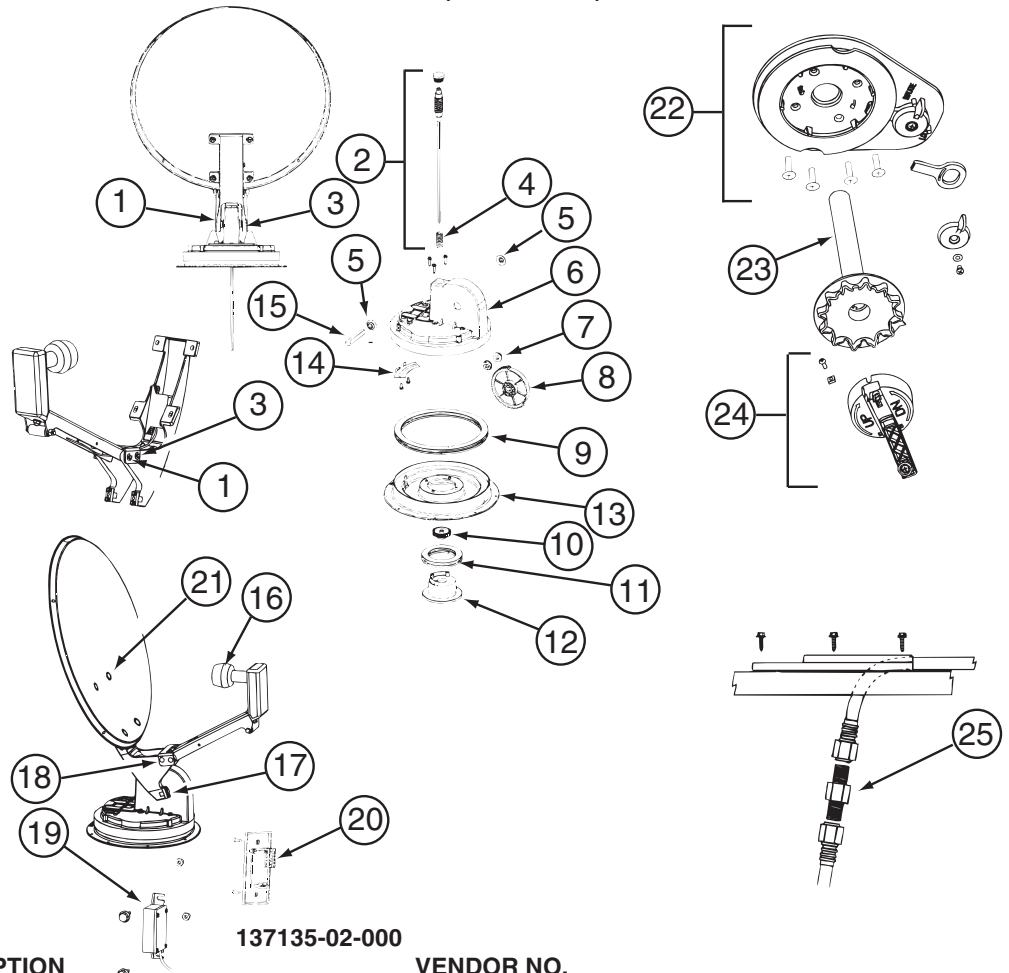

KEY	PART NUMBER	U/M	DESCRIPTION	VENDOR NO.
1	120233-01-714	EA	CLIP-E	5160818
2	137135-01-703	EA	KIT ELEV - SHAFT/GEAR/SPRING	RP-4400
3	137135-01-704	EA	PIN - 1/4" X 3.25"	2160813
4	137135-01-705	EA	SPRING	2160818
5	137135-01-707	EA	SEAL - PIVOT SHAFT	2200852
6	137135-01-708	EA	TURRET	3100728
7	137135-01-709	EA	PIVOT BEARING	2200470
8	137135-01-711	EA	GEAR - ELEVATING	2200464
9	137135-01-712	EA	BEARING - OUTER	2590347
10	137135-01-714	EA	GEAR - ELEVATING SHAFT	2200465
11	137135-01-715	EA	BEARING - INNER	2590348
12	137135-01-716	EA	HUB	3100731
13	137135-01-713	EA	TURRET BASE	3100730
14	137135-01-710	EA	PLATE - ROTATE LIMIT	3720052
16	137135-02-703	EA	LOW NOISE BLOCK FILTER	LB-6000 - DUAL
17	137135-01-722	EA	CLAMP	2590343
18	137135-01-719	EA	BRACKET - PIVOT	2744945
19	137135-01-720	EA	DE-SENSOR UNIT W/43" CABLE	DM4000
20	137135-02-701	EA	BOX - SURFACE MOUNT	SM-100
21	137135-01-717	EA	BOLT - FLAT HEAD	2160362
22	120233-01-737	EA	PLATE/INT-W/DIRECTIONAL HDLE	RK-CEIL
23	120233-01-704	EA	DIAL/DIRECTIONAL 4"W/SPRING	3200364
24	120233-01-738	EA	HDW PKG-HANDLE/SPRING/WASHER	RK-HAND
25	137135-01-701	EA	CONNECTOR - F - MALE TO MALE	FS-8100
	120233-04-700	EA	KIT-WALL PLATE/CABLE - GRAY	DM4000
	137135-01-700	EA	ROOF WEDGE W/GASKET	RW-5000
	137135-01-706	EA	KIT-TURRET/SEAL/BEARING/GEAR	RP-RM30
	137135-01-718	EA	REFLECTOR/WHITE-46CM W/HDW	RP-35RM
	137135-02-700	EA	DE-SENSOR	2780096
	137135-02-704	EA	KIT-UPDATE DIRECTIONAL HDL	RP-RMDH
	137135-02-705	EA	KIT-TURRET & SHAFT COMPLETE	RP-RM46

CONTACT WINNEBAGO PART SALES FOR UNLISTED COMPONENT(S)



**ELECTRICAL GROUP (CONTINUED)**  
**COMPONENT PARTS FOR WIRING (CONTINUED)**

**137135-05-000**

<b>KEY</b>	<b>PART NUMBER</b>	<b>U/M</b>	<b>DESCRIPTION</b>	<b>VENDOR NO.</b>
	120233-01-714	EA	CLIP-E	5160818
	120233-01-737	EA	PLATE/INT-W/DIRECTIONAL HDLE	RK-CEIL
	120233-01-738	EA	HDW PKG-HANDLE/SPRING/WASHER	RK-HAND
	120233-04-703	EA	KIT-DIRECTIONAL HDL UPGRADE	RP-RM46
	137135-01-703	EA	KIT ELEV-SHAFT/PLUG/SPRING	RP-4400
	137135-01-704	EA	PIN - 1/4" X 3.25"	2160813
	137135-01-708	EA	TURRET	3100728
	137135-01-710	EA	PLATE - ROTATE LIMIT	3720052
	137135-01-712	EA	BEARING - OUTER	2590347
	137135-01-713	EA	TURRET BASE	3100730
	137135-01-714	EA	GEAR - ELEVATING SHAFT	2200465
	137135-01-715	EA	BEARING - INNER	2590348
	137135-01-717	EA	BOLT - FLAT HEAD	2160362
	137135-01-719	EA	BRACKET - PIVOT	2744945
	137135-01-722	EA	CLAMP	2590343

**137417-01-01A, 137417-03-01A**

<b>KEY</b>	<b>PART NUMBER</b>	<b>U/M</b>	<b>DESCRIPTION</b>	<b>VENDOR NO.</b>
	137417-01-700	EA	LENS - SINGLE (FROSTED)	810868

**137417-02-01A**

<b>KEY</b>	<b>PART NUMBER</b>	<b>U/M</b>	<b>DESCRIPTION</b>	<b>VENDOR NO.</b>
	137417-02-700	EA	LENS - SINGLE OPTIC	810844

**137417-05-01A**

<b>KEY</b>	<b>PART NUMBER</b>	<b>U/M</b>	<b>DESCRIPTION</b>	<b>VENDOR NO.</b>
	137417-05-700	EA	LENS - DOUBLE OPTIC	810845

**137417-06-01A**

<b>KEY</b>	<b>PART NUMBER</b>	<b>U/M</b>	<b>DESCRIPTION</b>	<b>VENDOR NO.</b>
	137417-06-700	EA	LENS - DOUBLE WHITE	810867

**149040-04-000**

<b>KEY</b>	<b>PART NUMBER</b>	<b>U/M</b>	<b>DESCRIPTION</b>	<b>VENDOR NO.</b>
	149040-04-700	EA	REMOTE - TV	274596

**158703-01-000**

<b>KEY</b>	<b>PART NUMBER</b>	<b>U/M</b>	<b>DESCRIPTION</b>	<b>VENDOR NO.</b>
	158703-01-700	EA	REMOTE	PSVCJE2043
	158703-01-701	EA	SERVICE PACK-REMOTE & CABLES	PSVCJE2043

**159178-03-000**

<b>KEY</b>	<b>PART NUMBER</b>	<b>U/M</b>	<b>DESCRIPTION</b>	<b>VENDOR NO.</b>
	159178-03-700	EA	REMOTE	AE003331

**160123-01-000**

<b>KEY</b>	<b>PART NUMBER</b>	<b>U/M</b>	<b>DESCRIPTION</b>	<b>VENDOR NO.</b>
	160123-01-700	EA	REMOTE - TV	HV145-REM

**163097-01-000**

<b>KEY</b>	<b>PART NUMBER</b>	<b>U/M</b>	<b>DESCRIPTION</b>	<b>VENDOR NO.</b>
	163097-01-700	EA	KEY - #2382 (ILLINOIS LOCK)	2382
	163097-01-701	EA	KEY - #2341 (MILLER DIAL)	PART SALES

**164495-01-000**

<b>KEY</b>	<b>PART NUMBER</b>	<b>U/M</b>	<b>DESCRIPTION</b>	<b>VENDOR NO.</b>
	164495-01-700	EA	REMOTE - TV	P301P19HS3409A

**165074-01-000**

<b>KEY</b>	<b>PART NUMBER</b>	<b>U/M</b>	<b>DESCRIPTION</b>	<b>VENDOR NO.</b>
	165074-01-700	EA	REMOTE - TV	P301P27FC3408A

**166446-01-000**

<b>KEY</b>	<b>PART NUMBER</b>	<b>U/M</b>	<b>DESCRIPTION</b>	<b>VENDOR NO.</b>
	166446-01-700	EA	REMOTE - TV	PR7ATSC

**ELECTRICAL GROUP (CONTINUED)**  
**CIRCUIT BREAKERS, FUSES & RELAYS**

<b>KEY</b>	<b>PART NUMBER</b>	<b>U/M</b>	<b>DESCRIPTION</b>
	062901-02-000	EA	FUSE - 5 AMP - AUTOMOTIVE
	062901-05-000	EA	FUSE - 15 AMP - AUTOMOTIVE
	062901-07-000	EA	FUSE - 25 AMP - AUTOMOTIVE
	062901-08-000	EA	FUSE - 30 AMP - AUTOMOTIVE
	063910-01-000	EA	HOUSING - RELAY
	063912-02-000	EA	RELAY - CANISTER - SPDT
	083209-01-000	EA	CIRCUIT BREAKER - 15 AMP - 120 VOLT - CANADIAN
	083209-02-000	EA	CIRCUIT BREAKER - 15/15 AMP - 120 VOLT
	083209-03-000	EA	CIRCUIT BREAKER - 15/20 AMP - 120 VOLT
	083209-04-000	EA	CIRCUIT BREAKER - 30 AMP - 120 VOLT
	083209-05-000	EA	CIRCUIT BREAKER - 20 AMP - 120 VOLT
	083209-06-000	EA	CIRCUIT BREAKER - 30/15 AMP - 120 VOLT
	083209-07-000	EA	CIRCUIT BREAKER - 20/20 AMP - 120 VOLT
	083209-10-000	EA	CIRCUIT BREAKER - 20/30 AMP - 120 VOLT
	083209-11-000	EA	CIRCUIT BREAKER - 20/15 AMP - 120 VOLT
	092786-03-000	EA	BUSS BAR - 6.9" LONG
	092786-06-000	EA	BUSS BAR
	093654-01-000	EA	CIRCUIT BREAKER - 6 AMP - 12 VOLT - PUSH BUTTON - WHITE
	093654-02-000	EA	CIRCUIT BREAKER - 15 AMP - 12 VOLT - PUSH BUTTON - WHITE
	093654-03-000	EA	CIRCUIT BREAKER - 20 AMP - 12 VOLT - PUSH BUTTON - WHITE
	093654-05-000	EA	CIRCUIT BREAKER - 10 AMP - 12 VOLT - PUSH BUTTON - WHITE
	093655-01-000	EA	CIRCUIT BREAKER - 25 AMP - 12 VOLT - PUSH BUTTON - WHITE
	093655-02-000	EA	CIRCUIT BREAKER - 30 AMP - 12 VOLT - PUSH BUTTON - WHITE
	093655-03-000	EA	CIRCUIT BREAKER - 40 AMP - 12 VOLT - PUSH BUTTON - WHITE
	100341-01-000	EA	FUSE HOLDER - IN LINE TYPE
	113482-01-000	EA	CIRCUIT BREAKER - 55 AMP - MANUAL
	115187-01-000	EA	FUSE - 300 AMP - NON-DELAY
	115187-02-000	EA	HOLDER - FUSE
	115187-03-000	EA	FUSE - 60 AMP - NON-DELAY
	122811-01-000	EA	CIRCUIT BREAKER - 20/50/50/20 AMP - 250V
	141789-01-000	EA	SPACER - CIRCUIT BREAKER

## ELECTRICAL GROUP (CONTINUED)

### CONVERTER, INVERTER, LOAD CENTERS

KEY	PART NUMBER	U/M DESCRIPTION
	024924-02-000	EA RECEPTACLE - POWER CORD - W/PARTIAL PLATE
	099048-04-000	EA INVERTER - 300 WATT
	165488-01-02B	EA PANEL - INVERTER - E-COATED

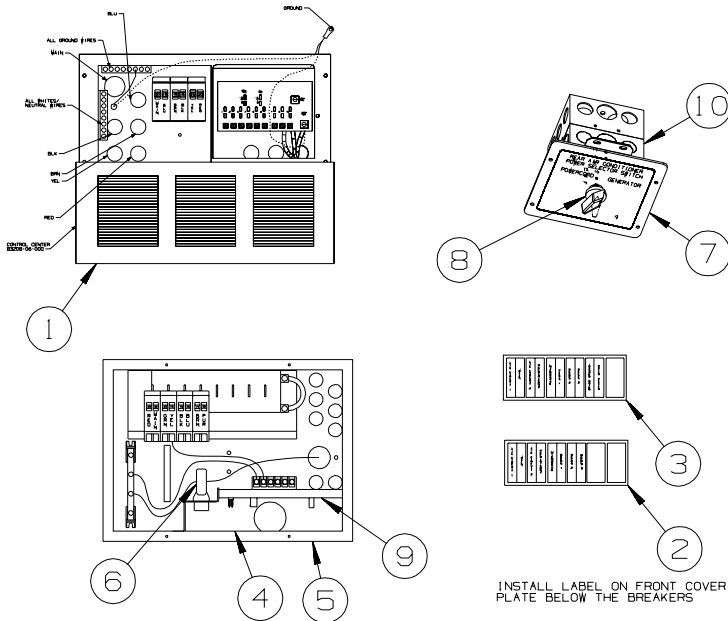

INSTALL LABEL ON FRONT COVER  
PLATE BELOW THE BREAKERS

KEY	PART NUMBER	U/M DESCRIPTION
1*	083208-07-000	EA CONTROL CENTER - 45 AMP - 120V/12V - W/O BREAKERS
2	095721-27-000	EA LABEL - CONTROL CENTER - 30 AMP
3	095721-31-000	EA LABEL - CONTROL CENTER - 30 AMP - US - <b>WTR HTR-6GAL/110/LP/MTR/AUTO</b>
4	141258-01-000	EA LOAD CENTER - 120/240 - 30/50 AMP
5	141258-02-000	EA LOAD CENTER - COVER
6	127002-07-000	EA SENSOR - CURRENT
7	121365-03-01A	EA COVER - REAR A/C POWER SELECT SWITCH - POWERCORD/GENERATOR
8	073937-03-000	EA SWITCH - ROTARY- AC - SELECTOR - 3 DECK
9	127002-11-000	EA MODULE - EMS CENTER - W/REMOTE SENSOR
10	074890-01-000	EA BOX - EXTENSION/STEEL - OPEN SIDES - 4" X 4" X 1 1/2"

\*COMPONENT PARTS LISTED LATER IN THIS GROUP

### COMPONENT PARTS FOR CONVERTOR, INVERTOR, LOAD CENTERS

083208-07-000

KEY	PART NUMBER	U/M DESCRIPTION	VENDOR NO.
	083208-06-701	EA CONVERTER ONLY (LOWER UNIT)	7345R

## ELECTRICAL GROUP (CONTINUED)

### BOXES & CORDS

KEY	PART NUMBER	U/M	DESCRIPTION
	008054-01-000	EA	CORD - POWER - 10/3 WIRE - 30 AMP - 25'
	008289-01-000	EA	BOX - ELECTRIC/STEEL - 4" X 4" - 1/2" & 3/4" KNOCKOUTS
	008294-01-000	EA	COVER - ELECTRIC BOX - BLANK/STEEL - 4" X 4" - GRAY
	069238-01-000	EA	COVER - ELECTRICAL BOX - W/HOLE - 4" X 4" - GRAY
	091910-01-000	EA	BOX - ELECTRIC/STEEL - 3.8" X 3.5" X 1.8" - PLASTIC
	091910-02-000	EA	BOX - ELECTRIC/STEEL - 2.2" X 3.5" - 1.8" - PLASTIC
	133070-01-000	EA	BOX - ELECTRIC/PLASTIC - 3" X 2" X 2.8" - UL
	133070-02-000	EA	BOX - ELECTRIC/PLASTIC - 3" X 2" X 2.8" - CSA - CANADIAN
	115832-01-000	FT	CORD - HEAVY DUTY - 14-2 W/GROUND

### WIRE ASSEMBLIES

KEY	PART NUMBER	U/M	DESCRIPTION
	077069-02-000	EA	CABLE/EXTENSION - RADIO ANTENNA - 96"
	077069-03-000	EA	CABLE/EXTENSION - RADIO ANTENNA - 260"
	114870-01-000	EA	PLUG - AUDIO W/LEADS - 48.5"
	125853-04-000	EA	WIRE LOOM - ENTERTAINMENT CENTER
	126030-01-000	EA	WIRE ASM-WIPER/WASHER
	136514-02-000	EA	CABLE - MONITOR/CAMERA
	136860-02-000	EA	CABLE - RCA - SHIELDED - 3 MALE TO MALE CONNECTORS - 50'
	137135-03-000	EA	WIRE LOOM - DIGITAL ELEVATION SENSOR
	137135-04-000	EA	WIRE HARNESS - POWER - DIGITAL ELEVATION SENSOR
	144677-07-000	EA	WIRE - MONITOR - POWER - 3 PIN TO 6 PIN (3 WIRE)
	144677-09-000	EA	WIRE - MONITOR - POWER - 3 PIN/2 PIN
	145210-01-000	FT	CABLE - COAXIAL
	147313-01-000	EA	WIRE - OUTSIDE TEMP SENSOR - W/O SENSOR
	149750-02-000	EA	CABLE - (RECEIVER TO MODULE) - 45'
	151316-03-000	EA	WIRE ASM - W/NON CONTACT SENSORS - GREY WATER - 43.2"
	151317-01-000	EA	WIRE ASM-W/NON CONTACT SENSORS-FRESH WATER/BLK TANK-3.9"
	151317-02-000	EA	WIRE ASM-W/NON CONTACT SENSORS-FRESH WATER/BLK TANK-23.6"
	155619-05-000	EA	WIRE ASSEMBLY - RADIO - 12 PIN
	160123-02-000	EA	WIRE/CABLE - POWER - PROVIEW WB101-06
	151316-01-000	EA	WIRE ASM - W/NON CONTACT SENSORS - GREY WATER - 3.9"
	165808-02-000	EA	WIRE/CABLE - POWER - MB QUART #MBQLC-15U-P
	136860-04-000	EA	CABLE - RCA - SHIELDED - 3 MALE TO MALE CONNECTORS - 20'
	155522-06-000	EA	WIRE ASM - SLIDEOUT RAMS

**ELECTRICAL GROUP (CONTINUED)**  
**CONNECTORS & CONDUIT**

KEY	PART NUMBER	U/M	DESCRIPTION
	007940-01-000	EA	RECEPTACLE/SLIDE 16 TO 12 AWG - FEMALE END
	007940-02-000	EA	RECEPTACLE/SLIDE 10 AWG
	007954-01-000	EA	RECEPTACLE - HOUSING - 6 POSITION
	007956-05-000	EA	INSULATOR - SHRINK - 1/4"ID X 1 1/2"
	008311-01-000	EA	CONNECTOR - WIRE NUT - INSULATED - RED
	008312-01-000	EA	CONNECTOR - WIRE NUT - INSULATED - BLUE
	008313-01-000	EA	CONNECTOR - WIRE NUT - INSULATED - YELLOW
	008314-01-000	EA	CONNECTOR - WIRE NUT - INSULATED - GRAY
	008328-01-000	EA	TERMINAL - RING - 12/10 WIRE - #10 STUD FIT
	008331-01-000	EA	TERMINAL - RING - TONGUE - #4 WIRE - 3/8" STUD - COPPER
	008348-01-000	EA	TERMINAL - RING - 3/8" STUD 2 GA. WIRE
	008355-01-000	EA	CONNECTOR - CABLE CLAMPING - 3/4"
	008356-01-000	EA	CONNECTOR - PLASTIC - 3/8"
	008356-02-000	EA	CONNECTOR - PLASTIC - 21/32"
	035416-04-000	EA	TERMINAL - RING - #10 STUD FIT - INSULATED BARREL #16/14
	041953-01-000	FT	CONDUIT - CONVOLUTE SLIT - .5" ID - POLYETHYLENE
	041953-02-000	FT	CONDUIT - CONVOLUTE SLIT - .6" ID - POLYETHYLENE
	041953-03-000	FT	CONDUIT - CONVOLUTE SLIT - 1" ID (CLOTHES ROD COVER)
	041953-05-000	FT	CONDUIT - CONVOLUTE SLIT - .62" ID - POLYETHYLENE
	041953-06-000	FT	CONDUIT - CONVOLUTE SLIT - .4" ID - POLYETHYLENE
	041953-07-000	FT	CONDUIT - CONVOLUTE SLIT - .25" ID - POLYETHYLENE
	041953-08-000	FT	CONDUIT - CONVOLUTE SLIT - 1.5" ID - POLYETHYLENE
	041953-09-000	FT	CONDUIT - CONVOLUTE SLIT - .5" ID - NYLON
	041953-10-000	FT	CONDUIT - CONVOLUTE SLIT - .75" ID - NYLON
	041953-11-000	FT	CONDUIT - CONVOLUTE SLIT - 1.06" ID - NYLON
	041953-12-000	FT	CONDUIT - CONVOLUTE SOLID - 1.1" ID - NYLON
	041953-13-000	FT	CONDUIT - CONVOLUTE SLIT - 1.25" ID
	041953-14-000	FT	CONDUIT - CONVOLUTE SLIT - 1.5" ID
	041953-15-000	FT	CONDUIT - CONVOLUTE SLIT - 2"
	041953-16-000	FT	CONDUIT - CONVOLUTE SLIT - 2"
	047441-01-000	EA	TERMINAL-BATTERY, HORIZONTAL LUG
	047443-01-000	EA	TERMINAL - .250 RECEPTACLE FIT - INSULATED - 16/14 AWG
	047443-02-000	EA	TERMINAL - .250 RECEPTACLE FIT - INSULATED - 12/10 AWG
	047443-05-000	EA	TERMINAL - .250 RECEPTACLE FIT - 18GA AWG
	058028-01-000	EA	CONNECTOR - ELECTRICAL PIGTAIL - NYLON - CLEAR
	062036-01-000	EA	TERMINAL - PACK - CON - 12/10 AWG
	076319-12-000	EA	CONNECTOR - COAXIAL - ONE PIECE
	077479-02-000	EA	BOOT - BATTERY TERMINAL - SINGLE CABLE
	080015-02-000	EA	RECEPTACLE - FLAG - .185 - 16/14 GAUGE
	080015-03-000	EA	RECEPTACLE - FLAG - .250 - 14/16 GAUGE
	080015-04-000	EA	RECEPTACLE - FLAG - .187 - 16/14 GAUGE
	082109-01-000	EA	HOUSING - CONNECTOR - PACKARD
	082741-01-000	EA	CONNECTOR BODY - 2 CONNECTOR MALE
	087225-01-000	FT	SLEEVING - 1/2" - TYPE H
	088473-01-000	EA	HOUSING - PIN - 12 CAVITY (3 ROWS OF 4)
	088473-02-000	EA	HOUSING - PIN - 15 CAVITY (3 ROWS OF 5)
	088473-03-000	EA	HOUSING - PIN - 9 CAVITY (3 ROWS OF 3)
	088473-04-000	EA	HOUSING - PIN - 8 CAVITY IN-LINE
	088473-06-000	EA	HOUSING - PIN - 6 CAVITY (2 ROWS OF 3)
	088473-07-000	EA	HOUSING - PIN - 5 CAVITY - IN-LINE
	088473-08-000	EA	HOUSING - PIN - 4 CAVITY - IN-LINE
	088473-09-000	EA	HOUSING - PIN - 3 CAVITY - IN-LINE
	088473-10-000	EA	HOUSING - PIN - 2 CAVITY - IN-LINE
	088473-12-000	EA	HOUSING - PIN - 3 CAVITY - BLUE
	088473-13-000	EA	HOUSING - PIN - 3 CAVITY - GREEN
	088473-14-000	EA	HOUSING - PIN - 3 CAVITY - RED
	088474-01-000	EA	HOUSING - SOCKET - 12 CAVITY
	088474-02-000	EA	HOUSING - SOCKET - 15 CAVITY
	088474-03-000	EA	HOUSING - SOCKET - 9 CAVITY
	088474-06-000	EA	HOUSING - SOCKET - 6 CAVITY
	088474-07-000	EA	HOUSING - SOCKET - 5 CAVITY
	088474-08-000	EA	HOUSING - SOCKET - 4 CAVITY
	088474-09-000	EA	HOUSING - SOCKET - 3 CAVITY

**ELECTRICAL GROUP (CONTINUED)**  
**CONNECTORS & CONDUIT (CONTINUED)**

KEY	PART NUMBER	U/M	DESCRIPTION
	088474-10-000	EA	HOUSING - SOCKET - 2 CAVITY
	088474-12-000	EA	HOUSING - SOCKET - 2 CAVITY - RED
	088475-01-000	EA	PIN - CONNECTOR - 14-20 AWG
	088475-02-000	EA	PIN - CONNECTOR - 10-12 AWG
	088476-01-000	EA	TERMINAL - ELECTRICAL
	088476-02-000	EA	SOCKET - CONNECTOR - 12-10 GA - PRE-TIN
	098261-01-000	EA	SOCKET - CONNECTOR - WEATHERPACK - 12 AWG
	098261-02-000	EA	SOCKET - CONNECTOR - WEATHERPACK - 14-18 AWG
	098262-01-000	EA	SEAL - CONNECTOR - WEATHERPACK
	098264-01-000	EA	HOUSING - 2 PIN - WEATHER PACK - MALE W/FEMALE PINS
	098264-02-000	EA	HOUSING - 2 PIN - WEATHER PACK - FEMALE W/MALE PINS
	098265-02-000	EA	PIN - CONNECTOR - WEATHER PACK
	102777-02-000	EA	TERMINAL - RING - #6 STUD - 10 AWG
	103608-01-000	EA	SOCKET - WEDGE BASE W/LEADS
	104100-01-000	EA	HOUSING - 1 POSITION - 75 AMPS
	104100-03-000	EA	TERMINAL - 75 AMP
	106007-02-000	EA	TERMINAL - FEMALE - 10-12 AWG
	110178-01-000	EA	HOUSING - WIPER MOTOR
	112823-01-000	EA	SPLICE - REDUCER - 16-14 TO 18-22
	113135-01-000	EA	TERMINAL - FEMALE - M/P - 14-16 - F/SEALED TERMINAL
	113308-01-000	EA	TERMINAL - FEMALE - M/P - 14-16 - 280
	113308-02-000	EA	TERMINAL - FEMALE - M/P - 14-18 - 280
	113468-01-000	EA	HOUSING - 2 POSITION-FEMALE-USED ON WIPER/WASHER WIRE ASM
	113468-02-000	EA	HOUSING - 2 POSITION - FEMALE
	116811-01-000	EA	TERMINAL - .110 RECEPTACLE - 16-14 AWG
	118571-01-000	EA	CONNECTOR - 3-WAY - MALE/SEALED
	118571-02-000	EA	CONNECTOR - 3-WAY - FEMALE/SEALED
	118571-05-000	EA	LOCK - SECONDARY - FEMALE
	118571-06-000	EA	LOCK - SECONDARY - MALE
	118599-02-000	EA	TERMINAL - MALE - M/P - 280/14-12
	118820-01-000	EA	INSULATOR - TERMINAL
	129233-01-000	EA	HOUSING - 2-POSITION/FEMALE - 280-SERIES
	129233-02-000	EA	HOUSING - 2-POSITION/FEMALE - 280-SERIES
	129233-03-000	EA	HOUSING - 2-POSITION/FEMALE - 280-SERIES
	131681-01-000	EA	CONNECTOR - 3/4" SO CORD - UL/CS
	137207-01-000	EA	HOUSING - PIN - 2 CAVITY/HIGH AMP
	137208-01-000	EA	HOUSING - SOCKET - 2 CAVITY/HIGH AMP
	137209-01-000	EA	PIN - CONNECTOR - 10AWG/HIGH AMP
	137210-01-000	EA	SOCKET - CONNECTOR - 10 AWG/HIGH AMP
	138996-04-000	EA	CONNECTOR - LAMP
	142520-01-000	EA	TERMINAL - FEMALE - MINI-FIT 16
	142522-01-000	EA	HOUSING - 4 PIN/MALE - MINI FIT
	142522-02-000	EA	HOUSING - 6 PIN/MALE - MINI FIT
	142522-03-000	EA	HOUSING - 8 PIN/MALE - MINI FIT
	142522-04-000	EA	HOUSING - 10 PIN/MALE - MINI FIT
	142522-05-000	EA	HOUSING - 12 PIN/MALE - MINI FIT
	142522-06-000	EA	HOUSING - 14 PIN/MALE - MINI FIT
	142524-01-000	EA	HOUSING - 4 PIN/FEMALE - WEATHER PACK
	142524-02-000	EA	HOUSING - 4 PIN/FEMALE - WEATHER PACK
	144283-01-000	EA	CONNECTOR - 110V - F/USE WITH SOW WIRE - BLUE
	144283-02-000	EA	CONNECTOR - 110V - F/USE WITH NM ROMEX WIRE - CLEAR
	145171-01-000	EA	CONNECTOR - COAXIAL
	148335-01-000	EA	HOUSING - 8-POSITION/MALE - 280-GT SERIES
	148335-02-000	EA	HOUSING - 4-POSITION/MALE - 280-GT SERIES
	148335-03-000	EA	HOUSING - 6-POSITION/MALE - 280-GT SERIES
	149683-01-000	EA	HOUSING - F/5 CAVITY RECEPTACLE - W/SQUARE GUIDE PIN
	149683-02-000	EA	HOUSING - F/5 CAVITY RECEPTACLE - W/ROUND GUIDE PIN
	149686-01-000	EA	TERMINAL - .250 RECEPTACLE
	149687-01-000	EA	HOUSING - 2 POSITION/MALE - PACKARD
	149687-02-000	EA	LOCK - F/2 POSITION HOUSING - PACKARD
	149688-01-000	EA	TERMINAL - MALE - 16 GAUGE WIRE
	156035-01-000	EA	HOUSING - 12-POSITION/FEMALE - 280-GT SERIES
	156041-01-000	EA	TERMINAL - FEMALE - 16-12 - 280-GT SERIES

**ELECTRICAL GROUP (CONTINUED)**  
**CONNECTORS & CONDUIT (CONTINUED)**

<b>KEY</b>	<b>PART NUMBER</b>	<b>U/M</b>	<b>DESCRIPTION</b>
	156043-01-000	EA	HOUSING - 2-POSITION/FEMALE - 480-MP SERIES
	156043-02-000	EA	LOCK - F/2 POSITION HOUSING - 480 SERIES
	156044-01-000	EA	TERMINAL - FEMALE - 16-12 - 280-GT - F/SEALED HOUSING
	156045-01-000	EA	HOUSING - 10-POSITION/FEMALE - 280-GT SERIES
	156045-02-000	EA	HOUSING - 4-POSITION/FEMALE - 280-GT SERIES
	156045-03-000	EA	HOUSING - 8-POSITION/FEMALE - 280-GT SERIES
	156045-04-000	EA	HOUSING - 6-POSITION/FEMALE - 280-GT SERIES
	156207-01-000	EA	HOUSING - 6-POSITION/MALE - 150-GT SERIES
	156208-01-000	EA	TERMINAL - MALE - 18-16 - 150-GT SERIES
	157590-01-000	EA	TERMINAL - FEMALE - M/P - 10-12 - 630
	157592-01-000	EA	HOUSING - 7-POSITION/FEMALE - M/P
	157592-02-000	EA	LOCK - SECONDARY - F/7 POSITION HOUSING
	157656-01-01A	EA	CONNECTOR - DASH LIGHT - BLACK
	158357-01-000	EA	HOUSING - 3 PIN/MALE - MINI FIT
	158373-01-000	EA	HOUSING - SOCKET - 16 CAVITY - MINI MATE-N-LOCK
	158374-01-000	EA	SOCKET - 16-20 CAVITY - MINI MATE-N-LOCK
	164687-01-000	EA	PIN - CONNECTOR - 16-14
	164685-01-000	EA	HOUSING - PIN - 7-POSITION
	164689-01-000	EA	SEAL - CONNECTOR
	168450-01-000	EA	CONNECTOR/ADAPTER - COAX

## ELECTRICAL GROUP (CONTINUED) CHASSIS

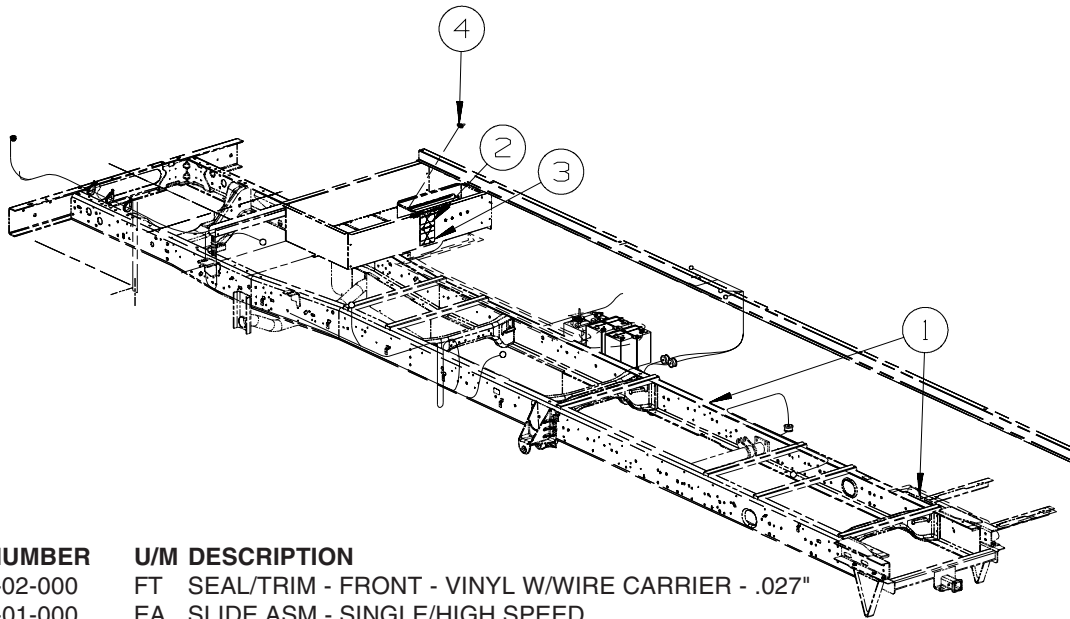

**FORD**

KEY	PART NUMBER	U/M	DESCRIPTION
1	113452-02-000	FT	SEAL/TRIM - FRONT - VINYL W/WIRE CARRIER - .027"
2	149828-01-000	EA	SLIDE ASM - SINGLE/HIGH SPEED
3	149825-01-000	EA	CONTROL MODULE - DIGISYNC/HIGH SPEED - F/C-BODY RAM
4	086233-01-000	EA	STUD - ISOLATED - 3/8" X 7/8" LONG

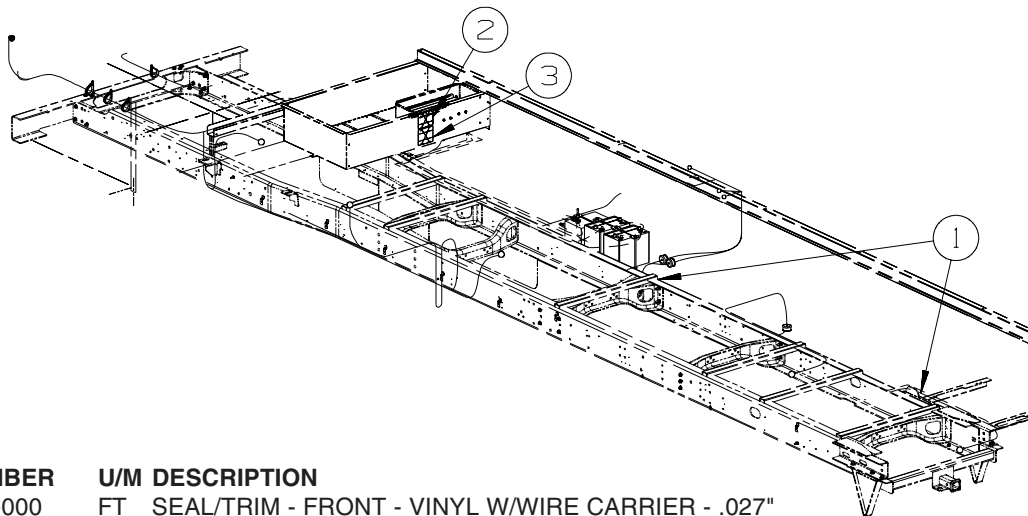

**WORKHORSE**

KEY	PART NUMBER	U/M	DESCRIPTION
1	113452-02-000	FT	SEAL/TRIM - FRONT - VINYL W/WIRE CARRIER - .027"
2	149828-01-000	EA	SLIDE ASM - SINGLE/HIGH SPEED
3	149825-01-000	EA	CONTROL MODULE - DIGISYNC/HIGH SPEED - F/C-BODY RAM



**ELECTRICAL GROUP (CONTINUED)**  
**CHASSIS (CONTINUED)**

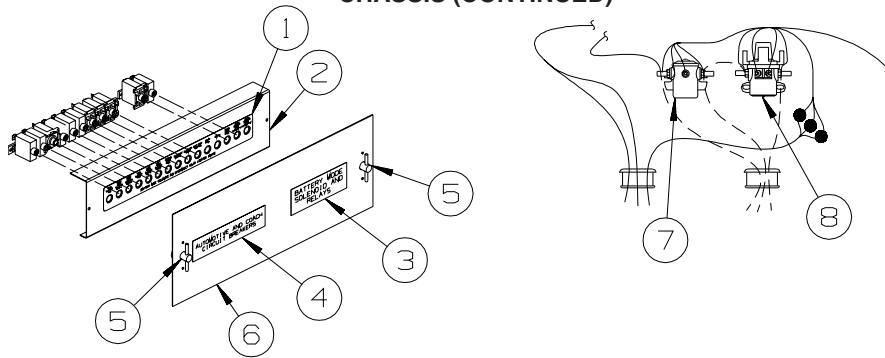

**ELECTRIC BOX**  
**FROM: 00-00-00**  
**THRU: 10-03-07**

KEY	PART NUMBER	U/M	DESCRIPTION
1	093236-53-000	EA	LABEL - CIRCUIT BREAKER
2	118531-07-02B	EA	PLATE - CIRCUIT BREAKER - E-COATED
3	098379-04-000	EA	LABEL - ELECTRICAL BOX - SIDE
4	098379-01-000	EA	LABEL - CIRCUIT BREAKER - FRONT BOX
5	098196-01-000	EA	LATCH - 1/4 TURN - T-BAR
6	109925-04-000	EA	DOOR - ELECTRICAL BOX - 6.9" X 18.5" - GM/FORD
	092492-11-000	EA	SEAL - ELECTRIC BOX - 7" X 18.4"
7	008188-01-000	EA	SOLENOID - 3 POST - BATTERY CHANGE OVER
8	086273-01-000	EA	RELAY - BATTERY DISCONNECT

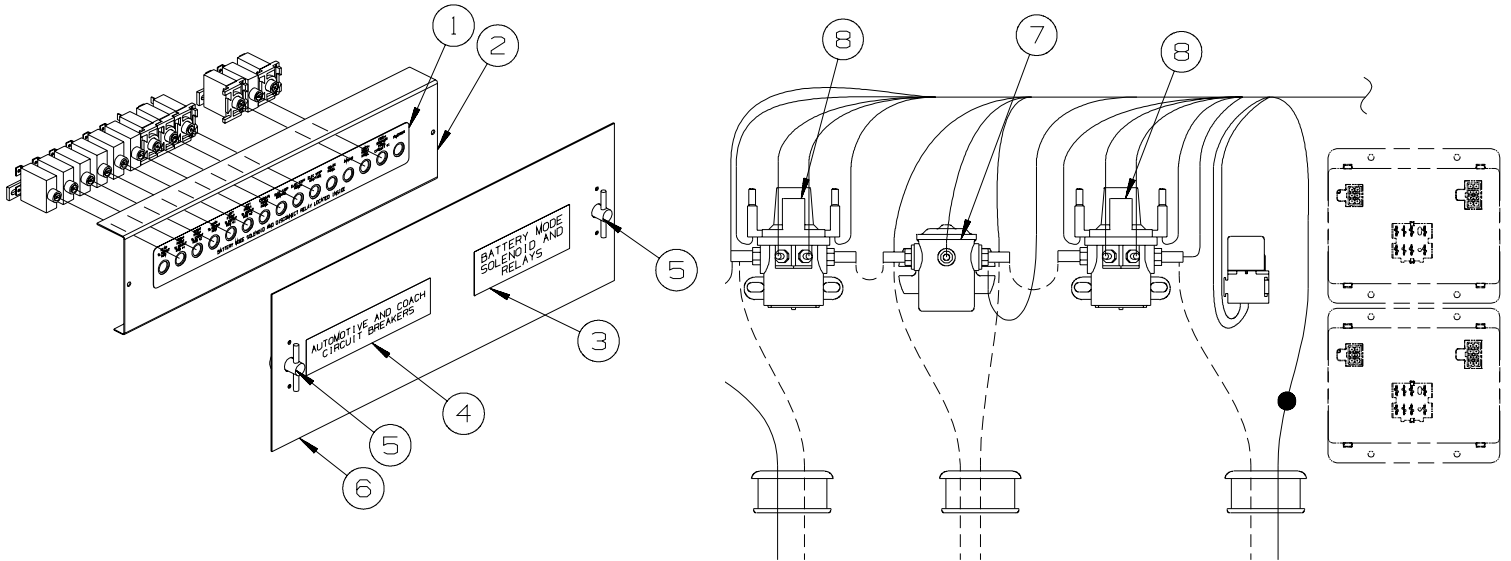

KEY	PART NUMBER	U/M	DESCRIPTION
1	093236-53-000	EA	LABEL - CIRCUIT BREAKER
2	118531-07-02B	EA	PLATE - CIRCUIT BREAKER - E-COATED
3	098379-04-000	EA	LABEL - ELECTRICAL BOX - SIDE
4	098379-01-000	EA	LABEL - CIRCUIT BREAKER - FRONT BOX
5	098196-01-000	EA	LATCH - 1/4 TURN - T-BAR
6	109925-04-000	EA	DOOR - ELECTRICAL BOX - E-COATED
			FROM: 00-00-00 THRU: 01-03-08
6	142145-01-02B	EA	DOOR - ELECTRICAL BOX - E-COATED
			FROM: 01-04-08 THRU: 99-99-99
	092492-11-000	EA	SEAL - ELECTRIC BOX - 7" X 18.4"
7	008188-01-000	EA	SOLENOID - 3 POST - BATTERY CHANGE OVER
8	086273-01-000	EA	RELAY - BATTERY DISCONNECT

**ELECTRIC BOX**  
**FROM: 10-04-07**  
**THRU: 99-99-99**

**ELECTRICAL GROUP (CONTINUED)**  
**CHASSIS (CONTINUED)**

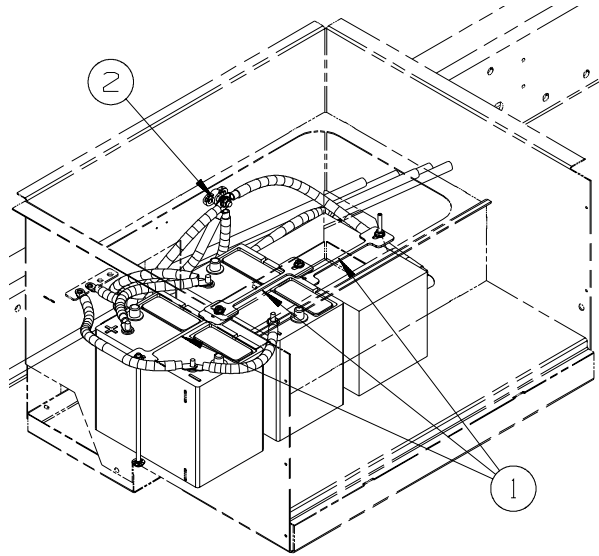

**BATTERY  
 INSTALLATION  
 FROM: 00-00-00  
 THRU: 10-03-07**

KEY	PART NUMBER	U/M DESCRIPTION
1	160014-01-02B	EA TIEDOWN - BATTERY - E-COATED
2	086233-01-000	EA STUD - ISOLATED - 3/8" X 7/8" LONG

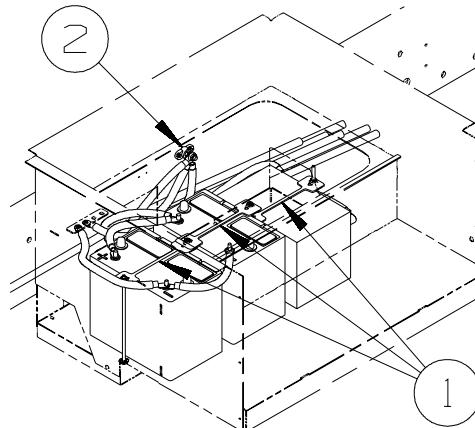

**BATTERY  
 INSTALLATION  
 FROM: 10-04-07  
 THRU: 99-99-99**

KEY	PART NUMBER	U/M DESCRIP
1	160014-01-02B	EA TIEDOWN - BATTERY - E-COATED
2	086233-01-000	EA STUD - ISOLATED - 3/8" X 7/8" LONG

# EXTERIOR BODY GROUP GRAPHICS & PAINT

# GRAPHICS

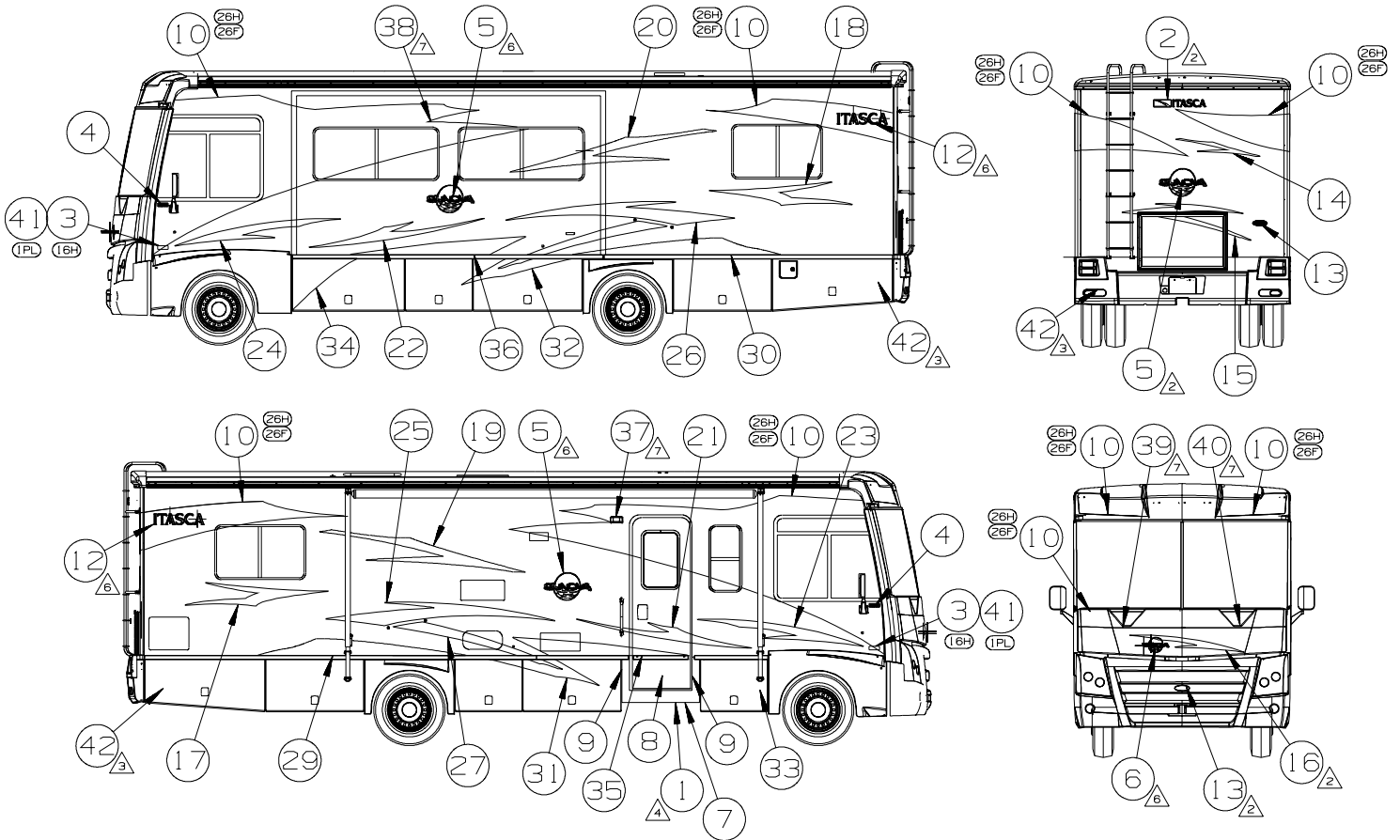

**(27G) KEY**

**PART NUMBER**

**U/M**

**DESCRIPTION**

(27G) KEY	PART NUMBER	U/M	DESCRIPTION
	109506-01-000	EA	FILM-URETHANE PROTECTANT
	124806-01-001-CHT(58A)	EA	DECAL-LOGO ITASCA W/ICON - DK CHERRY/BRT WHITE
(16H) (16M)	129922-001-CHT(O1A)	EA	DECAL-EMBLEM TRITON V-10 (3 VALVE) - CHASSIS SUPPLIED - BLACK/CHROME
	132664-001-CHT(O1A)	EA	DECAL-LOGO DOMED WINNEBAGO - CHROME/RED/BLACK
	135450-001-CHT(O1A)	EA	DECAL-LOGO SUNOVA VINYL LG - SLATE GRAY/SANDSTONE/GOLD/BLACK/BRT WHITE
	135450-004-CHT(O1A)	EA	DECAL-LOGO SUNOVA VINYL SML - SLATE GRAY/SANDSTONE/GOLD/BLACK/BRT WHITE
	138348-001-CHT(O2A)	EA	DECAL-DOOR TRIM - MED PARCHMENT
	138348-001-CHT(O2A)	EA	DECAL-DOOR TRIM - MED PARCHMENT
	139657-001-CHT(O2A)	EA	DECAL-DOOR TRIM - MED PARCHMENT
	141599-031-000	EA	PAINT-METALLIC GOLD DUPONT #373-P7436
(26F)	141599-037-000	EA	PAINT-IRON CLEAR 55 GAL - DUPONT #34405
	144587-002-CHT(33A)	EA	DECAL-LOGO ITASCA DK CHERRY/BRT WHITE
	151687-001-CHT(O1A)	EA	DECAL-LOGO DOMED NAMEPLATE ITASCA - CHROME/WHITE/BLACK/TEAL
	160657-001-CHT(O1A)	EA	DECAL-CHECKMARK REAR - SUNSET
	160658-001-CHT(O1A)	EA	DECAL-SLASH REAR - DK CHERRY
	160659-001-CHT(O1A)	EA	DECAL-CHECKMARK HOOD - SUNSET
	160660-001-CHT(O1A)	EA	DECAL-CHECKMARK #1 RH - NUTMEG
	160660-001-CHT(O1A)	EA	DECAL-CHECKMARK #1 LH - NUTMEG
	160661-001-CHT(O1A)	EA	DECAL-CHECKMARK #2 RH - SUNSET
	160661-001-CHT(O1A)	EA	DECAL-CHECKMARK #2 LH - SUNSET
	160662-001-CHT(O1A)	EA	DECAL-CHECKMARK #3 RH - NUTMEG
	160662-001-CHT(O1A)	EA	DECAL-CHECKMARK #3 LH - NUTMEG
	160663-001-CHT(O1A)	EA	DECAL-CHECKMARK #4 RH - DK CHERRY
	160663-001-CHT(O1A)	EA	DECAL-CHECKMARK #4 LH - DK CHERRY
	160664-001-CHT(O1A)	EA	DECAL-SLASH #1 RH - DK CHERRY
	160664-001-CHT(O1A)	EA	DECAL-SLASH #1 LH - DK CHERRY
	160665-001-CHT(O1A)	EA	DECAL-SLASH #2 RH - DK CHERRY
	160665-001-CHT(O1A)	EA	DECAL-SLASH #2 LH - DK CHERRY
	160666-001-CHT(O1A)	EA	DECAL-PAINT LINE #1 LH - MED PARCHMENT
	160667-001-CHT(O1A)	EA	DECAL-PAINT LINE #2 RH - BRT WHITE/DK CHERRY
	160668-001-CHT(O1A)	EA	DECAL-PAINT LINE #3 LH - BRT WHITE/DK CHERRY
	160668-001-CHT(O1A)	EA	DECAL-PAINT LINE #3 RH - BRT WHITE
	160669-001-CHT(O1A)	EA	DECAL-PAINT LINE #4 LH - MED PARCHMENT
	160669-001-CHT(O1A)	EA	DECAL-PAINT LINE #4 RH - MED PARCHMENT
	160670-001-CHT(O1A)	EA	DECAL-PAINT MASK MID UPPER RH - VINYL WHITE
	160670-001-CHT(O1A)	EA	DECAL-PAINT MASK MID UPPER LH - VINYL WHITE
	160671-001-CHT(O1A)	EA	DECAL-PAINT MASK HOOD UPPER RH - VINYL WHITE
	160671-001-CHT(O1A)	EA	DECAL-PAINT MASK HOOD UPPER LH - VINYL WHITE
	160672-001-CHT(O1A)	EA	DECAL-EMBLEM - CHASSIS SUPPLIED
	160673-001-CHT(O1A)	EA	COLOR PLASTIC AND STEEL - MED PARCHMENT
	165266-01-CHT(O1A)	EA	PAINT MASK-REFRIG VENT - YELLOW VINYL

- ▲ USE PAINT MASK ON REFRIGERATOR VENT ON STANDARD GRAPHICS WHEN PAINT IS APPLIED TO VENT.
- ▲ PAINT MASK TO BE REMOVED AFTER PAINT.
- ▲ LOGO IS TO BE HELD TO ±1 MM ON A HORIZONTAL PLANE (END TO END).
- ▲ CLEAR COAT TO BE APPLIED ON PAINTED AREAS TO PROTECT PAINT.
- ▲ FILM TO PROTECT BOTTOM OF DOOR FROM SCUFF MARKS.
- ▲ PARTS BELOW FEATURE LINE WILL BE COLORED PRIOR TO ASSEMBLY.
- ▲ CENTER ON UNIT.
- 1. APPLY PROTECTOR 116424-01 TO WATER HEATER LATCH.

- (1PG) WORKHORSE 21,200# GVWR
- (1PL) WORKHORSE 18,000# GVWR (W18)
- (1PJ) WORKHORSE 16,000# GVWR (W16)
- (16M) FORD CHASSIS 20,500#/V10 ENG
- (16H) FORD CHASSIS 18,000#/V10 ENG
- (26H) EXT GRAPHIC/PAINT-DLX PKG 2
- (26F) EXT GRAPHIC/PAINT DLX PKG 1
- (92K) EXTERIOR GRAPHICS PACKAGE #2
- (27G) EXTERIOR GRAPHICS PACKAGE #1

NOTES:

**EXTERIOR BODY GROUP (CONTINUED)**  
**GRAPHICS & PAINT (CONTINUED)**

**GRAPHICS**

KEY	PART NUMBER	U/M	DESCRIPTION
	1 109506-01-000	EA	FILM-URETHANE PROTECTANT
	2 124806-01-CHT(33A)	EA	DECAL-LOGO ITASCA W/ICON - DP BLUE STAR/BRT WHITE
(16M) (16H)	3 129922-02-CHT(01A)	EA	DECAL-EMBLEM TRITON V-10 (3 VALVE) - CHASSIS SUPPLIED - BLACK/CHROME
	4 132664-02-CHT(01A)	EA	DECAL-LOGO DOMED WINNEBAGO - CHROME/RED/BLACK
	5 135452-03-CHT(01A)	EA	DECAL-LOGO SUNOVA VINYL LG - SLATE GRAY/SANDSTONE/GOLD/BLACK/BRT WHITE
	6 135452-04-CHT(01A)	EA	DECAL-LOGO SUNOVA VINYL SML - SLATE GRAY/SANDSTONE/GOLD/BLACK/BRT WHITE
	7 138348-01-CHT(02A)	EA	DECAL-DOOR TRIM - MED PARCHMENT
	8 138349-01-CHT(02A)	EA	DECAL-DOOR - MED PARCHMENT
	9 139657-01-CHT(02A)	EA	DECAL-DOOR TRIM - MED PARCHMENT
△ 5 →	10 (26H) 141599-48-000	GL	PAINT-CATALINA BLUE MET - DUPONT #373-P758414
	11 141599-27-000	GL	PAINT-IMRON CLEAR 55 GAL - DUPONT #34405
	12 144587-02-CHT(04A)	EA	DECAL-LOGO ITASCA - DP BLUE STAR/BRT WHITE
	13 151687-02-CHT(01A)	EA	DECAL-LOGO DOMED NAMEPLATE ITASCA - CHROME/WHITE/BLACK/TEAL
	14 160657-01-CHT(02A)	EA	DECAL-CHECKMARK REAR - DP BLUE STAR
	15 160658-01-CHT(02A)	EA	DECAL-SLASH REAR - BLUE
	16 160659-01-CHT(02A)	EA	DECAL-CHECKMARK HOOD - BLUE
	17 160660-01-CHT(02A)	EA	DECAL-CHECKMARK #1 RH - FLINTSTONE
	18 160660-02-CHT(02A)	EA	DECAL-CHECKMARK #1 LH - FLINTSTONE
	19 160661-01-CHT(02A)	EA	DECAL-CHECKMARK #2 RH - DP BLUE STAR
	20 160661-02-CHT(02A)	EA	DECAL-CHECKMARK #2 LH - DP BLUE STAR
	21 160662-01-CHT(02A)	EA	DECAL-CHECKMARK #3 RH - FLINTSTONE
	22 160662-02-CHT(02A)	EA	DECAL-CHECKMARK #3 LH - FLINTSTONE
	23 160663-01-CHT(02A)	EA	DECAL-CHECKMARK #4 RH - BLUE
	24 160663-02-CHT(02A)	EA	DECAL-CHECKMARK #4 LH - BLUE
	25 160664-01-CHT(02A)	EA	DECAL-SLASH #1 RH - BLUE
	26 160664-02-CHT(02A)	EA	DECAL-SLASH #1 LH - BLUE
	27 160665-01-CHT(02A)	EA	DECAL-SLASH #2 RH - BLUE
	28 160665-02-CHT(02A)	EA	DECAL-SLASH #2 LH - BLUE
	29 160666-01-CHT(01A)	EA	DECAL-PAINT LINE #1 RH - MED PARCHMENT
	30 160666-02-CHT(01A)	EA	DECAL-PAINT LINE #1 LH - MED PARCHMENT
	31 160667-01-CHT(02A)	EA	DECAL-PAINT LINE #2 RH - BRT WHITE/BLUE
	32 160667-02-CHT(02A)	EA	DECAL-PAINT LINE #2 LH - BRT WHITE/BLUE
	33 160668-01-CHT(01A)	EA	DECAL-PAINT LINE #3 RH - BRT WHITE
	34 160668-02-CHT(01A)	EA	DECAL-PAINT LINE #3 LH - BRT WHITE
	35 160669-01-CHT(01A)	EA	DECAL-PAINT LINE #4 RH - MED PARCHMENT
	36 160669-02-CHT(01A)	EA	DECAL-PAINT LINE #4 LH - MED PARCHMENT
	37 160670-01-CHT(01A)	EA	DECAL-PAINT MASK MID UPPER RH - VINYL WHITE
	38 160670-02-CHT(01A)	EA	DECAL-PAINT MASK MID UPPER LH - VINYL WHITE
	39 160671-01-CHT(01A)	EA	DECAL-PAINT MASK HOOD UPPER RH - VINYL WHITE
	40 160671-02-CHT(01A)	EA	DECAL-PAINT MASK HOOD UPPER LH - VINYL WHITE
	41 -----	EA	DECAL-EMBLEM - CHASSIS SUPPLIED
△ 3 → (1PJ) (1PN)	42 -----	GL	COLORED PLASTIC AND STEEL - MED PARCHMENT
	43 ← △ (1PL)	EA	PAINT MASK-REFRIG VENT - YELLOW VINYL

# EXTERIOR BODY GROUP (CONTINUED) GRAPHICS & PAINT (CONTINUED)

# FULL BODY PAINT

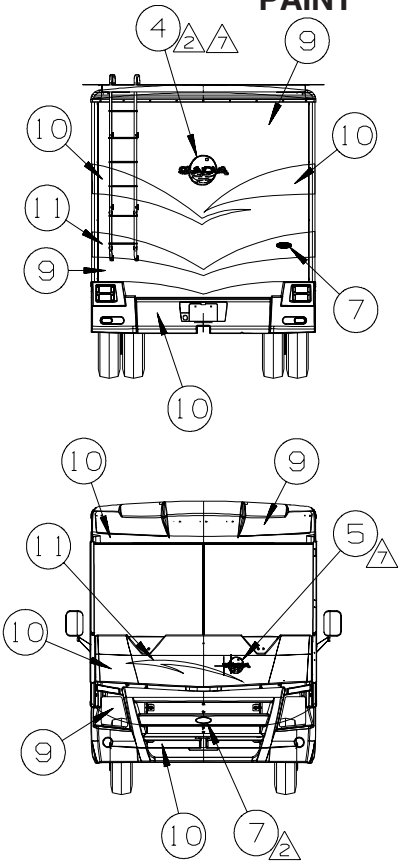
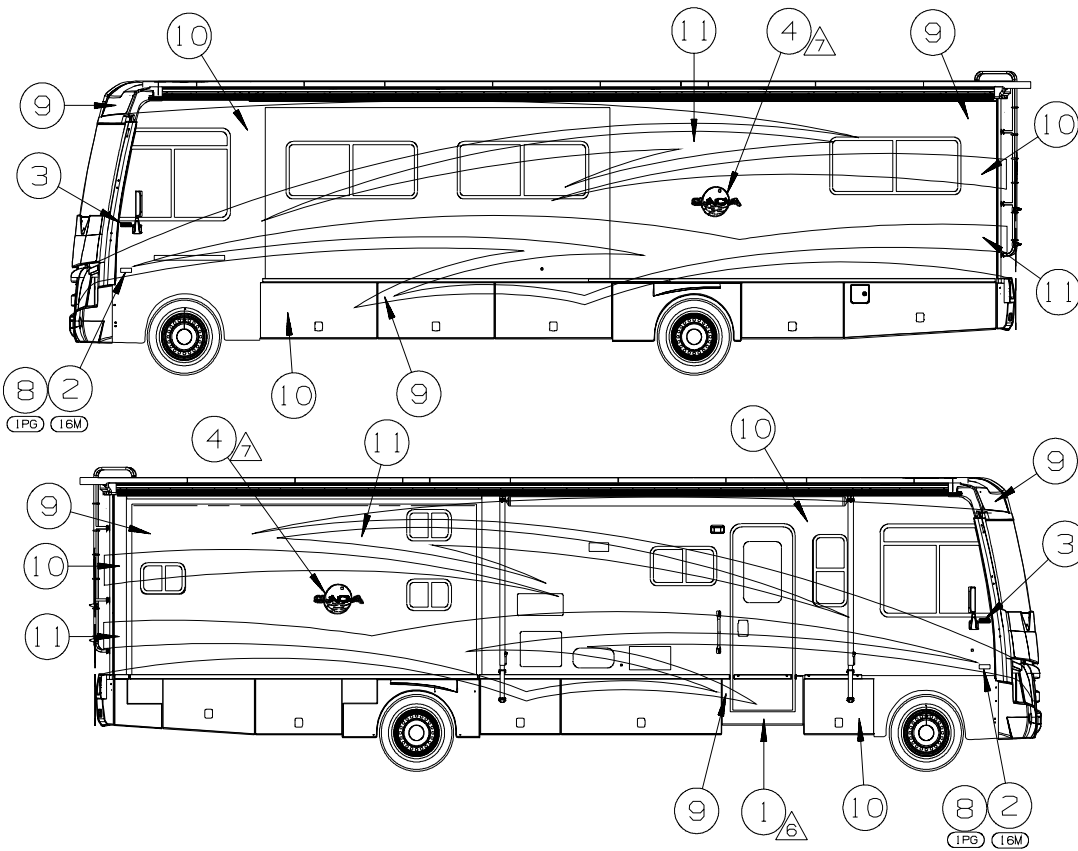

**(27A) KEY**

KEY	PART NUMBER	U/M
1	109506-01-000	EA
(16H) 2 (16M)	129922-02-CHT(01A)	EA
3	132664-02-CHT(01A)	EA
4	135452-05-CHT(01A)	EA
5	135452-06-CHT(01A)	EA
6	141599-27-000	GL
7	151687-02-CHT(01A)	EA
(1PJ) (1PN) 8 (1PL)	.....	EA
9	.....	GL
10	.....	GL
11	.....	GL
(A) 12 (24P)	167522-01-000	EA

**DESCRIPTION SAND**

FILM-URETHANE PROTECTANT  
 DECAL-EMBLEM TRITON V-10 (3 VALVE) - CHASSIS SUPPLIED - BLACK/CHROME  
 DECAL-LOGO DOMED WINNEBAGO - CHROME/RED/BLACK  
 DECAL-LOGO SUNOVA VINYL LG - SANDSTONE/SLATE GRAY/GOLD/BLACK/BRT WHITE  
 DECAL-LOGO SUNOVA VINYL SML - SANDSTONE/SLATE GRAY/GOLD/BLACK/BRT WHITE  
 PAINT-IMRON CLEAR 55 GAL - DUPONT #3440S  
 DECAL-LOGO DOMED NAMEPLATE ITASCA - CHROME/WHITE/BLACK/TEAL  
 DECAL-EMBLEM - CHASSIS SUPPLIED  
 PAINT-PLUMICE MET - SW #48438-6  
 PAINT-DARK BEIGE MET - SW #57776-2  
 PAINT-EXPRESSO BROWN MET - SW #64167  
 KIT-PAINT PROTECTION

**(92A) KEY**

KEY	PART NUMBER	U/M
1	109506-01-000	EA
(16H) 2 (16M)	129922-02-CHT(01A)	EA
3	132664-02-CHT(01A)	EA
4	135452-05-CHT(01A)	EA
5	135452-06-CHT(01A)	EA
6	141599-27-000	GL
7	151687-02-CHT(01A)	EA
(1PJ) (1PN) 8 (1PL)	.....	EA
9	.....	GL
10	.....	GL
11	.....	GL
(A) 12 (24P)	167522-01-000	EA

**DESCRIPTION CLOUD**

FILM-URETHANE PROTECTANT  
 DECAL-EMBLEM TRITON V-10 (3 VALVE) - CHASSIS SUPPLIED - BLACK/CHROME  
 DECAL-LOGO DOMED WINNEBAGO - CHROME/RED/BLACK  
 DECAL-LOGO SUNOVA VINYL LG - SANDSTONE/SLATE GRAY/GOLD/BLACK/BRT WHITE  
 DECAL-LOGO SUNOVA VINYL SML - SANDSTONE/SLATE GRAY/GOLD/BLACK/BRT WHITE  
 PAINT-IMRON CLEAR 55 GAL - DUPONT #3440S  
 DECAL-LOGO DOMED NAMEPLATE ITASCA - CHROME/WHITE/BLACK/TEAL  
 DECAL-EMBLEM - CHASSIS SUPPLIED  
 PAINT-COOL BEIGE MET - SW #62261  
 PAINT-ANTIQUE SAGE MET - SW #50655  
 PAINT-DARK GRAY MET - SW #64255  
 KIT-PAINT PROTECTION

**(24C) KEY**

KEY	PART NUMBER	U/M
1	109506-01-000	EA
(16H) 2 (16M)	129922-02-CHT(01A)	EA
3	132664-02-CHT(01A)	EA
4	135452-05-CHT(01A)	EA
5	135452-06-CHT(01A)	EA
6	141599-27-000	GL
7	151687-02-CHT(01A)	EA
(1PJ) (1PN) 8 (1PL)	.....	EA
9	.....	GL
10	.....	GL
11	.....	GL
(A) 12 (24P)	167522-01-000	EA

**DESCRIPTION IRON RANGE**

FILM-URETHANE PROTECTANT  
 DECAL-EMBLEM TRITON V-10 (3 VALVE) - CHASSIS SUPPLIED - BLACK/CHROME  
 DECAL-LOGO DOMED WINNEBAGO - CHROME/RED/BLACK  
 DECAL-LOGO SUNOVA VINYL LG - SANDSTONE/SLATE GRAY/GOLD/BLACK/BRT WHITE  
 DECAL-LOGO SUNOVA VINYL SML - SANDSTONE/SLATE GRAY/GOLD/BLACK/BRT WHITE  
 PAINT-IMRON CLEAR 55 GAL - DUPONT #3440S  
 DECAL-LOGO DOMED NAMEPLATE ITASCA - CHROME/WHITE/BLACK/TEAL  
 DECAL-EMBLEM - CHASSIS SUPPLIED  
 PAINT-IRON GRAY MET - SW #61766  
 PAINT-LT AUTUMWOOD MET - SW #49507  
 PAINT-SEDONA MET - SW #63814  
 KIT-PAINT PROTECTION

- (A) LOGO IS TO BE : MM ON A HORIZONTAL PLANE (END TO END).
- (B) FILM TO PROTECT BOTTOM OF DOOR FROM SCUFF MARKS.
- (C) DIE CUT ACRYLIC FILM,USED TO PROTECT FULL BODY PAINTED UNITS.
- 4. ON FULL BODY PAINTED UNITS USE 145487-02-000 (100 FT) TO COVER UNSEALED ROOF SEAMS.
- (A) CLEAR COAT TO BE APPLIED ON ENTIRE UNIT TO PROTECT PAINT.
- (A) CENTER ON UNIT.
- 1. APPLY PROTECTOR 116424-01-000 TO WATER HEATER DOOR LATCH.

- 9. APPLY SEALER BODY SEAM CLEAR 94401-04-000 TO HELP SECURE PAINT ON EDGES.
- 8. END PANELS OF SLIDEOUT ROOMS WILL BE PAINTED WITH BASE COAT AND CLEAR COAT ONLY. THERE WILL BE NO COLORED DESIGN GRAPHICS ELEMENTS PAINTED ON THE END PANELS.

- (24D) MASK FRONT EXT PROTECTIVE
- (17) BORNHORSE 21,2004 GVWR
- (16) BORNHORSE 18,0004 GVWR (181)
- (15) BORNHORSE 16,0004 GVWR (181)
- (14) BORNHORSE 16,0004 GVWR (181)
- (13) BORNHORSE 16,0004 GVWR (181)
- (12) BORNHORSE 16,0004 GVWR (181)
- (11) BORNHORSE 16,0004 GVWR (181)
- (10) BORNHORSE 16,0004 GVWR (181)
- (9) BORNHORSE 16,0004 GVWR (181)
- (8) BORNHORSE 16,0004 GVWR (181)
- (7) BORNHORSE 16,0004 GVWR (181)
- (6) BORNHORSE 16,0004 GVWR (181)
- (5) BORNHORSE 16,0004 GVWR (181)
- (4) BORNHORSE 16,0004 GVWR (181)
- (3) BORNHORSE 16,0004 GVWR (181)
- (2) BORNHORSE 16,0004 GVWR (181)
- (1) BORNHORSE 16,0004 GVWR (181)

KEY	PART NUMBER	U/M	DESCRIPTION
	093681-39-01A	FT	FILM - 3.1" - FLAT BLACK - SLIDEOUT ROOMS
	093681-40-01A	FT	FILM - 2" - FLAT BLACK - DRIVERS DOOR
	072882-01-000	EA	PAINT - 16 OUNCE SPRAY - OFF WHITE

**DUPONT COLOR CODES ARE NOW FOUND IN THE PAINT CODE MANUAL.  
YOU CAN FIND THIS MANUAL ON YOUR DEALER INDEX WEBPAGE UNDER SERVICE.**

# EXTERIOR BODY GROUP (CONTINUED)

## PANELS & TRIMS

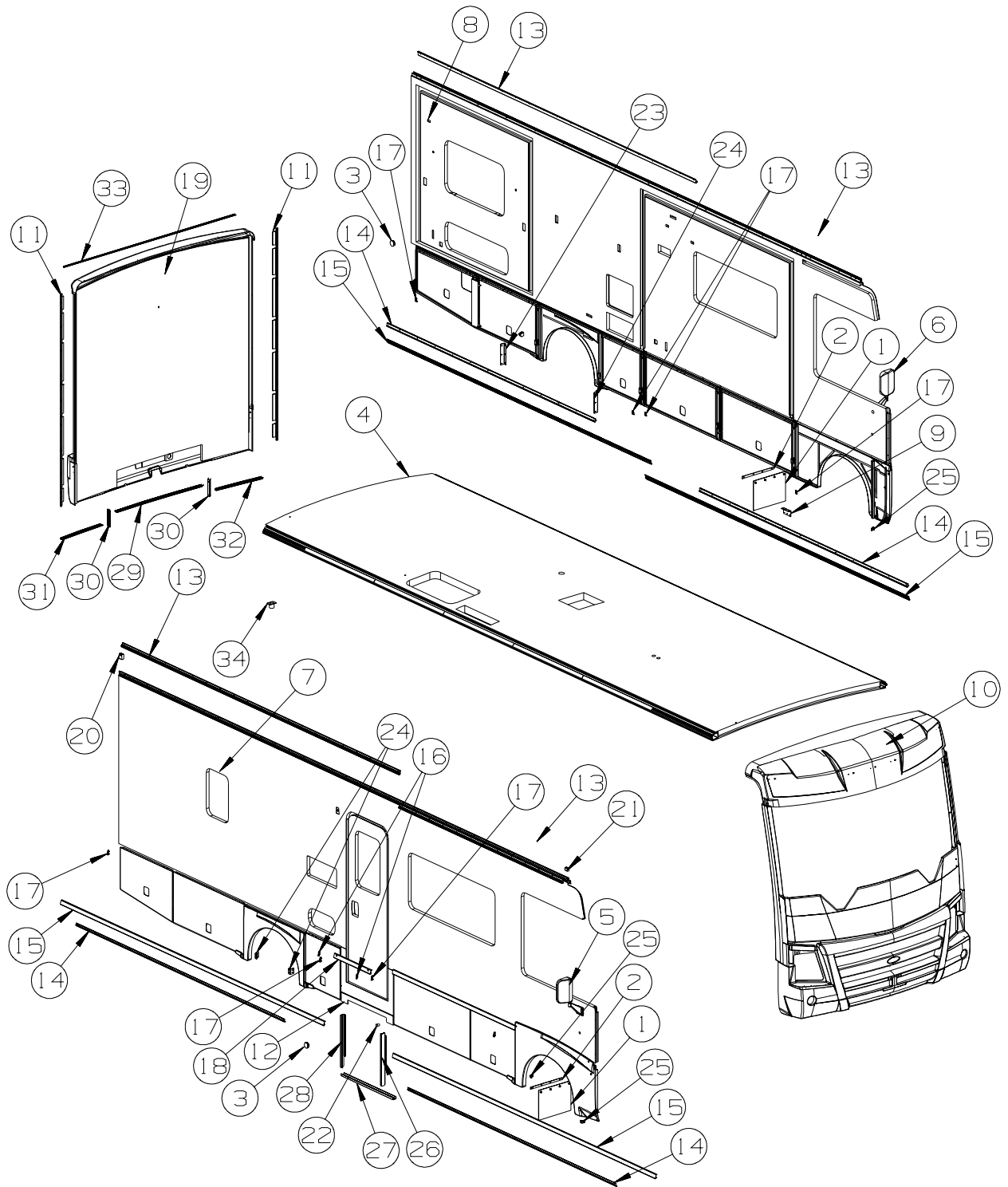

KEY	PART NUMBER	U/M DESCRIPTION
1	017516-01-000	EA MUD FLAP - 14"H X 18"W - W/O MOUNTING HOLES - RUBBER - BLK
2	140922-01-02B	EA RETAINER - MUD FLAP - 1" X 17.7" - E-COATED/BLACK
3	153498-01-01A	EA BUMPER - RUBBER - BLACK
4	162340-01-W51	EA ROOF - W/O LIGHTS/VENTS - W/WIRING
5*	106015-14-01A	EA MIRROR - EXTERIOR ADJUSTABLE GLASS - PASSENGER
5*	106015-12-01A	EA MIRROR - EXTERIOR REMOTE/HEAT - PASSENGER - MIRRORS-EXTERIOR W/DEFROST
6*	106015-15-01A	EA MIRROR - EXTERIOR ADJUSTABLE GLASS - DRIVER
6*	106015-13-01A	EA MIRROR - EXTERIOR REMOTE/HEAT - DRIVER - MIRRORS-EXTERIOR W/DEFROST
7	162339-01-W51	EA SIDEWALL - PASSENGER - W/O WINDOWS/TRIMS (W57, W58)
7	162339-01-W59	EA SIDEWALL - PASSENGER - W/O WINDOWS/TRIMS (W59, W60, W61, W62)
7	162339-02-W51	EA SIDEWALL - PASSENGER - W/O WINDOWS/TRIMS (W57, W58) - PREMIUM HIGH GLOSS SIDEWALL
7	162339-02-W59	EA SIDEWALL - PASS - W/O WINDOWS/TRIM (W59, W60, W61, W62) - PREMIUM HIGH GLOSS SIDEWALL

**EXTERIOR BODY GROUP (CONTINUED)**  
**PANELS & TRIMS (CONTINUED)**

KEY	PART NUMBER	U/M	DESCRIPTION
8	162338-01-W51	EA	SIDEWALL - DRIVER - W/O WINDOWS/TRIMS (W57, W58)
8	162338-01-W59	EA	SIDEWALL - DRIVER - W/O WINDOWS/TRIMS (W59, W60, W61, W62)
8	162338-02-W51	EA	SIDEWALL - DRIVER - W/O WINDOWS/TRIMS (W57, W58) - PREMIUM HIGH GLOSS SIDEWALL
8	162338-02-W59	EA	SIDEWALL - DRVR - W/O WINDOWS/TRIMS (W59, W60, W61, W62) - PREMIUM HIGH GLOSS SIDEWALL
8	162339-2A-W51	EA	SIDEWALL - PASSENGER - W/O WINDOWS/TRIMS (W57, W58) - FULL BODY PAINT
8	162339-2A-W55	EA	SIDEWALL - PASSENGER - W/O WINDOWS/TRIMS (W59, W60, W61, W62) - FULL BODY PAINT
9	113904-23-02B	EA	ANGLE - ATTACHMENT/WHEEL LIP - E-COATED
10	157016-02-W51	EA	CAP - ROOF/FRONT - W/O LIGHTS/WIRING
11	135270-02-02B	EA	BRACKET/Z - BACKWALL MOUNT - E-COAT
12	138021-05-18B	EA	VALANCE/PANEL - ENTRY STEP/U-SHAPED - 35.9" X 4.3" - PARCHMENT FROM: 00-00-00 THRU: 12-30-07
12	138021-05-02B	EA	VALANCE/PANEL - ENTRY STEP/U-SHAPED - 35.9" X 4.3" - E-COATED FROM: 00-00-00 THRU: 12-30-07
12	167953-01-02B	EA	PANEL/TRIM - ENTRY STEP/U-SHAPED - 35.9"X 4.3" - E-COATED FROM: 12-31-07 THRU: 99-99-99
13	157284-01-01A	EA	RAIL - AWNING - 192" - BRIGHT WHITE
14	146548-01-01A	EA	TRIM - RETAINER - 143.8" - MILL
15	146550-01-03A	EA	TRIM COVER - SIDEWALL - 182" - BRIGHT WHITE
15	146550-01-02A	EA	TRIM COVER - SIDEWALL - 182" - BLACK
16	146576-01-01A	EA	END CAP/TRIM - RIGHT HAND - BRIGHT WHITE
16	146576-01-02A	EA	END CAP/TRIM - RIGHT HAND - BLACK
17	146576-02-01A	EA	END CAP/TRIM - LEFT HAND - BRIGHT WHITE
17	146576-02-02A	EA	END CAP/TRIM - LEFT HAND - BLACK
18	149822-01-01A	EA	TRIM - SIDEWALL/ENTRY DOOR - 25.3" - BRIGHT WHITE
18	149822-01-01A	EA	TRIM - SIDEWALL/ENTRY DOOR - 25.3" - BLACK
19	P62342-01-W51	EA	BACKWALL - W/O WINDOW/TRIMS (W57, W58)
19	P62342-01-W59	EA	BACKWALL - W/O WINDOW/TRIMS (W59, W60, W61, W62)
19	P62342-02-W51	EA	BACKWALL - W/O WINDOW/TRIMS (W57, W58) - PREMIUM HIGH GLOSS SIDEWALL
19	P62342-02-W59	EA	BACKWALL - W/O WINDOW/TRIMS (W59, W60, W61, W62) - PREMIUM HIGH GLOSS SIDEWALL
20	156094-01-000	EA	FOAM - PLUG - SIDEWALL TUBE
21	156094-02-000	EA	FOAM - PLUG - SIDEWALL TUBE
22	120863-02-000	EA	BUMPER - RUBBER/RADIUS TOP - 1" X 1 1/2"
23	113904-18-02B	EA	ANGLE - ATTACHMENT/WHEEL LIP - E-COATED
24	113904-19-02B	EA	ANGLE - ATTACHMENT/WHEEL LIP - E-COATED
25	123512-06-02B	EA	BRACKET - DOOR/VALANCE - E-COATED
26	133100-01-02A	EA	TRIM - SIDEWALL - 24.5" - BRIGHT WHITE
26	133100-01-04A	EA	TRIM - SIDEWALL - 24.5" - PARCHMENT
26	133100-01-01A	EA	TRIM - SIDEWALL - 24.5" - BLACK
27	137599-05-04A	EA	TRIM - SIDEWALL/LOWER - 35.9" - PARCHMENT
27	137599-05-02A	EA	TRIM - SIDEWALL/LOWER - 35.9" - BLACK
28	133100-02-04A	EA	TRIM - SIDEWALL - 24.5" - PARCHMENT
28	133100-02-01A	EA	TRIM - SIDEWALL - 24.5" - BLACK
29	158141-01-01A	EA	TRIM - BACKWALL/LOWER - 49.3"
30	158141-02-01A	EA	TRIM - BACKWALL/LOWER - 8.6"
31	158141-03-01A	EA	TRIM - BACKWALL/LOWER - 24.6"
32	158141-04-01A	EA	TRIM - BACKWALL/LOWER - 24.6"
33	114248-02-04A	EA	ANGLE - PLASTIC - .7" X .4" X 96.7" - BEIGE
34	092776-01-000	EA	ADAPTER - DUCT - 2"

**\*COMPONENT PARTS LISTED LATER IN THIS GROUP**

## EXTERIOR BODY GROUP (CONTINUED) PANELS & TRIMS (CONTINUED)

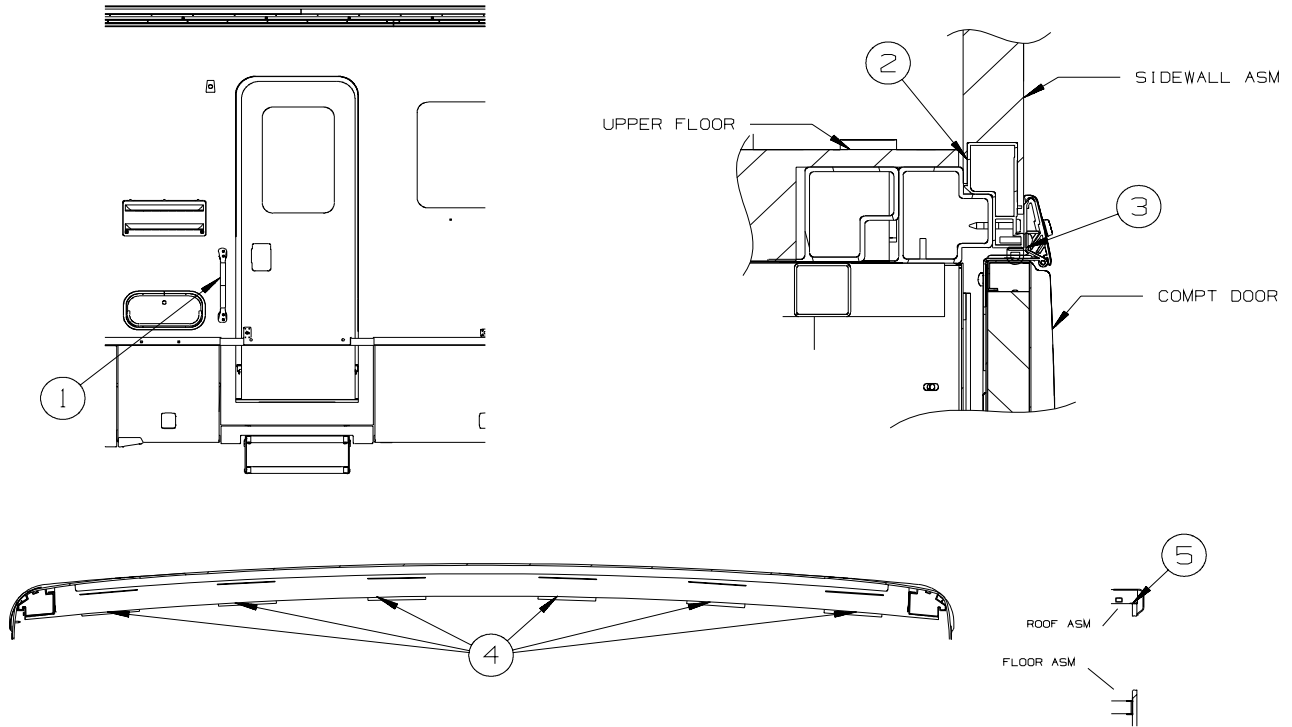

KEY	PART NUMBER	U/M	DESCRIPTION
1	152854-01-01A	EA	HANDLE - ASSIST - WHITE W/BLACK RUBBER GRIP - 18 5/8"
1	165309-01-01A	EA	ASSIST HANDLE - 18" - NON-LIGHTED - SST
2	104692-01-000	EA	SEAL - ADHESIVE BACKED FOAM - 3/4" THICK X 3/4" WIDE X 25'
3	099418-01-000	FT	SEAL - D-SECTION/ADHESIVE BACK - .44" X .44" - BLK RUBBER
4	140999-02-02B	EA	BRACKET - CAP ATTACHMENT - E-COATED
5	137023-01-03B	EA	PLATE - JOINT - BACKWALL/ROOF - E-COATED



**EXTERIOR BODY GROUP (CONTINUED)**  
**PANELS & TRIMS (CONTINUED)**

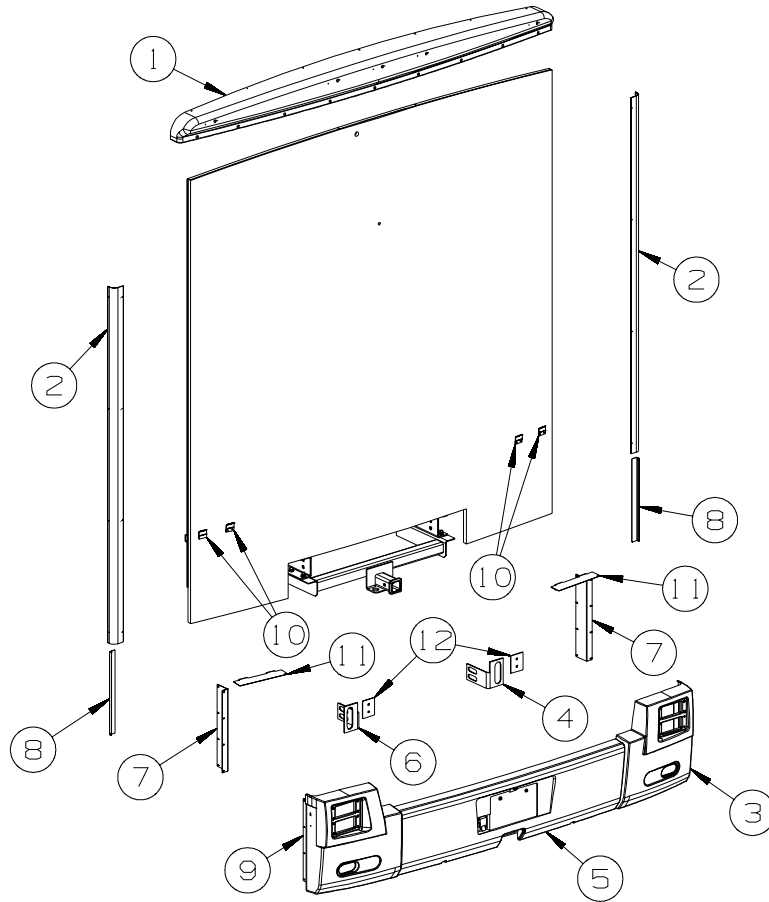

KEY	PART NUMBER	U/M	DESCRIPTION
1	137582-02-N21	EA	CAP - REAR/ROOF - W/O LIGHTS/VENTS - W/WIRING - BRIGHT WHITE
1	137582-02-AA1	EA	CAP - REAR/ROOF - W/O LIGHTS/VENTS/WIRING - PRIMED
2	139969-01-02A	EA	COVE - BACKWALL - BRIGHT WHITE
2	139969-01-03A	EA	COVE - BACKWALL - BLACK
3	157713-03-U57	EA	TRIM/POD - BACKWALL/TAILLIGHT - LOWER/PASSENGER - PARCHMENT
3	157713-03-AA1	EA	TRIM/POD - BACKWALL/TAILLIGHT - LOWER/PASSENGER - BLACK
4	138162-05-02B	EA	BRACKET/BUMPER - RR/RH HAND - 4.3"X 3.5"X 7.3" - E-COATED
5	P57727-02-U57	EA	PANEL - BUMPER/REAR - W/O HARDWARE - PARCHMENT
5	P57727-02-AA1	EA	PANEL - BUMPER/REAR - W/O HARDWARE - BLACK
6	138162-06-02B	EA	BRACKET/BUMPER - RR/LH HAND - 4.3"X 3.5"X 7.3" - E-COATED
7	139811-01-02B	EA	SEAL PLANE/ANGLE MOUNT FILLER (SIDEWALL/BACKWALL ATTACH)
8	132721-02-02B	EA	BRACKET/MOUNT - TRIM - REAR - E-COATED
9	157713-04-U57	EA	TRIM/POD - BACKWALL/TAILLIGHT - LOWER/DRIVER - PARCHMENT
9	157713-04-AA1	EA	TRIM/POD - BACKWALL/TAILLIGHT - LOWER/DRIVER - BLACK
10	130034-07-02B	EA	CLIP - TRIM - E-COATED
11	159554-01-02B	EA	BRACKET/MOUNT - TRIM/POD - TAILLIGHT - E-COATED
12	140371-05-02B	EA	PLATE - W/HOLE - BUMPER - 3.3" X 3.9" - E-COATED

**EXTERIOR BODY GROUP (CONTINUED)**  
**COMPONENT PARTS FOR PANELS & TRIMS**

**106015-12-01A**

<b>KEY</b>	<b>PART NUMBER</b>	<b>U/M</b>	<b>DESCRIPTION</b>	<b>VENDOR NO.</b>
	106015-12-700	EA	MIRROR-FLAT-W/W/O HEAT	709448
	106015-12-701	EA	MIRROR-CONVEX - W/W/O HEAT	709449
	106015-12-702	EA	CAP/SCREW - (PKG OF 4) - BLK	748329 RND
	106015-12-703	EA	CONVEX GLASS/HANDSET/HOUSING	7095892
	106015-19-701	EA	GLASS/FLAT-W/BEZEL/HEAT/ANTI	709644
	119774-09-700	EA	PLATE-INNER SUPT/MIRROR HEAD	709418-7RH
	131431-01-701	EA	MOTOR	7475400

**106015-13-01A**

<b>KEY</b>	<b>PART NUMBER</b>	<b>U/M</b>	<b>DESCRIPTION</b>	<b>VENDOR NO.</b>
	106015-12-700	EA	MIRROR-FLAT-W/W/O HEAT	709448
	106015-12-701	EA	MIRROR-CONVEX - W/W/O HEAT	709449
	106015-12-702	EA	CAP/SCREW - (PKG OF 4) - BLK	748329 RND
	106015-12-703	EA	CONVEX GLASS/HANDSET/HOUSING	7095892
	106015-19-701	EA	GLASS/FLAT-W/BEZEL/HEAT/ANTI	709644
	119774-09-701	EA	PLATE INNER SUPT/MIRROR HEAD	709419-7LH
	131431-01-701	EA	MOTOR	7475400

**106015-14-01A**

<b>KEY</b>	<b>PART NUMBER</b>	<b>U/M</b>	<b>DESCRIPTION</b>	<b>VENDOR NO.</b>
	106015-12-700	EA	MIRROR-FLAT-W/W/O HEAT	709448
	106015-12-701	EA	MIRROR-CONVEX - W/W/O HEAT	709449
	106015-12-702	EA	CAP/SCREW - (PKG OF 4) - BLK	748329 RND
	106015-12-703	EA	CONVEX GLASS/HANDSET/HOUSING	7095892
	106015-19-701	EA	GLASS/FLAT-W/BEZEL/HEAT/ANTI	709644
	119774-09-700	EA	PLATE-INNER SUPT/MIRROR HEAD	709418-7RH

**106015-15-01A**

<b>KEY</b>	<b>PART NUMBER</b>	<b>U/M</b>	<b>DESCRIPTION</b>	<b>VENDOR NO.</b>
	106015-12-700	EA	MIRROR-FLAT-W/W/O HEAT	709448
	106015-12-701	EA	MIRROR-CONVEX - W/W/O HEAT	709449
	106015-12-702	EA	CAP/SCREW - (PKG OF 4) - BLK	748329 RND
	106015-12-703	EA	CONVEX GLASS/HANDSET/HOUSING	7095892
	106015-19-701	EA	GLASS/FLAT-W/BEZEL/HEAT/ANTI	709644
	119774-09-701	EA	PLATE INNER SUPT/MIRROR HEAD	709419-7LH

# EXTERIOR BODY GROUP (CONTINUED)

## FRONT END

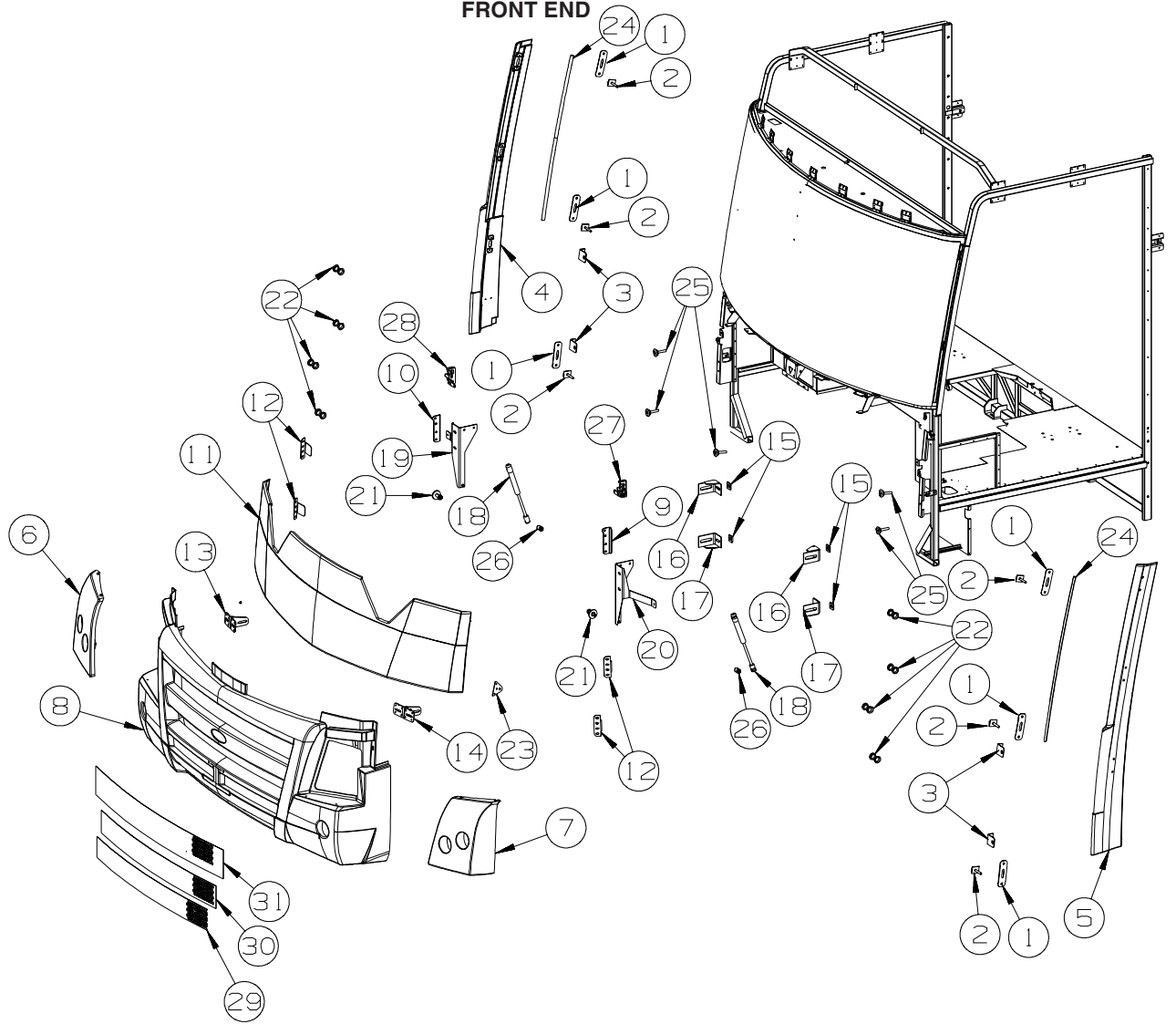

KEY	PART NUMBER	U/M DESCRIPTION
1	156929-01-W51	EA HOOD - FRONT - W/GLUED IN PARTS - W/O HDW - BRIGHT WHITE
1	156929-01-U79	EA HOOD - FRONT - W/GLUED IN PARTS - W/O HDW - BLACK
2	149358-01-01A	EA BOLT - STRIKER - .375"DIAMETER
3	155042-01-01A	EA BEARING/CLIP - CHARCOAL
4	126263-08-02B	EA BRACKET - GAS SPRING W/CENTERED BALL STUD - E-COATED
5	157720-01-02A	EA BEZEL - HEADLAMP - PASSENGER - BRIGHT WHITE
6	158297-01-000	FT SEAL - BULB - .5" X .7" - ADHESIVE BACK - BLACK
7	128455-07-02B	EA BRACKET - BUMPER - E-COATED
8	128455-08-02B	EA BRACKET - BUMPER - E-COATED
9	116617-02-02B	EA SPACER - BUMPER
10	157852-02-W51	EA PANEL - FRONT/LOWER - W/O HOOD/GRILLE/LIGHTS - BRIGHT WHITE
10	157852-02-Y51	EA PANEL - FRONT/LOWER - W/O HOOD/GRILLE/LIGHTS - PRIMED
11	157720-02-02A	EA BEZEL - HEADLAMP - DRIVER - BRIGHT WHITE
12	058786-01-000	EA BOLT - HOOD ADJUSTMENT - 5/16"-18 X 1.5"-2" - W/BLACK PAD
13	142569-30-000	EA SPRING/GAS - 90 LB - 9.6" EXTENDED/6.5" COMPRESSED
14	057460-02-000	EA BALL STUD - F/GAS SPRING .39" - 5/16"-18
15	158080-03-02A	EA GRILLE - FRONT/UPPER
16	158080-02-02A	EA GRILLE - FRONT/MIDDLE
17	158040-02-02B	EA BRACKET - HOOD - E-COATED - <b>NOT ILLUSTRATED</b>
		FROM: 00-00-00 THRU: 01-01-07
17	162971-02-02B	EA SUPPORT - HINGE/HOOD - E-COATED
		FROM: 01-02-07 THRU: 99-99-99
18	158040-01-02B	EA BRACKET - HOOD - E-COATED - <b>NOT ILLUSTRATED</b>
		FROM: 00-00-00 THRU: 01-01-07
18	162971-01-02B	EA SUPPORT - HINGE/HOOD - E-COATED
		FROM: 01-02-07 THRU: 99-99-99

**EXTERIOR BODY GROUP (CONTINUED)**  
**FRONT END (CONTINUED)**

KEY	PART NUMBER	U/M	DESCRIPTION
19	158033-01-02B	EA	ANGLE - LATCH/RH - E-COATED
20	149359-02-01A	EA	LATCH - SINGLE ROTOR - MINI/RIGHT HAND - ZINC
21	158033-02-02B	EA	ANGLE - LATCH/LH - E-COATED
22	149359-03-01A	EA	LATCH - SINGLE ROTOR - MINI/LEFT HAND - ZINC
23	157013-01-02B	EA	ANGLE - HOOD STOP - E-COATED
24	160724-02-02B	EA	BRACE - STRIKE/LH - E-COATED
25	160724-01-02B	EA	BRACE - STRIKE/RH - E-COATED
26	161353-01-01A	EA	TRIM - A-PILLAR - PASSENGER - W/O HDW - BLACK
27	161353-02-01A	EA	TRIM - A-PILLAR - DRIVER - W/O HDW - BLACK
28	158080-01-02A	EA	GRILLE - FRONT/UPPER
29	156169-01-02B	EA	BRACKET/ATTACHMENT - A-PILLAR - E-COATED
30	156170-02-02B	EA	PLATE/ATTACHMENT - A-PILLAR - E-COATED
31	157264-01-02B	EA	PLATE/ATTACHMENT - A-PILLAR - E-COATED

**LADDER**

KEY	PART NUMBER	U/M	DESCRIPTION
	161113-10-01A	EA	LADDER - 9 STEP - 113.6" - BRUSHED ALUMINUM

**STRUCTURAL COMPONENTS**

KEY	PART NUMBER	U/M	DESCRIPTION
	089297-01-000	SF	PLYWOOD - LUAN - OVERLAY GRADE - 4' X 8'
	089297-03-000	SF	PLYWOOD - LUAN - OVERLAY GRADE - 4' X 8.3'
	100619-B3-000	BF	FOAM - EXPANDED POLYSTYRENE - .42" X 48" X 96"
	100619-01-000	BF	FOAM - EXPANDED POLYSTYRENE - 1.34" X 48" X 96"
	100619-04-000	BF	FOAM - EXPANDED POLYSTYRENE - .5" X 48" X 96"
	100619-05-000	BF	FOAM - EXPANDED POLYSTYRENE - .75" X 48" X 96"-1.5"DENSITY
	100619-16-000	BF	FOAM - EXPANDED POLYSTYRENE - .75" X 48" X 96"-2" DENSITY
	108535-05-03A	SF	FIBERGLASS SHEET - 108" X 500' ROLL - BRIGHT WHITE
	116942-03-01A	LB	ALUMINUM - .7" X 40" X 158"
	120107-07-000	EA	FOAM - ROOF COVE
	128782-07-01A	EA	FIBERGLASS SHEET - 5/32" X 78.9" X 456" - HIGH GLOSS - B/W - PREMIUM HIGH GLOSS SIDEWALL
	128782-24-01A	EA	FIBERGLASS SHEET - 99.5" X 100.2" - HIGH GLOSS - BRT WHITE - PREMIUM HIGH GLOSS SIDEWALL
	128782-09-01A	EA	FIBERGLASS SHEET - 31" X 68.2" - HIGH GLOSS - BRIGHT WHITE - PREMIUM HIGH GLOSS SIDEWALL
	152490-01-000	EA	FOAM - PLUG - ROOF TUBE
	162931-08-01A	EA	FIBERGLASS SHEET - 22.1" X 68.2" - BRIGHT WHITE
	162931-15-01A	EA	FIBERGLASS SHEET - 4" X 93.8" - BRIGHT WHITE
	162931-32-01A	EA	FIBERGLASS SHEET - 25" X 47.9" - BRIGHT WHITE
	162931-24-01A	EA	FIBERGLASS SHEET - 107.3" X 100.2" - BRIGHT WHITE
	162931-11-01A	EA	FIBERGLASS SHEET - 78.9" X 309.4" - BRIGHT WHITE
	162931-10-01A	EA	FIBERGLASS SHEET - 31.1' X 68.2" - BRIGHT WHITE
	162931-19-01A	EA	FIBERGLASS SHEET - 96.7" X 355.7" - BRIGHT WHITE
	162931-33-01A	EA	FIBERGLASS SHEET - 30.9" X 69.3" - BRIGHT WHITE

**EXTERIOR BODY GROUP (CONTINUED)**  
**AWNINGS**

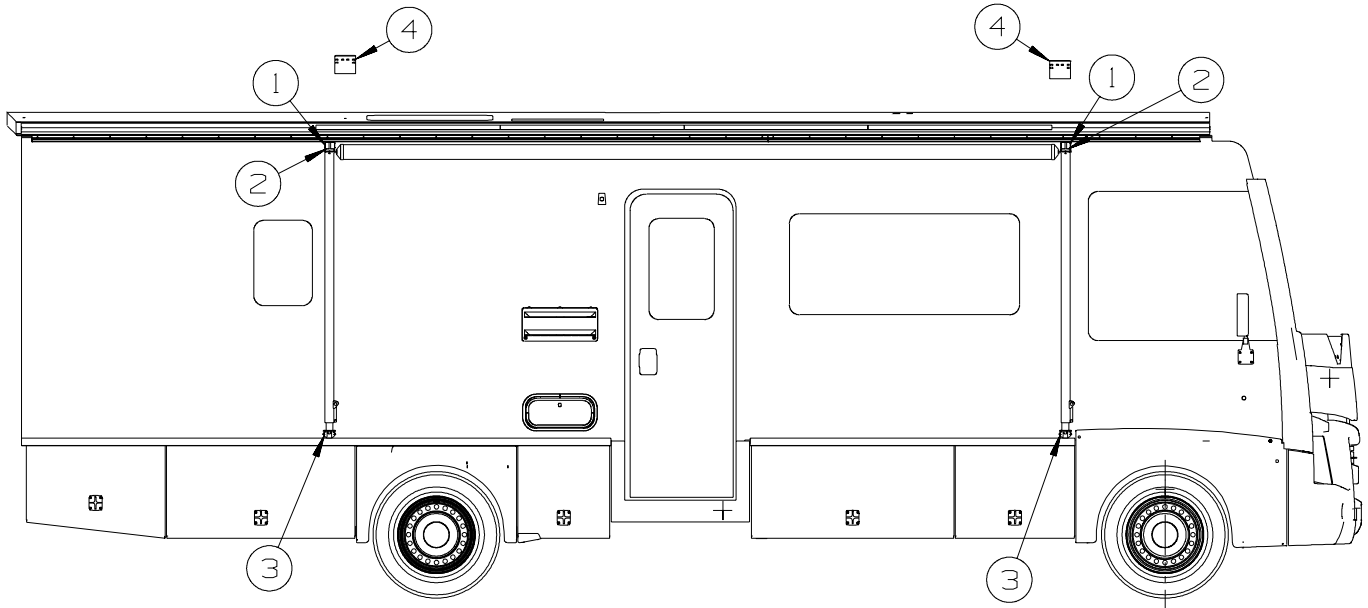

KEY	PART NUMBER	U/M	DESCRIPTION
1	161739-01-02A	EA	BRACKET - AWNING - BRIGHT WHITE
1	161739-01-01A	EA	BRACKET - AWNING - BLACK
2	113874-12-01A	EA	SCREW/LAG - AWNING - 1/4" X 2 3/4" STAINLESS STEEL
3	113874-11-01A	EA	SCREW/LAG - AWNING - 1/4" X 1" STAINLESS STEEL
4	146457-02-03A	EA	BRACKET - AWNING - BRIGHT WHITE - <b>D34M</b>
4	146457-02-02A	EA	BRACKET - AWNING - BLACK - <b>D34M</b>

**ORDER AWNINGS & REPAIR PARTS FROM DOMETIC. CALL #800-366-3842.**  
**THE DOMETIC AWNING INFORMATION YOU WILL NEED IS LOCATED ON THE MOTOR HOME NEAR**  
**THE TOP OF THE AWNING RAIL.**

# EXTERIOR DOORS & COMPARTMENTS GROUP

## DOOR & COMPARTMENT LAYOUT

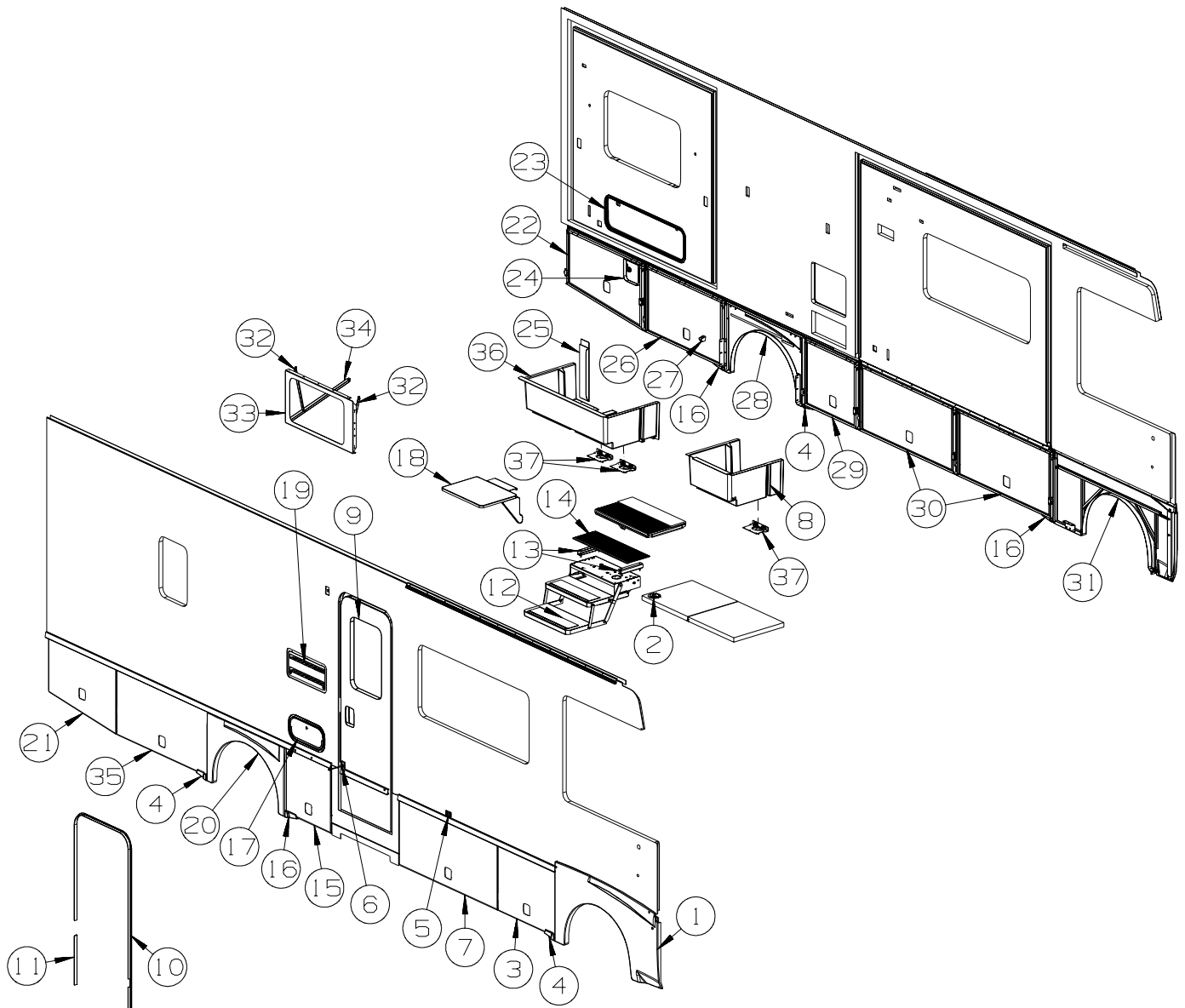

KEY	PART NUMBER	U/M	DESCRIPTION
1	157613-01-W51	EA	PANEL - WHEEL LIP - FRONT/PASSENGER - BRIGHT WHITE FROM: 00-00-00 THRU: 02-21-08
1	168404-01-W51	EA	PANEL - WHEEL LIP - FRONT/PASSENGER - BRIGHT WHITE FROM: 02-22-08 THRU: 99-99-99
1	157613-01-AA1	EA	PANEL - WHEEL LIP - FRONT/PASSENGER - BLACK FROM: 00-00-00 THRU: 02-21-08
1	168404-01-AA1	EA	PANEL - WHEEL LIP - FRONT/PASSENGER - BLACK FROM: 02-22-08 THRU: 99-99-99
2	009426-01-000	EA	HATCH - POWER CORD - WHITE
3	159965-01-W51	EA	VALANCE/DOOR - W/O LATCH/HDW/NON LOCKING - 31.1"W X 24.3"H - BRIGHT WHITE
3	159965-01-U57	EA	VALANCE/DOOR - W/O LATCH/HDW/NON LOCKING - 31.1"W X 24.3"H - BLACK
	132873-99-000	EA	ROD - LATCH - 9.4" W/3/4" DOG LEG
	135624-96-01B	EA	ROD - LATCH
	142569-12-000	EA	SPRING/GAS - 90 LB - 15" EXTENDED/9.5" COMPRESSED
	126263-02-02B	EA	BRACKET - GAS SPRING W/BALL STUD - E-COATED
	130053-02-01A	EA	STRIKER - LUGGAGE DOOR - OFF SET - BLACK
	143793-01-01A	EA	SHIM - STRIKER - LUGGAGE - 3/64" - BLACK
	099418-01-000	FT	SEAL - D-SECTION/ADHESIVE BACK - .44" X .44" - BLK RUBBER
	132892-08-01A	FT	SEAL - BULB/SINGLE - W/U CHANNEL - 1" X .8" - BLACK
4	157640-02-02A	EA	EXTENSION - WHEEL LIP/LH - BRIGHT WHITE
4	157640-02-03A	EA	EXTENSION - WHEEL LIP/LH - PARCHMENT
4	157640-02-01A	EA	EXTENSION - WHEEL LIP/LH - BLACK

**EXTERIOR DOORS & COMPARTMENTS GROUP (CONTINUED)**  
**DOOR & COMPARTMENT LAYOUT (CONTINUED)**

KEY	PART NUMBER	U/M	DESCRIPTION
5	104099-02-04A	EA	CATCH/RETAINER - DOOR HOLDER - BRIGHT WHITE
5	104099-02-05A	EA	CATCH/RETAINER - DOOR HOLDER - BLACK
6	104099-03-04A	EA	CATCH - DOOR HOLDER - STRIKE - 6" - BRIGHT WHITE
6	104099-03-05A	EA	CATCH - DOOR HOLDER - STRIKE - 6" - BLACK
7	159965-12-U57	EA	VALANCE/DOOR - W/O PADDLE LATCH/HDW - 52.7"W X 24.3"H
	132873-E6-000	EA	ROD - LATCH - 20.2" W/3/4" DOG LEG
	135624-B2-01B	EA	ROD - LATCH
	142569-12-000	EA	SPRING/GAS - 90 LB - 15" EXTENDED/9.5" COMPRESSED
	126263-02-02B	EA	BRACKET - GAS SPRING W/BALL STUD - E-COATED
	130053-02-01A	EA	STRIKER - LUGGAGE DOOR - OFF SET - BLACK
	143793-01-01A	EA	SHIM - STRIKER - LUGGAGE - 3/64" - BLACK
	099418-01-000	FT	SEAL - D-SECTION/ADHESIVE BACK - .44" X .44" - BLK RUBBER
	132892-08-01A	FT	SEAL - BULB/SINGLE - W/U CHANNEL - 1" X .8" - BLACK
8	149536-01-01A	EA	COMPARTMENT - DRAINAGE - PLASTIC
9	P32206-08-W70	EA	DOOR - ENTRY W/SCREEN DOOR - W/O WINDOW/LATCH (W57, W58)
9	P32206-08-W66	EA	DOOR - ENTRY W/SCREEN DOOR - W/O WINDOW/LATCH (W59, W60, W61, W62)
9	P32206-19-U51	EA	DR-ENTRY W/SCRN - W/O WINDOW/LATCH (W57, W58) - PREMIUM HIGH GLOSS SIDEWALL
9	P32206-19-W59	EA	DR-ENTRY W/SCRN - W/O WINDOW/LATCH (W59, W60, W61, W62) - PREM HIGH GLOSS SIDEWALL
9	M09574-03-W51	EA	DR-ENTRY W/SCRN DR - W/O WNDW/LTCH (W57, W58) - FULL BODY PAINT
9	M09574-03-W59	EA	DR-ENTRY W/SCRN DR-W/O WNDW/LTCH (W59, W60, W61, W62) - FULL BODY PAINT
<b>ENTRY DOOR LOCK CYLINDERS</b>			
	138287-11-000	EA	CYLINDER/LOCK - ENTRY DOOR - MASTER W/3M ICON - (3041)
	138287-12-000	EA	CYLINDER/LOCK - ENTRY DOOR - MASTER W/3M ICON - (3042)
	138287-13-000	EA	CYLINDER/LOCK - ENTRY DOOR - MASTER W/3M ICON - (3043)
	138287-14-000	EA	CYLINDER/LOCK - ENTRY DOOR - MASTER W/3M ICON - (3044)
	138287-15-000	EA	CYLINDER/LOCK - ENTRY DOOR - MASTER W/3M ICON - (3045)
	138287-16-000	EA	CYLINDER/LOCK - ENTRY DOOR - MASTER W/3M ICON - (3046)
	138287-17-000	EA	CYLINDER/LOCK - ENTRY DOOR - MASTER W/3M ICON - (3047)
	138287-18-000	EA	CYLINDER/LOCK - ENTRY DOOR - MASTER W/3M ICON - (3048)
	138287-19-000	EA	CYLINDER/LOCK - ENTRY DOOR - MASTER W/3M ICON - (3049)
	138287-20-000	EA	CYLINDER/LOCK - ENTRY DOOR - MASTER W/3M ICON - (3050)
	138292-01-000	EA	SEAL - LOCK CYLINDER
<b>VALANCE DOOR LOCK CYLINDERS</b>			
	138289-11-000	EA	CYLINDER/LOCK - ACCESS DOORS - REDUCED SENSITIVITY (3041)
	138289-12-000	EA	CYLINDER/LOCK - ACCESS DOORS - REDUCED SENSITIVITY (3042)
	138289-13-000	EA	CYLINDER/LOCK - ACCESS DOORS - REDUCED SENSITIVITY (3043)
	138289-14-000	EA	CYLINDER/LOCK - ACCESS DOORS - REDUCED SENSITIVITY (3044)
	138289-15-000	EA	CYLINDER/LOCK - ACCESS DOORS - REDUCED SENSITIVITY (3045)
	138289-16-000	EA	CYLINDER/LOCK - ACCESS DOORS - REDUCED SENSITIVITY (3046)
	138289-17-000	EA	CYLINDER/LOCK - ACCESS DOORS - REDUCED SENSITIVITY (3047)
	138289-18-000	EA	CYLINDER/LOCK - ACCESS DOORS - REDUCED SENSITIVITY (3048)
	138289-19-000	EA	CYLINDER/LOCK - ACCESS DOORS - REDUCED SENSITIVITY (3049)
	138289-20-000	EA	CYLINDER/LOCK - ACCESS DOORS - REDUCED SENSITIVITY (3050)
	138288-11-000	EA	KEY - REVERSIBLE - #3041 - T/M 16169-02-3041
	138288-12-000	EA	KEY - REVERSIBLE - #3042 - T/M 16169-02-3042
	138288-13-000	EA	KEY - REVERSIBLE - #3043 - T/M 16169-02-3043
	138288-14-000	EA	KEY - REVERSIBLE - #3044 - T/M 16169-02-3044
	138288-15-000	EA	KEY - REVERSIBLE - #3045 - T/M 16169-02-3045
	138288-16-000	EA	KEY - REVERSIBLE - #3046 - T/M 16169-02-3046
	138288-17-000	EA	KEY - REVERSIBLE - #3047 - T/M 16169-02-3047
	138288-18-000	EA	KEY - REVERSIBLE - #3048 - T/M 16169-02-3048
	138288-19-000	EA	KEY - REVERSIBLE - #3049 - T/M 16169-02-3049
	138288-20-000	EA	KEY - REVERSIBLE - #3050 - T/M 16169-02-3050
10	139100-01-01A	EA	GARNISH/RADIUS - ENTRY DOOR - BRIGHT WHITE
10	139100-01-02A	EA	GARNISH/RADIUS - ENTRY DOOR - BLACK
11	139101-01-01A	EA	GARNISH/STRAIGHT - 18.1" - BRIGHT WHITE
11	139101-01-02A	EA	GARNISH/STRAIGHT - 18.1" - BLACK
12*	094707-04-01A	EA	STEP - ELECTRIC DOUBLE - KWIKEE
	116975-01-01A	EA	LATCH - W/O STRIKE - BLACK - NEW STYLE
13	138787-02-02B	EA	CHANNEL/MOUNT - E-COAT
14	133114-01-01A	EA	TREAD - STEP/RUBBER - 29.3" X 10.1" - TAUPE
	064075-07-000	FT	SEAL - BULB - W/WIRED U CHANNEL - .3" X .5" CHANNEL-BLACK

**EXTERIOR DOORS & COMPARTMENTS GROUP (CONTINUED)**  
**DOOR & COMPARTMENT LAYOUT (CONTINUED)**

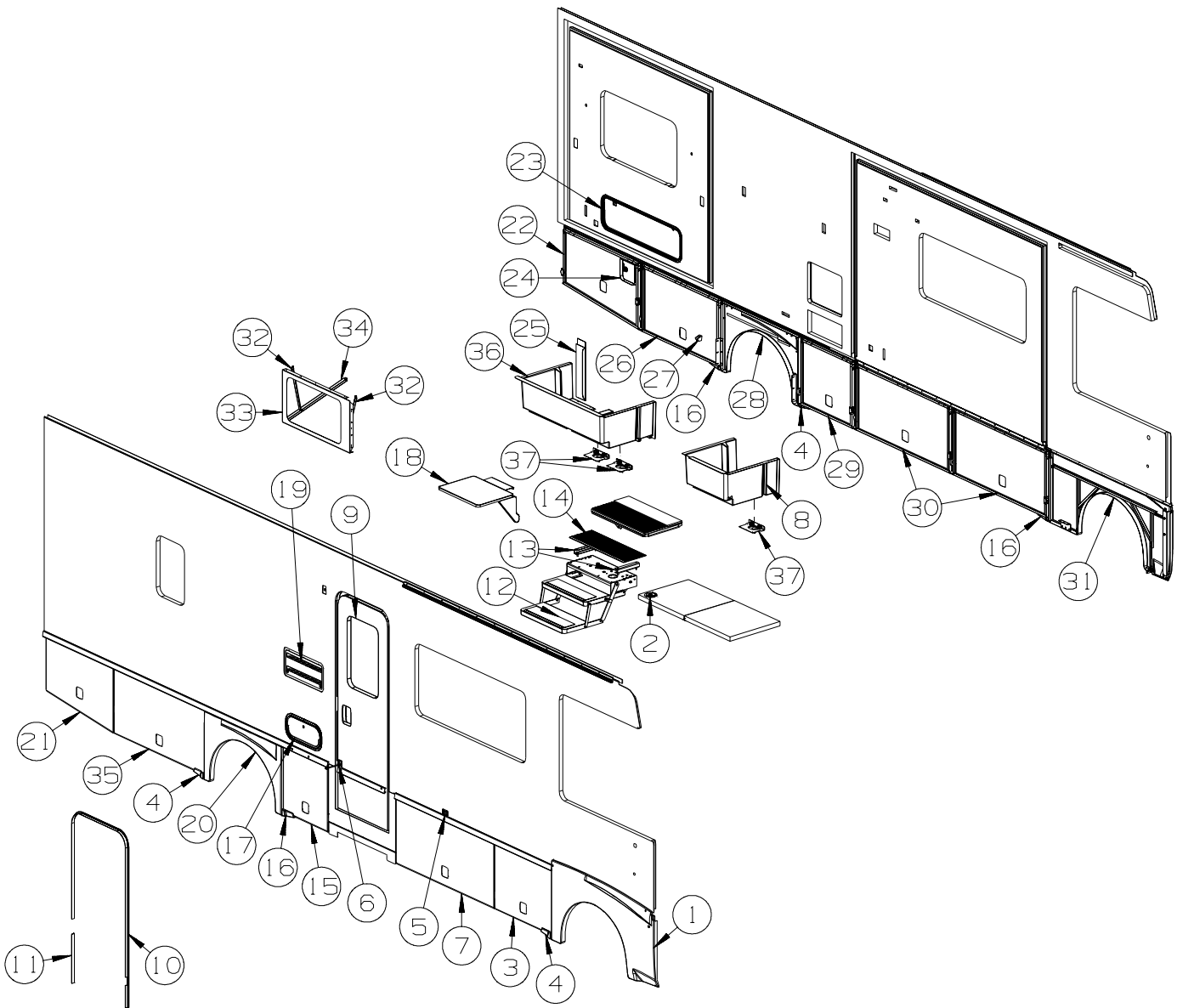

KEY	PART NUMBER	U/M	DESCRIPTION
15	159965-11-U57	EA	VALANCE/DOOR - W/O PADDLE LATCH/HDW - 23.9"W X 24.3"H
	132873-E4-000	EA	ROD - LATCH - 5.8" W/3/4" DOG LEG
	135624-B1-01B	EA	ROD - LATCH
	142569-12-000	EA	SPRING/GAS - 90 LB - 15" EXTENDED/9.5" COMPRESSED
	126263-02-02B	EA	BRACKET - GAS SPRING W/BALL STUD - E-COATED
	130053-02-01A	EA	STRIKER - LUGGAGE DOOR - OFF SET - BLACK
	143793-01-01A	EA	SHIM - STRIKER - LUGGAGE - 3/64" - BLACK
	099418-01-000	FT	SEAL - D-SECTION/ADHESIVE BACK - .44" X .44" - BLK RUBBER
	132892-08-01A	FT	SEAL - BULB/SINGLE - W/U CHANNEL - 1" X .8" - BLACK
16	157640-01-02A	EA	EXTENSION - WHEEL LIP/RH - BRIGHT WHITE
16	157640-01-03A	EA	EXTENSION - WHEEL LIP/RH - PARCHMENT
16	157640-01-01A	EA	EXTENSION - WHEEL LIP/RH - BLACK
17	126945-09-P07	EA	DOOR/STORAGE - W/O HARDWARE - 18.3" X 9.9"
18	142034-01-01A	EA	SHELF - F/EXTERIOR TV - BRIGHT WHITE
19*	084103-08-000	EA	DOOR - VENT - REFRIGERATOR - W/O JAMB - BRIGHT WHITE
19	084104-08-000	EA	JAMB - VENT DOOR/REFRIGERATOR - BRIGHT WHITE
20	157615-01-W51	EA	PANEL - WHEEL LIP - REAR - BRIGHT WHITE
20	157615-01-AA1	EA	PANEL - WHEEL LIP - REAR - BLACK
	139793-03-01A	EA	HINGE - CENTER/VALANCE DOOR - W/O BALL STUD



**EXTERIOR DOORS & COMPARTMENTS GROUP (CONTINUED)**  
**DOOR & COMPARTMENT LAYOUT (CONTINUED)**

KEY	PART NUMBER	U/M	DESCRIPTION
21	159965-13-U57	EA	VALANCE/DOOR - W/O PADDLE LATCH/HDW - 36.2"WX24.3"HX20.1"H
	132873-E8-000	EA	ROD - LATCH - 12" W/3/4" DOG LEG
	135624-B3-01B	EA	ROD - LATCH
	142569-17-000	EA	SPRING/GAS - 90 LB - 12" EXTENDED/8.5" COMPRESSED
	126263-02-02B	EA	BRACKET - GAS SPRING W/BALL STUD - E-COATED
	130053-02-01A	EA	STRIKER - LUGGAGE DOOR - OFF SET - BLACK
	143793-01-01A	EA	SHIM - STRIKER - LUGGAGE - 3/64" - BLACK
	099418-01-000	FT	SEAL - D-SECTION/ADHESIVE BACK - .44" X .44" - BLK RUBBER
	132892-08-01A	FT	SEAL - BULB/SINGLE - W/U CHANNEL - 1" X .8" - BLACK
22	159965-14-U57	EA	VALANCE/DOOR - W/O PADDLE LATCH/HDW - 42.3"WX20.1"HX24.3"H
	133049-04-T53	EA	TRIM - FUEL FILL
	132873-F1-000	EA	ROD - LATCH - 15" W/3/4" DOG LEG
	135624-B4-01B	EA	ROD - LATCH
	142569-17-000	EA	SPRING/GAS - 90 LB - 12" EXTENDED/8.5" COMPRESSED
	126263-02-02B	EA	BRACKET - GAS SPRING W/BALL STUD - E-COATED
	130053-02-01A	EA	STRIKER - LUGGAGE DOOR - OFF SET - BLACK
	143793-01-01A	EA	SHIM - STRIKER - LUGGAGE - 3/64" - BLACK
	076767-15-000	EA	CABLE - STAINLESS STEEL - 9.8"
	132892-08-01A	FT	SEAL - BULB/SINGLE - W/U CHANNEL - 1" X .8" - BLACK
23	126946-51-SJ0	EA	DOOR/STORAGE - W/O HARDWARE - 43.3" X 12.7" - BRIGHT WHITE
23	126946-75-U57	EA	DOOR/STORAGE - W/O HARDWARE - 43.2" X 12.7" - BRIGHT WHITE - PREMIUM HIGH GLOSS
<b>SIDEWALL</b>			
23	126946-75-AA1	EA	DOOR/STORAGE - W/O HARDWARE - 43.2" X 12.7" - BLACK
24	131905-03-T53	EA	PANEL/DOOR - FUEL FILL - W/O LOCK - SANDSTONE
	110506-40-000	EA	CLIP-E, LOCK ASM - BRIGGS & STRATTON 93981
	110506-41-000	EA	WASHER-TENSION LOCK ASM - BRIGGS & STRATTON 37512
	110506-42-000	EA	NUT-LOCK ASM - BRIGGS & STRATTON 310878
	110506-43-000	EA	WASHER-FLAT, LOCK ASM - BRIGGS & STRATTON 82089
	110506-44-000	EA	GASKET-LOCK ASM - BRIGGS & STRATTON - #47701
	110506-45-000	EA	WASHER - SPUR - BRIGGS & STRATTON - #94771
	110506-41-000	EA	WASHER-TENSION LOCK ASM - BRIGGS & STRATTON 37512
	110506-42-000	EA	NUT-LOCK ASM - BRIGGS & STRATTON 310878
	110506-44-000	EA	GASKET-LOCK ASM - BRIGGS & STRATTON - #47701
	110506-45-000	EA	WASHER - SPUR - BRIGGS & STRATTON - #94771
	110506-51-000	EA	CASE/CYLINDER - TWIST LATCH - W/O CAM - 1" - 596669
	110506-78-000	EA	CAM - LATCHING - 2.3"
	153306-01-01A	EA	HINGE - PIANO - 1 1/2" X 5" - UNPAINTED
25	132605-25-02B	EA	PLATE/SEAL - FILLER PANEL - E-COATED
26	159965-10-U57	EA	VALANCE/DOOR - W/O PADDLE LATCH/HDW - 43"W X 24.3"H
	132873-29-000	EA	ROD - LATCH - 15.4" W/3/4" DOG LEG
	135624-77-01B	EA	ROD - LATCH
	142569-12-000	EA	SPRING/GAS - 90 LB - 15" EXTENDED/9.5" COMPRESSED
	126263-02-02B	EA	BRACKET - GAS SPRING W/BALL STUD - E-COATED
	130053-02-01A	EA	STRIKER - LUGGAGE DOOR - OFF SET - BLACK
	143793-01-01A	EA	SHIM - STRIKER - LUGGAGE - 3/64" - BLACK
	076767-15-000	EA	CABLE - STAINLESS STEEL - 9.8"
	099418-01-000	FT	SEAL - D-SECTION/ADHESIVE BACK - .44" X .44" - BLK RUBBER
	107721-07-000	FT	SEAL - ACCESS DOOR - .9"WIDE X 1.1"HIGH
27	131383-03-02A	EA	BRACKET - SHOWER HEAD - WHITE
28	157615-04-W51	EA	PANEL - WHEEL LIP - REAR - BRIGHT WHITE
28	157615-04-AA1	EA	PANEL - WHEEL LIP - REAR - BLACK
	139793-03-01A	EA	HINGE - CENTER/VALANCE DOOR - W/O BALL STUD
29	159965-15-U57	EA	VALANCE/DOOR - W/O PADDLE LATCH/HDW - 29.7"W X 24.3"H
	132873-F3-000	EA	ROD - LATCH - 8.7" W/3/4" DOG LEG
	135624-06-01B	EA	ROD - LATCH
	142569-12-000	EA	SPRING/GAS - 90 LB - 15" EXTENDED/9.5" COMPRESSED
	126263-02-02B	EA	BRACKET - GAS SPRING W/BALL STUD - E-COATED
	130053-01-01A	EA	STRIKER - LUGGAGE DOOR - FLUSH - BLACK
	130053-02-01A	EA	STRIKER - LUGGAGE DOOR - OFF SET - BLACK
	143793-01-01A	EA	SHIM - STRIKER - LUGGAGE - 3/64" - BLACK
	120494-04-02B	EA	SHIM - STRIKER - LUGGAGE DOOR - 3/16" - E-COATED
	093249-01-000	EA	CAP/SCREW - MOLDED/VINYL - BLACK
	076767-15-000	EA	CABLE - STAINLESS STEEL - 9.8"
	099418-01-000	FT	SEAL - D-SECTION/ADHESIVE BACK - .44" X .44" - BLK RUBBER
	107721-07-000	FT	SEAL - ACCESS DOOR - .9"WIDE X 1.1"HIGH

**EXTERIOR DOORS & COMPARTMENTS GROUP (CONTINUED)**  
**DOOR & COMPARTMENT LAYOUT (CONTINUED)**

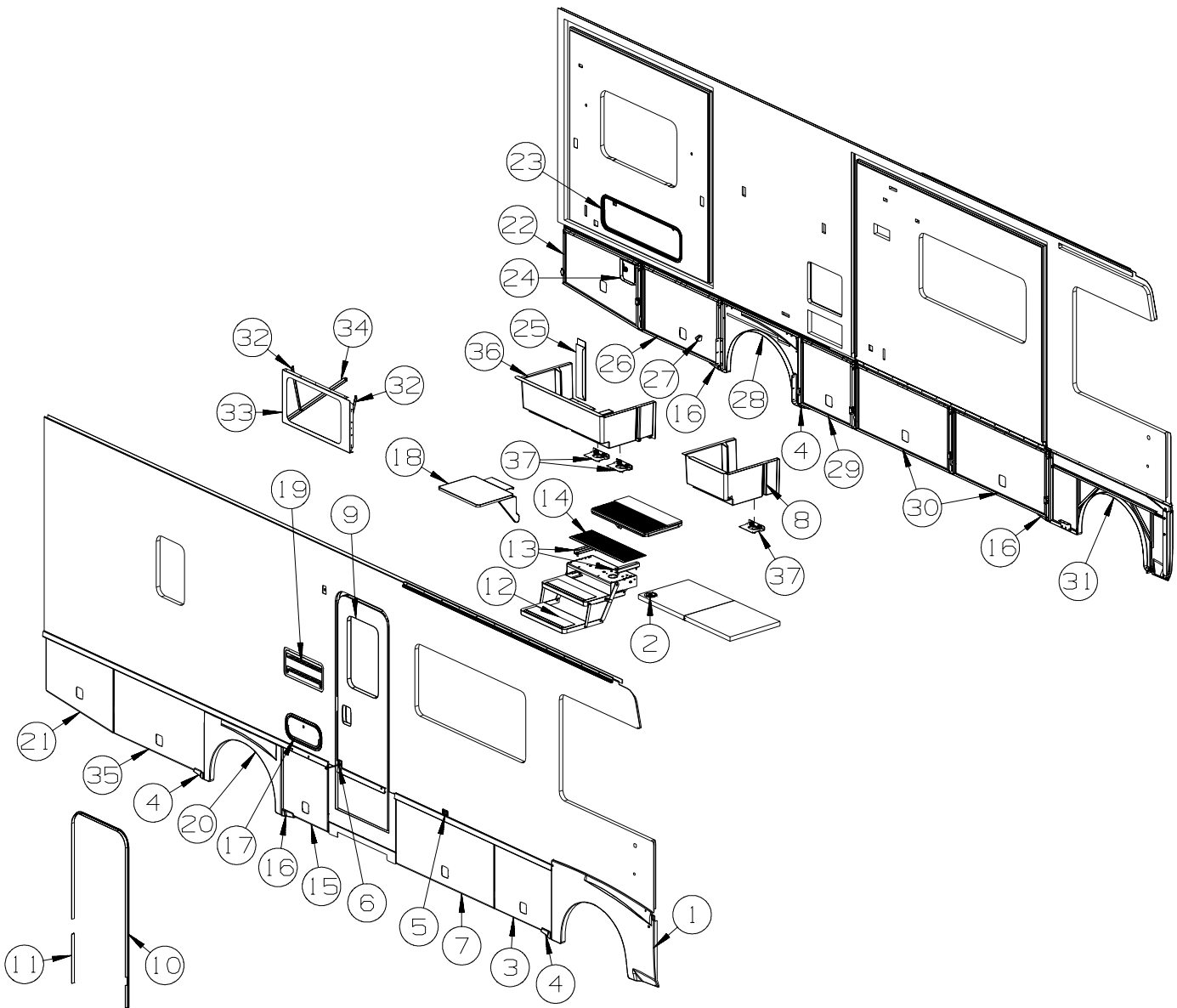

KEY	PART NUMBER	U/M	DESCRIPTION
30	159965-04-W51	EA	VALANCE/DOOR - W/O PADDLE LATCH/HDW - 52.1"W X 24.3"H - BRIGHT WHITE
30	159965-04-U57	EA	VALANCE/DOOR - W/O PADDLE LATCH/HDW - 52.1"W X 24.3"H - BLACK
	135624-98-01B	EA	ROD - LATCH
	142569-12-000	EA	SPRING/GAS - 90 LB - 15" EXTENDED/9.5" COMPRESSED
	126263-02-02B	EA	BRACKET - GAS SPRING W/BALL STUD - E-COATED
	130053-01-01A	EA	STRIKER - LUGGAGE DOOR - FLUSH - BLACK
	130053-02-01A	EA	STRIKER - LUGGAGE DOOR - OFF SET - BLACK
	143793-01-01A	EA	SHIM - STRIKER - LUGGAGE - 3/64" - BLACK
	120494-04-02B	EA	SHIM - STRIKER - LUGGAGE DOOR - 3/16" - E-COATED
	093249-01-000	EA	CAP/SCREW - MOLDED/VINYL - BLACK
	099418-01-000	FT	SEAL - D-SECTION/ADHESIVE BACK - .44" X .44" - BLK RUBBER
	132892-08-01A	FT	SEAL - BULB/SINGLE - W/U CHANNEL - 1" X .8" - BLACK
31	157613-02-W51	EA	PANEL - WHEEL LIP - FRONT/PASSENGER - BRIGHT WHITE FROM: 00-00-00 THRU: 01-02-08
31	168404-02-W51	EA	PANEL - WHEEL LIP - FRONT/PASSENGER - BRIGHT WHITE FROM: 01-03-08 THRU: 99-99-99
31	157613-02-AA1	EA	PANEL - WHEEL LIP - FRONT/PASSENGER - BLACK FROM: 00-00-00 THRU: 01-02-08
31	168404-02-AA1	EA	PANEL - WHEEL LIP - FRONT/PASSENGER - BLACK FROM: 01-03-08 THRU: 99-99-99
32	138075-07-02B	EA	ANGLE/SUPPORT - SEAL PLANE - E-COATED

**EXTERIOR DOORS & COMPARTMENTS GROUP (CONTINUED)**  
**DOOR & COMPARTMENT LAYOUT (CONTINUED)**

KEY	PART NUMBER	U/M DESCRIPTION
33	137934-17-02B	EA PLATE/SEAL - E-COATED
34	138075-01-02B	EA ANGLE/SUPPORT - SEAL PLANE - E-COATED
35	159965-07-U57	EA VALANCE/DOOR - W/O PADDLE LATCH/HDW - 49.1"W X 24.3"H
	132873-B8-000	EA ROD - LATCH - 18.4" W/3/4" DOG LEG
	135624-A4-01B	EA ROD - LATCH
	142569-12-000	EA SPRING/GAS - 90 LB - 15" EXTENDED/9.5" COMPRESSED
	126263-02-02B	EA BRACKET - GAS SPRING W/BALL STUD - E-COATED
	130053-02-01A	EA STRIKER - LUGGAGE DOOR - OFF SET - BLACK
	143793-01-01A	EA SHIM - STRIKER - LUGGAGE - 3/64" - BLACK
	099418-01-000	FT SEAL - D-SECTION/ADHESIVE BACK - .44" X .44" - BLK RUBBER
	132892-08-01A	FT SEAL - BULB/SINGLE - W/U CHANNEL - 1" X .8" - BLACK
36	149518-01-01A	EA COMPARTMENT - DRAINAGE - PLASTIC
37*	142226-02-01A	EA HATCH - POWER

\*COMPONENT PARTS LISTED LATER IN THIS GROUP

**DOOR &  
COMPARTMENT  
SECTIONS**

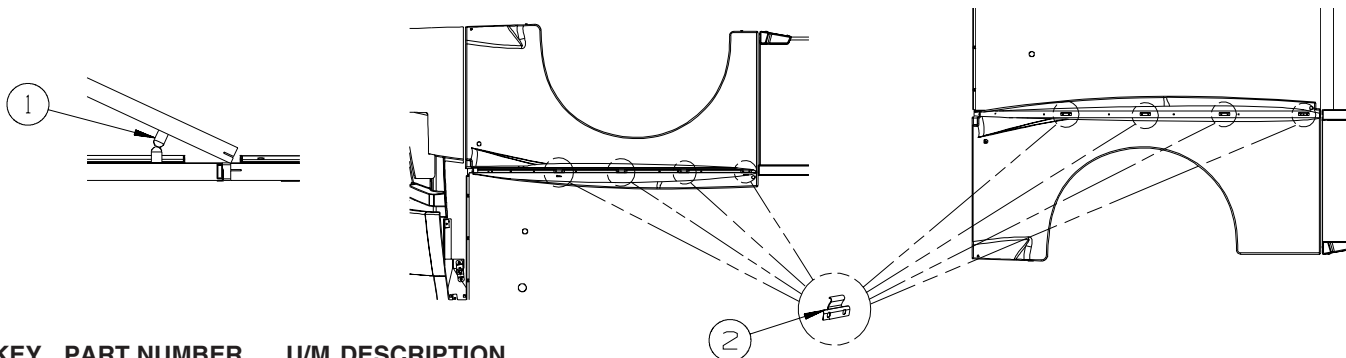

KEY	PART NUMBER	U/M DESCRIPTION
1	120863-02-000	EA BUMPER - RUBBER/RADIUS TOP - 1" X 1 1/2"
2	073050-04-000	EA CLIP/MOUNTING - VALANCE PANEL

FROM: 00-00-00 THRU: 02-02-08

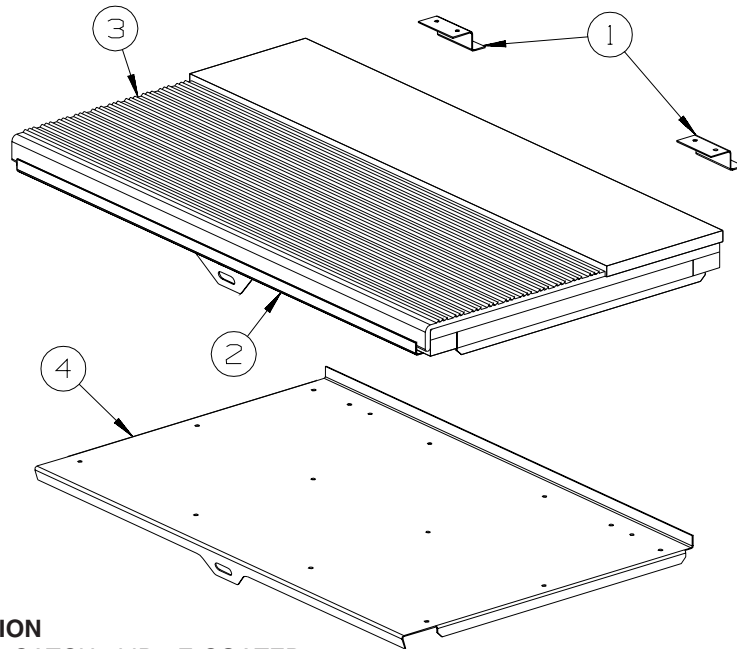

**ENTRY STEP LID**

KEY	PART NUMBER	U/M DESCRIPTION
1	101222-01-04A	EA BRACKET - CATCH - LID - E-COATED
2	P20256-07-000	EA LID/DOOR - ENTRY STEP - W/O CARPET/HARDWARE
3	133114-02-01A	EA TREAD - STEP/RUBBER - W/LIP - 28.5" X 9.8" - TAUPE
4	123330-03-02B	EA SUPPORT - ENTRY STEP - E-COATED

**FRONT VINYL FLOOR COVERING**

KEY	PART NUMBER	U/M DESCRIPTION
1	101222-01-04A	EA BRACKET - CATCH - LID - E-COATED
2	P20256-11-000	EA LID/DOOR - ENTRY STEP - W/O CARPET/HARDWARE
3	133114-02-01A	EA TREAD - STEP/RUBBER - W/LIP - 28.5" X 9.8" - TAUPE
4	123330-03-02B	EA SUPPORT - ENTRY STEP - E-COATED

## EXTERIOR DOORS & COMPARTMENTS GROUP (CONTINUED)

### COMPONENT PARTS FOR DOOR & COMPARTMENT LAYOUT

084103-08-000

KEY	PART NUMBER	U/M	DESCRIPTION	VENDOR NO.
	084104-01-700	EA	LOCK-MALE, FASTENER	201-721-010
	084104-01-701	EA	LOCK-FEMALE, FASTENER	201-802-010

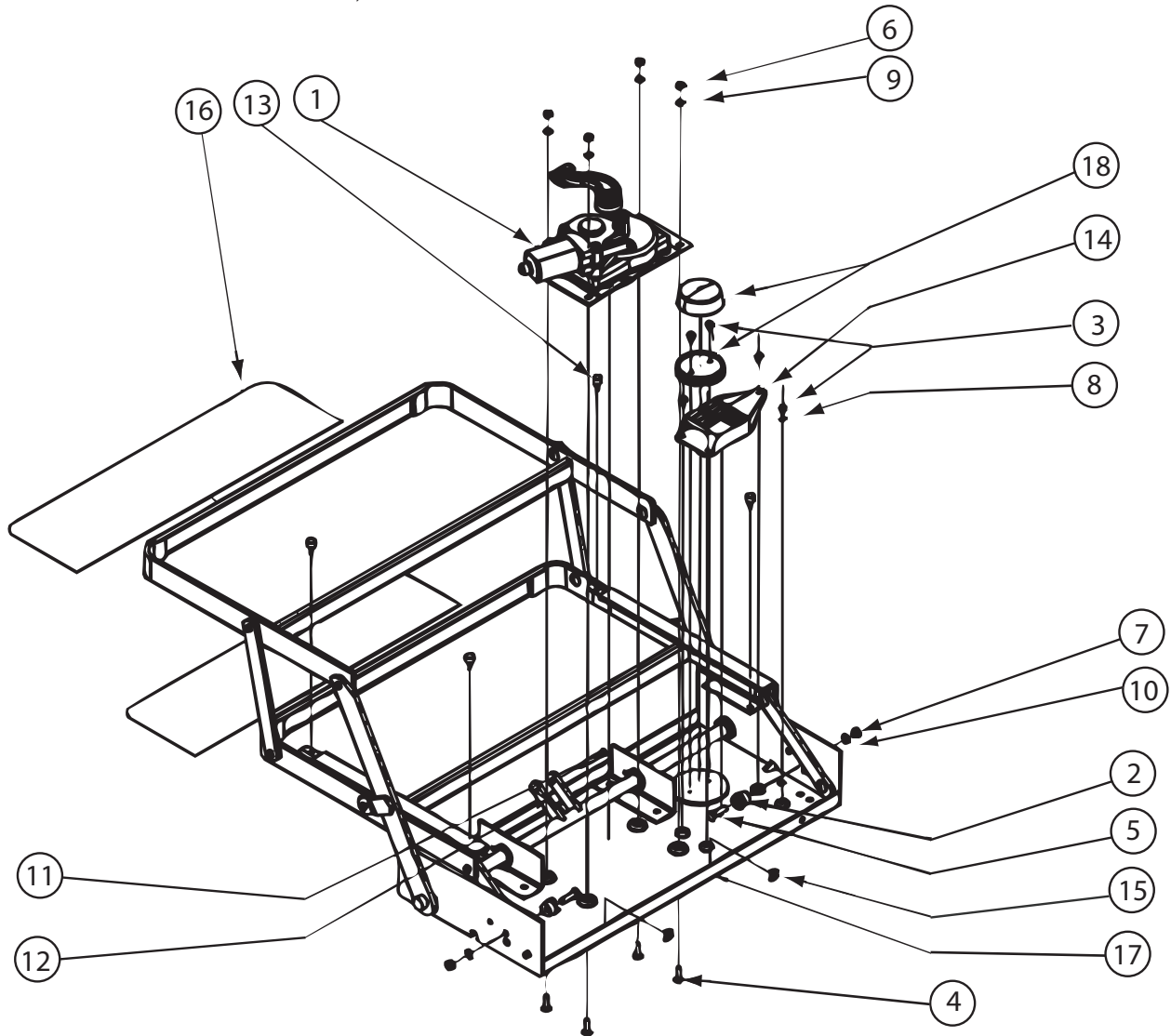

094707-04-01A

KEY	PART NUMBER	U/M	DESCRIPTION	VENDOR NO.
1	094707-04-701	EA	MOTOR "AM 214" F/IMGL STEPS	1101428
1	094707-04-703	EA	GEAR BOX W/LINKAGE-CURVED	1101425
2	143709-01-700	EA	CAM STOP	1102200
10	094707-04-712	EA	HARNES/JUMPER W/DIODE	1510000015
12	094707-04-702	EA	COTTOR PIN - W/CLEVIS PIN	905205000
13	143709-01-701	EA	BUMPER - BLACK (RUBBER STOP)	1602000
14	094707-04-700	EA	CONTROL UNIT W/OVERRIDE	909510000
16	143709-01-702	EA	TREAD/NON-SKID 6" X 21" BLK	1915260
17	094707-04-704	EA	FRAME W/DBL STEP-32REINF SRS	3202082
18	088746-01-705	EA	LIGHT-UNDER STEP	9004
	094707-03-701	EA	PLUG - 4-WAY - PACKARD	909306
	094707-04-711	EA	KWIKTEST - W/4-WAY PIGTAIL	909518000

CONTACT WINNEBAGO PART SALES FOR UNLISTED COMPONENT(S)

142226-02-01A

KEY	PART NUMBER	U/M	DESCRIPTION	VENDOR NO
	142226-02-700	EA	TAB/LOCKING - ESCAPE (RED)	9667709

**EXTERIOR DOORS & COMPARTMENTS GROUP (CONTINUED)**  
**COMPARTMENT DOOR PIECE PARTS**

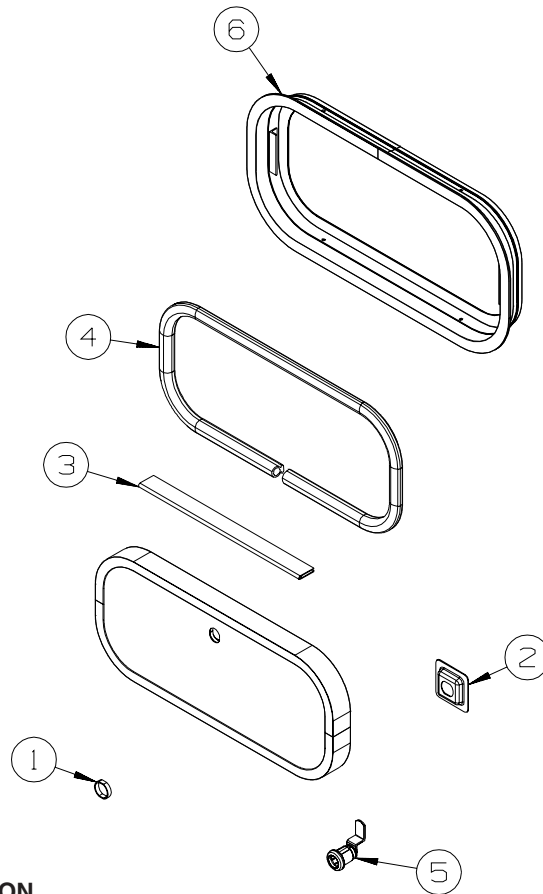

KEY	PART NUMBER	U/M	DESCRIPTION
1	139325-01-000	EA	SPACER - LOCK - 6MM
	139337-01-000	EA	GASKET - LOCK
2	0971111-02-04A	EA	POCKET - LOCK - REAR DOOR - BLACK
3	081801-FN-000	EA	HINGE - DOOR - PIANO - 2" X 96" - BLACK
3	081801-V3-000	EA	HINGE - DOOR - PIANO - 2" X 96" - BRIGHT WHITE
4	156386-01-01A	FT	SEAL - BULB - .4" X .5" - W/ADHESIVE BACK
5	138290-02-000	EA	CASE - W/CAM - W/O CYLINDER/KEY
6	056795-01-000	FT	TAPE - SEAL - 1/8" X 3/8" WIDE - PRESS ON

**EXTERIOR DOORS & COMPARTMENTS GROUP (CONTINUED)**  
**COMPARTMENT DOOR PIECE PARTS (CONTINUED)**

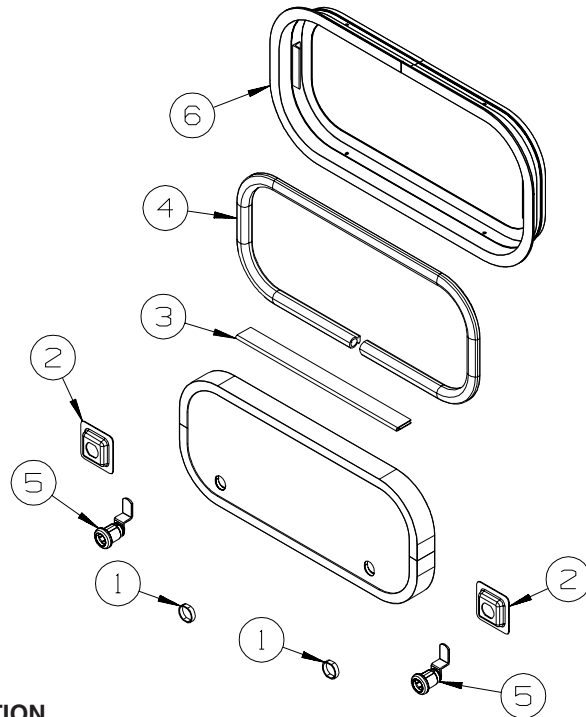

KEY	PART NUMBER	U/M	DESCRIPTION
1	144734-01-000	EA	SPACER - COMPARTMENT DOOR LOCK - 9/16" DEEP
1	139325-01-000	EA	SPACER - LOCK - 6MM - TRI/MARK KEY ONE
	139337-01-000	EA	GASKET - LOCK - TRI/MARK KEY ONE
2	097111-02-04A	EA	POCKET - LOCK - REAR DOOR - BLACK - TRI/MARK KEY ONE
3	081801-V3-000	EA	HINGE - DOOR - PIANO - 2" X 96" - BRIGHT WHITE
3	081801-FN-000	EA	HINGE - DOOR - PIANO - 2" X 96" - BLACK
4	156386-01-01A	FT	SEAL - BULB - .4" X .5" - W/ADHESIVE BACK
5	110506-27-000	EA	LOCK - TWIST - 1.6" - TWIST LOCK
	110506-55-000	EA	CASE/CYLINDER - TWIST LOCK - W/O CAM - 1.25" - 597312AA1 - TWIST LOCK
	110506-66-000	EA	CAM - LATCHING - DOG LEG - 1.5" LONG - TWIST LOCK
5	138290-02-000	EA	CASE - W/CAM - W/O CYLINDER/KEY - TRI/MARK KEY ONE
5	138637-04-000	EA	LOCK ASM. - KEYED - 1.5" CASE (CYLINDER/CAM/HDWR PKG) - KEYED LOCK
	110506-40-000	EA	CLIP-E, LOCK ASM - BRIGGS & STRATTON 93981- KEYED LOCK
	110506-41-000	EA	WASHER-TENSION LOCK ASM - BRIGGS & STRATTON 37512- KEYED LOCK
	110506-42-000	EA	NUT-LOCK ASM - BRIGGS & STRATTON 310878- KEYED LOCK
	110506-43-000	EA	WASHER-FLAT, LOCK ASM - BRIGGS & STRATTON 82089- KEYED LOCK
	110506-44-000	EA	GASKET-LOCK ASM - BRIGGS & STRATTON - #47701- KEYED LOCK
	110506-45-000	EA	WASHER - SPUR - BRIGGS & STRATTON - #94771 - KEYED LOCK
	144474-01-000	EA	ADAPTER - LOCK - 180 DEGREE- KEYED LOCK
	138637-63-000	EA	CAM - LATCHING - DOG LEG - 1 1/2" LONG- KEYED LOCK
	138637-53-000	EA	CASE/CYLINDER - LOCKING - W/O CAM/KEY - 1.5"- KEYED LOCK
	138637-53-001	EA	CASE/CYLINDER - LOCKING - W/O CAM/KEY - 1.5"- KEYED LOCK
	138637-53-002	EA	CASE/CYLINDER - LOCKING - W/O CAM/KEY - 1.5"- KEYED LOCK
	138637-53-003	EA	CASE/CYLINDER - LOCKING - W/O CAM/KEY - 1.5"- KEYED LOCK
	138637-53-004	EA	CASE/CYLINDER - LOCKING - W/O CAM/KEY - 1.5"- KEYED LOCK
	138637-53-005	EA	CASE/CYLINDER - LOCKING - W/O CAM/KEY - 1.5"- KEYED LOCK
	138637-53-006	EA	CASE/CYLINDER - LOCKING - W/O CAM/KEY - 1.5"- KEYED LOCK
	138637-53-007	EA	CASE/CYLINDER - LOCKING - W/O CAM/KEY - 1.5"- KEYED LOCK
	138637-53-008	EA	CASE/CYLINDER - LOCKING - W/O CAM/KEY - 1.5"- KEYED LOCK
	138637-53-009	EA	CASE/CYLINDER - LOCKING - W/O CAM/KEY - 1.5"- KEYED LOCK
6	056795-01-000	FT	TAPE-SEAL, 1/8" X 3/8" WIDE - PRESS ON

**EXTERIOR DOORS & COMPARTMENTS GROUP (CONTINUED)**  
**COMPARTMENT DOOR PIECE PARTS (CONTINUED)**

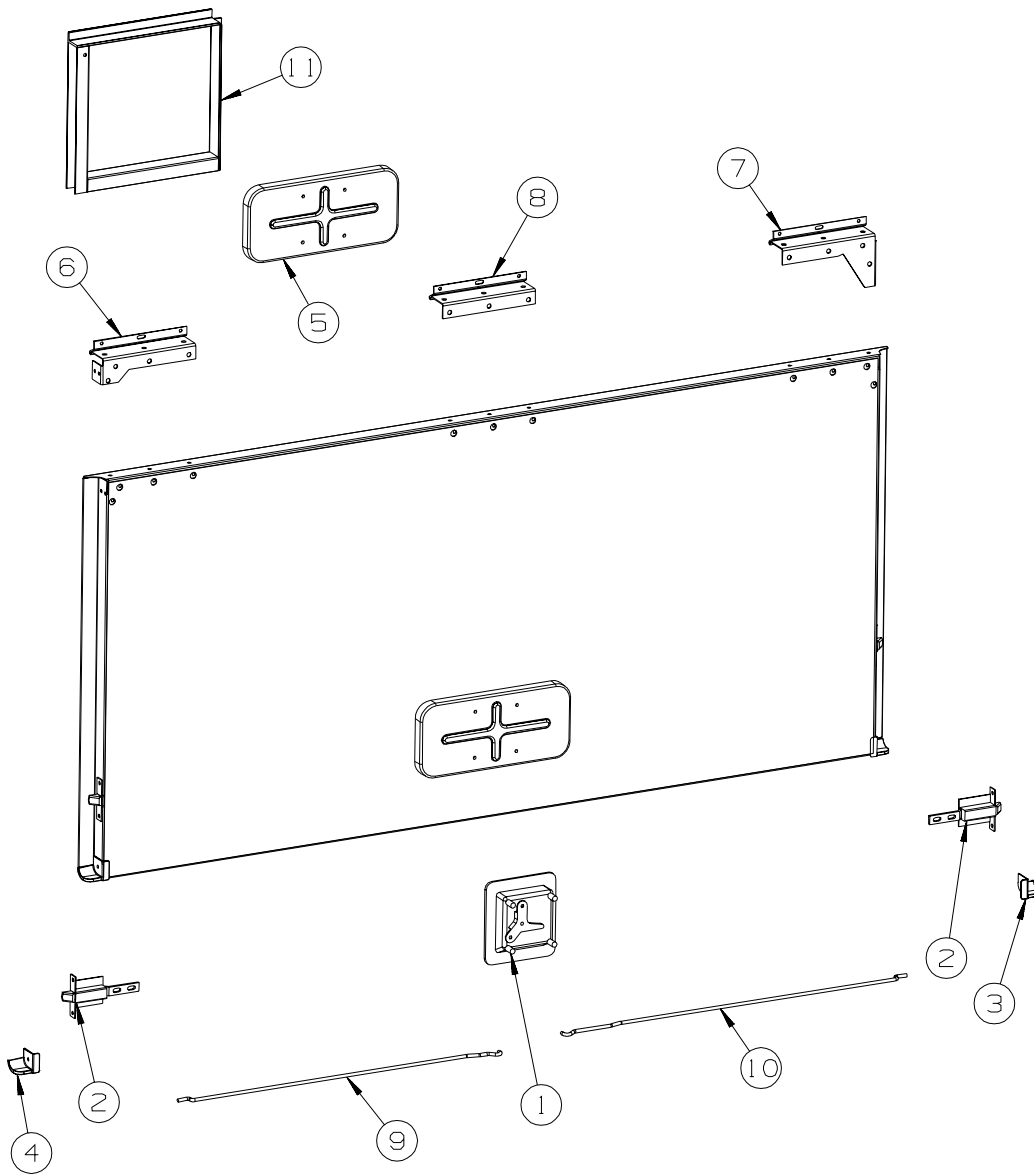

KEY	PART NUMBER	U/M	DESCRIPTION
1	154900-01-01A	EA	LATCH/PADDLE - LOCKING - COMPT DOOR - KEY ONE - BLACK
1	154900-01-02A	EA	LATCH/PADDLE - LOCKING - COMPT DOOR - KEY ONE - WHITE
1	154900-02-01A	EA	LATCH/PADDLE - NON LOCKING - COMPT DOOR - BLACK
1	154900-02-02A	EA	LATCH/PADDLE - NON LOCKING - COMPT DOOR - WHITE
2	121947-01-01A	EA	BOLT - SLIDE W/PLASTIC PLUNGER
3	135276-01-03A	EA	REINFORCEMENT - CORNER - LEFT HAND (FACING DOOR)-PARCHMENT
4	135276-02-03A	EA	REINFORCEMENT - CORNER -RIGHT HAND (FACING DOOR)-PARCHMENT
5	137359-01-01A	EA	COVER - LATCH - WHITE
6	139793-05-01A	EA	HINGE - LEFT HAND/VALANCE DOOR - W/O BALL STUD
6	139793-02-01A	EA	HINGE - VALANCE DOOR - W/BALL STUD - REAR PASSENGER
7	139793-01-01A	EA	HINGE - RIGHT HAND/VALANCE DOOR - W/BALL STUD
7	139793-04-01A	EA	HINGE - VALANCE DOOR - W/O BALL STUD - REAR PASSENGER
8	139793-03-01A	EA	HINGE - CENTER/VALANCE DOOR - W/O BALL STUD
9	132873-01-000	EA	ROD - LATCH (BLANK) - 37.3"
10	135624-71-01B	EA	ROD - LATCH (BLANK) - 37.3"
11	133049-07-T53	EA	TRIM - FUEL FILL

# EXTERIOR DOORS & COMPARTMENTS GROUP (CONTINUED)

## ENTRY

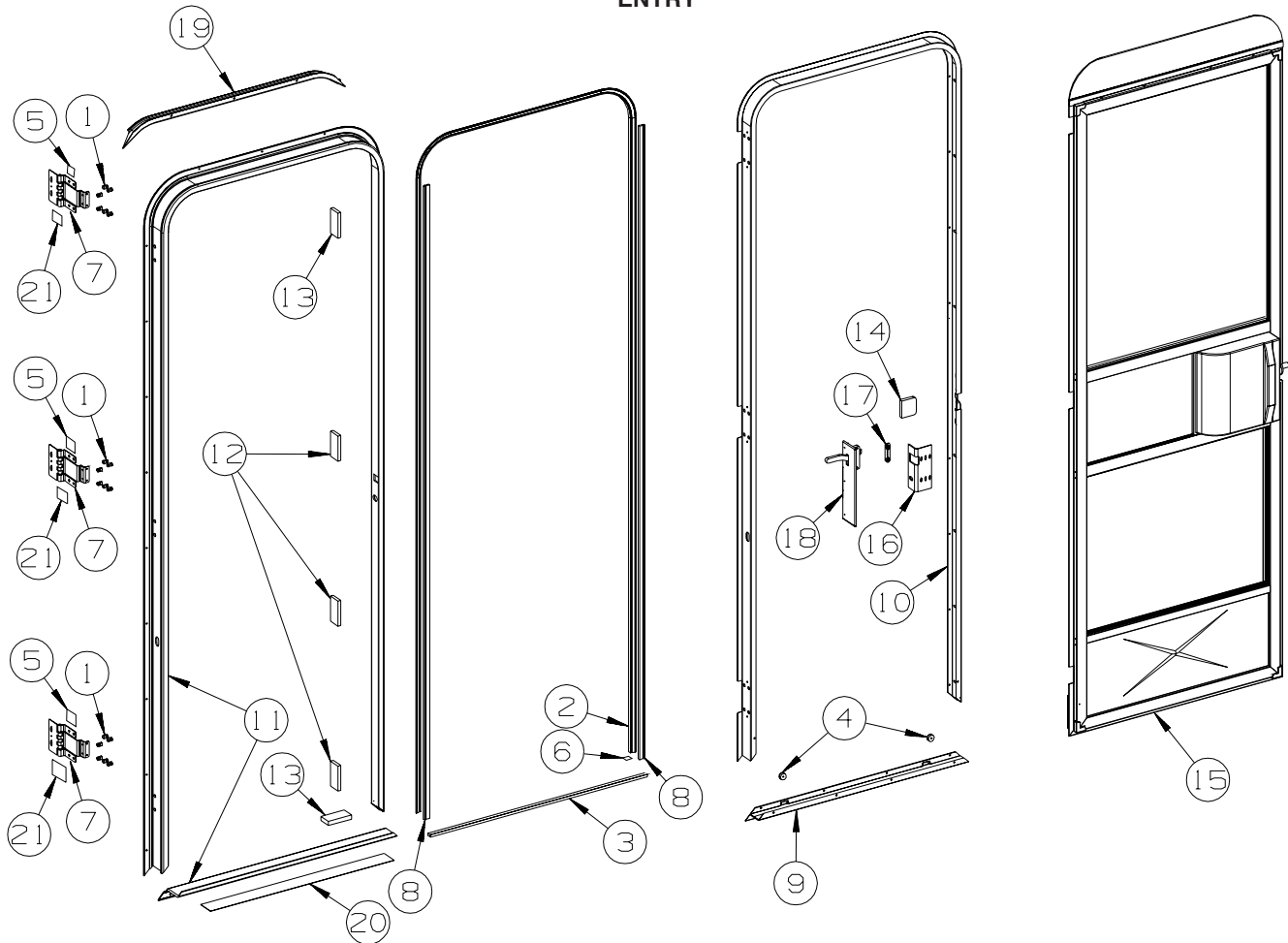

KEY	PART NUMBER	U/M	DESCRIPTION
1	039715-01-000	EA	NUT-SERT - 1/4" DIAMETER - 20 THREADS
2	075671-04-000	FT	SEAL - SPONGE - LAZY T - W/ADHESIVE STRIP - .5" WIDE
3	075673-05-000	FT	SEAL/PILE - .5" HIGH W/ADHESIVE BACK - BLACK
4	081914-02-000	EA	BUMPER - RUBBER - ROUND - 5/16" DIA. X 13/64" THICK
5	100128-02-000	FT	SEAL - FOAM/ADHESIVE BACK - .37" WIDE X .37" THICK
6	104692-01-000	FT	SEAL - ADHESIVE BACKED FOAM - 3/4" THICK X 3/4" WIDE X 25'
7	106719-01-05A	EA	HINGE - ENTRY DOOR - BRIGHT WHITE
8	118929-01-01A	FT	SEAL - PILE - PUSH ON
9	121893-03-02A	EA	FRAME - ENTRY DOOR/LOWER - BRIGHT WHITE
9	121893-03-03A	EA	FRAME - ENTRY DOOR/LOWER - BLACK
10	121894-27-01A	EA	FRAME - ENTRY DOOR - BRIGHT WHITE
10	121894-27-02A	EA	FRAME - ENTRY DOOR - BLACK
11	121898-14-01A	EA	JAMB - DOOR/ENTRANCE - BRIGHT WHITE
11	121898-14-02A	EA	JAMB - DOOR/ENTRANCE - BLACK
12	125724-01-000	EA	SHIM - DOOR, ENTRANCE
13	125724-02-000	EA	SHIM - DOOR, ENTRANCE
14	130096-05-000	EA	FOAM - SCREEN DOOR, RETAINER
15	P32208-02-L32	EA	DOOR - SCREEN - W/O HARDWARE - BRIGHT WHITE
16	137401-01-03B	EA	BRACKET - DOOR ANGLE - OFF WHITE
17	148364-01-12B	EA	STRIKE - SCREEN DOOR - BRIGHT WHITE
17	148364-01-04B	EA	STRIKE - SCREEN DOOR - BLACK
18	132915-01-01A	EA	LATCH - SCREEN DOOR - BLACK
19	139054-19-01A	EA	CAP - DRIP - JAMB MOUNTED - BRIGHT WHITE
19	139054-19-02A	EA	CAP - DRIP - JAMB MOUNTED - BLACK
20	038327-01-000	EA	TAPE - ANTI-SLIP - 2" X 60'
21	154585-01-01A	FT	SEAL - FOAM TAPE - ADHESIVE BACK - 3/8" X 3/8" - BLACK



**EXTERIOR DOORS & COMPARTMENTS GROUP (CONTINUED)**  
**ENTRY (CONTINUED)**

**PREMIUM HIGH GLOSS SIDEWALL AND FULL BODY PAINT**

<b>KEY</b>	<b>PART NUMBER</b>	<b>U/M</b>	<b>DESCRIPTION</b>
1	039715-01-000	EA	NUT-SERT - 1/4" DIAMETER - 20 THREADS
2	075671-04-000	FT	SEAL - SPONGE - LAZY T - W/ADHESIVE STRIP - .5" WIDE
3	075673-05-000	FT	SEAL/PILE - .5" HIGH W/ADHESIVE BACK - BLACK
4	081914-02-000	EA	BUMPER - RUBBER - ROUND - 5/16" DIA. X 13/64" THICK
5	100128-02-000	FT	SEAL - FOAM/ADHESIVE BACK - .37" WIDE X .37" THICK
6	104692-01-000	FT	SEAL - ADHESIVE BACKED FOAM - 3/4" THICK X 3/4" WIDE X 25'
7	106719-01-05A	EA	HINGE - ENTRY DOOR - BRIGHT WHITE
7	106719-01-08A	EA	HINGE - ENTRY DOOR - BLACK
8	118929-01-01A	FT	SEAL - PILE - PUSH ON
9	121893-03-02A	EA	FRAME - ENTRY DOOR/LOWER - BRIGHT WHITE
9	121893-03-03A	EA	FRAME - ENTRY DOOR/LOWER - BLACK
10	121894-27-01A	EA	FRAME - ENTRY DOOR - BRIGHT WHITE
10	121894-27-02A	EA	FRAME - ENTRY DOOR - BLACK
11	121898-14-01A	EA	JAMB - DOOR/ENTRANCE - BRIGHT WHITE
11	121898-14-02A	EA	JAMB - DOOR/ENTRANCE - BLACK
12	125724-01-000	EA	SHIM - DOOR, ENTRANCE
13	125724-02-000	EA	SHIM - DOOR, ENTRANCE
14	130096-05-000	EA	FOAM - SCREEN DOOR, RETAINER
15	P32208-02-L32	EA	DOOR - SCREEN - W/O HARDWARE - BRIGHT WHITE
15	P32208-02-S64	EA	DOOR - SCREEN - W/O HARDWARE - BLACK
16	137401-01-03B	EA	BRACKET - DOOR ANGLE - OFF WHITE
17	148364-01-12B	EA	STRIKE - SCREEN DOOR - BRIGHT WHITE
17	148364-01-04B	EA	STRIKE - SCREEN DOOR - BLACK
18	132915-01-01A	EA	LATCH - SCREEN DOOR - BLACK
19	139054-19-01A	EA	CAP - DRIP - JAMB MOUNTED - BRIGHT WHITE
19	139054-19-02A	EA	CAP - DRIP - JAMB MOUNTED - BLACK
20	038327-01-000	EA	TAPE - ANTI-SLIP - 2" X 60'
21	154585-01-01A	FT	SEAL - FOAM TAPE - ADHESIVE BACK - 3/8" X 3/8" - BLACK

## EXTERIOR DOORS & COMPARTMENTS GROUP (CONTINUED)

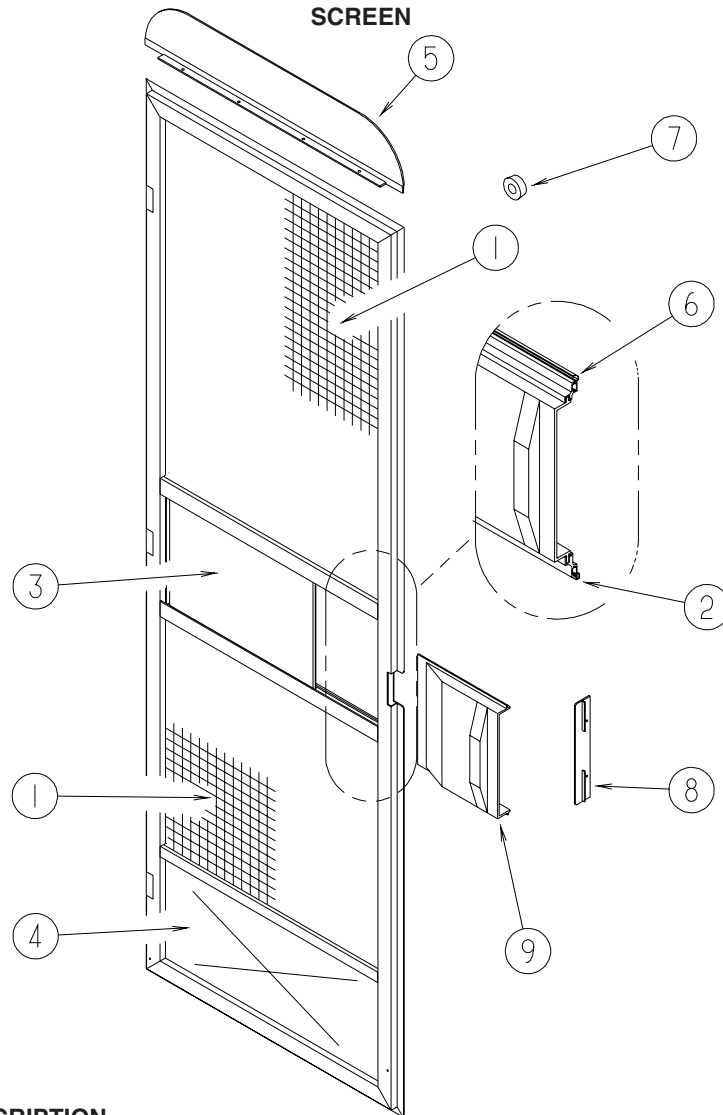

KEY	PART NUMBER	U/M	DESCRIPTION
1	002293-02-000	SF	SCREEN - 26" - CHARCOAL
2	002294-01-000	FT	SPLINE - SCREENING - .13" X .14"
3	016454-18-000	EA	INSERT/CENTER - SCREEN DOOR
4	078552-09-000	EA	INSERT - SCREEN DOOR - LOWER
5	078595-03-000	EA	PLATE - SCREEN DOOR
6	078777-08-000	FT	CHANNEL - SLIDER - 4 FOOT INCREMENTS
7	120863-09-000	EA	BUMPER - RUBBER/RADIUS TOP - 3/4" X 3/8" - LT GRAY
8	132081-01-01A	EA	STRIKE - SLIDER - SCREEN DOOR - BRIGHT WHITE
8	132081-01-03A	EA	STRIKE - SLIDER - SCREEN DOOR - BLACK
9	132082-01-01A	EA	SLIDER - SCREEN DOOR - BRIGHT WHITE
9	132082-01-03A	EA	SLIDER - SCREEN DOOR - BLACK

# EXTERIOR DOORS & COMPARTMENTS GROUP (CONTINUED)

## LATCH

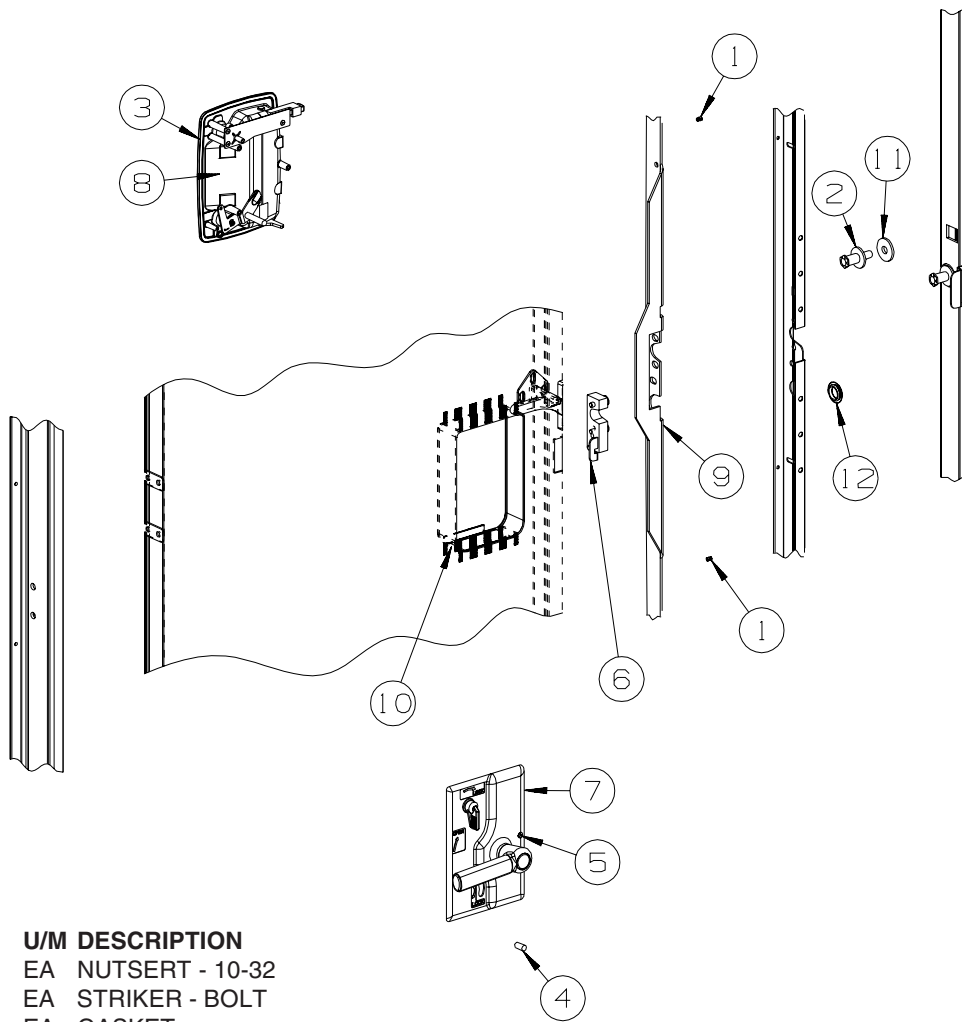

KEY	PART NUMBER	U/M	DESCRIPTION
1	072893-04-000	EA	NUTSERT - 10-32
2	092927-20-000	EA	STRIKER - BOLT
3	112782-04-01A	EA	GASKET
4	112782-05-01A	EA	CAP - VINYL - RED
5	112782-08-01A	EA	SCREW - MOUNTING/PLATE - ZINC
6	112782-22-01A	EA	LATCH - SINGLE ROTOR
7	112782-27-01A	EA	LATCH - INTERIOR PLATE - WHITE
8	112782-20-01A	EA	LATCH - EXTERIOR - W/O LOCK CYLINDER W/ICON-REVERSIBLE KEY
9	132207-01-02B	EA	STIFFENER/DOOR - FORMED - E-COATED
10	137230-01-01A	EA	SPACER - NOTCHED, MILL
11	147900-01-01A	EA	SPACER - STRIKE BOLT, MILL
12	061420-14-000	EA	PLUG/PLASTIC - 7/8" DIAMETER - BLACK

## EXTERIOR SLIDEOUT GROUP LEFT FRONT

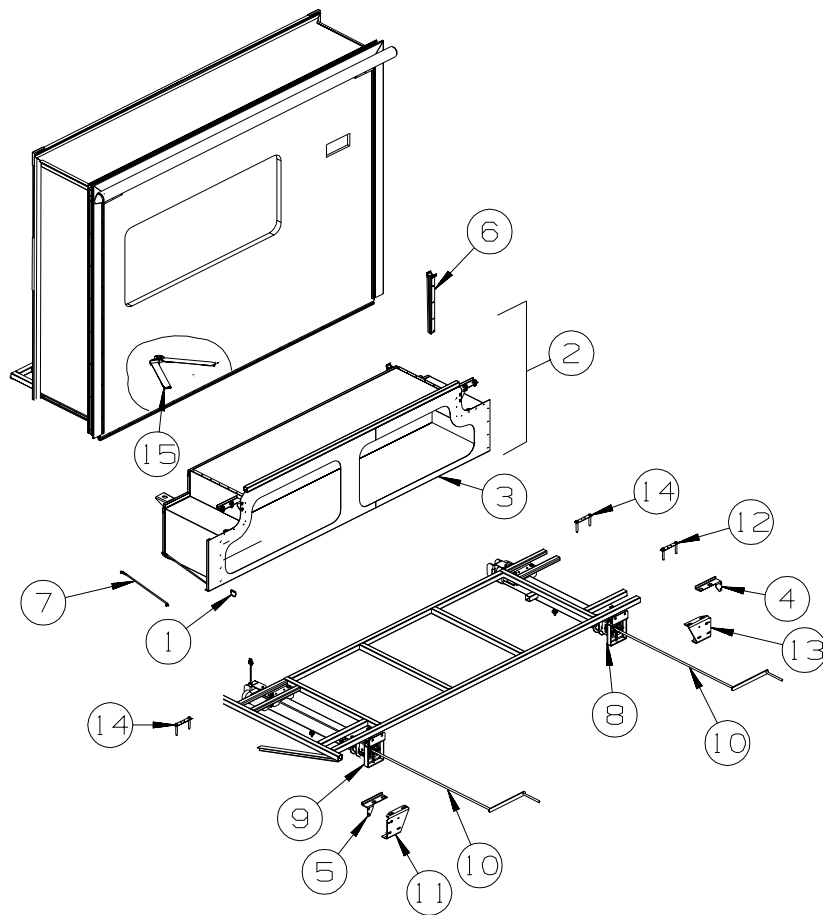

KEY	PART NUMBER	U/M	DESCRIPTION
1	126516-01-01A	FT	TRIM - VINYL/EXTRUDED - 8'
2	141162-10-S28	EA	COMPARTMENT - F/SLIDEOUT
3	137064-12-02B	EA	SEAL PLANE - F/SLIDEOUT - E-COATED
4	125888-05-02B	EA	BRACKET/SLIDEOUT COMPARTMENT - RIGHT HAND - E-COATED
5	125888-06-02B	EA	BRACKET/SLIDEOUT COMPARTMENT - LEFT HAND - E-COATED
6	126591-01-02B	EA	CARRIER/EXTENSION - F/SLIDEOUT-F/WIRE/HOSES - E-COATED
7	107865-26-000	EA	ROD - SUPPORT - VALANCE PANEL - 18.9"
8*	162827-01-000	EA	SLIDEOUT - ELECTRIC 20" - RIGHT HAND
9*	162827-02-000	EA	SLIDEOUT - ELECTRIC 20" - LEFT HAND
10	138173-05-000	EA	WRENCH - RETRACT CRANK HANDLE - F/SLIDEOUT
11	127030-07-02B	EA	BRACKET - INNER FRONT/MOUNT - E-COATED
12	136995-05-02B	EA	PLATE W/BOLTS - 5.9" X 1" W/7/16" X 3" BOLTS
13	127030-08-02B	EA	BRACKET - INNER REAR/MOUNT - E-COATED
14	136995-03-02B	EA	PLATE W/BOLTS - 6.9" X 2" W/1/2" X 3" BOLTS
15	160167-01-01A	EA	SEAT BELT - 2" X 102" - BLACK

**\*COMPONENT PARTS LISTED LATER IN THIS GROUP**

**EXTERIOR SLIDEOUT GROUP (CONTINUED)**  
**LEFT FRONT (CONTINUED)**

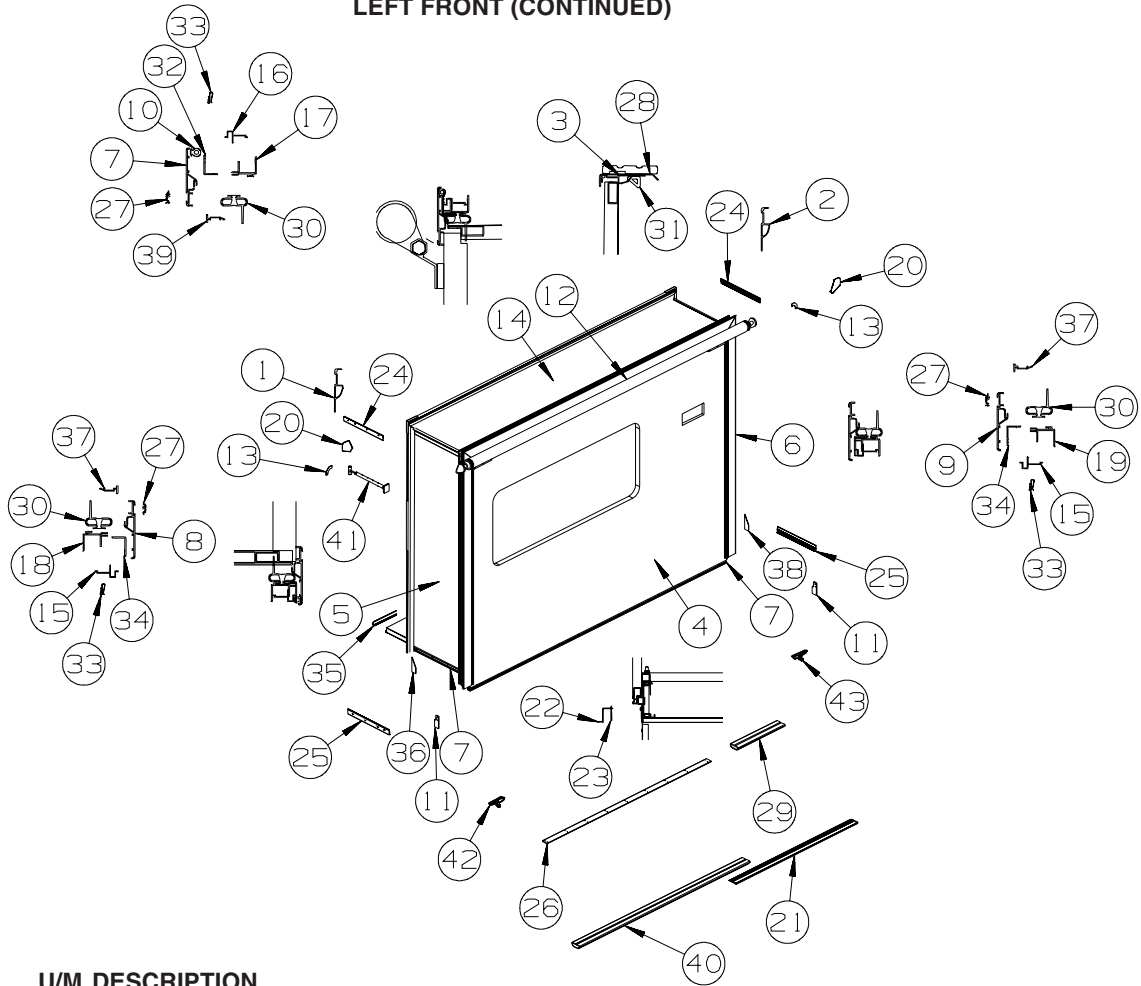

KEY	PART NUMBER	U/M	DESCRIPTION
1	139624-01-02A	EA	TRIM/SEAL - INNER/RIGHT HAND - 73.4" - ALMOND
2	139624-02-02A	EA	TRIM/SEAL - INNER/LEFT HAND - 73.4" - ALMOND
3	139624-23-02A	EA	TRIM/SEAL - INNER/TOP - 105.3" - ALMOND
4	162338-11-W51	EA	SLUG - F/SLIDEOUT (W57, W58)
4	162338-11-W59	EA	SLUG - F/SLIDEOUT (W59, W60, W61, W62)
4	162338-13-W51	EA	SLUG - F/SLIDEOUT (W57, W58) - PREMIUM HIGH GLOSS SIDEWALL
4	162338-13-W59	EA	SLUG - F/SLIDEOUT (W59, W60, W61, W62) - PREMIUM HIGH GLOSS SIDEWALL
5	153296-08-U57	EA	PANEL END - F/SLIDEOUT (W57, W58)
			FROM: 00-00-00 THRU: 03-04-07
5	162977-07-U57	EA	PANEL END - F/SLIDEOUT (W57, W58)
			FROM: 03-05-07 THRU: 99-99-99
5	153296-08-W59	EA	PANEL END - F/SLIDEOUT (W59, W60, W61, W62)
			FROM: 00-00-00 THRU: 03-04-07
5	162977-07-W59	EA	PANEL END - F/SLIDEOUT (W59, W60, W61, W62)
			FROM: 03-05-07 THRU: 99-99-99
5	153296-13-U57	EA	PANEL END - F/SLIDEOUT (W57, W58) - PREMIUM HIGH GLOSS SIDEWALL
			FROM: 00-00-00 THRU: 03-04-07
5	162977-09-U57	EA	PANEL END - F/SLIDEOUT (W57, W58) - PREMIUM HIGH GLOSS SIDEWALL
			FROM: 03-05-07 THRU: 99-99-99
5	153296-13-W59	EA	PANEL END - F/SLIDEOUT (W59, W60, W61, W62) - PREMIUM HIGH GLOSS SIDEWALL
			FROM: 00-00-00 THRU: 03-04-07
5	162977-09-W59	EA	PANEL END - F/SLIDEOUT (W59, W60, W61, W62) - PREMIUM HIGH GLOSS SIDEWALL
			FROM: 03-05-07 THRU: 99-99-99
6	153297-08-U57	EA	PANEL END - F/SLIDEOUT (W57, W58)
			FROM: 00-00-00 THRU: 03-04-07
6	162977-03-U57	EA	PANEL END - F/SLIDEOUT (W57, W58)
			FROM: 03-05-07 THRU: 07-15-07
6	162977-24-WN1	EA	PANEL END - F/SLIDEOUT (W57, W58)
			FROM: 07-16-07 THRU: 99-99-99

**EXTERIOR SLIDEOUT GROUP (CONTINUED)**  
**LEFT FRONT (CONTINUED)**

KEY	PART NUMBER	U/M	DESCRIPTION
6	153297-08-W59	EA	PANEL END - F/SLIDEOUT (W59, W60, W61, W62) FROM: 00-00-00 THRU: 03-04-07
6	162977-03-W59	EA	PANEL END - F/SLIDEOUT (W59, W60, W61, W62) FROM: 03-05-07 THRU: 07-15-07
6	162977-24-W59	EA	PANEL END - F/SLIDEOUT (W59, W60, W61, W62) FROM: 07-16-07 THRU: 99-99-99
6	153297-13-U57	EA	PANEL END - F/SLIDEOUT (W57, W58) - PREMIUM HIGH GLOSS SIDEWALL FROM: 00-00-00 THRU: 03-04-07
6	162977-04-U57	EA	PANEL END - F/SLIDEOUT (W57, W58) - PREMIUM HIGH GLOSS SIDEWALL FROM: 03-05-07 THRU: 07-15-07
6	162977-25-W51	EA	PANEL END - F/SLIDEOUT (W57, W58) - PREMIUM HIGH GLOSS SIDEWALL FROM: 07-16-07 THRU: 99-99-99
6	153297-13-W59	EA	PANEL END - F/SLIDEOUT (W59, W60, W61, W62) - PREMIUM HIGH GLOSS SIDEWALL FROM: 00-00-00 THRU: 03-04-07
6	162977-04-W59	EA	PANEL END - F/SLIDEOUT (W59, W60, W61, W62) - PREMIUM HIGH GLOSS SIDEWALL FROM: 03-05-07 THRU: 07-15-07
6	162977-25-W53	EA	PANEL END - F/SLIDEOUT (W59, W60, W61, W62) - PREMIUM HIGH GLOSS SIDEWALL FROM: 07-16-07 THRU: 99-99-99
7	156417-16-01A	EA	TRIM/SEAL - W/MITERED ENDS - 103.6" - BRIGHT WHITE FROM: 00-00-00 THRU: 03-04-07
7	162052-16-01A	EA	TRIM/SEAL - W/MITERED ENDS - 103.6" - BRIGHT WHITE FROM: 03-05-07 THRU: 99-99-99
7	162052-16-02A	EA	TRIM/SEAL - W/MITERED ENDS - 103.6" - BLACK
8	156417-23-01A	EA	TRIM/SEAL - W/MITERED ENDS - 74.5" - BRIGHT WHITE FROM: 00-00-00 THRU: 03-04-07
8	162052-23-01A	EA	TRIM/SEAL - W/MITERED ENDS - 74.5" - BRIGHT WHITE FROM: 03-05-07 THRU: 99-99-99
8	162052-23-02A	EA	TRIM/SEAL - W/MITERED ENDS - 74.5" - BLACK
9	156417-24-01A	EA	TRIM/SEAL - W/MITERED ENDS - 74.5" - BRIGHT WHITE FROM: 00-00-00 THRU: 03-04-07
9	162052-24-01A	EA	TRIM/SEAL - W/MITERED ENDS - 74.5" - BRIGHT WHITE FROM: 03-05-07 THRU: 99-99-99
9	162052-24-02A	EA	TRIM/SEAL - W/MITERED ENDS - 74.5" - BLACK
10	158297-01-000	FT	SEAL - BULB - .5" X .7" - ADHESIVE BACK - BLACK
11	126546-03-03A	EA	COVER - END/SIDEWALL - BLACK
12			SLIDEOUT AWNING

**ORDER AWNINGS & REPAIR PARTS FROM DOMETIC. CALL #800-366-3842.**  
**THE DOMETIC AWNING INFORMATION YOU WILL NEED IS LOCATED ON THE MOTOR HOME NEAR**  
**THE TOP OF THE AWNING RAIL.**

13	156416-01-12B	EA	BRACKET - CORNER TRIM/SLIDEOUT - 3.1"X 3.1" - BRIGHT WHITE - NOT ILLUSTRATED FROM: 00-00-00 THRU: 11-05-06
13	156416-01-02B	EA	BRACKET - CORNER TRIM/SLIDEOUT - 3.1"X 3.1" - E-COATED - NOT ILLUSTRATED FROM: 11-06-07 THRU: 12-31-06- NOT ILLUSTRATED
13	160421-01-01A	EA	CORNER TRIM/SLIDEOUT - 3.1"X 3.1" - BLACK FROM: 01-01-07 THRU: 99-99-99
14	153716-03-T53	EA	ROOF - F/SLIDEOUT
15	142718-01-01A	EA	RETAINER - SIDEWALL/SLIDEOUT - 72.8"
16	142718-16-01A	EA	RETAINER - SIDEWALL/SLIDEOUT - 104.7"
17	151761-16-02A	EA	TRIM - SIDEWALL/SLIDEOUT/TOP - 106.3" - ALMOND
18	151760-04-02A	EA	TRIM - SIDEWALL/SLIDEOUT - 74.5" - ALMOND
19	151760-03-02A	EA	TRIM - SIDEWALL/SLIDEOUT - 74.5" - ALMOND
20	156151-01-01A	EA	PROTECTOR - CORNER - SLIDEOUT - BLACK
21	134837-01-01A	EA	RAMP - SLIDEOUT - BLACK PVC
22	128621-40-01A	EA	BRACKET/ZEE - SLIDEOUT - 100.4" - MILL
23	115075-03-000	FT	SEAL - WIPE - .25" X 2.9"
24	158375-03-01A	EA	TRIM - FEATURE STRIP - 20.6" - BRIGHT WHITE
24	158375-03-02A	EA	TRIM - FEATURE STRIP - 20.6" - BLACK

**EXTERIOR SLIDEOUT GROUP (CONTINUED)**  
**LEFT FRONT (CONTINUED)**

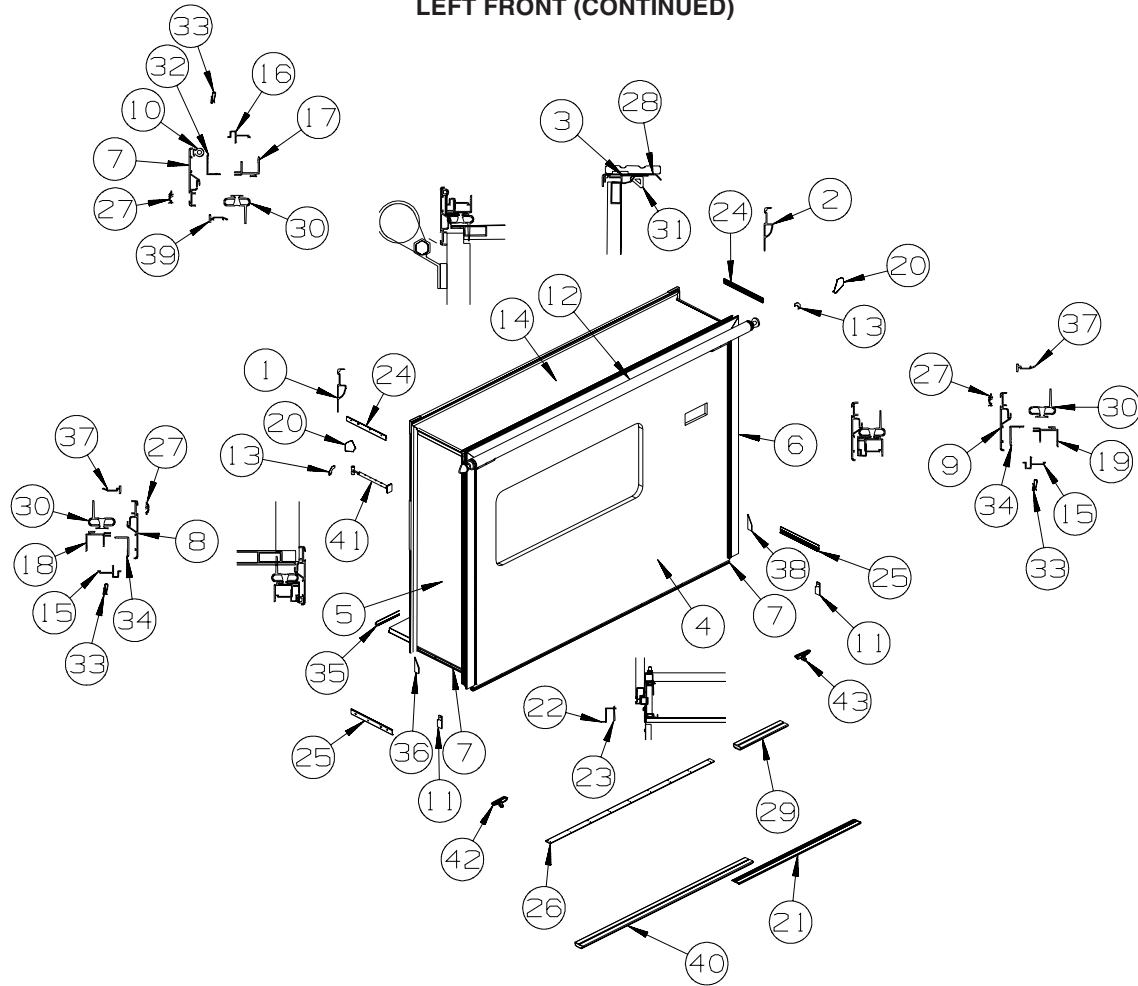

KEY	PART NUMBER	U/M	DESCRIPTION
25	158030-01-01A	EA	TRIM - FEATURE STRIP/LOWER - 2.3" X 20" - BRIGHT WHITE - <b>NOT ILLUSTRATED</b> FROM: 00-00-00 THRU: 03-04-07
25	163020-06-01A	EA	TRIM - FEATURE STRIP/LOWER - 2.3" X 19.8" - BRT WHT FROM: 03-05-07 THRU: 99-99-99
25	163020-06-02A	EA	TRIM - FEATURE STRIP/LOWER - 2.3" X 19.8" - BLACK
26	152641-01-000	EA	SKID/GLIDE - SLIDEOUT ROOM - 1/4"X2"X95.5" - POLYETHYLENE
27	105312-01-07A	FT	INSERT - FEATURE STRIP - VINYL - BRIGHT WHITE
28	125466-09-04A	EA	SUPPORT - ROOF/INTERIOR - ALMOND
29	134756-03-M30	EA	RAMP - FABRIC COVERED - SLIDEOUT - 18.3"
31	146056-01-000	FT	SEAL - TRIANGLE - W/PSA
32	162052-24-01A	EA	TRIM/SEAL - W/MITERED ENDS - 74.5" - BRIGHT WHITE
32	162052-24-02A	EA	TRIM/SEAL - W/MITERED ENDS - 74.5" - BLACK
33	142549-01-000	EA	CLIP - "S" TYPE
34	136824-45-01A	EA	TRIM - SIDEWALL/SLIDEOUT - 74.4"
34	136824-45-02A	EA	TRIM - SIDEWALL/SLIDEOUT - 74.4" - BLACK
35	151282-12-01A	EA	TRIM - CARPET EDGE/F-ANGLE - 72.5" - BLACK
36	157809-01-01A	EA	SEAL - FOAM BLOCK/RIGHT SIDE - ADHESIVE BACK
37	146606-48-01A	EA	TRIM/RETAINER - 69.3" - BRIGHT WHITE
37	146606-48-02A	EA	TRIM/RETAINER - 69.3" - BLACK
38	157809-02-01A	EA	SEAL - FOAM BLOCK/LEFT SIDE - ADHESIVE BACK
39	146606-70-01A	EA	TRIM/RETAINER - 98.3" - BRIGHT WHITE
39	146606-70-02A	EA	TRIM/RETAINER - 98.3" - BLACK
40	134756-01-L76	EA	RAMP - FABRIC COVERED - F/SLIDEOUT - 66.9" - <b>FLOORCOVERING-VINYL-THRU OUT</b> FROM: 00-00-00 THRU: 08-12-07
40	134756-12-W51	EA	RAMP - FABRIC COVERED - F/SLIDEOUT - 59" FROM: 08-13-07 THRU: 99-99-99
41	160471-02-01A	EA	PAN/DRAIN - FLOOR/RH SLIDEOUT - BLACK
42	160471-01-01A	EA	PAN/DRAIN - FLOOR/RH SLIDEOUT - BLACK
43	162495-01-01A	EA	ROD - LOCK/SLIDEOUT - ADJUSTABLE 17"/34" - W/STRAP/RING

**EXTERIOR SLIDEOUT GROUP (CONTINUED)**  
**COMPONENT PARTS FOR LEFT FRONT**

162827-01-000, 162827-02-000

<b>KEY</b>	<b>PART NUMBER</b>	<b>U/M</b>	<b>DESCRIPTION</b>	<b>VENDOR NO.</b>
	130294-04-700	EA	SCREW - 5/16"-18 X 1 1/2"	1202060
	131281-01-704	EA	HAIRPIN/COTTER - 3/8" SPRING	1213460
	131682-01-700	EA	ROLLER - (BEARING)	1912040
	138173-01-701	EA	POP RIVET - SS 3/16"X1/4"	1214630
	138173-01-707	EA	WEAR PUCK - PLASTIC F/DRIVE	1612523
	140457-01-701	EA	ROLLER - 1"OD X 1/2"ID	1614006
	140457-01-704	EA	SHAFT/AXLE - REAR ROLLER	7204523
	148875-01-702	EA	PIN/ROLL - 1/4" X 1"	1213701
	148875-01-703	EA	NUT - PLASTIC - 1"	1612548
	148875-01-704	EA	END CARRIER - PLASTIC - 1"	1612549
	148875-01-705	EA	MOTOR/LINEAR - SLIDE ROOM	1820111
	148875-01-707	EA	END GUIDE F/SCREW - 1"	1820450
	148875-01-708	EA	TUBE - OUTER - F/SLIDE RAM	7201200
	149165-01-701	EA	PIN/CLEVIS - 1/4" X 2"	1213204
	151027-01-700	EA	DRIVE SCREW 1" X 20"	1820402
	151027-01-701	EA	ROLL PIN - 3/16" X 1"	1213694
	151027-01-702	EA	CLEVIS PIN - 1/4" X 1 1/4"	1213202
	162827-01-700	EA	TUBE OUT STOP - ADJUSTABLE	7201198
	162832-01-700	EA	CLEVIS PIN - 5/16" X 2 1/4"	1213239
	162832-01-702	EA	NUT - 1" PLASTIC W/5/16" PIN	1612554



# EXTERIOR SLIDEOUT GROUP (CONTINUED)

LEFT REAR

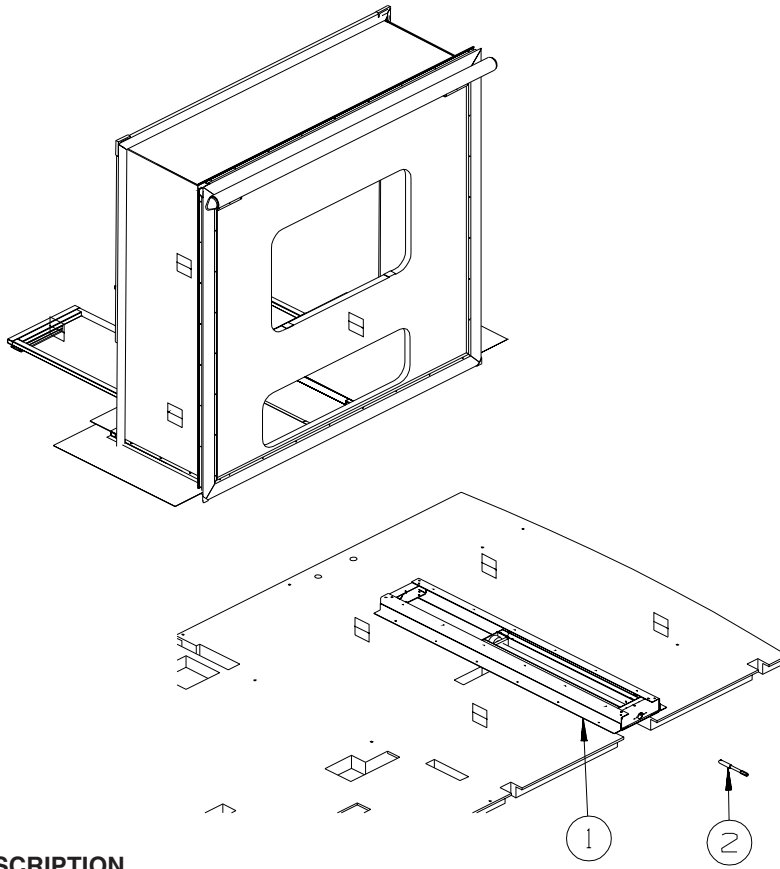

KEY	PART NUMBER	U/M	DESCRIPTION
1*	162834-01-000	EA	SLIDE ARM ASSEMBLY - 24"/REAR - ELECTRIC
2	140464-03-000	EA	WRENCH - SLIDE ROOM RETRACT - RATCHET W/2 EXTENSIONS

**\*COMPONENT PARTS LISTED LATER IN THIS GROUP**

**EXTERIOR SLIDEOUT GROUP (CONTINUED)**  
**LEFT REAR (CONTINUED)**

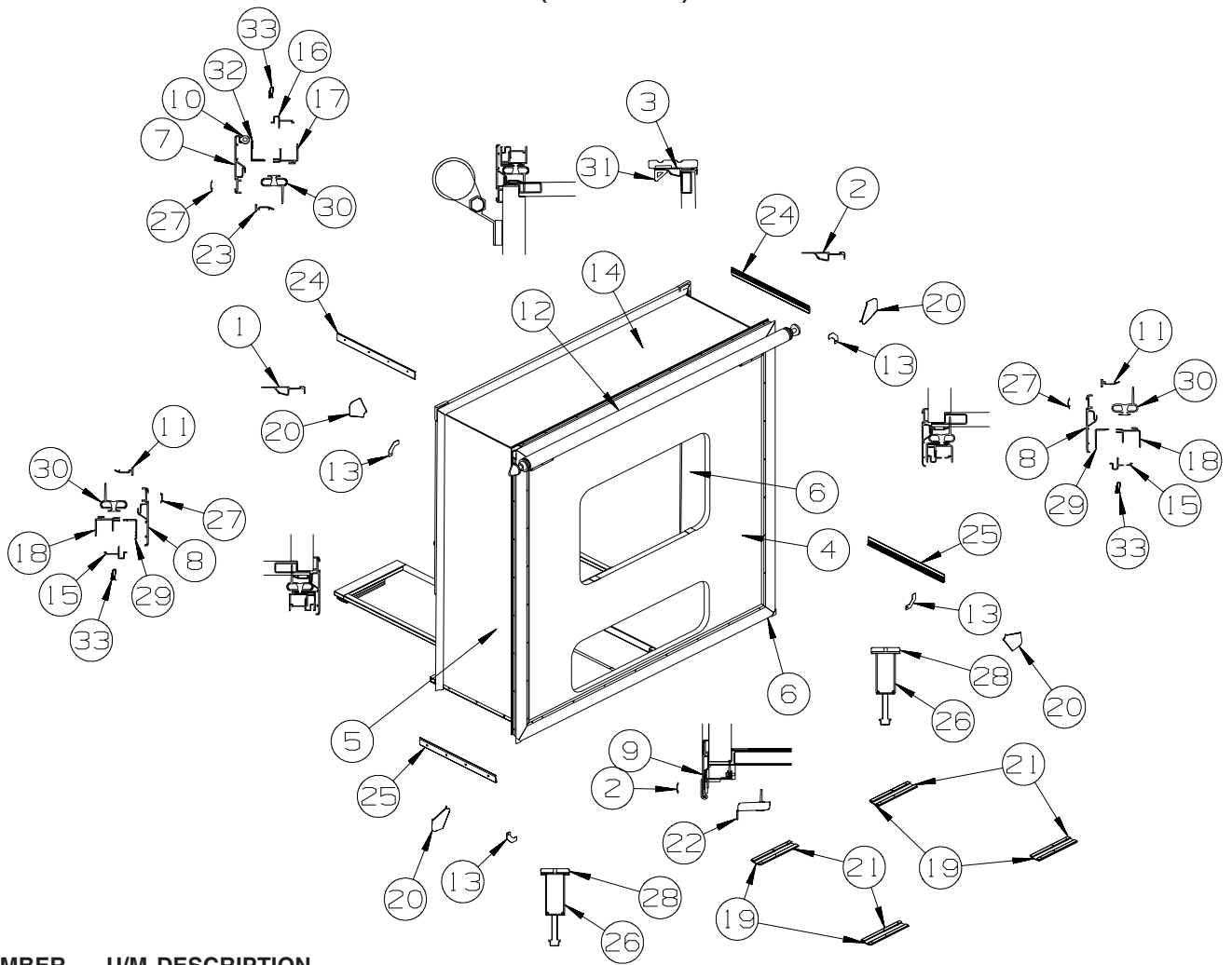

KEY	PART NUMBER	U/M	DESCRIPTION
1	139624-15-02A	EA	TRIM/SEAL - INNER/RIGHT HAND - 72.9" - ALMOND
2	139624-16-02A	EA	TRIM/SEAL - INNER/LEFT HAND - 72.9" - ALMOND
3	139624-04-02A	EA	TRIM/SEAL - INNER/TOP - 80.2" - ALMOND
4	162338-12-W51	EA	SLUG - F/SLIDEOUT (W57, W58)
4	162338-12-W59	EA	SLUG - F/SLIDEOUT (W59, W60, W61, W62)
4	162338-14-W51	EA	SLUG - F/SLIDEOUT (W57, W58) - PREMIUM HIGH GLOSS SIDEWALL
4	162338-14-W59	EA	SLUG - F/SLIDEOUT (W59, W60, W61, W62) - PREMIUM HIGH GLOSS SIDEWALL
5	153296-03-U57	EA	PANEL END - F/SLIDEOUT (W57, W58)
			FROM: 00-00-00 THRU: 03-04-07
5	162978-01-W51	EA	PANEL END - F/SLIDEOUT (W57, W58)
			FROM: 03-05-07 THRU: 99-99-99
5	153296-03-W59	EA	PANEL END - F/SLIDEOUT (W59, W60, W61, W62)
			FROM: 00-00-00 THRU: 03-04-07
5	162978-01-W59	EA	PANEL END - F/SLIDEOUT (W59, W60, W61, W62)
			FROM: 03-05-07 THRU: 99-99-99
5	153296-10-U57	EA	PANEL END - F/SLIDEOUT (W57, W58) - PREMIUM HIGH GLOSS SIDEWALL
			FROM: 00-00-00 THRU: 03-04-07
5	162978-02-W51	EA	PANEL END - F/SLIDEOUT (W57, W58) - PREMIUM HIGH GLOSS SIDEWALL
			FROM: 03-05-07 THRU: 99-99-99
5	153296-10-W59	EA	PANEL END - F/SLIDEOUT (W59, W60, W61, W62) - PREMIUM HIGH GLOSS SIDEWALL
			FROM: 00-00-00 THRU: 03-04-07
5	162978-02-W59	EA	PANEL END - F/SLIDEOUT (W59, W60, W61, W62) - PREMIUM HIGH GLOSS SIDEWALL
			FROM: 03-05-07 THRU: 99-99-99
6	153297-03-U57	EA	PANEL END - F/SLIDEOUT (W57, W58)
			FROM: 00-00-00 THRU: 03-04-07
6	162978-03-W51	EA	PANEL END - F/SLIDEOUT (W57, W58)
			FROM: 03-05-07 THRU: 99-99-99
6	153297-03-W59	EA	PANEL END - F/SLIDEOUT (W59, W60, W61, W62)
			FROM: 00-00-00 THRU: 03-04-07

**EXTERIOR SLIDEOUT GROUP (CONTINUED)**  
**LEFT REAR (CONTINUED)**

KEY	PART NUMBER	U/M	DESCRIPTION
6	162978-03-W59	EA	PANEL END - F/SLIDEOUT (W59, W60, W61, W62) FROM: 03-05-07 THRU: 99-99-99
6	153297-11-U57	EA	PANEL END - F/SLIDEOUT (W57, W58) - PREMIUM HIGH GLOSS SIDEWALL FROM: 00-00-00 THRU: 03-04-07
6	162978-04-W51	EA	PANEL END - F/SLIDEOUT (W57, W58) - PREMIUM HIGH GLOSS SIDEWALL FROM: 03-05-07 THRU: 99-99-99
6	153297-11-W59	EA	PANEL END - F/SLIDEOUT (W59, W60, W61, W62) - PREMIUM HIGH GLOSS SIDEWALL FROM: 00-00-00 THRU: 03-04-07
6	162978-04-W59	EA	PANEL END - F/SLIDEOUT (W59, W60, W61, W62) - PREMIUM HIGH GLOSS SIDEWALL FROM: 03-05-07 THRU: 99-99-99
7	156417-01-01A	EA	TRIM/SEAL - W/MITERED ENDS - 76.5" - BRIGHT WHITE FROM: 00-00-00 THRU: 03-04-07
7	162052-01-01A	EA	TRIM/SEAL - W/MITERED ENDS - 78.4" - BRIGHT WHITE FROM: 03-05-07 THRU: 99-99-99
7	162052-01-02A	EA	TRIM/SEAL - W/MITERED ENDS - 78.4" - BLACK
8	156417-09-01A	EA	TRIM/SEAL - W/MITERED ENDS - 76.3" - BRIGHT WHITE FROM: 00-00-00 THRU: 03-04-07
8	162052-09-01A	EA	TRIM/SEAL - W/MITERED ENDS - 76.3" - BRIGHT WHITE FROM: 03-04-07 THRU: 99-99-99
8	162052-09-02A	EA	TRIM/SEAL - W/MITERED ENDS - 76.3" - BLACK
9	142233-20-01A	EA	TRIM/SEAL - W/MITERED ENDS - 78.4" - BRIGHT WHITE FROM: 00-00-00 THRU: 03-04-07
9	162054-02-01A	EA	TRIM/SEAL - W/MITERED ENDS - 78.4" - BRIGHT WHITE FROM: 03-05-07 THRU: 99-99-99
9	162054-02-02A	EA	TRIM/SEAL - W/MITERED ENDS - 78.4" - BLACK
10	158297-01-000	FT	SEAL - BULB - .5" X .7" - ADHESIVE BACK - BLACK
11	146606-46-01A	EA	TRIM/RETAINER - 68.8" - BRIGHT WHITE
11	146606-46-02A	EA	TRIM/RETAINER - 68.8" - BLACK
12			SLIDEOUT AWNING

**ORDER AWNINGS & REPAIR PARTS FROM DOMETIC. CALL #800-366-3842.**  
**THE DOMETIC AWNING INFORMATION YOU WILL NEED IS LOCATED ON THE MOTOR HOME NEAR**  
**THE TOP OF THE AWNING RAIL.**

13	156416-01-12B	EA	BRACKET - CORNER TRIM/SLIDEOUT - 3.1" X 3.1" - BRIGHT WHITE - NOT ILLUSTRATED FROM: 00-00-00 THRU: 11-05-06
13	156416-01-02B	EA	BRACKET - CORNER TRIM/SLIDEOUT - 3.1"X 3.1" - E-COATED - NOT ILLUSTRATED FROM: 11-06-06 THRU: 12-31-06
13	160421-01-01A	EA	CORNER TRIM/SLIDEOUT - 3.1"X 3.1" - BLACK FROM: 01-01-07 THRU: 99-99-99
14	136557-01-S01	EA	ROOF - F/SLIDEOUT
15	142718-01-01A	EA	RETAINER - SIDEWALL/SLIDEOUT - 72.8"
16	142718-23-01A	EA	RETAINER - SIDEWALL/SLIDEOUT - 79.9"
17	151761-02-02A	EA	TRIM - SIDEWALL/SLIDEOUT/TOP - 81.2" - ALMOND
18	151760-18-02A	EA	TRIM - SIDEWALL/SLIDEOUT - 72.3" - ALMOND
19	115661-01-000	FT	SHOE/GLIDE - SLIDEOUT ROOM - 1/16" X 3" - POLYETHYLENE
20	156151-01-02A	EA	PROTECTOR - CORNER - SLIDEOUT - BRIGHT WHITE
21	115325-08-01A	EA	RAIL - FLOOR/SLIDEOUT ROOM - 12" LONG - BLACK
22	157584-02-AA1	EA	TRIM/ZEE - W/SEAL/END CAPS - SLIDEOUT/LOWER - 80.7" - BLACK
	123012-01-000	FT	SEAL - SLIDEOUT - .09"/.13" THICK X 1.3" - W/ADHESIVE
	165260-01-000	FT	SEAL - BULB - W/WIRED U CHANNEL - .55" THICK X 1.3"
23	146606-12-01A	EA	TRIM/RETAINER - 75.7" - BRIGHT WHITE
23	146606-12-02A	EA	TRIM/RETAINER - 75.7" - BLACK
24	158375-04-01A	EA	TRIM - FEATURE STRIP - 24.6" - BRIGHT WHITE
24	158375-04-02A	EA	TRIM - FEATURE STRIP - 24.6" - BLACK
25	157385-04-01A	EA	TRIM - FEATURE STRIP/LOWER - 21.8" - BRIGHT WHITE - NOT ILLUSTRATED FROM: 00-00-00 THRU: 03-04-07
25	163020-08-01A	EA	TRIM - FEATURE STRIP/LOWER - 2.3" X 23.8" - BRT WHT FROM: 03-05-07 THRU: 99-99-99
25	163020-08-02A	EA	TRIM - FEATURE STRIP/LOWER - 2.3" X 23.8" - BLACK
26	126313-02-02B	EA	SUPPORT - SLIDE - F/SLIDE-OUT ROOM - E-COATED

**EXTERIOR SLIDEOUT GROUP (CONTINUED)**  
**LEFT REAR (CONTINUED)**

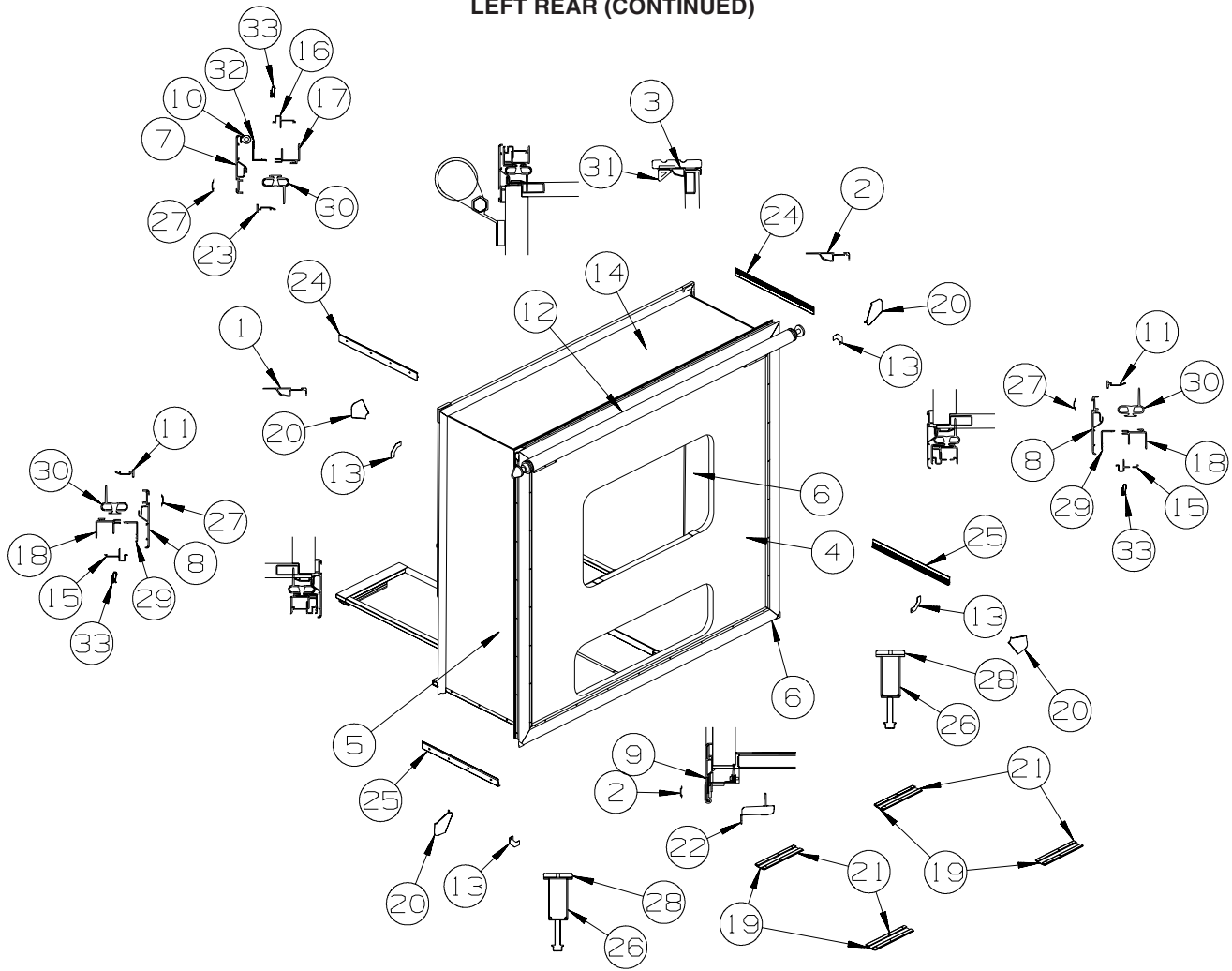

KEY	PART NUMBER	U/M DESCRIPTION
27	105312-01-07A	FT INSERT - FEATURE STRIP - VINYL - BRIGHT WHITE
27	105312-01-13A	FT INSERT - FEATURE STRIP - VINYL - BLACK
28	128599-03-000	EA PAD - F/SLIDEOUT - 2" X 2.6"
29	136824-16-01A	EA TRIM - SIDEWALL/SLIDEOUT - 72.7" - BRIGHT WHITE
29	136824-16-02A	EA TRIM - SIDEWALL/SLIDEOUT - 72.7" - BLACK
30	136978-01-01A	FT SEAL - SLIDEOUT - SINGLE WIPE LIP - BLACK
31	146056-01-000	FT SEAL - TRIANGLE - W/PSA
32	136824-02-01A	EA TRIM - SIDEWALL/SLIDEOUT - 81.2" - BRIGHT WHITE
32	136824-02-02A	EA TRIM - SIDEWALL/SLIDEOUT - 81.2" - BLACK
33	142549-01-000	EA CLIP - "S" TYPE

**COMPONENT PARTS FOR LEFT REAR**

162834-01-000

KEY	PART NUMBER	U/M DESCRIPTION	VENDOR NO.
	131281-01-702	EA PIN/CLEVIS-1/4" PLATED	1213190
	131281-01-704	EA HAIRPIN/COTTER - 3/8" SPRING	1213460
	138173-01-701	EA POP RIVET - SS 3/16"X1/4"	1214630
	138173-01-707	EA WEAR PUCK - PLASTIC F/DRIVE	1612523
	148875-01-700	EA PIN/COTTER - 3/32" X 1/2"	1213520
	148875-01-703	EA NUT - PLASTIC - 1"	1612548
	148875-01-705	EA MOTOR/LINEAR - SLIDE ROOM	1820111
	149165-01-700	EA BEARING - 5/8" ID	1102015
	149165-01-701	EA PIN/CLEVIS - 1/4" X 2"	1213204
	149165-01-703	EA SEAL/RUBBER - INNER FRAME	1612007
	149165-01-704	EA SEAL/LOWER ROOM - "Z"	1612009
	149165-01-705	EA DRIVE/WORM SCREW - 30"	1820400

**GENERATOR GROUP  
GAS**

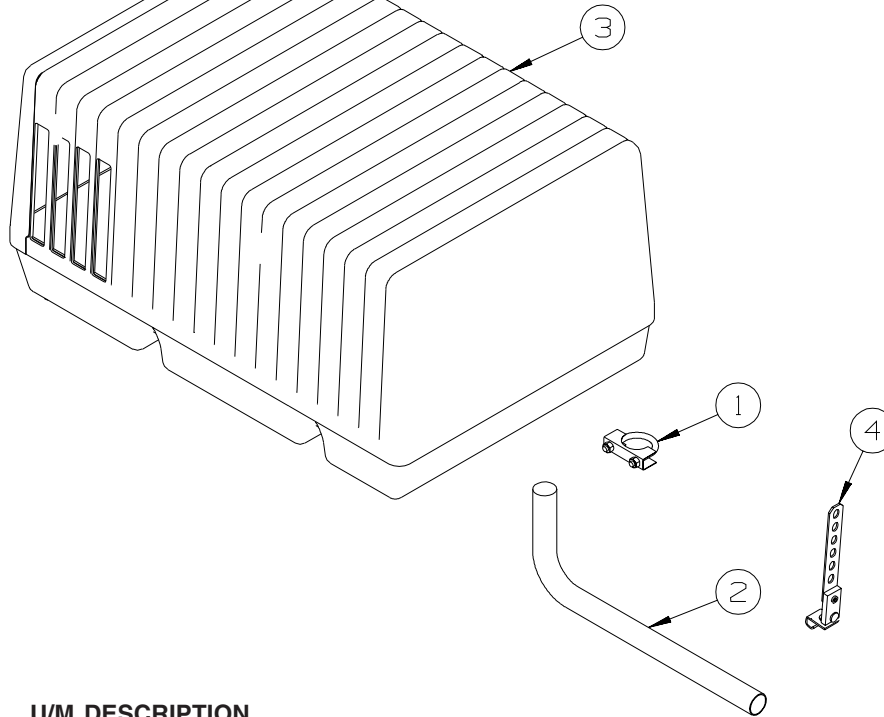

**MICROLITE  
D26P, D29R, D30B**

KEY	PART NUMBER	U/M DESCRIPTION
1	007125-04-000	EA CLAMP - MUFFLER - 1.12" DIAMETER
2	158240-01-000	EA PIPE - EXHAUST/GENERATOR - D26P - D30B
2	158240-02-000	EA PIPE - EXHAUST/GENERATOR - D29R
3	109982-03-000	EA GENERATOR - 4.0 MICROLITE
4	007131-01-000	EA HANGER - TAILPIPE - 6 SLOTS - D29R

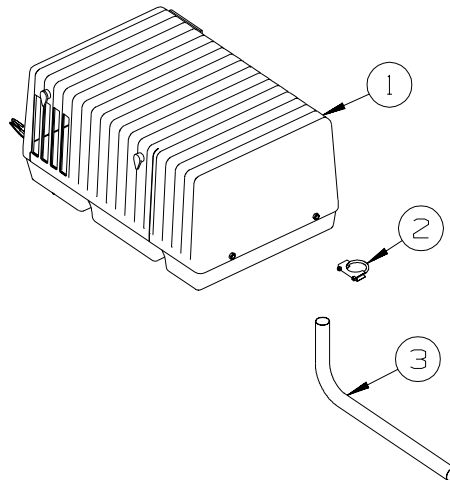

**MARQUIS GOLD  
D34M, D35J**

KEY	PART NUMBER	U/M DESCRIPTION
1	135707-07-000	EA GENERATOR - 5.5 - 30/20 - GAS - MARQUIS GOLD
2	007125-03-000	EA CLAMP - MUFFLER - 1.5" DIAMETER
3	105958-07-000	EA PIPE - EXHAUST - 1.4" INLET X 1.5" O.D. - 4.9" X 20.1"

## HEATING & A/C GROUP AUTOMOTIVE

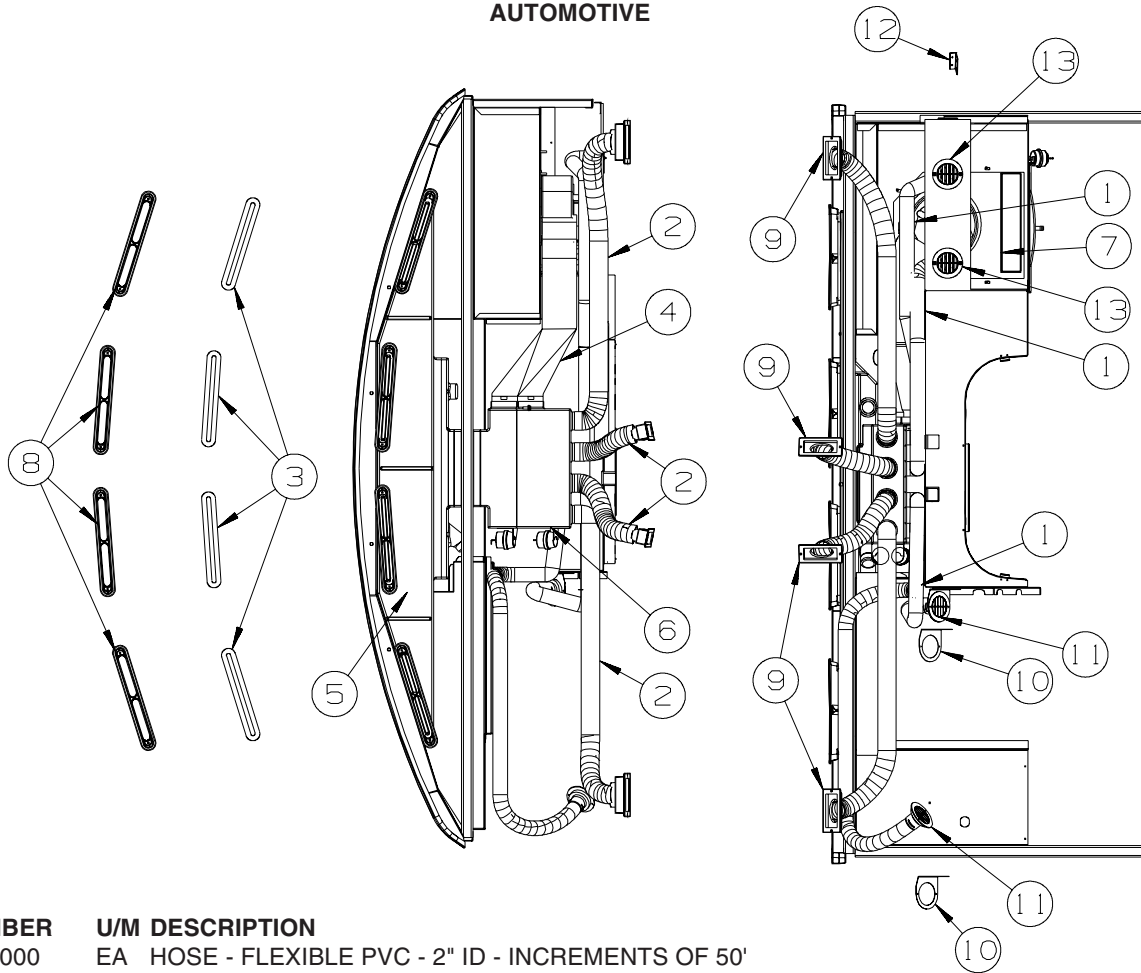

KEY	PART NUMBER	U/M	DESCRIPTION
1	007076-01-000	EA	HOSE - FLEXIBLE PVC - 2" ID - INCREMENTS OF 50'
2	007281-01-000	EA	HOSE - FLEXIBLE PVC - 2 1/2" ID X 50'
3	077075-01-000	EA	GASKET - INSTRUMENT PANEL/DEFROSTER PLENUM - .6" X 10.2"
4	103016-03-000	EA	PLENUM - TRANSITION
5	103017-03-000	EA	PLENUM - DEFROSTER
6*	103930-63-000	EA	CONTROL/PLENUM - VERTICAL
7*	103930-55-000	EA	EVAPORATOR/HEATER - NONCHARGED - SINGLE OUTPUT
8	135265-01-06A	EA	VENT - DEFROSTER - PLASTIC - CASHMERE
8	135265-01-07A	EA	VENT - DEFROSTER - PLASTIC - RIVERSTONE
9	135803-02-01A	EA	LOUVER/A/C - ADJ W/MOUNT HOLES - 2.5" X 5.8" F/2.5" HOSE
10	136157-03-02B	EA	BRACKET - HEATER - E-COATED
11	157225-01-01A	EA	OUTLET - DEFROSTER - W/SWIVEL - 2" SLEEVE/4"OD - BLACK
12	156732-01-01A	EA	BRACE
13	157225-01-05A	EA	OUTLET - DEFROSTER - W/SWIVEL - 2" SLEEVE/4"OD - RIVERSTONE
13	157225-01-06A	EA	OUTLET - DEFROSTER - W/SWIVEL - 2" SLEEVE/4"OD - CASHMERE
	113452-02-000	FT	SEAL/TRIM - FRONT - VINYL W/WIRE CARRIER - .027" - <b>WHERE WIRES &amp; HOSES CROSS METAL</b>

\*COMPONENT PARTS LISTED LATER IN THIS GROUP

**HEATING & A/C GROUP (CONTINUED)**  
**AUTOMOTIVE (CONTINUED)**

**WORKHORSE**

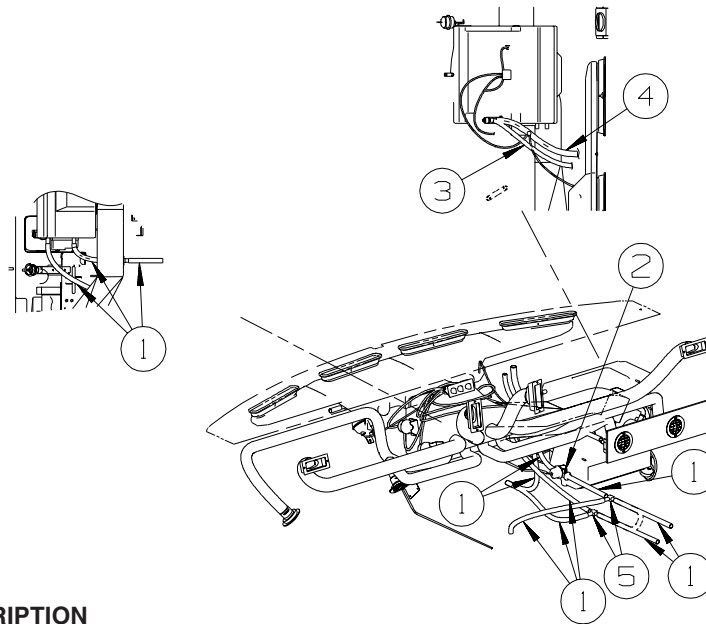

KEY	PART NUMBER	U/M	DESCRIPTION
1	007108-01-000	FT	HOSE - HEATER - 5/8"ID - HI-TEMP
2	103930-23-000	EA	VALVE/WATER - 2 PORT/VACUUM CONTROLLED - "NEW DESIGN"
3*	103930-46-000	EA	HOSE - EXPANSION BLOCK (EVAPORATOR) TO COMPRESSOR
4*	103930-47-000	EA	HOSE - EXPANSION VALVE (EVAPORATOR) TO DRIER
5	076776-01-000	EA	TEE - BEADED - 5/8" X 5/8" X 5/8"

**\*COMPONENT PARTS LISTED LATER IN THIS GROUP**

**FORD**

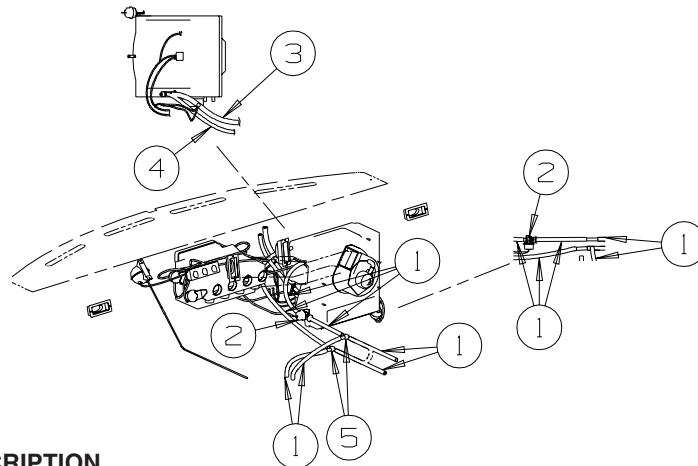

KEY	PART NUMBER	U/M	DESCRIPTION
1	007108-01-000	FT	HOSE - HEATER - 5/8"ID - HI-TEMP
2	103930-23-000	EA	VALVE/WATER - 2 PORT/VACUUM CONTROLLED - "NEW DESIGN"
3*	103930-44-000	EA	HOSE - EVAPORATOR/DRYER - #6
4*	103930-45-000	EA	HOSE - EVAPORATOR/COMPRESSOR - FORD - PRE 2007 FORD CHASSIS
4	103930-64-000	EA	HOSE - EVAPORATOR/COMPRESSOR - FORD - 2007 FORD CHASSIS
5	076776-01-000	EA	TEE - BEADED - 5/8" X 5/8" X 5/8"

**\*COMPONENT PARTS LISTED LATER IN THIS GROUP**

**HEATING & A/C GROUP (CONTINUED)**  
**COMPONENT PARTS FOR AUTOMOTIVE**

**103930-44-000**

<b>KEY</b>	<b>PART NUMBER</b>	<b>U/M</b>	<b>DESCRIPTION</b>	<b>VENDOR NO</b>
	103930-29-701	EA	O'RING F/LOW PRESSURE SWITCH	045-0483
	103930-44-700	EA	HOSE ASSEMBLY #6	085-0462
	113245-01-711	EA	O'RING #6	045-0129

**103930-45-000**

<b>KEY</b>	<b>PART NUMBER</b>	<b>U/M</b>	<b>DESCRIPTION</b>	<b>VENDOR NO.</b>
	103930-17-702	EA	O'RING #10	045-0127
	103930-45-700	EA	HOSE - #10 EVAP/COMP - 3'	085-0463

**103930-46-000**

<b>KEY</b>	<b>PART NUMBER</b>	<b>U/M</b>	<b>DESCRIPTION</b>	<b>VENDOR NO</b>
	103930-17-702	EA	O'RING #10	045-0127
	103930-29-701	EA	O'RING F/LOW PRESSURE SWITCH	045-0483
	103930-46-700	EA	HOSE - #10 EVAP/COMP - 4.3'	085-0486

**103930-47-000**

<b>KEY</b>	<b>PART NUMBER</b>	<b>U/M</b>	<b>DESCRIPTION</b>	<b>VENDOR NO</b>
	103930-47-700	EA	HOSE - #6-EVAP/DRIER - 2.2'	085-0485
	113245-01-710	EA	O'RING, #12	045-0128



**HEATING & A/C GROUP (CONTINUED)**  
**COMPONENT PARTS FOR AUTOMOTIVE (CONTINUED)**

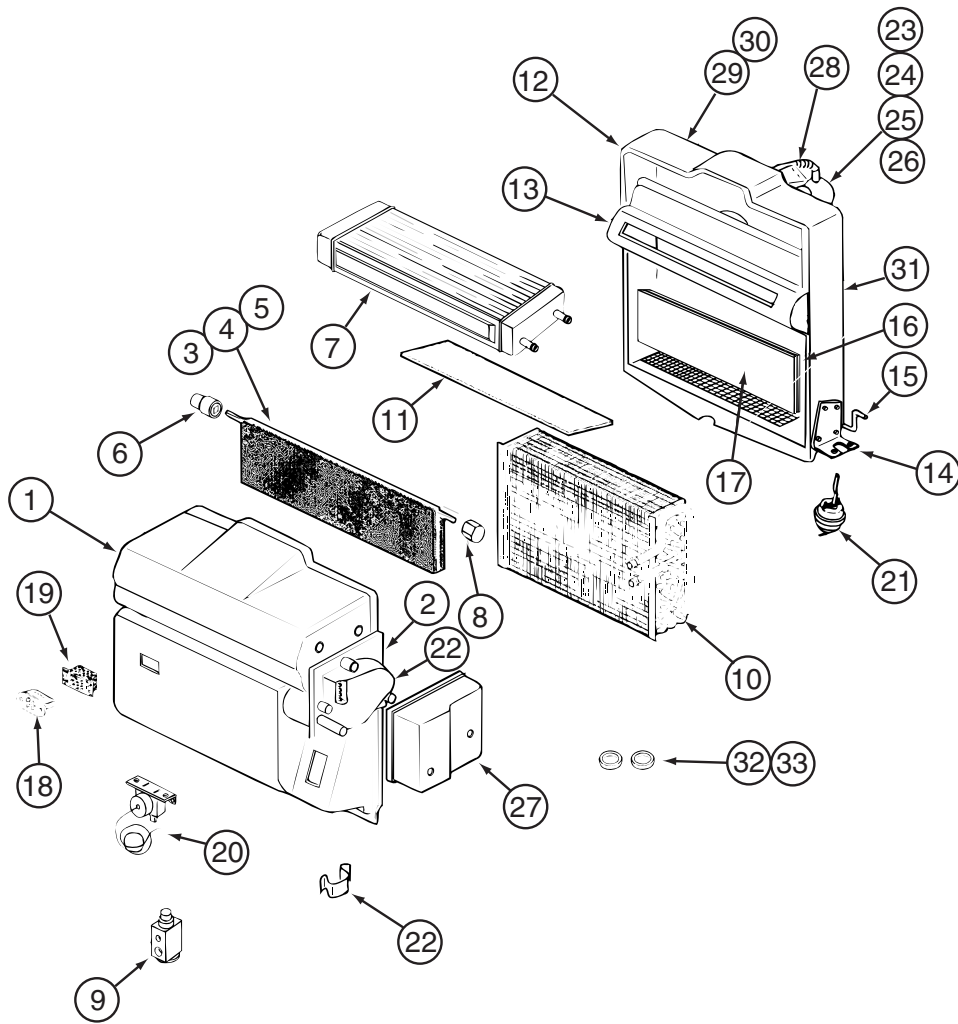

**103930-55-000**

KEY	PART NUMBER	U/M	DESCRIPTION	VENDOR NO.
1	103930-55-701	EA	CASE - FRONT	062-0658
2	103930-30-701	EA	PLATE - MOTOR MOUNT	062-0544
3	103930-55-705	EA	DOOR - BLEND AIR	071-0892
6	103930-30-702	EA	BUSHING/DRIVE (BLEND DOOR)	062-0168
7	103930-55-706	EA	CORE - HEATER - W/GASKET	084-0271
8	103930-30-709	EA	COUPLING - BLEND DOOR SHAFT	062-0634
9	103930-20-700	EA	VALVE-EXPANSION-BLOCK, 2 TON	034-0032
10	103930-55-700	EA	CORE-EVAPORATOR	041-00168
12	103930-55-702	EA	CASE-REAR	062-0657
14	103930-01-708	EA	BRACKET-VACUUM MOTOR	070-0113
15	103930-20-704	EA	ROD-DOOR-RECIRCULATING	073-0018
16	103930-55-707	EA	DOOR - RECIRCULATION	071-0891
18	103930-01-710	EA	RESISTOR-FUSED, A/C 4 TERM	035-0006
20	103930-01-711	EA	THERMOSTAT	033-0003
21	103930-02-708	EA	MOTOR-VACUUM SERVO, A/C	030-0025
22	103930-30-703	EA	MOTOR - SERVO	030-0104
23	103930-20-707	EA	HOUSING-BLOWER	062-0145
24	103930-55-703	EA	MOTOR-BLOWER W/O PIGTAIL	030-0137
25	103930-01-717	EA	WHEEL-BLOWER, CLOCKWISE	062-0010
26	103930-20-708	EA	CLIP-MOTOR SHAFT	022-0001
27	103930-30-704	EA	COVER - SERVO	062-0545
32	113245-01-707	EA	O'RING #8	045-0126
33	103930-17-702	EA	O'RING #10	045-0127
	103930-55-704	EA	CORE-HEATER	042-0059
	110279-01-703	EA	HOSE-VENT F/BLOWER MOTOR	051-0034

CONTACT WINNEBAGO PART SALES FOR UNLISTED COMPONENT(S)

**HEATING & A/C GROUP (CONTINUED)**  
**COMPONENT PARTS FOR AUTOMOTIVE (CONTINUED)**

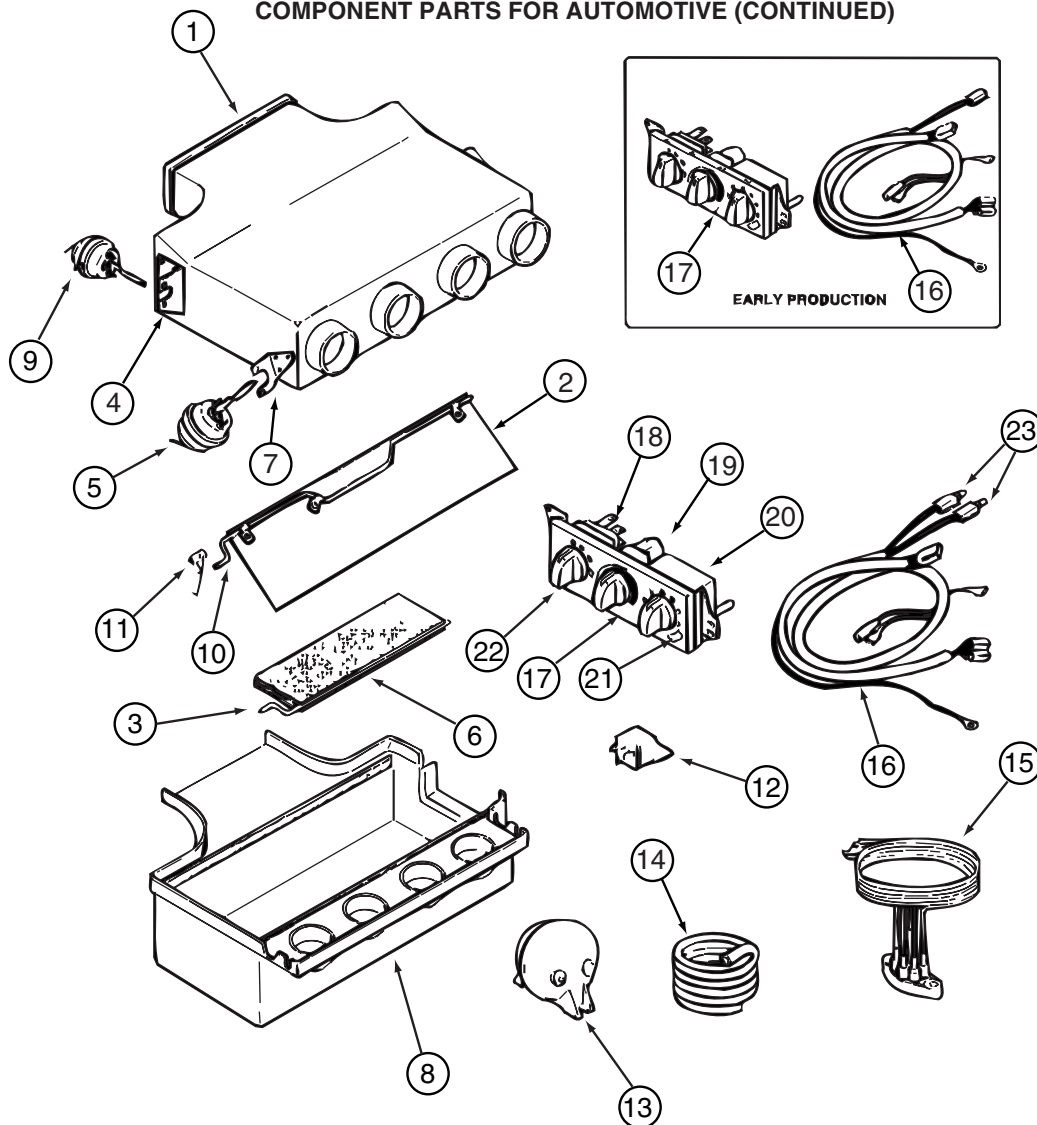

103930-63-000

KEY	PART NUMBER	U/M	DESCRIPTION	VENDOR NO.
1	103930-39-705	EA	PLENUM - TOP	060-0482
2	103930-04-700	EA	DOOR - DEFROSTER-A/C	071-0149
3	103930-39-700	EA	ROD - DOOR - AC/HEAT	073-067
5	103930-02-708	EA	MOTOR-VACUUM SERVO, A/C	030-0025
6	103930-39-706	EA	PLATE - DOOR - A/C	071-0623
8	103930-39-707	EA	PLENUM - BOTTOM	060-0483
9	103930-33-701	EA	MOTOR - VACUUM, 3 STAGE	030-0105
10	103930-39-701	EA	ROD - DOOR - AC/DEFROST	073-0069
11	103930-39-704	EA	SPRING	022-0119
12	103930-02-707	EA	RELAY-BOSCH W/RESISTER	031-0001
13	103930-02-710	EA	CANISTER-VACUUM	054-0002
15	103930-33-703	EA	VACUUM HARNESS	036-0466
18	103930-49-704	EA	SWITCH - BLOWER	032-0332
19	103930-49-705	EA	POTENTIOMETER	032-0182
20	103930-49-706	EA	SWITCH - VACUUM	032-0185
21	103930-63-700	EA	DECAL CONTROL PANEL-N/RECESS	058-00344
22	103930-49-708	EA	KNOB - BLOWER - NONRECESSED	062-0620

CONTACT WINNEBAGO PART SALES FOR UNLISTED COMPONENT(S)

## HEATING & A/C GROUP (CONTINUED)

### FURNACE

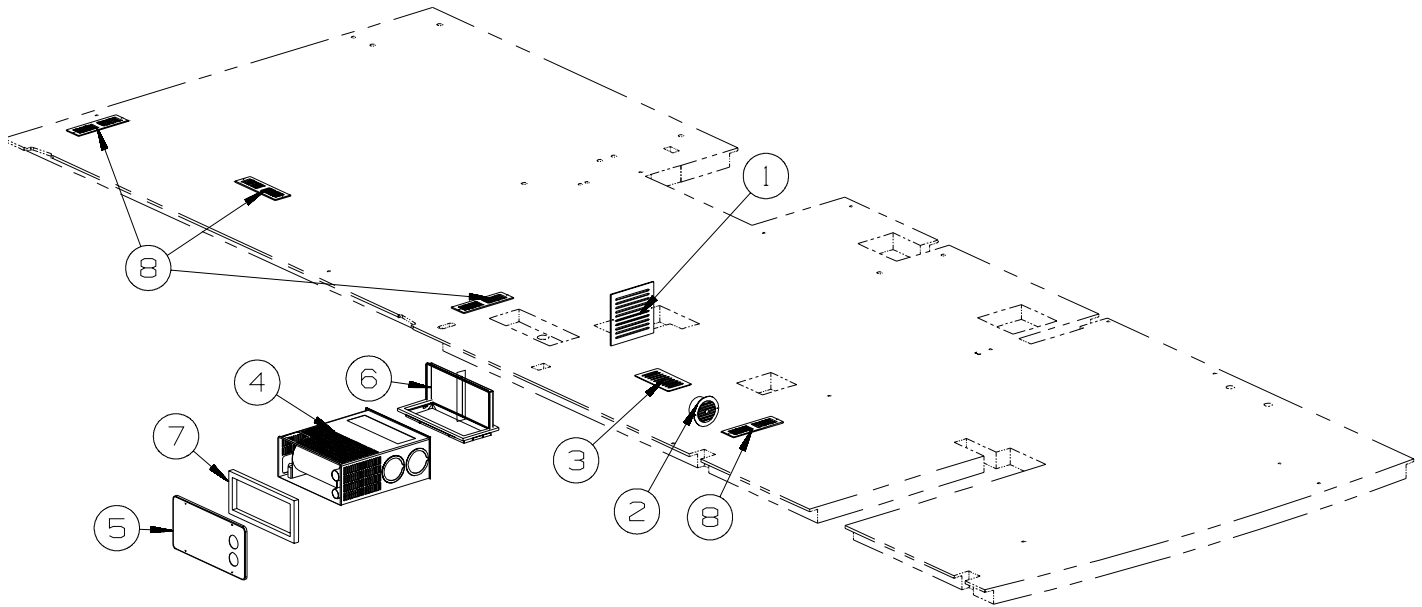

KEY	PART NUMBER	U/M	DESCRIPTION
1	093614-02-02A	EA	GRILLE - AIR RETURN - 9.9" X 9.9" - BEIGE
2	056464-10-000	EA	REGISTER W/O DAMPER - 4" DIAMETER - PLASTIC - BEIGE
3	130837-02-01A	EA	REGISTER - HEAT - W/DAMPER - DURA BEIGE
4*	139980-02-000	EA	FURNACE - 30000 BTU - SF QUIET - SUBURBAN SF-30 2321J
5	139980-10-02A	EA	DOOR - ACCESS/FURNACE - BRIGHT WHITE
5	139980-10-03A	EA	DOOR - ACCESS/FURNACE - BLACK
6	098668-26-000	EA	BOTTOM DUCT KIT - 40,000 BTU
7	143563-05-000	EA	GASKET - FIBERGLASS - SUBURBAN #071018
8	137965-02-02A	EA	REGISTER - 11.2" X 3.6"(9.7 X 2.1"R/O) W/DAMPER - ANT PWTR
	009198-01-000	FT	DUCT - HEAT - FLEXIBLE - 4" ID X 25'
	069636-02-000	EA	CONNECTOR - DUCT - 4" ID
	009200-01-000	EA	TAPE - FURNACE - 1 1/2"

**\*COMPONENT PARTS LISTED LATER IN THIS GROUP**

# HEATING & A/C GROUP (CONTINUED)

## COMPONENT PARTS FOR FURNACE

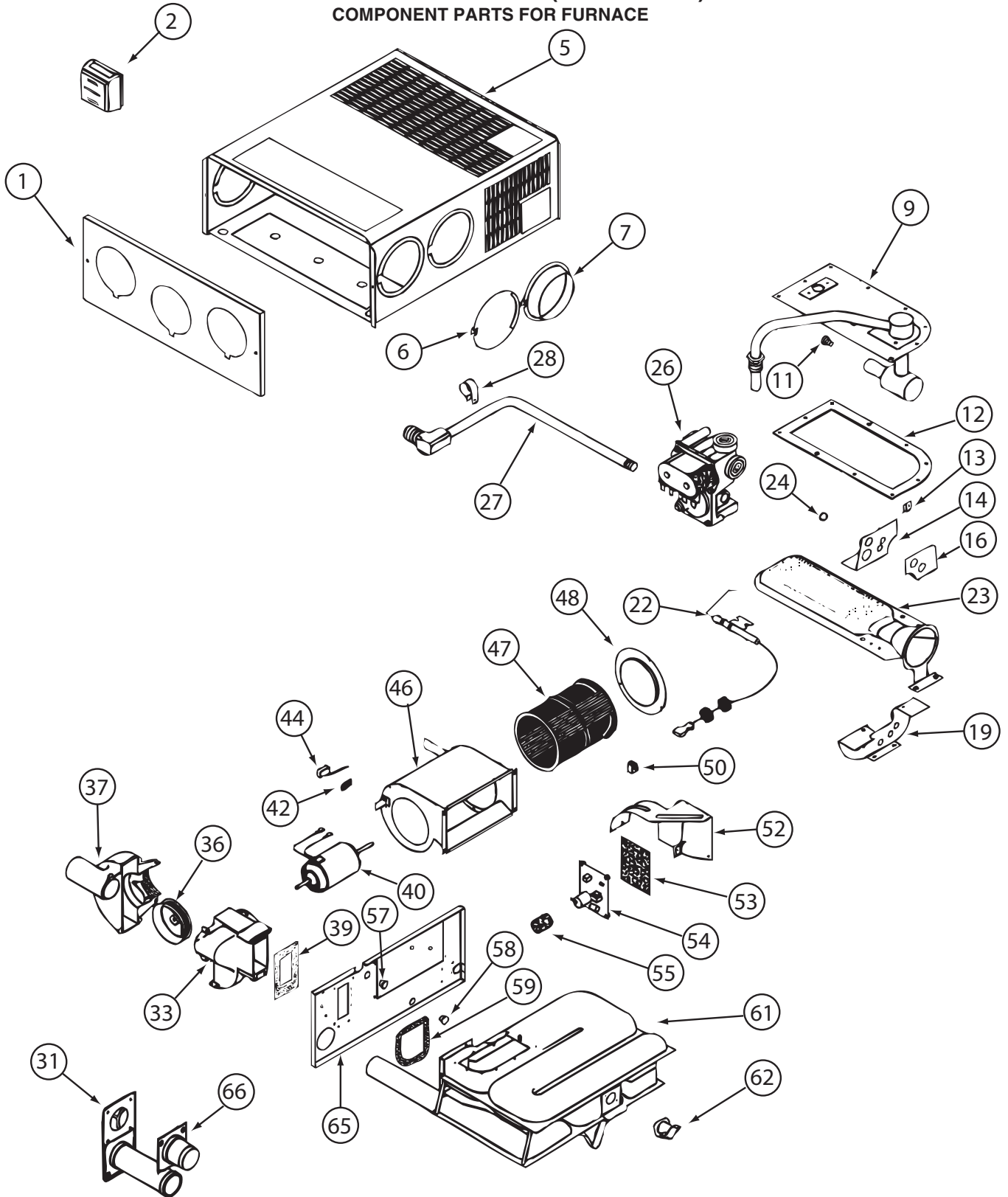

139980-02-000

**HEATING & A/C GROUP (CONTINUED)**  
**COMPONENT PARTS FOR FURNACE (CONTINUED)**

**139980-02-000 (CONTINUED)**

<b>KEY</b>	<b>PART NUMBER</b>	<b>U/M</b>	<b>DESCRIPTION</b>	<b>VENDOR NO.</b>
9	139980-01-700	EA	MANIFOLD ASSEMBLY	171571
11	092300-02-701	EA	ORIFICE-MAIN BURNER (NT-30BW	180214
12	098668-22-703	EA	GASKET - BURNER ACCESS COVER	070811
22	139980-01-701	EA	ELECTRODE	232286
23	098668-02-700	EA	BURNER ASSEMBLY,SF-30 & SF35	010745
26	098668-01-718	EA	VALVE-GAS SF S.N.974903079	161122
27	139980-01-702	EA	PIPE ASSEMBLY/GAS INLET	171574
31	098668-01-707	EA	TUBE ASSEMBLY, EXHAUST W/CAP	260231
33	139980-01-703	EA	HOUSING/COMB. - FRONT/HALF	390852
36	098668-01-706	EA	WHEEL-COMBUSTION AIR	350184
37	139980-01-704	EA	HOUSING/COMB. - REAR/HALF	390848
39	139980-01-705	EA	GASKET/FIREWALL-COMB AIR	071084
40	139980-01-706	EA	MOTOR ASSEMBLY W/GASKET	232682
42	101990-01-714	EA	GASKET-MICROSWITCH	230877
44	098668-21-700	EA	SWITCH-MICRO-W/O FLAG 3 1/4"	232261
46	139980-01-708	EA	BLOWER ASSEMBLY - ROOM AIR	390739BK
47	098668-01-711	EA	WHEEL-BLOWER, ROOM AIR	350129
48	139980-01-709	EA	ORFICE RING	390696
50	139980-01-710	EA	SWITCH - ON/OFF	232351
52	139980-01-711	EA	PANEL ASSEMBLY-MODULE BD	101663
53	139980-01-712	EA	INSULATOR - MODULE BD	070807
54	098668-22-705	EA	MODULE BD W/RELAY TIME DELAY	520820
55	139980-01-713	EA	CAP/INSULATOR-MODULE BD	070973
57	139980-01-714	EA	BUSHING - UNIVERSAL	070362
58	139980-01-715	EA	BUSHING - STRAIN RELIEF	231809
59	098668-01-716	EA	GASKET-FIREWALL,CHAMBER SIDE	070808
61	139980-01-716	EA	CHAMBER ASSEMBLY - FINAL	021149BK
62	098668-21-701	EA	SWITCH - LIMIT	232504
66	098668-01-713	EA	TUBE ASSEMBLY, INTAKE	051248
	139980-02-700	EA	BLOWER ASM-1/2 HOUSING/OUTER	390851
	139980-02-701	EA	BLOWER ASM-1/2 HOUSING/INNER	390872
			CONTACT WINNEBAGO PART SALES FOR UNLISTED COMPONENT(S)	

**HEATING & A/C GROUP (CONTINUED)**  
**COMPONENT PARTS FOR FURNACE (CONTINUED)**

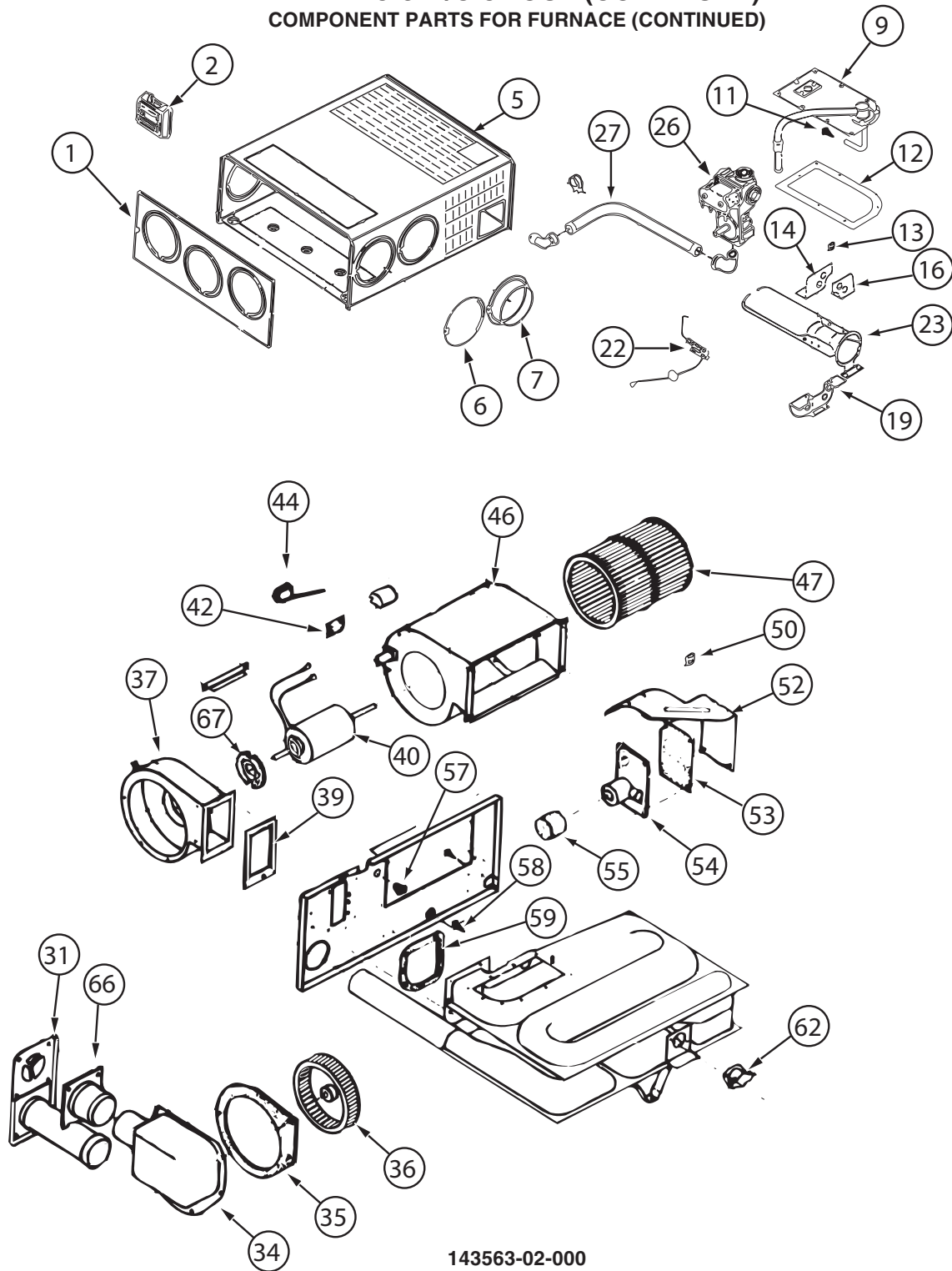

143563-02-000

**HEATING & A/C GROUP (CONTINUED)**  
**COMPONENT PARTS FOR FURNACE (CONTINUED)**

**143563-02-000 (CONTINUED)**

<b>KEY</b>	<b>PART NUMBER</b>	<b>U/M</b>	<b>DESCRIPTION</b>	<b>VENDOR NO.</b>
1	143563-01-700	EA	CABINET - FRONT	101907
2			SEE 12 VOLT WIRING AREAS FOR CORRECT THERMOSTAT	
5	143563-02-700	EA	CABINET	101915
7	075696-02-703	EA	COLLAR - DUCT	050715
9	143563-01-702	EA	MANIFOLD ASSEMBLY	171599
11	143563-02-701	EA	ORFICE - MAIN BURNER	180309
12	098668-22-703	EA	GASKET - BURNER ACCESS COVER	070811
14	143563-02-702	EA	PLATE - SECONDARY AIR/TOP BACK	063198
16	143563-02-703	EA	PLATE - SECONDARY AIR/TOP FRT	062933
19	143563-02-704	EA	PLATE - SECONDARY AIR/BOTTOM	062935
22	139980-01-701	EA	ELECTRODE	232286
23	098668-11-701	EA	BURNER ASSEMBLY, SF-42F	010799
26	098668-01-718	EA	VALVE-GAS SF S.N.974903079	161122
27	143563-01-707	EA	PIPE ASSEMBLY (GAS INLET)	171603
31	098668-01-707	EA	TUBE ASSEMBLY, EXHAUST W/CAP	260231
34	143563-01-708	EA	BOX ASM (COMB. AIR INTAKE)	051430BK
35	143563-01-709	EA	GASKET (COMB. AIR HOUSING)	071108
36	143563-01-710	EA	WHEEL (COMBUSTION AIR)	350199
37	143563-01-711	EA	HOUSING (COMBUSTION AIR)	390862BK
39	143563-01-715	EA	GASKET-FIREWALL/COMB. AIR	071107
40	143563-02-705	EA	MOTOR ASSEMBLY	232726
42	101990-01-714	EA	GASKET-MICROSWITCH	230877
44	098668-21-700	EA	SWITCH-MICRO-W/O FLAG 3 1/4"	232261
46	143563-01-713	EA	BLOWER ASSEMBLY(ROOM AIR)	390867BK
47	143563-01-714	EA	WHEEL - ROOM AIR	350198
50	139980-01-710	EA	SWITCH - ON/OFF	232351
52	139980-01-711	EA	PANEL ASSEMBLY-MODULE BD	101663
53	139980-01-712	EA	INSULATOR - MODULE BD	070807
54	098668-22-705	EA	MODULE BD W/RELAY TIME DELAY	520820
55	139980-01-713	EA	CAP/INSULATOR-MODULE BD	070973
57	139980-01-714	EA	BUSHING - UNIVERSAL	070362
58	139980-01-715	EA	BUSHING - STRAIN RELIEF	231809
59	098668-01-716	EA	GASKET-FIREWALL,CHAMBER SIDE	070808
62	143563-02-706	EA	SWITCH - LIMIT	232735
66	098668-01-713	EA	TUBE ASSEMBLY, INTAKE	051248
67	075697-07-703	EA	GASKET - MOTOR	070448
	143563-02-707	EA	CHAMBER ASM. - FINAL	021172BK
			CONTACT WINNEBAGO PART SALES FOR UNLISTED COMPONENT(S)	

## HEATING & A/C GROUP (CONTINUED)

### REAR HEATER

KEY	PART NUMBER	U/M	DESCRIPTION
*	084405-01-000	EA	HEATER - REAR/DUCTED - W/MOTOR AID
	007108-01-000	FT	HOSE - HEATER - 5/8" ID - HI-TEMP
	079059-22-000	EA	HOSE - 90 DEGREE - 5/8"ID X 4" X 22"
	079059-02-000	EA	HOSE - 90 DEGREE - .61" ID X 4" X 6"
	009198-01-000	FT	DUCT - HEAT - FLEXIBLE - 4" ID X 25
	069636-02-000	EA	CONNECTOR - DUCT - 4" ID
	118761-01-000	EA	REDUCER - 4"-2" - GALVANIZED
	076776-01-000	EA	TEE - BEADED - 5/8" X 5/8" X 5/8"
	056464-10-000	EA	REGISTER W/O DAMPER - 4" DIAMETER - PLASTIC - BEIGE

\*COMPONENT PARTS LISTED LATER IN THIS GROUP

### COMPONENT PARTS FOR REAR HEATER

084405-01-000

KEY	PART NUMBER	U/M	DESCRIPTION	VENDOR NO.
	084405-01-700	EA	CORE-HEATER	FT200229
	084405-01-701	EA	FAN	HV029931
	084405-01-702	EA	MOTOR ASSEMBLY, 12 VOLT	RV010348



## HEATING & A/C GROUP (CONTINUED)

### ROOF

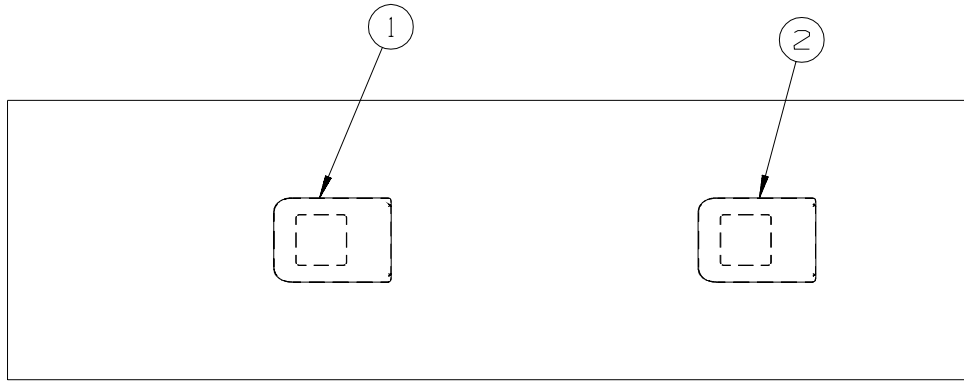

KEY	PART NUMBER	U/M	DESCRIPTION
1*	131188-05-01A	EA	A/C - ROOF - 14,800 BTU-MACH 15 - 2 PEICE SHROUD STYLE-WHT
1*	131188-05-02A	EA	A/C - ROOF - 14,800 BTU-MACH 15 - 2 PC SHROUD-BLACK
1*	131187-05-01A	EA	A/C - ROOF - MACH 3 POWER SAVER-2 PEICE SHROUD STYLE - WHT
1*	131187-05-02A	EA	A/C - ROOF - MACH 3 POWER SAVER-2 PEICE SHROUD
1*	131184-01-01A	EA	CEILING ASSEMBLY - A/C DUCTED - WHITE FROM: 00-00-00 THRU: 07-22-07
1*	131184-06-01A	EA	CEILING ASSEMBLY - A/C DUCTED - WHITE FROM: 07-23-07 THRU: 99-99-99
1*	131188-06-01A	EA	A/C - ROOF-14,800 BTU-MACH 15/HEAT PUMP-2 PCE SHROUD STYLE - A/C HEAT PUMP - 1
1*	131188-06-02A	EA	A/C - ROOF-14,800 BTU-MACH 15/HEAT PUMP-2 PCE SHROUD-BLACK - A/C HEAT PUMP - 1
1*	131184-05-01A	EA	CEILING ASM - HT PMP - WHT - AC HEAT PUMP/AC HEAT PUMP - A/C HEAT PUMP - 1 FROM: 00-00-00 THRU: 07-22-07
1*	131184-07-01A	EA	CEILING ASM - HT PMP - WHT - AC HEAT PUMP/AC HEAT PUMP - A/C HEAT PUMP - 1 FROM: 07-23-07 THRU: 99-99-99
1*	131187-06-01A	EA	A/C - ROOF - MACH 3 POWER SAVER-2 PEICE SHROUD STYLE - WHT - HEAT PUMP 2 HI EFFICIENCY
1*	131187-06-02A	EA	A/C - ROOF - MACH 3 PWR SVR-2 PC SHRD - BLACK - HEAT PUMP 2 HI EFFICIENCY
1*	131184-05-01A	EA	CEILING ASM - HT PMP - WHT - AC HEAT PUMP/AC HEAT PUMP - HEAT PUMP 2 HI EFFICIENCY FROM: 00-00-00 THRU: 07-22-07
1*	131184-07-01A	EA	CEILING ASM - HT PMP - WHT - AC HEAT PUMP/AC HEAT PUMP - HEAT PUMP 2 HI EFFICIENCY FROM: 07-23-07 THRU: 99-99-99
2*	131186-03-01A	EA	A/C - ROOF - MACH 1 PWR SAVER-11,000 BTU-2 PCE SHROUD-WHT FROM: 00-00-00 THRU: 09-09-07
2*	131187-05-01A	EA	A/C - ROOF - MACH 3 POWER SAVER-2 PEICE SHROUD STYLE - WHT FROM: 09-10-07 THRU: 99-99-99
2*	131187-05-02A	EA	A/C - ROOF - MACH 3 POWER SAVER-2 PEICE SHROUD FROM: 09-10-07 THRU: 99-99-99
2*	131184-01-01A	EA	CEILING ASSEMBLY - A/C DUCTED - WHITE FROM: 00-00-00 THRU: 07-22-07
2*	131184-06-01A	EA	CEILING ASSEMBLY - A/C DUCTED - WHITE FROM: 07-23-07 THRU: 99-99-99
2*	131187-06-01A	EA	A/C - ROOF - MACH 3 POWER SAVER-2 PEICE SHROUD STYLE - WHT - HEAT PUMP 2 HI EFFICIENCY
2*	131187-06-02A	EA	A/C - ROOF - MACH 3 PWR SVR-2 PC SHRD - BLACK - HEAT PUMP 2 HI EFFICIENCY
2*	131184-05-01A	EA	CEILING ASM - HT PMP - WHT - AC HEAT PUMP/AC HEAT PUMP - HEAT PUMP 2 HI EFFICIENCY FROM: 00-00-00 THRU: 07-22-07
2*	131184-07-01A	EA	CEILING ASM - HT PMP - WHT - AC HEAT PUMP/AC HEAT PUMP - HEAT PUMP 2 HI EFFICIENCY FROM: 07-23-07 THRU: 99-99-99
	131184-02-01A	EA	BOARD - DIVIDER - SILVER

\*COMPONENT PARTS LISTED LATER IN THIS GROUP

## HEATING & A/C GROUP (CONTINUED)

### COMPONENT PARTS FOR ROOF

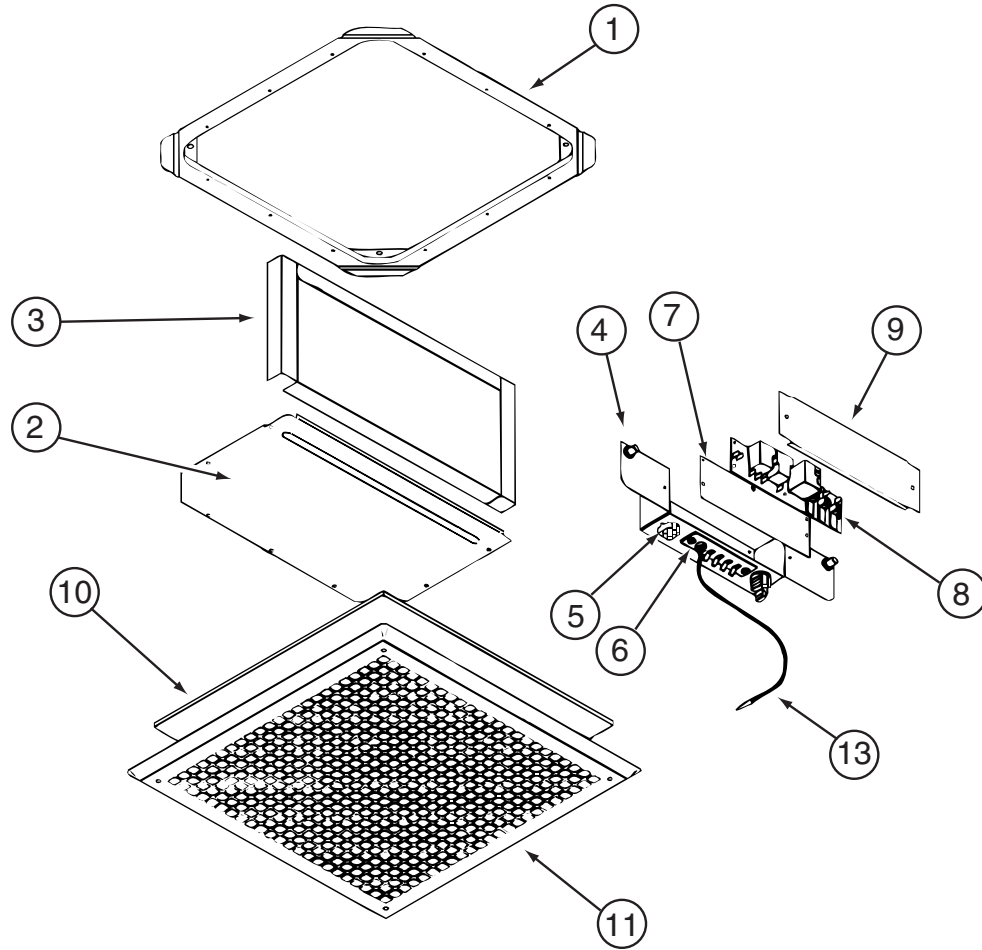

131184-01-01A

KEY	PART NUMBER	U/M	DESCRIPTION	VENDOR NO.
1	131184-01-707	EA	DUCT DIVIDER	8330-3501
5	131184-01-700	EA	PLUG ASSEMBLY	7330A389
6	131184-01-701	EA	TERMINAL BOARD	7330B3201
7	131184-01-702	EA	ISOLATOR - BLANK	7330C365
8	108892-01-702	EA	BOARD-P.C.	7330A3211
10	108892-01-703	EA	FILTER	6798A3761
11	108892-01-704	EA	GRILLE 16 3/8X16 3/8 RETURN	6798-3041
12	131184-01-704	EA	COIL SENSOR	7330-6111
13	131184-01-705	EA	JUNCTION BOX ASSEMBLY	7330B5551
	131184-01-703	EA	SMALL PARTS PKG	8330-5961

CONTACT WINNEBAGO PART SALES FOR UNLISTED COMPONENT(S)

**HEATING & A/C GROUP (CONTINUED)**  
**COMPONENT PARTS FOR ROOF (CONTINUED)**

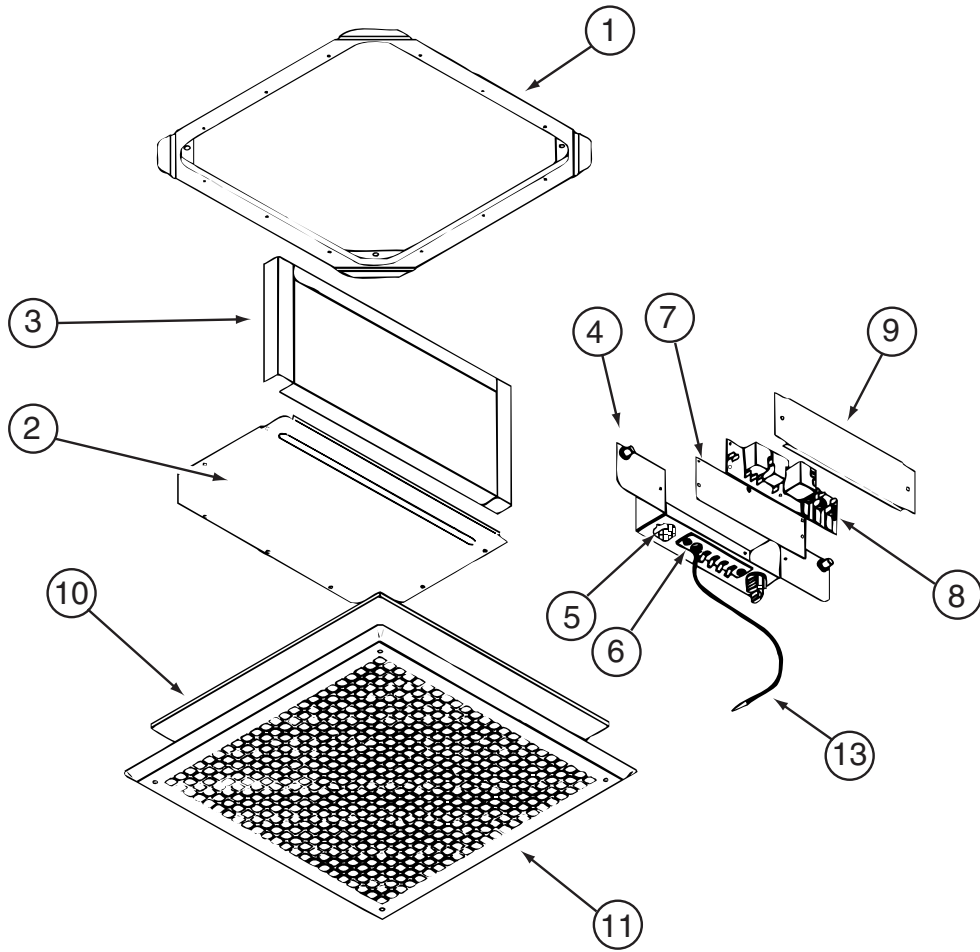

131184-05-01A

KEY	PART NUMBER	U/M	DESCRIPTION	VENDOR NO.
4	131184-05-700	EA	BOX - JUNCTION	8530-5091
5	131184-04-700	EA	PLUG ASSEMBLY	7530A340
6	131184-04-702	EA	BOARD - TERMINAL	7530B3201
7	131184-01-702	EA	ISOLATOR - BLANK	7330C365
8	131184-04-705	EA	BOARD - P.C.	7330B3311
10	108892-01-703	EA	FILTER	6798A3761
11	108892-01-704	EA	GRILLE 16 3/8X16 3/8 RETURN	6798-3041
13	105620-12-719	EA	COIL SENSOR	7330A3231
	131184-01-703	EA	SMALL PARTS PKG	8330-5961

CONTACT WINNEBAGO PART SALES FOR UNLISTED COMPONENT(S)

**HEATING & A/C GROUP (CONTINUED)**  
**COMPONENT PARTS FOR ROOF (CONTINUED)**

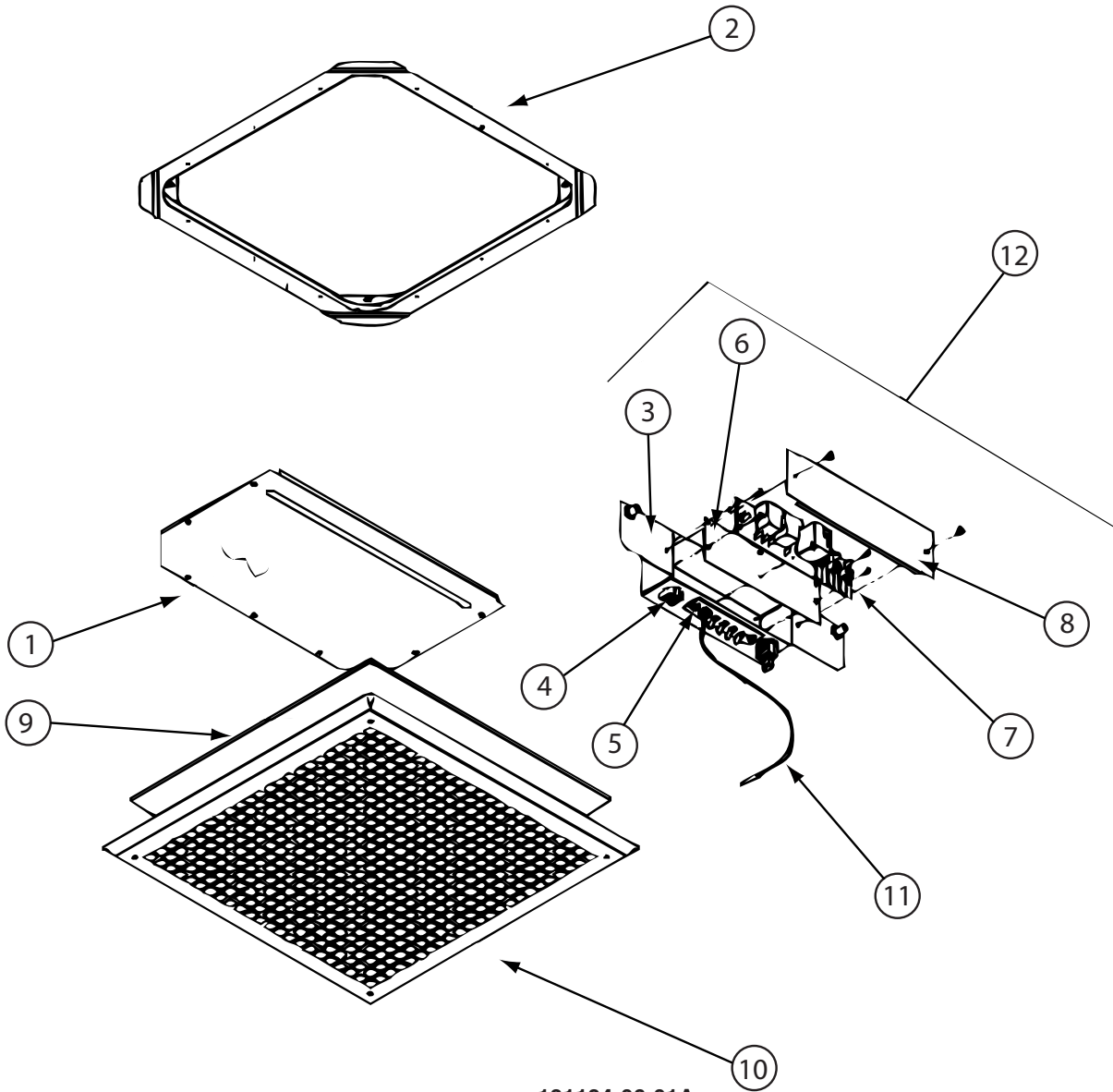

131184-06-01A

KEY	PART NUMBER	U/M	DESCRIPTION	VENDOR NO.
4	131184-01-700	EA	PLUG ASSEMBLY	7330A389
5	131184-01-701	EA	TERMINAL BOARD	7330B3201
6	131184-01-702	EA	ISOLATOR - BLANK	7330C365
7	131184-03-700	EA	BOARD - P.C.	7330D3211
9	108892-01-703	EA	FILTER	6798A3761
10	108892-01-704	EA	GRILLE 16 3/8X16 3/8 RETURN	6798-3041
11	105620-12-719	EA	COIL SENSOR	7330A3231
12	131184-01-705	EA	JUNCTION BOX ASSEMBLY	7330B5551
	131184-01-703	EA	SMALL PARTS PKG	8330-5961
	131184-01-706	EA	NUT/WING	1200-550

CONTACT WINNEBAGO PART SALES FOR UNLISTED COMPONENT(S)

**HEATING & A/C GROUP (CONTINUED)**  
**COMPONENT PARTS FOR ROOF (CONTINUED)**

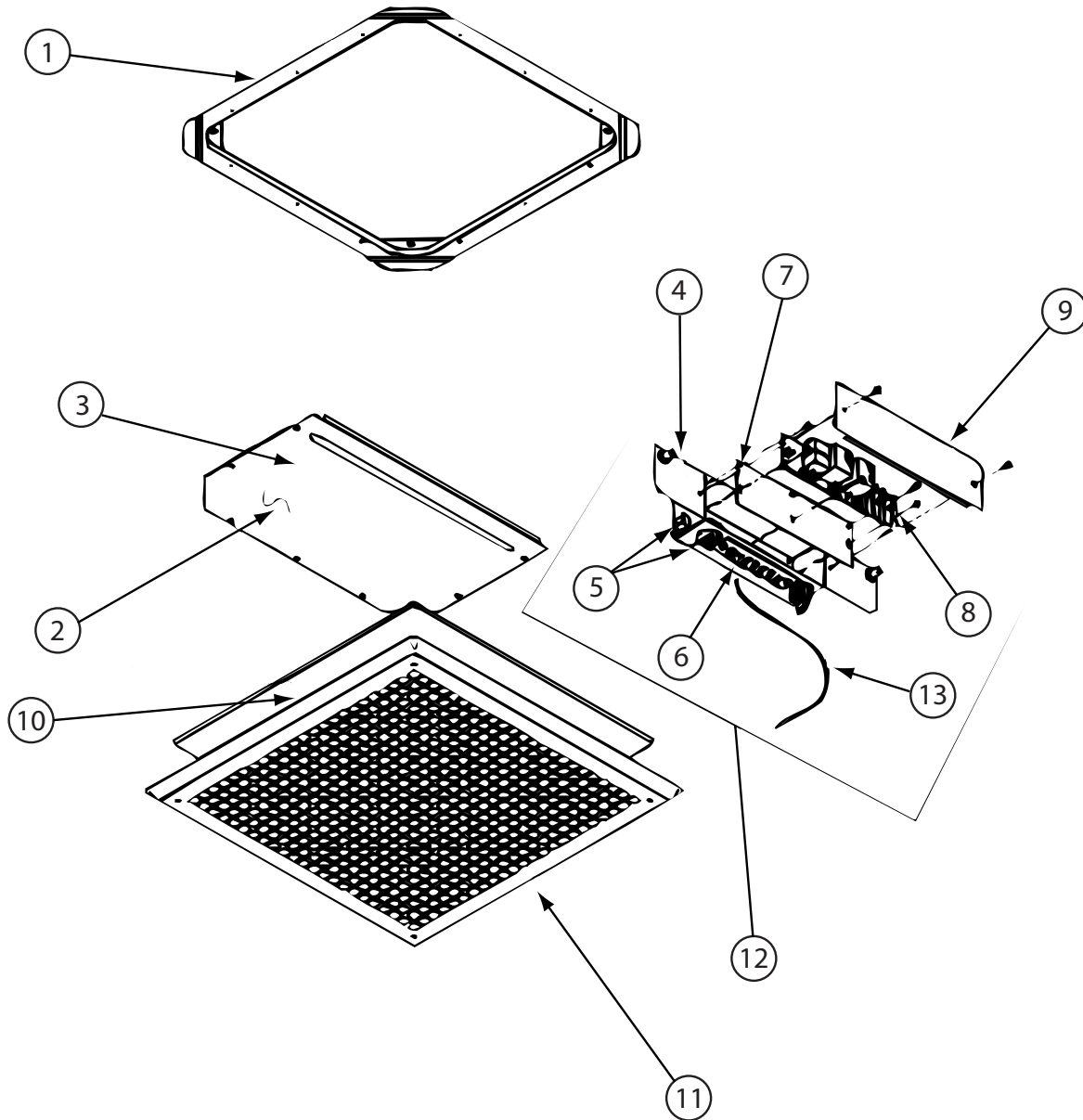

131184-07-01A

KEY	PART NUMBER	U/M	DESCRIPTION	VENDOR NO.
4	131184-04-703	EA	BOX - JUNCTION	7330-113
5	131184-04-700	EA	PLUG ASSEMBLY	7530A340
6	131184-04-702	EA	BOARD - TERMINAL	7530B3201
7	131184-01-702	EA	ISOLATOR - BLANK	7330C365
8	131184-04-705	EA	BOARD - P.C.	7330B3311
10	108892-01-703	EA	FILTER	6798A3761
11	108892-01-704	EA	GRILLE 16 3/8X16 3/8 RETURN	6798-3041
12	131184-04-706	EA	JUNCTION BOX ASM.(HEAT PUMP)	7530-508
13	105620-12-719	EA	COIL SENSOR	7330A3231
	131184-01-706	EA	NUT/WING	1200-550
	131184-07-700	EA	SMALL PARTS PKG	8330-5951

CONTACT WINNEBAGO PART SALES FOR UNLISTED COMPONENT(S)

## HEATING & A/C GROUP (CONTINUED)

### COMPONENT PARTS FOR ROOF (CONTINUED)

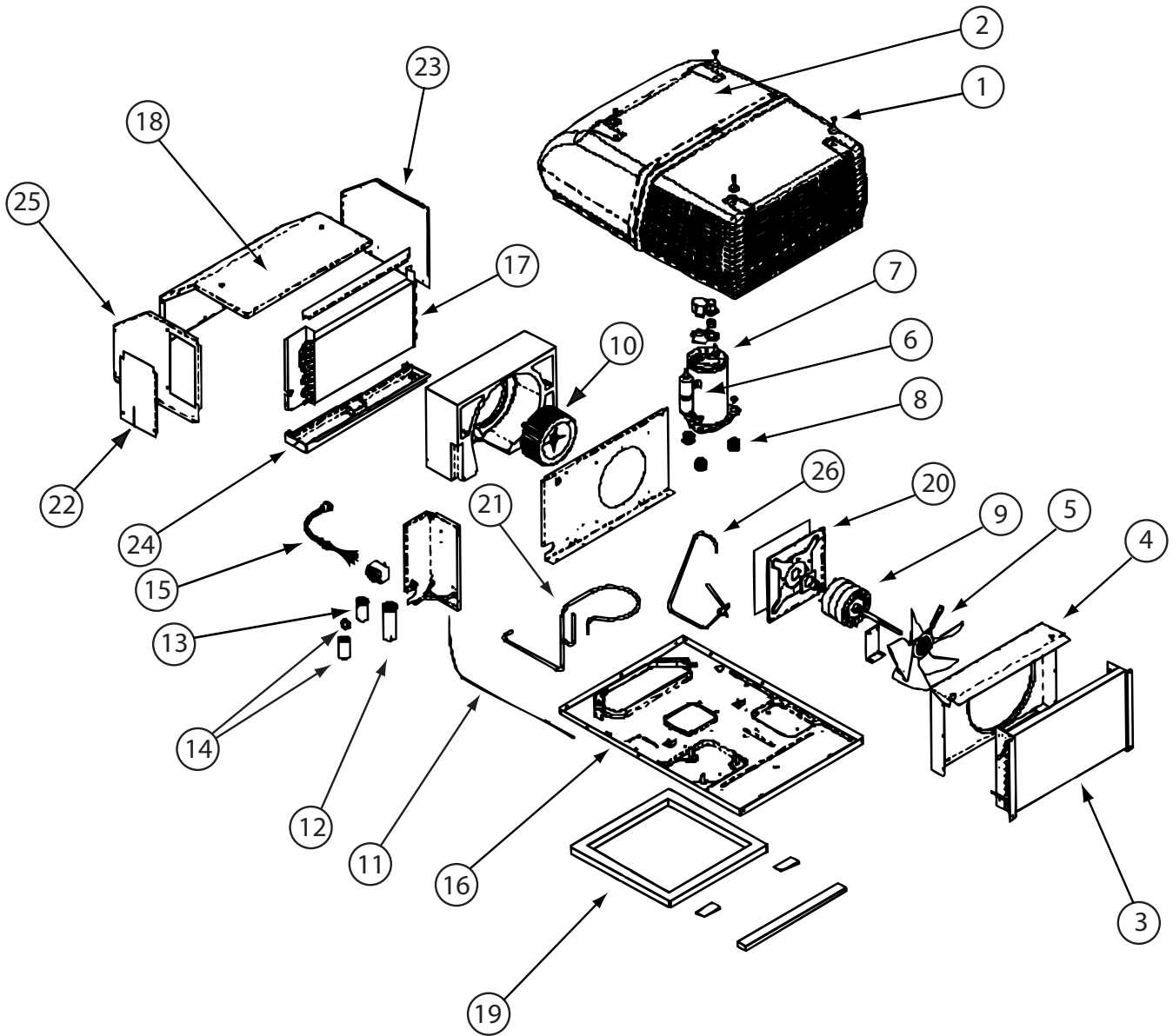

131186-03-01A

KEY	PART NUMBER	U/M	DESCRIPTION	VENDOR NO.
2	131188-05-700	EA	SHROUD-ROOF AIR/2 PIECE-WHT	8335-5261
3	115219-01-700	EA	COIL-CONDENSER	1452A1321
5	093763-01-712	EA	BLADE-FAN-CONDENSER	6733-3221
6	131186-03-700	EA	COMPRESSOR (TECHUMSEH)	1450-2249
7	147102-01-700	EA	OVERLOAD	1450-0121
8	105620-01-706	EA	MOUNTING PKG.,COMP., 3 PER	6759-3081
9	131186-01-700	EA	MOTOR - 115V, 60 HURTZ	1468-3109
10	131185-01-702	EA	BLOWER WHEEL PACKAGE	1472-1091
12	131188-01-701	EA	RUN CAP. (COMP-40MFD/370V)	1499-5721
13	093763-01-704	EA	CAPACITOR-FAN	1499-5461
14	105620-10-705	EA	PTCR (START DEVICE) - W/CAP.	8333A9021
17	131186-01-701	EA	EVAPORATOR COIL	1452-1521
19	037648-01-714	EA	GASKET PACKAGE	8332-3301
20	131185-01-704	EA	MOTOR MOUNT & SEAL KIT	8333-5151
	131188-05-702	EA	SHROUD BRACKET	8333B1551

CONTACT WINNEBAGO PART SALES FOR UNLISTED COMPONENT

**HEATING & A/C GROUP (CONTINUED)**  
**COMPONENT PARTS FOR ROOF (CONTINUED)**

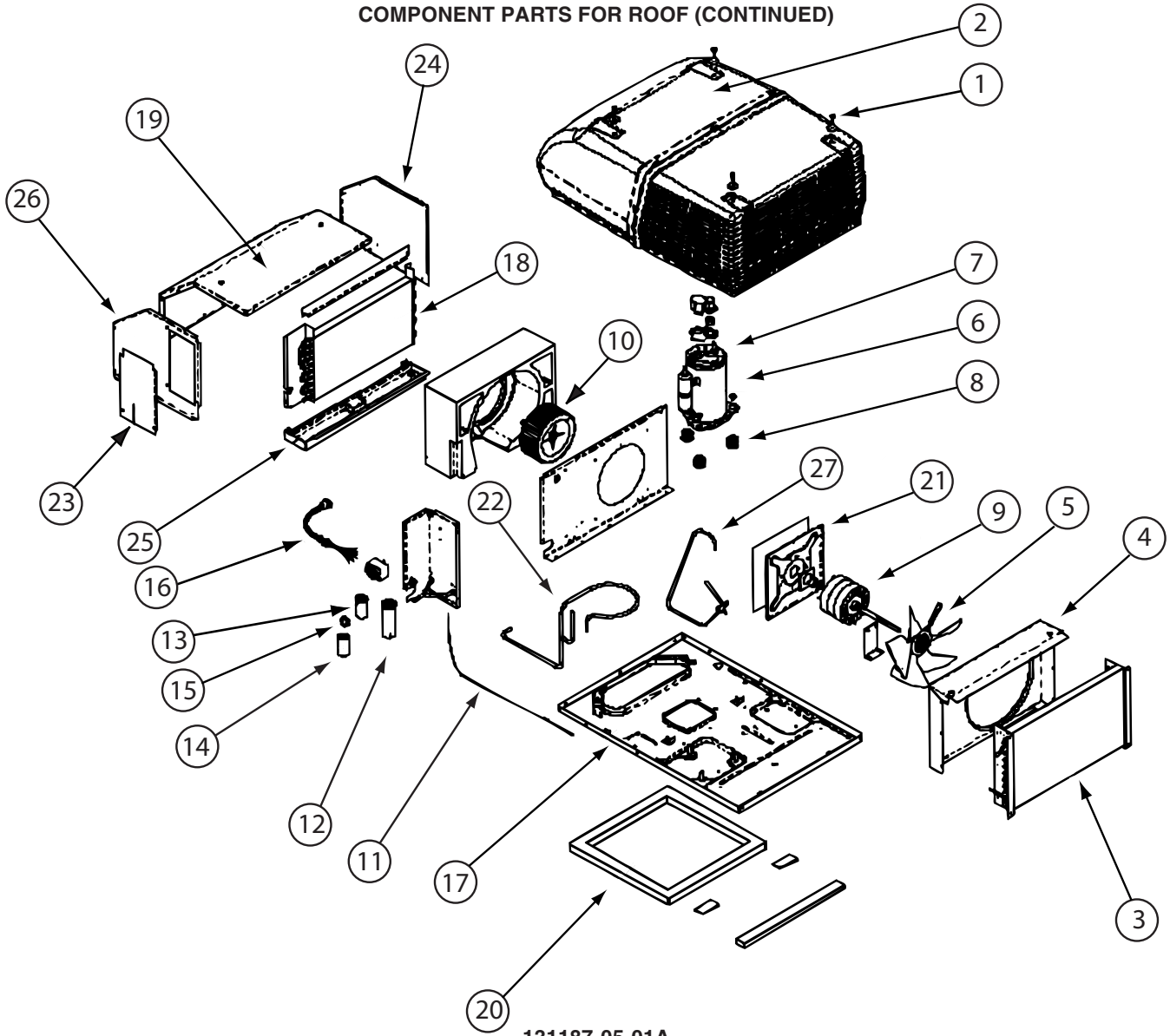

131187-05-01A

KEY	PART NUMBER	U/M	DESCRIPTION	VENDOR NO.
2	131187-05-700	EA	SHROUD-ROOF AIR/2 PIECE-WHT	8335-5261
3	115219-01-700	EA	COIL-CONDENSER	1452A1321
4	131187-03-700	EA	SHROUD FAN/INNER-LESS LOGO	6792-1071
5	093763-01-712	EA	BLADE-FAN-CONDENSER	6733-3221
6	126860-01-700	EA	COMPRESSOR RK136AT-002-A4Y	1450A2119
7	126860-01-701	EA	OVERLOAD PROTECTOR MRA# 1460	1450-0071
8	105620-01-706	EA	MOUNTING PKG.,COMP., 3 PER	6759-3081
9	131186-01-700	EA	MOTOR - 115V, 60 HURTZ	1468-3109
10	131185-01-702	EA	BLOWER WHEEL PACKAGE	1472-1091
12	123859-01-703	EA	CAPACITOR - RUN	1499-5671
13	093763-01-704	EA	CAPACITOR-FAN (INDOOR MOTOR)	1499-5461
15	105620-10-705	EA	PTCR (START DEVICE) - W/CAP.	8333A9021
18	131186-01-701	EA	EVAPORATOR COIL	1452-1521
20	037648-01-714	EA	GASKET PACKAGE	8332-3301
21	131185-01-704	EA	MOTOR MOUNT & SEAL KIT	8333-5151
22	126859-01-706	EA	LINE - SUCTION	7532A130
	131188-05-702	EA	SHROUD BRACKET	8333B1551

CONTACT WINNEBAGO PART SALES FOR UNLISTED COMPONENT

**HEATING & A/C GROUP (CONTINUED)**  
**COMPONENT PARTS FOR ROOF (CONTINUED)**

131187-05-02A

<b>KEY</b>	<b>PART NUMBER</b>	<b>U/M</b>	<b>DESCRIPTION</b>	<b>VENDOR NO.</b>
2	131188-05-701	EA	SHROUD-ROOF AIR/2 PIECE-BLK	8335-5291
3	115219-01-700	EA	COIL-CONDENSER	1452A1321
4	131187-03-700	EA	SHROUD FAN/INNER-LESS LOGO	6792-1071
5	093763-01-712	EA	BLADE-FAN-CONDENSER	6733-3221
6	126860-01-700	EA	COMPRESSOR RK136AT-002-A4Y	1450A2119
7	126860-01-701	EA	OVERLOAD PROTECTOR MRA# 1460	1450-0071
9	131186-01-700	EA	MOTOR - 115V, 60 HURTZ	1468-3109
10	131185-01-702	EA	BLOWER WHEEL PACKAGE	1472-1091
12	123859-01-703	EA	CAPACITOR - RUN	1499-5671
13	093763-01-704	EA	CAPACITOR-FAN (INDOOR MOTOR)	1499-5461
15	105620-10-705	EA	PTCR (START DEVICE) - W/CAP.	8333A9021
18	131186-01-701	EA	EVAPORATOR COIL	1452-1521
20	037648-01-714	EA	GASKET PACKAGE	8332-3301
21	131185-01-704	EA	MOTOR MOUNT & SEAL KIT	8333-5151
22	126859-01-706	EA	LINE - SUCTION	7532A130
	131188-05-702	EA	SHROUD BRACKET	8333B1551

CONTACT WINNEBAGO PART SALES FOR UNLISTED COMPONENT



## HEATING & A/C GROUP (CONTINUED)

### COMPONENT PARTS FOR ROOF (CONTINUED)

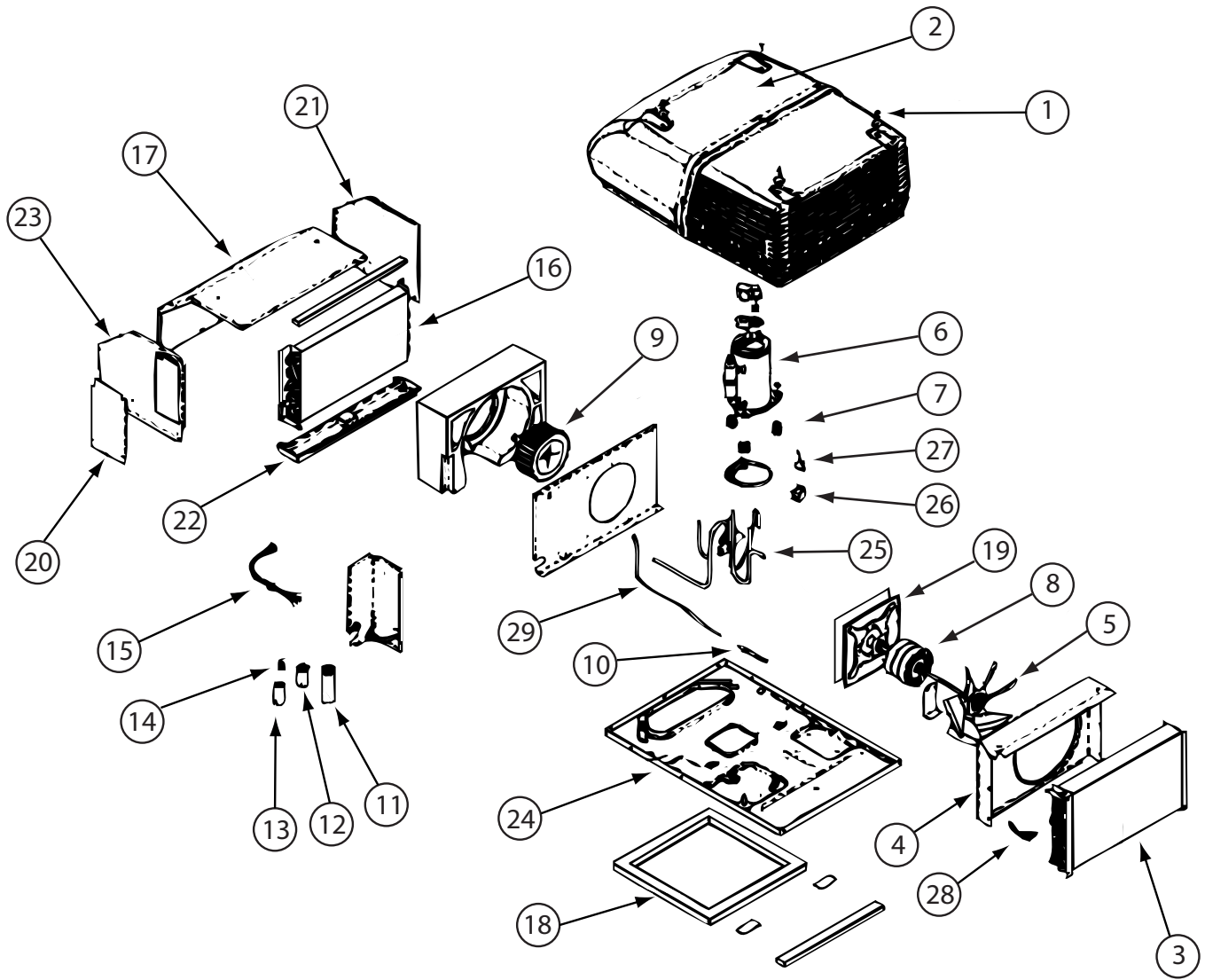

131187-06-01A

KEY	PART NUMBER	U/M	DESCRIPTION	VENDOR NO.
2	131188-05-700	EA	SHROUD-ROOF AIR/2 PIECE-WHT	8335-5261
3	131188-02-700	EA	CONDENSER COIL	1452-1441
4	131187-03-700	EA	SHROUD FAN/INNER-LESS LOGO	6792-1071
5	093763-01-712	EA	BLADE-FAN-CONDENSER	6733-3221
6	126860-01-700	EA	COMPRESSOR RK136AT-002-A4Y	1450A2119
7	105620-01-706	EA	MOUNTING PKG.,COMP., 3 PER	6759-3081
8	131186-01-700	EA	MOTOR - 115V, 60 HURTZ	1468-3109
9	131185-01-702	EA	BLOWER WHEEL PACKAGE	1472-1091
10	105620-12-711	EA	RESTRICTOR - BY FLOW	1454-2521
11	126859-01-703	EA	CAPACITOR - RUN	1499-5671
12	093763-01-704	EA	CAPACITOR-FAN (INDOOR MOTOR)	1499-5461
13	105620-10-705	EA	PTCR (START DEVICE) - W/CAP.	8333A9021
16	131187-06-700	EA	EVAPORATOR COIL	1452-1711
18	037648-01-714	EA	GASKET PACKAGE	8332-3301
19	131185-01-704	EA	MOTOR MOUNT & SEAL KIT	8333-5151
26	105620-12-708	EA	COIL - SOLENOID	1460-1081
28	131188-02-706	EA	SWITCH - FREEZE	1460-2041
29	131188-02-707	EA	LIQUID LINE	7535-135
	131188-05-702	EA	SHROUD BRACKET	8333B1551

CONTACT WINNEBAGO PART SALES FOR UNLISTED COMPONENT

**HEATING & A/C GROUP (CONTINUED)**  
**COMPONENT PARTS FOR ROOF (CONTINUED)**

131187-06-02A

<b>KEY</b>	<b>PART NUMBER</b>	<b>U/M</b>	<b>DESCRIPTION</b>	<b>VENDOR NO.</b>
2	131188-05-701	EA	SHROUD-ROOF AIR/2 PIECE-BLACK	8335-5261
3	131188-02-700	EA	CONDENSER COIL	1452-1441
4	131187-03-700	EA	SHROUD FAN/INNER-LESS LOGO	6792-1071
5	093763-01-712	EA	BLADE-FAN-CONDENSER	6733-3221
6	126860-01-700	EA	COMPRESSOR RK136AT-002-A4Y	1450A2119
7	105620-01-706	EA	MOUNTING PKG.,COMP., 3 PER	6759-3081
8	131186-01-700	EA	MOTOR - 115V, 60 HURTZ	1468-3109
9	131185-01-702	EA	BLOWER WHEEL PACKAGE	1472-1091
10	105620-12-711	EA	RESTRICTOR - BY FLOW	1454-2521
11	126859-01-703	EA	CAPACITOR - RUN	1499-5671
12	093763-01-704	EA	CAPACITOR-FAN (INDOOR MOTOR)	1499-5461
16	131187-06-700	EA	EVAPORATOR COIL	1452-1711
18	037648-01-714	EA	GASKET PACKAGE	8332-3301
19	131185-01-704	EA	MOTOR MOUNT & SEAL KIT	8333-5151
26	105620-12-708	EA	COIL - SOLENOID	1460-1081
28	131188-02-706	EA	SWITCH - FREEZE	1460-2041
29	131188-02-707	EA	LIQUID LINE	7535-135
	131188-05-702	EA	SHROUD BRACKET	8333B1551
			CONTACT WINNEBAGO PART SALES FOR UNLISTED COMPONENT	

**HEATING & A/C GROUP (CONTINUED)**  
**COMPONENT PARTS FOR ROOF (CONTINUED)**

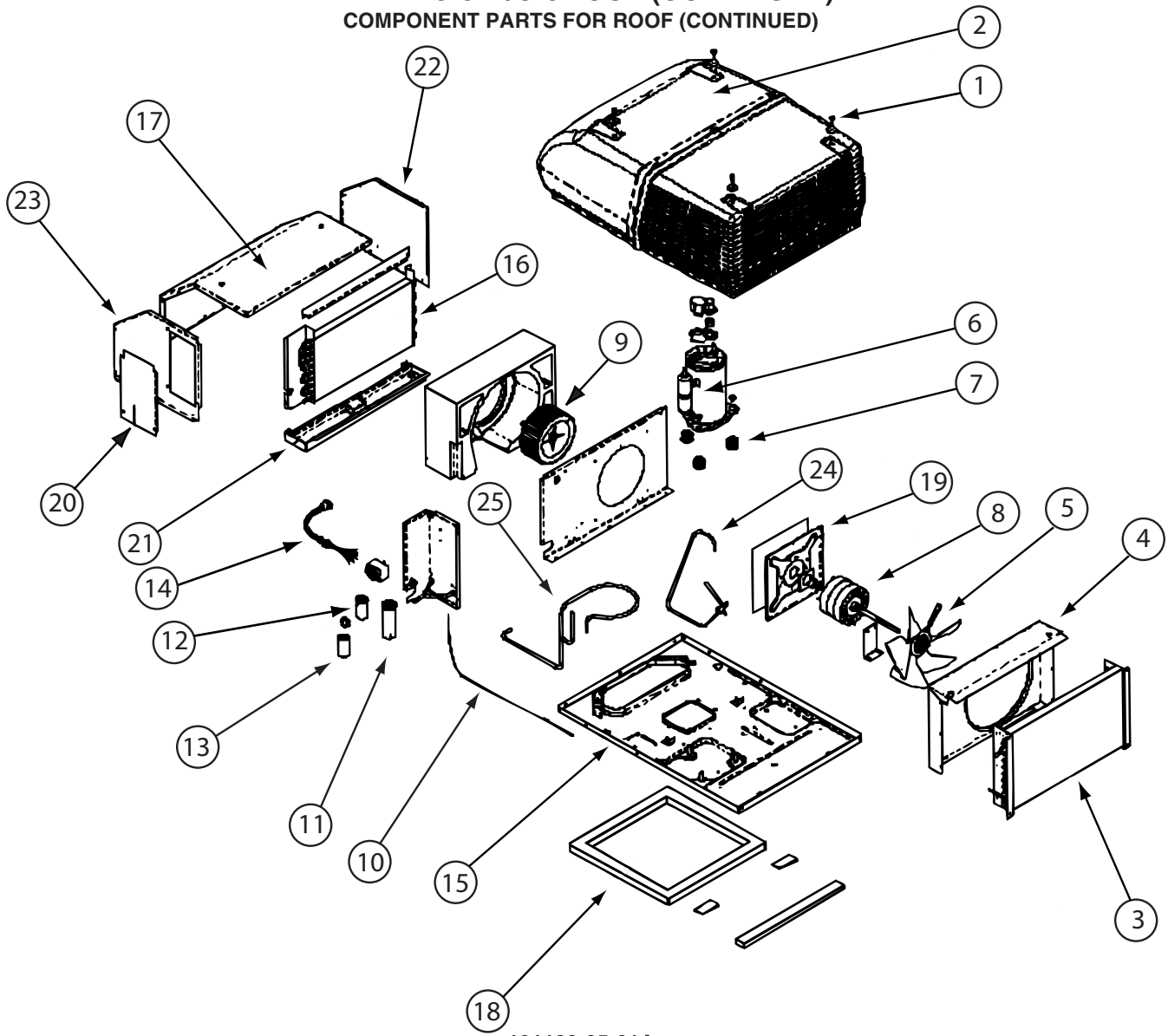

131188-05-01A

KEY	PART NUMBER	U/M	DESCRIPTION	VENDOR NO.
2	131188-05-700	EA	SHROUD-ROOF AIR/2 PIECE-WHT	8335-5261
3	115219-01-700	EA	COIL-CONDENSER	1452A1321
4	131187-03-700	EA	SHROUD FAN/INNER-LESS LOGO	6792-1071
5	093763-01-712	EA	BLADE-FAN-CONDENSER	6733-3221
6	131188-05-703	EA	COMPRESSOR (TECUMSEH)	1450B2299
7	105620-01-706	EA	MOUNTING PKG.,COMP., 3 PER	6759-3081
8	131185-01-701	EA	MOTOR (115V, 60HZ)	1468-3069
9	131185-01-702	EA	BLOWER WHEEL PACKAGE	1472-1091
11	126859-01-703	EA	CAPACITOR - RUN	1499-5671
12	093763-01-704	EA	CAPACITOR-FAN (INDOOR MOTOR)	1499-5461
13	105620-10-705	EA	PTCR (START DEVICE) - W/CAP.	8333A9021
16	131186-01-701	EA	EVAPORATOR COIL	1452-1521
18	037648-01-714	EA	GASKET PACKAGE	8332-3301
19	131185-01-704	EA	MOTOR MOUNT & SEAL KIT	83333-5151
	105620-01-705	EA	PROTECTOR-OVERLOAD, RH & LH	6759-3791
	131188-05-702	EA	SHROUD BRACKET	8333B1551

CONTACT WINNEBAGO PART SALES FOR UNLISTED COMPONENT(S)

**HEATING & A/C GROUP (CONTINUED)**  
**COMPONENT PARTS FOR ROOF (CONTINUED)**

131188-05-02A

<b>KEY</b>	<b>PART NUMBER</b>	<b>U/M</b>	<b>DESCRIPTION</b>	<b>VENDOR NO.</b>
2	131188-05-701	EA	SHROUD-ROOF AIR/2 PIECE-BLACK	8335-5291
3	115219-01-700	EA	COIL-CONDENSER	1452A1321
4	131187-03-700	EA	SHROUD FAN/INNER-LESS LOGO	6792-1071
5	093763-01-712	EA	BLADE-FAN-CONDENSER	6733-3221
6	131188-05-703	EA	COMPRESSOR (TECUMSEH)	1450B2299
7	105620-01-706	EA	MOUNTING PKG.,COMP., 3 PER	6759-3081
8	131185-01-701	EA	MOTOR (115V, 60HZ)	1468-3069
9	131185-01-702	EA	BLOWER WHEEL PACKAGE	1472-1091
11	126859-01-703	EA	CAPACITOR - RUN	1499-5671
12	093763-01-704	EA	CAPACITOR-FAN (INDOOR MOTOR)	1499-5461
13	105620-10-705	EA	PTCR (START DEVICE) - W/CAP.	8333A9021
16	131186-01-701	EA	EVAPORATOR COIL	1452-1521
18	037648-01-714	EA	GASKET PACKAGE	8332-3301
19	131185-01-704	EA	MOTOR MOUNT & SEAL KIT	83333-5151
	105620-01-705	EA	PROTECTOR-OVERLOAD, RH & LH	6759-3791
	131188-05-702	EA	SHROUD BRACKET	8333B1551

CONTACT WINNEBAGO PART SALES FOR UNLISTED COMPONENT(S)

**HEATING & A/C GROUP (CONTINUED)**  
**COMPONENT PARTS FOR ROOF (CONTINUED)**

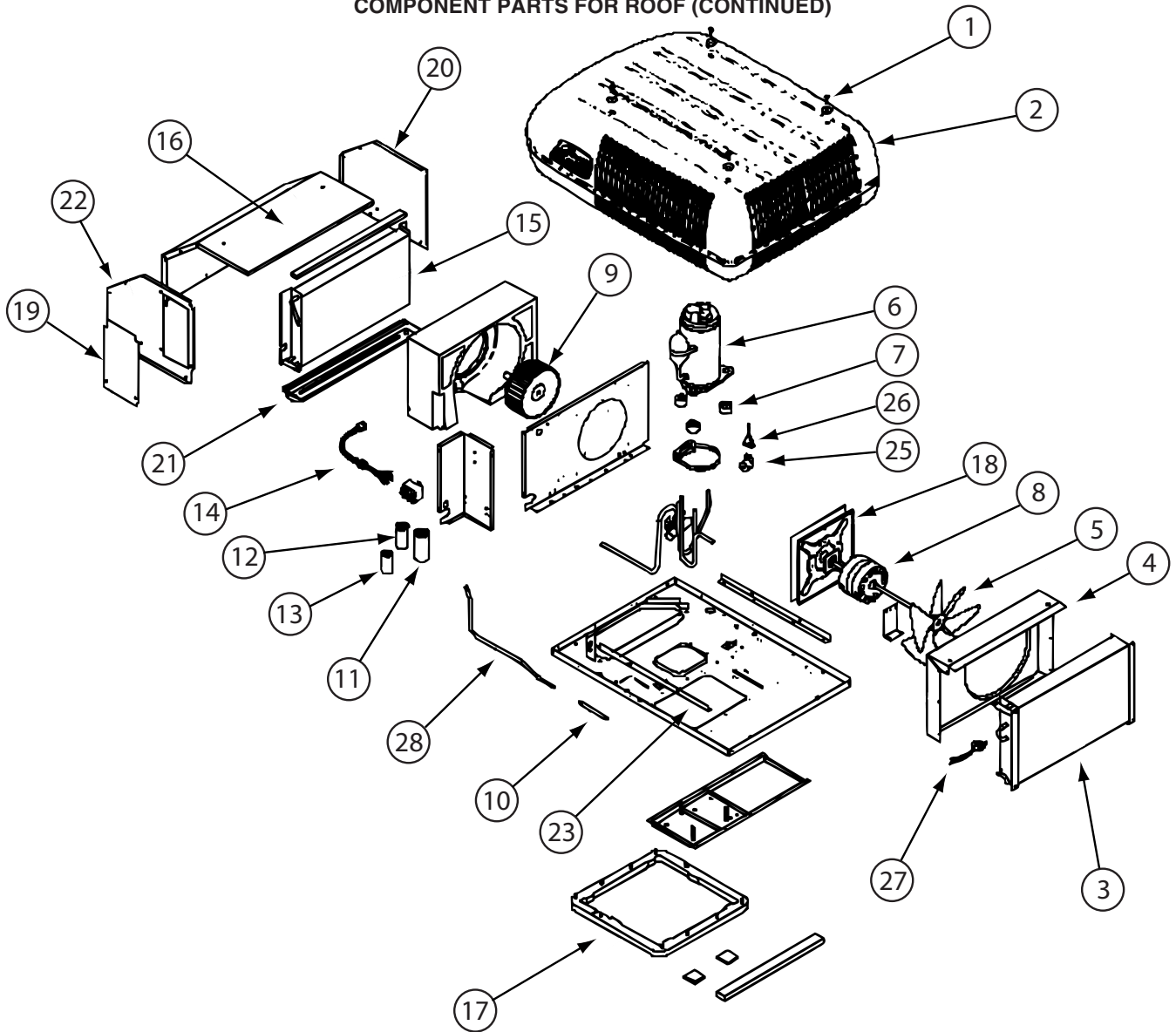

131188-06-01A

KEY	PART NUMBER	U/M	DESCRIPTION	VENDOR NO.
2	131188-05-700	EA	SHROUD-ROOF AIR/2 PIECE-WHT	8335-5261
3	131188-02-700	EA	CONDENSER COIL	1452-1441
4	131187-03-700	EA	SHROUD FAN/INNER-LESS LOGO	6792-1071
5	093763-01-712	EA	BLADE-FAN-CONDENSER	6733-3221
6	131188-05-703	EA	COMPRESSOR (TECUMSEH)	1450B2299
7	105620-01-706	EA	MOUNTING PKG.,COMP., 3 PER	6759-3081
8	131185-01-701	EA	MOTOR (115V, 60HZ)	1468-3069
9	131185-01-702	EA	BLOWER WHEEL PACKAGE	1472-1091
11	105620-12-725	EA	COMPRESSOR RUN CAPACITOR	1499-5731
12	093763-01-704	EA	CAPACITOR-FAN (INDOOR MOTOR)	1499-5461
13	105620-10-705	EA	PTCR (START DEVICE) - W/CAP.	8333A9021
15	131186-01-701	EA	EVAPORATOR COIL	1452-1521
17	037648-01-714	EA	GASKET PACKAGE	8332-3301
18	131185-01-704	EA	MOTOR MOUNT & SEAL KIT	8333-5151
25	105620-12-708	EA	COIL - SOLENOID	1460-1081
27	131188-02-706	EA	SWITCH - FREEZE	1460-2041
28	131188-02-707	EA	LIQUID LINE	7535-135
	105620-01-705	EA	PROTECTOR-OVERLOAD, RH & LH	6759-3791
	131188-05-702	EA	SHROUD BRACKET	8333B1551

CONTACT WINNEBAGO PART SALES FOR UNLISTED COMPONENT(S)

**HEATING & A/C GROUP (CONTINUED)**  
**COMPONENT PARTS FOR ROOF (CONTINUED)**

131188-06-02A

KEY	PART NUMBER	U/M	DESCRIPTION	VENDOR NO.
2	131188-05-701	EA	SHROUD-ROOF AIR/2 PIECE-BLACK	8335-5291
3	131188-02-700	EA	CONDENSER COIL	1452-1441
4	131187-03-700	EA	SHROUD FAN/INNER-LESS LOGO	6792-1071
5	093763-01-712	EA	BLADE-FAN-CONDENSER	6733-3221
6	131188-05-703	EA	COMPRESSOR (TECUMSEH)	1450B2299
7	105620-01-706	EA	MOUNTING PKG.,COMP., 3 PER	6759-3081
8	131185-01-701	EA	MOTOR (115V, 60HZ)	1468-3069
9	131185-01-702	EA	BLOWER WHEEL PACKAGE	1472-1091
11	105620-12-725	EA	COMPRESSOR RUN CAPACITOR	1499-5731
12	093763-01-704	EA	CAPACITOR-FAN (INDOOR MOTOR)	1499-5461
13	105620-10-705	EA	PTCR (START DEVICE) - W/CAP.	8333A9021
15	131186-01-701	EA	EVAPORATOR COIL	1452-1521
17	037648-01-714	EA	GASKET PACKAGE	8332-3301
18	131185-01-704	EA	MOTOR MOUNT & SEAL KIT	8333-5151
25	105620-12-708	EA	COIL - SOLENOID	1460-1081
27	131188-02-706	EA	SWITCH - FREEZE	1460-2041
28	131188-02-707	EA	LIQUID LINE	7535-135
	105620-01-705	EA	PROTECTOR-OVERLOAD, RH & LH	6759-3791
	131188-05-702	EA	SHROUD BRACKET	8333B1551
			CONTACT WINNEBAGO PART SALES FOR UNLISTED COMPONENT(S)	

**INTERIOR FINISH GROUP**  
**MOLDINGS & TRIMS**  
**HONEY CHERRY, WASHED MAPLE**

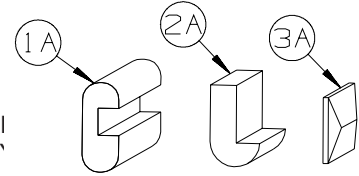

KEY	PART NUMBER	U/M	DESCRIPTION
1A	M09412-62-N42	EA	MOLDING/SHELF EDGE - .6" X 1.3" X 96" - PORTSMOUTH OAI
1A	M09412-62-M52	EA	MOLDING/SHELF EDGE - .6" X 1.3" X 96" - CONCERT CHERRY
1A	M09412-62-M62	EA	MOLDING/SHELF EDGE - .6" X 1.3" X 96" - WASHED MAPLE
1A	M09412-62-RC3	EA	MOLDING/SHELF EDGE - .6" X 1.3" X 96" - HONEY CHERRY
1A	M09412-62-SA3	EA	MOLDING/SHELF EDGE - .6" X 1.3" X 96" - SIERRA MAPLE
2A	M09511-43-T77	EA	MOLDING - TRIM - W/NOTCH - .8" X 1.4" X 86.3" - PORTSMOUT OAK
2A	M09525-80-UM1	EA	MOLDING - TRIM - W/NOTCH - .8" X 1.4" X 86.5" - CONCERT CHERRY
2A	M09525-80-U91	EA	MOLDING - TRIM - W/NOTCH - .8" X 1.4" X 86.5" - WASHED MAPLE
2A	M09525-80-U92	EA	MOLDING - TRIM - W/NOTCH - .8" X 1.4" X 86.5" - SIERRA MAPLE
2A	M09525-80-Y92	EA	MOLDING - TRIM - W/NOTCH - .8" X 1.4" X 86.5" - HONEY CHERRY
2A	M09501-85-TG3	EA	MOLDING/TRIM - W/NOTCH - 4" X 86.06" - HONEY CHERRY
2A	M09501-32-TG1	EA	MOLDING/TRIM - W/NOTCH - .8" X 2.5" X 86.2" - CONCERT CHERRY
2A	M09501-32-TG2	EA	MOLDING/TRIM - W/NOTCH - .8" X 2.5" X 86.2" - WASHED MAPLE
2A	M09501-32-TD3	EA	MOLDING/TRIM - W/NOTCH - .8" X 2.5" X 86.2" - SIERRA MAPLE
2A	M09501-32-TG3	EA	MOLDING/TRIM - W/NOTCH - .8" X 2.5" X 86.2" - HONEY CHERRY
2A	M09515-72-TD0	EA	MOLDING/TRIM - .8" X 2.2" X 86.1" - PORTSMOUTH OAK
2A	M09515-72-TD1	EA	MOLDING/TRIM - .8" X 2.2" X 86.1" - CONCERT CHERRY
2A	M09515-72-TD2	EA	MOLDING/TRIM - .8" X 2.2" X 86.1" - WASHED MAPLE
2A	M09515-72-TD3	EA	MOLDING/TRIM - .8" X 2.2" X 86.1" - SIERRA MAPLE
2A	M09511-44-T77	EA	MOLDING - TRIM - W/NOTCH - 1" X 86.4" - PORTSMOUTH OAK
2A	M09511-44-T78	EA	MOLDING - TRIM - W/NOTCH - 1" X 86.4" - CONCERT CHERRY
2A	M09511-44-T79	EA	MOLDING - TRIM - W/NOTCH - 1" X 86.4" - WASHED MAPLE
2A	M09511-44-T80	EA	MOLDING - TRIM - W/NOTCH - 1" X 86.4" - HONEY CHERRY
2A	M09438-25-RA3	EA	MOLDING - HARDWOOD-W/NOTCH - 1.4"X 80.2" - HONEY CHERRY
3A	M09477-63-S46	EA	MOLDING - TRIM/VEE-W/CUT ENDS - 1"X 64.1" - PORTSMOUTH OAK
3A	M09477-63-S47	EA	MOLDING - TRIM/VEE-W/CUT ENDS - 1"X 64.1" - CONCERT CHERRY
3A	M09477-63-S48	EA	MOLDING - TRIM/VEE-W/CUT ENDS - 1"X 64.1" - WASHED MAPLE
3A	M09477-63-W51	EA	MOLDING - TRIM/VEE-W/CUT ENDS - 1"X 64.1" - HONEY CHERRY
3A	M09477-64-S46	EA	MOLDING - TRIM/VEE-W/CUT ENDS - 1"X 14.9" - PORTSMOUTH OAK
3A	M09477-64-S47	EA	MOLDING - TRIM/VEE-W/CUT ENDS - 1"X 14.9" - CONCERT CHERRY
3A	M09477-64-S48	EA	MOLDING - TRIM/VEE-W/CUT ENDS - 1"X 14.9" - WASHED MAPLE
3A	M09477-64-W51	EA	MOLDING - TRIM/VEE-W/CUT ENDS - 1"X 14.9" - HONEY CHERRY
3A	M09501-30-SD0	EA	MOLDING - TRIM/VEE - .2" X 1" X 35.1" - PORTSMOUTH OAK
3A	M09501-30-SD1	EA	MOLDING - TRIM/VEE - .2" X 1" X 35.1" - CONCERT CHERRY
3A	M09501-30-SD2	EA	MOLDING - TRIM/VEE - .2" X 1" X 35.1" - WASHED MAPLE
3A	M09501-30-SD3	EA	MOLDING - TRIM/VEE - .2" X 1" X 35.1" - HONEY CHERRY
3A	M09515-97-WL4	EA	MOLDING - TRIM/VEE - .2" X 1" X 32.6" - CONCERT CHERRY
3A	M09515-97-WL5	EA	MOLDING - TRIM/VEE - .2" X 1" X 32.6" - WASHED MAPLE
3A	M09515-97-WL6	EA	MOLDING - TRIM/VEE - .2" X 1" X 32.6" - HONEY CHERRY
3A	M09534-17-UF3	EA	MOLDING - TRIM/VEE - .2" X 1" X 20.1" - SIERRA MAPLE
3A	M09534-17-UJ1	EA	MOLDING - TRIM/VEE - .2" X 1" X 20.1" - CONCERT CHERRY
3A	M09534-17-UJ2	EA	MOLDING - TRIM/VEE - .2" X 1" X 20.1" - WASHED MAPLE
3A	M09534-17-UJ3	EA	MOLDING - TRIM/VEE - .2" X 1" X 20.1" - HONEY CHERRY
3A	M09477-88-S34	EA	MOLDING - TRIM/VEE - .2" X 1" X 19.9" - WASHED MAPLE
3A	M09477-88-S35	EA	MOLDING - TRIM/VEE - .2" X 1" X 19.9" - SIERRA MAPLE
3A	M09568-03-W51	EA	MOLDING - TRIM/VEE - .2" X 1" X 19.8" - HONEY CHERRY
3A	M09568-03-W52	EA	MOLDING - TRIM/VEE - .2" X 1" X 19.8" - WASHED MAPLE
3A	M09565-51-W51	EA	MOLDING - TRIM/VEE - .2" X 1" X 19.4" - HONEY CHERRY
3A	M09565-51-W52	EA	MOLDING - TRIM/VEE - .2" X 1" X 19.4" - WASHED MAPLE
3A	M09553-79-W66	EA	MOLDING - TRIM/VEE - .2" X 1" X 15.6" - HONEY CHERRY
3A	M09515-10-W66	EA	MOLDING - TRIM/VEE - .2" X 1" X 15.4" - HONEY CHERRY
3A	M09501-63-T78	EA	MOLDING - TRIM/VEE - .2" X 1" X 15" - CONCERT CHERRY
3A	M09501-63-T79	EA	MOLDING - TRIM/VEE - .2" X 1" X 15" - WASHED MAPLE
3A	M09501-63-T80	EA	MOLDING - TRIM/VEE - .2" X 1" X 15" - SIERRA MAPLE
3A	M09501-63-W66	EA	MOLDING - TRIM/VEE - .2" X 1" X 15" - HONEY CHERRY
3A	M09553-09-W66	EA	MOLDING - TRIM/VEE - .2" X 1" X 13.4" - HONEY CHERRY
3A	M09566-04-WD3	EA	MOLDING - TRIM/VEE - .2" X 1" X 8.9" - HONEY CHERRY
3A	M09553-29-WH4	EA	MOLDING - TRIM/VEE - .4" X 1" X 94.4" - CONCERT CHERRY
3A	M09553-29-WH5	EA	MOLDING - TRIM/VEE - .4" X 1" X 94.4" - WASHED MAPLE
3A	M09553-29-WH6	EA	MOLDING - TRIM/VEE - .4" X 1" X 94.4" - SIERRA MAPLE
3A	M09565-04-WH4	EA	MOLDING - TRIM/VEE - .4" X 1" X 89.5" - CONCERT CHERRY

**INTERIOR FINISH GROUP (CONTINUED)**  
**MOLDINGS & TRIMS (CONTINUED)**

KEY	PART NUMBER	U/M	DESCRIPTION
3A	M09565-04-WH5	EA	MOLDING - TRIM/VEE - .4" X 1" X 89.5" - WASHED MAPLE
3A	M09565-04-WH6	EA	MOLDING - TRIM/VEE - .4" X 1" X 89.5" - SIERRA MAPLE
3A	M09544-86-W37	EA	MOLDING - TRIM/VEE - .4" X 1" X 88.1" - WASHED MAPLE
3A	M09544-86-W38	EA	MOLDING - TRIM/VEE - .4" X 1" X 88.1" - SIERRA MAPLE
3A	M09538-39-U67	EA	MOLDING - TRIM/VEE - .4" X 1" X 82.6" - WASHED MAPLE
3A	M09538-39-U68	EA	MOLDING - TRIM/VEE - .4" X 1" X 82.6" - SIERRA MAPLE
3A	M09553-62-WH4	EA	MOLDING - TRIM/VEE - .4" X 1" X 81.4" - CONCERT CHERRY
3A	M09553-62-WH5	EA	MOLDING - TRIM/VEE - .4" X 1" X 81.4" - WASHED MAPLE
3A	M09553-62-WH6	EA	MOLDING - TRIM/VEE - .4" X 1" X 81.4" - SIERRA MAPLE
3A	M09577-98-WH4	EA	MOLDING - TRIM/VEE - .4" X 1" X 80.2" - CONCERT CHERRY
3A	M09577-98-WH5	EA	MOLDING - TRIM/VEE - .4" X 1" X 80.2" - WASHED MAPLE
3A	M09577-98-WH6	EA	MOLDING - TRIM/VEE - .4" X 1" X 80.2" - SIERRA MAPLE
3A	M09544-37-W37	EA	MOLDING - TRIM/VEE - .4" X 1" X 78.8" - WASHED MAPLE
3A	M09544-37-W38	EA	MOLDING - TRIM/VEE - .4" X 1" X 78.8" - SIERRA MAPLE
3A	M09544-34-W37	EA	MOLDING - TRIM/VEE - .4" X 1" X 78.7" - WASHED MAPLE
3A	M09544-34-W38	EA	MOLDING - TRIM/VEE - .4" X 1" X 78.7" - SIERRA MAPLE
3A	M09538-37-U67	EA	MOLDING - TRIM/VEE - .4" X 1" X 77.5" - WASHED MAPLE
3A	M09538-37-U68	EA	MOLDING - TRIM/VEE - .4" X 1" X 77.5" - SIERRA MAPLE
3A	M09553-65-WH4	EA	MOLDING - TRIM/VEE - .4" X 1" X 77" - CONCERT CHERRY
3A	M09553-65-WH5	EA	MOLDING - TRIM/VEE - .4" X 1" X 77" - WASHED MAPLE
3A	M09553-65-WH6	EA	MOLDING - TRIM/VEE - .4" X 1" X 77" - SIERRA MAPLE
3A	M09553-64-WH4	EA	MOLDING - TRIM/VEE - .4" X 1" X 76.7" - CONCERT CHERRY
3A	M09553-64-WH5	EA	MOLDING - TRIM/VEE - .4" X 1" X 76.7" - WASHED MAPLE
3A	M09553-64-WH6	EA	MOLDING - TRIM/VEE - .4" X 1" X 76.7" - SIERRA MAPLE
3A	M09565-75-WH4	EA	MOLDING - TRIM/VEE - .4" X 1" X 75.9" - CONCERT CHERRY
3A	M09565-75-WH5	EA	MOLDING - TRIM/VEE - .4" X 1" X 75.9" - WASHED MAPLE
3A	M09565-75-WH6	EA	MOLDING - TRIM/VEE - .4" X 1" X 75.9" - SIERRA MAPLE
3A	M09565-02-WH4	EA	MOLDING - TRIM/VEE - .4" X 1" X 75.1" - CONCERT CHERRY
3A	M09565-02-WH5	EA	MOLDING - TRIM/VEE - .4" X 1" X 75.1" - WASHED MAPLE
3A	M09565-02-WH6	EA	MOLDING - TRIM/VEE - .4" X 1" X 75.1" - SIERRA MAPLE
3A	M09553-26-WH4	EA	MOLDING - TRIM/VEE - .4" X 1" X 74.1" - CONCERT CHERRY
3A	M09553-26-WH5	EA	MOLDING - TRIM/VEE - .4" X 1" X 74.1" - WASHED MAPLE
3A	M09553-26-WH6	EA	MOLDING - TRIM/VEE - .4" X 1" X 74.1" - SIERRA MAPLE
3A	M09538-91-WH4	EA	MOLDING - TRIM/VEE - .4" X 1" X 73.8" - CONCERT CHERRY
3A	M09538-91-WH5	EA	MOLDING - TRIM/VEE - .4" X 1" X 73.8" - WASHED MAPLE
3A	M09538-91-WH6	EA	MOLDING - TRIM/VEE - .4" X 1" X 73.8" - SIERRA MAPLE
3A	M09553-22-WH4	EA	MOLDING - TRIM/VEE - .4" X 1" X 73.2" - CONCERT CHERRY
3A	M09553-22-WH5	EA	MOLDING - TRIM/VEE - .4" X 1" X 73.2" - WASHED MAPLE
3A	M09553-22-WH6	EA	MOLDING - TRIM/VEE - .4" X 1" X 73.2" - SIERRA MAPLE
3A	M09565-97-WH4	EA	MOLDING - TRIM/VEE - .4" X 1" X 72.6" - CONCERT CHERRY
3A	M09565-97-WH5	EA	MOLDING - TRIM/VEE - .4" X 1" X 72.6" - WASHED MAPLE
3A	M09565-97-WH6	EA	MOLDING - TRIM/VEE - .4" X 1" X 72.6" - SIERRA MAPLE
3A	M09568-12-WH4	EA	MOLDING - TRIM/VEE - .4" X 1" X 71.9" - CONCERT CHERRY
3A	M09568-12-WH5	EA	MOLDING - TRIM/VEE - .4" X 1" X 71.9" - WASHED MAPLE
3A	M09568-12-WH6	EA	MOLDING - TRIM/VEE - .4" X 1" X 71.9" - SIERRA MAPLE
3A	M09565-01-WH4	EA	MOLDING - TRIM/VEE - .4" X 1" X 71.7" - CONCERT CHERRY
3A	M09565-01-WH5	EA	MOLDING - TRIM/VEE - .4" X 1" X 71.7" - WASHED MAPLE
3A	M09565-01-WH6	EA	MOLDING - TRIM/VEE - .4" X 1" X 71.7" - SIERRA MAPLE
3A	M09565-01-YR3	EA	MOLDING - TRIM/VEE - .4" X 1" X 71.7" - HONEY CHERRY
3A	M09544-15-WB4	EA	MOLDING - TRIM/VEE - .4" X 1" X 64.5" - CONCERT CHERRY
3A	M09544-15-WB5	EA	MOLDING - TRIM/VEE - .4" X 1" X 64.5" - WASHED MAPLE
3A	M09544-15-WB6	EA	MOLDING - TRIM/VEE - .4" X 1" X 64.5" - SIERRA MAPLE
3A	M09538-94-WH4	EA	MOLDING - TRIM/VEE - .4" X 1" X 71.1" - CONCERT CHERRY
3A	M09538-94-WH5	EA	MOLDING - TRIM/VEE - .4" X 1" X 71.1" - WASHED MAPLE
3A	M09538-94-WH6	EA	MOLDING - TRIM/VEE - .4" X 1" X 71.1" - SIERRA MAPLE
3A	M09565-78-WH4	EA	MOLDING - TRIM/VEE - .4" X 1" X 70.2" - CONCERT CHERRY
3A	M09565-78-WH5	EA	MOLDING - TRIM/VEE - .4" X 1" X 70.2" - WASHED MAPLE
3A	M09565-78-WH6	EA	MOLDING - TRIM/VEE - .4" X 1" X 70.2" - SIERRA MAPLE
3A	M09553-21-WH4	EA	MOLDING - TRIM/VEE - .4" X 1" X 70.1" - CONCERT CHERRY
3A	M09553-21-WH5	EA	MOLDING - TRIM/VEE - .4" X 1" X 70.1" - WASHED MAPLE
3A	M09553-21-WH6	EA	MOLDING - TRIM/VEE - .4" X 1" X 70.1" - SIERRA MAPLE
3A	M09501-92-T77	EA	MOLDING - TRIM/VEE - .4" X 1" X 70" - PORTSMOUTH OAK
3A	M09501-92-T78	EA	MOLDING - TRIM/VEE - .4" X 1" X 70" - CONCERT CHERRY
3A	M09501-92-T79	EA	MOLDING - TRIM/VEE - .4" X 1" X 70" - WASHED MAPLE



**INTERIOR FINISH GROUP (CONTINUED)**  
**MOLDINGS & TRIMS (CONTINUED)**

KEY	PART NUMBER	U/M	DESCRIPTION
3A	M09501-92-T80	EA	MOLDING - TRIM/VEE - .4" X 1" X 70" - SIERRA MAPLE
3A	M09538-27-WH4	EA	MOLDING - TRIM/VEE - .4" X 1" X 71.1" - CONCERT CHERRY
3A	M09538-27-U67	EA	MOLDING - TRIM/VEE - .4" X 1" X 71.1" - WASHED MAPLE
3A	M09538-27-U68	EA	MOLDING - TRIM/VEE - .4" X 1" X 71.1" - SIERRA MAPLE
3A	M09544-10-WH4	EA	MOLDING - TRIM/VEE - .4" X 1" X 68.2" - CONCERT CHERRY
3A	M09544-10-W91	EA	MOLDING - TRIM/VEE - .4" X 1" X 68.2" - WASHED MAPLE
3A	M09544-10-W92	EA	MOLDING - TRIM/VEE - .4" X 1" X 68.2" - SIERRA MAPLE
3A	M09553-03-WH4	EA	MOLDING - TRIM/VEE - .4" X 1" X 66.7" - CONCERT CHERRY
3A	M09553-03-WH5	EA	MOLDING - TRIM/VEE - .4" X 1" X 66.7" - WASHED MAPLE
3A	M09553-03-WH6	EA	MOLDING - TRIM/VEE - .4" X 1" X 66.7" - SIERRA MAPLE
3A	M09553-03-YR3	EA	MOLDING - TRIM/VEE - .4" X 1" X 66.7" - HONEY CHERRY
3A	M09538-93-WH4	EA	MOLDING - TRIM/VEE - .4" X 1" X 66.6" - CONCERT CHERRY
3A	M09538-93-WH5	EA	MOLDING - TRIM/VEE - .4" X 1" X 66.6" - WASHED MAPLE
3A	M09538-93-WH6	EA	MOLDING - TRIM/VEE - .4" X 1" X 66.6" - SIERRA MAPLE
3A	M09544-33-W37	EA	MOLDING - TRIM/VEE - .4" X 1" X 66.5" - SIERRA MAPLE
3A	M09544-33-W38	EA	MOLDING - TRIM/VEE - .4" X 1" X 66.5" - WASHED MAPLE
3A	M09553-02-WH4	EA	MOLDING - TRIM/VEE - .4" X 1" X 66.4" - CONCERT CHERRY
3A	M09553-02-WH5	EA	MOLDING - TRIM/VEE - .4" X 1" X 66.4" - WASHED MAPLE
3A	M09553-02-WH6	EA	MOLDING - TRIM/VEE - .4" X 1" X 66.4" - SIERRA MAPLE
3A	M09544-14-WB4	EA	MOLDING - TRIM/VEE - .4" X 1" X 64.5" - CONCERT CHERRY
3A	M09544-14-WB5	EA	MOLDING - TRIM/VEE - .4" X 1" X 64.5" - WASHED MAPLE
3A	M09544-14-WB6	EA	MOLDING - TRIM/VEE - .4" X 1" X 64.5" - SIERRA MAPLE
3A	M09515-78-T77	EA	MOLDING - TRIM/VEE - .4" X 1" X 64.1" - PORTSMOUTH OAK
3A	M09515-78-T78	EA	MOLDING - TRIM/VEE - .4" X 1" X 64.1" - CONCERT CHERRY
3A	M09515-78-T79	EA	MOLDING - TRIM/VEE - .4" X 1" X 64.1" - WASHED MAPLE
3A	M09515-78-T80	EA	MOLDING - TRIM/VEE - .4" X 1" X 64.1" - SIERRA MAPLE
3A	M09501-91-T77	EA	MOLDING - TRIM/VEE - .4" X 1" X 63.3" - PORTSMOUTH OAK
3A	M09501-91-T78	EA	MOLDING - TRIM/VEE - .4" X 1" X 63.3" - CONCERT CHERRY
3A	M09501-91-T79	EA	MOLDING - TRIM/VEE - .4" X 1" X 63.3" - WASHED MAPLE
3A	M09501-91-T80	EA	MOLDING - TRIM/VEE - .4" X 1" X 63.3" - SIERRA MAPLE
3A	M09503-91-T77	EA	MOLDING - TRIM/VEE - .4" X 1" X 63.1" - PORTSMOUTH OAK
3A	M09503-91-T78	EA	MOLDING - TRIM/VEE - .4" X 1" X 63.1" - CONCERT CHERRY
3A	M09503-91-T79	EA	MOLDING - TRIM/VEE - .4" X 1" X 63.1" - WASHED MAPLE
3A	M09503-91-T80	EA	MOLDING - TRIM/VEE - .4" X 1" X 63.1" - SIERRA MAPLE
3A	M09544-22-WB4	EA	MOLDING - TRIM/VEE - .4" X 1" X 61.7" - CONCERT CHERRY
3A	M09544-22-WB5	EA	MOLDING - TRIM/VEE - .4" X 1" X 61.7" - WASHED MAPLE
3A	M09544-22-WB6	EA	MOLDING - TRIM/VEE - .4" X 1" X 61.7" - SIERRA MAPLE
3A	M09583-41-WH4	EA	MOLDING - TRIM/VEE - .4" X 1" X 61" - CONCERT CHERRY
3A	M09583-41-WH5	EA	MOLDING - TRIM/VEE - .4" X 1" X 61" - WASHED MAPLE
3A	M09583-41-WH6	EA	MOLDING - TRIM/VEE - .4" X 1" X 61" - SIERRA MAPLE
3A	M09565-49-WH4	EA	MOLDING - TRIM/VEE - .4" X 1" X 58.7" - CONCERT CHERRY
3A	M09565-49-WH5	EA	MOLDING - TRIM/VEE - .4" X 1" X 58.7" - WASHED MAPLE
3A	M09565-49-WH6	EA	MOLDING - TRIM/VEE - .4" X 1" X 58.7" - SIERRA MAPLE
3A	M09544-36-W37	EA	MOLDING - TRIM/VEE - .4" X 1" X 52.6" - WASHED MAPLE
3A	M09544-36-W38	EA	MOLDING - TRIM/VEE - .4" X 1" X 52.6.5" - SIERRA MAPLE
3A	M09553-85-WB4	EA	MOLDING - TRIM/VEE - .4" X 1" X 43.4" - CONCERT CHERRY
3A	M09553-85-WB5	EA	MOLDING - TRIM/VEE - .4" X 1" X 43.4" - WASHED MAPLE
3A	M09553-85-WB6	EA	MOLDING - TRIM/VEE - .4" X 1" X 43.4" - SIERRA MAPLE
3A	M09553-28-WH4	EA	MOLDING - TRIM/VEE - .4" X 1" X 48" - CONCERT CHERRY
3A	M09553-28-WH5	EA	MOLDING - TRIM/VEE - .4" X 1" X 48" - WASHED MAPLE
3A	M09553-28-WH6	EA	MOLDING - TRIM/VEE - .4" X 1" X 48" - SIERRA MAPLE
3A	M09553-60-WH4	EA	MOLDING - TRIM/VEE - .4" X 1" X 47.2" - CONCERT CHERRY
3A	M09553-60-WH5	EA	MOLDING - TRIM/VEE - .4" X 1" X 47.2" - WASHED MAPLE
3A	M09553-60-WH6	EA	MOLDING - TRIM/VEE - .4" X 1" X 47.2" - SIERRA MAPLE
3A	M09544-24-WB4	EA	MOLDING - TRIM/VEE - .4" X 1" X 46.2" - CONCERT CHERRY
3A	M09544-24-WB5	EA	MOLDING - TRIM/VEE - .4" X 1" X 46.2" - WASHED MAPLE
3A	M09544-24-WB6	EA	MOLDING - TRIM/VEE - .4" X 1" X 46.2" - SIERRA MAPLE
3A	M09565-77-WH4	EA	MOLDING - TRIM/VEE - .4" X 1" X 42.5" - CONCERT CHERRY
3A	M09565-77-WH5	EA	MOLDING - TRIM/VEE - .4" X 1" X 42.5" - WASHED MAPLE
3A	M09565-77-WH6	EA	MOLDING - TRIM/VEE - .4" X 1" X 42.5" - SIERRA MAPLE
3A	M09544-35-W37	EA	MOLDING - TRIM/VEE - .4" X 1" X 66.5" - SIERRA MAPLE
3A	M09544-35-W38	EA	MOLDING - TRIM/VEE - .4" X 1" X 66.5" - WASHED MAPLE

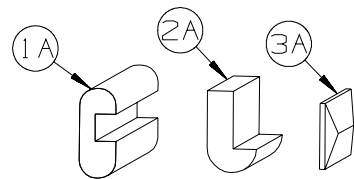

**INTERIOR FINISH GROUP (CONTINUED)**  
**MOLDINGS & TRIMS (CONTINUED)**

KEY	PART NUMBER	U/M	DESCRIPTION
3A	M09544-38-W37	EA	MOLDING - TRIM/VEE - .4" X 1" X 66.5" - SIERRA MAPLE
3A	M09544-38-W38	EA	MOLDING - TRIM/VEE - .4" X 1" X 66.5" - WASHED MAPLE
3A	M09565-03-WH4	EA	MOLDING - TRIM/VEE - .4" X 1" X 44.2" - CONCERT CHERRY
3A	M09565-03-WH5	EA	MOLDING - TRIM/VEE - .4" X 1" X 44.2" - WASHED MAPLE
3A	M09565-03-WH6	EA	MOLDING - TRIM/VEE - .4" X 1" X 44.2" - SIERRA MAPLE
3A	M09565-20-WH4	EA	MOLDING - TRIM/VEE - .4" X 1" X 43.2" - CONCERT CHERRY
3A	M09565-20-WH5	EA	MOLDING - TRIM/VEE - .4" X 1" X 43.2" - WASHED MAPLE
3A	M09565-20-WH6	EA	MOLDING - TRIM/VEE - .4" X 1" X 43.2" - SIERRA MAPLE
3A	M09553-24-WH4	EA	MOLDING - TRIM/VEE - .4" X 1" X 43" - CONCERT CHERRY
3A	M09553-24-WH5	EA	MOLDING - TRIM/VEE - .4" X 1" X 43" - WASHED MAPLE
3A	M09553-24-WH6	EA	MOLDING - TRIM/VEE - .4" X 1" X 43" - SIERRA MAPLE
3A	M09565-77-WH4	EA	MOLDING - TRIM/VEE - .4" X 1" X 42.5" - CONCERT CHERRY
3A	M09565-77-WH5	EA	MOLDING - TRIM/VEE - .4" X 1" X 42.5" - WASHED MAPLE
3A	M09565-77-WH6	EA	MOLDING - TRIM/VEE - .4" X 1" X 42.5" - SIERRA MAPLE
3A	M09565-50-WH4	EA	MOLDING - TRIM/VEE - .4" X 1" X 40.9" - CONCERT CHERRY
3A	M09565-50-WH5	EA	MOLDING - TRIM/VEE - .4" X 1" X 40.9" - WASHED MAPLE
3A	M09565-50-WH6	EA	MOLDING - TRIM/VEE - .4" X 1" X 40.9" - SIERRA MAPLE
3A	M09583-43-WH4	EA	MOLDING - TRIM/VEE - .4" X 1" X 40.1" - CONCERT CHERRY
3A	M09583-43-WH5	EA	MOLDING - TRIM/VEE - .4" X 1" X 40.1" - WASHED MAPLE
3A	M09583-43-WH6	EA	MOLDING - TRIM/VEE - .4" X 1" X 40.1" - SIERRA MAPLE
3A	M09565-76-WH4	EA	MOLDING - TRIM/VEE - .4" X 1" X 39.4" - CONCERT CHERRY
3A	M09565-76-WH5	EA	MOLDING - TRIM/VEE - .4" X 1" X 39.4" - WASHED MAPLE
3A	M09565-76-WH6	EA	MOLDING - TRIM/VEE - .4" X 1" X 39.4" - SIERRA MAPLE
3A	M09565-47-WH4	EA	MOLDING - TRIM/VEE - .4" X 1" X 38.9" - CONCERT CHERRY
3A	M09565-47-WH5	EA	MOLDING - TRIM/VEE - .4" X 1" X 38.9" - WASHED MAPLE
3A	M09565-47-WH6	EA	MOLDING - TRIM/VEE - .4" X 1" X 38.9" - SIERRA MAPLE
3A	M09553-27-WH4	EA	MOLDING - TRIM/VEE - .4" X 1" X 38.8" - CONCERT CHERRY
3A	M09553-27-WH5	EA	MOLDING - TRIM/VEE - .4" X 1" X 38.8" - WASHED MAPLE
3A	M09553-27-WH6	EA	MOLDING - TRIM/VEE - .4" X 1" X 38.8" - SIERRA MAPLE
3A	M09568-77-WH4	EA	MOLDING - TRIM/VEE - .4" X 1" X 37.5" - CONCERT CHERRY
3A	M09568-77-WH5	EA	MOLDING - TRIM/VEE - .4" X 1" X 37.5" - WASHED MAPLE
3A	M09568-77-WH6	EA	MOLDING - TRIM/VEE - .4" X 1" X 37.5" - SIERRA MAPLE
3A	M09553-23-WH4	EA	MOLDING - TRIM/VEE - .4" X 1" X 37" - CONCERT CHERRY
3A	M09553-23-WH5	EA	MOLDING - TRIM/VEE - .4" X 1" X 37" - WASHED MAPLE
3A	M09553-23-WH6	EA	MOLDING - TRIM/VEE - .4" X 1" X 37" - SIERRA MAPLE
3A	M09553-47-WB4	EA	MOLDING - TRIM/VEE - .4" X 1" X 35.9" - CONCERT CHERRY
3A	M09553-47-WB5	EA	MOLDING - TRIM/VEE - .4" X 1" X 35.9" - WASHED MAPLE
3A	M09553-47-WB6	EA	MOLDING - TRIM/VEE - .4" X 1" X 35.9" - SIERRA MAPLE
3A	M09553-47-W66	EA	MOLDING - TRIM/VEE - .4" X 1" X 35.9" - HONEY CHERRY
3A	M09568-48-U67	EA	MOLDING - TRIM/VEE - .4" X 1" X 35.4" - WASHED MAPLE
3A	M09568-48-U68	EA	MOLDING - TRIM/VEE - .4" X 1" X 35.4" - SIERRA MAPLE
3A	M09553-63-WH4	EA	MOLDING - TRIM/VEE - .4" X 1" X 35.1" - CONCERT CHERRY
3A	M09553-63-WH5	EA	MOLDING - TRIM/VEE - .4" X 1" X 35.1" - WASHED MAPLE
3A	M09553-63-WH6	EA	MOLDING - TRIM/VEE - .4" X 1" X 35.1" - SIERRA MAPLE
3A	M09553-63-W51	EA	MOLDING - TRIM/VEE - .4" X 1" X 35.1" - HONEY CHERRY
3A	M09565-94-WH4	EA	MOLDING - TRIM/VEE - .4" X 1" X 34.4" - CONCERT CHERRY
3A	M09565-94-WH5	EA	MOLDING - TRIM/VEE - .4" X 1" X 34.4" - WASHED MAPLE
3A	M09565-94-WH6	EA	MOLDING - TRIM/VEE - .4" X 1" X 34.4" - SIERRA MAPLE
3A	M09553-04-WH4	EA	MOLDING - TRIM/VEE - .4" X 1" X 34.2" - CONCERT CHERRY
3A	M09553-04-WH5	EA	MOLDING - TRIM/VEE - .4" X 1" X 34.2" - WASHED MAPLE
3A	M09553-04-WH6	EA	MOLDING - TRIM/VEE - .4" X 1" X 34.2" - SIERRA MAPLE
3A	M09566-02-U68	EA	MOLDING - TRIM/VEE - .4" X 1" X 32.7" - SIERRA MAPLE
3A	M09566-02-W51	EA	MOLDING - TRIM/VEE - .4" X 1" X 32.7" - HONEY CHERRY
3A	M09566-02-W52	EA	MOLDING - TRIM/VEE - .4" X 1" X 32.7" - WASHED MAPLE
3A	M09511-86-T77	EA	MOLDING - TRIM/VEE - .4" X 1" X 28.3" - PORTSMOUTH OAK
3A	M09511-86-T78	EA	MOLDING - TRIM/VEE - .4" X 1" X 28.3" - CONCERT CHERRY
3A	M09511-86-T79	EA	MOLDING - TRIM/VEE - .4" X 1" X 28.3" - WASHED MAPLE
3A	M09511-86-T80	EA	MOLDING - TRIM/VEE - .4" X 1" X 28.3" - SIERRA MAPLE
3A	M09553-61-WH4	EA	MOLDING - TRIM/VEE - .4" X 1" X 19.9" - CONCERT CHERRY
3A	M09553-61-WH5	EA	MOLDING - TRIM/VEE - .4" X 1" X 19.9" - WASHED MAPLE
3A	M09553-61-WH6	EA	MOLDING - TRIM/VEE - .4" X 1" X 19.9" - SIERRA MAPLE
3A	M09565-71-WH4	EA	MOLDING - TRIM/VEE - .4" X 1" X 11.4" - CONCERT CHERRY
3A	M09565-71-WH5	EA	MOLDING - TRIM/VEE - .4" X 1" X 11.4" - WASHED MAPLE
3A	M09565-71-WH6	EA	MOLDING - TRIM/VEE - .4" X 1" X 11.4" - SIERRA MAPLE

**INTERIOR FINISH GROUP (CONTINUED)**  
**MOLDINGS & TRIMS (CONTINUED)**

KEY	PART NUMBER	U/M	DESCRIPTION
3A	M09583-42-WH4	EA	MOLDING - TRIM/VEE - .4" X 1" X 8.3" - CONCERT CHERRY
3A	M09583-42-WH5	EA	MOLDING - TRIM/VEE - .4" X 1" X 8.3" - WASHED MAPLE
3A	M09583-42-WH6	EA	MOLDING - TRIM/VEE - .4" X 1" X 8.3" - SIERRA MAPLE
3A	M09544-55-WB4	EA	MOLDING - TRIM/VEE - .4" X 1" X 6.5" - CONCERT CHERRY
3A	M09544-55-WB5	EA	MOLDING - TRIM/VEE - .4" X 1" X 6.5" - WASHED MAPLE
3A	M09544-55-WB6	EA	MOLDING - TRIM/VEE - .4" X 1" X 6.5" - SIERRA MAPLE
3A	M09544-56-WB4	EA	MOLDING - TRIM/VEE - .4" X 1" X 6.1" - CONCERT CHERRY
3A	M09544-56-WB5	EA	MOLDING - TRIM/VEE - .4" X 1" X 6.1" - WASHED MAPLE
3A	M09544-56-WB6	EA	MOLDING - TRIM/VEE - .4" X 1" X 6.1" - SIERRA MAPLE
3A	M09538-70-U68	EA	MOLDING - TRIM/VEE - .4" X 1" X 63.9" - SIERRA MAPLE
3A	M09538-70-U67	EA	MOLDING - TRIM/VEE - .4" X 1" X 63.9" - WASHED MAPLE

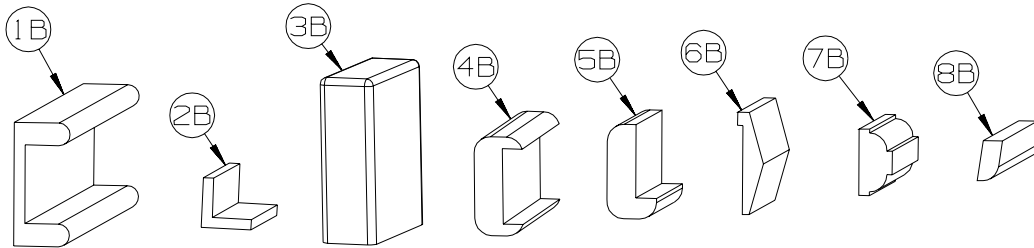
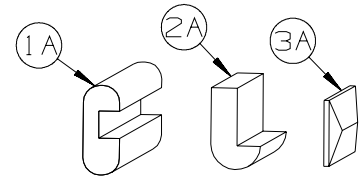

KEY	PART NUMBER	U/M	DESCRIPTION
1B	M09501-84-TG0	EA	MOLDING/TRIM - CAP/WALL - 2.2" X 85.9" - PORTSMOUTH OAK
1B	M09501-84-TG1	EA	MOLDING/TRIM - CAP/WALL - 2.2" X 85.9" - CONCERT CHERRY
1B	M09501-84-TG2	EA	MOLDING/TRIM - CAP/WALL - 2.2" X 85.9" - WASHED MAPLE
1B	M09501-84-TG3	EA	MOLDING/TRIM - CAP/WALL - 2.2" X 85.9" - HONEY CHERRY
1B	M09520-04-TD3	EA	MOLDING/TRIM - CAP/WALL - 2.2" X 80.5" - SIERRA MAPLE
2B	M09511-81-TA0	EA	MOLDING/TRIM - L SHAPE - .8"X .8"X 80.2" - PORTSMOUTH OAK
2B	M09511-81-TA1	EA	MOLDING/TRIM - L SHAPE - .8"X .8"X 80.2" - CONCERT CHERRY
2B	M09511-81-TA2	EA	MOLDING/TRIM - L SHAPE - .8"X .8"X 80.2" - WASHED MAPLE
2B	M09511-81-TA3	EA	MOLDING/TRIM - L SHAPE - .8"X .8"X 80.2" - SIERRA MAPLE
3B	M09515-81-T01	EA	MOLDING/HARDWOOD STRAIGHT - 74.3" - WASHED MAPLE
3B	M09515-81-T02	EA	MOLDING/HARDWOOD STRAIGHT - 74.3" - HONEY CHERRY
4B	M09511-42-T77	EA	MOLDING - TRIM - W/NOTCH - 1.5" X 86.4" - PORTSMOUTH OAK
4B	M09511-42-T78	EA	MOLDING - TRIM - W/NOTCH - 1.5" X 86.4" - CONCERT CHERRY
4B	M09511-42-T79	EA	MOLDING - TRIM - W/NOTCH - 1.5" X 86.4" - WASHED MAPLE
4B	M09511-42-T80	EA	MOLDING - TRIM - W/NOTCH - 1.5" X 86.4" - SIERRA MAPLE
4B	M09511-42-W66	EA	MOLDING - TRIM - W/NOTCH - 1.5" X 86.4" - HONEY CHERRY
5B	M09515-18-T77	EA	MOLDING - HARDWOOD-W/NOTCH - 1.4"X 86.2" - PORTSMOUTH OAK
5B	M09515-18-T78	EA	MOLDING - HARDWOOD-W/NOTCH - 1.4"X 86.2" - CONCERT CHERRY
5B	M09553-66-U22	EA	MOLDING - HARDWOOD-W/NOTCH - 1.4"X 96" - WASHED MAPLE
5B	M09515-18-T80	EA	MOLDING - HARDWOOD-W/NOTCH - 1.4"X 86.2" - SIERRA MAPLE
5B	M09553-66-U21	EA	MOLDING - HARDWOOD-W/NOTCH - 1.4"X 96" - HONEY CHERRY
6B	M09515-53-TG0	EA	MOLDING - TRIM/VEE - 1.5" X 73.9" - PORTSMOUTH OAK
6B	M09525-81-UJ1	EA	MOLDING - TRIM/VEE - 1.5" X 74.7" - CONCERT CHERRY
6B	M09525-81-UJ2	EA	MOLDING - TRIM/VEE - 1.5" X 74.7" - WASHED MAPLE
6B	M09552-81-UJ3	EA	MOLDING - TRIM/VEE - 1.5" X 74.7" - HONEY CHERRY
6B	M09553-53-WH6	EA	MOLDING - TRIM/VEE - NOTCHED - 1.5" X 20.6" - SIERRA MAPLE
7B	Y00076-32-438	EA	MOLDING/TRIM - .5" X 1" X 96" - CHERRY (UNSTAINED)
7B	Y00076-22-438	EA	MOLDING/TRIM - .5" X 1" X 96" - MAPLE (UNSTAINED)
8B	M09525-92-T77	EA	MOLDING/TRIM - .5" X 1" X 75.6" - PORTSMOUTH OAK
8B	M09525-92-T78	EA	MOLDING/TRIM - .5" X 1" X 75.6" - CONCERT CHERRY
8B	M09525-92-T79	EA	MOLDING/TRIM - .5" X 1" X 75.6" - WASHED MAPLE
8B	M09525-92-T80	EA	MOLDING/TRIM - .5" X 1" X 75.6" - SIERRA MAPLE
8B	Y00086-72-438	EA	MOLDING - VINYL WRAP - .7" X 1.6" X 96" - PORTSMOUTH OAK
8B	Y00086-D2-438	EA	MOLDING - VINYL WRAP - .7" X 1.6" X 96" - CONCERT CHERRY
8B	Y00086-A2-438	EA	MOLDING - VINYL WRAP - .7" X 1.6" X 96" - WASHED MAPLE
8B	Y00086-92-438	EA	MOLDING - VINYL WRAP - .7" X 1.6" X 96" - SIERRA MAPLE
8B	Y00086-82-438	EA	MOLDING - VINYL WRAP - .7" X 1.6" X 96" - HONEY CHERRY
8B	Y00087-72-438	EA	MOLDING - VINYL WRAP - .7" X 2.9" X 96" - PORTSMOUTH OAK
8B	Y00087-D2-438	EA	MOLDING - VINYL WRAP - .7" X 2.9" X 96" - CONCERT CHERRY
8B	Y00087-A2-438	EA	MOLDING - VINYL WRAP - .7" X 2.9" X 96" - WASHED MAPLE
8B	Y00087-92-438	EA	MOLDING - VINYL WRAP - .7" X 2.9" X 96" - SIERRA MAPLE
8B	Y00087-82-438	EA	MOLDING - VINYL WRAP - .7" X 2.9" X 96" - HONEY CHERRY

**INTERIOR FINISH GROUP (CONTINUED)**  
**MOLDINGS & TRIMS (CONTINUED)**

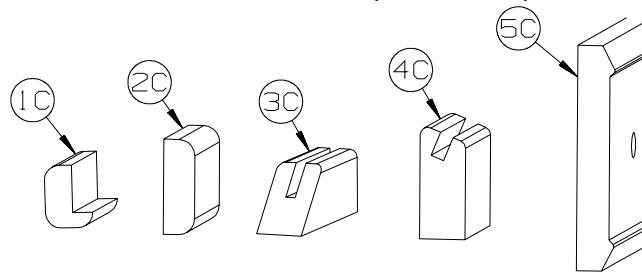

KEY	PART NUMBER	U/M	DESCRIPTION
1C	M09520-19-TD1	EA	MOLDING - TRIM - W/NOTCH - 1" X 86.3" - CONCERT CHERRY
1C	M09520-19-TD2	EA	MOLDING - TRIM - W/NOTCH - 1" X 86.3" - WASHED MAPLE
1C	M09520-19-TD3	EA	MOLDING - TRIM - W/NOTCH - 1" X 86.3" - HONEY CHERRY
1C	M09565-68-WH4	EA	MOLDING - HARDWOOD - .75" X 1.4" X 81.9" - CONCERT CHERRY
1C	M09565-68-WH5	EA	MOLDING - HARDWOOD - .75" X 1.4" X 81.9" - WASHED MAPLE
1C	M09565-68-WH6	EA	MOLDING - HARDWOOD - .75" X 1.4" X 81.9" - SIERRA MAPLE
2C	M09511-46-T77	EA	MOLDING/TRIM - .5" X 1.5" X 86.5" - PORTSMOUTH OAK
2C	M09511-46-T78	EA	MOLDING/TRIM - .5" X 1.5" X 86.5" - CONCERT CHERRY
2C	M09511-46-T79	EA	MOLDING/TRIM - .5" X 1.5" X 86.5" - WASHED MAPLE
2C	M09511-46-T80	EA	MOLDING/TRIM - .5" X 1.5" X 86.5" - SIERRA MAPLE
3C	Y00223-22-438	EA	MOLDING - HARDWOOD/MAPLE - .7" X 1" X 96" - UNSTAINED MAPLE
3C	Y00223-32-438	EA	MOLDING - HARDWOOD/CHERRY - .7" X 1" X 96" - UNSTAINED CHERRY
3C	Y00223-42-438	EA	MOLDING - HARDWOOD/CHERRY - .7" X 1" X 96" - UNSTAINED OAK
4C	Y00054-A2-438	EA	MOLDING - VINYL - W/SLOT - .7"X 1.9"X 96" - WASHED MAPLE
4C	Y00054-D2-438	EA	MOLDING - VINYL - W/SLOT - .7"X 1.9"X 96" - CONCERT CHERRY
4C	Y00054-22-438	EA	MOLDING - VINYL - W/SLOT - .7"X 1.9"X 96" - WASHED MAPLE
4C	Y00054-72-438	EA	MOLDING - VINYL - W/SLOT - .7"X 1.9"X 96" - PORTSMOUTH OAK
4C	Y00054-82-438	EA	MOLDING - VINYL - W/SLOT - .7"X 1.9"X 96" - HONEY CHERRY
4C	Y00054-92-438	EA	MOLDING - VINYL - W/SLOT - .7"X 1.9"X 96" - SIERRA MAPLE
4C	Y00276-A2-438	EA	MOLDING - VINYL - W/SLOT - .7"X 1.9"X 96" - WASHED MAPLE
4C	Y00276-D2-438	EA	MOLDING - VINYL - W/SLOT - .7"X 1.9"X 96" - CONCERT CHERRY
4C	Y00276-72-438	EA	MOLDING - VINYL - W/SLOT - .7"X 1.9"X 96" - PORTSMOUTH OAK
4C	Y00276-82-438	EA	MOLDING - VINYL - W/SLOT - .7"X 1.9"X 96" - HONEY CHERRY
4C	Y00276-92-438	EA	MOLDING - VINYL - W/SLOT - .7"X 1.9"X 96" - SIERRA MAPLE
5C	Y00152-A2-438	EA	MOLDING/TRIM - VINYL - .6" X 3.5" X 96" - WASHED MAPLE
5C	Y00152-D2-438	EA	MOLDING/TRIM - VINYL - .6" X 3.5" X 96" - CONCERT CHERRY
5C	Y00152-22-438	EA	MOLDING/TRIM - VINYL - .6" X 3.5" X 96" - WASHED MAPLE
5C	Y00152-72-438	EA	MOLDING/TRIM - VINYL - .6" X 3.5" X 96" - PORTSMOUTH OAK
5C	Y00152-92-438	EA	MOLDING/TRIM - VINYL - .6" X 3.5" X 96" - SIERRA MAPLE

**INTERIOR FINISH GROUP (CONTINUED)**  
**MOLDINGS & TRIMS (CONTINUED)**

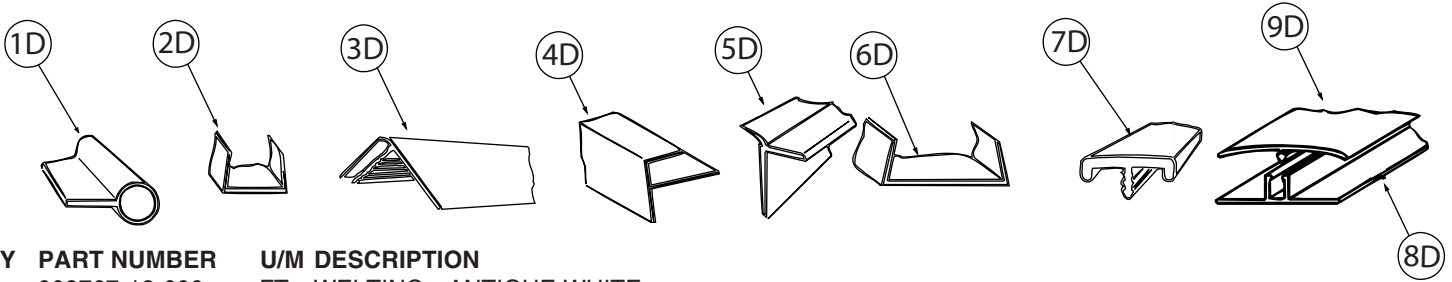

KEY	PART NUMBER	U/M	DESCRIPTION
1D	009767-12-000	FT	WELTING - ANTIQUE WHITE
2D	009778-25-000	FT	U-CHANNEL - 1" - BEIGE ILLUSION
2D	009778-26-000	FT	U-CHANNEL - 1 1/4" - BEIGE ILLUSION
2D	009778-38-000	FT	U-CHANNEL - 1" - BONE
2D	009778-32-000	FT	U-CHANNEL - 1" - PORTSMOUTH OAK
2D	009778-34-000	FT	U-CHANNEL - 1" - CONCERT CHERRY
2D	009778-27-000	FT	U-CHANNEL - 1" - WASHED MAPLE
2D	009778-35-000	FT	U-CHANNEL - 1" - HONEY CHERRY
2D	009778-36-000	FT	U-CHANNEL - 1" - SIERRA MAPLE
3D	009809-30-000	EA	MOLDING - CORNER - OUTSIDE - 1" X 84" - BEIGE ILLUSION
3D	009809-37-000	EA	MOLDING - CORNER - OUTSIDE - 1" X 84" - BONE
3D	009809-33-000	EA	MOLDING - CORNER - OUTSIDE - 1" X 84" - CONCERT CHERRY
3D	009809-31-000	EA	MOLDING - CORNER - OUTSIDE - 1" X 84" - WASHED MAPLE
3D	009809-35-000	EA	MOLDING - CORNER - OUTSIDE - 1" X 84" - SIERRA MAPLE
4D	009812-31-000	EA	MOLDING - CORNER - 1/2" W/1/4"CHAN X 84" - BEIGE ILLUSION
4D	009812-40-000	EA	MOLDING - CORNER - 1/2" W/1/4"CHAN X 84" - BONE
4D	009812-35-000	EA	MOLDING - CORNER - 1/2" W/1/4"CHAN X 84" - PORTSMOUTH OAK
4D	009812-36-000	EA	MOLDING - CORNER - 1/2" W/1/4"CHAN X 84" - CONCERT CHERRY
4D	009812-33-000	EA	MOLDING - CORNER - 1/2" W/1/4"CHAN X 84" - WASHED MAPLE
4D	009812-37-000	EA	MOLDING - CORNER - 1/2" W/1/4"CHAN X 84" - HONEY CHERRY
4D	009812-38-000	EA	MOLDING - CORNER - 1/2" W/1/4"CHAN X 84" - SIERRA MAPLE
5D	022992-11-000	FT	MOLDING - REVERSE COVE - T-SHAPED - IVORY
5D	022992-14-000	FT	MOLDING - REVERSE COVE - T-SHAPED - BRIGHT WHITE
5D	022992-18-000	FT	MOLDING - REVERSE COVE - T-SHAPED - BONE
6D	070504-42-000	FT	U-CHANNEL - PLASTIC - .13" X 84" - BEIGE ILLUSION
6D	070504-43-000	FT	U-CHANNEL - PLASTIC - .9" X 96" - BEIGE ILLUSION
6D	070504-69-000	FT	U-CHANNEL - PLASTIC - .13" X 84" - BONE
6D	070504-70-000	FT	U-CHANNEL - PLASTIC - .8" X 84" - BONE
6D	070504-57-000	FT	U-CHANNEL - PLASTIC - .13" X 96" - PORTSMOUTH OAK
6D	070504-58-000	FT	U-CHANNEL - PLASTIC - .9" X 96" - PORTSMOUTH OAK
6D	070504-60-000	FT	U-CHANNEL - PLASTIC - .13" X 84" - CONCERT CHERRY
6D	070504-61-000	FT	U-CHANNEL - PLASTIC - .9" X 84" - CONCERT CHERRY
6D	070504-50-000	FT	U-CHANNEL - PLASTIC - .13" X 96" - WASHED MAPLE
6D	070504-51-000	FT	U-CHANNEL - PLASTIC - .9" X 96" - WASHED MAPLE
6D	070504-62-000	FT	U-CHANNEL - PLASTIC - 1.65" X 84" - HONEY CHERRY
6D	070504-63-000	FT	U-CHANNEL - PLASTIC - .9" X 84" - HONEY CHERRY
6D	070504-65-000	FT	U-CHANNEL - PLASTIC - .07" X 96" - SIERRA MAPLE
6D	070504-66-000	FT	U-CHANNEL - PLASTIC - .8" X 84" - SIERRA MAPLE
7D	083620-25-000	FT	MOLDING-T - W/EDGE LIP - 7/8" FACE - BONE
7D	083620-20-000	FT	MOLDING-T - W/EDGE LIP - 7/8" FACE - PORTSMOUTH OAK
7D	083620-19-000	FT	MOLDING-T - W/EDGE LIP - 7/8" FACE - WASHED MAPLE
7D	083620-24-000	FT	MOLDING-T - W/EDGE LIP - 7/8" FACE - HONEY CHERRY
7D	083620-22-000	FT	MOLDING-T - W/EDGE LIP - 7/8" FACE - SIERRA MAPLE
8D	086229-01-000	EA	RETAINER - BATTEN - .75" X 92.1" - ANY COLOR
9D	086229-12-000	EA	BATTEN - 1.5" OFFSET X 96.8" - MODERN IVORY
9D	086229-20-000	EA	BATTEN - 1" X 96" - BEIGE

**INTERIOR FINISH GROUP (CONTINUED)**  
**MOLDINGS & TRIMS (CONTINUED)**

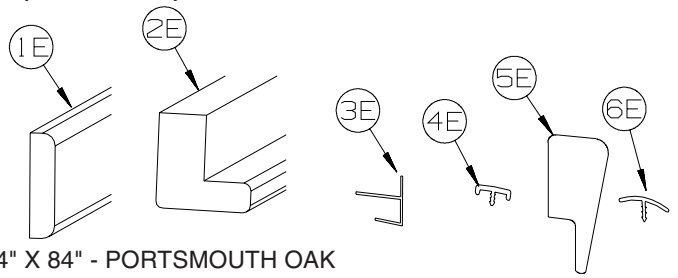

KEY	PART NUMBER	U/M	DESCRIPTION
1E	100818-01-12A	EA	MOLDING - VINYL WRAPPED - 1.6" X .4" X 84" - PORTSMOUTH OAK
1E	100818-01-23A	EA	MOLDING - VINYL WRPPD - 1.6" X .4" X 84" - CONCERT CHERRY
1E	100818-01-21A	EA	MOLDING - VINYL WRAPPED - 1.6" X .4" X 84" - WASHED MAPLE
1E	100818-01-14A	EA	MOLDING - VINYL WRAPPED - 1.6" X .4" X 84" - HONEY CHERRY
1E	100818-01-22A	EA	MOLDING - VINYL WRAPPED - 1.6" X .4" X 84" - SIERRA MAPLE
2E	100819-01-23A	EA	MOLDING - VYL WRPPD-L-SHPD-1.5"X1.5"X84" - CONCERT CHERRY
2E	100819-01-21A	EA	MOLDING - VINYL WRAPPED-L-SHAPED-1.5"X1.5"X84" - WASHED MAPLE
2E	100819-01-14A	EA	MOLDING - VINYL WRAPPED-L-SHAPED-1.5"X1.5"X84" - HONEY CHERRY
2E	100819-01-22A	EA	MOLDING - VINYL WRAPPED-L-SHAPED-1.5"X1.5"X84" - SIERRA MAPLE
3E	103186-01-07A	FT	MOLDING/PLASTIC - 3/8" U-CHANNEL-3/4" FACE - BEIGE ILLUSION
3E	103186-01-09A	FT	MOLDING/PLASTIC - 3/8" U-CHANNEL-3/4" FACE - PORTSMOUTH OAK
3E	103186-01-10A	FT	MOLDING/PLASTIC - 3/8" U-CHANNEL-3/4" FACE - CONCERT CHERRY
3E	103186-01-08A	FT	MOLDING/PLASTIC - 3/8" U-CHANNEL-3/4" FACE- 8' - WASHED MAPLE
3E	103186-01-11A	FT	MOLDING/PLASTIC - 3/8" U-CHANNEL-3/4" FACE - HONEY CHERRY
3E	103186-01-12A	FT	MOLDING/PLASTIC - 3/8" U-CHANNEL-3/4" FACE - SIERRA MAPLE
3E	103186-02-07A	FT	MOLDING/PLASTIC-1" U-CHANNEL-1 3/8" FACE - BEIGE ILLUSION
3E	103186-02-09A	FT	MOLDING/PLASTIC - 1" U-CHANNEL-1 3/8" FACE - PORTSMOUTH OAK
3E	103186-02-10A	FT	MOLDING/PLASTIC - 1" U-CHANNEL-1 3/8" FACE - CONCERT CHERRY
3E	103186-02-08A	FT	MOLDING/PLASTIC - 1" U-CHANNEL-1 3/8" FACE - WASHED MAPLE
3E	103186-02-11A	FT	MOLDING/PLASTIC - 1" U-CHANNEL-1 3/8" FACE - HONEY CHERRY
3E	103186-02-12A	FT	MOLDING/PLASTIC - 1" U-CHANNEL-1 3/8" FACE - SIERRA MAPLE
4E	104676-02-08A	FT	MOLDING-T - W/EDGE LIP - 11/16" FACE - PORTSMOUTH OAK
4E	104676-02-12A	FT	MOLDING-T - W/EDGE LIP - 11/16" FACE - SIERRA MAPLE
5E	105004-01-12A	EA	MOLDING - VINYL WRAP - 1" X 96" - PORTSMOUTH OAK
5E	105004-01-21A	EA	MOLDING - VINYL WRAP - 1" X 96" - WASHED MAPLE
5E	105004-01-24A	EA	MOLDING - VINYL WRAP - 1" X 96" - HONEY CHERRY
5E	105004-01-22A	EA	MOLDING - VINYL WRAP - 1" X 96" - SIERRA MAPLE
6E	105709-02-000	FT	MOLDING-T - W/EDGE LIP 3/4" FACE - BEIGE ILLUSION

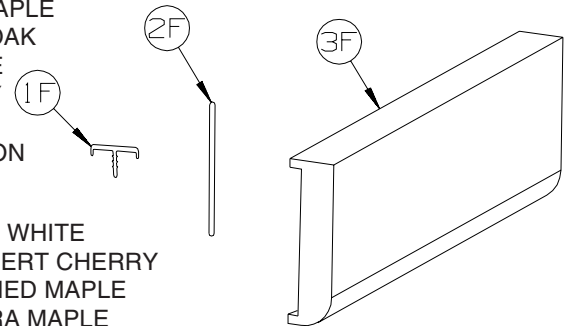

KEY	PART NUMBER	U/M	DESCRIPTION
1F	119520-01-01A	FT	MOLDING-T - OFFSET W/EDGE LIP - 1.3" FACE - OFF WHITE
1F	119520-03-02A	FT	MOLDING-T - OFFSET W/EDGE LIP - 1" FACE - CONCERT CHERRY
1F	119520-03-03A	FT	MOLDING-T - OFFSET W/EDGE LIP - 1" FACE - WASHED MAPLE
1F	119520-03-05A	FT	MOLDING-T - OFFSET W/EDGE LIP - 1" FACE - SIERRA MAPLE
1F	119520-03-06A	FT	MOLDING-T - OFFSET W/EDGE LIP - 1" FACE - HONEY CHERRY
2F	127842-01-01A	FT	SEAL - SIGHT SHIELD - 2" BLACK
	160300-A2-438	EA	LUMBER - VINYL WRAPPED - .7" X .75" X 96" - CONCERT CHERRY
	160300-D2-438	EA	LUMBER - VINYL WRAPPED - .7" X 1.5" X 96" - CONCERT CHERRY
	160300-E2-438	EA	LUMBER - VINYL WRAPPED - .7" X 2" X 96" - CONCERT CHERRY
	160300-F2-438	EA	LUMBER - VINYL WRAPPED - .7" X 2.5" X 96" - CONCERT CHERRY
	160300-G2-438	EA	LUMBER - VINYL WRAPPED - .7" X 3" X 96" - CONCERT CHERRY
	160300-H2-438	EA	LUMBER - VINYL WRAPPED - .7" X 3.5" X 96" - CONCERT CHERRY
	160300-J2-438	EA	LUMBER - VINYL WRAPPED - .7" X 5.5" X 96" - CONCERT CHERRY
	160300-K2-438	EA	LUMBER - VINYL WRAPPED - .7" X 3.9" X 96" - CONCERT CHERRY
	160300-R2-438	EA	LUMBER - VINYL WRAPPED - .7" X 3" X 96" - CONCERT CHERRY
3F	160301-D2-134	EA	MOLDING - VINYL WRAPPED - .7" X 1.6" X 84" - CONCERT CHERRY
3F	160301-D2-743	EA	MOLDING - VINYL WRAPPED - .7" X 1.6" X 108" - CONCERT CHERRY
3F	160301-F2-134	EA	MOLDING - VINYL WRAPPED - .7" X 2.5" X 84" - CONCERT CHERRY
3F	160301-F2-743	EA	MOLDING - VINYL WRPPD - .7" X 2.5" X 108" - CONCERT CHERRY
3F	160301-F2-438	EA	MOLDING - VINYL WRPPD - .7" X 2.5" X 96" - CONCERT CHERRY
	137894-A2-438	EA	LUMBER - VINYL WRAPPED - .7" X .75" X 96" - PORTSMOUTH OAK
	137894-D2-438	EA	LUMBER - VINYL WRAPPED - .7" X 1.5" X 96" - PORTSMOUTH OAK
	137894-E2-438	EA	LUMBER - VINYL WRAPPED - .7" X 2" X 96" - PORTSMOUTH OAK
	137894-F2-438	EA	LUMBER - VINYL WRAPPED - .7" X 2.5" X 96" - PORTSMOUTH OAK
	137894-G2-438	EA	LUMBER - VINYL WRAPPED - .7" X 3" X 96" - PORTSMOUTH OAK
	137894-H2-438	EA	LUMBER - VINYL WRAPPED - .7" X 3.5" X 96" - PORTSMOUTH OAK
	137894-J2-438	EA	LUMBER - VINYL WRAPPED - .7" X 5.5" X 96" - PORTSMOUTH OAK

**INTERIOR FINISH GROUP (CONTINUED)**  
**MOLDINGS & TRIMS (CONTINUED)**

KEY	PART NUMBER	U/M	DESCRIPTION
	137894-J2-743	EA	LUMBER - VINYL WRAPPED - .7" X 5.5" X 108" - PORTSMOUTH OAK
	137894-K2-438	EA	LUMBER - VINYL WRAPPED - .7" X 3.9" X 96" - PORTSMOUTH OAK
	137894-R2-438	EA	LUMBER - VINYL WRAPPED - .7" X 3" X 96" - PORTSMOUTH OAK
3F	137895-D2-134	EA	MOLDING - VINYL WRAP - .7" X 1.6" X 84" - PORTSMOUTH OAK
3F	137895-D2-743	EA	MOLDING - VINYL WRAP - .7" X 1.6" X 108" - PORTSMOUTH OAK
3F	137895-F2-134	EA	MOLDING - VINYL WRAP - .7" X 2.5" X 84" - PORTSMOUTH OAK
3F	137895-F2-438	EA	MOLDING - VINYL WRAP - .7" X 2.5" X 96" - PORTSMOUTH OAK
3F	137895-F2-743	EA	MOLDING - VINYL WRAP - .7" X 2.5" X 108" - PORTSMOUTH OAK
	146419-A2-438	EA	LUMBER - VINYL WRAPPED - .7" X .75" X 96" - HONEY CHERRY
	146419-D2-438	EA	LUMBER - VINYL WRAPPED - .7" X 1.5" X 96" - HONEY CHERRY
	146419-E2-438	EA	LUMBER - VINYL WRAPPED - .7" X 2" X 96" - HONEY CHERRY
	146419-F2-438	EA	LUMBER - VINYL WRAPPED - .7" X 2.5" X 96" - HONEY CHERRY
	146419-G2-438	EA	LUMBER - VINYL WRAPPED - .7" X 3" X 96" - HONEY CHERRY
	146419-H2-438	EA	LUMBER - VINYL WRAPPED - .7" X 3.5" X 96" - HONEY CHERRY
	146419-J2-438	EA	LUMBER - VINYL WRAPPED - .7" X 5.5" X 96" - HONEY CHERRY
	146419-J2-743	EA	LUMBER - VINYL WRAPPED - .7" X 5.5" X 108" - HONEY CHERRY
	146419-K2-438	EA	LUMBER - VINYL WRAPPED - .7" X 3.9" X 96" - HONEY CHERRY
	146419-R2-438	EA	LUMBER - VINYL WRAPPED - .7" X 3" X 96" - HONEY CHERRY
	146419-S2-438	EA	LUMBER - VINYL WRAPPED/FULL - .7" X 3.5" X 96" - HONEY CHERRY
	146419-T2-438	EA	LUMBER - VINYL WRAPPED/FULL - .7" X 5.5" X 96" - HONEY CHERRY
3F	146425-D2-134	EA	MOLDING - VINYL WRAPPED - .7" X 1.6" X 83.9" - HONEY CHERRY
3F	146425-F2-438	EA	MOLDING - VINYL WRAPPED - .7" X 2.6" X 96" - HONEY CHERRY
	149325-A2-438	EA	LUMBER - VINYL WRAPPED - .7" X .75" X 96" - WASHED MAPLE
	149325-D2-438	EA	LUMBER - VINYL WRAPPED - .7" X 1.5" X 96" - WASHED MAPLE
	149325-E2-438	EA	LUMBER - VINYL WRAPPED - .7" X 2" X 96" - WASHED MAPLE
	149325-F2-438	EA	LUMBER - VINYL WRAPPED - .7" X 2.5" X 96" - WASHED MAPLE
	149325-G2-438	EA	LUMBER - VINYL WRAPPED - .7" X 3" X 96" - WASHED MAPLE
	149325-H2-438	EA	LUMBER - VINYL WRAPPED - .7" X 3.5" X 96" - WASHED MAPLE
	149325-J2-438	EA	LUMBER - VINYL WRAPPED - .7" X 5.5" X 96" - WASHED MAPLE
	149325-J2-743	EA	LUMBER - VINYL WRAPPED - .7" X 5.5" X 108" - WASHED MAPLE
	149325-K2-438	EA	LUMBER - VINYL WRAPPED - .7" X 3.9" X 96" - WASHED MAPLE
	149325-R2-438	EA	LUMBER - VINYL WRAPPED - .7" X 3" X 96" - WASHED MAPLE
3F	149326-D2-134	EA	MOLDING - VINYL WRAPPED - .7" X 1.5" X 83.9" - WASHED MAPLE
3F	149326-D2-743	EA	MOLDING - VINYL WRAPPED - .7" X 1.5" X 108" - WASHED MAPLE
3F	149326-F2-134	EA	MOLDING - VINYL WRAPPED - .7" X 2.5" X 83.9" - WASHED MAPLE
3F	149326-F2-438	EA	MOLDING - VINYL WRAPPED - .7" X 2.5" X 96" - WASHED MAPLE
3F	149326-F2-743	EA	MOLDING - VINYL WRAPPED - .7" X 2.5" X 108" - WASHED MAPLE
	149330-A2-438	EA	LUMBER - VINYL WRAPPED - .7" X .75" X 96" - SIERRA MAPLE
	149330-D2-438	EA	LUMBER - VINYL WRAPPED - .7" X 1.5" X 96" - SIERRA MAPLE
	149330-E2-438	EA	LUMBER - VINYL WRAPPED - .7" X 2" X 96" - SIERRA MAPLE
	149330-F2-438	EA	LUMBER - VINYL WRAPPED - .7" X 2.5" X 96" - SIERRA MAPLE
	149330-G2-438	EA	LUMBER - VINYL WRAPPED - .7" X 3" X 96" - SIERRA MAPLE
	149330-H2-438	EA	LUMBER - VINYL WRAPPED - .7" X 3.5" X 96" - SIERRA MAPLE
	149330-J2-438	EA	LUMBER - VINYL WRAPPED - .7" X 5.5" X 96" - SIERRA MAPLE
	149330-J2-743	EA	LUMBER - VINYL WRAPPED - .7" X 5.5" X 108" - SIERRA MAPLE
	149330-K2-438	EA	LUMBER - VINYL WRAPPED - .7" X 3.9" X 96" - SIERRA MAPLE
	149330-R2-438	EA	LUMBER - VINYL WRAPPED - .7" X 3" X 96" - SIERRA MAPLE
3F	149331-D2-134	EA	MOLDING - VINYL WRAP - .7" X 1.5" X 83.9" - SIERRA MAPLE
3F	149331-D2-743	EA	MOLDING - VINYL WRAP - .7" X 1.5" X 108" - SIERRA MAPLE
3F	149331-F2-134	EA	MOLDING - VINYL WRAP - .7" X 2.5" X 83.9" - SIERRA MAPLE
3F	149331-F2-438	EA	MOLDING - VINYL WRAP - .7" X 2.5" X 96" - SIERRA MAPLE
3F	149331-F2-743	EA	MOLDING - VINYL WRAP - .7" X 2.5" X 108" - SIERRA MAPLE

**INTERIOR FINISH GROUP (CONTINUED)**  
**MOLDINGS & TRIMS (CONTINUED)**

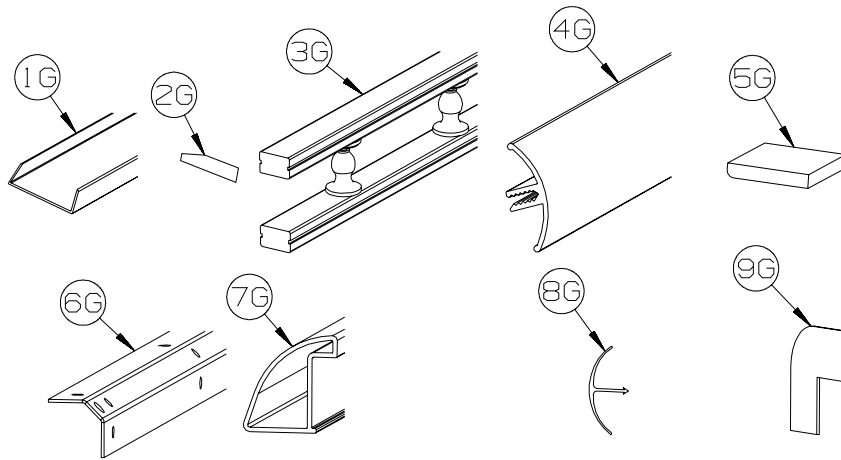

KEY	PART NUMBER	U/M	DESCRIPTION
1G	141260-01-01A	FT	U-CHANNEL - 1" - VILLAGE OAK
1G	141260-01-02A	FT	U-CHANNEL - 1" - GRADY BROWN
2G	146306-01-01A	FT	TRANSITION - CARPET/TILE
3G	150167-01-03A	EA	RAIL - DECORATIVE - 96" - WASHED MAPLE
3G	150167-01-07A	EA	RAIL - DECORATIVE - 96" - PORTSMOUTH OAK
3G	150167-01-08A	EA	RAIL - DECORATIVE - 96" - HONEY CHERRY
3G	150167-01-09A	EA	RAIL - DECORATIVE - 96" - SIERRA MAPLE
4G	151653-10-02A	EA	TRIM/RADIUS - CABINET CORNER - 79.6" - DULL METALLIC
4G	151653-13-02A	EA	TRIM/RADIUS - CABINET CORNER - 79.8" - DULL METALLIC
5G	M09568-04-W80	EA	MOLDING/TRIM - .3" X 1.5" X 73.6" - SIERRA MAPLE
5G	M09568-04-W79	EA	MOLDING/TRIM - .3" X 1.5" X 73.6" - WASHED MAPLE
6G	151861-01-02B	EA	ANGLE - SUPPORT/CORNER - 1.4" X 12.5" - E-COATED
6G	151861-02-02B	EA	ANGLE - SUPPORT/CORNER - 1.4" X 20.1" - E-COATED
6G	151861-03-02B	EA	ANGLE - SUPPORT/CORNER - 1.4" X 26.7" - E-COATED
6G	151861-04-02B	EA	ANGLE - SUPPORT/CORNER - 1.4" X 32.7" - E-COATED
6G	151861-05-02B	EA	ANGLE - SUPPORT/CORNER - 1.4" X 78.6" - E-COATED
6G	151861-06-02B	EA	ANGLE - SUPPORT/CORNER - 1.4" X 59" - E-COATED
6G	151861-08-02B	EA	ANGLE - SUPPORT/CORNER - 1.4" X 22.2" - E-COATED
6G	151861-09-02B	EA	ANGLE - SUPPORT/CORNER - 1.4" X 14.9" - E-COATED
7G	151893-01-02A	EA	TRIM/RADIUS - CABINET BOTTOM - 72.6" - DULL METALLIC
8G	156464-01-01A	FT	MOLDING - CORNER - RADIUS/PLASTIC - 8' - HONEY CHERRY
8G	156464-01-02A	FT	MOLDING - CORNER - RADIUS/PLASTIC - 8' - WASHED MAPLE
8G	156464-01-05A	FT	MOLDING - CORNER - RADIUS/PLASTIC - 8' - SIERRA MAPLE
8G	156464-01-06A	FT	MOLDING - CORNER - RADIUS/PLASTIC - 8' - CONCERT CHERRY
8G	156464-03-03A	FT	MOLDING - CORNER - RADIUS/PLASTIC - 8' - BONE
	081521-02-007	EA	MOUNT - METAL MOLDING - F/RADIUS CORNER MOLDING - 151.5"
9G	160989-01-06A	FT	CAP - CORNER - RADIUS MOLDING - PLASTIC - WASHED MAPLE
9G	160989-01-07A	FT	CAP - CORNER - RADIUS MOLDING - PLASTIC - HONEY CHERRY



**INTERIOR FINISH GROUP (CONTINUED)**  
**PANELING & LAMINATES**

<b>KEY</b>	<b>PART NUMBER</b>	<b>U/M</b>	<b>DESCRIPTION</b>
	074497-47-000	SF	PANELING - HONEY CHERRY - 1/8" X 4' X 8' - HONEY CHERRY
	074497-49-000	SF	PANELING - WASHED MAPLE - 1/8" X 4' X 8' - WASHED MAPLE
	076773-18-000	SF	PANELING - 2 SIDED/HONEY CHERRY - 1/8" X 4' X 8' - HONEY CHERRY
	076773-20-000	SF	PANELING - 2 SIDED/WASHED MAPLE - 1/8" X 4' X 8' - WASHED MAPLE
	088272-M7-000	SF	PANELING - KURTA/CANVAS - 4' X 7.4' (W57, W58)
	088272-N3-000	SF	PANELING - SPHINX/STONE - 4' X 7.4' (W59, W60, W61, W62)
	088272-M9-000	SF	PANELING - WHITE THATCHED - 4' X 8'
	088263-K3-000	EA	BATT STRIP - DECORATIVE - KURTA/CANVAS - 8' (W57, W58)
	088263-K9-000	EA	BATT STRIP - DECORATIVE - SPHINX/STONE - 8' (W59, W60, W61, W62)
	088263-K5-000	EA	BATT STRIP - DECORATIVE - WHITE THATCHED - 8' - HONEY CHERRY
	088263-J2-000	EA	BATT STRIP - DECORATIVE - NEAT/WASHED MAPLE
	085284-K7-000	FT	BATT TAPE - ADHESIVE BACKED - DECORATIVE - KURTA/CANVAS (W57, W58)
	085284-L3-000	FT	BATT TAPE - ADHESIVE BACKED - DECORATIVE - SPHINX/STONE (W59, W60, W61, W62)
	085284-J5-000	FT	BATT TAPE - ADHESIVE BACKED - DECORATIVE-NEAT/WASHED MAPLE
	085284-J6-000	FT	BATT TAPE - ADHESIVE BACKED - DECORATIVE - HONEY CHERRY
	076325-39-000	FT	MOLDING - EDGE BAND - 1 5/16" X .030" - ALMOND
	000885-B4-000	SF	PARTICLE BOARD - 3/8" X 4' X 8'- WASHED MAPLE - 2 SIDED - WASHED MAPLE
	000885-B5-000	SF	PARTICLE BOARD - 3/8" X 4' X 8'- WASHED MAPLE - 1 SIDED - WASHED MAPLE
	000885-B6-000	SF	PARTICLE BOARD - 3/4" X 4' X 8'- WASHED MAPLE - 2 SIDED - WASHED MAPLE
	000885-B7-000	SF	PARTICLE BOARD - 1/2" X 4' X 8'- WASHED MAPLE - 2 SIDED - WASHED MAPLE
	000885-A6-000	SF	PARTICLE BOARD - 1/2" X 4' X 8' - HONEY CHERRY - 2 SIDED - HONEY CHERRY
	000885-A7-000	SF	PARTICLE BOARD - 3/4" X 4' X 8' - HONEY CHERRY - 2 SIDED - HONEY CHERRY
	000885-A8-000	SF	PARTICLE BOARD - 3/8" X 4' X 8' - HONEY CHERRY - 1 SIDED - HONEY CHERRY
	000885-A9-000	SF	PARTICLE BOARD - 3/8" X 4' X 8' - HONEY CHERRY - 2 SIDED - HONEY CHERRY
	000885-C3-000	SF	PARTICLE BOARD - 3/8" X 4' X 8' - WHITE THATCH EMB-1 SIDED
	057882-06-000	SF	TAMBOUR - 48" X 96" SHEET - UNFINISHED
	057882-05-000	SF	TAMBOUR - 48" X 96" SHEET - UNFINISHED

## INTERIOR FINISH GROUP (CONTINUED)

### INTERIOR TRIM LAYOUT

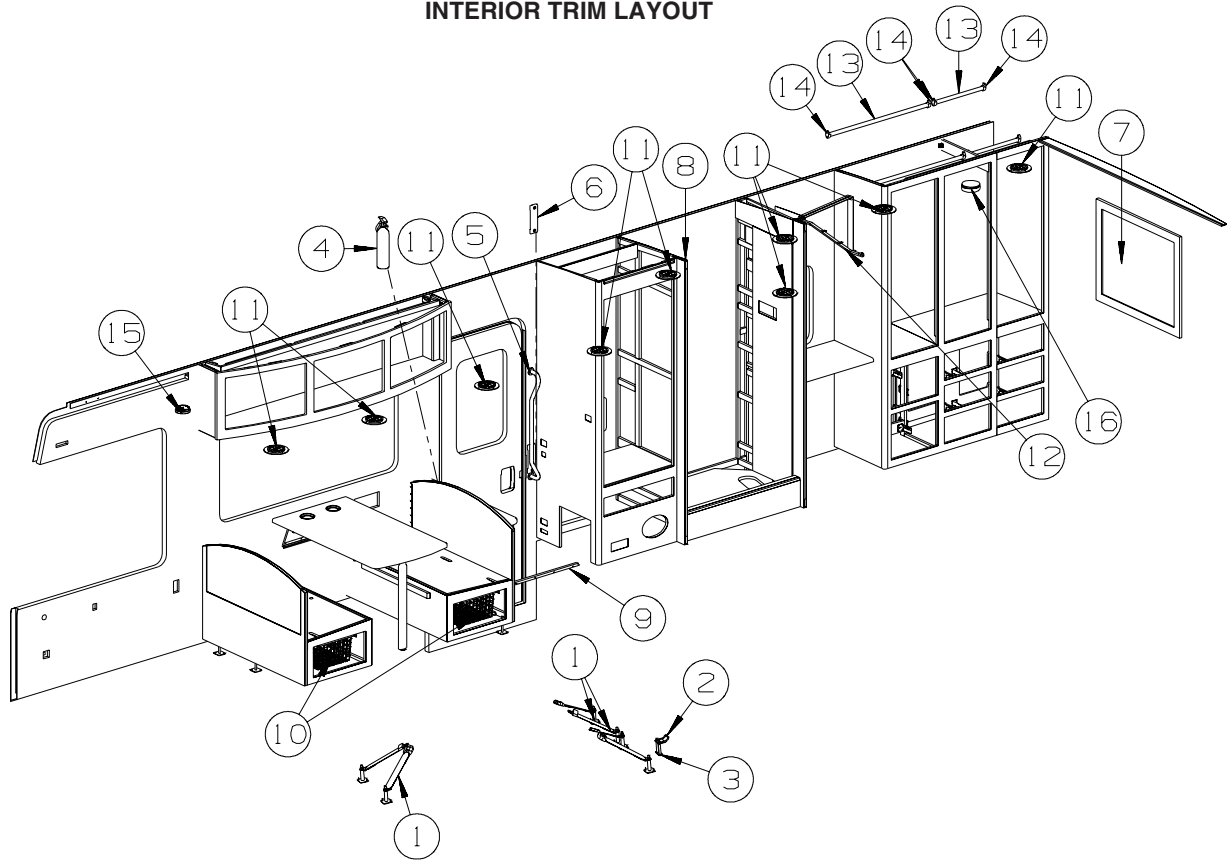

KEY	PART NUMBER	U/M	DESCRIPTION
1	160167-02-01A	EA	SEAT BELT - 2" X 90" - BLACK
2	150697-01-02B	EA	BRACKET - RESTRAINT/CHILD - E-COATED
3	150700-01-02B	EA	PLATE/MOUNTING - RESTRAINT/CHILD - 1" X 2.3" - E-COATED
4	094499-06-000	EA	EXTINGUISHER/FIRE - DRY - 10BC - W/BRACKET - UL/ULC - WHT
5	137605-01-01A	EA	HAND RAIL - INTERIOR ENTRY DOOR - BLACK
6	148362-01-02A	EA	COVER - BRACKET/STRIKE - MEDIUM OAK
	140151-02-03A	EA	COVER - SCREW - MEDIUM OAK
7	131493-07-06A	EA	PICTURE - DECORATIVE - 24" X 30" - TEAL PEONY (W57, W58)
7	131493-07-04A	EA	PICTURE - DECORATIVE - 24" X 30" - RED VELVET (W59, W60, W61, W62)
8*	115011-03-03A	EA	DOOR SHOWER - SLIDING/BYPASS W/40" LOWER TRACK-NICKEL/AQUA
9	139955-06-02A	EA	TRIM - STEP/ENTRY - 29.3" - TITANIUM
10	149728-01-01A	EA	BASKET/DRAWER - WHITE - 12.9"W X 20.7"D X 7.3"H - <b>INTERIOR UPGRADE PACKAGE</b>
10	149728-02-01A	EA	RUNNER/RAIL - F/BASKET - 21"DEEP - <b>INTERIOR UPGRADE PACKAGE</b>
11	120134-01-02A	EA	REGISTER - W/DAMPER - 4" PIPE/6.4" O.D. FACE - WHITE
12*	131595-01-01A	EA	DOOR/FOLDING-36.9"X 74.9"-4 CEILING BRKTS & STRAIGHT TRACK
12	131595-07-01A	EA	TRACK - DOOR - CURVED/RIGHT - 28.5"
	057534-03-000	EA	TIEBACK - CLEAR PLASTIC - 7.5"
13	Y00136-21-218	EA	DOWEL - WOOD - CLOTHES ROD - 1"DIAMETER X 4'
14	152301-01-01A	EA	FLANGE - PLASTIC - 1" CLOTHES ROD HOLDER - WHITE
15	072852-01-000	EA	DETECTOR - SMOKE - W/9 VOLT BATTERY - US
15	072852-02-000	EA	DETECTOR - SMOKE - W/9 VOLT BATTERY - CANADIAN
15	077956-01-000	EA	LABEL - WARNING/SMOKE DETECTOR
16	125136-02-000	EA	DETECTOR/CO - GAS MODEL - 9 VOLT

\*COMPONENT PARTS LISTED LATER IN THIS GROUP

**INTERIOR FINISH GROUP (CONTINUED)**  
**INTERIOR TRIM LAYOUT (CONTINUED)**

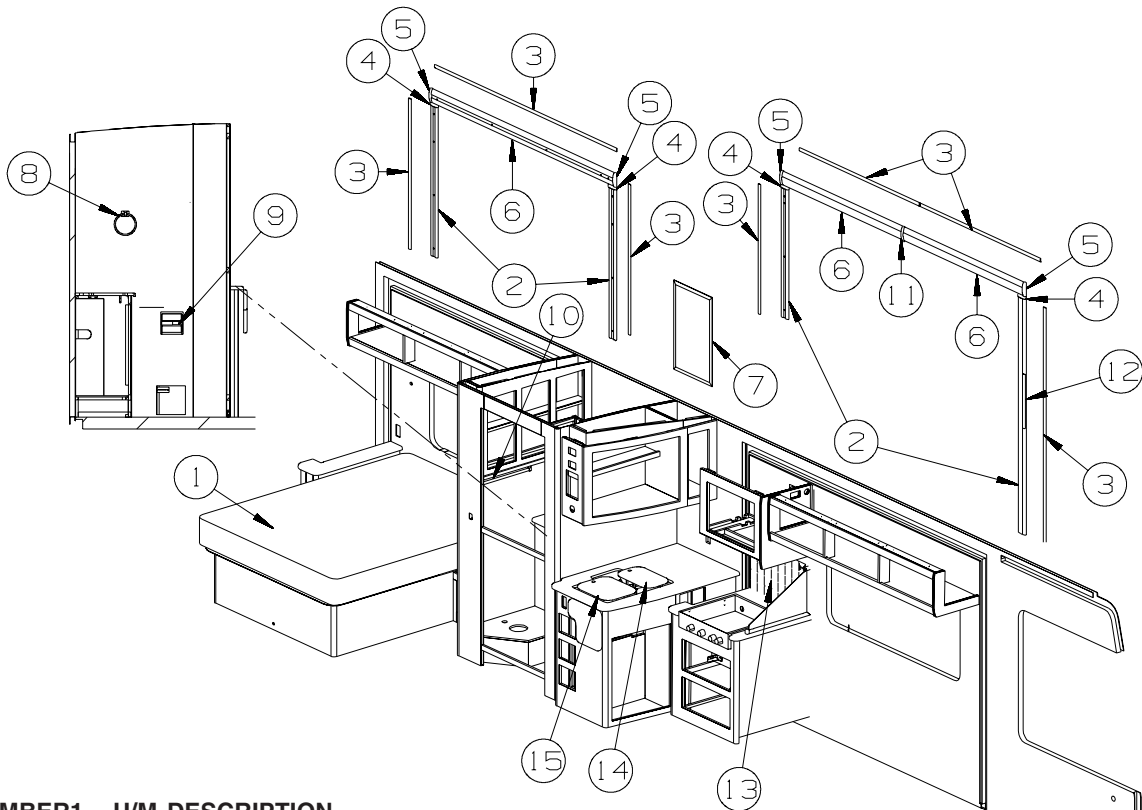

KEY	PART NUMBER1	U/M	DESCRIPTION
1	154430-01-000	EA	MATTRESS - INNERSPRING - 60" X 74.5"
2	Y00360-A2-438	EA	MOLDING - VINYL/CURVED - 3" X 96" - WASHED MAPLE
2	Y00360-82-438	EA	MOLDING - VINYL/CURVED - 3" X 96" - HONEY CHERRY
3	M09520-83-U22	EA	MOLDING/TRIM - .3" X 1" X 78.9" - WASHED MAPLE
3	M09520-83-U21	EA	MOLDING/TRIM - .3" X 1" X 78.9" - HONEY CHERRY
4	156636-04-U17	EA	MOLDING/BLOCK - .8" X 3.1" - WASHED MAPLE
4	156636-04-U21	EA	MOLDING/BLOCK - .8" X 3.1" - HONEY CHERRY
5	156636-05-U17	EA	MOLDING/BLOCK - .8" X 4" - WASHED MAPLE
5	156636-05-U21	EA	MOLDING/BLOCK - .8" X 4" - HONEY CHERRY
6	Y00361-A2-438	EA	MOLDING - VINYL/CURVED - 3.9" X 96" - WASHED MAPLE
6	Y00361-82-438	EA	MOLDING - VINYL/CURVED - 3.9" X 96" - HONEY CHERRY
7	113195-17-01A	EA	MIRROR - BEVELED SAFETY GLASS - CLEAR - 16.6" X 26.2"
8	163601-01-01A	EA	TOWEL RING - CHROME
9	145980-02-02A	EA	HOLDER - TOILET TISSUE - RECESSED - NICKEL
10	163599-02-01A	EA	TOWEL BAR - POST - PAIR - CHROME
10	163599-01-01A	EA	TOWEL BAR - 18" - W/O POSTS - CHROME
11	156636-06-W52	EA	MOLDING/BLOCK - .8" X 4.3" - WASHED MAPLE
11	156636-06-U21	EA	MOLDING/BLOCK - .8" X 4.3" - HONEY CHERRY
12	130262-05-000	EA	PROTECTOR - CORNER - .4" X .7"
13	162004-01-01A	EA	BACKSPLASH - 18" X 24" - THERMOPLASTIC - <b>INTERIOR UPGRADE PACKAGE</b>
13	162005-01-01A	EA	TRIM/BACKSPLASH - INSIDE CORNER - <b>INTERIOR UPGRADE PACKAGE</b>
14	162616-01-01A	EA	COVER/SINK - LARGE - PEARL GRAY - <b>INTERIOR UPGRADE PACKAGE</b> FROM: 00-00-00 THRU: 03-02-08
14	162616-05-01A	EA	COVER/SINK - LARGE - PEARL GRAY - <b>INTERIOR UPGRADE PACKAGE</b> FROM: 03-03-08 THRU: 99-99-99
15	162616-02-01A	EA	COVER/SINK - SMALL - PEARL GRAY - <b>INTERIOR UPGRADE PACKAGE</b> FROM: 00-00-00 THRU: 03-02-08
15	162616-06-01A	EA	COVER/SINK - SMALL - PEARL GRAY - <b>INTERIOR UPGRADE PACKAGE</b> FROM: 03-03-08 THRU: 99-99-99

**INTERIOR FINISH GROUP (CONTINUED)**  
**COMPONENT PARTS FOR INTERIOR TRIM LAYOUT**

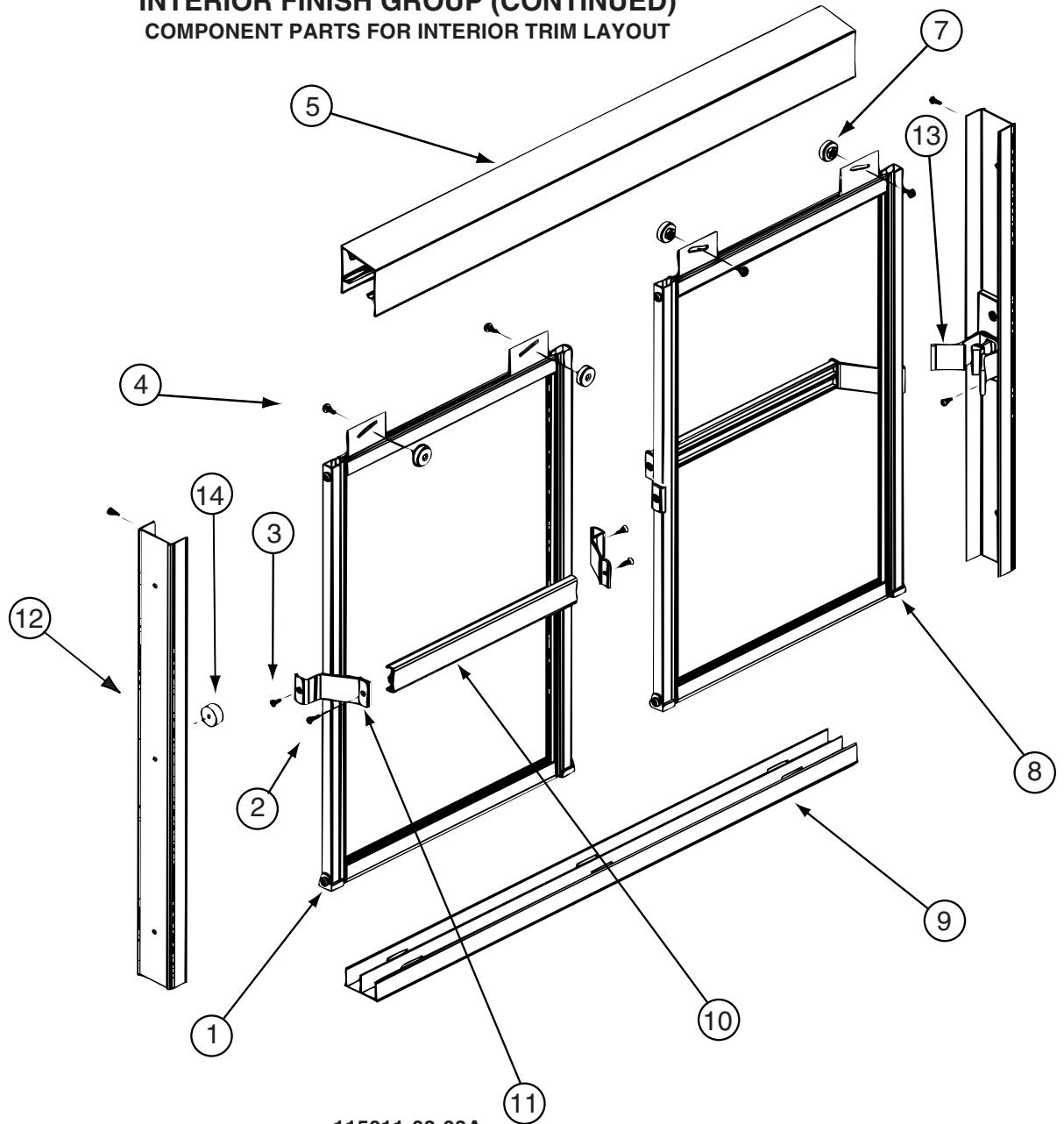

115011-03-03A

KEY	PART NUMBER	U/M	DESCRIPTION	VENDOR NO.
1	115011-03-708	EA	GUIDE/NYLON -F/DOOR BOTTOM	CP1105
2	115011-03-716	EA	SCREW F/TOWEL BAR - NICKEL	612F-N
3	115011-03-715	EA	SCREW F/TOWEL BAR BRKTS-NCKL	638F-N
4	115011-01-705	EA	SCREW-ROLLER, (HEX HEAD)	832HEX
5	115011-03-710	EA	HEADER - NICKEL	45N
7	115011-01-704	EA	ROLLERS	PN193
8	115011-01-706	FT	GLAZING VINYL-BLACK	C154B
9	115011-03-711	EA	TRACK/BOTTOM - 40" NICKEL	90N
10	115011-03-714	EA	TOWEL BAR - NICKEL	136N
11	115011-03-713	EA	BRACKET-TOWEL BAR - NICKEL	CP545 WAS 135
12	115011-03-712	EA	JAMB-WALL/SHOWER DOOR-NCKL	126N
13	115011-03-707	EA	TRAVEL LATCH - BLACK	9733B
14	115011-01-714	EA	BUMPER - RATTLE/SHOWER DOOR	5168S
	115011-03-719	EA	DOOR PANEL ASM - NICKEL/AQUA	WB60N-ADP

CONTACT WINNEBAGO PART SALES FOR UNLISTED COMPONENT(S)

131595-01-01A, 131595-05-01A, 131595-10-01A, 131595-13-01A

KEY	PART NUMBER	U/M	DESCRIPTION	VENDOR NO.
	117431-01-707	EA	BALL CATCH - PLASTIC	
	131595-01-700	EA	END STOP ONLY	
	131595-01-701	EA	BRACKET/MOUNTING	908956
	131595-01-702	EA	TRACK/STRAIGHT - 37"	

**INTERIOR FINISH GROUP (CONTINUED)**  
**FLOOR COVERINGS**

<b>KEY</b>	<b>PART NUMBER</b>	<b>U/M</b>	<b>DESCRIPTION</b>
	042720-41-000	SY	VINYL - FLOOR COVERING - CALAY/#69325
	075233-01-000	SY	PAD - CARPET - 3/8" X 6'W ROLL - SOLD BY THE SQUARE YARD
	093486-01-000	SY	CARPET - COMPARTMENT - 72" WIDE - DARK GRAY
	152251-05-08A	SY	CARPET - 4 SQUARE YARD INCREMENTS - CORDWOOD (W57, W58)
	152251-05-06A	SY	CARPET - 4 SQUARE YARD INCREMENTS - CAST IRON (W59, W60)
	152251-05-07A	SY	CARPET - 4 SQUARE YARD INCREMENTS - RAFFIA (W61, W62)
	089275-02-000	FT	STRIP - 3/4" X 84" BLACK POLYETHYLENE

## INTERIOR FINISH GROUP (CONTINUED)

### HARDWARE

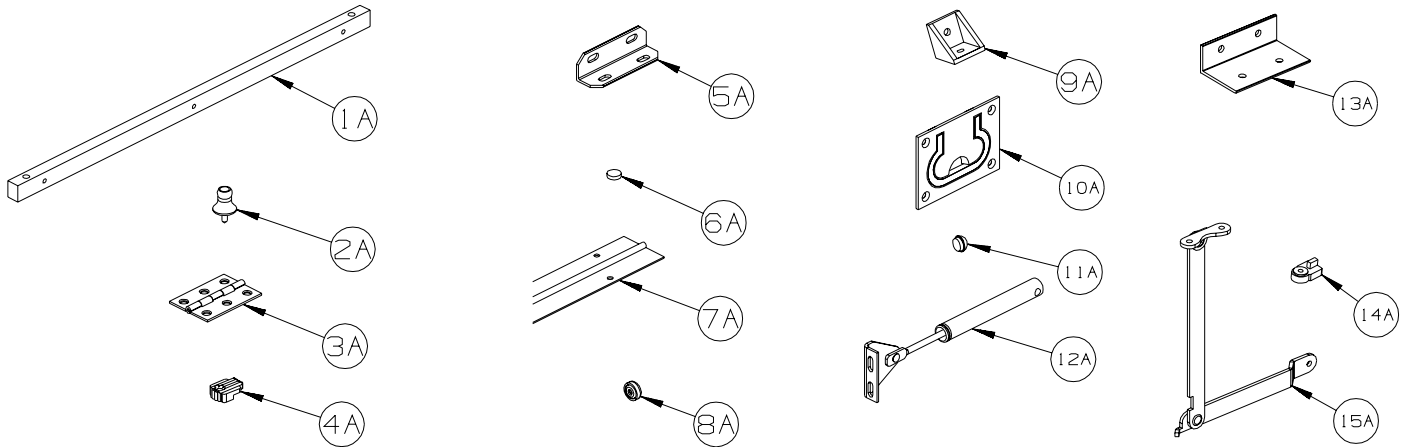

KEY	PART NUMBER	U/M	DESCRIPTION
1A	P34509-01-P14	EA	RAIL END - RH/LH - TOWEL RACK - CONCERT CHERRY
1A	P34509-01-J70	EA	RAIL END - RH/LH - TOWEL RACK - WASHED MAPLE
1A	P34509-01-RE0	EA	RAIL END - RH/LH - TOWEL RACK - HONEY CHERRY
1A	P34509-01-SA3	EA	RAIL END - RH/LH - TOWEL RACK - SIERRA MAPLE
2A	009013-01-000	EA	CATCH - BULLDOG - MALE/FEMALE
3A	009059-01-000	EA	HINGE - DOOR - 2" X 1.4" - BRASS
3A	009059-02-000	EA	HINGE - DOOR - 2" X 2.7" - BRASS
3A	009059-03-000	EA	HINGE - BRASS - 1.75"
3A	009059-04-000	EA	HINGE - 2" - ZINC
4A	009089-01-000	EA	CLIP - MIRROR
5A	016604-01-000	EA	BRACE - ANGLE - 2 1/2" - UNPAINTED METAL
5A	016604-05-000	EA	BRACE - ANGLE - 2 1/2" - OFF WHITE METAL
5A	016604-10-000	EA	BRACE - SEAT ANGLE - 2.5" - BLACK
6A	023320-01-000	EA	PAD - FELT 3/8" DIAMETER
7A	041389-19-000	EA	HINGE - PIANO - 1 1/2" X 71.9" - UNPAINTED
7A	041389-25-000	EA	HINGE - PIANO - 1 1/2" X 55" - UNPAINTED
7A	041389-32-000	EA	HINGE - PIANO - 68" - OFF WHITE
8A	166569-01-02A	EA	COVER - SCREW - #8 - BRIGHT WHITE
8A	166569-01-03A	EA	COVER - SCREW - #8 - SOFT WHITE
8A	166569-01-04A	EA	COVER - SCREW - #8 - CREAM
9A	065740-01-000	EA	BRACE - CABINET/CORNER - PLASTIC
10A	072871-01-000	EA	PULL - FLUSH - CHROME
11A	074045-13-000	EA	PLUG - 3/8" DOWEL-1/2" HEAD - PORTSMOUTH OAK
11A	074045-08-000	EA	PLUG - 3/8" DOWEL-1/2" HEAD - OAK/SALEM CHERRY - CONCERT CHERRY
11A	074045-12-000	EA	PLUG - 3/8" DOWEL-1/2" HEAD - WASHED MAPLE
11A	074045-14-000	EA	PLUG - 3/8" DOWEL-1/2" HEAD - HONEY CHERRY
11A	074045-15-000	EA	PLUG - 3/8" DOWEL-1/2" HEAD - SIERRA MAPLE
12A	074493-02-000	EA	SUPPORT/PISTON SPRING - CABINET DOOR - 26 LBS
12A	074493-03-000	EA	SUPPORT/PISTON SPRING - CABINET DOOR - 12 LBS
13A	156732-01-01A	EA	BRACE - ANGLE/COUCH - 2.5" - MILL
13A	156732-01-02A	EA	BRACE - ANGLE/COUCH - 2.5" - OFF WHITE
13A	156732-03-01A	EA	BRACE - ANGLE/COUCH - 2.5" - BLACK
14A	083204-03-000	EA	BUTTON - RETAINING MIRROR 5/16" TIP
15A	084412-01-000	EA	SUPPORT/HINGE KIT (LEFT & RIGHT HINGES)

**INTERIOR FINISH GROUP (CONTINUED)**  
**HARDWARE (CONTINUED)**

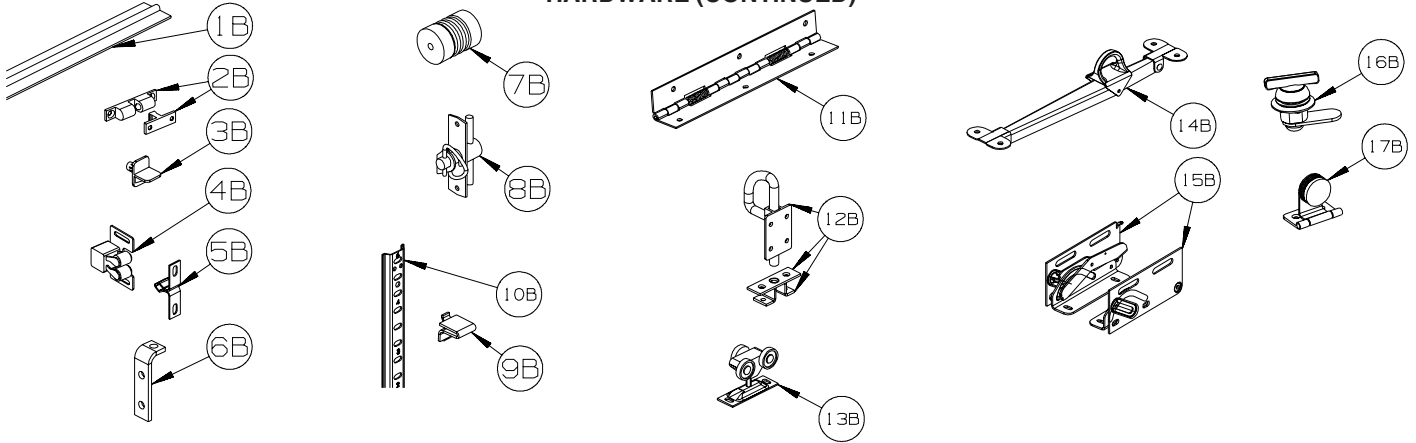

KEY	PART NUMBER	U/M	DESCRIPTION
1B	084413-01-000	EA	HINGE - 1" X 72" - ALUMINUM - W/HOLES
2B	084451-01-000	EA	CATCH & LATCH - 1.7" - BRASS
3B	092907-01-000	EA	SUPPORT - SHELF - PIN - 1/4" - CLEAR PLASTIC
4B	093586-03-000	EA	CATCH - SPRING ROLLER - .377"
4B	093586-06-000	EA	CATCH - W/STRIKE - SPRING ROLLER .236"/SPRINT STEEL .943"
5B	093586-04-000	EA	STRIKE - SPRING STEEL - 1.14"
6B	096826-01-01A	EA	BRACE - CABINET - 2" - E-COATED
6B	096826-02-01A	EA	BRACE - CABINET - 1" - E-COATED
7B	097872-04-000	EA	DOWEL - WOOD - 1" DIAMETER X 1.38" LONG - UNFINISHED
8B	098196-01-000	EA	LATCH - 1/4 TURN - T-BAR
9B	098979-01-000	EA	CLIP - ADJUSTABLE SHELF
10B	098980-01-000	EA	PILASTER - ADJUSTABLE SHELF - 18"
10B	098980-02-000	EA	PILASTER - ADJUSTABLE SHELF - 12"
10B	098980-03-000	EA	PILASTER - ADJUSTABLE SHELF - 9"
10B	098980-04-000	EA	PILASTER - ADJUSTABLE SHELF - 48"
10B	098980-05-000	EA	PILASTER - ADJUSTABLE SHELF - 15"
10B	098980-06-000	EA	PILASTER - ADJUSTABLE SHELF - 24"
11B	102920-01-02A	EA	HINGE - SPRING LOADED - NICKEL
11B	129753-01-01A	EA	HINGE - SPRING LOADED - 19" X 19" - BLACK
12B	103256-01-000	EA	LATCH COMPLETE (SLIDE)
13B	103874-01-000	EA	HANGER - SLIDING DOOR
14B	104181-01-01A	EA	SUPPORT - LEAF 5.3" EXTENDS TO 7.5" - SAFETY RING - METAL
15B	108126-01-000	EA	TRAY HINGE SET (QTY. 2 PER SET)
16B	100710-01-02A	EA	LOCK - GLASS DOOR/TWIST TYPE - NICKEL
17B	100711-01-02A	EA	HINGE - GLASS DOOR - BLACK

**INTERIOR FINISH GROUP (CONTINUED)**  
**HARDWARE (CONTINUED)**

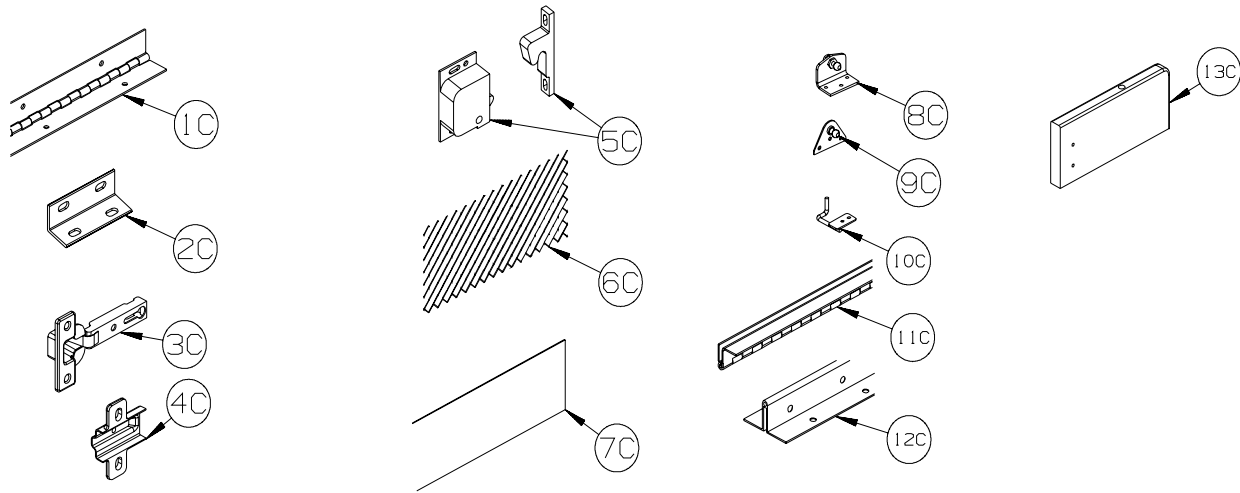

KEY	PART NUMBER	U/M	DESCRIPTION
1C	110496-01-02A	EA	HINGE - NICKEL - 2" X 32"
1C	110496-06-02A	EA	HINGE - NICKEL - 2" X 9.5"
1C	158921-01-04B	EA	HINGE - PIANO - TRUNK DOOR - 2" X 21.9" - BLACK
2C	111866-01-02A	EA	BRACE - SEAT - ANGLE - OFF WHITE
3C	114443-02-01A	EA	HINGE - CABINET DOOR - W/O CLIP - SILVER
4C	114443-03-01A	EA	CLIP - HINGE/CABINET DOOR - SILVER
5C	117095-02-01A	EA	LATCH - DOOR - GRABBER W/KEEPER - PLASTIC - BLK-10 LB PULL
5C	117095-03-01A	EA	LATCH - DOOR - GRABBER W/KEEPER - PLASTIC - BLK-15 LB PULL
6C	118200-01-01A	SF	MESH - PLASTIC 1/2" - 48" X LENGTH = SF - BLACK
7C	122717-06-01A	FT	PAD - NON-SKID - PSA - 5"W
8C	126263-06-02B	EA	BRACKET - GAS SPRING W/INSIDE BALL STUD - E-COATED
9C	126263-05-02B	EA	BRACKET - GAS SPRING W/BALL STUD - E-COATED
9C	126263-08-02B	EA	BRACKET - GAS SPRING W/CENTERED BALL STUD - E-COATED
10C	130798-01-02B	EA	GUIDE - POCKET DOOR - E-COATED
11C	134099-01-02A	EA	HINGE - PIANO - WRAP AROUND - 15.7" - NICKEL PLATED
12C	135538-03-02A	EA	HINGE - PIANO - FULL WRAP - 15.7" - CHROME
12C	135538-07-02A	EA	HINGE - PIANO - FULL WRAP - 9.8" - CHROME
13C	137445-03-T78	EA	STOP - F/SLIDING DOOR - CONCERT CHERRY
13C	137445-03-T79	EA	STOP - F/SLIDING DOOR - WASHED MAPLE
13C	137445-03-T80	EA	STOP - F/SLIDING DOOR - SIERRA MAPLE



**INTERIOR FINISH GROUP (CONTINUED)**  
**HARDWARE (CONTINUED)**

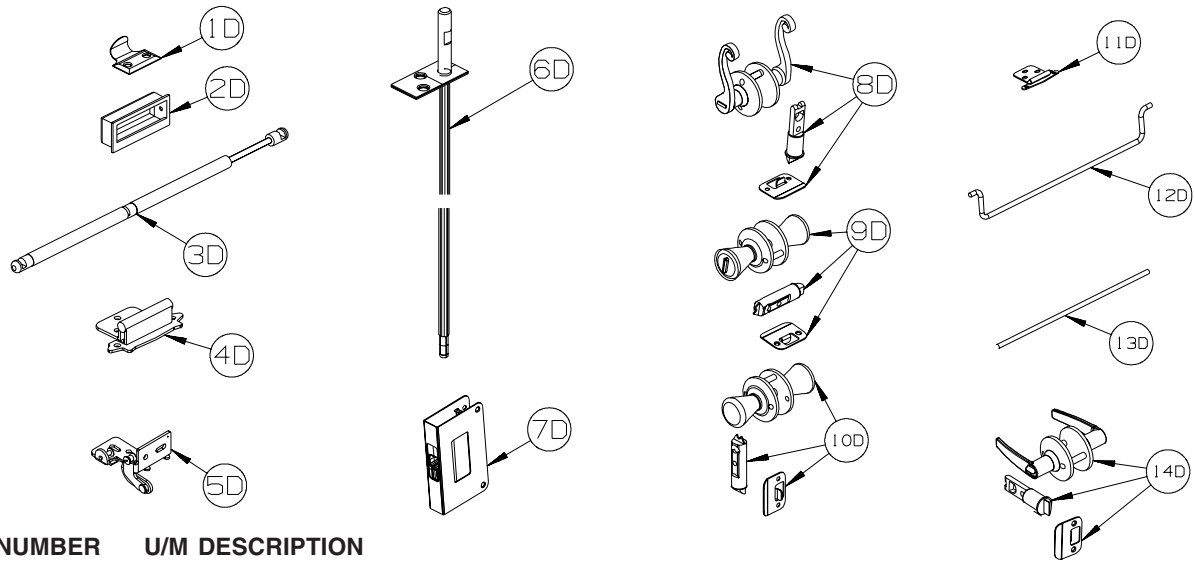

KEY	PART NUMBER	U/M	DESCRIPTION
1D	137463-01-02A	EA	LIFT - HOOK - PEWTER
2D	139136-02-02A	EA	HANDLE - .35" RECESSED - PEWTER
3D	142569-07-000	EA	SPRING/GAS - 20 LB - 20" EXTENDED/12" COMPRESSED
3D	142569-15-000	EA	SPRING/GAS - 120 LB - 20" EXTENDED/12" COMPRESSED
3D	142569-16-000	EA	SPRING/GAS - 90 LB - 20" EXTENDED/12" COMPRESSED
3D	142569-29-000	EA	SPRING/GAS - 20 LB - 9.9" EXTENDED/5.9" COMPRESSED
3D	142569-31-000	EA	SPRING/GAS - 30 LB - 11.8" EXTENDED/7.3" COMPRESSED
4D	143468-02-03A	EA	HINGE - SELF CLOSING - SATIN NICKEL
4D	143468-02-04A	EA	HINGE - SELF CLOSING - OIL RUBBED BRONZE
4D	143468-02-05A	EA	HINGE - SELF CLOSING - RUSTIC BRASS
5D	144488-01-01A	EA	HINGE - CABINET - ANTIQUE BRASS
5D	144488-01-02A	EA	HINGE - CABINET - NICKEL
6D	145939-05-02A	EA	ROD/LATCH - AISLE DOOR - NICKEL
7D	145939-04-02A	EA	LATCH/SLIDE - AISLE DOOR(1" THICK DOOR)-NICKEL/BLACK SLIDE
7D	145939-04-03A	EA	LATCH/SLIDE - AISLE DOOR(1" THICK DOOR)-OIL RUBBED BRONZE
8D	146064-01-02A	EA	LOCK/PRIVACY (LOCKING) LEVER STYLE - SATIN PEWTER
8D	146064-02-02A	EA	LOCK/PASSAGE (NON LOCKING) LEVER STYLE - PEWTER
9D	146064-05-01A	EA	LOCK/PRIVACY (LOCKING) "TULIP" STYLE KNOB - SATIN NICKEL
10D	146064-06-01A	EA	LOCK/PASSAGE (NON LOCKING) "TULIP" STYLE KNOB-SATIN NICKEL
11D	146553-01-03A	EA	HINGE - CABINET DOOR - SATIN NICKEL
12D	146801-01-02A	EA	ROD/TOWEL BAR (OFFSET) - PEWTER
13D	146840-03-02A	EA	ROD - .25" X 11.7" - PEWTER
13D	146840-04-02A	EA	ROD - .25" X 13.1" - PEWTER
14D	146064-08-01A	EA	LOCK/PASSAGE (NON LOCKING) LEVER STYLE - SATIN NICKEL
14D	146064-07-01A	EA	LOCK/PRIVACY (LOCKING) LEVER STYLE - SATIN NICKEL

## INTERIOR FINISH GROUP (CONTINUED) HARDWARE (CONTINUED)

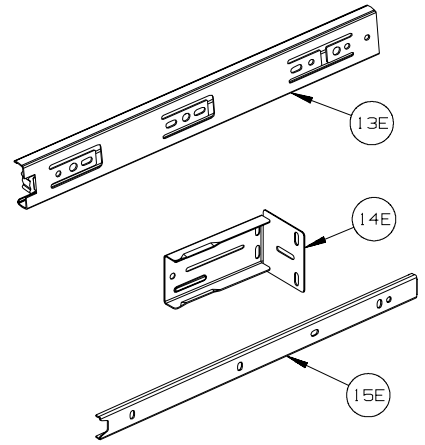
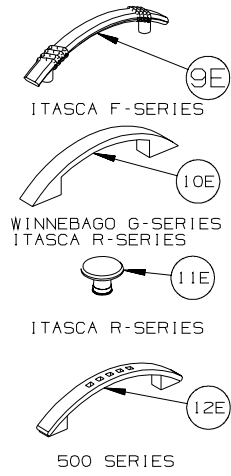
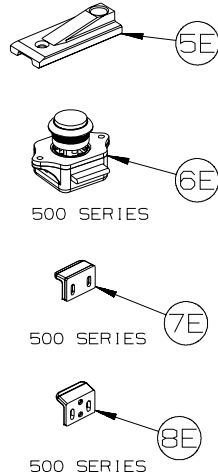
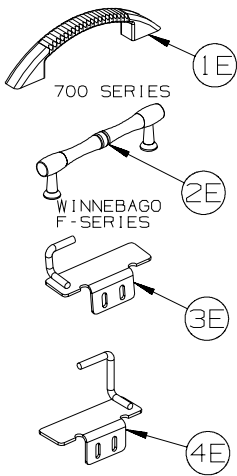

KEY	PART NUMBER	U/M	DESCRIPTION
1E	148816-01-02A	EA	PULL - CABINET DOOR - NICKEL - ASPECT, CAMBRIA 700-SERIES/ADVENTURER LIMITED EDITION
2E	149090-01-02A	EA	PULL - CABINET DOOR - NICKEL - VOYAGE F-SERIES
3E	149607-01-02B	EA	GUIDE - F/POCKET DOOR - 1.6" BENT ROD - E-COATED
3E	149607-03-02B	EA	GUIDE - F/POCKET DOOR - 2.9" BENT ROD - E-COATED
4E	149607-04-02B	EA	GUIDE - F/POCKET DOOR - E-COATED
5E	150983-01-01A	EA	STRIKE/BLOCK - WEDGE STYLE - F/SLIDE DOOR - 3" X 1.2" - BLACK
6E	151380-01-01A	EA	LATCH - CBNT DR - PUSH BTN - VIEW & NAVION 500-SERIES
6E	151380-01-02A	EA	LATCH - CABINET DOOR - PUSH BUTTON - BLACK - TOUR & ELLIPSE R-SERIES
7E	151380-02-01A	EA	STRIKE - CABINET DOOR - VIEW & NAVION 500-SERIES
8E	151380-03-01A	EA	STRIKE - CABINET DOOR - VIEW & NAVION 500-SERIES
9E	152302-01-01A	EA	PULL - CABINET DOOR - SATIN NICKEL - SUNRISE F-SERIES
10E	152304-01-01A	EA	PULL - CABINET DOOR - BRONZE- ADVENTURER G-SERIES, ELLIPSE R-SERIES
11E	152305-01-01A	EA	KNOB - DOOR/DRAWER - BRONZE - ELLIPSE R-SERIES
12E	152950-01-01A	EA	PULL - DOOR/DRAWER - BRUSHED NICKEL - VIEW & NAVION 500-SERIES
13E	153000-01-01A	EA	SLIDE - CABINET MOUNT - 11.8"
13E	153000-03-01A	EA	SLIDE - CABINET MOUNT - 13.8"
13E	153000-05-01A	EA	SLIDE - CABINET MOUNT - 15.7"
13E	153000-07-01A	EA	SLIDE - CABINET MOUNT - 17.7"
13E	153000-09-01A	EA	SLIDE - CABINET MOUNT - 19.7"
13E	153000-11-01A	EA	SLIDE - CABINET MOUNT - 21.6"
13E	153000-14-01A	EA	SLIDE - CABINET MOUNT - 23.6"
13E	153000-16-01A	EA	SLIDE - CABINET MOUNT - 7.9"
13E	153000-18-01A	EA	SLIDE - CABINET MOUNT - 9.8"
13E	153000-20-01A	EA	SLIDE - CABINET MOUNT - 25.6"
14E	153000-13-01A	EA	BACKSOCKET - DRAWER SLIDE
15E	153000-02-01A	EA	SLIDE - DRAWER MOUNT - 11.8"
15E	153000-04-01A	EA	SLIDE - DRAWER MOUNT - 13.8"
15E	153000-06-01A	EA	SLIDE - DRAWER MOUNT - 15.7"
15E	153000-08-01A	EA	SLIDE - DRAWER MOUNT - 17.7"
15E	153000-10-01A	EA	SLIDE - DRAWER MOUNT - 19.7"
15E	153000-12-01A	EA	SLIDE - DRAWER MOUNT - 21.6"
15E	153000-15-01A	EA	SLIDE - DRAWER MOUNT - 23.4"
15E	153000-17-01A	EA	SLIDE - DRAWER MOUNT - 7.7"
15E	153000-19-01A	EA	SLIDE - DRAWER MOUNT - 9.6"
15E	153000-21-01A	EA	SLIDE - DRAWER MOUNT - 25.4"

## INTERIOR FINISH GROUP (CONTINUED)

### HARDWARE (CONTINUED)

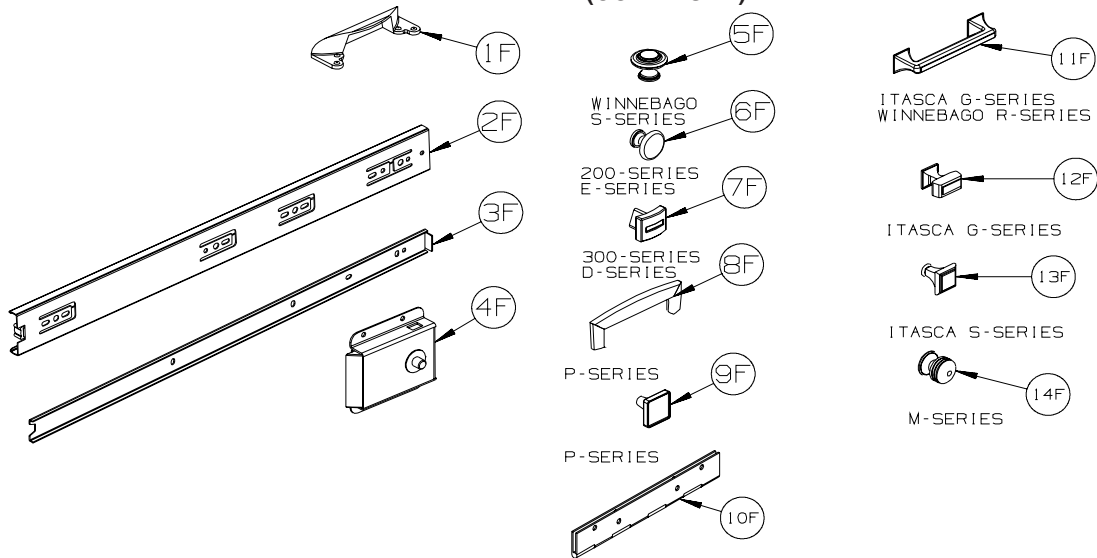

KEY	PART NUMBER	U/M	DESCRIPTION
1F	153308-01-01A	EA	PULL - VANITY STOOL - SATIN NICKEL
2F	153352-01-01A	EA	SLIDE - PANTRY - 19.7" - CABINET MOUNT
3F	153352-02-01A	EA	SLIDE - PANTRY - 19.5" - DRAWER MOUNT
4F	153353-01-01A	EA	LATCH - SLIDING/FLUSH - BLACK
5F	155803-01-01A	EA	KNOB CABINET DOOR - WROUGHT IRON - <b>VECTRA S-SERIES</b>
6F	155925-01-01A	EA	KNOB - DOOR/DRW - SATIN NICKEL - <b>ACCESS &amp; IMPULSE 200-SERIES/ VISTA &amp; SUNSTAR E-SERIES</b>
7F	156579-01-01A	EA	KNOB - DOOR/DRW - PEWTER - <b>OUTLOOK &amp; SPIRIT 300-SERIES/ SIGHTSEER &amp; SUNOVA D-SERIES</b>
8F	157246-01-01A	EA	PULL - CABINET DOOR/DRAWER - SATIN NICKEL - <b>JOURNEY &amp; MERIDIAN P-SERIES</b>
9F	157246-02-01A	EA	KNOB - CABINET DOOR/DRAWER-SATIN NICKEL - <b>JOURNEY &amp; MERIDIAN P-SERIES</b>
10F	158982-01-04B	EA	HINGE - CONTINUOUS - 2" X 8" - BLACK
10F	158982-01-01A	EA	HINGE - CONTINUOUS - 2" X 8" - ZINC
11F	162033-01-01A	EA	PULL - CABINET DOOR - BRUSHED NICKEL - <b>SUNCRUISER G-SERIES, TOUR R-SERIES</b>
12F	162033-02-01A	EA	KNOB - CABINET DOOR - BRUSHED NICKEL - <b>SUNCRUISER G-SERIES</b>
13F	162518-01-01A	EA	KNOB - DOOR/DRAWER - SATIN NICKEL - <b>HORIZON S-SERIES</b>
14F	163095-01-01A	EA	KNOB - CABINET DOOR - SATIN NICKEL - <b>DESTINATION &amp; LATTITUDE M-SERIES</b>

# LABELS GROUP

ALTERNATE LABEL LOCATION

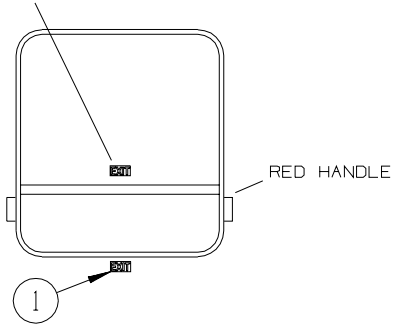

EXIT WINDOW  
(HINGE STYLE)

RED HANDLE

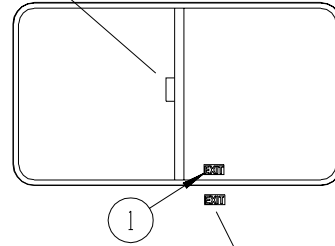

EXIT WINDOW  
(SLIDER STYLE)

KEY	PART NUMBER	U/M DESCRIPTION
1	039290-01-000	EA LABEL - WARNING - EXIT

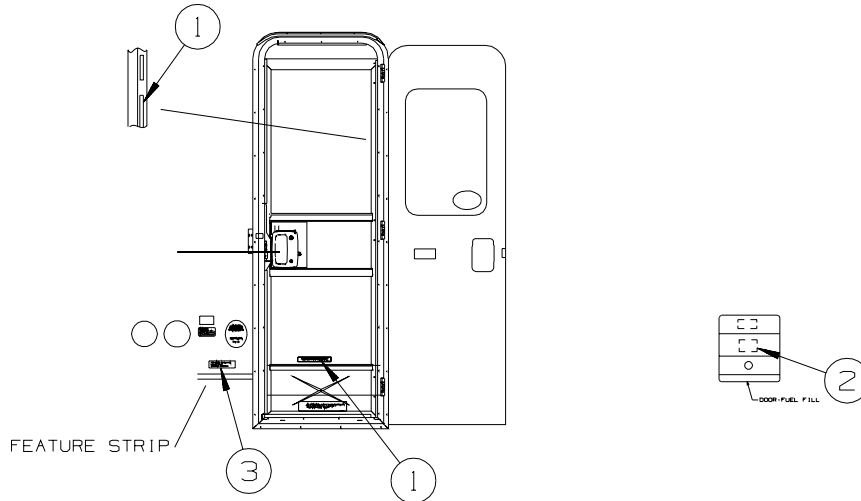

ENTRANCE DOOR

KEY	PART NUMBER	U/M DESCRIPTION
1	135869-01-01A	EA LABEL - MERCURY CONTENT - BLACK ON CLEAR
1	135869-01-02A	EA LABEL - MERCURY CONTENT - WHITE ON CLEAR
2	124519-01-01A	EA LABEL - WARNING/REFUELING - BLACK ON CLEAR
2	124519-02-01A	EA LABEL - WARNING/REFUELING - BLACK ON CLEAR - CSA
3	099509-01-000	EA LABEL - AWNING INSTALLATION
4	065748-01-000	EA LABEL - WARNING - BATTERY CHARGING - UL
4	065748-02-000	EA LABEL - WARNING - BATTERY CHARGING - CSA

## LABELS GROUP (CONTINUED)

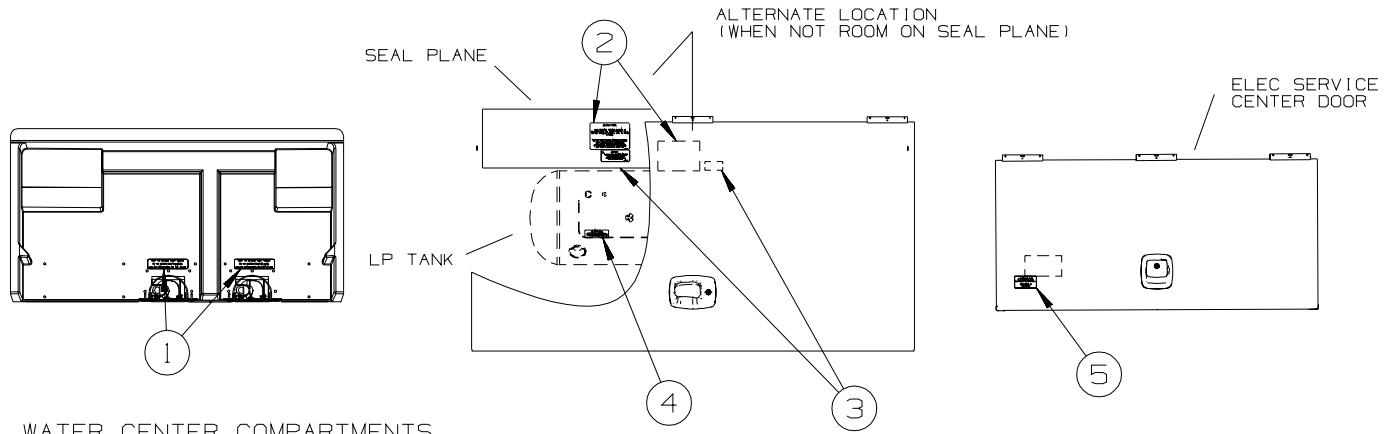

TYPICAL WATER CENTER COMPARTMENTS

KEY	PART NUMBER	U/M	DESCRIPTION
1	123562-01-000	EA	LABEL - SERVICE/UTILITY ACCESS
2	124520-01-01A	EA	LABEL - LP GAS ONLY - BLACK ON CLEAR
2	023769-01-000	EA	LABEL - WARNING - LPG - CANADIAN
3	124519-01-01A	EA	LABEL - WARNING/REFUELING - BLACK ON CLEAR
3	124519-02-01A	EA	LABEL - WARNING/REFUELING - BLACK ON CLEAR - CSA
4	079965-01-000	EA	LABEL - LPG - 80% CAPACITY
5	125306-01-01A	EA	LABEL - ELECTRICAL ENTRANCE - 110V 30 AMP - BLACK ON CLEAR

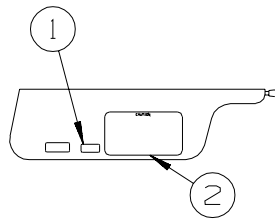

LABELS SHALL BE LOCATED ON OPPOSITE SIDE OF VISOR THAT THE AIR BAG LABEL IS INSTALLED ON

INSTRUMENT CLUSTER REF

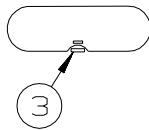

TYPICAL SEAT AND BELT CONFIGURATIONS

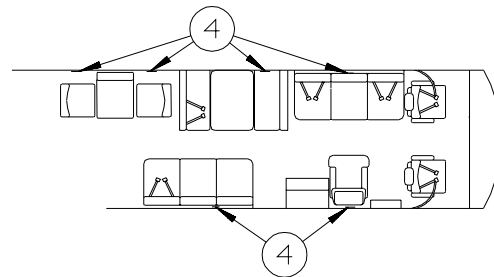

ATTACH LABEL ON OR NEXT TO:  
 +ANY SINGLE CHAIR WITHOUT BELTS.  
 +ANY DINETTE SEAT WITHOUT BELTS.  
 +ANY COUCH WITHOUT BELTS OR ANY SEATING POSITION ON THAT COUCH.  
 DO NOT ATTACH LABEL IF:  
 +DINETTE SEAT HAS AT LEAST ONE SET OF BELTS INSTALLED.

KEY	PART NUMBER	U/M	DESCRIPTION
1	099689-01-000	EA	LABEL - WARNING - CANCER/TOXICITY
2	056259-01-000	EA	LABEL - SAFETY CHECK LIST
3	155692-01-02A	EA	LABEL - ODOMETER - READ IN MILE - WHITE/CLEAR
4	134538-01-01A	EA	LABEL - OCCUPANCY - NO SEAT BELT - BLACK ON CLEAR - US
4	134538-02-01A	EA	LABEL - OCCUPANCY - NO SEAT BELT - BLACK ON CLEAR - CSA

## LABELS GROUP (CONTINUED)

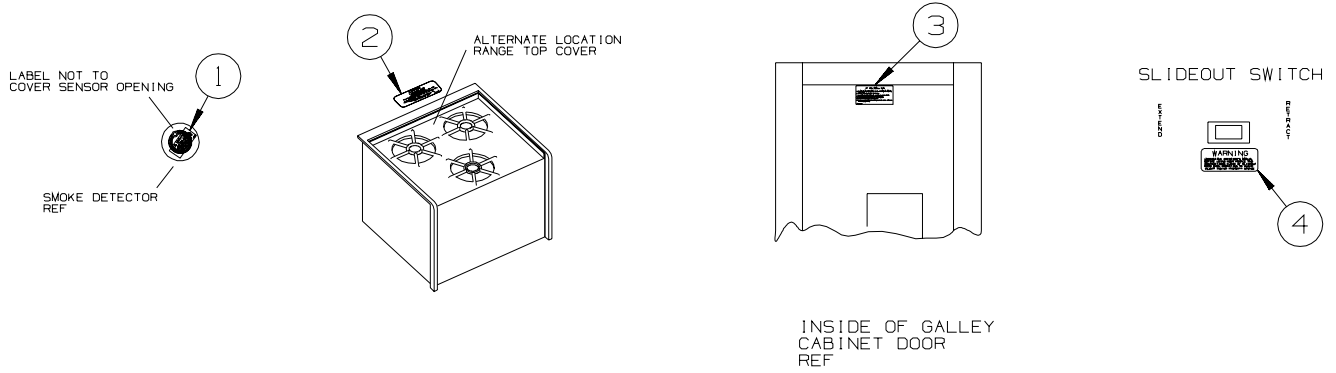

KEY	PART NUMBER	U/M	DESCRIPTION
1	077956-01-000	EA	LABEL - WARNING/SMOKE DETECTOR
2	134539-01-01A	EA	LABEL - WARNING - STOVE/HEATING - US - BLACK ON CLEAR
2	134540-01-01A	EA	LABEL - WARNING - STOVE/HEATING - CSA - BLACK ON CLEAR
3	073998-01-000	EA	LABEL - LPG/ODOR WARNING
4	116549-01-000	EA	LABEL - WARNING - .8" X 6.3" - SLIDEOUT
4	116549-02-000	EA	LABEL - WARNING - 1.5" X 3.4" - SLIDEOUT

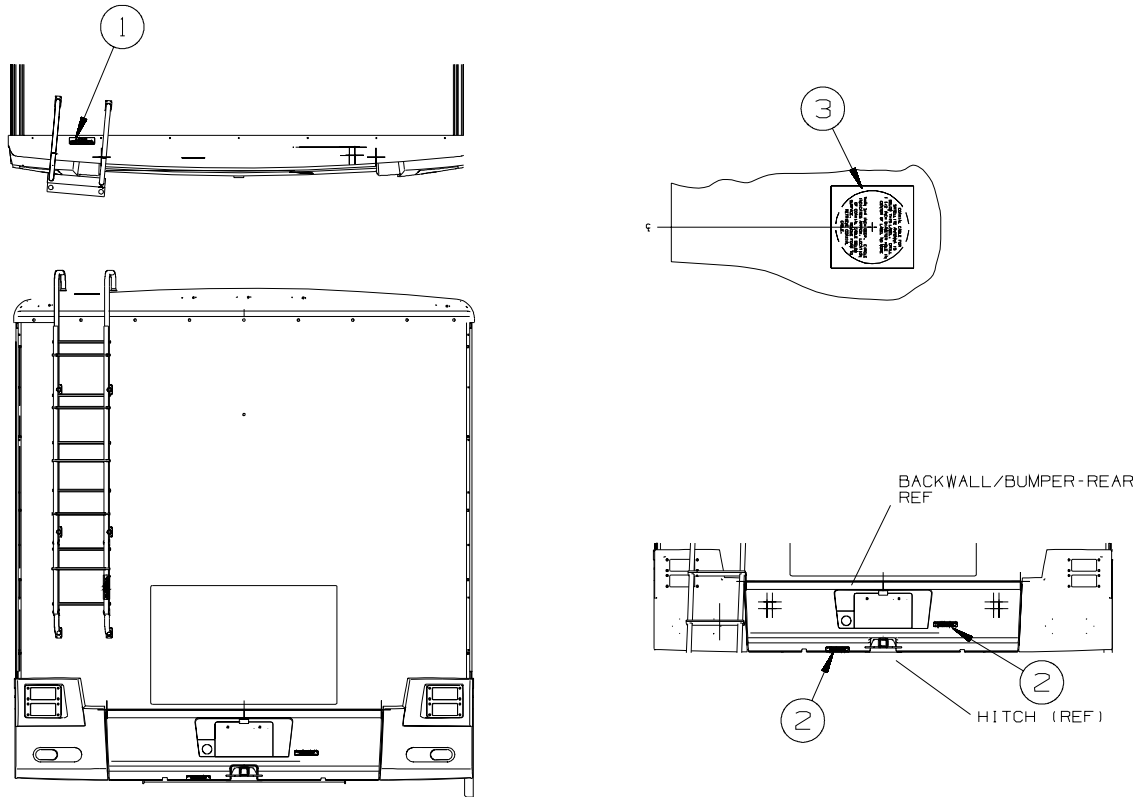

KEY	PART NUMBER	U/M	DESCRIPTION
1	163705-01-01A	EA	LABEL - WARNING - SLIPPERY ROOF
2	129669-02-01A	EA	LABEL - HITCH/VEHICLE RATE - 500 - WHITE ON CLEAR
2	129669-02-02A	EA	LABEL - HITCH/VEHICLE RATE - 500 - BLACK ON CLEAR
3	120431-01-000	EA	LABEL - LOCATION - COAXIAL CABLE/SATELLITE ANTENNA

## LABELS GROUP (CONTINUED)

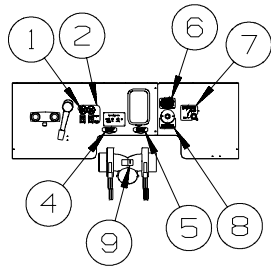

30B & 34M SERVICE PANEL

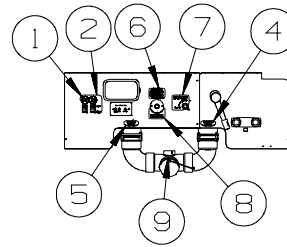

35J SERVICE PANEL

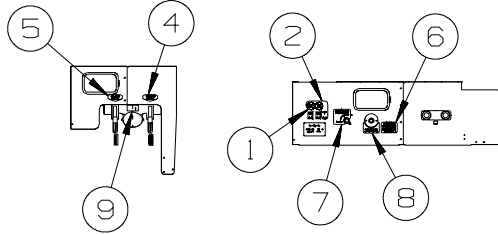

29R SERVICE PANEL

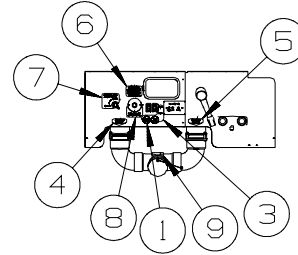

26P SERVICE PANEL

KEY	PART NUMBER	U/M	DESCRIPTION
1	152544-03-01A	EA	LABEL - SWITCHES - WATER PUMP
2	152544-07-01A	EA	LABEL - SWITCHES - WTR PUMP/AUTO LVL-W/LVL/STORE DWN
3	152544-08-01A	EA	LABEL - SWITCHES - WTR PUMP/AUTO LVL-W/LVL/STORE UP
4	152543-03-01A	EA	LABEL - BLACK WASTE
5	152541-03-01A	EA	LABEL - GRAY WASTE
6	128725-02-01A	EA	LABEL - POTABLE WATER ONLY - BLACK ON CLEAR
7	152548-01-01A	EA	LABEL - VALVE/FRESH
8	152538-01-01A	EA	LABEL - FRESH WATER - PANTONE/CLEAR
9	144649-01-01A	EA	LABEL - ADJUSTABLE VALVE - WHITE ON CLEAR

**LP GROUP  
LP SYSTEM**

<b>KEY</b>	<b>PART NUMBER</b>	<b>U/M</b>	<b>DESCRIPTION</b>
	045703-03-000	EA	HOSE - LP - 3/8"ID X 18" - 3/8"MPT X 1/2"F SWIVEL - US
	045703-12-000	EA	HOSE - LP - 3/8"ID X 18" - 3/8"MPT X 1/2"F SWIVEL - CSA
	045703-14-000	EA	HOSE - LP - 3/8"ID X 157.5" - 1/2"F SWIVEL X 1/2"F SWIVEL
	045703-15-000	EA	HOSE - LP - 3/8"ID X 142" - 1/2"F SWIVEL X 3/8"F SWIVEL
	045703-17-000	EA	HOSE - LP - 3/8"ID X 24" - 1/2"F SWIVEL X 3/8"F SWIVEL US
			FROM: 00-00-00 THRU: 09-30-07
	045703-18-000	EA	HOSE - LP - 3/8"ID X 28" W/1/2" FEMALE SWIVELS
			FROM: 10-01-07 THRU: 99-99-99
*	144116-04-000	EA	TANK - LP - 60 LB - 14"D X 29.75"L
	106150-05-000	EA	REGULATOR - TWO STAGE
	105658-01-000	EA	COMPARTMENT - LP REGULATOR
	144485-01-000	EA	COVER - LP REGULATOR
	139061-02-02B	EA	COVER - LP LINES - FRONT - E-COATED
	139061-03-02B	EA	COVER - LP LINES - FRONT - E-COATED
	040440-02-000	EA	TRANSMITTER - DIAL/BOLT-ON - 0-90 OHM 2 TERM(POWER/GROUND)
	141090-01-02B	EA	SHIELD - HEAT - E-COATED
	010380-02-000	EA	NUT - 1/2" FLARE - FORGED - BRASS
			FROM: 00-00-00 THRU: 02-07-07
	010377-02-000	EA	NUT - 3/8" FLARE - FORGED - BRASS
			FROM: 02-08-07 THRU: 99-99-99
	010265-01-000	EA	ELBOW - BRASS - 90 DEGREE - 3/8"F X 1/2"FPT
	010589-01-000	EA	NIPPLE - PIPE - 1/2" X 1 1/2" - BLACK
	010589-03-000	EA	NIPPLE - PIPE - 1/2" X 2 1/2" - BLACK
	010323-01-000	EA	ADAPTER - 3/8"F X 1/2"MPT - BRASS
	010326-01-000	EA	ADAPTER - FLARE - W/CONE GASKET - 3/8"F X 1/2"F
	010329-01-000	EA	ADAPTER - 1/2"F X 1/2"MPT - BRASS
	024250-01-000	EA	ADAPTER - BRASS - 3/8"F X 1/2"FPT

**\*COMPONENT PARTS LISTED LATER IN THIS GROUP**

**COMPONENT PARTS FOR LP SYSTEM**

**144116-04-000**

<b>KEY</b>	<b>PART NUMBER</b>	<b>U/M</b>	<b>DESCRIPTION</b>	<b>VENDOR NO.</b>
	040421-01-712	EA	VALVE-SERV. W/O VAPOR RELIEF	V20373/V21202
	040421-01-713	EA	VALVE-RELIEF 1" W/SPRING 7"	V12560/V21207
	144116-01-700	EA	VALVE-OUTAGE(NO STEM REMOVE)	V20058
	144116-01-701	EA	VALVE/FILL 80 % W/YELLOW CAP	V13414
	144116-04-700	EA	FLOAT/SENDING UNIT W/O DIAL	G11530
	144116-04-701	EA	DIAL - TRANSMITER	G12845



# SEALANTS & FASTENERS GROUP

## SEALANTS & ADHESIVES

KEY	PART NUMBER	U/M	DESCRIPTION
	010405-02-000	EA	TAPE - THREAD SEALING - 3/8"
	064075-07-000	FT	SEAL - BULB - W/WIRED U CHANNEL - .3" X .5" CHANNEL-BLACK
	067788-01-000	EA	ADHESIVE - SPRAY - 3M - 19.5 OZ AEROSOL CAN
	069640-01-000	FT	SEALER - RIBBON - 1/4"DIAMETER X 30 FT - BLACK OR GRAY
	069640-02-000	FT	SEALER - TAPE - 1/8"THICK X 1/2"WIDE X 60 FT - GRAY
	069640-03-000	FT	SEALER - TAPE - 1/8"THICK X 3/4"WIDE X 60 FT - BLACK
	069640-07-000	FT	SEALER - TAPE - 3/32"THICK X 2"WIDE X 45 FT - GRAY
	069640-09-000	FT	SEALER - TAPE - 1/32"THICK X 2 1/2"WIDE X 80 FT - BRT WHT
	069640-10-000	FT	SEALER - TAPE - 1/32"THICK X 1 1/2"WIDE X 90 FT - GRAY
	069640-11-000	FT	SEALER - TAPE - 3/16"THICK X 3/8"WIDE X 40 FT - BLACK
	069640-13-000	FT	SEALER - TAPE - 3/32"THICK X 2"WIDE X 45 FT - BLACK
	069640-14-000	FT	SEALER - TAPE - 1/16"THICK X 1"WIDE X 100 FT - BLACK
	069640-15-000	FT	SEALER - TAPE - 1/16"THICK X 3/8"WIDE X 100 FT - BRT WHT
	069640-17-000	FT	SEALER - TAPE - 1/32"THICK X 1"WIDE X 150 FT - GRAY
	069640-18-000	FT	SEALER - TAPE - 1/8"THICK X 1/2"WIDE X 60 FT - BRT WHT
	069640-19-000	FT	SEALER - TAPE - 1/8"THICK X 3/4"WIDE X 60 FT - BRT WHT
	069640-20-000	FT	SEALER - TAPE - 1/8"THICK X 1/2"WIDE X 60 FT - BLACK
	069640-21-000	FT	SEALER - TAPE - 1/16"THICK X 1/2"WIDE X 100 FT - BRT WHT
	069640-22-000	FT	SEALER - TAPE - 1/32"THICK X 1/4"WIDE X 200 FT - BRT WHT
	069640-23-000	FT	SEALER - TAPE - 1/16"THICK X 3/4"WIDE X 100 FT - BRT WHT
	069640-27-000	FT	SEALER - TAPE - 1/16"THICK X 2 1/4"WIDE X 50 FT - BRT WHT
	069640-28-000	FT	SEALER - TAPE - 1/32"THICK X 1 7/8"WIDE X 90 FT - GRAY
	069640-30-000	FT	SEALER - TAPE - 1/32"THICK X 5/8"WIDE X 50 FT - GRAY
	069640-31-000	FT	SEALER - TAPE - 1/4"THICK X 3/4"WIDE X 15 FT - BLACK
	069640-32-000	FT	SEALER - TAPE - 1/16"THICK X 3/8"WIDE X 100 FT - BLACK
	069640-33-000	FT	SEALER - RIBBON - 3/8"DIAMETER X 20 FT - BLACK
	069640-34-000	FT	SEALER - RIBBON - 1/4"DIAMETER X 30 FT - BRIGHT WHITE
	069640-36-000	EA	SEALER - TAPE - 1/16"THICK X 1/2"WIDE X 100 FT - BLACK
	069640-37-000	FT	SEALER - TAPE - 1/16"THICK X 3/4"WIDE X 100 FT - BLACK
	069640-38-000	FT	SEALER - TAPE - 1/16"THICK X 3/4"WIDE X 100 FT - BRT WHT
	069640-39-000	FT	SEALER - TAPE - 1/16"THICK X 3"WIDE X 50 FT - BRT WHT
	069640-40-000	FT	SEALER - TAPE - 1/16"THICK X 3"WIDE X 50 FT - BRT WHT
	072889-28-000	EA	SEALANT/URETHANE-10 OZ TUBE W/NOZZLE-SELF LEVELING-BRT WHT
	072889-31-000	EA	SEALANT/URETHANE-10 OZ TUBE W/NOZZLE-SELF LEVELING - BLACK
	076322-02-000	FT	TAPE-DOUBLE COATED/ADHESIVE BK-.05"THK X 1"W X 108' - WHT
	076322-03-000	FT	TAPE-DOUBLE COATED/ADHESIVE BK-.05"THK X .5"W X 108' - WHT
	076322-05-000	FT	TAPE-DOUBLE COATED/ADHESIVE BK-.05"THK X .8"W X 108' - WHT
	076322-07-000	FT	TAPE-DOUBLE COATED/ADHESIVE BK-.05"THK X .5"W X 200' - BLK
	076322-13-000	FT	TAPE - FOAM/DOUBLE COATED - .020"THK X .75"W - CLEAR
	076322-21-000	FT	TAPE - FOAM/DOUBLE COATED - .045"THK X .50"W
	076322-22-000	FT	TAPE - FOAM/DOUBLE COATED - .045"THK X .75"W
	076322-23-000	FT	TAPE - FOAM/DOUBLE COATED - .045"THK X 1"W
	076322-25-000	FT	TAPE - FOAM/DOUBLE COATED - .025"THK X .5"W
	086276-01-000	EA	TAPE - DOUBLE SIDED - 1/2" WIDE X 108' LONG (SOLD BY ROLL)
	088479-01-000	EA	TAPE - ALUMINUM - 3"
	090340-01-000	FT	SEAL - FOAM - CLOSED CELL - 1/4" X 1/2" X 50'
	090340-02-000	FT	SEAL - FOAM - CLOSED CELL - 3/8" X 1/2" X 50'
	091255-02-000	FT	SEAL - ADHESIVE BACKED/FOAM - 3/64"THICK X 3/16"W X 1000'
	091255-03-000	FT	SEAL - ADHESIVE BACKED/FOAM - 1/4" THICK X 1/4"W X 1000'
	094401-01-000	EA	SEALER - BODY SEAM - FLEXICLEAR
	094401-04-000	EA	SEALER - BODY SEAM - CLEAR
	094401-05-000	EA	SEALER - BODY SEAM - 20OZ BLACK
	094401-06-000	EA	SEALER - BODY SEAM - 12OZ BLACK
	094401-07-000	EA	SEALER - BODY SEAM - CLEAR
	098408-01-000	FT	SEAL - SPONGE RUBBER - CLOSED CELL
	099069-01-000	FT	SEAL - RUBBER - CLOSED SPONGE - .5" WIDE X .12" THICK-BLK
	099418-01-000	FT	SEAL - D-SECTION/ADHESIVE BACK - .44" X .44" - BLK RUBBER
	100128-02-000	FT	SEAL - FOAM/ADHESIVE BACK - .37" WIDE X .37" THICK X 60'
	104692-01-000	FT	SEAL - ADHESIVE BACKED FOAM - 3/4" THICK X 3/4" WIDE X 25'
	107721-07-000	FT	SEAL - ACCESS DOOR - .9"WIDE X 1.1"HIGH
	112864-01-000	FT	SEAL - FOAM/BUTYL COVERED - 3/8" X 35'
	112864-02-000	FT	SEAL - FOAM/BUTYL COVERED - 5/16" X 44'
	112864-05-000	FT	SEAL - FOAM/BUTYL COVERED - 1/2" X 3/16"
	112901-02-000	EA	ADHESIVE - PLEXUS - MA330 - 50ML - GRAY

## SEALANTS & FASTENERS GROUP (CONTINUED)

### SEALANTS & ADHESIVES (CONTINUED)

KEY	PART NUMBER	U/M	DESCRIPTION
	112901-03-000	EA	ADHESIVE - PLEXUS - MA300 - 50ML - WHITE
	112902-03-000	EA	MIXER NOZZLE - F/GUN #00400102000 - SCOTCH-WELD & PLEXUS
	112902-04-000	EA	NOZZLE - ELEMENT - 1/4" X 3.5"
	113452-01-000	FT	SEAL/TRIM - FRONT - VINYL W/WIRE CARRIER - .020"
	113452-02-000	FT	SEAL/TRIM - FRONT - VINYL W/WIRE CARRIER - .027"
	113366-01-000	EA	ADHESIVE - INSTANT - 1 OZ
	115870-01-000	FT	SEAL/EDGE - TRIM
	120074-02-03A	EA	SILICONE - TUBE - W/O NOZZLE - LOW ODOR - SMOKEY WHITE
	120534-01-01A	EA	TAPE - SCOTCH - 3M - 1/2" FINE LINE
	123655-01-000	FT	SEAL - CLOSED CELL/FOAM
	123816-01-000	FT	TAPE - DOUBLE SIDED - 1" X .020" X 200' - CLEAR
	123816-02-000	FT	TAPE - DOUBLE SIDED - 1/2" X .035" X 200' - CLEAR
	123816-03-000	FT	TAPE - DOUBLE SIDED - 1/2" X .020" X 200' - CLEAR
	123816-04-000	FT	TAPE - DOUBLE SIDED - 6" X .0035" X 750' - CLEAR
	123816-06-000	FT	TAPE - DOUBLE SIDED - 3/4" X 3/4" X 200' - CLEAR
	123816-07-000	FT	TAPE - DOUBLE SIDED - 1 3/4" X 200' - CLEAR
	126427-01-000	EA	ADHESIVE - ALL PURPOSE - ABS/PVC
	126427-02-000	EA	PRIMER - CLEANER - FLEX PIPING
	131264-01-12A	EA	SILICONE - TUBE - W/NOZZLE - BONE
	131264-01-13A	EA	SILICONE - TUBE - W/NOZZLE - TRANSLUCENT
	131264-03-01A	EA	SILICONE - TUBE - W/O NOZZLE - SELF LEVELING -BRIGHT WHITE
	131264-04-02A	EA	SILICONE/SEALANT/ADHESIVE-FAST CURE F/GLASS/VINYL-SOFT WHT
	131264-05-01A	EA	SILICONE/SEALANT - ODORLESS - TUBE - W/NOZZLE - BLACK
	131264-05-02A	EA	SILICONE/SEALANT - ODORLESS - TUBE - W/NOZZLE - CLEAR
	131384-01-000	EA	ADHESIVE - JET WELD - 10 OZ CARTRIDGE
	132892-07-01A	FT	SEAL - BULB/SINGLE - W/U CHANNEL - .5" X 1" - BLACK
	152038-01-01A	EA	TAPE - PRESERVATION SEAL - 2" X 36YD ROLL - BLACK
	154585-01-01A	FT	SEAL - FOAM TAPE - ADHESIVE BACK - 3/8" X 3/8" - BLACK
	154585-02-01A	FT	SEAL - FOAM TAPE - ADHESIVE BACK - 3/4" X 1/2" - BLACK
	154585-03-01A	FT	SEAL - FOAM TAPE - ADHESIVE 2 SIDED - 1/8" X 3/4" - BLACK
	154585-04-01A	FT	SEAL - FOAM TAPE - ADHESIVE BACK - 5/8" X 1/8" - WHITE
	156622-01-01A	FT	SEALER - TAPE - 1/4"THICK X 3"WIDE X 100 FT - WHITE
	156622-02-01A	FT	SEALER - TAPE - 1/4"THICK X 2"WIDE X 100 FT - WHITE

### BOLTS, NUTS AND WASHERS

KEY	PART NUMBER	U/M	DESCRIPTION
	0MD54F-06-000	EA	NUT - HEX W/SERATED FLANGE
	000C12-04-08B	EA	BOLT - HEX - 1/4-20 X 1/2 - GRADE #5 - ZINC
	000C12-04-12A	EA	BOLT - HEX - 1/4-20 X 3/4 - PLAIN 5
	000C12-04-40B	EA	BOLT - HEX - 1/4-20 X 2 1/2 - GRADE #5 ZINC
	000C12-05-16B	EA	BOLT - HEX - 5/16 - 18X1 - GRADE #5 - ZINC
	000C12-05-40B	EA	BOLT - HEX - 5/16"-18 X 2.5" - GRADE #5 - ZINC
	000C12-06-28B	EA	BOLT-HEX-3/8-16X13/4 ZN 5 - 5185-01
	000C12-08-24B	EA	BOLT - HEX - 1/2-13 X 1 1/2 - GRADE #5 - ZINC
	000C12-08-28B	EA	BOLT - HEX - 1/2-13 X 1 3/4 - GRADE #5 - ZINC
	000C12-08-44B	EA	BOLT - HEX - 1/2-13 X 2 3/4 - GRADE #5 - ZINC
	000C13-07-40B	EA	BOLT - HEX - 7/16-20 X 2 1/2 - GRADE #5 - ZINC
	000C13-07-48B	EA	BOLT - HEX - 7/16-20 X 3 - GRADE #5 - ZINC
	000C14-10-32B	EA	BOLT - HEX - 5/8-11 X 2.0 - GRADE #8 - ZINC
	000C18-05-40A	EA	BOLT - ELEVATOR - 5/16-18 X 2 1/2 - PL
	000C26-04-10B	EA	BOLT - HEX - SERRATED FLANGE - 1/4-20 X 5/8 - ZINC
	000C26-04-12F	EA	BOLT - HEX - SERRATED FLANGE -1/4-20 X 3/4-STAINLESS STEEL
	000C26-04-14B	EA	BOLT - HEX - SERRATED FLANGE - 1/4-20 X 7/8 - ZINC
	000C26-04-18B	EA	BOLT - HEX - SERRATED FLANGE - 1/4-20 X 1 1/8 - ZINC
	000C26-05-12B	EA	BOLT - HEX - SERRATED FLANGE - 5/16-18 X 3/4 - ZINC
	000C26-06-12B	EA	BOLT - HEX - SERRATED FLANGE - 3/8-16 X 3/4 - ZINC
	000C26-06-20B	EA	BOLT - HEX - SERRATED FLANGE - 3/8-16 X 1 1/4 - ZINC
	000C26-06-28B	EA	BOLT - HEX - SERRATED FLANGE - 3/8-16 X 1 3/4 - ZINC
	000C26-06-40B	EA	BOLT - HEX - SERRATED FLANGE - 3/8-16 X 2 1/2 - ZINC
	000C26-08-24B	EA	BOLT - HEX - SERRATED FLANGE - 1/2-13 X 1 1/2 - ZINC
	000C26-08-28B	EA	BOLT - HEX - SERRATED FLANGE - 1/2-13 X 1 3/4 - ZINC
	000C27-08-48B	EA	BOLT-CARR 1/2-13X3.00 GR5 - 97 M-SERIES
	000D24-10-00B	EA	NUT - HEX - SELF LOCKING - 10-32 - ZINC

**SEALANTS & FASTENERS GROUP (CONTINUED)**  
**BOLTS, NUTS AND WASHERS (CONTINUED)**

KEY	PART NUMBER	U/M	DESCRIPTION
	000D27-05-00B	EA	NUT - HEX LOCK - 5-40 - ZINC
	000D28-10-00B	EA	NUT - HEX - W/NYLON LOCK - 10-32 - ZINC
	000D29-04-00B	EA	NUT - HEX - SELF LOCKING - 1/4 X 20 - ZINC
	000D29-04-00F	EA	NUT - HEX - SELF LOCKING - 1/4 X 20 - STAINLESS STEEL
	000D29-06-00B	EA	NUT - HEX - W/NYLON LOCK - 3/8-16 - ZINC
	000D29-09-00B	EA	NUT - HEX - SELF LOCKING - 9/16-12 - ZINC
	000D34-04-00B	EA	NUT - HEX - LOCKING - 1/4-20 - ZINC
	000D34-06-00B	EA	NUT - HEX - LOCKING - 3/8-16 GRADE C - ZINC
	000D39-04-00B	EA	NUT - HEX - LOCKING W/SERRATED FLANGE - 1/4-20 - ZINC
	000D39-05-00B	EA	NUT - HEX - LOCKING W/SERRATED FLANGE - 5/16-18 - ZINC
	000D39-06-00B	EA	NUT - HEX - LOCKING W/SERRATED FLANGE - 3/8-18 - ZINC
	000D39-06-00D	EA	NUT - HEX - LOCKING W/SERRATED FLANGE - 3/8"-16 BLACK
	000D39-07-00B	EA	NUT - HEX - LOCKING W/SERRATED FLANGE - 7/16-14 - ZINC
	000D39-08-00B	EA	NUT - HEX - LOCKING W/SERRATED FLANGE - 1/2-13 - ZINC
	000D44-07-00B	EA	NUT - HEX - LOCKING W/SERRATED FLANGE - 7/16-20 - ZINC
	000D44-08-00B	EA	NUT - HEX - LOCKING W/SERRATED FLANGE - 1/2-20 - ZINC
	000D46-04-00A	EA	NUT - HEX - WELD - 1/4-20 - PLAIN
	000D65-08-00B	EA	NUT - HEX - LOCKING W/SERRATED FLANGE - 8-32 - ZINC
	000D73-08-00C	EA	NUT - HEX FLANGE - 1/2-13
	000D75-09-00B	EA	NUT - HEX LOCKING - 9/16-12 - ZINC
	000D76-06-00B	EA	NUT - HEX FLANGE - 3/8-16
	000E11-04-00F	EA	WASHER - LOCKING - 1/4 MED SPLIT - STAINLESS STEEL
	000E11-07-00B	EA	WASHER - LOCKING - 7/16 MED SPLIT - ZINC
	000E11-08-00B	EA	WASHER - LOCKING - 1/2 MED SPLIT - ZINC
	000E13-17-00B	EA	WASHER - FLAT - 3/8 AR - ZINC
	000E13-18-00B	EA	WASHER - FLAT - 3/8 WIDE - ZINC
	000E13-20-00B	EA	WASHER - FLAT - 7/16 WIDE - ZINC
	000E13-22-00B	EA	WASHER - FLAT - 1/2 WIDE - ZINC
	000E13-26-00B	EA	WASHER - FLAT - 5/8 WIDE - ZINC
	000E14-10-00B	EA	WASHER - LOCKING - #10 EXTERNAL TOOTH - ZINC
	000E16-10-00B	EA	WASHER - HARDENED - 5/8 - FLAT - ZINC
	000G45-05-16B	EA	BOLT - LAG - 5/16-9 X 1 - ZINC
	039715-01-000	EA	NUT-SERT - 1/4" DIAMETER - 20 THREADS
	040921-01-000	EA	NUT - SPEED - U TYPE - #10-24 - BLACK
	040921-03-000	EA	NUT - SPEED - U TYPE - #10
	040921-04-000	EA	NUT - SPEED - U TYPE - #8-.59" LENGTH X .44" WIDTH
	040921-05-000	EA	NUT - SPEED - U-TYPE - 8-.67" X .44" WIDE
	040921-11-000	EA	NUT - SPEED - U-TYPE - 8-.59" LENGTH X .44" WIDTH - BLACK
	041322-01-000	EA	WASHER - FLANGE - 15/32"ID X 2 3/8"OD - F/SEAT BELT MTG
	044364-02-000	EA	NUT - SPEED - FLAT - ROUND
	044533-01-000	EA	WASHER - 1 3/8"OD - FOR BUTTONS - PLASTIC
	051387-06-000	EA	BOLT - CARRIAGE W/O HOLE - 5/16-18 X 9 1/2 - ZINC
	058716-02-000	EA	WASHER - FLAT NYLON
	064081-03-000	EA	NUT - WING 3/8-16 - W/WELD NUT
	077071-01-000	EA	WASHER - FENDER - 3/16"ID X 1"OD
	087234-01-000	EA	NUT - JACK - 1/4 X 20 THD - MOLLY
	088787-12-000	EA	STUD - WELD - 1/4 - 20 X 1.0 LG - MN
	106956-03-000	EA	BOLT - HEX TAP - 1/2-13NC X 3 - GRADE 5 - FULL THREAD/ZINC
	106956-10-000	EA	BOLT - HEX TAP - 9/16-12NC X 3 5/8 -GRD 5-FULL THREAD/ZINC
	106956-11-000	EA	BOLT - HEX TAP - 1/2-13NC X 2 1/2 - GRD 5-FULL THREAD/ZINC
	106956-13-000	EA	BOLT - HEX TAP - 1/2-20 X 2 1/2 - GRD 5-FULL THREAD/ZINC
	106956-14-000	EA	BOLT - HEX TAP - 5/16 -18NC X 1 1/2 - GRD 5-FULL THREAD/ZINC
	107397-01-000	EA	WASHER - FENDER - 3/4"ID X 1"OD
	108067-03-000	EA	STUD - WELD - 1/4 - 20 X 1/2 CD
	109917-01-000	EA	WASHER - 1.5" X 1.25"
	109917-03-000	EA	WASHER - 1" X .50"
	109917-04-000	EA	WASHER - 1" X .75"
	128444-01-000	EA	WASHER - SPRING - CONICAL
	135092-02-01A	EA	BOLT - HEX - SERRATED FLANGE - 1/2-20 X 2 1/2-GRADE 5 ZINC
	135092-05-01A	EA	BOLT - HEX - SERRATED FLANGE - 1/2-20 X 1 - GRADE 5 ZINC
	143399-01-01A	EA	NUT/RETAINING - 3/8"- 24 NFT
	147284-02-000	EA	NUT/SELF RETAINING - 5/16"-18
	148817-01-000	EA	WASHER/SPUR - LOCKING

# SEALANTS & FASTENERS GROUP (CONTINUED)

## SCREWS

KEY	PART NUMBER	U/M	DESCRIPTION
	0G1208-12-170	EA	SCREW - 8-18 X 3/4 POH - BRIGHT WHITE
	0G3908-08-170	EA	SCREW - SF/DR - 8-18 X 1/2 PPH - BRIGHT WHITE
	0G3908-16-170	EA	SCREW - SF/DR - 8-18 X 1 PPH - BRIGHT WHITE
	0G3908-24-170	EA	SCREW - SF/DR - 8-18 X 1 1/2 PPH - BRIGHT WHITE
	0G3910-10-420	EA	SCREW - SF/DR - 10-16 X .62 PPH - BRIARWOOD
	0G3910-12-170	EA	SCREW - SF/DR - 10-16 X 3/4 PPH - BRIGHT WHITE
	0G3910-24-170	EA	SCREW - SF/DR - 10-16 X 1 1/2 PPH - BRIGHT WHITE
	0G5508-08-370	EA	SCREW - SF/DR - 8-18 X .5 PWH - RIVERSTONE
	0G5508-08-380	EA	SCREW - SF/DR - 8-18 X .5 PWH - CASHMERE
	0G5508-08-420	EA	SCREW - SF/DR - 8-18 X .5 PWH - BRIARWOOD
	0G5508-08-450	EA	SCREW - SF/DR - 8-18 X .5 PWH - SADDLE
	0G5508-12-170	EA	SCREW - SF/DR - 8-18 X 3/4 PWH - BRIGHT WHITE
	0G5508-12-330	EA	SCREW - SF/DR - 8-18 X 3/4 PWH - PUTTY
	0G5508-12-380	EA	SCREW - SF/DR - 8-18 X 3/4 PWH - CASHMERE
	0G5508-12-450	EA	SCREW - SF/DR - 8-18 X 3/4 PWH - SADDLE
	0G5508-16-330	EA	SCREW - SF/DR - 8-18 X 1 PWH - PUTTY
	0G5508-16-370	EA	SCREW - SF/DR - 8-18 X 1 PWH - RIVERSTONE
	0G5508-16-380	EA	SCREW - SF/DR - 8-18 X 1 PWH - CASHMERE
	0G5508-16-450	EA	SCREW - SF/DR - 8-18 X 1 PWH - SADDLE
	0G6008-16-170	EA	SCREW - SF/DR - 8-18 X 1 POH - BRIGHT WHITE
	0G6012-32-170	EA	SCREW - SF/DR - 12-14 X 2 POH - BRIGHT WHITE
	0G6710-08-170	EA	SCREW - 10-12 X 1/2 PPH - BRIGHT WHITE
	0G6710-12-170	EA	SCREW - 10-12 X 3/4 PPH - BRIGHT WHITE
	0G6806-16-170	EA	SCREW - 6-18 X 1 POH - BRIGHT WHITE
	0G6810-24-280	EA	SCREW - 10-12 X 1 1/2 POH - SOFT WHITE
	000C20-06-24T	EA	SCREW - 3/8-16 X 1 1/2 - FLAT SOCKET
	000G11-06-08B	EA	SCREW - 6-20 X 1/2 PPH - ZINC
	000G11-06-10B	EA	SCREW - 6-20 X 5/8 PPH - ZINC
	000G11-06-10J	EA	SCREW - 6-20 X 5/8 PPH - BRASS
	000G11-07-08B	EA	SCREW - 7-19 X 1/2 PPH - ZINC
	000G11-08-06B	EA	SCREW - 8-18 X 3/8 PPH - ZINC
	000G11-08-08T	EA	SCREW - 8-18 X 1/2 PPH - FLUOROCARBON COATING
	000G11-08-12B	EA	SCREW - 8-18 X 3/4 PPH - ZINC
	000G11-08-12P	EA	SCREW - 8-18 X 3/4 PPH - DARK BROWN
	000G11-08-12S	EA	SCREW - 8-18 X 3/4 PPH - OFF WHITE
	000G11-08-12T	EA	SCREW - 8-18 X 3/4 PPH - BLACK MAGNESIUM
	000G11-08-20B	EA	SCREW - 8-18 X 1 1/4 PPH - ZINC
	000G11-08-20G	EA	SCREW - 8-18 X 1 1/4 - ANTIQUE BRASS
	000G11-10-12D	EA	SCREW - 10-16 X 3/4 PPH - BLACK
	000G11-10-32P	EA	SCREW-10,16X2.00 PPH DK BRN
	000G12-06-08T	EA	SCREW - 6-20 X 1/2 POH - BLACK
	000G12-10-16F	EA	SCREW - 10-16 X 1 POH - STAINLESS STEEL
	000G13-05-10B	EA	SCREW - 5-12 X 5/8 PFH - ZINC
	000G13-06-06I	EA	SCREW - 6-20 X 3/8 PFH - BLACK ZINC
	000G13-06-08B	EA	SCREW - 6-20 X 1/2 PFH - ZINC
	000G13-06-08G	EA	SCREW - 6-20 X 1/2 PFH - ANTIQUE BRASS
	000G13-06-10G	EA	SCREW - 6-20 X 5/8 PFH - ANTIQUE BRASS
	000G13-06-16E	EA	SCREW - 6-20 X 1 PFH - CHROME
	000G13-06-16J	EA	SCREW - 6-20 X 1 PFH - BRASS
	000G13-06-24J	EA	SCREW - 6-20 X 1 1/2 PFH - BRASS
	000G13-07-10H	EA	SCREW - 7-19 X 5/8 PFH - BLACK
	000G13-07-12B	EA	SCREW - 7-19 X 3/4 PFH - ZINC
	000G11-08-08B	EA	SCREW - 8-18 X 1/2 PPH - ZINC
	000G13-08-10B	EA	SCREW - 8-18 X 5/8 PFH - ZINC
	000G13-08-109	EA	SCREW - 8-18 X 5/8 PFH
	000G13-08-16B	EA	SCREW - 8-18 X 1 PFH - ZINC
	000G13-08-24B	EA	SCREW - 8-18 X 1 1/2 PFH - ZINC
	000G16-04-24B	EA	SCREW - MACHINE - 1/4-20 X 1 1/2 PPH
	000G18-08-16B	EA	SCREW - MACHINE - 8-32 X 1 PPH - ZINC
	000G18-08-22B	EA	SCREW - MACHINE - 8-32 X 1 3/8 PPH - ZINC
	000G18-08-24B	EA	SCREW - MACHINE - 8-32 X 1 1/2 PPH - ZINC
	000G19-10-08B	EA	SCREW - MACHINE - 10-32 X 1/2 PPH - ZINC
	000G19-10-10B	EA	SCREW - MACHINE - 10-32 X 5/8 - PPH - ZINC
	000G19-10-12F	EA	SCREW - MACHINE - 10-32 X 3/4 PPH - STAINLESS STEEL

**SEALANTS & FASTENERS GROUP (CONTINUED)**  
**SCREWS (CONTINUED)**

KEY	PART NUMBER	U/M	DESCRIPTION
	000G19-10-20B	EA	SCREW - MACHINE - 10-32 X 1 1/2 PPH - ZINC
	000G32-10-06B	EA	SCREW - 10-32 X 3/8 PPH - ZINC
	000G34-05-12B	EA	SCREW - HEX HEAD TAPPING - 5/16 X 3/4 LONG
	000G39-06-10T	EA	SCREW - SF/DR - 6-20 X 5/8 PPH - BLACK
	000G39-06-16T	EA	SCREW - SF/DR - 6-20 X 1 PPH - BLACK
	000G39-08-06B	EA	SCREW - SF/DR - 8-18 X 3/8 PPH - ZINC
	000G39-08-08B	EA	SCREW - SF/DR - 8-18 X 1/2 PPH - ZINC
	000G39-08-08S	EA	SCREW - SF/DR - 8-18 X 1/2 PPH - OFF WHITE
	000G39-08-08T	EA	SCREW - SF/DR - 8-18 X 1/2 PPH - BLACK
	000G39-08-12T	EA	SCREW - SF/DR - 8-18 X 3/4 PPH - BLACK
	000G39-08-16B	EA	SCREW - SF/DR - 8-18 X 1 PPH - ZINC
	000G39-08-16T	EA	SCREW - SF/DR - 6-20 X 1 PPH - BLACK
	000G39-08-24B	EA	SCREW - SF/DR - 8-18 X 1 1/2 PPH - ZINC
	000G39-08-24T	EA	SCREW - SF/DR - 8-18 X 1 1/2 PPH - BLACK
	000G39-08-32B	EA	SCREW - SF/DR - 8-18 X 2 PPH - ZINC
	000G39-08-169	EA	SCREW-SF/DR,8-18X1.00 PPH - FLUROCARBON SILVER
	000G39-10-08B	EA	SCREW - SF/DR - 10-16 X 1/2 PPH - ZINC
	000G39-10-10B	EA	SCREW - SF/DR - 10-16 X 5/8 PPH - ZINC
	000G39-10-12B	EA	SCREW - SF/DR - 10-16 X 3/4 PPH - ZINC
	000G39-10-12S	EA	SCREW - SF/DR - 10-16 X 3/4 PPH - OFF WHITE
	000G39-10-129	EA	SCREW - SF/DR - 10-16 X 3/4 PPH - FLUOROCARBON SILVER
	000G39-10-169	EA	SCREW - SF/DR - 10-16 X 1 PPH - FLUOROCARBON SILVER
	000G39-10-20B	EA	SCREW - SF/DR - 10-16 X 1 1/4 PPH - ZINC
	000G39-10-20T	EA	SCREW - SF/DR - 10-16 X 1 1/4 PPH - BLACK
	000G39-10-24B	EA	SCREW - SF/DR - 10-16 X 1 1/2 PPH - ZINC
	000G39-10-24T	EA	SCREW - SF/DR - 10-16 X 1 1/2" PPH - BLACK
	000G39-10-32B	EA	SCREW - SF/DR - 10-16 X 2 - PPH - ZINC
	000G39-10-48B	EA	SCREW - SF/DR - 10-16 X 3 - PPH - ZINC
	000G39-10-48T	EA	SCREW - SF/DR - 10-16 X 3 PPH - BLACK
	000G42-04-16B	EA	SCREW - SF/DR - 1/4-14 X 1 HWH - ZINC
	000G42-04-24B	EA	SCREW - SF/DR - 1/4-14 X 1 1/2 - ZINC
	000G52-06-05B	EA	SCREW - MACHINE - 6-32 X 5/16 PTH - ZINC
	000G52-06-06B	EA	SCREW - MACHINE - 6-32 X 3/8 PTH - ZINC
	000G54-04-14B	EA	SCREW - 1/4-20 X 7/8 PTH - TYPE 23 - ZINC PLATED
	000G55-08-12T	EA	SCREW - SF/DR - 8-18 X 3/4 PWH - BLACK
	000G55-08-16S	EA	SCREW - SF/DR - 8-18 X 1.00 PWH - OFF WHITE
	000G55-08-16T	EA	SCREW - SF/DR - 8-18 X 1 PWH - BLACK
	000G56-12-48B	EA	SCREW - WOOD - 12-11 X 3 POH - SPECIAL HARDENED
	000G60-08-16E	EA	SCREW - SF/DR - 8-1 X 1 POH - CHROME
	000G60-08-20F	EA	SCREW - SF/DR - 8-19X1.25 POH
	000G60-08-22B	EA	SCREW - SF/DR - 8-18 X 1.38 POH - ZINC
	000G60-10-20B	EA	SCREW - SF/DR - 10-16 X 1 1/4 POH - ZINC
	000G60-10-209	EA	SCREW - SF/DR - 10-16 X 1 1/4 POH - SILVER STALGAARD
	000G60-10-28T	EA	SCREW - SF/DR - 10-16 X 1 3/4 - BLACK
	000G62-06-12B	EA	SCREW-SF/DR,6-20X.75 PFH - ZINC
	000G62-06-249	EA	SCREW - SF/DR - 8-18 X 1.5 PPH - SILVER
	000G62-08-24B	EA	SCREW - SF/DR - 8-18 X 1 1/2 PFH
	000G62-08-24T	EA	SCREW - SF/DR - 8-18 X 1 1/2 PFH - BLACK
	000G67-08-32B	EA	SCREW - 8-15 X 2 PPH - ZINC
	000G67-10-08B	EA	SCREW - 10-12 X 1/2 PPH - ZINC
	000G67-10-08S	EA	SCREW - 10-12 X 1/2 PPH - OFF WHITE
	000G67-10-10B	EA	SCREW - 10-12 X 5/8 PPH - ZINC - TYPE A
	000G67-10-10D	EA	SCREW - 10-12 X 5/8 PPH - BLACK - TYPE A
	000G67-10-10P	EA	SCREW - 10-12 X 5/8 PPH - DARK BROWN
	000G67-10-10S	EA	SCREW - 10-12 X 5/8 PPH - OFF WHITE
	000G67-10-10T	EA	SCREW - 10-12 X 5/8 PPH - BLACK
	000G67-10-10V	EA	SCREW-10-12X5/8 PPH ZN O/W - TYPE A
	000G67-10-12P	EA	SCREW - 10-12 X 3/4 PPH - DARK BROWN
	000G67-10-24B	EA	SCREW - 10-12 X 1 1/2 PPH - ZINC
	000G68-06-10J	EA	SCREW - 6-18 X 5/8 POH - BRASS
	000G68-06-12B	EA	SCREW - 6-18 X 3/4 POH - ZINC & CLEAR
	000G68-06-12S	EA	SCREW - 6-18 X 3/4 POH
	029130-01-000	EA	SCREW - SNAP STUD - #8-16 X 5/8" LONG
	029130-02-000	EA	SCREW - SNAP STUD - #8-16 X 1 1/2" LONG

**SEALANTS & FASTENERS GROUP (CONTINUED)**  
**SCREWS (CONTINUED)**

<b>KEY</b>	<b>PART NUMBER</b>	<b>U/M</b>	<b>DESCRIPTION</b>
	029130-03-000	EA	SCREW - SNAP STUD - #8-16 X 1" LONG
	049465-03-000	EA	SCREW - 10-16 X 1 POH W/WASHER - OFF WHITE
	049465-17-000	EA	SCREW - 10-16 X 1 POH W/WASHER - BRIGHT WHITE
	049465-18-000	EA	SCREW - 10-16 X 1 POH W/WASHER - VW GRAY
	054434-02-000	EA	SCREW - SF/DR - 10-16 X 2 - ZINC
	054434-03-000	EA	SCREW - SF/DR - 10-16 X 2 - PWH - ZINC
	075908-01-000	EA	SCREW - MACHINE - 10-32 X .56 PTH - EXTERNAL TOOTH - ZINC
	076790-01-000	EA	SCREW - 6-20 X 1 1/4 PPH - BLACK
	076790-05-000	EA	SCREW - 6-20 X 1/2 PPH - BLACK - THREAD CUTTING/WOOD
	083554-01-000	EA	SCREW - DRYWALL - 8 X 1 1/4
	087721-01-000	EA	SCREW - FLAT HEAD - TAPPING - 1/4" X 1 1/4" LONG - ZINC
	093249-01-000	EA	CAP/SCREW - MOLDED/VINYL - BLACK
	095772-01-000	EA	SOCKET-SNAP FASTNER1" SF/DR - SELF DRIVER
	097974-01-000	EA	SCREW - PARTICLE BOARD - 7-9 X 3/4 PPH
	101618-01-000	EA	SCREW - 1/4-20 X 3/4 HEX - TAPPING - STALGARD TYPE F
	113563-01-01A	EA	SCREW - 8 X 5/8 LONG SHOULDER/WASHER HEAD
	113563-01-02A	EA	SCREW - 8 X 5/8 LONG SHOULDER/WASHER HEAD - BRIGHT WHITE
	118383-01-12A	EA	RETAINER/RECESSED - F/.22" SCREW - RIVERSTONE
	118383-01-14A	EA	RETAINER/RECESSED - F/.22" SCREW - PEWTER
	118383-01-15A	EA	RETAINER/RECESSED - F/.22" SCREW - BRIARWOOD
	118383-02-13A	EA	RETAINER/RECESSED - F/.27" SCREW - OFF WHITE
	118383-04-04A	EA	CAP - F/RECESSED RETAINER - BRIGHT WHITE
	118383-04-10A	EA	CAP - F/RECESSED RETAINER - RIVERSTONE
	118383-04-13A	EA	CAP - F/RECESSED RETAINER - OFF WHITE
	118383-04-14A	EA	CAP - F/RECESSED RETAINER - PEWTER
	118383-04-15A	EA	CAP - F/RECESSED RETAINER - BRIARWOOD
	134126-01-01A	EA	SCREW/NAIL - HEX HEAD - 3/4"
	140040-01-000	EA	SCREW - 1/4-20 X 1 - BUTTON HEAD/SOCKET - W/LOCTITE
	149753-01-01A	EA	RETAINER/RECESSED - F/.22" SCREW - BLACK
	149753-01-02A	EA	RETAINER/RECESSED - F/.22" SCREW - BRIGHT WHITE
	149753-02-01A	EA	CAP - F/RECESSED RETAINER - BLACK
	149753-02-02A	EA	CAP - F/RECESSED RETAINER - BRIGHT WHITE
	154938-01-01A	EA	SCREW - SF/DR - 10-16 X 3/4 PPH - W/SELF SEAL - BRIGHT WHITE
	154938-01-02A	EA	SCREW - SF/DR - 10-16 X 3/4 PPH - W/SELF SEAL - BLACK
	154938-02-01A	EA	SCREW - SF/DR - 8-18 X 1 PFH - W/SELF SEAL - BRIGHT WHITE
	154938-02-02A	EA	SCREW - SF/DR - 8-18 X 1 PFH - W/SELF SEAL - BLACK
	154938-02-03A	EA	SCREW - SF/DR - 8-18 X 1 PFH - W/SELF SEAL - SILVER
	154938-03-01A	EA	SCREW - SF/DR - 8-18 X 5/8 PFH - W/SELF SEAL - BRT WHT
	154938-03-02A	EA	SCREW - SF/DR - 8-18 X 5/8 PFH - W/SELF SEAL - BLACK
	154938-04-01A	EA	SCREW - SF/DR - 10-16 X 1" TPH - W/SELF SEAL - BRT WHT
	154938-04-02A	EA	SCREW - SF/DR - 10-16 X 1" TPH - W/SELF SEAL - BLACK
	154938-05-03A	EA	SCREW - SF/DR - 8-18 X 1.25" PFH - W/SELF SEAL - SILVER

## SEALANTS & FASTENERS GROUP (CONTINUED)

### CLAMPS, CLIPS, GROMMETS, RIVETS & PLUGS

KEY	PART NUMBER	U/M	DESCRIPTION
	000H14-06-03R	EA	RIVET - MANDREL BLIND - 3/16 ALUMINUM
	000H16-04-06R	EA	RIVET - POP ALUMINUM - 1/8 X .313 - .375
	000H16-06-10R	EA	RIVET - POP ALUMINUM - 3/16 X .501 - .625
	007161-01-000	EA	CLAMP - HOSE - SPRING TYPE - 1/2"
	008386-01-000	EA	GROMMET - SNAP - 3/8" DIAMETER - NYLON
	010495-01-000	EA	CLAMP - CABLE - 9/16"ID - BLACK
	010495-02-000	EA	CLAMP - CABLE - 3/8"ID - BLACK
	010495-04-000	EA	CLAMP - CABLE - 11/16"ID - WHITE
	010497-01-000	EA	CLAMP - CLOSED - 5/8"ID
	010497-02-000	EA	CLAMP - CLOSED - 1.5"ID
	010497-03-000	EA	CLAMP - CLOSED - 1"ID - CUSHIONED
	010497-04-000	EA	CLAMP - CLOSED - 1 5/8"ID
	010497-05-000	EA	CLAMP - CLOSED - 1/2"ID
	010497-07-000	EA	CLAMP - CLOSED - 3/8"ID
	010497-09-000	EA	CLAMP - CLOSED - 5/16"ID
	010497-10-000	EA	CLAMP - CLOSED - 7/8"ID
	010499-01-000	EA	CLAMP - CLOSED - 3/8"ID
	016188-03-000	EA	GROMMET - LP LINE - 3/8"HOLE X 2 1/2"LONG - RUBBER
	016188-04-000	EA	GROMMET - LP LINE - 1/2"HOLE X 2 1/2"LONG - RUBBER
	016188-05-000	EA	GROMMET - LP LINE - 3/8"HOLE X 1 1/4"LONG - RUBBER
	016188-06-000	EA	GROMMET - LP LINE - 3/8"HOLE X 3 1/4"LONG - RUBBER
	016188-07-000	EA	GROMMET - L/P LINE - 1/2"HOLE X 3 1/4"LONG
	016188-08-000	EA	GROMMET - LP LINE - 1/2"HOLE X 1 1/4"LONG - RUBBER
	016188-09-000	EA	GROMMET - LP LINE - .68"HOLE X 1 1/4"LONG - RUBBER
	016188-10-000	EA	GROMMET - LP GAS - .68" X 2.5"
	023942-01-000	EA	GROMMET - RUBBER - 2"OD
	041930-11-000	EA	RIVET - POP ALUMINUM - 1/8 X .188 - .250 - BRIGHT WHITE
	061420-04-000	EA	PLUG/PLASTIC - 1 1/4" DIAMETER
	061420-05-000	EA	PLUG/PLASTIC - 1 1/2" DIAMETER
	061420-09-000	EA	PLUG/PLASTIC - 1.00" DIAMETER
	061420-10-000	EA	PLUG/PLASTIC - 1 1/2" DIAMETER - BLACK
	061420-12-000	EA	PLUG/PLASTIC - 1.50" DIAMETER - RED
	061420-13-000	EA	PLUG/PLASTIC - 3/8" - FLUSH
	061420-14-000	EA	PLUG/PLASTIC - 7/8" DIAMETER - BLACK
	061420-15-000	EA	PLUG/PLASTIC - 2" DIAMETER - BLACK
	061420-16-000	EA	PLUG/PLASTIC - 2 1/8" DIAMETER - BLACK
	061420-18-000	EA	PLUG/PLASTIC - 1 3/4" DIAMETER - BLACK
	062401-01-000	EA	CLAMP - HOSE - WORMGEAR - .25" - 1"
	062401-02-000	EA	CLAMP - HOSE - WORMGEAR - 1.56" - 2.5" ID
	062401-03-000	EA	CLAMP - HOSE - WORMGEAR - .22" - 1" ID
	062401-04-000	EA	CLAMP - HOSE - WORMGEAR - .69" - 1.25" ID
	062401-06-000	EA	CLAMP - HOSE - WORMGEAR - .22" - .62" ID
	062401-09-000	EA	CLAMP - HOSE - WORMGEAR - 2.8" - 3.75" ID
	062401-11-000	EA	CLAMP - HOSE - WORMGEAR - 3.50" - 4.50" ID
	062401-13-000	EA	CLAMP - HOSE - WORMGEAR
	071015-11-000	EA	GROMMET - RUBBER - 1"ID FITS .12 MATERIAL - BLACK
	071015-13-000	EA	GROMMET - RUBBER - .62"ID X 1"OD W/.09" GROOVE - BLACK
	071015-20-000	EA	GROMMET - .38 ID FITS .06 MTL
	071015-22-000	EA	GROMMET - RUBBER - .62"ID X 1.12"OD W/.19" GROOVE - BLACK
	071015-26-000	EA	GROMMET - RUBBER - 1.5"ID X 2.1"OD W/.06" GROOVE - BLACK
	071015-29-000	EA	GROMMET - RUBBER - .3"ID X 1.3"OD W/.12" GROOVE - BLACK
	071015-30-000	EA	GROMMET - RUBBER - .3"ID X .81"OD W/.12" GROOVE - BLACK
	071015-39-000	EA	GROMMET - .75 ID FITS .06 MTL
	071015-41-000	EA	GROMMET - .125 ID FITS .188 MTL
	071015-42-000	EA	GROMMET - .25 ID FITS .06 MTL
	071015-43-000	EA	GROMMET-.25 ID,FITS .07 MATL, MINOR Z-4139
	071015-44-000	EA	GROMMET - .31 ID FITS .25 MTL
	075148-02-000	EA	CLAMP - GROUNDING - BRONZE SCREWS
	077955-01-000	EA	CLIP/J - 3/8" - VINYL COATED
	081211-03-000	EA	PLUG - PLASTIC - .50"DIAMETER - TRUSS HEAD - BLACK
	081211-04-000	EA	PLUG - PLASTIC - .46"DIAMETER - TRUSS HEAD - BLACK
	081211-06-000	EA	PLUG-PLASTIC,.468DIA,BLACK , HEYCO 1669
	083609-01-000	EA	CLAMP - WIRE - DUAL - EQUAL DIAMETERS - 5/8"
	083610-01-000	EA	CLAMP - WIRE - DUAL - UNEQUAL DIAMETERS - 3/4" & 1 1/4"

**SEALANTS & FASTENERS GROUP (CONTINUED)**  
**CLAMPS, CLIPS, GROMMETS, RIVETS & PLUGS (CONTINUED)**

<b>KEY</b>	<b>PART NUMBER</b>	<b>U/M</b>	<b>DESCRIPTION</b>
	083610-02-000	EA	CLAMP - WIRE - DUAL - UNEQUAL DIAMETERS - 3/4" & 2"
	083610-03-000	EA	CLAMP - WIRE - DUAL - EQUAL DIAMETERS - 2"
	083610-02-000	EA	CLAMP - WIRE - DUAL - UNEQUAL DIAMETERS - 3/4" & 2"
	083610-03-000	EA	CLAMP - WIRE - DUAL - EQUAL DIAMETERS - 2"
	088756-01-000	EA	GROMMET - WEB - 1 1/8"ID
	089329-02-000	EA	CLIP - SPRING
	091952-01-000	EA	CLIP - GRIPPER - 1" - BLACK VINYL COATED
	091952-02-000	EA	CLIP - GRIPPER - 3/4" - BLACK VINYL COATED
	091952-03-000	EA	CLIP - GRIPPER - 1/2" - BLACK VINYL COATED
	094362-02-000	EA	CLIP - XMAS TREE - BINDER HEAD - .9" LONG/ANY COLOR
	113133-02-01A	EA	RIVET - POP - ALUMINUM - 3/16 X .252 - .504 - BLACK
	114208-05-000	EA	GROMMET - EDGE LINER - FITS 2"
	118626-01-01A	EA	RIVET/POP - ALUMINUM - 3/16 X 1.2"(GRIP RANGE .1"-.4")
	118626-01-02A	EA	RIVET/POP - ALUMINUM - 3/16 X .08 - .375
	118626-02-01A	EA	RIVET/POP - ALUMINUM - 3/16 X .500 - .750
	118626-03-01A	EA	RIVET/POP - STAINLESS STEEL - 3/16 X .500 - .750
	137014-01-01A	EA	GROMMET - CABLE - ALMOND
	139118-02-01A	EA	GROMMET - SCREW - PLASTIC
	155498-01-01A	EA	CLAMP - CLOSED - 7/8"ID - VINYL DIP/GALVONIZED - BLACK

**MISCELLANEOUS FASTENERS**

<b>KEY</b>	<b>PART NUMBER</b>	<b>U/M</b>	<b>DESCRIPTION</b>
	008343-01-000	EA	TIE - WIRE - 6"
	008343-02-000	EA	TIE - WIRE - 14"
	008343-03-000	EA	TIE - WIRE - 7 1/2" - BLACK
	029094-04-000	YD	VELCRO TAPE/LOOP - 1"WIDE - W/ADHESIVE BACK - BLACK
	029096-03-000	YD	VELCRO TAPE/HOOK - 1"WIDE - BLACK
	029096-04-000	YD	VELCRO TAPE/HOOK - 1"WIDE - BLACK - W/ADHESIVE BACK (PSA)
	048394-02-000	YD	VELCRO TAPE - HOOK - ADHESIVE BACK - 3/4" WIDE - BEIGE
	085774-01-000	FT	FASTENER - DUAL LOCK - 1" WIDE - ADHESIVE BACK - BLACK
	085774-02-000	FT	FASTENER - DUAL HOOK - 1" WIDE - ADHESIVE BACK - BLACK
	088792-02-000	YD	VELCRO TAPE - LOOP - 3/4" - ADHESIVE BACK - BEIGE
	088792-04-000	YD	VELCRO TAPE - HOOK - 5/8" - NON-ADHESIVE BACK - WHITE
	088792-05-000	YD	VELCRO TAPE - LOOP - 5/8" - NON-ADHESIVE BACK - WHITE
	108046-02-000	EA	CABLE TIE - SCREW MOUNT 15"



# WATER & SEWAGE GROUP DRAINAGE SYSTEM

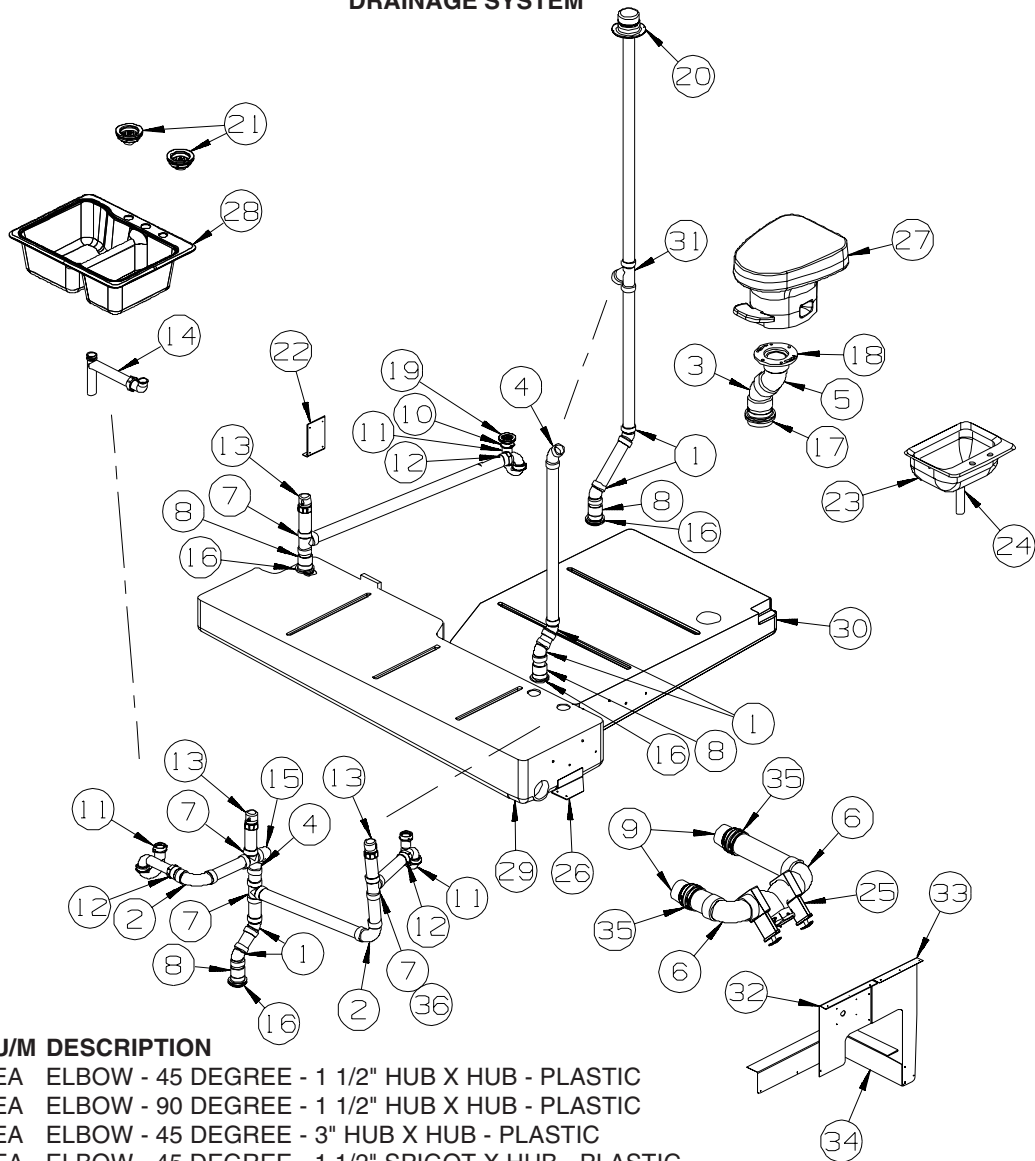

KEY	PART NUMBER	U/M	DESCRIPTION
1	010006-01-000	EA	ELBOW - 45 DEGREE - 1 1/2" HUB X HUB - PLASTIC
2	010008-01-000	EA	ELBOW - 90 DEGREE - 1 1/2" HUB X HUB - PLASTIC
3	010024-01-000	EA	ELBOW - 45 DEGREE - 3" HUB X HUB - PLASTIC
4	010051-01-000	EA	ELBOW - 45 DEGREE - 1 1/2" SPIGOT X HUB - PLASTIC
5	010061-01-000	EA	ELBOW - 45 DEGREE ST - 3" SPIGOT & HUB - PLASTIC
6	010062-01-000	EA	ELBOW - 3 90 SPIGOT X HUB - PLASTIC
7	010071-01-000	EA	TEE - SANITARY - 1 1/2" HUB X HUB X HUB - PLASTIC
8	010115-01-000	EA	COUPLING - 1 1/2" HUB X HUB - PLASTIC
9	010129-03-000	EA	NIPPLE - 3" X 3" TOE - PLASTIC
10	011069-02-000	EA	TAILPIECE - TUB/SHOWER - 1 1/2" X 1 1/4" X 4" - BRASS
	130403-01-000	EA	NUT - SLIP - W/WINGS 1 1/2"
11	107538-02-000	EA	P-TRAP - PLASTIC - 1 1/2" W/EXTENSION ARM
11	011071-01-000	EA	P-TRAP - 1 1/2" - CSA - PLASTIC - <b>CANADIAN</b>
12	152146-01-000	EA	CONNECTOR - 1 1/2" P X 1 1/2" MPT
13	079968-01-000	EA	VENT - MECHANICAL/TRAP ARM - ANTI-SIPHON-2" X 7.3" PLASTIC
14	011091-02-000	EA	WASTE - CONTINUOUS - DOUBLE SINK
15	033761-01-000	EA	ELBOW - 90 DEGREE - TURN - 1 1/2" HUB X 1 1/2" SPIGOT
16	061607-01-000	EA	GROMMET - HOLDING TANK - 1 1/2" NPS
17	061607-02-000	EA	GROMMET - HOLDING TANK - 3" NPS
18	063641-01-000	EA	FLANGE - CLOSET - 4" X 3"
19	066440-01-000	EA	STRAINER - SHOWER DRAIN - W/RUBBER WASHER
	127440-02-01A	EA	WASHER - RUBBER - 1.8" X .1"
20	083558-03-000	EA	VENT W/COVER F/PLUMBING STACK - OFF WHITE
21	092303-01-000	EA	STRAINER - W/BASKET - GALLEY SINK - 4" OD
22	094756-02-01A	EA	BRACKET - L - 6.1" LONG X 3.9" WIDE - STEEL
23	156661-01-01A	EA	SINK - LAVATORY - OVAL - 15" X 12" X 6.5" - GLACIER WHITE
24	106116-01-02A	EA	STRAINER/PLASTIC - STOPPER/TAILPIECE/GASKET & NUT-LAVATORY
	106116-02-01A	EA	GASKET - STRAINER
	130403-01-000	EA	NUT - SLIP - W/WINGS 1 1/2"

**WATER & SEWAGE GROUP (CONTINUED)**  
**DRAINAGE SYSTEM (CONTINUED)**

KEY	PART NUMBER	U/M	DESCRIPTION
25	136143-01-000	EA	VALVE - DUAL - 3" X 3"
	139513-01-000	EA	HOSE - SEWER - 3" X 10' - W/ADAPTER
	062416-01-000	EA	ADAPTER - SEWER HOSE TO 3" PIPE
26	139004-01-02B	EA	BRACKET/TIEDOWN - WATER TANK - E-COATED
27*	147421-03-01A	EA	TOILET/AQUA MAGIC 5 (LOW) FOOTFLUSH - W/O SPRAY - WHITE
28	163942-01-01A	EA	SINK/DOUBLE - LRG/SML BASIN - 25" X 19" - PLASTIC/SILVER
			FROM: 00-00-00 THRU: 03-02-08
28	163942-02-01A	EA	SINK/DOUBLE - LRG/SML BASIN - 25" X 19" - PLASTIC/SILVER
			FROM: 03-03-08 THRU: 99-99-99
29	149281-01-700	EA	TANK - HOLDING - 40 GALLON - W/3" NIPPLE - W/O FITTINGS
	049032-01-000	EA	PATCH - SPINWELD - 3/8" - PLASTIC
30	149332-01-700	EA	TANK - HOLDING - 37 GALLON - W/3" NIPPLE - W/O FITTINGS
	049032-01-000	EA	PATCH - SPINWELD - 3/8" - PLASTIC
31	010073-01-000	EA	WYE - 45 DEGREE - 1 1/2 HUB X HUB X HUB - PLASTIC
32	146164-03-12B	EA	PANEL - SERVICE CENTER - BRIGHT WHITE
33	146163-02-12B	EA	PANEL - SERVICE CENTER - BRIGHT WHITE
34	146163-03-12B	EA	PANEL - SERVICE CENTER - BRIGHT WHITE
35	078406-01-000	EA	COUPLER - RUBBER - W/CLAMPS - 3" X 3"
36	031365-02-000	EA	TEE - 1 1/2" EXTRA LONG TURN - PLASTIC - CANADIAN

**\*COMPONENT PARTS LISTED LATER IN THIS GROUP**

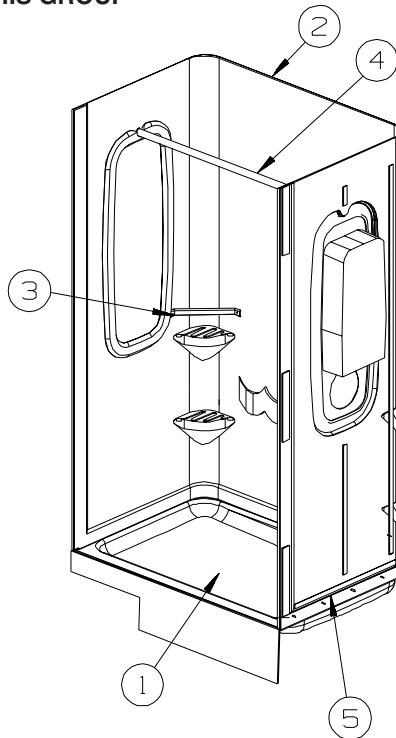

KEY	PART NUMBER	U/M	DESCRIPTION
1	M02630-80-R28	EA	SHOWER PAN - W/STRAINER - SOFT WHITE
2	147188-03-01A	EA	SURROUND/SHOWER - SOFT WHITE
3	113714-04-02A	EA	RETAINER - SHELF/SHOWER - SOFT WHITE
4	102075-18-02A	EA	ROD - SHOWER CURTAIN - 1" OD X 38.9" - SOFT WHITE
	081114-02-000	EA	CAP - INSERT/ROUND - 1" DIAMETER - WHITE PLASTIC
5	154585-03-01A	FT	SEAL - FOAM TAPE - ADHESIVE BACK - 1/8" X 3/4" - GRAY

**WATER & SEWAGE GROUP (CONTINUED)**  
**COMPONENT PARTS FOR DRAINAGE SYSTEM**

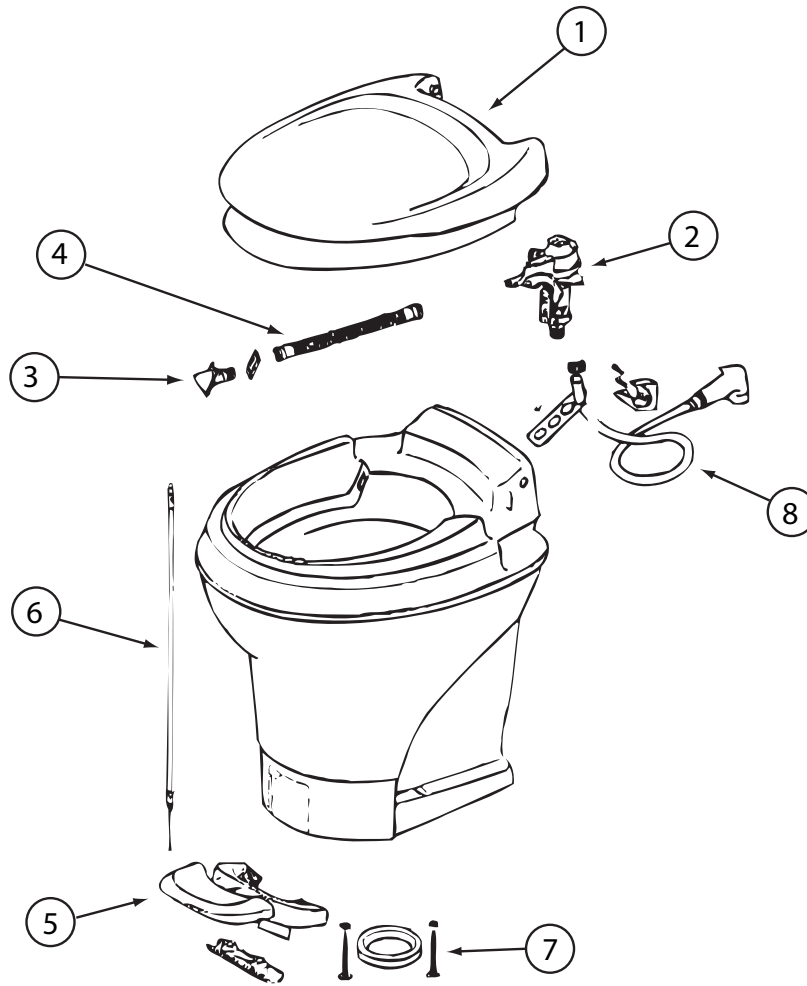

**147421-03-01A**

<b>KEY</b>	<b>PART NUMBER</b>	<b>U/M</b>	<b>DESCRIPTION</b>	<b>VENDOR NO.</b>
1	147421-01-700	EA	SEAT & COVER ASSEMBLY(WHT)	31703
2	147421-01-701	EA	WATER MODULE ASSEMBLY	31705
3	147421-01-702	EA	NOZZLE ASSEMBLY	31706
4	147421-01-703	EA	LINK - WATER MODULE	31621
5	147421-01-704	EA	PEDAL - WHITE	31709
6	147421-01-705	EA	FOOT CABLE	31711
7	063740-01-706	EA	BOLT PACKAGE-FLOOR FLANGE	12524 THETFORD
	147421-01-706	EA	SEAL - BLADE	31708
	147421-01-707	EA	CAP (UNIVERSAL BOLT) - WHITE	31713
			CONTACT WINNEBAGO PART SALES FOR UNLISTED COMPONENT(S)	

## WATER & SEWAGE GROUP (CONTINUED)

### WATER SYSTEM

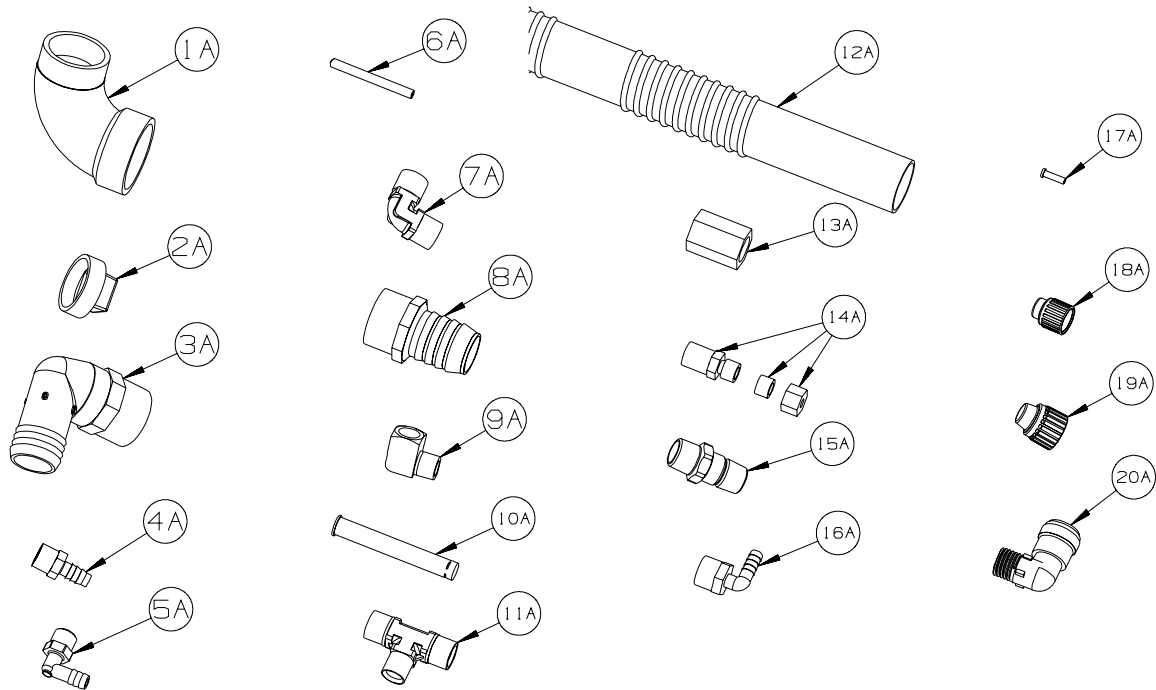

KEY	PART NUMBER	U/M	DESCRIPTION
1A	010009-01-000	EA	ELBOW - 90 DEGREE - 1/4 BEND - 1 1/2" PLASTIC
2A	010166-01-000	EA	PLUG/THREADED - 1 1/4"MPT - PLASTIC - BLACK - UL
3A	010219-01-000	EA	ELBOW - 1 1/4 MPT X 1 1/4 BARB - WATER FILL - PLASTIC
4A	010224-01-000	EA	ADAPTER - HOSE TO PIPE - 3/8 MPT X 3/8 BARB - PLASTIC
5A	035539-01-000	EA	ELBOW - 3/8 MPT X 3/8 BARB - PLASTIC
6A	039800-04-000	FT	TUBING - POLYBUTYL - 1/4"OD
6A	074462-02-000	FT	TUBING - VINYL - 3/8 ID X 20' - CLEAR
6A	112176-01-000	FT	TUBING - VINYL - REINFORCED - 1/2" ID
6A	124188-01-000	FT	TUBING - PEX - 1/2" ID X 20' - BLUE(COLD)
6A	124188-02-000	FT	TUBING - PEX - 1/2" ID X 20' - RED(HOT)
7A	039808-03-000	EA	ELBOW - 1/2" MPT X 1/2" MPT - PLASTIC
8A	044927-01-000	EA	ADAPTER - HOSE TO PIPE-1 1/4 MPTX1 1/4 BARB-BLACK PLASTIC
9A	065318-02-000	EA	ELBOW - 90 DEGREE - 3/8" MPT TO 3/8" FPT
10A	077954-02-000	EA	FILTER - WATER TANK - W/SCREEN IN TANK
11A	039798-01-000	EA	TEE - 1/2"MPT X 1/2"MPT X 1/2"MPT - PLASTIC
12A	079381-01-000	FT	TUBING - RIBBED FLEXIBLE/WATER FILL - 10 FT = 1EA-1.38ID
13A	101814-01-000	EA	COUPLING - FEMALE - 1/2" X 1/2" FPT - GRAY
14A	103798-01-000	EA	CONNECTOR - 1/4 OD X 3/8 MPT
15A	110438-02-000	EA	VALVE - CHECK - 1/2"MPT X 1/2"MPT - BRASS
16A	111223-02-000	EA	ELBOW - 1/2" MPT X 3/8" BARB - PLASTIC
16A	111223-04-000	EA	ELBOW - 1/2" MPT X 1/2" BARB - PLASTIC
16A	111888-01-000	EA	FERRULE - PLASTIC - .250 ID X .375 OD
17A	111888-02-000	EA	INSERT - BRASS - 1/4 COMP
18A	113697-01-000	EA	CAP - 3/8"P
19A	114427-01-000	EA	CAP - 1/2"P
20A	164906-01-000	EA	ELBOW - 90 DEGREE - 1/2" QUICK CONNECT X 1/2"MPT

**WATER & SEWAGE GROUP (CONTINUED)**  
**WATER SYSTEM (CONTINUED)**

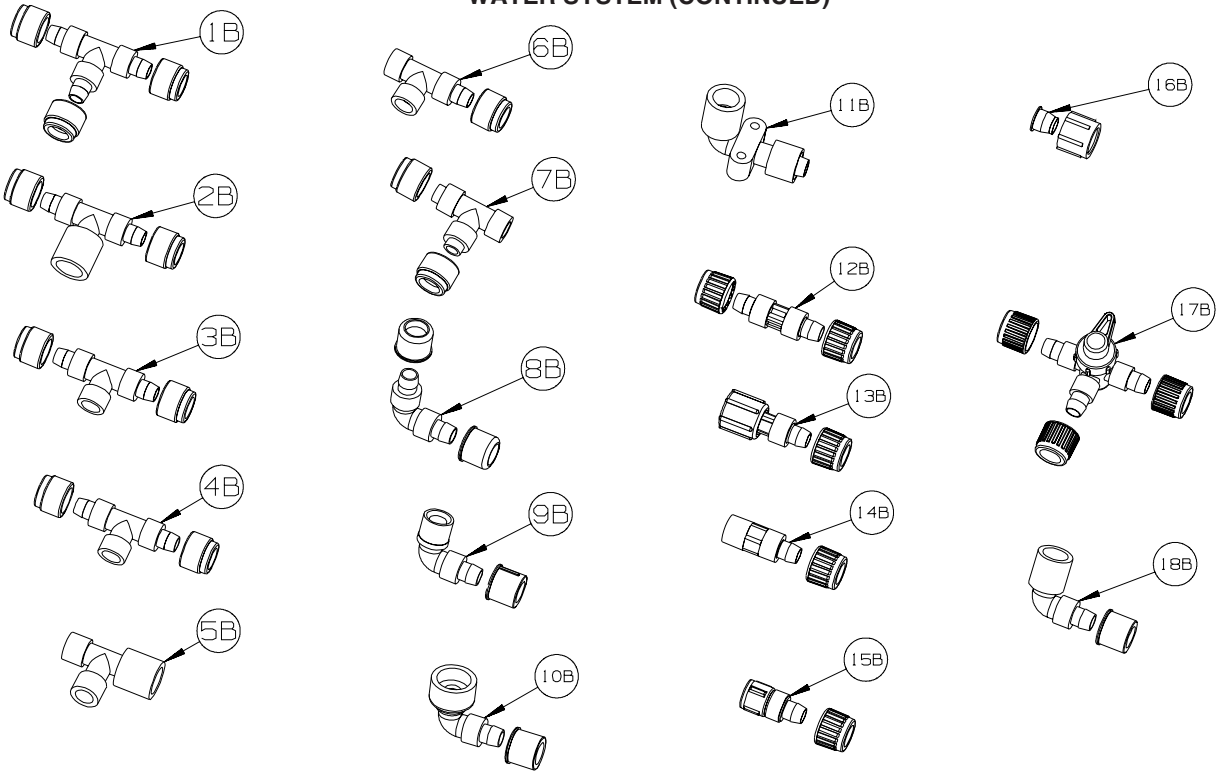

KEY	PART NUMBER	U/M	DESCRIPTION
1B	114428-01-000	EA	TEE - 1/2"P X 1/2"P X 1/2"P
2B	114428-02-000	EA	TEE - SWIVEL - 1/2"P X 1/2"P X 1/2"FPT
3B	114428-03-000	EA	TEE - 1/2"P X 1/2"P X 1/2"MPT
4B	114428-04-000	EA	TEE - 1/2"P X 1/2"P X 1/8"FPT
5B	114428-05-000	EA	TEE - 1/2" SWIVEL X 1/2" MPT X 1/2" MPT
6B	114428-06-000	EA	TEE - 1/2" P X 1/2" MPT X 1/2" MPT
7B	114428-07-000	EA	TEE - 1/2" P X 1/2" MPT X 1/2" P
8B	114429-01-000	EA	ELBOW - 1/2"P X 1/2"P
9B	114429-02-000	EA	ELBOW - 1/2"P X 1/2"MPT
9B	114429-04-000	EA	ELBOW - 1/2"P X 3/8"MPT
9B	114429-10-000	EA	ELBOW - SWIVEL - 1/2"MPT X 1/2"FPT
10B	114429-08-000	EA	ELBOW - SWIVEL - 1/2"P X 1/2"FPT
11B	114429-09-000	EA	ELBOW - 1/2"P X 1/2"FPT DROP EAR
12B	114430-01-000	EA	ADAPTER - 1/2"P X 1/2"P
13B	114430-02-000	EA	ADAPTER - SWIVEL - 1/2"P X 1/2"FPT
13B	114430-04-000	EA	ADAPTER - SWIVEL - 1/2"P X 3/8"MPT
14B	114430-03-000	EA	ADAPTER - 1/2"P X 1/2"MPT
15B	114430-06-000	EA	ADAPTER - 1/2"P X 3/8"FPT
15B	114430-09-000	EA	ADAPTER - 1/2"P X 1/2"FPT
16B	114430-10-000	EA	ADAPTER - NUT - PIPE CONNECTION - 1/2"
17B	114431-01-000	EA	VALVE - 180 DEGREE/CENTER DRAIN - 1/2"P - THREE WAY
18B	114429-11-000	EA	ELBOW - 1/2"P X 1/2"FPT

## WATER & SEWAGE GROUP (CONTINUED)

### WATER SYSTEM (CONTINUED)

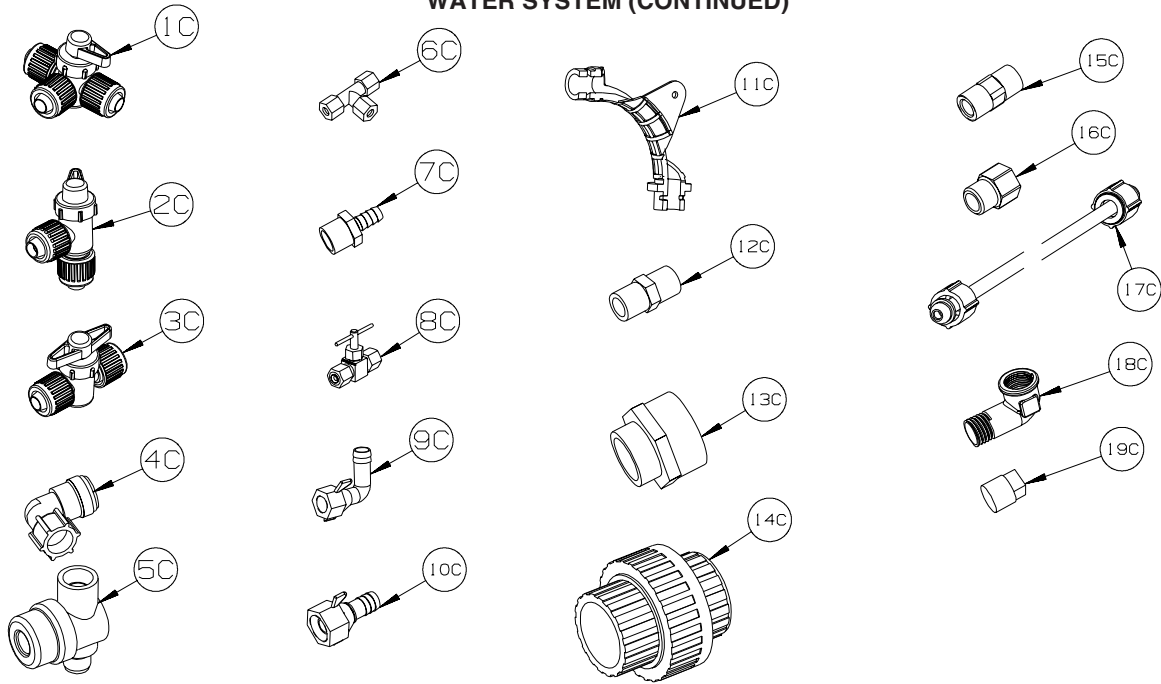

KEY	PART NUMBER	U/M	DESCRIPTION
1C	114431-02-000	EA	VALVE - WATER BYPASS - 1/2"P - THREE WAY (WATER HEATER)
2C	114431-03-000	EA	VALVE - 90 DEGREE DRAIN - 1/2"P
3C	114431-04-000	EA	VALVE - "INLINE SHUT-OFF" - 1/2"P
4C	164906-02-000	EA	ELBOW - 90 DEGREE - 1/2" QUICK CONNECT X 1/2"MPT - SWIVEL
5C	152925-01-01A	EA	FILTER - IN LINE - TWIST ON - 1/2" - BLACK
6C	118423-01-000	EA	FITTING - BRASS-TEE - 1/4C X 1/4C X 1/4C
7C	118809-01-000	EA	ADAPTER - 1/2" MPT X 3/8" BARB - PLASTIC
7C	118809-02-000	EA	ADAPTER - 1/2" MPT X 1/2" BARB - PLASTIC
8C	120868-01-000	EA	VALVE - NEEDLE - 1/4" COMPRESSION X 1/4" COMPRESSION
9C	123150-01-000	EA	ELBOW - 1/2 FPT X 1/2 BARB - SWIVEL
10C	123152-01-000	EA	ADAPTER - 1/2 FPT X 1/2 BARB - SWIVEL
11C	124184-01-000	EA	SUPPORT - WATER LINE - BEND
12C	132148-01-000	EA	CONNECTOR - 1/2" X 1/2"MPT - BRASS
13C	133835-01-000	EA	ADAPTER - REDUCING - 1 1/2" X 1 1/4"
14C	133889-01-000	EA	UNION - 1 1/2 DOUBLE SLIP - PVC
15C	135386-01-000	EA	NIPPLE - 1/2"
16C	136333-01-000	EA	ADAPTER - BRASS - 1/2"MPT X 1/2"FPT
17C	140821-01-000	EA	TUBE - WATER SUPPLY - 3/8" X 24"
17C	140821-02-000	EA	TUBE - WATER SUPPLY - 3/8" X 30"
17C	140821-03-000	EA	TUBE - WATER SUPPLY - 3/8" X 36"
17C	140821-04-000	EA	TUBE - WATER SUPPLY - 3/8" X 48"
17C	140821-05-000	EA	TUBE - WATER SUPPLY - 3/8" X 54"
17C	140821-06-000	EA	TUBE - WATER SUPPLY - 3/8" X 60"
17C	140821-07-000	EA	TUBE - WATER SUPPLY - 3/8" X 72"
17C	140821-08-000	EA	TUBE - WATER SUPPLY - 1/2" X 24"
17C	140821-09-000	EA	TUBE - WATER SUPPLY - 1/2" X 36"
17C	140821-10-000	EA	TUBE - WATER SUPPLY - 1/2" X 48"
18C	142812-01-000	EA	ELBOW - BRASS - 1/2"MPT X 1/2"FPT
19C	145609-01-000	EA	PLUG - BRASS - 1/2" MPT/HEX HEAD

**WATER & SEWAGE GROUP (CONTINUED)**  
**WATER SYSTEM (CONTINUED)**

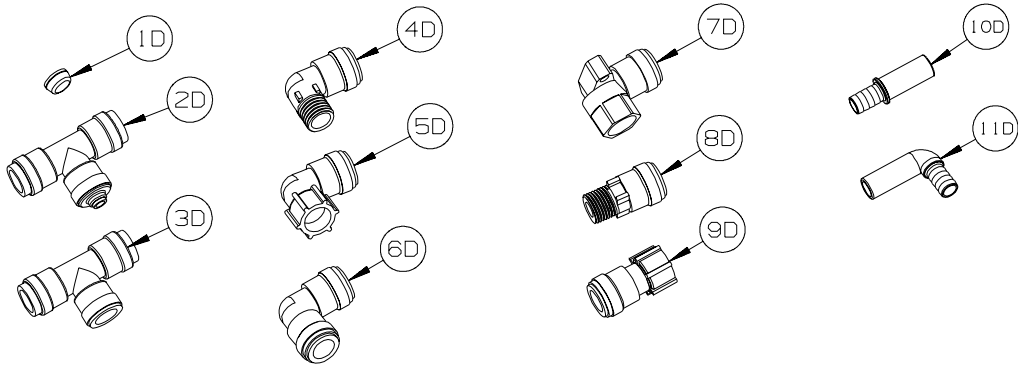

KEY	PART NUMBER	U/M	DESCRIPTION
1D	116473-01-000	EA	FERRIL - RUBBER SEALING - WATER LINE
2D	160949-01-000	EA	CONNECTOR - 1/2" X 1/2" X 1/4" REDUCER
3D	160949-02-000	EA	CONNECTOR - 1/2"CTS X 1/2"CTS X 1/2"CTS
4D	164906-01-000	EA	ELBOW - 90 DEGREE - 1/2" QUICK CONNECT X 1/2"MPT
5D	164906-02-000	EA	ELBOW - 90 DEGREE - 1/2" QUICK CONNECT X 1/2"FPT - SWIVEL
6D	164906-03-000	EA	ELBOW - 90 DEGREE - 1/2" X 1/2" QUICK CONNECTS
7D	164906-04-000	EA	ELBOW - 90 DEGREE - 1/2"CTS X 1/2"FPT
8D	164907-01-000	EA	ADAPTER - STRAIGHT - 1/2" QUICK CONNECT X 1/2"MPT
9D	164907-02-000	EA	ADAPTER - STRAIGHT - 1/2" QUICK CONNECT X 1/2"FPT/SWIVEL
10D	166212-01-000	EA	UNION - HOSE/BARB - CTS X 1/2"B - SEA TECH #3511-1008
11D	166212-02-000	EA	ELBOW - HOSE/BARB - CTS X 1/2"B - SEA TECH #3512-1008

**WATER & SEWAGE GROUP (CONTINUED)**  
**WATER SYSTEM (CONTINUED)**

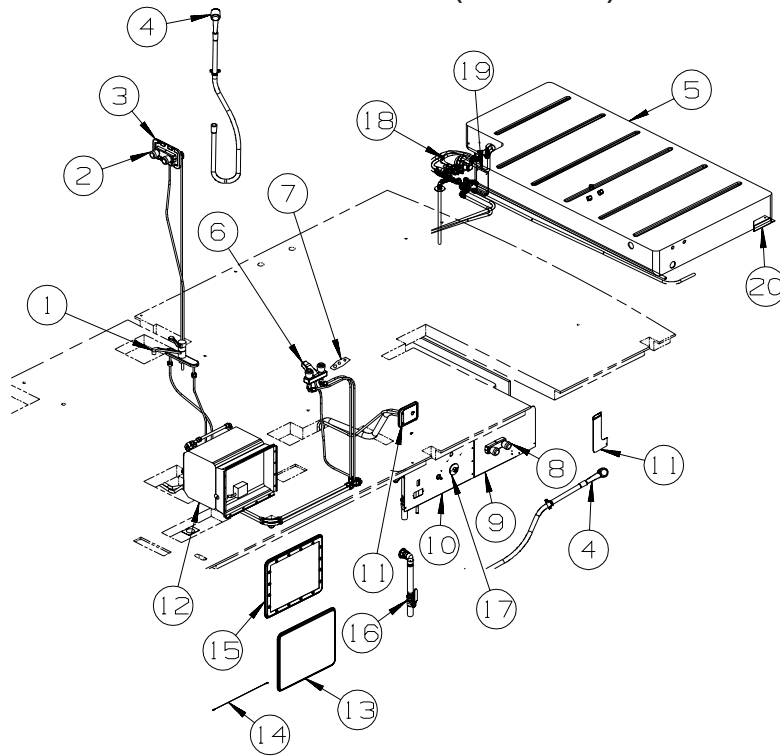

KEY	PART NUMBER	U/M	DESCRIPTION
1*	151678-01-01A	EA	FAUCET - GALLEY/DUAL CONTROL - CHROME FROM: 00-00-00 THRU: 02-20-07
1	149164-01-01A	EA	FAUCET - GALLEY - SINGLE CONTROL - CHROME FROM: 02-21-07 THRU: 99-99-99
2	163269-01-02A	EA	FAUCET/SHOWER -.5"MPT W/1.9" INLET PIPES- EXTERIOR/CHROME
3	075606-03-000	EA	PANEL - FAUCET SHOWER - SOFT WHITE
4	131383-01-02A	EA	SHOWER HEAD - W/60" HOSE & BRACKET - WHITE
5	149269-03-000	EA	TANK - WATER - 66 GALLON - W/FITTINGS
	042989-03-000	EA	FITTING - SPINWELD - 1 1/4"NPT - PLASTIC
	042989-05-000	EA	FITTING - SPINWELD - 1/2"FPT - PLASTIC
	049032-01-000	EA	PATCH - SPINWELD - 3/8" - PLASTIC
	149269-01-000	EA	TANK - WATER - 66 GALLON - W/O FITTINGS
6	148886-01-01A	EA	FAUCET - LAVATORY/DUAL CONTROL/4" CENTER - CHROME
6	152311-01-01A	EA	FAUCET - LAVATORY - SINGLE CONTROL - CHROME - INTERIOR UPGRADE PACKAGE FROM: 00-00-00 THRU: 03-17-08
6	165730-01-01A	EA	FAUCET - LAVATORY - SINGLE CONTROL - CHROME - INTERIOR UPGRADE PACKAGE FROM: 03-18-08 THRU: 99-99-99
8	163269-01-01A	EA	FAUCET/SHOWER -.5"MPT W/1.9" INLET PIPES- EXTERIOR/BRT WHT
9	150122-01-12B	EA	PANEL - SERVICE CENTER - BRIGHT WHITE
10	150123-02-12B	EA	PANEL - SERVICE CENTER - BRIGHT WHITE
11	159583-02-12B	EA	PANEL - SERVICE CENTER - BRIGHT WHITE
12*	051391-03-000	EA	WATER HEATER G6A-8E ELECTRONIC IGNITION
12*	145541-02-000	EA	WATER HEATER-6 GAL-GAS/ELEC/120'-REM IGN-W/HEAT EXC-4E-WTR HTR-6GAL/110/LP/MTR/AUTO
13	052009-06-000	EA	DOOR - WATER HEATER - 18" X 14.6" - BRIGHT WHITE FROM: 00-00-00 THRU: 06-17-07
13	125420-06-02A	EA	DOOR - WATER HEATER - 18" X 14.6" - BRIGHT WHITE FROM: 06-18-07 THRU: 99-99-99
13	125420-06-03A	EA	DOOR - WATER HEATER - 18" X 14.6" - BLACK
14	076767-03-000	EA	CABLE - STAINLESS STEEL - 18.5"
15	152239-01-01A	EA	FLANGE/MOUNTING/RECESSED - 19.3" X 15.8" - BRIGHT WHITE
15	152239-01-02A	EA	FLANGE/MOUNTING/RECESSED - 19.3" X 15.8" - BLACK
16	132483-01-000	EA	VALVE/BALL - 1" - THREADED ENDS
16	147564-01-000	EA	COUPLER - PLASTIC 1"FPT X 1"FPT
16	044927-02-000	EA	ADAPTER - REDUCING - 1" MPT X 1.3" BARB - PLASTIC
17	010230-06-000	EA	FILL - CITY WATER - W/CHECK VALVE - MPT - BRUSHED ALUM
18	160702-01-000	EA	PUMP - WATER - 3.0 GPM - W/1/2" MPT
19	094756-02-01A	EA	BRACKET - L - 6.1" LONG X 3.9" WIDE - STEEL
20	139004-01-02B	EA	BRACKET/TIEDOWN - WATER TANK - E-COATED

\*COMPONENT PARTS LISTED LATER IN THIS GROUP



**WATER & SEWAGE GROUP (CONTINUED)**  
**COMPONENT PARTS FOR WATER SYSTEM**

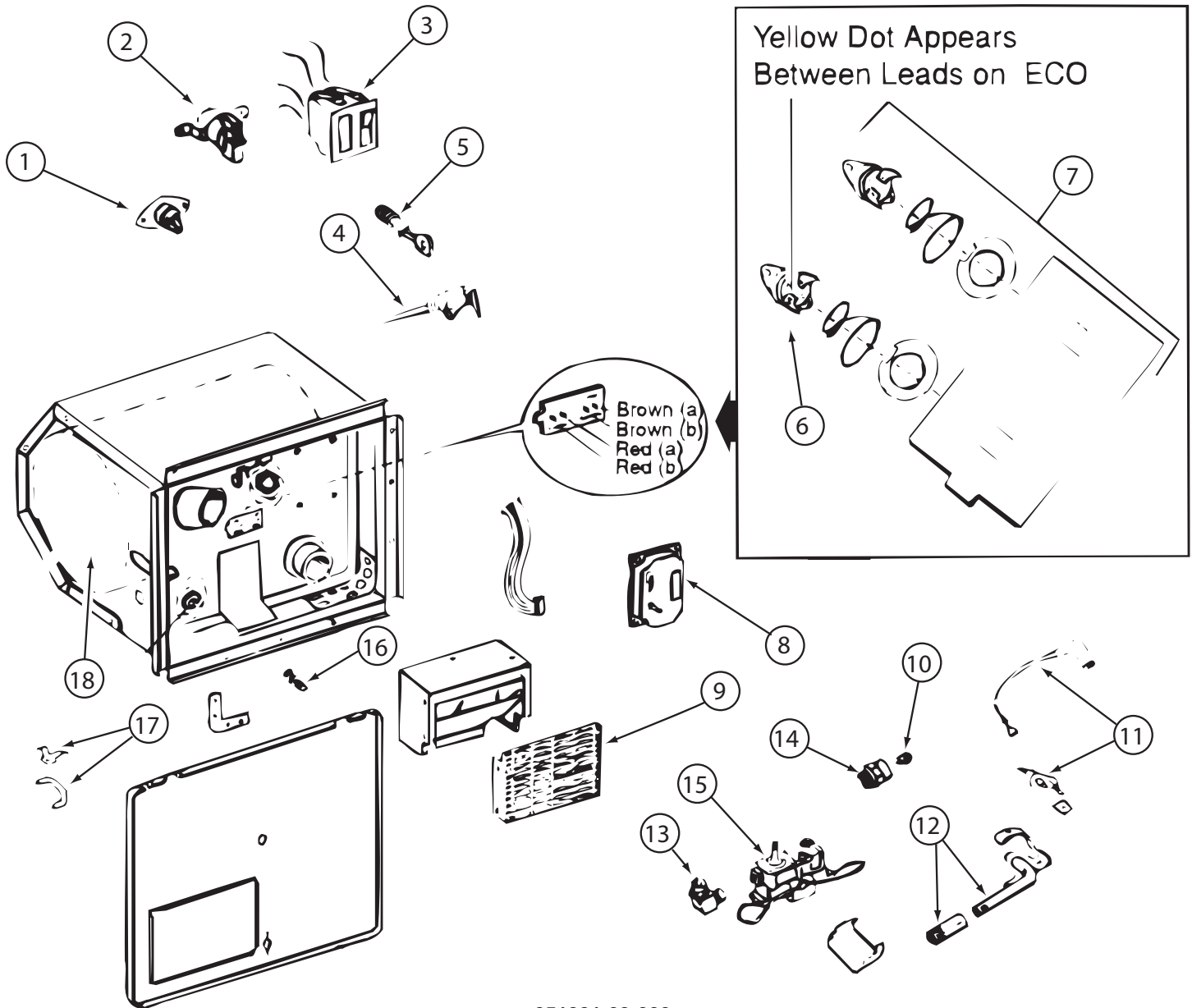

051391-03-000

KEY	PART NUMBER	U/M	DESCRIPTION	VENDOR NO.
3	051393-01-701	EA	SWITCH - REMOTE - W/LIGHT	91959
4	051391-01-704	EA	VALVE-RELIEF, 1/2" FITTING	91604
4	051391-03-701	EA	VALVE-RELIEF - 3/4" FITTING	90028
5	051391-01-705	EA	FASTENER-CAMLOCK	92609
6	051391-04-701	EA	THERMOSTAT 12V DC-120 PRESET	91470
7	051393-01-721	EA	THERMOSTAT W/ECO, 140 FRT MT	91447
9	051391-04-707	EA	KIT-EXHAUST, (FLUE & GASKET)	90960
10	051391-01-710	EA	ORIFICE-MAIN BURNER	92742
12	051391-04-703	EA	BURNER-MAIN/ELECTRONIC IG	91638
13	051391-01-714	EA	FITTING-ELBOW 45,3/8F X 3/8	MPT 1044
14	051391-03-700	EA	HOLDER-ORIFICE	91563
16	051391-01-715	EA	PLUG-DRAIN, 1 EA = 2 PER PKG	91857
17	051391-01-700	EA	HINGE KIT, (PIN & CLIP)	92568&92559
18	051391-04-706	EA	TANK-G6A-4E/6E/7E/8E-FRT.MT	91641 - INNER
	051391-01-717	EA	GRILLE-WATER HEATER DOOR	92640
	051393-01-723	EA	SWITCH - THERMAL CUTOUT 2/PK	93866 WAS 93853
	051393-01-724	EA	BOARD-CIRCUIT, SPADE TERMINAL	93865
	051393-01-725	EA	ELECTRODE-SGL SPADE CONNECT.	93868
	051393-01-726	EA	VALVE/SOLENOID - W/O BRACKET	93870
	111129-01-711	EA	BRACKET-CORNER, SET OF FOUR	91928

CONTACT WINNEBAGO PARTS SALES FOR UNLISTED COMPONENT(S)

**WATER & SEWAGE GROUP (CONTINUED)**  
**COMPONENT PARTS FOR WATER SYSTEM (CONTINUED)**

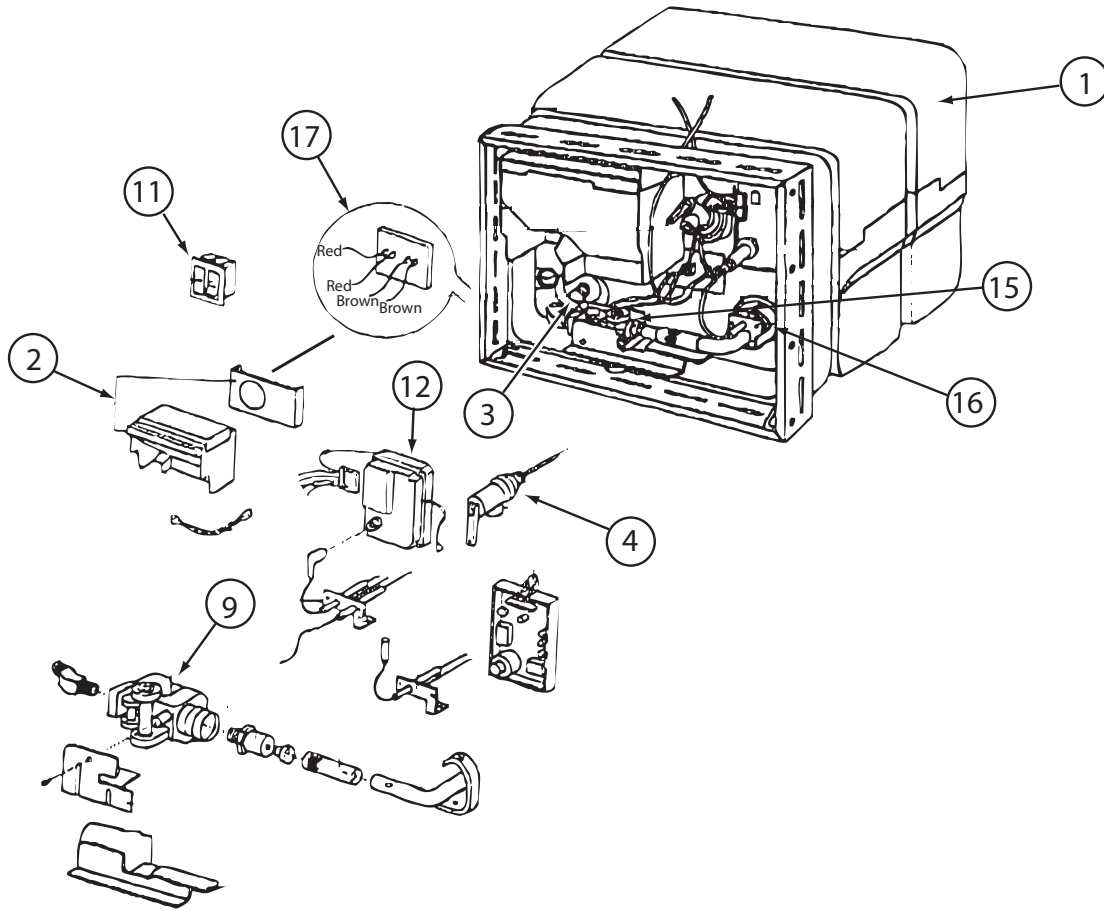

**145541-02-000**

KEY	PART NUMBER	U/M	DESCRIPTION	VENDOR NO.
1	145541-02-700	EA	TANK/SERVICE KIT PCS- 6 GAL	91053
2	051391-04-707	EA	KIT-EXHAUST, (FLUE & GASKET)	90960
3	051391-01-715	EA	PLUG-DRAIN, 1 EA = 2 PER PKG	91857
4	051391-01-704	EA	VALVE-RELIEF, 1/2" FITTING	91604
4	051931-03-701	EA	VALVE-RELIEF - 3/4" FITTING	90028
9	051393-01-726	EA	VALVE-SOLENOID - W/O BRACKET	93870
11	051393-01-701	EA	SWITCH - REMOTE - W/LIGHT	91959
11	145541-01-701	EA	SWITCH - ON/OFF - WHITE	91859
12	145541-01-702	EA	CIRCUIT BOARD	91226
15	145541-01-703	EA	SWITCH - THERMAL CUT OFF	93866
16	051393-01-725	EA	ELECTRODE-SGL SPADE CONNECT.	93868
17	051393-01-721	EA	THERMOSTAT W/ECO, 140 FRT MT	91447
	051391-05-706	EA	ELEMENT-HEATING 1500 WATT	92249 W/GASKET
	145541-01-704	EA	RELAY	90061
	145541-02-701	EA	JUNCTION BOX(PLASTIC) 6 GAL	91222

CONTACT WINNEBAGO PARTS SALES FOR UNLISTED COMPONENT(S)

**151678-01-01A**

KEY	PART NUMBER	U/M	DESCRIPTION	VENDOR NO.
	151678-01-700	EA	ADAPTOR	10015
	151678-01-701	EA	CARTRIDGE	10417
	151678-01-702	EA	WASHER	10269
	151680-01-700	EA	KNOB	10185
	151680-01-701	EA	INDICATOR CAP - RED	10178
	151680-01-702	EA	INDICATOR CAP - BLUE	10177

## WINDOW & VENTS GROUP

### WINDOW & VENT LAYOUT

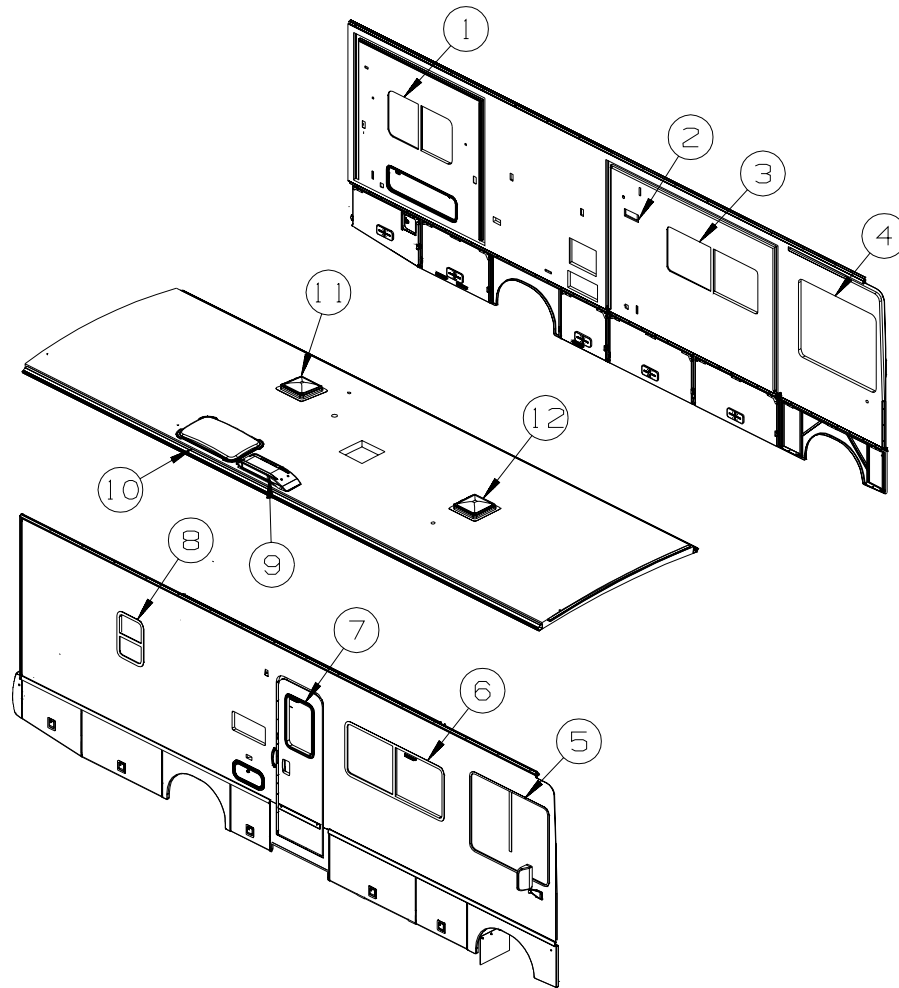

KEY	PART NUMBER	U/M	DESCRIPTION
1*	098647-63-01A	EA	WINDOW - DRVR HORIZ SLIDER/EGRESS W/TRIM - 41" X 24.2"
1*	150648-12-01A	EA	WINDOW-HORIZ SLIDER/ESCAPE/FLUSH/THERMO/LH - 24.5" X 41.2" - <b>DUAL PANE</b>
2	147821-01-01A	EA	VENT - EXHAUST/RANGE HOOD - BRIGHT WHITE
2	147821-01-02A	EA	VENT - EXHAUST/RANGE HOOD - BLACK
2	147821-02-01A	EA	SHROUD - EXHAUST VENT/RANGE HOOD - BRIGHT WHITE
3*	098647-47-02A	EA	WINDOW - DRVR HORIZ SLIDER W/TRIM - TINTED - 57.4" X 23.6"
3*	150648-07-01A	EA	WINDOW-HORIZ SLIDER/FLUSH/THERMO/LH - 23.8" X 57.7" - <b>DUAL PANE</b>
4*	125582-12-01A	EA	WINDOW - DRIVER CAB/3 WINDOW - 43.5"T X 39.9"H X 51.1"B
4*	151072-04-01A	EA	WINDOW - CAB/LEFT HAND/FLUSH/THERMO - 38.9" X 50.2"/42.4" - <b>DUAL PANE</b>
5*	125582-11-01A	EA	WINDOW - PASSENGER CAB/3 WINDOW - 43.5"T X 39.9"H X 51.1"B
5*	151072-03-01A	EA	WINDOW - CAB/RIGHT HAND/FLUSH/THERMO - 38.9" X 50.2"/42.4" - <b>DUAL PANE</b>
6*	098647-23-02A	EA	WINDOW - PASS HORIZ SLIDER TINTED W/RETAINER-26.1" X 59.7"
6*	150648-03-01A	EA	WINDOW-HORIZ SLIDER/FLUSH/THERMO/RH - 26.3" X 59.9" - <b>DUAL PANE</b>
7	117053-02-F36	EA	WINDOW - PICTURE - W/O TRIM - 60% TINTING - 26.4" X 17"
	002181-25-000	EA	GLASS - PICTURE WINDOW - 25.8"W X 16.4"H
	087561-01-000	FT	SEAL - GLASS - EXTERIOR - .5" WIDE - VINYL BLACK
7	117054-02-03A	EA	TRIM/RETAINER - INSIDE - 16.9" X 26.2" - BLACK
7*	150651-01-01A	EA	WINDOW - STATIONARY/FLUSH/THERMO - 26.3" X 17" - BLACK - <b>DUAL PANE</b>
8*	098644-01-01A	EA	WINDOW - VERTICLE SLIDER W/TRIM - TINTED - 22.2" X 15.2"
8*	150649-15-01A	EA	WINDOW - VERT SLIDER/FLUSH/THERMO - 22.2" X 15.2" - <b>DUAL PANE</b>
9	149508-01-02A	EA	CAP - ROOF/REFRIGERATOR VENT - WHITE
9	149508-01-02A	EA	CAP - ROOF/REFRIGERATOR VENT - GRAY
9	149508-02-02A	EA	BASE - ROOF/REFRIGERATOR VENT - BRIGHT WHITE
9	149508-02-01A	EA	BASE - ROOF/REFRIGERATOR VENT - BLACK
10	122191-01-02A	EA	PANEL - SKYLIGHT - INNER W/LIGHT CUTOUT - 20.7" X 35.4"
10	138372-01-02B	EA	TRIM - CORNER - SKYLIGHT - E-COATED
10	138380-01-01A	EA	PANEL/SKYLIGHT - LARGE/OUTER - RECTANGULAR - WHITE

**WINDOW & VENTS GROUP (CONTINUED)**  
**WINDOW & VENT LAYOUT (CONTINUED)**

KEY	PART NUMBER	U/M	DESCRIPTION
11*	122882-02-01A	EA	VENT - ROOF - W/FAN - W/O INSIDE GARNISH - UL
11*	122882-03-01A	EA	VENT - ROOF - W/FAN - W/O INSIDE GARNISH - <b>CANADIAN</b>
	009440-01-000	EA	GEAR/ARM - LIFT - ROOF VENT COVER
	048648-01-000	EA	MOTOR/ROOF VENT - W/RESISTER - 1/8"SHAFT - 12VOLT
	048649-01-000	EA	FAN BLADE - ROOF VENT - 6 BLADED - 6"RADIUS
11	122882-07-01A	EA	GARNISH - ROOF VENT - 2.5" TO 4.1"
12*	122882-01-01A	EA	VENT - ROOF - NONPOWERED - W/O INSIDE GARNISH
	009440-01-000	EA	GEAR/ARM - LIFT - ROOF VENT COVER
12	122882-07-01A	EA	GARNISH - ROOF VENT - 2.5" TO 4.1"
12*	123780-03-01A	EA	FANTASTIC VENT-3"/4"ROOF-W/FAN-W/O THERM/PWR LIFT/WHT CVR - <b>VENT-POWER VENTILATOR</b>
			FROM: 00-00-00 THRU: 02-21-07
	009440-01-000	EA	GEAR/ARM - LIFT - ROOF VENT COVER
			FROM: 00-00-00 THRU: 02-21-07
12*	123780-26-01A	EA	FANTASTIC VENT-4"ROOF- W/FAN/DBL DOME-W/O THERM/PWR LIFT
			FROM: 02-22-07 THRU: 99-99-99

**\*COMPONENT PARTS LISTED LATER IN THIS GROUP**

**WINDOW & VENTS GROUP (CONTINUED)**  
**COMPONENT PARTS FOR WINDOW & VENT LAYOUT**

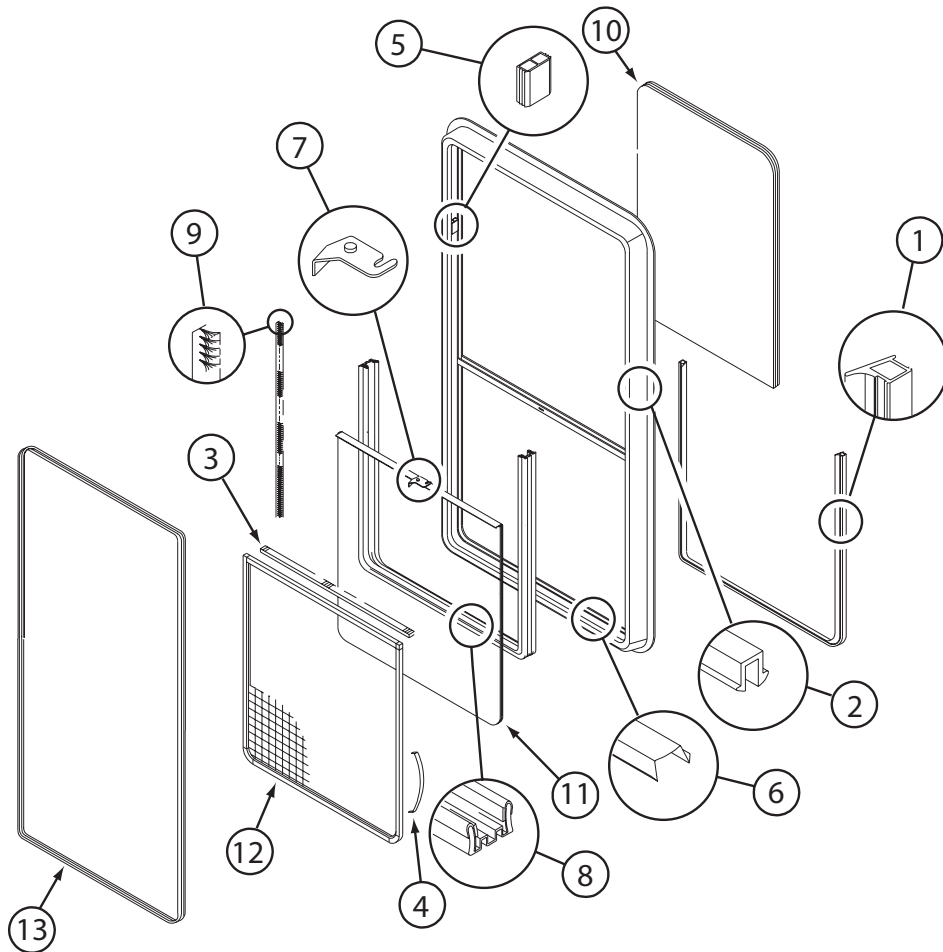

**098644-01-01A**

<b>KEY</b>	<b>PART NUMBER</b>	<b>U/M</b>	<b>DESCRIPTION</b>	<b>VENDOR NO.</b>
1	098644-01-704	EA	GLASS - STATIONARY 10"X13.7"	106-011866
2	164973-01-702	EA	GLASS-SLIDING-W/LATCH/HANDLE	B155G9
3	098644-01-716	FT	PLUG - FILLER	132-014470
4	098644-01-705	FT	GLAZING - STRIP	132-010231
5	098644-01-708	FT	CHANNEL - RUN PIERCED	122-016543
6	164973-01-701	EA	RETAINER - TRIM RING - BLK	B15566
7	098644-01-706	FT	WEATHERSTRIP - GLASS	171-010668
8	098644-01-712	EA	SCREEN ASM - W/SEALS & CLIPS	410-016476
9	098644-01-700	EA	LATCH - REPAIR KIT (BLACK)	B801-CK
	098644-01-710	FT	TRACK - SCREEN SPACER 12'	132-017135
	098644-01-711	FT	WEATHERSTRIP - SCREEN BLACK	171-016965
	098644-01-717	FT	SPLINE - SCREEN	132-004716
	112898-04-703	EA	VERTICAL LATCH/HOLD UP/OPEN	DH343-CK
			CONTACT WINNEBAGO PART SALES FOR UNLISTED COMPONENT(S)	

**WINDOW & VENTS GROUP (CONTINUED)**  
**COMPONENT PARTS FOR WINDOWS & VENT LAYOUT (CONTINUED)**

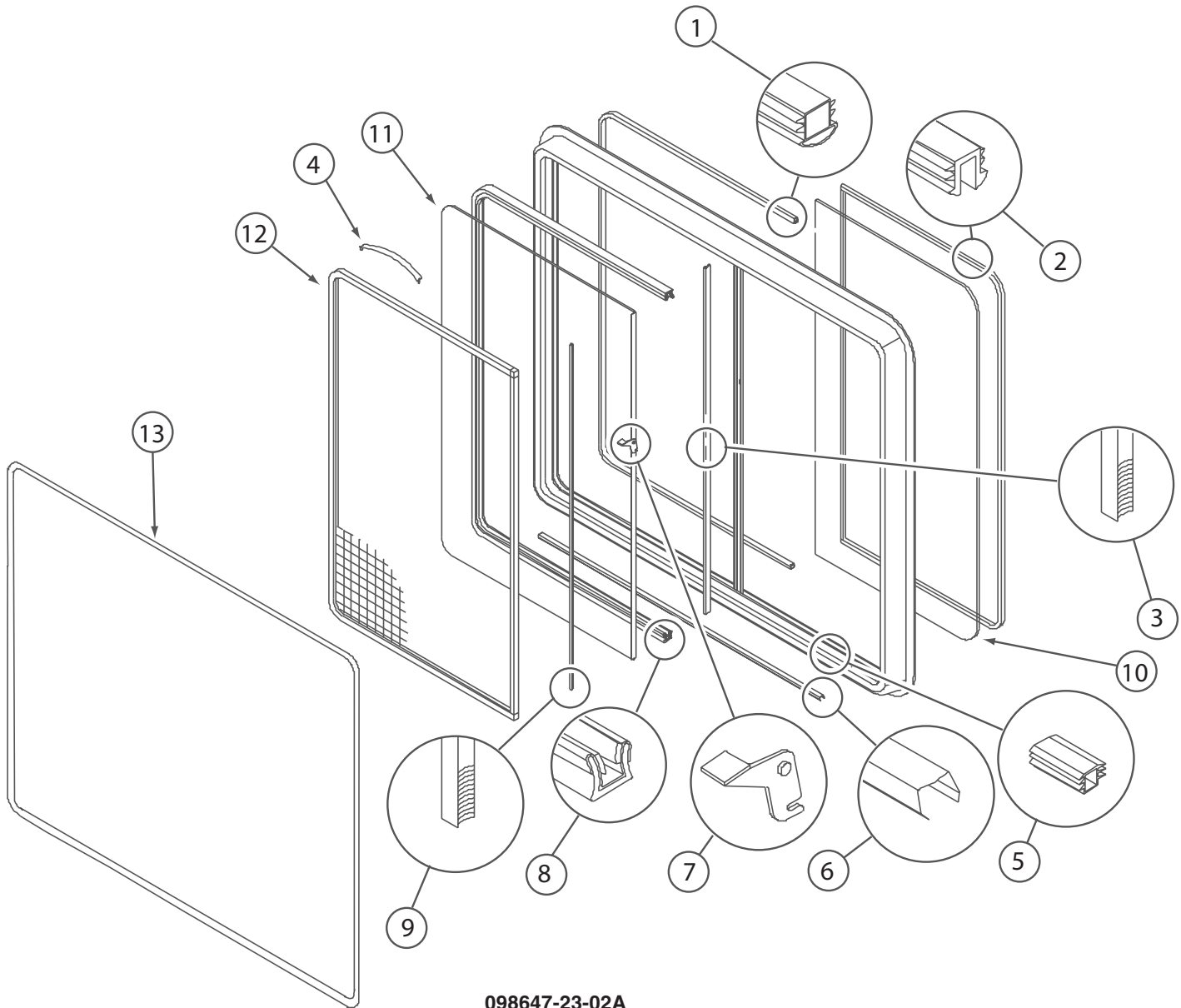

**098647-23-02A**

KEY	PART NUMBER	U/M	DESCRIPTION	VENDOR NO.
1	098644-01-716	FT	PLUG - FILLER	132-014470
2	098644-01-705	FT	GLAZING - STRIP	132-010231
3	098644-01-706	FT	WEATHERSTRIP - GLASS	171-010668
4	098644-01-713	EA	CLIP - SCREEN - METAL	226-016966
4	125582-01-701	EA	CLIP - SCREEN - PLASTIC	130-005153
5	098644-01-719	EA	STOP - SLIDER GLASS	132-014203
6	098644-01-710	FT	TRACK - SCREEN SPACER 12'	132-017135
7	098644-01-700	EA	LATCH - REPAIR KIT (BLACK)	B801-CK
7	098647-54-701	EA	LATCH - REPAIR KIT (RED)	B081-CK
8	098644-01-708	FT	CHANNEL - RUN PIERCED	122-016543
9	098644-01-711	FT	WEATHERSTRIP - SCREEN BLACK	171-016965
10	098647-23-703	EA	GLASS - STATIONARY	106-017622
11	098647-23-700	EA	GLASS SLIDING W/SASH & LATCH	H287-G9
12	098647-23-704	EA	SCREEN ASM - W/SEALS & CLIPS	410-019066
13	098647-22-701	EA	RETAINER - TRIM	H287-67
	098644-01-717	FT	SPLINE - SCREEN	132-004716

**WINDOW & VENTS GROUP (CONTINUED)**  
**COMPONENT PARTS FOR WINDOWS & VENT LAYOUT (CONTINUED)**

**098647-47-02A**

<b>KEY</b>	<b>PART NUMBER</b>	<b>U/M</b>	<b>DESCRIPTION</b>	<b>VENDOR NO.</b>
1	098644-01-716	FT	PLUG - FILLER	132-014470
2	098644-01-705	FT	GLAZING - STRIP	132-010231
3	098644-01-706	FT	WEATHERSTRIP - GLASS	171-010668
4	098644-01-713	EA	CLIP - SCREEN - METAL	226-016966
4	125582-01-701	EA	CLIP - SCREEN - PLASTIC	130-005153
5	098644-01-719	EA	STOP - SLIDER GLASS	132-014203
6	098644-01-710	FT	TRACK - SCREEN SPACER 12'	132-017135
7	098644-01-700	EA	LATCH - REPAIR KIT (BLACK)	B801-CK
7	098647-54-701	EA	LATCH - REPAIR KIT (RED)	B081-CK
8	098644-01-708	FT	CHANNEL - RUN PIERCED	122-016543
9	098644-01-711	FT	WEATHERSTRIP - SCREEN BLACK	171-016965
10	098647-47-700	EA	GLASS - STATIONARY	106-025224
11	098647-47-701	EA	GLASS-SLIDING W/SASH & LATCH	H493-G9
12	098647-47-702	EA	SCREEN ASM - W/SEALS & CLIPS	410-025226
13	098647-47-704	EA	RETAINER - TRIM	H493-66
	098644-01-717	FT	SPLINE - SCREEN	132-004716

**098647-63-01A**

<b>KEY</b>	<b>PART NUMBER</b>	<b>U/M</b>	<b>DESCRIPTION</b>	<b>VENDOR NO.</b>
1	098644-01-716	FT	PLUG - FILLER	132-014470
2	098644-01-705	FT	GLAZING - STRIP	132-010231
3	098644-01-706	FT	WEATHERSTRIP - GLASS	171-010668
4	098644-01-713	EA	CLIP - SCREEN - METAL	226-016966
4	125582-01-701	EA	CLIP - SCREEN - PLASTIC	130-0
5	098644-01-719	EA	STOP - SLIDER GLASS	132-014203
6	098644-01-710	FT	TRACK - SCREEN SPACER 12'	132-017135
7	098647-54-701	EA	LATCH REPAIR KIT (RED)	B081-CK
7	098644-01-700	EA	LATCH - REPAIR KIT (BLACK)	B801-CK
8	098644-01-708	FT	CHANNEL - RUN PIERCED	122-016543
9	098644-01-711	FT	WEATHERSTRIP - SCREEN BLACK	171-016965
10	098647-56-700	EA	GLASS - STATIONARY	106-019401
11	098647-63-700	EA	GLASS-SLIDING W/SASH & LATCH	H422-G9
12	112795-62-702	EA	SCREEN ASSY - W/SEAL & CLIPS	410-018866
13	112795-62-704	EA	RETAINER - TRIM	H422-64
	112898-06-707	EA	HANDLE/RH-EGRESS(SLD)ESC-RED	182-025911
	112898-06-708	EA	HANDLE/LH-EGRESS(SLD)ESC-RED	182-025912
	098644-01-717	FT	SPLINE - SCREEN	132-004716
	112795-24-706	FT	SEAL - SPLINE/GRAY - ESCAPE	132-010481

**WINDOW & VENTS GROUP (CONTINUED)**  
**COMPONENT PARTS FOR WINDOWS & VENT LAYOUT (CONTINUED)**

**122882-01-01A**

<b>KEY</b>	<b>PART NUMBER</b>	<b>U/M</b>	<b>DESCRIPTION</b>	<b>VENDOR NO.</b>
	064470-01-700	EA	COVER - VENT	J7291
	064470-01-701	EA	SLIDE BAR - VENT LID	JRP1291B
	122882-01-700	EA	HANDLE - CRANK - BLACK	90128
	122882-01-701	EA	SCREEN	JRP-1124-B
	122882-01-702	EA	HANDLE - CRANK - WHITE	JRP1031B

**122882-02-01A, 122882-03-01A**

<b>KEY</b>	<b>PART NUMBER</b>	<b>U/M</b>	<b>DESCRIPTION</b>	<b>VENDOR NO.</b>
	064470-01-700	EA	COVER - VENT	J7291
	064470-01-701	EA	SLIDE BAR - VENT LID	JRP1291B
	110051-03-700	EA	SWITCH-BLACK/PUSH BUTTON	27-0164
	122882-01-700	EA	HANDLE - CRANK - BLACK	90128
	122882-01-701	EA	SCREEN	JRP-1124-B
	122882-01-702	EA	HANDLE - CRANK - WHITE	JRP1031B



**WINDOW & VENTS GROUP (CONTINUED)**  
**COMPONENT PARTS FOR WINDOWS & VENT LAYOUT (CONTINUED)**

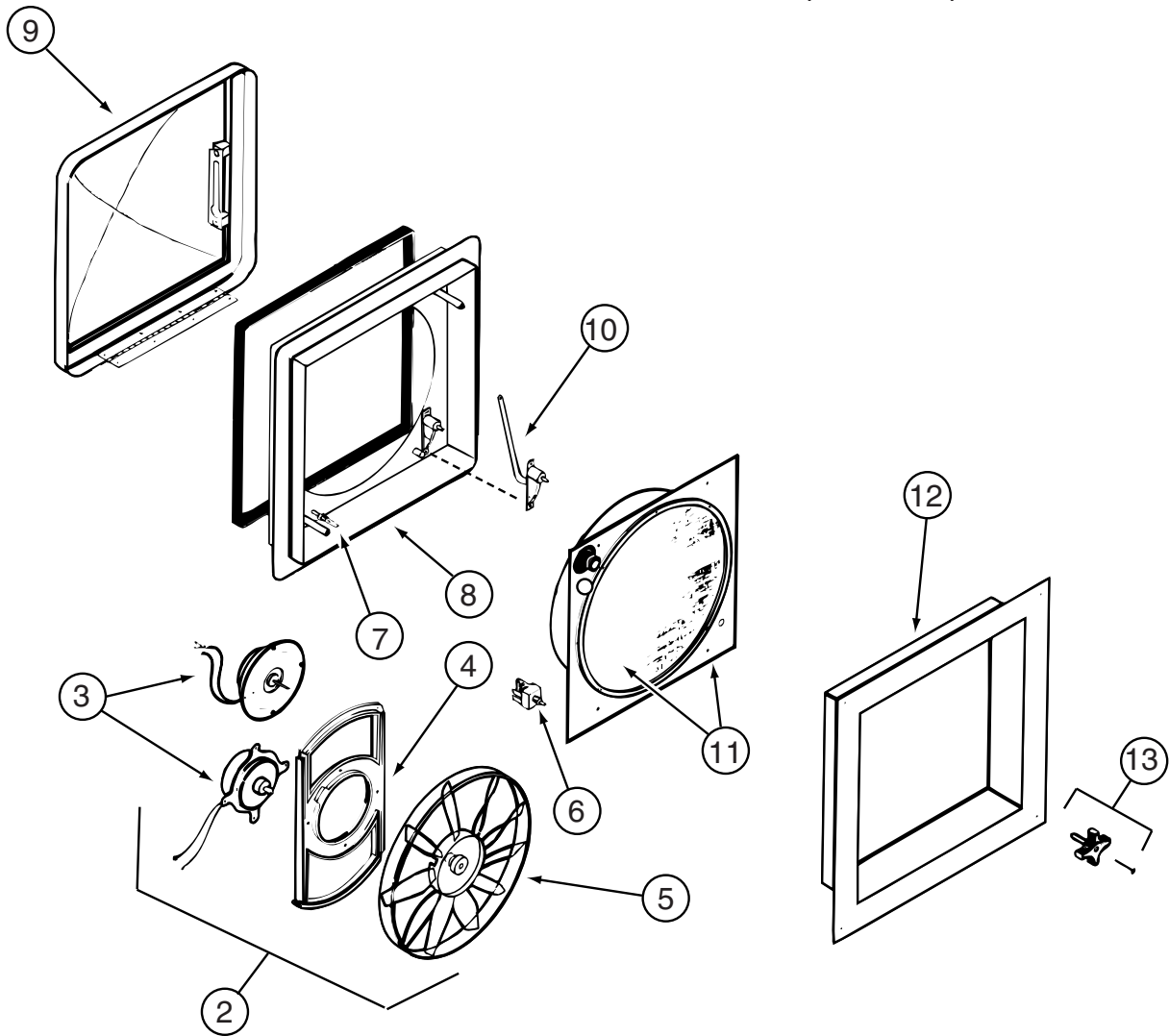

123780-03-01A

KEY	PART NUMBER	U/M	DESCRIPTION	VENDOR NO.
2	084079-11-700	EA	MOTOR & FAN BLADE W/BRACKET	K4017-09
3	084079-01-705	EA	MOTOR/EXT BRKT/FAN BLADE KIT	1080-00
4	084079-01-711	EA	MOTOR MOUNT (BOWTIE)	1015-00
5	084079-01-704	EA	BLADE-FAN	1138-00
6	084079-01-709	EA	SWITCH - MAIN - 3 SPEED	1031-05
7	084079-01-707	EA	SWITCH - SAFETY	1122-05
8	123780-05-700	EA	BASE/MAIN-BRT WHT W/GASKET	1010-81
9	123780-01-700	EA	COVER - VENT W/HINGE & SLIDE	1020K-81
10	009440-01-000	EA	GEAR-ARM-ROOF VENT	705221K38
11	123780-03-701	EA	SCREEN ASM 78-100MM W/SWITCH	1030BT-81
12	123780-03-700	EA	GARNISH - INT. 3"-4" BRT/WHT	2040-81
13	084079-01-703	EA	KNOB-LIFT	1140K-00
	084079-01-706	EA	PLUG, 12 VOLT	1090
	123780-01-702	EA	SCREEN INSERT (SCREEN RING)	K1035-81

CONTACT WINNEBAGO PART SALES FOR UNLISTED COMPONENT(S)

**WINDOW & VENTS GROUP (CONTINUED)**  
**COMPONENT PARTS FOR WINDOWS & VENT LAYOUT (CONTINUED)**

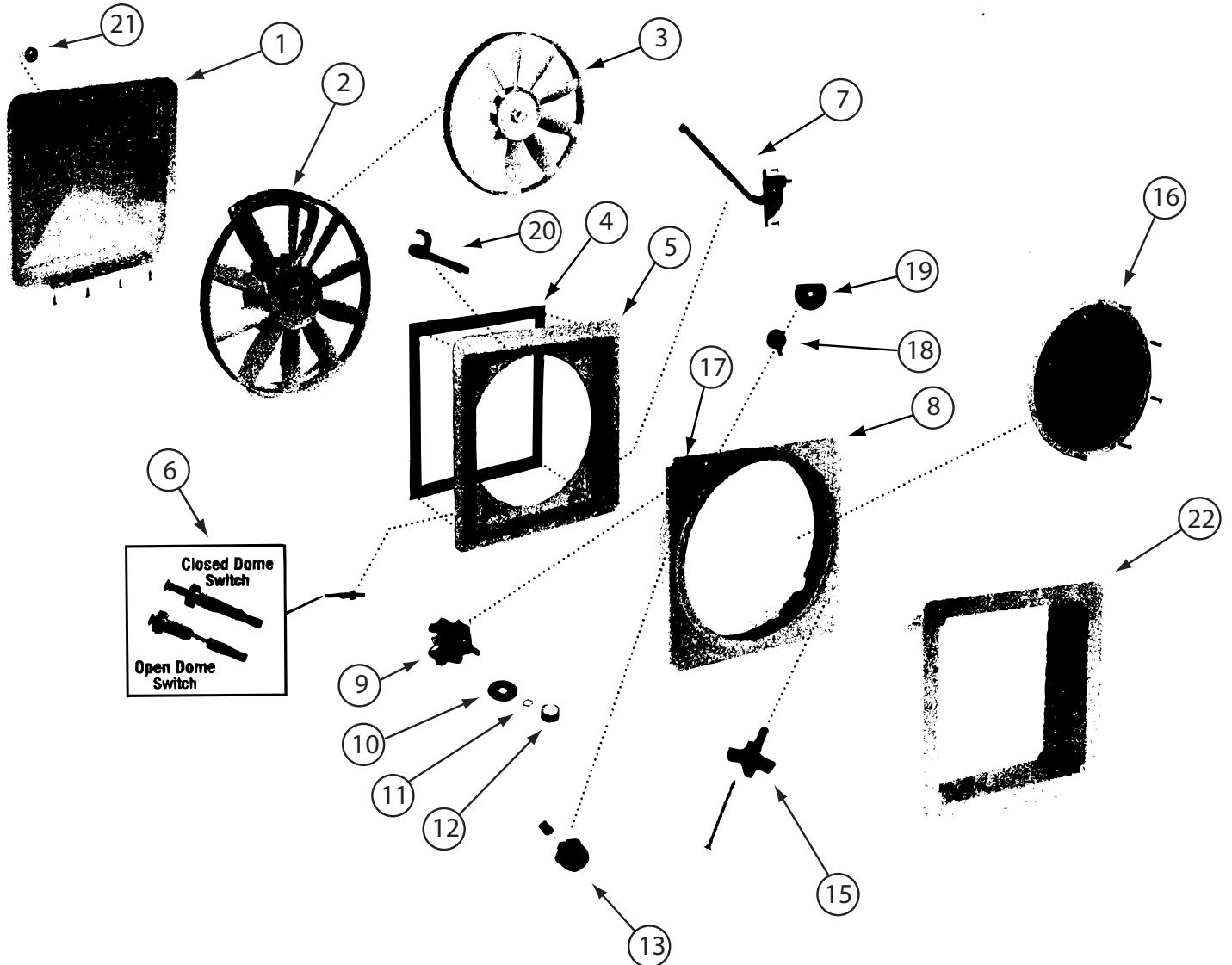

123780-26-01A

KEY	PART NUMBER	U/M	DESCRIPTION	VENDOR NO.
1	123780-22-700	EA	COVER - VENT W/HINGE & SLIDE	K8020-81
2	123780-26-700	EA	MOTOR & FAN BLADE W/BRACKET	XK8017-03 PANCAKE
3	123780-26-701	EA	BLADE/FAN - 12" OPAQUE WHT	8138-81 - 7MM
4	123780-22-701	EA	SEAL/RUBBER-4 1/2' W/GLUE	K1144-09
5	123780-22-702	EA	BASE/MAIN - W/LOCK/SEAL/ARM	XK8010-81 CLAMP STY
6	084079-01-707	EA	SWITCH - SAFETY	1122-05
7	084079-01-702	EA	ARM LIFT ASSEMBLY, MANUAL	101105
8	123780-22-703	EA	SCREEN KIT W/RING/ARM/LOCK	XK1220-81
9	084079-01-709	EA	SWITCH - MAIN - 3 SPEED	1031-05
13	123780-21-700	EA	FUSE HOLDER W/4 AMP FUSE	K9018-09
15	123780-16-700	EA	KNOB-BLK/AUTOMATIC LIFT MTR	K1140-09
16	123780-21-703	EA	SCREEN - POP N LOCK	2035-81
17	123780-22-704	EA	TRAVEL LOCK ASSEMBLY	4021-09
22	123780-22-705	EA	GARNISH-3 1/2"CLAMP STY-WHT	XK2040-81

CONTACT WINNEBAGO PART SALES FOR UNLISTED COMPONENT(S)

**WINDOW & VENTS GROUP (CONTINUED)**  
**COMPONENT PARTS FOR WINDOWS & VENT LAYOUT (CONTINUED)**

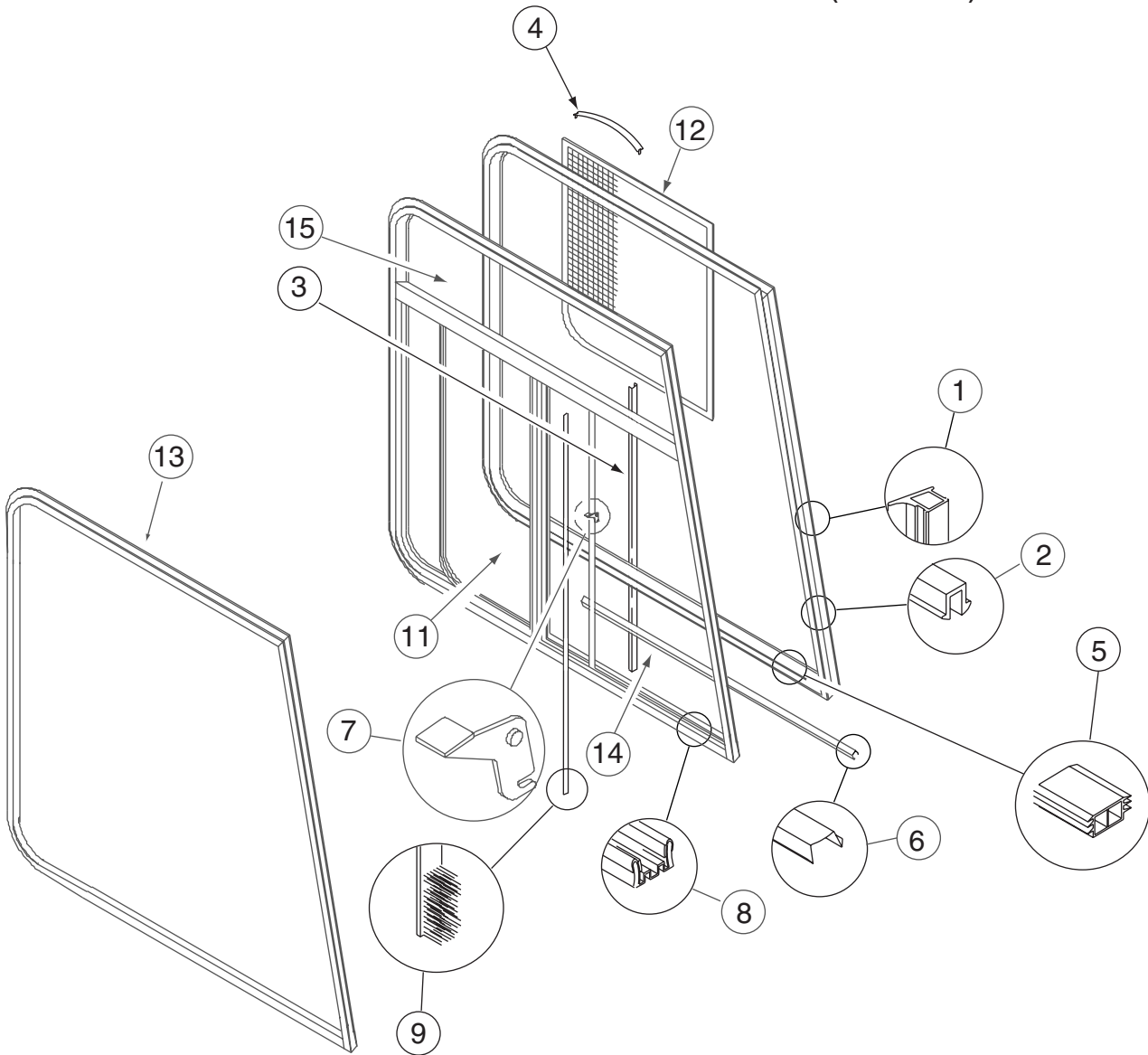

**125582-11-01A**

<b>KEY</b>	<b>PART NUMBER</b>	<b>U/M</b>	<b>DESCRIPTION</b>	<b>VENDOR NO.</b>
	125582-11-700	EA	SCREEN ASM - RIGHT CONTACT WINNEBAGO PART SALES FOR UNLISTED COMPONENT(S)	410-037944 (RH)

**125582-12-01A**

<b>KEY</b>	<b>PART NUMBER</b>	<b>U/M</b>	<b>DESCRIPTION</b>	<b>VENDOR NO.</b>
	125582-12-700	EA	SCREEN ASM - LEFT CONTACT WINNEBAGO PART SALES FOR UNLISTED COMPONENT(S)	410-037945 (LH)

**WINDOW & VENTS GROUP (CONTINUED)**  
**COMPONENT PARTS FOR WINDOWS & VENT LAYOUT (CONTINUED)**

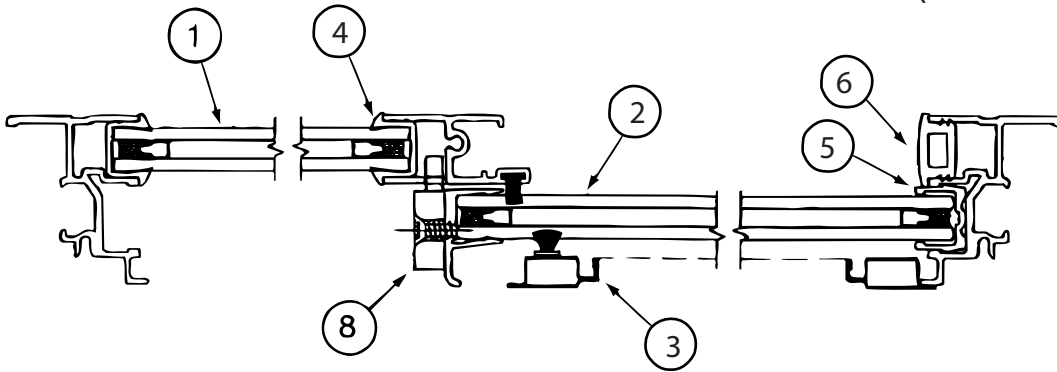

CROSS SECTION B-B

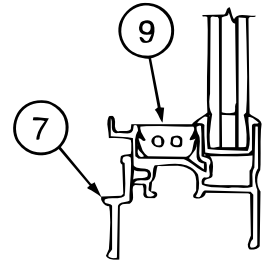
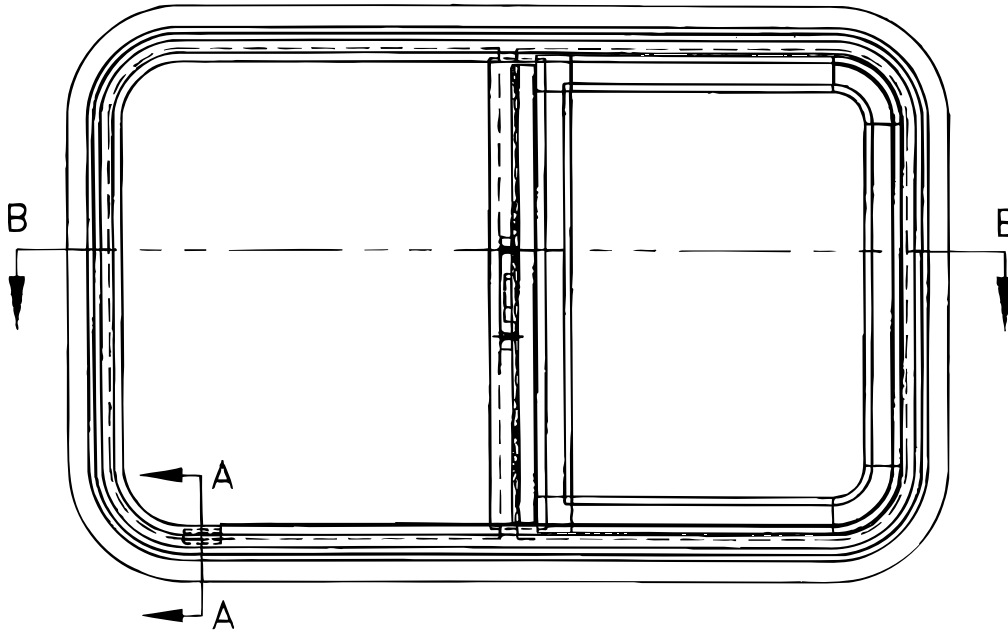

CROSS SECTION  
A-A

150648-02-01A, 150648-03-01A/3A

KEY	PART NUMBER	U/M	DESCRIPTION	VENDOR NO
1	112795-68-700	EA	GLASS - STATIONARY	390-028353
2	150648-02-700	EA	GLASS-SLIDING W/SASH & LATCH	FH3009G8
3	150648-19-700	EA	SCREEN ASM	410-035332
4	112795-01-705	FT	VINYL - GLAZING	132-027331
5	151069-01-700	EA	CHANNEL-RUN, SLIDING	122-030627
6	150648-01-703	EA	PLUG - FILLER	132-030308
7	098647-22-701	EA	RETAINER - TRIM	H287-67
8	150648-01-700	EA	LATCH-HORIZONTAL SLIDE-BLK	FH3000-CK
8	150648-01-701	EA	LATCH-HORIZONTAL SLIDE-RED	FH3003-CK
9	150648-01-704	EA	SLIDE STOP	132-030866
	150649-05-702	FT	FIN SEAL-F/LOCKING RAIL-BLK	171-062348

**WINDOW & VENTS GROUP (CONTINUED)**  
**COMPONENT PARTS FOR WINDOWS & VENT LAYOUT (CONTINUED)**

**150648-07-01A, 150648-22-01A**

<b>KEY</b>	<b>PART NUMBER</b>	<b>U/M</b>	<b>DESCRIPTION</b>	<b>VENDOR NO</b>
1	150648-07-701	EA	GLASS - STATIONARY	390-028314
2	150648-07-700	EA	GLASS-SLIDING W/SASH & LATCH	FH3000G8
3	150648-01-702	EA	SCREEN ASM	410-031156
4	112795-01-705	FT	VINYL - GLAZING	132-027331
5	151069-01-700	EA	CHANNEL-RUN, SLIDING	122-030627
6	150648-01-703	EA	PLUG - FILLER	132-030308
7	150648-01-707	EA	RETAINER - TRIM	H493-67
8	150648-01-700	EA	LATCH-HORIZONTAL SLIDE-BLK	FH3000-CK
8	150648-01-701	EA	LATCH-HORIZONTAL SLIDE-RED	FH3003-CK
9	150648-01-704	EA	SLIDE STOP	132-030866
	150649-05-702	FT	FIN SEAL-F/LOCKING RAIL-BLK	171-062348

**150648-12-01A**

<b>KEY</b>	<b>PART NUMBER</b>	<b>U/M</b>	<b>DESCRIPTION</b>	<b>VENDOR NO</b>
1	150648-15-700	EA	GLASS - STATIONARY	390-035689
2	150648-15-701	EA	GLASS-SLIDING W/SASH & LATCH	FH3060G8
3	150648-15-702	EA	SCREEN ASM	410-035691
4	112795-01-705	FT	VINYL - GLAZING	132-027331
5	151069-01-700	EA	CHANNEL-RUN, SLIDING	122-030627
6	150648-01-703	FT	PLUG - FILLER	132-030308
7	150648-15-703	EA	RETAINER - TRIM	FH814-60
8	150648-01-700	EA	LATCH-HORIZONTAL SLIDE-BLK	FH3000-CK
8	150648-01-701	EA	LATCH-HORIZONTAL SLIDE-RED	FH3003-CK
9	150648-01-704	EA	SLIDE STOP	132-030866
	112898-06-707	EA	HANDLE/RH - EGRESS (SLD) ESC-RED	182-025911
	112898-06-708	EA	HANDLE/LH - EGRESS (SLD) ESC-RED	182-025912
	150648-12-700	FT	SEAL/FOAM-FRAME TO SIDEWALL	138-035684
	150649-05-702	FT	FIN SEAL-F/LOCKING RAIL-BLK	171-062348

**WINDOW & VENTS GROUP (CONTINUED)**  
**COMPONENT PARTS FOR WINDOWS & VENT LAYOUT (CONTINUED)**

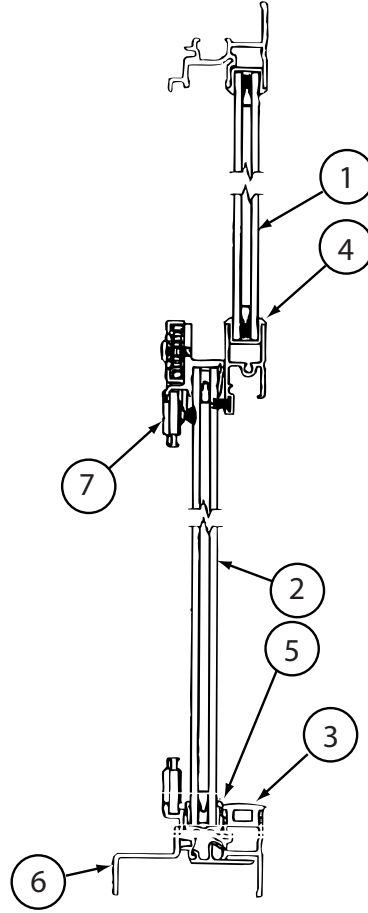
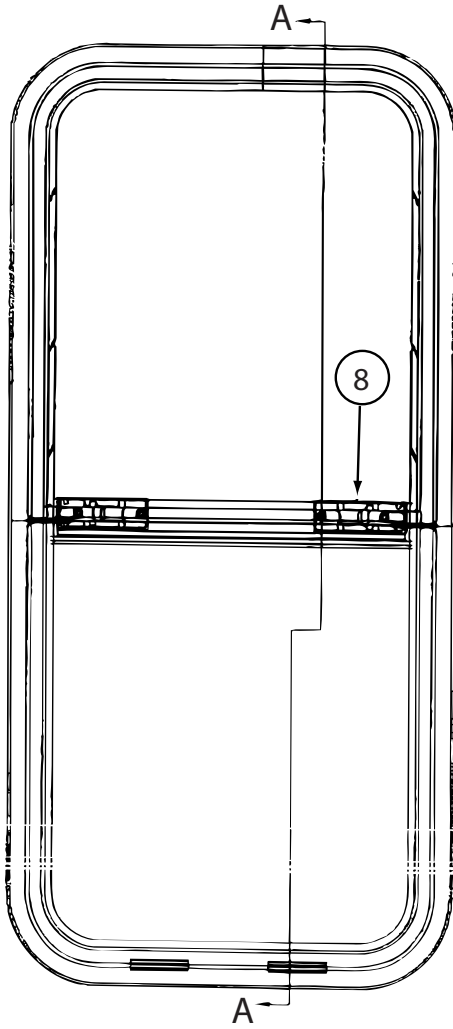

**CROSS SECTION A-A**

**150649-15-01A**

<b>KEY</b>	<b>PART NUMBER</b>	<b>U/M</b>	<b>DESCRIPTION</b>	<b>VENDOR NO</b>
1	150649-15-701	EA	GLASS - STATIONARY	390-035768
2	150649-15-702	EA	GLASS-SLIDING W/PULL & LATCH	FH3069G8
3	150648-01-703	FT	PLUG - FILLER	132-030308
4	112795-01-705	FT	VINYL - GLAZING	132-027331
5	151069-01-700	FT	CHANNEL-RUN, SLIDING	122-030627
6	150649-15-703	EA	RETAINER - TRIM	H3069-67
7	150649-15-700	EA	SCREEN ASM	410-035769
8	150649-01-700	EA	LATCH-VERTICLE SLIDE-BLK	FH3016-CK

**WINDOW & VENTS GROUP (CONTINUED)**  
**COMPONENT PARTS FOR WINDOWS & VENT LAYOUT (CONTINUED)**

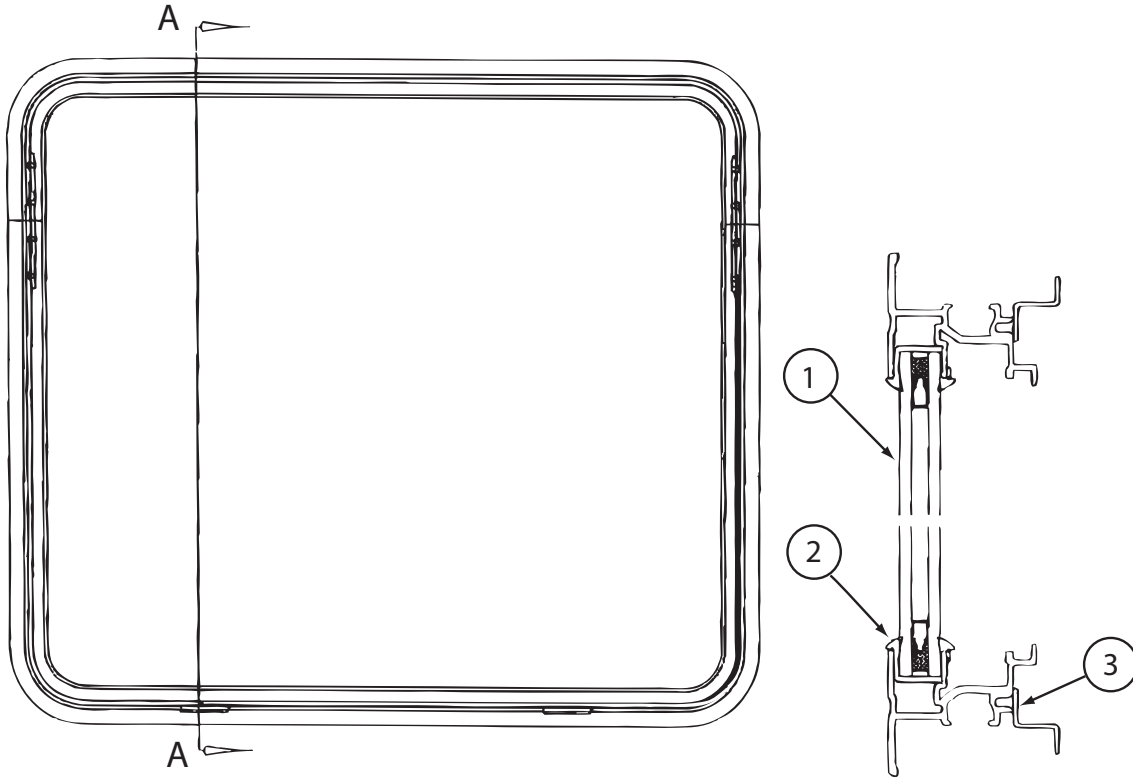

**CROSS SECTION A-A**

**150651-01-01A/03A**

KEY	PART NUMBER	U/M	DESCRIPTION	VENDOR NO
1	113733-10-700	EA	GLASS-STATIONARY	390-028306
2	112795-01-705	FT	VINYL - GLAZING	132-027331
3	150651-01-700	EA	RETAINER - TRIM	H416-67

**151072-03-01A**

KEY	PART NUMBER	U/M	DESCRIPTION	VENDOR NO
	125583-01-702	EA	GLASS - STATIONARY - R.H.	390-026101
	150648-01-700	EA	LATCH-HORIZONTAL SLIDE-BLK	FH3000-CK
	151069-01-700	FT	CHANNEL-RUN, SLIDING	122-030627
	151072-01-700	EA	SCREEN ASM	410-035507
	151072-01-701	EA	GLASS-SLIDING W/SASH & LATCH	FH3040A9R

**151072-04-01A**

KEY	PART NUMBER	U/M	DESCRIPTION	VENDOR NO
	125583-02-701	EA	GLASS - STATIONARY	390-026102
	151069-01-700	FT	CHANNEL-RUN, SLIDING	122-030627
	151072-02-700	EA	GLASS-SLIDING W/SASH & LATCH	FH3040A9L
	151072-02-704	EA	SCREEN ASM	410-037678

# WINDSHIELD & WIPER GROUP

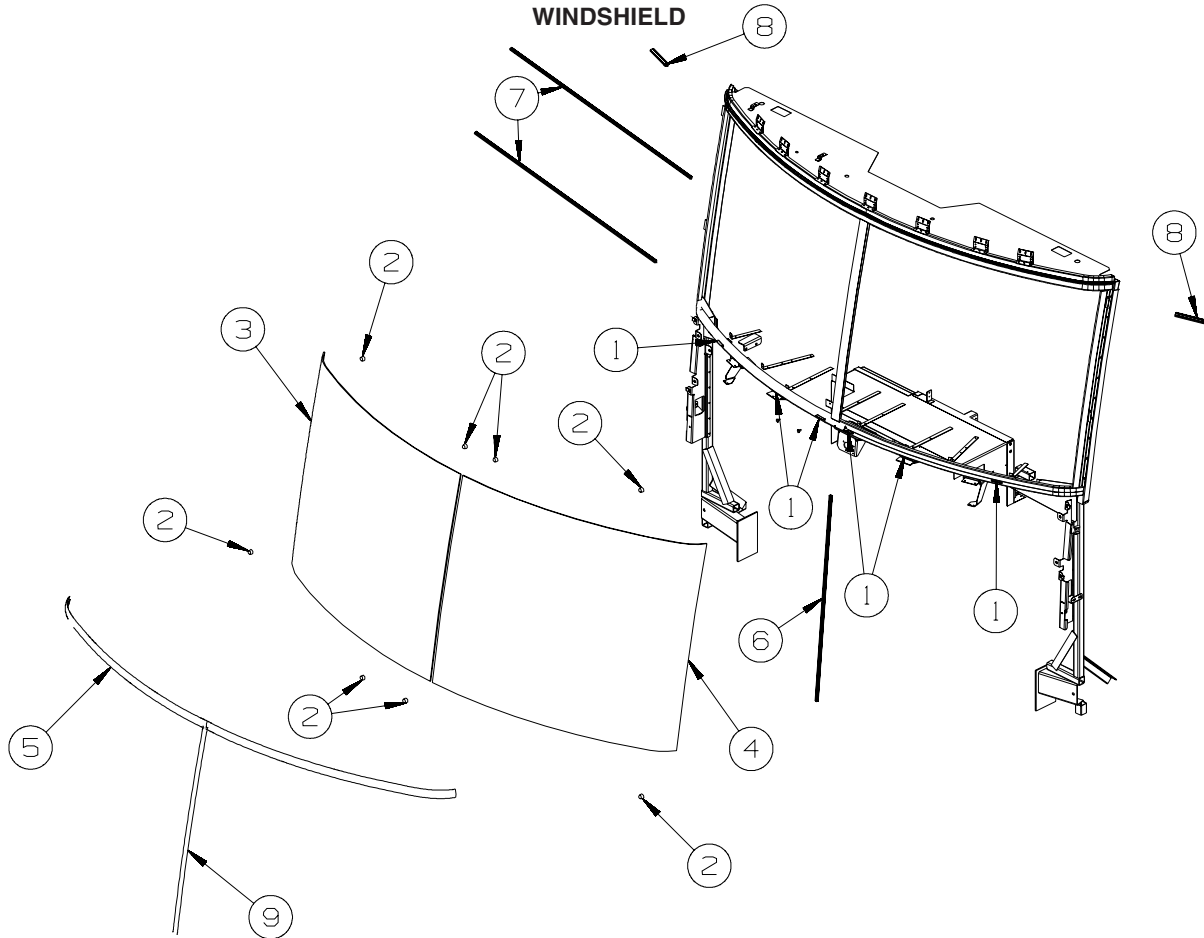

KEY	PART NUMBER	U/M	DESCRIPTION
1	002328-03-000	EA	BLOCK - WINDSHIELD - .125" X .5" X .98"
2	081914-02-000	EA	BUMPER - RUBBER - ROUND - 5/16" DIA. X 13/64" THICK
3	124328-01-000	EA	WINDSHIELD - PASSENGER - 52" X 41" (CURVED)
4	124328-02-000	EA	WINDSHIELD - DRIVER - 52" X 41" (CURVED)
5	120533-01-000	FT	MOLDING - REVEAL - WINDSHIELD
6	127862-06-000	EA	CARRIER/REVEAL - WINDSHIELD - 41.9"
7	127862-01-000	EA	CARRIER/REVEAL - WINDSHIELD - 47.2"
8	127862-01-045	EA	CARRIER/REVEAL - WINDSHIELD - 47.2"
9	159729-01-01A	FT	MOLDING - REVEAL - WINDSHIELD - SOLD BY THE FOOT
			FROM: 00-00-00 THRU: 12-30-07
9	159729-02-01A	FT	MOLDING - REVEAL - WINDSHIELD - 44" - SOLD AS EACH
			FROM: 12-31-07 THRU: 99-99-99



# WINDSHIELD & WIPER GROUP (CONTINUED)

## WIPER

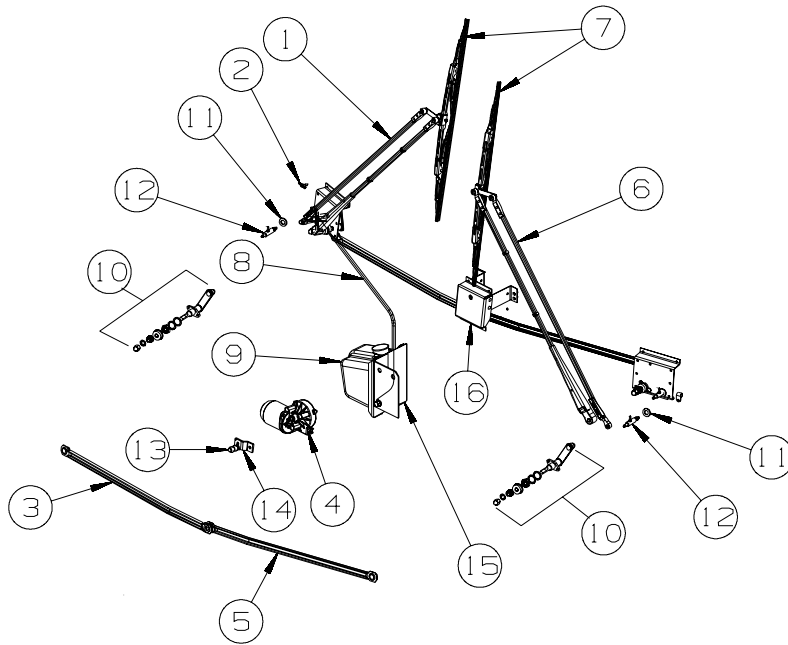

KEY	PART NUMBER	U/M	DESCRIPTION
1*	149402-03-000	EA	ARM - WINDSHIELD WIPER/PANTOGRAPH - RIGHT HAND - 28"
2	146486-01-000	EA	TEE - PLASTIC - 5/32" X 5/32" X 5/32"
3	149403-01-000	EA	LINK/CONNECTING-WINDSHIELD WIPER - CLOSED/CLOSED - 24"
4	149409-01-000	EA	MOTOR - WINDSHIELD WIPER - DYNAMIC PARK
5	149403-02-000	EA	LINK/CONNECTING-WINDSHIELD WIPER - OPEN/CLOSED GROMMET-24"
6*	149402-04-000	EA	ARM - WINDSHIELD WIPER/PANTOGRAPH - LEFT HAND - 28"
7	149399-01-000	EA	BLADE - WINDSHIELD WIPER - 24"
8	045794-01-000	FT	HOSE - WINDSHIELD WASHER - 5/32"ID - BLACK
9	117766-02-000	EA	RESERVOIR/PUMP - WINDSHIELD WASHER
10*	149401-02-000	EA	SHAFT/PIVOT - WINDSHIELD WIPER - 4.1" OVERALL
11	110742-03-000	EA	GASKET - WIPER ADAPTER SHAFT
12	145698-01-01A	EA	SHAFT/IDLER - PANTOGRAPH - W/WASHER DIVERTER - STAINLESS
13	149395-01-000	EA	STUD/DOUBLE BALL CRANK - WIPER MOTOR
14	149408-01-000	EA	ARM - DRIVE/WIPER MOTOR
15	156697-01-02B	EA	BRACKET - F/RESERVOIR - E-COATED - FORD
16	157842-01-02B	EA	BRACKET - WIPER SUPPORT - E-COATED

\*COMPONENT PARTS LISTED LATER IN THIS GROUP

### COMPONENT PARTS FOR WIPER

#### 149401-01-000,149401-02-000

KEY	PART NUMBER	U/M	DESCRIPTION	VENDOR NO.
	096505-02-703	EA	NUT/ACORN - HD W/.687 BRL	51065-40-NT27WC
	149401-01-700	EA	HARDWARE PKG - F/SHAFT&PIVOT	PSHWKIT
	149401-01-701	EA	SEAL CAP/RUBBER GROMMET	300749

#### 149402-03-000 & 149402-04-000

KEY	PART NUMBER	U/M	DESCRIPTION	VENDOR NO.
	149402-03-700	EA	WASHER NOZZLE KIT W/HDWR	19476
	149402-03-701	EA	COVER/CAP - BLACK	200342