

2008  
**SPIRIT**  
**IF331H**  
**300-SERIES**  
**HONEY CHERRY**  
**W29 WINTER SURF**  
**W31 RAIN STORM**  
**W33 BOARDWALK**  
**WASHED MAPLE**  
**W30 WINTER SURF**  
**W32 RAIN STORM**  
**W34 BOARDWALK**

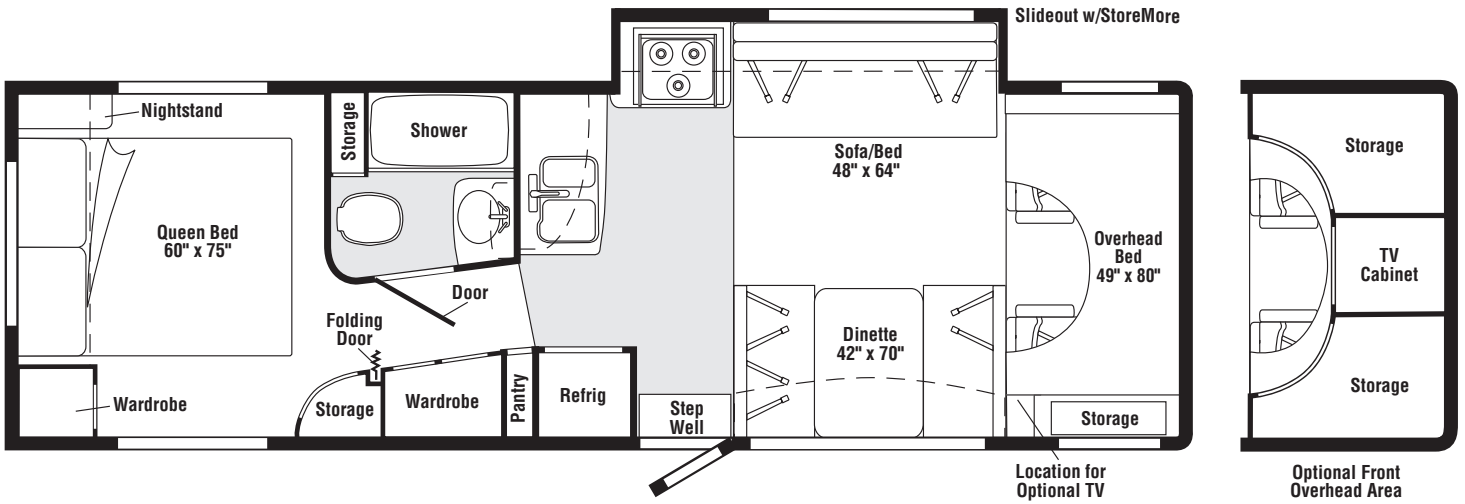

**FLOORPLAN**

# CONTENTS

<b>FLOORPLAN</b> .....	<b>1</b>
<b>ACCESSORIES GROUP</b> .....	<b>6</b>
OPERATORS MANUAL .....	6
<b>AUDIO VIDEO GROUP</b> .....	<b>7</b>
RADIO SYSTEM .....	7
REAR MONITOR .....	8
COMPONENT PARTS FOR REAR MONITOR .....	8
156442-02-01A, 156442-03-01A .....	8
156930-02-01A .....	8
<b>CABINET &amp; APPLIANCE GROUP</b> .....	<b>9</b>
CABINET & APPLIANCE LAYOUT .....	9
COMPONENT PARTS FOR CABINET & APPLIANCE LAYOUT .....	14
121568-06-01A, 121568-07-01A, 121568-08-01A .....	14
156801-01-01A .....	17
156801-03-01A .....	17
157570-01-01A, 157570-02-01A .....	18
161116-01-01A , 161116-02-01A .....	18
<b>CHASSIS GROUP</b> .....	<b>19</b>
FRAME .....	19
DRIVETRAIN .....	19
EXHAUST .....	19
HITCH .....	20
FUEL .....	20
HYDRAULIC LEVELING .....	21
SPARE TIRE .....	21
SUSPENSION .....	22
COMPONENT PARTS FOR SUSPENSION .....	22
144887-02-000 .....	22
156618-01-000 .....	22
WHEEL, TIRE, COVERS &/OR LINERS .....	22
COMPONENT PARTS FOR WHEEL, TIRE, COVERS &/OR LINERS .....	23
110435-13-000 .....	23
110435-23-000 .....	23
144647-01-000 .....	23
BRAKELINE .....	23
<b>CURTAIN &amp; CUSHION GROUP</b> .....	<b>24</b>
CURTAIN, CUSHION LAYOUT .....	24
SOFA .....	29
HARDWARE .....	30
FABRICS .....	32
<b>DRIVERS COMPARTMENT GROUP</b> .....	<b>34</b>
FRONT INTERIOR .....	34
CABINETS .....	36

# CONTENTS (CONTINUED)

<b>ELECTRICAL GROUP</b> .....	<b>38</b>
110V BODY WIRING .....	38
12V BODY WIRING .....	40
EXTERIOR LAMPS .....	44
FRONT END .....	45
FRONT TV/DVD .....	46
SIDE TV/DVD .....	47
COMPONENT PARTS FOR WIRING .....	48
076319-23-000 .....	48
076319-25-000 .....	48
087694-01-000 .....	48
097917-01-06A .....	49
120269-07-01A .....	49
121935-01-01A .....	49
133908-09-01A .....	49
134940-06-01A .....	49
134940-07-01A .....	50
137417-01-01A, 137417-03-01A .....	50
137417-02-01A .....	50
137417-05-01A .....	50
137417-06-01A .....	50
146298-02-000 .....	50
156413-01-01A .....	50
158703-01-000 .....	50
158836-01-000 .....	50
163031-01-01A .....	50
163097-01-000 .....	50
164270-01-000 .....	50
164495-01-000 .....	50
CIRCUIT BREAKERS, FUSES & RELAYS .....	51
CONVERTER, INVERTER, LOAD CENTERS .....	51
COMPONENT PARTS FOR CONVERTER, INVERTER, LOAD CENTER .....	51
083208-07-000 .....	51
BOXES & CORDS .....	52
WIRE ASSEMBLIES .....	52
CONNECTORS & CONDUIT .....	53
CHASSIS .....	55
<b>EXTERIOR BODY GROUP</b> .....	<b>57</b>
GRAPHICS & PAINT .....	57
PANELS & TRIMS .....	58
COMPONENT PARTS FOR PANELS & TRIMS .....	61
133908-05, 133908-06, 133908-10, 133908-11, 133908-14, 133908-15, -01A/02A .....	61
133908-07, 133908-08, 133908-12, -01A/-02A/-03A .....	61
133908-13-01A/-03A .....	61
FRONT END .....	62
STRUCTURAL COMPONENTS .....	63
AWNINGS .....	63
<b>EXTERIOR DOORS &amp; COMPARTMENTS GROUP</b> .....	<b>64</b>
DOOR & COMPARTMENT LAYOUT .....	64
COMPONENT PARTS FOR DOOR & COMPARTMENT LAYOUT .....	68
084103-08-000 .....	68
094708-05-01A .....	69
COMPARTMENT DOOR PIECE PARTS .....	70
ENTRY .....	73
SCREEN .....	74
LATCH - ENTRY .....	75

## CONTENTS (CONTINUED)

<b>EXTERIOR SLIDEOUT GROUP</b> .....	<b>76</b>
FRONT LEFT .....	76
COMPONENT PARTS FOR FRONT LEFT .....	79
162827-01-000, 162827-02-000 .....	79
<b>GENERATOR GROUP</b> .....	<b>80</b>
GAS .....	80
<b>HEATING &amp; A/C GROUP</b> .....	<b>81</b>
FURNACE .....	81
COMPONENT PARTS FOR FURNACE .....	82
139980-02-000 .....	82
REAR HEATER .....	83
COMPONENT PARTS FOR REAR HEATER .....	83
084405-01-000 .....	83
ROOF .....	84
COMPONENT PARTS FOR ROOF .....	84
131184-01-01A .....	84
131184-05-01A .....	85
131184-06-01A .....	86
131184-07-01A .....	87
131188-05-01A .....	88
131188-06-01A .....	89
<b>INTERIOR FINISH GROUP</b> .....	<b>90</b>
MOLDINGS & TRIMS .....	90
PANELING & LAMINATES .....	102
INTERIOR TRIM LAYOUT .....	103
COMPONENT PART FOR INTERIOR TRIM LAYOUT .....	106
094499-02-000 .....	106
131595-01-01A, 131595-05-01A, 131595-10-01A, 131595-13-01A .....	106
151578-02-01A .....	106
FLOOR COVERINGS .....	106
HARDWARE .....	107
<b>LABELS GROUP</b> .....	<b>113</b>
<b>LP GROUP</b> .....	<b>117</b>
LP SYSTEM .....	117
COMPONENT PARTS FOR LP SYSTEM .....	117
144116-04-000 .....	117
<b>SEALANTS &amp; FASTENERS GROUP</b> .....	<b>118</b>
SEALANTS & ADHESIVES .....	118
BOLTS, NUTS AND WASHERS .....	119
SCREWS .....	121
CLAMPS, CLIPS, GROMMETS, RIVETS & PLUGS .....	124
MISCELLANEOUS FASTENERS .....	125
<b>WATER &amp; SEWAGE GROUP</b> .....	<b>126</b>
DRAINAGE SYSTEM .....	126
COMPONENT PARTS FOR DRAINAGE SYSTEM .....	127
147421-03-01A .....	127
WATER SYSTEM .....	128
COMPONENT PARTS FOR WATER SYSTEM .....	134
051391-03-000 .....	134
145541-02-000 .....	135
152311-01-01A .....	135
165730-01-01A .....	135

## CONTENTS (CONTINUED)

<b>WINDOW &amp; VENTS GROUP .....</b>	<b>136</b>
WINDOW & VENT LAYOUT .....	136
COMPONENT PARTS FOR WINDOW & VENT LAYOUT .....	138
098647-27-03A .....	138
098647-29-03A, 098647-30-03A .....	138
098647-32-03A .....	139
098647-74-02A .....	139
098647-78-02A .....	139
122882-01-01A .....	140
122882-02-01A, 122882-03-01A .....	140
123780-26-01A .....	141
150648-02-01A, 150648-03-01A/3A .....	142
150648-05-03A .....	143
150648-07-02A .....	143
150648-31-01A/02A, 150648-32-01A .....	143
150651-01-01A/03A .....	144
150651-03-01A/02A .....	145
161452-01-01A/02A .....	146

**ACCESSORIES GROUP**  
**OPERATORS MANUAL**

<b>KEY</b>	<b>PART NUMBER</b>	<b>U/M</b>	<b>DESCRIPTION</b>
	158603-08-002	EA	MANUAL/OWNER - SUPPLEMENT - 300 SERIES - 2008
	159842-01-01A	EA	CASE - VINYL - F/MANUALS - W/SLEEVES - BLACK
	161500-08-004	EA	MANUAL/OWNER - SPIRIT - 300 SERIES - 2008
	162115-01-000	DW	TOP LEVEL-300,2008

## AUDIO VIDEO GROUP RADIO SYSTEM

KEY	PART NUMBER	U/M	DESCRIPTION
	163142-03-000	EA	REMOTE CONTROL/RADIO (CREDIT CARD SIZE) FROM: 00-00-00 THRU: 01-28-07
	163142-09-000	EA	REMOTE CONTROL/RADIO (CREDIT CARD SIZE) FROM: 01-29-07 THRU: 99-99-99
	163142-04-000	EA	REMOTE CONTROL/RADIO (STEERING WHEEL MOUNT) FROM: 00-00-00 THRU: 01-28-07
	163142-10-000	EA	REMOTE CONTROL/RADIO (STEERING WHEEL MOUNT) FROM: 01-29-07 THRU: 99-99-99
	163142-01-000	EA	RADIO-AM/FM/CD/WB - SATELLITE READY - FORD C-BODY FROM: 00-00-00 THRU: 01-28-07
	163142-07-000	EA	RADIO-AM/FM/CD/WB - SATELLITE READY - FORD C-BODY FROM: 01-29-07 THRU: 99-99-99
	163142-05-000	EA	RECEIVER (EYE) - INFRARED FROM: 00-00-00 THRU: 01-28-07
	163142-11-000	EA	RECEIVER (EYE) - INFRARED FROM: 01-29-07 THRU: 99-99-99
	163142-12-000	EA	CABLE/INTERFACE - I-POD

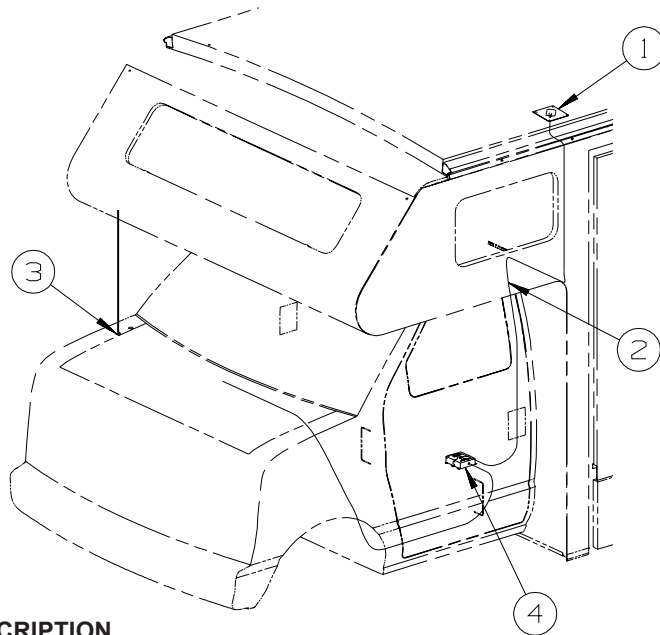

KEY	PART NUMBER	U/M	DESCRIPTION
1	158494-01-000	EA	ANTENNA/SATELLITE - RADIO/SIRIUS
2	158494-02-000	EA	CABLE/ANTENNA - SATELLITE RADIO SIRIUS
3	108137-01-000	EA	PLUG - ANTENNA - 2007 CHASSIS
4	163142-06-000	EA	RECEIVER - SATELLITE RADIO

**AUDIO VIDEO GROUP (CONTINUED)**  
**REAR MONITOR**

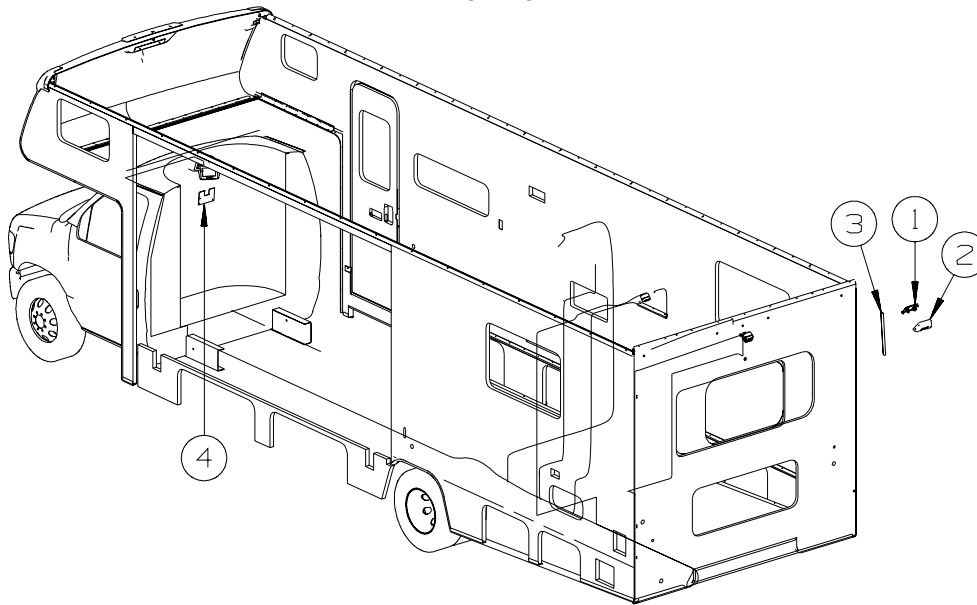

<b>KEY</b>	<b>PART NUMBER</b>	<b>U/M</b>	<b>DESCRIPTION</b>
*	156442-02-01A	EA	COLOR MONITOR/LCD - 5.6" - NO AUDIO-PLAS POD MOUNT-TAN/BLK
*	156442-03-01A	EA	MONITOR/COLOR-5.6"/LCD - W/AUDIO - PLAS POD MOUNT-TAN/BLK - <b>W/AUDIO</b>
*	156930-02-01A	EA	MONITOR/LCD - 5.6" - NO AUDIO - PLASTIC POD MOUNT - TAN - <b>CHEVY CHASSIS</b>
	156930-03-01A	EA	MONITOR/LCD - 5.6" - W/AUDIO - PLASTIC POD MOUNT - TAN - <b>W/AUDIO, CHEVY CHASSIS</b>
	144677-14-01A	EA	CAMERA - REAR VIEW W/BACKET - WHITE - VBCS150
1	NOT USED		
2	NOT USED		
3	NOT USED		
4	160883-01-02B	EA	BRACKET - MONITOR - E-COATED

**\*COMPONENT PARTS LISTED LATER IN THIS GROUP**

**COMPONENT PARTS FOR REAR MONITOR**

<b>156442-02-01A, 156442-03-01A</b>				
<b>KEY</b>	<b>PART NUMBER</b>	<b>U/M</b>	<b>DESCRIPTION</b>	<b>VENDOR NO.</b>
	156442-02-700	EA	SHROUD - REAR VIEW MONITOR	33200013
	156442-02-701	EA	BRACKET - MOUNTING	32300012
<b>156930-02-01A</b>				
<b>KEY</b>	<b>PART NUMBER</b>	<b>U/M</b>	<b>DESCRIPTION</b>	<b>VENDOR NO.</b>
	156930-02-700	EA	SHROUD - REAR VIEW MONITOR	33200012
	156930-02-701	EA	BRACKET - REAR VIEW MONITOR	32300009



# CABINET & APPLIANCE GROUP

## CABINET & APPLIANCE LAYOUT

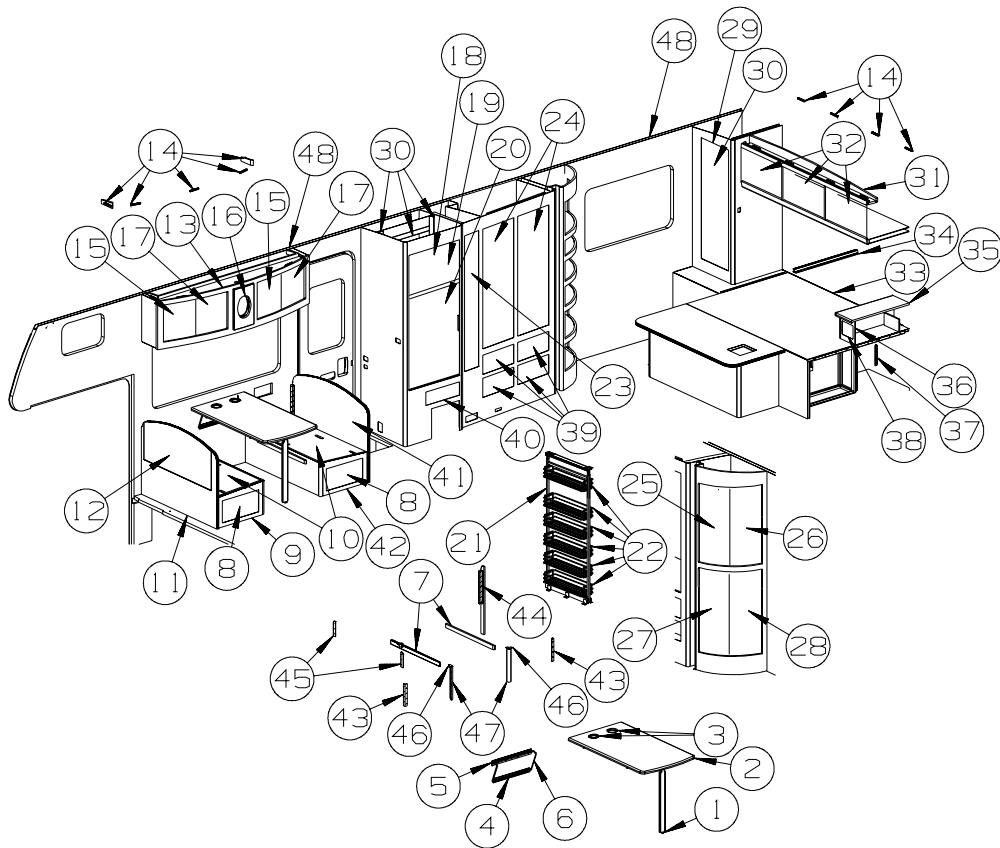

KEY	PART NUMBER	U/M	DESCRIPTION
1	143798-01-02A	EA	CATCH - FLOOR TO TABLE LEG - ALMOND
2	159010-01-W21	EA	TABLE - DINETTE - W/HANGER (W29, W30, W33, W34)
	157828-05-05A	EA	COUNTERTOP - TABLE - W/O HDW (W29, W30, W33, W34)
2	159010-01-W51	EA	TABLE - DINETTE - W/HANGER (W31, W32)
	157828-05-04A	EA	COUNTERTOP - TABLE - W/O HDW (W31, W32)
3	164128-02-03A	EA	HOLDER/CUP - TWO STEP - ALMOND
4	024281-12-000	EA	BRACKET/WALL - TABLE LIFT - 17.1" - ALMOND
5	140921-02-02A	EA	BRACKET/TABLE SUPPORT - 18.5" - ALMOND
6	024275-16-000	EA	ROD - TABLE LIFT - W/ARMS 8" & BASE ROD 18.5" - ALMOND
7	081295-01-RE0	EA	SUPPORT - BED/DINETTE - 28" LONG - HONEY CHERRY
7	081295-01-T01	EA	SUPPORT - BED/DINETTE - 28" LONG - WASHED MAPLE
8	160256-01-W21	EA	DOOR - FLAT/SQUARE EDGE - 19.1" X 10" - W/O HDW - HONEY CHERRY
8	160256-01-W22	EA	DOOR - FLAT/SQUARE EDGE - 19.1" X 10" - W/O HDW - WASHED MAPLE
9	P55741-05-U21	EA	CABINET/SEAT BASE - LEFT HAND - W/O DOOR/DRAWER/HDW - HONEY CHERRY
9	P55741-05-U22	EA	CABINET/SEAT BASE - LEFT HAND - W/O DOOR/DRAWER/HDW - WASHED MAPLE
10	096764-02-000	FT	SLIPNOT - ANTISLIP - 1'WIDE (20' ROLLS) - WHITE
11	155741-38-U29	EA	PANEL/BACK - DINETTE - LEFT HAND - W/O HINGED PORTION - HONEY CHERRY
11	155741-38-U30	EA	PANEL/BACK - DINETTE - LEFT HAND - W/O HINGED PORTION - WASHED MAPLE
12	155741-43-U21	EA	PANEL/BACK - DINETTE - HINGED PORTION - HONEY CHERRY
12	155741-43-U22	EA	PANEL/BACK - DINETTE - HINGED PORTION - WASHED MAPLE
13	157383-06-W21	EA	CABINET - OVERHEAD/DINETTE - W/O DOORS/HDW - HONEY CHERRY
13	157383-06-W22	EA	CABINET - OVERHEAD/DINETTE - W/O DOORS/HDW - WASHED MAPLE
13	157383-07-W21	EA	CABINET - OVHD/DINETTE - W/O DOORS/HDW - HONEY CHERRY - INTERIOR UPGRADE PACKAGE
13	157383-07-W22	EA	CABINET - OVHD/DINETTE - W/O DOORS/HDW - WASHED MAPLE - INTERIOR UPGRADE PACKAGE
14	146514-04-000	EA	CHANNEL/MOUNT - F/ROPE LIGHT
15	160242-01-W21	EA	DOOR - CURVED - 15.7"H X 13.8"W - W/O HDW - HONEY CHERRY
15	160242-01-W22	EA	DOOR - CURVED - 15.7"H X 13.8"W - W/O HDW - WASHED MAPLE
16	156100-02-U21	EA	COVER - SPEAKER - W/FABRIC
16	156100-02-U22	EA	COVER - SPEAKER - W/FABRIC
17	160242-02-W21	EA	DOOR - CURVED - 15.7"H X 13.8"W - W/O HDW - HONEY CHERRY
17	160242-02-W22	EA	DOOR - CURVED - 15.7"H X 13.8"W - W/O HDW - WASHED MAPLE
18*	121568-06-01A	EA	REFRIGERATOR - SMALL DBL DOOR-RH/2 WAY- 52.8"HX23.5"WX24"D
	116751-02-01A	EA	TRAY - REFRIGERATOR - BLACK
	054450-01-000	EA	LEVEL - REFRIGERATOR

**CABINET & APPLIANCE GROUP (CONTINUED)**  
**CABINET & APPLIANCE LAYOUT (CONTINUED)**

KEY	PART NUMBER	U/M	DESCRIPTION
19	103251-07-01A	EA	INSERT/REFRIGERATOR DOOR - 21.6" X 14.5" - BLACK ACRYLIC
19	158456-01-01A	EA	INSERT/REFRIGERATOR DOOR - 21.5"W X 14.5"H - TITANIUM SST - INTERIOR UPGRADE PACKAGE
20	103251-08-01A	EA	INSERT/REFRIGERATOR DOOR - 21.6" X 31.6" - BLACK ACRYLIC
20	158456-02-01A	EA	INSERT/REFRIGERATOR DOOR - 21.5"W X 31.6"H - TITANIUM SST - INTERIOR UPGRADE PACKAGE
21	148432-02-01A	EA	SLIDE FRAME - PANTRY - 22.1" DEEP X 49.8" TO 52.8" TALL
22	148432-10-01A	EA	PANTRY BASKET - 6" X 20.5" X 3.3"
23	160256-23-W21	EA	DOOR - FLAT/SQUARE EDGE - 53.9" X 7.9" - W/O HDW - HONEY CHERRY
23	160256-23-W22	EA	DOOR - FLAT/SQUARE EDGE - 53.9" X 7.9" - W/O HDW - WASHED MAPLE
24	160256-03-W51	EA	DOOR - FLAT/SQUARE EDGE - 48" X 16.7" - W/O HDW - HONEY CHERRY
24	160256-03-W52	EA	DOOR - FLAT/SQUARE EDGE - 48" X 16.7" - W/O HDW - WASHED MAPLE
25	160252-01-U21	EA	DOOR - CURVED - 21.8" X 12.7" - W/O HDW - HONEY CHERRY
25	160252-01-U22	EA	DOOR - CURVED - 21.8" X 12.7" - W/O HDW - WASHED MAPLE
26	160252-02-U21	EA	DOOR - CURVED - 21.8" X 12.7" - W/O HDW - HONEY CHERRY
26	160252-02-U22	EA	DOOR - CURVED - 21.8" X 12.7" - W/O HDW - WASHED MAPLE
27	160252-03-U21	EA	DOOR - CURVED - 43.6" X 12.7" - W/O HDW - HONEY CHERRY
27	160252-03-U22	EA	DOOR - CURVED - 43.6" X 12.7" - W/O HDW - WASHED MAPLE
28	160252-04-U21	EA	DOOR - CURVED - 43.6" X 12.7" - W/O HDW - HONEY CHERRY
28	160252-04-U22	EA	DOOR - CURVED - 43.6" X 12.7" - W/O HDW - WASHED MAPLE
29	159204-02-U21	EA	DOOR - MIRRORED - 16.7" X 48" - W/O HDW - HONEY CHERRY
29	159204-02-U22	EA	DOOR - MIRRORED - 16.7" X 48" - W/O HDW - WASHED MAPLE
	140374-85-000	EA	MIRROR - SAFETY GLASS - 12.8" X 44"
30			REFRIGERATOR CABINET SEALS
	090329-01-000	FT	SEAL - "T" - REFRIGERATOR CABINET
31	164218-01-W21	EA	CABINET - OVERHEAD/REAR - W/O DOORS/HDW - HONEY CHERRY
31	164218-01-W22	EA	CABINET - OVERHEAD/REAR - W/O DOORS/HDW - WASHED MAPLE
32	160245-02-W21	EA	DOOR - CURVED - 16.9" X 24.1" - W/O HDW - HONEY CHERRY
32	160245-02-W22	EA	DOOR - CURVED - 16.9" X 24.1" - W/O HDW - WASHED MAPLE
33	155693-01-U21	EA	CABINET - BED BASE - QUEEN - W/O DOORS/DRAWERS/HDW - HONEY CHERRY
33	155693-01-U22	EA	CABINET - BED BASE - QUEEN - W/O DOORS/DRAWERS/HDW - WASHED MAPLE
34	158079-01-01A	EA	SUPPORT - BUNK/REAR - OFF WHITE
35	157828-04-05A	EA	COUNTERTOP - NIGHTSTAND (W29, W30, W33, W34)
35	157828-04-04A	EA	COUNTERTOP - NIGHTSTAND (W31, W32)
36	155695-01-U21	EA	CABINET - NIGHTSTAND/RH - W/O COUNTERTOP/DOORS/DRAWERS/HDW - HONEY CHERRY
36	155695-01-U22	EA	CABINET - NIGHTSTAND/RH - W/O COUNTERTOP/DOORS/DRAWERS/HDW - WASHED MAPLE
37	081521-02-007	EA	MOUNT - METAL MOLDING - F/RADIUS CORNER MOLDING - 151.5"
38	161078-23-W21	EA	DRAWER - BROKEN EDGE - 5.3"W X 19.7"D - W/O SLIDES/HDW - HONEY CHERRY
38	161078-23-W22	EA	DRAWER - BROKEN EDGE - 5.3"W X 19.7"D - W/O SLIDES/HDW - WASHED MAPLE
39	161078-21-W51	EA	DRAWER - BROKEN EDGE - 14.7"W X 17.7"D - W/O SLIDES/HDW - HONEY CHERRY
39	161078-21-W52	EA	DRAWER - BROKEN EDGE - 14.7"W X 17.7"D - W/O SLIDES/HDW - WASHED MAPLE
40	161078-22-W21	EA	DRAWER - BROKEN EDGE - 14.7"W X 15.7"D - W/O SLIDES/HDW - HONEY CHERRY
40	161078-22-W22	EA	DRAWER - BROKEN EDGE - 14.7"W X 15.7"D - W/O SLIDES/HDW - WASHED MAPLE
41	155741-32-U21	EA	PANEL/BACK - DINETTE - RH - W/O HDW - HONEY CHERRY
41	155741-32-U22	EA	PANEL/BACK - DINETTE - RH - W/O HDW - WASHED MAPLE
41	155741-52-U21	EA	PANEL/BACK - DINETTE - RH - W/O HDW - HONEY CHERRY - WTR HTR-6G/110/LP/MA
41	155741-52-U22	EA	PANEL/BACK - DINETTE - RH - W/O HDW - WASHED MAPLE - WTR HTR-6G/110/LP/MA
42	P55741-06-U21	EA	CABINET/SEAT BASE - RH - W/O DOOR/DRWR/HDW - HONEY CHERRY
42	P55741-06-U22	EA	CABINET/SEAT BASE - RH - W/O DOOR/DRWR/HDW - WASHED MAPLE
42	P55741-09-U21	EA	CABINET/SEAT BASE - RH - W/O DOOR/DRWR/HDW - HONEY CHERRY - WTR HTR-6G/110/LP/MA
42	P55741-09-U22	EA	CABINET/SEAT BASE - RH - W/O DOOR/DRWR/HDW - WASHED MAPLE - WTR HTR-6G/110/LP/MA
43	122021-01-02A	EA	ANGLE - W/HOLES - 8.6" LONG - OFF WHITE
44	122021-02-02A	EA	ANGLE - W/HOLES - 13.7" LONG - OFF WHITE
			FROM: 00-00-00 THRU: 05-21-07
44	122021-10-02A	EA	ANGLE - W/HOLES - 13" LONG - OFF WHITE
			FROM: 05-22-07 THRU: 99-99-99
45	111474-01-01A	EA	PLATE-STOP O/W
46	160989-01-07A	EA	CAP - CORNER - RADIUS MOLDING - PLASTIC - HONEY CHERRY
46	160989-01-06A	EA	CAP - CORNER - RADIUS MOLDING - PLASTIC - WASHED MAPLE
47	156464-01-01A	EA	MOLDING - CORNER - RADIUS/PLASTIC - 8' - HONEY CHERRY
47	156464-01-02A	EA	MOLDING - CORNER - RADIUS/PLASTIC - 8' - WASHED MAPLE
48	M09471-79-RE0	EA	MOLDING - TRIM/COVE - .8" X .8" X 96" - HONEY CHERRY
48	M09471-79-R46	EA	MOLDING - TRIM/COVE - .8" X .8" X 96" - WASHED MAPLE

\*COMPONENT PARTS LISTED LATER IN THIS GROUP

## CABINET & APPLIANCE GROUP (CONTINUED)

### CABINET & APPLIANCE LAYOUT (CONTINUED)

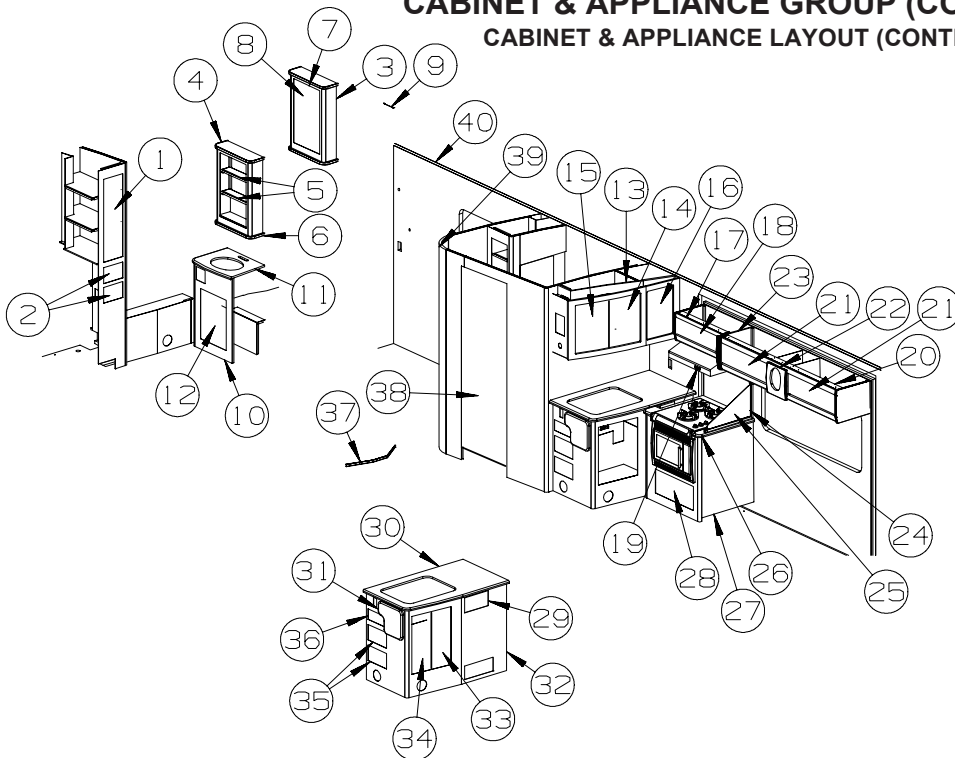

KEY	PART NUMBER	U/M	DESCRIPTION
1	160256-24-W21	EA	DOOR - FLAT/SQUARE EDGE - 33.4" X 9.8" - W/O HDW - HONEY CHERRY
1	160256-24-W22	EA	DOOR - FLAT/SQUARE EDGE - 33.4" X 9.8" - W/O HDW - WASHED MAPLE
2	161078-27-W21	EA	DRAWER - BROKEN EDGE - 8"W X 13.8"D - W/O SLIDES/HDW - HONEY CHERRY
2	161078-27-W22	EA	DRAWER - BROKEN EDGE - 8"W X 13.8"D - W/O SLIDES/HDW - WASHED MAPLE
3	157997-01-W21	EA	CABINET - OVERHEAD/MEDICINE - W/O DOORS/HDW - HONEY CHERRY
3	157997-01-W22	EA	CABINET - OVERHEAD/MEDICINE - W/O DOORS/HDW - WASHED MAPLE
4	158227-05-U21	EA	END CAP - OVERHEAD CABINET - HONEY CHERRY
4	158227-05-U22	EA	END CAP - OVERHEAD CABINET - WASHED MAPLE
5	157997-19-U21	EA	SHELF - W/PLASTIC EDGE MOLDING - HONEY CHERRY
5	157997-19-U22	EA	SHELF - W/PLASTIC EDGE MOLDING - WASHED MAPLE
6	158227-04-U21	EA	END CAP - OVERHEAD CABINET - HONEY CHERRY
6	158227-04-U22	EA	END CAP - OVERHEAD CABINET - WASHED MAPLE
7	145576-06-U21	EA	DOOR - W/MIRROR - 15.96" X 25.9" - W/O HARDWARE - HONEY CHERRY
7	145576-C0-W21	EA	DOOR - MIRRORED - 16" X 25.9" - W/O HARDWARE - HONEY CHERRY
7	145576-06-U22	EA	DOOR - W/MIRROR - 15.96" X 25.9" - W/O HARDWARE - WASHED MAPLE
7	145576-C0-W22	EA	DOOR - MIRRORED - 16" X 25.9" - W/O HARDWARE - WASHED MAPLE
8	093606-36-000	EA	MIRROR - BEVELED EDGE - 16" X 26"
9	076767-04-000	EA	CABLE - STAINLESS STEEL - 5.9"
10	157861-01-U21	EA	CABINET - LAVATORY - W/O COUNTERTOP/DOORS/DRAWERS/HDW - HONEY CHERRY
10	157861-01-U22	EA	CABINET - LAVATORY - W/O COUNTERTOP/DOORS/DRAWERS/HDW - WASHED MAPLE
11	157828-17-05A	EA	COUNTERTOP - LAVATORY CABINET (W29, W30, W33, W34)
11	157828-17-04A	EA	COUNTERTOP - LAVATORY CABINET (W31, W32)
12	160256-28-W21	EA	DOOR - FLAT/SQUARE EDGE - 20.4" X 15.7" - W/O HDW - HONEY CHERRY
12	160256-28-W22	EA	DOOR - FLAT/SQUARE EDGE - 20.4" X 15.7" - W/O HDW - WASHED MAPLE
13	158019-01-U21	EA	CABT - OVHD/GALLEY - W/O DOORS/HDW - HONEY CHERRY
13	158019-01-U22	EA	CABT - OVHD/GALLEY - W/O DOORS/HDW - WASHED MAPLE
13	158019-02-U21	EA	CABT - OVHD - W/O HDW - HONEY CHERRY - DRAIN SYST-HEATED OR WTR HTR-6G/110/LP/MA
13	158019-02-U22	EA	CABT - OVHD - W/O HDW - WASHED MAPLE - DRAIN SYST-HEATED OR WTR HTR-6G/110/LP/MA
13	158019-03-U21	EA	CABT - OVHD - W/O HDW - HONEY CHERRY - DRAIN SYST-HEATED/WTR HTR-6G/110/LP/MA
13	158019-03-U22	EA	CABT - OVHD - W/O HDW - WASHED MAPLE - DRAIN SYST-HEATED/WTR HTR-6G/110/LP/MA
13	158019-04-U21	EA	CABT - OVHD - W/O HDW - HONEY CHERRY - INTERIOR UPGRADE PKG
13	158019-04-U22	EA	CABT - OVHD - W/O HDW - WASHED MAPLE - INTERIOR UPGRADE PKG
13	158019-05-U21	EA	CABT - OVHD - HONEY CHERRY - INT. UPGRDE PKG/DRAIN SYS-HEATED OR WTR HTR-6G/110/LP/MA
13	158019-05-U22	EA	CABT - OVHD - WASHED MAPLE - INT. UPGRDE PKG/DRAIN SYS-HEATED OR WTR HTR-6G/110/LP/MA
13	158019-06-U21	EA	CABT - OVHD - HONEY CHERRY - INT. UPGRDE PKG/DRAIN SYS-HEATED/WTR HTR-6G/110/LP/MA
13	158019-06-U22	EA	CABT - OVHD - WASHED MAPLE - INT. UPGRDE PKG/DRAIN SYS-HEATED/WTR HTR-6G/110/LP/MA

**CABINET & APPLIANCE GROUP (CONTINUED)**  
**CABINET & APPLIANCE LAYOUT (CONTINUED)**

KEY	PART NUMBER	U/M	DESCRIPTION
14	160242-04-W51	EA	DOOR - CURVED - 19.9"H X 13.8"W - W/O HDW - HONEY CHERRY
14	160242-04-W52	EA	DOOR - CURVED - 19.9"H X 13.8"W - W/O HDW - WASHED MAPLE
15	160242-03-W51	EA	DOOR - CURVED - 19.9"H X 13.8"W - W/O HDW - HONEY CHERRY
15	160242-03-W52	EA	DOOR - CURVED - 19.9"H X 13.8"W - W/O HDW - WASHED MAPLE
16	160256-25-W21	EA	DOOR - FLAT/SQUARE EDGE - 19.9" X 12.6" - W/O HDW - HONEY CHERRY
16	160256-25-W22	EA	DOOR - FLAT/SQUARE EDGE - 19.9" X 12.6" - W/O HDW - WASHED MAPLE
17	163318-01-W21	EA	CABINET - OVERHEAD/RANGE - W/O DOORS/HDW - HONEY CHERRY
17	163318-01-W22	EA	CABINET - OVERHEAD/RANGE - W/O DOORS/HDW - WASHED MAPLE
17	157964-01-U21	EA	CABINET - OVERHEAD/RANGE - W/O DOORS/HDW - HONEY CHERRY - CANADIAN
17	157964-01-U22	EA	CABINET - OVERHEAD/RANGE - W/O DOORS/HDW - WASHED MAPLE - CANADIAN
18	160245-16-W21	EA	DOOR - CURVED - 9.8" X 27.4" - W/O HDW - HONEY CHERRY
18	160245-16-W22	EA	DOOR - CURVED - 9.8" X 27.4" - W/O HDW - WASHED MAPLE
19*	161116-01-01A	EA	HOOD - RANGE - W/DUAL LITE/FAN - SST
19*	157570-02-01A	EA	HOOD - RANGE 24" - W/LIGHT/FAN - BLACK TEXTURED - CANADIAN
20	164219-01-W21	EA	CABINET - OVERHEAD/COUCH - W/O DOORS/HDW - HONEY CHERRY
20	164219-01-W22	EA	CABINET - OVERHEAD/COUCH - W/O DOORS/HDW - WASHED MAPLE
21	160245-01-W21	EA	DOOR - CURVED - 11.8" X 27.9" - W/O HDW - HONEY CHERRY
21	160245-01-W22	EA	DOOR - CURVED - 11.8" X 27.9" - W/O HDW - WASHED MAPLE
22	156100-01-U21	EA	COVER - SPEAKER - W/FABRIC
22	156100-01-U22	EA	COVER - SPEAKER - W/FABRIC
23	158227-01-U21	EA	END CAP - OVERHEAD CABINET - HONEY CHERRY
23	158227-01-U22	EA	END CAP - OVERHEAD CABINET - WASHED MAPLE
24	145211-03-U21	EA	SPLASHGUARD - HONEY CHERRY
24	145211-03-U22	EA	SPLASHGUARD - WASHED MAPLE
25	127117-03-01A	EA	GLASS - STATIONARY - SPLASHGUARD
26	157828-16-05A	EA	COUNTERTOP - GALLEY CABINET (W29, W30, W33, W34)
26	157828-16-04A	EA	COUNTERTOP - GALLEY CABINET (W31, W32)
27	P57955-01-W21	EA	CABINET - GALLEY - W/O COUNTERTOP/DOORS/DRAWERS/HDW - HONEY CHERRY
27	P57955-01-W22	EA	CABINET - GALLEY - W/O COUNTERTOP/DOORS/DRAWERS/HDW - WASHED MAPLE
28	161078-24-W21	EA	DRAWER - BROKEN EDGE - 21"W X 19.7"D - W/O SLIDES/HDW - HONEY CHERRY
28	161078-24-W22	EA	DRAWER - BROKEN EDGE - 21"W X 19.7"D - W/O SLIDES/HDW - WASHED MAPLE
29	161078-28-W22	EA	DRAWER - BROKEN EDGE - 10"W X 19.7"D - W/O SLIDES/HDW - WASHED MAPLE
29	161078-28-W72	EA	DRAWER - BROKEN EDGE - 10"W X 19.7"D - W/O SLIDES/HDW - HONEY CHERRY
30	162784-10-05A	EA	COUNTERTOP - GALLEY (W29, W30, W33, W34)
30	162784-10-04A	EA	COUNTERTOP - GALLEY (W31, W32)
31	157828-18-05A	EA	COUNTERTOP - EXTENSION/GALLEY (W29, W30, W33, W34)
31	157828-18-04A	EA	COUNTERTOP - EXTENSION/GALLEY (W31, W32)
32	P57895-01-U21	EA	CABINET - GALLEY - W/O COUNTERTOP/DOORS/DRAWERS/HDW - HONEY CHERRY
32	P57895-01-U22	EA	CABINET - GALLEY - W/O COUNTERTOP/DOORS/DRAWERS/HDW - WASHED MAPLE
33	160256-27-W21	EA	DOOR - FLAT/SQUARE EDGE - 26.5" X 9" - W/O HDW - HONEY CHERRY
33	160256-27-W22	EA	DOOR - FLAT/SQUARE EDGE - 26.5" X 9" - W/O HDW - WASHED MAPLE
34	160256-26-W21	EA	DOOR - FLAT/SQUARE EDGE - 26.5" X 9" - W/O HDW - HONEY CHERRY
34	160256-26-W22	EA	DOOR - FLAT/SQUARE EDGE - 26.5" X 9" - W/O HDW - WASHED MAPLE
35	161078-25-W21	EA	DRAWER - BROKEN EDGE - 9.6"W X 15.7"D - W/O SLIDES/HDW - HONEY CHERRY
35	161078-25-W22	EA	DRAWER - BROKEN EDGE - 9.6"W X 15.7"D - W/O SLIDES/HDW - WASHED MAPLE
36	161078-26-W21	EA	DRAWER - BROKEN EDGE - 9.6"W X 15.7"D - W/O SLIDES/HDW - HONEY CHERRY
36	161078-26-W22	EA	DRAWER - BROKEN EDGE - 9.6"W X 15.7"D - W/O SLIDES/HDW - WASHED MAPLE
37	158186-01-01A	EA	TRIM - TOILET PLATFORM - SOFT WHITE
38	144645-02-U21	EA	DOOR - BATH - W/O FRAME (PICTURE)/TOWEL RACK/HDW - HONEY CHERRY
38	144645-02-S48	EA	DOOR - BATH - W/O FRAME (PICTURE)/TOWEL RACK/HDW - WASHED MAPLE
39	156080-02-U21	EA	WALL/CURVED - BATH (W29, W30)
39	156080-02-W31	EA	WALL/CURVED - BATH (W31, W32, W33, W34)
40	M09471-79-RE0	EA	MOLDING - TRIM/COVE - .8" X .8" X 96" - HONEY CHERRY
40	M09471-79-R46	EA	MOLDING - TRIM/COVE - .8" X .8" X 96" - WASHED MAPLE

\*COMPONENT PARTS LISTED LATER IN THIS GROUP

**CABINET & APPLIANCE GROUP (CONTINUED)**  
**CABINET & APPLIANCE LAYOUT (CONTINUED)**

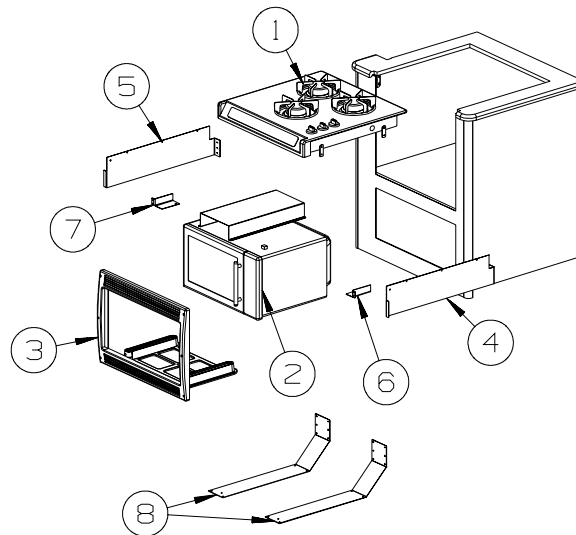

**RANGE-  
W/MICROWAVE  
INSTALLATION**

KEY	PART NUMBER	U/M	DESCRIPTION
1*	156801-01-01A	EA	RANGE - 3 BURNER - 8100 BTU - STAINLESS STEEL
	115870-01-000	FT	SEAL/EDGE - TRIM
2	156801-02-01A	EA	OVEN/MICROWAVE - 1 CU FT/TURN TABLE - STAINLESS STEEL FACE FROM: 00-00-00 THRU: 02-24-08
2	156801-02-02A	EA	OVEN/MICROWAVE - 1 CU FT/TURN TABLE - BLK/SST FACE FROM: 02-25-08 THRU: 99-99-99
3*	156801-03-01A	EA	TRIM KIT - MICROWAVE - STAINLESS STEEL
4	156800-01-02B	EA	BRACKET - MICROWAVE - E-COATED
5	156800-02-02B	EA	BRACKET - MICROWAVE - E-COATED
6	156798-03-02B	EA	BRACKET/TIEDOWN - STOVE - E-COATED
7	156798-04-02B	EA	BRACKET/TIEDOWN - STOVE - E-COATED
8	156799-02-02B	EA	BRACKET - MICROWAVE - E-COATED

\*COMPONENT PARTS LISTED LATER IN THIS GROUP

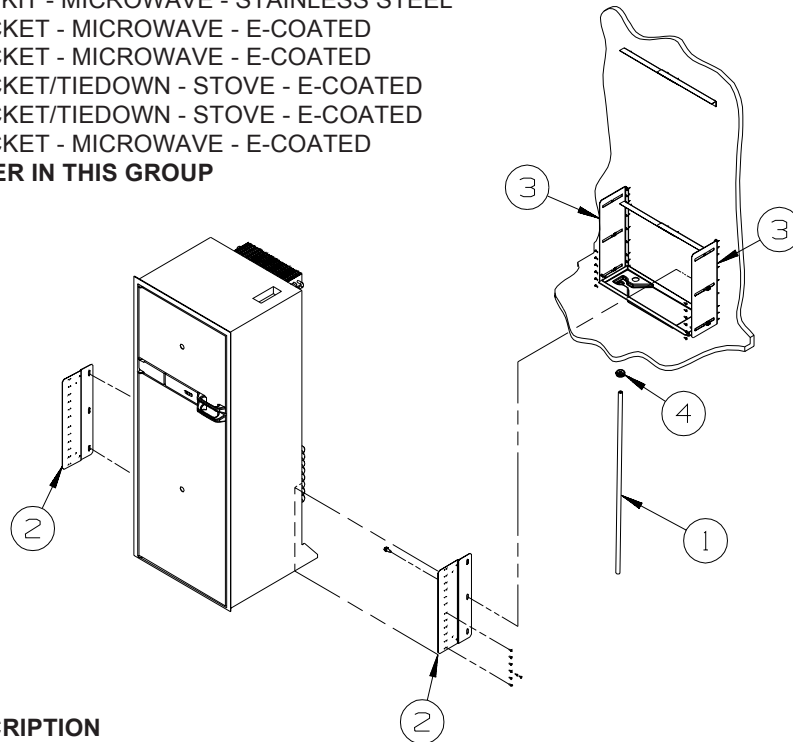

**REFRIGERATOR  
INSTALLATION**

KEY	PART NUMBER	U/M	DESCRIPTION
1	112176-01-000	FT	TUBING - VINYL - REINFORCED - 1/2" ID
2	150740-01-02B	EA	BRACKET/TIEDOWN - REFRIGERATOR - E-COATED
3	150740-02-02B	EA	BRACKET/TIEDOWN - REFRIGERATOR - E-COATED
4	152417-01-01A	EA	CLAMP/RATCHET - F/REFRIGERATOR DRIP TRAY HOSE - BLACK

**CABINET & APPLIANCE GROUP (CONTINUED)**  
**COMPONENT PARTS FOR CABINET & APPLIANCE LAYOUT**

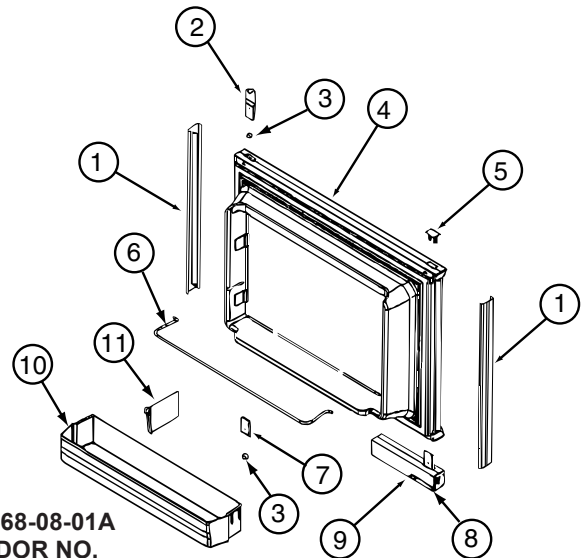

**121568-06-01A, 121568-07-01A, 121568-08-01A**

KEY	PART NUMBER	U/M	DESCRIPTION	VENDOR NO.
1	121568-03-700	EA	RETAINER-DOOR PNL/WAFFLE/BLK	619558-WDL-UPPER
2	120075-01-701	EA	HINGE-TOP RH/BOTTOM LH(DOOR)	618511
3	121568-03-701	EA	BUSHING - HINGE PIN/GRAY	619671
4	121568-03-702	EA	DOOR LINER-UPR/WAFFLED/BLACK	619627 - SMALL WDL
5	120075-01-702	EA	CAP, (HINGE PLUG)	618160
6	121568-01-700	EA	RAIL - DOOR UPPER	618618
7	120075-01-705	EA	HINGE-TOP LH/BOTTOM RH(DOOR)	618510
8	121568-03-705	EA	STORAGE LATCH - GRAY	619648
9	121568-03-721	EA	HANDLE/DOOR UPPER RH SWING	621465
9	121568-03-722	EA	HANDLE/DOOR LOWER RH SWING	621469
10	121568-01-701	EA	BIN - DOOR WHITE-WAFFLED LNR	618619 WDL

CONTACT WINNEBAGO PART SALES FOR UNLISTED COMPONENT(S)

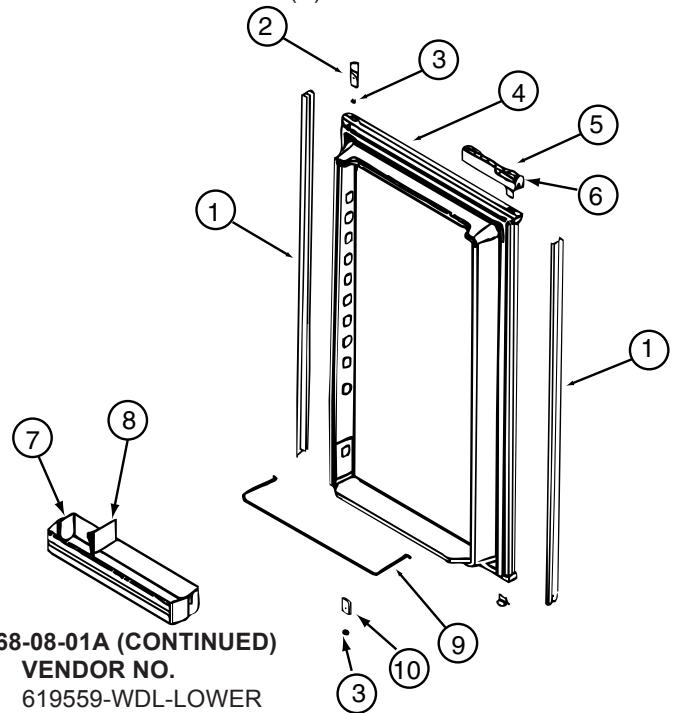

**121568-06-01A, 121568-07-01A, 121568-08-01A (CONTINUED)**

KEY	PART NUMBER	U/M	DESCRIPTION	VENDOR NO.
1	121568-03-706	EA	RETAINER-DOOR PNL/WAFFLE/BLK	619559-WDL-LOWER
2	120075-01-701	EA	HINGE-TOP RH/BOTTOM LH(DOOR)	618511
3	121568-03-701	EA	BUSHING - HINGE PIN/GRAY	619671
4	121568-03-707	EA	DOOR LINER-LWR/WAFFLED/B/TRM	619629
5	121568-03-722	EA	HANDLE/DOOR LOWER RH SWING	621469
6	121568-03-705	EA	STORAGE LATCH - GRAY	619648
7	121568-01-701	EA	BIN - DOOR WHITE-WAFFLED LNR	618619 WDL
9	121568-01-704	EA	RAIL - DOOR LOWER	618578
10	120075-01-705	EA	HINGE-TOP LH/BOTTOM RH(DOOR)	618510

CONTACT WINNEBAGO PART SALES FOR UNLISTED COMPONENT(S)

**CABINET & APPLIANCE GROUP (CONTINUED)**  
**COMPONENT PARTS FOR CABINET & APPLIANCE LAYOUT (CONTINUED)**

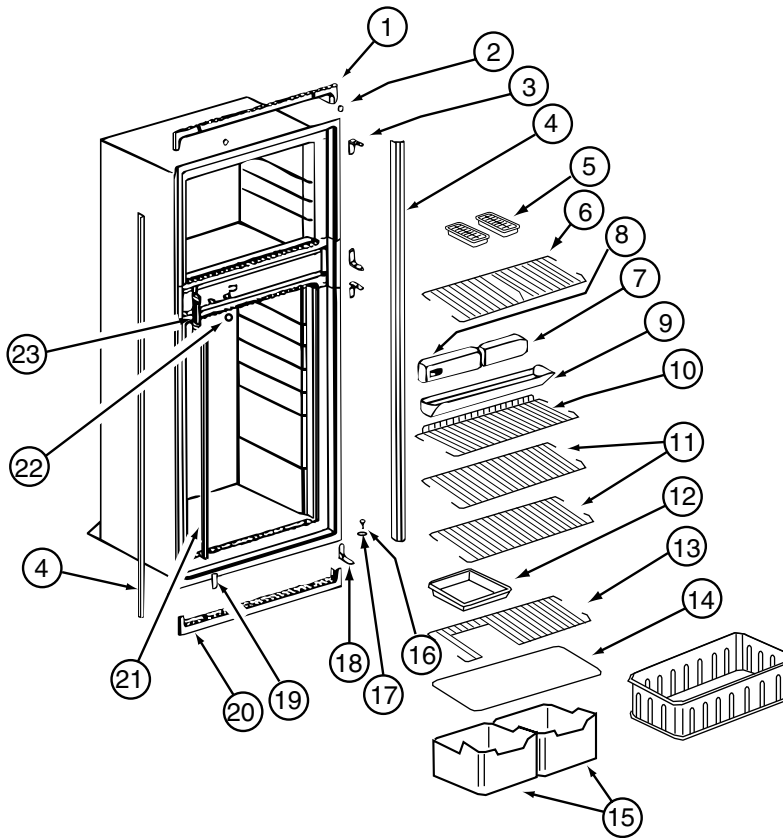

**121568-06-01A, 121568-07-01A, 121568-08-01A (CONTINUED)**

KEY	PART NUMBER	U/M	DESCRIPTION	VENDOR NO.
1	120075-01-713	EA	TRIM-TOP PIECE	619687
2	120075-01-714	EA	PLUG-HOLE (BLACK)	618170
3	121568-03-710	EA	HINGE/CABINET-TOP/RH-LWR/LH	619335 WAFFLED
4	121568-03-711	EA	TRIM - SIDE/BLACK	622295
6	121568-01-705	EA	SHELF - WIRE FREEZER	620250
7	121568-06-700	EA	FRONT BOX-N611	622002
8	121568-06-701	EA	CONTROL ASSY-OPTICAL/N611	621988 TO SN9056491
9	120075-01-720	EA	TRAY-DRIP	623250
9	120075-01-721	EA	LOUVER-DRIP TRAY	618176
11	121568-01-708	EA	SHELF - WIRE	620273
13	121568-01-707	EA	SHELF - WIRE - SHORT	620272
14	120075-01-725	EA	COVER-CRISPER - 18.5" WIDE	618158
15	121568-01-709	EA	CRISPER	618571
16	120075-01-727	EA	PIN-HINGE	618145
17	121568-03-701	EA	BUSHING - HINGE PIN/GRAY	619671
18	121568-03-715	EA	HINGE/CABINET-TOP/LH-LWR/RH	619336 WAFFLED
19	121568-03-716	EA	COVER - HINGE HOLES	619301
20	120075-01-729	EA	TRIM-BOTTOM PIECE	620958
21	121568-06-702	EA	CLIP - SHELF	61536522
22	121568-06-703	EA	HOLE PLUG - WHITE	620282
23	120075-01-732	EA	PLATE-STRIKE	618167

CONTACT WINNEBAGO PART SALES FOR UNLISTED COMPONENT(S)

**CABINET & APPLIANCE GROUP (CONTINUED)**  
**COMPONENT PARTS FOR CABINET & APPLIANCE LAYOUT (CONTINUED)**

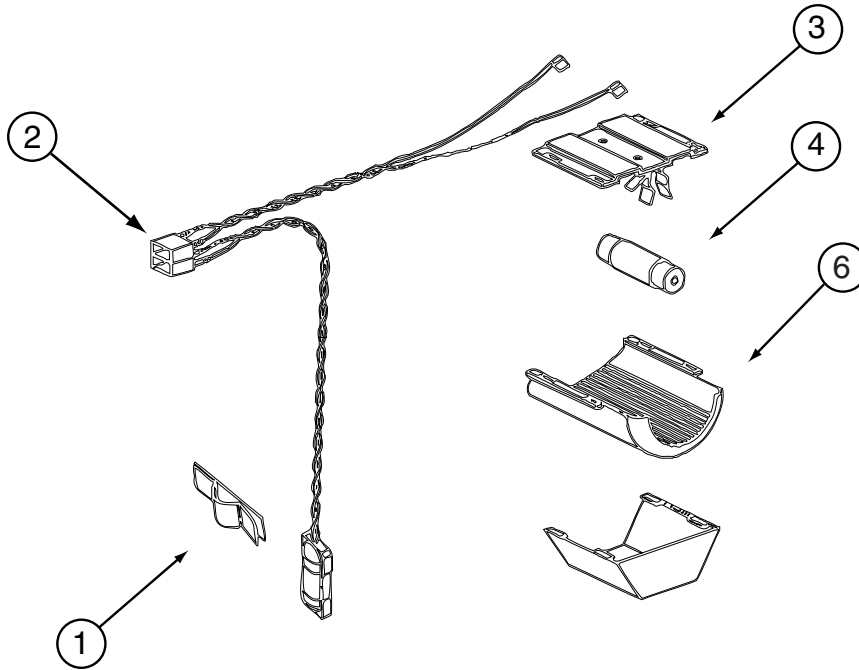

121568-03-01A, 121568-04-01A, 121568-05-01A, 121568-06-01A, 121568-07-01A, 121568-08-01A (CONTINUED)

KEY	PART NUMBER	U/M	DESCRIPTION	VENDOR NO.
1	084880-01-760	EA	CLIP (THERMISTER)	61689122
2	120075-01-735	EA	WIRE ASM - LAMP/THERMISTER	618548
3	084880-03-705	EA	BRACKET-LIGHT-INTERIOR	61629722
4	084880-03-706	EA	BULB-LAMP	61628922
6	084880-03-707	EA	COVER-LAMP, LENS	61627922

CONTACT WINNEBAGO PART SALES FOR UNLISTED COMPONENT(S)

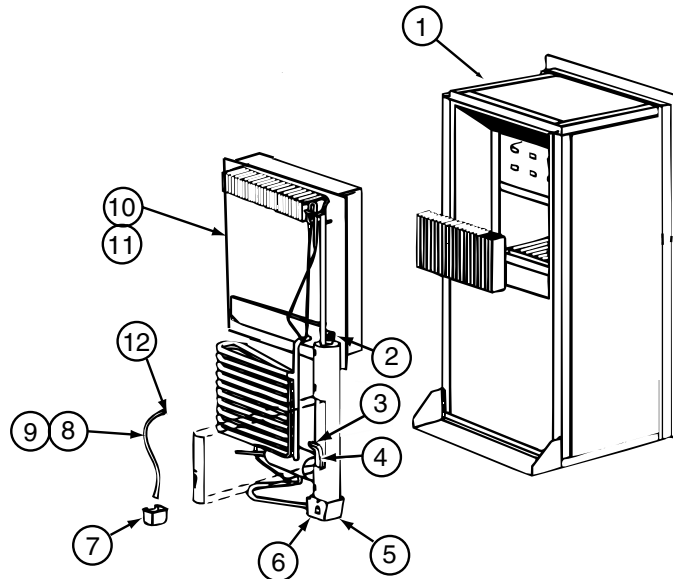

121568-06-01A, 121568-07-01A, 121568-08-01A (CONTINUED)

KEY	PART NUMBER	U/M	DESCRIPTION	VENDOR NO.
4	121568-06-704	EA	HEATER-AC/300W/120VAC	621702
10	120076-01-704	EA	COOLING UNIT, SERVICE PACK	618543

CONTACT WINNEBAGO PART SALES FOR UNLISTED COMPONENT(S)



**CABINET & APPLIANCE GROUP (CONTINUED)**  
**COMPONENT PARTS FOR CABINET & APPLIANCE LAYOUT (CONTINUED)**

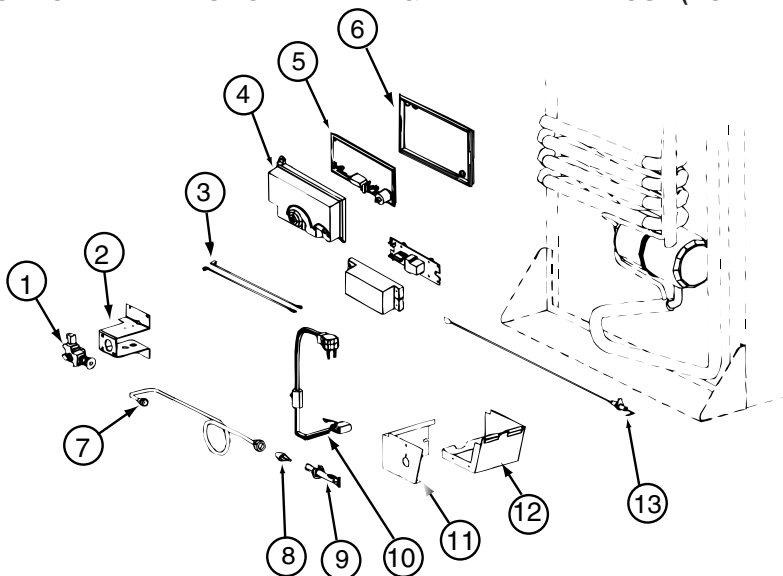

**121568-06-01A, 121568-07-01A, 121568-08-01A (CONTINUED)**

KEY	PART NUMBER	U/M	DESCRIPTION	VENDOR NO.
	121568-06-705	EA	GAS VALVE/BRKT ASSY-COMBO	621439
1	121568-06-706	EA	GAS VALVE-COMBO/WRENCH FLAT	621329
4	120075-01-738	EA	COVER-POWER BOARD	618185
5	121568-06-707	EA	BOARD/POWER-N611	621991 = 621991001
6	120075-01-740	EA	BASE - POWER BOARD	618186
8	121568-06-708	EA	BURNER/ORFICE-ADAPTER KIT	621957
13	104137-06-715	EA	ELECTRODE-SPARK/SENSOR, SGL	61692222
	121569-08-704	EA	TUBE/BURNER - N8/N6	624682
			CONTACT WINNEBAGO PART SALES FOR UNLISTED COMPONENT(S)	

**156801-01-01A**

KEY	PART NUMBER	U/M	DESCRIPTION	VENDOR NO.
	156801-01-718	EA	FITTING/OUTLET - REGULATOR	C18

**156801-03-01A**

KEY	PART NUMBER	U/M	DESCRIPTION	VENDOR NO.
	156801-03-700	EA	SCREW COVER F/TRIM KIT	FOR B12-S

**CABINET & APPLIANCE GROUP (CONTINUED)**  
**COMPONENT PARTS FOR CABINET & APPLIANCE LAYOUT (CONTINUED)**

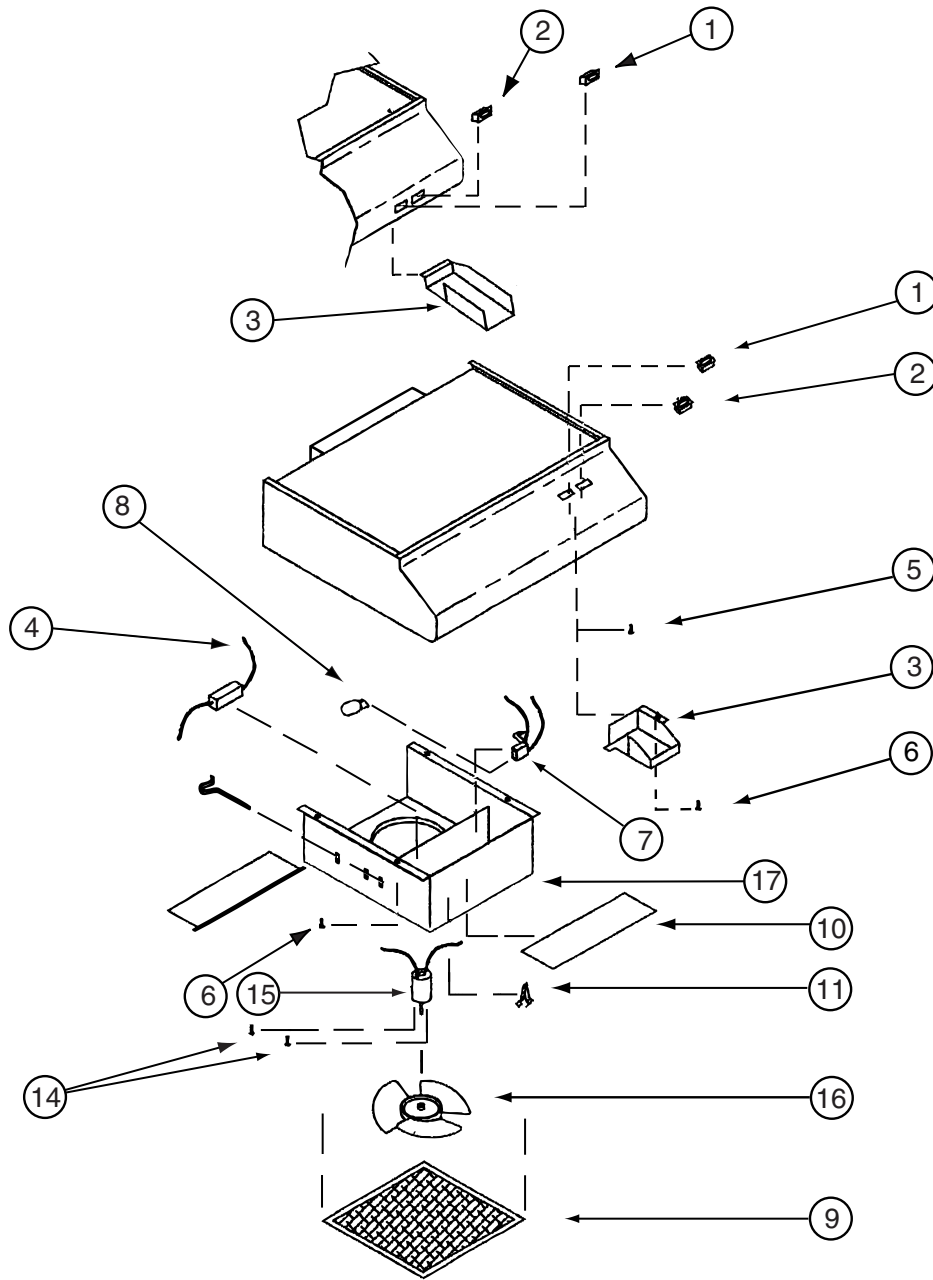

**157570-01-01A, 157570-02-01A**

KEY	PART NUMBER	U/M	DESCRIPTION	VENDOR NO.
1	157570-01-700	EA	SWITCH - LAMP/BLACK	L1196-00
2	157570-01-701	EA	SWITCH - FAN/BLACK	L1194-00
9	096983-01-707	EA	FILTER-MESH	CC0246-00
10	092696-02-701	EA	LENS-LAMP	CC0179
15	157570-01-702	EA	MOTOR-12 VOLT	VD0218-00
16	136354-05-701	EA	BLADE-FAN 7" DIA	VD0216-00
CONTACT WINNEBAGO PART SALES FOR UNLISTED COMPONENT(S)				

**161116-01-01A, 161116-02-01A**

KEY	PART NUMBER	U/M	DESCRIPTION	VENDOR NO.
	161116-01-700	EA	LIGHT/RND-CLEAR LENS W/BULB	W/WIRING/PLUG
	161116-02-700	EA	FILTER-ALUMINUM	02FP577295UL

## CHASSIS GROUP

### FRAME

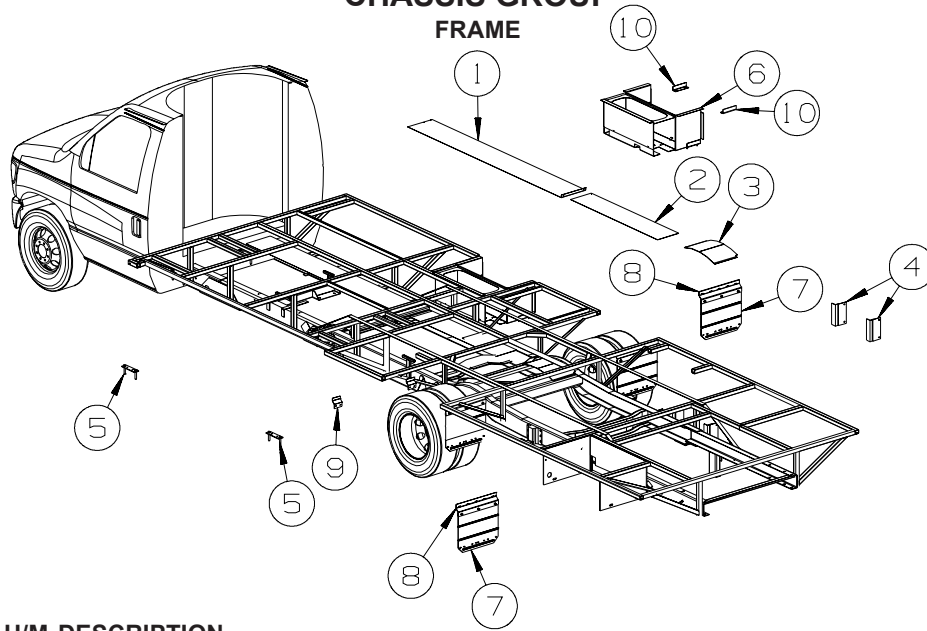

KEY	PART NUMBER	U/M DESCRIPTION
1	135676-05-02B	EA SHIELD - HEAT - E-COATED
2	145027-01-02B	EA SHIELD - HEAT - E-COATED
3	158704-01-02B	EA SHIELD - HEAT - E-COATED
4	136042-01-02B	EA BRACKET - LP SUPPORT - E-COATED
5	136995-03-02B	EA PLATE W/BOLTS - 6.9" X 2" W/1/2" X 3" BOLTS
6	162352-01-02B	EA BOX - ENTRANCE STEP - E-COATED
7	136391-02-02B	EA GUARD/ROCK - STEEL - W/ANGLE - 18"W X 15"H - E-COATED
8	157464-01-02B	EA BRACKET/MOUNTING - MUD GUARD - E-COATED
9	141003-01-02B	EA PLATE - VALVE - AIR SPRING - E-COATED - AIR SPRINGS REAR
10	139997-01-02B	EA ANGLE - STEEL - W/2 SLOTS - E-COATED

### DRIVETRAIN

KEY	PART NUMBER	U/M DESCRIPTION
	103653-23-000	EA BOLT - U-JOINT - 5/16-24 X .75
	103653-24-000	EA STRAP - U-JOINT

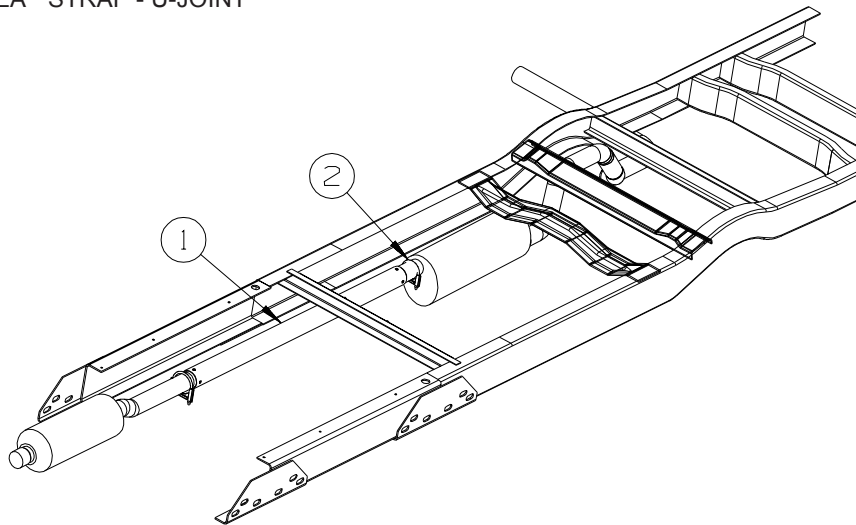

### EXHAUST

KEY	PART NUMBER	U/M DESCRIPTION
1	111478-06-000	EA EXHAUST PIPE - DOUBLE WALL STAINLESS STEEL - 58.9"
2	094918-06-000	EA CLAMP - EXHAUST - 3" - HEAVY DUTY

## CHASSIS GROUP (CONTINUED)

### HITCH

KEY	PART NUMBER	U/M DESCRIPTION
	154054-03-01A	EA HITCH RECEIVER - BOLT ON CLASS III - BLACK

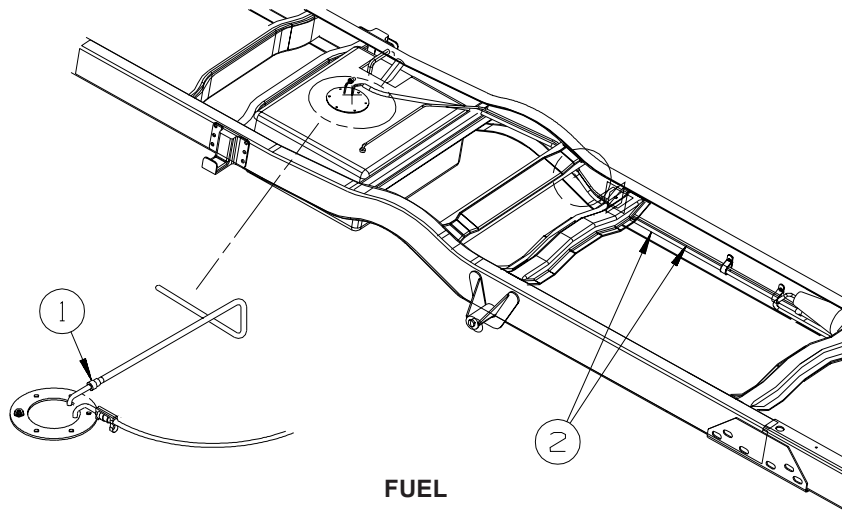

KEY	PART NUMBER	U/M DESCRIPTION
1	149468-01-000	EA FITTING - F/FUEL-SENDING UNIT - 1/4"
2	106388-12-000	EA FUEL LINE - 5/16 HP - W/FEMALE CONNECTOR - 65.8"

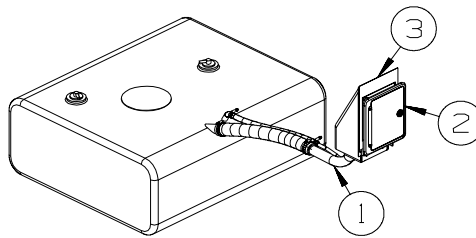

KEY	PART NUMBER	U/M DESCRIPTION
1	148789-01-000	EA NECK - FUEL FILL - FORD
2	147587-01-01A	EA DOOR - FUEL FILL
	138290-03-000	EA CASE - W/CAM - W/O CYLINDER/KEY
3	135557-01-01A	EA SHROUD - FUEL FILL - UPPER - 16" X 8.2"

## CHASSIS GROUP (CONTINUED) HYDRAULIC LEVELING

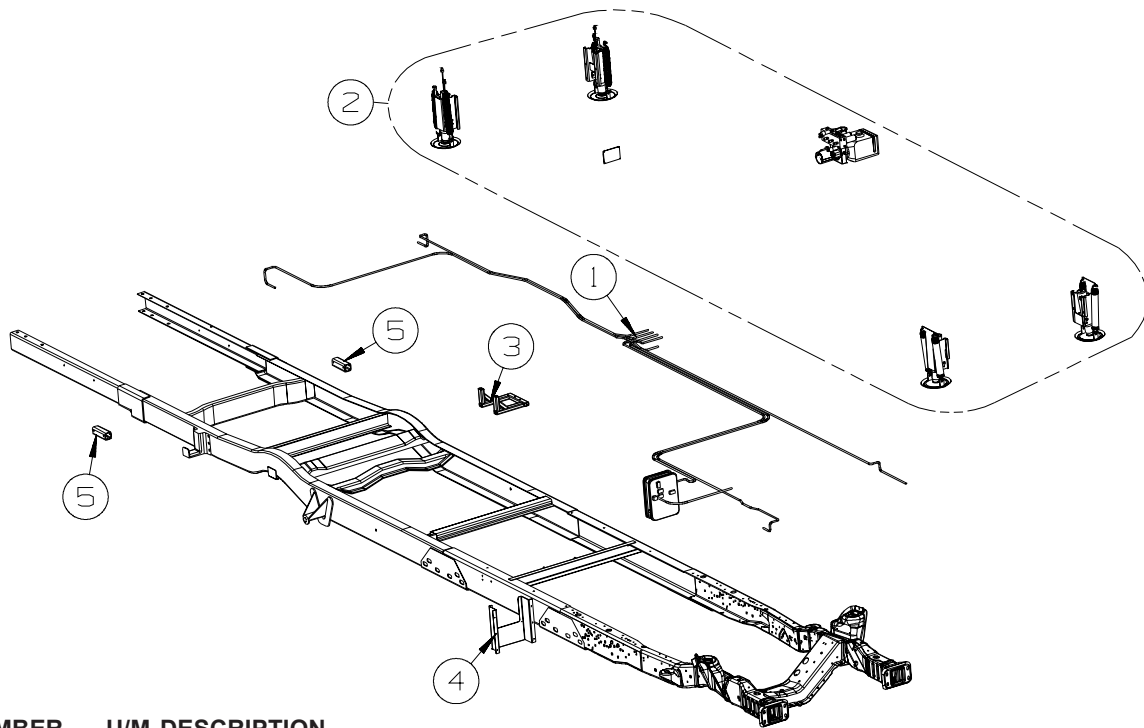

KEY	PART NUMBER	U/M	DESCRIPTION
1	100536-71-000	EA	HOSE KIT - F/LEVELING JACKS
2	157770-02-000	EA	LEVELING SYSTEM - 625 SYSTEM - FORD
3	162503-01-02B	EA	BRACKET/MOUNTING - PUMP - E-COATED
4	163043-01-02B	EA	BRACKET - CONTROL BOX/LEVELING - E-COATED
5	163995-02-02B	EA	TUBE - LEVELING JACK - E-COATED

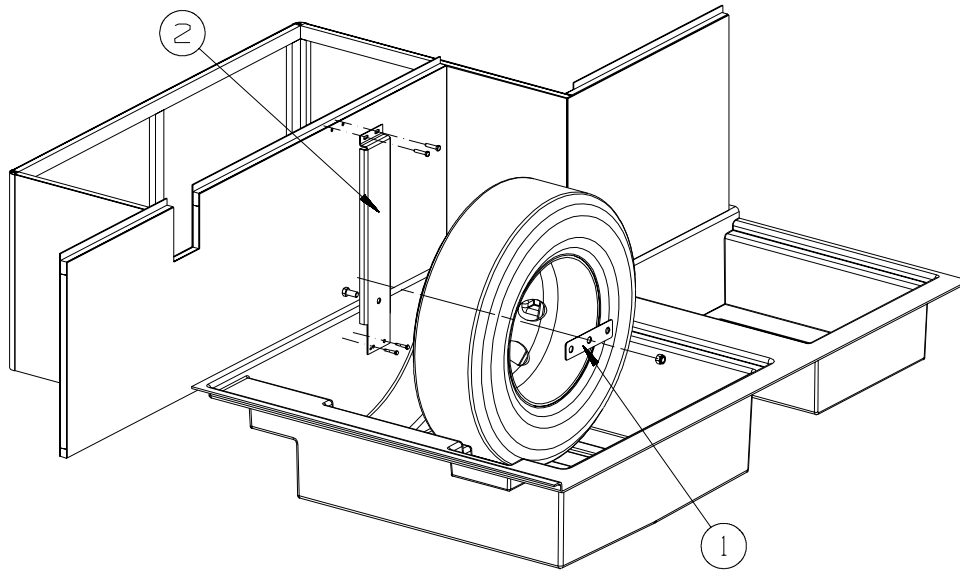

### SPARE TIRE

KEY	PART NUMBER	U/M	DESCRIPTION
1	143547-01-02B	EA	RETAINER - SPARE TIRE - E-COATED
2	157324-02-01B	EA	BRACKET - SPARE TIRE
	155645-01-000	EA	VALVE STEM - 1.25"

**CHASSIS GROUP (CONTINUED)**  
**SUSPENSION**

KEY	PART NUMBER	U/M	DESCRIPTION
*	144887-02-000	EA	AIRSPRING - 4" DIAMETER/TWIN BAG SYSTEM - FIRESTONE - FORD
*	156618-01-000	EA	AIRSPRING - AIR BAG KIT - GMT610/14050 CHEVY - FIRESTONE - CHEVY

\*COMPONENT PARTS LISTED LATER IN THIS GROUP

**COMPONENT PARTS FOR SUSPENSION**

**144887-02-000**

KEY	PART NUMBER	U/M	DESCRIPTION	VENDOR NO.
	084086-05-704	EA	BRACKET CLAMP	5086
	084086-05-706	EA	VALVE-INFLATION,PUSH TO CONN	3032
	144887-02-700	EA	AIRSPRING - BAG ONLY	9000
	144887-02-701	EA	BRACKET - LEFT UPPER	5390
	144887-02-702	EA	BRACKET - RIGHT UPPER	5389
	144887-02-703	EA	BRACKET - LOWER RH/LH	5391
	144887-02-704	EA	DISK	5204
	144887-02-705	EA	TUBING/AIR LINE - 22'	0937

**156618-01-000**

KEY	PART NUMBER	U/M	DESCRIPTION	VENDOR NO.
	084086-01-709	EA	SHIELD-HEAT-224 CR SYSTEM	21-1004
	084086-01-713	EA	BRACKET-AXLE STRAP, 4"	21-1163
	156618-01-700	EA	BAG - AIR SPRING - 1 ONLY	A01760672
	156618-01-701	EA	BRACKET - LEFT UPPER	5478
	156618-01-702	EA	BRACKET - RIGHT UPPER	5221
	156618-01-703	EA	BRACKET - LOWER RH/LH	5472

**WHEEL, TIRE, COVERS &/OR LINERS**

KEY	PART NUMBER	U/M	DESCRIPTION
	112358-02-000	EA	WRENCH - LUG - 7/8" - L-SHAPE
	080208-02-000	EA	BAR/LEVERAGE - LUG WRENCH - 13/16" DIA - ALUMINUM WHEELS
	080208-06-000	EA	LUG WRENCH - 1"/1.1" SOCKETS X 16.4" LONG - ALUMINUM WHEELS
	077030-01-000	EA	EXTENSION - VALVE STEM - 1.25" - METAL - ALUMINUM WHEELSD
	077030-10-000	EA	EXTENSION - VALVE STEM - .50" - METAL
	095012-05-000	EA	EXTENSION/VALVE STEM - LIVE - 5" - FORD
	095012-06-000	EA	STABILIZER/VALVE EXTENSION - LIVE - 2"
	095012-07-000	EA	STABILIZER/VALVE EXTENSION - LIVE - 4"
	095012-09-000	EA	EXTENSION/VALVE STEM - LIVE - 7.7" - CHEVY
*	110435-13-000	EA	LINER - WHEEL - SET OF 4 - 16" (8 HOLE) - FORD W/ STEEL WHEEL W/6 SLOTS
*	144647-01-000	EA	LINER - WHEEL SET (SET=4) 16" - FORD W/ STEEL WHEEL W/4 SLOTS FROM: 00-00-00 THRU: 03-30-07
*	110435-23-000	EA	LINER - WHEEL SET (SET=4) 16" - FORD W/ STEEL WHEEL W/4 SLOTS FROM: 03-31-07 THRU: 99-99-99
	149749-01-000	EA	WHEEL - ALUMINUM - 6" X 16" - FRONT - FORD E450 - ALUMINUM WHEELS
	149749-02-000	EA	WHEEL - ALUMINUM - 6" X 16" - REAR - FORD E450 - ALUMINUM WHEELS
	156797-01-000	EA	WHEEL - ALUMINUM/FRONT - 16" X 6.5" - 8 BOLT - CHEVY ALUMINUM WHEELS
	156797-02-000	EA	WHEEL - ALUMINUM/REAR - 16" X 6.5" - 8 BOLT - CHEVY ALUMINUM WHEELS
	156797-03-000	EA	COVER/HUB - FRONT - ALUMINUM WHEEL - ALUMINUM WHEELS
	156797-04-000	EA	COVER/HUB - FRONT - ALUMINUM WHEEL - ALUMINUM WHEELS
	149749-05-000	EA	COVER/NUT - ALUMINUM WHEELS
	149749-06-000	EA	NUT/WHEEL - 9/16"-18 - LOW PROFILE - FORD E450 - FORD ALUMINUM WHEELS
	156797-06-000	EA	NUT/LUG - 14MM X 1.5 - ALUMINUM WHEEL - CHEVY ALUMINUM WHEELS

\*COMPONENT PARTS LISTED LATER IN THIS GROUP

**CHASSIS GROUP (CONTINUED)**  
**COMPONENT PARTS FOR WHEEL, TIRE, COVERS &/OR LINERS**

**110435-13-000**

<b>KEY</b>	<b>PART NUMBER</b>	<b>U/M</b>	<b>DESCRIPTION</b>	<b>VENDOR NO.</b>
	110435-01-711	EA	DECAL-CENTER CAP, 2" - QTY 2	DIAMOND/2 PER BAG
	110435-10-705	EA	TOOL/JAMB NUT INSTALLATION	V195P7-TOL
	110435-13-700	EA	LINER - WHEEL - FRONT	V160F7-FWC
	110435-13-701	EA	LINER - WHEEL - REAR	V160F7-RWC
	110435-13-702	EA	JAMB NUT W/COVER - 9/16"	V160F7-EJN

**110435-23-000**

<b>KEY</b>	<b>PART NUMBER</b>	<b>U/M</b>	<b>DESCRIPTION</b>	<b>VENDOR NO.</b>
	110435-01-711	EA	DECAL-CENTER CAP- 2" - QTY 2	DIAMOND/2 PER BAG
	110435-23-700	EA	COVER/WHEEL - FRONT - 1 ONLY	FWCFL60-59
	110435-23-701	EA	COVER/WHEEL - REAR - 1 ONLY	RWCFL60-59

**144647-01-000**

<b>KEY</b>	<b>PART NUMBER</b>	<b>U/M</b>	<b>DESCRIPTION</b>	<b>VENDOR NO.</b>
	110435-01-711	EA	DECAL-CENTER CAP, 2" - QTY 2	DIAMOND/2 PER BAG
	144647-01-700	EA	WHEEL LINER - FRONT/1 PIECE	FL60-FWC
	144647-01-701	EA	WHEEL LINER - REAR/1 PIECE	FL60-RWC

**BRAKELINE**

<b>KEY</b>	<b>PART NUMBER</b>	<b>U/M</b>	<b>DESCRIPTION</b>
	088498-01-000	EA	UNION - INVERTED FLARE - BRASS - 3/16 - FORD CHASSIS

## CURTAIN & CUSHION GROUP

### CURTAIN, CUSHION LAYOUT

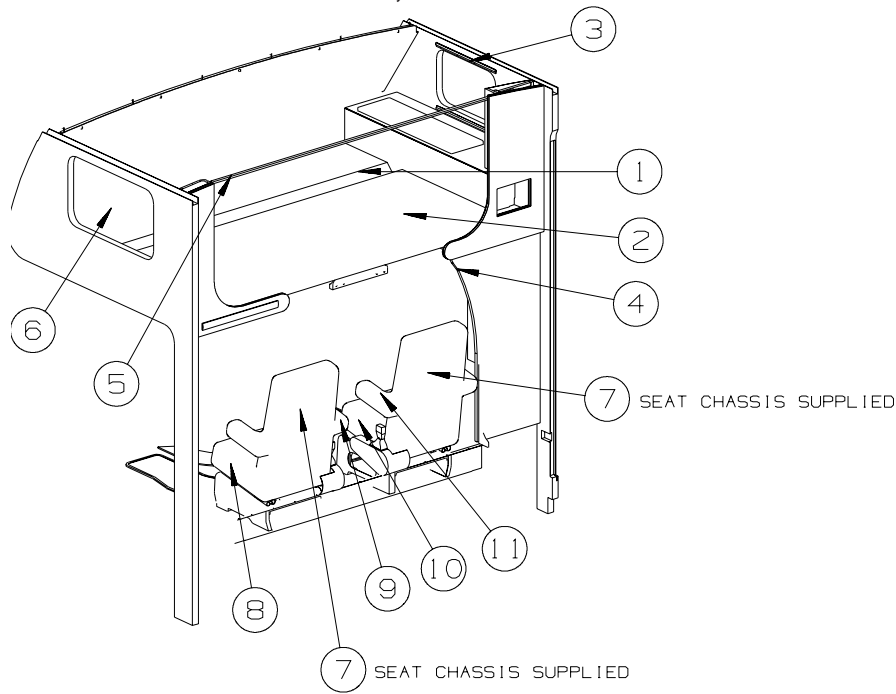

KEY	PART NUMBER	U/M	DESCRIPTION
1	157657-10-W29	EA	CUSHION - OVERHEAD BUNK - 22" X 80" X 6" - SINGLE BUNK (W29, W30)
1	157657-09-W31	EA	CUSHION - OVERHEAD BUNK - 22"X 80"X 6" - SINGLE BUNK (W31, W32)
1	157657-09-W33	EA	CUSHION - OVERHEAD BUNK - 22"X 80"X 6" - SINGLE BUNK (W33, W34)
1	157657-17-W29	EA	CUSHION - OVERHEAD BUNK - 27"/29" X 80" X 6" - W/ANGLE - DOUBLE BUNK (W29, W30)
1	157657-15-W31	EA	CUSHION - OVERHEAD BUNK - 27"/29" X 80" X 6" - DOUBLE BUNK (W31, W32)
1	157657-15-W33	EA	CUSHION - OVERHEAD BUNK - 27"/29" X 80" X 6" - DOUBLE BUNK (W33, W34)
	157657-B0-W29	EA	COVER - CUSHION/OVERHEAD - 22" X 80" X 6" - W/ANGLE - SINGLE BUNK (W29, W30)
	157657-A9-W31	EA	COVER - CUSHION/OVERHEAD - 22" X 80" X 6" - SINGLE BUNK (W31, W32)
	157657-A9-W33	EA	COVER - CUSHION/OVERHEAD - 22" X 80" X 6" - SINGLE BUNK (W33, W34)
	157657-B7-W29	EA	COVER - CUSHION/OVERHEAD - 27" X 80" X 6" - W/ANGLE - DOUBLE BUNK (W29, W30)
	157657-B5-W31	EA	COVER - CUSHION/OVERHEAD - 27" X 80" X 6" - DOUBLE BUNK (W31, W32)
	157657-B5-W33	EA	COVER - CUSHION/OVERHEAD - 27" X 80" X 6" - DOUBLE BUNK (W33, W34)
2	157657-02-W29	EA	CUSHION - OVERHEAD BUNK/REAR - 27"X80"X5" (W29, W30)
2	157657-04-W31	EA	CUSHION - OVERHEAD BUNK/REAR - 27"X80"X5" (W31, W32)
2	157657-04-W33	EA	CUSHION - OVERHEAD BUNK/REAR - 27"X80"X5" (W33, W34)
	157657-A2-W29	EA	COVER - CUSHION/OVERHEAD/BUNK/REAR - 27"X80"X5" (W29, W30)
	157657-A4-W31	EA	COVER - CUSHION/OVERHEAD/BUNK/REAR - 27"X80"X5" (W31, W32)
	157657-A4-W33	EA	COVER - CUSHION/OVERHEAD/BUNK/REAR - 27"X80"X5" (W33, W34)
3	101034-77-W29	EA	CURTAIN - PRIVACY - 16" X 25" (W29, W30)
3	101034-77-W31	EA	CURTAIN - PRIVACY - 16" X 25" (W31, W32)
3	101034-78-W33	EA	CURTAIN - PRIVACY - 16" X 25" (W33, W34)
	156172-03-01A	EA	TRACK/WALL - 21" - BONE
	156172-04-01A	EA	END CAP - WALL TRACK - CLEAR
4	076892-36-W29	EA	CURTAIN - CAB PRIVACY - 47.5" X 74"
4	076892-41-W29	EA	CURTAIN - CAB PRIVACY - 47.5" X 74" - CAB OVER ENTERTAINMENT CENTER
5	101668-80-W29	EA	CURTAIN - TAPE TOP - 27" X 90"
	073260-23-W29	EA	TIEBACK - 3" X 18"
	105450-15-01A	EA	TRACK - CURTAIN - 82.3" - OFF WHITE
6	101034-79-W29	EA	CURTAIN - PRIVACY - 19.5" X 34" (W29, W30)
6	101034-79-W31	EA	CURTAIN - PRIVACY - 19.5" X 34" (W31, W32)
6	101034-80-W33	EA	CURTAIN - PRIVACY - 19.5" X 34" (W33, W34)
	156172-02-01A	EA	TRACK/WALL - 32" - BONE
	156172-04-01A	EA	END CAP - WALL TRACK - CLEAR
7	158708-03-W41	EA	COVER - BACK (W29, W30, W33, W34) - ULTRALEATHER
7	158708-03-U25	EA	COVER - BACK (W31, W32) - ULTRALEATHER
7	159513-03-W21	EA	COVER - BACK (W29, W30, W33, W34) - ULTRALEATHER, CHEVY
7	159513-03-U25	EA	COVER - BACK (W31, W32) - ULTRALEATHER, CHEVY



**CURTAIN & CUSHION GROUP (CONTINUED)**  
**CURTAIN, CUSHION LAYOUT (CONTINUED)**

KEY	PART NUMBER	U/M	DESCRIPTION
8	158708-04-W41	EA	COVER - SEAT (W29, W30, W33, W34) - <b>ULTRALEATHER</b>
8	158708-04-U25	EA	COVER - SEAT (W31, W32) - <b>ULTRALEATHER</b>
8	159513-04-W21	EA	COVER - SEAT (W29, W30, W33, W34) - <b>ULTRALEATHER, CHEVY</b>
8	159513-04-U25	EA	COVER - SEAT (W31, W32) - <b>ULTRALEATHER, CHEVY</b>
9	158708-05-W41	EA	COVER - ARMREST/DRIVER (W29, W30, W33, W34) - <b>ULTRALEATHER</b>
9	158708-05-U25	EA	COVER - ARMREST/DRIVER (W31, W32) - <b>ULTRALEATHER</b>
9	159513-05-W21	EA	COVER - ARMREST/DRIVER (W29, W30, W33, W34) - <b>ULTRALEATHER, CHEVY</b>
9	159513-05-U25	EA	COVER - ARMREST/DRIVER (W31, W32) - <b>ULTRALEATHER, CHEVY</b>
10	158708-07-W41	EA	COVER - SEAT (W29, W30, W33, W34) - <b>ULTRALEATHER</b>
10	158708-07-U25	EA	COVER - SEAT (W31, W32) - <b>ULTRALEATHER</b>
10	159513-04-W21	EA	COVER - SEAT (W29, W30, W33, W34) - <b>ULTRALEATHER, CHEVY</b>
10	159513-04-U25	EA	COVER - SEAT (W31, W32) - <b>ULTRALEATHER, CHEVY</b>
11	158708-06-W41	EA	COVER - ARMREST/PASSENGER (W29, W30, W33, W34) - <b>ULTRALEATHER</b>
11	158708-06-U25	EA	COVER - ARMREST/PASSENGER (W31, W32) - <b>ULTRALEATHER</b>
11	159513-06-W21	EA	COVER - ARMREST/PASSENGER (W29, W30, W33, W34) - <b>ULTRALEATHER, CHEVY</b>
11	159513-06-U25	EA	COVER - ARMREST/PASSENGER (W31, W32) - <b>ULTRALEATHER, CHEVY</b>

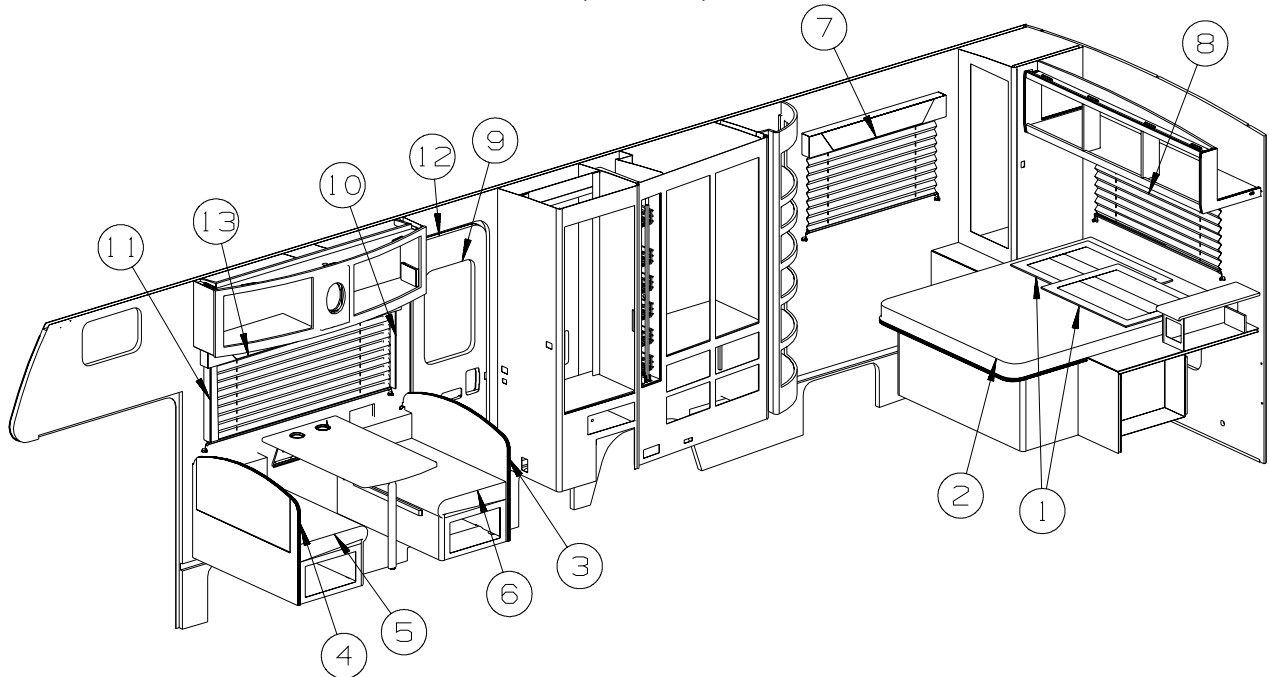

KEY	PART NUMBER	U/M	DESCRIPTION
1	145244-06-W29	EA	PILLOW SHAM - DELMONT - 1/4" WELT (W29, W30)
1	145244-06-W31	EA	PILLOW SHAM - DELMONT - 1/4" WELT (W31, W32)
1	145244-02-W33	EA	PILLOW SHAM - DELMONT - 1/4" WELT (W33, W34)
2	132336-01-W29	EA	BEDSPREAD/CAP - 60" X 75" (W29, W30)
2	132336-01-W31	EA	BEDSPREAD/CAP - 60" X 75" (W31, W32)
2	132336-01-W33	EA	BEDSPREAD/CAP - 60" X 75" (W33, W34)
3	153071-37-W29	EA	CUSHION/DINETTE - BACK/RH - 15" X 44" X 5" (W29, W30)
3	153071-37-W31	EA	CUSHION/DINETTE - BACK/RH - 15" X 44" X 5" (W31, W32)
3	153071-37-W33	EA	CUSHION/DINETTE - BACK/RH - 15" X 44" X 5" (W33, W34)
	P53071-37-W29	EA	COVER/BACK/RIGHT - 15" X 44" X 5" (W29, W30)
	P53071-37-W31	EA	COVER/BACK/RIGHT - 15" X 44" X 5" (W31, W32)
	P53071-37-W33	EA	COVER/BACK/RIGHT - 15" X 44" X 5" (W33, W34)
4	153071-38-W29	EA	CUSHION/DINETTE - BACK/LH - 15" X 44" X 5" (W29, W30)
4	153071-38-W31	EA	CUSHION/DINETTE - BACK/LH - 15" X 44" X 5" (W31, W32)
4	153071-38-W33	EA	CUSHION/DINETTE - BACK/LH - 15" X 44" X 5" (W33, W34)
	P53071-38-W29	EA	COVER/BACK/LEFT - 15" X 44" X 5" (W29, W30)
	P53071-38-W31	EA	COVER/BACK/LEFT - 15" X 44" X 5" (W31, W32)
	P53071-38-W33	EA	COVER/BACK/LEFT - 15" X 44" X 5" (W33, W34)

**CURTAIN & CUSHION GROUP (CONTINUED)**  
**CURTAIN, CUSHION LAYOUT (CONTINUED)**

KEY	PART NUMBER	U/M	DESCRIPTION
5	153671-13-W29	EA	CUSHION - SEAT - 23" X 44" X 5" (W29, W30)
5	153671-11-W31	EA	CUSHION - SEAT - 23" X 44" X 5" (W31, W32)
5	153671-11-W33	EA	CUSHION - SEAT - 23" X 44" X 5" (W33, W34)
	153671-B3-W29	EA	COVER/CUSHION - SEAT - 23" X 44" X 5" (W29, W30)
	153671-B1-W31	EA	COVER/CUSHION - SEAT - 23" X 44" X 5" (W31, W32)
	153671-B1-W33	EA	COVER/CUSHION - SEAT - 23" X 44" X 5" (W33, W34)
6	157487-04-W29	EA	CUSHION - FILLER - 7" X 21" X 5" (W29, W30)
6	157487-04-W31	EA	CUSHION - FILLER - 7" X 21" X 5" (W31, W32)
6	157487-04-W33	EA	CUSHION - FILLER - 7" X 21" X 5" (W33, W34)
	157487-A4-W29	EA	COVER/CUSHION - FILLER - 7" X 21" X 5" (W29, W30)
	157487-A4-W31	EA	COVER/CUSHION - FILLER - 7" X 21" X 5" (W31, W32)
	157487-A4-W33	EA	COVER/CUSHION - FILLER - 7" X 21" X 5" (W33, W34)
7	158536-21-W29	EA	VALANCE - ROSEMONT - 46" (W29, W30)
7	158536-21-W31	EA	VALANCE - ROSEMONT - 46" (W31, W32)
7	158536-25-W33	EA	VALANCE - ROSEMONT - 46" (W33, W34)
	105648-01-02A	EA	BRACE - VALANCE - 14" - OFF WHITE
7	157506-04-W21	EA	BLIND - PLEATED - 43" X 28" (W29, W30)
7	157506-04-W23	EA	BLIND - PLEATED - 43" X 28" (W31, W32, W33, W34)
7	140789-02-W21	EA	BLIND - DAY/NIGHTER - 43" X 28" (W29, W30) - INTERIOR UPGRADE PACKAGE
7	140789-02-W57	EA	BLIND - DAY/NIGHTER - 43" X 28" (W31, W32, W33, W34) - INTERIOR UPGRADE PACKAGE
	097565-01-000	EA	BRACKET - MOUNTING - PLEATED BLIND
8	158536-22-W29	EA	VALANCE - ROSEMONT - 54" (W29, W30)
8	158536-22-W31	EA	VALANCE - ROSEMONT - 54" (W31, W32)
8	158536-26-W33	EA	VALANCE - ROSEMONT - 54" (W33, W34)
8	157506-07-W21	EA	BLIND - PLEATED - 51" X 27" (W29, W30)
8	157506-07-W23	EA	BLIND - PLEATED - 51" X 27" (W31, W32, W33, W34)
8	140789-03-W21	EA	BLIND - DAY/NIGHTER - 51" X 27" (W29, W30) - INTERIOR UPGRADE PACKAGE
8	140789-03-W23	EA	BLIND - DAY/NIGHTER - 51" X 27" (W31, W32, W33, W34) - INTERIOR UPGRADE PACKAGE
	097565-01-000	EA	BRACKET - MOUNTING - PLEATED BLIND
9	084755-57-P37	EA	SHADE - PULL - 27.25"
	084434-01-000	EA	BRACKET - MOUNTING - ROLLER SHADE - 1 3/8"
10	152445-13-W23	EA	LEG - RIGHT - 25"(W29, W30)
10	152445-A9-W31	EA	LEG - RIGHT - 25" (W31, W32)
10	152445-13-W33	EA	LEG - RIGHT - 25" (W33, W34)
	154316-01-01A	EA	BRACE/ANGLE - W/HOLE - CASHMERE
11	152445-14-W23	EA	LEG - LEFT - 25" (W29, W30)
11	152445-B0-W31	EA	LEG - LEFT - 25" (W31, W32)
11	152445-14-W33	EA	LEG - LEFT - 25" (W33, W34)
	154316-01-01A	EA	BRACE/ANGLE - W/HOLE - CASHMERE
12	153643-70-W29	EA	VALANCE - MODERATE - 10" X 29" (W29, W30)
12	153643-70-W31	EA	VALANCE - MODERATE - 10" X 29" (W31, W32)
12	153643-70-W33	EA	VALANCE - MODERATE - 29" (W33, W34)
	105648-01-02A	EA	BRACE - VALANCE - 14" - OFF WHITE
13	158536-24-W29	EA	VALANCE - ROSEMONT - 65" (W29, W30)
13	158536-23-W31	EA	VALANCE - ROSEMONT - 65" (W31, W32)
13	158536-24-W33	EA	VALANCE - ROSEMONT - 65" (W33, W34)
13	157506-03-W09	EA	BLIND - PLEATED - 61" X 28.5" (W29, W30)
13	157506-03-W07	EA	BLIND - PLEATED - 61" X 28.5" (W31, W32, W33, W34)
13	140789-14-W51	EA	BLIND - DAY/NIGHTER - 61" X 28.5" (W29, W30) - INTERIOR UPGRADE PACKAGE
13	140789-14-W37	EA	BLIND - DAY/NIGHTER - 61" X 28.5" (W31, W32, W33, W34) - INTERIOR UPGRADE PACKAGE
	097565-01-000	EA	BRACKET - MOUNTING - PLEATED BLIND

**CURTAIN & CUSHION GROUP (CONTINUED)**  
**CURTAIN, CUSHION LAYOUT (CONTINUED)**

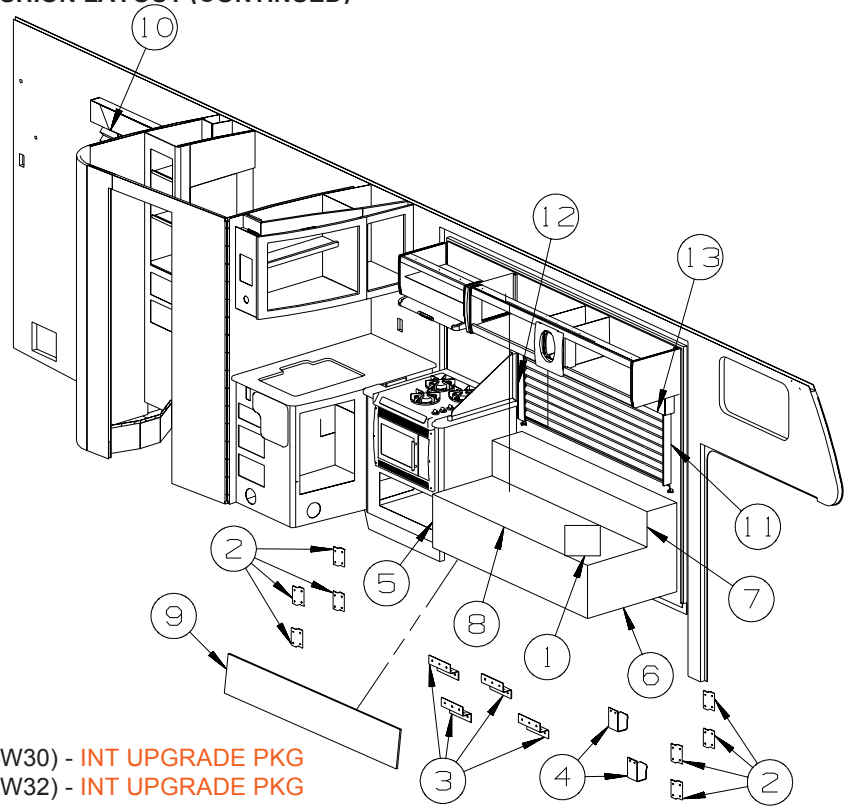

KEY	PART NUMBER	U/M	DESCRIPTION
1	155220-07-W29	EA	PILLOW - 18" - W/FRG(W29, W30) - INT UPGRADE PKG
1	155220-08-W31	EA	PILLOW - 18" - W/FRG(W31, W32) - INT UPGRADE PKG
1	155220-09-W33	EA	PILLOW - 18" - W/FRG(W33, W34) - INTUPGRADE PKG
2	101926-01-02A	EA	BRACKET - ZEE - 2" - BLACK
3	116104-04-02B	EA	BRACKET - ZEE W/HOLES - 3.2" - E-COATED
4	121906-01-02B	EA	BRACKET - KICKBOARD - E-COATED
	127335-07-000	EA	LEG - SOFA/BED - 8"
5	134282-08-W29	EA	PANEL - RIGHT END/FILLER - SOFA/BED - FABRIC COVERED (W29, W30)
5	134282-08-W31	EA	PANEL - RIGHT END/FILLER - SOFA/BED - FABRIC COVERED (W31, W32)
5	134282-08-W33	EA	PANEL - RIGHT END/FILLER - SOFA/BED - FABRIC COVERED (W33, W34)
6	134282-09-W29	EA	PANEL - LEFT END/FILLER - SOFA/BED - FABRIC COVERED (W29, W30)
6	134282-09-W31	EA	PANEL - LEFT END/FILLER - SOFA/BED - FABRIC COVERED (W31, W32)
6	134282-09-W33	EA	PANEL - LEFT END/FILLER - SOFA/BED - FABRIC COVERED (W33, W34)
	151290-19-000	EA	FRAME - BASE - 27.25" X 64"
7	153676-02-W29	EA	BACK - SOFA - 64" (W29, W30)
7	153676-02-W31	EA	BACK - SOFA - 64" (W31, W32)
7	153676-02-W33	EA	BACK - SOFA - 64" (W33, W34)
	P53676-02-W23	EA	COVER/BACK - SOFA - 64" (W29, W30)
	P53676-02-W31	EA	COVER/BACK - SOFA - 64" (W31, W32)
	P53676-02-W33	EA	COVER/BACK - SOFA - 64" (W33, W34)
	151290-18-000	EA	FRAME - BACK - 14.5" X 64"
8	153676-03-W29	EA	SEAT - SOFA - 64" (W29, W30)
8	153676-03-W31	EA	SEAT - SOFA - 64" (W31, W32)
8	153676-03-W33	EA	SEAT - SOFA - 64" (W33, W34)
	P53676-03-W29	EA	COVER/SEAT - SOFA - 64" (W29, W30)
	P53676-03-W31	EA	COVER/SEAT - SOFA - 64" (W31, W32)
	P53676-03-W33	EA	COVER/SEAT - SOFA - 64" (W33, W34)
	151290-17-000	EA	FRAME - SEAT - 26.5" X 64"
9	159380-01-W29	EA	PANEL/FRONT KICK - SOFA - 64" X 11" (W29, W30)
9	159380-01-W31	EA	PANEL/FRONT KICK - SOFA - 64" X 11" (W31, W32)
9	159380-01-W33	EA	PANEL/FRONT KICK - SOFA - 64" X 11" (W33, W34)
10	158536-21-W29	EA	VALANCE - ROSEMONT - 46" (W29, W30)
10	158536-21-W31	EA	VALANCE - ROSEMONT - 46" (W31, W32)
10	158536-25-W33	EA	VALANCE - ROSEMONT - 46" (W33, W34)
	105648-01-02A	EA	BRACE - VALANCE - 14" - OFF WHITE
10	157506-04-W21	EA	BLIND - PLEATED - 43" X 28" (W29, W30)
10	157506-04-W23	EA	BLIND - PLEATED - 43" X 28" (W31, W32, W33, W34)
10	140789-02-W21	EA	BLIND - DAY/NIGHTER - 43" X 28" (W29, W30) - INTERIOR UPGRADE PACKAGE
10	140789-02-W57	EA	BLIND - DAY/NIGHTER - 43" X 28" (W31, W32, W33, W34) - INTERIOR UPGRADE PACKAGE
	097565-01-000	EA	BRACKET - MOUNTING - PLEATED BLIND

**CURTAIN & CUSHION GROUP (CONTINUED)**  
**CURTAIN, CUSHION LAYOUT (CONTINUED)**

<b>KEY</b>	<b>PART NUMBER</b>	<b>U/M</b>	<b>DESCRIPTION</b>
11	152445-11-W29	EA	LEG - RIGHT - 23.5" (W29, W30)
11	152445-19-W31	EA	LEG - RIGHT - 23.5" (W31, W32)
11	152445-11-W33	EA	LEG - RIGHT - 23.5" (W33, W34)
12	154316-01-01A	EA	BRACE/ANGLE - W/HOLE - CASHMERE
12	152445-12-W29	EA	LEG - LEFT - 23.5" (W29, W30)
12	152445-20-W31	EA	LEG - LEFT - 23.5" (W31, W32)
12	152445-12-W33	EA	LEG - LEFT - 23.5" (W33, W34)
	154316-01-01A	EA	BRACE/ANGLE - W/HOLE - CASHMERE
13	158536-19-W29	EA	VALANCE - ROSEMONT - 63" (W29, W30)
13	158536-17-W31	EA	VALANCE - ROSEMONT - 63" (W31, W32)
13	158536-19-W33	EA	VALANCE - ROSEMONT - 63" (W33, W34)
13	157506-02-W21	EA	BLIND - PLEATED - 59" X 26.5" (W29, W30)
13	157506-02-W23	EA	BLIND - PLEATED - 59" X 26.5" (W31, W32,W33, W34)
13	140789-08-W39	EA	BLIND - DAY/NIGHTER - 59" X 26.5" (W29, W30) - INTERIOR UPGRADE PACKAGE
13	140789-08-W37	EA	BLIND - DAY/NIGHTER - 59" X 26.5" (W31, W32,W33, W34) - INTERIOR UPGRADE PACKAGE
	097565-01-000	EA	BRACKET - MOUNTING - PLEATED BLIND
14	101926-01-02A	EA	BRACKET - ZEE - 2" - BLACK

## CURTAIN & CUSHION GROUP (CONTINUED)

### SOFA

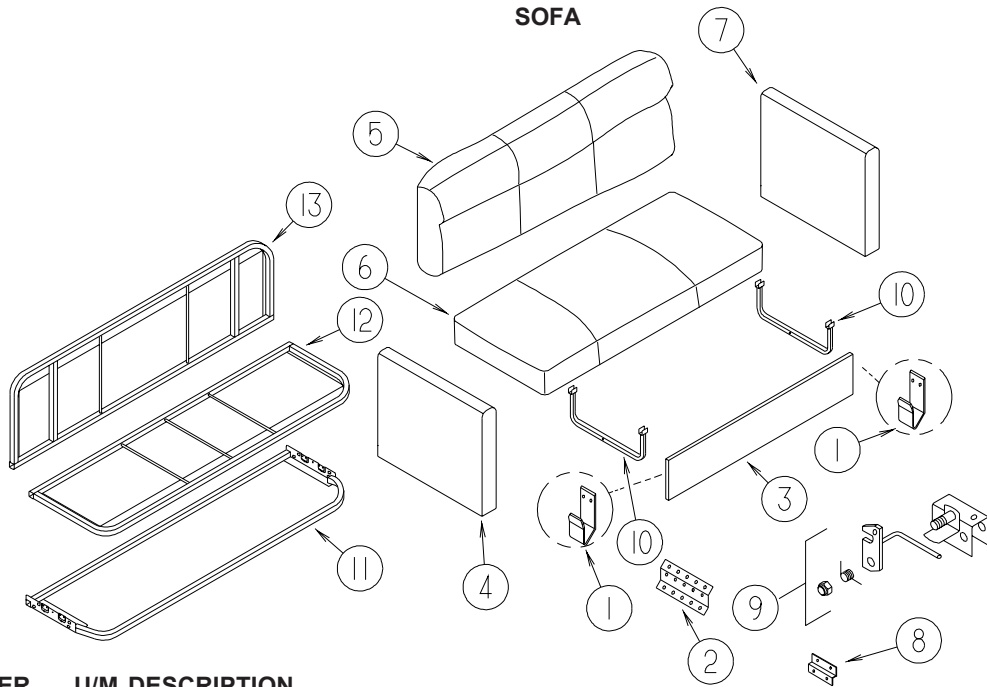

KEY	PART NUMBER	U/M	DESCRIPTION
1	121906-01-02B	EA	BRACKET - KICKBOARD - E-COATED
2	116104-04-02B	EA	BRACKET - ZEE W/HOLES - 3.2" - E-COATED
3	159380-01-W29	EA	PANEL/FRONT KICK - SOFA - 64" X 11" (W29, W30)
3	159380-01-W31	EA	PANEL/FRONT KICK - SOFA - 64" X 11" (W31, W32)
3	159380-01-W33	EA	PANEL/FRONT KICK - SOFA - 64" X 11" (W33, W34)
4	134282-08-W29	EA	PANEL - RIGHT END/FILLER - SOFA/BED - FABRIC COVERED (W29, W30)
4	134282-08-W31	EA	PANEL - RIGHT END/FILLER - SOFA/BED - FABRIC COVERED (W31, W32)
4	134282-08-W33	EA	PANEL - RIGHT END/FILLER - SOFA/BED - FABRIC COVERED (W33, W34)
5	153676-02-W29	EA	BACK - SOFA - 64" (W29, W30)
5	153676-02-W31	EA	BACK - SOFA - 64" (W31, W32)
5	153676-02-W33	EA	BACK - SOFA - 64" (W33, W34)
	P53676-02-W29	EA	COVER/BACK - SOFA - 64" (W29, W30)
	P53676-02-W31	EA	COVER/BACK - SOFA - 64" (W31, W32)
	P53676-02-W33	EA	COVER/BACK - SOFA - 64" (W33, W34)
6	153676-03-W29	EA	SEAT - SOFA - 64" (W29, W30)
6	153676-03-W31	EA	SEAT - SOFA - 64" (W31, W32)
6	153676-03-W33	EA	SEAT - SOFA - 64" (W33, W34)
	P53676-03-W29	EA	COVER/SEAT - SOFA - 64" (W29, W30)
	P53676-03-W31	EA	COVER/SEAT - SOFA - 64" (W31, W32)
	P53676-03-W33	EA	COVER/SEAT - SOFA - 64" (W33, W34)
7	134282-09-W29	EA	PANEL - LEFT END/FILLER - SOFA/BED - FABRIC COVERED (W29, W30)
7	134282-09-W31	EA	PANEL - LEFT END/FILLER - SOFA/BED - FABRIC COVERED (W31, W32)
7	134282-09-W33	EA	PANEL - LEFT END/FILLER - SOFA/BED - FABRIC COVERED (W33, W34)
8	101926-01-02A	EA	BRACKET - ZEE - 2" - BLACK
9	NOT USED		
10	127335-07-000	EA	LEG - SOFA/BED - 8"
11	151290-19-000	EA	FRAME - BASE - 27.25" X 64"
12	151290-17-000	EA	FRAME - SEAT - 26.5" X 64"
13	151290-18-000	EA	FRAME - BACK - 14.5" X 64"

## CURTAIN & CUSHION GROUP (CONTINUED)

### HARDWARE

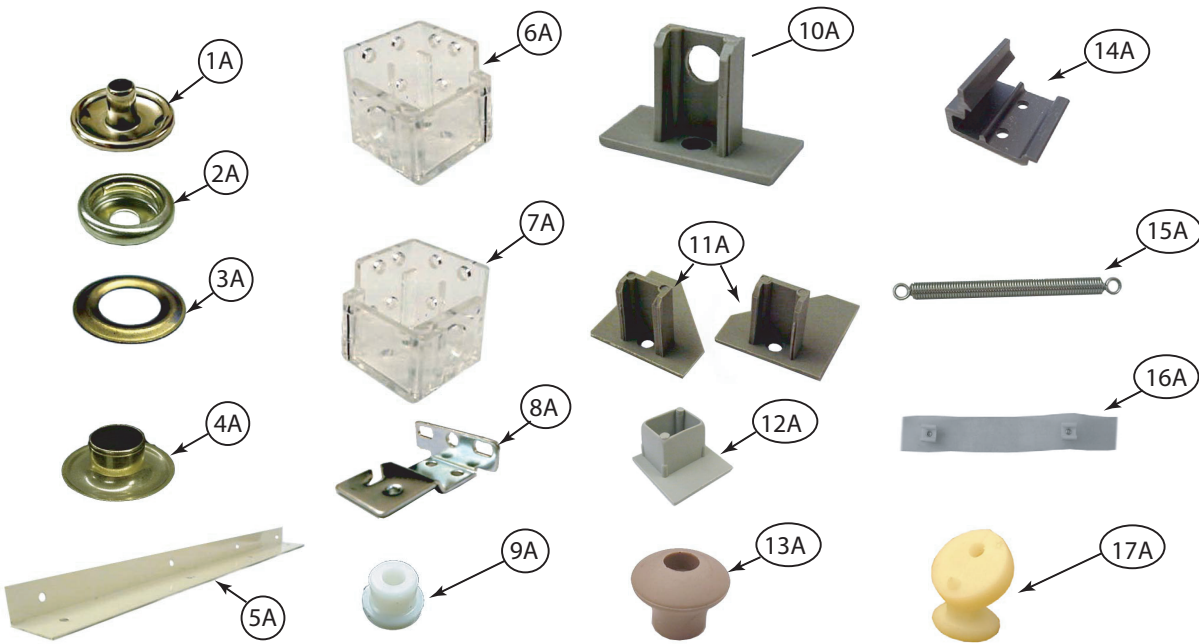

KEY	PART NUMBER	U/M	DESCRIPTION
1A	029155-01-000	EA	CAP - SNAP - 5/32" OUTSIDE DIAMETER OF PIN
2A	029156-01-000	EA	SOCKET - SNAP - 9/16" O.D.
3A	046867-05-000	EA	WASHER - #0
4A	046867-04-000	EA	GROMMET - #0
5A	160457-01-01A	EA	BRACE - VALANCE - L-SHAPED - 20" - OFF WHITE
6A	162496-01-01A	EA	BRACKET/BLIND - LEFT SIDE WHEN FACING WINDOW - CLEAR
7A	162496-02-01A	EA	BRACKET/BLIND - RIGHT SIDE WHEN FACING WINDOW - CLEAR
8A	084434-01-000	EA	BRACKET - MOUNTING - ROLLER SHADE - 1 3/8"
9A	094896-02-000	EA	GROMMET - CORD/PLEATED BLIND - NYLON - GRAY
10A	094907-02-000	EA	END CAP - PLEATED BLIND/TOP - RH/LH - GRAY PLASTIC
11A	094907-04-000	EA	END CAP - PLEATED BLIND/BOTTOM - RH/LH
12A	094907-09-000	EA	END CAP/BLIND - CENTER RAIL - RH/LH
13A	097564-03-000	EA	HANDLE - KNOB - E-Z LIFT SHADE - TAN
14A	097565-01-000	EA	BRACKET - MOUNTING - PLEATED BLIND
15A	155748-01-000	EA	SPRING - EXTENSION - DAY/NIGHTER BLIND
16A	101031-01-000	YD	TAPE/GLIDE - 4.25" SPACING
17A	102555-03-000	EA	BRACKET - (CLEAT TYPE) - F/BLIND HOLDOWN - MILKY WHITE

**CURTAIN & CUSHION GROUP (CONTINUED)**  
**HARDWARE (CONTINUED)**

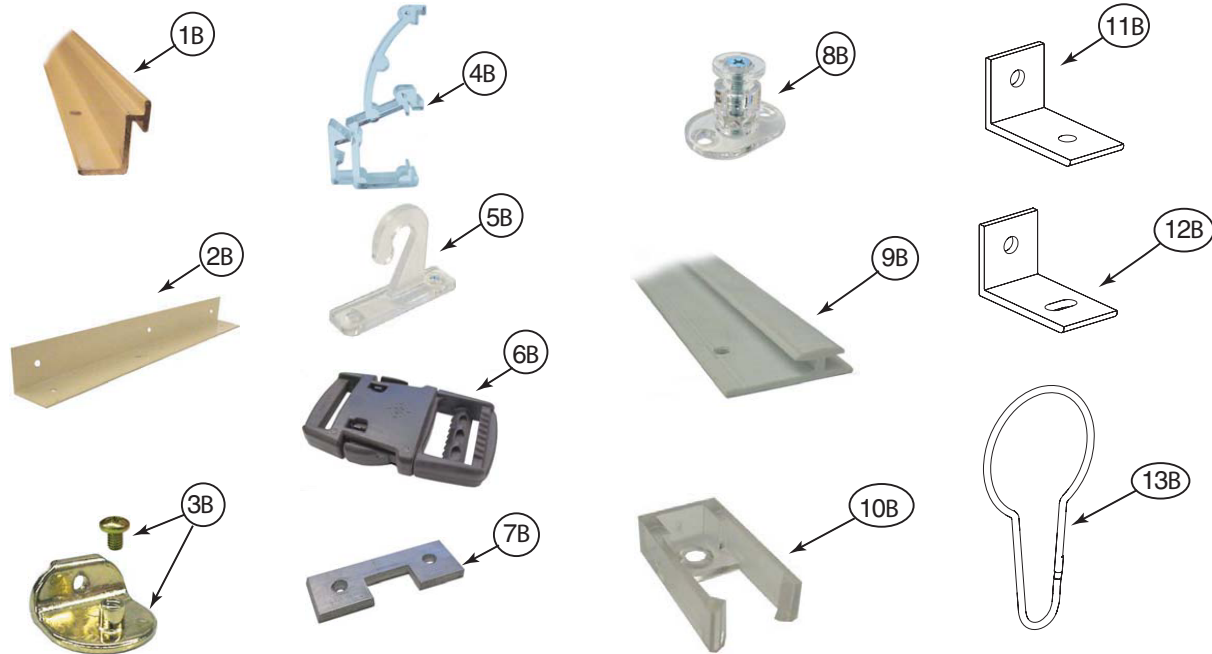

KEY	PART NUMBER	U/M	DESCRIPTION
1B	105450-14-01A	EA	TRACK - CURTAIN - 90" - OFF WHITE
2B	105648-01-02A	EA	BRACE - VALANCE - 14" - OFF WHITE
2B	105648-02-02A	EA	BRACE - VALANCE - 8.5" - OFF WHITE
3B	106544-01-000	EA	PULL - SHADE/BRASS
3B	106544-01-001	EA	SCREW - SHADE/BRASS
3B	106544-02-000	EA	PULL-SHADE - NICKEL
4B	109353-04-000	EA	CLIP - VALANCE SLAT MOUNTING - CLEAR PLASTIC
5B	109441-01-000	EA	BRACKET/HOOK - BLIND HOLD DOWN - LARGE - CLEAR
	109441-02-000	EA	SPACER/BRACKET - BLIND HOLD DOWN
6B	129491-01-000	EA	CATCH - SNAP HOOK - 1"
7B	130549-01-01A	EA	STOP - CURTAIN TRACK
8B	141634-01-000	EA	BRACKET-(BOBBIN TYPE) 7/8"H HOLDUPBASE(OVAL)-2 HOLE-CLEAR
9B	156172-02-01A	EA	TRACK/WALL - 32" - BONE
9B	156172-03-01A	EA	TRACK/WALL - 21" - BONE
10B	156172-04-01A	EA	END CAP - WALL TRACK - CLEAR
11B	154316-01-01A	EA	BRACE/ANGLE - W/HOLE - CASHMERE
12B	154316-02-01A	EA	BRACE/ANGLE - W/SLOT - CASHMERE
13B	159702-01-01A	EA	HOOK/RING - CURTAIN/SHOWER - NICKEL

## CURTAIN & CUSHION GROUP (CONTINUED)

### FABRICS

#### W29, W30

113979-09-01A CARPET-HEADLINER (SY) - CEILING  
FROM: 00-00-00 THRU: 01-13-08

113979-09-02A CARPET-HEADLINER (SY) - CEILING  
FROM: 01-14-08 THRU: 99-99-99

113979-10-01A CARPET-HEADLINER - SLDOUT (SY) - CEILING  
FROM: 00-00-00 THRU: 01-13-08

113979-10-02A CARPET-HEADLINER - SLDOUT (SY) - CEILING  
FROM: 01-14-08 THRU: 99-99-99

113979-11-01A CARPET-HEADLINER - SLDOUT (SY) - CEILING  
FROM: 00-00-00 THRU: 01-13-08

113979-11-02A CARPET-HEADLINER - SLDOUT (SY) - CEILING  
FROM: 01-14-08 THRU: 99-99-99

113979-16-01A CARPET - HEADLINER - 52" WIDE SLIDEOUT - CEILING  
FROM: 00-00-00 THRU: 01-13-08

113979-16-02A CARPET - HEADLINER - 52" WIDE SLIDEOUT - CEILING  
FROM: 01-14-08 THRU: 99-99-99

161246-01-000 FABRIC - DRAPERY, MAIN

148797-AP-000 FABRIC - UPHOLSTERY, MAIN

148797-AL-000 FABRIC - UPHOLSTERY, PLAIN ACCENT

148797-AQ-000 FABRIC - UPHOLSTERY, ACCENT PATTERN

156773-40-000 FABRIC - UPHOLSTERY, BEDSPREAD, MAIN

142523-19-000 FABRIC - UPHOLSTERY, ULTRALEATHER

148797-AQ-000 FABRIC - UPHOLSTERY, BEDSPREAD, PATTERN ACCENT

148797-H9-000 FABRIC - HEADLINER, PADS, BUNKS, TRANSITION PANELS

072333-98-000 FABRIC - SPEAKER COVER

148797-AP-000 FABRIC - OVERHEAD CABINET, DINETTE, LOUNGE, BEDROOM

103907-01-01A VINYL - FILM DRAPERY - BUNK CUSHIONS

142523-08-000 VINYL - HEADLINERS, BUNKS, CAB AREA

#### W31, W32

113979-09-01A CARPET-HEADLINER (SY) - CEILING  
FROM: 00-00-00 THRU: 01-13-08

113979-09-02A CARPET-HEADLINER (SY) - CEILING  
FROM: 01-14-08 THRU: 99-99-99

113979-10-01A CARPET-HEADLINER - SLDOUT (SY) - CEILING  
FROM: 00-00-00 THRU: 01-13-08

113979-10-02A CARPET-HEADLINER - SLDOUT (SY) - CEILING  
FROM: 01-14-08 THRU: 99-99-99

113979-11-01A CARPET-HEADLINER - SLDOUT (SY) - CEILING  
FROM: 00-00-00 THRU: 01-13-08

113979-11-02A CARPET-HEADLINER - SLDOUT (SY) - CEILING  
FROM: 01-14-08 THRU: 99-99-99

113979-16-01A CARPET - HEADLINER - 52" WIDE SLIDEOUT - CEILING  
FROM: 00-00-00 THRU: 01-13-08

113979-16-02A CARPET - HEADLINER - 52" WIDE SLIDEOUT - CEILING  
FROM: 01-14-08 THRU: 99-99-99

161246-01-000 FABRIC - DRAPERY, MAIN

148797-CN-000 FABRIC - UPHOLSTERY, MAIN

148797-CT-000 FABRIC - UPHOLSTERY, PLAIN ACCENT

137813-N0-000 FABRIC - UPHOLSTERY - 2ND PATTERN ACCENT

148797-CP-000 FABRIC - UPHOLSTERY, ACCENT PATTERN

156773-78-000 FABRIC - UPHOLSTERY, BEDSPREAD, MAIN

142523-02-000 FABRIC - UPHOLSTERY, ULTRALEATHER

156773-77-000 FABRIC - UPHOLSTERY, BEDSPREAD, PATTERN ACCENT

148797-CT-000 FABRIC - HEADLINER, PADS, BUNKS, TRANSITION PANELS

072333-98-000 FABRIC - SPEAKER COVER

148797-CN-000 FABRIC - OVERHEAD CABINET, DINETTE, LOUNGE, BEDROOM

103907-01-01A VINYL - FILM DRAPERY - BUNK CUSHIONS

142523-08-000 VINYL - HEADLINERS, BUNKS, CAB AREA



**CURTAIN & CUSHION GROUP (CONTINUED)**  
**FABRICS (CONTINUED)**

**W33, W34**

113979-09-01A CARPET-HEADLINER (SY) - CEILING  
FROM: 00-00-00 THRU: 01-13-08

113979-09-02A CARPET-HEADLINER (SY) - CEILING  
FROM: 01-14-08 THRU: 99-99-99

113979-10-01A CARPET-HEADLINER - SLDOUT (SY) - CEILING  
FROM: 00-00-00 THRU: 01-13-08

113979-10-02A CARPET-HEADLINER - SLDOUT (SY) - CEILING  
FROM: 01-14-08 THRU: 99-99-99

113979-11-01A CARPET-HEADLINER - SLDOUT (SY) - CEILING  
FROM: 00-00-00 THRU: 01-13-08

113979-11-02A CARPET-HEADLINER - SLDOUT (SY) - CEILING  
FROM: 01-14-08 THRU: 99-99-99

113979-16-01A CARPET - HEADLINER - 52" WIDE SLIDEOUT - CEILING  
FROM: 00-00-00 THRU: 01-13-08

113979-16-02A CARPET - HEADLINER - 52" WIDE SLIDEOUT - CEILING  
FROM: 01-14-08 THRU: 99-99-99

161246-01-000 FABRIC - DRAPERY, MAIN

148797-CJ-000 FABRIC - UPHOLSTERY, MAIN

148797-CR-000 FABRIC - UPHOLSTERY, PLAIN ACCENT

148797-CK-000 FABRIC - UPHOLSTERY, ACCENT PATTERN

156773-76-000 FABRIC - UPHOLSTERY, BEDSPREAD, MAIN

142523-19-000 FABRIC - UPHOLSTERY, ULTRALEATHER

156773-42-000 FABRIC - UPHOLSTERY, BEDSPREAD, PATTERN ACCENT

148797-H9-000 FABRIC - HEADLINER, PADS, BUNKS, TRANSITION PANELS

072333-98-000 FABRIC - SPEAKER COVER

148797-CR-000 FABRIC - OVERHEAD CABINET, DINETTE, LOUNGE, BEDROOM

103907-01-01A VINYL - FILM DRAPERY - BUNK CUSHIONS

142523-08-000 VINYL - HEADLINERS, BUNKS, CAB AREA

# DRIVERS COMPARTMENT GROUP FRONT INTERIOR

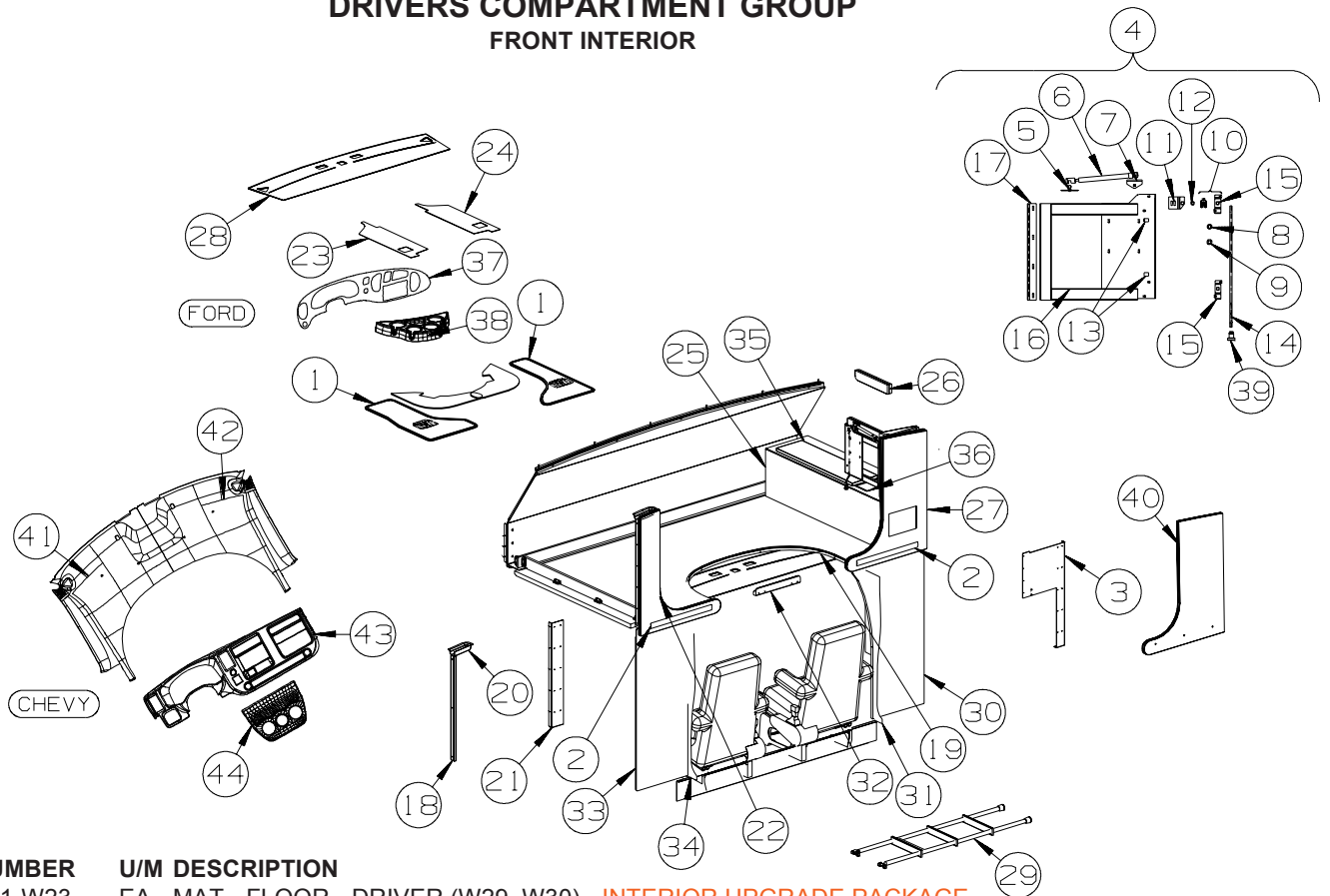

KEY	PART NUMBER	U/M	DESCRIPTION
1	163089-01-W23	EA	MAT - FLOOR - DRIVER (W29, W30) - <b>INTERIOR UPGRADE PACKAGE</b>
1	163089-01-W31	EA	MAT - FLOOR - DRIVER (W31, W32) - <b>INTERIOR UPGRADE PACKAGE</b>
1	163089-01-W21	EA	MAT - FLOOR - DRIVER (W33, W34) - <b>INTERIOR UPGRADE PACKAGE</b>
1	163089-02-W23	EA	MAT - FLOOR - PASSENGER (W29, W30) - <b>INTERIOR UPGRADE PACKAGE</b>
1	163089-02-W31	EA	MAT - FLOOR - PASSENGER (W31, W32) - <b>INTERIOR UPGRADE PACKAGE</b>
1	163089-02-W21	EA	MAT - FLOOR - PASSENGER (W33, W34) - <b>INTERIOR UPGRADE PACKAGE</b>
2	M09525-61-U21	EA	MOLDING - TRIM/VEE - 1.5" X 20.6" - HONEY CHERRY
2	M09525-61-U22	EA	MOLDING - TRIM/VEE - 1.5" X 20.6" - WASHED MAPLE
3	109709-09-03B	EA	BRACKET - WINGWALL - OFF WHITE
3	109709-10-03B	EA	BRACKET - WINGWALL - OFF WHITE - <b>ENTERTAINMENT CENTER-CABOVER</b>
4	159840-01-U21	EA	SUPPORT - TV - COMPLETE
			FROM: 00-00-00 THRU: 04-29-07
4	164660-01-W21	EA	SUPPORT - TV - COMPLETE
			FROM: 04-30-07 THRU: 99-99-99
5	126263-08-02B	EA	BRACKET - GAS SPRING W/CENTERED BALL STUD - E-COATED
6	142569-31-000	EA	SPRING/GAS - 30 LB - 11.8" EXTENDED/7.3" COMPRESSED
7	126263-03-02B	EA	BRACKET - GAS SPRING W/BALL STUD - E/COATED
8	150082-06-000	EA	NUT - F/TV LATCH-KEEPER
9	150082-07-000	EA	WASHER - F/TV LATCH-KEEPER
10	150082-02-000	EA	LATCH/TV - W/O KEEPER/BRACKET/ROD
11	150214-01-02B	EA	BRACKET/KEEPER - TV/SWINGOUT - E-COATED
			FROM: 00-00-00 THRU: 04-01-07
11	150214-02-02B	EA	BRACKET/KEEPER - TV/SWINGOUT - E-COATED
			FROM: 04-02-07 THRU: 99-99-99
12	150082-03-000	EA	KEEPER - W/O TV LATCH
13	099418-01-000	FT	SEAL - D-SECTION/ADHESIVE BACK - .44" X .44" - BLK RUBBER
14	150082-08-000	EA	ROD - F/TV LATCH-KEEPER
15	150082-04-000	EA	BRACKET - F/TV LATCH-KEEPER
16	164661-01-02B	EA	SUPPORT - TV - E-COATED
17	158921-02-01A	EA	HINGE - PIANO - TRUNK DOOR - 2" X 12.6"
18	154189-01-02A	EA	COVER/TRIM - WIRING - 29.5" - ALMOND
19	158191-01-01A	FT	MOLDING-T - W/EDGE LIP - OFF WHITE
20	153474-01-11A	EA	COVER/WIRE - SATELLITE RADIO - BRIGHT WHITE
	154189-03-02A	EA	COVER/TRIM - WIRING - 7.6" - ALMOND
21	109709-11-03B	EA	BRACKET - WINGWALL - OFF WHITE
21	109709-10-03B	EA	BRACKET - WINGWALL - OFF WHITE - <b>ENTERTAINMENT CENTER-CABOVER</b>

**DRIVERS COMPARTMENT GROUP (CONTINUED)**  
**FRONT INTERIOR (CONTINUED)**

KEY	PART NUMBER	U/M	DESCRIPTION
22	158629-03-U21	EA	PANEL - END CAP - HONEY CHERRY
22	158629-03-U22	EA	PANEL - END CAP - WASHED MAPLE
23	106447-10-T11	EA	TRIM - CAB DOOR - UPPER/LEFT HAND - FORD
24	106447-09-T11	EA	TRIM - CAB DOOR - UPPER/RIGHT HAND - FORD
25	156101-01-U21	EA	CABINET - HAMPER/STORAGE - W/O DOORS/DRAWERS/HDW - HONEY CHERRY
25	156101-01-U22	EA	CABINET - HAMPER/STORAGE - W/O DOORS/DRAWERS/HDW - WASHED MAPLE
25	156101-03-U21	EA	CABNT - HAMPER/STORAGE - W/O DOORS/DRWRS/HDW - HONEY CHERRY - TV-20"AC,LCD,CD/DVD
25	156101-03-U22	EA	CABNT - HAMPER/STORAGE - W/O DOORS/DRWRS/HDW - WASHED MAPLE - TV-20"AC,LCD,CD/DVD
26	161007-01-U21	EA	CABINET - SUPPORT/TV - HONEY CHERRY - TV-20"AC,LCD,STEREO/CD/DVD
26	161007-01-U22	EA	CABINET - SUPPORT/TV - WASHED MAPLE - TV-20"AC,LCD,STEREO/CD/DVD
27	158629-01-U21	EA	PANEL - END CAP - HONEY CHERRY - TV-20"AC,LCD,CD/DVD
27	158629-01-U22	EA	PANEL - END CAP - WASHED MAPLE - TV-20"AC,LCD,CD/DVD
28	106448-07-T11	EA	HEADLINER - W/VINYL - FORD
29	106025-05-01A	EA	LADDER - BUNK - 50.1" - BLACK
	162356-01-000	EA	STRAP/TIEDOWN - LADDER
30	157047-01-W29	EA	WINGWALL - INNER/LOWER (W29, W30, W33, W34)
30	157047-01-W31	EA	WINGWALL - INNER/LOWER (W31, W32)
	070578-19-T47	EA	BUTTON - #30 - SCREW/STUD - FABRIC COVERED (W29, W30, W33, W34)
	070578-19-W31	EA	BUTTON - #30 - SCREW/STUD - FABRIC COVERED (W31, W32)
	029092-02-000	EA	STUD-NICKEL FINISH-9532
31	125031-01-T11	EA	TRIM - CAB - B-PILLAR - PASSENGER SIDE
32	094658-04-T02	EA	HANDLE - BUNK - 1.1" X 2" X 14.9" - HONEY CHERRY
32	094658-04-T25	EA	HANDLE - BUNK - 1.1" X 2" X 14.9" - WASHED MAPLE
33	157047-02-W29	EA	WINGWALL - INNER/LOWER (W29, W30, W33, W34)
33	157047-02-W31	EA	WINGWALL - INNER/LOWER (W31, W32)
	070578-19-T47	EA	BUTTON - #30 - SCREW/STUD - FABRIC COVERED (W29, W30, W33, W34)
	070578-19-W31	EA	BUTTON - #30 - SCREW/STUD - FABRIC COVERED (W31, W32)
	029092-02-000	EA	STUD-NICKEL FINISH-9532
34	125031-02-T11	EA	TRIM - CAB - B-PILLAR - DRIVER SIDE
35	159216-AA-U21	EA	DOOR - FLAT/SQUARE EDGE - 8.7" X 31.5" - W/O HDW - HONEY CHERRY
35	159216-AA-U22	EA	DOOR - FLAT/SQUARE EDGE - 8.7" X 31.5" - W/O HDW - WASHED MAPLE
36	156101-19-U21	EA	PANEL/ACCESS - W/HOLE CUTOUT - HONEY CHERRY
36	156101-19-U22	EA	PANEL/ACCESS - W/HOLE CUTOUT - WASHED MAPLE
37	150974-01-05A	EA	APPLIQUE - BEZEL - INSTRUMENT PANEL - REGAL BURLWOOD - INTERIOR UPGRADE PKG
38	150974-05-05A	EA	APPLIQUE - BEZEL - MOTOR COVER - FORD - REGAL BURLWOOD - INTERIOR UPGRADE PKG
39	150109-01-01A	EA	KNOB - F/TV SWINGOUT - BLACK
40	158629-08-U21	EA	PANEL - END CAP - HONEY CHERRY
40	158629-08-U22	EA	PANEL - END CAP - WASHED MAPLE
41	156218-02-T11	EA	HEADLINER - W/VINYL - LEFT HAND - CHEVY
42	156218-03-T11	EA	HEADLINER - W/VINYL - RIGHT HAND - CHEVY
43	150974-03-05A	EA	APPLIQUE - BEZEL - INSTR PANEL - REGAL BURLWOOD - INTERIOR UPGRADE PKG - CHEVY
44	150974-04-05A	EA	APPLIQUE - BEZEL - MOTOR COVER - REGAL BURLWOOD - INTERIOR UPGRADE PKG - CHEVY

## DRIVERS COMPARTMENT GROUP (CONTINUED) CABINETS

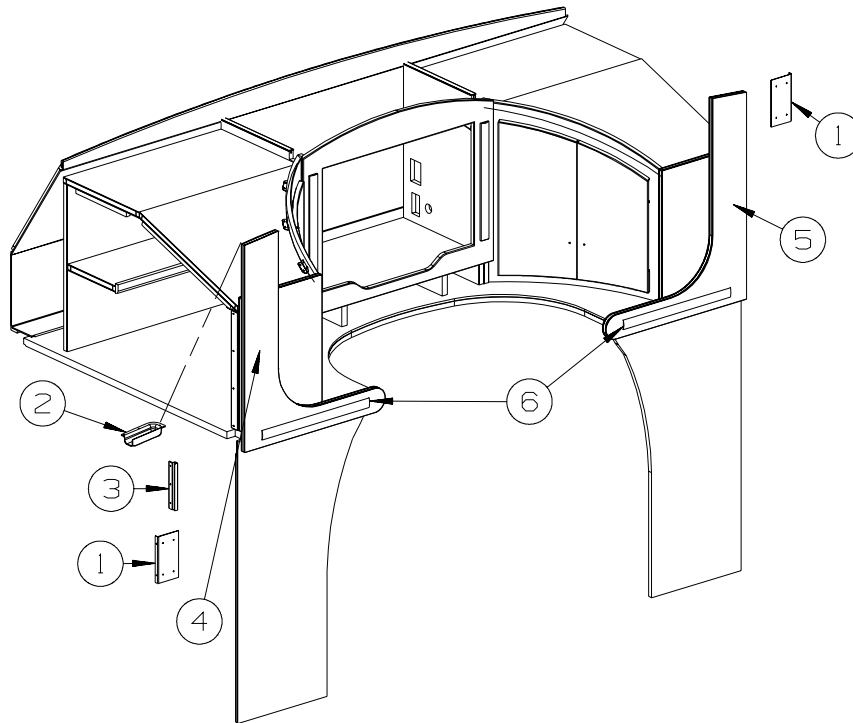

KEY	PART NUMBER	U/M	DESCRIPTION
1	109709-10-03B	EA	BRACKET - WINGWALL - OFF WHITE
2	153474-01-11A	EA	COVER/WIRE - SATELLITE RADIO - BRIGHT WHITE
3	154189-01-02A	EA	COVER/TRIM - WIRING - 29.5" - ALMOND
4	158629-03-U21	EA	PANEL - END CAP - HONEY CHERRY
4	158629-03-U22	EA	PANEL - END CAP - WASHED MAPLE
5	158629-04-U21	EA	PANEL - END CAP - HONEY CHERRY
5	158629-04-U22	EA	PANEL - END CAP - WASHED MAPLE
6	M09525-61-U21	EA	MOLDING - TRIM/VEE - 1.5" X 20.6" - HONEY CHERRY
6	M09525-61-U22	EA	MOLDING - TRIM/VEE - 1.5" X 20.6" - WASHED MAPLE

**DRIVERS COMPARTMENT GROUP (CONTINUED)**  
**CABINETS (CONTINUED)**

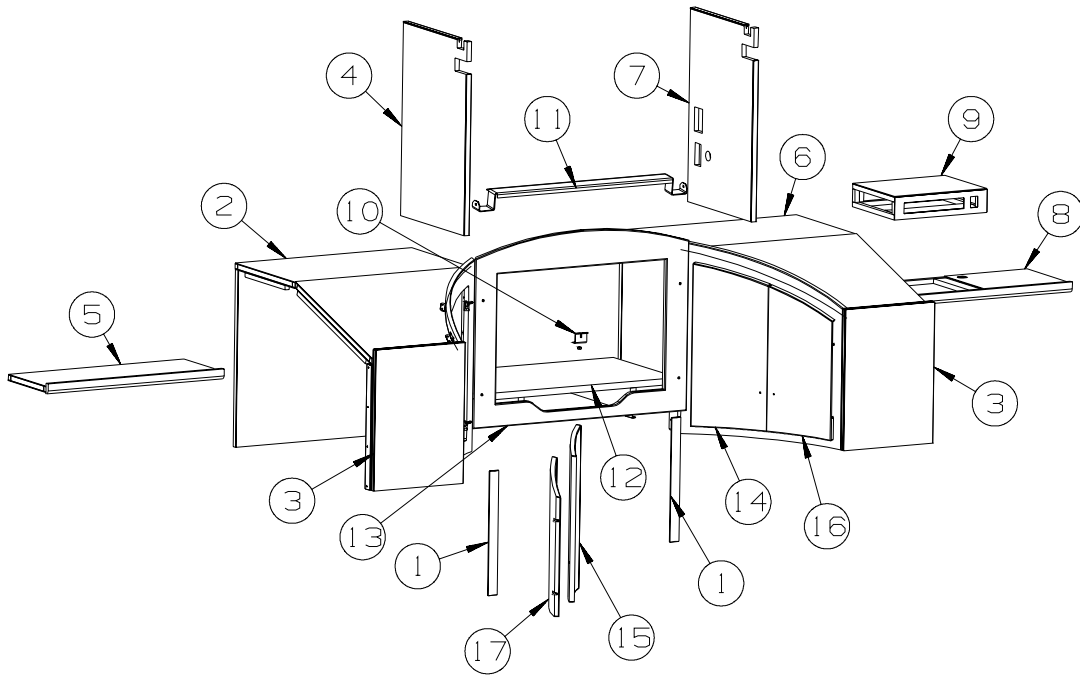

KEY	PART NUMBER	U/M	DESCRIPTION
1	M09525-60-U21	EA	MOLDING - TRIM/VEE - 1.5" X 18.9" - HONEY CHERRY
1	M09525-60-U22	EA	MOLDING - TRIM/VEE - 1.5" X 18.9" - WASHED MAPLE
2	157595-01-U21	EA	CABINET - ENTERTAINMENT CENTER/LEFT HAND - W/O DOORS/HDW - HONEY CHERRY
2	157595-01-U22	EA	CABINET - ENTERTAINMENT CENTER/LEFT HAND - W/O DOORS/HDW - WASHED MAPLE
3	158629-05-U21	EA	PANEL - END CAP - HONEY CHERRY
3	158629-05-U22	EA	PANEL - END CAP - WASHED MAPLE
4	158227-08-U21	EA	END CAP - OVERHEAD CABINET - HONEY CHERRY
4	158227-08-U22	EA	END CAP - OVERHEAD CABINET - WASHED MAPLE
5	157595-18-U21	EA	SHELF - CABINET - ENTERTAINMENT CENTER - HONEY CHERRY
5	157595-18-U22	EA	SHELF - CABINET - ENTERTAINMENT CENTER - WASHED MAPLE
6	157595-02-U21	EA	CABINET - ENTERTAINMENT CENTER/RIGHT HAND - W/O DOORS/HDW - HONEY CHERRY
6	157595-02-U22	EA	CABINET - ENTERTAINMENT CENTER/RIGHT HAND - W/O DOORS/HDW - WASHED MAPLE
7	158227-09-U21	EA	END CAP - OVERHEAD CABINET - HONEY CHERRY
7	158227-09-U22	EA	END CAP - OVERHEAD CABINET - WASHED MAPLE
8	157595-25-U21	EA	SHELF - CABINET - ENTERTAINMENT CENTER - HONEY CHERRY
8	157595-25-U22	EA	SHELF - CABINET - ENTERTAINMENT CENTER - WASHED MAPLE
9	157595-31-U21	EA	PANEL - SHELF - CABINET - ENTERTAINMENT CENTER - HONEY CHERRY
9	157595-31-U22	EA	PANEL - SHELF - CABINET - ENTERTAINMENT CENTER - WASHED MAPLE
10	152944-02-02B	EA	BRACKET - TIEDOWN/TV - E-COATED
11	155313-02-02B	EA	BRACKET - MOUNTING/TV - E-COATED
12	157616-01-U21	EA	CABINET - SHELF/TV
13	158935-01-U21	EA	FACE/FRAME (PICTURE) - TV CABINET - W/O HDW - HONEY CHERRY
13	158935-01-U22	EA	FACE/FRAME (PICTURE) - TV CABINET - W/O HDW - WASHED MAPLE
14	157639-01-U21	EA	DOOR - CURVED/ARCHED - 11.7" X 24.8" - W/O HDW - HONEY CHERRY
14	157639-01-U22	EA	DOOR - CURVED/ARCHED - 11.7" X 24.8" - W/O HDW - WASHED MAPLE
15	157639-02-U21	EA	DOOR - CURVED/ARCHED - 11.7" X 24.8" - W/O HDW - HONEY CHERRY
15	157639-02-U22	EA	DOOR - CURVED/ARCHED - 11.7" X 24.8" - W/O HDW - WASHED MAPLE
16	157639-03-U21	EA	DOOR - CURVED/ARCHED - 11.7" X 22.2" - W/O HDW - HONEY CHERRY
16	157639-03-U22	EA	DOOR - CURVED/ARCHED - 11.7" X 22.2" - W/O HDW - WASHED MAPLE
17	157639-04-U21	EA	DOOR - CURVED/ARCHED - 11.7" X 22.2" - W/O HDW - HONEY CHERRY
17	157639-04-U22	EA	DOOR - CURVED/ARCHED - 11.7" X 22.2" - W/O HDW - WASHED MAPLE

## ELECTRICAL GROUP 110V BODY WIRING

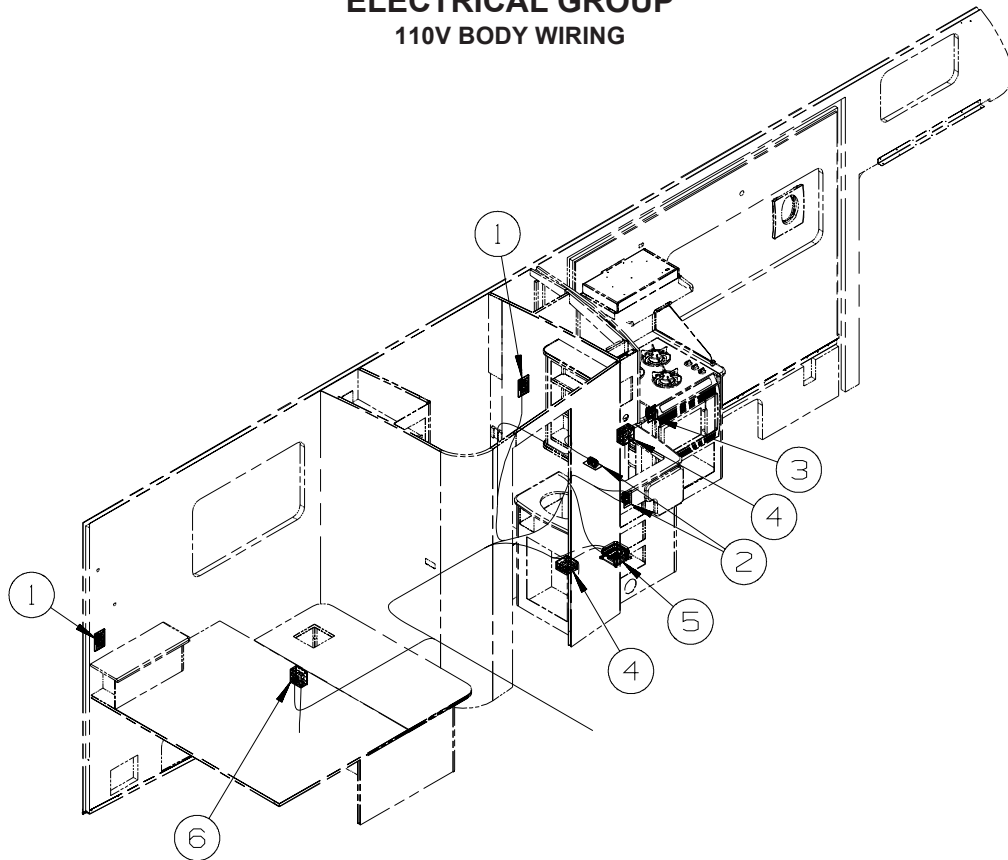

KEY	PART NUMBER	U/M	DESCRIPTION
1	058708-01-000	EA	RECEPTACLE - ELECTRIC - DOUBLE - BROWN
1	133713-01-23A	EA	SPACER/RECEPTACLE - VINYL - HONEY CHERRY
1	133713-01-21A	EA	SPACER/RECEPTACLE - VINYL - WASHED MAPLE
2	058708-01-000	EA	RECEPTACLE - ELECTRIC - DOUBLE - BROWN
3	157360-01-000	EA	RECEPTACLE - 20 AMP - SINGLE - SURFACE MOUNT - BROWN
4	008289-01-000	EA	BOX - ELECTRIC/STEEL - 4" X 4" - 1/2" & 3/4" KNOCKOUTS
4	008294-01-000	EA	COVER - ELECTRIC BOX - BLANK/STEEL - 4" X 4" - GRAY
5	136481-01-000	EA	MODULE - AUTO ENERGY SELECTOR
6	008289-01-000	EA	BOX - ELECTRIC/STEEL - 4" X 4" - 1/2" & 3/4" KNOCKOUTS - GEN-4.0KW-ONANGAS-MICROQUIET
6	008294-01-000	EA	COVER - ELECTRIC BOX - BLANK/STEEL - 4" X 4" - GRAY - GEN-4.0KW-ONANGAS-MICROQUIET

## ELECTRICAL GROUP (CONTINUED)

### 110V BODY WIRING (CONTINUED)

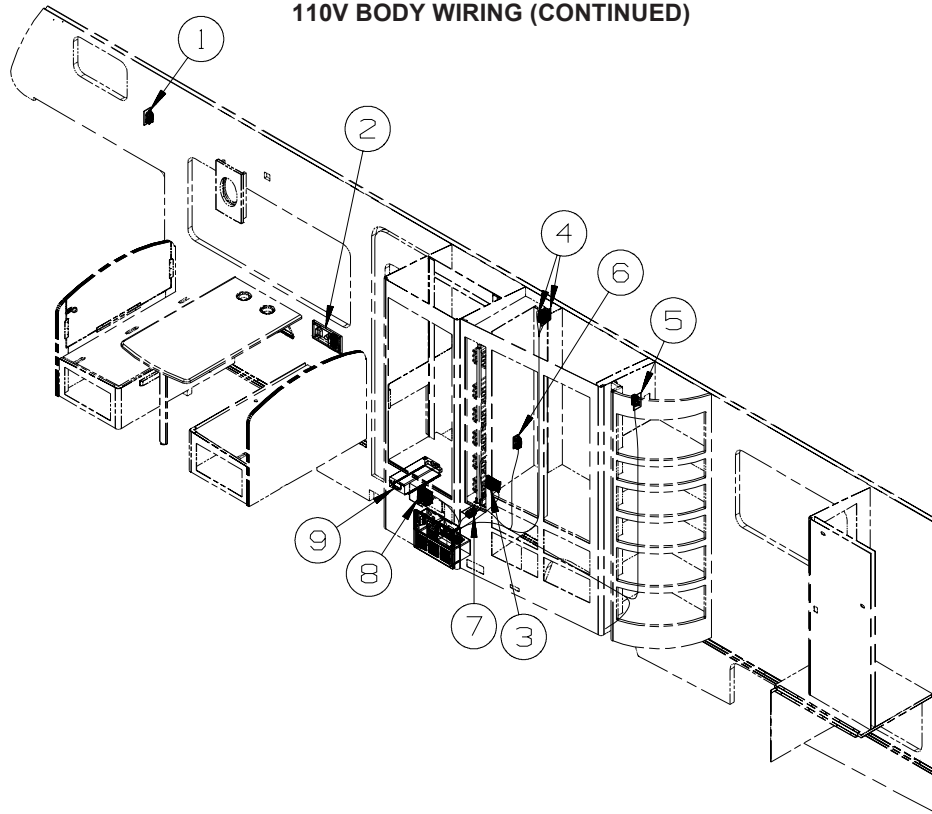

KEY	PART NUMBER	U/M	DESCRIPTION
1	058708-01-000	EA	RECEPT. - ELECTRIC - DBL - BRN-TV-19"AC,LCD,STEREO/CD/DVD/BUNK FRONT OVERHEAD-SINGLE
2	058708-01-000	EA	RECEPTACLE - ELECTRIC - DOUBLE - BROWN
2	133713-06-23A	EA	SPACER/RECEPTACLE - PHONE - VINYL - HONEY CHERRY
2	133713-06-21A	EA	SPACER/RECEPTACLE - PHONE - VINYL - WASHED MAPLE
3	131826-01-01A	EA	RECEPTACLE - EXTERIOR - W/COVER/GASKET - WHITE
4	058707-02-000	EA	RECEPTACLE - BLANK - JUNCTION BOX
5	058708-01-000	EA	RECEPTACLE - ELECTRIC - DOUBLE - BROWN
5	158542-02-01A	EA	LABEL - RECEPTACLE - ELECTRONICS - WHITE/BLACK - CANADIAN
6	058707-01-000	EA	RECEPTACLE - ELECTRIC - SINGLE - BROWN
7	058707-02-000	EA	RECEPTACLE - BLANK - JUNCTION BOX
7	058708-05-000	EA	RECEPT.-ELECTRICAL-SGL-BRN-ENTERTAINMENT CENTER-CABOVER/INVERTER-DC/AC, 300 WATT
8	163319-01-02A	EA	RECEPTACLE - GFCI - 15A 125V - BROWN
9	099048-04-000	EA	INVERTER - 300 WATT

## ELECTRICAL GROUP (CONTINUED)

### 12V BODY WIRING

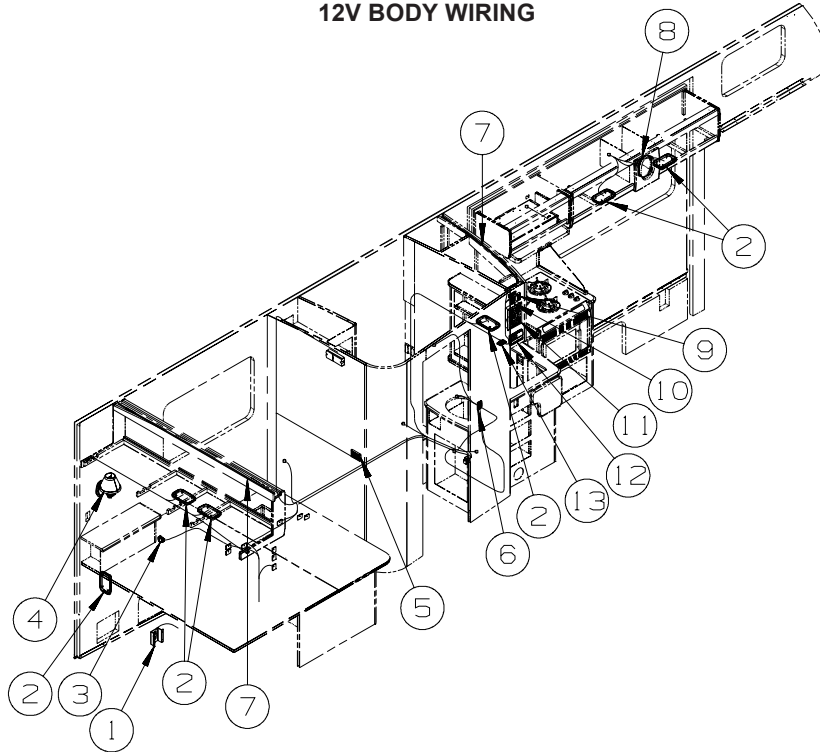

KEY	PART NUMBER	U/M	DESCRIPTION
1	130686-01-01A	EA	PLATE - WALL - TELEPHONE/COAX - WHITE
1	087236-01-000	EA	LABEL - CABLE - INPUT
2*	137417-02-01A	EA	LIGHT - DOME - SINGLE - W/SWITCH/OPTIC LENS - WHITE
3	108357-15-000	EA	SWITCH - ROCKER - DPDT - ON/NONE/ON - W/LIGHT W/O COVER
3	108356-04-01A	EA	COVER/ACTUATOR SWITCH - 2 ROWS DIMPLES W/LENS - BLACK
3	108355-01-000	EA	HOUSING - SWITCH
4	119258-55-01A	EA	LAMP - WALL - UL/CSA - BRUSHED NICKEL
4	119257-28-01A	EA	SHADE - LAMP - ROUND - IVORY
5	135740-01-01A	EA	SWITCH - ROCKER - SPST - ON/OFF - BROWN
5	135740-02-01A	EA	SWITCH - ROCKER - SPDT - ON/ON - BROWN
5	135741-03-01A	EA	SWITCH - BASE - TRIPLE - BROWN
5	135742-25-02A	EA	BEZEL - SWITCH - CEILING/AISLE/HALL - BROWN
6	135740-01-01A	EA	SWITCH - ROCKER - SPST - ON/OFF - BROWN
6	135741-01-01A	EA	SWITCH - BASE - SINGLE - BROWN
6	135742-07-02A	EA	BEZEL - SWITCH - CEILING - BROWN
7	146514-01-000	FT	LIGHT - FLEX - ROPE/ROUND - W/STRIP
7	146514-02-000	EA	CONNECTOR - LIGHT
7	146514-03-000	FT	LIGHT - FLEX - ROPE/ROUND - W/O MOUNT CHANNEL
7	146514-04-000	EA	CHANNEL/MOUNT - F/ROPE LIGHT
8	110465-01-000	EA	SPEAKER KIT,4 5X7 SPEAKERS
9	135740-06-01A	EA	SWITCH - ROCKER - ON/OFF - LIGHTED - RED - WTR HTR-6GAL/110/LP/MTR/AUTO
9	135741-01-01A	EA	SWITCH - BASE - SINGLE - BROWN - WTR HTR-6GAL/110/LP/MTR/AUTO
9	135742-35-02A	EA	BEZEL - SWITCH - WATER HEATER/110 VOLT - BROWN - WTR HTR-6GAL/110/LP/MTR/AUTO
10	135740-06-01A	EA	SW-ROCKER-ON/OFF-LIGHTED-RED-DRAINAGE SYSTEM-HEATED/DRAINAGE SYS/HEAT-PREWIRE
10	135741-01-01A	EA	SWITCH - BASE - SINGLE - BROWN-DRAINAGE SYSTEM-HEATED/DRAINAGE SYS/HEAT-PREWIRE
10	135742-01-01A	EA	BEZEL - SWITCH - SINGLE - BROWN-DRAINAGE SYSTEM-HEATED/DRAINAGE SYS/HEAT-PREWIRE
10	134563-01-02A	EA	LABEL - SWITCH - HEATER - BLK/WHT-DRAINAGE SYSTEM-HEATED/DRAINAGE SYS/HEAT-PREWIRE
11*	134940-06-01A	EA	PANEL - MONITOR - 2 TANK - W/GENERATOR SWITCH - GEN-4.0KW-ONANGAS-MICROQUIET
11*	134940-07-01A	EA	PANEL - MONITOR - 2 TANK
12	135618-03-01A	EA	THERMOSTAT - ROOF A/C & FURNACE - WHITE - A/C ROOF AIR (1) 14,800 BTU
12	135618-01-01A	EA	THERMOSTAT - HEAT PUMP/FURNACE - WHITE - AC HEAT PUMP-1
13	135740-01-01A	EA	SWITCH - ROCKER - SPST - ON/OFF - BROWN
13	135741-01-01A	EA	SWITCH - BASE - SINGLE - BROWN
13	135742-50-02A	EA	BEZEL - SWITCH - ACCENT - BROWN

\*COMPONENT PARTS LISTED LATER IN THIS GROUP



## ELECTRICAL GROUP (CONTINUED)

### 12V BODY WIRING (CONTINUED)

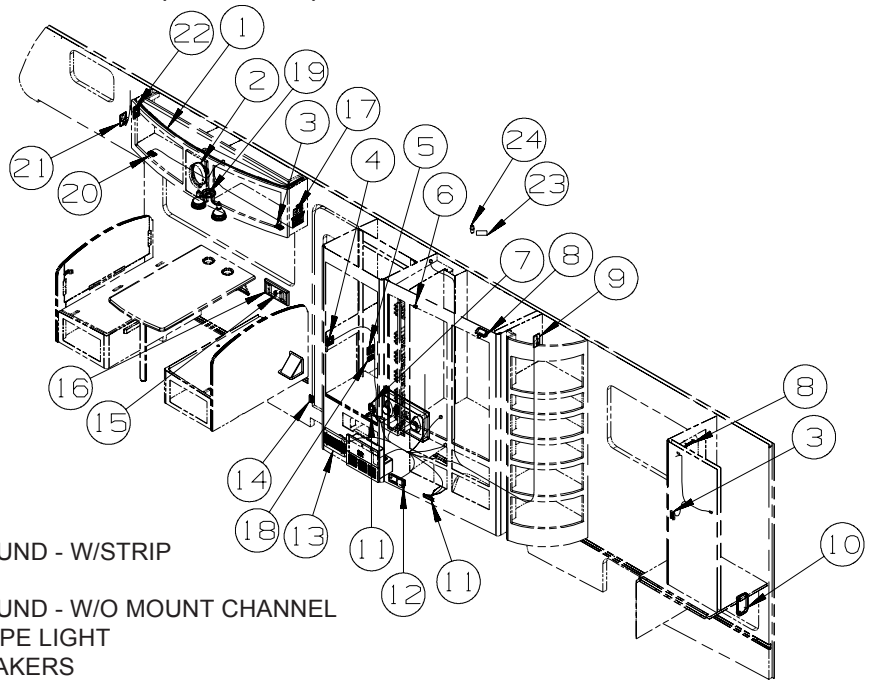

KEY	PART NUMBER	U/M	DESCRIPTION
1	146514-01-000	FT	LIGHT - FLEX - ROPE/ROUND - W/STRIP
1	146514-02-000	EA	CONNECTOR - LIGHT
1	146514-03-000	FT	LIGHT - FLEX - ROPE/ROUND - W/O MOUNT CHANNEL
1	146514-04-000	EA	CHANNEL/MOUNT - F/ROPE LIGHT
2	110465-01-000	EA	SPEAKER KIT,4 5X7 SPEAKERS
3	135740-01-01A	EA	SWITCH - ROCKER - SPST - ON/OFF - BROWN
3	135741-01-01A	EA	SWITCH - BASE - SINGLE - BROWN
3	135742-50-02A	EA	BEZEL - SWITCH - ACCENT - BROWN
4	135740-01-01A	EA	SWITCH - ROCKER - SPST - ON/OFF - BROWN
4	135740-02-01A	EA	SWITCH - ROCKER - SPDT - ON/ON - BROWN
4	135741-02-01A	EA	SWITCH - BASE - DOUBLE - BROWN
4	135742-16-02A	EA	BEZEL - SWITCH - CEILING/HALL - BROWN
5	135740-01-01A	EA	SWITCH - ROCKER - SPST - ON/OFF - BROWN
5	135741-02-01A	EA	SWITCH - BASE - DOUBLE - BROWN
5	135742-19-02A	EA	BEZEL - SWITCH - CEILING/PORCH - BROWN
6	056264-01-000	EA	SWITCH - LEAF ACTUATOR
7	108357-06-000	EA	SWITCH - ROCKER - DPDT - MOM/OFF/MOM - 6 TERM - W/O COVER
7	108356-11-01A	EA	COVER/ACTUATOR SWITCH - 3 GROOVES - AUX BATT - BLACK
7	108355-01-000	EA	HOUSING - SWITCH
7	098351-07-02A	EA	PLATE/SWITCH - 1 GANG - CHROME - GENERATOR SWITCH
8*	087694-01-000	EA	LIGHT - WARDROBE/CLOSET - W/SWITCH
9	076319-09-000	EA	WALLPLATE - TV CABLE RECEPTACLE - SINGLE - BROWN
10*	137417-02-01A	EA	LIGHT - DOME - SINGLE - W/SWITCH/OPTIC LENS - WHITE
11	061424-01-000	EA	LIGHT - AISLE - 12 VOLT - RECTANGULAR
12	150138-01-02A	EA	DETECTOR - LP GAS - BROWN
13	124884-01-000	EA	SPEAKER-6" X 9"-SUB-WOOFER-W/O GRILLE-TV-20"AC,LCD,STEREO/CD/DVD/ENTCENTER-CABOVER
13	151844-01-01A	EA	GRILLE-SPEAKER-6" X 9"-SUB WOOFER-BLK-TV-20"AC,LCD,STEREO/CD/DVD/ENTCENTER-CABOVER
14	116995-02-000	EA	SWITCH/MAGNET - ELECTRIC STEP - BLACK/WHITE- NORMALLY OPEN
15	132958-01-000	EA	RECEPTACLE - 12 VOLT - MOUNTING FLANGE - BLACK
16	093253-01-02A	EA	PLATE - WALL - TELEPHONE - BROWN
17	138173-04-000	EA	CONTROL PANEL (TOUCH PAD) - ELECTRIC SLIDEOUT - #1802931
17	116549-01-000	EA	LABEL - WARNING - .8" X 6.3" - SLIDEOUT
17	163992-01-01A	EA	LABEL - SLIDEOUT - DRIVER/FRONT - BLACK/WHITE
17	163988-01-01A	EA	LABEL - SLIDEOUT CONTROL/MANUAL - BLACK/WHITE
17*	163097-01-000	EA	SWITCH - SPST - KEY ACTIVATED - W/2 KEYS
18	135740-01-01A	EA	SWITCH - ROCKER - SPST - ON/OFF - BROWN
18	135741-01-01A	EA	SWITCH - BASE - SINGLE - BROWN
18	135742-11-02A	EA	BEZEL - SWITCH - STEP - BROWN
19	093575-46-01A	EA	LIGHT - CEILING/DOUBLE - BRUSHED NICKEL
20	135740-02-01A	EA	SWITCH - ROCKER - SPDT - ON/ON - BROWN
20	135741-01-01A	EA	SWITCH - BASE - SINGLE - BROWN
20	135742-06-02A	EA	BEZEL - SWITCH - AISLE - BROWN
21	086777-02-000	EA	WALLPLATE/TV CABLE W/ANT. SW/BOOSTER-2 TV-BLK-TV-20"AC,LCD,STEREO/CD/DVD
22	149557-05-01A	EA	PLATE/WALL - DUAL COAXIAL/HORIZONTAL - WHITE-TV-20"AC,LCD,STEREO/CD/DVD
23	086756-01-000	EA	SPLITTER - TV/2 WAY
24	082134-01-000	EA	ADAPTER - TV - CABLE TO CABLE

\*COMPONENT PARTS LISTED LATER IN THIS GROUP

## ELECTRICAL GROUP (CONTINUED)

### 12V BODY WIRING (CONTINUED)

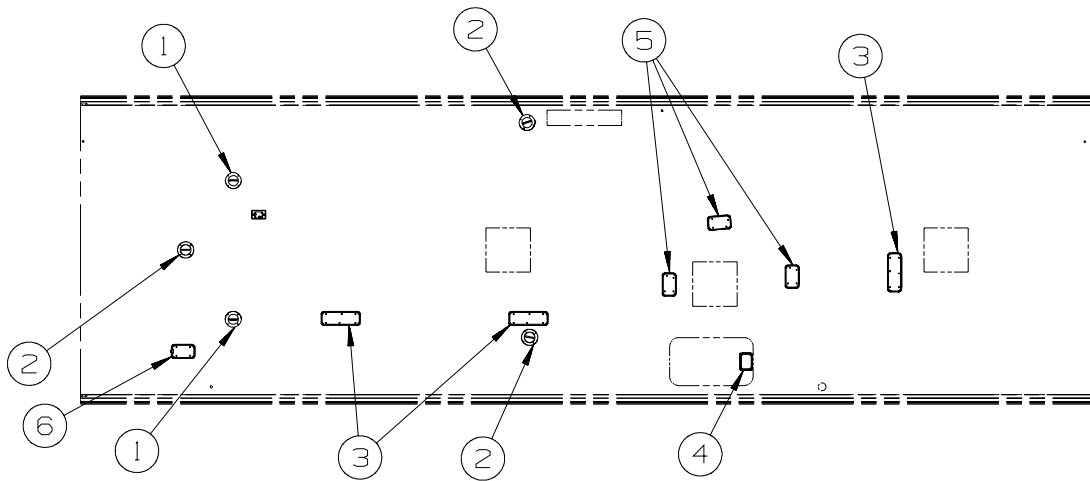

KEY	PART NUMBER	U/M	DESCRIPTION
1	160867-01-01A	EA	SPEAKER -ROUND/CEILING-MAGNADYNE-TV-20"AC,LCD,STEREO/CD/DVD/ENTCENTER-CABOVER
2	160867-01-01A	EA	SPEAKER -ROUND/CEILING-MAGNADYNE-ENTCENTER-CABOVER
3*	137417-06-01A	EA	LIGHT - DOME - DOUBLE - W/O SWITCH - W/FROSTED LENS-WHITE
4*	121935-01-01A	EA	LIGHT - DOME - SHOWER - W/HOLE IN LENS
5*	137417-03-01A	EA	LIGHT - DOME - SINGLE - W/O SWITCH - W/FROSTED LENS-WHITE
6*	137417-01-01A	EA	LIGHT - DOME - SINGLE - W/SWITCH/FROSTED LENS - WHITE

**\*COMPONENT PARTS LISTED LATER IN THIS GROUP**

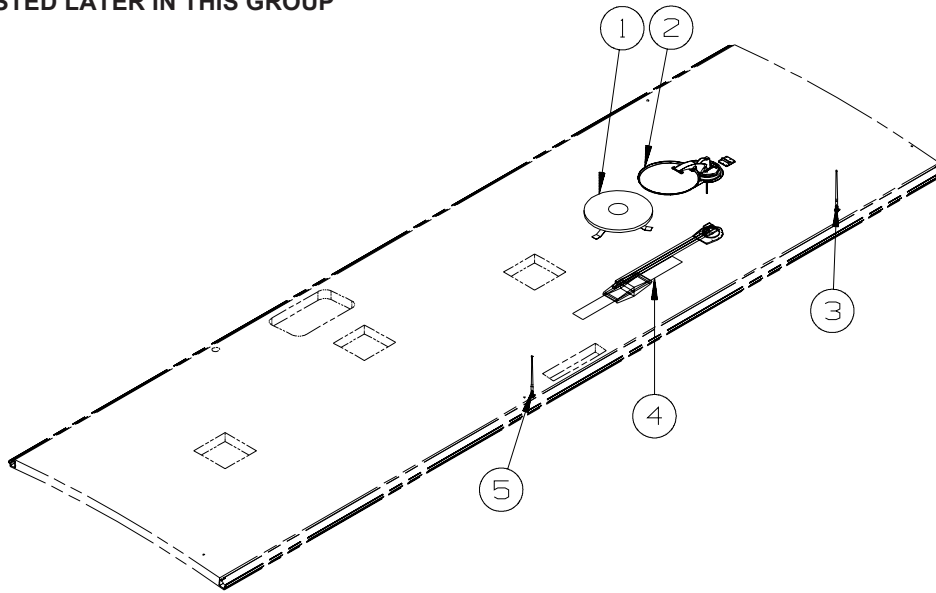

KEY	PART NUMBER	U/M	DESCRIPTION
1	132935-01-000	EA	ANTENNA - TV ROOF MOUNT - ROUND - W/O POWER SUPPLY - TV ANTENNA-OMNIDIRECTIONAL FROM: 00-00-00 THRU: 01-29-08
1	167632-01-01A	EA	ANTENNA - TV ROOF MOUNT/ROUND - W/O PWR SUPPLY - WHT - TV ANTENNA-OMNIDIRECTIONAL FROM: 01-30-08 THRU: 99-99-99
1	146488-01-000	EA	PLATE - ROOF - CABLE ENTRY - TV ANTENNA-OMNIDIRECTIONAL
1	082134-01-000	EA	ADAPTER - TV - CABLE TO CABLE - TV ANTENNA-OMNIDIRECTIONAL
2	137135-05-000	EA	ANTENNA - SATELLITE DSS - W/SENSOR - SATELLITE TV SYSTEM MANUAL
3	090944-01-000	EA	ANTENNA - RADIO - 16" RUBBER - W/72" LEAD WIRE - TV-20"AC,LCD,STEREO/CD/DVD
3	109889-04-000	EA	EXTENDER - ANTENNA SHAFT - 3.7" - TV-20"AC,LCD,STEREO/CD/DVD
3	147741-01-09B	EA	BRACKET - ANTENNA GROUND - GALVANIZED - TV-20"AC,LCD,STEREO/CD/DVD
4*	076319-23-000	EA	ANTENNA - TV ROOF MOUNT - 44.5" MAST
4*	076319-25-000	EA	KIT - HARDWARE INTERIOR
4	069726-02-000	EA	BUMPER - .88" OD X .40" THICK - BLACK
5	090944-01-000	EA	ANTENNA - RADIO - 16" RUBBER - W/72" LEAD WIRE - ENTERTAINMENT CENTR/EXT W/CD
5	109889-04-000	EA	EXTENDER - ANTENNA SHAFT - 3.7" - ENTERTAINMENT CENTR/EXT W/CD
5	147741-01-09B	EA	BRACKET - ANTENNA GROUND - GALVANIZED - ENTERTAINMENT CENTR/EXT W/CD

**\*COMPONENT PARTS LISTED LATER IN THIS GROUP**

**ELECTRICAL GROUP (CONTINUED)**  
**12V BODY WIRING (CONTINUED)**

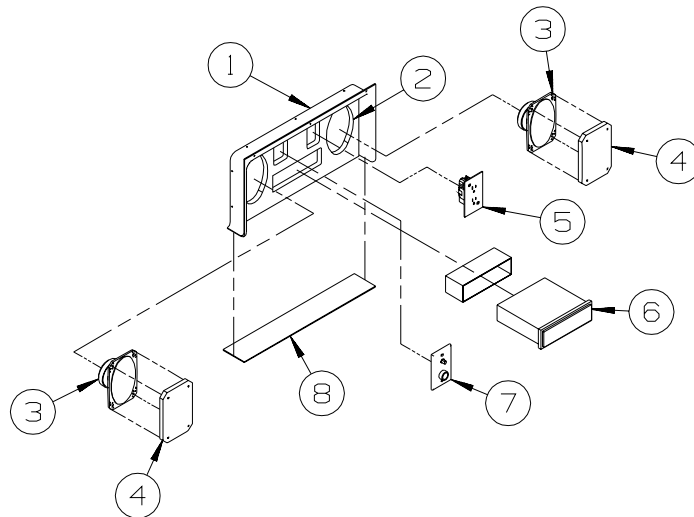

KEY	PART NUMBER	U/M	DESCRIPTION
1	124696-02-01A	EA	BOX-ENTERTAINMENT CTR/EXT-19.4"W X 10"H X 2.5"D - BRT WHT
	124696-01-01A	EA	BOX-ENTERTAINMENT CTR/EXT-19.4"W X 10"H X 10.2"D W/CUTOUTS
2	127409-02-L15	EA	PLATE - RADIO MOUNTING
3	110469-01-000	EA	SPEAKER - 4" X 6" OVAL - COAXIAL
4	110470-01-01A	EA	GRILLE - 4" X 6" - OVAL SPEAKER - BLACK
5	058708-01-000	EA	RECEPTACLE - ELECTRIC - DOUBLE - BROWN
6	155619-02-000	EA	RADIO - AM/FM CD-W/O REMOTE/WIRE HARNESS-MAGNADYNE M3200CD
	155619-03-000	EA	REMOTE - RADIO
7	076319-09-000	EA	WALLPLATE - TV CABLE RECEPTACLE - SINGLE - BROWN
8	104898-01-02A	EA	PLATE - PLASTIC BOTTOM - BRIGHT WHITE

## ELECTRICAL GROUP (CONTINUED)

### EXTERIOR LAMPS

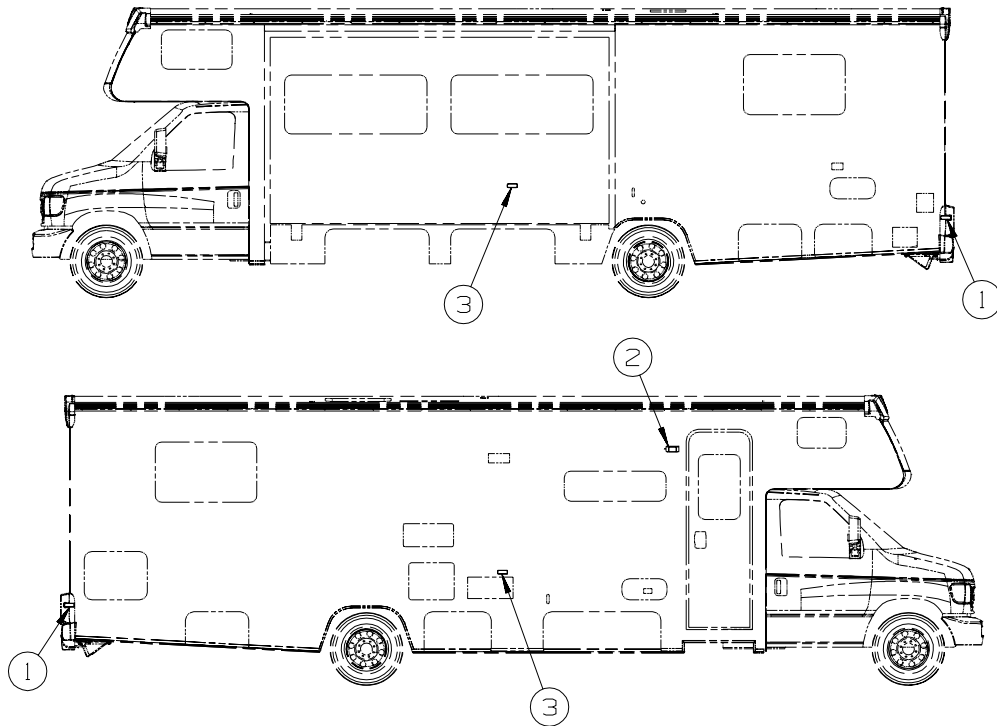

**KEY PART NUMBER**

1	111102-01-000	EA	BASE - MARKER LAMP
1	111102-03-000	EA	LENS - RED - MARKER LAMP
2*	097917-01-06A	EA	LIGHT - PORCH - ENTRY DOOR - BRIGHT WHITE
			FROM: 00-00-00 THRU: 02-10-08
2	097917-01-09A	EA	LIGHT - PORCH - ENTRY DOOR - WHITE
			FROM: 02-11-08 THRU: 99-99-99
3	111102-01-000	EA	BASE - MARKER LAMP
3	111102-02-000	EA	LENS - AMBER - MARKER LAMP

**\*COMPONENT PARTS LISTED LATER IN THIS GROUP**

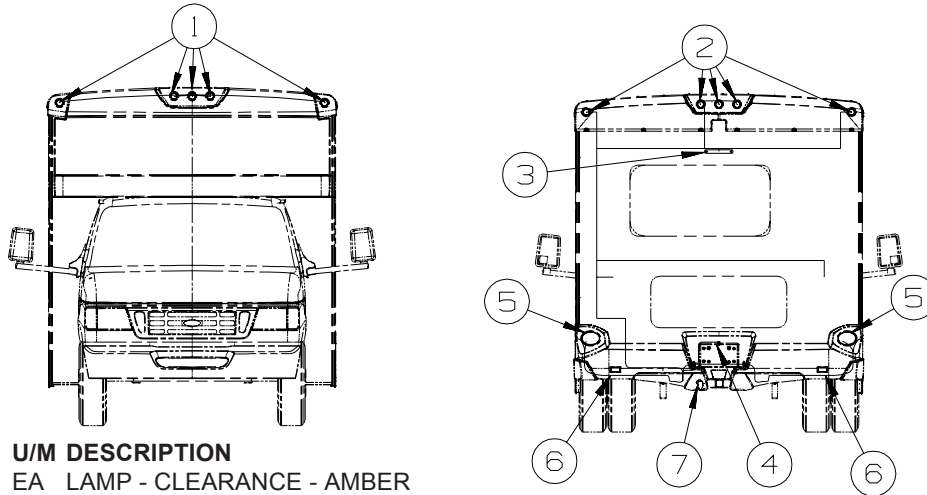

**KEY PART NUMBER**

KEY	PART NUMBER	U/M	DESCRIPTION
1	138996-01-000	EA	LAMP - CLEARANCE - AMBER
1	138996-03-000	EA	BRACKET - CLEARANCE LIGHT
1	138996-04-000	EA	CONNECTOR - LAMP
2	138996-02-000	EA	LAMP - CLEARANCE - RED
2	138996-03-000	EA	BRACKET - CLEARANCE LIGHT
2	138996-04-000	EA	CONNECTOR - LAMP
3	136916-01-000	EA	LIGHT - BRAKE - CENTER MOUNT - RECTANGLE - 1.3" X 9.8"
4	087201-01-000	EA	LIGHT - HALF ROUND - 1" X 1.7" - PLASTIC - BLACK OR WHITE
5	152070-03-000	EA	LIGHT - STOP/TAIL/BACK UP
5	148335-03-000	EA	HOUSING - 6-POSITION/MALE - 280=GT SERIES
6	106646-02-000	EA	REFLECTOR - STICK ON - RED
7	146246-01-000	EA	CONNECTOR/PLUG - TRAILER - 7 PIN
7	157593-01-000	EA	CONNECTOR - PLUG - TRAILER - 7 SOCKET

**ELECTRICAL GROUP (CONTINUED)**  
**FRONT END**

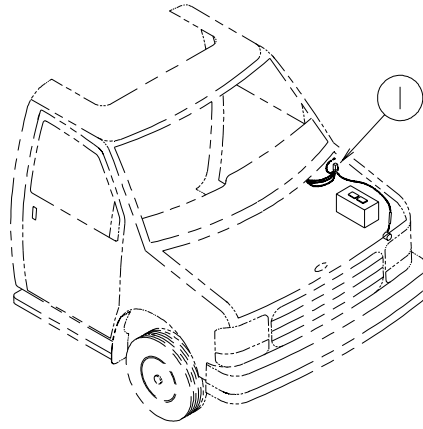

KEY	PART NUMBER	U/M DESCRIPTION
1	100138-01-000	EA MODULE - DAYTIME/RUNNING LIGHT - HAMSAR DRL #H8005B



KEY	PART NUMBER	U/M DESCRIPTION
*	120269-07-01A	EA PANEL - W/ELECTRIC MIRROR/HEAT SWITCH - F/#L28X OPTION - MIRRORS-EXTERIOR W/DEFROST
*	133908-09-01A	EA PANEL - F/ELECTRIC MIRROR ONLY - L28X OPTION - MIRRORS-EXTERIOR W/DEFROST - CHEVY

**\*COMPONENT PARTS LISTED LATER IN THIS GROUP**

## ELECTRICAL GROUP (CONTINUED)

### FRONT TV/DVD

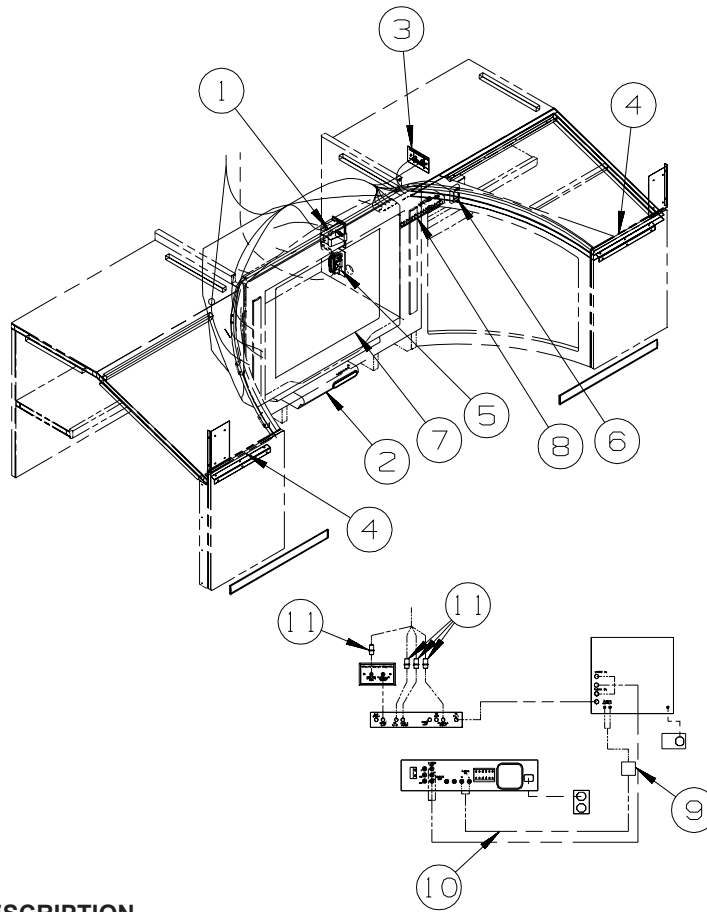

KEY	PART NUMBER	U/M	DESCRIPTION
1	156676-01-000	EA	CONTROLLER/OUTLET - POWER/TV - AUTO SHUTOFF W/IGNITION
2*	158836-01-000	EA	DVD - HOME THEATER - W/O SPEAKERS - MEMOREX STS71E-R FROM: 00-00-00 THRU: 06-10-07
2*	164270-01-000	EA	DVD - HOME THEATER - W/O SPEAKERS - MEMOREX STS2891-R FROM: 06-11-07 THRU: 99-99-99
3	149557-05-01A	EA	PLATE/WALL - DUAL COAXIAL/HORIZONTAL - WHITE
4	146514-01-000	FT	LIGHT - FLEX - ROPE/ROUND - W/STRIP
4	146514-02-000	EA	CONNECTOR - LIGHT
5	058708-01-000	EA	RECEPTACLE - ELECTRIC - DOUBLE - BROWN
5	158542-02-01A	EA	LABEL - RECEPTACLE - ELECTRONICS - WHITE/BLACK - <b>CANADIAN</b>
6	135740-01-01A	EA	SWITCH - ROCKER - SPST - ON/OFF - BROWN
6	135741-01-01A	EA	SWITCH - BASE - SINGLE - BROWN
6	135742-50-02A	EA	BEZEL - SWITCH - ACCENT - BROWN
7*	146298-02-000	EA	TV - 27" STEREO W/5 JACKS - SONY 27FS120
8	142258-01-000	EA	SWITCH - VIDEO/ANTENNA POWER SUPPLY
9	123324-01-000	EA	FILTER - GROUND LOOP - <b>ENTERTAINMENT CENTER-CABOVER</b>
10	117420-02-000	EA	CABLE - W/MALE RCA ENDS - SHIELDED - 4' - <b>ENTERTAINMENT CENTER-CABOVER</b>
11	082134-01-000	EA	ADAPTER - TV - CABLE TO CABLE - <b>ENTERTAINMENT CENTER-CABOVER</b>

\*COMPONENT PARTS LISTED LATER IN THIS GROUP

## ELECTRICAL GROUP (CONTINUED)

### SIDE TV/DVD

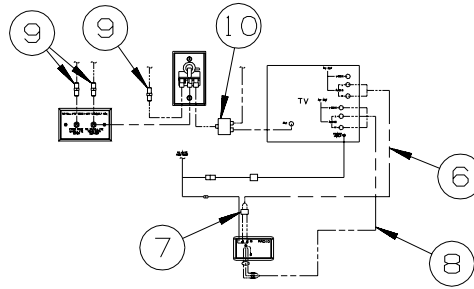
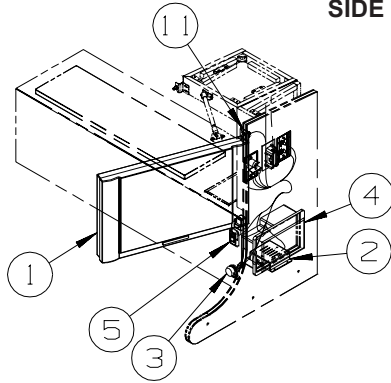

KEY	PART NUMBER	U/M	DESCRIPTION
1*	158703-01-000	EA	TV - 20" - LCD 4:3 - SIDE SPEAKER - JENSEN JE2043 FROM: 00-00-00 THRU: 04-29-07
1*	164495-01-000	EA	TV - 19" - LCD 16:9 - BOTTOM SPEAKER - JENSEN JE1907DC FROM: 04-30-07 THRU: 99-99-99
2	150140-01-000	EA	CROSSOVER BOX - STANDARD STEREO TO DELUXE SOUND
3	150140-02-000	EA	CROSSOVER COIL - F/SUBWOOFER SPEAKER/LOW FREQUENCY
4*	156413-01-01A	EA	RADIO - WALL MOUNT - DVD/CD - W/ALARM - JENSEN AWM950 FROM: 00-00-00 THRU: 01-01-07
4*	163031-01-01A	EA	RADIO - WALL MOUNT - DVD/CD - W/ALARM - JENSEN AWM960 FROM: 01-02-07 THRU: 99-99-99
5	135740-01-01A	EA	SWITCH - ROCKER - SPST - ON/OFF - BROWN
5	135741-01-01A	EA	SWITCH - BASE - SINGLE - BROWN
5	135742-45-02A	EA	BEZEL - SWITCH - TV - BROWN
6	117420-02-000	EA	CABLE - W/MALE RCA ENDS - SHIELDED - 4'
7	123324-01-000	EA	FILTER - GROUND LOOP
8	136860-01-000	EA	CABLE - RCA - SHIELDED - 3 MALE TO MALE CONNECTORS - 12'
9	082134-01-000	EA	ADAPTER - TV - CABLE TO CABLE
10	086756-01-000	EA	SPLITTER - TV/2 WAY
11	159814-01-000	EA	SWITCH - PLUNGER - SPST - OFF/ON

**\*COMPONENT PARTS LISTED LATER IN THIS GROUP**

**ELECTRICAL GROUP (CONTINUED)**  
**COMPONENT PARTS FOR WIRING**

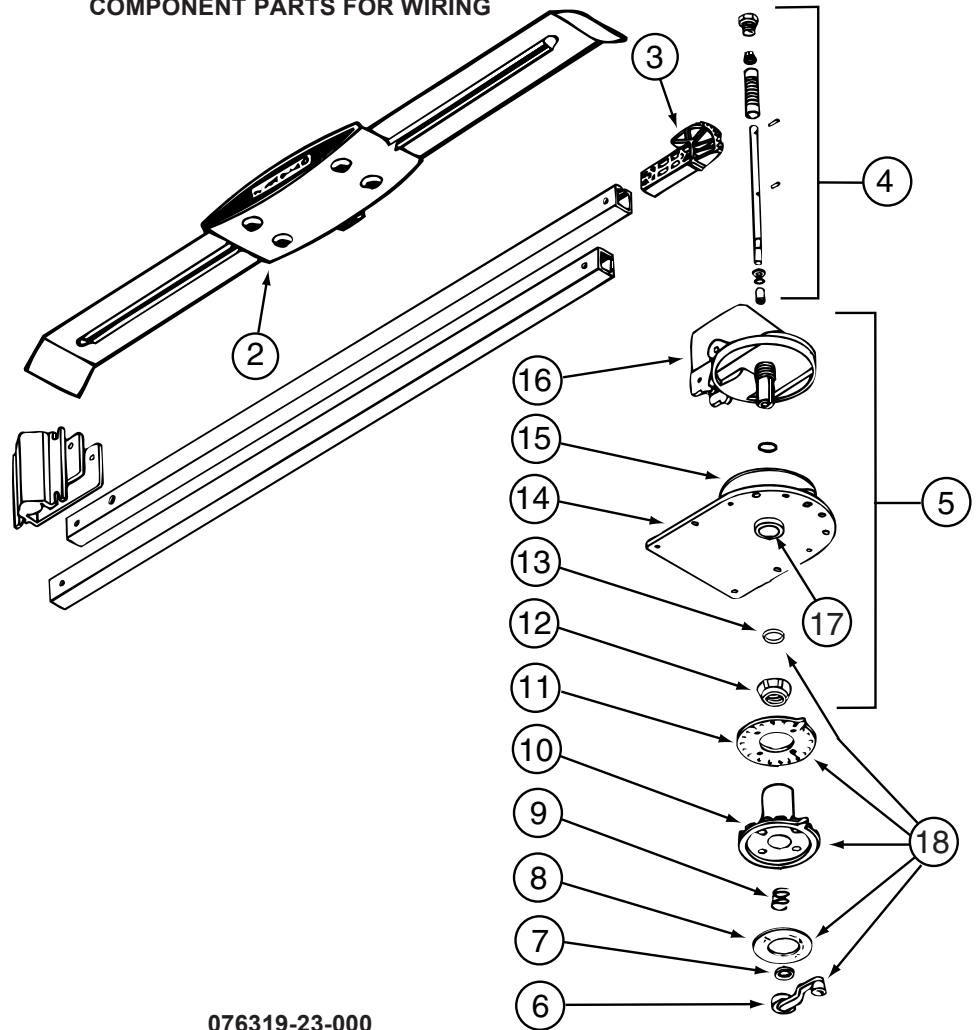

**076319-23-000**

KEY	PART NUMBER	U/M	DESCRIPTION	VENDOR NO.
2	076319-01-700	EA	HEAD-ANTENNA, AMPLIFIED	RVSA U/V
3	076319-01-701	EA	GEAR-ELEVATING, PLASTIC	2200046
4	076319-01-702	EA	SHAFT ASM-ELEVATING	RP-4000
5	076319-01-711	EA	BASE & LIFT ASM	2762802
7	076319-01-705	EA	GROMMET-NYLON, 7/8"ID	3200658
8	076319-01-708	EA	DECAL-CRANK	5413002
9	076319-01-707	EA	SPRING-HANDLE	2160822
11	076319-01-712	EA	PLATE - CEILING	3200608
12	076319-01-715	EA	NUT (GEAR HOUSING)	2200047
14	076319-01-713	EA	PLATE-BASE, STEEL	3100523
15	076319-01-703	EA	BEARING-NYLON, 5"OD	3200656
16	076319-01-714	EA	HOUSING, ROTATING GEAR	2200049
17	076319-01-704	EA	BEARING-NYLON, 1.25"OD	3200657
18	076319-01-709	EA	HANDLE-HEAD DIRECTIONAL	200644
	076319-01-716	EA	TUBING, ELEVATING	RP-2900
CONTACT WINNEBAGO PART SALES FOR UNLISTED COMPONENT(S)				

**076319-25-000**

KEY	PART NUMBER	U/M	DESCRIPTION	VENDOR NO.
6	076319-01-706	EA	CRANK-W/SET SCREW UNIV/BEIGE	2750897
6	120233-01-710	EA	HANDLE-CRANK W/SCREW - WHITE	RP-6795
8	076319-01-708	EA	DECAL-CRANK	5413002
10	076319-25-700	EA	DIRECTIONAL HANDLE(WHITE)	3200612
11	076319-25-701	EA	PLATE - CEILING(WHITE)	3200609
13	120233-01-709	EA	WASHER-NYLON	RP-2658
CONTACT WINNEBAGO PART SALES FOR UNLISTED COMPONENT(S)				

**087694-01-000**

KEY	PART NUMBER	U/M	DESCRIPTION	VENDOR NO.
	087694-01-700	EA	BULB	GE561



**ELECTRICAL GROUP (CONTINUED)**  
**COMPONENT PARTS FOR WIRING (CONTINUED)**

		<b>097917-01-06A</b>	
<b>KEY</b>	<b>PART NUMBER</b>	<b>U/M DESCRIPTION</b>	<b>VENDOR NO.</b>
	097917-01-700	EA LENS-LIGHT, CLEAR	30-78-021
		<b>120269-07-01A</b>	
<b>KEY</b>	<b>PART NUMBER</b>	<b>U/M DESCRIPTION</b>	<b>VENDOR NO.</b>
	120269-07-700	EA SWITCH - REMOTE	7475720
	133908-09-700	EA SWITCH - MIRROR HEATER	7475150
		<b>121935-01-01A</b>	
<b>KEY</b>	<b>PART NUMBER</b>	<b>U/M DESCRIPTION</b>	<b>VENDOR NO.</b>
	121935-01-700	EA LENS ONLY - W/CENTER HOLE	809511
		<b>133908-09-01A</b>	
<b>KEY</b>	<b>PART NUMBER</b>	<b>U/M DESCRIPTION</b>	<b>VENDOR NO.</b>
	133908-09-700	EA SWITCH-MIRROR HEATER	7475150

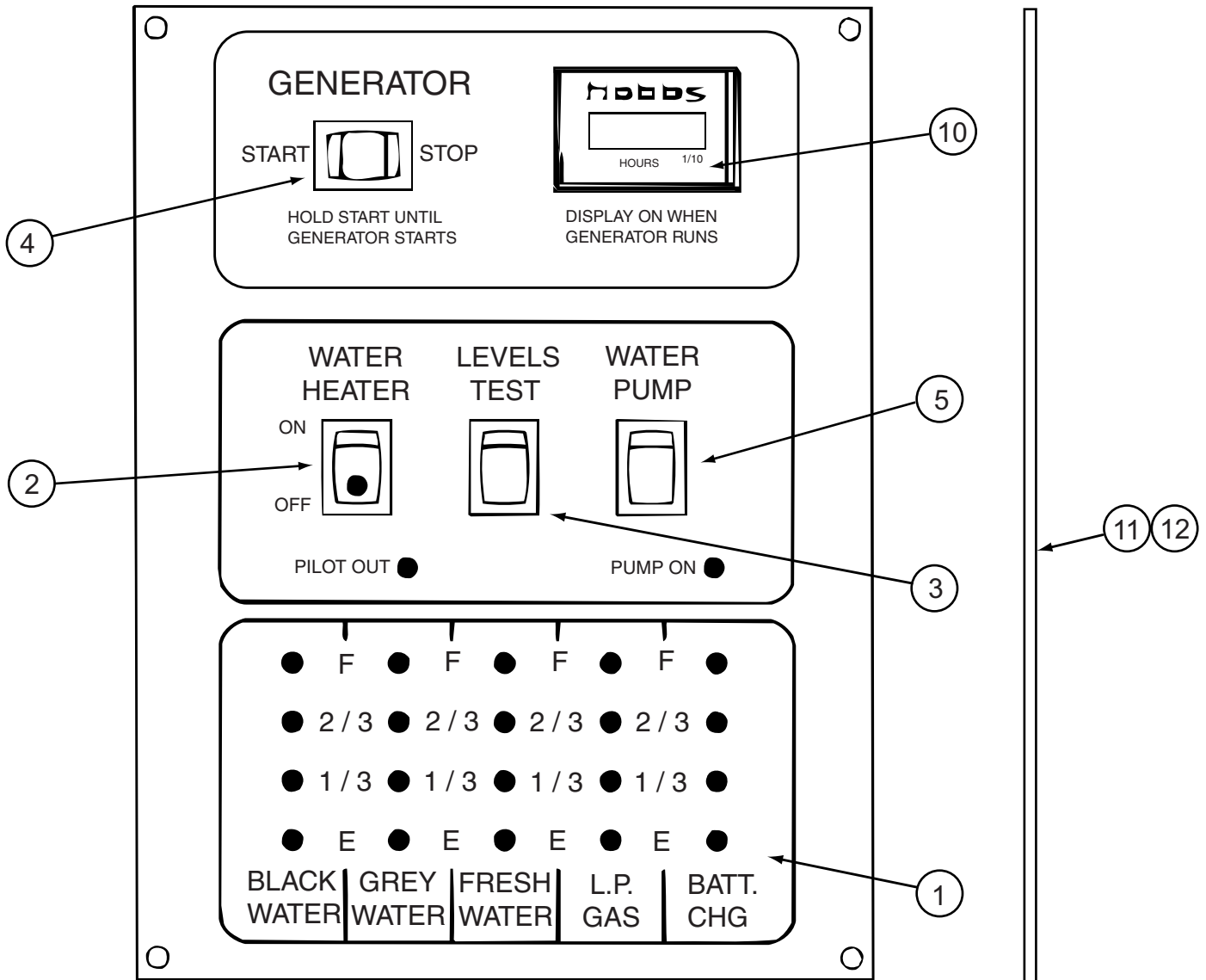

		<b>134940-06-01A</b>	
<b>KEY</b>	<b>PART NUMBER</b>	<b>U/M DESCRIPTION</b>	<b>VENDOR NO.</b>
1	134940-01-702	EA CHASSIS - SILKSCREENED	CC0558-00
2	134940-01-701	EA SWITCH-SPST/ON-OFF/BLK W/LGT	L0109
3	096983-01-701	EA SWITCH - SPST/MOM 2 TERMINAL	L0111-00
4	096983-01-702	EA SWITCH - MOM/OFF/MOM/3 TERM	L0112-00
5	096983-01-703	EA SWITCH - ON/ON	L0115-00
10	100258-10-701	EA GAUGE-HR METER ONLY (LCD)	L0775-00
11	134940-06-700	EA PC BOARD - SENSOR SYSTEM/RED	L5131-02
		CONTACT WINNEBAGO PART SALES FOR UNLISTED COMPONENT(S)	

**ELECTRICAL GROUP (CONTINUED)**  
**COMPONENT PARTS FOR WIRING (CONTINUED)**

**134940-07-01A**

KEY	PART NUMBER	U/M	DESCRIPTION	VENDOR NO.
1	134940-01-702	EA	CHASSIS - SILKSCREENED	CC0558-00
2	134940-01-701	EA	SWITCH-SPST/ON-OFF/BLK W/LGT	L0109
3	096983-01-701	EA	SWITCH - SPST/MOM 2 TERMINAL	L0111-00
4	096983-01-703	EA	SWITCH - ON/ON	L0115-00
5	134940-02-700	EA	SWITCH - DUMMY	L0118
11	134940-06-700	EA	PC BOARD - SENSOR SYSTEM/RED	L5131-02

CONTACT WINNEBAGO PART SALES FOR UNLISTED COMPONENT(S)

**137417-01-01A, 137417-03-01A**

KEY	PART NUMBER	U/M	DESCRIPTION	VENDOR NO.
	137417-01-700	EA	LENS - SINGLE (FROSTED)	810868

**137417-02-01A**

KEY	PART NUMBER	U/M	DESCRIPTION	VENDOR NO.
	137417-02-700	EA	LENS - SINGLE OPTIC	810844

**137417-05-01A**

KEY	PART NUMBER	U/M	DESCRIPTION	VENDOR NO.
	137417-05-700	EA	LENS - DOUBLE OPTIC	810845

**137417-06-01A**

KEY	PART NUMBER	U/M	DESCRIPTION	VENDOR NO.
	137417-06-700	EA	LENS - DOUBLE WHITE	810867

**146298-02-000**

KEY	PART NUMBER	U/M	DESCRIPTION	VENDOR NO.
	146298-02-700	EA	REMOTE - TV	1-478-707-11

**156413-01-01A**

KEY	PART NUMBER	U/M	DESCRIPTION	VENDOR NO.
	156413-01-700	EA	REMOTE	REMAWM950

**158703-01-000**

KEY	PART NUMBER	U/M	DESCRIPTION	VENDOR NO.
	158703-01-700	EA	REMOTE	PSVCJE2043
	158703-01-701	EA	SERVICE PACK-REMOTE & CABLES	PSVCJE2043

**158836-01-000**

KEY	PART NUMBER	U/M	DESCRIPTION	VENDOR NO.
	158836-01-700	EA	REMOTE	STS71WREM

**163031-01-01A**

KEY	PART NUMBER	U/M	DESCRIPTION	VENDOR NO.
	163031-01-700	EA	REMOTE	PSVCAWM960

**163097-01-000**

KEY	PART NUMBER	U/M	DESCRIPTION	VENDOR NO.
	163097-01-700	EA	KEY - #2382 (ILLINOIS LOCK)	2382
	163097-01-701	EA	KEY - #2341 (MILLER DIAL)	PART SALES

**164270-01-000**

KEY	PART NUMBER	U/M	DESCRIPTION	VENDOR NO.
	164270-01-700	EA	REMOTE	STS2891REM

**164495-01-000**

KEY	PART NUMBER	U/M	DESCRIPTION	VENDOR NO.
	164495-01-700	EA	REMOTE - TV	P301P19HS3409A

**ELECTRICAL GROUP (CONTINUED)**  
**CIRCUIT BREAKERS, FUSES & RELAYS**

KEY	PART NUMBER	U/M	DESCRIPTION
	062901-02-000	EA	FUSE - 5 AMP - AUTOMOTIVE
	062901-05-000	EA	FUSE - 15 AMP - AUTOMOTIVE
	062901-07-000	EA	FUSE - 25 AMP - AUTOMOTIVE
	062901-08-000	EA	FUSE - 30 AMP - AUTOMOTIVE
	063910-01-000	EA	HOUSING - RELAY
	063912-02-000	EA	RELAY - CANISTER - SPDT
	083209-01-000	EA	CIRCUIT BREAKER - 15 AMP - 120 VOLT - CANADIAN
	083209-02-000	EA	CIRCUIT BREAKER - 15/15 AMP - 120 VOLT
	083209-03-000	EA	CIRCUIT BREAKER - 15/20 AMP - 120 VOLT
	083209-04-000	EA	CIRCUIT BREAKER - 30 AMP - 120 VOLT
	083209-05-000	EA	CIRCUIT BREAKER - 20 AMP - 120 VOLT
	083209-06-000	EA	CIRCUIT BREAKER - 30/15 AMP - 120 VOLT
	083209-07-000	EA	CIRCUIT BREAKER - 20/20 AMP - 120 VOLT
	083209-10-000	EA	CIRCUIT BREAKER - 20/30 AMP - 120 VOLT
	083209-11-000	EA	CIRCUIT BREAKER - 20/15 AMP - 120 VOLT
	092786-03-000	EA	BUSS BAR - 6.9" LONG
	092786-06-000	EA	BUSS BAR
	093654-01-000	EA	CIRCUIT BREAKER - 6 AMP - 12 VOLT - PUSH BUTTON - WHITE
	093654-02-000	EA	CIRCUIT BREAKER - 15 AMP - 12 VOLT - PUSH BUTTON - WHITE
	093654-03-000	EA	CIRCUIT BREAKER - 20 AMP - 12 VOLT - PUSH BUTTON - WHITE
	093654-05-000	EA	CIRCUIT BREAKER - 10 AMP - 12 VOLT - PUSH BUTTON - WHITE
	093655-01-000	EA	CIRCUIT BREAKER - 25 AMP - 12 VOLT - PUSH BUTTON - WHITE
	093655-02-000	EA	CIRCUIT BREAKER - 30 AMP - 12 VOLT - PUSH BUTTON - WHITE
	093655-03-000	EA	CIRCUIT BREAKER - 40 AMP - 12 VOLT - PUSH BUTTON - WHITE
	100341-01-000	EA	FUSE HOLDER - IN LINE TYPE
	113482-01-000	EA	CIRCUIT BREAKER - 55 AMP - MANUAL
	115187-01-000	EA	FUSE - 300 AMP - NON-DELAY
	115187-02-000	EA	HOLDER - FUSE
	115187-03-000	EA	FUSE - 60 AMP - NON-DELAY
	122811-01-000	EA	CIRCUIT BREAKER - 20/50/50/20 AMP - 250V
	141789-01-000	EA	SPACER - CIRCUIT BREAKER

**CONVERTER, INVERTER, LOAD CENTERS**

KEY	PART NUMBER	U/M	DESCRIPTION
	099048-04-000	EA	INVERTER - 300 WATT

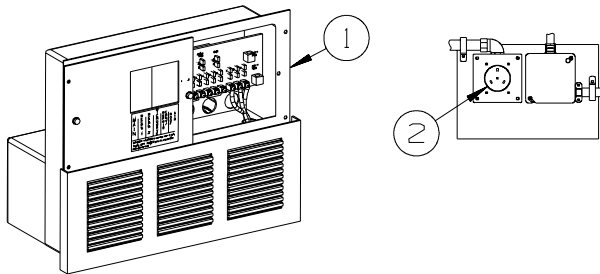

KEY	PART NUMBER	U/M	DESCRIPTION
1*	083208-07-000	EA	CONTROL CENTER - 45 AMP - 120V/12V - W/O BREAKERS
2	024924-02-000	EA	RECEPTACLE - POWER CORD - W/PARTIAL PLATE

\*COMPONENT PARTS LISTED LATER IN THIS GROUP

**COMPONENT PARTS FOR CONVERTER, INVERTER, LOAD CENTER**

**083208-07-000**

KEY	PART NUMBER	U/M	DESCRIPTION	VENDOR NO.
	083208-06-701	EA	CONVERTER ONLY (LOWER UNIT)	7345R

## ELECTRICAL GROUP (CONTINUED)

### BOXES & CORDS

KEY	PART NUMBER	U/M	DESCRIPTION
	008054-01-000	EA	CORD - POWER - 10/3 WIRE - 30 AMP - 25'
	115832-01-000	FT	CORD - HEAVY DUTY - 14-2 W/GROUND
	008289-01-000	EA	BOX - ELECTRIC/STEEL - 4" X 4" - 1/2" & 3/4" KNOCKOUTS
	091910-01-000	EA	BOX - ELECTRIC - 3.8" X 3.5" X 1.8" - PLASTIC
	091910-02-000	EA	BOX - ELECTRIC - 2.2" X 3.5" X 1.8" - PLASTIC
	131679-01-000	EA	BOX/ELECTRIC-WATERPROOF-4" X 4" - W/4 3/4"OUTLETS-UL/CSA
	133070-01-000	EA	BOX - ELECTRIC/PLASTIC - 3" X 2" X 2.8" - UL
	133070-02-000	EA	BOX - ELECTRIC/PLASTIC - 3" X 2" X 2.8" - CSA
	008294-01-000	EA	COVER - ELECTRIC BOX - BLANK/STEEL - 4" X 4" - GRAY
	069238-01-000	EA	COVER - ELECTRICAL BOX - W/HOLE - 4" X 4" - GRAY
	131680-01-000	EA	COVER - F/ELECTRIC BOX W/GASKET 4" X 4" - UL/CSA

### WIRE ASSEMBLIES

KEY	PART NUMBER	U/M	DESCRIPTION
	077069-02-000	EA	CABLE/EXTENSION - RADIO ANTENNA - 96"
	077069-03-000	EA	CABLE/EXTENSION - RADIO ANTENNA - 260"
	136514-02-000	EA	CABLE - MONITOR/CAMERA
			FROM: 00-00-00 THRU: 08-26-07
	136514-08-000	EA	CABLE - MONITOR/CAMERA
			FROM: 08-27-07 THRU: 99-99-99
	106851-01-000	EA	WIRE ASSEMBLY - RUNNING LIGHTS - FUSE
	134551-06-000	EA	WIRE ASSEMBLY - HEATER/TANKS - 3 PAD -196.5"(LONGEST WIRE)
	134551-08-000	EA	WIRE ASSEMBLY - HEATER/TANKS - 2 PAD -216.2"(LONGEST WIRE)
	134551-10-000	EA	WIRE ASSEMBLY - HEATER/TANKS - 2 PAD -167.1"(LONGEST WIRE)
	151316-03-000	EA	WIRE ASM - W/NON CONTACT SENSORS - GREY WATER - 43.2"
	151316-04-000	EA	WIRE ASM - W/NON CONTACT SENSORS - GREY WATER - 62.9"
	151316-06-000	EA	WIRE ASM - W/NON CONTACT SENSORS - GREY WATER - 78.6"
	151317-01-000	EA	WIRE ASM-W/NON CONTACT SENSORS-FRESH WATER/BLK TANK-3.9"
	151317-02-000	EA	WIRE ASM-W/NON CONTACT SENSORS-FRESH WATER/BLK TANK-23.6"
	151317-03-000	EA	WIRE ASM-W/NON CONTACT SENSORS-FRESH WATER/BLK TANK-43.2"
	153891-01-000	EA	WIRE ASM-HEATER,RELAY
	155522-05-000	EA	WIRE ASSEMBLY - SLIDEOUT RAMS
	155619-05-000	EA	WIRE ASSEMBLY - RADIO - 12 PIN
	157475-01-000	EA	WIRE ASSEMBLY - CLEARANCE LAMPS
	157476-01-000	EA	WIRE ASSEMBLY - TAILLAMPS
	120269-08-000	EA	HARNESS/WIRE - F/ELECTRIC MIRRORS
	137135-04-000	EA	WIRE HARNESS - POWER - DIGITAL ELEVATION SENSOR
	125853-04-000	EA	WIRE LOOM - ENTERTAINMENT CENTER
	137135-03-000	EA	WIRE LOOM - DIGITAL ELEVATION SENSOR
	142258-02-000	EA	WIRE LOOM - VIDEO SWITCH/POWER SUPPLY
	157423-01-000	EA	WIRE LOOM - TV/SIDE
	135420-17-000	EA	WIRE - RADIO - C FORD - 4 PIN
	145210-01-000	FT	CABLE - COAXIAL

**ELECTRICAL GROUP (CONTINUED)**  
**CONNECTORS & CONDUIT**

KEY	PART NUMBER	U/M	DESCRIPTION
	007940-01-000	EA	RECEPTACLE/SLIDE 16 TO 12 AWG - FEMALE END
	007940-02-000	EA	RECEPTACLE/SLIDE 10 AWG
	007954-01-000	EA	RECEPTACLE - HOUSING - 6 POSITION
	007956-05-000	EA	INSULATOR - SHRINK - 1/4"ID X 1 1/2"
	008311-01-000	EA	CONNECTOR - WIRE NUT - INSULATED - RED
	008312-01-000	EA	CONNECTOR - WIRE NUT - INSULATED - BLUE
	008313-01-000	EA	CONNECTOR - WIRE NUT - INSULATED - YELLOW
	008314-01-000	EA	CONNECTOR - WIRE NUT - INSULATED - GRAY
	008328-01-000	EA	TERMINAL - RING - 12/10 WIRE - #10 STUD FIT
	008331-01-000	EA	TERMINAL - RING - TONGUE - #4 WIRE - 3/8" STUD - COPPER
	008348-01-000	EA	TERMINAL - RING - 3/8" STUD 2 GA. WIRE
	008355-01-000	EA	CONNECTOR - CABLE CLAMPING - 3/4"
	008356-01-000	EA	CONNECTOR - PLASTIC - 3/8"
	008356-02-000	EA	CONNECTOR - PLASTIC - 21/32"
	035416-04-000	EA	TERMINAL - RING - #10 STUD FIT - INSULATED BARREL #16/14
	041953-01-000	FT	CONDUIT - CONVOLUTE SLIT - .5" ID - POLYETHYLENE
	041953-02-000	FT	CONDUIT - CONVOLUTE SLIT - .6" ID - POLYETHYLENE
	041953-03-000	FT	CONDUIT - CONVOLUTE SLIT - 1" ID (CLOTHES ROD COVER)
	041953-05-000	FT	CONDUIT - CONVOLUTE SLIT - .62" ID - POLYETHYLENE
	041953-06-000	FT	CONDUIT - CONVOLUTE SLIT - .4" ID - POLYETHYLENE
	041953-07-000	FT	CONDUIT - CONVOLUTE SLIT - .25" ID - POLYETHYLENE
	041953-08-000	FT	CONDUIT - CONVOLUTE SLIT - 1.5" ID - POLYETHYLENE
	041953-09-000	FT	CONDUIT - CONVOLUTE SLIT - .5" ID - NYLON
	041953-10-000	FT	CONDUIT - CONVOLUTE SLIT - .75" ID - NYLON
	041953-11-000	FT	CONDUIT - CONVOLUTE SLIT - 1.06" ID - NYLON
	041953-12-000	FT	CONDUIT - CONVOLUTE SOLID - 1.1" ID - NYLON
	041953-13-000	FT	CONDUIT - CONVOLUTE SLIT - 1.25" ID
	041953-14-000	FT	CONDUIT - CONVOLUTE SLIT - 1.5" ID
	041953-15-000	FT	CONDUIT - CONVOLUTE SLIT - 2"
	041953-16-000	FT	CONDUIT - CONVOLUTE SLIT - 2"
	047441-01-000	EA	TERMINAL-BATTERY, HORIZONTAL LUG
	047443-01-000	EA	TERMINAL - .250 RECEPTACLE FIT - INSULATED - 16/14 AWG
	047443-02-000	EA	TERMINAL - .250 RECEPTACLE FIT - INSULATED - 12/10 AWG
	047443-05-000	EA	TERMINAL - .250 RECEPTACLE FIT - 18GA AWG
	058028-01-000	EA	CONNECTOR - ELECTRICAL PIGTAIL - NYLON - CLEAR
	062036-01-000	EA	TERMINAL - PACK - CON - 12/10 AWG
	076319-12-000	EA	CONNECTOR - COAXIAL - ONE PIECE
	077479-02-000	EA	BOOT - BATTERY TERMINAL - SINGLE CABLE
	080015-02-000	EA	RECEPTACLE - FLAG - .185 - 16/14 GAUGE
	080015-03-000	EA	RECEPTACLE - FLAG - .250 - 14/16 GAUGE
	080015-04-000	EA	RECEPTACLE - FLAG - .187 - 16/14 GAUGE
	082109-01-000	EA	HOUSING - CONNECTOR - PACKARD
	082741-01-000	EA	CONNECTOR BODY - 2 CONNECTOR MALE
	087225-01-000	FT	SLEEVING - 1/2" - TYPE H
	088473-01-000	EA	HOUSING - PIN - 12 CAVITY (3 ROWS OF 4)
	088473-02-000	EA	HOUSING - PIN - 15 CAVITY (3 ROWS OF 5)
	088473-03-000	EA	HOUSING - PIN - 9 CAVITY (3 ROWS OF 3)
	088473-04-000	EA	HOUSING - PIN - 8 CAVITY IN-LINE
	088473-06-000	EA	HOUSING - PIN - 6 CAVITY (2 ROWS OF 3)
	088473-07-000	EA	HOUSING - PIN - 5 CAVITY - IN-LINE
	088473-08-000	EA	HOUSING - PIN - 4 CAVITY - IN-LINE
	088473-09-000	EA	HOUSING - PIN - 3 CAVITY - IN-LINE
	088473-10-000	EA	HOUSING - PIN - 2 CAVITY - IN-LINE
	088473-12-000	EA	HOUSING - PIN - 3 CAVITY - BLUE
	088473-13-000	EA	HOUSING - PIN - 3 CAVITY - GREEN
	088473-14-000	EA	HOUSING - PIN - 3 CAVITY - RED
	088474-01-000	EA	HOUSING - SOCKET - 12 CAVITY
	088474-02-000	EA	HOUSING - SOCKET - 15 CAVITY
	088474-03-000	EA	HOUSING - SOCKET - 9 CAVITY
	088474-06-000	EA	HOUSING - SOCKET - 6 CAVITY
	088474-07-000	EA	HOUSING - SOCKET - 5 CAVITY
	088474-08-000	EA	HOUSING - SOCKET - 4 CAVITY
	088474-09-000	EA	HOUSING - SOCKET - 3 CAVITY

**ELECTRICAL GROUP (CONTINUED)**  
**CONNECTORS & CONDUIT (CONTINUED)**

KEY	PART NUMBER	U/M	DESCRIPTION
	088474-10-000	EA	HOUSING - SOCKET - 2 CAVITY
	088474-12-000	EA	HOUSING - SOCKET - 2 CAVITY - RED
	088475-01-000	EA	PIN - CONNECTOR - 14-20 AWG
	088475-02-000	EA	PIN - CONNECTOR - 10-12 AWG
	088476-01-000	EA	TERMINAL - ELECTRICAL
	088476-02-000	EA	SOCKET - CONNECTOR - 12-10 GA - PRE-TIN
	098261-01-000	EA	SOCKET - CONNECTOR - WEATHERPACK - 12 AWG
	098261-02-000	EA	SOCKET - CONNECTOR - WEATHERPACK - 14-18 AWG
	098262-01-000	EA	SEAL - CONNECTOR - WEATHERPACK
	098264-01-000	EA	HOUSING - 2 PIN - WEATHER PACK - MALE W/FEMALE PINS
	098264-02-000	EA	HOUSING - 2 PIN - WEATHER PACK - FEMALE W/MALE PINS
	098265-02-000	EA	PIN - CONNECTOR - WEATHER PACK
	102777-02-000	EA	TERMINAL - RING - #6 STUD - 10 AWG
	103608-01-000	EA	SOCKET - WEDGE BASE W/LEADS
	104100-01-000	EA	HOUSING - 1 POSITION - 75 AMPS
	104100-03-000	EA	TERMINAL - 75 AMP
	106007-02-000	EA	TERMINAL - FEMALE - 10-12 AWG
	110178-01-000	EA	HOUSING - WIPER MOTOR
	112823-01-000	EA	SPLICE - REDUCER - 16-14 TO 18-22
	113135-01-000	EA	TERMINAL - FEMALE - M/P - 14-16 - F/SEALED TERMINAL
	113308-01-000	EA	TERMINAL - FEMALE - M/P - 14-16 - 280
	113308-02-000	EA	TERMINAL - FEMALE - M/P - 14-18 - 280
	113468-01-000	EA	HOUSING - 2 POSITION-FEMALE-USED ON WIPER/WASHER WIRE ASM
	113468-02-000	EA	HOUSING - 2 POSITION - FEMALE
	116811-01-000	EA	TERMINAL - .110 RECEPTACLE - 16-14 AWG
	118571-01-000	EA	CONNECTOR - 3-WAY - MALE/SEALED
	118571-02-000	EA	CONNECTOR - 3-WAY - FEMALE/SEALED
	118571-05-000	EA	LOCK - SECONDARY - FEMALE
	118571-06-000	EA	LOCK - SECONDARY - MALE
	118599-02-000	EA	TERMINAL - MALE - M/P - 280/14-12
	118820-01-000	EA	INSULATOR - TERMINAL
	129233-01-000	EA	HOUSING - 2-POSITION/FEMALE - 280-SERIES
	129233-02-000	EA	HOUSING - 2-POSITION/FEMALE - 280-SERIES
	129233-03-000	EA	HOUSING - 2-POSITION/FEMALE - 280-SERIES
	131681-01-000	EA	CONNECTOR - 3/4" SO CORD - UL/CS
	137207-01-000	EA	HOUSING - PIN - 2 CAVITY/HIGH AMP
	137208-01-000	EA	HOUSING - SOCKET - 2 CAVITY/HIGH AMP
	137209-01-000	EA	PIN - CONNECTOR - 10AWG/HIGH AMP
	137210-01-000	EA	SOCKET - CONNECTOR - 10 AWG/HIGH AMP
	138996-04-000	EA	CONNECTOR - LAMP
	142520-01-000	EA	TERMINAL - FEMALE - MINI-FIT 16
	142522-01-000	EA	HOUSING - 4 PIN/MALE - MINI FIT
	142522-02-000	EA	HOUSING - 6 PIN/MALE - MINI FIT
	142522-03-000	EA	HOUSING - 8 PIN/MALE - MINI FIT
	142522-04-000	EA	HOUSING - 10 PIN/MALE - MINI FIT
	142522-05-000	EA	HOUSING - 12 PIN/MALE - MINI FIT
	142522-06-000	EA	HOUSING - 14 PIN/MALE - MINI FIT
	142524-01-000	EA	HOUSING - 4 PIN/FEMALE - WEATHER PACK
	142524-02-000	EA	HOUSING - 4 PIN/FEMALE - WEATHER PACK
	144283-01-000	EA	CONNECTOR - 110V - F/USE WITH SOW WIRE - BLUE
	144283-02-000	EA	CONNECTOR - 110V - F/USE WITH NM ROMEX WIRE - CLEAR
	145171-01-000	EA	CONNECTOR - COAXIAL
	148335-01-000	EA	HOUSING - 8-POSITION/MALE - 280-GT SERIES
	148335-02-000	EA	HOUSING - 4-POSITION/MALE - 280-GT SERIES
	148335-03-000	EA	HOUSING - 6-POSITION/MALE - 280-GT SERIES
	149683-01-000	EA	HOUSING - F/5 CAVITY RECEPTACLE - W/SQUARE GUIDE PIN
	149683-02-000	EA	HOUSING - F/5 CAVITY RECEPTACLE - W/ROUND GUIDE PIN
	149686-01-000	EA	TERMINAL - .250 RECEPTACLE
	149687-01-000	EA	HOUSING - 2 POSITION/MALE - PACKARD
	149687-02-000	EA	LOCK - F/2 POSITION HOUSING - PACKARD
	149688-01-000	EA	TERMINAL - MALE - 16 GAUGE WIRE
	156035-01-000	EA	HOUSING - 12-POSITION/FEMALE - 280-GT SERIES
	156041-01-000	EA	TERMINAL - FEMALE - 16-12 - 280-GT SERIES

## ELECTRICAL GROUP (CONTINUED)

### CONNECTORS & CONDUIT (CONTINUED)

KEY	PART NUMBER	U/M	DESCRIPTION
	156043-01-000	EA	HOUSING - 2-POSITION/FEMALE - 480-MP SERIES
	156043-02-000	EA	LOCK - F/2 POSITION HOUSING - 480 SERIES
	156044-01-000	EA	TERMINAL - FEMALE - 16-12 - 280-GT - F/SEALED HOUSING
	156045-01-000	EA	HOUSING - 10-POSITION/FEMALE - 280-GT SERIES
	156045-02-000	EA	HOUSING - 4-POSITION/FEMALE - 280-GT SERIES
	156045-03-000	EA	HOUSING - 8-POSITION/FEMALE - 280-GT SERIES
	156045-04-000	EA	HOUSING - 6-POSITION/FEMALE - 280-GT SERIES
	156207-01-000	EA	HOUSING - 6-POSITION/MALE - 150-GT SERIES
	156208-01-000	EA	TERMINAL - MALE - 18-16 - 150-GT SERIES
	157590-01-000	EA	TERMINAL - FEMALE - M/P - 10-12 - 630
	157592-01-000	EA	HOUSING - 7-POSITION/FEMALE - M/P
	157592-02-000	EA	LOCK - SECONDARY - F/7 POSITION HOUSING
	157656-01-01A	EA	CONNECTOR - DASH LIGHT - BLACK
	158357-01-000	EA	HOUSING - 3 PIN/MALE - MINI FIT
	158373-01-000	EA	HOUSING - SOCKET - 16 CAVITY - MINI MATE-N-LOCK
	158374-01-000	EA	SOCKET - 16-20 CAVITY - MINI MATE-N-LOCK
	164687-01-000	EA	PIN - CONNECTOR - 16-14
	164685-01-000	EA	HOUSING - PIN - 7-POSITION
	164689-01-000	EA	SEAL - CONNECTOR
	168450-01-000	EA	CONNECTOR/ADAPTER - COAX

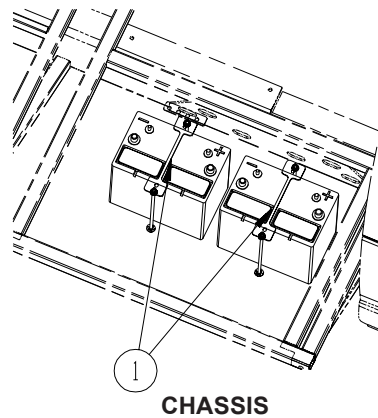

### BATTERY INSTALLATION

KEY	PART NUMBER	U/M	DESCRIPTION
1	160014-03-02B	EA	TIEDOWN - BATTERY - E-COATED

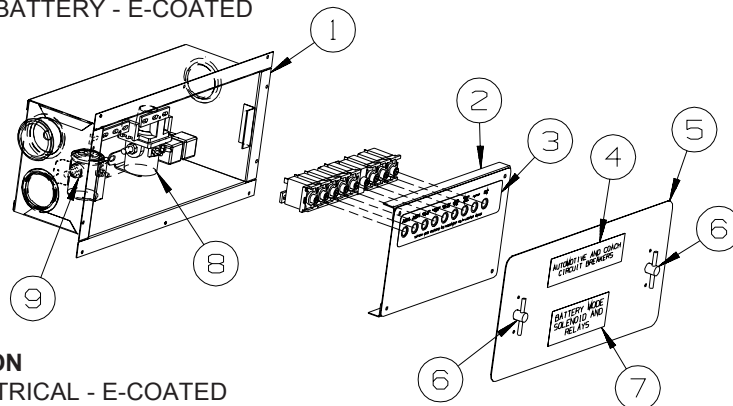

### CHASSIS ELECTRICAL BOX

KEY	PART NUMBER	U/M	DESCRIPTION
1	141272-01-02B	EA	BOX - ELECTRICAL - E-COATED
2	139067-04-02B	EA	PLATE - CIRCUIT BREAKER/HOUSE - E-COATED
3	093236-52-000	EA	LABEL - CIRCUIT BREAKER
4	098379-01-000	EA	LABEL - CIRCUIT BREAKER - FRONT BOX
5	141273-01-02B	EA	COVER - ELECTRICAL BOX - E-COATED
6	092492-16-000	EA	SEAL - ELECTRICAL BOX
6	098196-01-000	EA	LATCH - 1/4 TURN - T-BAR
7	098379-04-000	EA	LABEL - ELECTRICAL BOX - SIDE
8	086273-01-000	EA	RELAY - BATTERY DISCONNECT
9	008188-01-000	EA	SOLENOID - 3 POST - BATTERY CHANGE OVER

**ELECTRICAL GROUP (CONTINUED)**  
**CHASSIS (CONTINUED)**

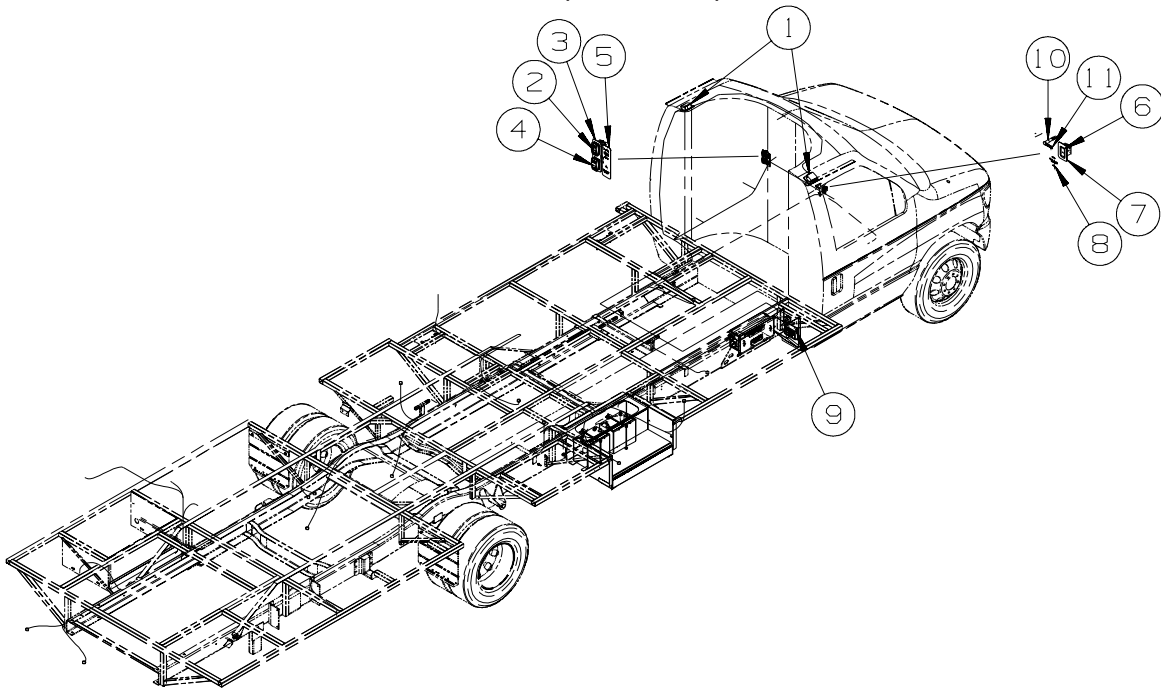

KEY	PART NUMBER	U/M	DESCRIPTION
1	112642-01-06A	EA	TRIM RING - SINGLE LIGHT - BLACK
1	112643-01-000	EA	LIGHT - SINGLE - SWIVEL
2	108357-08-000	EA	SWITCH - ROCKER - DPDT - 0N/NONE/ON - 6 TERM - W/O COVER
2	108356-02-01A	EA	COVER/ACTUATOR SWITCH - 2 ROWS DIMPLES - BLACK
2	108355-01-000	EA	HOUSING - SWITCH
3	144363-12-04B	EA	PLATE - SWITCH - BLACK
4	108357-09-000	EA	SWITCH - ROCKER - SPDT - ON/NONE/MOM - 3 TERM - W/O COVER
4	108356-02-01A	EA	COVER/ACTUATOR SWITCH - 2 ROWS DIMPLES - BLACK
4	108355-01-000	EA	HOUSING - SWITCH
5	145731-01-01A	EA	LABEL - SWITCH - RADIO/BATTERY - BLACK
6	108357-03-000	EA	SWITCH - ROCKER - SPDT - ON/OFF/ON - 3 TERM - W/O COVER
6	108356-02-01A	EA	COVER/ACTUATOR SWITCH - 2 ROWS DIMPLES - BLACK
6	108355-01-000	EA	HOUSING - SWITCH
7	144363-07-04B	EA	PLATE - SWITCH - BLACK
8	145731-03-01A	EA	LABEL - SWITCH - REAR AUTO HEATER
9	149825-01-000	EA	CONTROL MODULE - DIGISYNC/HIGH SPEED - F/C-BODY RAM
9	078040-04-000	EA	SHROUD - 8.2"W X 12.6"H X 5.1"D - BLACK
10	150237-01-000	EA	LIGHT - INDICATOR - RED
11	133533-01-01A	EA	LABEL - JACKS DOWN - CLEAR W/WHITE LETTERING



# EXTERIOR BODY GROUP GRAPHICS & PAINT

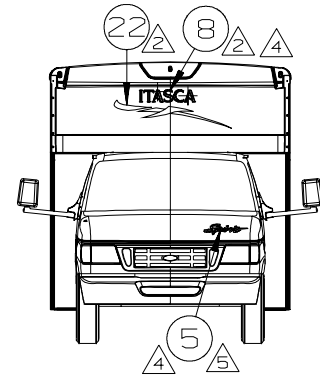
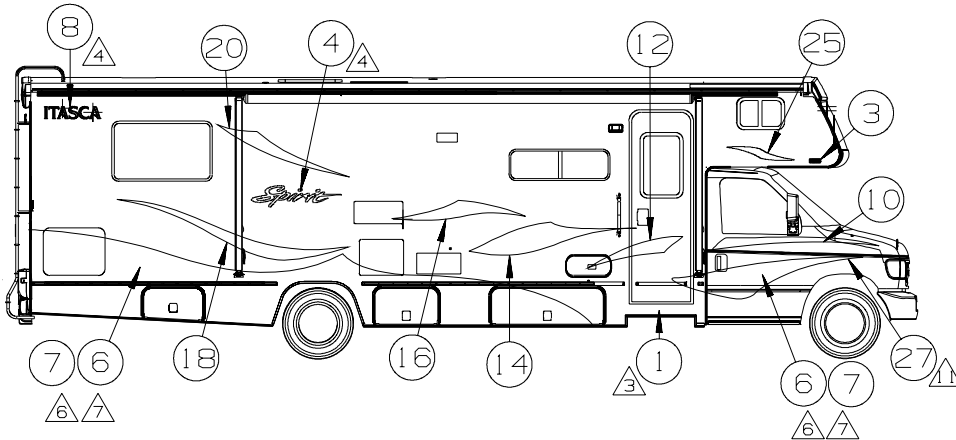
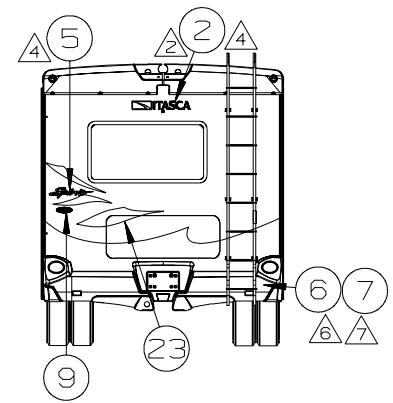
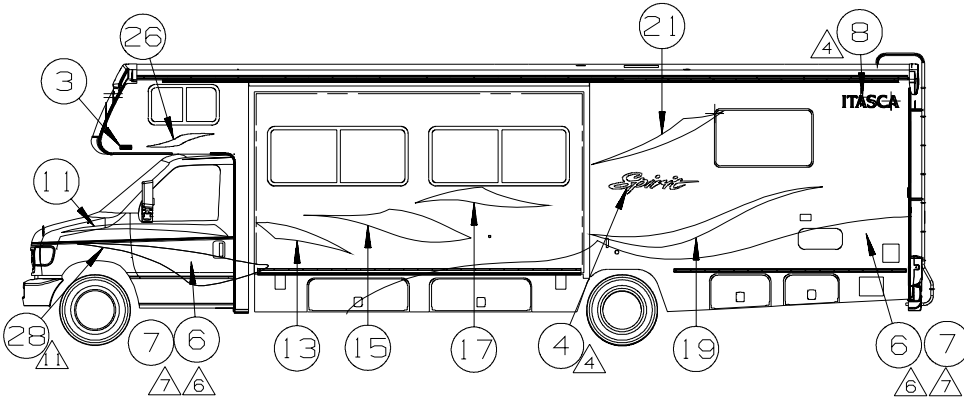

KEY	PART NUMBER	U/M	DESCRIPTION
	1 109506-01-000	EA	FILM-URETHANE PROTECTANT
	2 124806-01-CHT (62A)	EA	DECAL-ITASCA W/ICON - BROWN/BRT WHITE
	3 132664-02-CHT (01A)	EA	DECAL-LOGO DOMED WINNEBAGO - CHROME/RED/BLACK
	4 137508-01-CHT (07A)	EA	DECAL-SPIRIT LG - BROWN/LT GOLD/BRT WHITE
	5 137508-02-CHT (03A)	EA	DECAL-SPIRIT SML - BROWN/LT GOLD/BRT WHITE
	6 141599-47-000	GL	PAINT-BRT PLATINUM MET - DUPONT #373-P75354 OR SW #48823-3
	7 141599-31-000	GL	PAINT-METALLIC GOLD - DUPONT #373-P7436 OR SW #7436
	8 144587-02-CHT (38A)	EA	DECAL-ITASCA - BROWN/BRT WHITE
	9 151687-02-CHT (01A)	EA	DECAL/BEZEL DOMED NAMEPLATE ITASCA - CHROME/WHITE/BLACK/TEAL
	10 156699-01-CHT (02A)	EA	DECAL-CAB DOOR RH - DK CHARCOAL/PEWTER
	11 156698-02-CHT (02A)	EA	DECAL-CAB DOOR LH - DK CHARCOAL/PEWTER
	12 156699-01-CHT (02A)	EA	DECAL-#1 RH - DK CHARCOAL
	13 156699-02-CHT (02A)	EA	DECAL-#1 LH - DK CHARCOAL
	14 156700-01-CHT (02A)	EA	DECAL-#2 RH - PEWTER/BROWN
	15 156700-02-CHT (02A)	EA	DECAL-#2 LH - PEWTER/BROWN
	16 156701-01-CHT (02A)	EA	DECAL-#3 RH - DK TEAL
	17 156701-02-CHT (02A)	EA	DECAL-#3 LH - DK TEAL
	18 156702-01-CHT (02A)	EA	DECAL-SWEEP RH - BROWN/PEWTER
	19 156702-02-CHT (02A)	EA	DECAL-SWEEP LH - BROWN/PEWTER
	20 156704-01-CHT (02A)	EA	DECAL-#4 RH - DK TEAL/DK CHARCOAL
	21 156704-02-CHT (02A)	EA	DECAL-#4 LH - DK TEAL/DK CHARCOAL
	22 156706-01-CHT (02A)	EA	DECAL-OVHD - DK CHARCOAL/PEWTER/DK TEAL
	23 156707-01-CHT (02A)	EA	DECAL-BACKWALL - PEWTER/DK CHARCOAL/DK TEAL/BROWN
	24 -----	GL	PAINT-CLEAR COAT - SHERWIN WILLIAMS
	25 160518-01-CHT (03A)	EA	DECAL-OVERHEAD RH - BRWON
	26 160518-02-CHT (03A)	EA	DECAL-OVERHEAD LH - BROWN
	27 160734-01-CHT (01A)	EA	DECAL-PAINT MASK RH - WHITE VINYL
	28 160734-02-CHT (01A)	EA	DECAL-PAINT MASK LH - WHITE VINYL

- △ 7. PAINTED AREA IS TO BE BELOW FEATURE STRIP FOR OPTIONAL PAINTED MODELS & CONTINUES ON CAB DOORS TO WHEEL WELL.
- △ 6. CLEAR COAT TO BE APPLIED ON PAINTED AREAS TO PROTECT PAINT.
- △ 5. LOCATE DECAL 240 MM LEFT OF HOOD EDGE AND 60 MM UP FROM FRONT EDGE OF HOOD.
- △ 4. LOGO IS TO BE ±1 MM ON A HORIZONTAL PLANE (END TO END).
- △ 3. FILM TO PROTECT BOTTOM OF DOOR FROM SCUFF MARKS.
- △ 2. CENTERED ON UNIT.
- 1. APPLY PROTECTOR 116424-01-000 TO WATER HEATER DOOR LATCH.
- △ 13. LOCATE DECAL 290MM LEFT OF HOOD EDGE AND 100MM UP FROM FRONT EDGE OF HOOD.
- △ 12. CHEVY CAB NOT AVAILABLE.
- △ 11. UNIT WITH OPTIONAL PAINT WILL USE PAINT MASK, UNITS BUILT IN CHARLES CITY-CDI WILL CUT MASK FROM RAW MATERIAL, UNIT BUILT IN FOREST CITY-CDI WILL SUPPLY PAINT MASK CUT FROM RAW MATERIAL.
- △ 10. REFER TO UNIT BUILD SCHEDULE TO DETERMINE BRAND OF PAINT USED WHEN BUILT IN CC CDI PAINT USED IS SHERWIN WILLIAMS. WHEN BUILT IN FC PAINT USED IS DUPONT.
- 9. NO VINYL OR PAINT ON SLIDEOUT ROOM END PANELS.
- △ 8. OPTIONAL PAINT

- (16E) FORD CHASSIS 14,050 LB.GVMR      (1GF) EXT PAINT #1 W/FBGLS BOARDS      (276) EXTERIOR GRAPHICS PACKAGE #1
- (1PY) CHEVY CHASSIS 14,050 LB GVWR      (1GH) EXT PAINT #2 W/FBGLS BOARDS

KEY	PART NUMBER	U/M	DESCRIPTION
	072882-01-000	GL	PAINT - LOW BAKE - OFF WHITE

**DUPONT COLOR CODES ARE NOW FOUND IN THE PAINT CODE MANUAL.  
YOU CAN FIND THIS MANUAL ON YOUR DEALER INDEX WEBPAGE UNDER SERVICE.**

## EXTERIOR BODY GROUP (CONTINUED)

### PANELS & TRIMS

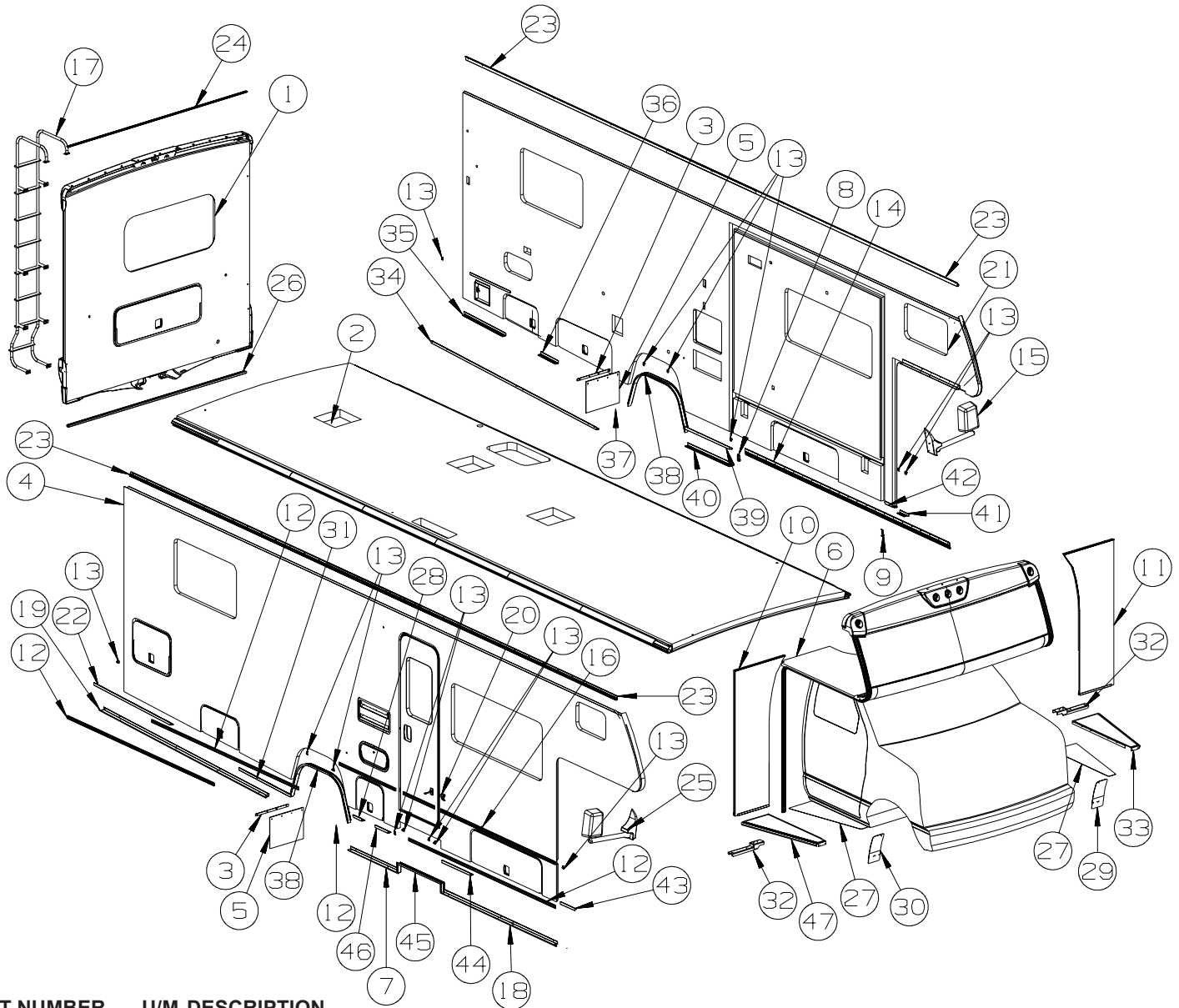

KEY	PART NUMBER	U/M	DESCRIPTION
1	162144-01-W21	EA	BACKWALL - W/O WINDOW/TRIMS (W29, W30)
1	162144-01-W31	EA	BACKWALL - W/O WINDOW/TRIMS (W31, W32, W33, W34)
1	162144-02-W21	EA	BACKWALL - W/O WINDOW/TRIMS (W29, W30) - <b>DUAL PANE WINDOW</b>
1	162144-02-W31	EA	BACKWALL - W/O WINDOW/TRIMS (W31, W32, W33, W34) - <b>DUAL PANE WINDOW</b>
2	162433-01-W21	EA	ROOF - W/O LIGHTS/VENTS - W/WIRING
3	140922-01-02B	EA	RETAINER - MUD FLAP - 1" X 17.7" - E-COATED/BLACK
4	P62435-01-W21	EA	SIDEWALL - PASSENGER - W/O WINDOWS/TRIMS (W29, W30)
4	P62435-01-W31	EA	SIDEWALL - PASSENGER - W/O WINDOWS/TRIMS (W31, W32, W33, W34)
5	017516-01-000	EA	MUD FLAP - 14"H X 18"W - W/O MOUNTING HOLES - RUBBER - BLK
6	156387-01-U21	EA	SLEEPERBOARD
7	148760-53-01A	EA	TRIM - ROCKER - NOTCHED - 75.6" - BRIGHT WHITE
8	151219-01-01A	EA	CAP - TRIM/SIDEWALL - RIGHT HAND - MILL FINISH
9	151219-02-01A	EA	CAP - TRIM/SIDEWALL - LEFT HAND - MILL FINISH
10	159600-01-T11	EA	WINGWALL
11	159600-02-T11	EA	WINGWALL
12	108688-06-03A	EA	STRIP - FEATURE - W/O INSERT/END CAPS - 96.9" - BRIGHT WHT
13	108651-01-01A	EA	END CAP - FEATURE STRIP
	108651-01-03A	EA	END CAP - FEATURE STRIP - BRIGHT WHITE
14	150188-02-01A	EA	TRIM/HINGE - SIDEWALL - 135.4" - BRIGHT WHITE
15*	133908-11-01A	EA	MIRROR/DRVR - 102" C BODY/FORD 4-BOLT MT - BRIGHT WHITE
15*	133908-13-01A	EA	MIRROR/DRVR-102" C BODY/FORD 4-BOLT MT-HEATD/RMTE-B/W - <b>MIRRORS EXTERIOR W/DEFROST</b>
16	153498-01-01A	EA	BUMPER - RUBBER - WHITE
17	161113-09-01A	EA	LADDER - 7 STEP - 99.6" - BRUSHED ALUMINUM

**EXTERIOR BODY GROUP (CONTINUED)**  
**PANELS & TRIMS (CONTINUED)**

KEY	PART NUMBER	U/M	DESCRIPTION
18	148760-52-01A	EA	TRIM - ROCKER - NOTCHED - 33.7" - BRIGHT WHITE
19	148760-51-01A	EA	TRIM - ROCKER - NOTCHED - 110.4" - BRIGHT WHITE
19	148760-51-03A	EA	TRIM - ROCKER - NOTCHED - 110.4" - BLACK
20	117046-02-000	EA	BUMPER - RUBBER/ROUND END - 1.5"
21	P62434-01-W21	EA	SIDEWALL - DRIVER - W/O WINDOWS/TRIMS (W29, W30)
21	P62434-01-W31	EA	SIDEWALL - DRIVER - W/O WINDOWS/TRIMS (W31, W32, W33, W34)
22	148759-C0-01A	EA	TRIM - SIDEWALL/LOWER - 50.8" - BRIGHT WHITE
23	157284-01-01A	EA	RAIL - AWNING - 192" - BRIGHT WHITE
24	114248-02-01A	EA	ANGLE - PLASTIC - .7" X .4" X 96.7" - MODERN IVORY
25*	133908-10-01A	EA	MIRROR/PASS - 102" C BODY/FORD 4-BOLT MT - BRIGHT WHITE
25*	133908-12-01A	EA	MIRROR/PASS-102" C BODY/FORD 4 BOLT MT-HEATD/RMTE-B/W - MIRRORS-EXTERIOR W/DEFROST
26	103335-05-02A	EA	TRIM - BACKWALL - LOWER - 96.3" - BRIGHT WHITE
27	146515-01-01A	EA	MAT - ANTI SLIP - RIGHT HAND - BLACK
27	146515-02-01A	EA	MAT - ANTI SLIP - LEFT HAND - BLACK
27	146515-03-01A	EA	MAT - ANTI SLIP - RIGHT HAND - BLACK - LOWER EXTERIOR PAINT
27	146515-04-01A	EA	MAT - ANTI SLIP - LEFT HAND - BLACK - LOWER EXTERIOR PAINT
28	148759-B8-01A	EA	TRIM - SIDEWALL/LOWER - 6" - BRIGHT WHITE
29	146148-04-01A	EA	GUARD - MUD FLAP/LEFT - BLACK
29	149604-08-02A	EA	WHEEL LIP - FIBERGLASS - DRVR - FORD - BRT WHT - LOWER EXTERIOR PAINT - NOT ILLUSTRATED
29	149604-06-01A	EA	MUD FLAP - FIBERGLASS - DRIVER - FORD - PRIMED - LOWER EXTERIOR PAINT - NOT ILLUSTRATED
30	146148-03-01A	EA	GUARD - MUD FLAP/RIGHT - BLACK
30	149604-07-02A	EA	WHEEL LIP - FIBERGLASS - PASS - FORD - BHT WHT - LOWER EXTERIOR PAINT - NOT ILLUSTRATED
30	146904-05-01A	EA	MUD FLAP-FIBERGLASS-PASSNGR-FORD-PRIMED - LOWER EXTERIOR PAINT - NOT ILLUSTRATED
31	148759-C5-01A	EA	TRIM - SIDEWALL/LOWER - 33.8" - BRIGHT WHITE
32	146180-01-02B	EA	BRACKET - RUNNING BOARD - E-COATED
			FROM: 00-00-00 THRU: 07-29-07
32	146180-02-02B	EA	BRACKET - RUNNING BOARD - E-COATED
			FROM: 07-30-07 THRU: 99-99-99
32	149604-09-000	EA	HARDWARE KIT (RUNNING BOARD INSTALL) - FORD - LOWER EXTERIOR PAINT - NOT ILLUSTRATED
33	146148-02-01A	EA	BOARD - RUNNING - LEFT HAND/TAPPERED - BLACK
33	149604-02-02A	EA	RUNNING BRD/WEDGE-DRVR-FD 300/400 - BRT WHT - LOWER EXTERIOR PAINT - NOT ILLUSTRATED
34	148759-C8-01A	EA	TRIM - SIDEWALL/LOWER - 27.7" - BRIGHT WHITE
35	148760-49-01A	EA	TRIM - ROCKER - NOTCHED - 110.4" - BRIGHT WHITE
35	148760-49-03A	EA	TRIM - ROCKER - NOTCHED - 110.4" - BLACK
36	148759-C7-01A	EA	TRIM - SIDEWALL/LOWER - 11.7" - BRIGHT WHITE
37	148759-B4-01A	EA	TRIM - SIDEWALL/LOWER - 11.1" - BRIGHT WHITE
38	127848-01-01A	EA	TRIM - WHEELWELL - BRIGHT WHITE
38	127848-01-02A	EA	TRIM - WHEELWELL - BLACK
39	148759-B7-01A	EA	TRIM - SIDEWALL/LOWER - 29.6" - BRIGHT WHITE
40	148760-50-01A	EA	TRIM - ROCKER - NOTCHED - 29.6" - BRIGHT WHITE
40	148760-50-03A	EA	TRIM - ROCKER - NOTCHED - 29.6" - BLACK
41	148759-59-01A	EA	TRIM - SIDEWALL/LOWER - W/LH NOTCH - 6.1"
42	148760-24-01A	EA	TRIM - ROCKER - LH NOTCHED - 6.1" - BRIGHT WHITE
43	148759-C1-01A	EA	TRIM - SIDEWALL/LOWER - 8.3" - BRIGHT WHITE
44	148759-C2-01A	EA	TRIM - SIDEWALL/LOWER - 19" - BRIGHT WHITE
45	128732-19-U21	EA	TRIM - PASSENGER SIDEWALL W/ENTRY DOOR NOTCH - 137.3"
46	148759-C4-01A	EA	TRIM - SIDEWALL/LOWER - 8.3" - BRIGHT WHITE
47	146148-01-01A	EA	BOARD - RUNNING - RIGHT HAND/TAPPERED - BLACK
47	149604-01-02A	EA	RUNNING BRD/WEDGE-PASS-FD 300/400 - BRT WHT - LOWER EXTERIOR PAINT - NOT ILLUSTRATED

\*COMPONENT PARTS LISTED LATER IN THIS GROUP

**EXTERIOR BODY GROUP (CONTINUED)**  
**PANELS & TRIMS (CONTINUED)**

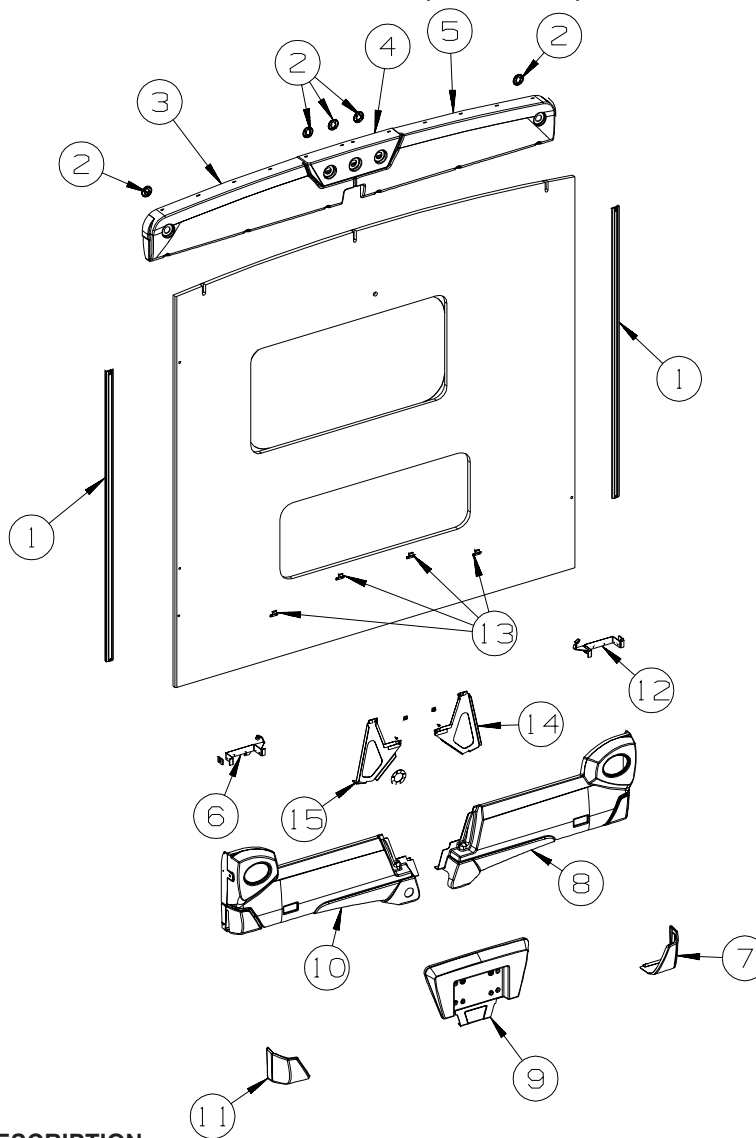

**BACKWALL  
TRIM  
W/BUMPER**

KEY	PART NUMBER	U/M	DESCRIPTION
1	158150-01-01A	EA	TRIM - CONTOUR - 66.8" - BRIGHT WHITE FROM: 00-00-00 THRU: 09-02-07
1	166487-01-01A	EA	TRIM - CONTOUR - 66.8" - BRIGHT WHITE FROM: 09-03-07 THRU: 99-99-99
1	158107-01-01A	FT	INSERT - FEATURE STRIP - VINYL - BRIGHT WHITE FROM: 00-00-00 THRU: 09-02-07
1	105312-01-07A	FT	INSERT - FEATURE STRIP - VINYL - BRIGHT WHITE FROM: 09-03-07 THRU: 99-99-99
2	138996-03-000	EA	BRACKET - CLEARANCE LIGHT
3	156058-06-U21	EA	TRIM - BACKWALL - TOP/DRIVER
4	156058-04-U21	EA	TRIM - BACKWALL - TOP/CENTER
5	156058-02-U21	EA	TRIM - BACKWALL - TOP/PASSENGER
6	156312-02-02B	EA	BRACKET/TAILLAMP - DRIVER - E-COATED
7	156059-07-25A	EA	TRIM/CAP - BACKWALL - LOWER/PASSENGER - SILVER
8	156059-02-U21	EA	TRIM - BACKWALL - LOWER/PASSENGER
8	156059-02-AA1	EA	TRIM - BACKWALL - LOWER/PASSENGER - LOWER EXTERIOR PAINT
9	156059-04-U21	EA	TRIM - BACKWALL - LOWER/CENTER
10	156059-06-U21	EA	TRIM - BACKWALL - LOWER/DRIVER
10	156059-06-AA1	EA	TRIM - BACKWALL - LOWER/DRIVER - LOWER EXTERIOR PAINT
11	156059-08-25A	EA	TRIM/CAP - BACKWALL - LOWER/DRIVER - SILVER
12	156312-01-02B	EA	BRACKET/TAILLAMP - PASSENGER - E-COATED
13	073050-04-000	EA	CLIP/MOUNTING - VALANCE PANEL
14	156314-01-02B	EA	BRACKET - BUMPER - PASSENGER - E-COATED
15	156314-02-02B	EA	BRACKET - BUMPER - DRIVER - E-COATED

**EXTERIOR BODY GROUP (CONTINUED)**  
**PANELS & TRIMS (CONTINUED)**

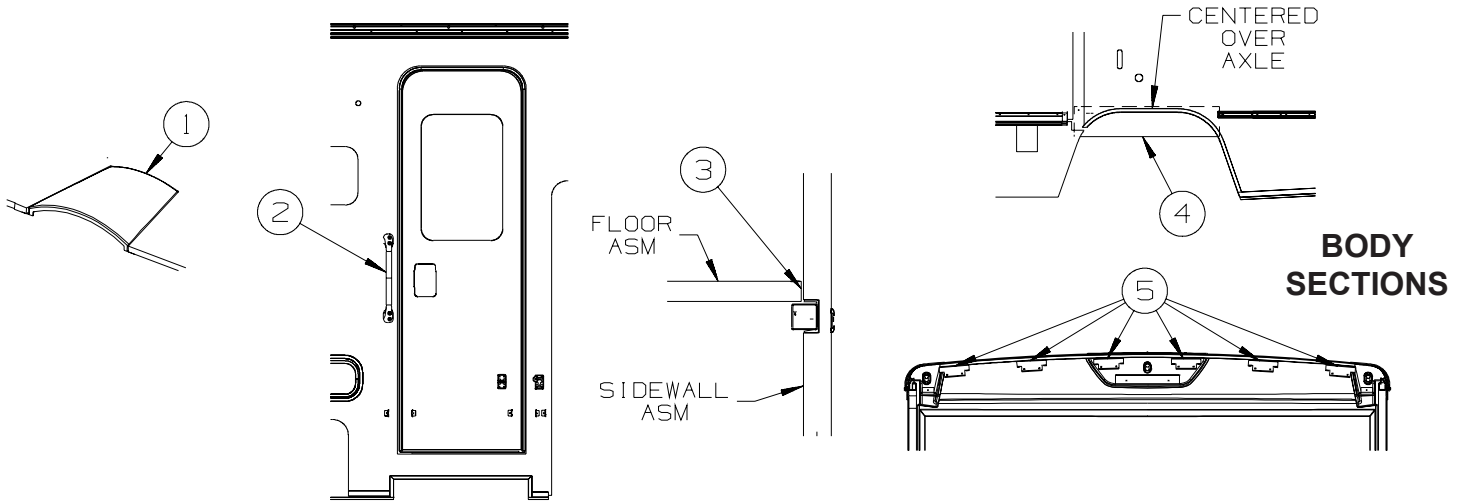

KEY	PART NUMBER	U/M	DESCRIPTION
1	112435-03-000	EA	WHEELWELL
2	152854-01-01A	EA	HANDLE - ASSIST - WHITE W/BLACK RUBBER GRIP - 18 5/8"
3	104692-01-000	FT	SEAL - ADHESIVE BACKED FOAM - 3/4" THICK X 3/4" WIDE X 25'
4	121948-02-000	EA	SHIELD - SIGHT
5	134774-01-02B	EA	BRACKET - CAB ATTACHMENT - E-COATED

**COMPONENT PARTS FOR PANELS & TRIMS**

**133908-05, 133908-06, 133908-10, 133908-11, 133908-14, 133908-15, -01A/02A**

KEY	PART NUMBER	U/M	DESCRIPTION	VENDOR NO.
	117051-01-700	EA	MIRROR-CONVEX	723068-4
	120269-01-700	EA	GLASS KIT W/BEZEL RH/LH	709407-8
	133908-03-700	EA	CAP - RECT/BLACK-W/O LIGHT	709577
	133908-04-700	EA	CAP-MIRROR/ROUND - W/O LIGHT	7095470

**133908-07, 133908-08, 133908-12, -01A/-02A/-03A**

KEY	PART NUMBER	U/M	DESCRIPTION	VENDOR NO.
	117051-01-700	EA	MIRROR-CONVEX	723068-4
	120269-05-701	EA	GLASS-HTD/REM RH/LH W/CONVEX	709411
	133908-03-700	EA	CAP - RECT/BLACK-W/O LIGHT	709557
	133908-04-700	EA	CAP-MIRROR/ROUND - W/O LIGHT	7095470

**133908-13-01A/-03A**

KEY	PART NUMBER	U/M	DESCRIPTION	VENDOR NO.
	117051-01-700	EA	MIRROR-CONVEX	723068-4
	120269-05-701	EA	GLASS-HTD/REM RH/LH W/CONVEX	709411
	133908-03-700	EA	CAP - RECT/BLACK-W/O LIGHT	709577
	133908-04-700	EA	CAP-MIRROR/ROUND - W/O LIGHT	7095470
	133908-13-700	EA	MOTOR/ACTUATOR	747782

**EXTERIOR BODY GROUP (CONTINUED)**  
**FRONT END**

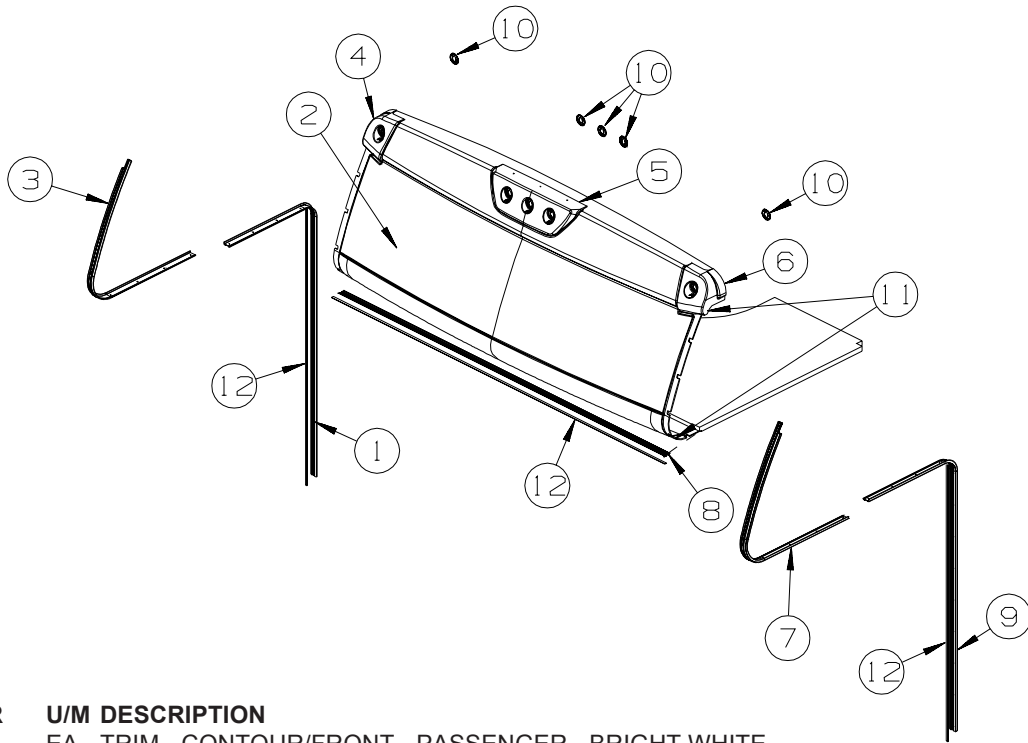

KEY	PART NUMBER	U/M	DESCRIPTION
1	158149-01-01A	EA	TRIM - CONTOUR/FRONT - PASSENGER - BRIGHT WHITE FROM: 00-00-00 THRU: 09-02-07
1	166486-01-01A	EA	TRIM - CONTOUR/FRONT - PASSENGER - BRIGHT WHITE FROM: 09-03-07 THRU: 99-99-99
2	157215-01-U21	EA	CAP - ROOF/FRONT - W/O LIGHTS/WIRING
3	158148-01-01A	EA	TRIM - CONTOUR/PASSENGER - 60.9" - BRIGHT WHITE FROM: 00-00-00 THRU: 09-02-07
3	166489-01-01A	EA	TRIM - CONTOUR/PASSENGER - 60.9" - BRIGHT WHITE FROM: 09-03-07 THRU: 99-99-99
4	156849-02-U21	EA	TRIM - FRONT CAP/SIDEWALL - TOP/PASSENGER
5	156849-04-U21	EA	TRIM - FRONT CAP - TOP/CENTER
6	156849-06-U21	EA	TRIM - FRONT CAP/SIDEWALL - TOP/DRIVER
7	158148-02-01A	EA	TRIM - CONTOUR/DRIVER - 60.9" - BRIGHT WHITE FROM: 00-00-00 THRU: 09-02-07
7	166489-02-01A	EA	TRIM - CONTOUR/DRIVER - 60.9" - BRIGHT WHITE FROM: 09-03-07 THRU: 99-99-99
8	158152-01-01A	EA	TRIM - CONTOUR - 96.1" - BRIGHT WHITE
9	158149-02-01A	EA	TRIM - CONTOUR/FRONT - DRIVER - BRIGHT WHITE FROM: 00-00-00 THRU: 09-02-07
9	166486-02-01A	EA	TRIM - CONTOUR/FRONT - DRIVER - BRIGHT WHITE FROM: 09-03-07 THRU: 99-99-99
10	138996-03-000	EA	BRACKET - CLEARANCE LIGHT
11	105290-01-000	SF	INSULATION - AIR POCKET W/FOIL - 4' WIDE
12	158107-01-01A	EA	INSERT - FEATURE STRIP - VINYL - BRIGHT WHITE
12	158107-01-01A	FT	INSERT - FEATURE STRIP - VINYL - BRIGHT WHITE FROM: 00-00-00 THRU: 09-02-07
12	105312-01-07A	FT	INSERT - FEATURE STRIP - VINYL - BRIGHT WHITE FROM: 09-03-07 THRU: 99-99-99

## EXTERIOR BODY GROUP (CONTINUED)

### STRUCTURAL COMPONENTS

KEY	PART NUMBER	U/M DESCRIPTION
	002365-03-006	EA U-CHANNEL - EXTRUDED - 1" X 192" - BRIGHT WHITE
	002726-01-001	EA GARNISH - U-CHANNEL - 1.38" X 19' - SERRATED
	089297-01-000	SF PLYWOOD - LUAN - OVERLAY GRADE - 4' X 8'
	089297-03-000	SF PLYWOOD - LUAN - OVERLAY GRADE - 4' X 8.3'
	100619-01-000	BF FOAM - EXPANDED POLYSTYRENE - 1.34" X 48" X 96"
	100619-02-000	BF FOAM - EXPANDED POLYSTYRENE - 1.5" X 48" X 96"
	100619-04-000	BF FOAM - EXPANDED POLYSTYRENE - .5" X 48" X 96"
	100619-05-000	BF FOAM - EXPANDED POLYSTYRENE - .75" X 48" X 96"-1.5"DENSITY
	100619-16-000	BF FOAM - EXPANDED POLYSTYRENE - .75" X 48" X 96"-2" DENSITY
	100619-27-000	BF FOAM - EXPANDED POLYSTYRENE - 3" X 48" X 92.8"
	116942-03-01A	LB ALUMINUM - .7" X 40" X 158"
	120107-01-000	EA FOAM - ROOF COVE - 2.8" X 48" LONG
	120107-02-000	EA FOAM - PLUG - ROOF TUBE - 2.2" X 2.9" X 1.8" LONG
	120107-03-000	EA FOAM - PLUG - SIDEWALL TUBE - 1.2" X 2.1" X 1.8" LONG
	108535-05-03A	SF FIBERGLASS SHEET - 108" X 500' ROLL - BRIGHT WHITE
	159631-02-01A	EA FIBERGLASS SHEET - 96.7" X 355.7" - BRIGHT WHITE
		FROM: 00-00-00 THRU: 01-14-07
	159631-06-01A	EA FIBERGLASS SHEET - 56.4" X 99.8" - BRIGHT WHITE
		FROM: 02-27-06 THRU: 01-14-07
	159631-07-01A	EA FIBERGLASS SHEET - 27.4" X 65.8" - BRIGHT WHITE
		FROM: 00-00-00 THRU: 01-14-07
	159631-08-01A	EA FIBERGLASS SHEET - 22.1" X 68.2" - BRIGHT WHITE
		FROM: 00-00-00 THRU: 01-14-07
	159631-15-01A	EA FIBERGLASS SHEET - 4" X 93.8" - BRIGHT WHITE
		FROM: 00-00-00 THRU: 01-14-07
	162931-06-01A	EA FIBERGLASS SHEET - 56.4" X 99.8" - BRIGHT WHITE
		FROM: 01-15-07 THRU: 99-99-99
	162931-07-01A	EA FIBERGLASS SHEET - 27.4" X 65.8" - BRIGHT WHITE
		FROM: 01-15-07 THRU: 99-99-99
	162931-08-01A	EA FIBERGLASS SHEET - 22.1" X 68.2" - BRIGHT WHITE
		FROM: 01-15-07 THRU: 99-99-99
	162931-10-01A	EA FIBERGLASS SHEET - 31.1" X 68.2" - BRIGHT WHITE
		FROM: 01-15-07 THRU: 99-99-99
	162931-15-01A	EA FIBERGLASS SHEET - 4" X 93.8" - BRIGHT WHITE
	162931-19-01A	EA FIBERGLASS SHEET - 96.7" X 355.7" - BRIGHT WHITE
	162931-33-01A	EA FIBERGLASS SHEET - 31.1" X 69.3" - BRIGHT WHITE

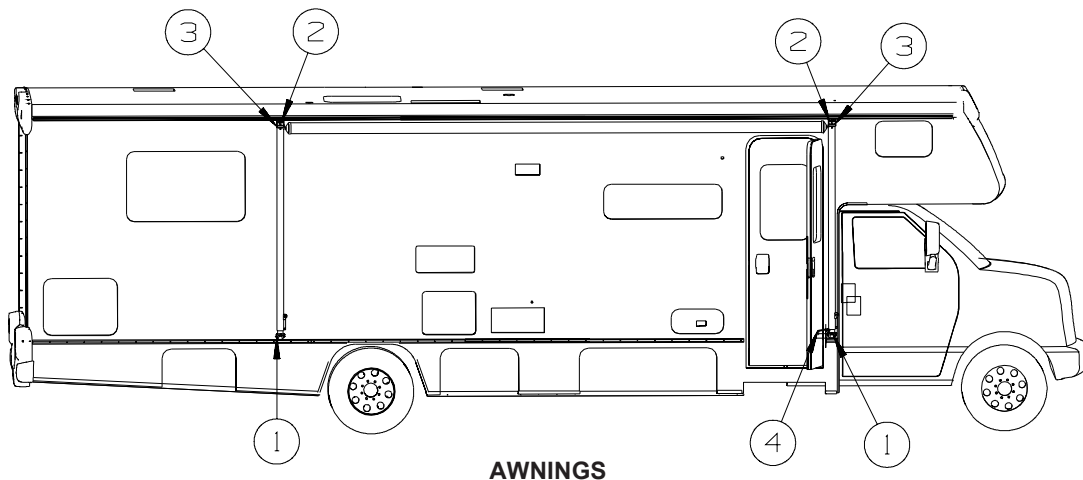

KEY	PART NUMBER	U/M DESCRIPTION
1	113874-11-01A	EA SCREW/LAG - AWNING - 1/4" X 1" STAINLESS STEEL
2	113874-12-01A	EA SCREW/LAG - AWNING - 1/4" X 2 3/4" STAINLESS STEEL
3	161739-01-02A	EA BRACKET - AWNING - BRIGHT WHITE
4	127647-02-01A	EA ROD/AWNING GUARD - ENTRY DOOR - 12.7" LONG - <b>331C</b>
4	127960-01-01A	EA RETAINER - EYE - 3/8" - STAINLESS STEEL - <b>331C</b>

**ORDER AWNINGS & REPAIR PARTS FROM DOMETIC. CALL #800-366-3842.**  
**THE DOMETIC AWNING INFORMATION YOU WILL NEED IS LOCATED ON THE MOTOR HOME NEAR THE TOP OF THE AWNING RAIL.**

# EXTERIOR DOORS & COMPARTMENTS GROUP

## DOOR & COMPARTMENT LAYOUT

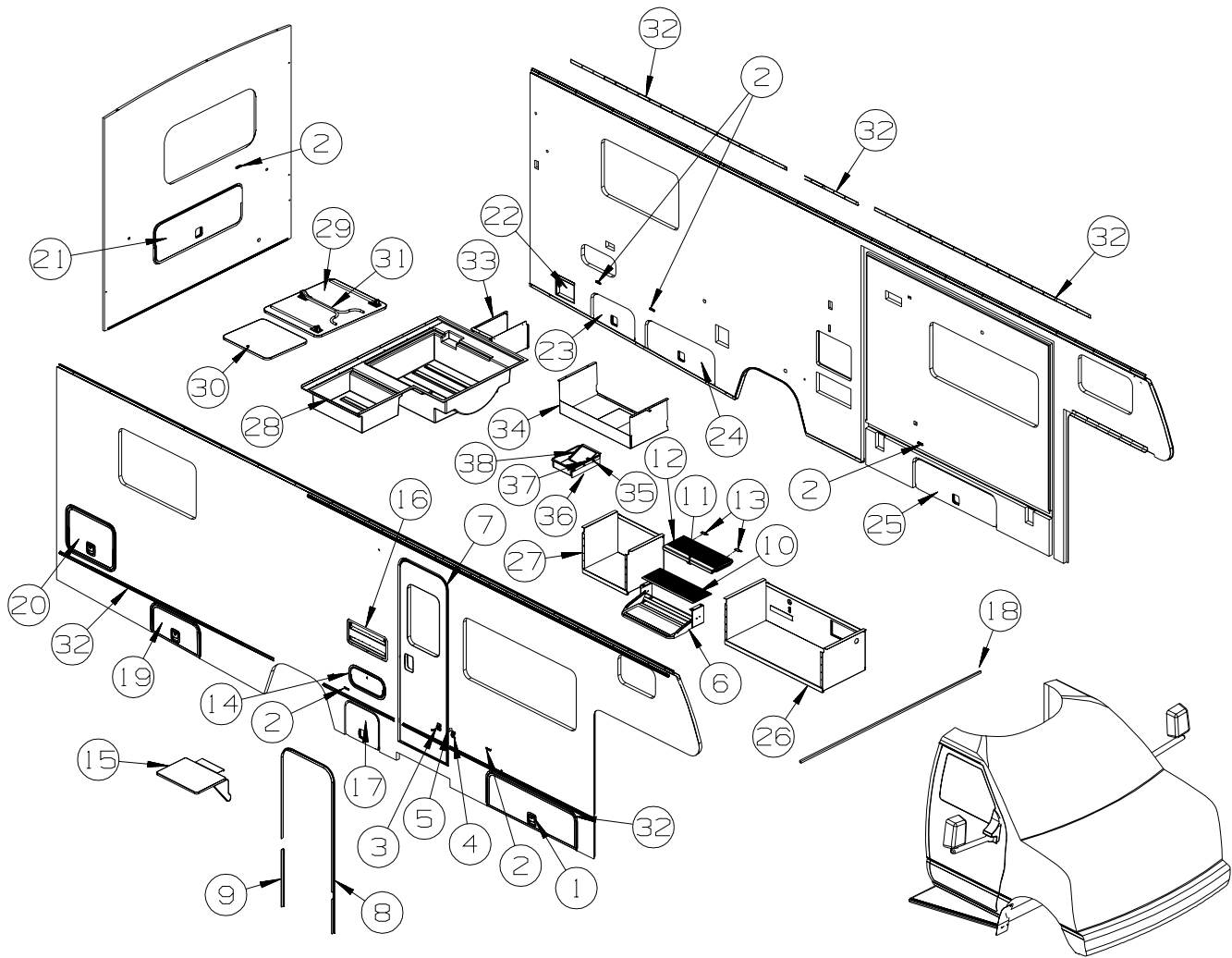

KEY	PART NUMBER	U/M	DESCRIPTION
1	148660-06-S01	EA	DOOR/STORAGE - W/O HDW/PADDLE LATCH - 47.3" X 16"
	150657-25-01B	EA	ROD/WIRE - LATCH
	150657-27-01B	EA	ROD/WIRE - LATCH
	056795-01-000	FT	TAPE-SEAL, 1/8" X 3/8" WIDE - PRESS ON
	107721-08-000	FT	SEAL - ACCESS DOOR - .9"WIDE X .9"HIGH
2	102768-01-000	EA	HOLDER - COMPARTMENT/ENTRY DOOR - METAL - MILL FINISH
3	104099-01-04A	EA	CATCH - DOOR HOLDER - STRIKE - 3.9" - BRIGHT WHITE
4	104099-02-04A	EA	CATCH/RETAINER - DOOR HOLDER - BRIGHT WHITE
5	117046-02-000	EA	BUMPER - RUBBER/ROUND END - 1.5"
6	139748-04-04B	EA	STEP/PULLOUT - W/BRACKETS - BLACK
	102569-04-000	EA	MAT - ANTI SLIP
6*	094708-05-01A	EA	STEP - ELECTRIC - SINGLE - BLACK - KWIKEE - <b>ENTRANCE STEP-ELECTRIC</b>
7	P32206-18-TR0	EA	DOOR - ENTRY W/SCREEN DOOR - W/O WINDOW/LATCH (W29, W30)
7	P32206-18-W31	EA	DOOR - ENTRY W/SCREEN DOOR - W/O WINDOW/LATCH (W31, W32, W33, W34)

### ENTRY DOOR LOCK CYLINDERS

138287-11-000	EA	CYLINDER/LOCK - ENTRY DOOR - MASTER W/3M ICON - (3041)
138287-12-000	EA	CYLINDER/LOCK - ENTRY DOOR - MASTER W/3M ICON - (3042)
138287-13-000	EA	CYLINDER/LOCK - ENTRY DOOR - MASTER W/3M ICON - (3043)
138287-14-000	EA	CYLINDER/LOCK - ENTRY DOOR - MASTER W/3M ICON - (3044)
138287-15-000	EA	CYLINDER/LOCK - ENTRY DOOR - MASTER W/3M ICON - (3045)
138287-16-000	EA	CYLINDER/LOCK - ENTRY DOOR - MASTER W/3M ICON - (3046)
138287-17-000	EA	CYLINDER/LOCK - ENTRY DOOR - MASTER W/3M ICON - (3047)
138287-18-000	EA	CYLINDER/LOCK - ENTRY DOOR - MASTER W/3M ICON - (3048)
138287-19-000	EA	CYLINDER/LOCK - ENTRY DOOR - MASTER W/3M ICON - (3049)
138287-20-000	EA	CYLINDER/LOCK - ENTRY DOOR - MASTER W/3M ICON - (3050)
138292-01-000	EA	SEAL - LOCK CYLINDER



**EXTERIOR DOORS & COMPARTMENTS GROUP (CONTINUED)**  
**DOOR & COMPARTMENT LAYOUT (CONTINUED)**

**KEY PART NUMBER U/M DESCRIPTION**

**VALANCE DOOR & WATER FILL DOOR LOCK CYLINDERS**

	138289-11-000	EA	CYLINDER/LOCK - ACCESS DOORS - REDUCED SENSITIVITY (3041)
	138289-12-000	EA	CYLINDER/LOCK - ACCESS DOORS - REDUCED SENSITIVITY (3042)
	138289-13-000	EA	CYLINDER/LOCK - ACCESS DOORS - REDUCED SENSITIVITY (3043)
	138289-14-000	EA	CYLINDER/LOCK - ACCESS DOORS - REDUCED SENSITIVITY (3044)
	138289-15-000	EA	CYLINDER/LOCK - ACCESS DOORS - REDUCED SENSITIVITY (3045)
	138289-16-000	EA	CYLINDER/LOCK - ACCESS DOORS - REDUCED SENSITIVITY (3046)
	138289-17-000	EA	CYLINDER/LOCK - ACCESS DOORS - REDUCED SENSITIVITY (3047)
	138289-18-000	EA	CYLINDER/LOCK - ACCESS DOORS - REDUCED SENSITIVITY (3048)
	138289-19-000	EA	CYLINDER/LOCK - ACCESS DOORS - REDUCED SENSITIVITY (3049)
	138289-20-000	EA	CYLINDER/LOCK - ACCESS DOORS - REDUCED SENSITIVITY (3050)
	138288-11-000	EA	KEY - REVERSIBLE - #3041 - T/M 16169-02-3041
	138288-12-000	EA	KEY - REVERSIBLE - #3042 - T/M 16169-02-3042
	138288-13-000	EA	KEY - REVERSIBLE - #3043 - T/M 16169-02-3043
	138288-14-000	EA	KEY - REVERSIBLE - #3044 - T/M 16169-02-3044
	138288-15-000	EA	KEY - REVERSIBLE - #3045 - T/M 16169-02-3045
	138288-16-000	EA	KEY - REVERSIBLE - #3046 - T/M 16169-02-3046
	138288-17-000	EA	KEY - REVERSIBLE - #3047 - T/M 16169-02-3047
	138288-18-000	EA	KEY - REVERSIBLE - #3048 - T/M 16169-02-3048
	138288-19-000	EA	KEY - REVERSIBLE - #3049 - T/M 16169-02-3049
	138288-20-000	EA	KEY - REVERSIBLE - #3050 - T/M 16169-02-3050
8	139100-02-01A	EA	GARNISH/RADIUS - ENTRY DOOR - BRIGHT WHITE
9	139101-02-01A	EA	GARNISH/STRAIGHT - 24.9" - BRIGHT WHITE
10	133114-03-01A	EA	TREAD - STEP/RUBBER - 27.1" X 10.1" - TAUPE
11	123330-05-02B	EA	SUPPORT - ENTRY STEP - E-COATED
	116975-01-01A	EA	LATCH - W/O STRIKE - BLACK - NEW STYLE
	151104-01-01A	FT	SEAL - BULB - W/WIRED U CHANNEL - .3" X .5" CHANNEL-BLACK
12	147781-01-01A	EA	TREAD/STEP - RUBBER - TAUPE
13	146747-01-02B	EA	BRACKET/CATCH - E-COATED
14	126945-09-P07	EA	DOOR/STORAGE - W/O HARDWARE - 18.3" X 9.9"
15	142034-01-01A	EA	SHELF - F/EXTERIOR TV - BRIGHT WHITE
16*	084103-08-000	EA	DOOR - VENT - REFRIGERATOR - W/O JAMB - BRIGHT WHITE
16	084104-08-000	EA	JAMB - VENT DOOR/REFRIGERATOR - BRIGHT WHITE
17	148660-03-S01	EA	DOOR/STORAGE - W/O HDW/PADDLE LATCH - 18.2" X 16"
17	148660-03-AA1	EA	DOOR/STORAGE - W/O HDW/PADDLE LATCH - 18.2" X 16" - LOWER EXTERIOR PAINT
	150657-03-01B	EA	ROD/WIRE - LATCH
	150657-07-01B	EA	ROD/WIRE - LATCH
	056795-01-000	FT	TAPE-SEAL, 1/8" X 3/8" WIDE - PRESS ON
	107721-08-000	FT	SEAL - ACCESS DOOR - .9"WIDE X .9"HIGH
18	098408-01-000	FT	SEAL - SPONGE RUBBER - CLOSED CELL
19	148661-33-U01	EA	DOOR/STORAGE - PASS W/O HDW/LATCH - 13.1" X 25.3" X 14.3"
19	148661-33-AA1	EA	DOOR/STORAGE - PASS W/O HDW/LATCH - 13.1" X 25.3" X 14.3" - LOWER EXTERIOR PAINT
	150657-10-01B	EA	ROD/WIRE - LATCH
	150657-13-01B	EA	ROD/WIRE - LATCH
	056795-01-000	FT	TAPE-SEAL, 1/8" X 3/8" WIDE - PRESS ON
	156662-01-01A	FT	SEALER - TAPE - 1/4"THICK X 3"WIDE X 100 FT - WHITE
20	150246-06-U21	EA	DOOR/STORAGE - W/O HARDWARE - 25.2" X 19.3"
	150657-13-01B	EA	ROD/WIRE - LATCH
	150657-42-01B	EA	ROD/WIRE - LATCH
	056795-01-000	FT	TAPE-SEAL, 1/8" X 3/8" WIDE - PRESS ON
21	150246-07-U21	EA	DOOR/STORAGE - W/O HARDWARE - 46.9" X 17.4"
	150657-25-01B	EA	ROD/WIRE - LATCH
	150657-43-01B	EA	ROD/WIRE - LATCH
	056795-01-000	FT	TAPE-SEAL, 1/8" X 3/8" WIDE - PRESS ON
22	142894-01-01A	EA	DOOR/POWER CORD - W/HATCH - W/LOCK - BRIGHT WHITE
23	148661-35-W21	EA	DOOR/STORAGE - DRVR W/O HDW/LATCH - 13.1" X 23" X 12.1"
23	148661-35-AA1	EA	DOOR/STORAGE - DRVR W/O HDW/LATCH - 13.1" X 23" X 12.1" - LOWER EXTERIOR PAINT
	150657-09-01B	EA	ROD/WIRE - LATCH
	150657-11-01B	EA	ROD/WIRE - LATCH
	056795-01-000	FT	TAPE-SEAL, 1/8" X 3/8" WIDE - PRESS ON
	107721-08-000	FT	SEAL - ACCESS DOOR - .9"WIDE X .9"HIGH
	156662-01-01A	FT	SEALER - TAPE - 1/4"THICK X 3"WIDE X 100 FT - WHITE

**EXTERIOR DOORS & COMPARTMENTS GROUP (CONTINUED)**  
**DOOR & COMPARTMENT LAYOUT (CONTINUED)**

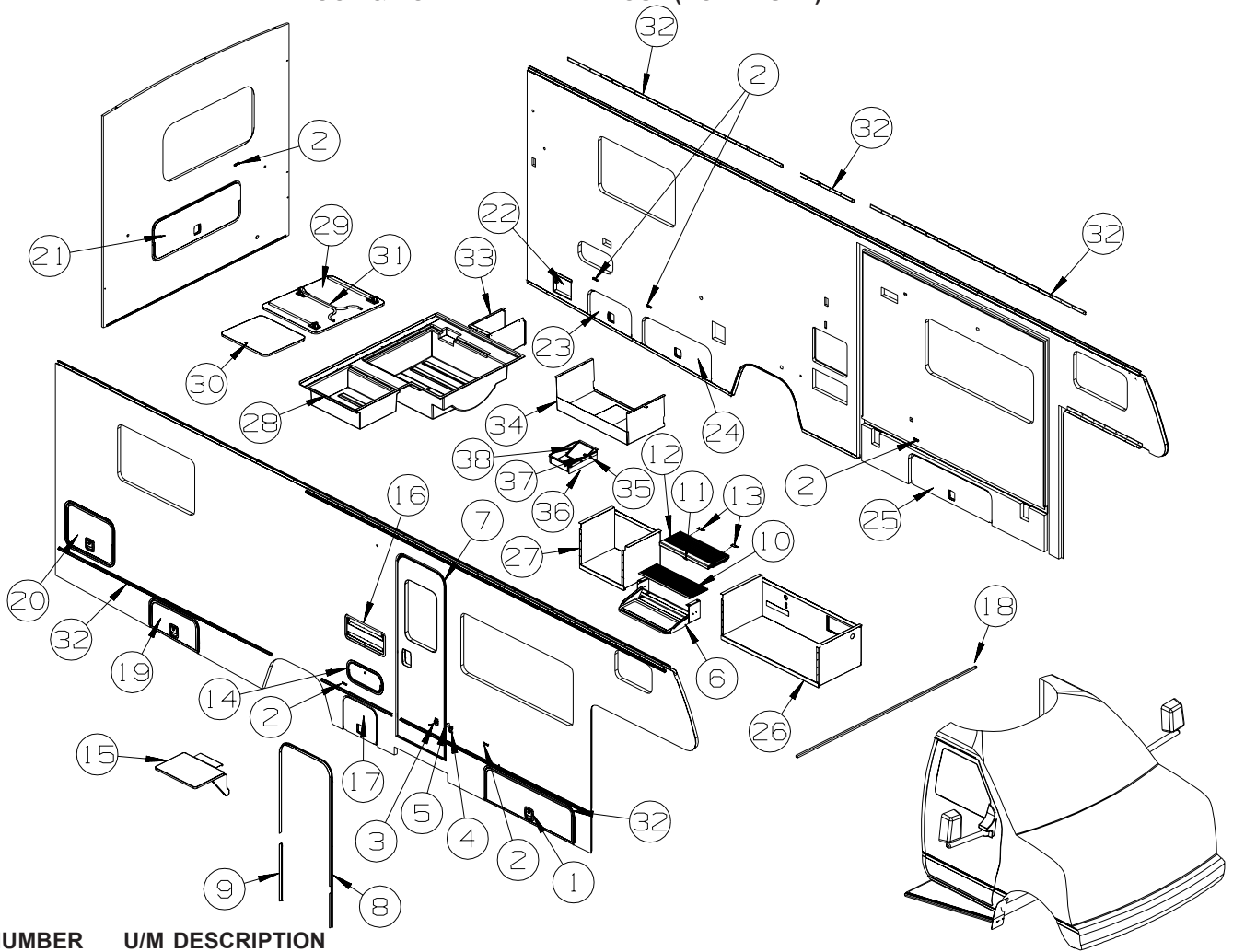

KEY	PART NUMBER	U/M	DESCRIPTION
24	148661-31-U01	EA	DOOR/STORAGE - DRVR W/O HDW/LATCH - 15.3" X 36.6" X 13.6"
24	148661-31-AA1	EA	DOOR/STORAGE - DRVR W/O HDW/LATCH - 15.3" X 36.6" X 13.6" - LOWER EXTERIOR PAINT
	150657-10-01B	EA	ROD/WIRE - LATCH
	150657-13-01B	EA	ROD/WIRE - LATCH
	056795-01-000	FT	TAPE-SEAL, 1/8" X 3/8" WIDE - PRESS ON
	107721-08-000	FT	SEAL - ACCESS DOOR - .9"WIDE X .9"HIGH
25	148660-09-S01	EA	DOOR/STORAGE - W/O HDW/PADDLE LATCH - 44" X 14.2"
	150657-23-01B	EA	ROD/WIRE - LATCH
	150657-26-01B	EA	ROD/WIRE - LATCH
	056795-01-000	FT	TAPE-SEAL, 1/8" X 3/8" WIDE - PRESS ON
	107721-08-000	FT	SEAL - ACCESS DOOR - .9"WIDE X .9"HIGH
26	137554-46-U21	EA	COMPARTMENT - LUGGAGE - MOTOR AID
26	137554-16-N01	EA	COMPARTMENT - LUGGAGE - PATIO AWNING
27	137554-23-R07	EA	COMPARTMENT - LUGGAGE
28	156199-01-01A	EA	COMPARTMENT - TRUNK
	111848-08-02B	EA	SHIELD - HEAT - EXHAUST - E-COATED - NOT ILLUSTRATED
29	160884-01-U01	EA	TABLE - 36.6" X 30.7" - W/FOLDING LEG/HDW
	158154-01-U01	EA	TABLE - 36.6" X 30.7" - W/O HDW
	160875-01-01A	EA	LEG - TABLE/FOLDING - 1 DOUBLE/2 SINGLES - W/HDW
30	158154-03-U21	EA	TABLE - 25.6" X 21.6" - W/O HDW
31	160875-01-01A	EA	LEG - TABLE/FOLDING - 1 DOUBLE/2 SINGLES - W/HDW
32	105312-01-07A	FT	INSERT - FEATURE STRIP - VINYL - BRIGHT WHITE
33	140662-01-02B	EA	COMPARTMENT - POWER CORD - E-COATED
34	140482-03-02B	EA	COMPARTMENT - DRAINAGE - E-COATED
35	140922-02-02B	EA	RETAINER - MUD FLAP - 1" X 14.5" - E-COATED
36	017516-10-000	EA	MUD FLAP - 3.9"H X 14.9"W - RUBBER - BLACK
37	153718-01-01A	EA	LATCH - HOLD DOWN PANEL - STAINLESS STEEL
38	153529-01-02B	EA	DOOR - SUMP - E-COATED
	104692-01-000	FT	SEAL - ADHESIVE BACKED FOAM - 3/4" THICK X 3/4" WIDE X 25'

\*COMPONENT PARTS LISTED LATER IN THIS GROUP

**EXTERIOR DOORS & COMPARTMENTS GROUP (CONTINUED)**  
**DOOR & COMPARTMENT LAYOUT (CONTINUED)**

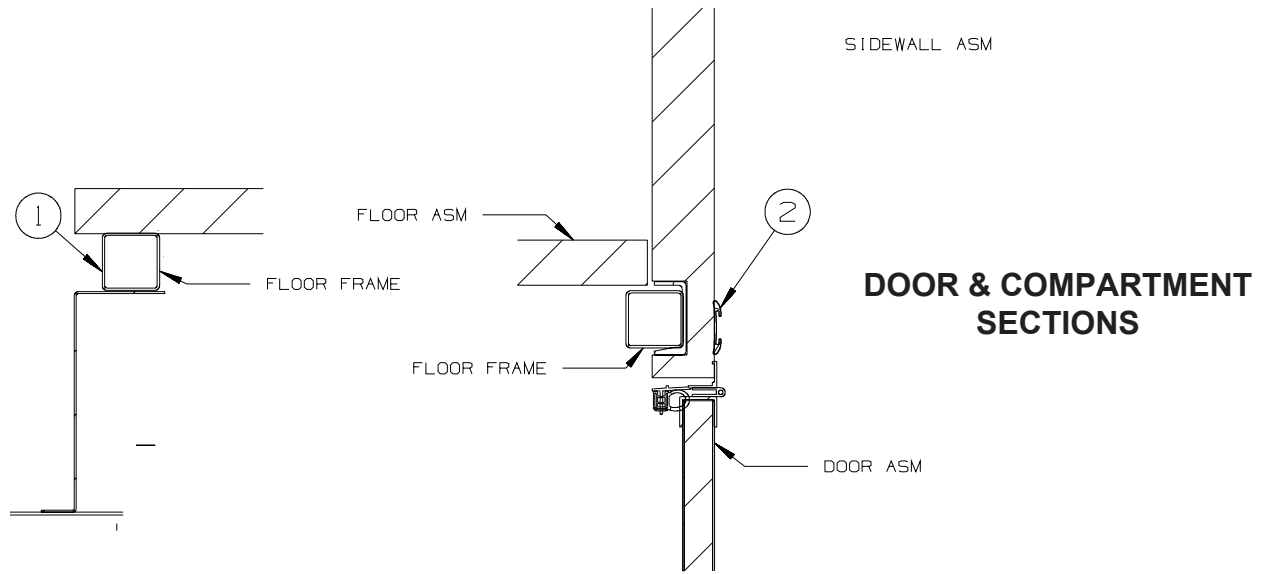

**DOOR & COMPARTMENT SECTIONS**

KEY	PART NUMBER	U/M	DESCRIPTION
1	098408-01-000	FT	SEAL - SPONGE RUBBER - CLOSED CELL
2	105312-01-07A	EA	INSERT - FEATURE STRIP - VINYL - BRIGHT WHITE

# EXTERIOR DOORS & COMPARTMENTS GROUP (CONTINUED)

## COMPONENT PARTS FOR DOOR & COMPARTMENT LAYOUT

084103-08-000

KEY	PART NUMBER	U/M	DESCRIPTION	VENDOR NO.
	084104-01-700	EA	LOCK-MALE, FASTENER	201-721-010
	084104-01-701	EA	LOCK-FEMALE, FASTENER	201-802-010

**EXTERIOR DOORS & COMPARTMENTS GROUP (CONTINUED)**  
**COMPONENT PARTS FOR DOORS & COMPARTMENTS LAYOUT (CONTINUED)**

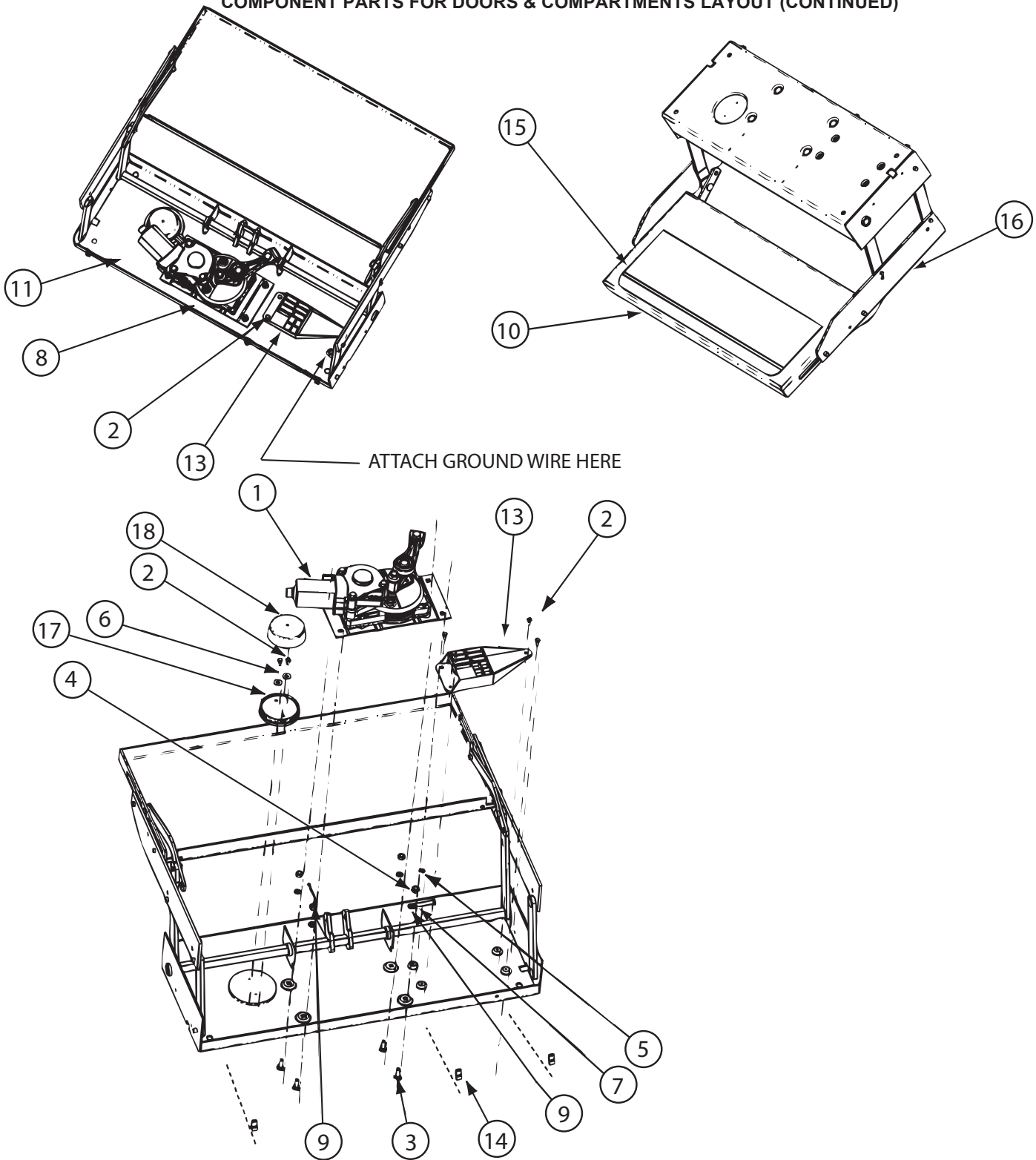

094708-05-01A

KEY	PART NUMBER	U/M	DESCRIPTION	VENDOR NO.
1	094707-04-701	EA	MOTOR "AM 214" F/IMGL STEPS	1101428
13	094707-04-700	EA	CONTROL UNIT W/OVERRIDE	909510000
15	143709-01-702	EA	TREAD/NON-SKID 6" X 21" BLK	1915260
16	094708-05-701	EA	FRAME W/SGL STEP,28 SERIES	908028000
17	088746-01-705	EA	LIGHT-UNDER STEP	9004
	094707-03-701	EA	PLUG - 4-WAY - PACKARD	909306
	094707-04-702	EA	COTTER PIN - W/CLEVIS PIN	905205000
	094707-04-711	EA	KWIKTEST - W/4-WAY PIGTAIL	909518000
	094708-05-700	EA	GEAR BOX W/LINKAGE-STRAIGHT	1101426

CONTACT WINNEBAGO PART SALES FOR UNLISTED COMPONENT(S)

**EXTERIOR DOORS & COMPARTMENTS GROUP (CONTINUED)**  
**COMPARTMENT DOOR PIECE PARTS**

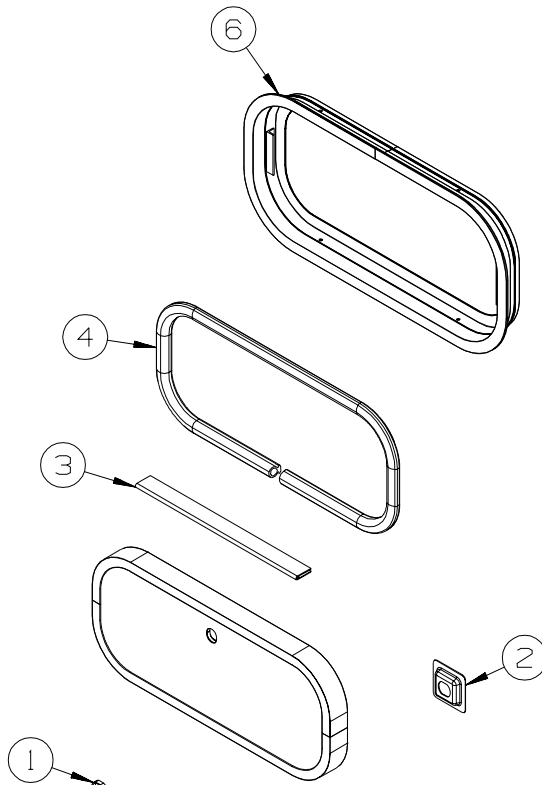

KEY	PART NUMBER	U/M	DESCRIPTION
1	139325-01-000	EA	SPACER - LOCK - 6MM
	139337-01-000	EA	GASKET - LOCK
2	097111-02-04A	EA	POCKET - LOCK - REAR DOOR - BLACK
3	081801-FN-000	EA	HINGE - DOOR - PIANO - 2" X 96" - BLACK
3	081801-V3-000	EA	HINGE - DOOR - PIANO - 2" X 96" - BRIGHT WHITE
4	156386-01-01A	FT	SEAL - BULB - .4" X .5" - W/ADHESIVE BACK
5	138290-02-000	EA	CASE - W/CAM - W/O CYLINDER/KEY
6	056795-01-000	FT	TAPE - SEAL - 1/8" X 3/8" WIDE - PRESS ON

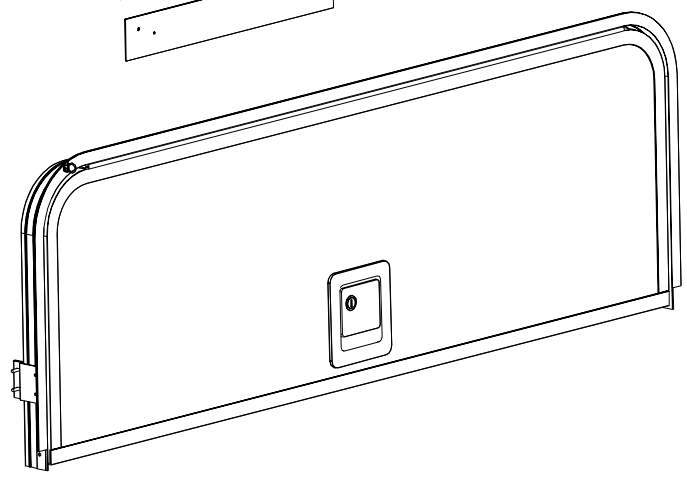
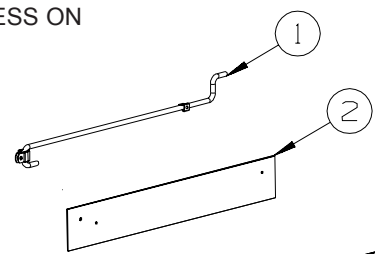

KEY	PART NUMBER	U/M	DESCRIPTION
1	155346-03-04B	EA	PROP ROD - 10.6" - BLACK
1	155346-04-04B	EA	PROP ROD - 15.3" - BLACK
1	155346-07-04B	EA	PROP ROD - 17.3" - BLACK
2	121577-02-01A	EA	STRAP/PLATE - W/HOLE - 2.25" X 11.8" - BRIGHT WHITE
2	121577-06-01A	EA	STRAP/PLATE - W/HOLE - 2.25" X 15.8" - BRIGHT WHITE
2	121577-07-01A	EA	STRAP/PLATE - W/HOLE - 2.25" X 3" - BRIGHT WHITE
2	121577-08-01A	EA	STRAP/PLATE - W/HOLE - 2.25" X 10" - BRIGHT WHITE
	035648-51-001	EA	STRAP - EXTRUSION - 2.25" X 80.6"

**EXTERIOR DOORS & COMPARTMENTS GROUP (CONTINUED)**  
**COMPARTMENT DOOR PIECE PARTS (CONTINUED)**

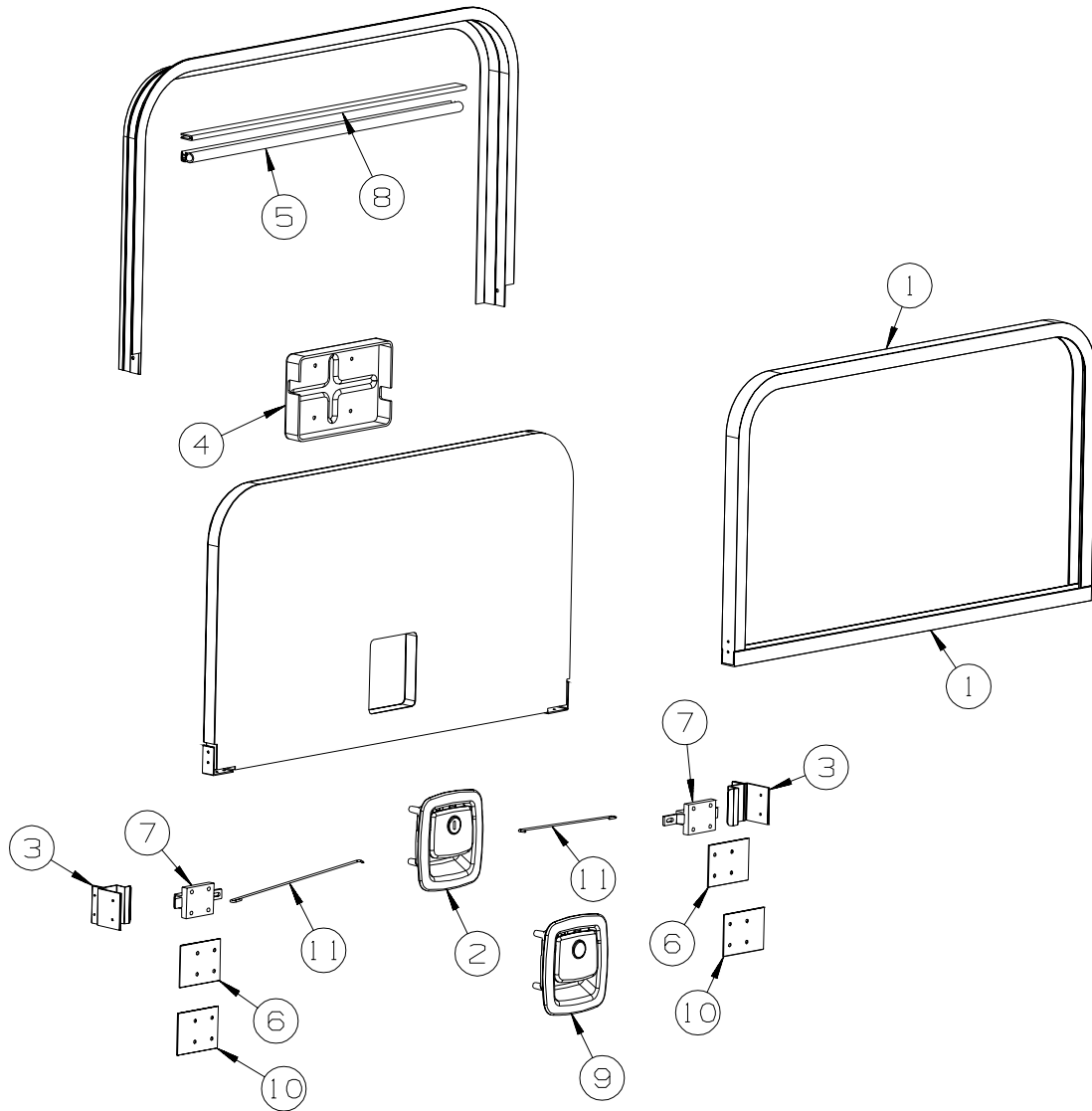

KEY	PART NUMBER	U/M	DESCRIPTION
1	096217-55-006	EA	U-CHANNEL - 210" - BRIGHT WHITE
1	096217-55-009	EA	U-CHANNEL - 210" - BLACK - LOWER EXTERIOR PAINT
2	154900-01-02A	EA	LATCH/PADDLE - LOCKING - COMPT DOOR - KEY ONE - WHITE
2	154900-01-01A	EA	LATCH/PADDLE - LOCKING - COMPT DOOR - KEY ONE - BLACK - LOWER EXTERIOR PAINT
3	150789-01-S01	EA	STRIKER - STORAGE DOOR
4	122277-06-02A	EA	COVER - LATCH - WHITE
5	151104-01-01A	FT	SEAL - BULB - W/WIRED U CHANNEL - .3" X .5" CHANNEL-BLACK
6	121577-07-01A	EA	STRAP/PLATE - W/HOLE - 2.25" X 3" - BRIGHT WHITE
7	149741-01-01A	EA	BOLT - SLIDE/LATCH
8	151229-06-01A	EA	HINGE - CONTINUOUS - 1.5" X 72.4" - BRIGHT WHITE
8	151229-06-02A	EA	HINGE - CONTINUOUS - 1.5" X 72.4" - BLACK - LOWER EXTERIOR PAINT
9	154900-02-02A	EA	LATCH/PADDLE - NON LOCKING - COMPT DOOR - WHITE
9	154900-02-01A	EA	LATCH/PADDLE - NON LOCKING - COMPT DOOR - BLACK - LOWER EXTERIOR PAINT
10	149738-01-01A	EA	SPACER - SLIDE BOLT
11	150150-01-000	EA	ROD - LATCH (BLANK) - 27.5" - STAINLESS STEEL

**EXTERIOR DOORS & COMPARTMENTS GROUP (CONTINUED)**  
**COMPARTMENT DOOR PIECE PARTS (CONTINUED)**

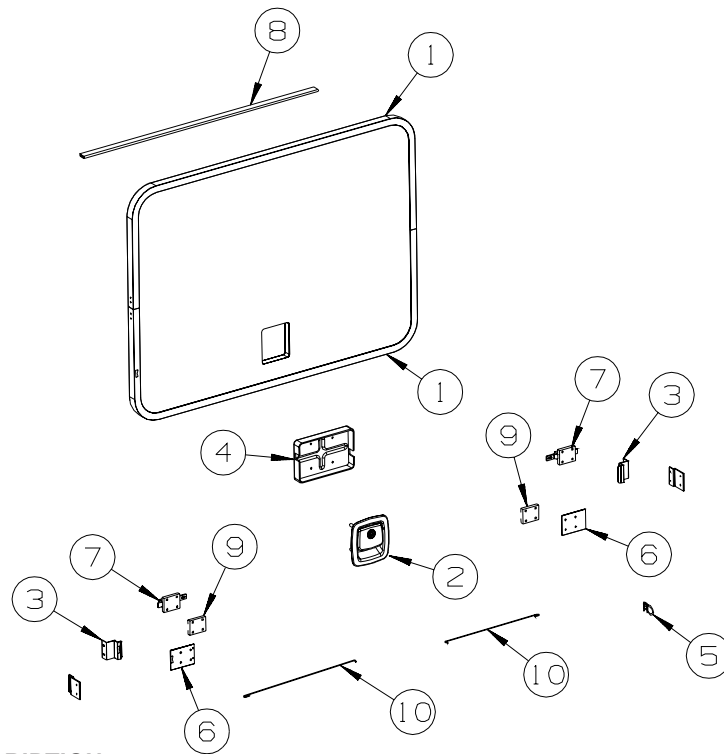

KEY	PART NUMBER	U/M	DESCRIPTION
1	096217-55-006	EA	U-CHANNEL - 210" - BRIGHT WHITE
2	154900-01-02A	EA	LATCH/PADDLE - LOCKING - COMPT DOOR - KEY ONE - WHITE
2	154900-01-01A	EA	LATCH/PADDLE - LOCKING - COMPT DOOR - KEY ONE - BLACK
3	150789-01-S01	EA	STRIKER - STORAGE DOOR
4	122277-06-02A	EA	COVER - LATCH - WHITE
5	151104-01-01A	FT	SEAL - BULB - W/WIRED U CHANNEL - .3" X .5" CHANNEL-BLACK
6	121577-07-01A	EA	PLATE - W/HOLE - BRIGHT WHITE
	035648-51-001	EA	STRAP - EXTRUSION - 2.25" X 80.6"
7	149741-01-01A	EA	BOLT - SLIDE/LATCH
8	151229-06-01A	EA	HINGE - CONTINUOUS - 1.5" X 72.4" - BRIGHT WHITE
9	149738-01-01A	EA	SPACER - SLIDE BOLT
10	150150-01-000	EA	ROD - LATCH (BLANK) - 27.5" - STAINLESS STEEL



# EXTERIOR DOORS & COMPARTMENTS GROUP (CONTINUED)

## ENTRY

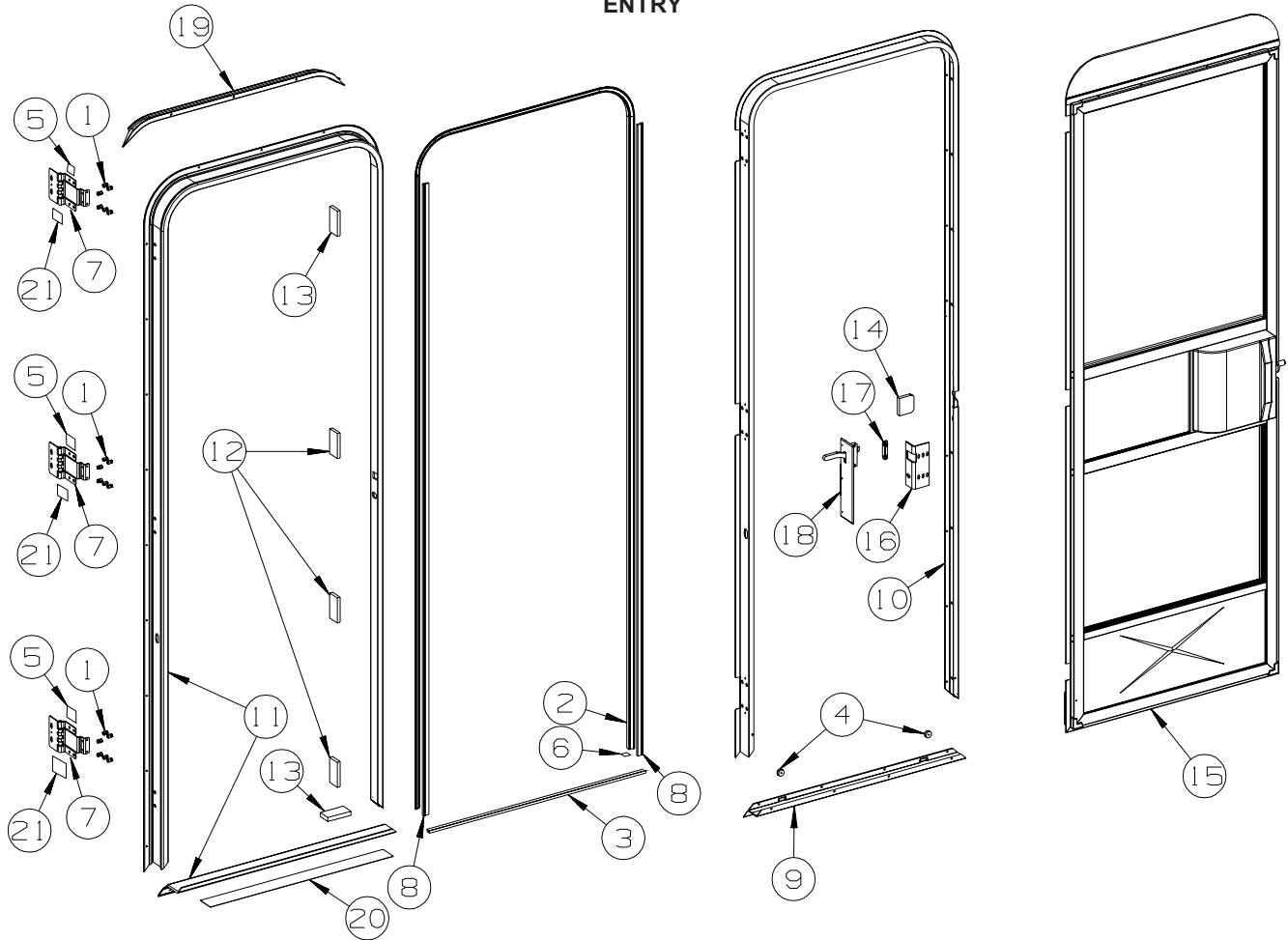

KEY	PART NUMBER	U/M	DESCRIPTION
1	039715-01-000	EA	NUT-SERT - 1/4" DIAMETER - 20 THREADS
2	075671-04-000	FT	SEAL - SPONGE - LAZY T - W/ADHESIVE STRIP - .5" WIDE
3	075673-05-000	FT	SEAL/PILE - .5" HIGH W/ADHESIVE BACK - BLACK
4	081914-02-000	EA	BUMPER - RUBBER - ROUND - 5/16" DIA. X 13/64" THICK
5	100128-02-000	FT	SEAL - FOAM/ADHESIVE BACK - .37" WIDE X .37" THICK
6	104692-01-000	FT	SEAL - ADHESIVE BACKED FOAM - 3/4" THICK X 3/4" WIDE X 25'
7	106719-01-05A	EA	HINGE - ENTRY DOOR - BRIGHT WHITE
8	118929-01-01A	FT	SEAL - PILE - PUSH ON
9	121893-01-01A	EA	FRAME - ENTRY DOOR/LOWER - BRIGHT WHITE
10	121894-30-01A	EA	FRAME - ENTRY DOOR - BRIGHT WHITE
11	121898-18-01A	EA	JAMB - DOOR/ENTRANCE - BRIGHT WHITE
12	125724-01-000	EA	SHIM - DOOR, ENTRANCE
13	125724-02-000	EA	SHIM - DOOR, ENTRANCE
14	130096-05-000	EA	FOAM - SCREEN DOOR, RETAINER
15	P32208-04-L07	EA	DOOR - SCREEN - W/O HARDWARE
16	137401-01-03B	EA	BRACKET - DOOR ANGLE - OFF WHITE
17	148364-01-12B	EA	STRIKE - SCREEN DOOR - BRIGHT WHITE
18	132915-01-01A	EA	LATCH - SCREEN DOOR - BLACK
19	139054-01-01A	EA	CAP - DRIP - JAMB MOUNTED - BRIGHT WHITE
20	038327-01-000	EA	TAPE - ANTI-SLIP - 2" X 60'
21	154585-01-01A	FT	SEAL - FOAM TAPE - ADHESIVE BACK - 3/8" X 3/8" - BLACK

# EXTERIOR DOORS & COMPARTMENTS GROUP (CONTINUED)

## SCREEN

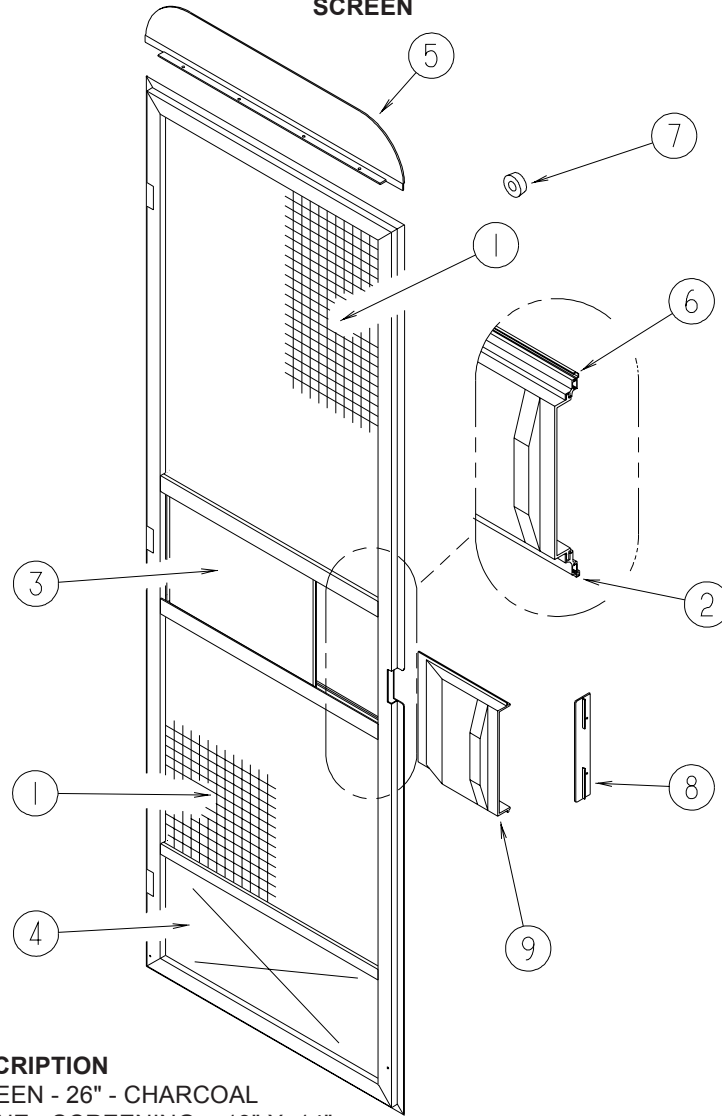

KEY	PART NUMBER	U/M	DESCRIPTION
1	002293-02-000	SF	SCREEN - 26" - CHARCOAL
2	002294-01-000	FT	SPLINE - SCREENING - .13" X .14"
3	016454-21-000	EA	INSERT/CENTER - SCREEN DOOR
4	078552-03-000	EA	KICK PANEL - SCREEN DOOR - LOWER INSERT - UNPAINTED
5	078595-01-000	EA	TOP PLATE - SCREEN DOOR - CURVED TOP - 4.7" X 25.35"
6	078777-08-000	FT	CHANNEL - SLIDER - 4 FOOT INCREMENTS
7	120863-09-000	EA	BUMPER - RUBBER/RADIUS TOP - 3/4" X 3/8" - LT GRAY
8	132081-01-01A	EA	STRIKE - SLIDER - SCREEN DOOR - BRIGHT WHITE
9	132082-01-01A	EA	SLIDER - SCREEN DOOR - BRIGHT WHITE

# EXTERIOR DOORS & COMPARTMENTS GROUP (CONTINUED)

## LATCH - ENTRY

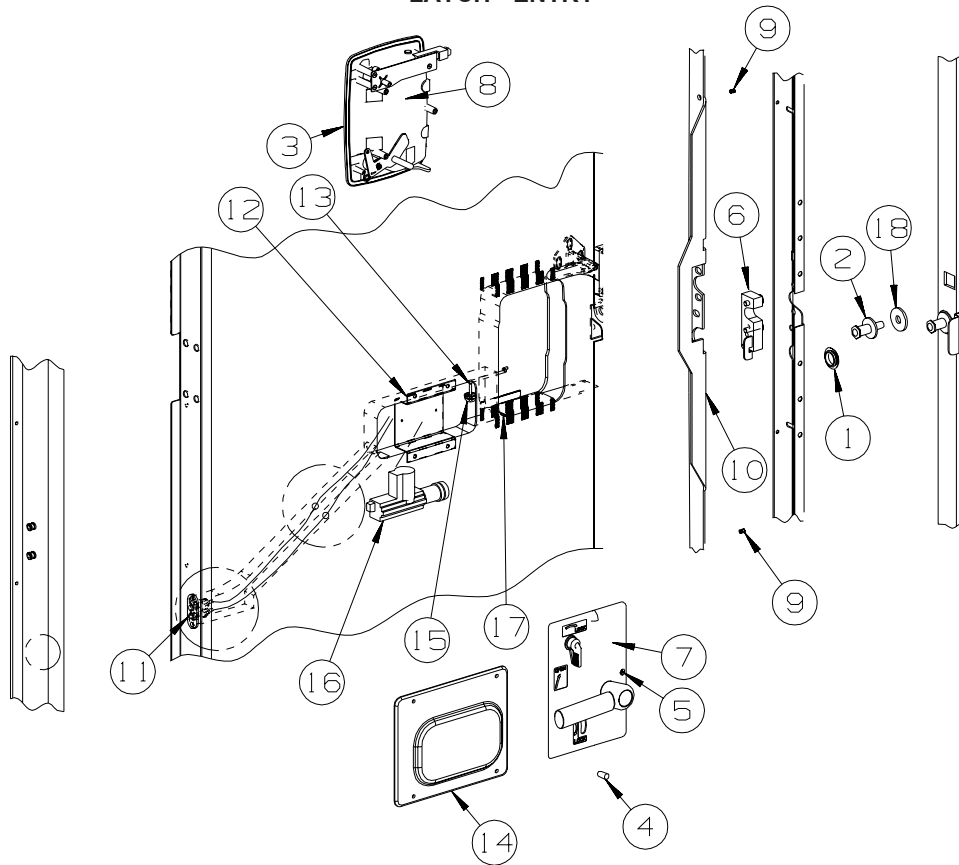

KEY	PART NUMBER	U/M	DESCRIPTION
1	061420-14-000	EA	PLUG/PLASTIC - 7/8" DIAMETER - BLACK
2	092927-20-000	EA	STRIKER - BOLT
3	112782-04-01A	EA	GASKET
4	112782-05-01A	EA	CAP - VINYL - RED
5	112782-08-01A	EA	SCREW - MOUNTING/PLATE - ZINC
6	112782-22-01A	EA	LATCH - SINGLE ROTOR
7	112782-27-01A	EA	LATCH - INTERIOR PLATE
8	112782-20-01A	EA	LATCH - EXTERIOR - W/O LOCK CYLINDER W/ICON-REVERSIBLE KEY
9	072893-04-000	EA	NUTSERT - 10-32
10	132207-01-02B	EA	STIFFENER/DOOR - FORMED - E-COATED
10	132207-03-02B	EA	STIFFENER/DOOR - FORMED - E-COATED - VIEW, ASPECT, NAVION, CAMBRIA
11	138897-01-000	EA	SWITCH - 2 PIN/SPRING LOADED CONTACTS (EA=1 SWITCH)
12	113650-02-02B	EA	BRACKET - ACTUATOR - ELECTRIC - E-COATED
13	113651-01-01A	EA	ROD - CONTROL - MOTOR/LOCK
14	113960-01-01A	EA	COVER - ACTUATOR - POWER LOCK
15	147900-01-01A	EA	SPACER-STRIKE BOLT, MILL
16	138898-01-000	EA	ACTUATOR/LOCK - ELECTRIC
17	137230-01-01A	EA	SPACER- NOTCHED, MILL

## EXTERIOR SLIDEOUT GROUP

FRONT LEFT

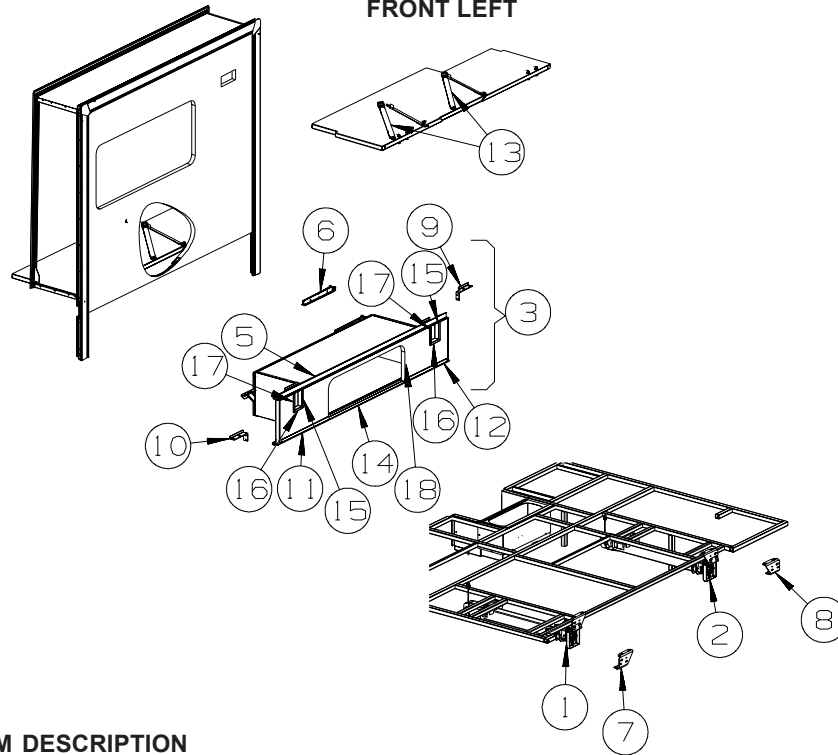

KEY	PART NUMBER	U/M	DESCRIPTION
1*	162827-01-000	EA	SLIDEOUT - ELECTRIC 20" - RIGHT HAND
2*	162827-02-000	EA	SLIDEOUT - ELECTRIC 20" - LEFT HAND
	138173-05-000	EA	WRENCH - RETRACT CRANK HANDLE - F/SLIDEOUT
3	140962-02-R07	EA	COMPARTMENT - SLIDEOUT
4	157262-02-W21	EA	PANEL/SEAL PLANE (W29, W30)
4	157262-02-W31	EA	PANEL/SEAL PLANE (W31, W32, W33, W34)
5	140976-06-01A	EA	JAMB - UPPER - BRIGHT WHITE
6	126591-01-02B	EA	CARRIER/EXTENSION - F/SLIDEOUT-F/WIRE/HOSES - E-COATED
7	127030-03-02B	EA	BRACKET - UPR FRT/MOUNT - OUTSIDE WALL/SLIDEOUT - E-COATED
8	127030-04-02B	EA	BRACKET - UPR REAR/MOUNT - OUTSIDE WALL/SLIDEOUT-E-COATED
9	127828-05-02B	EA	BRACKET - F/SLIDEOUT COMPARTMENT - E-COATED
10	127828-04-02B	EA	BRACKET - F/SLIDEOUT COMPARTMENT - E-COATED
11	148759-55-01A	EA	TRIM - SIDEWALL/LOWER - W/O MITER/NOTCH - 27.4"
12	148759-B3-01A	EA	TRIM - SIDEWALL/LOWER - 24.2" - BRIGHT WHITE
13	160167-01-01A	EA	SEAT BELT - 2" X 102" - BLACK
14	140981-05-01A	EA	JAMB - LOWER - BRIGHT WHITE
15	137970-06-01A	EA	TRIM - SIDEWALL - 6.9"
16	137970-08-01A	EA	TRIM - SIDEWALL - 5.7"
17	137970-09-01A	EA	TRIM - SIDEWALL - 6.9"
18	162434-12-W21	EA	SLUG - F/SLIDEOUT (W29, W30)
18	162434-12-W31	EA	SLUG - F/SLIDEOUT (W31, W32, W33, W34)

**\*COMPONENT PARTS LISTED LATER IN THIS GROUP**

**EXTERIOR SLIDEOUT GROUP (CONTINUED)**  
**FRONT LEFT (CONTINUED)**

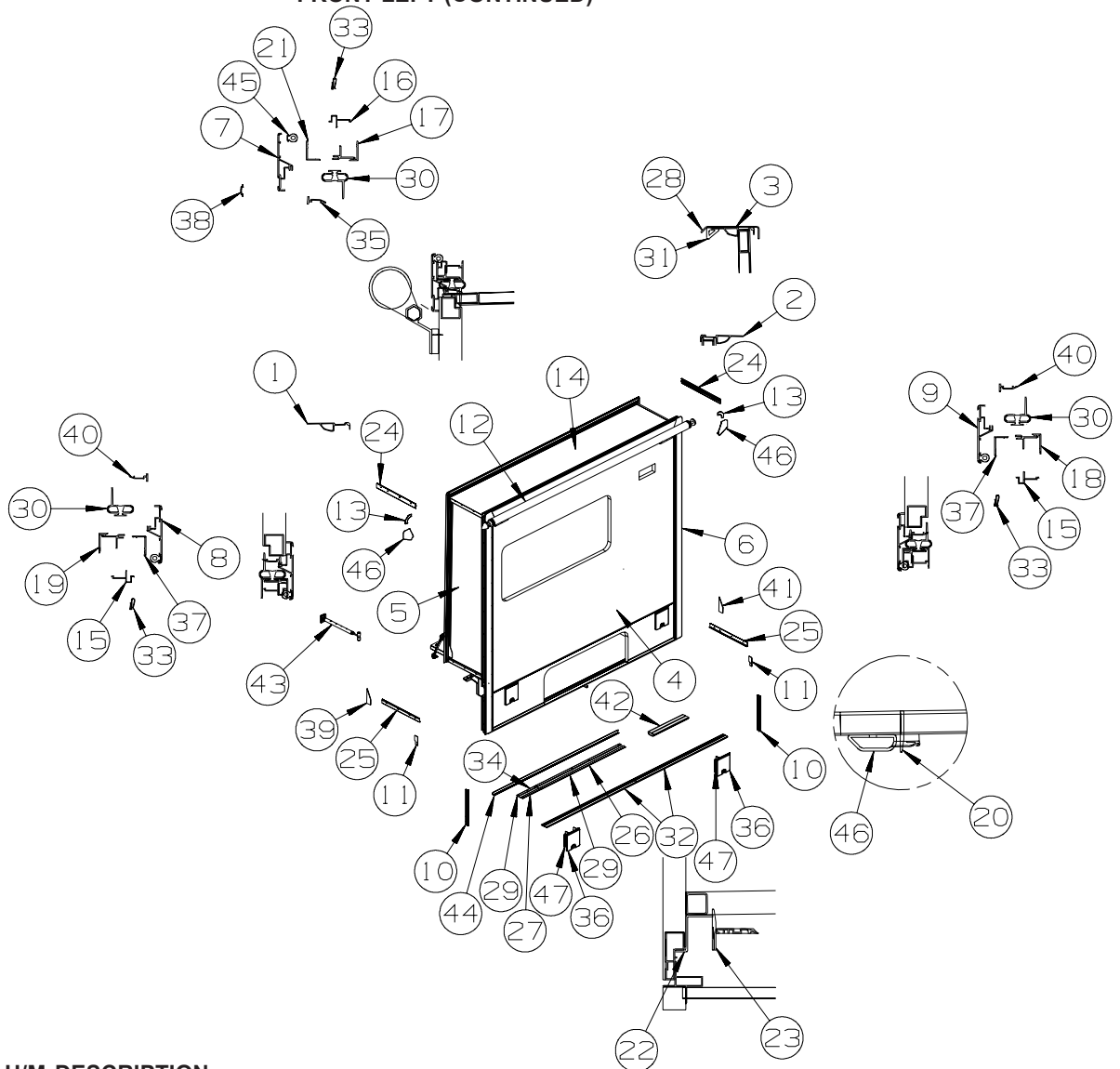

KEY	PART NUMBER	U/M	DESCRIPTION
1	139624-01-02A	EA	TRIM/SEAL - INNER/RIGHT HAND - 73.4" - ALMOND
2	139624-02-02A	EA	TRIM/SEAL - INNER/LEFT HAND - 73.4" - ALMOND
3	139624-56-02A	EA	TRIM/SEAL - INNER - 102.2" - ALMOND
4	162434-11-W21	EA	SLUG - F/SLIDEOUT (W29, W30)
4	162434-11-W31	EA	SLUG - F/SLIDEOUT (W31, W32, W33, W34)
5	158161-01-U21	EA	PANEL END - F/SLIDEOUT (W29, W30)
			FROM: 00-00-00 THRU: 03-11-07
5	162977-21-U21	EA	PANEL END - F/SLIDEOUT (W29, W30)
			FROM: 03-12-07 THRU: 99-99-99
5	158161-01-W31	EA	PANEL END - F/SLIDEOUT (W31, W32, W33, W34)
			FROM: 00-00-00 THRU: 03-11-07
5	162977-21-W31	EA	PANEL END - F/SLIDEOUT (W31, W32, W33, W34)
			FROM: 03-12-07 THRU: 99-99-99
6	158162-01-U21	EA	PANEL END - F/SLIDEOUT (W29, W30)
			FROM: 00-00-00 THRU: 03-11-07
6	162977-22-U21	EA	PANEL END - F/SLIDEOUT (W29, W30)
			FROM: 03-12-07 THRU: 99-99-99
6	158162-01-W31	EA	PANEL END - F/SLIDEOUT (W31, W32, W33, W34)
			FROM: 00-00-00 THRU: 03-11-07
6	162977-22-W31	EA	PANEL END - F/SLIDEOUT (W31, W32, W33, W34)
			FROM: 03-12-07 THRU: 99-99-99

**EXTERIOR SLIDEOUT GROUP (CONTINUED)**  
**FRONT LEFT (CONTINUED)**

KEY	PART NUMBER	U/M	DESCRIPTION
7	162052-38-01A	EA	TRIM/SEAL - W/MITERED ENDS - 78.4" - BRIGHT WHITE
8	162052-05-01A	EA	TRIM/SEAL - W/MITERED ENDS - 93.1" - BRIGHT WHITE
9	162052-21-01A	EA	TRIM/SEAL - W/MITERED ENDS - 93.1" - BRIGHT WHITE
10	142718-27-01A	EA	RETAINER - SIDEWALL/SLIDEOUT - 15.2"
11	126546-03-02A	EA	COVER - END/SIDEWALL - BRIGHT WHITE
12			SLIDEOUT AWNING

**ORDER AWNINGS & REPAIR PARTS FROM DOMETIC. CALL #800-366-3842.**

**THE DOMETIC AWNING INFORMATION YOU WILL NEED IS LOCATED ON THE MOTOR HOME NEAR THE TOP OF THE AWNING RAIL.**

13	156416-01-12B	EA	BRACKET - CORNER TRIM/SLIDEOUT - 3.1"X 3.1" - BRIGHT WHITE - <b>NOT ILLUSTRATED</b> FROM: 00-00-00 THRU: 01-06-07
13	156416-01-02B	EA	BRACKET - CORNER TRIM/SLIDEOUT - 3.1"X 3.1" - E-COATED - <b>NOT ILLUSTRATED</b> FROM: 00-00-00 THRU: 01-06-07
13	160421-01-01A	EA	CORNER TRIM/SLIDEOUT - 3.1" X 3.1" - BLACK FROM: 01-07-07 THRU: 99-99-99
14	157303-01-U21	EA	ROOF - F/SLIDEOUT
15	142718-01-01A	EA	RETAINER - SIDEWALL/SLIDEOUT - 72.8"
16	142718-45-01A	EA	RETAINER - SIDEWALL/SLIDEOUT - 101.4"
17	151761-21-02A	EA	TRIM - SIDEWALL/SLIDEOUT/TOP - 103.1" - ALMOND
18	158013-04-02A	EA	TRIM - SIDEWALL/SLIDEOUT - 93.3" - ALMOND
19	158013-02-02A	EA	TRIM - SIDEWALL/SLIDEOUT - 93.3" - ALMOND
20	115075-02-000	FT	SEAL - WIPE - .25" X 2.9" FROM: 00-00-00 THRU: 09-02-07
20	115075-03-000	FT	SEAL - WIPE - .25" X 2.9" FROM: 09-03-07 THRU: 99-99-99
21	136824-56-01A	EA	TRIM - SIDEWALL/SLIDEOUT - 103.2" - BRIGHT WHITE
22	128621-52-01A	EA	BRACKET/ZEE - SLIDEOUT - 97.2" - MILL
23	115075-03-000	FT	SEAL - WIPE - .25" X 2.9"
24	158375-03-01A	EA	TRIM - FEATURE STRIP - 20.6" - BRIGHT WHITE
25	158030-06-01A	EA	TRIM - FEATURE STRIP/LOWER - 2.3" X 19.8" - BRIGHT WHITE FROM: 00-00-00 THRU: 03-11-07
25	163020-06-01A	EA	TRIM - FEATURE STRIP/LOWER - 2.3" X 19.8" - BRT WHT FROM: 03-12-07 THRU: 99-99-99
26	115325-07-01A	EA	RAIL - FLOOR/SLIDEOUT ROOM - 44.4" LONG - BLACK
27	115325-16-01A	EA	RAIL - FLOOR/SLIDEOUT ROOM - 9.8" LONG - BLACK
28	125466-12-04A	EA	SUPPORT - ROOF/INTERIOR - ALMOND
29	115661-01-000	FT	SHOE/GLIDE - SLIDEOUT ROOM - 1/16" X 3" - POLYETHYLENE
30	136978-01-01A	FT	SEAL - SLIDEOUT - SINGLE WIPE LIP - BLACK
31	146056-01-000	FT	SEAL - TRIANGLE - W/PSA
32	134837-01-01A	EA	RAMP - SLIDEOUT - BLACK PVC - <b>VINYL FLOOR THRU OUT</b>
33	142549-01-000	EA	CLIP - "S" TYPE
34	134756-02-L76	EA	RAMP - FABRIC COVERED - SLIDEOUT - 51.2" - <b>VINYL FLOOR THRU OUT</b>
35	146606-68-01A	EA	TRIM/RETAINER - 98.5" - BRIGHT WHITE
36	154963-01-01A	EA	COVER - RAM - 6.8" X 7.6" - BRIGHT WHITE
37	136824-26-01A	EA	TRIM - SIDEWALL/SLIDEOUT - 93.3" - BRIGHT WHITE
38	105312-01-07A	FT	INSERT - FEATURE STRIP - VINYL - BRIGHT WHITE
39	157809-02-01A	EA	SEAL - FOAM BLOCK/LEFT SIDE - ADHESIVE BACK
40	146606-11-01A	EA	TRIM/RETAINER - 89.9" - BRIGHT WHITE
41	157809-01-01A	EA	SEAL - FOAM BLOCK/RIGHT SIDE - ADHESIVE BACK
42	134756-03-M30	EA	RAMP - FABRIC COVERED - SLIDEOUT - 18.3"
43	162495-01-01A	EA	ROD - LOCK/SLIDEOUT ROOM - BLACK W/WHITE PLASTIC ENDS
44	151282-13-01A	EA	TRIM - CARPET EDGE/F-ANGLE - 66" - BLACK
45	158297-01-000	FT	SEAL - D-SECTION/BULB/TEE - ADHESIVE BACK - BLACK
46	156151-01-02A	EA	PROTECTOR - CORNER - SLIDEOUT - BRIGHT WHITE

**EXTERIOR SLIDEOUT GROUP (CONTINUED)**  
**COMPONENT PARTS FOR FRONT LEFT**

162827-01-000, 162827-02-000

KEY	PART NUMBER	U/M	DESCRIPTION	VENDOR NO.
	130294-04-700	EA	SCREW - 5/16"-18 X 1 1/2"	1202060
	131281-01-704	EA	HAIRPIN/COTTER - 3/8" SPRING	1213460
	131682-01-700	EA	ROLLER - (BEARING)	1912040
	138173-01-701	EA	POP RIVET - SS 3/16"X1/4"	1214630
	138173-01-707	EA	WEAR PUCK - PLASTIC F/DRIVE	1612523
	140457-01-701	EA	ROLLER - 1"OD X 1/2"ID	1614006
	140457-01-704	EA	SHAFT/AXLE - REAR ROLLER	7204523
	148875-01-702	EA	PIN/ROLL - 1/4" X 1"	1213701
	148875-01-703	EA	NUT - PLASTIC - 1"	1612548
	148875-01-704	EA	END CARRIER - PLASTIC - 1"	1612549
	148875-01-705	EA	MOTOR/LINEAR - SLIDE ROOM	1820111
	148875-01-707	EA	END GUIDE F/SCREW - 1"	1820450
	148875-01-708	EA	TUBE - OUTER - F/SLIDE RAM	7201200
	149165-01-701	EA	PIN/CLEVIS - 1/4" X 2"	1213204
	151027-01-700	EA	DRIVE SCREW 1" X 20"	1820402
	151027-01-701	EA	ROLL PIN - 3/16" X 1"	1213694
	151027-01-702	EA	CLEVIS PIN - 1/4" X 1 1/4"	1213202
	162827-01-700	EA	TUBE OUT STOP - ADJUSTABLE	7201198
	162832-01-700	EA	CLEVIS PIN - 5/16" X 2 1/4"	1213239
	162832-01-702	EA	NUT - 1" PLASTIC W/5/16" PIN	1612554

# GENERATOR GROUP

## GAS

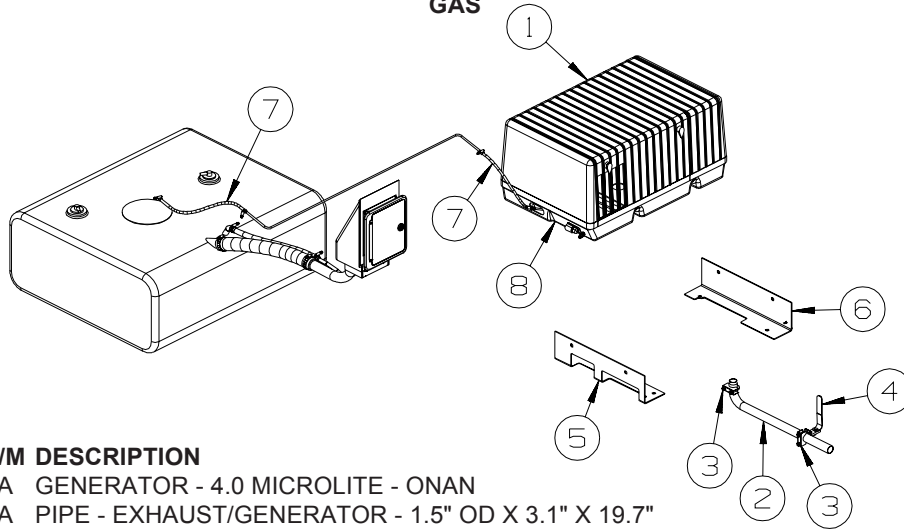

KEY	PART NUMBER	U/M	DESCRIPTION
1	109982-03-000	EA	GENERATOR - 4.0 MICROLITE - ONAN
2	105958-08-000	EA	PIPE - EXHAUST/GENERATOR - 1.5" OD X 3.1" X 19.7"
3	007125-04-000	EA	CLAMP - MUFFLER - 1.12"DIAMETER
4	007131-01-000	EA	HANGER - TAILPIPE - 6 SLOTS
5	114070-02-02B	EA	SUPPORT - GENERATOR - LEFT
6	114071-02-02B	EA	SUPPORT - GENERATOR - RIGHT
7	128139-03-000	FT	HOSE - FUEL - LOW PERMEABILITY - 1/4" DIAMETER
8	084884-01-000	EA	PLUG - BRASS - 3/8"



## HEATING & A/C GROUP FURNACE

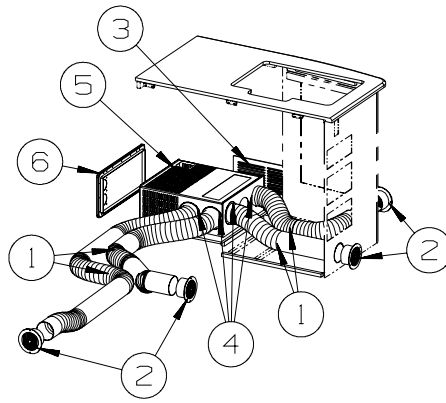

KEY	PART NUMBER	U/M	DESCRIPTION
1	009198-01-000	FT	DUCT - HEAT - FLEXIBLE - 4" ID X 25'
2	056464-10-000	EA	REGISTER W/O DAMPER - 4" DIAMETER - PLASTIC - BEIGE
3	093614-01-02A	EA	GRILLE - AIR RETURN - 15.9" X 7.9" - BEIGE
4	069636-02-000	EA	CONNECTOR - DUCT - 4" ID
5*	139980-02-000	EA	FURNACE-30000BTU-SF QUIET-SBRBN SF-30 2321J
6	139980-10-02A	EA	DOOR - ACCESS - FURNACE - BRIGHT WHITE

**\*COMPONENT PARTS LISTED LATER IN THIS GROUP**

**HEATING & A/C GROUP (CONTINUED)**  
**COMPONENT PARTS FOR FURNACE**

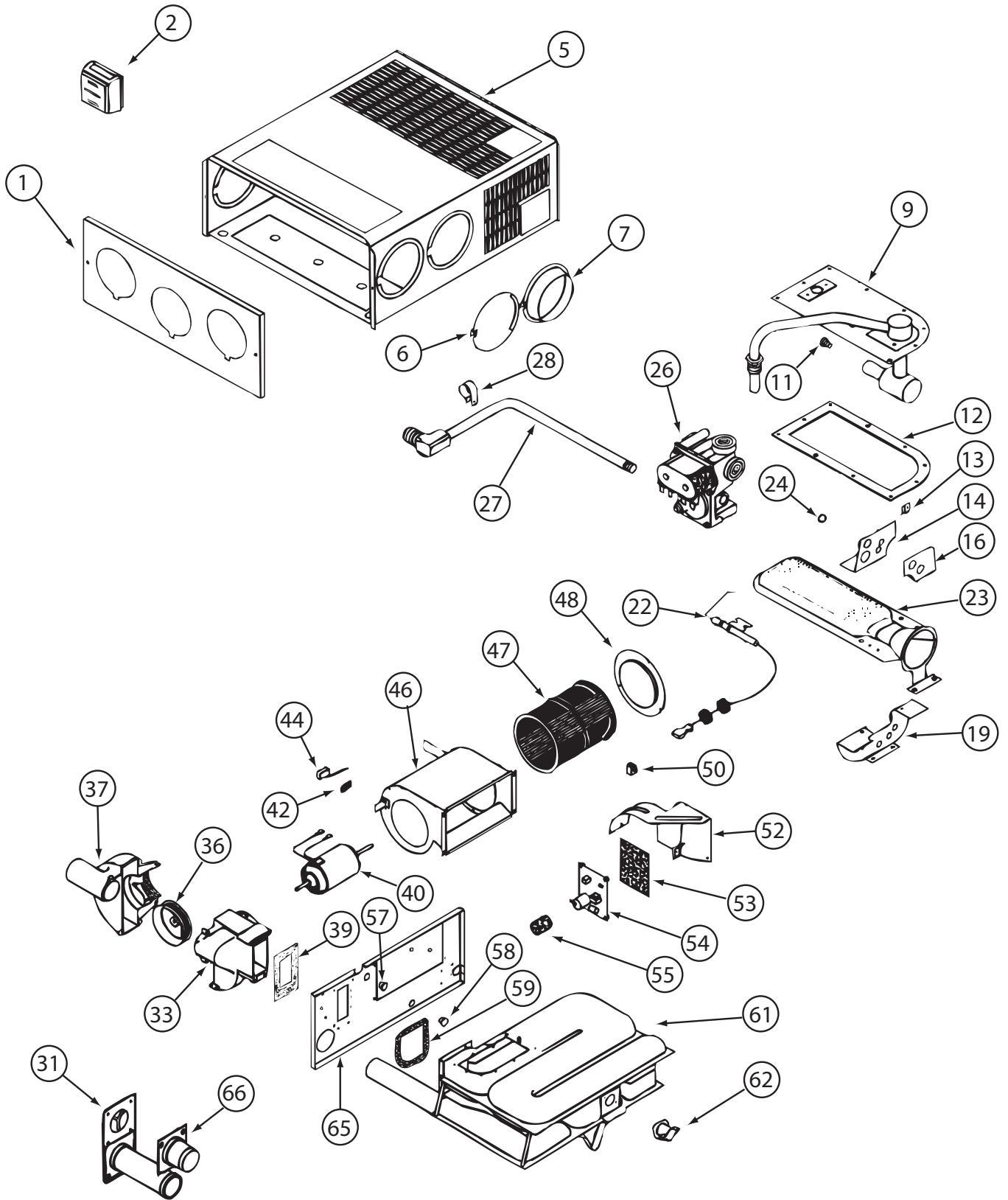

139980-02-000

**HEATING & A/C GROUP (CONTINUED)**  
**COMPONENT PARTS FOR FURNACE (CONTINUED)**

**139980-02-000 (CONTINUED)**

KEY	PART NUMBER	U/M	DESCRIPTION	VENDOR NO.
9	139980-01-700	EA	MANIFOLD ASSEMBLY	171571
11	092300-02-701	EA	ORIFICE-MAIN BURNER (NT-30BW	180214
12	098668-22-703	EA	GASKET - BURNER ACCESS COVER	070811
22	139980-01-701	EA	ELECTRODE	232286
23	098668-02-700	EA	BURNER ASSEMBLY,SF-30 & SF35	010745
26	098668-01-718	EA	VALVE-GAS SF S.N.974903079	161122
27	139980-01-702	EA	PIPE ASSEMBLY/GAS INLET	171574
31	098668-01-707	EA	TUBE ASSEMBLY, EXHAUST W/CAP	260231
33	139980-01-703	EA	HOUSING/COMB. - FRONT/HALF	390852
36	098668-01-706	EA	WHEEL-COMBUSTION AIR	350184
37	139980-01-704	EA	HOUSING/COMB. - REAR/HALF	390848
39	139980-01-705	EA	GASKET/FIREWALL-COMB AIR	071084
40	139980-01-706	EA	MOTOR ASSEMBLY W/GASKET	232682
42	101990-01-714	EA	GASKET-MICROSWITCH	230877
44	098668-21-700	EA	SWITCH-MICRO-W/O FLAG 3 1/4"	232261
46	139980-01-708	EA	BLOWER ASSEMBLY - ROOM AIR	390739BK
47	098668-01-711	EA	WHEEL-BLOWER, ROOM AIR	350129
48	139980-01-709	EA	ORFICE RING	390696
50	139980-01-710	EA	SWITCH - ON/OFF	232351
52	139980-01-711	EA	PANEL ASSEMBLY-MODULE BD	101663
53	139980-01-712	EA	INSULATOR - MODULE BD	070807
54	098668-22-705	EA	MODULE BD W/RELAY TIME DELAY	520820
55	139980-01-713	EA	CAP/INSULATOR-MODULE BD	070973
57	139980-01-714	EA	BUSHING - UNIVERSAL	070362
58	139980-01-715	EA	BUSHING - STRAIN RELIEF	231809
59	098668-01-716	EA	GASKET-FIREWALL,CHAMBER SIDE	070808
61	139980-01-716	EA	CHAMBER ASSEMBLY - FINAL	021149BK
62	098668-21-701	EA	SWITCH - LIMIT	232504
66	098668-01-713	EA	TUBE ASSEMBLY, INTAKE	051248
	139980-02-700	EA	BLOWER ASM-1/2 HOUSING/OUTER	390851
	139980-02-701	EA	BLOWER ASM-1/2 HOUSING/INNER	390872
			CONTACT WINNEBAGO PART SALES FOR UNLISTED COMPONENT(S)	

**REAR HEATER**

KEY	PART NUMBER	U/M	DESCRIPTION
*	084405-01-000	EA	HEATER - REAR/DUCTED - W/MOTOR AID
	007108-01-000	FT	HOSE - HEATER - 5/8"ID - HI-TEMP
	076776-01-000	EA	TEE - BEADED - 5/8" X 5/8" X 5/8"
	079059-01-000	EA	HOSE - 90 DEGREE - 5/8"ID X 4" X 36"
	079059-02-000	EA	HOSE - 90 DEGREE - .61" ID X 4" X 6"
	093614-02-02A	EA	GRILLE - AIR RETURN - 9.9" X 9.9" - BEIGE - MOTOR AID

\*COMPONENT PARTS LISTED LATER IN THIS GROUP

**COMPONENT PARTS FOR REAR HEATER**

**084405-01-000**

KEY	PART NUMBER	U/M	DESCRIPTION	VENDOR NO.
	084405-01-700	EA	CORE-HEATER	FT200229
	084405-01-701	EA	FAN	HV029931
	084405-01-702	EA	MOTOR ASSEMBLY, 12 VOLT	RV010348

## HEATING & A/C GROUP (CONTINUED)

### ROOF

KEY	PART NUMBER	U/M	DESCRIPTION
*	131188-05-01A	EA	A/C - ROOF - 14,800 BTU-MACH 15 - 2 PEICE SHROUD STYLE-WHT
*	131188-06-01A	EA	A/C - ROOF-14,800 BTU-MACH 15/HEAT PUMP-2 PCE SHROUD STYLE - AC HEAT PUMP
*	131184-01-01A	EA	CEILING ASSEMBLY - A/C DUCTED - WHITE FROM: 00-00-00 THRU: 07-15-07
*	131184-06-01A	EA	CEILING ASSEMBLY - A/C DUCTED - WHITE FROM: 07-16-07 THRU: 99-99-99
*	131184-05-01A	EA	CEILING ASSEMBLY - HEAT PUMP - WHITE - AC HEAT PUMP FROM: 00-00-00 THRU: 07-15-07
*	131184-07-01A	EA	CEILING ASSEMBLY - HEAT PUMP - DUCTED - WHITE - AC HEAT PUMP FROM: 07-16-07 THRU: 99-99-99
	131184-02-01A	EA	BOARD - DIVIDER - SILVER

**\*COMPONENT PARTS LISTED LATER IN THIS GROUP**

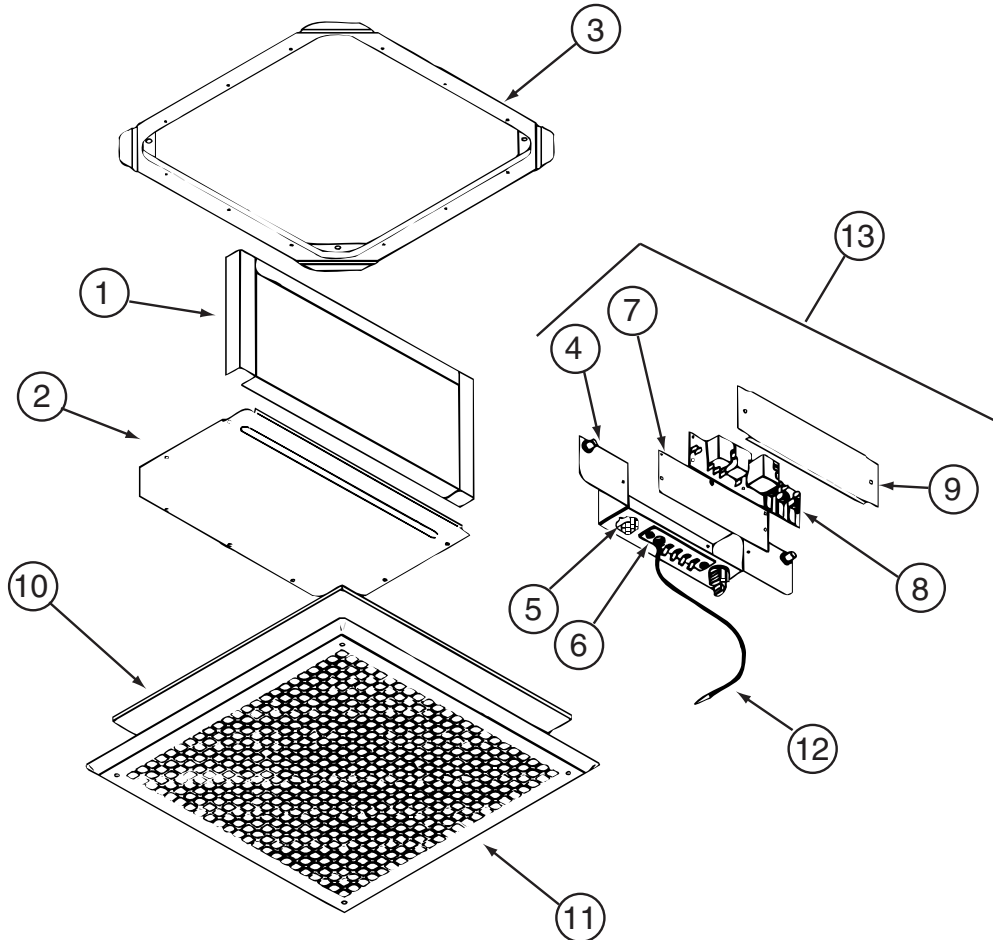

### COMPONENT PARTS FOR ROOF

131184-01-01A

KEY	PART NUMBER	U/M	DESCRIPTION	VENDOR NO.
1	131184-01-707	EA	DUCT DIVIDER	8330-3501
5	131184-01-700	EA	PLUG ASSEMBLY	7330A389
6	131184-01-701	EA	TERMINAL BOARD	7330B3201
7	131184-01-702	EA	ISOLATOR - BLANK	7330C365
8	108892-01-702	EA	BOARD-P.C.	7330A3211
10	108892-01-703	EA	FILTER	6798A3761
11	108892-01-704	EA	GRILLE 16 3/8X16 3/8 RETURN	6798-3041
12	131184-01-704	EA	COIL SENSOR	7330-6111
13	131184-01-705	EA	JUNCTION BOX ASSEMBLY	7330B5551
	131184-01-703	EA	SMALL PARTS PKG	8330-5961

CONTACT WINNEBAGO PART SALES FOR UNLISTED COMPONENT(S)

**HEATING & A/C GROUP (CONTINUED)**  
**COMPONENT PARTS FOR ROOF (CONTINUED)**

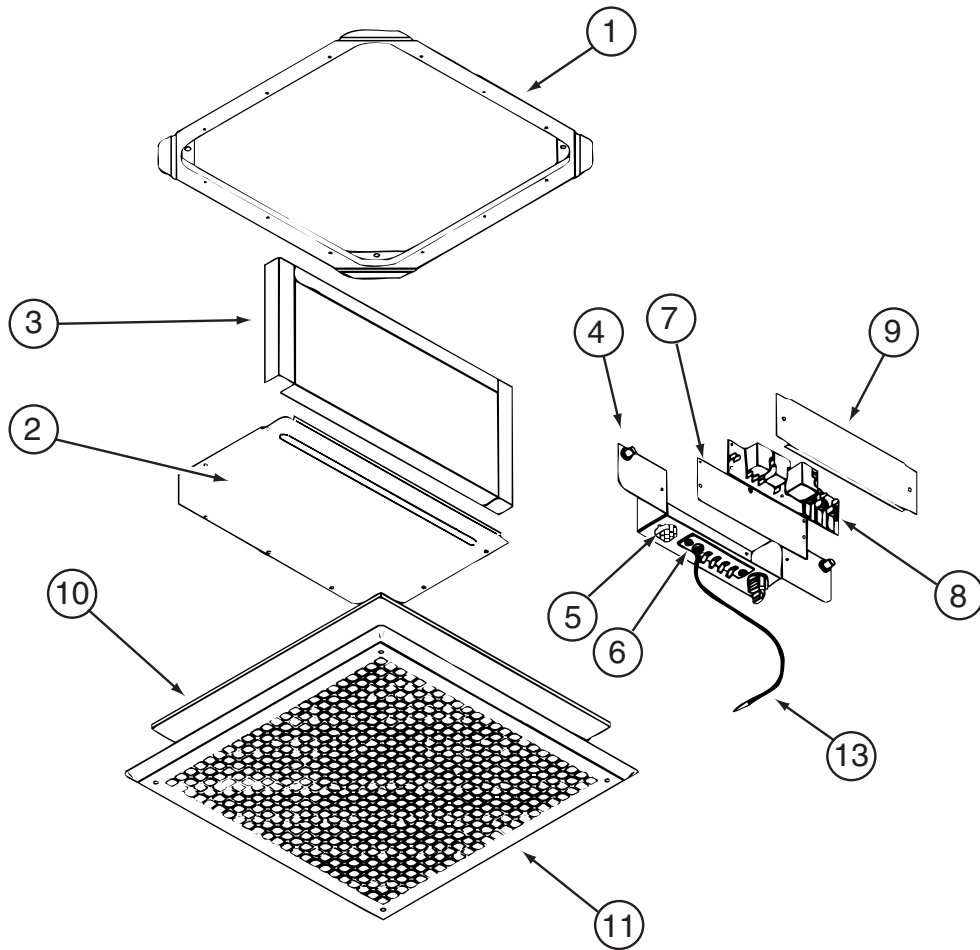

131184-05-01A

KEY	PART NUMBER	U/M	DESCRIPTION	VENDOR NO.
4	131184-05-700	EA	BOX - JUNCTION	8530-5091
5	131184-04-700	EA	PLUG ASSEMBLY	7530A340
6	131184-04-702	EA	BOARD - TERMINAL	7530B3201
7	131184-01-702	EA	ISOLATOR - BLANK	7330C365
8	131184-04-705	EA	BOARD - P.C.	7330B3311
10	108892-01-703	EA	FILTER	6798A3761
11	108892-01-704	EA	GRILLE 16 3/8X16 3/8 RETURN	6798-3041
13	105620-12-719	EA	COIL SENSOR	7330A3231
	131184-01-703	EA	SMALL PARTS PKG	8330-5961

CONTACT WINNEBAGO PART SALES FOR UNLISTED COMPONENT(S)

**HEATING & A/C GROUP (CONTINUED)**  
**COMPONENT PARTS FOR ROOF (CONTINUED)**

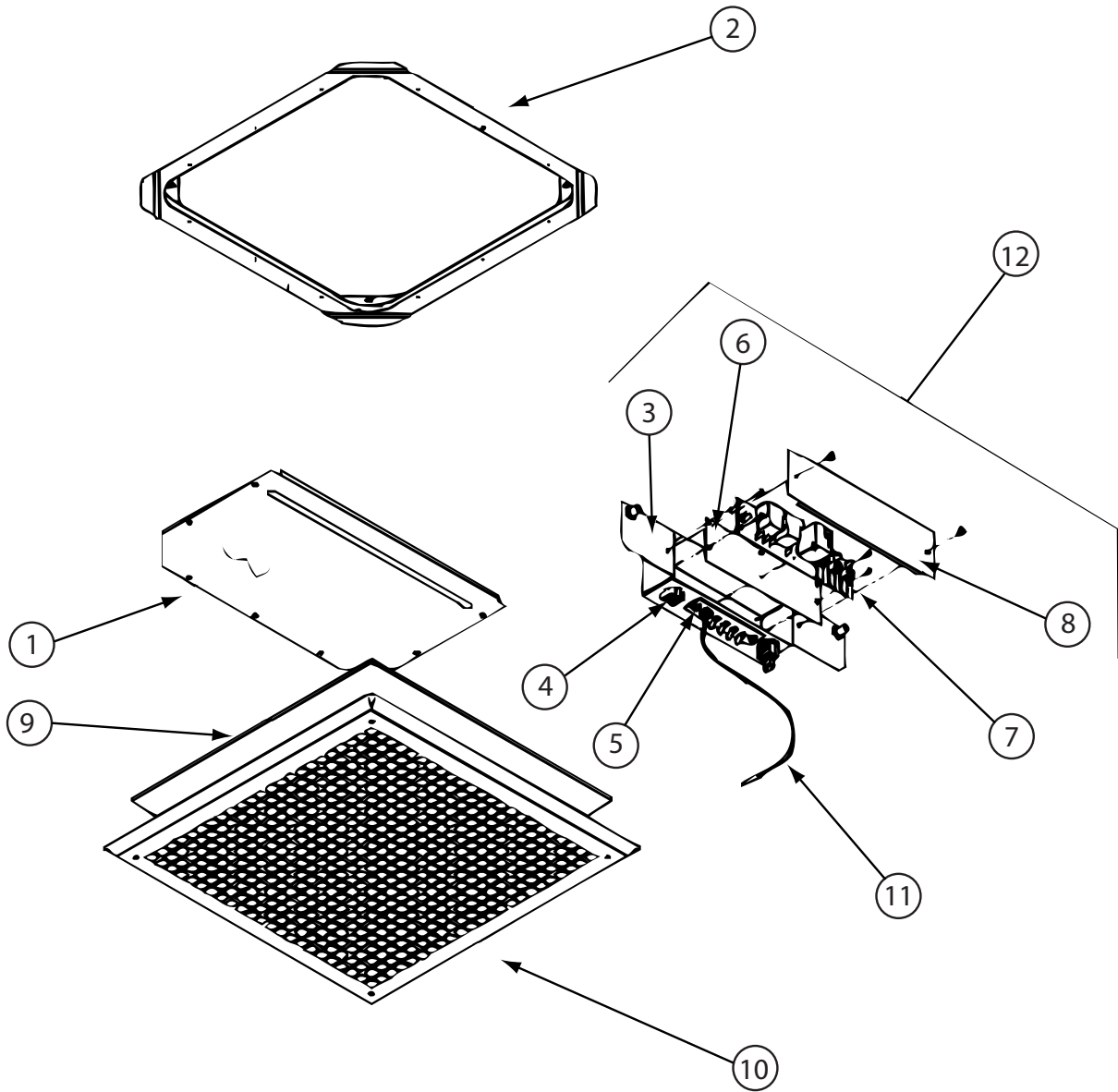

131184-06-01A

KEY	PART NUMBER	U/M	DESCRIPTION	VENDOR NO.
4	131184-01-700	EA	PLUG ASSEMBLY	7330A389
5	131184-01-701	EA	TERMINAL BOARD	7330B3201
6	131184-01-702	EA	ISOLATOR - BLANK	7330C365
7	131184-03-700	EA	BOARD - P.C.	7330D3211
9	108892-01-703	EA	FILTER	6798A3761
10	108892-01-704	EA	GRILLE 16 3/8X16 3/8 RETURN	6798-3041
11	105620-12-719	EA	COIL SENSOR	7330A3231
12	131184-01-705	EA	JUNCTION BOX ASSEMBLY	7330B5551
	131184-01-703	EA	SMALL PARTS PKG	8330-5961
	131184-01-706	EA	NUT/WING	1200-550

CONTACT WINNEBAGO PART SALES FOR UNLISTED COMPONENT(S)

**HEATING & A/C GROUP (CONTINUED)**  
**COMPONENT PARTS FOR ROOF (CONTINUED)**

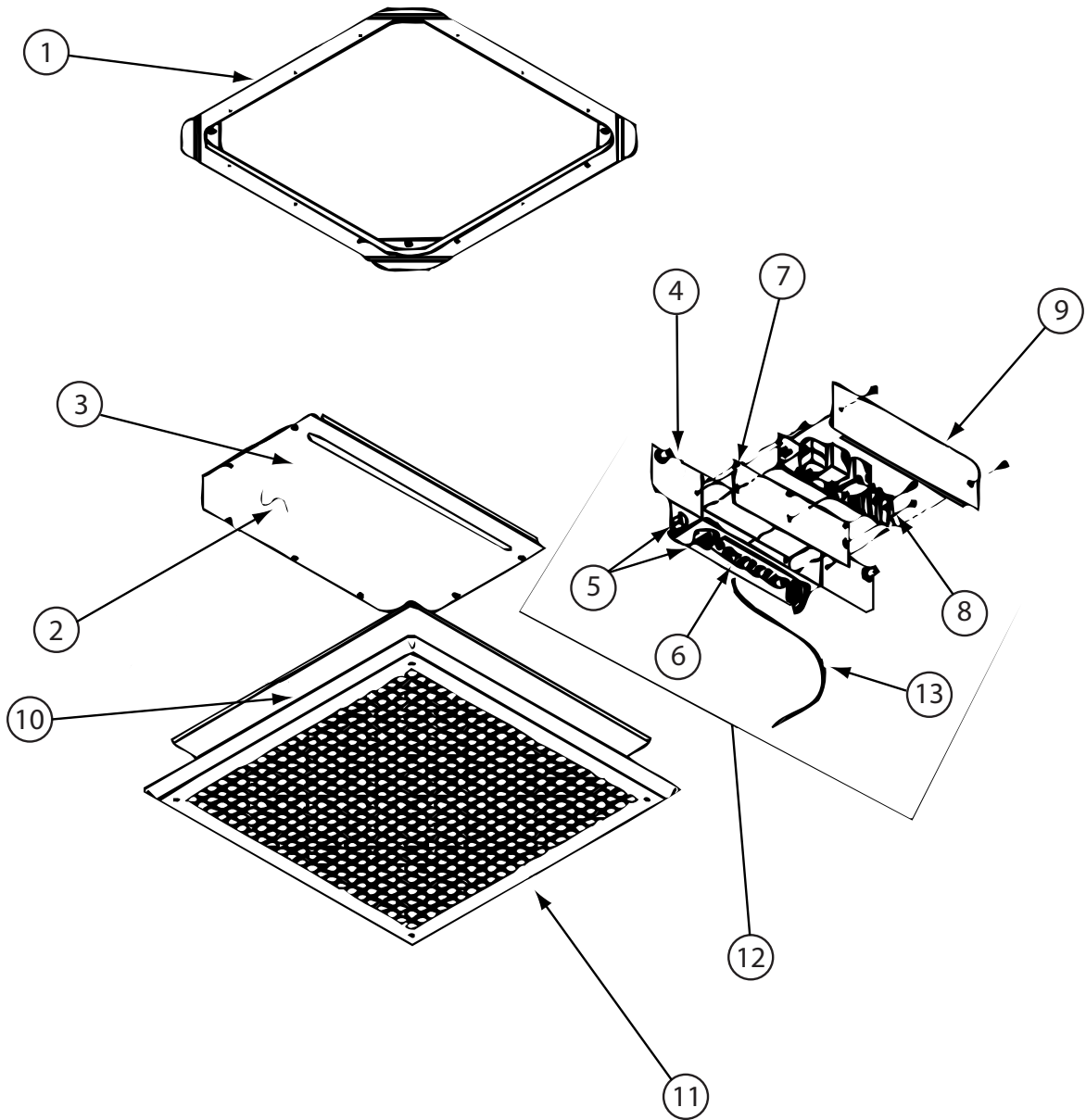

131184-07-01A

KEY	PART NUMBER	U/M	DESCRIPTION	VENDOR NO.
4	131184-04-703	EA	BOX - JUNCTION	7330-113
5	131184-04-700	EA	PLUG ASSEMBLY	7530A340
6	131184-04-702	EA	BOARD - TERMINAL	7530B3201
7	131184-01-702	EA	ISOLATOR - BLANK	7330C365
8	131184-04-705	EA	BOARD - P.C.	7330B3311
10	108892-01-703	EA	FILTER	6798A3761
11	108892-01-704	EA	GRILLE 16 3/8X16 3/8 RETURN	6798-3041
12	131184-04-706	EA	JUNCTION BOX ASM.(HEAT PUMP)	7530-508
13	105620-12-719	EA	COIL SENSOR	7330A3231
	131184-01-706	EA	NUT/WING	1200-550
	131184-07-700	EA	SMALL PARTS PKG	8330-5951

CONTACT WINNEBAGO PART SALES FOR UNLISTED COMPONENT(S)

**HEATING & A/C GROUP (CONTINUED)**  
**COMPONENT PARTS FOR ROOF (CONTINUED)**

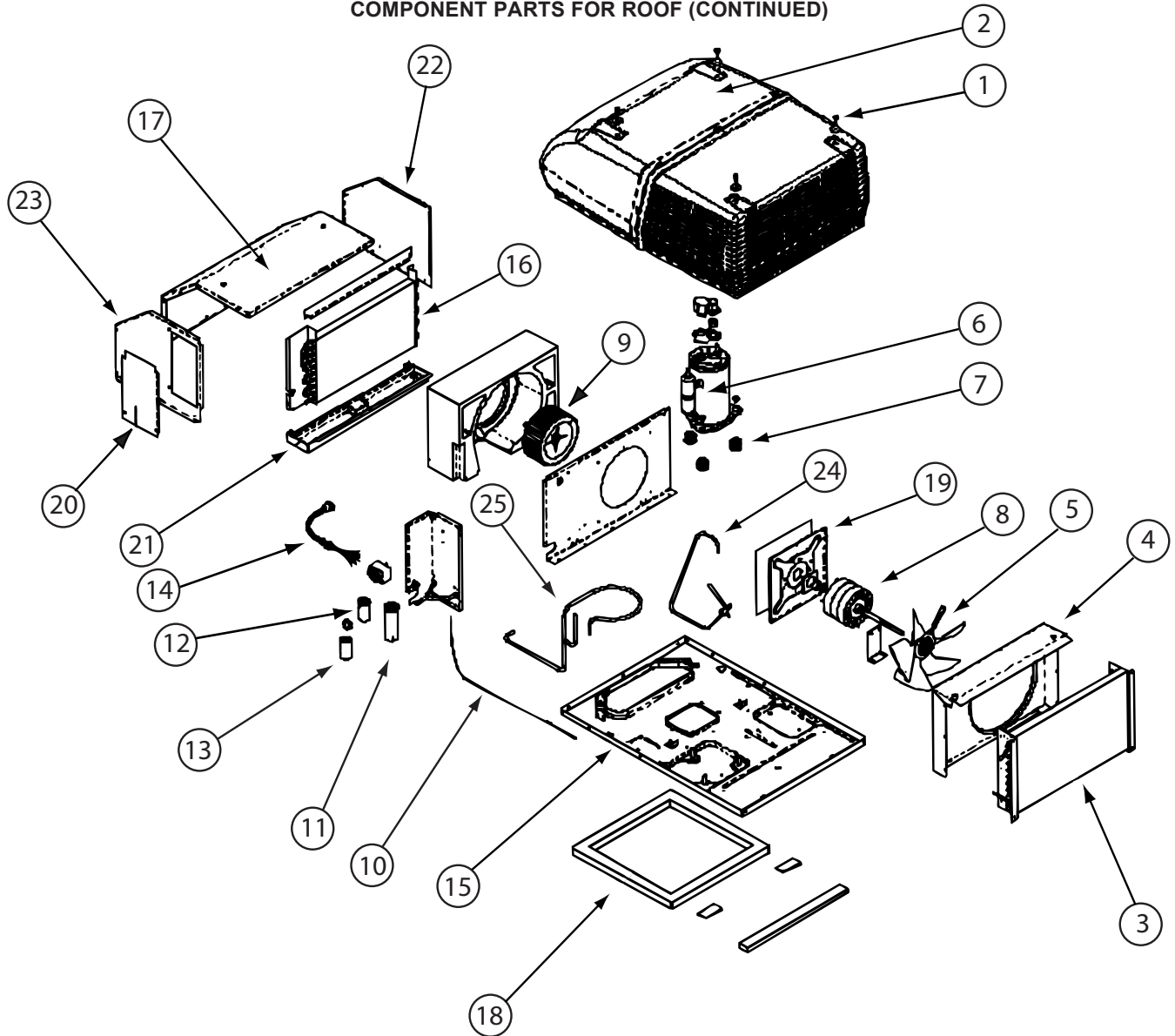

131188-05-01A

KEY	PART NUMBER	U/M	DESCRIPTION	VENDOR NO.
2	131188-05-700	EA	SHROUD-ROOF AIR/2 PIECE-WHT	8335-5261
3	115219-01-700	EA	COIL-CONDENSER	1452A1321
4	131187-03-700	EA	SHROUD FAN/INNER-LESS LOGO	6792-1071
5	093763-01-712	EA	BLADE-FAN-CONDENSER	6733-3221
6	131188-05-703	EA	COMPRESSOR (TECUMSEH)	1450B2299
7	105620-01-706	EA	MOUNTING PKG.,COMP., 3 PER	6759-3081
8	131185-01-701	EA	MOTOR (115V, 60HZ)	1468-3069
9	131185-01-702	EA	BLOWER WHEEL PACKAGE	1472-1091
11	126859-01-703	EA	CAPACITOR - RUN	1499-5671
12	093763-01-704	EA	CAPACITOR-FAN (INDOOR MOTOR)	1499-5461
13	105620-10-705	EA	PTCR (START DEVICE) - W/CAP.	8333A9021
16	131186-01-701	EA	EVAPORATOR COIL	1452-1521
18	037648-01-714	EA	GASKET PACKAGE	8332-3301
19	131185-01-704	EA	MOTOR MOUNT & SEAL KIT	83333-5151
	105620-01-705	EA	PROTECTOR-OVERLOAD, RH & LH	6759-3791
	131188-05-702	EA	SHROUD BRACKET	8333B1551

CONTACT WINNEBAGO PART SALES FOR UNLISTED COMPONENT(S)



**HEATING & A/C GROUP (CONTINUED)**  
**COMPONENT PARTS FOR ROOF (CONTINUED)**

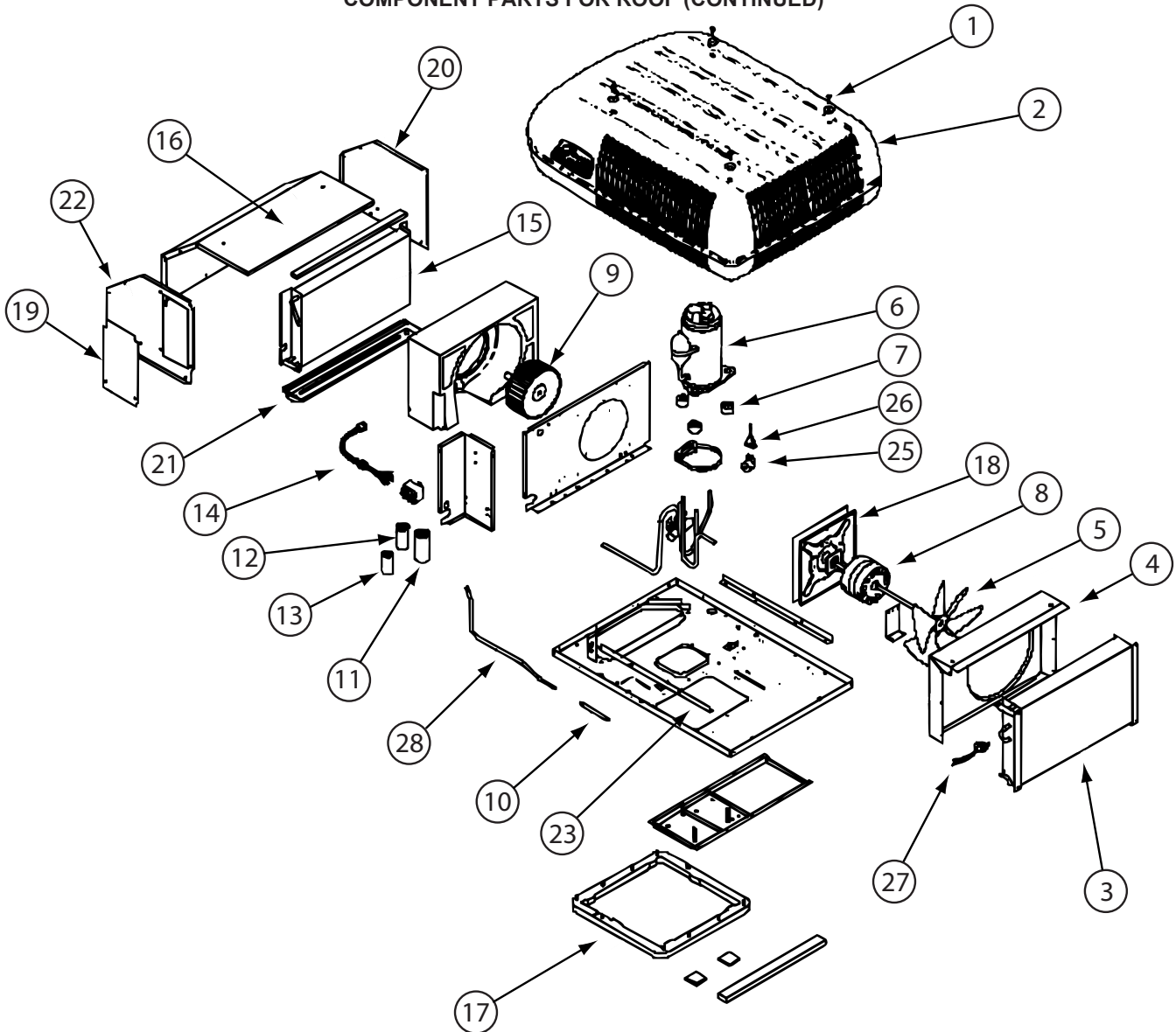

131188-06-01A

KEY	PART NUMBER	U/M	DESCRIPTION	VENDOR NO.
2	131188-05-700	EA	SHROUD-ROOF AIR/2 PIECE-WHT	8335-5261
3	131188-02-700	EA	CONDENSER COIL	1452-1441
4	131187-03-700	EA	SHROUD FAN/INNER-LESS LOGO	6792-1071
5	093763-01-712	EA	BLADE-FAN-CONDENSER	6733-3221
6	131188-05-703	EA	COMPRESSOR (TECUMSEH)	1450B2299
7	105620-01-706	EA	MOUNTING PKG.,COMP., 3 PER	6759-3081
8	131185-01-701	EA	MOTOR (115V, 60HZ)	1468-3069
9	131185-01-702	EA	BLOWER WHEEL PACKAGE	1472-1091
11	105620-12-725	EA	COMPRESSOR RUN CAPACITOR	1499-5731
12	093763-01-704	EA	CAPACITOR-FAN (INDOOR MOTOR)	1499-5461
13	105620-10-705	EA	PTCR (START DEVICE) - W/CAP.	8333A9021
15	131186-01-701	EA	EVAPORATOR COIL	1452-1521
17	037648-01-714	EA	GASKET PACKAGE	8332-3301
18	131185-01-704	EA	MOTOR MOUNT & SEAL KIT	8333-5151
25	105620-12-708	EA	COIL - SOLENOID	1460-1081
27	131188-02-706	EA	SWITCH - FREEZE	1460-2041
28	131188-02-707	EA	LIQUID LINE	7535-135
	105620-01-705	EA	PROTECTOR-OVERLOAD, RH & LH	6759-3791
	131188-05-702	EA	SHROUD BRACKET	8333B1551

CONTACT WINNEBAGO PART SALES FOR UNLISTED COMPONENT(S)

**INTERIOR FINISH GROUP**  
**MOLDINGS & TRIMS**  
**HONEY CHERRY & WASHED MAPLE**

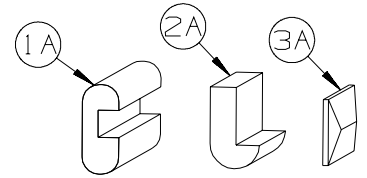

KEY	PART NUMBER	U/M	DESCRIPTION
1A	M09412-62-N42	EA	MOLDING/SHELF EDGE - .6" X 1.3" X 96" - PORTSMOUTH OAK
1A	M09412-62-M52	EA	MOLDING/SHELF EDGE - .6" X 1.3" X 96" - CONCERT CHERRY
1A	M09412-62-M62	EA	MOLDING/SHELF EDGE - .6" X 1.3" X 96" - WASHED MAPLE
1A	M09412-62-RC3	EA	MOLDING/SHELF EDGE - .6" X 1.3" X 96" - HONEY CHERRY
1A	M09412-62-SA3	EA	MOLDING/SHELF EDGE - .6" X 1.3" X 96" - SIERRA MAPLE
2A	M09511-43-T77	EA	MOLDING - TRIM - W/NOTCH - .8" X 1.4" X 86.3" - PORTSMOUT OAK
2A	M09525-80-UM1	EA	MOLDING - TRIM - W/NOTCH - .8" X 1.4" X 86.5" - CONCERT CHERRY
2A	M09525-80-U91	EA	MOLDING - TRIM - W/NOTCH - .8" X 1.4" X 86.5" - WASHED MAPLE
2A	M09525-80-U92	EA	MOLDING - TRIM - W/NOTCH - .8" X 1.4" X 86.5" - SIERRA MAPLE
2A	M09525-80-Y92	EA	MOLDING - TRIM - W/NOTCH - .8" X 1.4" X 86.5" - HONEY CHERRY
2A	M09501-85-TG3	EA	MOLDING/TRIM - W/NOTCH - 4" X 86.06" - HONEY CHERRY
2A	M09501-32-TG1	EA	MOLDING/TRIM - W/NOTCH - .8" X 2.5" X 86.2" - CONCERT CHERRY
2A	M09501-32-TG2	EA	MOLDING/TRIM - W/NOTCH - .8" X 2.5" X 86.2" - WASHED MAPLE
2A	M09501-32-TD3	EA	MOLDING/TRIM - W/NOTCH - .8" X 2.5" X 86.2" - SIERRA MAPLE
2A	M09501-32-TG3	EA	MOLDING/TRIM - W/NOTCH - .8" X 2.5" X 86.2" - HONEY CHERRY
2A	M09515-72-TD0	EA	MOLDING/TRIM - .8" X 2.2" X 86.1" - PORTSMOUTH OAK
2A	M09515-72-TD1	EA	MOLDING/TRIM - .8" X 2.2" X 86.1" - CONCERT CHERRY
2A	M09515-72-TD2	EA	MOLDING/TRIM - .8" X 2.2" X 86.1" - WASHED MAPLE
2A	M09515-72-TD3	EA	MOLDING/TRIM - .8" X 2.2" X 86.1" - SIERRA MAPLE
2A	M09511-44-T77	EA	MOLDING - TRIM - W/NOTCH - 1" X 86.4" - PORTSMOUTH OAK
2A	M09511-44-T78	EA	MOLDING - TRIM - W/NOTCH - 1" X 86.4" - CONCERT CHERRY
2A	M09511-44-T79	EA	MOLDING - TRIM - W/NOTCH - 1" X 86.4" - WASHED MAPLE
2A	M09511-44-T80	EA	MOLDING - TRIM - W/NOTCH - 1" X 86.4" - HONEY CHERRY
2A	M09438-25-RA3	EA	MOLDING - HARDWOOD-W/NOTCH - 1.4"X 80.2" - HONEY CHERRY
3A	M09477-63-S46	EA	MOLDING - TRIM/VEE-W/CUT ENDS - 1"X 64.1" - PORTSMOUTH OAK
3A	M09477-63-S47	EA	MOLDING - TRIM/VEE-W/CUT ENDS - 1"X 64.1" - CONCERT CHERRY
3A	M09477-63-S48	EA	MOLDING - TRIM/VEE-W/CUT ENDS - 1"X 64.1" - WASHED MAPLE
3A	M09477-63-W51	EA	MOLDING - TRIM/VEE-W/CUT ENDS - 1"X 64.1" - HONEY CHERRY
3A	M09477-64-S46	EA	MOLDING - TRIM/VEE-W/CUT ENDS - 1"X 14.9" - PORTSMOUTH OAK
3A	M09477-64-S47	EA	MOLDING - TRIM/VEE-W/CUT ENDS - 1"X 14.9" - CONCERT CHERRY
3A	M09477-64-S48	EA	MOLDING - TRIM/VEE-W/CUT ENDS - 1"X 14.9" - WASHED MAPLE
3A	M09477-64-W51	EA	MOLDING - TRIM/VEE-W/CUT ENDS - 1"X 14.9" - HONEY CHERRY
3A	M09501-30-SD0	EA	MOLDING - TRIM/VEE - .2" X 1" X 35.1" - PORTSMOUTH OAK
3A	M09501-30-SD1	EA	MOLDING - TRIM/VEE - .2" X 1" X 35.1" - CONCERT CHERRY
3A	M09501-30-SD2	EA	MOLDING - TRIM/VEE - .2" X 1" X 35.1" - WASHED MAPLE
3A	M09501-30-SD3	EA	MOLDING - TRIM/VEE - .2" X 1" X 35.1" - HONEY CHERRY
3A	M09515-97-WL4	EA	MOLDING - TRIM/VEE - .2" X 1" X 32.6" - CONCERT CHERRY
3A	M09515-97-WL5	EA	MOLDING - TRIM/VEE - .2" X 1" X 32.6" - WASHED MAPLE
3A	M09515-97-WL6	EA	MOLDING - TRIM/VEE - .2" X 1" X 32.6" - HONEY CHERRY
3A	M09534-17-UF3	EA	MOLDING - TRIM/VEE - .2" X 1" X 20.1" - SIERRA MAPLE
3A	M09534-17-UJ1	EA	MOLDING - TRIM/VEE - .2" X 1" X 20.1" - CONCERT CHERRY
3A	M09534-17-UJ2	EA	MOLDING - TRIM/VEE - .2" X 1" X 20.1" - WASHED MAPLE
3A	M09534-17-UJ3	EA	MOLDING - TRIM/VEE - .2" X 1" X 20.1" - HONEY CHERRY
3A	M09477-88-S34	EA	MOLDING - TRIM/VEE - .2" X 1" X 19.9" - WASHED MAPLE
3A	M09477-88-S35	EA	MOLDING - TRIM/VEE - .2" X 1" X 19.9" - SIERRA MAPLE
3A	M09568-03-W51	EA	MOLDING - TRIM/VEE - .2" X 1" X 19.8" - HONEY CHERRY
3A	M09568-03-W52	EA	MOLDING - TRIM/VEE - .2" X 1" X 19.8" - WASHED MAPLE
3A	M09565-51-W51	EA	MOLDING - TRIM/VEE - .2" X 1" X 19.4" - HONEY CHERRY
3A	M09565-51-W52	EA	MOLDING - TRIM/VEE - .2" X 1" X 19.4" - WASHED MAPLE
3A	M09553-79-W66	EA	MOLDING - TRIM/VEE - .2" X 1" X 15.6" - HONEY CHERRY
3A	M09515-10-W66	EA	MOLDING - TRIM/VEE - .2" X 1" X 15.4" - HONEY CHERRY
3A	M09501-63-T78	EA	MOLDING - TRIM/VEE - .2" X 1" X 15" - CONCERT CHERRY
3A	M09501-63-T79	EA	MOLDING - TRIM/VEE - .2" X 1" X 15" - WASHED MAPLE
3A	M09501-63-T80	EA	MOLDING - TRIM/VEE - .2" X 1" X 15" - SIERRA MAPLE
3A	M09501-63-W66	EA	MOLDING - TRIM/VEE - .2" X 1" X 15" - HONEY CHERRY
3A	M09553-09-W66	EA	MOLDING - TRIM/VEE - .2" X 1" X 13.4" - HONEY CHERRY
3A	M09566-04-WD3	EA	MOLDING - TRIM/VEE - .2" X 1" X 8.9" - HONEY CHERRY
3A	M09553-29-WH4	EA	MOLDING - TRIM/VEE - .4" X 1" X 94.4" - CONCERT CHERRY
3A	M09553-29-WH5	EA	MOLDING - TRIM/VEE - .4" X 1" X 94.4" - WASHED MAPLE
3A	M09553-29-WH6	EA	MOLDING - TRIM/VEE - .4" X 1" X 94.4" - SIERRA MAPLE
3A	M09565-04-WH4	EA	MOLDING - TRIM/VEE - .4" X 1" X 89.5" - CONCERT CHERRY

**INTERIOR FINISH GROUP (CONTINUED)**  
**MOLDINGS & TRIMS (CONTINUED)**

KEY	PART NUMBER	U/M	DESCRIPTION
3A	M09565-04-WH5	EA	MOLDING - TRIM/VEE - .4" X 1" X 89.5" - WASHED MAPLE
3A	M09565-04-WH6	EA	MOLDING - TRIM/VEE - .4" X 1" X 89.5" - SIERRA MAPLE
3A	M09544-86-W37	EA	MOLDING - TRIM/VEE - .4" X 1" X 88.1" - WASHED MAPLE
3A	M09544-86-W38	EA	MOLDING - TRIM/VEE - .4" X 1" X 88.1" - SIERRA MAPLE
3A	M09538-39-U67	EA	MOLDING - TRIM/VEE - .4" X 1" X 82.6" - WASHED MAPLE
3A	M09538-39-U68	EA	MOLDING - TRIM/VEE - .4" X 1" X 82.6" - SIERRA MAPLE
3A	M09553-62-WH4	EA	MOLDING - TRIM/VEE - .4" X 1" X 81.4" - CONCERT CHERRY
3A	M09553-62-WH5	EA	MOLDING - TRIM/VEE - .4" X 1" X 81.4" - WASHED MAPLE
3A	M09553-62-WH6	EA	MOLDING - TRIM/VEE - .4" X 1" X 81.4" - SIERRA MAPLE
3A	M09577-98-WH4	EA	MOLDING - TRIM/VEE - .4" X 1" X 80.2" - CONCERT CHERRY
3A	M09577-98-WH5	EA	MOLDING - TRIM/VEE - .4" X 1" X 80.2" - WASHED MAPLE
3A	M09577-98-WH6	EA	MOLDING - TRIM/VEE - .4" X 1" X 80.2" - SIERRA MAPLE
3A	M09544-37-W37	EA	MOLDING - TRIM/VEE - .4" X 1" X 78.8" - WASHED MAPLE
3A	M09544-37-W38	EA	MOLDING - TRIM/VEE - .4" X 1" X 78.8" - SIERRA MAPLE
3A	M09544-34-W37	EA	MOLDING - TRIM/VEE - .4" X 1" X 78.7" - WASHED MAPLE
3A	M09544-34-W38	EA	MOLDING - TRIM/VEE - .4" X 1" X 78.7" - SIERRA MAPLE
3A	M09538-37-U67	EA	MOLDING - TRIM/VEE - .4" X 1" X 77.5" - WASHED MAPLE
3A	M09538-37-U68	EA	MOLDING - TRIM/VEE - .4" X 1" X 77.5" - SIERRA MAPLE
3A	M09553-65-WH4	EA	MOLDING - TRIM/VEE - .4" X 1" X 77" - CONCERT CHERRY
3A	M09553-65-WH5	EA	MOLDING - TRIM/VEE - .4" X 1" X 77" - WASHED MAPLE
3A	M09553-65-WH6	EA	MOLDING - TRIM/VEE - .4" X 1" X 77" - SIERRA MAPLE
3A	M09553-64-WH4	EA	MOLDING - TRIM/VEE - .4" X 1" X 76.7" - CONCERT CHERRY
3A	M09553-64-WH5	EA	MOLDING - TRIM/VEE - .4" X 1" X 76.7" - WASHED MAPLE
3A	M09553-64-WH6	EA	MOLDING - TRIM/VEE - .4" X 1" X 76.7" - SIERRA MAPLE
3A	M09565-75-WH4	EA	MOLDING - TRIM/VEE - .4" X 1" X 75.9" - CONCERT CHERRY
3A	M09565-75-WH5	EA	MOLDING - TRIM/VEE - .4" X 1" X 75.9" - WASHED MAPLE
3A	M09565-75-WH6	EA	MOLDING - TRIM/VEE - .4" X 1" X 75.9" - SIERRA MAPLE
3A	M09565-02-WH4	EA	MOLDING - TRIM/VEE - .4" X 1" X 75.1" - CONCERT CHERRY
3A	M09565-02-WH5	EA	MOLDING - TRIM/VEE - .4" X 1" X 75.1" - WASHED MAPLE
3A	M09565-02-WH6	EA	MOLDING - TRIM/VEE - .4" X 1" X 75.1" - SIERRA MAPLE
3A	M09553-26-WH4	EA	MOLDING - TRIM/VEE - .4" X 1" X 74.1" - CONCERT CHERRY
3A	M09553-26-WH5	EA	MOLDING - TRIM/VEE - .4" X 1" X 74.1" - WASHED MAPLE
3A	M09553-26-WH6	EA	MOLDING - TRIM/VEE - .4" X 1" X 74.1" - SIERRA MAPLE
3A	M09538-91-WH4	EA	MOLDING - TRIM/VEE - .4" X 1" X 73.8" - CONCERT CHERRY
3A	M09538-91-WH5	EA	MOLDING - TRIM/VEE - .4" X 1" X 73.8" - WASHED MAPLE
3A	M09538-91-WH6	EA	MOLDING - TRIM/VEE - .4" X 1" X 73.8" - SIERRA MAPLE
3A	M09553-22-WH4	EA	MOLDING - TRIM/VEE - .4" X 1" X 73.2" - CONCERT CHERRY
3A	M09553-22-WH5	EA	MOLDING - TRIM/VEE - .4" X 1" X 73.2" - WASHED MAPLE
3A	M09553-22-WH6	EA	MOLDING - TRIM/VEE - .4" X 1" X 73.2" - SIERRA MAPLE
3A	M09565-97-WH4	EA	MOLDING - TRIM/VEE - .4" X 1" X 72.6" - CONCERT CHERRY
3A	M09565-97-WH5	EA	MOLDING - TRIM/VEE - .4" X 1" X 72.6" - WASHED MAPLE
3A	M09565-97-WH6	EA	MOLDING - TRIM/VEE - .4" X 1" X 72.6" - SIERRA MAPLE
3A	M09568-12-WH4	EA	MOLDING - TRIM/VEE - .4" X 1" X 71.9" - CONCERT CHERRY
3A	M09568-12-WH5	EA	MOLDING - TRIM/VEE - .4" X 1" X 71.9" - WASHED MAPLE
3A	M09568-12-WH6	EA	MOLDING - TRIM/VEE - .4" X 1" X 71.9" - SIERRA MAPLE
3A	M09565-01-WH4	EA	MOLDING - TRIM/VEE - .4" X 1" X 71.7" - CONCERT CHERRY
3A	M09565-01-WH5	EA	MOLDING - TRIM/VEE - .4" X 1" X 71.7" - WASHED MAPLE
3A	M09565-01-WH6	EA	MOLDING - TRIM/VEE - .4" X 1" X 71.7" - SIERRA MAPLE
3A	M09565-01-YR3	EA	MOLDING - TRIM/VEE - .4" X 1" X 71.7" - HONEY CHERRY
3A	M09544-15-WB4	EA	MOLDING - TRIM/VEE - .4" X 1" X 64.5" - CONCERT CHERRY
3A	M09544-15-WB5	EA	MOLDING - TRIM/VEE - .4" X 1" X 64.5" - WASHED MAPLE
3A	M09544-15-WB6	EA	MOLDING - TRIM/VEE - .4" X 1" X 64.5" - SIERRA MAPLE
3A	M09538-94-WH4	EA	MOLDING - TRIM/VEE - .4" X 1" X 71.1" - CONCERT CHERRY
3A	M09538-94-WH5	EA	MOLDING - TRIM/VEE - .4" X 1" X 71.1" - WASHED MAPLE
3A	M09538-94-WH6	EA	MOLDING - TRIM/VEE - .4" X 1" X 71.1" - SIERRA MAPLE
3A	M09565-78-WH4	EA	MOLDING - TRIM/VEE - .4" X 1" X 70.2" - CONCERT CHERRY
3A	M09565-78-WH5	EA	MOLDING - TRIM/VEE - .4" X 1" X 70.2" - WASHED MAPLE
3A	M09565-78-WH6	EA	MOLDING - TRIM/VEE - .4" X 1" X 70.2" - SIERRA MAPLE
3A	M09553-21-WH4	EA	MOLDING - TRIM/VEE - .4" X 1" X 70.1" - CONCERT CHERRY
3A	M09553-21-WH5	EA	MOLDING - TRIM/VEE - .4" X 1" X 70.1" - WASHED MAPLE
3A	M09553-21-WH6	EA	MOLDING - TRIM/VEE - .4" X 1" X 70.1" - SIERRA MAPLE
3A	M09501-92-T77	EA	MOLDING - TRIM/VEE - .4" X 1" X 70" - PORTSMOUTH OAK
3A	M09501-92-T78	EA	MOLDING - TRIM/VEE - .4" X 1" X 70" - CONCERT CHERRY
3A	M09501-92-T79	EA	MOLDING - TRIM/VEE - .4" X 1" X 70" - WASHED MAPLE

**INTERIOR FINISH GROUP (CONTINUED)**  
**MOLDINGS & TRIMS (CONTINUED)**

KEY	PART NUMBER	U/M	DESCRIPTION
3A	M09501-92-T80	EA	MOLDING - TRIM/VEE - .4" X 1" X 70" - SIERRA MAPLE
3A	M09538-27-WH4	EA	MOLDING - TRIM/VEE - .4" X 1" X 71.1" - CONCERT CHERRY
3A	M09538-27-U67	EA	MOLDING - TRIM/VEE - .4" X 1" X 71.1" - WASHED MAPLE
3A	M09538-27-U68	EA	MOLDING - TRIM/VEE - .4" X 1" X 71.1" - SIERRA MAPLE
3A	M09544-10-WH4	EA	MOLDING - TRIM/VEE - .4" X 1" X 68.2" - CONCERT CHERRY
3A	M09544-10-W91	EA	MOLDING - TRIM/VEE - .4" X 1" X 68.2" - WASHED MAPLE
3A	M09544-10-W92	EA	MOLDING - TRIM/VEE - .4" X 1" X 68.2" - SIERRA MAPLE
3A	M09553-03-WH4	EA	MOLDING - TRIM/VEE - .4" X 1" X 66.7" - CONCERT CHERRY
3A	M09553-03-WH5	EA	MOLDING - TRIM/VEE - .4" X 1" X 66.7" - WASHED MAPLE
3A	M09553-03-WH6	EA	MOLDING - TRIM/VEE - .4" X 1" X 66.7" - SIERRA MAPLE
3A	M09553-03-YR3	EA	MOLDING - TRIM/VEE - .4" X 1" X 66.7" - HONEY CHERRY
3A	M09538-93-WH4	EA	MOLDING - TRIM/VEE - .4" X 1" X 66.6" - CONCERT CHERRY
3A	M09538-93-WH5	EA	MOLDING - TRIM/VEE - .4" X 1" X 66.6" - WASHED MAPLE
3A	M09538-93-WH6	EA	MOLDING - TRIM/VEE - .4" X 1" X 66.6" - SIERRA MAPLE
3A	M09544-33-W37	EA	MOLDING - TRIM/VEE - .4" X 1" X 66.5" - SIERRA MAPLE
3A	M09544-33-W38	EA	MOLDING - TRIM/VEE - .4" X 1" X 66.5" - WASHED MAPLE
3A	M09553-02-WH4	EA	MOLDING - TRIM/VEE - .4" X 1" X 66.4" - CONCERT CHERRY
3A	M09553-02-WH5	EA	MOLDING - TRIM/VEE - .4" X 1" X 66.4" - WASHED MAPLE
3A	M09553-02-WH6	EA	MOLDING - TRIM/VEE - .4" X 1" X 66.4" - SIERRA MAPLE
3A	M09544-14-WB4	EA	MOLDING - TRIM/VEE - .4" X 1" X 64.5" - CONCERT CHERRY
3A	M09544-14-WB5	EA	MOLDING - TRIM/VEE - .4" X 1" X 64.5" - WASHED MAPLE
3A	M09544-14-WB6	EA	MOLDING - TRIM/VEE - .4" X 1" X 64.5" - SIERRA MAPLE
3A	M09515-78-T77	EA	MOLDING - TRIM/VEE - .4" X 1" X 64.1" - PORTSMOUTH OAK
3A	M09515-78-T78	EA	MOLDING - TRIM/VEE - .4" X 1" X 64.1" - CONCERT CHERRY
3A	M09515-78-T79	EA	MOLDING - TRIM/VEE - .4" X 1" X 64.1" - WASHED MAPLE
3A	M09515-78-T80	EA	MOLDING - TRIM/VEE - .4" X 1" X 64.1" - SIERRA MAPLE
3A	M09501-91-T77	EA	MOLDING - TRIM/VEE - .4" X 1" X 63.3" - PORTSMOUTH OAK
3A	M09501-91-T78	EA	MOLDING - TRIM/VEE - .4" X 1" X 63.3" - CONCERT CHERRY
3A	M09501-91-T79	EA	MOLDING - TRIM/VEE - .4" X 1" X 63.3" - WASHED MAPLE
3A	M09501-91-T80	EA	MOLDING - TRIM/VEE - .4" X 1" X 63.3" - SIERRA MAPLE
3A	M09503-91-T77	EA	MOLDING - TRIM/VEE - .4" X 1" X 63.1" - PORTSMOUTH OAK
3A	M09503-91-T78	EA	MOLDING - TRIM/VEE - .4" X 1" X 63.1" - CONCERT CHERRY
3A	M09503-91-T79	EA	MOLDING - TRIM/VEE - .4" X 1" X 63.1" - WASHED MAPLE
3A	M09503-91-T80	EA	MOLDING - TRIM/VEE - .4" X 1" X 63.1" - SIERRA MAPLE
3A	M09544-22-WB4	EA	MOLDING - TRIM/VEE - .4" X 1" X 61.7" - CONCERT CHERRY
3A	M09544-22-WB5	EA	MOLDING - TRIM/VEE - .4" X 1" X 61.7" - WASHED MAPLE
3A	M09544-22-WB6	EA	MOLDING - TRIM/VEE - .4" X 1" X 61.7" - SIERRA MAPLE
3A	M09583-41-WH4	EA	MOLDING - TRIM/VEE - .4" X 1" X 61" - CONCERT CHERRY
3A	M09583-41-WH5	EA	MOLDING - TRIM/VEE - .4" X 1" X 61" - WASHED MAPLE
3A	M09583-41-WH6	EA	MOLDING - TRIM/VEE - .4" X 1" X 61" - SIERRA MAPLE
3A	M09565-49-WH4	EA	MOLDING - TRIM/VEE - .4" X 1" X 58.7" - CONCERT CHERRY
3A	M09565-49-WH5	EA	MOLDING - TRIM/VEE - .4" X 1" X 58.7" - WASHED MAPLE
3A	M09565-49-WH6	EA	MOLDING - TRIM/VEE - .4" X 1" X 58.7" - SIERRA MAPLE
3A	M09544-36-W37	EA	MOLDING - TRIM/VEE - .4" X 1" X 52.6" - WASHED MAPLE
3A	M09544-36-W38	EA	MOLDING - TRIM/VEE - .4" X 1" X 52.6.5" - SIERRA MAPLE
3A	M09553-85-WB4	EA	MOLDING - TRIM/VEE - .4" X 1" X 43.4" - CONCERT CHERRY
3A	M09553-85-WB5	EA	MOLDING - TRIM/VEE - .4" X 1" X 43.4" - WASHED MAPLE
3A	M09553-85-WB6	EA	MOLDING - TRIM/VEE - .4" X 1" X 43.4" - SIERRA MAPLE
3A	M09553-28-WH4	EA	MOLDING - TRIM/VEE - .4" X 1" X 48" - CONCERT CHERRY
3A	M09553-28-WH5	EA	MOLDING - TRIM/VEE - .4" X 1" X 48" - WASHED MAPLE
3A	M09553-28-WH6	EA	MOLDING - TRIM/VEE - .4" X 1" X 48" - SIERRA MAPLE
3A	M09553-60-WH4	EA	MOLDING - TRIM/VEE - .4" X 1" X 47.2" - CONCERT CHERRY
3A	M09553-60-WH5	EA	MOLDING - TRIM/VEE - .4" X 1" X 47.2" - WASHED MAPLE
3A	M09553-60-WH6	EA	MOLDING - TRIM/VEE - .4" X 1" X 47.2" - SIERRA MAPLE
3A	M09544-24-WB4	EA	MOLDING - TRIM/VEE - .4" X 1" X 46.2" - CONCERT CHERRY
3A	M09544-24-WB5	EA	MOLDING - TRIM/VEE - .4" X 1" X 46.2" - WASHED MAPLE
3A	M09544-24-WB6	EA	MOLDING - TRIM/VEE - .4" X 1" X 46.2" - SIERRA MAPLE
3A	M09565-77-WH4	EA	MOLDING - TRIM/VEE - .4" X 1" X 42.5" - CONCERT CHERRY
3A	M09565-77-WH5	EA	MOLDING - TRIM/VEE - .4" X 1" X 42.5" - WASHED MAPLE
3A	M09565-77-WH6	EA	MOLDING - TRIM/VEE - .4" X 1" X 42.5" - SIERRA MAPLE
3A	M09544-35-W37	EA	MOLDING - TRIM/VEE - .4" X 1" X 66.5" - SIERRA MAPLE
3A	M09544-35-W38	EA	MOLDING - TRIM/VEE - .4" X 1" X 66.5" - WASHED MAPLE

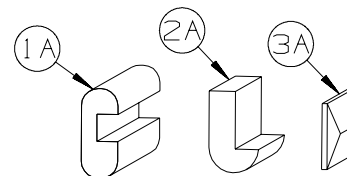

**INTERIOR FINISH GROUP (CONTINUED)**  
**MOLDINGS & TRIMS (CONTINUED)**

KEY	PART NUMBER	U/M	DESCRIPTION
3A	M09544-38-W37	EA	MOLDING - TRIM/VEE - .4" X 1" X 66.5" - SIERRA MAPLE
3A	M09544-38-W38	EA	MOLDING - TRIM/VEE - .4" X 1" X 66.5" - WASHED MAPLE
3A	M09565-03-WH4	EA	MOLDING - TRIM/VEE - .4" X 1" X 44.2" - CONCERT CHERRY
3A	M09565-03-WH5	EA	MOLDING - TRIM/VEE - .4" X 1" X 44.2" - WASHED MAPLE
3A	M09565-03-WH6	EA	MOLDING - TRIM/VEE - .4" X 1" X 44.2" - SIERRA MAPLE
3A	M09565-20-WH4	EA	MOLDING - TRIM/VEE - .4" X 1" X 43.2" - CONCERT CHERRY
3A	M09565-20-WH5	EA	MOLDING - TRIM/VEE - .4" X 1" X 43.2" - WASHED MAPLE
3A	M09565-20-WH6	EA	MOLDING - TRIM/VEE - .4" X 1" X 43.2" - SIERRA MAPLE
3A	M09553-24-WH4	EA	MOLDING - TRIM/VEE - .4" X 1" X 43" - CONCERT CHERRY
3A	M09553-24-WH5	EA	MOLDING - TRIM/VEE - .4" X 1" X 43" - WASHED MAPLE
3A	M09553-24-WH6	EA	MOLDING - TRIM/VEE - .4" X 1" X 43" - SIERRA MAPLE
3A	M09565-77-WH4	EA	MOLDING - TRIM/VEE - .4" X 1" X 42.5" - CONCERT CHERRY
3A	M09565-77-WH5	EA	MOLDING - TRIM/VEE - .4" X 1" X 42.5" - WASHED MAPLE
3A	M09565-77-WH6	EA	MOLDING - TRIM/VEE - .4" X 1" X 42.5" - SIERRA MAPLE
3A	M09565-50-WH4	EA	MOLDING - TRIM/VEE - .4" X 1" X 40.9" - CONCERT CHERRY
3A	M09565-50-WH5	EA	MOLDING - TRIM/VEE - .4" X 1" X 40.9" - WASHED MAPLE
3A	M09565-50-WH6	EA	MOLDING - TRIM/VEE - .4" X 1" X 40.9" - SIERRA MAPLE
3A	M09583-43-WH4	EA	MOLDING - TRIM/VEE - .4" X 1" X 40.1" - CONCERT CHERRY
3A	M09583-43-WH5	EA	MOLDING - TRIM/VEE - .4" X 1" X 40.1" - WASHED MAPLE
3A	M09583-43-WH6	EA	MOLDING - TRIM/VEE - .4" X 1" X 40.1" - SIERRA MAPLE
3A	M09565-76-WH4	EA	MOLDING - TRIM/VEE - .4" X 1" X 39.4" - CONCERT CHERRY
3A	M09565-76-WH5	EA	MOLDING - TRIM/VEE - .4" X 1" X 39.4" - WASHED MAPLE
3A	M09565-76-WH6	EA	MOLDING - TRIM/VEE - .4" X 1" X 39.4" - SIERRA MAPLE
3A	M09565-47-WH4	EA	MOLDING - TRIM/VEE - .4" X 1" X 38.9" - CONCERT CHERRY
3A	M09565-47-WH5	EA	MOLDING - TRIM/VEE - .4" X 1" X 38.9" - WASHED MAPLE
3A	M09565-47-WH6	EA	MOLDING - TRIM/VEE - .4" X 1" X 38.9" - SIERRA MAPLE
3A	M09553-27-WH4	EA	MOLDING - TRIM/VEE - .4" X 1" X 38.8" - CONCERT CHERRY
3A	M09553-27-WH5	EA	MOLDING - TRIM/VEE - .4" X 1" X 38.8" - WASHED MAPLE
3A	M09553-27-WH6	EA	MOLDING - TRIM/VEE - .4" X 1" X 38.8" - SIERRA MAPLE
3A	M09568-77-WH4	EA	MOLDING - TRIM/VEE - .4" X 1" X 37.5" - CONCERT CHERRY
3A	M09568-77-WH5	EA	MOLDING - TRIM/VEE - .4" X 1" X 37.5" - WASHED MAPLE
3A	M09568-77-WH6	EA	MOLDING - TRIM/VEE - .4" X 1" X 37.5" - SIERRA MAPLE
3A	M09553-23-WH4	EA	MOLDING - TRIM/VEE - .4" X 1" X 37" - CONCERT CHERRY
3A	M09553-23-WH5	EA	MOLDING - TRIM/VEE - .4" X 1" X 37" - WASHED MAPLE
3A	M09553-23-WH6	EA	MOLDING - TRIM/VEE - .4" X 1" X 37" - SIERRA MAPLE
3A	M09553-47-WB4	EA	MOLDING - TRIM/VEE - .4" X 1" X 35.9" - CONCERT CHERRY
3A	M09553-47-WB5	EA	MOLDING - TRIM/VEE - .4" X 1" X 35.9" - WASHED MAPLE
3A	M09553-47-WB6	EA	MOLDING - TRIM/VEE - .4" X 1" X 35.9" - SIERRA MAPLE
3A	M09553-47-W66	EA	MOLDING - TRIM/VEE - .4" X 1" X 35.9" - HONEY CHERRY
3A	M09568-48-U67	EA	MOLDING - TRIM/VEE - .4" X 1" X 35.4" - WASHED MAPLE
3A	M09568-48-U68	EA	MOLDING - TRIM/VEE - .4" X 1" X 35.4" - SIERRA MAPLE
3A	M09553-63-WH4	EA	MOLDING - TRIM/VEE - .4" X 1" X 35.1" - CONCERT CHERRY
3A	M09553-63-WH5	EA	MOLDING - TRIM/VEE - .4" X 1" X 35.1" - WASHED MAPLE
3A	M09553-63-WH6	EA	MOLDING - TRIM/VEE - .4" X 1" X 35.1" - SIERRA MAPLE
3A	M09553-63-W51	EA	MOLDING - TRIM/VEE - .4" X 1" X 35.1" - HONEY CHERRY
3A	M09565-94-WH4	EA	MOLDING - TRIM/VEE - .4" X 1" X 34.4" - CONCERT CHERRY
3A	M09565-94-WH5	EA	MOLDING - TRIM/VEE - .4" X 1" X 34.4" - WASHED MAPLE
3A	M09565-94-WH6	EA	MOLDING - TRIM/VEE - .4" X 1" X 34.4" - SIERRA MAPLE
3A	M09553-04-WH4	EA	MOLDING - TRIM/VEE - .4" X 1" X 34.2" - CONCERT CHERRY
3A	M09553-04-WH5	EA	MOLDING - TRIM/VEE - .4" X 1" X 34.2" - WASHED MAPLE
3A	M09553-04-WH6	EA	MOLDING - TRIM/VEE - .4" X 1" X 34.2" - SIERRA MAPLE
3A	M09566-02-U68	EA	MOLDING - TRIM/VEE - .4" X 1" X 32.7" - SIERRA MAPLE
3A	M09566-02-W51	EA	MOLDING - TRIM/VEE - .4" X 1" X 32.7" - HONEY CHERRY
3A	M09566-02-W52	EA	MOLDING - TRIM/VEE - .4" X 1" X 32.7" - WASHED MAPLE
3A	M09511-86-T77	EA	MOLDING - TRIM/VEE - .4" X 1" X 28.3" - PORTSMOUTH OAK
3A	M09511-86-T78	EA	MOLDING - TRIM/VEE - .4" X 1" X 28.3" - CONCERT CHERRY
3A	M09511-86-T79	EA	MOLDING - TRIM/VEE - .4" X 1" X 28.3" - WASHED MAPLE
3A	M09511-86-T80	EA	MOLDING - TRIM/VEE - .4" X 1" X 28.3" - SIERRA MAPLE
3A	M09553-61-WH4	EA	MOLDING - TRIM/VEE - .4" X 1" X 19.9" - CONCERT CHERRY
3A	M09553-61-WH5	EA	MOLDING - TRIM/VEE - .4" X 1" X 19.9" - WASHED MAPLE
3A	M09553-61-WH6	EA	MOLDING - TRIM/VEE - .4" X 1" X 19.9" - SIERRA MAPLE
3A	M09565-71-WH4	EA	MOLDING - TRIM/VEE - .4" X 1" X 11.4" - CONCERT CHERRY
3A	M09565-71-WH5	EA	MOLDING - TRIM/VEE - .4" X 1" X 11.4" - WASHED MAPLE
3A	M09565-71-WH6	EA	MOLDING - TRIM/VEE - .4" X 1" X 11.4" - SIERRA MAPLE

**INTERIOR FINISH GROUP (CONTINUED)**  
**MOLDINGS & TRIMS (CONTINUED)**

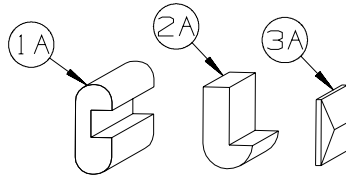

KEY	PART NUMBER	U/M	DESCRIPTION
3A	M09583-42-WH4	EA	MOLDING - TRIM/VEE - .4" X 1" X 8.3" - CONCERT CHERRY
3A	M09583-42-WH5	EA	MOLDING - TRIM/VEE - .4" X 1" X 8.3" - WASHED MAPLE
3A	M09583-42-WH6	EA	MOLDING - TRIM/VEE - .4" X 1" X 8.3" - SIERRA MAPLE
3A	M09544-55-WB4	EA	MOLDING - TRIM/VEE - .4" X 1" X 6.5" - CONCERT CHERRY
3A	M09544-55-WB5	EA	MOLDING - TRIM/VEE - .4" X 1" X 6.5" - WASHED MAPLE
3A	M09544-55-WB6	EA	MOLDING - TRIM/VEE - .4" X 1" X 6.5" - SIERRA MAPLE
3A	M09544-56-WB4	EA	MOLDING - TRIM/VEE - .4" X 1" X 6.1" - CONCERT CHERRY
3A	M09544-56-WB5	EA	MOLDING - TRIM/VEE - .4" X 1" X 6.1" - WASHED MAPLE
3A	M09544-56-WB6	EA	MOLDING - TRIM/VEE - .4" X 1" X 6.1" - SIERRA MAPLE
3A	M09538-70-U68	EA	MOLDING - TRIM/VEE - .4" X 1" X 63.9" - SIERRA MAPLE
3A	M09538-70-U67	EA	MOLDING - TRIM/VEE - .4" X 1" X 63.9" - WASHED MAPLE

**INTERIOR FINISH GROUP (CONTINUED)**  
**MOLDINGS & TRIMS (CONTINUED)**

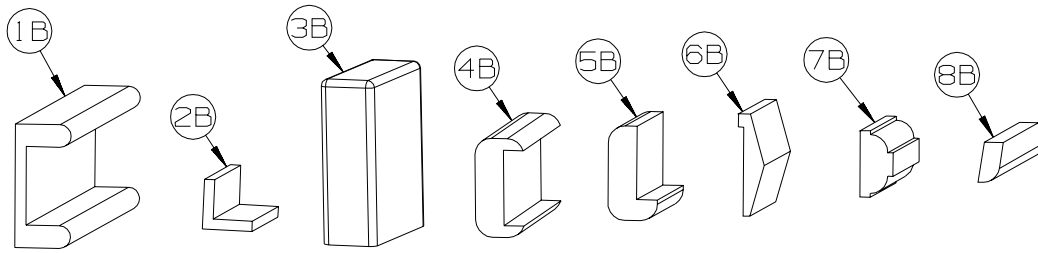

KEY	PART NUMBER	U/M	DESCRIPTION
1B	M09501-84-TG0	EA	MOLDING/TRIM - CAP/WALL - 2.2" X 85.9" - PORTSMOUTH OAK
1B	M09501-84-TG1	EA	MOLDING/TRIM - CAP/WALL - 2.2" X 85.9" - CONCERT CHERRY
1B	M09501-84-TG2	EA	MOLDING/TRIM - CAP/WALL - 2.2" X 85.9" - WASHED MAPLE
1B	M09501-84-TG3	EA	MOLDING/TRIM - CAP/WALL - 2.2" X 85.9" - HONEY CHERRY
1B	M09520-04-TD3	EA	MOLDING/TRIM - CAP/WALL - 2.2" X 80.5" - SIERRA MAPLE
2B	M09511-81-TA0	EA	MOLDING/TRIM - L SHAPE - .8"X .8"X 80.2" - PORTSMOUTH OAK
2B	M09511-81-TA1	EA	MOLDING/TRIM - L SHAPE - .8"X .8"X 80.2" - CONCERT CHERRY
2B	M09511-81-TA2	EA	MOLDING/TRIM - L SHAPE - .8"X .8"X 80.2" - WASHED MAPLE
2B	M09511-81-TA3	EA	MOLDING/TRIM - L SHAPE - .8"X .8"X 80.2" - SIERRA MAPLE
3B	M09515-81-T01	EA	MOLDING/HARDWOOD STRAIGHT - 74.3" - WASHED MAPLE
3B	M09515-81-T02	EA	MOLDING/HARDWOOD STRAIGHT - 74.3" - HONEY CHERRY
4B	M09511-42-T77	EA	MOLDING - TRIM - W/NOTCH - 1.5" X 86.4" - PORTSMOUTH OAK
4B	M09511-42-T78	EA	MOLDING - TRIM - W/NOTCH - 1.5" X 86.4" - CONCERT CHERRY
4B	M09511-42-T79	EA	MOLDING - TRIM - W/NOTCH - 1.5" X 86.4" - WASHED MAPLE
4B	M09511-42-T80	EA	MOLDING - TRIM - W/NOTCH - 1.5" X 86.4" - SIERRA MAPLE
4B	M09511-42-W66	EA	MOLDING - TRIM - W/NOTCH - 1.5" X 86.4" - HONEY CHERRY
5B	M09515-18-T77	EA	MOLDING - HARDWOOD-W/NOTCH - 1.4"X 86.2" - PORTSMOUTH OAK
5B	M09515-18-T78	EA	MOLDING - HARDWOOD-W/NOTCH - 1.4"X 86.2" - CONCERT CHERRY
5B	M09553-66-U22	EA	MOLDING - HARDWOOD-W/NOTCH - 1.4"X 96" - WASHED MAPLE
5B	M09515-18-T80	EA	MOLDING - HARDWOOD-W/NOTCH - 1.4"X 86.2" - SIERRA MAPLE
5B	M09553-66-U21	EA	MOLDING - HARDWOOD-W/NOTCH - 1.4"X 96" - HONEY CHERRY
6B	M09515-53-TG0	EA	MOLDING - TRIM/VEE - 1.5" X 73.9" - PORTSMOUTH OAK
6B	M09525-81-UJ1	EA	MOLDING - TRIM/VEE - 1.5" X 74.7" - CONCERT CHERRY
6B	M09525-81-UJ2	EA	MOLDING - TRIM/VEE - 1.5" X 74.7" - WASHED MAPLE
6B	M09552-81-UJ3	EA	MOLDING - TRIM/VEE - 1.5" X 74.7" - HONEY CHERRY
6B	M09553-53-WH6	EA	MOLDING - TRIM/VEE - NOTCHED - 1.5" X 20.6" - SIERRA MAPLE
7B	Y00076-32-438	EA	MOLDING/TRIM - .5" X 1" X 96" - CHERRY (UNSTAINED)
7B	Y00076-22-438	EA	MOLDING/TRIM - .5" X 1" X 96" - MAPLE (UNSTAINED)
8B	M09525-92-T77	EA	MOLDING/TRIM - .5" X 1" X 75.6" - PORTSMOUTH OAK
8B	M09525-92-T78	EA	MOLDING/TRIM - .5" X 1" X 75.6" - CONCERT CHERRY
8B	M09525-92-T79	EA	MOLDING/TRIM - .5" X 1" X 75.6" - WASHED MAPLE
8B	M09525-92-T80	EA	MOLDING/TRIM - .5" X 1" X 75.6" - SIERRA MAPLE
8B	Y00086-72-438	EA	MOLDING - VINYL WRAP - .7" X 1.6" X 96" - PORTSMOUTH OAK
8B	Y00086-D2-438	EA	MOLDING - VINYL WRAP - .7" X 1.6" X 96" - CONCERT CHERRY
8B	Y00086-A2-438	EA	MOLDING - VINYL WRAP - .7" X 1.6" X 96" - WASHED MAPLE
8B	Y00086-92-438	EA	MOLDING - VINYL WRAP - .7" X 1.6" X 96" - SIERRA MAPLE
8B	Y00086-82-438	EA	MOLDING - VINYL WRAP - .7" X 1.6" X 96" - HONEY CHERRY
8B	Y00087-72-438	EA	MOLDING - VINYL WRAP - .7" X 2.9" X 96" - PORTSMOUTH OAK
8B	Y00087-D2-438	EA	MOLDING - VINYL WRAP - .7" X 2.9" X 96" - CONCERT CHERRY
8B	Y00087-A2-438	EA	MOLDING - VINYL WRAP - .7" X 2.9" X 96" - WASHED MAPLE
8B	Y00087-92-438	EA	MOLDING - VINYL WRAP - .7" X 2.9" X 96" - SIERRA MAPLE
8B	Y00087-82-438	EA	MOLDING - VINYL WRAP - .7" X 2.9" X 96" - HONEY CHERRY

**INTERIOR FINISH GROUP (CONTINUED)**  
**MOLDINGS & TRIMS (CONTINUED)**

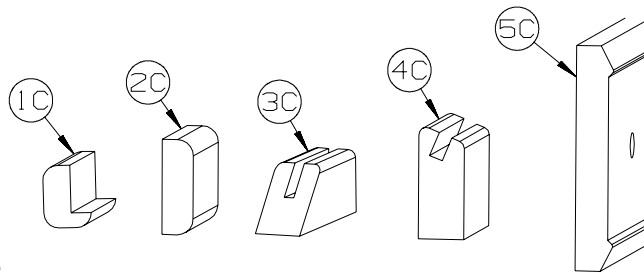

KEY	PART NUMBER	U/M	DESCR
1C	M09520-19-TD1	EA	MOLDING - TRIM - W/NOTCH - 1" X 86.3" - CONCERT CHERRY
1C	M09520-19-TD2	EA	MOLDING - TRIM - W/NOTCH - 1" X 86.3" - WASHED MAPLE
1C	M09520-19-TD3	EA	MOLDING - TRIM - W/NOTCH - 1" X 86.3" - HONEY CHERRY
1C	M09565-68-WH4	EA	MOLDING - HARDWOOD - .75" X 1.4" X 81.9" - CONCERT CHERRY
1C	M09565-68-WH5	EA	MOLDING - HARDWOOD - .75" X 1.4" X 81.9" - WASHED MAPLE
1C	M09565-68-WH6	EA	MOLDING - HARDWOOD - .75" X 1.4" X 81.9" - SIERRA MAPLE
2C	M09511-46-T77	EA	MOLDING/TRIM - .5" X 1.5" X 86.5" - PORTSMOUTH OAK
2C	M09511-46-T78	EA	MOLDING/TRIM - .5" X 1.5" X 86.5" - CONCERT CHERRY
2C	M09511-46-T79	EA	MOLDING/TRIM - .5" X 1.5" X 86.5" - WASHED MAPLE
2C	M09511-46-T80	EA	MOLDING/TRIM - .5" X 1.5" X 86.5" - SIERRA MAPLE
3C	Y00223-22-438	EA	MOLDING - HARDWOOD/MAPLE - .7" X 1" X 96" - UNSTAINED MAPLE
3C	Y00223-32-438	EA	MOLDING - HARDWOOD/CHERRY - .7" X 1" X 96" - UNSTAINED CHERRY
3C	Y00223-42-438	EA	MOLDING - HARDWOOD/CHERRY - .7" X 1" X 96" - UNSTAINED OAK
4C	Y00054-A2-438	EA	MOLDING - VINYL - W/SLOT - .7"X 1.9"X 96" - WASHED MAPLE
4C	Y00054-D2-438	EA	MOLDING - VINYL - W/SLOT - .7"X 1.9"X 96" - CONCERT CHERRY
4C	Y00054-22-438	EA	MOLDING - VINYL - W/SLOT - .7"X 1.9"X 96" - WASHED MAPLE
4C	Y00054-72-438	EA	MOLDING - VINYL - W/SLOT - .7"X 1.9"X 96" - PORTSMOUTH OAK
4C	Y00054-82-438	EA	MOLDING - VINYL - W/SLOT - .7"X 1.9"X 96" - HONEY CHERRY
4C	Y00054-92-438	EA	MOLDING - VINYL - W/SLOT - .7"X 1.9"X 96" - SIERRA MAPLE
4C	Y00276-A2-438	EA	MOLDING - VINYL - W/SLOT - .7"X 1.9"X 96" - WASHED MAPLE
4C	Y00276-D2-438	EA	MOLDING - VINYL - W/SLOT - .7"X 1.9"X 96" - CONCERT CHERRY
4C	Y00276-72-438	EA	MOLDING - VINYL - W/SLOT - .7"X 1.9"X 96" - PORTSMOUTH OAK
4C	Y00276-82-438	EA	MOLDING - VINYL - W/SLOT - .7"X 1.9"X 96" - HONEY CHERRY
4C	Y00276-92-438	EA	MOLDING - VINYL - W/SLOT - .7"X 1.9"X 96" - SIERRA MAPLE
5C	Y00152-A2-438	EA	MOLDING/TRIM - VINYL - .6" X 3.5" X 96" - WASHED MAPLE
5C	Y00152-D2-438	EA	MOLDING/TRIM - VINYL - .6" X 3.5" X 96" - CONCERT CHERRY
5C	Y00152-22-438	EA	MOLDING/TRIM - VINYL - .6" X 3.5" X 96" - WASHED MAPLE
5C	Y00152-72-438	EA	MOLDING/TRIM - VINYL - .6" X 3.5" X 96" - PORTSMOUTH OAK
5C	Y00152-92-438	EA	MOLDING/TRIM - VINYL - .6" X 3.5" X 96" - SIERRA MAPLE



**INTERIOR FINISH GROUP (CONTINUED)**  
**MOLDINGS & TRIMS (CONTINUED)**

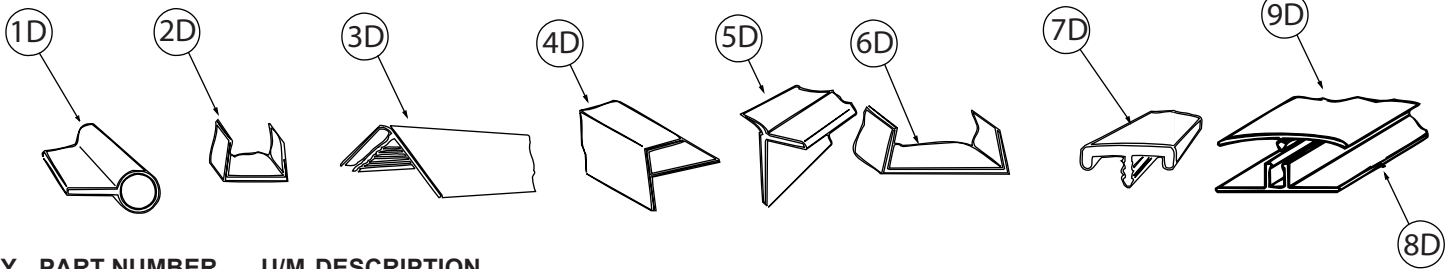

KEY	PART NUMBER	U/M	DESCRIPTION
1D	009767-12-000	FT	WELTING - ANTIQUE WHITE
2D	009778-25-000	FT	U-CHANNEL - 1" - BEIGE ILLUSION
2D	009778-26-000	FT	U-CHANNEL - 1 1/4" - BEIGE ILLUSION
2D	009778-38-000	FT	U-CHANNEL - 1" - BONE
2D	009778-32-000	FT	U-CHANNEL - 1" - PORTSMOUTH OAK
2D	009778-34-000	FT	U-CHANNEL - 1" - CONCERT CHERRY
2D	009778-27-000	FT	U-CHANNEL - 1" - WASHED MAPLE
2D	009778-35-000	FT	U-CHANNEL - 1" - HONEY CHERRY
2D	009778-36-000	FT	U-CHANNEL - 1" - SIERRA MAPLE
3D	009809-30-000	EA	MOLDING - CORNER - OUTSIDE - 1" X 84" - BEIGE ILLUSION
3D	009809-37-000	EA	MOLDING - CORNER - OUTSIDE - 1" X 84" - BONE
3D	009809-33-000	EA	MOLDING - CORNER - OUTSIDE - 1" X 84" - CONCERT CHERRY
3D	009809-31-000	EA	MOLDING - CORNER - OUTSIDE - 1" X 84" - WASHED MAPLE
3D	009809-35-000	EA	MOLDING - CORNER - OUTSIDE - 1" X 84" - SIERRA MAPLE
4D	009812-31-000	EA	MOLDING - CORNER - 1/2" W/1/4"CHAN X 84" - BEIGE ILLUSION
4D	009812-40-000	EA	MOLDING - CORNER - 1/2" W/1/4"CHAN X 84" - BONE
4D	009812-35-000	EA	MOLDING - CORNER - 1/2" W/1/4"CHAN X 84" - PORTSMOUTH OAK
4D	009812-36-000	EA	MOLDING - CORNER - 1/2" W/1/4"CHAN X 84" - CONCERT CHERRY
4D	009812-33-000	EA	MOLDING - CORNER - 1/2" W/1/4"CHAN X 84" - WASHED MAPLE
4D	009812-37-000	EA	MOLDING - CORNER - 1/2" W/1/4"CHAN X 84" - HONEY CHERRY
4D	009812-38-000	EA	MOLDING - CORNER - 1/2" W/1/4"CHAN X 84" - SIERRA MAPLE
5D	022992-11-000	FT	MOLDING - REVERSE COVE - T-SHAPED - IVORY
5D	022992-14-000	FT	MOLDING - REVERSE COVE - T-SHAPED - BRIGHT WHITE
5D	022992-18-000	FT	MOLDING - REVERSE COVE - T-SHAPED - BONE
6D	070504-42-000	FT	U-CHANNEL - PLASTIC - .13" X 84" - BEIGE ILLUSION
6D	070504-43-000	FT	U-CHANNEL - PLASTIC - .9" X 96" - BEIGE ILLUSION
6D	070504-69-000	FT	U-CHANNEL - PLASTIC - .13" X 84" - BONE
6D	070504-70-000	FT	U-CHANNEL - PLASTIC - .8" X 84" - BONE
6D	070504-57-000	FT	U-CHANNEL - PLASTIC - .13" X 96" - PORTSMOUTH OAK
6D	070504-58-000	FT	U-CHANNEL - PLASTIC - .9" X 96" - PORTSMOUTH OAK
6D	070504-60-000	FT	U-CHANNEL - PLASTIC - .13" X 84" - CONCERT CHERRY
6D	070504-61-000	FT	U-CHANNEL - PLASTIC - .9" X 84" - CONCERT CHERRY
6D	070504-50-000	FT	U-CHANNEL - PLASTIC - .13" X 96" - WASHED MAPLE
6D	070504-51-000	FT	U-CHANNEL - PLASTIC - .9" X 96" - WASHED MAPLE
6D	070504-62-000	FT	U-CHANNEL - PLASTIC - 1.65" X 84" - HONEY CHERRY
6D	070504-63-000	FT	U-CHANNEL - PLASTIC - .9" X 84" - HONEY CHERRY
6D	070504-65-000	FT	U-CHANNEL - PLASTIC - .07" X 96" - SIERRA MAPLE
6D	070504-66-000	FT	U-CHANNEL - PLASTIC - .8" X 84" - SIERRA MAPLE
7D	083620-25-000	FT	MOLDING-T - W/EDGE LIP - 7/8" FACE - BONE
7D	083620-20-000	FT	MOLDING-T - W/EDGE LIP - 7/8" FACE - PORTSMOUTH OAK
7D	083620-19-000	FT	MOLDING-T - W/EDGE LIP - 7/8" FACE - WASHED MAPLE
7D	083620-24-000	FT	MOLDING-T - W/EDGE LIP - 7/8" FACE - HONEY CHERRY
7D	083620-22-000	FT	MOLDING-T - W/EDGE LIP - 7/8" FACE - SIERRA MAPLE
8D	086229-01-000	EA	RETAINER - BATTEN - .75" X 92.1" - ANY COLOR
9D	086229-12-000	EA	BATTEN - 1.5" OFFSET X 96.8" - MODERN IVORY
9D	086229-20-000	EA	BATTEN - 1" X 96" - BEIGE

**INTERIOR FINISH GROUP (CONTINUED)**  
**MOLDINGS & TRIMS (CONTINUED)**

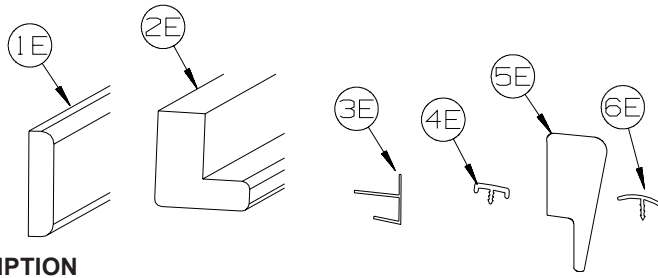

KEY	PART NUMBER	U/M	DESCRIPTION
1E	100818-01-12A	EA	MOLDING - VINYL WRAPPED - 1.6" X .4" X 84" - PORTSMOUTH OAK
1E	100818-01-23A	EA	MOLDING - VINYL WRPPD - 1.6" X .4" X 84" - CONCERT CHERRY
1E	100818-01-21A	EA	MOLDING - VINYL WRAPPED - 1.6" X .4" X 84" - WASHED MAPLE
1E	100818-01-14A	EA	MOLDING - VINYL WRAPPED - 1.6" X .4" X 84" - HONEY CHERRY
1E	100818-01-22A	EA	MOLDING - VINYL WRAPPED - 1.6" X .4" X 84" - SIERRA MAPLE
2E	100819-01-23A	EA	MOLDING - VYL WRPPD-L-SHPD-1.5"X1.5"X84" - CONCERT CHERRY
2E	100819-01-21A	EA	MOLDING - VINYL WRAPPED-L-SHAPED-1.5"X1.5"X84" - WASHED MAPLE
2E	100819-01-14A	EA	MOLDING - VINYL WRAPPED-L-SHAPED-1.5"X1.5"X84" - HONEY CHERRY
2E	100819-01-22A	EA	MOLDING - VINYL WRAPPED-L-SHAPED-1.5"X1.5"X84" - SIERRA MAPLE
3E	103186-01-07A	FT	MOLDING/PLASTIC - 3/8" U-CHANNEL-3/4" FACE - BEIGE ILLUSION
3E	103186-01-09A	FT	MOLDING/PLASTIC - 3/8" U-CHANNEL-3/4" FACE - PORTSMOUTH OAK
3E	103186-01-10A	FT	MOLDING/PLASTIC - 3/8" U-CHANNEL-3/4" FACE - CONCERT CHERRY
3E	103186-01-08A	FT	MOLDING/PLASTIC - 3/8" U-CHANNEL-3/4" FACE- 8' - WASHED MAPLE
3E	103186-01-11A	FT	MOLDING/PLASTIC - 3/8" U-CHANNEL-3/4" FACE - HONEY CHERRY
3E	103186-01-12A	FT	MOLDING/PLASTIC - 3/8" U-CHANNEL-3/4" FACE - SIERRA MAPLE
3E	103186-02-07A	FT	MOLDING/PLASTIC-1" U-CHANNEL-1 3/8" FACE - BEIGE ILLUSION
3E	103186-02-09A	FT	MOLDING/PLASTIC - 1" U-CHANNEL-1 3/8" FACE - PORTSMOUTH OAK
3E	103186-02-10A	FT	MOLDING/PLASTIC - 1" U-CHANNEL-1 3/8" FACE - CONCERT CHERRY
3E	103186-02-08A	FT	MOLDING/PLASTIC - 1" U-CHANNEL-1 3/8" FACE - WASHED MAPLE
3E	103186-02-11A	FT	MOLDING/PLASTIC - 1" U-CHANNEL-1 3/8" FACE - HONEY CHERRY
3E	103186-02-12A	FT	MOLDING/PLASTIC - 1" U-CHANNEL-1 3/8" FACE - SIERRA MAPLE
4E	104676-02-08A	FT	MOLDING-T - W/EDGE LIP - 11/16" FACE - PORTSMOUTH OAK
4E	104676-02-12A	FT	MOLDING-T - W/EDGE LIP - 11/16" FACE - SIERRA MAPLE
5E	105004-01-12A	EA	MOLDING - VINYL WRAP - 1" X 96" - PORTSMOUTH OAK
5E	105004-01-21A	EA	MOLDING - VINYL WRAP - 1" X 96" - WASHED MAPLE
5E	105004-01-24A	EA	MOLDING - VINYL WRAP - 1" X 96" - HONEY CHERRY
5E	105004-01-22A	EA	MOLDING - VINYL WRAP - 1" X 96" - SIERRA MAPLE
6E	105709-02-000	FT	MOLDING-T - W/EDGE LIP 3/4" FACE - BEIGE ILLUSION

**INTERIOR FINISH GROUP (CONTINUED)**  
**MOLDINGS & TRIMS (CONTINUED)**

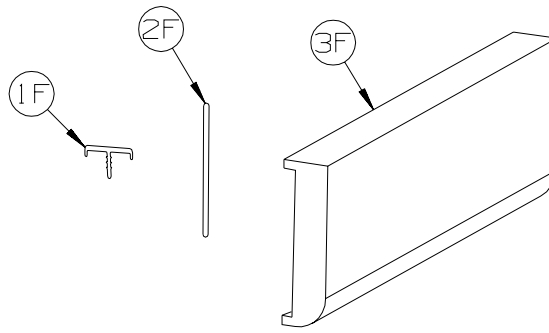

KEY	PART NUMBER	U/M	DESCRIPTION
1F	119520-01-01A	FT	MOLDING-T - OFFSET W/EDGE LIP - 1.3" FACE - OFF WHITE
1F	119520-03-02A	FT	MOLDING-T - OFFSET W/EDGE LIP - 1" FACE - CONCERT CHERRY
1F	119520-03-03A	FT	MOLDING-T - OFFSET W/EDGE LIP - 1" FACE - WASHED MAPLE
1F	119520-03-05A	FT	MOLDING-T - OFFSET W/EDGE LIP - 1" FACE - SIERRA MAPLE
1F	119520-03-06A	FT	MOLDING-T - OFFSET W/EDGE LIP - 1" FACE - HONEY CHERRY
2F	127842-01-01A	FT	SEAL - SIGHT SHIELD - 2" BLACK
	160300-A2-438	EA	LUMBER - VINYL WRAPPED - .7" X .75" X 96" - CONCERT CHERRY
	160300-D2-438	EA	LUMBER - VINYL WRAPPED - .7" X 1.5" X 96" - CONCERT CHERRY
	160300-E2-438	EA	LUMBER - VINYL WRAPPED - .7" X 2" X 96" - CONCERT CHERRY
	160300-F2-438	EA	LUMBER - VINYL WRAPPED - .7" X 2.5" X 96" - CONCERT CHERRY
	160300-G2-438	EA	LUMBER - VINYL WRAPPED - .7" X 3" X 96" - CONCERT CHERRY
	160300-H2-438	EA	LUMBER - VINYL WRAPPED - .7" X 3.5" X 96" - CONCERT CHERRY
	160300-J2-438	EA	LUMBER - VINYL WRAPPED - .7" X 5.5" X 96" - CONCERT CHERRY
	160300-K2-438	EA	LUMBER - VINYL WRAPPED - .7" X 3.9" X 96" - CONCERT CHERRY
	160300-R2-438	EA	LUMBER - VINYL WRAPPED - .7" X 3" X 96" - CONCERT CHERRY
3F	160301-D2-134	EA	MOLDING - VINYL WRAPPED - .7" X 1.6" X 84" - CONCERT CHERRY
3F	160301-D2-743	EA	MOLDING - VINYL WRAPPED - .7" X 1.6" X 108" - CONCERT CHERRY
3F	160301-F2-134	EA	MOLDING - VINYL WRAPPED - .7" X 2.5" X 84" - CONCERT CHERRY
3F	160301-F2-743	EA	MOLDING - VINYL WRAPPED - .7" X 2.5" X 108" - CONCERT CHERRY
3F	160301-F2-438	EA	MOLDING - VINYL WRAPPED - .7" X 2.5" X 96" - CONCERT CHERRY
	137894-A2-438	EA	LUMBER - VINYL WRAPPED - .7" X .75" X 96" - PORTSMOUTH OAK
	137894-D2-438	EA	LUMBER - VINYL WRAPPED - .7" X 1.5" X 96" - PORTSMOUTH OAK
	137894-E2-438	EA	LUMBER - VINYL WRAPPED - .7" X 2" X 96" - PORTSMOUTH OAK
	137894-F2-438	EA	LUMBER - VINYL WRAPPED - .7" X 2.5" X 96" - PORTSMOUTH OAK
	137894-G2-438	EA	LUMBER - VINYL WRAPPED - .7" X 3" X 96" - PORTSMOUTH OAK
	137894-H2-438	EA	LUMBER - VINYL WRAPPED - .7" X 3.5" X 96" - PORTSMOUTH OAK
	137894-J2-438	EA	LUMBER - VINYL WRAPPED - .7" X 5.5" X 96" - PORTSMOUTH OAK

**INTERIOR FINISH GROUP (CONTINUED)**  
**MOLDINGS & TRIMS (CONTINUED)**

KEY	PART NUMBER	U/M	DESCRIPTION
	137894-J2-743	EA	LUMBER - VINYL WRAPPED - .7" X 5.5" X 108" - PORTSMOUTH OAK
	137894-K2-438	EA	LUMBER - VINYL WRAPPED - .7" X 3.9" X 96" - PORTSMOUTH OAK
	137894-R2-438	EA	LUMBER - VINYL WRAPPED - .7" X 3" X 96" - PORTSMOUTH OAK
3F	137895-D2-134	EA	MOLDING - VINYL WRAP - .7" X 1.6" X 84" - PORTSMOUTH OAK
3F	137895-D2-743	EA	MOLDING - VINYL WRAP - .7" X 1.6" X 108" - PORTSMOUTH OAK
3F	137895-F2-134	EA	MOLDING - VINYL WRAP - .7" X 2.5" X 84" - PORTSMOUTH OAK
3F	137895-F2-438	EA	MOLDING - VINYL WRAP - .7" X 2.5" X 96" - PORTSMOUTH OAK
3F	137895-F2-743	EA	MOLDING - VINYL WRAP - .7" X 2.5" X 108" - PORTSMOUTH OAK
	146419-A2-438	EA	LUMBER - VINYL WRAPPED - .7" X .75" X 96" - HONEY CHERRY
	146419-D2-438	EA	LUMBER - VINYL WRAPPED - .7" X 1.5" X 96" - HONEY CHERRY
	146419-E2-438	EA	LUMBER - VINYL WRAPPED - .7" X 2" X 96" - HONEY CHERRY
	146419-F2-438	EA	LUMBER - VINYL WRAPPED - .7" X 2.5" X 96" - HONEY CHERRY
	146419-G2-438	EA	LUMBER - VINYL WRAPPED - .7" X 3" X 96" - HONEY CHERRY
	146419-H2-438	EA	LUMBER - VINYL WRAPPED - .7" X 3.5" X 96" - HONEY CHERRY
	146419-J2-438	EA	LUMBER - VINYL WRAPPED - .7" X 5.5" X 96" - HONEY CHERRY
	146419-J2-743	EA	LUMBER - VINYL WRAPPED - .7" X 5.5" X 108" - HONEY CHERRY
	146419-K2-438	EA	LUMBER - VINYL WRAPPED - .7" X 3.9" X 96" - HONEY CHERRY
	146419-R2-438	EA	LUMBER - VINYL WRAPPED - .7" X 3" X 96" - HONEY CHERRY
	146419-S2-438	EA	LUMBER - VINYL WRAPPED/FULL - .7" X 3.5" X 96" - HONEY CHERRY
	146419-T2-438	EA	LUMBER - VINYL WRAPPED/FULL - .7" X 5.5" X 96" - HONEY CHERRY
3F	146425-D2-134	EA	MOLDING - VINYL WRAPPED - .7" X 1.6" X 83.9" - HONEY CHERRY
3F	146425-F2-438	EA	MOLDING - VINYL WRAPPED - .7" X 2.6" X 96" - HONEY CHERRY
	149325-A2-438	EA	LUMBER - VINYL WRAPPED - .7" X .75" X 96" - WASHED MAPLE
	149325-D2-438	EA	LUMBER - VINYL WRAPPED - .7" X 1.5" X 96" - WASHED MAPLE
	149325-E2-438	EA	LUMBER - VINYL WRAPPED - .7" X 2" X 96" - WASHED MAPLE
	149325-F2-438	EA	LUMBER - VINYL WRAPPED - .7" X 2.5" X 96" - WASHED MAPLE
	149325-G2-438	EA	LUMBER - VINYL WRAPPED - .7" X 3" X 96" - WASHED MAPLE
	149325-H2-438	EA	LUMBER - VINYL WRAPPED - .7" X 3.5" X 96" - WASHED MAPLE
	149325-J2-438	EA	LUMBER - VINYL WRAPPED - .7" X 5.5" X 96" - WASHED MAPLE
	149325-J2-743	EA	LUMBER - VINYL WRAPPED - .7" X 5.5" X 108" - WASHED MAPLE
	149325-K2-438	EA	LUMBER - VINYL WRAPPED - .7" X 3.9" X 96" - WASHED MAPLE
	149325-R2-438	EA	LUMBER - VINYL WRAPPED - .7" X 3" X 96" - WASHED MAPLE
3F	149326-D2-134	EA	MOLDING - VINYL WRAPPED - .7" X 1.5" X 83.9" - WASHED MAPLE
3F	149326-D2-743	EA	MOLDING - VINYL WRAPPED - .7" X 1.5" X 108" - WASHED MAPLE
3F	149326-F2-134	EA	MOLDING - VINYL WRAPPED - .7" X 2.5" X 83.9" - WASHED MAPLE
3F	149326-F2-438	EA	MOLDING - VINYL WRAPPED - .7" X 2.5" X 96" - WASHED MAPLE
3F	149326-F2-743	EA	MOLDING - VINYL WRAPPED - .7" X 2.5" X 108" - WASHED MAPLE
	149330-A2-438	EA	LUMBER - VINYL WRAPPED - .7" X .75" X 96" - SIERRA MAPLE
	149330-D2-438	EA	LUMBER - VINYL WRAPPED - .7" X 1.5" X 96" - SIERRA MAPLE
	149330-E2-438	EA	LUMBER - VINYL WRAPPED - .7" X 2" X 96" - SIERRA MAPLE
	149330-F2-438	EA	LUMBER - VINYL WRAPPED - .7" X 2.5" X 96" - SIERRA MAPLE
	149330-G2-438	EA	LUMBER - VINYL WRAPPED - .7" X 3" X 96" - SIERRA MAPLE
	149330-H2-438	EA	LUMBER - VINYL WRAPPED - .7" X 3.5" X 96" - SIERRA MAPLE
	149330-J2-438	EA	LUMBER - VINYL WRAPPED - .7" X 5.5" X 96" - SIERRA MAPLE
	149330-J2-743	EA	LUMBER - VINYL WRAPPED - .7" X 5.5" X 108" - SIERRA MAPLE
	149330-K2-438	EA	LUMBER - VINYL WRAPPED - .7" X 3.9" X 96" - SIERRA MAPLE
	149330-R2-438	EA	LUMBER - VINYL WRAPPED - .7" X 3" X 96" - SIERRA MAPLE
3F	149331-D2-134	EA	MOLDING - VINYL WRAP - .7" X 1.5" X 83.9" - SIERRA MAPLE
3F	149331-D2-743	EA	MOLDING - VINYL WRAP - .7" X 1.5" X 108" - SIERRA MAPLE
3F	149331-F2-134	EA	MOLDING - VINYL WRAP - .7" X 2.5" X 83.9" - SIERRA MAPLE
3F	149331-F2-438	EA	MOLDING - VINYL WRAP - .7" X 2.5" X 96" - SIERRA MAPLE
3F	149331-F2-743	EA	MOLDING - VINYL WRAP - .7" X 2.5" X 108" - SIERRA MAPLE

**INTERIOR FINISH GROUP (CONTINUED)**  
**MOLDINGS & TRIMS (CONTINUED)**

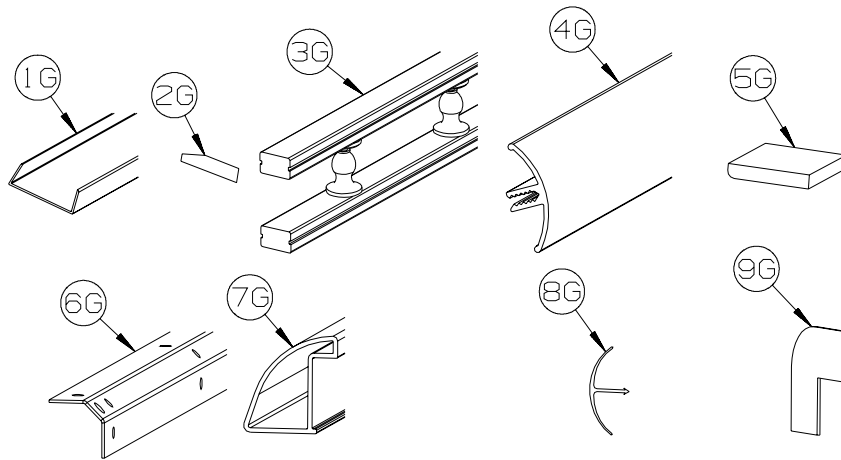

KEY	PART NUMBER	U/M	DESCRIPTION
	141260-01-01A	FT	U-CHANNEL - 1" - VILLAGE OAK
1G	141260-01-02A	FT	U-CHANNEL - 1" - GRADY BROWN
2G	146306-01-01A	FT	TRANSITION - CARPET/TILE
3G	150167-01-03A	EA	RAIL - DECORATIVE - 96" - WASHED MAPLE
3G	150167-01-07A	EA	RAIL - DECORATIVE - 96" - PORTSMOUTH OAK
3G	150167-01-08A	EA	RAIL - DECORATIVE - 96" - HONEY CHERRY
3G	150167-01-09A	EA	RAIL - DECORATIVE - 96" - SIERRA MAPLE
4G	151653-10-02A	EA	TRIM/RADIUS - CABINET CORNER - 79.6" - DULL METALLIC
4G	151653-13-02A	EA	TRIM/RADIUS - CABINET CORNER - 79.8" - DULL METALLIC
5G	M09568-04-W80	EA	MOLDING/TRIM - .3" X 1.5" X 73.6" - SIERRA MAPLE
5G	M09568-04-W79	EA	MOLDING/TRIM - .3" X 1.5" X 73.6" - WASHED MAPLE
6G	151861-01-02B	EA	ANGLE - SUPPORT/CORNER - 1.4" X 12.5" - E-COATED
6G	151861-02-02B	EA	ANGLE - SUPPORT/CORNER - 1.4" X 20.1" - E-COATED
6G	151861-03-02B	EA	ANGLE - SUPPORT/CORNER - 1.4" X 26.7" - E-COATED
6G	151861-04-02B	EA	ANGLE - SUPPORT/CORNER - 1.4" X 32.7" - E-COATED
6G	151861-05-02B	EA	ANGLE - SUPPORT/CORNER - 1.4" X 78.6" - E-COATED
6G	151861-06-02B	EA	ANGLE - SUPPORT/CORNER - 1.4" X 59" - E-COATED
6G	151861-08-02B	EA	ANGLE - SUPPORT/CORNER - 1.4" X 22.2" - E-COATED
6G	151861-09-02B	EA	ANGLE - SUPPORT/CORNER - 1.4" X 14.9" - E-COATED
7G	151893-01-02A	EA	TRIM/RADIUS - CABINET BOTTOM - 72.6" - DULL METALLIC
8G	156464-01-01A	FT	MOLDING - CORNER - RADIUS/PLASTIC - 8' - HONEY CHERRY
8G	156464-01-02A	FT	MOLDING - CORNER - RADIUS/PLASTIC - 8' - WASHED MAPLE
8G	156464-01-05A	FT	MOLDING - CORNER - RADIUS/PLASTIC - 8' - SIERRA MAPLE
8G	156464-01-06A	FT	MOLDING - CORNER - RADIUS/PLASTIC - 8' - CONCERT CHERRY
8G	156464-03-03A	FT	MOLDING - CORNER - RADIUS/PLASTIC - 8' - BONE
	081521-02-007	EA	MOUNT - METAL MOLDING - F/RADIUS CORNER MOLDING - 151.5"
9G	160989-01-06A	FT	CAP - CORNER - RADIUS MOLDING - PLASTIC - WASHED MAPLE
9G	160989-01-07A	FT	CAP - CORNER - RADIUS MOLDING - PLASTIC - HONEY CHERRY

**INTERIOR FINISH GROUP (CONTINUED)**  
**PANELING & LAMINATES**

<b>KEY</b>	<b>PART NUMBER</b>	<b>U/M</b>	<b>DESCRIPTION</b>
	000885-A7-000	SF	PARTICLE BOARD - 3/4" X 4' X 8' - HONEY CHERRY - 2 SIDED - HONEY CHERRY
	000885-A8-000	SF	PARTICLE BOARD - 3/8" X 4' X 8' - HONEY CHERRY - 1 SIDED - HONEY CHERRY
	000885-A9-000	SF	PARTICLE BOARD - 3/8" X 4' X 8' - HONEY CHERRY - 2 SIDED - HONEY CHERRY
	000885-B4-000	SF	PARTICLE BOARD - 3/8" X 4' X 8' - WASHED MAPLE - 2 SIDED - WASHED MAPLE
	000885-B5-000	SF	PARTICLE BOARD - 3/8" X 4' X 8' - WASHED MAPLE - 1 SIDED - WASHED MAPLE
	000885-B6-000	SF	PARTICLE BOARD - 3/4" X 4' X 8' - WASHED MAPLE - 2 SIDED - WASHED MAPLE
	000885-C3-000	SF	PARTICLE BOARD - 3/8" X 4' X 8' - WHITE THATCH EMB-1 SIDED
	074497-47-000	SF	PANELING - HONEY CHERRY - 1/8" X 4' X 8' - HONEY CHERRY
	074497-49-000	SF	PANELING - WASHED MAPLE - 1/8" X 4' X 8' - WASHED MAPLE
	088272-M7-000	SF	PANELING - KURTA/CANVAS - 4' X 7.4' (W29, W30)
	088272-N3-000	SF	PANELING - SPHINX/STONE - 4' X 7.4' (W31, W32, W33, W34)
	088272-M9-000	SF	PANELING - WHITE THATCHED - 4' X 8'
	074498-A2-000	SF	LAMINATE - PLASTIC - PHANTOM GRAY - 5' X 8'
	074498-B6-000	SF	LAMINATE - PLASTIC - SATIN OXIDE - 5' X 8'
	076325-71-000	FT	MOLDING - EDGE BAND - 1 5/16" X .038" - GRAY
	088263-J2-000	EA	BATT STRIP - DECORATIVE - NEAT/WASHED MAPLE - WASHED MAPLE
	088263-K5-000	EA	BATT STRIP - DECORATIVE - WHITE THATCHED - 8'
	088263-K3-000	EA	BATT STRIP - DECORATIVE - KURTA/CANVAS - 8' (W29, W30)
	088263-K9-000	EA	BATT STRIP - DECORATIVE - SPHINX/STONE - 8' (W31, W32, W33, W34)
	085284-J6-000	FT	BATT TAPE - ADHESIVE BACKED - DECORATIVE - HONEY CHERRY
	085284-J5-000	FT	BATT TAPE - ADHESIVE BACKED - DECORATIVE-NEAT/WASHED MAPLE - WASHED MAPLE
	085284-K7-000	FT	BATT TAPE - ADHESIVE BACKED - DECORATIVE - KURTA/CANVAS (W29, W30)
	085284-L3-000	FT	BATT TAPE - ADHESIVE BACKED - DECORATIVE - SPHINX/STONE (W31, W32, W33, W34)

## INTERIOR FINISH GROUP (CONTINUED)

### INTERIOR TRIM LAYOUT

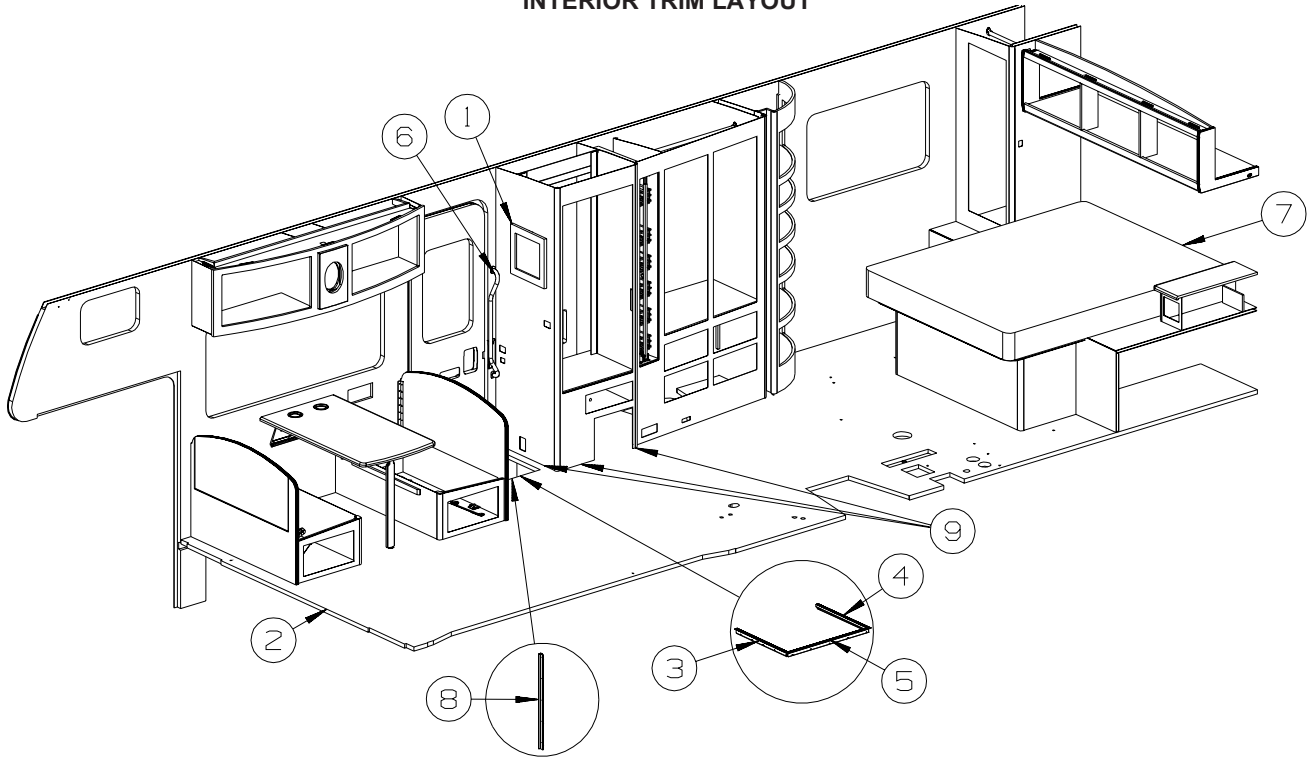

KEY	PART NUMBER	U/M	DESCRIPTION
1	131493-05-03A	EA	PICTURE - DECORATIVE - 10" X 10" - SAND DOLLAR (W29, W30) - <b>INTERIOR UPGRADE PACKAGE</b>
1	131493-05-03A	EA	PICTURE - DECORATIVE - 10" X 10" - SAND DOLLAR (W31, W32) - <b>INTERIOR UPGRADE PACKAGE</b>
1	131493-05-04A	EA	PICTURE - DECORATIVE - 10" X 10" - ARCHITECTURAL (W33, W34) - <b>INTERIOR UPGRADE PACKAGE</b>
	130120-01-01A	EA	BRACKET/MOUNTING - MIRROR
2	139955-18-03A	EA	TRIM - STEP/ENTRY - 62.3" - TITANIUM - <b>VINYL FLOOR COVERING</b>
3	139955-15-01A	EA	TRIM - STEP/ENTRY - 21.7" - MILL
4	139955-16-01A	EA	TRIM - STEP/ENTRY - 21.7" - MILL
5	139955-17-01A	EA	TRIM - STEP/ENTRY - 28" - MILL
6	137605-02-01A	EA	HAND RAIL - INTERIOR ENTRY DOOR - BLACK
7	154430-01-000	EA	MATTRESS - INNERSPRING - 60" X 74.5"
8	139955-14-04A	EA	TRIM - STEP/ENTRY - 26.7" - TITANIUM
9	M09471-79-R46	EA	MOLDING - TRIM/COVE - .8" X .8" X 96" - WASHED MAPLE
9	M09471-79-RE0	EA	MOLDING - TRIM/COVE - .8" X .8" X 96" - HONEY CHERRY

**INTERIOR FINISH GROUP (CONTINUED)**  
**INTERIOR TRIM LAYOUT (CONTINUED)**

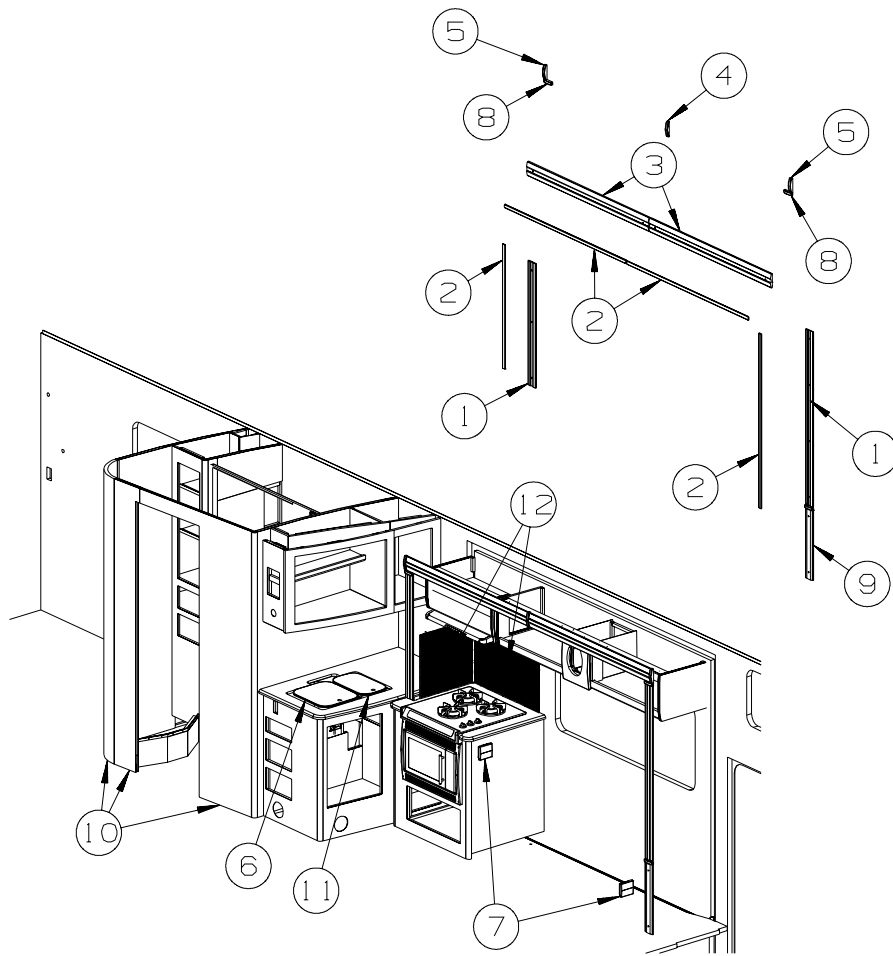

KEY	PART NUMBER	U/M	DESCRIPTION
1	Y00360-A2-438	EA	MOLDING - VINYL/CURVED - 3" X 96" - WASHED MAPLE
1	Y00360-82-438	EA	MOLDING - VINYL/CURVED - 3" X 96" - HONEY CHERRY
2	M09520-83-U21	EA	MOLDING/TRIM - .3" X 1" X 78.9" - WASHED MAPLE
2	M09520-83-U22	EA	MOLDING/TRIM - .3" X 1" X 78.9" - HONEY CHERRY
3	Y00361-A2-438	EA	MOLDING - VINYL/CURVED - 3.9" X 96" - WASHED MAPLE
3	Y00361-82-438	EA	MOLDING - VINYL/CURVED - 3.9" X 96" - HONEY CHERRY
4	156636-06-U21	EA	MOLDING/BLOCK - .8" X 3.1" - HONEY CHERRY
5	156636-05-U21	EA	MOLDING/BLOCK - .8" X 4" - HONEY CHERRY
6	162616-01-01A	EA	COVER/SINK - LARGE - PEARL GRAY - <b>INTERIOR UPGRADE PACKAGE</b>
7	118718-01-01A	EA	HOLDER/DRINK - COLLAPSIBLE MUG - BLACK PLASTIC
7	118718-01-02A	EA	HOLDER/DRINK - COLLAPSIBLE MUG - WHITE PLASTIC
8	156636-04-U21	EA	MOLDING/BLOCK - .8" X 3.1" - HONEY CHERRY
9	153973-02-U21	EA	MOLDING - CROWN/BLOCK - 3.1" X 20.4" - HONEY CHERRY
9	153973-02-U22	EA	MOLDING - CROWN/BLOCK - 3.1" X 20.4" - WASHED MAPLE
10	M09471-79-R46	EA	MOLDING - TRIM/COVE - .8" X .8" X 96" - WASHED MAPLE
10	M09471-79-RE0	EA	MOLDING - TRIM/COVE - .8" X .8" X 96" - HONEY CHERRY
11	162616-02-01A	EA	COVER/SINK - SMALL - PEARL GRAY - <b>INTERIOR UPGRADE PACKAGE</b>
12	162004-01-01A	EA	BACKSPLASH - 18" X 24" - THERMOPLASTIC - <b>INTERIOR UPGRADE PACKAGE</b>
12	162005-01-01A	EA	TRIM/BACKSPLASH - INSIDE CORNER - <b>INTERIOR UPGRADE PACKAGE</b>



**INTERIOR FINISH GROUP (CONTINUED)**  
**INTERIOR TRIM LAYOUT (CONTINUED)**

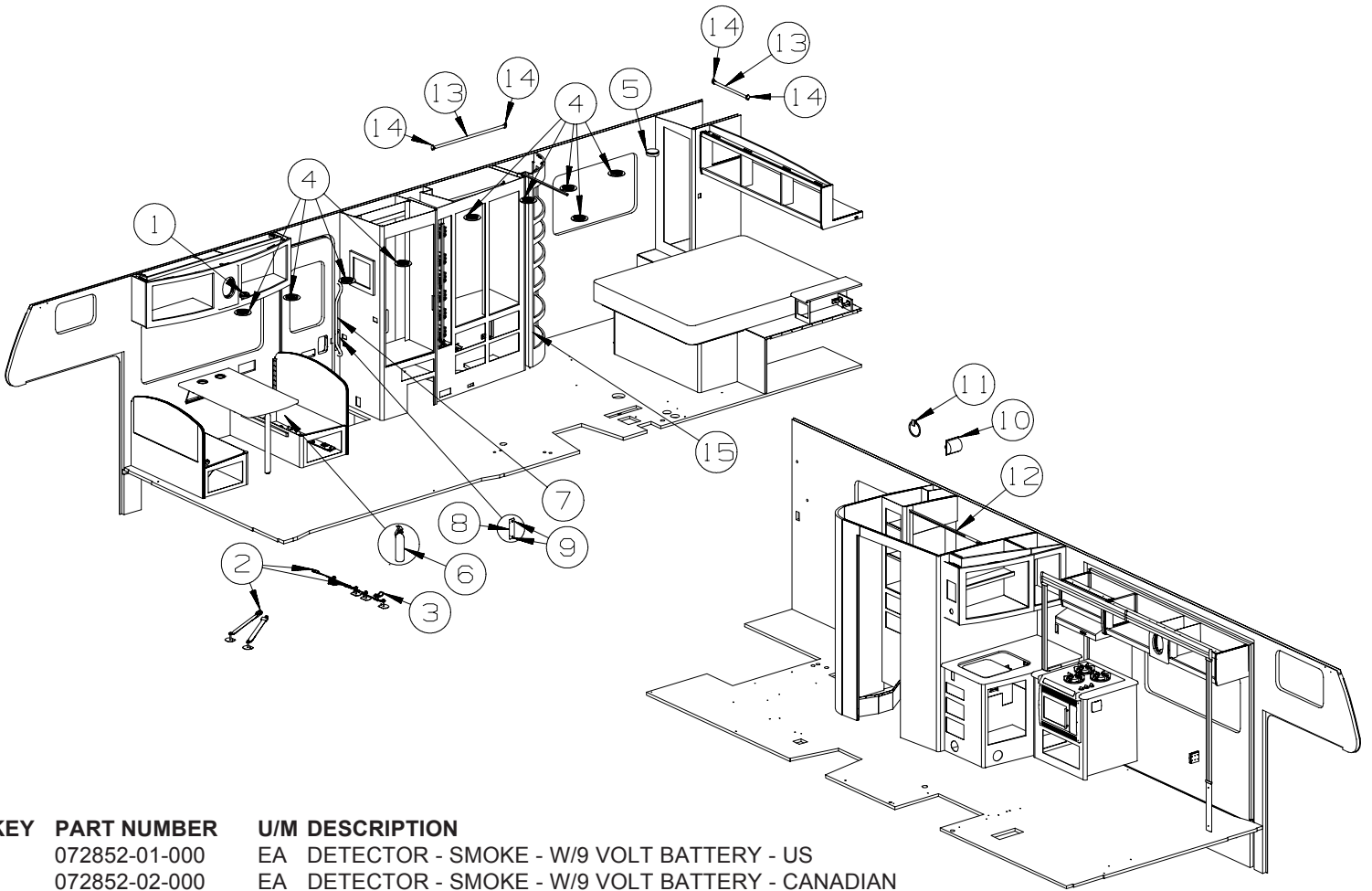

KEY	PART NUMBER	U/M	DESCRIPTION
1	072852-01-000	EA	DETECTOR - SMOKE - W/9 VOLT BATTERY - US
1	072852-02-000	EA	DETECTOR - SMOKE - W/9 VOLT BATTERY - CANADIAN
1	077956-01-000	EA	LABEL - WARNING/SMOKE DETECTOR
2	160167-02-01A	EA	SEAT BELT - 2" X 90" - BLACK
	150283-06-02B	EA	PLATE/WASHER - SEAT BELT - W/BOLT - E-COAT
3	150697-01-02B	EA	BRACKET - RESTRAINT/CHILD - E-COATED
4	120134-01-02A	EA	REGISTER - W/DAMPER - 4" PIPE/6.4" O.D. FACE - WHITE
5	125136-02-000	EA	DETECTOR/CO - GAS MODEL - 9 VOLT
6	094499-03-000	EA	EXTINGUISHER/FIRE - DRY - 10BC - W/GAUGE/BRACKET
6*	094499-02-000	EA	EXTINGUISHER/FIRE - DRY - 10BC - W/GAUGE - CANADIAN
6	094499-04-000	EA	STRAP - FIRE EXTINGUISHER MOUNTING - METAL
7	137605-02-01A	EA	HAND RAIL - INTERIOR ENTRY DOOR - BLACK
8	148362-01-02A	EA	COVER - BRACKET/STRIKE - MEDIUM OAK
9	140151-02-03A	EA	COVER - SCREW - MEDIUM OAK
10	163602-01-01A	EA	HOLDER - TOILET TISSUE - SURFACE MOUNT - CHROME
11	163601-01-01A	EA	TOWEL RING - CHROME
12*	151578-02-01A	EA	DOOR - SHOWER - 47.9" X 59.9" - WHT OPAQUE SCREEN/WHITE
13	Y00136-21-218	EA	DOWEL - WOOD - CLOTHES ROD - 1"DIAMETER X 4'
14	152301-01-01A	EA	FLANGE - PLASTIC - 1" CLOTHES ROD HOLDER - WHITE
15*	131595-01-01A	EA	DOOR/FOLDING-36.9"X 74.9"-4 CEILING BRKTS & STRAIGHT TRACK

**\*COMPONENT PARTS LISTED LATER IN THIS GROUP**

**INTERIOR FINISH GROUP (CONTINUED)**  
**COMPONENT PART FOR INTERIOR TRIM LAYOUT**

**094499-02-000**

<b>KEY</b>	<b>PART NUMBER</b>	<b>U/M</b>	<b>DESCRIPTION</b>	<b>VENDOR NO</b>
	094499-01-700	EA	BRACKET MTG. W/PLAS. STRAP	294039

**131595-01-01A, 131595-05-01A, 131595-10-01A, 131595-13-01A**

<b>KEY</b>	<b>PART NUMBER</b>	<b>U/M</b>	<b>DESCRIPTION</b>	<b>VENDOR NO.</b>
	117431-01-707	EA	BALL CATCH - PLASTIC	
	131595-01-700	EA	END STOP ONLY	
	131595-01-701	EA	BRACKET/MOUNTING	908956
	131595-01-702	EA	TRACK/STRAIGHT - 37"	

**151578-02-01A**

<b>KEY</b>	<b>PART NUMBER</b>	<b>U/M</b>	<b>DESCRIPTION</b>	<b>VENDOR NO.</b>
	151578-02-700	EA	UPPER/LOWER TRACK, 36" WHITE	

**FLOOR COVERINGS**

<b>KEY</b>	<b>PART NUMBER</b>	<b>U/M</b>	<b>DESCRIPTION</b>
	042720-41-000	SY	VINYL - FLOOR COVERING - CALAY/#69325
	075233-01-000	SY	PAD - CARPET - 3/8" X 6'W ROLL - SOLD BY THE SQUARE YARD
	093486-01-000	SY	CARPET - COMPARTMENT - 72" WIDE - DARK GRAY
	152251-05-08A	SY	CARPET - 4 SQUARE YARD INCREMENTS - CORDWOOD (W29, W30)
	152251-05-06A	SY	CARPET - 4 SQUARE YARD INCREMENTS - CAST IRON (W31, W32)
	152251-05-07A	SY	CARPET - 4 SQUARE YARD INCREMENTS - RAFFIA (W33, W34)

## INTERIOR FINISH GROUP (CONTINUED)

### HARDWARE

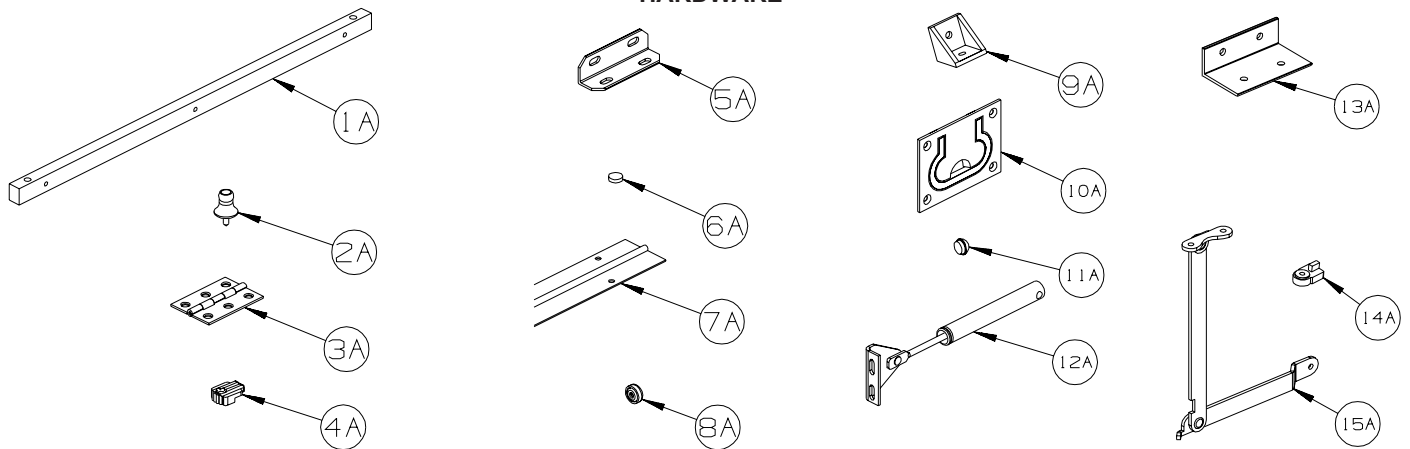

KEY	PART NUMBER	U/M	DESCRIPTION
1A	P34509-01-P14	EA	RAIL END - RH/LH - TOWEL RACK - CONCERT CHERRY
1A	P34509-01-J70	EA	RAIL END - RH/LH - TOWEL RACK - WASHED MAPLE
1A	P34509-01-RE0	EA	RAIL END - RH/LH - TOWEL RACK - HONEY CHERRY
1A	P34509-01-SA3	EA	RAIL END - RH/LH - TOWEL RACK - SIERRA MAPLE
2A	009013-01-000	EA	CATCH - BULLDOG - MALE/FEMALE
3A	009059-01-000	EA	HINGE - DOOR - 2" X 1.4" - BRASS
3A	009059-02-000	EA	HINGE - DOOR - 2" X 2.7" - BRASS
3A	009059-03-000	EA	HINGE - BRASS - 1.75"
3A	009059-04-000	EA	HINGE - 2" - ZINC
4A	009089-01-000	EA	CLIP - MIRROR
5A	016604-01-000	EA	BRACE - ANGLE - 2 1/2" - UNPAINTED METAL
5A	016604-05-000	EA	BRACE - ANGLE - 2 1/2" - OFF WHITE METAL
5A	016604-10-000	EA	BRACE - SEAT ANGLE - 2.5" - BLACK
6A	023320-01-000	EA	PAD - FELT 3/8" DIAMETER
7A	041389-19-000	EA	HINGE - PIANO - 1 1/2" X 71.9" - UNPAINTED
7A	041389-25-000	EA	HINGE - PIANO - 1 1/2" X 55" - UNPAINTED
7A	041389-32-000	EA	HINGE - PIANO - 68" - OFF WHITE
8A	166569-01-02A	EA	COVER - SCREW - #8 - BRIGHT WHITE
8A	166569-01-03A	EA	COVER - SCREW - #8 - SOFT WHITE
8A	166569-01-04A	EA	COVER - SCREW - #8 - CREAM
9A	065740-01-000	EA	BRACE - CABINET/CORNER - PLASTIC
10A	072871-01-000	EA	PULL - FLUSH - CHROME
11A	074045-13-000	EA	PLUG - 3/8" DOWEL-1/2" HEAD - PORTSMOUTH OAK
11A	074045-08-000	EA	PLUG - 3/8" DOWEL-1/2" HEAD - OAK/SALEM CHERRY - CONCERT CHERRY
11A	074045-12-000	EA	PLUG - 3/8" DOWEL-1/2" HEAD - WASHED MAPLE
11A	074045-14-000	EA	PLUG - 3/8" DOWEL-1/2" HEAD - HONEY CHERRY
11A	074045-15-000	EA	PLUG - 3/8" DOWEL-1/2" HEAD - SIERRA MAPLE
12A	074493-02-000	EA	SUPPORT/PISTON SPRING - CABINET DOOR - 26 LBS
12A	074493-03-000	EA	SUPPORT/PISTON SPRING - CABINET DOOR - 12 LBS
13A	156732-01-01A	EA	BRACE - ANGLE/COUCH - 2.5" - MILL
13A	156732-01-02A	EA	BRACE - ANGLE/COUCH - 2.5" - OFF WHITE
13A	156732-03-01A	EA	BRACE - ANGLE/COUCH - BLACK
14A	083204-03-000	EA	BUTTON - RETAINING MIRROR 5/16" TIP
15A	084412-01-000	EA	SUPPORT/HINGE KIT (LEFT & RIGHT HINGES)

**INTERIOR FINISH GROUP (CONTINUED)**  
**HARDWARE (CONTINUED)**

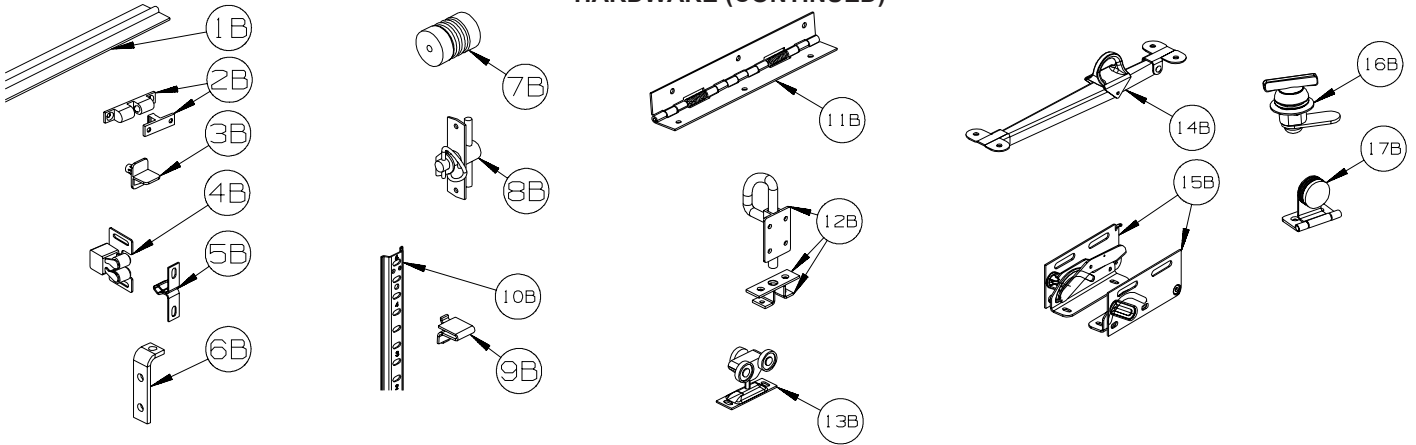

KEY	PART NUMBER	U/M	DESCRIPTION
1B	084413-01-000	EA	HINGE - 1" X 72" - ALUMINUM - W/HOLES
2B	084451-01-000	EA	CATCH & LATCH - 1.7" - BRASS
3B	092907-01-000	EA	SUPPORT - SHELF - PIN - 1/4" - CLEAR PLASTIC
4B	093586-03-000	EA	CATCH - SPRING ROLLER - .377"
4B	093586-06-000	EA	CATCH - W/STRIKE - SPRING ROLLER .236"/SPRINT STEEL .943"
5B	093586-04-000	EA	STRIKE - SPRING STEEL - 1.14"
6B	096826-01-01A	EA	BRACE - CABINET - 2" - E-COATED
6B	096826-02-01A	EA	BRACE - CABINET - 1" - E-COATED
7B	097872-04-000	EA	DOWEL - WOOD - 1" DIAMETER X 1.38" LONG - UNFINISHED
8B	098196-01-000	EA	LATCH - 1/4 TURN - T-BAR
9B	098979-01-000	EA	CLIP - ADJUSTABLE SHELF
10B	098980-01-000	EA	PILASTER - ADJUSTABLE SHELF - 18"
10B	098980-02-000	EA	PILASTER - ADJUSTABLE SHELF - 12"
10B	098980-03-000	EA	PILASTER - ADJUSTABLE SHELF - 9"
10B	098980-04-000	EA	PILASTER - ADJUSTABLE SHELF - 48"
10B	098980-05-000	EA	PILASTER - ADJUSTABLE SHELF - 15"
10B	098980-06-000	EA	PILASTER - ADJUSTABLE SHELF - 24"
11B	102920-01-02A	EA	HINGE - SPRING LOADED - NICKEL
11B	129753-01-01A	EA	HINGE - SPRING LOADED - 19" X 19" - BLACK
12B	103256-01-000	EA	LATCH COMPLETE (SLIDE)
13B	103874-01-000	EA	HANGER - SLIDING DOOR
14B	104181-01-01A	EA	SUPPORT - LEAF 5.3" EXTENDS TO 7.5" - SAFETY RING - METAL
15B	108126-01-000	EA	TRAY HINGE SET (QTY. 2 PER SET)
16B	100710-01-02A	EA	LOCK - GLASS DOOR/TWIST TYPE - NICKEL
17B	100711-01-02A	EA	HINGE - GLASS DOOR - BLACK

**INTERIOR FINISH GROUP (CONTINUED)**  
**HARDWARE (CONTINUED)**

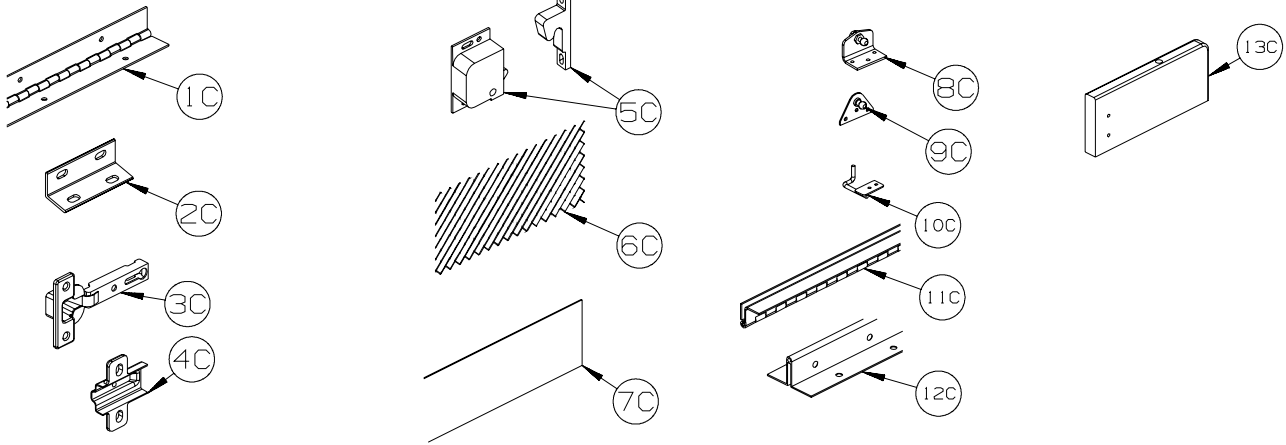

KEY	PART NUMBER	U/M	DESCRIPTION
1C	110496-01-02A	EA	HINGE - NICKEL - 2" X 32"
1C	110496-06-02A	EA	HINGE - NICKEL - 2" X 9.5"
1C	158921-01-04B	EA	HINGE - PIANO - TRUNK DOOR - 2" X 21.9" - BLACK
2C	111866-01-02A	EA	BRACE - SEAT - ANGLE - OFF WHITE
3C	114443-02-01A	EA	HINGE - CABINET DOOR - W/O CLIP - SILVER
4C	114443-03-01A	EA	CLIP - HINGE/CABINET DOOR - SILVER
5C	117095-02-01A	EA	LATCH - DOOR - GRABBER W/KEEPER - PLASTIC - BLK-10 LB PULL
5C	117095-03-01A	EA	LATCH - DOOR - GRABBER W/KEEPER - PLASTIC - BLK-15 LB PULL
6C	118200-01-01A	SF	MESH - PLASTIC 1/2" - 48" X LENGTH = SF - BLACK
7C	122717-06-01A	FT	PAD - NON-SKID - PSA - 5"W
8C	126263-06-02B	EA	BRACKET - GAS SPRING W/INSIDE BALL STUD - E-COATED
9C	126263-05-02B	EA	BRACKET - GAS SPRING W/BALL STUD - E-COATED
9C	126263-08-02B	EA	BRACKET - GAS SPRING W/CENTERED BALL STUD - E-COATED
10C	130798-01-02B	EA	GUIDE - POCKET DOOR - E-COATED
11C	134099-01-02A	EA	HINGE - PIANO - WRAP AROUND - 15.7" - NICKEL PLATED
12C	135538-03-02A	EA	HINGE - PIANO - FULL WRAP - 15.7" - CHROME
12C	135538-07-02A	EA	HINGE - PIANO - FULL WRAP - 9.8" - CHROME
13C	137445-03-T78	EA	STOP - F/SLIDING DOOR - CONCERT CHERRY
13C	137445-03-T79	EA	STOP - F/SLIDING DOOR - WASHED MAPLE
13C	137445-03-T80	EA	STOP - F/SLIDING DOOR - SIERRA MAPLE

**INTERIOR FINISH GROUP (CONTINUED)**  
**HARDWARE (CONTINUED)**

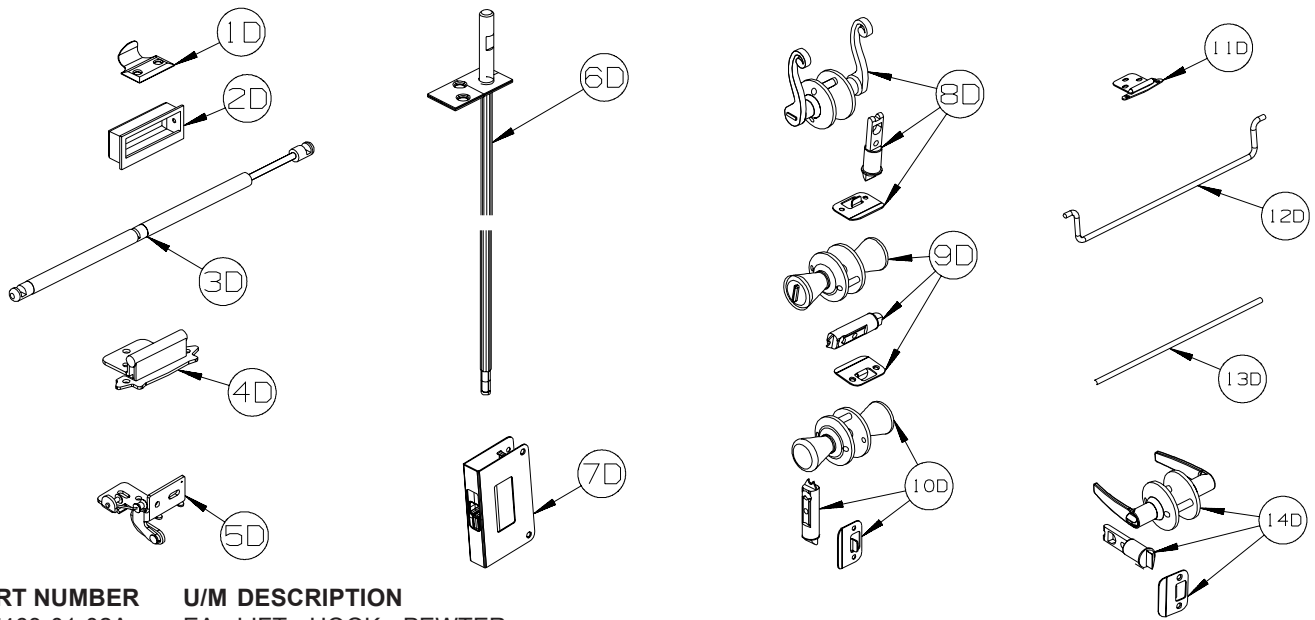

KEY	PART NUMBER	U/M	DESCRIPTION
1D	137463-01-02A	EA	LIFT - HOOK - PEWTER
2D	139136-02-02A	EA	HANDLE - .35" RECESSED - PEWTER
3D	142569-07-000	EA	SPRING/GAS - 20 LB - 20" EXTENDED/12" COMPRESSED
3D	142569-15-000	EA	SPRING/GAS - 120 LB - 20" EXTENDED/12" COMPRESSED
3D	142569-16-000	EA	SPRING/GAS - 90 LB - 20" EXTENDED/12" COMPRESSED
3D	142569-29-000	EA	SPRING/GAS - 20 LB - 9.9" EXTENDED/5.9" COMPRESSED
3D	142569-31-000	EA	SPRING/GAS - 30 LB - 11.8" EXTENDED/7.3" COMPRESSED
4D	143468-02-03A	EA	HINGE - SELF CLOSING - SATIN NICKEL
4D	143468-02-04A	EA	HINGE - SELF CLOSING - OIL RUBBED BRONZE
4D	143468-02-05A	EA	HINGE - SELF CLOSING - RUSTIC BRASS
5D	144488-01-01A	EA	HINGE - CABINET - ANTIQUE BRASS
5D	144488-01-02A	EA	HINGE - CABINET - NICKEL
6D	145939-05-02A	EA	ROD/LATCH - AISLE DOOR - NICKEL
7D	145939-04-02A	EA	LATCH/SLIDE - AISLE DOOR(1" THICK DOOR)-NICKEL/BLACK SLIDE
7D	145939-04-03A	EA	LATCH/SLIDE - AISLE DOOR(1" THICK DOOR)-OIL RUBBED BRONZE
8D	146064-01-02A	EA	LOCK/PRIVACY (LOCKING) LEVER STYLE - SATIN PEWTER
8D	146064-02-02A	EA	LOCK/PASSAGE (NON LOCKING) LEVER STYLE - PEWTER
9D	146064-05-01A	EA	LOCK/PRIVACY (LOCKING) "TULIP" STYLE KNOB - SATIN NICKEL
10D	146064-06-01A	EA	LOCK/PASSAGE (NON LOCKING) "TULIP" STYLE KNOB-SATIN NICKEL
11D	146553-01-03A	EA	HINGE - CABINET DOOR - SATIN NICKEL
12D	146801-01-02A	EA	ROD/TOWEL BAR (OFFSET) - PEWTER
13D	146840-03-02A	EA	ROD - .25" X 11.7" - PEWTER
13D	146840-04-02A	EA	ROD - .25" X 13.1" - PEWTER
14D	146064-08-01A	EA	LOCK/PASSAGE (NON LOCKING) LEVER STYLE - SATIN NICKEL
14D	146064-07-01A	EA	LOCK/PRIVACY (LOCKING) LEVER STYLE - SATIN NICKEL

## INTERIOR FINISH GROUP (CONTINUED) HARDWARE (CONTINUED)

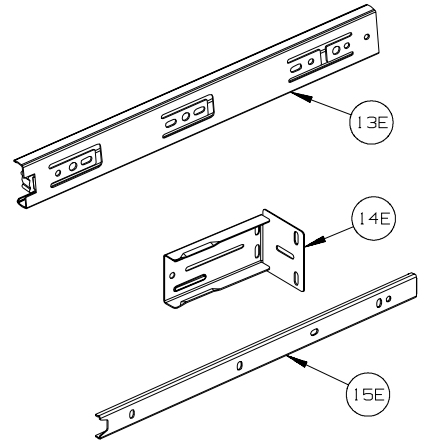
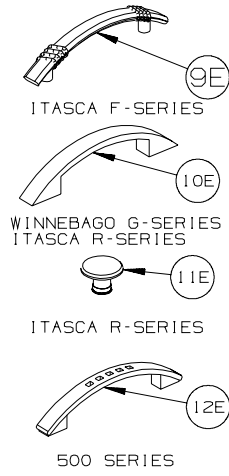
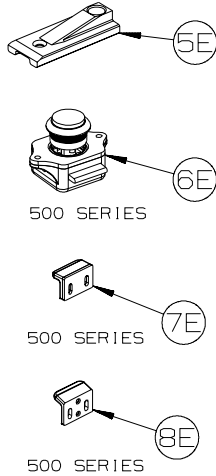
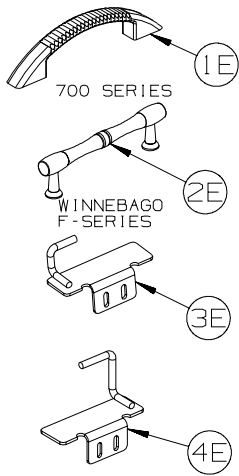

KEY	PART NUMBER	U/M	DESCRIPTION
1E	148816-01-02A	EA	PULL - CABINET DOOR - NICKEL - <b>ASPECT, CAMBRIA 700-SERIES/ADVENTURER LIMITED EDITION</b>
2E	149090-01-02A	EA	PULL - CABINET DOOR - NICKEL - <b>VOYAGE F-SERIES</b>
3E	149607-01-02B	EA	GUIDE - F/POCKET DOOR - 1.6" BENT ROD - E-COATED
3E	149607-03-02B	EA	GUIDE - F/POCKET DOOR - 2.9" BENT ROD - E-COATED
4E	149607-04-02B	EA	GUIDE - F/POCKET DOOR - E-COATED
5E	150983-01-01A	EA	STRIKE/BLOCK - WEDGE STYLE - F/SLIDE DOOR - 3" X 1.2" - BLACK
6E	151380-01-01A	EA	LATCH - CBNT DR - PUSH BTN - <b>VIEW &amp; NAVION 500-SERIES</b>
6E	151380-01-02A	EA	LATCH - CABINET DOOR - PUSH BUTTON - BLACK - <b>TOUR &amp; ELLIPSE R-SERIES</b>
7E	151380-02-01A	EA	STRIKE - CABINET DOOR - <b>VIEW &amp; NAVION 500-SERIES</b>
8E	151380-03-01A	EA	STRIKE - CABINET DOOR - <b>VIEW &amp; NAVION 500-SERIES</b>
9E	152302-01-01A	EA	PULL - CABINET DOOR - SATIN NICKEL - <b>SUNRISE F-SERIES</b>
10E	152304-01-01A	EA	PULL - CABINET DOOR - BRONZE- <b>ADVENTURER G-SERIES, ELLIPSE R-SERIES</b>
11E	152305-01-01A	EA	KNOB - DOOR/DRAWER - BRONZE - <b>ELLIPSE R-SERIES</b>
12E	152950-01-01A	EA	PULL - DOOR/DRAWER - BRUSHED NICKEL - <b>VIEW &amp; NAVION 500-SERIES</b>
13E	153000-01-01A	EA	SLIDE - CABINET MOUNT - 11.8"
13E	153000-03-01A	EA	SLIDE - CABINET MOUNT - 13.8"
13E	153000-05-01A	EA	SLIDE - CABINET MOUNT - 15.7"
13E	153000-07-01A	EA	SLIDE - CABINET MOUNT - 17.7"
13E	153000-09-01A	EA	SLIDE - CABINET MOUNT - 19.7"
13E	153000-11-01A	EA	SLIDE - CABINET MOUNT - 21.6"
13E	153000-14-01A	EA	SLIDE - CABINET MOUNT - 23.6"
13E	153000-16-01A	EA	SLIDE - CABINET MOUNT - 7.9"
13E	153000-18-01A	EA	SLIDE - CABINET MOUNT - 9.8"
13E	153000-20-01A	EA	SLIDE - CABINET MOUNT - 25.6"
14E	153000-13-01A	EA	BACKSOCKET - DRAWER SLIDE
15E	153000-02-01A	EA	SLIDE - DRAWER MOUNT - 11.8"
15E	153000-04-01A	EA	SLIDE - DRAWER MOUNT - 13.8"
15E	153000-06-01A	EA	SLIDE - DRAWER MOUNT - 15.7"
15E	153000-08-01A	EA	SLIDE - DRAWER MOUNT - 17.7"
15E	153000-10-01A	EA	SLIDE - DRAWER MOUNT - 19.7"
15E	153000-12-01A	EA	SLIDE - DRAWER MOUNT - 21.6"
15E	153000-15-01A	EA	SLIDE - DRAWER MOUNT - 23.4"
15E	153000-17-01A	EA	SLIDE - DRAWER MOUNT - 7.7"
15E	153000-19-01A	EA	SLIDE - DRAWER MOUNT - 9.6"
15E	153000-21-01A	EA	SLIDE - DRAWER MOUNT - 25.4"

## INTERIOR FINISH GROUP (CONTINUED) HARDWARE (CONTINUED)

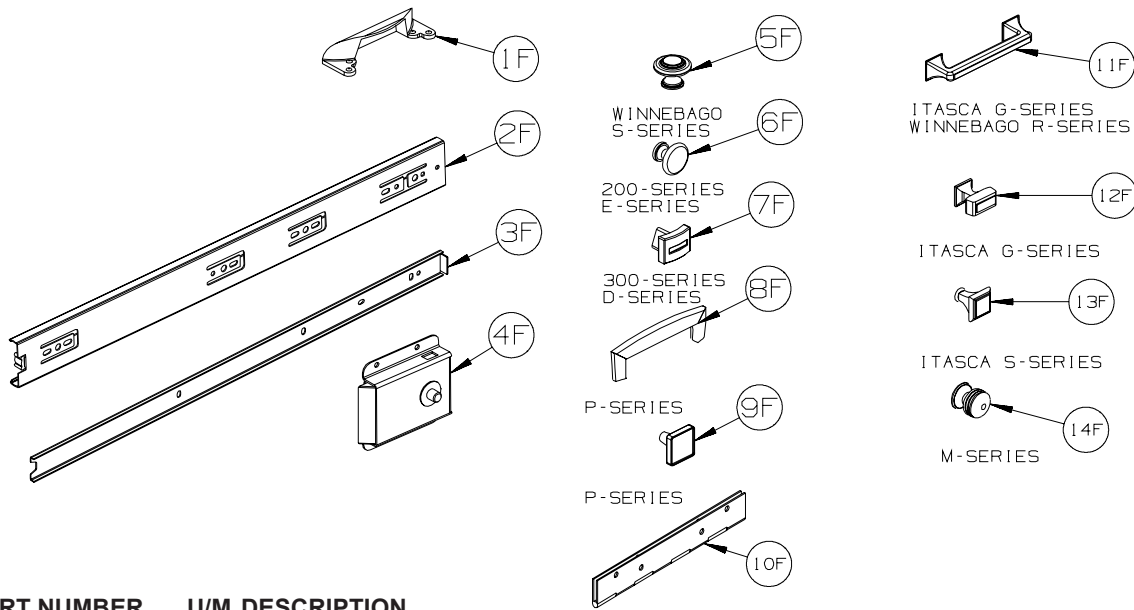

KEY	PART NUMBER	U/M	DESCRIPTION
1F	153308-01-01A	EA	PULL - VANITY STOOL - SATIN NICKEL
2F	153352-01-01A	EA	SLIDE - PANTRY - 19.7" - CABINET MOUNT
3F	153352-02-01A	EA	SLIDE - PANTRY - 19.5" - DRAWER MOUNT
4F	153353-01-01A	EA	LATCH - SLIDING/FLUSH - BLACK
5F	155803-01-01A	EA	KNOB CABINET DOOR - WROUGHT IRON - <b>VECTRA S-SERIES</b>
6F	155925-01-01A	EA	KNOB - DOOR/DRW - SATIN NICKEL - <b>ACCESS &amp; IMPULSE 200-SERIES/ VISTA &amp; SUNSTAR E-SERIES</b>
7F	156579-01-01A	EA	KNOB - DOOR/DRW - PEWTER - <b>OUTLOOK &amp; SPIRIT 300-SERIES/ SIGHTSEER &amp; SUNOVA D-SERIES</b>
8F	157246-01-01A	EA	PULL - CABINET DOOR/DRAWER - SATIN NICKEL - <b>JOURNEY &amp; MERIDIAN P-SERIES</b>
9F	157246-02-01A	EA	KNOB - CABINET DOOR/DRAWER-SATIN NICKEL - <b>JOURNEY &amp; MERIDIAN P-SERIES</b>
10F	158982-01-04B	EA	HINGE - CONTINUOUS - 2" X 8" - BLACK
10F	158982-01-01A	EA	HINGE - CONTINUOUS - 2" X 8" - ZINC
11F	162033-01-01A	EA	PULL - CABINET DOOR - BRUSHED NICKEL - <b>SUNCRUISER G-SERIES, TOUR R-SERIES</b>
12F	162033-02-01A	EA	KNOB - CABINET DOOR - BRUSHED NICKEL - <b>SUNCRUISER G-SERIES</b>
13F	162518-01-01A	EA	KNOB - DOOR/DRAWER - SATIN NICKEL - <b>HORIZON S-SERIES</b>
14F	163095-01-01A	EA	KNOB - CABINET DOOR - SATIN NICKEL - <b>DESTINATION &amp; LATTITUDE M-SERIES</b>



## LABELS GROUP

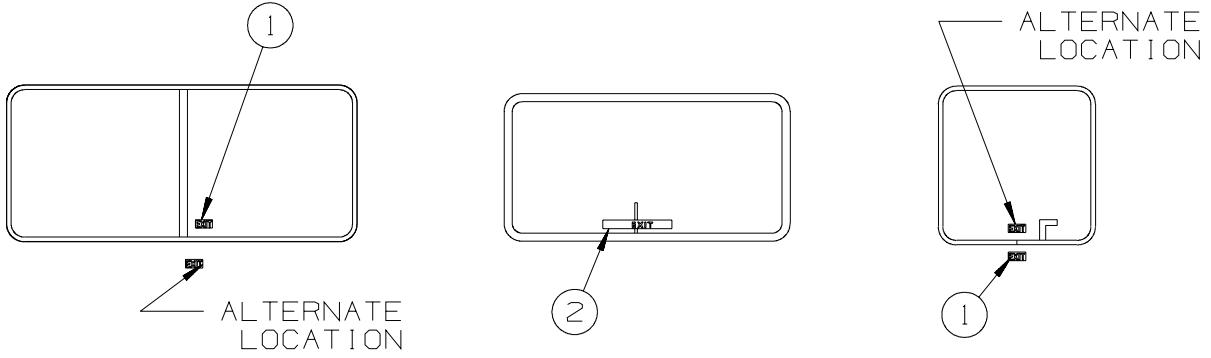

KEY	PART NUMBER	U/M	DESCRIPTION
1	039290-01-000	EA	LABEL - WARNING - EXIT
2	107571-01-000	EA	LABEL - EXIT/ESCAPE WINDOW

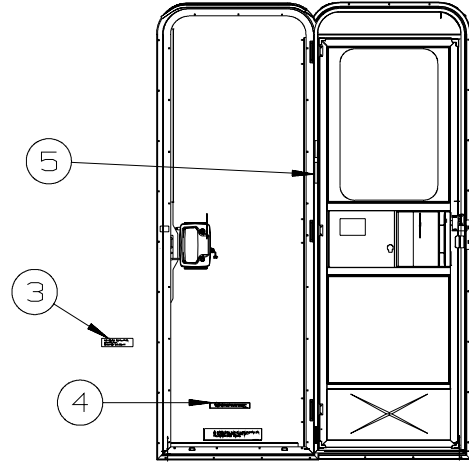
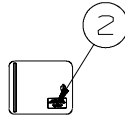
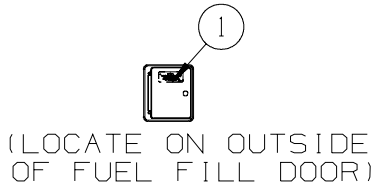

KEY	PART NUMBER	U/M	DESCRIPTION
1	124519-01-01A	EA	LABEL - WARNING/REFUELING - BLACK ON CLEAR
1	124519-02-01A	EA	LABEL - WARNING/REFUELING - BLACK ON CLEAR - CANADIAN
2	125306-01-01A	EA	LABEL - ELECTRICAL ENTRANCE - 110V 30 AMP - BLACK ON CLEAR
3	099509-01-000	EA	LABEL - AWNING INSTALLATION
4	065748-01-000	EA	LABEL - WARNING - BATTERY CHARGING - UL
4	065748-02-000	EA	LABEL - WARNING - BATTERY CHARGING - CANADIAN
5	135869-01-01A	EA	LABEL - MERCURY CONTENT - BLACK ON CLEAR

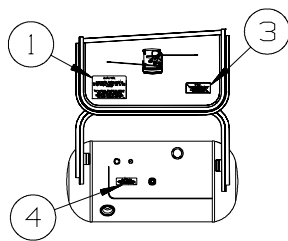

(DRAINAGE COMPARTMENT)

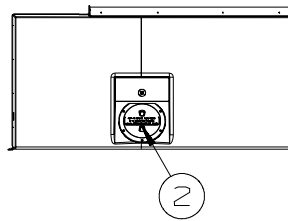

KEY	PART NUMBER	U/M	DESCRIPTION
1	124520-01-01A	EA	LABEL - LP GAS ONLY - BLACK ON CLEAR
1	023769-01-000	EA	LABEL - WARNING - LPG - CANADIAN
2	123562-01-000	EA	LABEL - SERVICE/UTILITY ACCESS
3	124519-01-01A	EA	LABEL - WARNING/REFUELING - BLACK ON CLEAR
3	124519-02-01A	EA	LABEL - WARNING/REFUELING - BLACK ON CLEAR - CANADIAN
4	079965-01-000	EA	LABEL - LPG - 80% CAPACITY

## LABELS GROUP (CONTINUED)

(LABELS SHALL BE LOCATED  
ON OPPOSITE SIDE OF VISOR  
THAT THE AIR BAG LABEL IS  
INSTALLED ON)

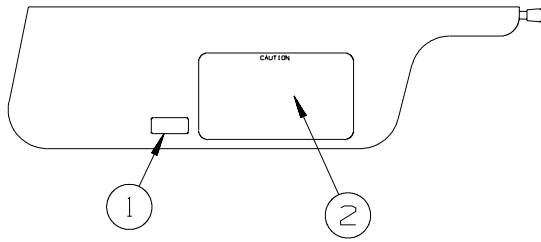

( INSTRUMENT  
CLUSTER )

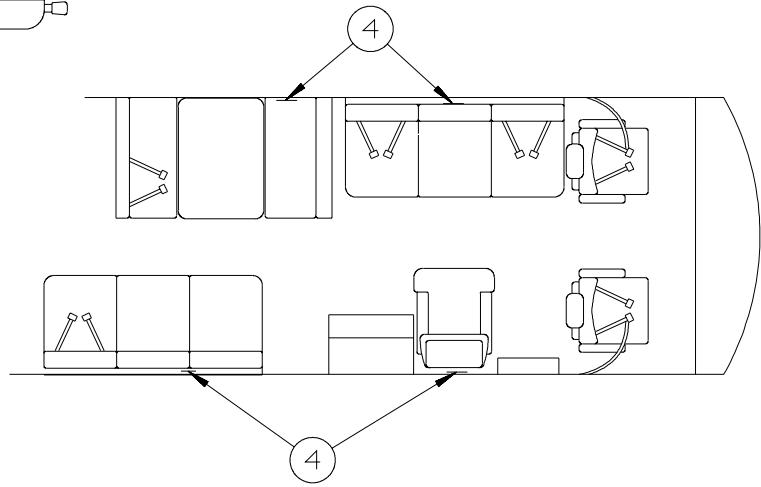
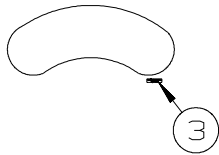

KEY	PART NUMBER	U/M	DESCRIPTION
	136360-01-01A	EA	LABEL - AIR BAGS
	136360-02-01A	EA	LABEL - AIR BAGS - BLACK/CLEAR
1	099689-01-000	EA	LABEL - WARNING - CANCER/TOXICITY
2	056259-01-000	EA	LABEL - SAFETY CHECK LIST
3	155692-01-02A	EA	LABEL - ODOMETER - READ IN MILE - WHITE/CLEAR
4	134538-01-01A	EA	LABEL - OCCUPANCY - NO SEAT BELT - BLACK ON CLEAR - US
4	134538-02-01A	EA	LABEL - OCCUPANCY - NO SEAT BELT - BLACK ON CLEAR - <b>CANADIAN</b>

## LABELS GROUP (CONTINUED)

(LABEL NOT TO COVER SENSOR OPENING)

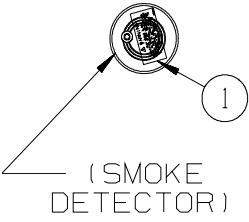

329B (ALTERNATE)  
(LOCATE TO LEFT OF BACKSPLASH)

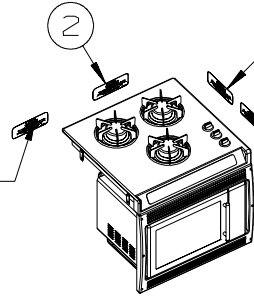

331H (ALTERNATE)  
(LOCATE ON SPLASH GUARD)

331C (ALTERNATE)  
(LOCATE BELOW MONITOR PANEL)

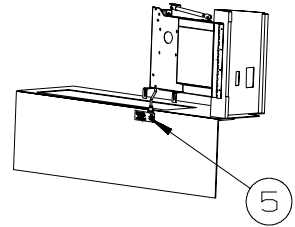
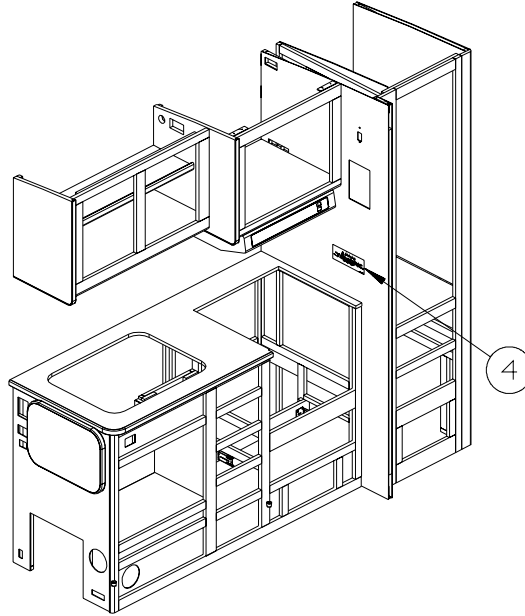
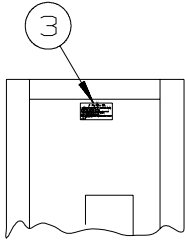

KEY	PART NUMBER	U/M	DESCRIPTION
1	077956-01-000	EA	LABEL - WARNING/SMOKE DETECTOR
2	134539-01-01A	EA	LABEL - WARNING - STOVE/HEATING - US - BLACK ON CLEAR
2	134540-01-01A	EA	LABEL - WARNING - STOVE/HEATING - CSA - BLACK ON CLEAR - CANADIAN
3	073998-01-000	EA	LABEL - LPG/ODOR WARNING
4	143911-01-01A	EA	LABEL - CURTAIN SECUREMENT - BLACK ON CLEAR
4	155196-01-01A	EA	LABEL - CURTAIN SECUREMENT - BLACK ON CLEAR - CANADIAN
5	159837-01-01A	EA	LABEL - CAUTION - SWINGOUT TV - BLACK/CLEAR/RED

## LABELS GROUP (CONTINUED)

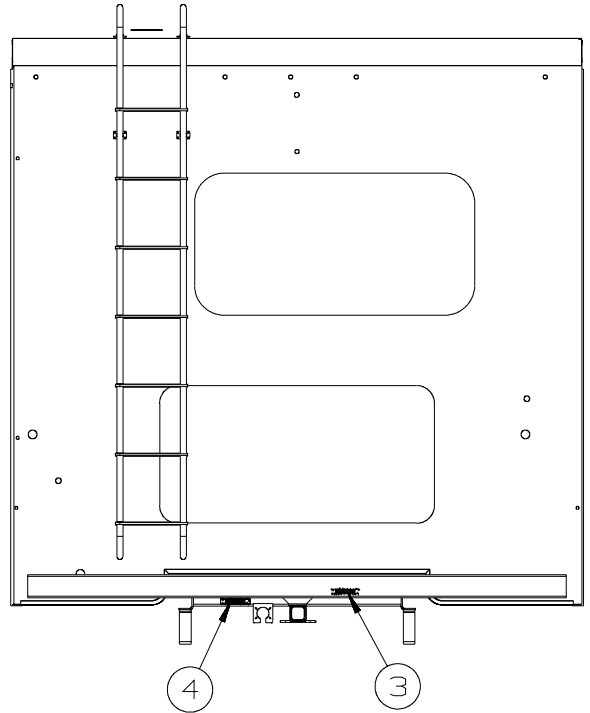
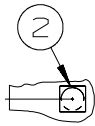
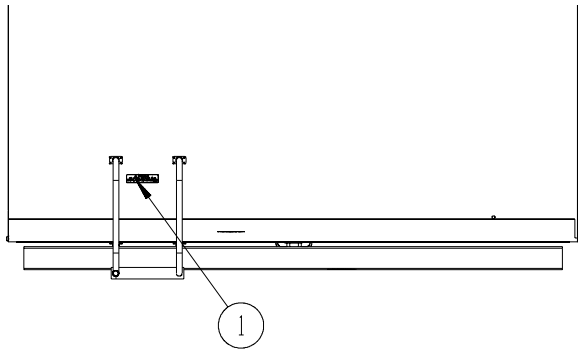

KEY	PART NUMBER	U/M DESCRIPTION
1	163705-01-01A	EA LABEL - WARNING - ROOF SLIPPERY - BLACK ON WHITE
2	120431-01-000	EA LABEL - LOCATION - COAXIAL CABLE/SATELLITE ANTENNA
3	129669-01-02A	EA LABEL - HITCH/VEHICLE RATE - 350 - BLACK ON CLEAR
4	129669-01-01A	EA LABEL - HITCH/VEHICLE RATE - 350 - WHITE ON CLEAR

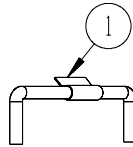

(PROP ROD  
ENTRANCE  
DOOR)

KEY	PART NUMBER	U/M DESCRIPTION
1	128658-01-000	EA LABEL - PROP ROD - ENTRY DOOR

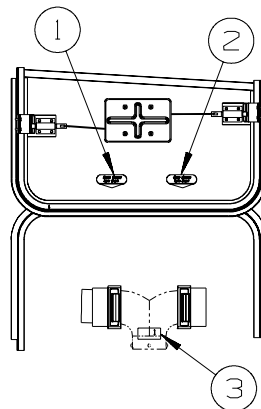

KEY	PART NUMBER	U/M DESCRIPTION
1	152543-03-01A	EA LABEL - BLACK WASTE
2	152541-03-01A	EA LABEL - GRAY WASTE
3	144649-01-01A	EA LABEL - ADJUSTABLE VALVE - WHITE ON CLEAR

**LP GROUP  
LP SYSTEM**

KEY	PART NUMBER	U/M	DESCRIPTION
	010329-01-000	EA	ADAPTER - 1/2"F X 1/2"MPT - BRASS
	010323-01-000	EA	ADAPTER - 3/8"F X 1/2"MPT - BRASS
	010326-01-000	EA	ADAPTER - FLARE - W/CONE GASKET - 3/8"F X 1/2"F
	024250-01-000	EA	ADAPTER - BRASS - 3/8"F X 1/2"FPT
	045703-03-000	EA	HOSE - LP - 3/8"ID X 18" - 3/8"MPT X 1/2"F SWIVEL - US
	045703-12-000	EA	HOSE - LP - 3/8"ID X 18" - 3/8"MPT X 1/2"F SWIVEL - CANADIAN
	045703-05-000	EA	HOSE - LP - 3/8"ID X 28" - 3/8"MPT X 1/2"F SWIVEL - US
	045703-06-000	EA	HOSE - LP - 3/8"ID X 28" - 3/8"MPT X 1/2"F SWIVEL - CANADIAN
	045703-14-000	EA	HOSE - LP - 3/8"ID X 157.5" - 1/2"F SWIVEL X 1/2"F SWIVEL
	045703-22-000	EA	HOSE - LP - 3/8"ID X 60" - 1/2"F SWIVEL X 1/2"F SWVL US/CANADIAN
	010589-01-000	EA	NIPPLE - PIPE - 1/2" X 1 1/2" - BLACK
	010589-03-000	EA	NIPPLE - PIPE - 1/2" X 2 1/2" - BLACK
	010380-02-000	EA	NUT - 1/2" FLARE - FORGED - BRASS
	010377-02-000	EA	NUT - 3/8" FLARE - FORGED - BRASS
	106150-05-000	EA	REGULATOR - TWO STAGE
	144485-01-000	EA	COVER - LP REGULATOR
*	144116-04-000	EA	TANK - LP - 60 LB - 14"D X 29.75"L
	040440-02-000	EA	TRANSMITTER - DIAL/BOLT-ON - 0-90 OHM 2 TERM(POWER/GROUND)

**\*COMPONENT PARTS LISTED LATER IN THIS GROUP**

**COMPONENT PARTS FOR LP SYSTEM**

**144116-04-000**

KEY	PART NUMBER	U/M	DESCRIPTION	VENDOR NO.
	040421-01-712	EA	VALVE-SERV. W/O VAPOR RELIEF	V20373/V21202
	040421-01-713	EA	VALVE-RELIEF 1" W/SPRING 7"	V12560/V21207
	144116-01-700	EA	VALVE-OUTAGE(NO STEM REMOVE)	V20058
	144116-01-701	EA	VALVE/FILL 80 % W/YELLOW CAP	V13414
	144116-04-700	EA	FLOAT/SENDING UNIT W/O DIAL	G11530
	144116-04-701	EA	DIAL - TRANSMITER	G12845

**SEALANTS & FASTENERS GROUP**  
**SEALANTS & ADHESIVES**

<b>KEY</b>	<b>PART NUMBER</b>	<b>U/M</b>	<b>DESCRIPTION</b>
	010405-02-000	EA	TAPE - THREAD SEALING - 3/8"
	064075-07-000	FT	SEAL - BULB - W/WIRED U CHANNEL - .3" X .5" CHANNEL-BLACK
	067788-01-000	EA	ADHESIVE - SPRAY - 3M - 19.5 OZ AEROSOL CAN
	069640-01-000	FT	SEALER - RIBBON - 1/4"DIAMETER X 30 FT - BLACK OR GRAY
	069640-02-000	FT	SEALER - TAPE - 1/8"THICK X 1/2"WIDE X 60 FT - GRAY
	069640-03-000	FT	SEALER - TAPE - 1/8"THICK X 3/4"WIDE X 60 FT - BLACK
	069640-07-000	FT	SEALER - TAPE - 3/32"THICK X 2"WIDE X 45 FT - GRAY
	069640-09-000	FT	SEALER - TAPE - 1/32"THICK X 2 1/2"WIDE X 80 FT - BRT WHT
	069640-10-000	FT	SEALER - TAPE - 1/32"THICK X 1 1/2"WIDE X 90 FT - GRAY
	069640-11-000	FT	SEALER - TAPE - 3/16"THICK X 3/8"WIDE X 40 FT - BLACK
	069640-13-000	FT	SEALER - TAPE - 3/32"THICK X 2"WIDE X 45 FT - BLACK
	069640-14-000	FT	SEALER - TAPE - 1/16"THICK X 1"WIDE X 100 FT - BLACK
	069640-15-000	FT	SEALER - TAPE - 1/16"THICK X 3/8"WIDE X 100 FT - BRT WHT
	069640-17-000	FT	SEALER - TAPE - 1/32"THICK X 1"WIDE X 150 FT - GRAY
	069640-18-000	FT	SEALER - TAPE - 1/8"THICK X 1/2"WIDE X 60 FT - BRT WHT
	069640-19-000	FT	SEALER - TAPE - 1/8"THICK X 3/4"WIDE X 60 FT - BRT WHT
	069640-20-000	FT	SEALER - TAPE - 1/8"THICK X 1/2"WIDE X 60 FT - BLACK
	069640-21-000	FT	SEALER - TAPE - 1/16"THICK X 1/2"WIDE X 100 FT - BRT WHT
	069640-22-000	FT	SEALER - TAPE - 1/32"THICK X 1/4"WIDE X 200 FT - BRT WHT
	069640-23-000	FT	SEALER - TAPE - 1/16"THICK X 3/4"WIDE X 100 FT - BRT WHT
	069640-27-000	FT	SEALER - TAPE - 1/16"THICK X 2 1/4"WIDE X 50 FT - BRT WHT
	069640-28-000	FT	SEALER - TAPE - 1/32"THICK X 1 7/8"WIDE X 90 FT - GRAY
	069640-30-000	FT	SEALER - TAPE - 1/32"THICK X 5/8"WIDE X 50 FT - GRAY
	069640-31-000	FT	SEALER - TAPE - 1/4"THICK X 3/4"WIDE X 15 FT - BLACK
	069640-32-000	FT	SEALER - TAPE - 1/16"THICK X 3/8"WIDE X 100 FT - BLACK
	069640-33-000	FT	SEALER - RIBBON - 3/8"DIAMETER X 20 FT - BLACK
	069640-34-000	FT	SEALER - RIBBON - 1/4"DIAMETER X 30 FT - BRIGHT WHITE
	069640-36-000	EA	SEALER - TAPE - 1/16"THICK X 1/2"WIDE X 100 FT - BLACK
	069640-37-000	FT	SEALER - TAPE - 1/16"THICK X 3/4"WIDE X 100 FT - BLACK
	069640-38-000	FT	SEALER - TAPE - 1/16"THICK X 3/4"WIDE X 100 FT - BRT WHT
	069640-39-000	FT	SEALER - TAPE - 1/16"THICK X 3"WIDE X 50 FT - BRT WHT
	069640-40-000	FT	SEALER - TAPE - 1/16"THICK X 3"WIDE X 50 FT - BRT WHT
	072889-28-000	EA	SEALANT/URETHANE-10 OZ TUBE W/NOZZLE-SELF LEVELING-BRT WHT
	072889-31-000	EA	SEALANT/URETHANE-10 OZ TUBE W/NOZZLE-SELF LEVELING - BLACK
	076322-02-000	FT	TAPE-DOUBLE COATED/ADHESIVE BK-.05"THK X 1"W X 108' - WHT
	076322-03-000	FT	TAPE-DOUBLE COATED/ADHESIVE BK-.05"THK X .5"W X 108' - WHT
	076322-05-000	FT	TAPE-DOUBLE COATED/ADHESIVE BK-.05"THK X .8"W X 108' - WHT
	076322-07-000	FT	TAPE-DOUBLE COATED/ADHESIVE BK-.05"THK X .5"W X 200' - BLK
	076322-13-000	FT	TAPE - FOAM/DOUBLE COATED - .020"THK X .75"W - CLEAR
	076322-21-000	FT	TAPE - FOAM/DOUBLE COATED - .045"THK X .50"W
	076322-22-000	FT	TAPE - FOAM/DOUBLE COATED - .045"THK X .75"W
	076322-23-000	FT	TAPE - FOAM/DOUBLE COATED - .045"THK X 1"W
	076322-25-000	FT	TAPE - FOAM/DOUBLE COATED - .025"THK X .5"W
	086276-01-000	EA	TAPE - DOUBLE SIDED - 1/2" WIDE X 108' LONG (SOLD BY ROLL)
	088479-01-000	EA	TAPE - ALUMINUM - 3"
	090340-01-000	FT	SEAL - FOAM - CLOSED CELL - 1/4" X 1/2" X 50'
	090340-02-000	FT	SEAL - FOAM - CLOSED CELL - 3/8" X 1/2" X 50'
	091255-02-000	FT	SEAL - ADHESIVE BACKED/FOAM - 3/64"THICK X 3/16"W X 1000'
	091255-03-000	FT	SEAL - ADHESIVE BACKED/FOAM - 1/4" THICK X 1/4"W X 1000'
	094401-01-000	EA	SEALER - BODY SEAM - FLEXICLEAR
	094401-04-000	EA	SEALER - BODY SEAM - CLEAR
	094401-05-000	EA	SEALER - BODY SEAM - 20OZ BLACK
	094401-06-000	EA	SEALER - BODY SEAM - 12OZ BLACK
	094401-07-000	EA	SEALER - BODY SEAM - CLEAR
	098408-01-000	FT	SEAL - SPONGE RUBBER - CLOSED CELL
	099069-01-000	FT	SEAL - RUBBER - CLOSED SPONGE - .5" WIDE X .12" THICK-BLK
	099418-01-000	FT	SEAL - D-SECTION/ADHESIVE BACK - .44" X .44" - BLK RUBBER
	100128-02-000	FT	SEAL - FOAM/ADHESIVE BACK - .37" WIDE X .37" THICK X 60'
	104692-01-000	FT	SEAL - ADHESIVE BACKED FOAM - 3/4" THICK X 3/4" WIDE X 25'
	107721-07-000	FT	SEAL - ACCESS DOOR - .9"WIDE X 1.1"HIGH
	112864-01-000	FT	SEAL - FOAM/BUTYL COVERED - 3/8" X 35'
	112864-02-000	FT	SEAL - FOAM/BUTYL COVERED - 5/16" X 44'
	112864-05-000	FT	SEAL - FOAM/BUTYL COVERED - 1/2" X 3/16"
	112901-02-000	EA	ADHESIVE - PLEXUS - MA330 - 50ML - GRAY

## SEALANTS & FASTENERS GROUP (CONTINUED)

### SEALANTS & ADHESIVES (CONTINUED)

KEY	PART NUMBER	U/M	DESCRIPTION
	112901-03-000	EA	ADHESIVE - PLEXUS - MA300 - 50ML - WHITE
	112902-03-000	EA	MIXER NOZZLE - F/GUN #00400102000 - SCOTCH-WELD & PLEXUS
	112902-04-000	EA	NOZZLE - ELEMENT - 1/4" X 3.5"
	113452-01-000	FT	SEAL/TRIM - FRONT - VINYL W/WIRE CARRIER - .020"
	113452-02-000	FT	SEAL/TRIM - FRONT - VINYL W/WIRE CARRIER - .027"
	113366-01-000	EA	ADHESIVE - INSTANT - 1 OZ
	115870-01-000	FT	SEAL/EDGE - TRIM
	120074-02-03A	EA	SILICONE - TUBE - W/O NOZZLE - LOW ODOR - SMOKEY WHITE
	120534-01-01A	EA	TAPE - SCOTCH - 3M - 1/2" FINE LINE
	123655-01-000	FT	SEAL - CLOSED CELL/FOAM
	123816-01-000	FT	TAPE - DOUBLE SIDED - 1" X .020" X 200' - CLEAR
	123816-02-000	FT	TAPE - DOUBLE SIDED - 1/2" X .035" X 200' - CLEAR
	123816-03-000	FT	TAPE - DOUBLE SIDED - 1/2" X .020" X 200' - CLEAR
	123816-04-000	FT	TAPE - DOUBLE SIDED - 6" X .0035" X 750' - CLEAR
	123816-06-000	FT	TAPE - DOUBLE SIDED - 3/4" X 3/4" X 200' - CLEAR
	123816-07-000	FT	TAPE - DOUBLE SIDED - 1 3/4" X 200' - CLEAR
	126427-01-000	EA	ADHESIVE - ALL PURPOSE - ABS/PVC
	126427-02-000	EA	PRIMER - CLEANER - FLEX PIPING
	131264-01-12A	EA	SILICONE - TUBE - W/NOZZLE - BONE
	131264-01-13A	EA	SILICONE - TUBE - W/NOZZLE - TRANSLUCENT
	131264-03-01A	EA	SILICONE - TUBE - W/O NOZZLE - SELF LEVELING -BRIGHT WHITE
	131264-04-02A	EA	SILICONE/SEALANT/ADHESIVE-FAST CURE F/GLASS/VINYL-SOFT WHT
	131264-05-01A	EA	SILICONE/SEALANT - ODORLESS - TUBE - W/NOZZLE - BLACK
	131264-05-02A	EA	SILICONE/SEALANT - ODORLESS - TUBE - W/NOZZLE - CLEAR
	131384-01-000	EA	ADHESIVE - JET WELD - 10 OZ CARTRIDGE
	132892-07-01A	FT	SEAL - BULB/SINGLE - W/U CHANNEL - .5" X 1" - BLACK
	152038-01-01A	EA	TAPE - PRESERVATION SEAL - 2" X 36YD ROLL - BLACK
	154585-01-01A	FT	SEAL - FOAM TAPE - ADHESIVE BACK - 3/8" X 3/8" - BLACK
	154585-02-01A	FT	SEAL - FOAM TAPE - ADHESIVE BACK - 3/4" X 1/2" - BLACK
	154585-03-01A	FT	SEAL - FOAM TAPE - ADHESIVE 2 SIDED - 1/8" X 3/4" - BLACK
	154585-04-01A	FT	SEAL - FOAM TAPE - ADHESIVE BACK - 5/8" X 1/8" - WHITE
	156622-01-01A	FT	SEALER - TAPE - 1/4"THICK X 3"WIDE X 100 FT - WHITE
	156622-02-01A	FT	SEALER - TAPE - 1/4"THICK X 2"WIDE X 100 FT - WHITE

### BOLTS, NUTS AND WASHERS

KEY	PART NUMBER	U/M	DESCRIPTION
	0MD54F-06-000	EA	NUT - HEX W/SERATED FLANGE
	000C12-04-08B	EA	BOLT - HEX - 1/4-20 X 1/2 - GRADE #5 - ZINC
	000C12-04-12A	EA	BOLT - HEX - 1/4-20 X 3/4 - PLAIN 5
	000C12-04-40B	EA	BOLT - HEX - 1/4-20 X 2 1/2 - GRADE #5 ZINC
	000C12-05-16B	EA	BOLT - HEX - 5/16 - 18X1 - GRADE #5 - ZINC
	000C12-05-40B	EA	BOLT - HEX - 5/16"-18 X 2.5" - GRADE #5 - ZINC
	000C12-06-28B	EA	BOLT-HEX-3/8-16X13/4 ZN 5 - 5185-01
	000C12-08-24B	EA	BOLT - HEX - 1/2-13 X 1 1/2 - GRADE #5 - ZINC
	000C12-08-28B	EA	BOLT - HEX - 1/2-13 X 1 3/4 - GRADE #5 - ZINC
	000C12-08-44B	EA	BOLT - HEX - 1/2-13 X 2 3/4 - GRADE #5 - ZINC
	000C13-07-40B	EA	BOLT - HEX - 7/16-20 X 2 1/2 - GRADE #5 - ZINC
	000C13-07-48B	EA	BOLT - HEX - 7/16-20 X 3 - GRADE #5 - ZINC
	000C14-10-32B	EA	BOLT - HEX - 5/8-11 X 2.0 - GRADE #8 - ZINC
	000C18-05-40A	EA	BOLT - ELEVATOR - 5/16-18 X 2 1/2 - PL
	000C26-04-10B	EA	BOLT - HEX - SERRATED FLANGE - 1/4-20 X 5/8 - ZINC
	000C26-04-12F	EA	BOLT - HEX - SERRATED FLANGE -1/4-20 X 3/4-STAINLESS STEEL
	000C26-04-14B	EA	BOLT - HEX - SERRATED FLANGE - 1/4-20 X 7/8 - ZINC
	000C26-04-18B	EA	BOLT - HEX - SERRATED FLANGE - 1/4-20 X 1 1/8 - ZINC
	000C26-05-12B	EA	BOLT - HEX - SERRATED FLANGE - 5/16-18 X 3/4 - ZINC
	000C26-06-12B	EA	BOLT - HEX - SERRATED FLANGE - 3/8-16 X 3/4 - ZINC
	000C26-06-20B	EA	BOLT - HEX - SERRATED FLANGE - 3/8-16 X 1 1/4 - ZINC
	000C26-06-28B	EA	BOLT - HEX - SERRATED FLANGE - 3/8-16 X 1 3/4 - ZINC
	000C26-06-40B	EA	BOLT - HEX - SERRATED FLANGE - 3/8-16 X 2 1/2 - ZINC
	000C26-08-24B	EA	BOLT - HEX - SERRATED FLANGE - 1/2-13 X 1 1/2 - ZINC
	000C26-08-28B	EA	BOLT - HEX - SERRATED FLANGE - 1/2-13 X 1 3/4 - ZINC
	000C27-08-48B	EA	BOLT-CARR 1/2-13X3.00 GR5 - 97 M-SERIES
	000D24-10-00B	EA	NUT - HEX - SELF LOCKING - 10-32 - ZINC

**SEALANTS & FASTENERS GROUP (CONTINUED)**  
**BOLTS, NUTS AND WASHERS (CONTINUED)**

KEY	PART NUMBER	U/M	DESCRIPTION
	000D27-05-00B	EA	NUT - HEX LOCK - 5-40 - ZINC
	000D28-10-00B	EA	NUT - HEX - W/NYLON LOCK - 10-32 - ZINC
	000D29-04-00B	EA	NUT - HEX - SELF LOCKING - 1/4 X 20 - ZINC
	000D29-04-00F	EA	NUT - HEX - SELF LOCKING - 1/4 X 20 - STAINLESS STEEL
	000D29-06-00B	EA	NUT - HEX - W/NYLON LOCK - 3/8-16 - ZINC
	000D29-09-00B	EA	NUT - HEX - SELF LOCKING - 9/16-12 - ZINC
	000D34-04-00B	EA	NUT - HEX - LOCKING - 1/4-20 - ZINC
	000D34-06-00B	EA	NUT - HEX - LOCKING - 3/8-16 GRADE C - ZINC
	000D39-04-00B	EA	NUT - HEX - LOCKING W/SERRATED FLANGE - 1/4-20 - ZINC
	000D39-05-00B	EA	NUT - HEX - LOCKING W/SERRATED FLANGE - 5/16-18 - ZINC
	000D39-06-00B	EA	NUT - HEX - LOCKING W/SERRATED FLANGE - 3/8-18 - ZINC
	000D39-06-00D	EA	NUT - HEX - LOCKING W/SERRATED FLANGE - 3/8"-16 BLACK
	000D39-07-00B	EA	NUT - HEX - LOCKING W/SERRATED FLANGE - 7/16-14 - ZINC
	000D39-08-00B	EA	NUT - HEX - LOCKING W/SERRATED FLANGE - 1/2-13 - ZINC
	000D44-07-00B	EA	NUT - HEX - LOCKING W/SERRATED FLANGE - 7/16-20 - ZINC
	000D44-08-00B	EA	NUT - HEX - LOCKING W/SERRATED FLANGE - 1/2-20 - ZINC
	000D46-04-00A	EA	NUT - HEX - WELD - 1/4-20 - PLAIN
	000D65-08-00B	EA	NUT - HEX - LOCKING W/SERRATED FLANGE - 8-32 - ZINC
	000D73-08-00C	EA	NUT - HEX FLANGE - 1/2-13
	000D75-09-00B	EA	NUT - HEX LOCKING - 9/16-12 - ZINC
	000D76-06-00B	EA	NUT - HEX FLANGE - 3/8-16
	000E11-04-00F	EA	WASHER - LOCKING - 1/4 MED SPLIT - STAINLESS STEEL
	000E11-07-00B	EA	WASHER - LOCKING - 7/16 MED SPLIT - ZINC
	000E11-08-00B	EA	WASHER - LOCKING - 1/2 MED SPLIT - ZINC
	000E13-17-00B	EA	WASHER - FLAT - 3/8 AR - ZINC
	000E13-18-00B	EA	WASHER - FLAT - 3/8 WIDE - ZINC
	000E13-20-00B	EA	WASHER - FLAT - 7/16 WIDE - ZINC
	000E13-22-00B	EA	WASHER - FLAT - 1/2 WIDE - ZINC
	000E13-26-00B	EA	WASHER - FLAT - 5/8 WIDE - ZINC
	000E14-10-00B	EA	WASHER - LOCKING - #10 EXTERNAL TOOTH - ZINC
	000E16-10-00B	EA	WASHER - HARDENED - 5/8 - FLAT - ZINC
	000G45-05-16B	EA	BOLT - LAG - 5/16-9 X 1 - ZINC
	039715-01-000	EA	NUT-SERT - 1/4" DIAMETER - 20 THREADS
	040921-01-000	EA	NUT - SPEED - U TYPE - #10-24 - BLACK
	040921-03-000	EA	NUT - SPEED - U TYPE - #10
	040921-04-000	EA	NUT - SPEED - U TYPE - #8-.59" LENGTH X .44" WIDTH
	040921-05-000	EA	NUT - SPEED - U-TYPE - 8-.67" X .44" WIDE
	040921-11-000	EA	NUT - SPEED - U-TYPE - 8-.59" LENGTH X .44" WIDTH - BLACK
	041322-01-000	EA	WASHER - FLANGE - 15/32"ID X 2 3/8"OD - F/SEAT BELT MTG
	044364-02-000	EA	NUT - SPEED - FLAT - ROUND
	044533-01-000	EA	WASHER - 1 3/8"OD - FOR BUTTONS - PLASTIC
	051387-06-000	EA	BOLT - CARRIAGE W/O HOLE - 5/16-18 X 9 1/2 - ZINC
	058716-02-000	EA	WASHER - FLAT NYLON
	064081-03-000	EA	NUT - WING 3/8-16 - W/WELD NUT
	077071-01-000	EA	WASHER - FENDER - 3/16"ID X 1"OD
	087234-01-000	EA	NUT - JACK - 1/4 X 20 THD - MOLLY
	088787-12-000	EA	STUD - WELD - 1/4 - 20 X 1.0 LG - MN
	106956-03-000	EA	BOLT - HEX TAP - 1/2-13NC X 3 - GRADE 5 - FULL THREAD/ZINC
	106956-10-000	EA	BOLT - HEX TAP - 9/16-12NC X 3 5/8 -GRD 5-FULL THREAD/ZINC
	106956-11-000	EA	BOLT - HEX TAP - 1/2-13NC X 2 1/2 - GRD 5-FULL THREAD/ZINC
	106956-13-000	EA	BOLT - HEX TAP - 1/2-20 X 2 1/2 - GRD 5-FULL THREAD/ZINC
	106956-14-000	EA	BOLT - HEX TAP - 5/16 -18NC X 1 1/2 - GRD 5-FULL THREAD/ZINC
	107397-01-000	EA	WASHER - FENDER - 3/4"ID X 1"OD
	108067-03-000	EA	STUD - WELD - 1/4 - 20 X 1/2 CD
	109917-01-000	EA	WASHER - 1.5" X 1.25"
	109917-03-000	EA	WASHER - 1" X .50"
	109917-04-000	EA	WASHER - 1" X .75"
	128444-01-000	EA	WASHER - SPRING - CONICAL
	135092-02-01A	EA	BOLT - HEX - SERRATED FLANGE - 1/2-20 X 2 1/2-GRADE 5 ZINC
	135092-05-01A	EA	BOLT - HEX - SERRATED FLANGE - 1/2-20 X 1 - GRADE 5 ZINC
	143399-01-01A	EA	NUT/RETAINING - 3/8"- 24 NFT
	147284-02-000	EA	NUT/SELF RETAINING - 5/16"-18
	148817-01-000	EA	WASHER/SPUR - LOCKING



## SEALANTS & FASTENERS GROUP (CONTINUED)

### SCREWS

KEY	PART NUMBER	U/M	DESCRIPTION
	0G1208-12-170	EA	SCREW - 8-18 X 3/4 POH - BRIGHT WHITE
	0G3908-08-170	EA	SCREW - SF/DR - 8-18 X 1/2 PPH - BRIGHT WHITE
	0G3908-16-170	EA	SCREW - SF/DR - 8-18 X 1 PPH - BRIGHT WHITE
	0G3908-24-170	EA	SCREW - SF/DR - 8-18 X 1 1/2 PPH - BRIGHT WHITE
	0G3910-10-420	EA	SCREW - SF/DR - 10-16 X .62 PPH - BRIARWOOD
	0G3910-12-170	EA	SCREW - SF/DR - 10-16 X 3/4 PPH - BRIGHT WHITE
	0G3910-24-170	EA	SCREW - SF/DR - 10-16 X 1 1/2 PPH - BRIGHT WHITE
	0G5508-08-370	EA	SCREW - SF/DR - 8-18 X .5 PWH - RIVERSTONE
	0G5508-08-380	EA	SCREW - SF/DR - 8-18 X .5 PWH - CASHMERE
	0G5508-08-420	EA	SCREW - SF/DR - 8-18 X .5 PWH - BRIARWOOD
	0G5508-08-450	EA	SCREW - SF/DR - 8-18 X .5 PWH - SADDLE
	0G5508-12-170	EA	SCREW - SF/DR - 8-18 X 3/4 PWH - BRIGHT WHITE
	0G5508-12-330	EA	SCREW - SF/DR - 8-18 X 3/4 PWH - PUTTY
	0G5508-12-380	EA	SCREW - SF/DR - 8-18 X 3/4 PWH - CASHMERE
	0G5508-12-450	EA	SCREW - SF/DR - 8-18 X 3/4 PWH - SADDLE
	0G5508-16-330	EA	SCREW - SF/DR - 8-18 X 1 PWH - PUTTY
	0G5508-16-370	EA	SCREW - SF/DR - 8-18 X 1 PWH - RIVERSTONE
	0G5508-16-380	EA	SCREW - SF/DR - 8-18 X 1 PWH - CASHMERE
	0G5508-16-450	EA	SCREW - SF/DR - 8-18 X 1 PWH - SADDLE
	0G6008-16-170	EA	SCREW - SF/DR - 8-18 X 1 POH - BRIGHT WHITE
	0G6012-32-170	EA	SCREW - SF/DR - 12-14 X 2 POH - BRIGHT WHITE
	0G6710-08-170	EA	SCREW - 10-12 X 1/2 PPH - BRIGHT WHITE
	0G6710-12-170	EA	SCREW - 10-12 X 3/4 PPH - BRIGHT WHITE
	0G6806-16-170	EA	SCREW - 6-18 X 1 POH - BRIGHT WHITE
	0G6810-24-280	EA	SCREW - 10-12 X 1 1/2 POH - SOFT WHITE
	000C20-06-24T	EA	SCREW - 3/8-16 X 1 1/2 - FLAT SOCKET
	000G11-06-08B	EA	SCREW - 6-20 X 1/2 PPH - ZINC
	000G11-06-10B	EA	SCREW - 6-20 X 5/8 PPH - ZINC
	000G11-06-10J	EA	SCREW - 6-20 X 5/8 PPH - BRASS
	000G11-07-08B	EA	SCREW - 7-19 X 1/2 PPH - ZINC
	000G11-08-06B	EA	SCREW - 8-18 X 3/8 PPH - ZINC
	000G11-08-08T	EA	SCREW - 8-18 X 1/2 PPH - FLUOROCARBON COATING
	000G11-08-12B	EA	SCREW - 8-18 X 3/4 PPH - ZINC
	000G11-08-12P	EA	SCREW - 8-18 X 3/4 PPH - DARK BROWN
	000G11-08-12S	EA	SCREW - 8-18 X 3/4 PPH - OFF WHITE
	000G11-08-12T	EA	SCREW - 8-18 X 3/4 PPH - BLACK MAGNESIUM
	000G11-08-20B	EA	SCREW - 8-18 X 1 1/4 PPH - ZINC
	000G11-08-20G	EA	SCREW - 8-18 X 1 1/4 - ANTIQUE BRASS
	000G11-10-12D	EA	SCREW - 10-16 X 3/4 PPH - BLACK
	000G11-10-32P	EA	SCREW-10,16X2.00 PPH DK BRN
	000G12-06-08T	EA	SCREW - 6-20 X 1/2 POH - BLACK
	000G12-10-16F	EA	SCREW - 10-16 X 1 POH - STAINLESS STEEL
	000G13-05-10B	EA	SCREW - 5-12 X 5/8 PFH - ZINC
	000G13-06-06I	EA	SCREW - 6-20 X 3/8 PFH - BLACK ZINC
	000G13-06-08B	EA	SCREW - 6-20 X 1/2 PFH - ZINC
	000G13-06-08G	EA	SCREW - 6-20 X 1/2 PFH - ANTIQUE BRASS
	000G13-06-10G	EA	SCREW - 6-20 X 5/8 PFH - ANTIQUE BRASS
	000G13-06-16E	EA	SCREW - 6-20 X 1 PFH - CHROME
	000G13-06-16J	EA	SCREW - 6-20 X 1 PFH - BRASS
	000G13-06-24J	EA	SCREW - 6-20 X 1 1/2 PFH - BRASS
	000G13-07-10H	EA	SCREW - 7-19 X 5/8 PFH - BLACK
	000G13-07-12B	EA	SCREW - 7-19 X 3/4 PFH - ZINC
	000G11-08-08B	EA	SCREW - 8-18 X 1/2 PPH - ZINC
	000G13-08-10B	EA	SCREW - 8-18 X 5/8 PFH - ZINC
	000G13-08-109	EA	SCREW - 8-18 X 5/8 PFH
	000G13-08-16B	EA	SCREW - 8-18 X 1 PFH - ZINC
	000G13-08-24B	EA	SCREW - 8-18 X 1 1/2 PFH - ZINC
	000G16-04-24B	EA	SCREW - MACHINE - 1/4-20 X 1 1/2 PPH
	000G18-08-16B	EA	SCREW - MACHINE - 8-32 X 1 PPH - ZINC
	000G18-08-22B	EA	SCREW - MACHINE - 8-32 X 1 3/8 PPH - ZINC
	000G18-08-24B	EA	SCREW - MACHINE - 8-32 X 1 1/2 PPH - ZINC
	000G19-10-08B	EA	SCREW - MACHINE - 10-32 X 1/2 PPH - ZINC
	000G19-10-10B	EA	SCREW - MACHINE - 10-32 X 5/8 - PPH - ZINC
	000G19-10-12F	EA	SCREW - MACHINE - 10-32 X 3/4 PPH - STAINLESS STEEL

## SEALANTS & FASTENERS GROUP (CONTINUED)

### SCREWS (CONTINUED)

KEY	PART NUMBER	U/M	DESCRIPTION
	000G19-10-20B	EA	SCREW - MACHINE - 10-32 X 1 1/2 PPH - ZINC
	000G32-10-06B	EA	SCREW - 10-32 X 3/8 PPH - ZINC
	000G34-05-12B	EA	SCREW - HEX HEAD TAPPING - 5/16 X 3/4 LONG
	000G39-06-10T	EA	SCREW - SF/DR - 6-20 X 5/8 PPH - BLACK
	000G39-06-16T	EA	SCREW - SF/DR - 6-20 X 1 PPH - BLACK
	000G39-08-06B	EA	SCREW - SF/DR - 8-18 X 3/8 PPH - ZINC
	000G39-08-08B	EA	SCREW - SF/DR - 8-18 X 1/2 PPH - ZINC
	000G39-08-08S	EA	SCREW - SF/DR - 8-18 X 1/2 PPH - OFF WHITE
	000G39-08-08T	EA	SCREW - SF/DR - 8-18 X 1/2 PPH - BLACK
	000G39-08-12T	EA	SCREW - SF/DR - 8-18 X 3/4 PPH - BLACK
	000G39-08-16B	EA	SCREW - SF/DR - 8-18 X 1 PPH - ZINC
	000G39-08-16T	EA	SCREW - SF/DR - 6-20 X 1 PPH - BLACK
	000G39-08-24B	EA	SCREW - SF/DR - 8-18 X 1 1/2 PPH - ZINC
	000G39-08-24T	EA	SCREW - SF/DR - 8-18 X 1 1/2 PPH - BLACK
	000G39-08-32B	EA	SCREW - SF/DR - 8-18 X 2 PPH - ZINC
	000G39-08-169	EA	SCREW-SF/DR,8-18X1.00 PPH - FLUROCARBON SILVER
	000G39-10-08B	EA	SCREW - SF/DR - 10-16 X 1/2 PPH - ZINC
	000G39-10-10B	EA	SCREW - SF/DR - 10-16 X 5/8 PPH - ZINC
	000G39-10-12B	EA	SCREW - SF/DR - 10-16 X 3/4 PPH - ZINC
	000G39-10-12S	EA	SCREW - SF/DR - 10-16 X 3/4 PPH - OFF WHITE
	000G39-10-129	EA	SCREW - SF/DR - 10-16 X 3/4 PPH - FLUOROCARBON SILVER
	000G39-10-169	EA	SCREW - SF/DR - 10-16 X 1 PPH - FLUOROCARBON SILVER
	000G39-10-20B	EA	SCREW - SF/DR - 10-16 X 1 1/4 PPH - ZINC
	000G39-10-20T	EA	SCREW - SF/DR - 10-16 X 1 1/4 PPH - BLACK
	000G39-10-24B	EA	SCREW - SF/DR - 10-16 X 1 1/2 PPH - ZINC
	000G39-10-24T	EA	SCREW - SF/DR - 10-16 X 1 1/2" PPH - BLACK
	000G39-10-32B	EA	SCREW - SF/DR - 10-16 X 2 - PPH - ZINC
	000G39-10-48B	EA	SCREW - SF/DR - 10-16 X 3 - PPH - ZINC
	000G39-10-48T	EA	SCREW - SF/DR - 10-16 X 3 PPH - BLACK
	000G42-04-16B	EA	SCREW - SF/DR - 1/4-14 X 1 HWH - ZINC
	000G42-04-24B	EA	SCREW - SF/DR - 1/4-14 X 1 1/2 - ZINC
	000G52-06-05B	EA	SCREW - MACHINE - 6-32 X 5/16 PTH - ZINC
	000G52-06-06B	EA	SCREW - MACHINE - 6-32 X 3/8 PTH - ZINC
	000G54-04-14B	EA	SCREW - 1/4-20 X 7/8 PTH - TYPE 23 - ZINC PLATED
	000G55-08-12T	EA	SCREW - SF/DR - 8-18 X 3/4 PWH - BLACK
	000G55-08-16S	EA	SCREW - SF/DR - 8-18 X 1.00 PWH - OFF WHITE
	000G55-08-16T	EA	SCREW - SF/DR - 8-18 X 1 PWH - BLACK
	000G56-12-48B	EA	SCREW - WOOD - 12-11 X 3 POH - SPECIAL HARDENED
	000G60-08-16E	EA	SCREW - SF/DR - 8-1 X 1 POH - CHROME
	000G60-08-20F	EA	SCREW - SF/DR - 8-19X1.25 POH
	000G60-08-22B	EA	SCREW - SF/DR - 8-18 X 1.38 POH - ZINC
	000G60-10-20B	EA	SCREW - SF/DR - 10-16 X 1 1/4 POH - ZINC
	000G60-10-209	EA	SCREW - SF/DR - 10-16 X 1 1/4 POH - SILVER STALGAARD
	000G60-10-28T	EA	SCREW - SF/DR - 10-16 X 1 3/4 - BLACK
	000G62-06-12B	EA	SCREW-SF/DR,6-20X.75 PFH - ZINC
	000G62-06-249	EA	SCREW - SF/DR - 8-18 X 1.5 PPH - SILVER
	000G62-08-24B	EA	SCREW - SF/DR - 8-18 X 1 1/2 PFH
	000G62-08-24T	EA	SCREW - SF/DR - 8-18 X 1 1/2 PFH - BLACK
	000G67-08-32B	EA	SCREW - 8-15 X 2 PPH - ZINC
	000G67-10-08B	EA	SCREW - 10-12 X 1/2 PPH - ZINC
	000G67-10-08S	EA	SCREW - 10-12 X 1/2 PPH - OFF WHITE
	000G67-10-10B	EA	SCREW - 10-12 X 5/8 PPH - ZINC - TYPE A
	000G67-10-10D	EA	SCREW - 10-12 X 5/8 PPH - BLACK - TYPE A
	000G67-10-10P	EA	SCREW - 10-12 X 5/8 PPH - DARK BROWN
	000G67-10-10S	EA	SCREW - 10-12 X 5/8 PPH - OFF WHITE
	000G67-10-10T	EA	SCREW - 10-12 X 5/8 PPH - BLACK
	000G67-10-10V	EA	SCREW-10-12X5/8 PPH ZN O/W - TYPE A
	000G67-10-12P	EA	SCREW - 10-12 X 3/4 PPH - DARK BROWN
	000G67-10-24B	EA	SCREW - 10-12 X 1 1/2 PPH - ZINC
	000G68-06-10J	EA	SCREW - 6-18 X 5/8 POH - BRASS
	000G68-06-12B	EA	SCREW - 6-18 X 3/4 POH - ZINC & CLEAR
	000G68-06-12S	EA	SCREW - 6-18 X 3/4 POH
	029130-01-000	EA	SCREW - SNAP STUD - #8-16 X 5/8" LONG
	029130-02-000	EA	SCREW - SNAP STUD - #8-16 X 1 1/2" LONG

**SEALANTS & FASTENERS GROUP (CONTINUED)**  
**SCREWS (CONTINUED)**

KEY	PART NUMBER	U/M	DESCRIPTION
	029130-03-000	EA	SCREW - SNAP STUD - #8-16 X 1" LONG
	049465-03-000	EA	SCREW - 10-16 X 1 POH W/WASHER - OFF WHITE
	049465-17-000	EA	SCREW - 10-16 X 1 POH W/WASHER - BRIGHT WHITE
	049465-18-000	EA	SCREW - 10-16 X 1 POH W/WASHER - VW GRAY
	054434-02-000	EA	SCREW - SF/DR - 10-16 X 2 - ZINC
	054434-03-000	EA	SCREW - SF/DR - 10-16 X 2 - PWH - ZINC
	075908-01-000	EA	SCREW - MACHINE - 10-32 X .56 PTH - EXTERNAL TOOTH - ZINC
	076790-01-000	EA	SCREW - 6-20 X 1 1/4 PPH - BLACK
	076790-05-000	EA	SCREW - 6-20 X 1/2 PPH - BLACK - THREAD CUTTING/WOOD
	083554-01-000	EA	SCREW - DRYWALL - 8 X 1 1/4
	087721-01-000	EA	SCREW - FLAT HEAD - TAPPING - 1/4" X 1 1/4" LONG - ZINC
	093249-01-000	EA	CAP/SCREW - MOLDED/VINYL - BLACK
	095772-01-000	EA	SOCKET-SNAP FASTNER1" SF/DR - SELF DRIVER
	097974-01-000	EA	SCREW - PARTICLE BOARD - 7-9 X 3/4 PPH
	101618-01-000	EA	SCREW - 1/4-20 X 3/4 HEX - TAPPING - STALGARD TYPE F
	113563-01-01A	EA	SCREW - 8 X 5/8 LONG SHOULDER/WASHER HEAD
	113563-01-02A	EA	SCREW - 8 X 5/8 LONG SHOULDER/WASHER HEAD - BRIGHT WHITE
	118383-01-12A	EA	RETAINER/RECESSED - F/.22" SCREW - RIVERSTONE
	118383-01-14A	EA	RETAINER/RECESSED - F/.22" SCREW - PEWTER
	118383-01-15A	EA	RETAINER/RECESSED - F/.22" SCREW - BRIARWOOD
	118383-02-13A	EA	RETAINER/RECESSED - F/.27" SCREW - OFF WHITE
	118383-04-04A	EA	CAP - F/RECESSED RETAINER - BRIGHT WHITE
	118383-04-10A	EA	CAP - F/RECESSED RETAINER - RIVERSTONE
	118383-04-13A	EA	CAP - F/RECESSED RETAINER - OFF WHITE
	118383-04-14A	EA	CAP - F/RECESSED RETAINER - PEWTER
	118383-04-15A	EA	CAP - F/RECESSED RETAINER - BRIARWOOD
	134126-01-01A	EA	SCREW/NAIL - HEX HEAD - 3/4"
	140040-01-000	EA	SCREW - 1/4-20 X 1 - BUTTON HEAD/SOCKET - W/LOCTITE
	149753-01-01A	EA	RETAINER/RECESSED - F/.22" SCREW - BLACK
	149753-01-02A	EA	RETAINER/RECESSED - F/.22" SCREW - BRIGHT WHITE
	149753-02-01A	EA	CAP - F/RECESSED RETAINER - BLACK
	149753-02-02A	EA	CAP - F/RECESSED RETAINER - BRIGHT WHITE
	154938-01-01A	EA	SCREW - SF/DR - 10-16 X 3/4 PPH - W/SELF SEAL - BRIGHT WHITE
	154938-01-02A	EA	SCREW - SF/DR - 10-16 X 3/4 PPH - W/SELF SEAL - BLACK
	154938-02-01A	EA	SCREW - SF/DR - 8-18 X 1 PFH - W/SELF SEAL - BRIGHT WHITE
	154938-02-02A	EA	SCREW - SF/DR - 8-18 X 1 PFH - W/SELF SEAL - BLACK
	154938-02-03A	EA	SCREW - SF/DR - 8-18 X 1 PFH - W/SELF SEAL - SILVER
	154938-03-01A	EA	SCREW - SF/DR - 8-18 X 5/8 PFH - W/SELF SEAL - BRT WHT
	154938-03-02A	EA	SCREW - SF/DR - 8-18 X 5/8 PFH - W/SELF SEAL - BLACK
	154938-04-01A	EA	SCREW - SF/DR - 10-16 X 1" TPH - W/SELF SEAL - BRT WHT
	154938-04-02A	EA	SCREW - SF/DR - 10-16 X 1" TPH - W/SELF SEAL - BLACK
	154938-05-03A	EA	SCREW - SF/DR - 8-18 X 1.25" PFH - W/SELF SEAL - SILVER

## SEALANTS & FASTENERS GROUP (CONTINUED)

### CLAMPS, CLIPS, GROMMETS, RIVETS & PLUGS

KEY	PART NUMBER	U/M	DESCRIPTION
	000H14-06-03R	EA	RIVET - MANDREL BLIND - 3/16 ALUMINUM
	000H16-04-06R	EA	RIVET - POP ALUMINUM - 1/8 X .313 - .375
	000H16-06-10R	EA	RIVET - POP ALUMINUM - 3/16 X .501 - .625
	007161-01-000	EA	CLAMP - HOSE - SPRING TYPE - 1/2"
	008386-01-000	EA	GROMMET - SNAP - 3/8" DIAMETER - NYLON
	010495-01-000	EA	CLAMP - CABLE - 9/16"ID - BLACK
	010495-02-000	EA	CLAMP - CABLE - 3/8"ID - BLACK
	010495-04-000	EA	CLAMP - CABLE - 11/16"ID - WHITE
	010497-01-000	EA	CLAMP - CLOSED - 5/8"ID
	010497-02-000	EA	CLAMP - CLOSED - 1.5"ID
	010497-03-000	EA	CLAMP - CLOSED - 1"ID - CUSHIONED
	010497-04-000	EA	CLAMP - CLOSED - 1 5/8"ID
	010497-05-000	EA	CLAMP - CLOSED - 1/2"ID
	010497-07-000	EA	CLAMP - CLOSED - 3/8"ID
	010497-09-000	EA	CLAMP - CLOSED - 5/16"ID
	010497-10-000	EA	CLAMP - CLOSED - 7/8"ID
	010499-01-000	EA	CLAMP - CLOSED - 3/8"ID
	016188-03-000	EA	GROMMET - LP LINE - 3/8"HOLE X 2 1/2"LONG - RUBBER
	016188-04-000	EA	GROMMET - LP LINE - 1/2"HOLE X 2 1/2"LONG - RUBBER
	016188-05-000	EA	GROMMET - LP LINE - 3/8"HOLE X 1 1/4"LONG - RUBBER
	016188-06-000	EA	GROMMET - LP LINE - 3/8"HOLE X 3 1/4"LONG - RUBBER
	016188-07-000	EA	GROMMET - L/P LINE - 1/2"HOLE X 3 1/4"LONG
	016188-08-000	EA	GROMMET - LP LINE - 1/2"HOLE X 1 1/4"LONG - RUBBER
	016188-09-000	EA	GROMMET - LP LINE - .68"HOLE X 1 1/4"LONG - RUBBER
	016188-10-000	EA	GROMMET - LP GAS - .68" X 2.5"
	023942-01-000	EA	GROMMET - RUBBER - 2"OD
	041930-11-000	EA	RIVET - POP ALUMINUM - 1/8 X .188 - .250 - BRIGHT WHITE
	061420-04-000	EA	PLUG/PLASTIC - 1 1/4" DIAMETER
	061420-05-000	EA	PLUG/PLASTIC - 1 1/2" DIAMETER
	061420-09-000	EA	PLUG/PLASTIC - 1.00" DIAMETER
	061420-10-000	EA	PLUG/PLASTIC - 1 1/2" DIAMETER - BLACK
	061420-12-000	EA	PLUG/PLASTIC - 1.50" DIAMETER - RED
	061420-13-000	EA	PLUG/PLASTIC - 3/8" - FLUSH
	061420-14-000	EA	PLUG/PLASTIC - 7/8" DIAMETER - BLACK
	061420-15-000	EA	PLUG/PLASTIC - 2" DIAMETER - BLACK
	061420-16-000	EA	PLUG/PLASTIC - 2 1/8" DIAMETER - BLACK
	061420-18-000	EA	PLUG/PLASTIC - 1 3/4" DIAMETER - BLACK
	062401-01-000	EA	CLAMP - HOSE - WORMGEAR - .25" - 1"
	062401-02-000	EA	CLAMP - HOSE - WORMGEAR - 1.56" - 2.5" ID
	062401-03-000	EA	CLAMP - HOSE - WORMGEAR - .22" - 1" ID
	062401-04-000	EA	CLAMP - HOSE - WORMGEAR - .69" - 1.25" ID
	062401-06-000	EA	CLAMP - HOSE - WORMGEAR - .22" - .62" ID
	062401-09-000	EA	CLAMP - HOSE - WORMGEAR - 2.8" - 3.75" ID
	062401-11-000	EA	CLAMP - HOSE - WORMGEAR - 3.50" - 4.50" ID
	062401-13-000	EA	CLAMP - HOSE - WORMGEAR
	071015-11-000	EA	GROMMET - RUBBER - 1"ID FITS .12 MATERIAL - BLACK
	071015-13-000	EA	GROMMET - RUBBER - .62"ID X 1"OD W/.09" GROOVE - BLACK
	071015-20-000	EA	GROMMET - .38 ID FITS .06 MTL
	071015-22-000	EA	GROMMET - RUBBER - .62"ID X 1.12"OD W/.19" GROOVE - BLACK
	071015-26-000	EA	GROMMET - RUBBER - 1.5"ID X 2.1"OD W/.06" GROOVE - BLACK
	071015-29-000	EA	GROMMET - RUBBER - .3"ID X 1.3"OD W/.12" GROOVE - BLACK
	071015-30-000	EA	GROMMET - RUBBER - .3"ID X .81"OD W/.12" GROOVE - BLACK
	071015-39-000	EA	GROMMET - .75 ID FITS .06 MTL
	071015-41-000	EA	GROMMET - .125 ID FITS .188 MTL
	071015-42-000	EA	GROMMET - .25 ID FITS .06 MTL
	071015-43-000	EA	GROMMET-.25 ID,FITS .07 MATL, MINOR Z-4139
	071015-44-000	EA	GROMMET - .31 ID FITS .25 MTL
	075148-02-000	EA	CLAMP - GROUNDING - BRONZE SCREWS
	077955-01-000	EA	CLIP/J - 3/8" - VINYL COATED
	081211-03-000	EA	PLUG - PLASTIC - .50"DIAMETER - TRUSS HEAD - BLACK
	081211-04-000	EA	PLUG - PLASTIC - .46"DIAMETER - TRUSS HEAD - BLACK
	081211-06-000	EA	PLUG-PLASTIC,.468DIA,BLACK , HEYCO 1669
	083609-01-000	EA	CLAMP - WIRE - DUAL - EQUAL DIAMETERS - 5/8"
	083610-01-000	EA	CLAMP - WIRE - DUAL - UNEQUAL DIAMETERS - 3/4" & 1 1/4"

**SEALANTS & FASTENERS GROUP (CONTINUED)**  
**CLAMPS, CLIPS, GROMMETS, RIVETS & PLUGS (CONTINUED)**

KEY	PART NUMBER	U/M	DESCRIPTION
	083610-02-000	EA	CLAMP - WIRE - DUAL - UNEQUAL DIAMETERS - 3/4" & 2"
	083610-03-000	EA	CLAMP - WIRE - DUAL - EQUAL DIAMETERS - 2"
	083610-02-000	EA	CLAMP - WIRE - DUAL - UNEQUAL DIAMETERS - 3/4" & 2"
	083610-03-000	EA	CLAMP - WIRE - DUAL - EQUAL DIAMETERS - 2"
	088756-01-000	EA	GROMMET - WEB - 1 1/8"ID
	089329-02-000	EA	CLIP - SPRING
	091952-01-000	EA	CLIP - GRIPPER - 1" - BLACK VINYL COATED
	091952-02-000	EA	CLIP - GRIPPER - 3/4" - BLACK VINYL COATED
	091952-03-000	EA	CLIP - GRIPPER - 1/2" - BLACK VINYL COATED
	094362-02-000	EA	CLIP - XMAS TREE - BINDER HEAD - .9" LONG/ANY COLOR
	113133-02-01A	EA	RIVET - POP - ALUMINUM - 3/16 X .252 - .504 - BLACK
	114208-05-000	EA	GROMMET - EDGE LINER - FITS 2"
	118626-01-01A	EA	RIVET/POP - ALUMINUM - 3/16 X 1.2"(GRIP RANGE .1"-.4")
	118626-01-02A	EA	RIVET/POP - ALUMINUM - 3/16 X .08 - .375
	118626-02-01A	EA	RIVET/POP - ALUMINUM - 3/16 X .500 - .750
	118626-03-01A	EA	RIVET/POP - STAINLESS STEEL - 3/16 X .500 - .750
	137014-01-01A	EA	GROMMET - CABLE - ALMOND
	139118-02-01A	EA	GROMMET - SCREW - PLASTIC
	155498-01-01A	EA	CLAMP - CLOSED - 7/8"ID - VINYL DIP/GALVONIZED - BLACK

**MISCELLANEOUS FASTENERS**

KEY	PART NUMBER	U/M	DESCRIPTION
	008343-01-000	EA	TIE - WIRE - 6"
	008343-02-000	EA	TIE - WIRE - 14"
	008343-03-000	EA	TIE - WIRE - 7 1/2" - BLACK
	029094-04-000	YD	VELCRO TAPE/LOOP - 1"WIDE - W/ADHESIVE BACK - BLACK
	029096-03-000	YD	VELCRO TAPE/HOOK - 1"WIDE - BLACK
	029096-04-000	YD	VELCRO TAPE/HOOK - 1"WIDE - BLACK - W/ADHESIVE BACK (PSA)
	048394-02-000	YD	VELCRO TAPE - HOOK - ADHESIVE BACK - 3/4" WIDE - BEIGE
	085774-01-000	FT	FASTENER - DUAL LOCK - 1" WIDE - ADHESIVE BACK - BLACK
	085774-02-000	FT	FASTENER - DUAL HOOK - 1" WIDE - ADHESIVE BACK - BLACK
	088792-02-000	YD	VELCRO TAPE - LOOP - 3/4" - ADHESIVE BACK - BEIGE
	088792-04-000	YD	VELCRO TAPE - HOOK - 5/8" - NON-ADHESIVE BACK - WHITE
	088792-05-000	YD	VELCRO TAPE - LOOP - 5/8" - NON-ADHESIVE BACK - WHITE
	108046-02-000	EA	CABLE TIE - SCREW MOUNT 15"

## WATER & SEWAGE GROUP DRAINAGE SYSTEM

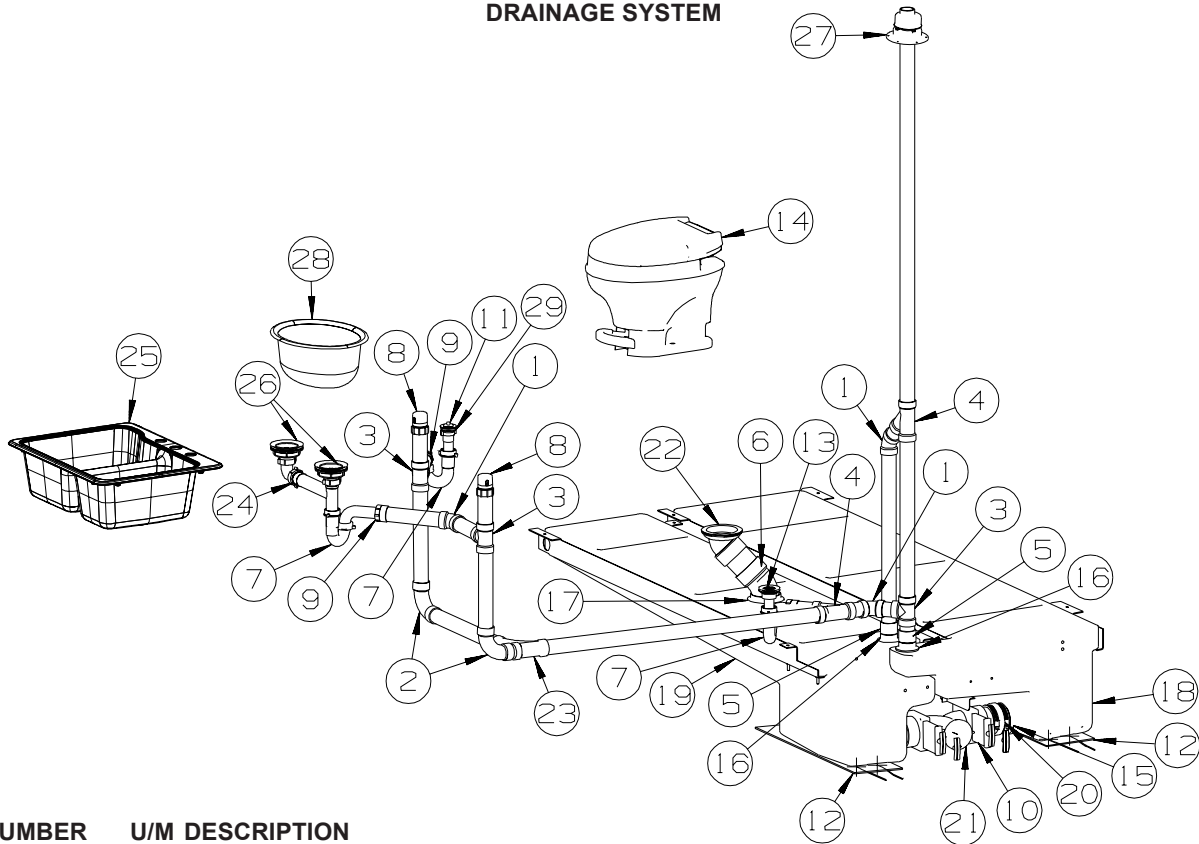

KEY	PART NUMBER	U/M	DESCRIPTION
1	010006-01-000	EA	ELBOW - 45 DEGREE - 1 1/2" HUB X HUB - PLASTIC
2	010008-01-000	EA	ELBOW - 90 DEGREE - 1 1/2" HUB X HUB - PLASTIC
3	010071-01-000	EA	TEE - SANITARY - 1 1/2" HUB X HUB X HUB - PLASTIC
4	010073-01-000	EA	WYE - 45 DEGREE - 1 1/2" HUB X HUB X HUB - PLASTIC
5	010115-01-000	EA	COUPLING - 1 1/2" HUB X HUB - PLASTIC
6	010061-01-000	EA	ELBOW - 45 DEGREE ST - 3" SPIGOT & HUB - PLASTIC
7	107538-02-000	EA	P-TRAP - PLASTIC - 1 1/2" W/EXTENSION ARM
7	011071-01-000	EA	P-TRAP - 1 1/2" - CSA - PLASTIC - <b>CANADIAN</b>
8	079968-01-000	EA	VENT - MECHANICAL/TRAP ARM - ANTI-SIPHON-2" X 7.3" PLASTIC
9	152146-01-000	EA	CONNECTOR - 1 1/2"P X 1 1/2"MPT
10	136143-01-000	EA	VALVE - DUAL - 3" X 3"
11	106116-01-02A	EA	STRAINER/PLASTIC - STOPPER/TAIPIECE/GASKET & NUT-LAVATORY
12	133972-04-000	EA	PAD/HEATER - HOLDING TANK - F/34 GALLON - <b>DRAINAGE SYSTEM-HEATED</b>
13	066440-01-000	EA	STRAINER - SHOWER DRAIN - W/RUBBER WASHER
	127440-02-01A	EA	WASHER - RUBBER - 1.8" X .1"
13	011069-02-000	EA	TAILPIECE - TUB/SHOWER - 1 1/2" X 1 1/4" X 4" - BRASS
	130403-01-000	EA	NUT - SLIP - W/WINGS 1 1/2"
14*	147421-03-01A	EA	TOILET/AQUA MAGIC 5 (LOW) FOOTFLUSH - W/O SPRAY - WHITE
15	010129-03-000	EA	NIPPLE - 3" X 3" TOE - PLASTIC
16	061607-01-000	EA	GROMMET - HOLDING TANK - 1 1/2" NPS
17	061607-02-000	EA	GROMMET - HOLDING TANK - 3" NPS
18	157730-01-700	EA	TANK - HOLDING W/3" NIPPLE
	049032-01-000	EA	PATCH - SPINWELD - 3/8" - PLASTIC
19	157729-01-700	EA	TANK - HOLDING W/3" NIPPLE
	049032-01-000	EA	PATCH - SPINWELD - 3/8" - PLASTIC
20	078406-01-000	EA	COUPLER - 3" X 3" W/CLAMPS - RUBBER
21	139513-01-000	EA	HOSE - SEWER - 3" X 10' - W/BAYONET TYPE ADAPTER
	062416-01-000	EA	ADAPTER - SEWER HOSE TO 3" PIPE
22	151541-01-000	EA	FLANGE - CLOSET - ELBOW/SWIVEL - 4" X 3"
23	031365-02-000	EA	TEE - 1 1/2" EXTRA LONG TURN - PLASTIC
24	011091-02-000	EA	WASTE - CONTINUOUS - DOUBLE SINK
25	163942-01-01A	EA	SINK/DOUBLE - LRG/SML BASIN - 25" X 19" - PLASTIC/SILVER
26	092303-01-000	EA	STRAINER - W/BASKET - GALLEY SINK - 4" OD
27	083558-03-000	EA	VENT - W/COVER - F/PLUMBING STACK - OFF WHITE
28	156661-01-01A	EA	SINK - LAVATORY - OVAL - 15" X 12" X 6.5" - GLACIER WHITE
29	106116-02-01A	EA	GASKET - STRAINER

\*COMPONENT PARTS LISTED LATER IN THIS GROUP

**WATER & SEWAGE GROUP (CONTINUED)**  
**DRAINAGE SYSTEM (CONTINUED)**

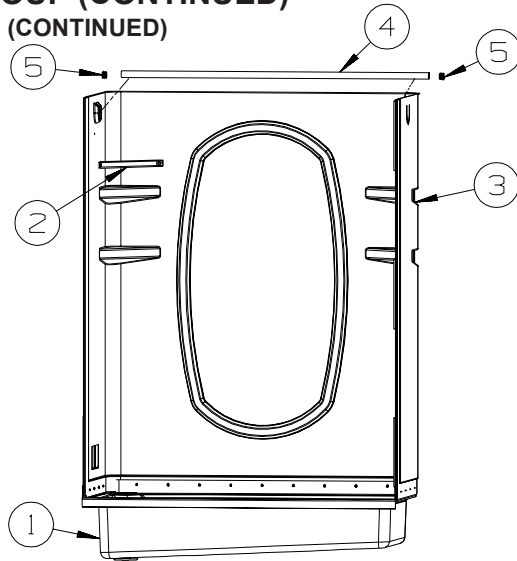

KEY	PART NUMBER	U/M	DESCRIPTION
1	M09530-01-U21	EA	SHOWER PAN - W/STRAINER
2	113714-02-02A	EA	RETAINER - SHELF/SHOWER - 10.6" - SOFT WHITE
3	158103-01-01A	EA	SURROUND - SHOWER/TUB - SOFT WHITE
4	102075-10-02A	EA	ROD - SHOWER CURTAIN - 1" OD X 46.3" - SOFT WHITE
5	081114-02-000	EA	CAP - INSERT/ROUND - 1" DIAMETER - WHITE PLASTIC

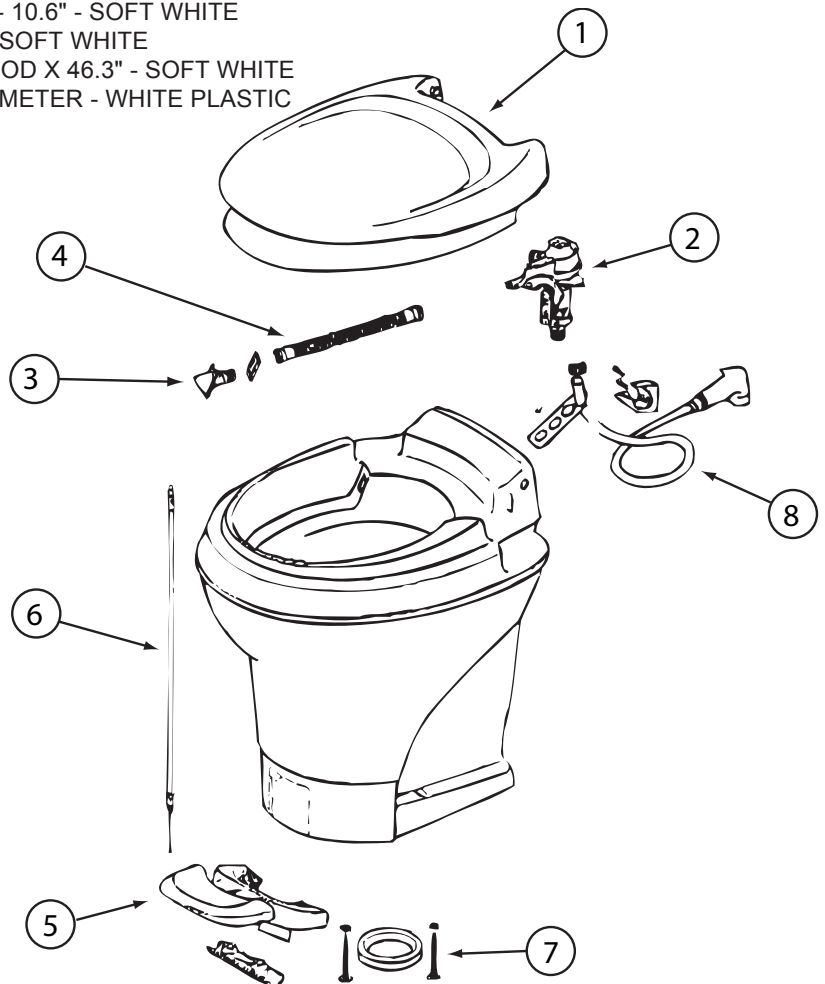

**COMPONENT PARTS FOR DRAINAGE SYSTEM**  
**147421-03-01A**

KEY	PART NUMBER	U/M	DESCRIPTION	VENDOR NO.
1	147421-01-700	EA	SEAT & COVER ASSEMBLY(WHT)	31703
2	147421-01-701	EA	WATER MODULE ASSEMBLY	31705
3	147421-01-702	EA	NOZZLE ASSEMBLY	31706
4	147421-01-703	EA	LINK - WATER MODULE	31621
5	147421-01-704	EA	PEDAL - WHITE	31709
6	147421-01-705	EA	FOOT CABLE	31711
7	063740-01-706	EA	BOLT PACKAGE-FLOOR FLANGE	12524 THETFORD
	147421-01-706	EA	SEAL - BLADE	31708
	147421-01-707	EA	CAP (UNIVERSAL BOLT) - WHITE	31713

CONTACT WINNEBAGO PART SALES FOR UNLISTED COMPONENT(S)

## WATER & SEWAGE GROUP (CONTINUED)

### WATER SYSTEM

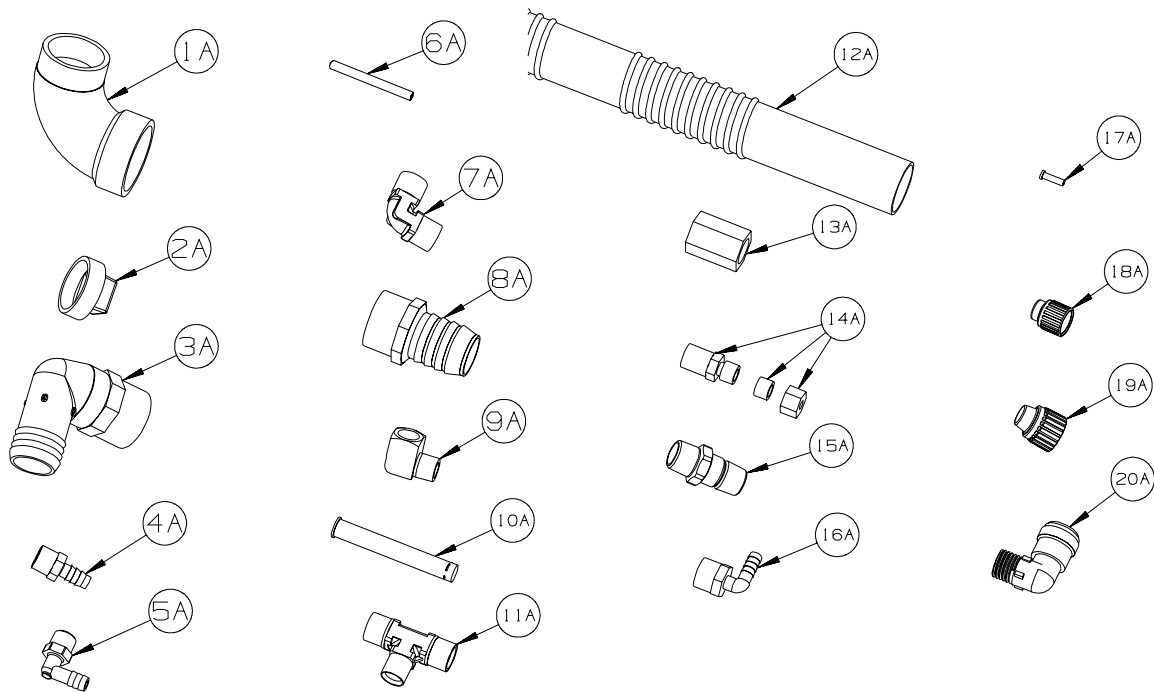

KEY	PART NUMBER	U/M	DESCRIPTION
1A	010009-01-000	EA	ELBOW - 90 DEGREE - 1/4 BEND - 1 1/2" PLASTIC
2A	010166-01-000	EA	PLUG/THREADED - 1 1/4"MPT - PLASTIC - BLACK - UL
3A	010219-01-000	EA	ELBOW - 1 1/4 MPT X 1 1/4 BARB - WATER FILL - PLASTIC
4A	010224-01-000	EA	ADAPTER - HOSE TO PIPE - 3/8 MPT X 3/8 BARB - PLASTIC
5A	035539-01-000	EA	ELBOW - 3/8 MPT X 3/8 BARB - PLASTIC
6A	039800-04-000	FT	TUBING - POLYBUTYL - 1/4"OD
6A	074462-02-000	FT	TUBING - VINYL - 3/8 ID X 20' - CLEAR
6A	112176-01-000	FT	TUBING - VINYL - REINFORCED - 1/2" ID
6A	124188-01-000	FT	TUBING - PEX - 1/2" ID X 20' - BLUE(COLD)
6A	124188-02-000	FT	TUBING - PEX - 1/2" ID X 20' - RED(HOT)
7A	039808-03-000	EA	ELBOW - 1/2" MPT X 1/2" MPT - PLASTIC
8A	044927-01-000	EA	ADAPTER - HOSE TO PIPE-1 1/4 MPTX1 1/4 BARB-BLACK PLASTIC
9A	065318-02-000	EA	ELBOW - 90 DEGREE - 3/8" MPT TO 3/8" FPT
10A	077954-02-000	EA	FILTER - WATER TANK - W/SCREEN IN TANK
11A	039798-01-000	EA	TEE - 1/2"MPT X 1/2"MPT X 1/2"MPT - PLASTIC
12A	079381-01-000	FT	TUBING - RIBBED FLEXIBLE/WATER FILL - 10 FT = 1EA-1.38ID
13A	101814-01-000	EA	COUPLING - FEMALE - 1/2" X 1/2" FPT - GRAY
14A	103798-01-000	EA	CONNECTOR - 1/4 OD X 3/8 MPT
15A	110438-02-000	EA	VALVE - CHECK - 1/2"MPT X 1/2"MPT - BRASS
16A	111223-02-000	EA	ELBOW - 1/2" MPT X 3/8" BARB - PLASTIC
16A	111223-04-000	EA	ELBOW - 1/2" MPT X 1/2" BARB - PLASTIC
16A	111888-01-000	EA	FERRULE - PLASTIC - .250 ID X .375 OD
17A	111888-02-000	EA	INSERT - BRASS - 1/4 COMP
18A	113697-01-000	EA	CAP - 3/8"P
19A	114427-01-000	EA	CAP - 1/2"P
20A	164906-01-000	EA	ELBOW - 90 DEGREE - 1/2" QUICK CONNECT X 1/2"MPT



**WATER & SEWAGE GROUP (CONTINUED)**  
**WATER SYSTEM (CONTINUED)**

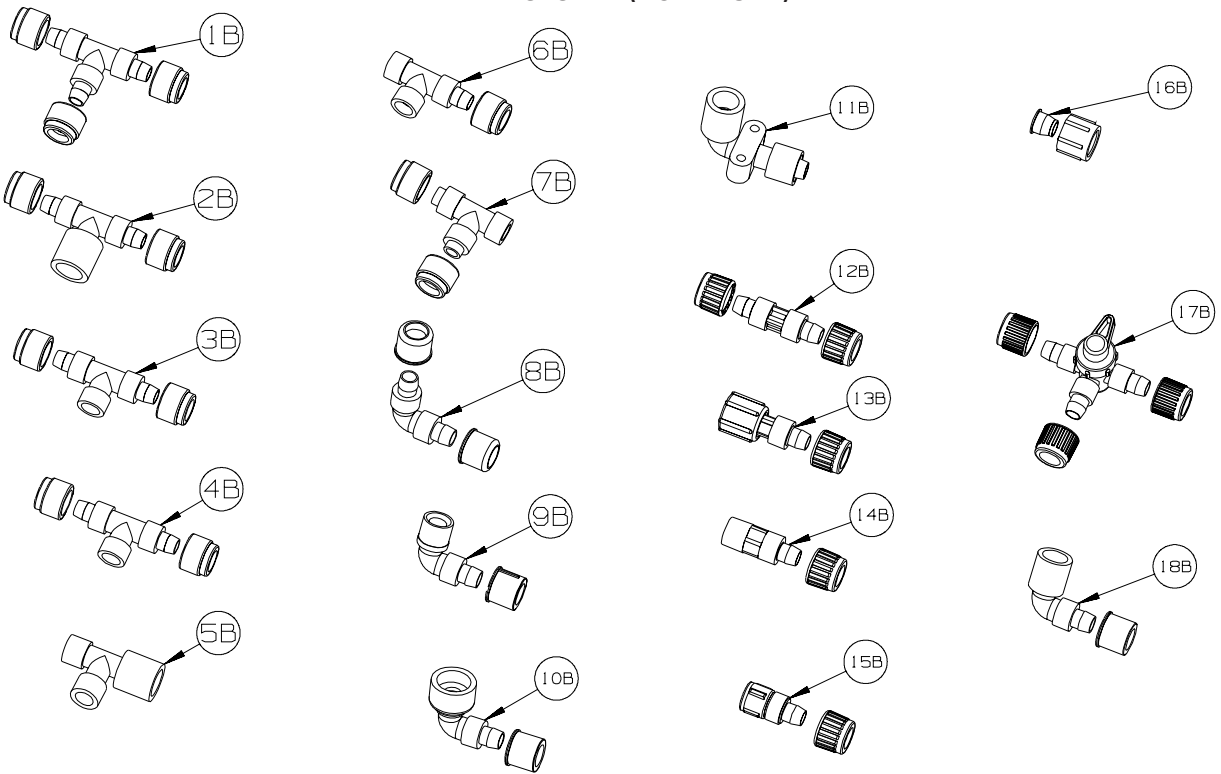

KEY	PART NUMBER	U/M	DESCRIPTION
1B	114428-01-000	EA	TEE - 1/2"P X 1/2"P X 1/2"P
2B	114428-02-000	EA	TEE - SWIVEL - 1/2"P X 1/2"P X 1/2"FPT
3B	114428-03-000	EA	TEE - 1/2"P X 1/2"P X 1/2"MPT
4B	114428-04-000	EA	TEE - 1/2"P X 1/2"P X 1/8"FPT
5B	114428-05-000	EA	TEE - 1/2" SWIVEL X 1/2" MPT X 1/2" MPT
6B	114428-06-000	EA	TEE - 1/2" P X 1/2" MPT X 1/2" MPT
7B	114428-07-000	EA	TEE - 1/2" P X 1/2" MPT X 1/2" P
8B	114429-01-000	EA	ELBOW - 1/2"P X 1/2"P
9B	114429-02-000	EA	ELBOW - 1/2"P X 1/2"MPT
9B	114429-04-000	EA	ELBOW - 1/2"P X 3/8"MPT
9B	114429-10-000	EA	ELBOW - SWIVEL - 1/2"MPT X 1/2"FPT
10B	114429-08-000	EA	ELBOW - SWIVEL - 1/2"P X 1/2"FPT
11B	114429-09-000	EA	ELBOW - 1/2"P X 1/2"FPT DROP EAR
12B	114430-01-000	EA	ADAPTER - 1/2"P X 1/2"P
13B	114430-02-000	EA	ADAPTER - SWIVEL - 1/2"P X 1/2"FPT
13B	114430-04-000	EA	ADAPTER - SWIVEL - 1/2"P X 3/8"MPT
14B	114430-03-000	EA	ADAPTER - 1/2"P X 1/2"MPT
15B	114430-06-000	EA	ADAPTER - 1/2"P X 3/8"FPT
15B	114430-09-000	EA	ADAPTER - 1/2"P X 1/2"FPT
16B	114430-10-000	EA	ADAPTER - NUT - PIPE CONNECTION - 1/2"
17B	114431-01-000	EA	VALVE - 180 DEGREE/CENTER DRAIN - 1/2"P - THREE WAY
18B	114429-11-000	EA	ELBOW - 1/2"P X 1/2"FPT

## WATER & SEWAGE GROUP (CONTINUED)

### WATER SYSTEM (CONTINUED)

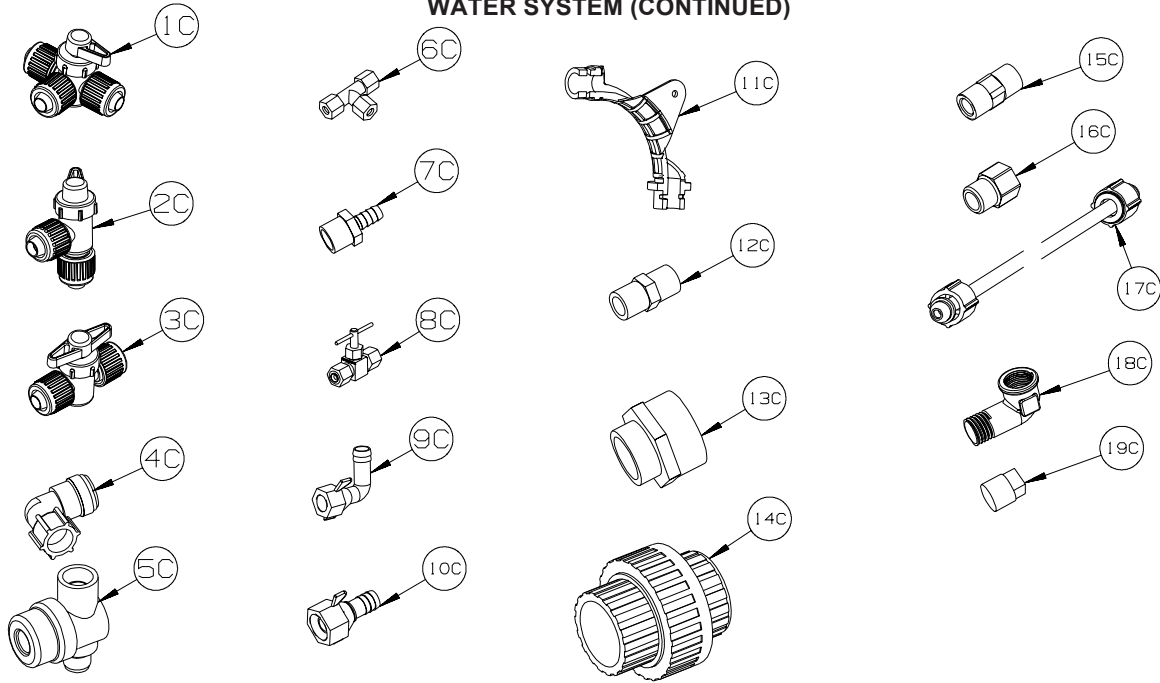

KEY	PART NUMBER	U/M	DESCRIPTION
1C	114431-02-000	EA	VALVE - WATER BYPASS - 1/2"P - THREE WAY (WATER HEATER)
2C	114431-03-000	EA	VALVE - 90 DEGREE DRAIN - 1/2"P
3C	114431-04-000	EA	VALVE - "INLINE SHUT-OFF" - 1/2"P
4C	164906-02-000	EA	ELBOW - 90 DEGREE - 1/2" QUICK CONNECT X 1/2"MPT - SWIVEL
5C	152925-01-01A	EA	FILTER - IN LINE - TWIST ON - 1/2" - BLACK
6C	118423-01-000	EA	FITTING - BRASS-TEE - 1/4" X 1/4" X 1/4"
7C	118809-01-000	EA	ADAPTER - 1/2" MPT X 3/8" BARB - PLASTIC
7C	118809-02-000	EA	ADAPTER - 1/2" MPT X 1/2" BARB - PLASTIC
8C	120868-01-000	EA	VALVE - NEEDLE - 1/4" COMPRESSION X 1/4" COMPRESSION
9C	123150-01-000	EA	ELBOW - 1/2 FPT X 1/2 BARB - SWIVEL
10C	123152-01-000	EA	ADAPTER - 1/2 FPT X 1/2 BARB - SWIVEL
11C	124184-01-000	EA	SUPPORT - WATER LINE - BEND
12C	132148-01-000	EA	CONNECTOR - 1/2" X 1/2"MPT - BRASS
13C	133835-01-000	EA	ADAPTER - REDUCING - 1 1/2" X 1 1/4"
14C	133889-01-000	EA	UNION - 1 1/2 DOUBLE SLIP - PVC
15C	135386-01-000	EA	NIPPLE - 1/2"
16C	136333-01-000	EA	ADAPTER - BRASS - 1/2"MPT X 1/2"FPT
17C	140821-01-000	EA	TUBE - WATER SUPPLY - 3/8" X 24"
17C	140821-02-000	EA	TUBE - WATER SUPPLY - 3/8" X 30"
17C	140821-03-000	EA	TUBE - WATER SUPPLY - 3/8" X 36"
17C	140821-04-000	EA	TUBE - WATER SUPPLY - 3/8" X 48"
17C	140821-05-000	EA	TUBE - WATER SUPPLY - 3/8" X 54"
17C	140821-06-000	EA	TUBE - WATER SUPPLY - 3/8" X 60"
17C	140821-07-000	EA	TUBE - WATER SUPPLY - 3/8" X 72"
17C	140821-08-000	EA	TUBE - WATER SUPPLY - 1/2" X 24"
17C	140821-09-000	EA	TUBE - WATER SUPPLY - 1/2" X 36"
17C	140821-10-000	EA	TUBE - WATER SUPPLY - 1/2" X 48"
18C	142812-01-000	EA	ELBOW - BRASS - 1/2"MPT X 1/2"FPT
19C	145609-01-000	EA	PLUG - BRASS - 1/2" MPT/HEX HEAD

**WATER & SEWAGE GROUP (CONTINUED)**  
**WATER SYSTEM (CONTINUED)**

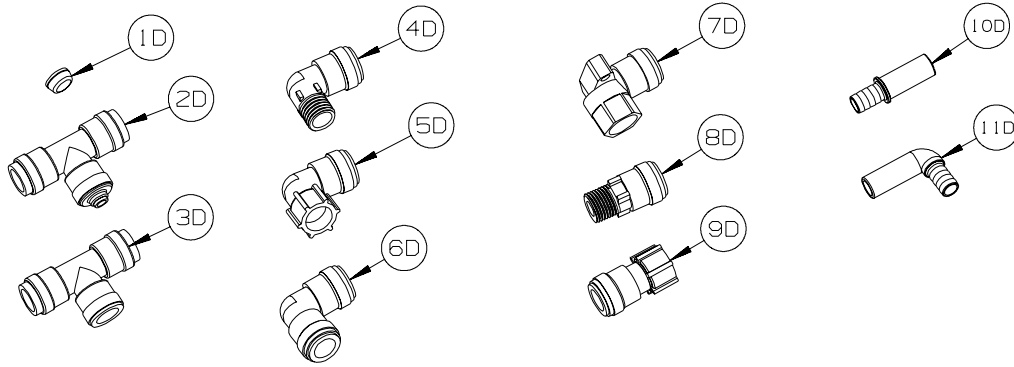

KEY	PART NUMBER	U/M	DESCRIPTION
1D	116473-01-000	EA	FERRIL - RUBBER SEALING - WATER LINE
2D	160949-01-000	EA	CONNECTOR - 1/2" X 1/2" X 1/4" REDUCER
3D	160949-02-000	EA	CONNECTOR - 1/2"CTS X 1/2"CTS X 1/2"CTS
4D	164906-01-000	EA	ELBOW - 90 DEGREE - 1/2" QUICK CONNECT X 1/2"MPT
5D	164906-02-000	EA	ELBOW - 90 DEGREE - 1/2" QUICK CONNECT X 1/2"FPT - SWIVEL
6D	164906-03-000	EA	ELBOW - 90 DEGREE - 1/2" X 1/2" QUICK CONNECTS
7D	164906-04-000	EA	ELBOW - 90 DEGREE - 1/2"CTS X 1/2"FPT
8D	164907-01-000	EA	ADAPTER - STRAIGHT - 1/2" QUICK CONNECT X 1/2"MPT
9D	164907-02-000	EA	ADAPTER - STRAIGHT - 1/2" QUICK CONNECT X 1/2"FPT/SWIVEL
10D	166212-01-000	EA	UNION - HOSE/BARB - CTS X 1/2"B - SEA TECH #3511-1008
11D	166212-02-000	EA	ELBOW - HOSE/BARB - CTS X 1/2"B - SEA TECH #3512-1008

## WATER & SEWAGE GROUP (CONTINUED)

### WATER SYSTEM (CONTINUED)

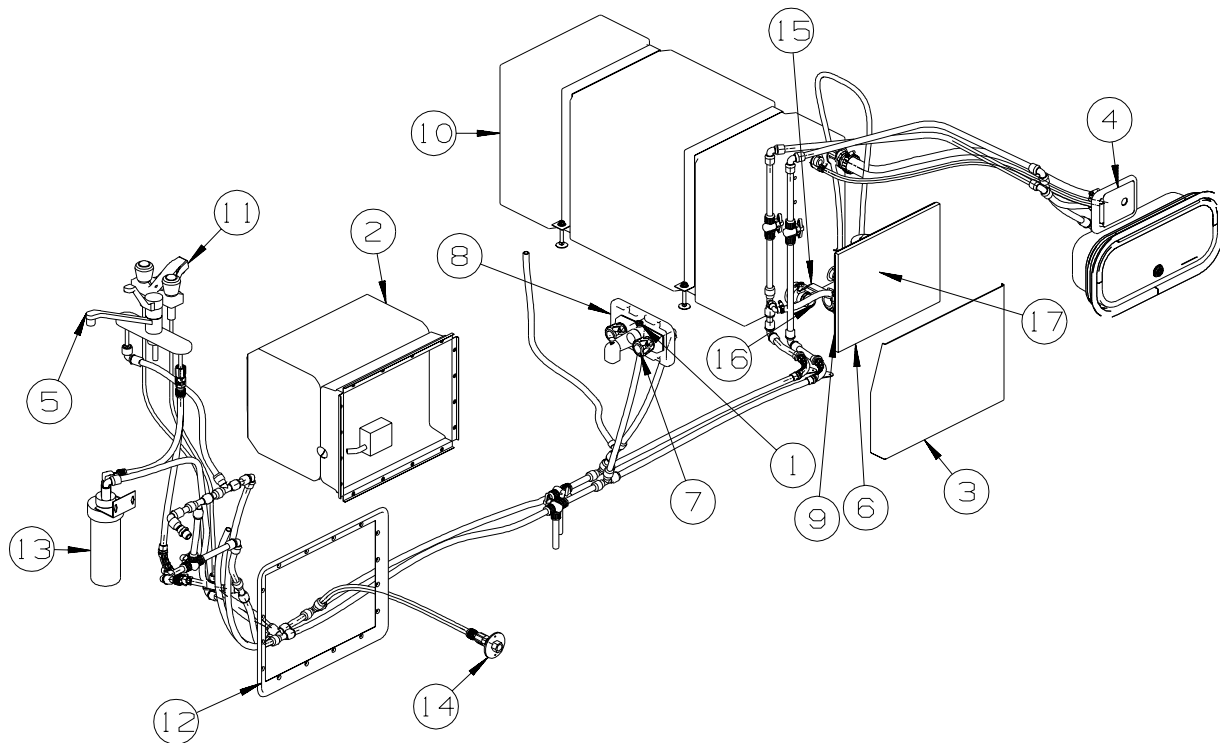

KEY	PART NUMBER	U/M	DESCRIPTION
1	131383-01-02A	EA	SHOWER HEAD - W/60" HOSE & BRACKET - WHITE
2*	051391-03-000	EA	WATER HEATER G6A-8E ELECTRONIC IGNITION
2*	145541-02-000	EA	WATER HEATER-6 GAL-GAS/ELEC/120'-REM IGN-W/HEAT EXC-4E - <b>WTR HTR-6GAL/110/LP/MTR/AUTO</b>
3	156298-02-02B	EA	BRACKET/MOUNTING - WATER PUMP - E-COATED
4	137169-01-01A	EA	WATER FILL/GRAVITY - W/DOOR - W/O LOCK - BRIGHT WHITE
	138290-03-000	EA	CASE - W/CAM - W/O CYLINDER/KEY
5	149164-01-01A	EA	FAUCET - GALLEY - SINGLE CONTROL - CHROME
6	149477-03-02B	EA	PANEL - WATER PUMP - E-COATED
7	156638-01-01A	EA	FAUCET - TUB/SHOWER - DUAL - 4" SPOUT W/DIVERTER - CHROME
8	075606-03-000	EA	PANEL - FAUCET SHOWER - SOFT WHITE
9	140364-05-01A	EA	FOAM - PAD - .5" X 12" X 15"
10	156167-02-000	EA	TANK - WATER - 36 GALLON - W/FITTINGS
	042989-03-000	EA	FITTING - SPINWELD - 1 1/4"NPT - PLASTIC
	042989-04-000	EA	FITTING - SPINWELD - 3/8"FPT - PLASTIC
	042989-05-000	EA	FITTING - SPINWELD - 1/2"FPT - PLASTIC
	042989-08-000	EA	FITTING - SPINWELD - 1"FPT - PLASTIC
	049032-01-000	EA	PATCH - SPINWELD - 3/8" - PLASTIC
11	148886-01-01A	EA	FAUCET - LAVATORY/DUAL CONTROL/4" CENTER - CHROME
11*	152311-01-01A	EA	FAUCET - LAVATORY - SINGLE CONTROL - CHROME - <b>INTERIOR UPGRADE PACKAGE</b>
			FROM: 00-00-00 THRU: 04-20-08
11*	165730-01-01A	EA	FAUCET - LAVATORY - SINGLE CONTROL - CHROME - <b>INTERIOR UPGRADE PACKAGE</b>
			FROM: 04-21-08 THRU: 99-99-99
12	052009-06-000	EA	DOOR - WATER HEATER - BRIGHT WHITE - 18" X 14.6"
12	152239-01-01A	EA	FLANGE/MOUNTING/RECESSED - 19.3" X 15.8" - BRIGHT WHITE
13	160946-03-000	EA	FILTER SYSTEM - WATER PURIFICATION - AQUA-PURE
14	010230-06-000	EA	FILL - CITY WATER - W/CHECK VALVE - MPT - BRUSHED ALUM
15	132483-01-000	EA	VALVE/BALL - 1" - THREADED ENDS
16	132484-01-000	EA	ELBOW - 90 DEGREE - 1MPT X 1FPT - PLASTIC
16	132782-01-000	EA	ELBOW - 1"FPT X 1.3" BARB - 90 DEGREE - PLASTIC
17	160702-01-000	EA	PUMP - WATER - 3.0 GPM - W/1/2" MPT

\*COMPONENT PARTS LISTED LATER IN THIS GROUP

**WATER & SEWAGE GROUP (CONTINUED)**  
**WATER SYSTEM (CONTINUED)**

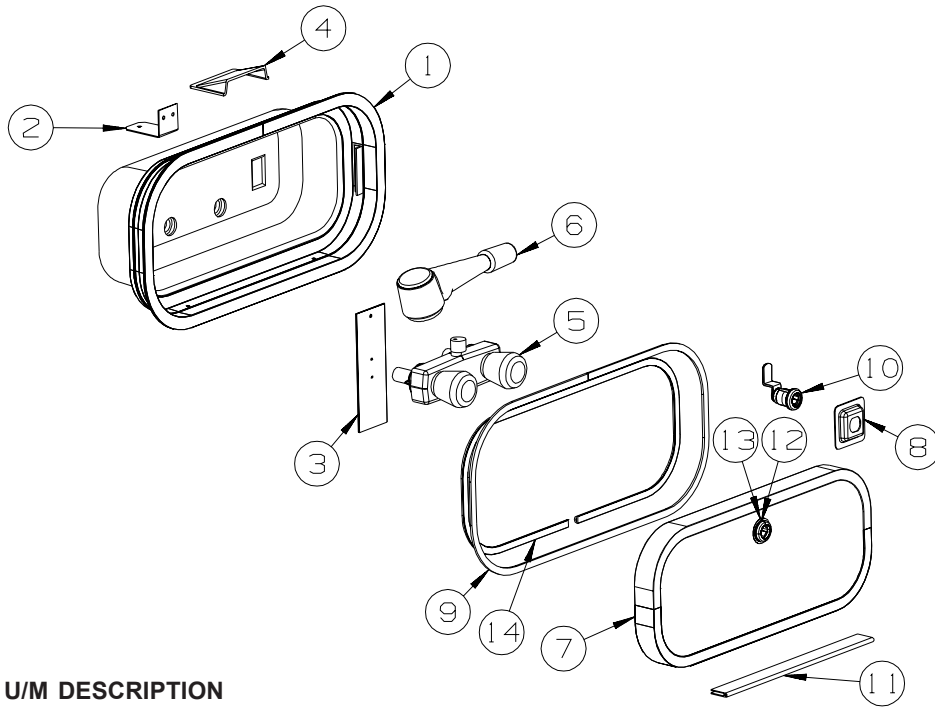

KEY	PART NUMBER	U/M	DESCRIPTION
1	106208-01-02A	EA	COMPARTMENT - EXTERIOR SHOWER - BRIGHT WHITE
2	131732-01-12B	EA	BRACKET - SQUEEGEE - BRIGHT WHITE
3	121577-04-01A	EA	STRAP/PLATE - W/HOLE - 2.25" X 6.5" - BRIGHT WHITE
4	054250-09-000	EA	SUPPORT - DIMMER SWITCH - BRIGHT WHITE
5	163269-01-01A	EA	FAUCET/SHOWER -.5"MPT W/1.9" INLET PIPES- EXTERIOR/BRT WHT
6	131383-01-02A	EA	SHOWER HEAD - W/60" HOSE & BRACKET - WHITE
7	126945-11-T11	EA	DOOR/STORAGE - W/O HARDWARE - 18" X 8.3"
8	097111-02-04A	EA	POCKET - LOCK - REAR DOOR - BLACK
9	056795-01-000	EA	TAPE-SEAL, 1/8~ X 3/8~ WIDE - PRESS ON
10	138290-02-000	EA	CASE - W/CAM - W/O CYLINDER/KEY
11	081801-V3-000	EA	HINGE - DOOR - PIANO - 2" X 96" - BRIGHT WHITE
12	139325-01-000	EA	SPACER - LOCK - 6MM
13	139337-01-000	EA	GASKET - LOCK
14	112160-02-000	FT	SEAL - D SECTION - .2 X .3" - FOAM RUBBER

**WATER & DRAINAGE GROUP (CONTINUED)**  
**COMPONENT PARTS FOR WATER SYSTEM**

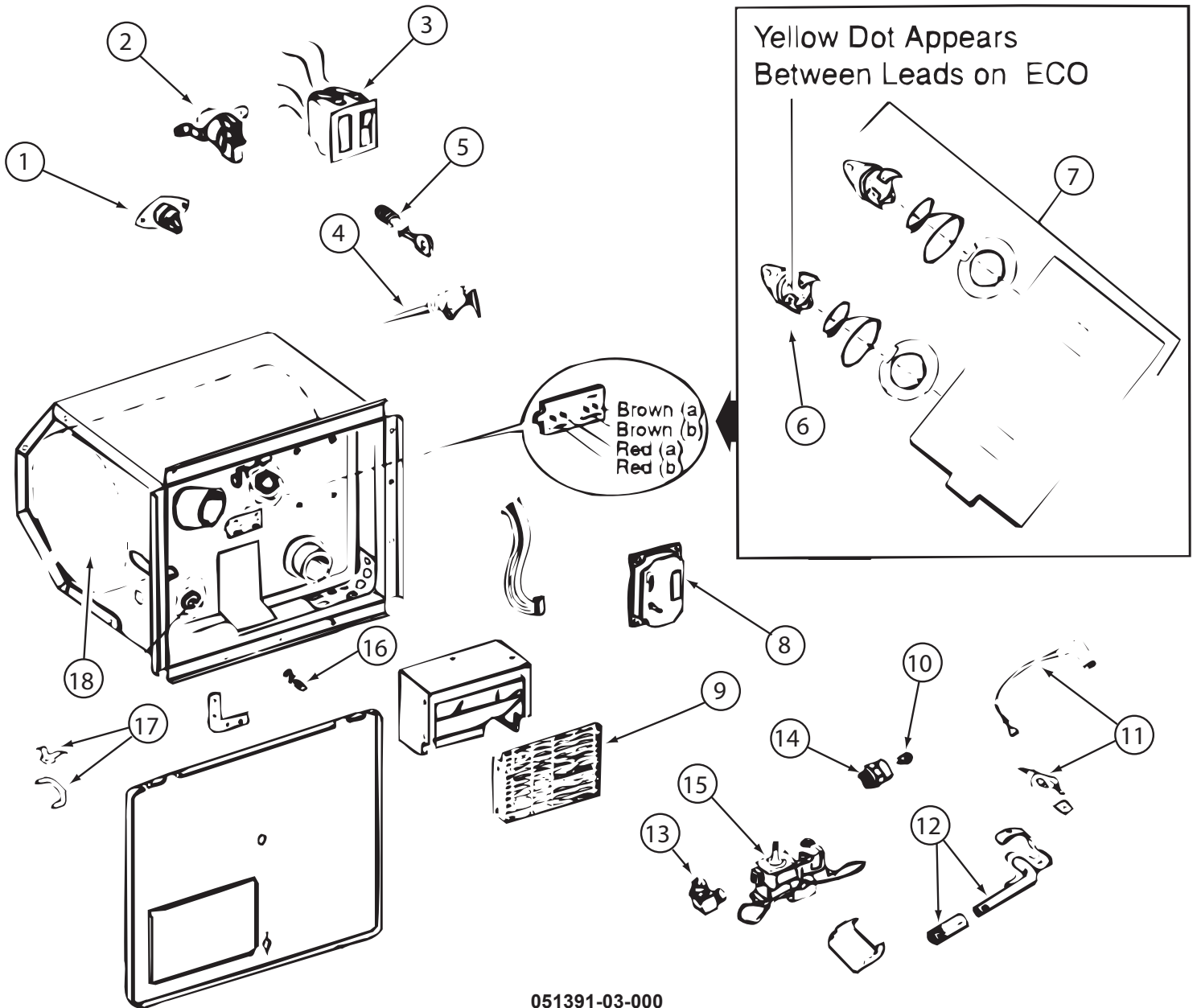

051391-03-000

KEY	PART NUMBER	U/M	DESCRIPTION	VENDOR NO.
3	051393-01-701	EA	SWITCH - REMOTE - W/LIGHT	91959
4	051391-01-704	EA	VALVE-RELIEF, 1/2" FITTING	91604
4	051391-03-701	EA	VALVE-RELIEF - 3/4" FITTING	90028
5	051391-01-705	EA	FASTENER-CAMLOCK	92609
6	051391-04-701	EA	THERMOSTAT 12V DC-120 PRESET	91470
7	051393-01-721	EA	THERMOSTAT W/ECO, 140 FRT MT	91447
9	051391-04-707	EA	KIT-EXHAUST, (FLUE & GASKET)	90960
10	051391-01-710	EA	ORIFICE-MAIN BURNER	92742
12	051391-04-703	EA	BURNER-MAIN/ELECTRONIC IG	91638
13	051391-01-714	EA	FITTING-ELBOW 45,3/8F X 3/8	MPT 1044
14	051391-03-700	EA	HOLDER-ORIFICE	91563
16	051391-01-715	EA	PLUG-DRAIN, 1 EA = 2 PER PKG	91857
17	051391-01-700	EA	HINGE KIT, (PIN & CLIP)	92568&92559
18	051391-04-706	EA	TANK-G6A-4E/6E/7E/8E-FRT.MT	91641 - INNER
	051391-01-717	EA	GRILLE-WATER HEATER DOOR	92640
	051393-01-723	EA	SWITCH - THERMAL CUTOUT 2/PK	93866 WAS 93853
	051393-01-724	EA	BOARD-CIRCUIT, SPADE TERMINAL	93865
	051393-01-725	EA	ELECTRODE-SGL SPADE CONNECT.	93868
	051393-01-726	EA	VALVE/SOLENOID - W/O BRACKET	93870
	111129-01-711	EA	BRACKET-CORNER, SET OF FOUR	91928

CONTACT WINNEBAGO PARTS SALES FOR UNLISTED COMPONENT(S)

**WATER & SEWAGE GROUP (CONTINUED)**  
**COMPONENT PARTS FOR WATER SYSTEM (CONTINUED)**

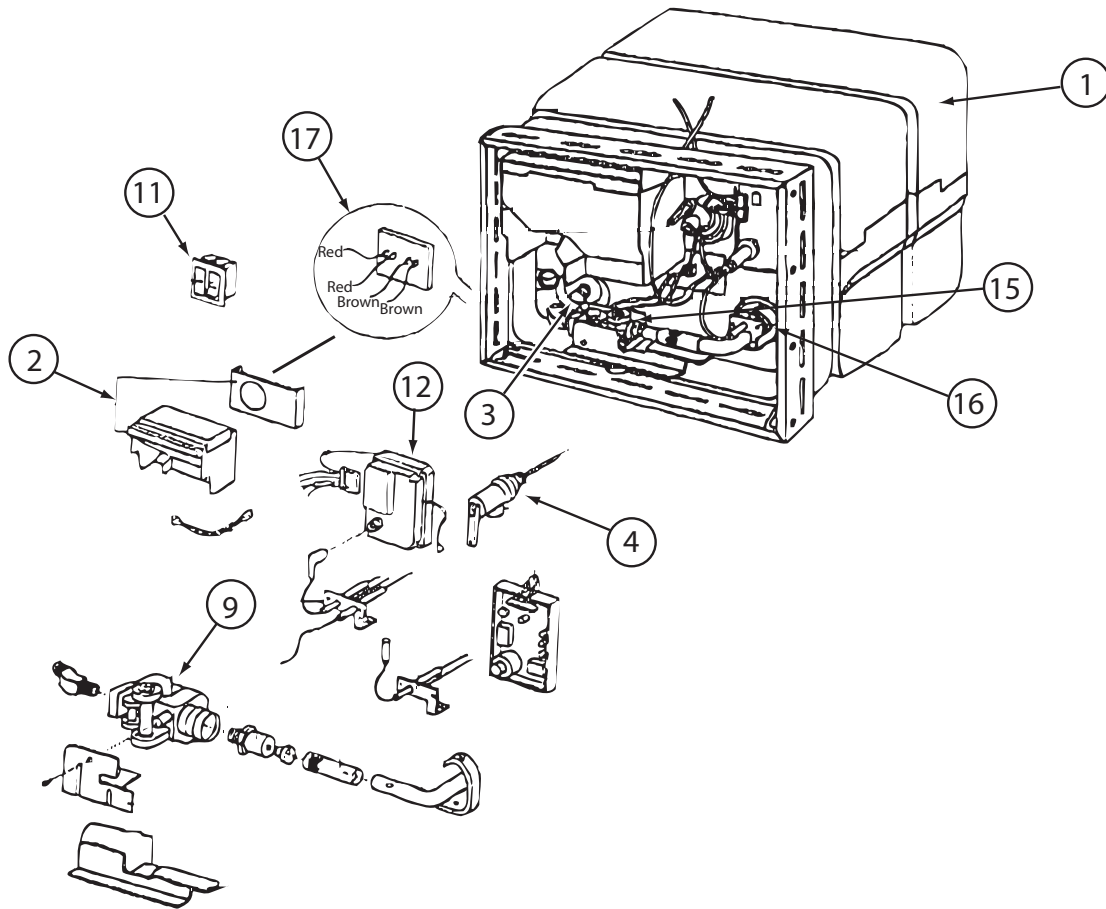

**145541-02-000**

KEY	PART NUMBER	U/M	DESCRIPTION	VENDOR NO.
1	145541-02-700	EA	TANK/SERVICE KIT PCS- 6 GAL	91053
2	051391-04-707	EA	KIT-EXHAUST, (FLUE & GASKET)	90960
3	051391-01-715	EA	PLUG-DRAIN, 1 EA = 2 PER PKG	91857
4	051391-01-704	EA	VALVE-RELIEF, 1/2" FITTING	91604
4	051931-03-701	EA	VALVE-RELIEF - 3/4" FITTING	90028
9	051393-01-726	EA	VALVE-SOLENOID - W/O BRACKET	93870
11	051393-01-701	EA	SWITCH - REMOTE - W/LIGHT	91959
11	145541-01-701	EA	SWITCH - ON/OFF - WHITE	91859
12	145541-01-702	EA	CIRCUIT BOARD	91226
15	145541-01-703	EA	SWITCH - THERMAL CUT OFF	93866
16	051393-01-725	EA	ELECTRODE-SGL SPADE CONNECT.	93868
17	051393-01-721	EA	THERMOSTAT W/ECO, 140 FRT MT	91447
	051391-05-706	EA	ELEMENT-HEATING 1500 WATT	92249 W/GASKET
	145541-01-704	EA	RELAY	90061
	145541-02-701	EA	JUNCTION BOX(PLASTIC) 6 GAL	91222

CONTACT WINNEBAGO PARTS SALES FOR UNLISTED COMPONENT(S)

**152311-01-01A**

KEY	PART NUMBER	U/M	DESCRIPTION	VENDOR NO.
	152311-01-700	EA	KNOB - CONTROL	AF-0908-HANDLE
	152311-01-701	EA	BUTTON-HOT/COLD	
	152311-02-701	EA	CARTRIDGE (KIT)	

**165730-01-01A**

KEY	PART NUMBER	U/M	DESCRIPTION	VENDOR NO.
	165730-02-700	EA	CARTRIDGE	CFG-40002

## WINDOW & VENTS GROUP

### WINDOW & VENT LAYOUT

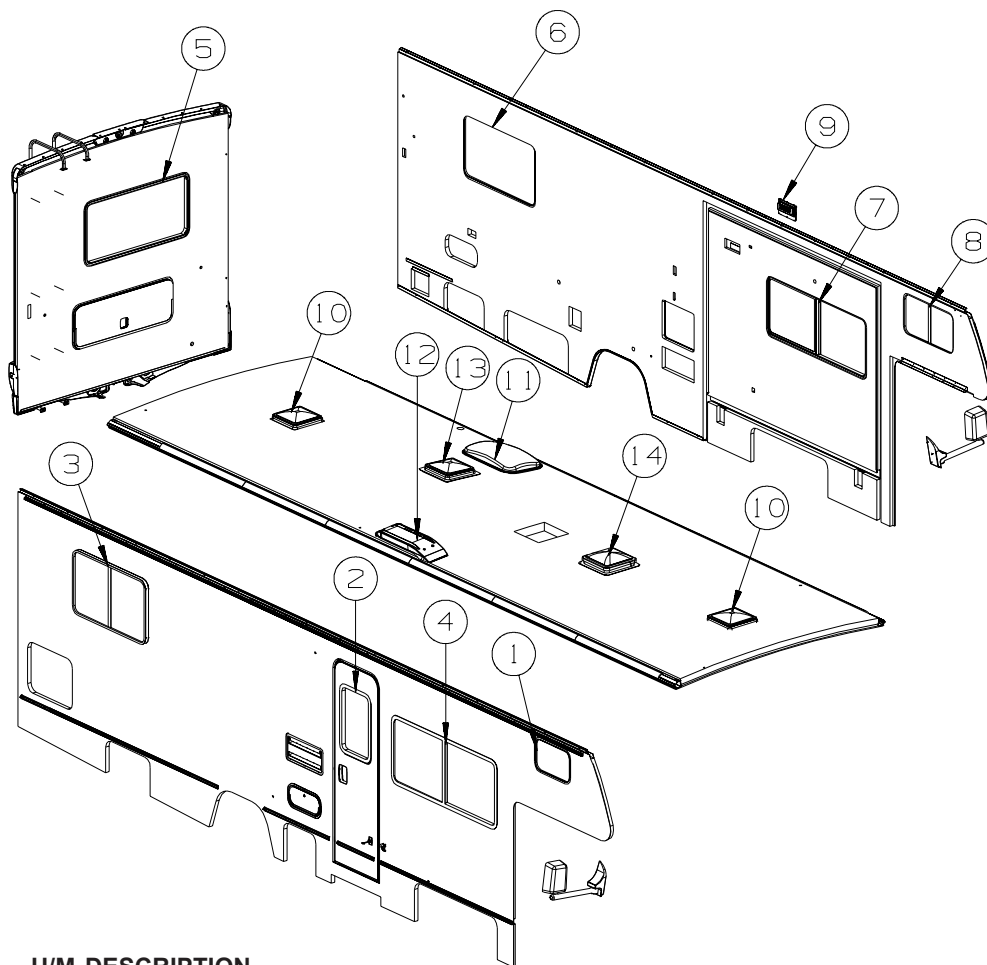

KEY	PART NUMBER	U/M	DESCRIPTION
1*	098647-78-02A	EA	WINDOW - PASS HORIZ SLIDER W/TRIM - 12.5" X 19.9" -SLV/BLK
1*	150648-31-02A	EA	INDOW-HORIZ SLIDER/FLUSH/THERMO/RH - 12.3" X 19.7"-SILVER - <b>DUAL PANE</b>
2	117053-04-W21	EA	WINDOW - PICTURE/CLEAR - W/O TRIM - 17" X 26.4"
	002181-27-000	EA	GLASS - PICTURE WINDOW - 25.8"W X 16.4"H - CLEAR
	087561-01-000	FT	SEAL - GLASS - EXTERIOR - .5" WIDE - VINYL BLACK
	117054-02-03A	EA	TRIM/RETAINER - INSIDE - 16.9" X 26.2" - BLACK
2*	150651-01-03A	EA	WINDOW - STATIONARY/FLUSH/THERMO - 26.3" X 17" - SILVER - <b>DUAL PANE</b>
3*	098647-29-03A	EA	WINDOW - PASS HORIZ SLIDER W/TRIM - CLEAR - 24.2" X 41"
3*	161452-01-02A	EA	WINDOW - TIPOUT/FLUSH/THERMO - 24.5" X 41.2" - SILVER - <b>DUAL PANE</b>
4*	098647-27-03A	EA	WINDOW - PASS HORIZ SLIDER W/TRIM - CLEAR - 26.1" X 59.7"
4*	150648-03-03A	EA	WINDOW-HORIZ SLIDER/FLUSH/THERMO/RH - 26.3" X 59.9" - SLV - <b>DUAL PANE</b>
5	078528-07-W21	EA	WINDOW - ESCAPE W/O INSIDE TRIM - CLEAR - 48.5"X 4.5"-GRAY
	002282-09-000	EA	WEATHERSTRIP - WINDOW - .125" X 130.5" - BLACK
	002285-01-000	FT	FILLER - WEATHERSTRIP - RUBBER - BLACK
	076337-13-000	EA	GLASS - EGRESS - 45.5" X 21.5"
5	074816-16-000	EA	FRAME - WINDOW - INSIDE ESCAPE - BLACK
5*	150651-03-02A	EA	WINDOW - STATIONARY/FLUSH/ESCAPE/THERMO - 24.7"X 48.7"-SLV, - <b>DUAL PANE</b>
6*	098647-30-03A	EA	WINDOW - DRVR HORIZ SLIDER W/TRIM - CLEAR - 24.2" X 41"
6*	161452-01-02A	EA	WINDOW - TIPOUT/FLUSH/THERMO - 24.5" X 41.2" - SILVER - <b>DUAL PANE</b>
7*	098647-74-02A	EA	WINDOW - DRIVER HORIZ SLIDER W/TRIM - 23.6" X 57.5"
7*	150648-07-02A	EA	WINDOW-HORIZ SLIDER/FLUSH/THERMO/LH - 23.8" X 57.7"-SILVER" - <b>DUAL PANE</b>
8*	098647-32-03A	EA	WINDOW - DRVR HORIZ SLIDER W/TRIM - CLEAR- 15.7" X 28.5"
8*	150648-05-03A	EA	WINDOW-HORIZ SLIDER/FLUSH/THERMO/LH - 16" X 28.7" - SILVER - <b>DUAL PANE</b>
9	147821-01-01A	EA	VENT - EXHAUST/RANGE HOOD - BRIGHT WHITE
9	147821-02-01A	EA	SHROUD - EXHAUST VENT/RANGE HOOD - BRIGHT WHITE
10*	122882-01-01A	EA	VENT - ROOF - NONPOWERED - W/O INSIDE GARNISH
	009440-01-000	EA	GEAR/ARM - LIFT - ROOF VENT COVER
10	122882-07-01A	EA	GARNISH - ROOF VENT - 2.5" TO 4.1"
11	122193-01-02A	EA	PANEL - SKYLITE - INNER - W/LIGHT INDENTATION
11	138372-01-02B	EA	TRIM - CORNER - SKYLIGHT - E-COATED
11	138379-02-01A	EA	PANEL/SKYLIGHT OTR - RECT/4"H CTR DOME - 18.4"X 29.5"- WHT



## WINDOW & VENTS GROUP (CONTINUED)

### WINDOW & VENT LAYOUT (CONTINUED)

KEY	PART NUMBER	U/M	DESCRIPTION
12	149508-01-02A	EA	CAP - ROOF/REFRIGERATOR VENT - WHITE
12	149508-02-02A	EA	BASE - ROOF/REFRIGERATOR VENT - BRIGHT WHITE
13*	122882-02-01A	EA	VENT - ROOF - W/FAN - W/O INSIDE GARNISH - UL
13*	122882-03-01A	EA	VENT - ROOF - W/FAN - W/O INSIDE GARNISH - CANADIAN
	009440-01-000	EA	GEAR/ARM - LIFT - ROOF VENT COVER
	048648-01-000	EA	MOTOR/ROOF VENT - W/RESISTER - 1/8"SHAFT - 12VOLT
	048649-01-000	EA	FAN BLADE - ROOF VENT - 6 BLADED - 6"RADIUS
13	122882-07-01A	EA	GARNISH - ROOF VENT - 2.5" TO 4.1"
14*	123780-26-01A	EA	FANTASTIC VENT-4"ROOF- W/FAN/DBL DOME-W/O THERM/PWR - VENT-POWER VENTILATOR

\*COMPONENT PARTS LISTED LATER IN THIS GROUP

**WINDOW & VENTS GROUP (CONTINUED)**  
**COMPONENT PARTS FOR WINDOW & VENT LAYOUT**

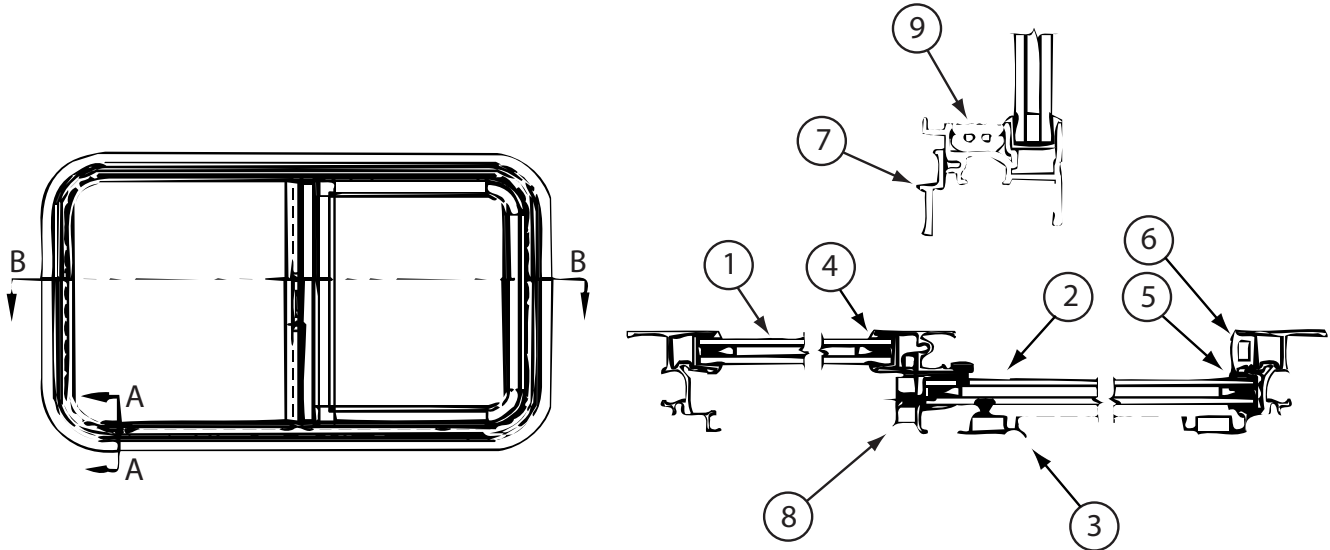

**098647-27-03A**

KEY	PART NUMBER	U/M	DESCRIPTION	VENDOR NO.
1	098647-27-702	EA	GLASS - STATIONARY	096-017868
2	098647-27-703	EA	GLASS SLIDING W/SASH & LATCH	H287-C8
3	098647-23-704	EA	SCREEN ASM	410-019066
4	098644-01-705	FT	GLAZING - STRIP	132-010231
5	098644-01-708	FT	CHANNEL - RUN PIERCED	122-016543
6	098644-01-716	FT	PLUG - FILLER	132-014470
7	098647-27-704	EA	RETAINER - TRIM - BLACK	H287-66
8	098644-01-700	EA	LATCH - REPAIR KIT (BLACK)	B801-CK
8	098647-54-701	EA	LATCH - REPAIR KIT (RED)	B081-CK
9	098644-01-719	EA	STOP - SLIDER GLASS	132-014203
	098644-01-706	FT	WEATHERSTRIP - GLASS	171-010668
	098644-01-710	FT	TRACK - SCREEN SPACER 12'	132-017135
	098644-01-711	FT	WEATHERSTRIP - SCREEN BLACK	171-016965
	098644-01-717	FT	SPLINE - SCREEN	132-004716
	125582-01-701	EA	CLIP - SCREEN - PLASTIC	130-005153

CONTACT WINNEBAGO PART SALES FOR UNLISTED COMPONENT(S)

**098647-29-03A, 098647-30-03A**

KEY	PART NUMBER	U/M	DESCRIPTION	VENDOR NO.
1	098647-29-702	EA	GLASS - STATIONARY	096-019295
2	098647-29-703	EA	GLASS-SLIDING W/SASH & LATCH	H172-C8
3	098647-29-704	EA	SCREEN ASM - W/SEALS & CLIPS	410-018864
4	098644-01-705	FT	GLAZING - STRIP	132-010231
5	098644-01-708	FT	CHANNEL - RUN PIERCED	122-016543
6	098644-01-717	FT	SPLINE - SCREEN	132-004716
7	098647-29-705	EA	RETAINER - TRIM	CH04-66
8	098647-54-701	EA	LATCH REPAIR KIT (RED)	B081-CK
9	098644-01-719	EA	STOP - SLIDER GLASS	132-014203
	098647-01-706	FT	WEATHERSTRIP-GLASS(FIN SEAL)	171-010668
	098647-01-710	FT	TRACK - SCREEN SPACER	132-017135
	098644-01-711	FT	WEATHERSTRIP-SCRN(FUZZY)BLK	171-017245/016965
	098644-01-717	FT	SPLINE - SCREEN	132-004716
	125582-01-701	EA	CLIP - SCREEN - PLASTIC	130-005153

CONTACT WINNEBAGO PART SALES FOR UNLISTED COMPONENT(S)

**WINDOW & VENTS GROUP (CONTINUED)**  
**COMPONENT PARTS FOR WINDOW & VENT LAYOUT (CONTINUED)**

**098647-32-03A**

KEY	PART NUMBER	U/M	DESCRIPTION	VENDOR NO.
1	098647-31-702	EA	GLASS - STATIONARY	096-019299
2	098647-31-703	EA	GLASS-SLIDING W/SASH & LATCH	H425-C8
3	098647-31-704	EA	SCREEN ASM - W/SEALS & CLIPS	410-019128
4	098644-01-705	FT	GLAZING - STRIP	132-010231
5	098644-01-708	FT	CHANNEL - RUN PIERCED	122-016543
6	098644-01-717	FT	SPLINE - SCREEN	132-004716
7	098647-31-705	EA	RETAINER - TRIM	CH29-66
8	098647-54-701	EA	LATCH REPAIR KIT (RED)	B081-CK
9	098644-01-719	EA	STOP - SLIDER GLASS	132-014203
	098647-01-706	FT	WEATHERSTRIP-GLASS(FIN SEAL)	171-010668
	098647-01-710	FT	TRACK - SCREEN SPACER	132-017135
	098644-01-711	FT	WEATHERSTRIP-SCRN(FUZZY)BLK	171-017245/016965
	098644-01-717	FT	SPLINE - SCREEN	132-004716
	125582-01-701	EA	CLIP - SCREEN - PLASTIC	130-005153
			CONTACT WINNEBAGO PART SALES FOR UNLISTED COMPONENT(S)	

**098647-74-02A**

KEY	PART NUMBER	U/M	DESCRIPTION	VENDOR NO.
1	098647-68-701	EA	GLASS - STATIONARY	096-029585
2	098647-74-700	EA	GLASS SLIDING W/SASH & LATCH	H493C8
3	098647-47-702	EA	SCREEN ASM	410-025226
4	098644-01-705	FT	GLAZING - STRIP	132-010231
5	098644-01-708	FT	CHANNEL - RUN PIERCED	122-016543
6	098644-01-716	FT	PLUG - FILLER	132-014470
7	098647-47-704	EA	RETAINER - TRIM - BLACK	H493-66
8	098644-01-700	EA	LATCH - REPAIR KIT (BLACK)	B801-CK
8	098647-54-701	EA	LATCH - REPAIR KIT (RED)	B081-CK
9	098644-01-719	EA	STOP - SLIDER GLASS	132-014203
	098644-01-706	FT	WEATHERSTRIP - GLASS	171-010668
	098644-01-710	FT	TRACK - SCREEN SPACER 12'	132-017135
	098644-01-711	FT	WEATHERSTRIP - SCREEN BLACK	171-016965
	098644-01-717	FT	SPLINE - SCREEN	132-004716
	125582-01-701	EA	CLIP - SCREEN - PLASTIC	130-005153
			CONTACT WINNEBAGO PART SALES FOR UNLISTED COMPONENT(S)	

**098647-78-02A**

KEY	PART NUMBER	U/M	DESCRIPTION	VENDOR NO.
1	098647-78-700	EA	GLASS - STATIONARY	096-036830
2	098647-78-703	EA	GLASS SLIDING W/SASH & LATCH	H996C8
3	098647-78-702	EA	SCREEN ASM	410-036304
4	098644-01-705	FT	GLAZING - STRIP	132-010231
5	098644-01-708	FT	CHANNEL - RUN PIERCED	122-016543
6	098644-01-716	FT	PLUG - FILLER	132-014470
7	098647-78-701	EA	RETAINER - TRIM	H996-66
8	098644-01-700	EA	LATCH - REPAIR KIT (BLACK)	B801-CK
8	098647-54-701	EA	LATCH - REPAIR KIT (RED)	B081-CK
9	098644-01-719	EA	STOP - SLIDER GLASS	132-014203
	098644-01-706	FT	WEATHERSTRIP - GLASS	171-010668
	098644-01-710	FT	TRACK - SCREEN SPACER 12'	132-017135
	098644-01-711	FT	WEATHERSTRIP - SCREEN BLACK	171-016965
	098644-01-717	FT	SPLINE - SCREEN	132-004716
	125582-01-701	EA	CLIP - SCREEN - PLASTIC	130-005153
			CONTACT WINNEBAGO PART SALES FOR UNLISTED COMPONENT(S)	

**WINDOW & VENTS GROUP (CONTINUED)**  
**COMPONENT PARTS FOR WINDOW & VENT LAYOUT (CONTINUED)**

**122882-01-01A**

<b>KEY</b>	<b>PART NUMBER</b>	<b>U/M</b>	<b>DESCRIPTION</b>	<b>VENDOR NO.</b>
	064470-01-700	EA	COVER - VENT	J7291
	064470-01-701	EA	SLIDE BAR - VENT LID	JRP1291B
	122882-01-700	EA	HANDLE - CRANK - BLACK	90128
	122882-01-701	EA	SCREEN	JRP-1124-B
	122882-01-702	EA	HANDLE - CRANK - WHITE	JRP1031B

**122882-02-01A, 122882-03-01A**

<b>KEY</b>	<b>PART NUMBER</b>	<b>U/M</b>	<b>DESCRIPTION</b>	<b>VENDOR NO.</b>
	064470-01-700	EA	COVER - VENT	J7291
	064470-01-701	EA	SLIDE BAR - VENT LID	JRP1291B
	110051-03-700	EA	SWITCH-BLACK/PUSH BUTTON	27-0164
	122882-01-700	EA	HANDLE - CRANK - BLACK	90128
	122882-01-701	EA	SCREEN	JRP-1124-B
	122882-01-702	EA	HANDLE - CRANK - WHITE	JRP1031B

**WINDOW & VENTS GROUP (CONTINUED)**  
**COMPONENT PARTS FOR WINDOW & VENT LAYOUT (CONTINUED)**

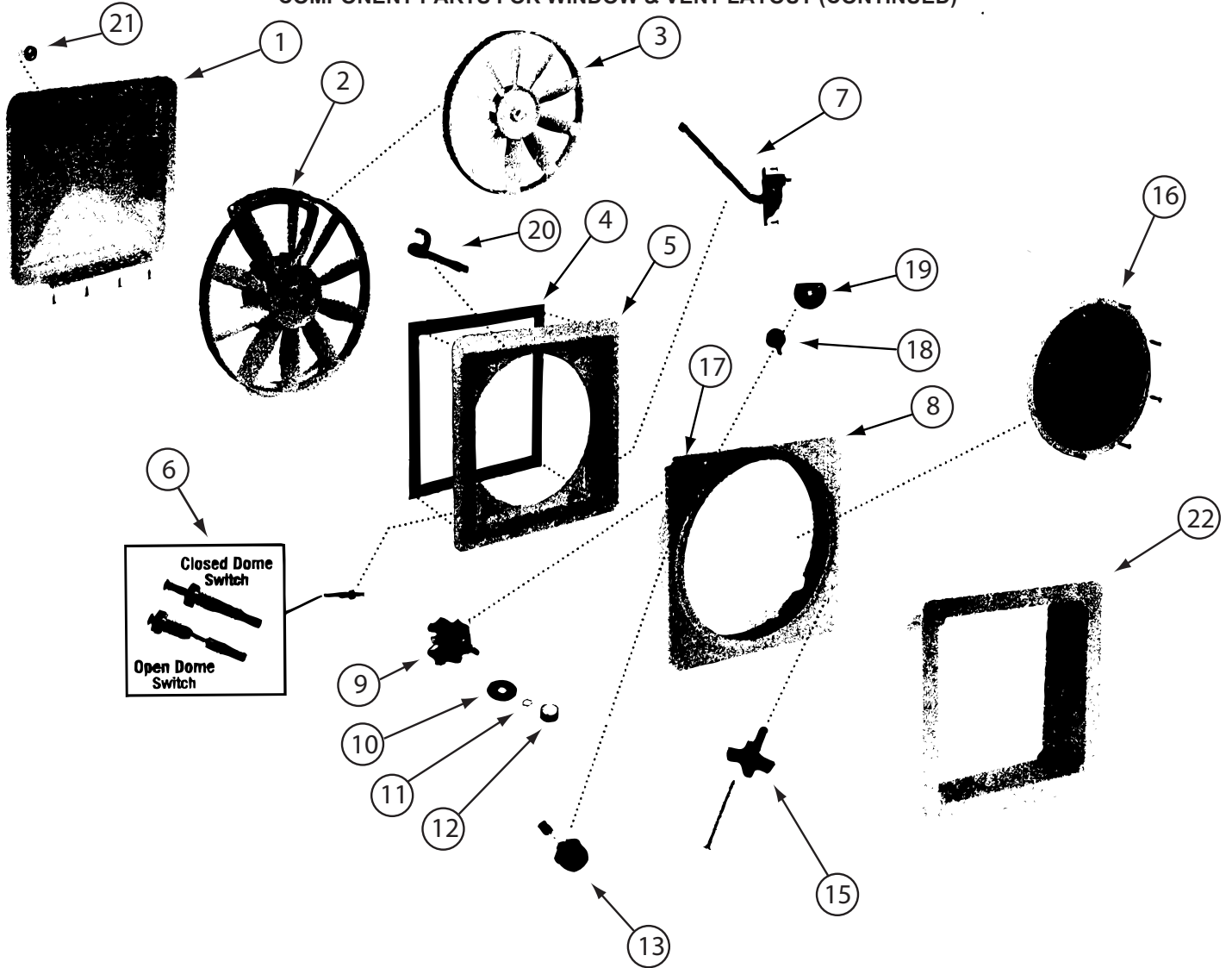

123780-26-01A

KEY	PART NUMBER	U/M	DESCRIPTION	VENDOR NO.
1	123780-22-700	EA	COVER - VENT W/HINGE & SLIDE	K8020-81
2	123780-26-700	EA	MOTOR & FAN BLADE W/BRACKET	XK8017-03 PANCAKE
3	123780-26-701	EA	BLADE/FAN - 12" OPAQUE WHT	8138-81 - 7MM
4	123780-22-701	EA	SEAL/RUBBER-4 1/2' W/GLUE	K1144-09
5	123780-22-702	EA	BASE/MAIN - W/LOCK/SEAL/ARM	XK8010-81 CLAMP STY
6	084079-01-707	EA	SWITCH - SAFETY	1122-05
7	084079-01-702	EA	ARM LIFT ASSEMBLY, MANUAL	101105
8	123780-22-703	EA	SCREEN KIT W/RING/ARM/LOCK	XK1220-81
9	084079-01-709	EA	SWITCH - MAIN - 3 SPEED	1031-05
13	123780-21-700	EA	FUSE HOLDER W/4 AMP FUSE	K9018-09
15	123780-16-700	EA	KNOB-BLK/AUTOMATIC LIFT MTR	K1140-09
16	123780-21-703	EA	SCREEN - POP N LOCK	2035-81
17	123780-22-704	EA	TRAVEL LOCK ASSEMBLY	4021-09
22	123780-22-705	EA	GARNISH-3 1/2"CLAMP STY-WHT	XK2040-81

CONTACT WINNEBAGO PART SALES FOR UNLISTED COMPONENT(S)

**WINDOW & VENTS GROUP (CONTINUED)**  
**COMPONENT PARTS FOR WINDOW & VENT LAYOUT (CONTINUED)**

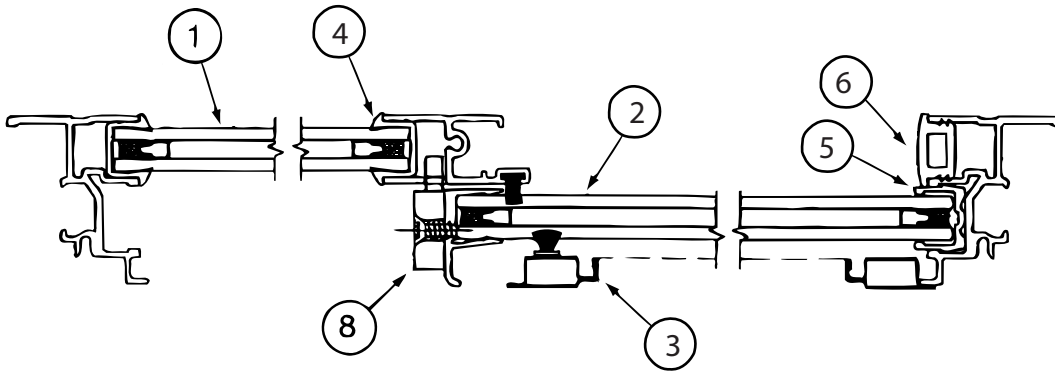

CROSS SECTION B-B

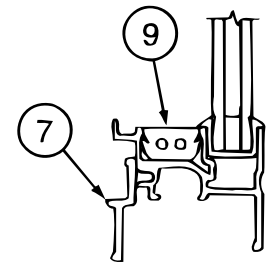
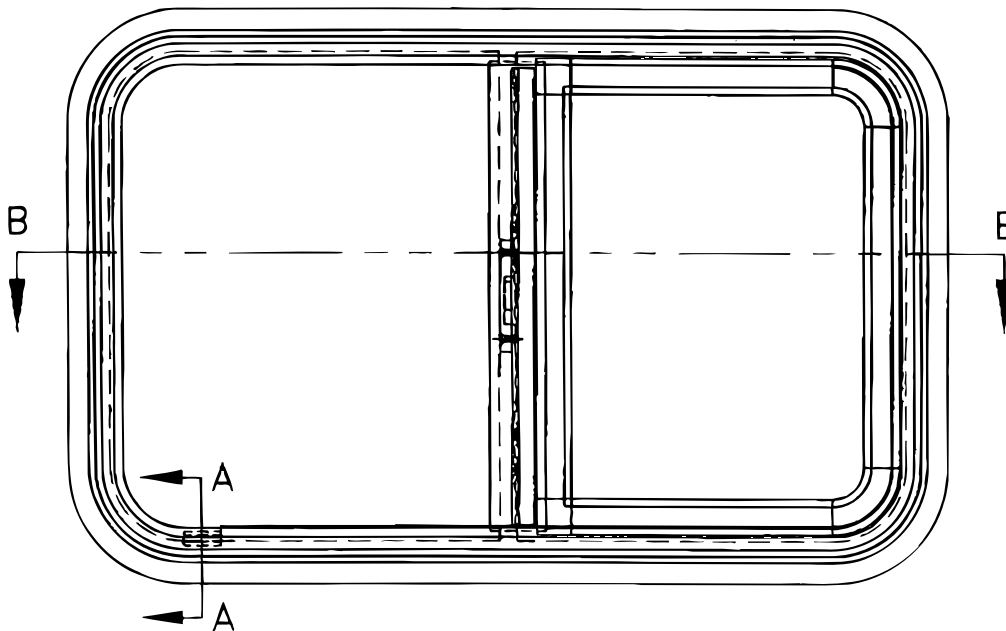

CROSS SECTION  
A-A

150648-02-01A, 150648-03-01A/3A				
KEY	PART NUMBER	U/M	DESCRIPTION	VENDOR NO
1	112795-68-700	EA	GLASS - STATIONARY	390-028353
2	150648-02-700	EA	GLASS-SLIDING W/SASH & LATCH	FH3009G8
3	150648-19-700	EA	SCREEN ASM	410-035332
4	112795-01-705	FT	VINYL - GLAZING	132-027331
5	151069-01-700	EA	CHANNEL-RUN, SLIDING	122-030627
6	150648-01-703	EA	PLUG - FILLER	132-030308
7	098647-22-701	EA	RETAINER - TRIM	H287-67
8	150648-01-700	EA	LATCH-HORIZONTAL SLIDE-BLK	FH3000-CK
8	150648-01-701	EA	LATCH-HORIZONTAL SLIDE-RED	FH3003-CK
9	150648-01-704	EA	SLIDE STOP	132-030866
	150649-05-702	FT	FIN SEAL-F/LOCKING RAIL-BLK	171-062348

**WINDOW & VENTS GROUP (CONTINUED)**  
**COMPONENT PARTS FOR WINDOW & VENT LAYOUT (CONTINUED)**

**150648-05-03A**

<b>KEY</b>	<b>PART NUMBER</b>	<b>U/M</b>	<b>DESCRIPTION</b>	<b>VENDOR NO</b>
1	150648-05-702	EA	GLASS - STATIONARY	390-028308
2	112795-72-701	EA	GLASS-SLIDING W/SASH & LATCH	DC29-G8
3	150648-05-700	EA	SCREEN ASM	410-031158
4	112795-01-705	FT	VINYL - GLAZING	132-027331
5	151069-01-700	EA	CHANNEL-RUN, SLIDING	122-030627
6	150648-01-703	EA	PLUG - FILLER	132-030308
7	150648-05-701	EA	RETAINER - TRIM	CH29-67
8	150648-01-700	EA	LATCH-HORIZONTAL SLIDE-BLK	FH3000-CK
8	150648-01-701	EA	LATCH-HORIZONTAL SLIDE-RED	FH3003-CK
9	150648-01-704	EA	SLIDE STOP	132-030866
	150649-05-702	FT	FIN SEAL-F/LOCKING RAIL-BLK	171-062348

**150648-07-02A**

<b>KEY</b>	<b>PART NUMBER</b>	<b>U/M</b>	<b>DESCRIPTION</b>	<b>VENDOR NO</b>
1	150648-07-701	EA	GLASS - STATIONARY	390-028314
2	112795-77-701	EA	GLASS-SLIDING W/SASH & LATCH	DH493-G8
3	150648-01-702	EA	SCREEN ASM	410-031156
4	112795-01-705	FT	VINYL - GLAZING	132-027331
5	151069-01-700	EA	CHANNEL-RUN, SLIDING	122-030627
6	150648-01-703	EA	PLUG - FILLER	132-030308
7	150648-01-707	EA	RETAINER - TRIM	H493-67
8	150648-01-700	EA	LATCH-HORIZONTAL SLIDE-BLK	FH3000-CK
8	150648-01-701	EA	LATCH-HORIZONTAL SLIDE-RED	FH3003-CK
9	150648-01-704	EA	SLIDE STOP	132-030866
	150649-05-702	FT	FIN SEAL-F/LOCKING RAIL-BLK	171-062348

**150648-31-01A/02A, 150648-32-01A**

<b>KEY</b>	<b>PART NUMBER</b>	<b>U/M</b>	<b>DESCRIPTION</b>	<b>VENDOR NO</b>
1	150648-31-700	EA	GLASS - STATIONARY	390-036848
2	150648-31-701	EA	GLASS-SLIDING W/PULL & LATCH	FH3093G8
3	150648-31-702	EA	SCREEN ASM	410-036850
4	112795-01-705	FT	VINYL - GLAZING	132-027331
5	151069-01-700	FT	CHANNEL-RUN, SLIDING	122-030627
6	150648-01-703	FT	PLUG - FILLER	132-030308
7	150648-31-703	EA	RETAINER - TRIM	H3093-67
8	150658-01-700	EA	LATCH-HORIZONTAL SLIDE-BLK	FH3000-CK
8	150648-01-701	EA	LATCH-HORIZONTAL SLIDE-RED	FH3003-CK
9	150648-01-704	EA	SLIDE STOP	132-030866
	150649-05-702	FT	FIN SEAL-F/LOCKING RAIL-BLK	171-062348

**WINDOW & VENTS GROUP (CONTINUED)**  
**COMPONENT PARTS FOR WINDOW & VENT LAYOUT (CONTINUED)**

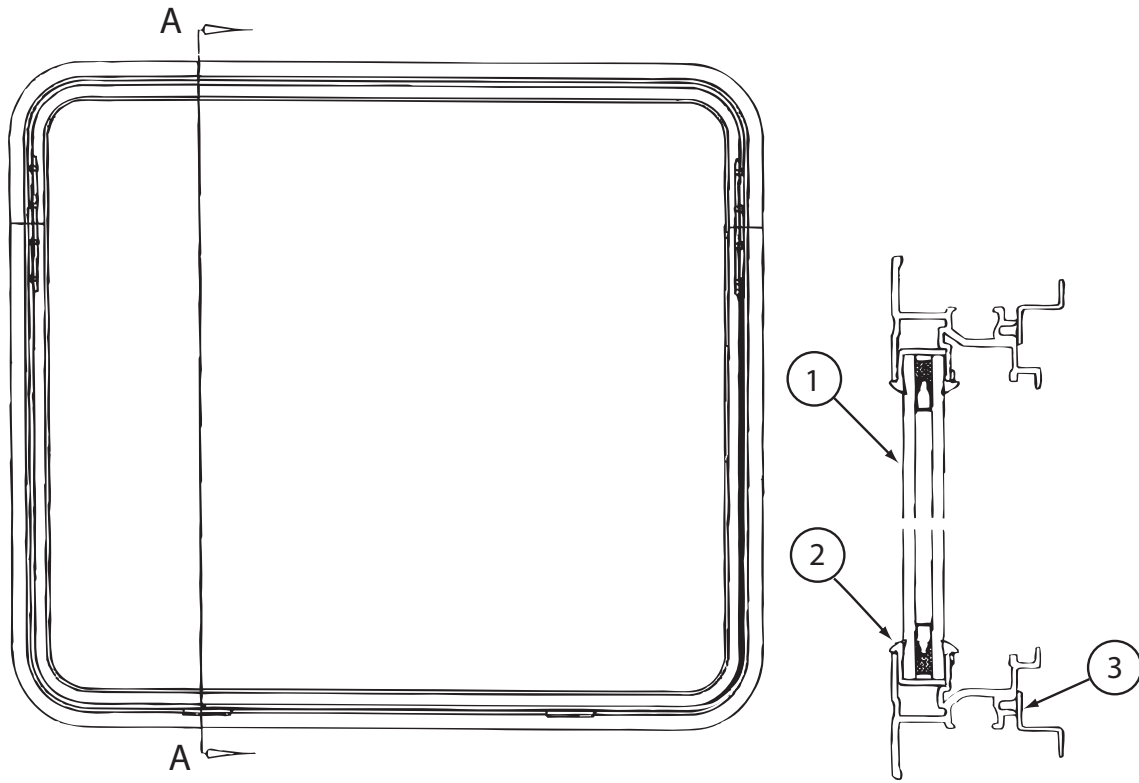

CROSS SECTION A-A

150651-01-01A/03A

KEY	PART NUMBER	U/M	DESCRIPTION	VENDOR NO
1	113733-10-700	EA	GLASS-STATIONARY	390-028306
2	112795-01-705	FT	VINYL - GLAZING	132-027331
3	150651-01-700	EA	RETAINER - TRIM	H416-67



**WINDOW & VENTS GROUP (CONTINUED)**  
**COMPONENT PARTS FOR WINDOW & VENT LAYOUT (CONTINUED)**

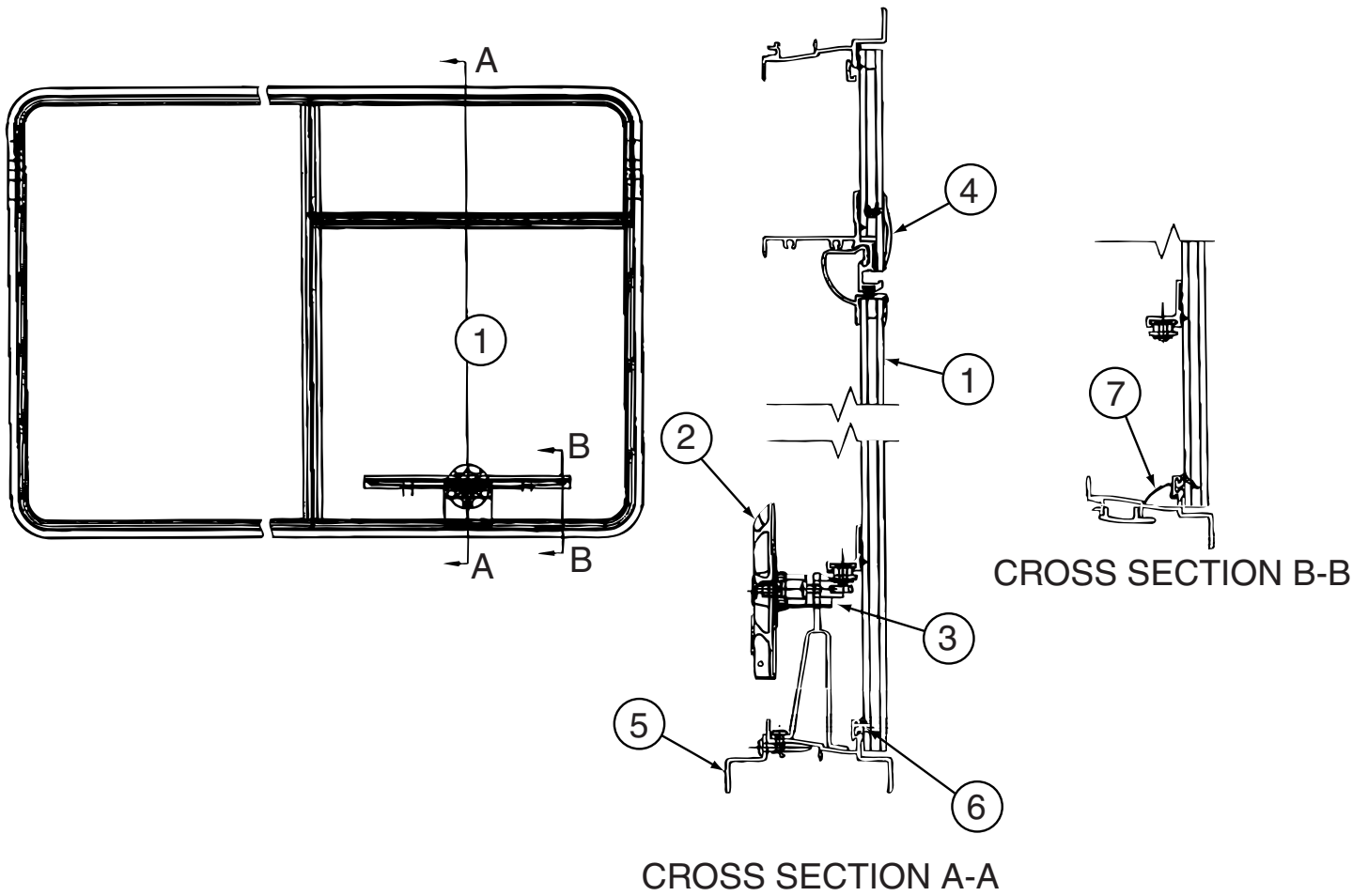

150651-03-01A/02A

KEY	PART NUMBER	U/M	DESCRIPTION	VENDOR NO
1	150651-03-700	EA	GLASS-TIPOUT-W/HNG/GDE RAIL	DTH3049G8R RH F/INS
2	150656-02-702	EA	HANDLE-DIAL	410-016081E
3	150656-08-701	EA	OPERATOR - TIPOUT/LARGE	410-036141
4	150656-08-700	EA	SEAL/DUAL - WINDOW - 100"	132-030725
5	150651-03-701	EA	RETAINER - TRIM	DTH3049-50
6	100322-01-701	FT	SEAL-VENT	122-016071
7	150651-03-702	EA	COVER - DRAIN SLOT	132-030723

**WINDOW & VENTS GROUP (CONTINUED)**  
**COMPONENT PARTS FOR WINDOW & VENT LAYOUT (CONTINUED)**

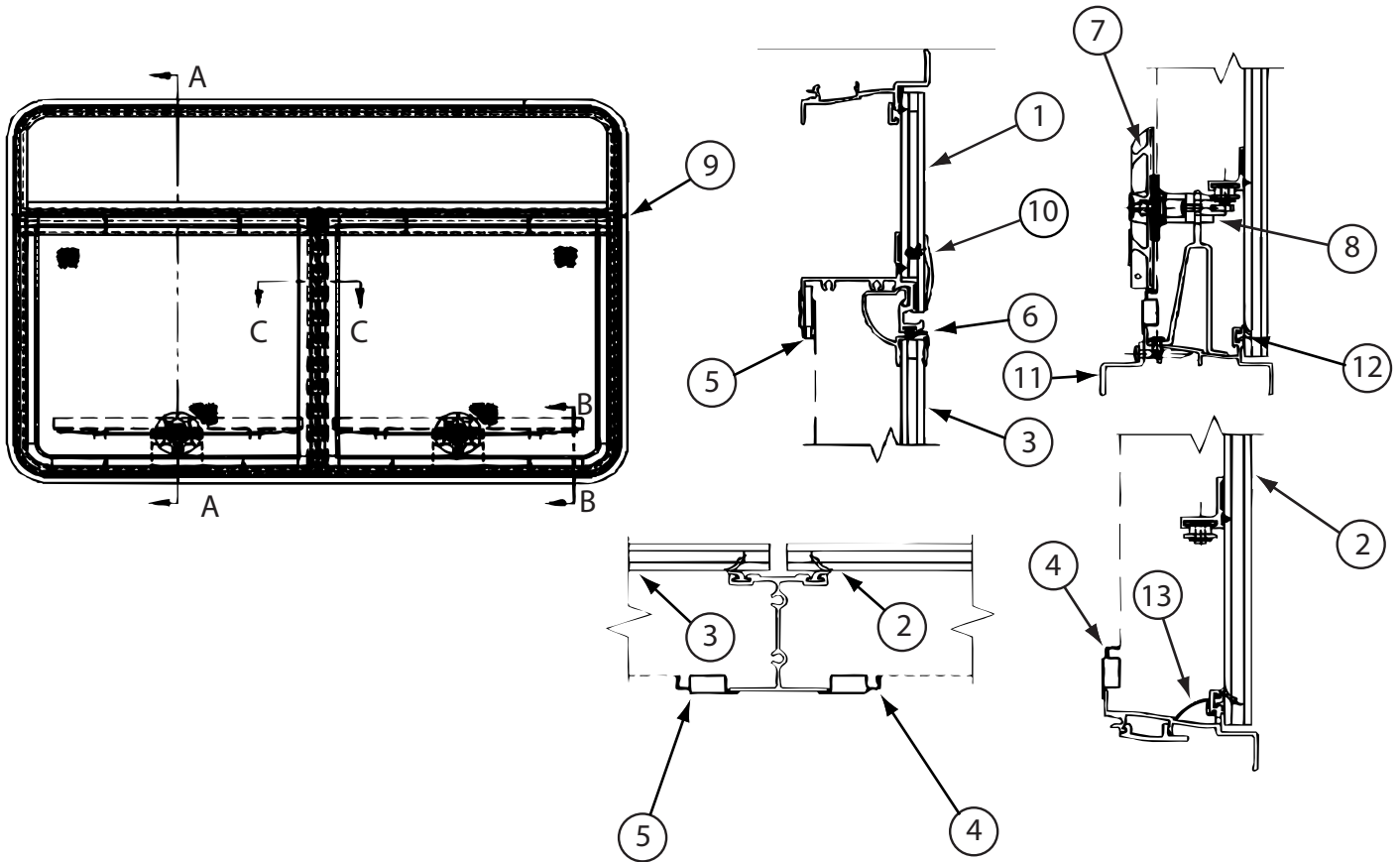

161452-01-01A/02A

KEY	PART NUMBER	U/M	DESCRIPTION	VENDOR NO.
2	150656-03-700	EA	GLASS-TIPOUT-RH-W/HNG/RAIL	DTH3023G8R RH F/INS
3	150656-03-701	EA	GLASS-TIPOUT-LH-W/HNG/RAIL	DTH3023G8L LH F/INS
4	150656-03-702	EA	SCREEN ASM - RIGHT	410-031152
5	150656-03-703	EA	SCREEN ASM - LEFT	410-031151
6	098644-01-706	FT	WEATHERSTRIP - GLASS	171-010668
7	100322-01-718	EA	HANDLE-DIAL	410-016081
8	150656-08-701	EA	OPERATOR - TIPOUT/LARGE	410-036141
9	161452-01-700	FT	FELT SEAL	160-014688
11	150656-03-704	EA	RETAINER - TRIM	DTH3023-56
12	100322-01-701	FT	SEAL-VENT	122-016071
13	150651-03-702	FT	COVER - DRAIN SLOT	132-030723

CONTACT WINNEBAGO PART SALES FOR UNLISTED COMPONENT(S)