

2007
VECTRA
WKS40KD
S-SERIES
CONCERT CHERRY
 UJ1 SERENITY
 UJ5 SANDY COVE
 UK1 CASPIAN BLU
WASHED MAPLE
 UJ2 SERENTIY
 UJ6 SANDY COVE
 UK2 CASPIAN BLU
HONEY CHERRY
 UJ3 SERENTIY
 UJ7 SANDY COVE
 UK3 CASPIAN BLU
DASH ACCENT COLORS
 UJ1, UJ2, UJ3, UJ5, UJ6, UJ7 - CASHMERE
 UK1, UK2, UK3 - BRIARWOOD

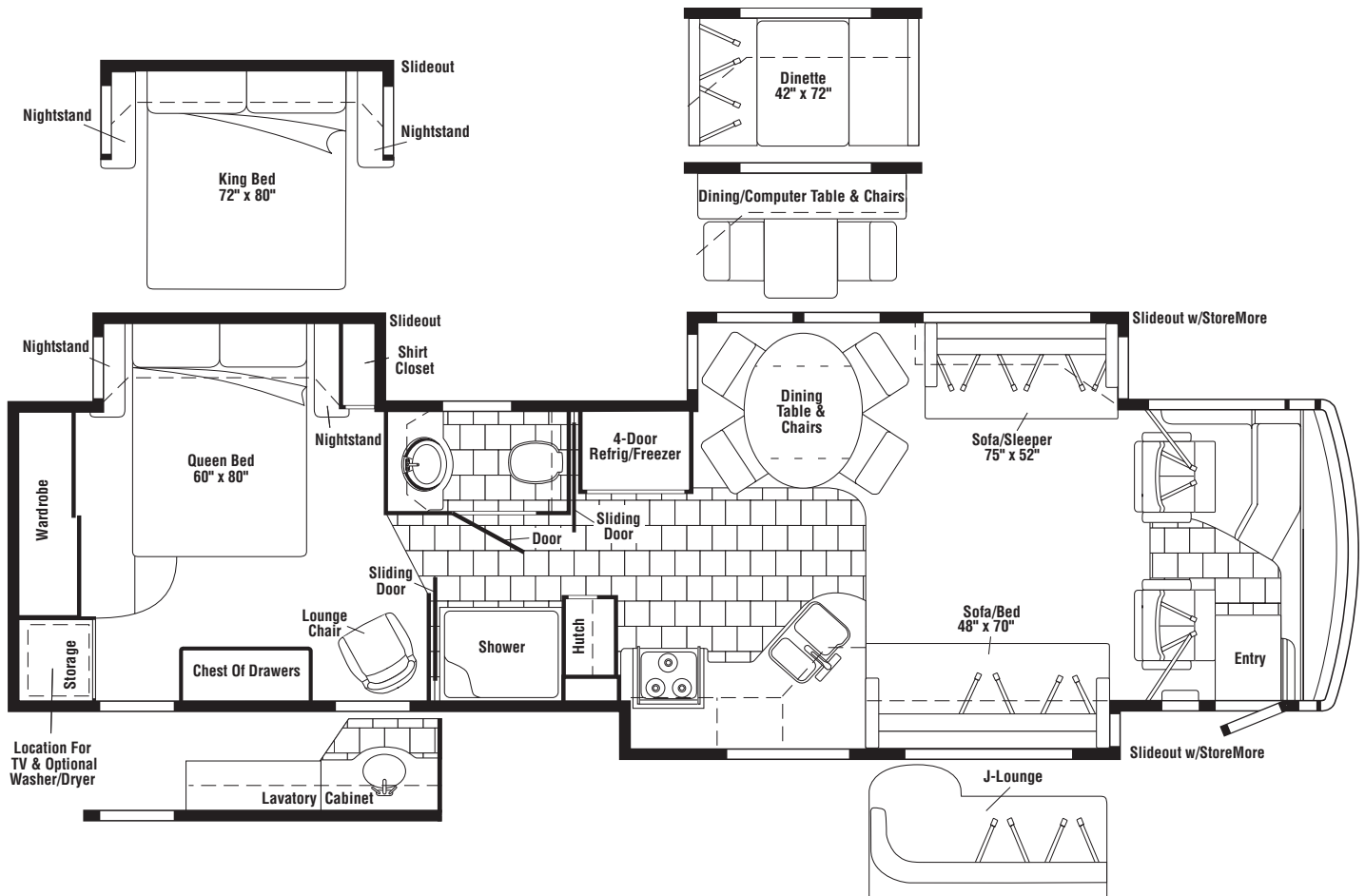

FLOORPLAN

CONTENTS

FLOORPLAN	1
ACCESSORIES GROUP	6
OPERATORS MANUAL	6
AUDIO VIDEO GROUP	7
RADIO SYSTEM	7
REAR MONITOR	7
CABINET & APPLIANCE GROUP	8
CABINET & APPLIANCE LAYOUT	8
COMPONENT PARTS FOR CABINET & APPLIANCE LAYOUT	27
108186-02-000	27
108186-03-000	27
119267-12-02A	27
119267-13-01A	27
125242-03-02A	28
125242-05-02A	38
135065-03-01A, 135065-03-03A, 135065-04-01A	48
140147-04-01A, 140147-04-02A, 140147-04-03A	50
CHASSIS GROUP	51
FRAME	51
FRONT END	53
INSULATION	54
STEPWELL COVER	55
COMPONENT PARTS FOR STEPWELL COVER	55
145122-01-01A	55
EXHAUST	56
HITCH	56
MUD FLAP	56
FUEL	57
HYDRAULIC LEVELING	58
COMPONENT PARTS FOR HYDRAULIC LEVELING	58
107889-12-000	58
100536-47-000	58
100536-50-000	58
153452-24-000	59
153452-25-000	59
153452-26-000	60
WHEEL, TIRE, COVERS &/LINERS	60
CURTAIN & CUSHION GROUP	61
NOTICE	61
CUSHION LAYOUT	62
BUCKET SEAT	66
COMPONENT PARTS FOR BUCKET SEATS	67
122611-02-000	67
WINDOW TREATMENTS	68
HARDWARE	70
ACCESSORIES	71
FABRICS	72
DRIVERS COMPARTMENT GROUP	73
DASH	73
FRONT INTERIOR	74
COMPONENT PARTS FOR FRONT INTERIOR	81
091990-08-01A	81
094499-02-000	81
147767-01-000, 147767-02-000	81
CABINETS	82

CONTENTS (CONTINUED)

ELECTRICAL GROUP	90
110V BODY WIRING	90
12V BODY WIRING	92
EXTERIOR LAMPS	105
FRONT END	107
GPS	110
FRONT TV/VCR	111
SIDE TV/VCR	112
COMPONENT PARTS FOR WIRING	114
076319-23-000	114
076319-25-000	114
086280-01-000	115
087694-01-000	115
093575-33-03A	115
108354-01-01A	115
121935-01-01A	115
123775-01-02A	115
129561-02-01A	116
130672-01-02A	116
133004-05-01A	117
136119-01-000	118
137417-01-01A, 137417-03-01A	118
137424-01-000	118
139134-01-03A	118
141454-03-01A	119
144858-02-000	120
150934-02-000	120
151458-01-000	120
153464-01/02/04/05-01A	120
153464-03/06-01A	120
154548-01-000	120
155330-01-000	120
155619-01-000	120
156413-01-01A	120
159759-01-000	120
CIRCUIT BREAKERS, FUSES & RELAYS	121
CONVERTER, INVERTER, LOAD CENTERS	121
BOXES & CORDS	122
COMPONENT PARTS FOR BOXES & CORDS	122
144858-02-000	122
WIRE ASSEMBLIES	123
CONNECTORS & CONDUIT	124
CHASSIS	127
EXTERIOR BODY GROUP	128
AIR HORN	128
COMPONENT PARTS FOR AIR HORN	128
077497-06-000	128
GRAPHICS & PAINT	129
PANELS & TRIMS	131
COMPONENT PARTS FOR PANELS & TRIMS	134
131431-08-02A	134
132442-06-01A, 132442-07-01A	134
142721-01-02A, 142721-02-02A	134
151458-02-000	134
FRONT END	135
LADDER	137
STRUCTURAL COMPONENTS	138
AWNINGS	139

CONTENTS (CONTINUED)

EXTERIOR DOORS & COMPARTMENTS GROUP	140
DOOR & COMPARTMENT LAYOUT	140
COMPONENT PARTS FOR DOOR & COMPARTMENT LAYOUT	149
084103-08-000	149
094707-04-01A	149
142226-02-01A	149
COMPARTMENT DOOR PIECE PARTS	150
ENTRY	154
COMPONENT PARTS FOR ENTRY	155
128913-15-06A	155
EXTERIOR SLIDEOUT GROUP	159
LEFT FRONT	159
COMPONENT PARTS FOR LEFT FRONT	162
100536-52-000	162
151323-01-000 , 151323-02-000, 151323-03-000	162
152553-01-000, 152553-02-000	162
152553-01-000, 152553-02-000	162
153651-02-01A	162
153651-04-01A	162
RIGHT FRONT	163
COMPONENT PARTS FOR RIGHT FRONT	165
100536-42-000	165
151323-01-000 , 151323-02-000, 151323-03-000	165
152710-01-000, 152710-02-000	165
153651-02-01A	165
153651-04-01A	165
155325-03-000	165
LEFT REAR	166
COMPONENT PARTS FOR LEFT REAR	168
100536-51-000	168
137390-01-000	168
GENERATOR GROUP	169
DIESEL	169
COMPONENT PARTS FOR DIESEL	169
130294-04-01A	169
HEATING & A/C GROUP	170
AUTOMOTIVE	170
COMPONENT PARTS FOR AUTOMOTIVE	171
072342-24-000	171
072342-27-000	171
103930-55-000	172
103930-58-000	173
103930-59-000	173
FURNACE	174
COMPONENT PARTS FOR FURNACE	175
139980-01-000	175
143563-08-000	177
CENTRAL	179
COMPONENT PARTS FOR CENTRAL	181
105620-16-000	181
INTERIOR FINISH GROUP	183
MOLDINGS & TRIMS	183
PANELING & LAMINATES	191
INTERIOR TRIM LAYOUT	192
COMPONENT PARTS FOR INTERIOR TRIM LAYOUT	199
158066-01-01A	199
FLOOR COVERINGS	200
HARDWARE	201
LABELS GROUP	207

CONTENTS (CONTINUED)

LP GROUP	212
LP SYSTEM	212
COMPONENT PARTS FOR LP SYSTEM	212
144251-01-000	212
SEALANTS & FASTENERS GROUP	213
SEALANTS & ADHESIVES	213
BOLTS, NUTS AND WASHERS	214
SCREWS	216
CLAMPS, CLIPS, GROMMETS, RIVETS & PLUGS	219
MISCELLANEOUS FASTENERS	221
WATER & SEWAGE GROUP	222
DRAINAGE SYSTEM	222
COMPONENT PARTS FOR DRAINAGE SYSTEM	224
144728-01-000	224
152830-01-01A	224
WATER SYSTEM	225
COMPONENT PARTS FOR WATER SYSTEM	233
075241-04-000, 075241-05-000, 075241-06-000	233
098607-01-000	233
125420-01-02A, 125420-01-03A, 125420-03-03A, 125420-04-03A	233
136915-01-000	233
144596-01-01A	233
142675-01-01A	233
144215-01-000	233
145541-03-000	234
144596-01-01A	234
149174-01-01A	234
WINDOW & VENTS GROUP	235
WINDOW & VENT LAYOUT	235
COMPONENT PARTS FOR WINDOWS & VENT LAYOUT	237
123780-15-01A	237
123780-17-01A	237
150648-01-01A	238
150648-07-01A, 150648-22-01A	238
150648-14-01A, 150648-27-01A, 150648-34-01A	239
150648-26-01A	239
150648-28-01A	239
150649-05-01A	240
150649-08-01A	240
150649-18-01A	241
150649-21-01A	241
150656-05-01A	242
150656-08-01A	243
151069-03-01A	244
161452-02-01A	245
161452-03-01A	246
WINDSHIELD & WIPER GROUP	247
WINDSHIELD	247
WIPER	248
COMPONENT PARTS FOR WIPER	248
149401-01-000, 149401-02-000	248
157512-01-000	248
157531-01-000	248

ACCESSORIES GROUP
OPERATORS MANUAL

KEY	PART NUMBER	U/M	DESCRIPTION
	156787-01-000	DW	TOP LEVEL-S,2007
	129079-04-01A	EA	CASE - VINYL/BLK-EXPANDABLE ACCORDION SIDES-11"WX9"HX14"L FROM: 00-00-00 THRU: 07-30-06
	159842-01-01A	EA	CASE - VINYL - F/MANUALS - W/SLEEVES - BLACK FROM: 07-31-06 THRU: 99-99-99
	132000-22-007	EA	MANUAL/OWNER - VECTRA - 2007
	158603-07-010	EA	MANUAL/OWNER - SUPPLEMENT - S-SERIES - 2007
	132001-16-007	EA	GUIDE/BASIC OPERATOR - AUDIO/VIDEO - S SERIES - 2007

AUDIO VIDEO GROUP RADIO SYSTEM

KEY	PART NUMBER	U/M	DESCRIPTION
	135420-18-000	EA	REMOTE CONTROL/RADIO (STEERING WHEEL MOUNT)
	135420-19-000	EA	REMOTE CONTROL/RADIO (CREDIT CARD SIZE)
	148134-01-000	EA	CHANGER - COMPACT DISC - SANYO EAX-510
	135420-07-000	EA	MOUNTING KIT - RADIO - A-BODY
	135420-14-000	EA	RECEIVER (EYE) - INFRARED
	135420-15-000	EA	RADIO-AM/FM/CD/SIRIUS SATELLITE READY-W/O REMOTES/WIRE ASM

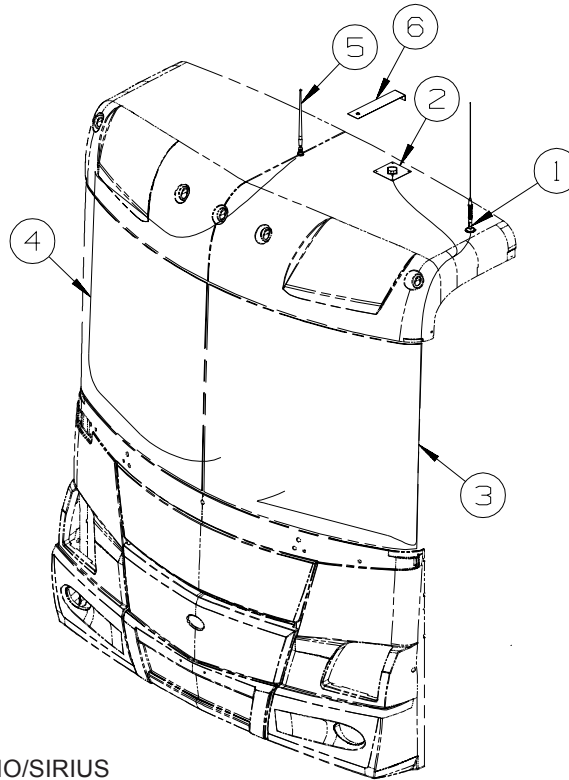

KEY	PART NUMBER	U/M	DESCRIPTION
1	NA	EA	ANTENNA - CB - W/O CABLE
2	158494-01-000	EA	ANTENNA/SATELLITE - RADIO/SIRIUS
3	NA	EA	CABLE - CB - COAX
4	090944-03-000	EA	CABLE - ANTENNA
5	090944-02-000	EA	ANTENNA - RADIO - 16" RUBBER - W/O LEAD WIRE
6	140600-06-01B	EA	BRACKET/ANTENNA MOUNT - MILL FINISH

REAR MONITOR

KEY	PART NUMBER	U/M	DESCRIPTION
	156655-02-01A	EA	CAMERA - REAR VIEW/PASSENGER SIDE - WHITE FROM: 00-00-00 THRU: 08-06-06
	156655-05-01A	EA	CAMERA - REAR VIEW/PASSENGER SIDE - WHITE FROM: 08-07-06 THRU: 99-99-99
	156655-03-01A	EA	CAMERA - REAR VIEW/DRIVER SIDE - WHITE FROM: 00-00-00 THRU: 08-06-06
	156655-06-01A	EA	CAMERA - REAR VIEW/DRIVER SIDE - WHITE FROM: 08-07-06 THRU: 99-99-99
	137919-02-01A	EA	SHROUD - CAMERA/OUTER - BRIGHT WHITE
	143363-05-000	EA	CAMERA/REAR - COLOR W/BRACKET - SONY VCB-MH3
	156655-01-000	EA	SWITCH BOX - VIDEO CAMERA - TURN SIGNAL ACTIVATED
	156655-04-000	EA	CABLE - MONITOR/CAMERA - 15'(SIDE CAMERA TO VIDEO SWITCH)
	143363-01-000	EA	MONITOR/REAR - COLOR - W/BRACKET - SONY VCB-MH1 FROM: 00-00-00 THRU: 06-04-06
	160313-01-000	EA	MONITOR/REAR - COLOR - 16" X 9" - SONY VCB-62MH FROM: 06-05-06 THRU: 99-99-99
	143363-03-000	EA	CABLE - MONITOR/CAMERA - COLOR - SONY VCB-MHC20
	143363-05-000	EA	CAMERA/REAR - COLOR W/BRACKET - SONY VCB-MH3 FROM: 00-00-00 THRU: 06-04-06
	160313-03-000	EA	CAMERA/REAR - COLOR - 16"X9" - W/BRACKET - SONY VCB-RV2MH FROM: 06-05-06 THRU: 99-99-99
	117420-01-000	EA	CABLE - W/MALE RCA ENDS - SHIELDED - 12"

CABINET & APPLIANCE GROUP

CABINET & APPLIANCE LAYOUT

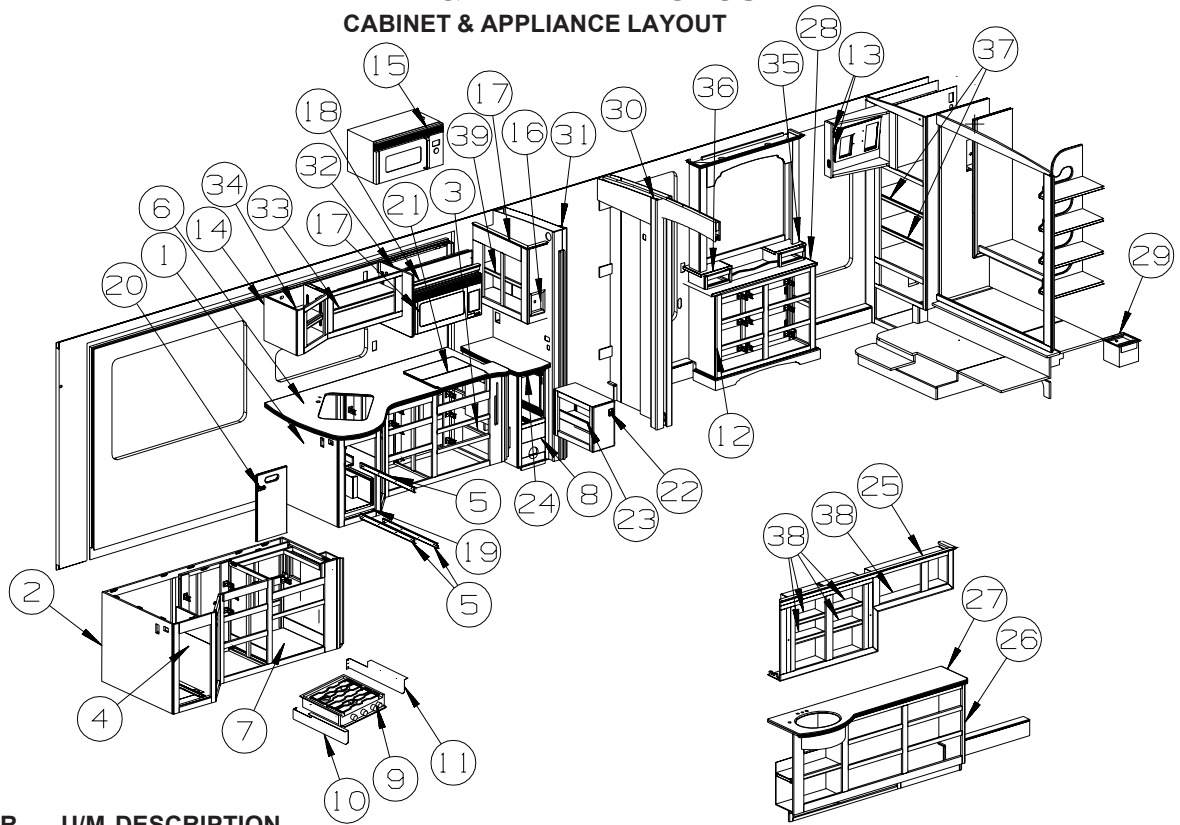

KEY	PART NUMBER	U/M	DESCRIPTION
1	P55724-01-UJ1	EA	CABINET - GALLEY - W/O COUNTERTOP/DOORS/DRAWERS/HDW - CONCERT CHERRY
1	P55724-01-UJ2	EA	CABINET - GALLEY - W/O COUNTERTOP/DOORS/DRAWERS/HDW - WASHED MAPLE
1	P55724-01-UJ3	EA	CABINET - GALLEY - W/O COUNTERTOP/DOORS/DRAWERS/HDW - HONEY CHERRY
2	P55724-03-UJ1	EA	CABINET - GALLEY - W/O COUNTERTOP/DOORS/DRWRS/HDW - CONCERT CHERRY - DISHWASHER
2	P55724-03-UJ2	EA	CABINET - GALLEY - W/O COUNTERTOP/DOORS/DRAWERS/HDW - WASHED MAPLE - DISHWASHER
2	P55724-03-UJ3	EA	CABINET - GALLEY - W/O COUNTERTOP/DOORS/DRAWERS/HDW - HONEY CHERRY - DISHWASHER
3	159170-17-UJ1	EA	DOOR - F/PANTRY - W/O HARDWARE - CONCERT CHERRY
3	159170-17-UJ2	EA	DOOR - F/PANTRY - W/O HARDWARE - WASHED MAPLE
3	159170-17-UJ3	EA	DOOR - F/PANTRY - W/O HARDWARE - HONEY CHERRY
	081914-02-000	EA	BUMPER - RUBBER - ROUND - 5/16" DIA. X 13/64" THICK
4	151226-02-01A	EA	STRIKE PLATE - BRASS
5	122360-05-000	EA	SLIDE - PANTRY - W/O LOCK
5	159481-01-01A	EA	SLIDE - PANTRY - 30" - W/O LOCK - NOT ILLUSTRATED
6	138775-23-08A	EA	COUNTERTOP - 1/2" CORIAN - PRAIRIE (UJ1, UJ2, UJ3)
6	138775-23-09C	EA	COUNTERTOP - 1/2" CORIAN - MOSS GLOSS (UJ1, UJ2, UJ3)
6	138775-23-03A	EA	COUNTERTOP - 1/2" CORIAN - FOSSIL (UJ5, UJ6, UJ7)
6	138775-23-11C	EA	COUNTERTOP - 1/2" CORIAN - COCOA BROWN GLOSS (UJ5, UJ6, UJ7)
6	138775-23-07A	EA	COUNTERTOP - 1/2" CORIAN - DOESKIN (UK1, UK2, UK3)
6	138775-23-09C	EA	COUNTERTOP - 1/2" CORIAN - MOSS GLOSS (UK1, UK2, UK3)
7	146340-02-01A	EA	DISHWASHER - DRAWER STYLE - STAINLESS STEEL FACE
8	P59170-01-UJ1	EA	CABINET - STORAGE/PANTRY - W/O HARDWARE - CONCERT CHERRY
8	P59170-01-UJ2	EA	CABINET - STORAGE/PANTRY - W/O HARDWARE - WASHED MAPLE
8	P59170-01-UJ3	EA	CABINET - STORAGE/PANTRY - W/O HARDWARE - HONEY CHERRY
9*	135065-03-03A	EA	RANGE-3 BURNER (SEALED)-W/O OVEN-NEW STYLE KNOBS-STAINLESS
9*	135065-04-01A	EA	RANGE - 3 BURNER (SEALED) - W/O OVEN - CSA - BLACK TOP - CANADIAN
10	144823-17-04B	EA	BRACKET/STOVE TIEDOWN - BLACK
11	144823-18-04B	EA	BRACKET/STOVE TIEDOWN - BLACK
12	P53240-01-TG1	EA	CABINET - DRESSER - W/O COUNTERTOP/DRAWERS/HDW - CONCERT CHERRY
12	P53240-01-TG2	EA	CABINET - DRESSER - W/O COUNTERTOP/DRAWERS/HDW - WASHED MAPLE
12	P53240-01-TG3	EA	CABINET - DRESSER - W/O COUNTERTOP/DRAWERS/HDW - HONEY CHERRY

CABINET & APPLIANCE GROUP (CONTINUED)
CABINET & APPLIANCE LAYOUT (CONTINUED)

KEY	PART NUMBER	U/M	DESCRIPTION
13	153191-01-01A	EA	HINGE - FRICTION - 16 IN-LBS - BLACK
	142569-06-000	EA	SPRING/GAS - 25 LB - 14.8" EXTENDED/8.9" COMPRESSED
14	158313-02-TG1	EA	CABINET - OVERHEAD/GALLEY - W/O DOORS/HDW - CONCERT CHERRY
14	158313-02-TG2	EA	CABINET - OVERHEAD/GALLEY - W/O DOORS/HDW - WASHED MAPLE
14	158313-02-TG3	EA	CABINET - OVERHEAD/GALLEY - W/O DOORS/HDW - HONEY CHERRY
15*	119267-12-02A	EA	OVEN - MICROWAVE/CONVECTION W/HOOD US - #R-1874 FROM: 00-00-00 THRU: 07-30-06
15	119267-17-01A	EA	OVEN - MICROWAVE/CONVECTION W/HOOD US - #R-1880LST FROM: 07-31-06 THRU: 99-99-99
15*	140147-04-03A	EA	OVEN/MICROWAVE - 1.4 CU FT - ADVANTIUM/STAINLESS STEEL - MICROWAVE/SPEEDCOOK
16	137602-D5-R84	EA	POCKET - THERMOSTAT - CHERRY
16	137602-D5-RW5	EA	POCKET - THERMOSTAT - WASHED MAPLE
16	137602-D5-RE0	EA	POCKET - THERMOSTAT - HONEY CHERRY
17	152653-01-TG1	EA	CABINET - OVERHEAD/STORAGE - W/O DOORS/HDW - CONCERT CHERRY
17	152653-01-TG2	EA	CABINET - OVERHEAD/STORAGE - W/O DOORS/HDW - WASHED MAPLE
17	152653-01-TG3	EA	CABINET - OVERHEAD/STORAGE - W/O DOORS/HDW - HONEY CHERRY
18	152554-01-TG1	EA	CABINET - OVERHEAD/MICROWAVE - W/O DOORS/HARDWARE - CONCERT CHERRY
18	152554-01-TG2	EA	CABINET - OVERHEAD/MICROWAVE - W/O DOORS/HARDWARE - WASHED MAPLE
18	152554-01-TG3	EA	CABINET - OVERHEAD/MICROWAVE - W/O DOORS/HARDWARE - HONEY CHERRY
19	147514-01-R69	EA	CABINET - PANTRY/UNDER COUNTER - CONCERT CHERRY
19	147514-01-RW7	EA	CABINET - PANTRY/UNDER COUNTER - WASHED MAPLE
19	147514-01-RE0	EA	CABINET - PANTRY/UNDER COUNTER - HONEY CHERRY
20	151226-01-01A	EA	LATCH - BARREL/BOLT - BRASS
21	144713-01-08A	EA	COVER - STOVE TOP - 1/2" CORIAN - 10.2" X 22.2" - PRAIRIE (UJ1, UJ2, UJ3) FROM: 00-00-00 THRU: 06-04-06
21	144713-01-09C	EA	COVER - STOVE TOP - 1/2" CORIAN - 10.2" X 22.2"-MOSS GLOSS (UJ1, UJ2, UJ3) FROM: 06-05-06 THRU: 99-99-99
21	144713-01-03A	EA	COVER - STOVE TOP - 1/2" CORIAN - 10.2" X 22.2" - FOSSIL (UJ5, UJ6, UJ7) FROM: 00-00-00 THRU: 06-04-06
21	144713-01-11C	EA	COVER - STOVE TOP-1/2" CORIAN-10.2"X 22.2"-COCOA BRN GLOSS (UJ5, UJ6, UJ7) FROM: 06-05-06 THRU: 99-99-99
21	144713-01-07A	EA	COVER - STOVE TOP - 1/2" CORIAN - 10.2" X 22.2" - DOESKIN (UK1, UK2, UK3) FROM: 00-00-00 THRU: 06-04-06
21	144713-01-09C	EA	COVER - STOVE TOP - 1/2" CORIAN - 10.2" X 22.2"-MOSS GLOSS (UK1, UK2, UK3) FROM: 06-05-06 THRU: 99-99-99
22	153343-05-TG1	EA	CABINET - PANTRY/SLIDE - W/O DOORS/DRAWERS/HDW - CONCERT CHERRY
22	153343-05-TG2	EA	CABINET - PANTRY/SLIDE - W/O DOORS/DRAWERS/HDW - WASHED MAPLE
22	153343-05-TG3	EA	CABINET - PANTRY/SLIDE - W/O DOORS/DRAWERS/HDW - HONEY CHERRY
23	153343-35-TG1	EA	SHELF - W/WOOD MOLDING - CONCERT CHERRY
23	153343-35-TG2	EA	SHELF - W/WOOD MOLDING - WASHED MAPLE
23	153343-35-TG3	EA	SHELF - W/WOOD MOLDING - HONEY CHERRY
24	152644-02-08A	EA	COUNTERTOP - 1/2" CORIAN - PRAIRIE (UJ1, UJ2, UJ3) FROM: 00-00-00 THRU: 06-04-06
24	152644-03-09C	EA	COUNTERTOP - 1/2" CORIAN - MOSS GLOSS (UJ1, UJ2, UJ3) FROM: 06-05-06 THRU: 99-99-99
24	152644-02-03A	EA	COUNTERTOP - 1/2" CORIAN - FOSSIL (UJ5, UJ6, UJ7) FROM: 00-00-00 THRU: 06-04-06
24	152644-02-11C	EA	COUNTERTOP - 1/2" CORIAN - COCOA BROWN GLOSS (UJ5, UJ6, UJ7) FROM: 06-05-06 THRU: 99-99-99
24	152644-02-07A	EA	COUNTERTOP - 1/2" CORIAN - DOESKIN (UK1, UK2, UK3) FROM: 00-00-00 THRU: 06-04-06
24	152644-03-09C	EA	COUNTERTOP - 1/2" CORIAN - MOSS GLOSS (UK1, UK2, UK3) FROM: 06-05-06 THRU: 99-99-99
25	152903-02-TG1	EA	CABINET - OVERHEAD/VANITY - W/O DOORS/HDW - CONCERT CHERRY - CABINET - LAVATORY
25	152903-02-TG2	EA	CABINET - OVERHEAD/VANITY - W/O DOORS/HDW - WASHED MAPLE - CABINET - LAVATORY
25	152903-02-TG3	EA	CABINET - OVERHEAD/VANITY - W/O DOORS/HDW - HONEY CHERRY - CABINET - LAVATORY
26	P53359-02-TG1	EA	CABINET - VANITY - W/O COUNTERTOP/DOORS/DRAWERS/HDW - CABINET - LAVATORY
26	P53359-02-TG2	EA	CABINET - VANITY - W/O COUNTERTOP/DOORS/DRAWERS/HDW - CABINET - LAVATORY
26	P53359-02-TG3	EA	CABINET - VANITY - W/O COUNTERTOP/DOORS/DRAWERS/HDW - CABINET - LAVATORY

CABINET & APPLIANCE GROUP (CONTINUED)
CABINET & APPLIANCE LAYOUT (CONTINUED)

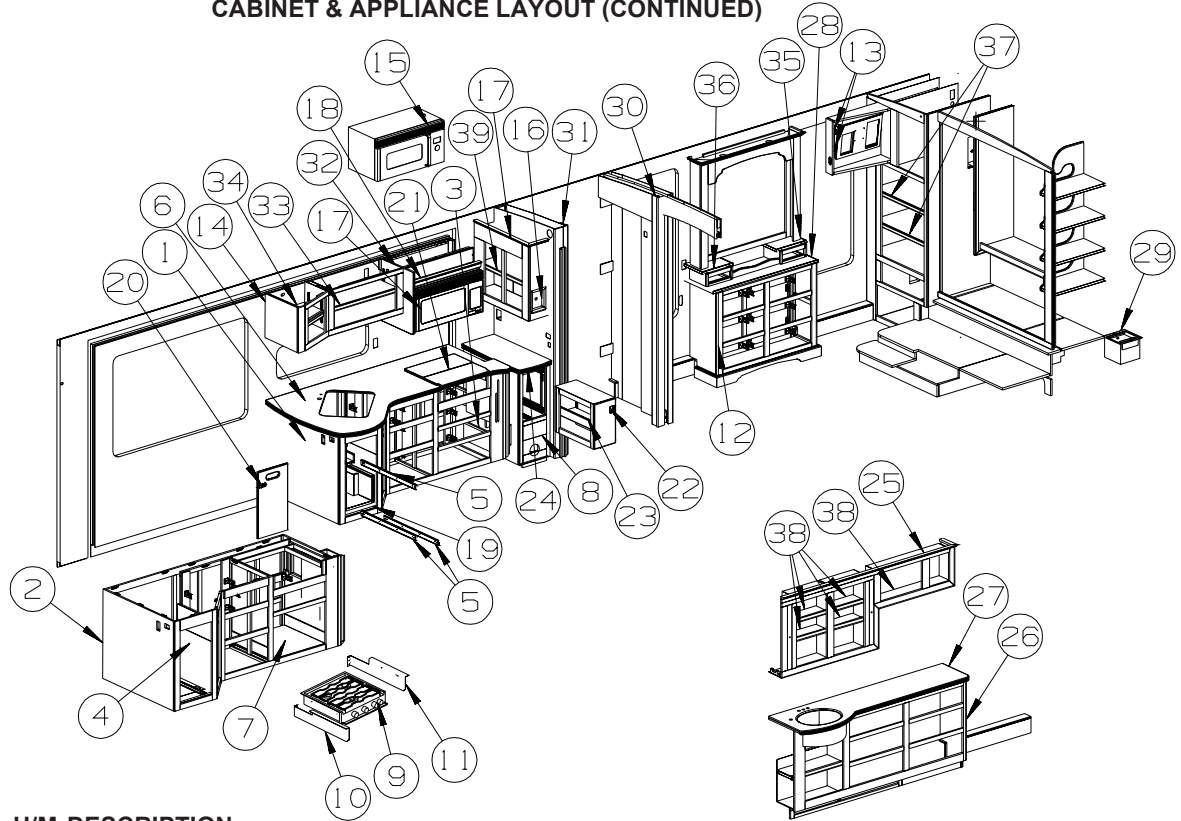

KEY	PART NUMBER	U/M	DESCRIPTION
27	138786-49-08A	EA	COUNTERTOP - 1/2" CORIAN - PRAIRIE (UJ1, UJ2, UJ3) FROM: 00-00-00 THRU: 06-04-06
27	138786-49-09C	EA	COUNTERTOP - 1/2" CORIAN - MOSS GLOSS (UJ1, UJ2, UJ3) FROM: 06-05-06 THRU: 99-99-99
27	138786-49-03A	EA	COUNTERTOP - 1/2" CORIAN - FOSSIL (UJ5, UJ6, UJ7) FROM: 00-00-00 THRU: 06-04-06
27	138786-49-11C	EA	COUNTERTOP - 1/2" CORIAN - COCOA BROWN GLOSS (UJ5, UJ6, UJ7) FROM: 06-05-06 THRU: 99-99-99
27	138786-49-07A	EA	COUNTERTOP - 1/2" CORIAN - DOESKIN (UK1, UK2, UK3) FROM: 00-00-00 THRU: 06-04-06
27	138786-49-09C	EA	COUNTERTOP - 1/2" CORIAN - MOSS GLOSS (UK1, UK2, UK3) FROM: 06-05-06 THRU: 99-99-99
28	145212-26-TG1	EA	COUNTERTOP - LAMINATED - CHERRY/CHERRY IV
28	145212-26-TG2	EA	COUNTERTOP - LAMINATED - MAPLE/WASHED MAPLE
28	145212-26-TG3	EA	COUNTERTOP - LAMINATED - CHERRY/HONEY
29	137943-01-000	EA	SAFE - STEEL - 9.8" X 9.8" FACE / 7.7" X 8.7" X 8.7" R.O.
30	157311-01-TD1	EA	TRIM - SHOWER/RH HAND - 3.2" X 86.1" - CONCERT CHERRY
30	157311-01-TD2	EA	TRIM - SHOWER/RH HAND - 3.2" X 86.1" - WASHED MAPLE
30	157311-01-UJ3	EA	TRIM - SHOWER/RH HAND - 3.2" X 86.1" - HONEY CHERRY
31	157311-02-TD1	EA	TRIM - SHOWER/LH HAND - 3.2" X 86.1" - CONCERT CHERRY
31	157311-02-TD2	EA	TRIM - SHOWER/LH HAND - 3.2" X 86.1" - WASHED MAPLE
31	157311-02-UJ3	EA	TRIM - SHOWER/LH HAND - 3.2" X 86.1" - HONEY CHERRY
32	145517-52-TG1	EA	END CAP - OVERHEAD CABINET - CONCERT CHERRY
32	145517-52-TG2	EA	END CAP - OVERHEAD CABINET - WASHED MAPLE
32	145517-52-TG3	EA	END CAP - OVERHEAD CABINET - HONEY CHERRY
33	158313-40-TG1	EA	SHELF - W/WOOD MOLDING - CONCERT CHERRY
33	158313-40-TG2	EA	SHELF - W/WOOD MOLDING - WASHED MAPLE
33	158313-40-TG3	EA	SHELF - W/WOOD MOLDING - HONEY CHERRY
34	158313-42-TG1	EA	SHELF - W/WOOD MOLDING - CONCERT CHERRY
34	158313-42-TG2	EA	SHELF - W/WOOD MOLDING - WASHED MAPLE
34	158313-42-TG3	EA	SHELF - W/WOOD MOLDING - HONEY CHERRY
35	145212-27-TG1	EA	COUNTERTOP - LAMINATED - CHERRY/CHERRY IV
35	145212-27-TG2	EA	COUNTERTOP - LAMINATED - MAPLE/WASHED MAPLE
35	145212-27-TG3	EA	COUNTERTOP - LAMINATED - CHERRY/HONEY
36	145212-28-TG1	EA	COUNTERTOP - LAMINATED - CHERRY/CHERRY IV
36	145212-28-TG2	EA	COUNTERTOP - LAMINATED - MAPLE/WASHED MAPLE
36	145212-28-TG3	EA	COUNTERTOP - LAMINATED - CHERRY/HONEY

CABINET & APPLIANCE GROUP (CONTINUED)
CABINET & APPLIANCE LAYOUT (CONTINUED)

KEY	PART NUMBER	U/M	DESCRIPTION
37	156635-33-UJ1	EA	SHELF - W/WOOD MOLDING - CONCERT CHERRY
37	156635-33-UJ2	EA	SHELF - W/WOOD MOLDING - WASHED MAPLE
37	156635-33-UJ3	EA	SHELF - W/WOOD MOLDING - HONEY CHERRY
38	152903-38-TG1	EA	SHELF - W/WOOD MOLDING - CONCERT CHERRY
38	152903-38-TG2	EA	SHELF - W/WOOD MOLDING - WASHED MAPLE
38	152903-38-TG3	EA	SHELF - W/WOOD MOLDING - HONEY CHERRY
39	152653-26-TG1	EA	SHELF - W/WOOD MOLDING - CONCERT CHERRY
39	152653-26-TG2	EA	SHELF - W/WOOD MOLDING - WASHED MAPLE
39	152653-26-TG3	EA	SHELF - W/WOOD MOLDING - HONEY CHERRY

***COMPONENT PARTS LISTED LATER IN THIS GROUP**

CABINET & APPLIANCE GROUP (CONTINUED)
CABINET & APPLIANCE LAYOUT (CONTINUED)

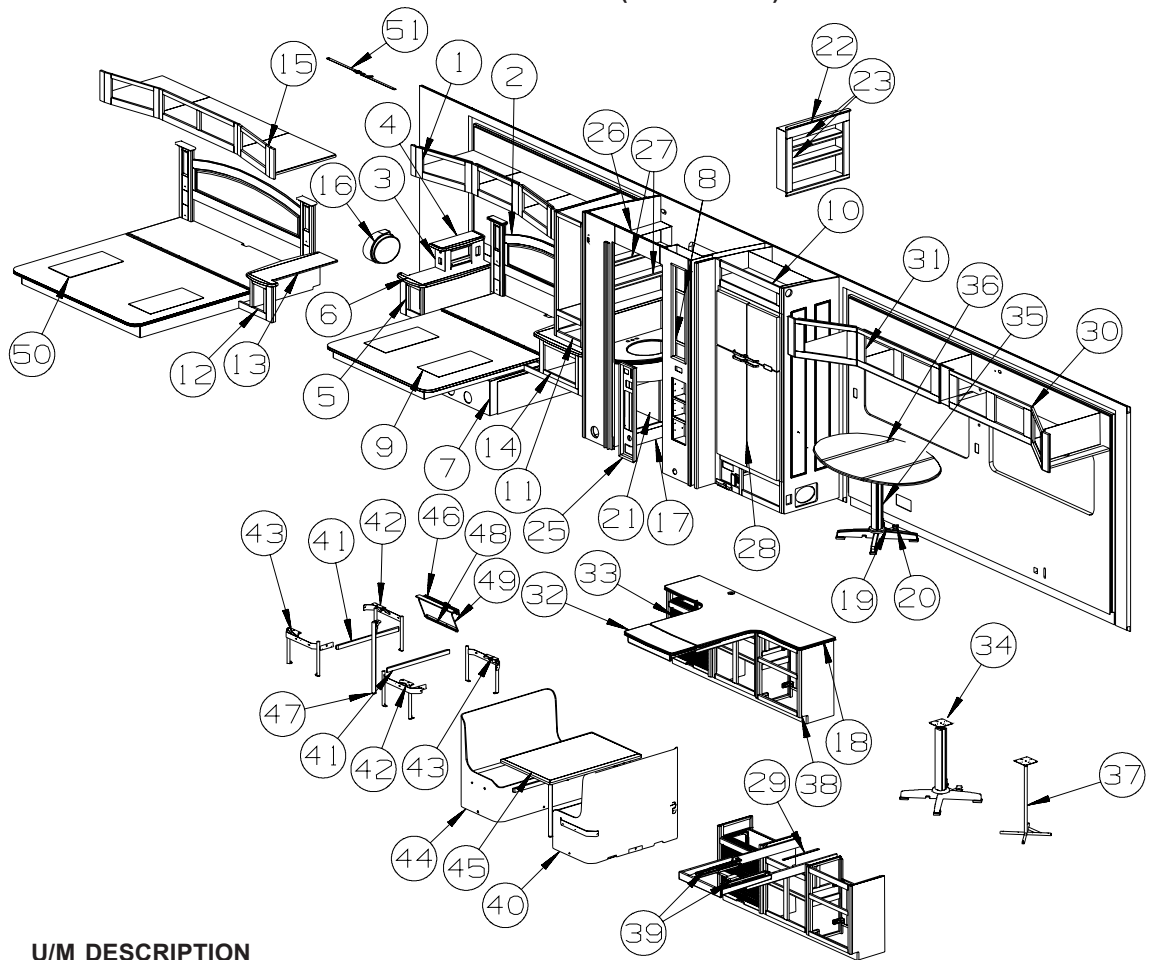

KEY	PART NUMBER	U/M	DESCRIPTION
1	157503-02-UJ1	EA	CABINET - OVERHEAD/REAR - W/O DOORS/HDW - CONCERT CHERRY
1	157503-02-UJ2	EA	CABINET - OVERHEAD/REAR - W/O DOORS/HDW - WASHED MAPLE
1	157503-02-UJ3	EA	CABINET - OVERHEAD/REAR - W/O DOORS/HDW - HONEY CHERRY
1	157503-01-UJ1	EA	CABINET - OVRHD/REAR - QUEEN - W/O DOORS/HDW - CONCERT CHERRY - STEREO W/CD/DVD
1	157503-01-UJ2	EA	CABINET - OVRHD/REAR - QUEEN - W/O DOORS/HDW - WASHED MAPLE - STEREO W/CD/DVD
1	157503-01-UJ3	EA	CABINET - OVRHD/REAR - QUEEN - W/O DOORS/HDW - HONEY CHERRY - STEREO W/CD/DVD
2	140843-01-N94	EA	CABINET/HEADBOARD - QUEEN - W/O HARDWARE - CONCERT CHERRY
2	140843-01-RW5	EA	CABINET/HEADBOARD - QUEEN - W/O HARDWARE - WASHED MAPLE
2	140843-01-RE0	EA	CABINET/HEADBOARD - QUEEN - W/O HARDWARE - HONEY CHERRY
2	140843-02-SD1	EA	CABINET/HEADBOARD - KING - W/O HDW - CONCERT CHERRY - SLEEP NUMBER BED-KING SIZE
2	140843-02-SD2	EA	CABINET/HEADBOARD - KING - W/O HDW - WASHED MAPLE - SLEEP NUMBER BED-KING SIZE
2	140843-02-SD3	EA	CABINET/HEADBOARD - KING - W/O HDW - HONEY CHERRY - SLEEP NUMBER BED-KING SIZE
3	140452-05-SD1	EA	CABINET - F/RADIO - W/O HARDWARE - CONCERT CHERRY - STEREO W/CD/DVD FROM: 00-00-00 THRU: 02-19-06
3	140452-07-TD1	EA	CABINET - F/RADIO - W/O HARDWARE - CONCERT CHERRY - STEREO W/CD/DVD FROM: 02-20-06 THRU: 99-99-99
3	140452-05-SD2	EA	CABINET - F/RADIO - W/O HARDWARE - WASHED MAPLE - STEREO W/CD/DVD FROM: 00-00-00 THRU: 02-19-06
3	140452-07-TD2	EA	CABINET - F/RADIO - W/O HARDWARE - WASHED MAPLE - STEREO W/CD/DVD FROM: 02-20-06 THRU: 99-99-99
3	140452-05-SD3	EA	CABINET - F/RADIO - W/O HARDWARE - HONEY CHERRY - STEREO W/CD/DVD FROM: 00-00-00 THRU: 02-19-06
3	140452-07-UJ3	EA	CABINET - F/RADIO - W/O HARDWARE - HONEY CHERRY - STEREO W/CD/DVD FROM: 02-20-06 THRU: 99-99-99
4	149296-03-SD1	EA	COUNTERTOP - LAMINATED - CONCERT CHERRY - STEREO W/CD/DVD FROM: 00-00-00 THRU: 02-19-06
4	149296-27-UJ1	EA	COUNTERTOP - LAMINATED - CONCERT CHERRY - STEREO W/CD/DVD FROM: 02-20-06 THRU: 99-99-99
4	149296-03-SD2	EA	COUNTERTOP - LAMINATED - WASHED MAPLE - STEREO W/CD/DVD FROM: 00-00-00 THRU: 02-19-06
4	149296-27-UJ2	EA	COUNTERTOP - LAMINATED - WASHED MAPLE - STEREO W/CD/DVD FROM: 02-20-06 THRU: 99-99-99

CABINET & APPLIANCE GROUP (CONTINUED)
CABINET & APPLIANCE LAYOUT (CONTINUED)

KEY	PART NUMBER	U/M	DESCRIPTION
4	149296-03-SD3	EA	COUNTERTOP - LAMINATED - HONEY CHERRY - STEREO W/CD/DVD FROM: 00-00-00 THRU: 02-19-06
4	149296-27-UJ3	EA	COUNTERTOP - LAMINATED - HONEY CHERRY - STEREO W/CD/DVD FROM: 02-20-06 THRU: 99-99-99
5	153361-01-TG1	EA	CABINET - NIGHTSTAND - W/O COUNTERTOP/DOORS/DRAWERS/HDW - CONCERT CHERRY
5	153361-01-TG2	EA	CABINET - NIGHTSTAND - W/O COUNTERTOP/DOORS/DRAWERS/HDW - WASHED MAPLE
5	153361-01-TG3	EA	CABINET - NIGHTSTAND - W/O COUNTERTOP/DOORS/DRAWERS/HDW - HONEY CHERRY
6	149296-01-SD1	EA	COUNTERTOP - LAMINATED - CONCERT CHERRY
6	149296-01-SD2	EA	COUNTERTOP - LAMINATED - WASHED MAPLE
6	149296-01-SD3	EA	COUNTERTOP - LAMINATED - HONEY CHERRY
6	149296-02-SD1	EA	COUNTERTOP - LAMINATED - CONCERT CHERRY - STEREO W/CD/DVD
6	149296-02-SD2	EA	COUNTERTOP - LAMINATED - WASHED MAPLE - STEREO W/CD/DVD
6	149296-02-SD3	EA	COUNTERTOP - LAMINATED - HONEY CHERRY - STEREO W/CD/DVD
7	157465-01-UJ1	EA	CABINET - BED BASE - QUEEN - W/O DOORS/DRAWERS/HDW - CONCERT CHERRY
7	157465-01-UJ2	EA	CABINET - BED BASE - QUEEN - W/O DOORS/DRAWERS/HDW - WASHED MAPLE
7	157465-01-UJ3	EA	CABINET - BED BASE - QUEEN - W/O DOORS/DRAWERS/HDW - HONEY CHERRY
7	157465-02-UJ1	EA	CABINET - BED BASE - QUEEN - CONCERT CHERRY - STEREO W/CD/DVD
7	157465-02-UJ2	EA	CABINET - BED BASE - QUEEN - WASHED MAPLE - STEREO W/CD/DVD
7	157465-02-UJ3	EA	CABINET - BED BASE - QUEEN - HONEY CHERRY - STEREO W/CD/DVD
8	154649-01-02B	EA	BRACKET - ONE PLACE - E-COATED
9	137406-04-N52	EA	BEDBOARD - W/HINGE/T-MOLDING/SLIPNOT - FLIP-UP
	096764-02-000	FT	SLIPNOT - ANTISLIP - 1'WIDE (180' ROLLS) - WHITE
10			REFRIGERATOR CABINET SEALS
	134651-01-000	FT	SEAL - 1/2" X 3/4" X 9' - PSA 1 SIDE FROM: 00-00-00 THRU: 05-21-06
	154585-02-01A	FT	SEAL - FOAM TAPE - ADHESIVE BACK - 3/4" X 1/2" - BLACK FROM: 05-22-06 THRU: 99-99-99
	090329-01-000	FT	SEAL - "T" - REFRIGERATOR CABINET
11	149296-08-SD1	EA	COUNTERTOP - LAMINATED - CONCERT CHERRY
11	149296-08-SD2	EA	COUNTERTOP - LAMINATED - WASHED MAPLE
11	149296-08-SD3	EA	COUNTERTOP - LAMINATED - HONEY CHERRY
12	153361-02-TG1	EA	CABINET - NIGHTSTAND - CONCERT CHERRY - SLEEP NUMBER BED-KING SIZE
12	153361-02-TG2	EA	CABINET - NIGHTSTAND - WASHED MAPLE - SLEEP NUMBER BED-KING SIZE
12	153361-02-TG3	EA	CABINET - NIGHTSTAND - HONEY CHERRY - SLEEP NUMBER BED-KING SIZE
13	149296-07-SD1	EA	COUNTERTOP - LAMINATED - CONCERT CHERRY - SLEEP NUMBER BED-KING SIZE
13	149296-07-SD2	EA	COUNTERTOP - LAMINATED - WASHED MAPLE - SLEEP NUMBER BED-KING SIZE
13	149296-07-SD3	EA	COUNTERTOP - LAMINATED - HONEY CHERRY - SLEEP NUMBER BED-KING SIZE
14	151765-01-SD1	EA	CABINET/COVER - REAR - W/O HDW - CONCERT CHERRY
14	151765-01-SD2	EA	CABINET/COVER - REAR - W/O HDW - WASHED MAPLE
14	151765-01-SD3	EA	CABINET/COVER - REAR - W/O HDW - HONEY CHERRY
15	157504-02-UJ1	EA	CABINET - OVERHEAD/REAR - KING - W/O DOORS/HDW - CONCERT CHERRY
15	157504-02-UJ2	EA	CABINET - OVERHEAD/REAR - KING - W/O DOORS/HDW - WASHED MAPLE
15	157504-02-UJ3	EA	CABINET - OVERHEAD/REAR - KING - W/O DOORS/HDW - HONEY CHERRY
15	157504-01-UJ1	EA	CABINET - OVHD/REAR - KING - W/O DOORS/HDW - CONCERT CHERRY - STEREO W/CD/DVD
15	157504-01-UJ2	EA	CABINET - OVHD/REAR - KING - W/O DOORS/HDW - WASHED MAPLE - STEREO W/CD/DVD
15	157504-01-UJ3	EA	CABINET - OVHD/REAR - KING - W/O DOORS/HDW - HONEY CHERRY - STEREO W/CD/DVD
16	142411-03-000	EA	AIR PUMP W/CONTROLS - F/SELECT COMFORT MATTRESS
17	138786-46-08A	EA	COUNTERTOP - 1/2" CORIAN - PRAIRIE (UJ1, UJ2, UJ3) FROM: 00-00-00 THRU: 06-04-06
17	138786-46-09C	EA	COUNTERTOP - 1/2" CORIAN - MOSS GLOSS (UJ1, UJ2, UJ3) FROM: 06-05-06 THRU: 99-99-99
17	138786-46-03A	EA	COUNTERTOP - 1/2" CORIAN - FOSSIL (UJ5, UJ6, UJ7) FROM: 00-00-00 THRU: 06-04-06
17	138786-46-11C	EA	COUNTERTOP - 1/2" CORIAN - COCOA BROWN GLOSS (UJ5, UJ6, UJ7) FROM: 06-05-06 THRU: 99-99-99
17	138786-46-07A	EA	COUNTERTOP - 1/2" CORIAN - DOESKIN (UK1, UK2, UK3) FROM: 00-00-00 THRU: 06-04-06
17	138786-46-09C	EA	COUNTERTOP - 1/2" CORIAN - MOSS GLOSS (UK1, UK2, UK3) FROM: 06-05-06 THRU: 99-99-99
18	156960-01-UJ1	EA	TABLE - DINETTE - W/EXTENSION
18	156960-01-UJ2	EA	TABLE - DINETTE - W/EXTENSION
18	156960-01-UJ3	EA	TABLE - DINETTE - W/EXTENSION
18	156960-01-UJ5	EA	TABLE - DINETTE - W/EXTENSION
18	156960-01-UJ6	EA	TABLE - DINETTE - W/EXTENSION

CABINET & APPLIANCE GROUP (CONTINUED)
CABINET & APPLIANCE LAYOUT (CONTINUED)

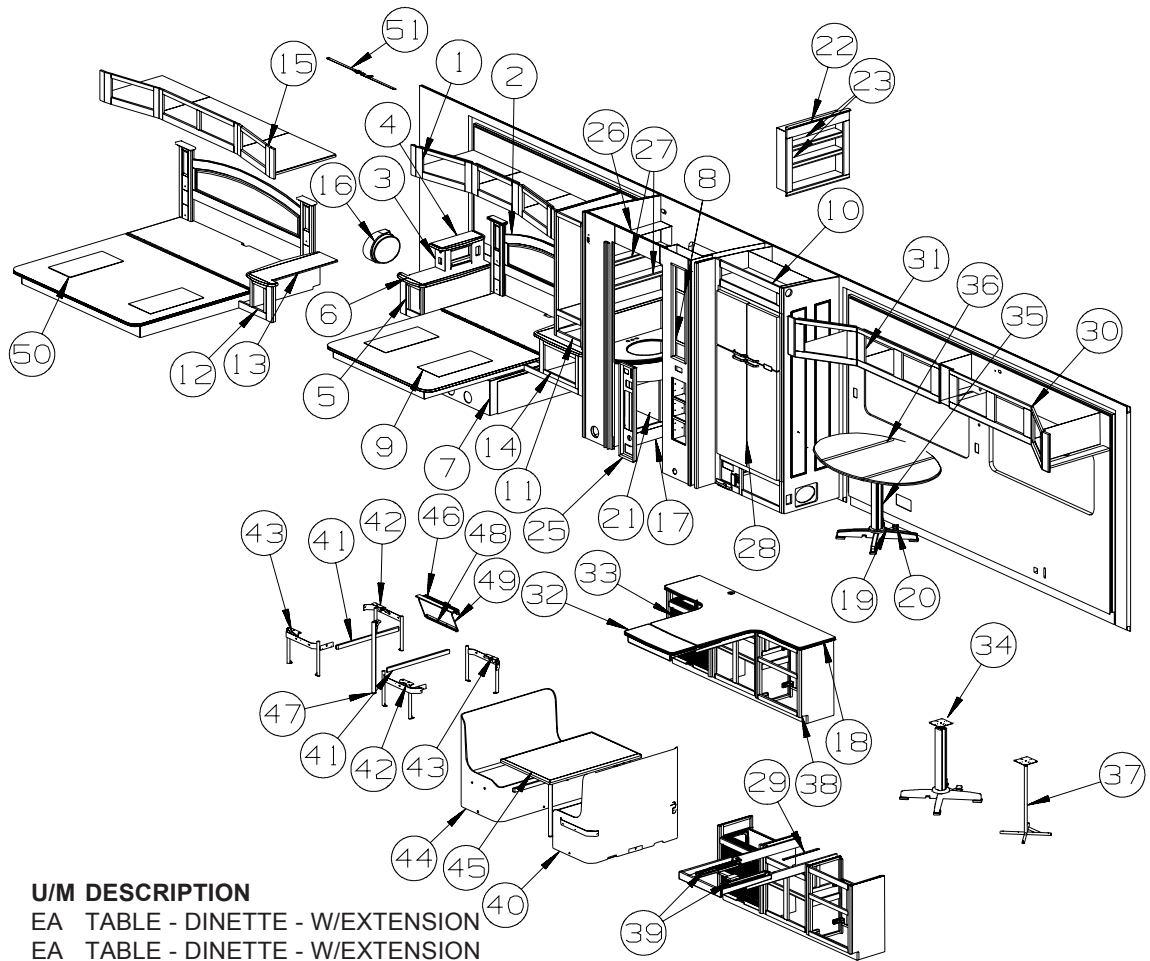

KEY	PART NUMBER	U/M	DESCRIPTION
18	156960-01-UJ7	EA	TABLE - DINETTE - W/EXTENSION
18	156960-01-UK1	EA	TABLE - DINETTE - W/EXTENSION
18	156960-01-UK2	EA	TABLE - DINETTE - W/EXTENSION
18	156960-01-UK3	EA	TABLE - DINETTE - W/EXTENSION
19	134057-04-11B	EA	BRACKET - RECLINER - FLAT BLACK
20	134194-02-01A	EA	KNOB - HOLD DOWN/RECLINER - BLACK
21	158117-02-UF1	EA	POCKET - MONITOR PANEL - CONCERT CHERRY
21	158117-02-UF2	EA	POCKET - MONITOR PANEL - WASHED MAPLE
21	158117-02-UJ3	EA	POCKET - MONITOR PANEL - HONEY CHERRY
22	152567-01-TG1	EA	CABINET - OVERHEAD/LINEN - W/O DOORS/HDW - CONCERT CHERRY
22	152567-01-TG2	EA	CABINET - OVERHEAD/LINEN - W/O DOORS/HDW - WASHED MAPLE
22	152567-01-TG3	EA	CABINET - OVERHEAD/LINEN - W/O DOORS/HDW - HONEY CHERRY
23	152567-20-TG1	EA	SHELF - W/WOOD MOLDING - CONCERT CHERRY
23	152567-20-TG2	EA	SHELF - W/WOOD MOLDING - WASHED MAPLE
23	152567-20-TG3	EA	SHELF - W/WOOD MOLDING - HONEY CHERRY
24	P53358-01-TG1	EA	CABINET - LAVATORY - W/O COUNTERTOP/DOORS/DRAWERS/HDW - CONCERT CHERRY
24	P53358-01-TG2	EA	CABINET - LAVATORY - W/O COUNTERTOP/DOORS/DRAWERS/HDW - WASHED MAPLE
24	P53358-01-TG3	EA	CABINET - LAVATORY - W/O COUNTERTOP/DOORS/DRAWERS/HDW - HONEY CHERRY
25	158117-04-UJ1	EA	POCKET - MONITOR PANEL - CONCERT CHERRY
25	158117-04-UJ2	EA	POCKET - MONITOR PANEL - WASHED MAPLE
25	158117-04-UJ3	EA	POCKET - MONITOR PANEL - HONEY CHERRY
26	157388-01-UJ1	EA	CABINET - OVERHEAD/MEDICINE - W/O DOORS/HDW - CONCERT CHERRY
26	157388-01-UJ2	EA	CABINET - OVERHEAD/MEDICINE - W/O DOORS/HDW - WASHED MAPLE
26	157388-01-UJ3	EA	CABINET - OVERHEAD/MEDICINE - W/O DOORS/HDW - HONEY CHERRY
27	157388-20-UJ1	EA	SHELF - W/WOOD MOLDING - CONCERT CHERRY
27	157388-20-UJ2	EA	SHELF - W/WOOD MOLDING - WASHED MAPLE
27	157388-20-UJ3	EA	SHELF - W/WOOD MOLDING - HONEY CHERRY
28*	125242-03-02A	EA	REFRIGERATOR - 4 DOOR - W/ICE MAKER - TITANIUM SST FROM: 00-00-00 THRU: 07-09-06
28*	125242-05-02A	EA	REFRIGERATOR - 4 DOOR - W/ICE MAKER - TITANIUM SST FROM: 07-10-06 THRU: 99-99-99
	118871-05-01A	EA	TRAY - REFRIGERATOR - SIDE/SIDE - BLACK - 35.5" LONG
	054450-01-000	EA	LEVEL - REFRIGERATOR
29	057534-08-000	EA	TIEBACK - CLEAR PLASTIC - 16"

CABINET & APPLIANCE GROUP (CONTINUED)
CABINET & APPLIANCE LAYOUT (CONTINUED)

KEY	PART NUMBER	U/M	DESCRIPTION
30	158254-02-TG1	EA	CABINET - OVERHEAD/SLIDEOUT - W/O DOORS/HDW - CONCERT CHERRY
30	158254-02-TG2	EA	CABINET - OVERHEAD/SLIDEOUT - W/O DOORS/HDW - WASHED MAPLE
30	158254-02-TG3	EA	CABINET - OVERHEAD/SLIDEOUT - W/O DOORS/HDW - HONEY CHERRY
30	158253-01-TG1	EA	CBNT - OVHD/SLIDEOUT - W/O DRS/HDW - CONCERT CHERRY - DINETTE/COMPUTER TABLE
30	158253-01-TG2	EA	CBNT - OVHD/SLIDEOUT - W/O DRS/HDW - WASHED MAPLE - DINETTE/COMPUTER TABLE
30	158253-01-TG3	EA	CBNT - OVHD/SLIDEOUT - W/O DRS/HDW - HONEY CHERRY - DINETTE/COMPUTER TABLE
31	158251-01-TG1	EA	CBNT - OVHD/SLIDEOUT - W/O DRS/HDW - CONCERT CHERRY - DINETTE/COMPUTER TABLE
31	158251-01-TG2	EA	CBNT - OVHD/SLIDEOUT - W/O DRS/HDW - WASHED MAPLE - DINETTE/COMPUTER TABLE
31	158251-01-TG3	EA	CBNT - OVHD/SLIDEOUT - W/O DRS/HDW - HONEY CHERRY - DINETTE/COMPUTER TABLE
32	156960-11-08A	EA	EXTENSION/TABLE TOP - W/O HDW - PRAIRIE (UJ1, UJ2, UJ3) FROM: 00-00-00 THRU: 06-04-06
32	156960-11-09C	EA	EXTENSION/TABLE TOP - W/O HDW - MOSS GLOSS(UJ1, UJ2, UJ3) FROM: 06-05-06 THRU: 99-99-99
32	156960-11-03A	EA	EXTENSION/TABLE TOP - W/O HDW - FOSSIL (UJ5, UJ6, UJ7) FROM: 00-00-00 THRU: 06-04-06
32	156960-11-11C	EA	EXTENSION/TABLE TOP - W/O HDW - COCOA BROWN GLOSS (UJ5, UJ6, UJ7) FROM: 06-05-06 THRU: 99-99-99
32	156960-11-07A	EA	EXTENSION/TABLE TOP - W/O HDW - DOESKIN (UK1, UK2, UK3) FROM: 00-00-00 THRU: 06-04-06
32	156960-11-09C	EA	EXTENSION/TABLE TOP - W/O HDW - MOSS GLOSS(UK1, UK2, UK3) FROM: 06-05-06 THRU: 99-99-99
33	156960-12-08A	EA	EXTENSION/TABLE TOP - W/O HDW - PRAIRIE (UJ1, UJ2, UJ3) FROM: 00-00-00 THRU: 06-04-06
33	156960-12-09C	EA	EXTENSION/TABLE TOP - W/O HDW - MOSS GLOSS(UJ1, UJ2, UJ3) FROM: 06-05-06 THRU: 99-99-99
33	156960-12-03A	EA	EXTENSION/TABLE TOP - W/O HDW - FOSSIL (UJ5, UJ6, UJ7) FROM: 00-00-00 THRU: 06-04-06
33	156960-12-11C	EA	EXTENSION/TABLE TOP - W/O HDW - COCOA BROWN GLOSS (UJ5, UJ6, UJ7) FROM: 06-05-06 THRU: 99-99-99
33	156960-12-07A	EA	EXTENSION/TABLE TOP - W/O HDW - DOESKIN (UK1, UK2, UK3) FROM: 00-00-00 THRU: 06-04-06
33	156960-12-09C	EA	EXTENSION/TABLE TOP - W/O HDW - MOSS GLOSS(UK1, UK2, UK3) FROM: 06-05-06 THRU: 99-99-99
34	148038-01-04B	EA	PLATE - TABLE TOP - BLACK
35	149677-13-S65	EA	PEDESTAL - TABLE LEG - CONCERT CHERRY FROM: 00-00-00 THRU: 01-14-07
35	149677-28-UJ1	EA	PEDESTAL - TABLE LEG - CONCERT CHERRY FROM: 01-15-07 THRU: 99-99-99
35	149677-13-S66	EA	PEDESTAL - TABLE LEG - WASHED MAPLE FROM: 00-00-00 THRU: 01-14-07
35	149677-28-UJ2	EA	PEDESTAL - TABLE LEG - WASHED MAPLE FROM: 01-15-07 THRU: 99-99-99
35	149677-13-SD3	EA	PEDESTAL - TABLE LEG - HONEY CHERRY FROM: 00-00-00 THRU: 01-14-07
35	149677-28-UJ3	EA	PEDESTAL - TABLE LEG - HONEY CHERRY FROM: 01-15-07 THRU: 99-99-99
36	149677-23-SD1	EA	TABLE TOP ONLY - OVAL DROP LEAF - W/O PEDESTAL - CONCERT CHERRY
36	149677-23-SD2	EA	TABLE TOP ONLY - OVAL DROP LEAF - W/O PEDESTAL - WASHED MAPLE
36	149677-23-SD3	EA	TABLE TOP ONLY - OVAL DROP LEAF - W/O PEDESTAL - HONEY CHERRY
37	149810-01-02B	EA	BASE/FRAME - F/TABLE PEDESTAL - E-COATED
38	P58250-01-TG1	EA	CABINET - DINETTE/COMPUTER - W/O COUNTERTOPS/DRAWERS/HDW - CONCERT CHERRY
38	P58250-01-TG2	EA	CABINET - DINETTE/COMPUTER - W/O COUNTERTOPS/DRAWERS/HDW - WASHED MAPLE
38	P58250-01-TG3	EA	CABINET - DINETTE/COMPUTER - W/O COUNTERTOPS/DRAWERS/HDW - HONEY CHERRY
	127156-01-01A	EA	RETAINER - STRAP/CHAIR FROM: 00-00-00 THRU: 05-21-06
39	110749-01-000	EA	SLIDE/EXTENSION - 19 3/4" TO 33 1/4"
40	141859-09-UJ1	EA	CABINET/DINETTE W/BACK(WRAPPED)-RIGHT HAND - W/O DOORS/HDW
40	141859-09-UJ2	EA	CABINET/DINETTE W/BACK(WRAPPED)-RIGHT HAND - W/O DOORS/HDW
40	141859-09-UJ3	EA	CABINET/DINETTE W/BACK(WRAPPED)-RIGHT HAND - W/O DOORS/HDW
40	141859-09-UJ5	EA	CABINET/DINETTE W/BACK(WRAPPED)-RIGHT HAND - W/O DOORS/HDW
40	141859-09-UJ6	EA	CABINET/DINETTE W/BACK(WRAPPED)-RIGHT HAND - W/O DOORS/HDW
40	141859-09-UJ7	EA	CABINET/DINETTE W/BACK(WRAPPED)-RIGHT HAND - W/O DOORS/HDW
40	141859-09-UK1	EA	CABINET/DINETTE W/BACK(WRAPPED)-RIGHT HAND - W/O DOORS/HDW
40	141859-09-UK2	EA	CABINET/DINETTE W/BACK(WRAPPED)-RIGHT HAND - W/O DOORS/HDW

CABINET & APPLIANCE GROUP (CONTINUED)
CABINET & APPLIANCE LAYOUT (CONTINUED)

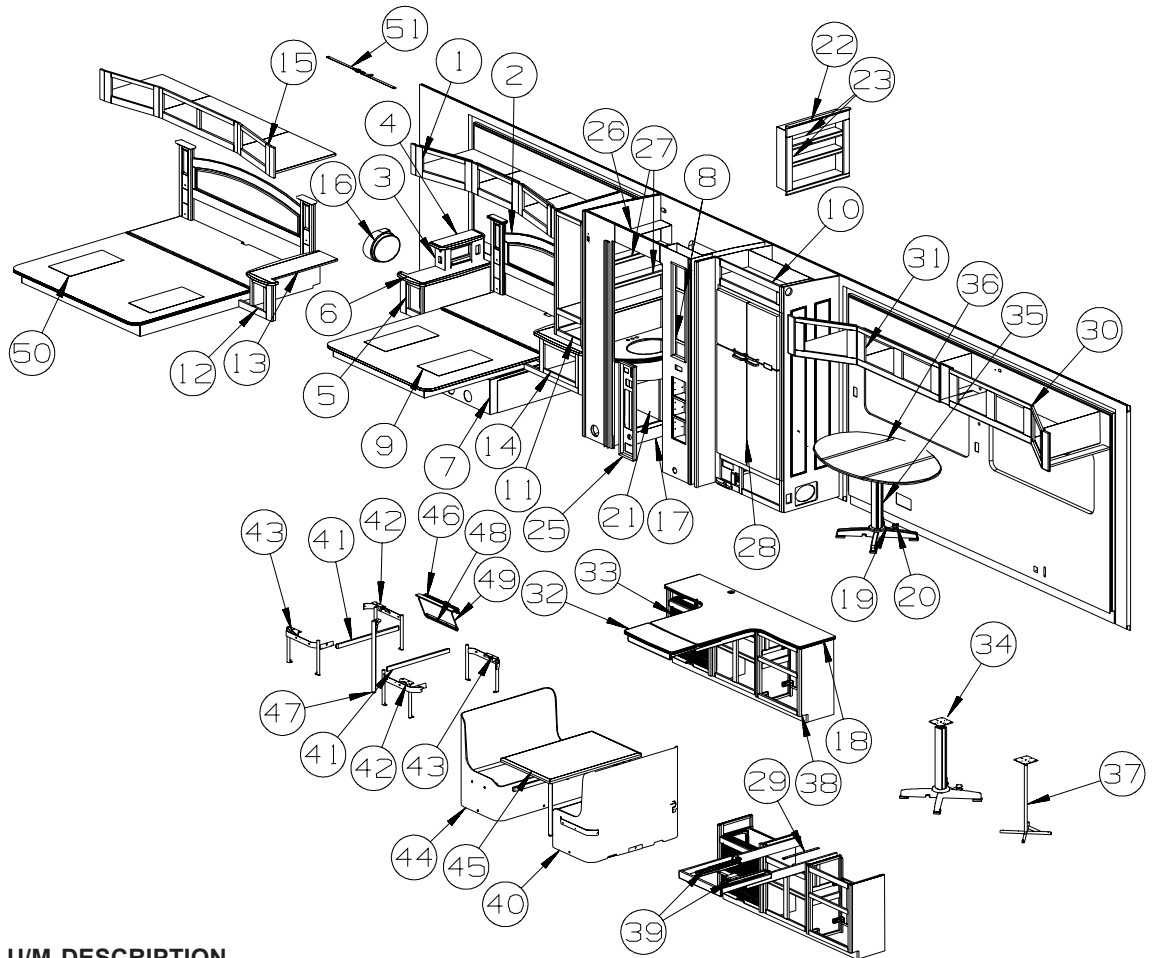

KEY	PART NUMBER	U/M	DESCRIPTION
40	141859-09-UK3	EA	CABINET/DINETTE W/BACK(WRAPPED)-RIGHT HAND - W/O DOORS/HDW
41	081295-01-M52	EA	SUPPORT - BED/DINETTE - 28" LONG - CONCERT CHERRY
41	081295-01-T03	EA	SUPPORT - BED/DINETTE - 28" LONG - WASHED MAPLE
41	081295-01-RE0	EA	SUPPORT - BED/DINETTE - 28" LONG - HONEY CHERRY
42	142033-01-000	EA	BRACKET - DINETTE - RIGHT HAND
43	142033-02-000	EA	BRACKET - DINETTE - LEFT HAND
44	141859-10-UJ1	EA	CABINET/DINETTE W/BACK(WRAPPED)-LEFT HAND - W/O DOORS/HDW
44	141859-10-UJ2	EA	CABINET/DINETTE W/BACK(WRAPPED)-LEFT HAND - W/O DOORS/HDW
44	141859-10-UJ3	EA	CABINET/DINETTE W/BACK(WRAPPED)-LEFT HAND - W/O DOORS/HDW
44	141859-10-UJ5	EA	CABINET/DINETTE W/BACK(WRAPPED)-LEFT HAND - W/O DOORS/HDW
44	141859-10-UJ6	EA	CABINET/DINETTE W/BACK(WRAPPED)-LEFT HAND - W/O DOORS/HDW
44	141859-10-UJ7	EA	CABINET/DINETTE W/BACK(WRAPPED)-LEFT HAND - W/O DOORS/HDW
44	141859-10-UK1	EA	CABINET/DINETTE W/BACK(WRAPPED)-LEFT HAND - W/O DOORS/HDW
44	141859-10-UK2	EA	CABINET/DINETTE W/BACK(WRAPPED)-LEFT HAND - W/O DOORS/HDW
44	141859-10-UK3	EA	CABINET/DINETTE W/BACK(WRAPPED)-LEFT HAND - W/O DOORS/HDW
45	143257-16-UJ1	EA	TABLE - 27.8" X 41.6" - CONCERT CHERRY
45	143257-16-UJ2	EA	TABLE - 27.8" X 41.6" - WASHED MAPLE
45	143257-16-UJ3	EA	TABLE - 27.8" X 41.6" - HONEY CHERRY
46	143798-02-02A	EA	CATCH - TABLE LEG TO FLOOR - ALMOND
46	140921-02-02A	EA	BRACKET/TABLE SUPPORT - 18.5" - ALMOND
47	143798-01-02A	EA	CATCH - FLOOR TO TABLE LEG - ALMOND
48	024281-12-000	EA	BRACKET/WALL - TABLE LIFT - 17.1" - ALMOND
49	024275-16-000	EA	ROD - TABLE LIFT - W/ARMS 8" & BASE ROD 18.5" - ALMOND
50	150016-01-SD0	EA	BEDBOARD - KING - W/HINGE/T-MOLDING/SLIPNOT - FLIP-UP - SLEEP NUMBER BED-KING SIZE
	096764-02-000	FT	SLIPNOT - ANTISLIP - 1"WIDE (180' ROLLS) - WHITE
51	099717-05-000	EA	STRAP - W/16.5" FEMALE STRAP AND 17.7" MALE STRAP

FROM: 02-19-07 THRU: 99-99-99

*COMPONENT PARTS LISTED LATER IN THIS GROUP

CABINET & APPLIANCE GROUP (CONTINUED)
CABINET & APPLIANCE LAYOUT (CONTINUED)

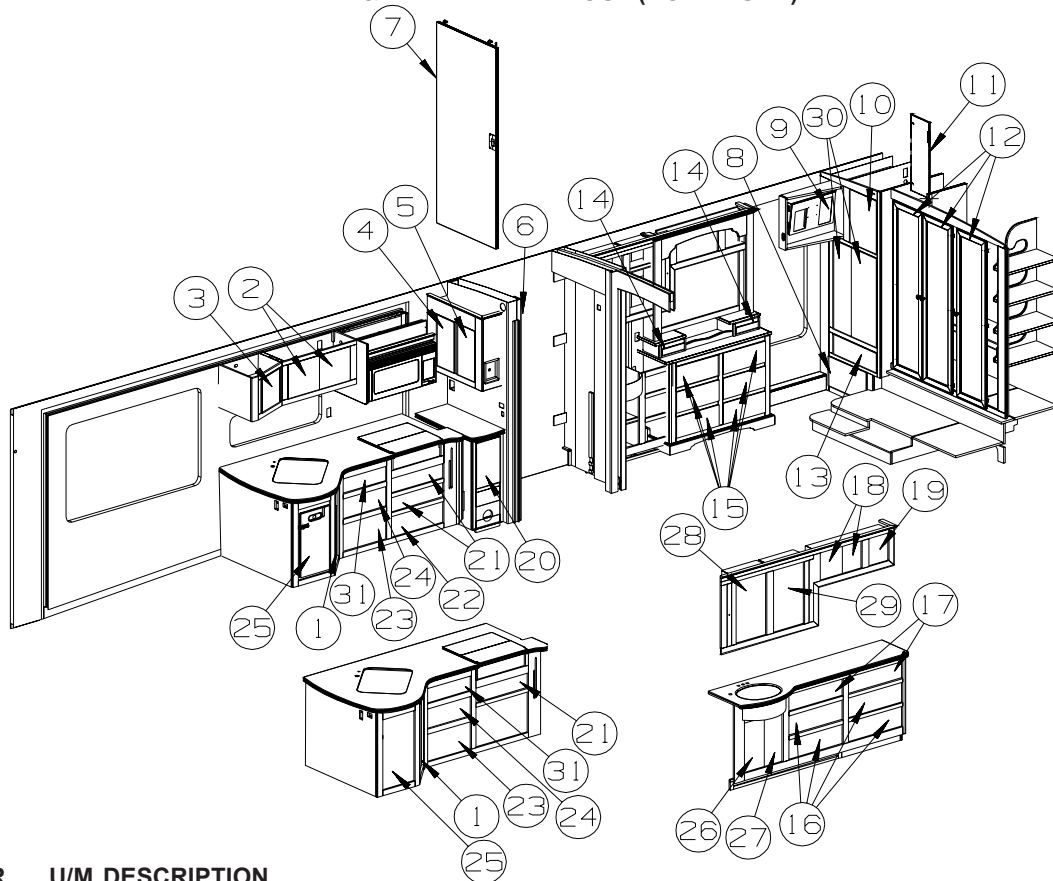

KEY	PART NUMBER	U/M	DESCRIPTION
1	156674-96-UJ1	EA	DOOR - RAISED PANEL/FLUTED EDGE - 13.6" X 30.3" - W/O HDW - CONCERT CHERRY
1	156674-96-UJ2	EA	DOOR - RAISED PANEL/FLUTED EDGE - 13.6" X 30.3" - W/O HDW - WASHED MAPLE
1	156674-96-UJ3	EA	DOOR - RAISED PANEL/FLUTED EDGE - 13.6" X 30.3" - W/O HDW - HONEY CHERRY
2	146890-A0-UJ1	EA	DOOR - ARCHED PANEL/FLUTED EDGE/LH - 14.4" X 14.4"-W/O HDW - CONCERT CHERRY
2	146890-A0-UJ2	EA	DOOR - ARCHED PANEL/FLUTED EDGE/LH - 14.4" X 14.4"-W/O HDW - WASHED MAPLE
2	146890-A0-UJ3	EA	DOOR - ARCHED PANEL/FLUTED EDGE/LH - 14.4" X 14.4"-W/O HDW - HONEY CHERRY
3	146891-A0-UJ1	EA	DOOR - ARCHED PANEL/FLUTED EDGE/RH - 14.4" X 14.4"-W/O HDW - CONCERT CHERRY
3	146891-A0-UJ2	EA	DOOR - ARCHED PANEL/FLUTED EDGE/RH - 14.4" X 14.4"-W/O HDW - WASHED MAPLE
3	146891-A0-UJ3	EA	DOOR - ARCHED PANEL/FLUTED EDGE/RH - 14.4" X 14.4"-W/O HDW - HONEY CHERRY
4	146890-40-UJ1	EA	DOOR - ARCHED PANEL/FLUTED EDGE/LH - 10.8" X 21.8"-W/O HDW - CONCERT CHERRY
4	146890-40-UJ2	EA	DOOR - ARCHED PANEL/FLUTED EDGE/LH - 10.8" X 21.8"-W/O HDW - WASHED MAPLE
4	146890-40-UJ3	EA	DOOR - ARCHED PANEL/FLUTED EDGE/LH - 10.8" X 21.8"-W/O HDW - HONEY CHERRY
5	146891-40-UJ1	EA	DOOR - ARCHED PANEL/FLUTED EDGE/RH - 10.8" X 21.8"-W/O HDW - CONCERT CHERRY
5	146891-40-UJ2	EA	DOOR - ARCHED PANEL/FLUTED EDGE/RH - 10.8" X 21.8"-W/O HDW - WASHED MAPLE
5	146891-40-UJ3	EA	DOOR - ARCHED PANEL/FLUTED EDGE/RH - 10.8" X 21.8"-W/O HDW - HONEY CHERRY
6	145608-10-01A	EA	TRACK - DOOR - 60.8" - OFF WHITE
7	157304-03-TG1	EA	DOOR - SLIDING - W/O HARDWARE - CONCERT CHERRY
7	157304-03-TG2	EA	DOOR - SLIDING - W/O HARDWARE - WASHED MAPLE
7	157304-03-TG3	EA	DOOR - SLIDING - W/O HARDWARE - HONEY CHERRY
8	146501-05-TG1	EA	DOOR - WIDE RAIL - MESH INSERT - 22" X 12.7" - W/O HDW - CONCERT CHERRY
8	146501-05-TG2	EA	DOOR - WIDE RAIL - MESH INSERT - 22" X 12.7" - W/O HDW - WASHED MAPLE
8	146501-05-TG3	EA	DOOR - WIDE RAIL - MESH INSERT - 22" X 12.7" - W/O HDW - HONEY CHERRY
9	146890-09-UJ1	EA	DOOR - ARCHED PANEL/FLUTED EDGE/LH - 9.2" X 21.8"-W/O HDW - CONCERT CHERRY
9	146890-09-UJ2	EA	DOOR - ARCHED PANEL/FLUTED EDGE/LH - 9.2" X 21.8"-W/O HDW - WASHED MAPLE
9	146890-09-UJ3	EA	DOOR - ARCHED PANEL/FLUTED EDGE/LH - 9.2" X 21.8"-W/O HDW - HONEY CHERRY
10	145522-41-UJ1	EA	DOOR - ARCHED PANEL/FLUTED EDGE - 15.9" X 21.8" - W/O HDW - CONCERT CHERRY
10	145522-41-UJ2	EA	DOOR - ARCHED PANEL/FLUTED EDGE - 15.9" X 21.8" - W/O HDW - WASHED MAPLE
10	145522-41-UJ3	EA	DOOR - ARCHED PANEL/FLUTED EDGE - 15.9" X 21.8" - W/O HDW - HONEY CHERRY
11	145298-46-TG1	EA	DOOR - SOLID PANEL/FLUTED EDGE - 10" X 29.5" - W/O HDW - CONCERT CHERRY
11	145298-46-TG2	EA	DOOR - SOLID PANEL/FLUTED EDGE - 10" X 29.5" - W/O HDW - WASHED MAPLE
11	145298-46-TG3	EA	DOOR - SOLID PANEL/FLUTED EDGE - 10" X 29.5" - W/O HDW - HONEY CHERRY
12	147873-09-UJ1	EA	DOOR - FLUTED EDGE/MIRRORED - 16.1" X 65.3" - W/O HDW - CONCERT CHERRY
12	147873-09-UJ2	EA	DOOR - FLUTED EDGE/MIRRORED - 16.1" X 65.3" - W/O HDW - WASHED MAPLE
12	147873-09-UJ3	EA	DOOR - FLUTED EDGE/MIRRORED - 16.1" X 65.3" - W/O HDW - HONEY CHERRY
	140374-68-000	EA	MIRROR - SAFETY GLASS - 12.2" X 61.3"

CABINET & APPLIANCE GROUP (CONTINUED)
CABINET & APPLIANCE LAYOUT (CONTINUED)

KEY	PART NUMBER	U/M	DESCRIPTION
13	153121-B7-TG1	EA	DRAWER - FLUTED EDGE - 23"W X 19.7"D - W/O SLIDES/HDW - CONCERT CHERRY
13	153121-B7-TG2	EA	DRAWER - FLUTED EDGE - 23"W X 19.7"D - W/O SLIDES/HDW - WASHED MAPLE
13	153121-B7-TG3	EA	DRAWER - FLUTED EDGE - 23"W X 19.7"D - W/O SLIDES/HDW - HONEY CHERRY
14	151043-02-TG1	EA	DRAWER - FLUTED EDGE - 10"W X 8.3"D - W/O SLIDES/HDW - CONCERT CHERRY
14	151043-02-TG2	EA	DRAWER - FLUTED EDGE - 10"W X 8.3"D - W/O SLIDES/HDW - WASHED MAPLE
14	151043-02-TG3	EA	DRAWER - FLUTED EDGE - 10"W X 8.3"D - W/O SLIDES/HDW - HONEY CHERRY
15	153121-A3-TG1	EA	DRAWER - FLUTED EDGE - 17.9"W X 11.8"D - W/O SLIDES/HDW - CONCERT CHERRY
15	153121-A3-TG2	EA	DRAWER - FLUTED EDGE - 17.9"W X 11.8"D - W/O SLIDES/HDW - WASHED MAPLE
15	153121-A3-TG3	EA	DRAWER - FLUTED EDGE - 17.9"W X 11.8"D - W/O SLIDES/HDW - HONEY CHERRY
16	153121-A4-TG1	EA	DRAWER - FLUTED EDGE - 23.4"W X 11.8"D - W/O SLIDES/HDW - CONCERT CHERRY
16	153121-A4-TG2	EA	DRAWER - FLUTED EDGE - 23.4"W X 11.8"D - W/O SLIDES/HDW - WASHED MAPLE
16	153121-A4-TG3	EA	DRAWER - FLUTED EDGE - 23.4"W X 11.8"D - W/O SLIDES/HDW - HONEY CHERRY
17	153121-A5-TG1	EA	DRAWER - FLUTED EDGE - 23.4"W X 11.8"D - W/O SLIDES/HDW - CONCERT CHERRY
17	153121-A5-TG2	EA	DRAWER - FLUTED EDGE - 23.4"W X 11.8"D - W/O SLIDES/HDW - WASHED MAPLE
17	153121-A5-TG3	EA	DRAWER - FLUTED EDGE - 23.4"W X 11.8"D - W/O SLIDES/HDW - HONEY CHERRY
18	146891-10-UJ1	EA	DOOR - ARCHED PANEL/FLUTED EDGE/RH - 9.8" X 12" - W/O HDW - CONCERT CHERRY
18	146891-10-UJ2	EA	DOOR - ARCHED PANEL/FLUTED EDGE/RH - 9.8" X 12" - W/O HDW - WASHED MAPLE
18	146891-10-UJ3	EA	DOOR - ARCHED PANEL/FLUTED EDGE/RH - 9.8" X 12" - W/O HDW - HONEY CHERRY
19	146890-10-UJ1	EA	DOOR - ARCHED PANEL/FLUTED EDGE/LH - 9.8" X 12" - W/O HDW - CONCERT CHERRY
19	146890-10-UJ2	EA	DOOR - ARCHED PANEL/FLUTED EDGE/LH - 9.8" X 12" - W/O HDW - WASHED MAPLE
19	146890-10-UJ3	EA	DOOR - ARCHED PANEL/FLUTED EDGE/LH - 9.8" X 12" - W/O HDW - HONEY CHERRY
20	156674-66-UJ1	EA	DOOR - RAISED PANEL/FLUTED EDGE - 12" X 18.7" - W/O HDW - CONCERT CHERRY
20	156674-66-UJ2	EA	DOOR - RAISED PANEL/FLUTED EDGE - 12" X 18.7" - W/O HDW - WASHED MAPLE
20	156674-66-UJ3	EA	DOOR - RAISED PANEL/FLUTED EDGE - 12" X 18.7" - W/O HDW - HONEY CHERRY
21	153121-LC-UJ1	EA	DRAWER - FLUTED EDGE - 22.6"W X 21.6"D - W/O SLIDES/HDW - CONCERT CHERRY
21	153121-LC-UJ2	EA	DRAWER - FLUTED EDGE - 22.6"W X 21.6"D - W/O SLIDES/HDW - WASHED MAPLE
21	153121-LC-UJ3	EA	DRAWER - FLUTED EDGE - 22.6"W X 21.6"D - W/O SLIDES/HDW - HONEY CHERRY
22	153121-LD-UJ1	EA	DRAWER - FLUTED EDGE - 22.6"W X 21.6"D - W/O SLIDES/HDW - CONCERT CHERRY
22	153121-LD-UJ2	EA	DRAWER - FLUTED EDGE - 22.6"W X 21.6"D - W/O SLIDES/HDW - WASHED MAPLE
22	153121-LD-UJ3	EA	DRAWER - FLUTED EDGE - 22.6"W X 21.6"D - W/O SLIDES/HDW - HONEY CHERRY
23	153121-LE-UJ1	EA	DRAWER - FLUTED EDGE - 18.6"W X 21.6"D - W/O SLIDES/HDW - CONCERT CHERRY
23	153121-LE-UJ2	EA	DRAWER - FLUTED EDGE - 18.6"W X 21.6"D - W/O SLIDES/HDW - WASHED MAPLE
23	153121-LE-UJ3	EA	DRAWER - FLUTED EDGE - 18.6"W X 21.6"D - W/O SLIDES/HDW - HONEY CHERRY
24	153121-LF-UJ1	EA	DRAWER - FLUTED EDGE - 18.6"W X 21.6"D - W/O SLIDES/HDW - CONCERT CHERRY
24	153121-LF-UJ2	EA	DRAWER - FLUTED EDGE - 18.6"W X 21.6"D - W/O SLIDES/HDW - WASHED MAPLE
24	153121-LF-UJ3	EA	DRAWER - FLUTED EDGE - 18.6"W X 21.6"D - W/O SLIDES/HDW - HONEY CHERRY
25	156674-C5-UJ1	EA	DOOR - RAISED PANEL/FLUTED EDGE - 15.5" X 29.5" - W/O HDW - CONCERT CHERRY
25	156674-C5-UJ2	EA	DOOR - RAISED PANEL/FLUTED EDGE - 15.5" X 29.5" - W/O HDW - WASHED MAPLE
25	156674-C5-UJ3	EA	DOOR - RAISED PANEL/FLUTED EDGE - 15.5" X 29.5" - W/O HDW - HONEY CHERRY
26	156674-08-UJ1	EA	DOOR - RAISED PANEL/FLUTED EDGE - 9.2" X 21.8" - W/O HDW - CONCERT CHERRY
26	156674-08-UJ2	EA	DOOR - RAISED PANEL/FLUTED EDGE - 9.2" X 21.8" - W/O HDW - WASHED MAPLE
26	156674-08-UJ3	EA	DOOR - RAISED PANEL/FLUTED EDGE - 9.2" X 21.8" - W/O HDW - HONEY CHERRY
27	156674-09-UJ1	EA	DOOR - RAISED PANEL/FLUTED EDGE - 9.2" X 21.8" - W/O HDW - CONCERT CHERRY
27	156674-09-UJ2	EA	DOOR - RAISED PANEL/FLUTED EDGE - 9.2" X 21.8" - W/O HDW - WASHED MAPLE
27	156674-09-UJ3	EA	DOOR - RAISED PANEL/FLUTED EDGE - 9.2" X 21.8" - W/O HDW - HONEY CHERRY
28	145576-01-R90	EA	DOOR - W/MIRROR - 14.5" X 25.9" - W/O HARDWARE - CONCERT CHERRY
28	145576-01-R91	EA	DOOR - W/MIRROR - 14.5" X 25.9" - W/O HARDWARE - WASHED MAPLE
28	145576-01-RE3	EA	DOOR - W/MIRROR - 14.5" X 25.9" - W/O HARDWARE - HONEY CHERRY
	093606-30-000	EA	MIRROR - BEVELED EDGE - 14.5" X 25.9"
	076767-04-000	EA	CABLE - STAINLESS STEEL - 5.9"
29	145576-02-R90	EA	DOOR - W/MIRROR - 14.5" X 25.9" - W/O HARDWARE - CONCERT CHERRY
29	145576-02-R91	EA	DOOR - W/MIRROR - 14.5" X 25.9" - W/O HARDWARE - WASHED MAPLE
29	145576-02-RE3	EA	DOOR - W/MIRROR - 14.5" X 25.9" - W/O HARDWARE - HONEY CHERRY
	093606-30-000	EA	MIRROR - BEVELED EDGE - 14.5" X 25.9"
	076767-04-000	EA	CABLE - STAINLESS STEEL - 5.9"
30	143959-B3-UJ1	EA	DOOR - RAISED PANEL/FLUTED EDGE - 12.4" X 36" - W/O HDW - CONCERT CHERRY
30	143959-B3-UJ2	EA	DOOR - RAISED PANEL/FLUTED EDGE - 12.4" X 36" - W/O HDW - WASHED MAPLE
30	143959-B3-UJ3	EA	DOOR - RAISED PANEL/FLUTED EDGE - 12.4" X 36" - W/O HDW - HONEY CHERRY
31	155684-04-UJ1	EA	DRAWER - TRAY/SILVERWARE - W/O SLIDES/HDW - CONCERT CHERRY
31	155684-04-UJ2	EA	DRAWER - TRAY/SILVERWARE - W/O SLIDES/HDW - WASHED MAPLE
31	155684-04-UJ3	EA	DRAWER - TRAY/SILVERWARE - W/O SLIDES/HDW - HONEY CHERRY

CABINET & APPLIANCE GROUP (CONTINUED)

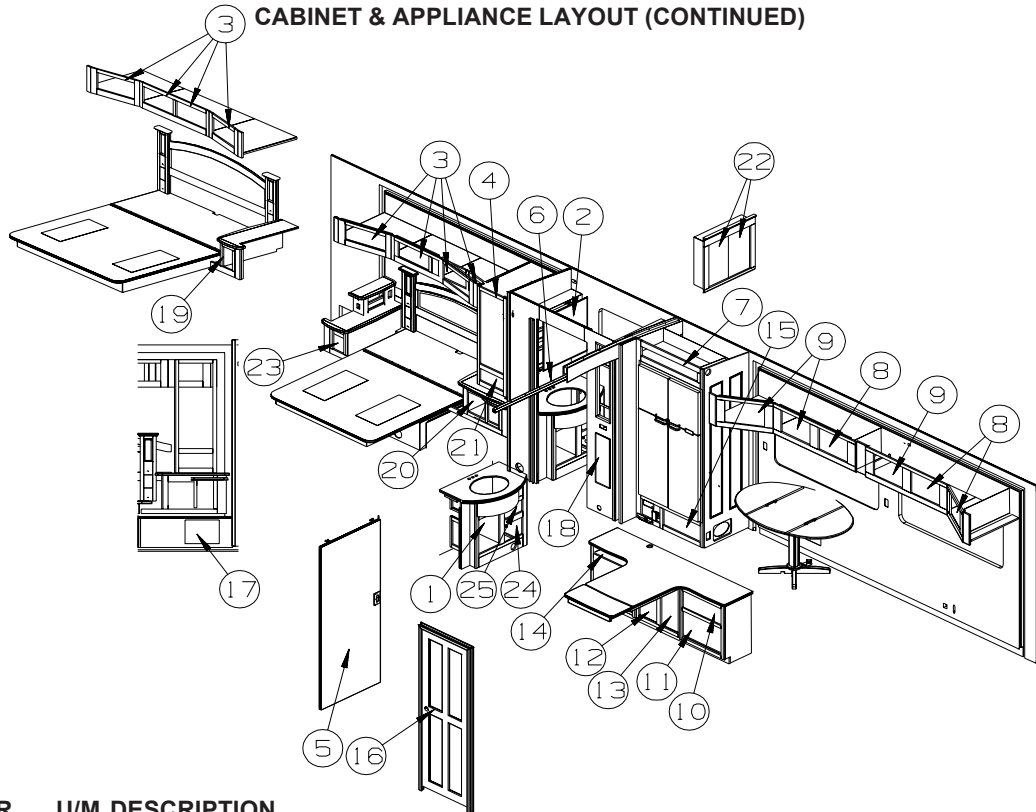

KEY	PART NUMBER	U/M	DESCRIPTION
1	156674-84-UJ1	EA	DOOR - RAISED PANEL/FLUTED EDGE - 12.8" X 17.7" - W/O HDW - CONCERT CHERRY
1	156674-84-UJ2	EA	DOOR - RAISED PANEL/FLUTED EDGE - 12.8" X 17.7" - W/O HDW - WASHED MAPLE
1	156674-84-UJ3	EA	DOOR - RAISED PANEL/FLUTED EDGE - 12.8" X 17.7" - W/O HDW - HONEY CHERRY
2	145576-09-R90	EA	DOOR - W/MIRROR - 24.5" X 25.9" - W/O HARDWARE - CONCERT CHERRY
2	145576-09-R91	EA	DOOR - W/MIRROR - 24.5" X 25.9" - W/O HARDWARE - WASHED MAPLE
2	145576-09-RE3	EA	DOOR - W/MIRROR - 24.5" X 25.9" - W/O HARDWARE - HONEY CHERRY
3	145522-43-UJ1	EA	DOOR - ARCHED PANEL/FLUTED EDGE - 19.9" X 9.3" - W/O HDW - CONCERT CHERRY
3	145522-43-UJ2	EA	DOOR - ARCHED PANEL/FLUTED EDGE - 19.9" X 9.3" - W/O HDW - WASHED MAPLE
3	145522-43-UJ3	EA	DOOR - ARCHED PANEL/FLUTED EDGE - 19.9" X 9.3" - W/O HDW - HONEY CHERRY
4	146891-B5-UJ1	EA	DOOR - ARCHED PANEL/FLUTED EDGE/RH - 14.4" X 36.4"-W/O HDW - CONCERT CHERRY
4	146891-B5-UJ2	EA	DOOR - ARCHED PANEL/FLUTED EDGE/RH - 14.4" X 36.4"-W/O HDW - WASHED MAPLE
4	146891-B5-UJ3	EA	DOOR - ARCHED PANEL/FLUTED EDGE/RH - 14.4" X 36.4"-W/O HDW - HONEY CHERRY
5	157304-03-TG1	EA	DOOR - SLIDING - W/O HARDWARE - CONCERT CHERRY
5	157304-03-TG2	EA	DOOR - SLIDING - W/O HARDWARE - WASHED MAPLE
5	157304-03-TG3	EA	DOOR - SLIDING - W/O HARDWARE - HONEY CHERRY
6	145608-10-01A	EA	TRACK - DOOR - 60.8" - OFF WHITE
7	145298-55-UJ1	EA	DOOR - SOLID PANEL/FLUTED EDGE - 5.7" X 33.6" - W/O HDW - CONCERT CHERRY
7	145298-55-UJ2	EA	DOOR - SOLID PANEL/FLUTED EDGE - 5.7" X 33.6" - W/O HDW - WASHED MAPLE
7	145298-55-UJ3	EA	DOOR - SOLID PANEL/FLUTED EDGE - 5.7" X 33.6" - W/O HDW - HONEY CHERRY
8	145522-45-UJ1	EA	DOOR - ARCHED PANEL/FLUTED EDGE - 16.9" X 12.8" - W/O HDW - CONCERT CHERRY
8	145522-45-UJ2	EA	DOOR - ARCHED PANEL/FLUTED EDGE - 16.9" X 12.8" - W/O HDW - WASHED MAPLE
8	145522-45-UJ3	EA	DOOR - ARCHED PANEL/FLUTED EDGE - 16.9" X 12.8" - W/O HDW - HONEY CHERRY
9	145522-44-UJ1	EA	DOOR - ARCHED PANEL/FLUTED EDGE - 16.9" X 12.8" - W/O HDW - CONCERT CHERRY
9	145522-44-UJ2	EA	DOOR - ARCHED PANEL/FLUTED EDGE - 16.9" X 12.8" - W/O HDW - WASHED MAPLE
9	145522-44-UJ3	EA	DOOR - ARCHED PANEL/FLUTED EDGE - 16.9" X 12.8" - W/O HDW - HONEY CHERRY
10	153121-LA-UJ1	EA	DRAWER - FLUTED EDGE - 20.6"W X 13.8"D - W/O SLIDES/HDW - CONCERT CHERRY
10	153121-LA-UJ2	EA	DRAWER - FLUTED EDGE - 20.6"W X 13.8"D - W/O SLIDES/HDW - WASHED MAPLE
10	153121-LA-UJ3	EA	DRAWER - FLUTED EDGE - 20.6"W X 13.8"D - W/O SLIDES/HDW - HONEY CHERRY
11	153121-LB-UJ1	EA	DRAWER - FLUTED EDGE - 20.6"W X 13.8"D - W/O SLIDES/HDW - CONCERT CHERRY
11	153121-LB-UJ2	EA	DRAWER - FLUTED EDGE - 20.6"W X 13.8"D - W/O SLIDES/HDW - WASHED MAPLE
11	153121-LB-UJ3	EA	DRAWER - FLUTED EDGE - 20.6"W X 13.8"D - W/O SLIDES/HDW - HONEY CHERRY
12	156674-35-UJ1	EA	DOOR - RAISED PANEL/FLUTED EDGE - 10.6" X 19.9" - W/O HDW - CONCERT CHERRY
12	156674-35-UJ2	EA	DOOR - RAISED PANEL/FLUTED EDGE - 10.6" X 19.9" - W/O HDW - WASHED MAPLE
12	156674-35-UJ3	EA	DOOR - RAISED PANEL/FLUTED EDGE - 10.6" X 19.9" - W/O HDW - HONEY CHERRY
13	156674-36-UJ1	EA	DOOR - RAISED PANEL/FLUTED EDGE - 10.6" X 19.9" - W/O HDW - CONCERT CHERRY
13	156674-36-UJ2	EA	DOOR - RAISED PANEL/FLUTED EDGE - 10.6" X 19.9" - W/O HDW - WASHED MAPLE
13	156674-36-UJ3	EA	DOOR - RAISED PANEL/FLUTED EDGE - 10.6" X 19.9" - W/O HDW - HONEY CHERRY

CABINET & APPLIANCE GROUP (CONTINUED)
CABINET & APPLIANCE LAYOUT (CONTINUED)

KEY	PART NUMBER	U/M	DESCRIPTION
14	P36353-04-UJ1	EA	DRAWER-KEYBOARD - W/DRAWER SLIDES - W/O CABINET SLIDES/HDW - CONCERT CHERRY
14	P36353-04-UJ2	EA	DRAWER-KEYBOARD - W/DRAWER SLIDES - W/O CABINET SLIDES/HDW - WASHED MAPLE
14	P36353-04-UJ3	EA	DRAWER-KEYBOARD - W/DRAWER SLIDES - W/O CABINET SLIDES/HDW - HONEY CHERRY
15	146501-06-TG1	EA	DOOR - WIDE RAIL - MESH INSERT - 22" X 8.8" - W/O HDW - CONCERT CHERRY
15	146501-06-TG2	EA	DOOR - WIDE RAIL - MESH INSERT - 22" X 8.8" - W/O HDW - WASHED MAPLE
15	146501-06-TG3	EA	DOOR - WIDE RAIL - MESH INSERT - 22" X 8.8" - W/O HDW - HONEY CHERRY
16	152734-03-TG1	EA	DOOR - BATH - 4 PANEL - W/O HARDWARE - CONCERT CHERRY
16	152734-03-TG2	EA	DOOR - BATH - 4 PANEL - W/O HARDWARE - WASHED MAPLE
16	152734-03-TG3	EA	DOOR - BATH - 4 PANEL - W/O HARDWARE - HONEY CHERRY
17	146501-07-TG1	EA	DOOR - WIDE RAIL - MESH INSERT - 14.5" X 11" - W/O HDW - CONCERT CHERRY
17	146501-07-TG2	EA	DOOR - WIDE RAIL - MESH INSERT - 14.5" X 11" - W/O HDW - WASHED MAPLE
17	146501-07-TG3	EA	DOOR - WIDE RAIL - MESH INSERT - 14.5" X 11" - W/O HDW - HONEY CHERRY
	140594-28-01A	EA	GRILL - RETURN AIR - 10.5" X 6.9" - BLACK
18	156674-06-UJ1	EA	DOOR - RAISED PANEL/FLUTED EDGE - 9" X 26.5" - W/O HDW - CONCERT CHERRY
18	156674-06-UJ2	EA	DOOR - RAISED PANEL/FLUTED EDGE - 9" X 26.5" - W/O HDW - WASHED MAPLE
18	156674-06-UJ3	EA	DOOR - RAISED PANEL/FLUTED EDGE - 9" X 26.5" - W/O HDW - HONEY CHERRY
19	153121-B6-TG1	EA	DRAWER - FLUTED EDGE - 5.7"W X 13.8"D - CONCERT CHERRY - SLEEP NUMBER BED-KING SIZE
19	153121-B6-TG2	EA	DRAWER - FLUTED EDGE - 5.7"W X 13.8"D - WASHED MAPLE - SLEEP NUMBER BED-KING SIZE
19	153121-B6-TG3	EA	DRAWER - FLUTED EDGE - 5.7"W X 13.8"D - HONEY CHERRY - SLEEP NUMBER BED-KING SIZE
20	153121-B4-TG1	EA	DRAWER - FLUTED EDGE - 17.1"W X 21.6"D - W/O SLIDES/HDW - CONCERT CHERRY
20	153121-B4-TG2	EA	DRAWER - FLUTED EDGE - 17.1"W X 21.6"D - W/O SLIDES/HDW - WASHED MAPLE
20	153121-B4-TG3	EA	DRAWER - FLUTED EDGE - 17.1"W X 21.6"D - W/O SLIDES/HDW - HONEY CHERRY
21	153121-B5-TG1	EA	DRAWER - FLUTED EDGE - 12.3"W X 21.6"D - W/O SLIDES/HDW - CONCERT CHERRY
21	153121-B5-TG2	EA	DRAWER - FLUTED EDGE - 12.3"W X 21.6"D - W/O SLIDES/HDW - WASHED MAPLE
21	153121-B5-TG3	EA	DRAWER - FLUTED EDGE - 12.3"W X 21.6"D - W/O SLIDES/HDW - HONEY CHERRY
22	146890-67-UJ1	EA	DOOR - ARCHED PANEL/FLUTED EDGE/LH - 12" X 21.8" - W/O HDW - CONCERT CHERRY
22	146890-67-UJ2	EA	DOOR - ARCHED PANEL/FLUTED EDGE/LH - 12" X 21.8" - W/O HDW - WASHED MAPLE
22	146890-67-UJ3	EA	DOOR - ARCHED PANEL/FLUTED EDGE/LH - 12" X 21.8" - W/O HDW - HONEY CHERRY
23	153121-B6-TG1	EA	DRAWER - FLUTED EDGE - 5.7"W X 13.8"D - CONCERT CHERRY
23	153121-B6-TG2	EA	DRAWER - FLUTED EDGE - 5.7"W X 13.8"D - WASHED MAPLE
23	153121-B6-TG3	EA	DRAWER - FLUTED EDGE - 5.7"W X 13.8"D - HONEY CHERRY
24	153121-B2-TG1	EA	DRAWER - FLUTED EDGE - 9.6"W X 11.8"D - W/O SLIDES/HDW - CONCERT CHERRY
24	153121-B2-TG2	EA	DRAWER - FLUTED EDGE - 9.6"W X 11.8"D - W/O SLIDES/HDW - WASHED MAPLE
24	153121-B2-TG3	EA	DRAWER - FLUTED EDGE - 9.6"W X 11.8"D - W/O SLIDES/HDW - HONEY CHERRY
25	153121-B3-TG1	EA	DRAWER - FLUTED EDGE - 9.6"W X 11.8"D - W/O SLIDES/HDW - CONCERT CHERRY
25	153121-B3-TG2	EA	DRAWER - FLUTED EDGE - 9.6"W X 11.8"D - W/O SLIDES/HDW - WASHED MAPLE
25	153121-B3-TG3	EA	DRAWER - FLUTED EDGE - 9.6"W X 11.8"D - W/O SLIDES/HDW - HONEY CHERRY

CABINET & APPLIANCE GROUP (CONTINUED)
CABINET & APPLIANCE LAYOUT (CONTINUED)

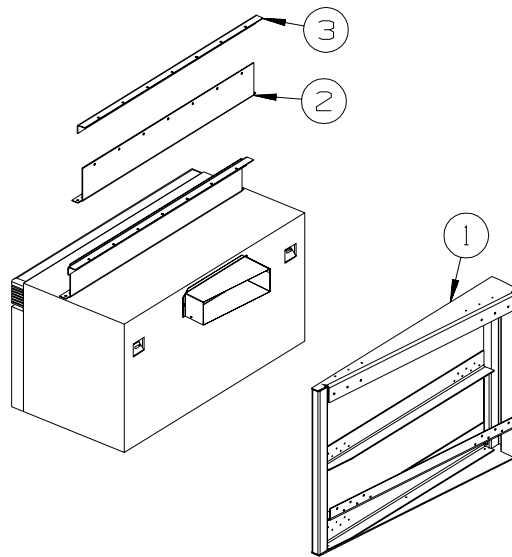

MICROWAVE/CONVECTION OVEN - S40FD

KEY	PART NUMBER	U/M	DESCRIPTION
1	139201-03-02B	EA	BRACKET - MICROWAVE - E-COATED
2	129836-09-02B	EA	ANGLE - W/HOLES - 1" X 5.5" X 29.5" - E-COATED
3	129836-02-02B	EA	ANGLE - W/HOLES - 1" X .8 X 29.5" - E-COATED

SPEED COOK OVEN - S40FD

KEY	PART NUMBER	U/M	DESCRIPTION
1	139201-03-02B	EA	BRACKET - MICROWAVE - E-COATED
2	129836-09-02B	EA	ANGLE - W/HOLES - 1" X 5.5" X 29.5" - E-COATED
3	129836-02-02B	EA	ANGLE - W/HOLES - 1" X .8 X 29.5" - E-COATED

CABINET & APPLIANCE GROUP (CONTINUED)
CABINET & APPLIANCE LAYOUT (CONTINUED)

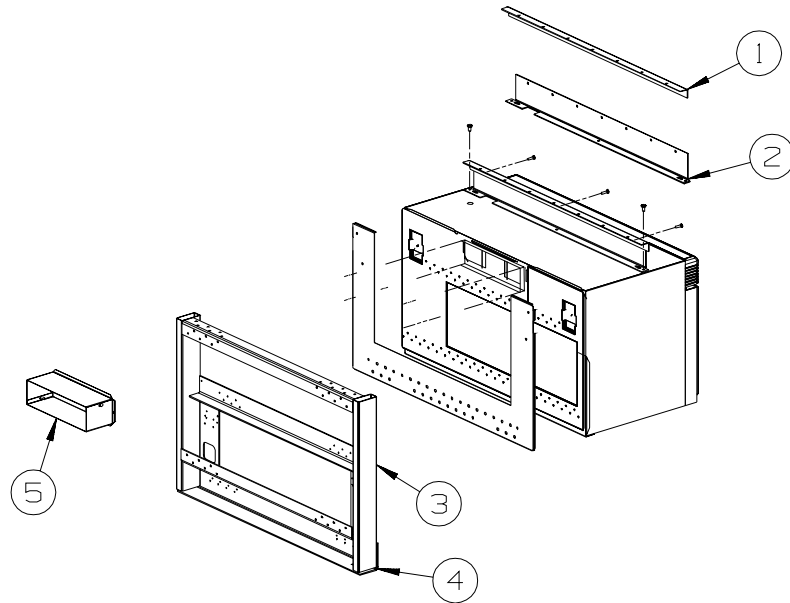

MICROWAVE/CONVECTION OVEN - S40KD

KEY	PART NUMBER	U/M	DESCRIPTION
1	129836-02-02B	EA	ANGLE - W/HOLES - 1" X .8" X 29.5" - E-COATED
2	129836-09-02B	EA	ANGLE - W/HOLES - 1" X 5.5" X 29.5" - E-COATED
3	137824-07-02B	EA	BRACKET - MICROWAVE - E-COATED
4	NOT USED		
5	140093-01-02B	EA	DUCT - E-COATED

SPEED COOK OVEN - S40KD

KEY	PART NUMBER	U/M	DESCRIPTION
1	129836-02-02B	EA	ANGLE - W/HOLES - 1" X .8" X 29.5" - E-COATED
2	129836-09-02B	EA	ANGLE - W/HOLES - 1" X 5.5" X 29.5" - E-COATED
3	137824-07-02B	EA	BRACKET - MICROWAVE - E-COATED
4	NOT USED		
5	140093-04-02B	EA	DUCT - E-COATED

CABINET & APPLIANCE GROUP (CONTINUED)
CABINET & APPLIANCE LAYOUT (CONTINUED)

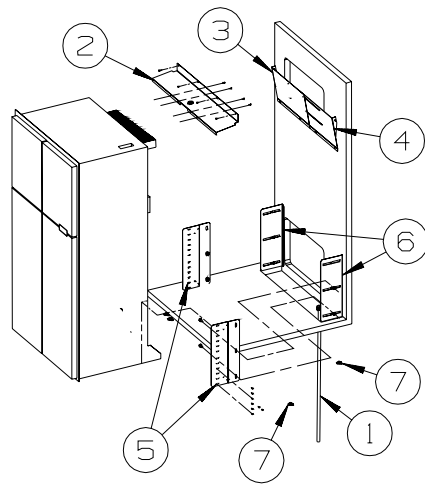

S40FD, S40TD

KEY	PART NUMBER	U/M	DESCRIPTION
1	112176-01-000	FT	TUBING - VINYL - REINFORCED - 1/2" ID
2	136966-04-02B	EA	BAFFLE - REFRIGERATOR - E-COATED
			FROM: 00-00-00 THRU: 05-14-06
2	136966-05-02B	EA	BAFFLE - REFRIGERATOR - E-COATED
			FROM: 05-15-06 THRU: 99-99-99
3	143195-01-02B	EA	BAFFLE - REFRIGERATOR - E-COATED
4	143195-02-02B	EA	BAFFLE - REFRIGERATOR - E-COATED
5	150740-01-02B	EA	BRACKET - REFRIGERATOR - E-COATED
6	150740-02-02B	EA	BRACKET - REFRIGERATOR - E-COATED
7	152417-01-01A	EA	CLAMP/RATCHET - F/REFRIDGERATOR DRIP TRAY HOSE - BLACK

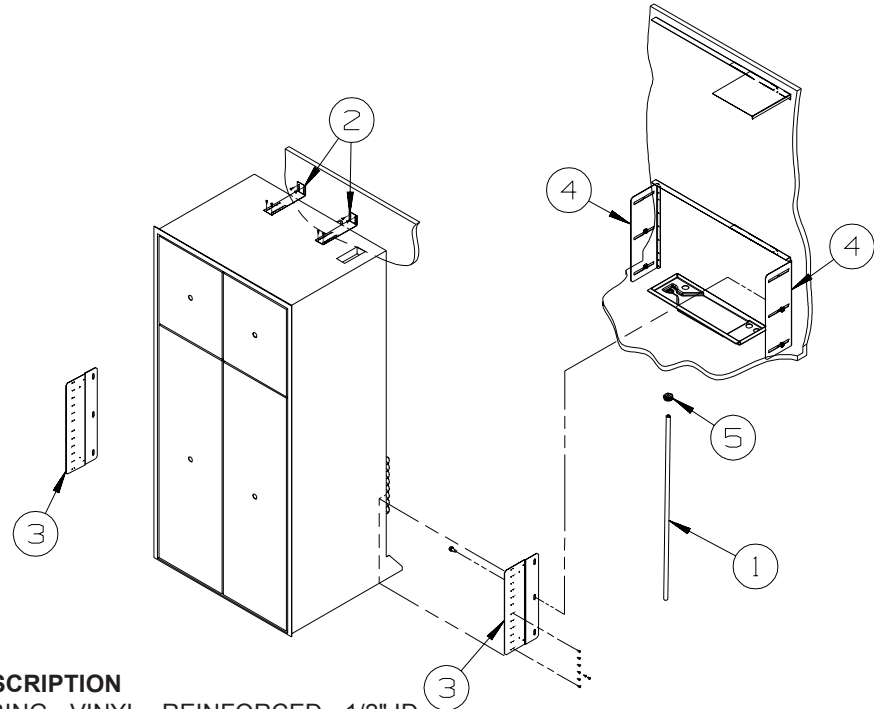

S40KD

KEY	PART NUMBER	U/M	DESCRIPTION
1	112176-01-000	FT	TUBING - VINYL - REINFORCED - 1/2" ID
2	145445-02-02B	EA	STRAP - REFRIGERATOR - E-COATED
3	150740-01-02B	EA	BRACKET - REFRIGERATOR - E-COATED
4	150740-02-02B	EA	BRACKET - REFRIGERATOR - E-COATED
5	152417-01-01A	EA	CLAMP/RATCHET - F/REFRIDGERATOR DRIP TRAY HOSE - BLACK

CABINET & APPLIANCE GROUP (CONTINUED)
CABINET & APPLIANCE LAYOUT (CONTINUED)

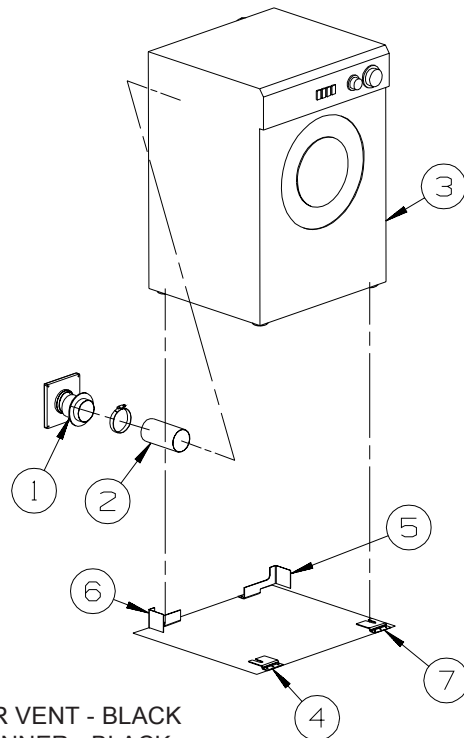

S40FD, S40KD

KEY	PART NUMBER	U/M	DESCRIPTION
1	146292-01-02A	EA	COVER - DRYER VENT - BLACK
1	146292-02-02A	EA	DRYER VENT - INNER - BLACK
2	116653-02-000	FT	DUCT - FLEXIBLE - 3' COMPRESSED/8' EXTENDED
3	153204-01-01A	EA	WASHER/DRYER - VENTED - UL/CSA - WHITE
4	111913-02-04B	EA	BRACKET/WASHER - TIE DOWN - BLACK
5	113795-01-02B	EA	BRACKET - WASHER - E-COATED
6	113795-02-02B	EA	BRACKET - WASHER - E-COATED
7	111913-03-04B	EA	BRACKET/WASHER - TIE DOWN - BLACK
	141523-01-01A	EA	LABEL - WASHER/DRYER BRACKETS - BLACK/WHITE

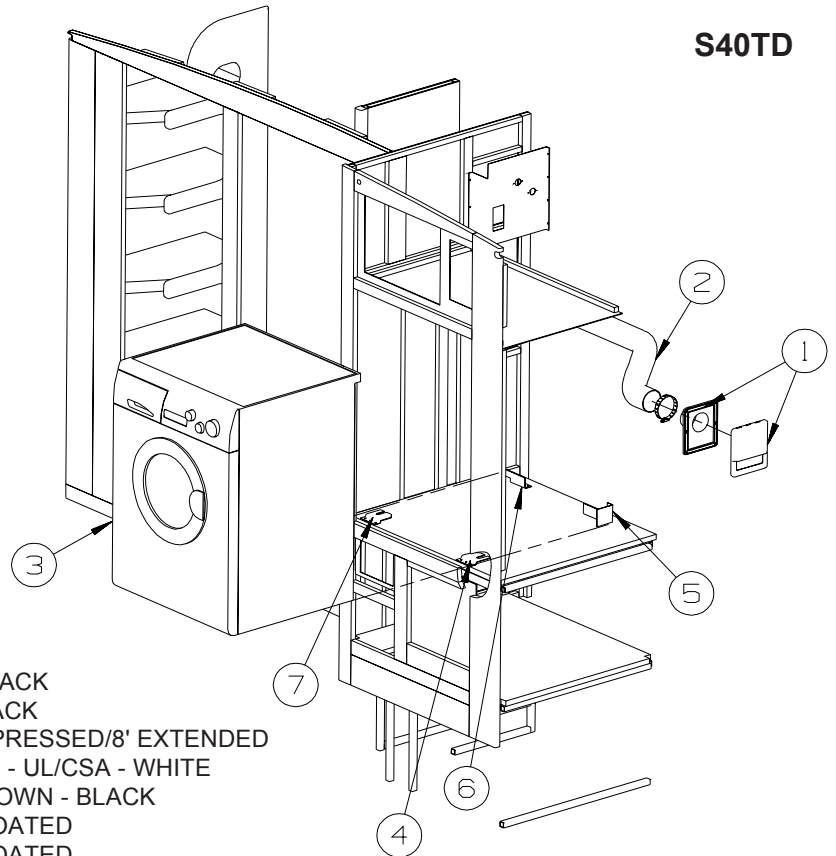

S40TD

KEY	PART NUMBER	U/M	DESCRIPTION
1	146292-01-02A	EA	COVER - DRYER VENT - BLACK
1	146292-02-02A	EA	DRYER VENT - INNER - BLACK
2	116653-02-000	FT	DUCT - FLEXIBLE - 3' COMPRESSED/8' EXTENDED
3	153204-01-01A	EA	WASHER/DRYER - VENTED - UL/CSA - WHITE
4	111913-03-04B	EA	BRACKET/WASHER - TIE DOWN - BLACK
5	113795-01-02B	EA	BRACKET - WASHER - E-COATED
6	113795-02-02B	EA	BRACKET - WASHER - E-COATED
7	111913-02-04B	EA	BRACKET/WASHER - TIE DOWN - BLACK
	141523-01-01A	EA	LABEL - WASHER/DRYER BRACKETS - BLACK/WHITE

CABINET & APPLIANCE GROUP (CONTINUED)
CABINET & APPLIANCE LAYOUT (CONTINUED)

FREEZER

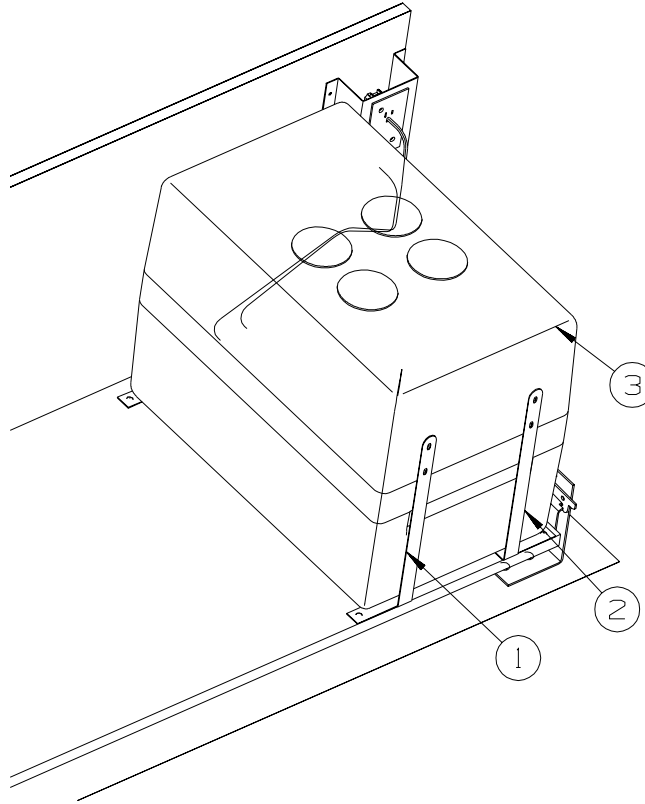

KEY	PART NUMBER	U/M	DESCRIPTION
1	155324-02-02B	EA	STRAP/TIEDOWN - FREEZER - E-COATED
2	155324-01-02B	EA	STRAP/TIEDOWN - FREEZER - E-COATED
3	155331-01-01A	EA	FREEZER - PORTABLE - 1.51 CU FT - GRAY/DARK GRAY
3	155331-02-000	EA	CORD/POWER - FREEZER - 90 DEGREE END - WAECO/CF-123-573

CABINET & APPLIANCE GROUP (CONTINUED)
CABINET & APPLIANCE LAYOUT (CONTINUED)

VACUUM SYS

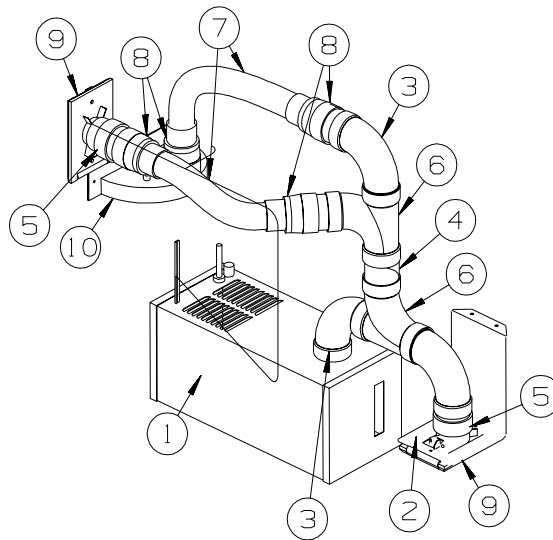

KEY	PART NUMBER	U/M	DESCRIPTION
1*	108186-02-000	EA	TOOL SET - VACUUM - W/O POWER BRUSH W/30' HOSE
1*	108186-03-000	EA	VACUUM CLEANER - BUILT IN - W/O HOSE/TOOL KIT
2	146946-04-02B	EA	BRACKET - CENTRAL VACUUM - E-COATED
			FROM: 00-00-00 THRU: 09-14-05
2	146946-08-02B	EA	BRACKET - CENTRAL VACUUM - E-COATED
			FROM: 09-15-06 THRU: 99-99-99
3	108187-02-000	EA	ELBOW - 90 DEGREE STREET - VACUUM SYSTEM - PVC
4	108187-01-000	EA	PIPE - 2" X 8' - VACUUM SYSTEM - PVC
5	108187-06-000	EA	INLET - REDUCER
			FROM: 00-00-00 THRU: 09-14-06
5	108187-17-000	EA	ADAPTER - INLET VALVE
			FROM: 09-15-06 THRU: 99-99-99
6	108187-10-000	EA	TEE - 90 DEGREE - TY 2"
	108187-12-000	EA	ELBOW - 90 DEGREE - 2"SPGXSP
			FROM: 00-00-00 THRU: 02-27-05
7	108187-14-000	EA	HOSE - FLEX - 1 1/4" - VACUUM CLEANER
			FROM: 02-28-05 THRU: 99-99-99
8	108187-15-000	EA	CONNECTOR - FLEX HOSE KIT (3 FITTINGS)
			FROM: 02-28-05 THRU: 99-99-99
9	108187-13-000	EA	VALVE/INLET - VACUUM CLEANER - WHITE
			FROM: 00-00-00 THRU: 09-14-06
9	108187-16-000	EA	VALVE/INLET - VACUUM CLEANER - BLACK
			FROM: 09-15-06 THRU: 99-99-99
10	142348-01-000	EA	VACPAN-WHITE
			FROM: 00-00-00 THRU: 09-14-06
10	142348-02-000	EA	VACPAN-BLACK
			FROM: 09-15-06 THRU: 99-99-99

***COMPONENT PARTS LISTED LATER IN THIS GROUP**

CABINET & APPLIANCE GROUP (CONTINUED)
COMPONENT PARTS FOR CABINET & APPLIANCE LAYOUT

108186-02-000

KEY	PART NUMBER	U/M	DESCRIPTION	VENDOR NO.
	092304-02-701	EA	TOOL-DUSTING	1142
	092304-02-702	EA	TOOL-RUG	4982
	092304-02-703	EA	TOOL-CREVICE	1141
	092304-02-707	EA	TOOL-UPHOLSTERY	7029
	092304-02-708	EA	WAND-PLASTIC	4978
	092304-02-709	EA	HOSE ASM., 30' COMPLETE	4988-30-G

108186-03-000

KEY	PART NUMBER	U/M	DESCRIPTION	VENDOR NO.
	092304-02-700	EA	BRUSH-POWER, VACUUM (RUGRAT)	6970
	092304-02-701	EA	TOOL-DUSTING	1142
	092304-02-702	EA	TOOL-RUG	4982
	092304-02-703	EA	TOOL-CREVICE	1141
	092304-02-707	EA	TOOL-UPHOLSTERY	7029
	092304-02-708	EA	WAND-PLASTIC	4978
	092304-02-709	EA	HOSE ASM., 30' COMPLETE	4988-30-G
	092304-02-710	EA	SECONDARY FILTER	4929
	108186-03-700	EA	PAPER BAG - 3-PKG	7767
	108186-03-701	EA	MOTOR F/RV2000	7756
	108186-03-702	EA	REDUCER	5531
	108186-03-703	EA	VALVE - INLET - WHITE	4935
	108186-03-704	EA	BRUSH - TURBINE (HAND HELD)	7834-B
	108186-03-705	EA	RELAY ASSEMBLY - W/PLATE	7090

119267-12-02A

KEY	PART NUMBER	U/M	DESCRIPTION	VENDOR NO.
	119267-04-700	EA	FILTER-GREASE	BOO2
	119267-04-703	EA	PLATE - MOUNTING	FANGTB003MRY0
	119267-04-704	EA	LIGHT COVER-F/MOD R1480/1850	FANGKB009MRYO
	119267-04-705	EA	SCREW	LX-BZB011MREO
	119267-12-701	EA	SUPPORT - F/GLASS TRAY	FROLPB020MRKO
	119267-12-702	EA	RACK - HIGH	FAMI-B006MR0
	119267-12-703	EA	RACK - LOW	FAMI-B005MR0
	119267-12-704	EA	LOUVER - EXHAUST	PDIF-BO13MRKO

119267-13-01A

KEY	PART NUMBER	U/M	DESCRIPTION	VENDOR NO.
	119267-04-700	EA	FILTER-GREASE	BOO2
	119267-12-702	EA	RACK - HIGH	FAMI-B006MR0
	119267-12-703	EA	RACK - LOW	FAMI-B005MR0

CABINET & APPLIANCE GROUP (CONTINUED)
COMPONENT PARTS FOR CABINET & APPLIANCE LAYOUT (CONTINUED)

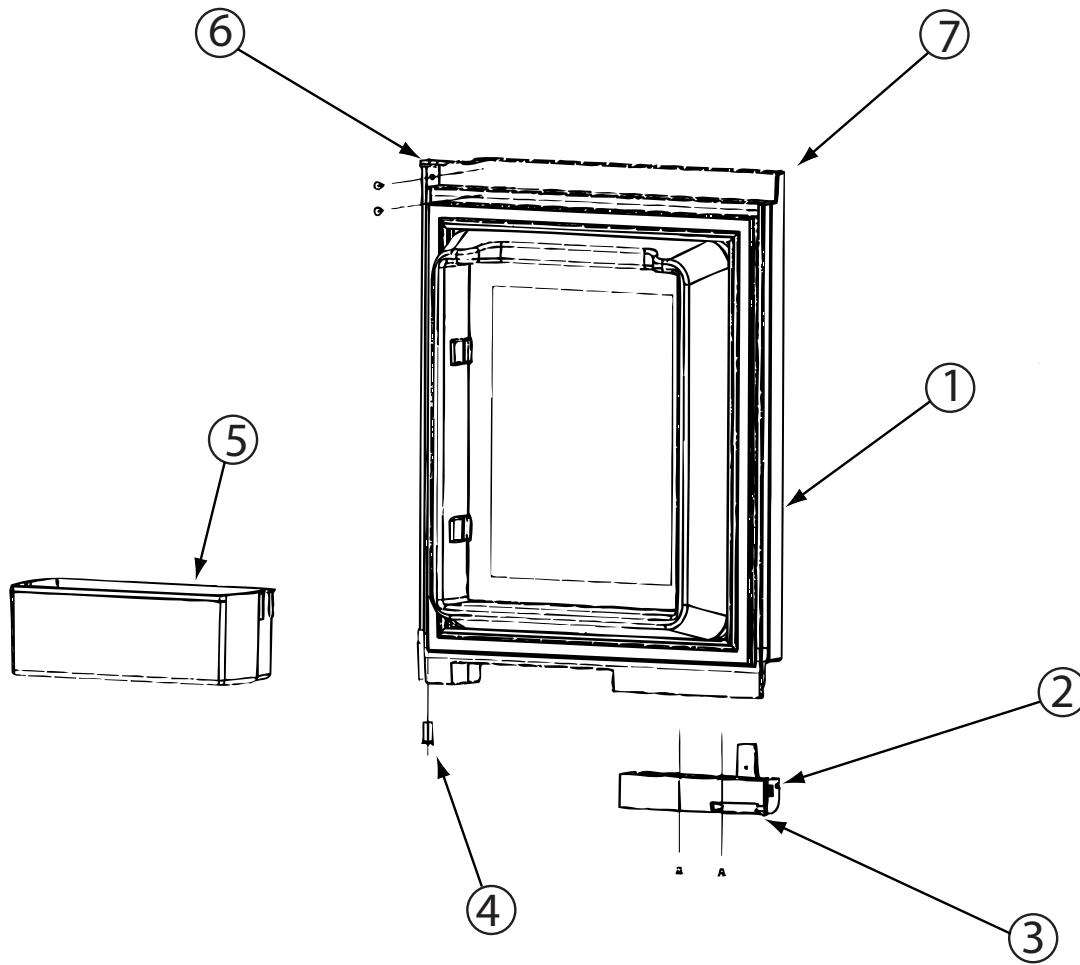

125242-03-02A

KEY	PART NUMBER	U/M	DESCRIPTION	VENDOR NO.
1	125242-03-721	EA	LINER-DOOR/UPPER RH/WRP WPM	62906101
2	125242-02-701	EA	HANDLE(CONTOUR)TOP RH LWR LH	621106
3	125242-02-722	EA	LATCH-STORAGE DR/BLK POINTED	619374
4	125242-01-704	EA	BUSHING-HINGE MIDDLE	618746
5	125242-03-704	EA	BIN - DOOR SHELF	622831
6	125242-03-722	EA	CAP/DOOR HINGE-UPR RH/LWR LH	623819
7	125242-03-723	EA	CAP/DR CENTER-UPR RH/LWR LH	623820

CABINET & APPLIANCE GROUP (CONTINUED)
COMPONENT PARTS FOR CABINET & APPLIANCE LAYOUT (CONTINUED)

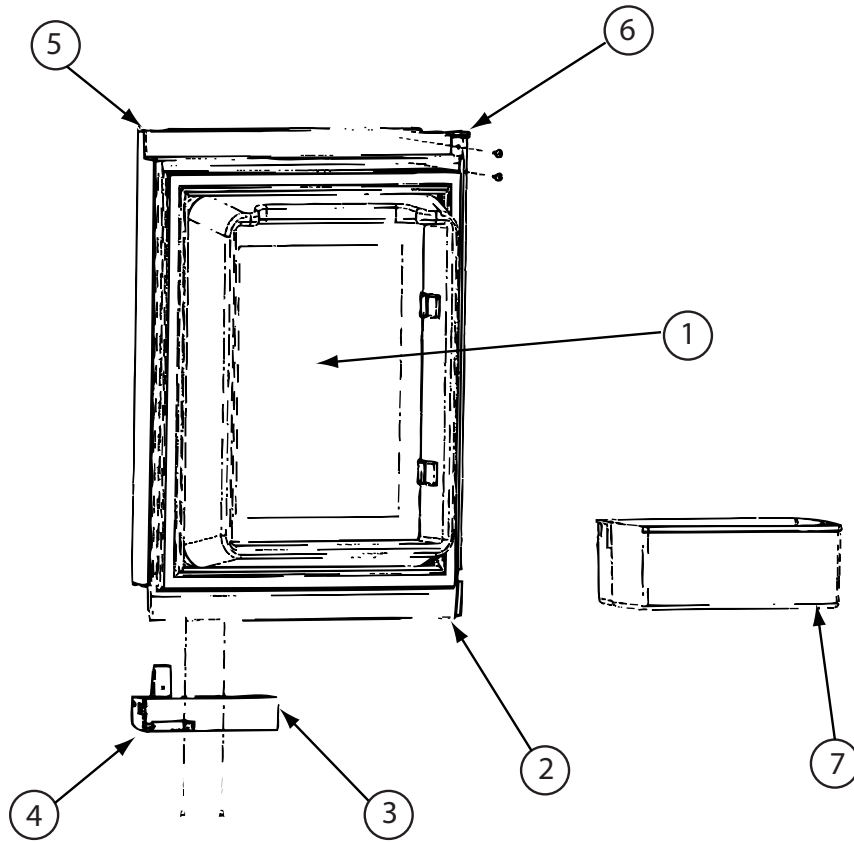

125242-03-02A (CONTINUED)

KEY	PART NUMBER	U/M	DESCRIPTION	VENDOR NO.
1	125242-03-724	EA	LINER-DOOR/UPPER LH/WRP WPM	62906001
2	125242-01-704	EA	BUSHING-HINGE MIDDLE	618746
3	125242-02-700	EA	HANDLE(CONTOUR)TOP LH BTM RH	621107
4	125242-02-722	EA	LATCH-STORAGE DR/BLK POINTED	619374
5	125242-03-726	EA	CAP/DR CENTER-UPR LH/LWR RH	623492
6	125242-03-725	EA	CAP/DOOR HINGE-UPR LH/LWR RH	623491
7	125242-03-704	EA	BIN - DOOR SHELF	622831

CABINET & APPLIANCE GROUP (CONTINUED)
COMPONENT PARTS FOR CABINET & APPLIANCE LAYOUT (CONTINUED)

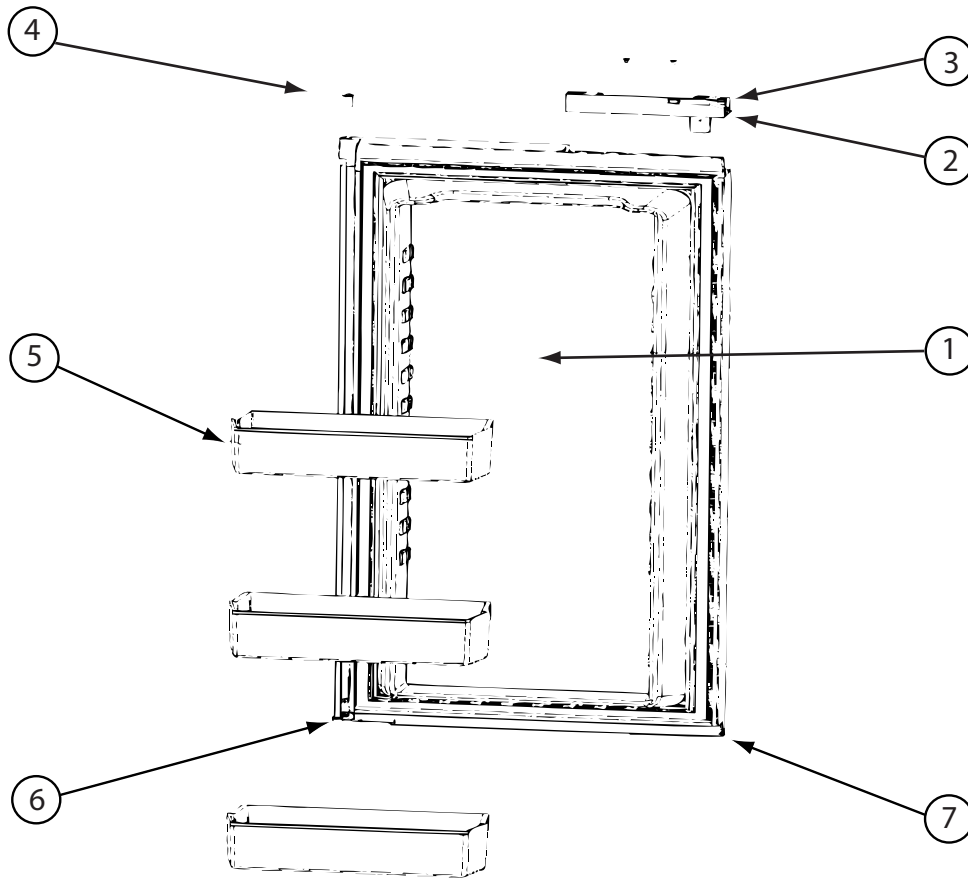

125242-03-02A (CONTINUED)

KEY	PART NUMBER	U/M	DESCRIPTION	VENDOR NO.
1	125242-03-727	EA	LINER-DOOR/LOWER RH/WRP WPM	62906301
2	125242-02-700	EA	HANDLE(CONTOUR)TOP LH BTM RH	621107
3	125242-02-722	EA	LATCH-STORAGE DR/BLK POINTED	619374
4	125242-01-704	EA	BUSHING-HINGE MIDDLE	618746
5	125242-03-704	EA	BIN - DOOR SHELF	622831
6	125242-03-725	EA	CAP/DOOR HINGE-UPR LH/LWR RH	623491
7	125242-03-726	EA	CAP/DR CENTER-UPR LH/LWR RH	623492
	125242-01-769	EA	SHIM DOOR HINGE SERVICE KIT	625129

CABINET & APPLIANCE GROUP (CONTINUED)
COMPONENT PARTS FOR CABINET & APPLIANCE LAYOUT (CONTINUED)

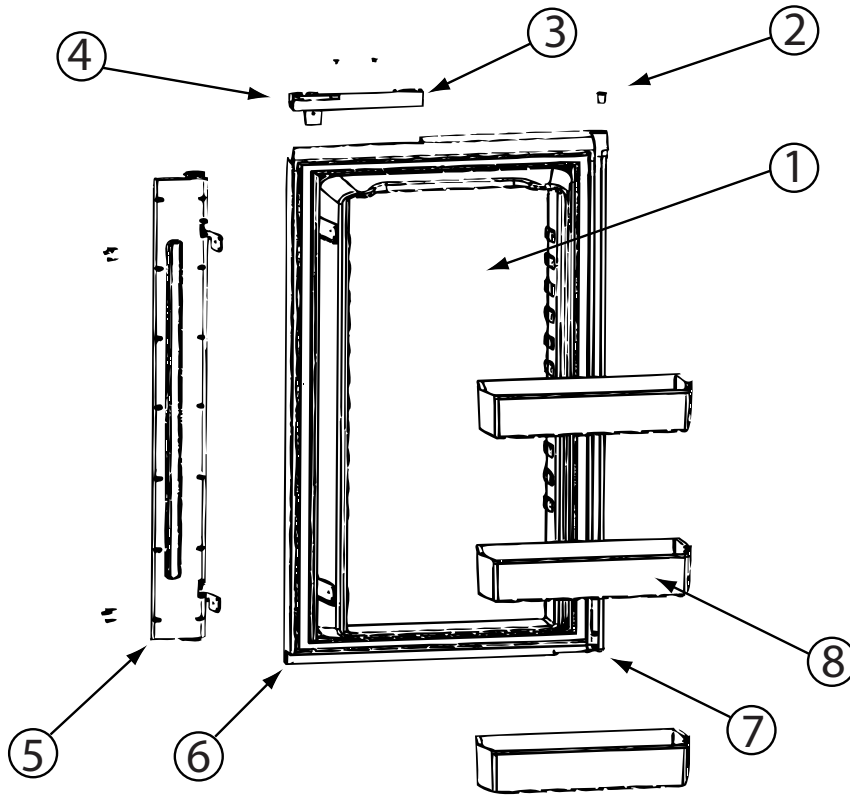

125242-03-02A (CONTINUED)

KEY	PART NUMBER	U/M	DESCRIPTION	VENDOR NO.
1	125242-03-728	EA	LINER-DOOR/LOWER LH/WRP WPM	62906201-NO FLAPPE
2	125242-01-704	EA	BUSHING-HINGE MIDDLE	618746
3	125242-02-701	EA	HANDLE(CONTOUR)TOP RH LWR LH	621106
4	125242-02-722	EA	LATCH-STORAGE DR/BLK POINTED	619374
5	125242-02-727	EA	FLAPPER/DOUBLE POLE - FOR S.N.#540295 TO 1291390	
5	125242-02-740	EA	FLAPPER/DBL POLE-SER#1291391AND UP	
6	125242-03-722	EA	CAP/DOOR HINGE-UPR RH/LWR LH	623819
7	125242-03-723	EA	CAP/DR CENTER-UPR RH/LWR LH	623820
8	125242-03-704	EA	BIN - DOOR SHELF	622831
	125242-01-769	EA	SHIM DOOR HINGE SERVICE KIT	625129

CABINET & APPLIANCE GROUP (CONTINUED)
COMPONENT PARTS FOR CABINET & APPLIANCE LAYOUT (CONTINUED)

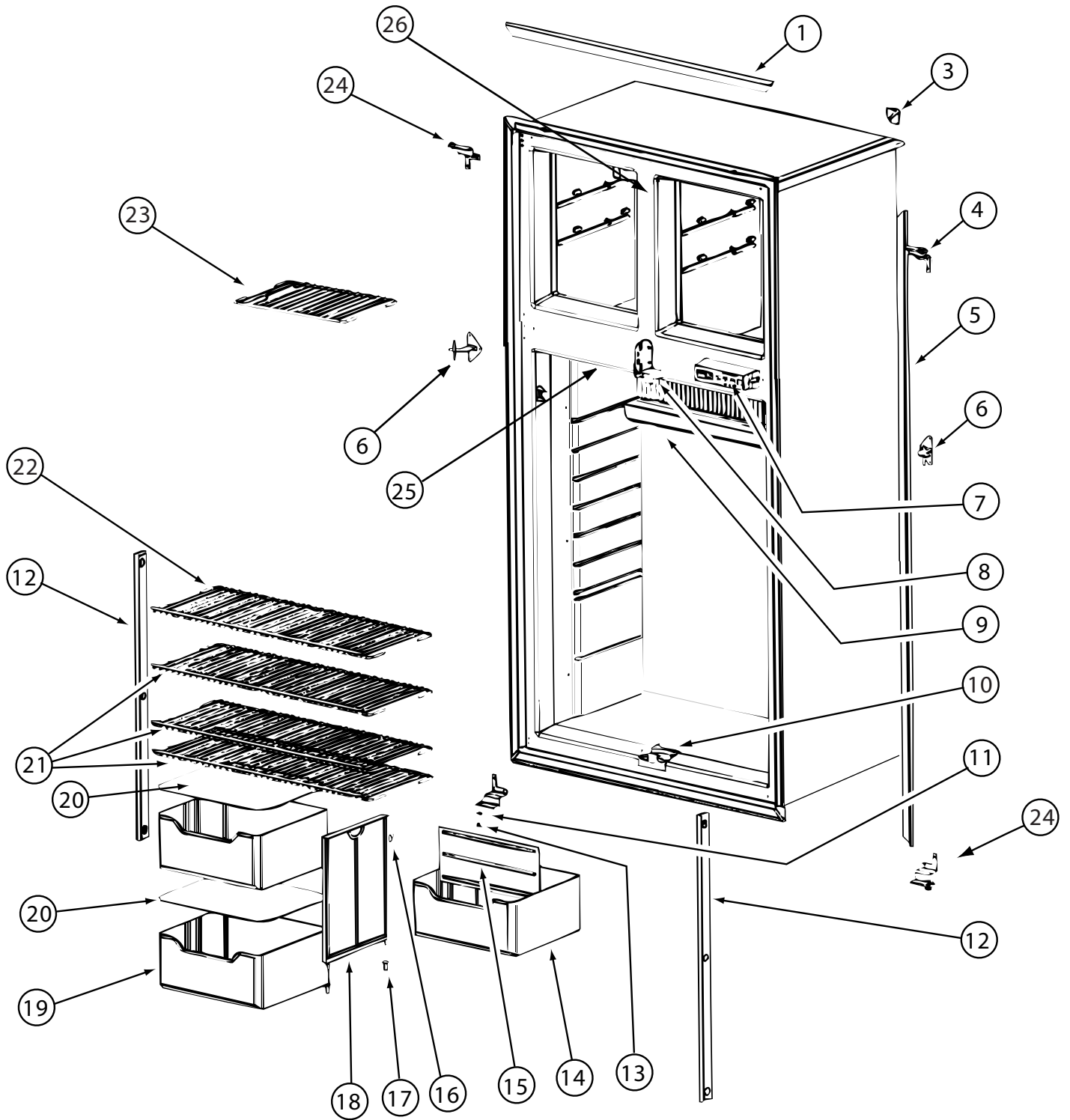

125242-03-02A (CONTINUED)

CABINET & APPLIANCE GROUP (CONTINUED)
COMPONENT PARTS FOR CABINET & APPLIANCE LAYOUT (CONTINUED)

125242-03-02A (CONTINUED)

KEY	PART NUMBER	U/M	DESCRIPTION	VENDOR NO.
1	125242-02-713	EA	TRIM/UPR/LWR - SIDE SNAP ON	621975
1	125242-02-730	EA	TRIM - TOP/BOTTOM - SCREW ON	623255
3	125242-01-722	EA	TRIM - CORNER	618844
4	125242-03-711	EA	HINGE-UPR RH/LWR LH WRAP/DRS	623824
5	125242-01-766	EA	TRIM-LT/RT HAND-SCREW ON	623254
5	125242-02-714	EA	TRIM/SIDES - SIDE SNAP ON	621976
6	125242-03-729	EA	HINGE - MIDDLE	627685
6	125242-03-730	EA	HINGE PIN - MIDDLE HINGE	627684
7	125242-03-731	EA	CONTROL-OPT/ SN8981139 & UP	628970
7	125242-03-712	EA	CONTROL-OPT/GRAY- SN832172 UP	624868
8	125242-01-721	EA	STRIKE PLATE	618835
9	125242-01-712	EA	DRIP TRAY	618774
10	125242-02-717	EA	GUIDE ASM LWR(SER#540295 UP)	620043
10	125242-02-719	EA	GUIDE ASM UPR(SER#540295 UP)	620041
10	125242-03-713	EA	GUIDE BLOCK/FLAPPER/BTM BLK	624140
10	125242-03-714	EA	GUIDE-FLAPPERTOP/BLACK	624141
12	120075-01-730	EA	RETAINER-SHELF(SER#926684 DN)	618181
12	125242-02-720	EA	RETAINER/SHEF(SER#926685 UP)	622033
13	125242-03-715	EA	HINGE PIN/UPR-WRAPPED DOORS	623899
15	125242-01-733	EA	DIVIDER-BOTTLE CRISPER	618877
16	125242-01-750	EA	CLIP	61409622
18	125242-01-749	EA	SUPPORT - WALL	618840
20	125242-01-706	EA	COVER-CRISPER	618757
21	125242-01-726	EA	SHELF-WIRE (LONG)	618848
22	125242-01-727	EA	SHELF-WIRE (SHORT)	618849
23	125242-01-725	EA	SHELF-FREEZER (WIRE)	618847
24	125242-03-716	EA	HINGE-TOP LH/WRAPPED DOORS	623823
25	125242-01-735	EA	SWITCH - DOOR LIGHT	618884
25	125242-01-768	EA	SWITCH - DOOR LIGHT	623918
	120075-01-714	EA	PLUG-HOLE (BLACK)	618170
	125242-01-728	EA	CAP-SCREW WHITE	618853
	125242-03-706	EA	PROBE - CONTACT/LARGE	620689

CONTACT WINNEBAGO PART SALES FOR UNLISTED COMPONENT(S)

CABINET & APPLIANCE GROUP (CONTINUED)
COMPONENT PARTS FOR CABINET & APPLIANCE LAYOUT (CONTINUED)

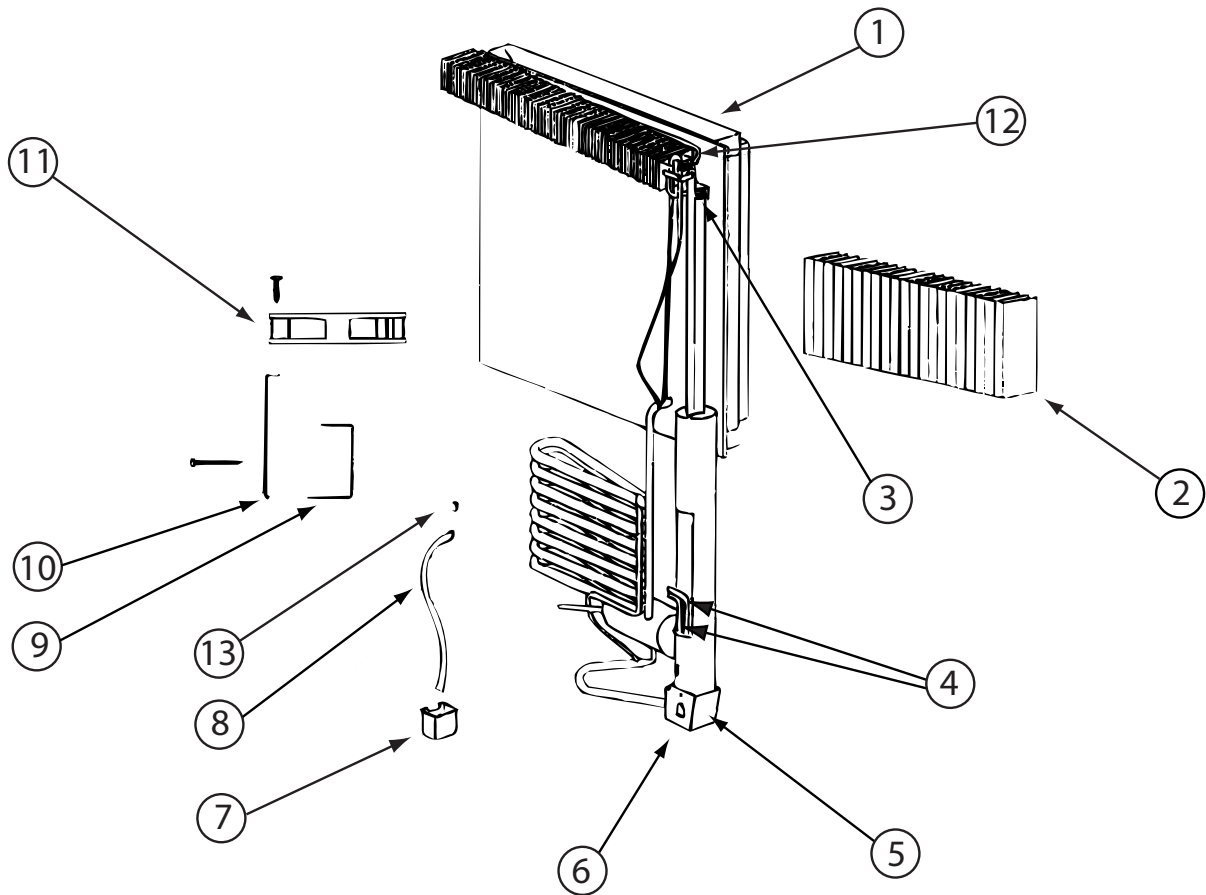

125242-03-02A (CONTINUED)

KEY	PART NUMBER	U/M	DESCRIPTION	VENDOR NO.
1	125242-01-746	EA	COOLING UNIT - 1200	618964
1	125242-05-719	EA	COOLING UNIT - SN 8835498 UP	629507
2	125242-05-713	EA	FINS	618785
4	125242-01-732	EA	HEATER AC - 225W/110VAC	618872
5	125242-01-739	EA	BASE-BURNER BOX	618902
6	125242-01-740	EA	COVER-BURNER BOX	618910
9	125242-01-730	EA	BRACKET-DC FAN	618857
9	125242-05-721	EA	BRACKET-DC FAN-SN 914576 UP	628747
10	125242-01-741	EA	SUPPORT-DC FAN	618912
11	125242-01-729	EA	FAN-EXTERNAL DC	618856
11	125242-05-722	EA	FAN-EXTRNL DC-SN 914576 UP	628685
12	113737-01-754	EA	THERMOSTAT (FAN 12V DC)	618093
	125242-01-742	EA	WIRE ASM.-BAFFLE 55.15"	618915

CONTACT WINNEBAGO PART SALES FOR UNLISTED COMPONENT(S)

CABINET & APPLIANCE GROUP (CONTINUED)
COMPONENT PARTS FOR CABINET & APPLIANCE LAYOUT (CONTINUED)

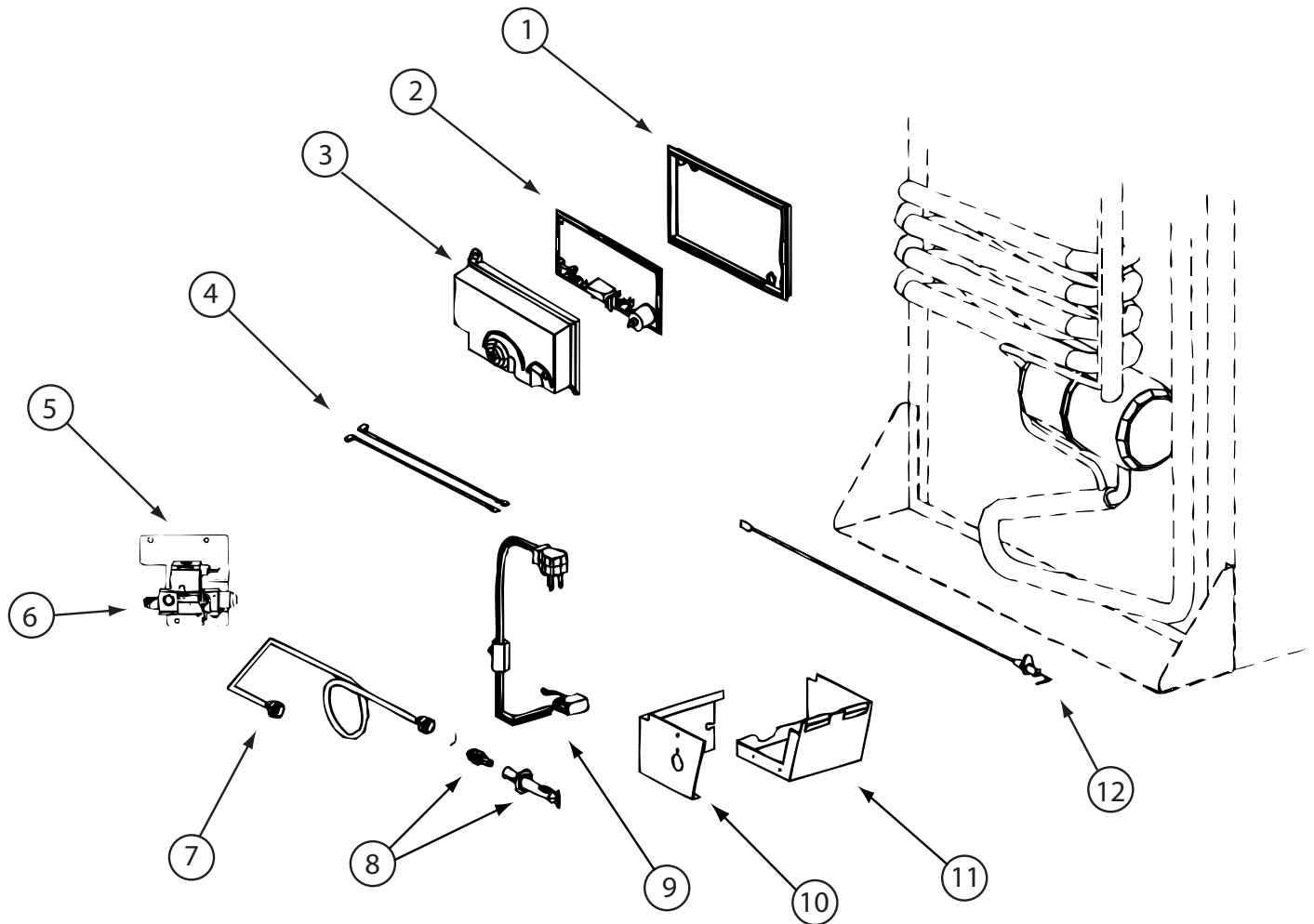

125242-03-02A & 125242-05-02A (CONTINUED)

KEY	PART NUMBER	U/M	DESCRIPTION	VENDOR NO.
1	121569-08-701	EA	BASE - POWER BOARD	628674
2	121568-06-709	EA	BOARD/POWER-N611/N822F	628661
3	121569-08-702	EA	COVER-POWER BOARD	628677
4	125242-02-709	EA	WIRE/WHITE/9"/GAS VALVE	621448
6	121569-08-703	EA	VALVE - SOLENOID	628741
7	125242-05-723	EA	BURNER TUBE	624683
8	125242-02-743	EA	BURNER ORFICE ADAPTER ASSY - NORCOLD# 629013	
9	121569-07-700	EA	CORD - AC POWER	61554422
10	125242-01-740	EA	COVER-BURNER BOX	618910
11	125242-01-739	EA	BASE-BURNER BOX	618902
12	104137-06-715	EA	ELECTRODE-SPARK/SENSOR, SGL	61692222

CONTACT WINNEBAGO PART SALES FOR UNLISTED COMPONENT(S)

CABINET & APPLIANCE GROUP (CONTINUED)
COMPONENT PARTS FOR CABINET & APPLIANCE LAYOUT (CONTINUED)

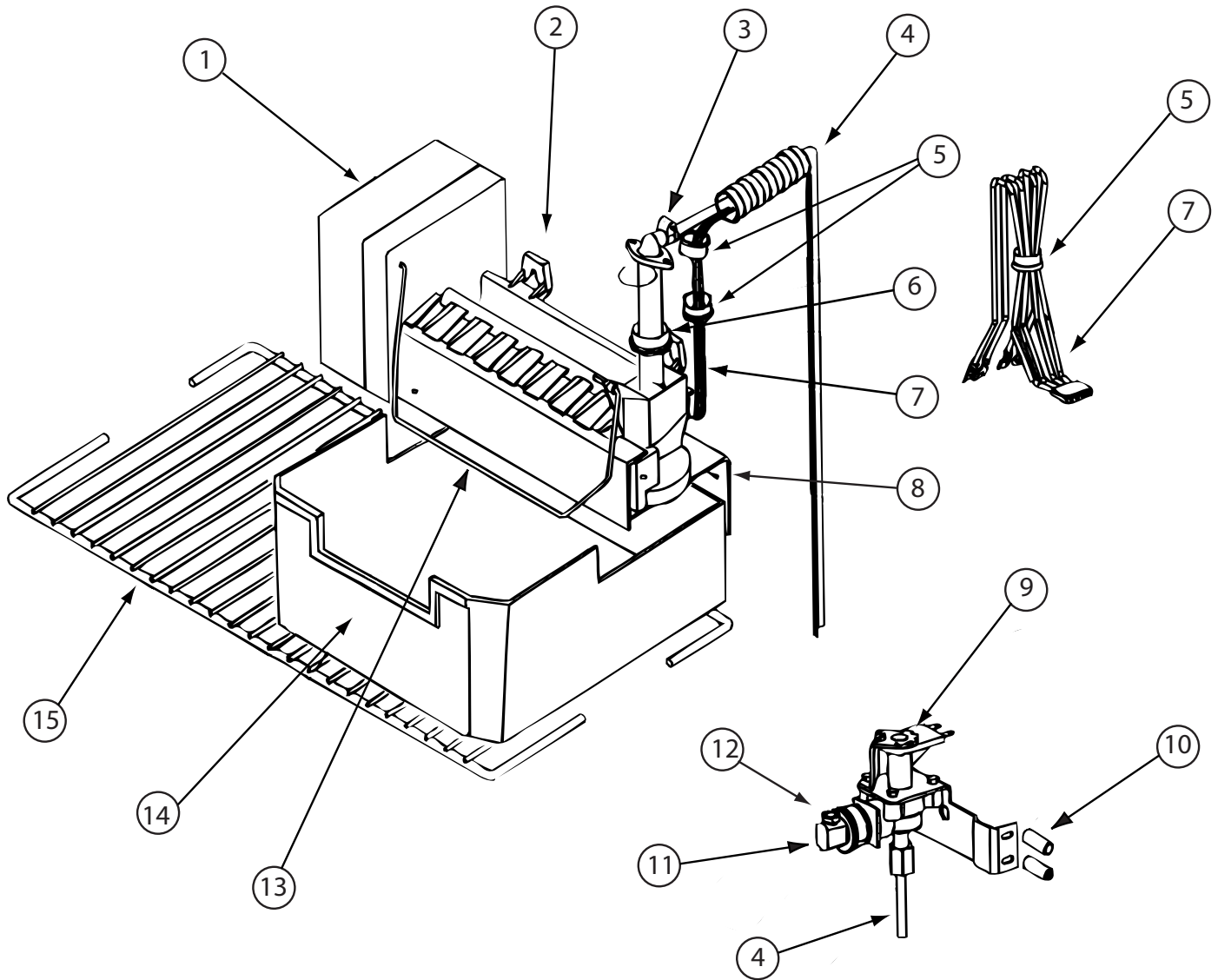

125242-03-02A & 125242-05-02A (CONTINUED)

KEY	PART NUMBER	U/M	DESCRIPTION	VENDOR NO.
2	094039-07-706	EA	ICE MAKER W/O PLATES	61656522
4	125242-05-724	EA	WATER TUBE/HEATER ASM	621429
6	120075-03-706	EA	FITTING WATER LINE	620039
8	125242-01-737	EA	BRACKET-MOUNTING (ICE MAKER)	618894/620890
9	120075-03-701	EA	WATER VALVE - W/BRACKET	618253
11	094039-07-707	EA	GARDEN HOSE ADAP W/BRASS NUT	61679622
12	094039-07-708	EA	NUT - COMPRESSION	622991
13	120075-03-703	EA	ARM-SHUT OFF	61656922
14	125242-01-716	EA	ICE BIN	618803
15	125242-01-725	EA	SHELF-FREEZER (WIRE)	618847
	120075-09-703	EA	THERMOSTAT	620240

CONTACT WINNEBAGO PART SALES FOR UNLISTED COMPONENT(S)

CABINET & APPLIANCE GROUP (CONTINUED)
COMPONENT PARTS FOR CABINET & APPLIANCE LAYOUT (CONTINUED)

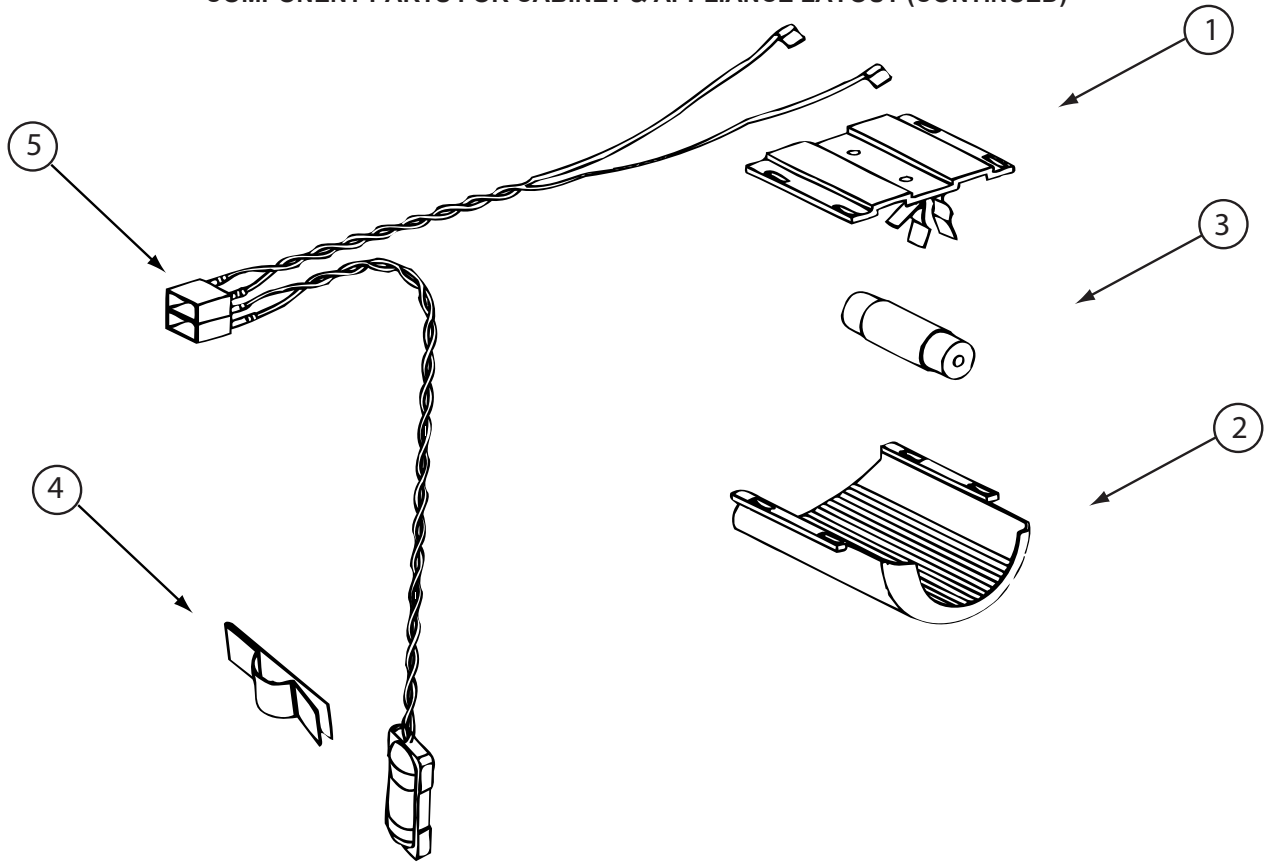

125242-03-02A & 125242-05-02A (CONTINUED)

KEY	PART NUMBER	U/M	DESCRIPTION	VENDOR NO.
1	084880-03-705	EA	BRACKET-LIGHT-INTERIOR	61629722
2	125242-02-708	EA	COVER/LAMP BRACKET	621827
3	084880-03-706	EA	BULB-LAMP	61628922
4	084880-01-760	EA	CLIP (THERMISTER)	61689122
5	125242-02-706	EA	LAMP/WIRE ASM/SER#849677 UP	620871

CABINET & APPLIANCE GROUP (CONTINUED)
COMPONENT PARTS FOR CABINET & APPLIANCE LAYOUT (CONTINUED)

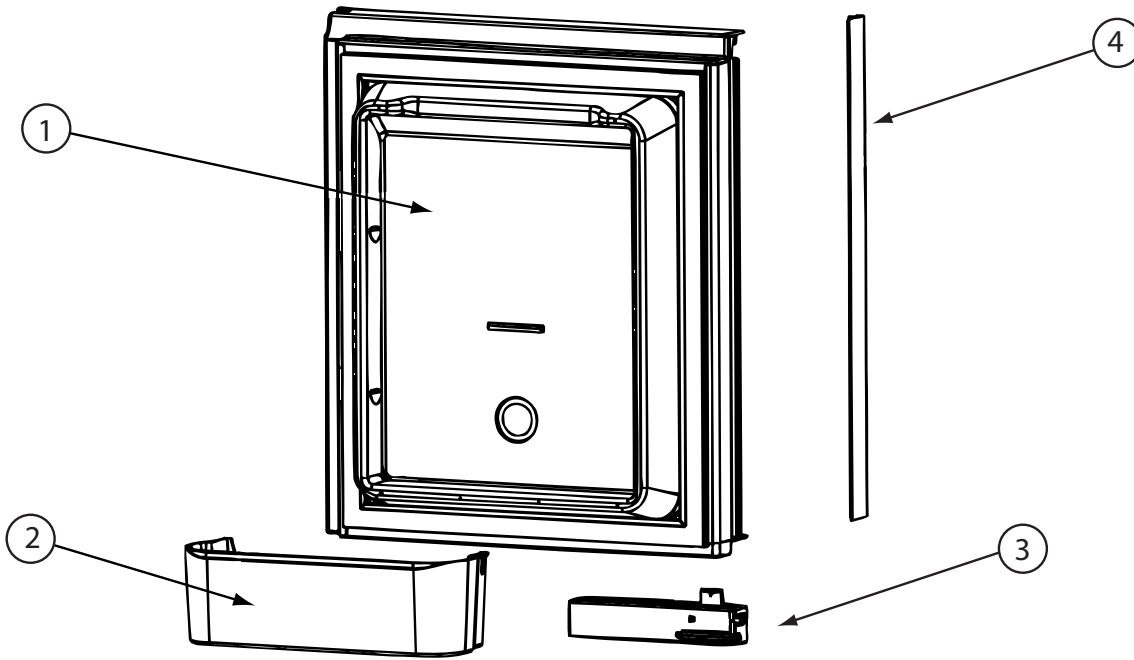

125242-05-02A

KEY	PART NUMBER	U/M	DESCRIPTION	VENDOR NO.
1	125242-05-700	EA	LINER-DOOR/UPPER RH/WRP WPM	62913401
2	125242-05-701	EA	BIN - DOOR SHELF	628686
3	125242-02-701	EA	HANDLE(CONTOUR)TOP RH LWR LH	621106
	125242-02-722	EA	LATCH-STORAGE DR/BLK POINTED	619374

CONTACT WINNEBAGO PART SALES FOR UNLISTED COMPONENT(S)

CABINET & APPLIANCE GROUP (CONTINUED)
COMPONENT PARTS FOR CABINET & APPLIANCE LAYOUT (CONTINUED)

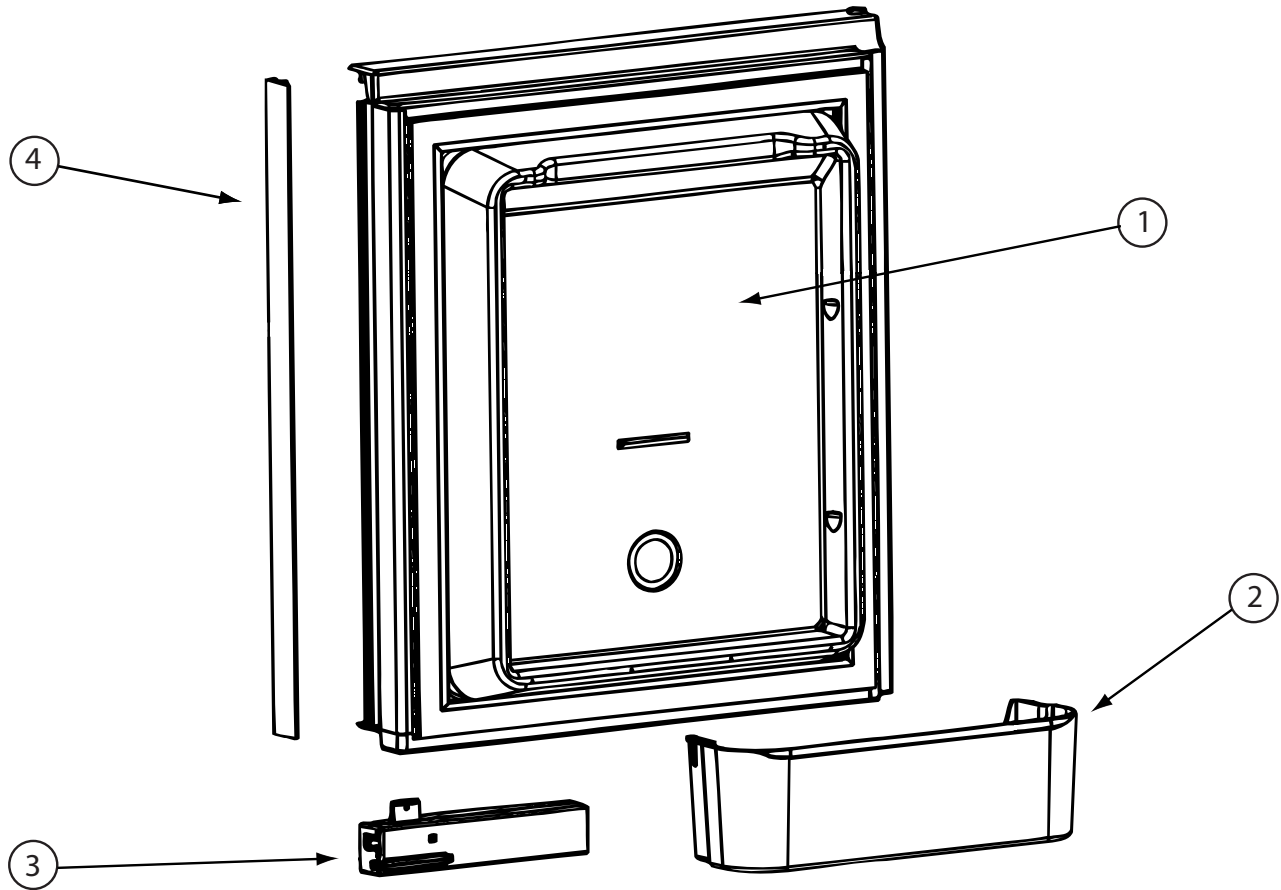

125242-05-02A (CONTINUED)

KEY	PART NUMBER	U/M	DESCRIPTION	VENDOR NO.
1	125242-05-702	EA	LINER-DOOR/UPPER LH/WRP WPM	62913301
2	125242-05-701	EA	BIN - DOOR SHELF	628686
3	125242-02-700	EA	HANDLE(CONTOUR)TOP LH BTM RH	621107
	125242-02-722	EA	LATCH-STORAGE DR/BLK POINTED	619374

CONTACT WINNEBAGO PART SALES FOR UNLISTED COMPONENT(S)

CABINET & APPLIANCE GROUP (CONTINUED)
COMPONENT PARTS FOR CABINET & APPLIANCE LAYOUT (CONTINUED)

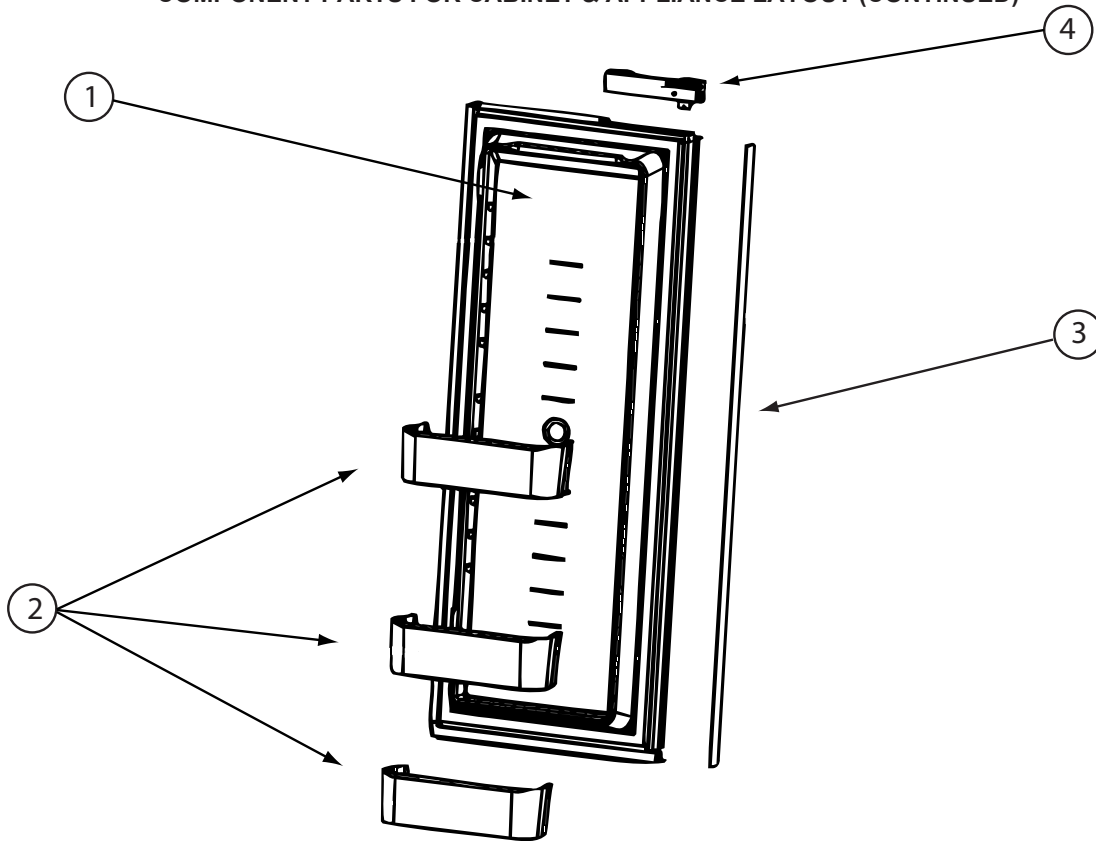

125242-05-02A (CONTINUED)

KEY	PART NUMBER	U/M	DESCRIPTION	VENDOR NO.
1	125242-05-703	EA	LINER-DOOR/LOWER RH/WRP WPM	62913601
2	125242-05-701	EA	BIN - DOOR SHELF	628686
4	125242-02-700	EA	HANDLE(CONTOUR)TOP LH BTM RH	621107
	125242-02-722	EA	LATCH-STORAGE DR/BLK POINTED	619374

CONTACT WINNEBAGO PART SALES FOR UNLISTED COMPONENT(S)

CABINET & APPLIANCE GROUP (CONTINUED)
COMPONENT PARTS FOR CABINET & APPLIANCE LAYOUT (CONTINUED)

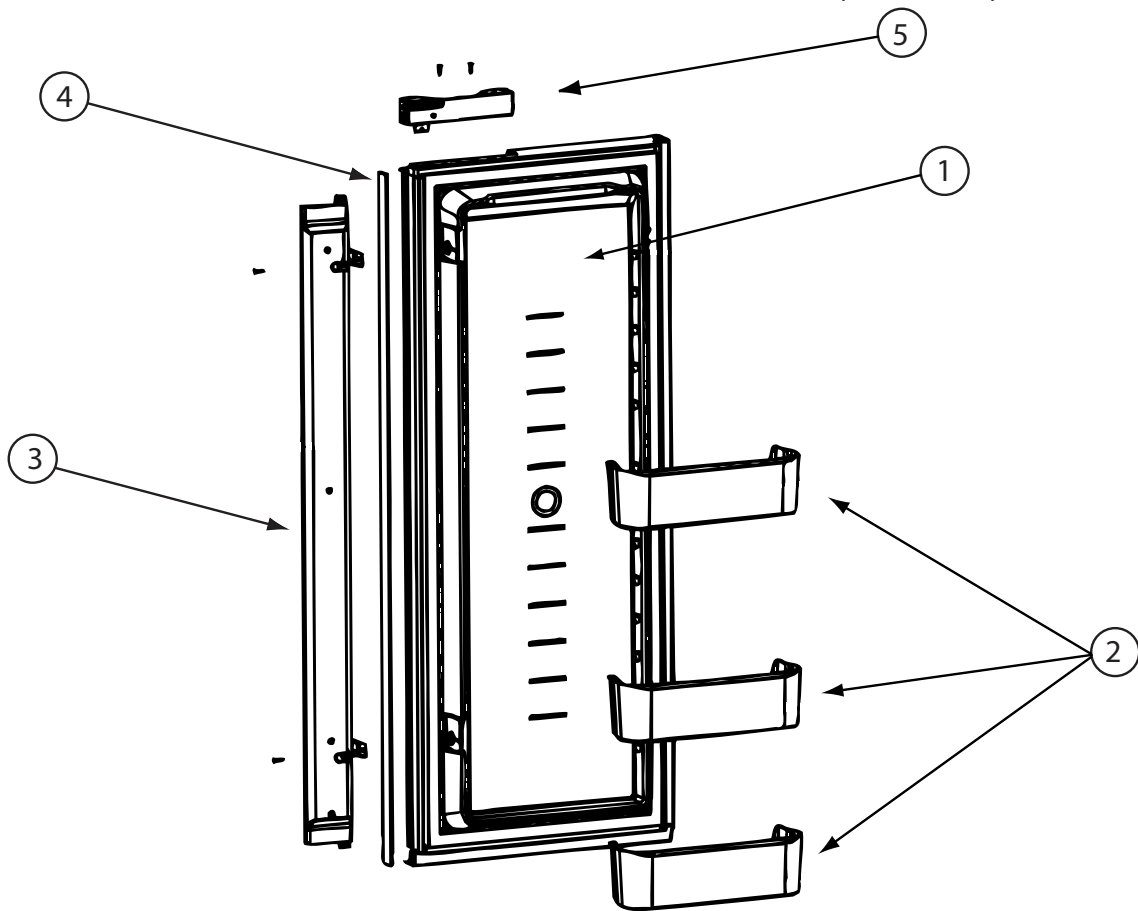

125242-05-02A (CONTINUED)

KEY	PART NUMBER	U/M	DESCRIPTION	VENDOR NO.
1	125242-05-704	EA	LINER-DOOR/LOWER LH/WRP WPM	62913501
2	125242-05-701	EA	BIN - DOOR SHELF	628686
3	125242-05-705	EA	FLAPPER ASM	629049
5	125242-02-701	EA	HANDLE(CONTOUR)TOP RH LWR LH	621106
	125242-02-722	EA	LATCH-STORAGE DR/BLK POINTED	619374

CONTACT WINNEBAGO PART SALES FOR UNLISTED COMPONENT(S)

CABINET & APPLIANCE GROUP (CONTINUED)
COMPONENT PARTS FOR CABINET & APPLIANCE LAYOUT (CONTINUED)

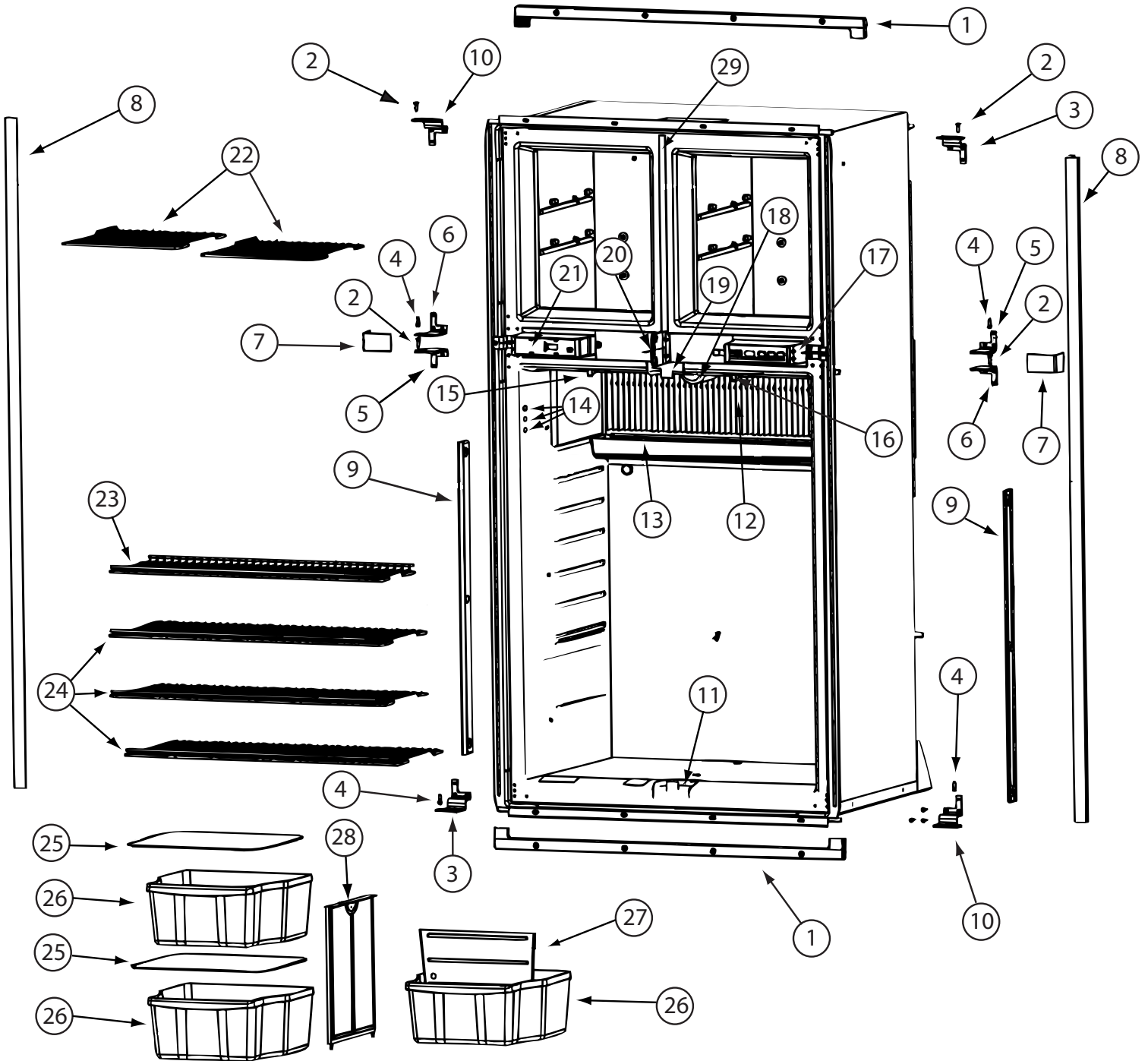

125242-05-02A (CONTINUED)

CABINET & APPLIANCE GROUP (CONTINUED)
COMPONENT PARTS FOR CABINET & APPLIANCE LAYOUT (CONTINUED)

125242-05-02A (CONTINUED)

KEY	PART NUMBER	U/M	DESCRIPTION	VENDOR NO.
1	125242-01-767	EA	KIT - UNIVERSAL TRIM (MAKE YOUR OWN)CORNERS/ETC - SCREW-ON	
2	125242-03-715	EA	HINGE PIN/UPR-WRAPPED DOORS	623899
3	125242-05-707	EA	HINGE-OUTER/UPPER RH/LWR LH	628946
4	113737-01-710	EA	PIN-HINGE, BOTTOM	61550722
5	125242-05-708	EA	HINGE-INNER/UPPER RH/LWR LH	624363
6	125242-05-709	EA	HINGE-INNER/UPPER LH/LWR RH	624364
7	125242-05-710	EA	COVER - HINGE	627955
8	125242-01-766	EA	TRIM - LEFT HAND/RIGHT HAND - VERTICAL - SCREW-ON	
9	125242-02-720	EA	RETAINER/SHELF(SER#926685 UP)	622033
10	125242-05-711	EA	HINGE-OUTER/UPPER LH/LWR RH	628945
11	125242-05-712	EA	GUIDE BLOCK-FLAPPER/BTM/BLK	629112
12	125242-05-713	EA	FINS	618785
13	125242-01-712	EA	DRIP TRAY	618774
14	125242-03-706	EA	PROBE - CONTACT/LARGE	620689
15	125242-01-768	EA	SWITCH - DOOR LIGHT	623918
16	125242-02-706	EA	LAMP/WIRE ASM/SER#849677 UP	620871
17	125242-05-706	EA	CONTROL ASM - OPTICAL	629113
18	125242-02-708	EA	COVER/LAMP BRACKET	621827
19	125242-05-714	EA	GUIDE BLOCK-FLAPPER/TOP/BLK	629111
20	125242-05-715	EA	PLATE/STRIKE - BLACK	628473
21	125242-05-716	EA	BOX/FRONT - DUMMY	624366
22	125242-01-725	EA	SHELF-FREEZER (WIRE)	618847
23	125242-01-727	EA	SHELF-WIRE (SHORT)	618849
24	125242-01-726	EA	SHELF-WIRE (LONG)	618848
25	125242-01-706	EA	COVER-CRISPER	618757
26	125242-05-717	EA	BIN - BOTTLE/CRISPER	628688
27	125242-05-718	EA	DIVIDER - BOTTLE/CRISPER	628694
28	125242-01-749	EA	SUPPORT - WALL	618840
29	125242-02-741	EA	STRIP-FREEZER-BLACK	625210 #1291391 &UP
	084880-03-705	EA	BRACKET-LIGHT-INTERIOR	61629722
	084880-03-706	EA	BULB-LAMP	61628922
	120075-01-714	EA	PLUG-HOLE (BLACK)	618170

CABINET & APPLIANCE GROUP (CONTINUED)
COMPONENT PARTS FOR CABINET & APPLIANCE LAYOUT (CONTINUED)

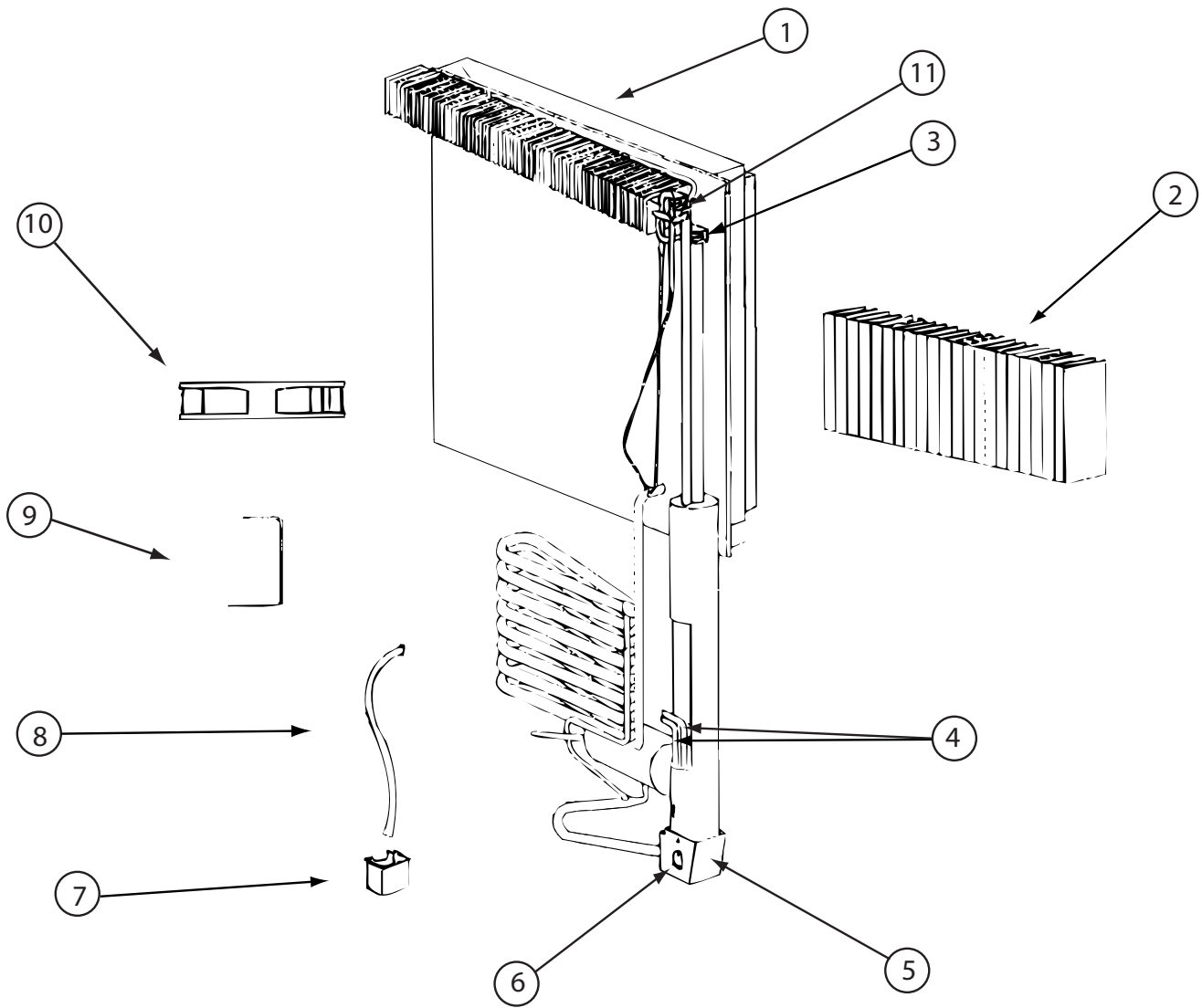

125242-05-02A (CONTINUED)

KEY	PART NUMBER	U/M	DESCRIPTION	VENDOR NO.
1	125242-05-719	EA	COOLING UNIT - SN 8835498 UP	629507
2	125242-05-713	EA	FINS	618785
4	125242-01-732	EA	HEATER AC - 225W/110VAC	618872
5	125242-01-739	EA	BASE-BURNER BOX	618902
6	125242-01-740	EA	COVER-BURNER BOX	618910
9	125242-05-721	EA	BRACKET-DC FAN-SN 9144576 UP	628747
10	125242-05-722	EA	FAN-EXTRNL DC-SN 9144576 UP	628685
11	113737-01-754	EA	THERMOSTAT (FAN 12V DC)	618093
	125242-01-742	EA	WIRE ASM.-BAFFLE 55.15"	618915
	125242-05-720	EA	SWITCH-THERMAL	628118

CONTACT WINNEBAGO PART SALES FOR UNLISTED COMPONENT(S)

CABINET & APPLIANCE GROUP (CONTINUED)
COMPONENT PARTS FOR CABINET & APPLIANCE LAYOUT (CONTINUED)

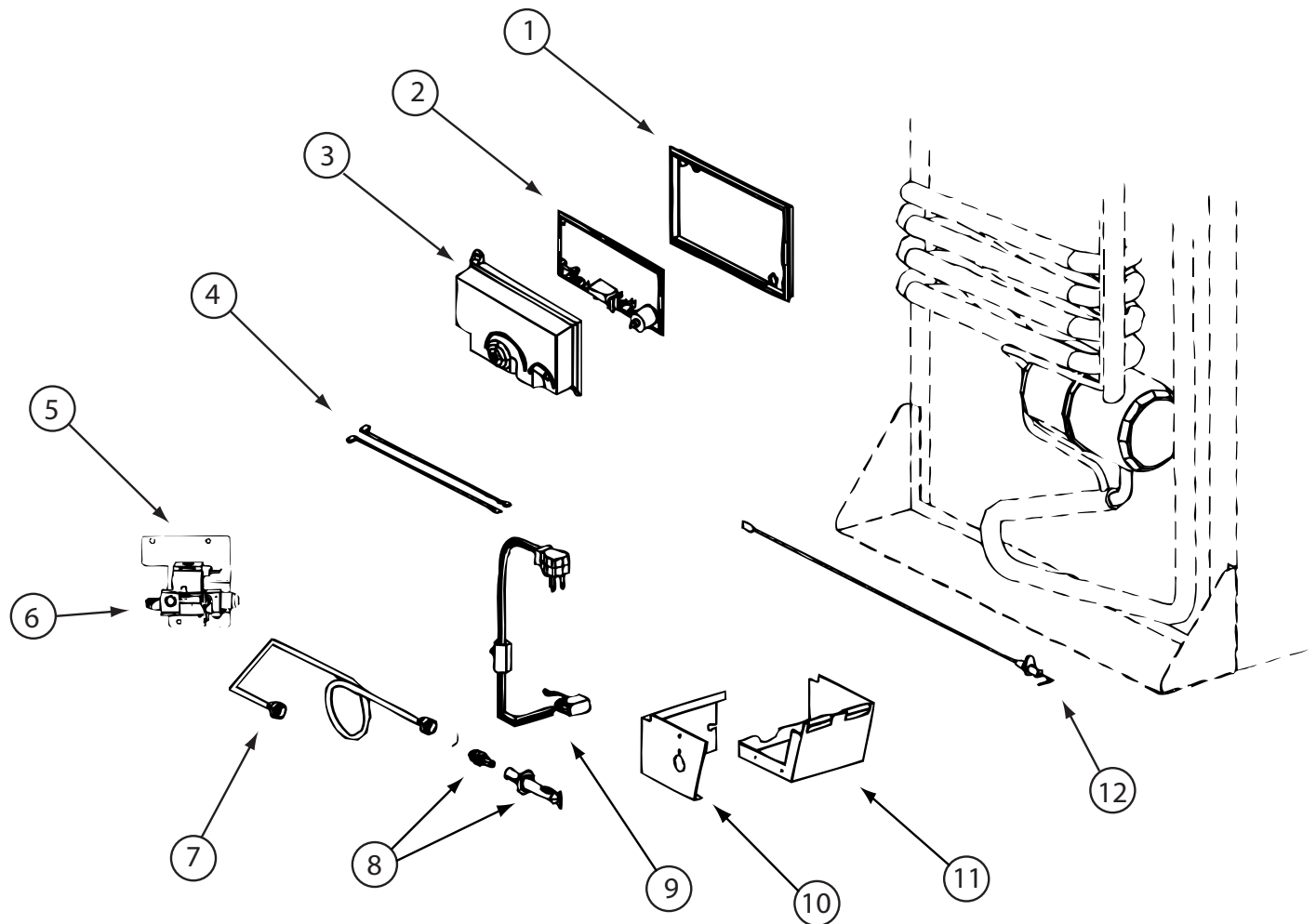

125242-03-02A & 125242-05-02A (CONTINUED)

KEY	PART NUMBER	U/M	DESCRIPTION	VENDOR NO.
1	121569-08-701	EA	BASE - POWER BOARD	628674
2	121568-06-709	EA	BOARD/POWER-N611/N822F	628661
3	121569-08-702	EA	COVER-POWER BOARD	628677
4	125242-02-709	EA	WIRE/WHITE/9"/GAS VALVE	621448
6	121569-08-703	EA	VALVE - SOLENOID	628741
7	125242-05-723	EA	BURNER TUBE	624683
8	125242-02-743	EA	BURNER ORFICE ADAPTER ASSY - NORCOLD# 629013	
9	121569-07-700	EA	CORD - AC POWER	61554422
10	125242-01-740	EA	COVER-BURNER BOX	618910
11	125242-01-739	EA	BASE-BURNER BOX	618902
12	104137-06-715	EA	ELECTRODE-SPARK/SENSOR, SGL	61692222

CONTACT WINNEBAGO PART SALES FOR UNLISTED COMPONENT(S)

CABINET & APPLIANCE GROUP (CONTINUED)
COMPONENT PARTS FOR CABINET & APPLIANCE LAYOUT (CONTINUED)

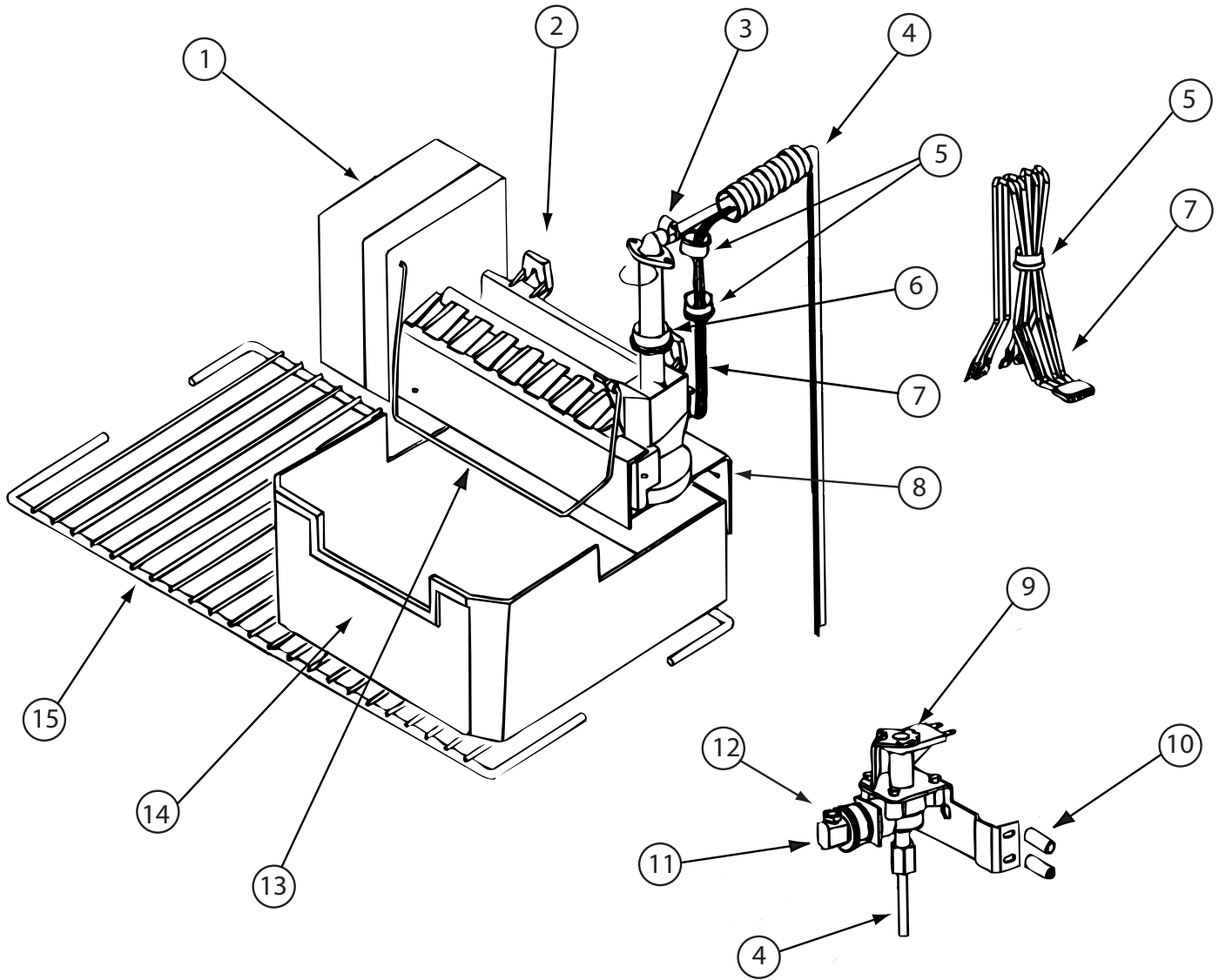

125242-03-02A & 125242-05-02A (CONTINUED)

KEY	PART NUMBER	U/M	DESCRIPTION	VENDOR NO.
2	094039-07-706	EA	ICE MAKER W/O PLATES	61656522
4	125242-05-724	EA	WATER TUBE/HEATER ASM	621429
6	120075-03-706	EA	FITTING WATER LINE	620039
8	125242-01-737	EA	BRACKET-MOUNTING (ICE MAKER)	618894/620890
9	120075-03-701	EA	WATER VALVE - W/BRACKET	618253
11	094039-07-707	EA	GARDEN HOSE ADAP W/BRASS NUT	61679622
12	094039-07-708	EA	NUT - COMPRESSION	622991
13	120075-03-703	EA	ARM-SHUT OFF	61656922
14	125242-01-716	EA	ICE BIN	618803
15	125242-01-725	EA	SHELF-FREEZER (WIRE)	618847
	120075-09-703	EA	THERMOSTAT	620240

CONTACT WINNEBAGO PART SALES FOR UNLISTED COMPONENT(S)

CABINET & APPLIANCE GROUP (CONTINUED)
COMPONENT PARTS FOR CABINET & APPLIANCE LAYOUT (CONTINUED)

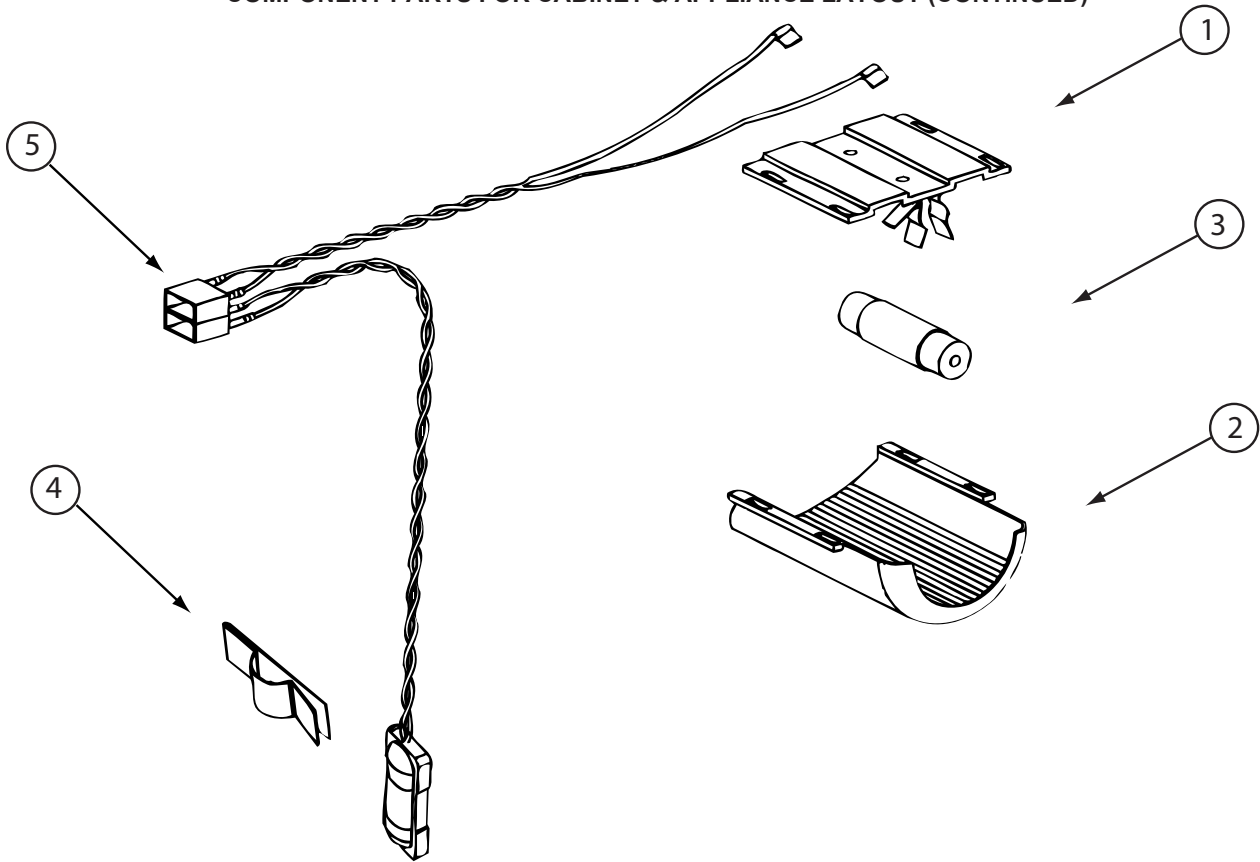

125242-03-02A & 125242-05-02A (CONTINUED)

KEY	PART NUMBER	U/M	DESCRIPTION	VENDOR NO.
1	084880-03-705	EA	BRACKET-LIGHT-INTERIOR	61629722
2	125242-02-708	EA	COVER/LAMP BRACKET	621827
3	084880-03-706	EA	BULB-LAMP	61628922
4	084880-01-760	EA	CLIP (THERMISTER)	61689122
5	125242-02-706	EA	LAMP/WIRE ASM/SER#849677 UP	620871

CABINET & APPLIANCE GROUP (CONTINUED)
COMPONENT PARTS FOR CABINET & APPLIANCE LAYOUT (CONTINUED)

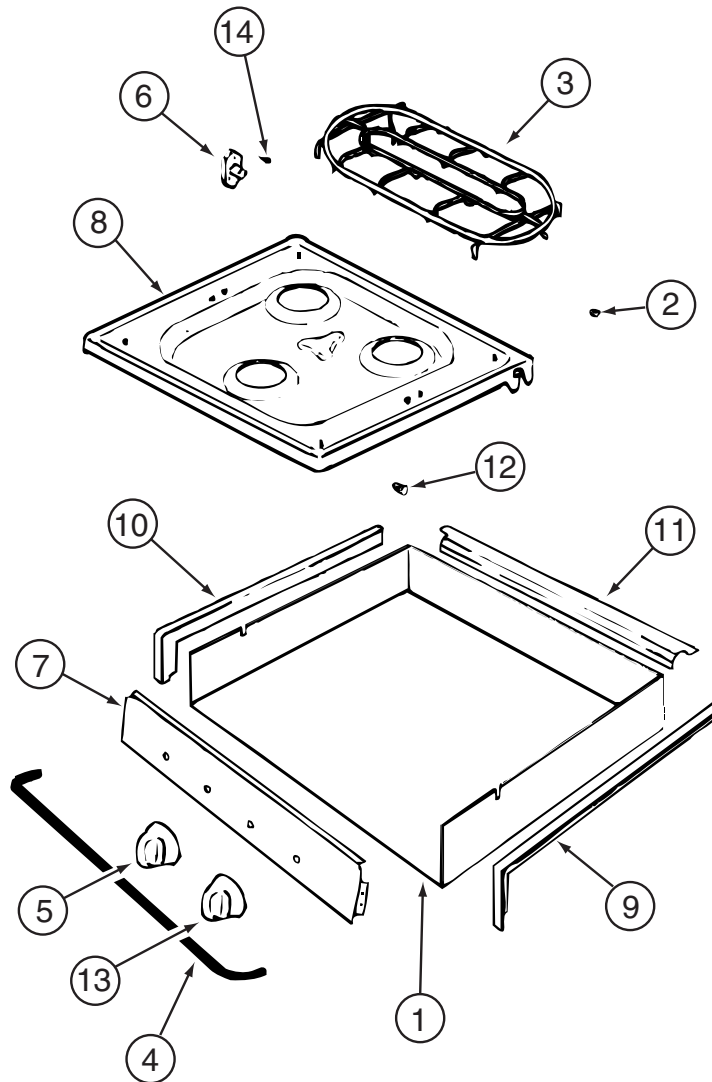

135065-03-01A, 135065-03-03A, 135065-04-01A

KEY	PART NUMBER	U/M	DESCRIPTION	VENDOR NO.
2	102020-01-709	EA	BUMPER-GRATE	8007-P020-60
3	135065-03-703	EA	GRATE - BLACK(SEALED BURNER)	74007304
4	114030-02-700	EA	GUARD/FABRIC - TOWEL BAR	3609F006-70
5	128728-01-701	EA	KNOB - BURNER - REAR	74003941
5	128728-01-702	EA	KNOB - BURNER - FRONT	74003942
6	128728-01-703	EA	PIN/T-NUT F/HINGE	7103P109-60
7	135065-03-704	EA	PANEL - MANIFOLD (BLACK)	74007330
8	128728-01-705	EA	TOP - MAIN - BLACK	74003928
8	135065-03-715	EA	TOP - MAIN - STAINLESS STEEL	74007299
9	114030-01-704	EA	TRIM - RIGHT/BLACK TEXTURED	74002839
10	114030-01-705	EA	TRIM - LEFT/BLACK TEXTURED	74002840
11	114030-01-706	EA	TRIM - REAR/BLACK TEXTURED	74002841
12	102020-01-724	EA	BUMPER-MAIN TOP	8003P008-60
13	128728-01-707	EA	KNOB - IGNITOR	74003944

CONTACT WINNEBAGO PART SALES FOR UNLISTED COMPONENT(S)

CABINET & APPLIANCE GROUP (CONTINUED)
COMPONENT PARTS FOR CABINET & APPLIANCE LAYOUT (CONTINUED)

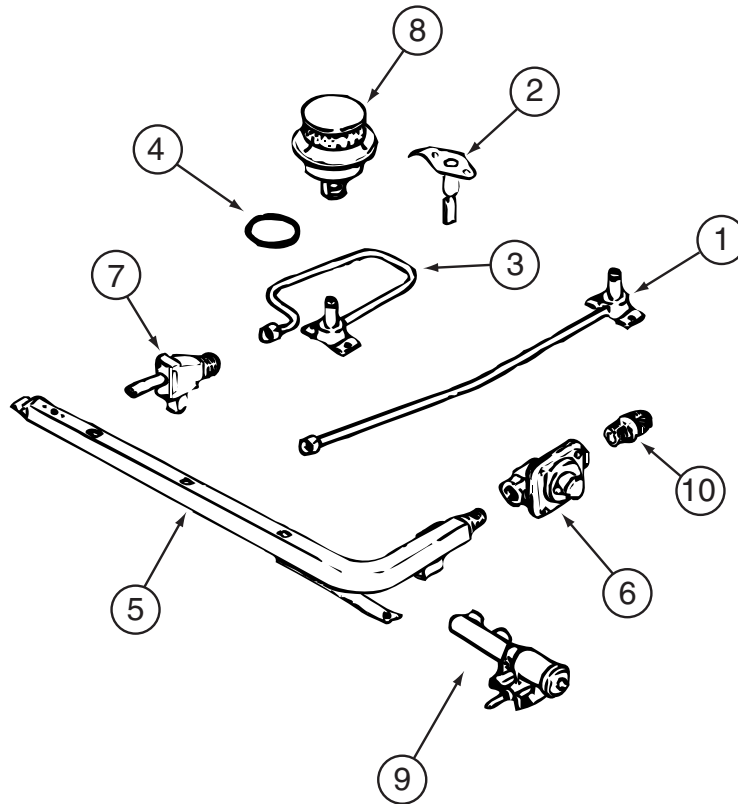

135065-03-01A, 135065-03-03A, 135065-04-01A (CONTINUED)

KEY	PART NUMBER	U/M	DESCRIPTION	VENDOR NO.
1	128728-01-708	EA	FITTING W/ORFICE/TUBE - REAR	74003931
2	135065-01-701	EA	IGNITOR/PORCELAIN-TOP BURNER	74004053
3	128728-01-710	EA	FITTING W/ORFICE/TUBE - FRT	74003930
4	135065-03-700	EA	FITTING - HALF UNION	74004234
5	135065-01-702	EA	PIPE/MANIFOLD	74004642
6	126023-02-703	EA	REGULATOR - PRESSURE	74004235
7	135065-01-703	EA	VALVE/BURNER - REAR	74004643
7	135065-01-704	EA	VALVE/BURNER-FRT-HI	74004644
7	135065-03-701	EA	SCREW - VALVE	71003231
8	135065-03-702	EA	SEALED BURNER ASM.(BLACK) RV	74003967
9	128728-01-716	EA	BURNER - IGNITOR	74003946
9	128728-01-717	EA	WIRES - IGNITOR	74003947

CABINET & APPLIANCE GROUP (CONTINUED)
COMPONENT PARTS FOR CABINET & APPLIANCE LAYOUT (CONTINUED)

140147-04-01A, 140147-04-02A, 140147-04-03A

KEY	PART NUMBER	U/M	DESCRIPTION	VENDOR NO.
	140147-02-700	EA	TRAY-GLASS	WB49X10074
	140147-02-701	EA	FILTER-GREASE (SOLD AS PAIR)	WB6X10309 - 2/PKG.
	140147-02-702	EA	TRAY-METAL PAN	WB49X10053

CHASSIS GROUP FRAME

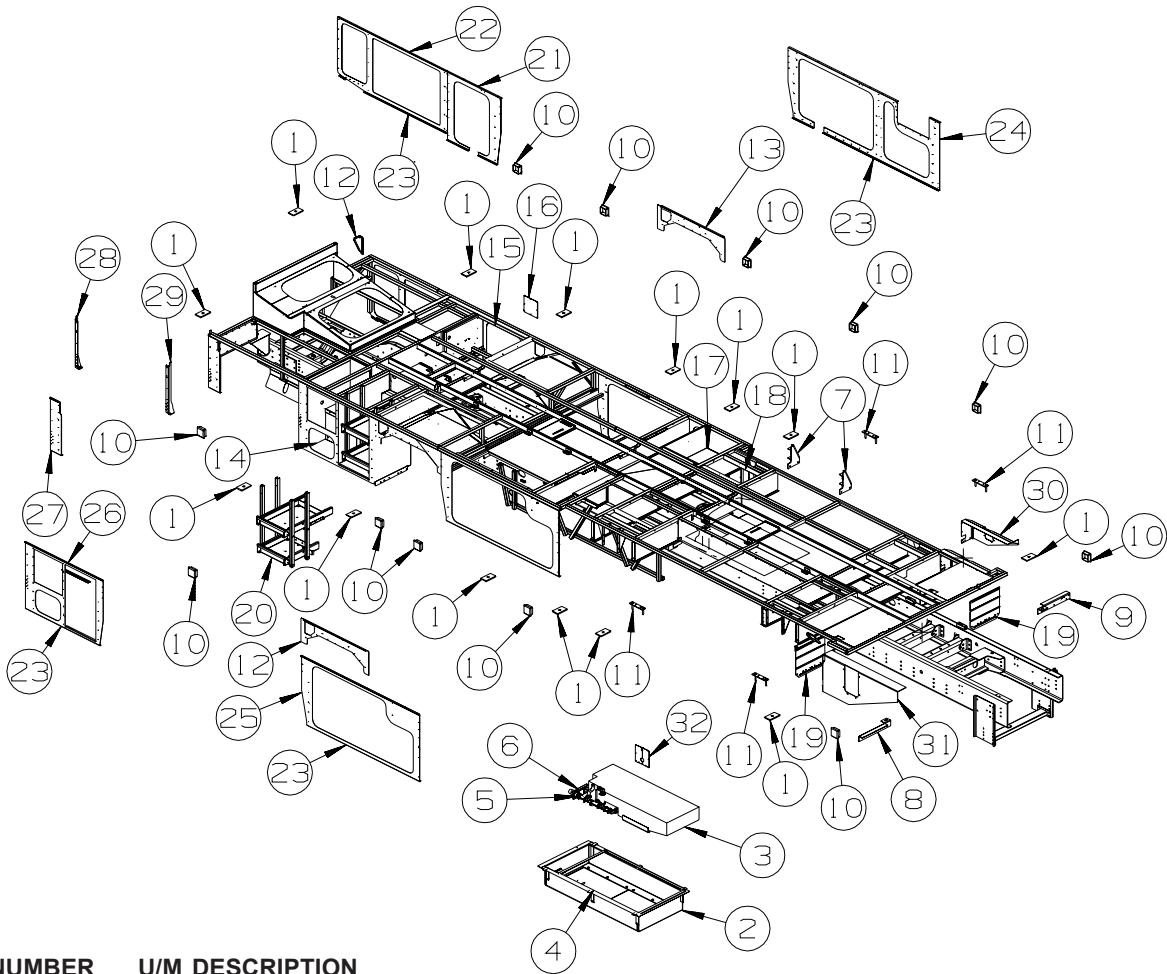

KEY	PART NUMBER	U/M	DESCRIPTION
1	135712-01-02B	EA	PLATE - BODY MOUNT - E-COATED
2	150033-01-02B	EA	COMPARTMENT - WATER - E-COATED
3	150153-02-000	EA	TANK - WATER - 33 GALLON - W/FITTINGS
	042989-03-000	EA	FITTING - SPINWELD - 1 1/4"NPT - PLASTIC
	042989-05-000	EA	FITTING - SPINWELD - 1/2"FPT - PLASTIC
	049032-01-000	EA	PATCH - SPINWELD - 3/8" - PLASTIC
	077954-02-000	EA	FILTER - WATER TANK - W/SCREEN IN TANK
	150153-01-000	EA	TANK - WATER - 33 GALLON - W/O FITTINGS
4	112091-01-000	FT	SEAL/D - NEOPRENE - HEAT ACTIVE ADHESIVE - .9" X .7"
5	010122-01-000	EA	BUSHING/PLASTIC - REDUCER - 1 1/2"SMTH X 1 1/4"THD - BLACK
6	150184-01-02B	EA	RETAINER - DUMP VALVE - E-COATED
7	144237-01-02B	EA	BRACKET - LP - E-COATED
8	157712-01-02B	EA	HANGER - ROCK GUARD - E-COATED
			FROM: 01-07-06 THRU: 99-99-99
9	157712-02-02B	EA	HANGER - ROCK GUARD - E-COATED
			FROM: 01-07-06 THRU: 99-99-99
10	119845-01-01A	EA	PLUG/PLASTIC - 1 1/2" SQUARE - BLACK
11	136995-09-02B	EA	PLATE W/BOLTS - 7.2" X 1" W/1/2" X 3" BOLTS
12	119750-09-02B	EA	PANEL/SEAL PLANE - WHEELWELL - E-COATED
13	119750-10-02B	EA	PANEL/SEAL PLANE - WHEELWELL - E-COATED
14	144252-01-RS2	EA	COMPARTMENT - WATER HEATER
15	144120-03-02B	EA	COMPARTMENT - POWER CORD - E-COATED
			FROM: 00-00-00 THRU: 11-16-05
15	158726-01-02B	EA	COMPARTMENT - POWER CORD - E-COATED
			FROM: 11-17-05 THRU: 99-99-99
16	134297-02-02B	EA	PLATE - COVER - E-COATED
17	144906-05-TG0	EA	COMPARTMENT
18	152907-01-02B	EA	COMPARTMENT - FURNACE - E-COATED

CHASSIS GROUP (CONTINUED)
FRAME (CONTINUED)

KEY	PART NUMBER	U/M	DESCRIPTION
19	140273-01-02B	EA	BRACE - ROCK GUARD - E-COATED FROM: 00-00-00 THRU: 01-31-06
19	136391-02-02B	EA	GUARD/ROCK - STEEL - W/ANGLE - 18"W X 15"H - E-COATED FROM: 02-01-06 THRU: 99-99-99
20	138866-02-01A	EA	SLIDE - BATTERY TRAY FROM: 00-00-00 THRU: 04-16-06
20	138866-03-01A	EA	SLIDE - BATTERY TRAY FROM: 04-17-06 THRU: 99-99-99
21	144047-01-02B	EA	PLATE SEAL - E-COATED
22	144048-01-02B	EA	PLATE SEAL - E-COATED
23	126516-01-01A	FT	TRIM - VINYL/EXTRUDED - 8'
24	144899-05-02B	EA	PLATE/SEAL - LEFT HAND - E-COATED
25	143902-02-02B	EA	PLATE/SEAL - E-COATED
26	144089-02-02B	EA	PLATE/SEAL - REAR - E-COATED
27	141650-02-02B	EA	PLATE/SEAL - E-COATED
28	141649-01-02B	EA	BRACKET - A/C - E-COATED
29	141649-02-02B	EA	BRACKET - A/C - E-COATED
30	158526-06-02B	EA	PANEL - FUEL FILL - LEFT HAND - E-COATED
31	158521-06-02B	EA	PANEL - FUEL FILL
32	098408-01-000	FT	SEAL - SPONGE RUBBER - CLOSED CELL

CHASSIS GROUP (CONTINUED)

FRONT END

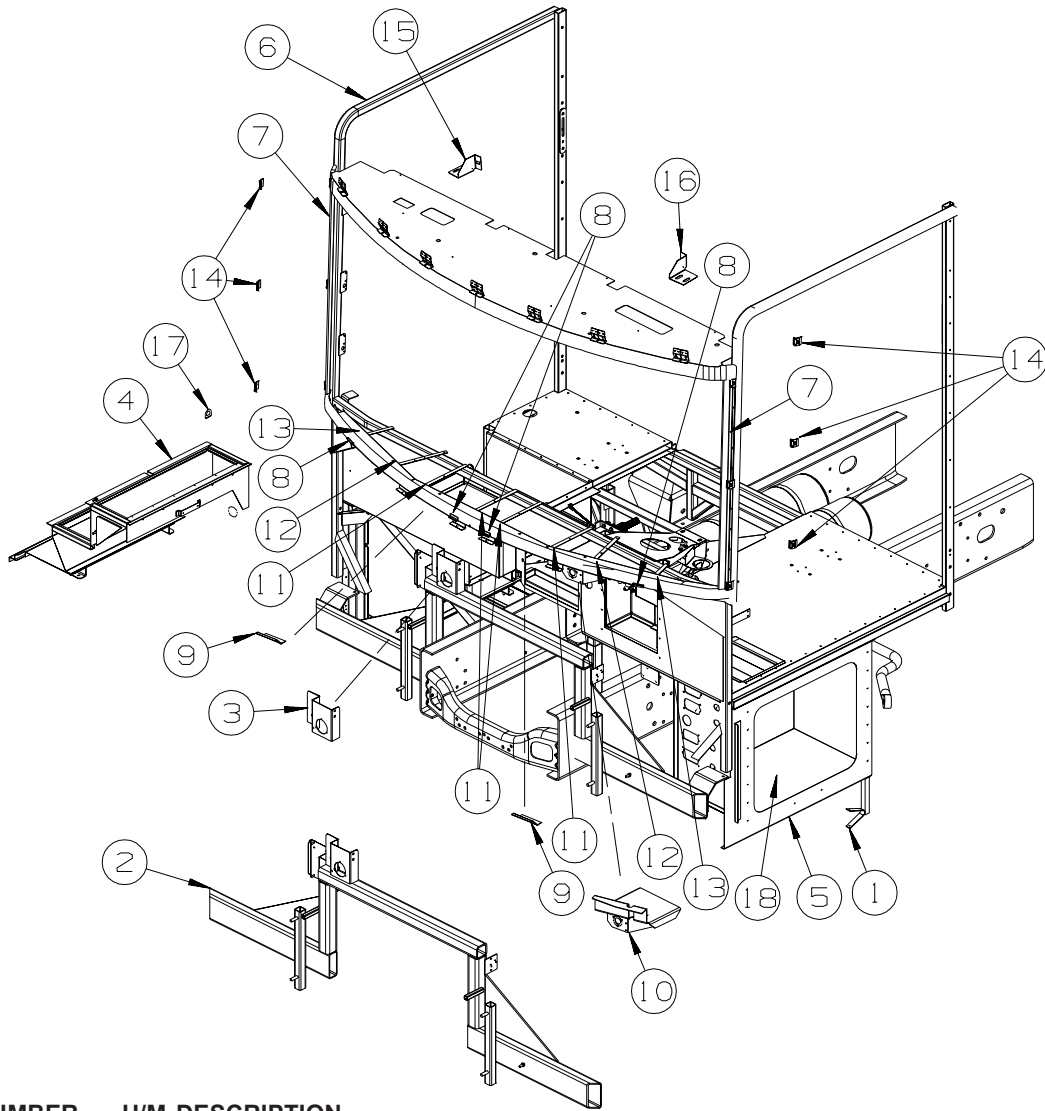

KEY	PART NUMBER	U/M	DESCRIPTION
1	115023-01-000	EA	ISOLATOR - RUBBER
2	135808-06-02B	EA	SUPPORT - FRONT - E-COATED
3	142478-01-01B	EA	BRACKET - GAUGE - AIR SOURCE - MILL
4	144034-01-02B	EA	STEP - ENTRANCE DOOR - E-COATED
			FROM: 00-00-00 THRU: 10-29-06
4	162109-01-02B	EA	STEP - ENTRANCE DOOR - E-COATED
			FROM: 10-30-06 THRU: 99-99-99
	009065-03-000	EA	HINGE - ALUMINUM - 2" X 72.5" - UNPAINTED
5	145992-01-02B	EA	PANEL - SEAL - FRONT - E-COATED
6	155558-02-02B	EA	FRONT END ASM - S40FD
6	155558-05-02B	EA	FRONT END ASM - S40KD - TV-32" COLOR,STEREO W/REMOTE
6	155558-06-02B	EA	FRONT END ASM - S40KD - TV(FRONT)-27" COLOR STEREO
6	155558-04-02B	EA	FRONT END ASM - S40TD
7	121269-13-01B	EA	FRAME-WINDSHIELD,A PILLAR,ML
8	126289-65-01B	EA	ANGLE - FORMED
9	134202-01-01B	EA	REINFORCEMENT - SUPPORT - LOWER WINDSHIELD/MIDDLE
10	156774-03-01B	EA	BRACKET ASM-WIPER MOTOR,MILL
11	137047-04-01B	EA	STRAP - DEFROSTER PLENUM
12	137047-05-01B	EA	STRAP - DEFROSTER PLENUM
13	137047-06-01B	EA	STRAP - DEFROSTER PLENUM
14	148935-01-01B	EA	BRACKET-WINDSHIELD ,MILL
15	153129-02-02B	EA	BRACKET - SUPPORT - TV - E-COATED
16	153129-03-02B	EA	BRACKET - SUPPORT - TV - E-COATED
17	099418-01-000	FT	SEAL - D-SECTION/ADHESIVE BACK - .44" X .44" - BLK RUBBER
18	123764-06-02B	EA	COMPARTMENT/LUGGAGE - E-COATED

CHASSIS GROUP (CONTINUED) INSULATION

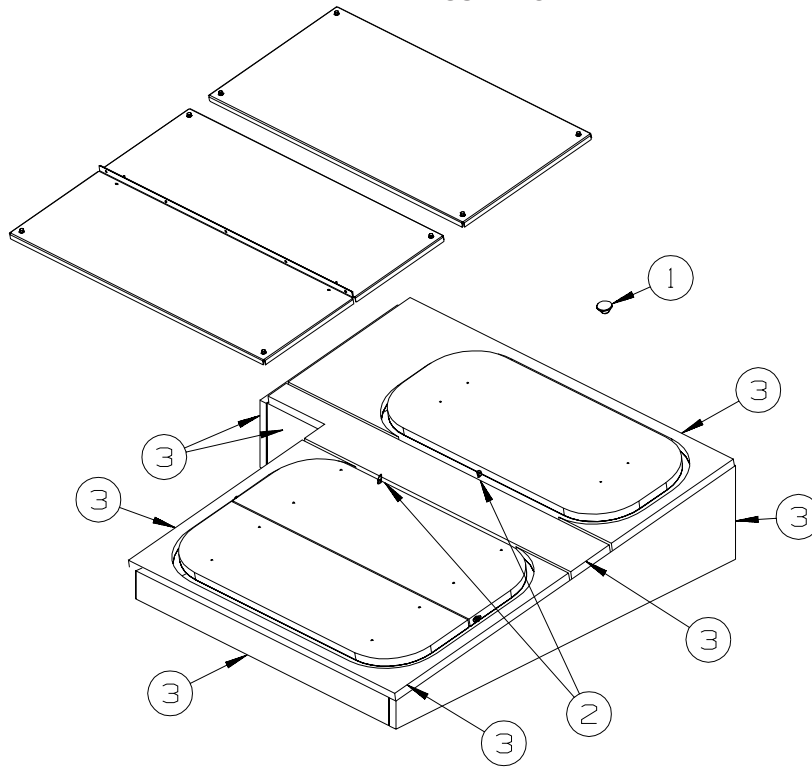

KEY	PART NUMBER	U/M	DESCRIPTION
1	106648-01-000	EA	CAP - STUD - .120 TO .130 DIAMETER
2	039623-01-000	FT	SEAL - MOTOR COVER - RUBBER BULB TYPE
3	072877-03-000	EA	INSULATION - SOUND BARRIER- 1" X 36" X 57" - ADHESIVE BACK FROM: 00-00-00 THRU: 12-10-06
3	072877-08-000	EA	INSULATION - SOUND BARRIER- 1" X 54" X 48" - ADHESIVE BACK FROM: 12-11-06 THRU: 99-99-99

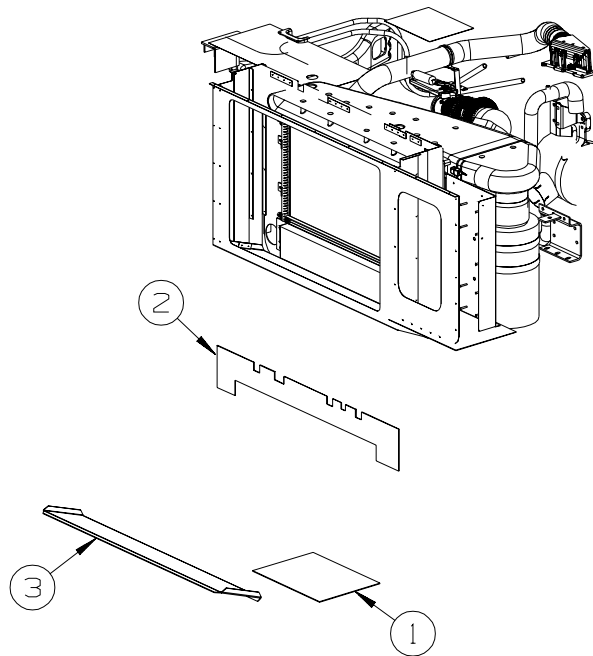

SIDE RADIATOR

KEY	PART NUMBER	U/M	DESCRIPTION
1	076310-13-000	EA	SHEET/RUBBER - RADIATER BAFFLE - .12" X 11.8" X 13.8"
2	146844-01-000	EA	SHEET/RUBBER - 7.9" X 49.9"
3	146200-01-000	EA	SHEET/RUBBER - 12.8" X 50.9"

CHASSIS GROUP (CONTINUED) STEPWELL COVER

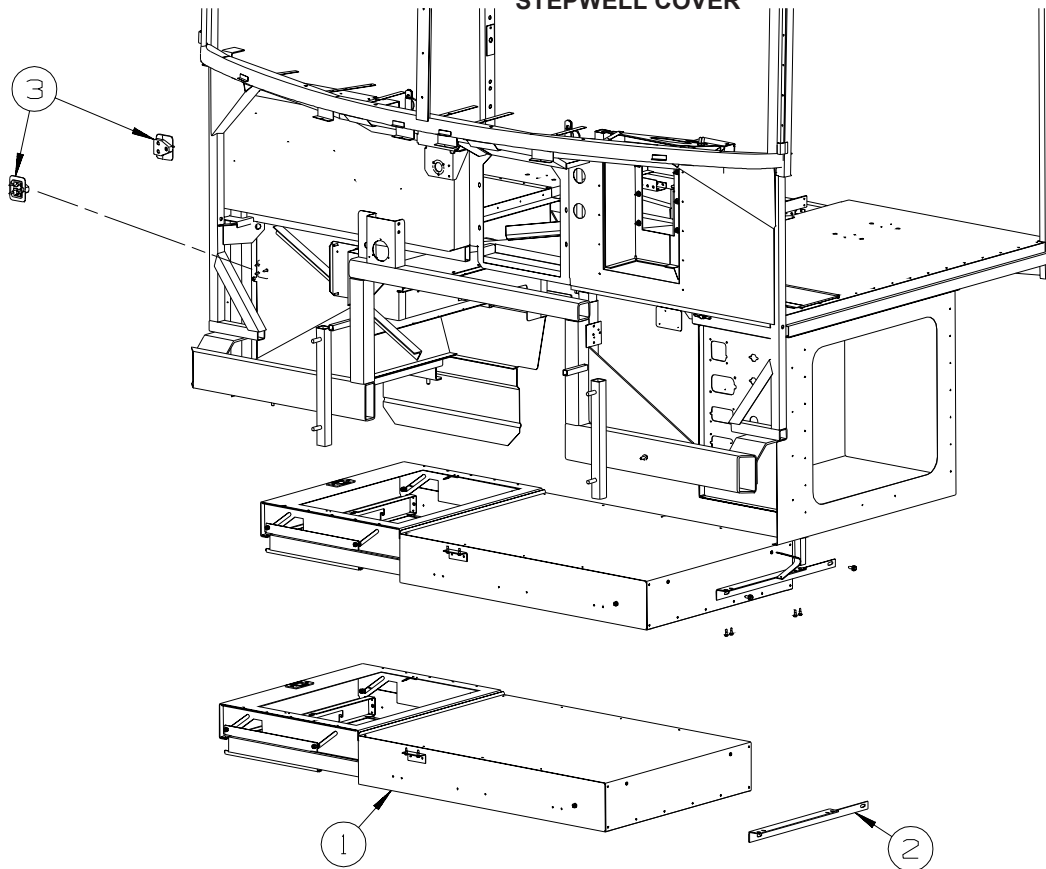

KEY	PART NUMBER	U/M	DESCRIPTION	
1*	145122-01-01A	EA	STEP COVER - SLIDING	FROM: 00-00-00 THRU: 09-13-06
1	145122-02-01A	EA	STEP COVER - SLIDING	FROM: 09-14-06 THRU: 99-99-99
2	145661-03-02B	EA	BRACKET - STEP COVER - E-COATED	FROM: 00-00-00 THRU: 06-13-04
2	145661-02-02B	EA	BRACKET - STEP COVER - E-COATED - NOT ILLUSTRATED	FROM: 06-14-04 THRU: 99-99-99
3	142499-02-01A	EA	BLOCK/SUPPORT (STEP COVER)	

***COMPONENT PARTS LISTED LATER IN THIS GROUP**

COMPONENT PARTS FOR STEPWELL COVER

145122-01-01A

KEY	PART NUMBER	U/M	DESCRIPTION	VENDOR NO.
	141691-01-703	EA	LATCH-CABLE RELEASE	1912125
	141691-01-704	EA	SPRING - CABLE PRELOAD	1217507
	141691-01-708	EA	MOTOR W/9 TOOTH PINION	1820122
	145122-01-700	EA	CABLE - 80" W/STOPS	1218753
	145122-01-701	EA	CABLE - 54" W/STOPS	1218754
	145122-01-702	EA	CAP/END - F/DRUM - PLASTIC	1612535
	145122-01-703	EA	BUSHING - .6"ID X .8"OD	1614003
	145122-01-704	EA	HARNESS/ADAPTER	1809938
	145122-01-705	EA	CABLE/RELEASE - 8" W/EYE	1213000
	145122-01-706	EA	COVER - EMERGENCY RETRACT	1612532
	145122-01-707	EA	SHOE/CABLE - PLASTIC	1612533
	145122-01-708	EA	GUIDE/ARM SLIDE - PLASTIC	1612542
	145122-01-709	EA	BUSHING/BRONZE - .38" X .50"	1614007
	145122-01-710	EA	BRACKET - SUPPORT	3610597
	145122-01-711	EA	STOP ROD BRACKET - LH	3610532

CHASSIS GROUP (CONTINUED)

EXHAUST

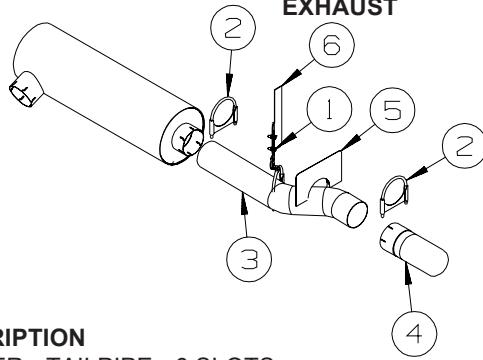

KEY	PART NUMBER	U/M DESCRIPTION
1	007131-01-000	EA HANGER - TAILPIPE - 6 SLOTS
2	094918-08-000	EA CLAMP - EXHAUST - 5"
3	114869-14-000	EA PIPE - EXHAUST
4	116425-04-000	EA EXTENSION - EXHAUST - CHROMED - 5"
5	143766-02-02B	EA SHIELD - EXHAUST/TAILPIPE - E-COATED
6	144916-01-02B	EA BRACKET/HANGER - TAILPIPE - E-COATED

HITCH

KEY	PART NUMBER	U/M DESCRIPTION
	134016-03-01A	EA DRAWBAR/HITCH - CLASS 4

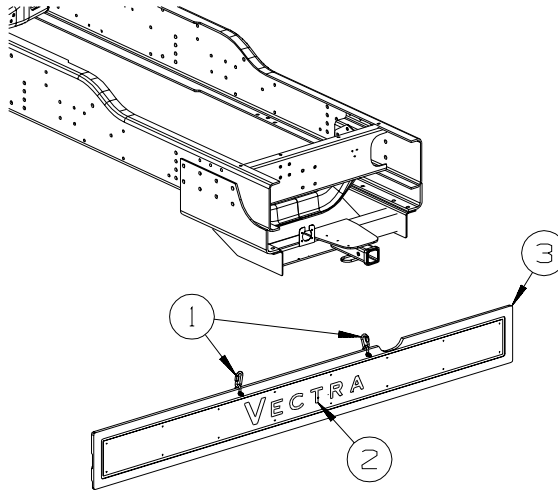

MUD FLAP

KEY	PART NUMBER	U/M DESCRIPTION
1	139818-01-01A	EA LINK - QUICK - STAINLESS STEEL
2	149830-01-01A	EA LOGO -"VECTRA"
3	151908-02-01A	EA MUD FLAP - REAR - 10.6" X 93.9"

CHASSIS GROUP (CONTINUED)

FUEL

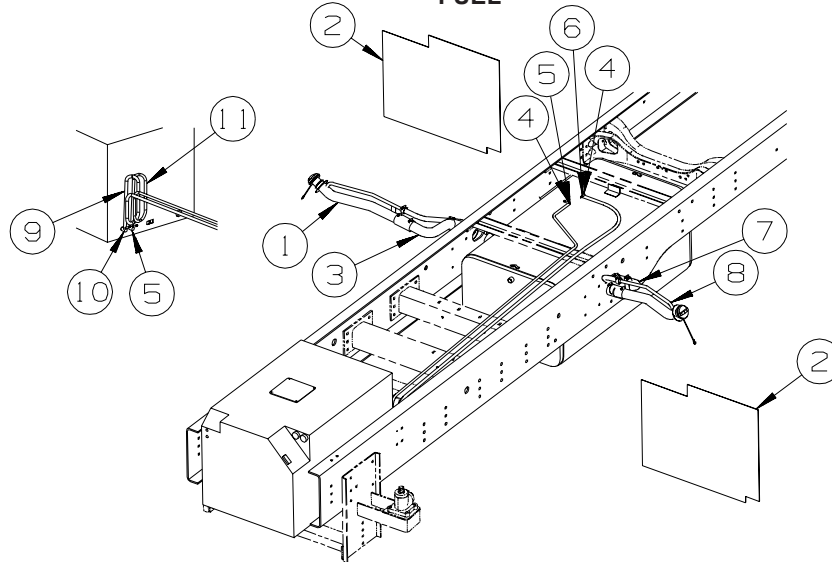

FROM: 00-00-00
THRU: 03-17-06

KEY	PART NUMBER	U/M	DESCRIPTION
1	144990-02-000	EA	NECK - FUEL FILL - RIGHT HAND
2	118726-05-000	EA	BAFFLE - FUEL FILL
3	145835-02-000	EA	ELBOW - FUEL FILL
4	068382-06-000	EA	BUSHING - BRASS - 3/8"MPT X 1/8"FPT
5	114253-01-000	EA	ELBOW - 1/4 SINGLE BARB X 1/8 MPT
6	114253-02-000	EA	ELBOW - 5/16 SINGLE BARB X 1/4 MPT
7	100140-09-000	EA	TUBE-FUEL INLET
8	144990-01-000	EA	NECK - FUEL FILL - LEFT HAND
9	024138-01-000	FT	HOSE - FUEL - 5/16" ID
10	114253-04-000	EA	ELBOW - 5/16 SINGLE BARB X 1/8 MPT
11	128139-03-000	FT	HOSE - FUEL - LOW PERMEABILITY - 1/4" DIAMETER

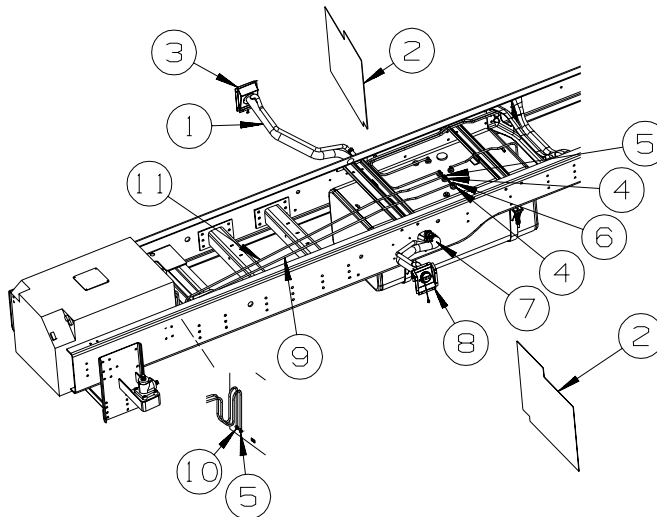

FROM: 03-18-06
THRU: 99-99-99

KEY	PART NUMBER	U/M	DESCRIPTION
1	157540-02-000	EA	NECK - FUEL FILL - RIGHT HAND
2	118726-05-000	EA	BAFFLE - FUEL FILL
3	157237-01-02B	EA	PANEL - FUEL FILL - E-COATED (R40FD,S40FD,R36LD)
3	157237-02-02B	EA	PANEL - FUEL FILL - E-COATED (R40KD,S40KD,R40TD,S40TD)
4	068382-06-000	EA	BUSHING - BRASS - 3/8"MPT X 1/8"FPT
5	114253-01-000	EA	ELBOW - 1/4 SINGLE BARB X 1/8 MPT
6	114253-02-000	EA	ELBOW - 5/16 SINGLE BARB X 1/4 MPT
7	157540-01-000	EA	NECK - FUEL FILL - LEFT HAND
8	157237-01-02B	EA	PANEL - FUEL FILL - E-COATED
9	024138-01-000	FT	HOSE - FUEL - 5/16" ID
10	114253-04-000	EA	ELBOW - 5/16 SINGLE BARB X 1/8 MPT
11	128139-03-000	FT	HOSE - FUEL - LOW PERMEABILITY - 1/4" DIAMETER

CHASSIS GROUP (CONTINUED)

HYDRAULIC LEVELING

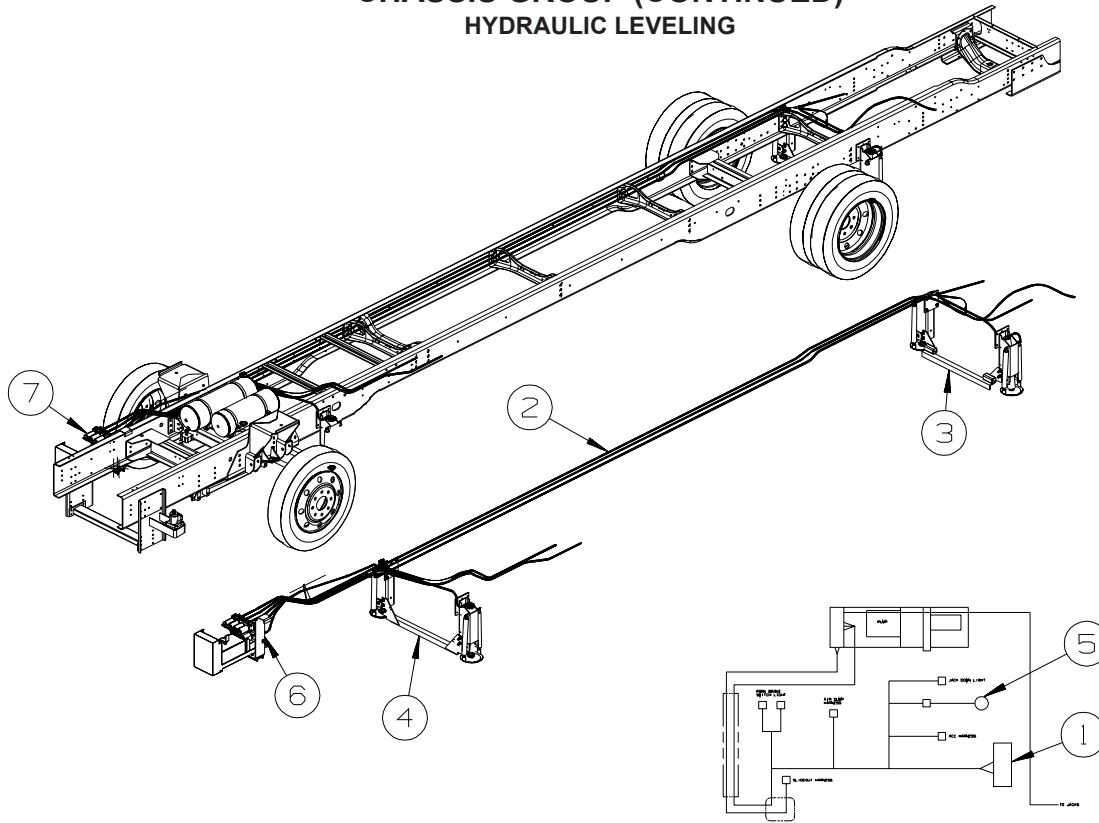

KEY	PART NUMBER	U/M	DESCRIPTION
1*	107889-12-000	EA	PANEL - CONTROL - 625 AIR DUMP W/PLUG F/REMOTE - W/HARNESS FROM: 00-00-00 THRU: 01-18-07
1	107889-13-000	EA	PANEL - CONTROL - 625 AIR DUMP W/PLUG F/REMOTE - W/HARNESS, FROM: 01-19-07 THRU: 99-99-99
2*	100536-50-000	EA	HOSE KIT - LEVELING JACKS FROM: 00-00-00 THRU: 06-06-06
2*	100536-47-000	EA	HOSE KIT - LEVELING JACKS FROM: 06-07-06 THRU: 99-99-99
3	114748-08-02B	EA	BRACKET - JACKS/REAR - E-COATED
4	128411-07-02B	EA	BRACKET - JACK - E-COATED
5	134092-05-000	EA	CHIME KIT - LEVELING SYSTEM - 325/625
6	144224-01-01A	EA	BRACKET - PUMP/LEVELING - BLACK
7*	153452-25-000	EA	LEVELING SYSTEM - 625 SYSTEM W/4 SLIDEOUTS - FREIGHTLINER - S40FD
7*	153452-24-000	EA	LEVELING SYSTEM - 625 SYSTEM W/3 SLIDEOUTS - FREIGHTLINER - S40KD
7*	153452-26-000	EA	LEVELING SYSTEM - 625 SYSTEM W/2 SLIDEOUTS - FREIGHTLINER - S40TD

*COMPONENT PARTS LISTED LATER IN THIS GROUP

COMPONENT PARTS FOR HYDRAULIC LEVELING

KEY	PART NUMBER	U/M	DESCRIPTION	VENDOR NO.
107889-12-000				
	107889-12-700	EA	TOUCH PANEL-625 W/AIR/REMOTE	RAP91862/AP34697
100536-47-000				
KEY	PART NUMBER	U/M	DESCRIPTION	VENDOR NO.
	100536-31-701	EA	HOSE - HYDRAULIC - 96"	RAP5352
	100536-47-700	EA	HOSE-HYDRAULIC - 1/4" X 416"	RAP91507
	100536-47-701	EA	HOSE-HYDRAULIC - 1/4" X 378"	RAP91501
	115767-01-704	EA	HOSE-HYDRAULIC - 1/4" X 146"	RAP90004/AP2443
100536-50-000				
KEY	PART NUMBER	U/M	DESCRIPTION	VENDOR NO.
	100536-31-701	EA	HOSE-HYDRAULIC - 1/4" X 96"	RAP5352/AP5352
	100536-46-700	EA	HOSE/HYDRAULIC - 1/4" X 408"	RAP4669/AP4669
	100536-46-701	EA	HOSE/HYDRAULIC - 1/4" X 432"	RAP6117/AP6117
	115767-01-704	EA	HOSE-HYDRAULIC - 1/4" X 146"	RAP90004/AP2443

CHASSIS GROUP (CONTINUED)
COMPONENT PARTS FOR HYDRAULIC LEVELING (CONTINUED)

153452-24-000

KEY	PART NUMBER	U/M	DESCRIPTION	VENDOR NO.
	100532-03-716	EA	SOLENOID-CONTINUOUS DUTY	RAP7505
	100532-03-726	EA	SWITCH - PRESSURE	RAP8003
	100532-09-704	EA	VALVE-PRESS SOLENOID(LARGE)	RAP0642
	100532-09-705	EA	SWITCH-PRESS - 3000 LB.	RAP0993
	100532-09-710	EA	SOLENOID-INTERMITENT DUTY	RAP0533
	100532-25-702	EA	CYLINDER ONLY (12,000# JACK)	RAP9517/AP29042
	100532-25-705	EA	SPRING KIT - 12K JACK (PAIR)	R91642
	100532-32-704	EA	CHIME - JACK WARNING	RAP90681/AP19765
	131306-02-701	EA	FOOT/JACK - 9K & 12K	RAP8464/AP17525
	131306-09-700	EA	VELOCITY VALVE ASM.W/4 VALVE	RAP90280
	131306-09-701	EA	VELOCITY VALVE - SINGLE	RAP90279/AP11578
	131306-11-704	EA	PRESSURE SWITCH - 50 PSI	RAP2082
	131306-12-702	EA	VALVE-PRESS SOLENOID (SMALL)	RAP90729/AP24604
	144226-01-700	EA	SWITCH - WARNING/MAGNETIC	RAP90968/AP26641
	144226-08-702	EA	SENSOR/BI-AXIS - PROGRAMABLE	RAP91172/AP28010
	153452-18-705	EA	MOTOR ONLY - 3.7" MONARCH	RAP91249
	153452-22-701	EA	BRACKET - 12K JACK MOUNT	AP91601
	153452-22-703	EA	PUMP/MOTOR/TANK ASM.	RAP91686/AP36694
	153452-23-700	EA	ENCLOSURE BOX W/SENSING UNIT	RAP91766/AP36769

153452-25-000

KEY	PART NUMBER	U/M	DESCRIPTION	VENDOR NO.
	100532-03-716	EA	SOLENOID-CONTINUOUS DUTY	RAP7505
	100532-03-717	EA	VALVE-PRESS., RETURN SHUTTLE	RAP7964
	100532-03-726	EA	SWITCH - PRESSURE	RAP8003
	100532-09-704	EA	VALVE-PRESS SOLENOID(LARGE)	RAP0642
	100532-09-705	EA	SWITCH-PRESS - 3000 LB.	RAP0993
	100532-09-710	EA	SOLENOID-INTERMITENT DUTY	RAP0533
	100532-25-702	EA	CYLINDER ONLY (12,000# JACK)	RAP9517/AP29042
	100532-25-705	EA	SPRING KIT - 12K JACK (PAIR)	R91642
	100532-32-704	EA	CHIME - JACK WARNING	RAP90681/AP19765
	131306-02-701	EA	FOOT/JACK - 9K & 12K	RAP8464/AP17525
	131306-09-700	EA	VELOCITY VALVE ASM.W/4 VALVE	RAP90280
	131306-09-701	EA	VELOCITY VALVE - SINGLE	RAP90279/AP11578
	131306-11-704	EA	PRESSURE SWITCH - 50 PSI	RAP2082
	131306-12-702	EA	VALVE-PRESS SOLENOID (SMALL)	RAP90729/AP24604
	144226-01-700	EA	SWITCH - WARNING/MAGNETIC	RAP90968/AP26641
	144226-08-702	EA	SENSOR/BI-AXIS - PROGRAMABLE	RAP91172/AP28010
	153452-18-705	EA	MOTOR ONLY - 3.7" MONARCH	RAP91249
	153452-22-701	EA	BRACKET - 12K JACK MOUNT	AP91601
	153452-22-703	EA	PUMP/MOTOR/TANK ASM.	RAP91686/AP36694
	153452-23-700	EA	ENCLOSURE BOX W/SENSING UNIT	RAP91766/AP36769

CHASSIS GROUP (CONTINUED)
COMPONENT PARTS FOR HYDRAULIC LEVELING (CONTINUED)

153452-26-000

KEY	PART NUMBER	U/M	DESCRIPTION	VENDOR NO.
	100532-03-716	EA	SOLENOID-CONTINUOUS DUTY	RAP7505
	100532-03-717	EA	VALVE-PRESS., RETURN SHUTTLE	RAP7964
	100532-03-726	EA	SWITCH - PRESSURE	RAP8003
	100532-09-704	EA	VALVE-PRESS SOLENOID(LARGE)	RAP0642
	100532-09-705	EA	SWITCH-PRESS - 3000 LB.	RAP0993
	100532-09-710	EA	SOLENOID-INTERMITENT DUTY	RAP0533
	100532-25-702	EA	CYLINDER ONLY (12,000# JACK)	RAP9517/AP29042
	100532-25-705	EA	SPRING KIT - 12K JACK (PAIR)	R91642
	100532-32-704	EA	CHIME - JACK WARNING	RAP90681/AP19765
	131306-02-701	EA	FOOT/JACK - 9K & 12K	RAP8464/AP17525
	131306-09-700	EA	VELOCITY VALVE ASM.W/4 VALVE	RAP90280
	131306-09-701	EA	VELOCITY VALVE - SINGLE	RAP90279/AP11578
	131306-11-704	EA	PRESSURE SWITCH - 50 PSI	RAP2082
	131306-12-702	EA	VALVE-PRESS SOLENOID (SMALL)	RAP90729/AP24604
	144226-01-700	EA	SWITCH - WARNING/MAGNETIC	RAP90968/AP26641
	144226-08-702	EA	SENSOR/BI-AXIS - PROGRAMABLE	RAP91172/AP28010
	153452-18-705	EA	MOTOR ONLY - 3.7" MONARCH	RAP91249
	153452-22-701	EA	BRACKET - 12K JACK MOUNT	AP91601
	153452-22-702	EA	ENCLOSURE BOX W/SENSING UNIT	RAP91764/AP36764
	153452-22-703	EA	PUMP/MOTOR/TANK ASM.	RAP91686/AP36694

WHEEL, TIRE, COVERS &/LINERS

KEY	PART NUMBER	U/M	DESCRIPTION
	080208-05-000	EA	BAR/LEVERAGE - LUG WRENCH - .75" DIA.
	080208-04-000	EA	LUG WRENCH - 1.2"/1.3" SOCKETS X 13.8" LONG

CURTAIN & CUSHION GROUP

NOTICE

IN ORDER TO ASSIST OUR PARTS SALES DEPT. IN PROVIDING INTERIOR SOFTWARE ITEMS, PLEASE INCLUDE THE SERIAL NUMBER AND THE COLOR CODE NUMBER FROM THE VEHICLE CERTIFICATION LABEL WHEN ORDERING. THIS LABEL IS LOCATED ON THE LEFT SIDEWALL AT THE END OF THE DASH (A-BODY), OR ON THE DRIVER'S DOOR LATCH PLATE (C-BODY).

AN EXAMPLE OF A COLOR CODE NUMBER IS B07, WHICH DESIGNATES AN OVERALL COLOR SCHEME OF A PARTICULAR UNIT. THE COLOR LISTED AFTER THE ITEM DESCRIPTION ON THE MICROFICHE, INDICATES THE OVERALL UNIT COLOR. ORDER THE ITEM YOU DESIRE ACCORDING TO UNIT COLOR CODE. IF ALL COLORS USE THE SAME ITEM NO COLOR CODE WILL BE NOTED.

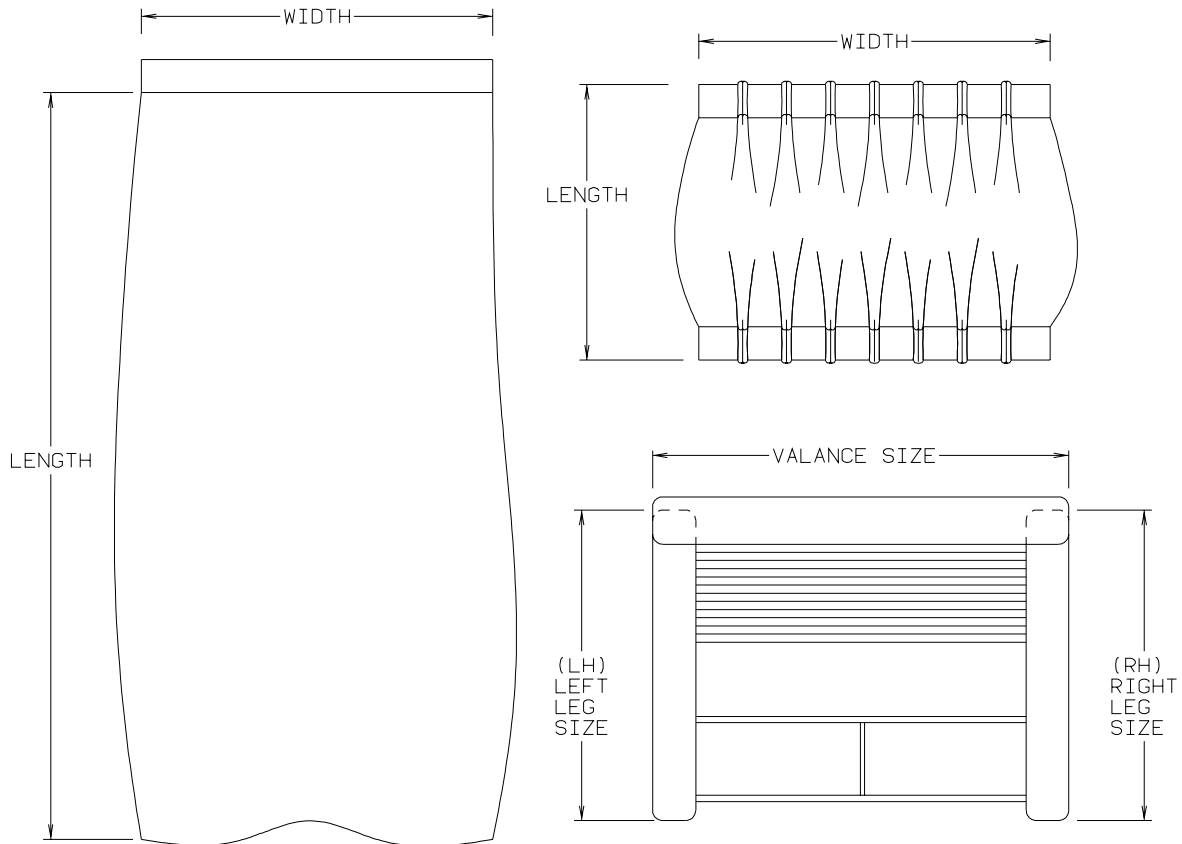

NOTE: USE THIS ILLUSTRATION WHEN DETERMINING LENGTH AND WIDTH MEASUREMENTS FOR CURTAINS. YOU WILL NOTE THE WIDTH MEASUREMENT IS TAKEN ON THE TOP OF THE CURTAIN WITH THE CURTAIN FULLY EXTENDED. THE LENGTH MEASUREMENT IS TAKEN FROM TOP TO BOTTOM. LEFT AND RIGHT WINDOW LEGS ARE DETERMINED WHEN FACING THE WINDOW.

CURTAIN & CUSHION GROUP (CONTINUED)
CUSHION LAYOUT

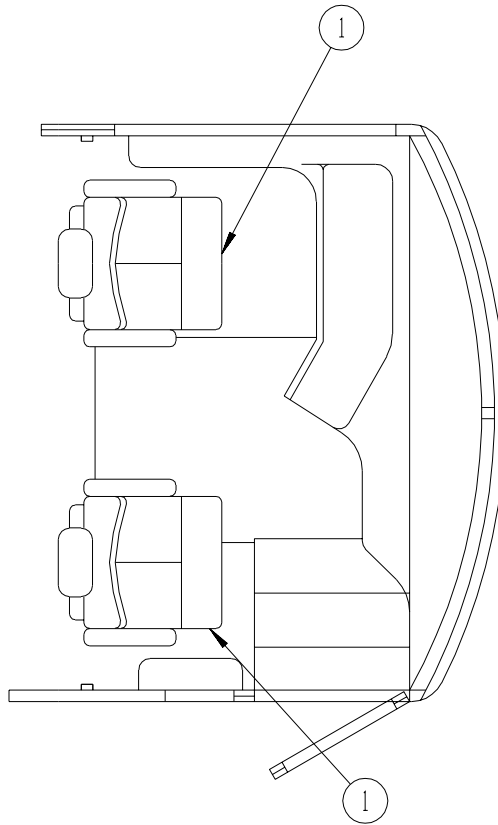

KEY	PART NUMBER	U/M	DESCRIPTION
1	146707-10-UJ1	EA	SEAT - BUCKET - W/LUMBAR/ADJUSTABLE ARMS - LEATHER (UJ1, UJ2, UJ3, UJ5, UJ6, UJ7)
1	146707-10-UK1	EA	SEAT - BUCKET - W/LUMBAR/ADJUSTABLE ARMS - LEATHER (UK1, UK2, UK3)

CURTAIN & CUSHION GROUP (CONTINUED)
CUSHION LAYOUT (CONTINUED)

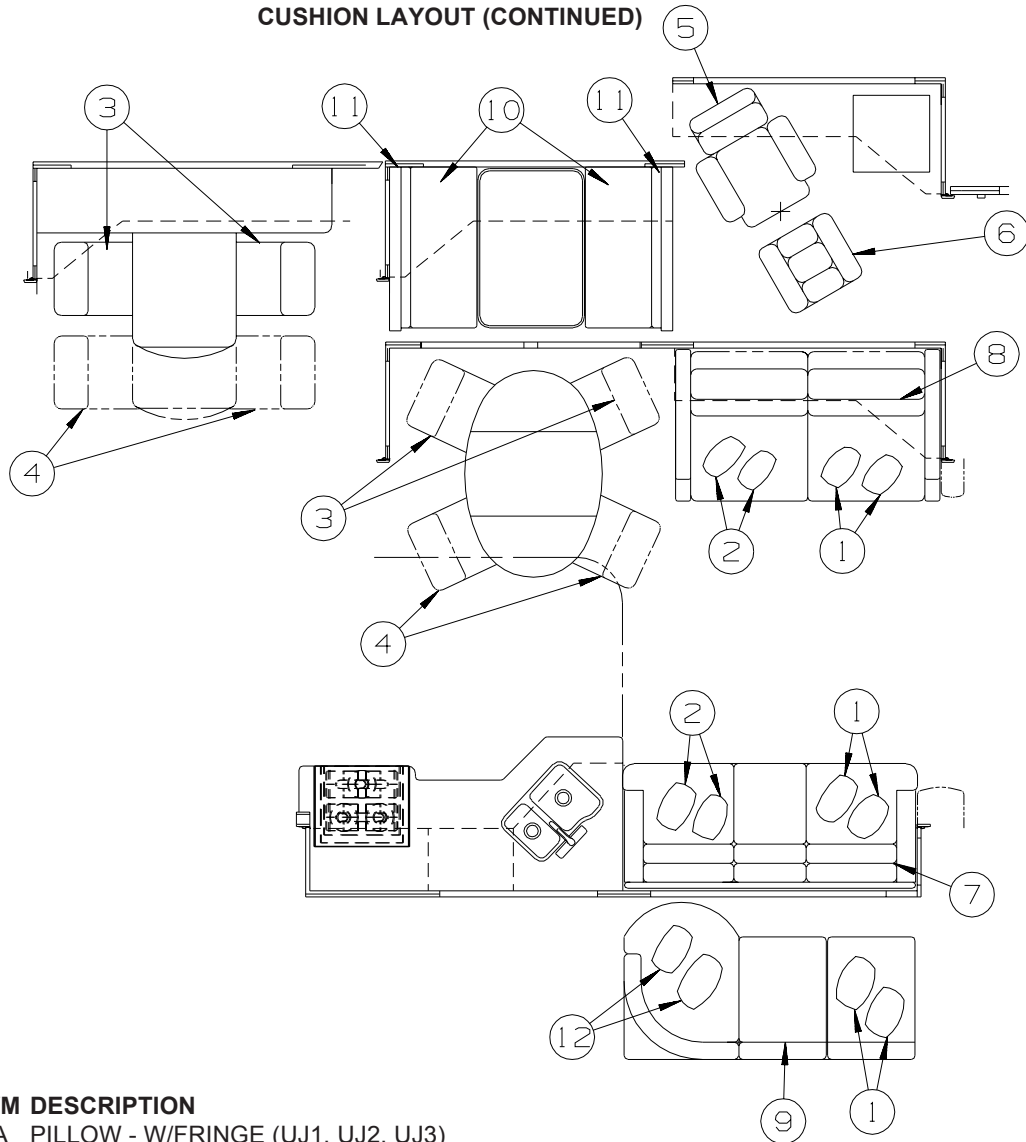

KEY	PART NUMBER	U/M	DESCRIPTION
1	154192-03-UJ1	EA	PILLOW - W/FRINGE (UJ1, UJ2, UJ3)
1	154192-03-UJ5	EA	PILLOW - W/FRINGE (UJ5, UJ6, UJ7)
1	154192-03-UK1	EA	PILLOW - W/FRINGE (UK1, UK2, UK3)
2	157810-01-UJ1	EA	PILLOW - 17" X 17" (UJ1, UJ2, UJ3)
2	154192-06-UJ1	EA	PILLOW - W/FRINGE (UJ1, UJ2, UJ3)
2	157810-02-UJ5	EA	PILLOW - 17" X 17" (UJ5, UJ6, UJ7)
2	154192-03-UJ5	EA	PILLOW - W/FRINGE (UJ5, UJ6, UJ7)
2	157810-01-UK1	EA	PILLOW - 17" X 17" (UK1, UK2, UK3)
2	154192-03-UK1	EA	PILLOW - W/FRINGE (UK1, UK2, UK3)
3	157839-01-UJ1	EA	CHAIR - DINING
3	157839-01-UJ2	EA	CHAIR - DINING
3	157839-01-UJ3	EA	CHAIR - DINING
3	157839-01-UJ5	EA	CHAIR - DINING
3	157839-01-UJ6	EA	CHAIR - DINING
3	157839-01-UJ7	EA	CHAIR - DINING
3	157839-01-UK1	EA	CHAIR - DINING
3	157839-01-UK2	EA	CHAIR - DINING
3	157839-01-UK3	EA	CHAIR - DINING

CURTAIN & CUSHION GROUP (CONTINUED)
CUSHION LAYOUT (CONTINUED)

KEY	PART NUMBER	U/M	DESCRIPTION
4	157868-01-UJ1	EA	CHAIR - FOLDING
4	157868-01-UJ2	EA	CHAIR - FOLDING
4	157868-01-UJ3	EA	CHAIR - FOLDING
4	135600-AZ-000	EA	CHAIR - FOLDING - FLAX/CONCERT CHERRY (UJ5)
4	135600-BA-000	EA	CHAIR - FOLDING - FLAX/WASHED MAPLE (UJ6)
4	135600-BB-000	EA	CHAIR - FOLDING - FLAX/HONEY CHERRY (UJ7)
4	135600-BD-000	EA	CHAIR - FOLDING - DRAMA/CONCERT CHERRY (UK1)
4	135600-BE-000	EA	CHAIR - FOLDING - DRAMA/WASHED MAPLE 9UK2)
4	135600-BF-000	EA	CHAIR - FOLDING - DRAMA/HONEY CHERRY (UK3)
	099856-13-000	EA	STRAP - TIEDOWN - 143.5"
5	157814-01-UJ1	EA	CHAIR - RECLINER - EURO/PALLISER - LEATHER (UJ1, UJ5)
5	157814-01-UJ2	EA	CHAIR - RECLINER - EURO/PALLISER - LEATHER (UJ2, UJ6)
5	157814-01-UJ3	EA	CHAIR - RECLINER - EURO/PALLISER - LEATHER (UJ3, UJ7)
5	157814-01-UK1	EA	CHAIR - RECLINER - EURO/PALLISER - LEATHER (UK1)
5	157814-01-UK2	EA	CHAIR - RECLINER - EURO/PALLISER - LEATHER (UK2)
5	157814-01-UK3	EA	CHAIR - RECLINER - EURO/PALLISER - LEATHER (UK3)
6	157814-02-UJ1	EA	OTTOMAN - CHAIR/PALLISER - LEATHER (UJ1, UJ5)
6	157814-02-UJ2	EA	OTTOMAN - CHAIR/PALLISER - LEATHER (UJ2, UJ6)
6	157814-02-UJ3	EA	OTTOMAN - CHAIR/PALLISER - LEATHER (UJ3, UJ7)
6	157814-02-UK1	EA	OTTOMAN - CHAIR/PALLISER - LEATHER (UK1)
6	157814-02-UK2	EA	OTTOMAN - CHAIR/PALLISER - LEATHER (UK2)
6	157814-02-UK3	EA	OTTOMAN - CHAIR/PALLISER - LEATHER (UK3)
7	157827-01-UJ1	EA	SOFA/SLEEPER - 74" - REMOVABLE FRONT PANEL/ARM - 20"RF (UJ1, UJ2, UJ3)
7	157827-01-UJ5	EA	SOFA/SLEEPER - 74" - REMOVABLE FRONT PANEL/ARM - 20"RF (UJ5, UJ6, UJ7)
7	157827-01-UK1	EA	SOFA/SLEEPER - 74" - REMOVABLE FRONT PANEL/ARM - 20"RF (UK1, UK2, UK3)
7	157827-02-UJ1	EA	SOFA/SLPR - 74" - RMVBL FRNT PANEL/ARM - 20"RF (UJ1, UJ2, UJ3, UJ5, UJ6, UJ7) - ULTRALEATHER
7	157827-02-UK1	EA	SOFA/SLEEPER - 74" - REMOVABLE FRONT PANEL/ARM - 20"RF (UK1, UK2, UK3) - ULTRALEATHER
8	157800-02-UJ1	EA	SOFA/SLEEPER - 68" - W/AIR MATTRESS - LEATHER (UJ1, UJ2, UJ3)
8	157800-02-UK1	EA	SOFA/SLEEPER - 68" - W/AIR MATTRESS - LEATHER (UK1, UK2, UK3)
8	157800-01-UJ1	EA	SOFA/SLEEPER - 68" - W/AIR MATTRESS (UJ1, UJ2, UJ3, UJ5, UJ6, UJ7) - ULTRALEATHER
8	157800-01-UK1	EA	SOFA/SLEEPER - 68" - W/AIR MATTRESS (UK1, UK2, UK3) - ULTRALEATHER
9	157830-01-UJ1	EA	SOFA - J-LOUNGE - 76" - LEATHER (UJ1, UJ2, UJ3, UJ5, UJ6, UJ7)
9	157830-01-UK1	EA	SOFA - J-LOUNGE - 76" - LEATHER (UK1, UK2, UK3)
10	142292-05-UJ1	EA	SEAT - DINETTE CUSHION (SPRUNG) - 23" X 38.5" (UJ1, UJ2, UJ3)
10	142292-05-TG4	EA	SEAT - DINETTE CUSHION (SPRUNG) - 23" X 38.5" (UJ5, UJ6, UJ7)
10	142292-05-TH0	EA	SEAT - DINETTE CUSHION (SPRUNG) - 23" X 38.5" (UK1, UK2, UK3)
	P42292-05-UJ1	EA	COVER/SEAT - DINETTE CUSHION (SPRUNG) - 23.5" X 38.5" (UJ1, UJ2, UJ3)
	P42292-05-TG4	EA	COVER/SEAT - DINETTE CUSHION (SPRUNG) - 23.5" X 38.5" (UJ5, UJ6, UJ7)
	P42292-05-TH0	EA	COVER/SEAT - DINETTE CUSHION (SPRUNG) - 23.5" X 38.5" (UK1, UK2, UK3)
	142366-01-000	EA	FRAME - SPRUNG - DINETTE SEAT
11	142431-01-UJ1	EA	CUSHION - BACK - 13.5" X 40" (UJ1, UJ2, UJ3)
11	142431-01-TG4	EA	CUSHION - BACK - 13.5" X 40" (UJ5, UJ6, UJ7)
11	142431-01-TH0	EA	CUSHION - BACK - 13.5" X 40" (UK1, UK2, UK3)
	P42431-01-UJ1	EA	COVER/BACK - 13.5" X 40" (UJ1, UJ2, UJ3)
	P42431-01-TG4	EA	COVER/BACK - 13.5" X 40" (UJ5, UJ6, UJ7)
	P42431-01-TH0	EA	COVER/BACK - 13.5" X 40" (UK1, UK2, UK3)
	143730-01-000	EA	CAP - F/DINETTE BRACKET TUBE - PLASTIC
12	157810-01-UJ1	EA	PILLOW - 17" X 17" (UJ1, UJ2, UJ3)
			FROM: 00-00-00 THRU: 05-21-06
12	157810-10-UJ1	EA	PILLOW - 17" X 17" (UJ1, UJ2, UJ3)
			FROM: 05-22-06 THRU: 99-99-99
12	157810-02-UJ5	EA	PILLOW - 17" X 17" (UJ5, UJ6, UJ7)
12	157810-01-UK1	EA	PILLOW - 17" X 17" (UK1, UK2, UK3)

CURTAIN & CUSHION GROUP (CONTINUED)

CUSHION LAYOUT (CONTINUED)

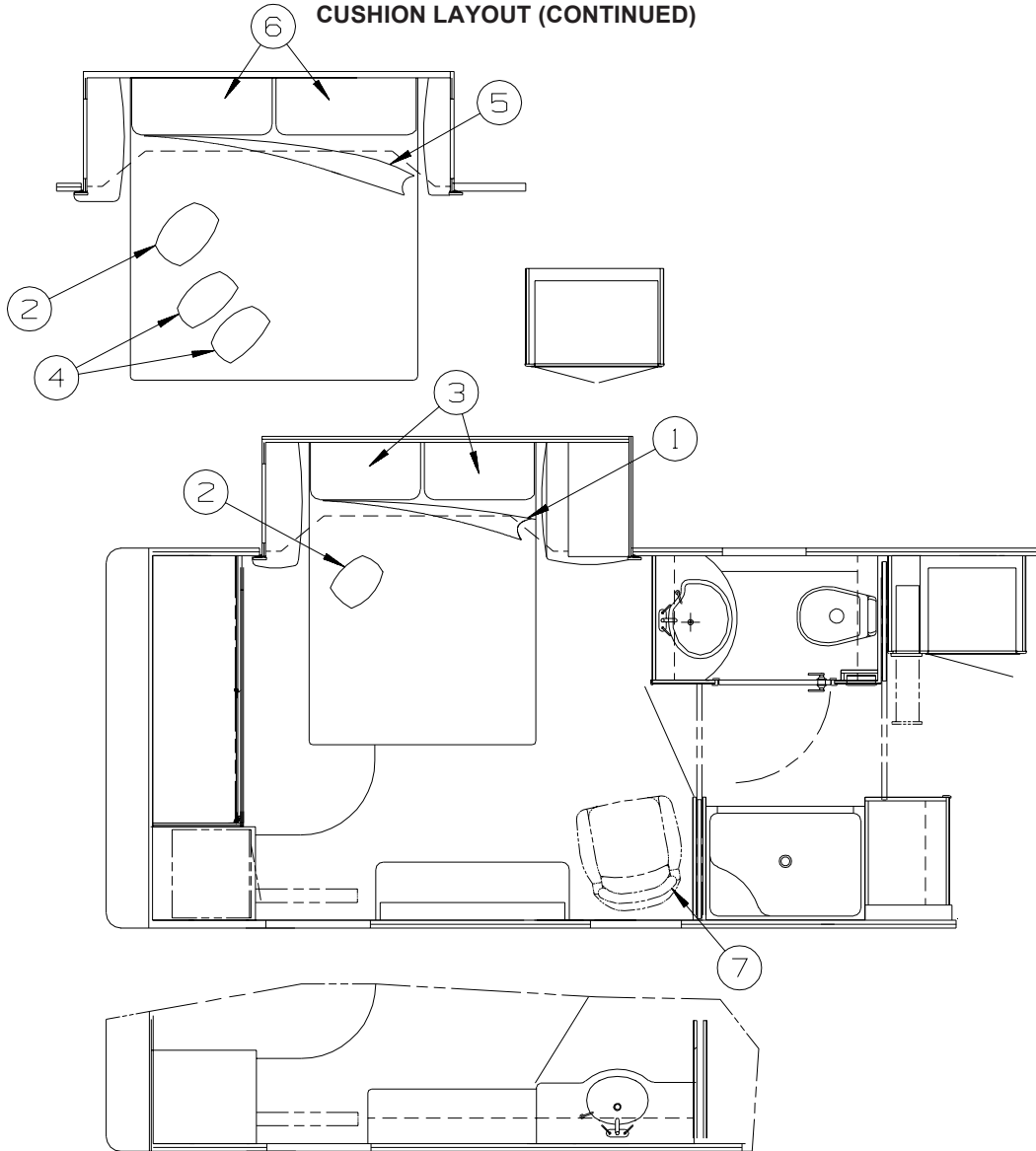

KEY	PART NUMBER	U/M	DESCRIPTION
1	143141-14-UJ1	EA	BEDSPREAD - 60" X 80" (UJ1, UJ2, UJ3)
1	143141-14-UJ5	EA	BEDSPREAD - 60" X 80" (UJ5, UJ6, UJ7)
1	143141-14-UK1	EA	BEDSPREAD - 60" X 80" (UK1, UK2, UK3)
2	154427-01-UJ1	EA	PILLOW - 18" X 18" - SQUARE W/TASSEL (UJ1, UJ2, UJ3)
2	154427-01-UJ5	EA	PILLOW - 18" X 18" - SQUARE W/TASSEL (UJ5, UJ6, UJ7)
2	154427-01-UK1	EA	PILLOW - 18" X 18" - SQUARE W/TASSEL (UK1, UK2, UK3)
3	155275-03-UJ1	EA	PILLOW SHAM (UJ1, UJ2, UJ3)
3	155275-03-UJ5	EA	PILLOW SHAM (UJ5, UJ6, UJ7)
3	155275-03-UK1	EA	PILLOW SHAM (UK1, UK2, UK3)
4	157835-01-UJ1	EA	PILLOW - 15" X 23" (UJ1, UJ2, UJ3)
4	157835-01-UK1	EA	PILLOW - 15" X 23" (UK1, UK2, UK3)
5	143141-15-UJ1	EA	BEDSPREAD - 72" X 80" (UJ1, UJ2, UJ3)
5	143141-15-UJ5	EA	BEDSPREAD - 72" X 80" (UJ5, UJ6, UJ7)
5	143141-15-UK1	EA	BEDSPREAD - 72" X 80" (UK1, UK2, UK3)
6	155275-06-UJ1	EA	PILLOW SHAM (UJ1, UJ2, UJ3)
6	155275-06-UJ5	EA	PILLOW SHAM (UJ5, UJ6, UJ7)
6	155275-06-UK1	EA	PILLOW SHAM (UK1, UK2, UK3)
7	157862-01-UJ1	EA	CHAIR - SUITE (UJ1, UJ2, UJ3)
7	157862-01-UJ5	EA	CHAIR - SUITE (UJ5, UJ6, UJ7)
7	157862-02-UK1	EA	CHAIR - SUITE (UK1, UK2, UK3)

CURTAIN & CUSHION GROUP (CONTINUED)

BUCKET SEAT

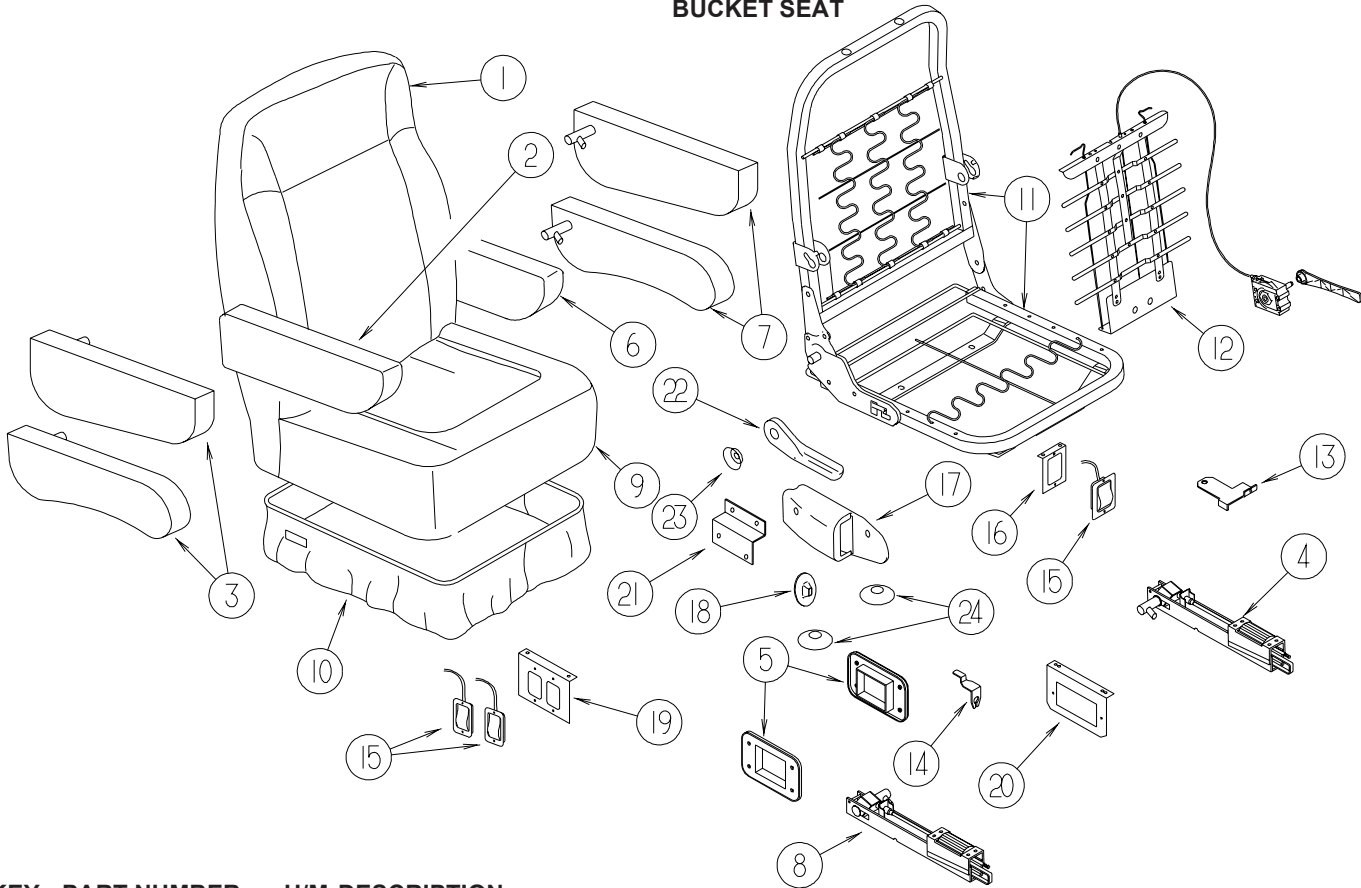

KEY	PART NUMBER	U/M	DESCRIPTION
1	M05962-W3-UJ1	EA	COVER/BACK - LEATHER (UJ1, UJ2, UJ3, UJ5, UJ6, UJ7)
1	M05962-W3-UK1	EA	COVER/BACK - LEATHER (UK1, UK2, UK3)
2	148705-03-UJ1	EA	ARMREST - RIGHT - LEATHER (UJ1, UJ2, UJ3, UJ5, UJ6, UJ7)
2	148705-03-TJ4	EA	ARMREST - RIGHT - LEATHER (UK1, UK2, UK3)
	P48705-03-UJ1	EA	COVER/ARMREST - RIGHT - LEATHER (UJ1, UJ2, UJ3, UJ5, UJ6, UJ7)
	P48705-03-TJ4	EA	COVER/ARMREST - RIGHT - LEATHER (UK1, UK2, UK3)
3	NOT USED		
4	148751-02-000	EA	BRACKET - LEFT (ADJUSTABLE) W/ROLLER
5	148751-03-000	EA	BRACKET - ROLLER TRIM PLATE
6	148705-04-UJ1	EA	ARMREST - LEFT - LEATHER (UJ1, UJ2, UJ3, UJ5, UJ6, UJ7)
6	148705-04-TJ4	EA	ARMREST - LEFT - LEATHER (UK1, UK2, UK3)
	P48705-04-UJ1	EA	COVER/ARMREST - LEFT - LEATHER (UJ1, UJ2, UJ3, UJ5, UJ6, UJ7)
	P48705-04-TJ4	EA	COVER/ARMREST - LEFT - LEATHER (UK1, UK2, UK3)
7	NOT USED		
8	148751-01-000	EA	BRACKET - RIGHT (ADJUSTABLE) W/ROLLER
9	M05962-W4-UJ1	EA	COVER/SEAT - LEATHER (UJ1, UJ2, UJ3, UJ5, UJ6, UJ7)
9	M05962-W4-UK1	EA	COVER/SEAT - LEATHER (UK1, UK2, UK3)
10	148630-02-UJ1	EA	SKIRT - W/SEAT BELT SLOT - LEATHER (UJ1, UJ2, UJ3, UJ5, UJ6, UJ7)
10	148630-02-UK1	EA	SKIRT - W/SEAT BELT SLOT - LEATHER (UK1, UK2, UK3)
10	148630-04-UJ1	EA	SKIRT - F/6-WAY POWER - LEATHER (UJ1, UJ2, UJ3, UJ5, UJ6, UJ7) - POWER SEAT
10	148630-04-TJ4	EA	SKIRT - F/6-WAY POWER - LEATHER (UK1, UK2, UK3) - POWER SEAT
10	148630-22-UJ1	EA	SKIRT - W/SEAT BELT/FOOTREST SLOTS - LEATHER (UJ1, UJ2, UJ3, UJ5, UJ6, UJ7)
10	148630-22-UK1	EA	SKIRT - W/SEAT BELT/FOOTREST SLOTS - LEATHER (UK1, UK2, UK3)
10	148630-24-UJ1	EA	SKIRT - POWER - W/SEAT BELT/FOOTREST SLOTS (UJ1, UJ2, UJ3, UJ5, UJ6, UJ7) - POWER SEAT
10	148630-24-UK1	EA	SKIRT - POWER - W/SEAT BELT/FOOTREST SLOTS - LEATHER (UK1, UK2, UK3) - POWER SEAT
11	134532-01-000	EA	FRAME - SEAT/HIGH BACK
12*	122611-02-000	EA	LUMBAR - W/LEVER
13	117125-01-02B	EA	BRACKET - CABLE MOUNT - ADJUSTER W/LOCK
14	108049-02-000	EA	CLIP - CABLE/PEDESTAL
15	108049-04-000	EA	CABLE - W/MINI LEVER ACTION SWITCH - 28" SHEATH/30" CABLE
16	127159-01-02B	EA	BRACKET - SEAT RELEASE - SINGLE REMOTE - E-COATED - 6-WAY POWER
17	NOT USED		
18	NOT USED		
19	127159-02-02B	EA	BRACKET - SEAT RELEASE - DUAL REMOTE - E-COATED
20	128699-01-02B	EA	BRACKET - SEAT SWITCH - E-COATED - 6-WAY POWER

CURTAIN & CUSHION GROUP (CONTINUED)
BUCKET SEAT (CONTINUED)

KEY	PART NUMBER	U/M	DESCRIPTION
21	147457-01-02B	EA	BRACKET - ZEE W/HOLES - 2.8" - E-COATED
22	130802-02-000	EA	LEVER - RIGHT HAND
	130802-03-000	EA	SCREW F/LEVER
23	148668-01-01A	EA	CUP/TRIM COVER - F/LEVER - BLACK
24	NOT USED		
	152337-01-000	EA	PROTECTOR - SEAT - CLEAR VINYL

***COMPONENT PARTS LISTED LATER IN THIS GROUP**

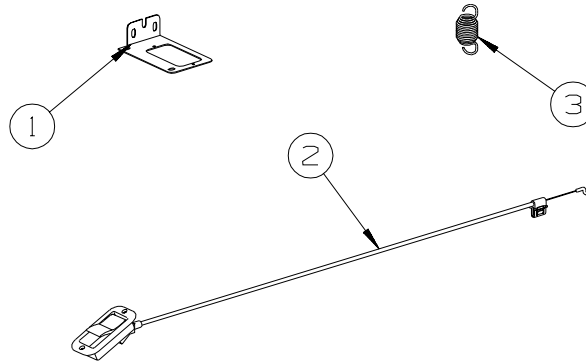

KEY	PART NUMBER	U/M	DESCRIPTION
	154060-02-UJ1	EA	FOOTREST - BUCKET SEAT/PASSENGER - LEATHER (UJ1, UJ2, UJ3, UJ5, UJ6, UJ7)
	154060-02-UK1	EA	FOOTREST - BUCKET SEAT/PASSENGER - LEATHER (UK1, UK2, UK3)
1	127159-01-02B	EA	BRACKET - SEAT RELEASE - SINGLE REMOTE - E-COATED
	131566-07-000	EA	5" DOUBLE LOCKING SLIDE W/TAB
2	153956-02-01A	EA	CABLE - FOOTREST - W/BLACK HANDLE
3	154190-06-000	EA	SPRING/FOOTREST - 2.8"

COMPONENT PARTS FOR BUCKET SEATS

122611-02-000

KEY	PART NUMBER	U/M	DESCRIPTION	VENDOR NO.
	122611-02-701	EA	LUMBAR - LEVER	412
	122611-02-702	EA	LUMBAR MECHANISM	24395-FLEXSTEEL

CURTAIN & CUSHION GROUP (CONTINUED)

WINDOW TREATMENTS

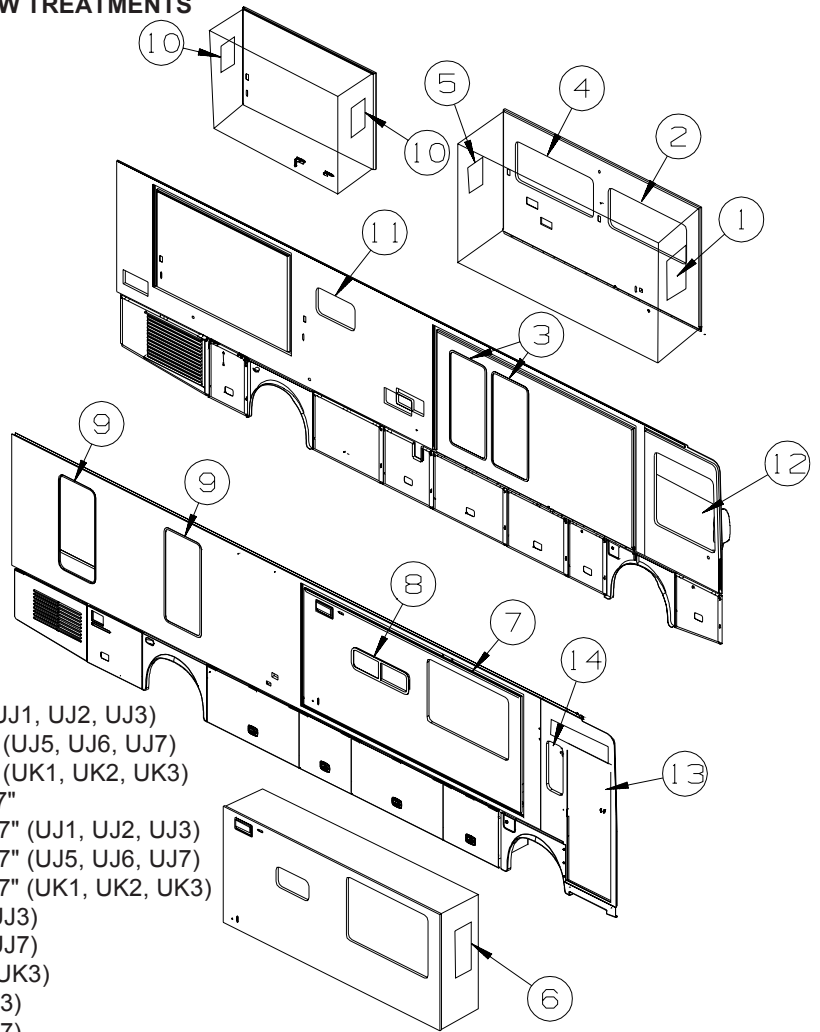

KEY	PART NUMBER	U/M	DESCRIPTION
1	150530-54-UJ1	EA	VALANCE - ABBOTT - 26" X 6" (UJ1, UJ2, UJ3)
1	150530-28-UJ5	EA	VALANCE - ABBOTT - 26.5" X 6" (UJ5, UJ6, UJ7)
1	150530-32-UK1	EA	VALANCE - ABBOTT - 26.5" X 6" (UK1, UK2, UK3)
1	140789-68-TG0	EA	BLIND - DAY/NIGHTER - 24" X 27"
2	150861-49-UJ1	EA	VALANCE - BROADWAY - 62" X 7" (UJ1, UJ2, UJ3)
2	150861-15-UJ5	EA	VALANCE - BROADWAY - 62" X 7" (UJ5, UJ6, UJ7)
2	150861-18-UK1	EA	VALANCE - BROADWAY - 62" X 7" (UK1, UK2, UK3)
2	150862-05-UJ1	EA	LEG - RIGHT - 23.5" (UJ1, UJ2, UJ3)
2	150862-13-UJ5	EA	LEG - RIGHT - 23.5" (UJ5, UJ6, UJ7)
2	150862-17-UK1	EA	LEG - RIGHT - 23.5" (UK1, UK2, UK3)
2	150862-06-UJ1	EA	LEG - LEFT - 23.5" (UJ1, UJ2, UJ3)
2	150862-14-UJ5	EA	LEG - LEFT - 23.5" (UJ5, UJ6, UJ7)
2	150862-18-UK1	EA	LEG - LEFT - 23.5" (UK1, UK2, UK3)
2	140789-08-SD0	EA	BLIND - DAY/NIGHTER - 59" X 26.5"
3	150861-50-UJ1	EA	VALANCE - BROADWAY - 62" X 9" (UJ1, UJ2, UJ3)
3	150861-16-UJ5	EA	VALANCE - BROADWAY - 62" X 9" (UJ5, UJ6, UJ7)
3	150861-19-UK1	EA	VALANCE - BROADWAY - 62" X 9" (UK1, UK2, UK3)
3	140789-86-TG0	EA	BLIND - DAY/NIGHTER - 28" X 62"
3	152445-65-UJ1	EA	LEG - RIGHT - 60" (UJ1, UJ2, UJ3)
3	152445-67-UJ5	EA	LEG - RIGHT - 60" (UJ5, UJ6, UJ7)
3	152445-69-UK1	EA	LEG - RIGHT - 60" (UK1, UK2, UK3)
3	152445-66-UJ1	EA	LEG - LEFT - 60" (UJ1, UJ2, UJ3)
3	152445-68-UJ5	EA	LEG - LEFT - 60" (UJ5, UJ6, UJ7)
3	152445-70-UK1	EA	LEG - LEFT - 60" (UK1, UK2, UK3)
3	155514-15-UJ1	EA	LEG - CENTER - 60" (UJ1, UJ2, UJ3)
3	155514-15-UJ5	EA	LEG - CENTER - 60" (UJ5, UJ6, UJ7)
3	155514-15-UK1	EA	LEG - CENTER - 60" (UK1, UK2, UK3)
4	150861-49-UJ1	EA	VALANCE - BROADWAY - 62" X 7" (UJ1, UJ2, UJ3)
4	150861-15-UJ5	EA	VALANCE - BROADWAY - 62" X 7" (UJ5, UJ6, UJ7)
4	150861-18-UK1	EA	VALANCE - BROADWAY - 62" X 7" (UK1, UK2, UK3)
4	150862-05-UJ1	EA	LEG - RIGHT - 23.5" (UJ1, UJ2, UJ3)
4	150862-13-UJ5	EA	LEG - RIGHT - 23.5" (UJ5, UJ6, UJ7)
4	150862-17-UK1	EA	LEG - RIGHT - 23.5" (UK1, UK2, UK3)
4	150862-06-UJ1	EA	LEG - LEFT - 23.5" (UJ1, UJ2, UJ3)
4	150862-14-UJ5	EA	LEG - LEFT - 23.5" (UJ5, UJ6, UJ7)
4	150862-18-UK1	EA	LEG - LEFT - 23.5" (UK1, UK2, UK3)
4	140789-08-SD0	EA	BLIND - DAY/NIGHTER - 59" X 26.5"
5	150530-55-UJ1	EA	VALANCE - ABBOTT - 26" X 9" (UJ1, UJ2, UJ3)
5	150530-29-UJ5	EA	VALANCE - ABBOTT - 26.5" X 9" (UJ5, UJ6, UJ7)
5	150530-33-UK1	EA	VALANCE - ABBOTT - 26.5" X 9" (UK1, UK2, UK3)
5	150530-54-UJ1	EA	VALANCE - ABBOTT - 26" X 6" (UJ1, UJ2, UJ3) - DINETTE OR COMPUTER TABLE
5	150530-28-UJ5	EA	VALANCE - ABBOTT - 26.5" X 6" (UJ5, UJ6, UJ7) - DINETTE OR COMPUTER TABLE

CURTAIN & CUSHION GROUP (CONTINUED)
WINDOW TREATMENTS (CONTINUED)

KEY	PART NUMBER	U/M	DESCRIPTION
5	150530-32-UK1	EA	VALANCE - ABBOTT - 26.5" X 6" (UK1, UK2, UK3) - DINETTE OR COMPUTER TABLE
5	140789-46-TG0	EA	BLIND - DAY/NIGHTER - 23.5" X 61"
5	140789-68-TG0	EA	BLIND - DAY/NIGHTER - 24" X 27" - DINETTE OR COMPUTER TABLE
6	150530-57-UJ1	EA	VALANCE - ABBOTT - 18" X 13" (UJ1, UJ2, UJ3)
6	150530-30-UJ5	EA	VALANCE - ABBOTT - 18" X 13" (UJ5, UJ6, UJ7)
6	150530-34-UK1	EA	VALANCE - ABBOTT - 18" X 13" (UK1, UK2, UK3)
6	159953-71-UJ1	EA	LEG - RIGHT - 35" (UJ1, UJ2, UJ3)
6	159953-73-UJ5	EA	LEG - RIGHT - 35" (UJ5, UJ6, UJ7)
6	159953-75-UK1	EA	LEG - RIGHT - 35" (UK1, UK2, UK3)
6	159953-72-UJ1	EA	LEG - LEFT - 35" (UJ1, UJ2, UJ3)
6	159953-74-UJ5	EA	LEG - LEFT - 35" (UJ5, UJ6, UJ7)
6	159953-76-UK1	EA	LEG - LEFT - 35" (UK1, UK2, UK3)
6	140789-51-SD0	EA	BLIND - DAY/NIGHTER - 14.5" X 32"
7	150861-59-UJ1	EA	VALANCE - BROADWAY - 65" X 12" (UJ1, UJ2, UJ3)
7	150861-17-UJ5	EA	VALANCE - BROADWAY - 65" X 12" (UJ5, UJ6, UJ7)
7	150861-20-UK1	EA	VALANCE - BROADWAY - 65" X 12" (UK1, UK2, UK3)
7	150862-09-UJ1	EA	LEG - RIGHT - 38.5" (UJ1, UJ2, UJ3)
7	150862-15-UJ5	EA	LEG - RIGHT - 38.5" (UJ5, UJ6, UJ7)
7	150862-19-UK1	EA	LEG - RIGHT - 38.5" (UK1, UK2, UK3)
7	150862-10-UJ1	EA	LEG - LEFT - 38.5" (UJ1, UJ2, UJ3)
7	150862-16-UJ5	EA	LEG - LEFT - 38.5" (UJ5, UJ6, UJ7)
7	150862-20-UK1	EA	LEG - LEFT - 38.5" (UK1, UK2, UK3)
7	140789-67-TG0	EA	BLIND - DAY/NIGHTER - 61" X 46"
8	150530-56-UJ1	EA	VALANCE - ABBOTT - 44.5" X 6" (UJ1, UJ2, UJ3)
8	150530-31-UJ5	EA	VALANCE - ABBOTT - 44.5" X 6" (UJ5, UJ6, UJ7)
8	150530-35-UK1	EA	VALANCE - ABBOTT - 44.5" X 6" (UK1, UK2, UK3)
8	111861-31-01A	EA	BLIND - MINI - 43" X 18" - ALABASTER PEARL
9	150861-54-UJ1	EA	VALANCE - BROADWAY - 33.5" X 7" (UJ1, UJ2, UJ3)
9	150861-54-UJ5	EA	VALANCE - BROADWAY - 33.5" X 7" (UJ5, UJ6, UJ7)
9	150861-54-UK1	EA	VALANCE - BROADWAY - 33.5" X 7" (UK1, UK2, UK3)
9	152664-89-UJ1	EA	LEG - RIGHT - 57" (UJ1, UJ2, UJ3)
9	152664-89-UJ5	EA	LEG - RIGHT - 57" (UJ5, UJ6, UJ7)
9	152664-89-UK1	EA	LEG - RIGHT - 57" (UK1, UK2, UK3)
9	152664-90-UJ1	EA	LEG - LEFT - 57" (UJ1, UJ2, UJ3)
9	152664-90-UJ5	EA	LEG - LEFT - 57" (UJ5, UJ6, UJ7)
9	152664-90-UK1	EA	LEG - LEFT - 57" (UK1, UK2, UK3)
9	140789-39-SD0	EA	BLIND - DAY/NIGHTER - 28" X 57"
10	150861-28-UJ1	EA	VALANCE - BROADWAY - 26" X 7" (UJ1, UJ2, UJ3)
10	150861-28-UJ5	EA	VALANCE - BROADWAY - 26" X 7" (UJ5, UJ6, UJ7)
10	150861-28-UK1	EA	VALANCE - BROADWAY - 26" X 7" (UK1, UK2, UK3)
10	159953-17-UJ1	EA	LEG - RIGHT - 26" (UJ1, UJ2, UJ3)
10	159953-17-UJ5	EA	LEG - RIGHT - 26" (UJ5, UJ6, UJ7)
10	159953-17-UK1	EA	LEG - RIGHT - 26" (UK1, UK2, UK3)
10	159953-18-UJ1	EA	LEG - LEFT - 26" (UJ1, UJ2, UJ3)
10	159953-18-UJ5	EA	LEG - LEFT - 26" (UJ5, UJ6, UJ7)
10	159953-18-UK1	EA	LEG - LEFT - 26" (UK1, UK2, UK3)
10	140789-72-TG0	EA	BLIND - DAY/NIGHTER - 23" X 27"
11	111861-25-01A	EA	BLIND - MINI - 29" X 27" - ALABASTER PEARL
12	139479-15-01A	EA	CURTAIN - DRIVER WRAP/PRIVACY/STEPPED - 41.75" X 90"
13	139479-16-01A	EA	CURTAIN - PASSENGER WRAP/PRIVACY/FRONT - 40.5" X 120"
14	139479-17-01A	EA	CURTAIN - PASSENGER WRAP/PRIVACY/REAR - 43" X 75"

CURTAIN & CUSHION GROUP (CONTINUED)

HARDWARE



KEY	PART NUMBER	U/M	DESCRIPTION
1A	029155-01-000	EA	CAP - SNAP - 5/32" OUTSIDE DIAMETER OF PIN
2A	029156-01-000	EA	SOCKET - SNAP - 9/16" O.D.
3A	046867-02-000	EA	WASHER - HANDY BUTTON #3
4A	046867-03-000	EA	GROMMET - HANDY BUTTON #3
5A	075943-10-000	EA	BRACE - VALANCE - 20" - OFF WHITE
6A	083170-01-000	EA	BRACKET/BLIND - LEFT SIDE WHEN FACING WINDOW - CLEAR
7A	083170-02-000	EA	BRACKET/BLIND - RIGHT SIDE WHEN FACING WINDOW - CLEAR
8A	084434-01-000	EA	BRACKET - MOUNTING - ROLLER SHADE - 1 3/8"
9A	094896-02-000	EA	GROMMET - CORD/PLEATED BLIND - NYLON - GRAY
10A	094907-02-000	EA	END CAP - PLEATED BLIND/TOP - RH/LH - GRAY PLASTIC
11A	094907-04-000	EA	END CAP - PLEATED BLIND/BOTTOM - RH/LH
12A	094907-09-000	EA	END CAP/BLIND - CENTER RAIL - RH/LH
13A	097564-03-000	EA	HANDLE - KNOB - E-Z LIFT SHADE - TAN
	097593-02-000	FT	CORD - BLIND - PLEATED - GRAY
	097593-10-000	FT	CORD - BLIND - PLEATED - VANILLA
14A	097565-01-000	EA	BRACKET - MOUNTING - PLEATED BLIND
15A	097591-01-000	EA	SPRING - EXTENSION - PLEATED BLIND
15A	155748-01-000	EA	SPRING - EXTENSION - DAY/NIGHTER BLIND
16A	101031-01-000	YD	TAPE/GLIDE - 4.25" SPACING
17A	102555-03-000	EA	BRACKET - (CLEAT TYPE) - F/BLIND HOLDOWN - MILKY WHITE

CURTAIN & CUSHION GROUP (CONTINUED)
HARDWARE (CONTINUED)

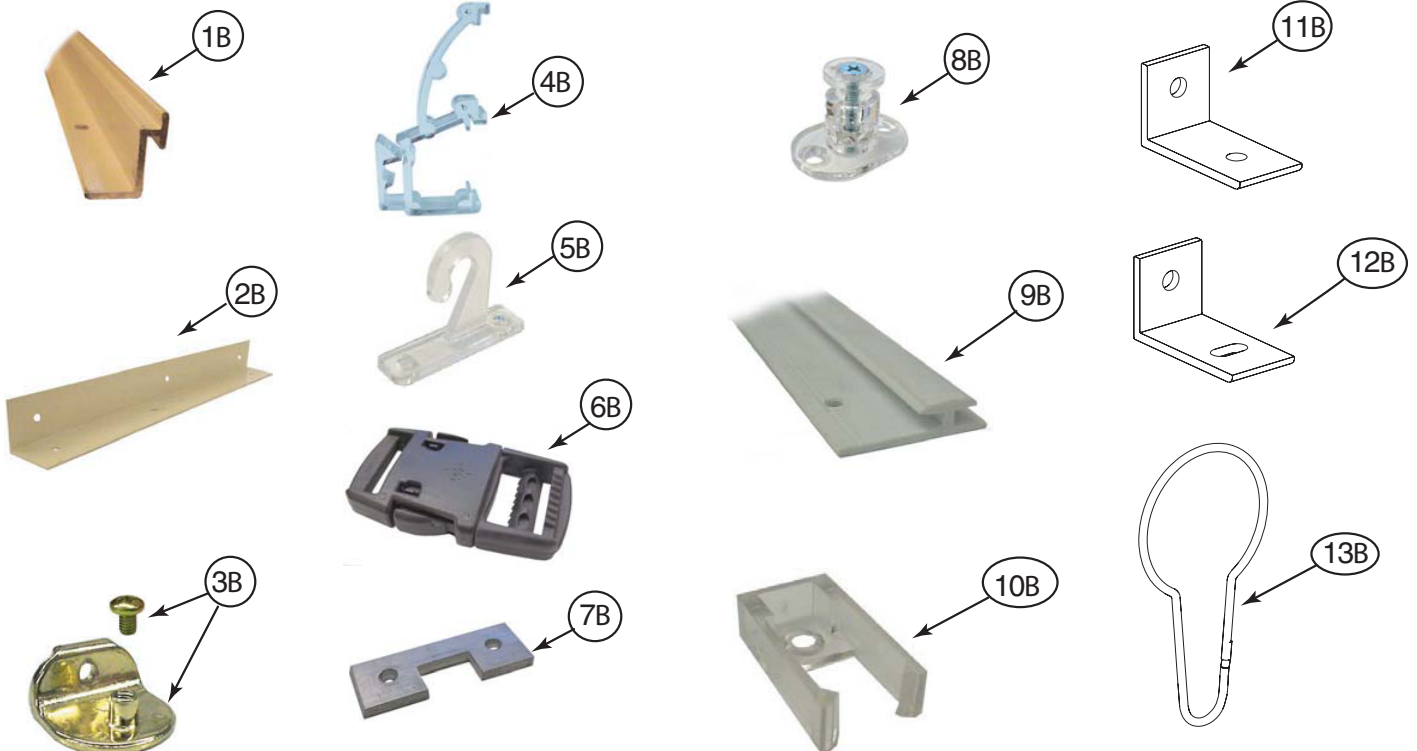

KEY	PART NUMBER	U/M	DESCRIPTION
1B	105450-14-01A	EA	TRACK-90"-OW - FRT BUNK PRIVACY OUTLOOK/SPIRIT 300-SERIES, ACCESS/IMPULSE 200-SERIES
2B	105648-01-02A	EA	BRACE - VALANCE - 14" - OFF WHITE
2B	105648-02-02A	EA	BRACE - VALANCE - 8.5" - OFF WHITE
3B	106544-01-000	EA	PULL - SHADE/BRASS
3B	106544-01-001	EA	SCREW - SHADE/BRASS
3B	106544-02-000	EA	PULL-SHADE - NICKEL
4B	109353-04-000	EA	CLIP - VALANCE SLAT MOUNTING - CLEAR PLASTIC
5B	109441-01-000	EA	BRACKET/HOOK - BLIND HOLD DOWN
	109441-02-000	EA	SPACER/BRACKET - BLIND HOLD DOWN
6B	129491-01-000	EA	CATCH - SNAP HOOK - 1"
7B	130549-01-01A	EA	STOP - CURTAIN TRACK
8B	141634-01-000	EA	BRACKET-(BOBBIN TYPE) 7/8"H HOLDUPBASE(OVAL)-2 HOLE-CLEAR
9B	156172-01-01A	EA	TRACK/WALL - 75" - BONE
9B	156172-02-01A	EA	TRACK/WALL - 32" - BONE
9B	156172-03-01A	EA	TRACK/WALL - 21" - BONE
10B	156172-04-01A	EA	END CAP - WALL TRACK - CLEAR
11B	154316-01-01A	EA	BRACE/ANGLE - W/HOLE - CASHMERE
12B	154316-02-01A	EA	BRACE/ANGLE - W/SLOT - CASHMERE
13B	159702-01-01A	EA	HOOK/RING - CURTAIN/SHOWER - NICKEL

ACCESSORIES

KEY	PART NUMBER	U/M	DESCRIPTION
	099856-11-000	EA	STRAP - TIEDOWN - 7.9"
	099856-12-000	EA	STRAP - TIEDOWN - 121.9"
	099856-13-000	EA	STRAP - TIEDOWN - 143.5"
	118337-15-UJ1	EA	BUTTON - #60 - FABRIC COVERED (UJ1, UJ2, UJ3)
	118337-15-UK1	EA	BUTTON - #60 - FABRIC COVERED (UK1, UK2, UK3)
	118337-21-UJ5	EA	BUTTON - #60 - DOUBLE SIDED - FABRIC COVERED (UJ5, UJ6, UJ7)
	074494-04-000	EA	BUTTON - JOINED/PIVOT - W 3/4 TACK

CURTAIN & CUSHION GROUP (CONTINUED)

FABRICS

UJ1, UJ2 UJ3

113979-09-01A CEILING MATERIAL - 102" - SOFT GEOMETRIC/PEARL CREAM
113979-10-01A CEILING MATERIAL - 21.5" - SOFT GEOMETRIC/PEARL CREAM
137813-S8-000 FABRIC-UPHOSTERY,BEDSPREAD MAIN
137813-T0-000 FABRIC-UPHOSTERY,BEDSPREAD PATTERN ACCENT
137813-T2-000 FABRIC-O/H CABT,BEDROOM
137813-T2-000 FABRIC-BEDSPREAD ACCENT PATTERN ACCENT "B"
142523-17-000 FABRIC-UPHOSTERY,ACCEN PLAIN "B"
142523-17-000 FABRIC-UPHL,SEAT INSERT
148797-J9-000 FABRIC-UPHOSTERY MAIN ONE
148797-P0-000 FABRIC-UPHLSTRY,PLAIN ACCENT
148797-P2-000 FABRIC-SPEAKER COVER
148797-P2-000 FABRIC-O/H CABT,DIN/LOUNGE
148797-P2-000 FABRIC-DINETTE WRAP DINETTES
148797-P2-000 FABRIC-LOUNGE TRIM UPHOLSTERY
148797-P2-000 FABRIC-UPHOLSTERY ACCENT PATTERN

UJ5, UJ6, UJ7

113979-09-01A CEILING MATERIAL - 102" - SOFT GEOMETRIC/PEARL CREAM
113979-10-01A CEILING MATERIAL - 21.5" - SOFT GEOMETRIC/PEARL CREAM
137813-X0-000 FABRIC-BEDSPREAD ACCENT PATTERN ACCENT "B"
137813-W4-000 FABRIC-UPHOSTERY,BEDSPREAD PATTERN ACCENT A
137813-Y9-000 FABRIC-UPHOSTERY,BEDSPREAD
137813-Y9-000 FABRIC-O/H CABT,BEDROOM
142523-17-000 FABRIC-UPHOSTERY,ACCEN PLAIN "B"
142523-17-000 FABRIC-UPHL,SEAT INSERT
148797-A6-000 FABRIC-UPHOSTERY MAIN ONE MAIN
148797-P1-000 FABRIC-UPHLSTRY,PLAIN ACCENT
148797-P1-000 FABRIC-UPHOLSTERY ACCENT PATTERN
148797-P1-000 FABRIC-O/H CABT,DIN/LOUNGE
148797-P1-000 FABRIC-DINETTE WRAP
148797-P1-000 FABRIC-LOUNGE TRIM UPHOLSTERY

UK1, UK2, UK3

113979-09-01A CEILING MATERIAL - 102" - SOFT GEOMETRIC/PEARL CREAM
113979-10-01A CEILING MATERIAL - 21.5" - SOFT GEOMETRIC/PEARL CREAM
148797-A9-000 FABRIC-UPHOSTERY MAIN ONE MAIN
148797-B0-000 FABRIC-UPHLSTRY,PLAIN ACCENT
148797-B0-000 FABRIC-UPHOLSTERY ACCENT PATTERN
137813-W3-000 FABRIC-UPHOSTERY,BEDSPREAD MAIN
142523-07-000 FABRIC-UPHOSTERY,ACCEN PLAIN "B"
142523-07-000 FABRIC-UPHL,SEAT INSERT
137813-T0-000 FABRIC-UPHOSTERY,BEDSPREAD PATTERN ACCENT A
148797-B0-000 FABRIC-SPEAKER COVER
137813-W5-000 FABRIC-O/H CABT,BEDROOM
148797-B0-000 FABRIC-DINETTE WRAP DINETTES
148797-B0-000 FABRIC-LOUNGE TRIM UPHOLSTERY

DRIVERS COMPARTMENT GROUP

DASH

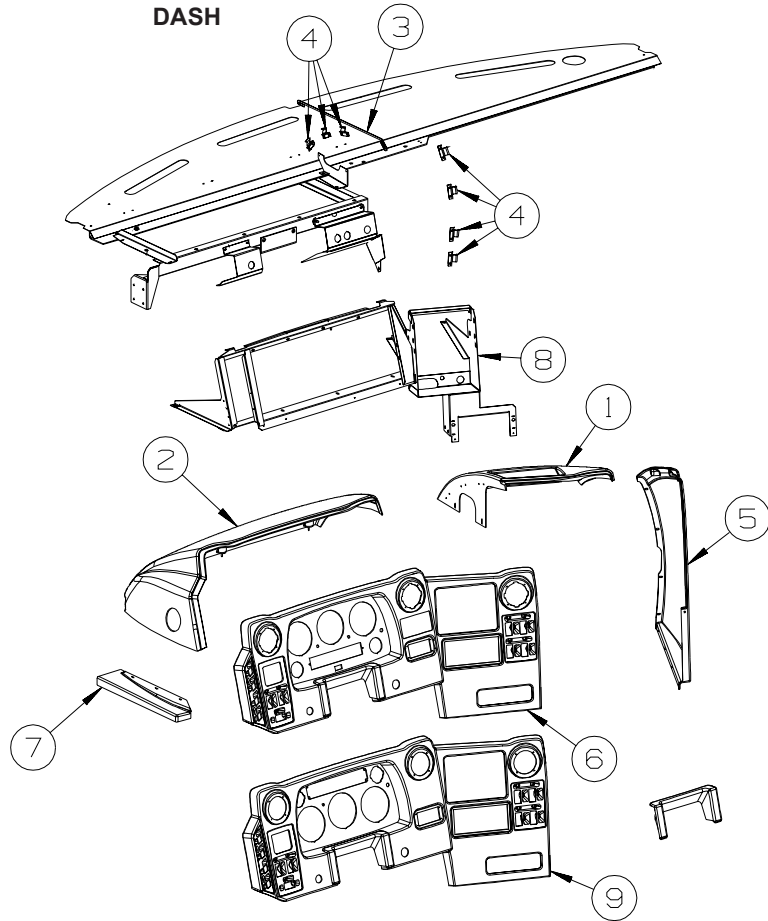
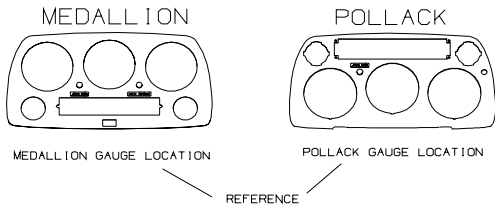

KEY	PART NUMBER	U/M	DESCRIPTION
1	144235-02-03A	EA	POD - INSTRUMENT PANEL - RIGHT HAND - CASHMERE
1	144235-02-04A	EA	POD - INSTRUMENT PANEL - RIGHT HAND - BRIARWOOD
2	144234-02-03A	EA	POD - INSTRUMENT PANEL - CASHMERE
2	144234-02-04A	EA	POD - INSTRUMENT PANEL - BRIARWOOD
3	118101-15-02B	EA	DASH PANEL/TOP ONLY - E-COATED
3	106569-09-09A	EA	VINYL - LAMINATE - 1/4" X 25" X 100" - DRIFTWOOD
3	106569-09-11A	EA	VINYL - LAMINATE - 1/4" X 25" X 100" - LT SANDLEWOOD
4	073050-04-000	EA	CLIP/MOUNTING - VALANCE PANEL
5	145041-02-03A	EA	PANEL - CENTER CONSOLE - RIGHT HAND - CASHMERE
5	145041-02-04A	EA	PANEL - CENTER CONSOLE - RIGHT HAND - BRIARWOOD
6	144236-09-02A	EA	BEZEL/POD - INSTRUMENT PANEL - CASHMERE - REFERENCE POLLACK GAUGES
6	144236-09-05A	EA	BEZEL/POD - INSTRUMENT PANEL - BRIARWOOD - REFERENCE POLLACK GAUGES
7	145604-02-05A	EA	PANEL/TRIM - DASH/LEFT HAND - CASHMERE
7	145604-02-06A	EA	PANEL/TRIM - DASH/LEFT HAND - BRIARWOOD
8	155178-01-02B	EA	REINFORCEMENT - INSTRUMENT PANEL - E-COATED
9	144236-07-02A	EA	BEZEL/POD - INSTRUMENT PANEL - CASHMERE - REFERENCE MEDALLION GAUGES
9	144236-07-05A	EA	BEZEL/POD - INSTRUMENT PANEL - BRIARWOOD - REFERENCE MEDALLION GAUGES

DRIVERS COMPARTMENT GROUP (CONTINUED)

FRONT INTERIOR

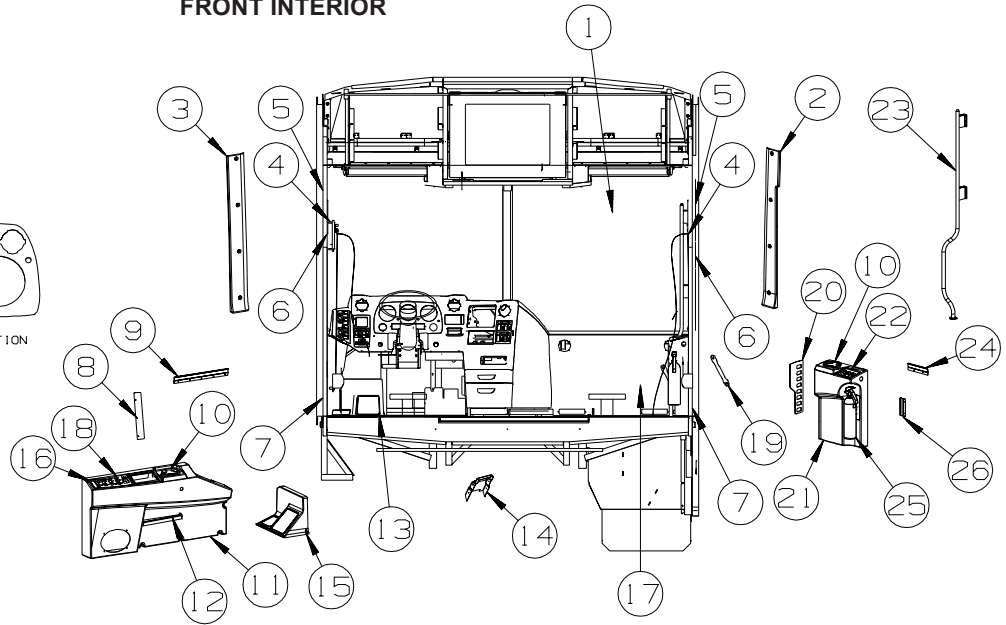
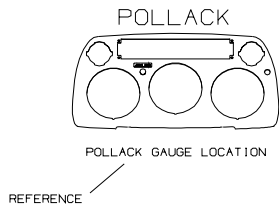
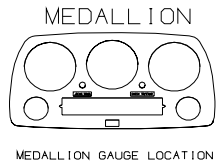

KEY	PART NUMBER	U/M	DESCRIPTION
1	157357-01-000	EA	SUNSCREEN/WINDSHIELD KIT - COMPLETE
1	157357-02-000	EA	TRACK - SUNSCREEN/WINDSHIELD - 96"
2	153275-01-20A	EA	TRIM - A-PILLAR/PASSENGER - INTERIOR - CASHMERE
2	153275-01-24A	EA	TRIM - A-PILLAR/PASSENGER - INTERIOR - BRIARWOOD
3	153276-01-20A	EA	TRIM - A-PILLAR/DRIVER - INTERIOR - CASHMERE
3	153276-01-24A	EA	TRIM - A-PILLAR/DRIVER - INTERIOR - BRIARWOOD
4	140151-01-01A	EA	COVER - SEAT BELT - OFF WHITE
4	140141-01-02A	EA	COVER - SEAT BELT - MEDIUM OAK
4	140151-02-01A	EA	COVER - SCREW - OFF WHITE
4	140151-02-03A	EA	COVER - SCREW - MEDIUM OAK
5	024700-58-000	EA	COVER - ROLL BAR - SIDEWALL - 16.5" - OFF WHITE
5	024700-71-000	EA	COVER - ROLL BAR - SIDEWALL - 16.5" - MEDIUM OAK
6	140151-03-01A	EA	COVER - SLIDING - F/SEATBELT - BLACK
6	140151-03-02A	EA	COVER - SLIDING - F/SEATBELT - MEDIUM OAK
7	024700-59-000	EA	COVER - ROLL BAR - SIDEWALL - 44.1" - OFF WHITE
7	024700-72-000	EA	COVER - ROLL BAR - SIDEWALL - 44.1" - MEDIUM OAK
8	130034-15-02B	EA	CLIP - TRIM - E-COATED
9	130034-10-02B	EA	CLIP - TRIM - E-COATED
10	133831-01-01A	EA	HOLDER - CUP W/THREE CENTERLINE RUBBER FINGERS
11	145231-04-04A	EA	PANEL/TRIM - INNER/LEFT HAND - CASHMERE- REFERENCE POLLACK GAUGES
11	145231-03-04A	EA	PANEL/TRIM - INNER/LEFT HAND - CASHMERE - REFERENCE MEDALLION GAUGES
11	145231-04-05A	EA	PANEL/TRIM - INNER/LEFT HAND - BRIARWOOD- REFERENCE POLLACK GAUGES
11	145231-03-05A	EA	PANEL/TRIM - INNER/LEFT HAND - BRIARWOOD - REFERENCE MEDALLION GAUGES
12	147266-01-04A	EA	SHELF - DRIVER CONSOLE - LEFT HAND - CONCERT CHERRY
12	147266-01-08A	EA	SHELF - DRIVER CONSOLE - LEFT HAND - CONCERT CHERRY
12	147266-01-05A	EA	SHELF - DRIVER CONSOLE - LEFT HAND - WASHED MAPLE
12	147266-01-07A	EA	SHELF - DRIVER CONSOLE - LEFT HAND - HONEY CHERRY
13	153366-01-UJ1	EA	MAT - FLOOR - DRIVER (UJ1, UJ2, UJ3)
13	153366-01-UJ5	EA	MAT - FLOOR - DRIVER (UJ5, UJ6, UJ7)
13	153366-01-UK1	EA	MAT - FLOOR - DRIVER (UK1, UK2, UK3)

DRIVERS COMPARTMENT GROUP (CONTINUED)
FRONT INTERIOR (CONTINUED)

KEY	PART NUMBER	U/M	DESCRIPTION
14	151048-02-01A	EA	COVER - STEERING COLUMN - UPPER/FRONT - BLACK - REFERENCE MEDALLION GAUGES
14	151048-01-01A	EA	COVER - STEERING COLUMN - UPPER/FRONT - BLACK - REFERENCE POLLACK GAUGES
15	151302-01-01A	EA	PANEL/FOOTREST - DRIVER - W/TREAD INSERTS - BLACK
16	144722-16-05A	EA	APPLIQUE - LEFT HAND - TEAK - SUNVISORS - POWERED (2)/REFERECE POLLACK GAUGES
16	144722-11-05A	EA	APPLIQUE - LEFT HAND - TEAK - SUNVISORS - POWERED (2)/REFERENCE MEDALLION GAUGES
16	144722-16-06A	EA	APPLIQUE - LEFT HAND - COCOA - SUNVISORS - POWERED (2)/REFERECE POLLACK GAUGES
16	144722-11-06A	EA	APPLIQUE - LEFT HAND - COCOA - SUNVISORS - POWERED (2)/REFERENCE MEDALLION GAUGES
16	144722-15-05A	EA	APPLIQUE - LEFT HAND - TEAK - SUNVISORS - POWERED (3)/REFERECE POLLACK GAUGES
16	144722-10-05A	EA	APPLIQUE - LEFT HAND - TEAK - SUNVISORS - POWERED (3)/REFERENCE MEDALLION GAUGES
16	144722-15-06A	EA	APPLIQUE - LEFT HAND - COCOA - SUNVISORS - POWERED (3)/REFERECE POLLACK GAUGES
16	144722-10-06A	EA	APPLIQUE - LEFT HAND - COCOA - SUNVISORS - POWERED (3)/REFERENCE MEDALLION GAUGES
17	145040-03-03A	EA	PANEL/TRIM - DASH/LOWER RIGHT - CASHMERE
17	145040-03-04A	EA	PANEL/TRIM - DASH/LOWER RIGHT - BRIARWOOD
18	145926-18-02B	EA	INSERT - SWITCH PLATE - 8 HOLE/RELAY SLOT - E-COATED - REFERENCE POLLACK GAUGES
18	145926-06-02B	EA	INSERT - SWITCH PLATE - 9 HOLE/RELAY SLOT - E-COATED - REFERENCE MEDALLION GAUGES
19	123246-01-07A	EA	HANDLE - GRAB - CASHMERE
19	123246-01-08A	EA	HANDLE - GRAB - BRIARWOOD
20	145926-16-02B	EA	INSERT - SWITCH PLATE - 9 HOLE - E-COATED
20	144722-04-05A	EA	APPLIQUE - PANEL - RIGHT HAND/UPPER - TEAK
20	144722-04-06A	EA	APPLIQUE - PANEL - RIGHT HAND/UPPER - COCOA
21	145219-03-04A	EA	PANEL/TRIM - INNER/RIGHT HAND - CASHMERE
21	145219-03-05A	EA	PANEL/TRIM - INNER/RIGHT HAND - BRIARWOOD
22	145926-02-02B	EA	INSERT - SWITCH PLATE - 3 HOLE - E-COATED
22	144722-14-05A	EA	APPLIQUE - PANEL - RIGHT HAND/LOWER - TEAK
22	144722-14-06A	EA	APPLIQUE - PANEL - RIGHT HAND/LOWER - COCOA
22	144722-18-05A	EA	APPLIQUE - PANEL - RIGHT HAND/LOWER - TEAK - S40TD FROM: 00-00-00 THRU: 10-15-06
22	144722-14-05A	EA	APPLIQUE - PANEL - RIGHT HAND/LOWER - TEAK - S40TD FROM: 10-16-06 THRU: 99-99-99
22	144722-18-06A	EA	APPLIQUE - PANEL - RIGHT HAND/LOWER - COCOA - S40TD FROM: 00-00-00 THRU: 10-15-06
22	144722-14-06A	EA	APPLIQUE - PANEL - RIGHT HAND/LOWER - COCOA - S40TD FROM: 10-16-06 THRU: 99-99-99
23	123577-01-01A	EA	HANDRAIL - ASSIST - ENTRY
24	130034-02-02B	EA	CLIP - TRIM - E-COATED
25*	094499-02-000	EA	EXTINGUISHER/FIRE - DRY - 10BC - W/GAUGE - CANADIAN
25	094499-03-000	EA	EXTINGUISHER/FIRE - DRY - 10BC - W/GAUGE/BRACKET
25	094499-04-000	EA	STRAP - FIRE EXTINGUISHER MOUNTING - METAL

*COMPONENT PARTS LISTED LATER IN THIS GROUP

DRIVERS COMPARTMENT GROUP (CONTINUED)
FRONT INTERIOR (CONTINUED)

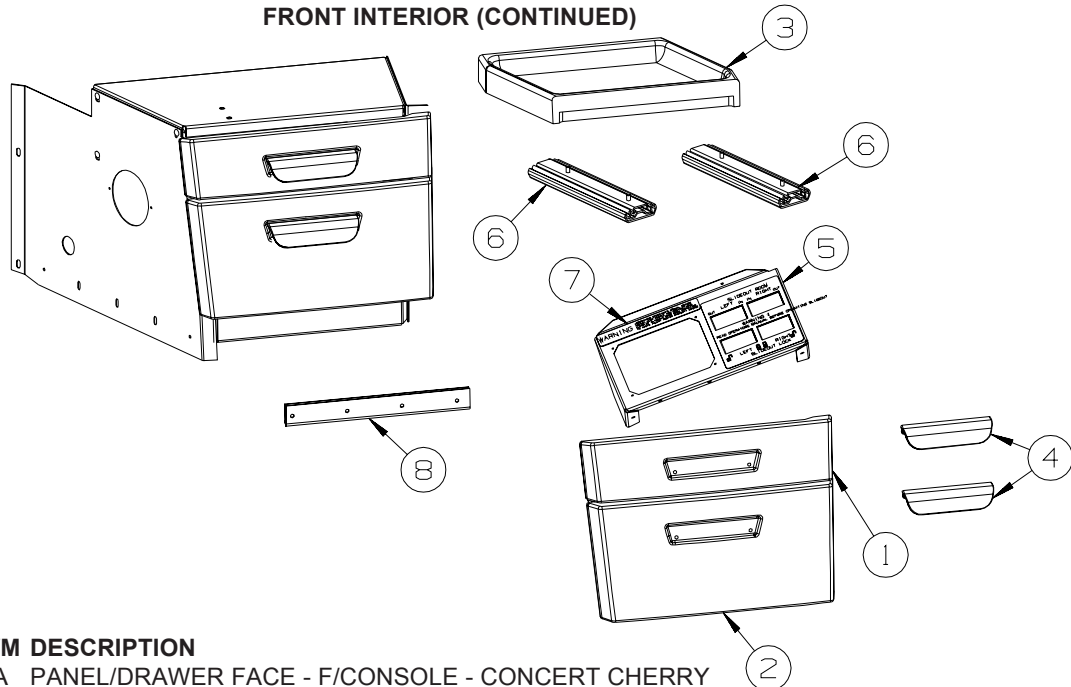

KEY	PART NUMBER	U/M	DESCRIPTION
1	146144-01-04A	EA	PANEL/DRAWER FACE - F/CONSOLE - CONCERT CHERRY FROM: 00-00-00 THRU: 05-31-06
1	146144-01-08A	EA	PANEL/DRAWER FACE - F/CONSOLE - CONCERT CHERRY FROM: 06-01-06 THRU: 99-99-99
1	146144-01-07A	EA	PANEL/DRAWER FACE - F/CONSOLE - WASHED MAPLE
1	146144-01-06A	EA	PANEL/DRAWER FACE - F/CONSOLE - HONEY CHERRY
2	146144-02-04A	EA	PANEL/DRAWER FACE - F/CONSOLE - CONCERT CHERRY FROM: 00-00-00 THRU: 05-31-06
2	146144-02-08A	EA	PANEL/DRAWER FACE - F/CONSOLE - CONCERT CHERRY FROM: 06-01-06 THRU: 99-99-99
2	146144-02-07A	EA	PANEL/DRAWER FACE - F/CONSOLE - WASHED MAPLE
2	146144-02-06A	EA	PANEL/DRAWER FACE - F/CONSOLE - HONEY CHERRY
3	146145-01-03A	EA	TRAY - CENTER CONSOLE - BEIGE SPECKLE
4	074762-01-000	EA	PULL - CABINET - 4.8" X .9" - BLACK PLASTIC
5	132946-09-01A	EA	APPLIQUE - SWITCH - F/SLIDEOUT - BLACK
6	146260-01-01A	EA	SLIDE - FULL EXTENSION 8"
7	116549-01-000	EA	LABEL - WARNING - SLIDEOUT
8	009065-03-000	EA	HINGE - ALUMINUM - 2" X 72.5" - UNPAINTED

DRIVERS COMPARTMENT GROUP (CONTINUED)
FRONT INTERIOR (CONTINUED)

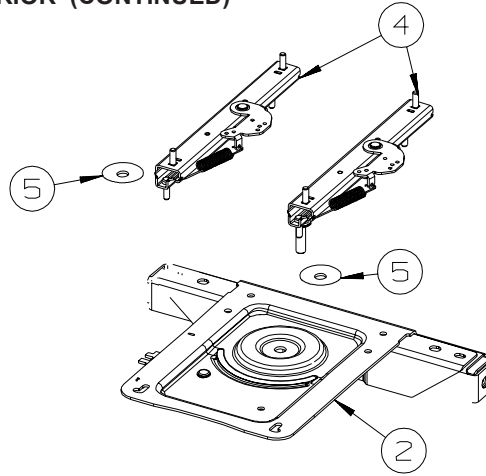

**DRIVER
MANUAL**

KEY	PART NUMBER	U/M	DESCRIPTION
1	133408-01-000	EA	PEDESTAL - SEAT - DRIVER/PASSENGER - 9 3/4"
2	133408-08-000	EA	TOP PLATE - W/BAR
3	107921-06-000	EA	BEARING KIT - PEDESTAL
4	131566-04-000	EA	SLIDE/SEAT - HEAVY DUTY LOCKING - 5"
	119952-07-000	EA	WIRE - LATCH RELEASE/ROTARY
5	131566-05-000	EA	WASHER - SLIDE SPACER

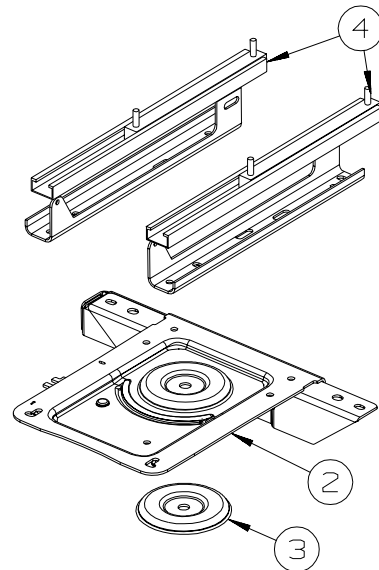
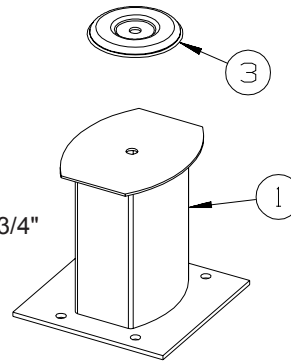

**DRIVER
POWERED**

KEY	PART NUMBER	U/M	DESCRIPTION
1	133408-05-000	EA	PEDESTAL - SEAT - 5.75"
2	133408-08-000	EA	TOP PLATE - W/BAR
3	107921-06-000	EA	BEARING KIT - PEDESTAL
4*	147767-01-000	EA	SEAT - POWER - 6-WAY - DRIVER

***COMPONENT PARTS LISTED LATER IN THIS GROUP**

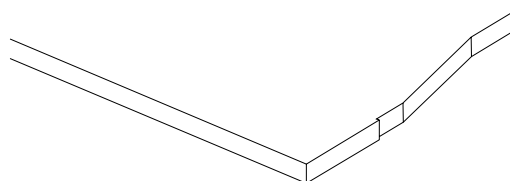

DRIVERS COMPARTMENT GROUP (CONTINUED)
FRONT INTERIOR (CONTINUED)

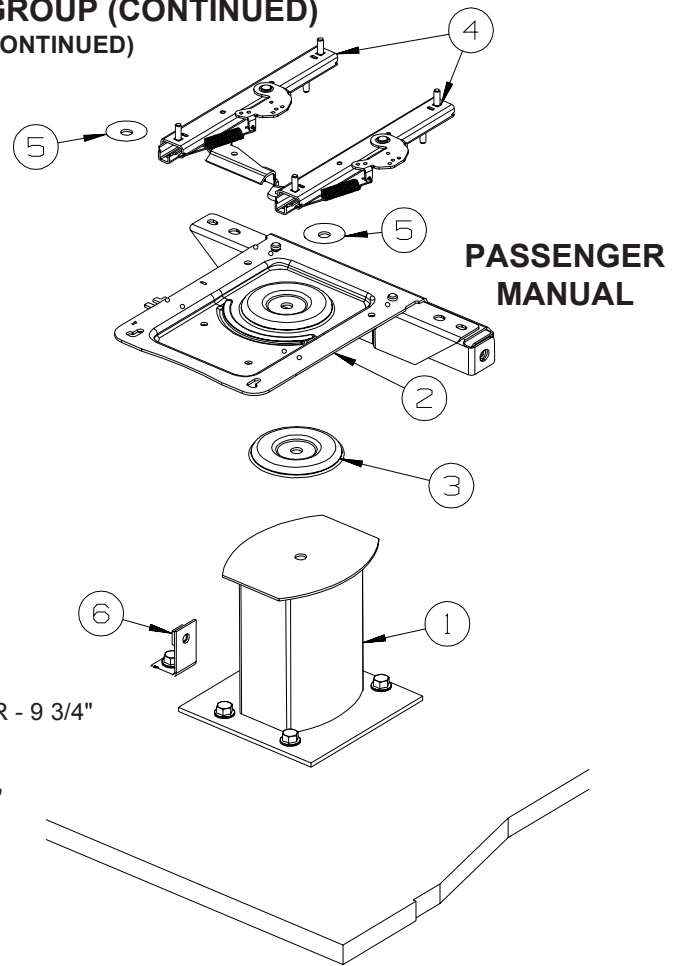

KEY	PART NUMBER	U/M	DESCRIPTION
1	133408-01-000	EA	PEDESTAL - SEAT - DRIVER/PASSENGER - 9 3/4"
2	133408-20-000	EA	TOP PLATE - PASSENGER - W/ANCHOR
3	107921-06-000	EA	BEARING KIT - PEDESTAL
4	131566-04-000	EA	SLIDE/SEAT - HEAVY DUTY LOCKING - 5"
4	131566-07-000	EA	5" DOUBLE LOCKING SLIDE W/TAB
	131566-06-000	EA	WIRE - LATCH RELEASE - 5"
5	131566-05-000	EA	WASHER - SLIDE SPACER
6	133408-04-000	EA	BRACKET - ANCHOR/FLOOR

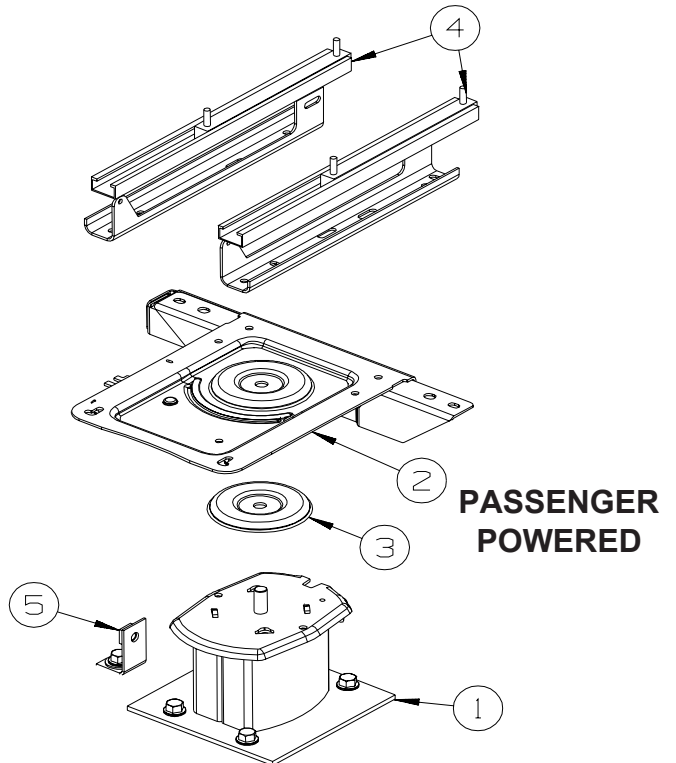
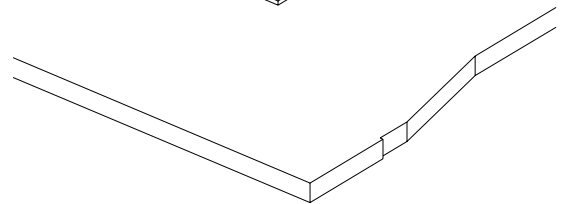

KEY	PART NUMBER	U/M	DESCRIPTION
1	133408-05-000	EA	PEDESTAL - SEAT - 5.75"
2	133408-20-000	EA	TOP PLATE - PASSENGER - W/ANCHOR
3	107921-06-000	EA	BEARING KIT - PEDESTAL
4*	147767-02-000	EA	SEAT - POWER - 6-WAY - PASSENGER
5	133408-04-000	EA	BRACKET - ANCHOR/FLOOR

*COMPONENT PARTS LISTED LATER IN THIS GROUP

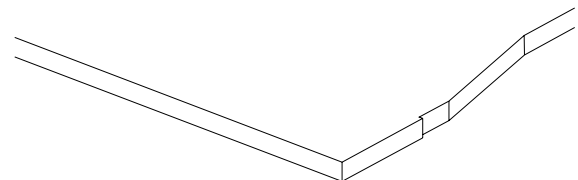

DRIVERS COMPARTMENT GROUP (CONTINUED)
FRONT INTERIOR (CONTINUED)

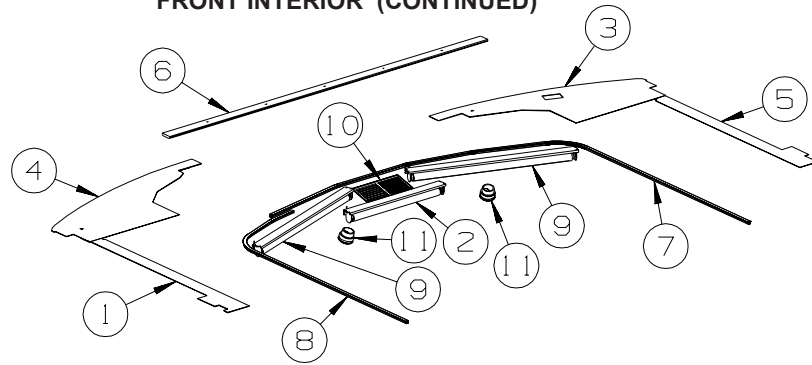

FRONT TV

KEY	PART NUMBER	U/M	DESCRIPTION
1	153339-02-TG0	EA	PANEL - OVERHEAD/LEFT HAND - CASHMERE
1	153339-02-TH0	EA	PANEL - OVERHEAD/LEFT HAND - BRIARWOOD
2	142380-01-01A	EA	SHADE - POWER - 25.7"
3	153074-05-UJ1	EA	PANEL - OVERHEAD/FRONT/BOTTOM/RIGHT HAND - CASHMERE
3	153074-05-TJ4	EA	PANEL - OVERHEAD/FRONT/BOTTOM/RIGHT HAND - BRIARWOOD
4	153074-06-UJ1	EA	PANEL - OVERHEAD/FRONT/BOTTOM/LEFT HAND - CASHMERE
4	153074-06-TJ4	EA	PANEL - OVERHEAD/FRONT/BOTTOM/LEFT HAND - BRIARWOOD
5	153339-01-TG0	EA	PANEL - OVERHEAD/RIGHT HAND - CASHMERE
5	153339-01-TH0	EA	PANEL - OVERHEAD/RIGHT HAND - BRIARWOOD
6	133771-06-TG1	EA	MOLDING - CAP - CONCERT CHERRY
6	133771-06-TG2	EA	MOLDING - CAP - WASHED MAPLE
6	133771-06-TG3	EA	MOLDING - CAP - HONEY CHERRY
	042356-01-000	EA	PLUG - MAHOGANY - 3/8" DOWEL X 1/2" HEAD
7	138460-07-04A	EA	TRACK/CURTAIN - PASSENGER - W/BRKT/CARRIER/PULLEY-CASHMERE
7	138460-07-03A	EA	TRACK/CURTAIN - PASSENGER-W/BRKT/CARRIER/PULLEY-RIVERSTONE
8	138460-08-04A	EA	TRACK/CURTAIN - DRIVER - W/BRKT/CARRIER/PULLEY - CASHMERE
8	138460-08-03A	EA	TRACK/CURTAIN - DRIVER - W/BRKT/CARRIER/PULLEY-RIVERSTONE
9	142380-08-01A	EA	SHADE - POWER - 37.5"W X 19"H
10	109918-01-05A	EA	VENT - RETURN AIR - 12.3" X 5.5" - BLACK
11	113244-01-01A	EA	LOUVER - BALL - 3" - BLACK
	134588-08-000	EA	GASKET - DUCT

DRIVERS COMPARTMENT GROUP (CONTINUED)
FRONT INTERIOR (CONTINUED)

SIDE TV

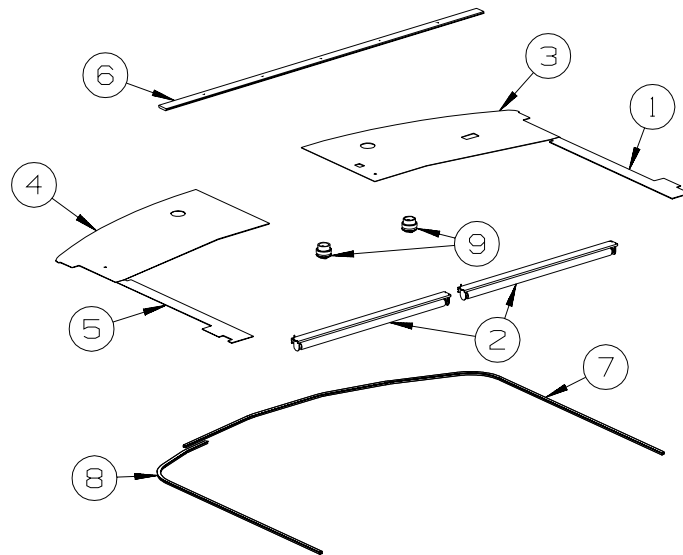

KEY	PART NUMBER	U/M	DESCRIPTION
1	153339-05-TG0	EA	PANEL - OVERHEAD/RIGHT HAND - CASHMERE
1	153339-05-TH0	EA	PANEL - OVERHEAD/RIGHT HAND - BRIARWOOD
2	142380-02-01A	EA	SHADE - POWER - 41.2"
3	154365-05-TH4	EA	PANEL - OVERHEAD/FRONT - BOTTOM/RH HAND - CASHMERE
3	154365-05-TJ4	EA	PANEL - OVERHEAD/FRONT - BOTTOM/RH HAND - BRIARWOOD
4	154365-06-TH4	EA	PANEL - OVERHEAD/FRONT - BOTTOM/LH HAND - CAHSMERE
4	154365-06-TJ4	EA	PANEL - OVERHEAD/FRONT - BOTTOM/LH HAND - BRIARWOOD
5	153339-06-TG0	EA	PANEL - OVERHEAD/RIGHT HAND - CASHMERE
5	153339-06-TH0	EA	PANEL - OVERHEAD/RIGHT HAND - BRIARWOOD
6	133771-06-TG1	EA	MOLDING - CAP - CONCERT CHERRY
6	133771-06-TG2	EA	MOLDING - CAP - WASHED MAPLE
6	133771-06-TG3	EA	MOLDING - CAP - HONEY CHERRY
	042356-01-000	EA	PLUG - MAHOGANY - 3/8" DOWEL X 1/2" HEAD
7	138460-07-04A	EA	TRACK/CURTAIN - PASSENGER - W/BRKT/CARRIER/PULLEY-CASHMERE
7	138460-07-03A	EA	TRACK/CURTAIN - PASSENGER-W/BRKT/CARRIER/PULLEY-RIVERSTONE
8	138460-08-04A	EA	TRACK/CURTAIN - DRIVER - W/BRKT/CARRIER/PULLEY - CASHMERE
8	138460-08-03A	EA	TRACK/CURTAIN - DRIVER - W/BRKT/CARRIER/PULLEY-RIVERSTONE
9	113244-01-01A	EA	LOUVER - BALL - 3" - BLACK

DRIVERS COMPARTMENT GROUP (CONTINUED)
FRONT INTERIOR (CONTINUED)

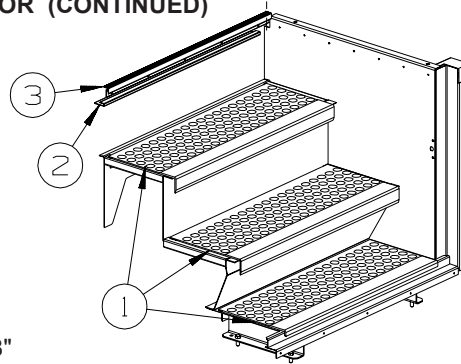

KEY	PART NUMBER	U/M	DESCRIPTION
1	120231-01-02A	EA	FLOORING - RUBBER - 66.4" X 19.8"
2	136839-07-01A	EA	TRIM-J - CARPET EDGE/SLIDEOUT - 28.3" - BLACK
3	139955-19-03A	EA	TRIM - STEP/ENTRY - 29.5" - BLACK

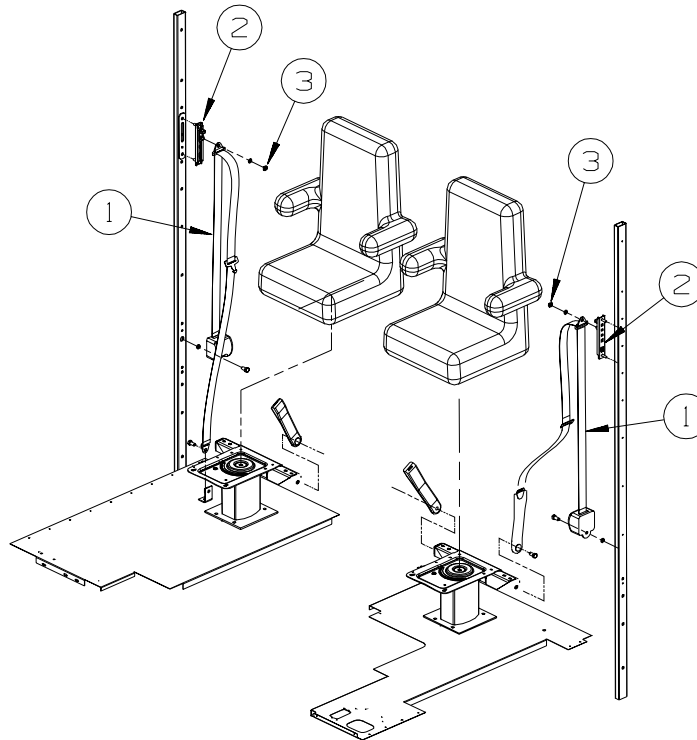

KEY	PART NUMBER	U/M	DESCRIPTION
1*	091990-08-01A	EA	SEAT BELT - 3 POINT - .766" DIAMETER HOLE IN D-LOOP BRKT
2	127598-01-01A	EA	ADJUSTER - SEATBELT - D-LOOP
3	127598-02-000	EA	NUT - HEX FLANGE - M10 X 1.5 - CLASS 10

*COMPONENT PARTS LISTED LATER IN THIS GROUP

COMPONENT PARTS FOR FRONT INTERIOR

091990-08-01A

KEY	PART NUMBER	U/M	DESCRIPTION	VENDOR NO.
	091990-01-701	EA	EXTENDER 9" FOR A8408 3 PT	I-1331-02
	091990-01-703	EA	RECEIVER/FEMALE END-SEATBELT	I-1159-02
	091990-05-700	EA	SLEEVE/BUCKLE COVER-PLASTIC	209S-2
	091990-05-701	EA	CAP/COVER - BOLT HOLE COVER	209SC-02
	091990-05-702	EA	SLEEVE/RETRACTABLE COVER	309C-02

094499-02-000

KEY	PART NUMBER	U/M	DESCRIPTION	VENDOR NO
	094499-01-700	EA	BRACKET MTG. W/PLAS. STRAP	294039

147767-01-000, 147767-02-000

KEY	PART NUMBER	U/M	DESCRIPTION	VENDOR NO
	147767-01-700	EA	SWITCH PLATE	SHROCK-9PT-SWT-PLTE
	147767-01-701	EA	MOTOR - VERTICAL	SHROCK 9PT-M0-VER-0
	147767-01-702	EA	MOTOR - HORIZONTAL	SHROCK 9PT-M0-HOZ-0

DRIVERS COMPARTMENT GROUP (CONTINUED)

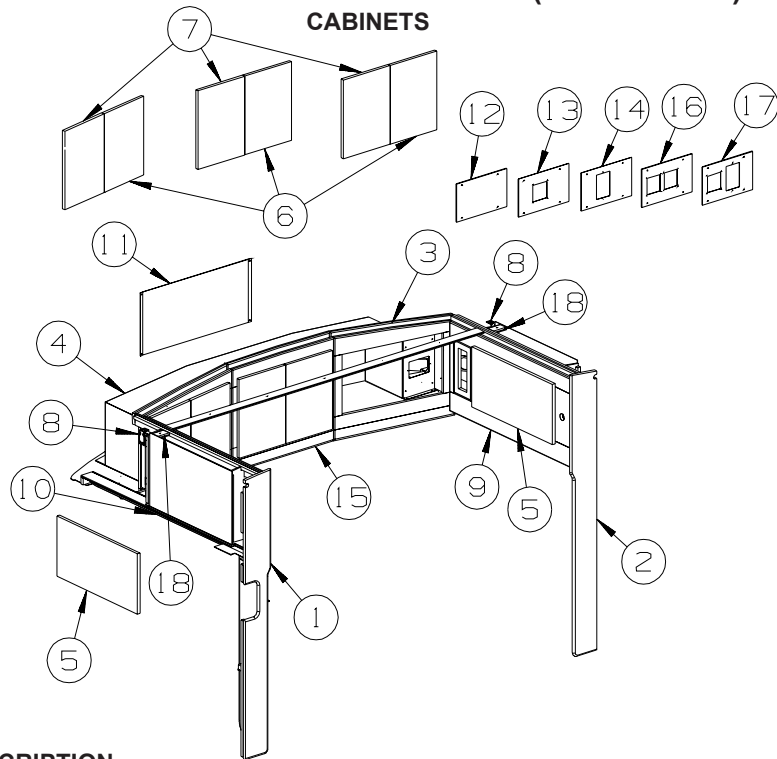

S40FD

KEY	PART NUMBER	U/M	DESCRIPTION
1	157310-02-UJ1	EA	CABINET - OVERHEAD/SIDE/LH HAND - W/O DOORS/HDW
1	157310-02-UJ2	EA	CABINET - OVERHEAD/SIDE/LH HAND - W/O DOORS/HDW
1	157310-02-UJ3	EA	CABINET - OVERHEAD/SIDE/LH HAND - W/O DOORS/HDW
1	157310-02-UJ5	EA	CABINET - OVERHEAD/SIDE/LH HAND - W/O DOORS/HDW
1	157310-02-UJ6	EA	CABINET - OVERHEAD/SIDE/LH HAND - W/O DOORS/HDW
1	157310-02-UJ7	EA	CABINET - OVERHEAD/SIDE/LH HAND - W/O DOORS/HDW
1	157310-02-UK1	EA	CABINET - OVERHEAD/SIDE/LH HAND - W/O DOORS/HDW
1	157310-02-UK2	EA	CABINET - OVERHEAD/SIDE/LH HAND - W/O DOORS/HDW
1	157310-02-UK3	EA	CABINET - OVERHEAD/SIDE/LH HAND - W/O DOORS/HDW
	146514-04-000	EA	LIGHT - FLEX - ROPE/ROUND - W/STRIP
2	157310-01-UJ1	EA	CABINET - OVERHEAD/SIDE/RH HAND - W/O DOORS/HDW
2	157310-01-UJ2	EA	CABINET - OVERHEAD/SIDE/RH HAND - W/O DOORS/HDW
2	157310-01-UJ3	EA	CABINET - OVERHEAD/SIDE/RH HAND - W/O DOORS/HDW
2	157310-01-UJ5	EA	CABINET - OVERHEAD/SIDE/RH HAND - W/O DOORS/HDW
2	157310-01-UJ6	EA	CABINET - OVERHEAD/SIDE/RH HAND - W/O DOORS/HDW
2	157310-01-UJ7	EA	CABINET - OVERHEAD/SIDE/RH HAND - W/O DOORS/HDW
2	157310-01-UK1	EA	CABINET - OVERHEAD/SIDE/RH HAND - W/O DOORS/HDW
2	157310-01-UK2	EA	CABINET - OVERHEAD/SIDE/RH HAND - W/O DOORS/HDW
2	157310-01-UK3	EA	CABINET - OVERHEAD/SIDE/RH HAND - W/O DOORS/HDW
	146514-04-000	EA	LIGHT - FLEX - ROPE/ROUND - W/STRIP
3	154271-01-TG1	EA	CABINET - OVERHEAD/FRONT - W/O DOORS/HDW - CONCERT CHERRY
3	154271-01-TG2	EA	CABINET - OVERHEAD/FRONT - W/O DOORS/HDW - WASHED MAPLE
3	154271-01-TG3	EA	CABINET - OVERHEAD/FRONT - W/O DOORS/HDW - HONEY CHERRY
4	154360-01-TG0	EA	PANEL/CLOSEOUT - OVERHEAD/FRONT
5	146892-91-UJ1	EA	DOOR - ARCHED/FLUTED EDGE/HORIZ - 13.6"X 27.1" - W/O HDW - CONCERT CHERRY
5	146892-91-UJ2	EA	DOOR - ARCHED/FLUTED EDGE/HORIZ - 13.6"X 27.1" - W/O HDW - WASHED MAPLE
5	146892-91-UJ3	EA	DOOR - ARCHED/FLUTED EDGE/HORIZ - 13.6"X 27.1" - W/O HDW - HONEY CHERRY
6	146891-83-UJ1	EA	DOOR - ARCHED PANEL/FLUTED EDGE/RH - 12.8" X 17.7"-W/O HDW - CONCERT CHERRY
6	146891-83-UJ2	EA	DOOR - ARCHED PANEL/FLUTED EDGE/RH - 12.8" X 17.7"-W/O HDW - WASHED MAPLE
6	146891-83-UJ3	EA	DOOR - ARCHED PANEL/FLUTED EDGE/RH - 12.8" X 17.7"-W/O HDW - HONEY CHERRY
7	146890-84-UJ1	EA	DOOR - ARCHED PANEL/FLUTED EDGE/RH - 12.8" X 17.7"-W/O HDW - CONCERT CHERRY
7	146890-84-UJ2	EA	DOOR - ARCHED PANEL/FLUTED EDGE/RH - 12.8" X 17.7"-W/O HDW - WASHED MAPLE
7	146890-84-UJ3	EA	DOOR - ARCHED PANEL/FLUTED EDGE/RH - 12.8" X 17.7"-W/O HDW - HONEY CHERRY
8	140309-03-02B	EA	ANGLE - FURNACE DOOR - E-COATED
			FROM: 00-00-00 THRU: 05-19-06
8	140309-05-02B	EA	ANGLE - FURNACE DOOR - E-COATED
			FROM: 05-20-06 THRU: 99-99-99
9	126841-05-000	EA	SHADE - PULL - CHARCOAL MESH - 30.3" X 60"
10	126841-09-000	EA	SHADE - PULL - CHARCOAL MESH - 40.25" X 60"
11	154360-03-TG0	EA	PANEL/CLOSEOUT - OVERHEAD/FRONT - CASHMERE

DRIVERS COMPARTMENT GROUP (CONTINUED)
CABINETS (CONTINUED)

KEY	PART NUMBER	U/M	DESCRIPTION
12	155127-01-TG0	EA	PANEL - VINYL COVERED - CASHMERE
12	155127-01-TH0	EA	PANEL - VINYL COVERED - BRIARWOOD
13	155127-02-TG0	EA	PANEL - VINYL COVERED - CASHMERE - TV ANT-AMPLIFIED PWR & SATELLITE SYS READY
13	155127-02-TH0	EA	PANEL - VINYL COVERED - BRIARWOOD - TV ANT-AMPLIFIED PWR & SATELLITE SYS READY
13	155127-02-TG0	EA	PANEL - VINYL COVERED - CASHMERE - SATELLITE TV SYSTEM AUTO FROM: 00-00-00 THRU: 01-28-07
13	155127-10-U68	EA	PANEL - VINYL COVERED - CASHMERE - SATELLITE TV SYSTEM AUTO - NOT ILLUSTRATED FROM: 01-29-07 THRU: 99-99-99
13	155127-02-TH0	EA	PANEL - VINYL COVERED - BRIARWOOD - SATELLITE TV SYSTEM AUTO FROM: 00-00-00 THRU: 01-28-07
13	155128-10-U67	EA	PANEL - VINYL COVERED - BRIARWOOD - SATELLITE TV SYSTEM AUTO - NOT ILLUSTRATED FROM: 01-29-07 THRU: 99-99-99
14	155127-03-TG0	EA	PANEL - VINYL COVERED - CASHMERE - SAT TV SYSTEM IN-MOTION
14	155127-03-TH0	EA	PANEL - VINYL COVERED - BRIARWOOD - SAT TV SYSTEM IN-MOTION
15	M09492-44-TG1	EA	FACE/FRAME (PICTURE) - OVERHEAD/FRONT - W/O DOORS/HDW - CONCERT CHERRY
15	M09492-44-TG2	EA	FACE/FRAME (PICTURE) - OVERHEAD/FRONT - W/O DOORS/HDW - WASHED MAPLE
15	M09492-44-TG3	EA	FACE/FRAME (PICTURE) - OVERHEAD/FRONT - W/O DOORS/HDW - HONEY CHERRY
16	155127-06-UJ1	EA	PANEL - VINYL COVERED - CASHMERE - TV ANT-AMPLIFIED PWR & SAT TV SYS AUTO FROM: 00-00-00 THRU: 01-28-07
16	155127-12-WK4	EA	PANEL - VINYL COVERED - CASHMERE - TV ANT-AMPLIFIED PWR & SAT TV SYS AUTO FROM: 01-29-07 THRU: 99-99-99
16	155127-06-UK1	EA	PANEL - VINYL COVERED - BRIARWOOD - TV ANT-AMPLIFIED PWR & SAT TV SYS AUTO FROM: 00-00-00 THRU: 01-28-07
16	155127-12-UK1	EA	PANEL - VINYL COVERED - BRIARWOOD - TV ANT-AMPLIFIED PWR & SAT TV SYS AUTO FROM: 01-29-07 THRU: 99-99-99
17	155127-07-UJ1	EA	PANEL - VINYL COVERED - CASHMERE - TV ANT-AMPLIFIED PWR & SAT SYS IN-MOTION
17	155127-07-UK1	EA	PANEL - VINYL COVERED - BRIARWOOD - TV ANT-AMPLIFIED PWR & SAT SYS IN-MOTION
18	133771-08-UF1	EA	MOLDING - CAP - CONCERT CHERRY FROM: 12-04-06 THRU: 99-99-99
18	133771-08-UF2	EA	MOLDING - CAP - WASHED MAPLE FROM: 12-04-06 THRU: 99-99-99
18	133771-08-UJ3	EA	MOLDING - CAP - HONEY CHERRY FROM: 12-04-06 THRU: 99-99-99
	042356-01-000	EA	PLUG - MAHOGANY - 3/8" DOWEL X 1/2" HEAD FROM: 12-04-06 THRU: 99-99-99

DRIVERS COMPARTMENT GROUP (CONTINUED)
CABINETS (CONTINUED)

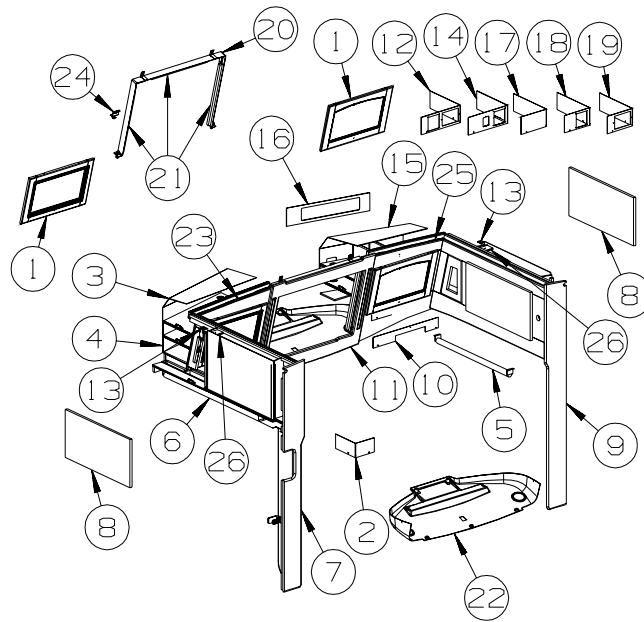

S40KD
27" TV

KEY	PART NUMBER	U/M	DESCRIPTION
1	146028-84-UJ1	EA	DOOR - GLASS INSERT/FLUTED EDGE - 14.4" X 21.8" - W/O HDW - CONCERT CHERRY
1	146028-84-UJ2	EA	DOOR - GLASS INSERT/FLUTED EDGE - 14.4" X 21.8" - W/O HDW - WASHED MAPLE
1	146028-84-UJ3	EA	DOOR - GLASS INSERT/FLUTED EDGE - 14.4" X 21.8" - W/O HDW - HONEY CHERRY
2	150628-03-TG0	EA	PANEL - VINYL COVERED - CASHMERE
2	150628-03-TH0	EA	PANEL - VINYL COVERED - BRIARWOOD
3	132909-12-TG0	EA	PANEL - VINYL COVERED
4	132909-14-TG0	EA	PANEL - VINYL COVERED
5	126841-05-000	EA	SHADE - PULL - CHARCOAL MESH - 30.3" X 60"
6	126841-09-000	EA	SHADE - PULL - CHARCOAL MESH - 40.25" X 60"
7	157308-02-UJ1	EA	CABINET - OVERHEAD/SIDE/LH HAND - W/O DOORS/HDW
7	157308-02-UJ2	EA	CABINET - OVERHEAD/SIDE/LH HAND - W/O DOORS/HDW
7	157308-02-UJ3	EA	CABINET - OVERHEAD/SIDE/LH HAND - W/O DOORS/HDW
7	157308-02-UJ5	EA	CABINET - OVERHEAD/SIDE/LH HAND - W/O DOORS/HDW
7	157308-02-UJ6	EA	CABINET - OVERHEAD/SIDE/LH HAND - W/O DOORS/HDW
7	157308-02-UJ7	EA	CABINET - OVERHEAD/SIDE/LH HAND - W/O DOORS/HDW
7	157308-02-UK1	EA	CABINET - OVERHEAD/SIDE/LH HAND - W/O DOORS/HDW
7	157308-02-UK2	EA	CABINET - OVERHEAD/SIDE/LH HAND - W/O DOORS/HDW
7	157308-02-UK3	EA	CABINET - OVERHEAD/SIDE/LH HAND - W/O DOORS/HDW
8	146892-91-UJ1	EA	DOOR - ARCHED/FLUTED EDGE/HORIZ - 13.6"X 27.1" - W/O HDW - CONCERT CHERRY
8	146892-91-UJ2	EA	DOOR - ARCHED/FLUTED EDGE/HORIZ - 13.6"X 27.1" - W/O HDW - WASHED MAPLE
8	146892-91-UJ3	EA	DOOR - ARCHED/FLUTED EDGE/HORIZ - 13.6"X 27.1" - W/O HDW - HONEY CHERRY
9	157308-01-UJ1	EA	CABINET - OVERHEAD/SIDE/RH HAND - W/O DOORS/HDW
9	157308-01-UJ2	EA	CABINET - OVERHEAD/SIDE/RH HAND - W/O DOORS/HDW
9	157308-01-UJ3	EA	CABINET - OVERHEAD/SIDE/RH HAND - W/O DOORS/HDW
9	157308-01-UJ5	EA	CABINET - OVERHEAD/SIDE/RH HAND - W/O DOORS/HDW
9	157308-01-UJ6	EA	CABINET - OVERHEAD/SIDE/RH HAND - W/O DOORS/HDW
9	157308-01-UJ7	EA	CABINET - OVERHEAD/SIDE/RH HAND - W/O DOORS/HDW
9	157308-01-UK1	EA	CABINET - OVERHEAD/SIDE/RH HAND - W/O DOORS/HDW
9	157308-01-UK2	EA	CABINET - OVERHEAD/SIDE/RH HAND - W/O DOORS/HDW
9	157308-01-UK3	EA	CABINET - OVERHEAD/SIDE/RH HAND - W/O DOORS/HDW
10	150628-04-TG0	EA	PANEL - VINYL COVERED - CASHMERE
10	150628-04-TH0	EA	PANEL - VINYL COVERED - BRIARWOOD
11	152167-01-TG1	EA	CABINET - OVERHEAD/TV - W/O DOORS/HARDWARE - CONCERT CHERRY
11	152167-01-TG2	EA	CABINET - OVERHEAD/TV - W/O DOORS/HARDWARE - WASHED MAPLE
11	152167-01-TG3	EA	CABINET - OVERHEAD/TV - W/O DOORS/HARDWARE - HONEY CHERRY
12	150628-14-UJ1	EA	PANEL - VINYL COVERED - CASHMERE - TV ANT-AMPLIFIED PWR & SAT SYS IN-MOTION
12	150628-14-UK1	EA	PANEL - VINYL COVERED - BRIARWOOD - TV ANT-AMPLIFIED PWR & SAT SYS IN-MOTION
13	140309-03-02B	EA	ANGLE - FURNACE DOOR - E-COATED
			FROM: 00-00-00 THRU: 05-19-06
13	140309-05-02B	EA	ANGLE - FURNACE DOOR - E-COATED
			FROM: 05-20-06 THRU: 99-99-99

DRIVERS COMPARTMENT GROUP (CONTINUED)
CABINETS (CONTINUED)

KEY	PART NUMBER	U/M	DESCRIPTION
14	150628-13-UJ1	EA	PANEL - CASHMERE - TV ANT-AMPLIFIED PWR & SAT TV SYS AUTO - NOT ILLUSTRATED FROM: 00-00-00 THRU: 01-28-07
14	150628-18-UJ1	EA	PANEL - VINYL COVERED - CASHMERE - TV ANT-AMPLIFIED PWR & SAT TV SYS AUTO FROM: 01-29-07 THRU: 99-99-99
14	150628-13-UK1	EA	PANEL - BRIARWOOD - TV ANT-AMPLIFIED PWR & SAT TV SYS AUTO - NOT ILLUSTRATED FROM: 00-00-00 THRU: 01-28-07
14	150628-18-UK1	EA	PANEL - VINYL COVERED - BRIARWOOD - TV ANT-AMPLIFIED PWR & SAT TV SYS AUTO FROM: 01-29-07 THRU: 99-99-99
15	132909-13-TG0	EA	PANEL - VINYL COVERED
16	132909-15-TG0	EA	PANEL - VINYL COVERED
17	150628-05-TG0	EA	PANEL - VINYL COVERED - CASHMERE
17	150628-05-TH0	EA	PANEL - VINYL COVERED - BRIARWOOD
18	150628-06-TG0	EA	PANEL - VINYL COVERED - CASHMERE - TV ANTENNA-AMPLIFIED SYS PWR
18	150628-06-TH0	EA	PANEL - VINYL COVERED - BRIARWOOD - TV ANTENNA-AMPLIFIED SYS PWR
18	150628-06-TG0	EA	PANEL - VINYL COVERED - CASHMERE - SATELLITE TV SYSTEM AUTO FROM: 00-00-00 THRU: 01-28-07
18	150628-17-WJ0	EA	PANEL - VINYL COVERED - CASHMERE - SATELLITE TV SYSTEM AUTO - NOT ILLUSTRATED FROM: 01-29-07 THRU: 99-99-99
18	150628-06-TH0	EA	PANEL - VINYL COVERED - BRIARWOOD - SATELLITE TV SYSTEM AUTO FROM: 00-00-00 THRU: 01-28-07
18	150628-17-TH0	EA	PANEL - VINYL COVERED - BRIARWOOD - SATELLITE TV SYSTEM AUTO - NOT ILLUSTRATED FROM: 01-29-07 THRU: 99-99-99
19	150628-07-TG0	EA	PANEL - VINYL COVERED - CASHMERE - SAT TV SYSTEM IN-MOTION
19	150628-07-TH0	EA	PANEL - VINYL COVERED - BRIARWOOD - SAT TV SYSTEM IN-MOTION
20	146656-01-02B	EA	STRAP/TIEDOWN - TV - E-COATED
21	104692-01-000	FT	SEAL - ADHESIVE BACKED FOAM - 3/4" THICK X 3/4" WIDE X 25'
22	153153-01-20A	EA	COVER - TV - OVERHEAD/FRONT - CASHMERE
22	153153-01-24A	EA	COVER - TV - OVERHEAD/FRONT - BRIARWOOD
23	151082-02-TG1	EA	CABINET - OVERHEAD/FRONT - W/O DOORS/HDW - CONCERT CHERRY
23	151082-02-TG2	EA	CABINET - OVERHEAD/FRONT - W/O DOORS/HDW - WASHED MAPLE
23	151082-02-TG3	EA	CABINET - OVERHEAD/FRONT - W/O DOORS/HDW - HONEY CHERRY
24	152944-02-02B	EA	BRACKET - TIEDOWN/TV - E-COATED
25	151082-01-TG1	EA	CABINET - OVERHEAD/FRONT/RIGHT - W/O DOORS/HDW - CONCERT CHERRY
25	151082-01-TG2	EA	CABINET - OVERHEAD/FRONT/RIGHT - W/O DOORS/HDW - WASHED MAPLE
25	151082-01-TG3	EA	CABINET - OVERHEAD/FRONT/RIGHT - W/O DOORS/HDW - HONEY CHERRY
25	151082-05-UJ1	EA	CABINET - OVERHEAD/FRONT/RIGHT - W/O DOORS/HDW - CONCERT CHERRY
25	151082-05-UJ2	EA	CABINET - OVERHEAD/FRONT/RIGHT - W/O DOORS/HDW - WASHED MAPLE
25	151082-05-UJ3	EA	CABINET - OVERHEAD/FRONT/RIGHT - W/O DOORS/HDW - HONEY CHERRY
26	133771-08-UF1	EA	MOLDING - CAP - CONCERT CHERRY FROM: 12-04-06 THRU: 99-99-99
26	133771-08-UF2	EA	MOLDING - CAP - WASHED MAPLE FROM: 12-04-06 THRU: 99-99-99
26	133771-08-UJ3	EA	MOLDING - CAP - HONEY CHERRY FROM: 12-04-06 THRU: 99-99-99
	042356-01-000	EA	PLUG - MAHOGANY - 3/8" DOWEL X 1/2" HEAD FROM: 12-04-06 THRU: 99-99-99

DRIVERS COMPARTMENT GROUP (CONTINUED)
CABINETS (CONTINUED)

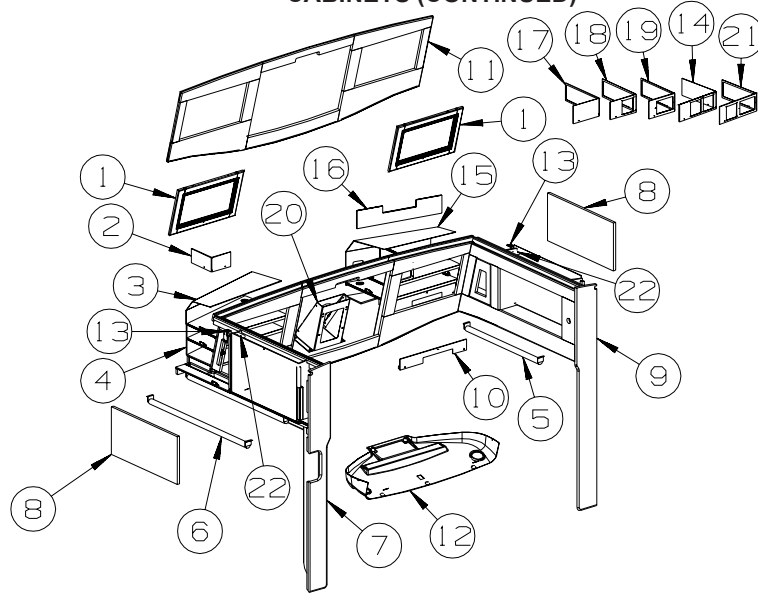

S40KD
32" TV

KEY	PART NUMBER	U/M	DESCRIPTION
1	146028-84-UJ1	EA	DOOR - GLASS INSERT/FLUTED EDGE - 14.4" X 21.8" - W/O HDW - CONCERT CHERRY
1	146028-84-UJ2	EA	DOOR - GLASS INSERT/FLUTED EDGE - 14.4" X 21.8" - W/O HDW - WASHED MAPLE
1	146028-84-UJ3	EA	DOOR - GLASS INSERT/FLUTED EDGE - 14.4" X 21.8" - W/O HDW - HONEY CHERRY
2	150628-03-TG0	EA	PANEL - VINYL COVERED - CASHMERE
2	150628-03-TH0	EA	PANEL - VINYL COVERED - BRIARWOOD
3	132909-12-TG0	EA	PANEL - VINYL COVERED
4	132909-14-TG0	EA	PANEL - VINYL COVERED
5	126841-05-000	EA	SHADE - PULL - CHARCOAL MESH - 30.3" X 60"
6	126841-09-000	EA	SHADE - PULL - CHARCOAL MESH - 40.25" X 60"
7	157308-02-UJ1	EA	CABINET - OVERHEAD/SIDE/LH HAND - W/O DOORS/HDW
7	157308-02-UJ2	EA	CABINET - OVERHEAD/SIDE/LH HAND - W/O DOORS/HDW
7	157308-02-UJ3	EA	CABINET - OVERHEAD/SIDE/LH HAND - W/O DOORS/HDW
7	157308-02-UJ5	EA	CABINET - OVERHEAD/SIDE/LH HAND - W/O DOORS/HDW
7	157308-02-UJ6	EA	CABINET - OVERHEAD/SIDE/LH HAND - W/O DOORS/HDW
7	157308-02-UJ7	EA	CABINET - OVERHEAD/SIDE/LH HAND - W/O DOORS/HDW
7	157308-02-UK1	EA	CABINET - OVERHEAD/SIDE/LH HAND - W/O DOORS/HDW
7	157308-02-UK2	EA	CABINET - OVERHEAD/SIDE/LH HAND - W/O DOORS/HDW
7	157308-02-UK3	EA	CABINET - OVERHEAD/SIDE/LH HAND - W/O DOORS/HDW
8	146892-91-UJ1	EA	DOOR - ARCHED/FLUTED EDGE/HORIZ - 13.6"X 27.1" - W/O HDW - CONCERT CHERRY
8	146892-91-UJ2	EA	DOOR - ARCHED/FLUTED EDGE/HORIZ - 13.6"X 27.1" - W/O HDW - WASHED MAPLE
8	146892-91-UJ3	EA	DOOR - ARCHED/FLUTED EDGE/HORIZ - 13.6"X 27.1" - W/O HDW - HONEY CHERRY
9	157308-01-UJ1	EA	CABINET - OVERHEAD/SIDE/RH HAND - W/O DOORS/HDW
9	157308-01-UJ2	EA	CABINET - OVERHEAD/SIDE/RH HAND - W/O DOORS/HDW
9	157308-01-UJ3	EA	CABINET - OVERHEAD/SIDE/RH HAND - W/O DOORS/HDW
9	157308-01-UJ5	EA	CABINET - OVERHEAD/SIDE/RH HAND - W/O DOORS/HDW
9	157308-01-UJ6	EA	CABINET - OVERHEAD/SIDE/RH HAND - W/O DOORS/HDW
9	157308-01-UJ7	EA	CABINET - OVERHEAD/SIDE/RH HAND - W/O DOORS/HDW
9	157308-01-UK1	EA	CABINET - OVERHEAD/SIDE/RH HAND - W/O DOORS/HDW
9	157308-01-UK2	EA	CABINET - OVERHEAD/SIDE/RH HAND - W/O DOORS/HDW
9	157308-01-UK3	EA	CABINET - OVERHEAD/SIDE/RH HAND - W/O DOORS/HDW
10	150628-04-TG0	EA	PANEL - VINYL COVERED - CASHMERE
10	150628-04-TH0	EA	PANEL - VINYL COVERED - BRIARWOOD
11	155273-11-TG1	EA	FACE/FRAME - TV CABINET/FRONT - W/O HARDWARE - CONCERT CHERRY FROM: 00-00-00 THRU: 04-02-06
11	159897-11-UJ1	EA	FACE/FRAME - TV CABINET/FRONT - W/O HARDWARE - CONCERT CHERRY FROM: 04-03-06 THRU: 99-99-99
11	155273-11-TG2	EA	FACE/FRAME - TV CABINET/FRONT - W/O HARDWARE - WASHED MAPLE FROM: 00-00-00 THRU: 04-02-06
11	159897-11-UJ2	EA	FACE/FRAME - TV CABINET/FRONT - W/O HARDWARE - WASHED MAPLE FROM: 04-03-06 THRU: 99-99-99
11	155273-11-TG3	EA	FACE/FRAME - TV CABINET/FRONT - W/O HARDWARE - HONEY CHERRY FROM: 00-00-00 THRU: 04-02-06
11	159897-11-UJ3	EA	FACE/FRAME - TV CABINET/FRONT - W/O HARDWARE - HONEY CHERRY FROM: 04-03-06 THRU: 99-99-99

DRIVERS COMPARTMENT GROUP (CONTINUED)
CABINETS (CONTINUED)

KEY	PART NUMBER	U/M	DESCRIPTION
12	155306-01-20A	EA	COVER - TV/OVERHEAD - CASHMERE
12	155306-01-24A	EA	COVER - TV/OVERHEAD - BRIARWOOD
13	140309-05-02B	EA	ANGLE - FURNACE DOOR - E-COATED
14	150628-13-UJ1	EA	PANEL - VINYL COVERED - - CASHMERE - TV ANT-AMPLIFIED PWR & SAT TV SYS AUTO FROM: 00-00-00 THRU: 01-28-07
14	150628-18-UJ1	EA	PANEL - CASHMERE - - TV ANT-AMPLIFIED PWR & SAT TV SYS AUTO - NOT ILLUSTRATED FROM: 01-29-07 THRU: 99-99-99
14	150628-13-UK1	EA	PANEL - VINYL COVERED - BRIARWOOD - - TV ANT-AMPLIFIED PWR & SAT TV SYS AUTO FROM: 00-00-00 THRU: 01-28-07
14	150628-18-UK1	EA	PANEL - BRIARWOOD - - TV ANT-AMPLIFIED PWR & SAT TV SYS AUTO - NOT ILLUSTRATED FROM: 01-29-07 THRU: 99-99-99
15	132909-13-TG0	EA	PANEL - VINYL COVERED
16	132909-15-TG0	EA	PANEL - VINYL COVERED FROM: 00-00-00 THRU: 04-02-06
16	132909-25-UJ1	EA	PANEL - VINYL COVERED FROM: 04-03-06 THRU: 99-99-99
17	150628-05-TG0	EA	PANEL - VINYL COVERED - CASHMERE
17	150628-05-TH0	EA	PANEL - VINYL COVERED - BRIARWOOD
18	150628-06-TG0	EA	PANEL - VINYL COVERED - CASHMERE - TV ANT-AMPLIFIED PWR & SATELLITE SYS READY
18	150628-06-TH0	EA	PANEL - VINYL COVERED - BRIARWOOD - TV ANT-AMPLIFIED PWR & SATELLITE SYS READY
18	150628-06-TG0	EA	PANEL - VINYL COVERED - CASHMERE - SATELLITE TV SYSTEM AUTO FROM: 00-00-00 THRU: 01-27-07
18	150628-17-WJ0	EA	PANEL - VINYL COVERED - CASHMERE - SATELLITE TV SYSTEM AUTO - NOT ILLUSTRATED FROM: 01-28-07 THRU: 99-99-99
18	150628-06-TH0	EA	PANEL - VINYL COVERED - BRIARWOOD - SATELLITE TV SYSTEM AUTO FROM: 00-00-00 THRU: 01-27-07
18	150628-17-TH0	EA	PANEL - VINYL COVERED - BRIARWOOD - SATELLITE TV SYSTEM AUTO - NOT ILLUSTRATED FROM: 01-28-07 THRU: 99-99-99
19	150628-07-TG0	EA	PANEL - VINYL COVERED - CASHMERE - SAT TV SYSTEM IN-MOTION
19	150628-07-TH0	EA	PANEL - VINYL COVERED - BRIARWOOD - SAT TV SYSTEM IN-MOTION
20	155219-01-02B	EA	MOUNT - TV - E-COATED FROM: 00-00-00 THRU: 04-02-06
20	159929-01-02B	EA	MOUNT - TV - E-COATED FROM: 04-03-06 THRU: 99-99-99
21	150628-14-UJ1	EA	PANEL - VINYL COVERED - CASHMERE - TV ANT-AMPLIFIED PWR & SAT TV SYSTEM IN-MOTION
21	150628-14-UK1	EA	PANEL - VINYL COVERED - BRIARWOOD - TV ANT-AMPLIFIED PWR & SAT TV SYSTEM IN-MOTION
22	133771-08-UF1	EA	MOLDING - CAP - CONCERT CHERRY FROM: 12-04-06 THRU: 99-99-99
22	133771-08-UF2	EA	MOLDING - CAP - WASHED MAPLE FROM: 12-04-06 THRU: 99-99-99
22	133771-08-UJ3	EA	MOLDING - CAP - HONEY CHERRY FROM: 12-04-06 THRU: 99-99-99
	042356-01-000	EA	PLUG - MAHOGANY - 3/8" DOWEL X 1/2" HEAD FROM: 12-04-06 THRU: 99-99-99
	155687-01-01A	EA	PLUG/PLASTIC - 1" SQUARE - BLACK FROM: 00-00-00 THRU: 04-02-06

DRIVERS COMPARTMENT GROUP (CONTINUED)
CABINETS (CONTINUED)

S40TD

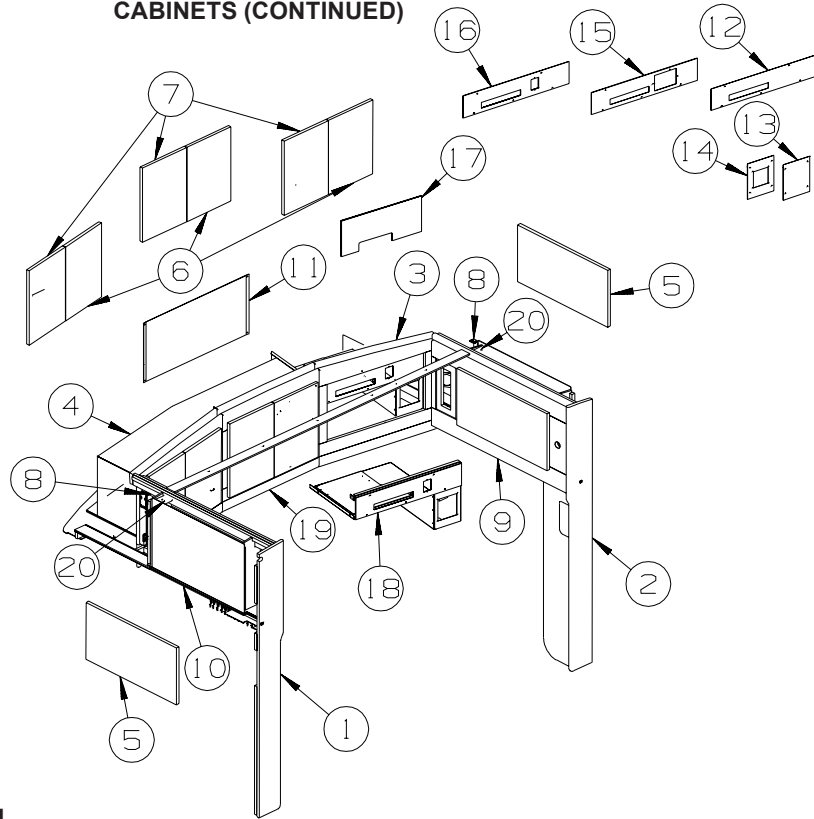

KEY	PART NUMBER	U/M	DESCRIPTION
1	157310-02-UJ1	EA	CABINET - OVERHEAD/SIDE/LH HAND - W/O DOORS/HDW
1	157310-02-UJ2	EA	CABINET - OVERHEAD/SIDE/LH HAND - W/O DOORS/HDW
1	157310-02-UJ3	EA	CABINET - OVERHEAD/SIDE/LH HAND - W/O DOORS/HDW
1	157310-02-UJ5	EA	CABINET - OVERHEAD/SIDE/LH HAND - W/O DOORS/HDW
1	157310-02-UJ6	EA	CABINET - OVERHEAD/SIDE/LH HAND - W/O DOORS/HDW
1	157310-02-UJ7	EA	CABINET - OVERHEAD/SIDE/LH HAND - W/O DOORS/HDW
1	157310-02-UK1	EA	CABINET - OVERHEAD/SIDE/LH HAND - W/O DOORS/HDW
1	157310-02-UK2	EA	CABINET - OVERHEAD/SIDE/LH HAND - W/O DOORS/HDW
1	157310-02-UK3	EA	CABINET - OVERHEAD/SIDE/LH HAND - W/O DOORS/HDW
2	157310-05-UJ1	EA	CABINET - OVERHEAD/SIDE/RH HAND - W/O DOORS/HDW
2	157310-05-UJ2	EA	CABINET - OVERHEAD/SIDE/RH HAND - W/O DOORS/HDW
2	157310-05-UJ3	EA	CABINET - OVERHEAD/SIDE/RH HAND - W/O DOORS/HDW
2	157310-05-UJ5	EA	CABINET - OVERHEAD/SIDE/RH HAND - W/O DOORS/HDW
2	157310-05-UJ6	EA	CABINET - OVERHEAD/SIDE/RH HAND - W/O DOORS/HDW
2	157310-05-UJ7	EA	CABINET - OVERHEAD/SIDE/RH HAND - W/O DOORS/HDW
2	157310-05-UK1	EA	CABINET - OVERHEAD/SIDE/RH HAND - W/O DOORS/HDW
2	157310-05-UK2	EA	CABINET - OVERHEAD/SIDE/RH HAND - W/O DOORS/HDW
2	157310-05-UK3	EA	CABINET - OVERHEAD/SIDE/RH HAND - W/O DOORS/HDW
3	154271-02-UJ1	EA	CABINET - OVERHEAD/FRONT - W/O DOORS/HDW - CONCERT CHERRY
3	154271-02-UJ2	EA	CABINET - OVERHEAD/FRONT - W/O DOORS/HDW - WASHED MAPLE
3	154271-02-UJ3	EA	CABINET - OVERHEAD/FRONT - W/O DOORS/HDW - HONEY CHERRY
4	154360-04-UJ1	EA	PANEL/CLOSEOUT - OVERHEAD/FRONT
5	146892-91-UJ1	EA	DOOR - ARCHED/FLUTED EDGE/HORIZ - 13.6"X 27.1" - W/O HDW - CONCERT CHERRY
5	146892-91-UJ2	EA	DOOR - ARCHED/FLUTED EDGE/HORIZ - 13.6"X 27.1" - W/O HDW - WASHED MAPLE
5	146892-91-UJ3	EA	DOOR - ARCHED/FLUTED EDGE/HORIZ - 13.6"X 27.1" - W/O HDW - HONEY CHERRY
6	146891-83-UJ1	EA	DOOR - ARCHED PANEL/FLUTED EDGE/RH - 12.8" X 17.7"-W/O HDW - CONCERT CHERRY
6	146891-83-UJ2	EA	DOOR - ARCHED PANEL/FLUTED EDGE/RH - 12.8" X 17.7"-W/O HDW - WASHED MAPLE
6	146891-83-UJ3	EA	DOOR - ARCHED PANEL/FLUTED EDGE/RH - 12.8" X 17.7"-W/O HDW - HONEY CHERRY
7	146890-84-UJ1	EA	DOOR - ARCHED PANEL/FLUTED EDGE/RH - 12.8" X 17.7"-W/O HDW - CONCERT CHERRY
7	146890-84-UJ2	EA	DOOR - ARCHED PANEL/FLUTED EDGE/RH - 12.8" X 17.7"-W/O HDW - WASHED MAPLE
7	146890-84-UJ3	EA	DOOR - ARCHED PANEL/FLUTED EDGE/RH - 12.8" X 17.7"-W/O HDW - HONEY CHERRY
8	140309-05-02B	EA	ANGLE - FURNACE DOOR - E-COATED
9	126841-05-000	EA	SHADE - PULL - CHARCOAL MESH - 30.3" X 60"
10	126841-09-000	EA	SHADE - PULL - CHARCOAL MESH - 40.25" X 60"
11	154360-03-TG0	EA	PANEL/CLOSEOUT - OVERHEAD/FRONT - CASHMERE
12	153820-03-T81	EA	PANEL - VINYL COVERED - CASHMERE
12	153820-03-T77	EA	PANEL - VINYL COVERED - BRIARWOOD

DRIVERS COMPARTMENT GROUP (CONTINUED)
CABINETS (CONTINUED)

KEY	PART NUMBER	U/M	DESCRIPTION
13	155127-09-UJ1	EA	PANEL - VINYL COVERED - CASHMERE
13	155127-09-UK1	EA	PANEL - VINYL COVERED - BRIARWOOD
14	155127-08-UJ1	EA	PANEL - VINYL COVERED - CASHMERE - TV ANTENNA-AMPLIFIED SYS PWR
14	155127-08-UK1	EA	PANEL - VINYL COVERED - BRIARWOOD - TV ANTENNA-AMPLIFIED SYS PWR
15	153820-02-T81	EA	PANEL - VINYL COVERED - CASHMERE - SAT TV SYSTEM IN-MOTION
15	153820-02-T77	EA	PANEL - VINYL COVERED - BRIARWOOD - SAT TV SYSTEM IN-MOTION
16	153820-01-T81	EA	PANEL - VINYL COVERED - SATELLITE TV SYSTEM AUTO FROM: 00-00-00 THRU: 01-28-07
16	153820-07-U94	EA	PANEL - VINYL COVERED - SATELLITE TV SYSTEM AUTO - NOT ILLUSTRATED FROM: 01-29-07 THRU: 99-99-99
16	153820-01-T77	EA	PANEL - VINYL COVERED - SATELLITE TV SYSTEM AUTO FROM: 00-00-00 THRU: 01-28-07
16	153820-07-U90	EA	PANEL - VINYL COVERED - SATELLITE TV SYSTEM AUTO - NOT ILLUSTRATED FROM: 01-29-07 THRU: 99-99-99
17	132909-23-UJ1	EA	PANEL - VINYL COVERED
18	126275-11-02B	EA	SHELF - OVERHEAD/FRONT - E-COATED
19	M09492-80-UJ1	EA	FACE/FRAME (PICTURE) - OVERHEAD/FRONT - W/O DOORS/HDW - CONCERT CHERRY
19	M09492-80-UJ2	EA	FACE/FRAME (PICTURE) - OVERHEAD/FRONT - W/O DOORS/HDW - WASHED MAPLE
19	M09492-80-UJ3	EA	FACE/FRAME (PICTURE) - OVERHEAD/FRONT - W/O DOORS/HDW - HONEY CHERRY
20	133771-08-UF1	EA	MOLDING - CAP - CONCERT CHERRY FROM: 12-04-06 THRU: 99-99-99
20	133771-08-UF2	EA	MOLDING - CAP - WASHED MAPLE FROM: 12-04-06 THRU: 99-99-99
20	133771-08-UJ3	EA	MOLDING - CAP - HONEY CHERRY FROM: 12-04-06 THRU: 99-99-99
	042356-01-000	EA	PLUG - MAHOGANY - 3/8" DOWEL X 1/2" HEAD FROM: 12-04-06 THRU: 99-99-99

ELECTRICAL GROUP 110V BODY WIRING

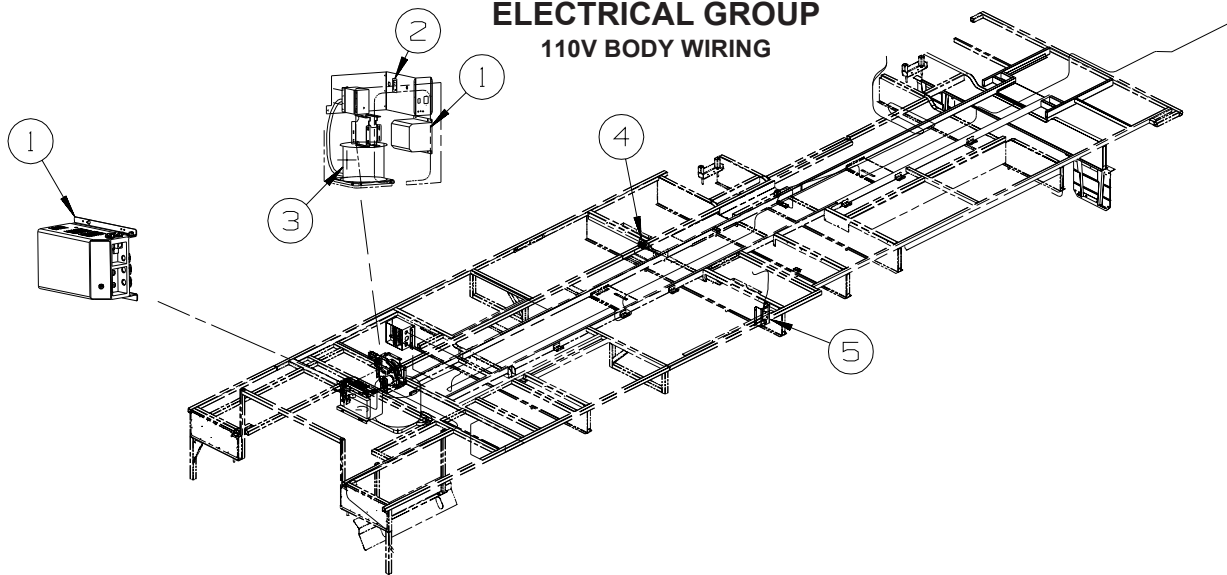

KEY	PART NUMBER	U/M	DESCRIPTION
1	148254-01-000	EA	INVERTER - CHARGER - 2000W AC
2	058708-05-000	EA	RECEPTACLE - ELECTRICAL - SINGLE - BROWN
3*	144858-02-000	EA	REEL - POWERED - W/36'-50 AMP PWR CORD - W/MOUNTED SWITCH
4	058708-05-000	EA	RECEPTACLE - ELECTRICAL - SINGLE - BROWN - VACUUM SYSTEM-CENTRAL
5	058708-05-000	EA	RECEPTACLE - ELECTRICAL - SINGLE - BROWN - REFRIGERATOR/FREEZER PORTABLE

***COMPONENT PARTS LISTED LATER IN THIS GROUP**

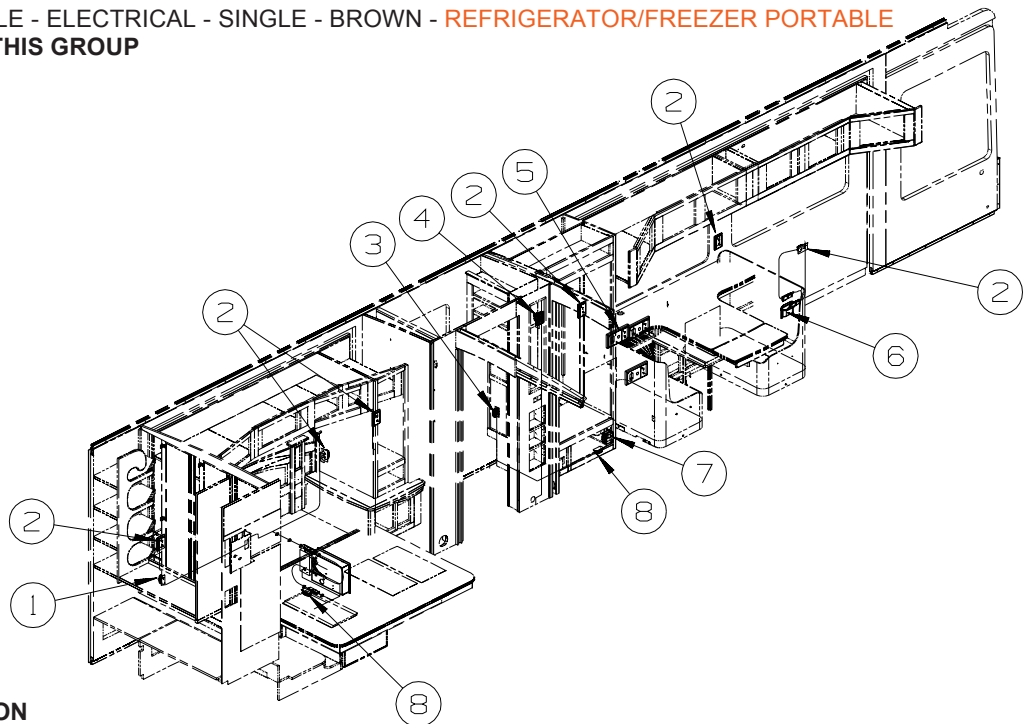

KEY	PART NUMBER	U/M	DESCRIPTION
1	058708-05-000	EA	RECEPTACLE - ELECTRICAL - SINGLE - BROWN - SLEEP NUMBER BED-QUEEN SIZE/KING SIZE
2	133713-20-SD1	EA	SPACER/RECEPTACLE - WOOD - CONCERT CHERRY
2	133713-20-SD2	EA	SPACER/RECEPTACLE - WOOD - WASHED MAPLE
2	133713-20-SD3	EA	SPACER/RECEPTACLE - WOOD - HONEY CHERRY
2	058708-01-000	EA	RECEPTACLE - ELECTRIC - DOUBLE - BROWN
3	058708-05-000	EA	RECEPTACLE - ELECTRICAL - SINGLE - BROWN
4	084420-01-000	EA	SWITCH - TOGGLE - 15 AMP/120 VOLT - BROWN
4	083588-02-000	EA	LABEL - ON/OFF - ENGINE HEATER
5	133713-25-SD1	EA	SPACER/RECEPTACLE - 110V/12V-PHONE - WOOD - CONCERT CHERRY
5	133713-25-SD1	EA	SPACER/RECEPTACLE - 110V/12V-PHONE - WOOD - WASHED MAPLE
5	133713-25-SD1	EA	SPACER/RECEPTACLE - 110V/12V-PHONE - WOOD - HONEY CHERRY
5	058708-01-000	EA	RECEPTACLE - ELECTRIC - DOUBLE - BROWN
6	153862-02-01A	EA	COVER - WIRE - 5.9" X 3.8" X 2.2" - BLACK
6	155469-01-01A	EA	COVER - WIRE - .9" X 6.3" X 5.6" - BLACK
7	147446-01-02A	EA	RECEPTACLE - GFCI - 15A 125V - BROWN
7	147450-01-02A	EA	PLATE - ELECTRICAL OUTLET - BROWN
8	058707-02-000	EA	RECEPTACLE - BLANK - JUNCTION BOX

ELECTRICAL GROUP (CONTINUED)
110V BODY WIRING (CONTINUED)

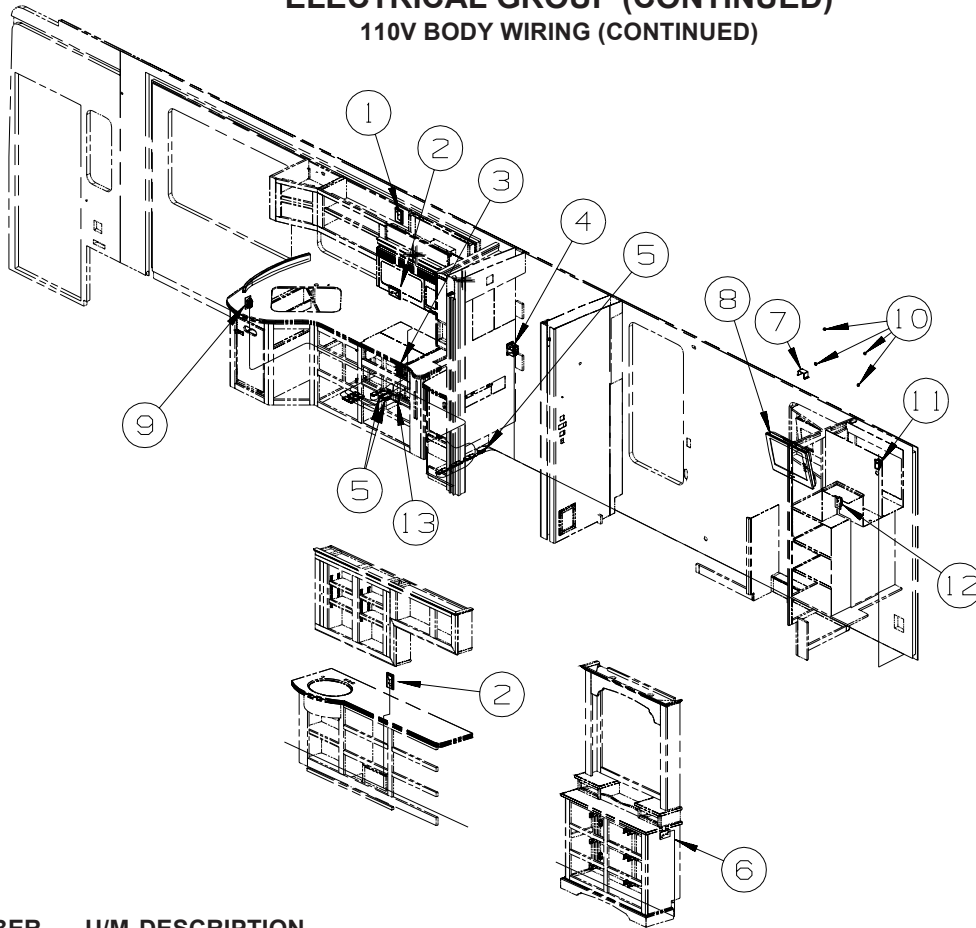

KEY	PART NUMBER	U/M	DESCRIPTION
1	133713-20-SD1	EA	SPACER/RECEPTACLE - WOOD - CONCERT CHERRY
1	133713-20-SD2	EA	SPACER/RECEPTACLE - WOOD - WASHED MAPLE
1	133713-20-SD3	EA	SPACER/RECEPTACLE - WOOD - HONEY CHERRY
1	058708-05-000	EA	RECEPTACLE - ELECTRICAL - SINGLE - BROWN
2	133713-20-SD1	EA	SPACER/RECEPTACLE - WOOD - CONCERT CHERRY
2	133713-20-SD2	EA	SPACER/RECEPTACLE - WOOD - WASHED MAPLE
2	133713-20-SD3	EA	SPACER/RECEPTACLE - WOOD - HONEY CHERRY
2	058708-01-000	EA	RECEPTACLE - ELECTRIC - DOUBLE - BROWN
3	058707-01-000	EA	RECEPTACLE - ELECTRIC - SINGLE - BROWN - DISHWASHER/BUILT-IN
4	147446-01-02A	EA	RECEPTACLE - GFCI - 15A 125V - BROWN
			FROM: 00-00-00 THRU: 12-20-06
	163319-01-02A	EA	RECEPTACLE - GFCI - 15A 125V - BROWN
			FROM: 12-21-06 THRU: 99-99-99
5	058707-02-000	EA	RECEPTACLE - BLANK - JUNCTION BOX
6	058708-01-000	EA	RECEPTACLE - ELECTRIC - DOUBLE - BROWN
7	150967-03-02B	EA	BRACKET - WIRE SUPPORT - E-COATED
8*	150934-02-000	EA	TV - 20" FLAT SCREEN/LCD/STEREO - SHARP LC-20S4U-S
			FROM: 00-00-00 THRU: 03-12-06
8*	159759-01-000	EA	TV - 20" FLAT PANEL/LCD/STEREO - SHARP LC-20SH3U
			FROM: 03-13-06 THRU: 99-99-99
9	058708-01-000	EA	RECEPTACLE - ELECTRIC - DOUBLE - BROWN
10	069726-02-000	EA	BUMPER - .88" OD X .40" THICK - BLACK
11	058707-01-000	EA	RECEPTACLE - ELECTRIC - SINGLE - BROWN
11	158542-02-01A	EA	LABEL - RECEPTACLE - ELECTRONICS - WHITE/BLACK
12	058708-05-000	EA	RECEPTACLE - ELECTRICAL - SINGLE - BROWN
12	158542-01-01A	EA	LABEL - RECEPTACLE - WASHER/DRYER - WHITE/BLACK
13	153862-03-01A	EA	COVER - WIRE - 5.9" X 3.7" X 1.4" - BLACK

***COMPONENT PARTS LISTED LATER IN THIS GROUP**

ELECTRICAL GROUP (CONTINUED)

12V BODY WIRING

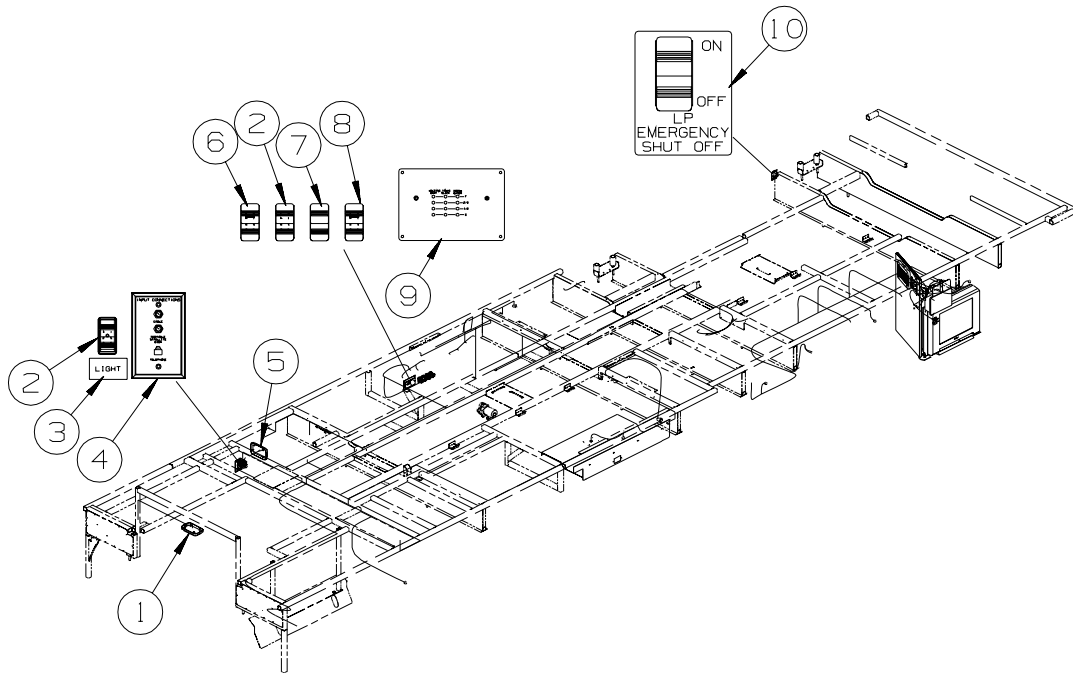

KEY	PART NUMBER	U/M	DESCRIPTION
1*	137417-01-01A	EA	LIGHT - DOME - SINGLE - W/SWITCH/FROSTED LENS - WHITE
2	108357-05-000	EA	SWITCH - ROCKER - SPDT - ON/NONE/ON - 3 TERM - W/O COVER
2	108356-01-01A	EA	COVER/ACTUATOR SWITCH - 3 GROOVES - BLACK
2	108355-01-000	EA	HOUSING - SWITCH
3	130170-05-000	EA	LABEL - SWITCH PANEL
4	149557-01-01A	EA	PLATE/WALL - PHONE/DUAL COAXIAL/VERTICAL - WHITE
5*	137417-03-01A	EA	LIGHT - DOME - SINGLE - W/O SWITCH - W/FROSTED LENS-WHITE
6	108357-15-000	EA	SWITCH - ROCKER - DPDT - ON/NONE/ON - W/LIGHT W/O COVER
6	108356-03-01A	EA	COVER/ACTUATOR SWITCH - 3 GROOVES W/LENS - BLACK
6	108355-01-000	EA	HOUSING - SWITCH
7	108357-09-000	EA	SWITCH - ROCKER - SPDT - ON/NONE/MOM - 3 TERM - W/O COVER
7	108356-01-01A	EA	COVER/ACTUATOR SWITCH - 3 GROOVES - BLACK
7	108355-01-000	EA	HOUSING - SWITCH
8	108357-18-000	EA	SWITCH - ROCKER - DPDT - MOM/OFF/MOM - W/O COVER
8	108356-03-01A	EA	COVER/ACTUATOR SWITCH - 3 GROOVES W/LENS - BLACK
8	108355-01-000	EA	HOUSING - SWITCH
9*	129561-02-01A	EA	PANEL/MONITOR - READ OUT ONLY - HOLDING/WATER TANK
10	108357-01-000	EA	SWITCH - ROCKER - SPST - ON/OFF - 2 TERMINAL - W/O COVER
10	108356-01-01A	EA	COVER/ACTUATOR SWITCH - 3 GROOVES - BLACK
10	108355-01-000	EA	HOUSING - SWITCH
10	130170-04-000	EA	LABEL - SWITCH PANEL

*COMPONENT PARTS LISTED LATER IN THIS GROUP

ELECTRICAL GROUP (CONTINUED)
12V BODY WIRING (CONTINUED)

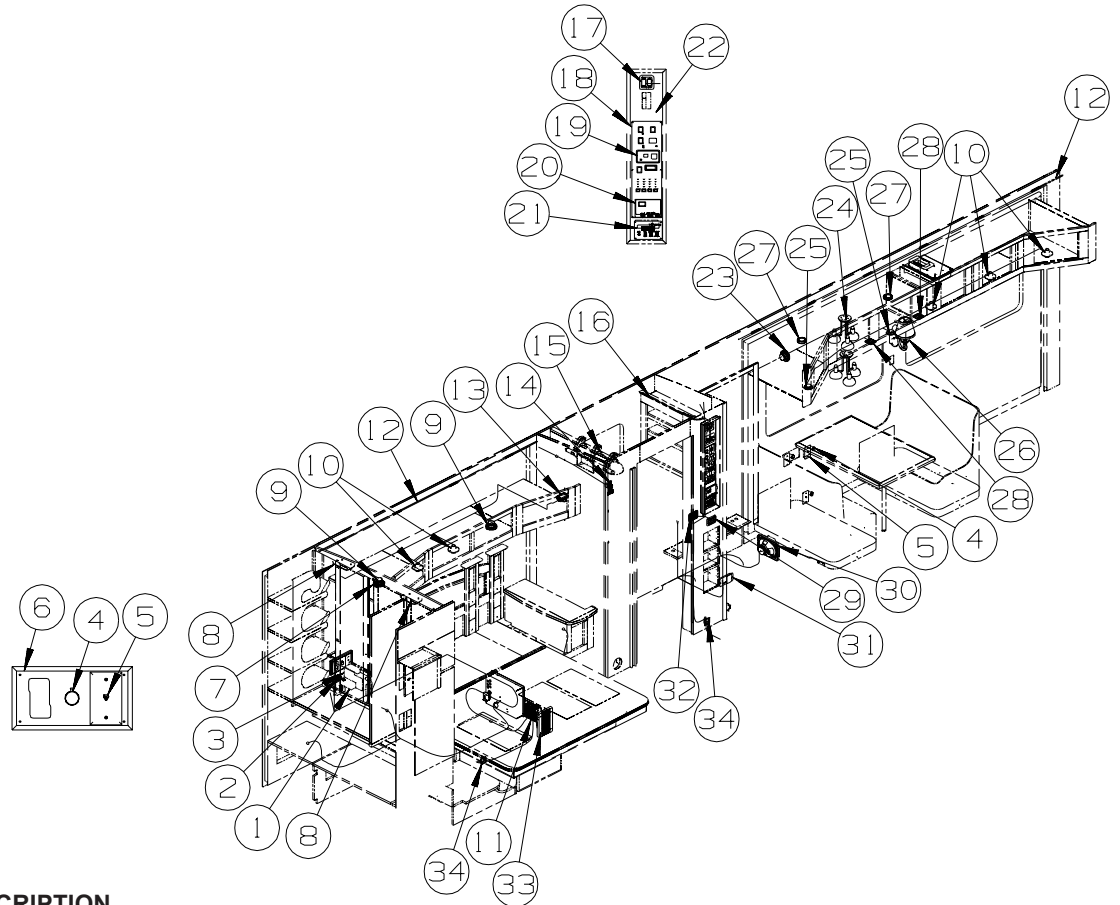

KEY	PART NUMBER	U/M	DESCRIPTION
1	150140-01-000	EA	CROSSOVER BOX - STANDARD STEREO TO DELUXE SOUND - STEREO SYSTEM/W/CD/DVD REAR
2	150140-02-000	EA	CROSSOVER COIL - F/SUBWOOFER SPEAKER/LOW FREQUENCY- STEREO SYSTEM/W/CD/DVD REAR
3	156413-01-01A	EA	RADIO - WALL MOUNT - DVD/CD - W/ALARM - JENSEN AWM950 - STEREO SYSTEM/W/CD/DVD REAR
3	163031-01-01A	EA	RADIO - WALL MOUNT - DVD/CD - W/ALARM - JENSEN AWM960 - STEREO SYSTEM/W/CD/DVD REAR FROM: 00-00-00 THRU: 01-01-07
4	132958-01-000	EA	RECEPTACLE - 12 VOLT - MOUNTING FLANGE - BLACK
5	093253-01-02A	EA	PLATE - WALL - TELEPHONE - BROWN
6	133713-25-SD1	EA	SPACER/RECEPTACLE - 110V/12V-PHONE - WOOD - CONCERT CHERRY
6	133713-25-SD2	EA	SPACER/RECEPTACLE - 110V/12V-PHONE - WOOD - WASHED MAPLE
6	133713-25-SD3	EA	SPACER/RECEPTACLE - 110V/12V-PHONE - WOOD - HONEY CHERRY
7	056264-01-000	EA	SWITCH - LEAF ACTUATOR
8*	087694-01-000	EA	LIGHT - WARDROBE/CLOSET - W/SWITCH FROM: 00-00-00 THRU: 05-02-06
9	148026-03-01A	EA	SPEAKER - CUBE - W/O CASE - STEREO SYSTEM/W/CD/DVD REAR FROM: 00-00-00 THRU: 07-30-06
9	160868-01-01A	EA	SPEAKER - ROUND/CEILING - W/O CASE - BLACK - STEREO SYSTEM/W/CD/DVD REAR FROM: 07-31-06 THRU: 99-99-99
9	148026-02-01A	EA	SPEAKER GRILLE - CUBE - SILVER - STEREO SYSTEM/W/CD/DVD REAR FROM: 00-00-00 THRU: 07-30-06
9	160868-02-01A	EA	GRILLE/ROUND - SPEAKER - SILVER - STEREO SYSTEM/W/CD/DVD REAR FROM: 07-31-06 THRU: 99-99-99
10	132427-01-02A	EA	LIGHT - READING/SWIVEL - ROUND - NICKEL
11	139067-06-02B	EA	PLATE - CIRCUIT BREAKER/HOUSE - E-COATED
11	092547-14-000	EA	LABEL - CIRCUIT BREAKER
12	146514-03-000	FT	LIGHT - FLEX - ROPE/ROUND - W/O MOUNT CHANNEL
12	146514-02-000	EA	CONNECTOR - LIGHT
12	146514-04-000	EA	CHANNEL/MOUNT - F/ROPE LIGHT
13*	087694-01-000	EA	LIGHT - WARDROBE/CLOSET - W/SWITCH - BED-QUEEN SIDEWALL

ELECTRICAL GROUP (CONTINUED)
12V BODY WIRING (CONTINUED)

KEY	PART NUMBER	U/M	DESCRIPTION
14	144363-09-02B	EA	PLATE - SWITCH - E-COATED
14	108357-06-000	EA	SWITCH - ROCKER - DPDT - MOM/OFF/MOM - 6 TERM - W/O COVER
14	108356-01-01A	EA	COVER/ACTUATOR SWITCH - 3 GROOVES - BLACK
14	108355-01-000	EA	HOUSING - SWITCH
14	116220-01-000	EA	APPLIQUE - SWITCH/SLIDEOUT
14	116549-02-000	EA	LABEL - WARNING - SLIDEOUT
15	157382-02-01A	EA	LIGHT - VANITY - W/O SHADES/BULBS (3)-UL/CSA-SATIN NICKEL
15	119257-24-01A	EA	SHADE - LAMP - SQUARE - BRIGHT WHITE
15	067479-01-000	EA	BULB - 12V - #1076 - 1.80 AMP
16	146514-01-000	FT	LIGHT - FLEX - ROPE/ROUND - W/STRIP
16	146514-02-000	EA	CONNECTOR - LIGHT
17	135740-01-01A	EA	SWITCH - ROCKER - SPST - ON/OFF - BROWN
17	135740-02-01A	EA	SWITCH - ROCKER - SPDT - ON/ON - BROWN
17	135741-02-01A	EA	SWITCH - BASE - DOUBLE - BROWN
17	135742-34-02A	EA	BEZEL - SWITCH - WATER HEATER/LP - BROWN
18*	133004-05-01A	EA	PANEL/MONITOR-2 TANK-DIGITAL VOLT MT/SOLAR-W/WATER HTR SWT
19	127002-10-000	EA	PANEL/MONITOR - ENERGY MANAGEMENT SYSTEMS CTRL - W/3 PLUG
20	105620-17-000	EA	THERMOSTAT - FURNACE-2 STAGE/HEAT PUMP-A/C -W/CHOKE MODULE
21	148254-05-000	EA	REMOTE/PANEL - INVERTER/CHARGER
21	148254-03-000	EA	CABLE/INVERTOR - W/8 PIN MODULAR PHONE JACK - 50'-DIMEN
22	158425-01-000	EA	MODULE - AUTO GENERATOR START - ONAN 018-02030
23	148026-03-01A	EA	SPEAKER - CUBE - W/O CASE
			FROM: 00-00-00 THRU: 07-30-06
23	160868-01-01A	EA	SPEAKER - ROUND/CEILING - W/O CASE - BLACK
			FROM: 07-31-06 THRU: 99-99-99
23	148026-02-01A	EA	SPEAKER GRILLE - CUBE - SILVER
			FROM: 00-00-00 THRU: 07-30-06
23	160868-02-01A	EA	GRILLE/ROUND - SPEAKER - SILVER
			FROM: 07-31-06 THRU: 99-99-99
24	093575-45-01A	EA	LIGHT - CEILING/DOUBLE - NICKEL
24	067479-01-000	EA	BULB - 12V - #1076 - 1.80 AMP
25*	123775-01-02A	EA	LIGHT - HALOGEN - ROUND - SATIN NICKEL - DINETTE/DINING/COMPUTER TABLE/CHAIRS
26	119258-52-01A	EA	LAMP - WALL - UL/CSA - NICKEL
26	067479-01-000	EA	BULB - 12V - #1076 - 1.80 AMP
27*	123775-01-02A	EA	LIGHT - HALOGEN - ROUND - SATIN NICKEL - DINING TABLE/CHAIRS
27	123775-02-02A	EA	LIGHT - HALOGEN - COLLAR - SATIN NICKEL - DINING TABLE/CHAIRS
28	135740-01-01A	EA	SWITCH - ROCKER - SPST - ON/OFF - BROWN
28	135741-02-01A	EA	SWITCH - BASE - DOUBLE - BROWN
28	135742-02-01A	EA	BEZEL - SWITCH - DOUBLE - BROWN
29	135740-01-01A	EA	SWITCH - ROCKER - SPST - ON/OFF - BROWN
29	135740-02-01A	EA	SWITCH - ROCKER - SPDT - ON/ON - BROWN
29	135741-03-01A	EA	SWITCH - BASE - TRIPLE - BROWN
29	135742-32-02A	EA	BEZEL - SWITCH - HALL/MONITOR/CEILING - BROWN
30	124884-01-000	EA	SPEAKER - 6" X 9" - SUB-WOOFER - W/O GRILLE
30	151844-01-01A	EA	GRILLE - SPEAKER - 6" X 9" - SUB WOOFER - BLACK
31	150138-01-02A	EA	DETECTOR - LP GAS - BROWN
32	135740-01-01A	EA	SWITCH - ROCKER - SPST - ON/OFF - BROWN
32	135741-03-01A	EA	SWITCH - BASE - TRIPLE - BROWN
32	135742-42-02A	EA	BEZEL - SWITCH - MAKEUP/ACCENT/FAN - BROWN
33	124884-01-000	EA	SPEAKER - 6" X 9" - SUB-WOOFER - W/O GRILLE - STEREO SYSTEM/W/CD/DVD REAR
33	151844-01-01A	EA	GRILLE - SPEAKER - 6" X 9" - SUB WOOFER - BLACK - STEREO SYSTEM/W/CD/DVD REAR
34*	108354-01-01A	EA	LIGHT - COURTESY

*COMPONENT PARTS LISTED LATER IN THIS GROUP

ELECTRICAL GROUP (CONTINUED)

12V BODY WIRING (CONTINUED)

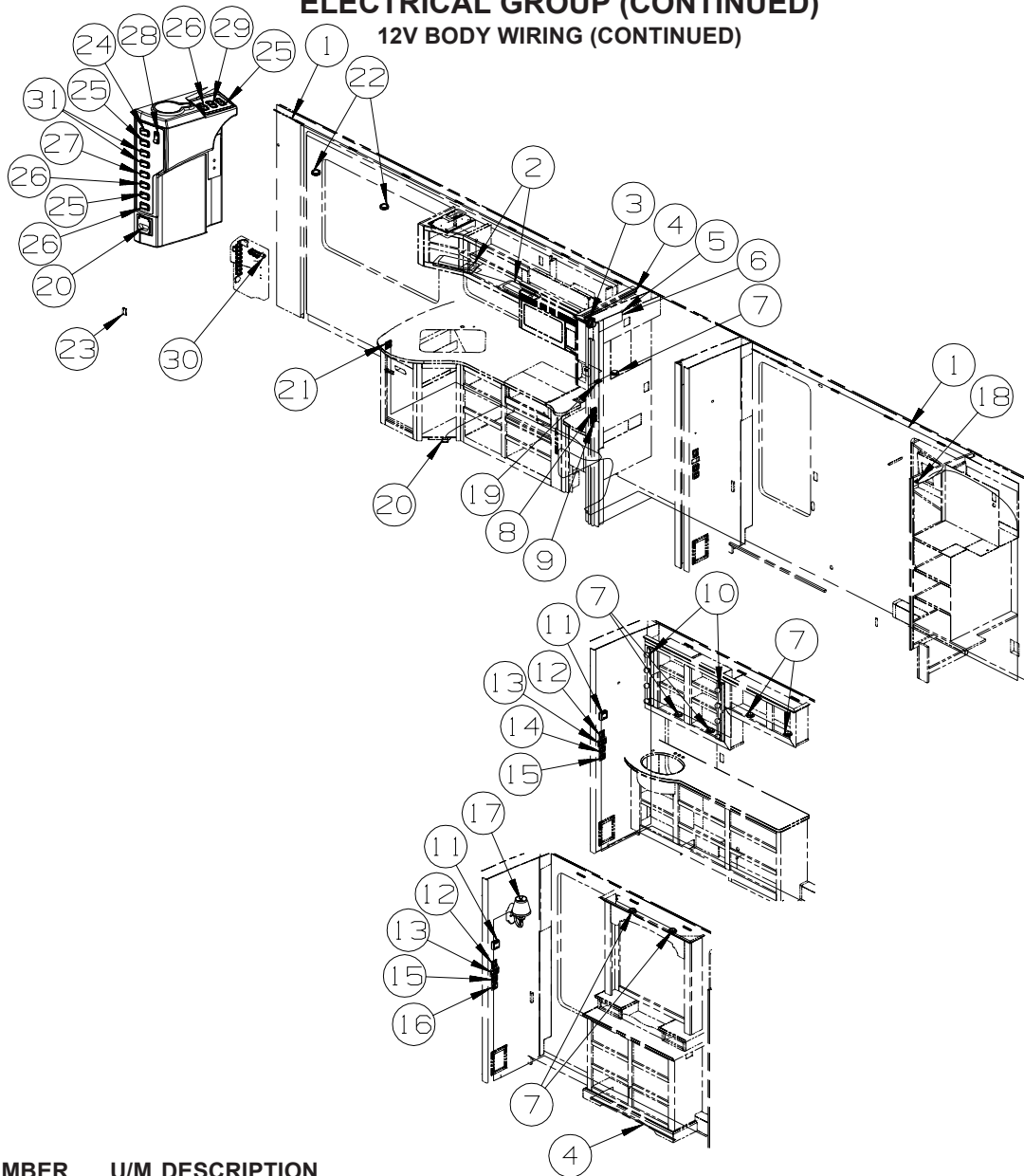

KEY	PART NUMBER	U/M	DESCRIPTION
1	146514-03-000	FT	LIGHT - FLEX - ROPE/ROUND - W/O MOUNT CHANNEL
1	146514-02-000	EA	CONNECTOR - LIGHT
1	146514-04-000	EA	CHANNEL/MOUNT - F/ROPE LIGHT
2*	153464-05-01A	EA	LIGHT-FLUORESCENT 16.1"- RECESSED/WARM WHT BULB - W/SWITCH
3	148026-03-01A	EA	SPEAKER - CUBE - W/O CASE
3	160868-01-01A	EA	SPEAKER - ROUND/CEILING - W/O CASE - BLACK
3	148026-02-01A	EA	SPEAKER GRILLE - CUBE - SILVER
3	160868-02-01A	EA	GRILLE/ROUND - SPEAKER - SILVER
4	146514-01-000	FT	LIGHT - FLEX - ROPE/ROUND - W/STRIP
4	146514-02-000	EA	CONNECTOR - LIGHT
5	086756-01-000	EA	SPLITTER - TV/2 WAY
6	082134-01-000	EA	ADAPTER - TV - CABLE TO CABLE
7*	123775-01-02A	EA	LIGHT - HALOGEN - ROUND - SATIN NICKEL
8	135740-01-01A	EA	SWITCH - ROCKER - SPST - ON/OFF - BROWN
8	135740-02-01A	EA	SWITCH - ROCKER - SPDT - ON/ON - BROWN
8	135741-02-01A	EA	SWITCH - BASE - DOUBLE - BROWN
8	135742-18-02A	EA	BEZEL - SWITCH - LOUNGE/GALLEY - BROWN
9	135740-01-01A	EA	SWITCH - ROCKER - SPST - ON/OFF - BROWN
9	135741-01-01A	EA	SWITCH - BASE - SINGLE - BROWN
9	135742-50-02A	EA	BEZEL - SWITCH - ACCENT - BROWN

ELECTRICAL GROUP (CONTINUED)
12V BODY WIRING (CONTINUED)

KEY	PART NUMBER	U/M	DESCRIPTION
9	135740-01-01A	EA	SWITCH - ROCKER - SPST - ON/OFF - BROWN - FAN - CEILING LOUNGE
9	135740-04-01A	EA	SWITCH - ROCKER - SPDT - ON/OFF/ON - BROWN - FAN - CEILING LOUNGE
9	135741-02-01A	EA	SWITCH - BASE - DOUBLE - BROWN - FAN - CEILING LOUNGE
9	135742-49-02A	EA	BEZEL - SWITCH - ACCENT/FAN - BROWN - FAN - CEILING LOUNGE
10	138116-02-02A	EA	LIGHT/MAKE UP - 4 BULB - CURVED - W/O BULB - SATIN NICKEL
10	123918-01-000	EA	BULB - 12V - MAKEUP - WHITE
11	115764-01-01A	EA	THERMOSTAT - FURNACE - WHITE
			FROM: 00-00-00 THRU: 10-01-06
11	115764-01-03A	EA	THERMOSTAT - FURNACE - BLACK
			FROM: 10-02-06 THRU: 99-99-99
12	137889-01-000	EA	SWITCH - LIGHT DIMMER
13	135740-01-01A	EA	SWITCH - ROCKER - SPST - ON/OFF - BROWN
13	135740-02-01A	EA	SWITCH - ROCKER - SPDT - ON/ON - BROWN
13	135741-03-01A	EA	SWITCH - BASE - TRIPLE - BROWN
13	135742-25-02A	EA	BEZEL - SWITCH - CEILING/AISLE/HALL - BROWN
14	135740-01-01A	EA	SWITCH - ROCKER - SPST - ON/OFF - BROWN
14	135741-02-01A	EA	SWITCH - BASE - DOUBLE - BROWN
14	135742-46-02A	EA	BEZEL - SWITCH - MAKEUP/ACCENT - BROWN
15	135740-01-01A	EA	SWITCH - ROCKER - SPST - ON/OFF - BROWN
15	135741-02-01A	EA	SWITCH - BASE - DOUBLE - BROWN
15	135742-36-02A	EA	BEZEL - SWITCH - ACCENT/VALANCE - BROWN
16	135740-01-01A	EA	SWITCH - ROCKER - SPST - ON/OFF - BROWN - FAN - CEILING_BEDROOM
16	135740-04-01A	EA	SWITCH - ROCKER - SPDT - ON/OFF/ON - BROWN - FAN - CEILING_BEDROOM
16	135741-02-01A	EA	SWITCH - BASE - DOUBLE - BROWN - FAN - CEILING_BEDROOM
16	135742-49-02A	EA	BEZEL - SWITCH - ACCENT/FAN - BROWN - FAN - CEILING_BEDROOM
16	135740-01-01A	EA	SWITCH - ROCKER - SPST - ON/OFF - BROWN
16	135741-01-01A	EA	SWITCH - BASE - SINGLE - BROWN
16	135742-07-02A	EA	BEZEL - SWITCH - CEILING - BROWN
17	119258-52-01A	EA	LAMP - WALL - UL/CSA - NICKEL
17	119257-24-01A	EA	SHADE - LAMP - SQUARE - BRIGHT WHITE
17	067479-01-000	EA	BULB - 12V - #1076 - 1.80 AMP
18	149750-01-000	EA	RECEIVER - (INFRA RED SIGNAL) - W/6"LEAD/PLUG
19	135740-01-01A	EA	SWITCH - ROCKER - SPST - ON/OFF - BROWN
19	135741-01-01A	EA	SWITCH - BASE - SINGLE - BROWN
19	135742-01-01A	EA	BEZEL - SWITCH - SINGLE - BROWN
20*	108354-01-01A	EA	LIGHT - COURTESY
21	135740-01-01A	EA	SWITCH - ROCKER - SPST - ON/OFF - BROWN
21	135740-02-01A	EA	SWITCH - ROCKER - SPDT - ON/ON - BROWN
21	135741-02-01A	EA	SWITCH - BASE - DOUBLE - BROWN
21	135742-13-02A	EA	BEZEL - SWITCH - CEILING/AISLE - BROWN
22*	123775-01-02A	EA	LIGHT - HALOGEN - ROUND - SATIN NICKEL
22	123775-02-02A	EA	LIGHT - HALOGEN - COLLAR - SATIN NICKEL
23	116995-03-000	EA	SWITCH/MAGNET - ELECTRIC STEP
24	145638-10-01A	EA	SWITCH/ROCKER - SPDT (ON/ON) - LIGHTED - BLACK
24	108355-02-000	EA	HOUSING - SWITCH - 12 POSITION
25	145638-01-01A	EA	SWITCH/ROCKER - SPST (ON/OFF) - BLACK
25	108355-02-000	EA	HOUSING - SWITCH - 12 POSITION
26	145638-09-01A	EA	SWITCH/ROCKER - DPDT (ON/OFF/ON) - BLACK
26	108355-02-000	EA	HOUSING - SWITCH - 12 POSITION
27	145638-07-01A	EA	SWITCH/ROCKER - DPDT (ON/ON) - BLACK
27	108355-02-000	EA	HOUSING - SWITCH - 12 POSITION
28	145638-06-01A	EA	SWITCH/ROCKER - SPDT (ON/OFF/ON) - LIGHTED - BLACK
28	108355-02-000	EA	HOUSING - SWITCH - 12 POSITION
29	145638-12-01A	EA	SWITCH/ROCKER - DPDT (ON/ON/ON) - BLACK
29	108355-02-000	EA	HOUSING - SWITCH - 12 POSITION
30	132958-01-000	EA	RECEPTACLE - 12 VOLT - MOUNTING FLANGE - BLACK
31	145638-13-01A	EA	SWITCH/ROCKER - SPDT (ON/OFF/ON) - W/GREEN LED - BLACK
			FROM: 00-00-00 THRU: 1-28-07
31	145638-05-01A	EA	SWITCH/ROCKER - SPDT (ON/OFF/ON) - BLACK
			FROM: 01-29-07 THRU: 99-99-99
31	108355-02-000	EA	HOUSING - SWITCH - 12 POSITION

*COMPONENT PARTS LISTED LATER IN THIS GROUP

ELECTRICAL GROUP (CONTINUED)

12V BODY WIRING (CONTINUED)

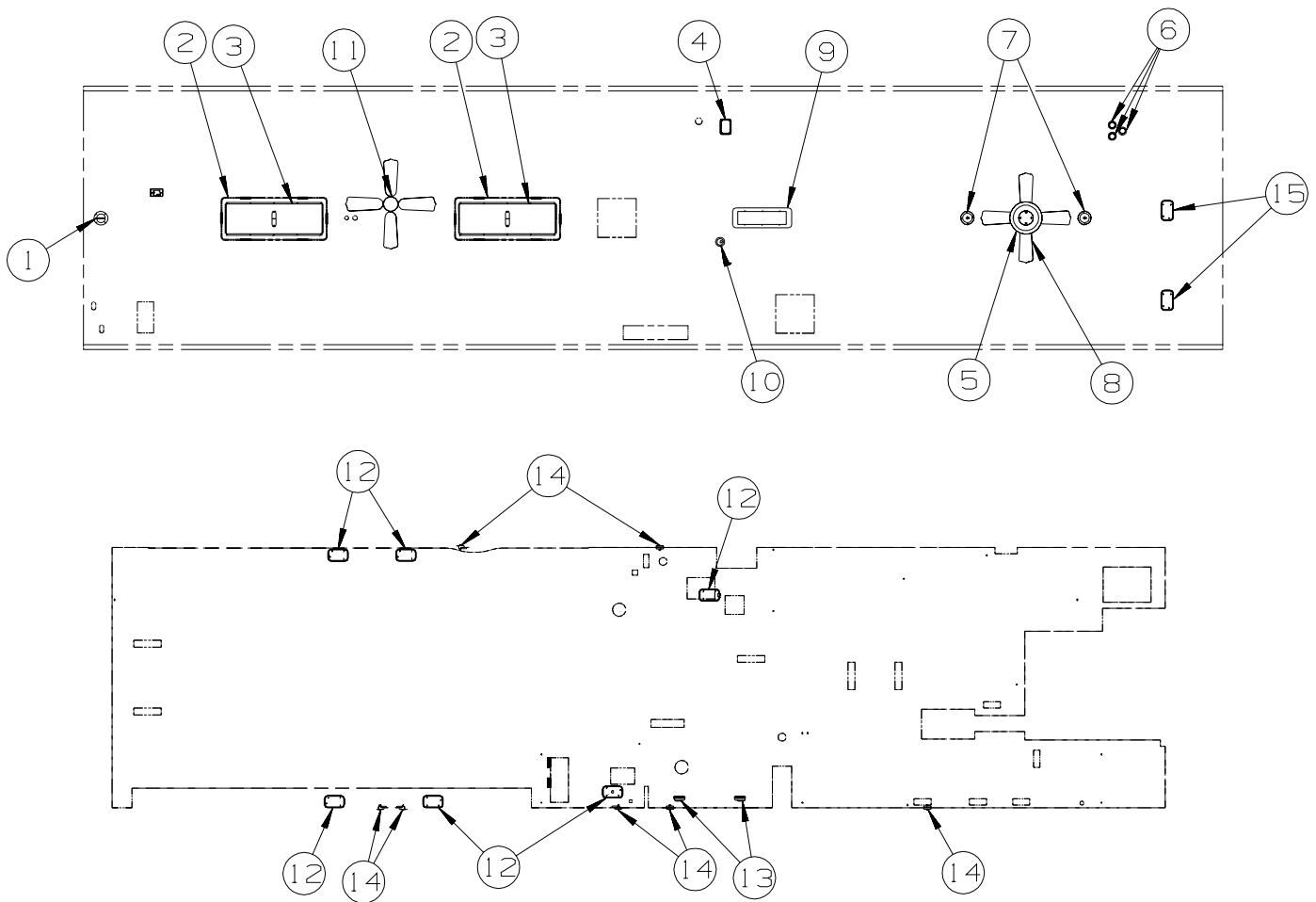

KEY	PART NUMBER	U/M	DESCRIPTION
1	151314-01-01A	EA	SPEAKER - CUBE/CEILING - WHITE - MAGNADYNE - LS3CM-WN FROM: 00-00-00 THRU: 07-30-06
1	160867-01-01A	EA	SPEAKER - ROUND/CEILING - CREAM - MAGNADYNE - LS3EYC-WN FROM: 07-31-06 THRU: 99-99-99
2	146514-03-000	FT	LIGHT - FLEX - ROPE/ROUND - W/O MOUNT CHANNEL
2	146514-02-000	EA	CONNECTOR - LIGHT
2	146514-04-000	EA	CHANNEL/MOUNT - F/ROPE LIGHT
3	133416-04-000	EA	LIGHT - FLUORESCENT - 36"/1 BULB/WARM WHITE
4*	121935-01-01A	EA	LIGHT - DOME - SHOWER
5*	093575-33-03A	EA	LIGHT - CEILING/ROUND - W/O BULBS - SATIN NICKEL
5	117805-02-000	EA	BULB - 12V - #921 - 1.4 AMPS
6*	123775-01-02A	EA	LIGHT - HALOGEN - ROUND - SATIN NICKEL
7	093575-40-01A	EA	LIGHT - CEILING/ROUND - NICKEL - FAN - CEILING_BEDROOM
7	117805-02-000	EA	BULB - 12V - #921 - 1.4 AMPS - FAN - CEILING_BEDROOM
8*	139134-01-03A	EA	FAN - CEILING - 35" - NICKEL - W/O SWITCH - #A70052NW - FAN - CEILING_BEDROOM
9*	153464-06-01A	EA	LIGHT-FLUORESCENT 21.8"- RECESSED/WARM WHT BULB-W/O SWITCH
10	146048-01-01A	EA	LIGHT - HALOGEN/ADJUSTABLE - WHITE
11*	139134-01-03A	EA	FAN - CEILING - 35" - NICKEL - W/O SWITCH - #A70052NW - FAN - CEILING LOUNGE
12*	137417-03-01A	EA	LIGHT - DOME - SINGLE - W/O SWITCH - W/FROSTED LENS-WHITE
13*	086280-01-000	EA	LIGHT - SURFACE MOUNT - 12 VOLT
14	041250-01-000	EA	SWITCH - PUSH BUTTON/DOOR JAMB - METAL/CHROME
14	138494-01-02B	EA	BRACKET - SWITCH/LIGHT - E-COATED
14	093249-01-000	EA	CAP/SCREW - MOLDED/VINYL - BLACK
15*	137417-03-01A	EA	LIGHT - DOME - SINGLE - W/O SWITCH - W/FROSTED LENS-WHITE FROM: 05-03-06 THRU: 99-99-99

*COMPONENT PARTS LISTED LATER IN THIS GROUP

ELECTRICAL GROUP (CONTINUED)
12V BODY WIRING (CONTINUED)

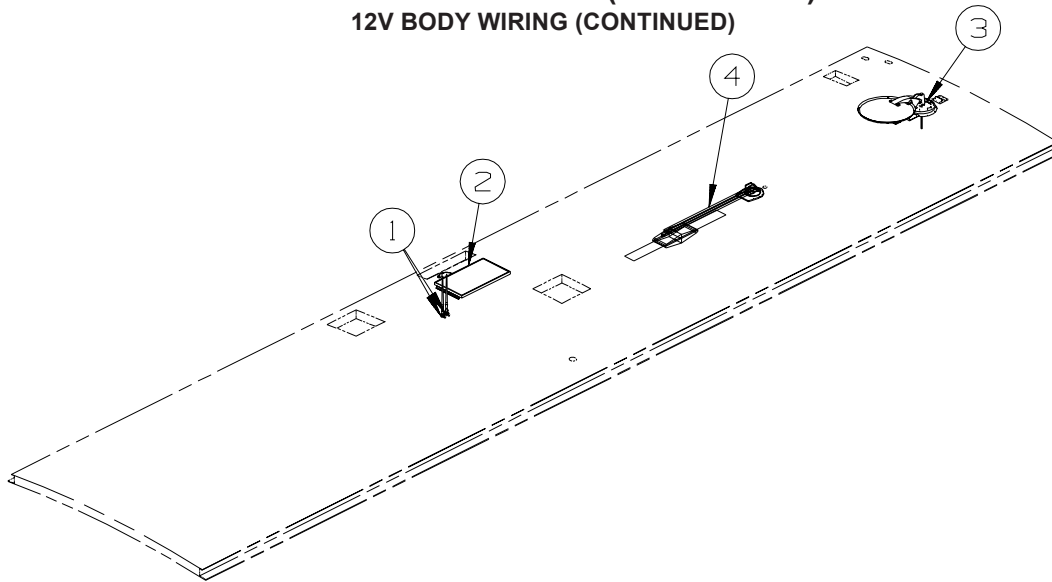

KEY	PART NUMBER	U/M	DESCRIPTION
1	090944-01-000	EA	ANTENNA - RADIO - 16" RUBBER - W/72" LEAD WIRE
1	109889-04-000	EA	EXTENDER - ANTENNA SHAFT - 3.7"
1	147741-01-09B	EA	BRACKET - ANTENNA GROUND - GALVANIZED
2	151647-01-000	EA	PANEL - SOLAR 10 WATT
3	154474-04-02A	EA	ANTENNA/SATELLITE - DISH IN DOME/SEARCH IN MOTION - BLACK - SAT SYS IN-MOTION W/O RCVR
3	146488-01-000	EA	PLATE - ROOF - CABLE ENTRY - SAT SYS IN-MOTION W/O RCVR
3	154474-02-000	EA	CONTROL/SATELLITE KIT-IDB BOX/IDD BOX-POWER SUPPLY-CABLE-SAT SYS IN-MOTION W/O RCVR
3	154474-03-000	EA	CABLE - SATELLITE - COAX - 8' W/CONNECTORS - SAT SYS IN-MOTION W/O RCVR
3*	141454-03-01A	EA	ANTENNA/SATELLITE - "AUTO SEARCH WHILE PARKED/GPS SYSTEM" - SAT DISH-AUTOMATIC FROM: 00-00-00 THRU: 01-28-07
3	163598-01-02A	EA	ANTENNA/SATELLITE - DISH IN DOME/AUTO - BLACK - SAT DISH-AUTOMATIC - NOT ILLUSTRATED FROM: 01-29-07 THRU: 99-99-99
	146488-03-000	EA	PLATE - ROOF - CABLE ENTRY - QUAD - SAT DISH-AUTOMATIC - NOT ILLUSTRATED FROM: 01-29-07 THRU: 99-99-99
3	141454-04-000	EA	WIRE - SATELLITE - AUTOMATIC - SATELLITE DISH-AUTOMATIC
4*	076319-23-000	EA	ANTENNA - TV ROOF MOUNT - 44.5" MAST - TV ANTENNA-AMPLIFIED SYSTEM
4*	076319-25-000	EA	KIT - HARDWARE INTERIOR - TV ANTENNA-AMPLIFIED SYSTEM
4	069726-02-000	EA	BUMPER - .88" OD X .40" THICK - BLACK - TV ANTENNA-AMPLIFIED SYSTEM
4	158270-01-01A	EA	ANT.-TV ROOF MT W/POWER LIFT/TURN-44.5" MAST-GRY/BLK-TV ANTENNA-AMPLIFIED SYS PWR

*COMPONENT PARTS LISTED LATER IN THIS GROUP

ELECTRICAL GROUP (CONTINUED)
12V BODY WIRING (CONTINUED)

**ENTERTAINMENT CENTER W/CD
S40FD**

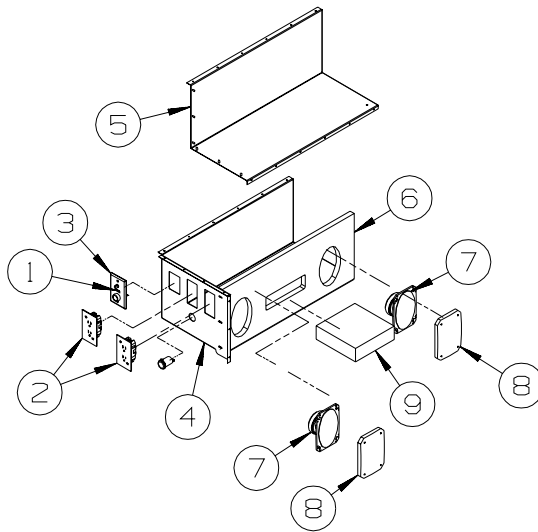

KEY	PART NUMBER	U/M	DESCRIPTION
1	087236-02-000	EA	LABEL - TV OUTLET
2	058708-01-000	EA	RECEPTACLE - ELECTRIC - DOUBLE - BROWN
3	076319-09-000	EA	WALLPLATE - TV CABLE RECEPTACLE - SINGLE - BROWN
4	156148-02-02B	EA	PANEL - ENTERTAINMENT CENTER - E-COATED
5	156145-01-02B	EA	PANEL - ENTERTAINMENT CENTER - E-COATED
6	156154-02-TG2	EA	FACE - ENTERTAINMENT CENTER - W/O HARDWARE
6	158891-06-05A	EA	FACE - ENTERTAINMENT CENTER - VINYL WRAPPED-SEAGRASS BLACK FROM: 00-00-00 THRU: 08-01-06 FROM: 08-02-06 THRU: 99-99-99
7	110469-01-000	EA	SPEAKER - 4" X 6" OVAL - COAXIAL
8	110470-01-01A	EA	GRILLE - 4" X 6" - OVAL SPEAKER - BLACK
9*	155619-01-000	EA	RADIO - AM/FM CD - W/REMOTE - MAGNADYNE M3200CD FROM: 00-00-00 THRU: 08-01-06
9	155619-02-000	EA	RADIO - AM/FM CD-W/O REMOTE/WIRE HARNESS-MAGNADYNE M3200CD FROM: 08-02-06 THRU: 99-99-99
	155619-03-000	EA	REMOTE - RADIO FROM: 08-02-06 THRU: 99-99-99

***COMPONENT PARTS LISTED LATER IN THIS GROUP**

ELECTRICAL GROUP (CONTINUED)
12V BODY WIRING (CONTINUED)

**ENTERTAINMENT CENTER W/CD
S40KD**

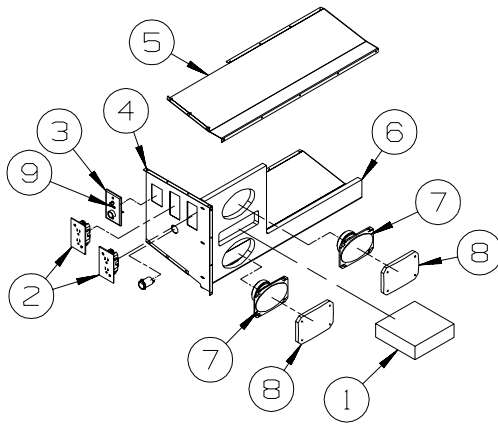

KEY	PART NUMBER	U/M	DESCRIPTION
1*	155619-01-000	EA	RADIO - AM/FM CD - W/REMOTE - MAGNADYNE M3200CD FROM: 00-00-00 THRU: 08-01-06
1	155619-02-000	EA	RADIO - AM/FM CD-W/O REMOTE/WIRE HARNESS-MAGNADYNE M3200CD FROM: 08-02-06 THRU: 99-99-99
	155619-03-000	EA	REMOTE - RADIO FROM: 08-02-06 THRU: 99-99-99
2	058708-01-000	EA	RECEPTACLE - ELECTRIC - DOUBLE - BROWN
3	076319-09-000	EA	WALLPLATE - TV CABLE RECEPTACLE - SINGLE - BROWN
4	156153-02-02B	EA	PANEL - ENTERTAINMENT CENTER - E-COATED
5	156152-01-02B	EA	PANEL - ENTERTAINMENT CENTER - E-COATED
6	156154-01-TG2	EA	FACE - ENTERTAINMENT CENTER - W/O HARDWARE FROM: 00-00-00 THRU: 08-13-06
6	158891-05-05A	EA	FACE - ENTERTAINMENT CENTER - VINYL WRAPPED-SEAGRASS BLACK FROM: 08-14-06 THRU: 99-99-99
7	110469-01-000	EA	SPEAKER - 4" X 6" OVAL - COAXIAL
8	110470-01-01A	EA	GRILLE - 4" X 6" - OVAL SPEAKER - BLACK
9	087236-02-000	EA	LABEL - TV OUTLET FROM: 05-17-06 THRU: 99-99-99

*COMPONENT PARTS LISTED LATER IN THIS GROUP

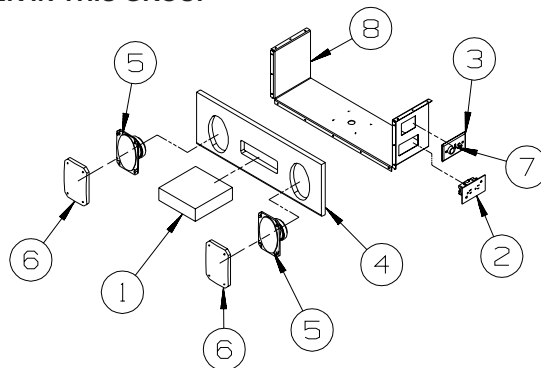

**ENTERTAINMENT CENTER W/CD
S40TD**

KEY	PART NUMBER	U/M	DESCRIPTION
1*	155619-01-000	EA	RADIO - AM/FM CD - W/REMOTE - MAGNADYNE M3200CD FROM: 00-00-00 THRU: 08-01-06
1	155619-02-000	EA	RADIO - AM/FM CD-W/O REMOTE/WIRE HARNESS-MAGNADYNE M3200CD FROM: 08-02-06 THRU: 99-99-99
	155619-03-000	EA	REMOTE - RADIO FROM: 08-02-06 THRU: 99-99-99
2	058708-01-000	EA	RECEPTACLE - ELECTRIC - DOUBLE - BROWN
3	076319-09-000	EA	WALLPLATE - TV CABLE RECEPTACLE - SINGLE - BROWN
4	156154-03-UJ2	EA	FACE - ENTERTAINMENT CENTER - W/O HARDWARE FROM: 00-00-00 THRU: 08-13-06
4	158891-07-05A	EA	FACE - ENTERTAINMENT CENTER - VINYL WRAPPED-SEAGRASS BLACK FROM: 08-14-06 THRU: 99-99-99
5	110469-01-000	EA	SPEAKER - 4" X 6" OVAL - COAXIAL
6	110470-01-01A	EA	GRILLE - 4" X 6" - OVAL SPEAKER - BLACK
7	087236-02-000	EA	LABEL - TV OUTLET
8	160348-01-02B	EA	PANEL - ENTERTAINMENT CENTER - E-COATED

*COMPONENT PARTS LISTED LATER IN THIS GROUP

ELECTRICAL GROUP (CONTINUED)
12V BODY WIRING (CONTINUED)

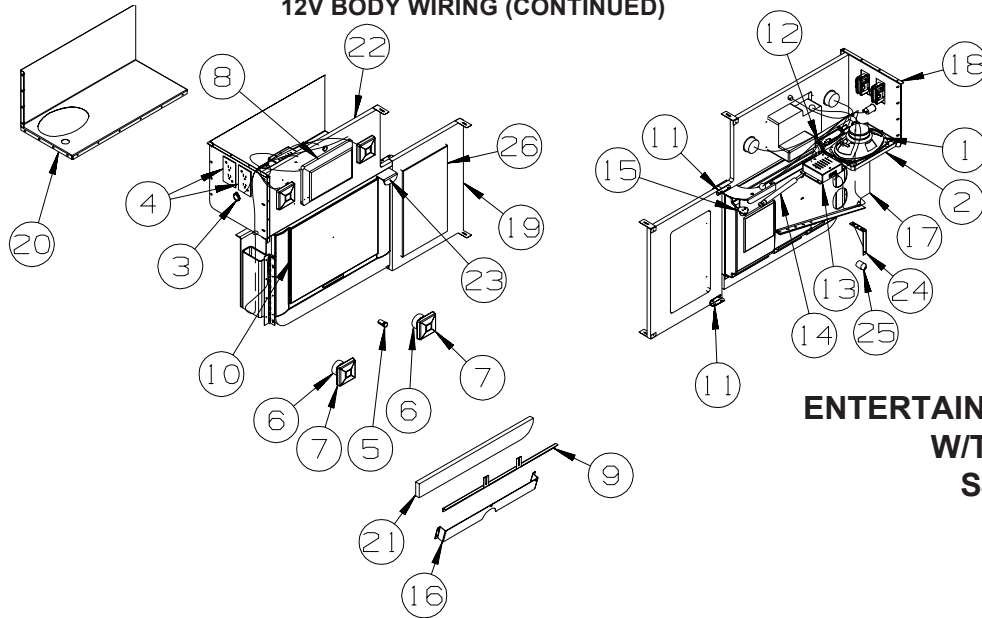

**ENTERTAINMENT CENTER
W/TV-DVD
S40FD**

KEY	PART NUMBER	U/M	DESCRIPTION
1	124884-01-000	EA	SPEAKER - 6" X 9" - SUB-WOOFER - W/O GRILLE
2	151844-01-01A	EA	GRILLE - SPEAKER - 6" X 9" - SUB WOOFER - BLACK
3	132958-01-000	EA	RECEPTACLE - 12 VOLT - MOUNTING FLANGE - BLACK
4	058708-01-000	EA	RECEPTACLE - ELECTRIC - DOUBLE - BROWN
5	149750-01-000	EA	RECEIVER - (INFRA RED SIGNAL) - W/6"LEAD/PLUG
6	148026-03-01A	EA	SPEAKER - CUBE - W/O CASE
7	148026-02-01A	EA	SPEAKER GRILLE - CUBE - SILVER
8*	156413-01-01A	EA	RADIO - WALL MOUNT - DVD/CD - W/ALARM - JENSEN AWM950 FROM: 00-00-00 THRU: 01-01-07
8	163031-01-01A	EA	RADIO - WALL MOUNT - DVD/CD - W/ALARM - JENSEN AWM960 FROM: 01-02-07 THRU: 99-99-99
9	158885-02-02B	EA	BRACKET/MOUNT - SPEAKER/TV - E-COATED
10*	158703-01-000	EA	TV - 20" - LCD 4:3 - SIDE SPEAKER - JENSEN JE2043
11	016604-01-000	EA	BRACE - ANGLE - 2 1/2" - UNPAINTED METAL
12	150140-02-000	EA	CROSSOVER COIL - F/SUBWOOFER SPEAKER/LOW FREQUENCY
13	150140-01-000	EA	CROSSOVER BOX - STANDARD STEREO TO DELUXE SOUND
14	142569-07-000	EA	SPRING/GAS - 20 LB - 20" EXTENDED/12" COMPRESSED
15	126263-25-02B	EA	BRACKET - GAS SPRING W/BALL STUD - E-COATED
16	158886-01-02B	EA	BRACKET/COVER - SPEAKER - E-COATED
17	158869-01-02B	EA	MOUNT/TV - E-COATED
18	158880-01-02B	EA	PANEL - ENTERTAINMENT CENTER - E-COATED
19	158891-03-03A	EA	FACE - ENTERTAINMENT CENTER - VINYL WRAPPED - WASHED MAPLE FROM: 00-00-00 THRU: 08-06-06
19	158891-03-05A	EA	FACE - ENTERTAINMENT CENTER - VINYL WRAPPED-SEAGRASS BLACK FROM: 08-07-06 THRU: 99-99-99
20	158879-02-02B	EA	PANEL - ENTERTAINMENT CENTER - E-COATED
21	158890-05-03A	EA	FACE - SPEAKER SUPPORT - VINYL WRAPPED - WASHED MAPLE FROM: 00-00-00 THRU: 08-06-06
21	158890-05-05A	EA	FACE - SPEAKER SUPPORT - VINYL WRAPPED - SEAGRASS BLACK FROM: 08-07-06 THRU: 99-99-99
22	158891-04-03A	EA	FACE - ENTERTAINMENT CENTER - VINYL WRAPPED - WASHED MAPLE FROM: 00-00-00 THRU: 08-06-06
22	158891-04-05A	EA	FACE - ENTERTAINMENT CENTER - VINYL WRAPPED-SEAGRASS BLACK FROM: 08-07-06 THRU: 99-99-99
23	158868-01-02B	EA	HANDLE - TV MOUNT - E-COATED
24	158851-01-02B	EA	BRACKET - STOPPER - W/O RUBBER BUMPER
25	117046-02-000	EA	BUMPER - RUBBER/ROUND END - 1.5"
26	157480-01-03A	EA	DOOR - EXTERIOR ENTERTAINMENT/MAPLE - 9.4"X 15.7"-W/O HDW FROM: 00-00-00 THRU: 08-06-06
26	157480-01-05A	EA	DOOR - EXTERIOR ENTERTAINMENT/BLACK - 9.4"X 15.7"-W/O HDW FROM: 08-07-06 THRU: 99-99-99

*COMPONENT PARTS LISTED LATER IN THIS GROUP

ELECTRICAL GROUP (CONTINUED)
12V BODY WIRING (CONTINUED)

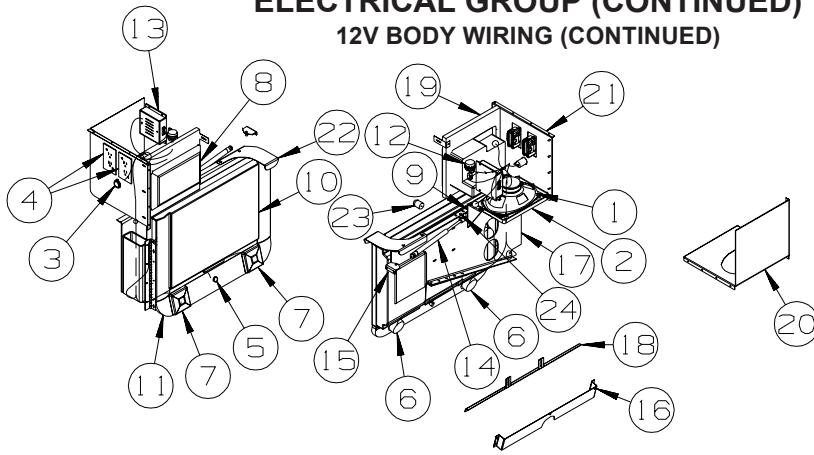

ENTERTAINMENT CENTER
W/TV-DVD
S40KD

KEY	PART NUMBER	U/M	DESCRIPTION
1	124884-01-000	EA	SPEAKER - 6" X 9" - SUB-WOOFER - W/O GRILLE
2	151844-01-01A	EA	GRILLE - SPEAKER - 6" X 9" - SUB WOOFER - BLACK
3	132958-01-000	EA	RECEPTACLE - 12 VOLT - MOUNTING FLANGE - BLACK
4	058708-01-000	EA	RECEPTACLE - ELECTRIC - DOUBLE - BROWN
5	149750-01-000	EA	RECEIVER - (INFRA RED SIGNAL) - W/6"LEAD/PLUG
6	148026-03-01A	EA	SPEAKER - CUBE - W/O CASE
7	148026-02-01A	EA	SPEAKER GRILLE - CUBE - SILVER
8*	156413-01-01A	EA	RADIO - WALL MOUNT - DVD/CD - W/ALARM - JENSEN AWM950 FROM: 00-00-00 THRU: 01-01-07
8	163031-01-01A	EA	RADIO - WALL MOUNT - DVD/CD - W/ALARM - JENSEN AWM960 FROM: 01-02-07 THRU: 99-99-99
9	158851-01-02B	EA	BRACKET - STOPPER - W/O RUBBER BUMPER
10*	158703-01-000	EA	TV - 20" - LCD 4:3 - SIDE SPEAKER - JENSEN JE2043
11	158890-02-03A	EA	FACE - SPEAKER SUPPORT - VINYL WRAPPED - WASHED MAPLE FROM: 00-00-00 THRU: 08-06-06
11	158890-02-05A	EA	FACE - SPEAKER SUPPORT - VINYL WRAPPED - SEAGRASS BLACK FROM: 08-07-06 THRU: 99-99-99
12	150140-02-000	EA	CROSSOVER COIL - F/SUBWOOFER SPEAKER/LOW FREQUENCY
13	150140-01-000	EA	CROSSOVER BOX - STANDARD STEREO TO DELUXE SOUND
14	142569-07-000	EA	SPRING/GAS - 20 LB - 20" EXTENDED/12" COMPRESSED
15	126263-12-02B	EA	BRACKET - GAS SPRING W/BALL STUD - E-COATED
16	158886-01-02B	EA	BRACKET/COVER - SPEAKER - E-COATED
17	158869-01-02B	EA	MOUNT/TV - E-COATED
18	158885-01-02B	EA	BRACKET/MOUNT - SPEAKER/TV - E-COATED
19	158891-01-03A	EA	FACE - ENTERTAINMENT CENTER - VINYL WRAPPED - WASHED MAPLE FROM: 00-00-00 THRU: 08-06-06
19	158891-01-05A	EA	FACE - ENTERTAINMENT CENTER - VINYL WRAPPED-SEAGRASS BLACK FROM: 08-07-06 THRU: 99-99-99
20	158879-01-02B	EA	PANEL - ENTERTAINMENT CENTER - E-COATED
21	158880-01-02B	EA	PANEL - ENTERTAINMENT CENTER - E-COATED
22	158868-01-02B	EA	HANDLE - TV MOUNT - E-COATED
23	117046-02-000	EA	BUMPER - RUBBER/ROUND END - 1.5"
24	126263-08-02B	EA	BRACKET - GAS SPRING W/CENTERED BALL STUD - E-COATED

***COMPONENT PARTS LISTED LATER IN THIS GROUP**

ELECTRICAL GROUP (CONTINUED)

12V BODY WIRING (CONTINUED)

ENTERTAINMENT CENTER W/TV-DVD S40TD

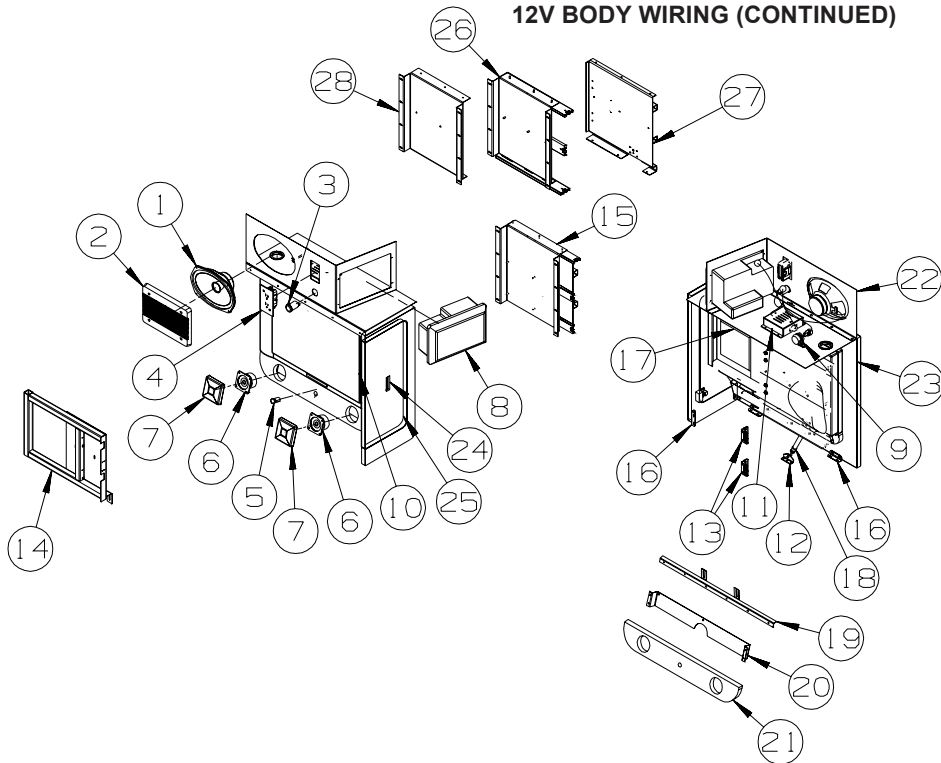

KEY	PART NUMBER	U/M	DESCRIPTION
1	124884-01-000	EA	SPEAKER - 6" X 9" - SUB-WOOFER - W/O GRILLE
2	151844-01-01A	EA	GRILLE - SPEAKER - 6" X 9" - SUB WOOFER - BLACK
3	132958-01-000	EA	RECEPTACLE - 12 VOLT - MOUNTING FLANGE - BLACK
4	058708-01-000	EA	RECEPTACLE - ELECTRIC - DOUBLE - BROWN
5	149750-01-000	EA	RECEIVER - (INFRA RED SIGNAL) - W/6"LEAD/PLUG
6	148026-03-01A	EA	SPEAKER - CUBE - W/O CASE
7	148026-02-01A	EA	SPEAKER GRILLE - CUBE - SILVER
8*	156413-01-01A	EA	RADIO - WALL MOUNT - DVD/CD - W/ALARM - JENSEN AWM950 FROM: 00-00-00 THRU: 01-01-07
8	163031-01-01A	EA	RADIO - WALL MOUNT - DVD/CD - W/ALARM - JENSEN AWM960 FROM: 01-02-07 THRU: 99-99-99
9	150140-02-000	EA	CROSSOVER COIL - F/SUBWOOFER SPEAKER/LOW FREQUENCY
10*	158703-01-000	EA	TV - 20" - LCD 4:3 - SIDE SPEAKER - JENSEN JE2043
11	150140-01-000	EA	CROSSOVER BOX - STANDARD STEREO TO DELUXE SOUND
12	126263-02-02B	EA	BRACKET - GAS SPRING W/BALL STUD - E-COATED
13	153191-01-01A	EA	HINGE - FRICTION - 16 IN-LBS - BLACK
14	159908-01-02B	EA	MOUNT - TV - E-COATED
15	159914-01-02B	EA	BASE - TV/SLIDE ASSEMBLY - E-COATED
16	016604-01-000	EA	BRACE - ANGLE - 2 1/2" - UNPAINTED METAL
17	159905-01-02B	EA	PANEL - ENTERTAINMENT CENTER - E-COATED
18	142569-06-000	EA	SPRING/GAS - 25 LB - 14.8" EXTENDED/8.9" COMPRESSED
19	158885-01-02B	EA	BRACKET/MOUNT - SPEAKER/TV - E-COATED
20	158886-01-02B	EA	BRACKET/COVER - SPEAKER - E-COATED
21	158890-02-03A	EA	FACE - SPEAKER SUPPORT - VINYL WRAPPED - WASHED MAPLE FROM: 00-00-00 THRU: 08-06-06
21	158890-02-05A	EA	FACE - SPEAKER SUPPORT - VINYL WRAPPED - SEAGRASS BLACK FROM: 08-07-06 THRU: 99-99-99
22	159904-01-02B	EA	PANEL - ENTERTAINMENT CENTER - E-COATED
23	160725-01-UJ1	EA	CABINET - ENTERTAINMENT CENTER - W/O DOOR/HDW - EXTERIOR
24	139136-02-02A	EA	HANDLE - RECESSED - PEWTER
25	160725-13-UJ1	EA	DOOR - ASM - W/O HDW
26	159914-02-02B	EA	BASE - TV/SLIDE ASSEMBLY - E-COATED
27	160299-02-02B	EA	BRACKET/SLIDE - TV - E-COATED
28	159913-02-02B	EA	BRACKET/MOUNT - TV - E-COATED

*COMPONENT PARTS LISTED LATER IN THIS GROUP

ELECTRICAL GROUP (CONTINUED)
12V BODY WIRING (CONTINUED)

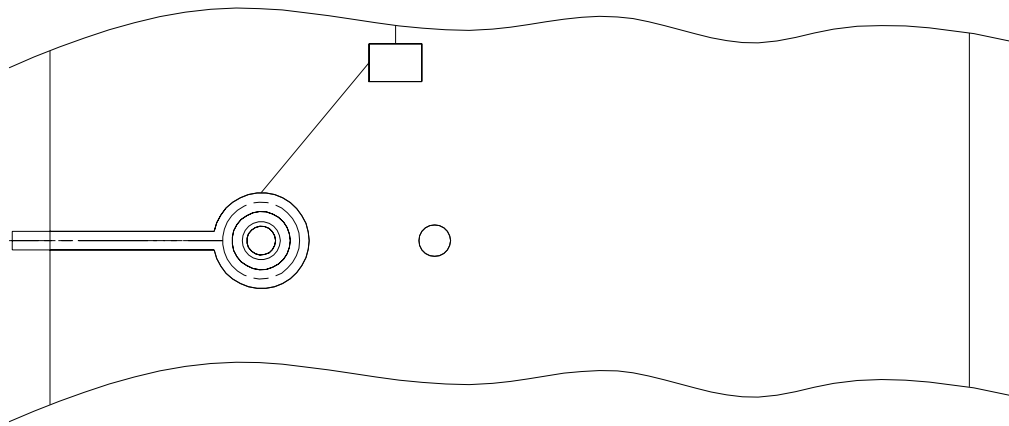

**SATELLITE WIRING
 DETAIL ON ROOF**

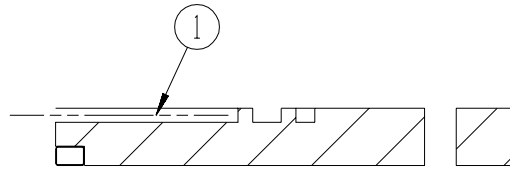

KEY	PART NUMBER	U/M	DESCRIPTION
1	154474-03-000	EA	CABLE - SATELLITE - COAX - 8' W/CONNECTORS - AUTOMATIC SATELLITE DISH
1	141454-04-000	EA	WIRE - SATELLITE - AUTOMATIC - AUTOMATIC SATELLITE DISH FROM: 00-00-00 THRU: 01-28-07
1	163598-03-000	EA	CABLE - SATELLITE CONTROL - AUTOMATIC SATELLITE DISH FROM: 01-29-07 THRU: 99-99-99

ELECTRICAL GROUP (CONTINUED)

EXTERIOR LAMPS

KEY PART NUMBER U/M DESCRIPTION
 * 130672-01-02A EA SPOTLIGHT - POWER/REMOTE - BLACK
 *COMPONENT PARTS LISTED LATER IN THIS GROUP

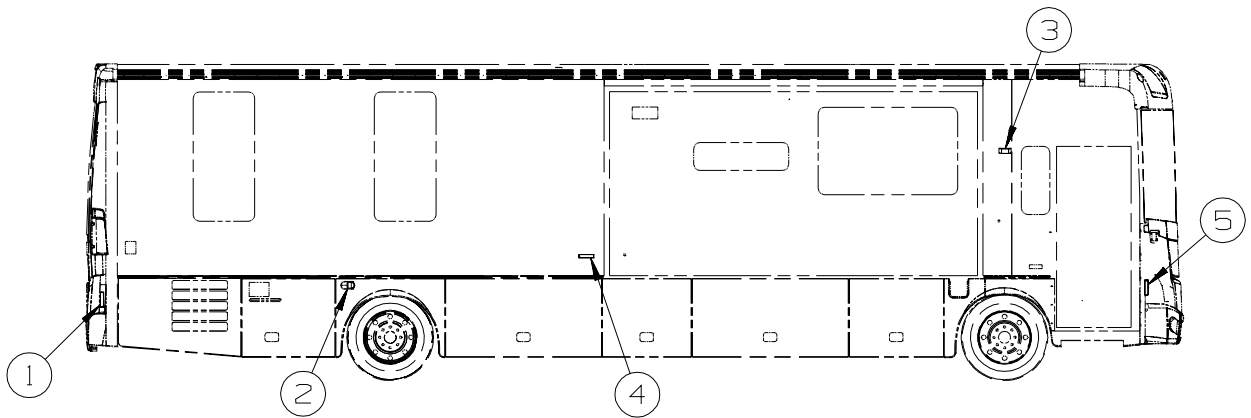
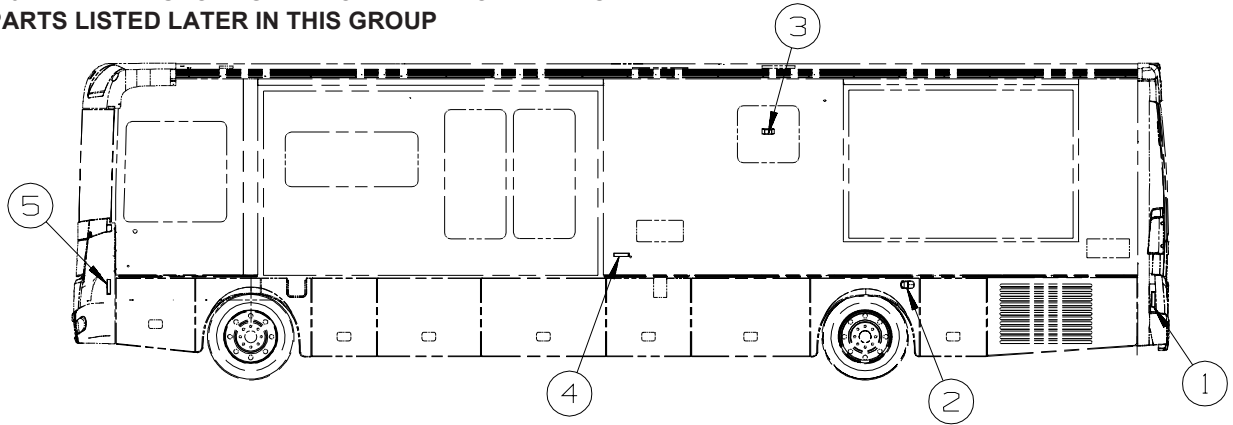

KEY	PART NUMBER	U/M DESCRIPTION
1	117826-03-000	EA GASKET/SIDE MARKER LIGHT
1	117826-01-000	EA LAMP/SIDE MARKER ASSEMBLY - RED
1	036196-01-000	EA BULB - 12V - #194 - .27 AMP - BAYONETTE
1	067789-02-000	EA SOCKET - LAMP
2	129746-01-000	EA LAMP - DOCKING/DRIVING W/MOUNT BRACKET
2	120494-03-02B	EA SHIM - STRIKER - LUGGAGE DOOR - 3/64"
3	097917-01-08A	EA CONNECTOR - ELECTRICAL PIGTAIL - NYLON - CLEAR
3	008215-01-000	EA BULB - 12 VOLT - #1003 - .94 AMP
4	111102-01-000	EA BASE - MARKER LAMP
4	111102-02-000	EA LENS - AMBER - MARKER LAMP
4	036196-01-000	EA BULB - 12V - #194 - .27 AMP - BAYONETTE
5	117826-02-000	EA LAMP/SIDE MARKER ASSEMBLY - AMBER
5	117826-03-000	EA GASKET/SIDE MARKER LIGHT
5	036196-01-000	EA BULB - 12V - #194 - .27 AMP - BAYONETTE
5	067789-02-000	EA SOCKET - LAMP

ELECTRICAL GROUP (CONTINUED)
EXTERIOR LAMPS (CONTINUED)

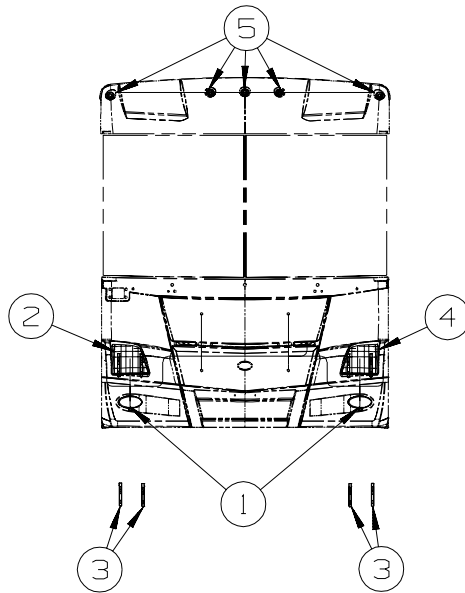

KEY	PART NUMBER	U/M	DESCRIPTION
1	146087-01-000	EA	LAMP - FOG - CLEAR/OVAL
2	146088-01-000	EA	HEADLAMP - W/PARK&TURN - RIGHT HAND - FORD IL2X-13008-EC
3	144385-01-01A	EA	RETAINER - HEADLAMP - BLACK
3	049359-01-000	EA	SPRING - RETAINER - HEADLAMP - GM #496096
4	146088-02-000	EA	HEADLAMP - W/PARK&TURN - LEFT HAND - FORD IL2X-13008-ED
5	138996-01-000	EA	LAMP - CLEARANCE - AMBER
5	138996-03-000	EA	BRACKET - CLEARANCE LIGHT
5	138996-04-000	EA	CONNECTOR - LAMP

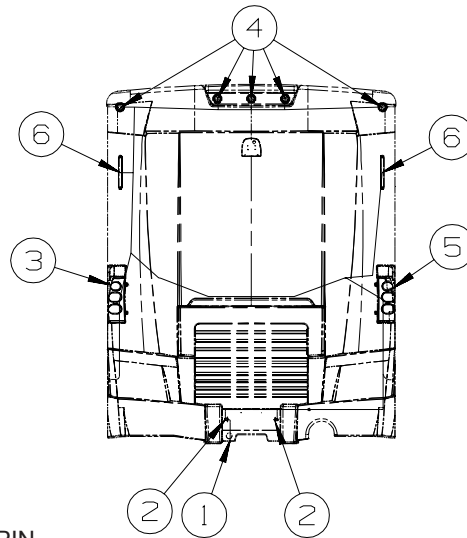

KEY	PART NUMBER	U/M	DESCRIPTION
1	146246-01-000	EA	CONNECTOR/PLUG - TRAILER - 7 PIN
2	087201-01-000	EA	LIGHT - HALF ROUND - 1" X 1.7" - PLASTIC - BLACK OR WHITE
3	154595-02-000	EA	LIGHT - STOP/TURN/TAIL/BACK UP - DRIVER
3	112708-01-000	EA	BULB - 12 VOLT - #3157 - .59/2.10 AMP
3	117805-02-000	EA	BULB - 12V - #921 - 1.4 AMPS
3	120760-01-000	EA	RUBBER BUMPER - CLEAR - .1" THICK X .8" DIAMETER
3	146326-05-000	EA	SOCKET - 2 WIRE - LIGHT GRAY
3	154619-01-000	EA	SOCKET - LIGHT - 3 WIRE
3	139001-02-000	EA	SOCKET ONLY - F/DOCKING LAMP
4	138996-02-000	EA	LAMP - CLEARANCE - RED
4	138996-03-000	EA	BRACKET - CLEARANCE LIGHT
4	138996-04-000	EA	CONNECTOR - LAMP
5	154595-01-000	EA	LIGHT - STOP/TURN/TAIL/BACK UP - PASSENGER
5	112708-01-000	EA	BULB - 12 VOLT - #3157 - .59/2.10 AMP
5	117805-02-000	EA	BULB - 12V - #921 - 1.4 AMPS
5	120760-01-000	EA	RUBBER BUMPER - CLEAR - .1" THICK X .8" DIAMETER
5	146326-05-000	EA	SOCKET - 2 WIRE - LIGHT GRAY
5	154619-01-000	EA	SOCKET - LIGHT - 3 WIRE
5	139001-02-000	EA	SOCKET ONLY - F/DOCKING LAMP
6	151076-01-000	EA	LIGHT - BRAKE - CENTER MOUNT

ELECTRICAL GROUP (CONTINUED)

FRONT END

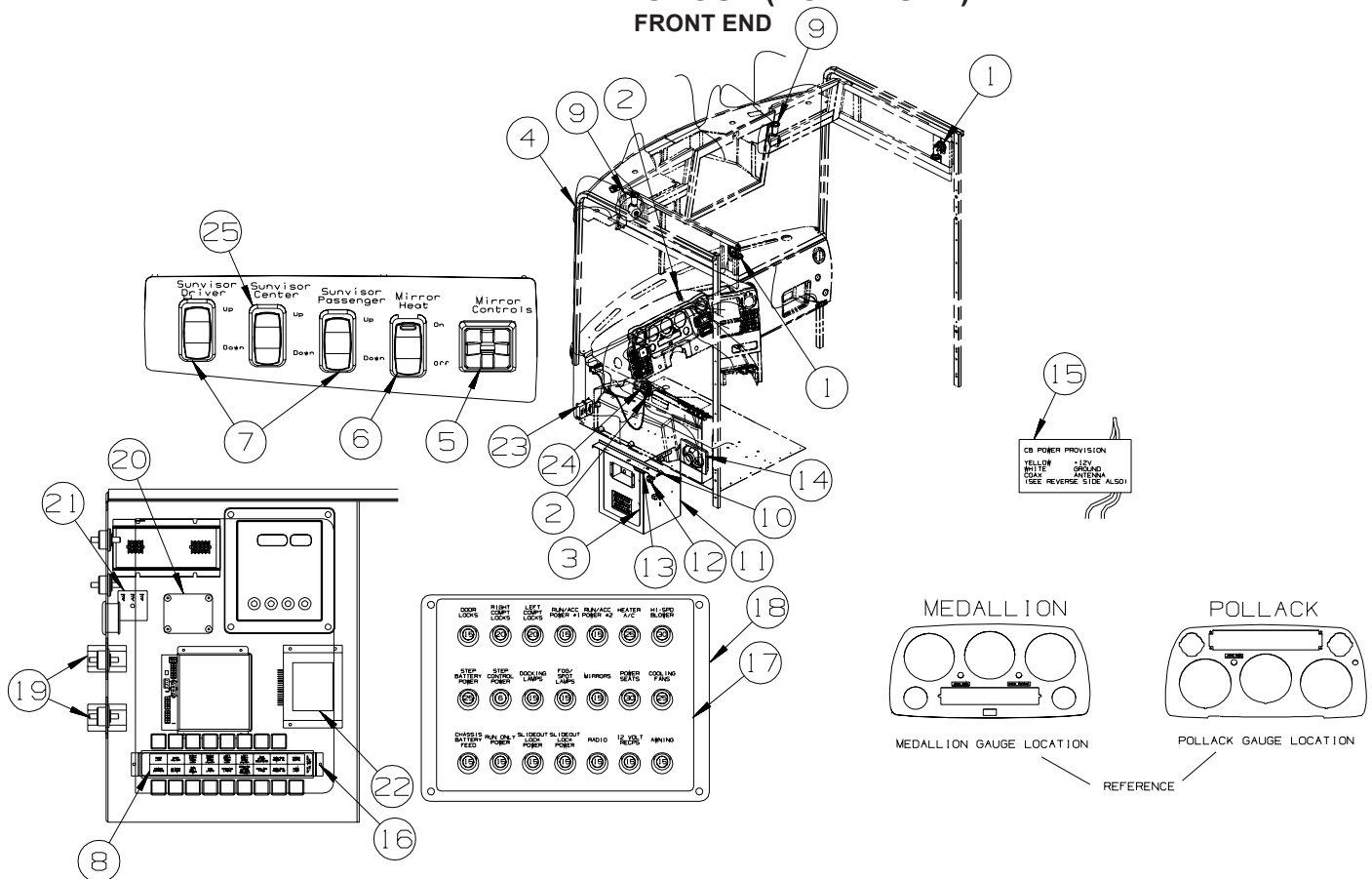

KEY	PART NUMBER	U/M	DESCRIPTION
1	128786-02-02A	EA	LIGHT - READING/SWIVEL - W/O SWITCH - SATIN NICKEL
1	123917-01-000	EA	BULB - 12V - HALOGEN SPOT
2	111414-01-000	EA	RECEPTACLE/SOCKET - 12 VOLT
3	145066-03-02B	EA	DOOR - ELECTRICAL COMPARTMENT - E-COATED
4	158494-02-000	EA	CABLE/ANTENNA - SATELLITE RADIO SIRRUS
5	088246-01-000	EA	SWITCH/REMOTE MIRROR - W/2PIN & 6 PIN CONNECTORS/PIGTAIL
6	145638-02-01A	EA	SWITCH/ROCKER - SPST (ON/OFF) - LIGHTED - BLACK
6	108355-02-000	EA	HOUSING - SWITCH - 12 POSITION
7	145638-12-01A	EA	SWITCH/ROCKER - DPDT (ON/ON/ON) - BLACK
7	108355-02-000	EA	HOUSING - SWITCH - 12 POSITION
	103603-01-000	EA	BULB - 12V - #74 - .12A WEDGE - GE 22-25 USED IN DASH
8	136161-03-01A	EA	LABEL - RELAY - MATTE BLACK/WHITE LETTERS
9	154851-01-000	EA	BLOWER - 3 SPEED - 12 VOLT/DC POWERED
10	145061-01-02B	EA	COVER - WIRE - LUGGAGE COMPARTMENT - E-COATED
11	145063-01-02B	EA	PANEL - CLOSEOUT/ELECTRICAL - E-COATED
12	041250-01-000	EA	SWITCH - PUSH BUTTON/DOOR JAMB - METAL/CHROME
13*	086280-01-000	EA	LIGHT - SURFACE MOUNT - 12 VOLT
14	124884-01-000	EA	SPEAKER - 6" X 9" - SUB-WOOFER - W/O GRILLE
14	151844-01-01A	EA	GRILLE - SPEAKER - 6" X 9" - SUB WOOFER - BLACK
15	104678-01-000	EA	LABEL - CB PREP
16	136120-02-02B	EA	BRACKET - RELAY - E-COATED
17	093236-45-000	EA	LABEL - CIRCUIT BREAKER
18	139067-07-02B	EA	PLATE - CIRCUIT BREAKER/HOUSE - E-COATED
19	118571-03-000	EA	BRACKET - MOUNTING
19	118571-04-000	EA	GASKET
20	128074-02-000	EA	FILTER - NOISE - 12 VOLT DC W/PLUGS
21	133535-01-000	EA	MODULE - TIMER 20 SECOND - WARNING LIGHT - TS61120P - REFERENCE MEDALLION GAUGES
22*	151458-01-000	EA	KEYLESS ENTRY SYSTEM - ENTRY DOOR & CARGO DOORS - W/REMOTE
23	135420-20-000	EA	RECEIVER - SATELLITE RADIO
24	151935-01-000	EA	RADIO/CB - 40 CHANNEL - COBRA C75WXST
	113452-01-000	FT	SEAL/TRIM - FRONT - VINYL W/WIRE CARRIER - .020" - TO PROTECT WIRES FROM SHARP EDGES
25	145638-12-01A	EA	SWITCH/ROCKER - DPDT (ON/ON/ON) - BLACK - SUNVISORS - POWERED (3)
25	108355-02-000	EA	HOUSING - SWITCH - 12 POSITION - SUNVISORS - POWERED (3)

*COMPONENT PARTS LISTED LATER IN THIS GROUP

ELECTRICAL GROUP (CONTINUED) FRONT END (CONTINUED)

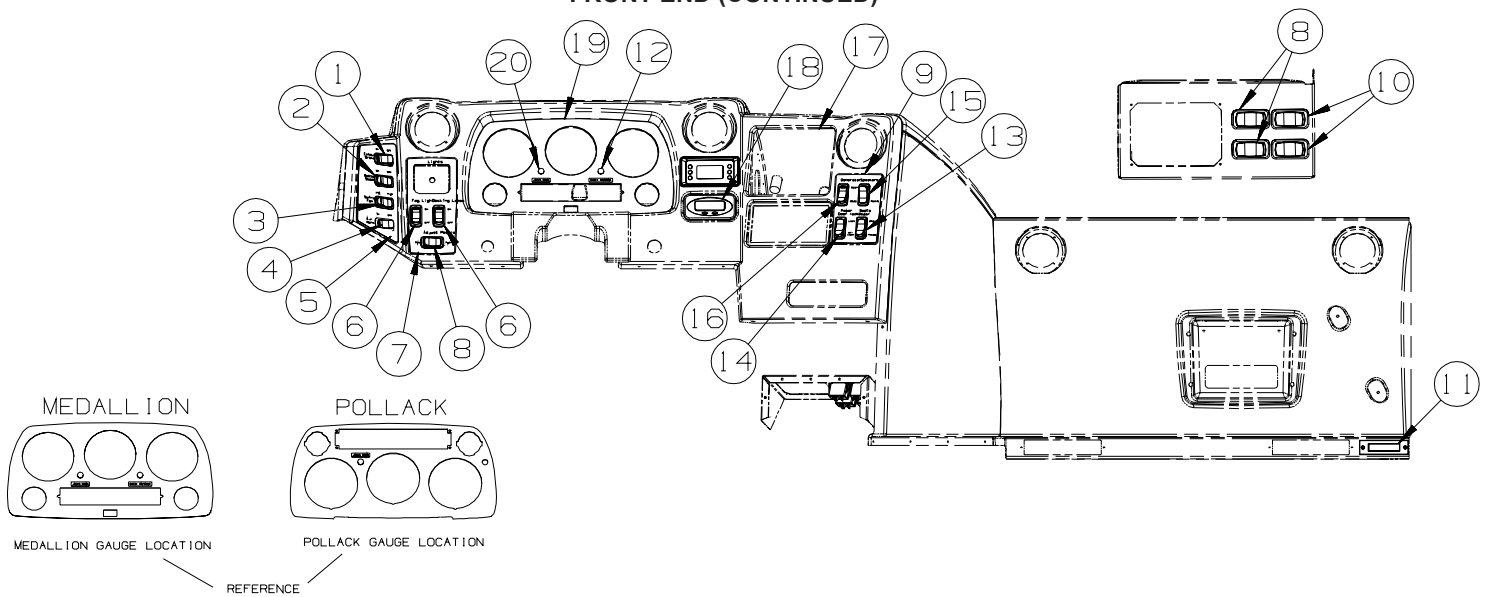

KEY	PART NUMBER	U/M	DESCRIPTION
1	145638-11-01A	EA	SWITCH/ROCKER - DPDT (ON/OFF/ON) - LIGHTED - BLACK
1	108355-02-000	EA	HOUSING - SWITCH - 12 POSITION
1	103603-01-000	EA	BULB - 12V - #74 - .12A WEDGE - GE 22-25 USED IN DASH
2	145638-04-01A	EA	SWITCH/ROCKER - SPDT (ON/ON) -BLACK
2	108355-02-000	EA	HOUSING - SWITCH - 12 POSITION
2	103603-01-000	EA	BULB - 12V - #74 - .12A WEDGE - GE 22-25 USED IN DASH
3	145638-03-01A	EA	SWITCH/ROCKER - SPDT (ON/OFF/ON) -BLACK
3	108355-02-000	EA	HOUSING - SWITCH - 12 POSITION
4	145754-01-000	EA	SWITCH - BLANK - BLACK
4	145638-08-01A	EA	SWITCH/ROCKER - DPDT (ON/ON) -LIGHTED - BLACK - AIR HORNS
4	108355-02-000	EA	HOUSING - SWITCH - 12 POSITION - AIR HORNS
4	103603-01-000	EA	BULB - 12V - #74 - .12A WEDGE - GE 22-25 USED IN DASH
5	144722-08-05A	EA	APPLIQUE - BEZEL - LEFT - TEAK
5	144722-08-06A	EA	APPLIQUE - BEZEL - LEFT - COCOA
6	145638-02-01A	EA	SWITCH/ROCKER - SPST (ON/OFF) - LIGHTED - BLACK
6	108355-02-000	EA	HOUSING - SWITCH - 12 POSITION
6	103603-01-000	EA	BULB - 12V - #74 - .12A WEDGE - GE 22-25 USED IN DASH
7	144722-12-05A	EA	APPLIQUE - BEZEL - CENTER/LEFT - TEAK
7	144722-12-06A	EA	APPLIQUE - BEZEL - CENTER/LEFT - COCOA
8	145638-09-01A	EA	SWITCH/ROCKER - DPDT (ON/OFF/ON) - BLACK
8	108355-01-000	EA	HOUSING - SWITCH
8	103603-01-000	EA	BULB - 12V - #74 - .12A WEDGE - GE 22-25 USED IN DASH
9	144722-01-05A	EA	APPLIQUE - BEZEL - RIGHT - TEAK
9	144722-01-06A	EA	APPLIQUE - BEZEL - RIGHT - COCOA
10	145754-01-01A	EA	SWITCH - BLANK - BLACK
10	145638-09-01A	EA	SWITCH/ROCKER - DOUBLE PULL/DOUBLE THROW - BLACK
10	108355-01-000	EA	HOUSING - SWITCH
10	103603-01-000	EA	BULB - 12V - #74 - .12A WEDGE - GE 22-25 USED IN DASH
11	061424-01-000	EA	LIGHT - AISLE - 12 VOLT - RECTANGULAR
	036196-01-000	EA	BULB - 12V - #194 - .27 AMP - BAYONETTE
12	150237-02-000	EA	LIGHT - INDICATOR - AMBER - REFERENCE MEDALLION GAUGES
13	145638-07-01A	EA	SWITCH/ROCKER - DPDT (ON/ON) - BLACK
13	108355-02-000	EA	HOUSING - SWITCH - 12 POSITION
13	103603-01-000	EA	BULB - 12V - #74 - .12A WEDGE - GE 22-25 USED IN DASH
14	145638-05-01A	EA	SWITCH/ROCKER - SPDT (ON/OFF/ON) - BLACK
14	108355-02-000	EA	HOUSING - SWITCH - 12 POSITION
14	103603-01-000	EA	BULB - 12V - #74 - .12A WEDGE - GE 22-25 USED IN DASH
15	145638-01-01A	EA	SWITCH/ROCKER - SPST (ON/OFF) - BLACK
15	108355-02-000	EA	HOUSING - SWITCH - 12 POSITION
15	103603-01-000	EA	BULB - 12V - #74 - .12A WEDGE - GE 22-25 USED IN DASH
16	145638-06-01A	EA	SWITCH/ROCKER - SPDT (ON/OFF/ON) - LIGHTED - BLACK
16	108355-02-000	EA	HOUSING - SWITCH - 12 POSITION
16	103603-01-000	EA	BULB - 12V - #74 - .12A WEDGE - GE 22-25 USED IN DASH

ELECTRICAL GROUP (CONTINUED)
FRONT END (CONTINUED)

KEY	PART NUMBER	U/M	DESCRIPTION
17*	136119-01-000	EA	COMPASS/THERMOMETER - ELECTRONIC- 4.5" X 2.3" DISPLAY FACE
18	147844-01-01A	EA	BEZEL - INFO CENTER DISPLAY - BLACK - REFERENCE MEDALLION GAUGES
19	144722-09-05A	EA	APPLIQUE - BEZEL - INSTRUMENT CLUSTER - TEAK- REFERENCE MEDALLION GAUGES
19	144722-17-05A	EA	APPLIQUE - BEZEL - INSTRUMENT CLUSTER - TEAK - REFERENCE POLLACK GAUGES
19	144722-09-06A	EA	APPLIQUE - BEZEL - INSTRUMENT CLUSTER - COCOA- REFERENCE MEDALLION GAUGES
19	144722-17-06A	EA	APPLIQUE - BEZEL - INSTRUMENT CLUSTER - COCOA - REFERENCE POLLACK GAUGES
19	103603-01-000	EA	BULB - 12V - #74 - .12A WEDGE - GE 22-25 USED IN DASH
20	150237-01-000	EA	LIGHT - INDICATOR - RED

***COMPONENT PARTS LISTED LATER IN THIS GROUP**

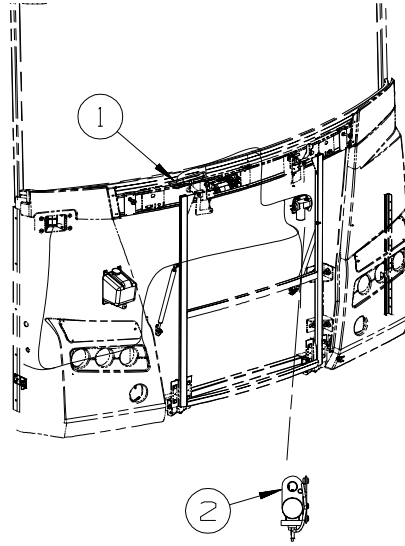

KEY	PART NUMBER	U/M	DESCRIPTION
1*	137417-01-01A	EA	LIGHT - DOME - SINGLE - W/SWITCH/FROSTED LENS - WHITE
2	114802-01-000	EA	PUMP - VACUUM - 12V

***COMPONENT PARTS LISTED LATER IN THIS GROUP**

ELECTRICAL GROUP (CONTINUED)

GPS

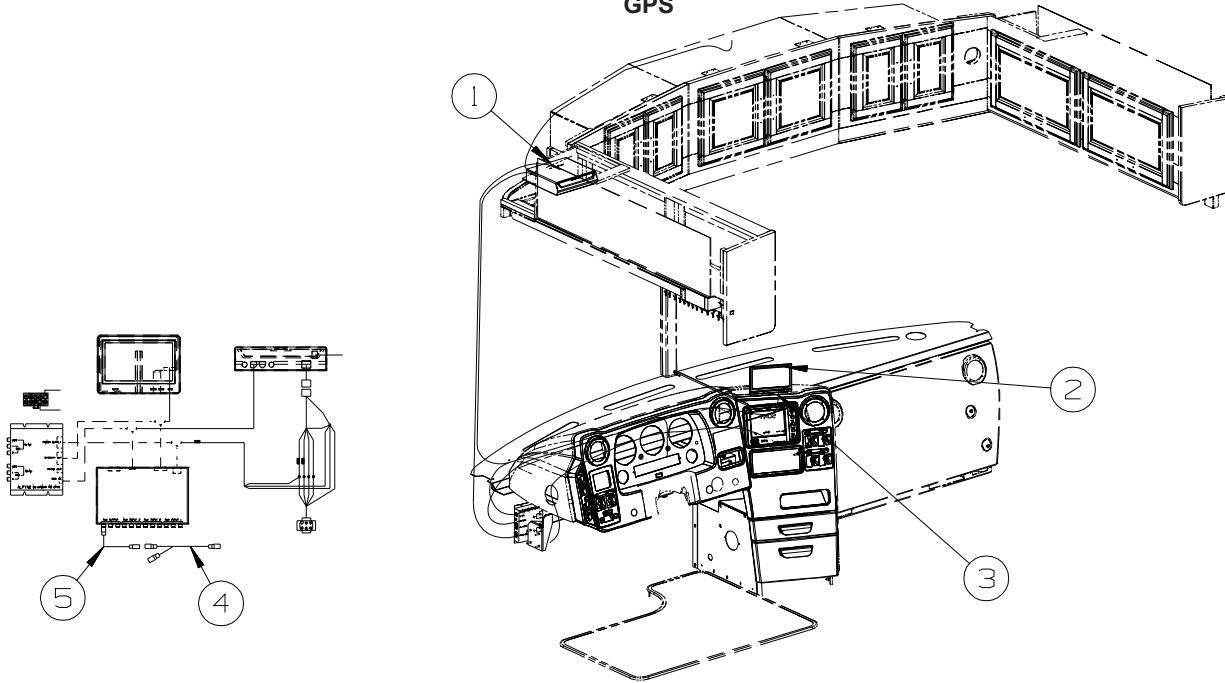

KEY	PART NUMBER	U/M	DESCRIPTION
1*	137424-01-000	EA	GPS-NAVAGATION SYS-W/DVD DIVIT/MAPS/GPS ANT & WIRE HARNESS FROM: 00-00-00 THRU: 04-02-06
1*	137424-08-000	EA	GPS-NAVAGATION SYS-W/DVD DIVIT/MAPS/GPS ANT/WIRE HARNESS FROM: 04-03-06 THRU: 99-99-99
2	137424-05-000	EA	MONITOR/LCD - COLOR - 6.5" FROM: 00-00-00 THRU: 01-22-06
2	137424-07-000	EA	MONITOR/LCD - COLOR - 6.5" FROM: 04-03-06 THRU: 03-11-07
2	137424-09-000	EA	MONITOR/LCD - COLOR - 7" - ALPINE #TME-M740BT FROM: 03-12-07 THRU: 99-99-99
3	137424-04-000	EA	BRACKET - MONITOR
4	148112-01-000	EA	CABLE - MONITOR - SONY AUX
5	148591-01-000	EA	CABLE - RCA MALE/RCA MALE - RIVER PARK 55-862-1

*COMPONENT PARTS LISTED LATER IN THIS GROUP

ELECTRICAL GROUP (CONTINUED)

FRONT TV/VCR

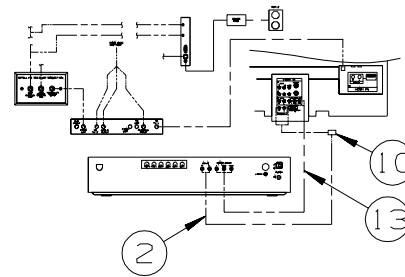
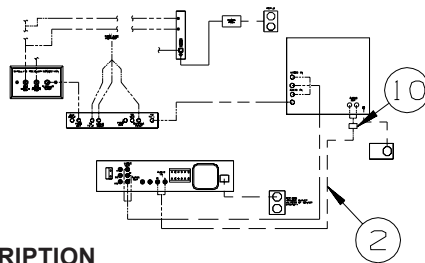
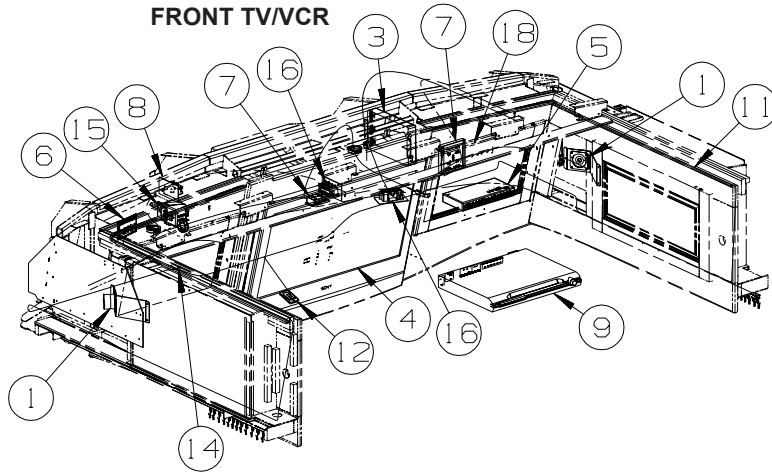

KEY	PART NUMBER	U/M	DESCRIPTION
1	148026-02-01A	EA	SPEAKER GRILLE - CUBE - SILVER
1	148026-03-01A	EA	SPEAKER - CUBE - W/O CASE
1	149422-02-02B	EA	BRACKET/MOUNTING - SPEAKER - E-COATED
2	117420-02-000	EA	CABLE - W/MALE RCA ENDS - SHIELDED - 4'
3	140062-01-000	EA	SWITCH - SPEAKER - 6 CHANNEL
4*	146298-02-000	EA	TV - 27" STEREO W/5 JACKS - SONY 27FS120 - TV(FRONT)-27" COLOR STEREO
4	155599-01-000	EA	TV - 32" - FLAT PANEL/LCD/HDTV - SONY KLV-32TM1 - TV-32" COLOR,STEREO W/REMOTE FROM: 00-00-00 THRU: 02-12-06
4	160064-01-000	EA	TV - 32" - FLAT PANEL/LCD/HDTV - SONY KDL-32S2000 - TV-32" COLOR,STEREO W/REMOTE FROM: 03-13-06 THRU: 99-99-99
5	142258-01-000	EA	SWITCH - VIDEO/ANTENNA POWER SUPPLY
6	149557-04-01A	EA	PLATE/WALL - TRIPLE COAXIAL/HORIZONTAL - WHITE
7	149750-05-000	EA	MODULE/INTERFACE - INFRA RED (RECEIVER TO TRANSMITTER)
8	058708-01-000	EA	RECEPTACLE - ELECTRIC - DOUBLE - BROWN
8	158542-02-01A	EA	LABEL - RECEPTACLE - ELECTRONICS - WHITE/BLACK - CANADIAN
9*	154548-01-000	EA	DVD/VCR - HOME THEATER COMBO - SONY HTV700DP FROM: 00-00-00 THRU: 02-12-06
9	158931-01-000	EA	DVD/VCR - HOME THEATER COMBO-W/O SPEAKERS-TOSHIBA SD-V57HT FROM: 02-13-06 THRU: 03-12-06
9	159916-01-000	EA	DVD - HOME THEATER - AM/FM - W/O SPEAKERS - SONY DAVDZ120W FROM: 03-13-06 THRU: 04-02-06
10	123324-01-000	EA	FILTER - GROUND LOOP
11	146514-03-000	EA	LIGHT - FLEX - ROPE/ROUND - W/O MOUNT CHANNEL
11	146514-02-000	EA	CONNECTOR - LIGHT
12	135740-01-01A	EA	SWITCH - ROCKER - SPST - ON/OFF - BROWN
12	135741-01-01A	EA	SWITCH - BASE - SINGLE - BROWN
12	135742-01-01A	EA	BEZEL - SWITCH - SINGLE - BROWN
13	155845-01-000	EA	CABLE - RCA - 12' - 3 RCA MALE CONNECTORS - BOTH ENDS
14	149750-03-000	EA	TRANSMITTER - F/INFRA RED RECEIVER
15	156676-01-000	EA	CONTROLLER/OUTLET - POWER/TV - AUTO SHUTOFF W/IGNITION
16	058708-01-000	EA	RECEPTACLE - ELECTRIC - DOUBLE - BROWN
17	158270-03-01A	EA	WALLPLATE/CONTROLLER - F/ANTENNA - BLACK -WINEGARD MA-CP4B FROM: 05-01-06 THRU: 99-99-99
18	163598-02-000	EA	SWITCH/CONTROL - SATELLITE FROM: 01-29-07 THRU: 99-99-99

*COMPONENT PARTS LISTED LATER IN THIS GROUP

ELECTRICAL GROUP (CONTINUED)

SIDE TV/VCR

S40FD

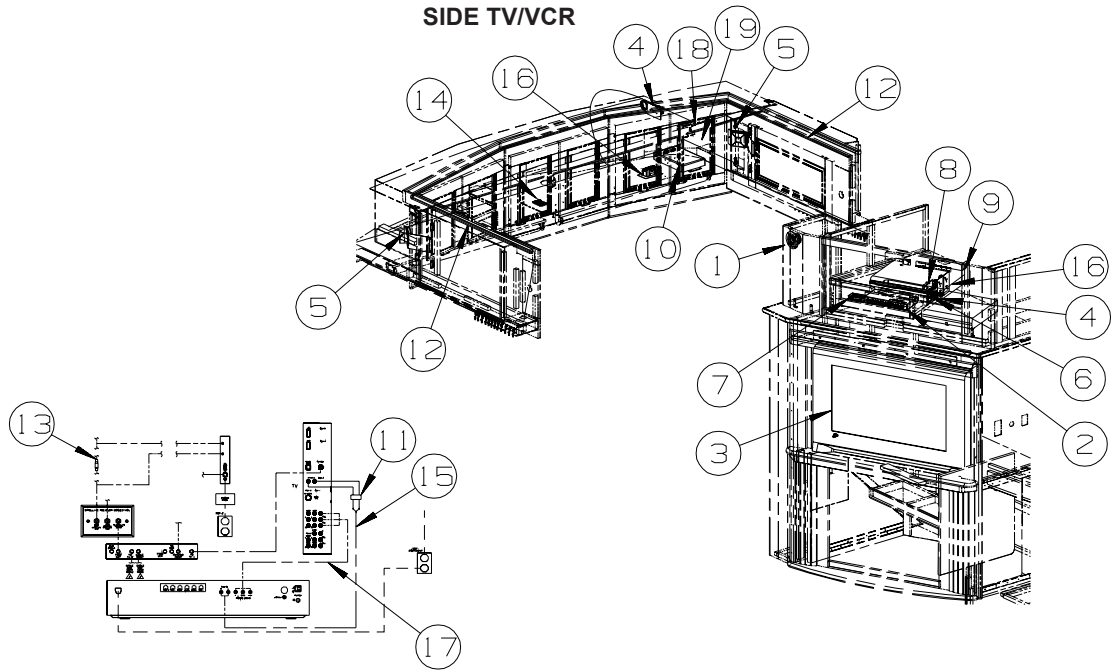

KEY	PART NUMBER	U/M	DESCRIPTION
1	148026-02-01A	EA	SPEAKER GRILLE - CUBE - SILVER
1	148026-03-01A	EA	SPEAKER - CUBE - W/O CASE
2	142258-01-000	EA	SWITCH - VIDEO/ANTENNA POWER SUPPLY
3*	155330-01-000	EA	TV - 30" HIGH DEFINITION - 16"X9" FORMAT - SONY KV-30HS420
3	160079-01-000	EA	TV - 37" - FLAT PANEL/LCD/HDTV - SHARP LC37D40U - TV-37" COLOR,STEREO W/REMOTE
4	058708-01-000	EA	RECEPTACLE - ELECTRIC - DOUBLE - BROWN
4	158542-02-01A	EA	LABEL - RECEPTACLE - ELECTRONICS - WHITE/BLACK - CANADIAN
5	148026-02-01A	EA	SPEAKER GRILLE - CUBE - SILVER
5	149422-02-02B	EA	BRACKET/MOUNTING - SPEAKER - E-COATED
6	149557-04-01A	EA	PLATE/WALL - TRIPLE COAXIAL/HORIZONTAL - WHITE
7	149750-05-000	EA	MODULE/INTERFACE - INFRA RED (RECEIVER TO TRANSMITTER)
8	149750-03-000	EA	TRANSMITTER - F/INFRA RED RECEIVER
9*	154548-01-000	EA	DVD/VCR - HOME THEATER COMBO - W/O SPEAKERS-SONY HTV700DP
			FROM: 00-00-00 THRU: 03-12-06
9	159916-01-000	EA	DVD - HOME THEATER - AM/FM - W/O SPEAKERS - SONY DAVDZ120W
			FROM: 03-13-06 THRU: 99-99-99
10	140062-01-000	EA	SWITCH - SPEAKER - 6 CHANNEL
11	123324-01-000	EA	FILTER - GROUND LOOP
12	146514-03-000	FT	LIGHT - FLEX - ROPE/ROUND - W/O MOUNT CHANNEL
12	146514-02-000	EA	CONNECTOR - LIGHT
13	082134-01-000	EA	ADAPTER - TV - CABLE TO CABLE
14	135740-01-000	EA	SWITCH - ROCKER - SPST - ON/OFF - BROWN
14	135741-01-01A	EA	SWITCH - BASE - SINGLE - BROW
14	135742-50-02A	EA	BEZEL - SWITCH - ACCENT - BROWN
15	117420-03-000	EA	CABLE - W/MALE RCA ENDS - SHIELDED - 20'
16	058708-01-000	EA	RECEPTACLE - ELECTRIC - DOUBLE - BROWN
17	155845-01-000	EA	CABLE - RCA - 12' - 3 RCA MALE CONNECTORS - BOTH ENDS
18	158270-03-01A	EA	WALLPLATE/CONTROLLER - F/ANTENNA - BLACK -WINEGARD MA-CP4B
19	163598-02-000	EA	SWITCH/CONTROL - SATELLITE
			FROM: 01-29-07 THRU: 99-99-99

*COMPONENT PARTS LISTED LATER IN THIS GROUP

ELECTRICAL GROUP (CONTINUED)
SIDE TV/VCR (CONTINUED)

S40TD

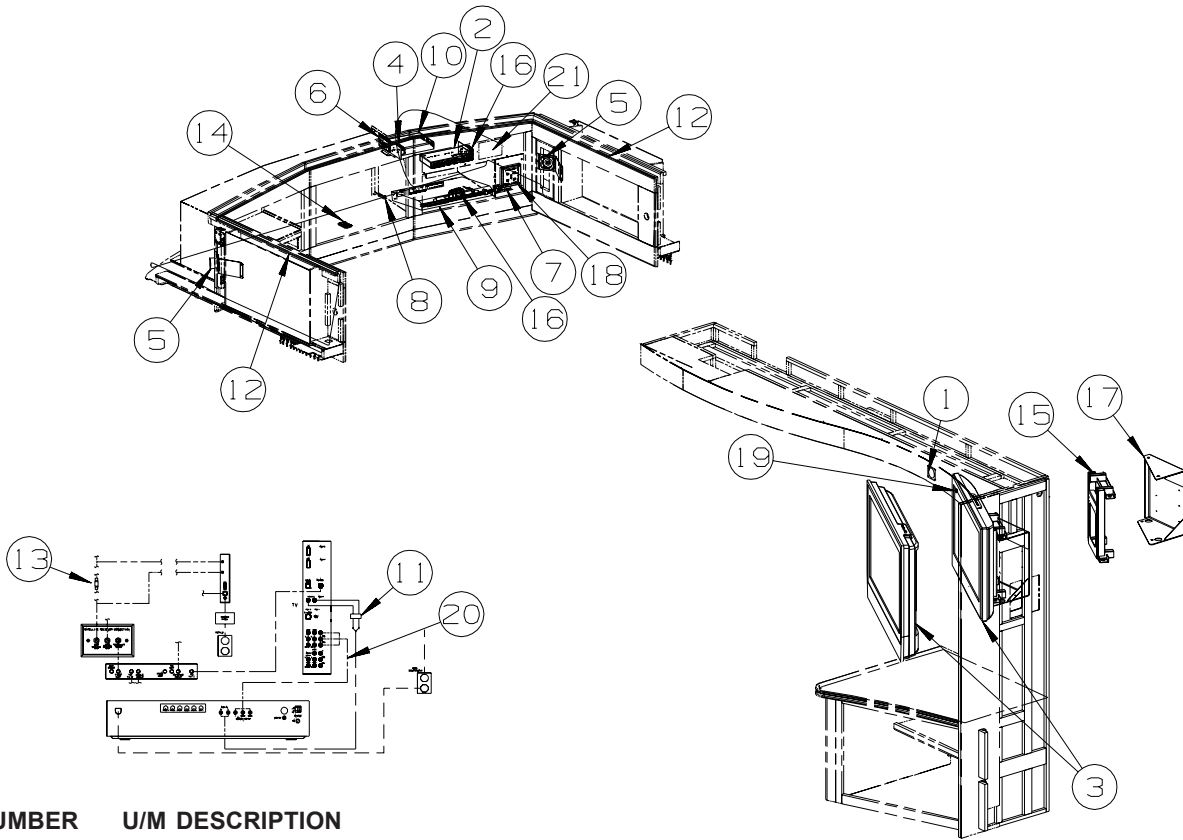

KEY	PART NUMBER	U/M	DESCRIPTION
1	148026-02-01A	EA	SPEAKER GRILLE - CUBE - SILVER
1	148026-03-01A	EA	SPEAKER - CUBE - W/O CASE
2	142258-01-000	EA	SWITCH - VIDEO/ANTENNA POWER SUPPLY
3	160064-01-000	EA	TV - 32" - FLAT PANEL/LCD/HDTV - SONY KDL-32S2000
3	160079-01-000	EA	TV - 37" - FLAT PANEL/LCD/HDTV - SHARP LC37D40U - TV-37" COLOR,STEREO W/REMOTE
4	058708-01-000	EA	RECEPTACLE - ELECTRIC - DOUBLE - BROWN
4	158542-02-01A	EA	LABEL - RECEPTACLE - ELECTRONICS - WHITE/BLACK - CANADIAN
5	148026-02-01A	EA	SPEAKER GRILLE - CUBE - SILVER
5	149422-02-02B	EA	BRACKET/MOUNTING - SPEAKER - E-COATED
6	149557-04-01A	EA	PLATE/WALL - TRIPLE COAXIAL/HORIZONTAL - WHITE
7	149750-05-000	EA	MODULE/INTERFACE - INFRA RED (RECEIVER TO TRANSMITTER)
8	149750-03-000	EA	TRANSMITTER - F/INFRA RED RECEIVER
9	159916-01-000	EA	DVD - HOME THEATER - AM/FM - W/O SPEAKERS - SONY DAVDZ120W
10	140062-01-000	EA	SWITCH - SPEAKER - 6 CHANNEL
11	123324-01-000	EA	FILTER - GROUND LOOP
12	146514-03-000	FT	LIGHT - FLEX - ROPE/ROUND - W/O MOUNT CHANNEL
12	146514-02-000	EA	CONNECTOR - LIGHT
13	082134-01-000	EA	ADAPTER - TV - CABLE TO CABLE
14	135740-01-000	EA	SWITCH - ROCKER - SPST - ON/OFF - BROWN
14	135741-01-01A	EA	SWITCH - BASE - SINGLE - BROW
14	135742-50-02A	EA	BEZEL - SWITCH - ACCENT - BROWN
15	159588-01-02B	EA	MOUNT - TV - E-COATED
16	058708-01-000	EA	RECEPTACLE - ELECTRIC - DOUBLE - BROWN
17	159612-01-02B	EA	PLATE/MOUNTING - TV - E-COATED
18	158270-03-01A	EA	WALLPLATE/CONTROLLER - F/ANTENNA - BLACK -WINEGARD MA-CP4B
19	149750-01-000	EA	RECEIVER - (INFRA RED SIGNAL) - W/6"LEAD/PLUG
20	136860-01-000	EA	CABLE - RCA - SHIELDED - 3 MALE TO MALE CONNECTORS - 12'
21	163598-02-000	EA	SWITCH/CONTROL - SATELLITE

FROM: 01-29-07 THRU: 99-99-99

ELECTRICAL GROUP (CONTINUED)
COMPONENT PARTS FOR WIRING

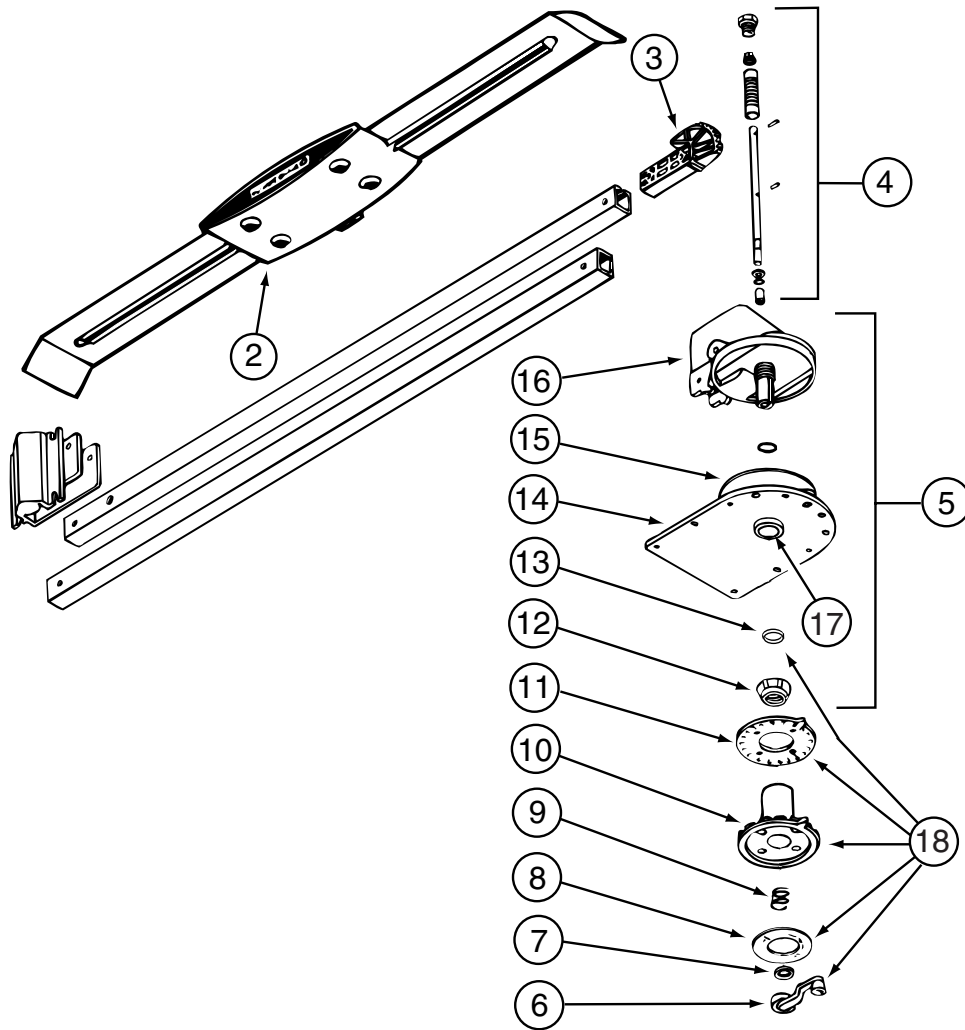

076319-23-000

KEY	PART NUMBER	U/M	DESCRIPTION	VENDOR NO.
2	076319-01-700	EA	HEAD-ANTENNA, AMPLIFIED	RVSA U/V
3	076319-01-701	EA	GEAR-ELEVATING, PLASTIC	2200046
4	076319-01-702	EA	SHAFT ASM-ELEVATING	RP-4000
5	076319-01-711	EA	BASE & LIFT ASM	2762802
7	076319-01-705	EA	GROMMET-NYLON, 7/8"ID	3200658
8	076319-01-708	EA	DECAL-CRANK	5413002
9	076319-01-707	EA	SPRING-HANDLE	2160822
11	076319-01-712	EA	PLATE - CEILING	3200608
12	076319-01-715	EA	NUT (GEAR HOUSING)	2200047
14	076319-01-713	EA	PLATE-BASE, STEEL	3100523
15	076319-01-703	EA	BEARING-NYLON, 5"OD	3200656
16	076319-01-714	EA	HOUSING, ROTATING GEAR	2200049
17	076319-01-704	EA	BEARING-NYLON, 1.25"OD	3200657
18	076319-01-709	EA	HANDLE-HEAD DIRECTIONAL	200644
	076319-01-716	EA	TUBING, ELEVATING	RP-2900

CONTACT WINNEBAGO PART SALES FOR UNLISTED COMPONENT(S)

076319-25-000

KEY	PART NUMBER	U/M	DESCRIPTION	VENDOR NO.
6	076319-01-706	EA	CRANK-W/SET SCREW UNIV/BEIGE	2750897
6	120233-01-710	EA	HANDLE-CRANK W/SCREW - WHITE	RP-6795
8	076319-01-708	EA	DECAL-CRANK	5413002
10	076319-25-700	EA	DIRECTIONAL HANDLE(WHITE)	3200612
11	076319-25-701	EA	PLATE - CEILING(WHITE)	3200609
13	120233-01-709	EA	WASHER-NYLON	RP-2658

CONTACT WINNEBAGO PART SALES FOR UNLISTED COMPONENT(S)

ELECTRICAL GROUP (CONTINUED)
COMPONENT PARTS FOR WIRING (CONTINUED)

086280-01-000			
KEY	PART NUMBER	U/M DESCRIPTION	VENDOR NO.
	086280-01-700	EA BULB,12V	ARP1089
087694-01-000			
KEY	PART NUMBER	U/M DESCRIPTION	VENDOR NO.
	087694-01-700	EA BULB	GE561
093575-33-03A			
KEY	PART NUMBER	U/M DESCRIPTION	VENDOR NO.
	093575-33-701	EA GLASS(WHITE SWIRL)W/IND HOLE	9111
	093575-33-702	EA FINIAL (MOON BALL)SATIN NICKL	12-139-TY
108354-01-01A			
KEY	PART NUMBER	U/M DESCRIPTION	VENDOR NO.
	108354-01-700	EA BULB-COURTESY LIGHT	395-B
121935-01-01A			
KEY	PART NUMBER	U/M DESCRIPTION	VENDOR NO.
	121935-01-700	EA LENS ONLY	809511
123775-01-02A			
KEY	PART NUMBER	U/M DESCRIPTION	VENDOR NO
	123775-01-702	EA BEZEL/LENS - SATIN NICKEL	99 953470

ELECTRICAL GROUP (CONTINUED)
COMPONENT PARTS FOR WIRING (CONTINUED)

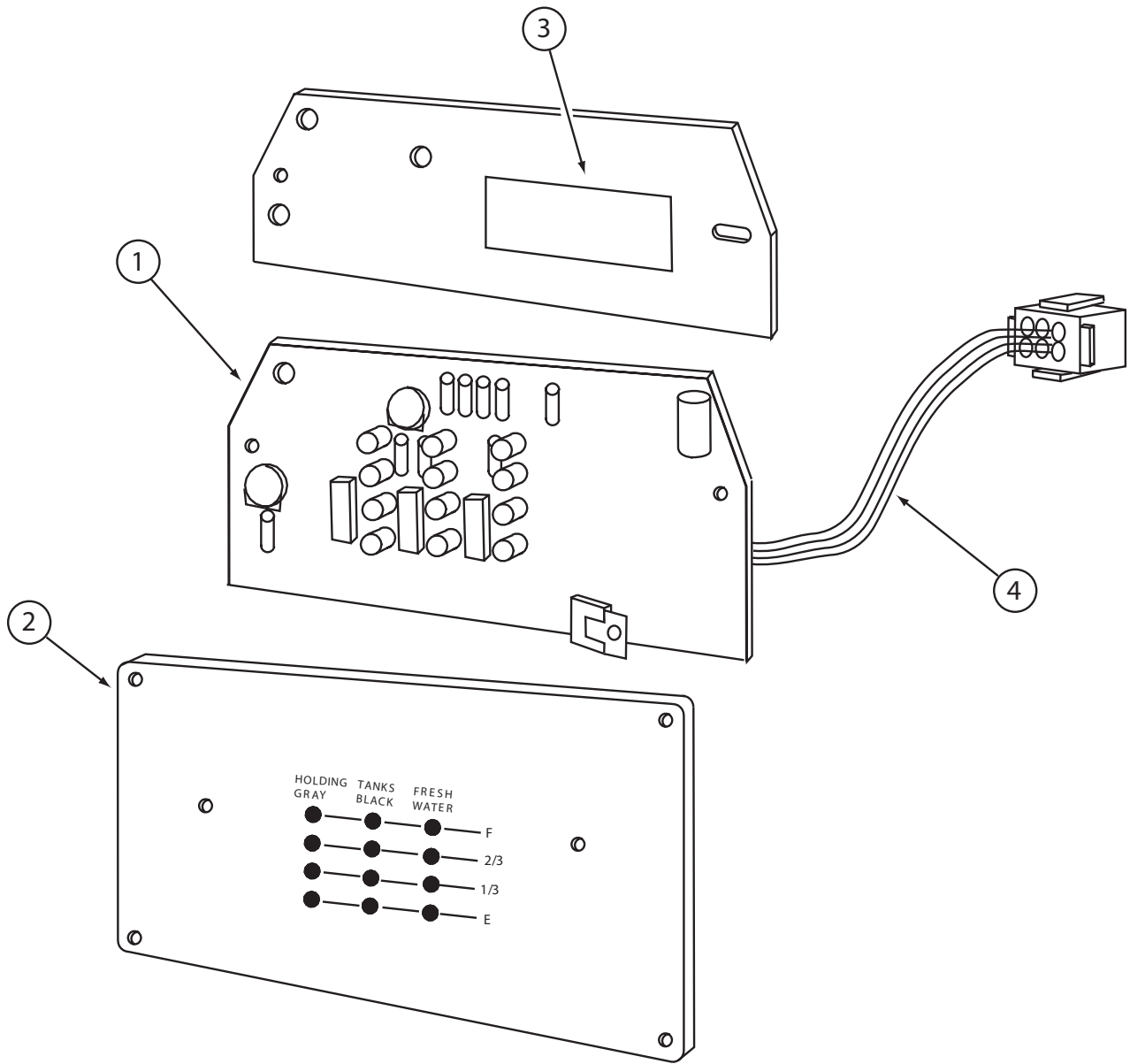

129561-02-01A

KEY	PART NUMBER	U/M	DESCRIPTION	VENDOR NO.
1	129561-02-700	EA	PC BOARD	L5132-02
2	129561-01-701	EA	CHASSIS SCREENED	C00399
4	129561-01-703	EA	HARNESS	L7694-00

130672-01-02A

KEY	PART NUMBER	U/M	DESCRIPTION	VENDOR NO.
	130672-02-700	EA	REMOTE-WHITE BEZEL(GOLIGHT)	7900T
	130672-02-701	EA	HEAD	49250
	130672-02-702	EA	BULB	49000

ELECTRICAL GROUP (CONTINUED)
COMPONENT PARTS FOR WIRING (CONTINUED)

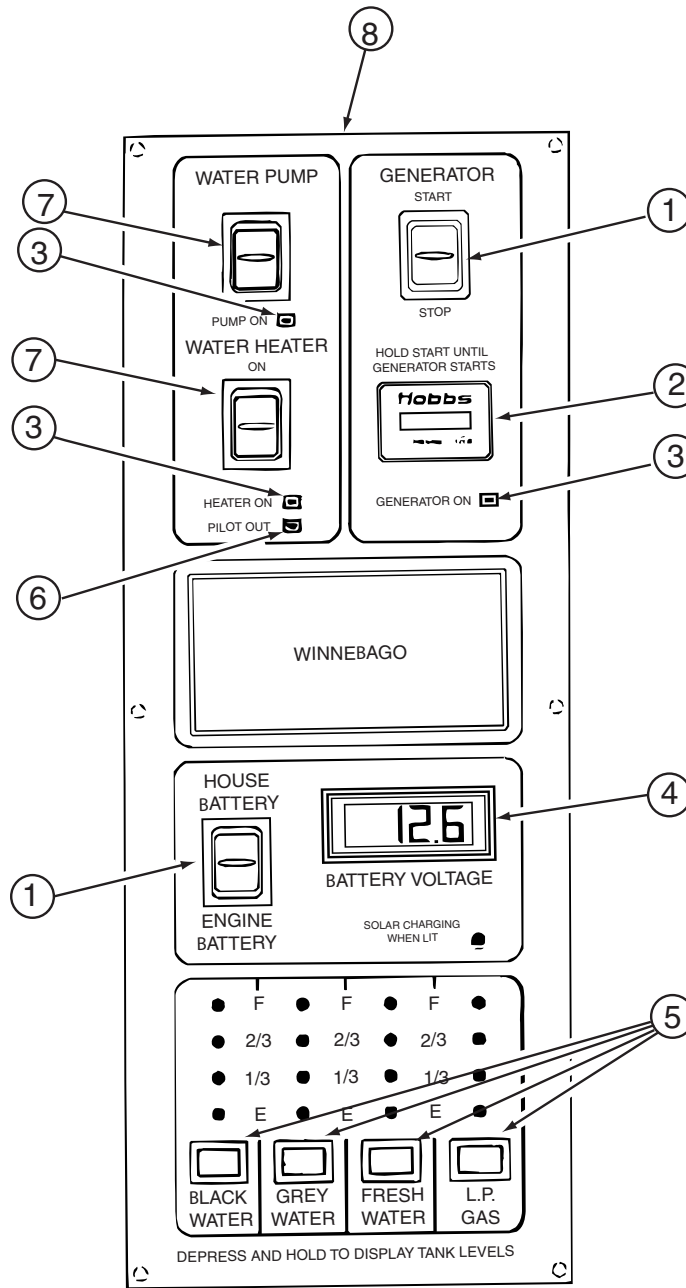

133004-05-01A

KEY	PART NUMBER	U/M	DESCRIPTION	VENDOR NO.
1	133004-01-702	EA	SWITCH/DPDT MOM=ON-OFF-ON	L1011-00
2	100258-10-701	EA	GAUGE-HR METER ONLY (LCD)	L0775-00
3	133004-01-706	EA	L.E.D. GREEN-PANEL MOUNT	L0785
4	133004-01-704	EA	METER/VOLT-DIGITAL - LCD	L1008-00
5	133004-01-705	EA	SWITCH/MOM ON - PUSH BUTTON	L0950-00
6	130004-01-703	EA	L.E.D. RED-PANEL MOUNT	L1009-00
7	133004-01-701	EA	SWITCH/DPDT ON-ON/MAINTAINED	L1025-00
8	133004-05-700	EA	SCREENED CHASSIS	CC0563-00
	133004-05-701	EA	BOARD - PC	L5130-02

ELECTRICAL GROUP (CONTINUED)
COMPONENT PARTS FOR WIRING (CONTINUED)

136119-01-000

KEY	PART NUMBER	U/M	DESCRIPTION	VENDOR NO.
	136119-01-700	EA	COMPASS SENSOR (BLACK BOX)	AP-SUB-005
	136119-01-701	EA	PROBE/TEMPERATURE SENSOR(V1)	AP-SUB-004A
	136119-01-702	EA	DISPLAY MODULE-LED (V1)	AP-SUB-004B
	136119-01-703	EA	HARNESS - COMPASS POWER	AP-HRN-175
	136119-01-704	EA	HARNESS - COMPASS ENGINE	AP-HRN-176
	136119-01-705	EA	HRNSS-COMP.TEMP SENSOR V1	AP-HRN-177
	136119-01-706	EA	PROBE/TEMPERATURE SENSOR (V2)	AP-SUB-006
	136119-01-707	EA	DISPLAY MODULE - VISUAL (V2)	AP-SUB-007
	136119-01-708	EA	HARNESS/COMP. COMP/THERM(V2)	AP-HRN-239 W/PACKRD

137417-01-01A, 137417-03-01A

KEY	PART NUMBER	U/M	DESCRIPTION	VENDOR NO.
	137417-01-700	EA	LENS - SINGLE (FROSTED)	810868

137424-01-000

KEY	PART NUMBER	U/M	DESCRIPTION	VENDOR NO.
	137424-01-700	EA	DISC - SETUP - DVD	NVD-A131
	137424-01-701	EA	REMOTE	RUE-4190
	137424-01-702	EA	CABLE/GPS-13 PIN RGB/6M EXTN	01T15696Y02

139134-01-03A

KEY	PART NUMBER	U/M	DESCRIPTION	VENDOR NO.
	139134-01-708	EA	DISC - F/BLADE HOLDER - NICKEL	
	139134-01-709	EA	BALANCING KIT - CLIP/PLATES	70050-21
	139134-01-710	EA	NOISE KIT - WASHERS	
	139134-01-711	EA	BLADES (36") WHITE MATT	A70050-5W
	139134-01-712	EA	MOTOR - FAN - WITH .75" MOUNT BRACKETS	
	139134-01-718	EA	HOLDER/BLADE(4 PC SET)NICKEL	70050-4N NICKEL
	139134-01-719	EA	HOUSING/MOTOR - NICKEL	70052-2N NICKEL

ELECTRICAL GROUP (CONTINUED)
COMPONENT PARTS FOR WIRING (CONTINUED)

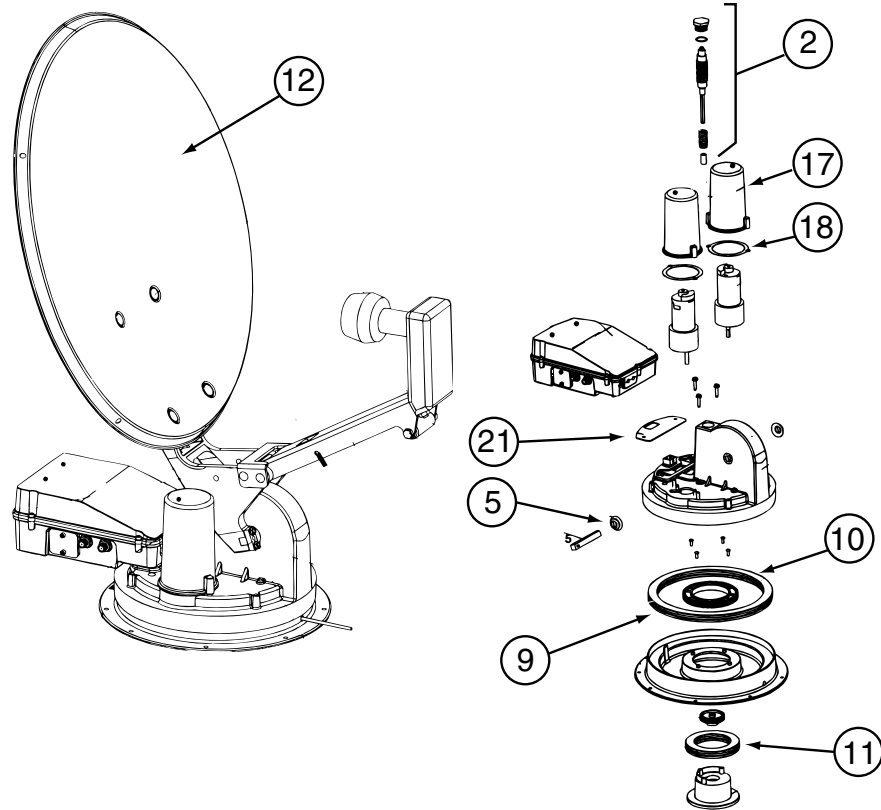

141454-03-01A

KEY	PART NUMBER	U/M	DESCRIPTION	VENDOR NO.
2	141454-01-700	EA	KIT ELEV-SHAFT/GEARS/SPRING	RP-RM20
4	137135-01-705	EA	SPRING	2160818
5	137135-01-707	EA	SEAL - PIVOT SHAFT	2200852
9	137135-01-712	EA	BEARING - OUTER	2590347
10	137135-01-714	EA	GEAR - ELEVATING SHAFT	2200465
10	141454-01-712	EA	GEAR - ROTATE	2200469
11	137135-01-715	EA	BEARING - INNER	2590348
12	137135-01-718	EA	REFLECTOR/WHITE-46CM W/HDWE	RP-35RM
13	137135-01-713	EA	TURRET BASE	3100730
17	141454-01-705	EA	HOUSING - MOTOR	3200260
18	141454-01-706	EA	GASKET - MOTOR HOUSING	2240054
21	141454-01-709	EA	GASKET	2240056
	120233-01-714	EA	CLIP-E	5160818
	137135-01-704	EA	PIN - 1/4" X 3.25"	2160813
	137135-01-719	EA	BRACKET - PIVOT	2744945
	137135-01-722	EA	CLAMP	2590343
	137135-01-723	EA	SUPPORT/FRAME-BACKUP-W/HDWE	RP-RM00
	137135-02-703	EA	LOW NOISE BLOCK FILTER	LB-6000 - DUAL
	141454-01-701	EA	KIT - GEAR/MOTOR-GEAR/ROTATE	RP-RM25
	141454-01-702	EA	HOUSING/ELECTRONICS - UPPER	RP-RM10
	141454-01-703	EA	HOUSING/ELECTRONICS - LOWER	RP-RM15
	141454-01-704	EA	KIT LIFT ASSEMBLY COMPLETE	RP-RM05
	141454-03-700	EA	MOTOR (AZIMUTH)	2665042
	141454-03-701	EA	MOTOR (ELEVATION)	2665041
	141454-03-702	EA	CIRCUIT BOARD(CONTROL BOARD)	RP-RM80
	141454-03-703	EA	CONTRL PANEL W/BOX (AS2003)	RP-AS85
			CONTACT WINNEBAGO PART SALES FOR UNLISTED COMPONENT(S)	

ELECTRICAL GROUP (CONTINUED)
COMPONENT PARTS FOR WIRING (CONTINUED)

144858-02-000

KEY	PART NUMBER	U/M	DESCRIPTION	VENDOR NO.
	144858-01-700	EA	POWER HEAD	04017
	144858-01-701	EA	CORD/POWER - 36'	04132-A
	144858-01-702	EA	COLLAR F/POWER CORD	85446
	144858-01-703	EA	MOTOR W/DRIVE GEAR	20409 W/52405
	144858-01-704	EA	CONTAINER F/POWER CORD	85448
	144858-01-705	EA	CAGE/REEL	19700-1
	144858-01-706	EA	HITCH PIN	70405
	144858-01-707	EA	CLEVIS PIN	70406
	144858-01-708	EA	ROLLER	85459 - 1 ONLY

150934-02-000

KEY	PART NUMBER	U/M	DESCRIPTION	VENDOR NO
	150934-02-700	EA	REMOTE - TV	RRMCGA293WJSA

151458-01-000

KEY	PART NUMBER	U/M	DESCRIPTION	VENDOR NO.
	102756-02-702	EA	BATTERY - 12 VOLT	402-1002
	102756-03-701	EA	REMOTE-KEYLESS ENTRY	412-1115
	102756-03-702	EA	RELAY- 30AMP - SPDT	463-1000
	151458-01-700	EA	MODULE BOARD	202-3227
	151458-01-701	EA	WIRE HARNESS - KEYLESS ENTRY	203-6908

153464-01/02/04/05-01A

KEY	PART NUMBER	U/M	DESCRIPTION	VENDOR NO.
	091937-09-700	EA	LENS - LIGHT - FLUORESCENT	D-762

153464-03/06-01A

KEY	PART NUMBER	U/M	DESCRIPTION	VENDOR NO.
	091937-08-700	EA	LENS - LIGHT - FLUORESCENT	D-766

154548-01-000

KEY	PART NUMBER	U/M	DESCRIPTION	VENDOR NO.
	154548-01-700	EA	REMOTE - DVD/VCR	1-478-247-11

155330-01-000

KEY	PART NUMBER	U/M	DESCRIPTION	VENDOR NO.
	155330-01-700	EA	REMOTE - TV	1-478-709-11

155619-01-000

KEY	PART NUMBER	U/M	DESCRIPTION	VENDOR NO.
	155619-01-700	EA	REMOTE	RC3200

156413-01-01A

KEY	PART NUMBER	U/M	DESCRIPTION	VENDOR NO.
	156413-01-700	EA	REMOTE	REMAWM950

159759-01-000

KEY	PART NUMBER	U/M	DESCRIPTION	VENDOR NO.
	159759-01-700	EA	REMOTE - TV	RRMCGA367WJSA

ELECTRICAL GROUP (CONTINUED)
CIRCUIT BREAKERS, FUSES & RELAYS

KEY	PART NUMBER	U/M	DESCRIPTION
	008235-01-000	EA	FUSE - 15 AMP/12VOLT - AUTOMOTIVE
	062901-02-000	EA	FUSE - 5 AMP - AUTOMOTIVE
	062901-04-000	EA	FUSE - 10 AMP - AUTOMOTIVE
	062901-05-000	EA	FUSE - 15 AMP - AUTOMOTIVE
	062901-06-000	EA	FUSE - 20 AMP - AUTOMOTIVE
	062901-07-000	EA	FUSE - 25 AMP - AUTOMOTIVE
	062901-08-000	EA	FUSE - 30 AMP - AUTOMOTIVE
	063910-01-000	EA	HOUSING - RELAY
	063912-02-000	EA	RELAY - CANISTER - SPDT
	083209-01-000	EA	CIRCUIT BREAKER - 15 AMP - 120 VOLT - CANADIAN
	083209-02-000	EA	CIRCUIT BREAKER - 15/15 AMP - 120 VOLT
	083209-03-000	EA	CIRCUIT BREAKER - 15/20 AMP - 120 VOLT
	083209-04-000	EA	CIRCUIT BREAKER - 30 AMP - 120 VOLT
	083209-05-000	EA	CIRCUIT BREAKER - 20 AMP - 120 VOLT
	083209-06-000	EA	CIRCUIT BREAKER - 30/15 AMP - 120 VOLT
	083209-07-000	EA	CIRCUIT BREAKER - 20/20 AMP - 120 VOLT
	083209-10-000	EA	CIRCUIT BREAKER - 20/30 AMP - 120 VOLT
	083209-11-000	EA	CIRCUIT BREAKER - 20/15 AMP - 120 VOLT
	092786-03-000	EA	BUSS BAR - 6.9" LONG
	092786-06-000	EA	BUSS BAR
	093654-01-000	EA	CIRCUIT BREAKER - 6 AMP - 12 VOLT - PUSH BUTTON - WHITE
	093654-02-000	EA	CIRCUIT BREAKER - 15 AMP - 12 VOLT - PUSH BUTTON - WHITE
	093654-03-000	EA	CIRCUIT BREAKER - 20 AMP - 12 VOLT - PUSH BUTTON - WHITE
	093655-01-000	EA	CIRCUIT BREAKER - 25 AMP - 12 VOLT - PUSH BUTTON - WHITE
	093655-02-000	EA	CIRCUIT BREAKER - 30 AMP - 12 VOLT - PUSH BUTTON - WHITE
	093655-03-000	EA	CIRCUIT BREAKER - 40 AMP - 12 VOLT - PUSH BUTTON - WHITE
	097611-01-000	EA	CIRCUIT BREAKER - 10 AMP
	100341-01-000	EA	FUSE HOLDER - IN LINE TYPE
	113482-01-000	EA	CIRCUIT BREAKER - 55 AMP - MANUAL
	115187-01-000	EA	FUSE - 300 AMP - NON-DELAY
	115187-02-000	EA	HOLDER - FUSE
	115187-03-000	EA	FUSE - 60 AMP - NON-DELAY
	122811-01-000	EA	CIRCUIT BREAKER - 20/50/50/20 AMP - 250V
	125986-02-000	EA	FUSE - 5 AMP - AUTO - MINI BLADE
	125986-05-000	EA	FUSE - 15 AMP - AUTO - MINI BLADE
	141789-01-000	EA	SPACER - CIRCUIT BREAKER

CONVERTER, INVERTER, LOAD CENTERS

KEY	PART NUMBER	U/M	DESCRIPTION
	148254-01-000	EA	INVERTER - CHARGER - 2000W AC
	148254-03-000	EA	CABLE/INVERTOR - W/8 PIN MODULAR PHONE JACK - 50'-DIMEN
	148254-05-000	EA	REMOTE/PANEL - INVERTER/CHARGER

ELECTRICAL GROUP (CONTINUED) CONVERTER, INVERTER, LOAD CENTERS (CONTINUED)

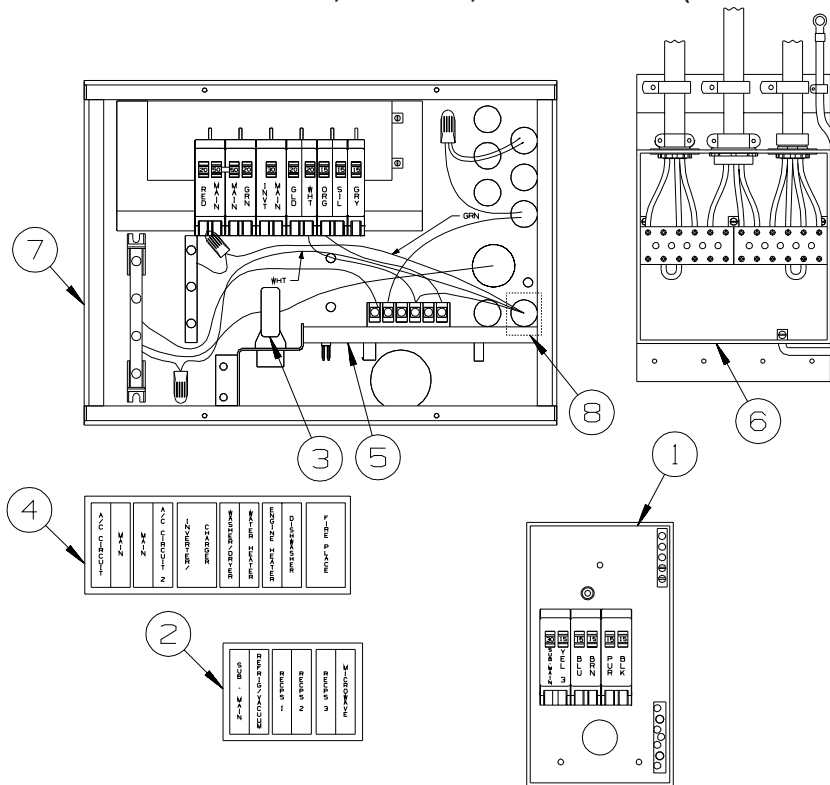

KEY	PART NUMBER	U/M	DESCRIPTION
1	109677-01-000	EA	LOAD CENTER - 120 VOLT - 40 AMP
2	095721-43-000	EA	LABEL - CONTROL CENTER - 50 AMP
3	127002-07-000	EA	SENSOR - CURRENT
4	095721-49-000	EA	LABEL - CONTROL CENTER - 50 AMP
5	127002-11-000	EA	MODULE - EMS CENTER - W/REMOTE SENSOR
6	106071-06-000	EA	SWITCH - AUTOMATIC TRANSFER - PARALLAX 5070 - 30/50 AMP
7	141258-01-000	EA	LOAD CENTER - 120/240 - 30/50 AMP
7	141258-02-000	EA	LOAD CENTER - COVER
8	158714-01-000	EA	TRANSFORMER - 120V/16V - 15 WATTS

BOXES & CORDS

KEY	PART NUMBER	U/M	DESCRIPTION
	115832-01-000	FT	CORD - HEAVY DUTY - 14-2 W/GROUND
	133070-01-000	EA	BOX - ELECTRIC/PLASTIC - 3" X 2" X 2.8" - UL
	133070-02-000	EA	BOX - ELECTRIC/PLASTIC - 3" X 2" X 2.8" - CSA
*	144858-02-000	EA	REEL - POWERED - W/36'-50 AMP PWR CORD - W/MOUNTED SWITCH

*COMPONENT PARTS LISTED LATER IN THIS GROUP

COMPONENT PARTS FOR BOXES & CORDS

KEY	PART NUMBER	U/M	DESCRIPTION	144858-02-000	VENDOR NO.
	144858-01-700	EA	POWER HEAD		04017
	144858-01-701	EA	CORD/POWER - 36'		04132-A
	144858-01-702	EA	COLLAR F/POWER CORD		85446
	144858-01-703	EA	MOTOR W/DRIVE GEAR		20409 W/52405
	144858-01-704	EA	CONTAINER F/POWER CORD		85448
	144858-01-705	EA	CAGE/REEL		19700-1
	144858-01-706	EA	HITCH PIN		70405
	144858-01-707	EA	CLEVIS PIN		70406
	144858-01-708	EA	ROLLER		85459 - 1 ONLY

ELECTRICAL GROUP (CONTINUED)
WIRE ASSEMBLIES

KEY	PART NUMBER	U/M	DESCRIPTION
	077069-02-000	EA	CABLE/EXTENSION - RADIO ANTENNA - 96"
	077069-03-000	EA	CABLE/EXTENSION - RADIO ANTENNA - 260"
	117420-04-000	EA	CABLE - RCA - (MALE/MALE) - 50 FT
	129560-01-000	EA	WIRE ASM/MONITOR PANEL - 3 WIRES (2 WHT/BRN & SOLID BRN)
	132267-01-000	EA	WIRE ASSEMBLY - DOOR LOCK
	135131-01-000	EA	WIRE LOOM - THERMOSTAT
	135420-16-000	EA	WIRE LOOM - RADIO
	136860-01-000	EA	CABLE - RCA - SHIELDED - 3 MALE TO MALE CONNECTORS - 12'
	136860-02-000	EA	CABLE - RCA - #3 MALE TO #50F MALE CONNECTOR
	136860-03-000	EA	CABLE - RCA - SHIELDED - 3 MALE TO MALE CONNECTORS - 6'
	155845-02-000	EA	CABLE - RCA - 55' - 3 MALE CONNECTORS - BOTH ENDS
	137135-03-000	EA	WIRE LOOM - DIGITAL ELEVATION SENSOR
	137135-04-000	EA	WIRE HARNESS - POWER - DIGITAL ELEVATION SENSOR
	139297-01-000	EA	RESISTOR - 10 OHM/10W CERAMIC
	140167-01-000	EA	WIRE LOOM - GPS ADAPTER
			FROM: 00-00-00 THRU: 03-11-07
	140167-02-000	EA	WIRE LOOM - GPS ADAPTER
			FROM: 03-12-07 THRU: 99-99-99
	140195-01-000	EA	WIRE LOOM - RESISTOR/FAN
	141454-04-000	EA	WIRE - SATELLITE - AUTOMATIC
	142258-02-000	EA	WIRE LOOM - VIDEO SWITCH/POWER SUPPLY
	143545-01-000	EA	WIRE ASSEMBLY - REAR MONITOR
	143545-02-000	EA	WIRE ASSEMBLY - REAR MONITOR
	155619-05-000	EA	WIRE ASSEMBLY - RADIO - 12 PIN
	160313-02-000	EA	WIRE - MONITOR - 12V - COLOR - SONY VM-HRN62W
	143591-10-000	EA	WIRE LOOM - COMPUTER TRIP/ENGINE MONITOR-TRIP TEK 04-04002
	145210-01-000	FT	CABLE - COAXIAL
	149214-02-000	EA	WIRE - WINDSHIELD WIPER/WASHER - F/FL MMDC ELECTRICAL SYST
	149750-02-000	EA	CABLE - (RECEIVER TO MODULE) - 45'
	151316-02-000	EA	WIRE ASM - W/NON CONTACT SENSORS - GREY WATER - 23.6"
	151317-02-000	EA	WIRE ASM-W/NON CONTACT SENSORS-FRESH WATER/BLK TANK-23.6"
	151808-01-000	EA	WIRE ADAPTER W/DIODE PACK - 2/M & 3/F SOCKET - GRAY TANK
	151808-02-000	EA	WIRE ADAPTER W/DIODE PACK-2/F & 3/M SOCKET- WATER/BLK TANK
	158270-02-000	EA	CABLE - ANTENNA/POWER - 3 WIRE
	151317-01-000	EA	WIRE ASM-W/NON CONTACT SENSORS-FRESH WATER/BLK TANK-3.9"
	160365-01-000	EA	WIRE - REAR MONITOR - COLOR
			FROM: 06-05-06 THRU: 99-99-99

ELECTRICAL GROUP (CONTINUED)
CONNECTORS & CONDUIT

KEY	PART NUMBER	U/M	DESCRIPTION
	007940-01-000	EA	RECEPTACLE/SLIDE 16 TO 12 AWG - FEMALE END
	007940-02-000	EA	RECEPTACLE/SLIDE 10 AWG
	007954-01-000	EA	RECEPTACLE - HOUSING - 6 POSITION
	007956-05-000	EA	INSULATOR - SHRINK - 1/4"ID X 1 1/2"
	008058-01-000	EA	ADAPTER - POWER CORD - 30 AMP TO 15 AMP
	008311-01-000	EA	CONNECTOR - WIRE NUT - INSULATED - RED
	008312-01-000	EA	CONNECTOR - WIRE NUT - INSULATED - BLUE
	008313-01-000	EA	CONNECTOR - WIRE NUT - INSULATED - YELLOW
	008314-01-000	EA	CONNECTOR - WIRE NUT - INSULATED - GRAY
	008328-01-000	EA	TERMINAL - RING - 12/10 WIRE - #10 STUD FIT
	008331-01-000	EA	TERMINAL - RING - TONGUE - #4 WIRE - 3/8" STUD - COPPER
	008348-01-000	EA	TERMINAL - RING - 3/8" STUD 2 GA. WIRE
	008355-01-000	EA	CONNECTOR - CABLE CLAMPING - 3/4"
	008356-01-000	EA	CONNECTOR - PLASTIC - 3/8"
	008356-02-000	EA	CONNECTOR - PLASTIC - 21/32"
	008398-01-000	EA	CONNECTOR - 1/2" X 90 DEGREE - FLEX CONDUIT - UL & CSA
	035416-04-000	EA	TERMINAL - RING - #10 STUD FIT - INSULATED BARREL #16/14
	041953-01-000	FT	CONDUIT - CONVOLUTE SLIT - .5" ID - POLYETHYLENE
	041953-02-000	FT	CONDUIT - CONVOLUTE SLIT - .6" ID - POLYETHYLENE
	041953-03-000	FT	CONDUIT - CONVOLUTE SLIT - 1" ID (CLOTHES ROD COVER)
	041953-06-000	FT	CONDUIT - CONVOLUTE SLIT - .4" ID - POLYETHYLENE
	041953-07-000	FT	CONDUIT - CONVOLUTE SLIT - .25" ID - POLYETHYLENE
	041953-08-000	FT	CONDUIT - CONVOLUTE SLIT - 1.5" ID - POLYETHYLENE
	041953-09-000	FT	CONDUIT - CONVOLUTE SLIT - .5" ID - NYLON
	041953-10-000	FT	CONDUIT - CONVOLUTE SLIT - .75" ID - NYLON
	041953-11-000	FT	CONDUIT - CONVOLUTE SLIT - 1.06" ID - NYLON
	041953-12-000	FT	CONDUIT - CONVOLUTE SOLID - 1.1" ID - NYLON
	041953-13-000	FT	CONDUIT - CONVOLUTE SLIT - 1.25" ID
	041953-14-000	FT	CONDUIT - CONVOLUTE SLIT - 1.5" ID
	041953-15-000	FT	CONDUIT - CONVOLUTE SLIT - 2"
	041953-16-000	FT	CONDUIT - CONVOLUTE SLIT - 2"
	047441-01-000	EA	TERMINAL-BATTERY, HORIZONTAL LUG
	047443-01-000	EA	TERMINAL - .250 RECEPTACLE FIT - INSULATED - 16/14 AWG
	047443-02-000	EA	TERMINAL - .250 RECEPTACLE FIT - INSULATED - 12/10 AWG
	047443-05-000	EA	TERMINAL - .250 RECEPTACLE FIT - 18GA AWG
	058028-01-000	EA	CONNECTOR - ELECTRICAL PIGTAIL - NYLON - CLEAR
	062036-01-000	EA	TERMINAL - PACK - CON - 12/10 AWG
	076319-12-000	EA	CONNECTOR - COAXIAL - ONE PIECE
	077479-01-000	EA	BOOT - BATTERY TERMINAL - DOUBLE CABLE
	077479-02-000	EA	BOOT - BATTERY TERMINAL - SINGLE CABLE
	080015-02-000	EA	RECEPTACLE - FLAG - .185 - 16/14 GAUGE
	080015-03-000	EA	RECEPTACLE - FLAG - .250 - 14/16 GAUGE
	080015-04-000	EA	RECEPTACLE - FLAG - .187 - 16/14 GAUGE
	082109-01-000	EA	HOUSING - CONNECTOR - PACKARD
	082741-01-000	EA	CONNECTOR BODY - 2 CONNECTOR MALE
	087225-01-000	FT	SLEEVING - 1/2" - TYPE H
	088473-01-000	EA	HOUSING - PIN - 12 CAVITY (3 ROWS OF 4)
	088473-02-000	EA	HOUSING - PIN - 15 CAVITY (3 ROWS OF 5)
	088473-03-000	EA	HOUSING - PIN - 9 CAVITY (3 ROWS OF 3)
	088473-04-000	EA	HOUSING - PIN - 8 CAVITY IN-LINE
	088473-06-000	EA	HOUSING - PIN - 6 CAVITY (2 ROWS OF 3)
	088473-07-000	EA	HOUSING - PIN - 5 CAVITY - IN-LINE
	088473-08-000	EA	HOUSING - PIN - 4 CAVITY - IN-LINE
	088473-09-000	EA	HOUSING - PIN - 3 CAVITY - IN-LINE
	088473-10-000	EA	HOUSING - PIN - 2 CAVITY - IN-LINE
	088473-12-000	EA	HOUSING - PIN - 3 CAVITY - BLUE
	088473-13-000	EA	HOUSING - PIN - 3 CAVITY - GREEN
	088473-14-000	EA	HOUSING - PIN - 3 CAVITY - RED
	088474-01-000	EA	HOUSING - SOCKET - 12 CAVITY
	088474-02-000	EA	HOUSING - SOCKET - 15 CAVITY
	088474-03-000	EA	HOUSING - SOCKET - 9 CAVITY
	088474-06-000	EA	HOUSING - SOCKET - 6 CAVITY
	088474-07-000	EA	HOUSING - SOCKET - 5 CAVITY
	088474-08-000	EA	HOUSING - SOCKET - 4 CAVITY

ELECTRICAL GROUP (CONTINUED)
CONNECTORS & CONDUIT (CONTINUED)

KEY	PART NUMBER	U/M	DESCRIPTION
	088474-09-000	EA	HOUSING - SOCKET - 3 CAVITY
	088474-10-000	EA	HOUSING - SOCKET - 2 CAVITY
	088475-01-000	EA	PIN - CONNECTOR - 14-20 AWG
	088475-02-000	EA	PIN - CONNECTOR - 10-12 AWG
	088476-01-000	EA	TERMINAL - ELECTRICAL
	088476-02-000	EA	SOCKET - CONNECTOR - 12-10 GA - PRE-TIN
	098261-01-000	EA	SOCKET - CONNECTOR - WEATHERPACK - 12 AWG
	098261-02-000	EA	SOCKET - CONNECTOR - WEATHERPACK - 14-18 AWG
	098262-01-000	EA	SEAL - CONNECTOR - WEATHERPACK
	098264-01-000	EA	HOUSING - 2 PIN - WEATHER PACK - MALE W/FEMALE PINS
	098264-02-000	EA	HOUSING - 2 PIN - WEATHER PACK - FEMALE W/MALE PINS
	098265-02-000	EA	PIN - CONNECTOR - WEATHER PACK
	102777-02-000	EA	TERMINAL - RING - #6 STUD - 10 AWG
	103608-01-000	EA	SOCKET - WEDGE BASE W/LEADS
	104100-01-000	EA	HOUSING - 1 POSITION - 75 AMPS
	104100-03-000	EA	TERMINAL - 75 AMP
	106007-02-000	EA	TERMINAL - FEMALE - 10-12 AWG
	110178-01-000	EA	HOUSING - WIPER MOTOR
	112823-01-000	EA	SPLICE - REDUCER - 16-14 TO 18-22
	113072-02-000	EA	HOUSING - ELECTRICAL - BACK-UP/TAIL LAMP
	113072-03-000	EA	HOUSING - ELECTRICAL - STOP/MARKER TAILLAMP
	113073-01-000	EA	WEDGELOCK - HOUSING - TAIL LAMP
	113074-01-000	EA	TERMINAL - TAILLAMP
	113135-01-000	EA	TERMINAL - FEMALE - M/P - 14-16 - F/SEALED TERMINAL
	113308-01-000	EA	TERMINAL - FEMALE - M/P - 14-16 - 280
	113308-02-000	EA	TERMINAL - FEMALE - M/P - 14-18 - 280
	113468-01-000	EA	HOUSING - 2 POSITION-FEMALE-USED ON WIPER/WASHER WIRE ASM
	113468-02-000	EA	HOUSING - 2 POSITION - FEMALE
	115931-02-000	EA	COVER - CONNECTOR - 50 AMP W/LOCKING RING
	115932-02-000	EA	CONNECTOR - FEMALE - 50 AMP/240 VOLT
	116811-01-000	EA	TERMINAL - .110 RECEPTACLE - 16-14 AWG
	118571-01-000	EA	CONNECTOR - 3-WAY - MALE/SEALED
	118571-02-000	EA	CONNECTOR - 3-WAY - FEMALE/SEALED
	118571-05-000	EA	LOCK - SECONDARY - FEMALE
	118571-06-000	EA	LOCK - SECONDARY - MALE
	118599-02-000	EA	TERMINAL - MALE - M/P - 280/14-12
	118820-01-000	EA	INSULATOR - TERMINAL
	129233-01-000	EA	HOUSING - 2-POSITION/FEMALE - 280-SERIES
	129233-02-000	EA	HOUSING - 2-POSITION/FEMALE - 280-SERIES
	129233-03-000	EA	HOUSING - 2-POSITION/FEMALE - 280-SERIES
	131681-01-000	EA	CONNECTOR - 3/4" SO CORD - UL/CS
	137207-01-000	EA	HOUSING - PIN - 2 CAVITY/HIGH AMP
	137208-01-000	EA	HOUSING - SOCKET - 2 CAVITY/HIGH AMP
	137209-01-000	EA	PIN - CONNECTOR - 10AWG/HIGH AMP
	137210-01-000	EA	SOCKET - CONNECTOR - 10 AWG/HIGH AMP
	138996-04-000	EA	CONNECTOR - LAMP
	142520-01-000	EA	TERMINAL - FEMALE - MINI-FIT 16
	142522-01-000	EA	HOUSING - 4 PIN/MALE - MINI FIT
	142522-02-000	EA	HOUSING - 6 PIN/MALE - MINI FIT
	142522-03-000	EA	HOUSING - 8 PIN/MALE - MINI FIT
	142522-04-000	EA	HOUSING - 10 PIN/MALE - MINI FIT
	142522-05-000	EA	HOUSING - 12 PIN/MALE - MINI FIT
	142522-06-000	EA	HOUSING - 14 PIN/MALE - MINI FIT
	142524-01-000	EA	HOUSING - 4 PIN/FEMALE - WEATHER PACK
	142524-02-000	EA	HOUSING - 4 PIN/FEMALE - WEATHER PACK
	144283-01-000	EA	CONNECTOR - 110V - F/USE WITH SOW WIRE - BLUE
	144283-02-000	EA	CONNECTOR - 110V - F/USE WITH NM ROMEX WIRE - CLEAR
	145171-01-000	EA	CONNECTOR - COAXIAL
	148335-01-000	EA	HOUSING - 8-POSITION/MALE - 280-GT SERIES
	148335-02-000	EA	HOUSING - 4-POSITION/MALE - 280-GT SERIES
	148335-03-000	EA	HOUSING - 6-POSITION/MALE - 280-GT SERIES
	149683-01-000	EA	HOUSING - F/5 CAVITY RECEPTACLE - W/SQUARE GUIDE PIN
	149683-02-000	EA	HOUSING - F/5 CAVITY RECEPTACLE - W/ROUND GUIDE PIN
	149686-01-000	EA	TERMINAL - .250 RECEPTACLE

ELECTRICAL GROUP (CONTINUED)
CONNECTORS & CONDUIT (CONTINUED)

KEY	PART NUMBER	U/M	DESCRIPTION
	149687-01-000	EA	HOUSING - 2 POSITION/MALE - PACKARD
	149687-02-000	EA	LOCK - F/2 POSITION HOUSING - PACKARD
	149688-01-000	EA	TERMINAL - MALE - 16 GAUGE WIRE
	156035-01-000	EA	HOUSING - 12-POSITION/FEMALE - 280-GT SERIES
	156041-01-000	EA	TERMINAL - FEMALE - 16-12 - 280-GT SERIES
	156043-01-000	EA	HOUSING - 2-POSITION/FEMALE - 480-MP SERIES
	156043-02-000	EA	LOCK - F/2 POSITION HOUSING - 480 SERIES
	156044-01-000	EA	TERMINAL - FEMALE - 16-12 - 280-GT - F/SEALED HOUSING
	156045-01-000	EA	HOUSING - 10-POSITION/FEMALE - 280-GT SERIES
	156045-02-000	EA	HOUSING - 4-POSITION/FEMALE - 280-GT SERIES
	156045-03-000	EA	HOUSING - 8-POSITION/FEMALE - 280-GT SERIES
	156045-04-000	EA	HOUSING - 6-POSITION/FEMALE - 280-GT SERIES
	156207-01-000	EA	HOUSING - 6-POSITION/MALE - 150-GT SERIES
	156208-01-000	EA	TERMINAL - MALE - 18-16 - 150-GT SERIES
	157590-01-000	EA	TERMINAL - FEMALE - M/P - 10-12 - 630
	157592-01-000	EA	HOUSING - 7-POSITION/FEMAL - M/P
	157592-02-000	EA	LOCK - SECONDARY - F/7 POSITION HOUSING
	157656-01-01A	EA	CONNECTOR - DASH LIGHT - BLACK
	158357-01-000	EA	HOUSING - 3 PIN/MALE - MINI FIT
	158373-01-000	EA	HOUSING - SOCKET - 16 CAVITY - MINI MATE-N-LOCK
	158374-01-000	EA	SOCKET - 16-20 CAVITY - MINI MATE-N-LOCK

ELECTRICAL GROUP (CONTINUED) CHASSIS

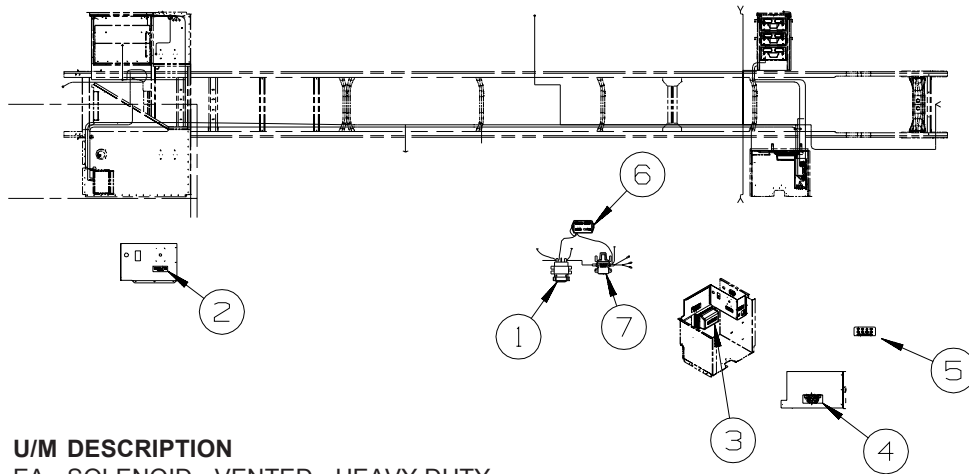

KEY	PART NUMBER	U/M	DESCRIPTION
1	008188-02-000	EA	SOLENOID - VENTED - HEAVY DUTY
2	098379-04-000	EA	LABEL - ELECTRICAL BOX - SIDE
3	098379-07-000	EA	LABEL - ELECTRICAL BOX - BLACK/WHITE
4	098379-08-000	EA	LABEL - ELECTRICAL BOX - BLACK/WHITE
5	093236-44-000	EA	LABEL - CIRCUIT BREAKER
6	156431-01-000	EA	CHARGER/BATTERY - CHASSIS TO HOUSE
7	086273-01-000	EA	RELAY - BATTERY DISCONNECT

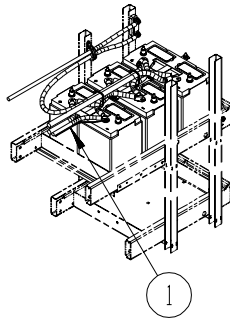

KEY	PART NUMBER	U/M	DESCRIPTION
1	148254-04-000	EA	CABLE - TEMPATURE/BATTERY - S40FD, S40KD
1	148254-06-000	EA	CABLE - TEMPATURE/BATTERY - S40TD

EXTERIOR BODY GROUP AIR HORN

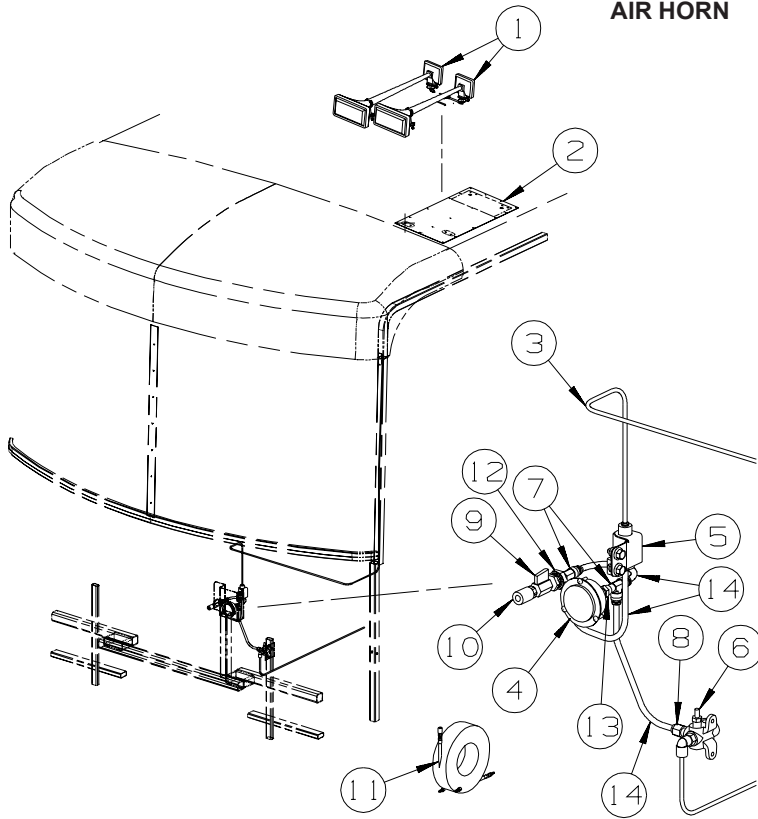

W/Air Horns

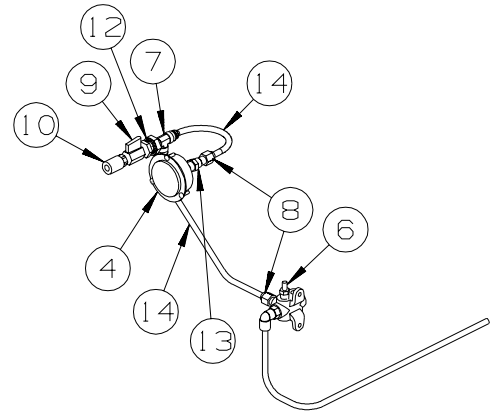

W/O Air Horns

KEY	PART NUMBER	U/M	DESCRIPTION
1*	077497-06-000	EA	HORN - AIR - CHROME - TWIN
2	125123-01-12B	EA	PLATE/MOUNT - AIR HORN - 25" X 13" - BRIGHT WHITE
3	071390-04-000	FT	TUBING - AIR BRAKE - 1/4" OD-BLK WEATHERHEAD(BRKS & HORN)
4	142609-01-000	EA	GAUGE/AIR - 2.5" MOUNTING FLANGE - 1/4" MPT
5	077497-11-000	EA	SOLENOID - HORN - REMOTE MOUNT
6	086241-01-000	EA	VALVE - AIR - 1/4 MPT X TIRE STEM
7	142570-01-000	EA	TEE - 3/8" T X 1/4" P
8	142571-01-000	EA	CONNECTOR - 3/8" T X 1/4" P
9	142597-01-000	EA	VALVE - BALL - AIR - 1/4" MFPT
10	142595-01-000	EA	COUPLER - QUICK CONNECT - AIR - 1/4" MPT
11	142607-03-000	EA	HOSE - AIR - 50'
12	071374-03-000	EA	FITTING - BULKHEAD - 1/4" X 1/4" MNPT
13	075155-03-000	EA	COUPLING-PIPE, 1/4 BRASS
14	071390-07-000	FT	TUBING - AIR BRAKE - 3/8" - BLACK

***COMPONENT PARTS LISTED LATER IN THIS GROUP**

COMPONENT PARTS FOR AIR HORN

077497-06-000

KEY	PART NUMBER	U/M	DESCRIPTION	VENDOR NO.
	077497-01-701	EA	SWITCH - COMPRESSOR	13940-S
	077497-01-702	EA	SWITCH - TOGGLE - W/WIRE	12949-S

EXTERIOR BODY GROUP (CONTINUED)

GRAPHICS & PAINT

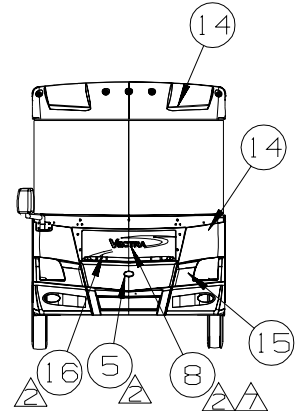
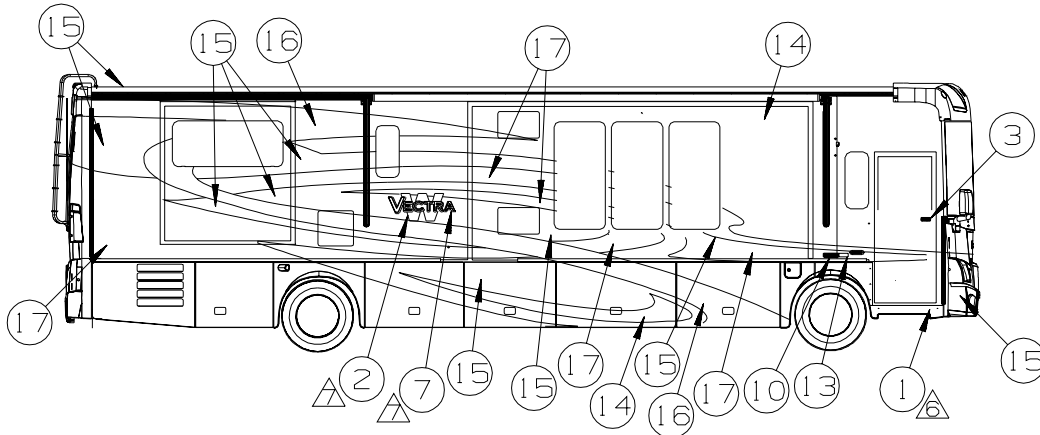
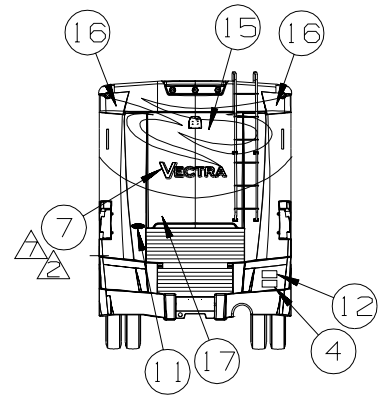
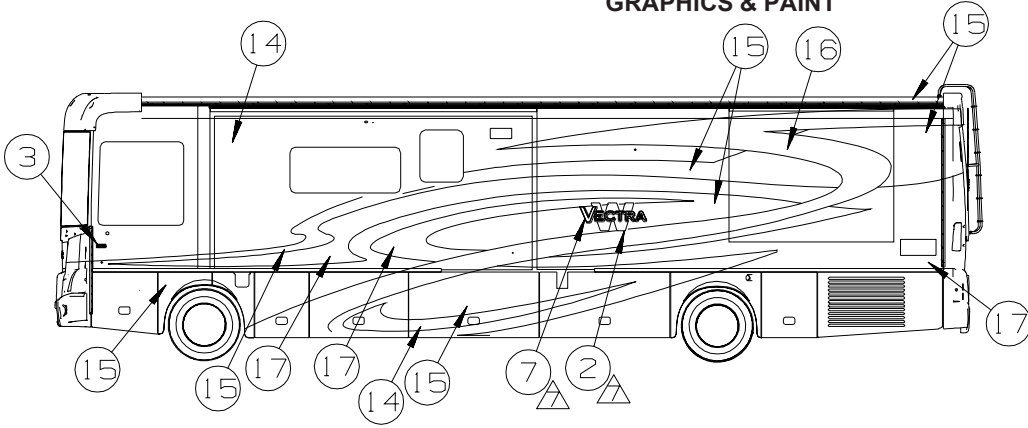

(27A) KEY	PART NUMBER	U/M	DESCRIPTION VALLEY SAGE
1	109506-01-000	EA	FILM-URETHANE PROTECTANT
2	120700-12-CHT(01A)	EA	DECAL-LOGO W - FROSTY JACK
3	132664-02-CHT(01A)	EA	DECAL-LOGO DOMED WINNEBAGO - CHROME/RED/BLACK
4	158621-03-CHT(01A)	EA	DECAL-HORSEPOWER 400 FLEXSCRIPT - CHROME
5	137618-04-CHT(01A)	EA	DECAL/BEZEL DOMED GRILL LOGO - CHROME/RED
6	GL	PAINT-CLEAR COAT - SHERWIN WILLIAMS
7	146735-03-CHT(01A)	EA	DECAL-LOGO DOMED VECTRA LG - CHROME/GOLD/BLACK/WHITE
8	146735-04-CHT(01A)	EA	DECAL-LOGO DOMED VECTRA SML - CHROME/GOLD/BLACK/WHITE
9	150133-01-000	EA	KIT-PAINT PROTECTION
10	148636-01-CHT(01A)	EA	DECAL-LOGO EVOLUTION CHASSIS - CHROME/BLACK/RED
11	151687-01-CHT(01A)	EA	DECAL/BEZEL DOMED NAMEPLATE WINNEBAGO - CHROME/RED
12	GL	PLATE-FREIGHTLINER LG - CHASSIS SUPPLIED
13	EA	PLATE-FREIGHTLINER SML - CHASSIS SUPPLIED
14	GL	PAINT-HAZELNUT MET - SHERWIN WILLIAMS #64211
15	GL	PAINT-HARVEST GOLD MET - SHERWIN WILLIAMS #57343
16	GL	PAINT-SEDONA MET - SHERWIN WILLIAMS #63814
17	GL	PAINT-NEW WIND VEIL MET - SHERWIN WILLIAMS #62974

(92A) KEY	PART NUMBER	U/M	DESCRIPTION DARK FOREST
1	109506-01-000	EA	FILM-URETHANE PROTECTANT
2	120700-12-CHT(01A)	EA	DECAL-LOGO W - FROSTY JACK
3	132664-02-CHT(01A)	EA	DECAL-LOGO DOMED WINNEBAGO - CHROME/RED/BLACK
4	158621-03-CHT(01A)	EA	DECAL-HORSEPOWER 400 FLEXSCRIPT - CHROME
5	137618-04-CHT(01A)	EA	DECAL/BEZEL DOMED GRILL LOGO - CHROME/RED
6	GL	PAINT-CLEAR COAT - SHERWIN WILLIAMS
7	146735-03-CHT(01A)	EA	DECAL-LOGO DOMED VECTRA LG - CHROME/GOLD/BLACK/WHITE
8	146735-04-CHT(01A)	EA	DECAL-LOGO DOMED VECTRA SML - CHROME/GOLD/BLACK/WHITE
9	150133-01-000	EA	KIT-PAINT PROTECTION
10	148636-01-CHT(01A)	EA	DECAL-LOGO EVOLUTION CHASSIS - CHROME/BLACK/RED
11	151687-01-CHT(01A)	EA	DECAL/BEZEL DOMED NAMEPLATE WINNEBAGO - CHROME/RED
12	GL	PLATE-FREIGHTLINER LG - CHASSIS SUPPLIED
13	EA	PLATE-FREIGHTLINER SML - CHASSIS SUPPLIED
14	GL	PAINT-SPRUCLE GREEN MET - SHERWIN WILLIAMS #53876
15	GL	PAINT-BLACK MET - SHERWIN WILLIAMS #40888
16	GL	PAINT-GOLD MET - SHERWIN WILLIAMS #YV293
17	GL	PAINT-WINTERGREEN MET - SHERWIN WILLIAMS #51108

(24C) KEY	PART NUMBER	U/M	DESCRIPTION ASPEN MIST
1	109506-01-000	EA	FILM-URETHANE PROTECTANT
2	120700-12-CHT(01A)	EA	DECAL-LOGO W - FROSTY JACK
3	132664-02-CHT(01A)	EA	DECAL-LOGO DOMED WINNEBAGO - CHROME/RED/BLACK
4	158621-03-CHT(01A)	EA	DECAL-HORSEPOWER 400 FLEXSCRIPT - CHROME
5	137618-04-CHT(01A)	EA	DECAL/BEZEL DOMED GRILL LOGO - CHROME/RED
6	GL	PAINT-CLEAR COAT - SHERWIN WILLIAMS
7	146735-03-CHT(01A)	EA	DECAL-LOGO DOMED VECTRA LG - CHROME/GOLD/BLACK/WHITE
8	146735-04-CHT(01A)	EA	DECAL-LOGO DOMED VECTRA SML - CHROME/GOLD/BLACK/WHITE
9	150133-01-000	EA	KIT-PAINT PROTECTION
10	148636-01-CHT(01A)	EA	DECAL-LOGO EVOLUTION CHASSIS - CHROME/BLACK/RED
11	151687-01-CHT(01A)	EA	DECAL/BEZEL DOMED NAMEPLATE WINNEBAGO - CHROME/RED
12	GL	PLATE-FREIGHTLINER LG - CHASSIS SUPPLIED
13	EA	PLATE-FREIGHTLINER SML - CHASSIS SUPPLIED
14	GL	PAINT-CANVAS BEIGE MET - SHERWIN WILLIAMS #64156
15	GL	PAINT-SPRUCLE GREEN MET - SHERWIN WILLIAMS #53876
16	GL	PAINT-GOLD MET - SHERWIN WILLIAMS #YV293
17	GL	PAINT-IRON GRAY MET - SHERWIN WILLIAMS #63300

△ DIE CUT ACRYLIC FILM USED TO PROTECT FULL BODY PAINTED UNITS.

4. ON FULL BODY PAINTED UNITS, USE 145487-02-000 (100 FT) TO COVER UNSEALED ROOF SEAMS.

△ CLEAR COAT TO BE APPLIED ON ENTIRE UNIT TO PROTECT PAINT.

△ CENTER ON UNIT.

1. APPLY PROTECTOR 116424-01-000 TO WATER HEATER LATCH.

8. END PANELS OF SLIDEOUT ROOM WILL BE PAINTED WITH THE BASE COAT, COLORED DESIGN GRAPHICS AND CLEAR COAT.

△ LOGO IS TO BE HELD TO ±1 MM ON A HORIZONTAL PLANE (END TO END).

△ FILM TO PROTECT BOTTOM OF DOOR FROM SCUFF MARKS.

(24P) MASK FRONT EXT PROTECTIVE

(24C) EXT FULL BODY PAINT PKG # 3

(92A) EXT FULL BODY PAINT PKG # 2

(27A) EXT FULL BODY PAINT PKG # 1

(1LH) FRTL 34,320 400 6SP 1FS

NOTES:

EXTERIOR BODY GROUP (CONTINUED)
GRAPHICS & PAINT (CONTINUED)

KEY	PART NUMBER	U/M	DESCRIPTION
	116424-01-000	EA	PROTECTOR - LATCH - WATER HEATER
	072882-01-000	GL	PAINT - LOW BAKE - OFF WHITE
	093681-39-01A	FT	FILM - 3.1" - MATTE BLACK

**DUPONT COLOR CODES ARE NOW FOUND IN THE PAINT CODE MANUAL.
YOU CAN FIND THIS MANUAL ON YOUR DEALER INDEX WEBPAGE UNDER SERVICE.**

EXTERIOR BODY GROUP (CONTINUED)

PANELS & TRIMS

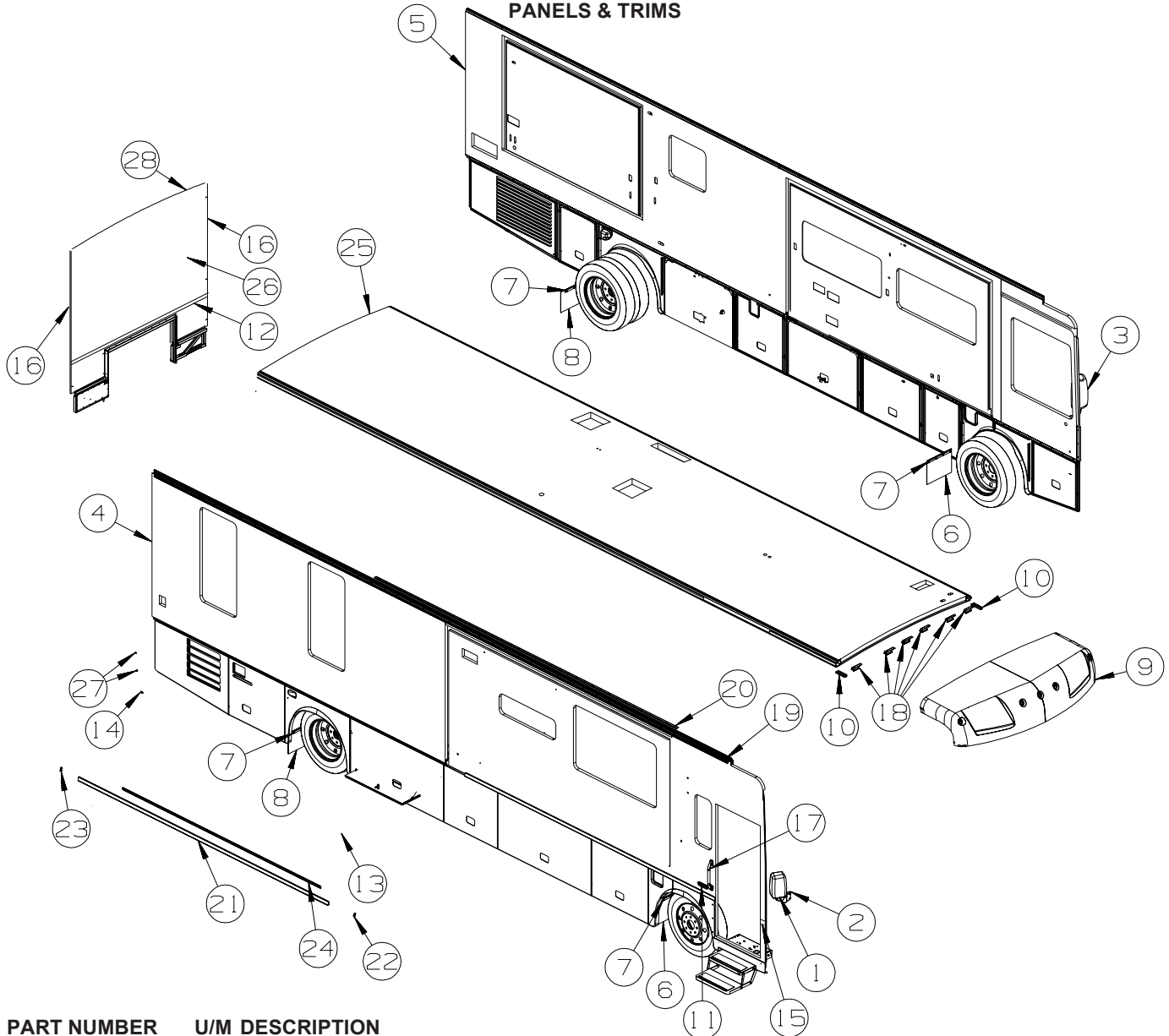

KEY	PART NUMBER	U/M	DESCRIPTION
1*	131431-08-02A	EA	MIRROR - EXTERIOR/REMOTE/HEAT/PASSENGER-W/TURN SIGNAL-CHR
	133379-01-01A	EA	SCREW - MACHINE - 5/16-18 X 2.00 - TORX
2	108825-03-000	EA	GASKET - MIRROR
3*	142721-02-02A	EA	MIRROR - EXTERIOR REMOTE/HEAT/DRVR - (BREAKAWAY) - CHROME
4	155579-01-UJ1	EA	SIDEWALL - PASSENGER - W/O WINDOWS/TRIMS (UJ1, UJ2, UJ3)
4	155579-01-UJ5	EA	SIDEWALL - PASSENGER - W/O WINDOWS/TRIMS (UJ5, UJ6, UJ7)
4	155579-01-UK1	EA	SIDEWALL - PASSENGER - W/O WINDOWS/TRIMS (UK1, UK2, UK3)
5	155580-01-UJ1	EA	SIDEWALL - DRIVER - W/O WINDOWS/TRIMS
5	155580-01-UJ2	EA	SIDEWALL - DRIVER - W/O WINDOWS/TRIMS
5	155580-01-UJ3	EA	SIDEWALL - DRIVER - W/O WINDOWS/TRIMS
5	155580-01-UJ5	EA	SIDEWALL - DRIVER - W/O WINDOWS/TRIMS
5	155580-01-UJ6	EA	SIDEWALL - DRIVER - W/O WINDOWS/TRIMS
5	155580-01-UJ7	EA	SIDEWALL - DRIVER - W/O WINDOWS/TRIMS
5	155580-01-UK1	EA	SIDEWALL - DRIVER - W/O WINDOWS/TRIMS
5	155580-01-UK2	EA	SIDEWALL - DRIVER - W/O WINDOWS/TRIMS
5	155580-01-UK3	EA	SIDEWALL - DRIVER - W/O WINDOWS/TRIMS
6	017516-09-000	EA	MUD FLAP - 12.2"H X 23.5"W - RUBBER - BLACK
	017516-07-000	EA	MUD FLAP - 14"H X 23.5"W - RUBBER - BLACK
7	140922-01-02B	EA	RETAINER - MUD FLAP - 1" X 17.7" - E-COATED/BLACK
8	017516-01-000	EA	MUD FLAP - 14"H X 18"W - W/O MOUNTING HOLES - RUBBER - BLK
9	150436-02-TG0	EA	CAP - ROOF/FRONT - W/O LIGHTS/WIRING
10	128072-04-02B	EA	BRACKET/SIDE - ROOF CAP - E-COATED
11*	151458-02-000	EA	KEYPAD - ENTRY DOOR/HORIZONTAL
12	104692-01-000	FT	SEAL - ADHESIVE BACKED FOAM - 3/4" THICK X 3/4" WIDE X 25'

EXTERIOR BODY GROUP (CONTINUED)
PANELS & TRIMS (CONTINUED)

KEY	PART NUMBER	U/M	DESCRIPTION
13	093873-01-01A	EA	TRIM - CARPET - L-ANGLE 1.1" X 1.3" X 12' - GRAY VINYL
14	143143-02-01A	EA	ANGLE - SUPPORT/TRIM
15	093673-01-06A	FT	TRIM/MOLDING - 1.4" WIDE X 8' LONG - BRIGHT WHITE
16	156622-01-01A	EA	SEALER - TAPE - 1/4"THICK X 3"WIDE X 100 FT
17	157749-02-01A	EA	ASSIST HANDLE - LIGHTED - 18" - CHROME - NOT ILLUSTRATED FROM: 00-00-00 THRU: 09-24-06
17*	132442-06-01A	EA	HANDLE - ASSIST/CLEAR-BLANK/LIGHTED - 20" - W/CHROME ENDS FROM: 09-25-06 THRU: 99-99-99
18	134774-01-02B	EA	BRACKET - CAB ATTACHMENT - E-COATED
19	157284-01-01A	EA	RAIL - AWNING - 192" - BRIGHT WHITE
20	142123-03-02A	EA	RAIL/AWNING - 220" - BLACK
21	146550-01-02A	EA	TRIM COVER - SIDEWALL - 182" - BLACK
22	146576-01-02A	EA	END CAP/TRIM - RIGHT HAND - BLACK
23	146576-02-02A	EA	END CAP/TRIM - LEFT HAND - BLACK
24	151782-01-01A	EA	TRIM - RETAINER - 143.8"
25	157044-01-UJ1	EA	ROOF - W/O LIGHTS/VENTS - W/WIRING
26	157041-01-UJ1	EA	BACKWALL/INNER - W/O REAR CAP (UJ1, UJ2, UJ3)
26	157041-01-UJ5	EA	BACKWALL/INNER - W/O REAR CAP (UJ5, UJ6, UJ7)
26	157041-01-UK5	EA	BACKWALL/INNER - W/O REAR CAP (UK1, UK2, UK3)
27	143143-01-01A	EA	ANGLE - SUPPORT/TRIM
28	114248-02-01A	EA	ANGLE - PLASTIC - .7" X .4" X 96.7" - MODERN IVORY

***COMPONENT PARTS LISTED LATER IN THIS GROUP**

EXTERIOR BODY GROUP (CONTINUED)
PANELS & TRIMS (CONTINUED)

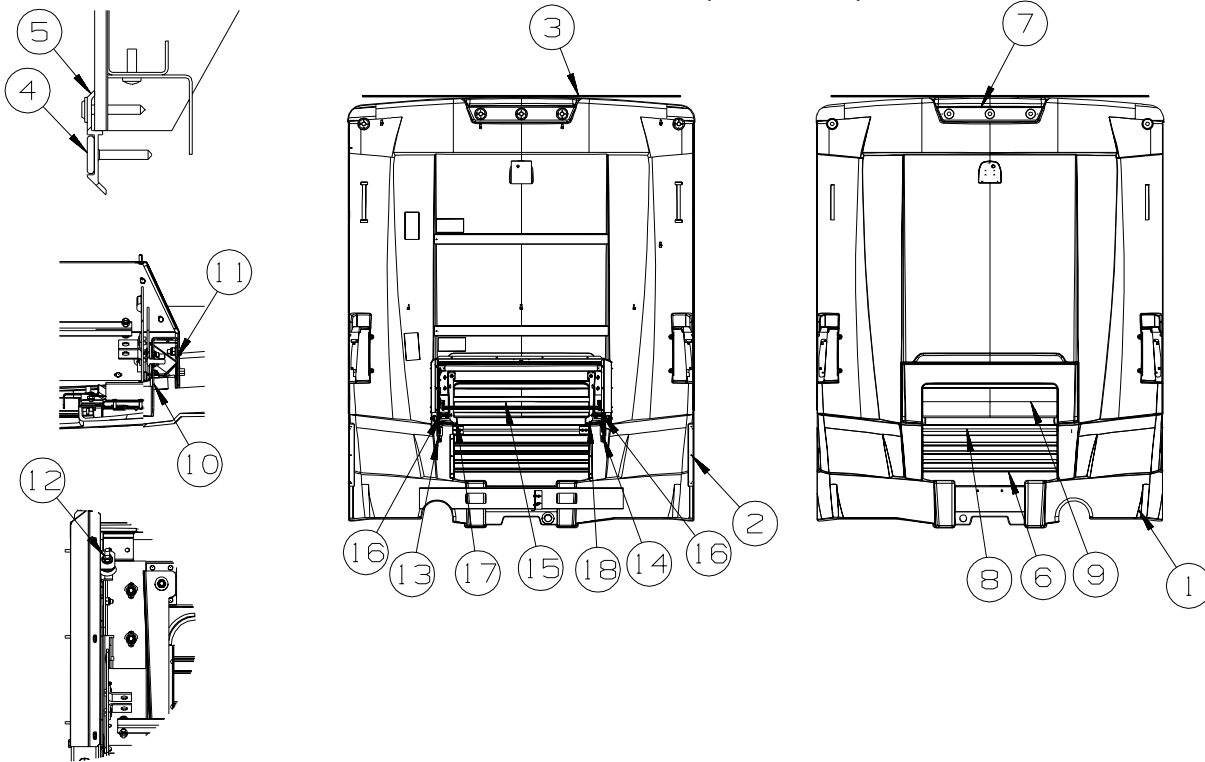

KEY	PART NUMBER	U/M	DESCRIPTION
1	150402-01-TG0	EA	PANEL - REAR CAP
	150387-01-01A	EA	PANEL - REAR CAP
2	138789-01-02B	EA	ANGLE/MOUNT - WHEEL LIP/BACKWALL - E-COATED
3	083805-23-000	EA	TRIM - ROOF CAP - 92.1" - BRIGHT WHITE
4	091985-01-07A	EA	INSERT - TRIM - REAR CAP TO SIDEWALL - .66" - BRIGHT WHITE
5	092041-12-01A	EA	TRIM - FRONT/REAR CAP (SIDEWALL) - 84" - BRIGHT WHITE
			FROM: 00-00-00 THRU: 05-25-06
5	092041-01-03A	EA	TRIM - FRONT/REAR CAP (SIDEWALL) - 83.1" - BRIGHT WHITE
			FROM: 05-26-06 THRU: 99-99-99
6	144171-01-R83	EA	GRILLE - REAR CAP
7	145389-01-01A	EA	TRIM - LIGHTS - REAR - BRUSHED STAINLESS STEEL
8	145388-01-01A	EA	TRIM - BUMPER - REAR - BRUSHED STAINLESS STEEL
9	P48209-01-R83	EA	DOOR - REAR ENGINE W/HARDWARE/GRILLE
10	130053-01-01A	EA	STRIKER - LUGGAGE DOOR - FLUSH - BLACK
11	145539-01-02B	EA	BRACKET - DOOR CATCH - E-COATED
12	058786-01-000	EA	BOLT - HOOD ADJUSTMENT - 5/16"-18 X 1.5"-2" - W/BLACK PAD
13	146226-01-01A	EA	HINGE/DOOR - REAR - RIGHT HAND - BLACK
14	146226-02-01A	EA	HINGE/DOOR - REAR - LEFT HAND - BLACK
15	137300-05-02B	EA	TUBE/TIMING - HOOD - 46" - E-COATED
16	113908-02-000	EA	LATCH/PLUNGER - F/HOOD/REAR TRUNK/ENGINE/GENERATOR DOOR
17	145540-03-02B	EA	HANDLE - DOOR LATCH - RIGHT HAND - E-COATED
18	145540-04-02B	EA	HANDLE - DOOR LATCH - LEFT HAND - E-COATED

EXTERIOR BODY GROUP (CONTINUED)
COMPONENT PARTS FOR PANELS & TRIMS

131431-08-02A

KEY	PART NUMBER	U/M DESCRIPTION	VENDOR NO.
	106015-16-700	EA GLASS/FLAT-W/HEAT ELEMENT	709450
	106015-18-700	EA GLASS/CONVEX	709650
	106015-18-701	EA ACTUATOR - CONVEX GLASS	7475410
	106015-18-702	EA MOTOR - FLAT GLASS	7471180
	106015-18-703	EA GLASS/CONVEX-ACT/HOUSING	709651 KIT
	106015-19-700	EA GLASS/FLAT-W/BEZEL/HEAT/ANTI	709645
	131431-03-700	EA LIGHT/TURN SIGNAL - AMBER	7475510
	131431-07-700	EA KIT(SCREW CVR BLK)ROUND/OVAL	748344
	131431-08-700	EA CAP/BASE - BLK - 1 PKG OF 2	Q7095150

132442-06-01A, 132442-07-01A

KEY	PART NUMBER	U/M DESCRIPTION	VENDOR NO.
	132442-01-701	EA LED ASM.	86430

142721-01-02A, 142721-02-02A

KEY	PART NUMBER	U/M DESCRIPTION	VENDOR NO.
	106015-16-700	EA GLASS/FLAT-W/HEAT ELEMENT	709450
	106015-18-700	EA GLASS/CONVEX	709650
	106015-18-701	EA ACTUATOR - CONVEX GLASS	7475410
	106015-18-702	EA MOTOR - FLAT GLASS	7471180
	106015-18-703	EA GLASS/CONVEX-ACT/HOUSING	709651 KIT
	131431-03-700	EA LIGHT/TURN SIGNAL - AMBER	7475510
	142721-01-700	EA COVER/CAP - BOTTOM	Q709678
	142721-01-701	EA CAP - RECTANGULAR (VELVAC)	709557
	142721-01-702	EA BRACKET/MOUNT - MIRROR	7096800
	142721-01-703	EA GASKET/MOUNT - MIRROR	7097400
	142721-01-704	EA SET SCREW - 5/16"-18 X 1.25"	4082140

151458-02-000

KEY	PART NUMBER	U/M DESCRIPTION	VENDOR NO.
	151458-02-700	EA COVERS (2 PER PKG) F/KEY PAD	208-3896
	151458-02-701	EA GASKET - OUTER - F/KEYPAD	308-2094

EXTERIOR BODY GROUP (CONTINUED)

FRONT END

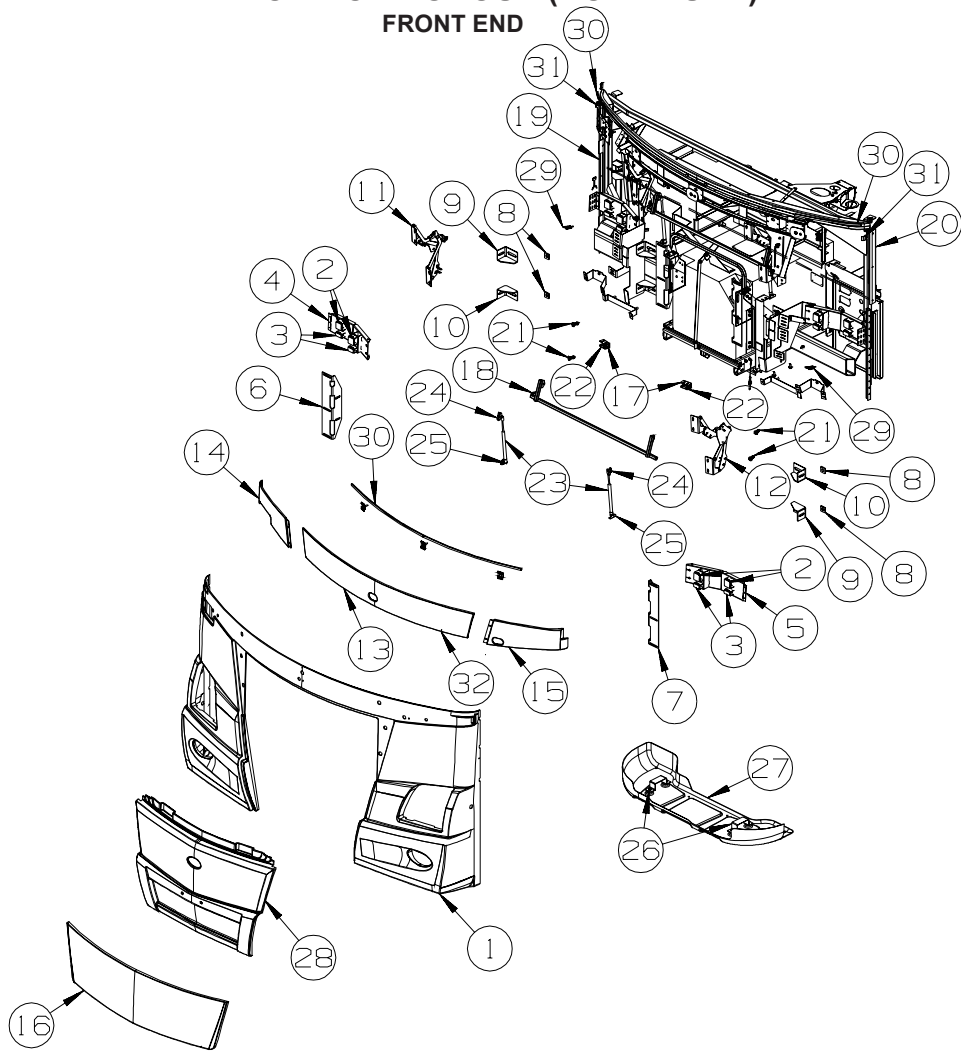

KEY	PART NUMBER	U/M	DESCRIPTION
1	156722-02-UJ1	EA	PANEL - FRONT/LOWER - W/O HOOD/GRILLE/LIGHTS
2	148217-01-01A	EA	PAD - URETHANE FOAM - W/ADHESIVE BACK-1/4"X 2"X 2" - BLACK
3	148217-02-01A	EA	PAD - URETHANE FOAM - W/ADHESIVE BACK-1/4"X 2"X 1" - BLACK
4	144142-01-02B	EA	SUPPORT - HEADLAMP - RIGHT HAND - E-COATED
5	144142-02-02B	EA	SUPPORT - HEADLAMP - LEFT HAND - E-COATED
6	114396-07-02B	EA	ANGLE - BUMPER MOUNT/PASSENGER - E-COATED
7	114396-08-02B	EA	ANGLE - BUMPER MOUNT/DRIVER - E-COATED
8	116617-02-02B	EA	SPACER - BUMPER
9	128455-01-02B	EA	BRACKET - BUMPER - E-COATED
10	128455-02-02B	EA	BRACKET - BUMPER - E-COATED
11	137072-07-01A	EA	HINGE - HOOD - PASSENGER - BLACK
12	137072-08-01A	EA	HINGE - HOOD - DRIVER - BLACK
13	156705-02-UJ1	EA	COWL - WINDSHIELD/CENTER
14	156708-03-UJ1	EA	COWL - WINDSHIELD - PASSENGER
15	156708-04-UJ1	EA	COWL - WINDSHIELD - DRIVER
16	144187-01-R83	EA	HOOD - FRONT
17	144209-01-02B	EA	ANGLE/STRIKER - HOOD - E-COATED
18	144395-01-02B	EA	TUBE/TIMING - HOOD - E-COATED
19	140447-02-01A	EA	TRIM - GRILLE PANEL/SIDEWALL - 47.4" - BRIGHT WHITE
20	140447-01-01A	EA	TRIM - GRILLE PANEL/SIDEWALL - 22" - BRIGHT WHITE
21	058786-01-000	EA	BOLT - HOOD ADJUSTMENT - 5/16"-18 X 1.5"-2"- W/BLACK PAD
22	130053-01-01A	EA	STRIKER - LUGGAGE DOOR - FLUSH - BLACK
23	142569-08-000	EA	SPRING/GAS - 45 LB. - 18.5" EXTENDED/11"COMPRESSED
24	126263-02-02B	EA	BRACKET - GAS SPRING W/BALL STUD - E-COATED
25	126263-03-02B	EA	BRACKET - GAS SPRING W/BALL STUD - E/COATED
26	146357-02-02B	EA	BRACKET/PLATE - SKID - E-COATED
27	146365-02-01A	EA	BELLY PAN - FRONT LOWER - PLASTIC
	146365-01-01A	EA	BELLY PAN - FRONT LOWER - PLASTIC - BLACK
28	144025-02-R83	EA	PANEL/DOOR - GENERATOR - F/CENTER/GRILLE PANEL

EXTERIOR BODY GROUP (CONTINUED) FRONT END (CONTINUED)

KEY	PART NUMBER	U/M	DESCRIPTION
29	049359-01-000	EA	SPRING - RETAINER - HEADLAMP - GM #496096
30	099418-01-000	FT	SEAL - D-SECTION/ADHESIVE BACK - .44" X .44" - BLK RUBBER
31	144170-01-02B	EA	ZEE - COWL - OUTSIDE - E-COATED
32	156705-01-01A	EA	COWL - WINDSHIELD/CENTER

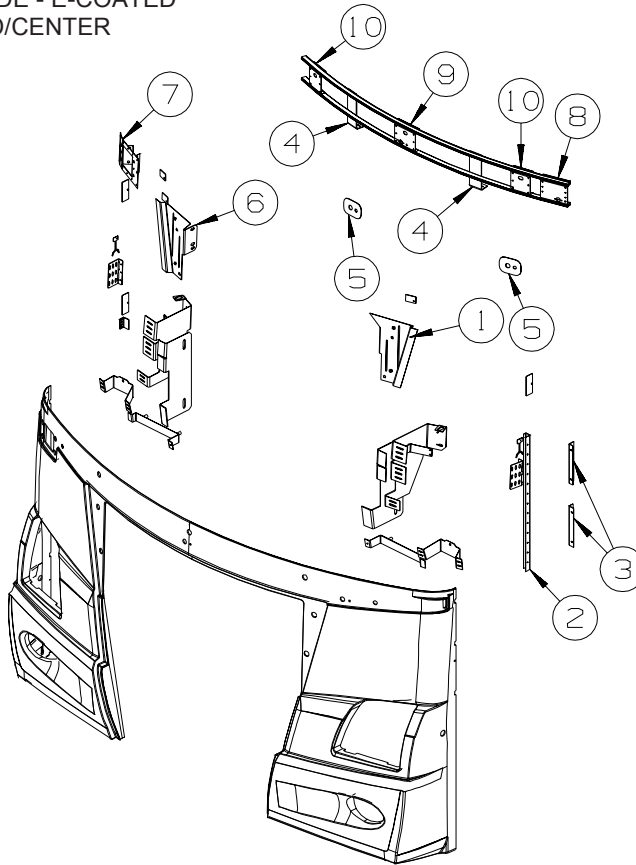

KEY	PART NUMBER	U/M	DESCRIPTION
1	144367-04-02B	EA	SUPPORT - HINGE - LEFT HAND - E-COATED
2	132071-06-02B	EA	BRACKET - BUMPER - REAR - E-COATED
3	113041-16-02B	EA	ANGLE/MOUNT - BUMPER - E-COATED
4	144208-01-02B	EA	BRACKET/STRIKER - HOOD - E-COATED
5	157080-01-01A	EA	BOOT/COWL - NEOPRENE W/ADHESIVE BACK - BLACK
6	144367-03-02B	EA	SUPPORT - HINGE - RIGHT HAND - E-COATED
7	120850-04-02B	EA	PLATE - SUPPORT/MIRROR - E-COATED
8	157051-02-02B	EA	SUPPORT - PIVOT SHAFT - E-COATED
9	157051-04-02B	EA	SUPPORT - PIVOT SHAFT - E-COATED
10	157051-05-02B	EA	SUPPORT - PIVOT SHAFT - E-COATED

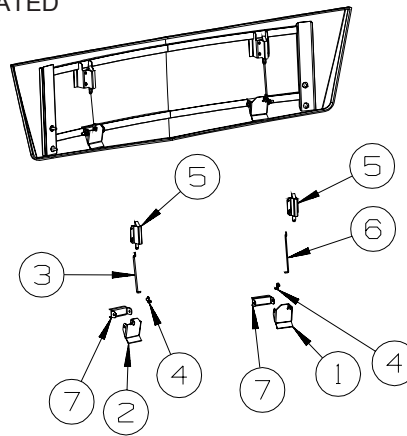

KEY	PART NUMBER	U/M	DESCRIPTION
1	147388-01-02B	EA	LATCH/PADDLE - E-COAT
2	147388-02-02B	EA	LATCH/PADDLE - E-COAT
3	145521-04-01A	EA	ROD - HOOD LATCH
4	102265-01-000	EA	CLIP/ROD END - 5/32" - BLACK PLASTIC
5	113908-02-000	EA	LATCH/PLUNGER - F/HOOD/REAR TRUNK/ENGINE/GENERATOR DOOR
6	145521-03-01A	EA	ROD - HOOD LATCH
7	139160-01-01A	EA	BRACKET - LATCH - PADDLE - MILL

EXTERIOR BODY GROUP (CONTINUED)

LADDER

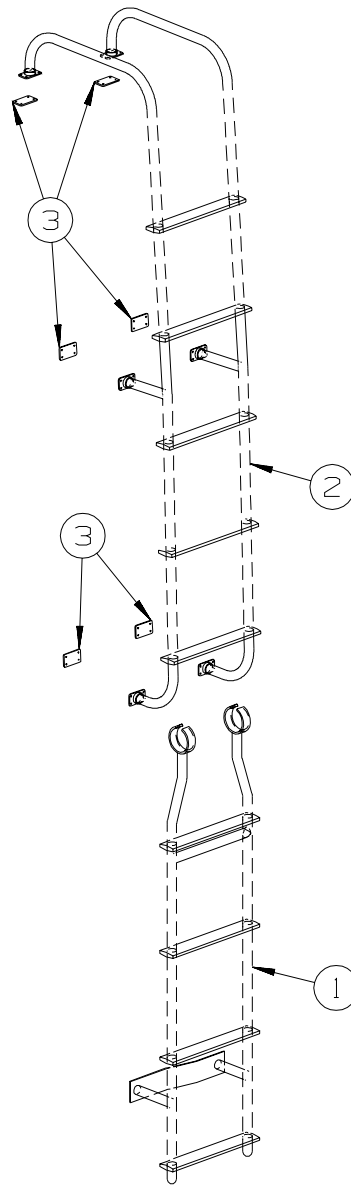

KEY	PART NUMBER	U/M	DESCRIPTION
1	150785-04-01A	EA	LADDER - LOWER - 47.6 ³ / ₄ STEP - HINGED STANDOFF
2	145614-03-01A	EA	LADDER - UPPER - BRUSHED ALUMINUM
3	129375-02-000	EA	SEAL - LADDER BRACKET

EXTERIOR BODY GROUP (CONTINUED)
STRUCTURAL COMPONENTS

KEY	PART NUMBER	U/M	DESCRIPTION
	002726-01-001	EA	GARNISH - U-CHANNEL - 1.38" X 19' - SERRATED
	002754-01-001	EA	ANGLE - EXTRUDED - 3/4" X 3/4" X 16' - MILL ALUMINUM
	089297-01-000	SF	PLYWOOD - LUAN - OVERLAY GRADE - 4' X 8'
	089297-03-000	SF	PLYWOOD - LUAN - OVERLAY GRADE - 4' X 8.3'
	100619-01-000	BF	FOAM - EXPANDED POLYSTYRENE - 1.34" X 48" X 96"
	100619-02-000	BF	FOAM - EXPANDED POLYSTYRENE - 1.5" X 48" X 96"
	100619-04-000	BF	FOAM - EXPANDED POLYSTYRENE - .5" X 48" X 96"
	100619-05-000	BF	FOAM - EXPANDED POLYSTYRENE - .75" X 48" X 96"-1.5"DENSITY
	100619-13-000	BF	FOAM - EXPANDED POLYSTYRENE-.34" X 34.7" X 96"-2" DENSITY
	100619-16-000	BF	FOAM - EXPANDED POLYSTYRENE - .75" X 48" X 96"-2" DENSITY
	100619-22-000	BF	FOAM - EXPANDED POLYSTYRENE - 1.34" X 48" X 120"
	120107-07-000	EA	FOAM - ROOF COVE
	152490-01-000	EA	FOAM - PLUG - ROOF TUBE
	116942-03-01A	LB	ALUMINUM - .7" X 40" X 158"
	113192-06-02A	EA	FIBERGLASS/LUAN LAMINATED - .2"X79"X446"- GRAY SANDING GEL
	113192-08-02A	EA	FIBERGLASS/LUAN LAMINATED - .2"X85.2"X448.1"-GRAY SAND GEL
	108535-05-03A	SF	FIBERGLASS SHEET - 108" X 500' ROLL - BRIGHT WHITE
	128782-09-01A	EA	FIBERGLASS SHEET - 31" X 68.2" - HIGH GLOSS - BRIGHT WHITE
	128782-21-01A	EA	FIBERGLASS SHEET - 31.1" X 75" - HIGH GLOSS - BRT WHITE
	128782-22-01A	EA	FIBERGLASS SHEET - 22" X 75" - HIGH GLOSS - BRT WHITE
	148884-20-01A	EA	FIBERGLASS SHEET - 4" X 93.8" - HIGH GLOSS - BRIGHT WHITE
	151523-01-02A	EA	CEILING PANEL - 48" X 97.1" - VINYL/FOAM/LUAN - SPINDRIFT
	159630-01-01A	EA	LAMINATE SHEET - 4" X 94" - CHOCOLATE/GREEN

EXTERIOR BODY GROUP (CONTINUED)
AWNINGS

ORDER AWNINGS & REPAIR PARTS FROM DOMETIC. CALL #800-366-3842.
THE DOMETIC AWNING INFORMATION YOU WILL NEED IS LOCATED ON THE MOTOR HOME NEAR
THE TOP OF THE AWNING RAIL.

KEY	PART NUMBER	U/M	DESCRIPTION
	136770-03-02A	EA	SPACER - AWNING - 2" - BLACK - ENTRANCE DOOR
	137029-01-02A	EA	BRACKET - AWNING - BLACK - ENTRANCE DOOR
	146457-02-02A	EA	BRACKET - AWNING - BLACK - PATIO
	153149-01-01A	EA	SPACER - AWNING/WINDOW - BLACK - S40FD
	158752-01-01A	EA	SPACER - AWNING/WINDOW - S40FD
	136770-03-01A	EA	SPACER - AWNING - 2" - BRIGHT WHITE- S40TD
			FROM: 10-16-06 THRU: 99-99-99
	136770-03-02A	EA	SPACER - AWNING - 2" - BLACK - S40TD
			FROM: 10-16-06 THRU: 99-99-99
	142123-02-02A	EA	RAIL/AWNING - 232" - BLACK - S40TD

EXTERIOR DOORS & COMPARTMENTS GROUP

DOOR & COMPARTMENT LAYOUT

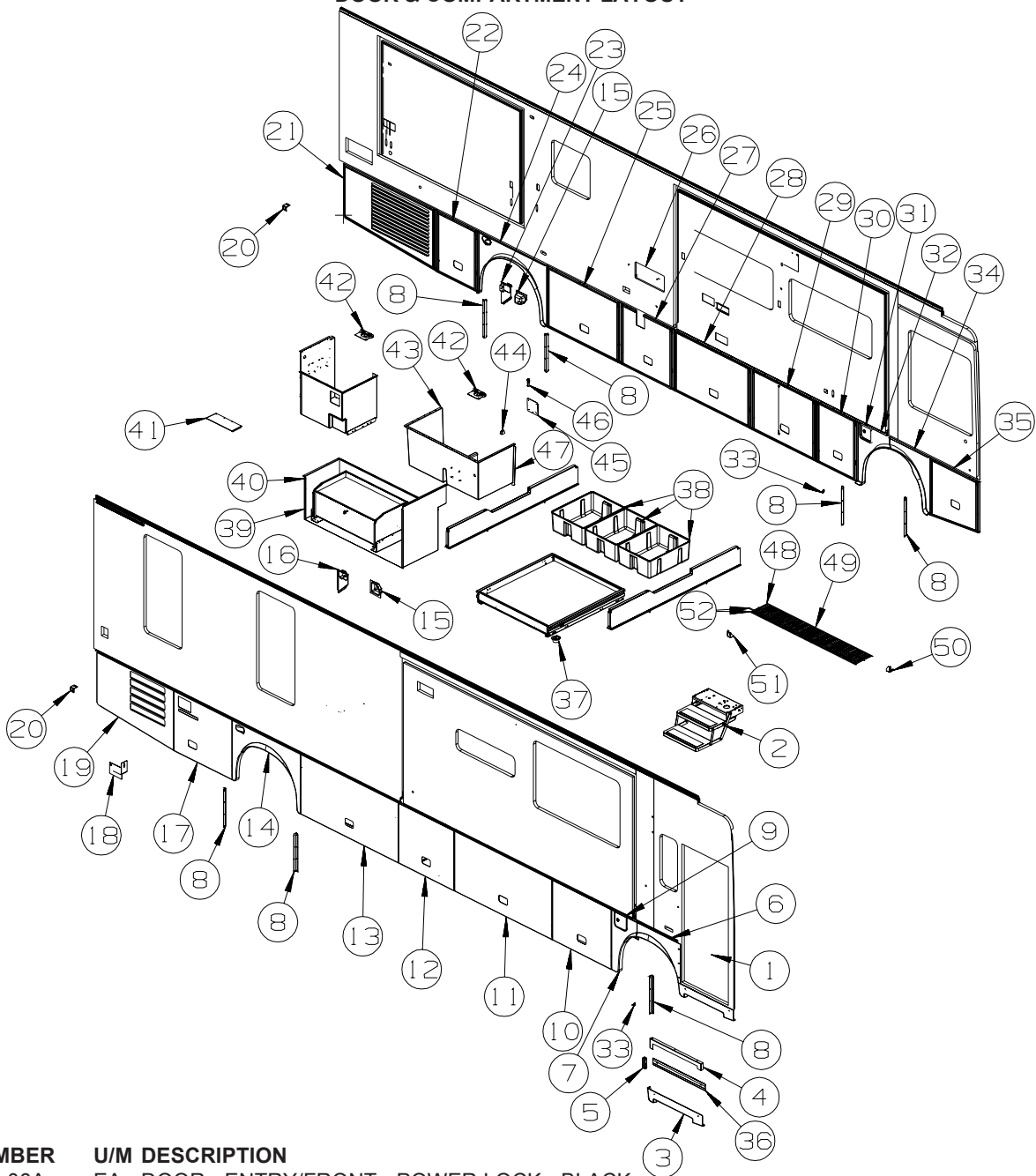

KEY PART NUMBER U/M DESCRIPTION
 1* 128913-15-06A EA DOOR - ENTRY/FRONT - POWER LOCK - BLACK

ENTRY DOOR LOCK CYLINDERS

138287-11-000	EA	CYLINDER/LOCK - ENTRY DOOR - MASTER W/3M ICON - (3041)
138287-12-000	EA	CYLINDER/LOCK - ENTRY DOOR - MASTER W/3M ICON - (3042)
138287-13-000	EA	CYLINDER/LOCK - ENTRY DOOR - MASTER W/3M ICON - (3043)
138287-14-000	EA	CYLINDER/LOCK - ENTRY DOOR - MASTER W/3M ICON - (3044)
138287-15-000	EA	CYLINDER/LOCK - ENTRY DOOR - MASTER W/3M ICON - (3045)
138287-16-000	EA	CYLINDER/LOCK - ENTRY DOOR - MASTER W/3M ICON - (3046)
138287-17-000	EA	CYLINDER/LOCK - ENTRY DOOR - MASTER W/3M ICON - (3047)
138287-18-000	EA	CYLINDER/LOCK - ENTRY DOOR - MASTER W/3M ICON - (3048)
138287-19-000	EA	CYLINDER/LOCK - ENTRY DOOR - MASTER W/3M ICON - (3049)
138287-20-000	EA	CYLINDER/LOCK - ENTRY DOOR - MASTER W/3M ICON - (3050)
138292-01-000	EA	SEAL - LOCK CYLINDER

EXTERIOR DOORS & COMPARTMENTS GROUP (CONTINUED)
DOOR & COMPARTMENT LAYOUT (CONTINUED)

KEY	PART NUMBER	U/M DESCRIPTION
	VALANCE DOOR, WATER FILL & FUEL FILL DOOR LOCK CYLINDERS	
	138289-11-000	EA CYLINDER/LOCK - ACCESS DOORS - REDUCED SENSITIVITY (3041)
	138289-12-000	EA CYLINDER/LOCK - ACCESS DOORS - REDUCED SENSITIVITY (3042)
	138289-13-000	EA CYLINDER/LOCK - ACCESS DOORS - REDUCED SENSITIVITY (3043)
	138289-14-000	EA CYLINDER/LOCK - ACCESS DOORS - REDUCED SENSITIVITY (3044)
	138289-15-000	EA CYLINDER/LOCK - ACCESS DOORS - REDUCED SENSITIVITY (3045)
	138289-16-000	EA CYLINDER/LOCK - ACCESS DOORS - REDUCED SENSITIVITY (3046)
	138289-17-000	EA CYLINDER/LOCK - ACCESS DOORS - REDUCED SENSITIVITY (3047)
	138289-18-000	EA CYLINDER/LOCK - ACCESS DOORS - REDUCED SENSITIVITY (3048)
	138289-19-000	EA CYLINDER/LOCK - ACCESS DOORS - REDUCED SENSITIVITY (3049)
	138289-20-000	EA CYLINDER/LOCK - ACCESS DOORS - REDUCED SENSITIVITY (3050)
	138288-11-000	EA KEY - REVERSIBLE - #3041 - T/M 16169-02-3041
	138288-12-000	EA KEY - REVERSIBLE - #3042 - T/M 16169-02-3042
	138288-13-000	EA KEY - REVERSIBLE - #3043 - T/M 16169-02-3043
	138288-14-000	EA KEY - REVERSIBLE - #3044 - T/M 16169-02-3044
	138288-15-000	EA KEY - REVERSIBLE - #3045 - T/M 16169-02-3045
	138288-16-000	EA KEY - REVERSIBLE - #3046 - T/M 16169-02-3046
	138288-17-000	EA KEY - REVERSIBLE - #3047 - T/M 16169-02-3047
	138288-18-000	EA KEY - REVERSIBLE - #3048 - T/M 16169-02-3048
	138288-19-000	EA KEY - REVERSIBLE - #3049 - T/M 16169-02-3049
	138288-20-000	EA KEY - REVERSIBLE - #3050 - T/M 16169-02-3050
2*	094707-04-01A	EA STEP - ELECTRIC DOUBLE - KWIKEE
3	131900-04-R83	EA VALANCE/PANEL - ENTRY DOOR - PLASTIC - BLK
4	134125-04-02B	EA SUPPORT - DOOR/VALANCE - E-COATED
5	113041-15-02B	EA ANGLE/MOUNT - BUMPER - E-COATED
6	144658-07-SD0	EA PANEL/WHEEL LIP - FRONT/PASSENGER
	139793-03-01A	EA HINGE - CENTER/VALANCE DOOR - W/O BALL STUD
7	144658-08-SD0	EA PANEL/WHEEL LIP - FRONT/PASSENGER
	139793-09-01A	EA HINGE - VALANCE DOOR - CENTER
8	113904-11-02B	EA ANGLE - ATTACHMENT/WHEEL LIP - 21.6" - E-COAT
9	131905-07-R83	EA PANEL/DOOR - FUEL FILL - W/O LOCK - BLACK
	138290-01-000	EA CASE - W/CAM - W/O CYLINDER/KEY
	153306-01-01A	EA HINGE - PIANO - 1 1/2" X 5" - UNPAINTED
10	147614-04-SD0	EA VALANCE/DOOR - W/O LATCH/HDW - 41" X 34.2"
	135624-32-01B	EA ROD - LATCH
	135624-33-01B	EA ROD - LATCH
	142569-02-000	EA SPRING/GAS - 67 LB - 21.1" EXTENDED/12.6" COMPRESSED
	126263-02-02B	EA BRACKET - GAS SPRING W/BALL STUD - E-COATED
	130053-01-01A	EA STRIKER - LUGGAGE DOOR - FLUSH - BLACK
	130053-02-01A	EA STRIKER - LUGGAGE DOOR - OFF SET - BLACK
	143793-01-01A	EA SHIM/STRIKER - LUGGAGE - 1.5" - BLACK
	107721-07-000	FT SEAL - ACCESS DOOR - .9"WIDE X 1.1"HIGH
	099418-01-000	FT SEAL - D-SECTION/ADHESIVE BACK - .44" X .44" - BLK RUBBER
11	144342-06-R83	EA VALANCE/DOOR - W/O LATCH/HDW - 67.9" X 34.2"
	135624-21-01B	EA ROD - LATCH
	135624-22-01B	EA ROD - LATCH
	142569-04-000	EA SPRING/GAS - 67 LB - 21.1" EXTENDED/12.6" COMPRESSED
	126263-02-02B	EA BRACKET - GAS SPRING W/BALL STUD - E-COATED
	130053-01-01A	EA STRIKER - LUGGAGE DOOR - FLUSH - BLACK
	143793-01-01A	EA SHIM/STRIKER - LUGGAGE - 1.5" - BLACK
	120494-04-02B	EA SHIM - STRIKER - LUGGAGE DOOR - 3/16" - E-COATED
	132892-09-01A	FT SEAL - BULB/SINGLE - SOLID - BLACK
	099418-01-000	FT SEAL - D-SECTION/ADHESIVE BACK - .44" X .44" - BLK RUBBER
12	144342-16-SD0	EA VALANCE/DOOR - W/O LATCH/HDW - 38.6" X 34.2"
	135624-62-01B	EA ROD - LATCH
	135624-63-01B	EA ROD - LATCH
	142569-16-000	EA SPRING/GAS - 90 LB - 20" EXTENDED/12" COMPRESSED
	126263-02-02B	EA BRACKET - GAS SPRING W/BALL STUD - E-COATED
	130053-01-01A	EA STRIKER - LUGGAGE DOOR - FLUSH - BLACK
	130053-02-01A	EA STRIKER - LUGGAGE DOOR - OFF SET - BLACK
	143793-01-01A	EA SHIM/STRIKER - LUGGAGE - 1.5" - BLACK
	120494-04-02B	EA SHIM - STRIKER - LUGGAGE DOOR - 3/16" - E-COATED
	132892-08-01A	FT SEAL - BULB/SINGLE - W/U CHANNEL - BLACK
	099418-01-000	FT SEAL - D-SECTION/ADHESIVE BACK - .44" X .44" - BLK RUBBER

EXTERIOR DOORS & COMPARTMENTS GROUP (CONTINUED)
DOOR & COMPARTMENT LAYOUT (CONTINUED)

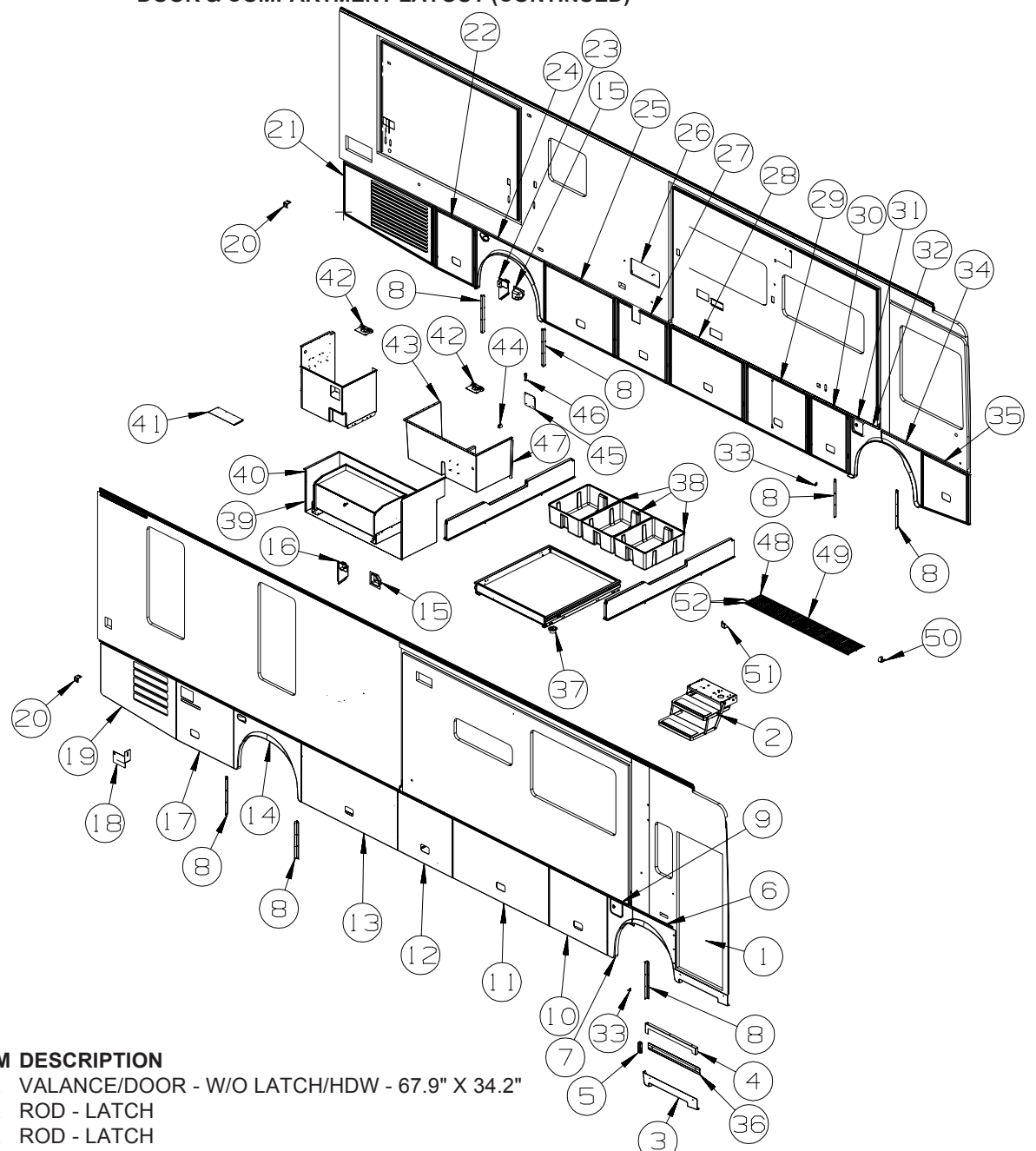

KEY	PART NUMBER	U/M	DESCRIPTION
13	144342-06-R83	EA	VALANCE/DOOR - W/O LATCH/HDW - 67.9" X 34.2"
	135624-21-01B	EA	ROD - LATCH
	135624-22-01B	EA	ROD - LATCH
	142569-01-000	EA	SPRING/GAS - 100 LB - 21.1" EXTENDED/12.6" COMPRESSED
	126263-02-02B	EA	BRACKET - GAS SPRING W/BALL STUD - E-COATED
	130053-01-01A	EA	STRIKER - LUGGAGE DOOR - FLUSH - BLACK
	143793-01-01A	EA	SHIM/STRIKER - LUGGAGE - 1.5" - BLACK
	120494-04-02B	EA	SHIM - STRIKER - LUGGAGE DOOR - 3/16" - E-COATED
	132892-08-01A	FT	SEAL - BULB/SINGLE - W/U CHANNEL - BLACK
	099418-01-000	FT	SEAL - D-SECTION/ADHESIVE BACK - .44" X .44" - BLK RUBBER
14	144658-03-R83	EA	PANEL/WHEEL LIP - REAR/PASSENGER
	139793-03-01A	EA	HINGE - CENTER/VALANCE DOOR - W/O BALL STUD
15	129301-04-01A	EA	COVER - DOCKING LIGHT - BLACK
16	129961-05-02B	EA	BRACKET - DOCKING LIGHT - E-COATED
17	144442-06-R83	EA	VALANCE/DOOR - W/O LATCH/HDW - 40.5" X 34.2"
	135624-27-01B	EA	ROD - LATCH
	135624-28-01B	EA	ROD - LATCH
	142569-14-000	EA	SPRING/GAS - 100 LB - 20" EXTENDED/12" COMPRESSED
	126263-02-02B	EA	BRACKET - GAS SPRING W/BALL STUD - E-COATED
	130053-01-01A	EA	STRIKER - LUGGAGE DOOR - FLUSH - BLACK
	143793-01-01A	EA	SHIM/STRIKER - LUGGAGE - 1.5" - BLACK
	120494-04-02B	EA	SHIM - STRIKER - LUGGAGE DOOR - 3/16" - E-COATED
	132892-08-01A	FT	SEAL - BULB/SINGLE - W/U CHANNEL - BLACK

EXTERIOR DOORS & COMPARTMENTS GROUP (CONTINUED)
DOOR & COMPARTMENT LAYOUT (CONTINUED)

KEY	PART NUMBER	U/M DESCRIPTION
18	115620-01-12B	EA PLATE - BACKING - BRIGHT WHITE
19	144442-10-R83	EA VALANCE/DOOR - PASS W/LOUVERS-W/O HDW- 34" X 53.3" X 29.7"
20	140309-03-02B	EA ANGLE - FURNACE DOOR - E-COATED
21	144442-01-R83	EA VALANCE/DOOR - DRVR REAR W/GRILLE - 34" X 65" X 29.8"
22	144342-08-R83	EA VALANCE/DOOR - W/O LATCH/HDW - 28.9" X 34.2"
	135624-06-01B	EA ROD - LATCH
	135624-25-01B	EA ROD - LATCH
	142569-02-000	EA SPRING/GAS - 67 LB - 21.1" EXTENDED/12.6" COMPRESSED
	126263-02-02B	EA BRACKET - GAS SPRING W/BALL STUD - E-COATED
	130053-01-01A	EA STRIKER - LUGGAGE DOOR - FLUSH - BLACK
	143793-01-01A	EA SHIM/STRIKER - LUGGAGE - 1.5" - BLACK
	120494-04-02B	EA SHIM - STRIKER - LUGGAGE DOOR - 3/16" - E-COATED
	107721-07-000	FT SEAL - ACCESS DOOR - .9"WIDE X 1.1"HIGH
	099418-01-000	FT SEAL - D-SECTION/ADHESIVE BACK - .44" X .44" - BLK RUBBER
23	129961-06-02B	EA BRACKET - DOCKING LIGHT - E-COATED
24	144658-06-R83	EA PANEL/WHEEL LIP - REAR/DRIVER
	139793-03-01A	EA HINGE - CENTER/VALANCE DOOR - W/O BALL STUD
25	144342-04-R83	EA VALANCE/DOOR - W/O LATCH/HDW - 51.4" X 34.2"
	135624-12-01B	EA ROD - LATCH
	135624-23-01B	EA ROD - LATCH
	142569-14-000	EA SPRING/GAS - 100 LB - 20" EXTENDED/12" COMPRESSED
	126263-02-02B	EA BRACKET - GAS SPRING W/BALL STUD - E-COATED
	130053-01-01A	EA STRIKER - LUGGAGE DOOR - FLUSH - BLACK
	143793-01-01A	EA SHIM/STRIKER - LUGGAGE - 1.5" - BLACK
	120494-04-02B	EA SHIM - STRIKER - LUGGAGE DOOR - 3/16" - E-COATED
	107721-07-000	FT SEAL - ACCESS DOOR - .9"WIDE X 1.1"HIGH
	099418-01-000	FT SEAL - D-SECTION/ADHESIVE BACK - .44" X .44" - BLK RUBBER
26*	084103-08-000	EA DOOR - VENT - REFRIGERATOR - W/O JAMB - BRIGHT WHITE
26	084104-08-000	EA JAMB - VENT DOOR/REFRIGERATOR - BRIGHT WHITE
27	144442-16-TG0	EA VALANCE/DOOR - W/O LATCH/HDW - W/NOTCH 36.6" X 34.2"
	135624-32-01B	EA ROD - LATCH
	135624-36-01B	EA ROD - LATCH
	142569-16-000	EA SPRING/GAS - 90 LB - 20" EXTENDED/12" COMPRESSED
	126263-02-02B	EA BRACKET - GAS SPRING W/BALL STUD - E-COATED
	130053-01-01A	EA STRIKER - LUGGAGE DOOR - FLUSH - BLACK
	143793-01-01A	EA SHIM/STRIKER - LUGGAGE - 1.5" - BLACK
	120494-04-02B	EA SHIM - STRIKER - LUGGAGE DOOR - 3/16" - E-COATED
	132892-08-01A	FT SEAL - BULB/SINGLE - W/U CHANNEL - BLACK
	099418-01-000	FT SEAL - D-SECTION/ADHESIVE BACK - .44" X .44" - BLK RUBBER
28	144342-14-R83	EA VALANCE/DOOR - W/O LATCH/HDW - 54" X 34.2"
	135624-13-01B	EA ROD - LATCH
	135624-14-01B	EA ROD - LATCH
	142569-14-000	EA SPRING/GAS - 100 LB - 20" EXTENDED/12" COMPRESSED
	126263-02-02B	EA BRACKET - GAS SPRING W/BALL STUD - E-COATED
	130053-01-01A	EA STRIKER - LUGGAGE DOOR - FLUSH - BLACK
	130053-02-01A	EA STRIKER - LUGGAGE DOOR - OFF SET - BLACK
	143793-01-01A	EA SHIM/STRIKER - LUGGAGE - 1.5" - BLACK
	120494-04-02B	EA SHIM - STRIKER - LUGGAGE DOOR - 3/16" - E-COATED
	132892-08-01A	FT SEAL - BULB/SINGLE - W/U CHANNEL - BLACK
	099418-01-000	FT SEAL - D-SECTION/ADHESIVE BACK - .44" X .44" - BLK RUBBER
29	144342-10-R83	EA VALANCE/DOOR - W/O LATCH/HDW - 44.8" X 34.2"
	135624-20-01B	EA ROD - LATCH
	135624-31-01B	EA ROD - LATCH
	142569-14-000	EA SPRING/GAS - 100 LB - 20" EXTENDED/12" COMPRESSED
	126263-02-02B	EA BRACKET - GAS SPRING W/BALL STUD - E-COATED
	130053-01-01A	EA STRIKER - LUGGAGE DOOR - FLUSH - BLACK
	143793-01-01A	EA SHIM/STRIKER - LUGGAGE - 1.5" - BLACK
	120494-04-02B	EA SHIM - STRIKER - LUGGAGE DOOR - 3/16" - E-COATED
	132892-08-01A	FT SEAL - BULB/SINGLE - W/U CHANNEL - BLACK
	099418-01-000	FT SEAL - D-SECTION/ADHESIVE BACK - .44" X .44" - BLK RUBBER

EXTERIOR DOORS & COMPARTMENTS GROUP (CONTINUED)
DOOR & COMPARTMENT LAYOUT (CONTINUED)

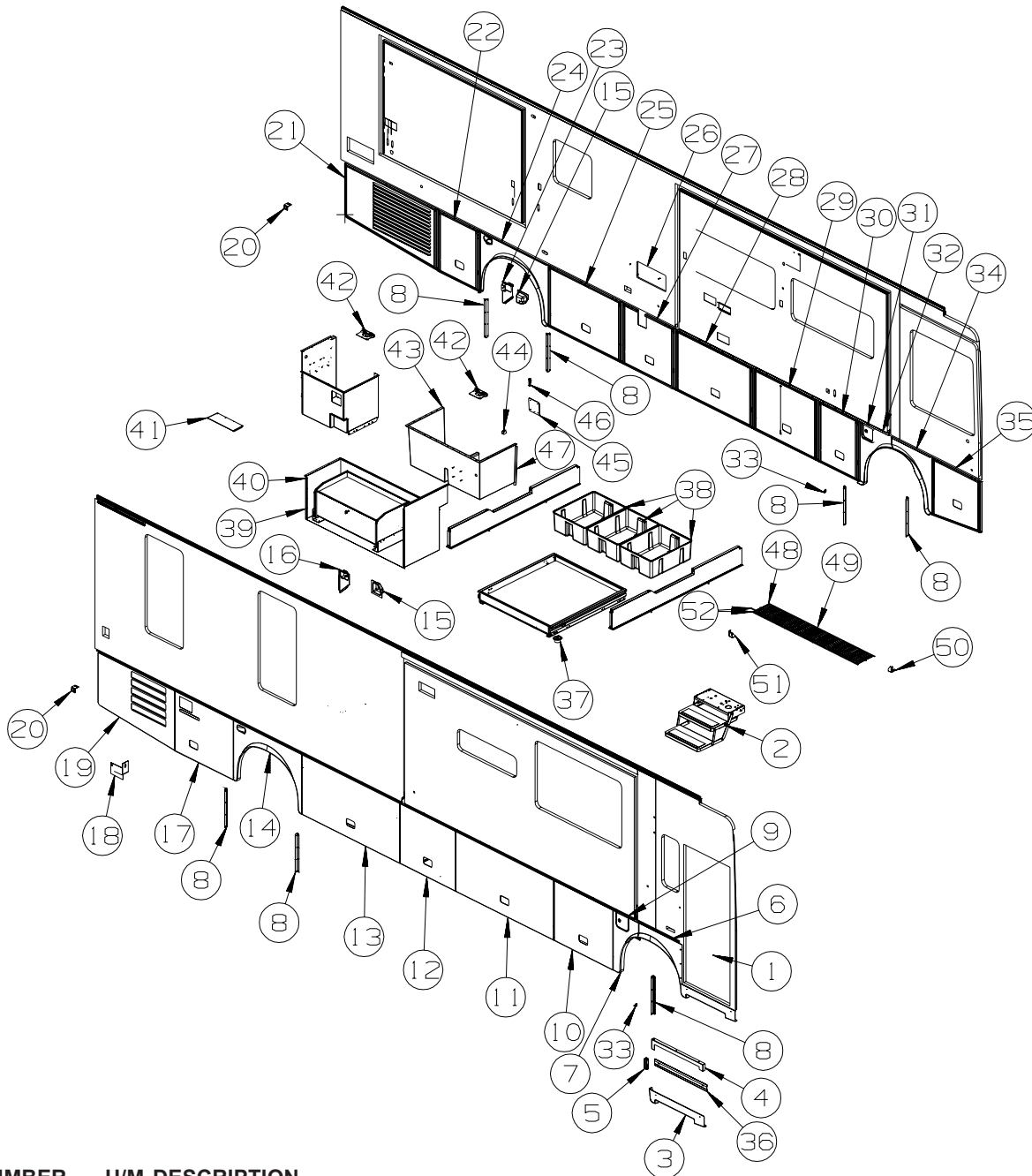

KEY	PART NUMBER	U/M	DESCRIPTION
30	144342-09-R83	EA	VALANCE/DOOR - W/O LATCH/HDWR - 28.2" X 34.2"
	135624-24-01B	EA	ROD - LATCH
	135624-26-01B	EA	ROD - LATCH
	142569-16-000	EA	SPRING/GAS - 90 LB - 20" EXTENDED/12" COMPRESSED
	126263-02-02B	EA	BRACKET - GAS SPRING W/BALL STUD - E-COATED
	130053-01-01A	EA	STRIKER - LUGGAGE DOOR - FLUSH - BLACK
	130053-02-01A	EA	STRIKER - LUGGAGE DOOR - OFF SET - BLACK
	143793-01-01A	EA	SHIM/STRIKER - LUGGAGE - 1.5" - BLACK
	120494-04-02B	EA	SHIM - STRIKER - LUGGAGE DOOR - 3/16" - E-COATED
	132892-08-01A	FT	SEAL - BULB/SINGLE - W/U CHANNEL - BLACK
099418-01-000	FT	SEAL - D-SECTION/ADHESIVE BACK - .44" X .44" - BLK RUBBER	
31	131905-05-N70	EA	PANEL/DOOR - FUEL FILL - W/O LOCK - BLACK
	138290-01-000	EA	CASE - W/CAM - W/O CYLINDER/KEY
	153306-01-01A	EA	HINGE - PIANO - 1 1/2" X 5" - UNPAINTED
32	144658-05-R83	EA	PANEL/WHEEL LIP - FRONT/LEFT HAND
	139793-03-01A	EA	HINGE - CENTER/VALANCE DOOR - W/O BALL STUD
33	123512-07-02B	EA	BRACKET - DOOR/VALANCE - E-COATED

FROM: 00-00-00 THRU: 09-26-06

EXTERIOR DOORS & COMPARTMENTS GROUP (CONTINUED)
DOOR & COMPARTMENT LAYOUT (CONTINUED)

KEY	PART NUMBER	U/M	DESCRIPTION
34	144658-04-R83	EA	PANEL/WHEEL LIP - FRONT/LEFT HAND
	139793-03-01A	EA	HINGE - CENTER/VALANCE DOOR - W/O BALL STUD
35	144442-05-R83	EA	VALANCE/DOOR - PASS W/O LATCH/HDW - 32.3" X 34.4" X 28.7"
	135624-29-01B	EA	ROD - LATCH
	135624-30-01B	EA	ROD - LATCH
	142569-22-000	EA	SPRING/GAS - 90 LB - 17" EXTENDED/12" COMPRESSED
	126263-02-02B	EA	BRACKET - GAS SPRING W/BALL STUD - E-COATED
	130053-01-01A	EA	STRIKER - LUGGAGE DOOR - FLUSH - BLACK
	143793-01-01A	EA	SHIM/STRIKER - LUGGAGE - 1.5" - BLACK
	120494-04-02B	EA	SHIM - STRIKER - LUGGAGE DOOR - 3/16" - E-COATED
	132892-08-01A	FT	SEAL - BULB/SINGLE - W/U CHANNEL - BLACK
	099418-01-000	FT	SEAL - D-SECTION/ADHESIVE BACK - .44" X .44" - BLK RUBBER
36	143362-02-02B	EA	CLIP - TRIM - E-COATED
37	009426-01-000	EA	HATCH - POWER CORD - WHITE
38	156656-01-01A	EA	CONTAINER/STORAGE - SLIDEOUT - 29"W X 22.8"D X 11"H
39	153355-01-TH0	EA	COMPARTMENT - STORAGE
39	153355-02-TH0	EA	COMPARTMENT - STORAGE - STORAGE BOX, SLIDEOUT
40	153355-03-UJ1	EA	COMPARTMENT - STORAGE
40	153355-04-UJ1	EA	COMPARTMENT - STORAGE - STORAGE BOX, SLIDEOUT/REFRIGERATOR/FREEZER PORTABLE
41	142436-02-02B	EA	PLATE - COVER - E-COATED
42*	142226-02-01A	EA	HATCH - POWER
43	145131-03-UJ1	EA	COMPARTMENT - DRAINAGE
	098408-01-000	FT	SEAL - SPONGE RUBBER - CLOSED CELL
44	131383-03-02A	EA	BRACKET - SHOWER HEAD - WHITE
45	145746-01-02B	EA	PLATE - BACKING - PUMP - E-COATED
46	130377-02-000	EA	TUBE/DRAIN - KAZOO - 1 1/2" X 4"
47	155644-01-01A	EA	COMPARTMENT - DRAINAGE
48	136891-01-01A	EA	SHELF & ROD - 12" X 143.8" - W/O ENDS
49	136891-53-01A	EA	BRACKET - U/CLAMP MOUNTING - F/SHELF
50	152900-01-02B	EA	BRACKET/SHELF - SLIDEOUT - E-COATED
51	152900-02-02B	EA	BRACKET/SHELF - SLIDEOUT - E-COATED
52	136891-52-01A	EA	END CAP - SMALL - F/SHELF

***COMPONENT PARTS LISTED LATER IN THIS GROUP**

EXTERIOR DOORS & COMPARTMENTS GROUP (CONTINUED)
DOOR & COMPARTMENT LAYOUT (CONTINUED)

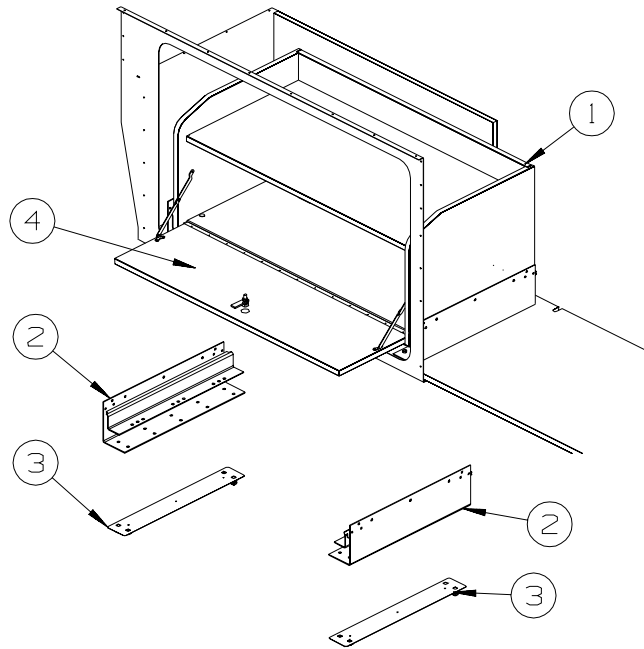

**SLIDING
STORAGE BOX**

KEY	PART NUMBER	U/M	DESCRIPTION
1	148728-01-R83	EA	CABINET - STORAGE BOX - W/DOOR - W/O HARDWARE
2	145663-01-000	EA	SLIDE - TRAY/LUGGAGE - KWIKEE
3	147393-01-02B	EA	RETAINER - COMPARTMENT - E-COATED
4	148728-11-R83	EA	DOOR - LAMINATED - F/EXTERIOR STORAGE CABINET - W/O HDW

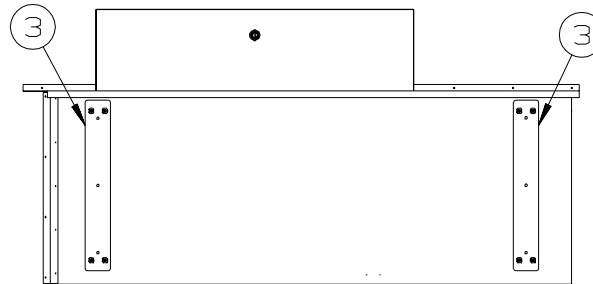

**SLIDING
STORAGE BOX
W/ FREEZER**

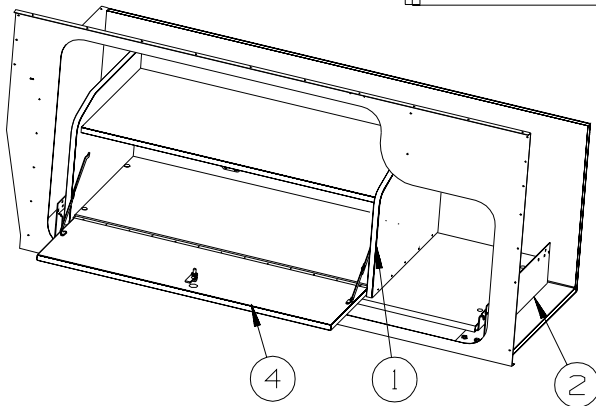

KEY	PART NUMBER	U/M	DESCRIPTION
1	148728-01-R83	EA	CABINET - STORAGE BOX - W/DOOR - W/O HARDWARE
2	145663-01-000	EA	SLIDE - TRAY/LUGGAGE - KWIKEE
3	147393-01-02B	EA	RETAINER - COMPARTMENT - E-COATED
4	148728-11-R83	EA	DOOR - LAMINATED - F/EXTERIOR STORAGE CABINET - W/O HDW

EXTERIOR DOORS & COMPARTMENTS GROUP (CONTINUED)
DOOR & COMPARTMENT LAYOUT (CONTINUED)

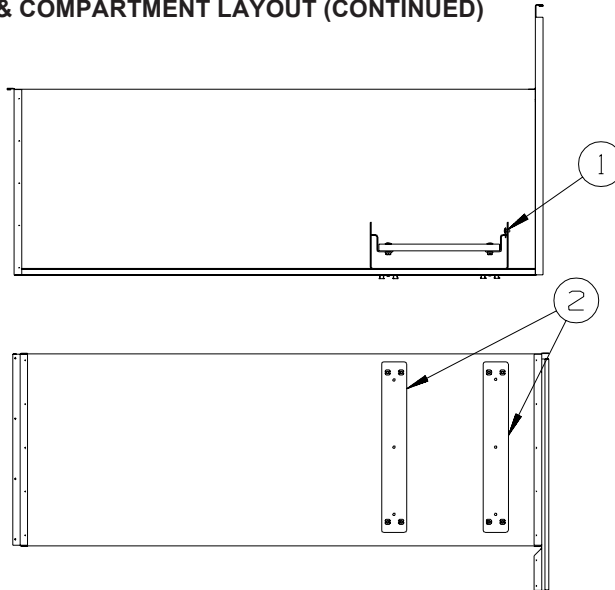

SLIDING TRAY

KEY	PART NUMBER	U/M	DESCRIPTION
1	145663-01-000	EA	SLIDE - TRAY/LUGGAGE - KWIKEE
2	147393-01-02B	EA	RETAINER - COMPARTMENT/SLIDE - E-COATED

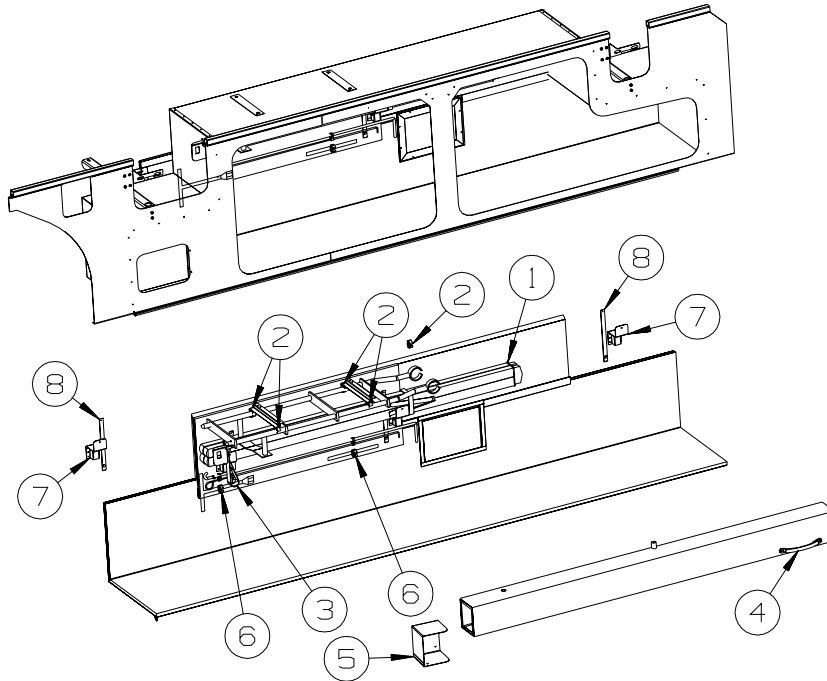

**S40FD, S40KD
 UP TO 09-17-06**

KEY	PART NUMBER	U/M	DESCRIPTION
1	148880-01-01A	EA	LADDER - FOLDING - ALUMINUM - S40KD, S40TD
1	148880-02-01A	EA	LADDER - FOLDING - ALUMINUM - S40FD
2	091952-01-000	EA	CLIP - GRIPPER - 1" - BLACK VINYL COATED
3	143505-01-01A	EA	STRAP - RETAINING W/VELCRO - BLACK
3	143506-01-000	EA	HOOK - J
4	009126-03-000	EA	HANDLE - ASSIST - BLACK TEXTURED
	115661-01-000	FT	SHOE/GLIDE - SLIDEOUT ROOM - 1/16" X 3" - POLYETHYLENE
5	149366-01-02B	EA	BRACKET - STORAGE BOX/LADDER - E-COATED - LADDER-STEP, FOLDING
6	091952-02-000	EA	CLIP - GRIPPER - 3/4" - BLACK VINYL COATED
7	160016-01-02B	EA	BRACKET - LADDER - E-COATED
8	057534-11-000	EA	TIEBACK - CLEAR PLASTIC

EXTERIOR DOORS & COMPARTMENTS GROUP (CONTINUED)
DOOR & COMPARTMENT LAYOUT (CONTINUED)

**S40FD, S40KD
 AFTER 09-18-06**

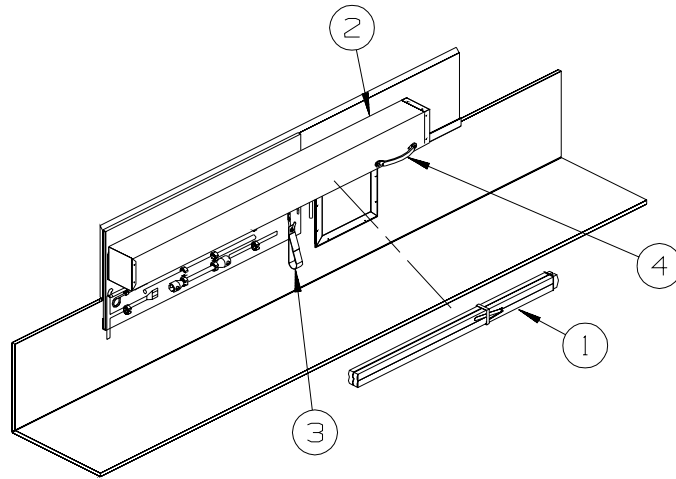

KEY	PART NUMBER	U/M	DESCRIPTION
1	148880-01-01A	EA	LADDER - FOLDING - ALUMINUM - S40KD
1	148880-02-01A	EA	LADDER - FOLDING - ALUMINUM - S40FD
2	148788-02-R83	EA	CABINET - LADDER BOX - S40KD
2	148788-01-R83	EA	CABINET - LADDER BOX - S40FD
3	143505-01-01A	EA	STRAP - RETAINING W/VELCRO - BLACK
3	143506-01-000	EA	HOOK - J
4	009126-03-000	EA	HANDLE - ASSIST - BLACK TEXTURED
	115661-01-000	FT	SHOE/GLIDE - SLIDEOUT ROOM - 1/16" X 3" - POLYETHYLENE

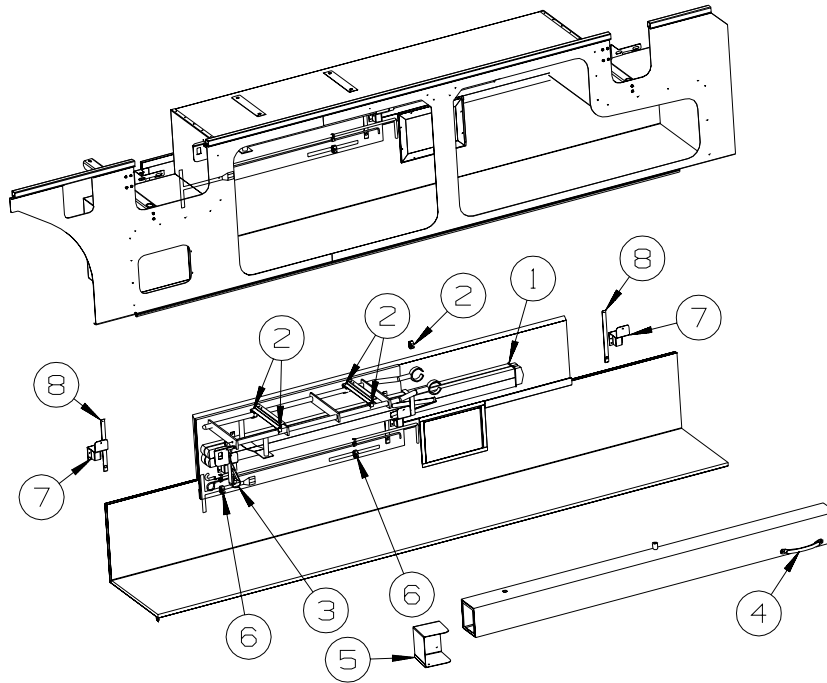

S40TD

KEY	PART NUMBER	U/M	DESCRIPTION
1	148880-01-01A	EA	LADDER - FOLDING - ALUMINUM - S40KD, S40TD
1	148880-02-01A	EA	LADDER - FOLDING - ALUMINUM - S40FD
2	091952-01-000	EA	CLIP - GRIPPER - 1" - BLACK VINYL COATED
3	143505-01-01A	EA	STRAP - RETAINING W/VELCRO - BLACK
3	143506-01-000	EA	HOOK - J
4	009126-03-000	EA	HANDLE - ASSIST - BLACK TEXTURED
	115661-01-000	FT	SHOE/GLIDE - SLIDEOUT ROOM - 1/16" X 3" - POLYETHYLENE
5	149366-01-02B	EA	BRACKET - STORAGE BOX/LADDER - E-COATED - LADDER-STEP, FOLDING
6	091952-02-000	EA	CLIP - GRIPPER - 3/4" - BLACK VINYL COATED
7	160016-01-02B	EA	BRACKET - LADDER - E-COATED
8	057534-11-000	EA	TIEBACK - CLEAR PLASTIC

EXTERIOR DOORS & COMPARTMENTS GROUP (CONTINUED)
COMPONENT PARTS FOR DOOR & COMPARTMENT LAYOUT

084103-08-000

KEY	PART NUMBER	U/M	DESCRIPTION	VENDOR NO.
	084104-01-700	EA	LOCK-MALE, FASTENER	201-721-010
	084104-01-701	EA	LOCK-FEMALE, FASTENER	201-802-010

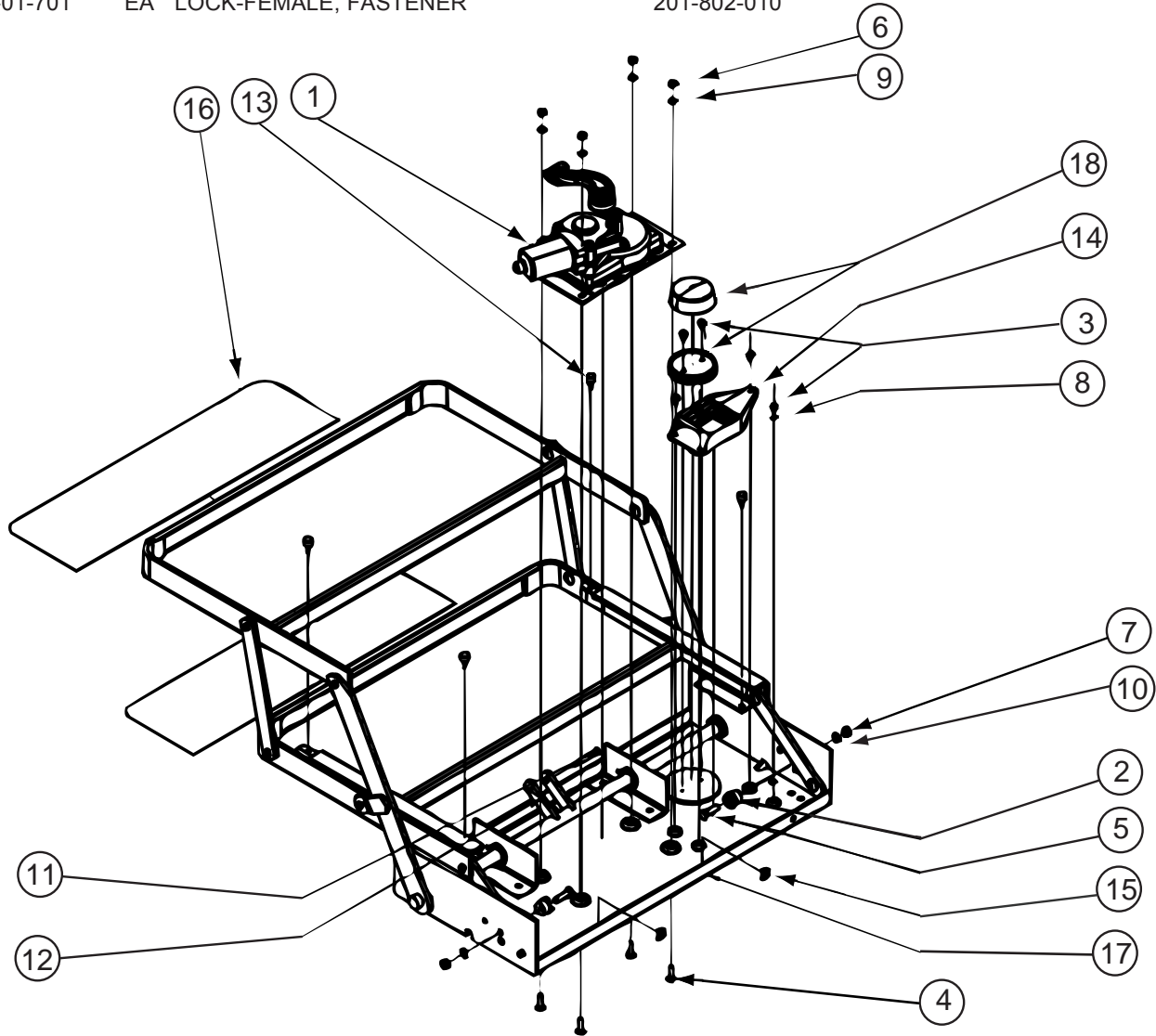

094707-04-01A

KEY	PART NUMBER	U/M	DESCRIPTION	VENDOR NO.
1	094707-04-701	EA	MOTOR "AM 214" F/IMGL STEPS	1101428
1	094707-04-703	EA	GEAR BOX W/LINKAGE-CURVED	1101425
2	143709-01-700	EA	CAM STOP	1102200
12	094707-04-702	EA	COTTOR PIN - W/CLEVIS PIN	905205000
13	143709-01-701	EA	BUMPER - BLACK (RUBBER STOP)	1602000
14	094707-04-700	EA	CONTROL UNIT W/OVERRIDE	909510000
16	143709-01-702	EA	TREAD/NON-SKID 6" X 21" BLK	1915260
17	094707-04-704	EA	FRAME W/DBL STEP-32REINF SRS	3202082
18	088746-01-705	EA	LIGHT-UNDER STEP	9004
	094707-03-701	EA	PLUG - 4-WAY - PACKARD	909306
	094707-04-711	EA	KWIKTEST - W/4-WAY PIGTAIL	909518000

CONTACT WINNEBAGO PART SALES FOR UNLISTED COMPONENT(S)

142226-02-01A

KEY	PART NUMBER	U/M	DESCRIPTION	VENDOR NO
	142226-02-700	EA	TAB/LOCKING - ESCAPE (RED)	9667709

EXTERIOR DOORS & COMPARTMENTS GROUP (CONTINUED)
COMPARTMENT DOOR PIECE PARTS

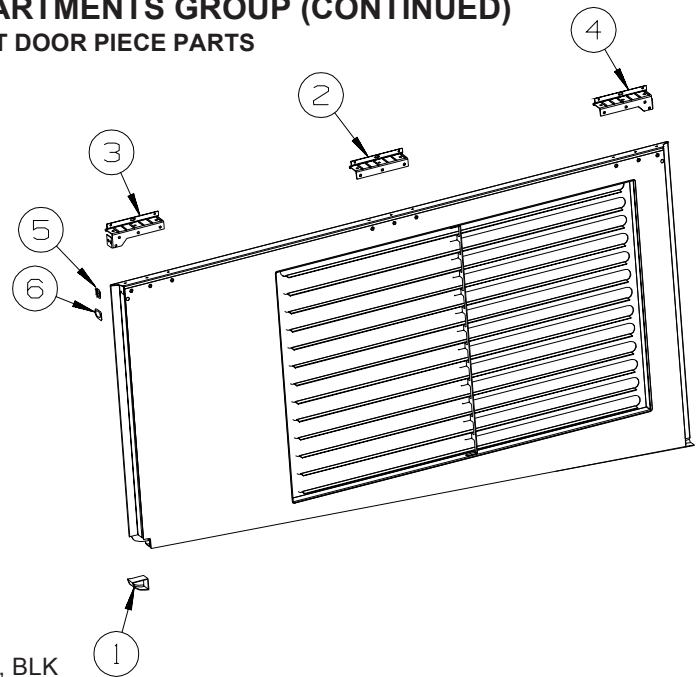

KEY	PART NUMBER	U/M	DESCRIPTION
1	138643-01-01A	EA	CORNER - VAL DOOR, REAR, RH, BLK
	138643-02-01A	EA	CORNER - VAL DOOR, REAR, LH, BLK
2	139793-03-01A	EA	HINGE - CENTER/VALANCE DOOR - W/O BALL STUD
3	139793-05-01A	EA	HINGE - LEFT HAND/VALANCE DOOR - W/O BALL STUD
4	139793-04-01A	EA	HINGE - RIGHT HAND/VALANCE DOOR - W/O BALL STUD
5	107721-07-000	FT	SEAL - ACCESS DOOR - .9"WIDE X 1.1"HIGH
6	145993-01-000	FT	SEAL - "D SECTION" W/ADHESIVE BACK

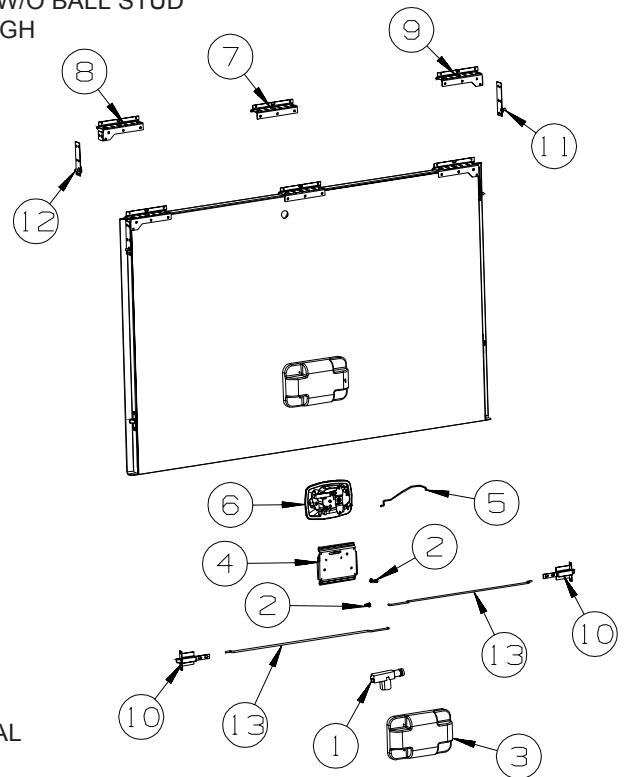

KEY	PART NUMBER	U/M	DESCRIPTION
1	138898-01-000	EA	ACTUATOR/LOCK - ELECTRIC
2	102265-03-000	EA	CLIP/ROD END - LEFT HAND - .18" - METAL
3	144172-01-01A	EA	COVER - LATCH - BRIGHT WHITE
4	141940-04-01A	EA	BRACKET - PADDLE LATCH
5	141940-03-01A	EA	ROD - PADDLE LATCH
6	141940-01-01A	EA	LATCH - PADDLE - BLACK
7	139793-03-01A	EA	HINGE - CENTER/VALANCE DOOR - W/O BALL STUD
8	139793-05-01A	EA	HINGE - LEFT HAND/VALANCE DOOR - W/O BALL STUD
9	139793-04-01A	EA	HINGE - RIGHT HAND/VALANCE DOOR - W/O BALL STUD
10	121947-01-01A	EA	BOLT - SLIDE/LATCH - W/PLASTIC PLUNGER
11	147513-01-01A	EA	BALL STUD
12	147513-02-01A	EA	BALL STUD
13	132873-01-000	EA	ROD - LATCH (BLANK) - 37.3"
13	135624-71-01B	EA	ROD - LATCH (BLANK) - 37.3"

FROM: 00-00-00 THRU: 07-31-05

FROM: 08-01-05 THRU: 99-99-99

EXTERIOR DOORS & COMPARTMENTS GROUP (CONTINUED)
COMPARTMENT DOOR PIECE PARTS (CONTINUED)

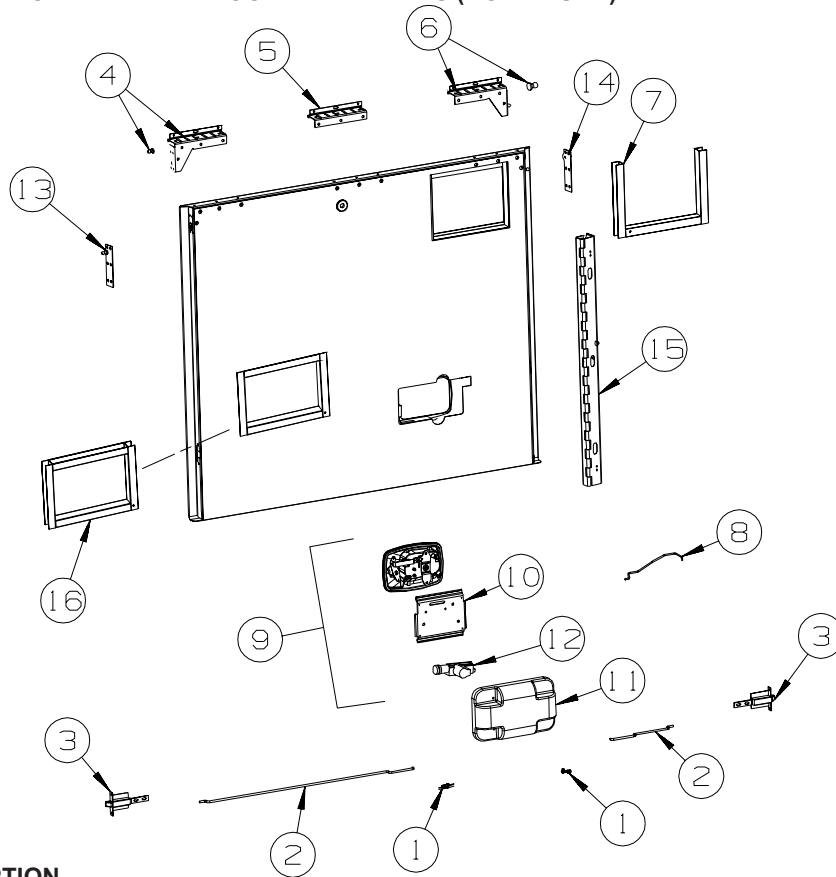

KEY	PART NUMBER	U/M	DESCRIPTION
1	102265-03-000	EA	CLIP/ROD END - LEFT HAND - .18" - METAL
2	135624-71-01B	EA	ROD - LATCH (BLANK) - 37.3"
3	121947-01-01A	EA	BOLT - SLIDE/LATCH - W/PLASTIC PLUNGER
4	139793-02-01A	EA	HINGE - LEFT HAND/VALANCE DOOR - W/BALL STUD
	139793-05-01A	EA	HINGE - LEFT HAND/VALANCE DOOR - W/O BALL STUD
5	139793-03-01A	EA	HINGE - CENTER/VALANCE DOOR - W/O BALL STUD
6	139793-01-01A	EA	HINGE - RIGHT HAND/VALANCE DOOR - W/BALL STUD
	139793-04-01A	EA	HINGE - RIGHT HAND/VALANCE DOOR - W/O BALL STUD
7	133049-12-R83	EA	TRIM - WATER HEATER COVER
8	141940-03-01A	EA	ROD - PADDLE LATCH
9	141940-01-01A	EA	LATCH - PADDLE - BLACK
	141940-02-01A	EA	LATCH - PADDLE - NON LOCKING - BLACK
10	141940-04-01A	EA	BRACKET - PADDLE LATCH
11	144172-01-01A	EA	COVER - LATCH - BRIGHT WHITE
12	138898-01-000	EA	ACTUATOR/LOCK - ELECTRIC
13	147513-02-01A	EA	BALL STUD
14	147513-01-01A	EA	BALL STUD
15	137228-05-02B	EA	HINGE - PIANO - COMPARTMENT DOOR - 27" - E-COATED
16	133049-09-R32	EA	TRIM - COVER - WATER HEATER

EXTERIOR DOORS & COMPARTMENTS GROUP (CONTINUED)
COMPARTMENT DOOR PIECE PARTS (CONTINUED)

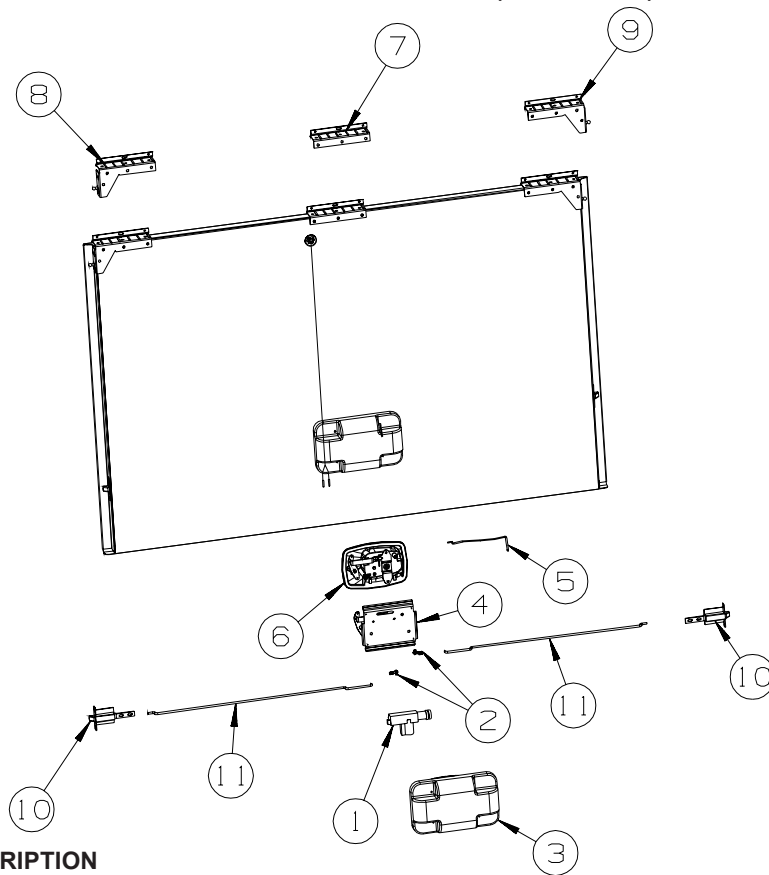

KEY	PART NUMBER	U/M	DESCRIPTION
1	138898-01-000	EA	ACTUATOR/LOCK - ELECTRIC
2	102265-03-000	EA	CLIP/ROD END - LEFT HAND - .18" - METAL
3	144172-01-01A	EA	COVER - LATCH - BRIGHT WHITE
4	141940-04-01A	EA	BRACKET - PADDLE LATCH
5	141940-03-01A	EA	ROD - PADDLE LATCH
6	141940-01-01A	EA	LATCH - PADDLE - BLACK
7	139793-03-01A	EA	HINGE - CENTER/VALANCE DOOR - W/O BALL STUD
8	139793-02-01A	EA	HINGE - LEFT HAND/VALANCE DOOR - W/BALL STUD
8	139793-05-01A	EA	HINGE - LEFT HAND/VALANCE DOOR - W/O BALL STUD
8	147513-02-01A	EA	BALL STUD - LEFT HAND
9	139793-01-01A	EA	HINGE - RIGHT HAND/VALANCE DOOR - W/BALL STUD
9	139793-04-01A	EA	HINGE - RIGHT HAND/VALANCE DOOR - W/O BALL STUD
9	147513-01-01A	EA	BALL STUD - RIGHT HAND
10	121947-01-01A	EA	BOLT - SLIDE/LATCH - W/PLASTIC PLUNGER
11	135624-71-01B	EA	ROD - LATCH (BLANK) - 37.3"

EXTERIOR DOORS & COMPARTMENTS GROUP (CONTINUED)
COMPARTMENT DOOR PIECE PARTS (CONTINUED)

S40TD

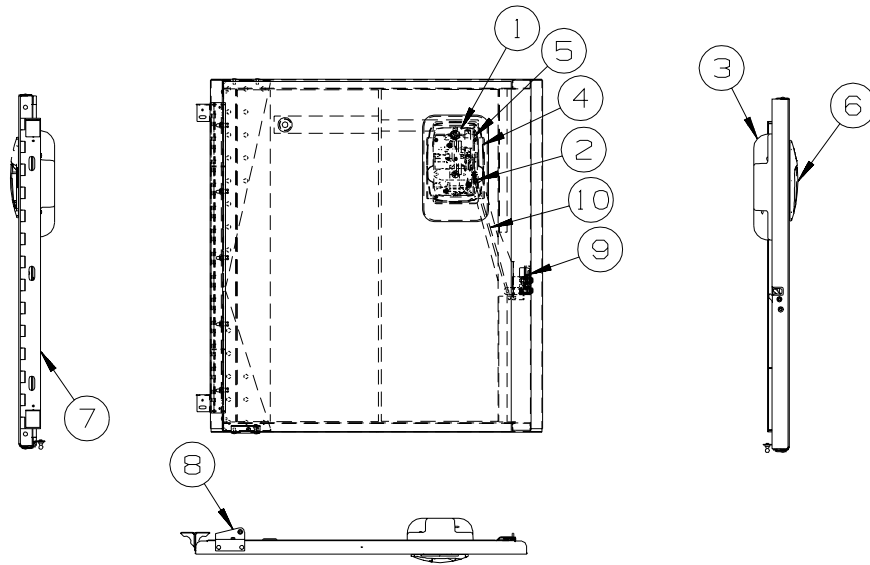

KEY	PART NUMBER	U/M	DESCRIPTION
1	138898-01-000	EA	ACTUATOR/LOCK - ELECTRIC
2	102265-03-000	EA	CLIP/ROD END - LEFT HAND - .18" - METAL
2	102265-02-000	EA	CLIP/ROD END - RIGHT HAND - .18" - METAL
3	144172-01-01A	EA	COVER - LATCH - BRIGHT WHITE
4	141940-04-01A	EA	BRACKET - PADDLE LATCH
4	141940-09-01A	EA	PLATE/MOUNTING - LEFT PADDLE LATCH
5	141940-03-01A	EA	ROD - PADDLE LATCH
5	141940-08-01A	EA	ROD - PADDLE LATCH/LEFT - POWER LOCK
6	141940-01-01A	EA	LATCH - PADDLE - BLACK
6	141940-06-01A	EA	LATCH - PADDLE/LH - LOCKING - BLACK15
7	137228-04-02B	EA	HINGE - PIANO - COMPARTMENT DOOR - 27" - E-COATED
7	137228-06-02B	EA	HINGE - PIANO - COMPARTMENT DOOR - 27" - E-COATED
8	126263-17-02B	EA	BRACKET - GAS SPRING W/BALL STUD - E-COATED
9	149359-01-01A	EA	LATCH - SINGLE ROTOR
9	149359-07-01A	EA	LATCH - SINGLE ROTOR - MINI/RIGHT HAND
9	149359-04-01A	EA	LATCH - SINGLE ROTOR - MINI/LEFT HAND
9	149359-08-01A	EA	LATCH - SINGLE ROTOR - MINI/LEFT HAND
10	132873-01-000	EA	ROD - LATCH (BLANK) - 37.3"

EXTERIOR DOORS & COMPARTMENTS GROUP (CONTINUED)
ENTRY

KEY	PART NUMBER	U/M	DESCRIPTION
	125724-01-000	EA	SHIM-DOOR,ENTRANCE
*	128913-15-06A	EA	DOOR - ENTRY/FRONT - POWER LOCK - BLACK
	112782-04-01A	EA	GASKET
	112782-20-01A	EA	LATCH - EXTERIOR - W/O LOCK CYLINDER W/ICON-REVERSIBLE KEY
	112782-21-01A	EA	LATCH - INTERIOR PLATE
	112782-22-01A	EA	LATCH - SINGLE ROTOR
	134450-02-01A	EA	TAPE - ANTI SLIP - 1.25" X 29.9" - BLACK
	138898-01-000	EA	ACTUATOR/LOCK - ELECTRIC

***COMPONENT PARTS LISTED LATER IN THIS GROUP**

EXTERIOR DOORS & COMPARTMENTS GROUP (CONTINUED)

COMPONENT PARTS FOR ENTRY

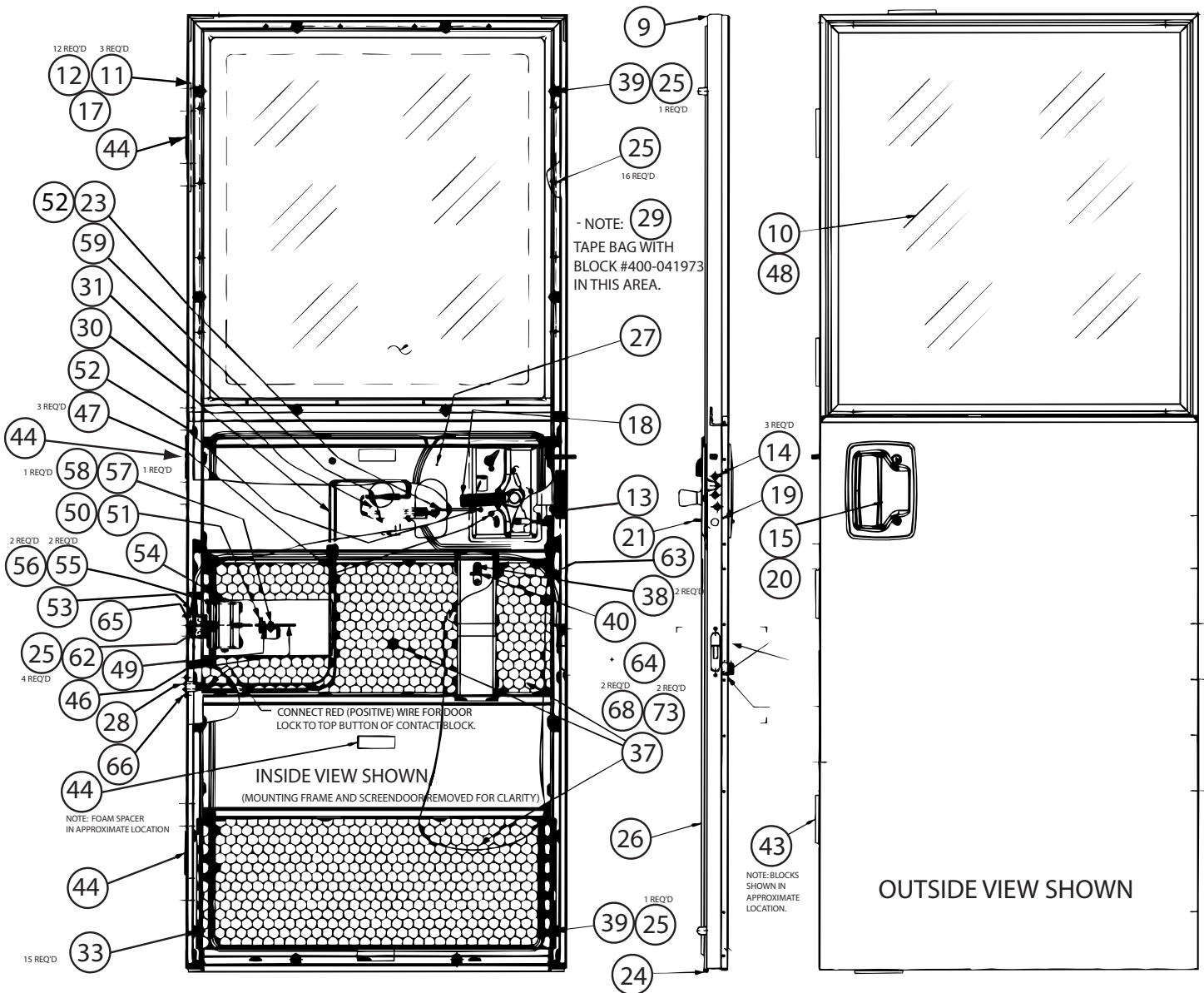

128913-15-06A

EXTERIOR DOORS & COMPARTMENTS GROUP (CONTINUED)
COMPONENT PARTS FOR ENTRY (CONTINUED)

128913-15-06A (CONTINUED)

KEY	PART NUMBER	U/M	DESCRIPTION	VENDOR NO.
9	128913-04-714	EA	RIVET - POP F/EXT DOOR PANEL	490219
10	128913-12-701	EA	WINDOW-DUAL PANE	490505
15	112782-20-01A	EA	LATCH ASM-EXT,W/O CYL,W/ICON	*T/M 20412-01
18	112782-21-01A	EA	LATCH ASM-INTERIOR PLATE	*T/M 18470-06
18	112782-22-01A	EA	LATCH-SINGLE ROTOR	*T/M 19007-01
19	128913-12-714	EA	COVER - BOLT HOLE - BLACK	292-042339
20	112782-04-01A	EA	GASKET	*T/M 81480
21	128913-04-717	EA	CAP - VINYL - RED	130-042257
23	128913-12-710	EA	ROD/LOCK - (POWER)	203-042371/17770-01
24	128913-01-744	EA	SEAL/BULB-STICK ON/THRESHOLD	122-042230
26	128913-15-711	EA	PANEL/INNER PLASTIC-BLACK	491099
27	128913-15-712	EA	BACKER PLATE - BLACK	490940
28	128913-01-714	EA	CONTACT - MALE/2-POSITION	400-041934
29	128913-01-713	EA	CONTACT - FEMALE/2-POSITION	400-041973
31	128913-15-702	EA	ACTUATOR - POWER LOCK	490932
40	128913-01-710	EA	STRIKER - LATCH/SCREEN DOOR	130-041815
44	128913-03-708	EA	SEAL/HINGE (3 PER DOOR	124-042236
47	128913-01-746	EA	SCREW #8 X 3/4" OVAL HEAD	276-042030
48	128913-04-700	FT	TAPE/BUTYL - FOAM CORE	154-041549
52	106469-05-700	EA	ROD CLIP	231-041095
54	128913-15-713	EA	DOOR CHECK KIT W/HOUSING	491109
62	128913-02-714	EA	GUIDE BLOCK - DOOR CHECK	146-042045
65	128913-04-709	EA	PIN/CLEVIS-GROOVED W/E-RING	245-042260
68	128913-01-748	FT	SEAL/BULB	132-042483
			CONTACT WINNEBAGO PARTS SALES FOR UNLISTED COMPONENT(S)	

EXTERIOR DOORS & COMPARTMENTS GROUP (CONTINUED)
COMPONENT PARTS FOR ENTRY (CONTINUED)

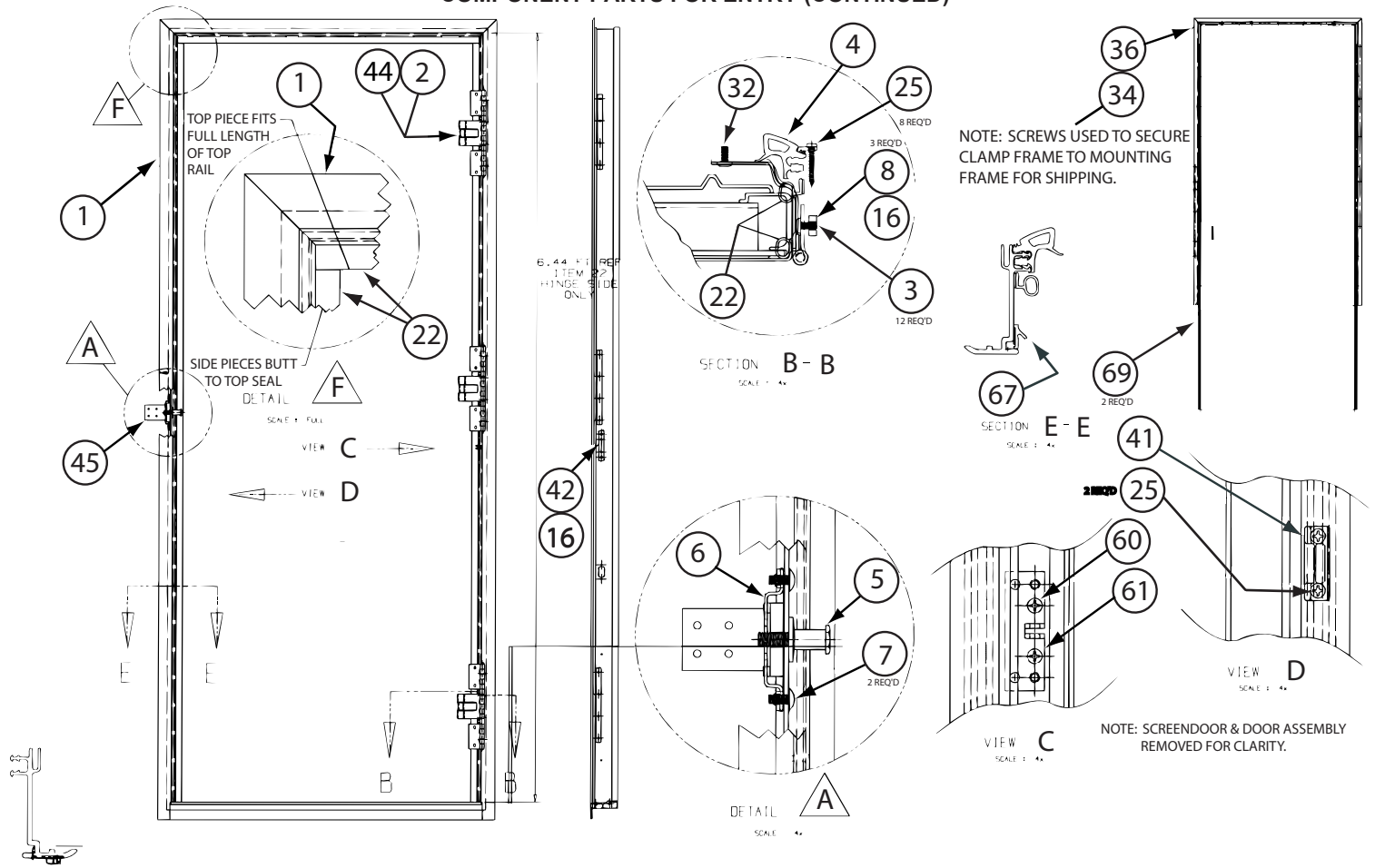

128913-15-06A (CONTINUED)

KEY	PART NUMBER	U/M	DESCRIPTION	VENDOR NO.
1	128913-15-703	EA	PANEL - OUTER DOOR - BLACK	490388
2	128913-12-703	EA	HINGE (TAKES 3)	490487
4	128913-01-728	EA	SEAL - DOOR/CORNER- MITERED	122-041917
5	128913-01-727	EA	STRIKER BOLT - SPEC COATING	490780—TM 11628-01
6	106469-04-704	EA	NUT ASSEMBLY-CAGED W/STRIKER	11920-16
22	128913-13-700	EA	BUMPER/RUBBER - ENTRY/SCREEN	490792
36	128913-15-705	EA	FRAME/CLAMP - WELD ASM BLACK	490811
41	128913-01-709	EA	TRIKER-SCREEN DR/FRAME MT	130-041824
44	128913-03-708	EA	SEAL/HINGE (3 PER DOOR)	124-042236
45	128913-15-706	EA	LATCH - BRACKET	490705
61	128913-01-704	EA	BRACKET - PIVOT/BRASS	370-042315
67	128913-01-732	EA	SEAL - LAZY T	122-041986

CONTACT WINNEBAGO PARTS SALES FOR UNLISTED COMPONENT(S)

EXTERIOR DOORS & COMPARTMENTS GROUP (CONTINUED)
COMPONENT PARTS FOR ENTRY (CONTINUED)

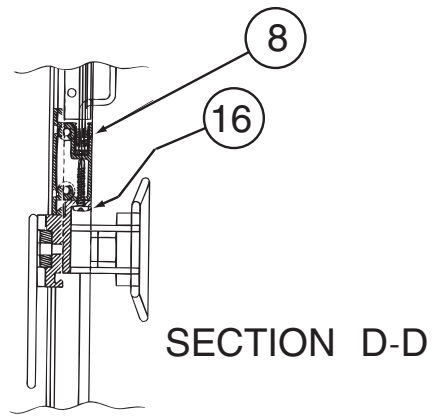
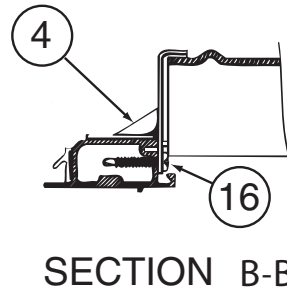
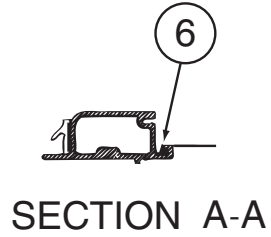
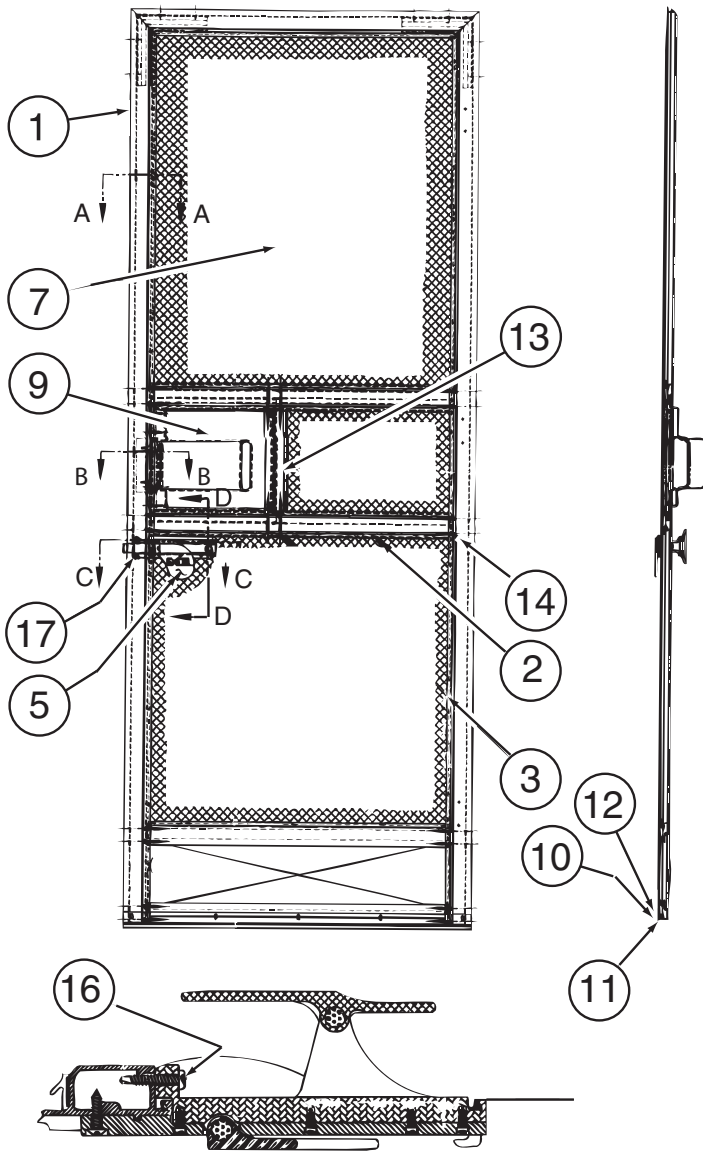

SECTION C-C

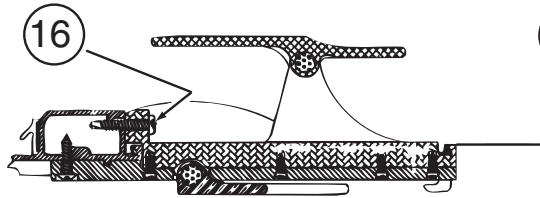

128913-10-01A/02A, 128913-11-01A, 128913-12-01A, 128913-13-01A/02A (CONTINUED)

KEY	PART NUMBER	U/M	DESCRIPTION	VENDOR NO.
2	128913-09-704	EA	RAIL/MID SCREEN-GLACIER BEIGE	490054
4	128913-09-703	EA	END CAP/SLIDER - GLACIER BEIGE	490061
5	128913-01-731	EA	LATCH - SCREEN DOOR	146-041950
6	128913-01-742	FT	SPLINE - SCREEN	132-041775
7	128913-01-741	EA	SCREEN ONLY - SCREENDOOR	110-041928
8	128913-01-740	FT	RUN CHANNEL-SCREEN DR SLIDER	170-041263
9	128913-09-702	EA	SLIDER/SCREENDOOR - GLACIER	490059
10	128913-09-701	EA	SWEEPER/SCREENDOOR- GLACIER	490052
11	128913-01-736	FT	WEATHERSTRIP-SCREEN DOOR	171-041284
13	128913-01-738	FT	WEATHERSTRIP - SLIDER	171-041285

CONTACT WINNEBAGO PARTS SALES FOR UNLISTED COMPONENT(S)

EXTERIOR SLIDEOUT GROUP LEFT FRONT

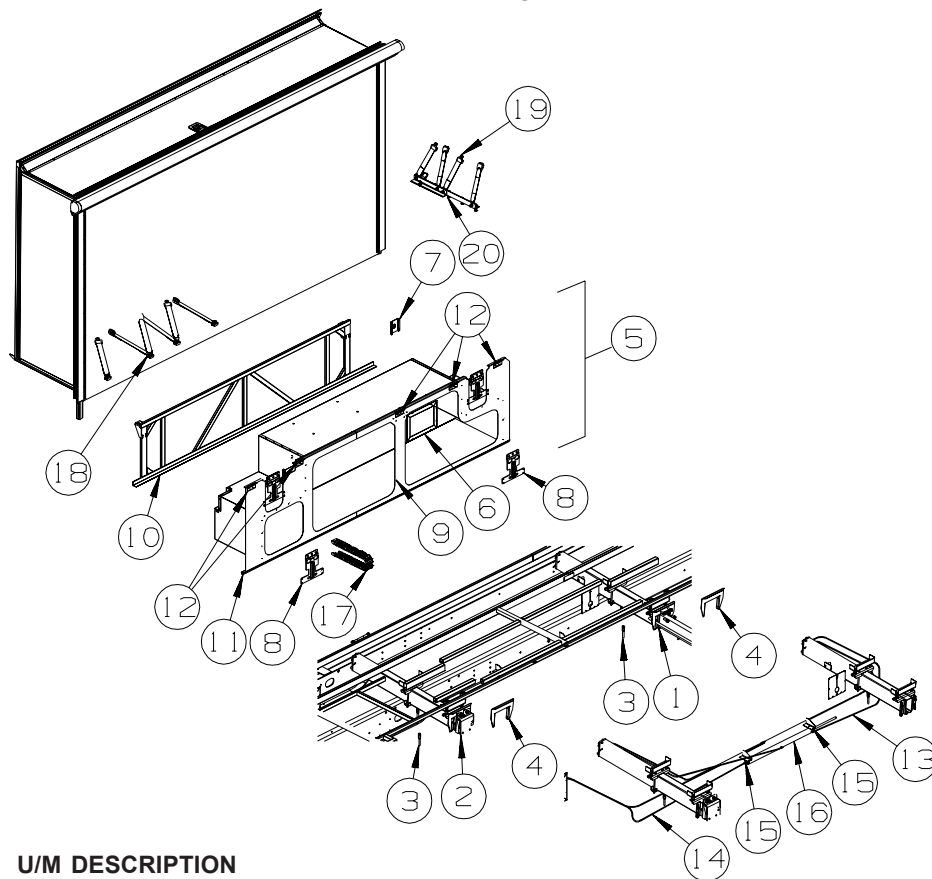

KEY	PART NUMBER	U/M	DESCRIPTION
1*	152553-01-000	EA	SLIDEOUT - ARM/HYDRAULIC - FLAT 29" - LEFT FROM: 00-00-00 THRU: 01-01-07
1	163494-02-000	EA	SLIDEOUT - ARM/HYDRAULIC - 29" - LEFT - NOT ILLUSTRATED FROM: 01-08-07 THRU: 99-99-99
	143738-01-000	EA	WRENCH - SLIDE ROOM RETRACT - RATCHET - 13/16" X 7/8"
2*	152553-02-000	EA	SLIDEOUT - ARM/HYDRAULIC - FLAT 29" - RIGHT FROM: 00-00-00 THRU: 01-07-07
2	163494-01-000	EA	SLIDEOUT - ARM/HYDRAULIC - 29" - RIGHT - NOT ILLUSTRATED FROM: 01-08-07 THRU: 99-99-99
	143738-01-000	EA	WRENCH - SLIDE ROOM RETRACT - RATCHET - 13/16" X 7/8"
3*	151323-02-000	EA	BOLT - HANGER/STOREMORE - LONG/4.5"X1/2" THREAD - AP31952
4	154254-01-02B	EA	BRACKET - ARM/SLIDEOUT - E-COATED
5	159311-01-UF1	EA	COMPARTMENT - SLIDEOUT/LEFT HAND
6	145973-01-R83	EA	DOOR/ACCESS - COMPARTMENT - 13.5" X 9.6"
7	154923-02-02B	EA	BRACKET - LP SWITCH - E-COATED
8	152741-03-02B	EA	BRACKET - MOUNT - SLIDEOUT - E-COATED
9	159310-02-02B	EA	SEAL PLANE - SLIDEOUT - E-COATED
10	155732-02-TD0	EA	SUPPORT - SLIDEOUT COMPARTMENT - LEFT HAND
11	126516-01-01A	FT	TRIM - VINYL/EXTRUDED - 8'
12	153821-01-01A	EA	BRACKET - MOUNT/SEAL PLANE - BLACK
13*	100536-68-000	EA	HOSE KIT - F/SLIDEOUT
14	155476-02-000	EA	HOSE KIT - SLIDEOUT
15	147732-01-02B	EA	BRACKET/CYLINDER SUPPORT - E-COATED
16*	152553-03-000	EA	HOSE KIT - SLIDEOUT/SYNCHRONIZING CYLINDER FROM: 00-00-00 THRU: 12-10-06
16	163102-03-000	EA	SLIDEOUT - HYDRAULIC - 29" - NOT ILLUSTRATED FROM: 12-11-06 THRU: 99-99-99
	163324-02-000	EA	BRACKETS/HARDWARE - 24"/29" RAM/SYNCH CYLINDER
17	143541-01-01A	EA	CARRIER/WIRING - F/SLIDE-OUT ROOM - 29 LINKS
18	160167-01-01A	EA	SEAT BELT - 2" X 102" - BLACK
19	160167-02-01A	EA	SEAT BELT - 2" X 90" - BLACK
20	151078-01-02B	EA	BRACKET - MOUNTING - SEATBELT - E-COATED

*COMPONENT PARTS LISTED LATER IN THIS GROUP

EXTERIOR SLIDEOUT GROUP (CONTINUED)
LEFT FRONT (CONTINUED)

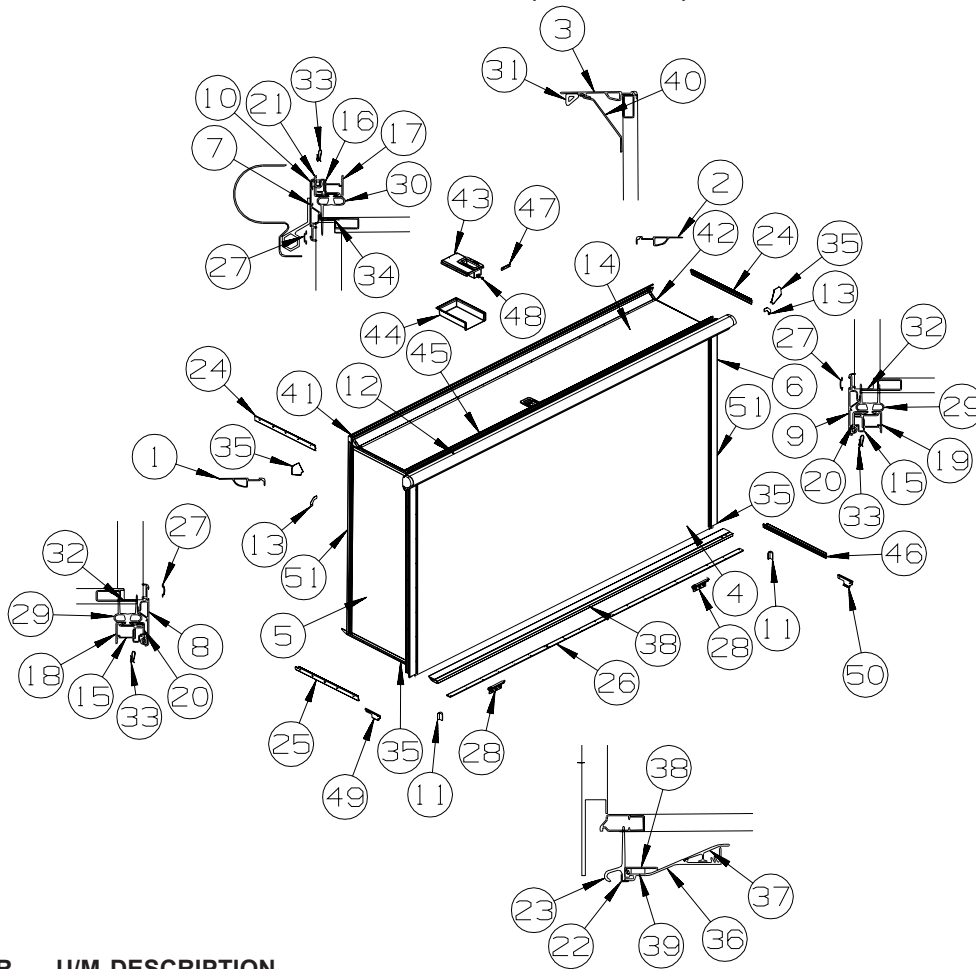

KEY	PART NUMBER	U/M	DESCRIPTION
1	139624-45-02A	EA	TRIM/SEAL - INNER - 77.8" - ALMOND
2	139624-44-02A	EA	TRIM/SEAL - INNER - 77.8" - ALMOND
3	153113-04-02A	EA	TRIM/SEAL - SLIDEOUT - 149.6" - ALMOND
4	155580-11-UJ1	EA	SLUG - F/SLIDEOUT
4	155580-11-UJ2	EA	SLUG - F/SLIDEOUT
4	155580-11-UJ3	EA	SLUG - F/SLIDEOUT
4	155580-11-UJ5	EA	SLUG - F/SLIDEOUT
4	155580-11-UJ6	EA	SLUG - F/SLIDEOUT
4	155580-11-UJ7	EA	SLUG - F/SLIDEOUT
4	155580-11-UK1	EA	SLUG - F/SLIDEOUT
4	155580-11-UK2	EA	SLUG - F/SLIDEOUT
4	155580-11-UK3	EA	SLUG - F/SLIDEOUT
5	153461-08-UJ1	EA	PANEL END - F/SLIDEOUT (UJ1, UJ2, UJ3)
5	153461-08-UJ5	EA	PANEL END - F/SLIDEOUT (UJ5, UJ6, UJ7)
5	153461-08-UK1	EA	PANEL END - F/SLIDEOUT (UK1, UK2, UK3)
6	153667-06-UJ1	EA	PANEL END - F/SLIDEOUT
6	153667-06-UJ2	EA	PANEL END - F/SLIDEOUT
6	153667-06-UJ3	EA	PANEL END - F/SLIDEOUT
6	153667-06-UJ5	EA	PANEL END - F/SLIDEOUT
6	153667-06-UJ6	EA	PANEL END - F/SLIDEOUT
6	153667-06-UJ7	EA	PANEL END - F/SLIDEOUT
6	153667-06-UK1	EA	PANEL END - F/SLIDEOUT
6	153667-06-UK2	EA	PANEL END - F/SLIDEOUT
6	153667-06-UK3	EA	PANEL END - F/SLIDEOUT

EXTERIOR SLIDEOUT GROUP (CONTINUED)
LEFT FRONT (CONTINUED)

KEY	PART NUMBER	U/M	DESCRIPTION
6	153667-07-UJ1	EA	PANEL END - F/SLIDEOUT - DINETTE OR COMPUTER TABLE & CHAIRS
6	153667-07-UJ2	EA	PANEL END - F/SLIDEOUT - DINETTE OR COMPUTER TABLE & CHAIRS
6	153667-07-UJ3	EA	PANEL END - F/SLIDEOUT - DINETTE OR COMPUTER TABLE & CHAIRS
6	153667-07-UJ5	EA	PANEL END - F/SLIDEOUT - DINETTE OR COMPUTER TABLE & CHAIRS
6	153667-07-UJ6	EA	PANEL END - F/SLIDEOUT - DINETTE OR COMPUTER TABLE & CHAIRS
6	153667-07-UJ7	EA	PANEL END - F/SLIDEOUT - DINETTE OR COMPUTER TABLE & CHAIRS
6	153667-07-UK1	EA	PANEL END - F/SLIDEOUT - DINETTE OR COMPUTER TABLE & CHAIRS
6	153667-07-UK2	EA	PANEL END - F/SLIDEOUT - DINETTE OR COMPUTER TABLE & CHAIRS
6	153667-07-UK3	EA	PANEL END - F/SLIDEOUT - DINETTE OR COMPUTER TABLE & CHAIRS
7	156417-13-02A	EA	TRIM/SEAL - W/MITERED ENDS - 147.9" - BLACK
8	156417-28-02A	EA	TRIM/SEAL - W/MITERED ENDS - 80.4" - BLACK
9	156417-29-02A	EA	TRIM/SEAL - W/MITERED ENDS - 80.4" - BLACK
10	158297-01-000	FT	SEAL - D-SECTION/BULB/TEE - ADHESIVE BACK - BLACK
11	156480-01-01A	EA	SEAL/BLOCK - SLIDEOUT - 2.6"W X 1.6"H X 1.6"D - BLACK
12			SLIDEOUT AWNING

ORDER AWNINGS & REPAIR PARTS FROM DOMETIC. CALL #800-366-3842.

THE DOMETIC AWNING INFORMATION YOU WILL NEED IS LOCATED ON THE MOTOR HOME NEAR THE TOP OF THE AWNING RAIL.

13	156416-01-02B	EA	TRIM/KEY CORNER - SLIDEOUT - 3.1" X 3.1" - E-COATED
14	155597-01-UJ1	EA	ROOF - F/SLIDEOUT
15	142718-38-01A	EA	RETAINER - SIDEWALL/SLIDEOUT - 79"
16	142718-18-01A	EA	RETAINER - SIDEWALL/SLIDEOUT - 149"
17	151761-08-02A	EA	TRIM - SIDEWALL/SLIDEOUT/TOP - 150.8" - ALMOND
18	151760-10-02A	EA	TRIM - SIDEWALL/SLIDEOUT - 80.6" - ALMOND
19	151760-11-02A	EA	TRIM - SIDEWALL/SLIDEOUT - 80.6" - ALMOND
20	136824-49-02A	EA	TRIM - SIDEWALL/SLIDEOUT - 80.9" - BLACK
21	136824-25-02A	EA	TRIM - SIDEWALL/SLIDEOUT - 150.9" - BLACK
22	153109-03-01A	EA	ANGLE/RETAINER - SEAL - .5" X .5" X 146.6" - MILL
23	152446-01-000	FT	SEAL - SLIDEOUT/FLOOR
24	158375-01-02A	EA	TRIM - FEATURE STRIP - 29.6" - BLACK
25	158349-03-02A	EA	TRIM - FEATURE - LOWER - 31.8" - BLACK
26	152641-01-000	EA	SKID/GLIDE - SLIDEOUT ROOM - 1/4"X2"X95.5"- POLYETHYLENE
27	105312-01-13A	FT	INSERT - FEATURE STRIP - VINYL - BLACK
28	153104-01-01A	EA	BRACKET/MOUNT - 1.7" X 3.2" X 5.9"
29	153161-01-01A	FT	SEAL - SLIDEOUT - DOUBLE WIPE LIP - BLACK
30	136978-02-01A	FT	SEAL - SLIDEOUT/TOP - SINGLE WIPE LIP - BLACK
31	146056-01-000	FT	SEAL - TRIANGLE - W/PSA
32	133954-66-02A	EA	TRIM/SEAL - 75.8" - BLACK
			FROM: 00-00-00 THRU: 04-09-06
32	146606-66-02A	EA	TRIM/RETAINER - 75.8" - BLACK
			FROM: 04-10-06 THRU: 99-99-99
33	142549-01-000	EA	CLIP - "S" TYPE
34	133954-36-02A	EA	TRIM/SEAL - 145.6" - BLACK
			FROM: 00-00-00 THRU: 04-09-06
34	146606-36-02A	EA	TRIM/RETAINER - 145.6" - BLACK
			FROM: 04-10-06 THRU: 99-99-99
35	156151-01-01A	EA	PROTECTOR - CORNER - SLIDEOUT - BLACK
36	152602-03-01A	EA	RAMP - SLIDEOUT - FLOOR/COACH - 147" - MILL
37	153106-03-01A	EA	COVER - RAMP/FLOOR - VINYL/CARPET - 3.2" X 147" - BRT WHT
38	153108-03-01A	EA	SPACER - RAMP - SLIDEOUT FLOOR - 146.2" - MILL
39	156475-01-000	EA	FILTER/FOAM - DRAIN HOLE COVER/SEAL - 60PPI - 1/4"X1"X3"
40	153114-04-02A	EA	TRIM/RETAINER - 145.4" - BLACK
41	153115-01-01A	EA	COVER - TRIM - SLIDEOUT - INNER/TOP/RH - BLACK
42	153115-02-01A	EA	COVER - TRIM - SLIDEOUT - INNER/TOP/LH - BLACK
43*	153651-02-01A	EA	LOCK/LATCH - TRAVEL/SLIDEOUT - W/MOTOR - LEFT HAND - BLACK - NOT ILLUSTRATED
			FROM: 00-00-00 THRU: 09-25-06
43*	153651-04-01A	EA	LOCK/LATCH - TRAVEL/SLIDEOUT - W/MOTOR - LEFT HAND - BLACK
			FROM: 09-26-06 THRU: 99-99-99
44	155194-01-01A	EA	COVER - LATCH/TRAVEL - PLASTIC - BLACK
45	156015-01-01A	EA	TAPE/PROTECTION - .06" X 1.25" X 3.5" - W/PSA - NATURAL WHT
46	158349-04-02A	EA	TRIM - FEATURE - LOWER - 31.8" - BLACK

EXTERIOR SLIDEOUT GROUP (CONTINUED)
LEFT FRONT (CONTINUED)

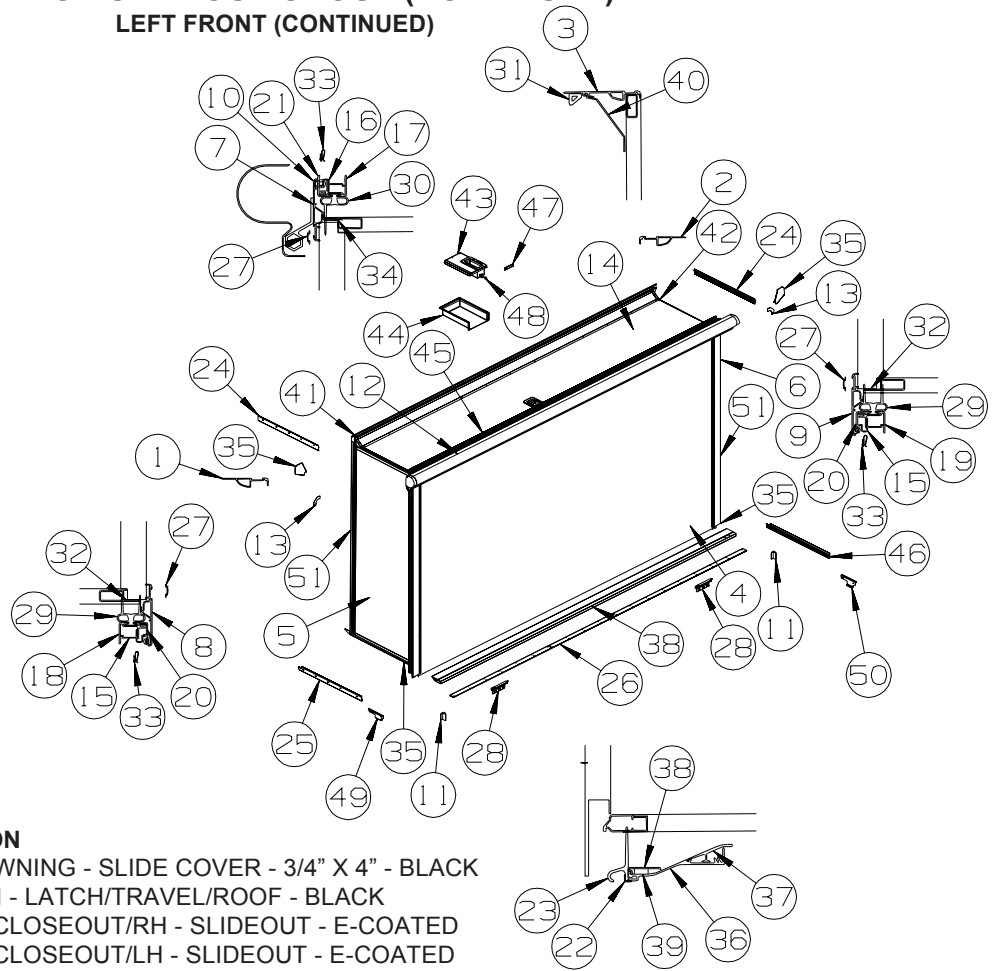

KEY	PART NUMBER	U/M	DESCRIPTION
	47	EA	SPACER - AWNING - SLIDE COVER - 3/4" X 4" - BLACK
	48	EA	TUBE/DRAIN - LATCH/TRAVEL/ROOF - BLACK
	49	EA	BRACKET - CLOSEOUT/RH - SLIDEOUT - E-COATED
	50	EA	BRACKET - CLOSEOUT/LH - SLIDEOUT - E-COATED
	51	FT	FILM - 3.1" - FLAT BLACK

*COMPONENT PARTS LISTED LATER IN THIS GROUP

COMPONENT PARTS FOR LEFT FRONT

100536-52-000

KEY	PART NUMBER	U/M	DESCRIPTION	VENDOR NO.
	100536-52-700	EA	HOSE-HYDRAULIC - 1/4" X 207"	RAP90119/AP11212
	100536-52-701	EA	HOSE-HYDRAULIC 1/4" X 228"	AP5924

151323-01-000 , 151323-02-000, 151323-03-000

KEY	PART NUMBER	U/M	DESCRIPTION	VENDOR NO.
	151323-01-700	EA	BOLT KIT - STORE-MORE	RAP91641

152553-01-000, 152553-02-000

KEY	PART NUMBER	U/M	DESCRIPTION	VENDOR NO.
	152553-01-700	EA	RAM/CYLINDER - SLIDEOUT ROOM	RAP91755
	145494-02-705	EA	KIT - ROOM RETRACTING	RAP91357

152553-01-000, 152553-02-000

KEY	PART NUMBER	U/M	DESCRIPTION	VENDOR NO.
	152553-01-700	EA	RAM/CYLINDER - SLIDEOUT ROOM	RAP91755
	145494-02-705	EA	KIT - ROOM RETRACTING	RAP91357

153651-02-01A

KEY	PART NUMBER	U/M	DESCRIPTION	VENDOR NO.
	153651-01-701	EA	LIMIT - SWITCH	1812996
	153651-01-702	EA	COVER/BOOT - SEAL	1612011
	153651-02-700	EA	MOTOR/LH - F/TRAVEL LOCK	1820131
	153651-02-701	EA	BRACKET/MOUNTING - MOTOR	1102223

153651-04-01A

KEY	PART NUMBER	U/M	DESCRIPTION	VENDOR NO.
	153651-02-700	EA	MOTOR/LH - F/TRAVEL LOCK	1820131

EXTERIOR SLIDEOUT GROUP (CONTINUED)

RIGHT FRONT

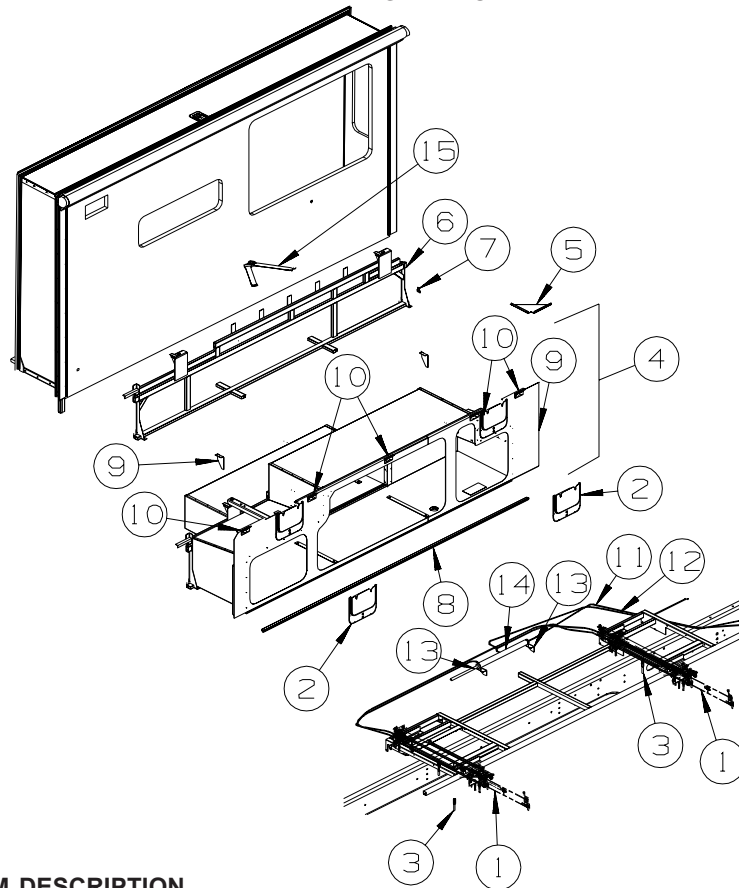

KEY	PART NUMBER	U/M	DESCRIPTION
1*	152710-02-000	EA	SLIDEOUT - ARM/HYDRAULIC - 20" - RIGHT
	143738-01-000	EA	WRENCH - SLIDE ROOM RETRACT - RATCHET - 13/16" X 7/8"
2	151826-02-01A	EA	COVER - SLIDE - BLACK
3*	151323-02-000	EA	BOLT - HANGER/STOREMORE - LONG/4.5"X1/2" THREAD - AP31952
4	159222-01-UF1	EA	COMPARTMENT - SLIDEOUT/RIGHT HAND
5	123440-12-02B	EA	SUPPORT - PANEL - 9.9"/8.3" X 5.7" - SLIDEOUT - E-COATED
6	149601-02-TD0	EA	SUPPORT - SLIDEOUT COMPARTMENT - FRONT/RIGHT HAND
7	152024-01-02B	EA	ANGLE/FORMED - W/HOLES - E-COATED
8	126516-01-01A	FT	TRIM - VINYL/EXTRUDED - 8'
9	159221-01-02B	EA	SEAL PLANE - SLIDEOUT/RIGHT HAND - E-COATED
10	153821-01-01A	EA	BRACKET - MOUNT/SEAL PLANE - BLACK
11*	100536-42-000	EA	HOSE KIT - PUMP TO SLIDE-OUT VALVE
12	155476-02-000	EA	HOSE KIT - SLIDEOUT
13	147732-01-02B	EA	BRACKET/CYLINDER SUPPORT - E-COATED
14*	155325-03-000	EA	SLIDEOUT KIT - MOUNTING HARDWARE/SYNCH CYLINDER/NO HOSES FROM: 00-00-00 THRU: 12-10-06
		EA	SLIDEOUT - HYDRAULIC - 20" - NOT ILLUSTRATED FROM: 12-11-06 THRU: 99-99-99
	166324-01-000	EA	BRACKETS/HARDWARE - 20" RAM/SYNCH CYLINDER
15	160167-01-01A	EA	SEAT BELT - 2" X 102" - BLACK

*COMPONENT PARTS LISTED LATER IN THIS GROUP

EXTERIOR SLIDEOUT GROUP (CONTINUED)
RIGHT FRONT (CONTINUED)

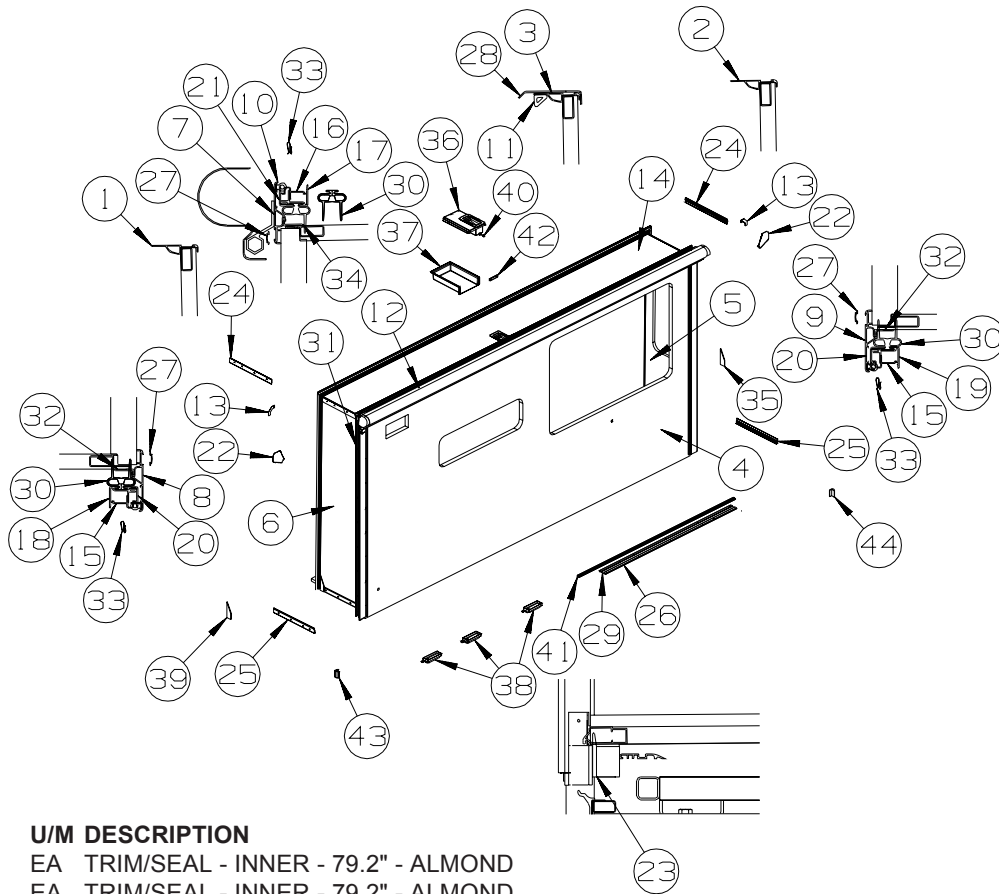

KEY	PART NUMBER	U/M	DESCRIPTION
1	139624-47-02A	EA	TRIM/SEAL - INNER - 79.2" - ALMOND
2	139624-46-02A	EA	TRIM/SEAL - INNER - 79.2" - ALMOND
3	139624-43-02A	EA	TRIM/SEAL - INNER - 164.2" - ALMOND
4	155579-11-UJ1	EA	SLUG - F/SLIDEOUT (UJ1, UJ2, UJ3)
4	155579-11-UJ5	EA	SLUG - F/SLIDEOUT (UJ5, UJ6, UJ7)
4	155579-11-UK1	EA	SLUG - F/SLIDEOUT (UK1, UK2, UK3)
5	152728-01-UJ1	EA	PANEL END - F/SLIDEOUT (UJ1, UJ2, UJ3)
5	152728-01-UJ5	EA	PANEL END - F/SLIDEOUT (UJ5, UJ6, UJ7)
5	152728-01-UK1	EA	PANEL END - F/SLIDEOUT (UK1, UK2, UK3)
6	152727-01-UJ1	EA	PANEL END - F/SLIDEOUT (UJ1, UJ2, UJ3)
6	152727-01-UJ5	EA	PANEL END - F/SLIDEOUT (UJ5, UJ6, UJ7)
6	152727-01-UK1	EA	PANEL END - F/SLIDEOUT (UK1, UK2, UK3)
7	156417-15-02A	EA	TRIM/SEAL - W/MITERED ENDS - 162.4" - BLACK
8	156417-28-02A	EA	TRIM/SEAL - W/MITERED ENDS - 80.4" - BLACK
9	156417-29-02A	EA	TRIM/SEAL - W/MITERED ENDS - 80.4" - BLACK
10	158297-01-000	FT	SEAL - D-SECTION/BULB/TEE - ADHESIVE BACK - BLACK
11	146056-01-000	FT	SEAL - TRIANGLE - W/PSA
12			SLIDEOUT AWNING

ORDER AWNINGS & REPAIR PARTS FROM DOMETIC. CALL #800-366-3842.

THE DOMETIC AWNING INFORMATION YOU WILL NEED IS LOCATED ON THE MOTOR HOME NEAR THE TOP OF THE AWNING RAIL.

13	156416-01-02B	EA	TRIM/KEY CORNER - SLIDEOUT - 3.1" X 3.1" - E-COATED
14	153233-02-UJ1	EA	ROOF - F/SLIDEOUT
15	142718-38-01A	EA	RETAINER - SIDEWALL/SLIDEOUT - 79"
16	142718-25-01A	EA	RETAINER - SIDEWALL/SLIDEOUT - 163.1"
17	151761-09-02A	EA	TRIM - SIDEWALL/SLIDEOUT/TOP - 165.5" - ALMOND
18	151760-10-02A	EA	TRIM - SIDEWALL/SLIDEOUT - 80.6" - ALMOND
19	151760-11-02A	EA	TRIM - SIDEWALL/SLIDEOUT - 80.6" - ALMOND
20	136824-55-02A	EA	TRIM - SIDEWALL/SLIDEOUT - 80.6" - BLACK
21	136824-28-02A	EA	TRIM - SIDEWALL/SLIDEOUT - 167.6" - BLACK
22	156151-01-01A	EA	PROTECTOR - CORNER - SLIDEOUT - BLACK
23	115075-03-000	FT	SEAL - WIPE - .25" X 2.9"
24	158375-03-02A	EA	TRIM/FEATURE STRIP - 20.6" - BLACK
25	157385-03-02A	EA	TRIM - FEATURE STRIP/LOWER - 17.8" - BLACK

**EXTERIOR SLIDEOUT GROUP (CONTINUED)
RIGHT FRONT (CONTINUED)**

KEY	PART NUMBER	U/M	DESCRIPTION	
26	115325-03-02A	EA	RAIL - FLOOR/SLIDEOUT ROOM - 64.5" LONG - BLACK	
27	105312-01-13A	FT	INSERT - FEATURE STRIP - VINYL - BLACK	
28	125466-11-04A	EA	SUPPORT - ROOF/INTERIOR - ALMOND	
29	115661-01-000	FT	SHOE/GLIDE - SLIDEOUT ROOM - 1/16" X 3" - POLYETHYLENE	
30	153161-01-01A	FT	SEAL - SLIDEOUT - DOUBLE WIPE LIP - BLACK	
31	156015-01-01A	EA	TAPE/PROTECTION - .06" X 1.25" X 3.5" - W/PSA - NATURAL WHT	
32	133954-66-02A	EA	TRIM/SEAL - 75.8" - BLACK	
				FROM: 00-00-00 THRU: 04-09-06
32	146606-66-02A	EA	TRIM/RETAINER - 75.8" - BLACK	
				FROM: 04-10-06 THRU: 99-99-99
33	142549-01-000	EA	CLIP - "S" TYPE	
34	133954-38-02A	EA	TRIM/SEAL - 160.4" - BLACK	
				FROM: 00-00-00 THRU: 04-09-06
34	146606-38-02A	EA	TRIM/RETAINER - 160" - BLACK	
				FROM: 04-10-06 THRU: 99-99-99
35	157809-01-01A	EA	SEAL - FOAM BLOCK/RIGHT SIDE - ADHESIVE BACK	
				FROM: 01-03-06 THRU: 99-99-99
36*	153651-02-01A	EA	LOCK/LATCH - TRAVEL/SLIDEOUT - W/MOTOR - LEFT HAND - BLACK - NOT ILLUSTRATED	
				FROM: 00-00-00 THRU: 09-25-06
36*	153651-04-01A	EA	LOCK/LATCH - TRAVEL/SLIDEOUT - W/MOTOR - LEFT HAND - BLACK	
				FROM: 09-26-06 THRU: 99-99-99
37	155194-01-01A	EA	COVER - LATCH/TRAVEL - PLASTIC - BLACK	
38	153088-03-01A	EA	ROLLER ASM - CERAMIC, DELRIN	
39	157809-02-01A	EA	SEAL - FOAM BLOCK/LEFT SIDE - ADHESIVE BACK	
40	155262-01-01A	EA	TUBE/DRAIN - LATCH/TRAVEL/ROOF - BLACK	
41	151282-02-01A	EA	TRIM - CARPET EDGE/F-ANGLE - 76.8" - BLACK	
42	150962-01-02A	EA	SPACER - AWNING - SLIDE COVER - 3/4" X 4" - BLACK	
*COMPONENT PARTS LISTED LATER IN THIS GROUP				

COMPONENT PARTS FOR RIGHT FRONT

100536-42-000

KEY	PART NUMBER	U/M	DESCRIPTION	VENDOR NO.
	100536-42-700	EA	HOSE/HYDRAULIC - 1/4" X 180"	RAP90120/AP5965
	100536-42-701	EA	HOSE/HYDRAULIC - 1/4" X 175"	RAP90350/AP7358

151323-01-000 , 151323-02-000, 151323-03-000

KEY	PART NUMBER	U/M	DESCRIPTION	VENDOR NO.
	151323-01-700	EA	BOLT KIT - STORE-MORE	RAP91641

152710-01-000, 152710-02-000

KEY	PART NUMBER	U/M	DESCRIPTION	VENDOR NO.
	125687-01-700	EA	CYLINDER/RAM - 21" STROKE	RAP90512/AP15190

153651-02-01A

KEY	PART NUMBER	U/M	DESCRIPTION	VENDOR NO.
	153651-01-701	EA	LIMIT - SWITCH	1812996
	153651-01-702	EA	COVER/BOOT - SEAL	1612011
	153651-02-700	EA	MOTOR/LH - F/TRAVEL LOCK	1820131
	153651-02-701	EA	BRACKET/MOUNTING - MOTOR	1102223

153651-04-01A

KEY	PART NUMBER	U/M	DESCRIPTION	VENDOR NO.
	153651-02-700	EA	MOTOR/LH - F/TRAVEL LOCK	1820131

155325-03-000

KEY	PART NUMBER	U/M	DESCRIPTION	VENDOR NO.
	125687-01-702	EA	CYLINDER - SYNCHRONIZING	RAP90471/AP13607

EXTERIOR SLIDEOUT GROUP (CONTINUED)

LEFT REAR

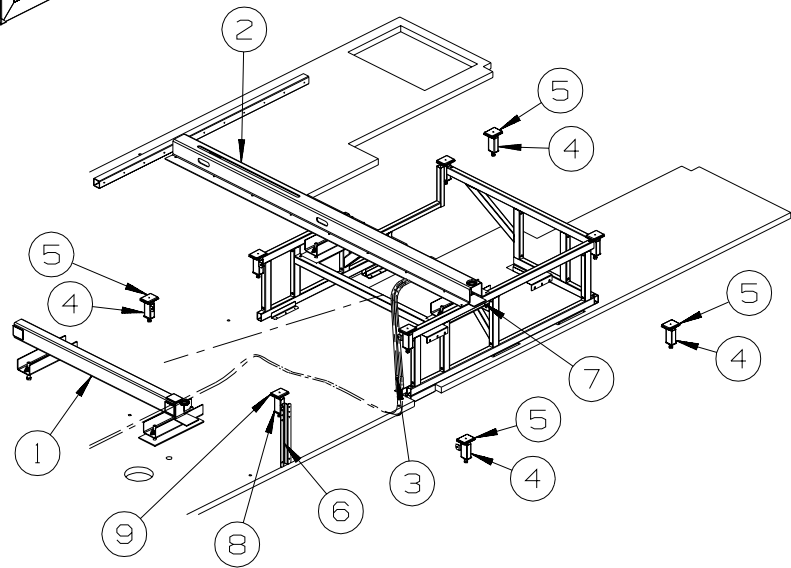
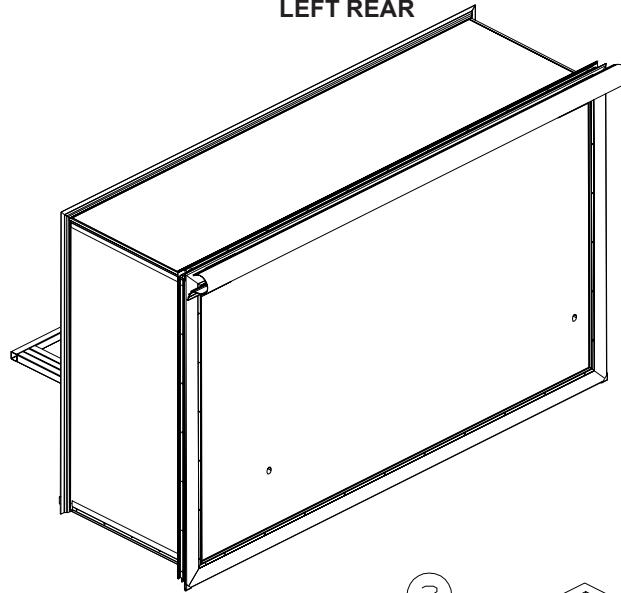

KEY	PART NUMBER	U/M	DESCRIPTION
1*	137390-01-000	EA	HYDRAULIC/BED - F/SLIDEOUT
2	137390-02-000	EA	CHANNEL - HYDRAULIC - F/SLIDEOUT
3*	100536-51-000	EA	HOSE KIT - F/SLIDEOUT
4	126313-11-02B	EA	SUPPORT - ROLLER - SLIDE-OUT ROOM - E-COATED
5	128599-03-000	EA	PAD - F/SLIDEOUT - 2" X 2.6"
6	140484-03-02B	EA	ADJUSTMENT - F/SLIDEOUT - E-COATED
7	142889-01-02B	EA	ANGLE/SUPPORT - SIDEWALL - E-COATED
8	126313-15-02B	EA	SUPPORT - SLIDE - F/SLIDE-OUT ROOM - E-COATED
9	134855-01-000	EA	BEARING PAD - NARROW

*COMPONENT PARTS LISTED LATER IN THIS GROUP

EXTERIOR SLIDEOUT GROUP (CONTINUED)
LEFT REAR (CONTINUED)

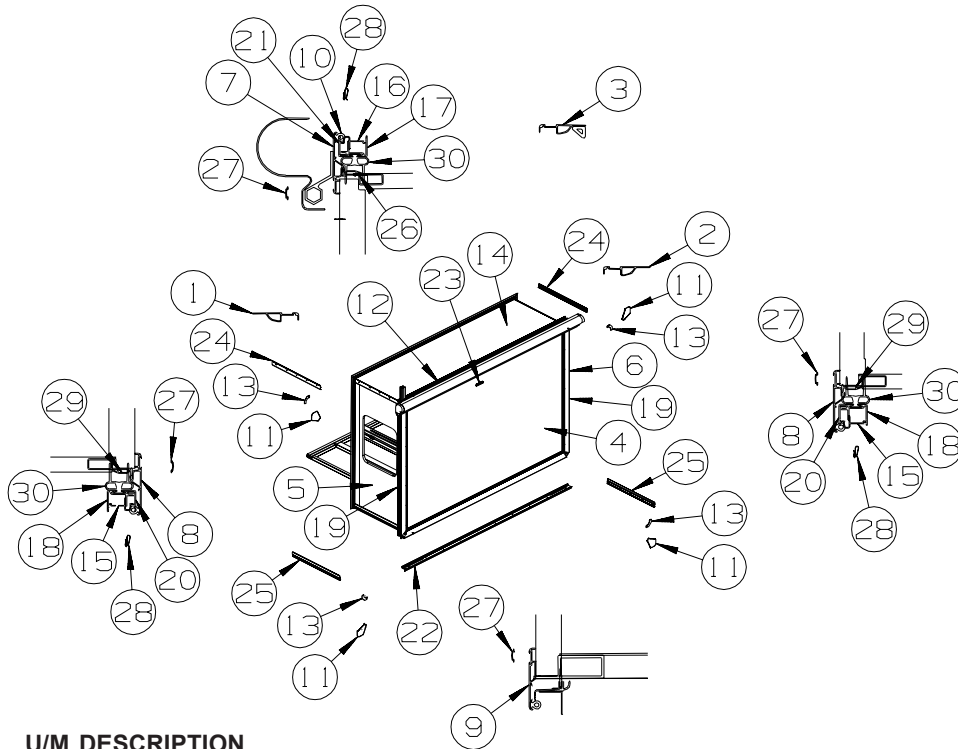

KEY	PART NUMBER	U/M	DESCRIPTION
1	139624-37-02A	EA	TRIM/SEAL - INNER - 66.9" - ALMOND
2	139624-38-02A	EA	TRIM/SEAL - INNER - 66.9" - ALMOND
3	139624-22-02A	EA	TRIM/SEAL - INNER/TOP - 101.8" - ALMOND
4	155580-12-UJ1	EA	SLUG - F/SLIDEOUT (UJ1, UJ2, UJ3)
4	155580-12-UJ5	EA	SLUG - F/SLIDEOUT (UJ5, UJ6, UJ7)
4	155580-12-UK1	EA	SLUG - F/SLIDEOUT (UK1, UK2, UK3)
5	153448-03-UJ1	EA	PANEL END - F/SLIDEOUT (UJ1, UJ2, UJ3)
5	153448-03-UJ5	EA	PANEL END - F/SLIDEOUT (UJ5, UJ6, UJ7)
5	153448-03-TH0	EA	PANEL END - F/SLIDEOUT (UK1, UK2, UK3)
5	153448-02-UJ1	EA	PANEL END - F/SLIDEOUT (UJ1, UJ2, UJ3) - SLEEP NUMBER BED KING
5	153448-02-UJ5	EA	PANEL END - F/SLIDEOUT (UJ5, UJ6, UJ7) - SLEEP NUMBER BED KING
5	153448-02-TH0	EA	PANEL END - F/SLIDEOUT (UK1, UK2, UK3) - SLEEP NUMBER BED KING
6	153447-01-TG0	EA	PANEL END - F/SLIDEOUT (UJ1, UJ2, UJ3)
6	153447-01-UJ5	EA	PANEL END - F/SLIDEOUT (UJ5, UJ6, UJ7)
6	153447-01-TH0	EA	PANEL END - F/SLIDEOUT (UK1, UK2, UK3)
7	156417-12-02A	EA	TRIM/SEAL - W/MITERED ENDS - 100.1" - BLACK
8	156417-27-02A	EA	TRIM/SEAL - W/MITERED ENDS - 66.2" - BLACK
9	142233-21-02A	EA	TRIM/SEAL - W/MITERED ENDS - 100.1" - BLACK
10	158297-01-000	FT	SEAL - D-SECTION/BULB/TEE - ADHESIVE BACK - BLACK
11	156151-01-01A	EA	PROTECTOR - CORNER - SLIDEOUT - BLACK
12			SLIDEOUT AWNING

ORDER AWNINGS & REPAIR PARTS FROM DOMETIC. CALL #800-366-3842.

THE DOMETIC AWNING INFORMATION YOU WILL NEED IS LOCATED ON THE MOTOR HOME NEAR THE TOP OF THE AWNING RAIL.

13	156416-01-02B	EA	TRIM/KEY CORNER - SLIDEOUT - 3.1" X 3.1" - E-COATED
14	141914-05-UJ1	EA	ROOF - F/SLIDEOUT
15	142718-40-01A	EA	RETAINER - SIDEWALL/SLIDEOUT - 66.4"
16	142718-17-01A	EA	RETAINER - SIDEWALL/SLIDEOUT - 100.2"
17	151761-07-02A	EA	TRIM - SIDEWALL/SLIDEOUT/TOP - 102.8" - ALMOND
18	151760-13-02A	EA	TRIM - SIDEWALL/SLIDEOUT - 66.4" - ALMOND
19	093681-39-01A	FT	FILM - 3.1" - FLAT BLACK
20	136824-34-02A	EA	TRIM - SIDEWALL/SLIDEOUT - 66.5" - BLACK
21	136824-23-02A	EA	TRIM - SIDEWALL/SLIDEOUT - 102.8" - BLACK
22	157584-04-AA1	EA	TRIM/ZEE - W/SEAL/END CAPS - SLIDEOUT/LOWER-102.4"-BLACK
23	150962-01-02A	EA	SPACER - AWNING - SLIDE COVER - 3/4" X 4" - BLACK
24	158375-01-02A	EA	TRIM - FEATURE STRIP - 29.6" - BRIGHT WHITE
25	158030-02-02A	EA	TRIM - FEATURE STRIP/LOWER - 2.3" X 29.1" - BLACK

EXTERIOR SLIDEOUT GROUP (CONTINUED)
LEFT REAR (CONTINUED)

KEY	PART NUMBER	U/M	DESCRIPTION	
26	133954-44-02A	EA	TRIM/SEAL - 96.8" - BLACK	FROM: 00-00-00 THRU: 04-09-06
26	146606-44-02A	EA	TRIM/RETAINER - 96.8" - BLACK	FROM: 04-10-06 THRU: 99-99-99
27	105312-01-13A	FT	INSERT - FEATURE STRIP - VINYL - BLACK	
28	142549-01-000	EA	CLIP - "S" TYPE	
29	133954-58-02A	EA	TRIM/SEAL - 62.8" - BLACK	FROM: 00-00-00 THRU: 04-09-06
29	146606-58-02A	EA	TRIM/RETAINER - 62.8" - BLACK	FROM: 04-10-06 THRU: 99-99-99
30	153161-01-01A	FT	SEAL - SLIDEOUT - DOUBLE WIPE LIP - BLACK	

COMPONENT PARTS FOR LEFT REAR

100536-51-000

KEY	PART NUMBER	U/M	DESCRIPTION	VENDOR NO.
	100536-51-700	EA	HOSE-HYDRAULIC - 1/4" X 444"	RAP91509
	100536-51-701	EA	HOSE-HYDRAULIC 1/4" X 456"	RAP6217

137390-01-000

KEY	PART NUMBER	U/M	DESCRIPTION	VENDOR NO.
	128599-06-700	EA	HOSE/HYDRAULIC -1/8" X 72"	RAP91424/AP24635
	128599-06-701	EA	HOSE/HYDRAULIC - 1/8" X 84"	RAP91240/AP24636
	128599-06-703	EA	BEARING KIT - SLIDE-OUT TUBE	RAP90698
	128599-06-704	EA	BEARING PAD - .8" X 2"	P14811
	137390-01-700	EA	RAM/CYLINDER - SLIDEOUT ROOM	RAP90876/AP23425
	137390-01-701	EA	CYLINDER NUT KIT - SLIDEOUT	RAP90947
	137390-01-702	EA	SLOT COVER ASM. - RUBBER	AP26959
	137390-01-703	EA	RAM/CYLINDER - SLIDEOUT RM	RAP91209/AP28686

GENERATOR GROUP

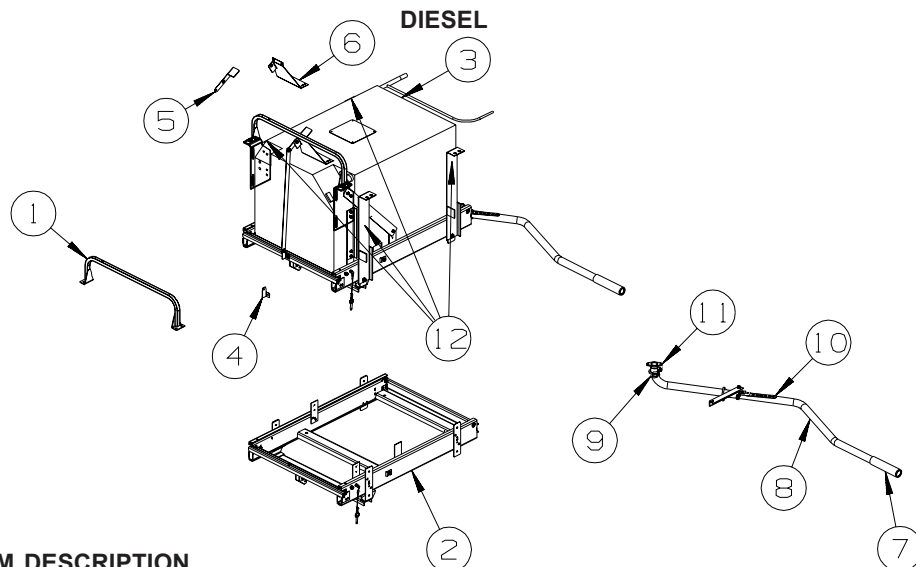

KEY	PART NUMBER	U/M	DESCRIPTION
1	114169-02-02B	EA	HANDLE - BUMPER MOUNT - E-COATED
2*	130294-04-01A	EA	SLIDE - GENERATOR - MANUAL
3	122425-01-000	EA	GENERATOR - DIESEL - 7.5
3	158258-01-000	EA	GENERATOR - 8.0KW DIESEL - ONAN #HDKAK/1145 - GEN-8.0KW ONAN QUIET DIESEL
4	131696-02-02B	EA	BRACKET - GENERATOR - E-COATED
5	131696-01-02B	EA	BRACKET - GENERATOR - E-COATED
6	131507-01-02B	EA	BRACKET - GENERATOR - E-COATED
7	138246-01-01A	EA	EXTENSION - TAILPIPE - 1.6"ID X 7.7" - STAINLESS STEEL
	116381-12-000	EA	PIPE - EXHAUST - GENERATOR
	116381-11-000	EA	PIPE - EXHAUST - GENERATOR
			FROM: 00-00-00 THRU: 03-28-05
8	116381-13-000	EA	PIPE - EXHAUST - GENERATOR
			FROM: 00-00-00 THRU: 03-28-05
8	116381-14-000	EA	PIPE - EXHAUST - GENERATOR
			FROM: 03-29-05 THRU: 07-17-05
9	007125-03-000	EA	CLAMP - MUFFLER - 1.5" DIAMETER
10	007131-03-000	EA	HANGER - TAILPIPE
11	106235-01-000	EA	ADAPTOR - STRAIGHT W/FLANGE - GENERATOR EXHAUST
12	123141-06-02B	EA	BRACKET/HANGER - GENERATOR - E-COATED
			FROM: 07-18-05 THRU: 99-99-99

*COMPONENT PARTS LISTED LATER IN THIS GROUP

COMPONENT PARTS FOR DIESEL

130294-04-01A

KEY	PART NUMBER	U/M	DESCRIPTION	VENDOR NO.
	130294-02-700	EA	PIN/QUICK RELEASE	1213100
	130294-04-700	EA	SCREW - 5/16" X 1 1/2"	1202060
	130294-04-701	EA	BOLT - 3/8" X 3/8" SHOULDER	1202300
	130294-04-702	EA	BOLT/SHOULDER - 3/8" X 3/8"	1202735
	130294-04-703	EA	GUIDE BUTTON - POP-IN	1612690
	130294-04-704	EA	HANDLE ASM - PAINTED	3624650
	131682-01-700	EA	ROLLER - (BEARING)	1912040
	131682-01-702	EA	SPRING - (LEFT HAND)	1217901
	131682-01-703	EA	SPRING - (RIGHT HAND)	1217911
	143709-01-701	EA	BUMPER - BLACK (RUBBER STOP)	1602000

HEATING & A/C GROUP AUTOMOTIVE

S40FD

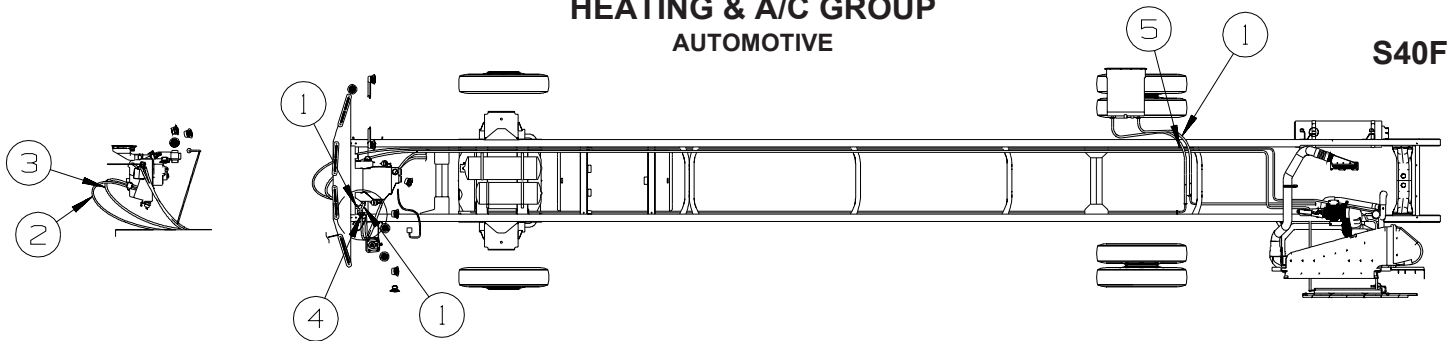

KEY	PART NUMBER	U/M	DESCRIPTION
1	007108-01-000	FT	HOSE - HEATER - 5/8"ID - HI-TEMP
2*	072342-24-000	EA	HOSE/#6 - 48" LONG (DRIER TO EVAPORATOR) FROM: 00-00-00 THRU: 08-17-06
2*	072342-27-000	EA	HOSE - #6-DRIER TO EVAP - 48"-PRESSURE SWITCH W/CONNECTOR FROM: 08-18-06 THRU: 99-99-99
3*	103930-59-000	EA	HOSE/#12 - 80" LONG (EVAPORATOR TO COMPRESSOR)
4	103930-24-000	EA	VALVE/WATER CONTROL - 4 PORT/VACUUM CONTROLLED
5	150528-01-02B 113452-02-000	EA FT	PLATE - W/HOLES - E-COATED SEAL/TRIM - FRONT - VINYL W/WIRE CARRIER - .027" - WHERE WIRES & HOSES CROSS METAL

***COMPONENT PARTS LISTED LATER IN THIS GROUP**

S40KD

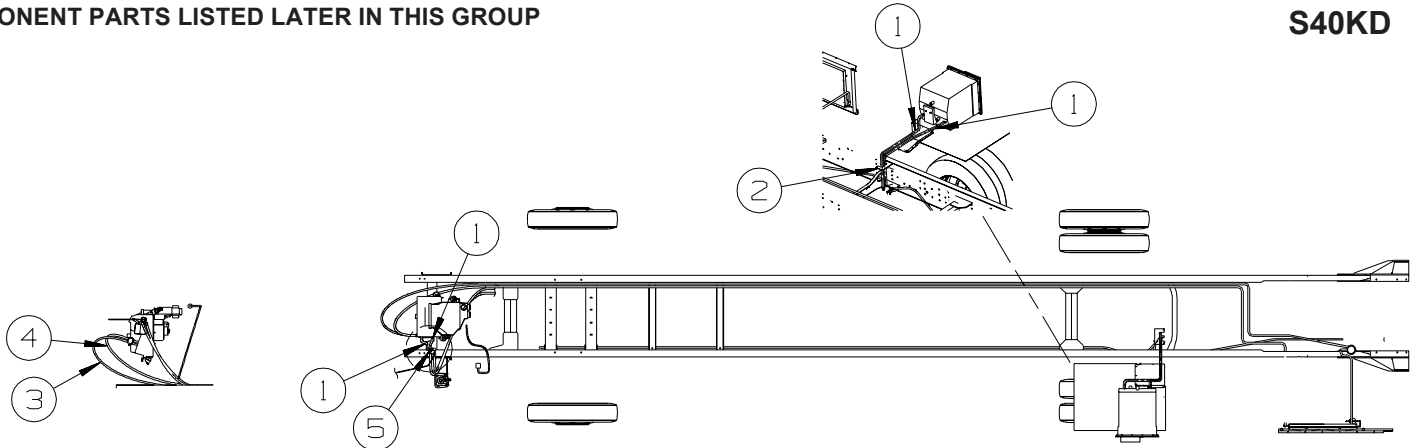

KEY	PART NUMBER	U/M	DESCRIPTION
1	079059-23-000	FT	HOSE - 90 DEGREE - 5/8"ID X 4" X 36"
2*	072342-24-000	EA	HOSE/#6 - 48" LONG (DRIER TO EVAPORATOR) FROM: 00-00-00 THRU: 08-17-06
2*	072342-27-000	EA	HOSE - #6-DRIER TO EVAP - 48"-PRESSURE SWITCH W/CONNECTOR FROM: 08-18-06 THRU: 99-99-99
3*	103930-59-000	EA	HOSE/#12 - 80" LONG (EVAPORATOR TO COMPRESSOR)
4	007108-01-000	EA	HOSE - HEATER - 5/8"ID - HI-TEMP
5	103930-24-000 113452-02-000	EA FT	VALVE/WATER CONTROL - 4 PORT/VACUUM CONTROLLED SEAL/TRIM - FRONT - VINYL W/WIRE CARRIER - .027" - WHERE WIRES & HOSES CROSS METAL

***COMPONENT PARTS LISTED LATER IN THIS GROUP**

S40TD

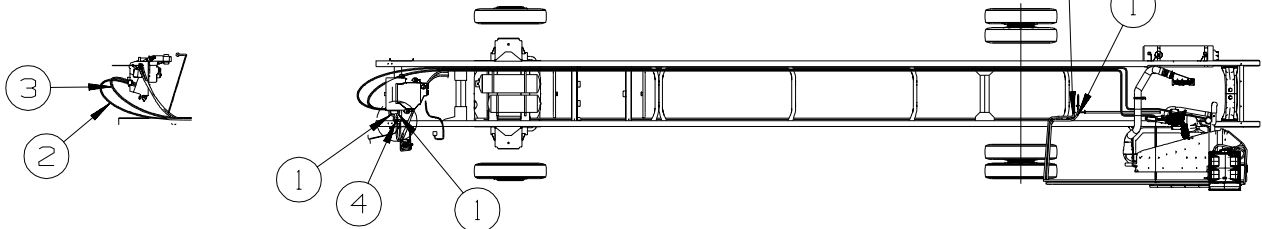

KEY	PART NUMBER	U/M	DESCRIPTION
1	007108-01-000	FT	HOSE - HEATER - 5/8"ID - HI-TEMP
2*	072342-24-000	EA	HOSE/#6 - 48" LONG (DRIER TO EVAPORATOR) FROM: 00-00-00 THRU: 08-17-06
2*	072342-27-000	EA	HOSE - #6-DRIER TO EVAP - 48"-PRESSURE SWITCH W/CONNECTOR FROM: 08-18-06 THRU: 99-99-99
3*	103930-59-000	EA	HOSE/#12 - 80" LONG (EVAPORATOR TO COMPRESSOR)
4	103930-24-000	EA	VALVE/WATER CONTROL - 4 PORT/VACUUM CONTROLLED
	113452-02-000	FT	SEAL/TRIM - FRONT - VINYL W/WIRE CARRIER - .027" - WHERE WIRES & HOSES CROSS METAL

***COMPONENT PARTS LISTED LATER IN THIS GROUP**

HEATING & A/C GROUP (CONTINUED)
AUTOMOTIVE (CONTINUED)

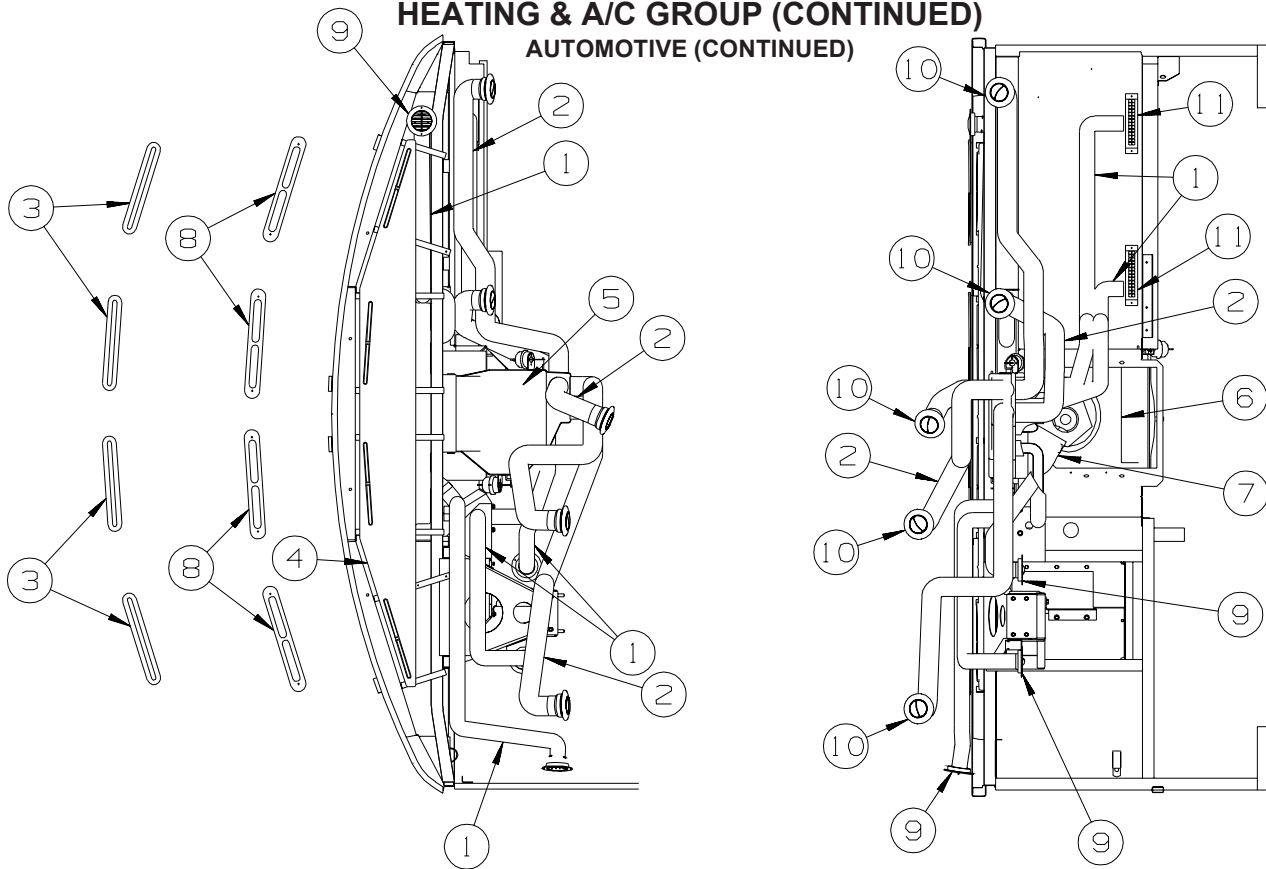

KEY	PART NUMBER	U/M	DESCRIPTION
1	007076-01-000	EA	HOSE - FLEXIBLE PVC - 2" ID - INCREMENTS OF 50'
2	007281-01-000	EA	HOSE - FLEXIBLE PVC - 2 1/2" ID X 50'
3	077075-01-000	EA	GASKET - INSTRUMENT PANEL/DEFROSTER PLENUM - .6" X 10.2"
4	103017-03-000	EA	PLENUM - DEFROSTER
5*	103930-58-000	EA	CONTROL/PLENUM - LARGE ROTARY
6*	103930-55-000	EA	EVAPORATOR/HEATER - NONCHARGED - SINGLE OUTPUT
7	134275-01-01A	EA	PLENUM - TRANSITION
8	135265-01-06A	EA	VENT - DEFROSTER - PLASTIC - CASHMERE
8	135265-01-08A	EA	VENT - DEFROSTER - PLASTIC - BRIARWOOD
9	157225-01-01A	EA	OUTLET - DEFROSTER - W/SWIVEL - 2" SLEEVE/4"OD - BLACK
9	157225-01-06A	EA	OUTLET - DEFROSTER - W/SWIVEL - 2" SLEEVE/4"OD - CASHMERE
9	157225-01-07A	EA	OUTLET - DEFROSTER - W/SWIVEL - 2" SLEEVE/4"OD - BRIARWOOD
10	146504-01-01A	EA	LOUVER - ROUND 2.5" - BLACK
11	146505-01-01A	EA	LOUVER - RECTANGULAR - 1.5" X 8" - BLACK
	113452-02-000	FT	SEAL/TRIM - FRONT - VINYL W/WIRE CARRIER - .027" - WHERE HOSES CROSS METAL

*COMPONENT PARTS LISTED LATER IN THIS GROUP

COMPONENT PARTS FOR AUTOMOTIVE

072342-24-000

KEY	PART NUMBER	U/M	DESCRIPTION	VENDOR NO.
	072342-24-700	EA	HOSE - A/C-#6 DRIER TO EVAP	085-0573
	103930-01-716	EA	SWITCH-PRESSURE/COND. FAN	032-0036
	103930-12-708	EA	SWITCH-BINARY-HI/LOW CUTOUT	032-0048
	103930-12-709	EA	FITTING-QUICK CONNECT	032-0120
	110279-02-702	EA	O'RING #12	045-0125
	113245-01-711	EA	O'RING #6	045-0129

072342-27-000

KEY	PART NUMBER	U/M	DESCRIPTION	VENDOR NO.
	072342-26-700	EA	SWITCH-BINARY W/PACKARD CONN	032-00384

HEATING & A/C GROUP (CONTINUED)
COMPONENT PARTS FOR AUTOMOTIVE (CONTINUED)

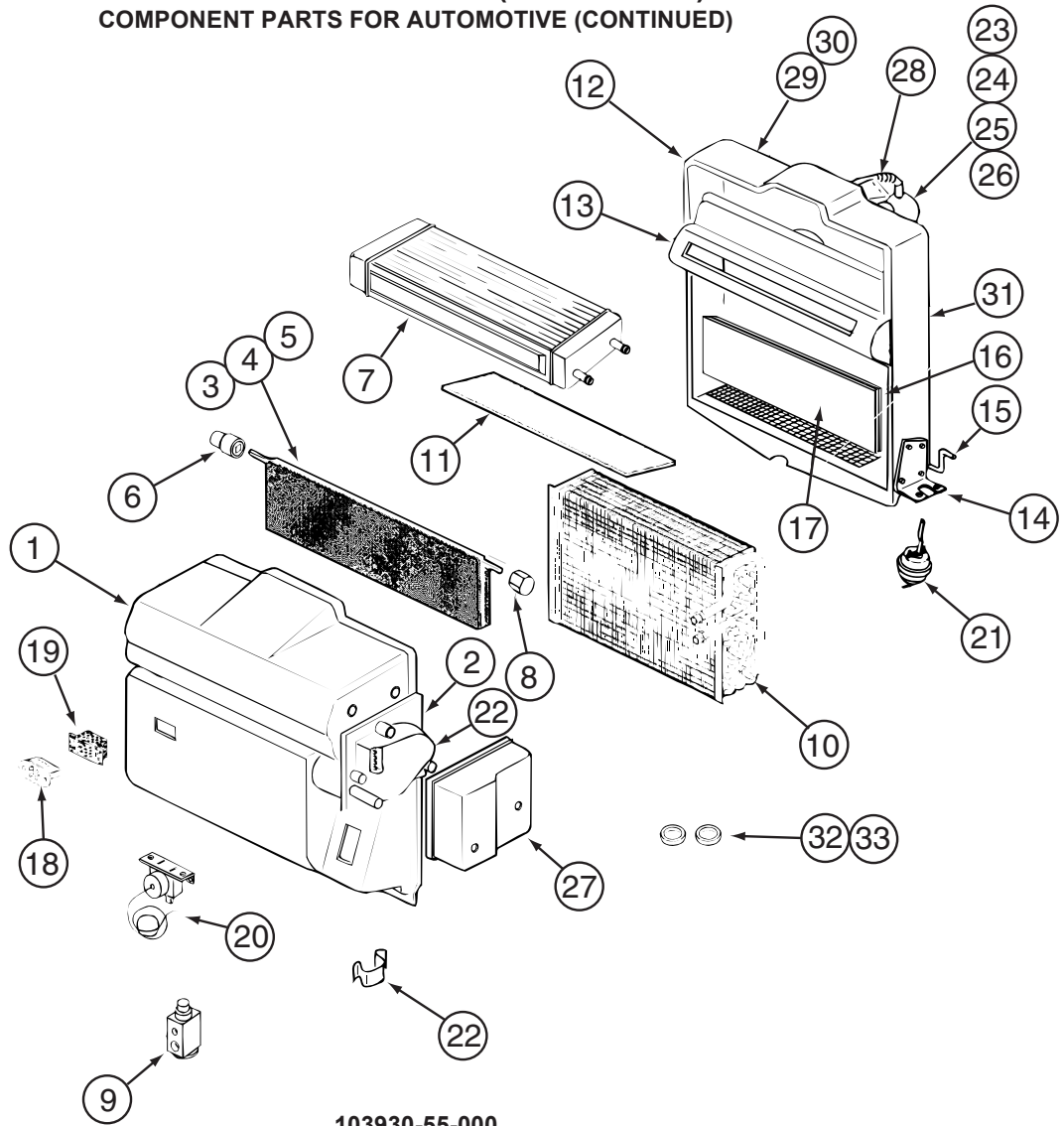

103930-55-000

KEY	PART NUMBER	U/M	DESCRIPTION	VENDOR NO.
1	103930-55-701	EA	CASE - FRONT	062-0658
2	103930-30-701	EA	PLATE - MOTOR MOUNT	062-0544
3	103930-55-705	EA	DOOR - BLEND AIR	071-0892
6	103930-30-702	EA	BUSHING/DRIVE (BLEND DOOR)	062-0168
7	103930-55-706	EA	CORE - HEATER - W/GASKET	084-0271
8	103930-30-709	EA	COUPLING - BLEND DOOR SHAFT	062-0634
9	103930-20-700	EA	VALVE-EXPANSION-BLOCK, 2 TON	034-0032
10	103930-55-700	EA	CORE-EVAPORATOR	041-00168
12	103930-55-702	EA	CASE-REAR	062-0657
14	103930-01-708	EA	BRACKET-VACUUM MOTOR	070-0113
15	103930-20-704	EA	ROD-DOOR-RECIRCULATING	073-0018
16	103930-55-707	EA	DOOR - RECIRCULATION	071-0891
18	103930-01-710	EA	RESISTOR-FUSED, A/C 4 TERM	035-0006
20	103930-01-711	EA	THERMOSTAT	033-0003
21	103930-02-708	EA	MOTOR-VACUUM SERVO, A/C	030-0025
22	103930-30-703	EA	MOTOR - SERVO	030-0104
23	103930-20-707	EA	HOUSING-BLOWER	062-0145
24	103930-55-703	EA	MOTOR-BLOWER W/O PIGTAIL	030-0137
25	103930-01-717	EA	WHEEL-BLOWER, CLOCKWISE	062-0010
26	103930-20-708	EA	CLIP-MOTOR SHAFT	022-0001
27	103930-30-704	EA	COVER - SERVO	062-0545
32	113245-01-707	EA	O'RING #8	045-0126
33	103930-17-702	EA	O'RING #10	045-0127
	103930-55-704	EA	CORE-HEATER	042-0059
	110279-01-703	EA	HOSE-VENT F/BLOWER MOTOR	051-0034

CONTACT WINNEBAGO PART SALES FOR UNLISTED COMPONENT(S)

HEATING & A/C GROUP (CONTINUED)
COMPONENT PARTS FOR AUTOMOTIVE (CONTINUED)

103930-58-000

KEY	PART NUMBER	U/M	DESCRIPTION	VENDOR NO
	103930-02-707	EA	RELAY-BOSCH W/RESISTER	031-0001
	103930-02-708	EA	MOTOR-VACUUM SERVO, A/C	030-0025
	103930-02-710	EA	CANISTER-VACUUM	054-0002
	103930-33-701	EA	MOTOR - VACUUM, 3 STAGE	030-0105
	103930-33-703	EA	VACUUM HARNESS	036-0466
	103930-33-705	EA	LIGHT BULBS	035-0030
	103930-49-701	EA	HARNESS - WIRE W/BULBS	036-0557
	103930-49-703	EA	CONTROL PANEL ASM. - DRIVER	083-0223
	103930-49-704	EA	SWITCH - BLOWER	032-0332
	103930-49-705	EA	POTENTIOMETER	032-0182
	103930-49-706	EA	SWITCH - VACUUM	032-0185
	103930-49-707	EA	DECAL CONTROL PANEL-N/RECESS	058-0144
	103930-49-708	EA	KNOB - BLOWER - NONRECESSED	062-0617
	103930-58-700	EA	PLENUM CASE - UPPER	060-0687
	103930-58-701	EA	DOOR/DIVERTOR - DEFROSTER	071-0929
	103930-58-702	EA	ROD - DEFROSTER DIVERTOR DR	073-0080
	103930-58-703	EA	DOOR/DIVERTOR - A/C-HEAT	071-0930
	103930-58-704	EA	ROD - A/C-HEAT DOOR	073-0079
	103930-58-705	EA	PLENUM CASE - LOWER	060-0688

103930-59-000

KEY	PART NUMBER	U/M	DESCRIPTION	VENDOR NO
	103930-17-702	EA	O'RING #10	045-0127
	103930-59-700	EA	HOSE - A/C-#12EVAP/COMP 80"	085-0574
	113245-01-710	EA	O'RING, #12	045-0128

HEATING & A/C GROUP (CONTINUED)

FURNACE

KEY	PART NUMBER	U/M	DESCRIPTION
	098668-23-000	EA	DOOR - ACCESS - FURNACE - BRIGHT WHITE - S40FD, S40KD
	143563-02-02A	EA	DOOR/ACCESS - FURNACE - W/FRAME - BLACK - S40TD
	143563-06-000	EA	DUCT KIT - BOTTOM - S40TD
*	139980-01-000	EA	FURNACE - 25000 BTU - SF QUIET - SUBURBAN SF-25 2320J
*	143563-08-000	EA	FURNACE - 40000 BTU DUAL QUIET - SUBURBAN SHD-2542
	143563-04-000	EA	PLATE END - COLLAR
	134651-01-000	FT	SEAL - 1/2" X 3/4" X 9' - PSA 1 SIDE
	009198-01-000	FT	DUCT - HEAT - FLEXIBLE - 4" ID X 25'
	009198-02-000	FT	DUCT - HEAT - FLEXIBLE - 2" ID X 25'
	009200-01-000	EA	TAPE - FURNACE - 1 1/2"
	069636-02-000	EA	CONNECTOR - DUCT - 4" ID
	089367-02-000	EA	TEE - 4" X 2" X 4"
	092776-01-000	EA	ADAPTER - DUCT - 2"
	092776-03-000	EA	ADAPTER - DUCT 2" X 4" X 3"
	139980-07-000	EA	ADAPTOR - VENT BOTTOM SF-30/35
	093614-01-02A	EA	GRILLE - AIR RETURN - 15.9" X 7.9" - BEIGE
	093614-02-02A	EA	GRILLE - AIR RETURN - 9.9" X 9.9" - BEIGE
	098668-16-000	EA	VENT - INTAKE
	126693-05-02B	EA	PANEL - EXHAUST/FURNACE - E-COATED
	145895-03-02B	EA	PANEL - CLOSEOUT - FURNACE - E-COATED
	145895-05-02B	EA	PANEL - CLOSEOUT - FURNACE - E-COATED
	133323-01-01A	EA	SHROUD - FURNACE - BRIGHT WHITE
	056464-10-000	EA	REGISTER W/O DAMPER - 4" DIAMETER - PLASTIC - BEIGE
	137965-01-02A	EA	REGISTER - 11.2" X 3.6"(9.7 X 2.1"R/O) W/O DAMPER-ANT PWTR
	137965-02-02A	EA	REGISTER - 11.2" X 3.6"(9.7 X 2.1"R/O) W/DAMPER - ANT PWTR
	137965-03-02A	EA	REGISTER - 11.2" X 3.6"(9.7 X 2.1"R/O) W/O DAMPER-ANT PWTR
	137965-04-02A	EA	REGISTER - 11.2" X 3.6"(9.7 X 2.1"R/O) W/DAMPER - ANT PWTR
	137965-06-02A	EA	REGISTER - 15.3" X 3.6"(13.9"X2.1"R/O) W/O DAMPER-ANT PWTR
	137965-10-02A	EA	REGISTER - 15.3" X 3.6"(13.8"X2.1"R/O) W/O DAMPER-ANT PWTR
	139980-08-000	EA	GASKET - BOTTOM VENT SF-30/35
	141337-01-01A	EA	GASKET - FURNACE
	143563-05-000	EA	GASKET - FIBERGLASS - SUBURBAN #071018
	146608-01-01B	EA	TUBE - EXTENSION/INTAKE - SUBURBAN
	146608-02-01B	EA	TUBE - EXTENSION/EXHAUST - SUBURBAN
	157225-01-01A	EA	OUTLET - DEFROSTER - W/SWIVEL - 2" SLEEVE/4"OD - BLACK

***COMPONENT PARTS LISTED LATER IN THIS GROUP**

HEATING & A/C GROUP (CONTINUED)
COMPONENT PARTS FOR FURNACE

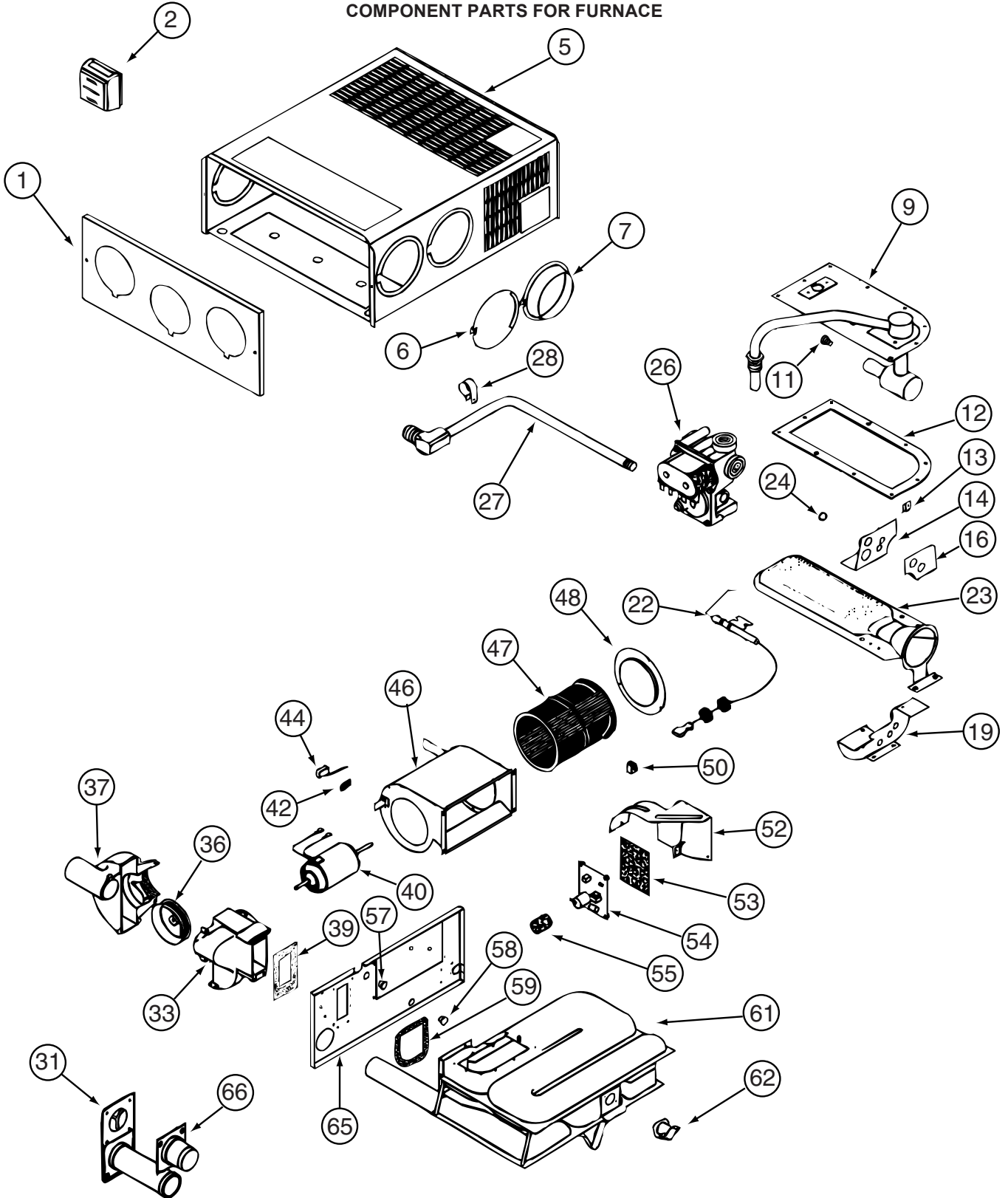

139980-01-000

HEATING & A/C GROUP (CONTINUED)
COMPONENT PARTS FOR FURNACE (CONTINUED)

139980-01-000 (CONTINUED)

KEY	PART NUMBER	U/M	DESCRIPTION	VENDOR NO.
9	139980-01-700	EA	MANIFOLD ASSEMBLY	171571
11	090039-01-703	EA	ORIFICE-MAIN BURNER	180193
12	098668-22-703	EA	GASKET - BURNER ACCESS COVER	070811
22	139980-01-701	EA	ELECTRODE	232286
23	098668-01-703	EA	BURNER ASSEMBLY	010762
26	098668-01-718	EA	VALVE-GAS SF S.N.974903079	161122
27	139980-01-702	EA	PIPE ASSEMBLY/GAS INLET	171574
31	098668-01-707	EA	TUBE ASSEMBLY, EXHAUST W/CAP	260231
33	139980-01-703	EA	HOUSING/COMB. - FRONT/HALF	390852
36	098668-01-706	EA	WHEEL-COMBUSTION AIR	350184
37	139980-01-704	EA	HOUSING/COMB. - REAR/HALF	390848
39	139980-01-705	EA	GASKET/FIREWALL-COMB AIR	071084
40	139980-01-706	EA	MOTOR ASSEMBLY W/GASKET	232682
42	101990-01-714	EA	GASKET-MICROSWITCH	230877
44	098668-21-700	EA	SWITCH-MICRO-W/O FLAG 3 1/4"	232261
46	139980-01-708	EA	BLOWER ASSEMBLY - ROOM AIR	390739BK
47	098668-01-711	EA	WHEEL-BLOWER, ROOM AIR	350129
48	139980-01-709	EA	ORFICE RING	390696
50	139980-01-710	EA	SWITCH - ON/OFF	232351
52	139980-01-711	EA	PANEL ASSEMBLY-MODULE BD	101663
53	139980-01-712	EA	INSULATOR - MODULE BD	070807
54	098668-22-705	EA	MODULE BD W/RELAY TIME DELAY	520820
55	139980-01-713	EA	CAP/INSULATOR-MODULE BD	070973
57	139980-01-714	EA	BUSHING - UNIVERSAL	070362
58	139980-01-715	EA	BUSHING - STRAIN RELIEF	231809
59	098668-01-716	EA	GASKET-FIREWALL,CHAMBER SIDE	070808
61	139980-01-716	EA	CHAMBER ASSEMBLY - FINAL	021149BK
62	098668-21-701	EA	SWITCH - LIMIT	232504
66	098668-01-713	EA	TUBE ASSEMBLY, INTAKE	051248
	098668-19-700	EA	DOOR/CABINET ACCESS	101888
	139980-02-700	EA	BLOWER ASM-1/2 HOUSING/OUTER	390851
	139980-02-701	EA	BLOWER ASM-1/2 HOUSING/INNER	390872
			CONTACT WINNEBAGO PART SALES FOR UNLISTED COMPONENT(S)	

HEATING & A/C GROUP (CONTINUED)
COMPONENT PARTS FOR FURNACE (CONTINUED)

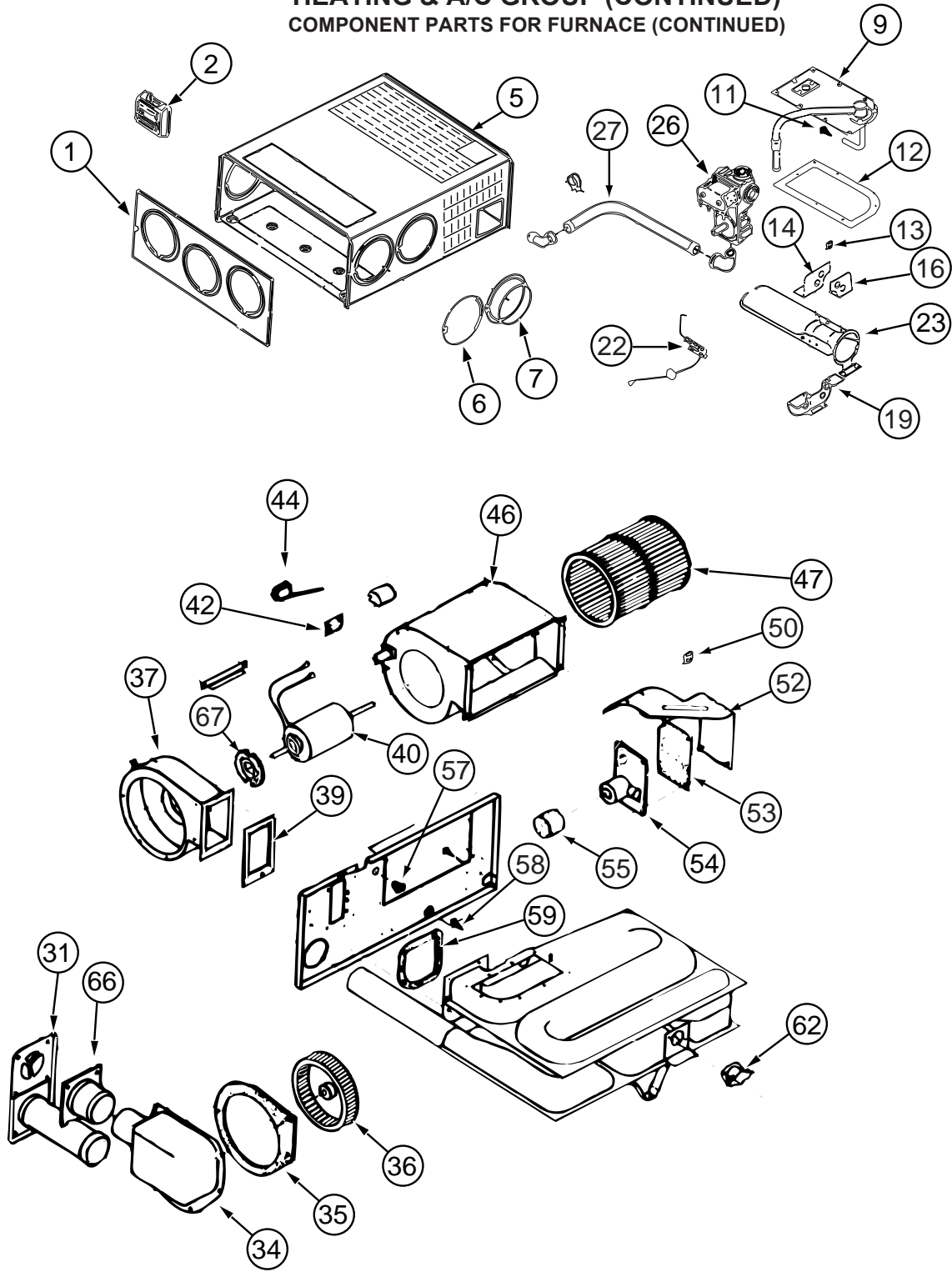

143563-08-000

HEATING & A/C GROUP (CONTINUED)
COMPONENT PARTS FOR FURNACE (CONTINUED)

143563-08-000 (CONTINUED)

KEY	PART NUMBER	U/M	DESCRIPTION	VENDOR NO.
1	143563-01-700	EA	CABINET - FRONT	101907
5	143563-08-700	EA	CABINET	102102
7	075696-02-703	EA	COLLAR - DUCT	050715
9	143563-08-701	EA	MANIFOLD ASSEMBLY	171638
11	143563-02-701	EA	ORFICE - MAIN BURNER	180309
12	098668-22-703	EA	GASKET - BURNER ACCESS COVER	070811
14	143563-02-702	EA	PLATE - SECONDARY AIR/TOP BACK	063198
16	143563-02-703	EA	PLATE - SECONDARY AIR/TOP FRT	062933
19	143563-02-704	EA	PLATE - SECONDARY AIR/BOTTOM	062935
22	139980-01-701	EA	ELECTRODE	232286
23	098668-11-701	EA	BURNER ASSEMBLY, SF-42F	010799
26	143563-08-702	EA	VALVE-GAS	161192
27	143563-08-703	EA	PIPE ASSEMBLY (GAS INLET)	171655
31	098668-01-707	EA	TUBE ASSEMBLY, EXHAUST W/CAP	260231
32	098668-01-713	EA	TUBE ASSEMBLY, INTAKE	051248
34	139980-01-703	EA	HOUSING/COMB. - FRONT/HALF	390852
37	139980-01-704	EA	HOUSING/COMB. - REAR/HALF	390848
38	098668-22-702	EA	WHEEL-COMBUSTION AIR	350183
39	139980-01-705	EA	GASKET/FIREWALL-COMB AIR	071084
40	143563-08-704	EA	MOTOR ASSEMBLY W/GASKET	232850
42	143563-08-705	EA	BLOWER ASM(ROOM AIR)FRONT1/2	390873
44	143563-08-706	EA	BLOWER ASM(ROOM AIR)REAR 1/2	
45	143563-08-707	EA	SWITCH-SAIL	232868
48	139980-01-710	EA	SWITCH - ON/OFF	232351
49	139980-01-712	EA	INSULATOR - MODULE BD	070807
50	098668-22-705	EA	MODULE BD W/RELAY TIME DELAY	520820
51	139980-01-713	EA	CAP/INSULATOR-MODULE BD	070973
52	098668-01-711	EA	WHEEL-BLOWER, ROOM AIR	350129
54	139980-01-714	EA	BUSHING - UNIVERSAL	070362
56	143563-08-708	EA	BUSHING - STRAIN RELIEF	230216
57	098668-01-716	EA	GASKET-FIREWALL,CHAMBER SIDE	070808
58	143563-02-707	EA	CHAMBER ASM. - FINAL	021172BK
59	098668-22-706	EA	SWITCH/LIMIT-195 TRIP TEMP	232505
65	143563-05-709	EA	PANEL ASSEMBLY-MODULE BD	102078
67	143563-08-710	EA	MODULE BOARD - DUAL CONTROL	232806

CONTACT WINNEBAGO PART SALES FOR UNLISTED COMPONENT(S)

HEATING & A/C GROUP (CONTINUED)

CENTRAL

S40FD, S40KD

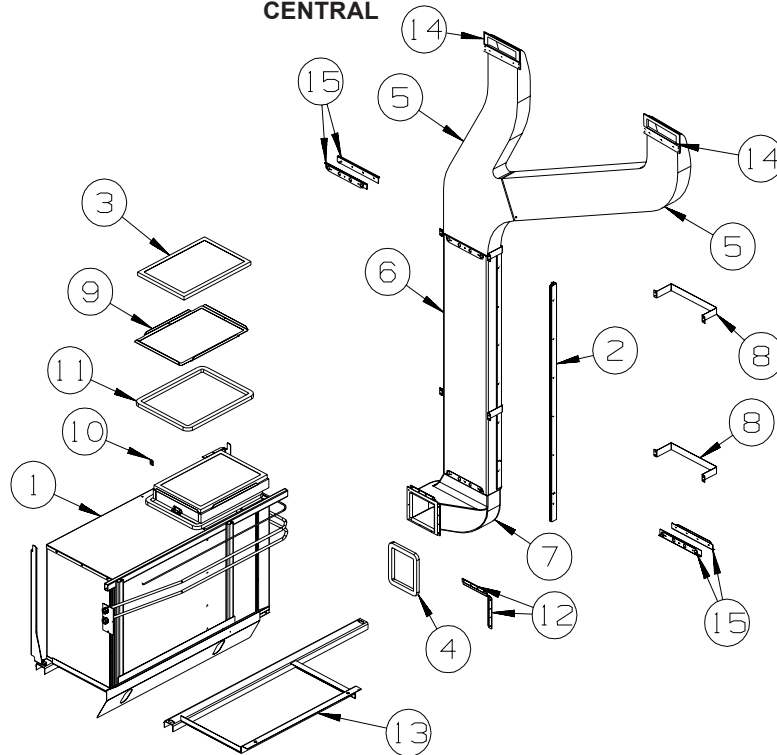

KEY	PART NUMBER	U/M	DESCRIPTION
1*	105620-16-000	EA	A/C - CENTRAL - RIGHT HAND/HEAT PUMP - TOP RETURN
2	159408-03-01A	EA	CORNER-W/HOLES,MILL,1373 MM
			FROM: 07-31-06 THRU: 99-99-99
3	109050-02-000	EA	FILTER/FURNACE-AC - FIBERGLASS - 1" X 14" X 20"
4	134588-02-000	EA	GASKET - DUCT - 13.9" X 18.2" IS - 15.9" X 20.2" OS
5	M09204-01-000	EA	DUCT/AC - UPPER RIGHT HAND/LEFT HAND
5	105290-01-000	SF	INSULATION - AIR POCKET W/FOIL
6	117870-12-01A	EA	PLENUM - A/C - 54.8"
			FROM: 00-00-00 THRU: 07-30-06
6	159404-03-000	EA	PLENUM-A/C
			FROM: 07-31-06 THRU: 99-99-99
7	P47621-01-000	EA	DUCT - CENTRAL AIR/FORCED - LOWER
7	105290-01-000	SF	INSULATION - AIR POCKET W/FOIL
8	129047-01-02B	EA	STRAP/MOUNTING - AIR DUCT - E-COATED
9	139757-01-02B	EA	PANEL - TRAY - A/C FILTER - E-COATED
10	107721-07-000	FT	SEAL - ACCESS DOOR - .9"WIDE X 1.1"HIGH
11	134588-04-000	EA	GASKET - DUCT - 13.9" X 18.2" IS - 15.9" X 20.2" OS
12	130481-01-01A	EA	BRACKET - ZEE W/HOLES - 7"
13	147613-01-02B	EA	CRADLE - A/C - E-COATED
14	104692-01-000	FT	SEAL - ADHESIVE BACKED FOAM - 3/4" THICK X 3/4" WIDE X 25'
15	115886-11-02A	EA	RETAINER - SIDEWALL - BRIGHT WHITE - 11.8" - NOT ILLUSTRATED
			FROM: 00-00-00 THRU: 07-30-06
15	160755-01-02B	EA	U-CHANNEL-W/HOLES
			FROM: 07-31-06 THRU: 99-99-99
	130262-02-000	EA	PROTECTOR - CORNER - .7" X .7" X 17.7"
			FROM: 00-00-00 THRU: 07-30-06
	130262-03-000	EA	PROTECTOR - CORNER - .75" X .75"
			FROM: 00-00-00 THRU: 07-30-06
	100128-02-000	FT	SEAL - FOAM/ADHESIVE BACK - .37" WIDE X .37" THICK X 60'
			FROM: 00-00-00 THRU: 07-30-06

*COMPONENT PARTS LISTED LATER IN THIS GROUP

HEATING & A/C GROUP (CONTINUED) CENTRAL (CONTINUED)

S40TD

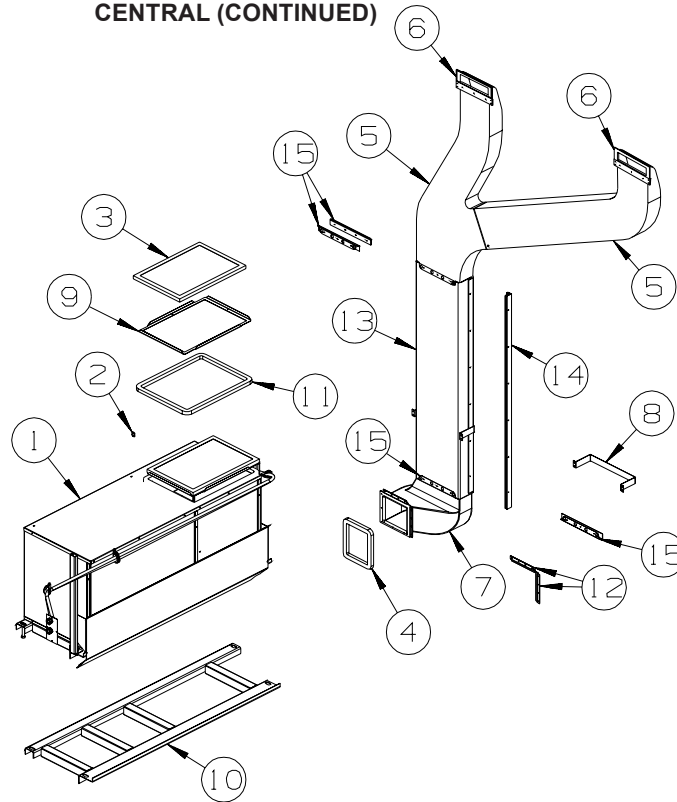

KEY	PART NUMBER	U/M	DESCRIPTION
1	105620-19-000	EA	A/C - CENTRAL - RIGHT HAND/HEAT PUMP - TOP RETURN
2	107721-07-000	FT	SEAL - ACCESS DOOR - .9"WIDE X 1.1"HIGH
3	109050-02-000	EA	FILTER/FURNACE-AC - FIBERGLASS - 1" X 14" X 20"
4	134588-02-000	EA	GASKET - DUCT - 13.9" X 18.2" IS - 15.9" X 20.2" OS
5	M09204-01-000	EA	DUCT/AC - UPPER RIGHT HAND/LEFT HAND
5	105290-01-000	SF	INSULATION - AIR POCKET W/FOIL
6	104692-01-000	FT	SEAL - ADHESIVE BACKED FOAM - 3/4" THICK X 3/4" WIDE X 25"
7	P47621-01-000	EA	DUCT - CENTRAL AIR/FORCED - LOWER
7	105290-01-000	SF	INSULATION - AIR POCKET W/FOIL
8	129047-01-02B	EA	STRAP/MOUNTING - AIR DUCT - E-COATED
9	139757-01-02B	EA	PANEL - TRAY - A/C FILTER - E-COATED
10	158964-01-02B	EA	CRADLE - A/C - E-COATED
11	134588-04-000	EA	GASKET - DUCT - 13.9" X 18.2" IS - 15.9" X 20.2" OS
12	130481-01-01A	EA	BRACKET - ZEE W/HOLES - 7"
13	159404-01-000	EA	PLENUM-A/C
13	159404-04-000	EA	PLENUM-A/C
14	159408-01-01A	EA	CORNER-W/HOLES,MILL,1212 MM
14	159408-04-01A	EA	CORNER-W/HOLES,MILL,1305 MM
15	115886-11-02A	EA	RETAINER - SIDEWALL - BRIGHT WHITE - 11.8" - NOT ILLUSTRATED
15	160755-01-02B	EA	U-CHANNEL-W/HOLES
	100128-02-000	FT	SEAL - FOAM/ADHESIVE BACK - .37" WIDE X .37" THICK X 60"

FROM: 00-00-00 THRU: 07-30-06

FROM: 07-31-06 THRU: 99-99-99

FROM: 00-00-00 THRU: 07-30-06

FROM: 07-31-06 THRU: 99-99-99

FROM: 00-00-00 THRU: 07-30-06

FROM: 07-31-06 THRU: 99-99-99

FROM: 00-00-00 THRU: 07-30-06

HEATING & A/C GROUP (CONTINUED)
COMPONENT PARTS FOR CENTRAL

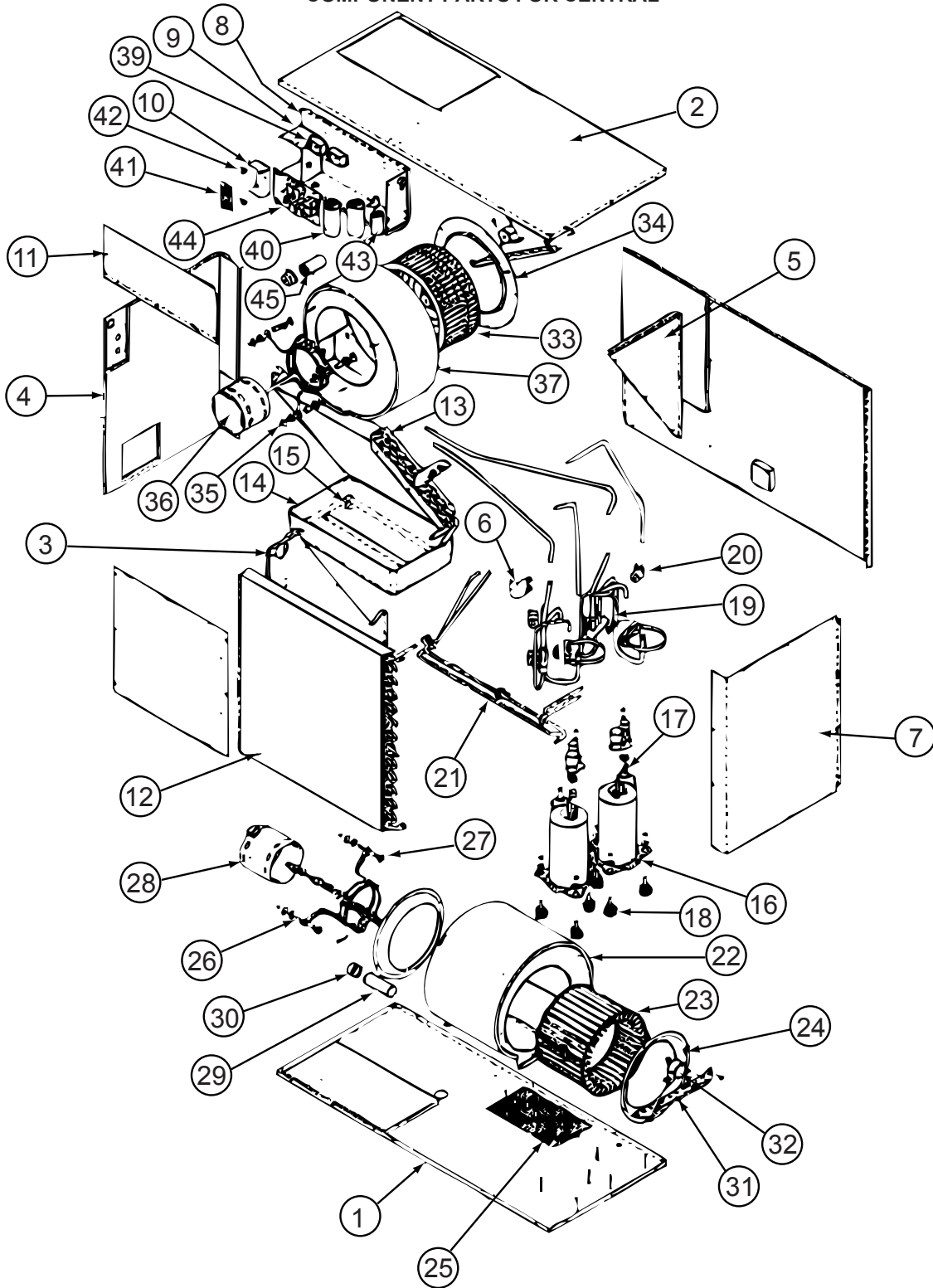

105620-16-000

HEATING & A/C GROUP (CONTINUED)
COMPONENT PARTS FOR CENTRAL (CONTINUED)

105620-16-000 (CONTINUED)

KEY	PART NUMBER	U/M	DESCRIPTION	VENDOR NO.
10	105620-01-733	EA	ISOLATOR-HIGH VOLTAGE	6795-117
10	105620-12-704	EA	COMPRESSOR (TECHUMSEH)	1450-2149
12	105620-16-700	EA	CONDENSOR COIL	1452-1681
13	105620-16-701	EA	EVAPORATOR COIL	14521671
14	105620-16-702	EA	DRAIN PAN	6537-104
15	105620-12-703	EA	VALVE - DRAIN	6795-200
16	105620-12-723	EA	COMPRESSOR (PANASONIC)	1450-2229
17	105620-16-703	EA	OVERLOAD	1450-0161
18	105620-01-706	EA	MOUNTING PKG.,COMP., 3 PER	6759-3081
19	105620-16-704	EA	REVERSING VALVE	6537-5321
20	105620-12-708	EA	COIL - SOLENOID	1460-1081
21	105620-16-705	EA	BY-FLO RESTRICTOR	1454-2561
22	105620-10-718	EA	BLOWER HOUSING/OUTSIDE AIR	6536-515
23	105620-01-713	EA	WHEEL-BLOWER/OUTSIDE AIR	1472-1011
24	105620-01-714	EA	VENTURI-BLOWER/OUTSIDE AIR	6795A150
26	105620-01-715	EA	MOUNT-BLOWER/OUTSIDE AIR	6795A3011
27	105620-01-716	EA	SLEEVE & GROMMET, 4 PER PKG	6795A3031
28	105620-10-721	EA	MOTOR/BLOWER-8 3/4" SHAFT	1468A3029
29	105620-01-718	EA	CAPACITOR-FAN(OUTDOOR MOTOR)	1499-5631
30	105620-10-715	EA	RUBBER CAPACITOR BOOT	1499-951
31	105620-12-713	EA	BRACKET/BEARING-O/S AIR BLWR	6536-514
32	105620-10-701	EA	BEARING/PILLOW BLOCK-O/S AIR	6536-3011
33	105620-11-701	EA	BLOWER WHEEL/INSIDE AIR	1472-1151
34	105620-12-715	EA	BLOWER VENTURI/INSIDE AIR	6535A287
35	105620-01-723	EA	MOUNT-BLOWER MOTOR - I/S AIR	6795-302
36	105620-12-716	EA	BLOWER MTR/IN AIR/REVERSIBLE	1468-3219
37	105620-16-707	EA	BLOWER HOUSING/INSIDE AIR	6537-590
38	105620-12-719	EA	COIL SENSOR	7330A3231
39	105620-01-729	EA	RELAY-COMPRESSOR -4 TERMINAL	1460-1131
40	105620-12-725	EA	COMPRESSOR RUN CAPACITOR	1499-5731
41	105620-16-708	EA	BOARD/TERMINAL- HIGH VOLTAGE	6795-3151
43	105620-10-705	EA	PTCR (START DEVICE) - W/CAP.	8333A9021
45	093763-01-704	EA	CAPACITOR-FAN (INDOOR MOTOR)	1499-5461
	105620-12-720	EA	KIT-CIRCUIT BD (6535-SERIES)	6535-3201

CONTACT WINNEBAGO PART SALES FOR UNLISTED COMPONENTS

INTERIOR FINISH GROUP
MOLDINGS & TRIMS
CONCERT CHERRY, WASHED MAPLE, HONEY CHERRY

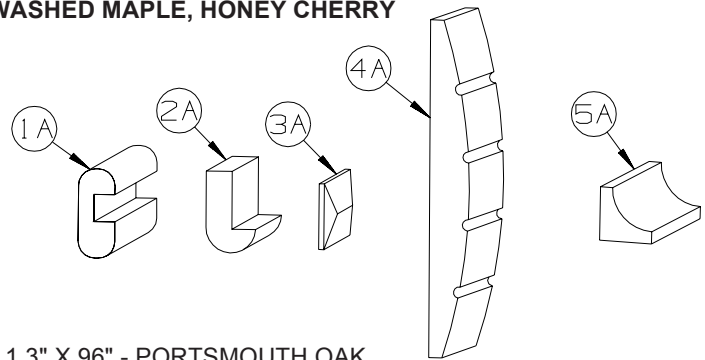

KEY	PART NUMBER	U/M	DESCRIPTION
1A	M09412-62-N42	EA	MOLDING/SHELF EDGE - .6" X 1.3" X 96" - PORTSMOUTH OAK
1A	M09412-62-M52	EA	MOLDING/SHELF EDGE - .6" X 1.3" X 96" - CHERRY - CONCERT CHERRY
1A	M09412-62-M62	EA	MOLDING/SHELF EDGE - .6" X 1.3" X 96" - WASHED MAPLE - WASHED MAPLE
1A	M09412-62-RC3	EA	MOLDING/SHELF EDGE - .6" X 1.3" X 96" - HONEY CHERRY - HONEY CHERRY
1A	M09412-62-SA3	EA	MOLDING/SHELF EDGE - .6" X 1.3" X 96" - MAPLE - SIERRA MAPLE
2A	M09450-77-PC0	EA	MOLDING - TRIM/HDWD W/LIP -.4"X3.2"X79.6" - PORTSMOUTH OAK
2A	M09450-77-PC1	EA	MOLDING - TRIM/HDWD W/LIP -.4"X3.2"X79.6" - CONCERT CHERRY
2A	M09450-77-PC2	EA	MOLDING - TRIM/HDWD W/LIP -.4"X3.2"X79.6" - WASHED MAPLE
2A	M09450-77-RC3	EA	MOLDING - TRIM/HDWD W/LIP -.4"X3.2"X79.6" - HONEY CHERRY
2A	M09501-32-TG1	EA	MOLDING/TRIM - W/NOTCH - .8" X 2.5" X 86.2"-CONCERT CHERRY
2A	M09501-32-TG2	EA	MOLDING/TRIM - W/NOTCH - .8" X 2.5" X 86.2" - WASHED MAPLE,
2A	M09501-32-TD3	EA	MOLDING/TRIM - W/NOTCH - .8" X 2.5" X 86.2" - SIERRA MAPLE
2A	M09503-52-T77	EA	MOLDING/TRIM - .75" X 1.2" X 86.5" - PORTSMOUTH OAK
2A	M09503-52-T78	EA	MOLDING/TRIM - .75" X 1.2" X 86.5" - CONCERT CHERRY
2A	M09503-52-T79	EA	MOLDING/TRIM - .75" X 1.2" X 86.5" - WASHED MAPLE
2A	M09503-52-T80	EA	MOLDING/TRIM - .75" X 1.2" X 86.5" - SIERRA MAPLE
2A	M09511-43-T78	EA	MOLDING - TRIM - W/NOTCH - .8" X 1.4" X 86.3" - CONCERT CHERRY
2A	M09525-80-UM1	EA	MOLDING - TRIM - W/NOTCH - .8"X 1.4"X 86.5" - CONCERT CHERRY
2A	M09511-43-T79	EA	MOLDING - TRIM - W/NOTCH - .8" X 1.4" X 86.3" - WASHED MAPLE
2A	M09525-80-U91	EA	MOLDING - TRIM - W/NOTCH - .8" X 1.4" X 86.5" - WASHED MAPLE
2A	M09511-43-T80	EA	MOLDING - TRIM - W/NOTCH - .8" X 1.4" X 86.3" - SIERRA MAPLE
2A	M09525-80-U92	EA	MOLDING - TRIM - W/NOTCH - .8" X 1.4" X 86.5" - SIERRA MAPLE
2A	M09438-25-RA3	EA	MOLDING - HARDWOOD-W/NOTCH - 1.4"X 80.2" - HONEY CHERRY
2A	M09515-72-TD1	EA	MOLDING/TRIM - .8" X 2.2" X 86.1" - CONCERT CHERRY
2A	M09515-72-TD2	EA	MOLDING/TRIM - .8" X 2.2" X 86.1" - WASHED MAPLE
2A	M09515-72-TD3	EA	MOLDING/TRIM - .8" X 2.2" X 86.1" - SIERRA MAPLE
3A	M09471-91-R69	EA	MOLDING - TRIM/VEE - .2" X 1" X 34.4" - CONCERT CHERRY
3A	M09471-91-R76	EA	MOLDING - TRIM/VEE - .2" X 1" X 34.4" - WASHED MAPLE
3A	M09471-91-SA3	EA	MOLDING - TRIM/VEE - .2" X 1" X 34.4" - SIERRA MAPLE
3A	M09477-88-S34	EA	MOLDING - TRIM/VEE - .2" X 1" X 19.9" - WASHED MAPLE
3A	M09477-88-S35	EA	MOLDING - TRIM/VEE - .2" X 1" X 19.9" - SIERRA MAPLE
3A	M09501-30-SD2	EA	MOLDING - TRIM/VEE - .2" X 1" X 35.1" - WASHED MAPLE
3A	M09501-30-SD3	EA	MOLDING - TRIM/VEE - .2" X 1" X 35.1" - HONEY CHERRY
3A	M09501-37-TG1	EA	MOLDING - TRIM/VEE - .2" X 1" X 19.2" - CONCERT CHERRY
3A	M09501-37-TG2	EA	MOLDING - TRIM/VEE - .2" X 1" X 19.2" - WASHED MAPLE
3A	M09501-37-TD3	EA	MOLDING - TRIM/VEE - .2" X 1" X 19.2" - SIERRA MAPLE
3A	M09501-37-TG3	EA	MOLDING - TRIM/VEE - .2" X 1" X 19.2" - HONEY CHERRY
3A	M09501-63-T78	EA	MOLDING - TRIM/VEE - .2" X 1" X 15" - CONCERT CHERRY
3A	M09501-63-T79	EA	MOLDING - TRIM/VEE - .2" X 1" X 15" - WASHED MAPLE
3A	M09501-63-T80	EA	MOLDING - TRIM/VEE - .2" X 1" X 15" - SIERRA MAPLE
3A	M09503-62-TG1	EA	MOLDING - TRIM/VEE - .2" X 1" X 26.3" - CONCERT CHERRY
3A	M09503-62-TG2	EA	MOLDING - TRIM/VEE - .2" X 1" X 26.3" - WASHED MAPLE
3A	M09503-62-TG3	EA	MOLDING - TRIM/VEE - .2" X 1" X 26.3" - HONEY CHERRY
3A	M09511-90-TG1	EA	MOLDING - TRIM/VEE - .2" X 1" X 42.1" - CONCERT CHERRY
3A	M09511-90-TG3	EA	MOLDING - TRIM/VEE - .2" X 1" X 42.1" - HONEY CHERRY
3A	M09511-90-TG2	EA	MOLDING - TRIM/VEE - .2" X 1" X 42.1" - WASHED MAPLE
3A	M09520-15-TD1	EA	MOLDING - TRIM/VEE - .2" X 1" X 15.3" - CONCERT CHERRY
3A	M09520-15-TD2	EA	MOLDING - TRIM/VEE - .2" X 1" X 15.3" - WASHED MAPLE
3A	M09520-15-TD3	EA	MOLDING - TRIM/VEE - .2" X 1" X 15.3" - SIERRA MAPLE
3A	M09520-96-T59	EA	MOLDING - TRIM/VEE - .2" X 1" X 32.7" - PORTSMOUTH OAK
3A	M09520-96-T60	EA	MOLDING - TRIM/VEE - .2" X 1" X 32.7" - CONCERT CHERRY
3A	M09520-96-T61	EA	MOLDING - TRIM/VEE - .2" X 1" X 32.7" - WASHED MAPLE
3A	M09520-96-TP0	EA	MOLDING - TRIM/VEE - .2" X 1" X 32.7" - SIERRA MAPLE

INTERIOR FINISH GROUP (CONTINUED)

MOLDINGS & TRIMS (CONTINUED)

KEY	PART NUMBER	U/M	DESCRIPTION
3A	M09525-96-TA0	EA	MOLDING - TRIM/VEE - .2" X 1" X 36.2" - PORTSMOUTH OAK
3A	M09525-96-TA1	EA	MOLDING - TRIM/VEE - .2" X 1" X 36.2" - CONCERT CHERRY
3A	M09525-96-TA2	EA	MOLDING - TRIM/VEE - .2" X 1" X 36.2" - WASHED MAPLE
3A	M09525-96-TA3	EA	MOLDING - TRIM/VEE - .2" X 1" X 36.2" - SIERRA MAPLE
3A	M09534-08-T01	EA	MOLDING - TRIM/VEE - .2" X 1" X 24.5" - SIERRA MAPLE
3A	M09534-08-T02	EA	MOLDING - TRIM/VEE - .2" X 1" X 24.5" - HONEY CHERRY
3A	M09511-32-T78	EA	MOLDING - TRIM/VEE - .4" X 1" X 26.8" - CONCERT CHERRY
3A	M09511-32-T79	EA	MOLDING - TRIM/VEE - .4" X 1" X 26.8" - WASHED MAPLE
3A	M09511-32-T80	EA	MOLDING - TRIM/VEE - .4" X 1" X 26.8" - SIERRA MAPLE
3A	M09511-86-T78	EA	MOLDING - TRIM/VEE - .4" X 1" X 28.3" - CONCERT CHERRY
3A	M09511-86-T79	EA	MOLDING - TRIM/VEE - .4" X 1" X 28.3" - WASHED MAPLE
3A	M09511-86-T80	EA	MOLDING - TRIM/VEE - .4" X 1" X 28.3" - SIERRA MAPLE
3A	M09477-63-S46	EA	MOLDING - TRIM/VEE - .4" X 1" X 64.1" - PORTSMOUTH OAK - BATH DOOR TRIM
3A	M09477-63-SR0	EA	MOLDING - TRIM/VEE - .4" X 1" X 64.1" - SIERRA MAPLE - BATH DOOR TRIM
3A	M09477-64-S46	EA	MOLDING - TRIM/VEE - .4" X 1" X 14.9" - PORTSMOUTH OAK - BATH DOOR TRIM
3A	M09477-64-SR0	EA	MOLDING - TRIM/VEE - .4" X 1" X 14.9" - SIERRA MAPLE - BATH DOOR TRIM
4A	M09462-54-R90	EA	MOLDING - FLUTED, CURVED - .6" X 6" X 82.7" - CONCERT CHERRY
4A	M09462-54-R91	EA	MOLDING - FLUTED, CURVED - .6" X 6" X 82.7" - WASHED MAPLE
4A	M09462-54-RE3	EA	MOLDING - FLUTED, CURVED - .6" X 6" X 82.7" - HONEY CHERRY
5A	M09471-79-R38	EA	MOLDING - TRIM/COVE - .8" X .8" X 95.8" - OAK/PORTS OAK - PORTSMOUTH OAK
5A	M09471-79-R39	EA	MOLDING - TRIM/COVE - .8" X .8" X 95.8" - CHERRY/CHERRY - CONCERT CHERRY
5A	M09471-79-R46	EA	MOLDING - TRIM/COVE - .8" X .8" X 95.8" - MAPLE/MAPLE - WASHED MAPLE
5A	M09471-79-RE0	EA	MOLDING - TRIM/COVE - .8" X .8" X 95.8" - HONEY/CHERRY- HONEY CHERRY
5A	M09471-79-SA3	EA	MOLDING - TRIM/COVE - .8" X .8" X 95.8" - HONEY/MAPLE - SIERRA MAPLE

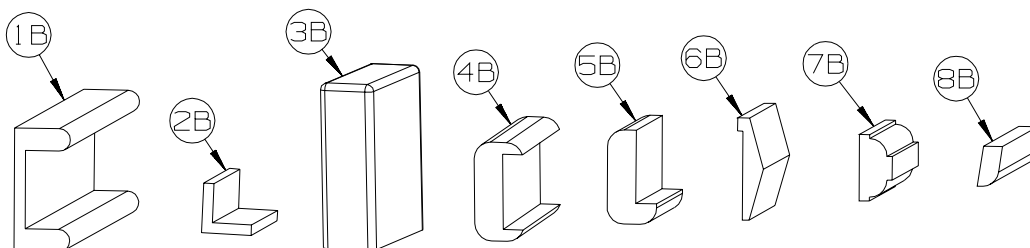

KEY	PART NUMBER	U/M	DESCRIPTION
1B	M09501-84-TG0	EA	MOLDING/TRIM - CAP/WALL - 2.2" X 85.9" - PORTSMOUTH OAK
1B	M09501-84-TG1	EA	MOLDING/TRIM - CAP/WALL - 2.2" X 85.9" - CONCERT CHERRY
1B	M09501-84-TG2	EA	MOLDING/TRIM - CAP/WALL - 2.2" X 85.9" - WASHED MAPLE
1B	M09520-07-TD3	EA	MOLDING/TRIM - CAP/WALL - 2.2" X 80.5" - SIERRA MAPLE
1B	M09501-84-TG3	EA	MOLDING/TRIM - CAP/WALL - 2.2" X 85.9" - HONEY CHERRY
2B	M09511-81-TA1	EA	MOLDING/TRIM - L SHAPE - .8"X .8"X 80.2" - CONCERT CHERRY
2B	M09511-81-TA2	EA	MOLDING/TRIM - L SHAPE - .8"X .8"X 80.2" - WASHED MAPLE
2B	M09511-81-TA3	EA	MOLDING/TRIM - L SHAPE - .8"X .8"X 80.2" - SIERRA MAPLE
3B	M09515-81-T01	EA	MOLDING/HARDWOOD STRAIGHT - 74.3" - WASHED MAPLE
3B	M09515-81-T02	EA	MOLDING/HARDWOOD STRAIGHT - 74.3" - HONEY CHERRY
4B	M09511-42-T77	EA	MOLDING - TRIM - W/NOTCH - 1.5" X 86.4" - PORTSMOUTH OAK
4B	M09511-42-T78	EA	MOLDING - TRIM - W/NOTCH - 1.5" X 86.4" - CONCERT CHERRY
4B	M09511-42-T79	EA	MOLDING - TRIM - W/NOTCH - 1.5" X 86.4" - WASHED MAPLE
4B	M09511-42-T80	EA	MOLDING - TRIM - W/NOTCH - 1.5" X 86.4" - SIERRA MAPLE
5B	M09515-18-T78	EA	MOLDING - HARDWOOD-W/NOTCH - 1.4"X 86.2" - CONCERT CHERRY
5B	M09515-18-T79	EA	MOLDING - HARDWOOD-W/NOTCH - 1.4"X 86.2" - WASHED MAPLE
5B	M09515-18-T80	EA	MOLDING - HARDWOOD-W/NOTCH - 1.4"X 86.2" - SIERRA MAPLE
6B	M09515-52-TG1	EA	MOLDING - TRIM/VEE - 1.5" X 73.9" - CONCERT CHERRY
6B	M09515-52-TG2	EA	MOLDING - TRIM/VEE - 1.5" X 73.9" - WASHED MAPLE
6B	M09515-52-TG3	EA	MOLDING - TRIM/VEE - 1.5" X 73.9" - HONEY CHERRY
7B	Y00076-32-438	EA	MOLDING/TRIM - .5" X 1" X 96" - CHERRY (UNSTAINED)
7B	Y00076-22-438	EA	MOLDING/TRIM - .5" X 1" X 96" - MAPLE (UNSTAINED)
8B	Y00086-72-438	EA	MOLDING - VINYL WRAP - .7" X 1.6" X 96" - PORTSMOUTH OAK - PORTSMOUTH OAK
8B	Y00086-62-438	EA	MOLDING - 96" - CONCERT CHERRY (U90/94/98/A1/A5/B1/C1/C5/D1/D5/E1/E5/F1/F5/G1/G5/H1/H5)
8B	Y00086-D2-438	EA	MOLDING - VINYL WRAP - .7" X 1.6" X 96" - CONCERT CHERRY (UM1 THRU UM9, UN1 THRU UN9)
8B	Y00086-A2-438	EA	MOLDING - VINYL WRAP - .7" X 1.6" X 96" - WASHED MAPLE
8B	Y00086-92-438	EA	MOLDING - VINYL WRAP - .7" X 1.6" X 96" - SIERRA MAPLE - SIERRA MAPLE

INTERIOR FINISH GROUP (CONTINUED)
MOLDINGS & TRIMS (CONTINUED)

KEY	PART NUMBER	U/M	DESCRIPTION
8B	Y00087-62-438	EA	MOLDING - 96" - CONCERT CHERRY (U90/94/98/A1/A5/B1/C1/C5/D1/D5/E1/E5/F1/F5/G1/G5/H1/H5)
8B	Y00087-D2-438	EA	MOLDING - VINYL WRAP - .7" X 2.9" X 96" - CONCERT CHERRY (UM1 THRU UM9, UN1 THRU UN9)
8B	Y00087-A2-438	EA	MOLDING - VINYL WRAP - .7" X 2.9" X 96" - WASHED MAPLE
8B	Y00087-92-438	EA	MOLDING - VINYL WRAP - .7" X 2.9" X 96" - SIERRA MAPLE
8B	Y00300-62-438	EA	MOLDING - 96" - CONCERT CHERRY (U90/94/98/A1/A5/B1/C1/C5/D1/D5/E1/E5/F1/F5/G1/G5/H1/H5)
8B	Y00300-D2-438	EA	MOLDING - VINYL WRAP - .3" X .6" X 96" - CONCERT CHERRY (UM1 THRU UM9, UN1 THRU UN9)
8B	Y00300-A2-438	EA	MOLDING - VINYL WRAP - .3" X .6" X 96" - WASHED MAPLE
8B	Y00300-92-438	EA	MOLDING - VINYL WRAP - .3" X .6" X 96" - SIERRA MAPLE

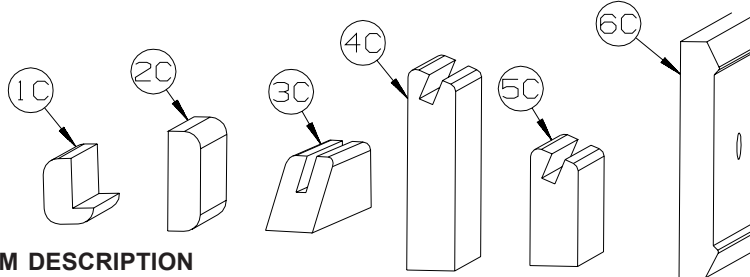

KEY	PART NUMBER	U/M	DESCRIPTION
1C	M09520-19-TD1	EA	MOLDING - TRIM - W/NOTCH - 1" X 86.3" - CONCERT CHERRY
1C	M09520-19-TD2	EA	MOLDING - TRIM - W/NOTCH - 1" X 86.3" - WASHED MAPLE
1C	M09520-19-TD3	EA	MOLDING - TRIM - W/NOTCH - 1" X 86.3" - HONEY CHERRY
1C	M09525-27-UF1	EA	MOLDING - HARDWOOD - .75" X 1.4" X 32.4" - CONCERT CHERRY
1C	M09525-27-UF2	EA	MOLDING - HARDWOOD - .75" X 1.4" X 32.4" - WASHED MAPLE
1C	M09525-27-UF3	EA	MOLDING - HARDWOOD - .75" X 1.4" X 32.4" - SIERRA MAPLE
2C	M09511-46-T77	EA	MOLDING/TRIM - .5" X 1.5" X 86.5" - PORTSMOUTH OAK
2C	M09511-46-T78	EA	MOLDING/TRIM - .5" X 1.5" X 86.5" - CONCERT CHERRY
2C	M09511-46-T79	EA	MOLDING/TRIM - .5" X 1.5" X 86.5" - WASHED MAPLE
2C	M09511-46-T80	EA	MOLDING/TRIM - .5" X 1.5" X 86.5" - SIERRA MAPLE
3C	Y00223-42-438	EA	MOLDING - HARDWOOD/OAK - .7" X 1" X 96"
3C	Y00223-32-438	EA	MOLDING - HARDWOOD/CHERRY - .7" X 1" X 96"
3C	Y00223-22-438	EA	MOLDING - HARDWOOD/MAPLE - .7" X 1" X 96"
4C	Y00054-62-438	EA	MOLDING- 96" - CONCERT CHERRY (U90/94/98/A1/A5/B1/C1/C5/D1/D5/E1/E5/F1/F5/G1/G5/H1/H5)
4C	Y00054-D2-438	EA	MOLDING/VYL WRP-BVLD-.73" X 3.1" X 96" - CONCERT CHERRY (UM1 THRU UM9, UN1 THRU UN9)
4C	Y00054-A2-438	EA	MOLDING/VINYL WRAP-BEVELED ENDS-.73"X3.1"X96" - WASHED MAPLE
4C	Y00054-92-438	EA	MOLDING/VINYL WRAP-BEVELED-.73" X 3.1" X 96" - SIERRA MAPLE
4C	Y00258-62-438	EA	MOLDING/VYL 96" - CONCERT CHERRY (U90/94/98/A1/A5/B1/C1/C5/D1/D5/E1/E5/F1/F5/G1/G5/H1/H5)
4C	Y00258-D2-438	EA	MOLDING/VINYL WRP-BVLD-.73" X 3.1" X 96" - CONCERT CHERRY (UM1 THRU UM9, UN1 THRU UN9)
4C	Y00258-A2-438	EA	MOLDING/VINYL WRAP-BEVELED ENDS-.73"X3.1"X96" - WASHED MAPLE
4C	Y00258-92-438	EA	MOLDING/VINYL WRAP-BEVELED-.73" X 3.1" X 96" - SIERRA MAPLE
5C	Y00259-62-438	EA	MOLDING/VYL 96" - CONCERT CHERRY (U90/94/98/A1/A5/B1/C1/C5/D1/D5/E1/E5/F1/F5/G1/G5/H1/H5)
5C	Y00259-D2-438	EA	MOLDING/VINYL WRP-BVLD-.73" X 1.8" X 96" - CONCERT CHERRY (UM1 THRU UM9, UN1 THRU UN9)
5C	Y00259-A2-438	EA	MOLDING/VINYL WRAP-BEVELED-.73"X1.8"X96" - WASHED MAPLE
5C	Y00259-92-438	EA	MOLDING/VINYL WRAP-BEVELED-.73"X1.8"X96" - SIERRA MAPLE
6C	Y00152-A2-438	EA	MOLDING/TRIM - VINYL - .6" X 3.5" X 96" - WASHED MAPLE
6C	Y00152-92-438	EA	MOLDING/TRIM - VINYL - .6" X 3.5" X 96" - SIERRA MAPLE

INTERIOR FINISH GROUP (CONTINUED)
MOLDINGS & TRIMS (CONTINUED)

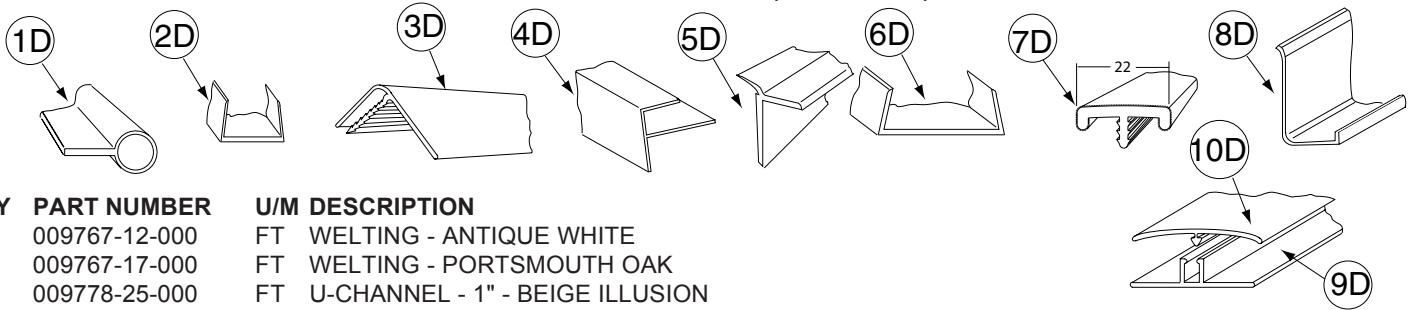

KEY	PART NUMBER	U/M	DESCRIPTION
1D	009767-12-000	FT	WELTING - ANTIQUE WHITE
1D	009767-17-000	FT	WELTING - PORTSMOUTH OAK
2D	009778-25-000	FT	U-CHANNEL - 1" - BEIGE ILLUSION
2D	009778-26-000	FT	U-CHANNEL - 1 1/4" - BEIGE ILLUSION
2D	009778-38-000	FT	U-CHANNEL - 1" - BONE
2D	009778-32-000	FT	U-CHANNEL - 1" - PORTSMOUTH OAK
2D	009778-34-000	FT	U-CHANNEL - 1" - CONCERT CHERRY
2D	009778-27-000	FT	U-CHANNEL - 1" - WASHED MAPLE
2D	009778-35-000	FT	U-CHANNEL - 1" - HONEY CHERRY
2D	009778-36-000	FT	U-CHANNEL - 1" - SIERRA MAPLE
3D	009809-30-000	EA	MOLDING - CORNER - OUTSIDE - 1" X 84" - BEIGE ILLUSION
3D	009809-37-000	EA	MOLDING - CORNER - OUTSIDE - 1" X 84" - BONE
3D	009809-32-000	EA	MOLDING - CORNER - OUTSIDE - 1" X 84" - PORTSMOUTH OAK
3D	009809-33-000	EA	MOLDING - CORNER - OUTSIDE - 1" X 84" - CONCERT CHERRY
3D	009809-31-000	EA	MOLDING - CORNER - OUTSIDE - 1" X 84" - WASHED MAPLE
3D	009809-34-000	EA	MOLDING - CORNER - OUTSIDE - 1" X 84" - HONEY CHERRY
3D	009809-35-000	EA	MOLDING - CORNER - OUTSIDE - 1" X 84" - SIERRA MAPLE
4D	009812-31-000	EA	MOLDING - CORNER - 1/2" W/1/4"CHAN X 84" - BEIGE ILLUSION
4D	009812-40-000	EA	MOLDING - CORNER - 1/2" W/1/4"CHAN X 84" - BONE
4D	009812-35-000	EA	MOLDING - CORNER - 1/2" W/1/4"CHAN X 84" - PORTSMOUTH OAK
4D	009812-36-000	EA	MOLDING - CORNER - 1/2" W/1/4"CHAN X 84" - CONCERT CHERRY
4D	009812-33-000	EA	MOLDING - CORNER - 1/2" W/1/4"CHAN X 84" - WASHED MAPLE
4D	009812-37-000	EA	MOLDING - CORNER - 1/2" W/1/4"CHAN X 84" - HONEY CHERRY
4D	009812-38-000	EA	MOLDING - CORNER - 1/2" W/1/4"CHAN X 84" - SIERRA MAPLE
5D	022992-11-000	FT	MOLDING - REVERSE COVE - T-SHAPED - IVORY
5D	022992-18-000	FT	MOLDING - REVERSE COVE - T-SHAPED - BONE
5D	022992-14-000	FT	MOLDING - REVERSE COVE - T-SHAPED - BRIGHT WHITE
6D	070504-42-000	FT	U-CHANNEL - PLASTIC - .13" X 84" - BEIGE ILLUSION
6D	070504-69-000	FT	U-CHANNEL - PLASTIC - .13" X 84" - BONE
6D	070504-43-000	FT	U-CHANNEL - PLASTIC - .9" X 96" - BEIGE ILLUSION
6D	070504-70-000	FT	U-CHANNEL - PLASTIC - .8" X 84" - BONE
6D	070504-57-000	FT	U-CHANNEL - PLASTIC - .13" X 84" - PORTSMOUTH OAK
6D	070504-58-000	FT	U-CHANNEL - PLASTIC - .9" X 84" - PORTSMOUTH OAK
6D	070504-60-000	FT	U-CHANNEL - PLASTIC - .13" X 84" - CONCERT CHERRY
6D	070504-61-000	FT	U-CHANNEL - PLASTIC - .9" X 84" - CONCERT CHERRY
6D	070504-50-000	FT	U-CHANNEL - PLASTIC - .13" X 96" - WASHED MAPLE
6D	070504-51-000	FT	U-CHANNEL - PLASTIC - .9" X 96" - WASHED MAPLE
6D	070504-62-000	FT	U-CHANNEL - PLASTIC - 1.65" X 84" - HONEY CHERRY
6D	070504-63-000	FT	U-CHANNEL - PLASTIC - .9" X 84" - HONEY CHERRY
6D	070504-65-000	FT	U-CHANNEL - PLASTIC - 1.65" X 84" - SIERRA MAPLE
6D	070504-66-000	FT	U-CHANNEL - PLASTIC - .9" X 84" - SIERRA MAPLE
7D	083620-15-000	FT	MOLDING-T - W/EDGE LIP - 7/8" FACE - BEIGE ILLUSION
7D	083620-25-000	FT	MOLDING-T - W/EDGE LIP - 7/8" FACE - BONE
7D	083620-20-000	FT	MOLDING-T - W/EDGE LIP - 7/8" FACE - PORTSMOUTH OAK
7D	083620-21-000	FT	MOLDING-T - W/EDGE LIP - 7/8" FACE - CONCERT CHERRY
7D	083620-19-000	FT	MOLDING-T - W/EDGE LIP - 7/8" FACE - WASHED MAPLE
7D	083620-24-000	FT	MOLDING-T - W/EDGE LIP - 7/8" FACE - HONEY CHERRY
7D	083620-22-000	FT	MOLDING-T - W/EDGE LIP - 7/8" FACE - SIERRA MAPLE
8D	085746-04-000	FT	TRIM-J - CARPET 1.2" X .5" ANGLE - 12' LONG - OFF WHITE
9D	086229-01-000	EA	RETAINER - BATTEN - .75" X 92.1" - ANY COLOR
10D	086229-20-000	EA	BATTEN - 1" X 96" - BEIGE

INTERIOR FINISH GROUP (CONTINUED)
MOLDINGS & TRIMS (CONTINUED)

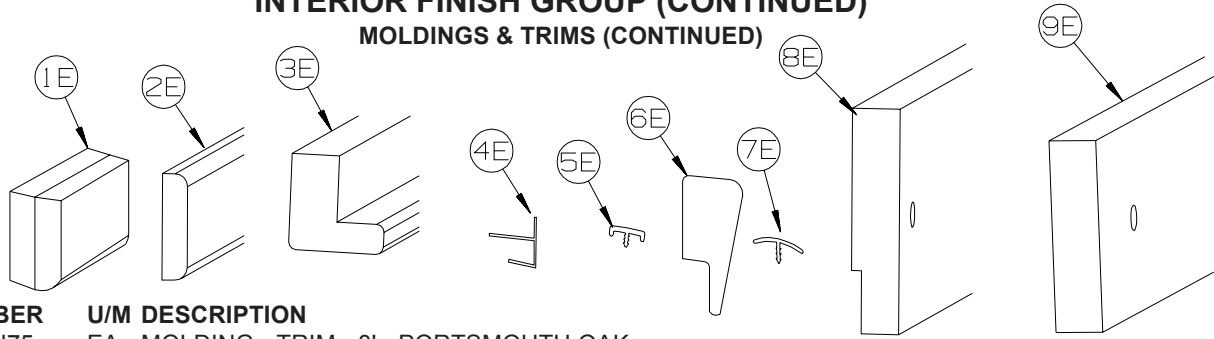

KEY	PART NUMBER	U/M	DESCRIPTION
1E	100659-30-N75	EA	MOLDING - TRIM - 8' - PORTSMOUTH OAK
1E	100659-30-N74	EA	MOLDING - TRIM - 8' - CONCERT CHERRY
1E	100659-30-M84	EA	MOLDING - TRIM - 8' - WASHED MAPLE
1E	100659-27-RA3	EA	MOLDING - TRIM - HONEY CHERRY
1E	100659-31-SA3	EA	MOLDING - TRIM - SIERRA MAPLE
2E	100818-01-12A	EA	MOLDING - VINYL WRAPPED - 1.6" X .4" X 84" - PORTSMOUTH OAK
2E	100818-01-13A	EA	MOLDING - VYL 84" - CONCERT CHERRY (U90/94/98/A1/A5/B1/C1/C5/D1/D5/E1/E5/F1/F5/G1/G5/H1/H5)
2E	100818-01-23A	EA	MOLDING - VINYL WRPPD - 1.6" X .4" X 84" - CONCERT CHERRY (UM1 THRU UM9, UN1 THRU UN9)
2E	100818-01-21A	EA	MOLDING - VINYL WRAPPED - 1.6" X .4" X 84" - WASHED MAPLE
2E	100818-01-14A	EA	MOLDING - VINYL WRAPPED - 1.6" X .4" X 84" - HONEY CHERRY
2E	100818-01-22A	EA	MOLDING - VINYL WRAPPED - 1.6" X .4" X 84" - SIERRA MAPLE
3E	100819-01-12A	EA	MOLDING - VINYL WRAPPED-L-SHAPED-1.5"X1.5"X84" - PORTSMOUTH OAK
3E	100819-01-13A	EA	MOLDING - VYL 84" - CONCERT CHERRY (U90/94/98/A1/A5/B1/C1/C5/D1/D5/E1/E5/F1/F5/G1/G5/H1/H5)
3E	100819-01-23A	EA	MOLDING - VYL WRPPD-L-SHPD-1.5"X1.5"X84" - CONCERT CHERRY (UM1 THRU UM9, UN1 THRU UN9)
3E	100819-01-21A	EA	MOLDING - VINYL WRAPPED-L-SHAPED-1.5"X1.5"X84" - WASHED MAPLE
3E	100819-01-14A	EA	MOLDING - VINYL WRAPPED-L-SHAPED-1.5"X1.5"X84" - HONEY CHERRY
3E	100819-01-22A	EA	MOLDING - VINYL WRAPPED-L-SHAPED-1.5"X1.5"X84" - SIERRA MAPLE
4E	103186-01-07A	FT	MOLDING/PLASTIC - 3/8" U-CHANNEL-3/4" FACE -BEIGE ILLUSION
4E	103186-01-09A	FT	MOLDING/PLASTIC - 3/8" U-CHAN'L-3/4" FACE - PORTSMOUTH OAK
4E	103186-01-10A	FT	MOLDING/PLASTIC - 3/8" U-CHAN'L-3/4" FACE - CONCERT CHERRY
4E	103186-01-08A	FT	MOLDING/PLASTIC - 3/8" U-CHANNEL-3/4"FACE-WASHED MAPLE 8' - WASHED MAPLE
4E	103186-01-11A	FT	MOLDING/PLASTIC - 3/8" U-CHAN'L-3/4" FACE - HONEY CHERRY
4E	103186-01-12A	FT	MOLDING/PLASTIC - 3/8" U-CHAN'L-3/4" FACE - SIERRA MAPLE
4E	103186-02-07A	FT	MOLDING/PLASTIC-1" U-CHAN'L-1 3/8" FACE - BEIGE ILLUSION
4E	103186-02-09A	FT	MOLDING/PLASTIC - 1" U-CHAN'L-1 3/8" FACE - PORTSMOUTH OAK
4E	103186-02-10A	FT	MOLDING/PLASTIC - 1" U-CHAN'L-1 3/8" FACE - CONCERT CHERRY
4E	103186-02-08A	FT	MOLDING/PLASTIC - 1" U-CHANNEL-1 3/8"FACE - WASHED MAPLE
4E	103186-02-11A	FT	MOLDING/PLASTIC - 1" U-CHAN'L-1 3/8" FACE - HONEY CHERRY
4E	103186-02-12A	FT	MOLDING/PLASTIC - 1" U-CHAN'L-1 3/8" FACE - SIERRA MAPLE
5E	104676-02-08A	FT	MOLDING-T - W/EDGE LIP - 11/16" FACE - PORTSMOUTH OAK
5E	104676-02-09A	FT	MOLDING-T - W/EDGE LIP - 11/16" FACE - CONCERT CHERRY
5E	104676-02-06A	FT	MOLDING-T - W/EDGE LIP - 11/16" FACE - WASHED MAPLE
5E	104676-02-10A	FT	MOLDING-T - W/EDGE LIP - 11/16" FACE - HONEY CHERRY
5E	104676-02-12A	FT	MOLDING-T - W/EDGE LIP - 11/16" FACE - SIERRA MAPLE
6E	105004-01-12A	EA	MOLDING - VINYL WRAPPED - 1" X 96" - PORTSMOUTH OAK
6E	105004-01-13A	EA	MOLDING - V W 8' - CONCERT CHERRY (U90/94/98/A1/A5/B1/C1/C5/D1/D5/E1/E5/F1/F5/G1/G5/H1/H5)
6E	105004-01-23A	EA	MOLDING - VINYL WRAPPED 1" X 8' - CONCERT CHERRY (UM1 THRU UM9, UN1 THRU UN9)
6E	105004-01-21A	EA	MOLDING - VINYL WRAPPED - 1" X 8' - WASHED MAPLE
6E	105004-01-24A	EA	MOLDING - VINYL WRAPPED - 1" X 8' - HONEY CHERRY
6E	105004-01-22A	EA	MOLDING - VINYL WRAPPED - 1" X 8' - SIERRA MAPLE
7E	105709-02-000	FT	MOLDING-T - W/EDGE LIP 3/4" FACE - BEIGE ILLUSION
8E	116951-45-R68	EA	MOLDING - TRIM - 3" X 30.3" - PORTSMOUTH OAK
8E	116951-45-R69	EA	MOLDING - TRIM - 3" X 30.3" - CONCERT CHERRY
8E	116951-45-R76	EA	MOLDING - TRIM - 3" X 30.3" - WASHED MAPLE
8E	116951-45-SA3	EA	MOLDING - TRIM - 3" X 30.3" - SIERRA MAPLE
9E	116951-37-R68	EA	MOLDING - TRIM - 3.5" X 38.6" - PORTSMOUTH OAK
9E	116951-37-R69	EA	MOLDING - TRIM - 3.5" X 38.6" - CONCERT CHERRY
9E	116951-37-R76	EA	MOLDING - TRIM - 3.5" X 38.6" - WASHED MAPLE
9E	116951-37-SA3	EA	MOLDING - TRIM - 3.5" X 38.6" - SIERRA MAPLE
9E	116951-51-SA0	EA	MOLDING - TRIM - 3.5" X 47.3" - PORTSMOUTH OAK
9E	116951-51-SA1	EA	MOLDING - TRIM - 3.5" X 47.3" - CONCERT CHERRY
9E	116951-51-SA2	EA	MOLDING - TRIM - 3.5" X 47.3" - WASHED MAPLE
9E	116951-51-SA3	EA	MOLDING - TRIM - 3.5" X 47.3" - SIERRA MAPLE

INTERIOR FINISH GROUP (CONTINUED)
MOLDINGS & TRIMS (CONTINUED)

KEY	PART NUMBER	U/M	DESCRIPTION
9E	116951-55-TD0	EA	MOLDING - TRIM - 4.5" X 52.3" - PORTSMOUTH OAK
9E	116951-55-TD1	EA	MOLDING - TRIM - 4.5" X 52.3" - CONCERT CHERRY
9E	116951-55-TD2	EA	MOLDING - TRIM - 4.5" X 52.3" - WASHED MAPLE
9E	116951-55-TD3	EA	MOLDING - TRIM - 4.5" X 52.3" - SIERRA MAPLE
9E	116951-56-TD0	EA	MOLDING - TRIM - 4.5" X 52.3" - PORTSMOUTH OAK
9E	116951-56-TD1	EA	MOLDING - TRIM - 4.5" X 52.3" - CONCERT CHERRY
9E	116951-56-TD2	EA	MOLDING - TRIM - 4.5" X 52.3" - WASHED MAPLE
9E	116951-56-TD3	EA	MOLDING - TRIM - 4.5" X 52.3" - SIERRA MAPLE

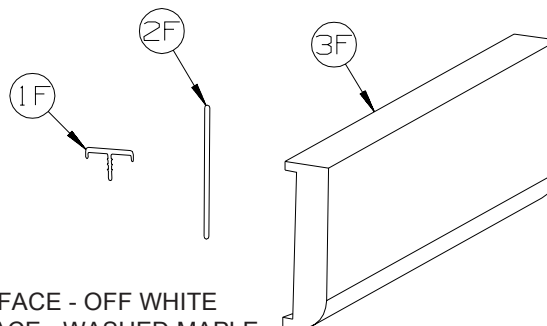

KEY	PART NUMBER	U/M	DESCRIPTION
1F	119520-01-01A	FT	MOLDING-T - OFFSET W/EDGE LIP - 1.3" FACE - OFF WHITE
1F	119520-03-03A	FT	MOLDING-T - OFFSET W/EDGE LIP - 1" FACE - WASHED MAPLE
1F	119520-03-06A	FT	MOLDING-T - OFFSET W/EDGE LIP - 1" FACE - HONEY CHERRY
2F	127842-01-01A	FT	SEAL - SIGHT SHIELD - 2" BLACK
	137885-A2-438	EA	LUMBER - VYL .75" - CONCERT CHERRY (U90/94/98/A1/A5/B1/C1/C5/D1/D5/E1/E5/F1/F5/G1/G5/H1/H5)
	160300-A2-438	EA	LUMBER - VINYL WRAPPED - .7" X .75" X 96" - CONCERT CHERRY (UM1 THRU UM9, UN1 THRU UN9)
	137885-D2-438	EA	LUMBER - VYL1.5" - CONCERT CHERRY (U90/94/98/A1/A5/B1/C1/C5/D1/D5/E1/E5/F1/F5/G1/G5/H1/H5)
	160300-D2-438	EA	LUMBER - VINYL WRAPPED - .7" X 1.5" X 96" - CONCERT CHERRY (UM1 THRU UM9, UN1 THRU UN9)
	137885-E2-438	EA	LUMBER - VYL2" -CONCERT CHERRY (U90/94/98/A1/A5/B1/C1/C5/D1/D5/E1/E5/F1/F5/G1/G5/H1/H5)
	160300-E2-438	EA	LUMBER - VINYL WRAPPED - .7" X 2" X 96" - CONCERT CHERRY (UM1 THRU UM9, UN1 THRU UN9)
	137885-F2-438	EA	LUMBER - VYL2.5" - CONCERT CHERRY (U90/94/98/A1/A5/B1/C1/C5/D1/D5/E1/E5/F1/F5/G1/G5/H1/H5)
	160300-F2-438	EA	LUMBER - VINYL WRAPPED - .7" X 2.5" X 96" - CONCERT CHERRY (UM1 THRU UM9, UN1 THRU UN9)
	137885-G2-438	EA	LUMBER - VYL3" - CONCERT CHERRY (U90/94/98/A1/A5/B1/C1/C5/D1/D5/E1/E5/F1/F5/G1/G5/H1/H5)
	160300-G2-438	EA	LUMBER - VINYL WRAPPED - .7" X 3" X 96" - CONCERT CHERRY (UM1 THRU UM9, UN1 THRU UN9)
	137885-H2-438	EA	LUMBER - VYL3.5" - CONCERT CHERRY (U90/94/98/A1/A5/B1/C1/C5/D1/D5/E1/E5/F1/F5/G1/G5/H1/H5)
	160300-H2-438	EA	LUMBER - VINYL WRAPPED - .7" X 3.5" X 96" - CONCERT CHERRY (UM1 THRU UM9, UN1 THRU UN9)
	137885-J2-438	EA	LUMBER - VYL5.5" - CONCERT CHERRY (U90/94/98/A1/A5/B1/C1/C5/D1/D5/E1/E5/F1/F5/G1/G5/H1/H5)
	160300-J2-438	EA	LUMBER - VINYL WRAPPED - .7" X 5.5" X 96" - CONCERT CHERRY (UM1 THRU UM9, UN1 THRU UN9)
	137885-J2-743	EA	LUMBER - VYL5.5" - CONCERT CHERRY (U90/94/98/A1/A5/B1/C1/C5/D1/D5/E1/E5/F1/F5/G1/G5/H1/H5)
	160300-J2-743	EA	LUMBER - VINYL WRAPPED - .7" X 5.5" X 108" - CONCERT CHERRY (UM1 THRU UM9, UN1 THRU UN9)
	137885-K2-438	EA	LUMBER - VYL3.9" - CONCERT CHERRY (U90/94/98/A1/A5/B1/C1/C5/D1/D5/E1/E5/F1/F5/G1/G5/H1/H5)
	160300-K2-438	EA	LUMBER - VINYL WRAPPED - .7" X 3.9" X 96" - CONCERT CHERRY (UM1 THRU UM9, UN1 THRU UN9)
	137885-R2-438	EA	LUMBER - VYL 3" - CONCERT CHERRY (U90/94/98/A1/A5/B1/C1/C5/D1/D5/E1/E5/F1/F5/G1/G5/H1/H5)
	160300-R2-438	EA	LUMBER - VINYL WRAPPED - .7" X 3" X 96" - CONCERT CHERRY (UM1 THRU UM9, UN1 THRU UN9)
3F	137887-D2-134	EA	MOLDING - 1.6" X 84"- CONCERT CHERRY (U90/94/98/A1/A5/B1/C1/C5/D1/D5/E1/E5/F1/F5/G1/G5/H1/H5)
3F	160301-D2-134	EA	MOLDING -VINYL WRAPPED - .7" X 1.6" X 84" - CONCERT CHERRY (UM1 THRU UM9, UN1 THRU UN9)
3F	137887-D2-743	EA	MLDG - 1.6" X 108" - CONCERT CHERRY (U90/94/98/A1/A5/B1/C1/C5/D1/D5/E1/E5/F1/F5/G1/G5/H1/H5)
3F	160301-D2-743	EA	MOLDING - VINYL WRAPPED- .7" X 1.6" X 108" - CONCERT CHERRY (UM1 THRU UM9, UN1 THRU UN9)
3F	137887-F2-134	EA	MLDNG - 2.5" X 84" - CONCERT CHERRY (U90/94/98/A1/A5/B1/C1/C5/D1/D5/E1/E5/F1/F5/G1/G5/H1/H5)
3F	160301-F2-134	EA	MOLDING - VINYL WRAPPED - .7" X 2.5" X 84" - CONCERT CHERRY (UM1 THRU UM9, UN1 THRU UN9)
3F	137887-F2-743	EA	MLDG - 2.5" X 108" - CONCERT CHERRY (U90/94/98/A1/A5/B1/C1/C5/D1/D5/E1/E5/F1/F5/G1/G5/H1/H5)
3F	160301-F2-743	EA	MOLDING - VINYL WRPPD - .7" X 2.5" X 108" - CONCERT CHERRY (UM1 THRU UM9, UN1 THRU UN9)
3F	137887-F2-438	EA	MLDG - 2.5" X 96" - CONCERT CHERRY (U90/94/98/A1/A5/B1/C1/C5/D1/D5/E1/E5/F1/F5/G1/G5/H1/H5)
3F	160301-F2-438	EA	MOLDING - VINYL WRPPD - .7" X 2.5" X 96" - CONCERT CHERRY (UM1 THRU UM9, UN1 THRU UN9)
	137894-A2-438	EA	LUMBER - VINYL WRAPPED - .7" X .75" X 96" - PORTSMOUTH OAK
	137894-D2-438	EA	LUMBER - VINYL WRAPPED - .7" X 1.5" X 96" - PORTSMOUTH OAK
	137894-E2-438	EA	LUMBER - VINYL WRAPPED - .7" X 2" X 96" - PORTSMOUTH OAK
	137894-F2-438	EA	LUMBER - VINYL WRAPPED - .7" X 2.5" X 96" - PORTSMOUTH OAK
	137894-G2-438	EA	LUMBER - VINYL WRAPPED - .7" X 3" X 96" - PORTSMOUTH OAK
	137894-H2-438	EA	LUMBER - VINYL WRAPPED - .7" X 3.5" X 96" - PORTSMOUTH OAK
	137894-J2-438	EA	LUMBER - VINYL WRAPPED - .7" X 5.5" X 80.2" - PORTSMOUTH OAK
	137894-J2-743	EA	LUMBER - VINYL WRAPPED - .7" X 5.5" X 96" - PORTSMOUTH OAK
	137894-K2-438	EA	LUMBER - VINYL WRAPPED - .7" X 3.9" X 96" - PORTSMOUTH OAK
	137894-R2-438	EA	LUMBER - VINYL WRAPPED - .7" X 3" X 96" - PORTSMOUTH OAK

INTERIOR FINISH GROUP (CONTINUED)
MOLDINGS & TRIMS (CONTINUED)

KEY	PART NUMBER	U/M	DESCRIPTION
3F	137895-D2-134	EA	MOLDING - VINYL WRAPPED - .7" X 1.6" X 84"-PORTSMOUTH OAK
3F	137895-D2-743	EA	MOLDING - VINYL WRAPPED - .7" X 1.6" X 108"-PORTSMOUTH OAK
3F	137895-F2-438	EA	MOLDING - VINYL WRAPPED - .7" X 2.5" X 96" - PORTSMOUTH OAK
3F	137895-F2-743	EA	MOLDING - VINYL WRAPPED - .7" X 2.5" X 108" - PORTSMOUTH OAK
	146419-A2-438	EA	LUMBER - VINYL WRAPPED - .7" X .75" X 96" - HONEY CHERRY
	146419-D2-438	EA	LUMBER - VINYL WRAPPED - .7" X 1.5" X 96" - HONEY CHERRY
	146419-E2-438	EA	LUMBER - VINYL WRAPPED - .7" X 2" X 96" - HONEY CHERRY
	146419-F2-438	EA	LUMBER - VINYL WRAPPED - .7" X 2.5" X 96" - HONEY CHERRY
	146419-G2-438	EA	LUMBER - VINYL WRAPPED - .7" X 3" X 96" - HONEY CHERRY
	146419-H2-438	EA	LUMBER - VINYL WRAPPED - .7" X 3.5" X 96" - HONEY CHERRY
	146419-J2-438	EA	LUMBER - VINYL WRAPPED - .7" X 5.5" X 96" - HONEY CHERRY
	146419-J2-743	EA	LUMBER - VINYL WRAPPED - .7" X 5.5" X 108" - HONEY CHERRY
	146419-K2-438	EA	LUMBER - VINYL WRAPPED - .7" X 3.9" X 96" - HONEY CHERRY
	146419-R2-438	EA	LUMBER - VINYL WRAPPED - .7" X 3" X 96" - HONEY CHERRY
	146419-S2-438	EA	LUMBER - VINYL WRAPPED/FULL - .7"X 3.5"X 96"- HONEY CHERRY
	146419-T2-438	EA	LUMBER - VINYL WRAPPED/FULL - .7"X 5.5"X 96"- HONEY CHERRY
3F	146425-D2-134	EA	MOLDING - VINYL WRAPPED - .7" X 1.6" X 83.9" - HONEY CHERRY
3F	146425-F2-438	EA	MOLDING - VINYL WRAPPED - .7" X 2.6" X 96" - HONEY CHERRY
	149325-A2-438	EA	LUMBER - VINYL WRAPPED - .7" X .75" X 96" - WASHED MAPLE
	149325-D2-438	EA	LUMBER - VINYL WRAPPED - .7" X 1.5" X 96" - WASHED MAPLE
	149325-E2-438	EA	LUMBER - VINYL WRAPPED - .7" X 2" X 96" - WASHED MAPLE
	149325-F2-438	EA	LUMBER - VINYL WRAPPED - .7" X 2.5" X 96" - WASHED MAPLE
	149325-G2-438	EA	LUMBER - VINYL WRAPPED - .7" X 3" X 96" - WASHED MAPLE
	149325-H2-438	EA	LUMBER - VINYL WRAPPED - .7" X 3.5" X 96" - WASHED MAPLE
	149325-J2-438	EA	LUMBER - VINYL WRAPPED - .7" X 5.5" X 96" - WASHED MAPLE
	149325-J2-743	EA	LUMBER - VINYL WRAPPED - .7" X 5.5" X 108" - WASHED MAPLE
	149325-K2-438	EA	LUMBER - VINYL WRAPPED - .7" X 3.9" X 96" - WASHED MAPLE
	149325-R2-438	EA	LUMBER - VINYL WRAPPED - .7" X 3" X 96" - WASHED MAPLE
3F	149326-D2-134	EA	MOLDING - VINYL WRAPPED - .7" X 1.5" X 83.9" - WASHED MAPLE
3F	149326-D2-743	EA	MOLDING - VINYL WRAPPED - .7" X 1.5" X 108" - WASHED MAPLE
3F	149326-F2-134	EA	MOLDING - VINYL WRAPPED - .7" X 2.5" X 83.9" - WASHED MAPLE
3F	149326-F2-438	EA	MOLDING - VINYL WRAPPED - .7" X 2.5" X 96" - WASHED MAPLE
3F	149326-F2-743	EA	MOLDING - VINYL WRAPPED - .7" X 2.5" X 108" - WASHED MAPLE
	149330-A2-438	EA	LUMBER - VINYL WRAPPED - .7" X .75" X 96" - SIERRA MAPLE
	149330-D2-438	EA	LUMBER - VINYL WRAPPED - .7" X 1.5" X 96" - SIERRA MAPLE
	149330-E2-438	EA	LUMBER - VINYL WRAPPED - .7" X 2" X 96" - SIERRA MAPLE
	149330-F2-438	EA	LUMBER - VINYL WRAPPED - .7" X 2.5" X 96" - SIERRA MAPLE
	149330-G2-438	EA	LUMBER - VINYL WRAPPED - .7" X 3" X 96" - SIERRA MAPLE
	149330-H2-438	EA	LUMBER - VINYL WRAPPED - .7" X 3.5" X 96" - SIERRA MAPLE
	149330-J2-438	EA	LUMBER - VINYL WRAPPED - .7" X 5.5" X 96" - SIERRA MAPLE
	149330-J2-743	EA	LUMBER - VINYL WRAPPED - .7" X 5.5" X 108" - SIERRA MAPLE
	149330-K2-438	EA	LUMBER - VINYL WRAPPED - .7" X 3.9" X 96" - SIERRA MAPLE
	149330-R2-438	EA	LUMBER - VINYL WRAPPED - .7" X 3" X 96" - SIERRA MAPLE
3F	149331-D2-134	EA	MOLDING - VINYL WRAPPED - .7" X 1.5" X 83.9" - SIERRA MAPLE
3F	149331-D2-743	EA	MOLDING - VINYL WRAP - .7" X 1.5" X 108" - SIERRA MAPLE
3F	149331-F2-134	EA	MOLDING - VINYL WRAPPED - .7" X 2.5" X 83.9" - SIERRA MAPLE
3F	149331-F2-438	EA	MOLDING - VINYL WRAPPED - .7" X 2.5" X 96" - SIERRA MAPLE
3F	149331-F2-743	EA	MOLDING - VINYL WRAPPED - .7" X 2.5" X 108" - SIERRA MAPLE

INTERIOR FINISH GROUP (CONTINUED)
MOLDINGS & TRIMS (CONTINUED)

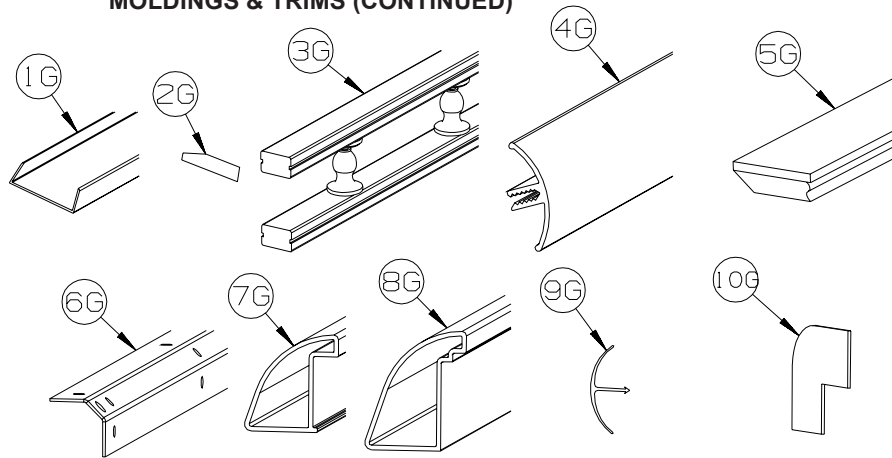

KEY	PART NUMBER	U/M	DESCRIPTION
1G	141260-01-01A	FT	U-CHANNEL - 1" - VILLAGE OAK
1G	141260-01-02A	FT	U-CHANNEL - 1" - GRADY BROWN
1G	141260-02-01A	FT	U-CHANNEL - 1 1/8" - VILLAGE OAK
1G	141260-02-02A	FT	U-CHANNEL - 1 1/8" - GRADY BROWN
2G	146306-01-01A	FT	TRANSITION - CARPET/TILE
3G	150167-01-07A	EA	RAIL - DECORATIVE - 96" W/O REVERSE SIDE GROOVE - PORTSMOUTH OAK
3G	150167-01-02A	EA	RAIL - DECORATIVE - 96" W/O REVERSE SIDE GROOVE - SALEM CHERRY - CONCERT CHERRY
3G	150167-01-03A	EA	RAIL - DECORATIVE - 96" W/O REVERSE SIDE GROOVE - WASHED MAPLE
3G	150167-01-09A	EA	RAIL - DECORATIVE - 96" W/O REVERSE SIDE GROOVE - SIERRA MAPLE
4G	151653-10-02A	EA	TRIM/RADIUS - CABINET CORNER - 79.6" - DULL METALLIC
4G	151653-13-02A	EA	TRIM/RADIUS - CABINET CORNER - 79.8" - DULL METALLIC
5G	151676-26-S46	EA	MOLDING/TRIM - .75" X 1.6" X 80.2" - PORTSMOUTH OAK
5G	151676-26-S47	EA	MOLDING/TRIM - .75" X 1.6" X 80.2" - CONCERT CHERRY
5G	151676-26-S48	EA	MOLDING/TRIM - .75" X 1.6" X 80.2" - WASHED MAPLE
5G	151676-26-SR0	EA	MOLDING/TRIM - .75" X 1.6" X 80.2" - SIERRA MAPLE
6G	151861-05-02B	EA	ANGLE - SUPPORT/CORNER - 1.4" X 78.6" - E-COATED
7G	151893-01-02A	EA	TRIM/RADIUS - CABINET BOTTOM - 72.6" - DULL METALLIC
8G	152077-01-02A	EA	TRIM/RADIUS - CABINET BOTTOM - 27.7" - DULL METALLIC
9G	156464-01-01A	FT	MOLDING - CORNER - RADIUS/PLASTIC - 8' - HONEY CHERRY
9G	156464-01-02A	FT	MOLDING - CORNER - RADIUS/PLASTIC - 8' - WASHED MAPLE
9G	156464-01-03A	FT	MOLDING - CORNER - RADIUS/PLASTIC - 8' - BONE
10G	160989-01-06A	FT	CAP - CORNER - RADIUS MOLDING - PLASTIC - WASHED MAPLE
10G	160989-01-07A	FT	CAP - CORNER - RADIUS MOLDING - PLASTIC - HONEY CHERRY

INTERIOR FINISH GROUP (CONTINUED)
PANELING & LAMINATES

KEY	PART NUMBER	U/M	DESCRIPTION
	P26866-11-N74	EA	HANDLE - DOOR/TAMBOUR - 20.8" - CHERRY
	P26866-11-N84	EA	HANDLE - DOOR/TAMBOUR - 20.8" - WASHED MAPLE
	P26866-11-RC3	EA	HANDLE - DOOR/TAMBOUR - 20.8" - HONEY CHERRY
	000885-C0-000	SF	PARTICLE BOARD - 3/4" X 4' X 8'- NEW CONC CHERRY - 2 SIDED
	000885-A7-000	SF	PARTICLE BOARD - 3/4" X 4' X 8' - HONEY CHERRY - 2 SIDED
	000885-B6-000	SF	PARTICLE BOARD - 3/4" X 4' X 8'- WASHED MAPLE - 2 SIDED
	000885-B8-000	SF	PARTICLE BOARD - 3/8" X 4' X 8'- NEW CONC CHERRY - 2 SIDED
	000885-B4-000	SF	PARTICLE BOARD - 3/8" X 4' X 8'- WASHED MAPLE - 2 SIDED
	000885-A9-000	SF	PARTICLE BOARD - 3/8" X 4' X 8' - HONEY CHERRY - 2 SIDED
	000885-B9-000	SF	PART BD-PAPER,N.CON.CHERRY
	000885-B5-000	SF	PARTICLE BOARD - 3/8" X 4' X 8'- WASHED MAPLE - 1 SIDED
	000885-A8-000	SF	PARTICLE BOARD - 3/8" X 4' X 8' - HONEY CHERRY - 1 SIDED
	000885-C3-000	SF	PARTICLE BOARD - 3/8" X 4' X 8' - WHITE THATCH EMB-1 SIDED
	074497-50-000	SF	PANELING - NEW CONCERT CHERRY - 1/8" X 4' X 8'
	074497-49-000	SF	PANELING - WASHED MAPLE - 1/8" X 4' X 8'
	074497-47-000	SF	PANELING - HONEY CHERRY - 1/8" X 4' X 8'
	076773-21-000	SF	PANELING - 2 SIDED/NEW CONC CHERRY - 1/8" X 4' X 8'
	076773-20-000	SF	PANELING - 2 SIDED/WASHED MAPLE - 1/8" X 4' X 8'
	076773-18-000	SF	PANELING - 2 SIDED/HONEY CHERRY - 1/8" X 4' X 8'
	079666-03-000	SF	PANELING - CLOSET - CEDAR - 4' X 7'
	088272-M3-000	SF	PANELING - VALENZA/STONE - 4' X 7.4' (UJ1, UJ2, UJ3)
	088272-N1-000	SF	PANELING - OASIS/RATTAN - 4' X 7.4' (UJ5, UJ6, UJ7)
			FROM: 00-00-00 THRU: 03-27-07
	088272-M7-000	SF	PANELING - KURTA/CANVAS - 4' X 7.4' (UJ5, UJ6, UJ7)
			FROM: 03-28-07 THRU: 99-99-99
	088272-M6-000	SF	PANELING - BISQUE - 4' X 7.4' (UK1, UK2, UK3)
	088272-M9-000	SF	PANELING - WHITE THATCHED - 4' X 8'
	154735-07-000	SF	PANELING - FLEXIBLE - VALENZA/STONE - 4' X 8' (UJ1, UJ2, UJ3)
	154735-05-000	SF	PANELING - FLEXIBLE - OASIS/RATTAN - 4' X 8' (UJ5, UJ6, UJ7)
			FROM: 00-00-00 THRU: 03-27-07
	154735-06-000	SF	PANELING - FLEXIBLE - KURTA/CANVAS - 4' X 8' (UJ5, UJ6, UJ7)
			FROM: 03-28-07 THRU: 99-99-99
	154735-08-000	SF	PANELING - FLEXIBLE - VILLA/BISQUE - 4' X 8' (UK1, UK2, UK3)
	074498-96-000	SF	LAMINATE - PLASTIC - CHERRY - 4' X 8' - CONCERT CHERRY
			FROM: 00-00-00 THRU: 10-02-06
	074498-C2-000	SF	LAMINATE - PLASTIC - CHERRY - 4' X 8' - CONCERT CHERRY
			FROM: 10-01-06 THRU: 99-99-99
	074498-A6-000	SF	LAMINATE - PLASTIC - HARDROCK MAPLE - 5' X 8' - WASHED MAPLE
	074498-A7-000	SF	LAMINATE - PLASTIC - GRAND ISLE - 5' X 8' - HONEY CHERRY
	074498-A2-000	SF	LAMINATE - PLASTIC - PHANTOM GRAY - 5' X 8'
	085284-F7-000	FT	TAPE/STRIP- TRUE GRIP - 1 1/2" WIDE - ADHESIVE BACKED
	085284-K3-000	FT	BATT TAPE - ADHESIVE BACKED - DECORATIVE - STONE (UJ1, UJ2, UJ3)
	085284-L1-000	FT	BATT TAPE - ADHESIVE BACKED - DECORATIVE - RATTAN (UJ5, UJ6, UJ7)
			FROM: 00-00-00 THRU: 03-27-07
	085284-K7-000	FT	BATT TAPE - ADHESIVE BACKED - DECORATIVE - KURTA/CANVAS (UJ5, UJ6, UJ7)
			FROM: 03-28-07 THRU: 99-99-99
	085284-K6-000	FT	BATT TAPE - ADHESIVE BACKED - DECORATIVE - BISQUE (UK1, UK2, UK3)
	088263-J9-000	EA	BATT STRIP - DECORATIVE - STONE (UJ1, UJ2, UJ3)
	088263-K7-000	EA	BATT STRIP - DECORATIVE - RATTAN - 8' (UJ5, UJ6, UJ7)
			FROM: 00-00-00 THRU: 03-27-07
	088263-K3-000	EA	BATT STRIP - DECORATIVE - KURTA/CANVAS - 8' (UJ5, UJ6, UJ7)
			FROM: 03-28-07 THRU: 99-99-99
	088263-K2-000	EA	BATT STRIP - DECORATIVE - BISQUE - 8' (UK1, UK2, UK3)
	093743-09-04A	FT	PLASTIC - ABS COIL - 6" WIDE - WHITE
	076325-71-000	FT	MOLDING - EDGE BAND - 1 5/16" X .038" - GRAY

INTERIOR FINISH GROUP (CONTINUED)

INTERIOR TRIM LAYOUT

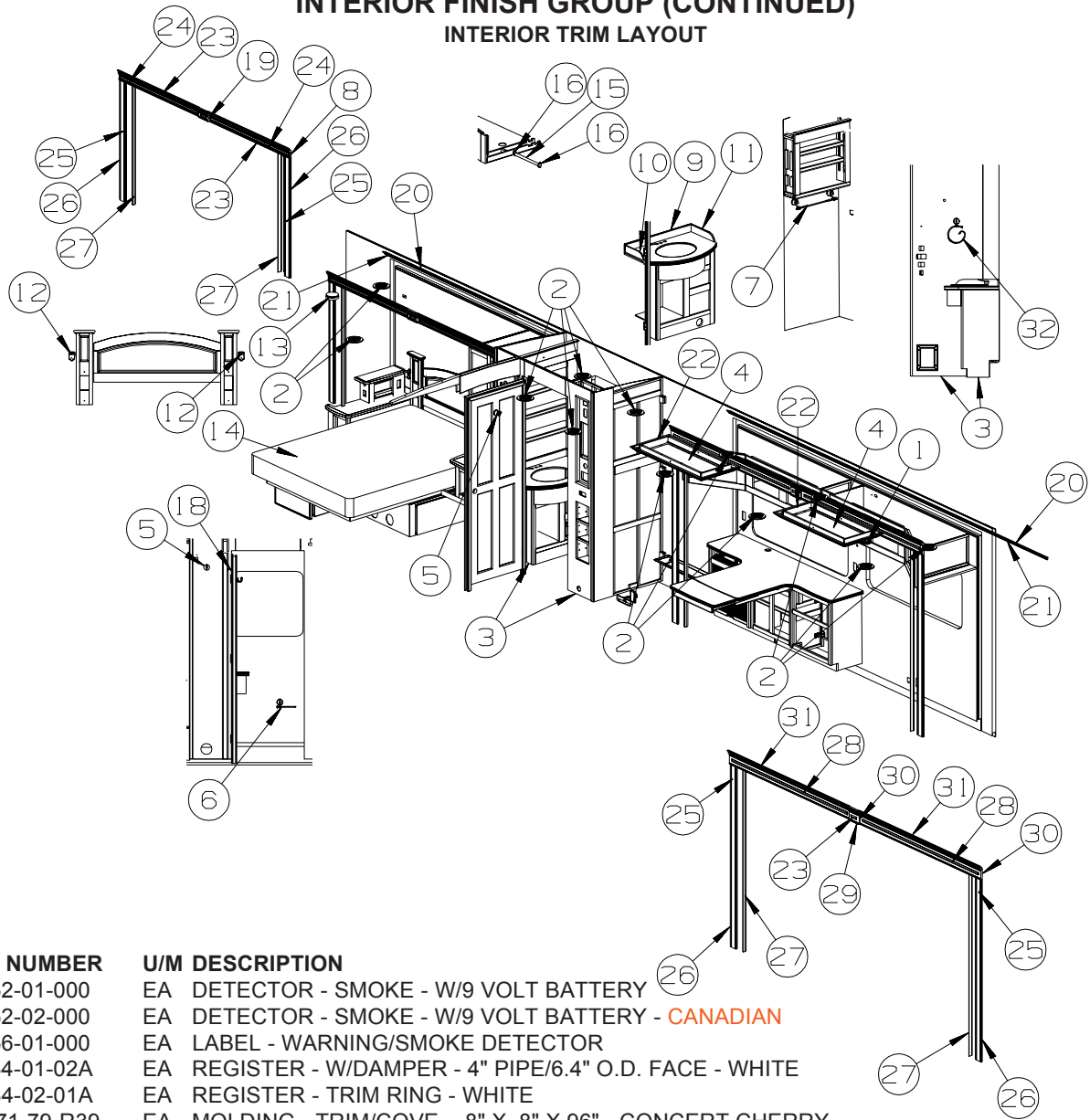

KEY	PART NUMBER	U/M	DESCRIPTION
1	072852-01-000	EA	DETECTOR - SMOKE - W/9 VOLT BATTERY
1	072852-02-000	EA	DETECTOR - SMOKE - W/9 VOLT BATTERY - CANADIAN
	077956-01-000	EA	LABEL - WARNING/SMOKE DETECTOR
2	120134-01-02A	EA	REGISTER - W/DAMPER - 4" PIPE/6.4" O.D. FACE - WHITE
2	120134-02-01A	EA	REGISTER - TRIM RING - WHITE
3	M09471-79-R39	EA	MOLDING - TRIM/COVE - .8" X .8" X 96" - CONCERT CHERRY
3	M09471-79-R46	EA	MOLDING - TRIM/COVE - .8" X .8" X 96" - WASHED MAPLE
3	M09471-79-RE0	EA	MOLDING - TRIM/COVE - .8" X .8" X 96" - HONEY CHERRY
4	145979-02-R84	EA	CABINET - OVERHEAD/LIGHT - CONCERT CHERRY
4	145979-02-SD2	EA	CABINET - OVERHEAD/LIGHT - WASHED MAPLE
4	145979-02-RE0	EA	CABINET - OVERHEAD/LIGHT - HONEY CHERRY
	133312-01-01A	EA	LENS - CLEAR DIFFUSER - 23.7" X 47.8"
5	152962-01-02A	EA	HOOK - ROBE - ANTIQUE NICKEL
6	152961-01-02A	EA	HOLDER - PAPER - ANTIQUE NICKEL
7	152960-01-02A	EA	TOWEL BAR - 18" - ANTIQUE NICKEL
8	153195-04-TG1	EA	MOLDING - F/SLIDEOUT - 48.4" - CONCERT CHERRY
8	153195-04-TG2	EA	MOLDING - F/SLIDEOUT - 48.4" - WASHED MAPLE
8	153195-04-TG3	EA	MOLDING - F/SLIDEOUT - 48.4" - HONEY CHERRY
9	153812-04-08A	EA	BACKSPLASH - COUNTERTOP - CORIAN - PRAIRIE (UJ1, UJ2, UJ3) FROM: 00-00-00 THRU: 06-04-06
9	153812-04-09C	EA	BACKSPLASH - COUNTERTOP - CORIAN - MOSS GLOSS (UJ1, UJ2, UJ3) FROM: 06-05-06 THRU: 99-99-99
9	153812-04-03A	EA	BACKSPLASH - COUNTERTOP - CORIAN - FOSSIL (UJ5, UJ6, UJ7) FROM: 00-00-00 THRU: 06-04-06
9	153812-04-11C	EA	BACKSPLASH - COUNTERTOP - CORIAN - COCOA BROWN GLOSS (UJ5, UJ6, UJ7) FROM: 06-05-06 THRU: 99-99-99
9	153812-04-07A	EA	BACKSPLASH - COUNTERTOP - CORIAN - DOESKIN (UK1, UK2, UK3) FROM: 00-00-00 THRU: 06-04-06
9	153812-04-09C	EA	BACKSPLASH - COUNTERTOP - CORIAN - MOSS GLOSS (UK1, UK2, UK3) FROM: 06-05-06 THRU: 99-99-99

INTERIOR FINISH GROUP (CONTINUED)
INTERIOR TRIM LAYOUT (CONTINUED)

KEY	PART NUMBER	U/M	DESCRIPTION
10	153812-05-08A	EA	BACKSPLASH - COUNTERTOP - CORIAN - PRAIRIE (UJ1, UJ2, UJ3) FROM: 00-00-00 THRU: 06-04-06
10	153812-05-09C	EA	BACKSPLASH - COUNTERTOP - CORIAN - MOSS GLOSS (UJ1, UJ2, UJ3) FROM: 06-05-06 THRU: 99-99-99
10	153812-05-03A	EA	BACKSPLASH - COUNTERTOP - CORIAN - FOSSIL (UJ5, UJ6, UJ7) FROM: 00-00-00 THRU: 06-04-06
10	153812-05-11C	EA	BACKSPLASH - COUNTERTOP - CORIAN - COCOA BROWN GLOSS (UJ5, UJ6, UJ7) FROM: 06-05-06 THRU: 99-99-99
10	153812-05-07A	EA	BACKSPLASH - COUNTERTOP - CORIAN - DOESKIN (UK1, UK2, UK3) FROM: 00-00-00 THRU: 06-04-06
10	153812-05-09C	EA	BACKSPLASH - COUNTERTOP - CORIAN - MOSS GLOSS (UK1, UK2, UK3) FROM: 06-05-06 THRU: 99-99-99
11	153812-06-08A	EA	BACKSPLASH - COUNTERTOP - CORIAN - PRAIRIE (UJ1, UJ2, UJ3) FROM: 00-00-00 THRU: 06-04-06
11	153812-06-09C	EA	BACKSPLASH - COUNTERTOP - CORIAN - MOSS GLOSS (UJ1, UJ2, UJ3) FROM: 06-05-06 THRU: 99-99-99
11	153812-06-03A	EA	BACKSPLASH - COUNTERTOP - CORIAN - FOSSIL (UJ5, UJ6, UJ7) FROM: 00-00-00 THRU: 06-04-06
11	153812-06-11C	EA	BACKSPLASH - COUNTERTOP - CORIAN - COCOA BROWN GLOSS (UJ5, UJ6, UJ7) FROM: 06-05-06 THRU: 99-99-99
11	153812-06-07A	EA	BACKSPLASH - COUNTERTOP - CORIAN - DOESKIN (UK1, UK2, UK3) FROM: 00-00-00 THRU: 06-04-06
11	153812-06-09C	EA	BACKSPLASH - COUNTERTOP - CORIAN - MOSS GLOSS (UK1, UK2, UK3) FROM: 06-05-06 THRU: 99-99-99
12	142411-05-000	EA	HOLDER - F/CONTROL (SELECT COMFORT)
13	125136-02-000	EA	DETECTOR/CO - GAS MODEL - 9 VOLT
14	154430-02-000	EA	MATTRESS - INNERSPRING - 60" X 79.5"
14	142411-02-000	EA	MATTRESS/AIR - 60" X 80" - SELECT COMFORT - SLEEP NUMBER BED-QUEEN SIZE
14	142411-06-000	EA	MATTRESS/AIR - 72" X 80" - SELECT COMFORT - SLEEP NUMBER BED-KING SIZE
15	Y00136-21-218	EA	DOWEL - WOOD - CLOTHES ROD - 1"DIAMETER X 4'
16	152301-01-01A	EA	FLANGE - PLASTIC - 1" CLOTHES ROD HOLDER - WHITE
17	007021-01-000	EA	SEAT BELT - 2" X 90" - BLACK
18	155436-01-02B	EA	STOP - DOOR/BATH - SATIN NICKEL
19	153195-03-TG1	EA	MOLDING - F/SLIDEOUT - 5.9" - CONCERT CHERRY
19	153195-03-TG2	EA	MOLDING - F/SLIDEOUT - 5.9" - WASHED MAPLE
19	153195-03-TG3	EA	MOLDING - F/SLIDEOUT - 5.9" - HONEY CHERRY
20	M09525-03-UJ1	EA	MOLDING/TRIM - .6" X 1" X 96" - CONCERT CHERRY
20	M09525-03-UJ2	EA	MOLDING/TRIM - .6" X 1" X 96" - WASHED MAPLE
20	M09525-03-UJ3	EA	MOLDING/TRIM - .6" X 1" X 96" - HONEY CHERRY
21	M09525-04-UJ1	EA	MOLDING/TRIM - ANGLED - 1" X 1" X 96" - CONCERT CHERRY
21	M09525-04-UJ2	EA	MOLDING/TRIM - ANGLED - 1" X 1" X 96" - WASHED MAPLE
21	M09525-04-UJ3	EA	MOLDING/TRIM - ANGLED - 1" X 1" X 96" - HONEY CHERRY
22	157478-01-UJ1	EA	CABINET - LIGHT/FLUORESCENT - CONCERT CHERRY
22	157478-01-UJ2	EA	CABINET - LIGHT/FLUORESCENT - WASHED MAPLE
22	157478-01-UJ3	EA	CABINET - LIGHT/FLUORESCENT - HONEY CHERRY
23	M09454-62-P55	EA	MOLDING - TRIM/VEE - .2" X 1" X 3.5" - CONCERT CHERRY
23	M09454-62-P56	EA	MOLDING - TRIM/VEE - .2" X 1" X 3.5" - WASHED MAPLE
23	M09454-62-RE0	EA	MOLDING - TRIM/VEE - .2" X 1" X 3.5" - HONEY CHERRY
24	M09503-30-TG1	EA	MOLDING - TRIM/VEE - .2" X 1" X 47.6" - CONCERT CHERRY
24	M09503-30-TG2	EA	MOLDING - TRIM/VEE - .2" X 1" X 47.6" - WASHED MAPLE
24	M09503-30-TG3	EA	MOLDING - TRIM/VEE - .2" X 1" X 47.6" - HONEY CHERRY
25	M09525-82-UJ1	EA	MOLDING/TRIM - 2.4" X 74.7" - CONCERT CHERRY
25	M09525-82-UJ2	EA	MOLDING/TRIM - 2.4" X 74.7" - WASHED MAPLE
25	M09525-82-UJ3	EA	MOLDING/TRIM - 2.4" X 74.7" - HONEY CHERRY
26	M09525-83-UJ1	EA	MOLDING/TRIM - 3.5" X 74.7" - CONCERT CHERRY
26	M09525-83-UJ2	EA	MOLDING/TRIM - 3.5" X 74.7" - WASHED MAPLE
26	M09525-83-UJ3	EA	MOLDING/TRIM - 3.5" X 74.7" - HONEY CHERRY
27	M09525-81-UJ1	EA	MOLDING - TRIM/VEE - 1.5" X 74.7" - CONCERT CHERRY
27	M09525-81-UJ2	EA	MOLDING - TRIM/VEE - 1.5" X 74.7" - WASHED MAPLE
27	M09525-81-UJ3	EA	MOLDING - TRIM/VEE - 1.5" X 74.7" - HONEY CHERRY
28	M09503-27-TG1	EA	MOLDING - TRIM/VEE - .2" X 1" X 69.7" - CONCERT CHERRY
28	M09503-27-TG2	EA	MOLDING - TRIM/VEE - .2" X 1" X 69.7" - WASHED MAPLE
28	M09503-27-TG3	EA	MOLDING - TRIM/VEE - .2" X 1" X 69.7" - HONEY CHERRY

INTERIOR FINISH GROUP (CONTINUED)
INTERIOR TRIM LAYOUT (CONTINUED)

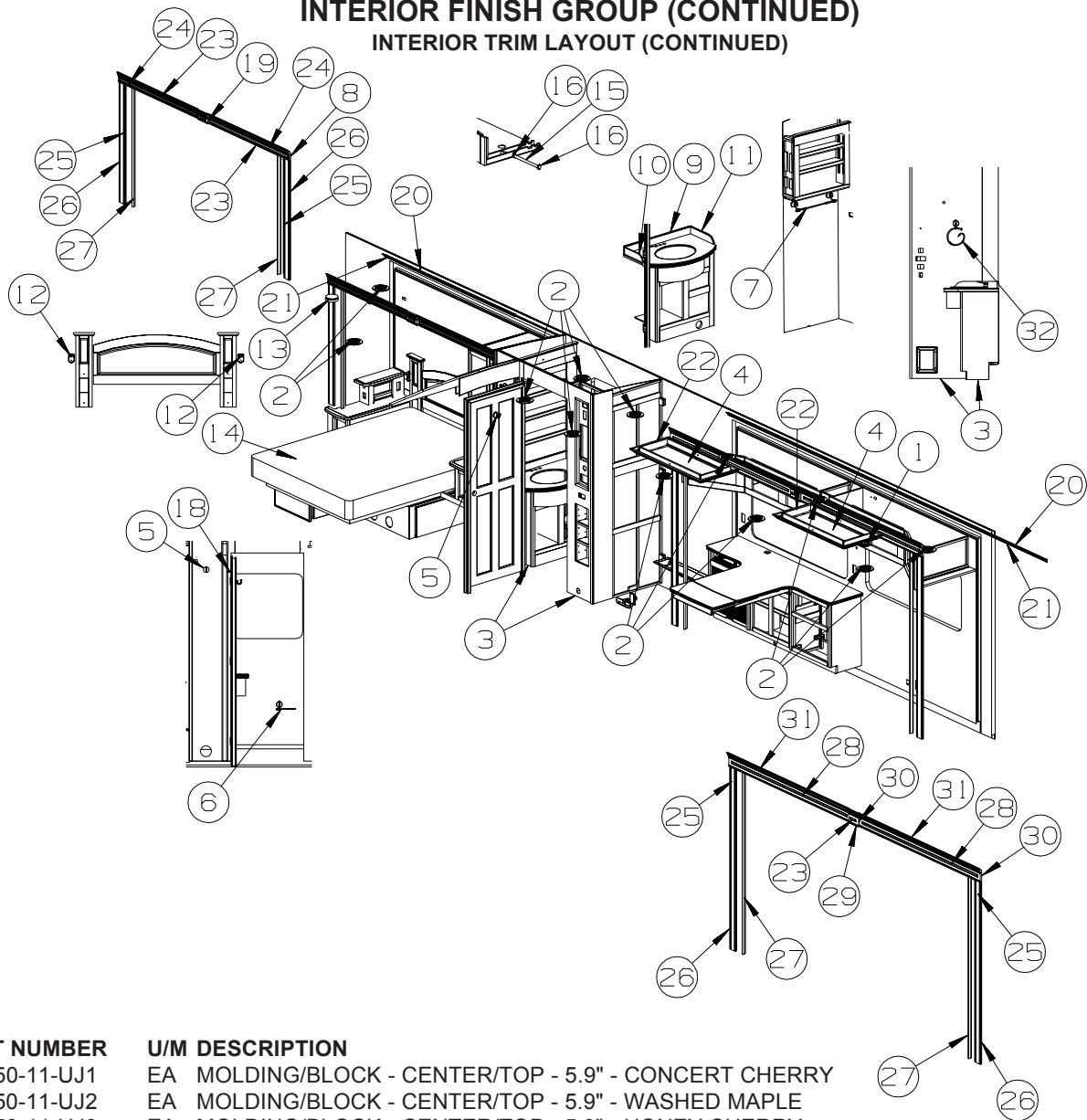

KEY	PART NUMBER	U/M	DESCRIPTION
29	157350-11-UJ1	EA	MOLDING/BLOCK - CENTER/TOP - 5.9" - CONCERT CHERRY
29	157350-11-UJ2	EA	MOLDING/BLOCK - CENTER/TOP - 5.9" - WASHED MAPLE
29	157350-11-UJ3	EA	MOLDING/BLOCK - CENTER/TOP - 5.9" - HONEY CHERRY
30	153117-02-TG1	EA	MOLDING - F/SLIDEOUT - 5.9" - CONCERT CHERRY
30	153117-02-TG2	EA	MOLDING - F/SLIDEOUT - 5.9" - WASHED MAPLE
30	153117-02-TG3	EA	MOLDING - F/SLIDEOUT - 5.9" - HONEY CHERRY
31	157350-12-UJ1	EA	MOLDING - SLIDEOUT/TOP - 72.8" - CONCERT CHERRY
31	157350-12-UJ2	EA	MOLDING - SLIDEOUT/TOP - 72.8" - WASHED MAPLE
31	157350-12-UJ3	EA	MOLDING - SLIDEOUT/TOP - 72.8" - HONEY CHERRY
32	152963-01-02A	EA	TOWEL RING - ANTIQUE NICKEL

INTERIOR FINISH GROUP (CONTINUED)
INTERIOR TRIM LAYOUT (CONTINUED)

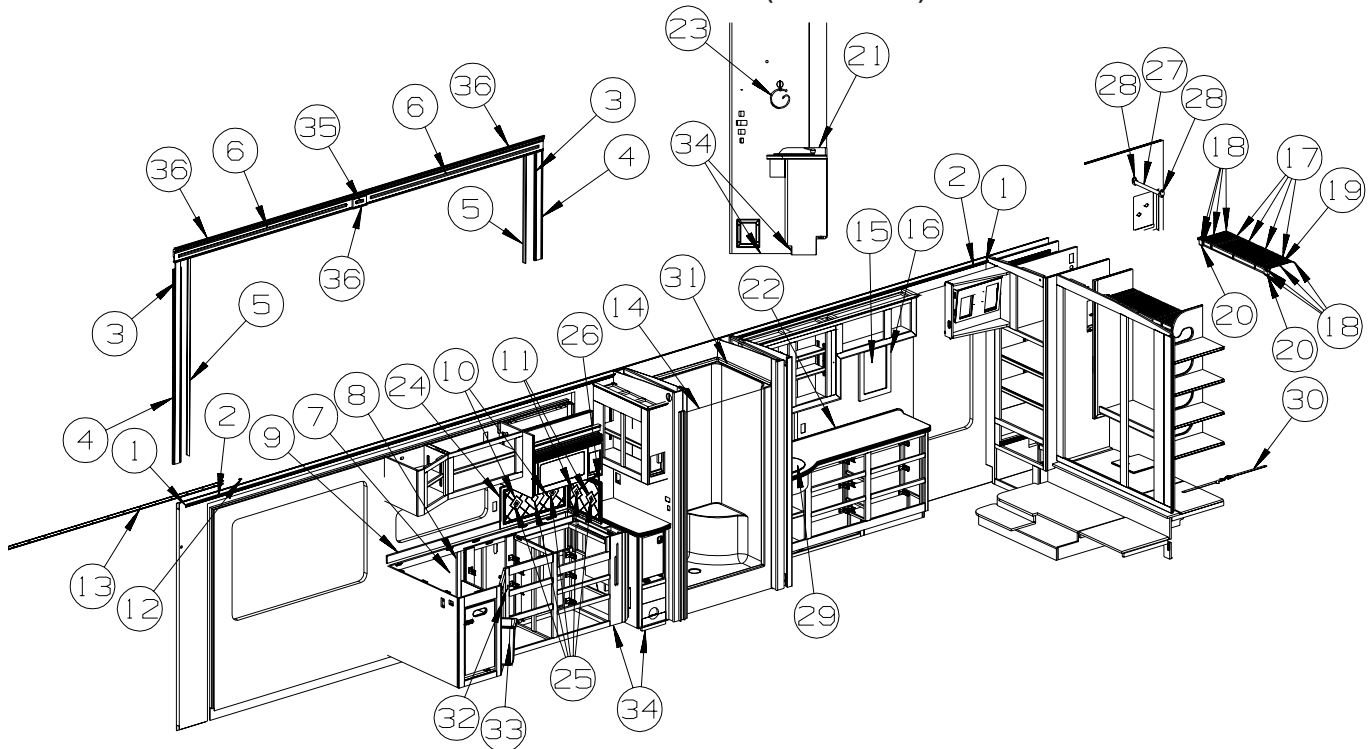

KEY	PART NUMBER	U/M	DESCRIPTION
1	M09525-03-UJ1	EA	MOLDING/TRIM - .6" X 1" X 96" - CONCERT CHERRY
1	M09525-03-UJ2	EA	MOLDING/TRIM - .6" X 1" X 96" - WASHED MAPLE
1	M09525-03-UJ3	EA	MOLDING/TRIM - .6" X 1" X 96" - HONEY CHERRY
2	M09525-04-UJ1	EA	MOLDING/TRIM - ANGLED - 1" X 1" X 96" - CONCERT CHERRY
2	M09525-04-UJ2	EA	MOLDING/TRIM - ANGLED - 1" X 1" X 96" - WASHED MAPLE
2	M09525-04-UJ3	EA	MOLDING/TRIM - ANGLED - 1" X 1" X 96" - HONEY CHERRY
3	M09525-82-UJ1	EA	MOLDING/TRIM - 2.4" X 74.7" - CONCERT CHERRY
3	M09525-82-UJ2	EA	MOLDING/TRIM - 2.4" X 74.7" - WASHED MAPLE
3	M09525-82-UJ3	EA	MOLDING/TRIM - 2.4" X 74.7" - HONEY CHERRY
4	M09525-83-UJ1	EA	MOLDING/TRIM - 3.5" X 74.7" - CONCERT CHERRY
4	M09525-83-UJ2	EA	MOLDING/TRIM - 3.5" X 74.7" - WASHED MAPLE
4	M09525-83-UJ3	EA	MOLDING/TRIM - 3.5" X 74.7" - HONEY CHERRY
5	M09525-81-UJ1	EA	MOLDING - TRIM/VEE - 1.5" X 74.7" - CONCERT CHERRY
5	M09525-81-UJ2	EA	MOLDING - TRIM/VEE - 1.5" X 74.7" - WASHED MAPLE
5	M09525-81-UJ3	EA	MOLDING - TRIM/VEE - 1.5" X 74.7" - HONEY CHERRY
6	M09520-84-UJ1	EA	MOLDING - TRIM/VEE - .2" X 1" X 75.3" - CONCERT CHERRY
6	M09520-84-UJ2	EA	MOLDING - TRIM/VEE - .2" X 1" X 75.3" - WASHED MAPLE
6	M09520-84-UJ3	EA	MOLDING - TRIM/VEE - .2" X 1" X 75.3" - HONEY CHERRY
7	107044-15-08A	EA	COVER - RECESSED SINK - 15" X 17" - CORIAN - PRAIRIE (UJ1, UJ2, UJ3) FROM: 00-00-00 THRU: 06-04-06
7	107044-15-09C	EA	COVER - RECESSED SINK - 15" X 17" - CORIAN - MOSS GLOSS (UJ1, UJ2, UJ3) FROM: 06-05-06 THRU: 99-99-99
7	107044-15-03A	EA	COVER - RECESSED SINK - 15" X 17" - CORIAN - FOSSIL (UJ5, UJ6, UJ7) FROM: 00-00-00 THRU: 06-04-06
7	107044-15-11C	EA	COVER - RECESSED SINK - 15" X 17"-CORIAN-COCOA BROWN GLOSS (UJ5, UJ6, UJ7) FROM: 06-05-06 THRU: 99-99-99
7	107044-15-07A	EA	COVER - RECESSED SINK - 15" X 17" - CORIAN - DOESKIN (UK1, UK2, UK3) FROM: 00-00-00 THRU: 06-04-06
7	107044-15-09C	EA	COVER - RECESSED SINK - 15" X 17" - CORIAN - MOSS GLOSS (UK1, UK2, UK3) FROM: 06-05-06 THRU: 99-99-99
8	107044-16-08A	EA	COVER - RECESSED SINK - 8.8" X 17" - CORIAN - PRAIRIE (UJ1, UJ2, UJ3) FROM: 00-00-00 THRU: 06-04-06
8	107044-16-09C	EA	COVER - RECESSED SINK - 8.8" X 17" - CORIAN - MOSS GLOSS (UJ1, UJ2, UJ3) FROM: 06-05-06 THRU: 99-99-99
8	107044-16-03A	EA	COVER - RECESSED SINK - 8.8" X 17" - CORIAN - FOSSIL (UJ5, UJ6, UJ7) FROM: 00-00-00 THRU: 06-04-06
8	107044-16-11C	EA	COVER - RECESSED SINK - 8.8" X 17"-CORIAN-COCOA BROWN GLOSS (UJ5, UJ6, UJ7) FROM: 06-05-06 THRU: 99-99-99

INTERIOR FINISH GROUP (CONTINUED)
INTERIOR TRIM LAYOUT (CONTINUED)

KEY	PART NUMBER	U/M	DESCRIPTION
8	107044-16-07A	EA	COVER - RECESSED SINK - 8.8" X 17" - CORIAN - DOESKIN (UK1, UK2, UK3) FROM: 00-00-00 THRU: 06-04-06
8	107044-16-09C	EA	COVER - RECESSED SINK - 8.8" X 17" - CORIAN - MOSS GLOSS (UK1, UK2, UK3) FROM: 06-05-06 THRU: 99-99-99
9	153812-01-08A	EA	BACKSPLASH - COUNTERTOP - CORIAN - PRAIRIE (UJ1, UJ2, UJ3) FROM: 00-00-00 THRU: 06-04-06
9	153812-01-09C	EA	BACKSPLASH - COUNTERTOP - CORIAN - MOSS GLOSS (UJ1, UJ2, UJ3) FROM: 06-05-06 THRU: 99-99-99
9	153812-01-03A	EA	BACKSPLASH - COUNTERTOP - CORIAN - FOSSIL (UJ5, UJ6, UJ7) FROM: 00-00-00 THRU: 06-04-06
9	153812-01-11C	EA	BACKSPLASH - COUNTERTOP - CORIAN - COCOA BROWN GLOSS (UJ5, UJ6, UJ7) FROM: 06-05-06 THRU: 99-99-99
9	153812-01-07A	EA	BACKSPLASH - COUNTERTOP - CORIAN - DOESKIN (UK1, UK2, UK3) FROM: 00-00-00 THRU: 06-04-06
9	153812-01-09C	EA	BACKSPLASH - COUNTERTOP - CORIAN - MOSS GLOSS (UK1, UK2, UK3) FROM: 06-05-06 THRU: 99-99-99
10	153811-03-08A	EA	BACKSPLASH - STOVE - CORIAN - PRAIRIE (UJ1, UJ2, UJ3) - NOT ILLUSTRATED FROM: 00-00-00 THRU: 06-04-06
10	160618-01-UJ1	EA	BACKSPLASH - W/ACCENTS - STOVE - CORIAN - MOSS/AGED BRONZE (UJ1, UJ2, UJ3) FROM: 06-05-06 THRU: 99-99-99
10	153811-03-03A	EA	BACKSPLASH - STOVE - CORIAN - FOSSIL (UJ5, UJ6, UJ7) - NOT ILLUSTRATED FROM: 00-00-00 THRU: 06-04-06
10	160618-01-UJ5	EA	BACKSPLASH - W/ACCENTS - STOVE -CORIAN-COCOA BRN/AGED BRNZ (UJ5, UJ6, UJ7) FROM: 06-05-06 THRU: 99-99-99
10	153811-03-07A	EA	BACKSPLASH - STOVE - CORIAN - DOESKIN (UK1, UK2, UK3) - NOT ILLUSTRATED FROM: 00-00-00 THRU: 06-04-06
10	160618-01-UJ1	EA	BACKSPLASH - W/ACCENTS - STOVE - CORIAN - MOSS/AGED BRONZE (UK1, UK2, UK3) FROM: 06-06-06 THRU: 99-99-99
11	153811-04-08A	EA	BACKSPLASH - STOVE - CORIAN - PRAIRIE (UJ1, UJ2, UJ3) - NOT ILLUSTRATED FROM: 00-00-00 THRU: 06-04-06
11	160618-02-UJ1	EA	BACKSPLASH - W/ACCENTS - STOVE - CORIAN - MOSS/AGED BRONZE (UJ1, UJ2, UJ3) FROM: 06-05-06 THRU: 99-99-99
11	153811-04-03A	EA	BACKSPLASH - STOVE - CORIAN - FOSSIL (UJ5, UJ6, UJ7) - NOT ILLUSTRATED FROM: 00-00-00 THRU: 06-04-06
11	160618-02-UJ5	EA	BACKSPLASH - W/ACCENTS - STOVE -CORIAN-COCOA BRN/AGED BRNZ (UJ5, UJ6, UJ7) FROM: 06-05-06 THRU: 99-99-99
11	153811-04-07A	EA	BACKSPLASH - STOVE - CORIAN - DOESKIN (UK1, UK2, UK3) - NOT ILLUSTRATED FROM: 00-00-00 THRU: 06-04-06
11	160618-02-UJ1	EA	BACKSPLASH - W/ACCENTS - STOVE - CORIAN - MOSS/AGED BRONZE (UK1, UK2, UK3) FROM: 06-05-06 THRU: 99-99-99
12	138359-01-01A	FT	COVER - ROOF BREAK - PEARL CREAM/PLASTIC - 96"
13	138403-01-01A	EA	TRIM - ROOF - MILL
14*	158066-01-01A	EA	DOOR - SHOWER - HINGE/PIVOT - 35" X 66.4" - BRONZE/RAIN
15	140374-63-000	EA	MIRROR - SAFETY GLASS - 42.5" X 38.4"
16	131493-02-38A	EA	PICTURE - DECORATIVE - 13" X 15" - ROSETTE II (UJ1, UJ2, UJ3, UK1, UK2, UK3) - CABINET-LAV
16	131493-01-06A	EA	PICTURE - DECORATIVE - 10" X 16" - PARADISE (UJ5, UJ6, UJ7) - CABINET-LAVATORY
	130120-01-01A	EA	BRACKET/MOUNTING - MIRROR
17	136891-53-01A	EA	BRACKET - U/CLAMP MOUNTING - F/SHELF
18	136891-52-01A	EA	END CAP - SMALL - F/SHELF
19	136891-01-01A	EA	SHELF & ROD - 12" X 143.8" - W/O ENDS
20	136891-50-01A	EA	BRACKET/END - F/SHELF
21	153812-02-08A	EA	BACKSPLASH - COUNTERTOP - CORIAN - PRAIRIE (UJ1, UJ2, UJ3) - CABINET-LAVATORY FROM: 00-00-00 THRU: 06-04-06
21	153812-02-09C	EA	BACKSPLASH - COUNTERTOP - CORIAN - MOSS GLOSS (UJ1, UJ2, UJ3) - CABINET-LAVATORY FROM: 06-05-06 THRU: 99-99-99
21	153812-02-03A	EA	BACKSPLASH - COUNTERTOP - CORIAN - FOSSIL (UJ5, UJ5, UJ7) - CABINET-LAVATORY FROM: 00-00-00 THRU: 06-04-06
21	153812-02-11C	EA	BACKSPLASH - COUNTERTOP - CORIAN - COCOA BROWN GLOSS (UJ5, UJ5, UJ7) - CABINET-LAV FROM: 06-05-06 THRU: 99-99-99
21	153812-02-07A	EA	BACKSPLASH - COUNTERTOP - CORIAN - DOESKIN (UK1, UK2, UK3) - CABINET-LAVATORY FROM: 00-00-00 THRU: 06-04-06
21	153812-02-09C	EA	BACKSPLASH - COUNTERTOP - CORIAN - MOSS GLOSS (UK1, UK2, UK3) - CABINET-LAVATORY FROM: 06-05-06 THRU: 99-99-99

INTERIOR FINISH GROUP (CONTINUED)
INTERIOR TRIM LAYOUT (CONTINUED)

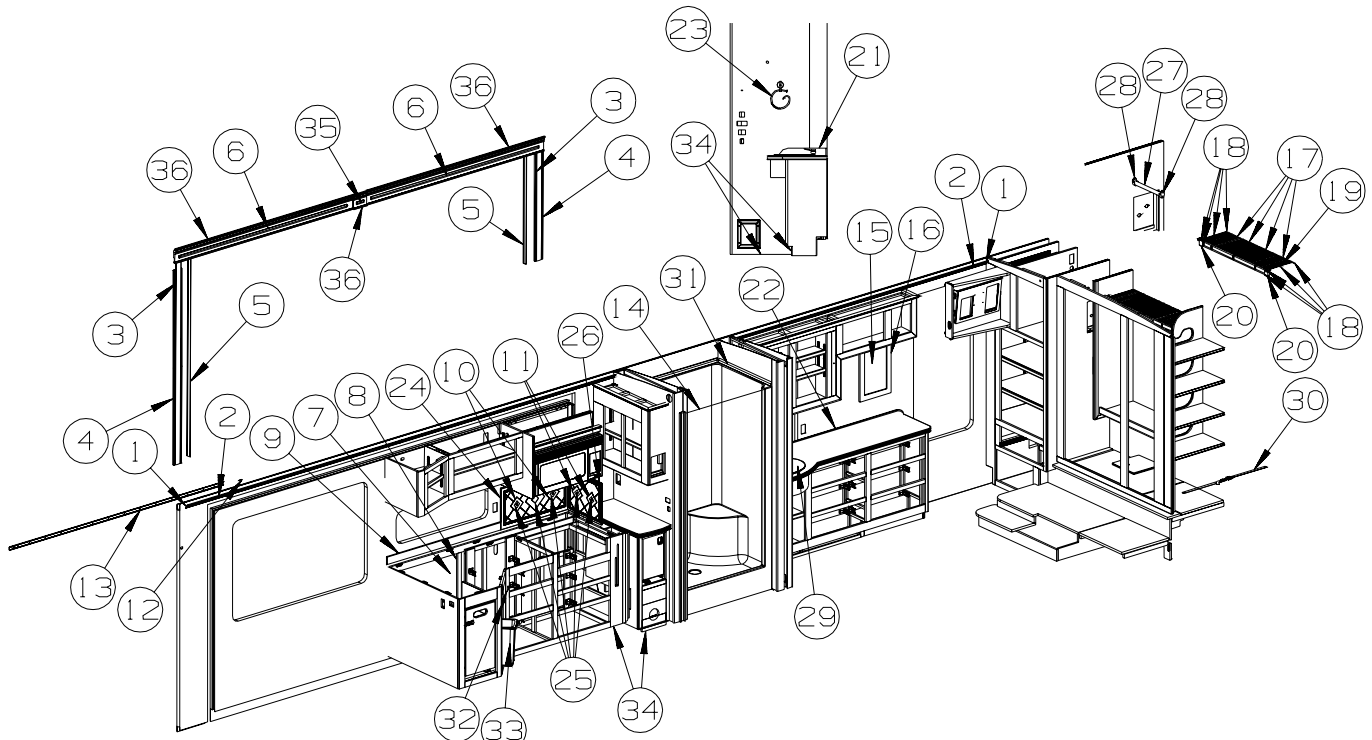

KEY	PART NUMBER	U/M	DESCRIPTION
22	153812-03-08A	EA	BACKSPLASH - COUNTERTOP - CORIAN - PRAIRIE (UJ1, UJ2, UJ3) - CABINET-LAVATORY FROM: 00-00-00 THRU: 06-04-06
22	153812-03-09C	EA	BACKSPLASH - COUNTERTOP - CORIAN - MOSS GLOSS (UJ1, UJ2, UJ3) - CABINET-LAVATORY FROM: 06-05-06 THRU: 99-99-99
22	153812-03-03A	EA	BACKSPLASH - COUNTERTOP - CORIAN - FOSSIL (UJ5, UJ5, UJ7) - CABINET-LAVATORY FROM: 00-00-00 THRU: 06-04-06
22	153812-03-11C	EA	BACKSPLASH - COUNTERTOP - CORIAN - COCOA BROWN GLOSS (UJ5, UJ5, UJ7) - CABINET-LAV FROM: 06-05-06 THRU: 99-99-99
22	153812-03-07A	EA	BACKSPLASH - COUNTERTOP - CORIAN - DOESKIN (UK1, UK2, UK3) - CABINET-LAVATORY FROM: 00-00-00 THRU: 06-04-06
22	153812-03-09C	EA	BACKSPLASH - COUNTERTOP - CORIAN - MOSS GLOSS (UK1, UK2, UK3) - CABINET-LAVATORY FROM: 06-05-06 THRU: 99-99-99
23	152963-01-02A	EA	TOWEL RING - ANTIQUE NICKEL
24	160618-51-09C	EA	BACKSPLASH - STOVE - CORIAN - HIGH GLOSS - MOSS (UJ1, UJ2, UJ3, UK1, UK2, UK3) FROM: 06-05-06 THRU: 99-99-99
24	160615-51-11C	EA	BACKSPLASH - STOVE - CORIAN - HIGH GLOSS - COCOA BROWN (UJ5, UJ6, UJ7) FROM: 06-05-06 THRU: 99-99-99
25	160645-03-02A	EA	BACKSPLASH - ACCENT 4" X 4" FROM: 06-05-06 THRU: 99-99-99
26	160618-52-09C	EA	BACKSPLASH - STOVE - CORIAN - HIGH GLOSS - MOSS (UJ1, UJ2, UJ3, UK1, UK2, UK3) FROM: 06-05-06 THRU: 99-99-99
26	160618-52-11C	EA	BACKSPLASH - STOVE - CORIAN - HIGH GLOSS - COCOA BROWN (UJ5, UJ6, UJ7) FROM: 06-05-06 THRU: 99-99-99
27	Y00136-21-218	EA	DOWEL - WOOD - CLOTHES ROD - 1"DIAMETER X 4'
28	152301-01-01A	EA	FLANGE - PLASTIC - 1" CLOTHES ROD HOLDER - WHITE
29	153609-02-08A	EA	COVER - SINK - LAVATORY/BEDROOM - PRAIRIE (UJ1, UJ2, UJ3) - CABINET-LAVATORY FROM: 00-00-00 THRU: 06-04-06
29	153609-02-09C	EA	COVER - SINK - LAVATORY/BEDROOM - MOSS GLOSS (UJ1, UJ2, UJ3) - CABINET-LAVATORY FROM: 06-05-06 THRU: 99-99-99
29	153609-02-03A	EA	COVER - SINK - LAVATORY/BEDROOM - FOSSIL (UJ5, UJ5, UJ7) - CABINET-LAVATORY FROM: 00-00-00 THRU: 06-04-06
29	153609-02-11C	EA	COVER - SINK - LAVATORY/BEDROOM - COCOA BROWN GLOSS (UJ5, UJ5, UJ7) - CABINET-LAV FROM: 06-05-06 THRU: 99-99-99
29	153609-02-07A	EA	COVER - SINK - LAVATORY/BEDROOM - DOESKIN (UK1, UK2, UK3) - CABINET-LAVATORY FROM: 00-00-00 THRU: 06-04-06
29	153609-02-09C	EA	COVER - SINK - LAVATORY/BEDROOM - MOSS GLOSS (UK1, UK2, UK3) - CABINET-LAVATORY FROM: 06-05-06 THRU: 99-99-99
30	099717-05-000	EA	STRAP - W/16.5" FEMALE STRAP AND 17.7" MALE STRAP

INTERIOR FINISH GROUP (CONTINUED)
INTERIOR TRIM LAYOUT (CONTINUED)

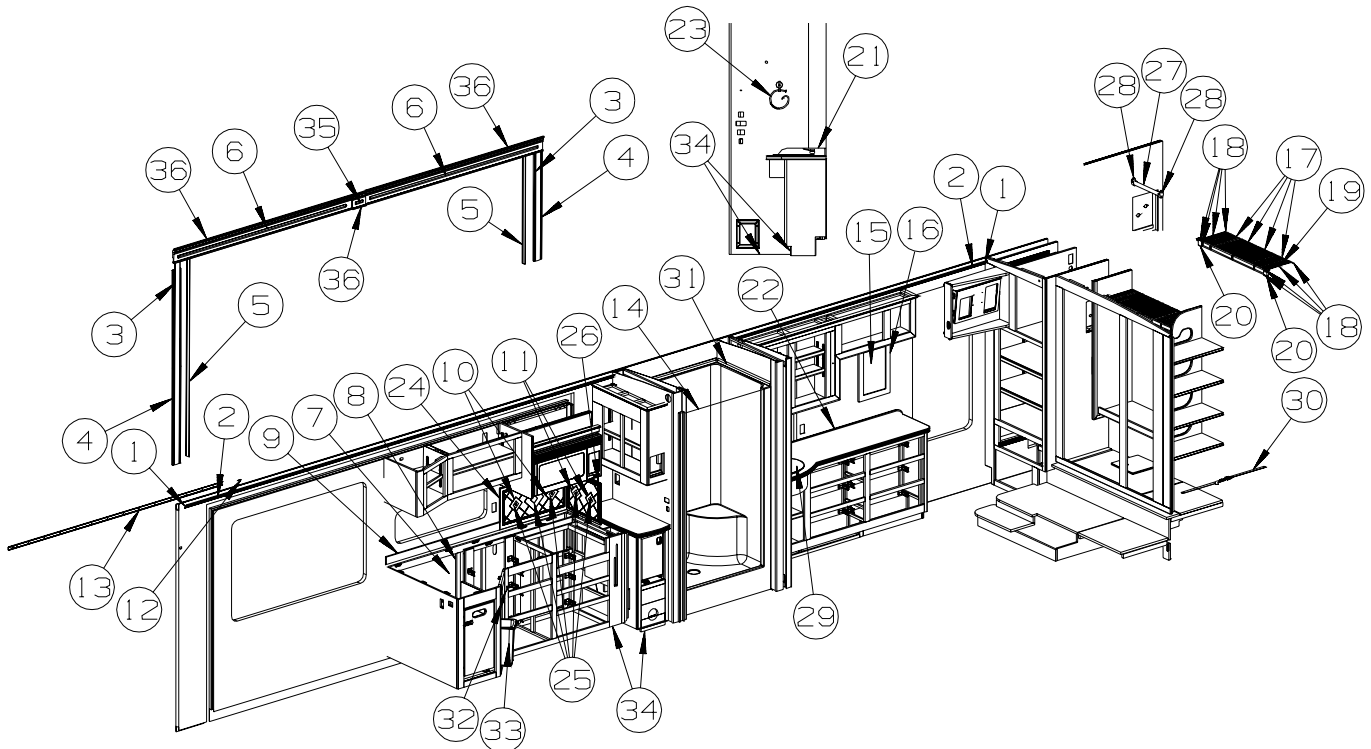

KEY	PART NUMBER	U/M	DESCRIPTION
31	153824-01-01A	EA	TRIM - SHOWER/UPPER - CONCERT CHERRY
31	153824-01-02A	EA	TRIM - SHOWER/UPPER - WASHED MAPLE
31	153824-01-05A	EA	TRIM - SHOWER/UPPER - HONEY CHERRY
32	093605-02-01A	EA	RACK - TOWEL/WIRE - ALMOND
33	159032-01-01A	EA	CONTAINER - WASTEBASKET - 14.3 QT - WHITE
34	M09471-79-R39	EA	MOLDING - TRIM/COVE - .8" X .8" X 96" - CONCERT CHERRY
34	M09471-79-R46	EA	MOLDING - TRIM/COVE - .8" X .8" X 96" - WASHED MAPLE
34	M09471-79-RE0	EA	MOLDING - TRIM/COVE - .8" X .8" X 96" - HONEY CHERRY
35	M09454-62-P55	EA	MOLDING - TRIM/VEE - .2" X 1" X 3.5" - CONCERT CHERRY
35	M09454-62-P56	EA	MOLDING - TRIM/VEE - .2" X 1" X 3.5" - WASHED MAPLE
35	M09454-62-RE0	EA	MOLDING - TRIM/VEE - .2" X 1" X 3.5" - HONEY CHERRY
36	153117-02-TG1	EA	MOLDING - F/SLIDEOUT - 5.9" - CONCERT CHERRY
36	153117-02-TG2	EA	MOLDING - F/SLIDEOUT - 5.9" - WASHED MAPLE
36	153117-02-TG3	EA	MOLDING - F/SLIDEOUT - 5.9" - HONEY CHERRY

***COMPONENT PARTS LISTED LATER IN THIS GROUP**

INTERIOR FINISH GROUP (CONTINUED)
COMPONENT PARTS FOR INTERIOR TRIM LAYOUT

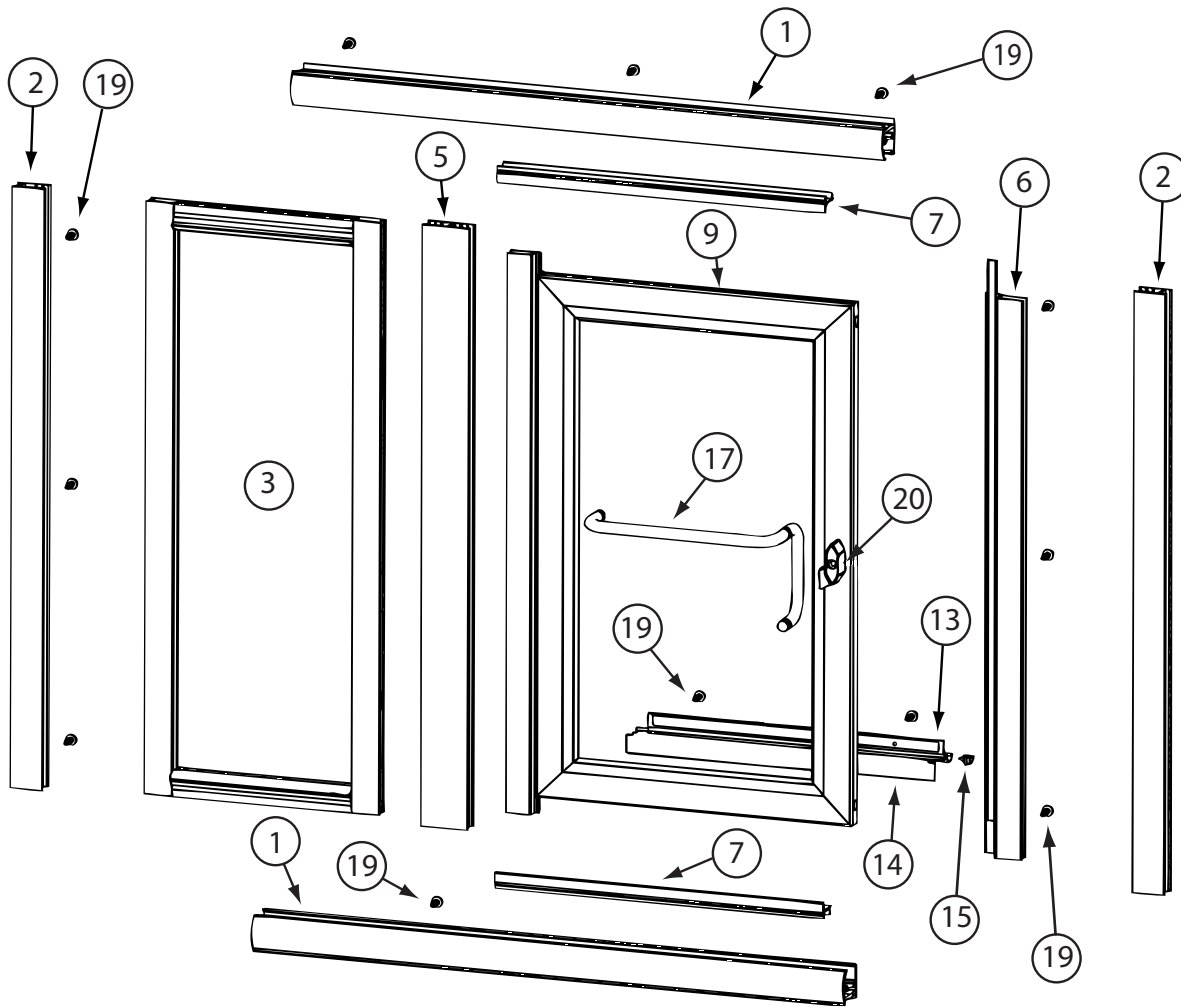

158066-01-01A

KEY	PART NUMBER	U/M	DESCRIPTION	VENDOR NO.
1	158076-01-700	EA	HEADER/SILL-30"(PAIR)BRONZE	900ORB
2	158076-01-702	EA	JAMB - WALL - 65.4"	903ORB
3	158066-01-700	EA	INLINE PANEL - FRAMED GLASS	WBP812ORB-RILP
4	115011-01-706	FT	GLAZING VINYL-BLACK	C154B
5	158066-01-701	EA	POST - INLINE	904ORB
6	158076-01-704	EA	STRIKE - JAMB - 64.2"	926ORB
7	158076-01-701	EA	DAM STRIP - TOP/BOTTOM	901ORB
8	158076-01-705	EA	HINGE/POST-DOOR-64.5"-BRONZ	920ORB
13	158076-01-706	EA	DRIP RAIL - OIL RUB BRONZE	927ORB
14	158076-03-704	EA	VINYL SWEEP	C176
15	139047-01-711	EA	PLUG - DRIP CAP (SET) BLACK	CP933 - BLACK
17	158076-01-707	EA	PULL/BAR COMBO (SET)-BRONZE	T618ORB
19	158076-01-709	EA	SCREW - ADJUSTMENT - BRONZE	638PHPT-ORB
20	089318-01-707	EA	LATCH/CATCH-TURN-SAFETY-BLK	9730N
	139047-01-706	EA	HINGE PINS	CP932
	139047-01-707	EA	WASHERS - HINGE	CP148TW
	139047-01-708	EA	HINGE - SLEEVE - 61.5"	C921B
	139047-01-709	EA	STRIP/MAGNETIC- 55" (NARROW	98-42
	158066-01-702	EA	DOOR PANEL ONLY-W/RAIN GLASS	WBP812ORB-RDP
	158076-01-708	EA	TOWEL BAR - OIL RUB BRONZE	T18ORB

INTERIOR FINISH GROUP (CONTINUED)
FLOOR COVERINGS

KEY	PART NUMBER	U/M	DESCRIPTION
	075233-01-000	SY	PAD - CARPET - 3/8" X 6'W ROLL - SOLD BY THE SQUARE YARD
	089275-02-000	FT	STRIP - 3/4" X 84" BLACK POLYETHYLENE
	093486-01-000	SY	CARPET - COMPARTMENT - 72" WIDE - DARK GRAY
	093486-01-563	EA	CARPET-COMPARTMENT 0524X0630
	123994-06-02A	EA	GROUT KIT - FLOOR TILE - LIGHT BUFF-CHAMOIS - 13 LB PKG
	123994-09-03A	EA	TILE - FLOOR - CERAMIC - 12" X 12" - FRESCO CAFFE
	152251-03-04A	SY	CARPET - 4 SQUARE YARD INCREMENTS - FLORINTINE (UJ1, UJ2, UJ3, UJ5, UJ6, UJ7) FROM: 00-00-00 THRU: 07-23-06
	152251-11-01A	SY	CARPET - 4 SQUARE YARD INCREMENTS - TEMECU - (UJ1, UJ2, UJ3) FROM: 07-24-06 THRU: 99-99-99
	152251-11-02A	EA	CARPET - 4 SQUARE YARD INCREMENTS - HONEY (UJ5, UJ6, UJ7) FROM: 07-24-06 THRU: 99-99-99
	152251-03-01A	SY	CARPET - 4 SQUARE YARD INCREMENTS - GOLDEN HONEY (UK1, UK2, UK3) FROM: 00-00-00 THRU: 07-23-06
	152251-11-03A	EA	CARPET - 4 SQUARE YARD INCREMENTS - CIGAR (UK1, UK2, UK3) FROM: 07-24-06 THRU: 99-99-99

INTERIOR FINISH GROUP (CONTINUED)

HARDWARE

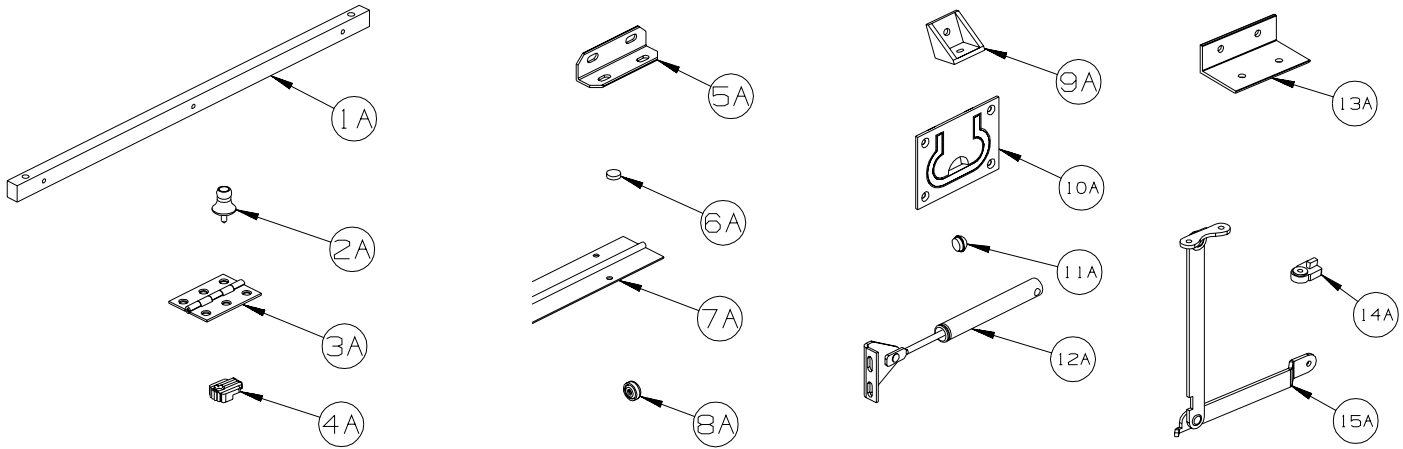

KEY	PART NUMBER	U/M	DESCRIPTION
1A	P34509-01-N01	EA	RAIL END - RH/LH - TOWEL RACK - PORTSMOUTH
1A	P34509-01-P14	EA	RAIL END - RH/LH - TOWEL RACK - CONCERT CHERRY
1A	P34509-01-J70	EA	RAIL END - RH/LH - TOWEL RACK - WASHED MAPLE
1A	P34509-01-RE0	EA	RAIL END - RH/LH - TOWEL RACK - HONEY CHERRY
1A	P34509-01-SA3	EA	RAIL END - RH/LH - TOWEL RACK - SIERRA MAPLE
2A	009013-01-000	EA	CATCH - BULLDOG - MALE/FEMALE
3A	009059-01-000	EA	HINGE - DOOR - 2" X 1.4" - BRASS
3A	009059-02-000	EA	HINGE - DOOR - 2" X 2.7" - BRASS
3A	009059-03-000	EA	HINGE - BRASS - 1.75"
3A	009059-04-000	EA	HINGE - 2" - ZINC
4A	009089-01-000	EA	CLIP - MIRROR
5A	016604-01-000	EA	BRACE - ANGLE - 2 1/2" - UNPAINTED METAL
5A	016604-05-000	EA	BRACE - ANGLE - 2 1/2" - OFF WHITE METAL
5A	016604-10-000	EA	BRACE - SEAT ANGLE - 2.5" - BLACK
6A	023320-01-000	EA	PAD - FELT 3/8" DIAMETER
7A	041389-19-000	EA	HINGE - PIANO - 1 1/2" X 71.9" - UNPAINTED
7A	041389-25-000	EA	HINGE - PIANO - 1 1/2" X 55" - UNPAINTED
7A	041389-32-000	EA	HINGE - PIANO - 68" - OFF WHITE
8A	057671-01-000	EA	COVER - SCREW - #8 - OFF WHITE
8A	057671-15-000	EA	COVER - SCREW - #8 - BRIGHT WHITE
8A	057671-16-000	EA	COVER - SCREW - #8 - SOFT WHITE
8A	057671-18-000	EA	COVER - SCREW - #8 - OFF WHITE
9A	065740-01-000	EA	BRACE - CABINET/CORNER - PLASTIC
10A	072871-01-000	EA	PULL - FLUSH - CHROME
11A	074045-13-000	EA	PLUG - OAK - 3/8" DOWEL-1/2" HEAD - PORTSMOUTH OAK
11A	074045-08-000	EA	PLUG - OAK - 3/8" DOWEL-1/2" HEAD - CONCERT CHERRY
11A	074045-12-000	EA	PLUG - OAK - 3/8" DOWEL-1/2" HEAD - WASHED MAPLE
11A	074045-14-000	EA	PLUG - OAK - 3/8" DOWEL-1/2" HEAD - HONEY CHERRY
11A	074045-15-000	EA	PLUG - OAK - 3/8" DOWEL-1/2" HEAD - SIERRA MAPLE
12A	074493-02-000	EA	SUPPORT - PISTON SPRING - CABINET DOOR - 26 LBS
12A	074493-03-000	EA	SUPPORT - PISTON SPRING - CABINET DOOR - 12 LBS
12A	074493-04-000	EA	SUPPORT - PISTON SPRING - CABINET DOOR - 32LBS
13A	156732-01-01A	EA	BRACE - ANGLE/COUCH - 2.5" - MILL
13A	156732-01-02A	EA	BRACE - ANGLE/COUCH - 2.5" - OFF WHITE
13A	156732-03-01A	EA	BRACE - ANGLE/COUCH - BLACK
14A	083204-03-000	EA	BUTTON - RETAINING MIRROR 5/16" TIP
15A	084412-01-000	EA	SUPPORT/HINGE KIT (LEFT & RIGHT HINGES)

INTERIOR FINISH GROUP (CONTINUED)

HARDWARE (CONTINUED)

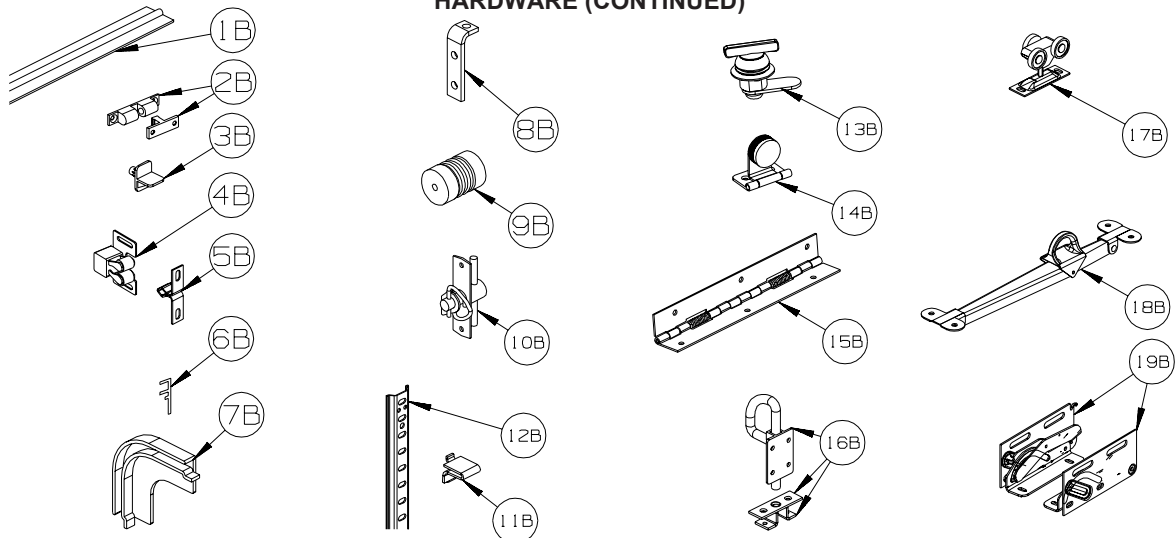

KEY	PART NUMBER	U/M	DESCRIPTION
1B	084413-01-000	EA	HINGE - 1" X 72" - ALUMINUM - W/HOLES
2B	084451-01-000	EA	CATCH & LATCH - 1.7" - BRASS
3B	092907-01-000	EA	SUPPORT - SHELF - PIN - 1/4" - CLEAR PLASTIC
4B	093586-03-000	EA	CATCH - SPRING ROLLER - .377"
4B	093586-06-000	EA	CATCH - SPRING ROLLER - .236"
5B	093586-04-000	EA	STRIKE - SPRING STEEL - 1.14"
6B	093622-01-000	EA	TRACK - DOOR - TAMBOUR - PLASTIC - 8' LENGTHS
7B	093623-01-000	EA	CORNER - TRACK - TAMBOUR DOOR
8B	096826-01-01A	EA	BRACE-CABINET E-COATED
9B	097872-04-000	EA	DOWEL - WOOD - 1" DIAMETER X 1.38" LONG - UNFINISHED
10B	098196-01-000	EA	LATCH - 1/4 TURN - T-BAR
11B	098979-01-000	EA	CLIP - ADJUSTABLE SHELF
12B	098980-01-000	EA	PILASTER - ADJUSTABLE SHELF - 18"
12B	098980-02-000	EA	PILASTER - ADJUSTABLE SHELF - 12"
12B	098980-03-000	EA	PILASTER - ADJUSTABLE SHELF - 9"
12B	098980-04-000	EA	PILASTER - ADJUSTABLE SHELF - 48"
12B	098980-05-000	EA	PILASTER - ADJUSTABLE SHELF - 15"
12B	098980-06-000	EA	PILASTER - ADJUSTABLE SHELF - 24"
13B	100710-01-02A	EA	LOCK - GLASS DOOR/TWIST TYPE - NICKEL
14B	100711-01-02A	EA	HINGE - GLASS DOOR - NICKEL
15B	102920-01-01A	EA	HINGE - SPRING LOADED - BRASS
15B	102920-01-02A	EA	HINGE - SPRING LOADED - NICKEL
15B	129753-01-01A	EA	HINGE - SPRING LOADED - 19" X 19" - BLACK
16B	103256-01-000	EA	LATCH COMPLETE (SLIDE)
17B	103874-01-000	EA	HANGER - SLIDING DOOR
18B	104181-01-01A	EA	SUPPORT - LEAF 5.3" EXTENDS TO 7.5" - SAFETY RING - METAL
19B	108126-01-000	EA	TRAY HINGE SET (QTY. 2 PER SET)

INTERIOR FINISH GROUP (CONTINUED)
HARDWARE (CONTINUED)

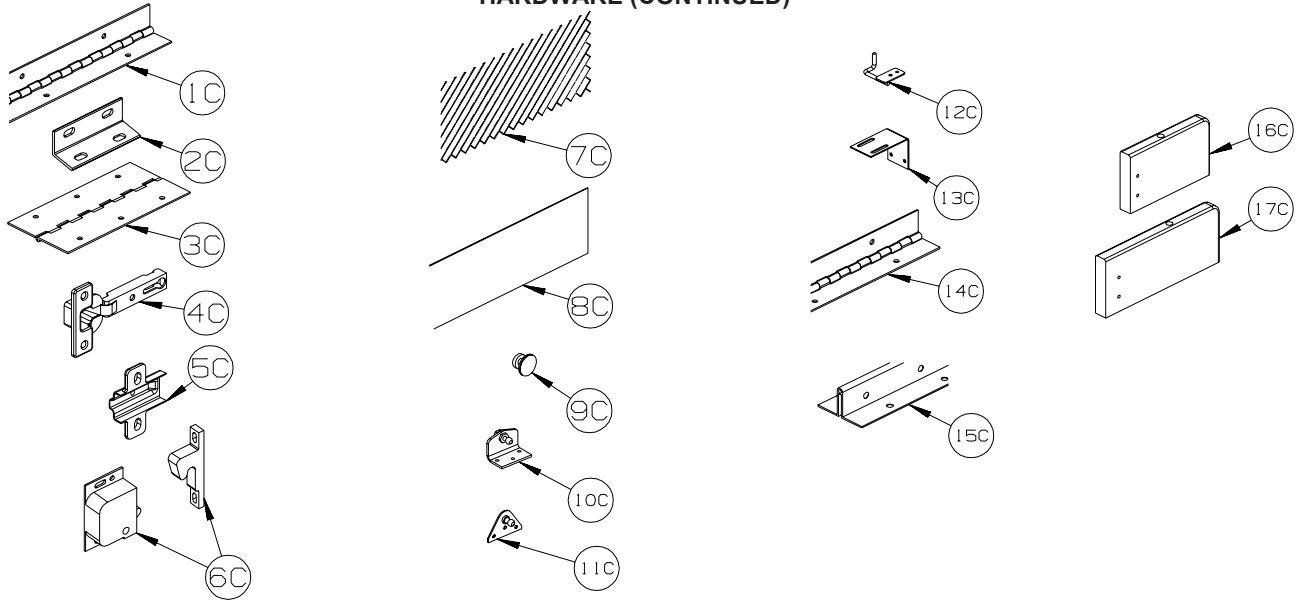

KEY	PART NUMBER	U/M	DESCRIPTION
1C	110496-01-01A	EA	HINGE - BRASS - 2" X 32"
1C	110496-01-02A	EA	HINGE - NICKEL - 2" X 32"
1C	110496-05-02A	EA	HINGE - NICKEL - 2" X 11.5"
1C	110496-06-02A	EA	HINGE - NICKEL - 2" X 9.5"
2C	111866-01-02A	EA	BRACE - SEAT - ANGLE - OFF WHITE
3C	114278-02-000	EA	HINGE - CONTINUOUS - 3" WIDE
4C	114443-02-01A	EA	HINGE - CABINET DOOR - W/O CLIP - SILVER
5C	114443-03-01A	EA	CLIP - HINGE/CABINET DOOR - SILVER
6C	117095-01-01A	EA	LATCH - DOOR - GRABBER W/KEEPER - PLASTIC - BLK-5 LB PULL
6C	117095-02-01A	EA	LATCH - DOOR - GRABBER W/KEEPER - PLASTIC - BLK-10 LB PULL
6C	117095-03-01A	EA	LATCH - DOOR - GRABBER W/KEEPER - PLASTIC - BLK-15 LB PULL
7C	118200-01-01A	SF	MESH - PLASTIC 1/2" - 48" X LENGTH = SF - BLACK
8C	122717-06-01A	FT	PAD - NON-SKID - PSA - 5"W
9C	125221-01-01A	EA	PULL - MIRROR - W/ROUND HANDLE
10C	126263-06-02B	EA	BRACKET - GAS SPRING W/INSIDE BALL STUD - E-COATED
11C	126263-05-02B	EA	BRACKET - GAS SPRING W/BALL STUD - E-COATED
11C	126263-08-02B	EA	BRACKET - GAS SPRING W/CENTERED BALL STUD - E-COATED
11C	126263-19-02B	EA	BRACKET - GAS SPRING W/BALL STUD - E-COATED
12C	130798-01-02B	EA	GUIDE - POCKET DOOR - E-COATED
13C	132871-02-02B	EA	BRACKET/L-ANGLE W/HOLES - 1.9" X 2.8" - E-COATED
14C	134099-01-02A	EA	HINGE - PIANO - WRAP AROUND - 15.7" - NICKEL PLATED
15C	135538-03-02A	EA	HINGE - PIANO - FULL WRAP - 15.7" - CHROME
16C	137445-02-P46	EA	STOP - F/SLIDING DOOR - CONCERT CHERRY
16C	137445-02-P56	EA	STOP - F/SLIDING DOOR - WASHED MAPLE
16C	137445-02-S67	EA	STOP - F/SLIDING DOOR - SIERRA MAPLE
17C	137445-03-T78	EA	STOP - F/SLIDING DOOR - CONCERT CHERRY
17C	137445-03-T79	EA	STOP - F/SLIDING DOOR - WASHED MAPLE
17C	137445-03-T80	EA	STOP - F/SLIDING DOOR - SIERRA MAPLE

INTERIOR FINISH GROUP (CONTINUED)

HARDWARE (CONTINUED)

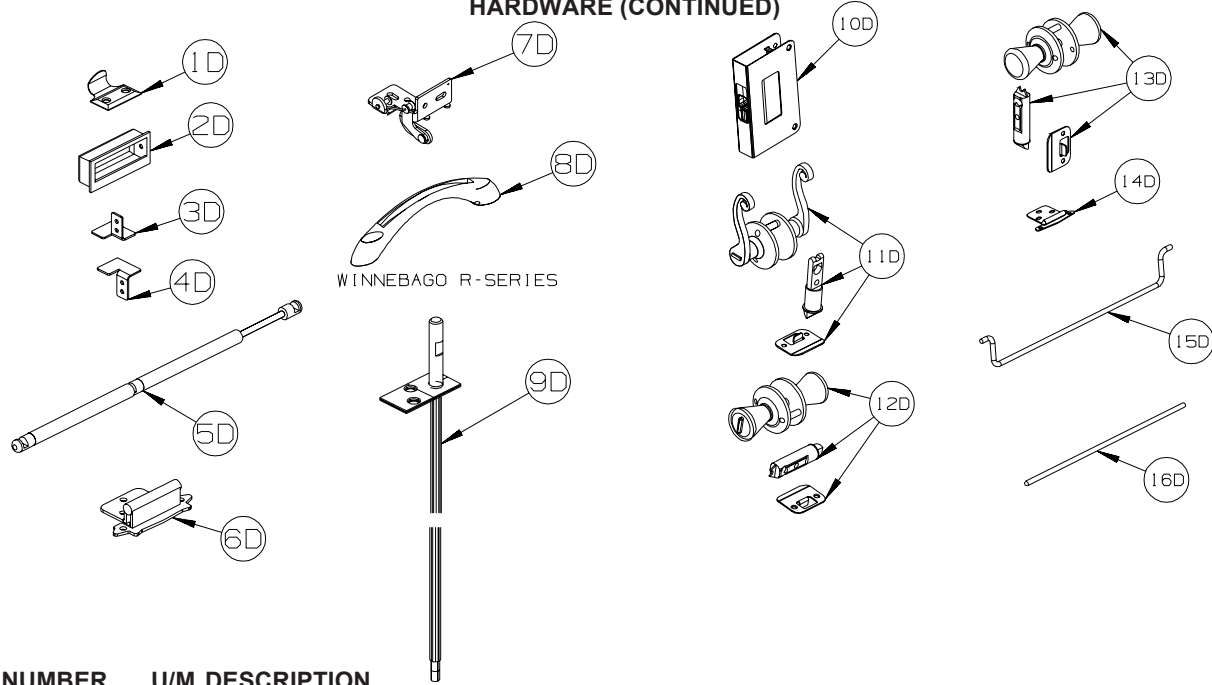

KEY	PART NUMBER	U/M	DESCRIPTION
1D	137463-01-02A	EA	LIFT - HOOK - PEWTER
2D	139136-01-02A	EA	HANDLE - .75" RECESSED - PEWTER
2D	139136-02-02A	EA	HANDLE - .35" RECESSED - PEWTER
3D	139264-01-02B	EA	STOP - DOOR - TAMBOUR/RH HAND - E-COATED
4D	139264-02-02B	EA	STOP - DOOR - TAMBOUR/LH HAND - E-COATED
5D	142569-07-000	EA	SPRING/GAS - 20 LB - 20" EXTENDED/12" COMPRESSED
5D	142569-15-000	EA	SPRING/GAS - 120 LB - 20" EXTENDED/12" COMPRESSED
5D	142569-16-000	EA	SPRING/GAS - 90 LB - 20" EXTENDED/12" COMPRESSED
5D	142569-29-000	EA	SPRING/GAS - 20 LB - 9.9" EXTENDED/5.9" COMPRESSED
6D	143468-02-03A	EA	HINGE - SELF CLOSING - SATIN NICKEL
7D	144488-01-02A	EA	HINGE - CABINET - NICKEL
8D	144917-01-01A	EA	PULL - DRAWER - SATIN NICKEL - TOUR R-SERIES
9D	145939-03-01A	EA	ROD/LATCH - AISLE DOOR - BRASS
			FROM: 00-00-00 THRU: 04-16-06
9D	145939-05-01A	EA	ROD/LATCH - AISLE DOOR - BRASS - NOT ILLUSTRATED
			FROM: 04-17-06 THRU: 07-30-06
9D	145939-05-02A	EA	ROD/LATCH - AISLE DOOR - NICKEL - NOT ILLUSTRATED
			FROM: 07-31-06 THRU: 99-99-99
10D	145939-04-02A	EA	LATCH/SLIDE - AISLE DOOR(1" THICK DOOR)-NICKEL/BLACK SLIDE
11D	146064-01-02A	EA	LOCK/PRIVACY (LOCKING) LEVER STYLE - SATIN PEWTER
12D	146064-05-01A	EA	LOCK/PRIVACY (LOCKING) KNOB STYLE - SATIN NICKEL
13D	146064-06-01A	EA	LOCK/PASSAGE (NON LOCKING) KNOB STYLE - SATIN NICKEL
14D	146553-01-01A	EA	HINGE - CABINET DOOR - BURNISHED BRASS
14D	146553-01-03A	EA	HINGE - CABINET DOOR - SATIN NICKEL
15D	146801-01-01A	EA	ROD/TOWEL BAR (OFFSET) - BRASS
15D	146801-01-02A	EA	ROD/TOWEL BAR (OFFSET) - PEWTER
16D	146840-03-01A	EA	ROD - .25" X 11.7" - BRASS
16D	146840-03-02A	EA	ROD - .25" X 11.7" - PEWTER
16D	146840-04-01A	EA	ROD - .25" X 13.1" - BRASS
16D	146840-04-02A	EA	ROD - .25" X 13.1" - PEWTER
16D	146840-05-01A	EA	ROD - .25" X 14.8" - BRASS
16D	146840-05-02A	EA	ROD - .25" X 14.8" - PEWTER
16D	146840-07-01A	EA	ROD - .25" X 4.2" - BRASS
16D	146840-07-02A	EA	ROD - .25" X 4.2" - PEWTER

INTERIOR FINISH GROUP (CONTINUED) HARDWARE (CONTINUED)

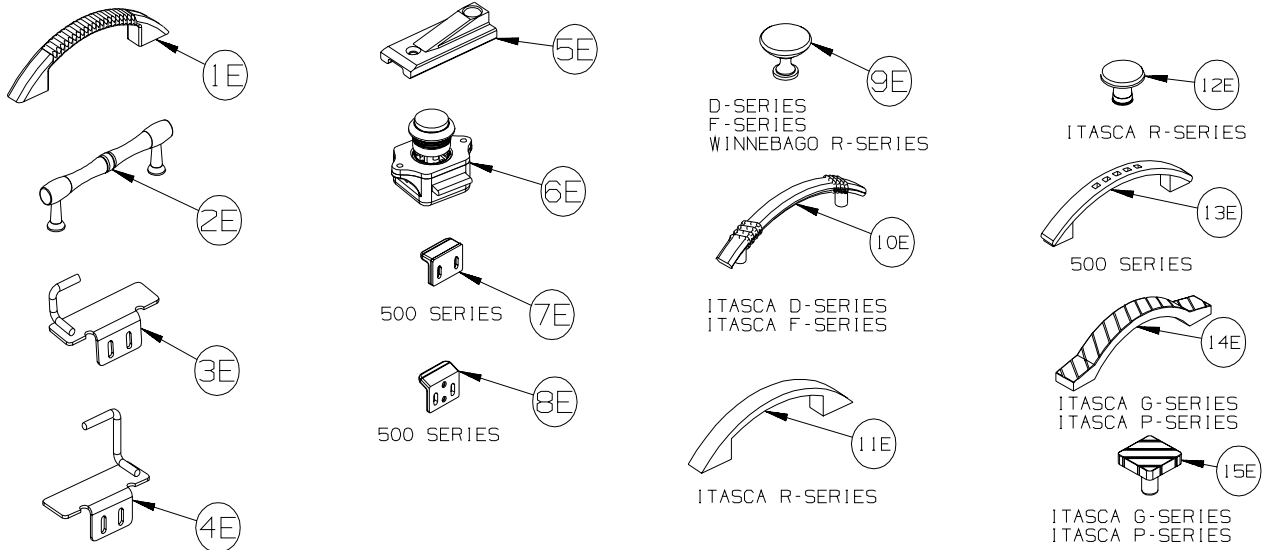

KEY	PART NUMBER	U/M	DESCRIPTION
1E	148816-01-02A	EA	PULL - CABINET DOOR - NICKEL - ASPECT, CAMBRIA 700-SERIES
2E	149090-01-02A	EA	PULL - CABINET DOOR - NICKEL - SIGHTSEER D-SERIES, VOYAGE F-SERIES
3E	149607-01-02B	EA	GUIDE - F/POCKET DOOR - 1.6" BENT ROD - E-COATED
3E	149607-03-02B	EA	GUIDE - F/POCKET DOOR - 2.9" BENT ROD - E-COATED
4E	149607-04-02B	EA	GUIDE - F/POCKET DOOR - E-COATED
5E	150983-01-01A	EA	STRIKE/BLOCK - WEDGE STYLE - F/SLIDE DOOR - 3" X 1.2" - BLACK
6E	151380-01-01A	EA	LATCH - CABINET DOOR - PUSH BUTTON - VIEW & NAVION 500-SERIES
7E	151380-02-01A	EA	STRIKE - CABINET DOOR - VIEW & NAVION 500-SERIES
8E	151380-03-01A	EA	STRIKE - CABINET DOOR - VIEW & NAVION 500-SERIES
9E	152080-01-01A	EA	PULL-NICKEL - SIGHTSEER & SUNOVA D-SERIES, VOYAGE & SUNRISE F-SERIES, TOUR R-SERIES
10E	152302-01-01A	EA	PULL - CABINET DOOR - SATIN NICKEL - SUNOVA D-SERIES, SUNRISE F-SERIES
11E	152304-01-01A	EA	PULL - CABINET DOOR - BRONZE- ELLIPSE R-SERIES
12E	152305-01-01A	EA	KNOB - DOOR/DRAWER - BRONZE - ELLIPSE R-SERIES
13E	152950-01-01A	EA	PULL - DOOR/DRAWER - BRUSHED NICKEL - VIEW & NAVION 500-SERIES
14E	152951-01-01A	EA	PULL - DOOR/DRAWER - PEWTER - SUNCRUISER G-SERIES, MERIDIAN P-SERIES
15E	152952-01-01A	EA	PULL - KNOB/DRAWER - PEWTER - SUNCRUISER G-SERIES, MERIDIAN P-SERIES

INTERIOR FINISH GROUP (CONTINUED) HARDWARE (CONTINUED)

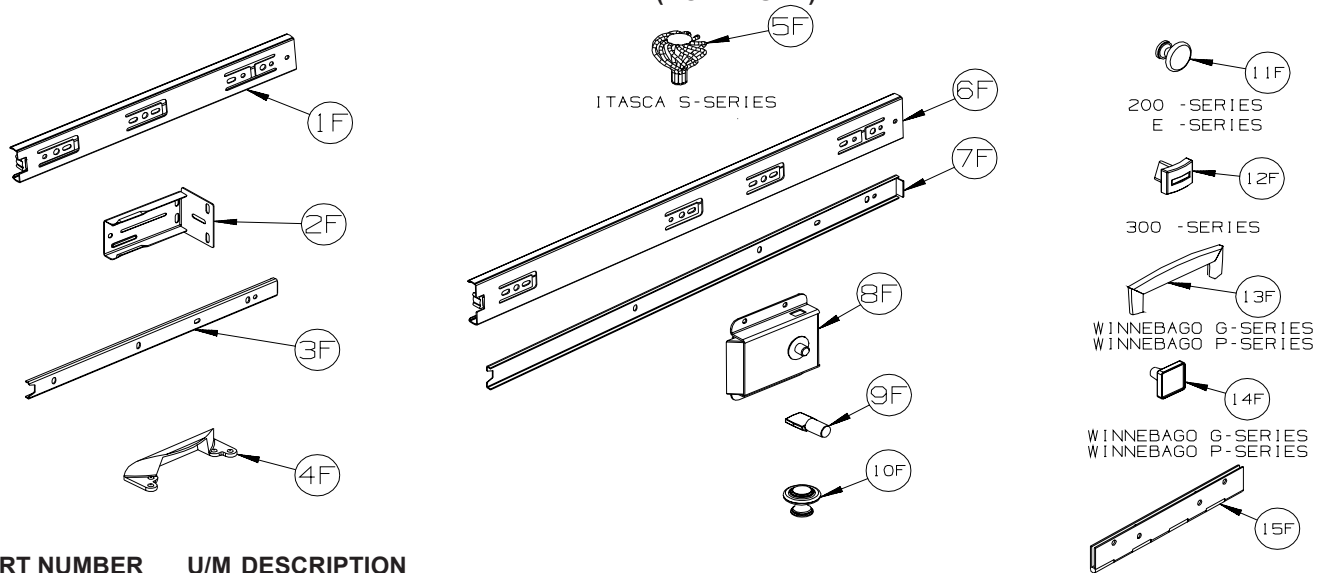

KEY	PART NUMBER	U/M	DESCRIPTION
1F	153000-01-01A	EA	SLIDE - CABINET MOUNT - 11.8"
1F	153000-03-01A	EA	SLIDE - CABINET MOUNT - 13.8"
1F	153000-05-01A	EA	SLIDE - CABINET MOUNT - 15.7"
1F	153000-07-01A	EA	SLIDE - CABINET MOUNT - 17.7"
1F	153000-09-01A	EA	SLIDE - CABINET MOUNT - 19.7"
1F	153000-11-01A	EA	SLIDE - CABINET MOUNT - 21.6"
1F	153000-14-01A	EA	SLIDE - CABINET MOUNT - 23.6"
1F	153000-18-01A	EA	SLIDE - CABINET MOUNT - 9.8"
1F	153000-20-01A	EA	SLIDE - CABINET MOUNT - 25.6"
2F	153000-13-01A	EA	BACKSOCKET - DRAWER SLIDE
3F	153000-02-01A	EA	SLIDE - DRAWER MOUNT - 11.8"
3F	153000-04-01A	EA	SLIDE - DRAWER MOUNT - 13.8"
3F	153000-06-01A	EA	SLIDE - DRAWER MOUNT - 15.7"
3F	153000-08-01A	EA	SLIDE - DRAWER MOUNT - 17.7"
3F	153000-10-01A	EA	SLIDE - DRAWER MOUNT - 19.7"
3F	153000-12-01A	EA	SLIDE - DRAWER MOUNT - 21.6"
3F	153000-15-01A	EA	SLIDE - DRAWER MOUNT - 23.4"
3F	153000-19-01A	EA	SLIDE - DRAWER MOUNT - 9.8"
3F	153000-21-01A	EA	SLIDE - DRAWER MOUNT - 25.4"
4F	153308-01-01A	EA	PULL - VANITY STOOL - SATIN NICKEL
5F	153335-01-02A	EA	PULL - KNOB - DOOR/DRAWER - FLAT BLACK - HORIZON S-SERIES
6F	153352-01-01A	EA	SLIDE - PANTRY - 19.7" - CABINET MOUNT
6F	153352-03-01A	EA	SLIDE - EXT ENTERTAINMENT CNTR - 13.8" - CABINET MOUNT
7F	153352-02-01A	EA	SLIDE - PANTRY - 19.5" - DRAWER MOUNT
7F	153352-04-01A	EA	SLIDE - EXT ENTERTAINMENT CNTR - 13.6" - DRAWER MOUNT
8F	153353-01-01A	EA	LATCH - SLIDING/FLUSH - BLACK
9F	154385-01-02A	EA	PIN - SUPPORT/GLASS DOOR - 1/4" - NICKEL
10F	155803-01-01A	EA	KNOB CABINET DOOR - WROUGHT IRON
11F	155925-01-01A	EA	KNOB - DOOR/DRAWER - SATIN NICKEL - ACCESS & IMPULSE 200-SERIES
12F	156579-01-01A	EA	KNOB - DOOR/DRAWER - PEWTER - OUTLOOK & SPIRIT 300-SERIES
13F	157246-01-01A	EA	PULL - CABINET DOOR/DRAWER - SATIN NICKEL - ADVENTURER G-SERIES, JOURNEY P-SERIES
14F	157246-02-01A	EA	KNOB - CABINET DOOR/DRAWER - SATIN NICKEL - ADVENTURER G-SERIES, JOURNEY P-SERIES
15F	158982-01-04B	EA	HINGE - CONTINUOUS - 2" X 8" - BLACK
	158982-01-01A	EA	HINGE - CONTINUOUS - 2" X 8" - ZINC

LABELS GROUP

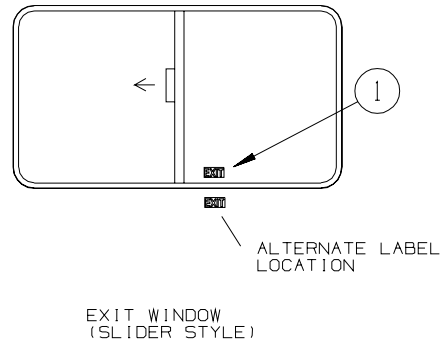
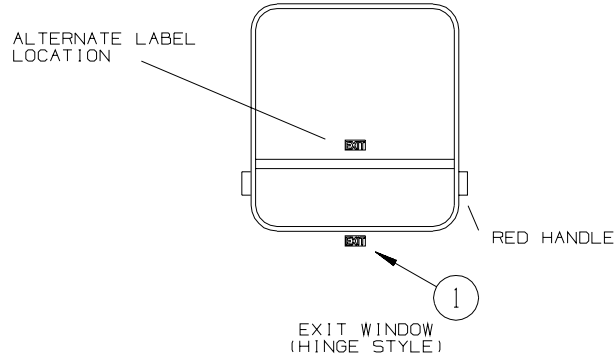

KEY	PART NUMBER	U/M DESCRIPTION
1	039290-01-000	EA LABEL - WARNING - EXIT

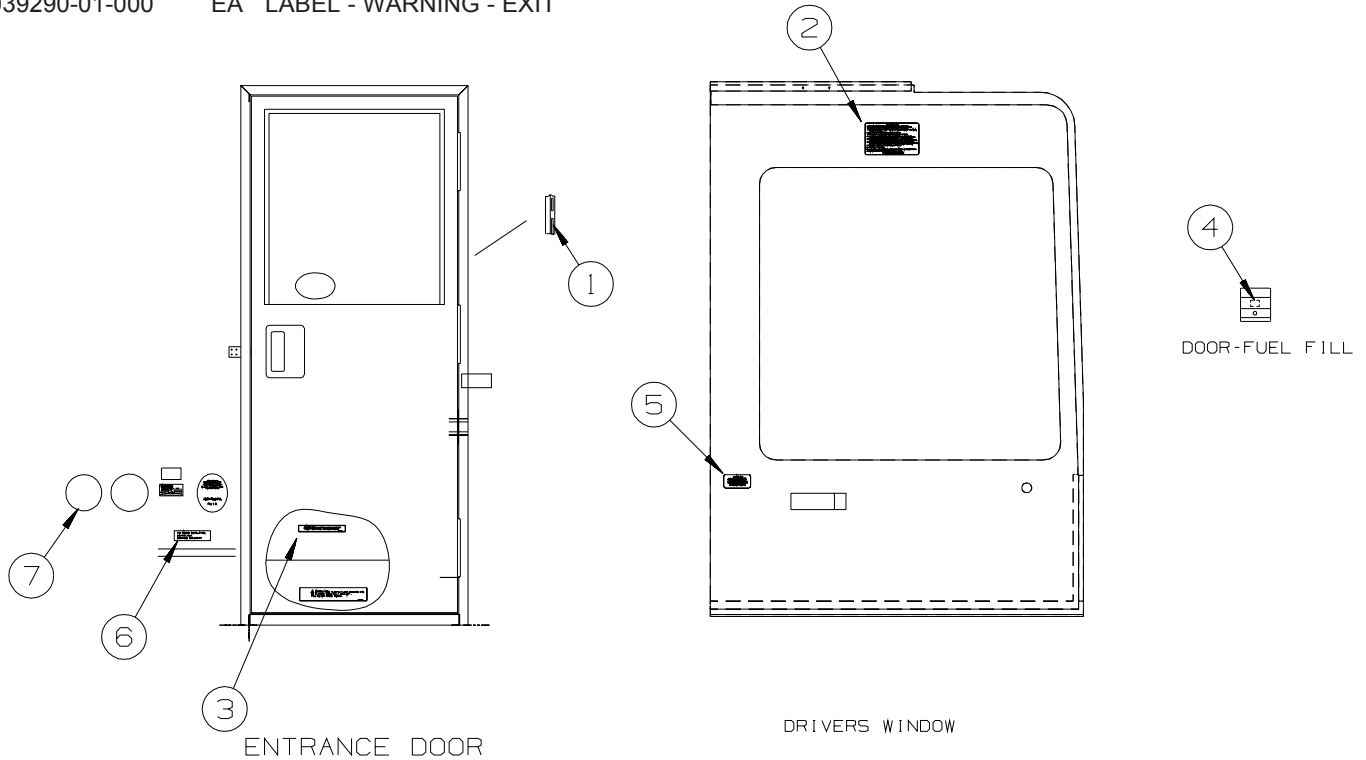

KEY	PART NUMBER	U/M DESCRIPTION
1	135869-01-02A	EA LABEL - MERCURY CONTENT - WHITE ON CLEAR
1	135869-01-01A	EA LABEL - MERCURY CONTENT - BLACK ON CLEAR
2	056259-01-000	EA LABEL - SAFETY CHECK LIST
3	065748-01-000	EA LABEL - WARNING - BATTERY CHARGING - UL
3	065748-02-000	EA LABEL - WARNING - BATTERY CHARGING -CSA - CANADIAN
4	068383-01-000	EA LABEL - DIESEL FUEL
5	099689-01-000	EA LABEL - WARNING - CANCER/TOXICITY
6	099509-01-000	EA LABEL - AWNING INSTALLATION
7	160649-01-01A	EA LABEL-CSA/CRVA,SET - RED/GOLD/WHT

LABELS GROUP (CONTINUED)

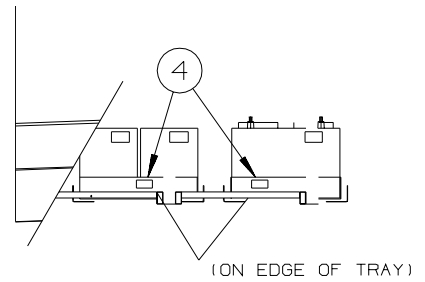
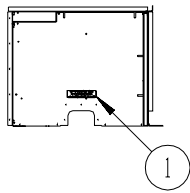
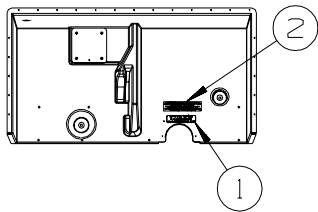

TYPICAL UTILITY CENTER COMPARTMENTS

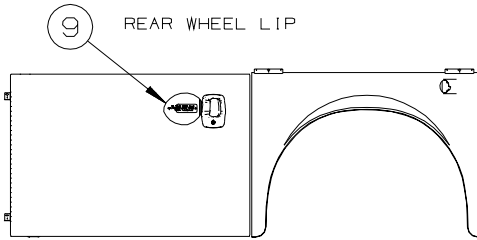

LH SIDE

S40TD ONLY

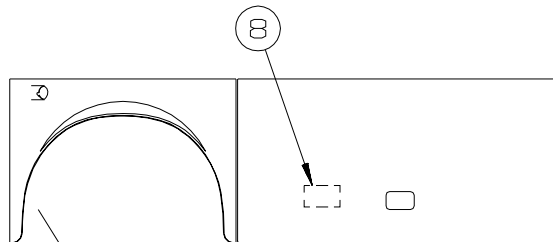

REAR RH WHEEL LIP

S40FD
S40KD

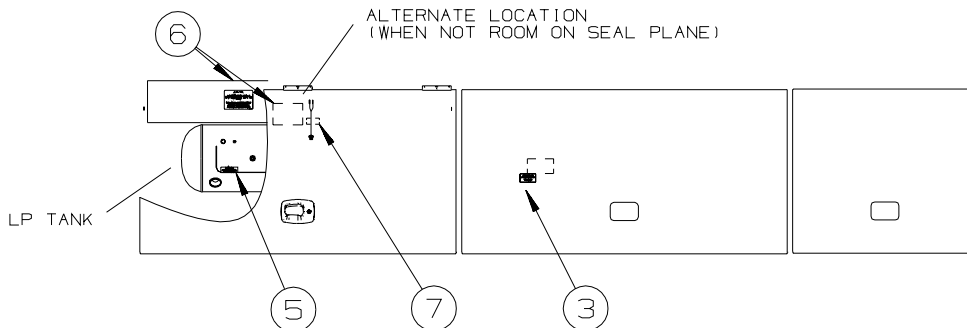

KEY	PART NUMBER	U/M DESCRIPTION
1	123562-01-000	EA LABEL - SERVICE/UTILITY ACCESS
2	147845-01-01A	EA LABEL - DRIP VALVE
3	125306-04-01A	EA LABEL - ELECTRICAL ENTRANCE-120/20V 50 AMP-BLACK ON CLEAR
3	125306-04-02A	EA LABEL - ELECTRICAL ENTRANCE-120/240V 50 AMP-WHITE ON CLEAR
4	065748-01-000	EA LABEL - WARNING - BATTERY CHARGING - UL
4	065748-02-000	EA LABEL - WARNING - BATTERY CHARGING - CSA - CANADIAN
5	079965-01-000	EA LABEL - LPG - 80% CAPACITY
6	124520-01-02A	EA LABEL - LP GAS ONLY - WHITE ON CLEAR
6	124520-01-01A	EA LABEL - LP GAS ONLY - BLACK ON CLEAR
6	023769-01-000	EA LABEL - WARNING - LPG - CANADIAN - CANADIAN
7	124519-01-02A	EA LABEL - WARNING/REFUELING - WHITE ON CLEAR
7	124519-01-01A	EA LABEL - WARNING/REFUELING - BLACK ON CLEAR
7	124519-02-02A	EA LABEL - WARNING/REFUELING - WHITE ON CLEAR - CSA - CANADIAN
7	124519-02-01A	EA LABEL - WARNING/REFUELING - BLACK ON CLEAR - CSA - CANADIAN
8	155040-01-01A	EA LABEL - AWNING - DOOR CLOSED - BLACK/CLEAR
9	160384-01-01A	EA LABEL - SLIDEOUT - DOOR CLOSED - BLACK/CLEAR

LABELS GROUP (CONTINUED)

TYPICAL SEAT AND BELT CONFIGURATIONS

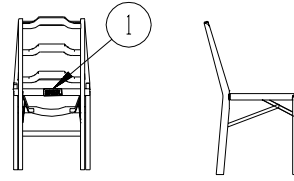
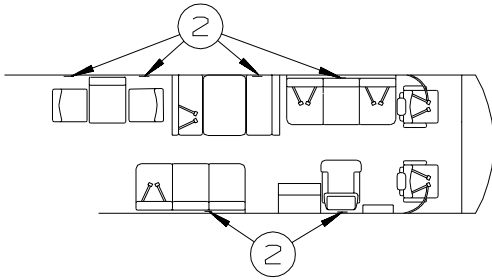

FOLDING CHAIRS

ATTACH LABEL ON OR NEXT TO:
 *ANY SINGLE CHAIR WITHOUT BELTS.
 *ANY DINETTE SEAT WITHOUT BELTS.
 *ANY COUCH WITHOUT BELTS OR ANY SEATING POSITION ON THAT COUCH.
 DO NOT ATTACH LABEL IF:
 *DINETTE SEAT HAS AT LEAST ONE SET OF BELTS INSTALLED.

KEY	PART NUMBER	U/M	DESCRIPTION
1	134537-01-01A	EA	LABEL - OCCUPANCY - CHAIR - US
1	134537-02-01A	EA	LABEL - OCCUPANCY - CHAIR - CSA - CANADIAN
2	134538-01-01A	EA	LABEL - OCCUPANCY - NO SEAT BELT - BLACK ON CLEAR - US
2	134538-02-01A	EA	LABEL - OCCUPANCY - NO SEAT BELT - BLACK ON CLEAR - CSA - CANADIAN

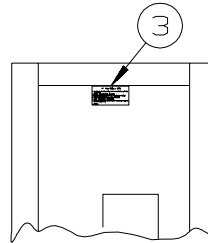
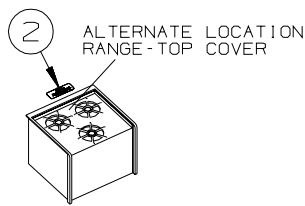
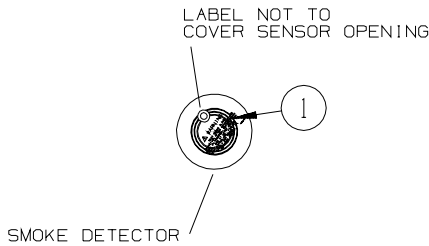

INSIDE OF GALLEY
CABINET DOOR
REF

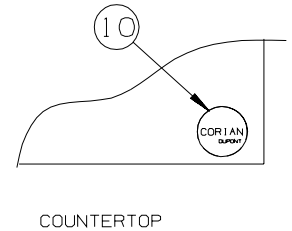

COUNTERTOP

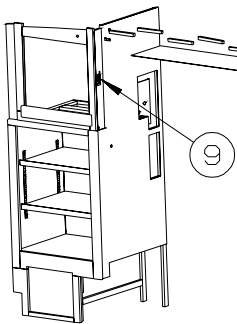

SWING OUT/SLIDING TV INSTL

SLIDEOUT SWITCH

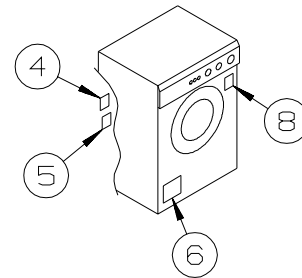
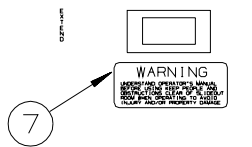

KEY	PART NUMBER	U/M	DESCRIPTION
1	077956-01-000	EA	LABEL - WARNING/SMOKE DETECTOR
2	134539-01-01A	EA	LABEL - WARNING - STOVE/HEATING - US - BLACK ON CLEAR
2	134540-01-01A	EA	LABEL - WARNING - STOVE/HEATING - CSA - BLACK ON CLEAR - CANADIAN
3	073998-01-000	EA	LABEL - LPG/ODOR WARNING
4	147525-01-000	EA	LABEL - DRYER VENT CUTOUT
5	147524-01-000	EA	LABEL - DRYER VENTING
6	130670-01-01A	EA	LABEL - CAUTION DRYER VENTING - BLACK ON CLEAR - WASHER/DRYER
7	116549-02-000	EA	LABEL - WARNING - SLIDEOUT - 1.18" x 3"
8	153640-01-01A	EA	LABEL - WINTERIZATION - WASHER DRYER - WASHER/DRYER
9	079966-01-000	EA	LABEL - WARNING - STOWED - MOTION
10	144040-02-02A	EA	MEDALLION/ROUND - COUNTERTOP/CORIAN - NICKEL

LABELS GROUP (CONTINUED)

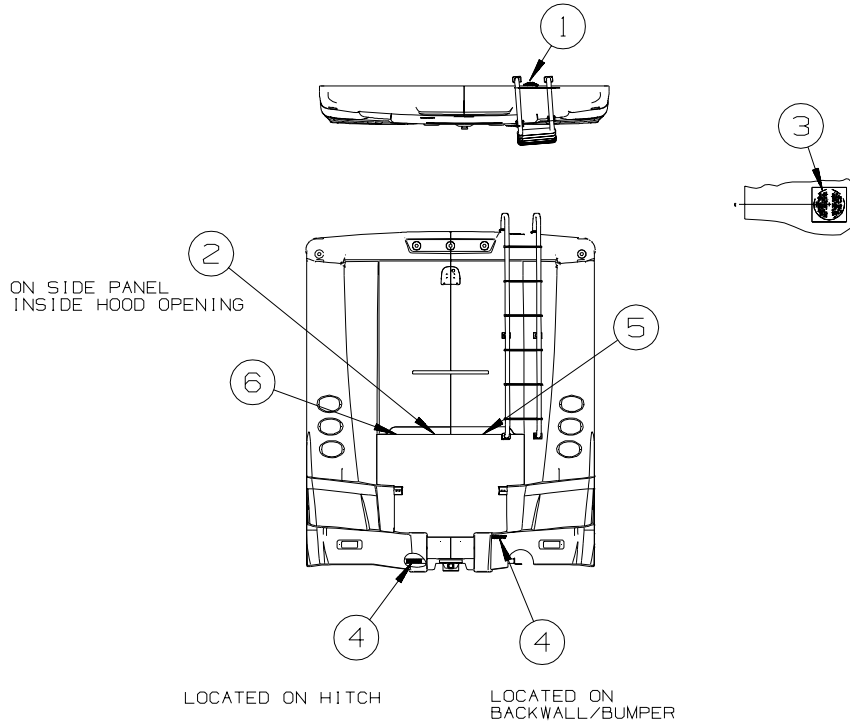

KEY	PART NUMBER	U/M DESCRIPTION
1	128218-01-01A	EA LABEL - WARNING - SLIPPERY ROOF
2	116756-03-000	EA LABEL - WARNING - ETHER/STARTING - RED W/WHITE BACKGROUND
3	120431-01-000	EA LABEL - LOCATION - COAXIAL CABLE/SATELLITE ANTENNA
4	129669-02-01A	EA LABEL - HITCH/VEHICLE RATE - 500 - WHITE ON CLEAR
4	129669-02-02A	EA LABEL - HITCH/VEHICLE RATE - 500 - BLACK ON CLEAR
5	156213-01-01A	EA LABEL - CHASSIS BATTERY DISCONNECT - WHITE/BLACK
6	134359-01-01A	EA LABEL - WARNING - DRIVE BELTS

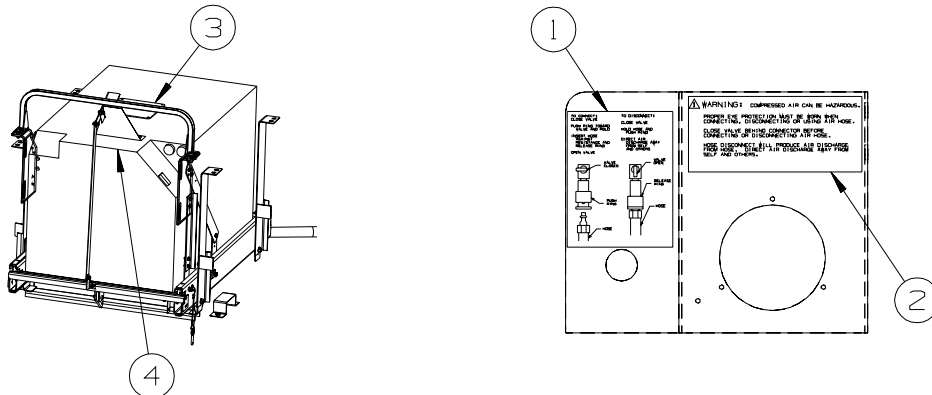

KEY	PART NUMBER	U/M DESCRIPTION
1	142773-01-01A	EA LABEL - CONNECT/COMPRESSED AIR - WHITE LETTERING ON CLEAR
2	142771-01-01A	EA LABEL - WARNING/COMPRESSED AIR - WHITE LETTERING ON CLEAR
3	116273-01-000	EA LABEL - WARNING - GENERATOR
4	131779-01-01A	EA LABEL - GENERATOR

LABELS GROUP (CONTINUED)

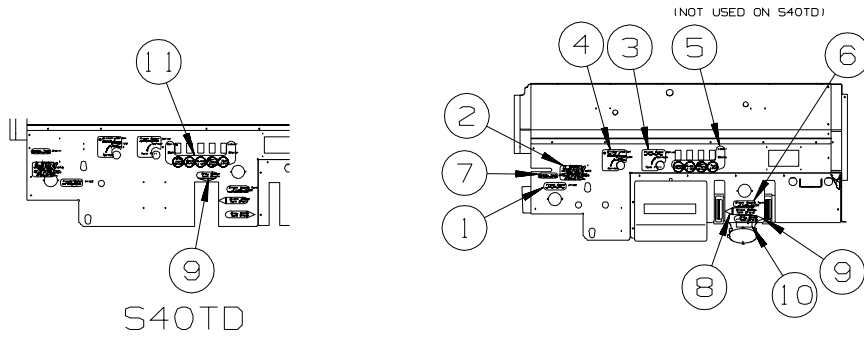

KEY	PART NUMBER	U/M	DESCRIPTION
1	152538-02-01A	EA	LABEL - FRESH WATER - PANTONE/CLEAR
2	128725-02-01A	EA	LABEL - POTABLE WATER ONLY - BLACK ON CLEAR
3	152548-01-01A	EA	LABEL - VALVE/FRESH
4	152545-01-01A	EA	LABEL - WINTERIZATION
5	152544-09-01A	EA	LABEL - SWITCHES - WTR PMP/LT/MNT/AUTO LVL-W/LVL/STORE UP
6	152546-02-01A	EA	LABEL - TANK FLUSH - PANTONE/CLEAR
7	152547-01-01A	EA	LABEL - TANK DRAIN
8	152543-01-01A	EA	LABEL - BLACK WASTE - BLACK/CLEAR
9	152541-01-01A	EA	LABEL - GRAY WASTE - COOL GRAY/CLEAR
10	144649-01-01A	EA	LABEL - ADJUSTABLE VALVE - WHITE ON CLEAR
11	152544-10-01A	EA	LABEL - SWITCHES - WTR PMP/LT/MNT/AUTO LVL-W/LVL/STORE UP

**LP GROUP
LP SYSTEM**

KEY	PART NUMBER	U/M	DESCRIPTION
	010377-02-000	EA	NUT - 3/8" FLARE - FORGED - BRASS
	010380-02-000	EA	NUT - 1/2" FLARE - FORGED - BRASS
	045703-01-000	EA	HOSE - LP - 3/8"ID X 24" - 3/8"MPT X 1/2"F SWIVEL - US
	045703-02-000	EA	HOSE - LP - 3/8"ID X 24" - 3/8"MPT X 1/2"F SWIVEL - CSA
	045703-14-000	EA	HOSE - LP - 3/8"ID X 157.5" - 1/2"F SWIVEL X 1/2"F SWIVEL
	045703-15-000	EA	HOSE - LP - 3/8"ID X 142" - 1/2"F SWIVEL X 3/8"F SWIVEL
	045703-18-000	EA	HOSE - LP - 3/8"ID X 28" W/1/2" FEMALE SWIVELS
	045703-19-000	EA	HOSE - LP - 3/8"ID X 102" - 1/2"F SWIVELX3/8"F SWVL US/CSA
	045703-21-000	EA	HOSE - LP - 3/8"ID X 60" - 1/2"F SWIVEL X3/8"F SWVL US/CSA
	045703-24-000	EA	HOSE - LP - 3/8"ID X 228.3"-1/2"F SWIVELX3/8"F SWVL US/CSA
	045703-25-000	EA	HOSE - LP - 3/8"ID X 177" - 1/2"F SWIVEL X 3/8"M FL US/CSA
	045703-26-000	EA	HOSE - LP - 3/8"ID X 24" - 1/4"MPTX3/8"F FLARE SWVL US/CSA
	146065-01-000	EA	HOSE - HIGH PRESSURE - WIRE BRAIDED - 110"
	146065-02-000	EA	HOSE - HIGH PRESSURE - WIRE BRAIDED - 90"
	146989-01-000	EA	HOSE - LP 1/2"ID X 132"(11') - 5/8" FEMALE SWIVEL
	010326-01-000	EA	ADAPTER - FLARE - W/CONE GASKET - 3/8"F X 1/2"F
	010329-01-000	EA	ADAPTER - 1/2"F X 1/2"MPT - BRASS
	146635-01-000	EA	ADAPTOR - PIPE - AWAY
	010589-01-000	EA	NIPPLE - PIPE - 1/2" X 1 1/2" - BLACK
	010589-03-000	EA	NIPPLE - PIPE - 1/2" X 2 1/2" - BLACK
	040440-03-000	EA	TRANSMITTER - DIAL/SNAP-ON - 0-90 OHM 2 TERM(POWER/GROUND)
	097372-06-01A	EA	SWITCH - BLANK
*	144251-01-000	EA	TANK - LP - 100 LB - 12" DIAMETER X 69" LONG
	145518-01-01A	EA	BRACKET - REMOTE FILL - GREY
	156026-01-02B	EA	BRACKET/SUPPORT - LP HOSE - E-COATED
	106150-06-000	EA	REGULATOR - TWO STAGE
	144485-01-000	EA	COVER - LP REGULATOR

***COMPONENT PARTS LISTED LATER IN THIS GROUP**

COMPONENT PARTS FOR LP SYSTEM

144251-01-000

KEY	PART NUMBER	U/M	DESCRIPTION	VENDOR NO.
	040421-01-713	EA	VALVE-RELIEF 1" W/SPRING 7"	V12560/V21207
	144251-01-700	EA	VALVE - OUTAGE	V13399
	144251-01-701	EA	VALVE/FILL 80% W/YELLOW CAP	V13415
	144251-01-702	EA	VALVE - SERVICE/VAPOR	V20533.1
	144251-01-703	EA	SENDING UNIT F/SNAP ON GAUGE	G13060

SEALANTS & FASTENERS GROUP
SEALANTS & ADHESIVES

KEY	PART NUMBER	U/M	DESCRIPTION
	004001-02-000	EA	GUN - PLEXUS ADHESIVE - W/O NOZZLE
	004001-05-000	EA	ADHESIVE - SCOTCH-WELD - 3M DP100 - CLEAR - 50ML
	004011-01-000	EA	ADHESIVE-3M-4475 TUBE
	010405-02-000	EA	TAPE - THREAD SEALING - 3/8"
	064075-07-000	FT	SEAL - BULB - W/WIRED U CHANNEL - .3" X .5" CHANNEL-BLACK
	067788-01-000	EA	ADHESIVE - SPRAY - 3M - 19.5 OZ AEROSOL CAN
	069640-01-000	FT	SEALER - RIBBON - 1/4"DIAMETER X 30 FT - BLACK OR GRAY
	069640-02-000	FT	SEALER - TAPE - 1/8"THICK X 1/2"WIDE X 60 FT - GRAY
	069640-03-000	FT	SEALER - TAPE - 1/8"THICK X 3/4"WIDE X 60 FT - BLACK
	069640-07-000	FT	SEALER - TAPE - 3/32"THICK X 2"WIDE X 45 FT - GRAY
	069640-09-000	FT	SEALER - TAPE - 1/32"THICK X 2 1/2"WIDE X 80 FT - BRT WHT
	069640-10-000	FT	SEALER - TAPE - 1/32"THICK X 1 1/2"WIDE X 90 FT - BRT WHT
	069640-11-000	FT	SEALER - TAPE - 3/16"THICK X 3/8"WIDE X 40 FT - BLACK
	069640-13-000	FT	SEALER - TAPE - 3/32"THICK X 2"WIDE X 45 FT - BLACK
	069640-14-000	FT	SEALER - TAPE - 1/16"THICK X 1"WIDE X 100 FT - BLACK
	069640-15-000	FT	SEALER - TAPE - 1/16"THICK X 3/8"WIDE X 100 FT - BRT WHT
	069640-17-000	FT	SEALER - TAPE - 1/32"THICK X 1"WIDE X 150 FT - GRAY
	069640-18-000	FT	SEALER - TAPE - 1/8"THICK X 1/2"WIDE X 60 FT - BRT WHT
	069640-19-000	FT	SEALER - TAPE - 1/8"THICK X 3/4"WIDE X 60 FT - BRT WHT
	069640-20-000	FT	SEALER - TAPE - 1/8"THICK X 1/2"WIDE X 60 FT - BLACK
	069640-21-000	FT	SEALER - TAPE - 1/16"THICK X 1/2"WIDE X 100 FT - BRT WHT
	069640-22-000	FT	SEALER - TAPE - 1/32"THICK X 1/4"WIDE X 200 FT - BRT WHT
	069640-23-000	FT	SEALER - TAPE - 1/16"THICK X 3/4"WIDE X 100 FT - BRT WHT
	069640-27-000	FT	SEALER - TAPE - 1/16"THICK X 2 1/4"WIDE X 50 FT - BRT WHT
	069640-28-000	FT	SEALER - TAPE - 1/32"THICK X 1 7/8"WIDE X 90 FT - GRAY
	069640-30-000	FT	SEALER - TAPE - 1/32"THICK X 5/8"WIDE X 50 FT - GRAY
	069640-31-000	FT	SEALER - TAPE - 1/4"THICK X 3/4"WIDE X 15 FT - BLACK
	069640-32-000	FT	SEALER - TAPE - 1/16"THICK X 3/8"WIDE X 100 FT - BLACK
	069640-33-000	FT	SEALER - RIBBON - 3/8"DIAMETER X 20 FT - BLACK
	069640-34-000	FT	SEALER - RIBBON - 1/4"DIAMETER X 30 FT - BRIGHT WHITE
	072889-28-000	EA	SEALANT/URETHANE-10 OZ TUBE W/NOZZLE-SELF LEVELING-BRT WHT
	076322-01-000	FT	TAPE-DOUBLE COATED/ADHESIVE BK-.03"THK X .8"W X 216'- WHT
	076322-02-000	FT	TAPE-DOUBLE COATED/ADHESIVE BK-.05"THK X 1"W X 108' - WHT
	076322-03-000	FT	TAPE-DOUBLE COATED/ADHESIVE BK-.05"THK X .5"W X 108' - WHT
	076322-05-000	FT	TAPE-DOUBLE COATED/ADHESIVE BK-.05"THK X .8"W X 108' - WHT
	076322-07-000	FT	TAPE-DOUBLE COATED/ADHESIVE BK-.05"THK X .5"W X 200' - BLK
	076322-13-000	FT	TAPE - FOAM/DOUBLE COATED - .020"THK X .75"W - CLEAR
	076322-21-000	FT	TAPE - FOAM/DOUBLE COATED - .045"THK X .50"W
	076322-22-000	FT	TAPE - FOAM/DOUBLE COATED - .045"THK X .75"W
	076322-23-000	FT	TAPE - FOAM/DOUBLE COATED - .045"THK X 1"W
	076322-25-000	FT	TAPE - FOAM/DOUBLE COATED - .025"THK X .5"W
	086276-01-000	EA	TAPE - DOUBLE SIDED - 1/2" WIDE X 108' LONG (SOLD BY ROLL)
	088479-01-000	EA	TAPE - ALUMINUM - 3"
	090340-01-000	FT	SEAL - FOAM - CLOSED CELL - 1/4" X 1/2" X 50'
	091255-02-000	FT	SEAL - ADHESIVE BACKED/FOAM - 3/64"THICK X 3/16"W X 1000'
	091255-03-000	FT	SEAL - ADHESIVE BACKED/FOAM - 1/4" THICK X 1/4"W X 1000'
	094401-01-000	EA	SEALER - BODY SEAM - FLEXICLEAR
	094401-04-000	EA	SEALER - BODY SEAM - CLEAR
	094401-05-000	EA	SEALER - BODY SEAM - 20OZ BLACK
	094401-06-000	EA	SEALER - BODY SEAM - 12OZ BLACK
	094401-07-000	EA	SEALER - BODY SEAM - CLEAR
	098408-01-000	FT	SEAL - SPONGE RUBBER - CLOSED CELL
	099069-01-000	FT	SEAL - RUBBER - CLOSED SPONGE - .5" WIDE X .12" THICK-BLK
	099418-01-000	FT	SEAL - D-SECTION/ADHESIVE BACK - .44" X .44" - BLK RUBBER
	107828-01-000	EA	SEALANT - SB - 190 EVERSEAL
	112864-01-000	FT	SEAL - FOAM/BUTYL COVERED - 3/8" X 35'
	112864-02-000	FT	FOAM - BUTYL COVERED - 5/16" X 44'
	112864-04-000	FT	FOAM - BUTYL COVERED - 3/8" X 1/8"
	112901-02-000	EA	ADHESIVE - PLEXUS - MA330 - 50ML - GRAY
	112901-03-000	EA	ADHESIVE - PLEXUS - MA300 - 50ML - WHITE
	112902-01-000	EA	NOZZLE - ELEMENT - 3/8" X 24
	112902-03-000	EA	MIXER NOZZLE - F/GUN #00400102000 - SCOTCH-WELD & PLEXUS
	112902-04-000	EA	NOZZLE - ELEMENT - 1/4" X 3.5"
	112902-05-000	EA	NOZZLE - BAYONET - 3/8" X 18

SEALANTS & FASTENERS GROUP (CONTINUED)

SEALANTS & ADHESIVES (CONTINUED)

KEY	PART NUMBER	U/M	DESCRIPTION
	112902-06-000	EA	NOZZLE - ELEMENT - 1/2" X 32
	113366-01-000	EA	ADHESIVE - INSTANT - 1 OZ
	120074-02-03A	EA	SILICONE - TUBE - W/O NOZZLE - LOW ODOR - SMOKEY WHITE
	120534-01-01A	EA	TAPE - SCOTCH - 3M - 1/2" FINE LINE
	123244-01-000	FT	TAPE - DOUBLE SIDED/FOAM - 5/64"THICK X 3/4"WIDE X 108'
	123816-01-000	FT	TAPE - DOUBLE SIDED - 1" X .020" X 200' - CLEAR
	123816-02-000	FT	TAPE - DOUBLE SIDED - 1/2" X .035" X 200' - CLEAR
	123816-03-000	FT	TAPE - DOUBLE SIDED - 1/2" X .020" X 200' - CLEAR
	123816-04-000	FT	TAPE - DOUBLE SIDED - 6" X .0035" X 750' - CLEAR
	123816-06-000	FT	TAPE - DOUBLE SIDED - 3/4" X 3/4" X 200' - CLEAR
	123816-07-000	FT	TAPE - DOUBLE SIDED - 1 3/4" X 200' - CLEAR
	126427-01-000	EA	ADHESIVE - ALL PURPOSE - ABS/PVC
	126427-02-000	EA	PRIMER - CLEANER - FLEX PIPING
	131264-01-11A	EA	SILICONE - TUBE - W/NOZZLE - BEIGE
	131264-01-12A	EA	SILICONE - TUBE - W/NOZZLE - BONE
	131264-01-13A	EA	SILICONE - TUBE - W/NOZZLE - TRANSLUCENT
	131264-02-01A	EA	SILICONE - TUBE - W/NOZZLE - VW GRAY - BATH ONLY
	131264-03-01A	EA	SILICONE - TUBE - W/O NOZZLE - SELF LEVELING -BRIGHT WHITE
	131264-04-01A	EA	SILICONE/SEALANT/ADHESIVE - FAST CURE F/GLASS/VINYL - B/W
	131264-04-02A	EA	SILICONE/SEALANT/ADHESIVE-FAST CURE F/GLASS/VINYL-SOFT WHT
	131264-05-01A	EA	SILICONE/SEALANT - ODORLESS - TUBE - W/NOZZLE - BLACK
	131264-05-02A	EA	SILICONE/SEALANT - ODORLESS - TUBE - W/NOZZLE - CLEAR
	131384-01-000	EA	ADHESIVE - JET WELD - 10 OZ CARTRIDGE
	132892-07-01A	FT	SEAL - BULB/SINGLE - W/U CHANNEL - .5" X 1" - BLACK
	152038-01-01A	EA	TAPE - PRESERVATION SEAL - 2" X 36YD ROLL - BLACK
	154585-01-01A	FT	SEAL - FOAM TAPE - ADHESIVE BACK - 3/8" X 3/8" - BLACK
	154585-02-01A	FT	SEAL - FOAM TAPE - ADHESIVE BACK - 3/4" X 1/2" - BLACK
	154585-03-01A	FT	SEAL - FOAM TAPE - ADHESIVE 2 SIDED - 1/8" X 3/4" - BLACK
	154585-04-01A	FT	SEAL - FOAM TAPE - ADHESIVE BACK - 5/8" X 1/8" - WHITE

BOLTS, NUTS AND WASHERS

KEY	PART NUMBER	U/M	DESCRIPTION
	0MD54F-06-000	EA	NUT - HEX W/SERATED FLANGE
	000C12-04-08B	EA	BOLT - HEX - 1/4-20 X 1/2 - GRADE #5 - ZINC
	000C12-04-40B	EA	BOLT - HEX - 1/4-20 X 2 1/2 - GRADE #5 ZINC
	000C12-04-20F	EA	BOLT - HEX - 1/4-20 X 1 1/4 - GRADE #5 - STAINLESS STEEL
	000C12-04-12A	EA	BOLT - HEX - 1/4-20 X 3/4 - PLAIN 5
	000C12-05-16B	EA	BOLT - HEX - 5/16 - 18X1 - GRADE #5 - ZINC
	000C12-05-40B	EA	BOLT - HEX - 5/16"-18 X 2.5" - GRADE #5 - ZINC
	000C12-06-28B	EA	BOLT-HEX-3/8-16X13/4 ZN 5 - 5185-01
	000C12-08-44B	EA	BOLT - HEX - 1/2-13 X 2 3/4 - GRADE #5 - ZINC
	000C12-08-24B	EA	BOLT - HEX - 1/2-13 X 1 1/2 - GRADE #5 - ZINC
	000C12-08-28B	EA	BOLT - HEX - 1/2-13 X 1 3/4 - GRADE #5 - ZINC
	000C13-07-40B	EA	BOLT - HEX - 7/16-20 X 2 1/2 - GRADE #5 - ZINC
	000C13-07-48B	EA	BOLT - HEX - 7/16-20 X 3 - GRADE #5 - ZINC
	000C13-07-72B	EA	BOLT - HEX - 7/16-20 X 4.5" - GRADE #5 - ZINC
	000C16-07-16B	EA	BOLT - CARRIAGE - ASSIST HANDLE - 7/16-14 X 1
	000C18-05-40A	EA	BOLT - ELEVATOR - 5/16-18 X 2 1/2 - PL
	000C26-04-18B	EA	BOLT - HEX - SERRATED FLANGE - 1/4-20 X 1 1/8 - ZINC
	000C26-04-14B	EA	BOLT - HEX - SERRATED FLANGE - 1/4-20 X 7/8 - ZINC
	000C26-04-12F	EA	BOLT - HEX - SERRATED FLANGE -1/4-20 X 3/4-STAINLESS STEEL
	000C26-04-10B	EA	BOLT - HEX - SERRATED FLANGE - 1/4-20 X 5/8 - ZINC
	000C26-04-40F	EA	BOLT - HEX - SERRATED FLANGE -1/4-20 X 2.5-STAINLESS STEEL
	000C26-05-12B	EA	BOLT - HEX - SERRATED FLANGE - 5/16-18 X 3/4 - ZINC
	000C26-06-12B	EA	BOLT - HEX - SERRATED FLANGE - 3/8-16 X 3/4 - ZINC
	000C26-06-20B	EA	BOLT - HEX - SERRATED FLANGE - 3/8-16 X 1 1/4 - ZINC
	000C26-06-28B	EA	BOLT - HEX - SERRATED FLANGE - 3/8-16 X 1 3/4 - ZINC
	000C26-06-40B	EA	BOLT - HEX - SERRATED FLANGE - 3/8-16 X 2 1/2 - ZINC
	000C26-08-28B	EA	BOLT - HEX - SERRATED FLANGE - 1/2-13 X 1 3/4 - ZINC
	000C26-08-24B	EA	BOLT - HEX - SERRATED FLANGE - 1/2-13 X 1 1/2 - ZINC
	000C26-08-40B	EA	BOLT - HEX - SERRATED FLANGE - 1/2-13 X 2 1/2-GRADE #5 ZINC
	000C27-08-48B	EA	BOLT-CARR 1/2-13X3.00 GR5 - 97 M-SERIES
	000C27-08-64B	EA	BOLT - CARRIAGE - 1/2-13 X 4 - GRADE 5
	000D16-07-00B	EA	NUT - HEX - 7/16-14 - ZINC

SEALANTS & FASTENERS GROUP (CONTINUED)
BOLTS, NUTS AND WASHERS (CONTINUED)

KEY	PART NUMBER	U/M	DESCRIPTION
	000D24-10-00B	EA	NUT - HEX - SELF LOCKING - 10-32 - ZINC
	000D27-05-00B	EA	NUT - HEX LOCK - 5-40 - ZINC
	000D28-10-00B	EA	NUT - HEX - W/NYLON LOCK - 10-32 - ZINC
	000D29-04-00F	EA	NUT - HEX - SELF LOCKING - 1/4 X 20 - STAINLESS STEEL
	000D29-04-00B	EA	NUT - HEX - SELF LOCKING - 1/4 X 20 - ZINC
	000D29-06-00B	EA	NUT - HEX - W/NYLON LOCK - 3/8-16 - ZINC
	000D29-09-00B	EA	NUT - HEX - SELF LOCKING - 9/16-12 - ZINC
	000D34-04-00B	EA	NUT - HEX - LOCKING - 1/4-20 - ZINC
	000D34-06-00B	EA	NUT - HEX - LOCKING - 3/8-16 GRADE C - ZINC
	000D39-04-00B	EA	NUT - HEX - LOCKING W/SERRATED FLANGE - 1/4-20 - ZINC
	000D39-05-00B	EA	NUT - HEX - LOCKING W/SERRATED FLANGE - 5/16-18 - ZINC
	000D39-06-00B	EA	NUT - HEX - LOCKING W/SERRATED FLANGE - 3/8-18 - ZINC
	000D39-06-00D	EA	NUT - HEX - LOCKING W/SERRATED FLANGE - 3/8"-16 BLACK
	000D39-07-00B	EA	NUT - HEX - LOCKING W/SERRATED FLANGE - 7/16-14 - ZINC
	000D39-08-00B	EA	NUT - HEX - LOCKING W/SERRATED FLANGE - 1/2-13 - ZINC
	000D39-09-00B	EA	NUT - HEX - LOCKING W/SERRATED FLANGE - 9/16-12 - ZINC
	000D44-04-00B	EA	NUT - HEX - LOCKING W/SERRATED FLANGE - 1/4-28 - ZINC
	000D44-07-00B	EA	NUT - HEX - LOCKING W/SERRATED FLANGE - 7/16-20 - ZINC
	000D44-08-00B	EA	NUT - HEX - LOCKING W/SERRATED FLANGE - 1/2-20 - ZINC
	000D46-04-00A	EA	NUT - HEX - WELD - 1/4-20 - PLAIN
	000D65-08-00B	EA	NUT - HEX - LOCKING W/SERRATED FLANGE - 8-32 - ZINC
	000D73-08-00C	EA	NUT - HEX FLANGE - 1/2-13
	000D75-09-00B	EA	NUT - HEX LOCKING - 9/16-12 - ZINC
	000D76-06-00B	EA	NUT - HEX FLANGE - 3/8-16
	000E11-04-00F	EA	WASHER - LOCKING - 1/4 MED SPLIT - STAINLESS STEEL
	000E11-07-00B	EA	WASHER - LOCKING - 7/16 MED SPLIT - ZINC
	000E11-08-00B	EA	WASHER - LOCKING - 1/2 MED SPLIT - ZINC
	000E13-17-00B	EA	WASHER - FLAT - 3/8 AR - ZINC
	000E13-18-00B	EA	WASHER - FLAT - 3/8 WIDE - ZINC
	000E13-20-00B	EA	WASHER - FLAT - 7/16 WIDE - ZINC
	000E13-22-00B	EA	WASHER - FLAT - 1/2 WIDE - ZINC
	000E13-26-00B	EA	WASHER - FLAT - 5/8 WIDE - ZINC
	000E14-10-00B	EA	WASHER - LOCKING - #10 EXTERNAL TOOTH - ZINC
	000E16-10-00B	EA	WASHER - HARDENED - 5/8 - FLAT - ZINC
	000G45-05-16B	EA	BOLT - LAG - 5/16-9 X 1 - ZINC
	005081-01-000	EA	NUT - SPEED - C-TYPE - #8 SCREW
	039715-01-000	EA	NUT-SERT - 1/4" DIAMETER - 20 THREADS
	040921-01-000	EA	NUT - SPEED - U TYPE - #10-24 - BLACK
	040921-03-000	EA	NUT - SPEED - U TYPE - #10
	040921-04-000	EA	NUT - SPEED - U TYPE - #8-.59" LENGTH X .44" WIDTH
	040921-05-000	EA	NUT - SPEED - U-TYPE - 8-.67" X .44" WIDE
	040921-11-000	EA	NUT - SPEED - U-TYPE - 8-.59" LENGTH X .44" WIDTH - BLACK
	041322-01-000	EA	WASHER - FLANGE - 15/32"ID X 2 3/8"OD - F/SEAT BELT MTG
	044364-02-000	EA	NUT - SPEED - FLAT - ROUND
	044533-01-000	EA	WASHER - 1 3/8"OD - FOR BUTTONS - PLASTIC
	051387-06-000	EA	BOLT - CARRIAGE W/O HOLE - 5/16-18 X 9 1/2 - ZINC
	058716-02-000	EA	WASHER - FLAT NYLON
	064081-03-000	EA	NUT - WING 3/8-16 - W/WELD NUT
	077071-01-000	EA	WASHER - FENDER - 3/16"ID X 1"OD
	087234-01-000	EA	NUT - JACK - 1/4 X 20 THD - MOLLY
	088787-12-000	EA	STUD - WELD - 1/4 - 20 X 1.0 LG - MN
	102540-02-000	EA	SEAL - SCREW
	106956-03-000	EA	BOLT - HEX TAP - 1/2-13NC X 3 - GRADE 5 - FULL THREAD/ZINC
	106956-10-000	EA	BOLT - HEX TAP - 9/16-12NC X 3 5/8 -GRD 5-FULL THREAD/ZINC
	106956-11-000	EA	BOLT - HEX TAP - 1/2-13NC X 2 1/2 - GRD 5-FULL THREAD/ZINC
	106956-13-000	EA	BOLT - HEX TAP - 1/2-20 X 2 1/2 - GRD 5-FULL THREAD/ZINC
	107397-01-000	EA	WASHER - FENDER - 3/4"ID X 1"OD
	108067-03-000	EA	STUD - WELD - 1/4 - 20 X 1/2 CD
	109917-03-000	EA	WASHER - 1" X .50"
	109917-04-000	EA	WASHER - 1" X .75"
	128444-01-000	EA	WASHER - SPRING - CONICAL
	135092-02-01A	EA	BOLT - HEX - SERRATED FLANGE - 1/2-20 X 2 1/2-GRADE 5 ZINC
	135092-05-01A	EA	BOLT - HEX - SERRATED FLANGE - 1/2-20 X 1 - GRADE 5 ZINC
	143399-01-01A	EA	NUT/RETAINING - 3/8"- 24 NFT

SEALANTS & FASTENERS GROUP (CONTINUED)
BOLTS, NUTS AND WASHERS (CONTINUED)

KEY	PART NUMBER	U/M	DESCRIPTION
	144904-01-01A	EA	BOLT - ADJUSTMENT - HEADLAMP
	147284-02-000	EA	NUT/SELF RETAINING - 5/16"-18
	148817-01-000	EA	WASHER/SPUR - LOCKING

SCREWS

KEY	PART NUMBER	U/M	DESCRIPTION
	0G1208-12-170	EA	SCREW - 8-18 X 3/4 POH - BRIGHT WHITE
	0G3908-08-170	EA	SCREW - SF/DR - 8-18 X 1/2 PPH - BRIGHT WHITE
	0G3908-08-410	EA	SCREW - SF/DR - 8-18 X 1/2 PPH - PARCHMENT
	0G3908-16-170	EA	SCREW - SF/DR - 8-18 X 1 PPH - BRIGHT WHITE
	0G3908-24-170	EA	SCREW - SF/DR - 8-18 X 1 1/2 PPH - BRIGHT WHITE
	0G3910-10-330	EA	SCREW - SF/DR - 20-16 X 5/8 PPH - PUTTY
	0G3910-12-170	EA	SCREW - SF/DR - 10-16 X 3/4 PPH - BRIGHT WHITE
	0G3910-12-240	EA	SCREW - SF/DR - 10-16 X .75 PPH - VW LIGHT GRAY
	0G3910-12-380	EA	SCREW - SF/DR - 10-16 X .75 PPH - CASHMERE
	0G3910-12-370	EA	SCREW - SF/DR - 10-16 X .75 PPH - RIVERSTONE
	0G3910-24-170	EA	SCREW - SF/DR - 10-16 X 1 1/2 PPH - BRIGHT WHITE
	0G3910-32-330	EA	SCREW - SF/DR - 10-16 X 2.00 PPH - PUTTY
	0G5508-08-380	EA	SCREW - SF/DR - 8-18 X .5 PWH - CASHMERE
	0G5508-08-370	EA	SCREW - SF/DR - 8-18 X .5 PWH - RIVERSTONE
	0G5508-12-170	EA	SCREW - SF/DR - 8-18 X 3/4 PWH - BRIGHT WHITE
	0G5508-12-320	EA	SCREW - SF/DR - 8-18 X 3/4 PWH - GLACIER
	0G5508-12-330	EA	SCREW - SF/DR - 8-18 X 3/4 PWH - PUTTY
	0G6008-16-170	EA	SCREW - SF/DR - 8-18 X 1 POH - BRIGHT WHITE
	0G5508-16-250	EA	SCREW - SF/DR - 8-18 X 1 PWH - VW DARK GRAY
	0G5508-16-330	EA	SCREW - SF/DR - 8-18 X 1 PWH - PUTTY
	0G5508-16-370	EA	SCREW - SF/DR - 8-18 X 1 PWH - RIVERSTONE
	0G5508-16-380	EA	SCREW - SF/DR - 8-18 X 1 PWH - CASHMERE
	0G5508-16-410	EA	SCREW - SF/DR - 8-18 X 1 PWH - MEDIUM PARCHMENT
	0G6012-32-170	EA	SCREW - SF/DR - 12-14 X 2 POH - BRIGHT WHITE
	0G6710-08-170	EA	SCREW - 10-12 X 1/2 PPH - BRIGHT WHITE
	0G6710-12-170	EA	SCREW - 10-12 X 3/4 PPH - BRIGHT WHITE
	0G6806-16-170	EA	SCREW - 6-18 X 1 POH - BRIGHT WHITE
	0G6810-24-280	EA	SCREW - 10-12 X 1 1/2 POH - SOFT WHITE
	000C20-06-24T	EA	SCREW - 3/8-16 X 1 1/2 - FLAT SOCKET
	000C28-05-24D	EA	CAPSCREW/BUTTON HEAD - 5/16-18 X 1 1/2 - #8-BLK PHOSPHATE
	000G11-06-08B	EA	SCREW - 6-20 X 1/2 PPH - ZINC
	000G11-06-10B	EA	SCREW - 6-20 X 5/8 PPH - ZINC
	000G11-06-10J	EA	SCREW - 6-20 X 5/8 PPH - BRASS
	000G11-07-08B	EA	SCREW - 7-19 X 1/2 PPH - ZINC
	000G11-08-06B	EA	SCREW - 8-18 X 3/8 PPH - ZINC
	000G11-08-08T	EA	SCREW - 8-18 X 1/2 PPH - FLUOROCARBON COATING
	000G11-08-12B	EA	SCREW - 8-18 X 3/4 PPH - ZINC
	000G11-08-12P	EA	SCREW - 8-18 X 3/4 PPH - DARK BROWN
	000G11-08-12S	EA	SCREW - 8-18 X 3/4 PPH - OFF WHITE
	000G11-08-12T	EA	SCREW - 8-18 X 3/4 PPH - BLACK MAGNESIUM
	000G11-08-20B	EA	SCREW - 8-18 X 1 1/4 PPH - ZINC
	000G11-08-20G	EA	SCREW - 8-18 X 1 1/4 - ANTIQUE BRASS
	000G11-10-12D	EA	SCREW - 10-16 X 3/4 PPH - BLACK
	000G12-06-08T	EA	SCREW - 6-20 X 1/2 POH - BLACK
	000G12-06-12J	EA	SCREW - 6-20 X .75 POH - BRASS
	000G12-10-16F	EA	SCREW - 10-16 X 1 POH - STAINLESS STEEL
	000G13-05-10B	EA	SCREW - 5-12 X 5/8 PFH - ZINC
	000G13-06-08B	EA	SCREW - 6-20 X 1/2 PFH - ZINC
	000G13-06-08G	EA	SCREW - 6-20 X 1/2 PFH - ANTIQUE BRASS
	000G13-06-10G	EA	SCREW - 6-20 X 5/8 PFH - ANTIQUE BRASS
	000G13-06-16J	EA	SCREW - 6-20 X 1 PFH - BRASS
	000G13-06-169	EA	SCREW - SF/DR - 6-20 X 1 PFH - SILVER
	000G13-06-24J	EA	SCREW - 6-20 X 1 1/2 PFH - BRASS
	000G13-07-10H	EA	SCREW - 7-19 X 5/8 PFH - BLACK
	000G13-07-12B	EA	SCREW - 7-19 X 3/4 PFH - ZINC
	000G13-08-109	EA	SCREW - 8-18 X 5/8 PFH
	000G13-08-10B	EA	SCREW - 8-18 X 5/8 PFH - ZINC
	000G13-08-16B	EA	SCREW - 8-18 X 1 PFH - ZINC

SEALANTS & FASTENERS GROUP (CONTINUED)
SCREWS (CONTINUED)

KEY	PART NUMBER	U/M	DESCRIPTION
	000G13-08-24B	EA	SCREW - 8-18 X 1 1/2 PFH - ZINC
	000G16-04-24B	EA	SCREW - MACHINE - 1/4-20 X 1 1/2 PPH
	000G18-08-12B	EA	SCREW - MACHINE - 8-32 X 3/4 PPH - ZINC
	000G18-08-16B	EA	SCREW - MACHINE - 8-32 X 1 PPH - ZINC
	000G18-08-24B	EA	SCREW - MACHINE - 8-32 X 1 1/2 PPH - ZINC
	000G18-08-22B	EA	SCREW - MACHINE - 8-32 X 1 3/8 PPH - ZINC
	000G19-10-08B	EA	SCREW - MACHINE - 10-32 X 1/2 PPH - ZINC
	000G19-10-10B	EA	SCREW - MACHINE - 10-32 X 5/8 - PPH - ZINC
	000G19-10-12F	EA	SCREW - MACHINE - 10-32 X 3/4 PPH - STAINLESS STEEL
	000G19-10-20B	EA	SCREW - MACHINE - 10-32 X 1 1/2 PPH - ZINC
	000G32-10-06B	EA	SCREW - 10-32 X 3/8 PPH - ZINC
	000G34-05-12B	EA	SCREW - HEX HEAD TAPPING - 5/16 X 3/4 LONG
	000G36-10-12T	EA	SCREW - 10-24X 3/4 PFH TYPE 23 - BLACK
	000G39-06-10T	EA	SCREW - SF/DR - 6-20 X 5/8 PPH - BLACK
	000G39-06-16T	EA	SCREW - SF/DR - 6-20 X 1 PPH - BLACK
	000G39-08-06B	EA	SCREW - SF/DR - 8-18 X 3/8 PPH - ZINC
	000G39-08-08B	EA	SCREW - SF/DR - 8-18 X 1/2 PPH - ZINC
	000G39-08-08S	EA	SCREW - SF/DR - 8-18 X 1/2 PPH - OFF WHITE
	000G39-08-08T	EA	SCREW - SF/DR - 8-18 X 1/2 PPH - BLACK
	000G39-08-12T	EA	SCREW - SF/DR - 8-18 X 3/4 PPH - BLACK
	000G39-08-16B	EA	SCREW - SF/DR - 8-18 X 1 PPH - ZINC
	000G39-08-16T	EA	SCREW - SF/DR - 6-20 X 1 PPH - BLACK
	000G39-08-24B	EA	SCREW - SF/DR - 8-18 X 1 1/2 PPH - ZINC
	000G39-08-24S	EA	SCREW - SF/DR - 8-18 X 1 1/2 - OFF WHITE
	000G39-08-24T	EA	SCREW - SF/DR - 8-18 X 1 1/2 PPH - BLACK
	000G39-08-32B	EA	SCREW - SF/DR - 8-18 X 2 PPH - ZINC
	000G39-10-08B	EA	SCREW - SF/DR - 10-16 X 1/2 PPH - ZINC
	000G39-10-10B	EA	SCREW - SF/DR - 10-16 X 5/8 PPH - ZINC
	000G39-10-12B	EA	SCREW - SF/DR - 10-16 X 3/4 PPH - ZINC
	000G39-10-129	EA	SCREW - SF/DR - 10-16 X 3/4 PPH - FLUOROCARBON SILVER
	000G39-10-169	EA	SCREW - SF/DR - 10-16 X 1 PPH - FLUOROCARBON SILVER
	000G39-10-20B	EA	SCREW - SF/DR - 10-16 X 1 1/4 PPH - ZINC
	000G39-10-20T	EA	SCREW - SF/DR - 10-16 X 1 1/4 PPH - BLACK
	000G39-10-24T	EA	SCREW - SF/DR - 10-16 X 1 1/2" PPH - BLACK
	000G39-10-28T	EA	SCREW - SF/DR - 10-16 X 1 3/4" PPH - BLACK
	000G39-10-32B	EA	SCREW - SF/DR - 10-16 X 2 - PPH - ZINC
	000G39-10-48B	EA	SCREW - SF/DR - 10-16 X 3 - PPH - ZINC
	000G39-10-48T	EA	SCREW - SF/DR - 10-16 X 3 PPH - BLACK
	000G42-04-16B	EA	SCREW - SF/DR - 1/4-14 X 1 HWH - ZINC
	000G42-04-24B	EA	SCREW - SF/DR - 1/4-14 X 1 1/2 - ZINC
	000G46-08-24T	EA	SCREW - MACHINE - 8-32 X 1 1/2 PFH - ZINC
	000G52-06-05B	EA	SCREW - MACHINE - 6-32 X 5/16 PTH - ZINC
	000G52-06-06B	EA	SCREW - MACHINE - 6-32 X 3/8 PTH - ZINC
	000G54-04-14B	EA	SCREW - 1/4-20 X 7/8 PTH - TYPE 23 - ZINC PLATED
	000G55-08-12T	EA	SCREW - SF/DR - 8-18 X 3/4 PWH - BLACK
	000G55-08-124	EA	SCREW - SF/DR - 8-18 X 3/4 PWH - ASH GRAY
	000G55-08-16T	EA	SCREW - SF/DR - 8-18 X 1 PWH - BLACK
	000G56-12-48B	EA	SCREW - WOOD - 12-11 X 3 POH - SPECIAL HARDENED
	000G57-14-64B	EA	SCREW - 14-10 X 4 PFH ZINC
	000G60-08-16E	EA	SCREW - SF/DR - 8-1 X 1 POH - CHROME
	000G60-08-20F	EA	SCREW - SF/DR - 8-19X1.25 POH
	000G60-08-22B	EA	SCREW - SF/DR - 8-18 X 1.38 POH - ZINC
	000G60-10-16J	EA	SCREW - SF/DR - 10-16 X 1 POH - BRIGHT BRASS
	000G60-10-20B	EA	SCREW - SF/DR - 10-16 X 1 1/4 POH - ZINC
	000G60-10-209	EA	SCREW - SF/DR - 10-16 X 1 1/4 POH - SILVER STALGAARD
	000G60-10-28T	EA	SCREW - SF/DR - 10-16 X 1 3/4 - BLACK
	000G62-06-24I	EA	SCREW - SF/DR - 8-18 X 1.5 PPH - BLACK
	000G62-06-249	EA	SCREW - SF/DR - 8-18 X 1.5 PPH - SILVER
	000G62-08-24B	EA	SCREW - SF/DR - 8-18 X 1 1/2 PFH
	000G67-08-32B	EA	SCREW - 8-15 X 2 PPH - ZINC
	000G67-10-08B	EA	SCREW - 10-12 X 1/2 PPH - ZINC
	000G67-10-08S	EA	SCREW - 10-12 X 1/2 PPH - OFF WHITE
	000G67-10-10B	EA	SCREW - 10-12 X 5/8 PPH - ZINC - TYPE A
	000G67-10-10S	EA	SCREW - 10-12 X 5/8 PPH - OFF WHITE

SEALANTS & FASTENERS GROUP (CONTINUED)
SCREWS (CONTINUED)

KEY	PART NUMBER	U/M	DESCRIPTION
	000G67-10-10T	EA	SCREW - 10-12 X 5/8 PPH - BLACK
	000G67-10-10P	EA	SCREW - 10-12 X 5/8 PPH - DARK BROWN
	000G67-10-12P	EA	SCREW - 10-12 X 3/4 PPH - DARK BROWN
	000G67-10-24B	EA	SCREW - 10-12 X 1 1/2 PPH - ZINC
	000G67-10-24S	EA	SCREW - 10-12 X 1 1/2 PPH - OFF WHITE
	000G67-10-32J	EA	SCREW-10-12X2 PPH - BRIGHT BRASS
	000G68-06-10J	EA	SCREW - 6-18 X 5/8 POH - BRASS
	000G68-06-12B	EA	SCREW - 6-18 X 3/4 POH - ZINC & CLEAR
	000G68-06-12J	EA	SCREW - 6-18 X 3/4 POH - BRASS
	000G68-06-12S	EA	SCREW - 6-18 X 3/4 POH
	029130-01-000	EA	SCREW - SNAP STUD - #8-16 X 5/8" LONG
	029130-03-000	EA	SCREW - SNAP STUD - #8-16 X 1" LONG
	049465-01-000	EA	SCREW - 10-16 PTH W/WASHER - DARK BROWN
	049465-03-000	EA	SCREW - 10-16 X 1 POH W/WASHER - OFF WHITE
	049465-13-000	EA	SCREW - 10-16 X 1 PTH W/WASHER - ASH GRAY
	049465-17-000	EA	SCREW - 10-16 X 1 POH W/WASHER - BRIGHT WHITE
	049465-18-000	EA	SCREW - 10-16 X 1 POH W/WASHER - VW GRAY
	054434-02-000	EA	SCREW - SF/DR - 10-16 X 2 - ZINC
	054434-03-000	EA	SCREW - SF/DR - 10-16 X 2 - PWH - ZINC
	075908-01-000	EA	SCREW - MACHINE - 10-32 X .56 PTH - EXTERNAL TOOTH - ZINC
	076790-01-000	EA	SCREW - 6-20 X 1 1/4 PPH - BLACK
	076790-05-000	EA	SCREW - 6-20 X 1/2 PPH - BLACK - THREAD CUTTING/WOOD
	083554-01-000	EA	SCREW - DRYWALL - 8 X 1 1/4
	083554-04-000	EA	SCREW - DRYWALL - 8 X 2 1/2
	087721-01-000	EA	SCREW - FLAT HEAD - TAPPING - 1/4" X 1 1/4" LONG - ZINC
	095772-01-000	EA	SOCKET-SNAP FASTNER1" SF/DR - SELF DRIVER
	097974-01-000	EA	SCREW - PARTICLE BOARD - 7-9 X 3/4 PPH
	097974-02-000	EA	SCREW-PART BD 8-9X.75 PFH - BEIGE
	101618-01-000	EA	SCREW - 1/4-20 X 3/4 HEX - TAPPING - STALGARD TYPE F
	113563-01-01A	EA	SCREW - 8 X 5/8 LONG SHOULDER/WASHER HEAD
	113563-01-02A	EA	SCREW - 8 X 5/8 LONG SHOULDER/WASHER HEAD - BRIGHT WHITE
	118383-01-09A	EA	RETAINER/RECESSED - F/.22" SCREW - GLACIER
	118383-01-12A	EA	RETAINER/RECESSED - F/.22" SCREW - RIVERSTONE
	118383-01-10A	EA	RETAINER/RECESSED - F/.22" SCREW - STORM GRAY
	118383-01-11A	EA	RETAINER/RECESSED - F/.22" SCREW - CASHMERE
	118383-02-10A	EA	RETAINER/RECESSED - F/.27" SCREW - RIVERSTONE
	118383-02-11A	EA	RETAINER/RECESSED - F/.27" SCREW - CASHMERE
	118383-02-13A	EA	RETAINER/RECESSED - F/.27" SCREW - OFF WHITE
	118383-03-09A	EA	RETAINER/RECESSED - F/.32" SCREW - GLACIER
	118383-04-04A	EA	CAP - F/RECESSED RETAINER - BRIGHT WHITE
	118383-04-09A	EA	CAP - F/RECESSED RETAINER - GLACIER
	118383-04-10A	EA	CAP - F/RECESSED RETAINER - RIVERSTONE
	118383-04-11A	EA	CAP - F/RECESSED RETAINER - CASHMERE
	118383-04-12A	EA	CAP - F/RECESSED RETAINER - STORM GRAY
	118383-04-13A	EA	CAP - F/RECESSED RETAINER - OFF WHITE
	134126-01-01A	EA	SCREW/NAIL - HEX HEAD - 3/4"
	140040-01-000	EA	SCREW - 1/4-20 X 1 - BUTTON HEAD/SOCKET - W/LOCTITE
	149753-01-01A	EA	RETAINER/RECESSED - F/.22" SCREW - BLACK
	149753-01-02A	EA	RETAINER/RECESSED - F/.22" SCREW - BRIGHT WHITE
	149753-02-01A	EA	CAP - F/RECESSED RETAINER - BLACK
	149753-02-02A	EA	CAP - F/RECESSED RETAINER - BRIGHT WHITE
	154938-01-01A	EA	SCREW - SF/DR - 10-16 X 3/4 PPH - W/SELF SEAL - BRIGHT WHITE
	154938-01-02A	EA	SCREW - SF/DR - 10-16 X 3/4 PPH - W/SELF SEAL - BLACK
	154938-02-01A	EA	SCREW - SF/DR - 8-18 X 1 PFH - W/SELF SEAL - BRIGHT WHITE
	154938-02-02A	EA	SCREW - SF/DR - 8-18 X 1 PFH - W/SELF SEAL - BLACK
	154938-02-03A	EA	SCREW - SF/DR - 8-18 X 1 PFH - W/SELF SEAL - SILVER
	154938-03-01A	EA	SCREW - SF/DR - 8-18 X 5/8 PFH - W/SELF SEAL - BRT WHT
	154935-03-02A	EA	SCREW - SF/DR - 8-18 X 5/8 PFH - W/SELF SEAL - BLACK
	154938-04-01A	EA	SCREW - SF/DR - 10-16 X 1" TPH - W/SELF SEAL - BRT WHT
	154938-04-02A	EA	SCREW - SF/DR - 10-16 X 1" TPH - W/SELF SEAL - BLACK
	154938-05-03A	EA	SCREW - SF/DR - 8-18 X 1.25" PFH - W/SELF SEAL - SILVER

SEALANTS & FASTENERS GROUP (CONTINUED)

CLAMPS, CLIPS, GROMMETS, RIVETS & PLUGS

KEY	PART NUMBER	U/M	DESCRIPTION
	000H16-04-06R	EA	RIVET - POP ALUMINUM - 1/8 X .313 - .375
	000H16-06-10R	EA	RIVET - POP ALUMINUM - 3/16 X .501 - .625
	007161-01-000	EA	CLAMP - HOSE - SPRING TYPE - 1/2"
	008386-01-000	EA	GROMMET - SNAP - 3/8" DIAMETER - NYLON
	010495-01-000	EA	CLAMP - CABLE - 9/16"ID - BLACK
	010495-02-000	EA	CLAMP - CABLE - 3/8"ID - BLACK
	010495-04-000	EA	CLAMP - CABLE - 11/16"ID - WHITE
	010497-01-000	EA	CLAMP - CLOSED - 5/8"ID
	010497-02-000	EA	CLAMP - CLOSED - 1.5"ID
	010497-03-000	EA	CLAMP - CLOSED - 1"ID - CUSHIONED
	010497-04-000	EA	CLAMP - CLOSED - 1 5/8"ID
	010497-05-000	EA	CLAMP - CLOSED - 1/2"ID
	010497-07-000	EA	CLAMP - CLOSED - 3/8"ID
	010497-09-000	EA	CLAMP - CLOSED - 5/16"ID
	010497-10-000	EA	CLAMP - CLOSED - 7/8"ID
	010499-01-000	EA	CLAMP - CLOSED - 3/8"ID
	016188-03-000	EA	GROMMET - LP LINE - 3/8"HOLE X 2 1/2"LONG - RUBBER
	016188-04-000	EA	GROMMET - LP LINE - 1/2"HOLE X 2 1/2"LONG - RUBBER
	016188-05-000	EA	GROMMET - LP LINE - 3/8"HOLE X 1 1/4"LONG - RUBBER
	016188-06-000	EA	GROMMET - LP LINE - 3/8"HOLE X 3 1/4"LONG - RUBBER
	016188-07-000	EA	GROMMET - L/P LINE - 1/2"HOLE X 3 1/4"LONG
	016188-08-000	EA	GROMMET - LP LINE - 1/2"HOLE X 1 1/4"LONG - RUBBER
	016188-09-000	EA	GROMMET - LP LINE - .68"HOLE X 1 1/4"LONG - RUBBER
	016188-10-000	EA	GROMMET - LP GAS - .68" X 2.5"
	023942-01-000	EA	GROMMET - RUBBER - 2"OD
	041930-11-000	EA	RIVET - POP ALUMINUM - 1/8 X .188 - .250 - BRIGHT WHITE
	061420-04-000	EA	PLUG/PLASTIC - 1 1/4" DIAMETER
	061420-05-000	EA	PLUG/PLASTIC - 1 1/2" DIAMETER
	061420-09-000	EA	PLUG/PLASTIC - 1.00" DIAMETER
	061420-10-000	EA	PLUG/PLASTIC - 1 1/2" DIAMETER - BLACK
	061420-12-000	EA	PLUG/PLASTIC - 1.50" DIAMETER - RED
	061420-13-000	EA	PLUG/PLASTIC - 3/8" - FLUSH
	061420-14-000	EA	PLUG/PLASTIC - 7/8" DIAMETER - BLACK
	061420-15-000	EA	PLUG/PLASTIC - 2" DIAMETER - BLACK
	061420-16-000	EA	PLUG/PLASTIC - 2 1/8" DIAMETER - BLACK
	062401-01-000	EA	CLAMP - HOSE - WORMGEAR - .25" - 1"
	062401-02-000	EA	CLAMP - HOSE - WORMGEAR - 1.56" - 2.5" ID
	062401-03-000	EA	CLAMP - HOSE - WORMGEAR - .22" - 1" ID
	062401-04-000	EA	CLAMP - HOSE - WORMGEAR - .69" - 1.25" ID
	062401-05-000	EA	CLAMP - HOSE - WORMGEAR - 2" - 3" ID
	062401-06-000	EA	CLAMP - HOSE - WORMGEAR - .22" - .62" ID
	062401-09-000	EA	CLAMP - HOSE - WORMGEAR - 2.8" - 3.75" ID
	062401-11-000	EA	CLAMP - HOSE - WORMGEAR - 3.50" - 4.50" ID
	062401-13-000	EA	CLAMP - HOSE - WORMGEAR
	063729-12-000	EA	RIVNUT - 5/16 - 18 UNCUT - FLATHEAD - STAINLESS
	071015-01-000	EA	GROMMET - RUBBER - .5"ID X 1"OD-W/.38" GROOVE - BLACK
	071015-11-000	EA	GROMMET - RUBBER - 1"ID FITS .12 MATERIAL - BLACK
	071015-13-000	EA	GROMMET - RUBBER - .62"ID X 1"OD W/.09" GROOVE - BLACK
	071015-22-000	EA	GROMMET - RUBBER - .62"ID X 1.12"OD W/.19" GROOVE - BLACK
	071015-26-000	EA	GROMMET - RUBBER - 1.5"ID X 2.1"OD W/.06" GROOVE - BLACK
	071015-29-000	EA	GROMMET - RUBBER - .3"ID X 1.3"OD W/.12" GROOVE - BLACK
	071015-30-000	EA	GROMMET - RUBBER - .3"ID X .81"OD W/.12" GROOVE - BLACK
	071015-39-000	EA	GROMMET - .75 ID FITS .06 MTL
	071015-41-000	EA	GROMMET - .125 ID FITS .188 MTL
	071015-42-000	EA	GROMMET - .25 ID FITS .06 MTL
	075148-02-000	EA	CLAMP - GROUNDING - BRONZE SCREWS
	077955-01-000	EA	CLIP/J - 3/8" - VINYL COATED
	080734-02-000	EA	CLIP - WIRE NYLON
	081211-01-000	EA	PLUG - PLASTIC - .31"DIA - BLACK
	081211-03-000	EA	PLUG - PLASTIC - .50"DIAMETER - TRUSS HEAD - BLACK
	081211-04-000	EA	PLUG - PLASTIC - .46"DIAMETER - TRUSS HEAD - BLACK
	083609-01-000	EA	CLAMP - WIRE - DUAL - EQUAL DIAMETERS - 5/8"
	083610-01-000	EA	CLAMP - WIRE - DUAL - UNEQUAL DIAMETERS - 3/4" & 1 1/4"
	083610-02-000	EA	CLAMP - WIRE - DUAL - UNEQUAL DIAMETERS - 3/4" & 2"

SEALANTS & FASTENERS GROUP (CONTINUED)
CLAMPS, CLIPS, GROMMETS, RIVETS & PLUGS (CONTINUED)

KEY	PART NUMBER	U/M	DESCRIPTION
	083610-03-000	EA	CLAMP - WIRE - DUAL - EQUAL DIAMETERS - 2"
	088756-01-000	EA	GROMMET - WEB - 1 1/8"ID
	089329-02-000	EA	CLIP - SPRING
	091952-01-000	EA	CLIP - GRIPPER - 1" - BLACK VINYL COATED
	091952-02-000	EA	CLIP - GRIPPER - 3/4" - BLACK VINYL COATED
	091952-03-000	EA	CLIP - GRIPPER - 1/2" - BLACK VINYL COATED
	094362-02-000	EA	CLIP - XMAS TREE - BINDER HEAD - .9" LONG/ANY COLOR
	094362-05-000	EA	CLIP - XMAS TREE - ROUND HEAD - 1.4" LONG/ANY COLOR
	113133-02-01A	EA	RIVET - POP - ALUMINUM - 3/16 X .252 - .504 - BLACK
	114208-05-000	EA	GROMMET - EDGE LINER - FITS 2"
	118626-01-02A	EA	RIVET/POP - ALUMINUM - 3/16 X .08 - .375
	118626-01-01A	EA	RIVET/POP - ALUMINUM - 3/16 X 1.2"(GRIP RANGE .1"-.4")
	118626-02-01A	EA	RIVET/POP - ALUMINUM - 3/16 X .500 - .750
	118626-03-01A	EA	RIVET/POP - STAINLESS STEEL - 3/16 X .500 - .750
	137014-01-02A	EA	GROMMET - CABLE - BROWN
	137014-01-01A	EA	GROMMET - CABLE - ALMOND
	137014-01-03A	EA	GROMMET - CABLE - BLACK
	139118-02-01A	EA	GROMMET - SCREW - PLASTIC
	155498-01-01A	EA	CLAMP - CLOSED - 7/8"ID - VINYL DIP/GALVONIZED - BLACK

SEALANTS & FASTENERS GROUP (CONTINUED)
MISCELLANEOUS FASTENERS

KEY	PART NUMBER	U/M	DESCRIPTION
	008343-01-000	EA	TIE - WIRE - 6"
	008343-02-000	EA	TIE - WIRE - 14"
	008343-03-000	EA	TIE - WIRE - 7 1/2" - BLACK
	029094-04-000	YD	VELCRO TAPE/LOOP - 1"WIDE - W/ADHESIVE BACK - BLACK
	029096-04-000	YD	VELCRO TAPE/HOOK - 1"WIDE - BLACK - W/ADHESIVE BACK (PSA)
	048394-02-000	YD	VELCRO TAPE - HOOK - ADHESIVE BACK - 3/4" WIDE - BEIGE
	085774-01-000	FT	FASTENER - DUAL LOCK - 1" WIDE - ADHESIVE BACK - BLACK
	085774-02-000	FT	FASTENER - DUAL HOOK - 1" WIDE - ADHESIVE BACK - BLACK
	088792-02-000	YD	VELCRO TAPE - LOOP - 3/4" - ADHESIVE BACK - BEIGE
	088792-04-000	YD	VELCRO TAPE - HOOK - 5/8" - NON-ADHESIVE BACK - WHITE
	088792-05-000	YD	VELCRO TAPE - LOOP - 5/8" - NON-ADHESIVE BACK - WHITE
	108046-02-000	EA	CABLE TIE - SCREW MOUNT 15"

WATER & SEWAGE GROUP DRAINAGE SYSTEM

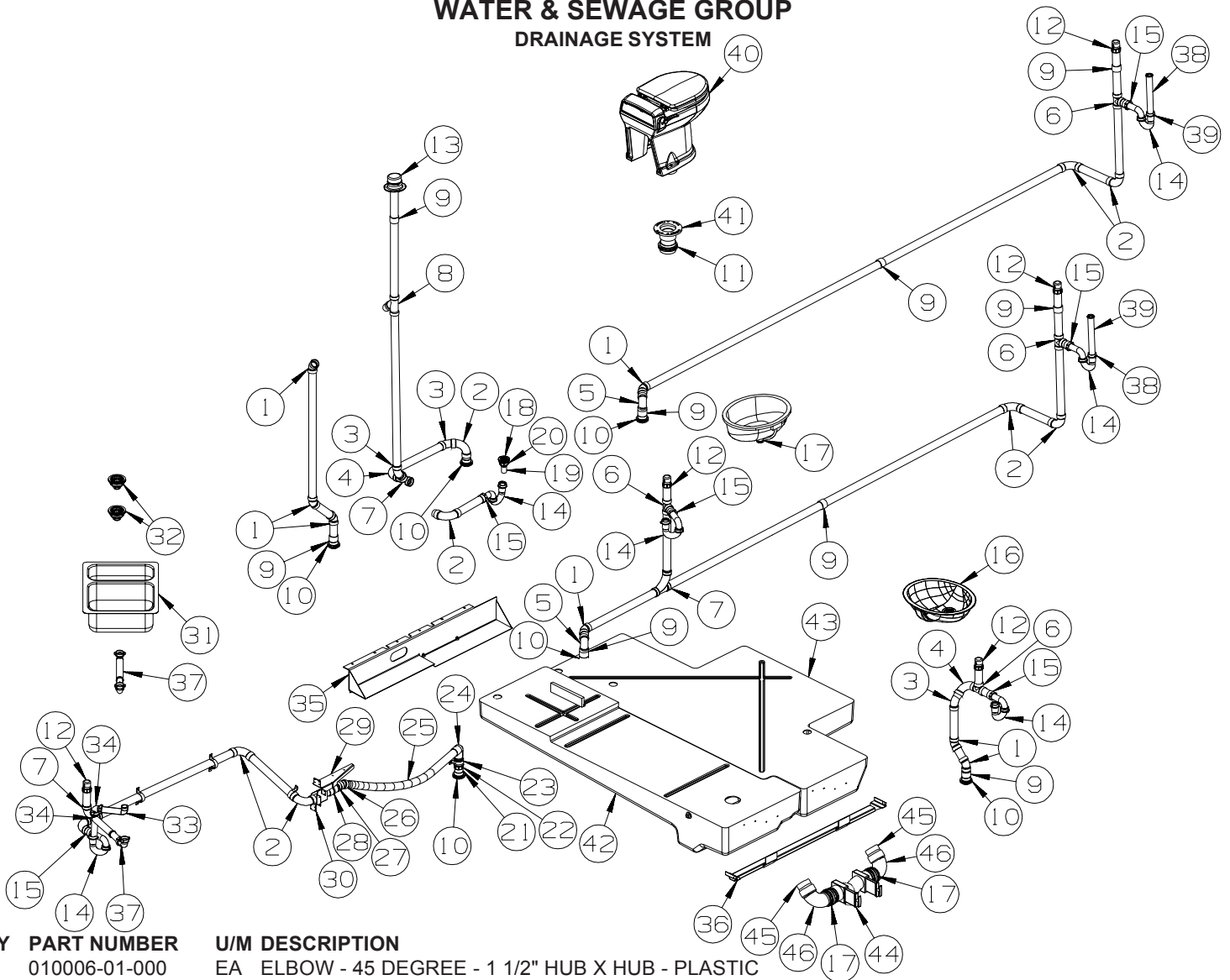

KEY	PART NUMBER	U/M	DESCRIPTION
1	010006-01-000	EA	ELBOW - 45 DEGREE - 1 1/2" HUB X HUB - PLASTIC
2	010008-01-000	EA	ELBOW - 90 DEGREE - 1 1/2" HUB X HUB - PLASTIC
3	010051-01-000	EA	ELBOW - 45 DEGREE - 1 1/2" SPIGOT X HUB - PLASTIC
4	033761-01-000	EA	ELBOW - 90 DEGREE - TURN - 1 1/2" HUB X 1 1/2" SPIGOT
5	034250-01-000	EA	ELBOW - 90 DEGREE - LONG TURN - 1 1/2" HUB X HUB - ABS
6	010071-01-000	EA	TEE - SANITARY - 1 1/2" HUB X HUB X HUB - PLASTIC
7	031365-02-000	EA	TEE - 1 1/2" EXTRA LONG TURN - PLASTIC
8	010073-01-000	EA	WYE - 45 DEGREE - 1 1/2" HUB X HUB X HUB - PLASTIC
9	010115-01-000	EA	COUPLING - 1 1/2" HUB X HUB - PLASTIC
10	061607-01-000	EA	GROMMET - HOLDING TANK - 1 1/2" NPS
11	061607-02-000	EA	GROMMET - HOLDING TANK - 3" NPS
12	079968-01-000	EA	VENT - MECHANICAL/TRAP ARM - ANTI-SIPHON-2" X 7.3" PLASTIC
13	083558-03-000	EA	VENT - W/COVER - F/PLUMBING STACK - OFF WHITE
14	107538-02-000	EA	P-TRAP - PLASTIC - 1 1/2" W/EXTENSION ARM
14	011071-01-000	EA	P-TRAP - 1 1/2" - CSA - PLASTIC - CANADIAN
15	152146-01-000	EA	CONNECTOR - 1 1/2"P X 1 1/2"MPT
16	155318-01-01A	EA	SINK - LAVATORY - OVAL - 19.5" X 16" X 6.1" - CREAM
17	078406-01-000	EA	COUPLER - 3" X 3" W/CLAMPS - RUBBER
18	066440-01-000	EA	STRAINER - SHOWER DRAIN - W/RUBBER WASHER
18	127440-02-01A	EA	WASHER - RUBBER - 1.8" X .1"
19	011069-06-000	EA	TAILPIECE - 1 1/2" X 1 1/4" X 2 1/2" - BRASS
20	130403-01-000	EA	NUT - SLIP - W/WINGS 1 1/2"
21	126424-01-000	EA	ADAPTER - 1 1/2" MPT X 1 1/2" HUB
22	126425-02-000	EA	ADAPTER - SWIVEL - 1 1/2 FPT X SPIGOT
23	130685-02-000	EA	ADAPTER - 1 7/8 FEMALE SLIP X 1 1/2" MALE THREAD/O-RING
24	136111-01-000	EA	ELBOW - 1/2" SOCKET X SLIP FIT
25	126426-01-000	FT	PIPE - 1 1/2" FLEXIBLE
26	010005-01-000	EA	ELBOW - 22.5 DEGREE - 1 1/2" HUB X HUB - PLASTIC

WATER & SEWAGE GROUP (CONTINUED)
DRAINAGE SYSTEM (CONTINUED)

KEY	PART NUMBER	U/M	DESCRIPTION
27	130685-03-000	EA	ADAPTER - 1 7/8" MALE SLIP X 1 1/2" MALE THREAD/O-RING
28	130685-01-000	EA	ADAPTER - 1 7/8" FEMALE SLIP X 1 1/2" FEMALE THREAD/O-RING
29	142526-01-02B	EA	BRACKET/COVER - PLUMBING - E-COATED
30	142527-02-02B	EA	BRACKET/CARRIER - PLUMBING - E-COATED
31	144445-01-01A	EA	SINK - DOUBLE BOWL - 25" X 18" - STAINLESS STEEL
32	092303-02-000	EA	STRAINER - W/BASKET
33	126588-01-000	EA	ARM - WASTE - 1 1/2" X 9 1/2" - FEMALE
34	125569-01-000	EA	ELBOW - 1 1/2" X 90 DEGREE - DOUBLE SLIP
35	152443-01-02B	EA	BRACKET - TANK DRAIN - E-COATED
36	152487-02-02B	EA	SUPPORT - HOLDING TANK - E-COATED
37	011091-02-000	EA	WASTE - CONTINUOUS - DOUBLE SINK
37	011091-04-000	EA	WASTE - CONTINUOUS - DOUBLE SINK - DISHWASHER
38	061420-10-000	EA	PLUG/PLASTIC - 1 1/2" DIAMETER - BLACK
39	126588-02-000	EA	ARM - WASTE - 1 1/2" X 20" - FEMALE
40*	152830-01-01A	EA	TOILET/AQUA MAGIC STYLE PLUS - 20" TALL - W/O SPRAY - WHITE
41	024676-01-000	EA	FLANGE/CLOSET - 4" X 3" - BLACK PLASTIC
42	152389-01-700	EA	TANK - HOLDING - 52 GALLON - W/3" SPINWELD - W/O FITTINGS
	010232-01-000	EA	FITTING - SPINWELD - PLASTIC 3FPT
	049032-01-000	EA	PATCH - SPINWELD - 3/8" - PLASTIC
	125697-02-000	EA	NOZZLE - WELD-A-FLUSH
43	152390-01-700	EA	TANK - HOLDING - 76 GALLON - W/SPINWELD - W/O FITTINGS
	010232-01-000	EA	FITTING - SPINWELD - PLASTIC 3FPT
	049032-01-000	EA	PATCH - SPINWELD - 3/8" - PLASTIC
44	136143-01-000	EA	VALVE - DUAL - 3" X 3"
	139513-02-000	EA	HOSE - SEWER - 3" X 20' - W/ADAPTER
	062416-01-000	EA	ADAPTER - SEWER HOSE TO 3" PIPE
*	144728-01-000	EA	VALVE - SEWER HOSE - 3"
	147845-01-01A	EA	LABEL - DRIP VALVE
45	010129-03-000	EA	NIPPLE - 3" X 3" TOE - PLASTIC
46	010062-01-000	EA	ELBOW - 3 90 SPIGOT X HUB - PLASTIC

***COMPONENT PARTS LISTED LATER IN THIS GROUP**

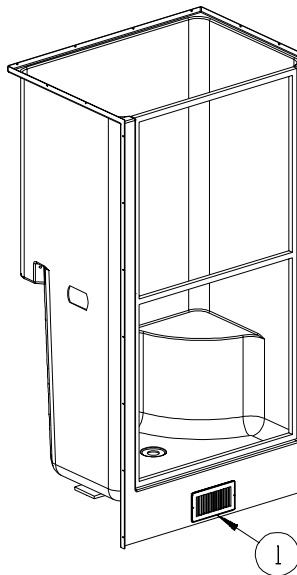

KEY	PART NUMBER	U/M	DESCRIPTION
1	137965-07-02A	EA	REGISTER - 9.5" X 5.3"(7.8" X 3.8"R/O) W/O DAMPER-ANT PWTR

WATER & SEWAGE GROUP (CONTINUED)

COMPONENT PARTS FOR DRAINAGE SYSTEM

144728-01-000

KEY	PART NUMBER	U/M	DESCRIPTION	VENDOR NO.
	144728-01-700	EA	GASKET-RUBBER, INSIDE VALVE	9667310-11
	144728-01-701	EA	GASKET-RUBBER, OUTSIDE	9667310-10

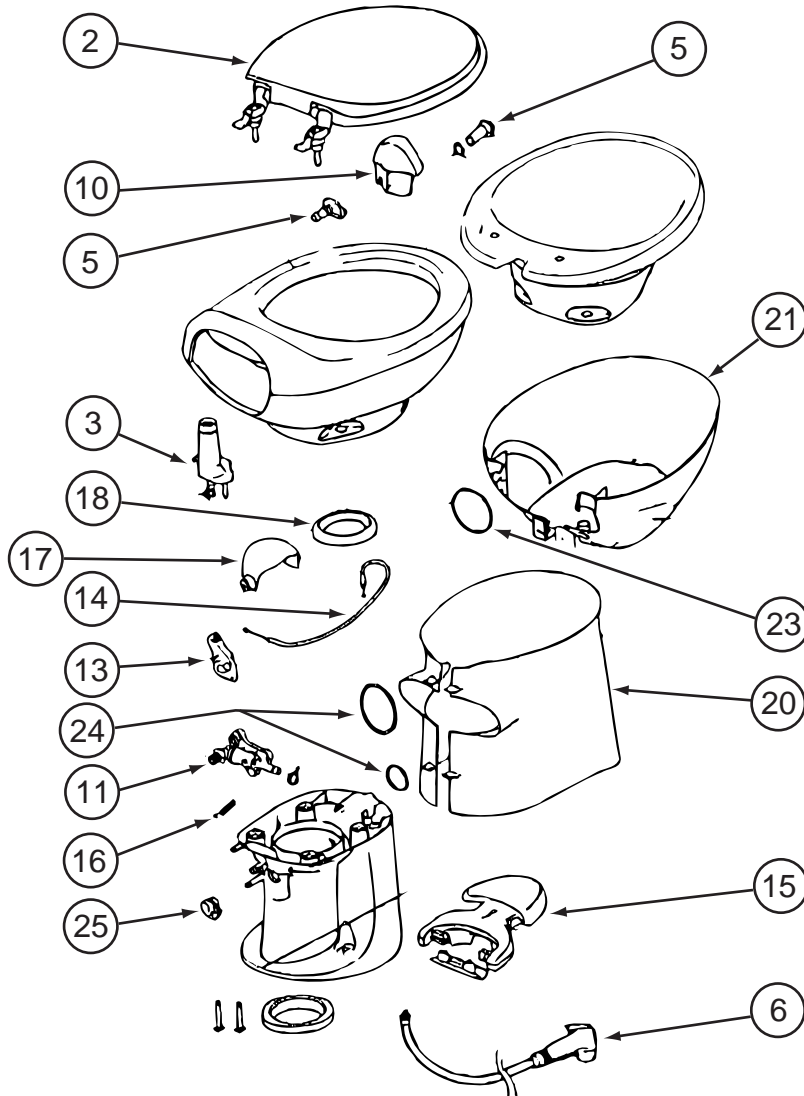

152830-01-01A

KEY	PART NUMBER	U/M	DESCRIPTION	VENDOR NO.
2	152829-01-700	EA	SEAT/COVER ASSEMBLY - WHITE	34144
3	152829-01-708	EA	VACUUM BREAKER	34122
5	152830-01-701	EA	FLUSH NOZZLE - WHITE	34127
11	152829-01-701	EA	WATER VALVE	34100
13	152829-01-703	EA	WATER VALVE DRIVE ARM	34104
14	152829-01-704	EA	CABLE - F/PEDAL	34106
15	152830-01-700	EA	PEDAL PACKAGE - WHITE	34114
16	152829-01-705	EA	SPRING/RETURN-F/WATER VALVE	34110
17	152829-01-706	EA	WASTE BALL - WHITE	34117
18	152829-01-707	EA	SEAL - F/WASTE BALL	34120
20	152830-01-703	EA	SHROUD - TALL/WHITE	34138
24	152830-01-702	EA	O-RING PKG - F/SHROUD	34136
25	152829-01-702	EA	WASTE BALL DRIVE ARM	34102

CONTACT WINNEBAGO PART SALES FOR UNLISTED COMPONENT(S)

WATER & SEWAGE GROUP (CONTINUED)

WATER SYSTEM

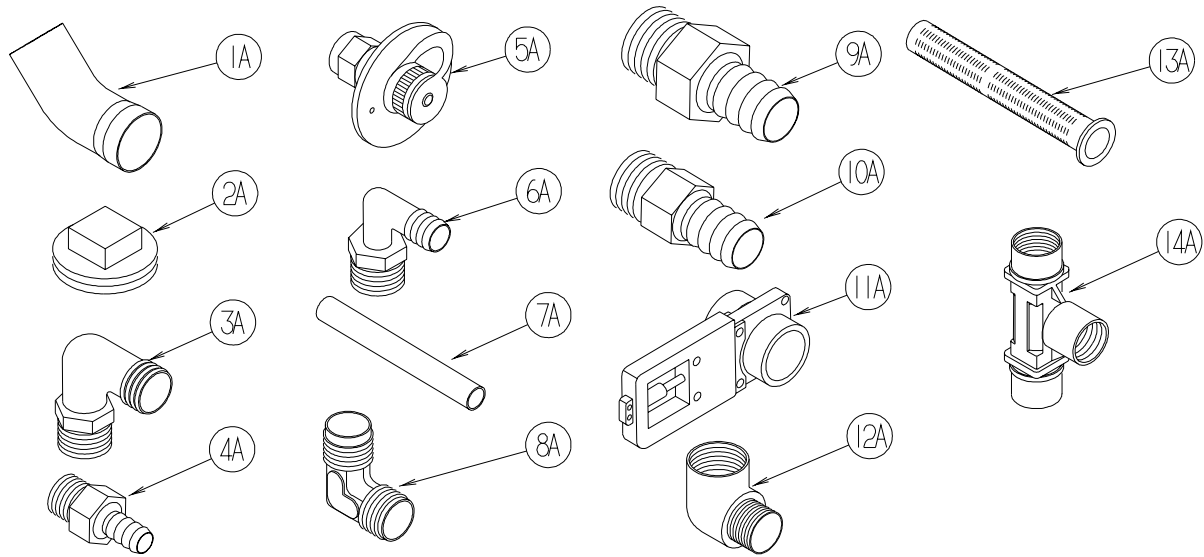

KEY	PART NUMBER	U/M	DESCRIPTION
1A	010009-01-000	EA	ELBOW - 90 DEGREE - 1/4 BEND - 1 1/2" PLASTIC
2A	010166-01-000	EA	PLUG/THREADED - 1 1/4"MPT - PLASTIC - BLACK - UL
3A	010219-01-000	EA	ELBOW - 1 1/4 MPT X 1 1/4 BARB - WATER FILL - PLASTIC
4A	010224-01-000	EA	ADAPTER - HOSE TO PIPE - 3/8 MPT X 3/8 BARB - PLASTIC
5A	010230-06-000	EA	FILL - CITY WATER - W/CHECK VALVE - MPT - BRUSHED ALUM
6A	035539-01-000	EA	ELBOW - 3/8 MPT X 3/8 BARB - PLASTIC
7A	039800-04-000	FT	TUBING - POLYBUTYL - 1/4"OD
7A	074462-02-000	FT	TUBING - VINYL - 3/8 ID X 20' - CLEAR
7A	112176-01-000	FT	TUBING - VINYL - REINFORCED - 1/2" ID
7A	124188-01-000	FT	TUBING - PEX - 1/2" ID X 20' - BLUE(COLD)
7A	124188-02-000	FT	TUBING - PEX - 1/2" ID X 20' - RED(HOT)
8A	039808-03-000	EA	ELBOW - 1/2" MPT X 1/2" MPT - PLASTIC
9A	044927-01-000	EA	ADAPTER - HOSE TO PIPE-1 1/4 MPTX1 1/4 BARB-BLACK PLASTIC
10A	044927-02-000	EA	ADAPTER - REDUCING - 1" MPT X 1.3" BARB - PLASTIC
11A	062421-03-000	EA	VALVE/DUMP W/O HANDLE - 1 1/2" X 1 1/2" HUB
	062421-05-000	EA	CABLE/ROD - F/DUMP VALVE - W/HANDLE - 48"
	062421-07-000	EA	CABLE/ROD - F/DUMP VALVE - W/HANDLE - 144"
	062421-08-000	EA	CABLE/ROD - F/DUMP VALVE - W/HANDLE - 108"
12A	065318-02-000	EA	ELBOW - 90 DEGREE - 3/8" MPT TO 3/8" FPT
13A	077954-02-000	EA	FILTER - WATER TANK - W/SCREEN IN TANK
14A	039798-01-000	EA	TEE - 1/2"MPT X 1/2"MPT X 1/2"MPT - PLASTIC

WATER & SEWAGE GROUP (CONTINUED)
WATER SYSTEM (CONTINUED)

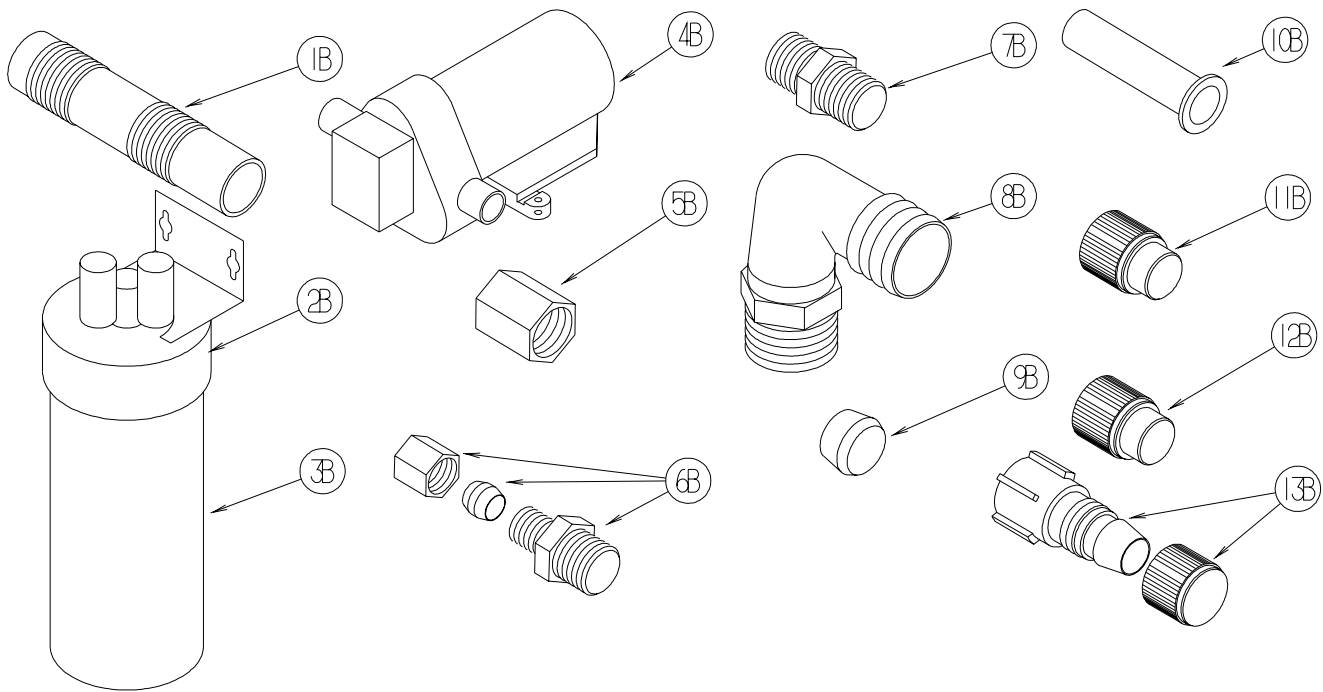

KEY	PART NUMBER	U/M	DESCRIPTION
1B	079381-01-000	FT	TUBING - RIBBED FLEXIBLE - WATER FILL - 1.4" ID
2B	087200-01-000	EA	FILTER-WATER PURIFCATION, EVERPURE QC2-AC
3B	087200-02-000	EA	CARTRIDGE-WATER FILTER, AC - EVERPURE 9601-11
4B*	098607-01-000	EA	PUMP - WATER - W/.5" MPT FITTING - FLOW 2.8 GPM
			FROM: 00-00-00 THRU: 06-21-06
4B	160702-01-000	EA	PUMP - WATER - 3.0 GPM - W/1/2" MPT
			FROM: 06-22-06 THRU: 99-99-99
5B	101814-01-000	EA	COUPLING - FEMALE - 1/2" X 1/2" FPT - GRAY
6B	103798-01-000	EA	CONNECTOR - 1/4 OD X 3/8 MPT
7B	110438-02-000	EA	VALVE - CHECK - BRASS - 1/2 MPT X 1/2 MPT
8B	111223-02-000	EA	ELBOW - 1/2" MPT X 3/8" BARB - PLASTIC
8B	111223-03-000	EA	ELBOW - 3/4" MPT X 1/2" BARB - PLASTIC
8B	111223-04-000	EA	ELBOW - 1/2" MPT X 1/2" BARB - PLASTIC
9B	111888-01-000	EA	FERRULE - PLASTIC - .250 ID X .375 OD
10B	111888-02-000	EA	INSERT - BRASS - 1/4 COMP
11B	113697-01-000	EA	CAP - 3/8"P
12B	114427-01-000	EA	CAP - 1/2"P
13B	114427-02-000	EA	PLUG - W/COMP NUT - 1/2" PLASTIC PIPE/1/2" FLAIR-IT

WATER & SEWAGE GROUP (CONTINUED)
WATER SYSTEM (CONTINUED)

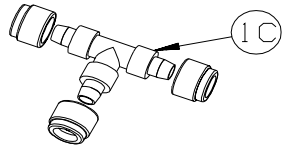

1C

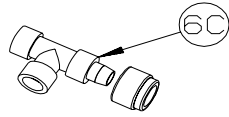

6C

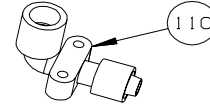

11C

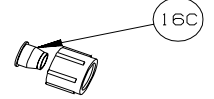

16C

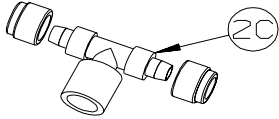

2C

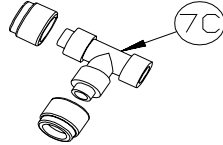

7C

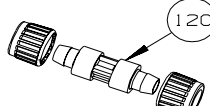

12C

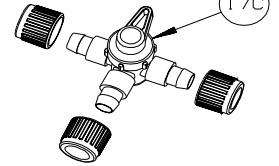

17C

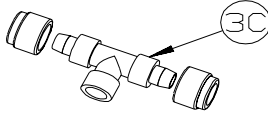

3C

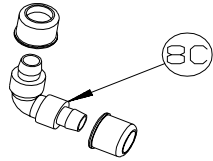

8C

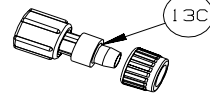

13C

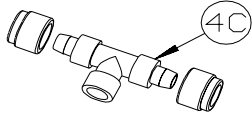

4C

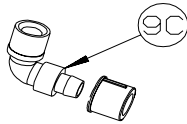

9C

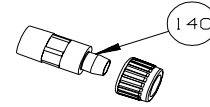

14C

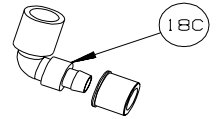

18C

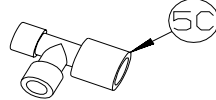

5C

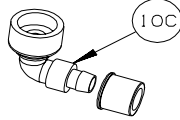

10C

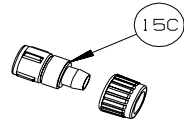

15C

KEY	PART NUMBER	U/M	DESCRIPTION
1C	114428-01-000	EA	TEE - 1/2"P X 1/2"P X 1/2"P
2C	114428-02-000	EA	TEE - SWIVEL - 1/2"P X 1/2"P X 1/2"FPT
3C	114428-03-000	EA	TEE - 1/2"P X 1/2"P X 1/2"MPT
4C	114428-04-000	EA	TEE - 1/2"P X 1/2"P X 1/8"FPT
5C	114428-05-000	EA	TEE - 1/2" SWIVEL X 1/2" MPT X 1/2" MPT
6C	114428-06-000	EA	TEE - 1/2" P X 1/2" MPT X 1/2" MPT
7C	114428-07-000	EA	TEE - 1/2" P X 1/2" MPT X 1/2" P
8C	114429-01-000	EA	ELBOW - 1/2"P X 1/2"P
9C	114429-02-000	EA	ELBOW - 1/2"P X 1/2"MPT
9C	114429-04-000	EA	ELBOW - 1/2"P X 3/8"MPT
9C	114429-05-000	EA	ELBOW - 1/2"P X 3/4"MPT
9C	114429-10-000	EA	ELBOW - SWIVEL - 1/2"MPT X 1/2"FPT
10C	114429-06-000	EA	ELBOW - SWIVEL - 1/2"P X 3/4"FPT
10C	114429-08-000	EA	ELBOW - SWIVEL - 1/2"P X 1/2"FPT
11C	114429-09-000	EA	ELBOW - 1/2"P X 1/2"FPT DROP EAR
12C	114430-01-000	EA	ADAPTER - 1/2"P X 1/2"P
13C	114430-02-000	EA	ADAPTER - SWIVEL - 1/2"P X 1/2"FPT
13C	114430-04-000	EA	ADAPTER - SWIVEL - 1/2"P X 3/8"MPT
14C	114430-03-000	EA	ADAPTER - 1/2"P X 1/2"MPT
15C	114430-06-000	EA	ADAPTER - 1/2"P X 3/8"FPT
15C	114430-09-000	EA	ADAPTER - 1/2"P X 1/2"FPT
16C	114430-10-000	EA	ADAPTER - NUT - PIPE CONNECTION - 1/2"
17C	114431-01-000	EA	VALVE - 180 DEGREE/CENTER DRAIN - 1/2"P - THREE WAY
18C	114429-11-000	EA	ELBOW - 1/2"P X 1/2"FPT

WATER & SEWAGE GROUP (CONTINUED)
WATER SYSTEM (CONTINUED)

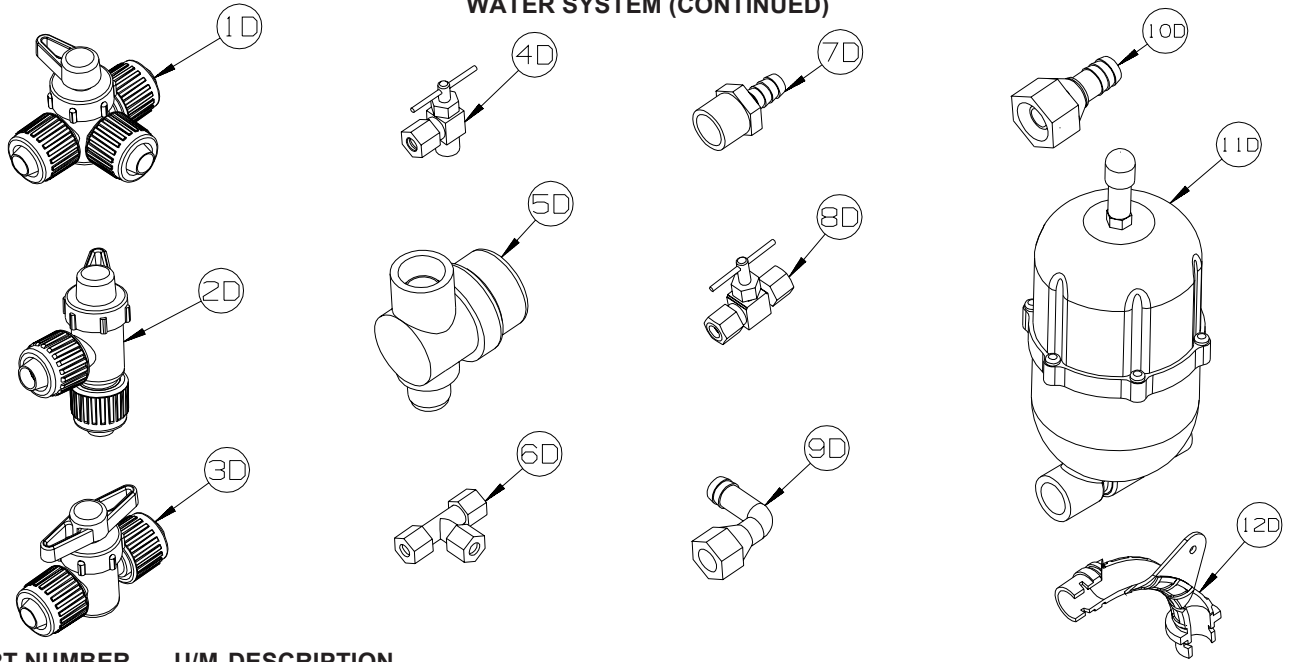

KEY	PART NUMBER	U/M	DESCRIPTION
1D	114431-02-000	EA	VALVE - WATER BYPASS - 1/2"P - THREE WAY (WATER HEATER)
2D	114431-03-000	EA	VALVE - 90 DEGREE DRAIN - 1/2"P
3D	114431-04-000	EA	VALVE - "INLINE SHUT-OFF" - 1/2"P
4D	114431-05-000	EA	VALVE - NEEDLE - 1/8" MPT X 1/4" COMPRESSION (ICE MAKER)
5D	152925-01-01A	EA	FILTER - IN LINE - TWIST ON - 1/2" - BLACK
6D	118423-01-000	EA	FITTING - BRASS-TEE - 1/4C X 1/4C X 1/4C
7D	118809-01-000	EA	ADAPTER - 1/2" MPT X 3/8" BARB - PLASTIC
7D	118809-02-000	EA	ADAPTER - 1/2" MPT X 1/2" BARB - PLASTIC
8D	120868-01-000	EA	VALVE - NEEDLE - 1/4" COMPRESSION X 1/4" COMPRESSION
9D	123150-01-000	EA	ELBOW - 1/2 FPT X 1/2 BARB - SWIVEL
10D	123152-01-000	EA	ADAPTER - 1/2 FPT X 1/2 BARB - SWIVEL
11D	123243-01-000	EA	TANK - ACCUMULATOR - 24 OZ
11D	123317-01-000	EA	TANK - ACCUMULATOR - 2 GALLON
12D	124184-01-000	EA	SUPPORT - WATER LINE - BEND

WATER & SEWAGE GROUP (CONTINUED)
WATER SYSTEM (CONTINUED)

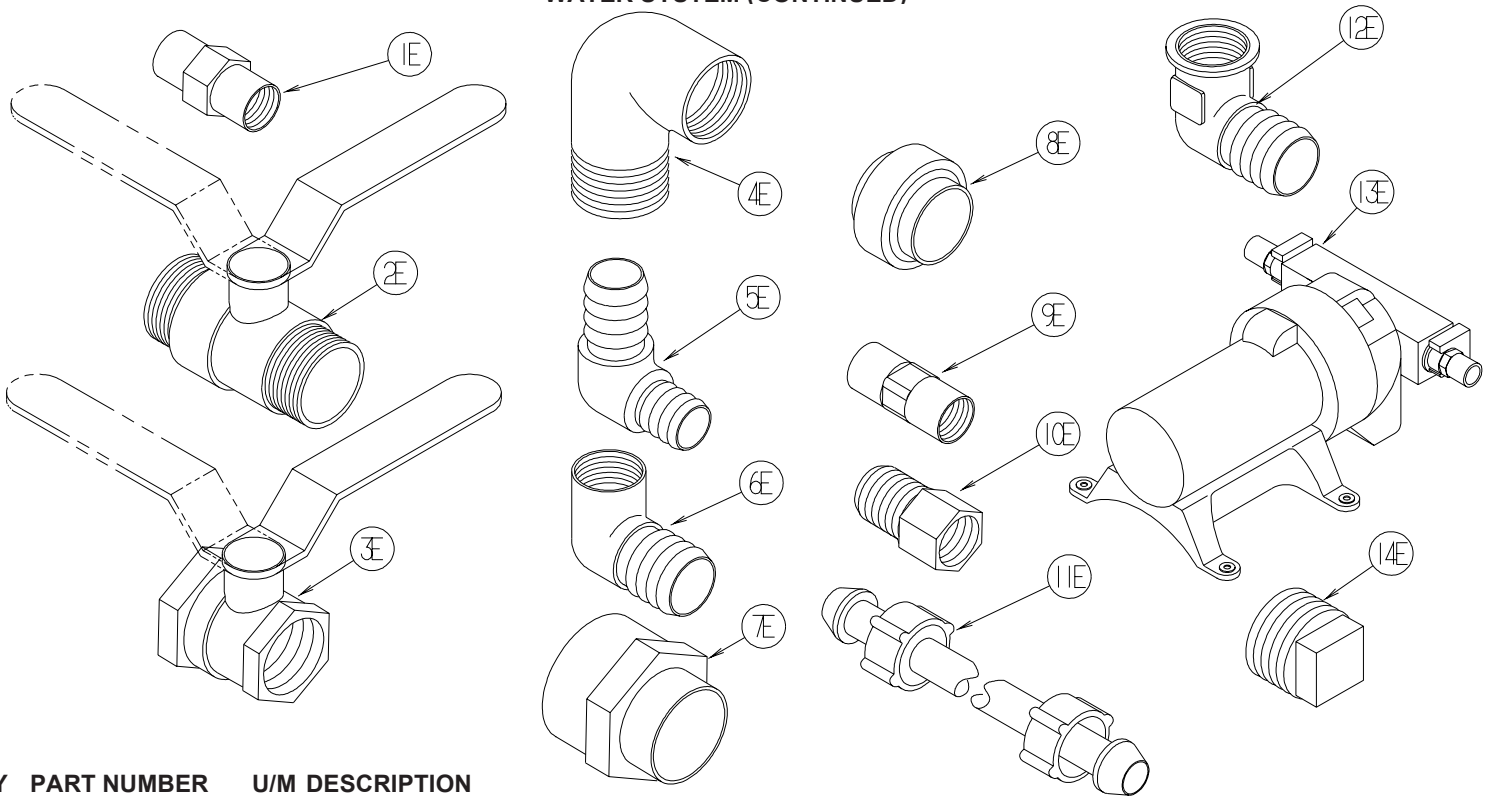

KEY	PART NUMBER	U/M	DESCRIPTION
1E	132148-01-000	EA	CONNECTOR - 1/2" X 1/2"MPT - BRASS
2E	132483-01-000	EA	VALVE/BALL - 1" - THREADED ENDS
3E	132483-02-000	EA	VALVE/BALL - 1/2" - BRASS - FPT
4E	132484-01-000	EA	ELBOW - 90 DEGREE - 1MPT X 1FPT - PLASTIC
5E	132781-01-000	EA	ELBOW - 1.3" BARB X 1.3" BARB - 90 DEGREE - PLASTIC
6E	132782-01-000	EA	ELBOW - 1"FPT X 1.3" BARB - 90 DEGREE - PLASTIC
7E	133835-01-000	EA	ADAPTER - REDUCING - 1 1/2" X 1 1/4"
8E	133889-01-000	EA	UNION - 1 1/2 DOUBLE SLIP - PVC
9E	135386-01-000	EA	NIPPLE - 1/2"
10E	136333-01-000	EA	ADAPTER - BRASS - 1/2"MPT X 1/2"FPT
11E	140821-01-000	EA	TUBE - WATER SUPPLY - 3/8" X 24"
11E	140821-02-000	EA	TUBE - WATER SUPPLY - 3/8" X 30"
11E	140821-03-000	EA	TUBE - WATER SUPPLY - 3/8" X 36"
11E	140821-04-000	EA	TUBE - WATER SUPPLY - 3/8" X 48"
11E	140821-05-000	EA	TUBE - WATER SUPPLY - 3/8" X 54"
11E	140821-06-000	EA	TUBE - WATER SUPPLY - 3/8" X 60"
11E	140821-07-000	EA	TUBE - WATER SUPPLY - 3/8" X 72"
11E	140821-08-000	EA	TUBE - WATER SUPPLY - 1/2" X 24"
11E	140821-09-000	EA	TUBE - WATER SUPPLY - 1/2" X 36"
11E	140821-10-000	EA	TUBE - WATER SUPPLY - 1/2" X 48"
12E	142812-01-000	EA	ELBOW - BRASS - 1/2"MPT X 1/2"FPT
13E*	144215-01-000	EA	PUMP - WATER - 5.7 GPM - W/1/2" MPT

FROM: 00-00-00 THRU: 02-05-06

14E 145609-01-000 EA PLUG - BRASS - 1/2" MPT/HEX HEAD

***COMPONENT PARTS LISTED LATER IN THIS GROUP**

WATER & SEWAGE GROUP (CONTINUED)

WATER SYSTEM (CONTINUED)

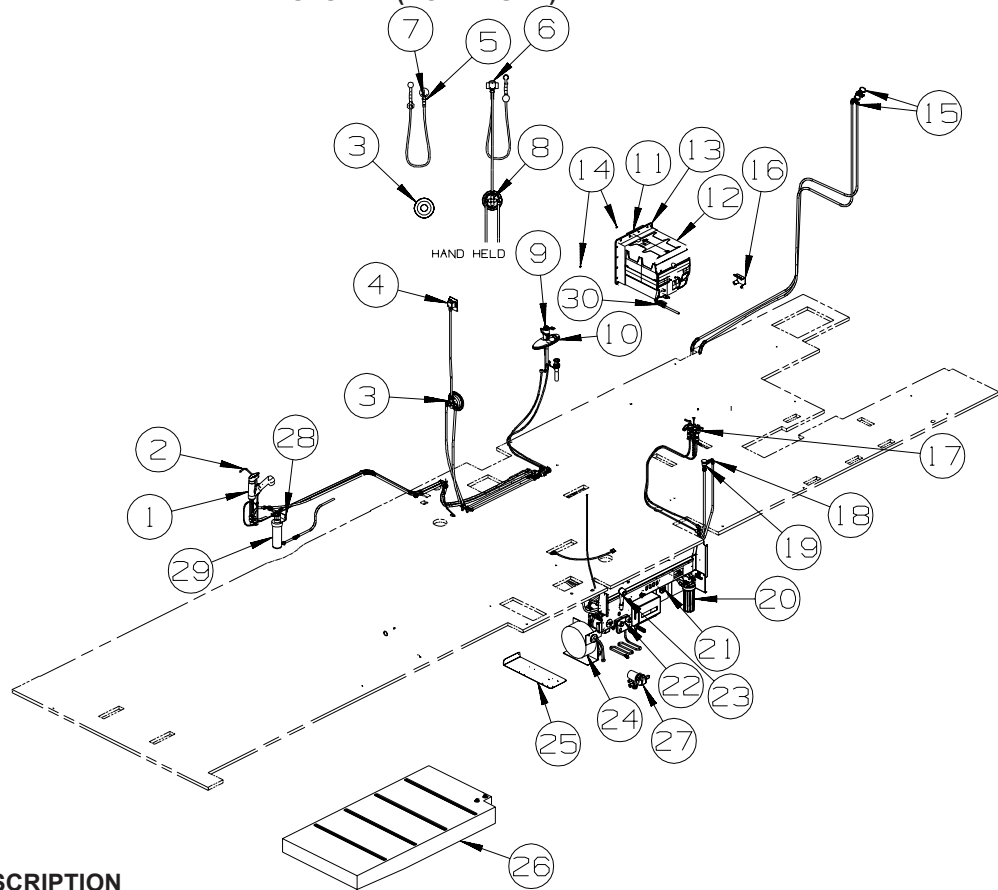

KEY	PART NUMBER	U/M	DESCRIPTION
1	123744-03-01A	EA	FAUCET - GALLEY/SINGLE CONTROL W/SPRAYER HEAD - CHROME
2	157212-01-01A	EA	FAUCET - WATER PURIFIER - NICKEL
3*	144596-01-01A	EA	FAUCET/VALVE ONLY - SHOWER - W/TEMP LIMIT STOP(MOEN 62300)
3	144596-05-03A	EA	TRIM KIT - LEVER/PLATE - W/O SPOUT/SHOWER HEAD - WRT IRON
4	143218-01-02A	EA	PLATE/COVER - SHOWER HEAD - SOFT WHITE
4	143101-01-01A	EA	BRACKET - SHOWER HEAD
5	128974-01-03A	EA	VALVE - SHOWER HEAD/WATER SAVER (ON/OFF) - BLACK - HAND HELD SHOWER HEAD
6	130041-01-19A	EA	SPACER/SHOWER HEAD - RIVERSTONE - HAND HELD SHOWER HEAD
7	135028-01-03A	EA	DROP ELL - F/HAND HELD SHOWER HEAD - W/1/2"IPS - BLACK - HAND HELD SHOWER HEAD
8	156138-01-03A	EA	SHOWER/HAND HELD-W/HOSE/HDW/VACUUM BRKR-WROUGHT IRON - HAND HELD SHOWER HEAD
9	155715-01-01A	EA	FAUCET - LAVATORY - DUAL CONTROL - ANTIQUE NICKEL
9*	149174-01-01A	EA	VALVE/WATER - W/DRAIN VALVE - F/LAVATORY
10	105218-01-01A	EA	SPACER - FAUCET/LAVATORY SINK - 2" X 5.9" - ABS PLASTIC
11*	125420-01-03A	EA	DOOR - WATER HEATER - 10 GALLON - 18" X 17.7" - BLACK
12*	145541-03-000	EA	WATER HEATER/MOTOR AID-GAS/ELECT IGN/110V-GEH16EXT-10 GAL
13	133224-01-02B	EA	PLATE - WATER HEATER - E-COATED
14	117047-02-000	EA	BUMPER - RUBBER/WASHER INSERT
15	098419-01-000	EA	FAUCET - 90 DEGREE
16	138618-02-12B	EA	COVER - VALVE - BYPASS - BRIGHT WHITE
17	155716-01-01A	EA	FAUCET - LAVATORY - SINGLE CONTROL - ANTIQUE NICKEL - CABINET - LAVATORY
18	125697-03-000	EA	CHECK VALVE - F/FLUSHING SYSTEM
19	125697-04-000	EA	BREAKER/VACUUM - F/FLUSHING SYSTEM
20	155482-01-01A	EA	HOUSING - PREFILTER - WATER/CITY FILL
21	125697-05-000	EA	INLET/WATER - F/FLUSHING SYSTEM
22*	075241-06-000	EA	FAUCET/SHOWER - .5"MPT W/1.9" INLET PIPES- EXTERIOR/BRT WHT FROM: 00-00-00 THRU: 01-01-07
23	163269-01-01A	EA	FAUCET/SHOWER - .5"MPT W/1.9" INLET PIPES- EXTERIOR/BRT WHT FROM: 01-02-07 THRU: 99-99-99
23	131383-01-02A	EA	SHOWER HEAD - W/60" HOSE & BRACKET - WHITE
24*	142675-01-01A	EA	HOSE REEL/WATER - POWERED - RETRIEVAL/STORAGE - WATER SUPPLY HOSE W/REEL
25	145758-01-02B	EA	BRACKET - HOSE REEL - WATER - E-COATED - WATER SUPPLY HOSE W/REEL

WATER & SEWAGE GROUP (CONTINUED)
WATER SYSTEM (CONTINUED)

KEY	PART NUMBER	U/M	DESCRIPTION
26	150152-03-000	EA	TANK - WATER - 70 GALLON - W/FITTINGS
	042989-03-000	EA	FITTING - SPINWELD - 1 1/4"NPT - PLASTIC
	042989-05-000	EA	FITTING - SPINWELD - 1/2"FPT - PLASTIC
	049032-01-000	EA	PATCH - SPINWELD - 3/8" - PLASTIC
	112628-05-02B	EA	BRACKET/TIEDOWN - WATER TANK - E-COATED
			FROM: 00-00-00 THRU: 05-01-06
27*	098607-01-000	EA	PUMP - WATER - W/.5" MPT FITTING - FLOW 2.8 GPM - NOT ILLUSTRATED
			FROM: 00-00-00 THRU: 06-21-06
27	160702-01-000	EA	PUMP - WATER - 3.0 GPM - W/1/2" MPT
			FROM: 06-22-06 THRU: 99-99-99
28	087200-01-000	EA	FILTER-WATER PURIFICATION, EVERPURE QC2-AC
29	087200-02-000	EA	CARTRIDGE-WATER FILTER,AC - EVERPURE 9601-11
30	132483-02-000	EA	VALVE/BALL - 1/2"FPT - BRASS

***COMPONENT PARTS LISTED LATER IN THIS GROUP**

WATER & SEWAGE GROUP (CONTINUED)
WATER SYSTEM (CONTINUED)

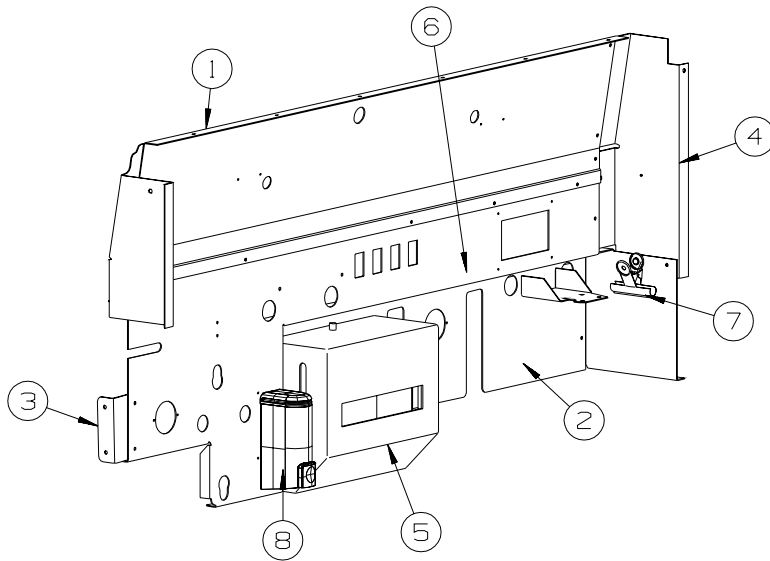

WKS40FD, WKS40KD

KEY	PART NUMBER	U/M	DESCRIPTION
1	146194-01-12B	EA	PANEL - SERVICE CENTER - UPPER - BRIGHT WHITE
2	155894-02-12B	EA	PANEL - SERVICE CENTER/MIDDLE - BRIGHT WHITE
3	147351-01-12B	EA	BRACKET/SUPPORT - SERVICE CENTER - BRIGHT WHITE
4	145317-01-12B	EA	PANEL - SERVICE CENTER - REAR - BRIGHT WHITE
5*	136915-01-000	EA	DISPENSER - TOWEL/PAPER - 9"H X 10.8"L X 4.8"D - WHITE
6	145726-08-12B	EA	PANEL - SERVICE CENTER/MIDDLE - BRIGHT WHITE
7	156695-01-01A	EA	CLIP - BULL DOG - SILVER/NICKEL
8	149894-01-01A	EA	DISPENSER/LIQUID SOAP - 200 ML - WHITE

FROM: 08-15-06 THRU: 99-99-99

***COMPONENT PARTS LISTED LATER IN THIS GROUP**

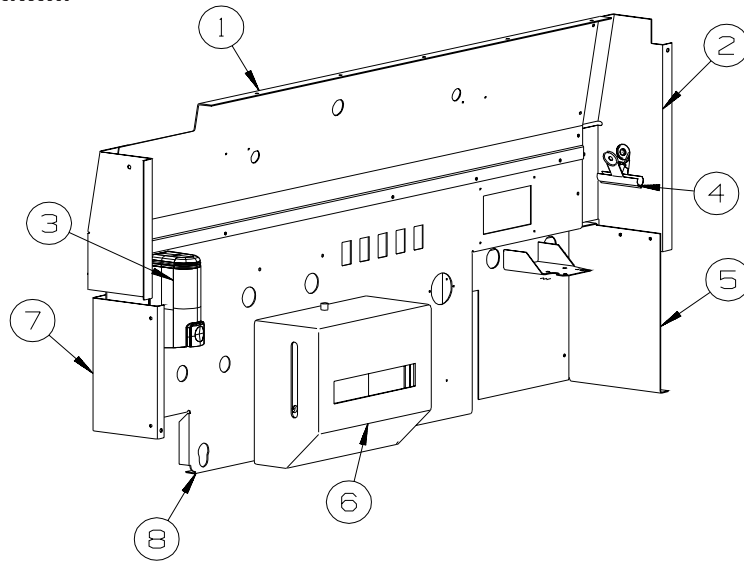

WKS40TD

KEY	PART NUMBER	U/M	DESCRIPTION
1	146194-04-12B	EA	PANEL - SERVICE CENTER/UPPER - BRIGHT WHITE
2	145317-01-12B	EA	PANEL - SERVICE CENTER/REAR - BRIGHT WHITE
3	149894-01-01A	EA	DISPENSER/LIQUID SOAP - 200 ML - WHITE
4	156695-01-01A	EA	CLIP - BULL DOG - SILVER/NICKEL
5	159427-01-12B	EA	PANEL - SERVICE CENTER - BRIGHT WHITE
6*	136915-01-000	EA	DISPENSER - TOWEL/PAPER - 9"H X 10.8"L X 4.8"D - WHITE
7	160433-01-12B	EA	PANEL - SERVICE CENTER/FRONT - BRIGHT WHITE
8	159426-01-12B	EA	PANEL ASM-SERVICE CENTE,BWHT

***COMPONENT PARTS LISTED LATER IN THIS GROUP**

WATER & SEWAGE GROUP (CONTINUED)
COMPONENT PARTS FOR WATER SYSTEM

075241-04-000, 075241-05-000, 075241-06-000

KEY	PART NUMBER	U/M	DESCRIPTION	VENDOR NO.
	075240-05-700	EA	CARTRIDGE - WASHERLESS	9-P42

098607-01-000

KEY	PART NUMBER	U/M	DESCRIPTION	VENDOR NO.
	098607-01-702	EA	DIAPHRAGM/DRIVE ASSEMBLY KIT	94-238-04
	098607-01-703	EA	VALVE KIT	94-232-00
	098607-01-705	EA	VALVE-CHECK, KIT	94-237-00
	098607-01-706	EA	HOUSING, W/SWITCH ONLY	94-231-20
	098607-01-707	EA	MOTOR W/BASEPLATE	11-148-04

125420-01-02A, 125420-01-03A, 125420-03-03A, 125420-04-03A

KEY	PART NUMBER	U/M	DESCRIPTION	VENDOR NO.
	051391-01-705	EA	FASTENER - CAMLOCK	92609

136915-01-000

KEY	PART NUMBER	U/M	DESCRIPTION	VENDOR NO.
	136915-01-700	EA	TOWEL - PAPER/FOLDING PKG.	1999

144596-01-01A

KEY	PART NUMBER	U/M	DESCRIPTION	VENDOR NO.
	144596-01-700	EA	CARTRIDGE (REPLACEMENT)	1222

142675-01-01A

KEY	PART NUMBER	U/M	DESCRIPTION	VENDOR NO.
	142675-01-700	EA	SWITCH ASM - HOSE REEL	19553- 1GLENDINNING
	142675-01-701	EA	HOSE WHEEL ASM W/35" HOSE	19551 GLENDINNING
	142675-01-702	EA	MOTOR W/DRIVE GEAR	20550 W/52553
	142675-01-703	EA	MOTOR F/HOSE REEL-SILVER	20550 + 52553

144215-01-000

KEY	PART NUMBER	U/M	DESCRIPTION	VENDOR NO.
	144215-01-700	EA	VALVE ASSEMBLY	94-030-01
	144215-01-701	EA	DRIVE ASSEMBLY	94-030-02
	144215-01-702	EA	FITTING KIT - W/ORINGS	94-615-06

WATER & SEWAGE GROUP (CONTINUED)
COMPONENT PARTS FOR WATER SYSTEM (CONTINUED)

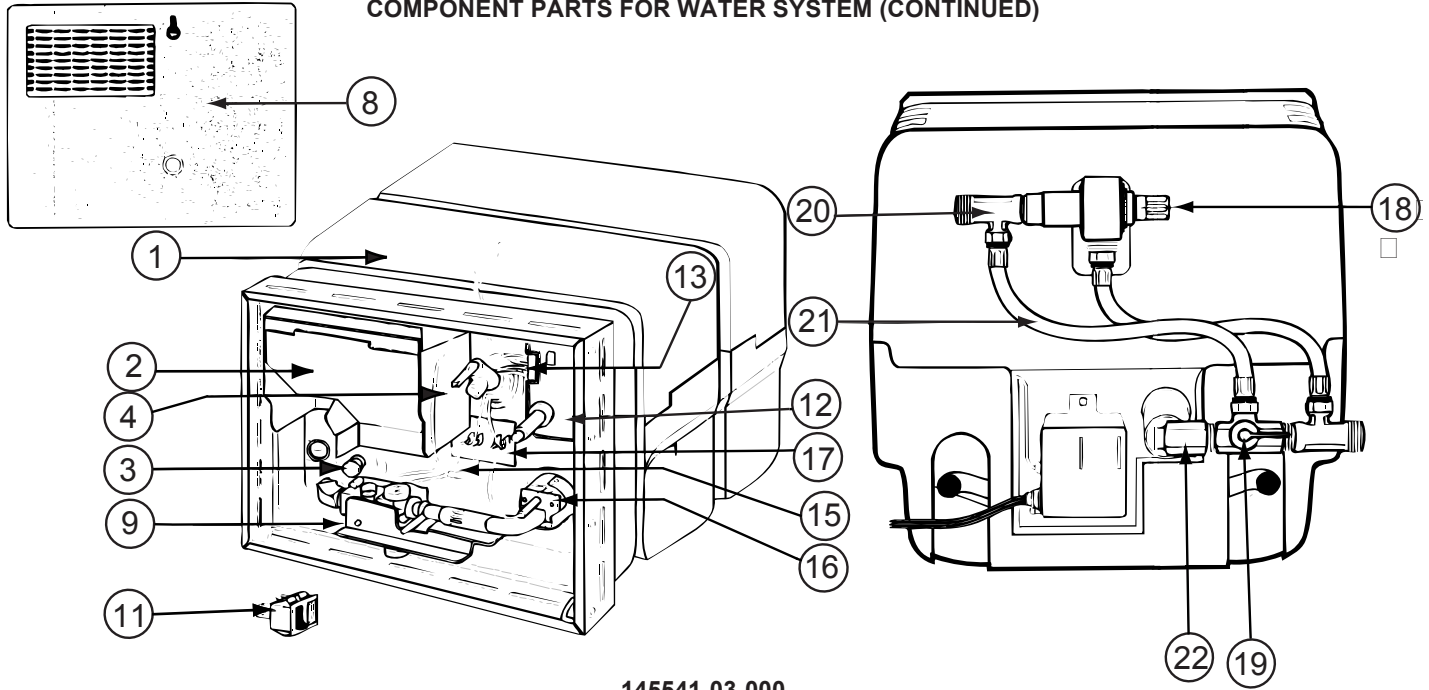

145541-03-000

KEY	PART NUMBER	U/M	DESCRIPTION	VENDOR NO.
1	145541-03-706	EA	TANK - INNER	91229
2	051391-04-707	EA	KIT-EXHAUST, (FLUE & GASKET)	90960
3	051391-01-715	EA	PLUG-DRAIN, 1 EA = 2 PER PKG	91857
4	051391-01-704	EA	VALVE-RELIEF, 1/2" FITTING	91604
9	051393-01-726	EA	VALVE/SOLENOID - W/O BRACKET	93870
11	051393-01-701	EA	SWITCH - REMOTE - W/LIGHT	91959
11	145541-01-701	EA	SWITCH - ON/OFF - WHITE	91859
12	145541-01-702	EA	CIRCUIT BOARD	91226
15	051393-01-723	EA	SWITCH - THERMAL CUTOUT 2/PK	93866 WAS 93853
16	051393-01-725	EA	ELECTRODE-SGL SPADE CONNECT	93868
17	145541-03-700	EA	THERMOSTAT	90063
18	145541-03-701	EA	MIXING VALVE	91569
19	145541-03-702	EA	BYPASS VALVE	91568
20	145541-03-703	EA	TEE	91556
21	145541-03-704	EA	HOSE F/MIXING VALVE	91576
22	145541-03-705	EA	ELBOW	91567
	145541-01-704	EA	RELAY	90061
	145541-01-705	EA	JUNCTION BOX(PLASTIC) 10 GAL	91224
	051391-05-706	EA	ELEMENT-HEATING 1500 WATT	92249 W/GASKET
			CONTACT WINNEBAGO PARTS SALES FOR UNLISTED COMPONENT(S)	

144596-01-01A

KEY	PART NUMBER	U/M	DESCRIPTION	VENDOR NO.
	144596-01-700	EA	CARTRIDGE (REPLACEMENT)	1222

149174-01-01A

KEY	PART NUMBER	U/M	DESCRIPTION	VENDOR NO.
	132410-01-700	EA	CARTRIDGE F/DBL HDLE FAUCET	1224

WINDOW & VENTS GROUP

WINDOW & VENT LAYOUT

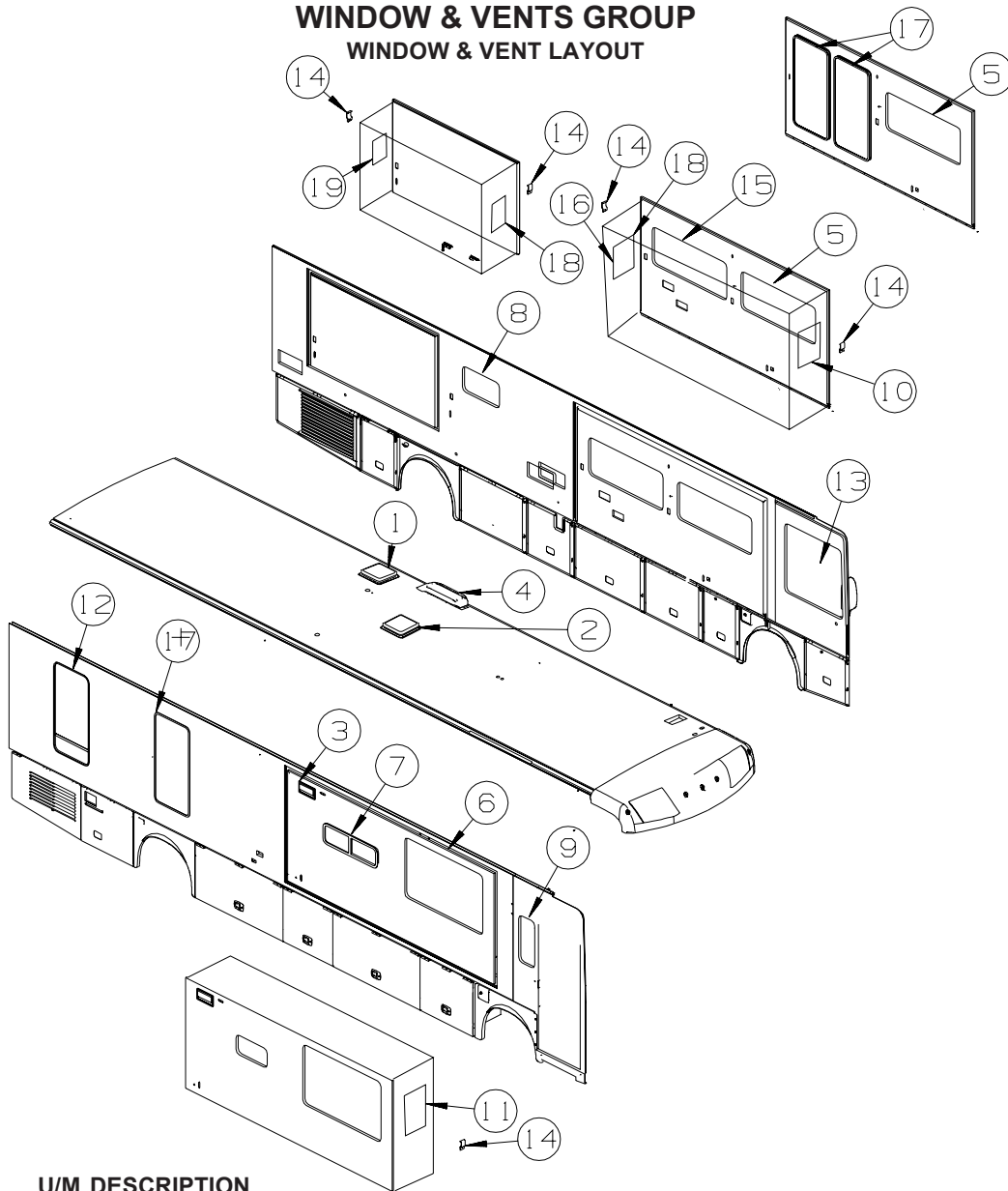

KEY	PART NUMBER	U/M	DESCRIPTION
1*	123780-17-01A	EA	FANTASTIC VENT-4"ROOF-W/FAN/PWR LIFT/RAIN SEN/DBL DOME-WHT
	009440-01-000	EA	GEAR/ARM - LIFT - ROOF VENT COVER
2*	123780-15-01A	EA	FANTASTIC VENT-3"ROOF-W/FAN/PWR LIFT/THERM/RAIN SEN/DBE DM
	009440-01-000	EA	GEAR/ARM - LIFT - ROOF VENT COVER
3	138983-01-02A	EA	VENT - MICROWAVE/OUTER - BLACK
3	138983-03-01A	EA	COVER - VENT MICROWAVE/OUTER - BRIGHT WHITE
4	149508-01-01A	EA	CAP - ROOF/REFRIGERATOR VENT - GRAY
4	149508-02-01A	EA	BASE - ROOF/REFRIGERATOR VENT - BLACK
5*	150648-01-01A	EA	WINDOW-HORIZ SLIDER/ESCAPE/FLUSH/THERMO/LH-23.8"X57.7"-BLK
6*	150648-14-01A	EA	WINDOW-HORIZ SLIDER/FLUSH/THERMO/RH - 37.9" X 60.4"
7*	150648-26-01A	EA	WINDOW-HORIZ SLIDER/FLUSH/THERMO/RH - 12.2"X 41.2" - BLACK
8*	150648-28-01A	EA	WINDOW-HORIZ SLIDER/FLUSH/THERMO/LH - 24.7"X 26.9" - BLACK
9*	150649-05-01A	EA	WINDOW - VERT SLIDER/FLUSH/THERMO - 29.6" X 12.3"
10*	150649-08-01A	EA	WINDOW - VERT SLIDER/FLUSH/THERMO - 23.8" X 20.8"
11*	150649-21-01A	EA	WINDOW - VERT SLIDER/FLUSH/THERMO - 37.9" X 12.2"
12*	150656-08-01A	EA	WINDOW - TIPOUT/FLUSH/ESCAPE/THERMO - 56.1" X 26.7"
			FROM: 00-00-00 THRU: 10-01-06
12*	161452-03-01A	EA	WINDOW - TIPOUT/FLUSH/ESCAPE/THERMO - 42.2" X 30.2"
			FROM: 10-02-06 THRU: 99-99-99
13*	151069-03-01A	EA	WINDOW - CAB/LEFT HAND/FLUSH/THERMO - 43.6" X 44.9"/43.6"
14	151905-01-01A	EA	CLIP/BRACKET - SCREEN RETAINER - BLACK
15*	150648-07-01A	EA	WINDOW-HORIZ SLIDER/FLUSH/THERMO/LH - 23.8" X 57.7" - DINETTE/COMPUTER TABLE
16*	150649-18-01A	EA	WINDOW - VERT SLIDER/FLUSH/THERMO - 55.4" X 22.1"
16*	150649-08-01A	EA	WINDOW - VERT SLIDER/FLUSH/THERMO - 23.8" X 20.8" - DINETTE/COMPUTER TABLE

WINDOW & VENTS GROUP (CONTINUED)
WINDOW & VENT LAYOUT (CONTINUED)

KEY	PART NUMBER	U/M	DESCRIPTION
17*	150656-05-01A	EA	WINDOW - TIPOUT/FLUSH/THERMO - 56.1" X 26.7" FROM: 00-00-00 THRU: 10-01-06
17*	161452-02-01A	EA	WINDOW - TIPOUT/FLUSH/THERMO - 56.1" X 26.7" FROM: 10-02-06 THRU: 99-99-99
18*	150649-08-01A	EA	WINDOW - VERT SLIDER/FLUSH/THERMO - 23.8" X 20.8" - SLEEP NUMBER BED-KING SIZE
19*	150649-08-01A	EA	WINDOW - VERT SLIDER/FLUSH/THERMO - 23.8" X 20.8"

***COMPONENT PARTS LISTED LATER IN THIS GROUP**

WINDOW & VENTS GROUP (CONTINUED)
COMPONENT PARTS FOR WINDOWS & VENT LAYOUT

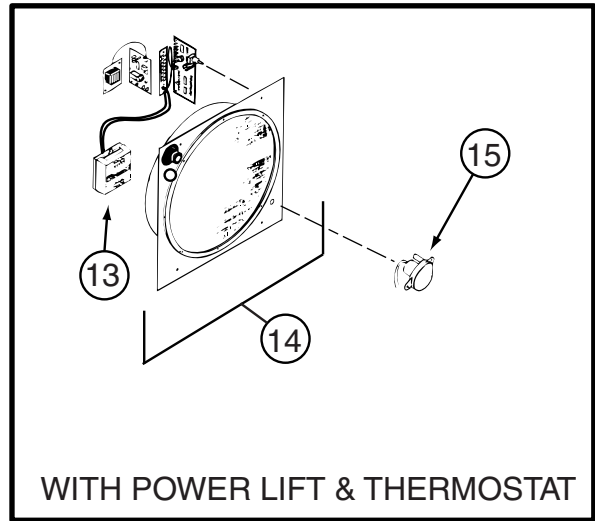
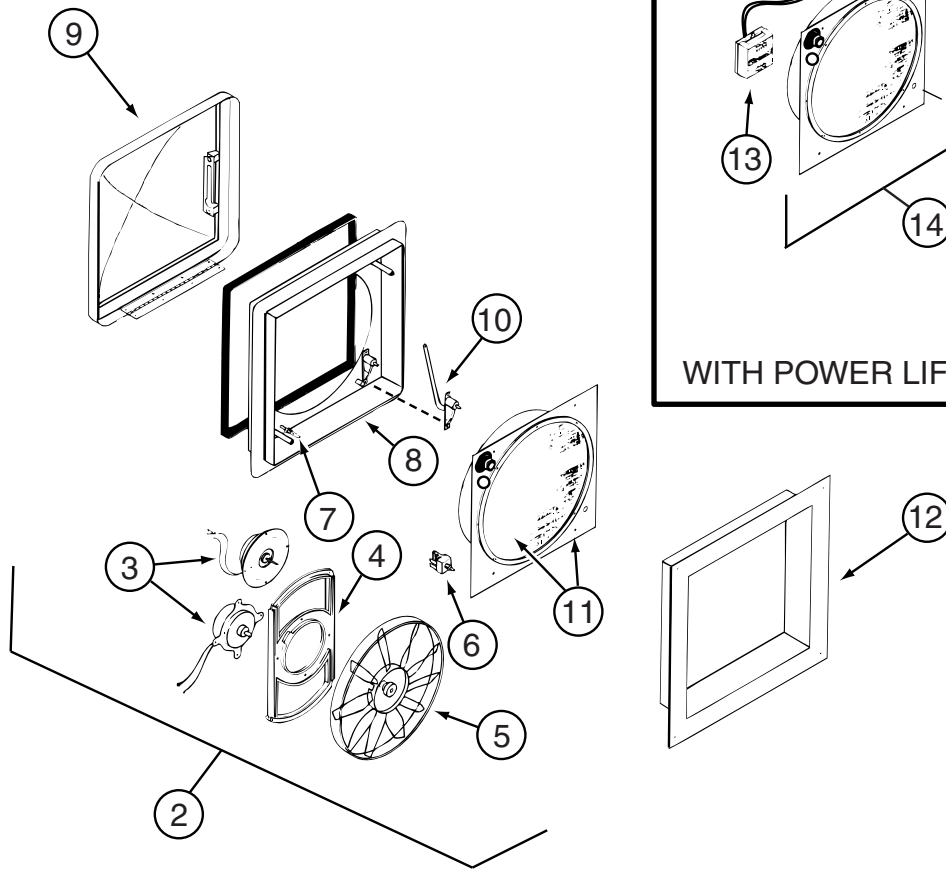

123780-15-01A

KEY	PART NUMBER	U/M	DESCRIPTION	VENDOR NO.
2	084079-11-700	EA	MOTOR & FAN BLADE W/BRACKET	K4017-09
4	084079-01-711	EA	MOTOR MOUNT (BOWTIE)	1015-00
5	084079-01-704	EA	BLADE-FAN	1138-00
6	084079-01-709	EA	SWITCH - MAIN - 3 SPEED	1031-05
7	084079-01-707	EA	SWITCH - SAFETY	1122-05
8	123780-05-700	EA	BASE/MAIN-BRT WHT W/GASKET	1010-81
9	123780-09-700	EA	DOME (DOUBLE)WHT TRANSPARENT	K2020-82
11	123780-01-702	EA	SCREEN INSERT (SCREEN RING)	K1035-81
12	123780-03-700	EA	GARNISH - INT. 3"-4" BRT/WHT	2040-81
13	084079-01-710	EA	THERMOSTAT(WALL MT)ANY COLOR	9988-81
14	123780-05-701	EA	SCREEN INT W/ALL SWITCHES	KIT-81
15	084079-11-703	EA	MOTOR/AUTO LIFT OFF/WHT CAP	6050-80 OS

CONTACT WINNEBAGO PART SALES FOR UNLISTED COMPONENT(S)

123780-17-01A

KEY	PART NUMBER	U/M	DESCRIPTION	VENDOR NO.
2	084079-11-700	EA	MOTOR & FAN BLADE W/BRACKET	K4017-09
4	084079-01-711	EA	MOTOR MOUNT (BOWTIE)	1015-00
5	084079-01-704	EA	BLADE-FAN	1138-00
6	084079-01-709	EA	SWITCH - MAIN - 3 SPEED	1031-05
7	084079-01-707	EA	SWITCH - SAFETY	1122-05
8	123780-05-700	EA	BASE/MAIN-BRT WHT W/GASKET	1010-81
9	123780-09-700	EA	DOME (DOUBLE)WHT TRANSPARENT	K2020-82
11	123780-01-702	EA	SCREEN INSERT (SCREEN RING)	K1035-81
12	123780-03-700	EA	GARNISH - INT. 3"-4" BRT/WHT	2040-81
15	084079-11-703	EA	MOTOR/AUTO LIFT OFF/WHT CAP	6050-80 OS

CONTACT WINNEBAGO PART SALES FOR UNLISTED COMPONENT(S)

WINDOW & VENTS GROUP (CONTINUED)
COMPONENT PARTS FOR WINDOWS & VENT LAYOUT (CONTINUED)

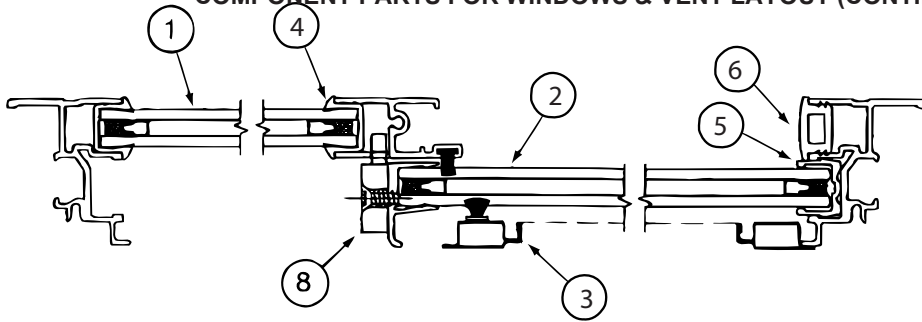

CROSS SECTION B-B

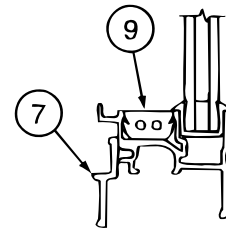
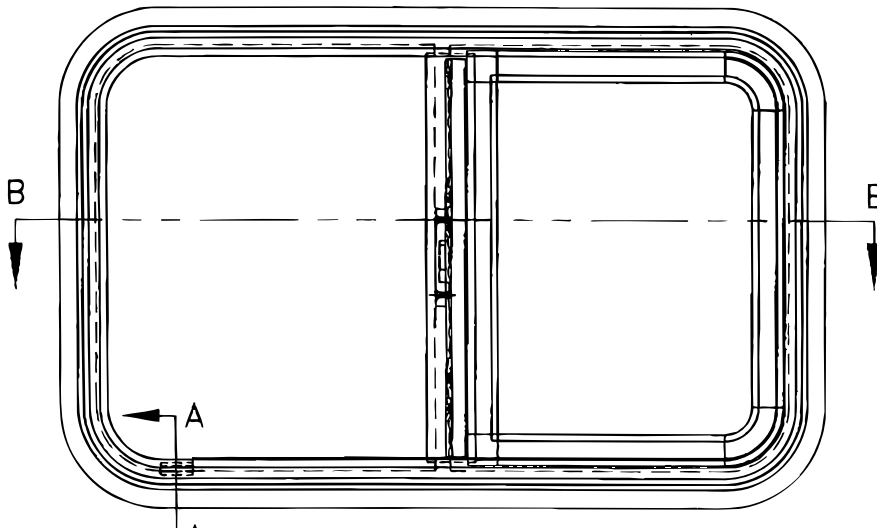

CROSS SECTION
A-A

150648-01-01A

KEY	PART NUMBER	U/M	DESCRIPTION	VENDOR NO
1	150648-01-705	EA	GLASS - STATIONARY	390-028313
2	150648-01-706	EA	GLASS-SLIDING W/SASH & LATCH	FH3003G8
3	150648-01-702	EA	SCREEN ASM	410-031156
4	112795-01-705	FT	VINYL - GLAZING	132-027331
5	151069-01-700	EA	CHANNEL-RUN, SLIDING	122-030627
6	150648-01-703	EA	PLUG - FILLER	132-030308
7	150648-01-707	EA	RETAINER - TRIM	H493-67
8	150648-01-700	EA	LATCH-HORIZONTAL SLIDE-BLK	FH3000-CK
8	150648-01-701	EA	LATCH-HORIZONTAL SLIDE-RED	FH3003-CK
9	150648-01-704	EA	SLIDE STOP	132-030866
	150648-05-702	FT	FIN SEAL-F/LOCKING RAIL-BLK	171-06234

150648-07-01A, 150648-22-01A

KEY	PART NUMBER	U/M	DESCRIPTION	VENDOR NO
1	150648-07-701	EA	GLASS - STATIONARY	390-028314
2	150648-07-700	EA	GLASS-SLIDING W/SASH & LATCH	FH3000G8
3	150648-01-702	EA	SCREEN ASM	410-031156
4	112795-01-705	FT	VINYL - GLAZING	132-027331
5	151069-01-700	EA	CHANNEL-RUN, SLIDING	122-030627
6	150648-01-703	EA	PLUG - FILLER	132-030308
7	150648-01-707	EA	RETAINER - TRIM	H493-67
8	150648-01-700	EA	LATCH-HORIZONTAL SLIDE-BLK	FH3000-CK
8	150648-01-701	EA	LATCH-HORIZONTAL SLIDE-RED	FH3003-CK
9	150648-01-704	EA	SLIDE STOP	132-030866
	150648-05-702	FT	FIN SEAL-F/LOCKING RAIL-BLK	171-062348

WINDOW & VENTS GROUP (CONTINUED)
COMPONENT PARTS FOR WINDOWS & VENT LAYOUT (CONTINUED)

150648-14-01A, 150648-27-01A, 150648-34-01A

KEY	PART NUMBER	U/M	DESCRIPTION	VENDOR NO
1	150648-14-701	EA	GLASS - STATIONARY	390-036160
2	150648-14-702	EA	GLASS-SLIDING W/SASH & LATCH	FH3010G8
3	150648-14-700	EA	SCREEN ASM	410-035333
4	112795-01-705	FT	VINYL - GLAZING	132-027331
5	151069-01-700	EA	CHANNEL-RUN, SLIDING	122-030627
6	150648-01-703	EA	PLUG - FILLER	132-030308
7	150648-14-703	EA	RETAINER - TRIM	H442-67
8	150648-01-700	EA	LATCH-HORIZONTAL SLIDE-BLK	FH3000-CK
8	150648-01-701	EA	LATCH-HORIZONTAL SLIDE-RED	FH3003-CK
9	150648-01-704	EA	SLIDE STOP	132-030866
	150648-05-702	FT	FIN SEAL-F/LOCKING RAIL-BLK	171-062348

150648-26-01A

KEY	PART NUMBER	U/M	DESCRIPTION	VENDOR NO
1	150648-26-700	EA	GLASS - STATIONARY	390-036023
2	150648-26-701	EA	GLASS-SLIDING W/SASH & LATCH	FH3075G8
3	150648-26-702	EA	SCREEN ASM	410-036025
4	112795-01-705	FT	VINYL - GLAZING	132-027331
5	151069-01-700	EA	CHANNEL-RUN, SLIDING	122-030627
6	150648-01-703	EA	PLUG - FILLER	132-030308
7	150648-26-703	EA	RETAINER - TRIM	H3075-67
8	150648-01-700	EA	LATCH-HORIZONTAL SLIDE-BLK	FH3000-CK
8	150648-01-701	EA	LATCH-HORIZONTAL SLIDE-RED	FH3003-CK
9	150648-01-704	EA	SLIDE STOP	132-030866
	150648-05-702	FT	FIN SEAL-F/LOCKING RAIL-BLK	171-062348

150648-28-01A

KEY	PART NUMBER	U/M	DESCRIPTION	VENDOR NO
1	150648-28-700	EA	GLASS - STATIONARY	390-036092
2	150648-28-701	EA	GLASS-SLIDING W/SASH & LATCH	FH3078G8
3	150648-28-702	EA	SCREEN ASM	410-036093
4	112795-01-705	FT	VINYL - GLAZING	132-027331
5	151069-01-700	EA	CHANNEL-RUN, SLIDING	122-030627
6	150648-01-703	EA	PLUG - FILLER	132-030308
7	150648-28-703	EA	RETAINER - TRIM	H3078-67
8	150648-01-700	EA	LATCH-HORIZONTAL SLIDE-BLK	FH3000-CK
8	150648-01-701	EA	LATCH-HORIZONTAL SLIDE-RED	FH3003-CK
9	150648-01-704	EA	SLIDE STOP	132-030866
	150648-05-702	FT	FIN SEAL-F/LOCKING RAIL-BLK	171-062348

WINDOW & VENTS GROUP (CONTINUED)
COMPONENT PARTS FOR WINDOWS & VENT LAYOUT (CONTINUED)

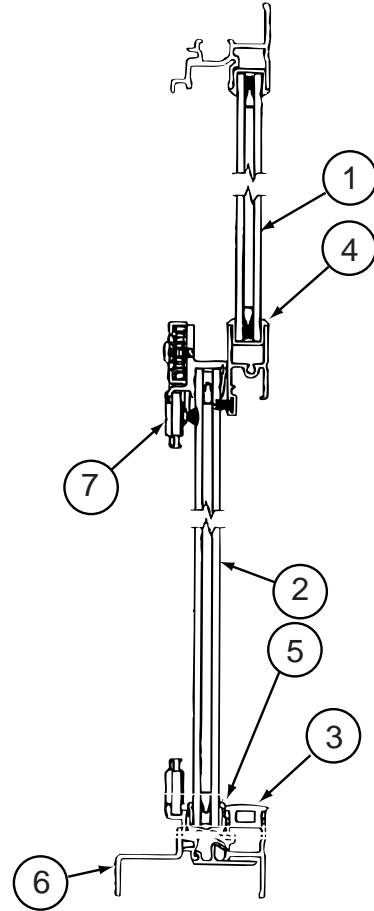
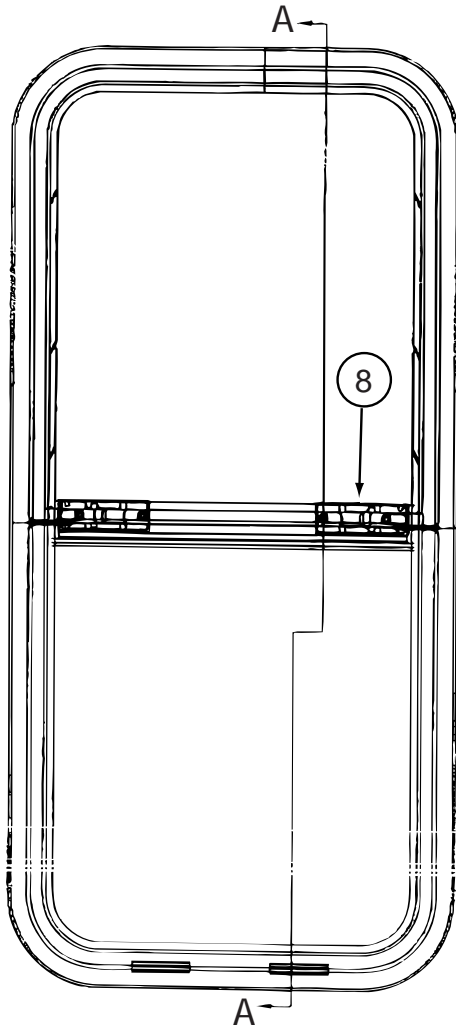

CROSS SECTION A-A

150649-05-01A

KEY	PART NUMBER	U/M	DESCRIPTION	VENDOR NO
1	150649-05-704	EA	GLASS - STATIONARY	390-035648
2	150649-05-705	EA	GLASS-SLIDING W/PULL & LATCH	FH3054A9
3	150648-01-703	EA	PLUG - FILLER	132-030308
4	112795-01-705	FT	VINYL-GLAZING	132-027331
5	151069-01-700	EA	CHANNEL-RUN, SLIDING	122-030627
6	150649-05-700	EA	RETAINER - TRIM	H754-67
7	150649-05-703	EA	SCREEN ASM	410-035633
8	150649-01-700	EA	LATCH KIT - F/VERTICAL SLIDE - BLACK	FH3016-CK
	150649-05-702	EA	FIN SEAL-F/LOCKING RAIL-BLK	171-062348

150649-08-01A

KEY	PART NUMBER	U/M	DESCRIPTION	VENDOR NO
1	150649-08-700	EA	GLASS - STATIONARY	390-035202
2	150649-08-701	EA	GLASS-SLIDING W/PULL & LATCH	FH3029G8
3	150648-01-703	EA	PLUG - FILLER	132-030308
4	112795-01-705	FT	VINYL-GLAZING	132-027331
5	151069-01-700	EA	FIN CHANNEL-RUN, SLIDING	122-030627
6	150649-08-702	EA	RETAINER - TRIM	H754-67
7	150649-07-701	EA	SCREEN ASM	410-035475
8	150649-01-700	EA	LATCH KIT - F/VERTICAL SLIDE - BLACK	FH3016-CK

WINDOW & VENTS GROUP (CONTINUED)
COMPONENT PARTS FOR WINDOWS & VENT LAYOUT (CONTINUED)

150649-18-01A

KEY	PART NUMBER	U/M	DESCRIPTION	VENDOR NO
1	112898-23-700	EA	GLASS - STATIONARY	390-028351
2	150649-09-700	EA	GLASS-SLIDING W/SASH & LATCH	FH3053G8
3	150648-01-703	EA	PLUG - FILLER	132-030308
4	112795-01-705	FT	VINYL-GLAZING	132-027331
5	151069-01-700	EA	FIN CHANNEL-RUN, SLIDING	122-030627
6	150649-18-700	EA	RETAINER - TRIM	H446-61
7	150649-09-701	EA	SCREEN ASM	410-035632
8	150649-01-700	EA	LATCH-VERTICLE SLIDE-BLK	FH3016-CK

150649-21-01A

KEY	PART NUMBER	U/M	DESCRIPTION	VENDOR NO
1	150649-21-700	EA	GLASS - STATIONARY	390-036038
2	150649-21-701	EA	GLASS-SLIDING W/PULL & LATCH	FH3076G8
3	150648-01-703	EA	PLUG - FILLER	132-030308
4	112795-01-705	FT	VINYL-GLAZING	132-027331
5	151069-01-700	EA	FIN CHANNEL-RUN, SLIDING	122-030627
6	150649-21-702	EA	RETAINER - TRIM	H3076-61
7	150649-11-702	EA	SCREEN ASM	410-035634
8	150649-01-700	EA	LATCH KIT - F/VERTICAL SLIDE - BLACK	FH3016-CK

WINDOW & VENTS GROUP (CONTINUED)
COMPONENT PARTS FOR WINDOWS & VENT LAYOUT (CONTINUED)

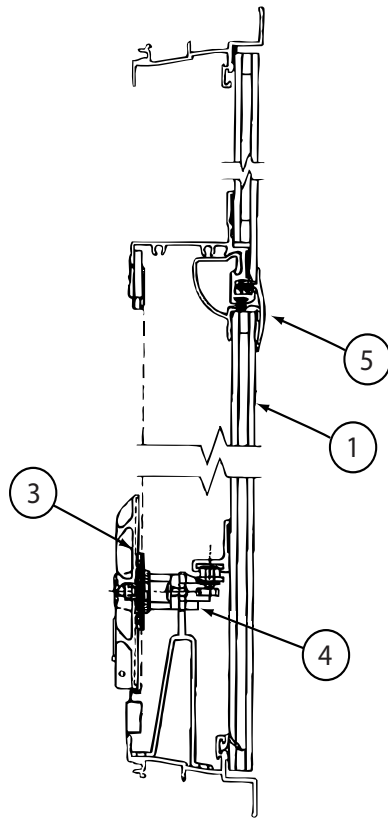
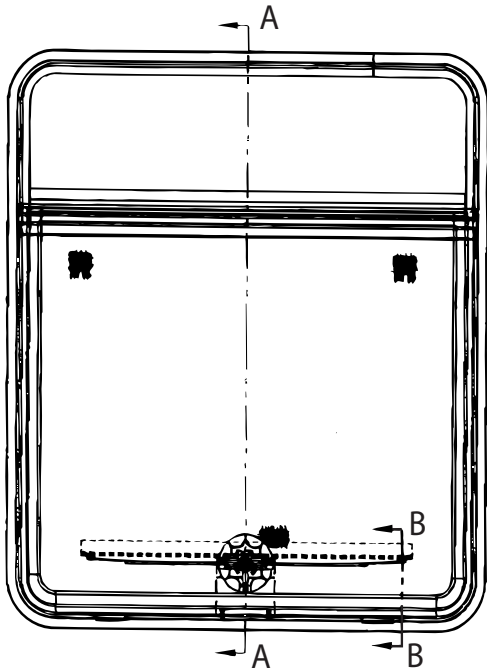

CROSS SECTION A-A

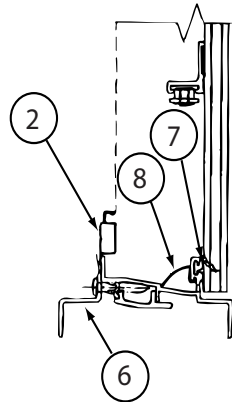

CROSS SECTION B-B

150656-05-01A

KEY	PART NUMBER	U/M	DESCRIPTION	VENDOR NO
1	150656-05-700	EA	GLASS-TIPOUT ASM	DTH3043G8
2	150656-05-701	EA	SCREEN ASM	410-035640
3	150656-02-702	EA	HANDLE-DIAL	410-016081E
4	150656-08-701	EA	OPERATOR - TIPOUT/LARGE	410-036141
5	150656-08-700	EA	SEAL/DUAL - WINDOW - 100"	132-030725
6	150656-05-702	EA	RETAINER - TRIM	DTH035-56
7	100322-01-701	EA	SEAL-VENT	122-016071
8	150651-03-702	EA	COVER - DRAIN SLOT	132-030723

WINDOW & VENTS GROUP (CONTINUED)
COMPONENT PARTS FOR WINDOWS & VENT LAYOUT (CONTINUED)

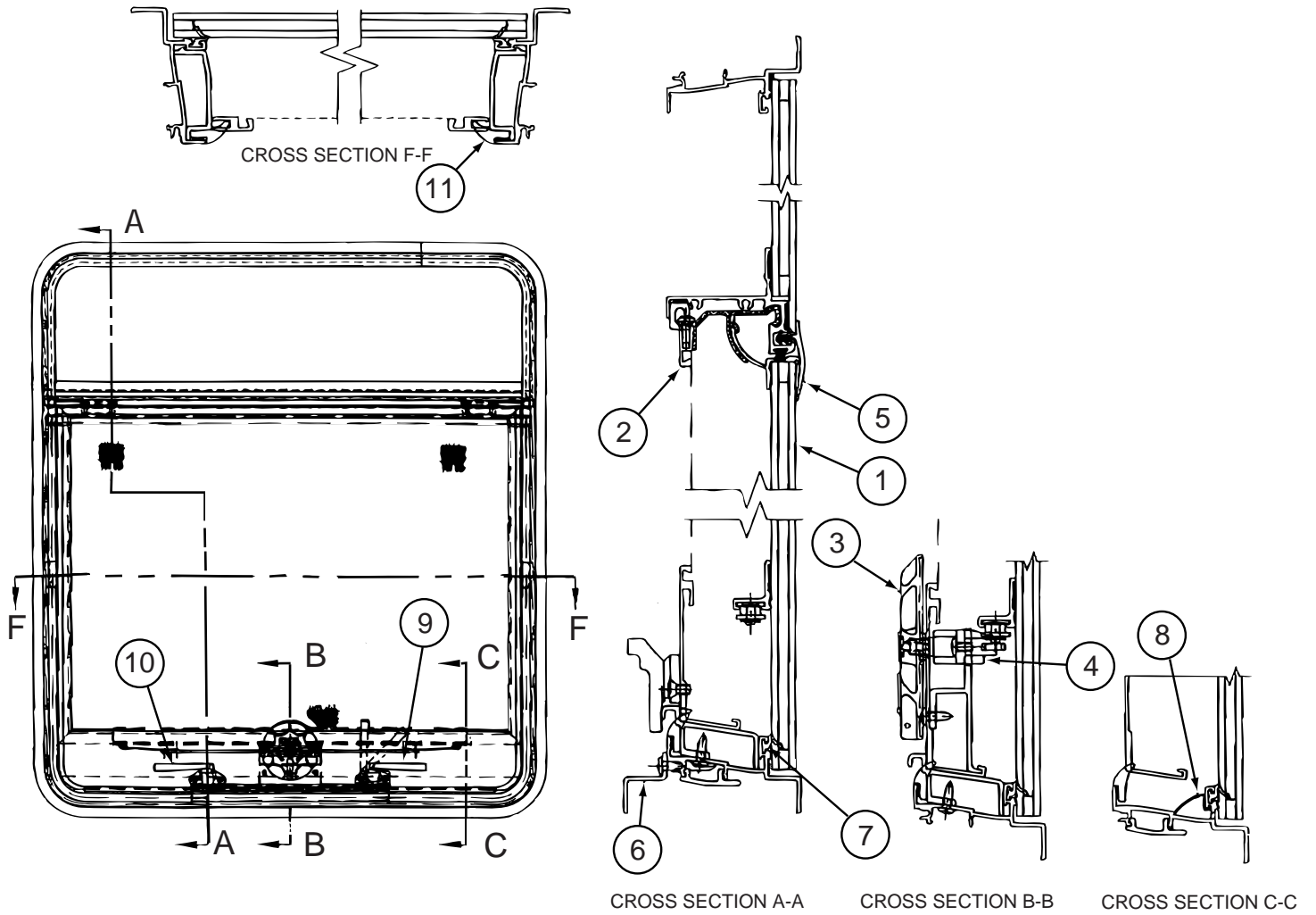

150656-08-01A

KEY	PART NUMBER	U/M	DESCRIPTION	VENDOR NO
1	150656-08-702	EA	GLASS-TIPOUT - W/HINGE/RAIL	DTH3038G8
2	150656-08-703	EA	SCREEN ASM	DTH3038-06
3	150656-02-702	EA	HANDLE-DIAL	410-016081E
4	150656-08-701	EA	OPERATOR - TIPOUT/LARGE	410-036141
5	150656-08-700	EA	SEAL/DUAL - WINDOW - 100"	132-030725
6	150656-05-702	EA	RETAINER - TRIM	DTH035-56
7	100322-01-701	FT	SEAL - VINYL - F/VENT GLASS	122-016071
8	150651-03-702	EA	COVER - DRAIN SLOT	132-030723
9	112898-06-707	EA	HANDLE/RH-EGRESS(SLD)ESC-RED	182-025911
10	112898-06-708	EA	HANDLE/LH-EGRESS(SLD)ESC-RED	182-025912
11	150656-09-700	EA	SEAL/SPONGE FOAM-SCREEN/FRME	140-035542

WINDOW & VENTS GROUP (CONTINUED)
COMPONENT PARTS FOR WINDOWS & VENT LAYOUT (CONTINUED)

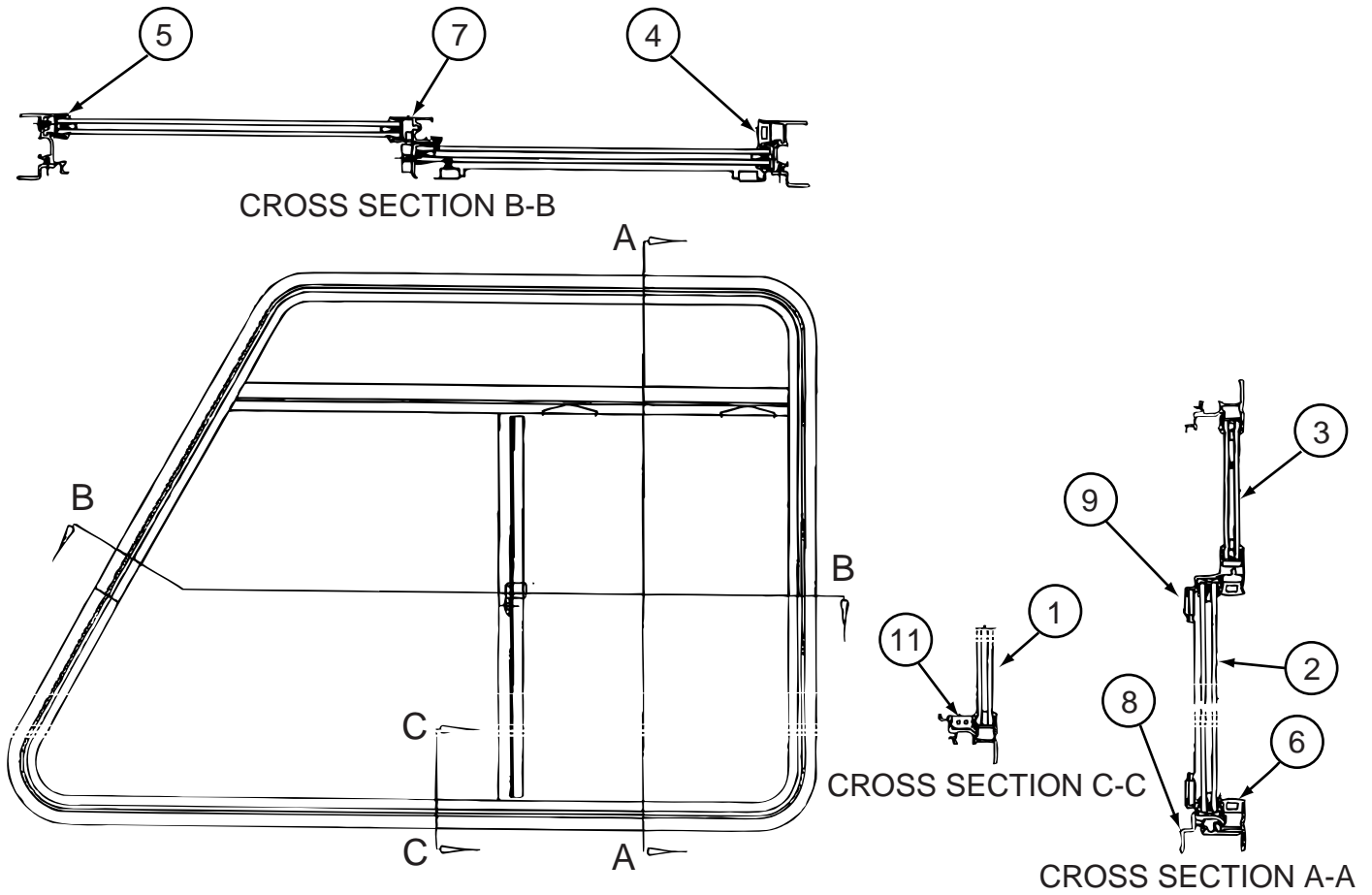

151069-03-01A

KEY	PART NUMBER	U/M	DESCRIPTION	VENDOR NO
1	151069-03-702	EA	GLASS - STATIONARY - LOWER	390-027478
2	151069-03-701	EA	GLASS-SLIDING W/SASH & LATCH	FH3041A9L
3	151069-03-703	EA	GLASS - STATIONARY - UPPER	390-035508
4	150648-01-703	FT	PLUG - FILLER	132-030308
5	151069-03-705	EA	VINYL GLAZING - F/STATIONARY	DH567-12 MITER/WELD
5	151069-03-706	EA	VINYL GLAZING - F/STATIONARY	DH373-12 MITER/WELD
6	151069-01-700	FT	CHANNEL-RUN, SLIDING	122-030627
7	098644-01-706	FT	WEATHERSTRIP - GLASS	171-010668
8	151069-03-704	EA	RETAINER - TRIM	H671-67L
9	151069-03-700	EA	SCREEN ASM	410-035962
10	150648-01-700	EA	LATCH-HORIZONTAL SLIDE-BLK	FH3000-CK
11	112795-01-701	EA	SLIDE-STOP	132-019092
	151069-01-703	EA	COVER - DRAIN SLOT - LH	130-030398 LEFT

WINDOW & VENTS GROUP (CONTINUED)
COMPONENT PARTS FOR WINDOWS & VENT LAYOUT (CONTINUED)

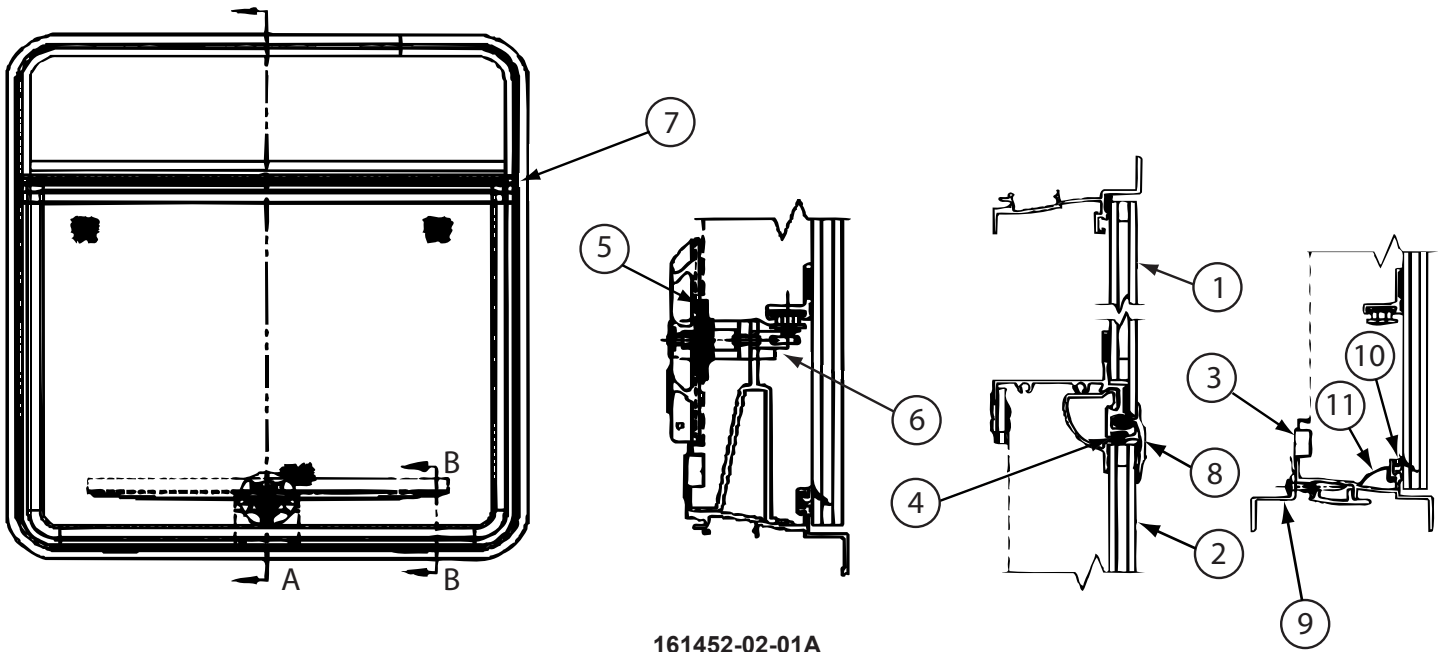

161452-02-01A

KEY	PART NUMBER	U/M	DESCRIPTION	VENDOR NO.
3	150656-05-701	EA	SCREEN ASM	410-035640
4	098644-01-706	FT	WEATHERSTRIP - GLASS	171-010668
5	100322-01-718	EA	HANDLE-DIAL	410-016081
6	150656-08-701	EA	OPERATOR - TIPOUT/LARGE	410-036141
7	161452-01-700	FT	FELT SEAL	160-014688
9	150656-05-702	EA	RETAINER - TRIM	DTH035-56
10	100322-01-701	FT	SEAL-VENT	122-016071
11	150651-03-702	FT	COVER - DRAIN SLOT	132-030723

CONTACT WINNEBAGO PARTS SALES FOR FOR UNLISTED COMPONENTS

WINDOW & VENTS GROUP (CONTINUED)
COMPONENT PARTS FOR WINDOWS & VENT LAYOUT (CONTINUED)

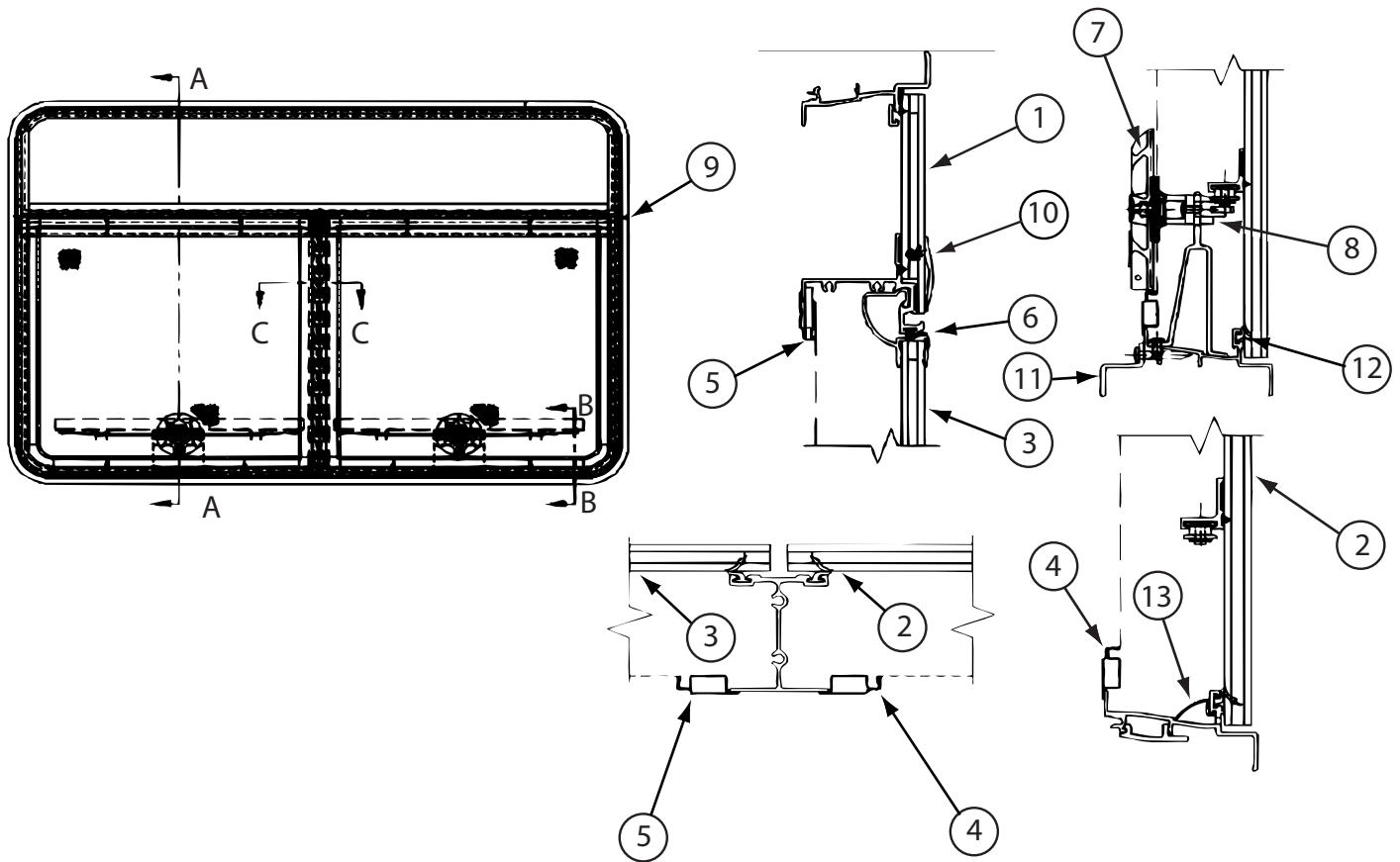

161452-03-01A

KEY	PART NUMBER	U/M	DESCRIPTION	VENDOR NO.
3	150656-08-701	EA	SCREEN ASM	DTH3038-06
4	098644-01-706	FT	WEATHERSTRIP - GLASS	171-010668
5	100322-01-718	EA	HANDLE-DIAL	410-016081
6	150656-08-701	EA	OPERATOR - TIPOUT/LARGE	410-036141
7	161452-01-700	FT	FELT SEAL	160-014688
9	150656-05-702	EA	RETAINER - TRIM	DTH035-56
10	100322-01-701	FT	SEAL-VENT	122-016071
11	150651-03-702	EA	COVER - DRAIN SLOT	132-030723
12	112898-06-707	EA	HANDLE/RH-EGRESS(SLD)ESC-RED	182-025911
13	112898-06-708	EA	HANDLE/LH-EGRESS(SLD)ESC-RED	182-025912
14	150656-09-700	FT	SEAL/SPONGE FOAM-SCREEN/FRME	40-035542
15	161452-01-701	FT	SEAL - SPONGE RUBBER	140-035407

WINDSHIELD & WIPER GROUP

WINDSHIELD

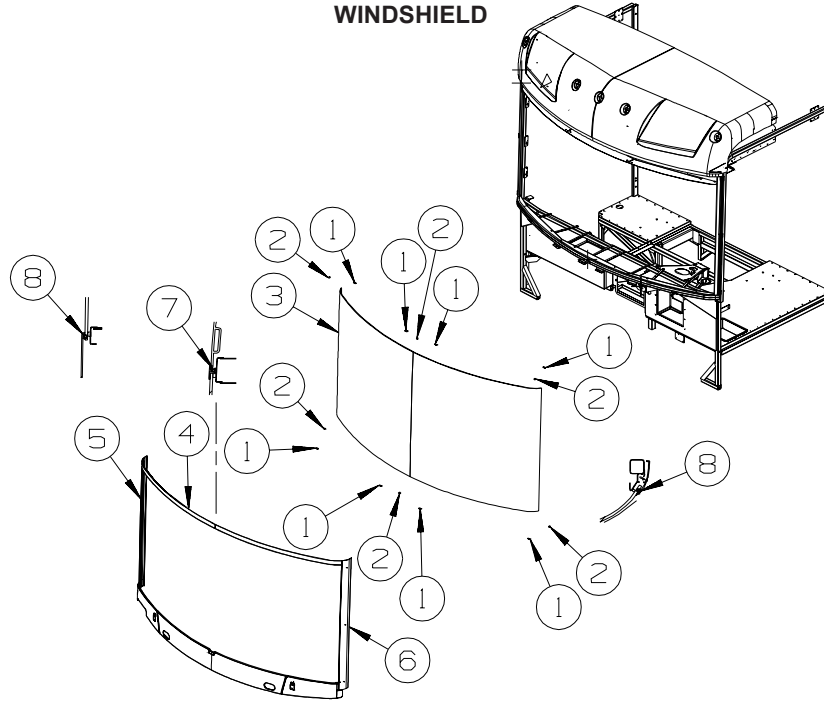

KEY	PART NUMBER	U/M	DESCRIPTION
1	002328-03-000	EA	BLOCK - WINDSHIELD - .125" X .5" X .98"
2	081914-02-000	EA	BUMPER - RUBBER - ROUND - 5/16" DIA. X 13/64" THICK
3	154704-01-000	EA	WINDSHIELD - SOLID/1 PIECE - 63"W X 49.4"H
4	120533-01-000	FT	MOLDING - REVEAL - WINDSHIELD
5	144054-03-02A	EA	TRIM - WINDSHIELD - A PILLAR - RIGHT HAND - BLACK
6	144054-04-02A	EA	TRIM - WINDSHIELD - A PILLAR - LEFT HAND - BLACK
7	127862-01-000	EA	CARRIER/REVEAL - WINDSHIELD - 47.2"
8	099418-01-000	FT	SEAL - D-SECTION/ADHESIVE BACK - .44" X .44" - BLK RUBBER
			FROM: 00-00-00 THRU: 05-14-06
8	158297-01-000	FT	SEAL - BULB - .5" X .7" - ADHESIVE BACK - BLACK - NOT ILLUSTRATED
			FROM: 05-15-06 THRU: 99-99-99

WINDSHIELD & WIPER GROUP (CONTINUED)

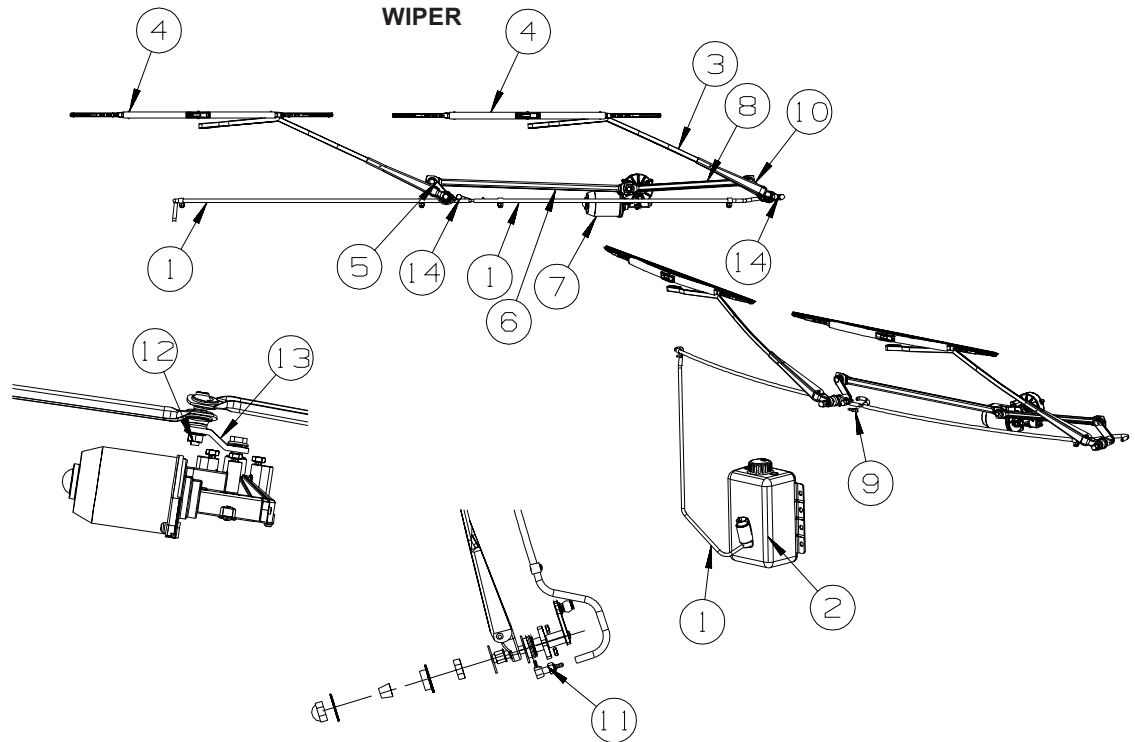

KEY	PART NUMBER	U/M	DESCRIPTION
1	045794-01-000	FT	HOSE - WINDSHIELD WASHER - 5/32"ID - BLACK
2	157507-01-000	EA	RESERVOIR/PUMP - WINDSHIELD WASHER
3*	157531-01-000	EA	ARM - WIPER - RADIAL - 28"
4	157532-01-000	EA	BLADE - WINDSHIELD WIPER - 28"
5*	157512-01-000	EA	SHAFT/PIVOT - WINDSHIELD WIPER - DRIVER/PASSENGER
6	157521-02-000	EA	LINK/WIPER - CONNECTING - PASSENGER
7	157508-01-000	EA	WIPER MOTOR - WINDSHIELD
8	157521-01-000	EA	LINK/WIPER - CONNECTING - DRIVER
9	146486-01-000	EA	TEE - PLASTIC - 5/32" X 5/32" X 5/32"
10*	149401-02-000	EA	SHAFT/PIVOT - WINDSHIELD WIPER - 4.1" OVERALL
11	157533-01-000	EA	FITTING/WIPER - BRASS - COWL
			FROM: 00-00-00 THRU: 02-20-07
11	157533-02-000	EA	FITTING/WIPER - COWL/TALL
			FROM: 02-21-07 THRU: 99-99-99
12	149395-01-000	EA	STUD/DOUBLE BALL CRANK - WIPER MOTOR
13	157578-01-000	EA	ARM/DRIVE - WIPER MOTOR
14	110742-03-000	EA	GASKET - WIPER ADAPTER SHAFT

*COMPONENT PARTS LISTED LATER IN THIS GROUP

COMPONENT PARTS FOR WIPER

149401-01-000,149401-02-000

KEY	PART NUMBER	U/M	DESCRIPTION	VENDOR NO.
	096505-02-703	EA	NUT/ACORN - HD W/.687 BRL	51065-40-NT27WC
	149401-01-700	EA	HARDWARE PKG - F/SHAFT&PIVOT	PSHWKIT
	149401-01-701	EA	SEAL CAP/RUBBER GROMMET	300749

157512-01-000

KEY	PART NUMBER	U/M	DESCRIPTION	VENDOR NO.
	096505-02-703	EA	NUT/ACORN - HD W/.687 BRL	51065-40-NT27WC
	149401-01-700	EA	HARDWARE PKG - F/SHAFT&PIVOT	PSHWKIT

157531-01-000

KEY	PART NUMBER	U/M	DESCRIPTION	VENDOR NO.
	157531-01-700	EA	WASHER NOZZLE KIT W/HDW	19475