

2007
VOYAGE
WFF33V
F-SERIES
WASHED MAPLE
U67 ICE TEA
U71 MULBERRY
U75 METEORITE
SIERRA MAPLE
U68 ICE TEA
U72 MULBERRY
U76 METEORITE

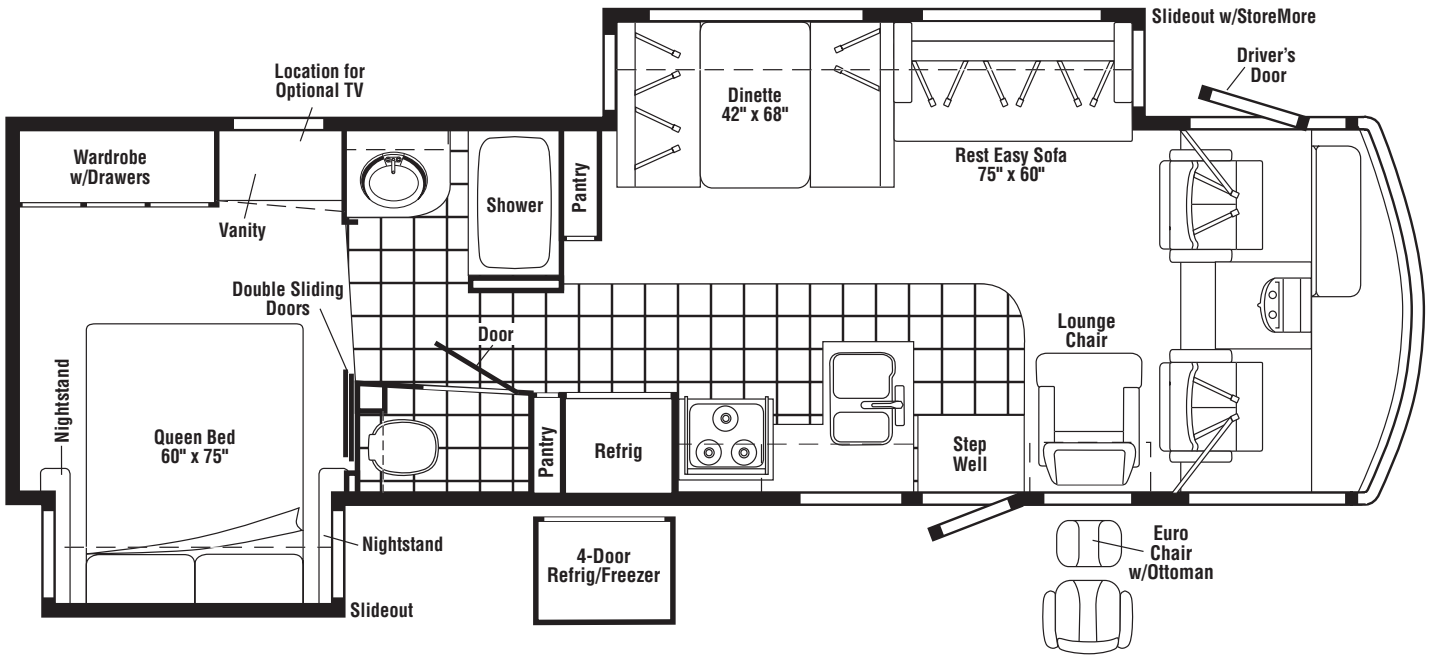

FLOORPLAN

CONTENTS

FLOORPLAN	1
ACCESSORIES GROUP	6
OPERATORS MANUAL	6
AUDIO VIDEO GROUP	7
RADIO SYSTEM	7
REAR MONITOR	7
COMPONENT PARTS FOR REAR MONITOR	7
144677-10-01A	7
144677-11-01A	7
CABINET & APPLIANCE GROUP	8
CABINET & APPLIANCE LAYOUT	8
COMPONENT PARTS FOR CABINET & APPLIANCE LAYOUT	19
114030-04-01A	19
119267-12-01A	20
119267-13-01A	20
119267-15-01A	20
120075-12-01A, 120075-13-01A, 120075-14-01A, 120075-15-01A	21
121569-05-01A, 121569-06-01A, 121569-07-01A	27
125242-02-01A	32
125242-03-02A	42
125242-05-02A	52
126022-01-01A, 126022-02-01A, 126022-03-01A	59
135065-03-01A, 135065-03-03A, 135065-04-01A	59
151277-03-01A, 151279-01-01A, 151279-02-01A/02A, 151279-03-01A	62
CHASSIS GROUP	64
FRAME	64
FRONT END	66
DRIVETRAIN	68
EXHAUST	68
FUEL	71
SPARE TIRE	73
HYDRAULIC LEVELING	73
COMPONENT PARTS FOR HYDRAULIC LEVELING	74
100536-57-000	74
139641-09-000	74
139641-10-000	75
WHEEL, TIRE, COVERS &/OR LINERS	76
COMPONENT PARTS FOR WHEEL, TIRE, COVERS &/OR LINERS	76
145580-02-000	76
145580-03-000	76
154672-01-000	76
BRAKE	76
BRAKELINE	76
CURTAIN & CUSHION GROUP	77
NOTICE	77
CUSHION LAYOUT	78
BUCKET SEATS	81
COMPONENT PARTS FOR BUCKET SEATS	82
122611-02-000	82
LOUNGE CHAIR	83
SOFA	84
COMPONENT PARTS FOR SOFA	85
136534-02-000, 136534-03-000, 136534-13-000, 136534-15-000	85
136534-17-000	85
148226-01-000, 148226-02-000, 148226-03-000	85
WINDOW TREATMENT	86
HARDWARE	88
ACCESSORIES	89
FABRICS	90

CONTENTS (CONTINUED)

DRIVERS COMPARTMENT GROUP	91
DASH	91
MOTOR COVER	93
BEVERAGE TRAY	94
FRONT INTERIOR	95
COMPONENT PARTS FOR FRONT INTERIOR	99
091990-08-01A	99
147767-01-000, 147767-02-000	99
CABINETS	100
ELECTRICAL GROUP	102
110V BODY WIRING	102
12V BODY WIRING	104
EXTERIOR LAMPS	110
FRONT END	112
FRONT TV/VCR	114
SIDE TV/VCR	115
COMPONENT PARTS FOR WIRING	116
076319-23-000	116
076319-25-000	116
086280-01-000	117
087694-01-000	117
097917-01-06A	117
108354-01-01A	117
121935-01-01A	117
134940-06-01A	118
134940-08-01A	118
137135-02-000	119
137417-01-01A, 137417-03-01A	120
137417-05-01A	120
137417-06-01A	120
141454-03-01A	120
146298-02-000	121
148658-01,02-000	121
149040-02-000	121
149040-03-000	121
149049-01-000,149049-02-000	121
153464-03/06-01A	121
154548-01-000	121
155619-01-000	121
158836-01-000	121
CIRCUIT BREAKERS, FUSES & RELAYS	122
CONVERTER, INVERTER, LOAD CENTERS	123
BOXES & CORDS	124
WIRE ASSEMBLIES	124
CONNECTORS & CONDUIT	125
CHASSIS	127
EXTERIOR BODY GROUP	128
GRAPHICS & PAINT	128
PANELS & TRIMS	130
COMPONENT PARTS FOR PANELS & TRIMS	132
106015-18-01A, 106015-19-01A	132
LADDER	132
FRONT END	133
STRUCTURAL COMPONENTS	134
AWNINGS	134

CONTENTS (CONTINUED)

EXTERIOR DOORS & COMPARTMENTS GROUP	135
DOOR & COMPARTMENT LAYOUT	135
COMPONENT PARTS FOR DOOR & COMPARTMENT LAYOUT	141
084103-08-000	141
094707-04-01A	141
110506-A1-000, 110506-A2-000, 110506-26-000, 110506-27-000, 110506-36-000	141
142226-02-01A	141
143709-02-01A	142
COMPARTMENT DOOR PIECE PARTS	143
DRIVERS	146
COMPONENT PARTS FOR DRIVERS	147
125581-09-01A	147
ENTRY	149
SCREEN	150
LATCH - ENTRY	151
EXTERIOR SLIDEOUT GROUP	152
FRONT LEFT	152
COMPONENT PARTS FOR FRONT LEFT	155
148875-01-000, 148875-02-000	155
REAR RIGHT	156
COMPONENT PARTS FOR REAR RIGHT	158
149165-01-000	158
GENERATOR GROUP	159
GAS	159
HEATING & A/C GROUP	160
AUTOMOTIVE	160
COMPONENT PARTS FOR AUTOMOTIVE	162
103930-44-000	162
103930-45-000	162
103930-46-000	162
103930-47-000	162
103930-49-000	162
103930-55-000	164
FURNACE	165
COMPONENT PARTS FOR FURNACE	166
143563-01-000	166
143563-02-000	168
REAR HEATER	170
CENTRAL	171
COMPONENT PARTS FOR CENTRAL	172
105620-12-000	172
INTERIOR FINISH GROUP	174
MOLDINGS & TRIMS	174
PANELING & LAMINATES	182
INTERIOR TRIM LAYOUT	183
COMPONENT PARTS FOR INTERIOR TRIM LAYOUT	187
094499-02-000	187
115011-03-02A	187
FLOOR COVERINGS	188
HARDWARE	189
LABELS GROUP	195
LP GROUP	198
LP SYSTEM	198
COMPONENT PARTS FOR LP SYSTEM	198
144116-01-000	198

CONTENTS (CONTINUED)

SEALANTS & FASTENERS GROUP	199
SEALANTS & ADHESIVES	199
BOLTS, NUTS AND WASHERS	200
SCREWS	202
CLAMPS, CLIPS, GROMMETS, RIVETS & PLUGS	205
MISCELLANEOUS FASTENERS	206
WATER & SEWAGE GROUP	207
DRAINAGE SYSTEM	207
COMPONENT PARTS FOR DRAINAGE SYSTEM	209
144728-01-000	209
152829-01-01A	209
WATER SYSTEM	210
COMPONENT PARTS FOR WATER SYSTEM	216
051393-01-000	216
098607-01-000	217
103635-01-000	217
123744-03-01A	217
125420-01-02A, 125420-01-03A, 125420-03-03A, 125420-04-03A	217
144215-01-000	217
145541-01-000	218
145541-02-000	218
WINDOW & VENTS GROUP	219
WINDOW & VENT LAYOUT	219
COMPONENT PARTS FOR WINDOW & VENT LAYOUT	221
098644-04-03A	221
098644-17-01A	222
098647-33-02A	223
098647-47-02A	224
113500-07-02A	225
122882-01-01A	226
122882-02-01A, 122882-03-01A	226
123780-03-01A	227
125582-01-01A	228
125584-01-01A	229
125586-01-01A	229
150648-04-01A, 150648-05-01A	229
150648-07-01A, 150648-22-01A	230
150649-08-01A	230
150649-12-01A	231
150649-19-01A	231
150651-07-01A	231
150656-09-01A	232
151072-01-01A	233
151073-01-01A	234
151074-01-01A	234
WINDSHIELD & WIPER GROUP	235
WINDSHIELD	235
WIPER	236
COMPONENT PARTS FOR WIPER	236
149401-01-000,149401-02-000	236
149402-03-000 & 149402-04-000	236

ACCESSORIES GROUP
OPERATORS MANUAL

KEY	PART NUMBER	U/M	DESCRIPTION
	157281-01-000	DW	TOP LEVEL-F,2007
	129079-01-01A	EA	CASE - VINYL/BLACK-EXPANDABLE ACCORDION SIDES-7"WX9"HX14"L FROM: 00-00-00 THRU: 07-09-06
	129079-04-01A	EA	CASE - VINYL/BLK-EXPANDABLE ACCORDION SIDES-11"WX9"HX14"L FROM: 07-10-06 THRU: 07-30-06
	159842-01-01A	EA	CASE - VINYL - F/MANUALS - W/SLEEVES - BLACK FROM: 07-31-06 THRU: 99-99-99
	132000-05-007	EA	MANUAL/OWNER - VOYAGE - 2007
	158603-07-006	EA	MANUAL/OWNER - SUPPLEMENT - F-SERIES - 2007

AUDIO VIDEO GROUP RADIO SYSTEM

KEY	PART NUMBER	U/M	DESCRIPTION
	135420-07-000	EA	MOUNTING KIT - RADIO - A-BODY
	135420-14-000	EA	RECEIVER (EYE) - INFRARED
	135420-15-000	EA	RADIO-AM/FM/CD/SIRIUS SATELLITE READY-W/O REMOTES/WIRE ASM
	135420-18-000	EA	REMOTE CONTROL/RADIO (STEERING WHEEL MOUNT)
	135420-19-000	EA	REMOTE CONTROL/RADIO (CREDIT CARD SIZE)

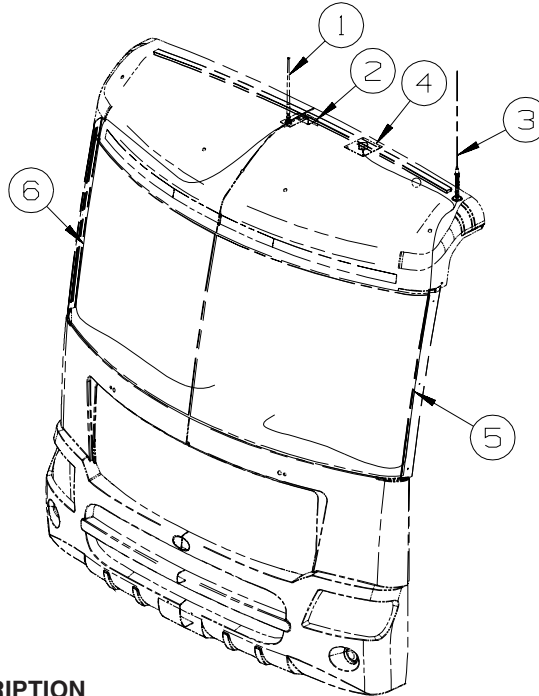

KEY	PART NUMBER	U/M	DESCRIPTION
1	090944-02-000	EA	ANTENNA - RADIO - 16" RUBBER - W/O LEAD WIRE
2	115916-01-01B	EA	BRACKET - ANTENNA MOUNT
3	NA	EA	ANTENNA - CB - W/O CABLE
4	158494-01-000	EA	ANTENNA/SATELLITE - RADIO/SIRIUS
5	NA	EA	CABLE - CB - COAX
6	090944-03-000	EA	CABLE - ANTENNA

REAR MONITOR

KEY	PART NUMBER	U/M	DESCRIPTION
	136514-02-000	EA	CABLE - MONITOR/CAMERA
	144677-06-000	EA	MONITOR/BLACK & WHITE - 7" - 3 PIN/MECH CONTROLS - RESIZED - REAR MONITOR SYS-AUDIO
	144677-04-000	EA	CAMERA - REAR VIEW W/BRACKET - BLACK & WHITE - VBGS150 - REAR MONITOR SYS-AUDIO
	137919-03-01A	EA	SHROUD - CAMERA/OUTER - BRIGHT WHITE - REAR MONITOR SYS-AUDIO
	144677-08-000	EA	MONITOR/BLACK & WHITE - 7" - W/O SIDE CAMERAS/WIRE ASM/CABLE - VIDEO CAMERA SYSTEM
*	144677-10-01A	EA	CAMERA - REAR VIEW - WALL MOUNT/RIGHT - BRIGHT WHITE - VIDEO CAMERA SYSTEM
*	144677-11-01A	EA	CAMERA - REAR VIEW - WALL MOUNT/LEFT - BRIGHT WHITE - VIDEO CAMERA SYSTEM
	144677-12-000	EA	CABLE - MONITOR/CAMERA - 12' - VIDEO CAMERA SYSTEM
	098819-01-000	EA	SPEAKER - 4" - 2 WATT - 8 OHM
	093214-01-05A	EA	GRILLE - SPEAKER - 4" - CASHMERE
	114870-01-000	EA	PLUG - AUDIO W/LEADS - 48.5"

COMPONENT PARTS FOR REAR MONITOR

144677-10-01A

KEY	PART NUMBER	U/M	DESCRIPTION	VENDOR NO.
	144677-10-700	EA	HOUSING/CAMERA-RT/LT-WHITE	SIDHSGWHT
	144677-10-702	EA	SERVICE PACK-SCREW COVER	PSVCSIDHSGWHT
	144677-10-703	EA	SERVICE PACK-SCREW COVER	PSVCSIDHSGGPR

144677-11-01A

KEY	PART NUMBER	U/M	DESCRIPTION	VENDOR NO.
	144677-10-700	EA	HOUSING/CAMERA-RT/LT-WHITE	SIDHSGWHT

CABINET & APPLIANCE GROUP

CABINET & APPLIANCE LAYOUT

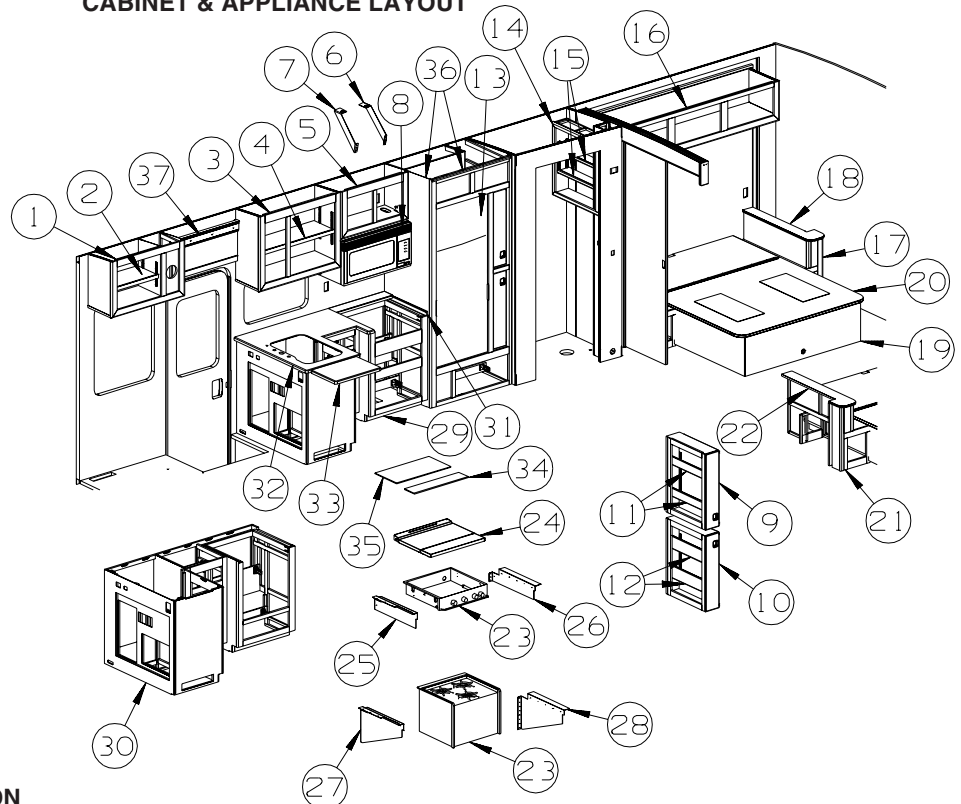

KEY	PART NUMBER	U/M	DESCRIPTION
1	157564-01-U67	EA	CABINET - OVERHEAD/FRONT - W/O DOORS/HDW - WASHED MAPLE
1	157564-01-U68	EA	CABINET - OVERHEAD/FRONT - W/O DOORS/HDW - SIERRA MAPLE
2	157564-15-U67	EA	SHELF - W/PLASTIC EDGE MOLDING - WASHED MAPLE
2	157564-15-U68	EA	SHELF - W/PLASTIC EDGE MOLDING - SIERRA MAPLE
3	157539-01-U67	EA	CABINET - OVERHEAD/GALLEY - W/O DOORS/HDW - WASHED MAPLE
3	157539-01-U68	EA	CABINET - OVERHEAD/GALLEY - W/O DOORS/HDW - SIERRA MAPLE
4	157539-21-U67	EA	SHELF - W/PLASTIC EDGE MOLDING - WASHED MAPLE
4	157539-21-U68	EA	SHELF - W/PLASTIC EDGE MOLDING - SIERRA MAPLE
5	157550-01-U67	EA	CABINET - OVERHEAD/MICROWAVE - W/O DOORS/HDW - WASHED MAPLE
5	157550-01-U68	EA	CABINET - OVERHEAD/MICROWAVE - W/O DOORS/HDW - SIERRA MAPLE
6	152316-01-02B	EA	BRACKET/SUPPORT - MICROWAVE - E-COATED
7	152316-02-02B	EA	BRACKET/SUPPORT - MICROWAVE - E-COATED
8*	119267-12-01A	EA	OVEN - MICROWAVE/CONVECTION W/HOOD US - #R-1874T - CONVECTION FROM: 00-00-00 THRU: 07-30-06
8	119267-17-01A	EA	OVEN - MICROWAVE/CONVECTION W/HOOD US - #R-1880LST - CONVECTION FROM: 07-31-06 THRU: 99-99-99
8*	119267-15-01A	EA	OVEN - MICROWAVE/NON/CONVECTION W/HOOD US - OVEN W/FAN
9	153343-01-SD2	EA	CABINET - PANTRY/SLIDE - W/O DOORS/DRAWERS/HDW - WASHED MAPLE
9	153343-01-S67	EA	CABINET - PANTRY/SLIDE - W/O DOORS/DRAWERS/HDW - SIERRA MAPLE
10	153343-03-SD2	EA	CABINET - PANTRY/SLIDE - W/O DOORS/DRAWERS/HDW - WASHED MAPLE
10	153343-03-S67	EA	CABINET - PANTRY/SLIDE - W/O DOORS/DRAWERS/HDW - SIERRA MAPLE
11	153343-21-SD2	EA	SHELF - W/WOOD MOLDING - WASHED MAPLE
11	153343-21-S67	EA	SHELF - W/WOOD MOLDING - SIERRA MAPLE
12	153343-27-SD2	EA	SHELF - W/WOOD MOLDING - WASHED MAPLE
12	153343-27-S67	EA	SHELF - W/WOOD MOLDING - SIERRA MAPLE
13*	121569-05-01A	EA	REFRIGERATOR-LRG DBL DR/2 WAY/NON-FLUSH HANDLE-BLK RH - REFRIGERATOR-DOUBLE DOOR
13*	120075-13-01A	EA	REFRIGERATOR-LG DBL DR-2-WAY/RH/ICE MKR/FLSH HDL-BLK-REFRIGERATOR/FRZR W/ICEMAKER
13*	125242-03-02A	EA	REFRIGERATOR - 4 DOOR - W/ICE MAKER - TITANIUM SST - REFRIGERATOR-4 DOOR FROM: 00-00-00 THRU: 07-09-06
13*	125242-05-02A	EA	REFRIGERATOR - 4 DOOR - W/ICE MAKER - TITANIUM SST - REFRIGERATOR-4 DOOR FROM: 07-10-06 THRU: 99-99-99
	116751-05-01A	EA	TRAY - REFRIGERATOR - BLACK
	118871-13-01A	EA	TRAY - REFRIGERATOR - SIDE/SIDE - BLACK - 4-DOOR REFRIGERATOR
	054450-01-000	EA	LEVEL - REFRIGERATOR
	158456-01-01A	EA	INSERT/REFRIGERATOR DOOR - 21.5"W X 14.5"H - TITANIUM SST
	158456-03-01A	EA	INSERT/REFRIGERATOR DOOR - 21.5"W X 38.5"H - TITANIUM SST
	P34457-01-L94	EA	PANEL - INSERT RSD MEMBRANE - 16.1" X 18.3" - WASHED MAPLE - 4-DOOR REFRIGERATOR
	P34457-01-SA3	EA	PANEL - INSERT RSD MEMBRANE - 16.1" X 18.3" - SIERRA MAPLE - 4-DOOR REFRIGERATOR

CABINET & APPLIANCE GROUP (CONTINUED)
CABINET & APPLIANCE LAYOUT (CONTINUED)

KEY	PART NUMBER	U/M	DESCRIPTION
	P34457-02-L94	EA	PANEL - INSERT RSD MEMBRANE - 16.1" X 41.1" - WASHED MAPLE - 4-DOOR REFRIGERATOR
	P34457-02-SA3	EA	PANEL - INSERT RSD MEMBRANE - 16.1" X 41.1" - SIERRA MAPLE - 4-DOOR REFRIGERATOR
14	157682-01-U67	EA	CABINET - OVERHEAD/LINEN - W/O DOORS/HDW - WASHED MAPLE
14	157682-01-U68	EA	CABINET - OVERHEAD/LINEN - W/O DOORS/HDW - SIERRA MAPLE
15	157682-15-U67	EA	SHELF - W/WOOD MOLDING - WASHED MAPLE
15	157682-15-U68	EA	SHELF - W/WOOD MOLDING - SIERRA MAPLE
16	156643-01-U91	EA	CABINET - OVERHEAD/REAR/RIGHT HAND - W/O DOORS/HDW - WASHED MAPLE
16	156643-01-U92	EA	CABINET - OVERHEAD/REAR/RIGHT HAND - W/O DOORS/HDW - SIERRA MAPLE
17	136885-04-RW4	EA	CABINET - NIGHTSTAND/RH - W/O CTRTP/DOOR/DWR/HDW - WASHED MAPLE
17	136885-04-S67	EA	CABINET - NIGHTSTAND/RH - W/O CTRTP/DOOR/DWR/HDW - SIERRA MAPLE
18	133655-26-U67	EA	COUNTERTOP - LAMINATED - SUNSTONE/WASHED MAPLE (U67, U75)
18	133655-26-U68	EA	COUNTERTOP - LAMINATED - SUNSTONE/SIERRA MAPLE (U68, U76)
18	133655-26-U71	EA	COUNTERTOP - LAMINATED - CLASSIC ROCK/WASHED MAPLE (U71)
18	133655-26-U72	EA	COUNTERTOP - LAMINATED - CLASSIC ROCK/SIERRA MAPLE (U72)
19	137388-03-S48	EA	CABINET/BASE - W/O DOOR/DRAWER/HDW - F/QUEEN BED - WASHED MAPLE
19	137388-03-SR0	EA	CABINET/BASE - W/O DOOR/DRAWER/HDW - F/QUEEN BED - SIERRA MAPLE
20	137406-01-N42	EA	BEDBOARD - W/HINGE/T-MOLDING/SLIPNOT - FLIP-UP
	096764-02-000	EA	SLIPNOT - ANTISLIP - 1"WIDE (180' ROLLS) - WHITE
21	136885-03-RW4	EA	CABINET - NIGHTSTAND/LH - W/O CTRTP/DOOR/DWR/HDW - WASHED MAPLE
21	136885-03-S67	EA	CABINET - NIGHTSTAND/LH - W/O CTRTP/DOOR/DWR/HDW - SIERRA MAPLE
22	133655-25-U67	EA	COUNTERTOP - LAMINATED - SUNSTONE/WASHED MAPLE (U67, U75)
22	133655-25-U68	EA	COUNTERTOP - LAMINATED - SUNSTONE/SIERRA MAPLE (U68, U76)
22	133655-25-U71	EA	COUNTERTOP - LAMINATED - CLASSIC ROCK/WASHED MAPLE (U71)
22	133655-25-U72	EA	COUNTERTOP - LAMINATED - CLASSIC ROCK/SIERRA MAPLE (U72)
23*	114030-04-01A	EA	RANGE - 3 BRNR TOP/NEW STYLE KNOBS/GRATES-W/O OVEN-BLK - RANGE TOP 3-BURNER
23*	151277-03-01A	EA	RANGE-22"-3 BURNER - MERCURY FREE - BLK DOOR/TEXTURED - RANGE 3 BURNER WITH OVEN
24*	126022-01-01A	EA	COVER/RANGE - BI-FOLD - 22" - BLACK TEXTURED
25	106936-50-04B	EA	BRACKET - TIEDOWN - RANGE/FRONT - BLACK - RANGE TOP 3-BURNER
26	106936-51-04B	EA	BRACKET - TIEDOWN - RANGE - BLACK - RANGE TOP 3-BURNER
27	136382-24-04B	EA	BRACKET - TIEDOWN - OVEN - BLACK - RANGE 3 BURNER WITH OVEN
28	136382-25-04B	EA	BRACKET - TIEDOWN - OVEN - BLACK - RANGE 3 BURNER WITH OVEN
29	P57536-01-U67	EA	CABINET - GALLEY - W/O CNTRTP/DOORS/DRWRS/HDW - WASHED MAPLE - RANGE TOP 3-BURNER
29	P57536-01-U68	EA	CABINET - GALLEY - W/O CNTRTP/DOORS/DRWRS/HDW - SIERRA MAPLE - RANGE TOP 3-BURNER
30	P57536-02-U67	EA	CABINET - GALLEY-W/O CTRTP/DRS/DRWRS/HDW - WASHED MAPLE - RANGE 3 BURNER WITH OVEN
30	P57536-02-U68	EA	CABINET - GALLEY-W/O CTRTP/DRS/DRWRS/HDW - SIERRA MAPLE - RANGE 3 BURNER WITH OVEN
31	130813-23-09A	EA	BACKSPLASH/COUNTERTOP - 1/2" VENDURA - BUTTER BRICKLE FROM: 00-00-00 THRU: 07-16-06
31	161006-02-U67	EA	BACKSPLASH - COUNTERTOP - 1/2" VENDURA FROM: 07-17-06 THRU: 99-99-99
32	137475-26-09A	EA	COUNTERTOP - 1/4" VENDURA - BUTTER BRICKLE FROM: 00-00-00 THRU: 02-09-06
32	149086-65-09A	EA	COUNTERTOP - 1/4" VENDURA - BUTTER BRICKLE FROM: 02-10-06 THRU: 07-16-06
32	160530-02-U67	EA	COUNTERTOP - W/BACKING - VENDURA FROM: 07-17-06 THRU: 99-99-99
33	141784-02-09A	EA	COUNTERTOP EXTENSION - 1/4"VENDURA - BUTTER BRICKLE FROM: 00-00-00 THRU: 07-16-06
33	160696-02-U67	EA	COUNTERTOP - W/BACKING - VENDURA FROM: 07-17-06 THRU: 99-99-99
34	130816-01-09A	EA	COUNTERTOP/STOVE LID-5.4" X 24.3"-1/4" VENDURA - BUTTER BRICKLE FROM: 00-00-00 THRU: 07-16-06
34	161004-02-U67	EA	COUNTERTOP - STOVE LID - 1/4" VENDURA FROM: 07-17-06 THRU: 99-99-99
35	130816-06-09A	EA	COUNTERTOP/STOVE LID - 1/4" VENDURA - BUTTER BRICKLE FROM: 00-00-00 THRU: 07-16-06
35	161004-04-U67	EA	COUNTERTOP - STOVE LID - 1/4" VENDURA FROM: 07-17-06 THRU: 99-99-99
36			REFRIGERATOR CABINET SEALS
	090329-01-000	FT	SEAL - "T" - REFRIGERATOR CABINET
	100128-02-000	FT	SEAL - FOAM/ADHESIVE BACK - .37" WIDE X .37" THICK X 60'
	154585-02-01A	FT	SEAL - FOAM TAPE - ADHESIVE BACK - 3/4" X 1/2" - BLACK
37	157962-01-U67	EA	CABINET - OVERHEAD/ENTRY DOOR - W/O DOORS/HDW - WASHED MAPLE
37	157962-01-U68	EA	CABINET - OVERHEAD/ENTRY DOOR - W/O DOORS/HDW - SIERRA MAPLE

*COMPONENT PARTS LISTED LATER IN THIS GROUP

CABINET & APPLIANCE GROUP (CONTINUED)
CABINET & APPLIANCE LAYOUT (CONTINUED)

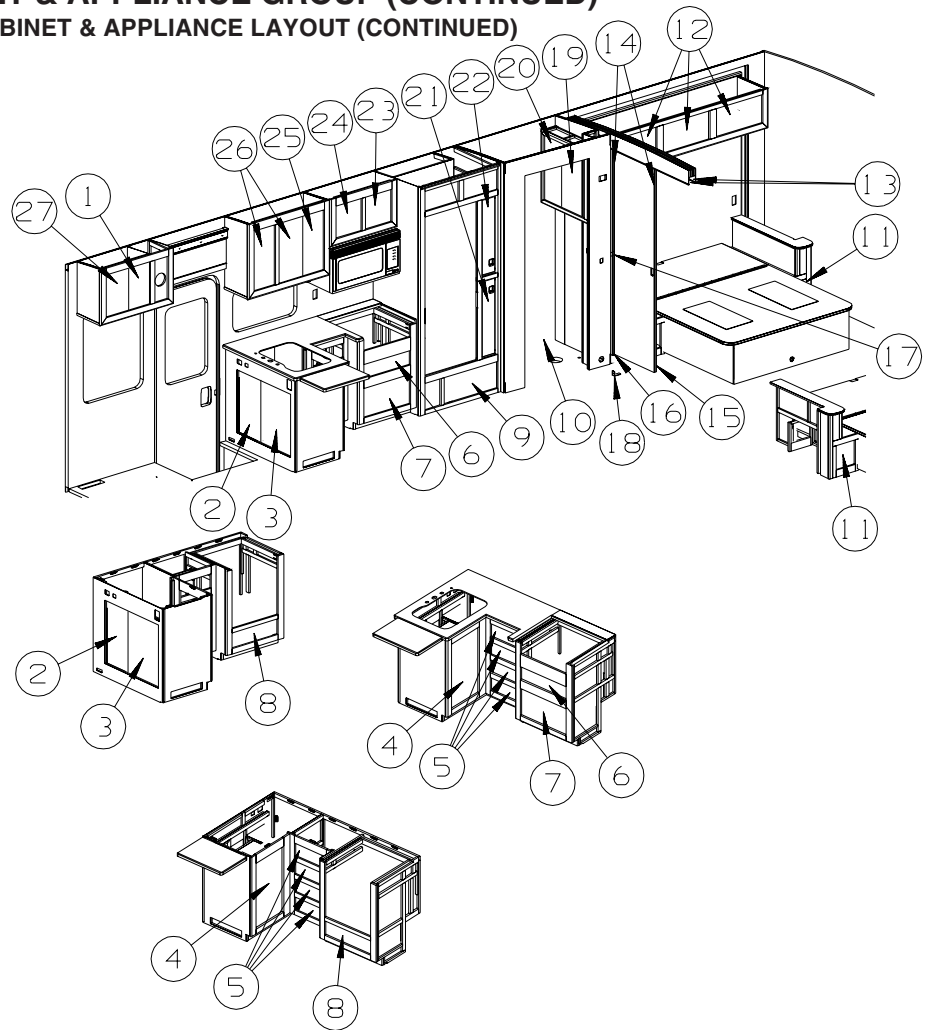

KEY	PART NUMBER	U/M	DESCRIPTION
1	136954-38-U67	EA	DOOR - RAISED PANEL/OGEE EDGE - 10.8" X 16.5" - W/O HDW - WASHED MAPLE
1	136954-38-U68	EA	DOOR - RAISED PANEL/OGEE EDGE - 10.8" X 16.5" - W/O HDW - SIERRA MAPLE
2	136918-C2-U67	EA	DOOR - FLAT/OGEE EDGE - 15.3" X 25.6" - W/O HARDWARE - WASHED MAPLE
2	136918-C2-TL0	EA	DOOR - FLAT/OGEE EDGE - 15.3" X 25.6" - W/O HARDWARE - SIERRA MAPLE
3	136918-C3-U67	EA	DOOR - FLAT/OGEE EDGE - 15.3" X 25.6" - W/O HARDWARE - WASHED MAPLE
3	136918-C3-TK0	EA	DOOR - FLAT/OGEE EDGE - 15.3" X 25.6" - W/O HARDWARE - SIERRA MAPLE
4	136918-D5-U67	EA	DOOR - FLAT/OGEE EDGE - 15.7" X 27.9" - W/O HARDWARE - WASHED MAPLE
4	136918-D5-U68	EA	DOOR - FLAT/OGEE EDGE - 15.7" X 27.9" - W/O HARDWARE - SIERRA MAPLE
5	153121-V3-T61	EA	DRAWER - OGEE EDGE - 13.5"W X 11.8"D - W/O SLIDES/HDW - WASHED MAPLE
5	153121-V3-TP0	EA	DRAWER - OGEE EDGE - 13.5"W X 11.8"D - W/O SLIDES/HDW - SIERRA MAPLE
6	153121-V4-T61	EA	DRAWER - OGEE EDGE-19.8"WX17.7"D-W/O SLIDES/HDW - WASHED MAPLE - RANGE TOP 3-BURNER
6	153121-V4-TP0	EA	DRAWER - OGEE EDGE-19.8"WX17.7"D-W/O SLIDES/HDW - SIERRA MAPLE - RANGE TOP 3-BURNER
7	153121-V6-T61	EA	DRAWER - OGEE EDGE-19.8"WX13.8"D-W/O SLIDES/HDW - WASHED MAPLE - RANGE TOP 3-BURNER
7	153121-V6-TP0	EA	DRAWER - OGEE EDGE-19.8"WX13.8"D-W/O SLIDES/HDW - SIERRA MAPLE - RANGE TOP 3-BURNER
8	153121-GT-T61	EA	DRAWER-OGEE EDGE-19.8"WX13.8"D-W/O SLDS/HDW- WASHED MAPLE - RANGE 3-BURNER W/OVEN
8	153121-GT-TP0	EA	DRAWER-OGEE EDGE-19.8"WX13.8"D-W/O SLDS/HDW- SIERRA MAPLE - RANGE 3-BURNER W/OVEN
9	153121-V5-T61	EA	DRAWER - OGEE EDGE - 23"W X 13.8"D - W/O SLIDES/HDW - WASHED MAPLE
9	153121-V5-TP0	EA	DRAWER - OGEE EDGE - 23"W X 13.8"D - W/O SLIDES/HDW - SIERRA MAPLE
10	153095-01-T79	EA	DOOR - BATH - 25.6" X 75.7" - W/O HDW - WASHED MAPLE
10	153095-01-T80	EA	DOOR - BATH - 25.6" X 75.7" - W/O HDW - SIERRA MAPLE
11	153121-47-T79	EA	DRAWER - OGEE EDGE - 7.6"W X 23.6"D - W/O SLIDES/HDW - WASHED MAPLE
11	153121-47-T80	EA	DRAWER - OGEE EDGE - 7.6"W X 23.6"D - W/O SLIDES/HDW - SIERRA MAPLE
12	136954-85-U67	EA	DOOR - RAISED PANEL/OGEE EDGE - 12.8" X 21.8" - W/O HDW - WASHED MAPLE
12	136954-85-TK0	EA	DOOR - RAISED PANEL/OGEE EDGE - 12.8" X 21.8" - W/O HDW - SIERRA MAPLE
13	137422-01-01A	EA	TRACK - DOOR - 66.4" - OFF WHITE - NOT ILLUSTRATED
			FROM: 00-00-00 THRU: 06-04-06
13	145608-01-01A	EA	TRACK - DOOR - 66.5" - OFF WHITE
			FROM: 06-05-06 THRU: 99-99-99
14	137421-03-U67	EA	DOOR - SLIDING/DOUBLE - WASHED MAPLE
14	137421-03-U68	EA	DOOR - SLIDING/DOUBLE - SIERRA MAPLE

CABINET & APPLIANCE GROUP (CONTINUED)
CABINET & APPLIANCE LAYOUT (CONTINUED)

KEY	PART NUMBER	U/M	DESCRIPTION
15	137421-24-U67	EA	PANEL - SLIDING DOOR - W/O HANGER - WASHED MAPLE
15	137421-24-U68	EA	PANEL - SLIDING DOOR - W/O HANGER - SIERRA MAPLE
16	137421-27-U67	EA	PANEL - SLIDING DOOR - W/O HANGER - WASHED MAPLE
16	137421-27-U68	EA	PANEL - SLIDING DOOR - W/O HANGER - SIERRA MAPLE
17	057534-03-000	EA	TIEBACK - CLEAR PLASTIC - 7.5"
18	138136-02-02B	EA	GUIDE - DOOR - E-COATED
19	136954-71-U67	EA	DOOR - RAISED PANEL/OGEE EDGE - 12" X 26" - W/O HDW - WASHED MAPLE
19	136954-71-U68	EA	DOOR - RAISED PANEL/OGEE EDGE - 12" X 26" - W/O HDW - SIERRA MAPLE
20	136954-72-U67	EA	DOOR - RAISED PANEL/OGEE EDGE - 12" X 26" - W/O HDW - WASHED MAPLE
20	136954-72-U68	EA	DOOR - RAISED PANEL/OGEE EDGE - 12" X 26" - W/O HDW - SIERRA MAPLE
20	076767-04-000	EA	CABLE - STAINLESS STEEL - 5.9"
21	154289-05-U67	EA	DOOR - RAISED PANEL/OGEE EDGE - 7.9" X 30.3" - W/O HDW - WASHED MAPLE
21	154289-05-U68	EA	DOOR - RAISED PANEL/OGEE EDGE - 7.9" X 30.3" - W/O HDW - SIERRA MAPLE
22	154289-06-U67	EA	DOOR - RAISED PANEL/OGEE EDGE - 7.9" X 30.3" - W/O HDW - WASHED MAPLE
22	154289-06-U68	EA	DOOR - RAISED PANEL/OGEE EDGE - 7.9" X 30.3" - W/O HDW - SIERRA MAPLE
23	136954-80-U67	EA	DOOR - RAISED PANEL/OGEE EDGE - 12.4" X 14.4" - W/O HDW - WASHED MAPLE
23	136954-80-U68	EA	DOOR - RAISED PANEL/OGEE EDGE - 12.4" X 14.4" - W/O HDW - SIERRA MAPLE
24	136954-81-U67	EA	DOOR - RAISED PANEL/OGEE EDGE - 12.4" X 14.4" - W/O HDW - WASHED MAPLE
24	136954-81-U68	EA	DOOR - RAISED PANEL/OGEE EDGE - 12.4" X 14.4" - W/O HDW - SIERRA MAPLE
25	136954-44-U67	EA	DOOR - RAISED PANEL/OGEE EDGE - 10.8" X 23.8" - W/O HDW - WASHED MAPLE
25	136954-44-U68	EA	DOOR - RAISED PANEL/OGEE EDGE - 10.8" X 23.8" - W/O HDW - SIERRA MAPLE
26	136954-45-U67	EA	DOOR - RAISED PANEL/OGEE EDGE - 10.8" X 23.8" - W/O HDW - WASHED MAPLE
26	136954-45-U68	EA	DOOR - RAISED PANEL/OGEE EDGE - 10.8" X 23.8" - W/O HDW - SIERRA MAPLE
27	136954-39-U67	EA	DOOR - RAISED PANEL/OGEE EDGE - 10.8" X 16.5" - W/O HDW - WASHED MAPLE
27	136954-39-U68	EA	DOOR - RAISED PANEL/OGEE EDGE - 10.8" X 16.5" - W/O HDW - SIERRA MAPLE

CABINET & APPLIANCE GROUP (CONTINUED)

CABINET & APPLIANCE LAYOUT (CONTINUED)

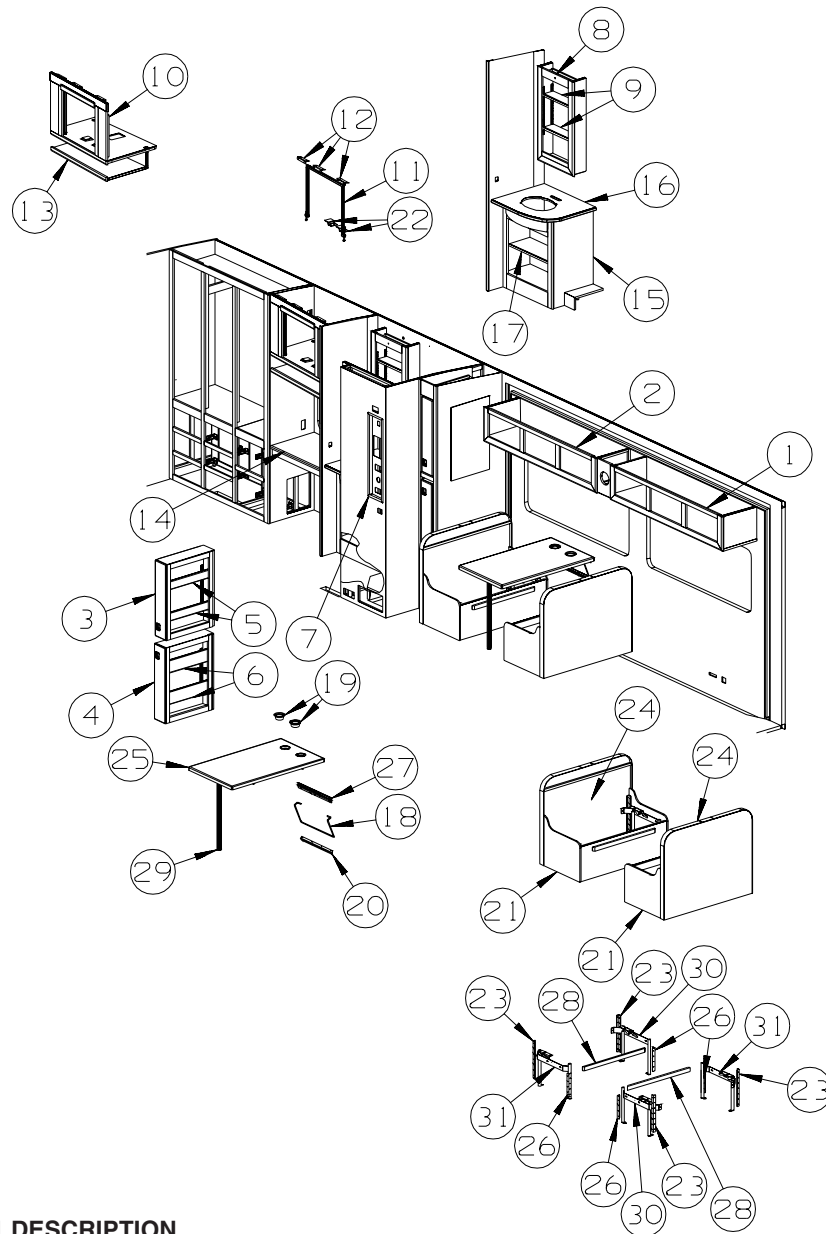

KEY	PART NUMBER	U/M	DESCRIPTION
1	158493-01-U67	EA	CABINET - OVERHEAD/COUCH - W/O DOORS/HDW - WASHED MAPLE
1	158493-01-U68	EA	CABINET - OVERHEAD/COUCH - W/O DOORS/HDW - SIERRA MAPLE
2	153229-01-T61	EA	CABINET - OVERHEAD/DINETTE - W/O DOORS/HDW - WASHED MAPLE
2	153229-01-TP0	EA	CABINET - OVERHEAD/DINETTE - W/O DOORS/HDW - SIERRA MAPLE
3	153343-02-SD2	EA	CABINET - PANTRY/SLIDE - W/O DOORS/DRAWERS/HDW - WASHED MAPLE
3	153343-02-S67	EA	CABINET - PANTRY/SLIDE - W/O DOORS/DRAWERS/HDW - SIERRA MAPLE
4	153343-04-S66	EA	CABINET - PANTRY/SLIDE - W/O DOORS/DRAWERS/HDW - WASHED MAPLE
4	153343-04-S67	EA	CABINET - PANTRY/SLIDE - W/O DOORS/DRAWERS/HDW - SIERRA MAPLE
5	153343-21-SD2	EA	SHELF - W/WOOD MOLDING - WASHED MAPLE
5	153343-21-S67	EA	SHELF - W/WOOD MOLDING - SIERRA MAPLE
6	153343-27-SD2	EA	SHELF - W/WOOD MOLDING - WASHED MAPLE
6	153343-27-S67	EA	SHELF - W/WOOD MOLDING - SIERRA MAPLE
7	137602-G9-T61	EA	POCKET - MONITOR PANEL - WASHED MAPLE
7	137602-G9-TP0	EA	POCKET - MONITOR PANEL - SIERRA MAPLE
7	137602-G7-T61	EA	POCKET - MONITOR PANEL - WASHED MAPLE - INVERTER DC/AC, 600W
7	137602-G7-TP0	EA	POCKET - MONITOR PANEL - SIERRA MAPLE - INVERTER DC/AC, 600W
8	157624-01-U67	EA	CABINET - OVERHEAD/MEDICINE - W/O DOORS/HDW - WASHED MAPLE
8	157624-01-U68	EA	CABINET - OVERHEAD/MEDICINE - W/O DOORS/HDW - SIERRA MAPLE
9	157624-12-U67	EA	SHELF - W/PLASTIC EDGE MOLDING - WASHED MAPLE
9	157624-12-U68	EA	SHELF - W/PLASTIC EDGE MOLDING - SIERRA MAPLE

CABINET & APPLIANCE GROUP (CONTINUED)

CABINET & APPLIANCE LAYOUT (CONTINUED)

KEY	PART NUMBER	U/M	DESCRIPTION
10	154426-01-T61	EA	CABINET - TV/REAR - W/O DOORS/HARDWARE - WASHED MAPLE FROM: 00-00-00 THRU: 02-19-06
10	159562-01-U67	EA	CABINET - TV/REAR - W/O DOORS/HARDWARE - WASHED MAPLE FROM: 02-20-06 THRU: 04-02-06
10	159924-01-U67	EA	CABINET - TV/REAR - W/O DOORS/HARDWARE - WASHED MAPLE FROM: 04-03-06 THRU: 05-14-06
10	159858-01-U67	EA	CABINET - TV/REAR - W/O DOORS/HARDWARE - WASHED MAPLE FROM: 05-15-06 THRU: 99-99-99
10	154426-01-TP0	EA	CABINET - TV/REAR - W/O DOORS/HARDWARE - SIERRA MAPLE FROM: 00-00-00 THRU: 02-19-06
10	159562-01-U68	EA	CABINET - TV/REAR - W/O DOORS/HARDWARE - SIERRA MAPLE FROM: 02-20-06 THRU: 04-02-06
10	159924-01-U68	EA	CABINET - TV/REAR - W/O DOORS/HARDWARE - SIERRA MAPLE FROM: 04-03-06 THRU: 05-14-06
10	159858-01-U68	EA	CABINET - TV/REAR - W/O DOORS/HARDWARE - SIERRA MAPLE FROM: 05-15-06 THRU: 99-99-99
10	154426-02-T61	EA	CABINET - TV/REAR - W/O DOORS/HARDWARE - WASHED MAPLE - TV (REAR)-20"COLOR, STEREO FROM: 00-00-00 THRU: 02-19-06
10	159562-02-U67	EA	CABINET - TV/REAR - W/O DOORS/HARDWARE - WASHED MAPLE - TV (REAR)-20"COLOR, STEREO FROM: 02-20-06 THRU: 04-02-06
10	159924-02-U67	EA	CABINET - TV/REAR - W/O DOORS/HARDWARE - WASHED MAPLE - TV (REAR)-20"COLOR, STEREO FROM: 04-03-06 THRU: 05-14-06
10	159858-02-U67	EA	CABINET - TV/REAR - W/O DOORS/HARDWARE - WASHED MAPLE - TV (REAR)-20"COLOR, STEREO FROM: 05-15-06 THRU: 99-99-99
10	154426-02-TP0	EA	CABINET - TV/REAR - W/O DOORS/HARDWARE - SIERRA MAPLE - TV (REAR)-20"COLOR, STEREO FROM: 00-00-00 THRU: 02-19-06
10	159562-02-U68	EA	CABINET - TV/REAR - W/O DOORS/HARDWARE - SIERRA MAPLE - TV (REAR)-20"COLOR, STEREO FROM: 02-20-06 THRU: 04-02-06
10	159924-02-U68	EA	CABINET - TV/REAR - W/O DOORS/HARDWARE - SIERRA MAPLE - TV (REAR)-20"COLOR, STEREO FROM: 04-03-06 THRU: 05-14-06
10	159858-02-U68	EA	CABINET - TV/REAR - W/O DOORS/HARDWARE - SIERRA MAPLE - TV (REAR)-20"COLOR, STEREO FROM: 05-15-06 THRU: 99-99-99
	152024-01-02B	EA	ANGLE/FORMED - W/HOLES - E-COATED FROM: 00-00-00 THRU: 04-02-06
	152025-03-02B	EA	ANGLE/FORMED - W/O STUD - E-COATED FROM: 00-00-00 THRU: 04-02-06
	152665-01-01A	EA	CAP - TUBE - 3/4" X 3/4" X 1" - RUBBER/BLACK FROM: 00-00-00 THRU: 04-02-06
11	151954-04-02B	EA	BRACKET/HOLD DOWN - TV - E-COATED - NOT ILLUSTRATED FROM: 00-00-00 THRU: 04-02-06
11	148247-05-02B	EA	STRAP/TIEDOWN - TV - E-COATED - NOT ILLUSTRATED FROM: 04-03-06 THRU: 05-14-06
11	151954-06-02B	EA	BRACKET/HOLD DOWN - TV - E-COATED FROM: 05-15-06 THRU: 99-99-99
12	106699-01-01A	EA	BRACKET F/TV INSTALLATION - OVERHEAD CABINET
13	153144-02-U67	EA	CABINET - TV SHELF - W/O HARDWARE - WASHED MAPLE
13	153144-02-U68	EA	CABINET - TV SHELF - W/O HARDWARE - SIERRA MAPLE
14	140889-44-U67	EA	COUNTERTOP - LAMINATED (U67, U68, U75, U76)
14	140889-44-U71	EA	COUNTERTOP - LAMINATED (U71, U72)
15	P38515-01-S48	EA	CABINET - LAVATORY - W/O COUNTERTOP/DOORS/DRAWERS/HARDWARE - WASHED MAPLE
15	P38515-01-SR0	EA	CABINET - LAVATORY - W/O COUNTERTOP/DOORS/DRAWERS/HARDWARE - SIERRA MAPLE
16	133654-52-U67	EA	COUNTERTOP - LAMINATED - SUNSTONE/WASHED MAPLE (U67, U75)
16	133654-52-U68	EA	COUNTERTOP - LAMINATED - SUNSTONE/SIERRA MAPLE (U68, U76)
16	133654-52-U71	EA	COUNTERTOP - LAMINATED - CLASSIC ROCK/WASHED MAPLE (U71)
16	133654-52-U72	EA	COUNTERTOP - LAMINATED - CLASSIC ROCK/SIERRA MAPLE (U72)
17	138515-20-N30	EA	SHELF - W/PLASTIC EDGE MOLDING
18	024275-16-000	EA	ROD - TABLE LIFT - W/ARMS 8" & BASE ROD 18.5" - ALMOND
19	064781-06-000	EA	HOLDER/CUP - TWO STEP - OFF WHITE
20	024281-12-000	EA	BRACKET/WALL - TABLE LIFT - 17.1" - ALMOND
21	142046-A7-U67	EA	CABINET/BASE - DINETTE W/O BACK-F/FLIP UP CUSHION
21	142046-A7-U68	EA	CABINET/BASE - DINETTE W/O BACK-F/FLIP UP CUSHION
21	142046-A7-U71	EA	CABINET/BASE - DINETTE W/O BACK-F/FLIP UP CUSHION
21	142046-A7-U72	EA	CABINET/BASE - DINETTE W/O BACK-F/FLIP UP CUSHION
21	142046-A7-U75	EA	CABINET/BASE - DINETTE W/O BACK-F/FLIP UP CUSHION
21	142046-A7-U76	EA	CABINET/BASE - DINETTE W/O BACK-F/FLIP UP CUSHION

CABINET & APPLIANCE GROUP (CONTINUED)
CABINET & APPLIANCE LAYOUT (CONTINUED)

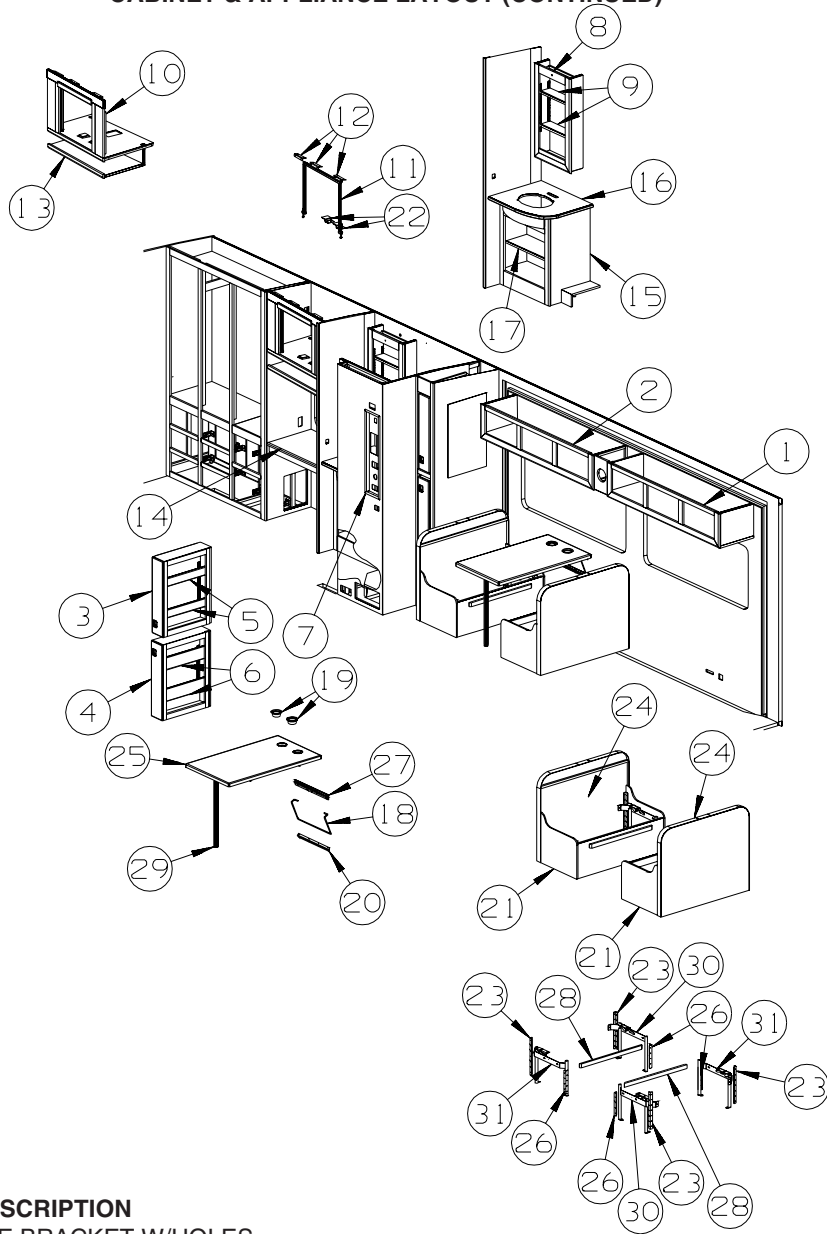

KEY	PART NUMBER	U/M	DESCRIPTION
22	159879-01-02B	EA	ZEE BRACKET W/HOLES
FROM: 05-15-06 THRU: 99-99-99			
23	122021-02-02A	EA	ANGLE - W/HOLES - 13.7" LONG - OFF WHITE
24	142046-A9-U67	EA	PANEL/BACK - DINETTE SEAT
24	142046-A9-U68	EA	PANEL/BACK - DINETTE SEAT
24	142046-A9-U71	EA	PANEL/BACK - DINETTE SEAT
24	142046-A9-U72	EA	PANEL/BACK - DINETTE SEAT
24	142046-A9-U75	EA	PANEL/BACK - DINETTE SEAT
24	142046-A9-U76	EA	PANEL/BACK - DINETTE SEAT
25	149294-03-U67	EA	TABLE/DINETTE - W/LEG - 24"W X 41.6"D (U67, U68, U75, U76)
25	149294-03-U71	EA	TABLE/DINETTE - W/LEG - 24"W X 41.6"D (U71, U72)
26	122021-01-02A	EA	ANGLE - W/HOLES - 8.6" LONG - OFF WHITE
27	140921-02-02A	EA	BRACKET/TABLE SUPPORT - 18.5" - ALMOND
28	081295-01-T03	EA	SUPPORT - BED/DINETTE - 28" LONG - WASHED MAPLE
28	081295-01-RE0	EA	SUPPORT - BED/DINETTE - 28" LONG - SIERRA MAPLE
29	143798-01-02A	EA	CATCH - FLOOR TO TABLE LEG - ALMOND
30	142033-01-000	EA	BRACKET - DINETTE - RIGHT HAND
31	142033-02-000	EA	BRACKET - DINETTE - LEFT HAND

CABINET & APPLIANCE GROUP (CONTINUED)
CABINET & APPLIANCE LAYOUT (CONTINUED)

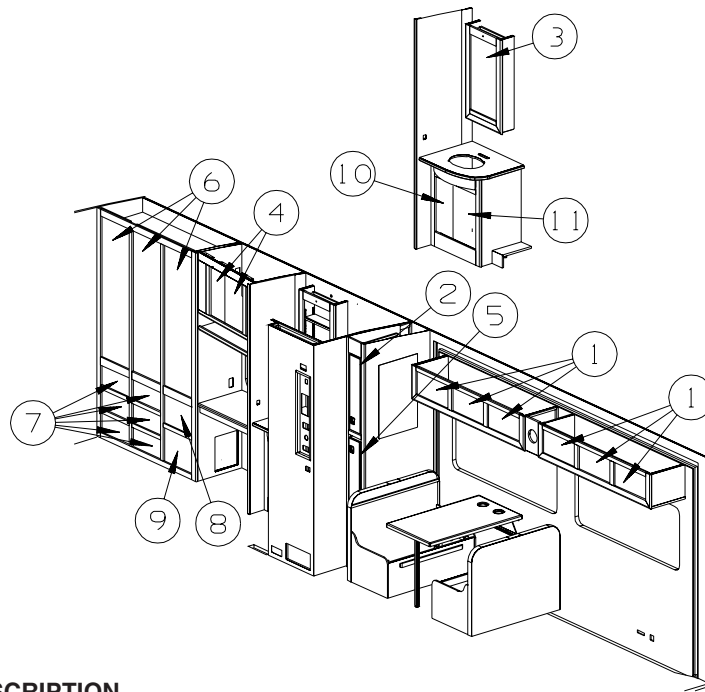

KEY	PART NUMBER	U/M	DESCRIPTION
1	136954-22-U67	EA	DOOR - RAISED PANEL/OGEE EDGE - 10" X 19.1" - W/O HDW - WASHED MAPLE
1	136954-22-TL0	EA	DOOR - RAISED PANEL/OGEE EDGE - 10" X 19.1" - W/O HDW - SIERRA MAPLE
2	154289-06-U67	EA	DOOR - RAISED PANEL/OGEE EDGE - 7.9" X 30.3" - W/O HDW - WASHED MAPLE
2	154289-06-U68	EA	DOOR - RAISED PANEL/OGEE EDGE - 7.9" X 30.3" - W/O HDW - SIERRA MAPLE
3	145576-B1-U67	EA	DOOR - MIRRORED - 15.6" X 29.5" - W/O HARDWARE - WASHED MAPLE
3	145576-B1-U68	EA	DOOR - MIRRORED - 15.6" X 29.5" - W/O HARDWARE - SIERRA MAPLE
3	093606-50-000	EA	MIRROR - BEVELED EDGE - 15.6" X 29.5"
3	076767-04-000	EA	CABLE - STAINLESS STEEL - 5.9"
4	136954-88-U67	EA	DOOR - RAISED PANEL/OGEE EDGE - 13.4" X 21.9" - W/O HDW - WASHED MAPLE
4	136954-88-TK0	EA	DOOR - RAISED PANEL/OGEE EDGE - 13.4" X 21.9" - W/O HDW - SIERRA MAPLE
5	154289-05-U67	EA	DOOR - RAISED PANEL/OGEE EDGE - 7.9" X 30.3" - W/O HDW - WASHED MAPLE
5	154289-05-U68	EA	DOOR - RAISED PANEL/OGEE EDGE - 7.9" X 30.3" - W/O HDW - SIERRA MAPLE
6	141506-09-U67	EA	DOOR - MIRRORED/OGEE EDGE - 16.7" X 54.4" - W/O HDW - WASHED MAPLE
6	141506-09-U68	EA	DOOR - MIRRORED/OGEE EDGE - 16.7" X 54.4" - W/O HDW - SIERRA MAPLE
6	140374-76-000	EA	MIRROR - SAFETY GLASS - 13.4" X 51.2"
6	076767-04-000	EA	CABLE - STAINLESS STEEL - 5.9"
7	153121-57-U91	EA	DRAWER - OGEE EDGE - 14.7"W X 17.7"D - W/O SLIDES/HDW - WASHED MAPLE
7	153121-57-U92	EA	DRAWER - OGEE EDGE - 14.7"W X 17.7"D - W/O SLIDES/HDW - SIERRA MAPLE
8	153121-59-T79	EA	DRAWER - OGEE EDGE - 14.7"W X 11.8"D - W/O SLIDES/HDW - WASHED MAPLE
8	153121-59-T80	EA	DRAWER - OGEE EDGE - 14.7"W X 11.8"D - W/O SLIDES/HDW - SIERRA MAPLE
9	153121-61-T79	EA	DRAWER - OGEE EDGE - 14.7"W X 11.8"D - W/O SLIDES/HDW - WASHED MAPLE
9	153121-61-T80	EA	DRAWER - OGEE EDGE - 14.7"W X 11.8"D - W/O SLIDES/HDW - SIERRA MAPLE
10	136918-68-U67	EA	DOOR - FLAT/OGEE EDGE - 12" X 21.8" - W/O HARDWARE - WASHED MAPLE
10	136918-68-U68	EA	DOOR - FLAT/OGEE EDGE - 12" X 21.8" - W/O HARDWARE - SIERRA MAPLE
11	136918-69-U67	EA	DOOR - FLAT/OGEE EDGE - 12" X 21.8" - W/O HARDWARE - WASHED MAPLE
11	136918-69-U68	EA	DOOR - FLAT/OGEE EDGE - 12" X 21.8" - W/O HARDWARE - SIERRA MAPLE

CABINET & APPLIANCE GROUP (CONTINUED)
CABINET & APPLIANCE LAYOUT (CONTINUED)

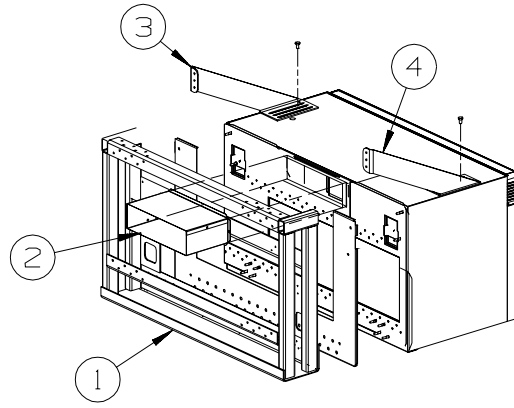

35A, 38J

KEY	PART NUMBER	U/M	DESCRIPTION
1	137824-06-02B	EA	BRACKET - MICROWAVE - E-COATED
2	140093-06-02B	EA	DUCT - E-COATED
3	153314-01-02B	EA	BRACKET/SUPPORT - MICROWAVE - E-COATED
4	153314-02-02B	EA	BRACKET/SUPPORT - MICROWAVE - E-COATED

CABINET & APPLIANCE GROUP (CONTINUED)
CABINET & APPLIANCE LAYOUT (CONTINUED)

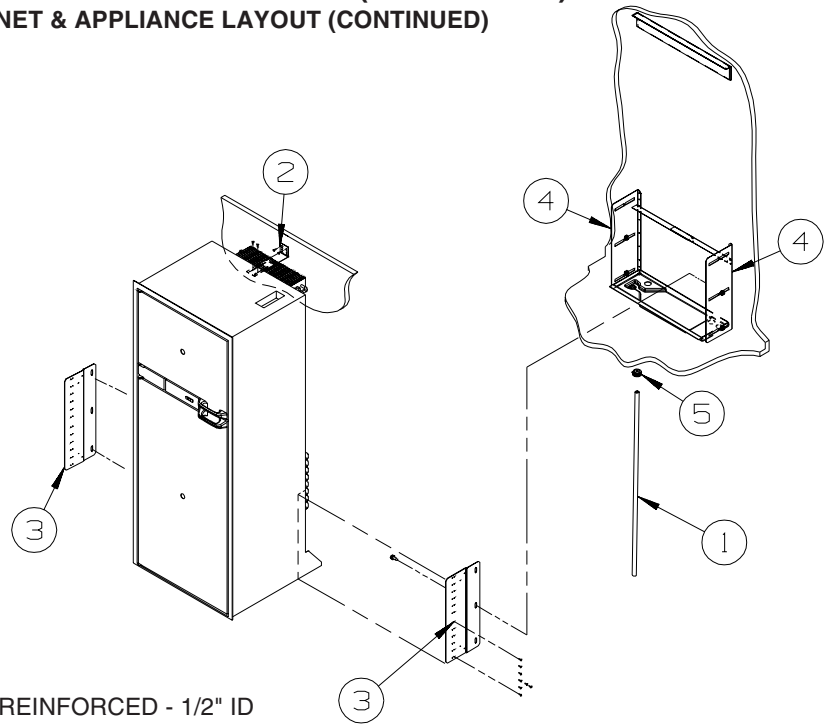

KEY	PART NUMBER	U/M	DESCRIPTION
1	112176-01-000	FT	TUBING - VINYL - REINFORCED - 1/2" ID
2	145445-02-02B	EA	STRAP - REFRIGERATOR - E-COATED
3	150740-01-02B	EA	BRACKET - REFRIGERATOR - E-COATED
4	150740-02-02B	EA	BRACKET - REFRIGERATOR - E-COATED
5	152417-01-01A	EA	CLAMP/RATCHET - F/REFRIGERATOR DRIP TRAY HOSE - BLACK

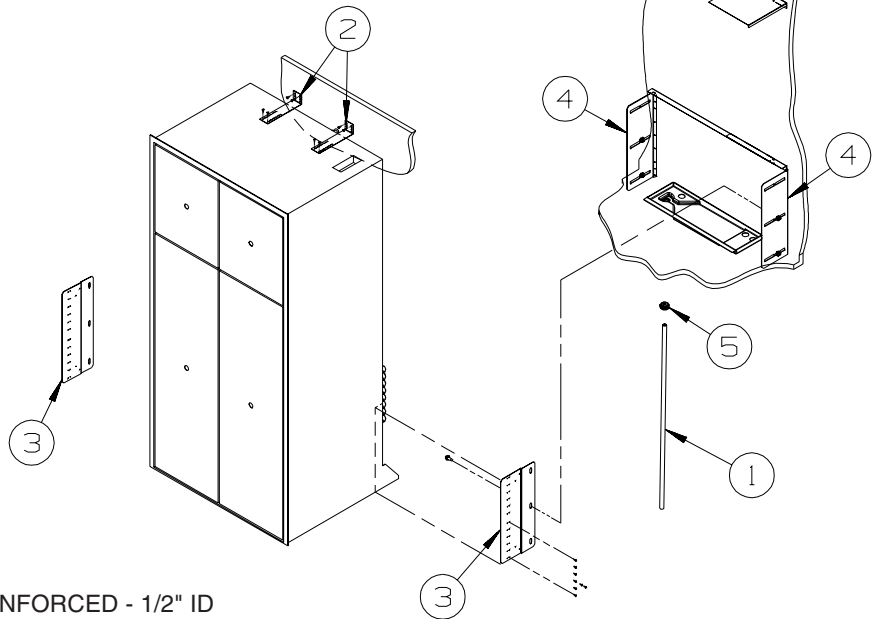

KEY	PART NUMBER	U/M	DESCRIPTION
1	112176-01-000	FT	TUBING - VINYL - REINFORCED - 1/2" ID
2	145445-02-02B	EA	STRAP - REFRIGERATOR - E-COATED
3	150740-01-02B	EA	BRACKET - REFRIGERATOR - E-COATED
4	150740-02-02B	EA	BRACKET - REFRIGERATOR - E-COATED
5	152417-01-01A	EA	CLAMP/RATCHET - F/REFRIDGERATOR DRIP TRAY HOSE - BLACK

CABINET & APPLIANCE GROUP (CONTINUED)
CABINET & APPLIANCE LAYOUT (CONTINUED)

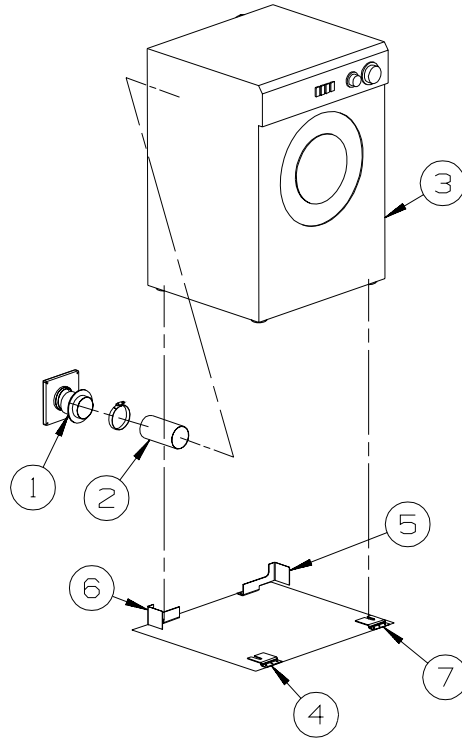

KEY	PART NUMBER	U/M	DESCRIPTION
1	146292-01-01A	EA	COVER - DRYER VENT - BRIGHT WHITE
1	146292-01-02A	EA	COVER - DRYER VENT - BLACK - FULL BODY PAINT
1	146292-02-01A	EA	DRYER VENT - INNER - BRIGHT WHITE
1	146292-02-02A	EA	DRYER VENT - INNER - BLACK - FULL BODY PAINT
2	116653-02-000	FT	DUCT - FLEXIBLE - 3' COMPRESSED/8' EXTENDED
3	153204-01-01A	EA	WASHER/DRYER - VENTED - UL/CSA - WHITE
4	111913-02-04B	EA	BRACKET/WASHER - TIE DOWN - BLACK
5	113795-01-02B	EA	BRACKET - WASHER - E-COATED
6	113795-02-02B	EA	BRACKET - WASHER - E-COATED
7	111913-03-04B	EA	BRACKET/WASHER - TIE DOWN - BLACK
	141523-01-01A	EA	LABEL - WASHER/DRYER BRACKETS - BLACK/WHITE
	157665-01-000	GL	RV ANTIFREEZE-50 POTABLE WTR

CABINET & APPLIANCE GROUP (CONTINUED)
COMPONENT PARTS FOR CABINET & APPLIANCE LAYOUT

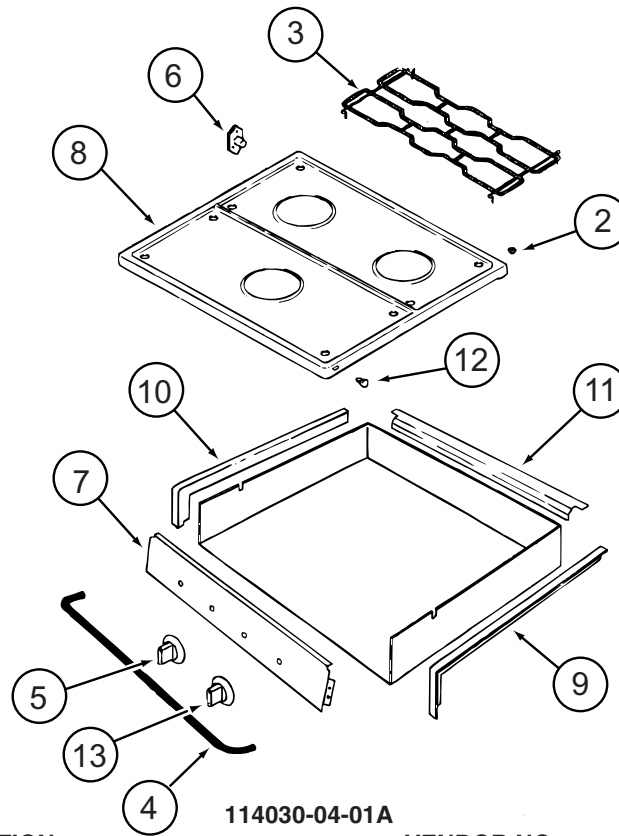

KEY	PART NUMBER	U/M	DESCRIPTION	VENDOR NO.
2	102020-01-709	EA	BUMPER-GRATE	8007P020-60
3	112881-04-702	EA	GRATE - BLACK	74007277
4	114030-02-700	EA	GUARD/FABRIC - TOWEL BAR	3609F006-70
5	128728-01-701	EA	KNOB - BURNER - REAR	74003941 (1 PER)
5	128728-01-702	EA	KNOB - BURNER - FRONT	74003942
6	128728-01-703	EA	PIN/T-NUT F/HINGE	7103P109-60
7	114030-04-700	EA	PANEL - MANIFOLD - BLACK	74007325
8	126023-01-728	EA	TOP - MAIN (BLACK)	74003323
9	114030-01-704	EA	TRIM - RIGHT/BLACK TEXTURED	74002839
10	114030-01-705	EA	TRIM - LEFT/BLACK TEXTURED	74002840
11	114030-01-706	EA	TRIM - REAR/BLACK TEXTURED	74002841
12	102020-01-724	EA	BUMPER - MAIN TOP	8003P008-60
13	128728-01-707	EA	KNOB - IGNITER	74003944

114030-04-01A

CONTACT WINNEBAGO PART SALES FOR UNLISTED COMPONENT(S)

CABINET & APPLIANCE GROUP (CONTINUED)
COMPONENT PARTS FOR CABINET & APPLIANCE LAYOUT (CONTINUED)

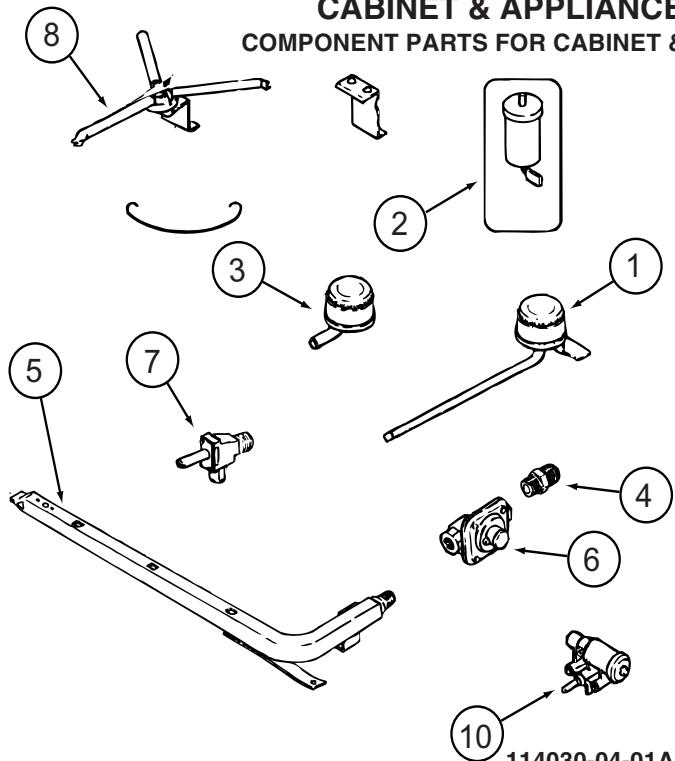

114030-04-01A (CONTINUED)

KEY	PART NUMBER	U/M	DESCRIPTION	VENDOR NO.
1	112881-04-700	EA	BURNER - TOP /LEFT REAR	74004584
1	126023-01-700	EA	BURNER - TOP (RT-REAR) 5100 BTU	74004583
2	112881-04-705	EA	PUSH RING (ELECTRODE MTG)	7104P002-60
2	126023-01-711	EA	ELECTRODE - IGNITER (ONLY)	7432P077-60
3	112881-04-701	EA	BURNER - TOP/FRONT	74004582
4	135065-03-700	EA	FITTING - HALF UNION	74004234
5	135065-01-702	EA	PIPE/MANIFOLD	74004642
6	126023-02-702	EA	PIPE - MANIFOLD	74004360
7	126023-02-705	EA	VALVE - BURNER - REAR	74004362
7	126023-02-706	EA	VALVE - BURNER - FRONT	74004363
8	126023-01-736	EA	FLASH TUBE EXTENSION (REAR)	74003326
8	126023-01-737	EA	FLASH TUBE EXTENSION (FRONT)	74003327
10	126023-01-719	EA	IGNITER HEAD - TOP BURNER	74002413
	126023-02-703	EA	REGULATOR - PRESSURE	74004235

CONTACT WINNEBAGO PART SALES FOR UNLISTED COMPONENT(S)

119267-12-01A

KEY	PART NUMBER	U/M	DESCRIPTION	VENDOR NO.
	119267-04-700	EA	FILTER-GREASE	BOO2
	119267-04-703	EA	PLATE - MOUNTING	FANGTB003MRY0
	119267-04-704	EA	LIGHT COVER-F/MOD R1480/1850	FANGKB009MRYO
	119267-12-700	EA	LOUVER-EXHAUST	PDIF-BO32MRFO
	119267-12-702	EA	RACK - HIGH	FAMI-B006MR0
	119267-12-703	EA	RACK - LOW	FAMI-B005MR0

119267-13-01A

KEY	PART NUMBER	U/M	DESCRIPTION	VENDOR NO.
	119267-04-700	EA	FILTER-GREASE	BOO2
	119267-12-702	EA	RACK - HIGH	FAMI-B006MR0
	119267-12-703	EA	RACK - LOW	FAMI-B005MR0

119267-15-01A

KEY	PART NUMBER	U/M	DESCRIPTION	VENDOR NO.
	119267-15-700	EA	SUPPORT - F/GLASS TRAY	FROLPB025MRKO
	119267-15-701	EA	TRAY - GLASS	NTNT-A10WREZ

CABINET & APPLIANCE GROUP (CONTINUED)
COMPONENT PARTS FOR CABINET & APPLIANCE LAYOUT (CONTINUED)

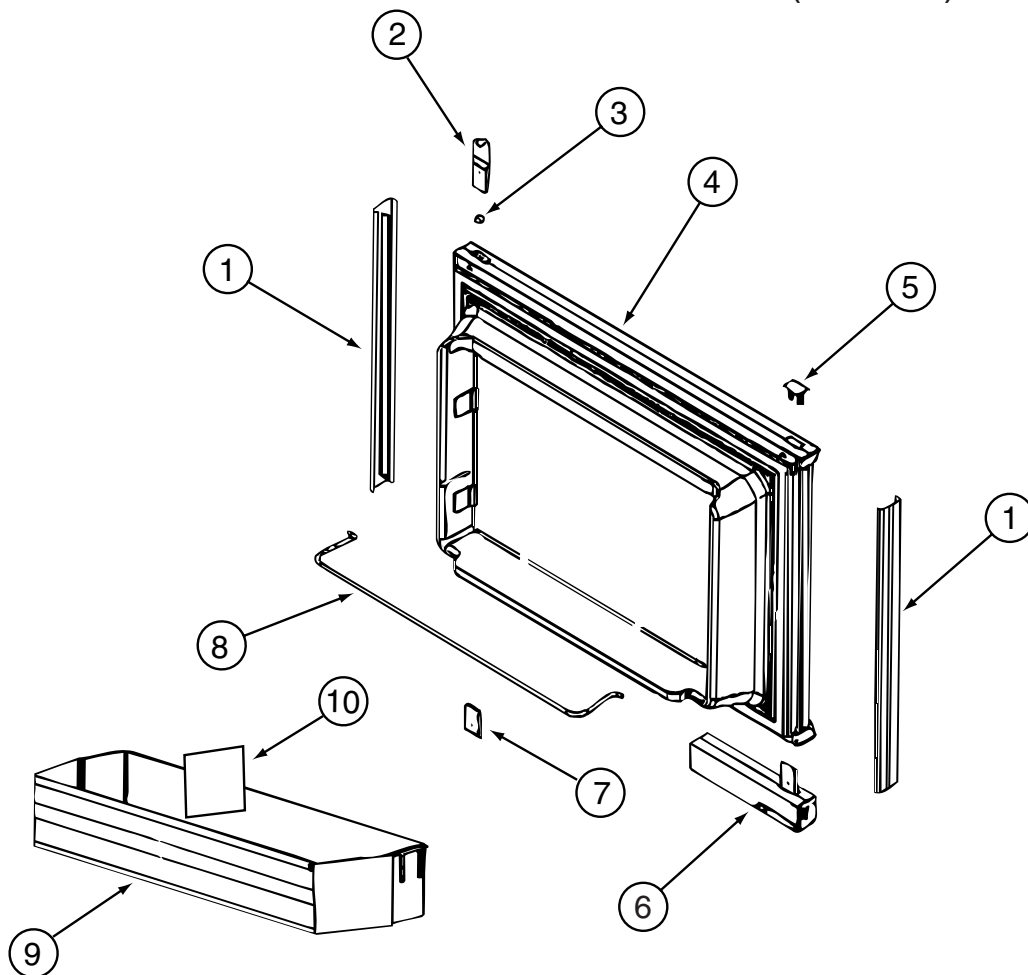

120075-12-01A, 120075-13-01A, 120075-14-01A, 120075-15-01A

KEY	PART NUMBER	U/M	DESCRIPTION	VENDOR NO.
1	121568-03-700	EA	RETAINER - DOOR PNL/WAFFLE/BLK	619558-WDL-UPPER
2	120075-01-701	EA	HINGE-TOP RH/BOTTOM LH(DOOR)	618511
3	121568-03-701	EA	BUSHING - HINGE PIN/GRAY	619671
4	121568-03-702	EA	DOOR LINER-UPR/WAFFLED/BLACK	619627 - SMALL WDL
5	120075-01-702	EA	CAP, (HINGE PLUG)	618160
6	120075-12-700	EA	HANDLE(CONTOUR)TOP LH/BTM RH	621105
6	120075-12-701	EA	HANDLE(CONTOUR)TOP RH/BTM LH	621104
6	121568-03-703	EA	HANDLE/FLUSH-TOP/RH-LWR/LH	619865
6	121568-03-708	EA	HANDLE/FLUSH-TOP/LH-LWR/RH	619866
7	120075-01-705	EA	HINGE-TOP LH/BOTTOM RH(DOOR)	618510
8	121568-01-700	EA	RAIL - DOOR UPPER	618618
9	120075-07-700	EA	DOOR BIN - SMALL/CLEAR F/WDL	619006 WDL
10	120075-07-701	EA	DIVIDER/DOOR BIN CLEAR	619008 WDL & SDL
	121568-03-704	EA	TRAVEL LATCH - GRAY	619647
	121568-03-705	EA	STORAGE LATCH - GRAY	619648

CABINET & APPLIANCE GROUP (CONTINUED)
COMPONENT PARTS FOR CABINET & APPLIANCE LAYOUT (CONTINUED)

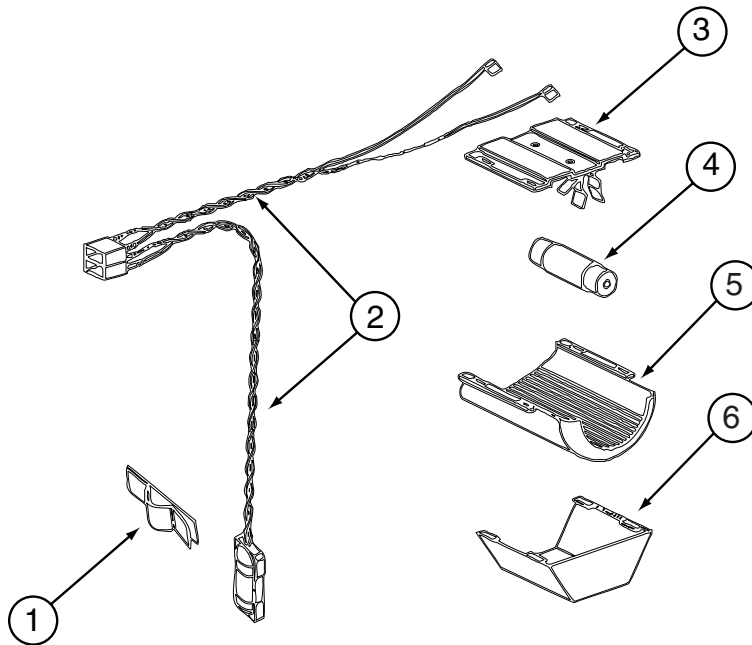

120075-09-01A, 120075-10-01A, 120075-12-01A, 120075-13-01A, 120075-14-01A, 120075-15-01A (CONTINUED)

KEY	PART NUMBER	U/M	DESCRIPTION	VENDOR NO.
1	084880-01-760	EA	CLIP (THERMISTER)	61689122
2	120075-01-735	EA	THERMISTER W/LAMP & WIRE/ASM	618548
3	084880-03-705	EA	BRACKET-LIGHT-INTERIOR	61629722
4	084880-03-706	EA	BULB-LAMP	61628922
5	120075-01-734	EA	COVER-LENS	618190
6	084880-03-707	EA	COVER-LAMP, LENS	61627922

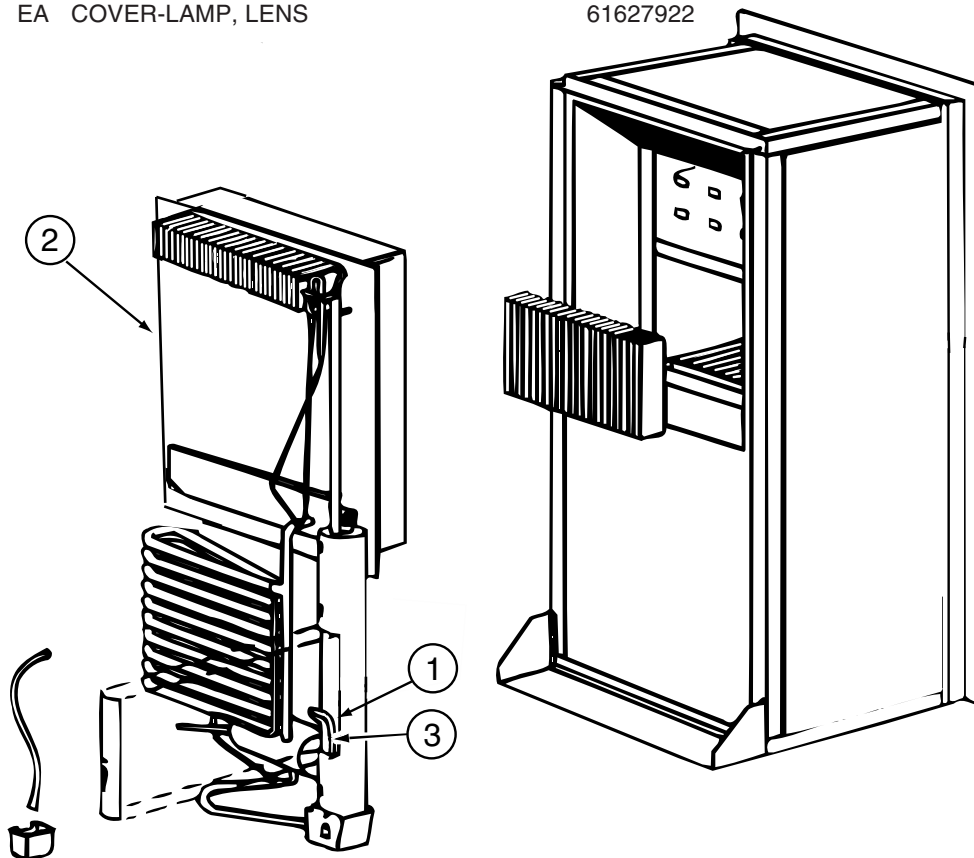

120075-09-01A, 120075-10-01A, 120075-12-01A, 120075-13-01A, 120075-14-01A, 120075-15-01A (CONTINUED)

KEY	PART NUMBER	U/M	DESCRIPTION	VENDOR NO.
1	088248-01-710	EA	HEATER DC (HORIZONTAL)	61562822
2	120075-01-736	EA	COOLING UNIT, SERVICE PACK	618542
3	088248-01-709	EA	HEATER-AC (HORIZONTAL)	61562722

CABINET & APPLIANCE GROUP (CONTINUED)
COMPONENT PARTS FOR CABINET & APPLIANCE LAYOUT (CONTINUED)

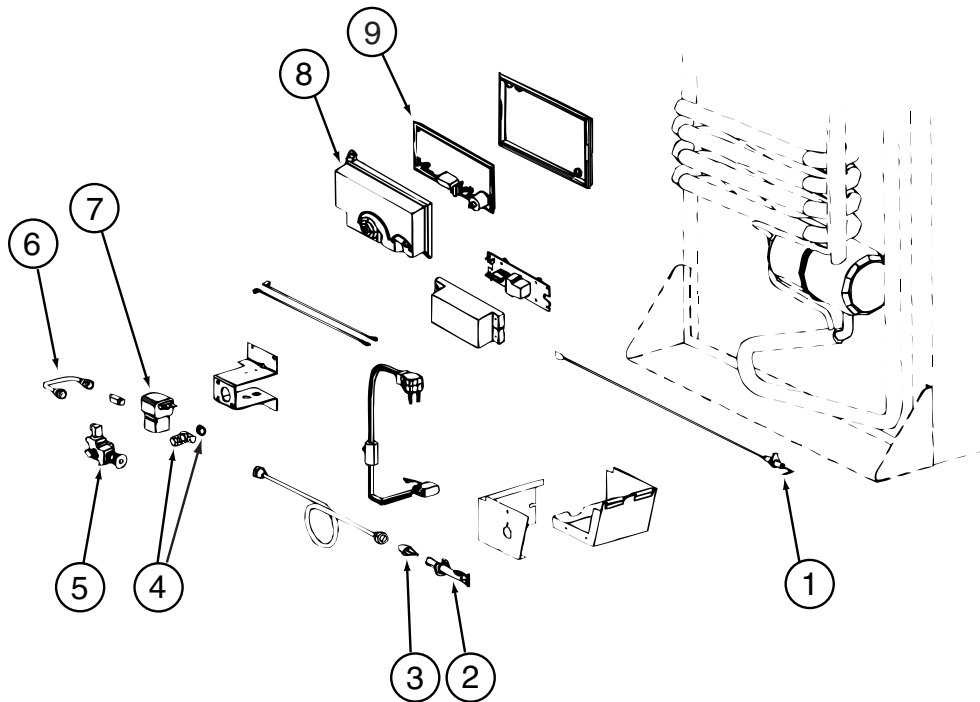

120075-09-01A, 120075-10-01A, 120075-12-01A, 120075-13-01A, 120075-14-01A, 120075-15-01A (CONTINUED)

KEY	PART NUMBER	U/M	DESCRIPTION	VENDOR NO.
1	104137-06-715	EA	ELECTRODE-SPARK/SENSOR, SGL	61692222
2	104137-06-714	EA	BURNER ASSEMBLY, 5-SLOT	61705222
3	120075-01-737	EA	ORIFICE - JEWEL - .0155	618284
4	113737-01-702	EA	PLUG 1/8" F/PRESSURE TAP	61445322
4	113737-01-716	EA	TAP-PRESSURE	61594422
5	104137-06-709	EA	VALVE-SHUT OFF/MAN-OLD STYLE	61694922
5	104137-06-734	EA	VALVE-SHUT OFF/MAN-NEW STYLE	618696
6	113737-01-750	EA	TUBE-UNION	61694622
7	084880-01-718	EA	VALVE-GAS, (ASCO)	621447
8	120075-01-738	EA	COVER-POWER BOARD	618185
9	120075-07-710	EA	POWER - BOARD - 2-WAY	619360 = 621269
	120075-01-744	EA	KIT - GAS VALVE/BURNER TUBE	620609

CABINET & APPLIANCE GROUP (CONTINUED)
COMPONENT PARTS FOR CABINET & APPLIANCE LAYOUT (CONTINUED)

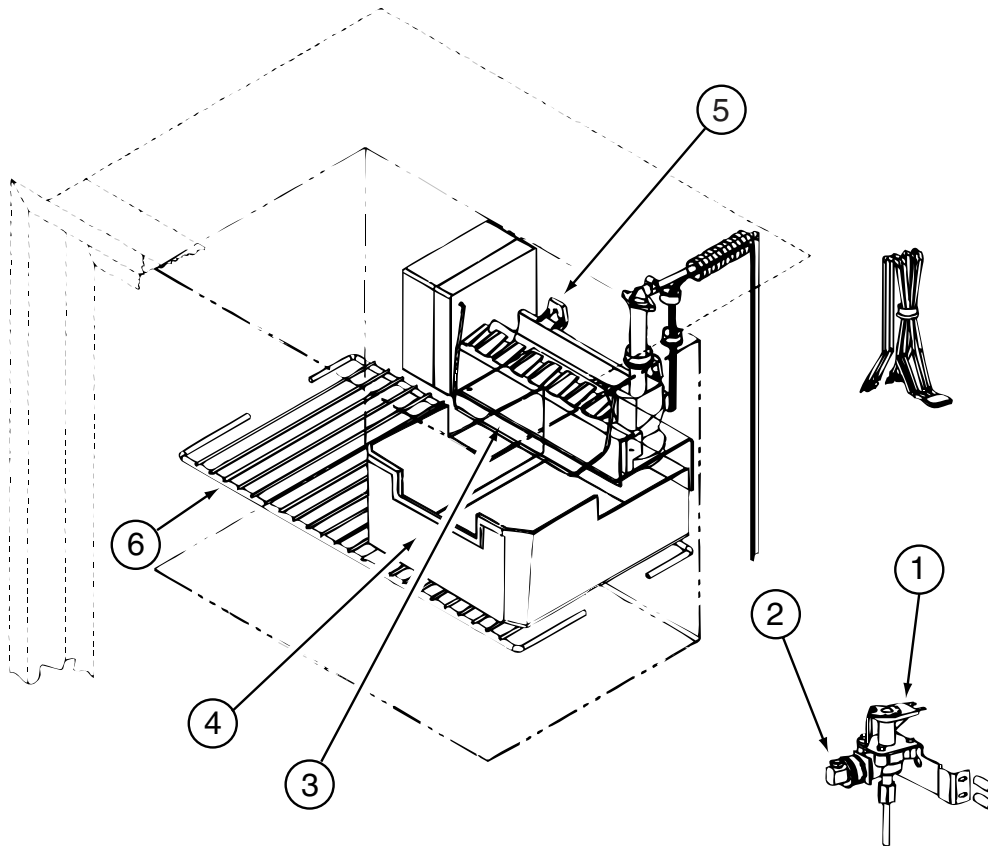

120075-09-01A, 120075-10-01A, 120075-13-01A, 120075-14-01A (CONTINUED)

KEY	PART NUMBER	U/M	DESCRIPTION	VENDOR NO.
1	120075-09-701	EA	WATER VALVE W/BRACKET	618253
2	120075-03-702	EA	NUT/COMPRESSION - FITTING	61678722
3	120075-03-703	EA	ARM-SHUT OFF	61656922
4	120075-03-704	EA	BIN-ICE CUBE	618154
5	094039-07-706	EA	ICE MAKER W/O PLATES	61656522
6	120075-01-717	EA	SHELF-FREEZER, WIRE	618172

CABINET & APPLIANCE GROUP (CONTINUED)
COMPONENT PARTS FOR CABINET & APPLIANCE LAYOUT (CONTINUED)

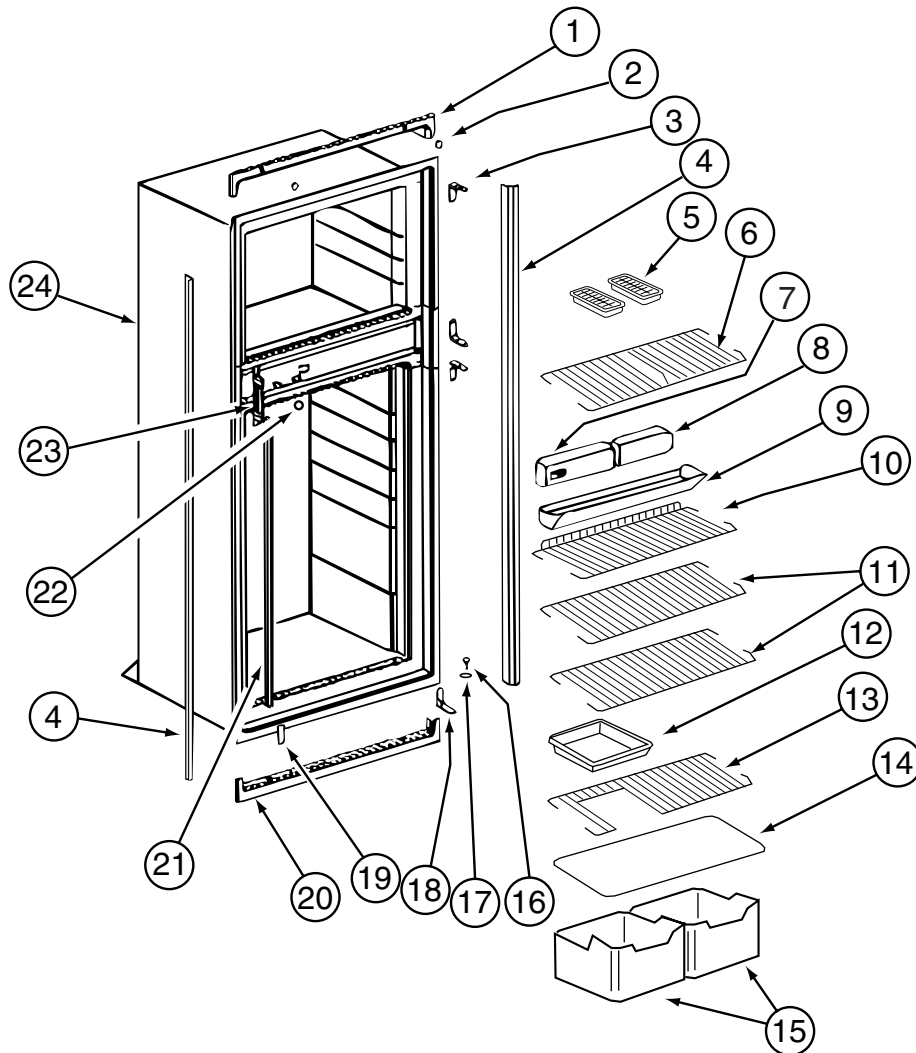

120075-09-01A, 120075-10-01A, 120075-12-01A, 120075-13-01A, 120075-14-01A, 120075-15-01A (CONTINUED)

KEY	PART NUMBER	U/M	DESCRIPTION	VENDOR NO.
1	121568-03-709	EA	TRIM - TOP/BLACK	619687
2	120075-01-714	EA	PLUG-HOLE (BLACK)	618170
3	121568-03-710	EA	HINGE/CABINET-TOP/RH-LWR/LH	619335 WAFFLED
4	120075-07-705	EA	TRIM - SIDE - BLACK	622296
5	104137-06-724	EA	ICE TRAY	61630422
6	120075-07-706	EA	SHELF - WIRE F/ICEMAKER MODELS	620249
7	120075-07-707	EA	CONTROL BOX - BLACK	619665
8	121568-03-713	EA	FRONT BOX/DECORATIVE-BLACK	619282
9	120075-01-720	EA	TRAY-DRIP	623250
10	120075-01-722	EA	SHELF-WIRE, SHORT	620269
11	120075-01-723	EA	SHELF-WIRE	620270
12	104137-06-718	EA	SHELF-TRAY, WHITE, W/CUTOUT	617756
13	120075-01-724	EA	SHELF-WIRE, W/CUTOUT	620268
14	120075-01-725	EA	COVER-CRISPER	618158
15	120075-07-708	EA	CRISPER/ICE BIN	619007
16	120075-01-727	EA	PIN-HINGE	618145
17	121568-03-701	EA	BUSHING - HINGE PIN/GRAY	619671
18	121568-03-715	EA	HINGE/CABINET-TOP/LH-LWR/RH	619336 WAFFLED
19	121568-03-716	EA	COVER - HINGE HOLES	619301
20	120075-01-729	EA	TRIM-BOTTOM PIECE	620958
21	120075-01-730	EA	RETAINER-SHELF(SER#926684 DN)	618181
22	121568-03-717	EA	HOLE PLUG - WHITE	619561
23	120075-01-732	EA	PLATE-STRIKE	618167
24	120075-09-700	EA	CABINET - FOAMED	619660
	120075-01-721	EA	LOUVER-DRIP TRAY	618176

CABINET & APPLIANCE GROUP (CONTINUED)
COMPONENT PARTS FOR CABINET & APPLIANCE LAYOUT (CONTINUED)

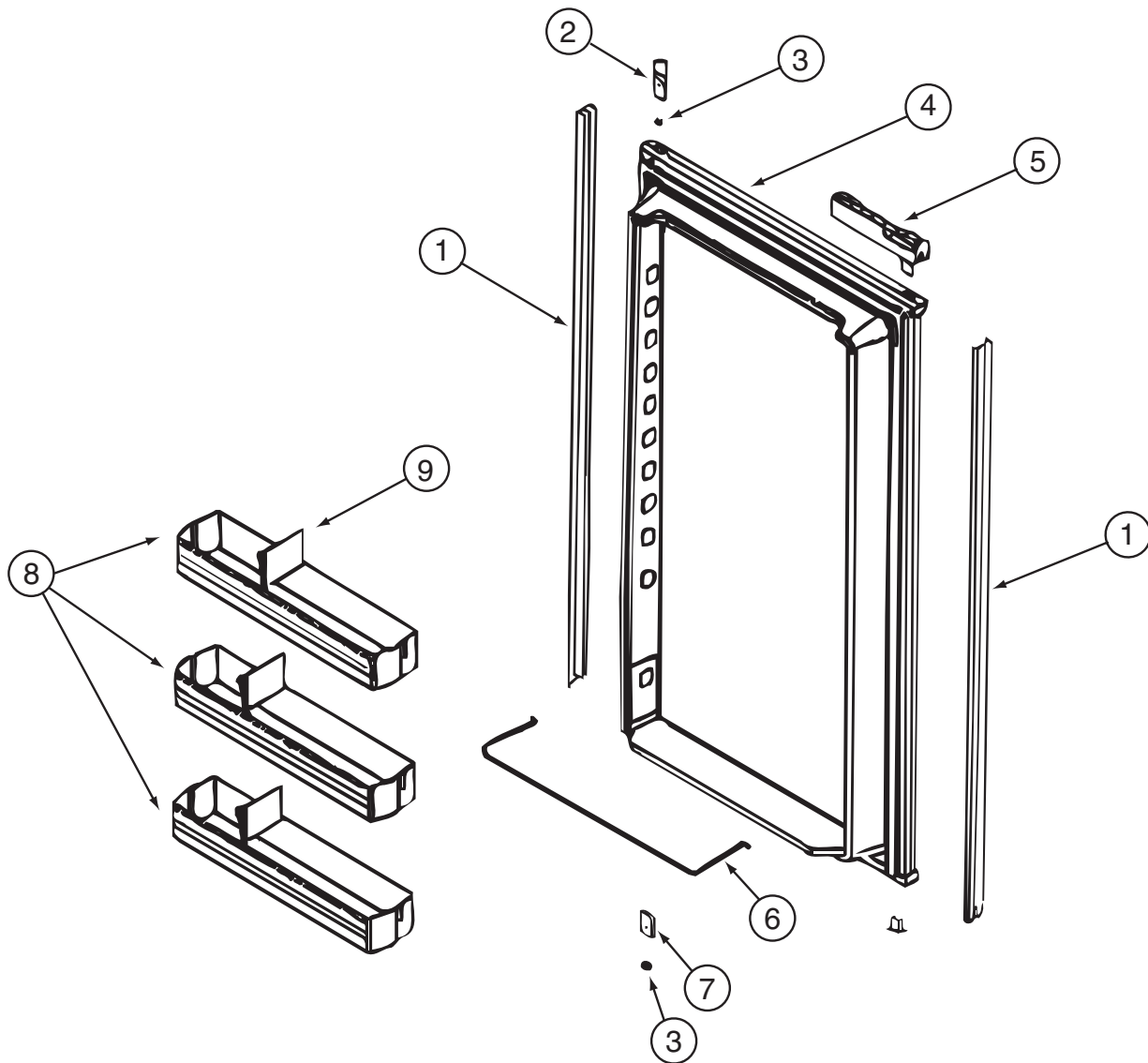

120075-12-01A, 120075-13-01A, 120075-14-01A, 120075-15-01A (CONTINUED)

KEY	PART NUMBER	U/M	DESCRIPTION	VENDOR NO.
1	120075-07-702	EA	RETAINER-DOOR PNL/WAFFLE/BLK	619560-WDL-LOWER
2	120075-01-701	EA	HINGE-TOP RH/BOTTOM LH(DOOR)	618511
3	121568-03-701	EA	BUSHING - HINGE PIN/GRAY	619671
4	120075-07-703	EA	DOOR LINER-LWR/WAFFLED/BLACK	619631 - LARGE WDL
5	120075-12-700	EA	HANDLE(CONTOUR)TOP LH/BTM RH	621105
5	120075-12-701	EA	HANDLE(CONTOUR)TOP RH/BTM LH	621104
5	121568-03-703	EA	HANDLE/FLUSH-TOP/RH-LWR/LH	619865
5	121568-03-708	EA	HANDLE/FLUSH-TOP/LH-LWR/RH	619866
6	121568-01-704	EA	RAIL - DOOR LOWER	618578
7	120075-01-705	EA	HINGE-TOP LH/BOTTOM RH(DOOR)	618510
8	120075-07-700	EA	DOOR BIN - SMALL/CLEAR F/WDL	619006 WDL
8	120075-07-704	EA	DOOR BIN - LARGE/CLEAR F/WDL	619005 WDL
9	120075-07-701	EA	DIVIDER/DOOR BIN CLEAR	619008 WDL & SDL
	121568-03-704	EA	TRAVEL LATCH - GRAY	619647
	121568-03-705	EA	STORAGE LATCH - GRAY	619648

CABINET & APPLIANCE GROUP (CONTINUED)
COMPONENT PARTS FOR CABINET & APPLIANCE LAYOUT (CONTINUED)

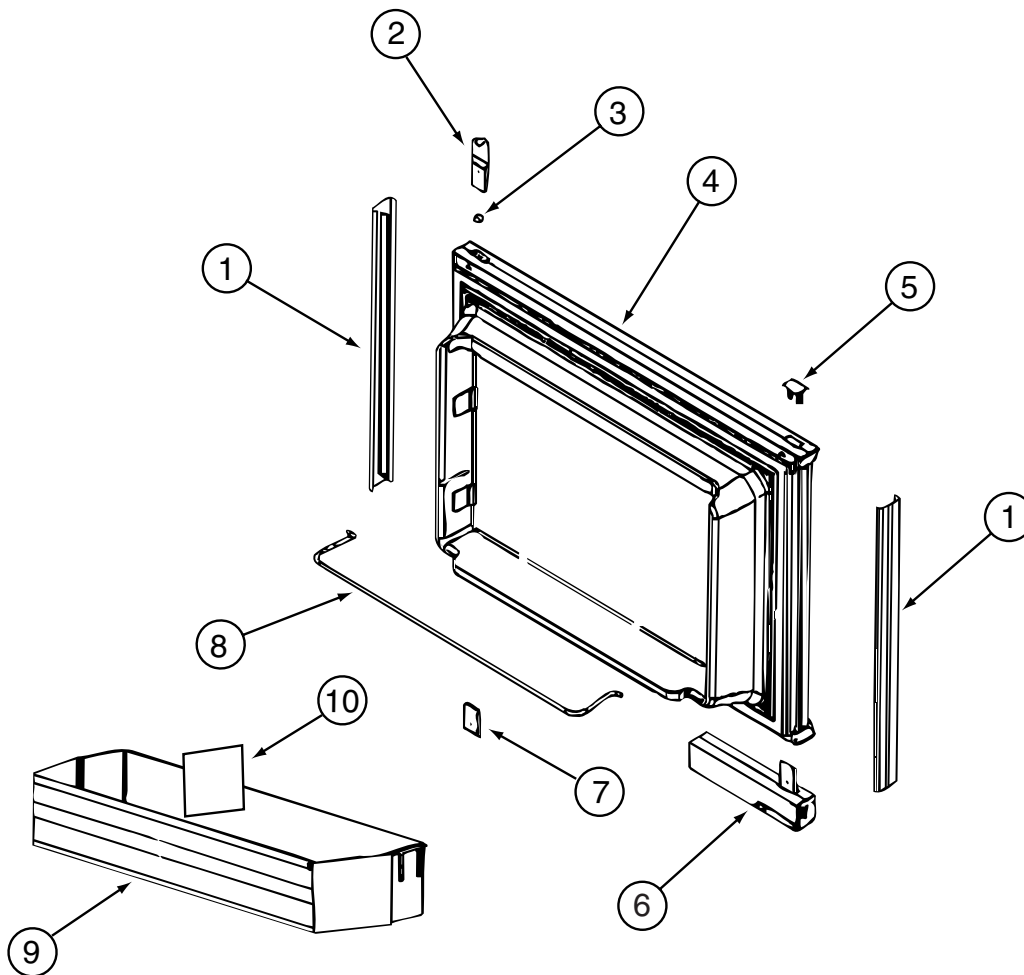

121569-05-01A, 121569-06-01A, 121569-07-01A

KEY	PART NUMBER	U/M	DESCRIPTION	VENDOR NO.
1	121568-03-700	EA	RETAINER - DOOR PNL/WAFFLE/BLK	619558-WDL-UPPER
2	120075-01-701	EA	HINGE-TOP RH/BOTTOM LH(DOOR)	618511
3	121568-03-701	EA	BUSHING - HINGE PIN/GRAY	619671
4	121568-03-702	EA	DOOR LINER-UPR/WAFFLED/BLACK	619627 - SMALL WDL
5	120075-01-702	EA	CAP, (HINGE PLUG)	618160
6	120075-12-700	EA	HANDLE(CONTOUR)TOP LH/BTM RH	621105
7	120075-01-705	EA	HINGE-TOP LH/BOTTOM RH(DOOR)	618510
8	121568-01-700	EA	RAIL - DOOR UPPER	618618
9	120075-07-700	EA	DOOR BIN - SMALL/CLEAR F/WDL	619006 WDL
10	120075-07-701	EA	DIVIDER/DOOR BIN CLEAR	619008 WDL & SDL
	121568-03-705	EA	STORAGE LATCH - GRAY	619648

CABINET & APPLIANCE GROUP (CONTINUED)
COMPONENT PARTS FOR CABINET & APPLIANCE LAYOUT (CONTINUED)

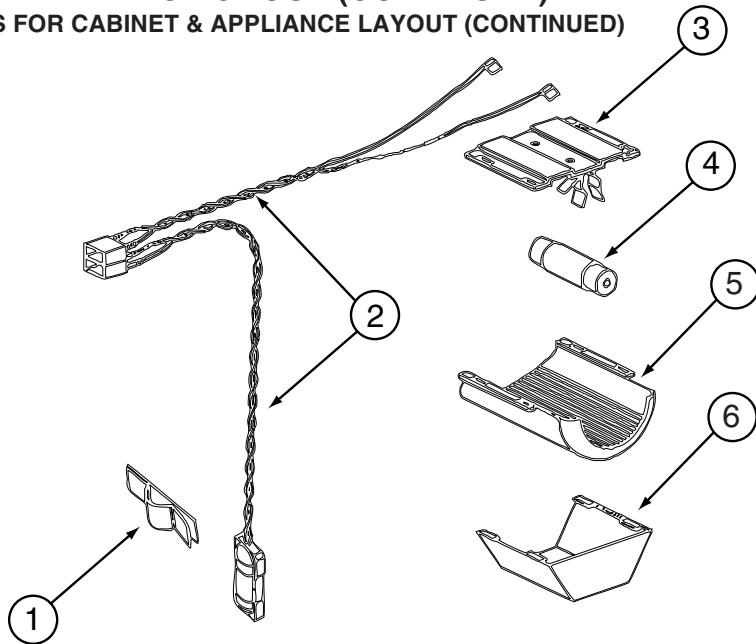

121569-03-01A, 121569-04-01A, 121569-05-01A, 121569-06-01A, 121569-07-01A (CONTINUED)

KEY	PART NUMBER	U/M	DESCRIPTION	VENDOR NO.
1	084880-01-760	EA	CLIP (THERMISTER)	61689122
2	120075-01-735	EA	THERMISTER W/LAMP & WIRE/ASM	618548
3	084880-03-705	EA	BRACKET-LIGHT-INTERIOR	61629722
4	084880-03-706	EA	BULB-LAMP	61628922
6	084880-03-707	EA	COVER-LAMP, LENS	61627922

CONTACT WINNEBAGO PART SALES FOR UNLISTED COMPONENT(S)

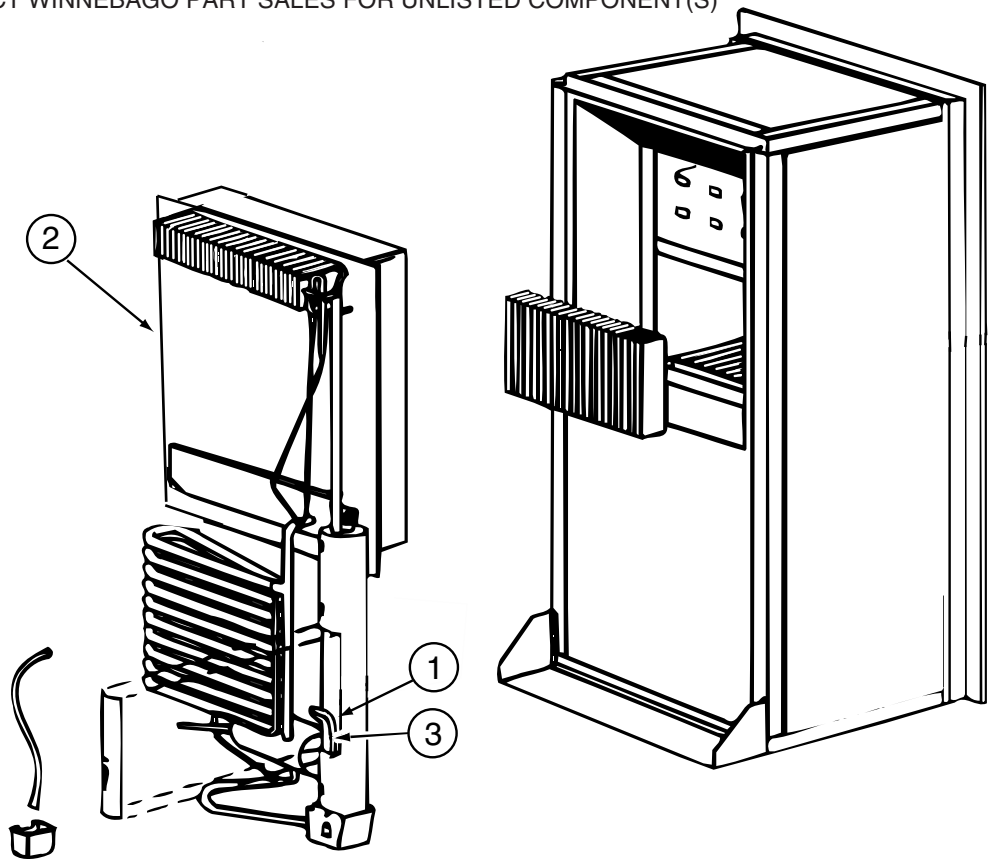

121569-03-01A, 121569-04-01A, 121569-05-01A, 121569-06-01A, 121569-07-01A (CONTINUED)

KEY	PART NUMBER	U/M	DESCRIPTION	VENDOR NO.
2	120075-01-736	EA	COOLING UNIT, SERVICE PACK	618542
3	088248-01-709	EA	HEATER-AC (HORIZONTAL)	61562722
	120075-01-744	EA	KIT - GAS VALVE/BURNER TUBE	620609

CONTACT WINNEBAGO PART SALES FOR UNLISTED COMPONENT(S)

CABINET & APPLIANCE GROUP (CONTINUED)
COMPONENT PARTS FOR CABINET & APPLIANCE LAYOUT (CONTINUED)

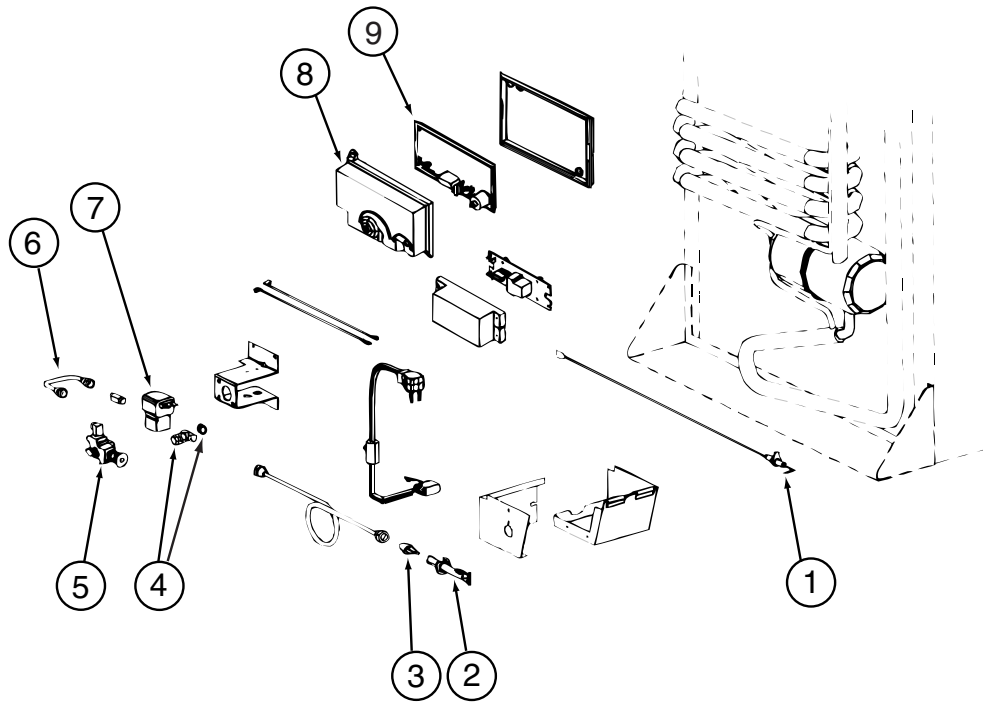

121569-03-01A, 121569-04-01A, 121569-05-01A, 121569-06-01A, 121569-07-01A (CONTINUED)

KEY	PART NUMBER	U/M	DESCRIPTION	VENDOR NO.
1	104137-06-715	EA	ELECTRODE-SPARK/SENSOR, SGL	61692222
2	104137-06-714	EA	BURNER ASSEMBLY, 5-SLOT	61705222
3	120075-01-737	EA	ORIFICE - JEWEL - .0155	618284
4	113737-01-702	EA	PLUG 1/8" F/PRESSURE TAP	61445322
4	113737-01-716	EA	TAP-PRESSURE	61594422
6	113737-01-750	EA	TUBE-UNION	61694622
7	084880-01-718	EA	KIT-GAS VALVE/SOLENOID/TUBE	621447
8	120075-01-738	EA	COVER-POWER BOARD	618185
9	121568-03-719	EA	POWER - BOARD - 2-WAY	621267
	121568-03-720	EA	VALVE/SOLENOID-MAN SHUT OFF	618696
	121569-07-700	EA	CORD - AC POWER	61554422

CONTACT WINNEBAGO PART SALES FOR UNLISTED COMPONENT(S)

CABINET & APPLIANCE GROUP (CONTINUED)
COMPONENT PARTS FOR CABINET & APPLIANCE LAYOUT (CONTINUED)

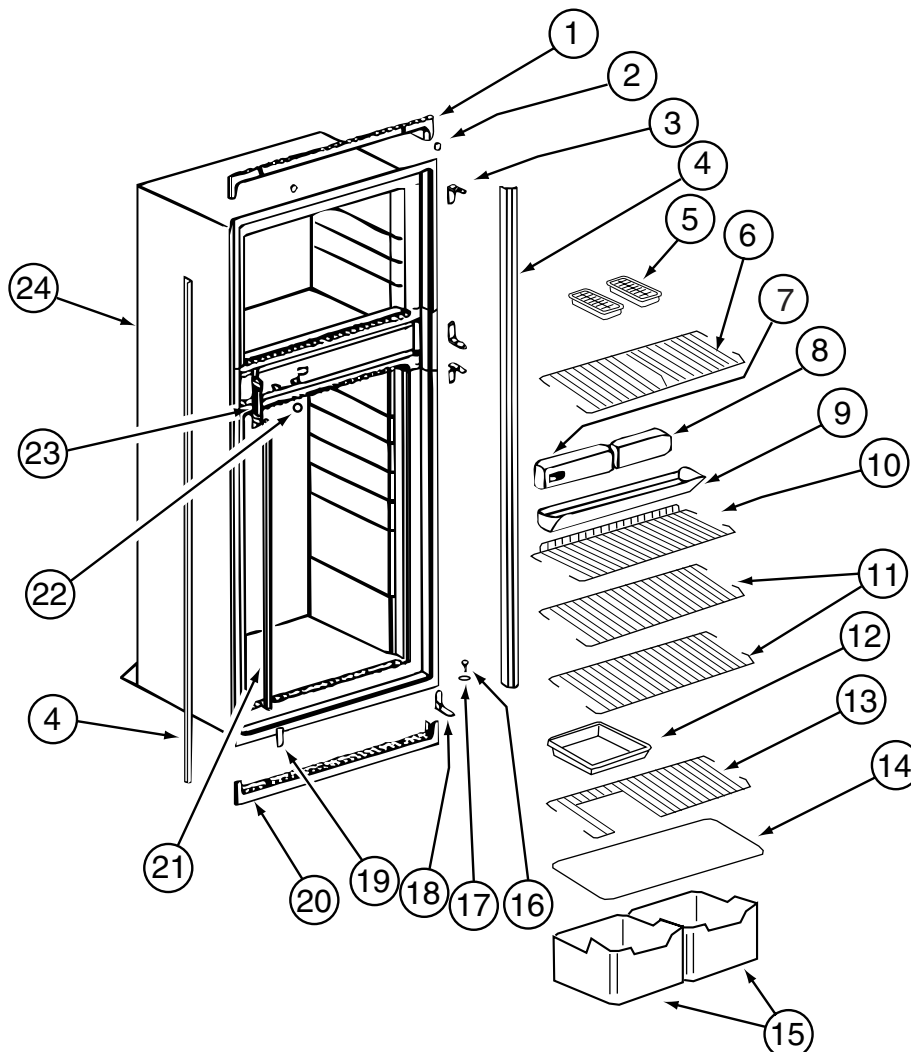

121569-03-01A, 121569-04-01A, 121569-05-01A, 121569-06-01A, 121569-07-01A (CONTINUED)

KEY	PART NUMBER	U/M	DESCRIPTION	VENDOR NO.
1	121568-03-709	EA	TRIM - TOP/BLACK	619687
2	120075-01-714	EA	PLUG-HOLE (BLACK)	618170
3	121568-03-710	EA	HINGE/CABINET-TOP/RH-LWR/LH	619335 WAFFLED
4	120075-07-705	EA	TRIM - SIDE - BLACK	622296
6	121568-03-712	EA	SHELF - WIRE/FREEZER	620250
7	121568-03-714	EA	CONTROL ASM - 2 WAY BLACK	619350
8	121568-03-713	EA	FRONT BOX/DECORATIVE-BLACK	619282
9	120075-01-720	EA	TRAY-DRIP	623250
10	121568-01-707	EA	SHELF - WIRE - SHORT	620272
11	121568-01-708	EA	SHELF - WIRE	620273
14	120075-01-725	EA	COVER-CRISPER	618158
15	121568-01-709	EA	CRISPER	618571
16	120075-01-727	EA	PIN-HINGE	618145
18	121568-03-715	EA	HINGE/CABINET-TOP/LH-LWR/RH	619336 WAFFLED
19	121568-03-716	EA	COVER - HINGE HOLES	619301
20	120075-01-729	EA	TRIM-BOTTOM PIECE	620958
21	120075-01-730	EA	RETAINER-SHELF(SER#926684 DN)	618181
22	121568-03-717	EA	HOLE PLUG - WHITE	619561
23	120075-01-732	EA	PLATE-STRIKE	618167
24	120075-07-709	EA	CABINET - FOAMED	619347
	120075-01-721	EA	LOUVER-DRIP TRAY	618176

CONTACT WINNEBAGO PART SALES FOR UNLISTED COMPONENT(S)

CABINET & APPLIANCE GROUP (CONTINUED)
COMPONENT PARTS FOR CABINET & APPLIANCE LAYOUT (CONTINUED)

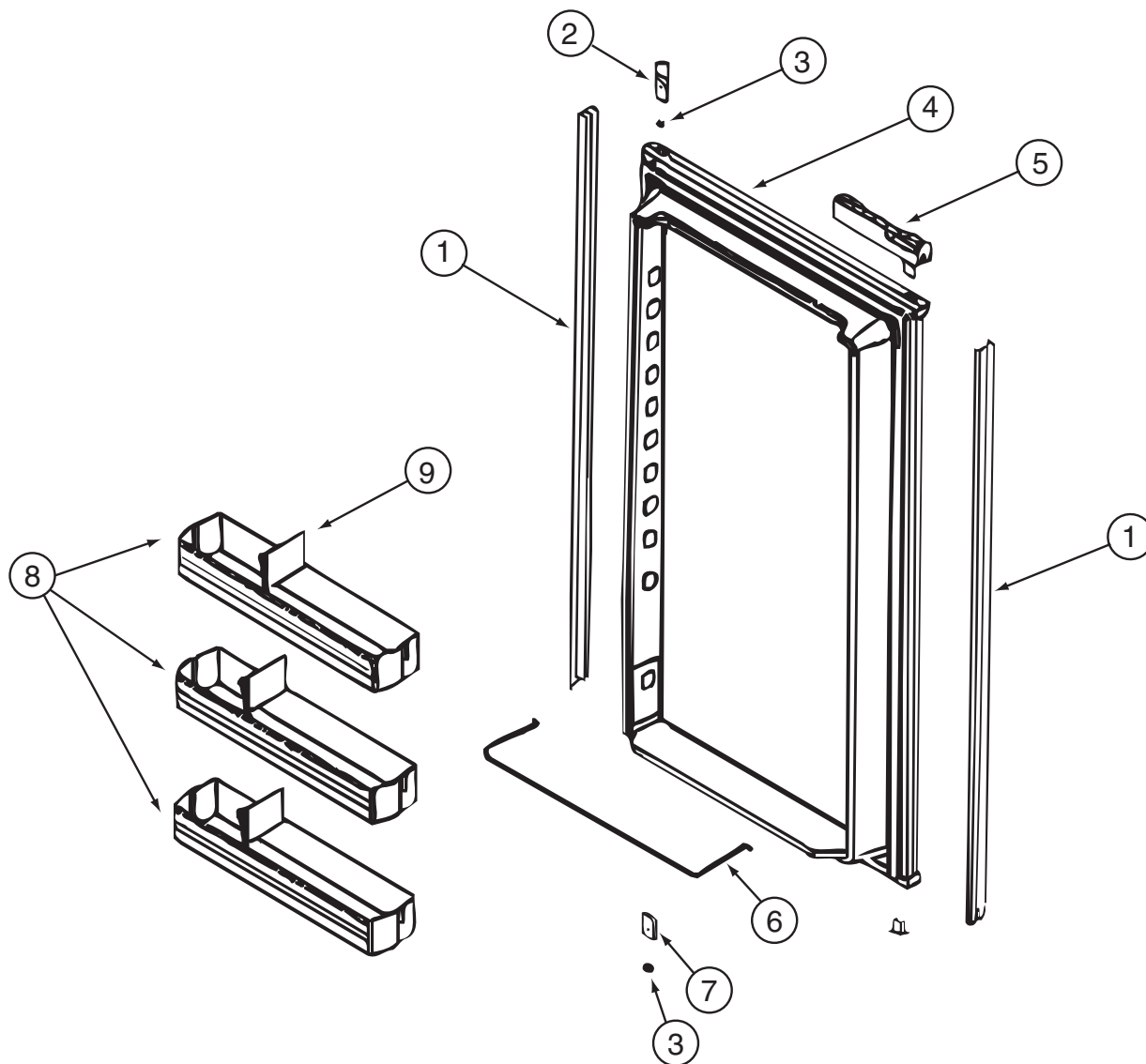

121569-05-01A, 121569-06-01A, 121569-07-01A (CONTINUED)

KEY	PART NUMBER	U/M	DESCRIPTION	VENDOR NO.
1	120075-07-702	EA	RETAINER - DOOR PNL/WAFFLE/BLK	619560 -WDL-LOWER
2	120075-01-701	EA	HINGE-TOP RH/BOTTOM LH(DOOR)	618511
3	121568-03-701	EA	BUSHING - HINGE PIN/GRAY	619671
4	120075-07-703	EA	DOOR LINER-LWR/WAFFLED/BLACK	619631 LARGE WDL
5	120075-12-701	EA	HANDLE(CONTOUR)TOP RH/BTM LH	621104
6	121568-01-704	EA	RAIL - DOOR LOWER	618578
7	120075-01-705	EA	HINGE-TOP LH/BOTTOM RH(DOOR)	618510
8	121568-01-701	EA	BIN - DOOR WHITE-WAFFLED LNR	618619 WDL
9	120075-07-701	EA	DIVIDER/DOOR BIN CLEAR	619008 WDL & SDL
	121568-03-705	EA	STORAGE LATCH - GRAY	619648

CABINET & APPLIANCE GROUP (CONTINUED)
COMPONENT PARTS FOR CABINET & APPLIANCE LAYOUT (CONTINUED)

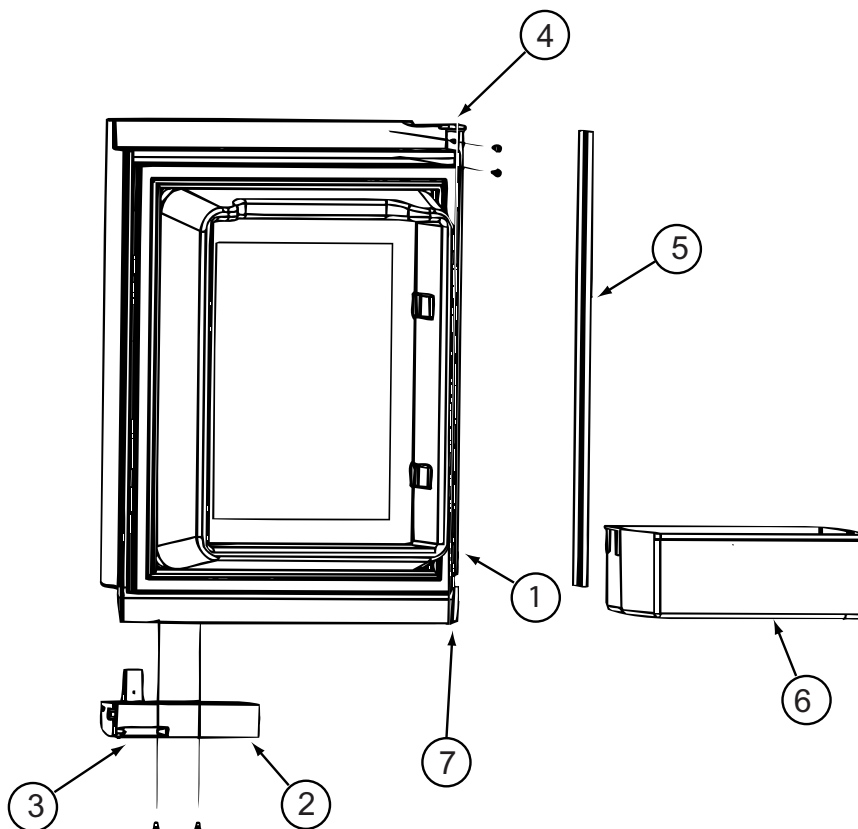

125242-02-01A

KEY	PART NUMBER	U/M	DESCRIPTION	VENDOR NO.
1	125242-01-762	EA	LINER/FOAMED-UPPER/LH-WHITE	619839
1	125242-02-734	EA	LINER/FOAMED-UPPER/LH-BLACK	625212 AFT #1291390
2	125242-02-700	EA	HANDLE(CONTOUR)TOP LH BTM RH	621107
3	125242-02-722	EA	LATCH-STORAGE DR/BLK POINTED	619374
4	125242-02-724	EA	HINGE - DOOR	618792
5	125242-02-723	EA	RETAINER/PANEL-UPPER DOOR	623166
6	125242-03-704	EA	DOOR BIN	622831
7	125242-01-704	EA	BUSHING-HINGE MIDDLE	618746
	125242-02-725	EA	DOOR ASM/UPR LH/WHITE GASKET	621148
	125242-02-735	EA	DOOR ASM/UPR LH/BLACK GASKET	625220 AFT #1291390
	125242-01-719	EA	RETAINER-UPPER PANEL	618825 = 623166

CABINET & APPLIANCE GROUP (CONTINUED)
COMPONENT PARTS FOR CABINET & APPLIANCE LAYOUT (CONTINUED)

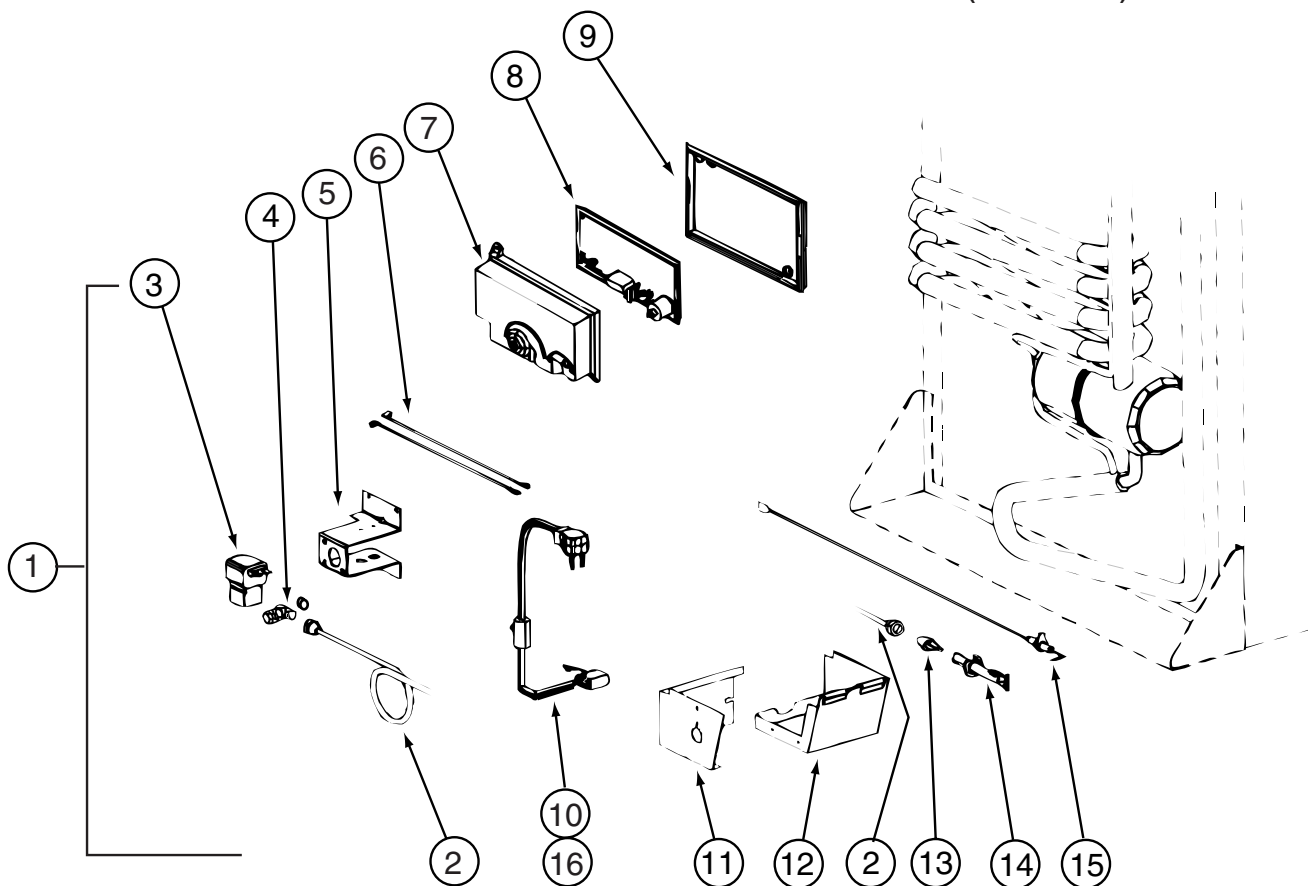

125242-02-01A (CONTINUED)

KEY	PART NUMBER	U/M	DESCRIPTION	VENDOR NO.
1	125242-01-753	EA	KIT-GAS VALVE/SOLENOID/TUBE	621445
2	125242-01-744	EA	BURNER TUBE	618937
4	113737-01-716	EA	TAP-PRESSURE	61594422
7	120075-01-738	EA	COVER-POWER BOARD	618185
8	125242-02-703	EA	POWER BOARD (SER #832171 UP)	621271
9	120075-01-740	EA	COVER-BASE, POWER BOARD	618186
11	125242-01-740	EA	COVER-BURNER BOX	618910
12	125242-01-739	EA	BASE-BURNER BOX	618902
13	125242-01-717	EA	ORIFICE-JEWELED	618814
14	125242-01-743	EA	BURNER - 8 SLOT	618932
15	104137-06-715	EA	ELECTRODE-SPARK/SENSOR, SGL	61692222
	113737-01-753	EA	PIN (TRAVEL LATCH)	618046

CONTACT WINNEBAGO PART SALES FOR UNLISTED COMPONENT(S)

CABINET & APPLIANCE GROUP (CONTINUED)
COMPONENT PARTS FOR CABINET & APPLIANCE LAYOUT (CONTINUED)

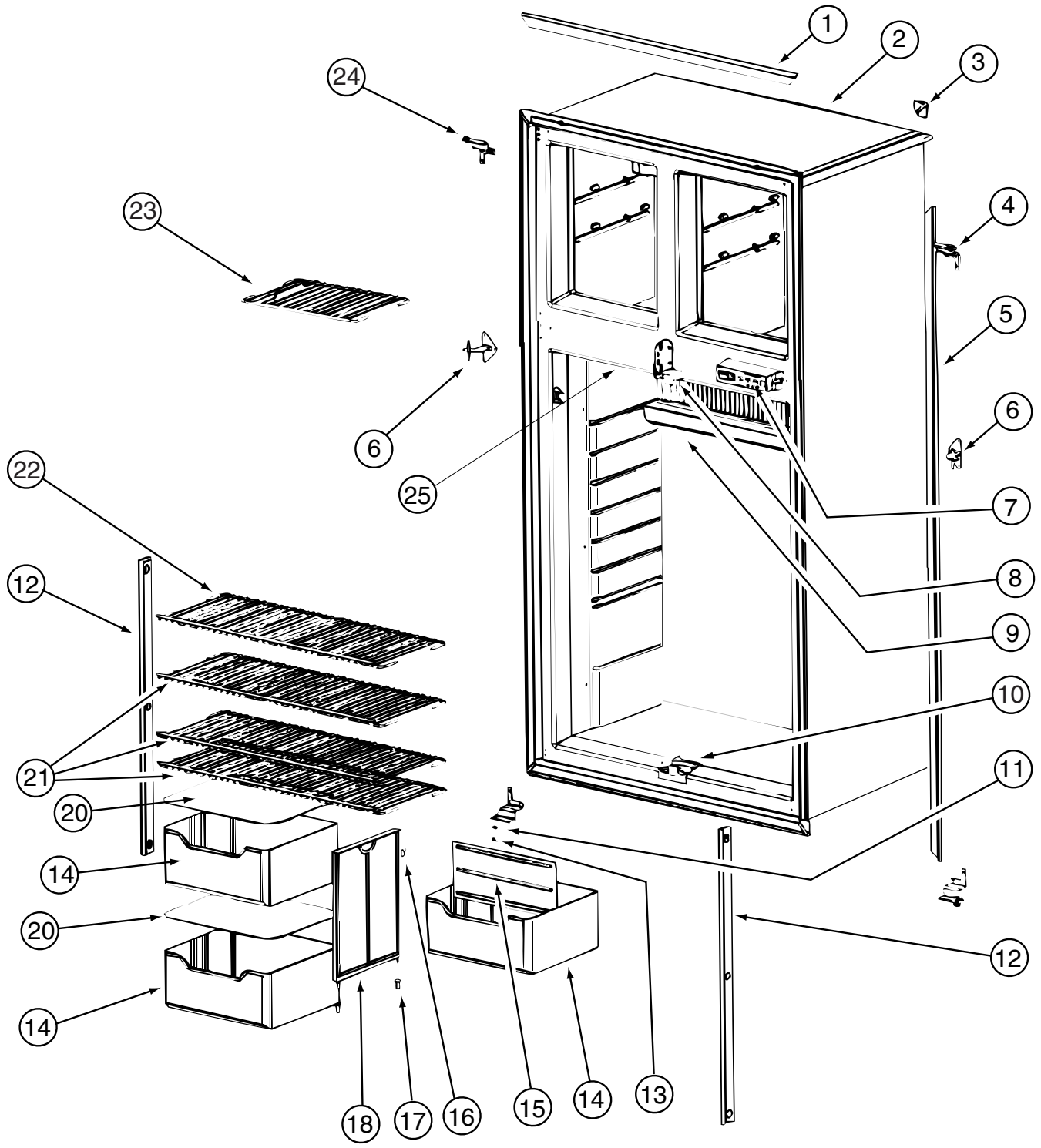

125242-02-01A (CONTINUED)

CABINET & APPLIANCE GROUP (CONTINUED)
COMPONENT PARTS FOR CABINET & APPLIANCE LAYOUT (CONTINUED)

125242-02-01A (CONTINUED)

KEY	PART NUMBER	U/M	DESCRIPTION	VENDOR NO.
1	125242-01-723	EA	TRIM-HORIZONTAL-FRT SNAP ON	618845
1	125242-02-713	EA	TRIM/UPR/LWR - SIDE SNAP ON	621975
1	125242-02-730	EA	TRIM - TOP/BOTTOM - SCREW ON	623255
2	125242-01-748	EA	CABINET/FOAMED ASSEMBLY	618748
3	125242-01-722	EA	TRIM-CORNER	618844
3	125242-01-767	EA	KIT INSTALL(U TRIM PCS)HDW	623528
4	125242-01-715	EA	HINGE - TOP RH/BOTTOM LH	618798
5	125242-01-724	EA	TRIM-LT/RT-FRT VERT SNAPON	618846
5	125242-01-766	EA	TRIM-LT/RT HAND-SCREW ON	623254
5	125242-02-714	EA	TRIM/SIDES - SIDE SNAP ON	621976
6	125242-01-713	EA	HINGE-MIDDLE (PAINTED)	618794
7	125242-01-705	EA	CONTROL ASM(SER#832171) DWN	618750
7	125242-02-704	EA	DISPLAY ASM (SER#832172) UP	621188
8	125242-01-751	EA	BLOCK - GUIDE - UPPER	618789
9	125242-01-712	EA	DRIP TRAY	618774
10	125242-01-752	EA	BLOCK - GUIDE - LOWER	618788
11	120075-01-708	EA	BUSHING-DOOR HINGE	618144
12	120075-01-730	EA	RETAINER-SHELF(SER#926684) DN	618181
12	125242-02-720	EA	RETAINER/SHELF(SER#926685) UP	622033
13	120075-01-727	EA	PIN-HINGE	618145
14	125242-01-734	EA	CRISPER/BOTTLE BIN	618878
15	125242-01-733	EA	DIVIDER-BOTTLE CRISPER	618877
16	125242-01-750	EA	CLIP	61409622
17	113737-01-701	EA	BUSHING-HINGE	61742022
18	125242-01-749	EA	SUPPORT - WALL	618840
20	125242-01-706	EA	COVER-CRISPER	618757
21	125242-01-726	EA	SHELF-WIRE (LONG)	618848
22	125242-01-727	EA	SHELF-WIRE (SHORT)	618849
23	125242-01-725	EA	SHELF-FREEZER (WIRE)	618847
24	125242-01-714	EA	HINGE - TOP LH/BOTTOM RH	618796
25	125242-01-735	EA	SWITCH - DOOR LIGHT	618884
25	125242-01-768	EA	SWITCH - DOOR LIGHT	623918
	120075-01-714	EA	PLUG-HOLE (BLACK)	618170
	125242-01-728	EA	CAP-SCREW WHITE	618853
	125242-02-741	EA	STRIP-FREEZER-BLACK	625210 #1291391 & UP

CABINET & APPLIANCE GROUP (CONTINUED)
COMPONENT PARTS FOR CABINET & APPLIANCE LAYOUT (CONTINUED)

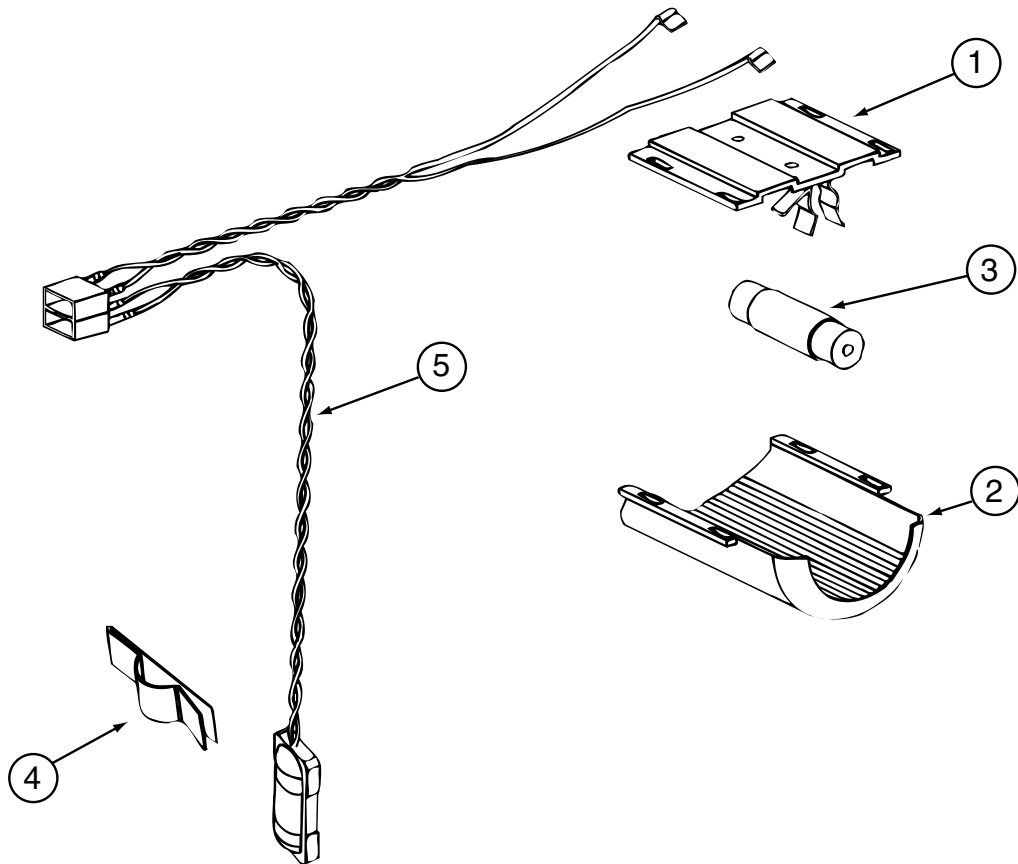

125242-02-01A & 125242-03-01A (CONTINUED)

KEY	PART NUMBER	U/M	DESCRIPTION	VENDOR NO.
1	084880-03-705	EA	BRACKET-LIGHT-INTERIOR	61629722
2	120075-01-734	EA	COVER-LENS	618190
3	084880-03-706	EA	BULB-LAMP	61628922
4	084880-01-760	EA	CLIP (THERMISTER)	61689122
5	120075-01-735	EA	THERMISTER W/LAMP & WIRE/ASM	618548
	125242-02-706	EA	LAMP/WIRE ASM/SER#849677 UP	620871
	125242-02-707	EA	LAMP/WIRE ASM SER#849677 DWN	621742

CABINET & APPLIANCE GROUP (CONTINUED)
COMPONENT PARTS FOR CABINET & APPLIANCE LAYOUT (CONTINUED)

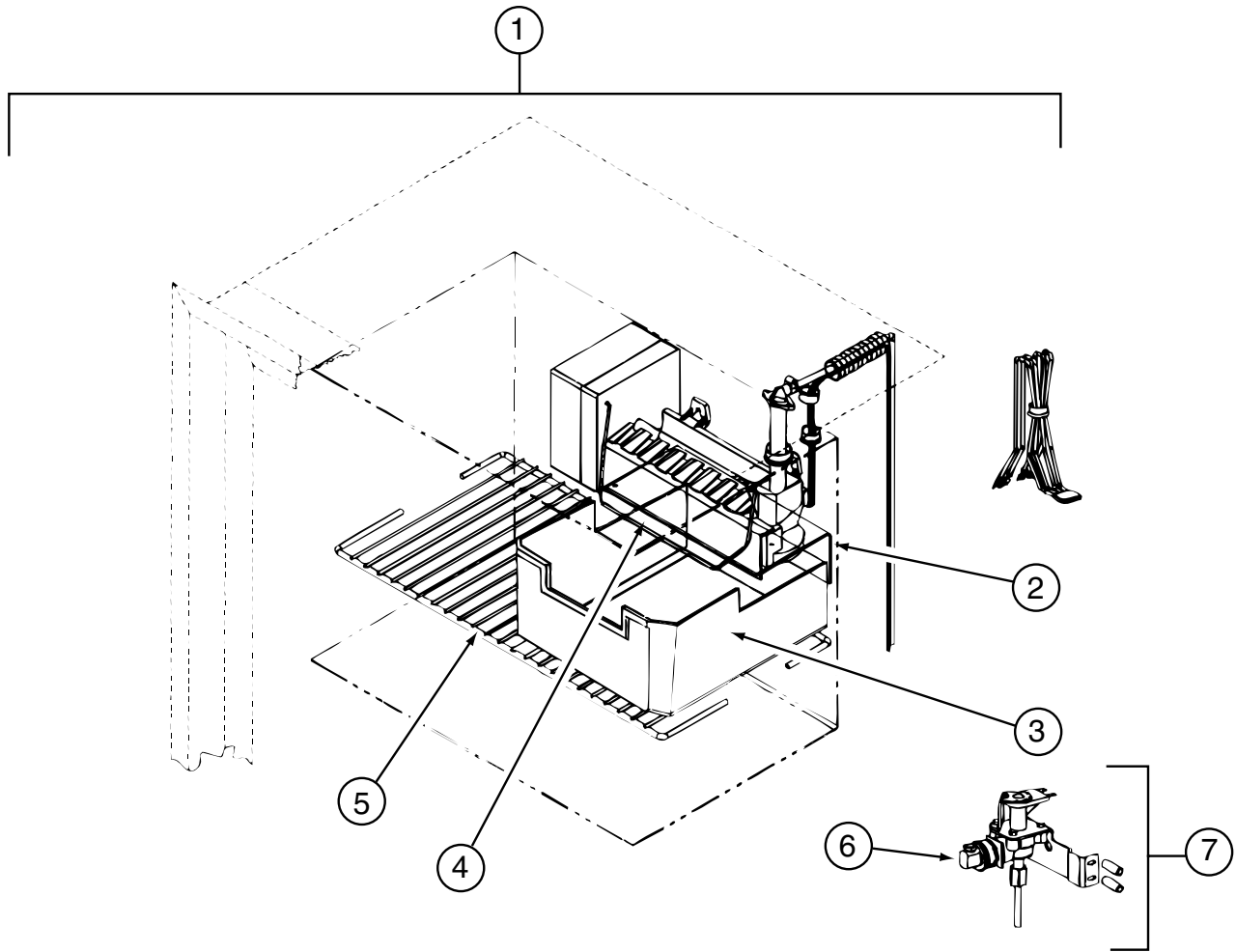

125242-02-01A & 125242-03-01A (CONTINUED)

KEY	PART NUMBER	U/M	DESCRIPTION	VENDOR NO.
1	094039-07-706	EA	ICE MAKER W/O PLATES	61656522
2	125242-01-737	EA	BRACKET-MOUNTING (ICE MAKER)	618894/620890
3	125242-01-716	EA	ICE BIN	618803
4	120075-03-703	EA	ARM-SHUT OFF	61656922
5	125242-01-725	EA	SHELF-FREEZER (WIRE)	618847
6	120075-03-702	EA	NUT/COMPRESSION - FITTING	61678722
7	120075-03-701	EA	VALVE ASM., WATER, W/BRACKET	618253
	094039-07-707	EA	GARDEN HOSE ADAP W/BRASS NUT	61679622
	094039-07-708	EA	NUT - COMPRESSION	622991

CABINET & APPLIANCE GROUP (CONTINUED)
COMPONENT PARTS FOR CABINET & APPLIANCE LAYOUT (CONTINUED)

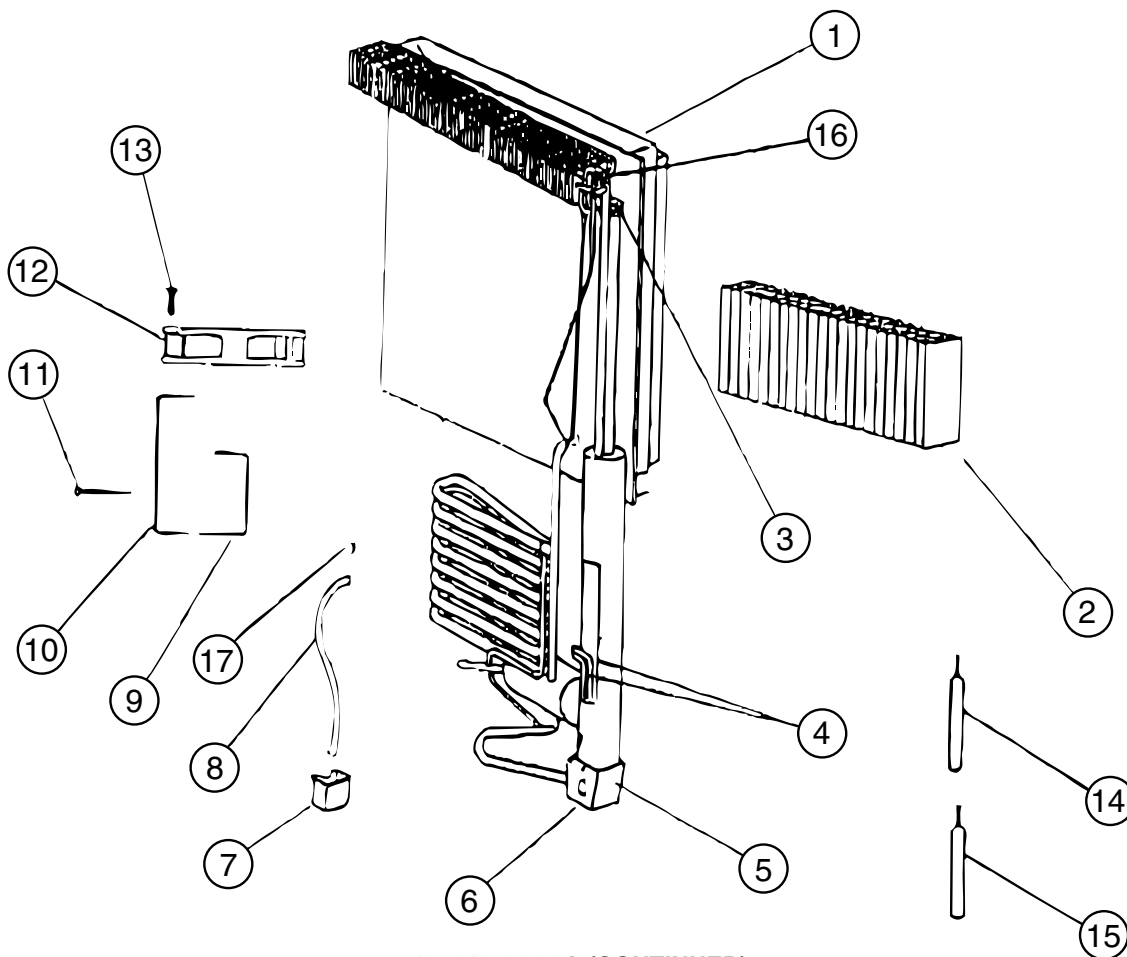

125242-02-01A (CONTINUED)

KEY	PART NUMBER	U/M	DESCRIPTION	VENDOR NO.
1	125242-01-746	EA	COOLING UNIT - 1200	618964
4	125242-01-732	EA	HEATER AC - 225W/110VAC	618872
5	125242-01-739	EA	BASE-BURNER BOX	618902
6	125242-01-740	EA	COVER-BURNER BOX	618910
9	125242-01-730	EA	BRACKET-DC FAN	618857
10	125242-01-741	EA	SUPPORT-DC FAN	618912
12	125242-01-729	EA	FAN-EXTERNAL DC	618856
16	113737-01-754	EA	THERMOSTAT (FAN 12V DC)	618093

CONTACT WINNEBAGO PART SALES FOR UNLISTED COMPONENT(S)

CABINET & APPLIANCE GROUP (CONTINUED)
COMPONENT PARTS FOR CABINET & APPLIANCE LAYOUT (CONTINUED)

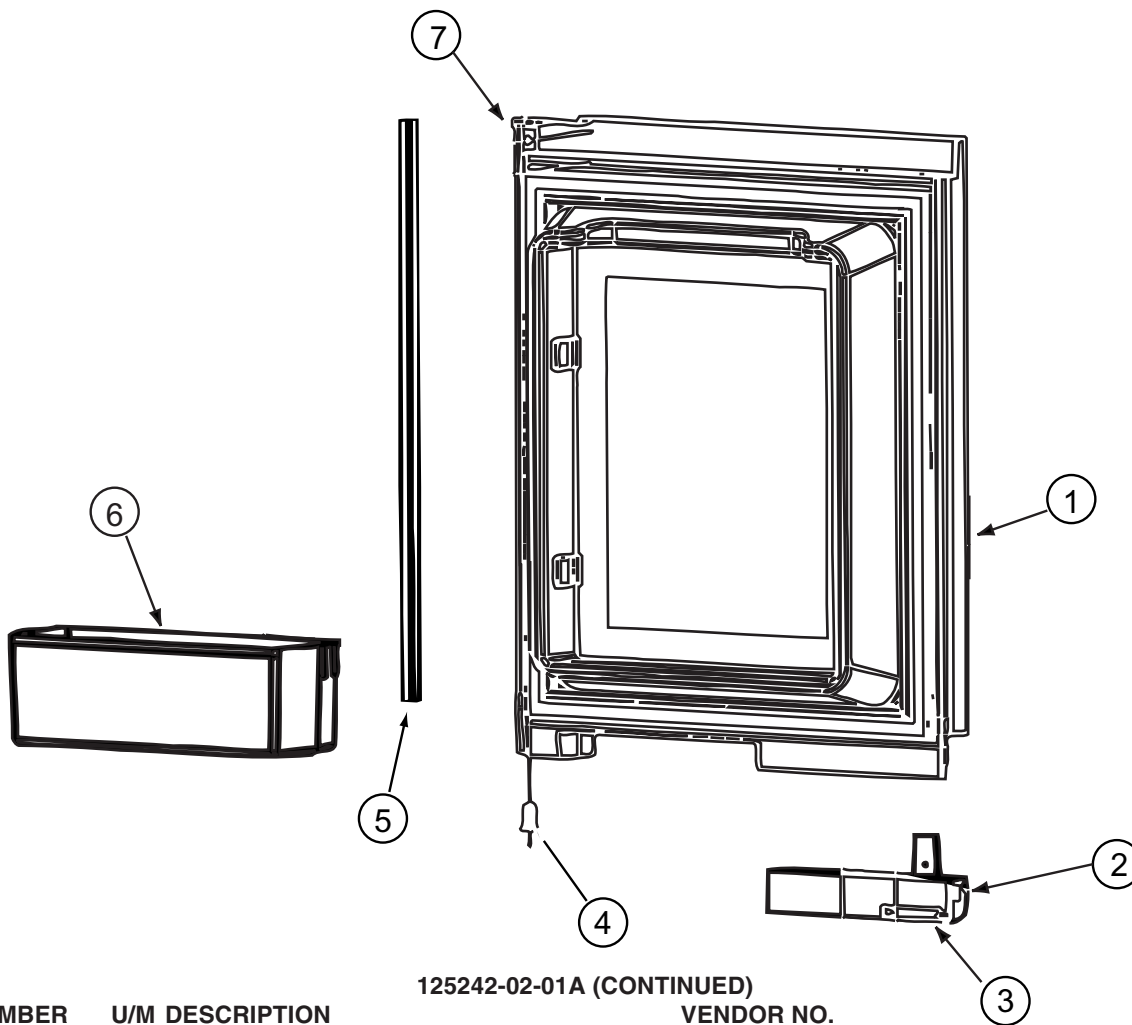

125242-02-01A (CONTINUED)

KEY	PART NUMBER	U/M	DESCRIPTION	VENDOR NO.
1	125242-01-763	EA	LINER/FOAMED-UPPER/RH-WHITE	619840
1	125242-02-733	EA	LINER/FOAMED-UPPER/RH-BLACK	625213 1291391 & UP
2	125242-02-701	EA	HANDLE(CONTOUR)TOP RH LWR LH	621106
3	125242-02-722	EA	LATCH-STORAGE DR/BLK POINTED	619374
4	125242-01-704	EA	BUSHING-HINGE MIDDLE	618746
5	125242-02-723	EA	RETAINER/PANEL-UPPER DOOR	623166
6	125242-03-704	EA	BIN - DOOR SHELF	622831
7	125242-02-724	EA	HINGE - DOOR	618792
	125242-02-721	EA	DOOR ASM-UPR/RH/WHITE GASKET	621149
	125242-02-732	EA	DOOR ASM-UPR/RH/BLACK GASKET	625221 1291391 & UP
	125242-01-719	EA	RETAINER-UPPER PANEL	618825 = 623166

CABINET & APPLIANCE GROUP (CONTINUED)
COMPONENT PARTS FOR CABINET & APPLIANCE LAYOUT (CONTINUED)

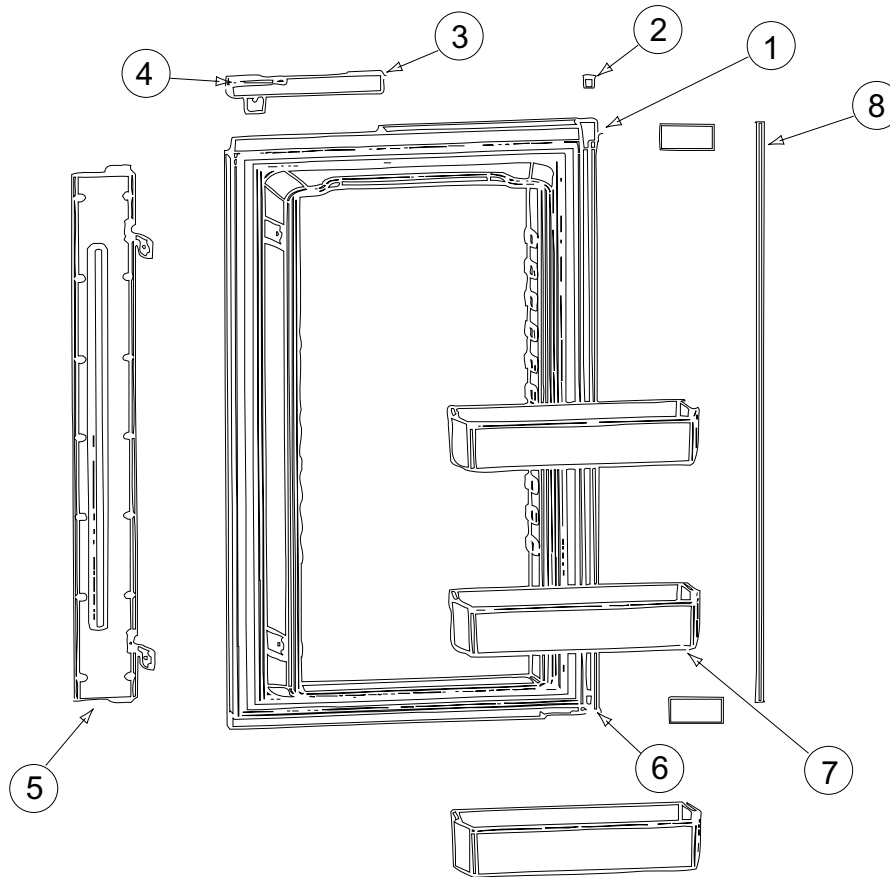

125242-02-01A (CONTINUED)

KEY	PART NUMBER	U/M	DESCRIPTION	VENDOR NO.
1	125242-01-765	EA	LINER/FOAMED-LOWER-LH-WHITE	619837
1	125242-02-739	EA	LINER/FOAMED-LOWER-LH-BLACK	625214 1291390 & UP
2	125242-01-704	EA	BUSHING-HINGE MIDDLE	618746
3	125242-02-701	EA	HANDLE(CONTOUR)TOP RH LWR LH	621106
4	125242-02-722	EA	LATCH-STORAGE DR/BLK POINTED	619374
5	125242-02-727	EA	FLAPPER/DBL POLE (SER#540295) UP	619845
5	125242-02-740	EA	FLAPPER/DBL POLE SER#1291391	623887 1291391 & UP
6	125242-02-724	EA	HINGE - DOOR	618792
7	125242-03-704	EA	BIN - DOOR SHELF	622831
8	125242-02-728	EA	RETAINER/PANEL - LOWER	623167
	125242-02-726	EA	DOOR ASM-LWR LH/WHITE GASKET	621150
	125242-02-738	EA	DOOR ASM-LWR LH/BLACK GASKET	625222 1291390 & UP
	125242-02-716	EA	GUIDE ASM LWR(SER#540294 DN)	620042
	125242-02-717	EA	GUIDE ASM LWR(SER#540295 UP)	620043
	125242-03-706	EA	PROBE - CONTACT/LARGE	620689

CABINET & APPLIANCE GROUP (CONTINUED)
COMPONENT PARTS FOR CABINET & APPLIANCE LAYOUT (CONTINUED)

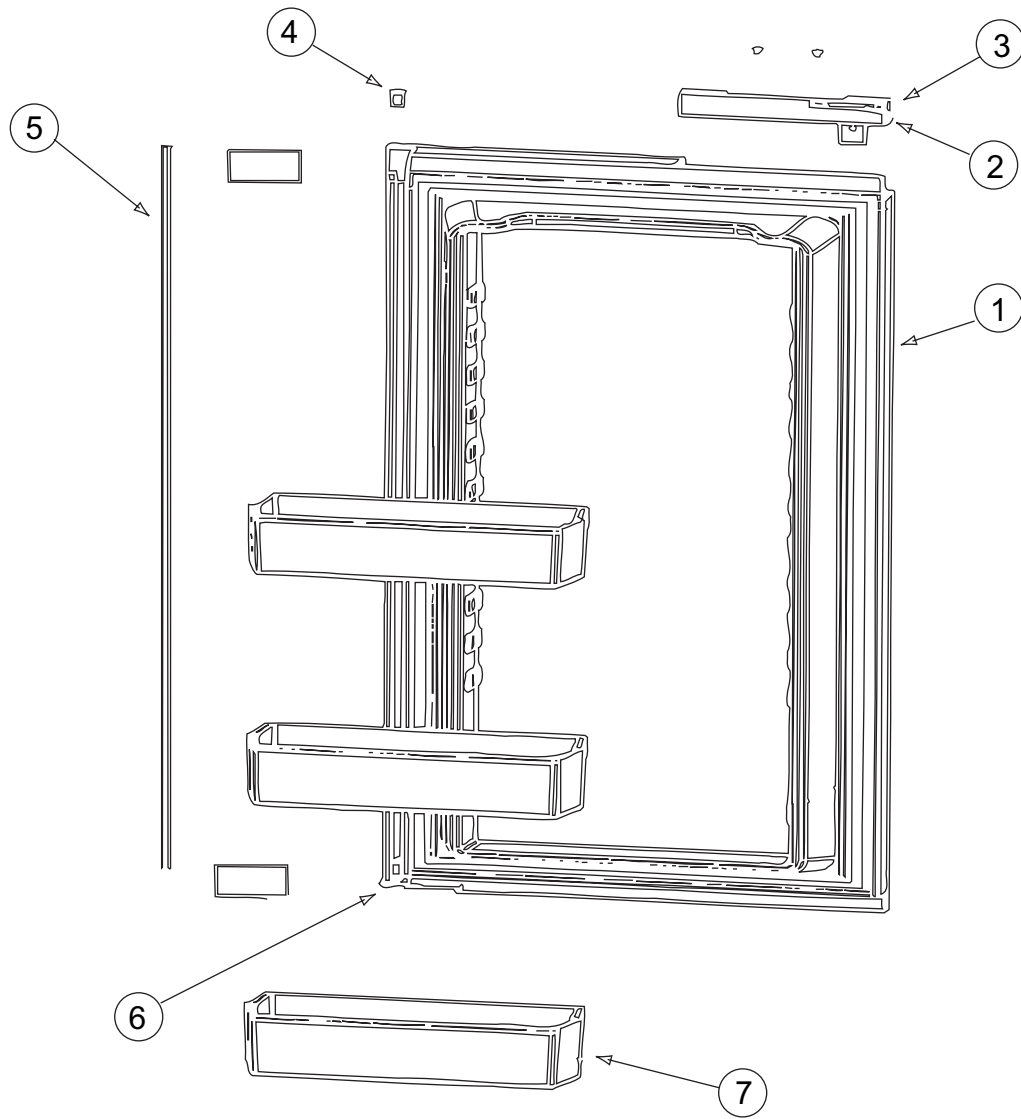

125242-02-01A (CONTINUED)

KEY	PART NUMBER	U/M	DESCRIPTION	VENDOR NO.
1	125242-01-764	EA	LINER/FOAMED-LOWER/RH-WHITE	619838
1	125242-02-737	EA	LINER/FOAMED-LOWER/RH-BLACK	625215 F/1291391&UP
2	125242-02-700	EA	HANDLE(CONTOUR)TOP LH BTM RH	621107
3	125242-02-722	EA	LATCH-STORAGE DR/BLK POINTED	619374
4	125242-01-704	EA	BUSHING-HINGE MIDDLE	618746
5	125242-02-728	EA	RETAINER/PANEL - LOWER	623167
6	125242-02-724	EA	HINGE - DOOR	618792
7	125242-03-704	EA	BIN - DOOR SHELF	622831
	125242-02-729	EA	DOOR ASM-LWR RH/WHITE GASKET	621151
	125242-02-736	EA	DOOR ASM-LWR RH/BLACK GASKET	625223 F/1291391&UP
	125242-02-716	EA	GUIDE ASM LWR(SER#540294 DN)	620042
	125242-02-717	EA	GUIDE ASM LWR(SER#540295 UP)	620043

CABINET & APPLIANCE GROUP (CONTINUED)
COMPONENT PARTS FOR CABINET & APPLIANCE LAYOUT (CONTINUED)

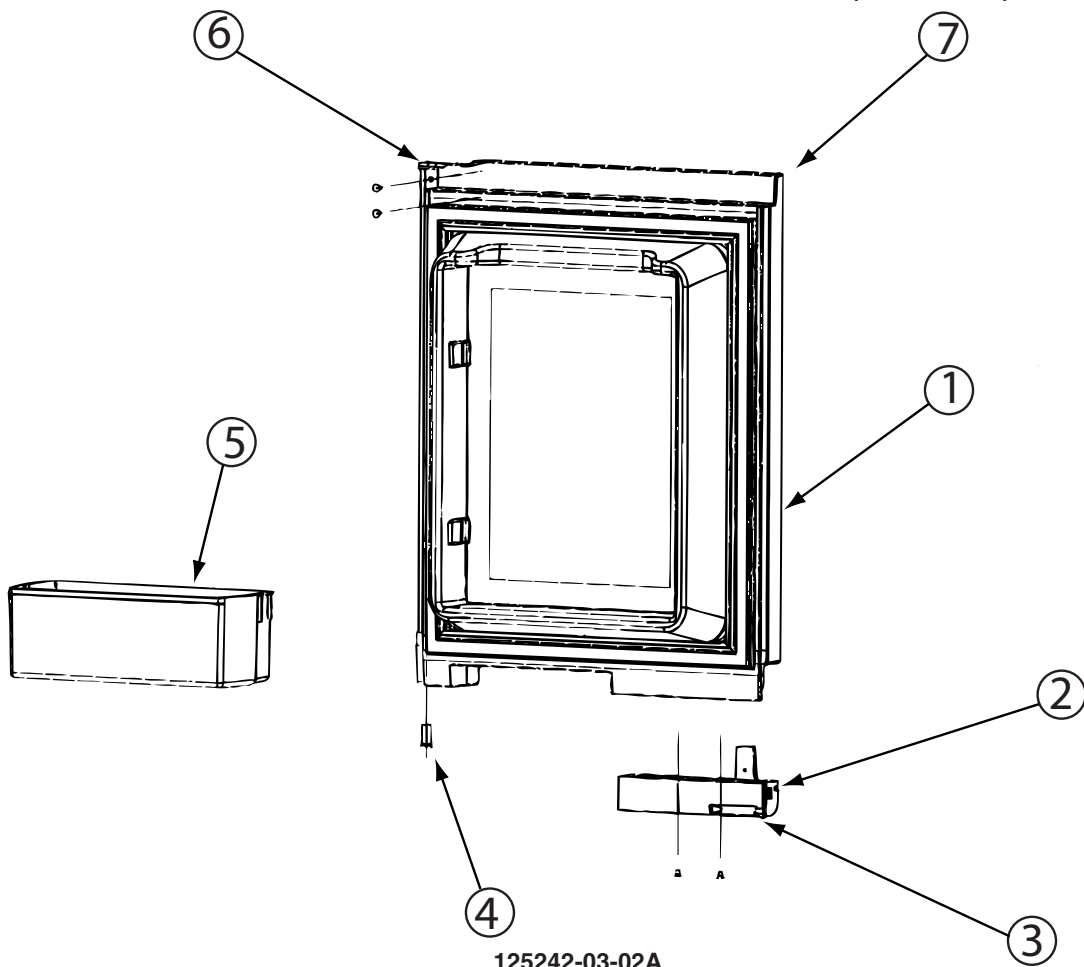

125242-03-02A

KEY	PART NUMBER	U/M	DESCRIPTION	VENDOR NO.
1	125242-03-721	EA	LINER-DOOR/UPPER RH/WRP WPM	62906101
2	125242-02-701	EA	HANDLE(CONTOUR)TOP RH LWR LH	621106
3	125242-02-722	EA	LATCH-STORAGE DR/BLK POINTED	619374
4	125242-01-704	EA	BUSHING-HINGE MIDDLE	618746
5	125242-03-704	EA	BIN - DOOR SHELF	622831
6	125242-03-722	EA	CAP/DOOR HINGE-UPR RH/LWR LH	623819
7	125242-03-723	EA	CAP/DR CENTER-UPR RH/LWR LH	623820

CABINET & APPLIANCE GROUP (CONTINUED)
COMPONENT PARTS FOR CABINET & APPLIANCE LAYOUT (CONTINUED)

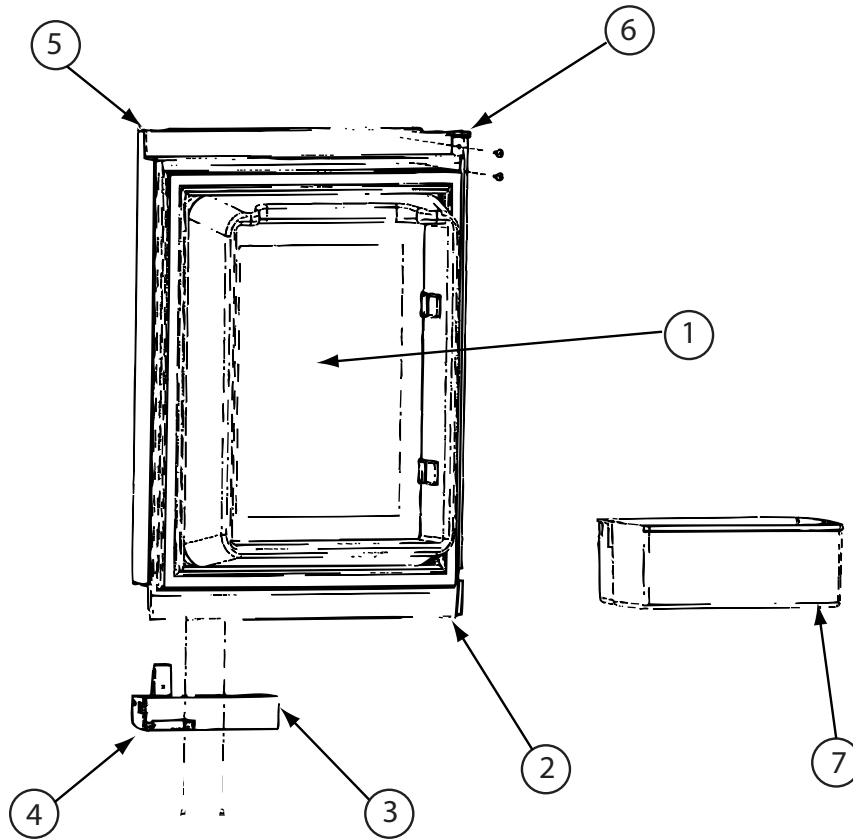

125242-03-02A (CONTINUED)

KEY	PART NUMBER	U/M	DESCRIPTION	VENDOR NO.
1	125242-03-724	EA	LINER-DOOR/UPPER LH/WRP WPM	62906001
2	125242-01-704	EA	BUSHING-HINGE MIDDLE	618746
3	125242-02-700	EA	HANDLE(CONTOUR)TOP LH BTM RH	621107
4	125242-02-722	EA	LATCH-STORAGE DR/BLK POINTED	619374
5	125242-03-726	EA	CAP/DR CENTER-UPR LH/LWR RH	623492
6	125242-03-725	EA	CAP/DOOR HINGE-UPR LH/LWR RH	623491
7	125242-03-704	EA	BIN - DOOR SHELF	622831

CABINET & APPLIANCE GROUP (CONTINUED)
COMPONENT PARTS FOR CABINET & APPLIANCE LAYOUT (CONTINUED)

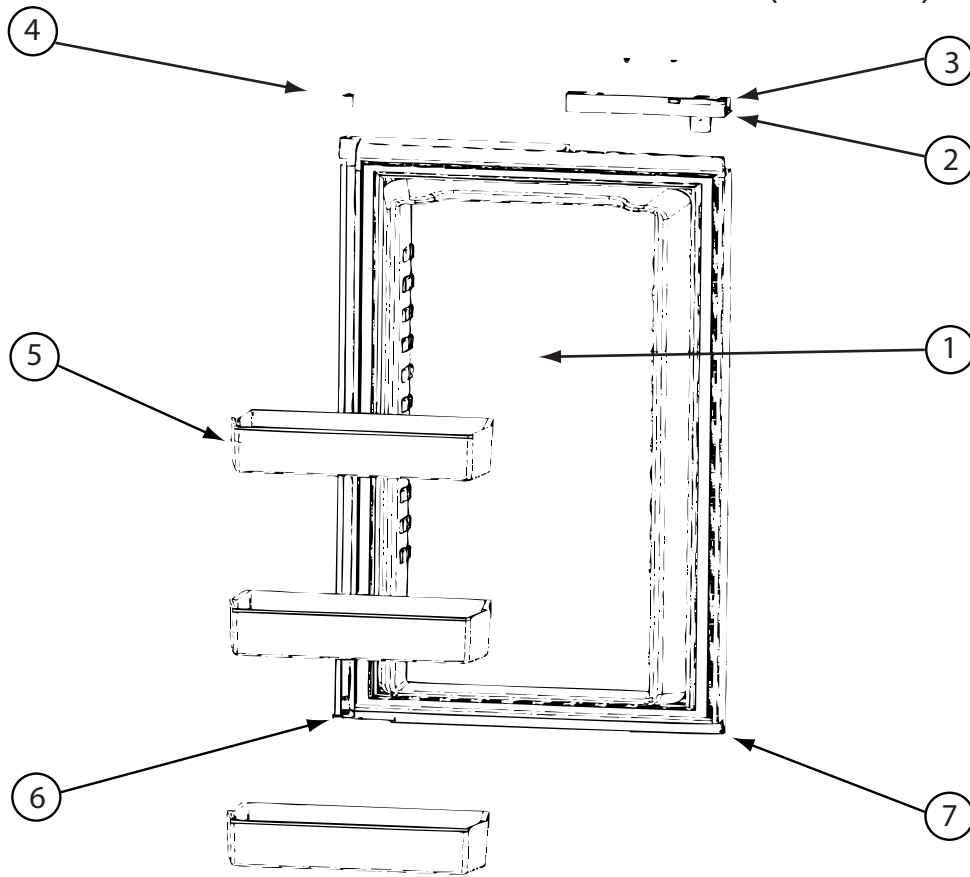

125242-03-02A (CONTINUED)

KEY	PART NUMBER	U/M	DESCRIPTION	VENDOR NO.
1	125242-03-727	EA	LINER-DOOR/LOWER RH/WRP WPM	62906301
2	125242-02-700	EA	HANDLE(CONTOUR)TOP LH BTM RH	621107
3	125242-02-722	EA	LATCH-STORAGE DR/BLK POINTED	619374
4	125242-01-704	EA	BUSHING-HINGE MIDDLE	618746
5	125242-03-704	EA	BIN - DOOR SHELF	622831
6	125242-03-725	EA	CAP/DOOR HINGE-UPR LH/LWR RH	623491
7	125242-03-726	EA	CAP/DR CENTER-UPR LH/LWR RH	623492
	125242-01-769	EA	SHIM DOOR HINGE SERVICE KIT	625129

CABINET & APPLIANCE GROUP (CONTINUED)
COMPONENT PARTS FOR CABINET & APPLIANCE LAYOUT (CONTINUED)

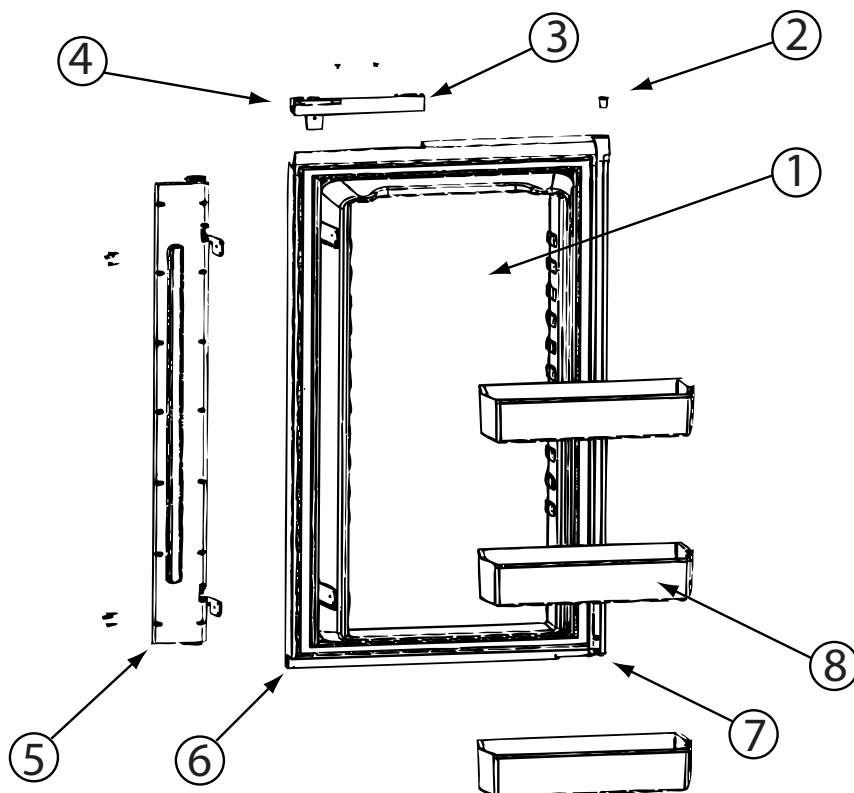

125242-03-02A (CONTINUED)

KEY	PART NUMBER	U/M	DESCRIPTION	VENDOR NO.
1	125242-03-728	EA	LINER-DOOR/LOWER LH/WRP WPM	62906201-NO FLAPPE
2	125242-01-704	EA	BUSHING-HINGE MIDDLE	618746
3	125242-02-701	EA	HANDLE(CONTOUR)TOP RH LWR LH	621106
4	125242-02-722	EA	LATCH-STORAGE DR/BLK POINTED	619374
5	125242-02-727	EA	FLAPPER/DOUBLE POLE - FOR S.N.#540295 TO 1291390	
5	125242-02-740	EA	FLAPPER/DBL POLE-SER#1291391AND UP	
6	125242-03-722	EA	CAP/DOOR HINGE-UPR RH/LWR LH	623819
7	125242-03-723	EA	CAP/DR CENTER-UPR RH/LWR LH	623820
8	125242-03-704	EA	BIN - DOOR SHELF	622831
	125242-01-769	EA	SHIM DOOR HINGE SERVICE KIT	625129

CABINET & APPLIANCE GROUP (CONTINUED)
COMPONENT PARTS FOR CABINET & APPLIANCE LAYOUT (CONTINUED)

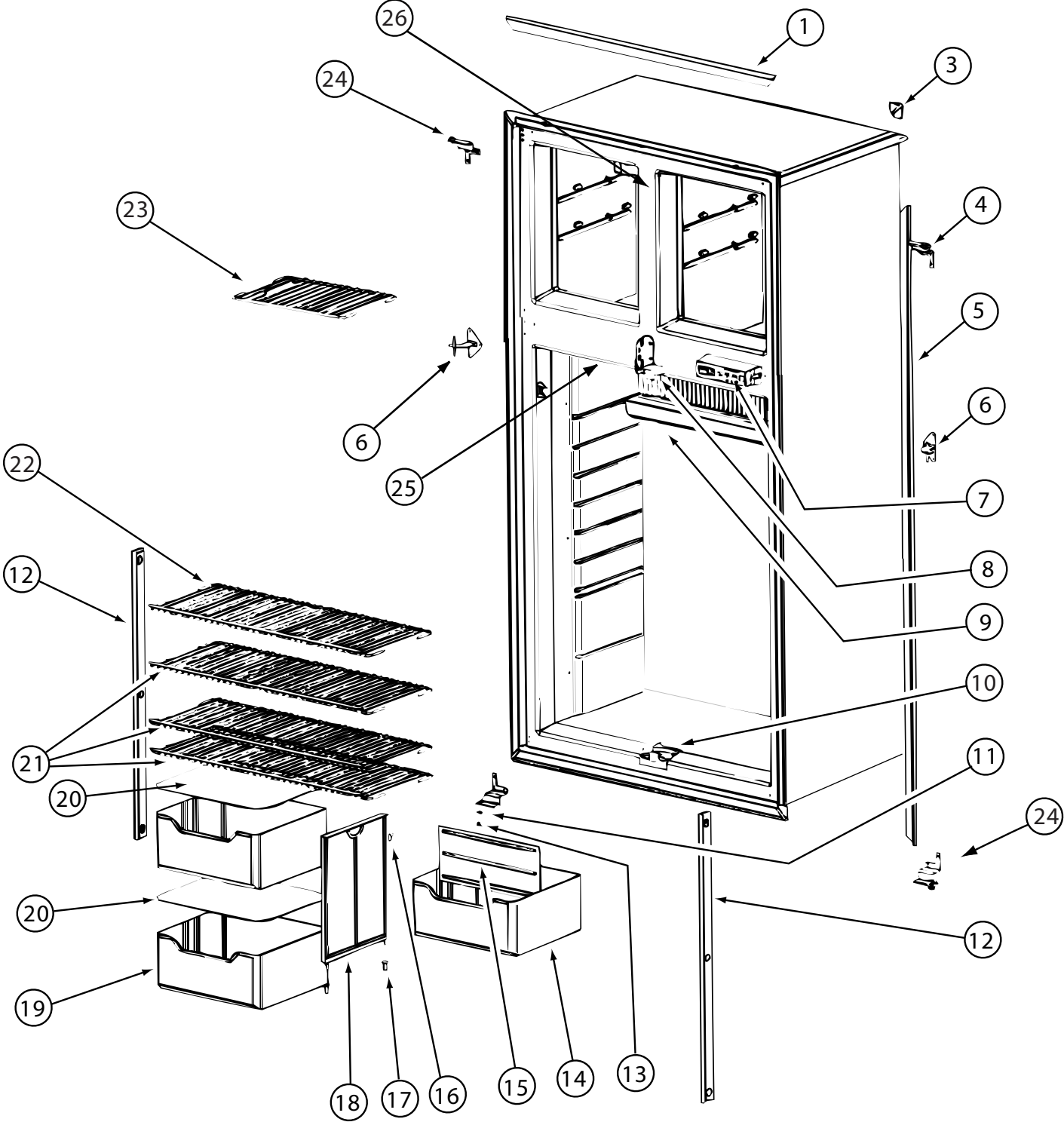

125242-03-02A (CONTINUED)

CABINET & APPLIANCE GROUP (CONTINUED)
COMPONENT PARTS FOR CABINET & APPLIANCE LAYOUT (CONTINUED)

125242-03-02A (CONTINUED)

KEY	PART NUMBER	U/M	DESCRIPTION	VENDOR NO.
1	125242-02-713	EA	TRIM/UPR/LWR - SIDE SNAP ON	621975
1	125242-02-730	EA	TRIM - TOP/BOTTOM - SCREW ON	623255
3	125242-01-722	EA	TRIM - CORNER	618844
4	125242-03-711	EA	HINGE-UPR RH/LWR LH WRAP/DRS	623824
5	125242-01-766	EA	TRIM-LT/RT HAND-SCREW ON	623254
5	125242-02-714	EA	TRIM/SIDES - SIDE SNAP ON	621976
6	125242-03-729	EA	HINGE - MIDDLE	627685
6	125242-03-730	EA	HINGE PIN - MIDDLE HINGE	627684
7	125242-03-731	EA	CONTROL-OPT/ SN8981139 & UP	628970
7	125242-03-712	EA	CONTROL-OPT/GRAY- SN832172 UP	624868
8	125242-01-721	EA	STRIKE PLATE	618835
9	125242-01-712	EA	DRIP TRAY	618774
10	125242-02-717	EA	GUIDE ASM LWR(SER#540295 UP)	620043
10	125242-02-719	EA	GUIDE ASM UPR(SER#540295 UP)	620041
10	125242-03-713	EA	GUIDE BLOCK/FLAPPER/BTM BLK	624140
10	125242-03-714	EA	GUIDE-FLAPPERTOP/BLACK	624141
12	120075-01-730	EA	RETAINER-SHELF(SER#926684 DN)	618181
12	125242-02-720	EA	RETAINER/SHEF(SER#926685 UP)	622033
13	125242-03-715	EA	HINGE PIN/UPR-WRAPPED DOORS	623899
15	125242-01-733	EA	DIVIDER-BOTTLE CRISPER	618877
16	125242-01-750	EA	CLIP	61409622
18	125242-01-749	EA	SUPPORT - WALL	618840
20	125242-01-706	EA	COVER-CRISPER	618757
21	125242-01-726	EA	SHELF-WIRE (LONG)	618848
22	125242-01-727	EA	SHELF-WIRE (SHORT)	618849
23	125242-01-725	EA	SHELF-FREEZER (WIRE)	618847
24	125242-03-716	EA	HINGE-TOP LH/WRAPPED DOORS	623823
25	125242-01-735	EA	SWITCH - DOOR LIGHT	618884
25	125242-01-768	EA	SWITCH - DOOR LIGHT	623918
	120075-01-714	EA	PLUG-HOLE (BLACK)	618170
	125242-01-728	EA	CAP-SCREW WHITE	618853
	125242-03-706	EA	PROBE - CONTACT/LARGE	620689

CONTACT WINNEBAGO PART SALES FOR UNLISTED COMPONENT(S)

CABINET & APPLIANCE GROUP (CONTINUED)
COMPONENT PARTS FOR CABINET & APPLIANCE LAYOUT (CONTINUED)

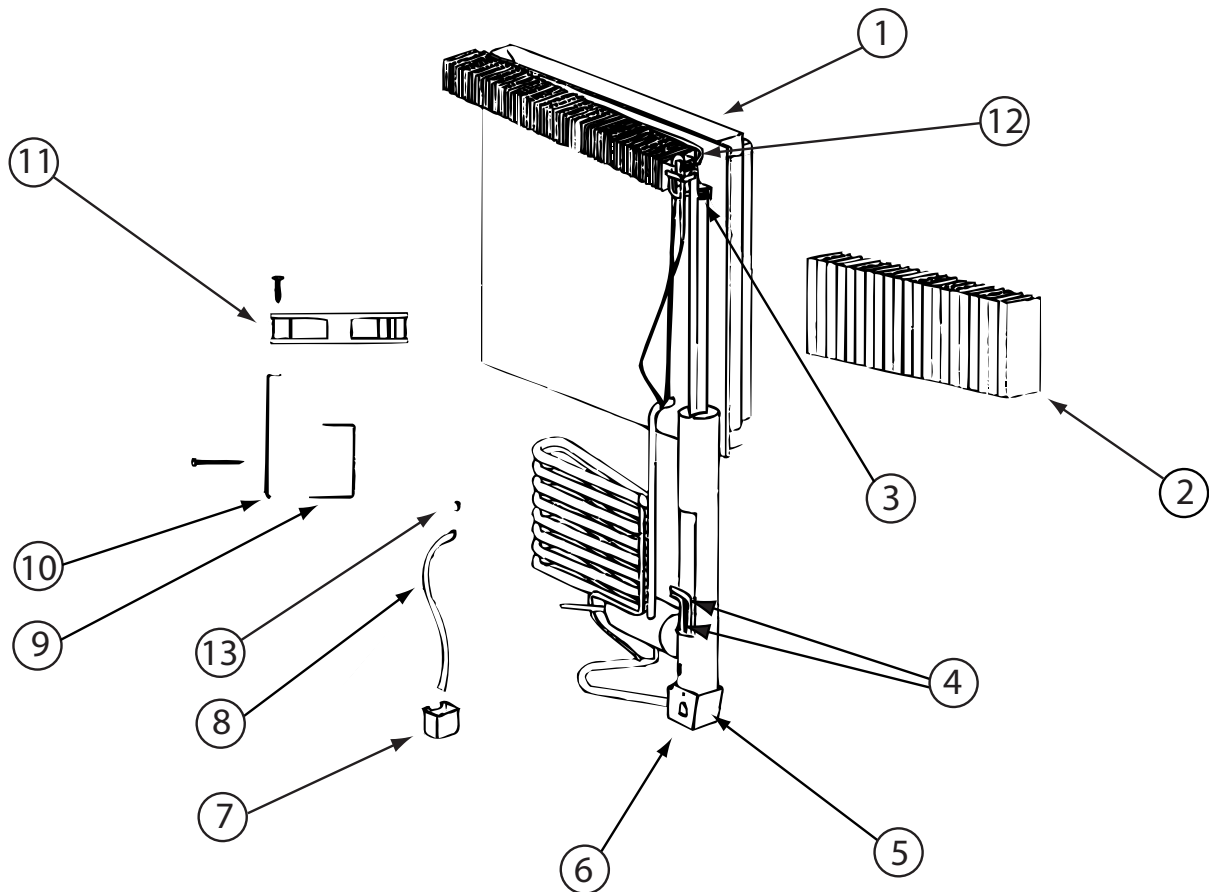

125242-03-02A (CONTINUED)

KEY	PART NUMBER	U/M	DESCRIPTION	VENDOR NO.
1	125242-01-746	EA	COOLING UNIT - 1200	618964
1	125242-05-719	EA	COOLING UNIT - SN 8835498 UP	629507
2	125242-05-713	EA	FINS	618785
4	125242-01-732	EA	HEATER AC - 225W/110VAC	618872
5	125242-01-739	EA	BASE-BURNER BOX	618902
6	125242-01-740	EA	COVER-BURNER BOX	618910
9	125242-01-730	EA	BRACKET-DC FAN	618857
9	125242-05-721	EA	BRACKET-DC FAN-SN 914576 UP	628747
10	125242-01-741	EA	SUPPORT-DC FAN	618912
11	125242-01-729	EA	FAN-EXTERNAL DC	618856
11	125242-05-722	EA	FAN-EXTRNL DC-SN 914576 UP	628685
12	113737-01-754	EA	THERMOSTAT (FAN 12V DC)	618093
	125242-01-742	EA	WIRE ASM.-BAFFLE 55.15"	618915

CONTACT WINNEBAGO PART SALES FOR UNLISTED COMPONENT(S)

CABINET & APPLIANCE GROUP (CONTINUED)
COMPONENT PARTS FOR CABINET & APPLIANCE LAYOUT (CONTINUED)

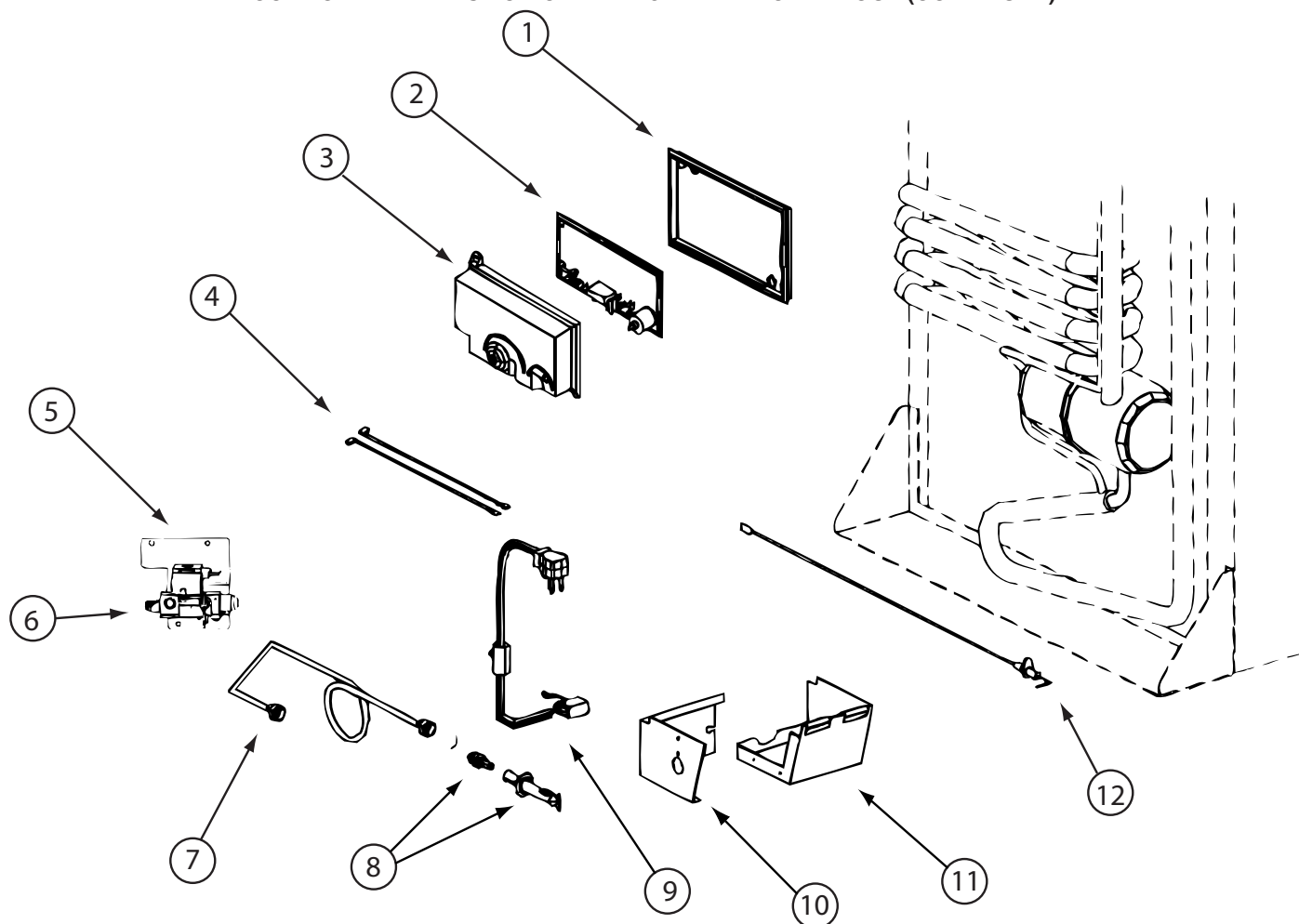

125242-03-02A & 125242-05-02A (CONTINUED)

KEY	PART NUMBER	U/M	DESCRIPTION	VENDOR NO.
1	121569-08-701	EA	BASE - POWER BOARD	628674
2	121568-06-709	EA	BOARD/POWER-N611/N822F	628661
3	121569-08-702	EA	COVER-POWER BOARD	628677
4	125242-02-709	EA	WIRE/WHITE/9"/GAS VALVE	621448
6	121569-08-703	EA	VALVE - SOLENOID	628741
7	125242-05-723	EA	BURNER TUBE	624683
8	125242-02-743	EA	BURNER ORFICE ADAPTER ASSY - NORCOLD# 629013	
9	121569-07-700	EA	CORD - AC POWER	61554422
10	125242-01-740	EA	COVER-BURNER BOX	618910
11	125242-01-739	EA	BASE-BURNER BOX	618902
12	104137-06-715	EA	ELECTRODE-SPARK/SENSOR, SGL	61692222

CONTACT WINNEBAGO PART SALES FOR UNLISTED COMPONENT(S)

CABINET & APPLIANCE GROUP (CONTINUED)
COMPONENT PARTS FOR CABINET & APPLIANCE LAYOUT (CONTINUED)

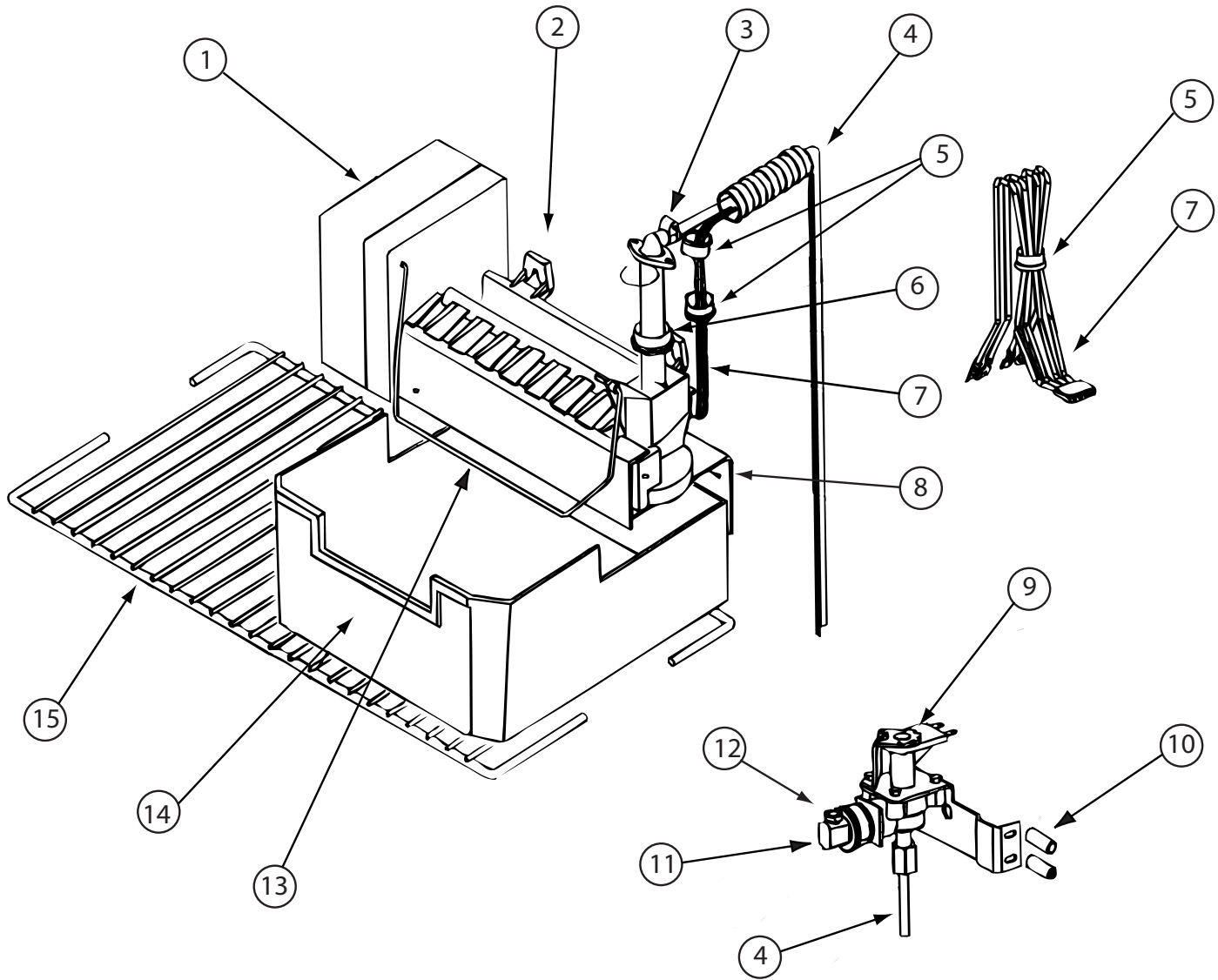

125242-03-02A & 125242-05-02A (CONTINUED)

KEY	PART NUMBER	U/M	DESCRIPTION	VENDOR NO.
2	094039-07-706	EA	ICE MAKER W/O PLATES	61656522
4	125242-05-724	EA	WATER TUBE/HEATER ASM	621429
6	120075-03-706	EA	FITTING WATER LINE	620039
8	125242-01-737	EA	BRACKET-MOUNTING (ICE MAKER)	618894/620890
9	120075-03-701	EA	WATER VALVE - W/BRACKET	618253
11	094039-07-707	EA	GARDEN HOSE ADAP W/BRASS NUT	61679622
12	094039-07-708	EA	NUT - COMPRESSION	622991
13	120075-03-703	EA	ARM-SHUT OFF	61656922
14	125242-01-716	EA	ICE BIN	618803
15	125242-01-725	EA	SHELF-FREEZER (WIRE)	618847
	120075-09-703	EA	THERMOSTAT	620240

CONTACT WINNEBAGO PART SALES FOR UNLISTED COMPONENT(S)

CABINET & APPLIANCE GROUP (CONTINUED)
COMPONENT PARTS FOR CABINET & APPLIANCE LAYOUT (CONTINUED)

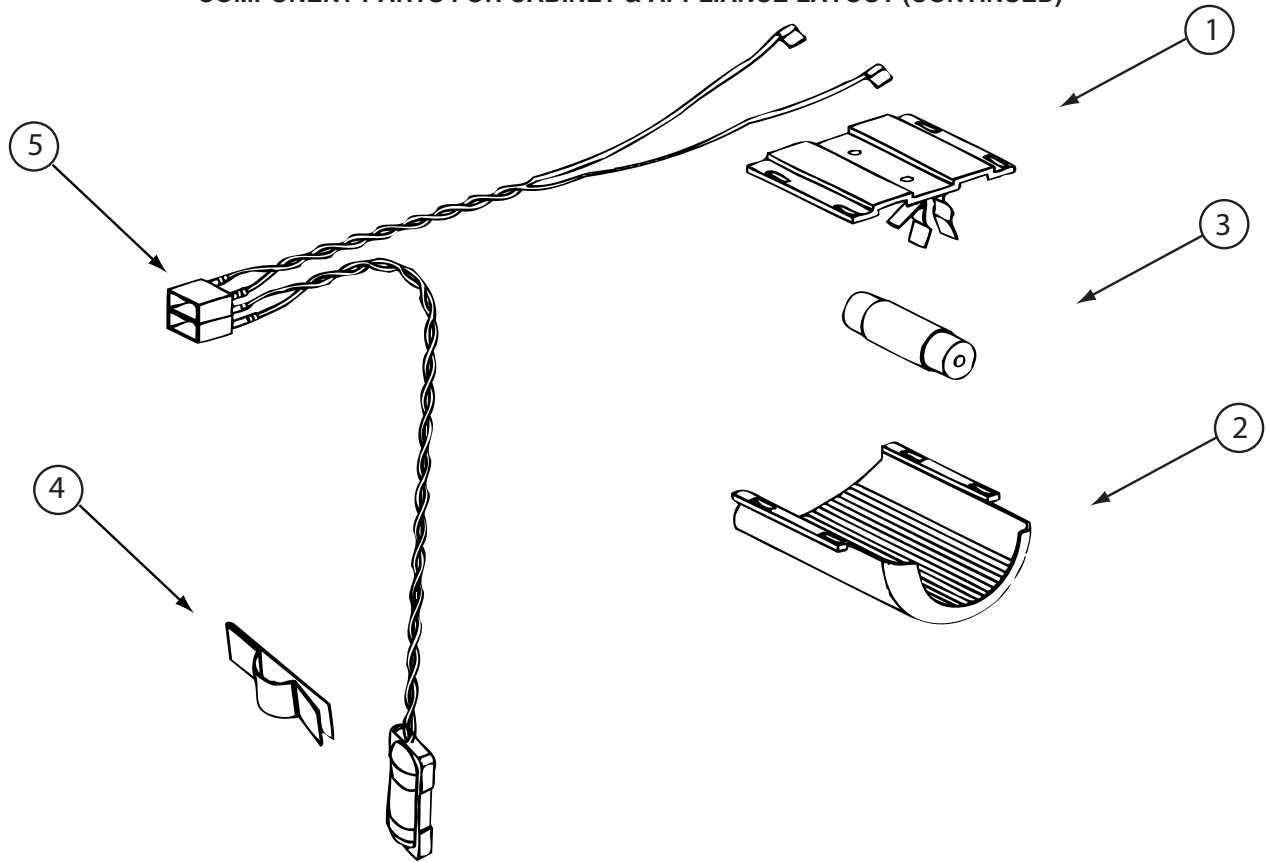

125242-03-02A & 125242-05-02A (CONTINUED)

KEY	PART NUMBER	U/M	DESCRIPTION	VENDOR NO.
1	084880-03-705	EA	BRACKET-LIGHT-INTERIOR	61629722
2	125242-02-708	EA	COVER/LAMP BRACKET	621827
3	084880-03-706	EA	BULB-LAMP	61628922
4	084880-01-760	EA	CLIP (THERMISTER)	61689122
5	125242-02-706	EA	LAMP/WIRE ASM/SER#849677 UP	620871

CABINET & APPLIANCE GROUP (CONTINUED)
COMPONENT PARTS FOR CABINET & APPLIANCE LAYOUT (CONTINUED)

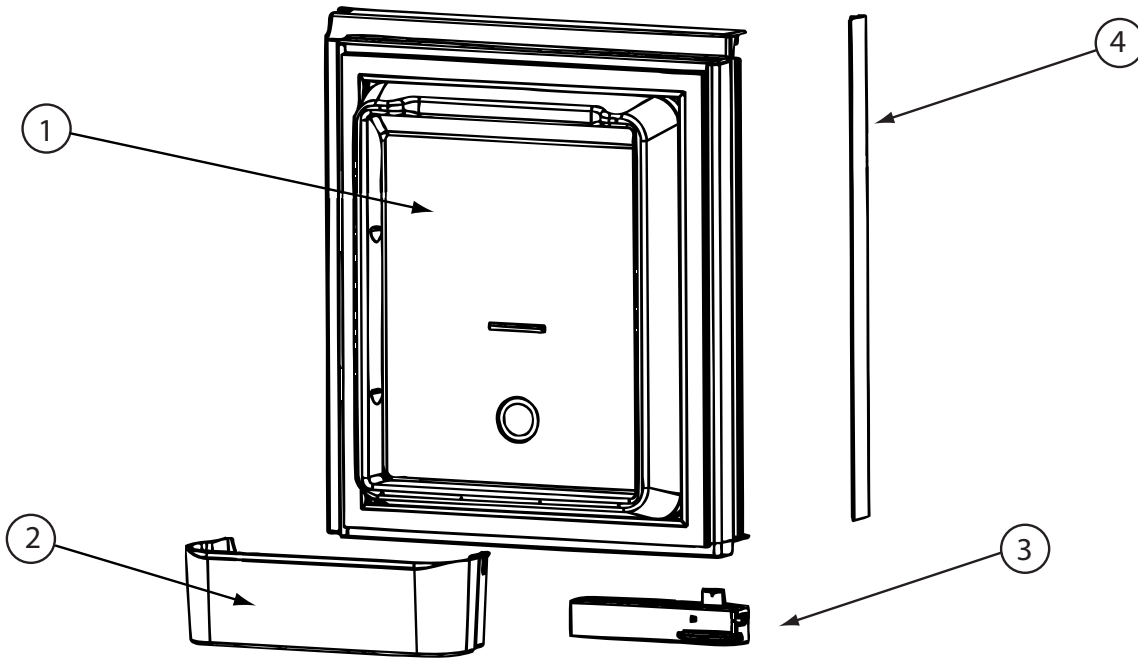

125242-05-02A

KEY	PART NUMBER	U/M	DESCRIPTION	VENDOR NO.
1	125242-05-700	EA	LINER-DOOR/UPPER RH/WRP WPM	62913401
2	125242-05-701	EA	BIN - DOOR SHELF	628686
3	125242-02-701	EA	HANDLE(CONTOUR)TOP RH LWR LH	621106
	125242-02-722	EA	LATCH-STORAGE DR/BLK POINTED	619374

CONTACT WINNEBAGO PART SALES FOR UNLISTED COMPONENT(S)

CABINET & APPLIANCE GROUP (CONTINUED)
COMPONENT PARTS FOR CABINET & APPLIANCE LAYOUT (CONTINUED)

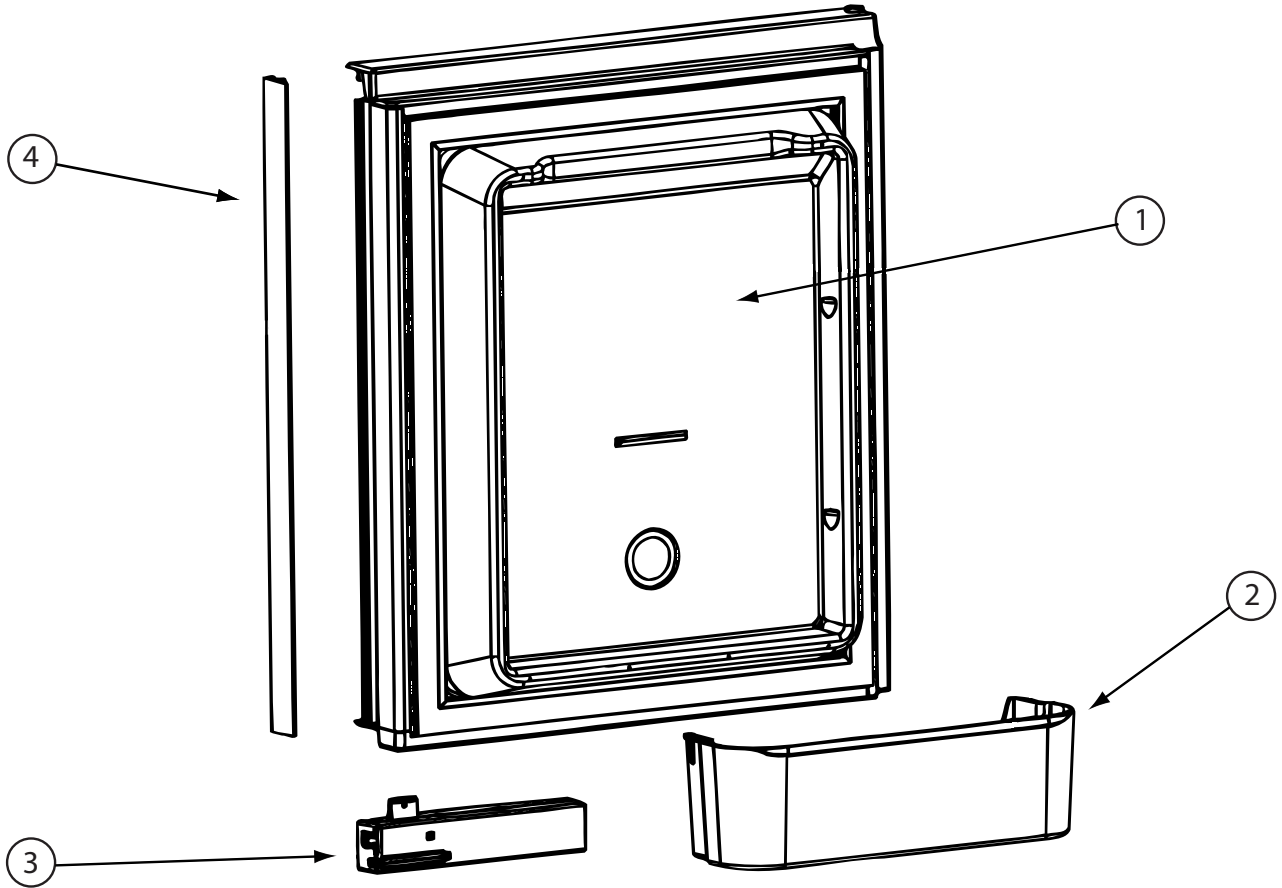

125242-05-02A (CONTINUED)

KEY	PART NUMBER	U/M	DESCRIPTION	VENDOR NO.
1	125242-05-702	EA	LINER-DOOR/UPPER LH/WRP WPM	62913301
2	125242-05-701	EA	BIN - DOOR SHELF	628686
3	125242-02-700	EA	HANDLE(CONTOUR)TOP LH BTM RH	621107
	125242-02-722	EA	LATCH-STORAGE DR/BLK POINTED	619374

CONTACT WINNEBAGO PART SALES FOR UNLISTED COMPONENT(S)

CABINET & APPLIANCE GROUP (CONTINUED)
COMPONENT PARTS FOR CABINET & APPLIANCE LAYOUT (CONTINUED)

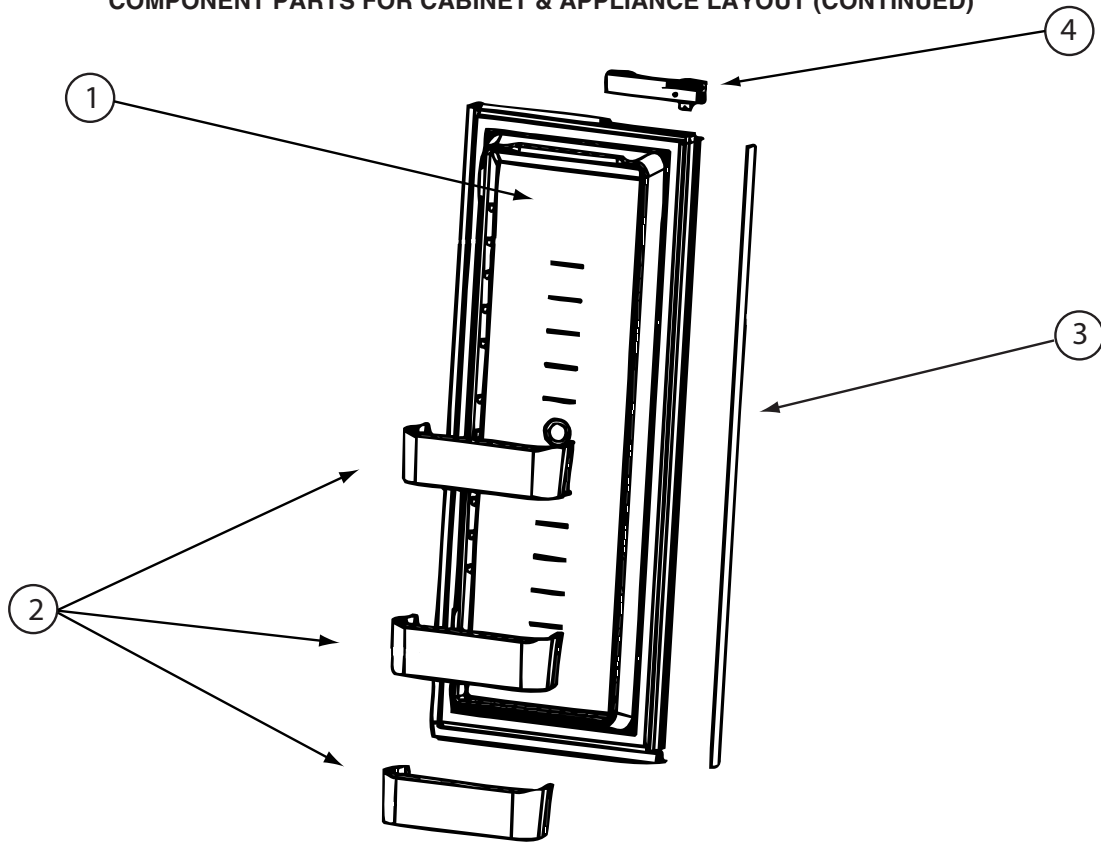

125242-05-02A (CONTINUED)

KEY	PART NUMBER	U/M	DESCRIPTION	VENDOR NO.
1	125242-05-703	EA	LINER-DOOR/LOWER RH/WRP WPM	62913601
2	125242-05-701	EA	BIN - DOOR SHELF	628686
4	125242-02-700	EA	HANDLE(CONTOUR)TOP LH BTM RH	621107
	125242-02-722	EA	LATCH-STORAGE DR/BLK POINTED	619374

CONTACT WINNEBAGO PART SALES FOR UNLISTED COMPONENT(S)

CABINET & APPLIANCE GROUP (CONTINUED)
COMPONENT PARTS FOR CABINET & APPLIANCE LAYOUT (CONTINUED)

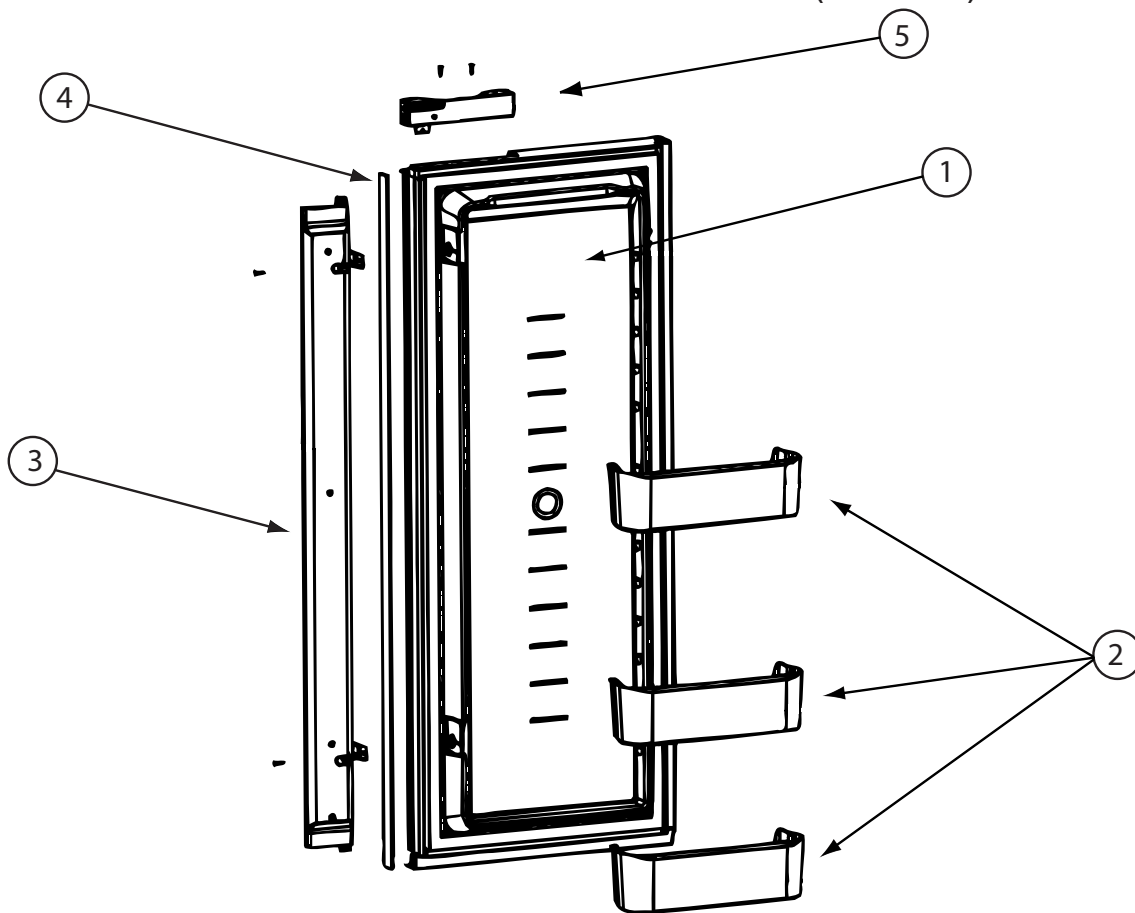

125242-05-02A (CONTINUED)

KEY	PART NUMBER	U/M	DESCRIPTION	VENDOR NO.
1	125242-05-704	EA	LINER-DOOR/LOWER LH/WRP WPM	62913501
2	125242-05-701	EA	BIN - DOOR SHELF	628686
3	125242-05-705	EA	FLAPPER ASM	629049
5	125242-02-701	EA	HANDLE(CONTOUR)TOP RH LWR LH	621106
	125242-02-722	EA	LATCH-STORAGE DR/BLK POINTED	619374
			CONTACT WINNEBAGO PART SALES FOR UNLISTED COMPONENT(S)	

CABINET & APPLIANCE GROUP (CONTINUED)
COMPONENT PARTS FOR CABINET & APPLIANCE LAYOUT (CONTINUED)

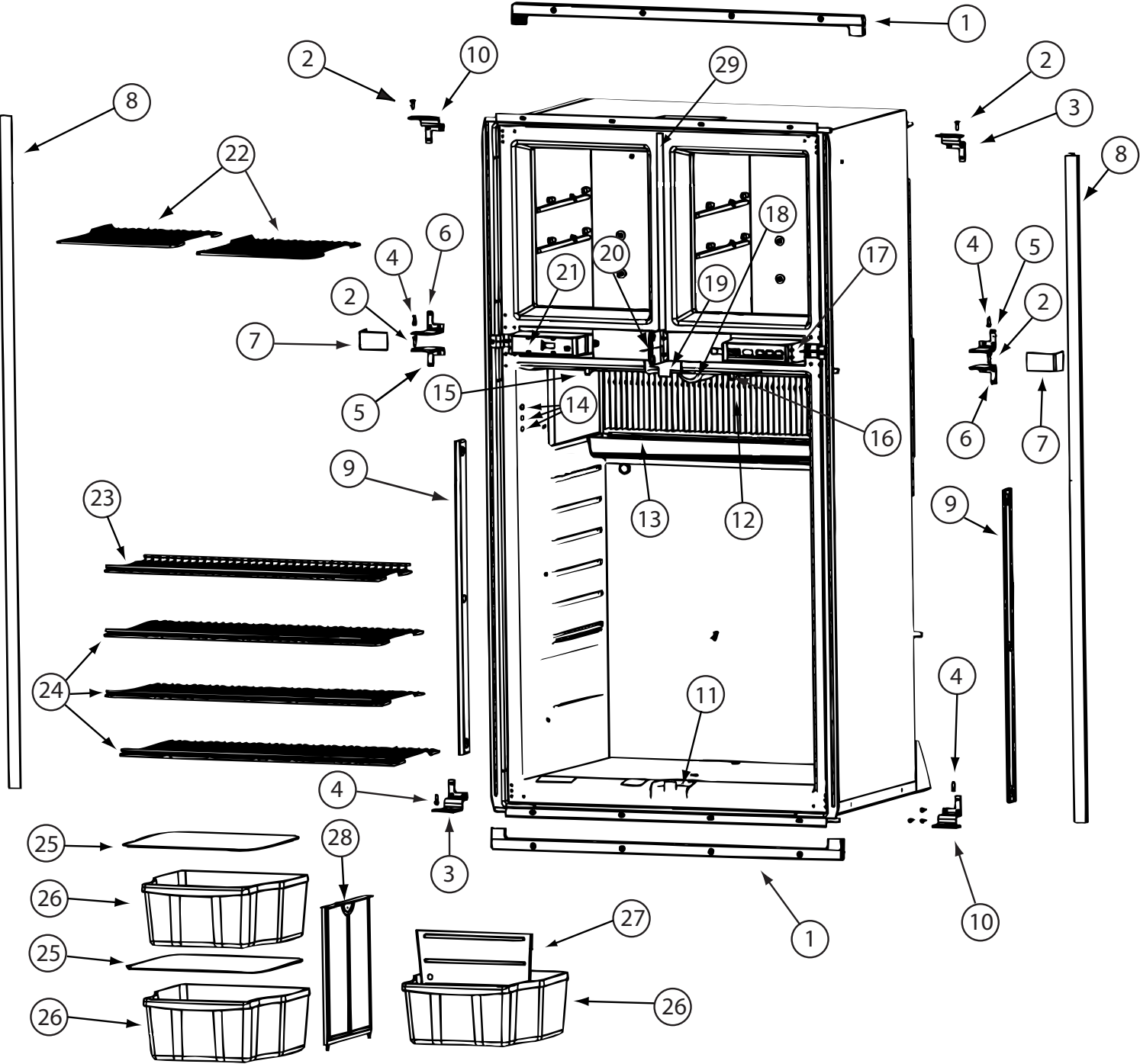

125242-05-02A (CONTINUED)

CABINET & APPLIANCE GROUP (CONTINUED)
COMPONENT PARTS FOR CABINET & APPLIANCE LAYOUT (CONTINUED)

125242-05-02A (CONTINUED)

KEY	PART NUMBER	U/M	DESCRIPTION	VENDOR NO.
1	125242-01-767	EA	KIT - UNIVERSAL TRIM (MAKE YOUR OWN)CORNERS/ETC - SCREW-ON	
2	125242-03-715	EA	HINGE PIN/UPR-WRAPPED DOORS	623899
3	125242-05-707	EA	HINGE-OUTER/UPPER RH/LWR LH	628946
4	113737-01-710	EA	PIN-HINGE, BOTTOM	61550722
5	125242-05-708	EA	HINGE-INNER/UPPER RH/LWR LH	624363
6	125242-05-709	EA	HINGE-INNER/UPPER LH/LWR RH	624364
7	125242-05-710	EA	COVER - HINGE	627955
8	125242-01-766	EA	TRIM - LEFT HAND/RIGHT HAND - VERTICAL - SCREW-ON	
9	125242-02-720	EA	RETAINER/SHELF(SER#926685 UP)	622033
10	125242-05-711	EA	HINGE-OUTER/UPPER LH/LWR RH	628945
11	125242-05-712	EA	GUIDE BLOCK-FLAPPER/BTM/BLK	629112
12	125242-05-713	EA	FINS	618785
13	125242-01-712	EA	DRIP TRAY	618774
14	125242-03-706	EA	PROBE - CONTACT/LARGE	620689
15	125242-01-768	EA	SWITCH - DOOR LIGHT	623918
16	125242-02-706	EA	LAMP/WIRE ASM/SER#849677 UP	620871
17	125242-05-706	EA	CONTROL ASM - OPTICAL	629113
18	125242-02-708	EA	COVER/LAMP BRACKET	621827
19	125242-05-714	EA	GUIDE BLOCK-FLAPPER/TOP/BLK	629111
20	125242-05-715	EA	PLATE/STRIKE - BLACK	628473
21	125242-05-716	EA	BOX/FRONT - DUMMY	624366
22	125242-01-725	EA	SHELF-FREEZER (WIRE)	618847
23	125242-01-727	EA	SHELF-WIRE (SHORT)	618849
24	125242-01-726	EA	SHELF-WIRE (LONG)	618848
25	125242-01-706	EA	COVER-CRISPER	618757
26	125242-05-717	EA	BIN - BOTTLE/CRISPER	628688
27	125242-05-718	EA	DIVIDER - BOTTLE/CRISPER	628694
28	125242-01-749	EA	SUPPORT - WALL	618840
29	125242-02-741	EA	STRIP-FREEZER-BLACK	625210 #1291391 &UP
	084880-03-705	EA	BRACKET-LIGHT-INTERIOR	61629722
	084880-03-706	EA	BULB-LAMP	61628922
	120075-01-714	EA	PLUG-HOLE (BLACK)	618170

CABINET & APPLIANCE GROUP (CONTINUED)
COMPONENT PARTS FOR CABINET & APPLIANCE LAYOUT (CONTINUED)

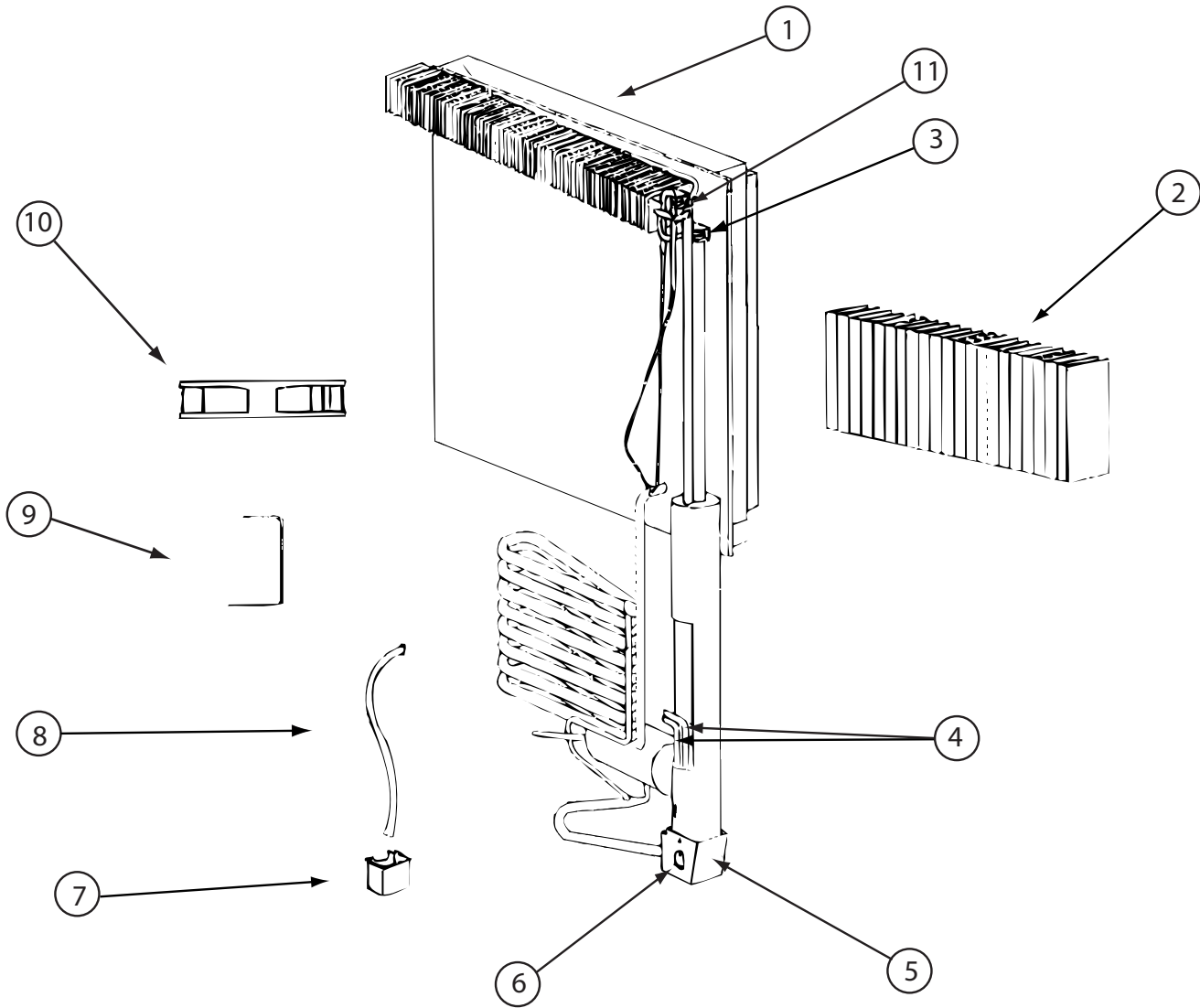

125242-05-02A (CONTINUED)

KEY	PART NUMBER	U/M	DESCRIPTION	VENDOR NO.
1	125242-05-719	EA	COOLING UNIT - SN 8835498 UP	629507
2	125242-05-713	EA	FINS	618785
4	125242-01-732	EA	HEATER AC - 225W/110VAC	618872
5	125242-01-739	EA	BASE-BURNER BOX	618902
6	125242-01-740	EA	COVER-BURNER BOX	618910
9	125242-05-721	EA	BRACKET-DC FAN-SN 9144576 UP	628747
10	125242-05-722	EA	FAN-EXTRNL DC-SN 9144576 UP	628685
11	113737-01-754	EA	THERMOSTAT (FAN 12V DC)	618093
	125242-01-742	EA	WIRE ASM.-BAFFLE 55.15"	618915
	125242-05-720	EA	SWITCH-THERMAL	628118

CONTACT WINNEBAGO PART SALES FOR UNLISTED COMPONENT(S)

CABINET & APPLIANCE GROUP (CONTINUED)
COMPONENT PARTS FOR CABINET & APPLIANCE LAYOUT (CONTINUED)

126022-01-01A, 126022-02-01A, 126022-03-01A

KEY	PART NUMBER	U/M	DESCRIPTION	VENDOR NO.
	114030-01-707	EA	PLUG BUTTON BLACK	74002628
	126022-01-700	EA	BUMPER - RANGE BIFOLD COVER	MAGIC 8003P007-60
	126022-01-701	EA	HINGE-RANGE BIFOLD COVER-22"	MAGIC 3418F067-34

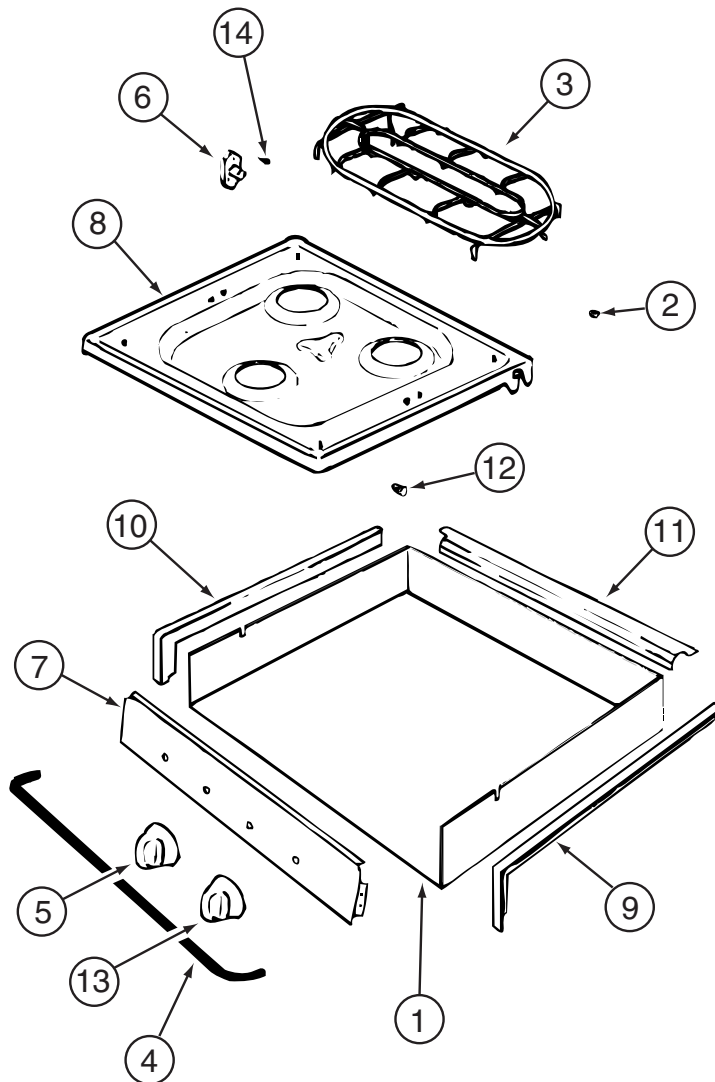

135065-03-01A, 135065-03-03A, 135065-04-01A

KEY	PART NUMBER	U/M	DESCRIPTION	VENDOR NO.
2	102020-01-709	EA	BUMPER-GRATE	8007-P020-60
3	135065-03-703	EA	GRATE - BLACK(SEALED BURNER)	74007304
4	114030-02-700	EA	GUARD/FABRIC - TOWEL BAR	3609F006-70
5	128728-01-701	EA	KNOB - BURNER - REAR	74003941
5	128728-01-702	EA	KNOB - BURNER - FRONT	74003942
6	128728-01-703	EA	PIN/T-NUT F/HINGE	7103P109-60
7	135065-03-704	EA	PANEL - MANIFOLD (BLACK)	74007330
8	128728-01-705	EA	TOP - MAIN - BLACK	74003928
8	135065-03-715	EA	TOP - MAIN - STAINLESS STEEL	74007299
9	114030-01-704	EA	TRIM - RIGHT/BLACK TEXTURED	74002839
10	114030-01-705	EA	TRIM - LEFT/BLACK TEXTURED	74002840
11	114030-01-706	EA	TRIM - REAR/BLACK TEXTURED	74002841
12	102020-01-724	EA	BUMPER-MAIN TOP	8003P008-60
13	128728-01-707	EA	KNOB - IGNITOR	74003944

CONTACT WINNEBAGO PART SALES FOR UNLISTED COMPONENT(S)

CABINET & APPLIANCE GROUP (CONTINUED)
COMPONENT PARTS FOR CABINET & APPLIANCE LAYOUT (CONTINUED)

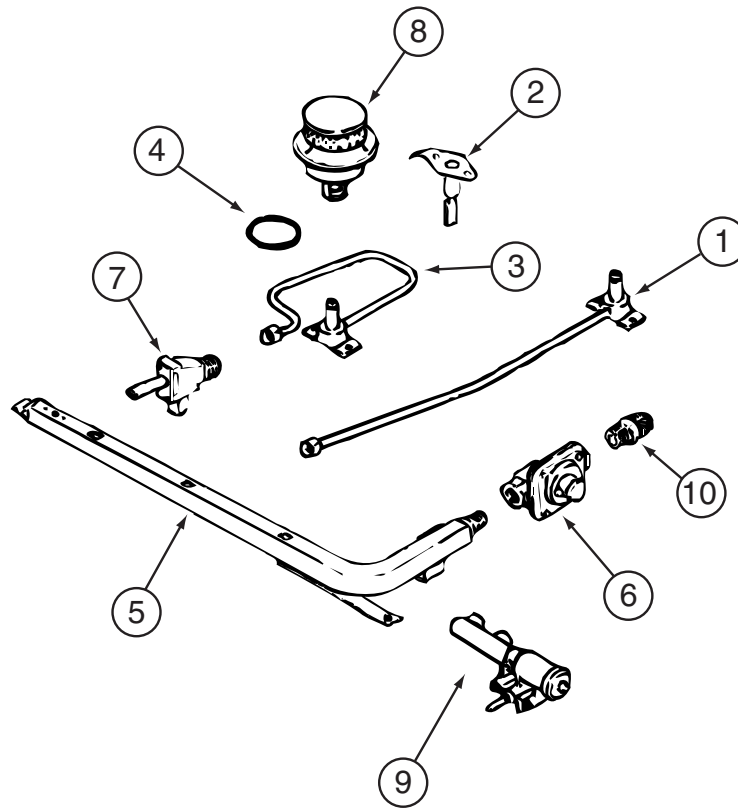

135065-03-01A, 135065-03-03A, 135065-04-01A (CONTINUED)

KEY	PART NUMBER	U/M	DESCRIPTION	VENDOR NO.
1	128728-01-708	EA	FITTING W/ORFICE/TUBE - REAR	74003931
2	135065-01-701	EA	IGNITOR/PORCELAIN-TOP BURNER	74004053
3	128728-01-710	EA	FITTING W/ORFICE/TUBE - FRT	74003930
4	135065-03-700	EA	FITTING - HALF UNION	74004234
5	135065-01-702	EA	PIPE/MANIFOLD	74004642
6	126023-02-703	EA	REGULATOR - PRESSURE	74004235
7	135065-01-703	EA	VALVE/BURNER - REAR	74004643
7	135065-01-704	EA	VALVE/BURNER-FRT-HI	74004644
7	135065-03-701	EA	SCREW - VALVE	71003231
8	135065-03-702	EA	SEALED BURNER ASM.(BLACK) RV	74003967
9	128728-01-716	EA	BURNER - IGNITOR	74003946
9	128728-01-717	EA	WIRES - IGNITOR	74003947

CABINET & APPLIANCE GROUP (CONTINUED)
COMPONENT PARTS FOR CABINET & APPLIANCE LAYOUT (CONTINUED)

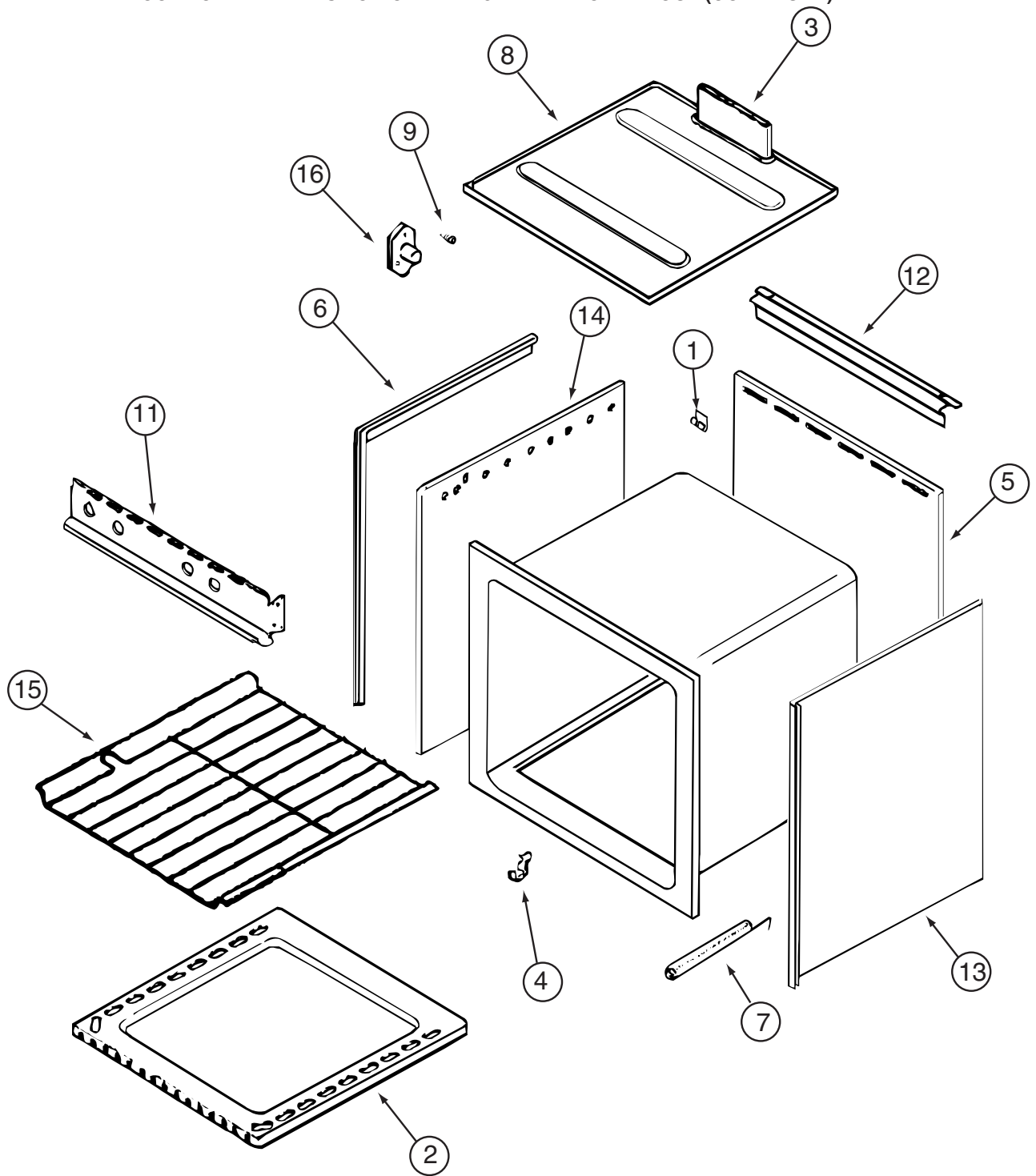

135066-03-01A/04A, 150778-01-01A, 151277-03-01A, 151279-02-01A/02A, 151279-03-01A (CONTINUED)

KEY	PART NUMBER	U/M	DESCRIPTION	VENDOR NO.
1	112881-03-702	EA	CLIP - MAIN TOP	74003998
2	126023-01-731	EA	BOTTOM - OVEN	2205F016-19
3	126023-01-718	EA	FLUE BOX ASSEMBLY	4006W075-80
6	126023-01-713	EA	TRIM - SIDE (RIGHT)	74002827
6	126023-01-714	EA	TRIM - SIDE (LEFT)	74002828
7	135066-03-708	EA	SPRING - OVEN DOOR	7803P053-60
9	128728-01-703	EA	PIN/T-NUT F/HINGE	7103P109-60
11	135066-03-701	EA	PANEL - MANIFOLD - BLACK	74007306
12	112881-01-721	EA	DEFLECTOR/FLUE-BLK-SEALED BR	74002829
15	126023-01-716	EA	RACK - OVEN	74003106

CONTACT WINNEBAGO PART SALES FOR UNLISTED COMPONENT(S)

CABINET & APPLIANCE GROUP (CONTINUED)
COMPONENT PARTS FOR CABINET & APPLIANCE LAYOUT (CONTINUED)

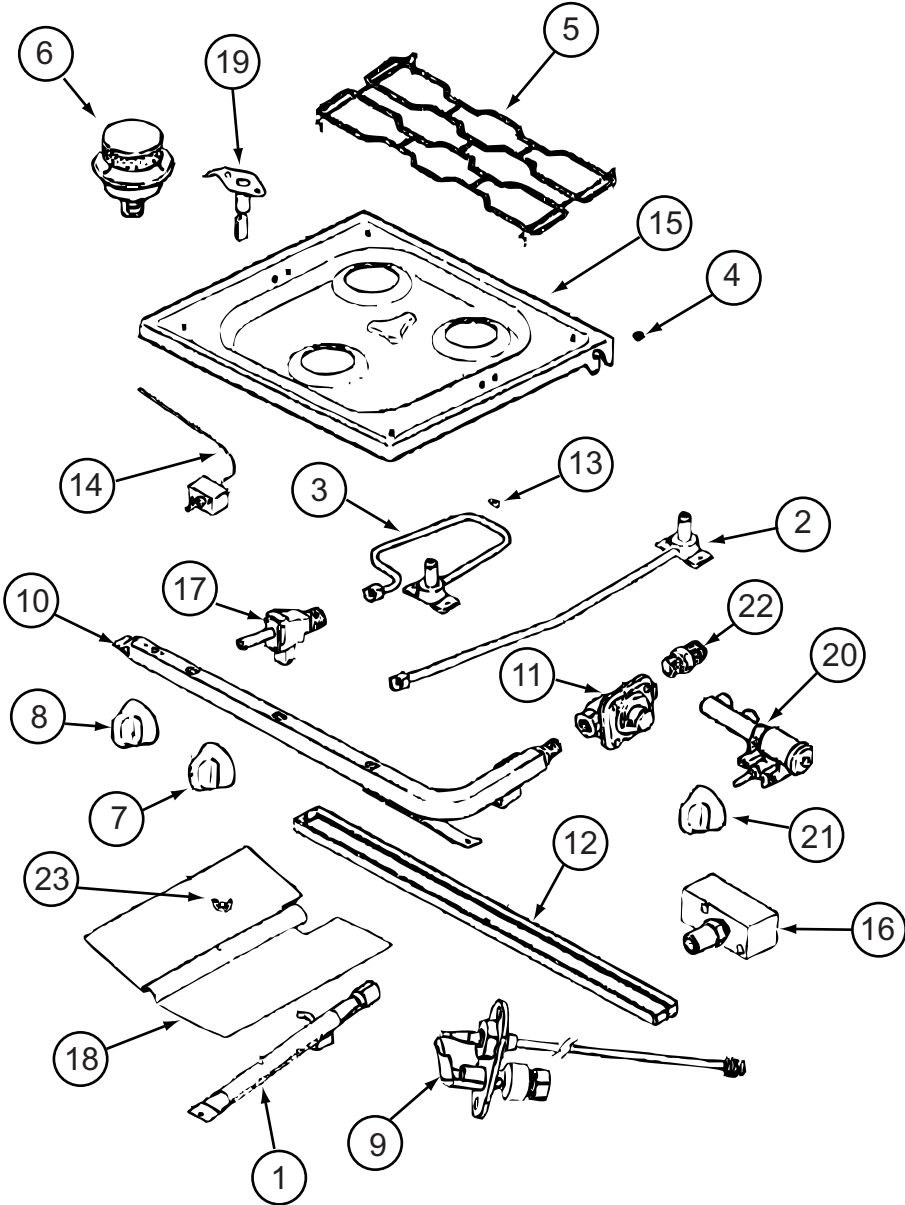

151277-03-01A, 151279-01-01A, 151279-02-01A/02A, 151279-03-01A

CABINET & APPLIANCE GROUP (CONTINUED)
COMPONENT PARTS FOR CABINET & APPLIANCE LAYOUT (CONTINUED)

151277-03-01A, 151279-01-01A, 151279-02-01A/02A, 151279-03-01A (CONTINUED)

KEY	PART NUMBER	U/M	DESCRIPTION	VENDOR NO.
1	151279-02-700	EA	BURNER - OVEN - W/SHUTTER	74009853
2	128728-01-708	EA	FITTING W/ORFICE/TUBE - REAR	74003931
3	128728-01-710	EA	FITTING W/ORFICE/TUBE - FRT	74003930
4	102020-01-709	EA	BUMPER-GRATE	8007P020-60
5	135065-03-703	EA	GRATE - BLACK(SEALED BURNER)	74007304
6	135065-03-702	EA	SEALED BURNER ASM.(BLACK) RV	74003967
7	128728-01-701	EA	KNOB - BURNER - REAR	74003941 (1 PER)
7	128728-01-702	EA	KNOB - BURNER - FRONT	74003942 (2 PER)
8	151279-02-701	EA	KNOB - THERMOSTAT - BLACK	74009858
9	112881-04-706	EA	PILOT-OVEN (151279-01-01A ONLY)	74006334
9	151279-01-700	EA	PILOT-BURNER- 16" (151279-01-01A ONLY)	74009852
9	151279-02-705	EA	PILOT - OVEN - 22" SERIES	74010544
10	151279-02-702	EA	PIPE - MANIFOLD	74009856
11	126023-02-703	EA	REGULATOR - PRESSURE	74004235
11	112881-03-701	EA	REGULATOR KIT W/FITTINGS	12001285
13	102020-01-724	EA	BUMPER-MAIN TOP	8003P008-60
14	151279-02-703	EA	THERMOSTAT	74009855
15	128728-01-705	EA	TOP - MAIN - BLACK	74003928
15	135065-03-715	EA	TOP - MAIN - STAINLESS STEEL	74007299
16	151279-02-704	EA	ELBOW BLOCK ASM (VALVE-OVEN)	74009864
17	135065-01-703	EA	VALVE/BURNER - REAR	74004643
17	135065-01-704	EA	VALVE/BURNER-FRT-HI	74004644
18	135656-01-701	EA	MIXER/AIR	3411F003-34
19	135065-01-701	EA	IGNITOR/PORCELAIN-TOP BURNER	74004053
20	128728-01-716	EA	IGNITOR - F/BURNERS	74003946
20	128728-01-717	EA	WIRES - IGNITOR	74003947
21	128728-01-707	EA	KNOB - IGNITOR	74003944
22	135065-03-700	EA	FITTING - HALF UNION	74004234

CONTACT WINNEBAGO PART SALES FOR UNLISTED COMPONENT(S)

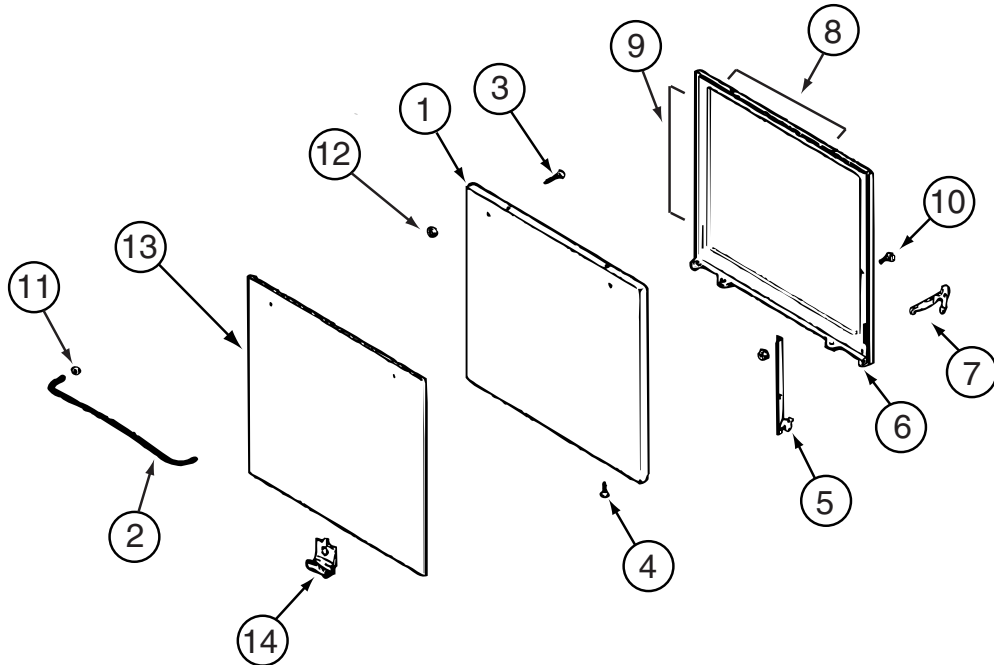

150778-01-01A, 151277-03-01A, 151279-02-01A, 151279-03-01A (CONTINUED)

KEY	PART NUMBER	U/M	DESCRIPTION	VENDOR NO.
1	126023-01-712	EA	PANEL - DOOR (BLACK)	74001190
2	128727-01-701	EA	HANDLE - OVEN DOOR	74003929
5	151277-01-704	EA	HINGE KIT-OVEN DR/LT	12400028
5	151277-01-705	EA	HINGE KIT-OVEN DR/RT	12400029
8	126023-01-732	EA	SEAL/OVEN DR TOP	7212P014-60
9	135066-03-714	EA	SEAL - OVEN DOOR SIDES	7212P039-60
13	102020-01-725	EA	GLASS OUTER	7902P266-60
14	126023-01-738	EA	CLIP - GLASS OVEN/BLACK	7112P093-60

CONTACT WINNEBAGO PART SALES FOR UNLISTED COMPONENT(S)

CHASSIS GROUP

FRAME

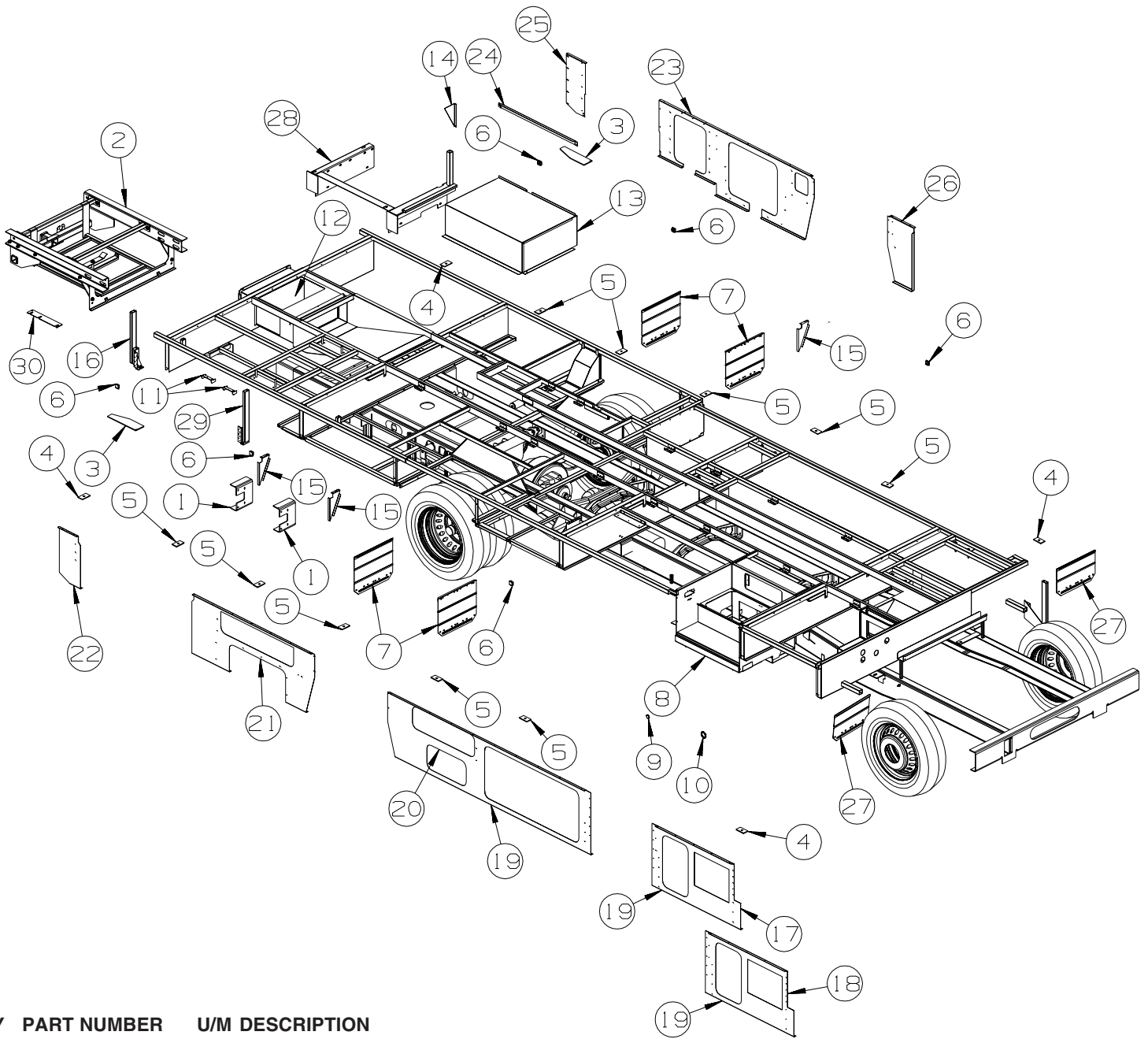

KEY	PART NUMBER	U/M	DESCRIPTION
1	120867-01-02B	EA	MOUNT - LP TANK - E-COAT
2	154052-02-01A	EA	CLIP/REAR EXTENSION RAIL - W/HITCH/TIRE CARRIER
3	133095-01-02B	EA	PLATE - CLIP - E-COATED
4	135712-02-02B	EA	PLATE - BODY MOUNT - E-COATED
5	135712-01-02B	EA	PLATE - BODY MOUNT - E-COATED
6	119845-01-01A	EA	PLUG/PLASTIC - 1 1/2" SQUARE - BLACK
7	136391-02-02B	EA	GUARD/ROCK - STEEL - W/ANGLE - 18"W X 15"H - E-COATED
8	152362-01-02B	EA	BOX/ENTRANCE STEP - E-COATED
8	161763-01-02B	EA	BOX/ENTRANCE STEP - E-COATED
9	061420-09-000	EA	PLUG/PLASTIC - 1.00" DIAMETER
10	061420-15-000	EA	PLUG/PLASTIC - 2.00" DIAMETER - BLACK
11	156785-05-02B	EA	BRACKET - A/C SUPPORT - E-COATED
12	144746-12-02B	EA	COMPARTMENT - FURNACE - E-COATED
13	140930-02-02B	EA	COMPARTMENT - GENERATOR - E-COATED
14	123440-07-02B	EA	SUPPORT - PANEL - 8.7" X 4.7" - E-COATED
15	123440-02-02B	EA	SUPPORT - PANEL - 9.9"/7.6" X 4.7" - E-COATED
16	156548-04-02B	EA	SUPPORT - A/C - E-COATED
17	144365-01-02B	EA	PLATE/SEAL - E-COATED

FROM: 00-00-00 THRU: 10-10-06

FROM: 10-11-06 THRU: 99-99-99

CHASSIS GROUP (CONTINUED)
FRAME (CONTINUED)

KEY	PART NUMBER	U/M	DESCRIPTION
18	144365-57-02B	EA	PLATE/SEAL - E-COATED
19	126516-01-01A	FT	TRIM - VINYL/EXTRUDED - 8'
20	137098-32-02B	EA	PLATE/SEAL - E-COATED
21	137098-40-02B	EA	PLATE/SEAL - E-COATED
22	137098-36-02B	EA	PLATE/SEAL - E-COATED
23	144365-12-02B	EA	PLATE/SEAL - E-COATED
24	133612-05-02B	EA	ZEE/SEAL PLANE - BOTTOM - E-COATED
25	137103-23-02B	EA	PLATE/SEAL - E-COATED
26	137103-01-02B	EA	PLATE/SEAL - E-COATED
27	136388-07-02B	EA	GUARD/ROCK - STEEL - 18" X 11" - E-COATED
28	138113-01-02B	EA	OUTRIGGER/GENERATOR - E-COATED
29	133833-01-02B	EA	HANGER - A/C - E-COATED
30	136538-01-02B	EA	SHIM - HITCH - E-COATED
	113452-01-000	EA	SEAL/TRIM - FRONT - VINYL W/WIRE CARRIER - .020"

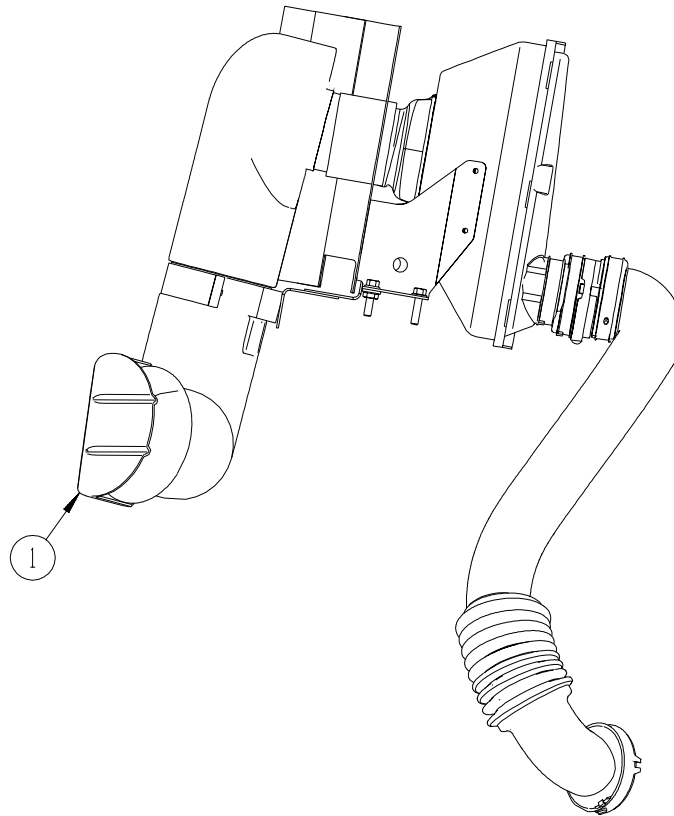

AIR INTAKE

KEY	PART NUMBER	U/M	DESCRIPTION
1	154181-01-10A	EA	DEFLECTOR - AIR INTAKE - WORKHORSE - BLACK

CHASSIS GROUP (CONTINUED) FRONT END

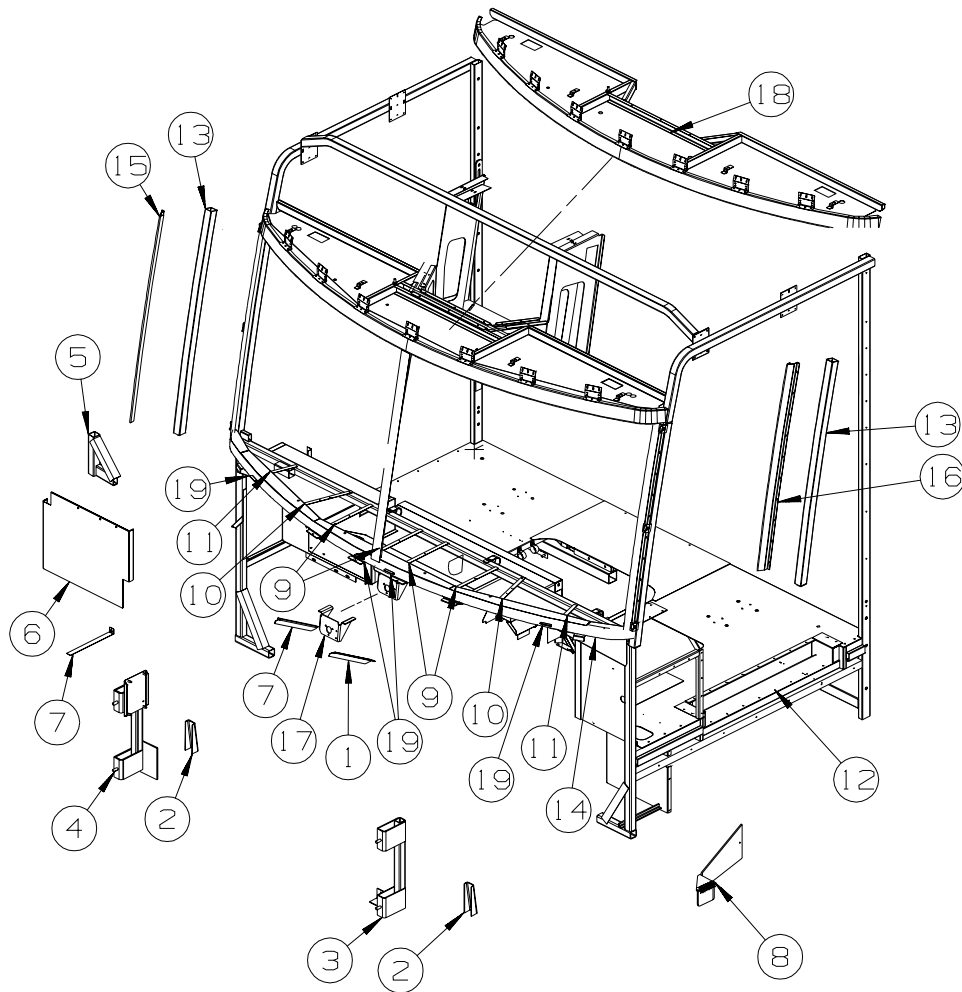

FORD

KEY	PART NUMBER	U/M	DESCRIPTION
1	134371-01-01B	EA	ANGLE/MOUNT - WIPER MOTOR
2	117622-01-02B	EA	BRACE - TUBE/BUMPER - VERTICAL - E-COATED
3	152916-01-02B	EA	SUPPORT - FRONT - E-COATED
4	152916-05-02B	EA	SUPPORT - FRONT - E-COATED
5	152725-02-02B	EA	SUPPORT - WHEEL LIP - E-COATED
6	144679-02-02B	EA	SHIELD/SPLASH - HEADLIGHT - E-COATED
7	134371-02-01B	EA	ANGLE/MOUNT - WIPER MOTOR
8	152131-01-04B	EA	STEP - DRIVER DOOR - BLACK - F33V
9	137047-04-01B	EA	STRAP - DEFROSTER PLENUM
10	137047-05-01B	EA	STRAP - DEFROSTER PLENUM
11	137047-06-01B	EA	STRAP - DEFROSTER PLENUM
12	146492-02-01B	EA	PANEL - STEPWELL
13	117273-01-01A	EA	TUBE - SUPPORT - A-PILLAR
14	124974-01-01B	EA	SUPPORT - WINDSHIELD, LOWER, MILL FINISH
15	156767-01-01B	EA	FRAME - WINDSHIELD - A-PILLAR - MILL
16	156767-02-01B	EA	FRAME - WINDSHIELD - A-PILLAR - MILL
17	134506-04-01B	EA	BRACKET - WIPER MOTOR
18	132793-03-01B	EA	HEADER - WINDSHIELD
19	126289-65-01B	EA	ANGLE - FORMED - 4 USED

CHASSIS GROUP (CONTINUED) FRONT END (CONTINUED)

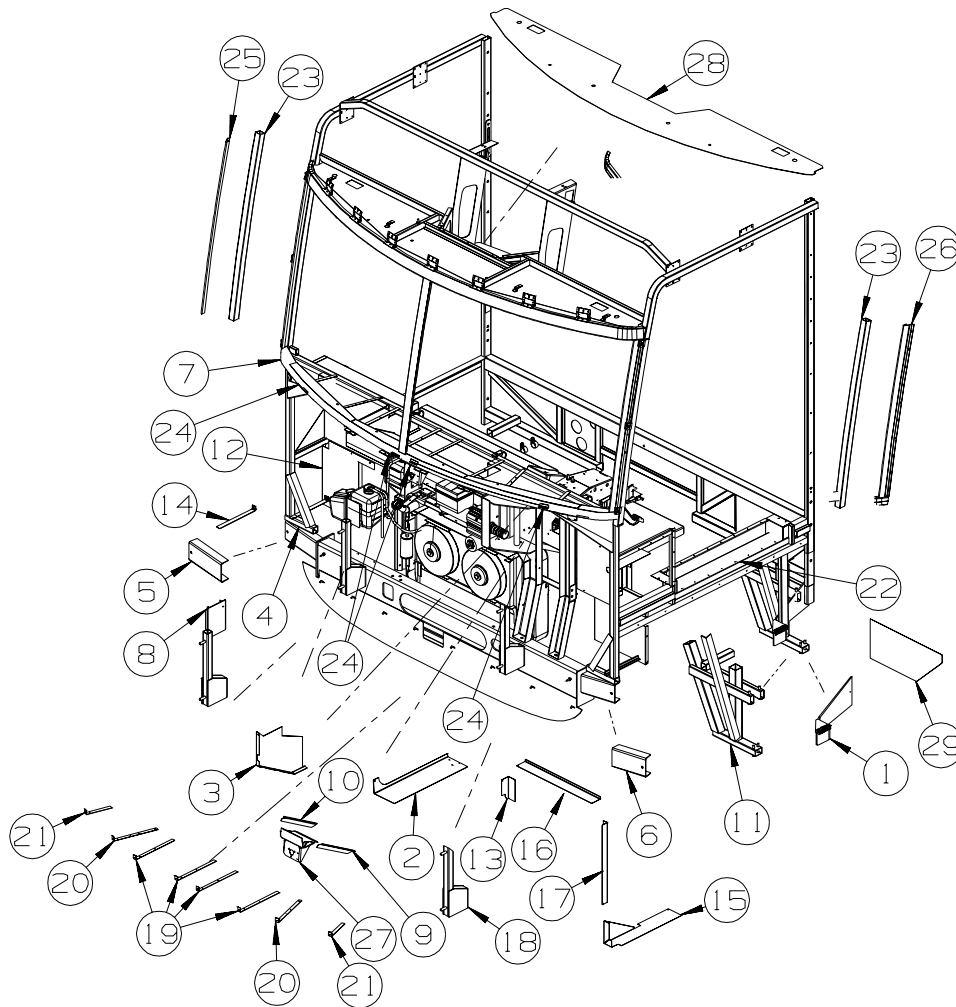

WORKHORSE

KEY	PART NUMBER	U/M	DESCRIPTION
1	152131-01-04B	EA	STEP - DRIVER DOOR - BLACK - F33V
2	137041-01-02B	EA	ANGLE/FILLER - MOTOR COVER - E-COATED
3	150565-01-02B	EA	PANEL - CLOSE OUT - CAB - E-COATED
4	152725-02-02B	EA	SUPPORT - WHEEL LIP - E-COATED
5	137048-02-02B	EA	CHANNEL/SUPPORT - FRONT END - E-COATED
6	137048-01-02B	EA	CHANNEL/SUPPORT - FRONT END - E-COATED
7	124974-01-01B	EA	SUPPORT - WINDSHIELD, LOWER, MILL
8	134807-11-02B	EA	SUPPORT - FRONT - E-COATED - INCLUDES RESERVOIR BRACKET
9	134371-01-01B	EA	ANGLE/MOUNT - WIPER MOTOR
10	134371-02-01B	EA	ANGLE/MOUNT - WIPER MOTOR
11	138340-01-02B	EA	SUPPORT/STEP - DRIVER - E-COATED - CHASSIS W/22.5 TIRE - F35A, F35L, F38J
12	121962-02-02B	EA	SHIELD/SPLASH - HEADLIGHT - E-COATED
13	139131-01-02B	EA	ANGLE - W/NOTCH - E-COATED
14	139119-01-02B	EA	STRAP - BENT, W/HOLE - E-COATED
15	137045-01-02B	EA	PANEL - FILLER, BULKHEAD - E-COATED
16	137037-01-02B	EA	ANGLE/FILLER - E-COATED
17	137037-02-02B	EA	ANGLE/FILLER - E-COATED
18	134807-12-02B	EA	SUPPORT - FRONT - E-COATED
19	137047-04-01B	EA	STRAP - DEFROSTER PLENUM
20	137047-05-01B	EA	STRAP - DEFROSTER PLENUM
21	137047-06-01B	EA	STRAP - DEFROSTER PLENUM
22	146492-02-01B	EA	PANEL - STEPWELL
23	117273-01-01A	EA	TUBE - SUPPORT - A-PILLAR
24	126289-65-01B	EA	ANGLE - FORMED
25	156767-01-01B	EA	FRAME - WINDSHIELD - A-PILLAR - MILL
26	156767-02-01B	EA	FRAME - WINDSHIELD - A-PILLAR - MILL
27	134506-04-01B	EA	BRACKET - WIPER MOTOR
28	132793-03-01B	EA	HEADER - WINDSHIELD, MILL
29	137496-01-01B	EA	PANEL - SPLASH GUARD - F35A, F35L, F38J

CHASSIS GROUP (CONTINUED)
DRIVETRAIN

WORKHORSE F38J

KEY	PART NUMBER	U/M	DESCRIPTION
	128528-03-000	EA	BOLT - U-JOINT - 3/8-24 X 3/4
	128528-04-000	EA	STRAP - BEARING - 1480 JOINT
	138616-01-02B	EA	BRACKET/BEARING MOUNT - FRONT/248" W B - E-COATED - 228 STRETCH TO 248, 24000 GVWR
	138616-02-02B	EA	BRACKET/BEARING MOUNT - MID-RR/248" W B - E-COATED - 228 STRETCH TO 248, 24000 GVWR
	138126-05-000	EA	DRIVESHAFT-BAL-4 SEC-WH W2 -248" WB - 228 STRETCH TO 248, 24000 GVWR W/DISC PARK BRAKE

EXHAUST

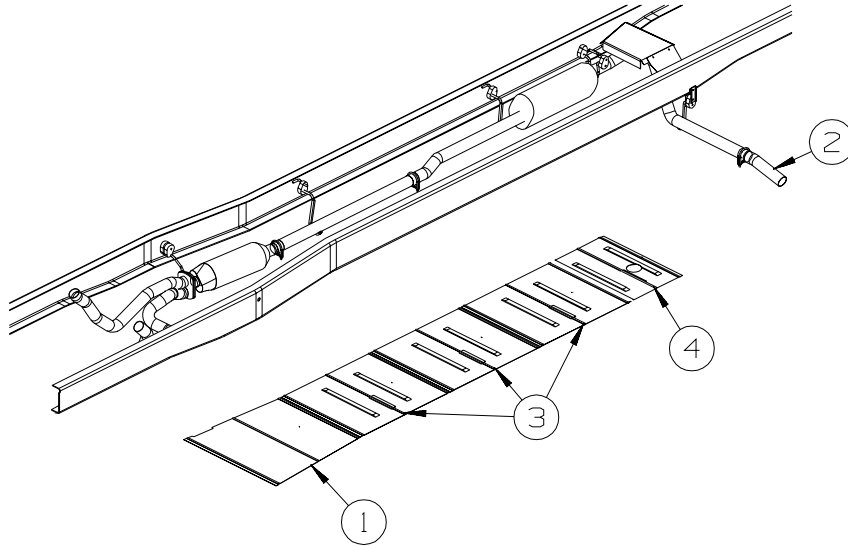

228" WHEELBASE

**FORD
F35A, F35L**

KEY	PART NUMBER	U/M	DESCRIPTION
1	128756-01-02B	EA	SHIELD - HEAT/EXHAUST - 33.9" X 16.9" - E-COATED
2	142985-01-000	EA	PIPE - EXHAUST
3	143712-05-02B	EA	SHIELD/HEAT - EXHAUST - E-COATED
4	143712-07-02B	EA	SHIELD/HEAT - EXHAUST - E-COATED

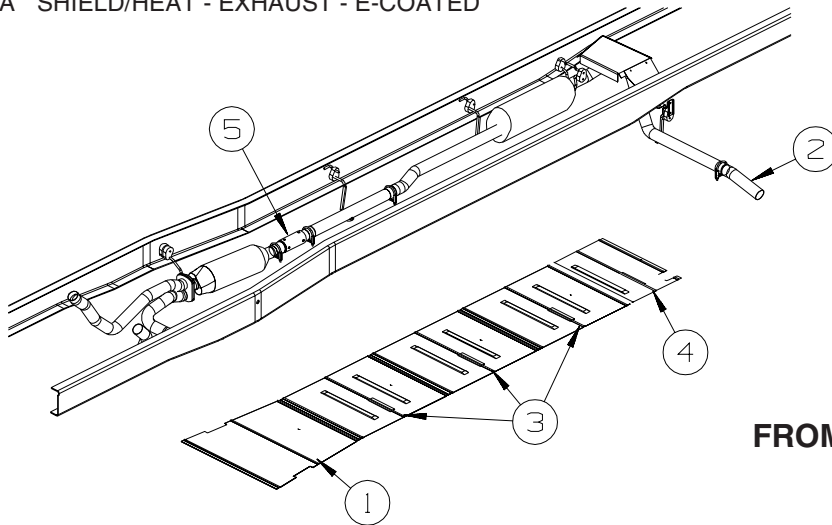

STRETCH 208" WHEELBASE
TO 228" WHEELBASE

**FORD
F35A, F35L
FROM 01-20-07 THRU 02-09-07**

KEY	PART NUMBER	U/M	DESCRIPTION
1	128756-01-02B	EA	SHIELD - HEAT/EXHAUST - 33.9" X 16.9" - E-COATED
2	142985-01-000	EA	PIPE - EXHAUST
3	143712-05-02B	EA	SHIELD/HEAT - EXHAUST - E-COATED
4	143712-07-02B	EA	SHIELD/HEAT - EXHAUST - E-COATED
5	112012-03-000	EA	PIPE - EXHAUST - 3" DIAMETER - FORD CHASSIS

CHASSIS GROUP (CONTINUED)
EXHAUST (CONTINUED)

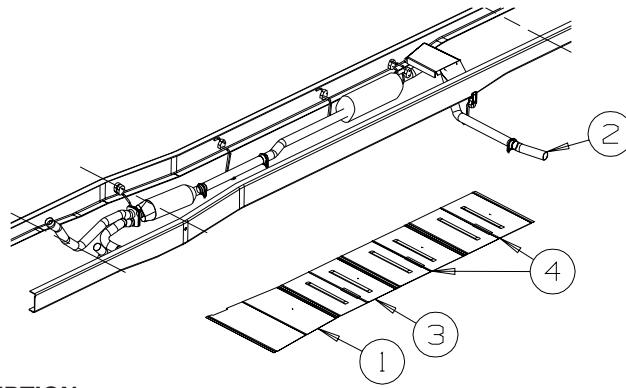

**FORD
F33V**

KEY	PART NUMBER	U/M	DESCRIPTION
1	128756-01-02B	EA	SHIELD - HEAT/EXHAUST - 33.9" X 16.9" - E-COATED
2	142985-01-000	EA	PIPE - EXHAUST
3	143712-02-02B	EA	SHIELD - HEAT/EXHAUST - E-COATED
4	143712-05-02B	EA	SHIELD/HEAT - EXHAUST - E-COATED

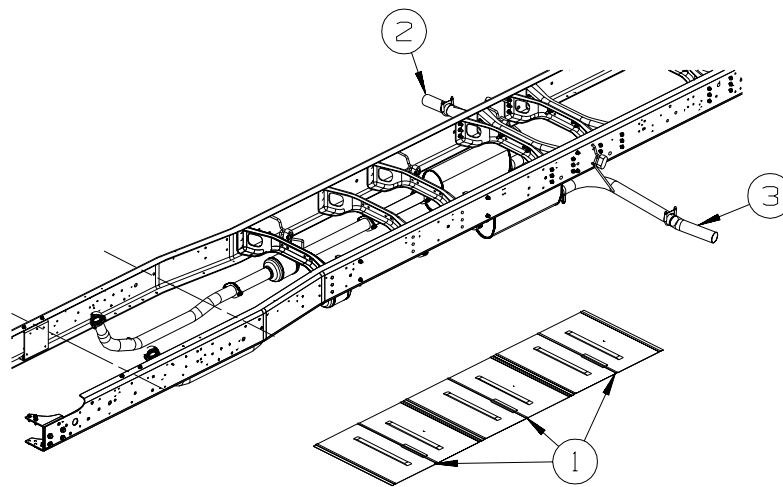

**WORKHORSE
F33V**

208" WHEELBASE

KEY	PART NUMBER	U/M	DESCRIPTION
1	143712-05-02B	EA	SHIELD - HEAT/EXHAUST - E-COATED
2	098762-05-000	EA	EXTENSION - EXHAUST - STRAIGHT - 3" O.D X 7.9" LONG - SST
	094918-01-000	EA	CLAMP - EXHAUST - 3" - GUILLOTINE STYLE
3	142985-01-000	EA	PIPE - EXHAUST

CHASSIS GROUP (CONTINUED)
EXHAUST (CONTINUED)

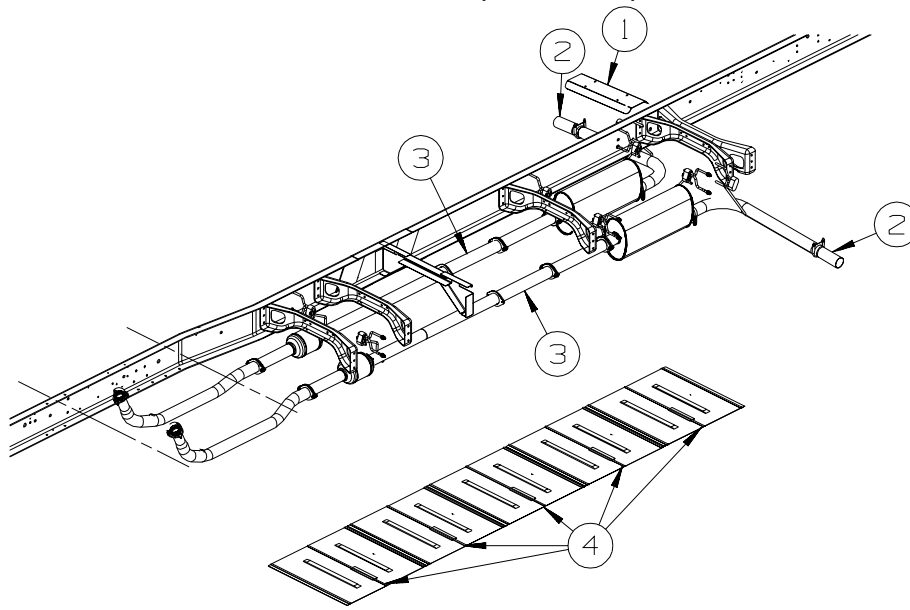

**WORKHORSE
F38J**

248" WHEELBASE

KEY	PART NUMBER	U/M	DESCRIPTION
1	150346-01-09B	EA	SHIELD - TAILPIPE - GALVANIZED
2	098762-05-000	EA	EXTENSION - EXHAUST - STRAIGHT - 3" O.D X 7.9" LONG - SST
3	137652-06-000	EA	PIPE - EXHAUST W/FLANGES
4	143712-02-02B	EA	SHIELD/HEAT - EXHAUST - E-COATED
	094918-01-000	EA	CLAMP - EXHAUST - 3" - GUILLOTINE STYLE

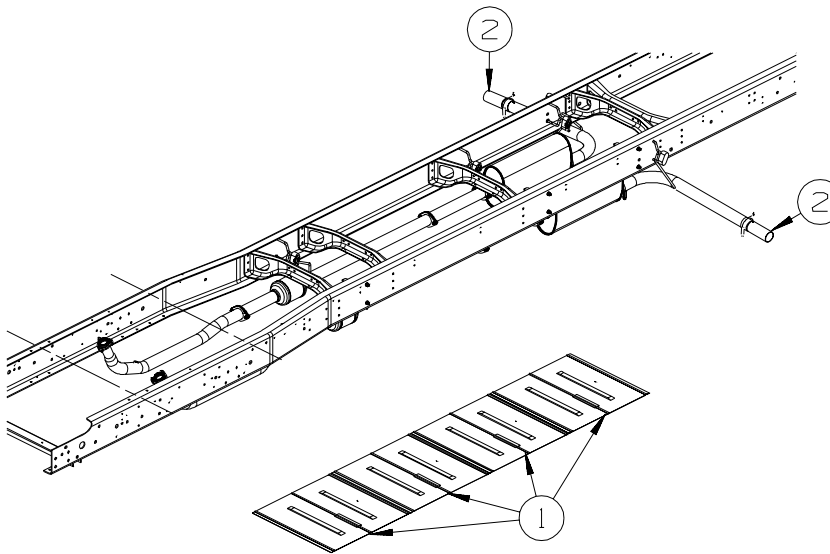

**WORKHORSE
F35A, F35L**

228" WHEELBASE

KEY	PART NUMBER	U/M	DESCRIPTION
1	128756-01-02B	EA	SHIELD - HEAT/EXHAUST - 33.9" X 16.9" - E-COATED
2	098762-05-000	EA	EXTENSION - EXHAUST - STRAIGHT - 3" O.D X 7.9" LONG - SST
	094918-01-000	EA	CLAMP - EXHAUST - 3" - GUILLOTINE STYLE

CHASSIS GROUP (CONTINUED)

FUEL

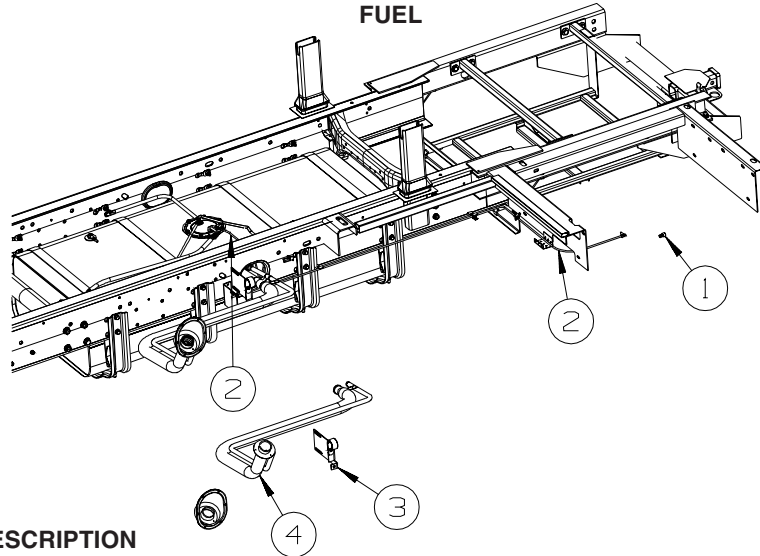

FORD

KEY	PART NUMBER	U/M	DESCRIPTION
1	084884-01-000	EA	PLUG - BRASS - 3/8"
2	128139-03-000	FT	HOSE - FUEL - LOW PERMEABILITY - 1/4" DIAMETER
3	140728-02-02B	EA	BRACKET - FUEL FILL - E-COATED
4	153027-01-000	EA	NECK - FUEL FILL

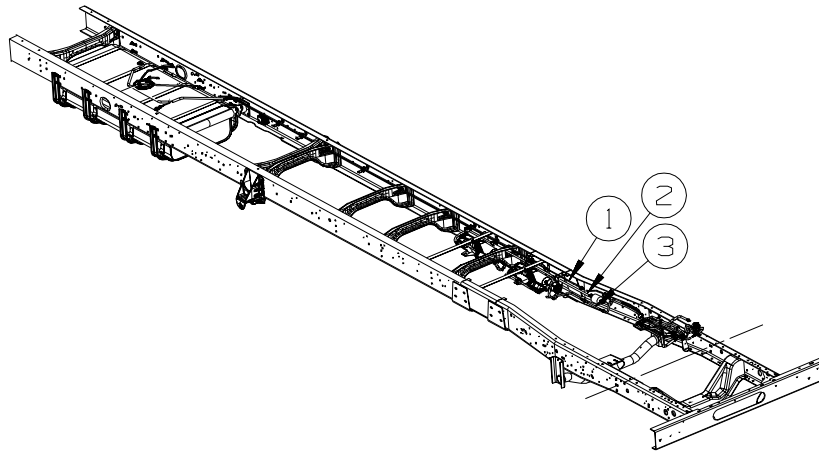

FORD
F38J

KEY	PART NUMBER	U/M	DESCRIPTION
1	155360-02-000	EA	EXTENSION - TUBE/VAPOR 5/16" - FUEL TANK VENT
2	129494-03-000	EA	FUEL LINE - 5/16" X 21.2" - FORD CHASSIS
3	155359-01-000	EA	EXTENSION - TUBE/VAPOR 1/2" - EMISSION CANISTER

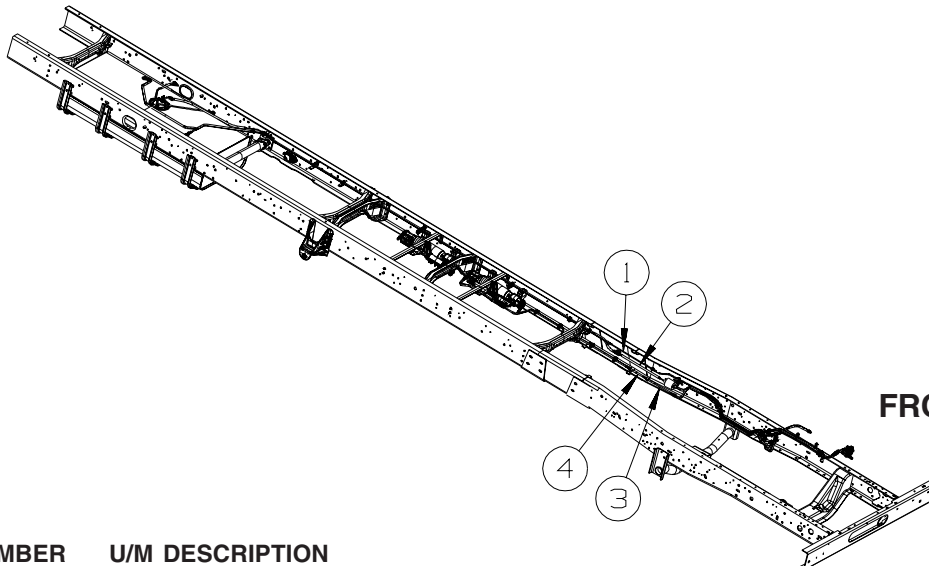

FORD
F35A, F35L
FROM 01-20-07 THRU 02-09-07

KEY	PART NUMBER	U/M	DESCRIPTION
1	155360-02-000	EA	EXTENSION - TUBE/VAPOR 5/16" - FUEL TANK VENT
2	129494-03-000	EA	FUEL LINE - 5/16" X 21.2" - FORD CHASSIS
3	155359-01-000	EA	EXTENSION - TUBE/VAPOR 1/2" - EMISSION CANISTER
3	155359-03-000	EA	EXTENSION - TUBE/VAPOR 1/2" - EMISSION CANISTER

CHASSIS GROUP (CONTINUED)
FUEL (CONTINUED)

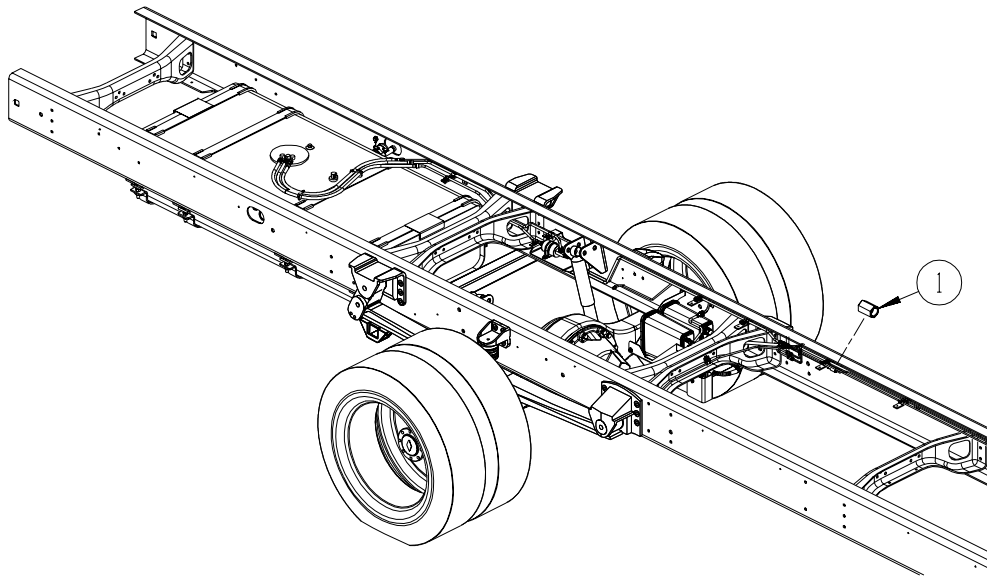

WORKHORSE

KEY	PART NUMBER	U/M DESCRIPTION
1	098779-02-000	EA COUPLER - FUEL LINE - 1.2" LONG X 16MM THREAD - STRETCHED CHASSIS ONLY

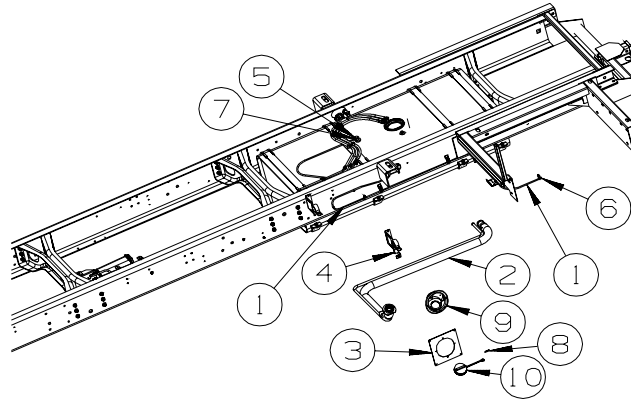

WORKHORSE

KEY	PART NUMBER	U/M DESCRIPTION
1	128139-03-000	FT HOSE - FUEL - LOW PERMEABILITY - 1/4" DIAMETER
2	136300-02-000	EA NECK - FUEL FILL
3	139138-01-02B	EA PLATE - FUEL FILL - E-COATED
4	140728-03-02B	EA BRACKET - FUEL FILL - E-COATED
5	068382-06-000	EA BUSHING - BRASS - 3/8"MPT X 1/8"FPT
6	084884-01-000	EA PLUG - BRASS - 3/8"
7	114254-01-000	EA ADAPTER - 1/4 BARB X 1/8 MPT
8	099069-01-000	EA SEAL - RUBBER - CLOSED SPONGE - .5" WIDE X .12" THICK-BLK
9	128299-02-01A	EA SHROUD - FUEL FILL
10	163743-01-000	EA CAP - FUEL FILL - 1/4 TURN - WORKHORSE

CHASSIS GROUP (CONTINUED)

SPARE TIRE

KEY	PART NUMBER	U/M	DESCRIPTION
	102340-08-000	EA	TIRE - 245/70R X 19.5F - GOODYEAR - FORD
	091673-07-000	EA	TIRE - 225/70R19.5 LRF - MICHELIN XRV - W16/W18 16000/18000 GVWR WORKHORSE
	102340-07-000	EA	TIRE - 245/70R X 19.5F - MICHELIN XRV - W20 20700 GVWR WORKHORSE
	102340-09-000	EA	TIRE - 245/70R X 19.5G - GOODYEAR - W21 21200 GVWR WORKHORSE WHEEL - FORD IS CHASSIS SUPPLIED
	156482-01-000	EA	WHEEL - STEEL - 19.5" X 6" - 10 BOLT - W16/W18 16000/18000 GVWR WORKHORSE
	118814-05-000	EA	WHEEL - STEEL - 19.5" X 6.75" - W/STEM - GRAY - W20/W21 20700/21200 GVWR WORKHORSE
	051377-07-000	EA	VALVE STEM - 1.5" - W16/W18 16000/18000 GVWR WORKHORSE
	051377-01-000	EA	VALVE STEM - W20 20700 GVWR WORKHORSE
	051377-06-000	EA	VALVE STEM - .5" X 2 1/3" W/22 DEGREE BEND - W21 21200 GVWR WORKHORSE

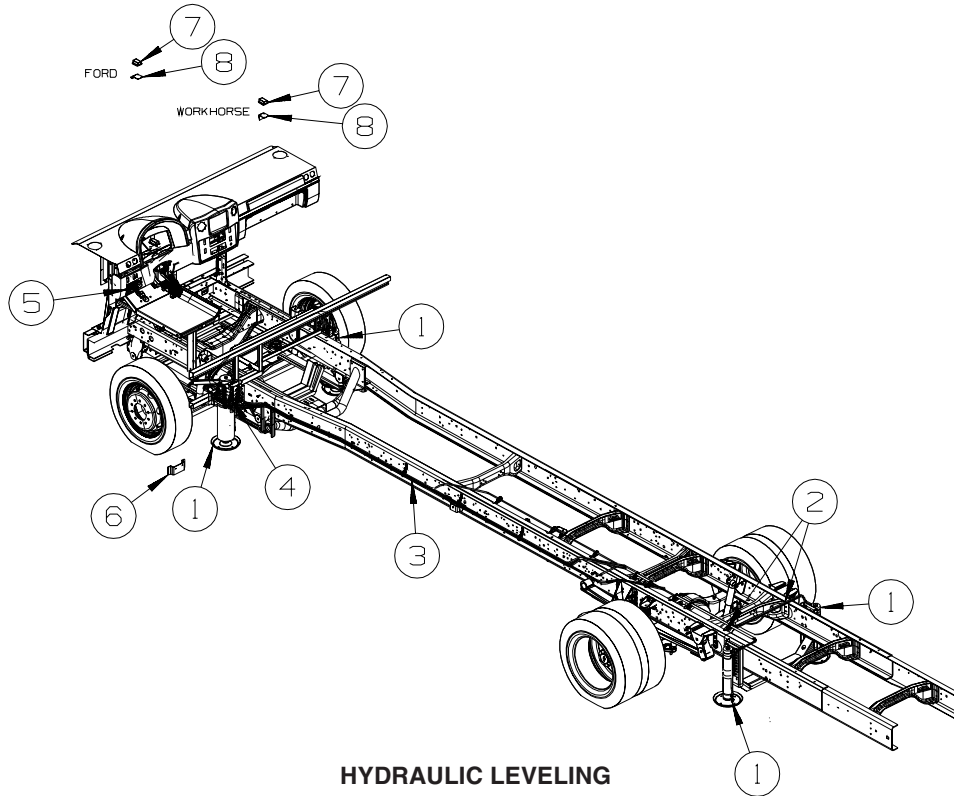

HYDRAULIC LEVELING

KEY	PART NUMBER	U/M	DESCRIPTION
1*	139641-09-000	EA	LEVELING SYSTEM - W/O PUMP - W/HARNESS/RMT SWITCH CAPABLE - FORD - F33V, F35A, F35L
1*	139641-10-000	EA	LEVELING SYSTEM-W/O PUMP-W/HARNESS/RMT SWITCH CAPABLE - WH - F33V, F35A, F35L
2	126624-01-02B	EA	ANGLE - WIRE SUPPORT - E-COAT
3	139644-03-000	EA	HOSE KIT - LEVELING JACKS
4	156056-01-000	EA	PUMP - F/MANUAL LEVELING SYSTEM
4	156056-02-000	EA	PUMP - F/AUTOMATIC LEVELING SYSTEM
5	139643-02-000	EA	CONTROL - LEVEL W/O INDIVIDUAL CONTROLS - RECTANGLE BOX
5	139643-08-000	EA	CONTROL - LEVEL - AUTO SYST-W/SENSOR HARNESS/RMT SW CAPABLE
6	154816-01-02B	EA	BRACKET - PUMP/LEVELING - E-COATED
7	156057-01-000	EA	SENSOR - F/AUTOMATIC LEVELING SYSTEM - #1802923
8	153870-01-02B	EA	BRACKET - SENSOR/LEVEL - E-COATED - WORKHORSE
8	153870-02-02B	EA	BRACKET - SENSOR/LEVEL - E-COATED - FORD

*COMPONENT PARTS LISTED LATER IN THIS GROUP

CHASSIS GROUP (CONTINUED)
HYDRAULIC LEVELING (CONTINUED)

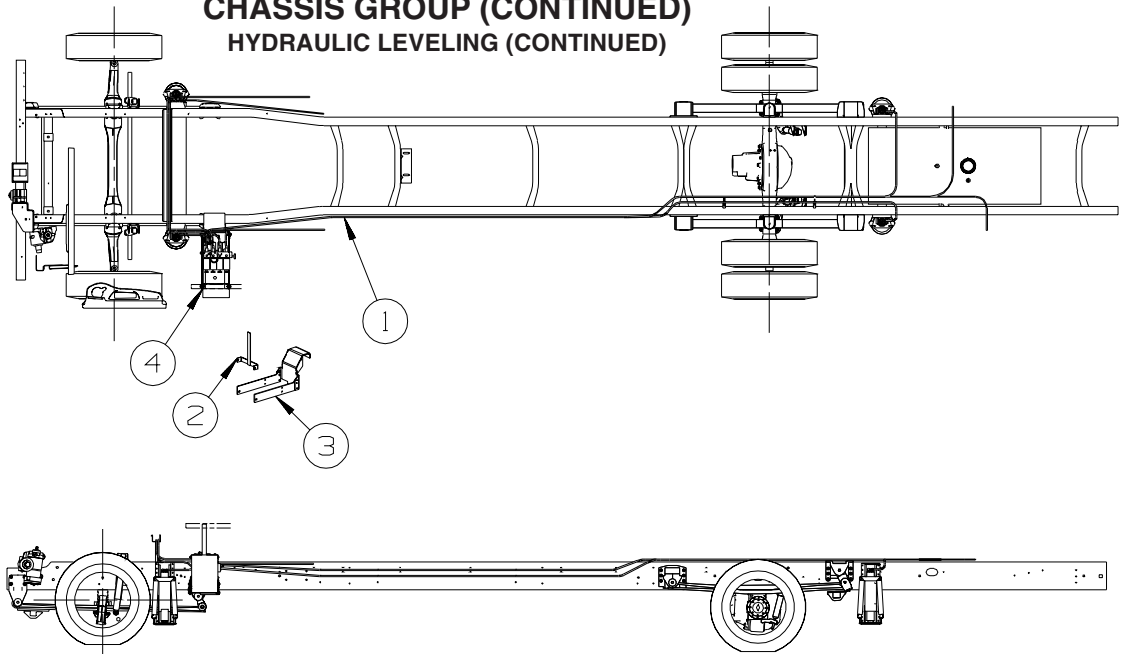

KEY	PART NUMBER	U/M	DESCRIPTION
1*	100536-57-000	EA	HOSE KIT - F/LEVELING JACKS
2	149900-01-02B	EA	BRACKET - PUMP/LEVELING SYSTEM - E-COATED
3	150001-01-02B	EA	BRACKET - PUMP/LEVELING SYSTEM - E-COATED
4	153452-19-000	EA	LEVELING SYSTEM - 625 SYSTEM W/3 SLIDEOUTS - WORKHORSE - F38J

***COMPONENT PARTS LISTED LATER IN THIS GROUP**

COMPONENT PARTS FOR HYDRAULIC LEVELING

100536-57-000

KEY	PART NUMBER	U/M	DESCRIPTION	VENDOR NO.
	100536-09-700	EA	HOSE-HYDRAULIC-324"	RAP91489/AP2464
	100536-26-700	EA	HOSE - HYDRAULIC-1/4" X 100"	RAP90077/AP7832
	115767-01-705	EA	HOSE-HYDRAULIC - 1/4" X 60"	RAP4073/AP4073
	135250-02-700	EA	HOSE-HYDRAULIC - 1/4" X 300"	RAP90806/AP4064

139641-09-000

KEY	PART NUMBER	U/M	DESCRIPTION	VENDOR NO.
	139641-01-701	EA	HARNES - AIR PUMP/WARN LIGHT	1809891
	139641-01-704	EA	SWITCH/SENSOR-JACK (UP/DOWN)	1812992
	139641-01-705	EA	FITTING HYD (1/4"X90 DEGREE)	1904500
	139641-01-706	EA	FITTING HYD (1/4" STRAIGHT)	1904510
	139641-01-709	EA	JACK - REAR 15"/10K	3700701
	139641-01-710	EA	CYLINDER ONLY - 15"/10K	1905200
	139641-01-715	EA	BOLT KIT(CROSS MBR/JK/PUMP)	3717794
	139641-01-720	EA	JACK - FRONT 15"/10K	3700702
	139641-01-723	EA	FOOT PAD - JACK	3700367
	139641-01-724	EA	BOLT/FOOT - 3/4-10 X 1 1/2"	1204645
	139641-01-725	EA	HARNES - EMERGENCY RETRACT	1809908
	139641-02-700	EA	HARNES F/READ SWITCH (FORD)	1809911
	139641-02-701	EA	BRACKET MTG (F53/W22 REAR)	3717742
	139641-02-703	EA	CROSS MEMBER/REAR (F53/W22)	3717795
	139641-09-700	EA	BRACKET/MOUNTING (F53 FRONT)	3717809
	139641-09-701	EA	BRACKET/FRONT X-MEMBER	3717808

CHASSIS GROUP (CONTINUED)
COMPONENT PARTS FOR HYDRAULIC LEVELING (CONTINUED)

139641-10-000

KEY	PART NUMBER	U/M	DESCRIPTION	VENDOR NO.
	139641-01-701	EA	HARNESS -AIR PUMP/WARN LIGHT	1809891
	139641-01-704	EA	SWITCH/SENSOR-JACK (UP/DOWN)	1812992
	139641-01-705	EA	FITTING HYD (1/4"X90 DEGREE)	1904500
	139641-01-706	EA	FITTING HYD (1/4" STRAIGHT)	1904510
	139641-01-709	EA	JACK - REAR 15"/10K	3700701
	139641-01-710	EA	CYLINDER ONLY - 15"/10K	1905200
	139641-01-711	EA	BRACKET MTG (WORKHORSE REAR)	3717740
	139641-01-715	EA	BOLT KIT(CROSS MBR/JK/PUMP)	3717794
	139641-01-720	EA	JACK - FRONT 15"/10K	3700702
	139641-01-723	EA	FOOT PAD - JACK	3700367
	139641-01-724	EA	BOLT/FOOT - 3/4-10 X 1 1/2"	1204645
	139641-01-725	EA	HARNESS - EMERGENCY RETRACT	1809908
	139641-02-700	EA	HARNESS F/READ SWITCH (FORD)	1809911
	139641-02-701	EA	BRACKET MTG (F53/W22 REAR)	3717742
	139641-02-703	EA	CROSS MEMBER/REAR (F53/W22)	3717795
	139641-03-700	EA	CROSSMEMBER/FRONT (W22)	3717804

CHASSIS GROUP (CONTINUED)

WHEEL, TIRE, COVERS &/OR LINERS

KEY	PART NUMBER	U/M	DESCRIPTION
*	145580-03-000	EA	LINER - WHEEL(SET OF 4) - 19.5" - 8 BOLT/4HAND HOLE - WORKHORSE W/19.5 TIRE
*	145580-02-000	EA	LINER - WHEEL(SET OF 4) - 22.5"/10 BOLT - WORKHORSE W/22.5 TIRE
*	154672-01-000	EA	LINER - WHEEL - SET/4 - 19.5 - 10 BOLT - FORD
*	150723-01-000	EA	COVER/HUB-SET-FT & RR HUBS/NUT CVRS/TOOL - FORD ALUMINUM WHEELS
	077030-10-000	EA	EXTENSION - VALVE STEM - .50" - METAL
	095012-10-000	EA	EXTENSION/VALVE STEM - LIVE - 8.5"
	095012-07-000	EA	STABILIZER/VALVE EXTENSION - LIVE - 4"

*COMPONENT PARTS LISTED LATER IN THIS GROUP

COMPONENT PARTS FOR WHEEL, TIRE, COVERS &/OR LINERS

145580-02-000

KEY	PART NUMBER	U/M	DESCRIPTION	VENDOR NO.
	110435-04-705	EA	DECAL-CTR HUB 2 3/4" DIAMO	2 3/4 DECAL DIAMOND
	110435-05-700	EA	CAP-CENTER, POP-OUT 4 1/2"	V22510-POC
	145580-01-702	EA	COVER-LUG NUT/JAM NUT 22M	V22501-EJN
	145580-01-703	EA	TOOL-INSTALLATION	V22501-TOL
	145580-02-700	EA	LINER - WHEEL/FRONT - 1EA=1	V22569-FWC
	145580-02-701	EA	LINER - WHEEL/REAR - 1EA=1	V22569-RWC

145580-03-000

KEY	PART NUMBER	U/M	DESCRIPTION	VENDOR NO.
	110435-04-705	EA	DECAL-CTR HUB 2 3/4"	2 3/4 DECAL DIAMOND
	110435-05-700	EA	CAP-CENTER 4.50"D W/O DECAL	V22510-POC
	110435-12-700	EA	LINER - WHEEL - FRONT	V19580-FWC
	110435-12-701	EA	LINER - WHEEL - REAR	V19580-RWC
	145580-01-702	EA	COVER-LUG NUT/JAM NUT 22M	V19582-EJN
	145580-01-703	EA	TOOL-INSTALLATION	V22501-TOL

154672-01-000

KEY	PART NUMBER	U/M	DESCRIPTION	VENDOR NO.
	154672-01-700	EA	LINER - WHEEL - FRONT	V195F6-FWC
	154672-01-701	EA	LINER - WHEEL - REAR	V195F6-RWC

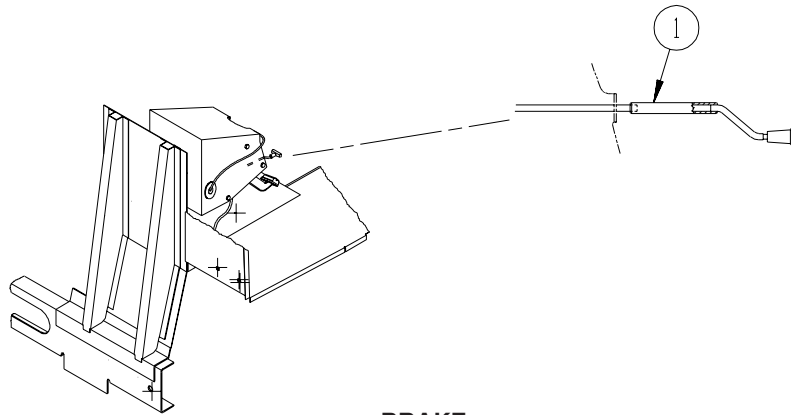

BRAKE

KEY	PART NUMBER	U/M	DESCRIPTION
1	113007-01-000	EA	PIN - SPRING - .375 X 3"

BRAKELINE

KEY	PART NUMBER	U/M	DESCRIPTION
	075466-01-000	EA	UNION - INVERTED FLAIR - 1/4"

CURTAIN & CUSHION GROUP

NOTICE

IN ORDER TO ASSIST OUR PARTS SALES DEPT. IN PROVIDING INTERIOR SOFTWARE ITEMS, PLEASE INCLUDE THE SERIAL NUMBER AND THE COLOR CODE NUMBER FROM THE VEHICLE CERTIFICATION LABEL WHEN ORDERING. THIS LABEL IS LOCATED ON THE LEFT SIDEWALL AT THE END OF THE DASH (A-BODY), OR ON THE DRIVER'S DOOR LATCH PLATE (C-BODY).

AN EXAMPLE OF A COLOR CODE NUMBER IS B07, WHICH DESIGNATES AN OVERALL COLOR SCHEME OF A PARTICULAR UNIT. THE COLOR LISTED AFTER THE ITEM DESCRIPTION ON THE MICROFICHE, INDICATES THE OVERALL UNIT COLOR. ORDER THE ITEM YOU DESIRE ACCORDING TO UNIT COLOR CODE. IF ALL COLORS USE THE SAME ITEM NO COLOR CODE WILL BE NOTED.

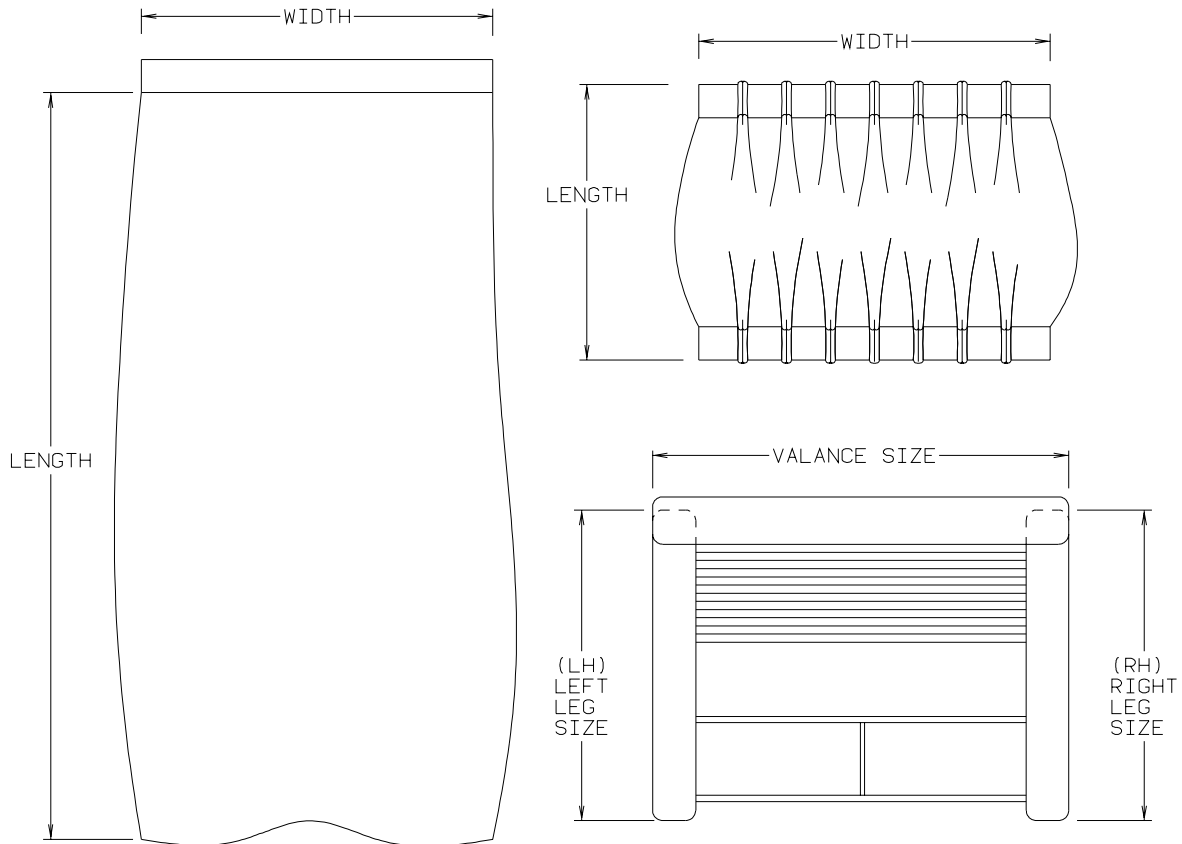

NOTE: USE THIS ILLUSTRATION WHEN DETERMINING LENGTH AND WIDTH MEASUREMENTS FOR CURTAINS. YOU WILL NOTE THE WIDTH MEASUREMENT IS TAKEN ON THE TOP OF THE CURTAIN WITH THE CURTAIN FULLY EXTENDED. THE LENGTH MEASUREMENT IS TAKEN FROM TOP TO BOTTOM. LEFT AND RIGHT WINDOW LEGS ARE DETERMINED WHEN FACING THE WINDOW.

CURTAIN & CUSHION GROUP (CONTINUED)

CUSHION LAYOUT

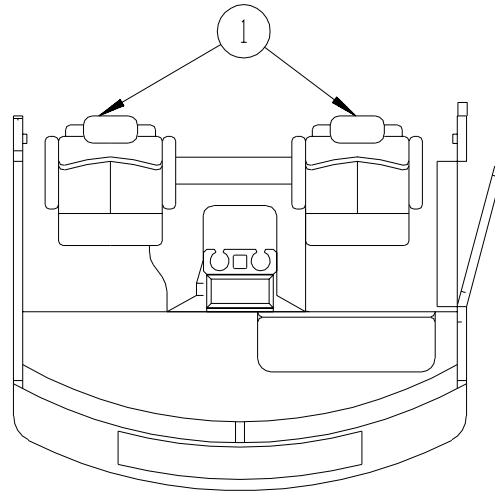

KEY	PART NUMBER	U/M	DESCRIPTION
1	145491-07-U67	EA	SEAT - BUCKET - W/LUMBAR (U67,U68)
1	145491-08-U71	EA	SEAT - BUCKET - W/LUMBAR (U71,U72)
1	145491-08-U75	EA	SEAT - BUCKET - W/LUMBAR (U75,U76)
1	145491-09-U67	EA	SEAT - BUCKET - W/LUMBAR - LEATHER - LEATHER

CURTAIN & CUSHION GROUP (CONTINUED)
CUSHION LAYOUT (CONTINUED)

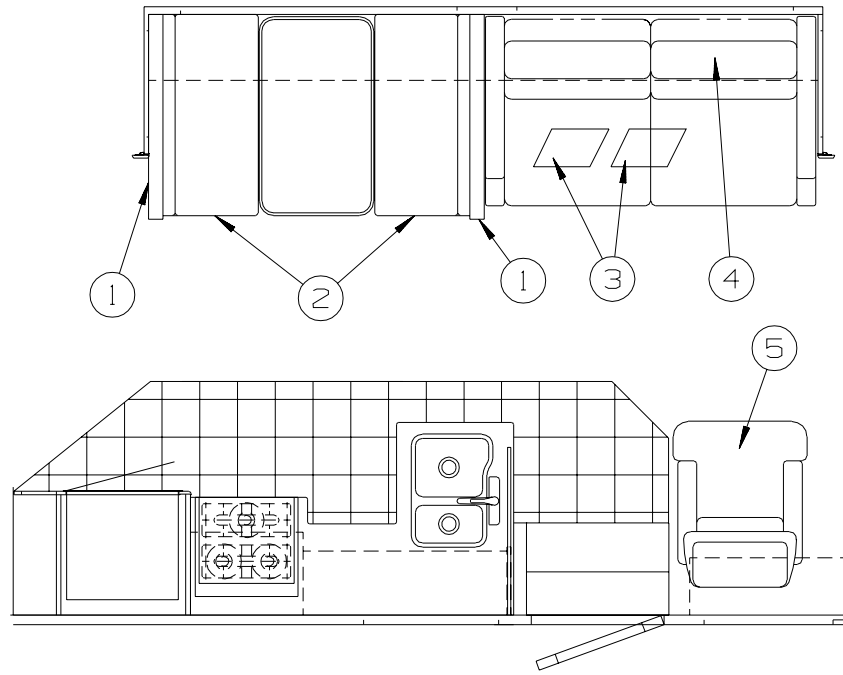

KEY	PART NUMBER	U/M	DESCRIPTION
1	155036-06-U67	EA	BACK - DINETTE CUSHION - 10" X 40" (U67,U68)
1	155036-06-U71	EA	BACK - DINETTE CUSHION - 10" X 40" (U71,U72)
1	155036-06-U75	EA	BACK - DINETTE CUSHION - 10" X 40" (U75,U76)
	P55036-06-U67	EA	COVER/BACK - DINETTE CUSHION - 10" X 40" (U67,U68)
	P55036-06-U71	EA	COVER/BACK - DINETTE CUSHION - 10" X 40" (U71,U72)
	P55036-06-U75	EA	COVER/BACK - DINETTE CUSHION - 10" X 40" (U75,U76)
	143730-01-000	EA	CAP - F/DINETTE BRACKET TUBE - PLASTIC
2	142292-01-U67	EA	SEAT - DINETTE CUSHION (SPRUNG) - 22" X 37" (U67,U68)
2	142292-01-U71	EA	SEAT - DINETTE CUSHION (SPRUNG) - 22" X 37" (U71,U72)
2	142292-01-U75	EA	SEAT - DINETTE CUSHION (SPRUNG) - 22" X 37" (U75,U76)
	P42292-01-U67	EA	COVER/SEAT - DINETTE CUSHION (SPRUNG) - 22" X 37" (U67,U68)
	P42292-01-U71	EA	COVER/SEAT - DINETTE CUSHION (SPRUNG) - 22" X 37" (U71,U72)
	P42292-01-U75	EA	COVER/SEAT - DINETTE CUSHION (SPRUNG) - 22" X 37" (U75,U76)
	142366-03-000	EA	FRAME - SPRUNG - DINETTE SEAT
3	149993-01-U67	EA	PILLOW - 18" - W/FRINGE (U67,U68)
3	149993-01-U71	EA	PILLOW - 18" - W/FRINGE (U71,U72)
3	149993-01-U75	EA	PILLOW - 18" - W/FRINGE (U75,U76)
4	158135-01-U67	EA	SOFA/SLEEPER - REST EASY #805/826 ARMS - 30" RAISED (U67,U68) - REST EASY
4	158135-01-U71	EA	SOFA/SLEEPER - REST EASY #805/826 ARMS - 30" RAISED (U71,U72) - REST EASY
4	158135-01-U75	EA	SOFA/SLEEPER - REST EASY #805/826 ARMS - 30" RAISED (U75,U76) - REST EASY
4	158135-02-U67	EA	SOFA/SLEEPER - REST EASY #805/826 ARMS - 30" RAISED-LTH - REST EASY/LEATHER
5	135477-14-U67	EA	CHAIR - RECLINER/SWIVEL/ROCKER - W/FOOTREST (U67,U68)
5	135477-14-U71	EA	CHAIR - RECLINER/SWIVEL/ROCKER - W/FOOTREST (U71,U72)
5	135477-14-U75	EA	CHAIR - RECLINER/SWIVEL/ROCKER - W/FOOTREST (U75,U76)
5	135477-15-U67	EA	CHAIR - RECLINER/SWIVEL/ROCKER - W/FOOTREST - LEATHER - LEATHER
5	155369-02-T97	EA	CHAIR/EURO - APOLLO - W/OTTOMAN - LEATHER - EURO LEATHER

CURTAIN & CUSHION GROUP (CONTINUED)
CUSHION LAYOUT (CONTINUED)

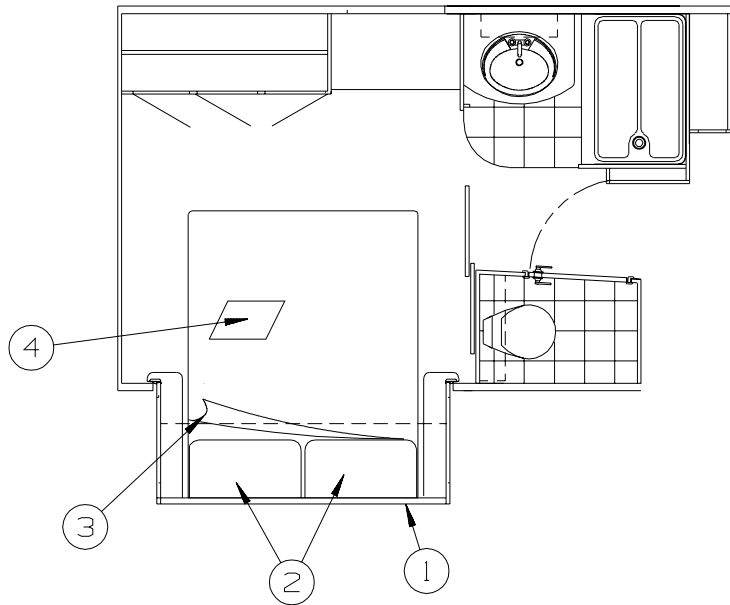

KEY	PART NUMBER	U/M	DESCRIPTION
1	150040-03-U67	EA	HEADBOARD - DELMONT - 30" X 60" (U67,U68)
1	150040-03-U71	EA	HEADBOARD - DELMONT - 30" X 60" (U71,U72)
1	150040-03-U75	EA	HEADBOARD - DELMONT - 30" X 60" (U75,U76)
2	145244-01-U67	EA	PILLOW SHAM - DELMONT - 1/4" WELT (U67,U68)
2	145244-03-U71	EA	PILLOW SHAM - DELMONT - 1/4" WELT (U71,U72)
			FROM: 00-00-00 THRU: 04-30-06
2	145244-01-U71	EA	PILLOW SHAM - DELMONT - 1/4" WELT (U71,U72)
			FROM: 05-01-06 THRU: 99-99-99
2	145244-01-U75	EA	PILLOW SHAM - DELMONT - 1/4" WELT (U75,U76)
			FROM: 00-00-00 THRU: 04-30-06
2	145244-03-U76	EA	PILLOW SHAM - DELMONT - 1/4" WELT (U75,U76)
			FROM: 05-01-06 THRU: 99-99-99
3	132336-05-U67	EA	BEDSPREAD/CAP - 60" X 75" (U67,U68)
3	132336-05-U71	EA	BEDSPREAD/CAP - 60" X 75" (U71,U72)
3	132336-05-U75	EA	BEDSPREAD/CAP - 60" X 75" (U75,U76)
4	154192-02-U67	EA	PILLOW - PIPER - W/FRINGE (U67,U68)
			FROM: 00-00-00 THRU: 04-30-06
4	154192-04-U67	EA	PILLOW - PIPER - W/FRINGE (U67,U68)
			FROM: 05-01-06 THRU: 99-99-99
4	154192-01-U71	EA	PILLOW - PIPER - W/FRINGE (U71,U72)
			FROM: 00-00-00 THRU: 04-30-06
4	154192-05-U71	EA	PILLOW - PIPER - W/FRINGE (U71,U72)
			FROM: 05-01-06 THRU: 99-99-99
4	154192-02-U75	EA	PILLOW - PIPER - W/FRINGE (U75,U76)
			FROM: 00-00-00 THRU: 04-30-06
4	154192-04-U75	EA	PILLOW - PIPER - W/FRINGE (U75,U76)
			FROM: 05-01-06 THRU: 99-99-99

CURTAIN & CUSHION GROUP (CONTINUED)

BUCKET SEATS

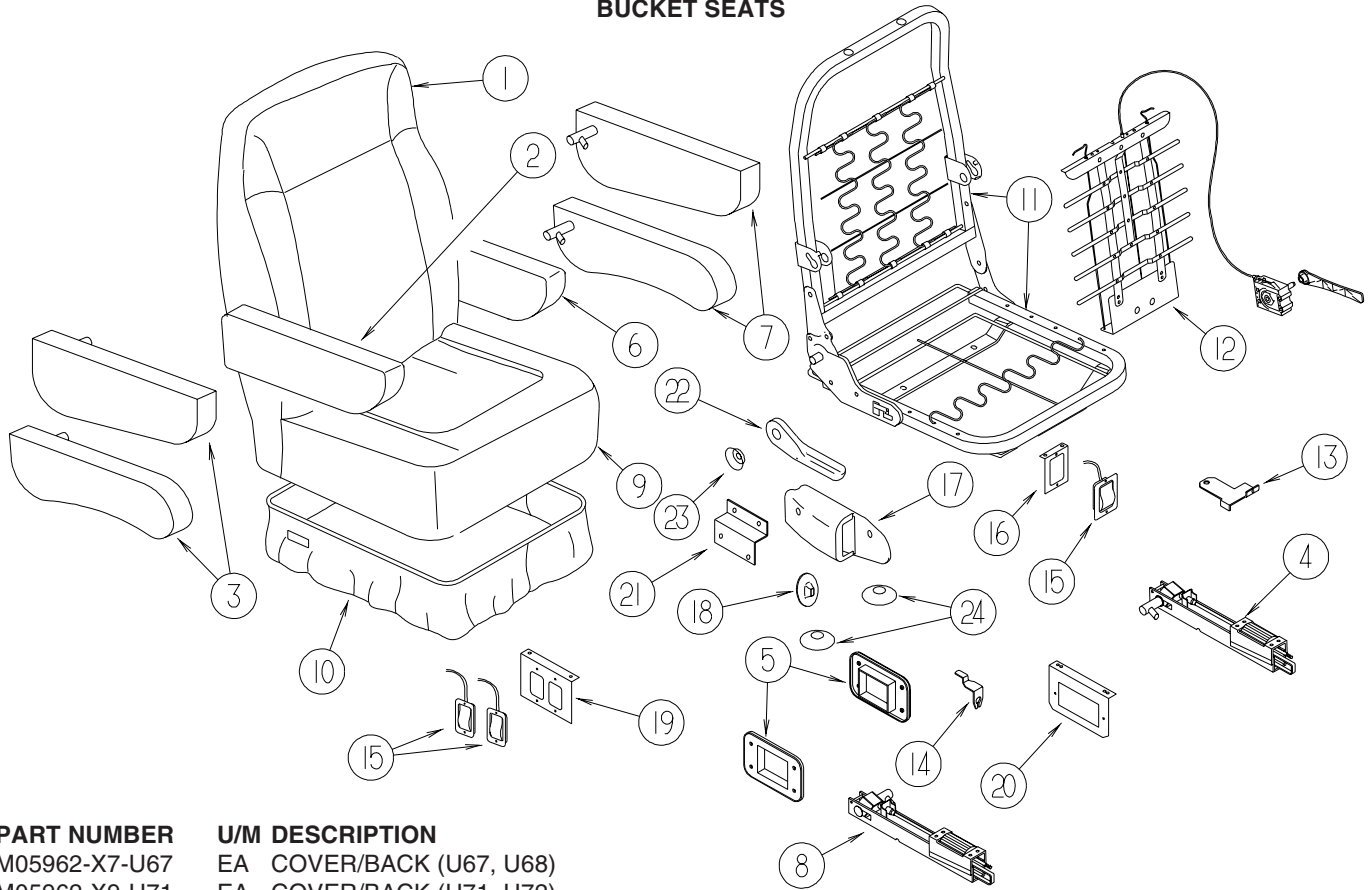

KEY	PART NUMBER	U/M	DESCRIPTION
1	M05962-X7-U67	EA	COVER/BACK (U67, U68)
1	M05962-X9-U71	EA	COVER/BACK (U71, U72)
1	M05962-X9-U75	EA	COVER/BACK (U75, U76)
1	M05962-Y1-U67	EA	COVER/BACK (U67, U68, U71, U72, U75, U76) - LEATHER
2	148652-01-U67	EA	ARMREST - RIGHT (U67, U68)
2	148652-07-U71	EA	ARMREST - RIGHT (U71, U72)
2	148652-07-U75	EA	ARMREST - RIGHT (U75, U76)
2	148652-03-S58	EA	ARMREST - RIGHT (U67, U68, U71, U72, U75, U76) - LEATHER
	P48652-01-U67	EA	COVER/ARMREST - RIGHT (U67, U68)
	P48652-07-U71	EA	COVER/ARMREST - RIGHT (U71, U72)
	P48652-07-U75	EA	COVER/ARMREST - RIGHT (U75, U76)
	P48652-03-S58	EA	COVER/ARMREST - RIGHT (U67, U68, U71, U72, U75, U76) - LEATHER
3	130698-03-000	EA	ARMREST/MOLDED - RIGHT - W/O COVER
4	NOT USED		
5	NOT USED		
6	148652-02-U67	EA	ARMREST - LEFT (U67, U68)
6	148652-08-U71	EA	ARMREST - LEFT (U71, U72)
6	148652-08-U75	EA	ARMREST - LEFT (U75, U76)
6	148652-04-S58	EA	ARMREST - LEFT (U67, U68, U71, U72, U75, U76) - LEATHER
	P48652-02-U67	EA	COVER/ARMREST - LEFT (U67, U68)
	P48652-08-U71	EA	COVER/ARMREST - LEFT (U71, U72)
	P48652-08-U75	EA	COVER/ARMREST - LEFT (U75, U76)
	P48652-04-S58	EA	COVER/ARMREST - LEFT (U67, U68, U71, U72, U75, U76) - LEATHER
7	130698-04-000	EA	ARMREST/MOLDED - LEFT - W/O COVER
8	NOT USED		
9	M05962-X8-U67	EA	COVER/SEAT (U67, U68)
9	M05962-Y0-U71	EA	COVER/SEAT (U71, U72)
9	M05962-Y0-U75	EA	COVER/SEAT (U75, U76)
9	M05962-Y2-U67	EA	COVER/SEAT (U90, U91, U92) - LEATHER
10	148630-01-U67	EA	SKIRT - W/SEAT BELT SLOT (U67, U68)
10	148630-14-U71	EA	SKIRT - W/SEAT BELT SLOT (U71, U72)
10	148630-14-U75	EA	SKIRT - W/SEAT BELT SLOT (U75, U76)
10	148630-15-TB4	EA	SKIRT - W/SEAT BELT SLOT (U67, U68, U71, U72, U75, U76) - LEATHER
10	148630-03-U67	EA	SKIRT - F/6-WAY POWER (U67, U68) - 6-WAY POWER
10	148630-18-U71	EA	SKIRT - F/6-WAY POWER (U71, U72) - 6-WAY POWER
10	148630-18-U75	EA	SKIRT - F/6-WAY POWER (U75, U76) - 6-WAY POWER
10	148630-16-TB4	EA	SKIRT - F/6-WAY POWER (U67, U68, U71, U72, U75, U76) - LEATHER, 6-WAY POWER

CURTAIN & CUSHION GROUP (CONTINUED)
BUCKET SEATS (CONTINUED)

KEY	PART NUMBER	U/M	DESCRIPTION
11	134532-01-000	EA	FRAME - SEAT/HIGH BACK
12*	122611-02-000	EA	LUMBAR - W/LEVER
13	117125-01-02B	EA	BRACKET - CABLE MOUNT - ADJUSTER W/LOCK
14	108049-02-000	EA	CLIP - CABLE/PEDESTAL
15	108049-04-000	EA	CABLE - W/MINI LEVER ACTION SWITCH - 28" SHEATH/30" CABLE
16	127159-01-02B	EA	BRACKET - SEAT RELEASE - SINGLE REMOTE - E-COATED - 6-WAY POWER
17	NOT USED		
18	NOT USED		
19	127159-02-02B	EA	BRACKET - SEAT RELEASE - DUAL REMOTE - E-COATED
20	128699-01-02B	EA	BRACKET - SEAT SWITCH - E-COATED - 6-WAY POWER
21	147457-01-02B	EA	BRACKET - ZEE W/HOLES - 2.8" - E-COATED
22	130802-02-000	EA	LEVER - RIGHT HAND
	130802-03-000	EA	SCREW F/LEVER
23	148668-01-01A	EA	CUP/TRIM COVER - F/LEVER - BLACK
24	NOT USED		
	152337-01-000	EA	PROTECTOR - SEAT - CLEAR VINYL

***COMPONENT PARTS LISTED LATER IN THIS GROUP**

COMPONENT PARTS FOR BUCKET SEATS

122611-02-000

KEY	PART NUMBER	U/M	DESCRIPTION	VENDOR NO.
	122611-02-701	EA	LUMBAR - LEVER	412
	122611-02-702	EA	LUMBAR MECHANISM	24395-FLEXSTEEL

CURTAIN & CUSHION GROUP (CONTINUED)

LOUNGE CHAIR

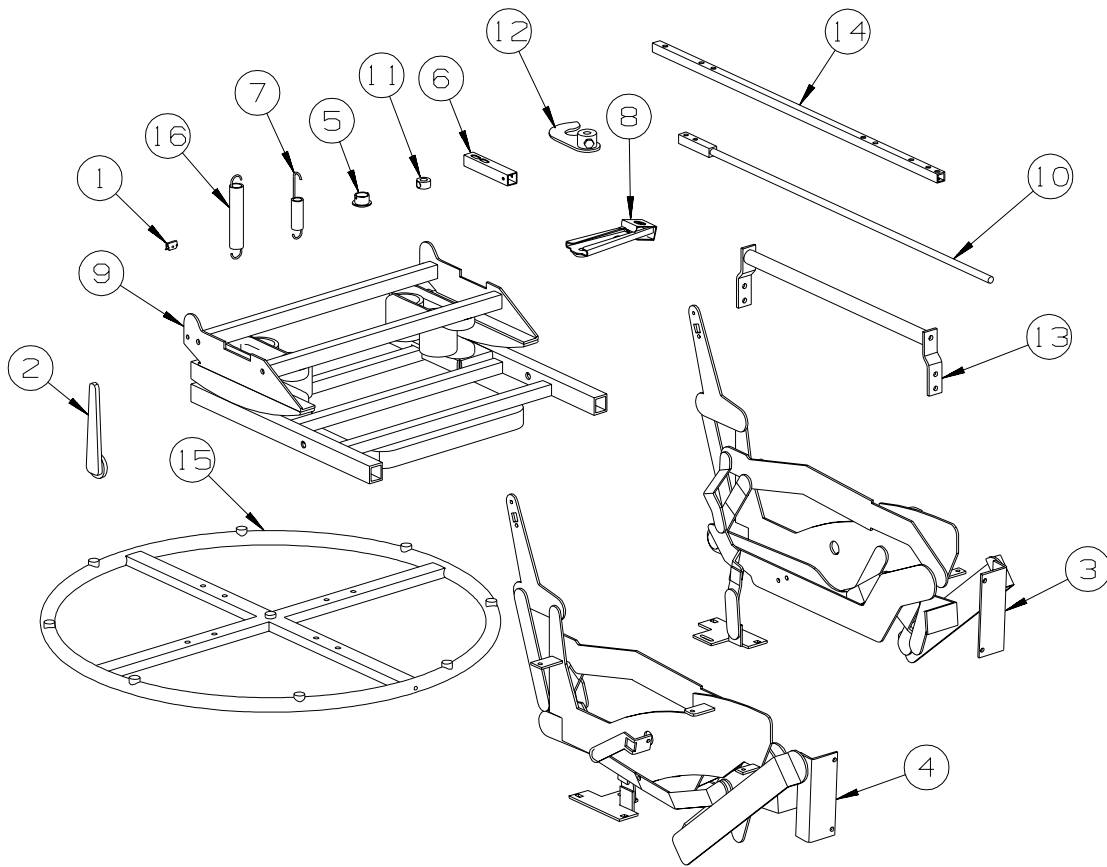

KEY	PART NUMBER	U/M	DESCRIPTION
	P35477-14-U67	EA	COVER - RECLINER/SWIVEL/ROCKER - W/FOOTREST (U67,U68)
	P35477-14-U71	EA	COVER - RECLINER/SWIVEL/ROCKER - W/FOOTREST (U71,U72)
	P35477-14-U75	EA	COVER - RECLINER/SWIVEL/ROCKER - W/FOOTREST (U75,U76)
	P35477-15-U67	EA	COVER - RECLINER/SWIVEL/ROCKER - W/FOOTREST - LEATHER
1	029134-01-000	EA	CLIP - FINISH - UPHOLSTERY
2	133126-11-000	EA	HANDLE/RECLINE - PLASTIC
3	154077-01-000	EA	RECLINER MECHANISM - RIGHT HAND (WHEN SITTING IN CHAIR)
4	154077-02-000	EA	RECLINER MECHANISM - LEFT HAND (WHEN SITTING IN CHAIR)
5	154077-03-000	EA	BUSHING - PLASTIC/WHITE
6	154077-04-000	EA	TUBE/HANDLE MOUNTING - 3.6" LONG - BLACK
7	154077-05-000	EA	SPRING - EXTENSION - 3.7"
8	154077-06-000	EA	SLEEVE/CLIP - 1.6" X 5.1"
9	154077-07-000	EA	BASE - SWIVEL/ROCKER - BLACK
10	154077-08-000	EA	LATCH ROD - 25.5" - BLACK
11	154077-09-000	EA	LOCK COLLAR - W/SET SCREW LOCK-OUT
12	154077-10-000	EA	LATCH BRACKET - RIGHT FRONT LOCK OUT - BLACK
13	154077-11-000	EA	LATCH TUBE - W/LOCK OUT ENDS - 15.1" - BLACK
14	154077-12-000	EA	LOCK TUBE - .5" X .5" X 23.5"
15	154077-13-000	EA	GRID RING - 24" - BLACK
16	154077-14-000	EA	SPRING/EXTENSION - 4.7"

CURTAIN & CUSHION GROUP (CONTINUED)

SOFA

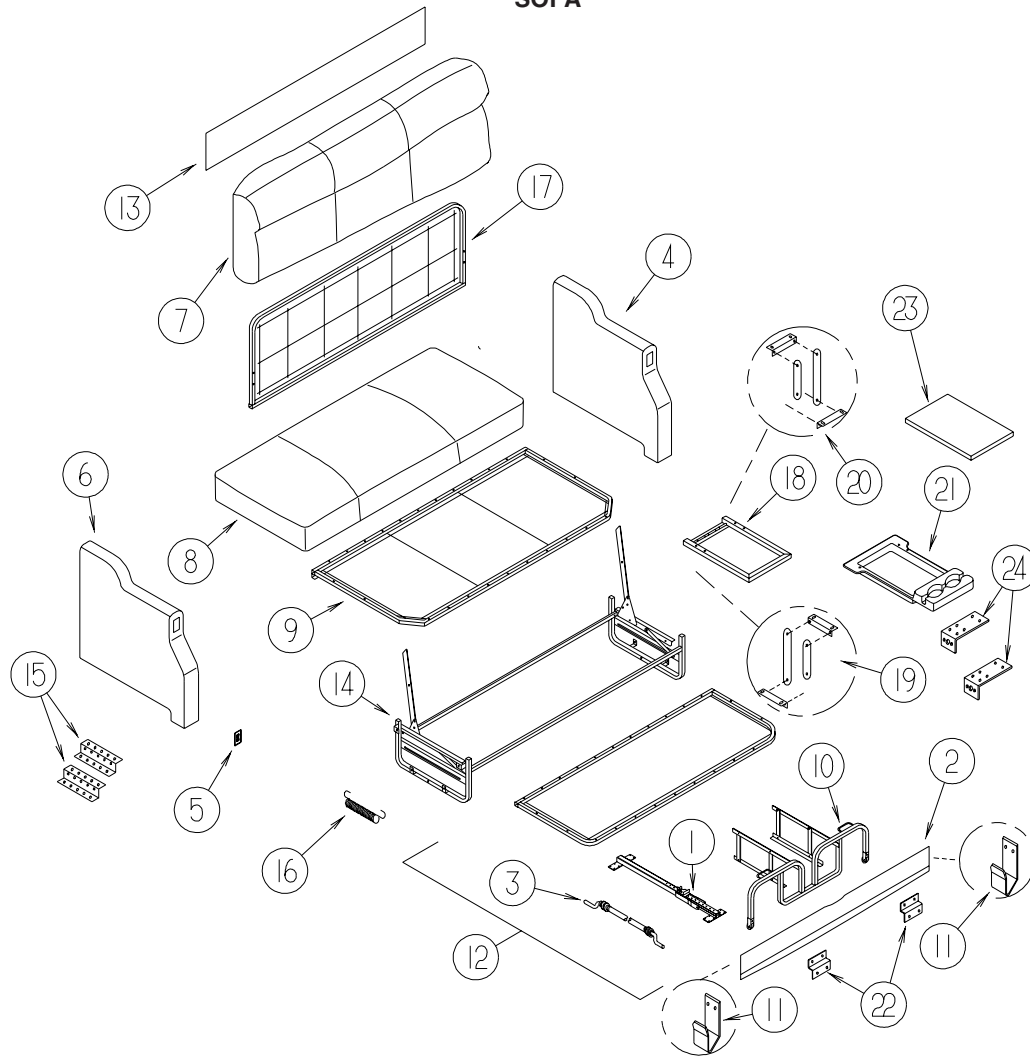

REST EASY

KEY	PART NUMBER	U/M	DESCRIPTION
1	159707-02-000	EA	SLIDE RAIL - W/LATCH MECH/PLATES/STOP F/30" RAISED FLOOR
2	135824-07-U67	EA	PANEL/FRONT KICK - SOFA/SLEEPER - 59.5" - FABRIC COVERED (U67,U68)
2	135824-07-U71	EA	PANEL/FRONT KICK - SOFA/SLEEPER - 59.5" - FABRIC COVERED (U71,U72)
2	135824-07-U75	EA	PANEL/FRONT KICK - SOFA/SLEEPER - 59.5" - FABRIC COVERED (U75,U76)
2	135824-09-SB4	EA	PANEL/FRONT KICK - SOFA/SLEEPER - 59.5" - LEATHER - LEATHER
3	148225-01-000	EA	CABLE ONLY - REMOTE - 31.9" W/Z-ENDS
4	149893-14-U67	EA	ARMREST - SOFA/SLEEPER - LEFT HAND (U67,U68)
4	149893-14-U71	EA	ARMREST - SOFA/SLEEPER - LEFT HAND (U71,U72)
4	149893-14-U75	EA	ARMREST - SOFA/SLEEPER - LEFT HAND (U75,U76)
4	149893-22-U67	EA	ARMREST - SOFA/SLEEPER - LEFT HAND - W/SWITCH - LEATHER - LEATHER
	P49893-02-U67	EA	COVER/ARMREST - SOFA/LEFT HAND (U67,U68)
	P49893-02-U71	EA	COVER/ARMREST - SOFA/LEFT HAND (U71,U72)
	P49893-02-U75	EA	COVER/ARMREST - SOFA/LEFT HAND (U75,U76)
	P49893-04-U67	EA	COVER/ARMREST - SOFA/LEFT HAND - LEATHER
5	136118-01-000	EA	SWITCH - SOFA/RECLINER
6	149893-13-U67	EA	ARMREST - SOFA/SLEEPER - RIGHT HAND - W/SWITCH (U67,U68)
6	149893-13-U71	EA	ARMREST - SOFA/SLEEPER - RIGHT HAND - W/SWITCH (U71,U72)
6	149893-13-U75	EA	ARMREST - SOFA/SLEEPER - RIGHT HAND - W/SWITCH (U75,U76)
6	149893-21-U67	EA	ARMREST - SOFA/SLEEPER - RIGHT HAND - W/SWITCH - LEATHER - LEATHER
	P49893-01-U67	EA	COVER/ARMREST - SOFA/RIGHT HAND (U67,U68)
	P49893-01-U71	EA	COVER/ARMREST - SOFA/RIGHT HAND (U71,U72)
	P49893-01-U75	EA	COVER/ARMREST - SOFA/RIGHT HAND (U75,U76)
	P49893-03-U67	EA	COVER/ARMREST - SOFA/RIGHT HAND - LEATHER

CURTAIN & CUSHION GROUP (CONTINUED)
SOFA (CONTINUED)

KEY	PART NUMBER	U/M	DESCRIPTION
7	158146-01-U67	EA	BACK - SOFA/SLEEPER REST EASY (U67,U68)
7	158146-01-U71	EA	BACK - SOFA/SLEEPER REST EASY (U71,U72)
7	158146-01-U75	EA	BACK - SOFA/SLEEPER REST EASY (U75,U76)
7	158146-02-U67	EA	BACK - SOFA/SLEEPER REST EASY - LEATHER - LEATHER
	158146-A1-U67	EA	COVER/BACK - SOFA/SLEEPER REST EASY (U67,U68)
	158146-A1-U71	EA	COVER/BACK - SOFA/SLEEPER REST EASY (U71,U72)
	158146-A1-U75	EA	COVER/BACK - SOFA/SLEEPER REST EASY (U75,U76)
	158146-A2-U67	EA	COVER/BACK - SOFA/SLEEPER REST EASY - LEATHER - LEATHER
8	149744-15-U67	EA	SEAT - SOFA/SLEEPER REST EASY (U67,U68)
8	149744-15-U71	EA	SEAT - SOFA/SLEEPER REST EASY (U71,U72)
8	149744-15-U75	EA	SEAT - SOFA/SLEEPER REST EASY (U75,U76)
8	149744-20-U67	EA	SEAT - SOFA/SLEEPER REST EASY - LEATHER - LEATHER
	P49744-15-U67	EA	COVER/SEAT - SOFA/SLEEPER REST EASY (U67,U68)
	P49744-15-U71	EA	COVER/SEAT - SOFA/SLEEPER REST EASY (U71,U72)
	P49744-15-U75	EA	COVER/SEAT - SOFA/SLEEPER REST EASY (U75,U76)
	P49744-20-U67	EA	COVER/SEAT - SOFA/SLEEPER REST EASY - LEATHER - LEATHER
9	151290-04-000	EA	FRAME - SEAT - 60"
10*	136534-17-000	EA	TRUNDLE FRAME - 17.5" X 55" - W/LINKAGE, LATCH & HANDLE
11	121906-01-02B	EA	BRACKET - KICKBOARD - E-COATED
12	155647-01-U67	EA	TRUNDLE - SOFA/SLEEPER - 60" (U67,U68)
12	155647-01-U71	EA	TRUNDLE - SOFA/SLEEPER - 60" (U71,U72)
12	155647-01-U75	EA	TRUNDLE - SOFA/SLEEPER - 60" (U75,U76)
12	155647-03-T97	EA	TRUNDLE - SOFA/SLEEPER - 60" - LEATHER - LEATHER
	155647-A1-U67	EA	COVER/TRUNDLE - SOFA/SLEEPER - 60" (U67,U68)
	155647-A1-U71	EA	COVER/TRUNDLE - SOFA/SLEEPER - 60" (U71,U72)
	155647-A1-U75	EA	COVER/TRUNDLE - SOFA/SLEEPER - 60" (U75,U76)
	155647-A3-T97	EA	COVER/TRUNDLE - SOFA/SLEEPER - 60" - LEATHER - LEATHER
13	139716-01-U67	EA	SIGHT SHIELD - 58" - FULL BACK (U67,U68)
13	139716-01-U71	EA	SIGHT SHIELD - 58" - FULL BACK (U71,U72)
13	139716-01-U75	EA	SIGHT SHIELD - 58" - FULL BACK (U75,U76)
13	139716-19-U67	EA	SIGHT SHIELD - 58" - FULL BACK - LEATHER
14*	136534-13-000	EA	BASE - 27.25" X 60" - POWERED
15	NOT USED		
16	136534-33-000	EA	SPRING/ASSIST - 1/2" X 7" W/HOOK ENDS - REST EASY SOFAS
17	136534-18-000	EA	FRAME/BACK - 16.5" X 60"
18	NOT USED		
19	NOT USED		
20	NOT USED		
21	NOT USED		
22	101926-01-02A	EA	BRACKET - ZEE - 2" - BLACK
23	NOT USED		
24	NOT USED		

***COMPONENT PARTS LISTED LATER IN THIS GROUP**

COMPONENT PARTS FOR SOFA

136534-02-000, 136534-03-000, 136534-13-000, 136534-15-000

KEY	PART NUMBER	U/M	DESCRIPTION	VENDOR NO.
	136534-02-700	EA	MOTOR	9PL-MO-W/T-1
	136534-02-701	EA	CABLE/DRV MTR-REST EASY SOFA	9PL-FCA27.75

136534-17-000

KEY	PART NUMBER	U/M	DESCRIPTION	VENDOR NO.
	136534-07-701	EA	WHEEL - NYLON - 1 5/8"	9WHEEL-1.62

148226-01-000, 148226-02-000, 148226-03-000

KEY	PART NUMBER	U/M	DESCRIPTION	VENDOR NO.
	148226-01-700	EA	BUSHING/GUIDE - F/MECHANISM	9TN-SLD-GR-1
	148226-01-701	EA	SLIDE MECHANISM ASM W/LATCH	PTN-SLD-BUSH1

CURTAIN & CUSHION GROUP (CONTINUED)

WINDOW TREATMENT

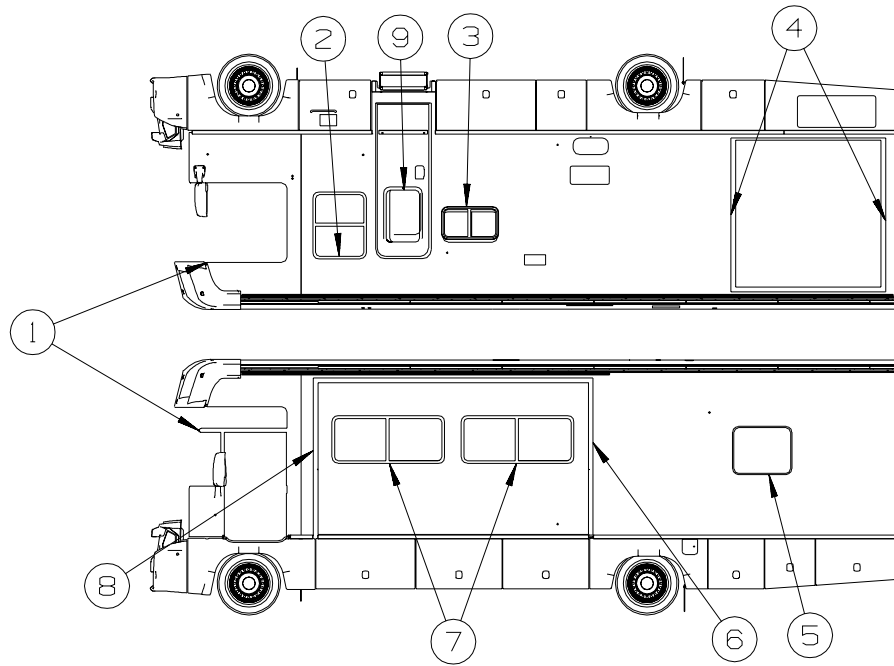

KEY	PART NUMBER	U/M	DESCRIPTION
1	101668-67-J22	EA	CURTAIN - RIGHT HAND/LEFT HAND - 42" X 110"
1	073260-42-TT4	EA	TIEBACK - 6" X 18"
2	158115-04-U67	EA	VALANCE - MORGAN - 32" (U67,U68)
2	158115-04-U71	EA	VALANCE - MORGAN - 32" (U71,U72)
2	158115-04-U75	EA	VALANCE - MORGAN - 32" (U75,U76)
2	152664-K2-U67	EA	LEG - RIGHT - 35" (U67,U68)
2	152664-K2-U71	EA	LEG - RIGHT - 35" (U71,U72)
2	152664-K2-U75	EA	LEG - RIGHT - 35" (U75,U76)
2	152664-K3-U67	EA	LEG - LEFT - 35" (U67,U68)
2	152664-K3-U71	EA	LEG - LEFT - 35" (U71,U72)
2	152664-K3-U75	EA	LEG - LEFT - 35" (U75,U76)
2	140789-70-U67	EA	BLIND - DAY/NIGHTER - 28" X 33" (U67,U68)
2	140789-70-U71	EA	BLIND - DAY/NIGHTER - 28" X 33" (U71,U72,U75,U76)
3	109041-58-03A	EA	BLIND - MINI - 30.5" X 17" (U67,U68)
3	109041-58-04A	EA	BLIND - MINI - 30.5" X 17" (U71,U72,U75,U76)
4	158115-12-U67	EA	VALANCE - MORGAN - 26.5" (U67,U68)
4	158115-12-U71	EA	VALANCE - MORGAN - 26.5" (U71,U72)
4	158115-13-U75	EA	VALANCE - MORGAN - 26.5" (U75,U76)
4	152664-29-U67	EA	LEG - RIGHT - 26" (U67,U68)
4	152664-29-U71	EA	LEG - RIGHT - 26" (U71,U72)
4	152664-23-U75	EA	LEG - RIGHT - 26" (U75,U76)
4	152664-30-U67	EA	LEG - LEFT - 26" (U67,U68)
4	152664-30-U71	EA	LEG - LEFT - 26" (U71,U72)
4	152664-24-U75	EA	LEG - LEFT - 26" (U75,U76)
4	140789-40-U67	EA	BLIND - DAY/NIGHTER - 22.5" X 27" (U67,U68)
4	140789-40-S46	EA	BLIND - DAY/NIGHTER - 22.5" X 27" (U71,U72,U75,U76)
5	158115-10-U67	EA	VALANCE - MORGAN - 33" (U67,U68)
5	158115-10-U71	EA	VALANCE - MORGAN - 33" (U71,U72)
5	158115-11-U75	EA	VALANCE - MORGAN - 33" (U75,U76)
5	140789-01-N31	EA	BLIND - DAY/NIGHTER - 31" X 28.5" (U67,U68)
5	140789-01-S46	EA	BLIND - DAY/NIGHTER - 31" X 28.5" (U71,U72,U75,U76)

CURTAIN & CUSHION GROUP (CONTINUED)
WINDOW TREATMENT (CONTINUED)

KEY	PART NUMBER	U/M	DESCRIPTION
6	158115-07-U67	EA	VALANCE - MORGAN - 26.5" (U67,U68)
6	158115-07-U71	EA	VALANCE - MORGAN - 26.5" (U71,U72)
6	158115-07-U75	EA	VALANCE - MORGAN - 26.5" (U75,U76)
6	152664-19-U67	EA	LEG - RIGHT - 32" (U67,U68)
6	152664-19-U71	EA	LEG - RIGHT - 32" (U71,U72)
6	152664-19-U75	EA	LEG - RIGHT - 32" (U75,U76)
6	152664-20-U67	EA	LEG - LEFT - 32" (U67,U68)
6	152664-20-U71	EA	LEG - LEFT - 32" (U71,U72)
6	152664-20-U75	EA	LEG - LEFT - 32" (U75,U76)
6	140789-07-N02	EA	BLIND - DAY/NIGHTER - 22.5" X 23" (U67,U68)
6	140789-07-S46	EA	BLIND - DAY/NIGHTER - 22.5" X 23" (U71,U72,U75,U76)
7	158115-01-U67	EA	VALANCE - MORGAN - 63" (U67,U68)
7	158115-01-U71	EA	VALANCE - MORGAN - 63" (U71,U72)
7	158115-01-U75	EA	VALANCE - MORGAN - 63" (U75,U76)
7	152445-07-U67	EA	LEG - RIGHT - 23.5" (U67,U68)
7	152445-07-U71	EA	LEG - RIGHT - 23.5" (U71,U72)
7	152445-07-U75	EA	LEG - RIGHT - 23.5" (U75,U76)
7	152445-08-U67	EA	LEG - LEFT - 23.5" (U67,U68)
7	152445-08-U71	EA	LEG - LEFT - 23.5" (U71,U72)
7	152445-08-U75	EA	LEG - LEFT - 23.5" (U75,U76)
7	140789-08-N02	EA	BLIND - DAY/NIGHTER - 59" X 26.5" (U67,U68)
7	140789-08-S46	EA	BLIND - DAY/NIGHTER - 59" X 26.5" (U71,U72,U75,U76)
8	158115-07-U67	EA	VALANCE - MORGAN - 26.5" (U67,U68)
8	158115-07-U71	EA	VALANCE - MORGAN - 26.5" (U71,U72)
8	158115-07-U75	EA	VALANCE - MORGAN - 26.5" (U75,U76)
8	152664-17-U67	EA	LEG - RIGHT - 24" (U67,U68)
8	152664-17-U71	EA	LEG - RIGHT - 24" (U71,U72)
8	152664-17-U75	EA	LEG - RIGHT - 24" (U75,U76)
8	152664-18-U67	EA	LEG - LEFT - 24" (U67,U68)
8	152664-18-U71	EA	LEG - LEFT - 24" (U71,U72)
8	152664-18-U75	EA	LEG - LEFT - 24" (U75,U76)
8	140789-71-U67	EA	BLIND - DAY/NIGHTER - 23" X 36" (U67,U68)
8	140789-71-U71	EA	BLIND - DAY/NIGHTER - 23" X 36" (U71,U72,U75,U76)
9	084755-57-P37	EA	SHADE - PULL - 27.25"

CURTAIN & CUSHION GROUP (CONTINUED)

HARDWARE



KEY	PART NUMBER	U/M	DESCRIPTION
1A	029155-01-000	EA	CAP - SNAP - 5/32" OUTSIDE DIAMETER OF PIN
2A	029156-01-000	EA	SOCKET - SNAP - 9/16" O.D.
3A	046867-02-000	EA	WASHER - HANDY BUTTON #3
4A	046867-03-000	EA	GROMMET - HANDY BUTTON #3
5A	075943-10-000	EA	BRACE - VALANCE - 20" - OFF WHITE
6A	083170-01-000	EA	BRACKET/BLIND - LEFT SIDE WHEN FACING WINDOW - CLEAR
7A	083170-02-000	EA	BRACKET/BLIND - RIGHT SIDE WHEN FACING WINDOW - CLEAR
8A	084434-01-000	EA	BRACKET - MOUNTING - ROLLER SHADE - 1 3/8"
9A	094896-02-000	EA	GROMMET - CORD/PLEATED BLIND - NYLON - GRAY
10A	094907-02-000	EA	END CAP - PLEATED BLIND/TOP - RH/LH - GRAY PLASTIC
11A	094907-04-000	EA	END CAP - PLEATED BLIND/BOTTOM - RH/LH
12A	094907-09-000	EA	END CAP/BLIND - CENTER RAIL - RH/LH
13A	097564-03-000	EA	HANDLE - KNOB - E-Z LIFT SHADE - TAN
	097593-02-000	FT	CORD - BLIND - PLEATED - GRAY
	097593-10-000	FT	CORD - BLIND - PLEATED - VANILLA
14A	097565-01-000	EA	BRACKET - MOUNTING - PLEATED BLIND
15A	097591-01-000	EA	SPRING - EXTENSION - PLEATED BLIND
15A	155748-01-000	EA	SPRING - EXTENSION - DAY/NIGHTER BLIND
16A	101031-01-000	YD	TAPE/GLIDE - 4.25" SPACING
17A	102555-03-000	EA	BRACKET - (CLEAT TYPE) - F/BLIND HOLDOWN - MILKY WHITE

CURTAIN & CUSHION GROUP (CONTINUED)
HARDWARE (CONTINUED)

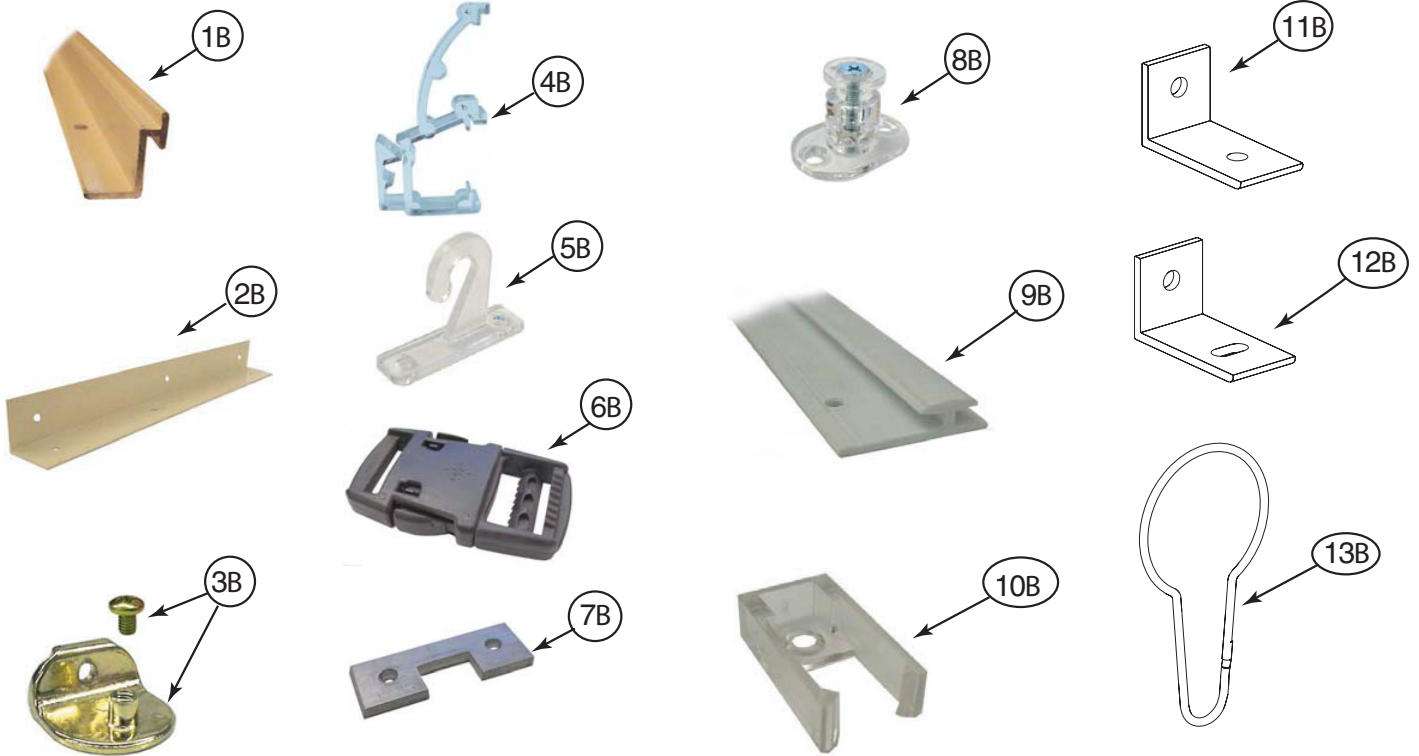

KEY	PART NUMBER	U/M	DESCRIPTION
1B	105450-14-01A	EA	TRACK-90"-OW - FRT BUNK PRIVACY OUTLOOK/SPIRIT 300-SERIES, ACCESS/IMPULSE 200-SERIES
2B	105648-01-02A	EA	BRACE - VALANCE - 14" - OFF WHITE
2B	105648-02-02A	EA	BRACE - VALANCE - 8.5" - OFF WHITE
3B	106544-01-000	EA	PULL - SHADE/BRASS
3B	106544-01-001	EA	SCREW - SHADE/BRASS
3B	106544-02-000	EA	PULL-SHADE - NICKEL
4B	109353-04-000	EA	CLIP - VALANCE SLAT MOUNTING - CLEAR PLASTIC
5B	109441-01-000	EA	BRACKET/HOOK - BLIND HOLD DOWN
5B	109441-02-000	EA	SPACER/BRACKET - BLIND HOLD DOWN
6B	129491-01-000	EA	CATCH - SNAP HOOK - 1"
7B	130549-01-01A	EA	STOP - CURTAIN TRACK
8B	141634-01-000	EA	BRACKET-(BOBBIN TYPE) 7/8"H HOLDUPBASE(OVAL)-2 HOLE-CLEAR
9B	156172-01-01A	EA	TRACK/WALL - 75" - BONE
9B	156172-02-01A	EA	TRACK/WALL - 32" - BONE
9B	156172-03-01A	EA	TRACK/WALL - 21" - BONE
10B	156172-04-01A	EA	END CAP - WALL TRACK - CLEAR
11B	154316-01-01A	EA	BRACE/ANGLE - W/HOLE - CASHMERE
12B	154316-02-01A	EA	BRACE/ANGLE - W/SLOT - CASHMERE
13B	159702-01-01A	EA	HOOK/RING - CURTAIN/SHOWER - NICKEL

ACCESSORIES

KEY	PART NUMBER	U/M	DESCRIPTION
	099856-11-000	EA	STRAP - TIEDOWN - 7.9"
	057534-01-000	EA	TIEBACK - CLEAR PLASTIC - 6"
	070578-02-N30	EA	BUTTON - SCREW - STUD - #30 VINYL

CURTAIN & CUSHION GROUP (CONTINUED)

FABRICS

U67, U68

072333-85-000 FABRIC-DRAPERY, MAIN
079680-47-000 FABRIC-UPHOSTERY,ACCENT PLAIN
079680-47-000 FABRIC-UPHL,SEAT INSERT
079680-50-000 FABRIC-HEADLINER/PADS/BUNKS
113979-09-01A CARPET-HEADLINER - CEILING
113979-11-01A CARPET-HEADLINER, SLIDEOUT - CEILING
142523-04-000 VINYL-CABINET ENDS, CAB AREA
148797-S8-000 FABRIC-UPHOSTERY MAIN ONE
148797-S8-000 FABRIC-INSERT S/O TRIM FRONT
148797-S9-000 FABRIC-UPHLSTRY,PLAIN ACCENT
148797-S9-000 FABRIC-DINETTE WRAP
148797-S9-000 FABRIC-OVERLAY S/O TRIM FRT
148797-S9-000 FABRIC-LOUNGE TRIM
148797-T0-000 FABRIC-UPHOLSTERY, 2ND PATTERN
148797-T0-000 FABRIC-UPHOLSTERY ACCENT
148797-T0-000 FABRIC-O/H CABT, DIN/LOUNGE
156773-01-000 FABRIC-UPHOSTERY,BEDSPREAD MAIN
156773-02-000 FABRIC-UPHOLSTERY, BEDSPREAD PATTERN ACCENT
156773-02-000 FABRIC-O/H CABT, BEDROOM
156773-02-000 FABRIC-INSERT S/O TRIM REAR

U71, U72

072333-85-000 FABRIC-DRAPERY, MAIN
079680-47-000 FABRIC-UPHOSTERY,ACCENT PLAIN
079680-47-000 FABRIC-UPHL,SEAT INSERT
079680-50-000 FABRIC-HEADLINER/PADS/BUNKS
113979-09-01A CARPET-HEADLINER - CEILING
113979-11-01A CARPET-HEADLINER, SLIDEOUT - CEILING
137813-Y0-000 FABRIC-UPHOSTERY,BEDSPREAD PATTERN ACCENT
137813-Y0-000 FABRIC-O/H CABT, BEDROOM
137813-Y0-000 FABRIC-INSERT S/O TRIM REAR
142523-04-000 VINYL-CABINET ENDS, CAB AREA
148797-T1-000 FABRIC-UPHOSTERY MAIN ONE
148797-T1-000 FABRIC-INSERT S/O TRIM FRONT
148797-T2-000 FABRIC-UPHLSTRY,PLAIN ACCENT
148797-T2-000 FABRIC-DINETTE WRAP
148797-T2-000 FABRIC-OVERLAY S/O TRIM FRT
148797-T2-000 FABRIC-LOUNGE TRIM
148797-T3-000 FABRIC-UPHOLSTERY, 2ND PATTERN
148797-T3-000 FABRIC-UPHOLSTERY ACCENT
148797-T3-000 FABRIC-O/H CABT, DIN/LOUNGE
156773-03-000 FABRIC-UPHOSTERY,BEDSPREAD MAIN

U75, U76

072333-85-000 FABRIC-DRAPERY, MAIN
079680-47-000 FABRIC-UPHOSTERY,ACCENT PLAIN
079680-47-000 FABRIC-UPHL,SEAT INSERT
079680-50-000 FABRIC-HEADLINER/PADS/BUNKS
113979-09-01A CARPET-HEADLINER - CEILING
113979-11-01A CARPET-HEADLINER, SLIDEOUT - CEILING
142523-04-000 VINYL-CABINET ENDS, CAB AREA
148797-T4-000 FABRIC-UPHOSTERY MAIN ONE
148797-T4-000 FABRIC-INSERT S/O TRIM FRONT
148797-T5-000 FABRIC-UPHLSTRY,PLAIN ACCENT
148797-T5-000 FABRIC-DINETTE WRAP
148797-T5-000 FABRIC-OVERLAY S/O TRIM FRT
148797-T5-000 FABRIC-LOUNGE TRIM
148797-T6-000 FABRIC-UPHOLSTERY, 2ND PATTERN
148797-T6-000 FABRIC-UPHOLSTERY ACCENT
148797-T6-000 FABRIC-O/H CABT, DIN/LOUNGE
156773-04-000 FABRIC-UPHOSTERY,BEDSPREAD MAIN
156773-05-000 FABRIC-UPHOSTERY,BEDSPREAD PATTERN ACCENT
156773-05-000 FABRIC-O/H CABT, BEDROOM
156773-05-000 FABRIC-INSERT S/O TRIM REAR

DRIVERS COMPARTMENT GROUP

DASH

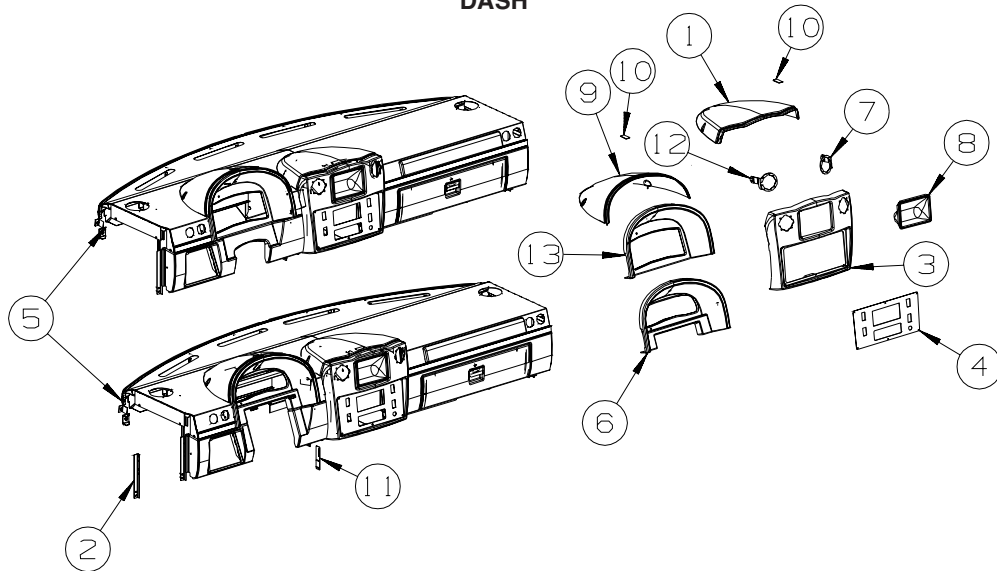

KEY	PART NUMBER	U/M	DESCRIPTION
1	155702-01-01A	EA	POD - DASH CENTER - BRIARWOOD
1	155702-02-01A	EA	POD - DASH CENTER - BRIARWOOD - RR MONITOR SYS-AUDIO
2	128692-01-02B	EA	ANGLE-FORMED,DASH SUPPORT, E-COAT
3	155701-01-01A	EA	BEZEL - DASH/CENTER - BRIARWOOD
4	156051-01-02B	EA	PANEL/BEZEL - DASH/CENTER - E-COATED
5	154743-02-U67	EA	DASH COMPLETE - CASHMERE
5	154743-01-U67	EA	DASH COMPLETE - CASHMERE - WORKHORSE
6	155699-01-01A	EA	BEZEL - INSTRUMENT PANEL - FORD - BRIARWOOD
7	156255-01-02B	EA	RETAINER - LOUVER/RIGHT - E-COATED
8	111350-02-20A	EA	POCKET - INSTRUMENT PANEL - UPPER/RIGHT - CASHMERE
9	155700-01-01A	EA	POD - INSTRUMENT PANEL - BRIARWOOD
10	110530-01-000	FT	SEAL - SPONGE - .31" X .62"
11	139603-01-02B	EA	STRAP-DASH SUPPORT, CTR - E-COAT
12	156255-02-02B	EA	RETAINER - LOUVER/LEFT - E-COATED
13	155698-01-01A	EA	BEZEL - INSTRUMENT PANEL - WORKHORSE - BRIARWOOD - WORKHORSE

DRIVERS COMPARTMENT GROUP (CONTINUED)

DASH (CONTINUED)

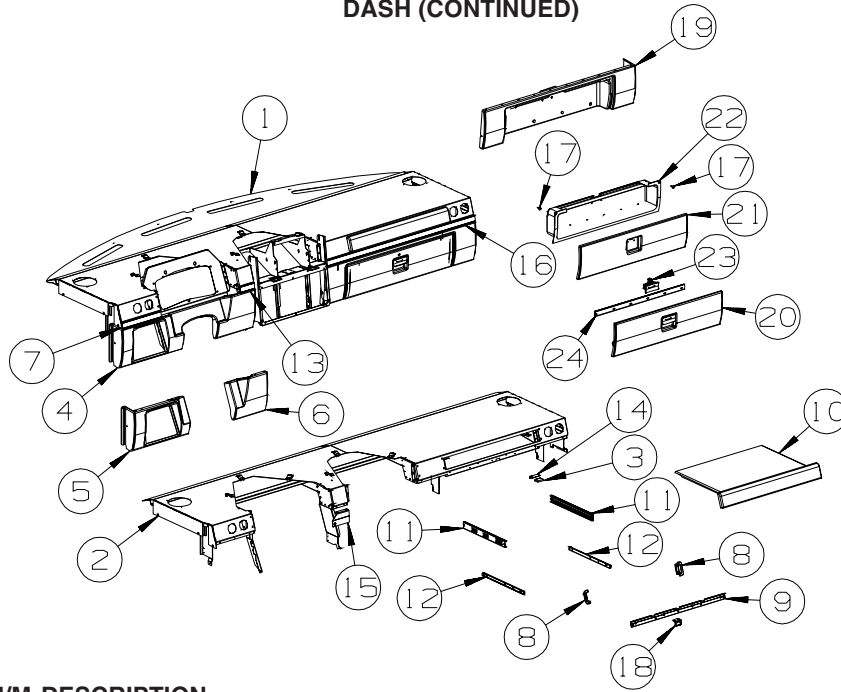

KEY	PART NUMBER	U/M	DESCRIPTION
1	154741-02-02B	EA	PANEL - DASH - FRONT/TOP - W/O VINYL
	106569-07-09A	EA	VINYL - LAMINATE - 1/4" X 17" X 100" - DRIFTWOOD
	106569-16-09A	EA	VINYL - LAMINATE - 1/4" X 30" X 100" - DRIFTWOOD
2	154742-01-02B	EA	DASH - W/O VINYL - E-COATED
3	137018-01-01A	EA	CATCH - MAGNETIC - 1.6"
4	155129-01-02A	EA	PANEL/TRIM - DASH/LOWER LEFT - CASHMERE - WORKHORSE
5	156254-01-02A	EA	PANEL/TRIM - DASH/LOWER - DRIVER/LEFT - CASHMERE - FORD
6	156253-01-02A	EA	PANEL/TRIM - DASH/LOWER - DRIVER/RIGHT - CASHMERE - FORD
7	155053-03-20A	EA	TRIM - DASH/LOWER/LEFT - CASHMERE
8	156580-01-02A	EA	TRIM - DASH/SLIDEOUT TABLE - CASHMERE
9	156585-01-02B	EA	RETAINER - VINYL/LOWER - E-COATED
10	156646-01-01A	EA	TABLE TOP - PULLOUT/WORKSTATION - FUSION JAZZ
11	135314-01-01A	EA	SLIDE - DASH WORK STATION - RIGHT HAND - NOT ILLUSTRATED FROM: 00-00-00 THRU: 02-23-06
11	153000-03-01A	EA	SLIDE - CABINET MOUNT - 13.8" FROM: 02-24-06 THRU: 99-99-99
12	135314-02-01A	EA	SLIDE - DASH WORK STATION - LEFT HAND - NOT ILLUSTRATED FROM: 00-00-00 THRU: 02-23-06
12	153000-04-01A	EA	SLIDE - DRAWER MOUNT - 13.8" FROM: 02-24-06 THRU: 99-99-99
13	155053-02-20A	EA	TRIM - DASH/LOWER/CENTER - CASHMERE
14	137018-03-01A	EA	BRACKET - MOUNTING - 2"
15	155948-01-02B	EA	SUPPORT - PARK BRAKE SWITCH - E-COATED - WORKHORSE 24,000-22.5
16	155053-01-20A	EA	TRIM - DASH/LOWER/RIGHT - CASHMERE
17	120863-10-000	EA	BUMPER - RUBBER/RADIUS TOP/PULL - 1"
18	152171-07-01A	EA	KEEPER - LATCH - METAL
19	155130-02-U65	EA	PANEL/TRIM - DASH/LOWER/RIGHT - W/O DOOR/HDW - CASHMERE
20	155133-01-U65	EA	COMPARTMENT/GLOVE - W/DOOR - W/O HINGE/HDW - CASHMERE
21	155132-01-02A	EA	PANEL/DOOR - GLOVE COMPARTMENT - W/O HDW - CASHMERE
22	155134-01-02A	EA	COMPARTMENT/GLOVE - CASHMERE
23	155757-01-01A	EA	LATCH - GLOVE COMPARTMENT - BLACK
24	156730-01-01A	EA	HINGE - CONTINUOUS - GLOVE BOX
	009065-03-000	EA	HINGE - ALUMINUM - 2" X 72.5" - UNPAINTED

DRIVERS COMPARTMENT GROUP (CONTINUED)

MOTOR COVER

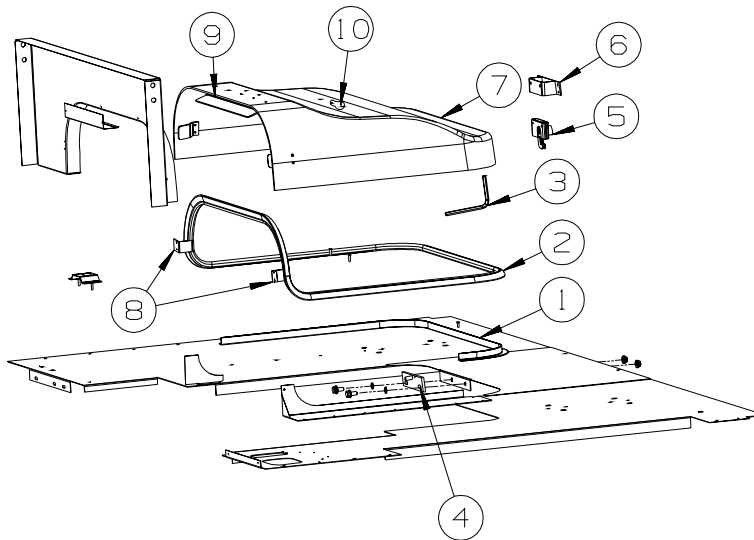

FORD

KEY	PART NUMBER	U/M	DESCRIPTION
1	115860-06-01A	EA	TRIM - MOTOR COVER - FORD - MILL FINISH
2	039623-01-000	FT	SEAL - MOTOR COVER - RUBBER BULB TYPE
3	116833-01-02B	EA	WRENCH - HEX MOTOR COVER - E-COATED
4	115852-01-02B	EA	STRIKE - LATCH - MOTOR COVER - E-COATED
5	116581-01-000	EA	LATCH - W/O STRIKE - MOTOR COVER
6	115850-01-02B	EA	RETAINER - LATCH - MOTOR COVER - RIGHT HAND - E-COATED
7	156754-01-U59	EA	COVER - MOTOR - W/CARPET - FORD (U67, U68)
7	156754-01-U57	EA	COVER - MOTOR - W/CARPET - FORD (U71, U72)
7	156754-01-U75	EA	COVER - MOTOR - W/CARPET - FORD (U75, U76)
	153970-02-01A	EA	COVER - MOTOR - W/O CARPET
8	115855-04-02B	EA	RETAINER - MOTOR COVER/SIDE - E-COATED
9	115855-01-02B	EA	RETAINER - MOTOR COVER/TOP - E-COATED
10	134497-01-000	SF	FOIL/ALUMINUM - REINFORCED

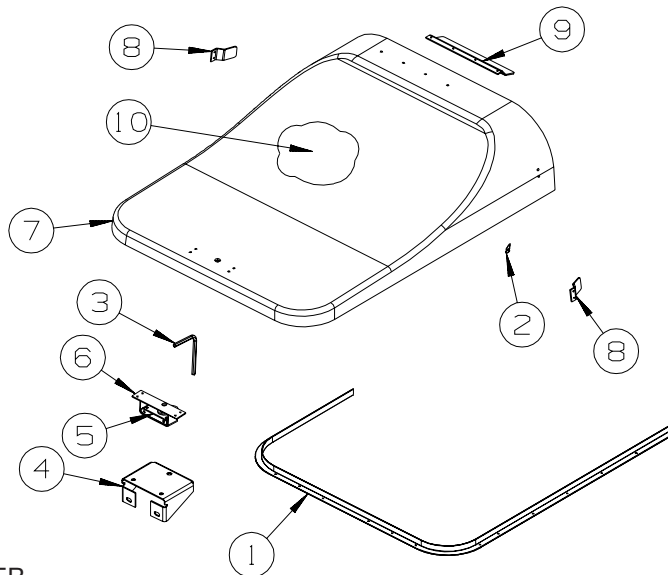

WORKHORSE

KEY	PART NUMBER	U/M	DESCRIPTION
1	137332-01-01A	EA	TRIM - MOTOR COVER
2	039623-01-000	FT	SEAL - MOTOR COVER - RUBBER BULB TYPE
3	116833-01-02B	EA	WRENCH - HEX MOTOR COVER - E-COATED
4	137305-02-02B	EA	BRACKET - STRIKE SUPPORT - E-COATED
5	116581-01-000	EA	LATCH - W/O STRIKE - MOTOR COVER
6	115850-01-02B	EA	RETAINER - LATCH - MOTOR COVER - RIGHT HAND - E-COATED
7	137097-01-T53	EA	COVER - MOTOR - W/CARPET (U67, U68)
7	137097-01-U57	EA	COVER - MOTOR - W/CARPET (U71, U72)
7	137097-01-T65	EA	COVER - MOTOR - W/CARPET (U75, U76)
	137096-01-01A	EA	COVER - MOTOR - W/O CARPET
8	115855-04-02B	EA	RETAINER - MOTOR COVER/SIDE - E-COATED
9	115855-03-02B	EA	RETAINER - MOTOR COVER/TOP - E-COATED
10	134497-01-000	SF	FOIL/ALUMINUM - REINFORCED

DRIVERS COMPARTMENT GROUP (CONTINUED)
BEVERAGE TRAY

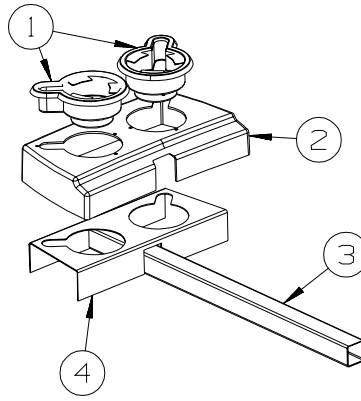

KEY	PART NUMBER	U/M	DESCRIPTION
1	133831-01-01A	EA	HOLDER - CUP W/THREE CENTERLINE RUBBER FINGERS
2	156018-01-20A	EA	TRAY - BEVERAGE - CASHMERE
3	156047-01-02B	EA	SUPPORT - BEVERAGE TRAY - E-COATED
4	156016-01-01B	EA	BRACKET - BEVERAGE TRAY - E-COATED

DRIVERS COMPARTMENT GROUP (CONTINUED)

FRONT INTERIOR

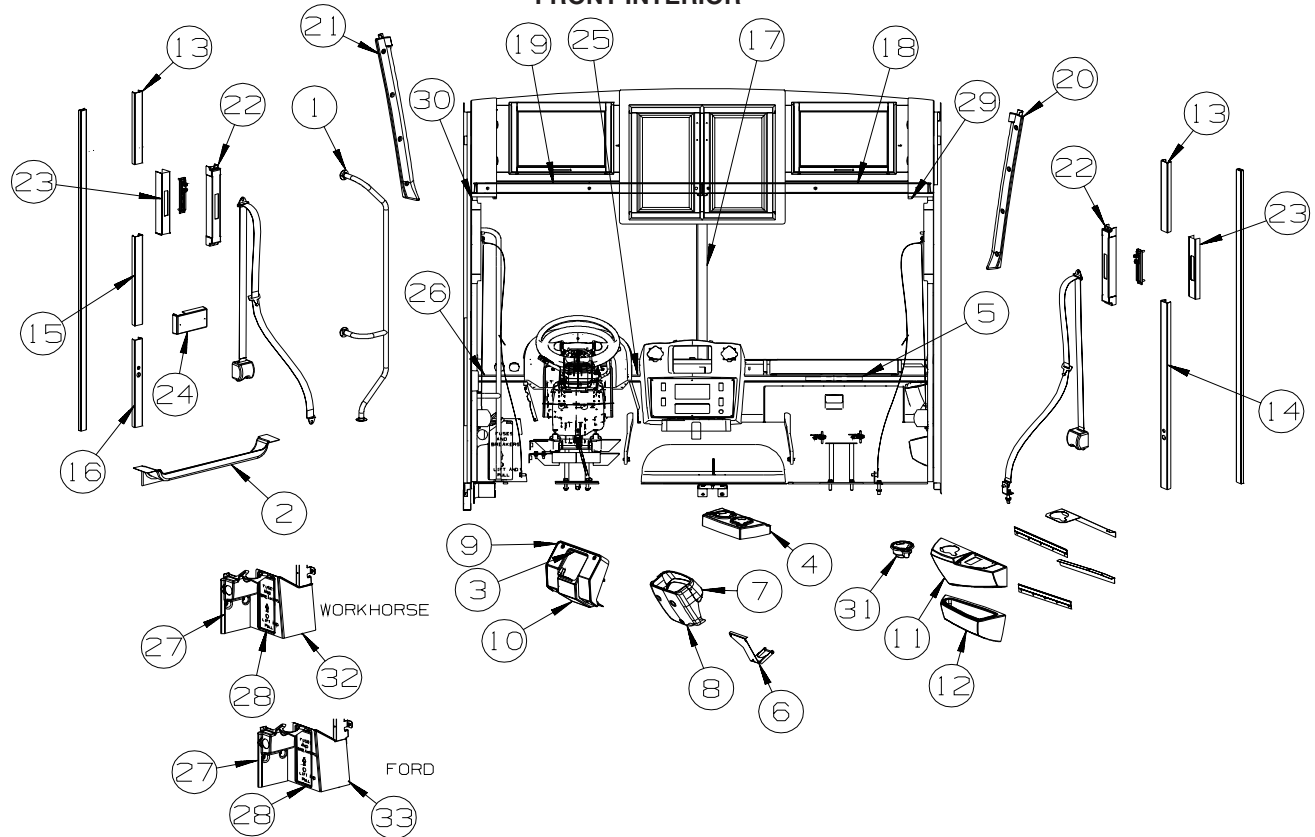

KEY	PART NUMBER	U/M	DESCRIPTION
1	131058-04-02A	EA	HAND RAIL - INTERIOR CAB DOOR - BLACK
2	131849-01-20A	EA	TRIM/STEP - DRIVER DOOR - CASHMERE
	102569-02-000	EA	MAT - ANTI SLIP - LOWER
3	110530-01-000	FT	SEAL - SPONGE - .31" X .62" - FORD
4	156018-01-20A	EA	TRAY - BEVERAGE - CASHMERE
5	126340-09-01A	EA	DECAL - LOGO - "VOYAGE" - SMALL/PASS SIDE PARCHMENT
6	148806-01-02B	EA	MOUNT ASM-STEERING COVE, E-COAT - WORKHORSE
7	155934-01-20A	EA	COVER - STEERING COLUMN - UPPER - WORKHORSE - CASHMERE - WORKHORSE
8	155935-01-20A	EA	COVER - STEERING COLUMN - LOWER - WORKHORSE - CASHMERE - WORKHORSE
9	148815-02-20A	EA	COVER - STEERING COLUMN - UPPER - CASHMERE - FORD
10	125795-01-20A	EA	COVER - STEERING COLUMN/LOWER - CASHMERE - FORD
11	148829-01-S64	EA	PANEL - PASSENGER SIDE/UPPER - CASHMERE
	130034-08-02B	EA	CLIP - TRIM - E-COATED
	148830-01-20A	EA	PANEL - PASSENGER SIDE - UPPER - CASHMERE
	149218-01-02B	EA	BRACKET - MOUNTING - CUPHOLDER - E-COATED
12	148831-01-S64	EA	PANEL - PASSENGER SIDE/LOWER - CASHMERE
	130034-08-02B	EA	CLIP - TRIM - E-COATED
	148828-01-20A	EA	POCKET/STORAGE - PASSENGER SIDE - CASHMERE
	148832-01-20A	EA	PANEL - PASSENGER SIDE - LOWER - CASHMERE
	149229-01-02B	EA	BRACKET - PANEL MOUNTING - E-COATED
13	024700-58-000	EA	COVER - ROLL BAR - SIDEWALL - 16.5" - OFF WHITE
14	024700-59-000	EA	COVER - ROLL BAR - SIDEWALL - 44.1" - OFF WHITE
15	024700-66-000	EA	COVER - ROLL BAR - SIDEWALL - 20.6" - OFF WHITE
16	024700-67-000	EA	COVER - ROLL BAR - SIDEWALL - 20.1" - OFF WHITE
17	118452-04-20A	EA	TRIM - WINDSHIELD - CENTER - CASHMERE
18	118453-03-05A	EA	TRIM - WINDSHIELD - INNER/TOP/PASSENGER - CASHMERE
19	118453-04-05A	EA	TRIM - WINDSHIELD - INNER/TOP/DRIVER - CASHMERE
20	155329-01-05A	EA	TRIM - A-PILLAR/PASSENGER - CASHMERE
21	155329-02-05A	EA	TRIM - A-PILLAR/DRIVER - CASHMERE
22	140151-01-01A	EA	COVER - SEAT BELT - OFF WHITE
23	140151-03-01A	EA	COVER - SLIDING - F/SEATBELT - BLACK

DRIVERS COMPARTMENT GROUP (CONTINUED)
FRONT INTERIOR (CONTINUED)

KEY	PART NUMBER	U/M	DESCRIPTION
24	141072-01-01A	EA	COVER - BRACKET/LATCH - OFF WHITE
	140151-02-01A	EA	COVER - SCREW - OFF WHITE
25	149510-04-02A	EA	APPLIQUE - LOWER DASH - DARK ANTELOPE
26	149510-05-02A	EA	APPLIQUE - LOWER DASH - DARK ANTELOPE
27	148825-01-20A	EA	PANEL/TRIM - UNDER DASH/LEFT HAND - CASHMERE
28	148826-01-20A	EA	PANEL/DOOR - FUSE PANEL/LEFT HAND - CASHMERE
29	127254-14-20A	EA	TRACK/WRAPAROUND - PASSENGER - CASHMERE
30	127254-04-20A	EA	TRACK/WRAPAROUND - DRIVER - CASHMERE
31	133831-01-01A	EA	HOLDER - CUP W/THREE CENTERLINE RUBBER FINGERS
32	148824-01-20A	EA	PANEL/TRIM - FUSE PANEL/LEFT HAND - CASHMERE - WORKHORSE
33	148824-02-20A	EA	PANEL/TRIM - FUSE PANEL/LEFT HAND - CASHMERE - FORD

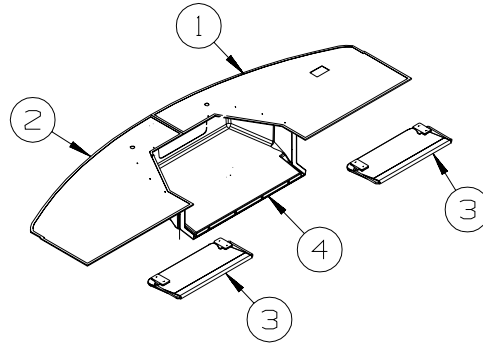

WITH FRONT TV

KEY	PART NUMBER	U/M	DESCRIP
1	126440-35-U67	EA	PANEL - OVERHEAD/FRONT/BOTTOM/RIGHT HAND - VINYL COVERED
2	126440-36-U67	EA	PANEL - OVERHEAD/FRONT/BOTTOM/LEFT HAND - VINYL COVERED
3	123298-04-09A	EA	SUNVISOR - 10.5" X 21" - DRIVER/PASSENGER - DRIFTWOOD
4	152485-01-20A	EA	COVER - FRONT TV - CASHMERE

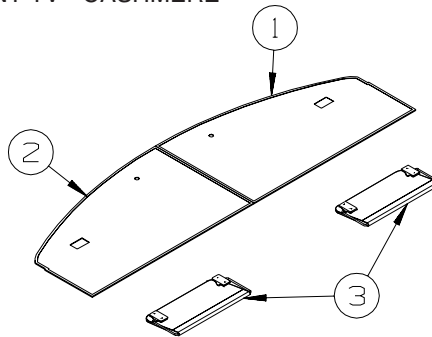

WITHOUT FRONT TV

KEY	PART NUMBER	U/M	DESCRIPTION
1	126440-37-U67	EA	PANEL - OVERHEAD/FRONT/BOTTOM/RIGHT HAND - VINYL COVERED
2	126440-38-U67	EA	PANEL - OVERHEAD/FRONT/BOTTOM/LEFT HAND - VINYL COVERED
3	123298-04-09A	EA	SUNVISOR - 10.5" X 21" - DRIVER/PASSENGER - DRIFTWOOD

DRIVERS COMPARTMENT GROUP (CONTINUED)

FRONT INTERIOR (CONTINUED)

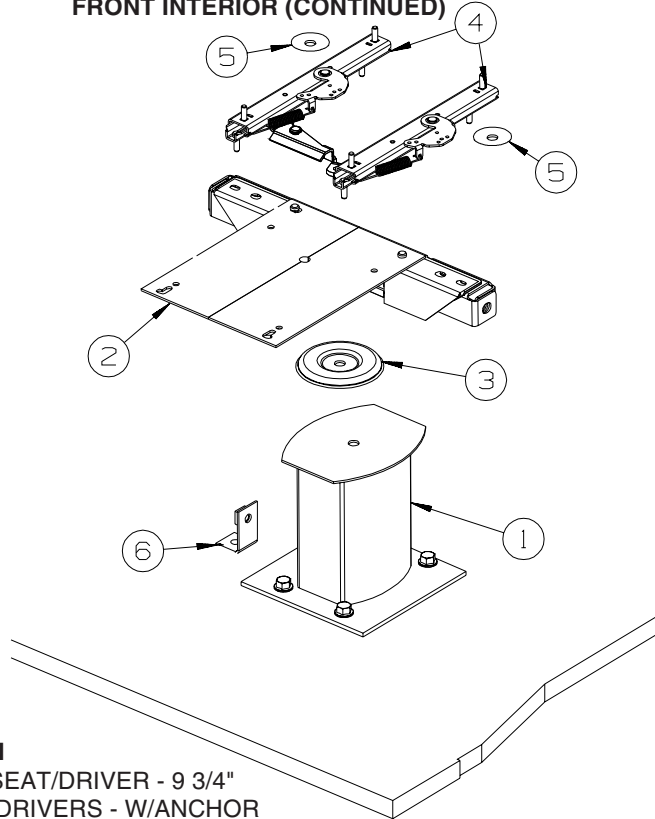

DRIVER MANUAL

KEY	PART NUMBER	U/M	DESCRIPTION
1	133408-01-000	EA	PEDESTAL - SEAT/DRIVER - 9 3/4"
2	133408-19-000	EA	TOP PLATE - DRIVERS - W/ANCHOR
3	107921-06-000	EA	BEARING KIT - PEDE
4	131566-04-000	EA	SLIDE/SEAT - HEAVY
	119952-07-000	EA	WIRE - LATCH RELE,
5	131566-05-000	EA	WASHER - SLIDE SP.
6	133408-04-000	EA	BRACKET - ANCHOR

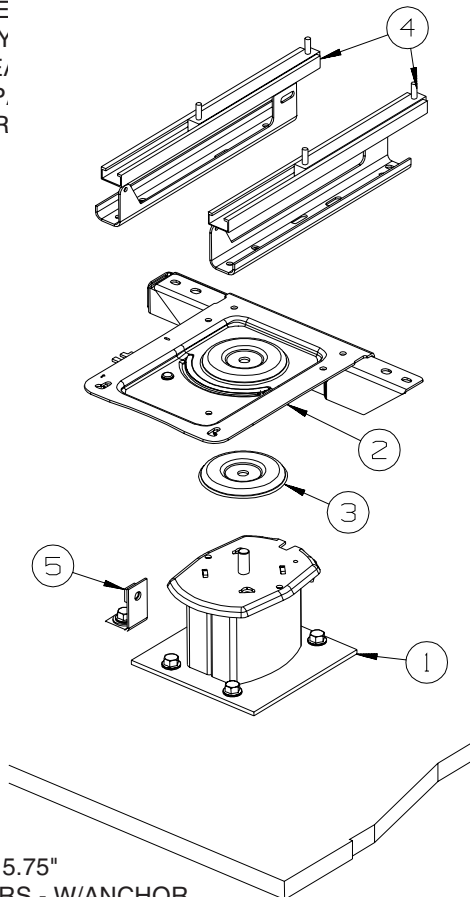

DRIVER POWERED

KEY	PART NUMBER	U/M	DESCRIPTION
1	133408-05-000	EA	PEDESTAL - SEAT - 5.75"
2	133408-19-000	EA	TOP PLATE - DRIVERS - W/ANCHOR
3	107921-06-000	EA	BEARING KIT - PEDESTAL
4*	147767-01-000	EA	SEAT - POWER - 6-WAY - DRIVER
5	133408-04-000	EA	BRACKET - ANCHOR/FLOOR

***COMPONENT PARTS LISTED LATER IN THIS GROUP**

DRIVERS COMPARTMENT GROUP (CONTINUED)
FRONT INTERIOR (CONTINUED)

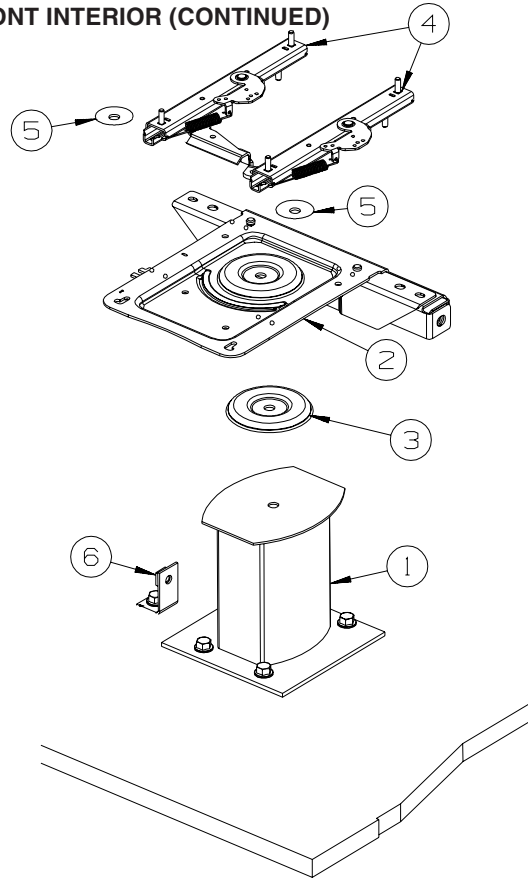

PASSENGER MANUAL

KEY	PART NUMBER	U/M	DESCRIPTION
1	133408-01-000	EA	PEDESTAL - SEAT - DRIVER/PASSENGER - 9 3/4"
2	133408-20-000	EA	TOP PLATE - PASSENGER - W/ANCHOR
3	107921-06-000	EA	BEARING KIT - PEDESTAL
4	131566-04-000	EA	SLIDE/SEAT - HEAVY DUTY LOCKING - 5"
	119952-07-000	EA	WIRE - LATCH RELEASE/ROTARY
5	131566-05-000	EA	WASHER - SLIDE SPACER
6	133408-04-000	EA	BRACKET - ANCHOR/FLOOR

DRIVERS COMPARTMENT GROUP (CONTINUED)
FRONT INTERIOR (CONTINUED)

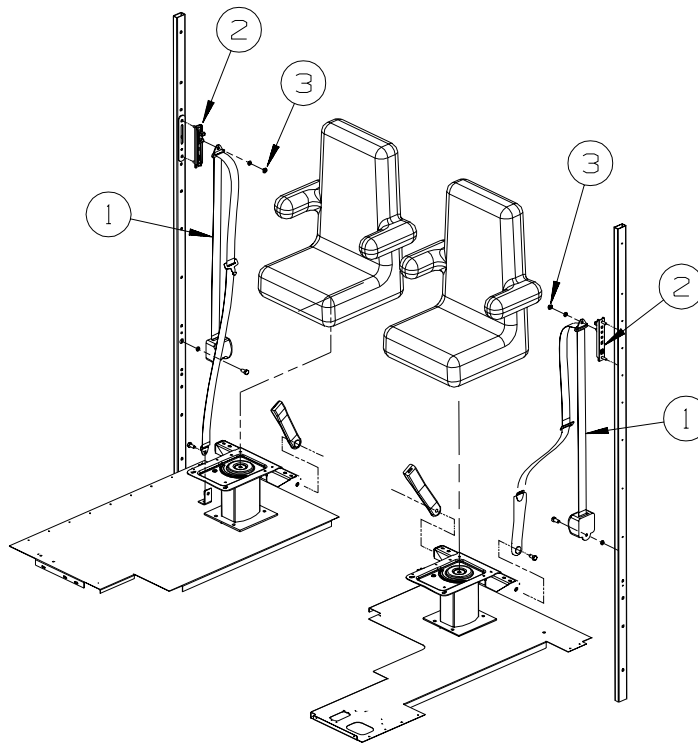

KEY	PART NUMBER	U/M	DESCRIPTION
1*	091990-08-01A	EA	SEAT BELT - 3 POINT - .766" DIAMETER HOLE IN D-LOOP BRKT
2	127598-01-01A	EA	ADJUSTER - SEATBELT - D-LOOP
3	127598-02-000	EA	NUT - HEX FLANGE - M10 X 1.5 - CLASS 10

***COMPONENT PARTS LISTED LATER IN THIS GROUP**

COMPONENT PARTS FOR FRONT INTERIOR

091990-08-01A

KEY	PART NUMBER	U/M	DESCRIPTION	VENDOR NO.
	091990-01-701	EA	EXTENDER 9" FOR A8408 3 PT	I-1331-02
	091990-01-703	EA	RECEIVER/FEMALE END-SEATBELT	I-1159-02
	091990-05-700	EA	SLEEVE/BUCKLE COVER-PLASTIC	209S-2
	091990-05-701	EA	CAP/COVER - BOLT HOLE COVER	209SC-02
	091990-05-702	EA	SLEEVE/RETRACTABLE COVER	309C-02

147767-01-000, 147767-02-000

KEY	PART NUMBER	U/M	DESCRIPTION	VENDOR NO
	147767-01-700	EA	SWITCH PLATE	SHROCK-9PT-SWT-PLTE
	147767-01-701	EA	MOTOR - VERTICAL	SHROCK 9PT-M0-VER-0
	147767-01-702	EA	MOTOR - HORIZONTAL	SHROCK 9PT-M0-HOZ-0

DRIVERS COMPARTMENT GROUP (CONTINUED)

CABINETS

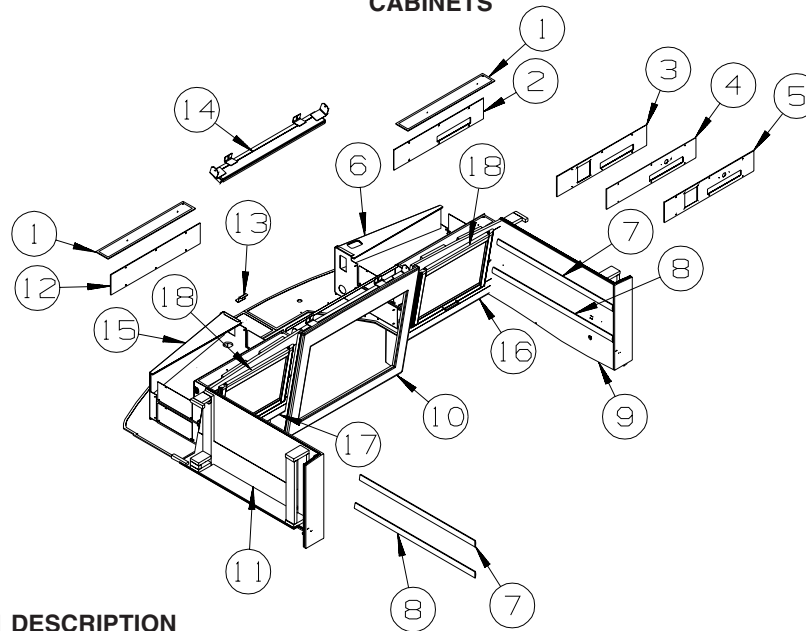

WITH FRONT TV

KEY	PART NUMBER	U/M	DESCRIPTION
1	150628-08-T81	EA	PANEL - VINYL COVERED
2	150628-01-T81	EA	PANEL - VINYL COVERED - HOME THEATER SYS
3	150628-09-T81	EA	PANEL - VINYL COVERED - AUTOMATIC SATELLITE DISH/HOME THEATER SYS
			FROM: 00-00-00 THRU: 01-28-07
3	150628-15-U67	EA	PANEL - VINYL COVERED - AUTOMATIC SATELLITE DISH/HOME THEATER SYS
			FROM: 01-29-07 THRU: 99-99-99
4	150628-11-U67	EA	PANEL - VINYL COVERED
5	150628-12-U67	EA	PANEL - VINYL COVERED - AUTOMATIC SATELLITE DISH
			FROM: 00-00-00 THRU: 01-28-07
5	150628-16-U67	EA	PANEL - VINYL COVERED - AUTOMATIC SATELLITE DISH
			FROM: 01-29-07 THRU: 99-99-99
6	132909-16-R32	EA	PANEL - VINYL COVERED
7	M09525-25-U67	EA	MOLDING - TRIM/VEE - 1.5" X 34.3" - WASHED MAPLE
7	M09525-25-U68	EA	MOLDING - TRIM/VEE - 1.5" X 34.3" - SIERRA MAPLE
8	M09525-26-U67	EA	MOLDING - TRIM/VEE - 1.5" X 35.8" - WASHED MAPLE
8	M09525-26-U68	EA	MOLDING - TRIM/VEE - 1.5" X 35.8" - SIERRA MAPLE
9	157841-01-U67	EA	PANEL - OVERHEAD/FRONT - RIGHT HAND - VINYL COVERED
10	152404-01-T79	EA	CABINET - FRONT/TV FACE - W/O DOORS/HDW - WASHED MAPLE
10	152404-01-T80	EA	CABINET - FRONT/TV FACE - W/O DOORS/HDW - SIERRA MAPLE
11	157841-02-U67	EA	PANEL - OVERHEAD/FRONT - LEFT HAND - VINYL COVERED
12	150628-02-U67	EA	PANEL - VINYL COVERED
13	152944-02-02B	EA	BRACKET - TIEDOWN/TV - E-COATED
14	155314-02-02B	EA	BRACKET - TV - 32.6" - W/ANGLES - W/O FOAM TAPE - E-COATED
15	132909-17-U67	EA	PANEL - VINYL COVERED - LH HAND
16	152403-01-T79	EA	CABINET - OVERHEAD/FRONT/RH HAND - W/O DOORS/HDW - WASHED MAPLE
16	152403-01-T80	EA	CABINET - OVERHEAD/FRONT/RH HAND - W/O DOORS/HDW - SIERRA MAPLE
17	152403-02-T79	EA	CABINET - OVERHEAD/FRONT - W/O DOORS/HDW - WASHED MAPLE
17	152403-02-T80	EA	CABINET - OVERHEAD/FRONT - W/O DOORS/HDW - SIERRA MAPLE
18	146028-63-U67	EA	DOOR - GLASS INSERT/OGEE EDGE - 15.7" X 21.8" - W/O HDW - WASHED MAPLE
			FROM: 00-00-00 THRU: 02-22-06
18	146028-A3-U67	EA	DOOR - GLASS INSERT/OGEE EDGE - 15.7" X 21.8" - W/O HDW - WASHED MAPLE
			FROM: 02-23-06 THRU: 99-99-99
18	146028-63-U68	EA	DOOR - GLASS INSERT/OGEE EDGE - 15.7" X 21.8" - W/O HDW - SIERRA MAPLE
			FROM: 00-00-00 THRU: 02-22-06
18	146028-A3-U68	EA	DOOR - GLASS INSERT/OGEE EDGE - 15.7" X 21.8" - W/O HDW - SIERRA MAPLE
			FROM: 02-23-06 THRU: 99-99-99
	100708-50-000	EA	DOOR/GLASS - TV CABINET - 13" X 19.1" - W/O HARDWARE
			FROM: 02-23-06 THRU: 99-99-99

DRIVERS COMPARTMENT GROUP (CONTINUED)
CABINETS (CONTINUED)

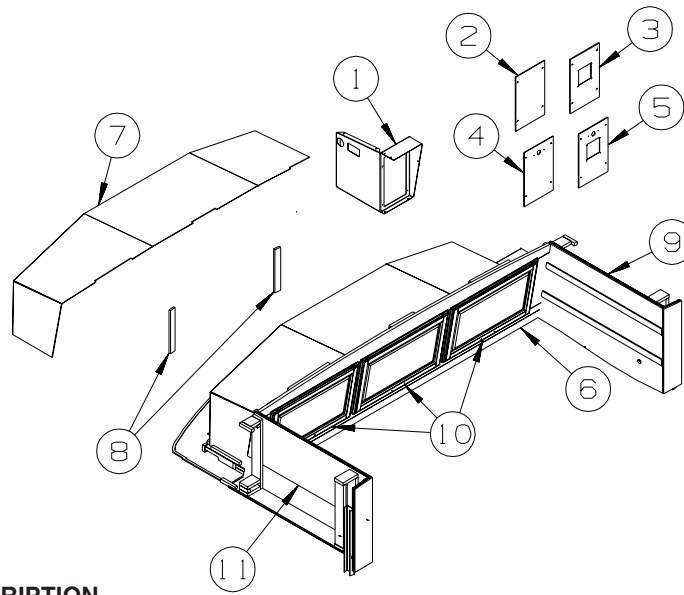

**WITHOUT FRONT TV
F38J ONLY**

KEY	PART NUMBER	U/M	DESCRIPTION
1	155123-02-02B	EA	PANEL - END, CLOSEOUT
2	155127-01-TG0	EA	PANEL - VINYL COVERED
3	155127-02-TG0	EA	PANEL - VINYL COVERED - AUTOMATIC SATELLITE DISH
			FROM: 00-00-00 THRU: 01-28-07
3	155127-10-U87	EA	PANEL - VINYL COVERED - AUTOMATIC SATELLITE DISH
			FROM: 01-29-07 THRU: 99-99-99
4	155127-04-U67	EA	PANEL - VINYL COVERED - HOME THEATER SYS
5	155127-05-U67	EA	PANEL - VINYL COVERED - AUTOMATIC SATELLITE DISH/HOME THEATER SYS
			FROM: 00-00-00 THRU: 01-28-07
5	155127-11-U67	EA	PANEL - VINYL COVERED - AUTOMATIC SATELLITE DISH/HOME THEATER SYS
			FROM: 01-29-07 THRU: 99-99-99
6	153644-01-T79	EA	CABINET - OVERHEAD/FRONT - W/O DOORS/HDW - WASHED MAPLE
6	153644-01-T80	EA	CABINET - OVERHEAD/FRONT - W/O DOORS/HDW - SIERRA MAPLE
7	140015-06-U67	EA	PANEL ASM - CLOSEOUT, OVERHEAD FRONT
8	118608-21-U67	EA	PANEL-HEADLINER
9	157841-01-U67	EA	PANEL - OVERHEAD/FRONT - RIGHT HAND - VINYL COVERED
10	136954-C1-U67	EA	DOOR - RAISED PANEL/OGEE EDGE - 15.4" X 25.6" - W/O HDW - WASHED MAPLE
10	136954-C1-TL0	EA	DOOR - RAISED PANEL/OGEE EDGE - 15.4" X 25.6" - W/O HDW - SIERRA MAPLE
11	157841-02-U67	EA	PANEL - OVERHEAD/FRONT - LEFT HAND - VINYL COVERED

ELECTRICAL GROUP 110V BODY WIRING

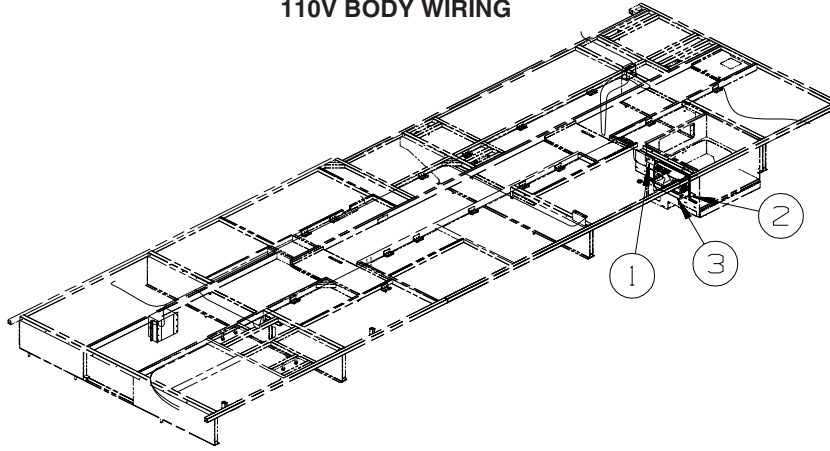

KEY	PART NUMBER	U/M	DESCRIPTION
1	058708-05-000	EA	RECEPTACLE - ELECTRICAL - SINGLE - BROWN
2	154367-07-02B	EA	BRACKET/MOUNT - INVERTER - E-COATED
3	154511-01-000	EA	INVERTER - 600 WATT - W/O REMOTE PANEL - INVERTER-DC/AC,600 WATT

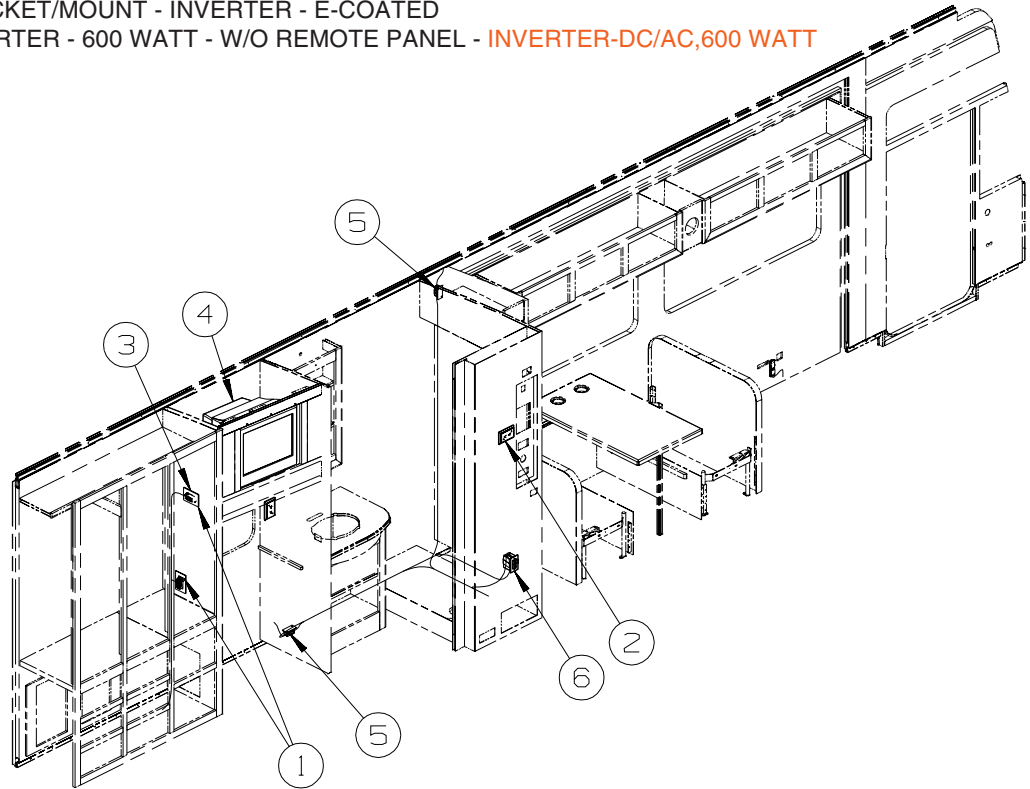

KEY	PART NUMBER	U/M	DESCRIPTION
1	058708-01-000	EA	RECEPTACLE - ELECTRIC - DOUBLE - BROWN
1	058708-06-000	EA	RECEPTACLE - DUPLEX - WHITE
2	133713-01-21A	EA	SPACER/RECEPTACLE - VINYL - WASHED MAPLE
2	133713-01-22A	EA	SPACER/RECEPTACLE - VINYL - SIERRA MAPLE
2	058708-01-000	EA	RECEPTACLE - ELECTRIC - DOUBLE - BROWN
2	058708-06-000	EA	RECEPTACLE - DUPLEX - WHITE
3	158542-02-01A	EA	LABEL - RECEPTACLE - ELECTRONICS - WHITE/BLACK
4*	149049-02-000	EA	TV - 20" COLOR/STEREO - FLAT - SONY KV-20FS120
			FROM: 00-00-00 THRU: 04-02-06
4*	149040-02-000	EA	TV - 20" FLAT SCREEN/STEREO - RCA 20F410T
			FROM: 04-03-06 THRU: 05-14-06
4	149040-03-000	EA	TV - 20" FLAT SCREEN/STEREO - RCA 20F420T
			FROM: 05-15-06 THRU: 99-99-99
5	058707-02-000	EA	RECEPTACLE - BLANK - JUNCTION BOX
6	147446-01-02A	EA	RECEPTACLE - GFCI - 15A 125V - BROWN
			FROM: 00-00-00 THRU: 12-20-06
6	163319-01-02A	EA	RECEPTACLE - GFCI - 15A 125V - BROWN
			FROM: 12-21-06 THRU: 99-99-99
6	147450-01-02A	EA	PLATE - ELECTRICAL OUTLET - BROWN

***COMPONENT PARTS LISTED LATER IN THIS GROUP**

ELECTRICAL GROUP (CONTINUED)
110V BODY WIRING (CONTINUED)

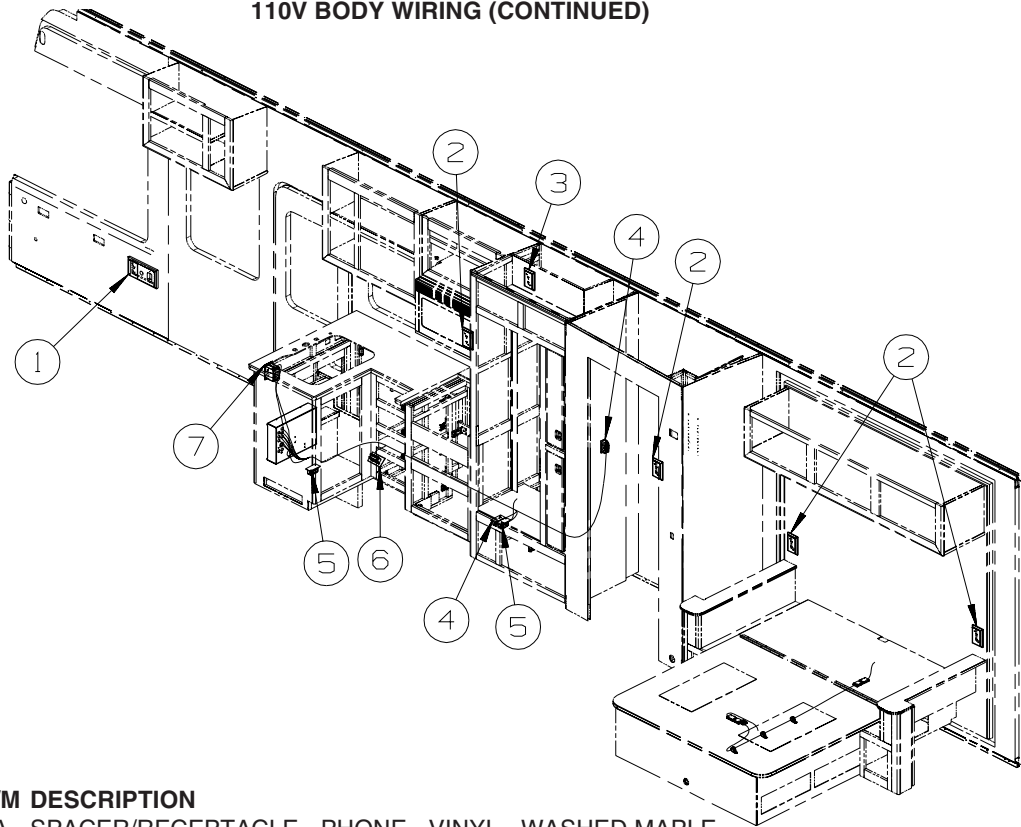

KEY	PART NUMBER	U/M	DESCRIPTION
1	133713-06-21A	EA	SPACER/RECEPTACLE - PHONE - VINYL - WASHED MAPLE
1	133713-06-22A	EA	SPACER/RECEPTACLE - PHONE - VINYL - SIERRA MAPLE
1	058708-01-000	EA	RECEPTACLE - ELECTRIC - DOUBLE - BROWN
1	058708-06-000	EA	RECEPTACLE - DUPLEX - WHITE
2	133713-01-21A	EA	SPACER/RECEPTACLE - VINYL - WASHED MAPLE
2	133713-01-22A	EA	SPACER/RECEPTACLE - VINYL - SIERRA MAPLE
2	058708-01-000	EA	RECEPTACLE - ELECTRIC - DOUBLE - BROWN
2	058708-06-000	EA	RECEPTACLE - DUPLEX - WHITE
3	133713-01-21A	EA	SPACER/RECEPTACLE - VINYL - WASHED MAPLE
3	133713-01-22A	EA	SPACER/RECEPTACLE - VINYL - SIERRA MAPLE
3	058708-05-000	EA	RECEPTACLE - ELECTRICAL - SINGLE - BROWN
4	058707-01-000	EA	RECEPTACLE - ELECTRIC - SINGLE - BROWN
5	058707-02-000	EA	RECEPTACLE - BLANK - JUNCTION BOX
6	058708-01-000	EA	RECEPTACLE - ELECTRIC - DOUBLE - BROWN
6	058708-06-000	EA	RECEPTACLE - DUPLEX - WHITE
7	147446-01-02A	EA	RECEPTACLE - GFCI - 15A 125V - BROWN
			FROM: 00-00-00 THRU: 12-20-06
7	163319-01-02A	EA	RECEPTACLE - GFCI - 15A 125V - BROWN
			FROM: 12-21-06 THRU: 99-99-99
7	147450-01-02A	EA	PLATE - ELECTRICAL OUTLET - BROWN

ELECTRICAL GROUP (CONTINUED)

12V BODY WIRING

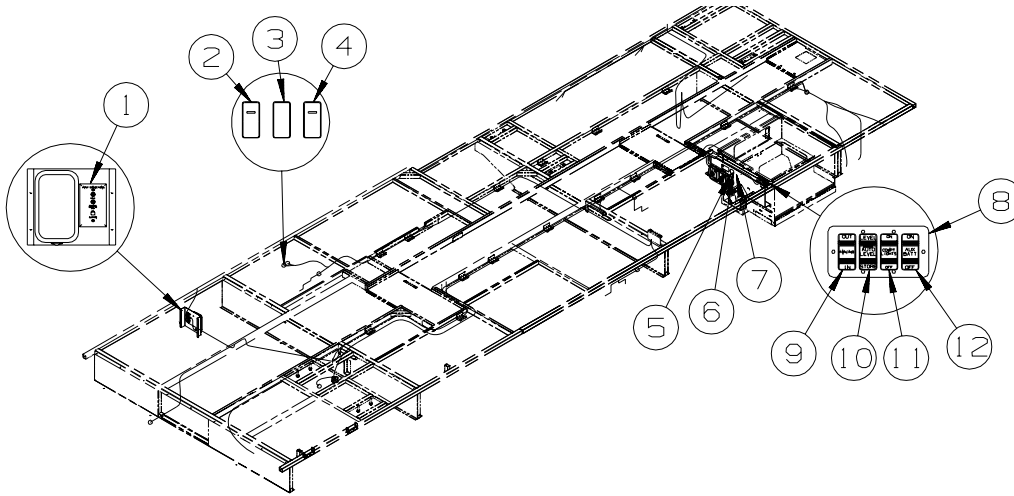

KEY	PART NUMBER	U/M	DESCRIPTION
1	149557-01-01A	EA	PLATE/WALL - PHONE/DUAL COAXIAL/VERTICAL - WHITE
2	108357-15-000	EA	SWITCH - ROCKER - DPDT - ON/NONE/ON - W/LIGHT W/O COVER
2	108356-03-01A	EA	COVER/ACTUATOR SWITCH - 3 GROOVES W/LENS - BLACK
2	108355-01-000	EA	HOUSING - SWITCH
3	108357-01-000	EA	SWITCH - ROCKER - SPST - ON/OFF - 2 TERMINAL - W/O COVER
3	108356-01-01A	EA	COVER/ACTUATOR SWITCH - 3 GROOVES - BLACK
3	108355-01-000	EA	HOUSING - SWITCH
4	108357-18-000	EA	SWITCH - ROCKER - DPDT - MOM/OFF/MOM - W/O COVER - HYDRAULIC LEVEL JACKS-AUTO
4	108356-03-01A	EA	COVER/ACTUATOR SWITCH - 3 GROOVES W/LENS - BLACK - HYDRAULIC LEVEL JACKS-AUTO
4	108355-01-000	EA	HOUSING - SWITCH - HYDRAULIC LEVEL JACKS-AUTO
4	096241-03-000	EA	SWITCH - BLANK - BLACK
5	082134-01-000	EA	ADAPTER - TV - CABLE TO CABLE
6	082136-01-000	EA	NUT - HEX JAM - 3/8-32
7	157486-01-02A	EA	LABEL - TV/EXTERIOR
8	158431-01-02B	EA	PLATE - SWITCH - E-COATED
9	108357-07-000	EA	SWITCH - ROCKER - SPDT - MOM/OFF/MOM - 3 TERM - W/O COVER - AWNING - PATIO, ELECTRIC
9	108356-12-01A	EA	COVER/ACTUATOR SWITCH - 3 GROOVES - AWNING/IN/OUT - AWNING - PATIO, ELECTRIC
9	108355-01-000	EA	HOUSING - SWITCH - AWNING - PATIO, ELECTRIC
9	096241-03-000	EA	SWITCH - BLANK - BLACK
10	108357-18-000	EA	SWITCH - ROCKER - DPDT - MOM/OFF/MOM - W/O COVER - HYDRAULIC LEVEL JACKS-AUTO
10	108356-15-01A	EA	COVER/ACTUATOR SW.-3 GROOVES-LEVELING JACKS/REMOTE-HYDRAULIC LEVEL JACKS-AUTO
10	108355-01-000	EA	HOUSING - SWITCH - HYDRAULIC LEVEL JACKS-AUTO
10	096241-03-000	EA	SWITCH - BLANK - BLACK
11	108357-01-000	EA	SWITCH - ROCKER - SPST - ON/OFF - 2 TERMINAL - W/O COVER
11	108356-14-01A	EA	COVER/ACTUATOR SWITCH - 3 GROOVES - COMPT LIGHTS
11	108355-01-000	EA	HOUSING - SWITCH
12	108357-06-000	EA	SWITCH - ROCKER - DPDT - MOM/OFF/MOM - 6 TERM - W/O COVER
12	108356-11-01A	EA	COVER/ACTUATOR SWITCH - 3 GROOVES - AUX BATT - BLACK
12	108355-01-000	EA	HOUSING - SWITCH

ELECTRICAL GROUP (CONTINUED)

12V BODY WIRING (CONTINUED)

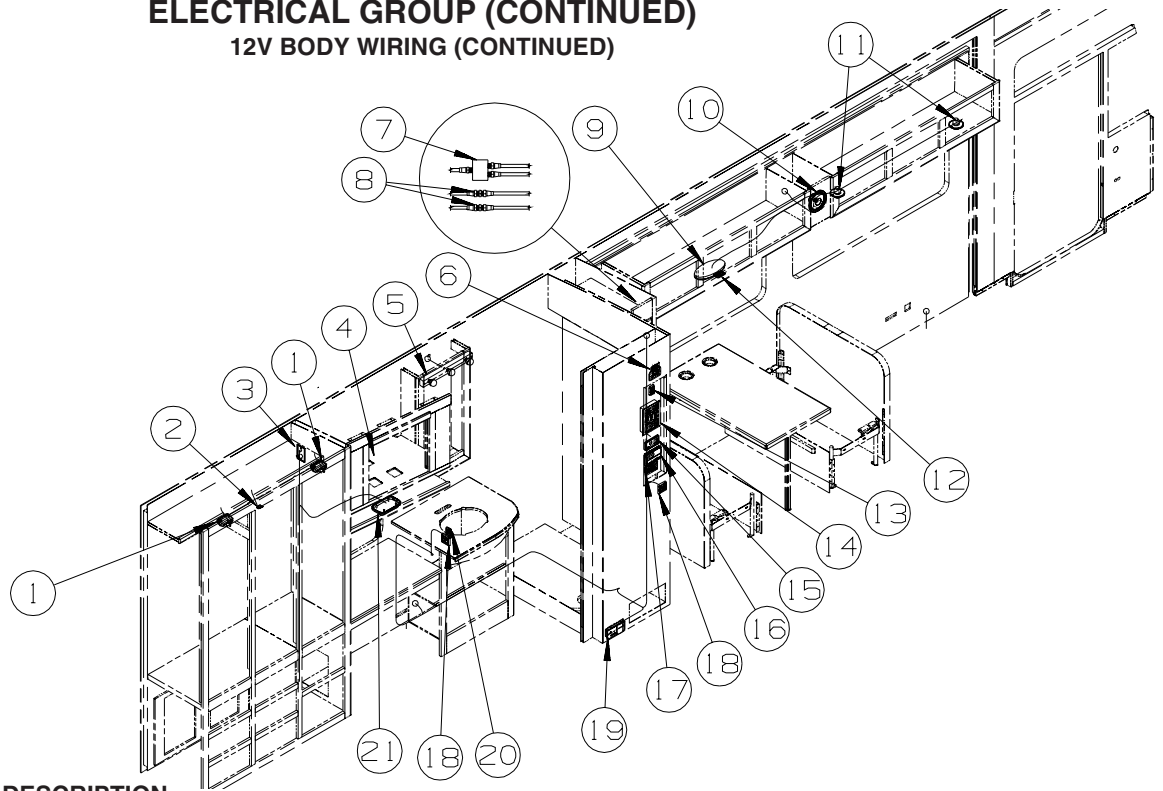

KEY	PART NUMBER	U/M	DESCRIPTION
1*	087694-01-000	EA	LIGHT - WARDROBE/CLOSET - W/SWITCH
2	056264-01-000	EA	SWITCH - LEAF ACTUATOR
3	076319-09-000	EA	WALLPLATE - TV CABLE RECEPTACLE - SINGLE - BROWN
4	136860-03-000	EA	CABLE - RCA - SHIELDED - 3 MALE TO MALE CONNECTORS - 6' - TV (REAR)-20"COLOR, STEREO
4	159064-01-01A	EA	LABEL - CABLE/RCA - WHITE ON BLACK - TV (REAR)-20"COLOR, STEREO
5	138116-01-02A	EA	LIGHT/MAKE UP - 3 BULB - CURVED - W/O BULB - SATIN NICKEL
5	123918-01-000	EA	BULB - 12V - MAKEUP - WHITE
6	116549-02-000	EA	LABEL - WARNING - SLIDEOUT
6	138173-04-000	EA	CONTROL PANEL (TOUCH PAD) - ELECTRIC SLIDEOUT - #1802931
7	086756-01-000	EA	SPLITTER - TV/2 WAY
8	082134-01-000	EA	ADAPTER - TV - CABLE TO CABLE
9	093575-39-01A	EA	LIGHT - CEILING/DOUBLE - SATIN NICKEL
9	117805-01-000	EA	BULB - 12V - #921F - 1.4 AMPS
10	094097-01-000	EA	SPEAKER - RADIO/TV - W/O GRILLE - 5.25" DIAMETER
11	132427-01-02A	EA	LIGHT - READING/SWIVEL - ROUND - NICKEL
12	135740-01-01A	EA	SWITCH - ROCKER - SPST - ON/OFF - BROWN
12	135741-01-01A	EA	SWITCH - BASE - SINGLE - BROWN
12	135742-01-01A	EA	BEZEL - SWITCH - SINGLE - BROWN
13	138253-01-02A	EA	SWITCH - BLANK - BROWN
13	135741-01-01A	EA	SWITCH - BASE - SINGLE - BROWN
13	135742-01-01A	EA	BEZEL - SWITCH - SINGLE - BROWN
13	135740-06-01A	EA	SWITCH - ROCKER - ON/OFF - LIGHTED - RED - WTR HTR-6GAL OR 10 GAL/ELE/LP/MOTORAID
13	135741-01-01A	EA	SWITCH - BASE - SINGLE - BROWN - WTR HTR-6GAL OR 10 GAL/ELE/LP/MOTORAID
13	135742-35-02A	EA	BEZEL-SWITCH-WATER HEATER/110 VOLT - BROWN - WTR HTR-6GAL OR 10 GAL/ELE/LP/MOTORAID
14*	134940-06-01A	EA	PANEL - MONITOR - 2 TANK - W/GENERATOR SWITCH
14*	134940-08-01A	EA	PANEL - MONITOR - 2 TANK-W/GENERATOR SWITCH/SOLAR CHARGER - SOLAR PANEL-10 WATT
15	127002-10-000	EA	PANEL/MONITOR - ENERGY MANAGEMENT SYSTEMS CTRL - W/3 PLUG
16	105620-18-000	EA	THERMOSTAT - FURNACE/HEAT PUMP-A/C
17	154511-02-000	EA	REMOTE/PANEL - INVERTER/600 WATT - INVERTER-DC/AC,600 WATT
17	148254-03-000	EA	CABLE/INVERTOR - W/8 PIN MODULAR PHONE JACK - 50'-DIMEN - INVERTER-DC/AC,600 WATT
18	135740-01-01A	EA	SWITCH - ROCKER - SPST - ON/OFF - BROWN
18	135740-02-01A	EA	SWITCH - ROCKER - SPDT - ON/ON - BROWN
18	135741-02-01A	EA	SWITCH - BASE - DOUBLE - BROWN
18	135742-16-02A	EA	BEZEL - SWITCH - CEILING/HALL - BROWN
19	150138-01-01A	EA	DETECTOR - LP GAS - WHITE
20	135740-01-01A	EA	SWITCH - ROCKER - SPST - ON/OFF - BROWN
20	135741-01-01A	EA	SWITCH - BASE - SINGLE - BROWN
20	135742-08-02A	EA	BEZEL - SWITCH - MAKEUP - BROWN
21*	137417-01-01A	EA	LIGHT - DOME - SINGLE - W/SWITCH/FROSTED LENS - WHITE

*COMPONENT PARTS LISTED LATER IN THIS GROUP

ELECTRICAL GROUP (CONTINUED)

12V BODY WIRING (CONTINUED)

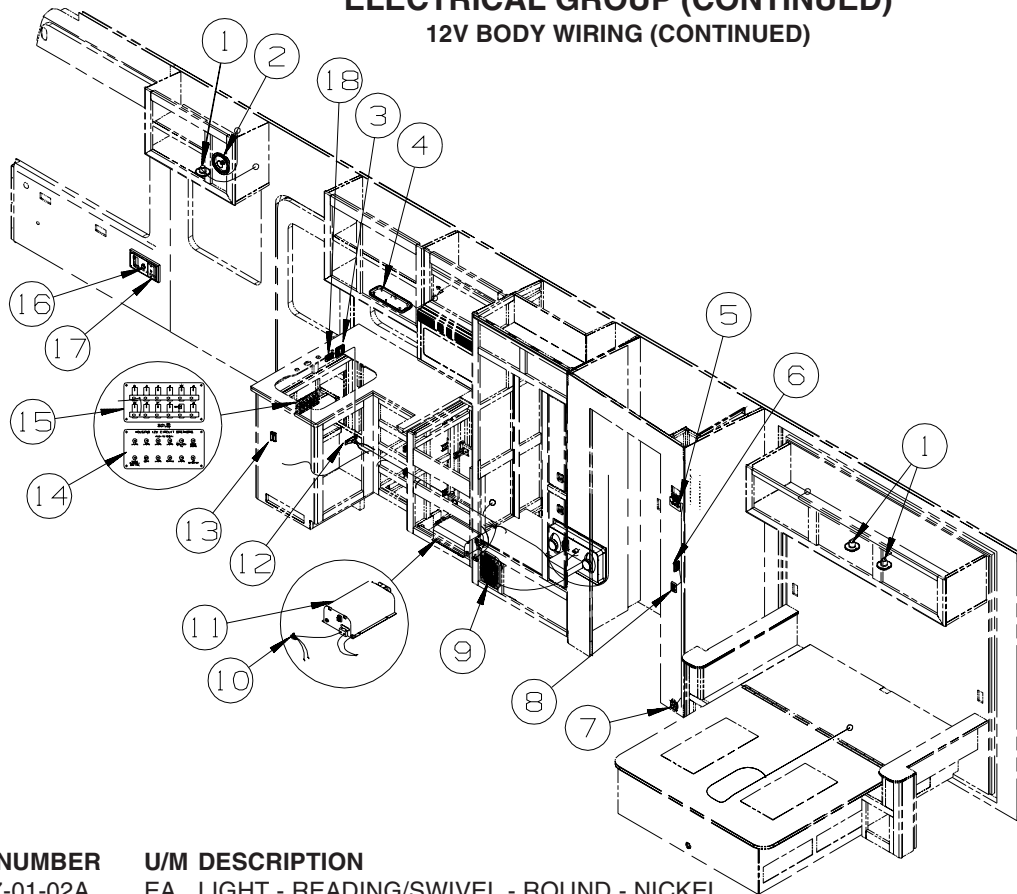

KEY	PART NUMBER	U/M	DESCRIPTION
1	132427-01-02A	EA	LIGHT - READING/SWIVEL - ROUND - NICKEL
2	094097-01-000	EA	SPEAKER - RADIO/TV - W/O GRILLE - 5.25" DIAMETER
3	135740-01-01A	EA	SWITCH - ROCKER - SPST - ON/OFF - BROWN
3	135741-02-01A	EA	SWITCH - BASE - DOUBLE - BROWN
3	135742-19-02A	EA	BEZEL - SWITCH - CEILING/PORCH - BROWN
4*	137417-05-01A	EA	LIGHT - DOME - DOUBLE - W/SWITCH/OPTIC LENS - WHITE
5	116549-02-000	EA	LABEL - WARNING - SLIDEOUT
5	138173-04-000	EA	CONTROL PANEL (TOUCH PAD) - ELECTRIC SLIDEOUT - #1802931
6	135740-01-01A	EA	SWITCH - ROCKER - SPST - ON/OFF - BROWN
6	135741-01-01A	EA	SWITCH - BASE - SINGLE - BROWN
6	135742-07-02A	EA	BEZEL - SWITCH - CEILING - BROWN
7*	108354-01-01A	EA	LIGHT - COURTESY
8	135740-01-01A	EA	SWITCH - ROCKER - SPST - ON/OFF - BROWN
8	135741-01-01A	EA	SWITCH - BASE - SINGLE - BROWN
8	135742-06-02A	EA	BEZEL - SWITCH - AISLE - BROWN
9	150090-01-000	EA	SPEAKER - 6" X 9" - SUB-WOOFER - MAGNADYNE LS69W
9	124884-01-000	EA	SPEAKER - 6" X 9" - SUB-WOOFER - W/O GRILLE
9	151569-01-01A	EA	GRILLE - SPEAKER - 6" X 9" - SUB WOOFER - BLACK
9	151844-01-01A	EA	GRILLE - SPEAKER - 6" X 9" - SUB WOOFER - BLACK
10	086233-01-000	EA	STUD - ISOLATED - 3/8" X 7/8" LONG
11	123058-02-000	EA	CONVERTER - 45 AMP - ELECTRONIC - 4 1/8"H X 7"W X 12 3/8"L
12	061424-01-000	EA	LIGHT - AISLE - 12 VOLT - RECTANGULAR
13	116995-02-000	EA	SWITCH/MAGNET - ELECTRIC STEP - BLACK/WHITE- NORMALLY OPEN
14	092547-10-000	EA	LABEL - CIRCUIT BREAKER
15	139067-02-02B	EA	PLATE - CIRCUIT BREAKER/HOUSE - E-COATED
16	132958-01-000	EA	RECEPTACLE - 12 VOLT - MOUNTING FLANGE - BLACK
17	093253-01-03A	EA	PLATE - WALL - TELEPHONE - WHITE
17	093253-01-02A	EA	PLATE - WALL - TELEPHONE - BROWN
18	135740-01-01A	EA	SWITCH - ROCKER - SPST - ON/OFF - BROWN
18	135741-01-01A	EA	SWITCH - BASE - SINGLE - BROWN
18	135742-11-02A	EA	BEZEL - SWITCH - STEP - BROWN

*COMPONENT PARTS LISTED LATER IN THIS GROUP

ELECTRICAL GROUP (CONTINUED)
12V BODY WIRING (CONTINUED)

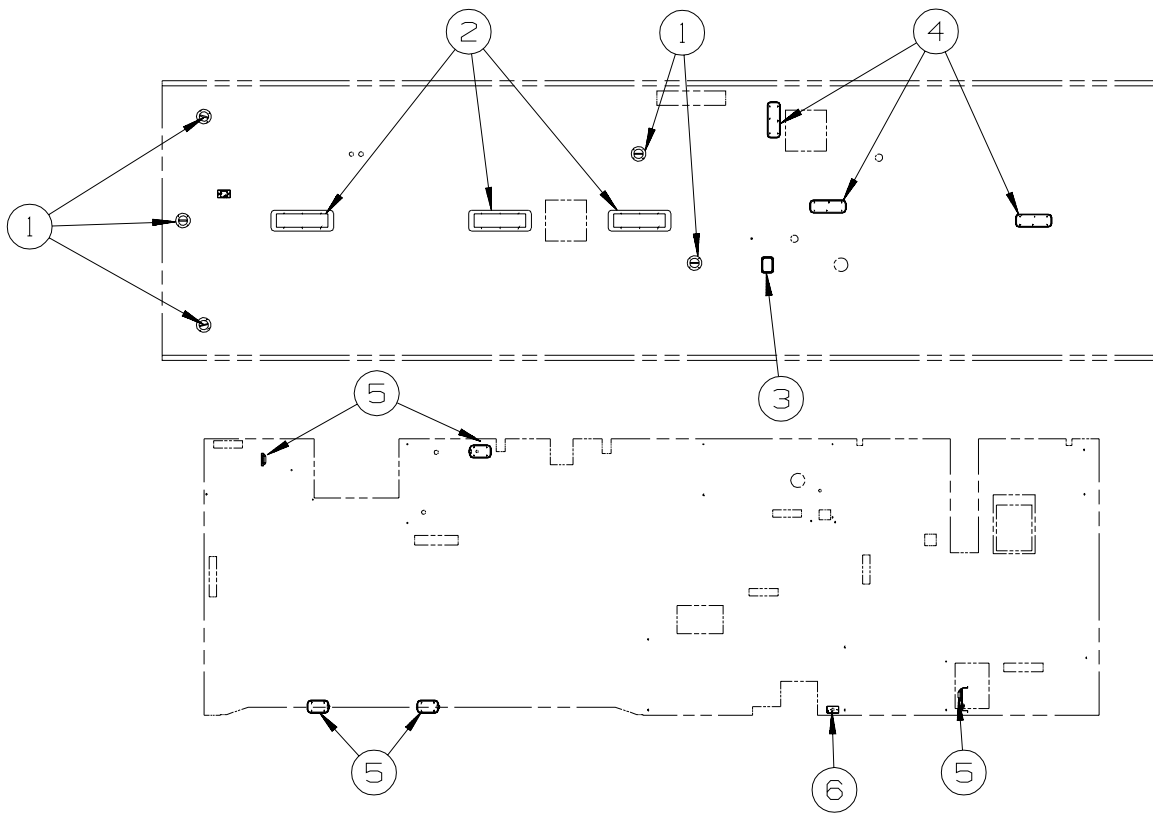

KEY	PART NUMBER	U/M	DESCRIPTION
1	151314-01-01A	EA	SPEAKER - CUBE/CEILING - WHITE - MAGNADYNE - LS3CM-WN - HOME THEATER SOUND SYSTEM FROM: 00-00-00 THRU: 07-16-06
1	160867-01-01A	EA	SPEAKER - ROUND/CEILING - CREAM - MAGNADYNE-LS3EYC-WN - HOME THEATER SOUND SYSTEM FROM: 07-17-06 THRU: 99-99-99
2*	153464-06-01A	EA	LIGHT-FLUORESCENT 21.8"- RECESSED/WARM WHT BULB-W/O SWITCH
3*	121935-01-01A	EA	LIGHT - DOME - SHOWER - W/HOLE IN LENS
4*	137417-06-01A	EA	LIGHT - DOME - DOUBLE - W/O SWITCH - W/FROSTED LENS-WHITE
5*	137417-01-01A	EA	LIGHT - DOME - SINGLE - W/SWITCH/FROSTED LENS - WHITE
6*	086280-01-000	EA	LIGHT - SURFACE MOUNT - 12 VOLT

***COMPONENT PARTS LISTED LATER IN THIS GROUP**

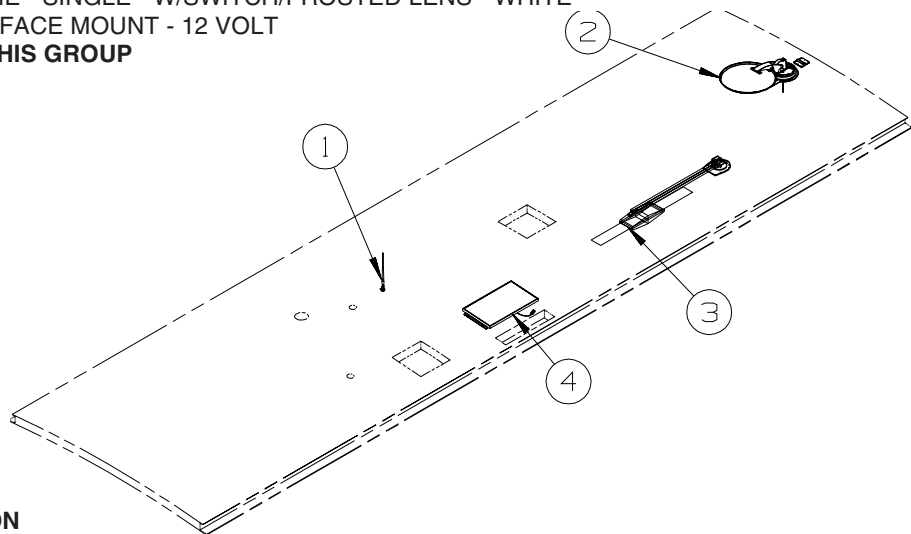

KEY	PART NUMBER	U/M	DESCRIPTION
1	090944-01-000	EA	ANTENNA - RADIO - 16" RUBBER - W/72" LEAD WIRE
1	109889-04-000	EA	EXTENDER - ANTENNA SHAFT - 3.7"
1	147741-01-09B	EA	BRACKET - ANTENNA GROUND - GALVANIZED
2*	141454-03-01A	EA	ANTENNA/SATELLITE - "AUTO SEARCH WHILE PARKED/GPS SYSTEM" - SATELLITE DISH-AUTOMATIC
2*	137135-02-000	EA	ANTENNA - SATELLITE DSS - W/SENSOR - SATELLITE DISH & ELEV.SENSOR
3*	076319-23-000	EA	ANTENNA - TV ROOF MOUNT - 44.5" MAST
3*	076319-25-000	EA	KIT - HARDWARE INTERIOR
3	069726-02-000	EA	BUMPER - .88" OD X .40" THICK - BLACK
4	151647-01-000	EA	PANEL - SOLAR 10 WATT

***COMPONENT PARTS LISTED LATER IN THIS GROUP**

ELECTRICAL GROUP (CONTINUED)
12V BODY WIRING (CONTINUED)

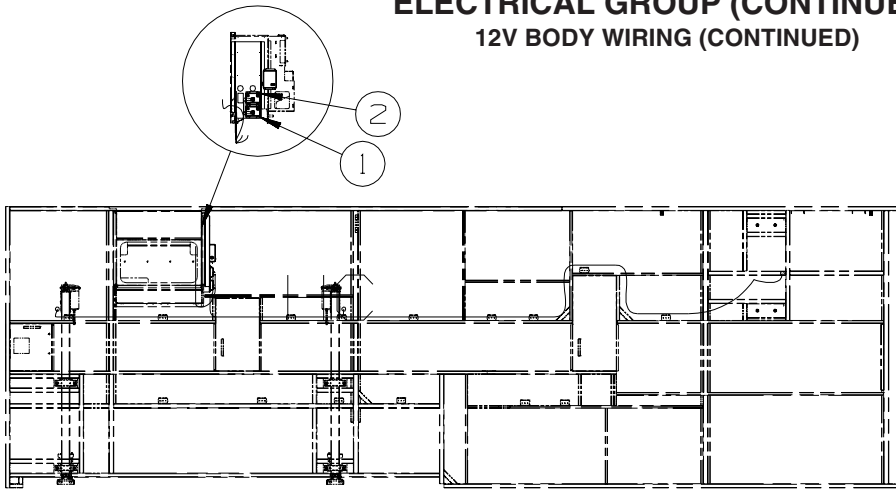

KEY	PART NUMBER	U/M	DESCRIPTION
1	149828-01-000	EA	SLIDE ASM - SINGLE/HIGH SPEED
2	149825-01-000	EA	CONTROL MODULE - DIGISYNC/HIGH SPEED - F/C-BODY RAM

ELECTRICAL GROUP (CONTINUED)
12V BODY WIRING (CONTINUED)

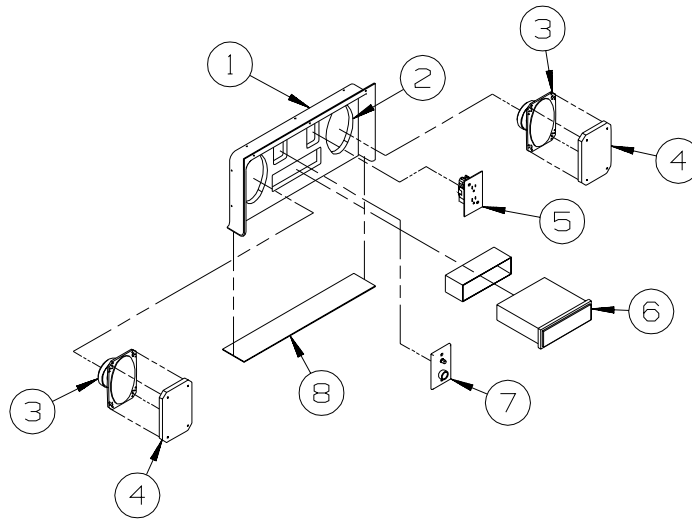

**EXTERIOR
ENTERTAINMENT**

KEY	PART NUMBER	U/M	DESCRIPTION
1	124696-02-01A	EA	BOX-ENTERTAINMENT CTR/EXT-19.4"W X 10"H X 2.5"D - BRT WHT
	124696-01-01A	EA	BOX-ENTERTAINMENT CTR/EXT-19.4"W X 10"H X 10.2"D W/CUTOUTS
2	127409-03-U89	EA	PLATE - RADIO MOUNTING
3	110469-01-000	EA	SPEAKER - 4" X 6" OVAL - COAXIAL
4	110470-01-01A	EA	GRILLE - 4" X 6" - OVAL SPEAKER - BLACK
5	058708-01-000	EA	RECEPTACLE - ELECTRIC - DOUBLE - BROWN
6*	155619-01-000	EA	RADIO - AM/FM CD - W/REMOTE - MAGNADYNE M3200CD
			FROM: 00-00-00 THRU: 08-01-06
6	155619-02-000	EA	RADIO - AM/FM CD-W/O REMOTE/WIRE HARNESS-MAGNADYNE M3200CD
			FROM: 08-02-06 THRU: 99-99-99
	155619-03-000	EA	REMOTE - RADIO
			FROM: 08-02-06 THRU: 99-99-99
7	132958-01-000	EA	RECEPTACLE - 12 VOLT - MOUNTING FLANGE - BLACK
8	104898-01-02A	EA	PLATE - PLASTIC BOTTOM - BRIGHT WHITE

***COMPONENT PARTS LISTED LATER IN THIS GROUP**

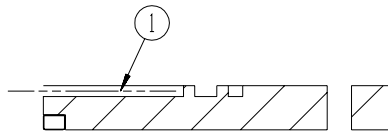
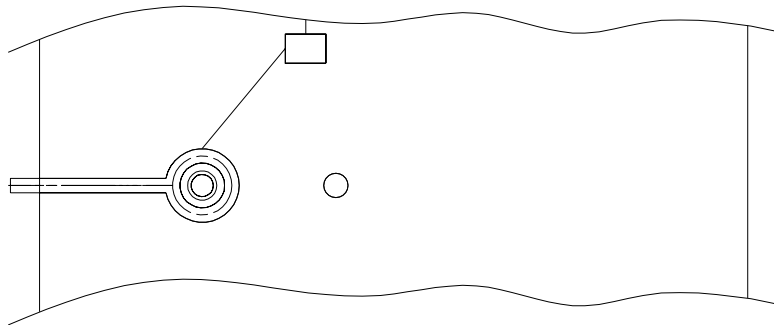

**SATELLITE WIRING DETAIL
ON ROOF**

KEY	PART NUMBER	U/M	DESCRIPTION
1	154474-03-000	EA	CABLE - SATELLITE - COAX - 8' W/CONNECTORS - AUTOMATIC SATELLITE DISH
1	141454-04-000	EA	WIRE - SATELLITE - AUTOMATIC - AUTOMATIC SATELLITE DISH
			FROM: 00-00-00 THRU: 01-28-07
1	163598-03-000	EA	CABLE - SATELLITE CONTROL - AUTOMATIC SATELLITE DISH
			FROM: 01-29-07 THRU: 99-99-99

ELECTRICAL GROUP (CONTINUED)

EXTERIOR LAMPS

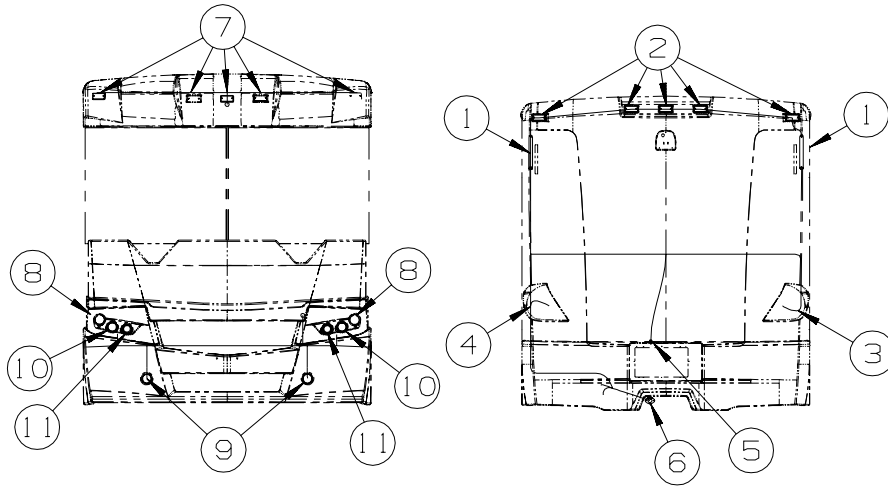

KEY	PART NUMBER	U/M	DESCRIPTION
1	151076-01-000	EA	LIGHT - BRAKE - CENTER MOUNT
2	102520-02-000	EA	LIGHT - CLEARANCE - W/O SOCKET/HOUSING - RED
2	102541-01-000	EA	GASKET - CLEARANCE LIGHT
2	036196-01-000	EA	BULB - 12V - #194 - .27 AMP - BAYONETTE
2	067789-02-000	EA	SOCKET - LAMP
3*	148658-01-000	EA	TAILLAMP - PASSENGER/REAR
4*	148658-02-000	EA	TAILLAMP - DRIVER/REAR
5	087201-01-000	EA	LIGHT - HALF ROUND - 1" X 1.7" - PLASTIC - BLACK OR WHITE
6	157593-01-000	EA	CONNECTOR - PLUG - TRAILER - 7 SOCKET
6	146246-01-000	EA	CONNECTOR/PLUG - TRAILER - 7 PIN
7	102520-01-000	EA	LIGHT - CLEARANCE - W/O SOCKET/HOUSING - AMBER
7	102541-01-000	EA	GASKET - CLEARANCE LIGHT
7	036196-01-000	EA	BULB - 12V - #194 - .27 AMP - BAYONETTE
8	146560-03-000	EA	LAMP - PARK/TURN - AMBER
8	112708-01-000	EA	BULB - 12 VOLT - #3157 - .59/2.10 AMP
8	146560-02-000	EA	SOCKET - LAMP - 3 WIRE - FORD
9	151421-01-000	EA	LAMP - FOG - CLEAR/ROUND - HAMSAR - W/PACKARD CONNECTOR
9	139686-01-02B	EA	ANGLE - MOUNT - FOGLAMP - E-COATED
10	146527-01-000	EA	HEADLAMP - LOWBEAM
10	147103-01-000	EA	HOUSING/CONNECTOR - HEADLAMP - W/PIGTAIL - FORD
11	146527-02-000	EA	HEADLAMP - HIGH BEAM
11	147103-01-000	EA	HOUSING/CONNECTOR - HEADLAMP - W/PIGTAIL - FORD
	067789-02-000	EA	SOCKET - LAMP - FORD

*COMPONENT PARTS LIST LATER IN THIS GROUP

ELECTRICAL GROUP (CONTINUED)
EXTERIOR LAMPS (CONTINUED)

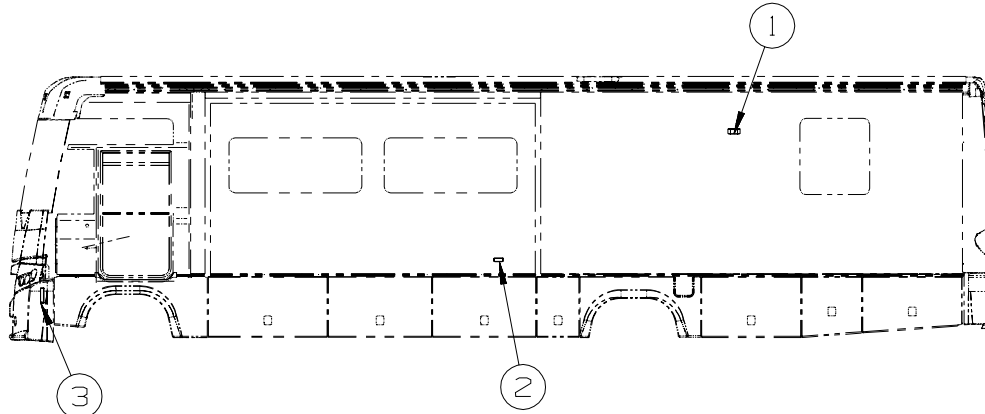
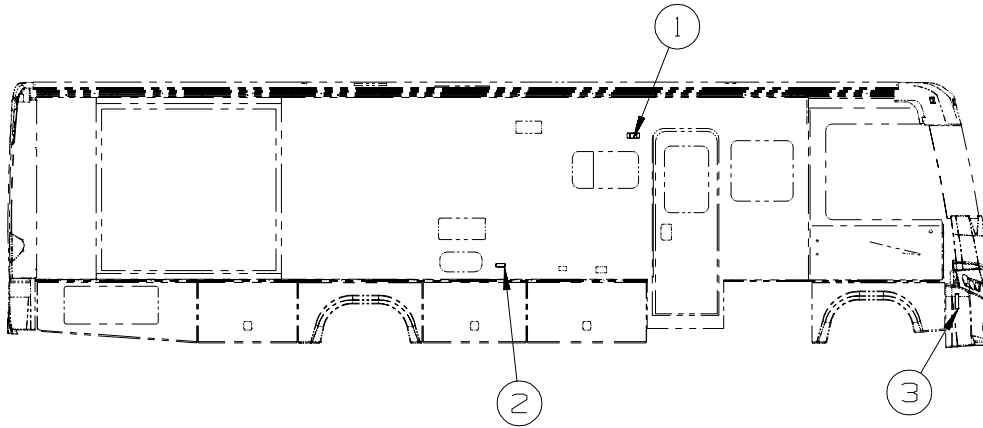

KEY	PART NUMBER	U/M	DESCRIPTION
1*	097917-01-06A	EA	LIGHT - PORCH - ENTRY DOOR - BRIGHT WHITE
	008215-01-000	EA	BULB - 12 VOLT - #1003 - .94 AMP
2	111102-02-000	EA	LENS - AMBER - MARKER LAMP
2	111102-01-000	EA	BASE - MARKER LAMP
2	036196-01-000	EA	BULB - 12V - #194 - .27 AMP - BAYONETTE
3	117826-02-000	EA	LAMP/SIDE MARKER ASSEMBLY - AMBER
3	117826-03-000	EA	GASKET/SIDE MARKER LIGHT
3	036196-01-000	EA	BULB - 12V - #194 - .27 AMP - BAYONETTE

***COMPONENT PARTS LISTED LATER IN THIS GROUP**

ELECTRICAL GROUP (CONTINUED)

FRONT END

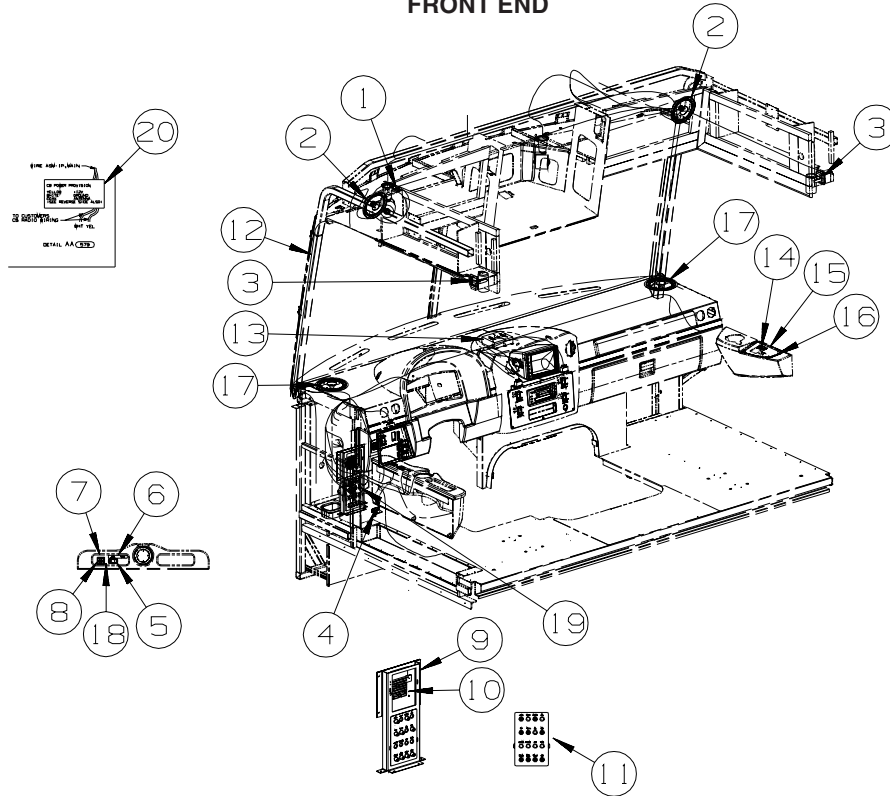

KEY	PART NUMBER	U/M	DESCRIPTION
1	122856-01-01A	EA	FAN-DEFROSTER-2 SPEED W/SWIVEL BASE/NON-OSCILLATING-CHROME
2	094097-01-000	EA	SPEAKER - RADIO/TV - W/O GRILLE - 5.25" DIAMETER
3	149590-01-02A	EA	LIGHT - READING/SWIVEL - W/O SWITCH - NICKEL
	123917-01-000	EA	BULB - 12V - HALOGEN SPOT
4	147428-01-02B	EA	BRACKET/ZEE - F/TEMPERATURE SENSOR - E-COATED - WORKHORSE
5	NOT USED		
6	NOT USED		
7	NOT USED		
8	NOT USED		
9	149689-01-02B	EA	BRACKET - CIRCUIT BREAKER - E-COATED
10	149690-01-02B	EA	BRACKET - FUSE PANEL - E-COATED - WORKHORSE
10	149690-02-02B	EA	BRACKET - FUSE PANEL - E-COATED - FORD
11	093236-47-000	EA	LABEL - CIRCUIT BREAKER
12	158494-02-000	EA	CABLE/ANTENNA - SATELLITE RADIO SIRRUS
13	135420-20-000	EA	RECEIVER - SATELLITE RADIO
14	145638-01-01A	EA	SWITCH/ROCKER - SPST (ON/OFF) - LIGHTED - BLACK
15	156292-05-01A	EA	APPLIQUE - PASSENGER/RIGHT - DARK ANTELOPE
16	145926-14-02B	EA	INSERT - SWITCH PLATE - 1 HOLE - NICKEL
17	094097-01-000	EA	SPEAKER - RADIO/TV - W/O GRILLE - 5.25" DIAMETER
18	139111-01-02A	EA	GRILLE - SPEAKER - 6" ROUND - GLACIER
			FROM: 00-00-00 THRU: 03-12-06
18	159430-01-01A	EA	GRILLE - SPEAKER - 6" ROUND - CASHMERE
			FROM: 03-13-06 THRU: 99-99-99
19	041250-01-000	EA	SWITCH - PUSH BUTTON/DOOR JAMB - METAL/CHROME
20	104678-01-000	EA	LABEL - CB PREP

CANADIAN DAY RUN LAMPS ON 2007 OR NEWER FORD CHASSIS

KEY	PART NUMBER	U/M	DESCRIPTION
	163912-01-000	EA	RESISITOR - DAYTIME RUNNING LIGHTS - FORD/CSA
	163913-01-000	EA	RELAY - DAYTIME RUNNING LIGHTS - FORD/CSA

ELECTRICAL GROUP (CONTINUED) FRONT END (CONTINUED)

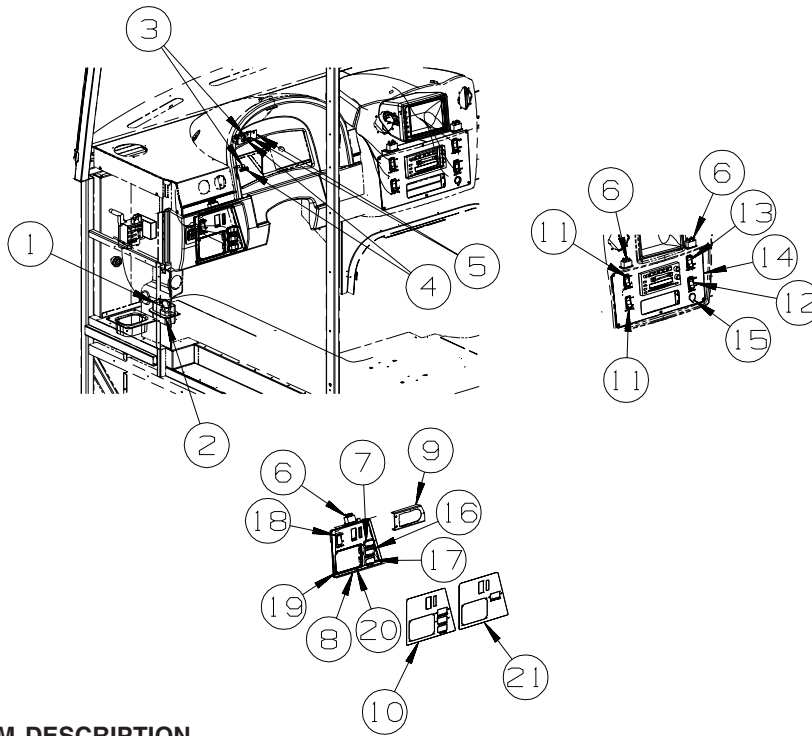

KEY	PART NUMBER	U/M	DESCRIPTION
1	118571-03-000	EA	BRACKET - MOUNTING
2	118571-04-000	EA	GASKET
3	150237-01-000	EA	LIGHT - INDICATOR - RED
4	133533-01-01A	EA	LABEL - JACKS DOWN - CLEAR W/WHITE LETTERING
5	063912-01-000	EA	RELAY - CANISTER - SPDT
6	157655-01-01A	EA	LIGHT - DASH/SWITCH - 2 LAMP INCANDESCANT - BLACK HOUSING
7	145638-04-01A	EA	SWITCH/ROCKER - SPDT (ON/ON) - BLACK
8	156292-03-01A	EA	APPLIQUE - DRIVERS/LEFT - FORD - DARK ANTELOPE
9	155516-01-02B	EA	MOUNT - HEADLAMP SWITCH - E-COATED
10	156292-02-01A	EA	APPLIQUE - DRIVERS/LEFT - WORKHORSE - DARK ANTELOPE
11	145638-03-01A	EA	SWITCH/ROCKER - SPDT (ON/OFF/ON) - BLACK
12	145638-06-01A	EA	SWITCH/ROCKER - SPDT (ON/OFF/ON) - LIGHTED - BLACK
13	145638-07-01A	EA	SWITCH/ROCKER - DPDT (ON/ON) - BLACK
14	156292-01-01A	EA	APPLIQUE - BEZEL - CENTER - DARK ANTELOPE
15	111414-01-000	EA	RECEPTACLE/SOCKET - 12 VOLT
16	145638-01-01A	EA	SWITCH/ROCKER - SPST (ON/OFF) - BLACK - WORKHORSE
17	145638-14-01A	EA	SWITCH/ROCKER - DPDT (ON/OFF/ON) - BLACK - WORKHORSE
18	145638-02-01A	EA	SWITCH/ROCKER - SPST (ON/OFF) - LIGHTED - BLACK
19	NOT USED		
20	NOT USED		

ELECTRICAL GROUP (CONTINUED)

FRONT TV/VCR

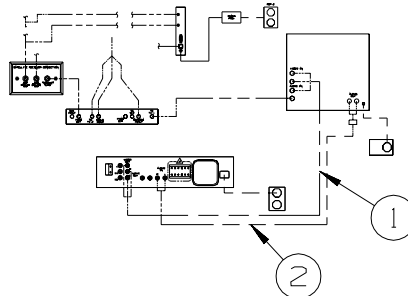
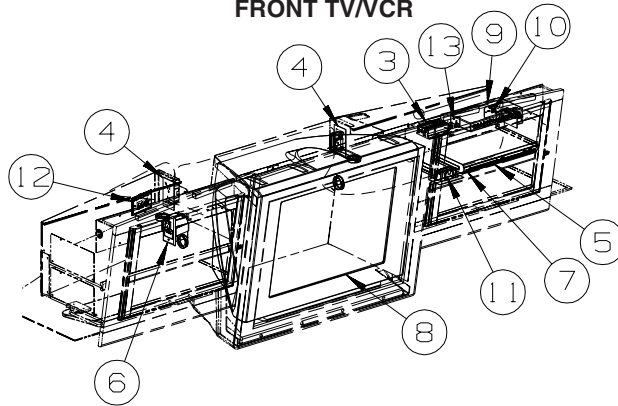

KEY	PART NUMBER	U/M	DESCRIPTION
1	136860-01-000	EA	CABLE - RCA - #3 MALE TO #12F MALE CONNECTOR
2	117420-02-000	EA	CABLE - W/MALE RCA ENDS - SHIELDED - 4'
3	147139-01-000	EA	AMPLIFIER - STEREO 2 CHANNEL
4	058708-01-000	EA	RECEPTACLE - ELECTRIC - DOUBLE - BROWN
4	158542-02-01A	EA	LABEL - RECEPTACLE - ELECTRONICS - WHITE/BLACK - CANADIAN
5	159771-01-000	EA	DVD/MP3 PLAYER - PROGRESSIVE SCAN - MEMOREX MVD2022 - DVD PLAYER
5	158931-01-000	EA	DVD/VCR - HOME THEATER COMBO - TOSHIBA SD-V57HT - HOME THEATER SYSTEM FROM: 00-00-00 THRU: 03-12-06
5*	158836-01-000	EA	DVD - HOME THEATER - W/O SPEAKERS - MEMOREX STS71E-R - HOME THEATER SYSTEM FROM: 03-13-06 THRU: 99-99-99
6	156676-01-000	EA	CONTROLLER/OUTLET - POWER/TV - AUTO SHUTOFF W/IGNITION
7	058707-02-000	EA	RECEPTACLE - BLANK - JUNCTION BOX
8*	146298-02-000	EA	TV - 27" STEREO W/5 JACKS - SONY 27FS120
9	142258-01-000	EA	SWITCH - VIDEO/ANTENNA POWER SUPPLY
10	079364-04-000	EA	SWITCH - ON/OFF ROCKER - 2 TERMINAL - BLACK
10	098351-09-02A	EA	PLATE/SWITCH - 1 GANG - CHROME - SPEAKER SELECT/TV
11	058708-01-000	EA	RECEPTACLE - ELECTRIC - DOUBLE - BROWN
12	149557-04-01A	EA	PLATE/WALL - TRIPLE COAXIAL/HORIZONTAL - WHITE
13	163598-02-000	EA	SWITCH/CONTROL - SATELLITE

FROM: 01-29-07 THRU: 99-99-99

***COMPONENT PARTS LISTED LATER IN THIS GROUP**

ELECTRICAL GROUP (CONTINUED)

SIDE TV/VCR

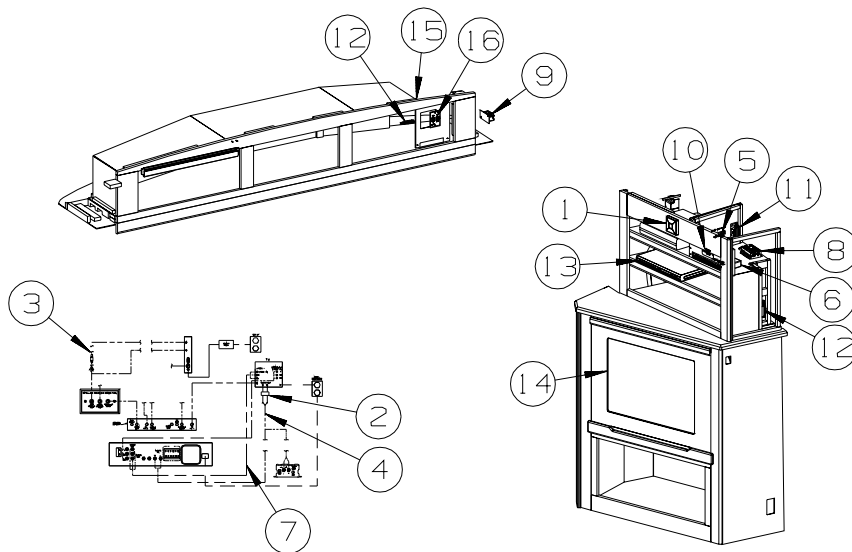

KEY	PART NUMBER	U/M	DESCRIPTION
1	148026-02-01A	EA	SPEAKER GRILLE - CUBE - SILVER
1	148026-03-01A	EA	SPEAKER - CUBE - W/O CASE
2	123324-01-000	EA	FILTER - GROUND LOOP
3	082134-01-000	EA	ADAPTER - TV - CABLE TO CABLE
4	117420-03-000	EA	CABLE - W/MALE RCA ENDS - SHIELDED - 20'
5	149557-04-01A	EA	PLATE/WALL - TRIPLE COAXIAL/HORIZONTAL - WHITE
6	142258-01-000	EA	SWITCH - VIDEO/ANTENNA POWER SUPPLY
7	136860-01-000	EA	CABLE - RCA - #3 MALE TO #12F MALE CONNECTOR
8	147139-01-000	EA	AMPLIFIER - STEREO 2 CHANNEL
9	058707-02-000	EA	RECEPTACLE - BLANK - JUNCTION BOX
10	079364-04-000	EA	SWITCH - ON/OFF ROCKER - 2 TERMINAL - BLACK
10	098351-09-02A	EA	PLATE/SWITCH - 1 GANG - CHROME - SPEAKER SELECT/TV
11	058708-01-000	EA	RECEPTACLE - ELECTRIC - DOUBLE - BROWN
11	158542-02-01A	EA	LABEL - RECEPTACLE - ELECTRONICS - WHITE/BLACK - CANADIAN
12	058708-01-000	EA	RECEPTACLE - ELECTRIC - DOUBLE - BROWN
13	159771-01-000	EA	DVD/VCR PLAYER - SONY SLV-D360P - DVD PLAYER
13*	158836-01-000	EA	DVD - HOME THEATER - W/O SPEAKERS - MEMOREX STS71E-R - HOME THEATER SYSTEM
14*	146298-02-000	EA	TV - 27" STEREO W/5 JACKS - SONY 27FS120
15	115539-01-000	EA	RELAY - RADIO/TV SPEAKER SWITCH W/WIRE - #SCLD-W-B-4PDT-C FROM: 06-26-06 THRU: 99-99-99
16	163598-02-000	EA	SWITCH/CONTROL - SATELLITE FROM: 01-29-07 THRU: 99-99-99

*COMPONENT PARTS LISTED LATER IN THIS GROUP

ELECTRICAL GROUP (CONTINUED)
COMPONENT PARTS FOR WIRING

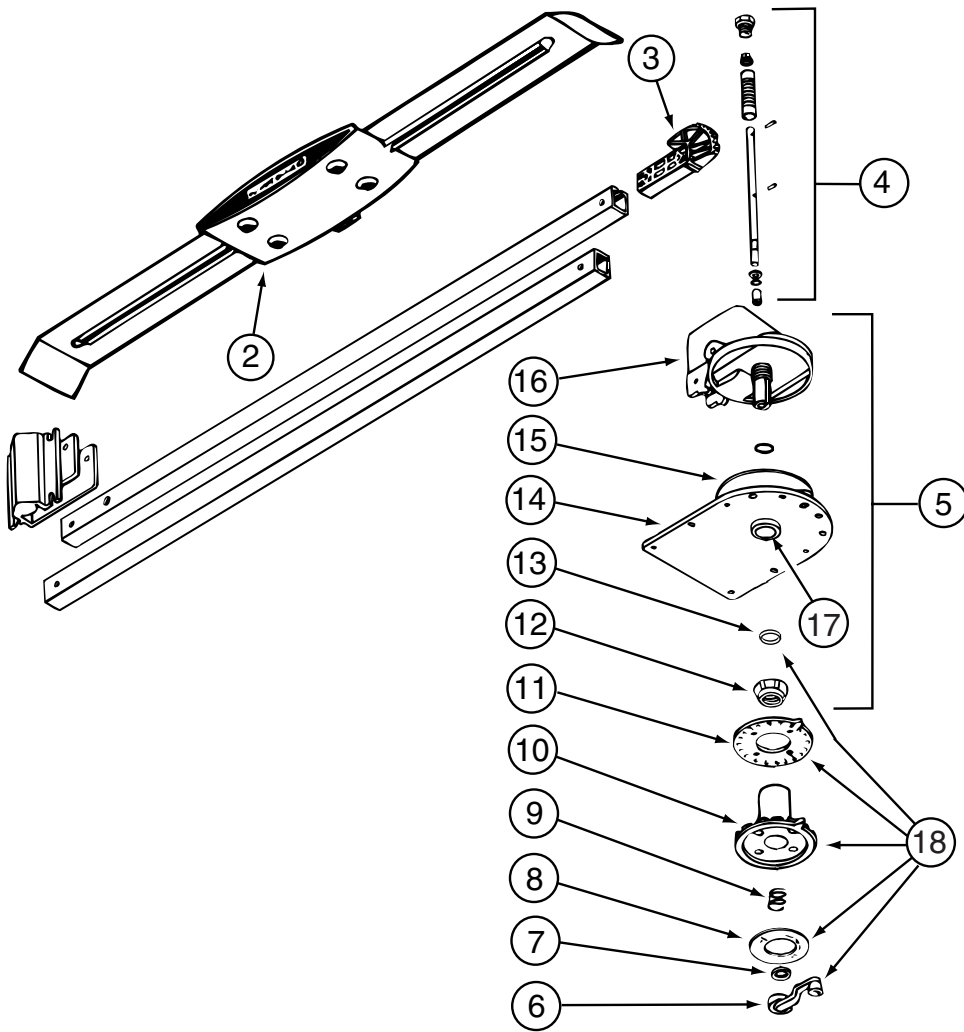

076319-23-000

KEY	PART NUMBER	U/M	DESCRIPTION	VENDOR NO.
2	076319-01-700	EA	HEAD-ANTENNA, AMPLIFIED	RVSA U/V
3	076319-01-701	EA	GEAR-ELEVATING, PLASTIC	2200046
4	076319-01-702	EA	SHAFT ASM-ELEVATING	RP-4000
5	076319-01-711	EA	BASE & LIFT ASM	2762802
7	076319-01-705	EA	GROMMET-NYLON, 7/8"ID	3200658
8	076319-01-708	EA	DECAL-CRANK	5413002
9	076319-01-707	EA	SPRING-HANDLE	2160822
11	076319-01-712	EA	PLATE - CEILING	3200608
12	076319-01-715	EA	NUT (GEAR HOUSING)	2200047
14	076319-01-713	EA	PLATE-BASE, STEEL	3100523
15	076319-01-703	EA	BEARING-NYLON, 5"OD	3200656
16	076319-01-714	EA	HOUSING, ROTATING GEAR	2200049
17	076319-01-704	EA	BEARING-NYLON, 1.25"OD	3200657
18	076319-01-709	EA	HANDLE-HEAD DIRECTIONAL	200644
	076319-01-716	EA	TUBING, ELEVATING	RP-2900

CONTACT WINNEBAGO PART SALES FOR UNLISTED COMPONENT(S)

076319-25-000

KEY	PART NUMBER	U/M	DESCRIPTION	VENDOR NO.
6	076319-01-706	EA	CRANK-W/SET SCREW UNIV/BEIGE	2750897
6	120233-01-710	EA	HANDLE-CRANK W/SCREW - WHITE	RP-6795
8	076319-01-708	EA	DECAL-CRANK	5413002
10	076319-25-700	EA	DIRECTIONAL HANDLE(WHITE)	3200612
11	076319-25-701	EA	PLATE - CEILING(WHITE)	3200609
13	120233-01-709	EA	WASHER-NYLON	RP-2658

CONTACT WINNEBAGO PART SALES FOR UNLISTED COMPONENT(S)

ELECTRICAL GROUP (CONTINUED)
COMPONENT PARTS FOR WIRING (CONTINUED)

KEY	PART NUMBER	U/M	DESCRIPTION		VENDOR NO.
	086280-01-700	EA	BULB,12V	086280-01-000	ARP1089
	087694-01-700	EA	BULB	087694-01-000	GE561
	097917-01-700	EA	LENS-LIGHT, CLEAR	097917-01-06A	30-78-021
	108354-01-700	EA	BULB-COURTESY LIGHT	108354-01-01A	395-B
	121935-01-700	EA	LENS ONLY	121935-01-01A	809511

ELECTRICAL GROUP (CONTINUED)
COMPONENT PARTS FOR WIRING (CONTINUED)

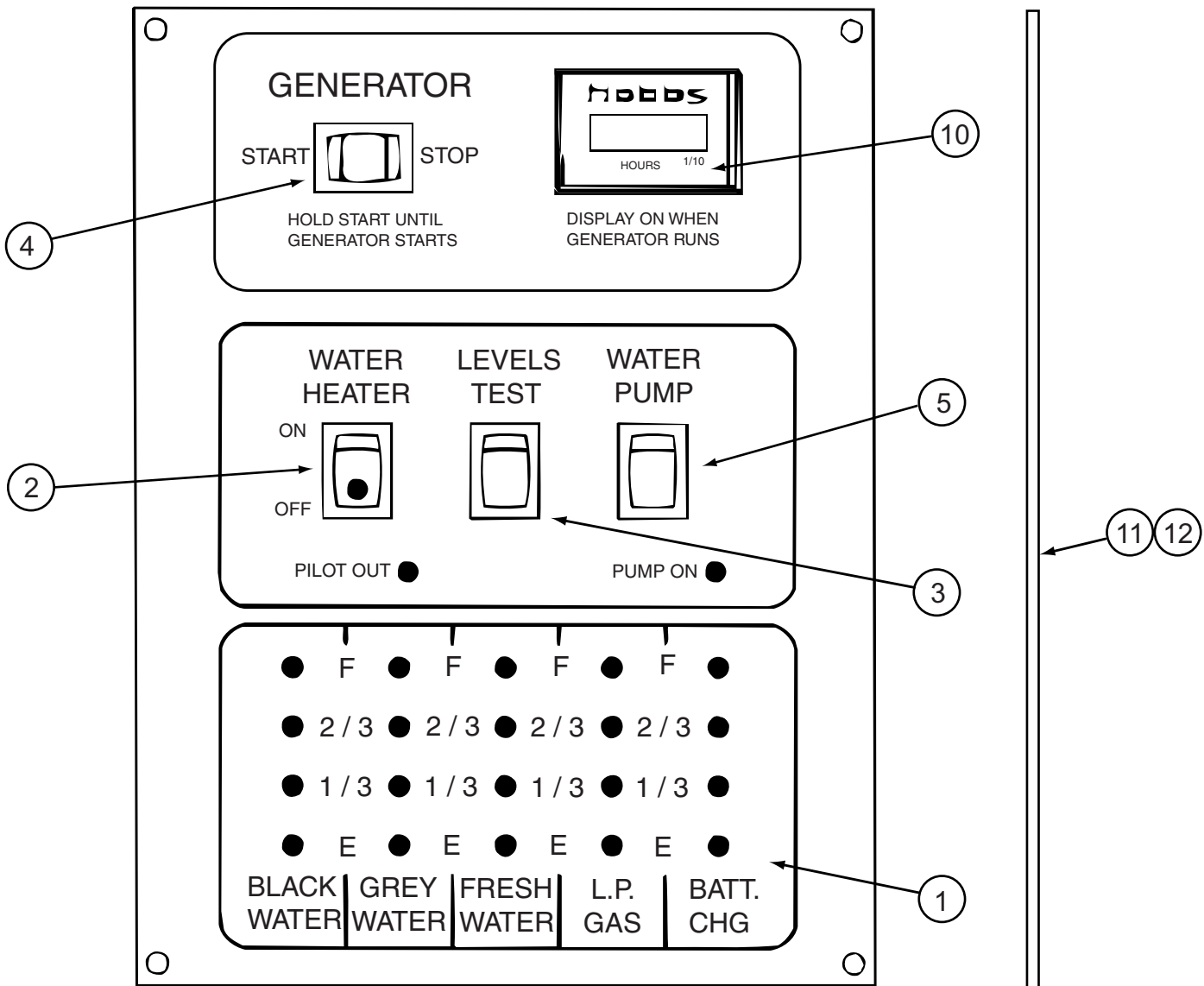

134940-06-01A

KEY	PART NUMBER	U/M	DESCRIPTION	VENDOR NO.
1	134940-01-702	EA	CHASSIS - SILKSCREENED	CC0558-00
2	134940-01-701	EA	SWITCH-SPST/ON-OFF/BLK W/LGT	L0109
3	096983-01-701	EA	SWITCH - SPST/MOM 2 TERMINAL	L0111-00
4	096983-01-702	EA	SWITCH - MOM/OFF/MOM/3 TERM	L0112-00
5	096983-01-703	EA	SWITCH - ON/ON	L0115-00
10	100258-10-701	EA	GAUGE-HR METER ONLY (LCD)	L0775-00
11	134940-06-700	EA	PC BOARD - SENSOR SYSTEM/RED	L5131-02

CONTACT WINNEBAGO PART SALES FOR UNLISTED COMPONENT(S)

134940-08-01A

KEY	PART NUMBER	U/M	DESCRIPTION	VENDOR NO.
1	134940-04-700	EA	CHASSIS - SILKSCREENED	CE0136-00
2	134940-01-701	EA	SWITCH-SPST/ON-OFF/BLK W/LGT	L0109
3	096983-01-701	EA	SWITCH - SPST/MOM 2 TERMINAL	L0111-00
4	096983-01-702	EA	SWITCH - MOM/OFF/MOM/3 TERM	L0112-00
5	096983-01-703	EA	SWITCH - ON/ON	L0115-00
10	100258-10-701	EA	GAUGE-HR METER ONLY (LCD)	L0775-00
11	134940-06-700	EA	PC BOARD - SENSOR SYSTEM/RED	L5131-02
12	134940-04-701	EA	BOARD - PC - SOLAR LIGHT	L5121-01

CONTACT WINNEBAGO PART SALES FOR UNLISTED COMPONENT(S)

ELECTRICAL GROUP (CONTINUED)
COMPONENT PARTS FOR WIRING (CONTINUED)

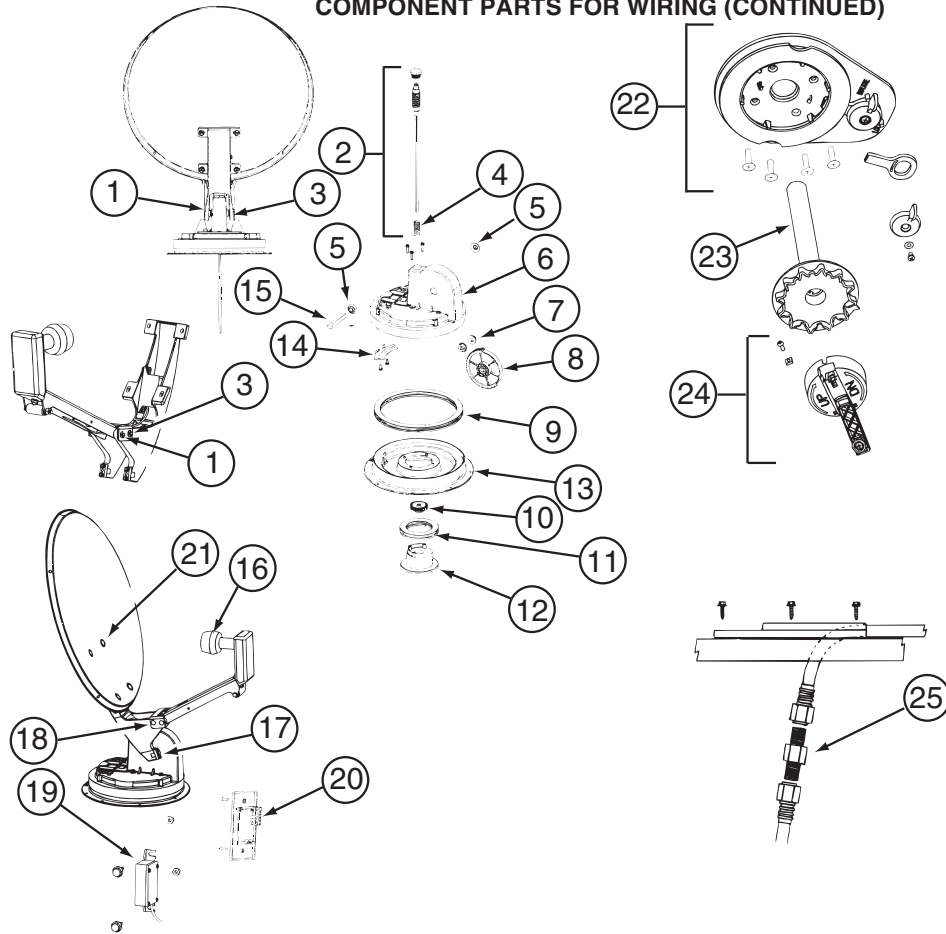

137135-02-000

KEY	PART NUMBER	U/M	DESCRIPTION	VENDOR NO.
1	120233-01-714	EA	CLIP-E	5160818
2	137135-01-703	EA	KIT ELEV - SHAFT/GEAR/SPRING	RP-4400
3	137135-01-704	EA	PIN - 1/4" X 3.25"	2160813
4	137135-01-705	EA	SPRING	2160818
5	137135-01-707	EA	SEAL - PIVOT SHAFT	2200852
6	137135-01-708	EA	TURRET	3100728
7	137135-01-709	EA	PIVOT BEARING	2200470
8	137135-01-711	EA	GEAR - ELEVATING	2200464
9	137135-01-712	EA	BEARING - OUTER	2590347
10	137135-01-714	EA	GEAR - ELEVATING SHAFT	2200465
11	137135-01-715	EA	BEARING - INNER	2590348
12	137135-01-716	EA	HUB	3100731
13	137135-01-713	EA	TURRET BASE	3100730
14	137135-01-710	EA	PLATE - ROTATE LIMIT	3720052
16	137135-02-703	EA	LOW NOISE BLOCK FILTER	LB-6000 - DUAL
17	137135-01-722	EA	CLAMP	2590343
18	137135-01-719	EA	BRACKET - PIVOT	2744945
19	137135-01-720	EA	DE-SENSOR UNIT W/43" CABLE	DM4000
20	137135-02-701	EA	BOX - SURFACE MOUNT	SM-100
21	137135-01-717	EA	BOLT - FLAT HEAD	2160362
22	120233-01-737	EA	PLATE/INT-W/DIRECTIONAL HDLE	RK-CEIL
23	120233-01-704	EA	DIAL/DIRECTIONAL 4"W/SPRING	3200364
24	120233-01-738	EA	HDW PKG-HANDLE/SPRING/WASHER	RK-HAND
25	137135-01-701	EA	CONNECTOR - F - MALE TO MALE	FS-8100
	120233-04-700	EA	KIT-WALL PLATE/CABLE - GRAY	DM4000
	137135-01-700	EA	ROOF WEDGE W/GASKET	RW-5000
	137135-01-706	EA	KIT-TURRET/SEAL/BEARING/GEAR	RP-RM30
	137135-01-718	EA	REFLECTOR/WHITE-46CM W/HDW	RP-35RM
	137135-02-700	EA	DE-SENSOR	2780096
	137135-02-704	EA	KIT-UPDATE DIRECTIONAL HDL	RP-RMDH
	137135-02-705	EA	KIT-TURRET & SHAFT COMPLETE	RP-RM46

CONTACT WINNEBAGO PART SALES FOR UNLISTED COMPONENT(S)

ELECTRICAL GROUP (CONTINUED)
COMPONENT PARTS FOR WIRING (CONTINUED)

137417-01-01A, 137417-03-01A

KEY	PART NUMBER	U/M	DESCRIPTION	VENDOR NO.
	137417-01-700	EA	LENS - SINGLE (FROSTED)	810868

137417-05-01A

KEY	PART NUMBER	U/M	DESCRIPTION	VENDOR NO.
	137417-05-700	EA	LENS - DOUBLE OPTIC	810845

137417-06-01A

KEY	PART NUMBER	U/M	DESCRIPTION	VENDOR NO.
	137417-06-700	EA	LENS - DOUBLE WHITE	810867

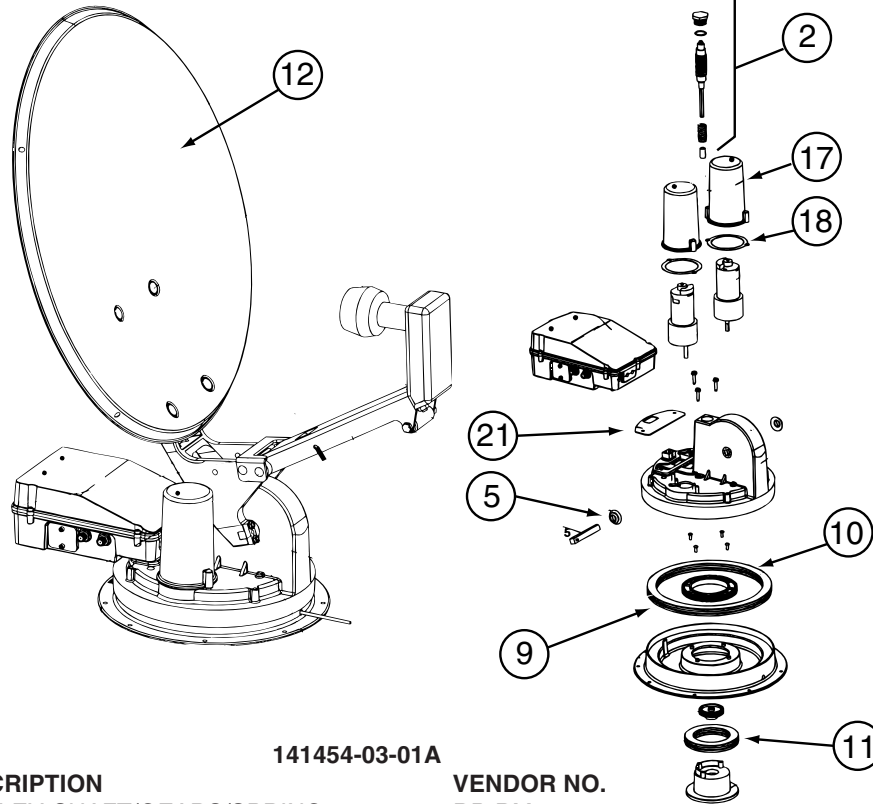

141454-03-01A

KEY	PART NUMBER	U/M	DESCRIPTION	VENDOR NO.
2	141454-01-700	EA	KIT ELEV-SHAFT/GEARS/SPRING	RP-RM20
4	137135-01-705	EA	SPRING	2160818
5	137135-01-707	EA	SEAL - PIVOT SHAFT	2200852
9	137135-01-712	EA	BEARING - OUTER	2590347
10	137135-01-714	EA	GEAR - ELEVATING SHAFT	2200465
10	141454-01-712	EA	GEAR - ROTATE	2200469
11	137135-01-715	EA	BEARING - INNER	2590348
12	137135-01-718	EA	REFLECTOR/WHITE-46CM W/HDWE	RP-35RM
13	137135-01-713	EA	TURRET BASE	3100730
17	141454-01-705	EA	HOUSING - MOTOR	3200260
18	141454-01-706	EA	GASKET - MOTOR HOUSING	2240054
21	141454-01-709	EA	GASKET	2240056
	120233-01-714	EA	CLIP-E	5160818
	137135-01-704	EA	PIN - 1/4" X 3.25"	2160813
	137135-01-719	EA	BRACKET - PIVOT	2744945
	137135-01-722	EA	CLAMP	2590343
	137135-01-723	EA	SUPPORT/FRAME-BACKUP-W/HDWE	RP-RM00
	137135-02-703	EA	LOW NOISE BLOCK FILTER	LB-6000 - DUAL
	141454-01-701	EA	KIT - GEAR/MOTOR-GEAR/ROTATE	RP-RM25
	141454-01-702	EA	HOUSING/ELECTRONICS - UPPER	RP-RM10
	141454-01-703	EA	HOUSING/ELECTRONICS - LOWER	RP-RM15
	141454-01-704	EA	KIT LIFT ASSEMBLY COMPLETE	RP-RM05
	141454-03-700	EA	MOTOR (AZIMUTH)	2665042
	141454-03-701	EA	MOTOR (ELEVATION)	2665041
	141454-03-702	EA	CIRCUIT BOARD(CONTROL BOARD)	RP-RM80
	141454-03-703	EA	CONTRL PANEL W/BOX (AS2003)	RP-AS85

CONTACT WINNEBAGO PART SALES FOR UNLISTED COMPONENT(S)

ELECTRICAL GROUP (CONTINUED)
COMPONENT PARTS FOR WIRING (CONTINUED)

146298-02-000

KEY	PART NUMBER	U/M DESCRIPTION	VENDOR NO.
	146298-02-700	EA REMOTE - TV	1-478-707-11

148658-01,02-000

KEY	PART NUMBER	U/M DESCRIPTION	VENDOR NO.
	148658-01-700	EA WIRE ASM-PIGTAIL/SOCKETS	81555AA050

149040-02-000

KEY	PART NUMBER	U/M DESCRIPTION	VENDOR NO.
	149040-02-700	EA REMOTE - TV	RCR311TBM1-RCA

149040-03-000

KEY	PART NUMBER	U/M DESCRIPTION	VENDOR NO.
	149040-03-700	EA REMOTE - TV	265714

149049-01-000,149049-02-000

KEY	PART NUMBER	U/M DESCRIPTION	VENDOR NO.
	149049-01-700	EA REMOTE (TV)	RM-Y1735

153464-03/06-01A

KEY	PART NUMBER	U/M DESCRIPTION	VENDOR NO.
	091937-08-700	EA LENS - LIGHT - FLUORESCENT	D-766

154548-01-000

KEY	PART NUMBER	U/M DESCRIPTION	VENDOR NO.
	154548-01-700	EA REMOTE - DVD/VCR	1-478-247-11

155619-01-000

KEY	PART NUMBER	U/M DESCRIPTION	VENDOR NO.
	155619-01-700	EA REMOTE	RC3200

158836-01-000

KEY	PART NUMBER	U/M DESCRIPTION	VENDOR NO.
	158836-01-700	EA REMOTE	STS71WREM

ELECTRICAL GROUP (CONTINUED)
CIRCUIT BREAKERS, FUSES & RELAYS

KEY	PART NUMBER	U/M	DESCRIPTION
	008235-01-000	EA	FUSE - 15 AMP/12VOLT - AUTOMOTIVE
	062901-02-000	EA	FUSE - 5 AMP - AUTOMOTIVE
	062901-04-000	EA	FUSE - 10 AMP - AUTOMOTIVE
	062901-05-000	EA	FUSE - 15 AMP - AUTOMOTIVE
	062901-06-000	EA	FUSE - 20 AMP - AUTOMOTIVE
	062901-07-000	EA	FUSE - 25 AMP - AUTOMOTIVE
	062901-08-000	EA	FUSE - 30 AMP - AUTOMOTIVE
	063910-01-000	EA	HOUSING - RELAY
	063912-02-000	EA	RELAY - CANISTER - SPDT
	083209-01-000	EA	CIRCUIT BREAKER - 15 AMP - 120 VOLT - CANADIAN
	083209-02-000	EA	CIRCUIT BREAKER - 15/15 AMP - 120 VOLT
	083209-03-000	EA	CIRCUIT BREAKER - 15/20 AMP - 120 VOLT
	083209-04-000	EA	CIRCUIT BREAKER - 30 AMP - 120 VOLT
	083209-05-000	EA	CIRCUIT BREAKER - 20 AMP - 120 VOLT
	083209-06-000	EA	CIRCUIT BREAKER - 30/15 AMP - 120 VOLT
	083209-07-000	EA	CIRCUIT BREAKER - 20/20 AMP - 120 VOLT
	083209-10-000	EA	CIRCUIT BREAKER - 20/30 AMP - 120 VOLT
	083209-11-000	EA	CIRCUIT BREAKER - 20/15 AMP - 120 VOLT
	092786-03-000	EA	BUSS BAR - 6.9" LONG
	092786-06-000	EA	BUSS BAR
	093654-01-000	EA	CIRCUIT BREAKER - 6 AMP - 12 VOLT - PUSH BUTTON - WHITE
	093654-02-000	EA	CIRCUIT BREAKER - 15 AMP - 12 VOLT - PUSH BUTTON - WHITE
	093654-03-000	EA	CIRCUIT BREAKER - 20 AMP - 12 VOLT - PUSH BUTTON - WHITE
	093655-01-000	EA	CIRCUIT BREAKER - 25 AMP - 12 VOLT - PUSH BUTTON - WHITE
	093655-02-000	EA	CIRCUIT BREAKER - 30 AMP - 12 VOLT - PUSH BUTTON - WHITE
	093655-03-000	EA	CIRCUIT BREAKER - 40 AMP - 12 VOLT - PUSH BUTTON - WHITE
	097611-01-000	EA	CIRCUIT BREAKER - 10 AMP
	100341-01-000	EA	FUSE HOLDER - IN LINE TYPE
	113482-01-000	EA	CIRCUIT BREAKER - 55 AMP - MANUAL
	115187-01-000	EA	FUSE - 300 AMP - NON-DELAY
	115187-02-000	EA	HOLDER - FUSE
	115187-03-000	EA	FUSE - 60 AMP - NON-DELAY
	122811-01-000	EA	CIRCUIT BREAKER - 20/50/50/20 AMP - 250V
	125986-02-000	EA	FUSE - 5 AMP - AUTO - MINI BLADE
	125986-05-000	EA	FUSE - 15 AMP - AUTO - MINI BLADE
	141789-01-000	EA	SPACER - CIRCUIT BREAKER

ELECTRICAL GROUP (CONTINUED)

CONVERTER, INVERTER, LOAD CENTERS

KEY	PART NUMBER	U/M	DESCRIPTION
	123058-02-000	EA	CONVERTER - 45 AMP - ELECTRONIC - 4 1/8"H X 7"W X 12 3/8"L
	148254-03-000	EA	CABLE/INVERTOR - W/8 PIN MODULAR PHONE JACK - 50' DIMEN
	154511-01-000	EA	INVERTER - 600 WATT - W/O REMOTE PANEL
	154511-02-000	EA	REMOTE/PANEL - INVERTER/600 WATT

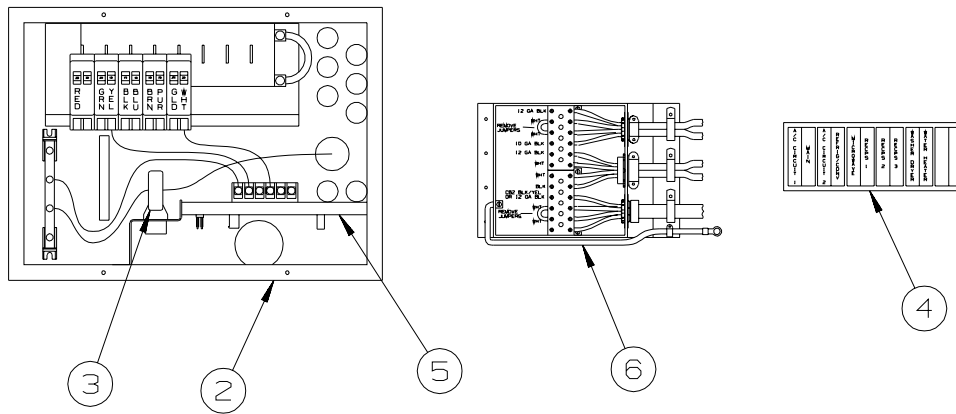

30 AMP

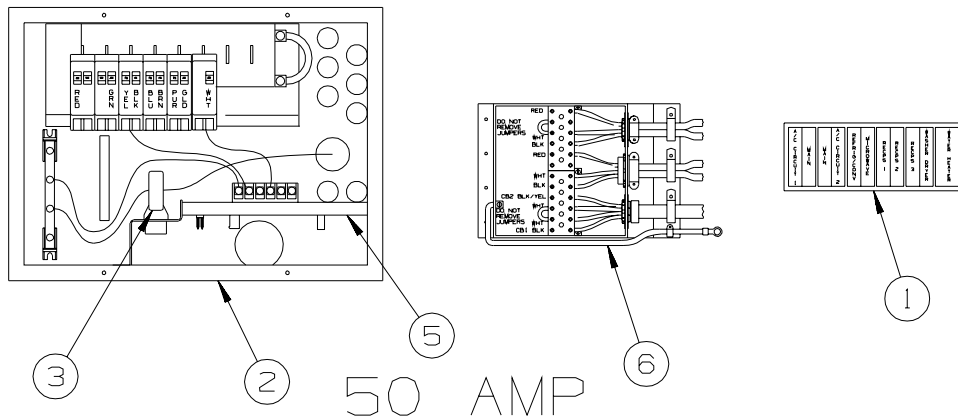

50 AMP

KEY	PART NUMBER	U/M	DESCRIPTION
1	095721-33-000	EA	LABEL - CONTROL CENTER - 50 AMP - US
2	141258-01-000	EA	LOAD CENTER - 120/240 - 30/50 AMP
2	141258-02-000	EA	LOAD CENTER - COVER
3	127002-07-000	EA	SENSOR - CURRENT
4	095721-31-000	EA	LABEL - CONTROL CENTER - 30 AMP - US
5	127002-11-000	EA	MODULE - EMS CENTER - W/REMOTE SENSOR
6	106071-06-000	EA	SWITCH - AUTOMATIC TRANSFER - PARALLAX 5070 - 30/50 AMP

ELECTRICAL GROUP (CONTINUED)

BOXES & CORDS

KEY	PART NUMBER	U/M	DESCRIPTION
	008054-01-000	EA	CORD - POWER - 10/3 WIRE - 30 AMP - 25'
	108934-02-000	EA	CORD - POWER - 50 AMP - 4-WIRE - 36'
	115832-01-000	FT	CORD - HEAVY DUTY - 14-2 W/GROUND
	131679-01-000	EA	BOX/ELECTRIC-WATERPROOF-4" X 4" - W/4 3/4"OUTLETS-UL/CSA
	131680-01-000	EA	COVER - F/ELECTRIC BOX W/GASKET 4" X 4" - UL/CSA
	133070-01-000	EA	BOX - ELECTRIC/PLASTIC - 3" X 2" X 2.8" - UL
	133070-02-000	EA	BOX - ELECTRIC/PLASTIC - 3" X 2" X 2.8" - CSA

WIRE ASSEMBLIES

KEY	PART NUMBER	U/M	DESCRIPTION
	077069-02-000	EA	CABLE/EXTENSION - RADIO ANTENNA - 96"
	077069-03-000	EA	CABLE/EXTENSION - RADIO ANTENNA - 260"
	125853-04-000	EA	WIRE LOOM - ENTERTAINMENT CENTER
	126030-01-000	EA	WIRE ASM - WIPER/WASHER
	131279-02-000	EA	WIRE LOOM - POWER SEAT - DRIVER
	135131-01-000	EA	WIRE LOOM - THERMOSTAT
	135420-16-000	EA	WIRE LOOM - RADIO
	136028-01-000	EA	WIRE ASM - SOFA, REST EASY
	137135-03-000	EA	WIRE LOOM - DIGITAL ELEVATION SENSOR
	137135-04-000	EA	WIRE HARNESS - POWER - DIGITAL ELEVATION SENSOR
	141454-04-000	EA	WIRE - SATELLITE - AUTOMATIC
			FROM: 00-00-00 THRU: 01-28-07
	163598-03-000	EA	CABLE - SATELLITE CONTROL
			FROM: 01-29-07 THRU: 99-99-99
	142258-02-000	EA	WIRE LOOM - VIDEO SWITCH/POWER SUPPLY
	144677-07-000	EA	WIRE - MONITOR - POWER - 3 PIN TO 6 PIN (3 WIRE)
	144677-09-000	EA	WIRE - MONITOR - POWER - 3 PIN/2PIN
	147139-02-000	EA	WIRE - STEREO KIT - ASA 100ZXIHAR
	147313-01-000	EA	WIRE - OUTSIDE TEMP SENSOR - W/O SENSOR
	151316-02-000	EA	WIRE ASM - W/NON CONTACT SENSORS - GREY WATER - 23.6"
	151317-01-000	EA	WIRE ASM-W/NON CONTACT SENSORS-FRESH WATER/BLK TANK-3.9"
	151317-02-000	EA	WIRE ASM-W/NON CONTACT SENSORS-FRESH WATER/BLK TANK-23.6"
	151422-01-000	EA	PIGTAIL - F/FOG LIGHT
	155619-05-000	EA	WIRE ASSEMBLY - RADIO - 12 PIN
	155522-01-000	EA	WIRE ASSEMBLY - SLIDEOUT RAMS
	155522-02-000	EA	WIRE ASSEMBLY - SLIDEOUT RAMS
	156832-01-000	EA	WIRE ASSEMBLY - INSTRUMENT PANEL - MAIN - WORKHORSE
	156833-01-000	EA	WIRE ASSEMBLY - INSTRUMENT PANEL - MAIN - FORD

ELECTRICAL GROUP (CONTINUED)
CONNECTORS & CONDUIT

KEY	PART NUMBER	U/M	DESCRIPTION
	007940-01-000	EA	RECEPTACLE/SLIDE 16 TO 12 AWG - FEMALE END
	007940-02-000	EA	RECEPTACLE/SLIDE 10 AWG
	007954-01-000	EA	RECEPTACLE - HOUSING - 6 POSITION
	007956-05-000	EA	INSULATOR - SHRINK - 1/4"ID X 1 1/2"
	008058-01-000	EA	ADAPTER - POWER CORD - 30 AMP TO 15 AMP
	008311-01-000	EA	CONNECTOR - WIRE NUT - INSULATED - RED
	008312-01-000	EA	CONNECTOR - WIRE NUT - INSULATED - BLUE
	008313-01-000	EA	CONNECTOR - WIRE NUT - INSULATED - YELLOW
	008314-01-000	EA	CONNECTOR - WIRE NUT - INSULATED - GRAY
	008328-01-000	EA	TERMINAL - RING - 12/10 WIRE - #10 STUD FIT
	008331-01-000	EA	TERMINAL - RING - TONGUE - #4 WIRE - 3/8" STUD - COPPER
	008348-01-000	EA	TERMINAL - RING - 3/8" STUD 2 GA. WIRE
	008355-01-000	EA	CONNECTOR - CABLE CLAMPING - 3/4"
	008356-01-000	EA	CONNECTOR - PLASTIC - 3/8"
	008356-02-000	EA	CONNECTOR - PLASTIC - 21/32"
	008398-01-000	EA	CONNECTOR - 1/2" X 90 DEGREE - FLEX CONDUIT - UL & CSA
	035416-04-000	EA	TERMINAL - RING - #10 STUD FIT - INSULATED BARREL #16/14
	041953-01-000	FT	CONDUIT - CONVOLUTE SLIT - .5" ID - POLYETHYLENE
	041953-02-000	FT	CONDUIT - CONVOLUTE SLIT - .6" ID - POLYETHYLENE
	041953-03-000	FT	CONDUIT - CONVOLUTE SLIT - 1" ID (CLOTHES ROD COVER)
	041953-06-000	FT	CONDUIT - CONVOLUTE SLIT - .4" ID - POLYETHYLENE
	041953-07-000	FT	CONDUIT - CONVOLUTE SLIT - .25" ID - POLYETHYLENE
	041953-08-000	FT	CONDUIT - CONVOLUTE SLIT - 1.5" ID - POLYETHYLENE
	041953-09-000	FT	CONDUIT - CONVOLUTE SLIT - .5" ID - NYLON
	041953-10-000	FT	CONDUIT - CONVOLUTE SLIT - .75" ID - NYLON
	041953-11-000	FT	CONDUIT - CONVOLUTE SLIT - 1.06" ID - NYLON
	041953-12-000	FT	CONDUIT - CONVOLUTE SOLID - 1.1" ID - NYLON
	041953-13-000	FT	CONDUIT - CONVOLUTE SLIT - 1.25" ID
	041953-14-000	FT	CONDUIT - CONVOLUTE SLIT - 1.5" ID
	041953-15-000	FT	CONDUIT - CONVOLUTE SLIT - 2"
	041953-16-000	FT	CONDUIT - CONVOLUTE SLIT - 2"
	047441-01-000	EA	TERMINAL-BATTERY, HORIZONTAL LUG
	047443-01-000	EA	TERMINAL - .250 RECEPTACLE FIT - INSULATED - 16/14 AWG
	047443-02-000	EA	TERMINAL - .250 RECEPTACLE FIT - INSULATED - 12/10 AWG
	047443-05-000	EA	TERMINAL - .250 RECEPTACLE FIT - 18GA AWG
	058028-01-000	EA	CONNECTOR - ELECTRICAL PIGTAIL - NYLON - CLEAR
	062036-01-000	EA	TERMINAL - PACK - CON - 12/10 AWG
	076319-12-000	EA	CONNECTOR - COAXIAL - ONE PIECE
	077479-01-000	EA	BOOT - BATTERY TERMINAL - DOUBLE CABLE
	077479-02-000	EA	BOOT - BATTERY TERMINAL - SINGLE CABLE
	080015-02-000	EA	RECEPTACLE - FLAG - .185 - 16/14 GAUGE
	080015-03-000	EA	RECEPTACLE - FLAG - .250 - 14/16 GAUGE
	080015-04-000	EA	RECEPTACLE - FLAG - .187 - 16/14 GAUGE
	082109-01-000	EA	HOUSING - CONNECTOR - PACKARD
	082741-01-000	EA	CONNECTOR BODY - 2 CONNECTOR MALE
	087225-01-000	FT	SLEEVING - 1/2" - TYPE H
	088473-01-000	EA	HOUSING - PIN - 12 CAVITY (3 ROWS OF 4)
	088473-02-000	EA	HOUSING - PIN - 15 CAVITY (3 ROWS OF 5)
	088473-03-000	EA	HOUSING - PIN - 9 CAVITY (3 ROWS OF 3)
	088473-04-000	EA	HOUSING - PIN - 8 CAVITY IN-LINE
	088473-06-000	EA	HOUSING - PIN - 6 CAVITY (2 ROWS OF 3)
	088473-07-000	EA	HOUSING - PIN - 5 CAVITY - IN-LINE
	088473-08-000	EA	HOUSING - PIN - 4 CAVITY - IN-LINE
	088473-09-000	EA	HOUSING - PIN - 3 CAVITY - IN-LINE
	088473-10-000	EA	HOUSING - PIN - 2 CAVITY - IN-LINE
	088473-12-000	EA	HOUSING - PIN - 3 CAVITY - BLUE
	088473-13-000	EA	HOUSING - PIN - 3 CAVITY - GREEN
	088473-14-000	EA	HOUSING - PIN - 3 CAVITY - RED
	088474-01-000	EA	HOUSING - SOCKET - 12 CAVITY
	088474-02-000	EA	HOUSING - SOCKET - 15 CAVITY
	088474-03-000	EA	HOUSING - SOCKET - 9 CAVITY
	088474-06-000	EA	HOUSING - SOCKET - 6 CAVITY
	088474-07-000	EA	HOUSING - SOCKET - 5 CAVITY
	088474-08-000	EA	HOUSING - SOCKET - 4 CAVITY

ELECTRICAL GROUP (CONTINUED)
CONNECTORS & CONDUIT (CONTINUED)

KEY	PART NUMBER	U/M	DESCRIPTION
	088474-09-000	EA	HOUSING - SOCKET - 3 CAVITY
	088474-10-000	EA	HOUSING - SOCKET - 2 CAVITY
	088475-01-000	EA	PIN - CONNECTOR - 14-20 AWG
	088475-02-000	EA	PIN - CONNECTOR - 10-12 AWG
	088476-01-000	EA	TERMINAL - ELECTRICAL
	088476-02-000	EA	SOCKET - CONNECTOR - 12-10 GA - PRE-TIN
	098261-01-000	EA	SOCKET - CONNECTOR - WEATHERPACK - 12 AWG
	098261-02-000	EA	SOCKET - CONNECTOR - WEATHERPACK - 14-18 AWG
	098262-01-000	EA	SEAL - CONNECTOR - WEATHERPACK
	098264-01-000	EA	HOUSING - 2 PIN - WEATHER PACK - MALE W/FEMALE PINS
	098264-02-000	EA	HOUSING - 2 PIN - WEATHER PACK - FEMALE W/MALE PINS
	098265-02-000	EA	PIN - CONNECTOR - WEATHER PACK
	102777-02-000	EA	TERMINAL - RING - #6 STUD - 10 AWG
	103608-01-000	EA	SOCKET - WEDGE BASE W/LEADS
	104100-01-000	EA	HOUSING - 1 POSITION - 75 AMPS
	104100-03-000	EA	TERMINAL - 75 AMP
	106007-02-000	EA	TERMINAL - FEMALE - 10-12 AWG
	110178-01-000	EA	HOUSING - WIPER MOTOR
	112823-01-000	EA	SPLICE - REDUCER - 16-14 TO 18-22
	113072-02-000	EA	HOUSING - ELECTRICAL - BACK-UP/TAIL LAMP
	113072-03-000	EA	HOUSING - ELECTRICAL - STOP/MARKER TAILLAMP
	113073-01-000	EA	WEDGELOCK - HOUSING - TAIL LAMP
	113074-01-000	EA	TERMINAL - TAILLAMP
	113135-01-000	EA	TERMINAL - FEMALE - M/P - 14-16 - F/SEALED TERMINAL
	113308-01-000	EA	TERMINAL - FEMALE - M/P - 14-16 - 280
	113308-02-000	EA	TERMINAL - FEMALE - M/P - 14-18 - 280
	113468-01-000	EA	HOUSING - 2 POSITION-FEMALE-USED ON WIPER/WASHER WIRE ASM
	113468-02-000	EA	HOUSING - 2 POSITION - FEMALE
	115931-02-000	EA	COVER - CONNECTOR - 50 AMP W/LOCKING RING
	115932-02-000	EA	CONNECTOR - FEMALE - 50 AMP/240 VOLT
	116811-01-000	EA	TERMINAL - .110 RECEPTACLE - 16-14 AWG
	118571-01-000	EA	CONNECTOR - 3-WAY - MALE/SEALED
	118571-02-000	EA	CONNECTOR - 3-WAY - FEMALE/SEALED
	118571-05-000	EA	LOCK - SECONDARY - FEMALE
	118571-06-000	EA	LOCK - SECONDARY - MALE
	118599-02-000	EA	TERMINAL - MALE - M/P - 280/14-12
	118820-01-000	EA	INSULATOR - TERMINAL
	129233-01-000	EA	HOUSING - 2-POSITION/FEMALE - 280-SERIES
	129233-02-000	EA	HOUSING - 2-POSITION/FEMALE - 280-SERIES
	129233-03-000	EA	HOUSING - 2-POSITION/FEMALE - 280-SERIES
	131681-01-000	EA	CONNECTOR - 3/4" SO CORD - UL/CS
	137207-01-000	EA	HOUSING - PIN - 2 CAVITY/HIGH AMP
	137208-01-000	EA	HOUSING - SOCKET - 2 CAVITY/HIGH AMP
	137209-01-000	EA	PIN - CONNECTOR - 10AWG/HIGH AMP
	137210-01-000	EA	SOCKET - CONNECTOR - 10 AWG/HIGH AMP
	138996-04-000	EA	CONNECTOR - LAMP
	142520-01-000	EA	TERMINAL - FEMALE - MINI-FIT 16
	142522-01-000	EA	HOUSING - 4 PIN/MALE - MINI FIT
	142522-02-000	EA	HOUSING - 6 PIN/MALE - MINI FIT
	142522-03-000	EA	HOUSING - 8 PIN/MALE - MINI FIT
	142522-04-000	EA	HOUSING - 10 PIN/MALE - MINI FIT
	142522-05-000	EA	HOUSING - 12 PIN/MALE - MINI FIT
	142522-06-000	EA	HOUSING - 14 PIN/MALE - MINI FIT
	142524-01-000	EA	HOUSING - 4 PIN/FEMALE - WEATHER PACK
	142524-02-000	EA	HOUSING - 4 PIN/FEMALE - WEATHER PACK
	144283-01-000	EA	CONNECTOR - 110V - F/USE WITH SOW WIRE - BLUE
	144283-02-000	EA	CONNECTOR - 110V - F/USE WITH NM ROMEX WIRE - CLEAR
	145171-01-000	EA	CONNECTOR - COAXIAL
	148335-01-000	EA	HOUSING - 8-POSITION/MALE - 280-GT SERIES
	148335-02-000	EA	HOUSING - 4-POSITION/MALE - 280-GT SERIES
	148335-03-000	EA	HOUSING - 6-POSITION/MALE - 280-GT SERIES
	149683-01-000	EA	HOUSING - F/5 CAVITY RECEPTACLE - W/SQUARE GUIDE PIN
	149683-02-000	EA	HOUSING - F/5 CAVITY RECEPTACLE - W/ROUND GUIDE PIN
	149686-01-000	EA	TERMINAL - .250 RECEPTACLE

ELECTRICAL GROUP (CONTINUED)

CONNECTORS & CONDUIT (CONTINUED)

KEY	PART NUMBER	U/M	DESCRIPTION
	149687-01-000	EA	HOUSING - 2 POSITION/MALE - PACKARD
	149687-02-000	EA	LOCK - F/2 POSITION HOUSING - PACKARD
	149688-01-000	EA	TERMINAL - MALE - 16 GAUGE WIRE
	156035-01-000	EA	HOUSING - 12-POSITION/FEMALE - 280-GT SERIES
	156041-01-000	EA	TERMINAL - FEMALE - 16-12 - 280-GT SERIES
	156043-01-000	EA	HOUSING - 2-POSITION/FEMALE - 480-MP SERIES
	156043-02-000	EA	LOCK - F/2 POSITION HOUSING - 480 SERIES
	156044-01-000	EA	TERMINAL - FEMALE - 16-12 - 280-GT - F/SEALED HOUSING
	156045-01-000	EA	HOUSING - 10-POSITION/FEMALE - 280-GT SERIES
	156045-02-000	EA	HOUSING - 4-POSITION/FEMALE - 280-GT SERIES
	156045-03-000	EA	HOUSING - 8-POSITION/FEMALE - 280-GT SERIES
	156045-04-000	EA	HOUSING - 6-POSITION/FEMALE - 280-GT SERIES
	156207-01-000	EA	HOUSING - 6-POSITION/MALE - 150-GT SERIES
	156208-01-000	EA	TERMINAL - MALE - 18-16 - 150-GT SERIES
	157590-01-000	EA	TERMINAL - FEMALE - M/P - 10-12 - 630
	157592-01-000	EA	HOUSING - 7-POSITION/FEMAL - M/P
	157592-02-000	EA	LOCK - SECONDARY - F/7 POSITION HOUSING
	157656-01-01A	EA	CONNECTOR - DASH LIGHT - BLACK
	158357-01-000	EA	HOUSING - 3 PIN/MALE - MINI FIT
	158373-01-000	EA	HOUSING - SOCKET - 16 CAVITY - MINI MATE-N-LOCK
	158374-01-000	EA	SOCKET - 16-20 CAVITY - MINI MATE-N-LOCK

CHASSIS

KEY	PART NUMBER	U/M	DESCRIPTION
	160014-01-02B	EA	TIEDOWN - BATTERY - E-COATED
	086233-01-000	EA	STUD - ISOLATED - 3/8" X 7/8" LONG
	113452-02-000	FT	SEAL/TRIM - FRONT - VINYL W/WIRE CARRIER - .027"

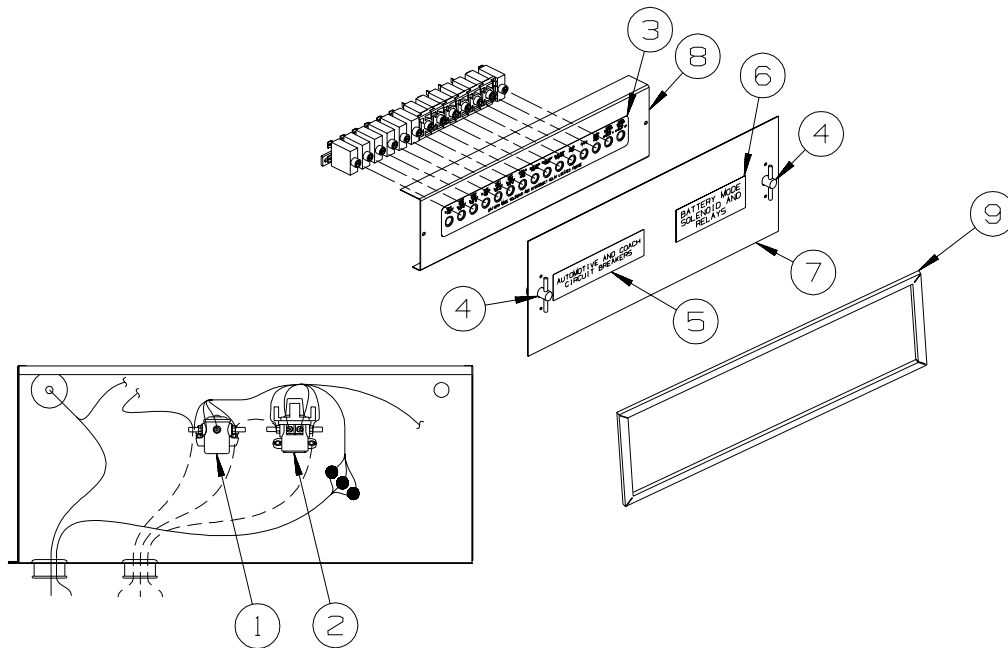

KEY	PART NUMBER	U/M	DESCRIPTION
1	008188-01-000	EA	SOLENOID - 3 POST - BATTERY CHANGE OVER
2	086273-01-000	EA	RELAY - BATTERY DISCONNECT
3	093236-43-000	EA	LABEL - CIRCUIT BREAKER
4	098196-01-000	EA	LATCH - 1/4 TURN - T-BAR
5	098379-01-000	EA	LABEL - CIRCUIT BREAKER - FRONT BOX
6	098379-04-000	EA	LABEL - ELECTRICAL BOX - SIDE
7	109925-04-000	EA	DOOR - ELECTRICAL BOX - 6.9" X 18.5" - GM/FORD
8	118531-07-02B	EA	PLATE - CIRCUIT BREAKER - E COATED
9	092492-11-000	EA	SEAL - ELECTRIC BOX - 7" X 18.4"

EXTERIOR BODY GROUP GRAPHICS & PAINT

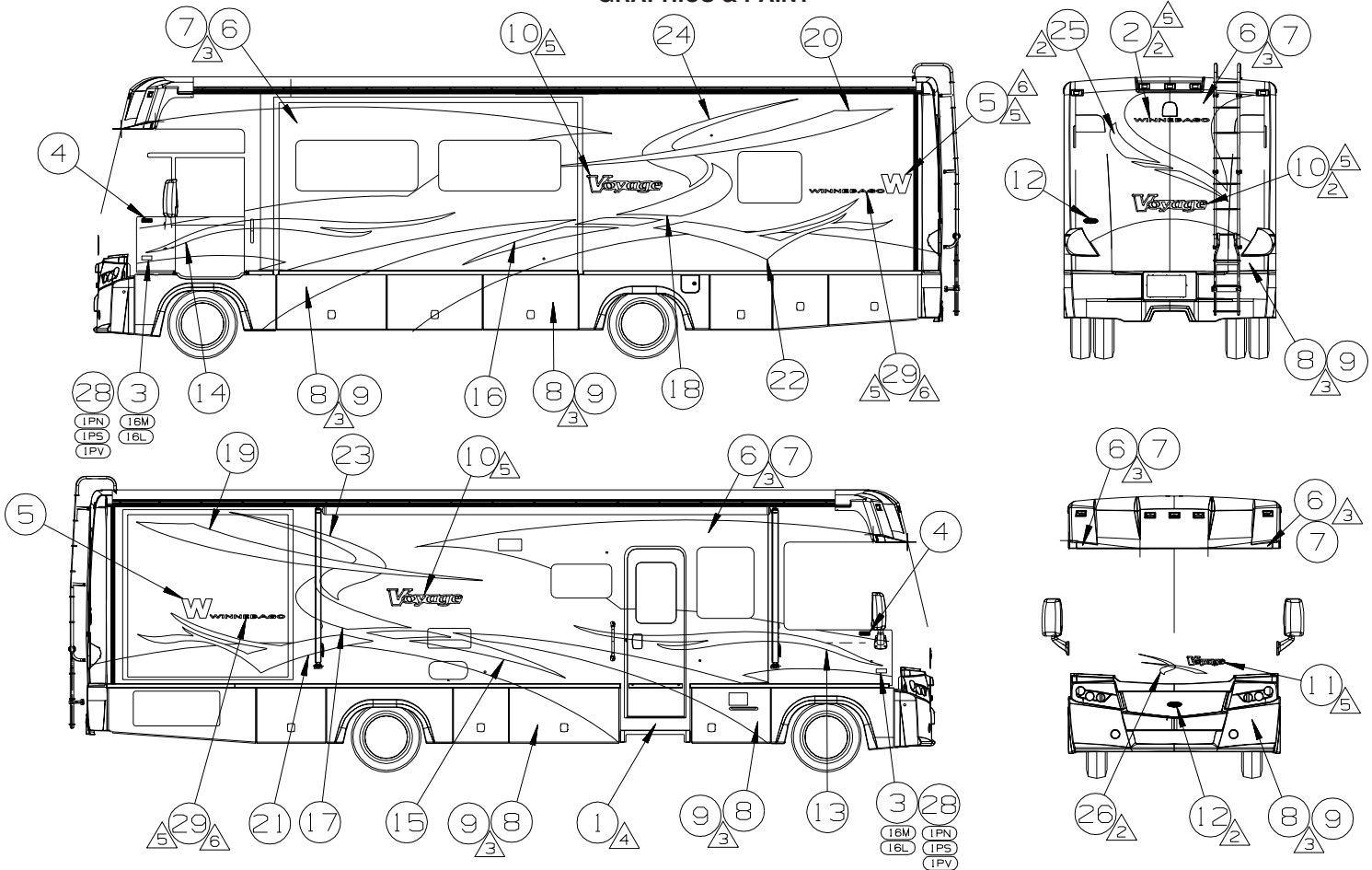

KEYS	PART NUMBER	U/M	DESCRIPTION
	109506-01-000	EA	FILM-URETHANE PROTECTANT
	120702-03-CHT 133A1	EA	DECAL-LOGO WINNEBAGO - BRT WHITE
(16M) (16L)	129922-02-CHT 101A1	EA	EMBLEM-TRITON V10 (3 VALVE) - BLACK/CHROME
(276)	132664-02-CHT 101A1	EA	DECAL-LOGO DOMED WINNEBAGO - CHROME/RED/BLACK
	135381-02-CHT 09A1	EA	DECAL-LOGO W - LT GOLD 11
	135381-02-CHT 112A1	EA	DECAL-LOGO W - GOLD
(276) (92K)	141599-64-000	GL	PAINT-SEDONA BRONZE MET - DUPONT #373-P759115
	141599-31-000	GL	PAINT-METALLIC GOLD - DUPONT #373-P7436
(276) (92K)	141599-37-000	GL	PAINT-LT AUTUMNWOOD MET - DUPONT #373-P7441
	141599-42-000	GL	PAINT-DK TITANIUM MET - DUPONT #373-P76528
	149819-01-CHT 101A1	EA	DECAL-LOGO VOYAGE LG - BRT WHITE/BLACK/SILVER/LT CHARCOAL
	149819-02-CHT 101A1	EA	DECAL-LOGO VOYAGE SML - BRT WHITE/BLACK/SILVER/LT CHARCOAL
	151637-01-CHT 101A1	EA	DECAL/BEZEL DOMED NAMEPLATE WINNEBAGO - CHROME/RED
(276) (92K)	157843-01-CHT 101A1	EA	DECAL-SWEEP #1 RH - NUTMEG
(276) (92K)	157843-01-CHT 102A1	EA	DECAL-SWEEP #1 RH - SUNSET
(276) (92K)	157843-02-CHT 101A1	EA	DECAL-SWEEP #1 LH - NUTMEG
(276) (92K)	157843-02-CHT 102A1	EA	DECAL-SWEEP #1 LH - SUNSET
(276) (92K)	157845-01-CHT 101A1	EA	DECAL-SWEEP #3 LOWER RH - LT GOLD/NUTMEG
(276) (92K)	157845-01-CHT 102A1	EA	DECAL-SWEEP #3 LOWER RH - GOLD/NUTMEG
(276) (92K)	157845-02-CHT 101A1	EA	DECAL-SWEEP #3 LOWER LH - LT GOLD/NUTMEG
(276) (92K)	157845-02-CHT 102A1	EA	DECAL-SWEEP #3 LOWER LH - GOLD/NUTMEG
(276) (92K)	157846-01-CHT 101A1	EA	DECAL-SWEEP #3 UPPER RH - DK COPPER/LT GOLD
(276) (92K)	157846-01-CHT 102A1	EA	DECAL-SWEEP #3 UPPER RH - CHOCOLATE BROWN/GOLD
(276) (92K)	157846-02-CHT 101A1	EA	DECAL-SWEEP #3 UPPER LH - DK COPPER/LT GOLD
(276) (92K)	157846-02-CHT 102A1	EA	DECAL-SWEEP #3 UPPER LH - CHOCOLATE BROWN/GOLD
(276) (92K)	157847-01-CHT 101A1	EA	DECAL-SWEEP #4 RH - DP BROWN DIAMOND
(276) (92K)	157847-01-CHT 102A1	EA	DECAL-SWEEP #4 RH - SUNSET
(276) (92K)	157847-02-CHT 101A1	EA	DECAL-SWEEP #4 LH - DP BROWN DIAMOND
(276) (92K)	157847-02-CHT 102A1	EA	DECAL-SWEEP #4 LH - SUNSET
(276) (92K)	157850-01-CHT 101A1	EA	DECAL-TAIL RH - NUTMEG/LT AUTUMNWOOD
(276) (92K)	157850-01-CHT 102A1	EA	DECAL-TAIL RH - CHOCOLATE BROWN/DK TITANIUM
(276) (92K)	157850-02-CHT 101A1	EA	DECAL-TAIL LH - NUTMEG/LT AUTUMNWOOD
(276) (92K)	157850-02-CHT 102A1	EA	DECAL-TAIL LH - CHOCOLATE BROWN/DK TITANIUM
(276) (92K)	157854-01-CHT 101A1	EA	DECAL-HOOK RH - DK COPPER/LT GOLD
(276) (92K)	157854-01-CHT 102A1	EA	DECAL-HOOK RH - CHOCOLATE BROWN/GOLD
(276) (92K)	157854-02-CHT 101A1	EA	DECAL-HOOK LH - DK COPPER/LT GOLD
(276) (92K)	157854-02-CHT 102A1	EA	DECAL-HOOK LH - CHOCOLATE BROWN/GOLD
(276) (92K)	157855-01-CHT 101A1	EA	DECAL-SWEEP RR - DK COPPER/LT GOLD/NUTMEG
(276) (92K)	157855-01-CHT 102A1	EA	DECAL-SWEEP RR - CHOCOLATE BROWN/GOLD/NUTMEG
(276) (92K)	157856-01-CHT 101A1	EA	DECAL-HOOD - DK COPPER/LT GOLD/DP BROWN DIAMOND
(276) (92K)	157856-01-CHT 102A1	EA	DECAL-HOOD - CHOCOLATE BROWN/GOLD/SUNSET
(IPV) (IPS) (IPN)	141599-27-000	GL	PAINT-IMRON CLEAR 55 GAL - DUPONT #34405
	120702-03-CHT 159A1	EA	DECAL-EMBLEM-CHASSIS SUPPLIED
		EA	DECAL-LOGO WINNEBAGO - CHOCOLATE BROWN

- △ (6) DISTANCE BETWEEN DECAL'S IS TO BE 19 MM.
 - △ (3) LOGO IS TO BE HELD TO ±1MM ON A HORIZONTAL PLANE (END TO END).
 - △ (5) FILM TO PROTECT BOTTOM OF DOOR FROM SCUFF MARKS.
 - △ (4) CLEAR COAT TO BE APPLIED ON PAINTED AREAS TO PROTECT PAINT.
 - △ (2) CENTER ON UNIT.
1. APPLY PROTECTOR 116424-01-000 TO WATER HEATER LATCH.

NOTES:

- (16L) FORD 22,000*-22.5 AL WHL
- (IPV) WORKHORSE 24,000*-22.5 TIRE
- (IPS) WORKHORSE 22,000*-22.5 TIRE
- (IPN) WORKHORSE 20,700*
- (16M) FORD CHASSIS 20,500*/V10 ENG
- (92K) EXTERIOR GRAPHICS PACKAGE #2
- (276) EXTERIOR GRAPHICS PACKAGE #1

EXTERIOR BODY GROUP (CONTINUED)
GRAPHICS & PAINT (CONTINUED)

**DUPONT COLOR CODES ARE NOW FOUND IN THE PAINT CODE MANUAL.
YOU CAN FIND THIS MANUAL ON YOUR DEALER INDEX WEBPAGE UNDER SERVICE.**

KEY	PART NUMBER	U/M	DESCRIPTION
	072882-01-000	GL	PAINT - LOW BAKE - OFF WHITE
	093681-40-01A	FT	FILM - 2" - FLAT BLACK - DRIVERS DOOR

EXTERIOR BODY GROUP (CONTINUED)

PANELS & TRIMS

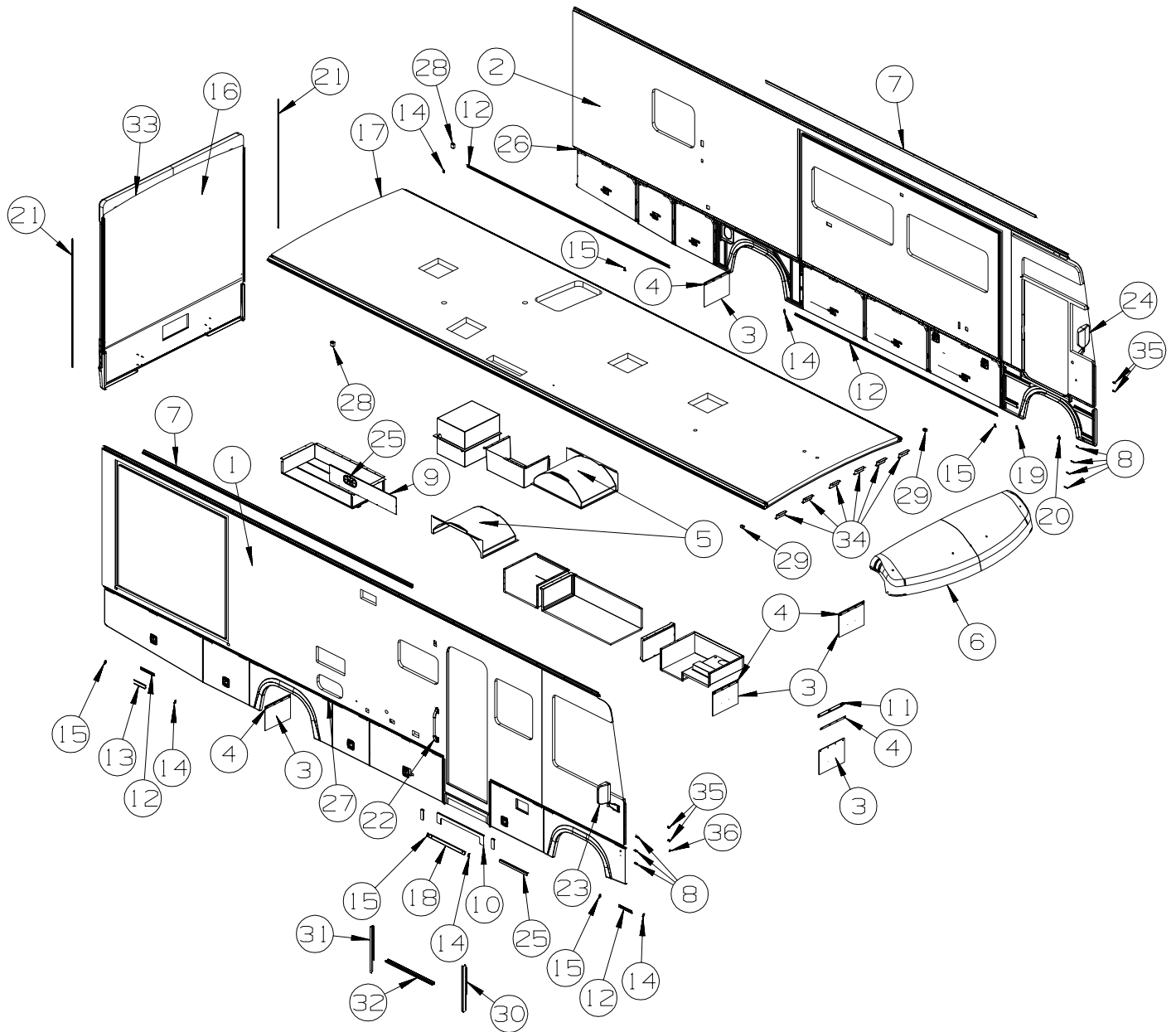

KEY	PART NUMBER	U/M	DESCRIPTION
1	156875-01-U67	EA	SIDEWALL - PASSENGER - W/O WINDOWS/TRIMS (U67, U68)
1	156875-01-U71	EA	SIDEWALL - PASSENGER - W/O WINDOWS/TRIMS (U71, U72)
1	156875-01-U75	EA	SIDEWALL - PASSENGER - W/O WINDOWS/TRIMS (U75, U76)
2	156876-01-U67	EA	SIDEWALL - DRIVER - W/O WINDOWS/TRIMS (U67, U68)
2	156876-01-U71	EA	SIDEWALL - DRIVER - W/O WINDOWS/TRIMS (U71, U72)
2	156876-01-U75	EA	SIDEWALL - DRIVER - W/O WINDOWS/TRIMS (U75, U76)
3	017516-01-000	EA	MUD FLAP - 14"H X 18"W - W/O MOUNTING HOLES - RUBBER - BLK
4	140922-01-02B	EA	RETAINER - MUD FLAP - 1" X 17.7" - E-COATED/BLACK
5	131365-01-000	EA	WHEELWELL - PLASTIC
6	157633-02-U67	EA	CAP - ROOF/FRONT - W/O LIGHTS/WIRING
7	157284-01-01A	EA	RAIL - AWNING - 192" - BRIGHT WHITE
8	132597-01-02B	EA	ANGLE/SUPPORT/TRIM - 2" - E-COATED
9	133386-02-02B	EA	PANEL - CLOSEOUT - HOLDING TANK - E-COATED
			FROM: 00-00-00 THRU: 07-18-06
9	133386-05-02B	EA	PANEL - CLOSEOUT - HOLDING TANK - E-COATED
			FROM: 07-19-06 THRU: 99-99-99
10	138021-02-01B	EA	VALANCE/PANEL - ENTRY STEP/U-SHAPED - 33.2" X 4.1" - MILL
11	132695-01-02B	EA	ANGLE - MUDFLAP - E-COATED
12	146548-01-01A	EA	TRIM - RETAINER - 143.8" - MILL
13	146550-01-02A	EA	TRIM COVER - SIDEWALL - 182" - BLACK
14	146576-01-01A	EA	END CAP/TRIM - RIGHT HAND - BRIGHT WHITE

EXTERIOR BODY GROUP (CONTINUED)
PANELS & TRIMS (CONTINUED)

KEY	PART NUMBER	U/M	DESCRIPTION
15	146576-02-01A	EA	END CAP/TRIM - LEFT HAND - BRIGHT WHITE
16	157162-01-U67	EA	BACKWALL/INNER - W/O REAR CAP (U67, U68)
16	157162-01-U71	EA	BACKWALL/INNER - W/O REAR CAP (U71, U72)
16	157162-01-U75	EA	BACKWALL/INNER - W/O REAR CAP (U75, U76)
17	156877-01-U67	EA	ROOF - W/O LIGHTS/VENTS - W/WIRING
18	149822-01-01A	EA	TRIM - SIDEWALL/ENTRY DOOR - 25.3" - BRIGHT WHITE
19	150742-01-02A	EA	CAP/TRIM - DRIVER DOOR - BLACK
20	150742-02-02A	EA	CAP/TRIM - DRIVER DOOR - BLACK
21	156622-01-01A	FT	SEALER - TAPE - 1/4"THICK X 3"WIDE X 100 FT
22	152854-01-01A	EA	HANDLE - ASSIST - WHITE W/BLACK RUBBER GRIP - 18 5/8"
23*	106015-18-01A	EA	MIRROR - EXTERIOR/REMOTE/HEAT - PASSENGER
24*	106015-19-01A	EA	MIRROR - EXTERIOR/REMOTE/HEAT - DRIVER
25	148331-01-01A	EA	PLUG - OVAL/LARGE - BLACK
			FROM: 07-20-06 THRU: 99-99-99
26	104692-01-000	FT	SEAL - ADHESIVE BACKED FOAM - 3/4" THICK X 3/4" WIDE X 25'
	099418-01-000	FT	SEAL - D-SECTION/ADHESIVE BACK - .44" X .44" - BLK RUBBER
			FROM: 01-02-07 THRU: 99-99-99
27	153498-01-02A	EA	BUMPER - RUBBER - BLACK
28	156094-01-000	EA	FOAM - PLUG - SIDEWALL TUBE
29	156094-02-000	EA	FOAM - PLUG - SIDEWALL TUBE
30	133100-05-02A	EA	TRIM - SIDEWALL - 26.5" - BRIGHT WHITE
31	133100-06-02A	EA	TRIM - SIDEWALL - 26.5" - BRIGHT WHITE
32	152800-01-02A	EA	TRIM - SIDEWALL/ENTRY STEP - 33.2" - BRIGHT WHITE
33	114248-04-04A	EA	ANGLE - PLASTIC - .2" X .4" X 96.5" - BEIGE
34	134774-01-02B	EA	BRACKET - CAB ATTACHMENT - E-COATED
			FROM: 06-16-06 THRU: 99-99-99
35	143143-02-01A	EA	ANGLE - SUPPORT/TRIM
36	143143-01-01A	EA	ANGLE - SUPPORT/TRIM

***COMPONENT PARTS LISTED LATER IN THIS GROUP**

**EXTERIOR BODY GROUP (CONTINUED)
PANELS & TRIMS (CONTINUED)**

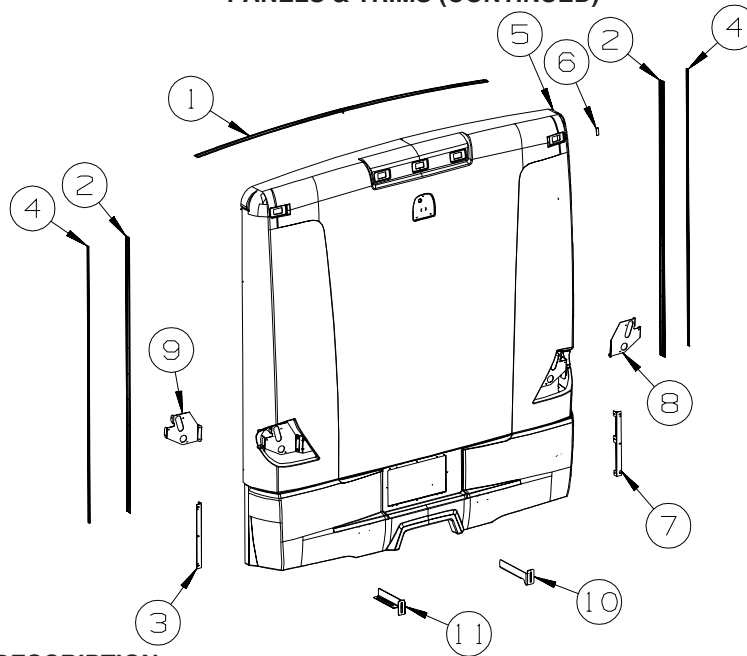

KEY	PART NUMBER	U/M	DESCRIPTION
1	083805-23-000	EA	TRIM - ROOF CAP - 92.1" - BRIGHT WHITE
2	092041-12-01A	EA	TRIM - FRONT/REAR CAP (SIDEWALL) - 84" - BRIGHT WHITE FROM: 00-00-00 THRU: 05-25-06
2	092041-01-03A	EA	TRIM - FRONT/REAR CAP (SIDEWALL) - 83.1" - BRIGHT WHITE FROM: 05-26-06 THRU: 99-99-99
3	138789-01-02B	EA	ANGLE/MOUNT - WHEEL LIP/BACKWALL - E-COATED
4	091985-01-07A	FT	INSERT - TRIM - REAR CAP TO SIDEWALL - .66" - BRIGHT WHITE
5	157591-03-U65	EA	PANEL - REAR CAP - W/O CAMERA MOUNT
5	157591-04-U65	EA	PANEL - REAR CAP - W/CAMERA MOUNT - REARVIEW MONITOR SYS W/AUDIO
6	104692-03-000	EA	SEAL - ADHESIVE BACKED FOAM - 1" THICK X 1 3/16"WIDE X 15'
7	150703-01-02B	EA	ANGLE - MOUNT - SEAL PLANE - E-COATED
8	149005-03-02B	EA	SUPPORT - TAIL LAMP - RIGHT - E-COATED
9	149005-04-02B	EA	SUPPORT - TAIL LAMP - LEFT - E-COATED
10	149152-01-02B	EA	BRACE-REAR CAP, LOWER, RH - E-COATED
11	149152-02-02B	EA	BRACE-REAR CAP, LOWER, LH - E-COATED

COMPONENT PARTS FOR PANELS & TRIMS

106015-18-01A, 106015-19-01A

KEY	PART NUMBER	U/M	DESCRIPTION	VENDOR NO.
	106015-12-702	EA	CAP/SCREW - (PKG OF 4) - BLK	748329 RND
	106015-16-700	EA	GLASS-FLAT W/HEAT ELEMENT	709450
	106015-18-700	EA	GLASS/CONVEX-KIT W/CLIP	709650
	106015-18-701	EA	ACTUATOR - CONVEX GLASS	7475410
	106015-18-702	EA	MOTOR - FLAT GLASS	747118
	106015-18-703	EA	CONVEX REBUILT KIT	709651
	106015-19-700	EA	VIBRATION KIT - MIRROR GLASS, VELVAC	709645

LADDER

KEY	PART NUMBER	U/M	DESCRIPTION
	129375-02-000	EA	SEAL - LADDER BRACKET
	149238-02-01A	EA	LADDER - UPPER - BRUSHED ALUMINUM
	150785-02-01A	EA	LADDER - LOWER - 35.6" / 3 STEP W/DOG LEG - HINGED STANDOFF

EXTERIOR BODY GROUP (CONTINUED)

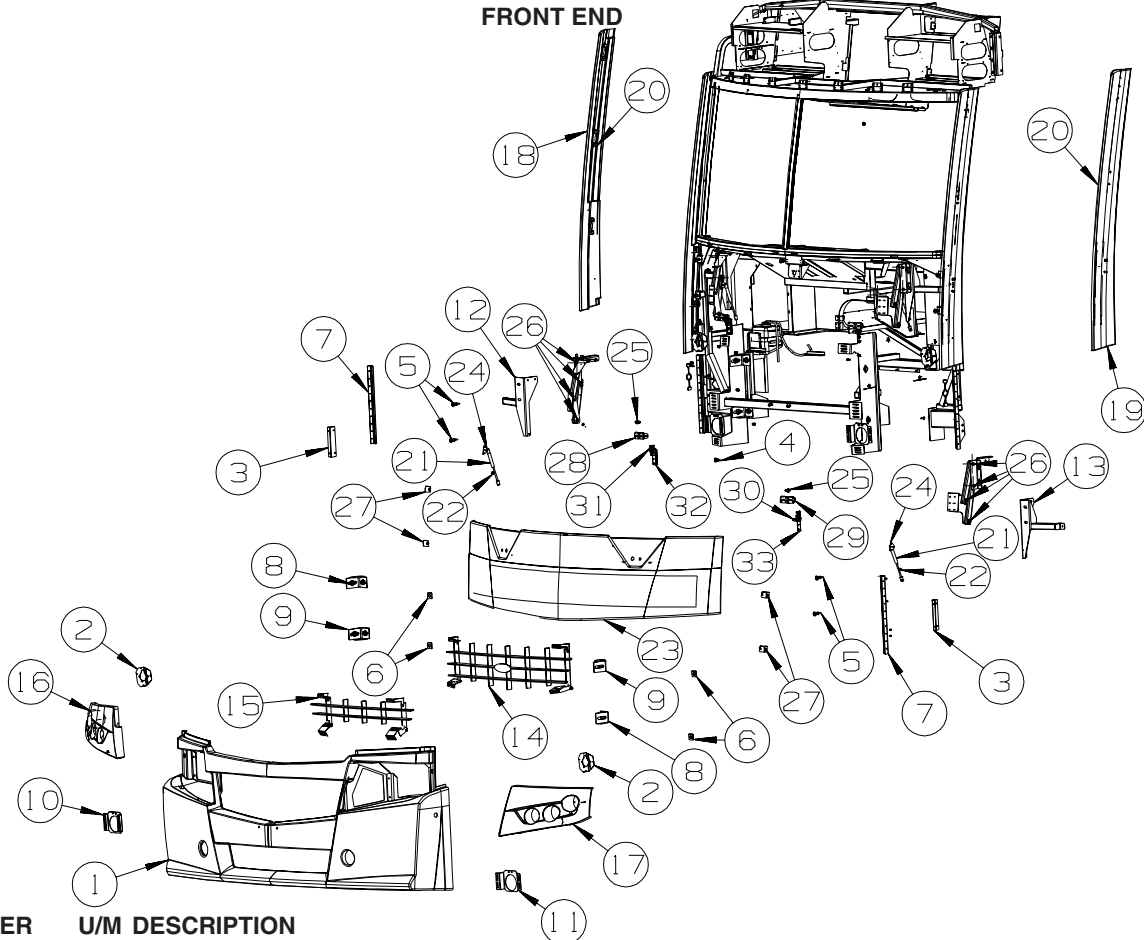

KEY	PART NUMBER	U/M	DESCRIPTION
1	156609-02-U65	EA	PANEL - FRONT/LOWER - W/O HOOD/LIGHTS/HDW
2	156472-01-02B	EA	PLATE/MOUNTING - TURNLAMP - E-COATED
3	113041-21-02B	EA	ANGLE/MOUNT - BUMPER - E-COATED
4	058786-01-000	EA	BOLT - HOOD ADJUSTMENT - 5/16"-18 X 1.5"-2"- W/BLACK PAD
5	058786-04-000	EA	BOLT - HOOD ADJUSTMENT - 5/16"-18 X 2"-2.5"- W/BLACK PAD
5	058786-01-000	EA	BOLT - HOOD ADJUSTMENT - 5/16"-18 X 1.5"-2"- W/BLACK PAD FROM: 00-00-00 THRU: 01-07-07 FROM: 01-08-07 THRU: 99-99-99
6	116617-02-02B	EA	SPACER - BUMPER
7	132071-07-02B	EA	BRACKET - BUMPER - REAR - E-COATED
8	128455-07-02B	EA	BRACKET - BUMPER - E-COATED
9	128455-08-02B	EA	BRACKET - BUMPER - E-COATED
10	158969-02-02B	EA	SUPPORT - FOGLAMP - PASSENGER - E-COATED
11	158969-04-02B	EA	SUPPORT - FOGLAMP - DRIVER - E-COATED
12	158040-01-02B	EA	BRACKET - HOOD - E-COATED
12	162971-01-02B	EA	SUPPORT - HINGE/HOOD - E-COATED FROM: 00-00-00 THRU: 01-07-07 FROM: 01-08-07 THRU: 99-99-99
13	158040-02-02B	EA	BRACKET - HOOD - E-COATED
13	162971-02-02B	EA	SUPPORT - HINGE/HOOD - E-COATED FROM: 00-00-00 THRU: 01-07-07 FROM: 01-08-07 THRU: 99-99-99
14	156505-01-01A	EA	GRILLE - FRONT/UPPER
15	156666-01-01A	EA	GRILLE - FRONT/LOWER
16	156515-01-03A	EA	BEZEL - HEADLAMP/PARK TURN - PASSENGER - BLACK
17	156515-02-03A	EA	BEZEL - HEADLAMP/PARK TURN - DRIVER - BLACK
18	156198-01-U65	EA	TRIM - A-PILLAR - PASSENGER
18	P61380-01-U67	EA	TRIM - A-PILLAR - PASSENGER - NOT ILLUSTRATED FROM: 00-00-00 THRU: 10-08-06 FROM: 10-09-06 THRU: 99-99-99
19	156198-02-U65	EA	TRIM - A-PILLAR - DRIVER
19	P61380-02-U67	EA	TRIM - A-PILLAR - DRIVER - NOT ILLUSTRATED FROM: 00-00-00 THRU: 10-08-06 FROM: 10-09-06 THRU: 99-99-99

EXTERIOR BODY GROUP (CONTINUED)
FRONT END (CONTINUED)

KEY	PART NUMBER	U/M	DESCRIPTION
20	158297-01-000	FT	SEAL - D-SECTION/BULB/TEE - ADHESIVE BACK - BLACK
21	142569-30-000	EA	SPRING/GAS - 90 LB - 9.6" EXTENDED/6.5" COMPRESSED
22	057460-02-000	EA	BALL STUD - F/GAS SPRING .39" - 5/16"-18
23	156587-02-U65	EA	HOOD - FRONT - W/O HDW
24	126263-08-02B	EA	BRACKET - GAS SPRING W/CENTERED BALL STUD - E-COATED
25	149358-01-01A	EA	BOLT - STRIKER - .375" DIAMETER
26	155042-01-01A	EA	BEARING/CLIP - F/ELECTRIC SLIDING TV MECHANISM - CHARCOAL
27	157013-01-02B	EA	ANGLE - HOOD STOP - E-COATED
28	160724-01-02B	EA	BRACE ASM - STRIKE/RH - E-COATED
29	160724-02-02B	EA	BRACE ASM - STRIKE/LH - E-COATED
30	149359-02-01A	EA	LATCH - SINGLE ROTOR - MINI/RIGHT HAND - HOOD - ZINC
31	149359-03-01A	EA	LATCH - SINGLE ROTOR - MINI/LEFT HAND - HOOD - ZINC
32	158033-01-02B	EA	ANGLE - LATCH/RH - E-COATED
33	158033-02-02B	EA	ANGLE - LATCH/LH - E-COATED

STRUCTURAL COMPONENTS

KEY	PART NUMBER	U/M	DESCRIPTION
	002766-01-001	EA	ANGLE - EXTRUDED - 1" X 1 1/2" X 17'
	089297-01-000	SF	PLYWOOD - LUAN - OVERLAY GRADE - 4' X 8'
	089297-03-000	SF	PLYWOOD - LUAN - OVERLAY GRADE - 4' X 8.3'
	100619-01-000	BF	FOAM - EXPANDED POLYSTYRENE - 1.34" X 48" X 96"
	100619-02-000	BF	FOAM - EXPANDED POLYSTYRENE - 1.5" X 48" X 96"
	100619-04-000	BF	FOAM - EXPANDED POLYSTYRENE - .5" X 48" X 96"
	100619-05-000	BF	FOAM - EXPANDED POLYSTYRENE - .75" X 48" X 96"-1.5"DENSITY
	100619-13-000	BF	FOAM - EXPANDED POLYSTYRENE-.34" X 34.7" X 96"-2" DENSITY
	100619-16-000	BF	FOAM - EXPANDED POLYSTYRENE - .75" X 48" X 96"-2" DENSITY
	100619-22-000	BF	FOAM - EXPANDED POLYSTYRENE - 1.34" X 48" X 120"
	105077-08-000	EA	FOAM - PLUG - ROOF CAP
	108535-05-03A	SF	FIBERGLASS SHEET - 108" X 500' ROLL - BRIGHT WHITE
	116942-03-01A	LB	ALUMINUM - .7" X 40" X 158"
	120107-07-000	EA	FOAM - ROOF COVE
	128782-17-01A	EA	FIBERGLASS SHEET - 30.9" X 74.7" - HIGH GLOSS - BRT WHITE
	128782-18-01A	EA	FIBERGLASS SHEET - 85.2" X 448.1" - HIGH GLOSS - BRT WHITE
	148884-20-01A	EA	FIBERGLASS SHEET - 4" X 93.8" - HIGH GLOSS - BRIGHT WHITE
	152490-01-000	EA	FOAM - PLUG - ROOF TUBE

AWNINGS

ORDER AWNINGS & REPAIR PARTS FROM DOMETIC. CALL #800-366-3842.

**THE DOMETIC AWNING INFORMATION YOU WILL NEED IS LOCATED ON THE MOTOR HOME NEAR
THE TOP OF THE AWNING RAIL.**

KEY	PART NUMBER	U/M	DESCRIPTION
	113874-11-01A	EA	SCREW/LAG - AWNING - 1/4" X 1" STAINLESS STEEL
	113874-12-01A	EA	SCREW/LAG - AWNING - 1/4" X 2 3/4" STAINLESS STEEL
	137054-01-02A	EA	BRACKET - AWNING - BRIGHT WHITE - MANUAL FROM: 00-00-00 THRU: 12-10-06
	161739-01-02A	EA	BRACKET - AWNING - BRIGHT WHITE - MANUAL FROM: 12-11-06 THRU: 99-99-99

EXTERIOR DOORS & COMPARTMENTS GROUP

DOOR & COMPARTMENT LAYOUT

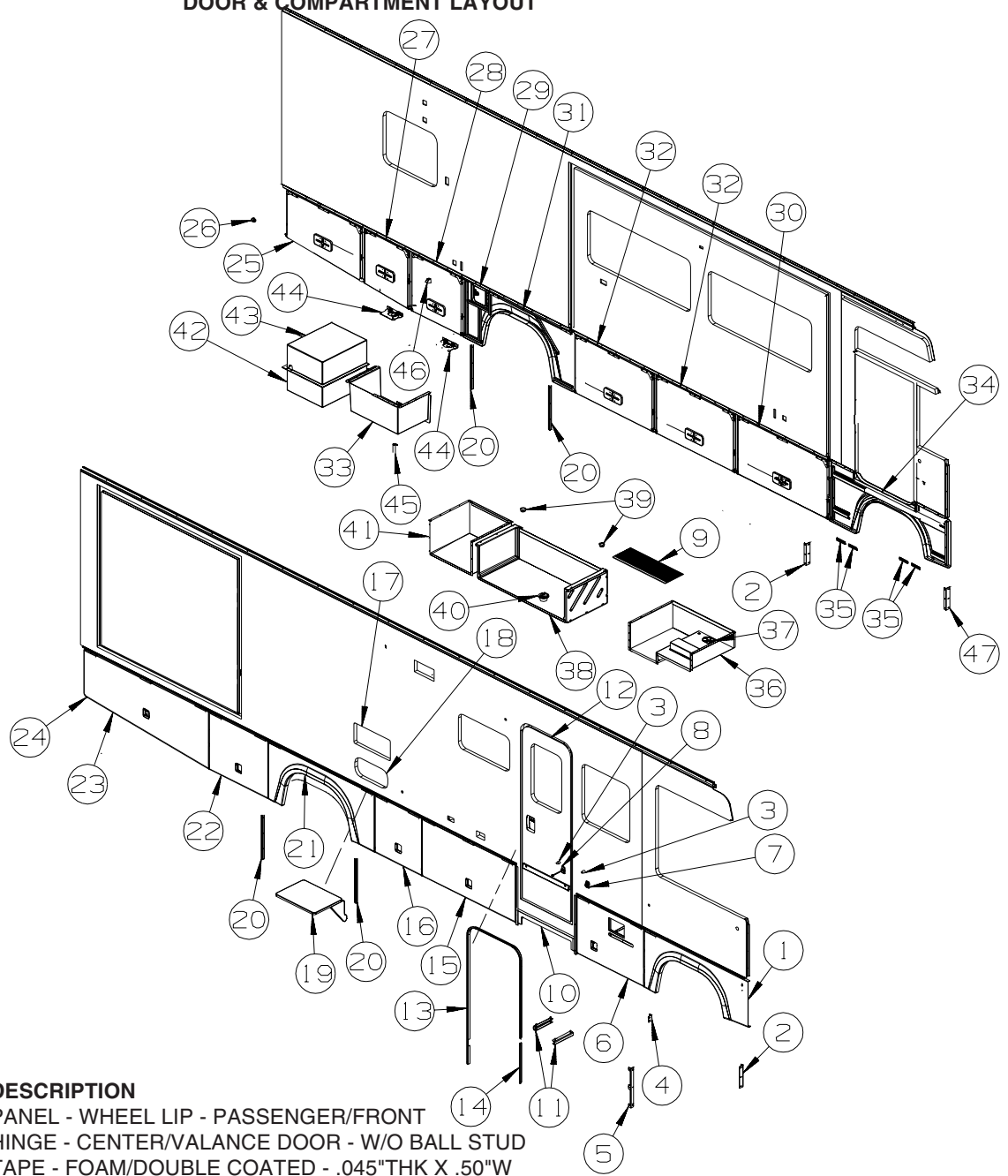

KEY	PART NUMBER	U/M	DESCRIPTION
1	156541-01-U67	EA	PANEL - WHEEL LIP - PASSENGER/FRONT
	139793-03-01A	EA	HINGE - CENTER/VALANCE DOOR - W/O BALL STUD
	076322-21-000	FT	TAPE - FOAM/DOUBLE COATED - .045"THK X .50"W
	076322-22-000	FT	TAPE - FOAM/DOUBLE COATED - .045" X .75"
2	113904-18-02B	EA	ANGLE - ATTACHMENT/WHEEL LIP - E-COATED
			FROM: 00-00-00 THRU: 03-30-06
2	113904-16-02B	EA	ANGLE - ATTACHMENT/WHEEL LIP - E-COATED
			FROM: 03-31-06 THRU: 99-99-99
3	120863-02-000	EA	BUMPER - RUBBER/RADIUS TOP - 1" X 1 1/2"
4	113904-19-02B	EA	ANGLE - ATTACHMENT/WHEEL LIP - E-COATED
5	138789-01-02B	EA	ANGLE/MOUNT - WHEEL LIP/BACKWALL - E-COATED
6	147682-04-U67	EA	VALANCE/DOOR - W/O LATCH/HDWR - W/CUT-OUT - 37.2" X 26.9"
	132873-D5-000	EA	ROD - LATCH - 21.7" W/3/4" DOG LEG
	135624-A7-01B	EA	ROD - LATCH
	142569-12-000	EA	SPRING/GAS - 90 LB - 15" EXTENDED/9.5" COMPRESSED
	126263-02-02B	EA	BRACKET - GAS SPRING W/BALL STUD - E-COATED
	130053-01-01A	EA	STRIKER - LUGGAGE DOOR - FLUSH - BLACK
	143793-01-01A	EA	SHIM - STRIKER - LUGGAGE - 3/64" - BLACK
	132892-08-01A	FT	SEAL - BULB/SINGLE - W/U CHANNEL - BLACK
	099418-01-000	FT	SEAL - D-SECTION/ADHESIVE BACK - .44" X .44" - BLK RUBBER
			FROM: 01-02-07 THRU: 99-99-99
7	104099-02-04A	EA	CATCH/RETAINER - DOOR HOLDER - BRIGHT WHITE
8	104099-03-04A	EA	CATCH - DOOR HOLDER - STRIKE - 6" - BRIGHT WHITE

EXTERIOR DOORS & COMPARTMENTS GROUP (CONTINUED)
DOOR & COMPARTMENT LAYOUT (CONTINUED)

KEY	PART NUMBER	U/M	DESCRIPTION
9	133114-01-01A	EA	TREAD - STEP/RUBBER - 29.3" X 10.1" - TAUPE
10*	094707-04-01A	EA	STEP - ELECTRIC DOUBLE - KWIKEE
	116975-01-01A	EA	LATCH - W/O STRIKE - BLACK - NEW STYLE
11	138787-02-02B	EA	CHANNEL/MOUNT - E-COAT
12	P32206-17-U67	EA	DOOR - ENTRY W/SCREEN DOOR - W/O WINDOW/LATCH (U67, U68)
12	P32206-17-U71	EA	DOOR - ENTRY W/SCREEN DOOR - W/O WINDOW/LATCH (U71, U72)
12	P32206-17-U75	EA	DOOR - ENTRY W/SCREEN DOOR - W/O WINDOW/LATCH (U75, U76)
ENTRY DOOR LOCK CYLINDERS			
	138287-11-000	EA	CYLINDER/LOCK - ENTRY DOOR - MASTER W/3M ICON - (3041)
	138287-12-000	EA	CYLINDER/LOCK - ENTRY DOOR - MASTER W/3M ICON - (3042)
	138287-13-000	EA	CYLINDER/LOCK - ENTRY DOOR - MASTER W/3M ICON - (3043)
	138287-14-000	EA	CYLINDER/LOCK - ENTRY DOOR - MASTER W/3M ICON - (3044)
	138287-15-000	EA	CYLINDER/LOCK - ENTRY DOOR - MASTER W/3M ICON - (3045)
	138287-16-000	EA	CYLINDER/LOCK - ENTRY DOOR - MASTER W/3M ICON - (3046)
	138287-17-000	EA	CYLINDER/LOCK - ENTRY DOOR - MASTER W/3M ICON - (3047)
	138287-18-000	EA	CYLINDER/LOCK - ENTRY DOOR - MASTER W/3M ICON - (3048)
	138287-19-000	EA	CYLINDER/LOCK - ENTRY DOOR - MASTER W/3M ICON - (3049)
	138287-20-000	EA	CYLINDER/LOCK - ENTRY DOOR - MASTER W/3M ICON - (3050)
	138292-01-000	EA	SEAL - LOCK CYLINDER
VALANCE DOOR, DRIVER DOOR & WATER FILL DOOR LOCK CYLINDERS			
	138289-11-000	EA	CYLINDER/LOCK - ACCESS DOORS - REDUCED SENSITIVITY (3041)
	138289-12-000	EA	CYLINDER/LOCK - ACCESS DOORS - REDUCED SENSITIVITY (3042)
	138289-13-000	EA	CYLINDER/LOCK - ACCESS DOORS - REDUCED SENSITIVITY (3043)
	138289-14-000	EA	CYLINDER/LOCK - ACCESS DOORS - REDUCED SENSITIVITY (3044)
	138289-15-000	EA	CYLINDER/LOCK - ACCESS DOORS - REDUCED SENSITIVITY (3045)
	138289-16-000	EA	CYLINDER/LOCK - ACCESS DOORS - REDUCED SENSITIVITY (3046)
	138289-17-000	EA	CYLINDER/LOCK - ACCESS DOORS - REDUCED SENSITIVITY (3047)
	138289-18-000	EA	CYLINDER/LOCK - ACCESS DOORS - REDUCED SENSITIVITY (3048)
	138289-19-000	EA	CYLINDER/LOCK - ACCESS DOORS - REDUCED SENSITIVITY (3049)
	138289-20-000	EA	CYLINDER/LOCK - ACCESS DOORS - REDUCED SENSITIVITY (3050)
	138288-11-000	EA	KEY - REVERSIBLE - #3041 - T/M 16169-02-3041
	138288-12-000	EA	KEY - REVERSIBLE - #3042 - T/M 16169-02-3042
	138288-13-000	EA	KEY - REVERSIBLE - #3043 - T/M 16169-02-3043
	138288-14-000	EA	KEY - REVERSIBLE - #3044 - T/M 16169-02-3044
	138288-15-000	EA	KEY - REVERSIBLE - #3045 - T/M 16169-02-3045
	138288-16-000	EA	KEY - REVERSIBLE - #3046 - T/M 16169-02-3046
	138288-17-000	EA	KEY - REVERSIBLE - #3047 - T/M 16169-02-3047
	138288-18-000	EA	KEY - REVERSIBLE - #3048 - T/M 16169-02-3048
	138288-19-000	EA	KEY - REVERSIBLE - #3049 - T/M 16169-02-3049
	138288-20-000	EA	KEY - REVERSIBLE - #3050 - T/M 16169-02-3050
13	139100-01-01A	EA	GARNISH/RADIUS - ENTRY DOOR - BRIGHT WHITE
14	139101-01-01A	EA	GARNISH/STRAIGHT - W/NOTCH - 36.31" - BRIGHT WHITE
15	147682-01-U67	EA	VALANCE/DOOR - W/O PADDLE LATCH/HDWR - 51.8" X 26.3"
	132873-D1-000	EA	ROD - LATCH - 19.7" W/3/4" DOG LEG
	135624-A5-01B	EA	ROD - LATCH
	142569-12-000	EA	SPRING/GAS - 90 LB - 15" EXTENDED/9.5" COMPRESSED
	126263-02-02B	EA	BRACKET - GAS SPRING W/BALL STUD - E-COATED
	130053-01-01A	EA	STRIKER - LUGGAGE DOOR - FLUSH - BLACK
	143793-01-01A	EA	SHIM - STRIKER - LUGGAGE - 3/64" - BLACK
	132892-08-01A	FT	SEAL - BULB/SINGLE - W/U CHANNEL - BLACK
	099418-01-000	FT	SEAL - D-SECTION/ADHESIVE BACK - .44" X .44" - BLK RUBBER FROM: 01-02-07 THRU: 99-99-99
16	140982-02-P37	EA	VALANCE/DOOR - W/O LATCH/HINGE - 26.1" X 26.3"
	132873-21-000	EA	ROD - LATCH - 6.8" W/3/4" DOG LEG
	135624-75-01B	EA	ROD - LATCH
	142569-12-000	EA	SPRING/GAS - 90 LB - 15" EXTENDED/9.5" COMPRESSED
	126263-02-02B	EA	BRACKET - GAS SPRING W/BALL STUD - E-COATED
	130053-01-01A	EA	STRIKER - LUGGAGE DOOR - FLUSH - BLACK
	143793-01-01A	EA	SHIM - STRIKER - LUGGAGE - 3/64" - BLACK
	132892-08-01A	FT	SEAL - BULB/SINGLE - W/U CHANNEL - BLACK
	099418-01-000	FT	SEAL - D-SECTION/ADHESIVE BACK - .44" X .44" - BLK RUBBER FROM: 01-02-07 THRU: 99-99-99
17*	084103-08-000	EA	DOOR - VENT - REFRIGERATOR - W/O JAMB - BRIGHT WHITE
17	084104-08-000	EA	JAMB - VENT DOOR/REFRIGERATOR - BRIGHT WHITE

EXTERIOR DOORS & COMPARTMENTS GROUP (CONTINUED)
DOOR & COMPARTMENT LAYOUT (CONTINUED)

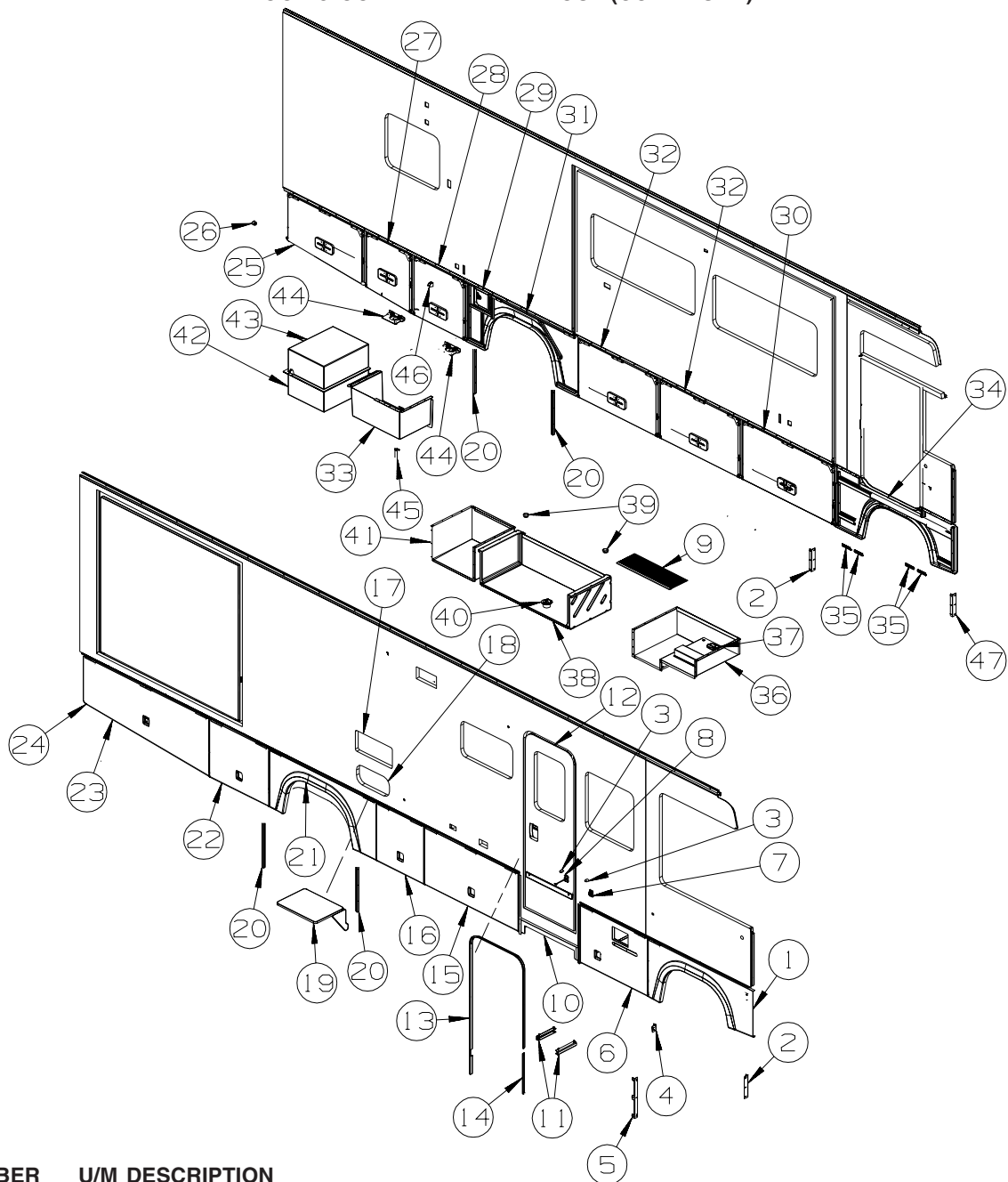

KEY	PART NUMBER	U/M	DESCRIPTION
18	126945-09-P07	EA	DOOR/STORAGE - W/O HARDWARE - 18.3" X 9.9"
19	142034-01-01A	EA	SHELF - F/EXTERIOR TV - BRIGHT WHITE
20	113904-13-02B	EA	ANGLE - ATTACHMENT/WHEEL LIP - 15.7" - E-COAT
21	141621-34-S46	EA	PANEL/WHEEL LIP - PASSENGER/REAR - 59.4"
	139793-03-01A	EA	HINGE - CENTER/VALANCE DOOR - W/O BALL STUD
	076322-21-000	FT	TAPE - FOAM/DOUBLE COATED - .045"THK X .50"W
	076322-22-000	FT	TAPE - FOAM/DOUBLE COATED - .045" X .75"
22	140982-05-P37	EA	VALANCE/DOOR - W/O LATCH/HINGE - 32.8" X 26.3"
	132873-25-000	EA	ROD - LATCH - 10.2" W/3/4" DOG LEG
	135624-08-01B	EA	ROD - LATCH
	142569-17-000	EA	SPRING/GAS - 90 LB - 12" EXTENDED/8.5" COMPRESSED
	126263-02-02B	EA	BRACKET - GAS SPRING W/BALL STUD - E-COATED
	130053-01-01A	EA	STRIKER - LUGGAGE DOOR - FLUSH - BLACK
	143793-01-01A	EA	SHIM - STRIKER - LUGGAGE - 3/64" - BLACK
	076767-14-000	EA	CABLE - STAINLESS STEEL - 14.9"
	132892-08-01A	FT	SEAL - BULB/SINGLE - W/U CHANNEL - BLACK
23	147682-11-R38	EA	VALANCE/DOOR - PASS W/O LATCH/HDWR - 26.4" X 69.5" X 21.4"
	107721-07-000	FT	SEAL - ACCESS DOOR - .9"WIDE X 1.1"HIGH
	076322-13-000	FT	TAPE - FOAM/DOUBLE COATED - .020"THK X .75"W - CLEAR
24	140309-03-02B	EA	ANGLE - FURNACE DOOR - E-COATED

EXTERIOR DOORS & COMPARTMENTS GROUP (CONTINUED)
DOOR & COMPARTMENT LAYOUT (CONTINUED)

KEY	PART NUMBER	U/M	DESCRIPTION
25	147682-08-R32	EA	VALANCE/DOOR - DRVR W/O LATCH/HDWR - 24.4" X 43.1" X 21.3"
	132873-29-000	EA	ROD - LATCH - 15.4" W/3/4" DOG LEG
	135624-77-01B	EA	ROD - LATCH
	142569-17-000	EA	SPRING/GAS - 90 LB - 12" EXTENDED/8.5" COMPRESSED
	126263-02-02B	EA	BRACKET - GAS SPRING W/BALL STUD - E-COATED
	130053-01-01A	EA	STRIKER - LUGGAGE DOOR - FLUSH - BLACK
	143793-01-01A	EA	SHIM - STRIKER - LUGGAGE - 3/64" - BLACK
	132892-08-01A	FT	SEAL - BULB/SINGLE - W/U CHANNEL - BLACK
26	117047-01-000	EA	BUMPER - RUBBER/WASHER INSERT
27	140982-15-P37	EA	VALANCE/DOOR - DRVR W/O LATCH/HINGE- 26.3" X 26.1" X 24.4"
	132873-21-000	EA	ROD - LATCH - 6.8" W/3/4" DOG LEG
	135624-75-01B	EA	ROD - LATCH
	142569-12-000	EA	SPRING/GAS - 90 LB - 15" EXTENDED/9.5" COMPRESSED
	126263-02-02B	EA	BRACKET - GAS SPRING W/BALL STUD - E-COATED
	130053-01-01A	EA	STRIKER - LUGGAGE DOOR - FLUSH - BLACK
	143793-01-01A	EA	SHIM - STRIKER - LUGGAGE - 3/64" - BLACK
	107721-07-000	FT	SEAL - ACCESS DOOR - .9"WIDE X 1.1"HIGH
	099418-01-000	FT	SEAL - D-SECTION/ADHESIVE BACK - .44" X .44" - BLK RUBBER
			FROM: 01-02-07 THRU: 99-99-99
28	140982-03-P37	EA	VALANCE/DOOR - W/O LATCH/HINGE - 29.3" X 26.3"
	132873-23-000	EA	ROD - LATCH - 8.5" W/3/4" DOG LEG
	132873-24-000	EA	ROD - LATCH - 10.3" W/3/4" DOG LEG
			FROM: 00-00-00 THRU: 08-28-05
	135624-26-01B	EA	ROD - LATCH
			FROM: 08-29-05 THRU: 99-99-99
	142569-12-000	EA	SPRING/GAS - 90 LB - 15" EXTENDED/9.5" COMPRESSED
	126263-02-02B	EA	BRACKET - GAS SPRING W/BALL STUD - E-COATED
	130053-01-01A	EA	STRIKER - LUGGAGE DOOR - FLUSH - BLACK
	143793-01-01A	EA	SHIM/STRIKER - LUGGAGE - 1.5" - BLACK
	107721-07-000	FT	SEAL - ACCESS DOOR - .9"WIDE X 1.1"HIGH
	099418-01-000	FT	SEAL - D-SECTION/ADHESIVE BACK - .44" X .44" - BLK RUBBER
			FROM: 01-02-07 THRU: 99-99-99
29	131905-03-L32	EA	PANEL/DOOR - FUEL FILL - W/O LOCK - BLACK
*	110506-A2-000	EA	LOCK - TWIST - 26.45MM
	110506-51-000	EA	CASE/CYLINDER - TWIST LATCH - W/O CAM - 1" - 596669
	110506-78-000	EA	CAM - LATCHING - 2.3"
	153306-01-01A	EA	HINGE - PIANO - 1 1/2" X 5" - UNPAINTED
30	147682-01-U67	EA	VALANCE/DOOR - W/O PADDLE LATCH/HDWR - 51.8" X 26.3"
	132873-D1-000	EA	ROD - LATCH - 19.7" W/3/4" DOG LEG
	135624-A5-01B	EA	ROD - LATCH
	142569-12-000	EA	SPRING/GAS - 90 LB - 15" EXTENDED/9.5" COMPRESSED
	126263-02-02B	EA	BRACKET - GAS SPRING W/BALL STUD - E-COATED
	130053-01-01A	EA	STRIKER - LUGGAGE DOOR - FLUSH - BLACK
	130053-02-01A	EA	STRIKER - LUGGAGE DOOR - OFF SET - BLACK
	143793-01-01A	EA	SHIM/STRIKER - LUGGAGE - 1.5" - BLACK
	132892-08-01A	FT	SEAL - BULB/SINGLE - W/U CHANNEL - BLACK
	099418-01-000	FT	SEAL - D-SECTION/ADHESIVE BACK - .44" X .44" - BLK RUBBER
			FROM: 01-02-07 THRU: 99-99-99
31	144686-13-S46	EA	PANEL/WHEEL LIP - DRIVER/REAR
	139793-03-01A	EA	HINGE - CENTER/VALANCE DOOR - W/O BALL STUD
	076322-21-000	FT	TAPE - FOAM/DOUBLE COATED - .045"THK X .50"W
	076322-22-000	FT	TAPE - FOAM/DOUBLE COATED - .045" X .75"
32	140982-09-U67	EA	VALANCE/DOOR - W/O LATCH/HINGE - 45" X 26.3"
	132873-31-000	EA	ROD - LATCH - 16.3" W/3/4" DOG LEG
	135624-78-01B	EA	ROD - LATCH
	142569-12-000	EA	SPRING/GAS - 90 LB - 15" EXTENDED/9.5" COMPRESSED
	126263-02-02B	EA	BRACKET - GAS SPRING W/BALL STUD - E-COATED
	130053-01-01A	EA	STRIKER - LUGGAGE DOOR - FLUSH - BLACK
	143793-01-01A	EA	SHIM - STRIKER - LUGGAGE - 3/64" - BLACK
	132892-08-01A	FT	SEAL - BULB/SINGLE - W/U CHANNEL - BLACK
	099418-01-000	FT	SEAL - D-SECTION/ADHESIVE BACK - .44" X .44" - BLK RUBBER
			FROM: 01-02-07 THRU: 99-99-99
33	144654-01-000	EA	COMPARTMENT - DRAINAGE

EXTERIOR DOORS & COMPARTMENTS GROUP (CONTINUED)
DOOR & COMPARTMENT LAYOUT (CONTINUED)

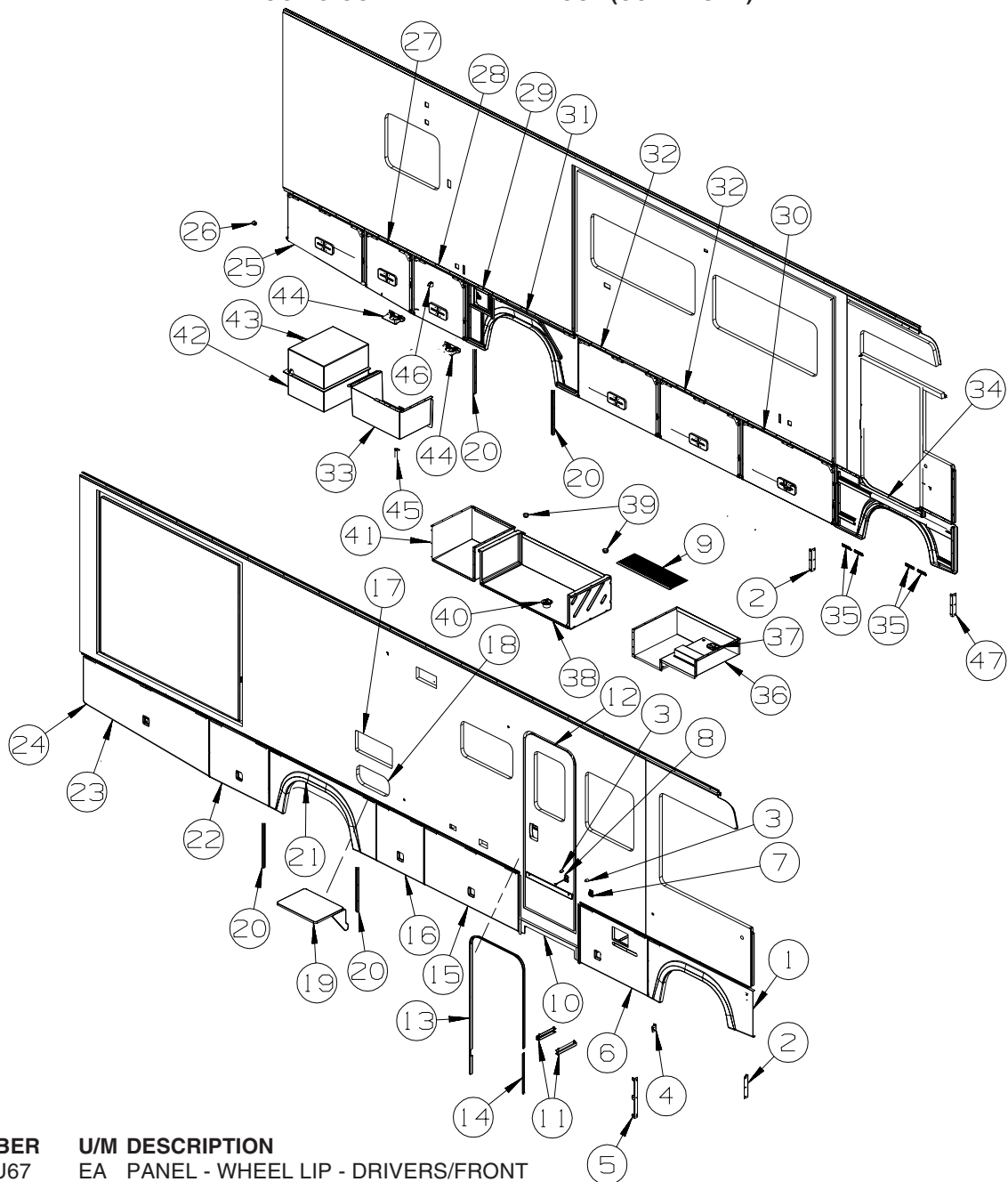

KEY	PART NUMBER	U/M	DESCRIPTION
34	156503-01-U67	EA	PANEL - WHEEL LIP - DRIVERS/FRONT
	139793-03-01A	EA	HINGE - CENTER/VALANCE DOOR - W/O BALL STUD
	076322-22-000	FT	TAPE - FOAM/DOUBLE COATED - .045" X .75"
35	132654-07-01A	EA	SUPPORT - WHEEL LIP - BLACK - 4.5"
36	141698-36-S46	EA	COMPARTMENT - LUGGAGE
36	141698-37-S46	EA	COMPARTMENT - LUGGAGE - WATER HEATER -10GAL/ELEC/LP/MOTOR AID
37	148331-01-01A	EA	PLUG - OVAL/LARGE - BLACK
38	144629-16-RS2	EA	COMPARTMENT - LUGGAGE
			FROM: 00-00-00 THRU: 02-02-06
38	144629-41-U67	EA	COMPARTMENT - LUGGAGE
			FROM: 02-03-06 THRU: 99-99-99
39	081211-03-000	EA	PLUG - PLASTIC - .50"DIAMETER - TRUSS HEAD - BLACK
40	009426-01-000	EA	HATCH - POWER CORD - WHITE
41	141698-26-P45	EA	COMPARTMENT - LUGGAGE
42	132315-03-000	EA	COMPARTMENT - POWER CORD - GEN-5.5KW -GAS-MARQ GOLD-GEN-7.0KW -GAS-MARQ GOLD
43	132315-06-000	EA	COMPARTMENT - POWER CORD
44*	142226-02-01A	EA	HATCH - POWER
45	130377-02-000	EA	UBE/DRAIN - KAZOO - 1 1/2" X 4"
46	131383-03-02A	EA	BRACKET - SHOWER HEAD - WHITE
47	113904-18-02B	EA	ANGLE - ATTACHMENT/WHEEL LIP - E-COATED

*COMPONENT PARTS LISTED LATER IN THIS GROUP

EXTERIOR DOORS & COMPARTMENTS GROUP (CONTINUED)
DOOR & COMPARTMENT LAYOUT (CONTINUED)

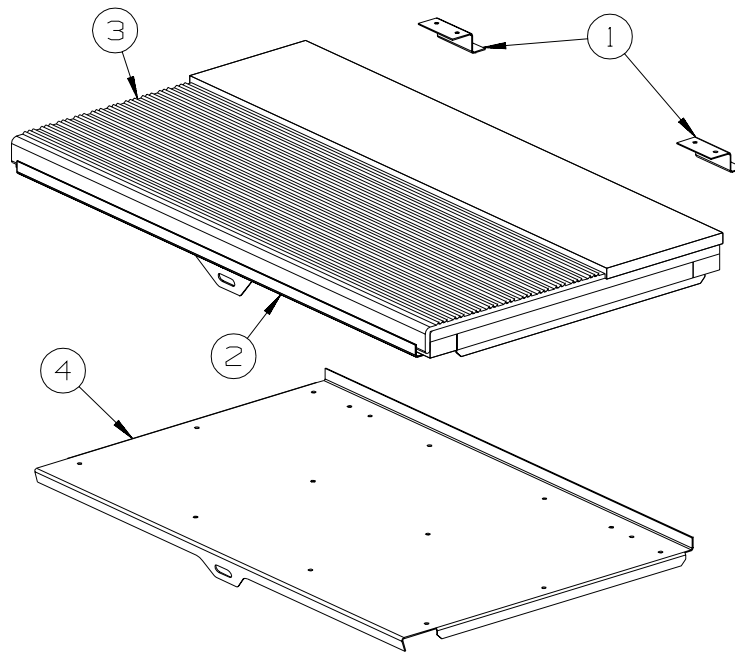

KEY	PART NUMBER	U/M	DESCRIPTION
1	101222-01-04A	EA	BRACKET - CATCH - LID - E-COATED
2	P20256-07-000	EA	LID/DOOR - ENTRY STEP - W/O CARPET/HARDWARE
3	133114-02-01A	EA	TREAD - STEP/RUBBER - W/LIP - 28.5" X 9.8" - TAUPE
4	123330-03-02B	EA	SUPPORT - ENTRY STEP - E-COATED

EXTERIOR DOORS & COMPARTMENTS GROUP (CONTINUED)

COMPONENT PARTS FOR DOOR & COMPARTMENT LAYOUT

084103-08-000

KEY	PART NUMBER	U/M	DESCRIPTION	VENDOR NO.
	084104-01-700	EA	LOCK-MALE, FASTENER	201-721-010
	084104-01-701	EA	LOCK-FEMALE, FASTENER	201-802-010

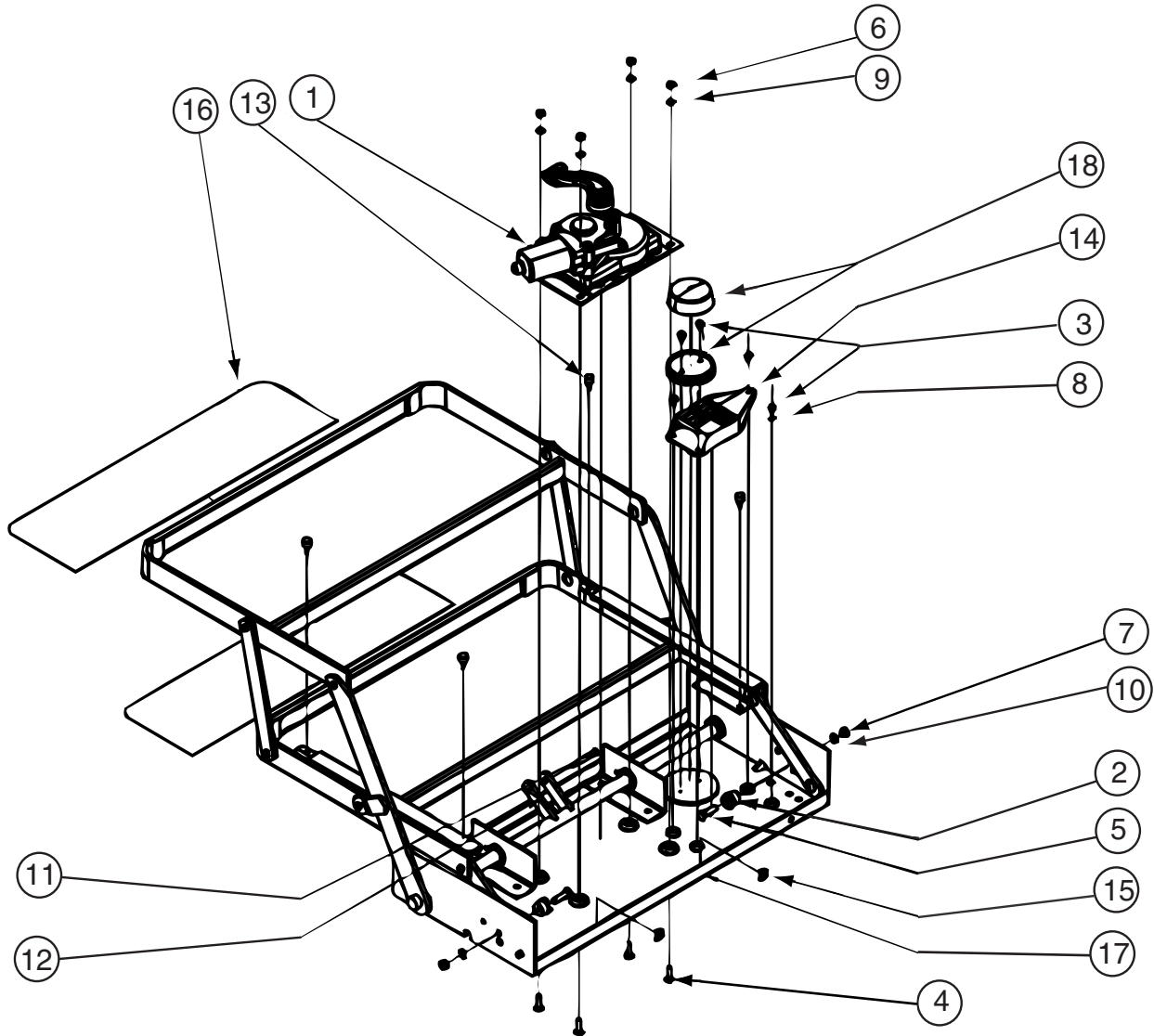

094707-04-01A

KEY	PART NUMBER	U/M	DESCRIPTION	VENDOR NO.
1	094707-04-701	EA	MOTOR "AM 214" F/IMGL STEPS	1101428
1	094707-04-703	EA	GEAR BOX W/LINKAGE-CURVED	1101425
2	143709-01-700	EA	CAM STOP	1102200
12	094707-04-702	EA	COTTOR PIN - W/CLEVIS PIN	905205000
13	143709-01-701	EA	BUMPER - BLACK (RUBBER STOP)	1602000
14	094707-04-700	EA	CONTROL UNIT W/OVERRIDE	909510000
16	143709-01-702	EA	TREAD/NON-SKID 6" X 21" BLK	1915260
17	094707-04-704	EA	FRAME W/DBL STEP-32REINF SRS	3202082
18	088746-01-705	EA	LIGHT-UNDER STEP	9004
	094707-03-701	EA	PLUG - 4-WAY - PACKARD	909306
	094707-04-711	EA	KWIKTEST - W/4-WAY PIGTAIL	909518000

CONTACT WINNEBAGO PART SALES FOR UNLISTED COMPONENT(S)

110506-A1-000, 110506-A2-000, 110506-26-000, 110506-27-000, 110506-36-000

KEY	PART NUMBER	U/M	DESCRIPTION	VENDOR NO.
	110506-40-700	EA	HDWE KIT	596950AAL

142226-02-01A

KEY	PART NUMBER	U/M	DESCRIPTION	VENDOR NO
	142226-02-700	EA	TAB/LOCKING - ESCAPE (RED)	9667709

EXTERIOR DOORS & COMPARTMENTS GROUP (CONTINUED)
COMPONENT PARTS FOR DOOR & COMPARTMENT LAYOUT (CONTINUED)

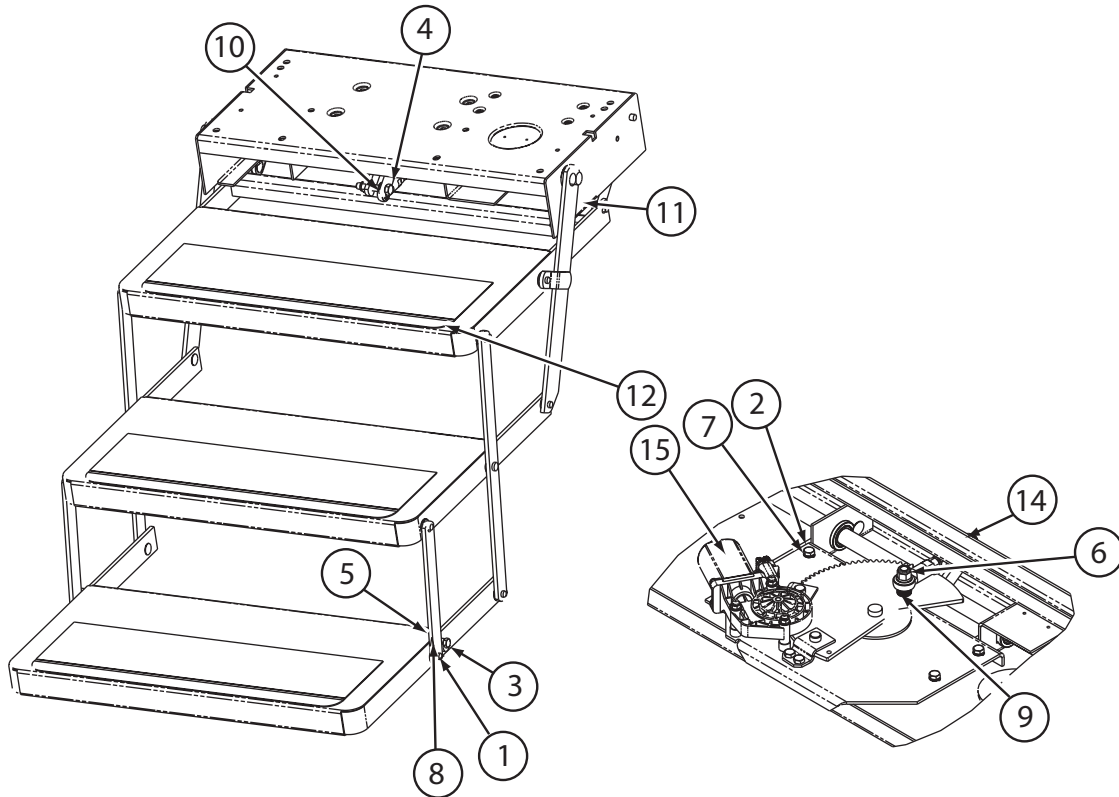

143709-02-01A

KEY	PART NUMBER	U/M	DESCRIPTION	VENDOR NO.
1	143709-01-700	EA	CAM STOP	1102200
13	143709-01-701	EA	BUMPER - BLACK (RUBBER STOP)	1602000
15	143709-01-702	EA	TREAD/NON-SKID _6" X 21" BLK	1915260
16	143709-01-703	EA	FRAME ONLY PAINTED BLACK 25	908025000
17	143709-02-700	EA	LINK/ASSEMBLY 24/25 SERIES	3380050
18	143709-02-701	EA	MOTOR ASM W/TABLE 24/25 STEP	3392152
18	094707-04-701	EA	MOTOR "AM 214" F/IMGL STEPS	1101428
	088746-01-705	EA	LIGHT-UNDER STEP	9004
	094707-033-701	EA	PLUG - 4-WAY - PACKARD	909306
	094707-04-700	EA	CONTROL UNIT W/OVERRIDE	909510000
	094707-04-711	EA	KWIKTEST - W/4-WAY PIGTAIL	909518000

CONTACT WINNEBAGO PART SALES FOR UNLISTED COMPONENT(S)

EXTERIOR DOORS & COMPARTMENTS GROUP (CONTINUED)
COMPARTMENT DOOR PIECE PARTS

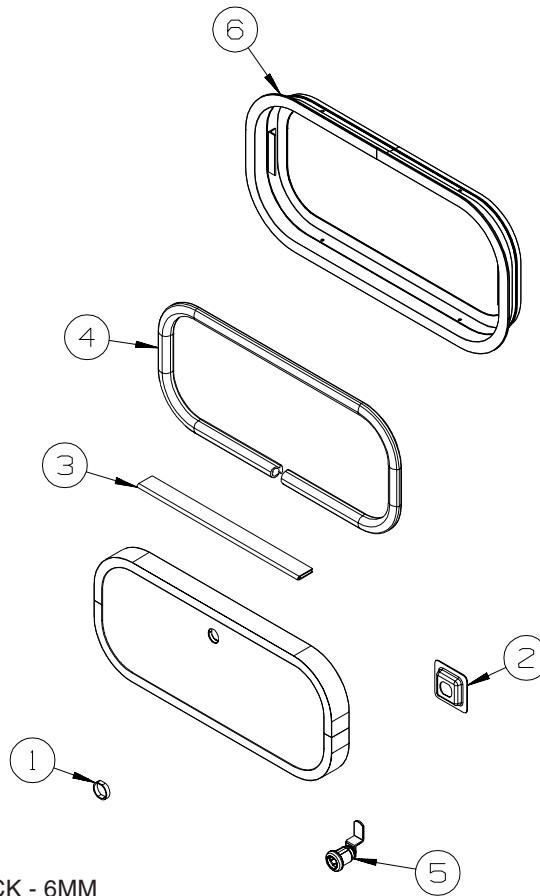

KEY	PART NUMBER	U/M	DESCRIPTION
1	139325-01-000	EA	SPACER - LOCK - 6MM
	139337-01-000	EA	GASKET - LOCK
2	097111-02-04A	EA	POCKET - LOCK - REAR DOOR - BLACK
2	097111-02-05A	EA	POCKET - LOCK - REAR DOOR - BRIGHT WHITE
3	081801-FN-000	EA	HINGE - DOOR - PIANO - 2" X 96" - BLACK
3	081801-V3-000	EA	HINGE - DOOR - PIANO - 2" X 96" - BRIGHT WHITE
4	156386-01-01A	FT	SEAL - BULB - W/ADHESIVE BACK
5	138290-02-000	EA	CASE - W/CAM - W/O CYLINDER/KEY
6	056795-01-000	FT	TAPE - SEAL - 1/8" X 3/8" WIDE - PRESS ON

EXTERIOR DOORS & COMPARTMENTS GROUP (CONTINUED)
COMPARTMENT DOOR PIECE PARTS (CONTINUED)

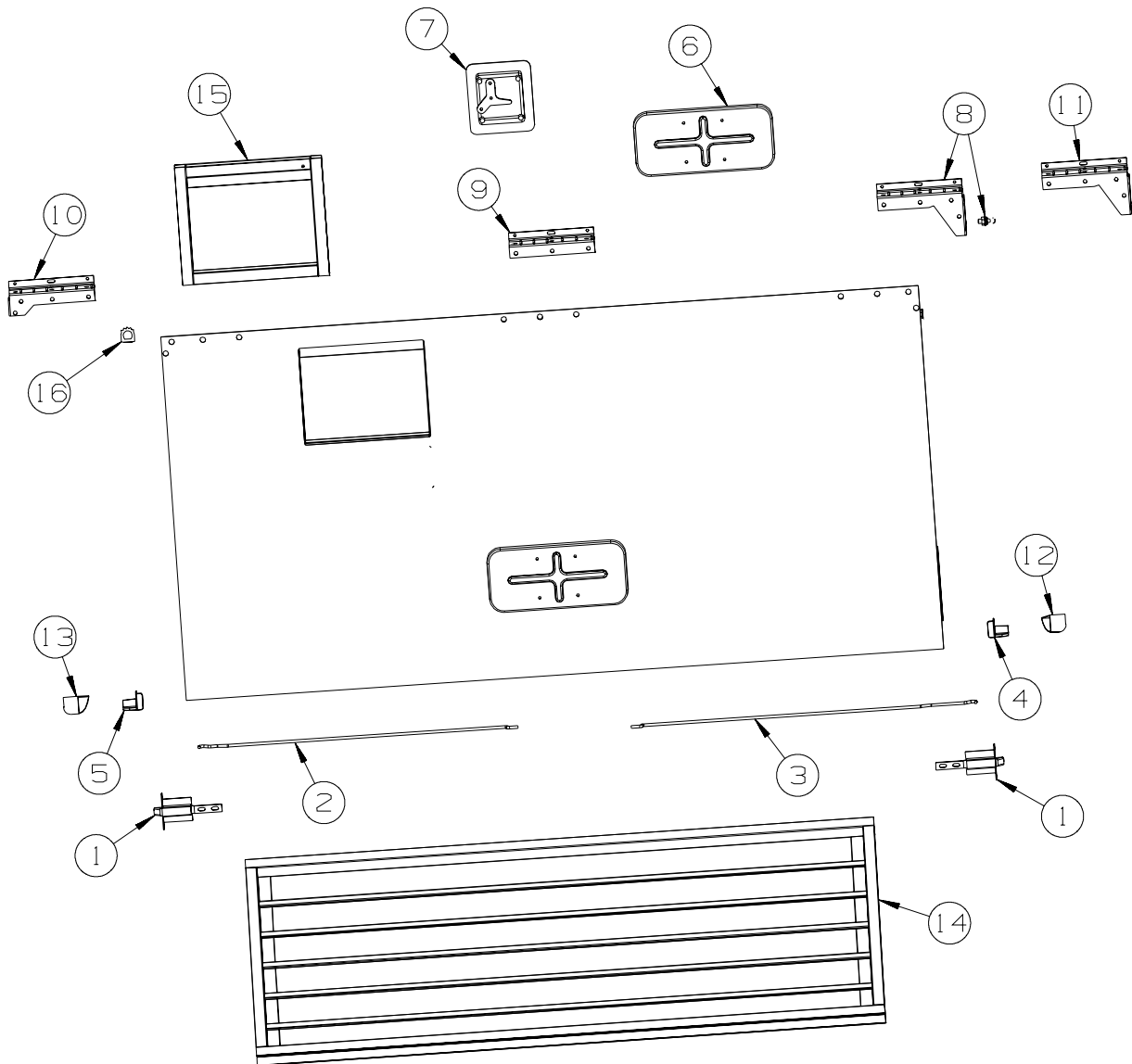

KEY	PART NUMBER	U/M	DESCRIPTION
1	121947-01-01A	EA	BOLT - SLIDE/LATCH - W/PLASTIC PLUNGER
2	132873-01-000	EA	ROD - LATCH (BLANK) - 37.3"
3	135624-71-01B	EA	ROD - LATCH (BLANK) - 37.3"
4	135276-01-01A	EA	REINFORCEMENT - CORNER - LEFT HAND (FACING DOOR) - BLACK
5	135276-02-01A	EA	REINFORCEMENT - CORNER - RIGHT HAND (FACING DOOR) - BLACK
6	137359-01-01A	EA	COVER - LATCH - WHITE
7	154900-01-01A	EA	LATCH/PADDLE - LOCKING - COMPT DOOR - KEY ONE - BLACK
8	139793-01-01A	EA	HINGE - RIGHT HAND/VALANCE DOOR - W/BALL STUD
9	139793-03-01A	EA	HINGE - CENTER/VALANCE DOOR - W/O BALL STUD
10	139793-05-01A	EA	HINGE - LEFT HAND/VALANCE DOOR - W/O BALL STUD
11	139793-04-01A	EA	HINGE - RIGHT HAND/VALANCE DOOR - W/O BALL STUD
12	141601-02-01A	EA	END CAP/VALANCE DOOR - DRVR SIDE/REAR OF DOOR/1MM NOTCH
13	141601-01-01A	EA	END CAP/VALANCE DOOR - PASS SIDE/REAR OF DOOR-W1MM NOTCH
14	113333-10-M42	EA	GRILLE - A/C DOOR
15	133049-11-R32	EA	TRIM - COVER/WATER HEATER - F33V
15	133049-09-U67	EA	TRIM - COVER/WATER HEATER - F35A, F35L
16	107721-07-000	FT	SEAL - ACCESS DOOR - .9"WIDE X 1.1"HIGH

EXTERIOR DOORS & COMPARTMENTS GROUP (CONTINUED)
COMPARTMENT DOOR PIECE PARTS (CONTINUED)

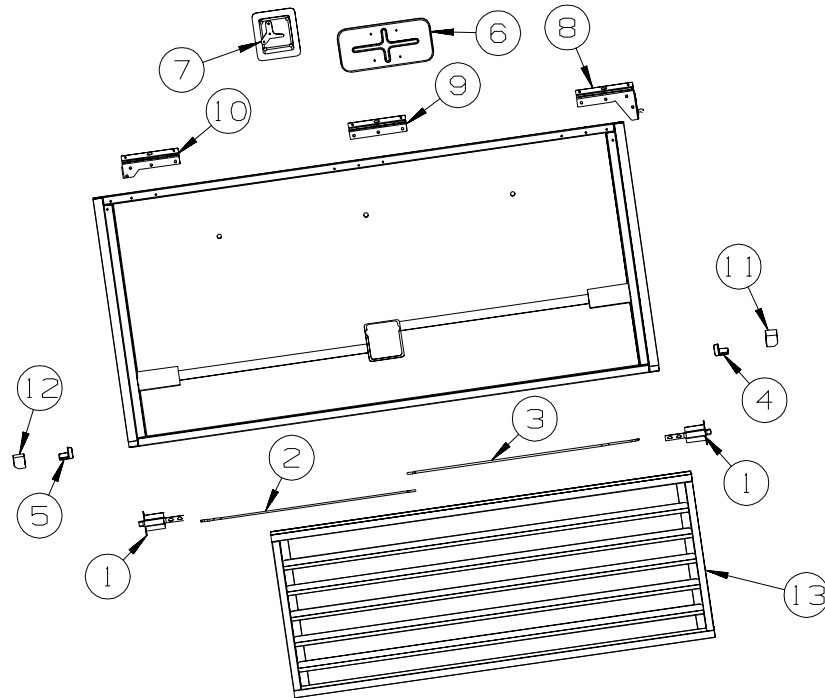

KEY	PART NUMBER	U/M	DESCRIPTION
1	121947-01-01A	EA	BOLT - SLIDE/LATCH - W/PLASTIC PLUNGER
2	132873-01-000	EA	ROD - LATCH (BLANK) - 37.3"
3	135624-71-01B	EA	ROD - LATCH (BLANK) - 37.3"
4	135276-01-01A	EA	REINFORCEMENT - CORNER - LEFT HAND (FACING DOOR) - BLACK
5	135276-02-01A	EA	REINFORCEMENT - CORNER - RIGHT HAND (FACING DOOR) - BLACK
6	137359-01-01A	EA	COVER - LATCH - WHITE
7	154900-01-01A	EA	LATCH/PADDLE - LOCKING - COMPT DOOR - KEY ONE - BLACK
7	154900-02-01A	EA	LATCH/PADDLE - NON LOCKING - COMPT DOOR - BLACK
8	139793-01-01A	EA	HINGE - RIGHT HAND/VALANCE DOOR - W/BALL STUD
9	139793-03-01A	EA	HINGE - CENTER/VALANCE DOOR - W/O BALL STUD
10	139793-05-01A	EA	HINGE - LEFT HAND/VALANCE DOOR - W/O BALL STUD
11	NOT USED		
12	NOT USED		
13	NOT USED		

EXTERIOR DOORS & COMPARTMENTS GROUP (CONTINUED)

DRIVERS

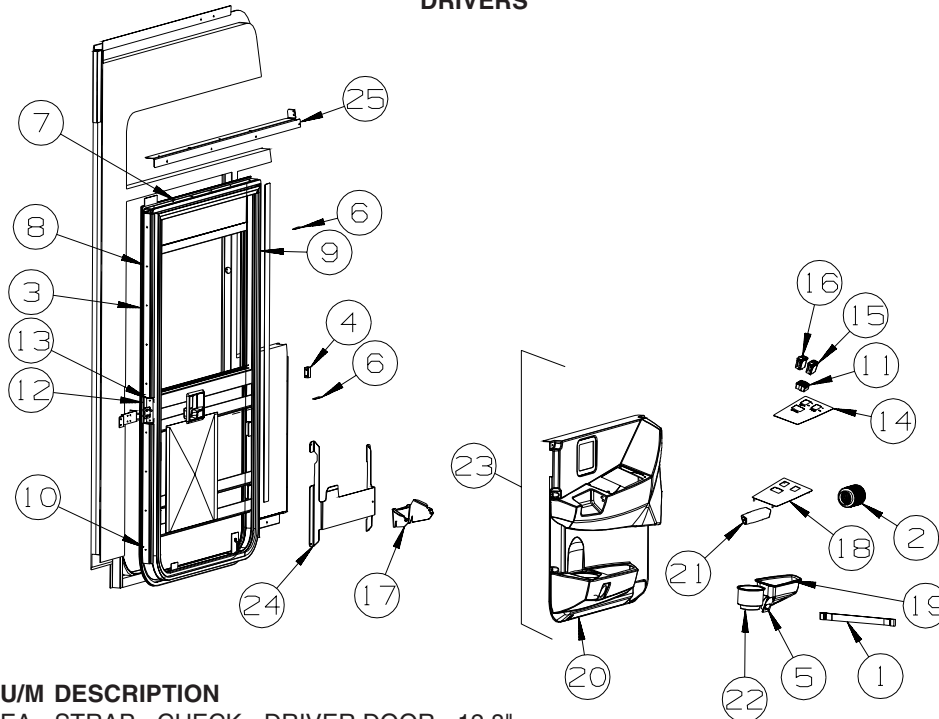

KEY	PART NUMBER	U/M	DESCRIPTION
1	109378-01-000	EA	STRAP - CHECK - DRIVER DOOR - 12.8"
2	117802-01-000	EA	GROMMET - CONVOLUTED - 2"
3*	125581-09-01A	EA	DOOR - DRIVER - POWER WINDOW/LOCK
4	128131-01-01A	EA	SPACER/SWITCH - DOME - BLACK
5	108354-01-01A	EA	LIGHT - COURTESY
6	109235-01-01A	FT	COVER - SCREW - MAT BLACK
6	109235-01-05A	FT	COVER - SCREW - BRIGHT WHITE
7	125725-01-01A	EA	FRAME - DRIVER DOOR - 33.5" - BLACK
8	125725-03-01A	EA	FRAME - DRIVER DOOR - 27.8" - BLACK
9	125725-07-01A	EA	FRAME - DRIVER DOOR - 53.3" - BLACK
10	125725-08-01A	EA	FRAME - DRIVER DOOR - 21.4" - BLACK
11	088246-01-000	EA	SWITCH/REMOTE MIRROR - W/2PIN & 6 PIN CONNECTORS/PIGTAIL
12	126506-01-02B	EA	BRACKET - STRIKE - DRIVER DOOR - E-COATED
13	126534-01-02B	EA	SPACER - STRIKE - DRIVER DOOR - E-COATED
14	156292-04-01A	EA	APPLIQUE - DRIVERS DOOR - DARK ANTELOPE
15	145638-09-01A	EA	SWITCH/ROCKER - DPDT - (ON/OFF/ON) - BLACK - POWER WINDOW
15	108355-02-000	EA	HOUSING - SWITCH - 12 POSITION
16	145638-02-01A	EA	SWITCH/ROCKER - SPST - (ON/OFF) - LIGHTED - BLACK - HEATED MIRROR
16	108355-02-000	EA	HOUSING - SWITCH - 12 POSITION
17	149512-01-02B	EA	BRACKET - DOOR HANDLE - E-COATED
18	145926-12-02B	EA	INSERT - SWITCH PLATE - 2 HOLE/RELAY SLOT - E-COATED
19	148827-01-20A	EA	POCKET/STORAGE - DRIVER DOOR - CASHMERE
20	155341-01-20A	EA	PANEL - INNER/DRIVER DOOR - CASHMERE
21	148833-01-02A	EA	HANDLE - DRIVER DOOR - CASHMERE
22	134566-01-01A	EA	HOLDER - CUP - TWO STEP - BLACK
23	155342-01-U67	EA	PANEL - INNER/DRIVER DOOR
24	149513-01-02B	EA	BRACKET - SUPPORT/DOOR HANDLE - E-COATED
25	125804-02-02B	EA	ANGLE - DOOR SUPPORT - E-COATED
	093681-40-01A	FT	FILM - 2" - FLAT BLACK

*COMPONENT PARTS LISTED LATER IN THIS GROUP

EXTERIOR DOORS & COMPARTMENTS GROUP (CONTINUED)
COMPONENT PARTS FOR DRIVERS

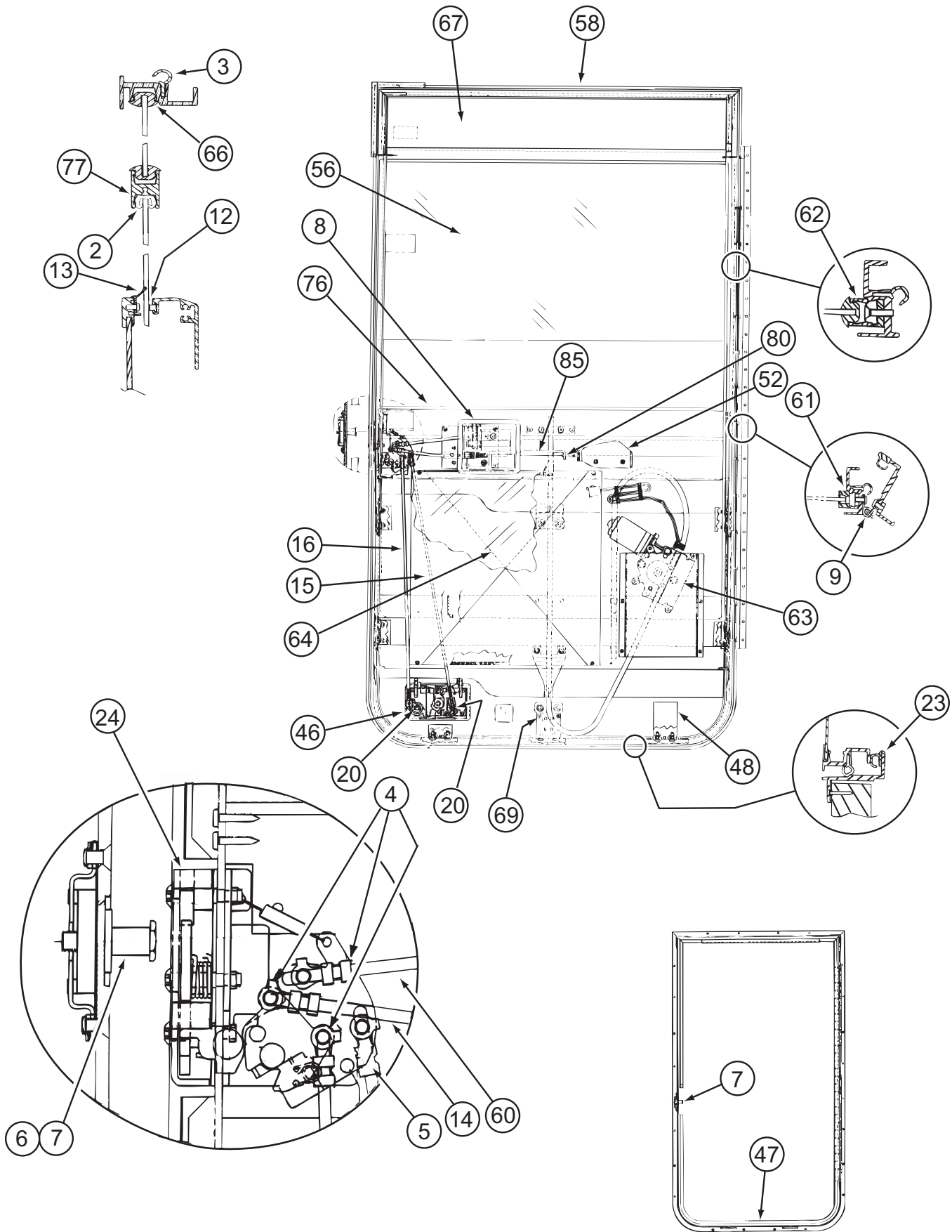

125581-09-01A

EXTERIOR DOORS & COMPARTMENTS GROUP (CONTINUED)
COMPONENT PARTS FOR DRIVERS (CONTINUED)

125581-09-01A (CONTINUED)

KEY	PART NUMBER	U/M	DESCRIPTION	VENDOR NO.
2	106469-01-705	FT	CHANNEL-RUN, SLIDING	122-010850
3	106469-01-702	EA	SEAL-DOOR FRAME (DOOR)EA=1	122-040984
4	106469-04-714	EA	ROD-CLIP, RH	80801
5	106469-04-713	EA	ROD-CLIP, LH	80802
6	106469-04-704	EA	NUT ASSEMBLY-CAGED W/STRIKER	11920-16
7	106469-04-703	EA	BOLT-STRIKER, W/WASHER	10335-16
8	106469-04-712	EA	HANDLE/DOOR-INNER W/HARDWARE	11297-01
9	106469-05-702	EA	HINGE - 42"	211-041194
12	106469-01-709	FT	WEATHERSTRIP FUZZY	171-040630
13	125581-03-703	EA	WEATHERSTRIP - BELTING	132-041069
13	125581-09-712	EA	WEATHERSTRIP/BELT - F/GLASS	490664
14	106469-04-711	EA	ROD-LOCK, HORIZONTAL	15508-01
15	125581-04-700	EA	ROD - LATCH/VERTICAL ADJUST.	203-041767
16	125581-04-701	EA	ROD - LOCK/VERTICAL ADJUST.	203-041768
20	128913-01-707	EA	NUT - HEX/NYLOCK - 1/4 - 20	233-062447
23	106469-01-723	EA	SEAL-BULB ASM. (DOOR JAMB)	171-040985
24	106469-05-706	EA	LATCH-ROTARY, W/LINKAGE	16512-01
46	125581-09-700	EA	PADDLE-W/O LOCK RH (REV KEY)	17191-02
46	125581-09-701	EA	LATCH/LOCK-DRVR DR (REV KEY)	PARTS DEPT
46	125581-09-702	EA	LATCH/LOCK-DRVR DR (REV KEY)	PARTS DEPT
46	125581-09-703	EA	LATCH/LOCK-DRVR DR (REV KEY)	PARTS DEPT
46	125581-09-704	EA	LATCH/LOCK-DRVR DR (REV KEY)	PARTS DEPT
46	125581-09-705	EA	LATCH/LOCK-DRVR DR (REV KEY)	PARTS DEPT
46	125581-09-706	EA	LATCH/LOCK-DRVR DR (REV KEY)	PARTS DEPT
46	125581-09-707	EA	LATCH/LOCK-DRVR DR (REV KEY)	PARTS DEPT
46	125581-09-708	EA	LATCH/LOCK-DRVR DR (REV KEY)	PARTS DEPT
46	125581-09-709	EA	LATCH/LOCK-DRVR DR (REV KEY)	PARTS DEPT
46	125581-09-710	EA	LATCH/LOCK-DRVR DR (REV KEY)	PARTS DEPT
46	125581-09-721	EA	LATCH/LOCK-DRVR DR (3041)	PARTS DEPT (3041)
46	125581-09-722	EA	LATCH/LOCK-DRVR DR (3042)	PARTS DEPT (3042)
46	125581-09-723	EA	LATCH/LOCK-DRVR DR (3043)	PARTS DEPT (3043)
46	125581-09-724	EA	LATCH/LOCK-DRVR DR (3044)	PARTS DEPT (3044)
46	125581-09-725	EA	LATCH/LOCK-DRVR DR (3045)	PARTS DEPT (3045)
46	125581-09-726	EA	LATCH/LOCK-DRVR DR (3046)	PARTS DEPT (3046)
46	125581-09-727	EA	LATCH/LOCK-DRVR DR (3047)	PARTS DEPT (3047)
46	125581-09-728	EA	LATCH/LOCK-DRVR DR (3048)	PARTS DEPT (3048)
46	125581-09-729	EA	LATCH/LOCK-DRVR DR (3049)	PARTS DEPT (3049)
46	125581-09-730	EA	LATCH/LOCK-DRVR DR (3050)	PARTS DEPT (3050)
47	125581-04-703	EA	FRAME - MOUNTING - BLACK	V180-35L
48	125581-07-703	EA	BRACKET-ALUMINUM "L"(INSIDE)	N135-55
56	125581-08-703	EA	GLASS-ROLL-UP 29.46"X29.37"	106-042081
56	125581-09-711	EA	GLASS-ROLL UP 24"H X 29.37"W	490207
58	125581-08-702	EA	FRAME/DOOR - SUB ASSY-BLACK	V220-98L
60	106469-04-705	EA	ROD-LATCH, HORIZONTAL	203-041139
61	125581-08-701	EA	CHANNEL/VERT ROLL UP-BLACK	V220-60
62	125581-08-700	EA	CHANNEL/VERT STA GLASS-BLACK	V220-61
63	125581-03-702	EA	REGULATOR-ELECTRIC-SPEC RH	410-040966
64	125581-06-700	EA	PANEL/INTERIOR	V164-97
66	125581-04-710	FT	VINYL - GLAZING	132-041484
67	125581-07-701	EA	GLASS-STATIONERY/4.95"X29.5"	106-042082
69	125581-04-711	EA	CHANNEL-GLASS - LIFT BRKT	N135-66
76	125581-03-701	EA	SILL - INNER - BLACK	V123-68L
77	125581-03-700	EA	MULLION RAIL- BLACK	V123-84
	106469-04-716	EA	LEVER-LOCKING-BLACK	80978-00
	125581-07-705	EA	BRACKET (L) F/SEAL PROTECT	490201
	125581-07-704	EA	BRACKET - STRAP/JAMB & DOOR	248-080394
	125581-10-701	EA	CLIP - CABLE	130-042047
	125581-09-731	EA	SPLINE-DRIVER DOOR WDO SEAL	491279

CONTACT WINNEBAGO PART SALES FOR UNLISTED COMPONENT(S)

EXTERIOR DOORS & COMPARTMENTS GROUP (CONTINUED)

ENTRY

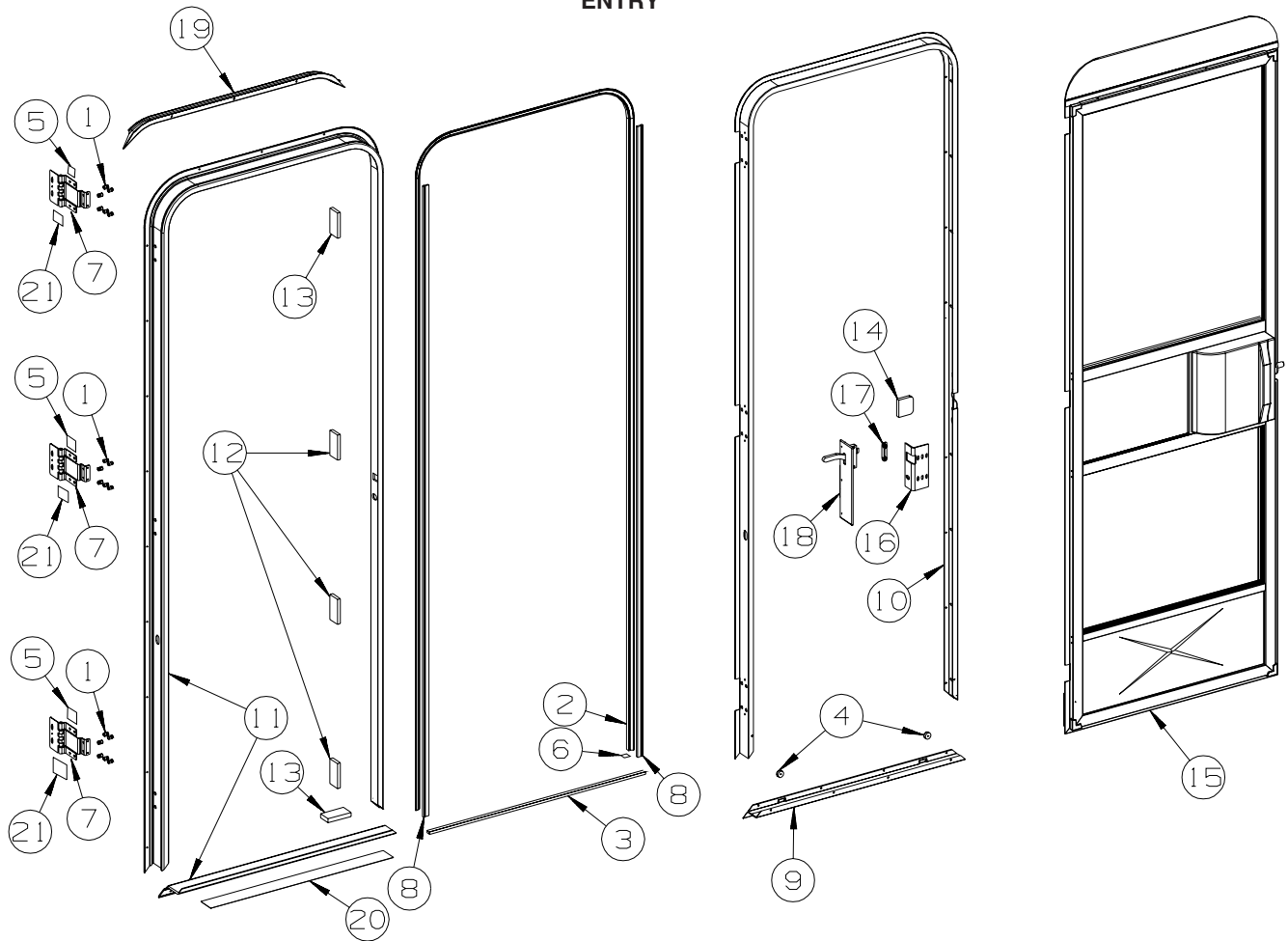

KEY	PART NUMBER	U/M	DESCRIPTION
1	039715-01-000	EA	NUT-SERT - 1/4" DIAMETER - 20 THREADS
2	075671-04-000	FT	SEAL - SPONGE - LAZY T - W/ADHESIVE STRIP - .5" WIDE
3	075673-05-000	FT	SEAL/PILE - .5" HIGH W/ADHESIVE BACK - BLACK
4	081914-02-000	EA	BUMPER - RUBBER - ROUND - 5/16" DIA. X 13/64" THICK
5	100128-02-000	FT	SEAL - FOAM/ADHESIVE BACK - .37" WIDE X .37" THICK X 60'
6	104692-01-000	FT	SEAL - ADHESIVE BACKED FOAM - 3/4" THICK X 3/4" WIDE X 25'
7	106719-01-05A	EA	HINGE - ENTRY DOOR - BRIGHT WHITE
8	118929-01-01A	FT	SEAL - PILE - PUSH ON
9	121893-03-02A	EA	FRAME - ENTRY DOOR/LOWER - BRIGHT WHITE
10	121894-27-01A	EA	FRAME - ENTRY DOOR - BRIGHT WHITE
11	121898-14-01A	EA	JAMB - DOOR/ENTRANCE - BRIGHT WHITE
12	125724-01-000	EA	SHIM - DOOR, ENTRANCE
13	125724-02-000	EA	SHIM - DOOR, ENTRANCE
14	130096-05-000	EA	FOAM - SCREEN DOOR, RETAINER
15	P32208-02-L32	EA	DOOR - SCREEN - W/O HARDWARE
16	137401-01-03B	EA	BRACKET - DOOR ANGLE - OFF WHITE
17	148364-01-12B	EA	STRIKE - SCREEN DOOR - BRIGHT WHITE
18	132915-01-01A	EA	LATCH - SCREEN DOOR - BLACK
19	139054-19-01A	EA	CAP - DRIP - JAMB MOUNTED - BRIGHT WHITE
20	038327-01-000	EA	TAPE - ANTI-SLIP - 2" X 60'
21	154585-01-01A	FT	SEAL - FOAM TAPE - ADHESIVE BACK - 3/8" X 3/8" - BLACK

EXTERIOR DOORS & COMPARTMENTS GROUP (CONTINUED)

SCREEN

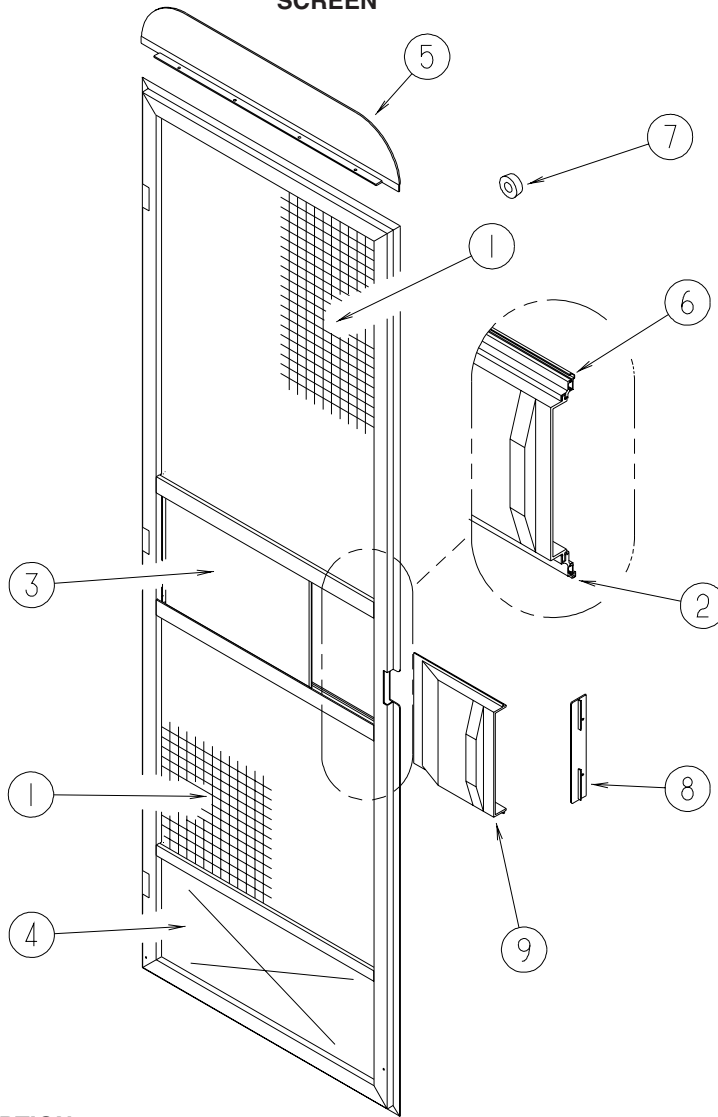

KEY	PART NUMBER	U/M	DESCRIPTION
1	002293-02-000	SF	SCREEN - 26" - CHARCOAL
2	002294-01-000	FT	SPLINE - SCREENING - .13" X .14"
3	016454-18-000	EA	INSERT/CENTER - SCREEN DOOR
4	078552-09-000	EA	INSERT - SCREEN DOOR - LOWER
5	078595-03-000	EA	PLATE - SCREEN DOOR
6	078777-08-000	FT	CHANNEL - SLIDER - 4 FOOT INCREMENTS
7	120863-09-000	EA	BUMPER - RUBBER/RADIUS TOP - 3/4" X 3/8" - LT GRAY
8	132081-01-01A	EA	STRIKE - SLIDER - SCREEN DOOR - BRIGHT WHITE
9	132082-01-01A	EA	SLIDER - SCREEN DOOR - BRIGHT WHITE

EXTERIOR DOORS & COMPARTMENTS GROUP (CONTINUED)

LATCH - ENTRY

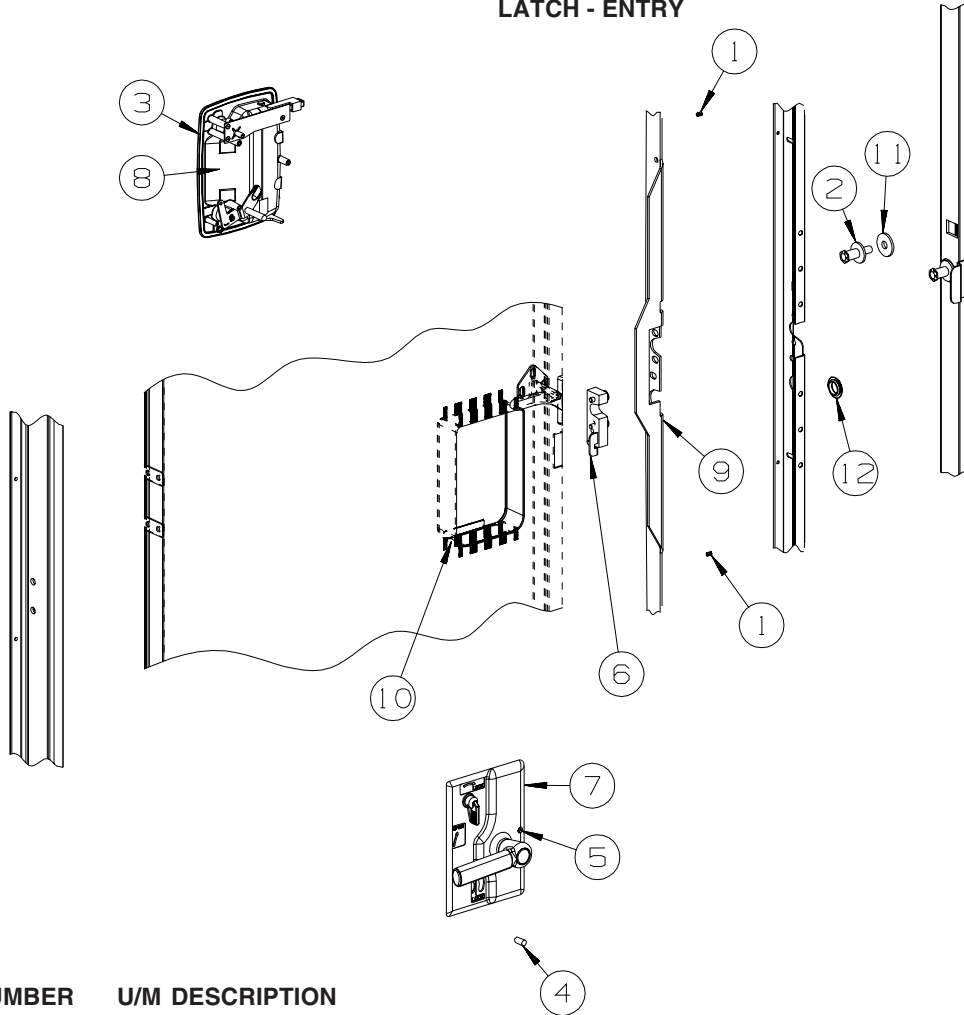

KEY	PART NUMBER	U/M	DESCRIPTION
1	072893-04-000	EA	NUTSERT - 10-32
2	092927-20-000	EA	STRIKER - BOLT
3	112782-04-01A	EA	GASKET
4	112782-05-01A	EA	CAP - VINYL - RED
5	112782-08-01A	EA	SCREW - MOUNTING/PLATE - ZINC
6	112782-22-01A	EA	LATCH - SINGLE ROTOR
7	112782-21-01A	EA	LATCH - INTERIOR PLATE
7	112782-27-01A	EA	LATCH - INTERIOR PLATE - WHITE
8	112782-20-01A	EA	LATCH - EXTERIOR - W/O LOCK CYLINDER W/ICON-REVERSIBLE KEY
9	132207-01-02B	EA	STIFFENER/DOOR - FORMED - E-COATED
10	137230-01-01A	EA	SPACER - NOTCHED, MILL
11	147900-01-01A	EA	SPACER - STRIKE BOLT, MILL
12	061420-14-000	EA	PLUG/PLASTIC - 7/8" DIAMETER - BLACK

FROM: 00-00-00 THRU: 05-28-06

FROM: 05-29-06 THRU: 99-99-99

EXTERIOR SLIDEOUT GROUP

FRONT LEFT

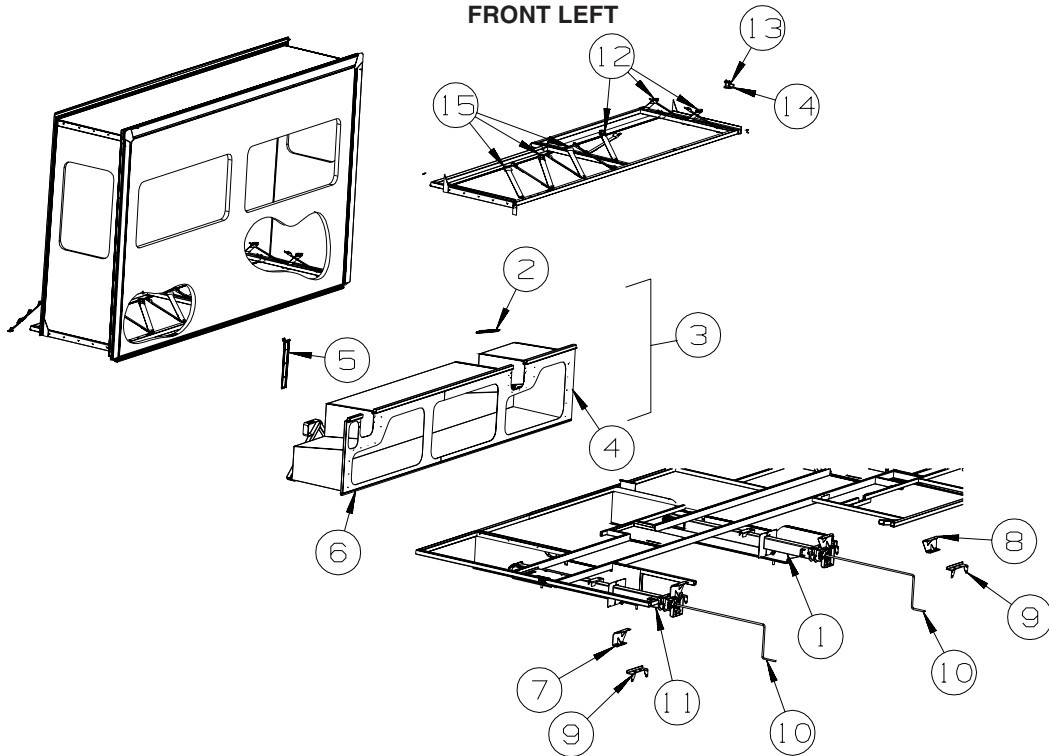

KEY	PART NUMBER	U/M	DESCRIPTION
1*	148875-02-000	EA	SLIDEOUT - ELECTRIC 30" - LEFT HAND
2	148331-01-01A	EA	PLUG - OVAL/LARGE - BLACK
3	144137-34-U65	EA	COMPARTMENT - F/SLIDEOUT
4	144138-33-02B	EA	SEAL PLANE - E-COATED
5	126591-01-02B	EA	CARRIER/EXTENSION - F/SLIDEOUT-F/WIRE/HOSES - E-COATED
6	126516-01-01A	FT	TRIM - VINYL/EXTRUDED - 8'
7	145328-02-02B	EA	BRACKET/MOUNT - SLIDEOUT - E-COATED
8	145328-01-02B	EA	BRACKET/MOUNT - SLIDEOUT - E-COATED
9	128386-01-02B	EA	BRACKET - SLIDEOUT COMPARTMENT - E-COATED
10	138173-06-000	EA	CRANK - SLIDEOUT
11*	148875-01-000	EA	SLIDEOUT - ELECTRIC 30" - RIGHT HAND
12	160167-02-01A	EA	SEAT BELT - 2" X 90" - BLACK
13	150700-01-02B	EA	PLATE/MOUNTING - RESTRAINT/CHILD - 1" X 2.3" - E-COATED
14	150697-02-02B	EA	BRACKET - RESTRAINT/CHILD - E-COATED
15	160167-01-01A	EA	SEAT BELT - 2" X 102" - BLACK
	093249-01-000	EA	CAP/SCREW - MOLDED/VINYL - BLACK

***COMPONENT PARTS LISTED LATER IN THIS GROUP**

EXTERIOR SLIDEOUT GROUP (CONTINUED)
FRONT LEFT (CONTINUED)

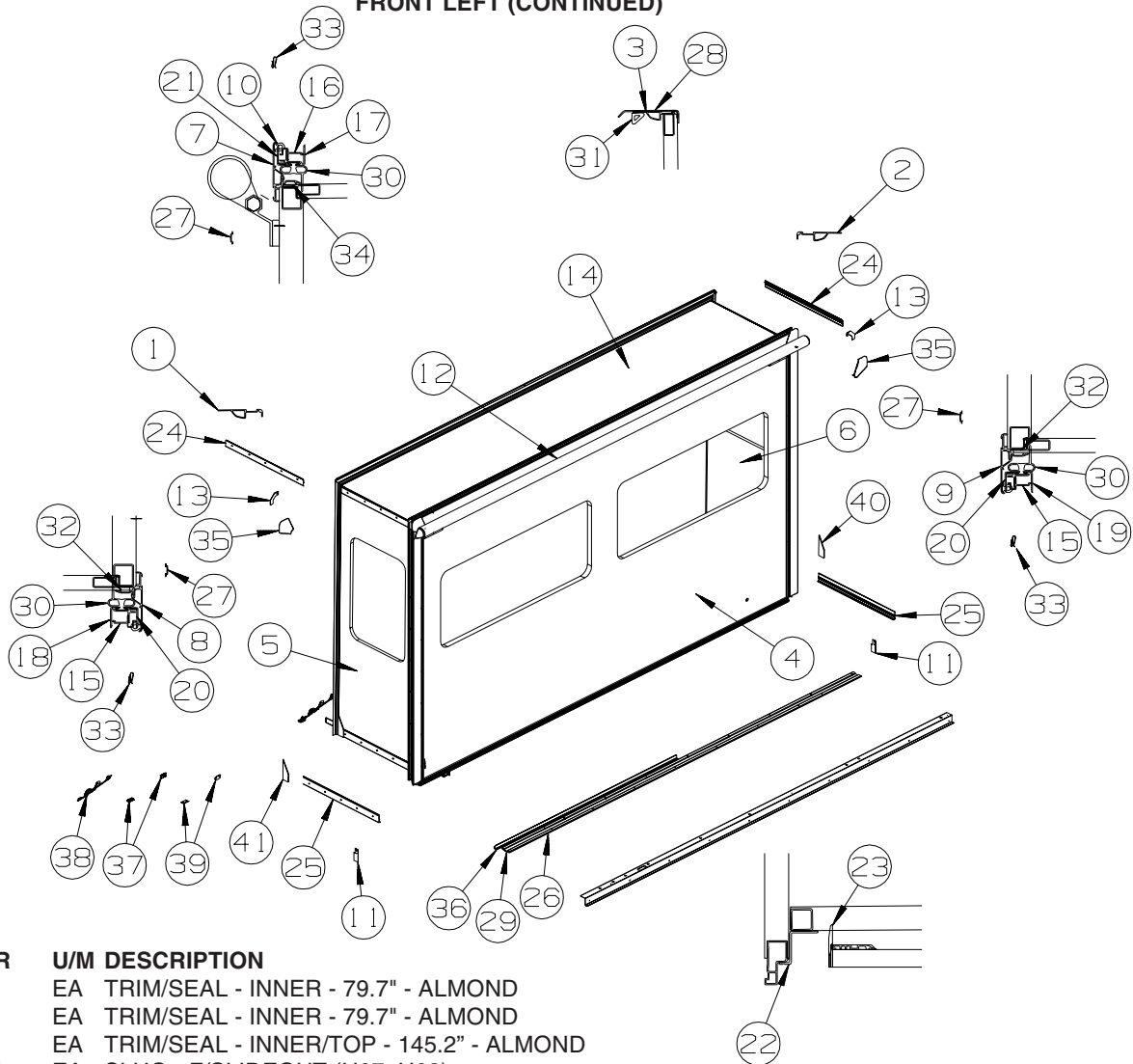

KEY	PART NUMBER	U/M	DESCRIPTION
1	139624-59-02A	EA	TRIM/SEAL - INNER - 79.7" - ALMOND
2	139624-60-02A	EA	TRIM/SEAL - INNER - 79.7" - ALMOND
3	139624-06-02A	EA	TRIM/SEAL - INNER/TOP - 145.2" - ALMOND
4	156876-11-U67	EA	SLUG - F/SLIDEOUT (U67, U68)
4	156876-11-U71	EA	SLUG - F/SLIDEOUT (U71, U72)
4	156876-11-U75	EA	SLUG - F/SLIDEOUT (U75, U76)
5	152610-01-U67	EA	PANEL END - F/SLIDEOUT (U67, U68)
5	152610-01-U71	EA	PANEL END - F/SLIDEOUT (U71, U72)
5	152610-01-T85	EA	PANEL END - F/SLIDEOUT (U75, U76)
6	152611-02-U67	EA	PANEL END - F/SLIDEOUT (U67, U68)
6	152611-02-U71	EA	PANEL END - F/SLIDEOUT (U71, U72)
6	152611-02-T85	EA	PANEL END - F/SLIDEOUT (U75, U76)
7	156417-04-01A	EA	TRIM/SEAL - W/MITERED ENDS - 143.6" - BRIGHT WHITE
			FROM: 00-00-00 THRU: 02-11-07
7	162052-04-01A	EA	TRIM/SEAL - W/MITERED ENDS - 143.6" - BRIGHT WHITE - NOT ILLUSTRATED
			FROM: 02-12-07 THRU: 99-99-99
8	156417-33-01A	EA	TRIM/SEAL - W/MITERED ENDS - 80.8" - BRIGHT WHITE
			FROM: 00-00-00 THRU: 02-16-06
8	156417-28-01A	EA	TRIM/SEAL - W/MITERED ENDS - 80.4" - BRIGHT WHITE
			FROM: 02-17-06 THRU: 02-11-07
8	162052-28-01A	EA	TRIM/SEAL - W/MITERED ENDS - 80.4" - BRIGHT WHITE - NOT ILLUSTRATED
			FROM: 02-12-07 THRU: 99-99-99
9	156417-32-01A	EA	TRIM/SEAL - W/MITERED ENDS - 80.8" - BRIGHT WHITE
			FROM: 00-00-00 THRU: 02-16-06
9	156417-29-01A	EA	TRIM/SEAL - W/MITERED ENDS - 80.4" - BRIGHT WHITE
			FROM: 02-17-06 THRU: 02-11-07
9	162052-29-01A	EA	TRIM/SEAL - W/MITERED ENDS - 80.4" - BRIGHT WHITE - NOT ILLUSTRATED
			FROM: 02-12-07 THRU: 99-99-99
10	158297-01-000	FT	SEAL - D-SECTION/BULB/TEE - ADHESIVE BACK - BLACK
11	126546-03-03A	EA	COVER - END/SIDEWALL - BLACK

EXTERIOR SLIDEOUT GROUP (CONTINUED)
FRONT LEFT (CONTINUED)

KEY	PART NUMBER	U/M	DESCRIPTION
12			SLIDEOUT AWNING

ORDER AWNINGS & REPAIR PARTS FROM DOMETIC. CALL #800-366-3842.

**THE DOMETIC AWNING INFORMATION YOU WILL NEED IS LOCATED ON THE MOTOR HOME NEAR
THE TOP OF THE AWNING RAIL.**

13	156416-01-12B	EA	BRACKET - CORNER TRIM/SLIDEOUT - 3.1"X 3.1" - BRIGHT WHITE FROM: 00-00-00 THRU: 01-06-07
13	156416-01-02B	EA	BRACKET - CORNER TRIM/SLIDEOUT - 3.1"X 3.1" - E-COATED FROM: 00-00-00 THRU: 01-06-07
13	160421-01-01A	EA	CORNER TRIM/SLIDEOUT - 3.1"X 3.1" - BLACK - NOT ILLUSTRATED FROM: 01-07-07 THRU: 99-99-99
14	154274-01-SB8	EA	ROOF - F/SLIDEOUT
15	142718-38-01A	EA	RETAINER - SIDEWALL/SLIDEOUT - 79"
16	142718-02-01A	EA	RETAINER - SIDEWALL/SLIDEOUT - 144.9" - MILL
17	151761-01-02A	EA	TRIM - SIDEWALL/SLIDEOUT/TOP - 146.4" - ALMOND
18	151760-22-02A	EA	TRIM - SIDEWALL/SLIDEOUT - 81.1" - ALMOND
19	151760-23-02A	EA	TRIM - SIDEWALL/SLIDEOUT - 81.1" - ALMOND
20	136824-49-01A	EA	TRIM - SIDEWALL/SLIDEOUT - 80.9" - BRIGHT WHITE
21	136824-05-01A	EA	TRIM - SIDEWALL/SLIDEOUT - 146.4" - BRIGHT WHITE
22	131520-31-01A	EA	EXTRUSION/ZEE - F/SLIDEOUT - 140.4" - MILL
23	115075-03-000	FT	SEAL - WIPE - .25" X 2.9"
24	158375-01-01A	EA	TRIM/FEATURE STRIP - 29.6" - BRIGHT WHITE
25	158030-02-01A	EA	TRIM - FEATURE STRIP/LOWER - 2.3" X 29.1" - BRIGHT WHITE FROM: 00-00-00 THRU: 02-11-07
25	158030-07-01A	EA	TRIM - FEATURE STRIP/LOWER - 2.3" X 28.9" - BRIGHT WHITE FROM: 02-12-07 THRU: 99-99-99
26	115325-04-02A	EA	RAIL - FLOOR/SLIDEOUT ROOM - 134.2" LONG - BLACK
27	105312-01-07A	FT	INSERT - FEATURE STRIP - VINYL - BRIGHT WHITE
28	125466-02-04A	EA	SUPPORT - ROOF/INTERIOR - ALMOND
29	115661-01-000	FT	SHOE/GLIDE - SLIDEOUT ROOM - 1/16" X 3" - POLYETHYLENE
30	136978-01-01A	FT	SEAL - SLIDEOUT - SINGLE WIPE LIP - BLACK
31	146056-01-000	FT	SEAL - TRIANGLE - W/PSA
32	133954-66-01A	EA	TRIM/SEAL - 75.8" - BRIGHT WHITE - NOT ILLUSTRATED FROM: 00-00-00 THRU: 04-16-06
32	146606-66-01A	EA	TRIM/RETAINER - 75.8" - BRIGHT WHITE FROM: 04-17-06 THRU: 99-99-99
33	142549-01-000	EA	CLIP - "S" TYPE
34	133954-07-01A	EA	TRIM/SEAL - 141.8" - BRIGHT WHITE - NOT ILLUSTRATED FROM: 00-00-00 THRU: 04-16-06
34	146606-07-01A	EA	TRIM/RETAINER - 141" - BRIGHT WHITE FROM: 04-17-06 THRU: 99-99-99
35	156151-01-02A	EA	PROTECTOR - CORNER - SLIDEOUT - BRIGHT WHITE
36	151282-03-01A	EA	TRIM - CARPET EDGE/F-ANGLE - 69.6" - BLACK
37	135619-02-01A	EA	PLATE - TIEDOWN - SLIDEOUT ROOM
38	135619-01-01A	EA	STRAP - TIEDOWN - SLIDEOUT ROOM
39	135622-01-02B	EA	PLATE - TIEDOWN - SLIDEOUT ROOM
40	157809-01-01A	EA	SEAL - FOAM BLOCK/RIGHT SIDE - ADHESIVE BACK
41	157809-02-01A	EA	SEAL - FOAM BLOCK/LEFT SIDE - ADHESIVE BACK

EXTERIOR SLIDEOUT GROUP (CONTINUED)
COMPONENT PARTS FOR FRONT LEFT

148875-01-000, 148875-02-000

KEY	PART NUMBER	U/M	DESCRIPTION	VENDOR NO.
	130294-04-700	EA	SCREW - 5/16"-18 X 1 1/2"	1202060
	131281-01-702	EA	PIN/CLEVIS-1/4" PLATED	1213190
	131281-01-704	EA	HAIRPIN/COTTER - 3/8" SPRING	1213460
	131682-01-700	EA	ROLLER - (BEARING)	1912040
	138173-01-701	EA	POP RIVET - SS 3/16"X1/4"	1214630
	138173-01-707	EA	WEAR PUCK - PLASTIC F/DRIVE	1612523
	140457-01-701	EA	BUSHING - 1" X 3/4" X 1/2"ID	1614006
	140457-01-704	EA	SHAFT/AXLE - REAR ROLLER	7204523
	148875-01-700	EA	PIN/COTTER - 3/32" X 1/2"	1213520
	148875-01-701	EA	PIN/ROLL - 3/16" X 3/4"	1213693
	148875-01-702	EA	PIN/ROLL - 1/4" X 1"	1213701
	148875-01-703	EA	NUT - PLASTIC - 1"	1612548
	148875-01-704	EA	END CARRIER - PLASTIC - 1"	1612549
	148875-01-705	EA	MOTOR/LINEAR - SLIDE ROOM	1820111
	148875-01-706	EA	DRIVE SCREW - SLIDE ROOM	1820401
	148875-01-707	EA	END GUIDE F/SCREW - 1"	1820450

EXTERIOR SLIDEOUT GROUP (CONTINUED)

REAR RIGHT

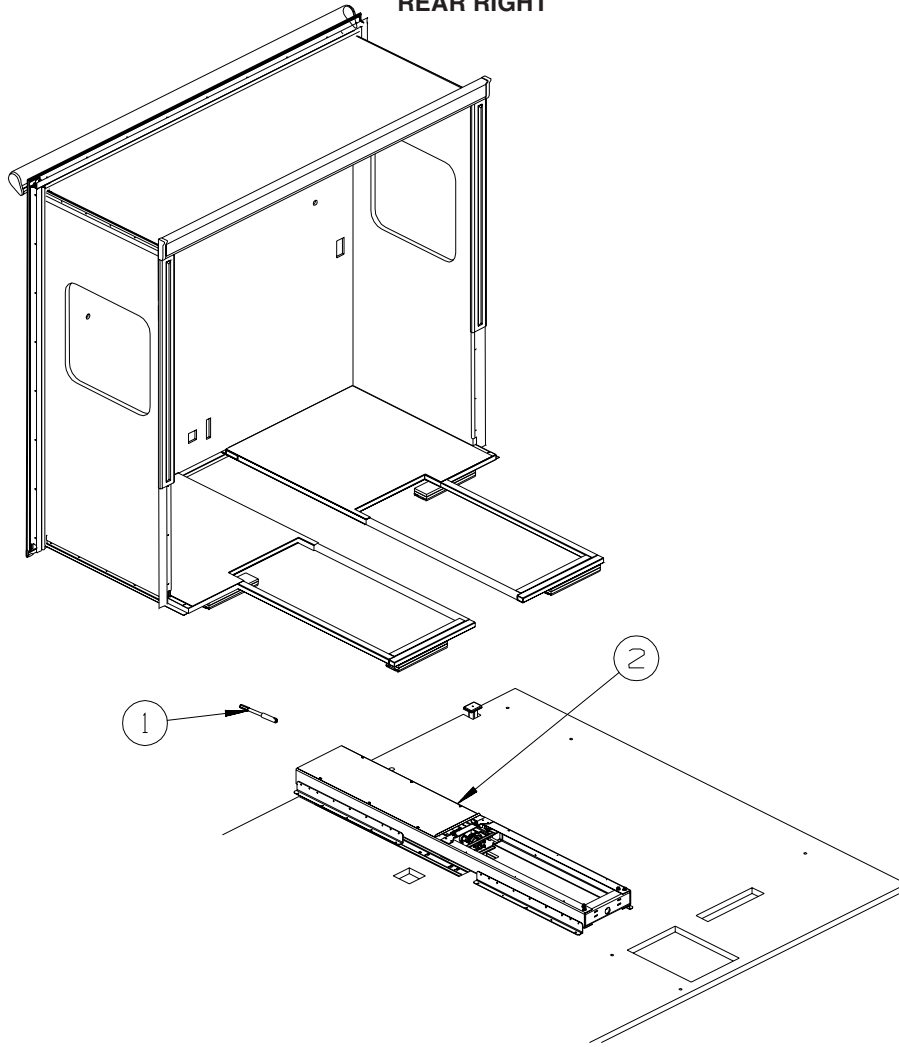

KEY	PART NUMBER	U/M	DESCRIPTION
1	140464-03-000	EA	WRENCH - SLIDE ROOM RETRACT - RATCHET W/2 EXTENSIONS
2*	149165-01-000	EA	SLIDEOUT - ELECTRIC/REAR/SINGLE

*COMPONENT PARTS LISTED LATER IN THIS GROUP

EXTERIOR SLIDEOUT GROUP (CONTINUED)
REAR RIGHT (CONTINUED)

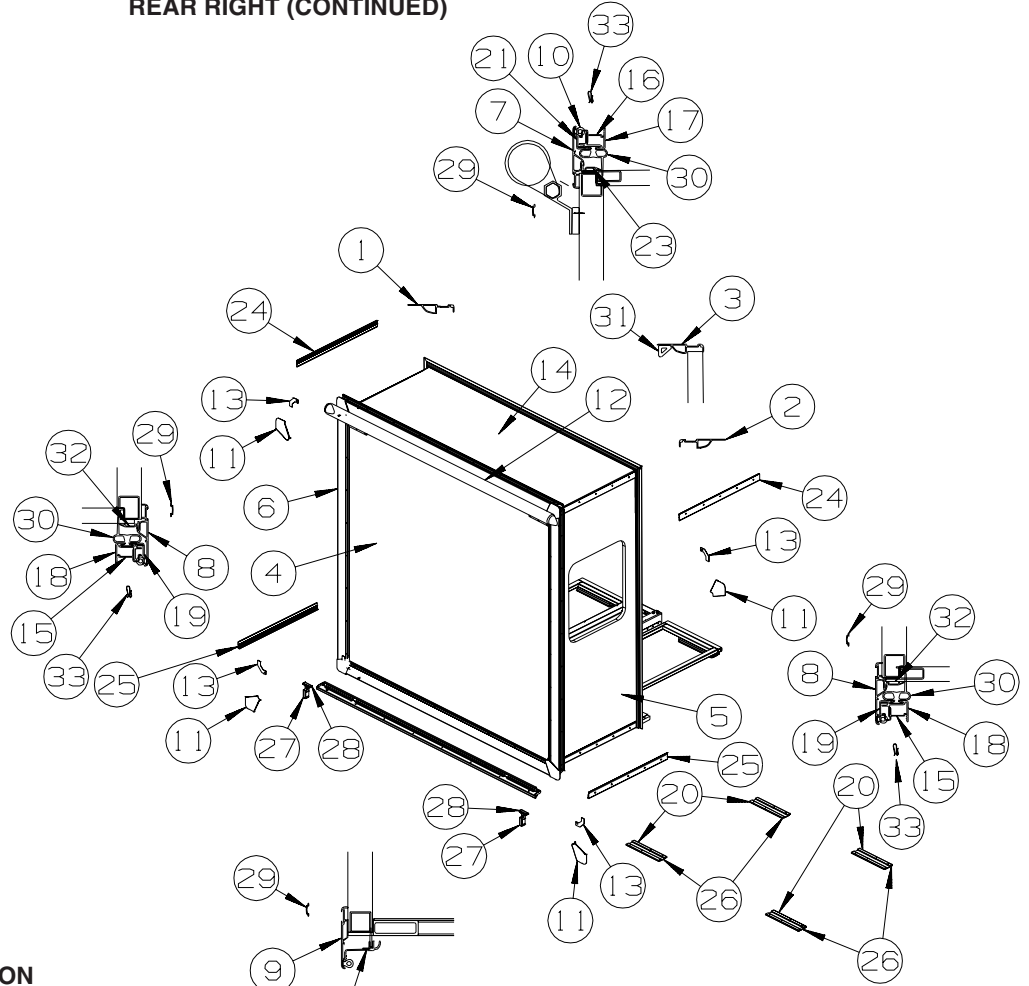

KEY	PART NUMBER	U/M	DESCRIPTION
1	139624-41-02A	EA	TRIM/SEAL - INNER - 79.2" - ALMOND
2	139624-42-02A	EA	TRIM/SEAL - INNER - 79.2" - ALMOND
3	139624-04-02A	EA	TRIM/SEAL - INNER/TOP - 80.2" - ALMOND
4	156875-11-U67	EA	SLUG - F/SLIDEOUT (U67, U68)
4	156875-11-U71	EA	SLUG - F/SLIDEOUT (U71, U72)
4	156875-11-U75	EA	SLUG - F/SLIDEOUT (U75, U76)
5	152693-01-U67	EA	PANEL END - F/SLIDEOUT (U67, U68)
5	152693-01-U93	EA	PANEL END - F/SLIDEOUT (U71, U72)
5	152693-01-T85	EA	PANEL END - F/SLIDEOUT (U75, U76)
6	152694-01-U67	EA	PANEL END - F/SLIDEOUT (U67, U68)
6	152694-01-U93	EA	PANEL END - F/SLIDEOUT (U71, U72)
6	152694-01-T85	EA	PANEL END - F/SLIDEOUT (U75, U76)
7	156417-01-01A	EA	TRIM/SEAL - W/MITERED ENDS - 78.4" - BRIGHT WHITE FROM: 00-00-00 THRU: 02-11-07
7	162052-01-01A	EA	TRIM/SEAL - W/MITERED ENDS - 78.4" - BRIGHT WHITE - NOT ILLUSTRATED FROM: 02-12-07 THRU: 99-99-99
8	156417-30-01A	EA	TRIM/SEAL - W/MITERED ENDS - 78.6" - BRIGHT WHITE FROM: 00-00-00 THRU: 02-11-07
8	162052-30-01A	EA	TRIM/SEAL - W/MITERED ENDS - 78.6" - BRIGHT WHITE - NOT ILLUSTRATED FROM: 02-12-07 THRU: 99-99-99
9	142233-20-01A	EA	TRIM/SEAL - W/MITERED ENDS - 78.4" - BRIGHT WHITE FROM: 00-00-00 THRU: 02-11-07
9	162054-02-01A	EA	TRIM/SEAL - W/MITERED ENDS - 78.4" - BRIGHT WHITE - NOT ILLUSTRATED FROM: 02-12-07 THRU: 99-99-99
10	158297-01-000	FT	SEAL - D-SECTION/BULB/TEE - ADHESIVE BACK - BLACK
11	156151-01-02A	EA	PROTECTOR - CORNER - SLIDEOUT - BRIGHT WHITE
12			SLIDEOUT AWNING

ORDER AWNINGS & REPAIR PARTS FROM DOMETIC. CALL #800-366-3842.
THE DOMETIC AWNING INFORMATION YOU WILL NEED IS LOCATED ON THE MOTOR HOME NEAR
THE TOP OF THE AWNING RAIL.

EXTERIOR SLIDEOUT GROUP (CONTINUED)
REAR RIGHT (CONTINUED)

KEY	PART NUMBER	U/M	DESCRIPTION
13	156416-01-12B	EA	BRACKET - CORNER TRIM/SLIDEOUT - 3.1"X 3.1" - BRIGHT WHITE FROM: 00-00-00 THRU: 01-06-07
13	156416-01-02B	EA	BRACKET - CORNER TRIM/SLIDEOUT - 3.1"X 3.1" - E-COATED FROM: 00-00-00 THRU: 01-06-07
13	160421-01-01A	EA	CORNER TRIM/SLIDEOUT - 3.1"X 3.1" - BLACK - NOT ILLUSTRATED FROM: 01-07-07 THRU: 99-99-99
14	153392-01-T59	EA	ROOF - F/SLIDEOUT
15	142718-38-01A	EA	RETAINER - SIDEWALL/SLIDEOUT - 79"
16	142718-23-01A	EA	RETAINER - SIDEWALL/SLIDEOUT - 79.9"
17	151761-02-02A	EA	TRIM - SIDEWALL/SLIDEOUT/TOP - 81.2" - ALMOND
18	151760-24-02A	EA	TRIM - SIDEWALL/SLIDEOUT - 78.6" - ALMOND
19	136824-50-01A	EA	TRIM - SIDEWALL/SLIDEOUT - 79.2" - BRIGHT WHITE
20	115325-08-01A	EA	RAIL - FLOOR/SLIDEOUT ROOM - 12" LONG - BLACK
21	136824-02-01A	EA	TRIM - SIDEWALL/SLIDEOUT - 81.2" - BRIGHT WHITE
22	157584-02-AA2	EA	TRIM/ZEE - W/SEAL/END CAPS - SLIDEOUT/LOWER-80.7" - BRT WHT
23	133954-18-01A	EA	TRIM/SEAL - 76.5" - BRIGHT WHITE - NOT ILLUSTRATED FROM: 00-00-00 THRU: 04-16-06
23	146606-18-01A	EA	TRIM/RETAINER - 76.5" - BRIGHT WHITE FROM: 04-17-06 THRU: 05-29-06
23	146606-12-01A	EA	TRIM/RETAINER - 75.7" - BRIGHT WHITE FROM: 05-30-06 THRU: 99-99-99
24	158375-01-01A	EA	TRIM - FEATURE STRIP - 29.6" - BRIGHT WHITE
25	157385-01-01A	EA	TRIM - FEATURE STRIP/LOWER - 26.9" - BRIGHT WHITE FROM: 00-00-00 THRU: 02-11-07
25	157385-08-01A	EA	TRIM - FEATURE STRIP/LOWER - 26.7" - BRIGHT WHITE FROM: 02-12-07 THRU: 99-99-99
26	115661-01-000	FT	SHOE/GLIDE - SLIDEOUT ROOM - 1/16" X 3" - POLYETHYLENE
27	126313-12-02B	EA	SUPPORT - SLIDE - F/SLIDE-OUT ROOM - E-COATED
28	128599-03-000	EA	PAD - F/SLIDEOUT - 2" X 2.6"
29	105312-01-07A	FT	INSERT - FEATURE STRIP - VINYL - BRIGHT WHITE
30	136978-01-01A	FT	SEAL - SLIDEOUT - BLACK
31	146056-01-000	FT	SEAL - TRIANGLE - W/PSA
32	133954-62-01A	EA	TRIM/SEAL - 75.1" - BRIGHT WHITE - NOT ILLUSTRATED FROM: 00-00-00 THRU: 04-16-06
32	146606-62-01A	EA	TRIM/RETAINER - 75.1" - BRIGHT WHITE FROM: 04-17-06 THRU: 99-99-99
33	142549-01-000	EA	CLIP - "S" TYPE

COMPONENT PARTS FOR REAR RIGHT

149165-01-000

KEY	PART NUMBER	U/M	DESCRIPTION	VENDOR NO.
	131281-01-702	EA	PIN/CLEVIS-1/4" PLATED	1213190
	131281-01-704	EA	HAIRPIN/COTTER - 3/8" SPRING	1213460
	138173-01-701	EA	POP RIVET - SS 3/16"X1/4"	1214630
	138173-01-707	EA	WEAR PUCK - PLASTIC F/DRIVE	1612523
	148875-01-703	EA	NUT - PLASTIC - 1"	1612548
	148875-01-705	EA	MOTOR/LINEAR - SLIDE ROOM	1820111
	149165-01-700	EA	BEARING - 5/8" ID	1102015
	149165-01-701	EA	PIN/CLEVIS - 1/4" X 2"	1213204
	149165-01-702	EA	SEAL/RUBBER - LOWER ROOM "Z"	1611999
	149165-01-703	EA	SEAL/RUBBER - INNER FRAME	1612007
	149165-01-704	EA	SEAL/LOWER ROOM - "Z"	1612009
	149165-01-705	EA	DRIVE/WORM SCREW - 30"	1820400

GENERATOR GROUP

GAS

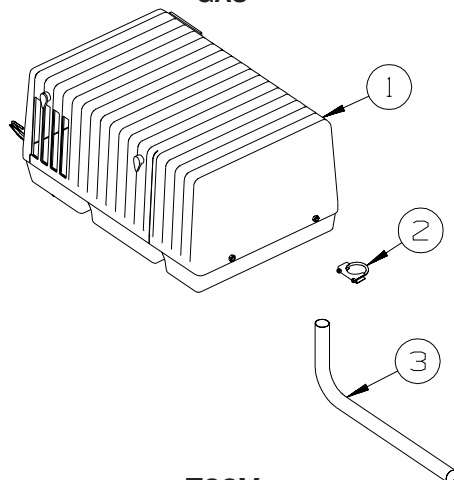

F33V

KEY	PART NUMBER	U/M	DESCRIPTION
1	135707-06-000	EA	GENERATOR - 5.5 - 30/30 - GAS - MARQUIS GOLD - 50 AMP
1	135707-07-000	EA	GENERATOR - 5.5 - 30/20 - GAS - MARQUIS GOLD - 30 AMP
2	007125-03-000	EA	CLAMP - MUFFLER - 1.5" DIAMETER
3	105958-30-000	EA	PIPE - EXHAUST/GENERATOR

F35A UP TO 08-15-06

KEY	PART NUMBER	U/M	DESCRIPTION
1	135707-06-000	EA	GENERATOR - 5.5 - 30/30 - GAS - MARQUIS GOLD - 50 AMP
1	135707-07-000	EA	GENERATOR - 5.5 - 30/20 - GAS - MARQUIS GOLD - 30 AMP
2	007125-03-000	EA	CLAMP - MUFFLER - 1.5" DIAMETER
3	105958-27-000	EA	PIPE - EXHAUST/GENERATOR

F35A AFTER 08-15-06

KEY	PART NUMBER	U/M	DESCRIPTION
1	135707-06-000	EA	GENERATOR - 5.5 - 30/30 - GAS - MARQUIS GOLD - 50 AMP
1	135707-07-000	EA	GENERATOR - 5.5 - 30/20 - GAS - MARQUIS GOLD - 30 AMP
2	007125-03-000	EA	CLAMP - MUFFLER - 1.5" DIAMETER
3	105958-07-000	EA	PIPE - EXHAUST - 1.4" INLET X 1.5" O.D. - 4.9" X 20.1"

F35L, F38J UP TO 08-15-06

KEY	PART NUMBER	U/M	DESCRIPTION
1	135707-06-000	EA	GENERATOR - 5.5 - 30/30 - GAS - MARQUIS GOLD - 50 AMP
1	135707-07-000	EA	GENERATOR - 5.5 - 30/20 - GAS - MARQUIS GOLD - 30 AMP
2	007125-03-000	EA	CLAMP - MUFFLER - 1.5" DIAMETER
3	105958-30-000	EA	PIPE - EXHAUST/GENERATOR

F35L, F38J AFTER 08-15-06

KEY	PART NUMBER	U/M	DESCRIPTION
1	135707-06-000	EA	GENERATOR - 5.5 - 30/30 - GAS - MARQUIS GOLD - 50 AMP
1	135707-07-000	EA	GENERATOR - 5.5 - 30/20 - GAS - MARQUIS GOLD - 30 AMP
2	007125-03-000	EA	CLAMP - MUFFLER - 1.5" DIAMETER
3	105958-07-000	EA	PIPE - EXHAUST - 1.4" INLET X 1.5" O.D. - 4.9" X 20.1"

HEATING & A/C GROUP AUTOMOTIVE

WORKHORSE

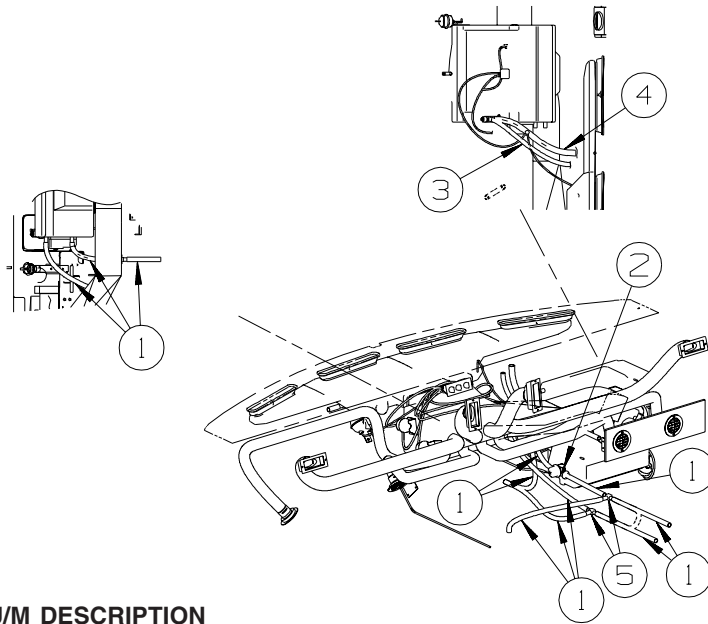

KEY	PART NUMBER	U/M	DESCRIPTION
1	007108-01-000	FT	HOSE - HEATER - 5/8"ID - HI-TEMP
2	103930-23-000	EA	VALVE/WATER - 2 PORT/VACUUM CONTROLLED - "NEW DESIGN"
3*	103930-46-000	EA	HOSE - EXPANSION BLOCK (EVAPORATOR) TO COMPRESSOR
4*	103930-47-000	EA	HOSE - EXPANSION VALVE (EVAPORATOR) TO DRIER
5	076776-01-000	EA	TEE - BEADED - 5/8" X 5/8" X 5/8"

***COMPONENT PARTS LISTED LATER IN THIS GROUP**

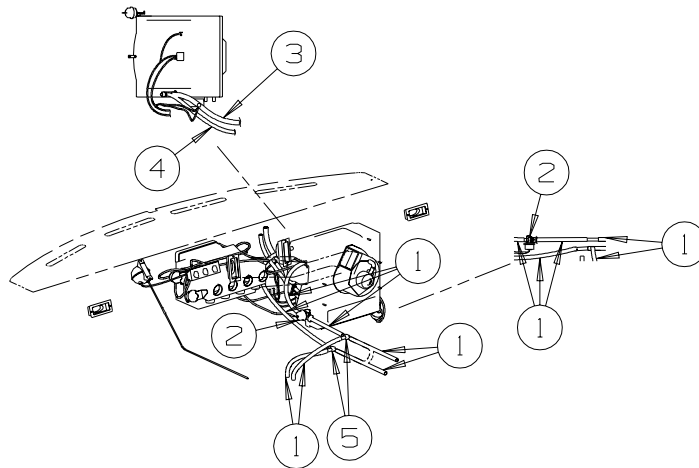

FORD

KEY	PART NUMBER	U/M	DESCRIPTION
1	007108-01-000	FT	HOSE - HEATER - 5/8"ID - HI-TEMP
2	103930-23-000	EA	VALVE/WATER - 2 PORT/VACUUM CONTROLLED - "NEW DESIGN"
3*	103930-44-000	EA	HOSE - EVAPORATOR/DRYER - #6
4*	103930-45-000	EA	HOSE - EVAPORATOR/COMPRESSOR - PRIOR TO 2007 FORD CHASSIS
4	103930-64-000	EA	HOSE - EVAPORATOR/COMPRESSOR - 2007 FORD CHASSIS
5	076776-01-000	EA	TEE - BEADED - 5/8" X 5/8" X 5/8"

***COMPONENT PARTS LISTED LATER IN THIS GROUP**

HEATING & A/C GROUP (CONTINUED)

AUTOMOTIVE (CONTINUED)

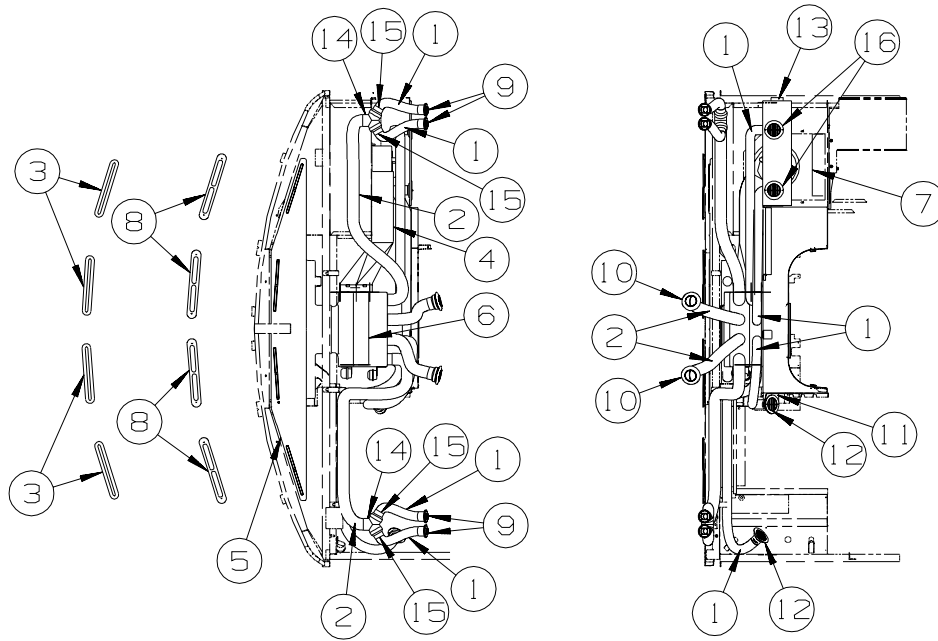

KEY	PART NUMBER	U/M	DESCRIPTION
1	007076-01-000	EA	HOSE - FLEXIBLE PVC - 2" ID - INCREMENTS OF 50'
2	007281-01-000	EA	HOSE - FLEXIBLE PVC - 2 1/2" ID X 50'
3	077075-01-000	EA	GASKET - INSTRUMENT PANEL/DEFROSTER PLENUM - .6" X 10.2"
4	103016-03-000	EA	PLENUM - TRANSITION
5	103017-03-000	EA	PLENUM - DEFROSTER
6*	103930-49-000	EA	CONTROL/PLENUM - LARGE ROTARY
7*	103930-55-000	EA	EVAPORATOR/HEATER - NONCHARGED - SINGLE OUTPUT
8	135265-01-06A	EA	VENT - DEFROSTER - PLASTIC - CASHMERE
9	158174-01-01A	EA	LOUVER - ROUND - 2" HOSE - BLACK
10	146504-01-01A	EA	LOUVER - ROUND 2.5" - BLACK
11	136157-03-02B	EA	BRACKET - HEATER - E-COATED
12	157225-01-01A	EA	OUTLET - DEFROSTER - W/SWIVEL - 2" SLEEVE/4"OD - BLACK
13	156732-01-01A	EA	BRACE
14	098342-01-000	EA	CONNECTOR/WYE - 2.5" - FLEXHOSE
15	098342-02-000	EA	ADAPTOR - HOSE - 2.5" TO 2"
16	157225-01-06A	EA	OUTLET - DEFROSTER - W/SWIVEL - 2" SLEEVE/4"OD - CASHMERE
	113452-02-000	FT	SEAL/TRIM - FRONT - VINYL W/WIRE CARRIER - .027" - WHERE WIRES & HOSES CROSS METAL

***COMPONENT PARTS LISTED LATER IN THIS GROUP**

HEATING & A/C GROUP (CONTINUED)

COMPONENT PARTS FOR AUTOMOTIVE

103930-44-000

KEY	PART NUMBER	U/M	DESCRIPTION	VENDOR NO
	103930-29-701	EA	O'RING F/LOW PRESSURE SWITCH	045-0483
	103930-44-700	EA	HOSE ASSEMBLY #6	085-0462
	113245-01-711	EA	O'RING #6	045-0129

103930-45-000

KEY	PART NUMBER	U/M	DESCRIPTION	VENDOR NO.
	103930-17-702	EA	O'RING #10	045-0127
	103930-45-700	EA	HOSE - #10 EVAP/COMP - 3'	085-0463

103930-46-000

KEY	PART NUMBER	U/M	DESCRIPTION	VENDOR NO
	103930-17-702	EA	O'RING #10	045-0127
	103930-29-701	EA	O'RING F/LOW PRESSURE SWITCH	045-0483
	103930-46-700	EA	HOSE - #10 EVAP/COMP - 4.3'	085-0486

103930-47-000

KEY	PART NUMBER	U/M	DESCRIPTION	VENDOR NO
	103930-47-700	EA	HOSE - #6-EVAP/DRIER - 2.2'	085-0485
	113245-01-710	EA	O'RING, #12	045-0128

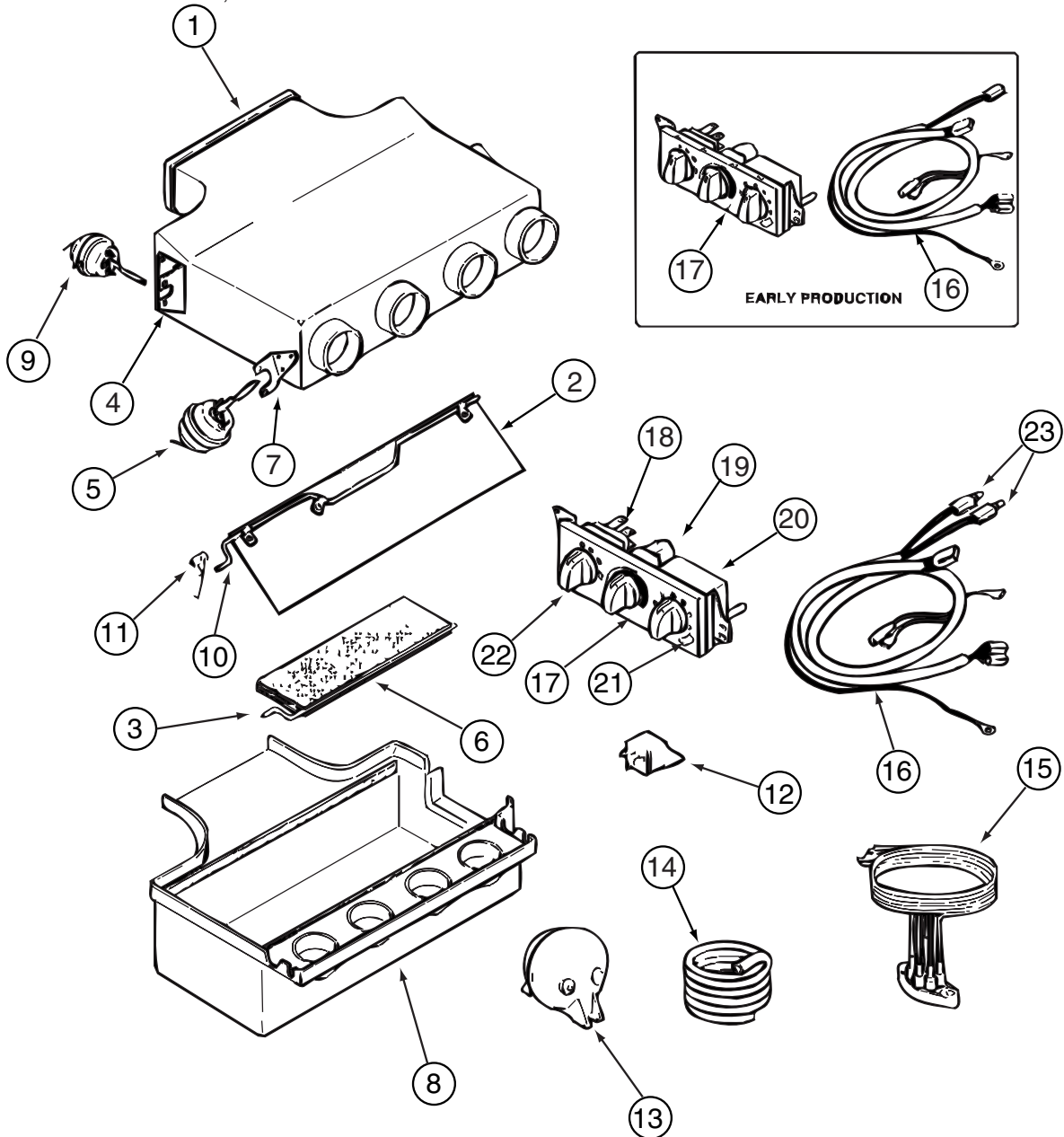

103930-49-000

HEATING & A/C GROUP (CONTINUED)
COMPONENT PARTS FOR AUTOMOTIVE (CONTINUED)

103930-49-000 (CONTINUED)

KEY	PART NUMBER	U/M	DESCRIPTION	VENDOR NO.
1	103930-39-705	EA	PLENUM - TOP	060-0482
2	103930-04-700	EA	DOOR - DEFROSTER-A/C	071-0149
3	103930-39-700	EA	ROD - DOOR - AC/HEAT	073-067
5	103930-02-708	EA	MOTOR-VACUUM SERVO, A/C	030-0025
6	103930-39-706	EA	PLATE - DOOR - A/C	071-0623
8	103930-39-707	EA	PLENUM - BOTTOM	060-0483
9	103930-33-701	EA	MOTOR - VACUUM, 3 STAGE	030-0105
10	103930-39-701	EA	ROD - DOOR - AC/DEFROST	073-0069
11	103930-39-704	EA	SPRING	022-0119
12	103930-02-707	EA	RELAY-BOSCH W/RESISTER	031-0001
13	103930-02-710	EA	CANISTER-VACUUM	054-0002
15	103930-33-703	EA	VACUUM HARNESS	036-0466
16	103930-49-700	EA	HARNESS - WIRE	036-556
16	103930-49-701	EA	HARNESS - WIRE W/BULBS	036-0557
17	103930-49-702	EA	CONTROL PANEL-RECESSED FACE	032-0054
17	103930-49-703	EA	CONTROL PANEL - NON RECESSED	083-0223
18	103930-49-704	EA	SWITCH - BLOWER	032-0332
19	103930-49-705	EA	POTENTIOMETER	032-0182
20	103930-49-706	EA	SWITCH - VACUUM	032-0185
21	103930-49-707	EA	DECAL CONTROL PANEL-N/RECESS	058-0144
22	103930-49-708	EA	KNOB - BLOWER - NONRECESSED	062-0620
23	103930-33-705	EA	LIGHT BULBS	035-0030

CONTACT WINNEBAGO PART SALES FOR UNLISTED COMPONENT(S)

HEATING & A/C GROUP (CONTINUED)
COMPONENT PARTS FOR AUTOMOTIVE (CONTINUED)

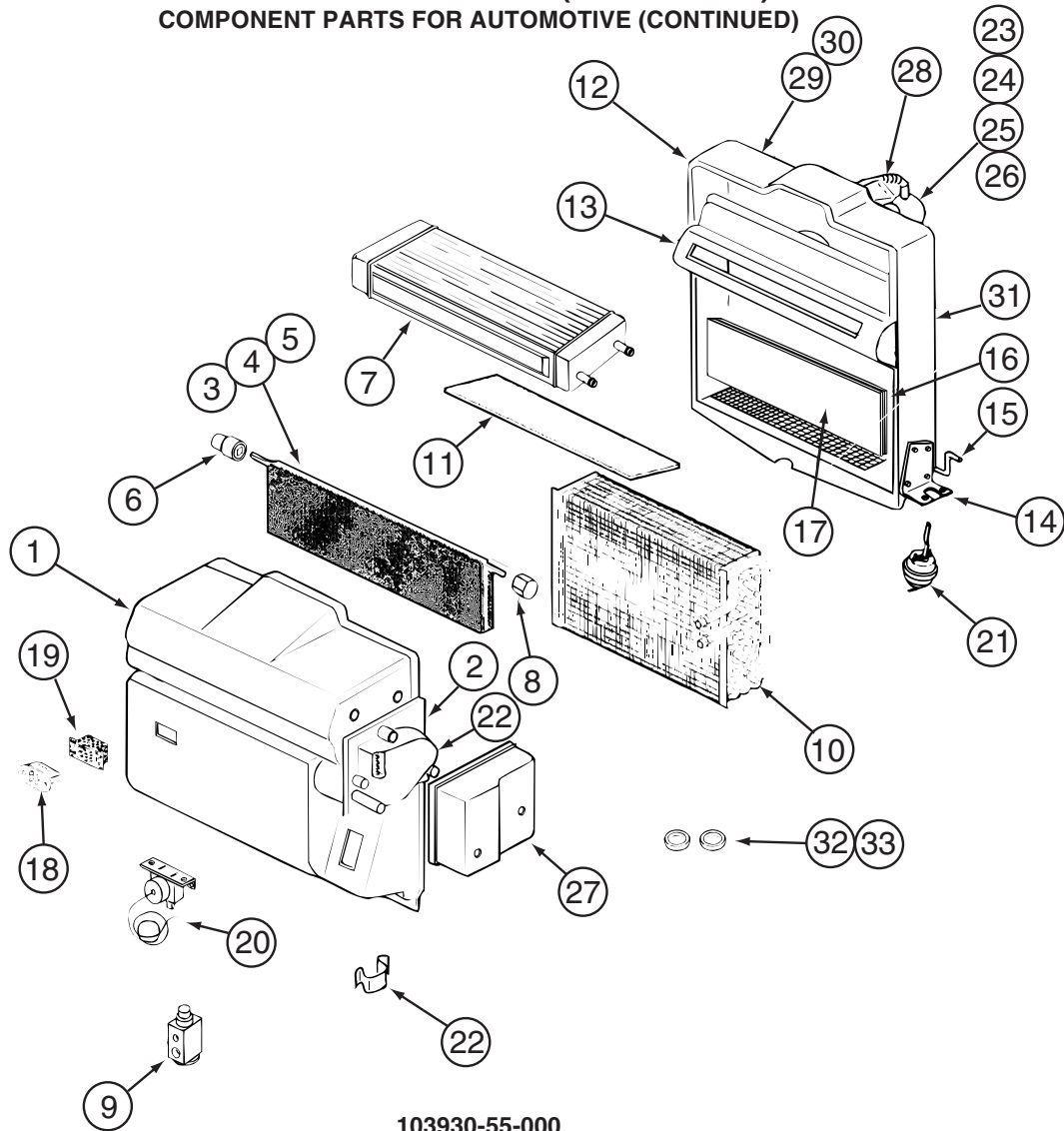

103930-55-000

KEY	PART NUMBER	U/M	DESCRIPTION	VENDOR NO.
1	103930-55-701	EA	CASE - FRONT	062-0658
2	103930-30-701	EA	PLATE - MOTOR MOUNT	062-0544
3	103930-55-705	EA	DOOR - BLEND AIR	071-0892
6	103930-30-702	EA	BUSHING/DRIVE (BLEND DOOR)	062-0168
7	103930-55-706	EA	CORE - HEATER - W/GASKET	084-0271
8	103930-30-709	EA	COUPLING - BLEND DOOR SHAFT	062-0634
9	103930-20-700	EA	VALVE-EXPANSION-BLOCK, 2 TON	034-0032
10	103930-55-700	EA	CORE-EVAPORATOR	041-00168
12	103930-55-702	EA	CASE-REAR	062-0657
14	103930-01-708	EA	BRACKET-VACUUM MOTOR	070-0113
15	103930-20-704	EA	ROD-DOOR-RECIRCULATING	073-0018
16	103930-55-707	EA	DOOR - RECIRCULATION	071-0891
18	103930-01-710	EA	RESISTOR-FUSED, A/C 4 TERM	035-0006
20	103930-01-711	EA	THERMOSTAT	033-0003
21	103930-02-708	EA	MOTOR-VACUUM SERVO, A/C	030-0025
22	103930-30-703	EA	MOTOR - SERVO	030-0104
23	103930-20-707	EA	HOUSING-BLOWER	062-0145
24	103930-55-703	EA	MOTOR-BLOWER W/O PIGTAIL	030-0137
25	103930-01-717	EA	WHEEL-BLOWER, CLOCKWISE	062-0010
26	103930-20-708	EA	CLIP-MOTOR SHAFT	022-0001
27	103930-30-704	EA	COVER - SERVO	062-0545
32	113245-01-707	EA	O'RING #8	045-0126
33	103930-17-702	EA	O'RING #10	045-0127
	103930-55-704	EA	CORE-HEATER	042-0059
	110279-01-703	EA	HOSE-VENT F/BLOWER MOTOR	051-0034

CONTACT WINNEBAGO PART SALES FOR UNLISTED COMPONENT(S)

HEATING & A/C GROUP (CONTINUED)

FURNACE

KEY	PART NUMBER	U/M	DESCRIPTION
*	143563-01-000	EA	FURNACE - 35000 BTU/HIGH QUIET - SUBURBAN SH-35 2322 - FURNACE - 35,000 BTU
*	143563-02-000	EA	FURNACE - 40000 BTU HIGH QUIET - SUBURBAN SH-42 2346A - FURNACE - 40,000 BTU
	009198-02-000	FT	DUCT - HEAT - FLEXIBLE - 2" ID X 25'
	092776-01-000	EA	ADAPTER - DUCT - 2"
	093614-13-02A	EA	GRILLE - AIR RETURN - 15.9" X 11.9" - BEIGE
	126693-05-02B	EA	PANEL - EXHAUST/FURNACE - E-COATED
	134651-01-000	FT	SEAL - 1/2" X 3/4" X 9' - PSA 1 SIDE
	137965-01-02A	EA	REGISTER - 11.2" X 3.6"(9.7 X 2.1"R/O) W/O DAMPER-ANT PWTR
	137965-02-02A	EA	REGISTER - 11.2" X 3.6"(9.7 X 2.1"R/O) W/DAMPER - ANT PWTR
	137965-03-02A	EA	REGISTER - 11.2" X 3.6"(9.7 X 2.1"R/O) W/O DAMPER - ANT PWTR
	137965-04-02A	EA	REGISTER - 11.2" X 3.6"(9.7 X 2.1"R/O) W/DAMPER - ANT PWTR
	137965-06-02A	EA	REGISTER - 15.3" X 3.6"(13.9"X2.1"R/O) W/O DAMPER-ANT PWTR
	137965-10-02A	EA	REGISTER - 15.3" X 3.6"(13.8"X2.1"R/O) W/O DAMPER-ANT PWTR - W/O MOUNTING HOLES
	139980-05-000	EA	VENT - INTAKE
	139980-06-000	EA	VENT CAP
	141194-03-02B	EA	PANEL/FURNACE CLOSEOUT - E-COATED
	141337-01-01A	EA	GASKET - FURNACE
	143563-03-02A	EA	DOOR/ACCESS - FURNACE - W/FRAME - BLACK
	143563-04-000	EA	PLATE END - COLLAR
	143563-05-000	EA	GASKET - FIBERGLASS - SUBURBAN #071018
	157225-01-06A	EA	OUTLET - DEFROSTER - W/SWIVEL - 2" SLEEVE/4"OD - CASHMERE
	158710-01-000	EA	ELBOW/DUCT - 2 1/4" ID X 14"

*COMPONENT PARTS LISTED LATER IN THIS GROUP

HEATING & A/C GROUP (CONTINUED)

COMPONENT PARTS FOR FURNACE

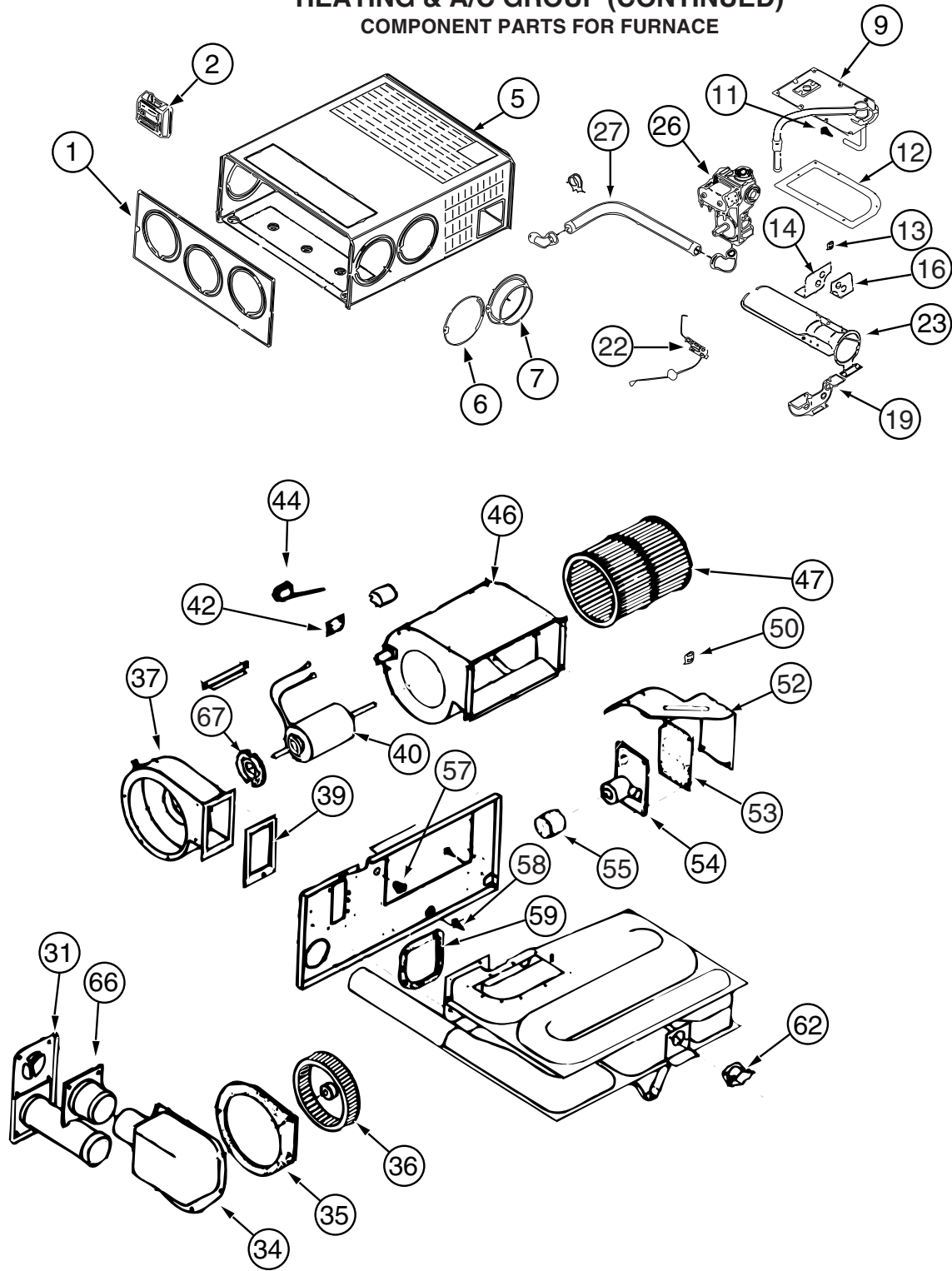

143563-01-000

HEATING & A/C GROUP (CONTINUED)
COMPONENT PARTS FOR FURNACE (CONTINUED)

143563-01-000 (CONTINUED)

KEY	PART NUMBER	U/M	DESCRIPTION	VENDOR NO.
1	143563-01-700	EA	CABINET - FRONT	101907
2			12 VOLT WIRING AREAS FOR CORRECT THERMOSTAT	
5	143563-01-701	EA	CABINET	101921
7	075696-02-703	EA	COLLAR - DUCT	050715
9	143563-01-702	EA	MANIFOLD ASSEMBLY	171599
11	143563-01-703	EA	ORFICE - MAIN BURNER	180308
12	098668-22-703	EA	GASKET - BURNER ACCESS COVER	070811
14	143563-01-704	EA	PLATE - SECONDARY AIR/TOP BACK	063199
16	143563-01-705	EA	PLATE - SECONDARY AIR/TOP FRT	062936
19	143563-01-706	EA	PLATE - SECONDARY AIR/BOTTOM	062938
22	139980-01-701	EA	ELECTRODE	232286
23	098668-02-700	EA	BURNER ASSEMBLY,SF-30 & SF35	010745
26	098668-01-718	EA	VALVE-GAS SF S.N.974903079	161122
27	143563-01-707	EA	PIPE ASSEMBLY (GAS INLET)	171603
31	098668-01-707	EA	TUBE ASSEMBLY, EXHAUST W/CAP	260231
34	143563-01-708	EA	BOX ASM (COMB. AIR INTAKE)	051430BK
35	143563-01-709	EA	GASKET (COMB. AIR HOUSING)	071108
36	143563-01-710	EA	WHEEL (COMBUSTION AIR)	350199
37	143563-01-711	EA	HOUSING (COMBUSTION AIR)	390862BK
39	143563-01-715	EA	GASKET-FIREWALL/COMB. AIR	071107
40	143563-01-712	EA	MOTOR ASSEMBLY	232727
42	101990-01-714	EA	GASKET-MICROSWITCH	230877
44	098668-21-700	EA	SWITCH-MICRO-W/O FLAG 3 1/4"	232261
46	143563-01-713	EA	BLOWER ASSEMBLY(ROOM AIR)	390867BK
47	143563-01-714	EA	WHEEL - ROOM AIR	350198
50	139980-01-710	EA	SWITCH - ON/OFF	232351
52	139980-01-711	EA	PANEL ASSEMBLY-MODULE BD	101663
53	139980-01-712	EA	INSULATOR - MODULE BD	070807
54	098668-22-705	EA	MODULE BD W/RELAY TIME DELAY	520820
55	139980-01-713	EA	CAP/INSULATOR-MODULE BD	070973
57	139980-01-714	EA	BUSHING - UNIVERSAL	070362
58	139980-01-715	EA	BUSHING - STRAIN RELIEF	231809
59	098668-01-716	EA	GASKET-FIREWALL,CHAMBER SIDE	070808
62	098668-21-701	EA	SWITCH - LIMIT	232504
66	098668-01-713	EA	TUBE ASSEMBLY, INTAKE	051248
67	075697-07-703	EA	GASKET - MOTOR	070448
	143563-01-716	EA	CHAMBER ASM. - FINAL	
			CONTACT WINNEBAGO PART SALES FOR UNLISTED COMPONENT(S)	

HEATING & A/C GROUP (CONTINUED)
COMPONENT PARTS FOR FURNACE (CONTINUED)

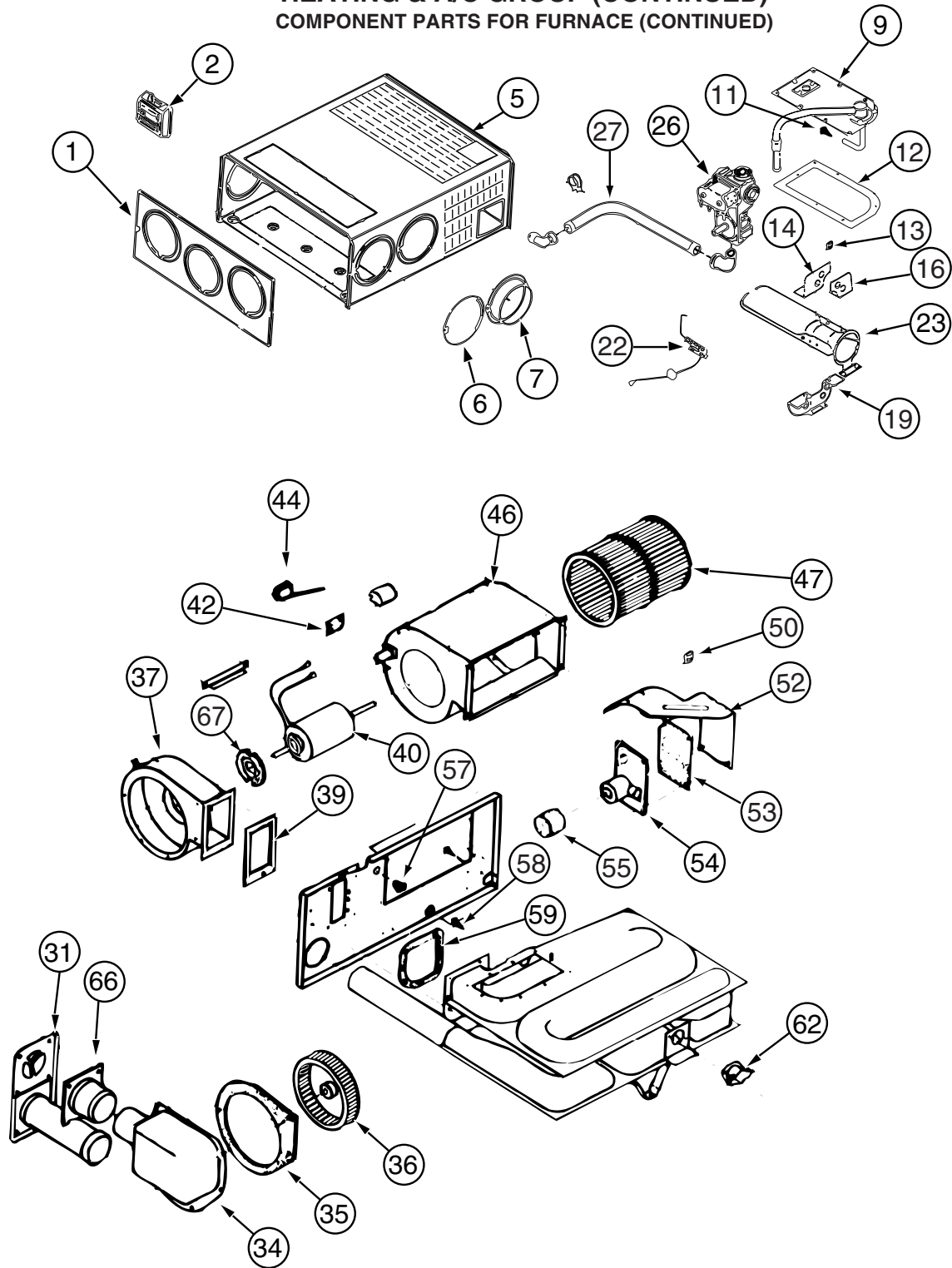

143563-02-000

HEATING & A/C GROUP (CONTINUED)
COMPONENT PARTS FOR FURNACE (CONTINUED)

143563-02-000 (CONTINUED)

KEY	PART NUMBER	U/M	DESCRIPTION	VENDOR NO.
1	143563-01-700	EA	CABINET - FRONT	101907
2			SEE 12 VOLT WIRING AREAS FOR CORRECT THERMOSTAT	
5	143563-02-700	EA	CABINET	101915
7	075696-02-703	EA	COLLAR - DUCT	050715
9	143563-01-702	EA	MANIFOLD ASSEMBLY	171599
11	143563-02-701	EA	ORFICE - MAIN BURNER	180309
12	098668-22-703	EA	GASKET - BURNER ACCESS COVER	070811
14	143563-02-702	EA	PLATE - SECONDARY AIR/TOP BACK	063198
16	143563-02-703	EA	PLATE - SECONDARY AIR/TOP FRT	062933
19	143563-02-704	EA	PLATE - SECONDARY AIR/BOTTOM	062935
22	139980-01-701	EA	ELECTRODE	232286
23	098668-11-701	EA	BURNER ASSEMBLY, SF-42F	010799
26	098668-01-718	EA	VALVE-GAS SF S.N.974903079	161122
27	143563-01-707	EA	PIPE ASSEMBLY (GAS INLET)	171603
31	098668-01-707	EA	TUBE ASSEMBLY, EXHAUST W/CAP	260231
34	143563-01-708	EA	BOX ASM (COMB. AIR INTAKE)	051430BK
35	143563-01-709	EA	GASKET (COMB. AIR HOUSING)	071108
36	143563-01-710	EA	WHEEL (COMBUSTION AIR)	350199
37	143563-01-711	EA	HOUSING (COMBUSTION AIR)	390862BK
39	143563-01-715	EA	GASKET-FIREWALL/COMB. AIR	071107
40	143563-02-705	EA	MOTOR ASSEMBLY	232726
42	101990-01-714	EA	GASKET-MICROSWITCH	230877
44	098668-21-700	EA	SWITCH-MICRO-W/O FLAG 3 1/4"	232261
46	143563-01-713	EA	BLOWER ASSEMBLY(ROOM AIR)	390867BK
47	143563-01-714	EA	WHEEL - ROOM AIR	350198
50	139980-01-710	EA	SWITCH - ON/OFF	232351
52	139980-01-711	EA	PANEL ASSEMBLY-MODULE BD	101663
53	139980-01-712	EA	INSULATOR - MODULE BD	070807
54	098668-22-705	EA	MODULE BD W/RELAY TIME DELAY	520820
55	139980-01-713	EA	CAP/INSULATOR-MODULE BD	070973
57	139980-01-714	EA	BUSHING - UNIVERSAL	070362
58	139980-01-715	EA	BUSHING - STRAIN RELIEF	231809
59	098668-01-716	EA	GASKET-FIREWALL,CHAMBER SIDE	070808
62	143563-02-706	EA	SWITCH - LIMIT	232735
66	098668-01-713	EA	TUBE ASSEMBLY, INTAKE	051248
67	075697-07-703	EA	GASKET - MOTOR	070448
	143563-02-707	EA	CHAMBER ASM. - FINAL	021172BK
			CONTACT WINNEBAGO PART SALES FOR UNLISTED COMPONENT(S)	

HEATING & A/C GROUP (CONTINUED)
REAR HEATER

KEY	PART NUMBER	U/M	DESCRIPTION
	147610-01-000	EA	HEATER - AUTO/AUX - F33V, F35A, F35L
	147610-02-000	EA	HEATER - AUTO/AUX - F38J
	104692-01-000	FT	SEAL - ADHESIVE BACKED FOAM - 3/4" THICK X 3/4" WIDE X 25'
	007108-01-000	FT	HOSE - HEATER - 5/8" ID - HI-TEMP
	079059-01-000	EA	HOSE - 90 DEGREE - 5/8"ID X 4" X 36"
	079059-13-000	EA	HOSE - 90 DEGREE - .61"ID X 4" X 48"
	137965-01-02A	EA	REGISTER - 11.2" X 3.6"(9.7 X 2.1"R/O) W/O DAMPER-ANT PWTR

HEATING & A/C GROUP (CONTINUED) CENTRAL

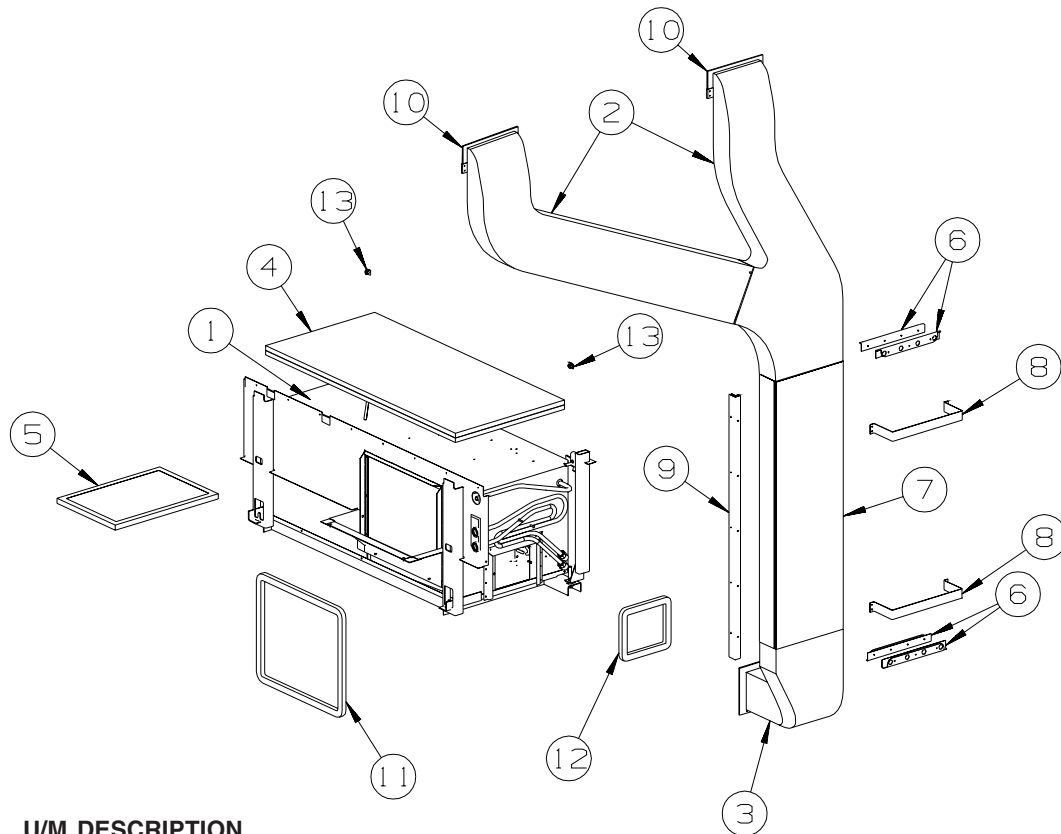

KEY	PART NUMBER	U/M	DESCRIPTION
1*	105620-12-000	EA	A/C-CENTRAL - RH HAND/HEAT PUMP/12,000 BTU - TECUMSEH COMP
2	M09204-01-000	EA	DUCT/AC - UPPER RIGHT HAND/LEFT HAND
3	P38842-01-000	EA	DUCT - CENTRAL AIR/FORCED - W/INSULATION - LOWER
	105290-01-000	SF	INSULATION - AIR POCKET W/FOIL - 4' WIDE
4	100619-16-000	BF	FOAM - EXPANDED POLYSTYRENE - .75" X 48" X 96"-2" DENSITY
5	109050-02-000	EA	FILTER/FURNACE-AC - FIBERGLASS - 1" X 14" X 20"
	100128-02-000	FT	SEAL - FOAM/ADHESIVE BACK - .37" WIDE X .37" THICK X 60' FROM: 00-00-00 THRU: 07-30-06
6	115886-11-02A	EA	RETAINER - SIDEWALL - BRIGHT WHITE - 11.8" - NOT ILLUSTRATED FROM: 00-00-00 THRU: 07-30-06
6	160755-01-02B	EA	U-CHANNEL W/HOLES FROM: 07-31-06 THRU: 99-99-99
	130262-06-000	EA	PROTECTOR - CORNER SAVER - .7" X .7" FROM: 00-00-00 THRU: 07-30-06
7	117870-11-01A	EA	PLENUM - A/C - 43" FROM: 00-00-00 THRU: 07-30-06
7	159404-02-000	EA	PLENUM - A/C FROM: 07-31-06 THRU: 99-99-99
8	129047-01-02B	EA	STRAP/MOUNTING - AIR DUCT - E-COATED
9	159408-02-01A	EA	CORNER - W/HOLES FROM: 07-31-06 THRU: 99-99-99
10	104692-01-000	FT	SEAL - ADHESIVE BACKED FOAM - 3/4" THICK X 3/4" WIDE X 25'
11	134588-01-000	EA	GASKET - DUCT - 15.5" X 18.2" IS - 17.4" X 20.2" OS
12	134588-02-000	EA	GASKET - DUCT - 6.4" X 7.4" IS - 8.3" X 9.4" OS
13	142913-01-000	EA	J-CLIP - F/TV HOLD DOWN

*COMPONENT PARTS LISTED LATER IN THIS GROUP

HEATING & A/C GROUP (CONTINUED)

COMPONENT PARTS FOR CENTRAL

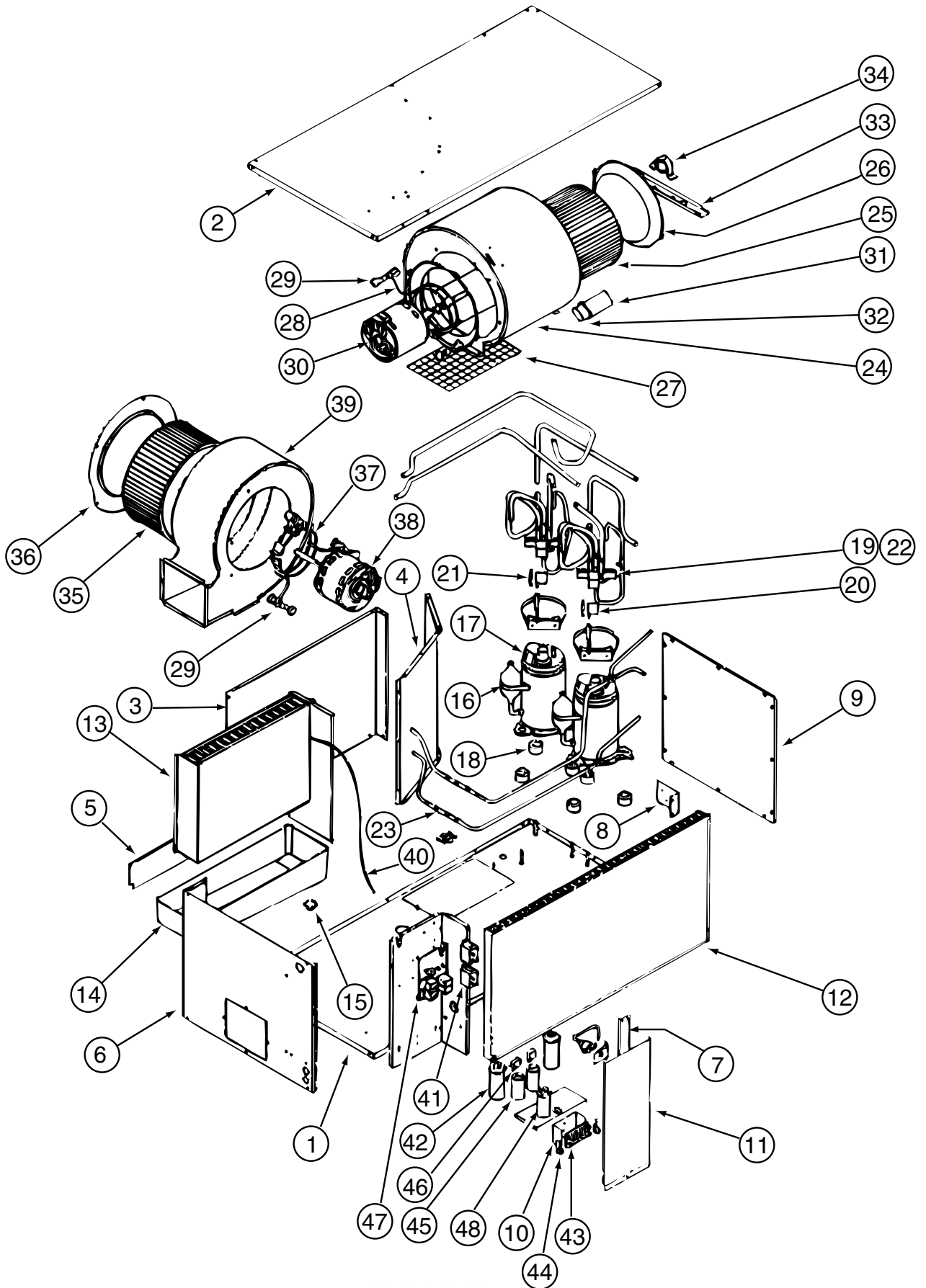

105620-12-000

HEATING & A/C GROUP (CONTINUED)
COMPONENT PARTS FOR CENTRAL (CONTINUED)

105620-12-000 (CONTINUED)

KEY	PART NUMBER	U/M	DESCRIPTION	VENDOR NO.
10	105620-01-733	EA	ISOLATOR-HIGH VOLTAGE	6795-117
11	105620-10-716	EA	DOOR - ELECTRIC BOX	6535B346
12	105620-12-701	EA	COIL - CONDENSER	1452A1621
13	105620-12-702	EA	COIL - EVAPORATOR	1452A1611
15	105620-12-703	EA	VALVE - DRAIN	6795-200
16	105620-12-723	EA	COMPRESSOR (PANASONIC)	1450-2229
17	105620-12-705	EA	OVERLOAD	1450-0081
18	105620-01-706	EA	MOUNTING PKG.,COMP., 3 PER	6759-3081
19	105620-12-724	EA	REVERSING VALVE ASSEMBLY	6535-535
20	105620-12-708	EA	COIL - SOLENOID	1460-1081
21	105620-12-709	EA	WIRE HARNESS-REVERSING VALVE	6536-111
22	105620-12-710	EA	VALVE - REVERSE ONLY	1454A350
23	105620-12-711	EA	RESTRICTOR - BY FLOW	1454-2521
24	105620-10-718	EA	BLOWER HOUSING/OUTSIDE AIR	6536-515
25	105620-01-713	EA	WHEEL-BLOWER/OUTSIDE AIR	1472-1011
26	105620-01-714	EA	VENTURI-BLOWER/OUTSIDE AIR	6795A150
28	105620-01-715	EA	MOUNT-BLOWER/OUTSIDE AIR	6795A3011
29	105620-01-716	EA	SLEEVE & GROMMET, 4 PER PKKG.	6795A3031
30	105620-10-721	EA	MOTOR/BLOWER-8 3/4" SHAFT	1468A3029
31	105620-01-718	EA	CAPACITOR-FAN (OUTDOOR MOTOR))	1499-5631
32	105620-10-715	EA	RUBBER CAPACITOR BOOT	1499-951
33	105620-10-700	EA	BEARING BRACKET/OUTSIDE AIR	6536-514
34	105620-10-701	EA	BEARING/PILLOW BLOCK-O/S AIR	6536-3011
35	105620-11-701	EA	BLOWER WHEEL/INSIDE AIR	1472-1151
36	105620-12-715	EA	BLOWER VENTURI/INSIDE AIR	6535A287
37	105620-01-723	EA	MOUNT-BLOWER MOTOR - I/S AIR	6795-302
38	105620-12-716	EA	BLOWER MTR/IN AIR/REVERSIBLE	1468-3219
39	105620-11-706	EA	MOTOR/BLOWER KIT	6535B5901
40	105620-12-719	EA	COIL SENSOR	7330A3231
41	105620-01-729	EA	RELAY-COMPRESSOR -4 TERMINAL	1460-1131
42	105620-12-725	EA	COMPRESSOR RUN CAPACITOR	1499-5731
43	105620-01-738	EA	BOARD-TERMINAL, HIGH VOLTAGE	6795-315
46	105620-10-705	EA	PTCR (START DEVICE) - W/CAP.	8333A9021
47	105620-12-721	EA	CIRCUIT BD (6535 A SERIES)	6535A3201
48	093763-01-704	EA	CAPACITOR-FAN (INDOOR MOTOR)	1499-5461
	105620-10-720	EA	FUSE/BUSS(8AMP/250V) 2 PKG	6535-3081
			CONTACT WINNEBAGO PART SALES FOR UNLISTED COMPONENT(S)	

INTERIOR FINISH GROUP
MOLDINGS & TRIMS
LIST WOOD TONES FROM 1ST PAGE OF DOCUMENT

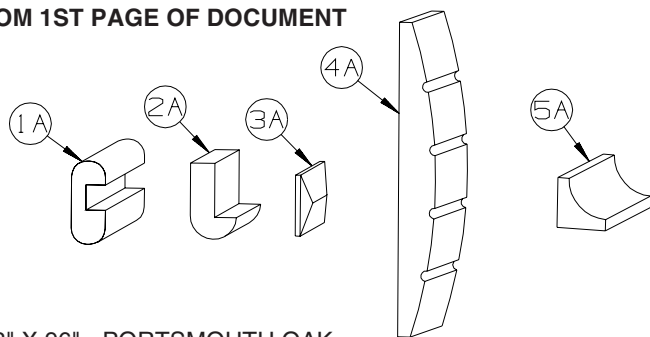

KEY	PART NUMBER	U/M	DESCRIPTION
1A	M09412-62-N42	EA	MOLDING/SHELF EDGE - .6" X 1.3" X 96" - PORTSMOUTH OAK
1A	M09412-62-M52	EA	MOLDING/SHELF EDGE - .6" X 1.3" X 96" - CHERRY - CONCERT CHERRY
1A	M09412-62-M62	EA	MOLDING/SHELF EDGE - .6" X 1.3" X 96" - WASHED MAPLE - WASHED MAPLE
1A	M09412-62-RC3	EA	MOLDING/SHELF EDGE - .6" X 1.3" X 96" - HONEY CHERRY - HONEY CHERRY
1A	M09412-62-SA3	EA	MOLDING/SHELF EDGE - .6" X 1.3" X 96" - MAPLE - SIERRA MAPLE
2A	M09450-77-PC0	EA	MOLDING - TRIM/HDWD W/LIP -.4"X3.2"X79.6" - PORTSMOUTH OAK
2A	M09450-77-PC1	EA	MOLDING - TRIM/HDWD W/LIP -.4"X3.2"X79.6" - CONCERT CHERRY
2A	M09450-77-PC2	EA	MOLDING - TRIM/HDWD W/LIP -.4"X3.2"X79.6" - WASHED MAPLE
2A	M09450-77-RC3	EA	MOLDING - TRIM/HDWD W/LIP -.4"X3.2"X79.6" - HONEY CHERRY
2A	M09501-32-TG1	EA	MOLDING/TRIM - W/NOTCH - .8" X 2.5" X 86.2"-CONCERT CHERRY
2A	M09501-32-TG2	EA	MOLDING/TRIM - W/NOTCH - .8" X 2.5" X 86.2" - WASHED MAPLE,
2A	M09501-32-TD3	EA	MOLDING/TRIM - W/NOTCH - .8" X 2.5" X 86.2" - SIERRA MAPLE
2A	M09503-52-T77	EA	MOLDING/TRIM - .75" X 1.2" X 86.5" - PORTSMOUTH OAK
2A	M09503-52-T78	EA	MOLDING/TRIM - .75" X 1.2" X 86.5" - CONCERT CHERRY
2A	M09503-52-T79	EA	MOLDING/TRIM - .75" X 1.2" X 86.5" - WASHED MAPLE
2A	M09503-52-T80	EA	MOLDING/TRIM - .75" X 1.2" X 86.5" - SIERRA MAPLE
2A	M09511-43-T78	EA	MOLDING - TRIM - W/NOTCH - .8" X 1.4" X 86.3" - CONCERT CHERRY
2A	M09525-80-UM1	EA	MOLDING - TRIM - W/NOTCH - .8"X 1.4"X 86.5" - CONCERT CHERRY
2A	M09511-43-T79	EA	MOLDING - TRIM - W/NOTCH - .8" X 1.4" X 86.3" - WASHED MAPLE
2A	M09525-80-U91	EA	MOLDING - TRIM - W/NOTCH - .8" X 1.4" X 86.5" - WASHED MAPLE
2A	M09511-43-T80	EA	MOLDING - TRIM - W/NOTCH - .8" X 1.4" X 86.3" - SIERRA MAPLE
2A	M09525-80-U92	EA	MOLDING - TRIM - W/NOTCH - .8" X 1.4" X 86.5" - SIERRA MAPLE
2A	M09438-25-RA3	EA	MOLDING - HARDWOOD-W/NOTCH - 1.4"X 80.2" - HONEY CHERRY
2A	M09515-72-TD1	EA	MOLDING/TRIM - .8" X 2.2" X 86.1" - CONCERT CHERRY
2A	M09515-72-TD2	EA	MOLDING/TRIM - .8" X 2.2" X 86.1" - WASHED MAPLE
2A	M09515-72-TD3	EA	MOLDING/TRIM - .8" X 2.2" X 86.1" - SIERRA MAPLE
3A	M09471-91-R69	EA	MOLDING - TRIM/VEE - .2" X 1" X 34.4" - CONCERT CHERRY
3A	M09471-91-R76	EA	MOLDING - TRIM/VEE - .2" X 1" X 34.4" - WASHED MAPLE
3A	M09471-91-SA3	EA	MOLDING - TRIM/VEE - .2" X 1" X 34.4" - SIERRA MAPLE
3A	M09477-88-S34	EA	MOLDING - TRIM/VEE - .2" X 1" X 19.9" - WASHED MAPLE
3A	M09477-88-S35	EA	MOLDING - TRIM/VEE - .2" X 1" X 19.9" - SIERRA MAPLE
3A	M09501-30-SD2	EA	MOLDING - TRIM/VEE - .2" X 1" X 35.1" - WASHED MAPLE
3A	M09501-30-SD3	EA	MOLDING - TRIM/VEE - .2" X 1" X 35.1" - HONEY CHERRY
3A	M09501-37-TG1	EA	MOLDING - TRIM/VEE - .2" X 1" X 19.2" - CONCERT CHERRY
3A	M09501-37-TG2	EA	MOLDING - TRIM/VEE - .2" X 1" X 19.2" - WASHED MAPLE
3A	M09501-37-TD3	EA	MOLDING - TRIM/VEE - .2" X 1" X 19.2" - SIERRA MAPLE
3A	M09501-37-TG3	EA	MOLDING - TRIM/VEE - .2" X 1" X 19.2" - HONEY CHERRY
3A	M09501-63-T78	EA	MOLDING - TRIM/VEE - .2" X 1" X 15" - CONCERT CHERRY
3A	M09501-63-T79	EA	MOLDING - TRIM/VEE - .2" X 1" X 15" - WASHED MAPLE
3A	M09501-63-T80	EA	MOLDING - TRIM/VEE - .2" X 1" X 15" - SIERRA MAPLE
3A	M09503-62-TG1	EA	MOLDING - TRIM/VEE - .2" X 1" X 26.3" - CONCERT CHERRY
3A	M09503-62-TG2	EA	MOLDING - TRIM/VEE - .2" X 1" X 26.3" - WASHED MAPLE
3A	M09503-62-TG3	EA	MOLDING - TRIM/VEE - .2" X 1" X 26.3" - HONEY CHERRY
3A	M09511-90-TG1	EA	MOLDING - TRIM/VEE - .2" X 1" X 42.1" - CONCERT CHERRY
3A	M09511-90-TG3	EA	MOLDING - TRIM/VEE - .2" X 1" X 42.1" - HONEY CHERRY
3A	M09511-90-TG2	EA	MOLDING - TRIM/VEE - .2" X 1" X 42.1" - WASHED MAPLE
3A	M09520-15-TD1	EA	MOLDING - TRIM/VEE - .2" X 1" X 15.3" - CONCERT CHERRY
3A	M09520-15-TD2	EA	MOLDING - TRIM/VEE - .2" X 1" X 15.3" - WASHED MAPLE
3A	M09520-15-TD3	EA	MOLDING - TRIM/VEE - .2" X 1" X 15.3" - SIERRA MAPLE
3A	M09520-96-T59	EA	MOLDING - TRIM/VEE - .2" X 1" X 32.7" - PORTSMOUTH OAK
3A	M09520-96-T60	EA	MOLDING - TRIM/VEE - .2" X 1" X 32.7" - CONCERT CHERRY
3A	M09520-96-T61	EA	MOLDING - TRIM/VEE - .2" X 1" X 32.7" - WASHED MAPLE
3A	M09520-96-TP0	EA	MOLDING - TRIM/VEE - .2" X 1" X 32.7" - SIERRA MAPLE

INTERIOR FINISH GROUP (CONTINUED)
MOLDINGS & TRIMS (CONTINUED)

KEY	PART NUMBER	U/M	DESCRIPTION
3A	M09525-96-TA0	EA	MOLDING - TRIM/VEE - .2" X 1" X 36.2" - PORTSMOUTH OAK
3A	M09525-96-TA1	EA	MOLDING - TRIM/VEE - .2" X 1" X 36.2" - CONCERT CHERRY
3A	M09525-96-TA2	EA	MOLDING - TRIM/VEE - .2" X 1" X 36.2" - WASHED MAPLE
3A	M09525-96-TA3	EA	MOLDING - TRIM/VEE - .2" X 1" X 36.2" - SIERRA MAPLE
3A	M09534-08-T01	EA	MOLDING - TRIM/VEE - .2" X 1" X 24.5" - SIERRA MAPLE
3A	M09534-08-T02	EA	MOLDING - TRIM/VEE - .2" X 1" X 24.5" - HONEY CHERRY
3A	M09511-32-T78	EA	MOLDING - TRIM/VEE - .4" X 1" X 26.8" - CONCERT CHERRY
3A	M09511-32-T79	EA	MOLDING - TRIM/VEE - .4" X 1" X 26.8" - WASHED MAPLE
3A	M09511-32-T80	EA	MOLDING - TRIM/VEE - .4" X 1" X 26.8" - SIERRA MAPLE
3A	M09511-86-T78	EA	MOLDING - TRIM/VEE - .4" X 1" X 28.3" - CONCERT CHERRY
3A	M09511-86-T79	EA	MOLDING - TRIM/VEE - .4" X 1" X 28.3" - WASHED MAPLE
3A	M09511-86-T80	EA	MOLDING - TRIM/VEE - .4" X 1" X 28.3" - SIERRA MAPLE
3A	M09477-63-S46	EA	MOLDING - TRIM/VEE - .4" X 1" X 64.1" - PORTSMOUTH OAK - BATH DOOR TRIM
3A	M09477-63-SR0	EA	MOLDING - TRIM/VEE - .4" X 1" X 64.1" - SIERRA MAPLE - BATH DOOR TRIM
3A	M09477-64-S46	EA	MOLDING - TRIM/VEE - .4" X 1" X 14.9" - PORTSMOUTH OAK - BATH DOOR TRIM
3A	M09477-64-SR0	EA	MOLDING - TRIM/VEE - .4" X 1" X 14.9" - SIERRA MAPLE - BATH DOOR TRIM
4A	M09462-54-R90	EA	MOLDING - FLUTED, CURVED - .6" X 6" X 82.7" - CONCERT CHERRY
4A	M09462-54-R91	EA	MOLDING - FLUTED, CURVED - .6" X 6" X 82.7" - WASHED MAPLE
4A	M09462-54-RE3	EA	MOLDING - FLUTED, CURVED - .6" X 6" X 82.7" - HONEY CHERRY
5A	M09471-79-R38	EA	MOLDING - TRIM/COVE - .8" X .8" X 95.8" - OAK/PORTS OAK - PORTSMOUTH OAK
5A	M09471-79-R39	EA	MOLDING - TRIM/COVE - .8" X .8" X 95.8" - CHERRY/CHERRY - CONCERT CHERRY
5A	M09471-79-R46	EA	MOLDING - TRIM/COVE - .8" X .8" X 95.8" - MAPLE/MAPLE - WASHED MAPLE
5A	M09471-79-RE0	EA	MOLDING - TRIM/COVE - .8" X .8" X 95.8" - HONEY/CHERRY- HONEY CHERRY
5A	M09471-79-SA3	EA	MOLDING - TRIM/COVE - .8" X .8" X 95.8" - HONEY/MAPLE - SIERRA MAPLE

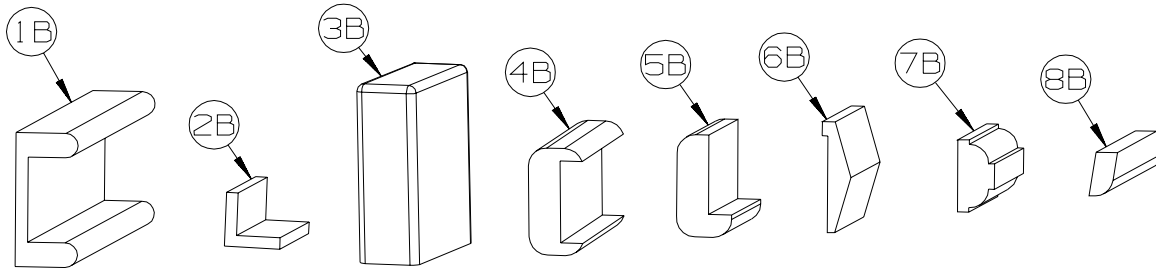

KEY	PART NUMBER	U/M	DESCRIPTION
1B	M09501-84-TG0	EA	MOLDING/TRIM - CAP/WALL - 2.2" X 85.9" - PORTSMOUTH OAK
1B	M09501-84-TG1	EA	MOLDING/TRIM - CAP/WALL - 2.2" X 85.9" - CONCERT CHERRY
1B	M09501-84-TG2	EA	MOLDING/TRIM - CAP/WALL - 2.2" X 85.9" - WASHED MAPLE
1B	M09520-07-TD3	EA	MOLDING/TRIM - CAP/WALL - 2.2" X 80.5" - SIERRA MAPLE
1B	M09501-84-TG3	EA	MOLDING/TRIM - CAP/WALL - 2.2" X 85.9" - HONEY CHERRY
2B	M09511-81-TA1	EA	MOLDING/TRIM - L SHAPE - .8"X .8"X 80.2" - CONCERT CHERRY
2B	M09511-81-TA2	EA	MOLDING/TRIM - L SHAPE - .8"X .8"X 80.2" - WASHED MAPLE
2B	M09511-81-TA3	EA	MOLDING/TRIM - L SHAPE - .8"X .8"X 80.2" - SIERRA MAPLE
3B	M09515-81-T01	EA	MOLDING/HARDWOOD STRAIGHT - 74.3" - WASHED MAPLE
3B	M09515-81-T02	EA	MOLDING/HARDWOOD STRAIGHT - 74.3" - HONEY CHERRY
4B	M09511-42-T77	EA	MOLDING - TRIM - W/NOTCH - 1.5" X 86.4" - PORTSMOUTH OAK
4B	M09511-42-T78	EA	MOLDING - TRIM - W/NOTCH - 1.5" X 86.4" - CONCERT CHERRY
4B	M09511-42-T79	EA	MOLDING - TRIM - W/NOTCH - 1.5" X 86.4" - WASHED MAPLE
4B	M09511-42-T80	EA	MOLDING - TRIM - W/NOTCH - 1.5" X 86.4" - SIERRA MAPLE
5B	M09515-18-T78	EA	MOLDING - HARDWOOD-W/NOTCH - 1.4"X 86.2" - CONCERT CHERRY
5B	M09515-18-T79	EA	MOLDING - HARDWOOD-W/NOTCH - 1.4"X 86.2" - WASHED MAPLE
5B	M09515-18-T80	EA	MOLDING - HARDWOOD-W/NOTCH - 1.4"X 86.2" - SIERRA MAPLE
6B	M09515-52-TG1	EA	MOLDING - TRIM/VEE - 1.5" X 73.9" - CONCERT CHERRY
6B	M09515-52-TG2	EA	MOLDING - TRIM/VEE - 1.5" X 73.9" - WASHED MAPLE
6B	M09515-52-TG3	EA	MOLDING - TRIM/VEE - 1.5" X 73.9" - HONEY CHERRY
7B	Y00076-32-438	EA	MOLDING/TRIM - .5" X 1" X 96" - CHERRY (UNSTAINED)
7B	Y00076-22-438	EA	MOLDING/TRIM - .5" X 1" X 96" - MAPLE (UNSTAINED)
8B	Y00086-72-438	EA	MOLDING - VINYL WRAP - .7" X 1.6" X 96" - PORTSMOUTH OAK - PORTSMOUTH OAK
8B	Y00086-62-438	EA	MOLDING - 96" - CONCERT CHERRY (U90/94/98/A1/A5/B1/C1/C5/D1/D5/E1/E5/F1/F5/G1/G5/H1/H5)
8B	Y00086-D2-438	EA	MOLDING - VINYL WRAP - .7" X 1.6" X 96" - CONCERT CHERRY (UM1 THRU UM9, UN1 THRU UN9)
8B	Y00086-A2-438	EA	MOLDING - VINYL WRAP - .7" X 1.6" X 96" - WASHED MAPLE
8B	Y00086-92-438	EA	MOLDING - VINYL WRAP - .7" X 1.6" X 96" - SIERRA MAPLE - SIERRA MAPLE

INTERIOR FINISH GROUP (CONTINUED)
MOLDINGS & TRIMS (CONTINUED)

KEY	PART NUMBER	U/M	DESCRIPTION
8B	Y00087-62-438	EA	MOLDING - 96" - CONCERT CHERRY (U90/94/98/A1/A5/B1/C1/C5/D1/D5/E1/E5/F1/F5/G1/G5/H1/H5)
8B	Y00087-D2-438	EA	MOLDING - VINYL WRAP - .7" X 2.9" X 96" - CONCERT CHERRY (UM1 THRU UM9, UN1 THRU UN9)
8B	Y00087-A2-438	EA	MOLDING - VINYL WRAP - .7" X 2.9" X 96" - WASHED MAPLE
8B	Y00087-92-438	EA	MOLDING - VINYL WRAP - .7" X 2.9" X 96" - SIERRA MAPLE
8B	Y00300-62-438	EA	MOLDING - 96" - CONCERT CHERRY (U90/94/98/A1/A5/B1/C1/C5/D1/D5/E1/E5/F1/F5/G1/G5/H1/H5)
8B	Y00300-D2-438	EA	MOLDING - VINYL WRAP - .3" X .6" X 96" - CONCERT CHERRY (UM1 THRU UM9, UN1 THRU UN9)
8B	Y00300-A2-438	EA	MOLDING - VINYL WRAP - .3" X .6" X 96" - WASHED MAPLE
8B	Y00300-92-438	EA	MOLDING - VINYL WRAP - .3" X .6" X 96" - SIERRA MAPLE

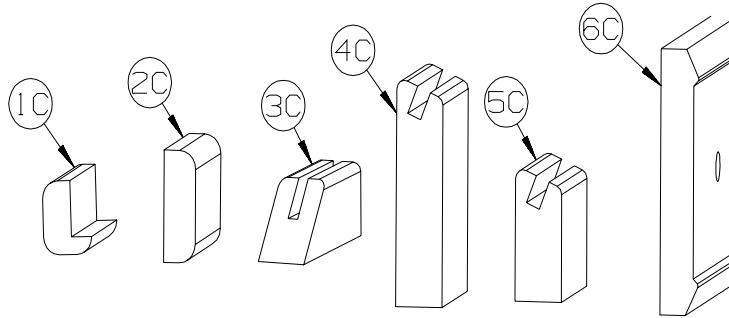

KEY	PART NUMBER	U/M	DESCRIPTION
1C	M09520-19-TD1	EA	MOLDING - TRIM - W/NOTCH - 1" X 86.3" - CONCERT CHERRY
1C	M09520-19-TD2	EA	MOLDING - TRIM - W/NOTCH - 1" X 86.3" - WASHED MAPLE
1C	M09520-19-TD3	EA	MOLDING - TRIM - W/NOTCH - 1" X 86.3" - HONEY CHERRY
1C	M09525-27-UF1	EA	MOLDING - HARDWOOD - .75" X 1.4" X 32.4" - CONCERT CHERRY
1C	M09525-27-UF2	EA	MOLDING - HARDWOOD - .75" X 1.4" X 32.4" - WASHED MAPLE
1C	M09525-27-UF3	EA	MOLDING - HARDWOOD - .75" X 1.4" X 32.4" - SIERRA MAPLE
2C	M09511-46-T77	EA	MOLDING/TRIM - .5" X 1.5" X 86.5" - PORTSMOUTH OAK
2C	M09511-46-T78	EA	MOLDING/TRIM - .5" X 1.5" X 86.5" - CONCERT CHERRY
2C	M09511-46-T79	EA	MOLDING/TRIM - .5" X 1.5" X 86.5" - WASHED MAPLE
2C	M09511-46-T80	EA	MOLDING/TRIM - .5" X 1.5" X 86.5" - SIERRA MAPLE
3C	Y00223-42-438	EA	MOLDING - HARDWOOD/OAK - .7" X 1" X 96"
3C	Y00223-32-438	EA	MOLDING - HARDWOOD/CHERRY - .7" X 1" X 96"
3C	Y00223-22-438	EA	MOLDING - HARDWOOD/MAPLE - .7" X 1" X 96"
4C	Y00054-62-438	EA	MOLDING- 96" - CONCERT CHERRY (U90/94/98/A1/A5/B1/C1/C5/D1/D5/E1/E5/F1/F5/G1/G5/H1/H5)
4C	Y00054-D2-438	EA	MOLDING/VYL WRP-BVLD-.73" X 3.1" X 96" - CONCERT CHERRY (UM1 THRU UM9, UN1 THRU UN9)
4C	Y00054-A2-438	EA	MOLDING/VINYL WRAP-BEVELED ENDS-.73"X3.1"X96" - WASHED MAPLE
4C	Y00054-92-438	EA	MOLDING/VINYL WRAP-BEVELED-.73" X 3.1" X 96" - SIERRA MAPLE
4C	Y00258-62-438	EA	MOLDING/VYL 96" - CONCERT CHERRY (U90/94/98/A1/A5/B1/C1/C5/D1/D5/E1/E5/F1/F5/G1/G5/H1/H5)
4C	Y00258-D2-438	EA	MOLDING/VINYL WRP-BVLD-.73" X 3.1" X 96" - CONCERT CHERRY (UM1 THRU UM9, UN1 THRU UN9)
4C	Y00258-A2-438	EA	MOLDING/VINYL WRAP-BEVELED ENDS-.73"X3.1"X96" - WASHED MAPLE
4C	Y00258-92-438	EA	MOLDING/VINYL WRAP-BEVELED-.73" X 3.1" X 96" - SIERRA MAPLE
5C	Y00259-62-438	EA	MOLDING/VYL 96" - CONCERT CHERRY (U90/94/98/A1/A5/B1/C1/C5/D1/D5/E1/E5/F1/F5/G1/G5/H1/H5)
5C	Y00259-D2-438	EA	MOLDING/VINYL WRP-BVLD-.73" X 1.8" X 96" - CONCERT CHERRY (UM1 THRU UM9, UN1 THRU UN9)
5C	Y00259-A2-438	EA	MOLDING/VINYL WRAP-BEVELED-.73"X1.8"X96" - WASHED MAPLE
5C	Y00259-92-438	EA	MOLDING/VINYL WRAP-BEVELED-.73"X1.8"X96" - SIERRA MAPLE
6C	Y00152-A2-438	EA	MOLDING/TRIM - VINYL - .6" X 3.5" X 96" - WASHED MAPLE
6C	Y00152-92-438	EA	MOLDING/TRIM - VINYL - .6" X 3.5" X 96" - SIERRA MAPLE

INTERIOR FINISH GROUP (CONTINUED)
MOLDINGS & TRIMS (CONTINUED)

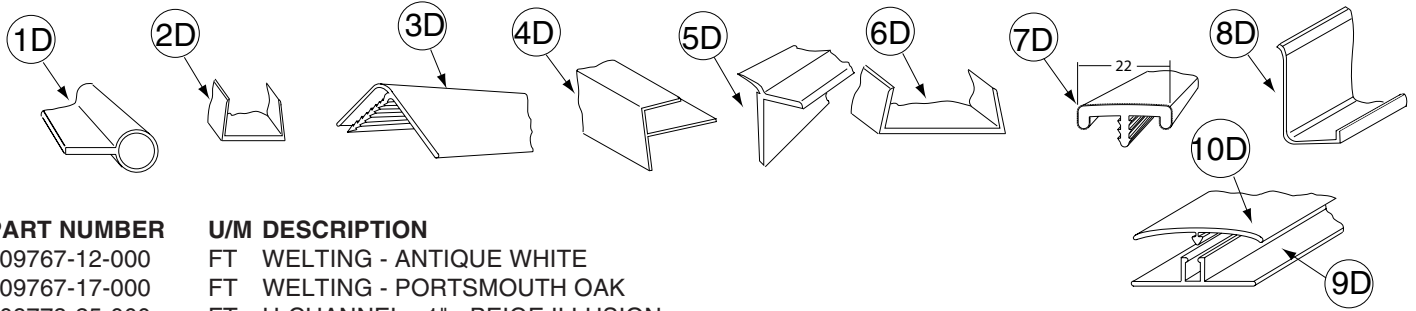

KEY	PART NUMBER	U/M	DESCRIPTION
1D	009767-12-000	FT	WELTING - ANTIQUE WHITE
1D	009767-17-000	FT	WELTING - PORTSMOUTH OAK
2D	009778-25-000	FT	U-CHANNEL - 1" - BEIGE ILLUSION
2D	009778-26-000	FT	U-CHANNEL - 1 1/4" - BEIGE ILLUSION
2D	009778-38-000	FT	U-CHANNEL - 1" - BONE
2D	009778-32-000	FT	U-CHANNEL - 1" - PORTSMOUTH OAK
2D	009778-34-000	FT	U-CHANNEL - 1" - CONCERT CHERRY
2D	009778-27-000	FT	U-CHANNEL - 1" - WASHED MAPLE
2D	009778-35-000	FT	U-CHANNEL - 1" - HONEY CHERRY
2D	009778-36-000	FT	U-CHANNEL - 1" - SIERRA MAPLE
3D	009809-30-000	EA	MOLDING - CORNER - OUTSIDE - 1" X 84" - BEIGE ILLUSION
3D	009809-37-000	EA	MOLDING - CORNER - OUTSIDE - 1" X 84" - BONE
3D	009809-32-000	EA	MOLDING - CORNER - OUTSIDE - 1" X 84" - PORTSMOUTH OAK
3D	009809-33-000	EA	MOLDING - CORNER - OUTSIDE - 1" X 84" - CONCERT CHERRY
3D	009809-31-000	EA	MOLDING - CORNER - OUTSIDE - 1" X 84" - WASHED MAPLE
3D	009809-34-000	EA	MOLDING - CORNER - OUTSIDE - 1" X 84" - HONEY CHERRY
3D	009809-35-000	EA	MOLDING - CORNER - OUTSIDE - 1" X 84" - SIERRA MAPLE
4D	009812-31-000	EA	MOLDING - CORNER - 1/2" W/1/4"CHAN X 84" - BEIGE ILLUSION
4D	009812-40-000	EA	MOLDING - CORNER - 1/2" W/1/4"CHAN X 84" - BONE
4D	009812-35-000	EA	MOLDING - CORNER - 1/2" W/1/4"CHAN X 84" - PORTSMOUTH OAK
4D	009812-36-000	EA	MOLDING - CORNER - 1/2" W/1/4"CHAN X 84" - CONCERT CHERRY
4D	009812-33-000	EA	MOLDING - CORNER - 1/2" W/1/4"CHAN X 84" - WASHED MAPLE
4D	009812-37-000	EA	MOLDING - CORNER - 1/2" W/1/4"CHAN X 84" - HONEY CHERRY
4D	009812-38-000	EA	MOLDING - CORNER - 1/2" W/1/4"CHAN X 84" - SIERRA MAPLE
5D	022992-11-000	FT	MOLDING - REVERSE COVE - T-SHAPED - IVORY
5D	022992-18-000	FT	MOLDING - REVERSE COVE - T-SHAPED - BONE
5D	022992-14-000	FT	MOLDING - REVERSE COVE - T-SHAPED - BRIGHT WHITE
6D	070504-42-000	FT	U-CHANNEL - PLASTIC - .13" X 84" - BEIGE ILLUSION
6D	070504-69-000	FT	U-CHANNEL - PLASTIC - .13" X 84" - BONE
6D	070504-43-000	FT	U-CHANNEL - PLASTIC - .9" X 96" - BEIGE ILLUSION
6D	070504-70-000	FT	U-CHANNEL - PLASTIC - .8" X 84" - BONE
6D	070504-57-000	FT	U-CHANNEL - PLASTIC - .13" X 84" - PORTSMOUTH OAK
6D	070504-58-000	FT	U-CHANNEL - PLASTIC - .9" X 84" - PORTSMOUTH OAK
6D	070504-60-000	FT	U-CHANNEL - PLASTIC - .13" X 84" - CONCERT CHERRY
6D	070504-61-000	FT	U-CHANNEL - PLASTIC - .9" X 84" - CONCERT CHERRY
6D	070504-50-000	FT	U-CHANNEL - PLASTIC - .13" X 96" - WASHED MAPLE
6D	070504-51-000	FT	U-CHANNEL - PLASTIC - .9" X 96" - WASHED MAPLE
6D	070504-62-000	FT	U-CHANNEL - PLASTIC - 1.65" X 84" - HONEY CHERRY
6D	070504-63-000	FT	U-CHANNEL - PLASTIC - .9" X 84" - HONEY CHERRY
6D	070504-65-000	FT	U-CHANNEL - PLASTIC - 1.65" X 84" - SIERRA MAPLE
6D	070504-66-000	FT	U-CHANNEL - PLASTIC - .9" X 84" - SIERRA MAPLE
7D	083620-15-000	FT	MOLDING-T - W/EDGE LIP - 7/8" FACE - BEIGE ILLUSION
7D	083620-25-000	FT	MOLDING-T - W/EDGE LIP - 7/8" FACE - BONE
7D	083620-20-000	FT	MOLDING-T - W/EDGE LIP - 7/8" FACE - PORTSMOUTH OAK
7D	083620-21-000	FT	MOLDING-T - W/EDGE LIP - 7/8" FACE - CONCERT CHERRY
7D	083620-19-000	FT	MOLDING-T - W/EDGE LIP - 7/8" FACE - WASHED MAPLE
7D	083620-24-000	FT	MOLDING-T - W/EDGE LIP - 7/8" FACE - HONEY CHERRY
7D	083620-22-000	FT	MOLDING-T - W/EDGE LIP - 7/8" FACE - SIERRA MAPLE
8D	085746-04-000	FT	TRIM-J - CARPET 1.2" X .5" ANGLE - 12' LONG - OFF WHITE
9D	086229-01-000	EA	RETAINER - BATTEN - .75" X 92.1" - ANY COLOR
10D	086229-20-000	EA	BATTEN - 1" X 96" - BEIGE

INTERIOR FINISH GROUP (CONTINUED)
MOLDINGS & TRIMS (CONTINUED)

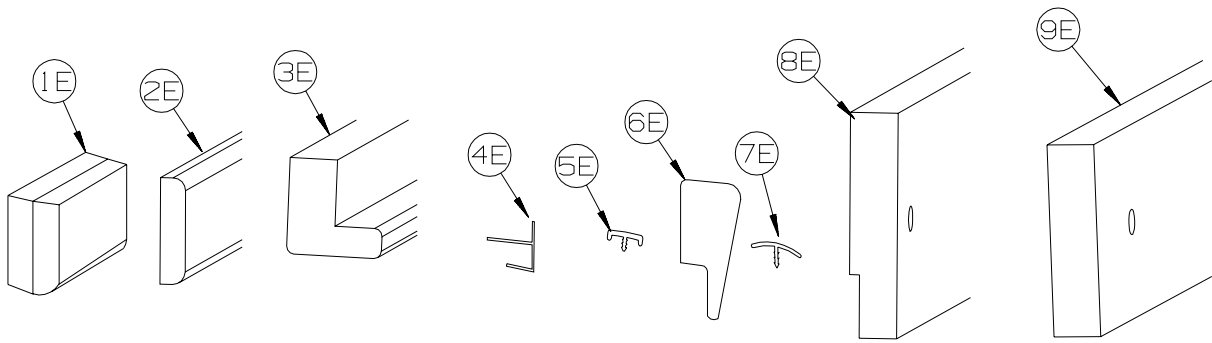

KEY	PART NUMBER	U/M	DESCRIPTION
1E	100659-30-N75	EA	MOLDING - TRIM - 8' - PORTSMOUTH OAK
1E	100659-30-N74	EA	MOLDING - TRIM - 8' - CONCERT CHERRY
1E	100659-30-M84	EA	MOLDING - TRIM - 8' - WASHED MAPLE
1E	100659-27-RA3	EA	MOLDING - TRIM - HONEY CHERRY
1E	100659-31-SA3	EA	MOLDING - TRIM - SIERRA MAPLE
2E	100818-01-12A	EA	MOLDING - VINYL WRAPPED - 1.6" X .4" X 84" - PORTSMOUTH OAK
2E	100818-01-13A	EA	MOLDING - VYL 84" - CONCERT CHERRY (U90/94/98/A1/A5/B1/C1/C5/D1/D5/E1/E5/F1/F5/G1/G5/H1/H5)
2E	100818-01-23A	EA	MOLDING - VINYL WRPPD - 1.6" X .4" X 84" - CONCERT CHERRY (UM1 THRU UM9, UN1 THRU UN9)
2E	100818-01-21A	EA	MOLDING - VINYL WRAPPED - 1.6" X .4" X 84" - WASHED MAPLE
2E	100818-01-14A	EA	MOLDING - VINYL WRAPPED - 1.6" X .4" X 84" - HONEY CHERRY
2E	100818-01-22A	EA	MOLDING - VINYL WRAPPED - 1.6" X .4" X 84" - SIERRA MAPLE
3E	100819-01-12A	EA	MOLDING - VINYL WRAPPED-L-SHAPED-1.5"X1.5"X84" - PORTSMOUTH OAK
3E	100819-01-13A	EA	MOLDING - VYL 84" - CONCERT CHERRY (U90/94/98/A1/A5/B1/C1/C5/D1/D5/E1/E5/F1/F5/G1/G5/H1/H5)
3E	100819-01-23A	EA	MOLDING - VYL WRPPD-L-SHPD-1.5"X1.5"X84" - CONCERT CHERRY (UM1 THRU UM9, UN1 THRU UN9)
3E	100819-01-21A	EA	MOLDING - VINYL WRAPPED-L-SHAPED-1.5"X1.5"X84" - WASHED MAPLE
3E	100819-01-14A	EA	MOLDING - VINYL WRAPPED-L-SHAPED-1.5"X1.5"X84" - HONEY CHERRY
3E	100819-01-22A	EA	MOLDING - VINYL WRAPPED-L-SHAPED-1.5"X1.5"X84" - SIERRA MAPLE
4E	103186-01-07A	FT	MOLDING/PLASTIC - 3/8" U-CHANNEL-3/4" FACE -BEIGE ILLUSION
4E	103186-01-09A	FT	MOLDING/PLASTIC - 3/8" U-CHAN'L-3/4" FACE - PORTSMOUTH OAK
4E	103186-01-10A	FT	MOLDING/PLASTIC - 3/8" U-CHAN'L-3/4" FACE - CONCERT CHERRY
4E	103186-01-08A	FT	MOLDING/PLASTIC - 3/8" U-CHANNEL-3/4"FACE-WASHED MAPLE 8' - WASHED MAPLE
4E	103186-01-11A	FT	MOLDING/PLASTIC - 3/8" U-CHAN'L-3/4" FACE - HONEY CHERRY
4E	103186-01-12A	FT	MOLDING/PLASTIC - 3/8" U-CHAN'L-3/4" FACE - SIERRA MAPLE
4E	103186-02-07A	FT	MOLDING/PLASTIC-1" U-CHAN'L-1 3/8" FACE - BEIGE ILLUSION
4E	103186-02-09A	FT	MOLDING/PLASTIC - 1" U-CHAN'L-1 3/8" FACE - PORTSMOUTH OAK
4E	103186-02-10A	FT	MOLDING/PLASTIC - 1" U-CHAN'L-1 3/8" FACE - CONCERT CHERRY
4E	103186-02-08A	FT	MOLDING/PLASTIC - 1" U-CHANNEL-1 3/8"FACE - WASHED MAPLE
4E	103186-02-11A	FT	MOLDING/PLASTIC - 1" U-CHAN'L-1 3/8" FACE - HONEY CHERRY
4E	103186-02-12A	FT	MOLDING/PLASTIC - 1" U-CHAN'L-1 3/8" FACE - SIERRA MAPLE
5E	104676-02-08A	FT	MOLDING-T - W/EDGE LIP - 11/16" FACE - PORTSMOUTH OAK
5E	104676-02-09A	FT	MOLDING-T - W/EDGE LIP - 11/16" FACE - CONCERT CHERRY
5E	104676-02-06A	FT	MOLDING-T - W/EDGE LIP - 11/16" FACE - WASHED MAPLE
5E	104676-02-10A	FT	MOLDING-T - W/EDGE LIP - 11/16" FACE - HONEY CHERRY
5E	104676-02-12A	FT	MOLDING-T - W/EDGE LIP - 11/16" FACE - SIERRA MAPLE
6E	105004-01-12A	EA	MOLDING - VINYL WRAPPED - 1" X 96" - PORTSMOUTH OAK
6E	105004-01-13A	EA	MOLDING - V W 8' - CONCERT CHERRY (U90/94/98/A1/A5/B1/C1/C5/D1/D5/E1/E5/F1/F5/G1/G5/H1/H5)
6E	105004-01-23A	EA	MOLDING - VINYL WRAPPD 1" X 8' - CONCERT CHERRY (UM1 THRU UM9, UN1 THRU UN9)
6E	105004-01-21A	EA	MOLDING - VINYL WRAPPED - 1" X 8' - WASHED MAPLE
6E	105004-01-24A	EA	MOLDING - VINYL WRAPPED - 1" X 8' - HONEY CHERRY
6E	105004-01-22A	EA	MOLDING - VINYL WRAPPED - 1" X 8' - SIERRA MAPLE
7E	105709-02-000	FT	MOLDING-T - W/EDGE LIP 3/4" FACE - BEIGE ILLUSION
8E	116951-45-R68	EA	MOLDING - TRIM - 3" X 30.3" - PORTSMOUTH OAK
8E	116951-45-R69	EA	MOLDING - TRIM - 3" X 30.3" - CONCERT CHERRY
8E	116951-45-R76	EA	MOLDING - TRIM - 3" X 30.3" - WASHED MAPLE
8E	116951-45-SA3	EA	MOLDING - TRIM - 3" X 30.3" - SIERRA MAPLE
9E	116951-37-R68	EA	MOLDING - TRIM - 3.5" X 38.6" - PORTSMOUTH OAK
9E	116951-37-R69	EA	MOLDING - TRIM - 3.5" X 38.6" - CONCERT CHERRY
9E	116951-37-R76	EA	MOLDING - TRIM - 3.5" X 38.6" - WASHED MAPLE
9E	116951-37-SA3	EA	MOLDING - TRIM - 3.5" X 38.6" - SIERRA MAPLE
9E	116951-51-SA0	EA	MOLDING - TRIM - 3.5" X 47.3" - PORTSMOUTH OAK
9E	116951-51-SA1	EA	MOLDING - TRIM - 3.5" X 47.3" - CONCERT CHERRY
9E	116951-51-SA2	EA	MOLDING - TRIM - 3.5" X 47.3" - WASHED MAPLE
9E	116951-51-SA3	EA	MOLDING - TRIM - 3.5" X 47.3" - SIERRA MAPLE

INTERIOR FINISH GROUP (CONTINUED)
MOLDINGS & TRIMS (CONTINUED)

KEY	PART NUMBER	U/M	DESCRIPTION
9E	116951-55-TD0	EA	MOLDING - TRIM - 4.5" X 52.3" - PORTSMOUTH OAK
9E	116951-55-TD1	EA	MOLDING - TRIM - 4.5" X 52.3" - CONCERT CHERRY
9E	116951-55-TD2	EA	MOLDING - TRIM - 4.5" X 52.3" - WASHED MAPLE
9E	116951-55-TD3	EA	MOLDING - TRIM - 4.5" X 52.3" - SIERRA MAPLE
9E	116951-56-TD0	EA	MOLDING - TRIM - 4.5" X 52.3" - PORTSMOUTH OAK
9E	116951-56-TD1	EA	MOLDING - TRIM - 4.5" X 52.3" - CONCERT CHERRY
9E	116951-56-TD2	EA	MOLDING - TRIM - 4.5" X 52.3" - WASHED MAPLE
9E	116951-56-TD3	EA	MOLDING - TRIM - 4.5" X 52.3" - SIERRA MAPLE

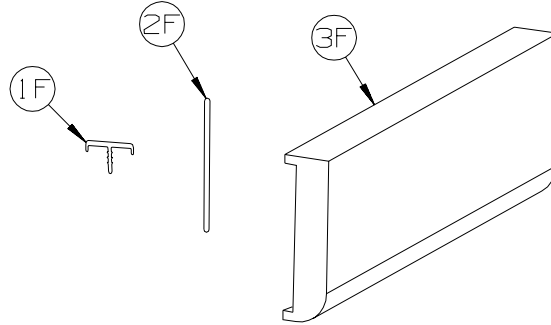

KEY	PART NUMBER	U/M	DESCRIPTION
1F	119520-01-01A	FT	MOLDING-T - OFFSET W/EDGE LIP - 1.3" FACE - OFF WHITE
1F	119520-03-03A	FT	MOLDING-T - OFFSET W/EDGE LIP - 1" FACE - WASHED MAPLE
1F	119520-03-06A	FT	MOLDING-T - OFFSET W/EDGE LIP - 1" FACE - HONEY CHERRY
2F	127842-01-01A	FT	SEAL - SIGHT SHIELD - 2" BLACK
	137885-A2-438	EA	LUMBER - VYL .75" - CONCERT CHERRY (U90/94/98/A1/A5/B1/C1/C5/D1/D5/E1/E5/F1/F5/G1/G5/H1/H5)
	160300-A2-438	EA	LUMBER - VINYL WRAPPED - .7" X .75" X 96" - CONCERT CHERRY (UM1 THRU UM9, UN1 THRU UN9)
	137885-D2-438	EA	LUMBER - VYL1.5" - CONCERT CHERRY (U90/94/98/A1/A5/B1/C1/C5/D1/D5/E1/E5/F1/F5/G1/G5/H1/H5)
	160300-D2-438	EA	LUMBER - VINYL WRAPPED - .7" X 1.5" X 96" - CONCERT CHERRY (UM1 THRU UM9, UN1 THRU UN9)
	137885-E2-438	EA	LUMBER - VYL2" -CONCERT CHERRY (U90/94/98/A1/A5/B1/C1/C5/D1/D5/E1/E5/F1/F5/G1/G5/H1/H5)
	160300-E2-438	EA	LUMBER - VINYL WRAPPED - .7" X 2" X 96" - CONCERT CHERRY (UM1 THRU UM9, UN1 THRU UN9)
	137885-F2-438	EA	LUMBER - VYL2.5" - CONCERT CHERRY (U90/94/98/A1/A5/B1/C1/C5/D1/D5/E1/E5/F1/F5/G1/G5/H1/H5)
	160300-F2-438	EA	LUMBER - VINYL WRAPPED - .7" X 2.5" X 96" - CONCERT CHERRY (UM1 THRU UM9, UN1 THRU UN9)
	137885-G2-438	EA	LUMBER - VYL3" - CONCERT CHERRY (U90/94/98/A1/A5/B1/C1/C5/D1/D5/E1/E5/F1/F5/G1/G5/H1/H5)
	160300-G2-438	EA	LUMBER - VINYL WRAPPED - .7" X 3" X 96" - CONCERT CHERRY (UM1 THRU UM9, UN1 THRU UN9)
	137885-H2-438	EA	LUMBER - VYL3.5" - CONCERT CHERRY (U90/94/98/A1/A5/B1/C1/C5/D1/D5/E1/E5/F1/F5/G1/G5/H1/H5)
	160300-H2-438	EA	LUMBER - VINYL WRAPPED - .7" X 3.5" X 96" - CONCERT CHERRY (UM1 THRU UM9, UN1 THRU UN9)
	137885-J2-438	EA	LUMBER - VYL5.5" - CONCERT CHERRY (U90/94/98/A1/A5/B1/C1/C5/D1/D5/E1/E5/F1/F5/G1/G5/H1/H5)
	160300-J2-438	EA	LUMBER - VINYL WRAPPED - .7" X 5.5" X 96" - CONCERT CHERRY (UM1 THRU UM9, UN1 THRU UN9)
	137885-J2-743	EA	LUMBER - VYL5.5" - CONCERT CHERRY (U90/94/98/A1/A5/B1/C1/C5/D1/D5/E1/E5/F1/F5/G1/G5/H1/H5)
	160300-J2-743	EA	LUMBER - VINYL WRAPPED - .7" X 5.5" X 108" - CONCERT CHERRY (UM1 THRU UM9, UN1 THRU UN9)
	137885-K2-438	EA	LUMBER - VYL3.9" - CONCERT CHERRY (U90/94/98/A1/A5/B1/C1/C5/D1/D5/E1/E5/F1/F5/G1/G5/H1/H5)
	160300-K2-438	EA	LUMBER - VINYL WRAPPED - .7" X 3.9" X 96" - CONCERT CHERRY (UM1 THRU UM9, UN1 THRU UN9)
	137885-R2-438	EA	LUMBER - VYL 3" - CONCERT CHERRY (U90/94/98/A1/A5/B1/C1/C5/D1/D5/E1/E5/F1/F5/G1/G5/H1/H5)
	160300-R2-438	EA	LUMBER - VINYL WRAPPED - .7" X 3" X 96" - CONCERT CHERRY (UM1 THRU UM9, UN1 THRU UN9)
3F	137887-D2-134	EA	MOLDING - 1.6" X 84"- CONCERT CHERRY (U90/94/98/A1/A5/B1/C1/C5/D1/D5/E1/E5/F1/F5/G1/G5/H1/H5)
3F	160301-D2-134	EA	MOLDING -VINYL WRAPPED - .7" X 1.6" X 84" - CONCERT CHERRY (UM1 THRU UM9, UN1 THRU UN9)
3F	137887-D2-743	EA	MLDG - 1.6" X 108" - CONCERT CHERRY (U90/94/98/A1/A5/B1/C1/C5/D1/D5/E1/E5/F1/F5/G1/G5/H1/H5)
3F	160301-D2-743	EA	MOLDING - VINYL WRAPPED- .7" X 1.6" X 108" - CONCERT CHERRY (UM1 THRU UM9, UN1 THRU UN9)
3F	137887-F2-134	EA	MLDNG - 2.5" X 84" - CONCERT CHERRY (U90/94/98/A1/A5/B1/C1/C5/D1/D5/E1/E5/F1/F5/G1/G5/H1/H5)
3F	160301-F2-134	EA	MOLDING - VINYL WRAPPED - .7" X 2.5" X 84" - CONCERT CHERRY (UM1 THRU UM9, UN1 THRU UN9)
3F	137887-F2-743	EA	MLDG - 2.5" X 108" - CONCERT CHERRY (U90/94/98/A1/A5/B1/C1/C5/D1/D5/E1/E5/F1/F5/G1/G5/H1/H5)
3F	160301-F2-743	EA	MOLDING - VINYL WRPPD - .7" X 2.5" X 108" - CONCERT CHERRY (UM1 THRU UM9, UN1 THRU UN9)
3F	137887-F2-438	EA	MLDG - 2.5" X 96" - CONCERT CHERRY (U90/94/98/A1/A5/B1/C1/C5/D1/D5/E1/E5/F1/F5/G1/G5/H1/H5)
3F	160301-F2-438	EA	MOLDING - VINYL WRPPD - .7" X 2.5" X 96" - CONCERT CHERRY (UM1 THRU UM9, UN1 THRU UN9)
	137894-A2-438	EA	LUMBER - VINYL WRAPPED - .7" X .75" X 96" - PORTSMOUTH OAK
	137894-D2-438	EA	LUMBER - VINYL WRAPPED - .7" X 1.5" X 96" - PORTSMOUTH OAK
	137894-E2-438	EA	LUMBER - VINYL WRAPPED - .7" X 2" X 96" - PORTSMOUTH OAK
	137894-F2-438	EA	LUMBER - VINYL WRAPPED - .7" X 2.5" X 96" - PORTSMOUTH OAK
	137894-G2-438	EA	LUMBER - VINYL WRAPPED - .7" X 3" X 96" - PORTSMOUTH OAK
	137894-H2-438	EA	LUMBER - VINYL WRAPPED - .7" X 3.5" X 96" - PORTSMOUTH OAK
	137894-J2-438	EA	LUMBER - VINYL WRAPPED - .7" X 5.5" X 80.2" - PORTSMOUTH OAK
	137894-J2-743	EA	LUMBER - VINYL WRAPPED - .7" X 5.5" X 96" - PORTSMOUTH OAK
	137894-K2-438	EA	LUMBER - VINYL WRAPPED - .7" X 3.9" X 96" - PORTSMOUTH OAK
	137894-R2-438	EA	LUMBER - VINYL WRAPPED - .7" X 3" X 96" - PORTSMOUTH OAK

INTERIOR FINISH GROUP (CONTINUED)
MOLDINGS & TRIMS (CONTINUED)

KEY	PART NUMBER	U/M	DESCRIPTION
3F	137895-D2-134	EA	MOLDING - VINYL WRAPPED - .7" X 1.6" X 84"-PORTSMOUTH OAK
3F	137895-D2-743	EA	MOLDING - VINYL WRAPPED - .7" X 1.6" X 108"-PORTSMOUTH OAK
3F	137895-F2-438	EA	MOLDING - VINYL WRAPPED - .7" X 2.5" X 96" - PORTSMOUTH OAK
3F	137895-F2-743	EA	MOLDING - VINYL WRAPPED - .7" X 2.5" X 108" - PORTSMOUTH OAK
	146419-A2-438	EA	LUMBER - VINYL WRAPPED - .7" X .75" X 96" - HONEY CHERRY
	146419-D2-438	EA	LUMBER - VINYL WRAPPED - .7" X 1.5" X 96" - HONEY CHERRY
	146419-E2-438	EA	LUMBER - VINYL WRAPPED - .7" X 2" X 96" - HONEY CHERRY
	146419-F2-438	EA	LUMBER - VINYL WRAPPED - .7" X 2.5" X 96" - HONEY CHERRY
	146419-G2-438	EA	LUMBER - VINYL WRAPPED - .7" X 3" X 96" - HONEY CHERRY
	146419-H2-438	EA	LUMBER - VINYL WRAPPED - .7" X 3.5" X 96" - HONEY CHERRY
	146419-J2-438	EA	LUMBER - VINYL WRAPPED - .7" X 5.5" X 96" - HONEY CHERRY
	146419-J2-743	EA	LUMBER - VINYL WRAPPED - .7" X 5.5" X 108" - HONEY CHERRY
	146419-K2-438	EA	LUMBER - VINYL WRAPPED - .7" X 3.9" X 96" - HONEY CHERRY
	146419-R2-438	EA	LUMBER - VINYL WRAPPED - .7" X 3" X 96" - HONEY CHERRY
	146419-S2-438	EA	LUMBER - VINYL WRAPPED/FULL - .7"X 3.5"X 96"- HONEY CHERRY
	146419-T2-438	EA	LUMBER - VINYL WRAPPED/FULL - .7"X 5.5"X 96"- HONEY CHERRY
3F	146425-D2-134	EA	MOLDING - VINYL WRAPPED - .7" X 1.6" X 83.9" - HONEY CHERRY
3F	146425-F2-438	EA	MOLDING - VINYL WRAPPED - .7" X 2.6" X 96" - HONEY CHERRY
	149325-A2-438	EA	LUMBER - VINYL WRAPPED - .7" X .75" X 96" - WASHED MAPLE
	149325-D2-438	EA	LUMBER - VINYL WRAPPED - .7" X 1.5" X 96" - WASHED MAPLE
	149325-E2-438	EA	LUMBER - VINYL WRAPPED - .7" X 2" X 96" - WASHED MAPLE
	149325-F2-438	EA	LUMBER - VINYL WRAPPED - .7" X 2.5" X 96" - WASHED MAPLE
	149325-G2-438	EA	LUMBER - VINYL WRAPPED - .7" X 3" X 96" - WASHED MAPLE
	149325-H2-438	EA	LUMBER - VINYL WRAPPED - .7" X 3.5" X 96" - WASHED MAPLE
	149325-J2-438	EA	LUMBER - VINYL WRAPPED - .7" X 5.5" X 96" - WASHED MAPLE
	149325-J2-743	EA	LUMBER - VINYL WRAPPED - .7" X 5.5" X 108" - WASHED MAPLE
	149325-K2-438	EA	LUMBER - VINYL WRAPPED - .7" X 3.9" X 96" - WASHED MAPLE
	149325-R2-438	EA	LUMBER - VINYL WRAPPED - .7" X 3" X 96" - WASHED MAPLE
3F	149326-D2-134	EA	MOLDING - VINYL WRAPPED - .7" X 1.5" X 83.9" - WASHED MAPLE
3F	149326-D2-743	EA	MOLDING - VINYL WRAPPED - .7" X 1.5" X 108" - WASHED MAPLE
3F	149326-F2-134	EA	MOLDING - VINYL WRAPPED - .7" X 2.5" X 83.9" - WASHED MAPLE
3F	149326-F2-438	EA	MOLDING - VINYL WRAPPED - .7" X 2.5" X 96" - WASHED MAPLE
3F	149326-F2-743	EA	MOLDING - VINYL WRAPPED - .7" X 2.5" X 108" - WASHED MAPLE
	149330-A2-438	EA	LUMBER - VINYL WRAPPED - .7" X .75" X 96" - SIERRA MAPLE
	149330-D2-438	EA	LUMBER - VINYL WRAPPED - .7" X 1.5" X 96" - SIERRA MAPLE
	149330-E2-438	EA	LUMBER - VINYL WRAPPED - .7" X 2" X 96" - SIERRA MAPLE
	149330-F2-438	EA	LUMBER - VINYL WRAPPED - .7" X 2.5" X 96" - SIERRA MAPLE
	149330-G2-438	EA	LUMBER - VINYL WRAPPED - .7" X 3" X 96" - SIERRA MAPLE
	149330-H2-438	EA	LUMBER - VINYL WRAPPED - .7" X 3.5" X 96" - SIERRA MAPLE
	149330-J2-438	EA	LUMBER - VINYL WRAPPED - .7" X 5.5" X 96" - SIERRA MAPLE
	149330-J2-743	EA	LUMBER - VINYL WRAPPED - .7" X 5.5" X 108" - SIERRA MAPLE
	149330-K2-438	EA	LUMBER - VINYL WRAPPED - .7" X 3.9" X 96" - SIERRA MAPLE
	149330-R2-438	EA	LUMBER - VINYL WRAPPED - .7" X 3" X 96" - SIERRA MAPLE
3F	149331-D2-134	EA	MOLDING - VINYL WRAPPED - .7" X 1.5" X 83.9" - SIERRA MAPLE
3F	149331-D2-743	EA	MOLDING - VINYL WRAP - .7" X 1.5" X 108" - SIERRA MAPLE
3F	149331-F2-134	EA	MOLDING - VINYL WRAPPED - .7" X 2.5" X 83.9" - SIERRA MAPLE
3F	149331-F2-438	EA	MOLDING - VINYL WRAPPED - .7" X 2.5" X 96" - SIERRA MAPLE
3F	149331-F2-743	EA	MOLDING - VINYL WRAPPED - .7" X 2.5" X 108" - SIERRA MAPLE

INTERIOR FINISH GROUP (CONTINUED)
MOLDINGS & TRIMS (CONTINUED)

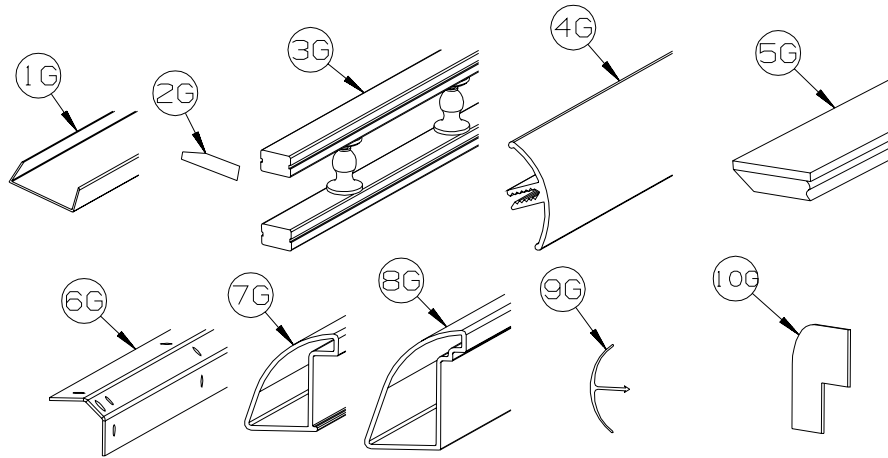

KEY	PART NUMBER	U/M	DESCRIPTION
1G	141260-01-01A	FT	U-CHANNEL - 1" - VILLAGE OAK
1G	141260-01-02A	FT	U-CHANNEL - 1" - GRADY BROWN
1G	141260-02-01A	FT	U-CHANNEL - 1 1/8" - VILLAGE OAK
1G	141260-02-02A	FT	U-CHANNEL - 1 1/8" - GRADY BROWN
2G	146306-01-01A	FT	TRANSITION - CARPET/TILE
3G	150167-01-07A	EA	RAIL - DECORATIVE - 96" W/O REVERSE SIDE GROOVE - PORTSMOUTH OAK
3G	150167-01-02A	EA	RAIL - DECORATIVE - 96" W/O REVERSE SIDE GROOVE - SALEM CHERRY - CONCERT CHERRY
3G	150167-01-03A	EA	RAIL - DECORATIVE - 96" W/O REVERSE SIDE GROOVE - WASHED MAPLE
3G	150167-01-09A	EA	RAIL - DECORATIVE - 96" W/O REVERSE SIDE GROOVE - SIERRA MAPLE
4G	151653-10-02A	EA	TRIM/RADIUS - CABINET CORNER - 79.6" - DULL METALLIC
4G	151653-13-02A	EA	TRIM/RADIUS - CABINET CORNER - 79.8" - DULL METALLIC
5G	151676-26-S46	EA	MOLDING/TRIM - .75" X 1.6" X 80.2" - PORTSMOUTH OAK
5G	151676-26-S47	EA	MOLDING/TRIM - .75" X 1.6" X 80.2" - CONCERT CHERRY
5G	151676-26-S48	EA	MOLDING/TRIM - .75" X 1.6" X 80.2" - WASHED MAPLE
5G	151676-26-SR0	EA	MOLDING/TRIM - .75" X 1.6" X 80.2" - SIERRA MAPLE
6G	151861-05-02B	EA	ANGLE - SUPPORT/CORNER - 1.4" X 78.6" - E-COATED
7G	151893-01-02A	EA	TRIM/RADIUS - CABINET BOTTOM - 72.6" - DULL METALLIC
8G	152077-01-02A	EA	TRIM/RADIUS - CABINET BOTTOM - 27.7" - DULL METALLIC
9G	156464-01-01A	FT	MOLDING - CORNER - RADIUS/PLASTIC - 8' - HONEY CHERRY
9G	156464-01-02A	FT	MOLDING - CORNER - RADIUS/PLASTIC - 8' - WASHED MAPLE
9G	156464-01-03A	FT	MOLDING - CORNER - RADIUS/PLASTIC - 8' - BONE
10G	160989-01-06A	FT	CAP - CORNER - RADIUS MOLDING - PLASTIC - WASHED MAPLE
10G	160989-01-07A	FT	CAP - CORNER - RADIUS MOLDING - PLASTIC - HONEY CHERRY

INTERIOR FINISH GROUP (CONTINUED)
PANELING & LAMINATES

KEY	PART NUMBER	U/M	DESCRIPTION
	000885-C3-000	SF	PARTICLE BOARD - 3/8" X 4' X 8' - WHITE THATCH EMB-1 SIDED
	000885-B4-000	SF	PARTICLE BOARD - 3/8" X 4' X 8' - WASHED MAPLE - 2 SIDED - WASHED MAPLE
	000885-B5-000	SF	PARTICLE BOARD - 3/8" X 4' X 8' - WASHED MAPLE - 1 SIDED - WASHED MAPLE
	000885-B6-000	SF	PARTICLE BOARD - 3/4" X 4' X 8' - WASHED MAPLE - 2 SIDED - WASHED MAPLE
	000885-B7-000	SF	PARTICLE BOARD - 1/2" X 4' X 8' - WASHED MAPLE - 2 SIDED - WASHED MAPLE
	000885-B1-000	SF	PARTICLE BOARD - 3/8" X 4' X 8' - SIERRA MAPLE - 1-SIDED - SIERRA MAPLE
	000885-B0-000	SF	PARTICLE BOARD - 3/8" X 4' X 8' - SIERRA MAPLE - 2-SIDED - SIERRA MAPLE
	000885-B2-000	SF	PARTICLE BOARD - 3/4" X 4' X 8' - SIERRA MAPLE - 2-SIDED - SIERRA MAPLE
	000885-B3-000	SF	PARTICLE BOARD - 1/2" X 4' X 8' - SIERRA MAPLE - 2-SIDED - SIERRA MAPLE
	079666-03-000	SF	PANELING - CLOSET - CEDAR - 4' X 7'
	074497-49-000	SF	PANELING - WASHED MAPLE - 1/8" X 4' X 8' - WASHED MAPLE
	074497-48-000	SF	PANELING - SIERRA MAPLE - 1/8" X 4' X 8' - SIERRA MAPLE
	088272-M9-000	SF	PANELING - WHITE THATCHED - 4' X 8'
	088272-L8-000	SF	PANELING - D'VINCI ALMOND - 4' X 7' (U67, U68) FROM: 00-00-00 THRU: 03-37-07
	088272-M7-000	SF	PANELING - KURTA CANVAS - 4' X 7.4' (U67, U68) FROM: 03-28-07 THRU: 99-99-99
	088272-M7-000	SF	PANELING - KURTA CANVAS - 4' X 7.4' (U71, U72)
	088272-M1-000	SF	PANELING - MORITZ/TUSCANY - 4' X 7.4' (U75, U76)
	076773-20-000	SF	PANELING - 2 SIDED/WASHED MAPLE - 1/8" X 4' X 8' - WASHED MAPLE
	076773-19-000	SF	PANELING - 2 SIDED/SIERRA MAPLE - 1/8" X 4' X 8' - SIERRA MAPLE
	088263-J2-000	EA	BATT STRIP - DECORATIVE - NEAT/WASHED MAPLE - WASHED MAPLE
	088263-J1-000	EA	BATT STRIP - DECORATIVE - SIERRA MAPLE
	088263-J0-000	EA	BATT STRIP - DECORATIVE - D'VINCI ALMOND (U67, U68) FROM: 00-00-00 THRU: 03-37-07
	088263-K3-000	EA	BATT STRIP - DECORATIVE - KURTA/CANVAS - 8' (U67, U68) FROM: 03-28-07 THRU: 99-99-99
	088263-K3-000	EA	BATT STRIP - DECORATIVE - KURTA/CANVAS - 8' (U71, U72)
	088263-J7-000	EA	BATT STRIP - DECORATIVE - MORITZ/TUSCANY (U75, U76)
	085284-F7-000	FT	TAPE/STRIP - TRUE GRIP - 1 1/2" WIDE - ADHESIVE BACKED
	085284-J3-000	FT	BATT TAPE - ADHESIVE BACKED - DECORATIVE - D'VINCI ALMOND (U67, U68) FROM: 00-00-00 THRU: 03-37-07
	085284-K7-000	FT	BATT TAPE - ADHESIVE BACKED - DECORATIVE - KURTA/CANVAS (U67, U68) FROM: 03-28-07 THRU: 99-99-99
	085284-K7-000	FT	BATT TAPE - ADHESIVE BACKED - DECORATIVE - KURTA/CANVAS (U71, U72)
	085284-K1-000	FT	BATT TAPE - ADHESIVE BACKED - DECORATIVE - MORITZ/TUSCANY (U75, U76)
	085284-J5-000	FT	BATT TAPE - ADHESIVE BACKED - DECORATIVE-NEAT/WASHED MAPLE - WASHED MAPLE
	085284-J4-000	FT	BATT TAPE - ADHESIVE BACKED - DECORATIVE - SIERRA MAPLE
	074498-40-000	SF	LAMINATE - PLASTIC - OFF WHITE - 4' X 8'
	074498-A6-000	SF	LAMINATE - PLASTIC - HARDROCK MAPLE - 5' X 8' - WASHED MAPLE
	074498-A8-000	SF	LAMINATE - PLASTIC - SUEDE/HONEY MAPLE - 5' X 8' - SIERRA MAPLE
	074498-B9-000	SF	LAMINATE - PLASTIC - SUNSTONE - 5' X 8' (U67, U68, U75, U76)
	074498-B8-000	SF	LAMINATE - PLASTIC - CLASSIC ROCK - 5' X 8' (U71, U72)
	074498-A6-000	SF	LAMINATE - PLASTIC - HARDROCK MAPLE - 5' X 8' - WASHED MAPLE
	074498-A8-000	SF	LAMINATE - PLASTIC - SIERRA MAPLE - 4' X 8' - SIERRA MAPLE
	076325-73-000	FT	MOLDING - EDGE BAND - .93" X .024" - OFF WHITE
	076325-81-000	FT	MOLDING - EDGE BAND - 1 5/16" X .30" - NEAT/WASHED MAPLE - WASHED MAPLE
	076325-83-000	FT	MOLDING - EDGE BAND - .93" X .024" - SIERRA MAPLE

INTERIOR FINISH GROUP (CONTINUED)

INTERIOR TRIM LAYOUT

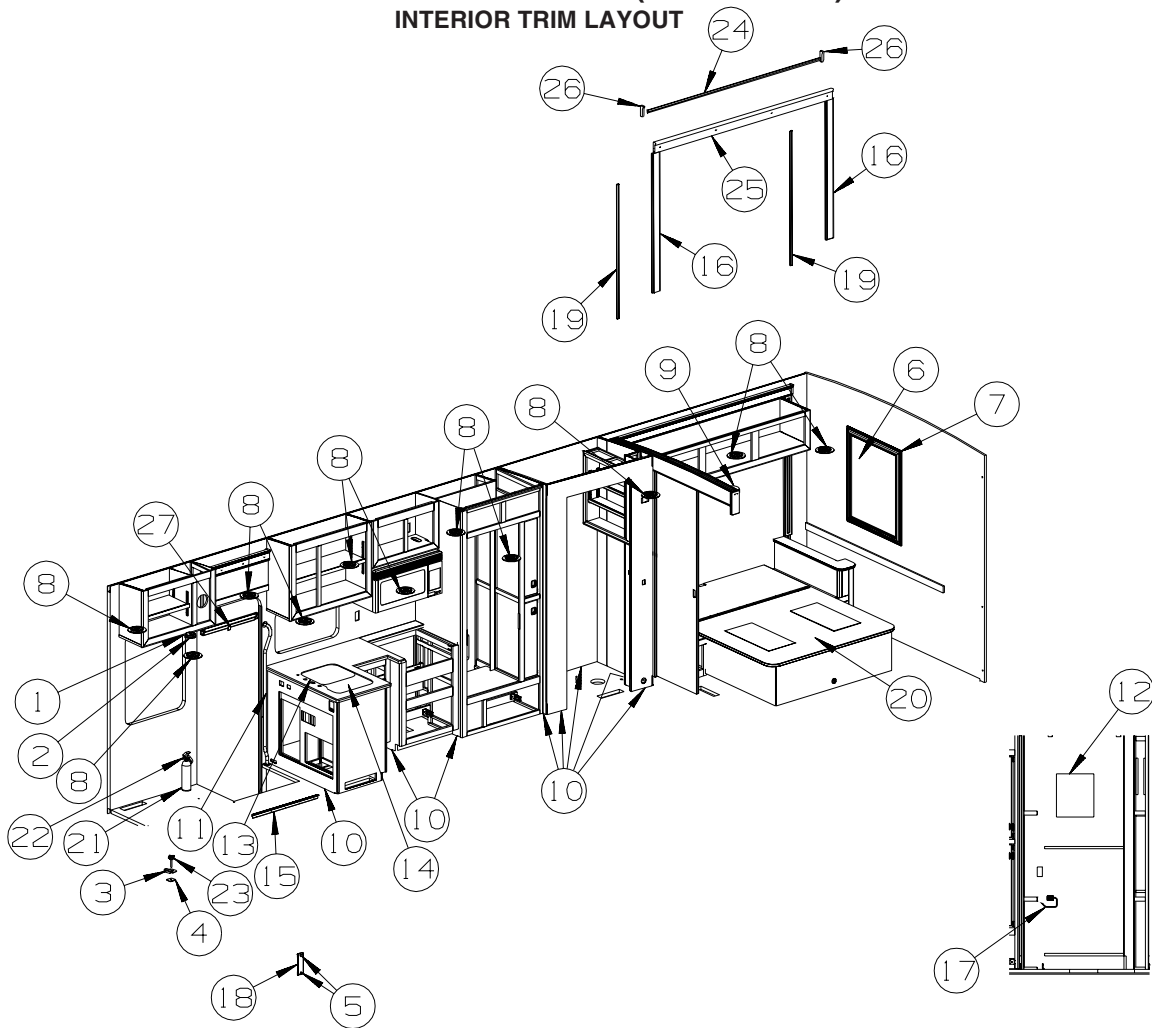

KEY	PART NUMBER	U/M	DESCRIPTION
1	072852-01-000	EA	DETECTOR - SMOKE - W/9 VOLT BATTERY - US
1	072852-02-000	EA	DETECTOR - SMOKE - W/9 VOLT BATTERY - CANADIAN
2	077956-01-000	EA	LABEL - WARNING/SMOKE DETECTOR
3	134057-01-11B	EA	BRACKET - RECLINER - FLAT BLACK
3	143956-03-04B	EA	BRACKET/TIEDOWN - EURO CHAIR - BLACK - LOUNGE CHAIR-EURO/LNG CHR-HOOP-ULTRLTR
4	134128-02-02B	EA	PLATE - W/HOLES - W/WELDNUT - E-COATED
5	140151-02-02A	EA	COVER - SCREW - BRIGHT WHITE
5	140151-02-03A	EA	COVER - SCREW - MEDIUM OAK
			FROM: 00-00-00 THRU: 07-31-06
6	140374-30-000	EA	MIRROR - SAFETY GLASS - 25.6" X 31.5"
7	142631-02-02A	EA	FRAME - MIRROR - 35.7"H X 30"W - WASHED MAPLE
7	142631-02-04A	EA	FRAME - MIRROR - 35.7"H X 30"W - SIERRA MAPLE
8	120134-01-02A	EA	REGISTER - W/DAMPER - 4" PIPE/6.4" O.D. FACE - WHITE
9	125136-02-000	EA	DETECTOR/CO - GAS MODEL - 9 VOLT
10	M09471-79-R46	EA	MOLDING - TRIM/COVE - .8" X .8" X 96" - WASHED MAPLE
10	M09471-79-SA3	EA	MOLDING - TRIM/COVE - .8" X .8" X 96" - SIERRA MAPLE
11	131058-03-02A	EA	HAND RAIL - INTERIOR ENTRY DOOR - BLACK
12	131493-05-03A	EA	PICTURE - DECORATIVE - 10" X 10" - SAND DOLLAR (U67, U68)
12	131493-02-39A	EA	PICTURE - DECORATIVE - 13" X 15" - CASUAL ELEGANCE (U71, U72, U75, U76)
12	130120-01-01A	EA	BRACKET/MOUNTING - MIRROR
13	137489-01-09A	EA	COVER - SINK/LARGE - 13.8"X17"X1/4" VENDURA-BUTTER BRICKLE
			FROM: 00-00-00 THRU: 07-16-06
13	161005-02-U67	EA	COVER - SINK - 1/4" VENDURA - BUTTER BRICKLE
			FROM: 07-17-06 THRU: 99-99-99
14	137489-02-09A	EA	COVER - SINK/SMALL - 9.6"X15.7"X1/4"VENDURA-BUTTER BRICKLE
			FROM: 00-00-00 THRU: 07-16-06
14	161005-04-U67	EA	COVER - SINK - 1/4" VENDURA - BUTTER BRICKLE
			FROM: 07-17-06 THRU: 99-99-99
15	139955-06-02A	EA	TRIM - STEP/ENTRY - 29.3" - TITANIUM

INTERIOR FINISH GROUP (CONTINUED)
INTERIOR TRIM LAYOUT (CONTINUED)

KEY	PART NUMBER	U/M	DESCRIPTION
16	Y00152-A2-438	EA	MOLDING/TRIM - VINYL - .6" X 3.5" X 96" - WASHED MAPLE
16	Y00152-92-438	EA	MOLDING/TRIM - VINYL - .6" X 3.5" X 96" - SIERRA MAPLE
17	145980-03-03A	EA	HOLDER - TOILET TISSUE - EURO - CHROME
18	148362-01-01A	EA	COVER - BRACKET/STRIKE - BRIGHT WHITE
			FROM: 00-00-00 THRU: 07-31-06
18	148362-01-02A	EA	COVER - BRACKET/STRIKE - MEDIUM OAK
			FROM: 08-01-06 THRU: 99-99-99
19	M09525-09-U79	EA	MOLDING - TRIM/VEE - .2" X 1" X 50.4" - WASHED MAPLE
			FROM: 00-00-00 THRU: 06-25-06
19	M09538-34-U67	EA	MOLDING - TRIM/VEE - .4" X 1" X 52.2" - WASHED MAPLE
			FROM: 06-26-06 THRU: 99-99-99
19	M09525-09-U80	EA	MOLDING - TRIM/VEE - .2" X 1" X 50.4" - SIERRA MAPLE
			FROM: 00-00-00 THRU: 06-25-06
19	M09538-34-U68	EA	MOLDING - TRIM/VEE - .4" X 1" X 52.2" - SIERRA MAPLE
			FROM: 06-26-06 THRU: 99-99-99
20	154430-01-000	EA	MATTRESS - INNERSPRING - 60" X 74.5"
21	094499-03-000	EA	EXTINGUISHER/FIRE - DRY - 10BC - W/GAUGE/BRACKET
21*	094499-02-000	EA	EXTINGUISHER/FIRE - DRY - 10BC - W/GAUGE - CANADIAN
22	094499-04-000	EA	STRAP - FIRE EXTINGUISHER MOUNTING - METAL
23	134194-01-01A	EA	KNOB - HOLD DOWN/RECLINER - BLACK - LNG CHR-HOOP BASE W/CABINET
24	M09515-05-TH6	EA	MOLDING - TRIM/VEE - .2" X 1" X 77.6" - WASHED MAPLE
			FROM: 00-00-00 THRU: 02-05-06
24	M09525-34-U67	EA	MOLDING - TRIM/VEE - .2" X 1" X 77.5" - WASHED MAPLE
			FROM: 02-06-06 THRU: 06-25-06
24	M09538-37-U67	EA	MOLDING - TRIM/VEE - .4" X 1" X 77.5" - WASHED MAPLE
			FROM: 06-26-06 THRU: 99-99-99
24	M09515-05-U68	EA	MOLDING - TRIM/VEE - .2" X 1" X 77.6" - SIERRA MAPLE
			FROM: 00-00-00 THRU: 02-05-06
24	M09525-34-U68	EA	MOLDING - TRIM/VEE - .2" X 1" X 77.5" - SIERRA MAPLE
			FROM: 02-06-06 THRU: 06-25-06
24	M09525-34-U68	EA	MOLDING - TRIM/VEE - .4" X 1" X 77.5" - SIERRA MAPLE
			FROM: 06-26-06 THRU: 99-99-99
25	Y00282-A2-438	EA	MOLDING - SLIDEOUT/VINYL WRAP - 3.9"X 96" - WASHED MAPL
25	Y00282-92-438	EA	MOLDING - SLIDEOUT/VINYL WRAP - 3.9"X 96" - SIERRA MAPLE
26	149151-01-S48	EA	MOLDING/BLOCK - WASHED MAPLE
26	149151-01-SR0	EA	MOLDING/BLOCK - SIERRA MAPLE
27	144628-02-01A	EA	SHADE - SCREEN DOOR - 23" X 33.4" - BRIGHT WHITE

*COMPONENT PARTS LISTED LATER IN THIS GROUP

INTERIOR FINISH GROUP (CONTINUED)
INTERIOR TRIM LAYOUT (CONTINUED)

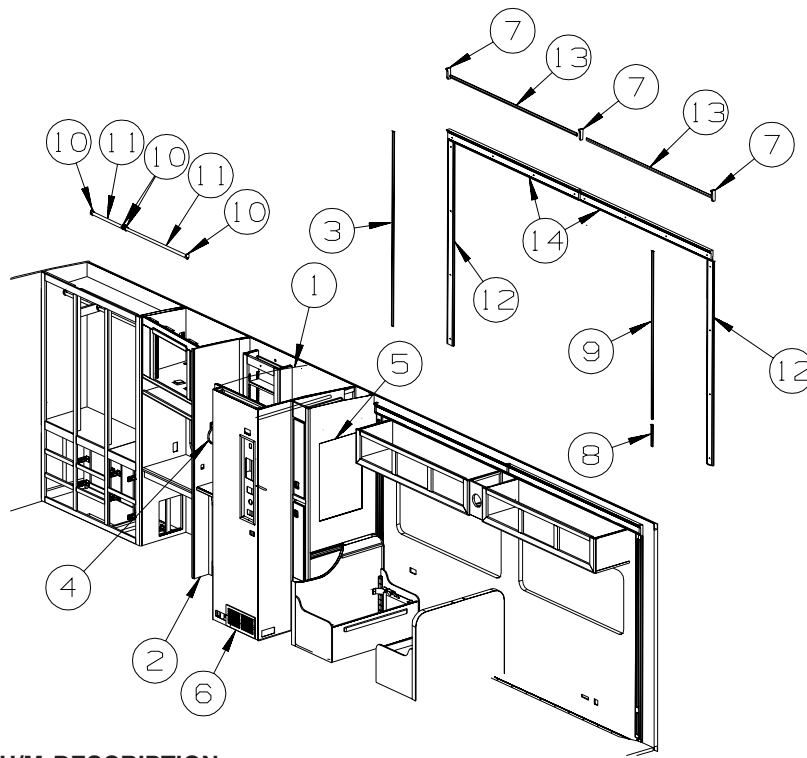

KEY	PART NUMBER	U/M	DESCRIPTION
1*	115011-03-02A	EA	DOOR SHOWER - SLIDING/BYPASS W/40" LOWER TRACK-CHROME/AQUA
2	M09471-79-R46	EA	MOLDING - TRIM/COVE - .8" X .8" X 96" - WASHED MAPLE
2	M09471-79-SA3	EA	MOLDING - TRIM/COVE - .8" X .8" X 96" - SIERRA MAPLE
3	M09525-07-U67	EA	MOLDING - TRIM/VEE - .2" X 1" X 73" - WASHED MAPLE
			FROM: 00-00-00 THRU: 06-25-06
3	M09538-29-U67	EA	MOLDING - TRIM/VEE - .4" X 1" X 76.5" - WASHED MAPLE
			FROM: 06-26-06 THRU: 99-99-99
3	M09525-07-U68	EA	MOLDING - TRIM/VEE - .2" X 1" X 73" - SIERRA MAPLE
			FROM: 00-00-00 THRU: 06-25-06
3	M09525-29-U68	EA	MOLDING - TRIM/VEE - .4" X 1" X 76.5" - SIERRA MAPLE
			FROM: 06-26-06 THRU: 99-99-99
4	145980-06-03A	EA	TOWEL RING - CHROME
5	149147-01-03A	EA	MIRROR - FRAMED W/ETCHING - WASHED MAPLE
5	149147-01-05A	EA	MIRROR - FRAMED W/ETCHING - SIERRA MAPLE
6	093614-01-02A	EA	GRILLE - AIR RETURN - 15.9" X 7.9" - BEIGE
7	149151-01-S48	EA	MOLDING/BLOCK - WASHED MAPLE
7	149151-01-SR0	EA	MOLDING/BLOCK - SIERRA MAPLE
8	M09525-24-U67	EA	MOLDING - TRIM/VEE - .2" X 1" X 8.2" - WASHED MAPLE
			FROM: 00-00-00 THRU: 06-25-06
8	M09538-30-U67	EA	MOLDING - TRIM/VEE - .4" X 1" X 10.9" - WASHED MAPLE
			FROM: 06-26-06 THRU: 99-99-99
8	M09525-24-U68	EA	MOLDING - TRIM/VEE - .2" X 1" X 8.2" - SIERRA MAPLE
			FROM: 00-00-00 THRU: 06-25-06
8	M09538-30-U68	EA	MOLDING - TRIM/VEE - .4" X 1" X 10.9" -SIERRA MAPLE
			FROM: 06-26-06 THRU: 99-99-99
9	M09511-93-TG2	EA	MOLDING - TRIM/VEE - .2" X 1" X 63" - WASHED MAPLE
			FROM: 00-00-00 THRU: 06-25-06
9	M09538-28-U67	EA	MOLDING - TRIM/VEE - .4" X 1" X 64.5" - WASHED MAPLE
			FROM: 06-26-06 THRU: 99-99-99
9	M09511-93-U68	EA	MOLDING - TRIM/VEE - .2" X 1" X 63" - SIERRA MAPLE
			FROM: 00-00-00 THRU: 06-25-06
9	M09538-28-U68	EA	MOLDING - TRIM/VEE - .4" X 1" X 64.5" - WASHED MAPLE
			FROM: 06-26-06 THRU: 99-99-99
10	152301-01-01A	EA	FLANGE - PLASTIC - 1" CLOTHES ROD HOLDER - WHITE
11	Y00136-21-218	EA	DOWEL - WOOD - CLOTHES ROD - 1"DIAMETER X 4'
12	Y00152-A2-438	EA	MOLDING/TRIM - VINYL - .6" X 3.5" X 96" - WASHED MAPLE
12	Y00152-92-438	EA	MOLDING/TRIM - VINYL - .6" X 3.5" X 96" - SIERRA MAPLE

INTERIOR FINISH GROUP (CONTINUED)
INTERIOR TRIM LAYOUT (CONTINUED)

KEY	PART NUMBER	U/M	DESCRIPTION
13	M09525-32-U67	EA	MOLDING - TRIM/VEE - .2" X 1" X 69.9" - WASHED MAPLE FROM: 00-00-00 THRU: 06-25-06
13	M09538-27-U67	EA	MOLDING - TRIM/VEE - .4" X 1" X 69.9" - WASHED MAPLE FROM: 06-26-06 THRU: 99-99-99
13	M09525-32-U68	EA	MOLDING - TRIM/VEE - .2" X 1" X 69.9" - SIERRA MAPLE FROM: 00-00-00 THRU: 06-25-06
13	M09538-27-U68	EA	MOLDING - TRIM/VEE - .4" X 1" X 69.9" - SIERRA MAPLE FROM: 06-26-06 THRU: 99-99-99
14	Y00282-A2-438	EA	MOLDING - SLIDEOUT/VINYL WRAP - 3.9"X 96" - WASHED MAPLE
14	Y00282-92-438	EA	MOLDING - SLIDEOUT/VINYL WRAP - 3.9"X 96" - SIERRA MAPLE

***COMPONENT PARTS LISTED LATER IN THIS GROUP**

INTERIOR FINISH GROUP (CONTINUED)
COMPONENT PARTS FOR INTERIOR TRIM LAYOUT

094499-02-000

KEY	PART NUMBER	U/M DESCRIPTION	VENDOR NO
	094499-01-700	EA BRACKET MTG. W/PLAS. STRAP	294039

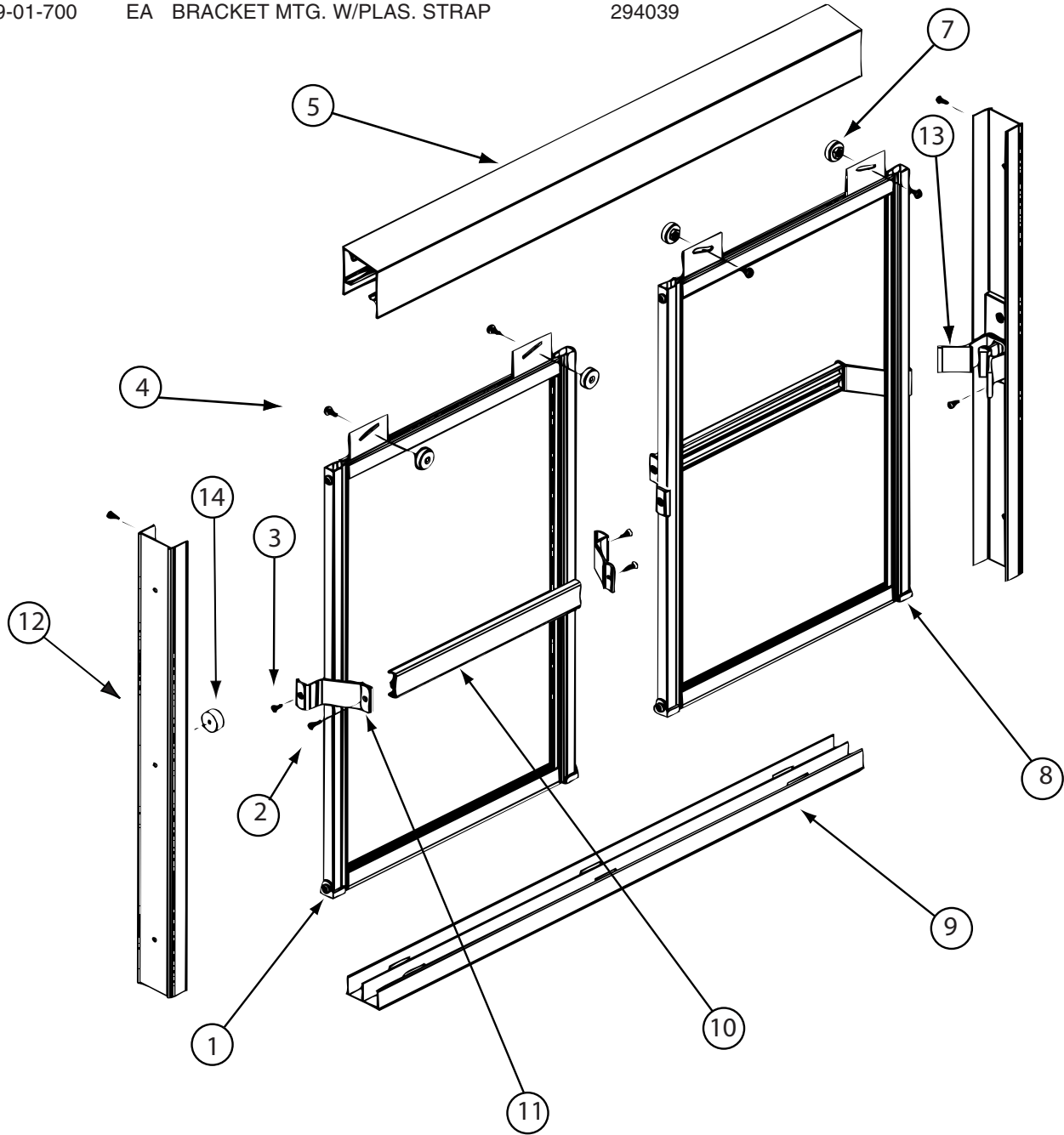

115011-03-02A

KEY	PART NUMBER	U/M DESCRIPTION	VENDOR NO.
1	115011-03-708	EA GUIDE/NYLON - F/DOOR BOTTOM	CP1105
2	115011-03-700	EA SCREW F/TOWEL BAR/HEADER	612F-B
3	115011-03-703	EA SCREW F/TOWEL BAR BRKTS	638F-B CHROME
4	115011-01-705	EA SCREW-ROLLER, (HEX HEAD)	832HEX
5	115011-03-709	EA HEADER - CHROME	45B
7	115011-01-704	EA ROLLERS	PN193
8	115011-01-706	FT GLAZING VINYL-BLACK	C154B
9	115011-03-704	EA TRACK/BOTTOM - 50" CHROME	90B
10	115011-03-701	EA TOWEL BAR - SILVER	136B - 17"
11	115011-03-702	EA BRACKET-TOWEL BAR - SILVER	135B
12	115011-03-706	EA JAMB - WALL SHOWER DOOR	126B
13	115011-03-707	EA TRAVEL LATCH - BLACK	9733B
14	115011-01-714	EA BUMPER - RATTLE/SHOWER DOOR	5168S
	115011-01-715	EA PAD - FOAM	116R

CONTACT WINNEBAGO PART SALES FOR UNLISTED COMPONENT(S)

INTERIOR FINISH GROUP (CONTINUED)
FLOOR COVERINGS

KEY	PART NUMBER	U/M	DESCRIPTION
	075233-01-000	SY	PAD - CARPET - 3/8" X 6'W ROLL - SOLD BY THE SQUARE YARD
	089275-02-000	FT	STRIP - 3/4" X 84" BLACK POLYETHYLENE
	093486-01-000	SY	CARPET - COMPARTMENT - 72" WIDE - DARK GRAY
	152251-05-02A	EA	CARPET - 4 SQUARE YARD INCREMENTS - BURLWOOD (U67, U68)
	152251-05-07A	SY	CARPET - 4 SQUARE YARD INCREMENTS - RAFFIA (U71, U72, U75, U76)
	131711-01-13A	SY	TILE/FLOOR - VINYL - 12" X 12" - MESA

INTERIOR FINISH GROUP (CONTINUED) HARDWARE

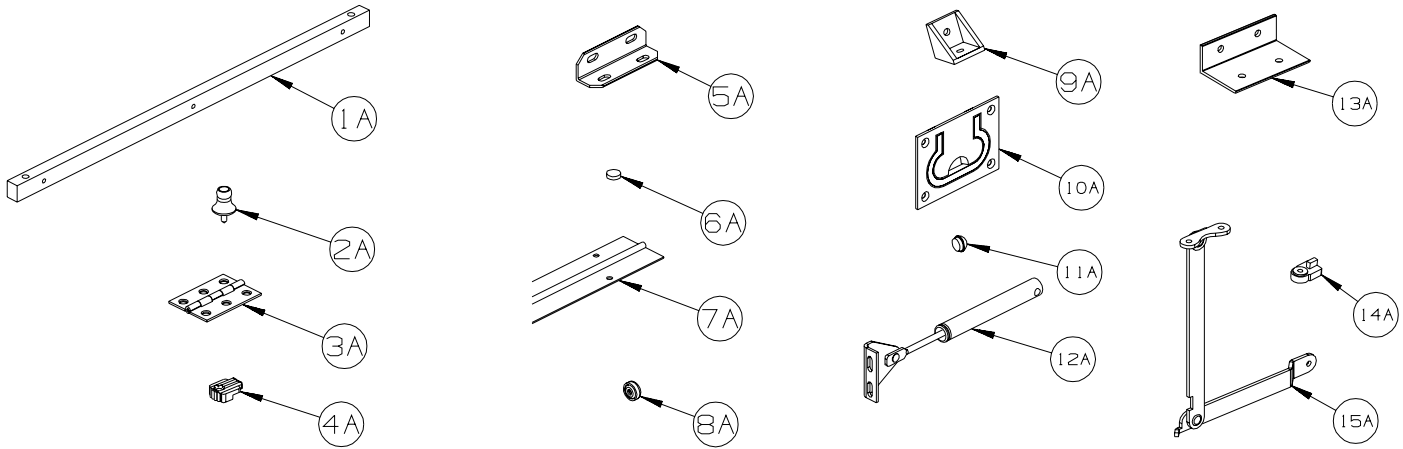

KEY	PART NUMBER	U/M	DESCRIPTION
1A	P34509-01-N01	EA	RAIL END - RH/LH - TOWEL RACK - PORTSMOUTH
1A	P34509-01-P14	EA	RAIL END - RH/LH - TOWEL RACK - CONCERT CHERRY
1A	P34509-01-J70	EA	RAIL END - RH/LH - TOWEL RACK - WASHED MAPLE
1A	P34509-01-RE0	EA	RAIL END - RH/LH - TOWEL RACK - HONEY CHERRY
1A	P34509-01-SA3	EA	RAIL END - RH/LH - TOWEL RACK - SIERRA MAPLE
2A	009013-01-000	EA	CATCH - BULLDOG - MALE/FEMALE
3A	009059-01-000	EA	HINGE - DOOR - 2" X 1.4" - BRASS
3A	009059-02-000	EA	HINGE - DOOR - 2" X 2.7" - BRASS
3A	009059-03-000	EA	HINGE - BRASS - 1.75"
3A	009059-04-000	EA	HINGE - 2" - ZINC
4A	009089-01-000	EA	CLIP - MIRROR
5A	016604-01-000	EA	BRACE - ANGLE - 2 1/2" - UNPAINTED METAL
5A	016604-05-000	EA	BRACE - ANGLE - 2 1/2" - OFF WHITE METAL
5A	016604-10-000	EA	BRACE - SEAT ANGLE - 2.5" - BLACK
6A	023320-01-000	EA	PAD - FELT 3/8" DIAMETER
7A	041389-19-000	EA	HINGE - PIANO - 1 1/2" X 71.9" - UNPAINTED
7A	041389-25-000	EA	HINGE - PIANO - 1 1/2" X 55" - UNPAINTED
7A	041389-32-000	EA	HINGE - PIANO - 68" - OFF WHITE
8A	057671-01-000	EA	COVER - SCREW - #8 - OFF WHITE
8A	057671-15-000	EA	COVER - SCREW - #8 - BRIGHT WHITE
8A	057671-16-000	EA	COVER - SCREW - #8 - SOFT WHITE
8A	057671-18-000	EA	COVER - SCREW - #8 - OFF WHITE
9A	065740-01-000	EA	BRACE - CABINET/CORNER - PLASTIC
10A	072871-01-000	EA	PULL - FLUSH - CHROME
11A	074045-13-000	EA	PLUG - OAK - 3/8" DOWEL-1/2" HEAD - PORTSMOUTH OAK
11A	074045-08-000	EA	PLUG - OAK - 3/8" DOWEL-1/2" HEAD - CONCERT CHERRY
11A	074045-12-000	EA	PLUG - OAK - 3/8" DOWEL-1/2" HEAD - WASHED MAPLE
11A	074045-14-000	EA	PLUG - OAK - 3/8" DOWEL-1/2" HEAD - HONEY CHERRY
11A	074045-15-000	EA	PLUG - OAK - 3/8" DOWEL-1/2" HEAD - SIERRA MAPLE
12A	074493-02-000	EA	SUPPORT - PISTON SPRING - CABINET DOOR - 26 LBS
12A	074493-03-000	EA	SUPPORT - PISTON SPRING - CABINET DOOR - 12 LBS
12A	074493-04-000	EA	SUPPORT - PISTON SPRING - CABINET DOOR - 32LBS
13A	156732-01-01A	EA	BRACE - ANGLE/COUCH - 2.5" - MILL
13A	156732-01-02A	EA	BRACE - ANGLE/COUCH - 2.5" - OFF WHITE
13A	156732-03-01A	EA	BRACE - ANGLE/COUCH - BLACK
14A	083204-03-000	EA	BUTTON - RETAINING MIRROR 5/16" TIP
15A	084412-01-000	EA	SUPPORT/HINGE KIT (LEFT & RIGHT HINGES)

INTERIOR FINISH GROUP (CONTINUED)

HARDWARE (CONTINUED)

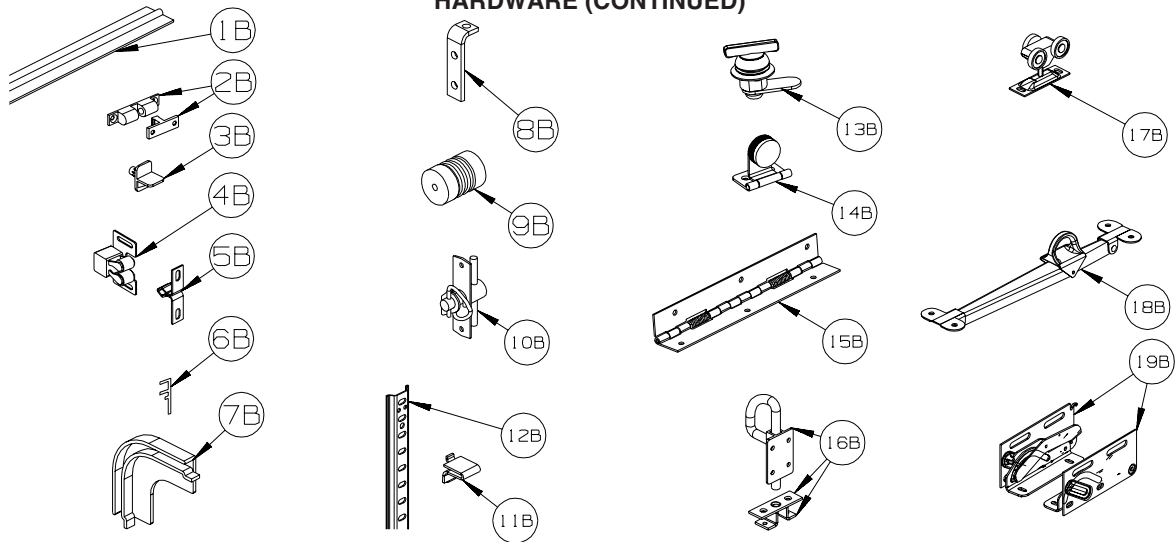

KEY	PART NUMBER	U/M	DESCRIPTION
1B	084413-01-000	EA	HINGE - 1" X 72" - ALUMINUM - W/HOLES
2B	084451-01-000	EA	CATCH & LATCH - 1.7" - BRASS
3B	092907-01-000	EA	SUPPORT - SHELF - PIN - 1/4" - CLEAR PLASTIC
4B	093586-03-000	EA	CATCH - SPRING ROLLER - .377"
4B	093586-06-000	EA	CATCH - SPRING ROLLER - .236"
5B	093586-04-000	EA	STRIKE - SPRING STEEL - 1.14"
6B	093622-01-000	EA	TRACK - DOOR - TAMBOUR - PLASTIC - 8' LENGTHS
7B	093623-01-000	EA	CORNER - TRACK - TAMBOUR DOOR
8B	096826-01-01A	EA	BRACE-CABINET E-COATED
9B	097872-04-000	EA	DOWEL - WOOD - 1" DIAMETER X 1.38" LONG - UNFINISHED
10B	098196-01-000	EA	LATCH - 1/4 TURN - T-BAR
11B	098979-01-000	EA	CLIP - ADJUSTABLE SHELF
12B	098980-01-000	EA	PILASTER - ADJUSTABLE SHELF - 18"
12B	098980-02-000	EA	PILASTER - ADJUSTABLE SHELF - 12"
12B	098980-03-000	EA	PILASTER - ADJUSTABLE SHELF - 9"
12B	098980-04-000	EA	PILASTER - ADJUSTABLE SHELF - 48"
12B	098980-05-000	EA	PILASTER - ADJUSTABLE SHELF - 15"
12B	098980-06-000	EA	PILASTER - ADJUSTABLE SHELF - 24"
13B	100710-01-02A	EA	LOCK - GLASS DOOR/TWIST TYPE - NICKEL
14B	100711-01-02A	EA	HINGE - GLASS DOOR - NICKEL
15B	102920-01-01A	EA	HINGE - SPRING LOADED - BRASS
15B	102920-01-02A	EA	HINGE - SPRING LOADED - NICKEL
15B	129753-01-01A	EA	HINGE - SPRING LOADED - 19" X 19" - BLACK
16B	103256-01-000	EA	LATCH COMPLETE (SLIDE)
17B	103874-01-000	EA	HANGER - SLIDING DOOR
18B	104181-01-01A	EA	SUPPORT - LEAF 5.3" EXTENDS TO 7.5" - SAFETY RING - METAL
19B	108126-01-000	EA	TRAY HINGE SET (QTY. 2 PER SET)

INTERIOR FINISH GROUP (CONTINUED)
HARDWARE (CONTINUED)

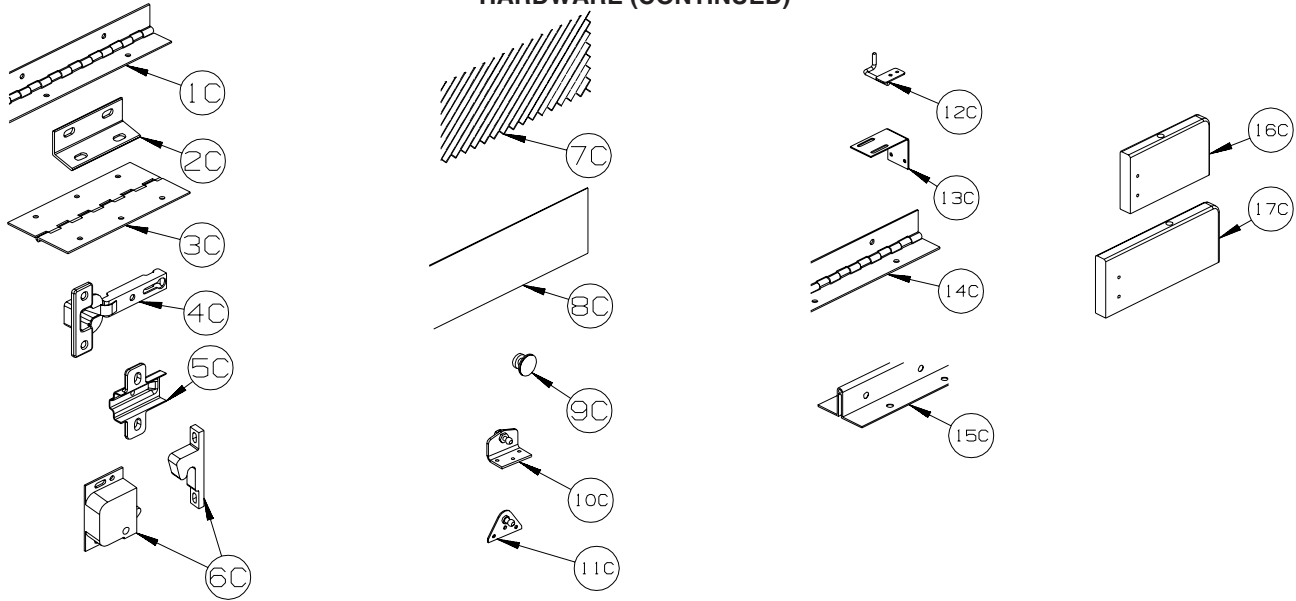

KEY	PART NUMBER	U/M	DESCRIPTION
1C	110496-01-01A	EA	HINGE - BRASS - 2" X 32"
1C	110496-01-02A	EA	HINGE - NICKEL - 2" X 32"
1C	110496-05-02A	EA	HINGE - NICKEL - 2" X 11.5"
1C	110496-06-02A	EA	HINGE - NICKEL - 2" X 9.5"
2C	111866-01-02A	EA	BRACE - SEAT - ANGLE - OFF WHITE
3C	114278-02-000	EA	HINGE - CONTINUOUS - 3" WIDE
4C	114443-02-01A	EA	HINGE - CABINET DOOR - W/O CLIP - SILVER
5C	114443-03-01A	EA	CLIP - HINGE/CABINET DOOR - SILVER
6C	117095-01-01A	EA	LATCH - DOOR - GRABBER W/KEEPER - PLASTIC - BLK-5 LB PULL
6C	117095-02-01A	EA	LATCH - DOOR - GRABBER W/KEEPER - PLASTIC - BLK-10 LB PULL
6C	117095-03-01A	EA	LATCH - DOOR - GRABBER W/KEEPER - PLASTIC - BLK-15 LB PULL
7C	118200-01-01A	SF	MESH - PLASTIC 1/2" - 48" X LENGTH = SF - BLACK
8C	122717-06-01A	FT	PAD - NON-SKID - PSA - 5"W
9C	125221-01-01A	EA	PULL - MIRROR - W/ROUND HANDLE
10C	126263-06-02B	EA	BRACKET - GAS SPRING W/INSIDE BALL STUD - E-COATED
11C	126263-05-02B	EA	BRACKET - GAS SPRING W/BALL STUD - E-COATED
11C	126263-08-02B	EA	BRACKET - GAS SPRING W/CENTERED BALL STUD - E-COATED
11C	126263-19-02B	EA	BRACKET - GAS SPRING W/BALL STUD - E-COATED
12C	130798-01-02B	EA	GUIDE - POCKET DOOR - E-COATED
13C	132871-02-02B	EA	BRACKET/L-ANGLE W/HOLES - 1.9" X 2.8" - E-COATED
14C	134099-01-02A	EA	HINGE - PIANO - WRAP AROUND - 15.7" - NICKEL PLATED
15C	135538-03-02A	EA	HINGE - PIANO - FULL WRAP - 15.7" - CHROME
16C	137445-02-P46	EA	STOP - F/SLIDING DOOR - CONCERT CHERRY
16C	137445-02-P56	EA	STOP - F/SLIDING DOOR - WASHED MAPLE
16C	137445-02-S67	EA	STOP - F/SLIDING DOOR - SIERRA MAPLE
17C	137445-03-T78	EA	STOP - F/SLIDING DOOR - CONCERT CHERRY
17C	137445-03-T79	EA	STOP - F/SLIDING DOOR - WASHED MAPLE
17C	137445-03-T80	EA	STOP - F/SLIDING DOOR - SIERRA MAPLE

INTERIOR FINISH GROUP (CONTINUED) HARDWARE (CONTINUED)

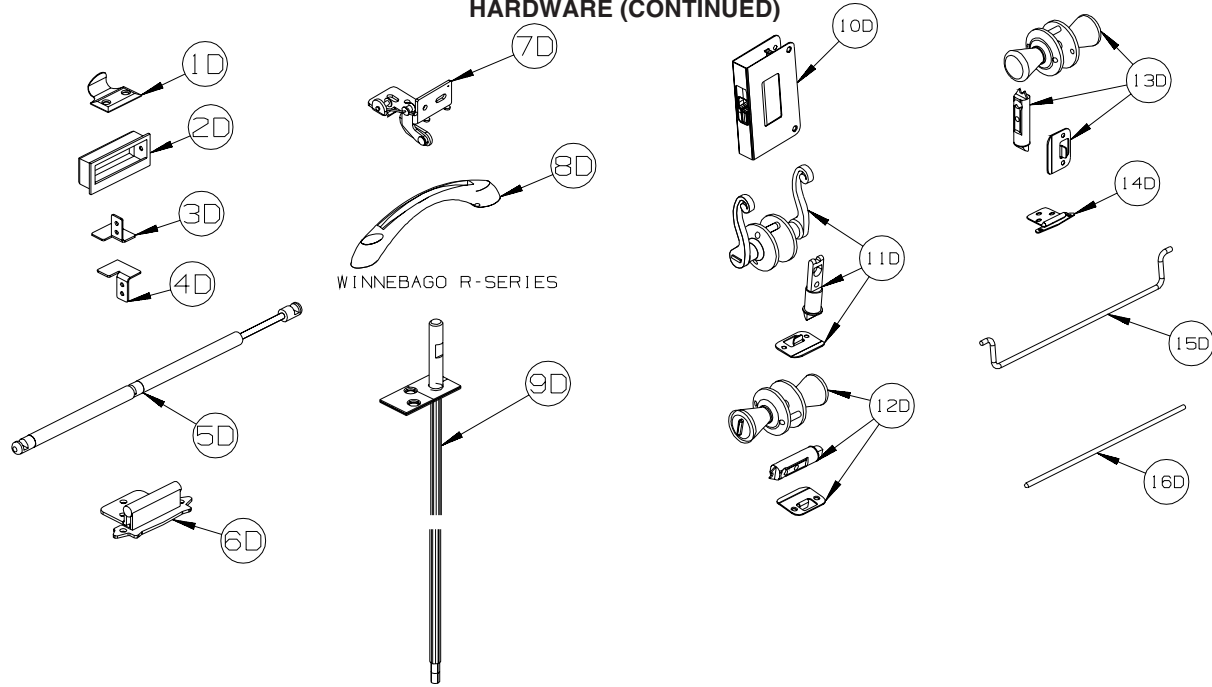

KEY	PART NUMBER	U/M	DESCRIPTION
1D	137463-01-02A	EA	LIFT - HOOK - PEWTER
2D	139136-01-02A	EA	HANDLE - .75" RECESSED - PEWTER
2D	139136-02-02A	EA	HANDLE - .35" RECESSED - PEWTER
3D	139264-01-02B	EA	STOP - DOOR - TAMBOUR/RH HAND - E-COATED
4D	139264-02-02B	EA	STOP - DOOR - TAMBOUR/LH HAND - E-COATED
5D	142569-07-000	EA	SPRING/GAS - 20 LB - 20" EXTENDED/12" COMPRESSED
5D	142569-15-000	EA	SPRING/GAS - 120 LB - 20" EXTENDED/12" COMPRESSED
5D	142569-16-000	EA	SPRING/GAS - 90 LB - 20" EXTENDED/12" COMPRESSED
5D	142569-29-000	EA	SPRING/GAS - 20 LB - 9.9" EXTENDED/5.9" COMPRESSED
6D	143468-02-03A	EA	HINGE - SELF CLOSING - SATIN NICKEL
7D	144488-01-02A	EA	HINGE - CABINET - NICKEL
8D	144917-01-01A	EA	PULL - DRAWER - SATIN NICKEL - TOUR R-SERIES
9D	145939-03-01A	EA	ROD/LATCH - AISLE DOOR - BRASS
9D	145939-05-01A	EA	ROD/LATCH - AISLE DOOR - BRASS - NOT ILLUSTRATED
			FROM: 00-00-00 THRU: 04-16-06
9D	145939-05-02A	EA	ROD/LATCH - AISLE DOOR - NICKEL - NOT ILLUSTRATED
			FROM: 04-17-06 THRU: 07-30-06
			FROM: 07-31-06 THRU: 99-99-99
10D	145939-04-02A	EA	LATCH/SLIDE - AISLE DOOR(1" THICK DOOR)-NICKEL/BLACK SLIDE
11D	146064-01-02A	EA	LOCK/PRIVACY (LOCKING) LEVER STYLE - SATIN PEWTER
12D	146064-05-01A	EA	LOCK/PRIVACY (LOCKING) KNOB STYLE - SATIN NICKEL
13D	146064-06-01A	EA	LOCK/PASSAGE (NON LOCKING) KNOB STYLE - SATIN NICKEL
14D	146553-01-01A	EA	HINGE - CABINET DOOR - BURNISHED BRASS
14D	146553-01-03A	EA	HINGE - CABINET DOOR - SATIN NICKEL
15D	146801-01-01A	EA	ROD/TOWEL BAR (OFFSET) - BRASS
15D	146801-01-02A	EA	ROD/TOWEL BAR (OFFSET) - PEWTER
16D	146840-03-01A	EA	ROD - .25" X 11.7" - BRASS
16D	146840-03-02A	EA	ROD - .25" X 11.7" - PEWTER
16D	146840-04-01A	EA	ROD - .25" X 13.1" - BRASS
16D	146840-04-02A	EA	ROD - .25" X 13.1" - PEWTER
16D	146840-05-01A	EA	ROD - .25" X 14.8" - BRASS
16D	146840-05-02A	EA	ROD - .25" X 14.8" - PEWTER
16D	146840-07-01A	EA	ROD - .25" X 4.2" - BRASS
16D	146840-07-02A	EA	ROD - .25" X 4.2" - PEWTER

INTERIOR FINISH GROUP (CONTINUED) HARDWARE (CONTINUED)

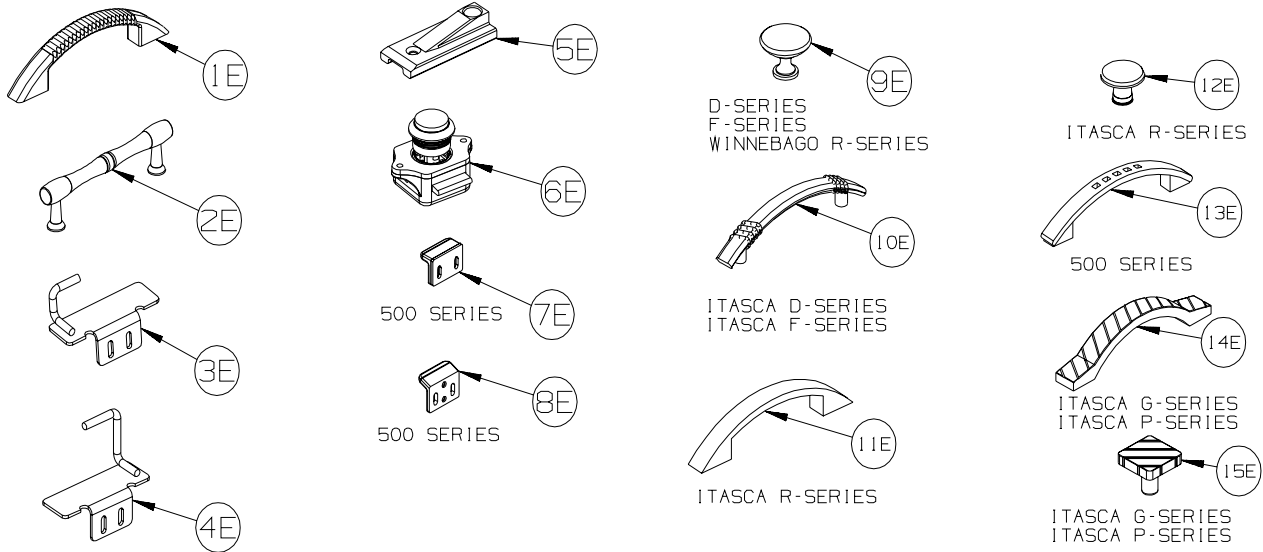

KEY	PART NUMBER	U/M	DESCRIPTION
1E	148816-01-02A	EA	PULL - CABINET DOOR - NICKEL - ASPECT, CAMBRIA 700-SERIES
2E	149090-01-02A	EA	PULL - CABINET DOOR - NICKEL - SIGHTSEER D-SERIES, VOYAGE F-SERIES
3E	149607-01-02B	EA	GUIDE - F/POCKET DOOR - 1.6" BENT ROD - E-COATED
3E	149607-03-02B	EA	GUIDE - F/POCKET DOOR - 2.9" BENT ROD - E-COATED
4E	149607-04-02B	EA	GUIDE - F/POCKET DOOR - E-COATED
5E	150983-01-01A	EA	STRIKE/BLOCK - WEDGE STYLE - F/SLIDE DOOR - 3" X 1.2" - BLACK
6E	151380-01-01A	EA	LATCH - CABINET DOOR - PUSH BUTTON - VIEW & NAVION 500-SERIES
7E	151380-02-01A	EA	STRIKE - CABINET DOOR - VIEW & NAVION 500-SERIES
8E	151380-03-01A	EA	STRIKE - CABINET DOOR - VIEW & NAVION 500-SERIES
9E	152080-01-01A	EA	PULL-NICKEL - SIGHTSEER & SUNOVA D-SERIES, VOYAGE & SUNRISE F-SERIES, TOUR R-SERIES
10E	152302-01-01A	EA	PULL - CABINET DOOR - SATIN NICKEL - SUNOVA D-SERIES, SUNRISE F-SERIES
11E	152304-01-01A	EA	PULL - CABINET DOOR - BRONZE- ELLIPSE R-SERIES
12E	152305-01-01A	EA	KNOB - DOOR/DRAWER - BRONZE - ELLIPSE R-SERIES
13E	152950-01-01A	EA	PULL - DOOR/DRAWER - BRUSHED NICKEL - VIEW & NAVION 500-SERIES
14E	152951-01-01A	EA	PULL - DOOR/DRAWER - PEWTER - SUNCRUISER G-SERIES, MERIDIAN P-SERIES
15E	152952-01-01A	EA	PULL - KNOB/DRAWER - PEWTER - SUNCRUISER G-SERIES, MERIDIAN P-SERIES

INTERIOR FINISH GROUP (CONTINUED) HARDWARE (CONTINUED)

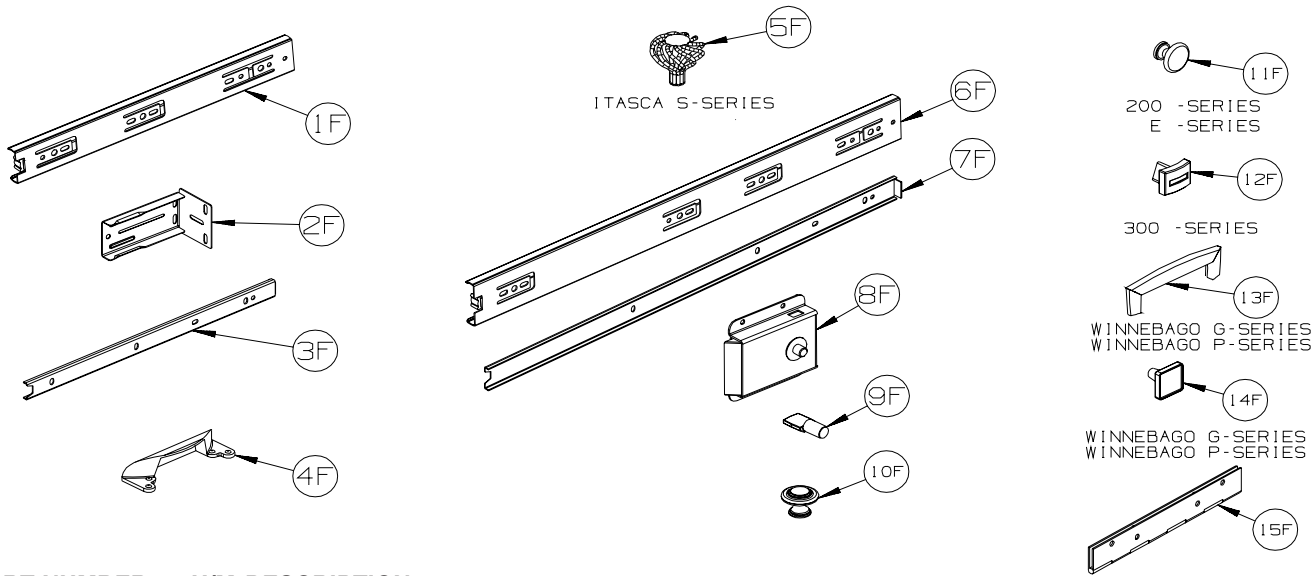

KEY	PART NUMBER	U/M	DESCRIPTION
1F	153000-01-01A	EA	SLIDE - CABINET MOUNT - 11.8"
1F	153000-03-01A	EA	SLIDE - CABINET MOUNT - 13.8"
1F	153000-05-01A	EA	SLIDE - CABINET MOUNT - 15.7"
1F	153000-07-01A	EA	SLIDE - CABINET MOUNT - 17.7"
1F	153000-09-01A	EA	SLIDE - CABINET MOUNT - 19.7"
1F	153000-11-01A	EA	SLIDE - CABINET MOUNT - 21.6"
1F	153000-14-01A	EA	SLIDE - CABINET MOUNT - 23.6"
1F	153000-18-01A	EA	SLIDE - CABINET MOUNT - 9.8"
1F	153000-20-01A	EA	SLIDE - CABINET MOUNT - 25.6"
2F	153000-13-01A	EA	BACKSOCKET - DRAWER SLIDE
3F	153000-02-01A	EA	SLIDE - DRAWER MOUNT - 11.8"
3F	153000-04-01A	EA	SLIDE - DRAWER MOUNT - 13.8"
3F	153000-06-01A	EA	SLIDE - DRAWER MOUNT - 15.7"
3F	153000-08-01A	EA	SLIDE - DRAWER MOUNT - 17.7"
3F	153000-10-01A	EA	SLIDE - DRAWER MOUNT - 19.7"
3F	153000-12-01A	EA	SLIDE - DRAWER MOUNT - 21.6"
3F	153000-15-01A	EA	SLIDE - DRAWER MOUNT - 23.4"
3F	153000-19-01A	EA	SLIDE - DRAWER MOUNT - 9.8"
3F	153000-21-01A	EA	SLIDE - DRAWER MOUNT - 25.4"
4F	153308-01-01A	EA	PULL - VANITY STOOL - SATIN NICKEL
5F	153335-01-02A	EA	PULL - KNOB - DOOR/DRAWER - FLAT BLACK - HORIZON S-SERIES
6F	153352-01-01A	EA	SLIDE - PANTRY - 19.7" - CABINET MOUNT
6F	153352-03-01A	EA	SLIDE - EXT ENTERTAINMENT CNTR - 13.8" - CABINET MOUNT
7F	153352-02-01A	EA	SLIDE - PANTRY - 19.5" - DRAWER MOUNT
7F	153352-04-01A	EA	SLIDE - EXT ENTERTAINMENT CNTR - 13.6" - DRAWER MOUNT
8F	153353-01-01A	EA	LATCH - SLIDING/FLUSH - BLACK
9F	154385-01-02A	EA	PIN - SUPPORT/GLASS DOOR - 1/4" - NICKEL
10F	155803-01-01A	EA	KNOB CABINET DOOR - WROUGHT IRON
11F	155925-01-01A	EA	KNOB - DOOR/DRAWER - SATIN NICKEL - ACCESS & IMPULSE 200-SERIES
12F	156579-01-01A	EA	KNOB - DOOR/DRAWER - PEWTER - OUTLOOK & SPIRIT 300-SERIES
13F	157246-01-01A	EA	PULL - CABINET DOOR/DRAWER - SATIN NICKEL - ADVENTURER G-SERIES, JOURNEY P-SERIES
14F	157246-02-01A	EA	KNOB - CABINET DOOR/DRAWER - SATIN NICKEL - ADVENTURER G-SERIES, JOURNEY P-SERIES
15F	158982-01-04B	EA	HINGE - CONTINUOUS - 2" X 8" - BLACK
	158982-01-01A	EA	HINGE - CONTINUOUS - 2" X 8" - ZINC

LABELS GROUP

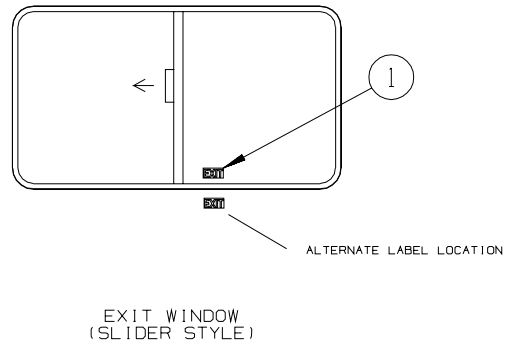
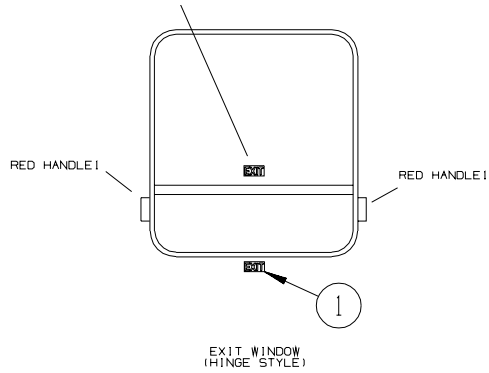

KEY	PART NUMBER	U/M DESCRIPTION
1	039290-01-000	EA LABEL - WARNING - EXIT

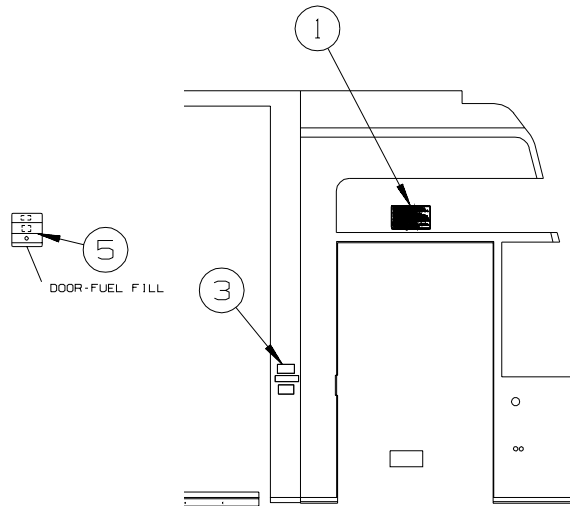
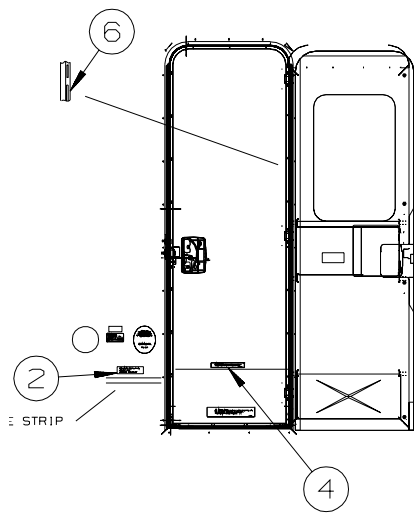

ENTRANCE DOOR

DRIVERS DOOR

KEY	PART NUMBER	U/M DESCRIPTION
1	056259-01-000	EA LABEL - SAFETY CHECK LIST
2	099509-01-000	EA LABEL - AWNING INSTALLATION
3	099689-01-000	EA LABEL - WARNING - CANCER/TOXICITY
4	065748-01-000	EA LABEL - WARNING - BATTERY CHARGING - UL
4	065748-02-000	EA LABEL - WARNING - BATTERY CHARGING - CSA
5	124519-01-02A	EA LABEL - WARNING/REFUELING - WHITE ON CLEAR - US
5	124519-02-01A	EA LABEL - WARNING/REFUELING - BLACK ON CLEAR - CSA
6	135869-01-01A	EA LABEL - MERCURY CONTENT - BLACK ON CLEAR

LABELS GROUP (CONTINUED)

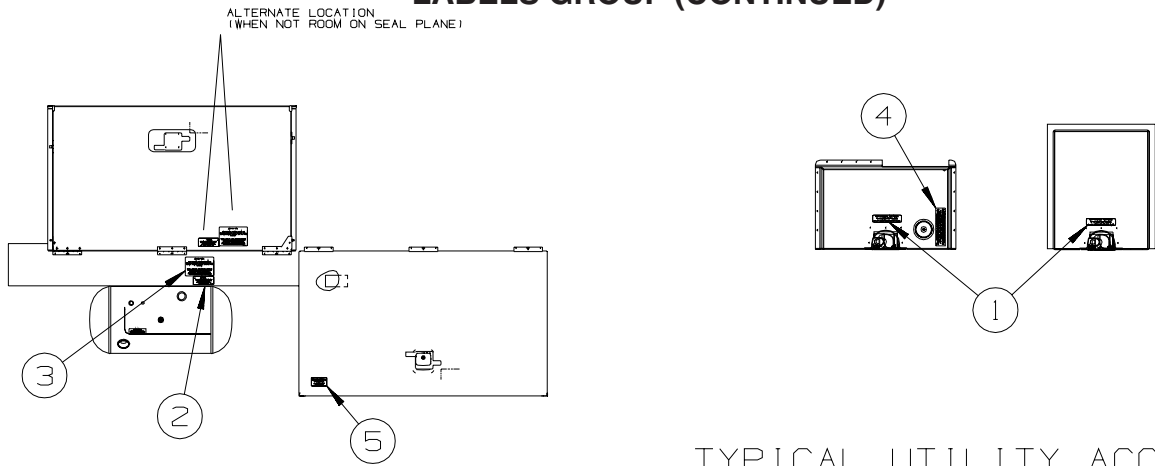

TYPICAL UTILITY ACCESS

KEY	PART NUMBER	U/M	DESCRIPTION
1	123562-01-000	EA	LABEL - SERVICE/UTILITY ACCESS
2	124519-01-02A	EA	LABEL - WARNING/REFUELING - WHITE ON CLEAR - US
2	124519-02-01A	EA	LABEL - WARNING/REFUELING - BLACK ON CLEAR - CSA
3	124520-01-02A	EA	LABEL - LP GAS ONLY - WHITE ON CLEAR
3	023769-01-000	EA	LABEL - WARNING - LPG - CANADIAN
4	147845-01-01A	EA	LABEL - DRIP VALVE
5	125306-01-01A	EA	LABEL - ELECTRICAL ENTRANCE - 110V 30 AMP - BLACK ON CLEAR

TYPICAL SEAT AND BELT CONFIGURATIONS

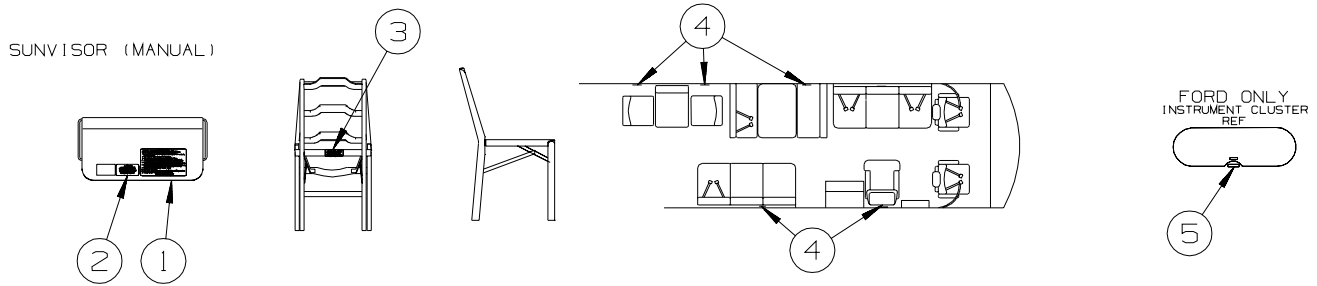

ATTACH LABEL ON OR NEXT TO:
 • ANY SINGLE CHAIR WITHOUT BELTS.
 • ANY DINETTE SEAT WITHOUT BELTS.
 • ANY COUCH WITHOUT BELTS OR ANY SEATING POSITION ON THAT COUCH.
 DO NOT ATTACH LABEL IF:
 • DINETTE SEAT HAS AT LEAST ONE SET OF BELTS INSTALLED.

KEY	PART NUMBER	U/M	DESCRIPTION
1	056259-01-000	EA	LABEL - SAFETY CHECK LIST
2	099689-01-000	EA	LABEL - WARNING - CANCER/TOXICITY
3	134537-01-01A	EA	LABEL - OCCUPANCY - CHAIR - US
3	134537-02-01A	EA	LABEL - OCCUPANCY - CHAIR - CSA
4	134538-01-01A	EA	LABEL - OCCUPANCY - NO SEAT BELT - BLACK ON CLEAR - US
4	134538-02-01A	EA	LABEL - OCCUPANCY - NO SEAT BELT - BLACK ON CLEAR - CSA
5	155692-01-02A	EA	LABEL - ODOMETER - READ IN MILE - WHITE/CLEAR

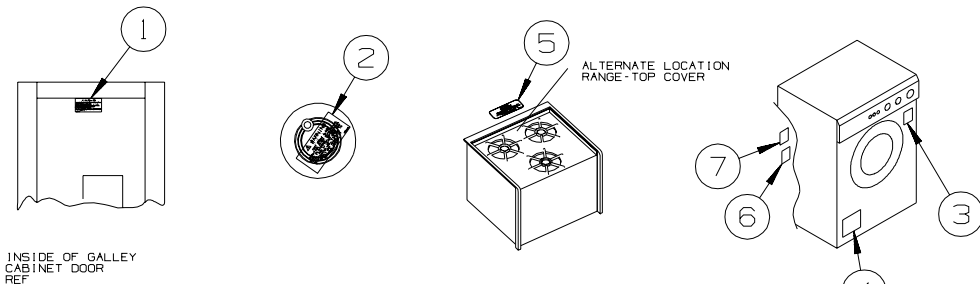

KEY	PART NUMBER	U/M	DESCRIPTION
1	073998-01-000	EA	LABEL - LPG/ODOR WARNING
2	077956-01-000	EA	LABEL - WARNING/SMOKE DETECTOR
3	153640-01-01A	EA	LABEL - WINTERIZATION - WASHER/DRYER
4	130670-01-01A	EA	LABEL - CAUTION DRYER VENTING - BLACK ON CLEAR
5	134539-01-01A	EA	LABEL - WARNING - STOVE/HEATING - US - BLACK ON CLEAR
5	134540-01-01A	EA	LABEL - WARNING - STOVE/HEATING - CSA - BLACK ON CLEAR - CANADIAN
6	147524-01-000	EA	LABEL - DRYER VENTING
7	147525-01-000	EA	LABEL - DRYER VENT CUTOUT

LABELS GROUP (CONTINUED)

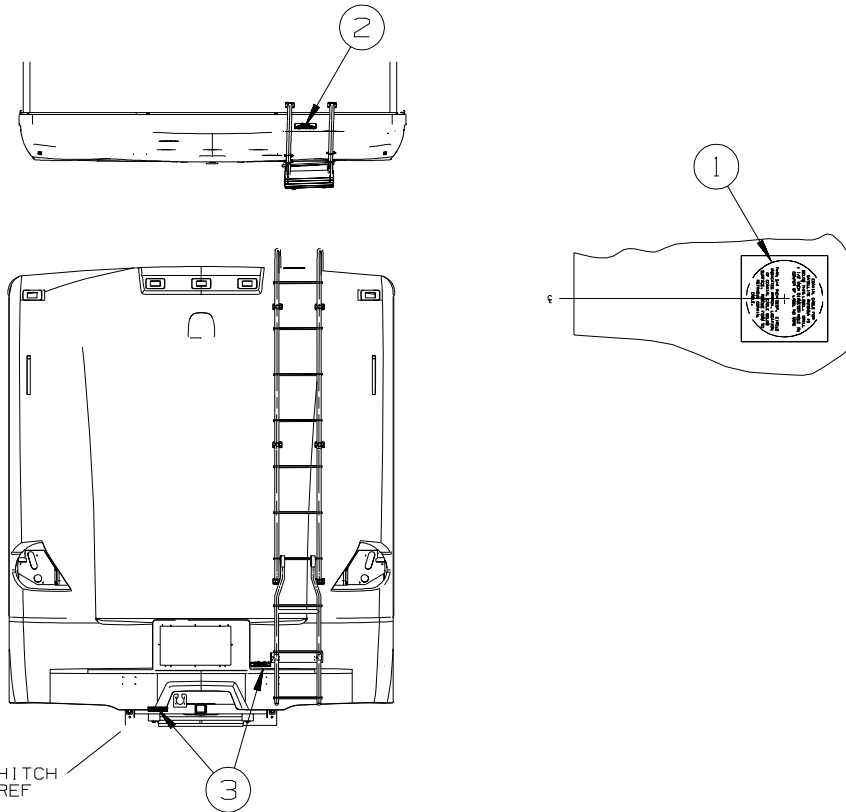

KEY	PART NUMBER	U/M DESCRIPTION
1	120431-01-000	EA LABEL - LOCATION - COAXIAL CABLE/SATELLITE ANTENNA
2	128218-01-01A	EA LABEL - WARNING - SLIPPERY ROOF
3	129669-02-01A	EA LABEL - HITCH/VEHICLE RATE - 500 - WHITE ON CLEAR
3	129669-02-02A	EA LABEL - HITCH/VEHICLE RATE - 500 - BLACK ON CLEAR

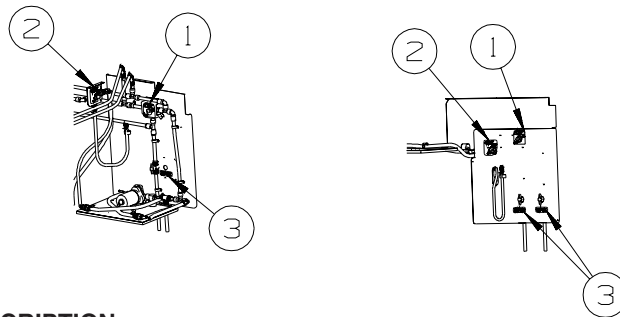

KEY	PART NUMBER	U/M DESCRIPTION
1	152539-01-01A	EA LABEL - BYPASS
2	152545-01-01A	EA LABEL - WINTERIZATION
3	154302-01-01A	EA LABEL - FRESH WATER DRAIN - PANTONE/CLEAR

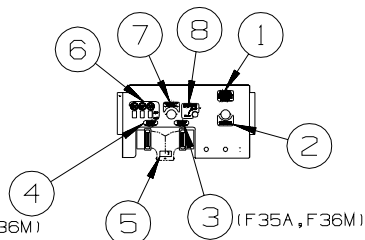

KEY	PART NUMBER	U/M DESCRIPTION
1	128725-02-01A	EA LABEL - POTABLE WATER ONLY - BLACK ON CLEAR
2	152538-01-01A	EA LABEL - FRESH WATER - PANTONE/CLEAR
3	152541-03-01A	EA LABEL - GRAY WASTE - F35A, F36M
3	152543-03-01A	EA LABEL - BLACK WASTE
4	152541-03-01A	EA LABEL - GRAY WASTE
4	152543-03-01A	EA LABEL - BLACK WASTE - F35A, F36M
5	144649-01-01A	EA LABEL - ADJUSTABLE VALVE - WHITE ON CLEAR
6	152544-06-01A	EA LABEL - SWITCHES - WTR PUMP/LIGHT/AUTO LVL-W/LVL/STORE DWN
7	152546-01-01A	EA LABEL - TANK FLUSH - PANTONE/CLEAR
8	152548-01-01A	EA LABEL - VALVE/FRESH

LP GROUP
LP SYSTEM

KEY	PART NUMBER	U/M	DESCRIPTION
	010323-01-000	EA	ADAPTER - 3/8"F X 1/2"MPT - BRASS
	010326-01-000	EA	ADAPTER - FLARE - W/CONE GASKET - 3/8"F X 1/2"F
	010377-02-000	EA	NUT - 3/8" FLARE - FORGED - BRASS
	010380-02-000	EA	NUT - 1/2" FLARE - FORGED - BRASS
	010589-01-000	EA	NIPPLE - PIPE - 1/2" X 1 1/2" - BLACK
	024250-01-000	EA	ADAPTER - BRASS - 3/8"F X 1/2"FPT
	040440-03-000	EA	TRANSMITTER - DIAL/SNAP-ON - 0-90 OHM 2 TERM(POWER/GROUND)
	045703-01-000	EA	HOSE - LP - 3/8"ID X 24" - 3/8"MPT X 1/2"F SWIVEL - US
	045703-02-000	EA	HOSE - LP - 3/8"ID X 24" - 3/8"MPT X 1/2"F SWIVEL - CSA
	106150-05-000	EA	REGULATOR - TWO STAGE
*	144116-01-000	EA	TANK - LP - 100 LB - 14"D X 47"L
	144485-01-000	EA	COVER - LP REGULATOR

***COMPONENT PARTS LISTED LATER IN THIS GROUP**

COMPONENT PARTS FOR LP SYSTEM

KEY	PART NUMBER	U/M	DESCRIPTION	VENDOR NO.
	040421-01-712	EA	VALVE-SERV. W/O VAPOR RELIEF	29000853
	040421-01-713	EA	VALVE-RELIEF 1" W/SPRING 7"	V-20479
	088253-09-700	EA	SENDING UNIT-F/SNAP ON DIAL	SG14C0001466
	144116-01-700	EA	VALVE-OUTAGE(NO STEM REMOVE)	V20058
	144116-01-701	EA	VALVE/FILL 80 % W/YELLOW CAP	V13414

SEALANTS & FASTENERS GROUP
SEALANTS & ADHESIVES

KEY	PART NUMBER	U/M	DESCRIPTION
	004001-02-000	EA	GUN - PLEXUS ADHESIVE - W/O NOZZLE
	004001-05-000	EA	ADHESIVE - SCOTCH-WELD - 3M DP100 - CLEAR - 50ML
	004011-01-000	EA	ADHESIVE-3M-4475 TUBE
	010405-02-000	EA	TAPE - THREAD SEALING - 3/8"
	064075-07-000	FT	SEAL - BULB - W/WIRED U CHANNEL - .3" X .5" CHANNEL-BLACK
	067788-01-000	EA	ADHESIVE - SPRAY - 3M - 19.5 OZ AEROSOL CAN
	069640-01-000	FT	SEALER - RIBBON - 1/4"DIAMETER X 30 FT - BLACK OR GRAY
	069640-02-000	FT	SEALER - TAPE - 1/8"THICK X 1/2"WIDE X 60 FT - GRAY
	069640-03-000	FT	SEALER - TAPE - 1/8"THICK X 3/4"WIDE X 60 FT - BLACK
	069640-07-000	FT	SEALER - TAPE - 3/32"THICK X 2"WIDE X 45 FT - GRAY
	069640-09-000	FT	SEALER - TAPE - 1/32"THICK X 2 1/2"WIDE X 80 FT - BRT WHT
	069640-10-000	FT	SEALER - TAPE - 1/32"THICK X 1 1/2"WIDE X 90 FT - BRT WHT
	069640-11-000	FT	SEALER - TAPE - 3/16"THICK X 3/8"WIDE X 40 FT - BLACK
	069640-13-000	FT	SEALER - TAPE - 3/32"THICK X 2"WIDE X 45 FT - BLACK
	069640-14-000	FT	SEALER - TAPE - 1/16"THICK X 1"WIDE X 100 FT - BLACK
	069640-15-000	FT	SEALER - TAPE - 1/16"THICK X 3/8"WIDE X 100 FT - BRT WHT
	069640-17-000	FT	SEALER - TAPE - 1/32"THICK X 1"WIDE X 150 FT - GRAY
	069640-18-000	FT	SEALER - TAPE - 1/8"THICK X 1/2"WIDE X 60 FT - BRT WHT
	069640-19-000	FT	SEALER - TAPE - 1/8"THICK X 3/4"WIDE X 60 FT - BRT WHT
	069640-20-000	FT	SEALER - TAPE - 1/8"THICK X 1/2"WIDE X 60 FT - BLACK
	069640-21-000	FT	SEALER - TAPE - 1/16"THICK X 1/2"WIDE X 100 FT - BRT WHT
	069640-22-000	FT	SEALER - TAPE - 1/32"THICK X 1/4"WIDE X 200 FT - BRT WHT
	069640-23-000	FT	SEALER - TAPE - 1/16"THICK X 3/4"WIDE X 100 FT - BRT WHT
	069640-27-000	FT	SEALER - TAPE - 1/16"THICK X 2 1/4"WIDE X 50 FT - BRT WHT
	069640-28-000	FT	SEALER - TAPE - 1/32"THICK X 1 7/8"WIDE X 90 FT - GRAY
	069640-30-000	FT	SEALER - TAPE - 1/32"THICK X 5/8"WIDE X 50 FT - GRAY
	069640-31-000	FT	SEALER - TAPE - 1/4"THICK X 3/4"WIDE X 15 FT - BLACK
	069640-32-000	FT	SEALER - TAPE - 1/16"THICK X 3/8"WIDE X 100 FT - BLACK
	069640-33-000	FT	SEALER - RIBBON - 3/8"DIAMETER X 20 FT - BLACK
	069640-34-000	FT	SEALER - RIBBON - 1/4"DIAMETER X 30 FT - BRIGHT WHITE
	072889-28-000	EA	SEALANT/URETHANE-10 OZ TUBE W/NOZZLE-SELF LEVELING-BRT WHT
	076322-01-000	FT	TAPE-DOUBLE COATED/ADHESIVE BK-.03"THK X .8"W X 216' - WHT
	076322-02-000	FT	TAPE-DOUBLE COATED/ADHESIVE BK-.05"THK X 1"W X 108' - WHT
	076322-03-000	FT	TAPE-DOUBLE COATED/ADHESIVE BK-.05"THK X .5"W X 108' - WHT
	076322-05-000	FT	TAPE-DOUBLE COATED/ADHESIVE BK-.05"THK X .8"W X 108' - WHT
	076322-07-000	FT	TAPE-DOUBLE COATED/ADHESIVE BK-.05"THK X .5"W X 200' - BLK
	076322-13-000	FT	TAPE - FOAM/DOUBLE COATED - .020"THK X .75"W - CLEAR
	076322-21-000	FT	TAPE - FOAM/DOUBLE COATED - .045"THK X .50"W
	076322-22-000	FT	TAPE - FOAM/DOUBLE COATED - .045"THK X .75"W
	076322-23-000	FT	TAPE - FOAM/DOUBLE COATED - .045"THK X 1"W
	076322-25-000	FT	TAPE - FOAM/DOUBLE COATED - .025"THK X .5"W
	086276-01-000	EA	TAPE - DOUBLE SIDED - 1/2" WIDE X 108' LONG (SOLD BY ROLL)
	088479-01-000	EA	TAPE - ALUMINUM - 3"
	090340-01-000	FT	SEAL - FOAM - CLOSED CELL - 1/4" X 1/2" X 50'
	091255-02-000	FT	SEAL - ADHESIVE BACKED/FOAM - 3/64"THICK X 3/16"W X 1000'
	091255-03-000	FT	SEAL - ADHESIVE BACKED/FOAM - 1/4" THICK X 1/4"W X 1000'
	094401-01-000	EA	SEALER - BODY SEAM - FLEXICLEAR
	094401-04-000	EA	SEALER - BODY SEAM - CLEAR
	094401-05-000	EA	SEALER - BODY SEAM - 20OZ BLACK
	094401-06-000	EA	SEALER - BODY SEAM - 12OZ BLACK
	094401-07-000	EA	SEALER - BODY SEAM - CLEAR
	098408-01-000	FT	SEAL - SPONGE RUBBER - CLOSED CELL
	099069-01-000	FT	SEAL - RUBBER - CLOSED SPONGE - .5" WIDE X .12" THICK-BLK
	099418-01-000	FT	SEAL - D-SECTION/ADHESIVE BACK - ..44" X .44" - BLK RUBBER
	107828-01-000	EA	SEALANT - SB - 190 EVERSEAL
	112864-01-000	FT	SEAL - FOAM/BUTYL COVERED - 3/8" X 35'
	112864-02-000	FT	FOAM - BUTYL COVERED - 5/16" X 44'
	112864-04-000	FT	FOAM - BUTYL COVERED - 3/8" X 1/8"
	112901-02-000	EA	ADHESIVE - PLEXUS - MA330 - 50ML - GRAY
	112901-03-000	EA	ADHESIVE - PLEXUS - MA300 - 50ML - WHITE
	112902-01-000	EA	NOZZLE - ELEMENT - 3/8" X 24
	112902-03-000	EA	MIXER NOZZLE - F/GUN #00400102000 - SCOTCH-WELD & PLEXUS
	112902-04-000	EA	NOZZLE - ELEMENT - 1/4" X 3.5"
	112902-05-000	EA	NOZZLE - BAYONET - 3/8" X 18

SEALANTS & FASTENERS GROUP (CONTINUED)

SEALANTS & ADHESIVES (CONTINUED)

KEY	PART NUMBER	U/M	DESCRIPTION
	112902-06-000	EA	NOZZLE - ELEMENT - 1/2" X 32
	113366-01-000	EA	ADHESIVE - INSTANT - 1 OZ
	120074-02-03A	EA	SILICONE - TUBE - W/O NOZZLE - LOW ODOR - SMOKEY WHITE
	120534-01-01A	EA	TAPE - SCOTCH - 3M - 1/2" FINE LINE
	123244-01-000	FT	TAPE - DOUBLE SIDED/FOAM - 5/64"THICK X 3/4"WIDE X 108'
	123816-01-000	FT	TAPE - DOUBLE SIDED - 1" X .020" X 200' - CLEAR
	123816-02-000	FT	TAPE - DOUBLE SIDED - 1/2" X .035" X 200' - CLEAR
	123816-03-000	FT	TAPE - DOUBLE SIDED - 1/2" X .020" X 200' - CLEAR
	123816-04-000	FT	TAPE - DOUBLE SIDED - 6" X .0035" X 750' - CLEAR
	123816-06-000	FT	TAPE - DOUBLE SIDED - 3/4" X 3/4" X 200' - CLEAR
	123816-07-000	FT	TAPE - DOUBLE SIDED - 1 3/4" X 200' - CLEAR
	126427-01-000	EA	ADHESIVE - ALL PURPOSE - ABS/PVC
	126427-02-000	EA	PRIMER - CLEANER - FLEX PIPING
	131264-01-11A	EA	SILICONE - TUBE - W/NOZZLE - BEIGE
	131264-01-12A	EA	SILICONE - TUBE - W/NOZZLE - BONE
	131264-01-13A	EA	SILICONE - TUBE - W/NOZZLE - TRANSLUCENT
	131264-02-01A	EA	SILICONE - TUBE - W/NOZZLE - VW GRAY - BATH ONLY
	131264-03-01A	EA	SILICONE - TUBE - W/O NOZZLE - SELF LEVELING -BRIGHT WHITE
	131264-04-01A	EA	SILICONE/SEALANT/ADHESIVE - FAST CURE F/GLASS/VINYL - B/W
	131264-04-02A	EA	SILICONE/SEALANT/ADHESIVE-FAST CURE F/GLASS/VINYL-SOFT WHT
	131264-05-01A	EA	SILICONE/SEALANT - ODORLESS - TUBE - W/NOZZLE - BLACK
	131264-05-02A	EA	SILICONE/SEALANT - ODORLESS - TUBE - W/NOZZLE - CLEAR
	131384-01-000	EA	ADHESIVE - JET WELD - 10 OZ CARTRIDGE
	132892-07-01A	FT	SEAL - BULB/SINGLE - W/U CHANNEL - .5" X 1" - BLACK
	152038-01-01A	EA	TAPE - PRESERVATION SEAL - 2" X 36YD ROLL - BLACK
	154585-01-01A	FT	SEAL - FOAM TAPE - ADHESIVE BACK - 3/8" X 3/8" - BLACK
	154585-02-01A	FT	SEAL - FOAM TAPE - ADHESIVE BACK - 3/4" X 1/2" - BLACK
	154585-03-01A	FT	SEAL - FOAM TAPE - ADHESIVE 2 SIDED - 1/8" X 3/4" - BLACK
	154585-04-01A	FT	SEAL - FOAM TAPE - ADHESIVE BACK - 5/8" X 1/8" - WHITE

BOLTS, NUTS AND WASHERS

KEY	PART NUMBER	U/M	DESCRIPTION
	0MD54F-06-000	EA	NUT - HEX W/SERATED FLANGE
	000C12-04-08B	EA	BOLT - HEX - 1/4-20 X 1/2 - GRADE #5 - ZINC
	000C12-04-40B	EA	BOLT - HEX - 1/4-20 X 2 1/2 - GRADE #5 ZINC
	000C12-04-20F	EA	BOLT - HEX - 1/4-20 X 1 1/4 - GRADE #5 - STAINLESS STEEL
	000C12-04-12A	EA	BOLT - HEX - 1/4-20 X 3/4 - PLAIN 5
	000C12-05-16B	EA	BOLT - HEX - 5/16 - 18X1 - GRADE #5 - ZINC
	000C12-05-40B	EA	BOLT - HEX - 5/16"-18 X 2.5" - GRADE #5 - ZINC
	000C12-06-28B	EA	BOLT-HEX-3/8-16X13/4 ZN 5 - 5185-01
	000C12-08-44B	EA	BOLT - HEX - 1/2-13 X 2 3/4 - GRADE #5 - ZINC
	000C12-08-24B	EA	BOLT - HEX - 1/2-13 X 1 1/2 - GRADE #5 - ZINC
	000C12-08-28B	EA	BOLT - HEX - 1/2-13 X 1 3/4 - GRADE #5 - ZINC
	000C13-07-40B	EA	BOLT - HEX - 7/16-20 X 2 1/2 - GRADE #5 - ZINC
	000C13-07-48B	EA	BOLT - HEX - 7/16-20 X 3 - GRADE #5 - ZINC
	000C13-07-72B	EA	BOLT - HEX - 7/16-20 X 4.5" - GRADE #5 - ZINC
	000C16-07-16B	EA	BOLT - CARRIAGE - ASSIST HANDLE - 7/16-14 X 1
	000C18-05-40A	EA	BOLT - ELEVATOR - 5/16-18 X 2 1/2 - PL
	000C26-04-18B	EA	BOLT - HEX - SERRATED FLANGE - 1/4-20 X 1 1/8 - ZINC
	000C26-04-14B	EA	BOLT - HEX - SERRATED FLANGE - 1/4-20 X 7/8 - ZINC
	000C26-04-12F	EA	BOLT - HEX - SERRATED FLANGE -1/4-20 X 3/4-STAINLESS STEEL
	000C26-04-10B	EA	BOLT - HEX - SERRATED FLANGE - 1/4-20 X 5/8 - ZINC
	000C26-04-40F	EA	BOLT - HEX - SERRATED FLANGE -1/4-20 X 2.5-STAINLESS STEEL
	000C26-05-12B	EA	BOLT - HEX - SERRATED FLANGE - 5/16-18 X 3/4 - ZINC
	000C26-06-12B	EA	BOLT - HEX - SERRATED FLANGE - 3/8-16 X 3/4 - ZINC
	000C26-06-20B	EA	BOLT - HEX - SERRATED FLANGE - 3/8-16 X 1 1/4 - ZINC
	000C26-06-28B	EA	BOLT - HEX - SERRATED FLANGE - 3/8-16 X 1 3/4 - ZINC
	000C26-06-40B	EA	BOLT - HEX - SERRATED FLANGE - 3/8-16 X 2 1/2 - ZINC
	000C26-08-28B	EA	BOLT - HEX - SERRATED FLANGE - 1/2-13 X 1 3/4 - ZINC
	000C26-08-24B	EA	BOLT - HEX - SERRATED FLANGE - 1/2-13 X 1 1/2 - ZINC
	000C26-08-40B	EA	BOLT - HEX - SERRATED FLANGE - 1/2-13 X 2 1/2-GRADE #5 ZINC
	000C27-08-48B	EA	BOLT-CARR 1/2-13X3.00 GR5 - 97 M-SERIES
	000C27-08-64B	EA	BOLT - CARRIAGE - 1/2-13 X 4 - GRADE 5
	000D16-07-00B	EA	NUT - HEX - 7/16-14 - ZINC

SEALANTS & FASTENERS GROUP (CONTINUED)
BOLTS, NUTS AND WASHERS (CONTINUED)

KEY	PART NUMBER	U/M	DESCRIPTION
	000D24-10-00B	EA	NUT - HEX - SELF LOCKING - 10-32 - ZINC
	000D27-05-00B	EA	NUT - HEX LOCK - 5-40 - ZINC
	000D28-10-00B	EA	NUT - HEX - W/NYLON LOCK - 10-32 - ZINC
	000D29-04-00F	EA	NUT - HEX - SELF LOCKING - 1/4 X 20 - STAINLESS STEEL
	000D29-04-00B	EA	NUT - HEX - SELF LOCKING - 1/4 X 20 - ZINC
	000D29-06-00B	EA	NUT - HEX - W/NYLON LOCK - 3/8-16 - ZINC
	000D29-09-00B	EA	NUT - HEX - SELF LOCKING - 9/16-12 - ZINC
	000D34-04-00B	EA	NUT - HEX - LOCKING - 1/4-20 - ZINC
	000D34-06-00B	EA	NUT - HEX - LOCKING - 3/8-16 GRADE C - ZINC
	000D39-04-00B	EA	NUT - HEX - LOCKING W/SERRATED FLANGE - 1/4-20 - ZINC
	000D39-05-00B	EA	NUT - HEX - LOCKING W/SERRATED FLANGE - 5/16-18 - ZINC
	000D39-06-00B	EA	NUT - HEX - LOCKING W/SERRATED FLANGE - 3/8-18 - ZINC
	000D39-06-00D	EA	NUT - HEX - LOCKING W/SERRATED FLANGE - 3/8"-16 BLACK
	000D39-07-00B	EA	NUT - HEX - LOCKING W/SERRATED FLANGE - 7/16-14 - ZINC
	000D39-08-00B	EA	NUT - HEX - LOCKING W/SERRATED FLANGE - 1/2-13 - ZINC
	000D39-09-00B	EA	NUT - HEX - LOCKING W/SERRATED FLANGE - 9/16-12 - ZINC
	000D44-04-00B	EA	NUT - HEX - LOCKING W/SERRATED FLANGE - 1/4-28 - ZINC
	000D44-07-00B	EA	NUT - HEX - LOCKING W/SERRATED FLANGE - 7/16-20 - ZINC
	000D44-08-00B	EA	NUT - HEX - LOCKING W/SERRATED FLANGE - 1/2-20 - ZINC
	000D46-04-00A	EA	NUT - HEX - WELD - 1/4-20 - PLAIN
	000D65-08-00B	EA	NUT - HEX - LOCKING W/SERRATED FLANGE - 8-32 - ZINC
	000D73-08-00C	EA	NUT - HEX FLANGE - 1/2-13
	000D75-09-00B	EA	NUT - HEX LOCKING - 9/16-12 - ZINC
	000D76-06-00B	EA	NUT - HEX FLANGE - 3/8-16
	000E11-04-00F	EA	WASHER - LOCKING - 1/4 MED SPLIT - STAINLESS STEEL
	000E11-07-00B	EA	WASHER - LOCKING - 7/16 MED SPLIT - ZINC
	000E11-08-00B	EA	WASHER - LOCKING - 1/2 MED SPLIT - ZINC
	000E13-17-00B	EA	WASHER - FLAT - 3/8 AR - ZINC
	000E13-18-00B	EA	WASHER - FLAT - 3/8 WIDE - ZINC
	000E13-20-00B	EA	WASHER - FLAT - 7/16 WIDE - ZINC
	000E13-22-00B	EA	WASHER - FLAT - 1/2 WIDE - ZINC
	000E13-26-00B	EA	WASHER - FLAT - 5/8 WIDE - ZINC
	000E14-10-00B	EA	WASHER - LOCKING - #10 EXTERNAL TOOTH - ZINC
	000E16-10-00B	EA	WASHER - HARDENED - 5/8 - FLAT - ZINC
	000G45-05-16B	EA	BOLT - LAG - 5/16-9 X 1 - ZINC
	005081-01-000	EA	NUT - SPEED - C-TYPE - #8 SCREW
	039715-01-000	EA	NUT-SERT - 1/4" DIAMETER - 20 THREADS
	040921-01-000	EA	NUT - SPEED - U TYPE - #10-24 - BLACK
	040921-03-000	EA	NUT - SPEED - U TYPE - #10
	040921-04-000	EA	NUT - SPEED - U TYPE - #8-.59" LENGTH X .44" WIDTH
	040921-05-000	EA	NUT - SPEED - U-TYPE - 8-.67" X .44" WIDE
	040921-11-000	EA	NUT - SPEED - U-TYPE - 8-.59" LENGTH X .44" WIDTH - BLACK
	041322-01-000	EA	WASHER - FLANGE - 15/32"ID X 2 3/8"OD - F/SEAT BELT MTG
	044364-02-000	EA	NUT - SPEED - FLAT - ROUND
	044533-01-000	EA	WASHER - 1 3/8"OD - FOR BUTTONS - PLASTIC
	051387-06-000	EA	BOLT - CARRIAGE W/O HOLE - 5/16-18 X 9 1/2 - ZINC
	058716-02-000	EA	WASHER - FLAT NYLON
	064081-03-000	EA	NUT - WING 3/8-16 - W/WELD NUT
	077071-01-000	EA	WASHER - FENDER - 3/16"ID X 1"OD
	087234-01-000	EA	NUT - JACK - 1/4 X 20 THD - MOLLY
	088787-12-000	EA	STUD - WELD - 1/4 - 20 X 1.0 LG - MN
	102540-02-000	EA	SEAL - SCREW
	106956-03-000	EA	BOLT - HEX TAP - 1/2-13NC X 3 - GRADE 5 - FULL THREAD/ZINC
	106956-10-000	EA	BOLT - HEX TAP - 9/16-12NC X 3 5/8 -GRD 5-FULL THREAD/ZINC
	106956-11-000	EA	BOLT - HEX TAP - 1/2-13NC X 2 1/2 - GRD 5-FULL THREAD/ZINC
	106956-13-000	EA	BOLT - HEX TAP - 1/2-20 X 2 1/2 - GRD 5-FULL THREAD/ZINC
	107397-01-000	EA	WASHER - FENDER - 3/4"ID X 1"OD
	108067-03-000	EA	STUD - WELD - 1/4 - 20 X 1/2 CD
	109917-03-000	EA	WASHER - 1" X .50"
	109917-04-000	EA	WASHER - 1" X .75"
	128444-01-000	EA	WASHER - SPRING - CONICAL
	135092-02-01A	EA	BOLT - HEX - SERRATED FLANGE - 1/2-20 X 2 1/2-GRADE 5 ZINC
	135092-05-01A	EA	BOLT - HEX - SERRATED FLANGE - 1/2-20 X 1 - GRADE 5 ZINC
	143399-01-01A	EA	NUT/RETAINING - 3/8"- 24 NFT

SEALANTS & FASTENERS GROUP (CONTINUED)
BOLTS, NUTS AND WASHERS (CONTINUED)

KEY	PART NUMBER	U/M	DESCRIPTION
	144904-01-01A	EA	BOLT - ADJUSTMENT - HEADLAMP
	147284-02-000	EA	NUT/SELF RETAINING - 5/16"-18
	148817-01-000	EA	WASHER/SPUR - LOCKING

SCREWS

KEY	PART NUMBER	U/M	DESCRIPTION
	0G1208-12-170	EA	SCREW - 8-18 X 3/4 POH - BRIGHT WHITE
	0G3908-08-170	EA	SCREW - SF/DR - 8-18 X 1/2 PPH - BRIGHT WHITE
	0G3908-08-410	EA	SCREW - SF/DR - 8-18 X 1/2 PPH - PARCHMENT
	0G3908-16-170	EA	SCREW - SF/DR - 8-18 X 1 PPH - BRIGHT WHITE
	0G3908-24-170	EA	SCREW - SF/DR - 8-18 X 1 1/2 PPH - BRIGHT WHITE
	0G3910-10-330	EA	SCREW - SF/DR - 20-16 X 5/8 PPH - PUTTY
	0G3910-12-170	EA	SCREW - SF/DR - 10-16 X 3/4 PPH - BRIGHT WHITE
	0G3910-12-240	EA	SCREW - SF/DR - 10-16 X .75 PPH - VW LIGHT GRAY
	0G3910-12-380	EA	SCREW - SF/DR - 10-16 X .75 PPH - CASHMERE
	0G3910-12-370	EA	SCREW - SF/DR - 10-16 X .75 PPH - RIVERSTONE
	0G3910-24-170	EA	SCREW - SF/DR - 10-16 X 1 1/2 PPH - BRIGHT WHITE
	0G3910-32-330	EA	SCREW - SF/DR - 10-16 X 2.00 PPH - PUTTY
	0G5508-08-380	EA	SCREW - SF/DR - 8-18 X .5 PWH - CASHMERE
	0G5508-08-370	EA	SCREW - SF/DR - 8-18 X .5 PWH - RIVERSTONE
	0G5508-12-170	EA	SCREW - SF/DR - 8-18 X 3/4 PWH - BRIGHT WHITE
	0G5508-12-320	EA	SCREW - SF/DR - 8-18 X 3/4 PWH - GLACIER
	0G5508-12-330	EA	SCREW - SF/DR - 8-18 X 3/4 PWH - PUTTY
	0G6008-16-170	EA	SCREW - SF/DR - 8-18 X 1 POH - BRIGHT WHITE
	0G5508-16-250	EA	SCREW - SF/DR - 8-18 X 1 PWH - VW DARK GRAY
	0G5508-16-330	EA	SCREW - SF/DR - 8-18 X 1 PWH - PUTTY
	0G5508-16-370	EA	SCREW - SF/DR - 8-18 X 1 PWH - RIVERSTONE
	0G5508-16-380	EA	SCREW - SF/DR - 8-18 X 1 PWH - CASHMERE
	0G5508-16-410	EA	SCREW - SF/DR - 8-18 X 1 PWH - MEDIUM PARCHMENT
	0G6012-32-170	EA	SCREW - SF/DR - 12-14 X 2 POH - BRIGHT WHITE
	0G6710-08-170	EA	SCREW - 10-12 X 1/2 PPH - BRIGHT WHITE
	0G6710-12-170	EA	SCREW - 10-12 X 3/4 PPH - BRIGHT WHITE
	0G6806-16-170	EA	SCREW - 6-18 X 1 POH - BRIGHT WHITE
	0G6810-24-280	EA	SCREW - 10-12 X 1 1/2 POH - SOFT WHITE
	000C20-06-24T	EA	SCREW - 3/8-16 X 1 1/2 - FLAT SOCKET
	000C28-05-24D	EA	CAPSCREW/BUTTON HEAD - 5/16-18 X 1 1/2 - #8-BLK PHOSPHATE
	000G11-06-08B	EA	SCREW - 6-20 X 1/2 PPH - ZINC
	000G11-06-10B	EA	SCREW - 6-20 X 5/8 PPH - ZINC
	000G11-06-10J	EA	SCREW - 6-20 X 5/8 PPH - BRASS
	000G11-07-08B	EA	SCREW - 7-19 X 1/2 PPH - ZINC
	000G11-08-06B	EA	SCREW - 8-18 X 3/8 PPH - ZINC
	000G11-08-08T	EA	SCREW - 8-18 X 1/2 PPH - FLUOROCARBON COATING
	000G11-08-12B	EA	SCREW - 8-18 X 3/4 PPH - ZINC
	000G11-08-12P	EA	SCREW - 8-18 X 3/4 PPH - DARK BROWN
	000G11-08-12S	EA	SCREW - 8-18 X 3/4 PPH - OFF WHITE
	000G11-08-12T	EA	SCREW - 8-18 X 3/4 PPH - BLACK MAGNESIUM
	000G11-08-20B	EA	SCREW - 8-18 X 1 1/4 PPH - ZINC
	000G11-08-20G	EA	SCREW - 8-18 X 1 1/4 - ANTIQUE BRASS
	000G11-10-12D	EA	SCREW - 10-16 X 3/4 PPH - BLACK
	000G12-06-08T	EA	SCREW - 6-20 X 1/2 POH - BLACK
	000G12-06-12J	EA	SCREW - 6-20 X .75 POH - BRASS
	000G12-10-16F	EA	SCREW - 10-16 X 1 POH - STAINLESS STEEL
	000G13-05-10B	EA	SCREW - 5-12 X 5/8 PFH - ZINC
	000G13-06-08B	EA	SCREW - 6-20 X 1/2 PFH - ZINC
	000G13-06-08G	EA	SCREW - 6-20 X 1/2 PFH - ANTIQUE BRASS
	000G13-06-10G	EA	SCREW - 6-20 X 5/8 PFH - ANTIQUE BRASS
	000G13-06-16J	EA	SCREW - 6-20 X 1 PFH - BRASS
	000G13-06-169	EA	SCREW - SF/DR - 6-20 X 1 PFH - SILVER
	000G13-06-24J	EA	SCREW - 6-20 X 1 1/2 PFH - BRASS
	000G13-07-10H	EA	SCREW - 7-19 X 5/8 PFH - BLACK
	000G13-07-12B	EA	SCREW - 7-19 X 3/4 PFH - ZINC
	000G13-08-109	EA	SCREW - 8-18 X 5/8 PFH
	000G13-08-10B	EA	SCREW - 8-18 X 5/8 PFH - ZINC
	000G13-08-16B	EA	SCREW - 8-18 X 1 PFH - ZINC

SEALANTS & FASTENERS GROUP (CONTINUED)
SCREWS (CONTINUED)

KEY	PART NUMBER	U/M	DESCRIPTION
	000G13-08-24B	EA	SCREW - 8-18 X 1 1/2 PFH - ZINC
	000G16-04-24B	EA	SCREW - MACHINE - 1/4-20 X 1 1/2 PPH
	000G18-08-12B	EA	SCREW - MACHINE - 8-32 X 3/4 PPH - ZINC
	000G18-08-16B	EA	SCREW - MACHINE - 8-32 X 1 PPH - ZINC
	000G18-08-24B	EA	SCREW - MACHINE - 8-32 X 1 1/2 PPH - ZINC
	000G18-08-22B	EA	SCREW - MACHINE - 8-32 X 1 3/8 PPH - ZINC
	000G19-10-08B	EA	SCREW - MACHINE - 10-32 X 1/2 PPH - ZINC
	000G19-10-10B	EA	SCREW - MACHINE - 10-32 X 5/8 - PPH - ZINC
	000G19-10-12F	EA	SCREW - MACHINE - 10-32 X 3/4 PPH - STAINLESS STEEL
	000G19-10-20B	EA	SCREW - MACHINE - 10-32 X 1 1/2 PPH - ZINC
	000G32-10-06B	EA	SCREW - 10-32 X 3/8 PPH - ZINC
	000G34-05-12B	EA	SCREW - HEX HEAD TAPPING - 5/16 X 3/4 LONG
	000G36-10-12T	EA	SCREW - 10-24X 3/4 PFH TYPE 23 - BLACK
	000G39-06-10T	EA	SCREW - SF/DR - 6-20 X 5/8 PPH - BLACK
	000G39-06-16T	EA	SCREW - SF/DR - 6-20 X 1 PPH - BLACK
	000G39-08-06B	EA	SCREW - SF/DR - 8-18 X 3/8 PPH - ZINC
	000G39-08-08B	EA	SCREW - SF/DR - 8-18 X 1/2 PPH - ZINC
	000G39-08-08S	EA	SCREW - SF/DR - 8-18 X 1/2 PPH - OFF WHITE
	000G39-08-08T	EA	SCREW - SF/DR - 8-18 X 1/2 PPH - BLACK
	000G39-08-12T	EA	SCREW - SF/DR - 8-18 X 3/4 PPH - BLACK
	000G39-08-16B	EA	SCREW - SF/DR - 8-18 X 1 PPH - ZINC
	000G39-08-16T	EA	SCREW - SF/DR - 6-20 X 1 PPH - BLACK
	000G39-08-24B	EA	SCREW - SF/DR - 8-18 X 1 1/2 PPH - ZINC
	000G39-08-24S	EA	SCREW - SF/DR - 8-18 X 1 1/2 - OFF WHITE
	000G39-08-24T	EA	SCREW - SF/DR - 8-18 X 1 1/2 PPH - BLACK
	000G39-08-32B	EA	SCREW - SF/DR - 8-18 X 2 PPH - ZINC
	000G39-10-08B	EA	SCREW - SF/DR - 10-16 X 1/2 PPH - ZINC
	000G39-10-10B	EA	SCREW - SF/DR - 10-16 X 5/8 PPH - ZINC
	000G39-10-12B	EA	SCREW - SF/DR - 10-16 X 3/4 PPH - ZINC
	000G39-10-129	EA	SCREW - SF/DR - 10-16 X 3/4 PPH - FLUOROCARBON SILVER
	000G39-10-169	EA	SCREW - SF/DR - 10-16 X 1 PPH - FLUOROCARBON SILVER
	000G39-10-20B	EA	SCREW - SF/DR - 10-16 X 1 1/4 PPH - ZINC
	000G39-10-20T	EA	SCREW - SF/DR - 10-16 X 1 1/4 PPH - BLACK
	000G39-10-24T	EA	SCREW - SF/DR - 10-16 X 1 1/2" PPH - BLACK
	000G39-10-28T	EA	SCREW - SF/DR - 10-16 X 1 3/4" PPH - BLACK
	000G39-10-32B	EA	SCREW - SF/DR - 10-16 X 2 - PPH - ZINC
	000G39-10-48B	EA	SCREW - SF/DR - 10-16 X 3 - PPH - ZINC
	000G39-10-48T	EA	SCREW - SF/DR - 10-16 X 3 PPH - BLACK
	000G42-04-16B	EA	SCREW - SF/DR - 1/4-14 X 1 HWH - ZINC
	000G42-04-24B	EA	SCREW - SF/DR - 1/4-14 X 1 1/2 - ZINC
	000G46-08-24T	EA	SCREW - MACHINE - 8-32 X 1 1/2 PFH - ZINC
	000G52-06-05B	EA	SCREW - MACHINE - 6-32 X 5/16 PTH - ZINC
	000G52-06-06B	EA	SCREW - MACHINE - 6-32 X 3/8 PTH - ZINC
	000G54-04-14B	EA	SCREW - 1/4-20 X 7/8 PTH - TYPE 23 - ZINC PLATED
	000G55-08-12T	EA	SCREW - SF/DR - 8-18 X 3/4 PWH - BLACK
	000G55-08-124	EA	SCREW - SF/DR - 8-18 X 3/4 PWH - ASH GRAY
	000G55-08-16T	EA	SCREW - SF/DR - 8-18 X 1 PWH - BLACK
	000G56-12-48B	EA	SCREW - WOOD - 12-11 X 3 POH - SPECIAL HARDENED
	000G57-14-64B	EA	SCREW - 14-10 X 4 PFH ZINC
	000G60-08-16E	EA	SCREW - SF/DR - 8-1 X 1 POH - CHROME
	000G60-08-20F	EA	SCREW - SF/DR - 8-19X1.25 POH
	000G60-08-22B	EA	SCREW - SF/DR - 8-18 X 1.38 POH - ZINC
	000G60-10-16J	EA	SCREW - SF/DR - 10-16 X 1 POH - BRIGHT BRASS
	000G60-10-20B	EA	SCREW - SF/DR - 10-16 X 1 1/4 POH - ZINC
	000G60-10-209	EA	SCREW - SF/DR - 10-16 X 1 1/4 POH - SILVER STALGAARD
	000G60-10-28T	EA	SCREW - SF/DR - 10-16 X 1 3/4 - BLACK
	000G62-06-24I	EA	SCREW - SF/DR - 8-18 X 1.5 PPH - BLACK
	000G62-06-249	EA	SCREW - SF/DR - 8-18 X 1.5 PPH - SILVER
	000G62-08-24B	EA	SCREW - SF/DR - 8-18 X 1 1/2 PFH
	000G67-08-32B	EA	SCREW - 8-15 X 2 PPH - ZINC
	000G67-10-08B	EA	SCREW - 10-12 X 1/2 PPH - ZINC
	000G67-10-08S	EA	SCREW - 10-12 X 1/2 PPH - OFF WHITE
	000G67-10-10B	EA	SCREW - 10-12 X 5/8 PPH - ZINC - TYPE A
	000G67-10-10S	EA	SCREW - 10-12 X 5/8 PPH - OFF WHITE

SEALANTS & FASTENERS GROUP (CONTINUED)
SCREWS (CONTINUED)

KEY	PART NUMBER	U/M	DESCRIPTION
	000G67-10-10T	EA	SCREW - 10-12 X 5/8 PPH - BLACK
	000G67-10-10P	EA	SCREW - 10-12 X 5/8 PPH - DARK BROWN
	000G67-10-12P	EA	SCREW - 10-12 X 3/4 PPH - DARK BROWN
	000G67-10-24B	EA	SCREW - 10-12 X 1 1/2 PPH - ZINC
	000G67-10-24S	EA	SCREW - 10-12 X 1 1/2 PPH - OFF WHITE
	000G67-10-32J	EA	SCREW-10-12X2 PPH - BRIGHT BRASS
	000G68-06-10J	EA	SCREW - 6-18 X 5/8 POH - BRASS
	000G68-06-12B	EA	SCREW - 6-18 X 3/4 POH - ZINC & CLEAR
	000G68-06-12J	EA	SCREW - 6-18 X 3/4 POH - BRASS
	000G68-06-12S	EA	SCREW - 6-18 X 3/4 POH
	029130-01-000	EA	SCREW - SNAP STUD - #8-16 X 5/8" LONG
	029130-03-000	EA	SCREW - SNAP STUD - #8-16 X 1" LONG
	049465-01-000	EA	SCREW - 10-16 PTH W/WASHER - DARK BROWN
	049465-03-000	EA	SCREW - 10-16 X 1 POH W/WASHER - OFF WHITE
	049465-13-000	EA	SCREW - 10-16 X 1 PTH W/WASHER - ASH GRAY
	049465-17-000	EA	SCREW - 10-16 X 1 POH W/WASHER - BRIGHT WHITE
	049465-18-000	EA	SCREW - 10-16 X 1 POH W/WASHER - VW GRAY
	054434-02-000	EA	SCREW - SF/DR - 10-16 X 2 - ZINC
	054434-03-000	EA	SCREW - SF/DR - 10-16 X 2 - PWH - ZINC
	075908-01-000	EA	SCREW - MACHINE - 10-32 X .56 PTH - EXTERNAL TOOTH - ZINC
	076790-01-000	EA	SCREW - 6-20 X 1 1/4 PPH - BLACK
	076790-05-000	EA	SCREW - 6-20 X 1/2 PPH - BLACK - THREAD CUTTING/WOOD
	083554-01-000	EA	SCREW - DRYWALL - 8 X 1 1/4
	083554-04-000	EA	SCREW - DRYWALL - 8 X 2 1/2
	087721-01-000	EA	SCREW - FLAT HEAD - TAPPING - 1/4" X 1 1/4" LONG - ZINC
	095772-01-000	EA	SOCKET-SNAP FASTNER1" SF/DR - SELF DRIVER
	097974-01-000	EA	SCREW - PARTICLE BOARD - 7-9 X 3/4 PPH
	097974-02-000	EA	SCREW-PART BD 8-9X.75 PFH - BEIGE
	101618-01-000	EA	SCREW - 1/4-20 X 3/4 HEX - TAPPING - STALGARD TYPE F
	113563-01-01A	EA	SCREW - 8 X 5/8 LONG SHOULDER/WASHER HEAD
	113563-01-02A	EA	SCREW - 8 X 5/8 LONG SHOULDER/WASHER HEAD - BRIGHT WHITE
	118383-01-09A	EA	RETAINER/RECESSED - F/.22" SCREW - GLACIER
	118383-01-12A	EA	RETAINER/RECESSED - F/.22" SCREW - RIVERSTONE
	118383-01-10A	EA	RETAINER/RECESSED - F/.22" SCREW - STORM GRAY
	118383-01-11A	EA	RETAINER/RECESSED - F/.22" SCREW - CASHMERE
	118383-02-10A	EA	RETAINER/RECESSED - F/.27" SCREW - RIVERSTONE
	118383-02-11A	EA	RETAINER/RECESSED - F/.27" SCREW - CASHMERE
	118383-02-13A	EA	RETAINER/RECESSED - F/.27" SCREW - OFF WHITE
	118383-03-09A	EA	RETAINER/RECESSED - F/.32" SCREW - GLACIER
	118383-04-04A	EA	CAP - F/RECESSED RETAINER - BRIGHT WHITE
	118383-04-09A	EA	CAP - F/RECESSED RETAINER - GLACIER
	118383-04-10A	EA	CAP - F/RECESSED RETAINER - RIVERSTONE
	118383-04-11A	EA	CAP - F/RECESSED RETAINER - CASHMERE
	118383-04-12A	EA	CAP - F/RECESSED RETAINER - STORM GRAY
	118383-04-13A	EA	CAP - F/RECESSED RETAINER - OFF WHITE
	134126-01-01A	EA	SCREW/NAIL - HEX HEAD - 3/4"
	140040-01-000	EA	SCREW - 1/4-20 X 1 - BUTTON HEAD/SOCKET - W/LOCTITE
	149753-01-01A	EA	RETAINER/RECESSED - F/.22" SCREW - BLACK
	149753-01-02A	EA	RETAINER/RECESSED - F/.22" SCREW - BRIGHT WHITE
	149753-02-01A	EA	CAP - F/RECESSED RETAINER - BLACK
	149753-02-02A	EA	CAP - F/RECESSED RETAINER - BRIGHT WHITE
	154938-01-01A	EA	SCREW - SF/DR - 10-16 X 3/4 PPH - W/SELF SEAL - BRIGHT WHITE
	154938-01-02A	EA	SCREW - SF/DR - 10-16 X 3/4 PPH - W/SELF SEAL - BLACK
	154938-02-01A	EA	SCREW - SF/DR - 8-18 X 1 PFH - W/SELF SEAL - BRIGHT WHITE
	154938-02-02A	EA	SCREW - SF/DR - 8-18 X 1 PFH - W/SELF SEAL - BLACK
	154938-02-03A	EA	SCREW - SF/DR - 8-18 X 1 PFH - W/SELF SEAL - SILVER
	154938-03-01A	EA	SCREW - SF/DR - 8-18 X 5/8 PFH - W/SELF SEAL - BRT WHT
	154935-03-02A	EA	SCREW - SF/DR - 8-18 X 5/8 PFH - W/SELF SEAL - BLACK
	154938-04-01A	EA	SCREW - SF/DR - 10-16 X 1" TPH - W/SELF SEAL - BRT WHT
	154938-04-02A	EA	SCREW - SF/DR - 10-16 X 1" TPH - W/SELF SEAL - BLACK
	154938-05-03A	EA	SCREW - SF/DR - 8-18 X 1.25" PFH - W/SELF SEAL - SILVER

SEALANTS & FASTENERS GROUP (CONTINUED)
CLAMPS, CLIPS, GROMMETS, RIVETS & PLUGS

KEY	PART NUMBER	U/M	DESCRIPTION
	000H16-04-06R	EA	RIVET - POP ALUMINUM - 1/8 X .313 - .375
	000H16-06-10R	EA	RIVET - POP ALUMINUM - 3/16 X .501 - .625
	007161-01-000	EA	CLAMP - HOSE - SPRING TYPE - 1/2"
	008386-01-000	EA	GROMMET - SNAP - 3/8" DIAMETER - NYLON
	010495-01-000	EA	CLAMP - CABLE - 9/16"ID - BLACK
	010495-02-000	EA	CLAMP - CABLE - 3/8"ID - BLACK
	010495-04-000	EA	CLAMP - CABLE - 11/16"ID - WHITE
	010497-01-000	EA	CLAMP - CLOSED - 5/8"ID
	010497-02-000	EA	CLAMP - CLOSED - 1.5"ID
	010497-03-000	EA	CLAMP - CLOSED - 1"ID - CUSHIONED
	010497-04-000	EA	CLAMP - CLOSED - 1 5/8"ID
	010497-05-000	EA	CLAMP - CLOSED - 1/2"ID
	010497-07-000	EA	CLAMP - CLOSED - 3/8"ID
	010497-09-000	EA	CLAMP - CLOSED - 5/16"ID
	010497-10-000	EA	CLAMP - CLOSED - 7/8"ID
	010499-01-000	EA	CLAMP - CLOSED - 3/8"ID
	016188-03-000	EA	GROMMET - LP LINE - 3/8"HOLE X 2 1/2"LONG - RUBBER
	016188-04-000	EA	GROMMET - LP LINE - 1/2"HOLE X 2 1/2"LONG - RUBBER
	016188-05-000	EA	GROMMET - LP LINE - 3/8"HOLE X 1 1/4"LONG - RUBBER
	016188-06-000	EA	GROMMET - LP LINE - 3/8"HOLE X 3 1/4"LONG - RUBBER
	016188-07-000	EA	GROMMET - L/P LINE - 1/2"HOLE X 3 1/4"LONG
	016188-08-000	EA	GROMMET - LP LINE - 1/2"HOLE X 1 1/4"LONG - RUBBER
	016188-09-000	EA	GROMMET - LP LINE - .68"HOLE X 1 1/4"LONG - RUBBER
	016188-10-000	EA	GROMMET - LP GAS - .68" X 2.5"
	023942-01-000	EA	GROMMET - RUBBER - 2"OD
	041930-11-000	EA	RIVET - POP ALUMINUM - 1/8 X .188 - .250 - BRIGHT WHITE
	061420-04-000	EA	PLUG/PLASTIC - 1 1/4" DIAMETER
	061420-05-000	EA	PLUG/PLASTIC - 1 1/2" DIAMETER
	061420-09-000	EA	PLUG/PLASTIC - 1.00" DIAMETER
	061420-10-000	EA	PLUG/PLASTIC - 1 1/2" DIAMETER - BLACK
	061420-12-000	EA	PLUG/PLASTIC - 1.50" DIAMETER - RED
	061420-13-000	EA	PLUG/PLASTIC - 3/8" - FLUSH
	061420-14-000	EA	PLUG/PLASTIC - 7/8" DIAMETER - BLACK
	061420-15-000	EA	PLUG/PLASTIC - 2" DIAMETER - BLACK
	061420-16-000	EA	PLUG/PLASTIC - 2 1/8" DIAMETER - BLACK
	062401-01-000	EA	CLAMP - HOSE - WORMGEAR - .25" - 1"
	062401-02-000	EA	CLAMP - HOSE - WORMGEAR - 1.56" - 2.5" ID
	062401-03-000	EA	CLAMP - HOSE - WORMGEAR - .22" - 1" ID
	062401-04-000	EA	CLAMP - HOSE - WORMGEAR - .69" - 1.25" ID
	062401-05-000	EA	CLAMP - HOSE - WORMGEAR - 2" - 3" ID
	062401-06-000	EA	CLAMP - HOSE - WORMGEAR - .22" - .62" ID
	062401-09-000	EA	CLAMP - HOSE - WORMGEAR - 2.8" - 3.75" ID
	062401-11-000	EA	CLAMP - HOSE - WORMGEAR - 3.50" - 4.50" ID
	062401-13-000	EA	CLAMP - HOSE - WORMGEAR
	063729-12-000	EA	RIVNUT - 5/16 - 18 UNCUT - FLATHEAD - STAINLESS
	071015-01-000	EA	GROMMET - RUBBER - .5"ID X 1"OD-W/.38" GROOVE - BLACK
	071015-11-000	EA	GROMMET - RUBBER - 1"ID FITS .12 MATERIAL - BLACK
	071015-13-000	EA	GROMMET - RUBBER - .62"ID X 1"OD W/.09" GROOVE - BLACK
	071015-22-000	EA	GROMMET - RUBBER - .62"ID X 1.12"OD W/.19" GROOVE - BLACK
	071015-26-000	EA	GROMMET - RUBBER - 1.5"ID X 2.1"OD W/.06" GROOVE - BLACK
	071015-29-000	EA	GROMMET - RUBBER - .3"ID X 1.3"OD W/.12" GROOVE - BLACK
	071015-30-000	EA	GROMMET - RUBBER - .3"ID X .81"OD W/.12" GROOVE - BLACK
	071015-39-000	EA	GROMMET - .75 ID FITS .06 MTL
	071015-41-000	EA	GROMMET - .125 ID FITS .188 MTL
	071015-42-000	EA	GROMMET - .25 ID FITS .06 MTL
	075148-02-000	EA	CLAMP - GROUNDING - BRONZE SCREWS
	077955-01-000	EA	CLIP/J - 3/8" - VINYL COATED
	080734-02-000	EA	CLIP - WIRE NYLON
	081211-01-000	EA	PLUG - PLASTIC - .31"DIA - BLACK
	081211-03-000	EA	PLUG - PLASTIC - .50"DIAMETER - TRUSS HEAD - BLACK
	081211-04-000	EA	PLUG - PLASTIC - .46"DIAMETER - TRUSS HEAD - BLACK
	083609-01-000	EA	CLAMP - WIRE - DUAL - EQUAL DIAMETERS - 5/8"
	083610-01-000	EA	CLAMP - WIRE - DUAL - UNEQUAL DIAMETERS - 3/4" & 1 1/4"
	083610-02-000	EA	CLAMP - WIRE - DUAL - UNEQUAL DIAMETERS - 3/4" & 2"

SEALANTS & FASTENERS GROUP (CONTINUED)
CLAMPS, CLIPS, GROMMETS, RIVETS, & PLUGS (CONTINUED)

KEY	PART NUMBER	U/M	DESCRIPTION
	083610-03-000	EA	CLAMP - WIRE - DUAL - EQUAL DIAMETERS - 2"
	088756-01-000	EA	GROMMET - WEB - 1 1/8"ID
	089329-02-000	EA	CLIP - SPRING
	091952-01-000	EA	CLIP - GRIPPER - 1" - BLACK VINYL COATED
	091952-02-000	EA	CLIP - GRIPPER - 3/4" - BLACK VINYL COATED
	091952-03-000	EA	CLIP - GRIPPER - 1/2" - BLACK VINYL COATED
	094362-02-000	EA	CLIP - XMAS TREE - BINDER HEAD - .9" LONG/ANY COLOR
	094362-05-000	EA	CLIP - XMAS TREE - ROUND HEAD - 1.4" LONG/ANY COLOR
	113133-02-01A	EA	RIVET - POP - ALUMINUM - 3/16 X .252 - .504 - BLACK
	114208-05-000	EA	GROMMET - EDGE LINER - FITS 2"
	118626-01-02A	EA	RIVET/POP - ALUMINUM - 3/16 X .08 - .375
	118626-01-01A	EA	RIVET/POP - ALUMINUM - 3/16 X 1.2"(GRIP RANGE .1"-.4")
	118626-02-01A	EA	RIVET/POP - ALUMINUM - 3/16 X .500 - .750
	118626-03-01A	EA	RIVET/POP - STAINLESS STEEL - 3/16 X .500 - .750
	137014-01-02A	EA	GROMMET - CABLE - BROWN
	137014-01-01A	EA	GROMMET - CABLE - ALMOND
	137014-01-03A	EA	GROMMET - CABLE - BLACK
	139118-02-01A	EA	GROMMET - SCREW - PLASTIC
	155498-01-01A	EA	CLAMP - CLOSED - 7/8"ID - VINYL DIP/GALVONIZED - BLACK

MISCELLANEOUS FASTENERS

KEY	PART NUMBER	U/M	DESCRIPTION
	008343-01-000	EA	TIE - WIRE - 6"
	008343-02-000	EA	TIE - WIRE - 14"
	008343-03-000	EA	TIE - WIRE - 7 1/2" - BLACK
	029094-04-000	YD	VELCRO TAPE/LOOP - 1"WIDE - W/ADHESIVE BACK - BLACK
	029096-04-000	YD	VELCRO TAPE/HOOK - 1"WIDE - BLACK - W/ADHESIVE BACK (PSA)
	048394-02-000	YD	VELCRO TAPE - HOOK - ADHESIVE BACK - 3/4" WIDE - BEIGE
	085774-01-000	FT	FASTENER - DUAL LOCK - 1" WIDE - ADHESIVE BACK - BLACK
	085774-02-000	FT	FASTENER - DUAL HOOK - 1" WIDE - ADHESIVE BACK - BLACK
	088792-02-000	YD	VELCRO TAPE - LOOP - 3/4" - ADHESIVE BACK - BEIGE
	088792-04-000	YD	VELCRO TAPE - HOOK - 5/8" - NON-ADHESIVE BACK - WHITE
	088792-05-000	YD	VELCRO TAPE - LOOP - 5/8" - NON-ADHESIVE BACK - WHITE
	108046-02-000	EA	CABLE TIE - SCREW MOUNT 15"

WATER & SEWAGE GROUP DRAINAGE SYSTEM

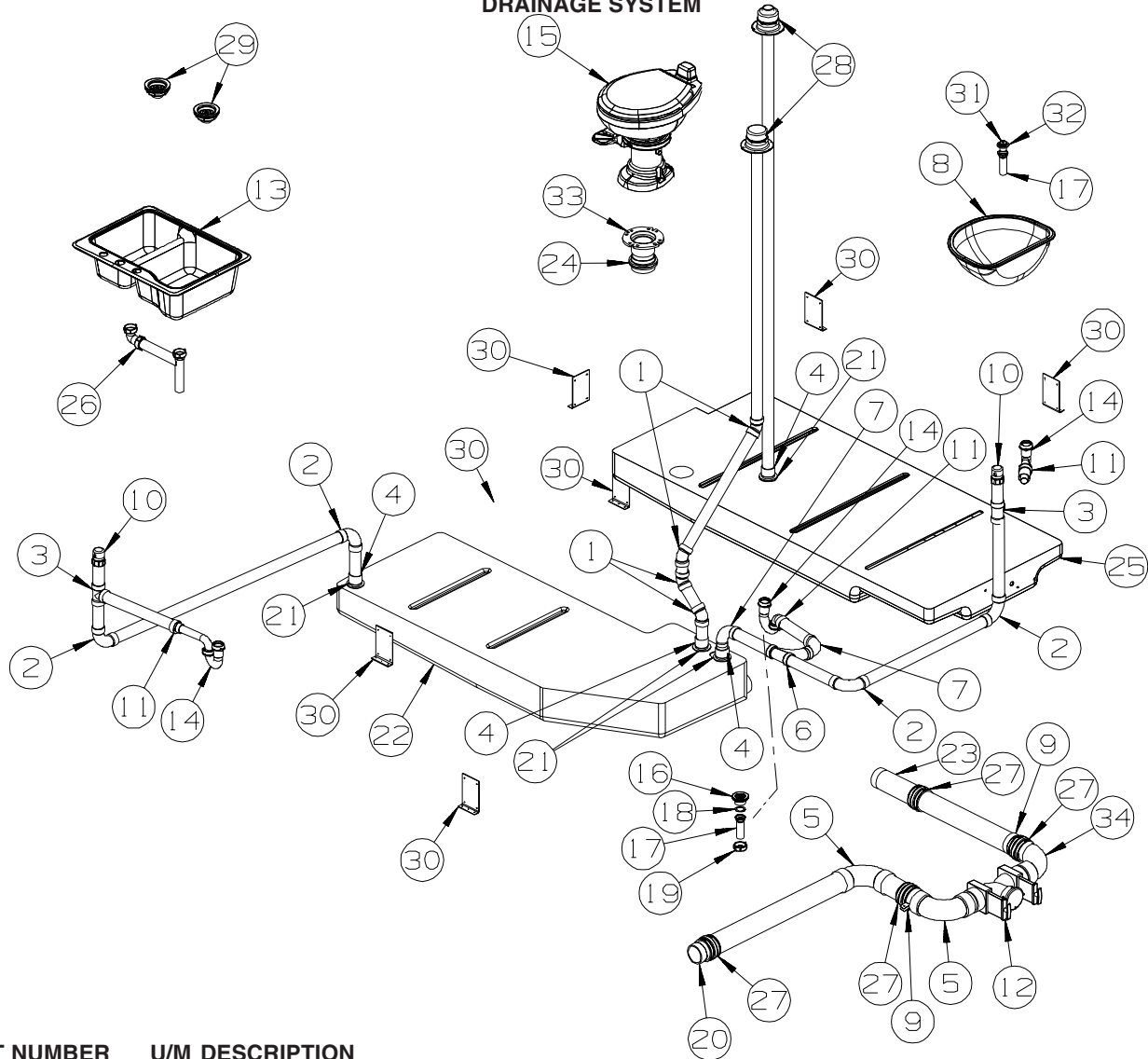

KEY	PART NUMBER	U/M	DESCRIPTION
1	010006-01-000	EA	ELBOW - 45 DEGREE - 1 1/2" HUB X HUB - PLASTIC
2	010008-01-000	EA	ELBOW - 90 DEGREE - 1 1/2" HUB X HUB - PLASTIC
3	010071-01-000	EA	TEE - SANITARY - 1 1/2" HUB X HUB X HUB - PLASTIC
4	010115-01-000	EA	COUPLING - 1 1/2" HUB X HUB - PLASTIC
5	031126-01-000	EA	ELBOW - 1/4 BEND - 3" X 90" XLT - BLACK PLASTIC
6	031365-02-000	EA	TEE - 1 1/2" EXTRA LONG TURN - PLASTIC
7	033761-01-000	EA	ELBOW - 90 DEGREE - TURN - 1 1/2" HUB X 1 1/2" SPIGOT
8	156661-01-01A	EA	SINK - LAVATORY - OVAL - 15" X 12" X 6.5" - GLACIER WHITE
9	141443-01-02B	EA	HOLDER - RING - 3.6" DIAMETER - METAL
10	079968-01-000	EA	VENT - MECHANICAL/TRAP ARM - ANTI-SIPHON-2" X 7.3" PLASTIC
11	152146-01-000	EA	CONNECTOR - 1 1/2" P X 1 1/2" MPT
12	136143-01-000	EA	VALVE - DUAL - 3" X 3"
	139513-01-000	EA	HOSE - SEWER - 3" X 10' - W/ADAPTER
	062416-01-000	EA	ADAPTER - SEWER HOSE TO 3" PIPE
13	148870-01-01A	EA	SINK/DOUBLE - LRG/SML BASIN - 25" X 19" X 7"
14	107538-02-000	EA	P-TRAP - PLASTIC - 1 1/2" W/EXTENSION ARM
14	011071-01-000	EA	P-TRAP - 1 1/2" - CSA - PLASTIC - CANADIAN
15*	152829-01-01A	EA	TOILET/AQUA MAGIC STYLE LITE - TALL - W/SPRAY - WHITE
			FROM: 00-00-00 THRU: 02-18-07
15	160815-01-01A	EA	TOILET/STYLE II - TALL - W/SPRAY - WHITE
			FROM: 02-19-06 THRU: 99-99-99
16	066440-01-000	EA	STRAINER - SHOWER DRAIN - W/RUBBER WASHER
17	011069-02-000	EA	TAILPIECE - TUB/SHOWER - 1 1/2" X 1 1/4" X 4" - BRASS
18	127440-02-01A	EA	WASHER - RUBBER - 1.8" X .1"
19	130403-01-000	EA	NUT - SLIP - W/WINGS 1 1/2"
20	010129-03-000	EA	NIPPLE - 3" X 3" TOE - PLASTIC
21	061607-01-000	EA	GROMMET - HOLDING TANK - 1 1/2" NPS

WATER & SEWAGE GROUP (CONTINUED)
DRAINAGE SYSTEM (CONTINUED)

KEY	PART NUMBER	U/M	DESCRIPTION
22	135367-01-700	EA	TANK - HOLDING - 45 GALLON - W/3" NIPPLE - W/O FITTINGS
	049032-01-000	EA	PATCH - SPINWELD - 3/8" - PLASTIC
23	010129-05-000	EA	NIPPLE - PLASTIC - 3" X 10"
24	061607-02-000	EA	GROMMET - HOLDING TANK - 3" NPS
25	139423-01-700	EA	TANK - HOLDING - 52 GALLON - W/O FITTINGS
	049032-01-000	EA	PATCH - SPINWELD - 3/8" - PLASTIC
	125697-02-000	EA	NOZZLE - WELD-A-FLUSH
	130685-01-000	EA	ADAPTER - 1 7/8" FEMALE SLIP X 1 1/2" FEMALE THREAD/O-RING
26	011091-02-000	EA	WASTE - CONTINUOUS - DOUBLE SINK
27	078406-01-000	EA	COUPLER - 3" X 3" W/CLAMPS - RUBBER
28	083558-03-000	EA	VENT W/COVER F/PLUMBING STACK - OFF WHITE
29	092303-01-000	EA	STRAINER - W/BASKET - GALLEY SINK - 4" OD
30	094756-02-01A	EA	BRACKET - L - 6.1" LONG X 3.9" WIDE - STEEL
31	106116-01-02A	EA	STRAINER/PLASTIC - STOPPER/TAILPIECE/GASKET & NUT-LAVATORY
32	106116-02-01A	EA	GASKET - STRAINER
33	116644-01-000	EA	FLANGE/CLOSET - 3" FEMALE - 4 BOLT
			FROM: 00-00-00 THRU: 01-10-06
33	024676-01-000	EA	FLANGE/CLOSET - 4" X 3" - BLACK PLASTIC
			FROM: 01-11-06 THRU: 99-99-99
34	041956-01-000	EA	ELBOW - 3" STREET - 90 DEGREE - PLASTIC

***COMPONENT PARTS LISTED LATER IN THIS GROUP**

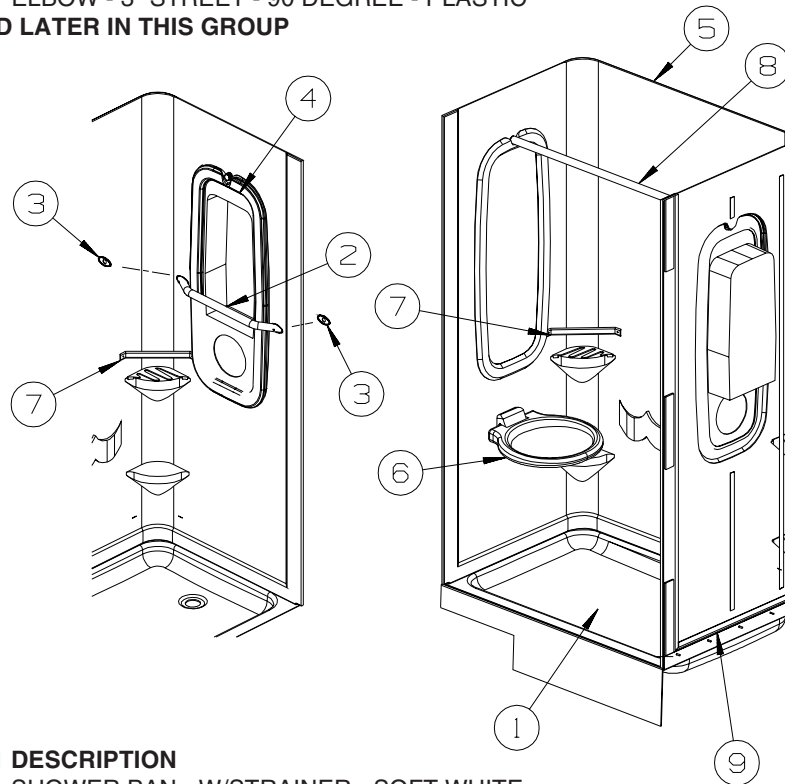

KEY	PART NUMBER	U/M	DESCRIPTION
1	M02630-79-R38	EA	SHOWER PAN - W/STRAINER - SOFT WHITE
2	132083-01-02A	EA	HANDRAIL/ASSIST - 1" DIAMETER/W/END CAPS - SOFT WHITE
3	132083-02-01A	EA	PAD - OVAL - BLACK RUBBER
4	132192-02-01A	EA	CADDY - SHOWER - SOFT WHITE
5	147188-02-01A	EA	SURROUND - SHOWER - SOFT WHITE
6	NOT USED		
7	NOT USED		
8	102075-18-02A	EA	ROD - SHOWER CURTAIN - 1" OD X 38.9" - SOFT WHITE
	081114-02-000	EA	CAP - INSERT/ROUND - 1" DIAMETER - WHITE PLASTIC
9	154585-03-01A	FT	SEAL - FOAM TAPE - ADHESIVE BACK - 1/8" X 3/4" - GRAY

WATER & SEWAGE GROUP (CONTINUED)

COMPONENT PARTS FOR DRAINAGE SYSTEM

144728-01-000

KEY	PART NUMBER	U/M	DESCRIPTION	VENDOR NO.
	144728-01-700	EA	GASKET-RUBBER, INSIDE VALVE	9667310-11
	144728-01-701	EA	GASKET-RUBBER, OUTSIDE	9667310-10

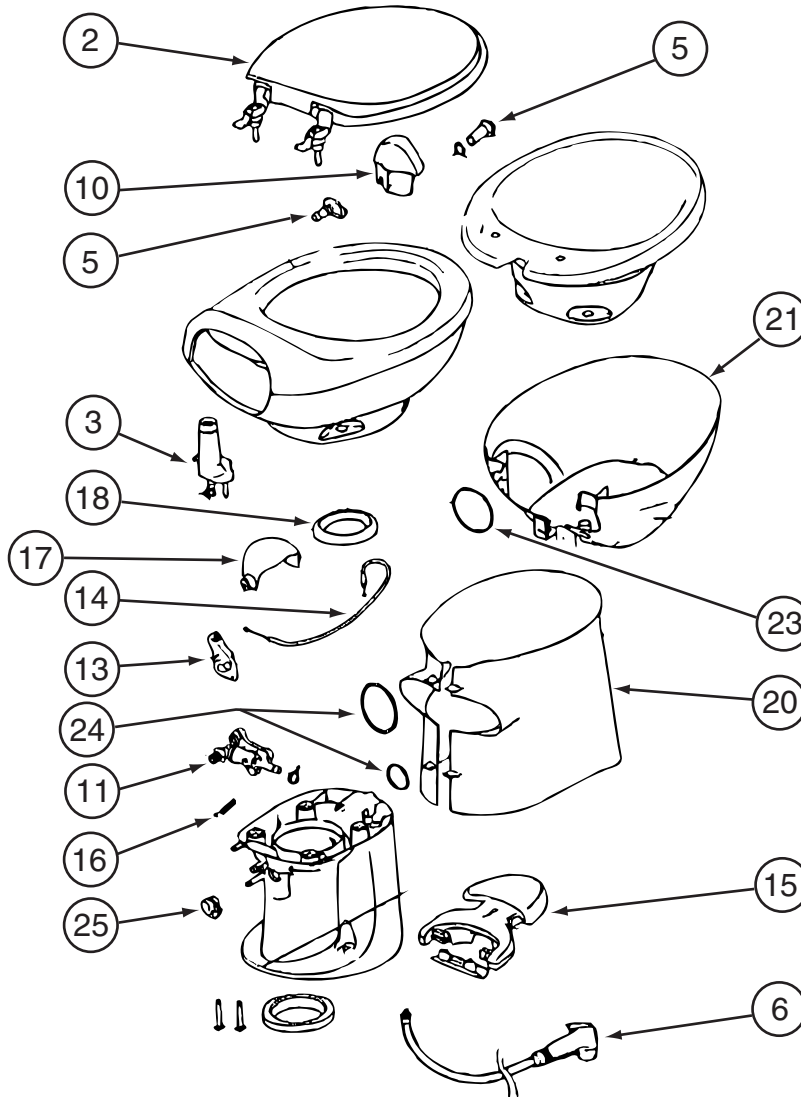

152829-01-01A

KEY	PART NUMBER	U/M	DESCRIPTION	VENDOR NO.
2	152829-01-700	EA	SEAT/COVER ASSEMBLY - WHITE	34144
3	152829-01-708	EA	VACUUM BREAKER	34122
5	152829-01-710	EA	FLUSH NOZZLE - WHITE	34124
6	147421-01-708	EA	HAND SPRAY KIT - WHITE HEAD	33226
10	152829-01-711	EA	POD - WHITE	34129
11	152829-01-701	EA	WATER VALVE	34100
13	152829-01-703	EA	WATER VALVE DRIVE ARM	34104
14	152829-01-704	EA	CABLE - F/PEDAL	34106
15	152829-01-709	EA	PEDAL PACKAGE - WHITE	34112
16	152829-01-705	EA	SPRING/RETURN-FWATER VALVE	34110
17	152829-01-706	EA	WASTE BALL - WHITE	34117
18	152829-01-707	EA	SEAL - F/WASTE BALL	34120
21	152829-01-713	EA	BOWL WRAP - WHITE	34133
23	152829-01-712	EA	O-RING - F/BOWL WRAP	34131
25	152829-01-702	EA	WASTE BALL DRIVE ARM	34102

CONTACT WINNEBAGO PARTS SALES FOR UNLISTED COMPONENT(S)

WATER & SEWAGE GROUP (CONTINUED)

WATER SYSTEM

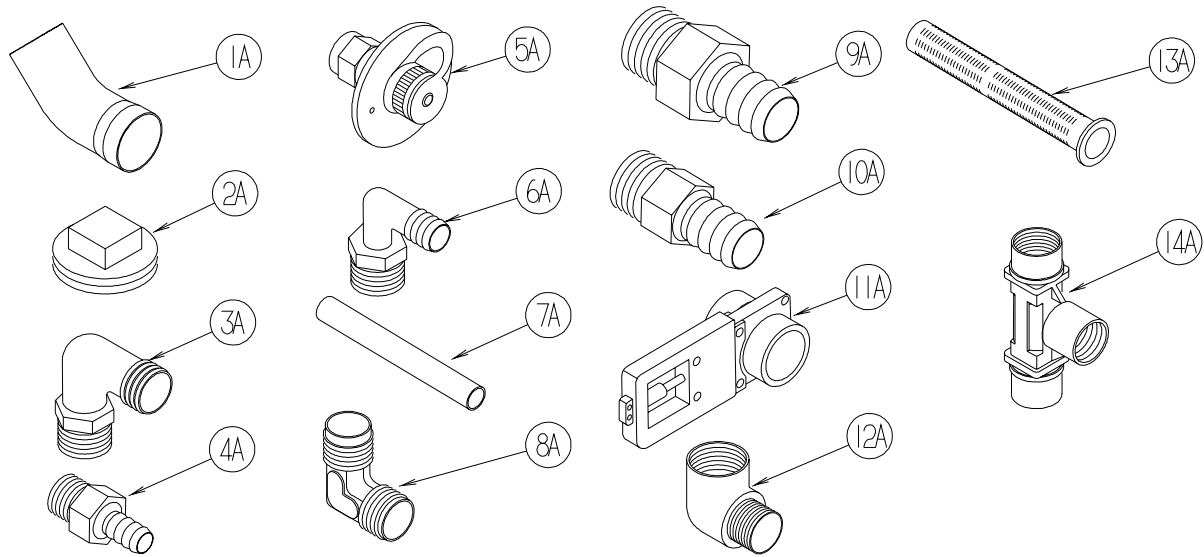

KEY	PART NUMBER	U/M	DESCRIPTION
1A	010009-01-000	EA	ELBOW - 90 DEGREE - 1/4 BEND - 1 1/2" PLASTIC
2A	010166-01-000	EA	PLUG/THREADED - 1 1/4"MPT - PLASTIC - BLACK - UL
3A	010219-01-000	EA	ELBOW - 1 1/4 MPT X 1 1/4 BARB - WATER FILL - PLASTIC
4A	010224-01-000	EA	ADAPTER - HOSE TO PIPE - 3/8 MPT X 3/8 BARB - PLASTIC
5A	010230-06-000	EA	FILL - CITY WATER - W/CHECK VALVE - MPT - BRUSHED ALUM
6A	035539-01-000	EA	ELBOW - 3/8 MPT X 3/8 BARB - PLASTIC
7A	039800-04-000	FT	TUBING - POLYBUTYL - 1/4"OD
7A	074462-02-000	FT	TUBING - VINYL - 3/8 ID X 20' - CLEAR
7A	112176-01-000	FT	TUBING - VINYL - REINFORCED - 1/2" ID
7A	124188-01-000	FT	TUBING - PEX - 1/2" ID X 20' - BLUE(COLD)
7A	124188-02-000	FT	TUBING - PEX - 1/2" ID X 20' - RED(HOT)
8A	039808-03-000	EA	ELBOW - 1/2" MPT X 1/2" MPT - PLASTIC
9A	044927-01-000	EA	ADAPTER - HOSE TO PIPE-1 1/4 MPTX1 1/4 BARB-BLACK PLASTIC
10A	044927-02-000	EA	ADAPTER - REDUCING - 1" MPT X 1.3" BARB - PLASTIC
11A	062421-03-000	EA	VALVE/DUMP W/O HANDLE - 1 1/2" X 1 1/2" HUB
	062421-05-000	EA	CABLE/ROD - F/DUMP VALVE - W/HANDLE - 48"
	062421-07-000	EA	CABLE/ROD - F/DUMP VALVE - W/HANDLE - 144"
	062421-08-000	EA	CABLE/ROD - F/DUMP VALVE - W/HANDLE - 108"
12A	065318-02-000	EA	ELBOW - 90 DEGREE - 3/8" MPT TO 3/8" FPT
13A	077954-02-000	EA	FILTER - WATER TANK - W/SCREEN IN TANK
14A	039798-01-000	EA	TEE - 1/2"MPT X 1/2"MPT X 1/2"MPT - PLASTIC

WATER & SEWAGE GROUP (CONTINUED)
WATER SYSTEM (CONTINUED)

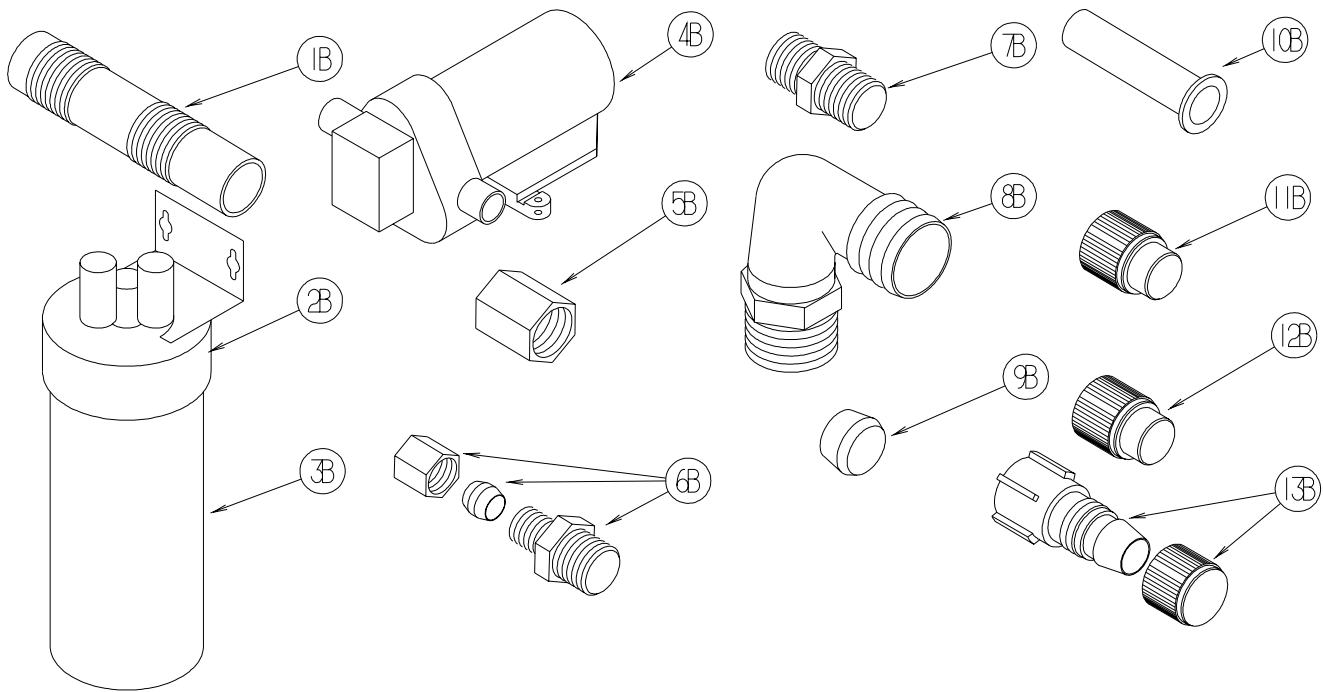

KEY	PART NUMBER	U/M	DESCRIPTION
1B	079381-01-000	FT	TUBING - RIBBED FLEXIBLE - WATER FILL - 1.4" ID
2B	087200-01-000	EA	FILTER-WATER PURIFCATION, EVERPURE QC2-AC
3B	087200-02-000	EA	CARTRIDGE-WATER FILTER,AC - EVERPURE 9601-11
4B*	098607-01-000	EA	PUMP - WATER - W/.5" MPT FITTING - FLOW 2.8 GPM
			FROM: 00-00-00 THRU: 06-21-06
4B	160702-01-000	EA	PUMP - WATER - 3.0 GPM - W/1/2" MPT
			FROM: 06-22-06 THRU: 99-99-99
5B	101814-01-000	EA	COUPLING - FEMALE - 1/2" X 1/2" FPT - GRAY
6B	103798-01-000	EA	CONNECTOR - 1/4 OD X 3/8 MPT
7B	110438-02-000	EA	VALVE - CHECK - BRASS - 1/2 MPT X 1/2 MPT
8B	111223-02-000	EA	ELBOW - 1/2" MPT X 3/8" BARB - PLASTIC
8B	111223-03-000	EA	ELBOW - 3/4" MPT X 1/2" BARB - PLASTIC
8B	111223-04-000	EA	ELBOW - 1/2" MPT X 1/2" BARB - PLASTIC
9B	111888-01-000	EA	FERRULE - PLASTIC - .250 ID X .375 OD
10B	111888-02-000	EA	INSERT - BRASS - 1/4 COMP
11B	113697-01-000	EA	CAP - 3/8"P
12B	114427-01-000	EA	CAP - 1/2"P
13B	114427-02-000	EA	PLUG - W/COMP NUT - 1/2" PLASTIC PIPE/1/2" FLAIR-IT

WATER & SEWAGE GROUP (CONTINUED)
WATER SYSTEM (CONTINUED)

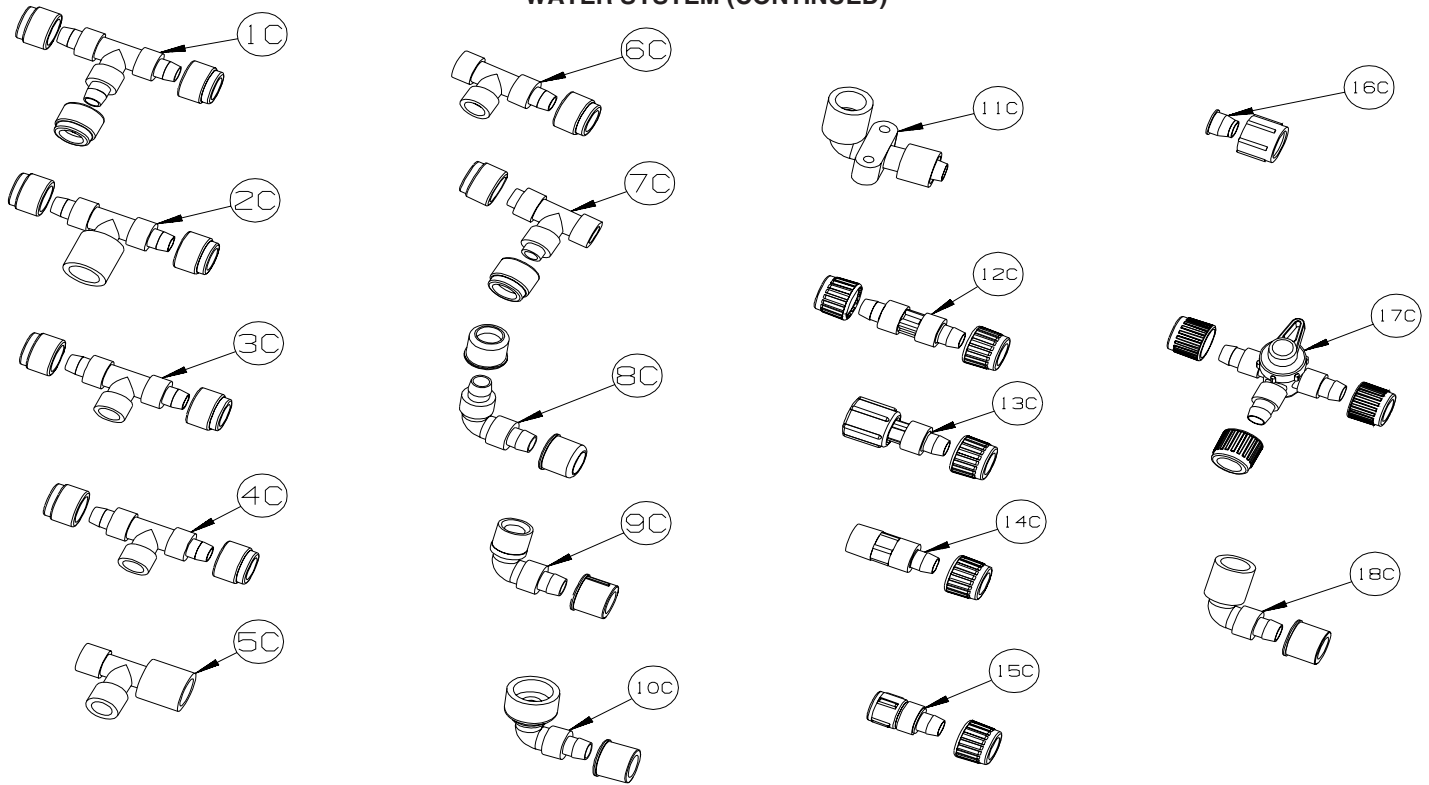

KEY	PART NUMBER	U/M	DESCRIPTION
1C	114428-01-000	EA	TEE - 1/2"P X 1/2"P X 1/2"P
2C	114428-02-000	EA	TEE - SWIVEL - 1/2"P X 1/2"P X 1/2"FPT
3C	114428-03-000	EA	TEE - 1/2"P X 1/2"P X 1/2"MPT
4C	114428-04-000	EA	TEE - 1/2"P X 1/2"P X 1/8"FPT
5C	114428-05-000	EA	TEE - 1/2" SWIVEL X 1/2" MPT X 1/2" MPT
6C	114428-06-000	EA	TEE - 1/2" P X 1/2" MPT X 1/2" MPT
7C	114428-07-000	EA	TEE - 1/2" P X 1/2" MPT X 1/2" P
8C	114429-01-000	EA	ELBOW - 1/2"P X 1/2"P
9C	114429-02-000	EA	ELBOW - 1/2"P X 1/2"MPT
9C	114429-04-000	EA	ELBOW - 1/2"P X 3/8"MPT
9C	114429-05-000	EA	ELBOW - 1/2"P X 3/4"MPT
9C	114429-10-000	EA	ELBOW - SWIVEL - 1/2"MPT X 1/2"FPT
10C	114429-06-000	EA	ELBOW - SWIVEL - 1/2"P X 3/4"FPT
10C	114429-08-000	EA	ELBOW - SWIVEL - 1/2"P X 1/2"FPT
11C	114429-09-000	EA	ELBOW - 1/2"P X 1/2"FPT DROP EAR
12C	114430-01-000	EA	ADAPTER - 1/2"P X 1/2"P
13C	114430-02-000	EA	ADAPTER - SWIVEL - 1/2"P X 1/2"FPT
13C	114430-04-000	EA	ADAPTER - SWIVEL - 1/2"P X 3/8"MPT
14C	114430-03-000	EA	ADAPTER - 1/2"P X 1/2"MPT
15C	114430-06-000	EA	ADAPTER - 1/2"P X 3/8"FPT
15C	114430-09-000	EA	ADAPTER - 1/2"P X 1/2"FPT
16C	114430-10-000	EA	ADAPTER - NUT - PIPE CONNECTION - 1/2"
17C	114431-01-000	EA	VALVE - 180 DEGREE/CENTER DRAIN - 1/2"P - THREE WAY
18C	114429-11-000	EA	ELBOW - 1/2"P X 1/2"FPT

WATER & SEWAGE GROUP (CONTINUED)
WATER SYSTEM (CONTINUED)

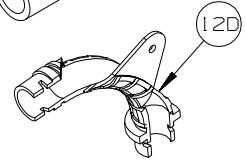
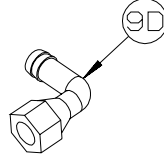
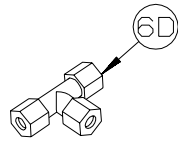
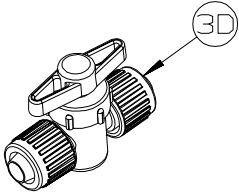
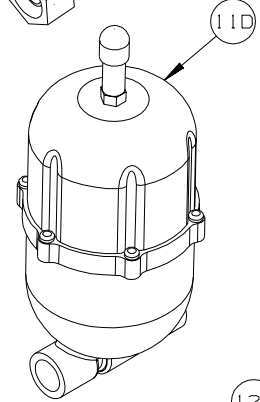
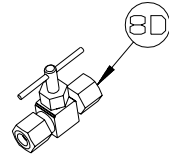
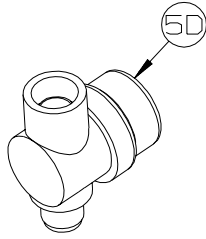
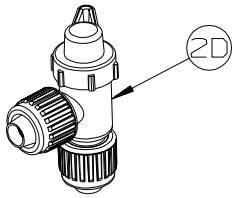
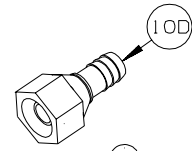
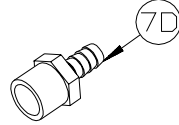
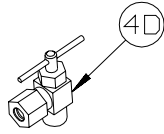
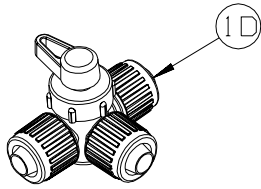

KEY	PART NUMBER	U/M	DESCRIPTION
1D	114431-02-000	EA	VALVE - WATER BYPASS - 1/2"P - THREE WAY (WATER HEATER)
2D	114431-03-000	EA	VALVE - 90 DEGREE DRAIN - 1/2"P
3D	114431-04-000	EA	VALVE - "INLINE SHUT-OFF" - 1/2"P
4D	114431-05-000	EA	VALVE - NEEDLE - 1/8" MPT X 1/4" COMPRESSION (ICE MAKER)
5D	152925-01-01A	EA	FILTER - IN LINE - TWIST ON - 1/2" - BLACK
6D	118423-01-000	EA	FITTING - BRASS-TEE - 1/4C X 1/4C X 1/4C
7D	118809-01-000	EA	ADAPTER - 1/2" MPT X 3/8" BARB - PLASTIC
7D	118809-02-000	EA	ADAPTER - 1/2" MPT X 1/2" BARB - PLASTIC
8D	120868-01-000	EA	VALVE - NEEDLE - 1/4" COMPRESSION X 1/4" COMPRESSION
9D	123150-01-000	EA	ELBOW - 1/2 FPT X 1/2 BARB - SWIVEL
10D	123152-01-000	EA	ADAPTER - 1/2 FPT X 1/2 BARB - SWIVEL
11D	123243-01-000	EA	TANK - ACCUMULATOR - 24 OZ
	123317-01-000	EA	TANK - ACCUMULATOR - 2 GALLON
12D	124184-01-000	EA	SUPPORT - WATER LINE - BEND

WATER & SEWAGE GROUP (CONTINUED)
WATER SYSTEM (CONTINUED)

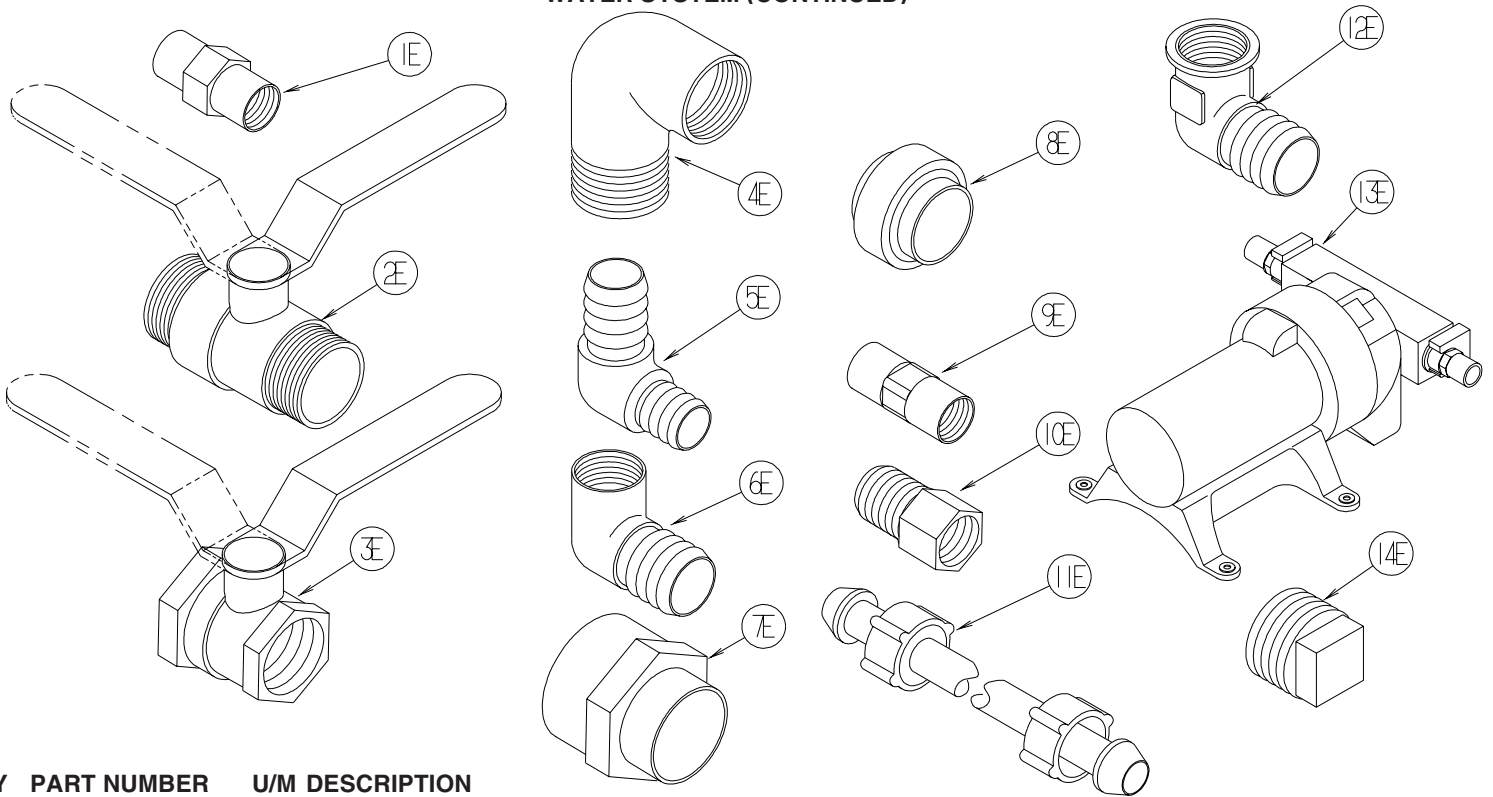

KEY	PART NUMBER	U/M	DESCRIPTION
1E	132148-01-000	EA	CONNECTOR - 1/2" X 1/2" MPT - BRASS
2E	132483-01-000	EA	VALVE/BALL - 1" - THREADED ENDS
3E	132483-02-000	EA	VALVE/BALL - 1/2" - BRASS - FPT
4E	132484-01-000	EA	ELBOW - 90 DEGREE - 1MPT X 1FPT - PLASTIC
5E	132781-01-000	EA	ELBOW - 1.3" BARB X 1.3" BARB - 90 DEGREE - PLASTIC
6E	132782-01-000	EA	ELBOW - 1" FPT X 1.3" BARB - 90 DEGREE - PLASTIC
7E	133835-01-000	EA	ADAPTER - REDUCING - 1 1/2" X 1 1/4"
8E	133889-01-000	EA	UNION - 1 1/2" DOUBLE SLIP - PVC
9E	135386-01-000	EA	NIPPLE - 1/2"
10E	136333-01-000	EA	ADAPTER - BRASS - 1/2" MPT X 1/2" FPT
11E	140821-01-000	EA	TUBE - WATER SUPPLY - 3/8" X 24"
11E	140821-02-000	EA	TUBE - WATER SUPPLY - 3/8" X 30"
11E	140821-03-000	EA	TUBE - WATER SUPPLY - 3/8" X 36"
11E	140821-04-000	EA	TUBE - WATER SUPPLY - 3/8" X 48"
11E	140821-05-000	EA	TUBE - WATER SUPPLY - 3/8" X 54"
11E	140821-06-000	EA	TUBE - WATER SUPPLY - 3/8" X 60"
11E	140821-07-000	EA	TUBE - WATER SUPPLY - 3/8" X 72"
11E	140821-08-000	EA	TUBE - WATER SUPPLY - 1/2" X 24"
11E	140821-09-000	EA	TUBE - WATER SUPPLY - 1/2" X 36"
11E	140821-10-000	EA	TUBE - WATER SUPPLY - 1/2" X 48"
12E	142812-01-000	EA	ELBOW - BRASS - 1/2" MPT X 1/2" FPT
13E*	144215-01-000	EA	PUMP - WATER - 5.7 GPM - W/1/2" MPT

FROM: 00-00-00 THRU: 02-05-06

14E 145609-01-000 EA PLUG - BRASS - 1/2" MPT/HEX HEAD
***COMPONENT PARTS LISTED LATER IN THIS GROUP**

WATER & SEWAGE GROUP (CONTINUED)

WATER SYSTEM (CONTINUED)

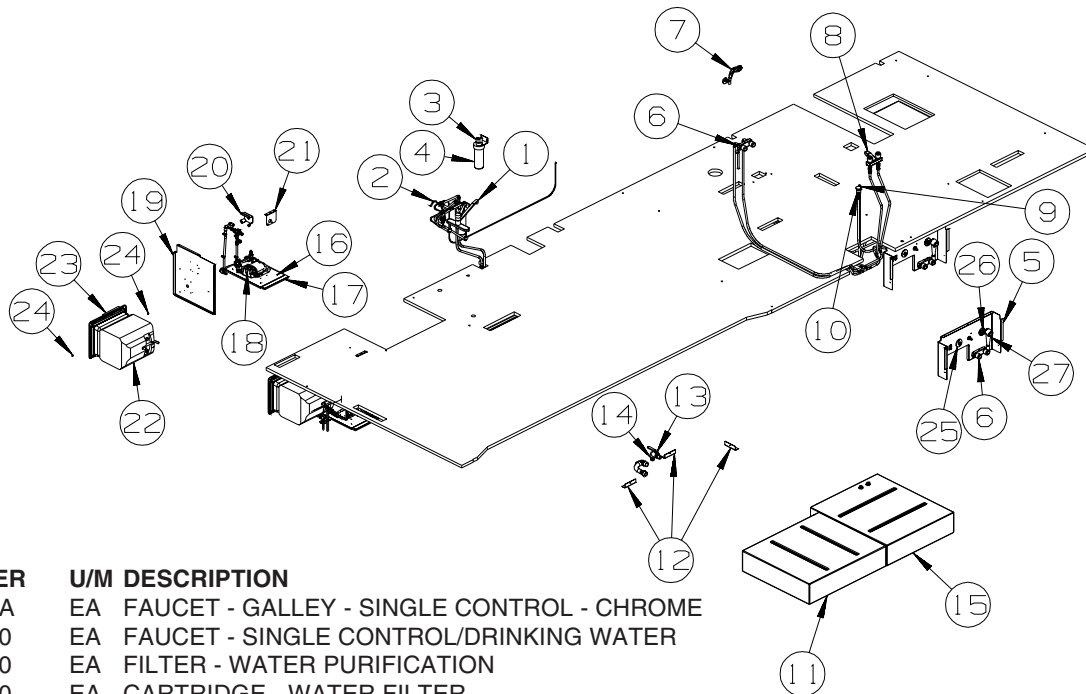

KEY	PART NUMBER	U/M	DESCRIPTION
1	149164-01-01A	EA	FAUCET - GALLEY - SINGLE CONTROL - CHROME
2*	103635-01-000	EA	FAUCET - SINGLE CONTROL/DRINKING WATER
3	087200-01-000	EA	FILTER - WATER PURIFICATION
4	087200-02-000	EA	CARTRIDGE - WATER FILTER
5	136034-12-12B	EA	PANEL - SERVICE CENTER - BRIGHT WHITE
6	163269-01-01A	EA	FAUCET/SHOWER - .5" MPT W/1.9" INLET PIPES- EXTERIOR/BRT WHITE
7	129390-04-01A	EA	SHOWER HEAD - W/HOSE & BRACKET - WHITE
8	148886-01-01A	EA	FAUCET - LAVATORY/DUAL CONTROL/4" CENTER - CHROME
9	125697-03-000	EA	CHECK VALVE - F/FLUSHING SYSTEM
10	125697-04-000	EA	BREAKER/VACUUM - F/FLUSHING SYSTEM
11	132224-05-000	EA	TANK - WATER - 40 GALLON - W/FITTINGS - 37.8"X 33.1"X 8.3"
	042989-03-000	EA	FITTING - SPINWELD - 1 1/4"NPT - PLASTIC
	042989-05-000	EA	FITTING - SPINWELD - 1/2"FPT - PLASTIC
	049032-01-000	EA	PATCH - SPINWELD - 3/8" - PLASTIC
	077594-02-000	EA	FILTER - WATER TANK - W/SCREEN IN TANK
12	142053-30-134	EA	ANGLE-STL,ROOF JOINT,0134 MM - TOP COAT OFF WHITE
13	132483-01-000	EA	VALVE/BALL - 1" - THREADED ENDS
14	132782-01-000	EA	ELBOW - 1"FPT X 1.3" BARB - 90 DEGREE - PLASTIC
15	132224-38-000	EA	TANK - WATER - 40 GALLON - W/FITTINGS - 37.8"X 33.1"X 8.3"
	042989-03-000	EA	FITTING - SPINWELD - 1 1/4"NPT - PLASTIC
	042989-04-000	EA	FITTING - SPINWELD - 3/8"FPT - PLASTIC
	042989-05-000	EA	FITTING - SPINWELD - 1/2"FPT - PLASTIC
	042989-08-000	EA	FITTING - SPINWELD - 1"FPT - PLASTIC
	049032-01-000	EA	PATCH - SPINWELD - 3/8" - PLASTIC
16	149477-01-02B	EA	PANEL - WATER PUMP - E-COATED
17	140364-04-01A	EA	FOAM - PAD - .5" X 12" X 18"
18*	098607-01-000	EA	PUMP - WATER - W/.5" MPT FITTING - FLOW 2.8 GPM - NOT ILLUSTRATED FROM: 00-00-00 THRU: 06-21-06
18	160702-01-000	EA	PUMP - WATER - 3.0 GPM - W/1/2" MPT FROM: 06-22-06 THRU: 99-99-99
19	149497-02-12B	EA	PANEL - F/VALVE BYPASS - BRIGHT WHITE
20	138618-01-12B	EA	COVER - VALVE - BYPASS - BRIGHT WHITE
21	137410-02-02B	EA	BRACKET - VALVE - WINTERIZATION - E-COATED
22*	145541-02-000	EA	WATER HEATER-6 GAL-GAS/ELEC/120'-REM IGN-W/HEAT EXC-4E
22*	145541-01-000	EA	WATER HEATER/MOTOR AID-GAS/ELECT IGN - GCH10A-4E - WTR HTR-10GAL/ELEC/LP/MTRAIID
22*	051393-01-000	EA	WATER HEATER - GH6-8E - ELECTRONIC IGNITION W/MOTOR AID - WTR HTR-AUX AUTO/MOTORAIID
23*	125420-04-03A	EA	DOOR - WATER HEATER - 18" X 14.6" - BLACK
23*	125420-03-03A	EA	DOOR - WATER HEATER - 18" X 17.7" - BLACK - WTR HTR-10GAL/ELEC/LP/MTRAIID
24	117047-02-000	EA	BUMPER - RUBBER/WASHER INSERT
25	125697-05-000	EA	INLET/WATER - F/FLUSHING SYSTEM
26	010230-06-000	EA	FILL - CITY WATER - W/CHECK VALVE - MPT - BRUSHED ALUM
27	131383-01-02A	EA	SHOWER HEAD - W/60" HOSE & BRACKET - WHITE

*COMPONENT PARTS LISTED LATER IN THIS GROUP

WATER & SEWAGE GROUP (CONTINUED)
COMPONENT PARTS FOR WATER SYSTEM

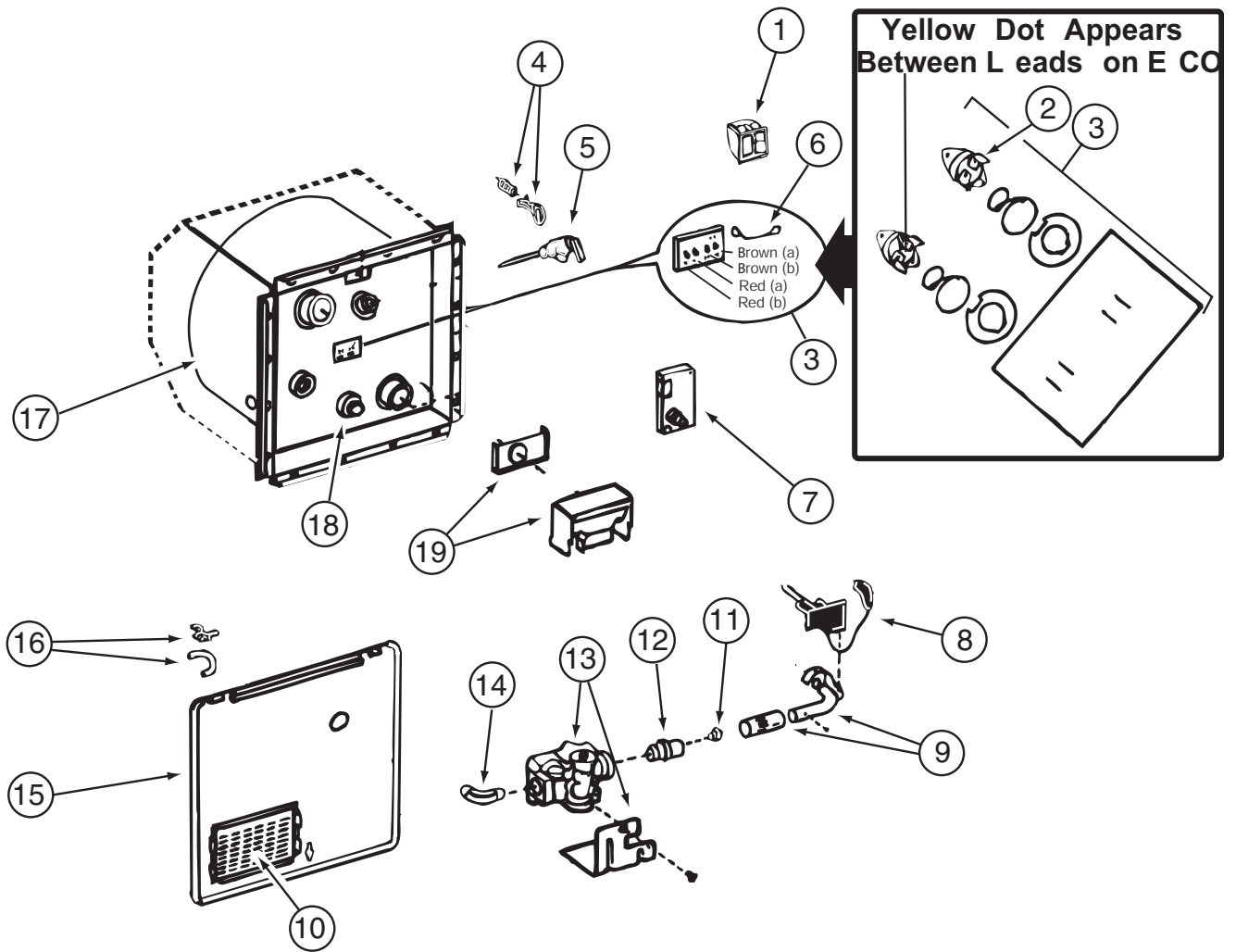

051393-01-000

KEY	PART NUMBER	U/M	DESCRIPTION	VENDOR NO.
1	051393-01-701	EA	SWITCH PACKAGE	91959
2	051391-04-701	EA	THERMOSTAT 12V DC-120 PRESET	91470
3	051393-01-721	EA	ECO & THERMOSTAT ASM - FRT MT - 140°	91447
4	051391-01-705	EA	FASTENER - CAMLOC	92609
5	051391-01-704	EA	VALVE - RELIEF - 1/2" FITTING	91604
6	051393-01-723	EA	SWITCH - ENERGY CUT-OFF	93866
7	051393-01-724	EA	CIRCUIT BOARD - W/ SPADE TERMINAL	93867
8	051393-01-725	EA	ELECTRODE - SINGLE SPADE CNT	93868
9	051391-04-703	EA	BURNER - MAIN	91638
10	051391-01-717	EA	GRILLE	92640
11	051391-01-710	EA	ORIFICE - MAIN BURNER	92742
12	051391-03-700	EA	ORIFICE HOLDER	91563
13	051393-01-726	EA	SOLENOID VALVE & BRACKET	93870
14	051391-01-714	EA	ELBOW - 45 DEGREE - 3/8" F X 3/8" MPT	91044
15		EA	DOOR-WATER HEATER - SEE EXTERIOR DOOR & COMPARTMENT GROUP BY MODEL	
16	051391-01-700	EA	HINGE KIT - W/CLIP	92568 & 92559
17	051391-04-704	EA	TANK - INNER	91642
18	051391-01-715	EA	DRAIN PLUG	91857
19	051391-04-707	EA	FLUE & GASKET	90960
	111129-01-711	EA	BRACKET-CORNER, SET OF FOUR	91928

WATER & SEWAGE GROUP (CONTINUED)
COMPONENT PARTS FOR WATER SYSTEM (CONTINUED)

098607-01-000

KEY	PART NUMBER	U/M	DESCRIPTION	VENDOR NO.
	098607-01-702	EA	DIAPHRAGM/DRIVE ASSEMBLY KIT	94-238-04
	098607-01-703	EA	VALVE KIT	94-232-00
	098607-01-705	EA	VALVE-CHECK, KIT	94-237-00
	098607-01-706	EA	HOUSING, W/SWITCH ONLY	94-231-20
	098607-01-707	EA	MOTOR W/BASEPLATE	11-148-04

103635-01-000

KEY	PART NUMBER	U/M	DESCRIPTION	VENDOR NO.
	103635-01-703	EA	CARTRIDGE - 10"	ADC-959201

123744-03-01A

KEY	PART NUMBER	U/M	DESCRIPTION	VENDOR NO.
	135027-01-700	EA	CLIP - RETAINER	883
	135027-01-705	EA	CARTRIDGE F/SGL LEVER FAUCET	1225

125420-01-02A, 125420-01-03A, 125420-03-03A, 125420-04-03A

KEY	PART NUMBER	U/M	DESCRIPTION	VENDOR NO.
	051391-01-705	EA	FASTENER - CAMLOCK	92609

144215-01-000

KEY	PART NUMBER	U/M	DESCRIPTION	VENDOR NO.
	144215-01-700	EA	VALVE ASSEMBLY	94-030-01
	144215-01-701	EA	DRIVE ASSEMBLY	94-030-02
	144215-01-702	EA	FITTING KIT - W/ORINGS	94-615-06

WATER & SEWAGE GROUP (CONTINUED)
COMPONENT PARTS FOR WATER SYSTEM (CONTINUED)

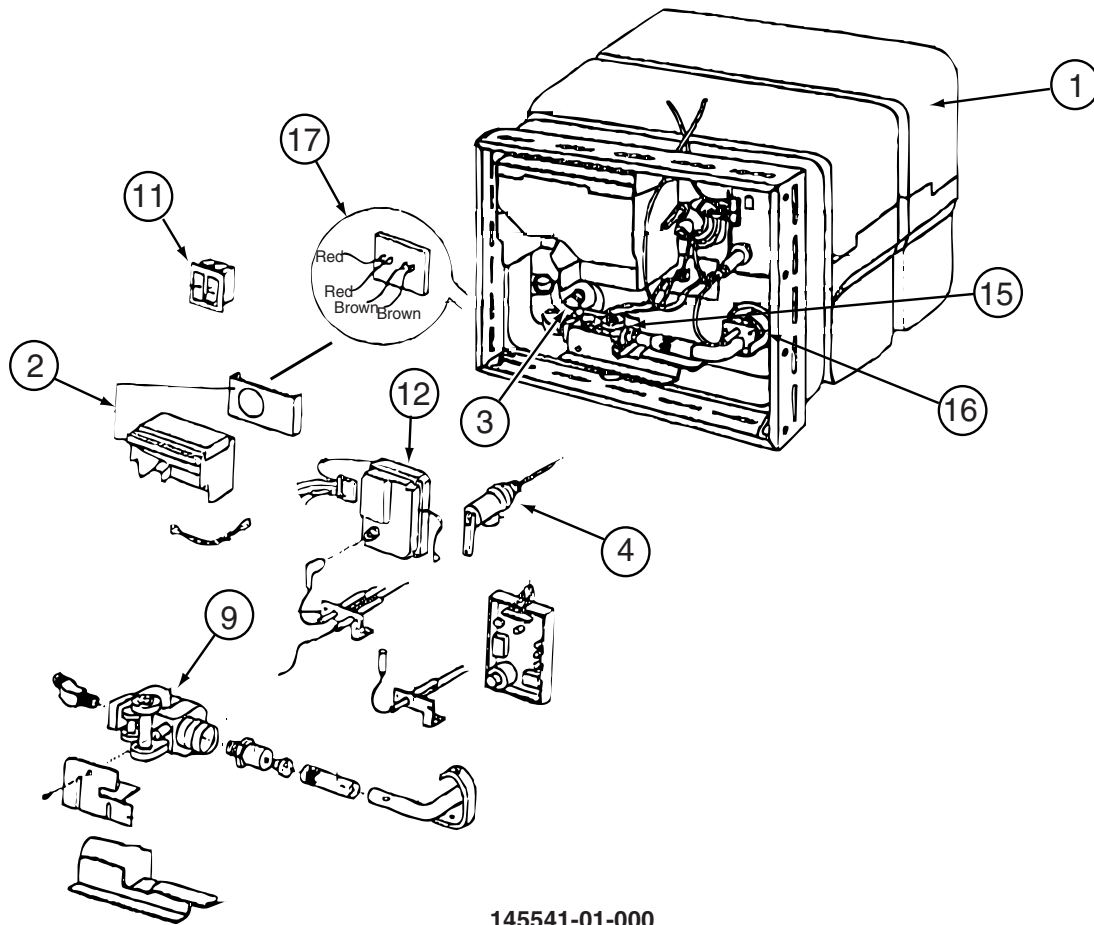

145541-01-000

KEY	PART NUMBER	U/M	DESCRIPTION	VENDOR NO.
1	145541-01-700	EA	TANK - W/INSULATION - 10 GAL	91028
2	051391-04-707	EA	KIT-EXHAUST, (FLUE & GASKET)	90960
3	051391-01-715	EA	PLUG-DRAIN, 1 EA = 2 PER PKG	91857
4	051391-01-704	EA	VALVE-RELIEF, 1/2" FITTING	91604
9	051393-01-726	EA	VALVE/SOLENOID - W/O BRACKET	93870
11	145541-01-701	EA	SWITCH - ON/OFF - WHITE	91859
12	145541-01-702	EA	CIRCUIT BOARD	91226
15	145541-01-703	EA	SWITCH - THERMAL CUT OFF	93866
16	051393-01-725	EA	ELECTRODE-SGL SPADE CONNECT.	93868
17	051393-01-721	EA	THERMOSTAT W/ECO, 140 FRT MT	91447
	051391-05-706	EA	ELEMENT-HEATING 1500 WATT	92249 W/GASKET
	051393-01-701	EA	SWITCH - REMOTE - W/LIGHT	91959
	145541-01-704	EA	RELAY	90061
	145541-01-705	EA	JUNCTION BOX(PLASTIC) 10 GAL	91224

CONTACT WINNEBAGO PARTS SALES FOR UNLISTED COMPONENT(S)

145541-02-000

KEY	PART NUMBER	U/M	DESCRIPTION	VENDOR NO.
1	145541-02-700	EA	TANK/SERVICE KIT PCS- 6 GAL	91053
2	051391-04-707	EA	KIT-EXHAUST, (FLUE & GASKET)	90960
3	051391-01-715	EA	PLUG-DRAIN, 1 EA = 2 PER PKG	91857
4	051391-01-704	EA	VALVE-RELIEF, 1/2" FITTING	91604
9	051393-01-726	EA	VALVE-SOLENOID - W/O BRACKET	93870
11	051393-01-701	EA	SWITCH - REMOTE - W/LIGHT	91959
11	145541-01-701	EA	SWITCH - ON/OFF - WHITE	91859
12	145541-01-702	EA	CIRCUIT BOARD	91226
15	145541-01-703	EA	SWITCH - THERMAL CUT OFF	93866
16	051393-01-725	EA	ELECTRODE-SGL SPADE CONNECT.	93868
17	051393-01-721	EA	THERMOSTAT W/ECO, 140 FRT MT	91447
	051391-05-706	EA	ELEMENT-HEATING 1500 WATT	92249 W/GASKET
	145541-01-704	EA	RELAY	90061
	145541-02-701	EA	JUNCTION BOX(PLASTIC) 6 GAL	91222

CONTACT WINNEBAGO PARTS SALES FOR UNLISTED COMPONENT(S)

WINDOW & VENTS GROUP

WINDOW & VENT LAYOUT

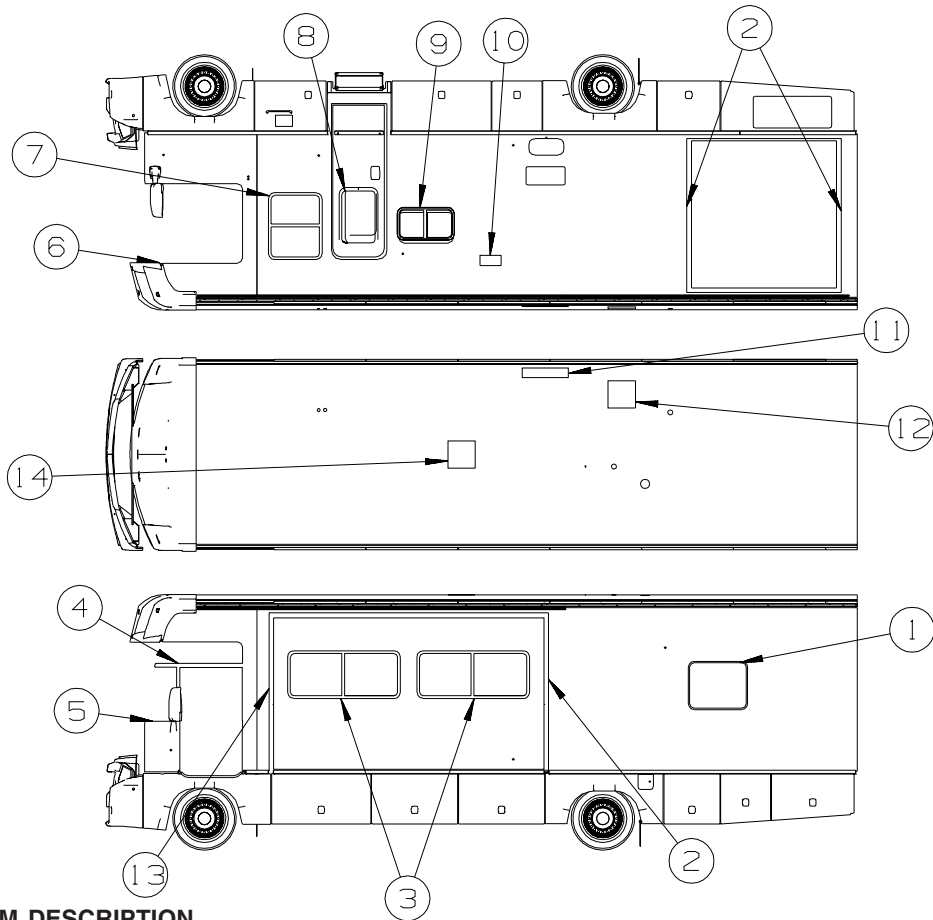

KEY	PART NUMBER	U/M	DESCRIPTION
1*	113500-07-02A	EA	WINDOW - DBL TIPOUT/ESCAPE W/TRIM - TINTED - 30.2" X 24.2"
1*	150656-09-01A	EA	WINDOW - TIPOUT/FLUSH/ESCAPE/THERMO - 24.2" X 30.2" - DUAL PANE FROM: 00-00-00 THRU: 10-01-06
1	161452-04-01A	EA	WINDOW - TIPOUT/FLUSH/ESCAPE/THERMO - 24.2" X 30.2" FROM: 10-02-06 THRU: 99-99-99
2*	098644-17-01A	EA	WINDOW - VERTICAL SLIDER W/TRIM - 23.8" X 20.8"
2*	150649-08-01A	EA	WINDOW - VERT SLIDER/FLUSH/THERMO - 23.8" X 20.8" - DUAL PANE
3*	098647-47-02A	EA	WINDOW - DRVR HORIZ SLIDER W/TRIM - TINTED - 57.4" X 23.6"
3*	150648-07-01A	EA	WINDOW-HORIZ SLIDER/FLUSH/THERMO/LH - 23.8" X 57.7" - DUAL PANE
4*	125586-01-01A	EA	WINDOW - VISTA
4*	151074-01-01A	EA	WINDOW - CAB/VISTA/FLUSH/THERMO - 11.3" X 44.7"/41.8" - DUAL PANE
5*	125584-01-01A	EA	WINDOW/WING - DRIVER W/TRIM - 11.6" X 29.2" X 16.8"- WINNE
5*	151073-01-01A	EA	WINDOW - CAB/FRT SLANT/FLUSH/THERMO - 28.1" X 19.7"/6.6" - DUAL PANE
6*	125582-01-01A	EA	WINDOW - PASSENGER CAB/3 WINDOW - 42.9" X 42.6" X 51.2"B
6*	151072-01-01A	EA	WINDOW - CAB/RIGHT HAND/FLUSH/THERMO - 41.5" X 50.2"/41.8" - DUAL PANE
7*	150649-12-01A	EA	WINDOW - VERT SLIDER/FLUSH/THERMO - 33.4" X 26.9"
8	117053-09-T59	EA	WINDOW - PICTURE - W/O TRIM - 60% TINTING - 19.1" X 28.9"
	002181-35-000	EA	GLASS - PICTURE WINDOW - 28.3"W X 18.5"H - DARK TINT
	087561-01-000	FT	SEAL - GLASS - EXTERIOR - .5" WIDE - VINYL BLACK
8	117054-08-03A	EA	TRIM/RETAINER - INSIDE - 19.1" X 28.9" - BLACK
8*	150651-07-01A	EA	WINDOW - STATIONARY/FLUSH/THERMO - 26.3" X 19.1" - BLACK - DUAL PANE
9*	098647-33-02A	EA	WINDOW - PASS HORIZ SLIDER W/TRIM - CLEAR - 28.5" X 15.7"
9*	150648-04-01A	EA	WINDOW-HORIZ SLIDER/FLUSH/THERMO/RH - 16" X 28.7" - DUAL PANE
10	138983-01-01A	EA	VENT - MICROWAVE/OUTER - BRIGHT WHITE
10	138983-03-01A	EA	COVER - VENT MICROWAVE/OUTER - BRIGHT WHITE
11	149508-01-02A	EA	CAP - ROOF/REFRIGERATOR VENT - WHITE
11	149508-02-02A	EA	BASE - ROOF/REFRIGERATOR VENT - BRIGHT WHITE
12*	122882-02-01A	EA	VENT - ROOF - W/FAN - W/O INSIDE GARNISH - UL
12*	122882-03-01A	EA	VENT - ROOF - W/FAN - W/O INSIDE GARNISH - CSA - CANADIAN
	009440-01-000	EA	GEAR/ARM - LIFT - ROOF VENT COVER
	048648-01-000	EA	MOTOR/ROOF VENT - W/RESISTER - 1/8"SHAFT - 12VOLT
	048649-01-000	EA	FAN BLADE - ROOF VENT - 6 BLADED - 6"RADIUS
12	122882-07-01A	EA	GARNISH - ROOF VENT - 2.5" TO 4.1"

WINDOW & VENTS GROUP (CONTINUED)
WINDOW & VENT LAYOUT (CONTINUED)

KEY	PART NUMBER	U/M	DESCRIPTION
13*	098644-04-03A	EA	WINDOW - VERTICAL SLIDER W/TRIM - TINTED - 31.7" X 21.1"
13*	150649-19-01A	EA	WINDOW - VERT SLIDER/FLUSH/THERMO - 31.7" X 21.1"
14*	122882-01-01A	EA	VENT - ROOF - NONPOWERED - W/O INSIDE GARNISH
	009440-01-000	EA	GEAR/ARM - LIFT - ROOF VENT COVER
14	122882-07-01A	EA	GARNISH - ROOF VENT - 2.5" TO 4.1"
14*	123780-03-01A	EA	FANTASTIC VENT-3"/4"ROOF-W/FAN-W/O THERM/PWR LIFT/WHT CVR
	009440-01-000	EA	GEAR/ARM - LIFT - ROOF VENT COVER

***COMPONENT PARTS LISTED LATER IN THIS GROUP**

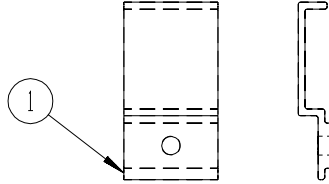

SCREEN RETAINER

KEY	PART NUMBER	U/M	DESCRIPTION
1	151905-01-01A	EA	CLIP/BRACKET - SCREEN RETAINER - BLACK

WINDOW & VENTS GROUP (CONTINUED)
COMPONENT PARTS FOR WINDOW & VENT LAYOUT

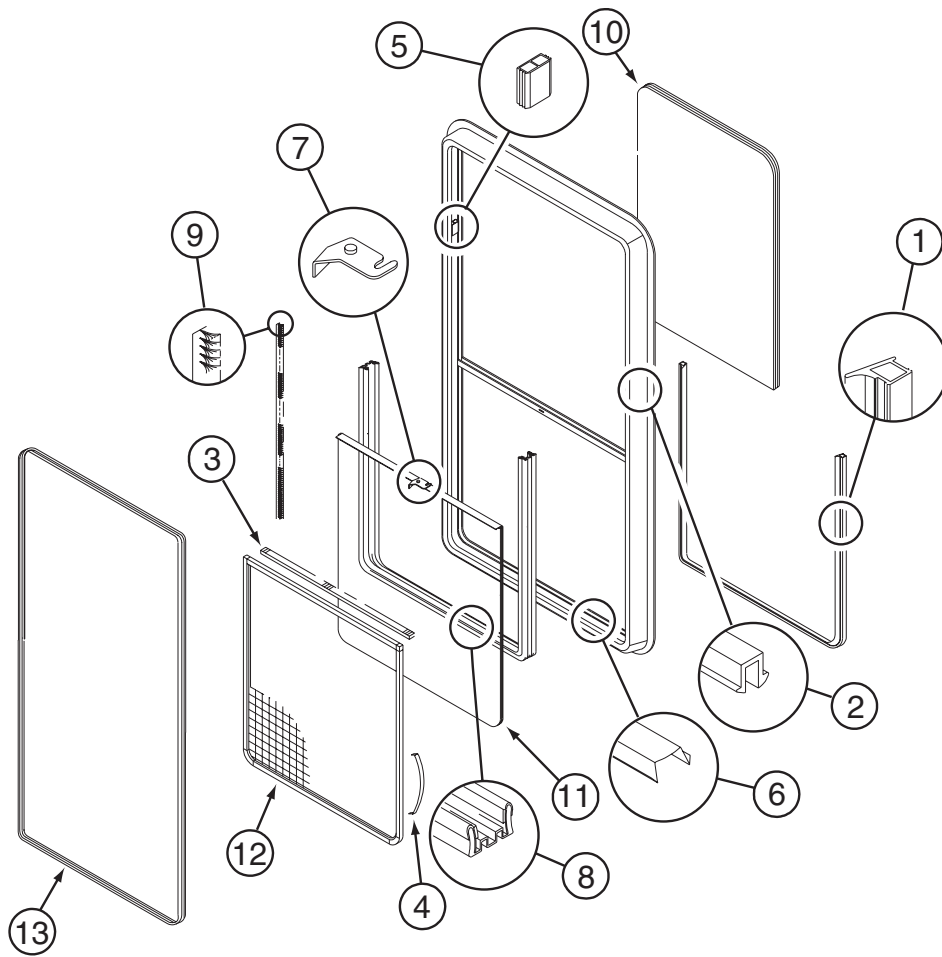

098644-04-03A

KEY	PART NUMBER	U/M	DESCRIPTION	VENDOR NO.
1	098644-01-716	FT	PLUG - FILLER	132-014470
2	098644-01-705	FT	GLAZING - STRIP	132-010231
3	098644-01-706	FT	WEATHERSTRIP - GLASS	171-010668
4	098644-01-713	EA	CLIP - SCREEN - METAL	226-016966
4	125582-01-701	EA	CLIP - SCREEN - PLASTIC	130-005153
5	098644-01-719	EA	STOP - SLIDER GLASS	132-014203
6	098644-01-710	FT	TRACK - SCREEN SPACER 12'	132-017135
7	098647-54-701	EA	LATCH - REPAIR KIT (RED)	B081-CK
8	098644-01-708	FT	CHANNEL - RUN PIERCED	122-016543
9	098644-01-711	FT	WEATHERSTRIP - SCREEN BLACK	171-016965
	098644-01-717	FT	SPLINE - SCREEN	132-004716
10	098644-04-701	EA	GLASS - STATIONARY	106-017953
11	098644-04-702	EA	GLASS-SLIDING W/SASH & LATCH	H332-G9
12	098644-04-703	EA	SCREEN ASM - W/SEALS & CLIPS	410-017955
13	098644-04-704	EA	RETAINER - TRIM	H332-67

WINDOW & VENTS GROUP (CONTINUED)
COMPONENT PARTS FOR WINDOW & VENT LAYOUT (CONTINUED)

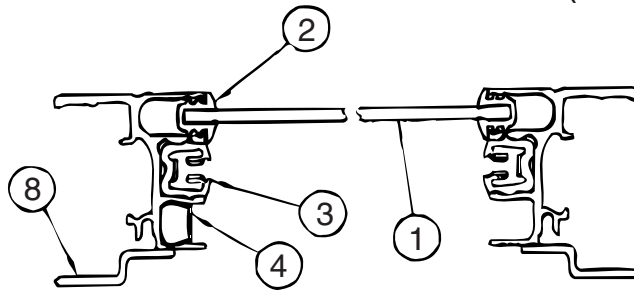

CROSS SECTION A-A

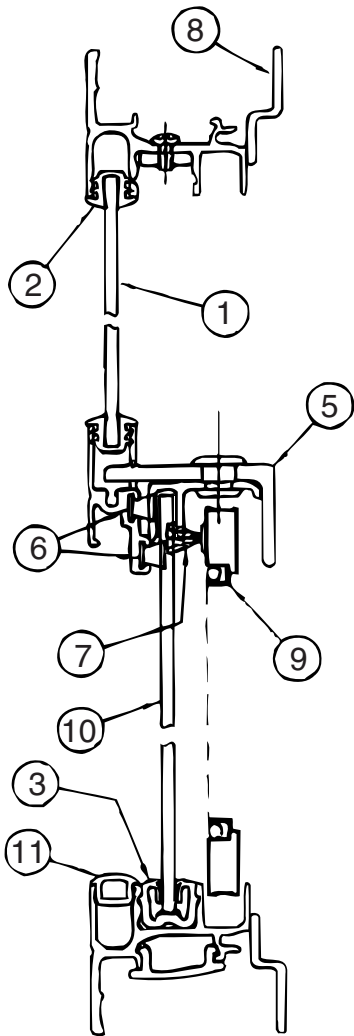

CROSS SECTION B-B

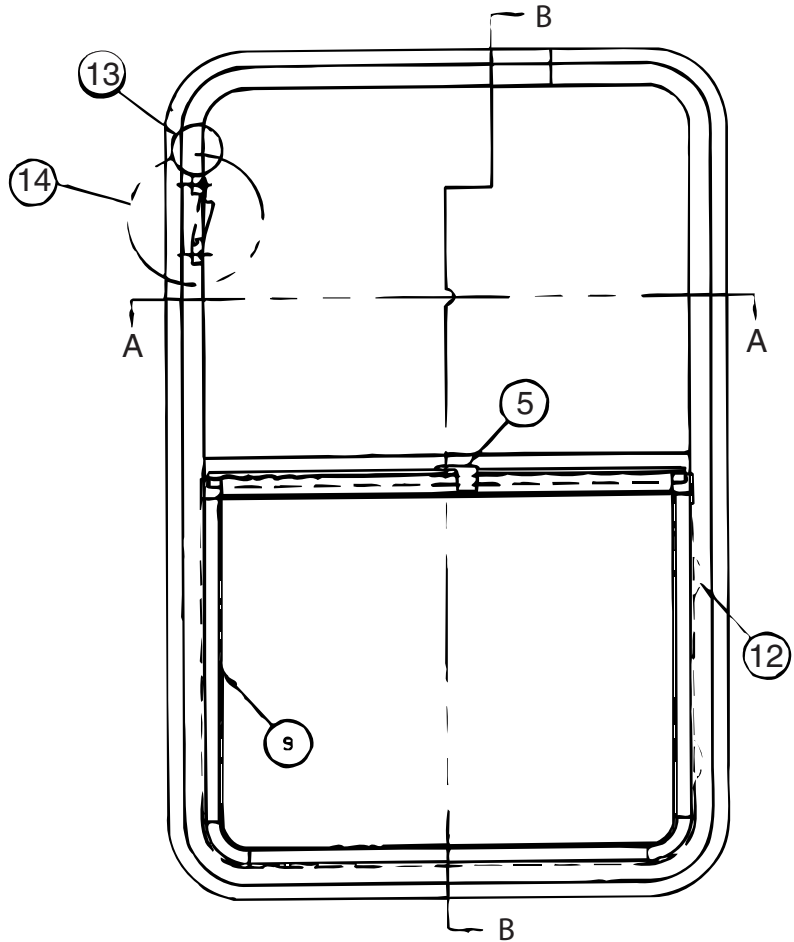

098644-17-01A

KEY	PART NUMBER	U/M	DESCRIPTION	VENDOR NO.
1	098644-17-700	EA	GLASS - STATIONARY	106-036029
2	098644-01-705	FT	GLAZING - STRIP	132-010231
3	098644-01-708	FT	CHANNEL - RUN PIERCED	122-016543
4	098644-01-710	FT	TRACK - SCREEN SPACER 12'	132-017135
5	098644-01-700	EA	LATCH - REPAIR KIT (BLACK)	B801-CK
6	098644-01-706	FT	WEATHERSTRIP - GLASS	171-010668
7	098644-01-711	FT	WEATHERSTRIP - SCREEN BLACK	171-016965
8	098644-17-701	EA	RETAINER - TRIM	H908-66
9	098644-13-702	EA	SCREEN ASM W/SEALS & CLIPS	410-028663
	098644-01-717	FT	SPLINE - SCREEN	132-004716
10	098644-17-702	EA	GLASS - SLIDING W/PULL & LATCH	H908-G9
11	098644-01-716	FT	PLUG - FILLER	132-014470
12	098644-01-713	EA	CLIP - SCREEN - METAL	226-016966
12	125582-01-701	EA	CLIP - SCREEN - PLASTIC	130-005153
13	098644-01-719	EA	STOP - SLIDER GLASS	132-014203
14	112898-04-703	EA	VERTICAL LATCH/HOLD UP/OPEN	DH343CK

WINDOW & VENTS GROUP (CONTINUED)
COMPONENT PARTS FOR WINDOW & VENT LAYOUT (CONTINUED)

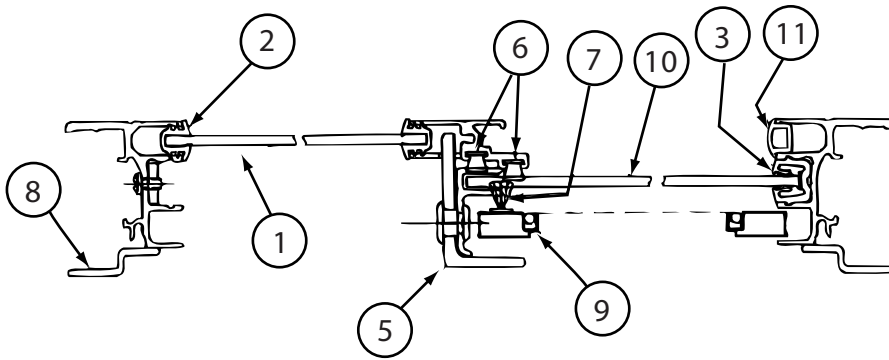

CROSS SECTION B-B

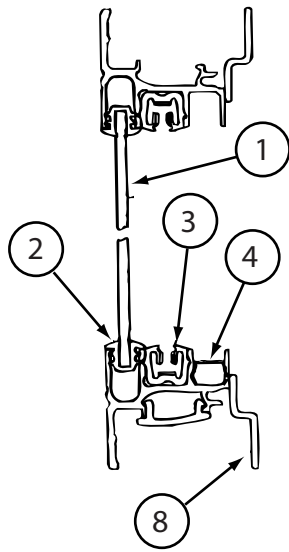

CROSS SECTION A-A

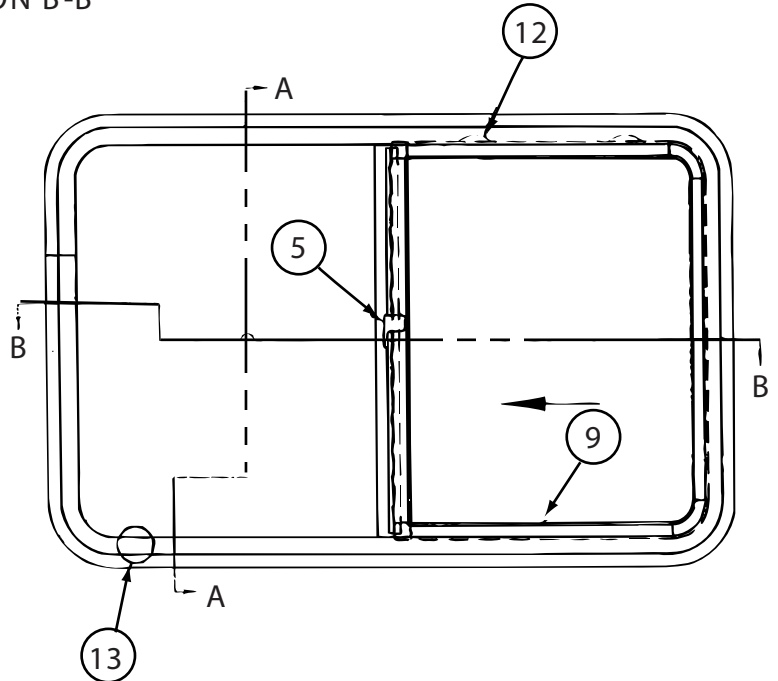

098647-33-02A

KEY	PART NUMBER	U/M	DESCRIPTION	VENDOR NO.
1	098644-01-716	FT	PLUG - FILLER	132-014470
2	098644-01-705	FT	GLAZING - STRIP	132-010231
3	098644-01-706	FT	WEATHERSTRIP - GLASS	171-010668
4	098644-01-713	EA	CLIP - SCREEN - METAL	226-016966
4	125582-01-701	EA	CLIP - SCREEN - PLASTIC	130-0
5	098644-01-719	EA	STOP - SLIDER GLASS	132-014203
6	098644-01-710	FT	TRACK - SCREEN SPACER 12'	132-017135
7	098647-54-701	EA	LATCH - REPAIR KIT (RED)	B081-CK
8	098644-01-708	FT	CHANNEL - RUN PIERCED	122-016543
9	098644-01-711	FT	WEATHERSTRIP - SCREEN BLACK	171-016965
10	098647-33-702	EA	GLASS - STATIONARY	106-019297
11	098647-33-703	EA	GLASS-SLIDING W/SASH & LATCH	H425-G9
12	098647-33-704	EA	SCREEN ASM - W/SEALS & CLIPS	410-019134
13	098647-31-705	EA	RETAINER - TRIM	CH29-66
	098644-01-717	FT	SPLINE - SCREEN	132-004716

WINDOW & VENTS GROUP (CONTINUED)
COMPONENT PARTS FOR WINDOW & VENT LAYOUT (CONTINUED)

098647-47-02A

KEY	PART NUMBER	U/M	DESCRIPTION	VENDOR NO.
1	098644-01-716	FT	PLUG - FILLER	132-014470
2	098644-01-705	FT	GLAZING - STRIP	132-010231
3	098644-01-706	FT	WEATHERSTRIP - GLASS	171-010668
4	098644-01-713	EA	CLIP - SCREEN - METAL	226-016966
4	125582-01-701	EA	CLIP - SCREEN - PLASTIC	130-005153
5	098644-01-719	EA	STOP - SLIDER GLASS	132-014203
6	098644-01-710	FT	TRACK - SCREEN SPACER 12'	132-017135
7	098644-01-700	EA	LATCH - REPAIR KIT (BLACK)	B801-CK
7	098647-54-701	EA	LATCH - REPAIR KIT (RED)	B081-CK
8	098644-01-708	FT	CHANNEL - RUN PIERCED	122-016543
9	098644-01-711	FT	WEATHERSTRIP - SCREEN BLACK	171-016965
10	098647-47-700	EA	GLASS - STATIONARY	106-025224
11	098647-47-701	EA	GLASS-SLIDING W/SASH & LATCH	H493-G9
12	098647-47-702	EA	SCREEN ASM - W/SEALS & CLIPS	410-025226
13	098647-47-704	EA	RETAINER - TRIM	H493-66
	098644-01-717	FT	SPLINE - SCREEN	132-004716

WINDOW & VENTS GROUP (CONTINUED)
COMPONENT PARTS FOR WINDOW & VENT LAYOUT (CONTINUED)

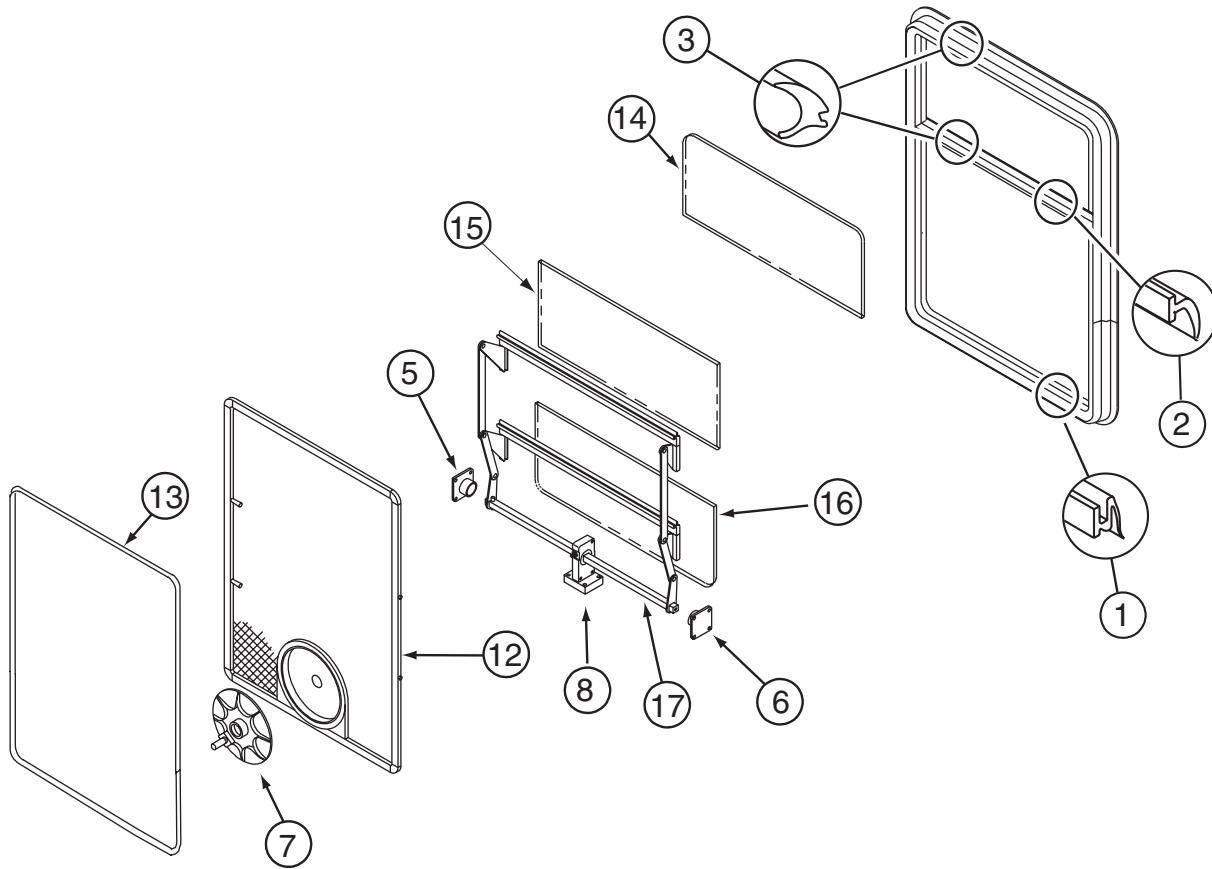

113500-07-02A

KEY	PART NUMBER	U/M	DESCRIPTION	VENDOR NO.
1	116976-01-702	FT	FILLER PLUG	132-016065
2	100322-01-701	FT	SEAL-VENT	122-016071
3	100322-01-702	EA	WEATHERSTRIP-HORIZ RAIL-148"	132-019631
	100322-01-703	FT	VINYL-GLAZING, BUTYL	132-010723
5	100322-01-714	EA	SUPPORT-TORQUE BAR, LH	130-015978
6	100322-01-715	EA	SUPPORT-TORQUE BAR, RH	130-015979
7	100322-01-718	EA	HANDLE-DIAL	410-016081
8	112519-01-702	EA	TORQUE-CTR SUPPORT (4 HOLE)	410-016123
12	113500-07-703	EA	SCREEN - W/SEALS & CLIPS	410-029103
13	113500-07-704	EA	RETAINER - TRIM	CH11G-59
14	113500-07-700	EA	GLASS - STATIONARY	106-029247
15	113500-07-701	EA	GLASS - UPPER VENT ASSEMBLY	CH116-G7
16	113500-07-702	EA	GLASS - LOWER VENT ASSEMBLY	CH116-G9
17	112463-05-702	EA	OPERATOR & BAR ASSEMBLY	CH65-15
18	112898-06-704	EA	HANDLE-LATCH/RED-RH (TIPOUT)	182-11293
19	112898-06-705	EA	HANDLE-LATCH/RED-LH (TIPOUT)	182-11294
	112463-02-706	FT	SEAL - FOAM RUBBER	140-014727
	100322-01-717	EA	E-RING	245-015975
	112463-02-706	FT	SEAL - FOAM RUBBER	140-014727

CONTACT WINNEBAGO PART SALES FOR UNLISTED COMPONENTS

WINDOW & VENTS GROUP (CONTINUED)
COMPONENT PARTS FOR WINDOW & VENT LAYOUT (CONTINUED)

122882-01-01A

KEY	PART NUMBER	U/M	DESCRIPTION	VENDOR NO.
	064470-01-700	EA	COVER - VENT	J7291
	064470-01-701	EA	SLIDE BAR - VENT LID	JRP1291B
	122882-01-700	EA	HANDLE - CRANK - BLACK	90128
	122882-01-701	EA	SCREEN	JRP-1124-B
	122882-01-702	EA	HANDLE - CRANK - WHITE	JRP1031B

122882-02-01A, 122882-03-01A

KEY	PART NUMBER	U/M	DESCRIPTION	VENDOR NO.
	064470-01-700	EA	COVER - VENT	J7291
	064470-01-701	EA	SLIDE BAR - VENT LID	JRP1291B
	110051-03-700	EA	SWITCH-BLACK/PUSH BUTTON	27-0164
	122882-01-700	EA	HANDLE - CRANK - BLACK	90128
	122882-01-701	EA	SCREEN	JRP-1124-B
	122882-01-702	EA	HANDLE - CRANK - WHITE	JRP1031B

WINDOW & VENTS GROUP (CONTINUED)
COMPONENT PARTS FOR WINDOW & VENT LAYOUT (CONTINUED)

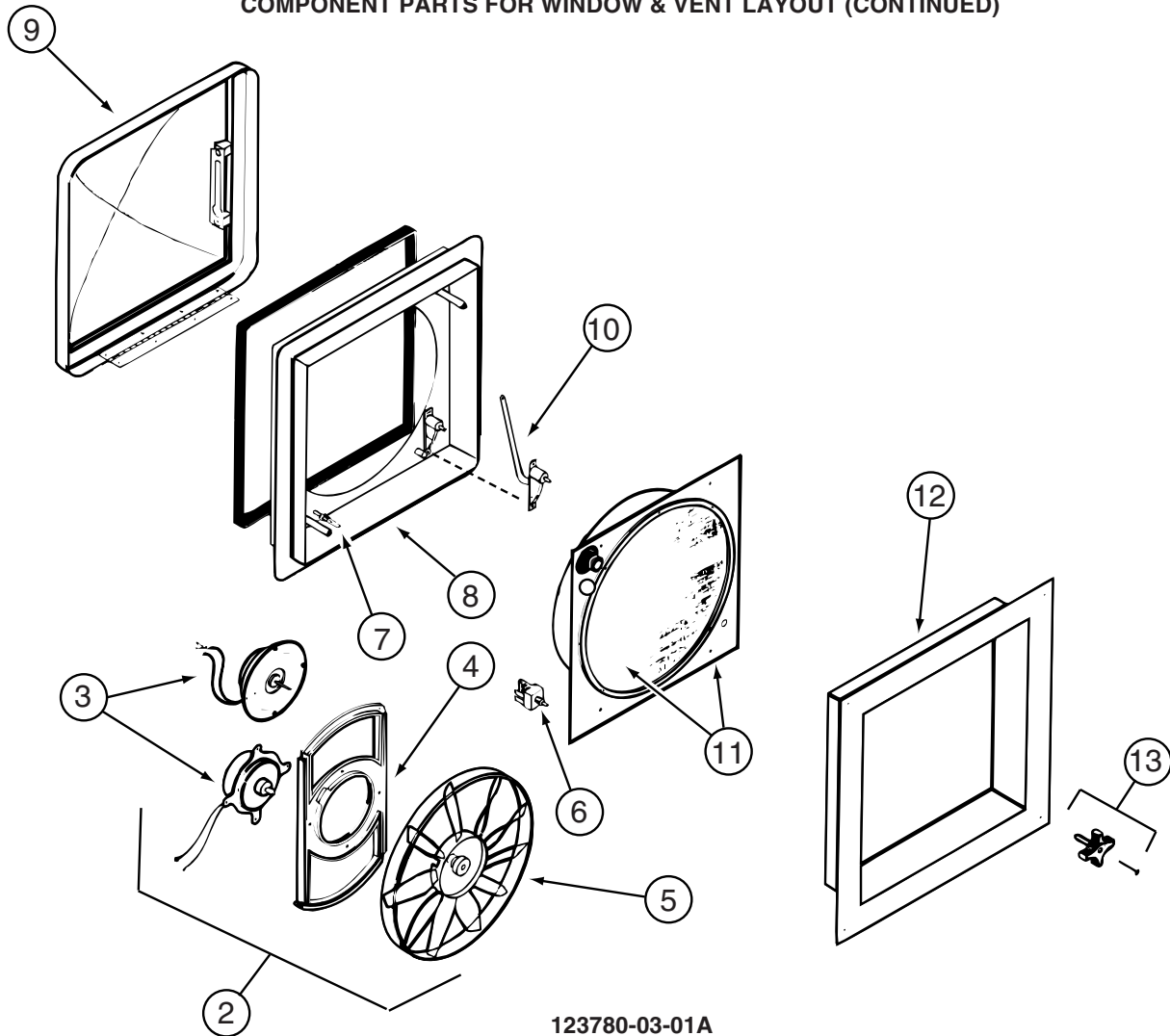

123780-03-01A

KEY	PART NUMBER	U/M	DESCRIPTION	VENDOR NO.
2	084079-11-700	EA	MOTOR & FAN BLADE W/BRACKET	K4017-09
3	084079-01-705	EA	MOTOR/EXT BRKT/FAN BLADE KIT	1080-00
4	084079-01-711	EA	MOTOR MOUNT (BOWTIE)	1015-00
5	084079-01-704	EA	BLADE-FAN	1138-00
6	084079-01-709	EA	SWITCH - MAIN - 3 SPEED	1031-05
7	084079-01-707	EA	SWITCH - SAFETY	1122-05
8	123780-05-700	EA	BASE/MAIN-BRT WHT W/GASKET	1010-81
9	123780-01-700	EA	COVER - VENT W/HINGE & SLIDE	1020K-81
10	009440-01-000	EA	GEAR-ARM-ROOF VENT	705221K38
11	123780-03-701	EA	SCREEN ASM 78-100MM W/SWITCH	1030BT-81
12	123780-03-700	EA	GARNISH - INT. 3"-4" BRT/WHT	2040-81
13	084079-01-703	EA	KNOB-LIFT	1140K-00
	084079-01-706	EA	PLUG, 12 VOLT	1090
	123780-01-702	EA	SCREEN INSERT (SCREEN RING)	K1035-81

CONTACT WINNEBAGO PART SALES FOR UNLISTED COMPONENT(S)

WINDOW & VENTS GROUP (CONTINUED)
COMPONENT PARTS FOR WINDOW & VENT LAYOUT (CONTINUED)

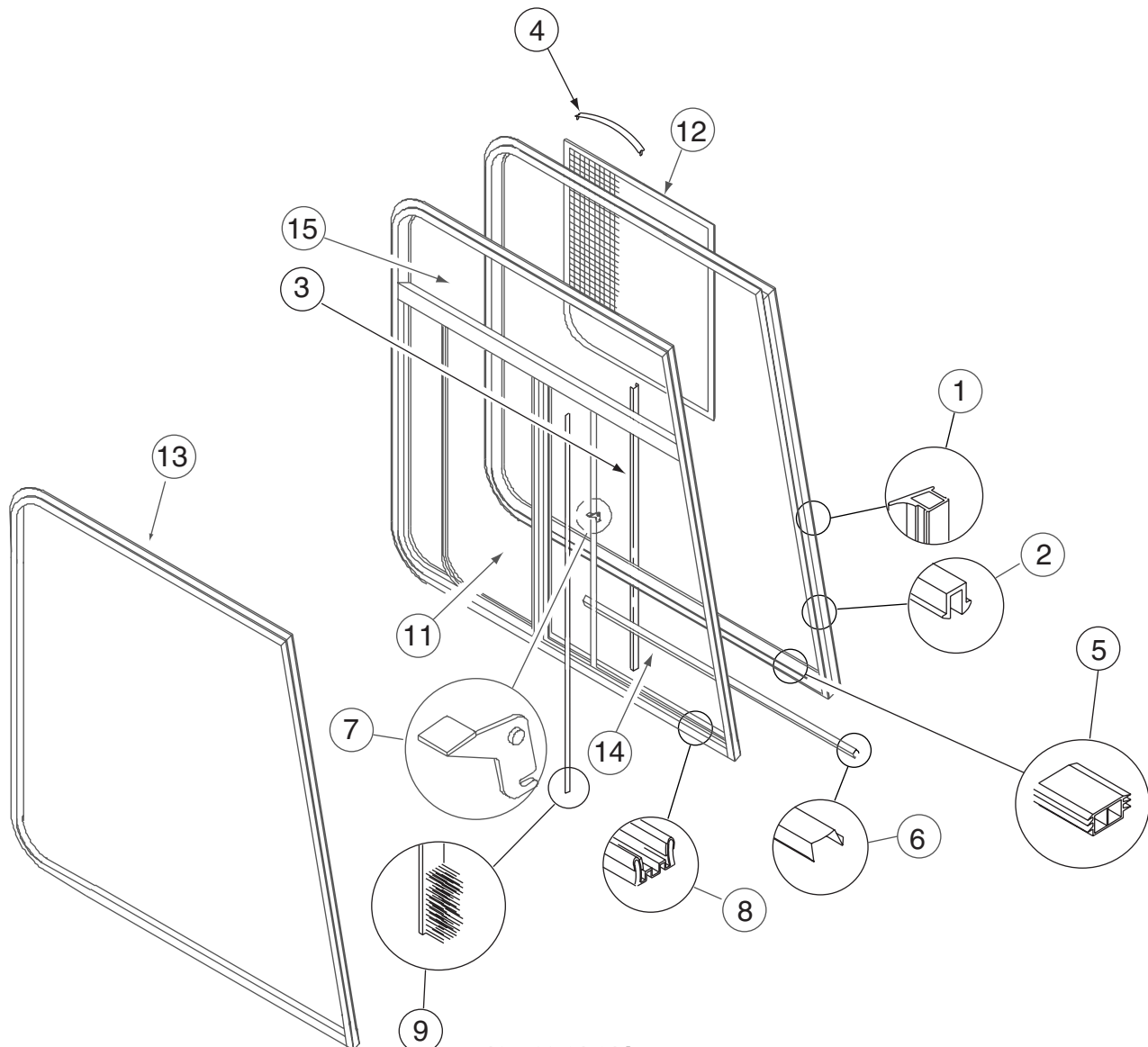

125582-01-01A

KEY	PART NUMBER	U/M	DESCRIPTION	VENDOR NO.
1	098644-01-716	FT	PLUG - FILLER	132-014470
2	098644-01-705	FT	GLAZING - STRIP	132-010231
3	098644-01-706	FT	WEATHERSTRIP - GLASS	171-010668
4	098644-01-713	EA	CLIP - SCREEN - METAL	226-016966
4	125582-01-701	EA	CLIP - SCREEN - PLASTIC	130-005153
5	098644-01-719	EA	STOP - SLIDER GLASS	132-014203
6	098644-01-710	FT	TRACK - SCREEN SPACER 12'	132-017135
7	098644-01-700	EA	LATCH - REPAIR KIT (BLACK)	B801-CK
8	098644-01-708	FT	CHANNEL - RUN PIERCED	122-016543
9	098644-01-711	FT	WEATHERSTRIP - SCREEN BLACK	171-016965
11	125582-01-704	EA	GLASS-SLIDING W/SASH & LATCH	H573-A9R
12	125582-01-705	EA	SCREEN - PASSENGER - W/SEALS & CLIPS	410-026545
13	125582-01-706	EA	RETAINER - TRIM	H573-27R
14	125582-01-703	EA	GLASS - STATIONARY - LOWER	106-026083
15	125582-01-702	EA	GLASS - STATIONARY - UPPER	106-026082
	098644-01-717	FT	SPLINE - SCREEN	132-004716
	112520-01-706	EA	WEATHERSTRIP-SCREEN, (FUZZY)	171-017245
	125582-01-708	EA	WEEPHOLE COVER - RIGHT HAND	130-026598
	125582-01-709	EA	WEEPHOLE COVER - LEFT HAND	130-026599

WINDOW & VENTS GROUP (CONTINUED)
COMPONENT PARTS FOR WINDOW & VENT LAYOUT (CONTINUED)

125584-01-01A

KEY	PART NUMBER	U/M	DESCRIPTION	VENDOR NO.
	125584-01-700	EA	GLASS - STATIONARY	106026078
	100322-01-703	EA	VINYL - GLAZING, BUTYL	132-010723
	125584-01-701	EA	RETAINER - TRIM	H56927L B969 GRL

125586-01-01A

KEY	PART NUMBER	U/M	DESCRIPTION	VENDOR NO.
	125586-01-700	EA	GLASS - STATIONARY	106026079
	100322-01-703	EA	VINYL - GLAZING, BUTYL	132-010723
	125586-01-701	EA	RETAINER - TRIM	H57027L

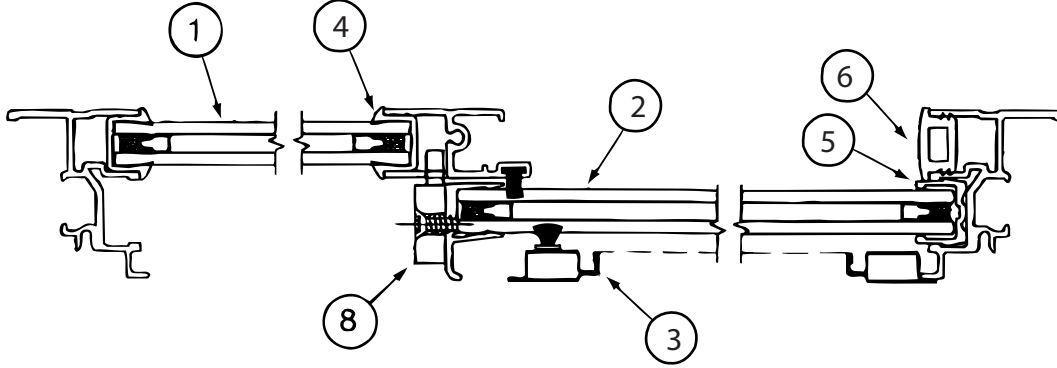

CROSS SECTION B-B

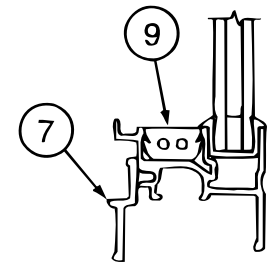
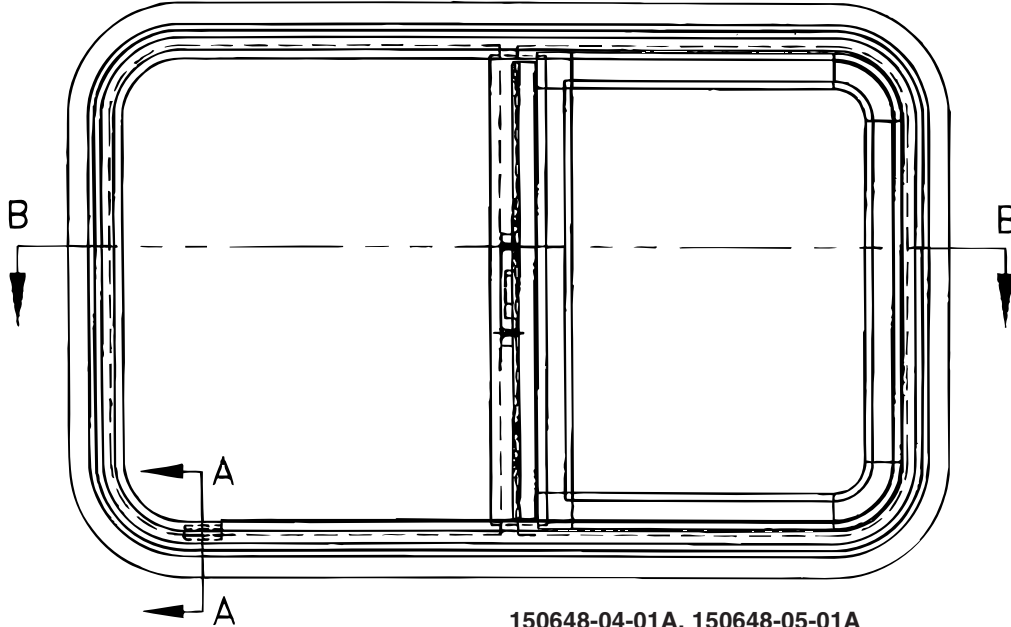

CROSS SECTION A-A

150648-04-01A, 150648-05-01A

KEY	PART NUMBER	U/M	DESCRIPTION	VENDOR NO
1	112795-72-700	EA	GLASS - STATIONARY	390-028307
2	150648-04-700	EA	GLASS-SLIDING W/SASH & LATCH	FH3002G8
3	150648-05-700	EA	SCREEN ASM	410-031158
4	112795-01-705	FT	VINYL - GLAZING	132-027331
5	151069-01-700	EA	CHANNEL-RUN, SLIDING	122-030627
6	150648-01-703	EA	PLUG - FILLER	132-030308
7	150648-05-701	EA	RETAINER - TRIM	CH29-67
8	150648-01-700	EA	LATCH-HORIZONTAL SLIDE-BLK	FH3000-CK
8	150648-01-701	EA	LATCH-HORIZONTAL SLIDE-RED	FH3003-CK
9	150648-01-704	EA	SLIDE STOP	132-030866
	150648-05-702	FT	FIN SEAL-F/LOCKING RAIL-BLK	171-062348

WINDOW & VENTS GROUP (CONTINUED)
COMPONENT PARTS FOR WINDOW & VENT LAYOUT (CONTINUED)

150648-07-01A, 150648-22-01A

KEY	PART NUMBER	U/M	DESCRIPTION	VENDOR NO
1	150648-07-701	EA	GLASS - STATIONARY	390-028314
2	150648-07-700	EA	GLASS-SLIDING W/SASH & LATCH	FH3000G8
3	150648-01-702	EA	SCREEN ASM	410-031156
4	112795-01-705	FT	VINYL - GLAZING	132-027331
5	151069-01-700	EA	CHANNEL-RUN, SLIDING	122-030627
6	150648-01-703	EA	PLUG - FILLER	132-030308
7	150648-01-707	EA	RETAINER - TRIM	H493-67
8	150648-01-700	EA	LATCH-HORIZONTAL SLIDE-BLK	FH3000-CK
8	150648-01-701	EA	LATCH-HORIZONTAL SLIDE-RED	FH3003-CK
9	150648-01-704	EA	SLIDE STOP	132-030866
	150648-05-702	FT	FIN SEAL-F/LOCKING RAIL-BLK	171-062348

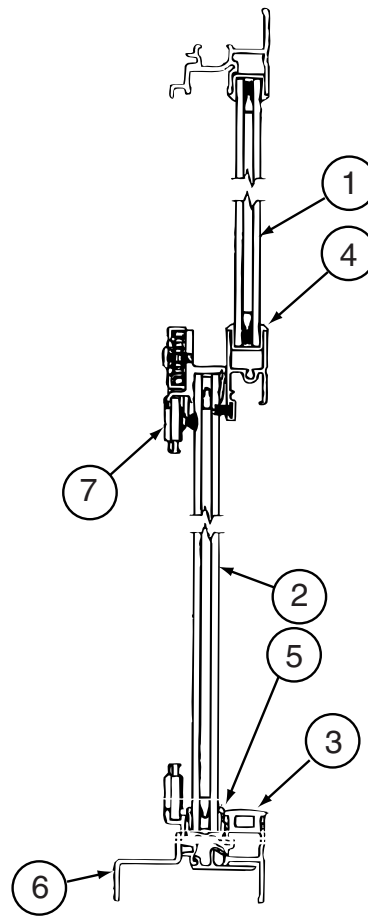
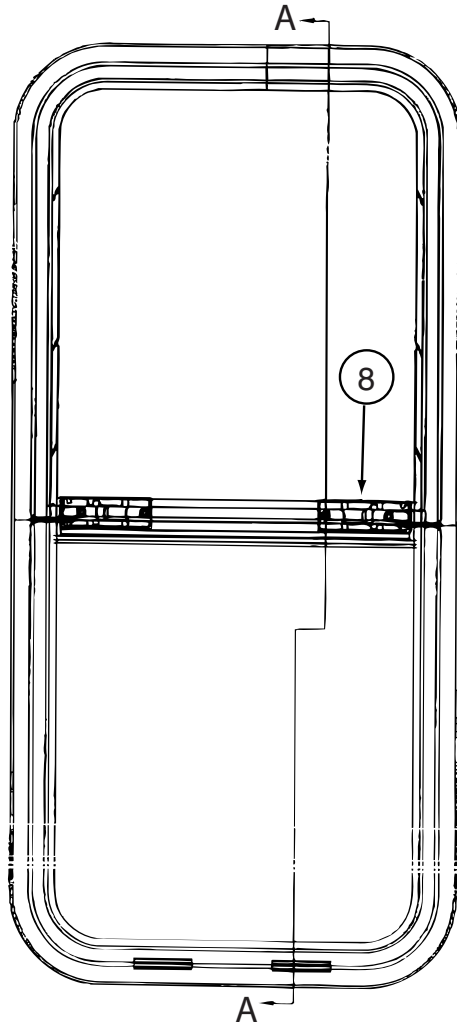

CROSS SECTION A-A

150649-08-01A

KEY	PART NUMBER	U/M	DESCRIPTION	VENDOR NO
1	150649-08-700	EA	GLASS - STATIONARY	390-035202
2	150649-08-701	EA	GLASS-SLIDING W/PULL & LATCH	FH3029G8
3	150648-01-703	EA	PLUG - FILLER	132-030308
4	112795-01-705	FT	VINYL-GLAZING	132-027331
5	151069-01-700	EA	FIN CHANNEL-RUN, SLIDING	122-030627
6	150649-08-702	EA	RETAINER - TRIM	H754-67
7	150649-07-701	EA	SCREEN ASM	410-035475
8	150649-01-700	EA	LATCH KIT - F/VERTICAL SLIDE - BLACK	FH3016-CK

WINDOW & VENTS GROUP (CONTINUED)
COMPONENT PARTS FOR WINDOW & VENT LAYOUT (CONTINUED)

150649-12-01A

KEY	PART NUMBER	U/M	DESCRIPTION	VENDOR NO
1	150649-12-700	EA	GLASS - STATIONARY	390-031007
2	150649-12-701	EA	GLASS-SLIDING W/PULL & LATCH	FH3026G8
3	150648-01-703	EA	PLUG - FILLER	132-030308
4	112795-01-705	FT	VINYL-GLAZING	132-027331
5	151069-01-700	EA	FIN CHANNEL-RUN, SLIDING	122-030627
6	150649-12-702	EA	RETAINER - TRIM	H3026-67
7	150649-12-703	EA	SCREEN ASM	410-035472
8	150649-01-700	EA	LATCH KIT - F/VERTICAL SLIDE - BLACK	FH3016-CK

150649-19-01A

KEY	PART NUMBER	U/M	DESCRIPTION	VENDOR NO
1	112898-26-700	EA	GLASS - STATIONARY	390-028343
2	150649-10-700	EA	GLASS-SLIDING W/PULL & LATCH	FH3019G8
3	150648-01-703	EA	PLUG - FILLER	132-030308
4	112795-01-705	FT	VINYL-GLAZING	132-027331
5	151069-01-700	EA	FIN CHANNEL-RUN, SLIDING	122-030627
6	150649-19-700	EA	RETAINER - TRIM	H332-61
7	150649-10-701	EA	SCREEN ASM	410-035465
8	150649-01-700	EA	LATCH-VERTICLE SLIDE-BLK	FH3016-CK

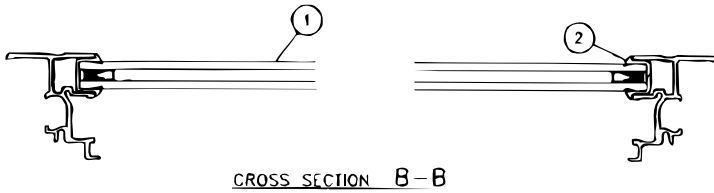

CROSS SECTION B-B

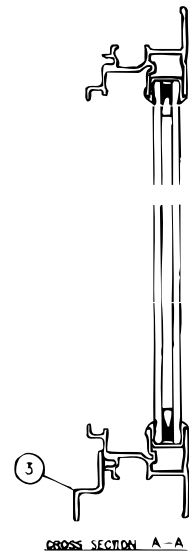
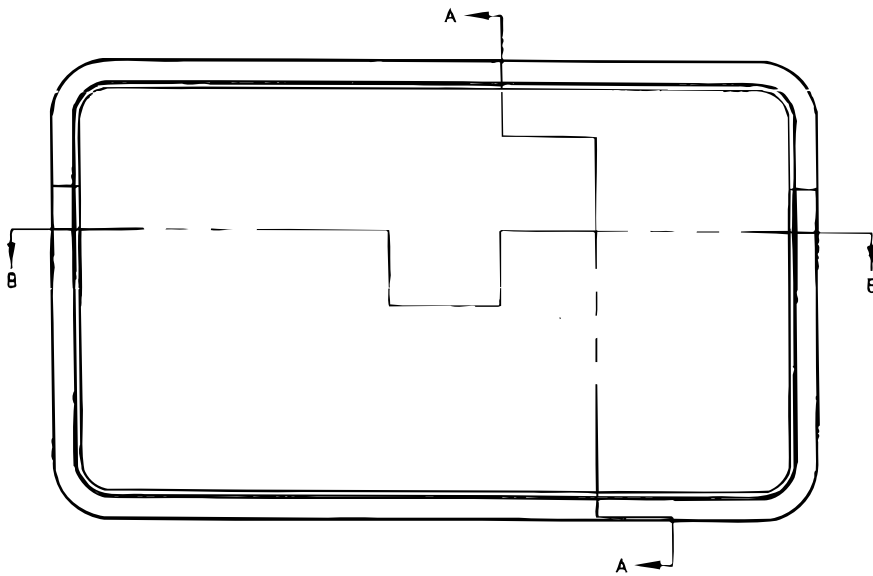

CROSS SECTION A-A

150651-07-01A

KEY	PART NUMBER	U/M	DESCRIPTION	VENDOR NO
1	150651-07-700	EA	GLASS - STATIONARY	390-036022
2	150651-07-701	EA	RETAINER - TRIM	H3074-67
3	112795-01-705	FT	VINYL - GLAZING	132-027331

WINDOW & VENTS GROUP (CONTINUED)
COMPONENT PARTS FOR WINDOW & VENT LAYOUT (CONTINUED)

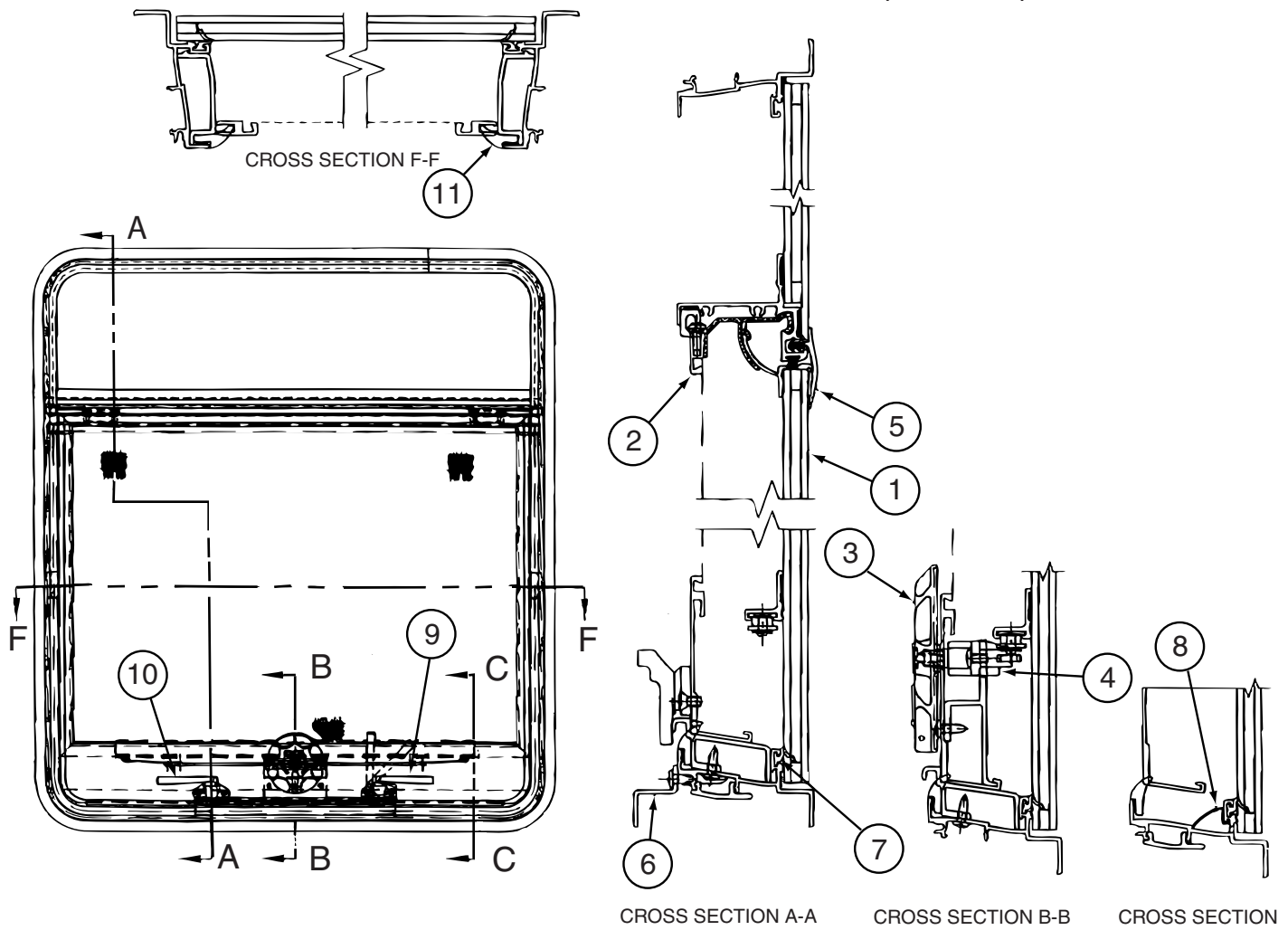

150656-09-01A

KEY	PART NUMBER	U/M	DESCRIPTION	VENDOR NO
1	150656-09-701	EA	GLASS-TIPOUT - W/HINGE/RAIL	DTH3027G8
2	150656-09-702	EA	SCREEN ASM	DTH3027-06
3	150656-02-702	EA	HANDLE-DIAL	410-016081E
4	150656-08-701	EA	OPERATOR - TIPOUT/LARGE	410-036141
5	150656-08-700	EA	SEAL/DUAL - WINDOW - 100"	132-030725
6	150656-09-703	EA	RETAINER - TRIM	DTH3027-56
7	100322-01-701	FT	SEAL-VENT	122-016071
8	150651-03-702	EA	COVER - DRAIN SLOT	132-030723
9	112898-06-707	EA	HANDLE/RH-EGRESS(SLD)ESC-RED	182-025911
10	112898-06-708	EA	HANDLE/LH-EGRESS(SLD)ESC-RED	182-025912
11	150656-09-700	EA	SEAL/SPONGE FOAM-SCREEN/FRME	140-035542

WINDOW & VENTS GROUP (CONTINUED)
COMPONENT PARTS FOR WINDOW & VENT LAYOUT (CONTINUED)

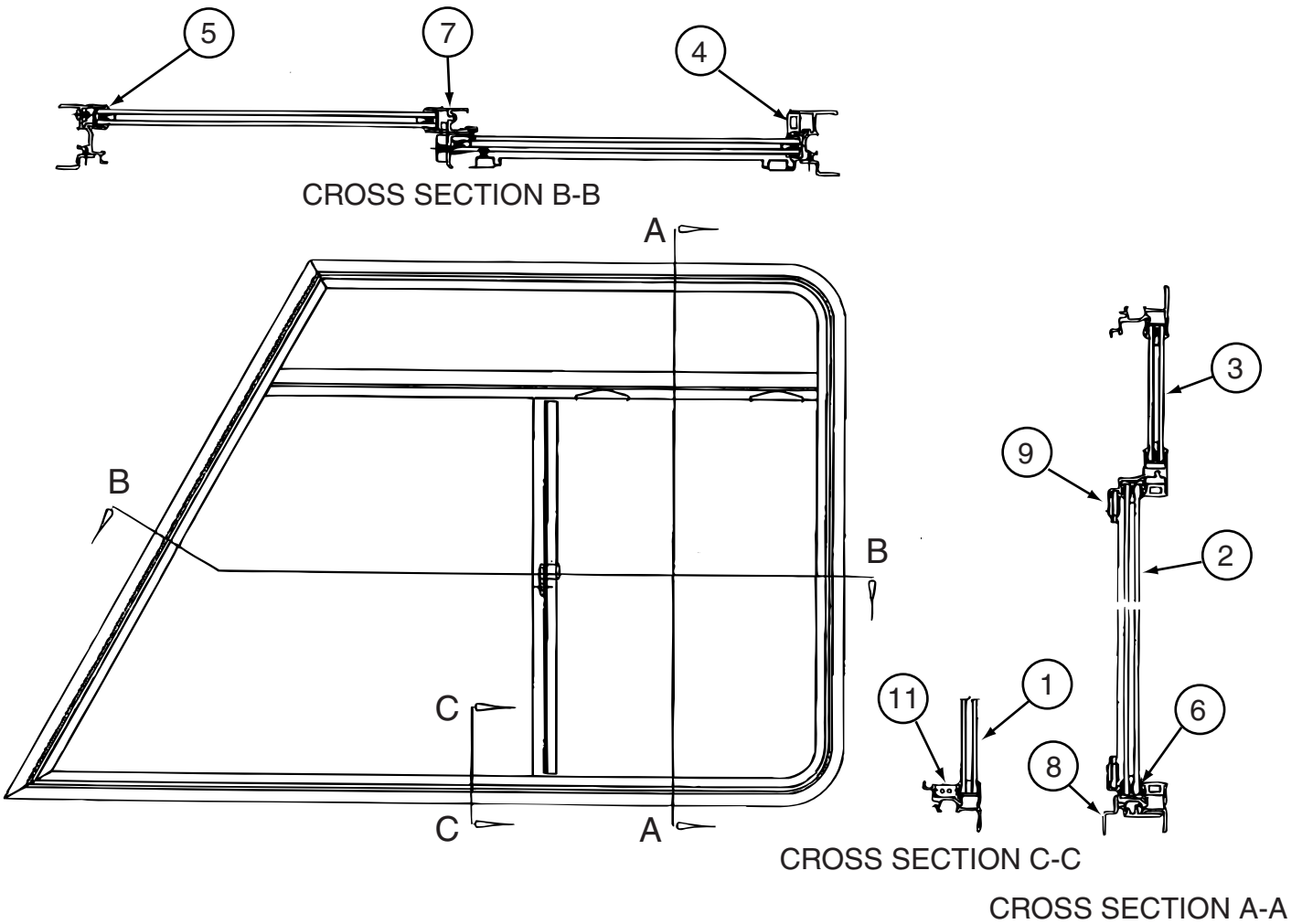

151072-01-01A

KEY	PART NUMBER	U/M	DESCRIPTION	VENDOR NO
1	125583-01-702	EA	GLASS - STATIONARY - R.H.	390-026101
2	151072-01-701	EA	GLASS-SLIDING W/SASH & LATCH	FH3040A9R
3	151072-01-702	EA	GLASS - STATIONARY - UPPER	390-036521
4	150648-01-703	FT	PLUG - FILLER	132-030308
5	151069-03-705	EA	VINYL GLAZING - F/STATIONARY	DH567-12 MITER/WELD
5	151069-03-706	EA	VINYL GLAZING - F/STATIONARY	DH373-12 MITER/WELD
6	151069-01-700	EA	CHANNEL-RUN, SLIDING	122-030627
7	098644-01-706	FT	WEATHERSTRIP - GLASS	171-010668
8	151072-01-703	EA	RETAINER-TRIM - 1 OF 2 PCE	H573K67RA
8	151072-01-704	EA	RETAINER-TRIM - 1 OF 2 PCE	H573K67RB
9	151072-01-700	EA	SCREEN ASM	410-035507
10	150648-01-700	EA	LATCH-HORIZONTAL SLIDE-BLK	FH3000-CK
11	112795-01-701	EA	SLIDE-STOP	132-019092

CONTACT WINNEBAGO PARTS SALES FOR FOR UNLISTED COMPONENTS

WINDOW & VENTS GROUP (CONTINUED)
COMPONENT PARTS FOR WINDOW & VENT LAYOUT (CONTINUED)

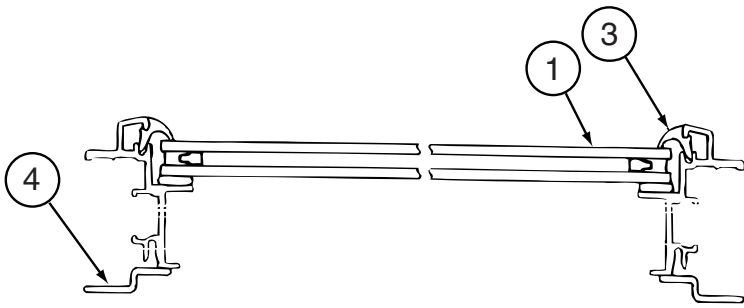

CROSS SECTION B-B

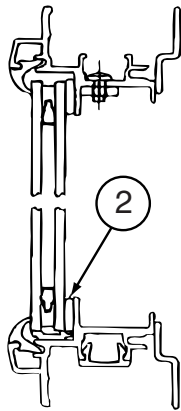
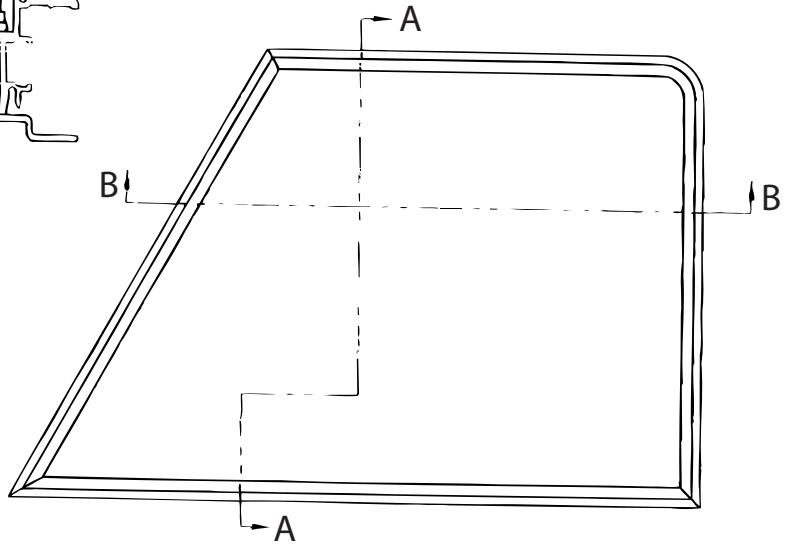

CROSS SECTION A-A

151073-01-01A

KEY	PART NUMBER	U/M	DESCRIPTION	VENDOR NO
1	125585-01-700	EA	GLASS - STATIONARY	390026092
2	115630-01-705	EA	TAPE - BUTYL	154-011956
3	151073-01-700	EA	VINYL BUTYL-MITERED/FORMED	FH56912
4	151073-01-701	EA	RETAINER - TRIM	H569K67L

151074-01-01A

KEY	PART NUMBER	U/M	DESCRIPTION	VENDOR NO
1	151074-01-700	EA	GLASS - STATIONARY	390-028331
2	115630-01-705	FT	TAPE - BUTYL	154-011956
3	151074-01-701	EA	VINYL GLAZING-MITERED/FORMED	FH570-12
4	151074-01-702	EA	RETAINER - TRIM	H570K67L

WINDSHIELD & WIPER GROUP

WINDSHIELD

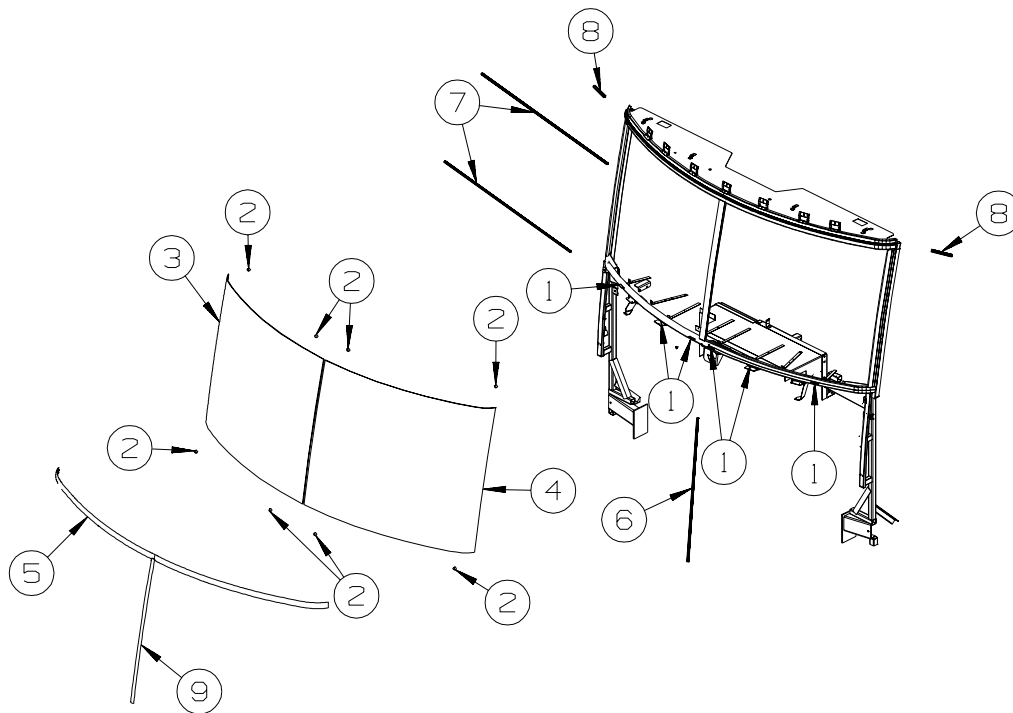

KEY	PART NUMBER	U/M	DESCRIPTION
1	002328-03-000	EA	BLOCK - WINDSHIELD - .125" X .5" X .98"
2	081914-02-000	EA	BUMPER - RUBBER - ROUND - 5/16" DIA. X 13/64" THICK
3	124328-01-000	EA	WINDSHIELD - PASSENGER - 52" X 41" (CURVED)
4	124328-02-000	EA	WINDSHIELD - DRIVER - 52" X 41" (CURVED)
5	120533-01-000	FT	MOLDING - REVEAL - WINDSHIELD
6	127862-06-000	EA	CARRIER/REVEAL - WINDSHIELD - 41.9"
7	127862-01-000	EA	CARRIER/REVEAL - WINDSHIELD - 47.2"
8	127862-01-045	EA	CARRIER/REVEAL - WINDSHIELD - 47.2"
9	159729-01-01A	FT	MOLDING - REVEAL - WINDSHIELD

WINDSHIELD & WIPER GROUP (CONTINUED)

WIPER

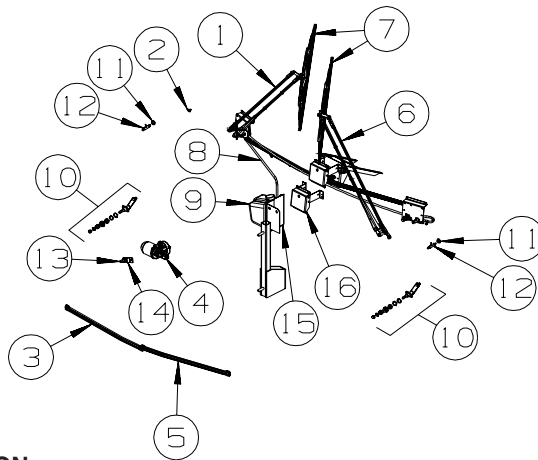

KEY	PART NUMBER	U/M	DESCRIPTION
1*	149402-03-000	EA	ARM - WINDSHIELD WIPER/PANTOGRAPH - RIGHT HAND - 28"
2	146486-01-000	EA	TEE - PLASTIC - 5/32" X 5/32" X 5/32"
3	149403-01-000	EA	LINK/CONNECTING-WINDSHIELD WIPER - CLOSED/CLOSED - 24"
4	149409-01-000	EA	MOTOR - WINDSHIELD WIPER - DYNAMIC PARK
5	149403-02-000	EA	LINK/CONNECTING-WINDSHIELD WIPER - OPEN/CLOSED GROMMET-24"
6*	149402-04-000	EA	ARM - WINDSHIELD WIPER/PANTOGRAPH - LEFT HAND - 28"
7	149399-01-000	EA	BLADE - WINDSHIELD WIPER - 24"
8	045794-01-000	FT	HOSE - WINDSHIELD WASHER - 5/32"ID - BLACK
9	117766-02-000	EA	RESERVOIR/PUMP - WINDSHIELD WASHER
10*	149401-02-000	EA	SHAFT/PIVOT - WINDSHIELD WIPER - 4.1" OVERALL
11	110742-03-000	EA	GASKET - WIPER ADAPTER SHAFT
12	145698-01-01A	EA	SHAFT/IDLER - PANTOGRAPH - W/WASHER DIVERTER - STAINLESS
13	149395-01-000	EA	STUD/DOUBLE BALL CRANK - WIPER MOTOR
14	149408-01-000	EA	ARM - DRIVE/WIPER MOTOR
15	156697-01-02B	EA	BRACKET - F/RESERVOIR - E-COATED - FORD
16	157842-01-02B	EA	BRACKET - WIPER SUPPORT - E-COATED

*COMPONENT PARTS LISTED LATER IN THIS GROUP

COMPONENT PARTS FOR WIPER

149401-01-000,149401-02-000

KEY	PART NUMBER	U/M	DESCRIPTION	VENDOR NO.
	096505-02-703	EA	NUT/ACORN - HD W/.687 BRL	51065-40-NT27WC
	149401-01-700	EA	HARDWARE PKG - F/SHAFT&PIVOT	PSHWKIT
	149401-01-701	EA	SEAL CAP/RUBBER GROMMET	300749

149402-03-000 & 149402-04-000

KEY	PART NUMBER	U/M	DESCRIPTION	VENDOR NO.
	149402-03-700	EA	WASHER NOZZLE KIT W/HDWR	19476
	149402-03-701	EA	COVER/CAP - BLACK	200342