

2007
SIGHTSEER
WFD33T
D-SERIES
PORTSMOUTH OAK
U51 EMBER GLOW
U53 GINGERSNAP
U55 LINEN MOSS
SIERRA MAPLE
U52 EMBER GLOW
U54 GINGERSNAP
U56 LINEN MOSS
DASH ACCENT COLORS
U51, U52, U53, U54 - CASHMERE
U55, U56 - RIVERSTONE

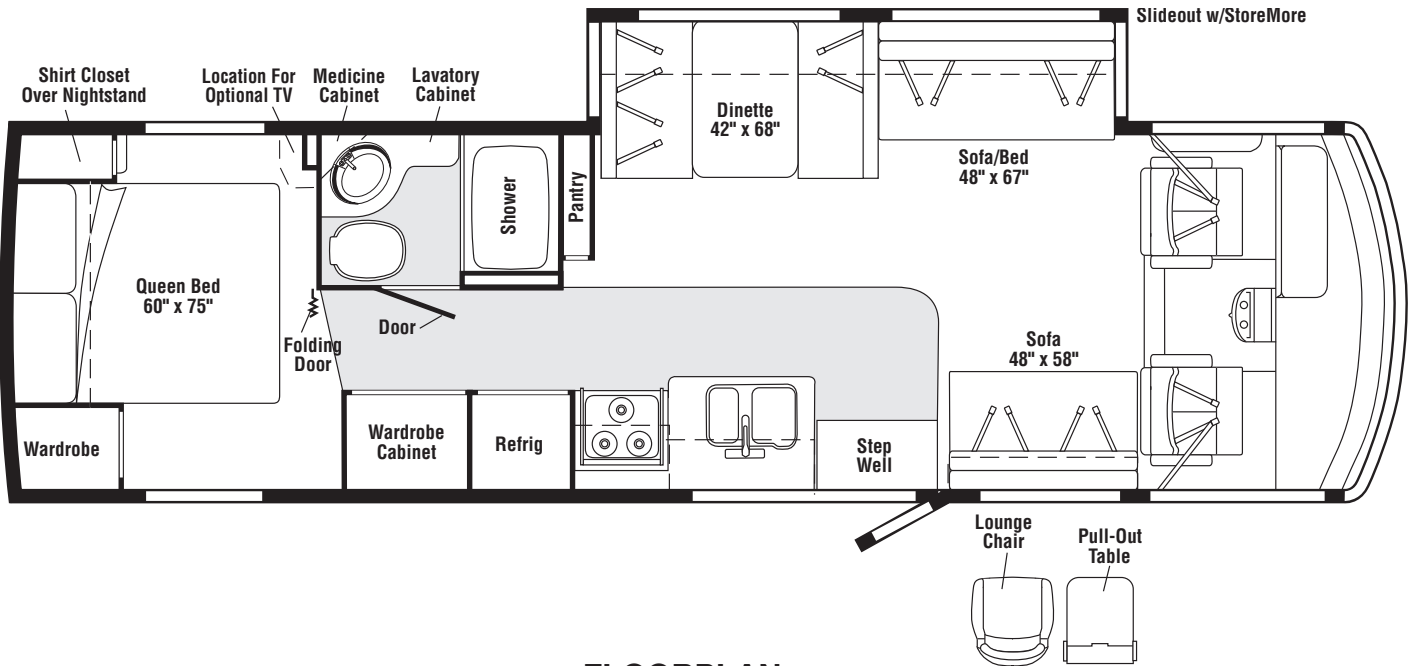

FLOORPLAN

CONTENTS

FLOORPLAN	1
ACCESSORIES GROUP	6
OPERATORS MANUAL	6
AUDIO VIDEO GROUP	7
RADIO SYSTEM	7
COMPONENT PARTS FOR RADIO SYSTEM	7
135420-20-000	7
REAR MONITOR	8
COMPONENT PARTS FOR REAR MONITOR	9
144677-10-01A	9
144677-11-01A	9
CABINET & APPLIANCE GROUP	10
CABINET & APPLIANCE LAYOUT	10
COMPONENT PARTS FOR CABINET & APPLIANCE LAYOUT	19
114030-04-01A	19
121568-06-01A, 121568-07-01A, 121568-08-01A	21
135065-03-01A, 135065-03-03A, 135065-04-01A	26
136354-01-02A	28
136354-02-02A	29
136354-05-01A, 136354-05-02A	29
136354-06-01A, 136354-06-02A	29
150606-04-01A, 150606-04-02A	29
151277-01-01A, 151277-02-01A	30
151277-03-01A, 151279-01-01A, 151279-02-01A/02A, 151279-03-01A	34
158686-01-01A	37
CHASSIS GROUP	38
FRAME	38
FRONT END	40
EXHAUST	42
FUEL	46
SPARE TIRE	48
HYDRAULIC LEVELING	49
COMPONENT PARTS FOR HYDRAULIC LEVELING	50
139641-09-000	50
139641-10-000	50
156056-02-000	50
WHEEL, TIRE, COVERS &/OR LINERS	51
COMPONENT PARTS FOR WHEEL, TIRE, COVERS &/OR LINERS	51
145580-03-000	51
145580-06-000	51
154672-01-000	51
BRAKE	51
CURTAIN & CUSHION GROUP	52
NOTICE	52
CUSHION LAYOUT	53
BUCKET SEATS	55
LOUNGE CHAIR	56
SOFA	57
WINDOW TREATMENT	59
HARDWARE	61
ACCESSORIES	63
FABRICS	63

CONTENTS (CONTINUED)

DRIVERS COMPARTMENT GROUP	64
DASH	64
MOTOR COVER	65
BEVERAGE TRAY	66
FRONT INTERIOR	67
COMPONENT PARTS FOR FRONT INTERIOR	70
091990-04-01A	70
CABINETS	71
ELECTRICAL GROUP	72
110V BODY WIRING	72
12V BODY WIRING	74
EXTERIOR LAMPS	79
FRONT END	81
FRONT TV/VCR	83
COMPONENT PARTS FOR WIRING	84
076319-23-000	84
076319-25-000	84
083208-07-000	85
087694-01-000	85
097917-01-06A	85
121935-01-01A	85
134940-06-01A	85
137135-02-000	86
137417-01-01A, 137417-03-01A	87
137417-02-01A	87
137417-05-01A	87
137417-06-01A	87
150089-01-000	87
155619-01-000	87
158836-01-000	87
CIRCUIT BREAKERS, FUSES & RELAYS	88
CONVERTER, INVERTER, LOAD CENTERS	89
BOXES & CORDS	90
WIRE ASSEMBLIES	90
CONNECTORS & CONDUIT	91
CHASSIS	93
EXTERIOR BODY GROUP	94
GRAPHICS & PAINT	94
PANELS & TRIMS	96
COMPONENT PARTS FOR PANELS & TRIMS	99
106015-12-01A	99
106015-13-01A	99
106015-14-01A	99
106015-15-01A	99
FRONT END	100
LADDER	101
STRUCTURAL COMPONENTS	101
AWNINGS	101
EXTERIOR DOORS & COMPARTMENTS GROUP	102
DOOR & COMPARTMENT LAYOUT	102
COMPONENT PARTS FOR DOOR & COMPARTMENT LAYOUT	108
084103-08-000	108
094707-04-01A	108
110506-A1-000, 110506-A2-000, 110506-26-000, 110506-27-000	108
142226-02-01A	108
COMPARTMENT DOOR PIECE PARTS	109
ENTRY	112
SCREEN	113
LATCH - ENTRY	114

CONTENTS (CONTINUED)

EXTERIOR SLIDEOUT GROUP	115
FRONT LEFT	115
COMPONENT PARTS FOR FRONT LEFT	117
148875-01-000, 148875-02-000	117
GENERATOR GROUP	118
GAS	118
HEATING & A/C GROUP	119
AUTOMOTIVE	119
COMPONENT PARTS FOR AUTOMOTIVE	121
103930-44-000	121
103930-45-000	121
103930-46-000	121
103930-47-000	121
103930-49-000	122
103930-55-000	124
FURNACE	125
COMPONENT PARTS FOR FURNACE	126
139980-02-000	126
143563-01-000	128
REAR HEATER	130
COMPONENT PARTS FOR REAR HEATER	130
084405-01-000	130
ROOF	130
COMPONENT PARTS FOR ROOF	131
131184-01-01A	131
131184-05-01A	132
131186-02-01A	133
131187-03-01A	134
131187-04-01A	135
131188-03-01A	136
131188-04-01A	137
INTERIOR FINISH GROUP	138
MOLDINGS & TRIMS	138
PANELING & LAMINATES	146
INTERIOR TRIM LAYOUT	147
COMPONENT PARTS FOR INTERIOR TRIM LAYOUT	150
094499-02-000	150
115011-03-02A	150
115011-03-02A	151
131595-01-01A, 131595-05-01A, 131595-10-01A	152
FLOOR COVERINGS	152
HARDWARE	153
LABELS GROUP	159
LP GROUP	162
LP SYSTEM	162
COMPONENT PARTS FOR LP SYSTEM	162
144116-04-000	162
SEALANTS & FASTENERS GROUP	163
SEALANTS & ADHESIVES	163
BOLTS, NUTS AND WASHERS	164
SCREWS	166
CLAMPS, CLIPS, GROMMETS, RIVETS & PLUGS	169
MISCELLANEOUS FASTENERS	170

CONTENTS (CONTINUED)

WATER & SEWAGE GROUP	171
DRAINAGE SYSTEM	171
COMPONENT PARTS FOR DRAINAGE SYSTEM	173
147421-01-01A, 147421-02-01A	173
WATER SYSTEM	174
COMPONENT PARTS FOR WATER SYSTEM	180
051391-03-000	180
098607-01-000	181
145541-02-000	181
WINDOW & VENTS GROUP	182
WINDOW & VENT LAYOUT	182
COMPONENT PARTS FOR WINDOW & VENT LAYOUT	184
098644-13-01A	184
098647-33-02A	185
098647-41-02A	186
098647-47-02A	186
098647-63-01A	186
098647-69-01A	187
122882-01-01A	188
122882-02-01A, 122882-03-01A	188
123780-03-01A	189
145573-05-01A	190
145573-06-01A	190
150648-04-01A, 150648-05-01A	191
150648-06-01A & 150648-35-01A	192
150648-07-01A, 150648-22-01A	192
150648-11-01A	192
150648-12-01A & 150648-15-01A	192
150649-07-01A	193
150651-01-01A	194
151069-04-01A	195
151069-05-01A	195
WINDSHIELD & WIPER GROUP	196
WINDSHIELD	196
WIPER	197
COMPONENT PARTS FOR WIPER	197
149401-03-000	197
149402-03-000 & 149402-04-000	197

ACCESSORIES GROUP
OPERATORS MANUAL

KEY	PART NUMBER	U/M	DESCRIPTION
	129079-01-01A	EA	CASE - VINYL/BLACK-EXPANDABLE ACCORDION SIDES-7"WX9"HX14"L FROM: 00-00-00 THRU: 07-09-06
	129079-04-01A	EA	CASE - VINYL/BLK-EXPANDABLE ACCORDION SIDES-11"WX9"HX14"L FROM: 07-10-06 THRU: 07-30-06
	159842-01-01A	EA	CASE - VINYL - F/MANUALS - W/SLEEVES - BLACK
	132000-17-007	EA	MANUAL/OWNER - SIGHTSEER - 2007
	132001-11-007	EA	GUIDE/BASIC OPERATOR - AUDIO/VIDEO - D SERIES - 2007
	158603-07-005	EA	MANUAL/OWNER - SUPPLEMENT - D-SERIES - 2007
	157011-01-000	DW	TOP LEVEL - D - 2007

AUDIO VIDEO GROUP RADIO SYSTEM

KEY	PART NUMBER	U/M	DESCRIPTION
	135420-07-000	EA	MOUNTING KIT - RADIO - A-BODY
	135420-19-000	EA	REMOTE CONTROL/RADIO (CREDIT CARD SIZE)
	135420-18-000	EA	REMOTE CONTROL/RADIO (STEERING WHEEL MOUNT)
	135420-15-000	EA	RADIO-AM/FM/CD/SIRIUS SATELLITE READY/IR REMOTE
	135420-14-000	EA	RECEIVER (EYE) - INFRARED
*	135420-20-000	EA	RECEIVER - SATELLITE RADIO - W/CABLE

***COMPONENT PARTS LISTED LATER IN THIS GROUP**

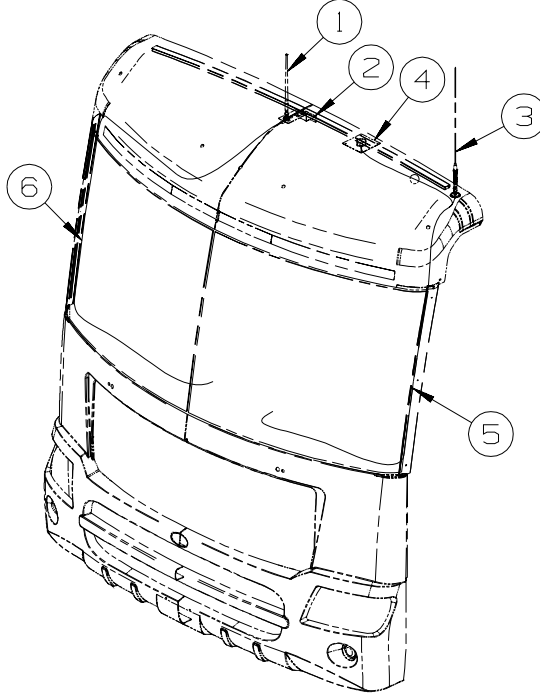

KEY	PART NUMBER	U/M	DESCRIPTION
1	090944-02-000	EA	ANTENNA - RADIO - 16" RUBBER - W/O LEAD WIRE
2	115916-01-01B	EA	BRACKET - ANTENNA MOUNT
3	NA	EA	ANTENNA - CB - W/O CABLE
4	158494-01-000	EA	ANTENNA/SATELLITE - RADIO/SIRIUS
5	NA	EA	CABLE - CB - COAX
6	090944-03-000	EA	CABLE - ANTENNA

COMPONENT PARTS FOR RADIO SYSTEM

KEY	PART NUMBER	U/M	DESCRIPTION	135420-20-000	VENDOR NO.
	135420-20-700	EA	CABLE-RECIEVER TO RADIO		M9CABLE

AUDIO VIDEO GROUP (CONTINUED)

REAR MONITOR

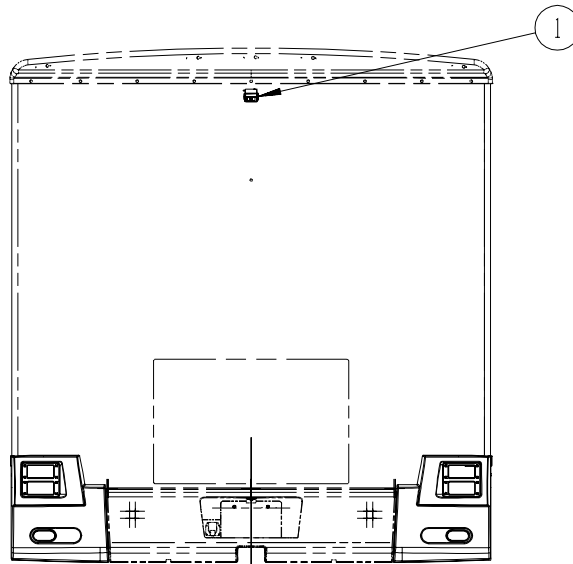

KEY	PART NUMBER	U/M DESCRIPTION
1	144677-04-000	EA CAMERA-REAR VIEW W/BRACKET-BLACK/WHITE-VBCS150 - REARVIEW MONITOR SYSTEM W/AUDIO

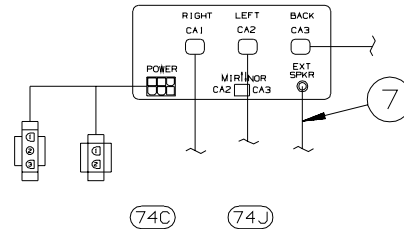
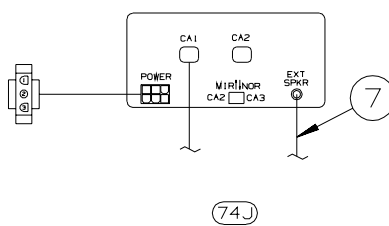
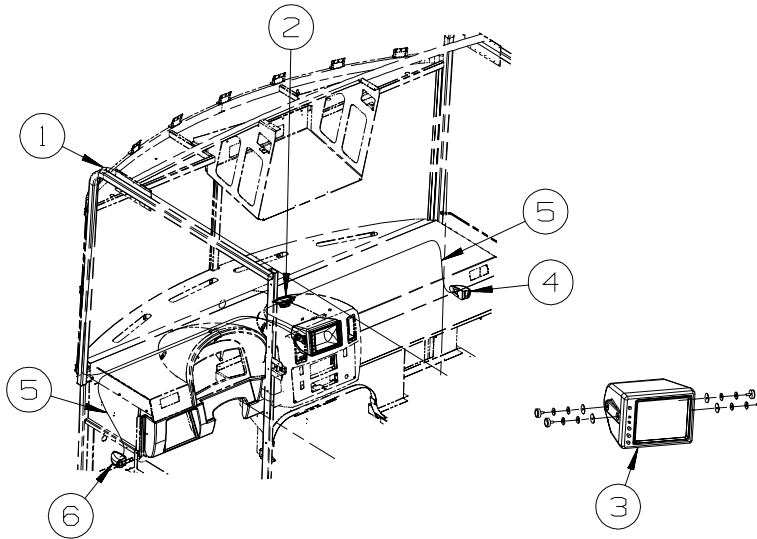

KEY	PART NUMBER	U/M DESCRIPTION
1	136514-02-000	EA CABLE - MONITOR/CAMERA
2	098819-01-000	EA SPEAKER - 4" - 2 WATT - 8 OHM
2	093214-01-05A	EA GRILLE - SPEAKER - 4" - CASHMERE
2	093214-01-04A	EA GRILLE - SPEAKER - 4" - RIVERSTONE
3	144677-06-000	EA MONITOR/BLACK & WHITE-7"-3 PIN/MECH CONTROLS - REARVIEW MONITOR SYSTEM W/AUDIO
3	144677-08-000	EA MONITOR/BLACK & WHITE- 7" -W/O SIDE CAMERAS/WIRE ASM/CABLE - VIDEO CAMERA SYSTEM
4*	144677-10-01A	EA CAMERA - REAR VIEW - DASH MOUNT/RIGHT - WHITE - VIDEO CAMERA SYSTEM
5	144677-12-000	EA CABLE - MONITOR/CAMERA - 12'
6*	144677-11-01A	EA CAMERA - REAR VIEW - DASH MOUNT/LEFT - WHITE - VIDEO CAMERA SYSTEM
7	114870-01-000	EA PLUG - AUDIO W/LEADS - 48.5"

*COMPONENT PARTS LISTED LATER IN THIS GROUP

AUDIO VIDEO GROUP (CONTINUED)
COMPONENT PARTS FOR REAR MONITOR

144677-10-01A

KEY	PART NUMBER	U/M	DESCRIPTION	VENDOR NO.
	144677-10-700	EA	HOUSING/CAMERA-RT/LT-WHITE	SIDHSGWHT
	144677-10-702	EA	SERVICE PACK-SCREW COVER	PSVCSIDHSGWHT
	144677-10-703	EA	ERVICE PACK-SCREW COVER	PSVCSIDHSGGPR

144677-11-01A

KEY	PART NUMBER	U/M	DESCRIPTION	VENDOR NO.
	144677-10-700	EA	HOUSING/CAMERA-RT/LT-WHITE	SIDHSGWHT

CABINET & APPLIANCE GROUP

CABINET & APPLIANCE LAYOUT

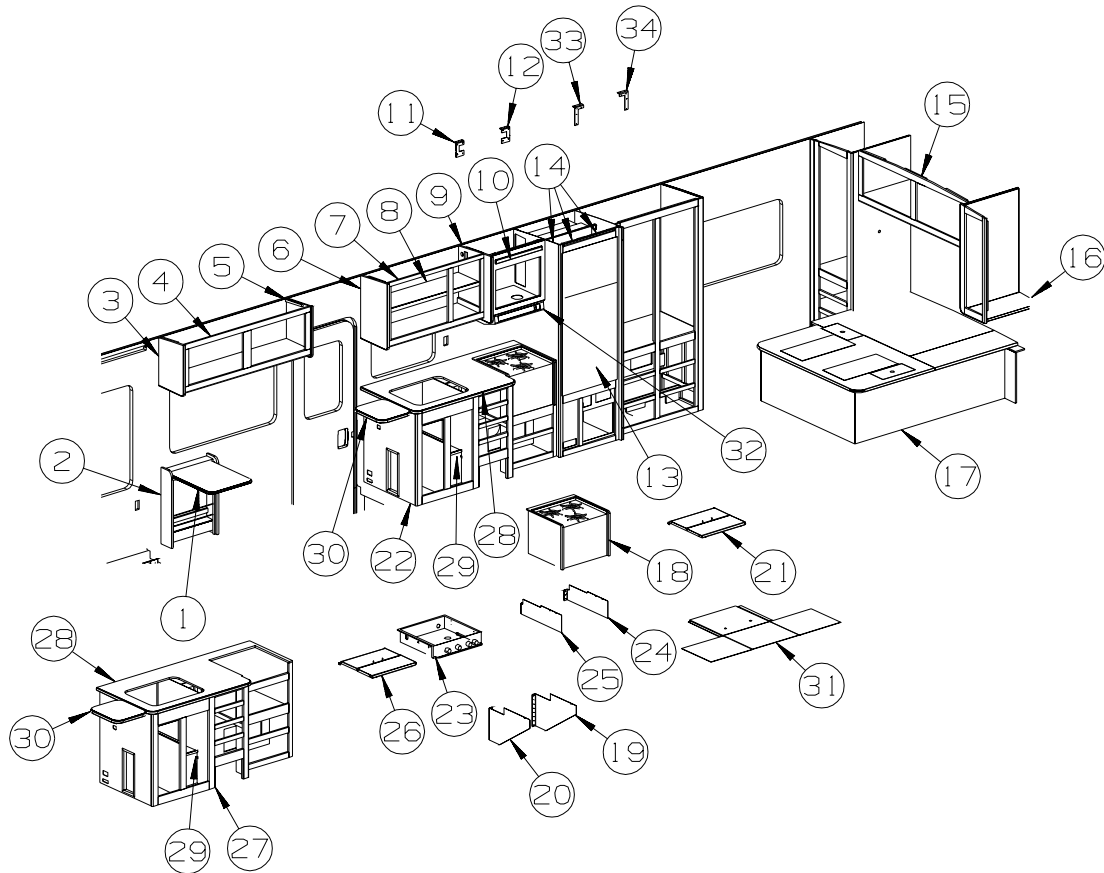

KEY	PART NUMBER	U/M	DESCRIPTION
1	136683-16-N75	EA	TABLE TOP ONLY - F/PULLOUT TABLE - PORTSMOUTH OAK
1	136683-16-SR0	EA	TABLE TOP ONLY - F/PULLOUT TABLE - SIERRA MAPLE
2	136683-01-T53	EA	CABINET - W/PULLOUT TABLE - 19.7" X 23.8" - PORTSMOUTH OAK
2	136683-01-TL0	EA	CABINET - W/PULLOUT TABLE - 19.7" X 23.8" - SIERRA MAPLE
3	103128-02-M22	EA	END CAP - OVERHEAD CABINET - LEFT HAND - PORTSMOUTH OAK
3	103128-02-SJ0	EA	END CAP - OVERHEAD CABINET - LEFT HAND - SIERRA MAPLE
4	155719-01-T53	EA	CABINET - OVERHEAD/FRONT - W/O DOORS/HDW - PORTSMOUTH OAK
4	155719-01-TL0	EA	CABINET - OVERHEAD/FRONT - W/O DOORS/HDW - SIERRA MAPLE
5	103128-01-M22	EA	END CAP - OVERHEAD CABINET - RIGHT HAND - PORTSMOUTH OAK
5	103128-01-SJ0	EA	END CAP - OVERHEAD CABINET - RIGHT HAND - SIERRA MAPLE
6	081319-20-M24	EA	END CAP - OVERHEAD CABINET - PORTSMOUTH OAK
6	081319-20-SJ0	EA	END CAP - OVERHEAD CABINET - SIERRA MAPLE
7	143234-01-U57	EA	CABINET - OVERHEAD/GALLEY - W/O DOORS/HDW - PORTSMOUTH OAK
7	143234-01-U58	EA	CABINET - OVERHEAD/GALLEY - W/O DOORS/HDW - SIERRA MAPLE
7	143234-03-T53	EA	CABINET - GALLEY - W/O DRS/HDW - PORTSMOUTH OAK - MICROWAVE/CONVECTION OVEN
7	143234-03-TL0	EA	CABINET - GALLEY - W/O DOORS/HDW - SIERRA MAPLE - MICROWAVE/CONVECTION OVEN
8	143234-13-P31	EA	SHELF - W/PLASTIC EDGE MOLDING - PORTSMOUTH OAK
8	143234-13-SJ0	EA	SHELF - W/PLASTIC EDGE MOLDING - SIERRA MAPLE
9	081319-14-M24	EA	END CAP - OVERHEAD CABINET - PORTSMOUTH OAK
9	081319-14-SJ0	EA	END CAP - OVERHEAD CABINET - SIERRA MAPLE
9	140307-40-R13	EA	END CAP - OVERHEAD CABINET - PORTSMOUTH OAK - MICROWAVE/CONVECTION OVEN
9	140307-40-SJ0	EA	END CAP - OVERHEAD CABINET - SIERRA MAPLE - MICROWAVE/CONVECTION OVEN
10	145568-01-U51	EA	CABINET - OVERHEAD/MICROWAVE - W/O DOORS/HARDWARE - PORTSMOUTH OAK
10	145568-01-U52	EA	CABINET - OVERHEAD/MICROWAVE - W/O DOORS/HARDWARE - SIERRA MAPLE
10	157258-01-TU0	EA	CABINET - MICROWAVE - W/O DRS/HDWRE - PORTSMOUTH OAK - MICROWAVE/CONVECTION OVEN
10	157258-01-TU1	EA	CABINET - MICROWAVE - W/O DRS/HARDWARE - SIERRA MAPLE - MICROWAVE/CONVECTION OVEN
11	098916-33-02B	EA	BRACE - MICROWAVE CABINET - LEFT HAND - E-COATED
			FROM: 00-00-00 THRU: 11-26-06
11	098916-35-02B	EA	BRACE - MICROWAVE - LEFT HAND - E-COATED
			FROM: 11-27-06 THRU: 99-99-99

CABINET & APPLIANCE GROUP (CONTINUED)
CABINET & APPLIANCE LAYOUT (CONTINUED)

KEY	PART NUMBER	U/M	DESCRIPTION
12	098916-34-02B	EA	BRACE - MICROWAVE CABINET - RIGHT HAND - E-COATED FROM: 00-00-00 THRU: 11-26-06
12	098916-36-02B	EA	BRACE - MICROWAVE - LEFT HAND - E-COATED FROM: 11-27-06 THRU: 99-99-99
13*	121568-06-01A	EA	REFRIGERATOR - SMALL DBL DOOR-RH/2 WAY- 52.8"HX23.5"WX24"D
	P34457-03-N47	EA	PANEL - INSERT RAISED MEMBRANE - 21.5" X 14.5" - PORTSMOUTH OAK
	P34457-03-SA3	EA	PANEL - INSERT RAISED MEMBRANE - 21.5" X 14.5" - SIERRA MAPLE
	P34457-74-T11	EA	PANEL - INSERT RAISED MEMBRANE - 21.5" X 31.5" - PORTSMOUTH OAK
	P34457-74-TK0	EA	PANEL - INSERT RAISED MEMBRANE - 21.5" X 31.5" - SIERRA MAPLE
	116751-02-01A	EA	TRAY - REFRIGERATOR - BLACK
	054450-01-000	EA	LEVEL - REFRIGERATOR
14			REFRIGERATOR CABINET SEALS
	090329-01-000	FT	SEAL - "T" - REFRIGERATOR CABINET
	154585-02-01A	FT	SEAL - FOAM TAPE - ADHESIVE BACK - 3/4" X 1/2" - BLACK
15	137983-01-N21	EA	CABINET - OVERHEAD/REAR - W/O DOORS/HARDWARE - PORTSMOUTH OAK
15	137983-01-SJ0	EA	CABINET - OVERHEAD/REAR - W/O DOORS/HARDWARE - SIERRA MAPLE
16	137960-01-N21	EA	CABINET - OVERHEAD/SHIRT/LEFT HAND - W/O DOORS/HARDWARE - PORTSMOUTH OAK
16	137960-01-SJ0	EA	CABINET - OVERHEAD/SHIRT/LEFT HAND - W/O DOORS/HARDWARE - SIERRA MAPLE
17	158086-01-U57	EA	CABINET - BED BASE - QUEEN - W/O DOORS/DRAWERS/HDW (U51)
17	158086-01-U58	EA	CABINET - BED BASE - QUEEN - W/O DOORS/DRAWERS/HDW (U52)
17	158086-01-U59	EA	CABINET - BED BASE - QUEEN - W/O DOORS/DRAWERS/HDW (U53)
17	158086-01-U60	EA	CABINET - BED BASE - QUEEN - W/O DOORS/DRAWERS/HDW (U54)
17	158086-01-U55	EA	CABINET - BED BASE - QUEEN - W/O DOORS/DRAWERS/HDW (U55)
17	158086-01-U56	EA	CABINET - BED BASE - QUEEN - W/O DOORS/DRAWERS/HDW (U56)
17	158086-02-U57	EA	CABINET - BED BASE - QUEEN - W/O DOORS/DRAWERS/HDW (U51) - WATER HEATER-6G/110/LP/MA
17	158086-02-U58	EA	CABINET - BED BASE - QUEEN - W/O DOORS/DRAWERS/HDW (U52) - WATER HEATER-6G/110/LP/MA
17	158086-02-U59	EA	CABINET - BED BASE - QUEEN - W/O DOORS/DRAWERS/HDW (U53) - WATER HEATER-6G/110/LP/MA
17	158086-02-U60	EA	CABINET - BED BASE - QUEEN - W/O DOORS/DRAWERS/HDW (U54) - WATER HEATER-6G/110/LP/MA
17	158086-02-U55	EA	CABINET - BED BASE - QUEEN - W/O DOORS/DRAWERS/HDW (U55) - WATER HEATER-6G/110/LP/MA
17	158086-02-U56	EA	CABINET - BED BASE - QUEEN - W/O DOORS/DRAWERS/HDW (U56) - WATER HEATER-6G/110/LP/MA
	096764-02-000	FT	SLIPNOT - ANTISLIP - 1'WIDE (180' ROLLS) - WHITE
18*	151277-01-01A	EA	RANGE - 16" - 3 BURNER - BLACK DOOR/TEXTURED
19	140176-03-02B	EA	BRACKET/TIEDOWN - STOVE - E-COATED
20	140176-04-02B	EA	BRACKET/TIEDOWN - STOVE - E-COATED
21	126022-04-01A	EA	COVER/RANGE - BI-FOLD - 16" - NEW GRATES - GALLEY UPGRADE PACKAGE
22	P58784-01-U57	EA	CABINET - GALLEY - W/O COUNTERTOP/DOORS/DRAWERS/HDW - PORTSMOUTH OAK
22	P58784-01-U58	EA	CABINET - GALLEY - W/O COUNTERTOP/DOORS/DRAWERS/HDW - SIERRA MAPLE
23*	114030-04-01A	EA	RANGE - TOP - 3 BURNER NEW STYLE KNOBS/GRATES-W/O OVEN - BLACK - RANGE TOP
24	142139-03-02B	EA	BRACKET/TIEDOWN - STOVE - E-COATED
25	142139-04-02B	EA	BRACKET/TIEDOWN - STOVE - E-COATED
26	126022-05-01A	EA	COVER/RANGE - BI-FOLD - 22" - NEW GRATES - RANGE TOP - GALLEY UPGRADE PACKAGE
27	P58784-02-U57	EA	CABINET - GALLEY - W/O CNTRTP/DRS/DRWRS/HDW - PORTSMOUTH OAK - RANGE TOP - 3-BURNER
27	P58784-02-U58	EA	CABINET - GALLEY - W/O CNTRTP/DRS/DRWRS/HDW - SIERRA MAPLE - RANGE TOP - 3-BURNER
28	133653-54-U57	EA	COUNTERTOP - LAMINATED - SUNSTONE/PORTSMOUTH OAK (U51) FROM: 00-00-00 THRU: 03-05-06
28	133653-26-U57	EA	COUNTERTOP - LAMINATED - SUNSTONE/PORTSMOUTH OAK (U51) FROM: 03-06-06 THRU: 99-99-99
28	133653-54-U58	EA	COUNTERTOP - LAMINATED - SUNSTONE/SIERRA MAPLE (U52) FROM: 00-00-00 THRU: 03-05-06
28	133653-26-U58	EA	COUNTERTOP - LAMINATED - SUNSTONE/SIERRA MAPLE (U52) FROM: 03-06-06 THRU: 99-99-99
28	133653-54-U59	EA	COUNTERTOP - LAMINATED - CLASSIC ROCK/PORTSMOUTH OAK (U53) FROM: 00-00-00 THRU: 03-05-06
28	133653-26-U59	EA	COUNTERTOP - LAMINATED - CLASSIC ROCK/PORTSMOUTH OAK (U53) FROM: 03-06-06 THRU: 99-99-99
28	133653-54-U60	EA	COUNTERTOP - LAMINATED - CLASSIC ROCK/SIERRA MAPLE ((U54) FROM: 00-00-00 THRU: 03-05-06
28	133653-26-U60	EA	COUNTERTOP - LAMINATED - CLASSIC ROCK/SIERRA MAPLE (U54) FROM: 03-06-06 THRU: 99-99-99
28	133653-54-U61	EA	COUNTERTOP - LAMINATED - KALHARI TPZ/PORTSMOUTH OAK (U55) FROM: 00-00-00 THRU: 03-05-06
28	133653-26-U61	EA	COUNTERTOP - LAMINATED - KALHARI TPZ/PORTSMOUTH OAK (U55) FROM: 03-06-06 THRU: 99-99-99

CABINET & APPLIANCE GROUP (CONTINUED)
CABINET & APPLIANCE LAYOUT (CONTINUED)

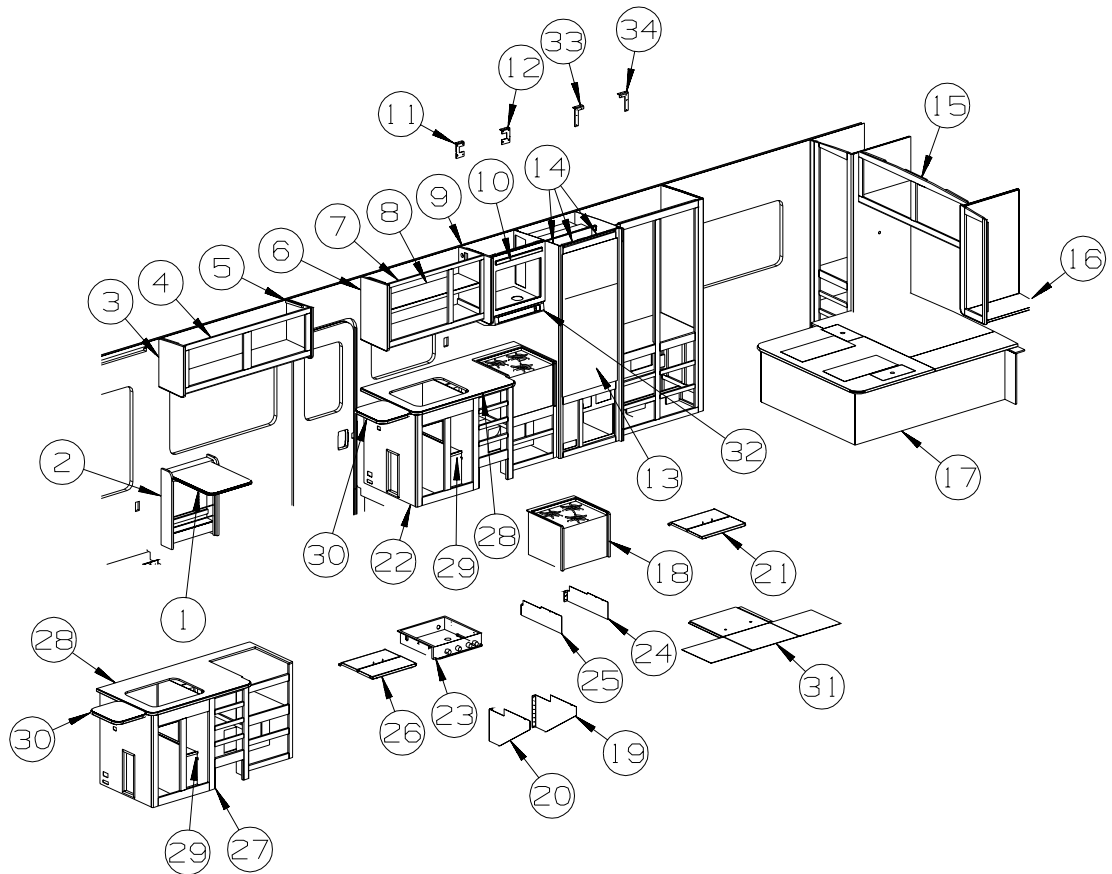

KEY	PART NUMBER	U/M	DESCRIPTION
28	133653-54-U62	EA	COUNTERTOP - LAMINATED - KALHARI TPZ/SIERRA MAPLE (U56) FROM: 00-00-00 THRU: 03-05-06
28	133653-26-U62	EA	COUNTERTOP - LAMINATED - KALHARI TPZ/SIERRA MAPLE (U56) FROM: 03-06-06 THRU: 99-99-99
29	158784-34-U57	EA	SHELF - W/PLASTIC EDGE MOLDING - PORTSMOUTH OAK
29	158784-34-U58	EA	SHELF - W/PLASTIC EDGE MOLDING - SIERRA MAPLE
30	129503-04-U57	EA	EXTENSION - GALLEY COUNTERTOP - W/O HDW (U51)
30	129503-04-U58	EA	EXTENSION - GALLEY COUNTERTOP - W/O HDW (U52)
30	129503-04-U59	EA	EXTENSION - GALLEY COUNTERTOP - W/O HDW (U53)
30	129503-04-U60	EA	EXTENSION - GALLEY COUNTERTOP - W/O HDW (U54)
30	129503-04-U61	EA	EXTENSION - GALLEY COUNTERTOP - W/O HDW (U55)
30	129503-04-U62	EA	EXTENSION - GALLEY COUNTERTOP - W/O HDW (U56)
31	162694-01-01A	EA	ENCLOSURE - STOVE - 20.7"W X 16.1"H X 18.7"D FROM: 01-02-07 THRU: 99-99-99
32*	136354-01-02A	EA	HOOD - RANGE - W/LITE/FAN - BLACK TEXTURED
32*	136354-02-02A	EA	HOOD - RANGE - W/LITE/FAN - BLACK TEXTURED - CANADIAN
32*	136354-05-01A	EA	HOOD - RANGE - W/LITE/FAN - BLACK TEXTURED - MICROWAVE/CONVECTION OVEN
32*	136354-06-01A	EA	HOOD - RANGE - W/LITE/FAN - BLACK TEXTURED - CANADIAN - MICROWAVE/CONVECTION OVEN
	117806-01-000	EA	BULB - 12V - #912 - 1.0 AMP
33	149420-05-02B	EA	BRACE - MICROWAVE - E-COATED - MICROWAVE/CONVECTION OVEN
34	149420-06-02B	EA	BRACE - MICROWAVE - E-COATED - MICROWAVE/CONVECTION OVEN

*COMPONENT PARTS LISTED LATER IN THIS GROUP

CABINET & APPLIANCE GROUP (CONTINUED)
CABINET & APPLIANCE LAYOUT (CONTINUED)

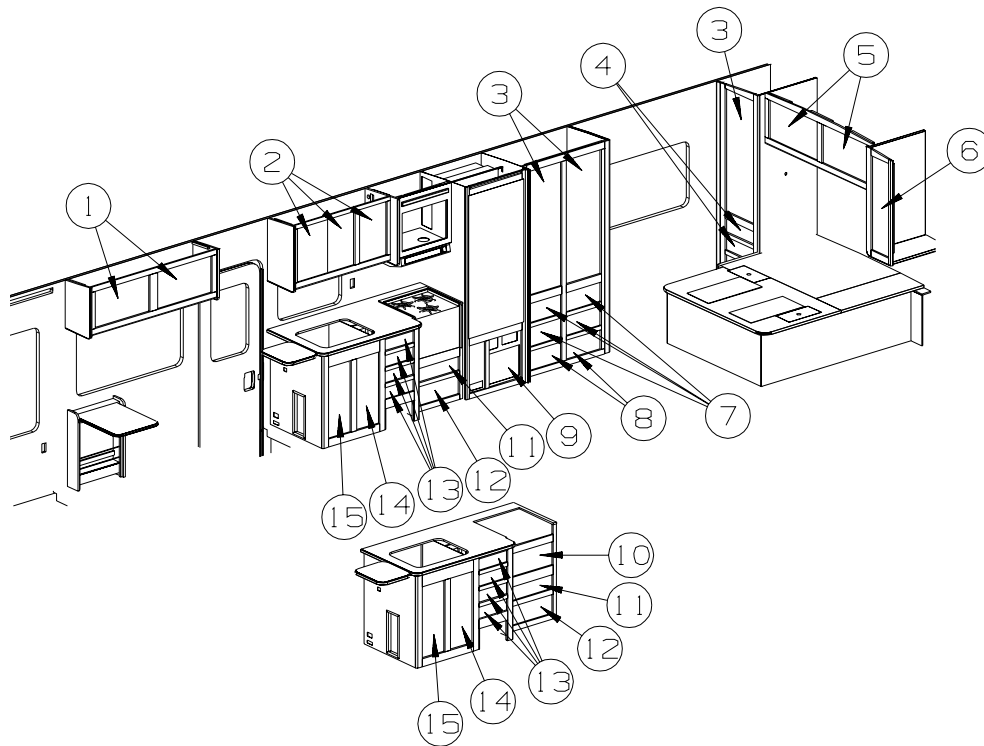

KEY	PART NUMBER	U/M	DESCRIPTION
1	136954-C1-T53	EA	DOOR - RAISED PANEL/OGEE EDGE - 15.4" X 25.6" - W/O HDW - PORTSMOUTH OAK
1	136954-C1-TL0	EA	DOOR - RAISED PANEL/OGEE EDGE - 15.4" X 25.6" - W/O HDW - SIERRA MAPLE
2	136954-88-T11	EA	DOOR - RAISED PANEL/OGEE EDGE - 13.4" X 21.9" - W/O HDW - PORTSMOUTH OAK
2	136954-88-TK0	EA	DOOR - RAISED PANEL/OGEE EDGE - 13.4" X 21.9" - W/O HDW - SIERRA MAPLE
2	136954-85-T11	EA	DOOR-RAISED PNL/OG EDGE - 12.8" X 21.8" - PORTSMOUTH OAK - MICROWAVE/CONVECTION OVEN
2	136954-85-TK0	EA	DOOR-RAISED PNL/OG EDGE - 12.8" X 21.8" - SIERRA MAPLE - MICROWAVE/CONVECTION OVEN
3	141506-03-T53	EA	DOOR - MIRRORED/OGEE EDGE - 16.7" X 48" - W/O HDW - PORTSMOUTH OAK
3	141506-03-TK0	EA	DOOR - MIRRORED/OGEE EDGE - 16.7" X 48" - W/O HDW - SIERRA MAPLE
4	153121-T6-T53	EA	DRAWER - OGEE EDGE - 14.7"W X 17.7"D - W/O SLIDES/HDW - PORTSMOUTH OAK
4	153121-T6-TL0	EA	DRAWER - OGEE EDGE - 14.7"W X 17.7"D - W/O SLIDES/HDW - SIERRA MAPLE
5	136918-D3-T53	EA	DOOR - FLAT/OGEE EDGE - 15.7" X 27.9" - W/O HARDWARE - PORTSMOUTH OAK
5	136918-D3-TL0	EA	DOOR - FLAT/OGEE EDGE - 15.7" X 27.9" - W/O HARDWARE - SIERRA MAPLE
6	136918-49-T11	EA	DOOR - FLAT/OGEE EDGE - 10.8" X 36.4" - W/O HARDWARE - PORTSMOUTH OAK
6	136918-49-TK0	EA	DOOR - FLAT/OGEE EDGE - 10.8" X 36.4" - W/O HARDWARE - SIERRA MAPLE
7	153121-GJ-T53	EA	DRAWER - OGEE EDGE - 14.7"W X 19.7"D - W/O SLIDES/HDW - PORTSMOUTH OAK
7	153121-GJ-TL0	EA	DRAWER - OGEE EDGE - 14.7"W X 19.7"D - W/O SLIDES/HDW - SIERRA MAPLE
8	153121-GG-T53	EA	DRAWER - OGEE EDGE - 14.7"W X 11.8"D - W/O SLIDES/HDW - PORTSMOUTH OAK
8	153121-GG-TL0	EA	DRAWER - OGEE EDGE - 14.7"W X 11.8"D - W/O SLIDES/HDW - SIERRA MAPLE
9	147084-01-T53	EA	DOOR - FLAT PANEL/OGEE EDGE - 15.7" X 20.4" - W/O HDW - PORTSMOUTH OAK
9	147084-01-TL0	EA	DOOR - FLAT PANEL/OGEE EDGE - 15.7" X 20.4" - W/O HDW - SIERRA MAPLE
10	153121-N4-U51	EA	DRAWER - OGEE EDGE - 19.8"W X 11.8"D - W/O SLIDES/HDW - PORTSMOUTH OAK
10	153121-N4-TL2	EA	DRAWER - OGEE EDGE - 19.8"W X 11.8"D - W/O SLIDES/HDW - SIERRA MAPLE
11	153121-M2-T54	EA	DRAWER - OGEE EDGE - 19.8"W X 11.8"D - W/O SLIDES/HDW - PORTSMOUTH OAK
11	153121-M2-TL0	EA	DRAWER - OGEE EDGE - 19.8"W X 11.8"D - W/O SLIDES/HDW - SIERRA MAPLE
12	153121-M5-T53	EA	DRAWER - OGEE EDGE - 19.8"W X 11.8"D - W/O SLIDES/HDW - PORTSMOUTH OAK
12	153121-M5-TL0	EA	DRAWER - OGEE EDGE - 19.8"W X 11.8"D - W/O SLIDES/HDW - SIERRA MAPLE
13	153121-L6-T53	EA	DRAWER - OGEE EDGE - 12"W X 19.7"D - W/O SLIDES/HDW - PORTSMOUTH OAK
13	153121-L6-TL0	EA	DRAWER - OGEE EDGE - 12"W X 19.7"D - W/O SLIDES/HDW - SIERRA MAPLE
15	136918-62-T53	EA	DOOR - FLAT/OGEE EDGE - 11.4" X 28.1" - W/O HARDWARE - PORTSMOUTH OAK
15	136918-62-TL0	EA	DOOR - FLAT/OGEE EDGE - 11.4" X 28.1" - W/O HARDWARE - SIERRA MAPLE
16	136918-63-T53	EA	DOOR - FLAT/OGEE EDGE - 11.4" X 28.1" - W/O HARDWARE - PORTSMOUTH OAK
16	136918-63-TL0	EA	DOOR - FLAT/OGEE EDGE - 11.4" X 28.1" - W/O HARDWARE - SIERRA MAPLE

CABINET & APPLIANCE GROUP (CONTINUED)
CABINET & APPLIANCE LAYOUT (CONTINUED)

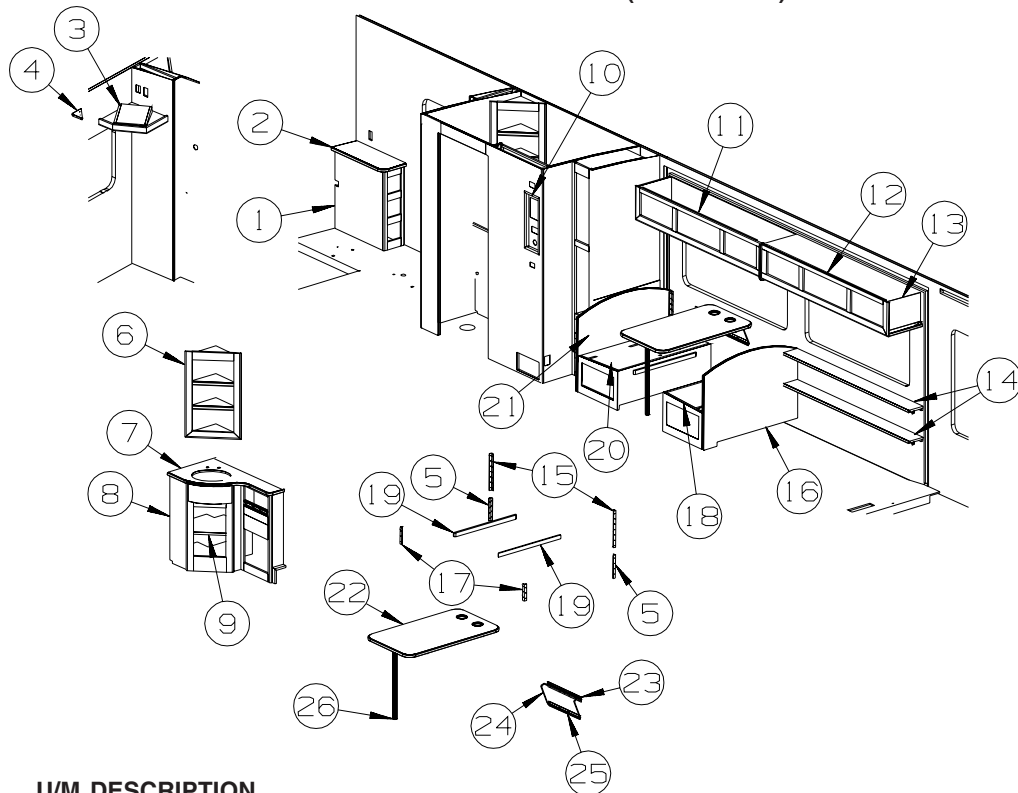

KEY	PART NUMBER	U/M	DESCRIPTION
1	158378-01-U51	EA	CABINET - NIGHTSTAND - W/O COUNTERTOP/DOORS/DRAWERS/HDW - PORTSMOUTH OAK
1	158378-01-U52	EA	CABINET - NIGHTSTAND - W/O COUNTERTOP/DOORS/DRAWERS/HDW - SIERRA MAPLE
2	133655-32-U57	EA	COUNTERTOP - LAMINATED - SUNSTONE/PORTSMOUTH OAK (U51)
2	133655-32-U58	EA	COUNTERTOP - LAMINATED - SUNSTONE/SIERRA MAPLE (U52)
2	133655-32-U59	EA	COUNTERTOP - LAMINATED - CLASSIC ROCK/PORTSMOUTH OAK (U53)
2	133655-32-U60	EA	COUNTERTOP - LAMINATED - CLASSIC ROCK/SIERRA MAPLE (U54)
2	133655-32-U61	EA	COUNTERTOP - LAMINATED - KALHARI TOPAZ/PORTSMOUTH OAK (U55)
2	133655-32-U62	EA	COUNTERTOP - LAMINATED - KALHARI TOPAZ/SIERRA MAPLE (U56)
3	146774-01-R28	EA	CABINET - TV SHELF/LEFT HAND - W/O DOORS/HARDWARE - PORTSMOUTH OAK
3	146774-01-SJ0	EA	CABINET - TV SHELF/LEFT HAND - W/O DOORS/HARDWARE - SIERRA MAPLE
4	146782-01-02B	EA	BRACKET - TV SHELF - E-COATED
5	122021-01-02A	EA	ANGLE - W/HOLES - 8.6" LONG - OFF WHITE
			FROM: 10-16-06 THRU: 99-99-99
6	143253-02-P31	EA	CABINET - MEDICINE - W/O DOORS/HARDWARE - PORTSMOUTH OAK
6	143253-02-S35	EA	CABINET - MEDICINE - W/O DOORS/HARDWARE - SIERRA MAPLE
7	133654-59-U57	EA	COUNTERTOP - LAMINATED - SUNSTONE/PORTSMOUTH OAK (U51)
7	133654-59-U58	EA	COUNTERTOP - LAMINATED - SUNSTONE/SIERRA MAPLE (U52)
7	133654-59-U59	EA	COUNTERTOP - LAMINATED - CLASSIC ROCK/PORTSMOUTH OAK (U53)
7	133654-59-U60	EA	COUNTERTOP - LAMINATED - CLASSIC ROCK/SIERRA MAPLE (U54)
7	133654-59-U61	EA	COUNTERTOP - LAMINATED - KALHARI TOPAZ/PORTSMOUTH OAK (U55)
7	133654-59-U62	EA	COUNTERTOP - LAMINATED - KALHARI TOPAZ/SIERRA MAPLE (U56)
8	P50412-01-T58	EA	CABINET - LAVATORY - W/O COUNTERTOP/DOORS/DRAWERS/HARDWARE - PORTSMOUTH OAK
8	P50412-01-TL2	EA	CABINET - LAVATORY - W/O COUNTERTOP/DOORS/DRAWERS/HARDWARE - SIERRA MAPLE
9	150412-22-S28	EA	SHELF - W/PLASTIC MOLDING - PORTSMOUTH OAK
9	150412-22-SJ0	EA	SHELF - W/PLASTIC MOLDING - SIERRA MAPLE
10	137602-04-N30	EA	POCKET - MONITOR PANEL - PORTSMOUTH OAK
10	137602-04-SJ0	EA	POCKET - MONITOR PANEL - SIERRA MAPLE
10	137602-C7-R32	EA	POCKET - MONITOR PANEL - PORTSMOUTH OAK - WATER HEATER-6GAL/110/LP/MTR/AUTO
10	137602-C7-SR0	EA	POCKET - MONITOR PANEL - SIERRA MAPLE - WATER HEATER-6GAL/110/LP/MTR/AUTO
11	159314-01-U57	EA	CABINET - OVERHEAD/DINETTE - W/O DOORS/HDW - PORTSMOUTH OAK
11	159314-01-U58	EA	CABINET - OVERHEAD/DINETTE - W/O DOORS/HDW - SIERRA MAPLE
12	139373-01-N21	EA	CABINET - OVERHEAD/COUCH - W/O DOORS/HARDWAR - PORTSMOUTH OAK
12	139373-01-SJ0	EA	CABINET - OVERHEAD/COUCH - W/O DOORS/HARDWARE - SIERRA MAPLE
13	156296-04-T53	EA	END CAP - OVERHEAD CABINE - PORTSMOUTH OAK
13	156296-04-TL0	EA	END CAP - OVERHEAD CABINET - SIERRA MAPLE
14	140246-05-T53	EA	SHELF - W/EDGE MOLDING - F/SLIDEOUT - 69.1" - PORTSMOUTH OAK
14	140246-05-TL0	EA	SHELF - W/EDGE MOLDING - F/SLIDEOUT - 69.1" - SIERRA MAPLE
15	122021-02-02A	EA	ANGLE - W/HOLES - 13.7" LONG - OFF WHITE

CABINET & APPLIANCE GROUP (CONTINUED)
CABINET & APPLIANCE LAYOUT (CONTINUED)

KEY	PART NUMBER	U/M	DESCRIPTION
16	137092-J4-T53	EA	DINETTE SEAT BACK - W/O HARDWARE - RH - PORTSMOUTH OAK
16	137092-J4-TL0	EA	DINETTE SEAT BACK - W/O HARDWARE - RH - SIERRA MAPLE
16	137092-K1-T53	EA	DINETTE SEAT BACK - W/O HARDWARE - RH - PORTSMOUTH OAK - GALLEY UPGRADE PACKAGE
16	137092-K1-TL0	EA	DINETTE SEAT BACK - W/O HARDWARE - RH - SIERRA MAPLE - GALLEY UPGRADE PACKAGE
17	122021-09-02A	EA	ANGLE - W/HOLES - OFF WHITE
18	P37092-29-T53	EA	CABINET/SEAT BASE - RIGHT HAND - W/O DOOR/DRAWER/HDW - PORTSMOUTH OAK
18	P37092-29-TL0	EA	CABINET/SEAT BASE - RIGHT HAND - W/O DOOR/DRAWER/HDW - SIERRA MAPLE
18	P37092-31-T53	EA	CABINET/SEAT BASE - RH - W/O DOOR/HDW - PORTSMOUTH OAK - GALLEY UPGRADE PACKAGE
18	P37092-31-TL0	EA	CABINET/SEAT BASE - RH - W/O DOOR/HDW - SIERRA MAPL - GALLEY UPGRADE PACKAGE
	096764-02-000	FT	SLIPNOT - ANTISLIP - 1'WIDE (20' ROLLS) - WHITE
19	081295-01-N70	EA	SUPPORT - BED/DINETTE - 28" LONG - PORTSMOUTH OAK
19	081295-01-RE0	EA	SUPPORT - BED/DINETTE - 28" LONG - SIERRA MAPLE
20	P37092-28-T53	EA	CABINET/SEAT BASE - LEFT HAND - W/O DOOR/DRAWER/HDW - PORTSMOUTH OAK
20	P37092-28-TL0	EA	CABINET/SEAT BASE - LEFT HAND - W/O DOOR/DRAWER/HDW - SIERRA MAPLE
20	P37092-30-T53	EA	CABINET/SEAT BASE - LH - W/O DOOR/HDW - PORTSMOUTH OAK - GALLEY UPGRADE PACKAGE
20	P37092-30-TL0	EA	CABINET/SEAT BASE - LH - W/O DOOR/HDW - SIERRA MAPLE - GALLEY UPGRADE PACKAGE
	096764-02-000	FT	SLIPNOT - ANTISLIP - 1'WIDE (20' ROLLS) - WHITE
21	137092-H9-T53	EA	DINETTE SEAT BACK - W/O HARDWARE - LH - PORTSMOUTH OAK
21	137092-H9-TL0	EA	DINETTE SEAT BACK - W/O HARDWARE - LH - SIERRA MAPLE
21	137092-J9-T53	EA	DINETTE SEAT BACK - W/O HARDWARE - LH - PORTSMOUTH OAK - GALLEY UPGRADE PACKAGE
21	137092-J9-TL0	EA	DINETTE SEAT BACK - W/O HARDWARE - LH - SIERRA MAPLE - GALLEY UPGRADE PACKAGE
21	144605-06-U57	EA	TABLE - DINETTE - 41.6" X 24" - W/O HARDWARE (U51)
21	144605-06-U58	EA	TABLE - DINETTE - 41.6" X 24" - W/O HARDWARE (U52)
21	144605-06-U59	EA	TABLE - DINETTE - 41.6" X 24" - W/O HARDWARE (U53)
21	144605-06-U60	EA	TABLE - DINETTE - 41.6" X 24" - W/O HARDWARE (U54)
21	144605-06-U61	EA	TABLE - DINETTE - 41.6" X 24" - W/O HARDWARE (U55)
21	144605-06-U62	EA	TABLE - DINETTE - 41.6" X 24" - W/O HARDWARE (U56)
23	140921-02-02A	EA	BRACKET/TABLE SUPPORT - 18.5" - ALMOND
24	024275-16-000	EA	ROD - TABLE LIFT - W/ARMS 8" & BASE ROD 18.5" - ALMOND
25	024281-12-000	EA	BRACKET/WALL - TABLE LIFT - 17.1" - ALMOND
26	143798-01-02A	EA	CATCH - FLOOR TO TABLE LEG - ALMOND

CABINET & APPLIANCE GROUP (CONTINUED)
CABINET & APPLIANCE LAYOUT (CONTINUED)

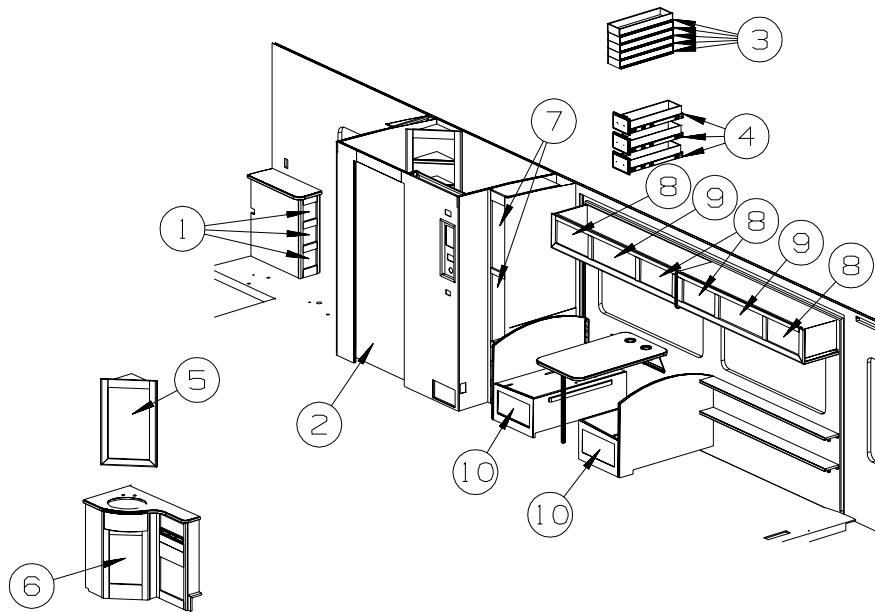

KEY	PART NUMBER	U/M	DESCRIPTION
1	153121-L0-T53	EA	DRAWER - OGEE EDGE - 5.3"W X 19.7"D - W/O SLIDES/HDW - PORTSMOUTH OAK
1	153121-L0-TL0	EA	DRAWER - OGEE EDGE - 5.3"W X 19.7"D - W/O SLIDES/HDW - SIERRA MAPLE
2	144645-04-R13	EA	DOOR - BATH - W/O FRAME (PICTURE)/TOWEL RACK/HDW - PORTSMOUTH OAK
2	144645-04-S67	EA	DOOR - BATH - W/O FRAME (PICTURE)/TOWEL RACK/HDW - SIERRA MAPLE
3	153120-N9-T53	EA	DRAWER/BOX - PANTRY - 6.8"W X 23.6"D - W/O SLIDES/HDW
4	153121-P0-T53	EA	DRAWER - OGEE EDGE - 6.8"W X 23.6"D - W/O SLIDES/HDW - PORTSMOUTH OAK
4	153121-P0-TL0	EA	DRAWER - OGEE EDGE - 6.8"W X 23.6"D - W/O SLIDES/HDW - SIERRA MAPLE
5	141506-06-T53	EA	DOOR - MIRRORED/OGEE EDGE - 15.7" X 27.9" - W/O HDW - PORTSMOUTH OAK
5	141506-06-TL0	EA	DOOR - MIRRORED/OGEE EDGE - 15.7" X 27.9" - W/O HDW - SIERRA MAPLE
6	136918-87-T53	EA	DOOR - FLAT/OGEE EDGE - 12.8" X 21.8" - W/O HARDWARE - PORTSMOUTH OAK
6	136918-87-TL0	EA	DOOR - FLAT/OGEE EDGE - 12.8" X 21.8" - W/O HARDWARE - SIERRA MAPLE
7	136918-04-T53	EA	DOOR - FLAT/OGEE EDGE - 9" X 26.5" - W/O HARDWARE - PORTSMOUTH OAK
7	136918-04-TL0	EA	DOOR - FLAT/OGEE EDGE - 9" X 26.5" - W/O HARDWARE - SIERRA MAPLE
8	136954-22-T53	EA	DOOR - RAISED PANEL/OGEE EDGE - 10" X 19.1" - W/O HDW - PORTSMOUTH OAK
8	136954-22-TL0	EA	DOOR - RAISED PANEL/OGEE EDGE - 10" X 19.1" - W/O HDW - SIERRA MAPLE
9	136954-25-T11	EA	DOOR - RAISED PANEL/OGEE EDGE - 10" X 25.2" - W/O HDW - PORTSMOUTH OAK
9	136954-25-TL0	EA	DOOR - RAISED PANEL/OGEE EDGE - 10" X 25.2" - W/O HDW - SIERRA MAPLE
10	147084-07-T11	EA	DOOR - FLAT PANEL/OGEE EDGE - 10" X 19.1" - W/O HDW - PORTSMOUTH OAK
10	147084-07-TK0	EA	DOOR - FLAT PANEL/OGEE EDGE - 10" X 19.1" - W/O HDW - SIERRA MAPLE

CABINET & APPLIANCE GROUP (CONTINUED)
CABINET & APPLIANCE LAYOUT (CONTINUED)

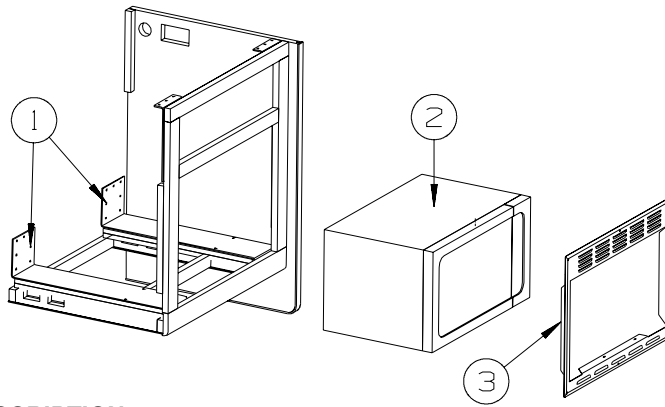

KEY	PART NUMBER	U/M	DESCRIPTION
1	094750-10-000	EA	BRACKET - MICROWAVE - 89 DEGREE
2*	158686-01-01A	EA	OVEN/MICROWAVE - .9 CU FT - NON-CONV - BLACK FROM: 00-00-00 THRU: 04-08-07
2	158686-02-01A	EA	OVEN/MICROWAVE - .9 CU FT - NON-CONV - W/O TRIM/VENTS-BLK FROM: 04-09-07 THRU: 99-99-99
3	164197-01-01A	EA	TRIM KIT - MICROWAVE - BLACK FROM: 04-09-07 THRU: 99-99-99

***COMPONENT PARTS LISTED LATER IN THIS GROUP**

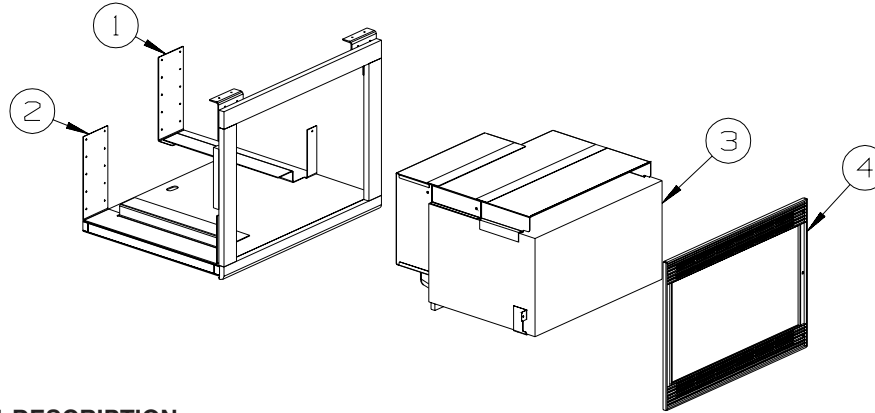

CONVECTION

KEY	PART NUMBER	U/M	DESCRIPTION
1	149418-11-02B	EA	BRACKET - MICROWAVE - E-COATED
2	149418-12-02B	EA	BRACKET - MICROWAVE - E-COATED
3*	150606-04-01A	EA	OVEN - MICROWAVE/CONVECTION/BLACK - .9 CU FT - #R-820BK
4	150606-05-01A	EA	TRIM KIT - MICROWAVE .9 CU FT - BLACK - MAGNADYNE #R820

***COMPONENT PARTS LISTED LATER IN THIS GROUP**

CABINET & APPLIANCE GROUP (CONTINUED)
CABINET & APPLIANCE LAYOUT (CONTINUED)

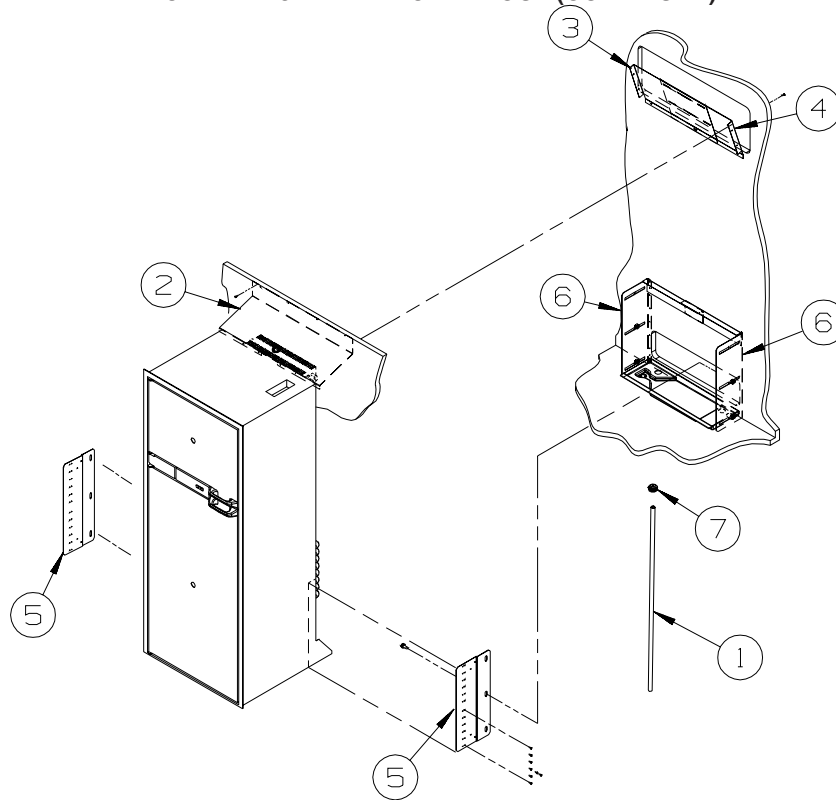

D26P

KEY	PART NUMBER	U/M	DESCRIPTION
1	112176-01-000	FT	TUBING - VINYL - REINFORCED - 1/2" ID
2	136966-04-02B	EA	BAFFLE - REFRIGERATOR - E-COATED
3	143195-01-02B	EA	BAFFLE - REFRIGERATOR - E-COATED
4	143195-02-02B	EA	BAFFLE - REFRIGERATOR - E-COATED
5	150740-01-02B	EA	BRACKET - REFRIGERATOR - E-COATED
6	150740-02-02B	EA	BRACKET - REFRIGERATOR - E-COATED
7	152417-01-01A	EA	CLAMP/RATCHET - F/REFRIDGERATOR DRIP TRAY HOSE - BLACK

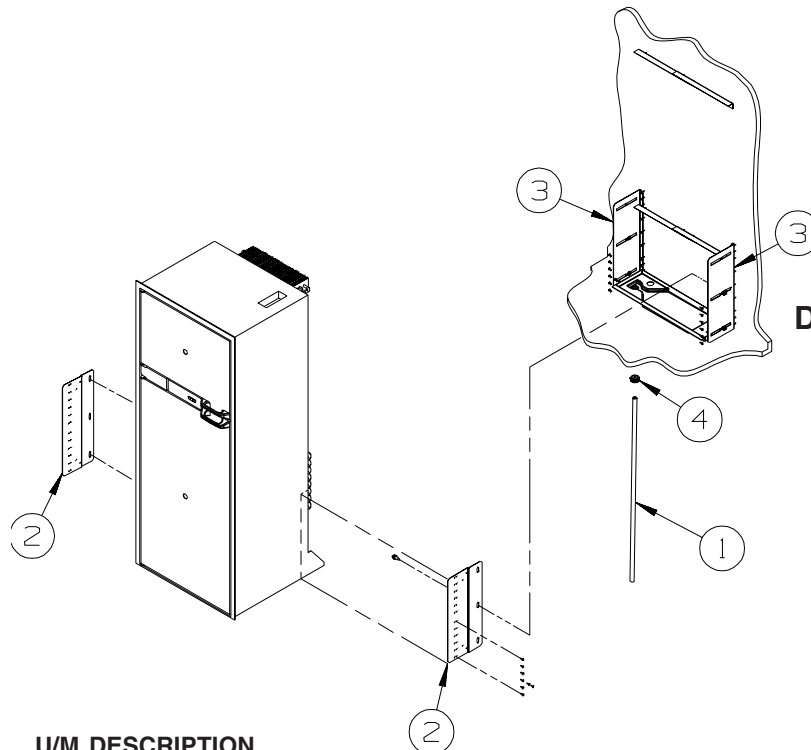

D29R, D30B, D33T, D34A, D35J

KEY	PART NUMBER	U/M	DESCRIPTION
1	112176-01-000	FT	TUBING - VINYL - REINFORCED - 1/2" ID
2	150740-01-02B	EA	BRACKET/TIEDOWN - REFRIGERATOR - E-COATED
3	150740-02-02B	EA	BRACKET/TIEDOWN - REFRIGERATOR - E-COATED
4	152417-01-01A	EA	CLAMP/RATCHET - F/REFRIDGERATOR DRIP TRAY HOSE - BLACK

CABINET & APPLIANCE GROUP (CONTINUED)
COMPONENT PARTS FOR CABINET & APPLIANCE LAYOUT

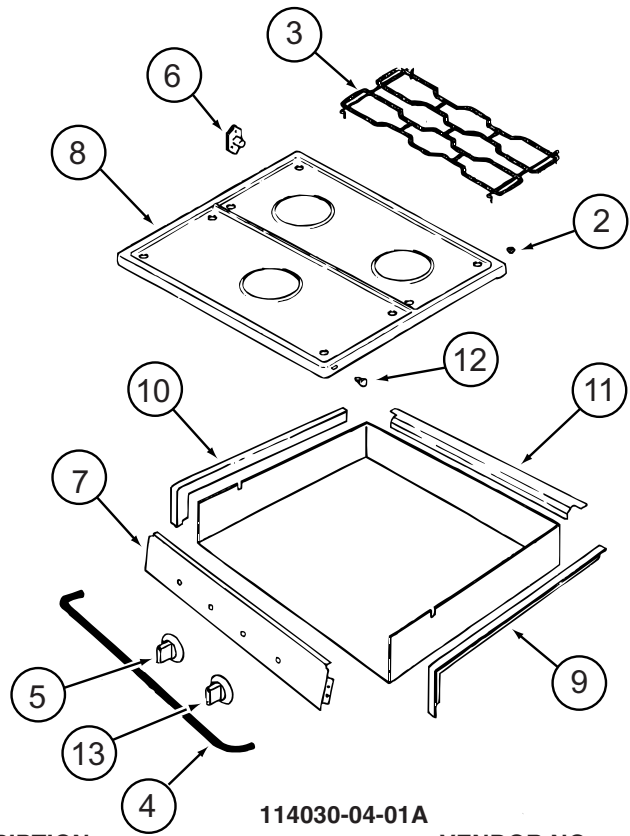

114030-04-01A

KEY	PART NUMBER	U/M	DESCRIPTION	VENDOR NO.
2	102020-01-709	EA	BUMPER-GRATE	8007P020-60
3	112881-04-702	EA	GRATE - BLACK	74007277
4	114030-02-700	EA	GUARD/FABRIC - TOWEL BAR	3609F006-70
5	128728-01-701	EA	KNOB - BURNER - REAR	74003941 (1 PER)
5	128728-01-702	EA	KNOB - BURNER - FRONT	74003942
6	128728-01-703	EA	PIN/T-NUT F/HINGE	7103P109-60
7	114030-04-700	EA	PANEL - MANIFOLD - BLACK	74007325
8	126023-01-728	EA	TOP - MAIN (BLACK)	74003323
9	114030-01-704	EA	TRIM - RIGHT/BLACK TEXTURED	74002839
10	114030-01-705	EA	TRIM - LEFT/BLACK TEXTURED	74002840
11	114030-01-706	EA	TRIM - REAR/BLACK TEXTURED	74002841
12	102020-01-724	EA	BUMPER - MAIN TOP	8003P008-60
13	128728-01-707	EA	KNOB - IGNITER	74003944

CONTACT WINNEBAGO PART SALES FOR UNLISTED COMPONENT(S)

CABINET & APPLIANCE GROUP (CONTINUED)
COMPONENT PARTS FOR CABINET & APPLIANCE LAYOUT (CONTINUED)

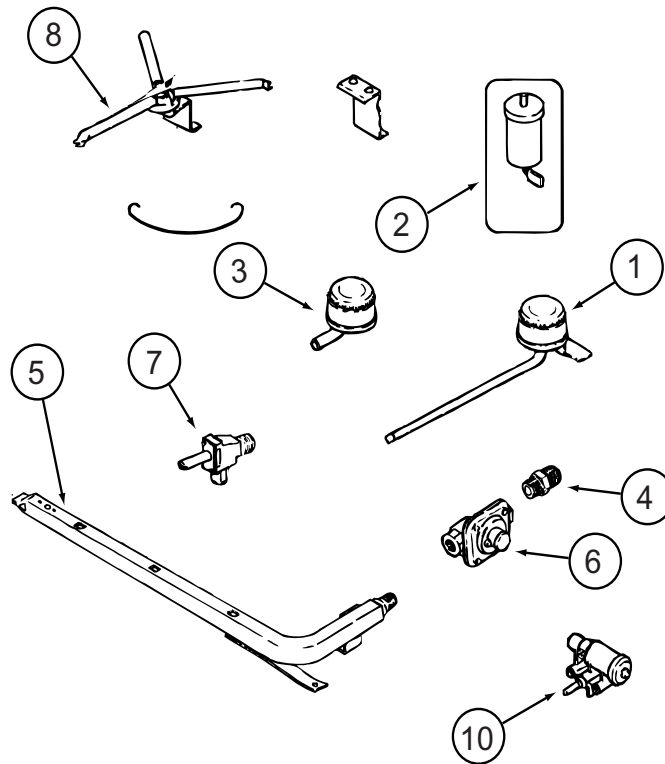

114030-04-01A (CONTINUED)

KEY	PART NUMBER	U/M	DESCRIPTION	VENDOR NO.
1	112881-04-700	EA	BURNER - TOP /LEFT REAR	74004584
1	126023-01-700	EA	BURNER - TOP (RT-REAR) 5100 BTU	74004583
2	112881-04-705	EA	PUSH RING (ELECTRODE MTG)	7104P002-60
2	126023-01-711	EA	ELECTRODE - IGNITER (ONLY)	7432P077-60
3	112881-04-701	EA	BURNER - TOP/FRONT	74004582
4	135065-03-700	EA	FITTING - HALF UNION	74004234
5	135065-01-702	EA	PIPE/MANIFOLD	74004642
6	126023-02-702	EA	PIPE - MANIFOLD	74004360
7	126023-02-705	EA	VALVE - BURNER - REAR	74004362
7	126023-02-706	EA	VALVE - BURNER - FRONT	74004363
8	126023-01-736	EA	FLASH TUBE EXTENSION (REAR)	74003326
8	126023-01-737	EA	FLASH TUBE EXTENSION (FRONT)	74003327
10	126023-01-719	EA	IGNITER HEAD - TOP BURNER	74002413
	126023-02-703	EA	REGULATOR - PRESSURE	74004235

CONTACT WINNEBAGO PART SALES FOR UNLISTED COMPONENT(S)

CABINET & APPLIANCE GROUP (CONTINUED)
COMPONENT PARTS FOR CABINET & APPLIANCE LAYOUT (CONTINUED)

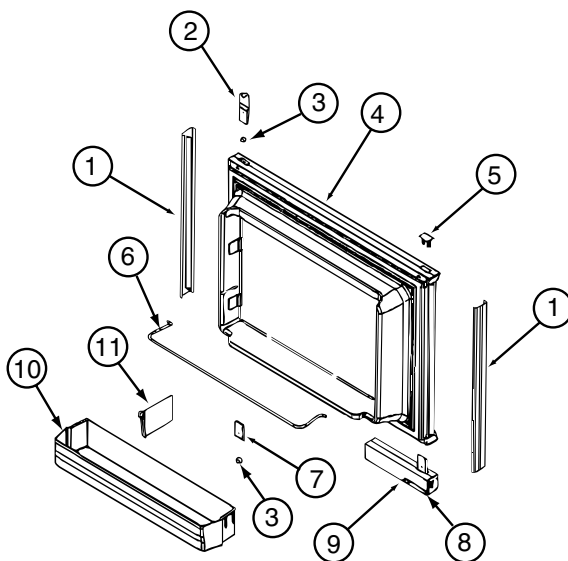

121568-06-01A, 121568-07-01A, 121568-08-01A

KEY	PART NUMBER	U/M	DESCRIPTION	VENDOR NO.
1	121568-03-700	EA	RETAINER-DOOR PNL/WAFFLE/BLK	619558-WDL-UPPER
2	120075-01-701	EA	HINGE-TOP RH/BOTTOM LH(DOOR)	618511
3	121568-03-701	EA	BUSHING - HINGE PIN/GRAY	619671
4	121568-03-702	EA	DOOR LINER-UPR/WAFFLED/BLACK	619627 - SMALL WDL
5	120075-01-702	EA	CAP, (HINGE PLUG)	618160
6	121568-01-700	EA	RAIL - DOOR UPPER	618618
7	120075-01-705	EA	HINGE-TOP LH/BOTTOM RH(DOOR)	618510
8	121568-03-705	EA	STORAGE LATCH - GRAY	619648
9	121568-03-721	EA	HANDLE/DOOR UPPER RH SWING	621465
9	121568-03-722	EA	HANDLE/DOOR LOWER RH SWING	621469
10	121568-01-701	EA	BIN - DOOR WHITE-WAFFLED LNR	618619 WDL

CONTACT WINNEBAGO PART SALES FOR UNLISTED COMPONENT(S)

CABINET & APPLIANCE GROUP (CONTINUED)
COMPONENT PARTS FOR CABINET & APPLIANCE LAYOUT (CONTINUED)

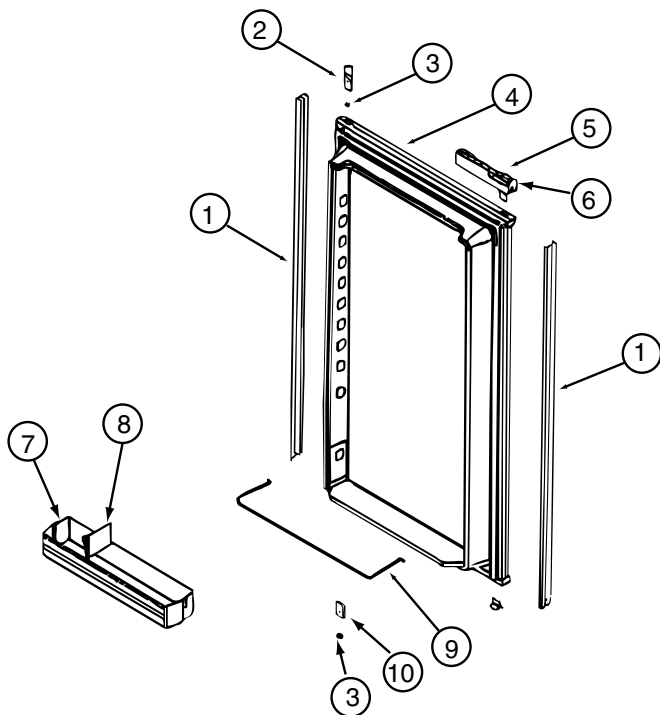

121568-06-01A, 121568-07-01A, 121568-08-01A (CONTINUED)

KEY	PART NUMBER	U/M	DESCRIPTION	VENDOR NO.
1	121568-03-706	EA	RETAINER-DOOR PNL/WAFFLE/BLK	619559-WDL-LOWER
2	120075-01-701	EA	HINGE-TOP RH/BOTTOM LH(DOOR)	618511
3	121568-03-701	EA	BUSHING - HINGE PIN/GRAY	619671
4	121568-03-707	EA	DOOR LINER-LWR/WAFFLED/B/TRM	619629
5	121568-03-721	EA	HANDLE/DOOR UPPER RH SWING	621465
5	121568-03-722	EA	HANDLE/DOOR LOWER RH SWING	621469
6	121568-03-705	EA	STORAGE LATCH - GRAY	619648
7	121568-01-701	EA	BIN - DOOR WHITE-WAFFLED LNR	618619 WDL
9	121568-01-704	EA	RAIL - DOOR LOWER	618578
10	120075-01-705	EA	HINGE-TOP LH/BOTTOM RH(DOOR)	618510

CONTACT WINNEBAGO PART SALES FOR UNLISTED COMPONENT(S)

CABINET & APPLIANCE GROUP (CONTINUED)
COMPONENT PARTS FOR CABINET & APPLIANCE LAYOUT (CONTINUED)

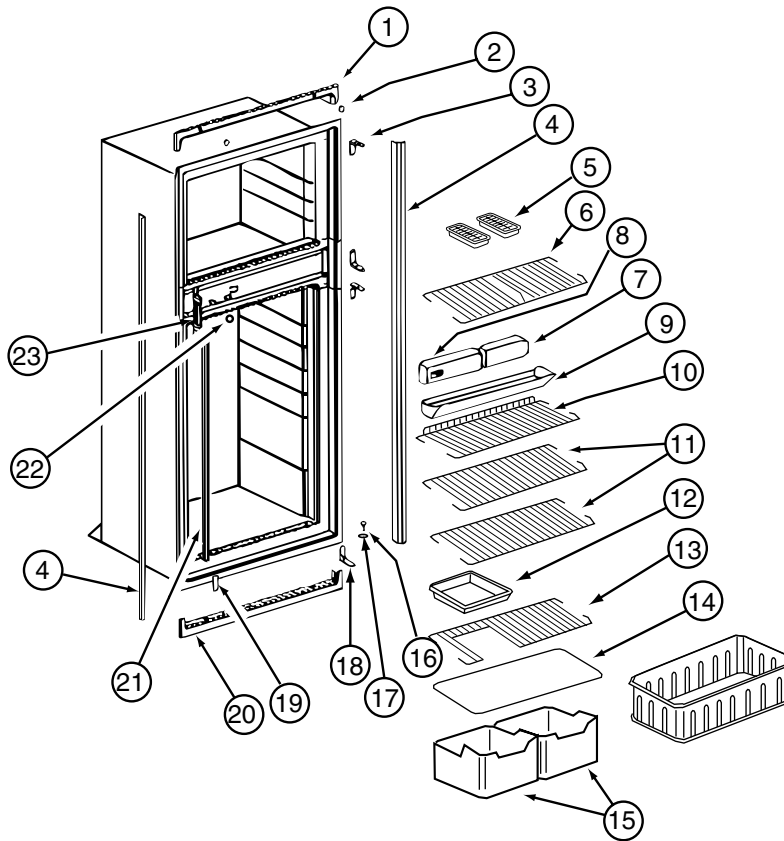

121568-06-01A, 121568-07-01A, 121568-08-01A (CONTINUED)

KEY	PART NUMBER	U/M	DESCRIPTION	VENDOR NO.
1	120075-01-713	EA	TRIM-TOP PIECE	619687
2	120075-01-714	EA	PLUG-HOLE (BLACK)	618170
3	121568-03-710	EA	HINGE/CABINET-TOP/RH-LWR/LH	619335 WAFFLED
4	121568-03-711	EA	TRIM - SIDE/BLACK	622295
6	121568-01-705	EA	SHELF - WIRE FREEZER	620250
7	121568-06-700	EA	FRONT BOX-N611	622002
8	121568-06-701	EA	CONTROL ASSY-OPTICAL/N611	621988
9	120075-01-720	EA	TRAY-DRIP	623250
9	120075-01-721	EA	LOUVER-DRIP TRAY	618176
11	121568-01-708	EA	SHELF - WIRE	620273
13	121568-01-707	EA	SHELF - WIRE - SHORT	620272
14	120075-01-725	EA	COVER-CRISPER - 18.5" WIDE	618158
15	121568-01-709	EA	CRISPER	618571
16	120075-01-727	EA	PIN-HINGE	618145
17	121568-03-701	EA	BUSHING - HINGE PIN/GRAY	619671
18	121568-03-715	EA	HINGE/CABINET-TOP/LH-LWR/RH	619336 WAFFLED
19	121568-03-716	EA	COVER - HINGE HOLES	619301
20	120075-01-729	EA	TRIM-BOTTOM PIECE	620958
21	121568-06-702	EA	CLIP - SHELF	61536522
22	121568-06-703	EA	HOLE PLUG - WHITE	620282
23	120075-01-732	EA	PLATE-STRIKE	618167

CONTACT WINNEBAGO PART SALES FOR UNLISTED COMPONENT(S)

CABINET & APPLIANCE GROUP (CONTINUED)
COMPONENT PARTS FOR CABINET & APPLIANCE LAYOUT (CONTINUED)

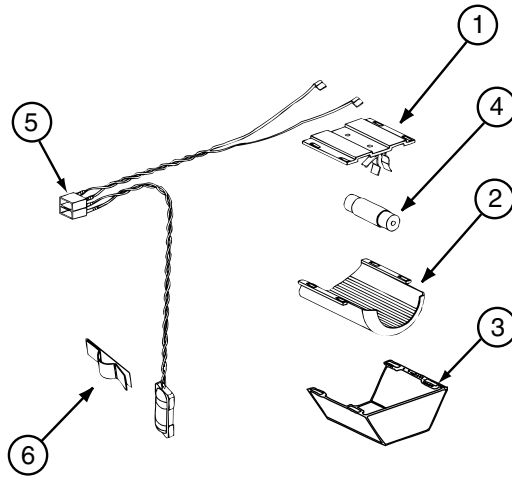

121568-03-01A, 121568-04-01A, 121568-05-01A, 121568-06-01A, 121568-07-01A, 121568-08-01A (CONTINUED)

KEY	PART NUMBER	U/M	DESCRIPTION	VENDOR NO.
1	084880-01-760	EA	CLIP (THERMISTER)	61689122
2	120075-01-735	EA	THERMISTER W/LAMP & WIRE/ASM	618548
3	084880-03-705	EA	BRACKET-LIGHT-INTERIOR	61629722
4	084880-03-706	EA	BULB-LAMP	61628922
6	084880-03-707	EA	COVER-LAMP, LENS	61627922

CONTACT WINNEBAGO PART SALES FOR UNLISTED COMPONENT(S)

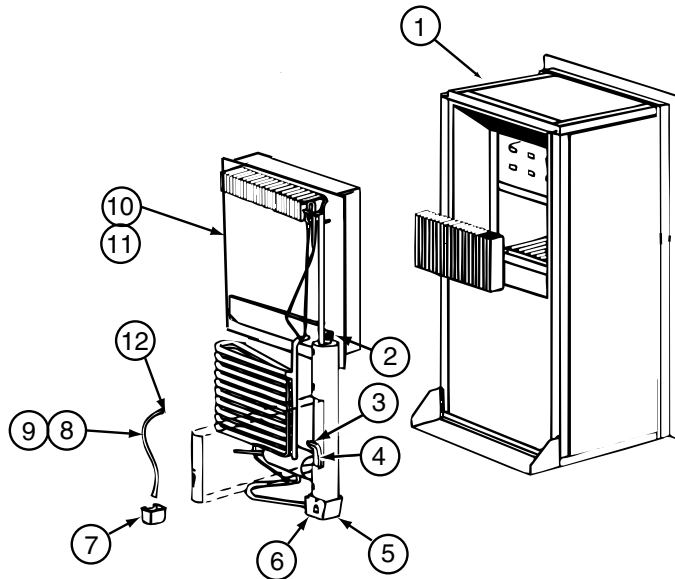

121568-06-01A, 121568-07-01A, 121568-08-01A (CONTINUED)

KEY	PART NUMBER	U/M	DESCRIPTION	VENDOR NO.
4	121568-06-704	EA	HEATER-AC/300W/120VAC	621702
10	120076-01-704	EA	COOLING UNIT, SERVICE PACK	618543

CONTACT WINNEBAGO PART SALES FOR UNLISTED COMPONENT(S)

CABINET & APPLIANCE GROUP (CONTINUED)
COMPONENT PARTS FOR CABINET & APPLIANCE LAYOUT (CONTINUED)

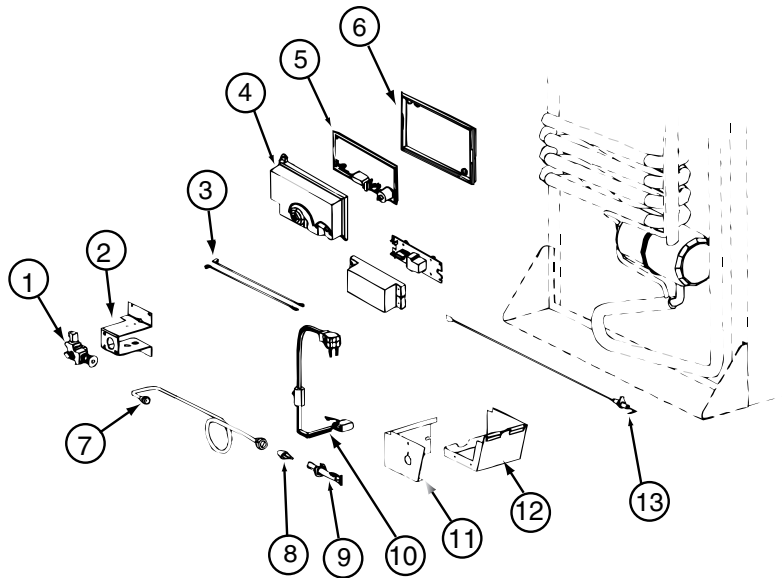

121568-06-01A, 121568-07-01A, 121568-08-01A (CONTINUED)

KEY	PART NUMBER	U/M	DESCRIPTION	VENDOR NO.
1	121568-06-705	EA	GAS VALVE/BRKT ASSY-COMBO	621439
1	121568-06-706	EA	GAS VALVE-COMBO/WRENCH FLAT	621329
4	120075-01-738	EA	COVER-POWER BOARD	618185
5	121568-06-707	EA	BOARD/POWER-N611	621991 = 621991001
6	120075-01-740	EA	BASE - POWER BOARD	618186
8	121568-06-708	EA	BURNER/ORFICE-ADAPTER KIT	621957
13	104137-06-715	EA	ELECTRODE-SPARK/SENSOR, SGL	61692222
	121569-08-704	EA	TUBE/BURNER - N8/N6	624682

CONTACT WINNEBAGO PART SALES FOR UNLISTED COMPONENT(S)

CABINET & APPLIANCE GROUP (CONTINUED)
COMPONENT PARTS FOR CABINET & APPLIANCE LAYOUT (CONTINUED)

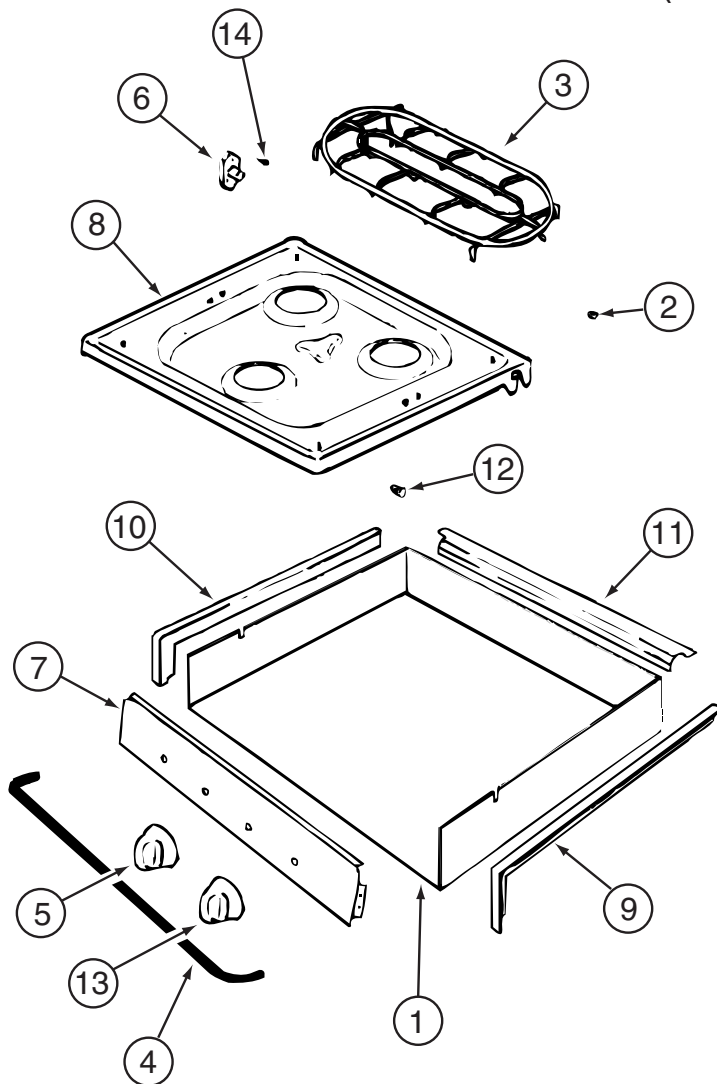

135065-03-01A, 135065-03-03A, 135065-04-01A

KEY	PART NUMBER	U/M	DESCRIPTION	VENDOR NO.
2	102020-01-709	EA	BUMPER-GRATE	8007-P020-60
3	135065-03-703	EA	GRATE - BLACK(SEALED BURNER)	74007304
4	114030-02-700	EA	GUARD/FABRIC - TOWEL BAR	3609F006-70
5	128728-01-701	EA	KNOB - BURNER - REAR	74003941
5	128728-01-702	EA	KNOB - BURNER - FRONT	74003942
6	128728-01-703	EA	PIN/T-NUT F/HINGE	7103P109-60
7	135065-03-704	EA	PANEL - MANIFOLD (BLACK)	74007330
8	128728-01-705	EA	TOP - MAIN - BLACK	74003928
8	135065-03-715	EA	TOP - MAIN - STAINLESS STEEL	74007299
9	114030-01-704	EA	TRIM - RIGHT/BLACK TEXTURED	74002839
10	114030-01-705	EA	TRIM - LEFT/BLACK TEXTURED	74002840
11	114030-01-706	EA	TRIM - REAR/BLACK TEXTURED	74002841
12	102020-01-724	EA	BUMPER-MAIN TOP	8003P008-60
13	128728-01-707	EA	KNOB - IGNITOR	74003944

CONTACT WINNEBAGO PART SALES FOR UNLISTED COMPONENT(S)

CABINET & APPLIANCE GROUP (CONTINUED)
COMPONENT PARTS FOR CABINET & APPLIANCE LAYOUT (CONTINUED)

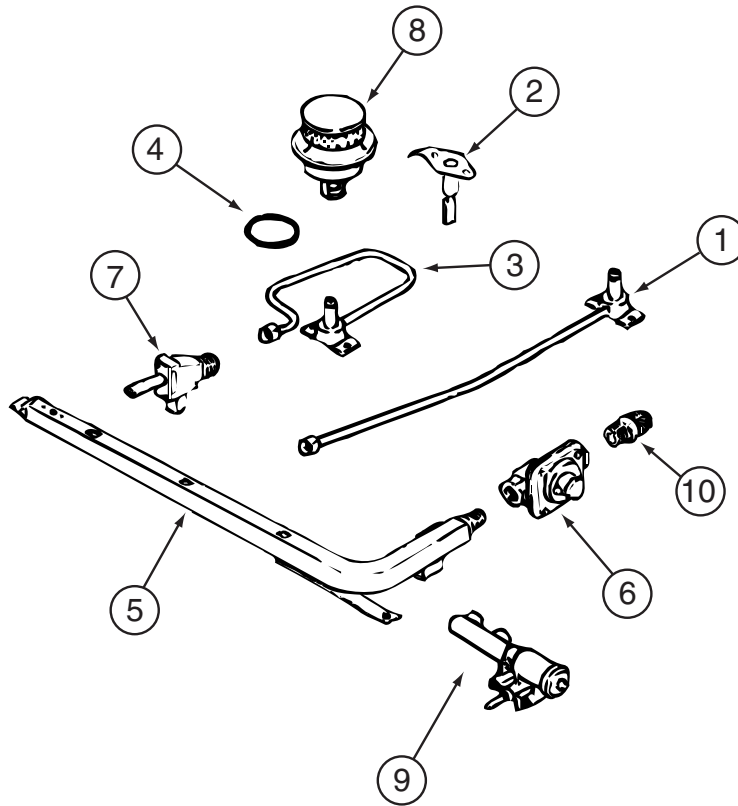

135065-03-01A, 135065-03-03A, 135065-04-01A (CONTINUED)

KEY	PART NUMBER	U/M	DESCRIPTION	VENDOR NO.
1	128728-01-708	EA	FITTING W/ORFICE/TUBE - REAR	74003931
2	135065-01-701	EA	IGNITOR/PORCELAIN-TOP BURNER	74004053
3	128728-01-710	EA	FITTING W/ORFICE/TUBE - FRT	74003930
4	135065-03-700	EA	FITTING - HALF UNION	74004234
5	135065-01-702	EA	PIPE/MANIFOLD	74004642
6	126023-02-703	EA	REGULATOR - PRESSURE	74004235
7	135065-01-703	EA	VALVE/BURNER - REAR	74004643
7	135065-01-704	EA	VALVE/BURNER-FRT-HI	74004644
7	135065-03-701	EA	SCREW - VALVE	71003231
8	135065-03-702	EA	SEALED BURNER ASM.(BLACK) RV	74003967
9	128728-01-716	EA	BURNER - IGNITOR	74003946
9	128728-01-717	EA	WIRES - IGNITOR	74003947

CABINET & APPLIANCE GROUP (CONTINUED)
COMPONENT PARTS FOR CABINET & APPLIANCE LAYOUT (CONTINUED)

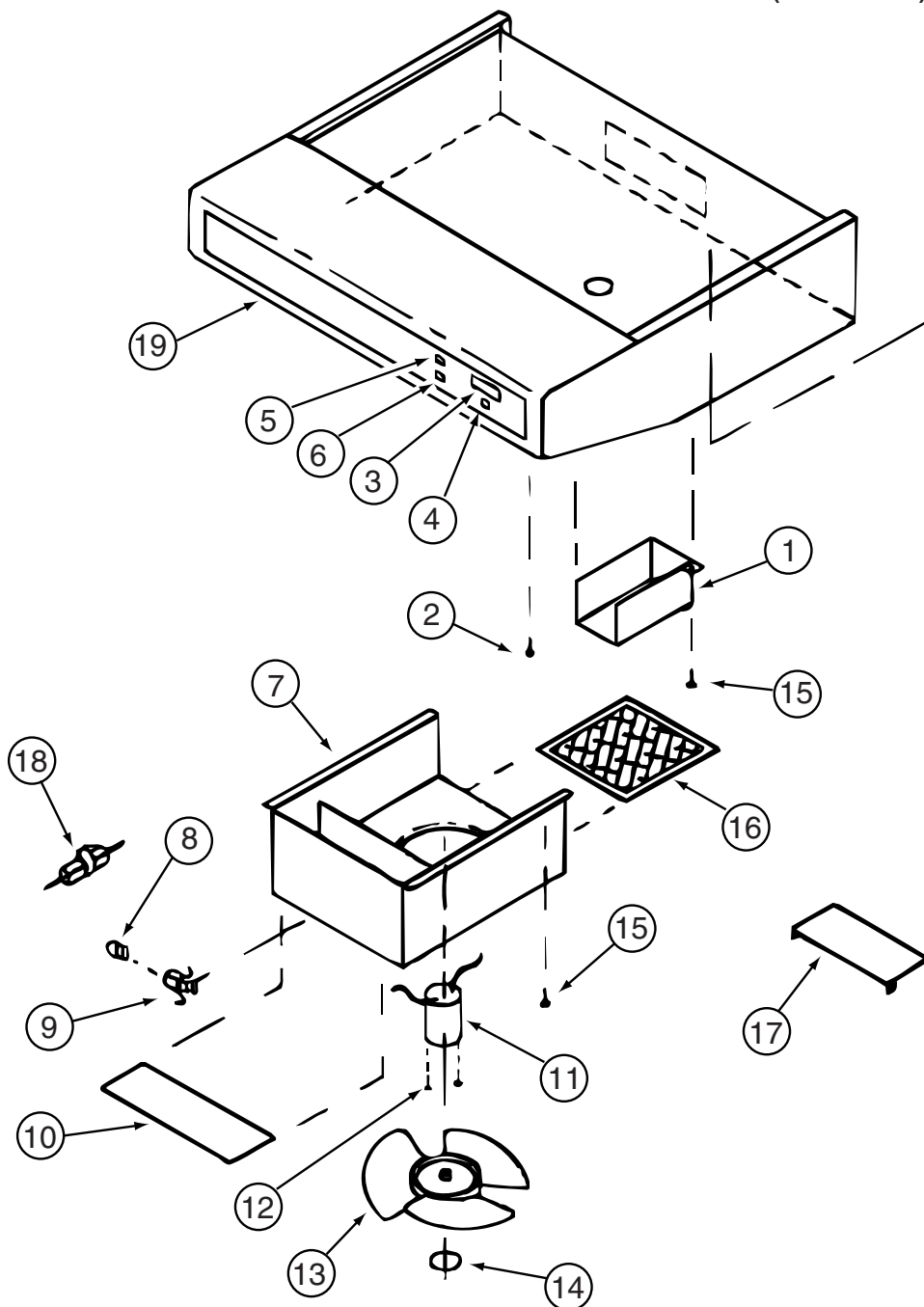

136354-01-02A

KEY	PART NUMBER	U/M	DESCRIPTION	VENDOR NO.
3	100258-10-700	EA	GAUGE-HOUR METER, SCREW ON	L0150-00 WAS 150
4	096983-01-702	EA	SWITCH - MOM/OFF/MOM/3 TERM	L0112-00
5	096983-01-700	EA	SWITCH/1 SPEED -ON/OFF- BLK	L0108-00
8	117806-01-000	EA	BULB - 12V NO.912 1.0 AMPS	
9	092696-01-710	EA	HOLDER-LAMP	CB267-02
10	096983-01-708	EA	LENS-LAMP	CC0179
11	136354-05-700	EA	MOTOR-12 VOLT	VC0536-02
13	136354-05-701	EA	BLADE-FAN 7" DIA	VD0216-00
16	096983-01-707	EA	FILTER-MESH	CC0246-00
17	100258-01-701	EA	DAMPER ASSEMBLY (METAL FLAP)	CA0565-00
19	100258-01-700	EA	LABEL-HOOD NOSE	CC0428-00

CONTACT WINNEBAGO PART SALES FOR UNLISTED COMPONENT(S)

CABINET & APPLIANCE GROUP (CONTINUED)
COMPONENT PARTS FOR CABINET & APPLIANCE LAYOUT (CONTINUED)

136354-02-02A

KEY	PART NUMBER	U/M	DESCRIPTION	VENDOR NO.
5	096983-01-700	EA	SWITCH/1 SPEED -ON/OFF- BLK	L0108-00
9	092696-01-710	EA	HOLDER-LAMP	CB267-02
10	096983-01-708	EA	LENS-LAMP	CC0179
11	136354-06-700	EA	MOTOR - FAN (CSA)	VC0535-02
13	136354-05-701	EA	BLADE-FAN 7" DIA	VD0216-00
16	096983-01-707	EA	FILTER-MESH	CC0246-00
17	100258-01-701	EA	DAMPER ASSEMBLY (METAL FLAP)	CA0565-00
19	100258-01-700	EA	LABEL-HOOD NOSE	CC0428-00
CONTACT WINNEBAGO PART SALES FOR UNLISTED COMPONENT(S)				

136354-05-01A, 136354-05-02A

KEY	PART NUMBER	U/M	DESCRIPTION	VENDOR NO.
3	100258-10-700	EA	GAUGE-HOUR METER, SCREW ON	L0150-00 WAS 150
4	096983-01-702	EA	SWITCH - MOM/OFF/MOM/3 TERM	L0112-00
6	096983-01-700	EA	SWITCH/1 SPEED -ON/OFF- BLK	L0108-00
8	117806-01-000	EA	BULB-12V NO.912 1.0 AMPS	GENERAL MOTOR HOMES
9	092696-01-710	EA	HOLDER-LAMP	CB0267-02
10	096983-01-708	EA	LENS-LAMP	CC0179
11	136354-05-700	EA	MOTOR-12 VOLT	VC0536-02
13	136354-05-701	EA	BLADE-FAN 7" DIA	VD0216-00
16	096983-01-707	EA	FILTER-MESH	CC0246-00
17	100258-01-701	EA	DAMPER ASSEMBLY (METAL FLAP)	CA0565-00
19	100258-01-700	EA	LABEL-HOOD NOSE	CC0428-00
CONTACT WINNEBAGO PART SALES FOR UNLISTED COMPONENT(S)				

136354-06-01A, 136354-06-02A

KEY	PART NUMBER	U/M	DESCRIPTION	VENDOR NO.
3	100258-10-700	EA	GAUGE-HOUR METER, SCREW ON	L0150-00 WAS 150
4	096983-01-702	EA	SWITCH - MOM/OFF/MOM/3 TERM	L0112-00
5	096983-01-700	EA	SWITCH/1 SPEED -ON/OFF- BLK	L0108-00
8	117806-01-000	EA	BULB-12V NO.912 1.0 AMPS	GENERAL MOTOR HOMES
9	092696-01-710	EA	HOLDER-LAMP	CB0267-02
10	096983-01-708	EA	LENS-LAMP	CC0179
11	136354-06-700	EA	MOTOR - FAN (CSA)	VC0535-02
13	136354-05-701	EA	BLADE-FAN 7" DIA	VD0216-00
16	096983-01-707	EA	FILTER-MESH	CC0246-00
17	100258-01-701	EA	DAMPER ASSEMBLY (METAL FLAP)	CA0565-00
19	100258-01-700	EA	LABEL-HOOD NOSE	CC0428-00
CONTACT WINNEBAGO PART SALES FOR UNLISTED COMPONENT(S)				

150606-04-01A, 150606-04-02A

KEY	PART NUMBER	U/M	DESCRIPTION	VENDOR NO.
	122753-02-700	EA	PLATE/CAROUSEL-GLASS	NTNT-A097WREO
	150606-04-700	EA	RACK - BAKING	FAMI-A104WRM0

CABINET & APPLIANCE GROUP (CONTINUED)
COMPONENT PARTS FOR CABINET & APPLIANCE LAYOUT (CONTINUED)

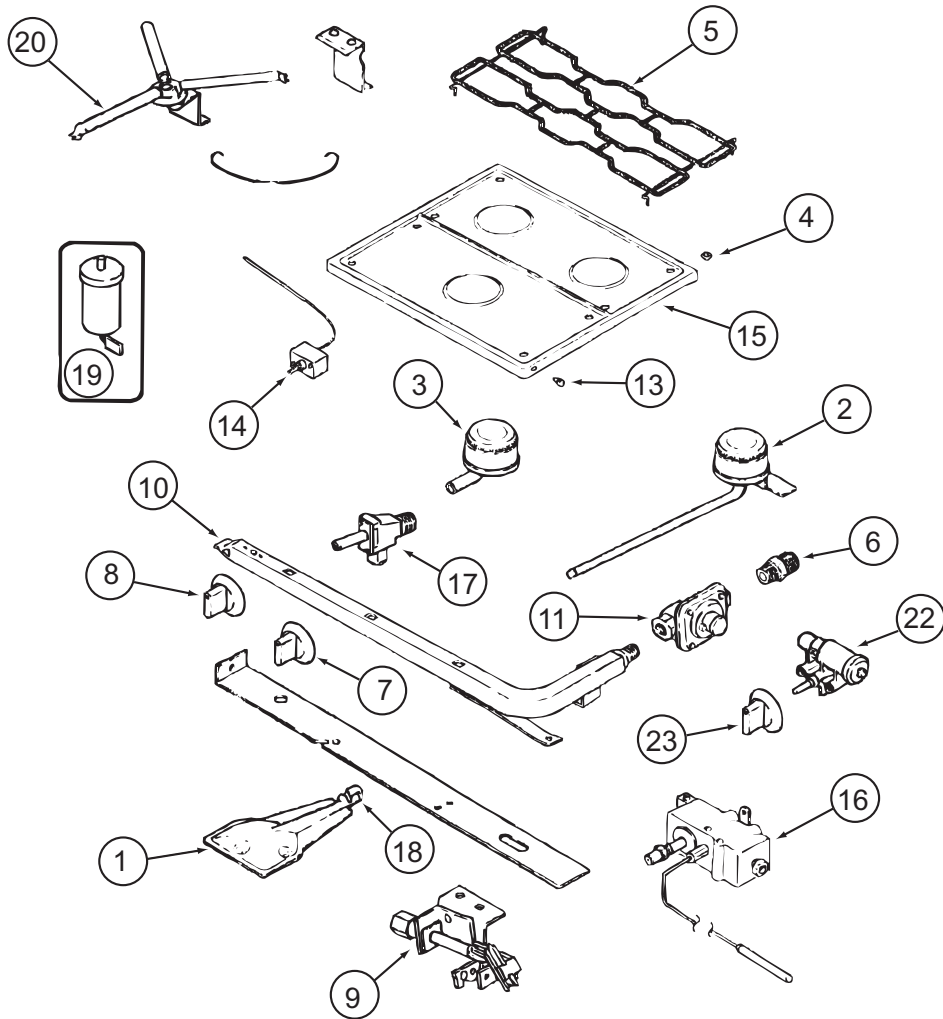

151277-01-01A, 151277-02-01A

CABINET & APPLIANCE GROUP (CONTINUED)
COMPONENT PARTS FOR CABINET & APPLIANCE LAYOUT (CONTINUED)

151277-01-01A, 151277-02-01A (CONTINUED)

KEY	PART NUMBER	U/M	DESCRIPTION	VENDOR NO.
1	151279-02-700	EA	BURNER - OVEN - W/SHUTTER	74009853
2	112881-04-700	EA	BURNER - TOP/LEFT REAR	74004584
2	126023-01-700	EA	BURNER-TOP (RT-REAR) 5100BTU	74004583
3	112881-04-701	EA	BURNER - TOP/FRONT	74004582
4	102020-01-709	EA	BUMPER-GRATE	8007P020-60
5	112881-04-702	EA	GRATE - BLACK	74007277
6	135065-03-700	EA	FITTING - HALF UNION	74004234
7	128728-01-701	EA	KNOB - BURNER - REAR	74003941 (1 PER)
7	128728-01-702	EA	KNOB - BURNER - FRONT	74003942
8	151279-02-701	EA	KNOB - THERMOSTAT - BLACK	74009858
9	151279-01-700	EA	PILOT - BURNER - 16" SERIES	74009852
10	151279-02-702	EA	PIPE - MANIFOLD	74009856
11	112881-03-701	EA	REGULATOR KIT W/FITTINGS	12001285
13	102020-01-724	EA	BUMPER-MAIN TOP	8003P008-60
14	151279-02-703	EA	THERMOSTAT	74009855
15	151277-01-700	EA	TOP - MAIN (BLACK)	74007287
16	151279-02-704	EA	ELBOW BLOCK ASM (VALVE-OVEN)	74009864
17	151277-01-701	EA	VALVE/REAR - W/SET SCREW	12002254
17	151277-01-702	EA	VALVE/FRONT - W/SET SCREW	12002246
19	112881-04-705	EA	PUSH RING (ELECTRODE MTG)	7104P002-60
19	126023-01-711	EA	ELECTRODE - IGNITER (ONLY)	7432P077-60
20	126023-01-736	EA	FLASH TUBE EXTENSION (REAR)	74003326
20	126023-01-737	EA	FLASH TUBE EXTENSION (FRONT)	74003327
21	112881-04-708	EA	CLIP-FLASH TUBE	7112P068-60
22	126023-01-735	EA	KIT - IGNITOR TOP BRNER & KNOB	12001296=74002413&4
23	128728-01-707	EA	KNOB - IGNITOR	74003944
26	112881-04-709	EA	SHIELD-SPARK	3604F211-45
			CONTACT WINNEBAGO PART SALES FOR UNLISTED COMPONENT(S)	

CABINET & APPLIANCE GROUP (CONTINUED)
COMPONENT PARTS FOR CABINET & APPLIANCE LAYOUT (CONTINUED)

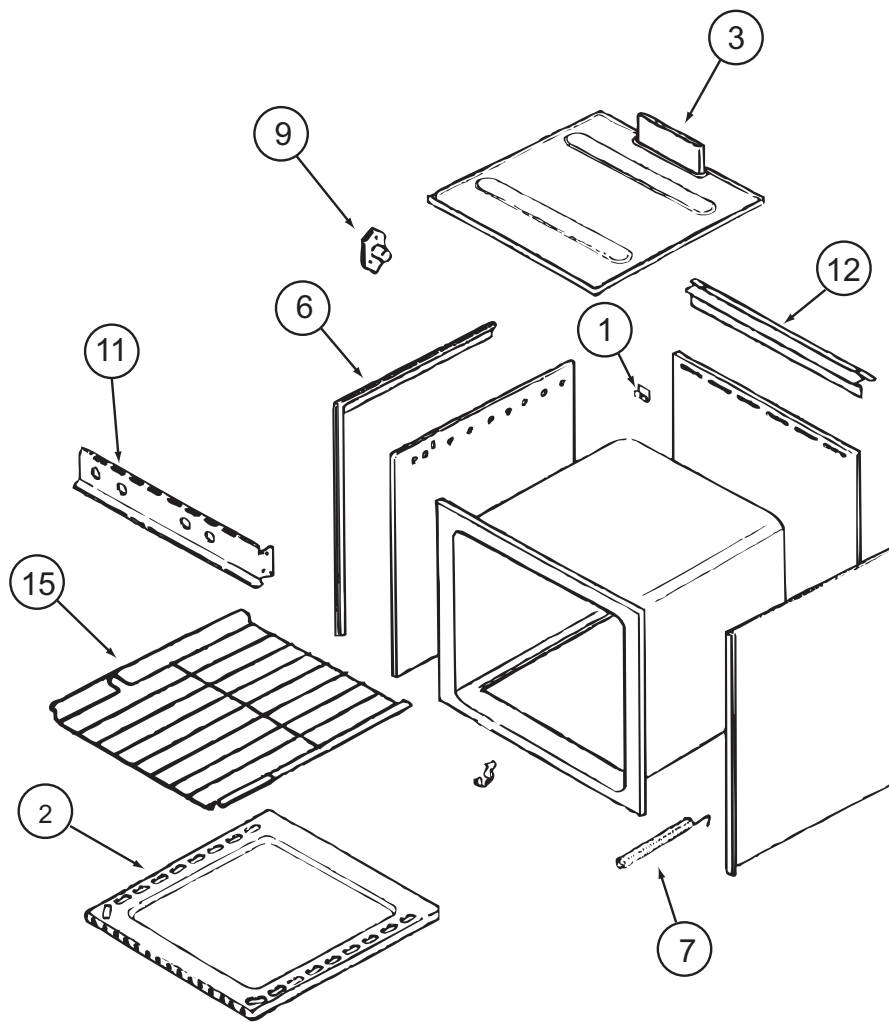

151277-01-01A (CONTINUED)

KEY	PART NUMBER	U/M	DESCRIPTION	VENDOR NO.
1	112881-03-702	EA	CLIP - MAIN TOP	74003998
2	126023-01-731	EA	BOTTOM - OVEN	2205F016-19
3	126023-01-718	EA	FLUE BOX ASSEMBLY	4006W075-80
6	126023-01-713	EA	TRIM - SIDE (RIGHT) BLACK	74002827
6	126023-01-714	EA	TRIM - SIDE (LEFT) BLACK	74002828
7	135066-03-700	EA	SPRING - OVEN DOOR	74001835
9	128728-01-703	EA	PIN/T-NUT F/HINGE	7103P109-60
11	112881-04-707	EA	MANIFOLD - BLACK	74007296
12	112881-01-721	EA	DEFLECTOR/FLUE-BLK-SEALED BR	74002829
15	126023-01-716	EA	RACK - OVEN	74003106

CONTACT WINNEBAGO PART SALES FOR UNLISTED COMPONENT(S)

CABINET & APPLIANCE GROUP (CONTINUED)
COMPONENT PARTS FOR CABINET & APPLIANCE LAYOUT (CONTINUED)

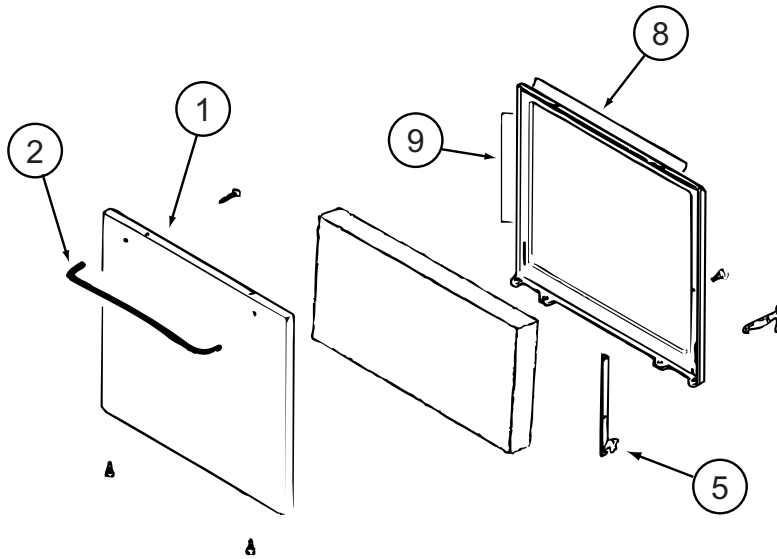

151277-01-01A (CONTINUED)

KEY	PART NUMBER	U/M	DESCRIPTION	VENDOR NO.
1	102022-01-704	EA	GLASS-OUTER	7902P261-60
1	112881-01-713	EA	DOOR/OVEN-TEXT/BLK NO WINDOW	2401F126-70
2	128727-01-701	EA	HANDLE - OVEN DOOR	74003929
5	151277-01-704	EA	HINGE KIT-OVEN DR/LT	12400028
5	151277-01-705	EA	HINGE KIT-OVEN DR/RT	12400029
8	126023-01-732	EA	SEAL/OVEN DR TOP	7212P014-60
9	135066-03-714	EA	SEAL - OVEN DOOR SIDES	7212P039-60

CONTACT WINNEBAGO PART SALES FOR UNLISTED COMPONENT(S)

CABINET & APPLIANCE GROUP (CONTINUED)
COMPONENT PARTS FOR CABINET & APPLIANCE LAYOUT (CONTINUED)

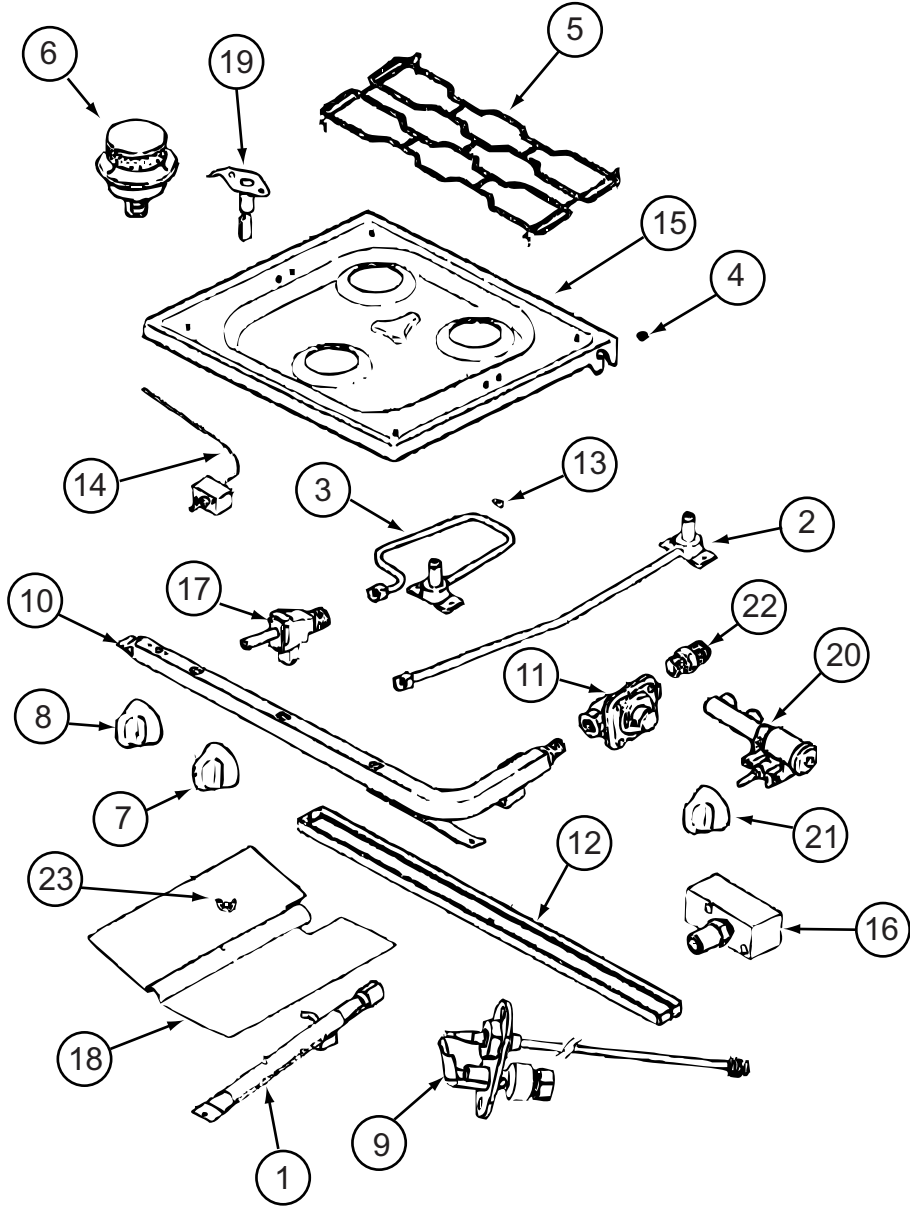

151277-03-01A, 151279-01-01A, 151279-02-01A/02A, 151279-03-01A

CABINET & APPLIANCE GROUP (CONTINUED)
COMPONENT PARTS FOR CABINET & APPLIANCE LAYOUT (CONTINUED)

151277-03-01A, 151279-01-01A, 151279-02-01A/02A, 151279-03-01A (CONTINUED)

KEY	PART NUMBER	U/M DESCRIPTION	VENDOR NO.
1	151279-02-700	EA BURNER - OVEN - W/SHUTTER	74009853
2	128728-01-708	EA FITTING W/ORFICE/TUBE - REAR	74003931
3	128728-01-710	EA FITTING W/ORFICE/TUBE - FRT	74003930
4	102020-01-709	EA BUMPER-GRATE	8007P020-60
5	135065-03-703	EA GRATE - BLACK(SEALED BURNER)	74007304
6	135065-03-702	EA SEALED BURNER ASM.(BLACK) RV	74003967
7	128728-01-701	EA KNOB - BURNER - REAR	74003941 (1 PER)
7	128728-01-702	EA KNOB - BURNER - FRONT	74003942 (2 PER)
8	151279-02-701	EA KNOB - THERMOSTAT - BLACK	74009858
9	112881-04-706	EA PILOT-OVEN (151279-01-01A ONLY)	74006334
9	151279-01-700	EA PILOT-BURNER- 16" (151279-01-01A ONLY)	74009852
9	151279-02-705	EA PILOT - OVEN - 22" SERIES	74010544
10	151279-02-702	EA PIPE - MANIFOLD	74009856
11	126023-02-703	EA REGULATOR - PRESSURE	74004235
11	112881-03-701	EA REGULATOR KIT W/FITTINGS	12001285
13	102020-01-724	EA BUMPER-MAIN TOP	8003P008-60
14	151279-02-703	EA THERMOSTAT	74009855
15	128728-01-705	EA TOP - MAIN - BLACK	74003928
15	135065-03-715	EA TOP - MAIN - STAINLESS STEEL	74007299
16	151279-02-704	EA ELBOW BLOCK ASM (VALVE-OVEN)	74009864
17	135065-01-703	EA VALVE/BURNER - REAR	74004643
17	135065-01-704	EA VALVE/BURNER-FRT-HI	74004644
18	135656-01-701	EA MIXER/AIR	3411F003-34
19	135065-01-701	EA IGNITOR/PORCELAIN-TOP BURNER	74004053
20	128728-01-716	EA IGNITOR - F/BURNERS	74003946
20	128728-01-717	EA WIRES - IGNITOR	74003947
21	128728-01-707	EA KNOB - IGNITOR	74003944
22	135065-03-700	EA FITTING - HALF UNION	74004234

CONTACT WINNEBAGO PART SALES FOR UNLISTED COMPONENT(S)

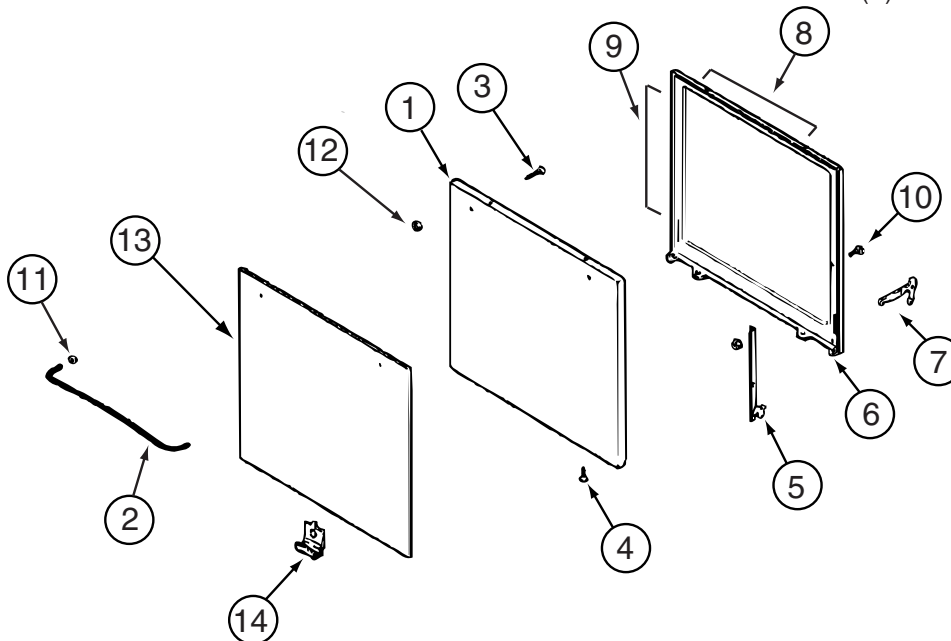

150778-01-01A, 151277-03-01A, 151279-02-01A, 151279-03-01A (CONTINUED)

KEY	PART NUMBER	U/M DESCRIPTION	VENDOR NO.
1	126023-01-712	EA PANEL - DOOR (BLACK)	74001190
2	128727-01-701	EA HANDLE - OVEN DOOR	74003929
5	151277-01-704	EA HINGE KIT-OVEN DR/LT	12400028
5	151277-01-705	EA HINGE KIT-OVEN DR/RT	12400029
8	126023-01-732	EA SEAL/OVEN DR TOP	7212P014-60
9	135066-03-714	EA SEAL - OVEN DOOR SIDES	7212P039-60
13	102020-01-725	EA GLASS OUTER	7902P266-60
14	126023-01-738	EA CLIP - GLASS OVEN/BLACK	7112P093-60

CONTACT WINNEBAGO PART SALES FOR UNLISTED COMPONENT(S)

CABINET & APPLIANCE GROUP (CONTINUED)
COMPONENT PARTS FOR CABINET & APPLIANCE LAYOUT (CONTINUED)

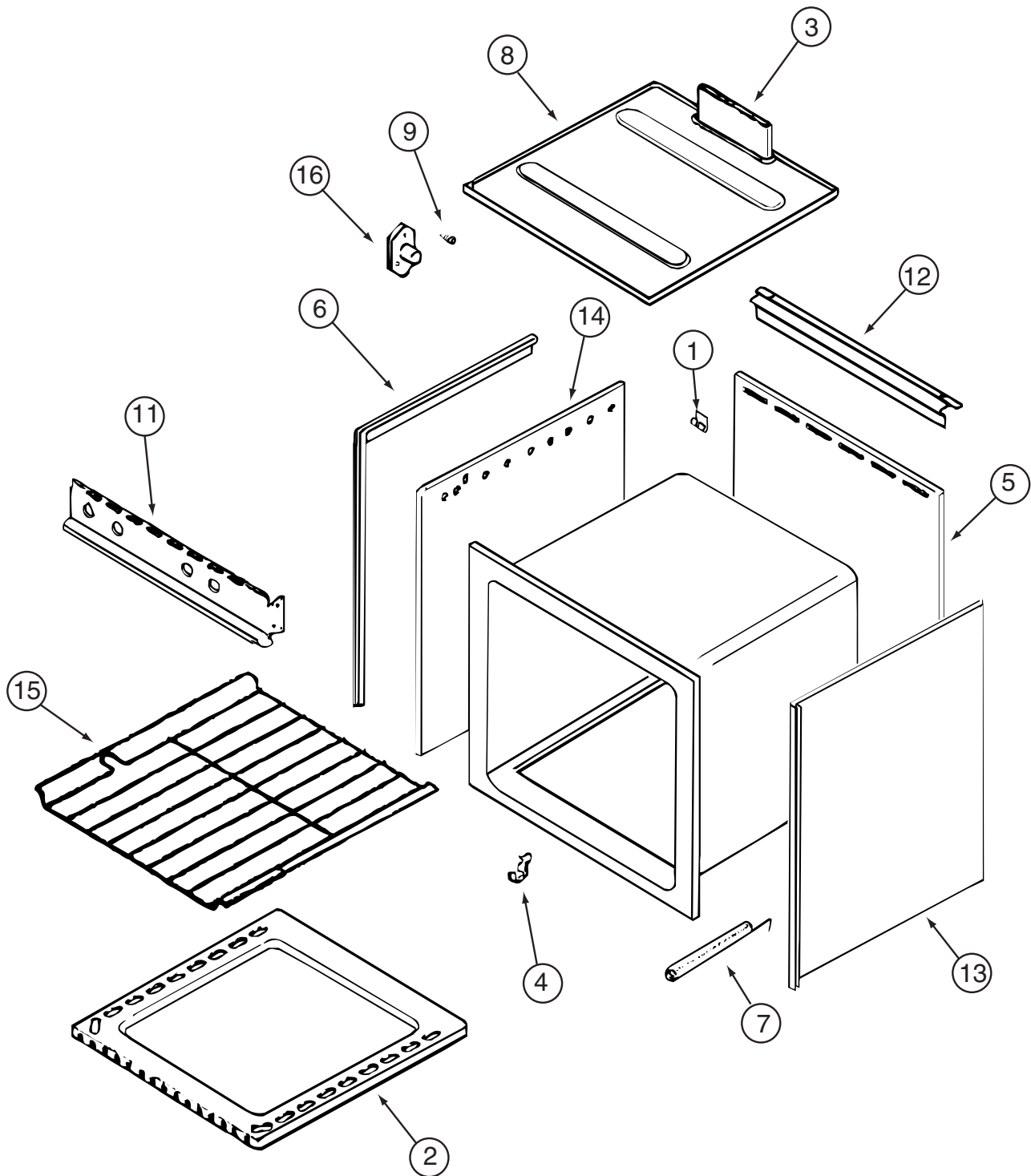

135066-03-01A/04A, 150778-01-01A, 151277-03-01A, 151279-02-01A/02A, 151279-03-01A (CONTINUED)

KEY	PART NUMBER	U/M	DESCRIPTION	VENDOR NO.
1	112881-03-702	EA	CLIP - MAIN TOP	74003998
2	126023-01-731	EA	BOTTOM - OVEN	2205F016-19
3	126023-01-718	EA	FLUE BOX ASSEMBLY	4006W075-80
6	126023-01-713	EA	TRIM - SIDE (RIGHT)	74002827
6	126023-01-714	EA	TRIM - SIDE (LEFT)	74002828
7	135066-03-708	EA	SPRING - OVEN DOOR	7803P053-60
9	128728-01-703	EA	PIN/T-NUT F/HINGE	7103P109-60
11	135066-03-701	EA	PANEL - MANIFOLD - BLACK	74007306
12	112881-01-721	EA	DEFLECTOR/FLUE-BLK-SEALED BR	74002829
15	126023-01-716	EA	RACK - OVEN	74003106

CONTACT WINNEBAGO PART SALES FOR UNLISTED COMPONENT(S)

CABINET & APPLIANCE GROUP (CONTINUED)
COMPONENT PARTS FOR CABINET & APPLIANCE LAYOUT (CONTINUED)

158686-01-01A

KEY	PART NUMBER	U/M	DESCRIPTION	VENDOR NO.
	158686-01-700	EA	PLATE-GLASS	SR11092PLATE
	158686-01-701	EA	TRIM KIT - 2 PC.	ODY-2-92KIT

CHASSIS GROUP FRAME

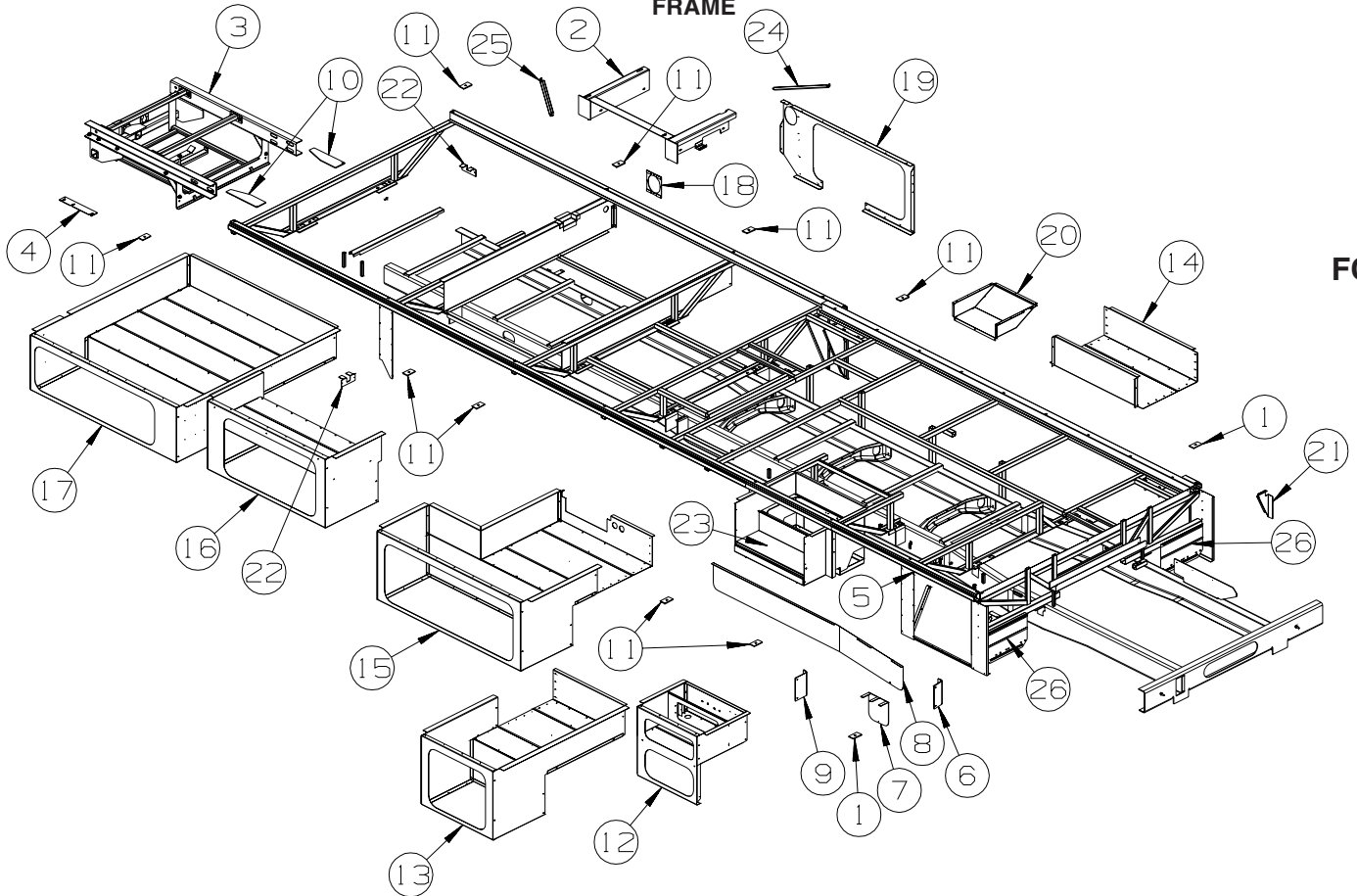

FORD

KEY	PART NUMBER	U/M	DESCRIPTION
1	135712-02-02B	EA	PLATE - BODY MOUNT - E-COATED
2	138113-05-02B	EA	OUTRIGGER/GENERATOR - E-COATED
3	154052-14-01A	EA	CLIP/REAR EXTENSION RAIL - W/HITCH/TIRE CARRIER
4	136538-01-02B	EA	SHIM - HITCH - E-COATED
5	113452-01-000	FT	SEAL/TRIM - FRONT - VINYL W/WIRE CARRIER - .020"
6	139189-01-02B	EA	BRACKET - LP SUPPORT - E-COATED
7	134325-04-02B	EA	SHIELD - HEAT/EXHAUST - E-COATED
8	134325-01-02B	EA	SHIELD - HEAT/EXHAUST - E-COATED
9	139188-01-02B	EA	BRACKET - LP SUPPORT
10	133095-01-02B	EA	PLATE - CLIP - E-COATED
11	135712-01-02B	EA	PLATE - BODY MOUNT - E-COATED
12	137815-05-02B	EA	COMPARTMENT - RIGHT/FRONT - E-COATED
13	137814-08-02B	EA	COMPARTMENT - RIGHT - E-COATED
14	137814-09-02B	EA	COMPARTMENT - RIGHT - E-COATED
15	138726-09-02B	EA	COMPARTMENT - MIDDLE - E-COATED
16	138044-02-02B	EA	COMPARTMENT - DRAINAGE - RIGHT HAND - E-COATED
17	153020-10-02B	EA	COMPARTMENT - REAR - E-COATED
18	154223-01-02B	EA	SPACER/PLATE - FUEL FILL - E-COATED
19	142221-02-02B	EA	PLATE/SEAL - E-COATED
20	138056-05-02B	EA	PANEL - FURNACE COMPARTMENT - E-COATED
21	123440-14-02B	EA	SUPPORT - PANEL - 9.9"/7.6" X 4.8" - E-COATED
22	145642-01-02B	EA	COVER-COMPARTMENT
23	132607-08-02B	EA	BOX/ENTRANCE STEP - E-COATED
23	162351-01-02B	EA	BOX - ENTRY STEP - E-COATED
24	138075-09-02B	EA	ANGLE/SUPPORT - SEAL PLANE - E-COATED
25	138075-03-02B	EA	ANGLE/SUPPORT - SEAL PLANE - E-COATED
26	136391-01-02B	EA	GUARD/ROCK - STEEL - W/ANGLE - 18"W X 11"H - E-COATED

FROM: 00-00-00 THRU: 11-26-06

FROM: 11-27-06 THRU: 99-99-99

CHASSIS GROUP (CONTINUED) FRAME (CONTINUED)

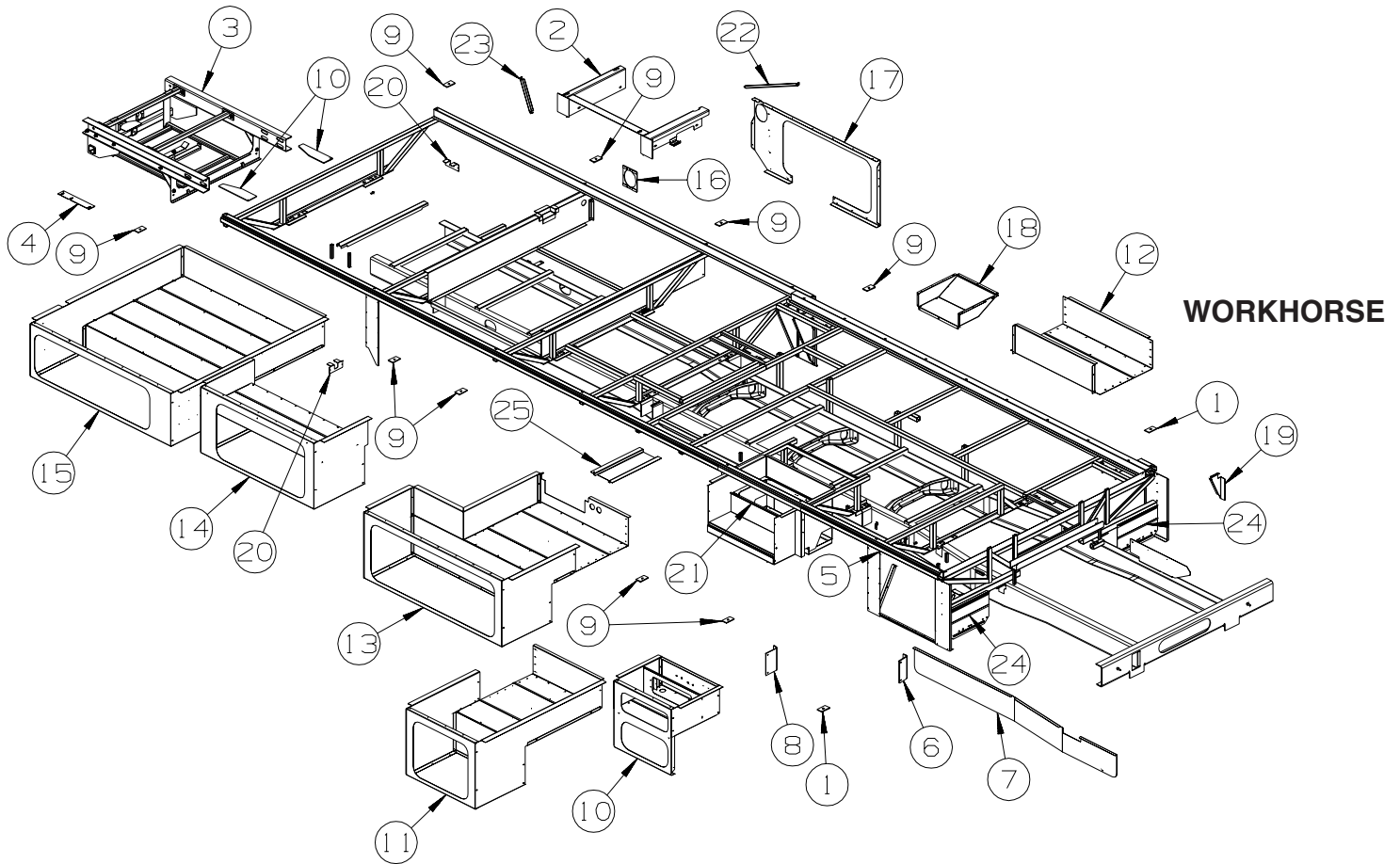

KEY	PART NUMBER	U/M	DESCRIPTION
1	135712-02-02B	EA	PLATE - BODY MOUNT - E-COATED
2	138113-05-02B	EA	OUTRIGGER/GENERATOR - E-COATED
3	154052-14-01A	EA	CLIP/REAR EXTENSION RAIL - W/HITCH/TIRE CARRIER
4	136538-01-02B	EA	SHIM - HITCH - E-COATED
5	113452-01-000	FT	SEAL/TRIM - FRONT - VINYL W/WIRE CARRIER - .020"
6	139189-01-02B	EA	BRACKET - LP SUPPORT - E-COATED
7	134325-02-02B	EA	SHIELD - HEAT/EXHAUST - E-COATED
8	139188-02-02B	EA	BRACKET - LP SUPPORT
9	135712-01-02B	EA	PLATE - BODY MOUNT - E-COATED
10	137815-05-02B	EA	COMPARTMENT - RIGHT/FRONT - E-COATED
11	137814-08-02B	EA	COMPARTMENT - RIGHT - E-COATED
12	137814-09-02B	EA	COMPARTMENT - RIGHT - E-COATED
13	138726-09-02B	EA	COMPARTMENT - MIDDLE - E-COATED
14	138044-02-02B	EA	COMPARTMENT - DRAINAGE - RIGHT HAND - E-COATED
15	153020-10-02B	EA	COMPARTMENT - REAR - E-COATED
16	154223-01-02B	EA	SPACER/PLATE - FUEL FILL - E-COATED
17	142221-02-02B	EA	PLATE/SEAL - E-COATED
18	138056-05-02B	EA	PANEL - FURNACE COMPARTMENT - E-COATED
19	123440-14-02B	EA	SUPPORT - PANEL - 9.9"X7.6" X 4.8" - E-COATED
20	145642-01-02B	EA	COVER-COMPARTMENT
21	132607-08-02B	EA	BOX/ENTRANCE STEP - E-COATED
			FROM: 00-00-00 THRU: 11-26-06
21	162351-01-02B	EA	BOX - ENTRY STEP - E-COATED
			FROM: 11-27-06 THRU: 99-99-99
22	138075-09-02B	EA	ANGLE/SUPPORT - SEAL PLANE - E-COATED
23	138075-03-02B	EA	ANGLE/SUPPORT - SEAL PLANE - E-COATED
24	136391-01-02B	EA	GUARD/ROCK - STEEL - W/ANGLE - 18"W X 11"H - E-COATED
25	140963-01-02B	EA	SHIELD - EXHAUST - E-COATED

CHASSIS GROUP (CONTINUED)

FRONT END

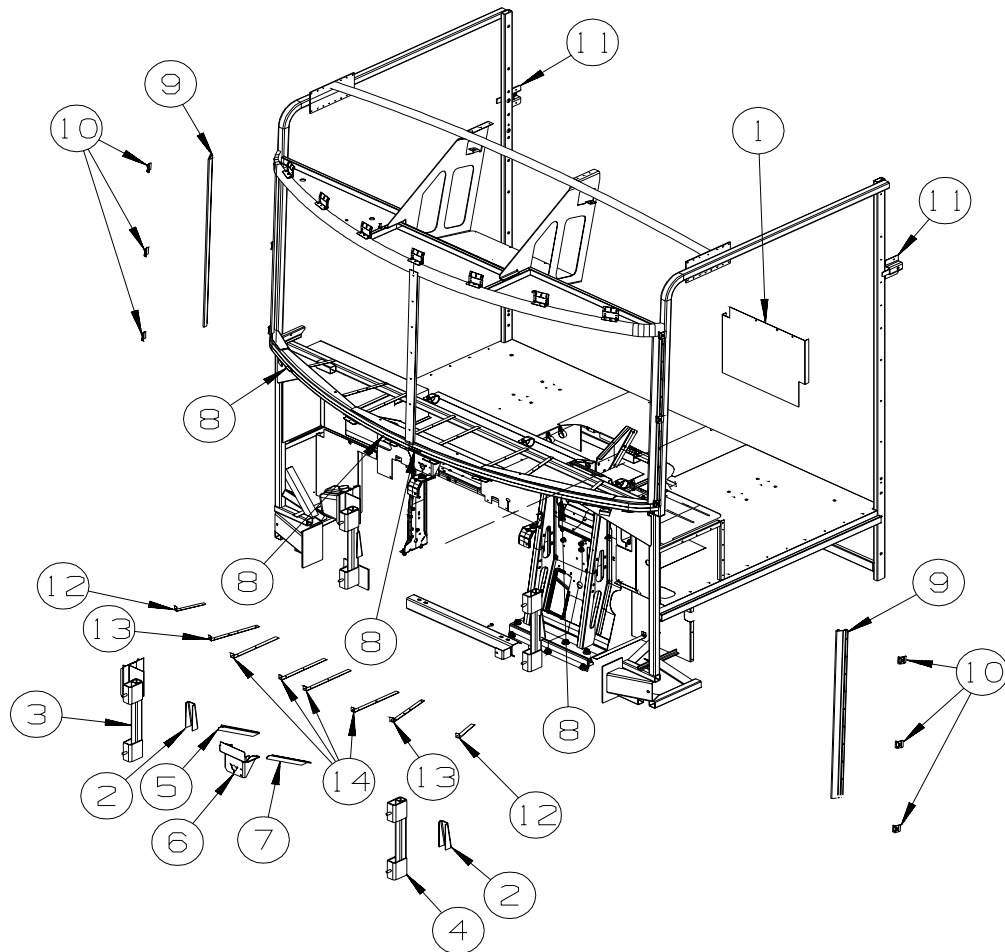

FORD

KEY	PART NUMBER	U/M	DESCRIPTION
1	157869-01-02B	EA	FRONT END - CHASSIS - E-COATED
2	117622-01-02B	EA	BRACE - TUBE/BUMPER - VERTICAL - E-COATED
3	152916-02-02B	EA	SUPPORT - FRONT - E-COATED
4	152916-01-02B	EA	SUPPORT - FRONT - E-COATED
5	134371-02-01B	EA	ANGLE/MOUNT - WIPER MOTOR
6	134506-01-01B	EA	BRACKET - WIPER MOTOR
			FROM: 00-00-00 THRU: 02-22-07
6	134506-05-01B	EA	BRACKET - WIPER MOTOR
			FROM: 02-23-07 THRU: 99-99-99
7	134371-01-01B	EA	ANGLE/MOUNT - WIPER MOTOR
8	126289-65-01B	EA	ANGLE - FORMED
9	137584-01-01B	EA	FRAME/PILLAR - WINDSHIELD
10	148935-01-01B	EA	BRACKET - WINDSHIELD - MILL
11	140387-02-01B	EA	MOUNT - SEATBELT/WALL - E-COATED
12	137047-06-01B	EA	STRAP - DEFROSTER PLENUM
13	137047-05-01B	EA	STRAP - DEFROSTER PLENUM
14	137047-04-01B	EA	STRAP - DEFROSTER PLENUM
15	144679-02-02B	EA	SHIELD/SPLASH - HEADLIGHT - E-COATED

CHASSIS GROUP (CONTINUED) FRONT END (CONTINUED)

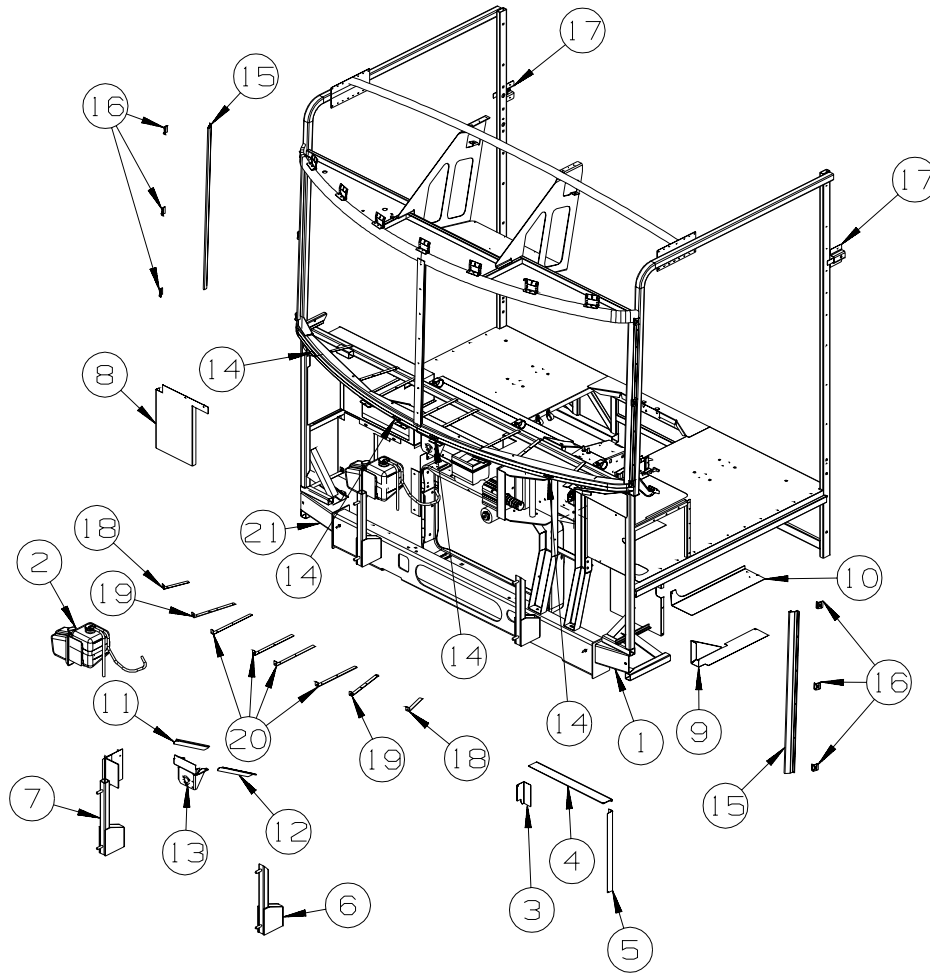

WORKHORSE

KEY	PART NUMBER	U/M	DESCRIPTION
1	137048-02-02B	EA	CHANNEL/SUPPORT - FRONT END - E-COATED
2	117766-02-000	EA	RESERVOIR/PUMP - WINDSHIELD WASHER
			FROM: 00-00-00 THRU: 08-31-06
3	139131-01-02B	EA	ANGLE - W/NOTCH - E-COATED
4	137037-01-02B	EA	ANGLE/FILLER - E-COATED
5	137037-02-02B	EA	ANGLE/FILLER - E-COATED
6	134807-12-02B	EA	SUPPORT - FRONT - E-COATED
7	134807-11-02B	EA	SUPPORT - FRONT - E-COATED
8	121962-02-02B	EA	SHIELD/SPLASH - HEADLIGHT - E-COATED
9	137045-01-02B	EA	PANEL - FILLER - BULKHEAD - E-COATED
10	137041-01-02B	EA	ANGLE/FILLER - MOTOR COVER - E-COATED
11	134371-02-01B	EA	ANGLE/MOUNT - WIPER MOTOR
12	134371-01-01B	EA	ANGLE/MOUNT - WIPER MOTOR
13	134506-01-01B	EA	BRACKET - WIPER MOTOR
			FROM: 00-00-00 THRU: 02-22-07
13	134506-05-01B	EA	BRACKET - WIPER MOTOR
			FROM: 02-23-07 THRU: 99-99-99
14	126289-65-01B	EA	ANGLE - FORMED
15	137584-01-01B	EA	FRAME/PILLAR - WINDSHIELD
16	148935-01-01B	EA	BRACKET - WINDSHIELD - MILL
17	140387-02-01B	EA	MOUNT - SEATBELT/WALL - E-COATED
18	137047-06-01B	EA	STRAP - DEFROSTER PLENUM
19	137047-05-01B	EA	STRAP - DEFROSTER PLENUM
20	137047-04-01B	EA	STRAP - DEFROSTER PLENUM
21	137048-01-02B	EA	CHANNEL/SUPPORT - FRONT END - E-COATED

CHASSIS GROUP (CONTINUED)

EXHAUST

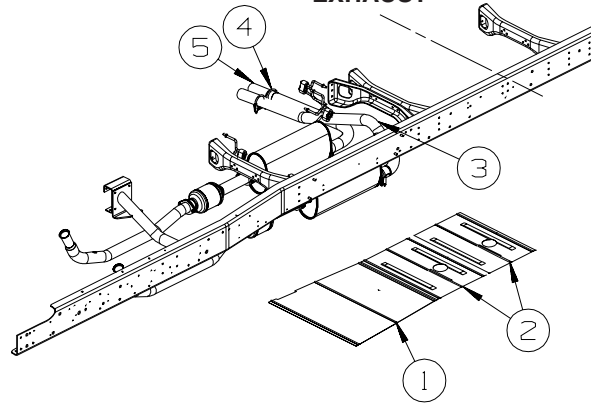

**WORKHORSE
D26P**

158.5" WHEELBASE

KEY	PART NUMBER	U/M	DESCRIPTION
1	128756-01-02B	EA	SHIELD - HEAT/EXHAUST - 33.9" X 16.9" - E-COATED
2	143712-01-02B	EA	SHIELD - HEAT/EXHAUST - E-COATED
3	141412-01-000	EA	PIPE - EXHAUST
4	098762-05-000	EA	EXTENSION - EXHAUST - STRAIGHT - 3" O.D X 7.9" LONG - SST
5	155919-01-02B	EA	HANGER - TAILPIPE - DOUBLE - E-COATED

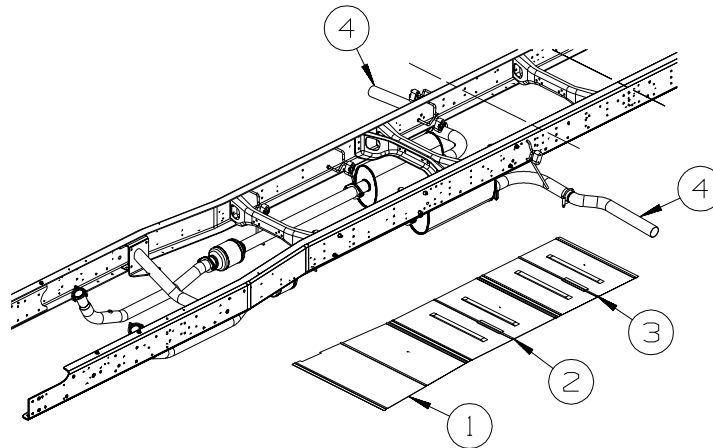

**WORKHORSE
D29R**

KEY	PART NUMBER	U/M	DESCRIPTION
1	128756-01-02B	EA	SHIELD - HEAT/EXHAUST - 33.9" X 16.9" - E-COATED
2	143712-05-02B	EA	SHIELD - HEAT/EXHAUST - E-COATED
3	143712-02-02B	EA	SHIELD - HEAT/EXHAUST - E-COATED
4	129726-02-000	EA	PIPE - EXHAUST

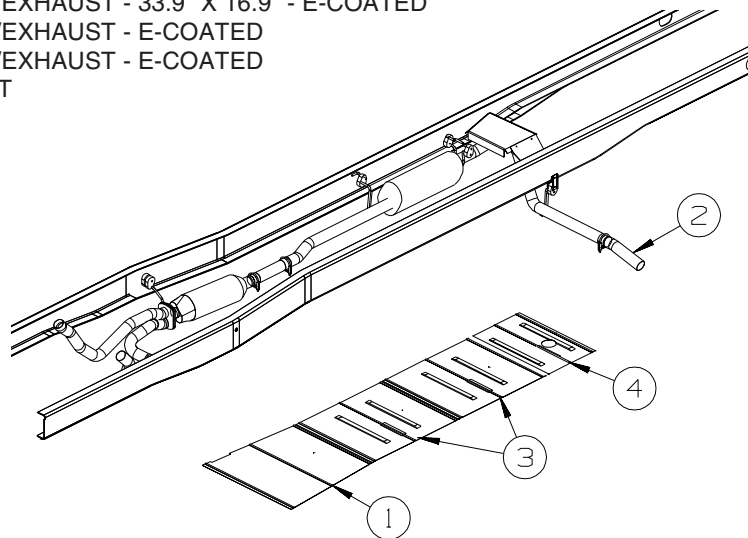

**FORD
D29R**

190" WHEELBASE

KEY	PART NUMBER	U/M	DESCRIPTION
1	128756-01-02B	EA	SHIELD - HEAT/EXHAUST - 33.9" X 16.9" - E-COATED
2	142985-01-000	EA	PIPE - EXHAUST
3	143712-05-02B	EA	SHIELD/HEAT - EXHAUST - E-COATED
4	143712-07-02B	EA	SHIELD/HEAT - EXHAUST - E-COATED

CHASSIS GROUP (CONTINUED)
EXHAUST (CONTINUED)

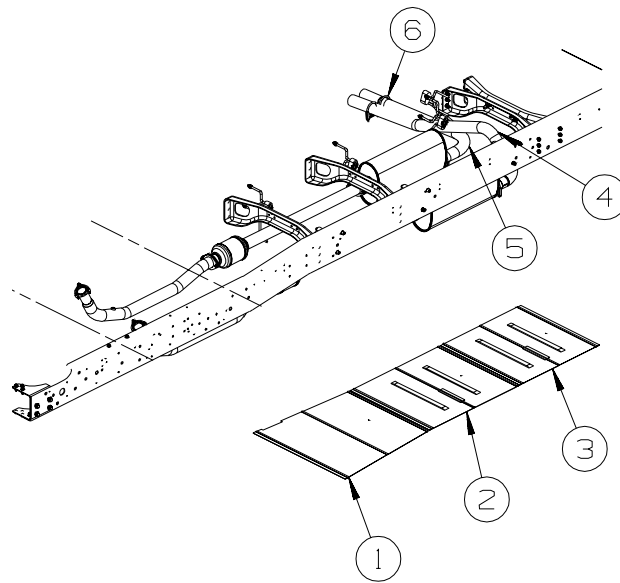

**WORKHORSE
D30B**

190" WHEELBASE

KEY	PART NUMBER	U/M	DESCRIPTION
1	128756-01-02B	EA	SHIELD - HEAT/EXHAUST - 33.9" X 16.9" - E-COATED
2	143712-05-02B	EA	SHIELD - HEAT/EXHAUST - E-COATED
3	143712-02-02B	EA	SHIELD - HEAT/EXHAUST - E-COATED
4	141412-01-000	EA	PIPE - EXHAUST
5	098762-05-000	EA	EXTENSION - EXHAUST - STRAIGHT - 3" O.D X 7.9" LONG - SST
6	155919-01-02B	EA	HANGER - TAILPIPE - DOUBLE - E-COATED

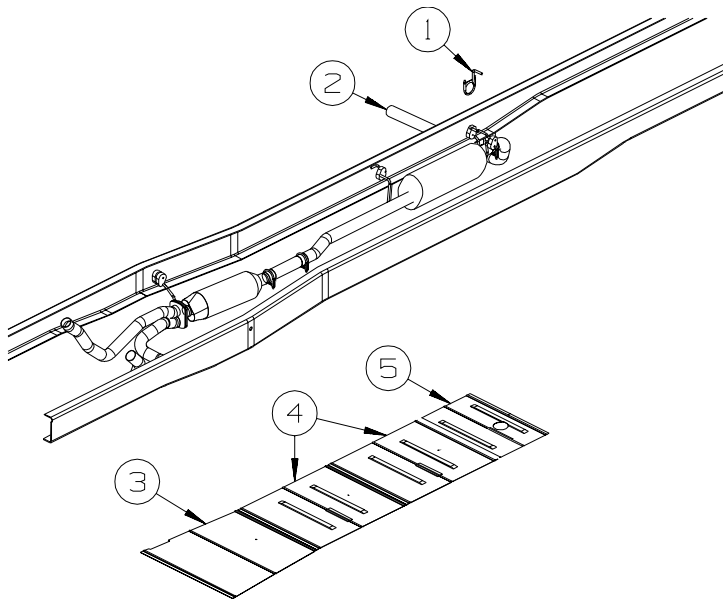

**FORD
D30B**

190" WHEELBASE

KEY	PART NUMBER	U/M	DESCRIPTION
1	122392-16-02B	EA	HANGER - TAILPIPE - E-COATED
	094918-01-000	EA	CLAMP - EXHAUST - 3" - GUILLOTINE STYLE
2	122529-03-000	EA	PIPE - EXHAUST
3	128756-01-02B	EA	SHIELD - HEAT/EXHAUST - 33.9" X 16.9" - E-COATED
4	143712-05-02B	EA	SHIELD/HEAT - EXHAUST - E-COATED
5	143712-07-02B	EA	SHIELD/HEAT - EXHAUST - E-COATED

CHASSIS GROUP (CONTINUED)
EXHAUST (CONTINUED)

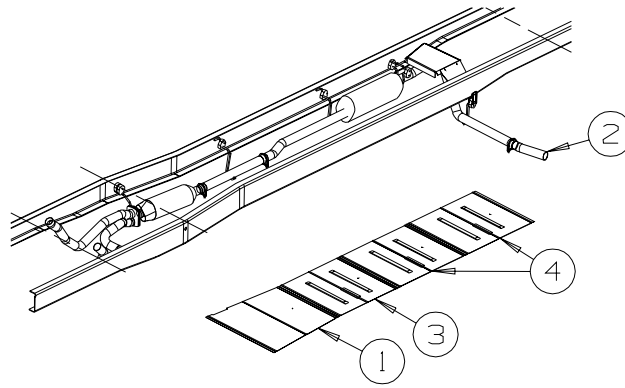

**FORD
D33T**

KEY	PART NUMBER	U/M	DESCRIPTION
1	128756-01-02B	EA	SHIELD - HEAT/EXHAUST - 33.9" X 16.9" - E-COATED
2	142985-01-000	EA	PIPE - EXHAUST
3	143712-02-02B	EA	SHIELD - HEAT/EXHAUST - E-COATED
4	143712-05-02B	EA	SHIELD/HEAT - EXHAUST - E-COATED

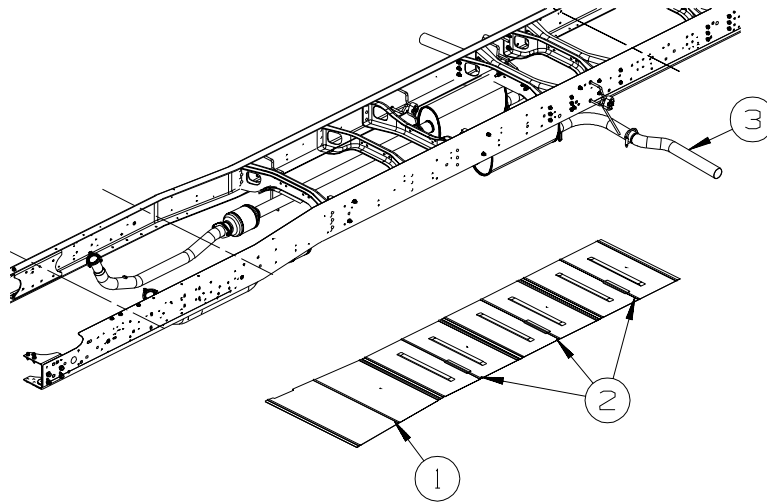

**WORKHORSE
D33T**

KEY	PART NUMBER	U/M	DESCRIPTION
1	128756-01-02B	EA	SHIELD - HEAT/EXHAUST - 33.9" X 16.9" - E-COATED
2	143712-02-02B	EA	SHIELD - HEAT/EXHAUST - E-COATED
3	129726-02-000	EA	PIPE - EXHAUST

208" WHEELBASE

CHASSIS GROUP (CONTINUED)
EXHAUST (CONTINUED)

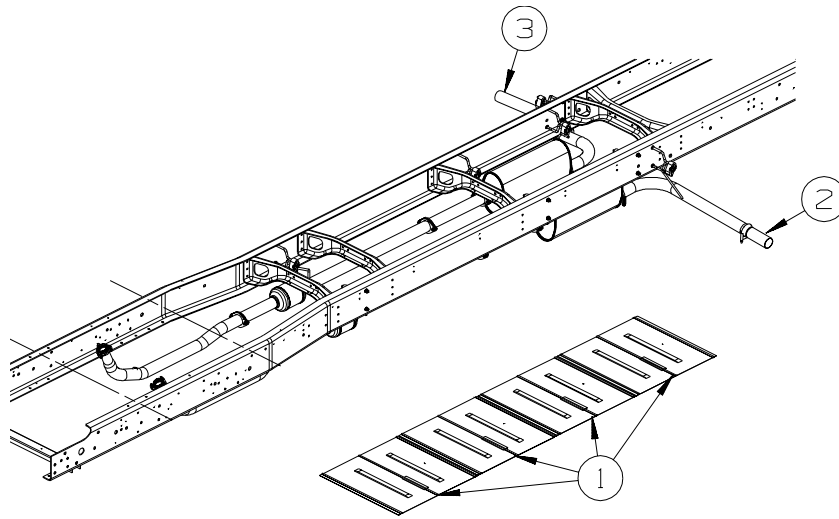

**WORKHORSE
D34A - D35J**

228" WHEELBASE

KEY	PART NUMBER	U/M	DESCRIPTION
1	143712-02-02B	EA	SHIELD - HEAT/EXHAUST - E-COATED
2	098762-05-000	EA	EXTENSION - EXHAUST - STRAIGHT - 3" O.D X 7.9" LONG - SST
	094918-01-000	EA	CLAMP - EXHAUST - 3" - GUILLOTINE STYLE
3	129726-02-000	EA	PIPE - EXHAUST

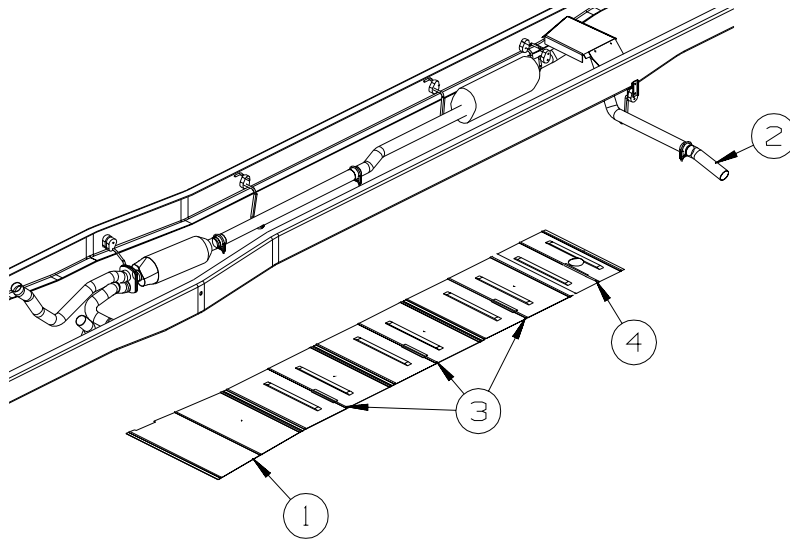

**FORD
D34A - D35J**

228" WHEELBASE

KEY	PART NUMBER	U/M	DESCRIPTION
1	128756-01-02B	EA	SHIELD - HEAT/EXHAUST - 33.9" X 16.9" - E-COATED
2	142985-01-000	EA	PIPE - EXHAUST
3	143712-05-02B	EA	SHIELD/HEAT - EXHAUST - E-COATED
4	143712-07-02B	EA	SHIELD/HEAT - EXHAUST - E-COATED

CHASSIS GROUP (CONTINUED)

FUEL

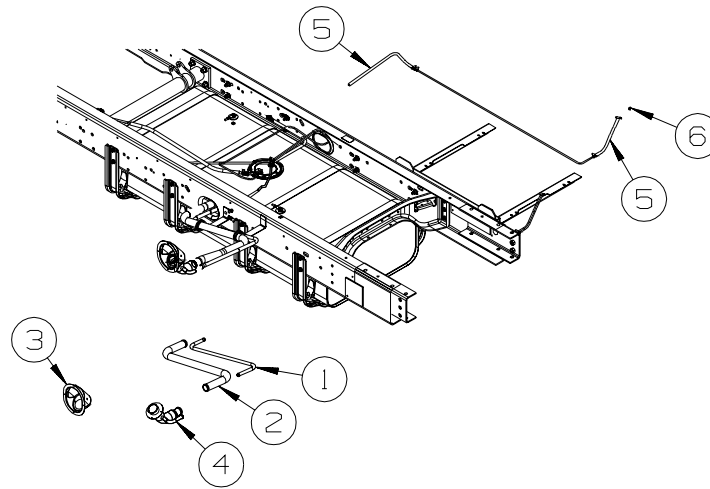

FORD

KEY	PART NUMBER	U/M	DESCRIPTION
1	129320-13-000	EA	PIPE - VENT - FILL - D29R
1	129320-06-000	EA	PIPE - VENT - FILL - D30B, D33T, D34A, D35J
2	129321-14-000	EA	TUBE - FUEL INLET - D29R
2	129321-06-000	EA	TUBE - FUEL INLET - D30B, D33T, D34A, D35J
3	128299-02-01A	EA	SHROUD - FUEL FILL
4	138884-02-000	EA	NECK - FUEL FILL - FORD
5	128139-03-000	FT	HOSE - FUEL - LOW PERMEABILITY - 1/4" DIAMETER
6	084884-01-000	EA	PLUG - BRASS - 3/8"
	068382-06-000	EA	BUSHING - 3/8"MPT X 1/8"FPT - BRASS

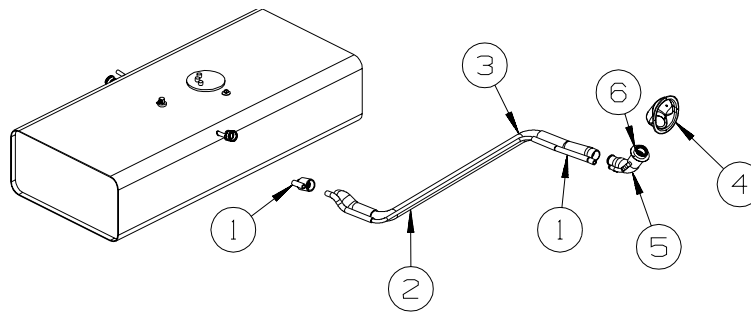

WORKHORSE

KEY	PART NUMBER	U/M	DESCRIPTION
1	128139-03-000	FT	HOSE - FUEL - LOW PERMEABILITY - 1/4" DIAMETER
2	128524-08-000	EA	PIPE - VENT - FUEL FILL - D26P
2	128524-04-000	EA	PIPE - VENT - FUEL FILL - D29R
2	128524-09-000	EA	PIPE - VENT - FUEL FILL - D30B - D33T
2	128524-06-000	EA	PIPE - VENT - FUEL FILL - D34A, D35J
3	124327-13-000	EA	TUBE - FUEL INLET - D26P
3	124327-08-000	EA	TUBE - FUEL INLET - D29R
3	124327-14-000	EA	TUBE - FUEL INLET - D30B - D33T
3	124327-11-000	EA	TUBE - FUEL INLET - D34A, D35J
4	128299-02-01A	EA	SHROUD - FUEL FILL
5	127301-05-000	EA	NECK - FUEL FILL - UNLEADED
6	163743-01-000	EA	CAP - FUEL FILL - 1/4 TURN - WORKHORSE
	010499-01-000	EA	CLAMP - CLOSED - 3/8"ID - D33T - D34A, D35J
	068382-06-000	EA	BUSHING - 3/8"MPT X 1/8"FPT - BRASS

CHASSIS GROUP (CONTINUED)
FUEL (CONTINUED)

WORKHORSE

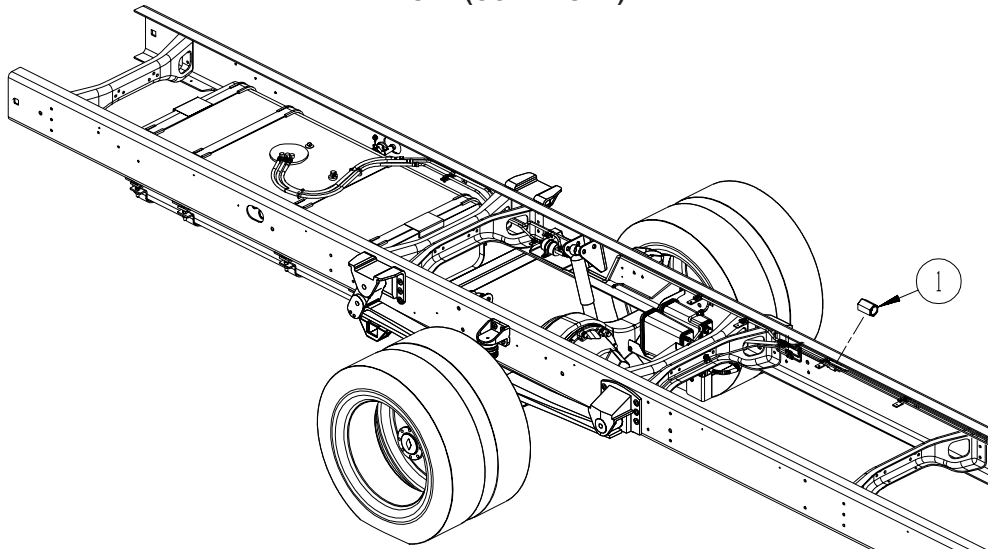

KEY	PART NUMBER	U/M DESCRIPTION
1	098779-02-000	EA COUPLER - FUEL LINE - 1.2" LONG X 16MM THREAD - STRETCHED CHASSIS ONLY

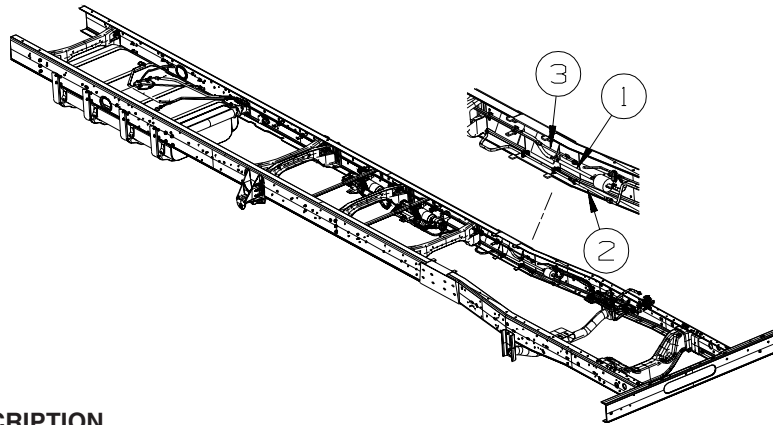

FORD

KEY	PART NUMBER	U/M DESCRIPTION
1	129494-02-000	EA FUEL LINE - 5/16" X 34.9" - FORD CHASSIS
2	155359-01-000	EA EXTENSION - TUBE/VAPOR 1/2" - EMISSION CANISTER
3	155360-01-000	EA EXTENSION - TUBE/VAPOR 5/16" - FUEL TANK VENT

CHASSIS GROUP (CONTINUED)

SPARE TIRE

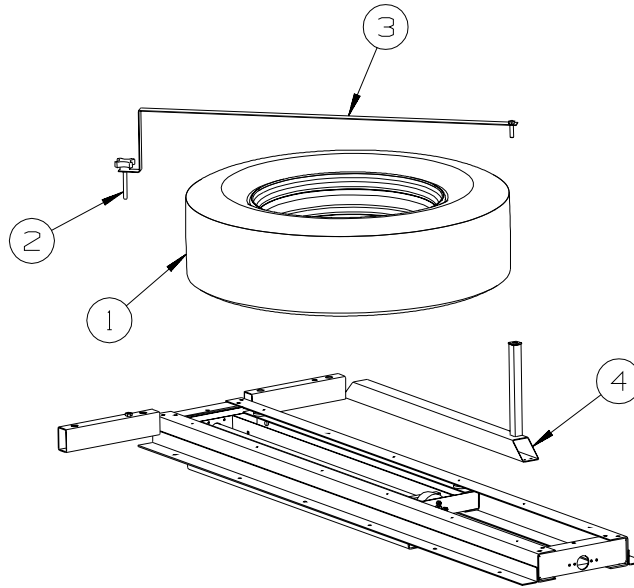

KEY	PART NUMBER	U/M	DESCRIPTION
1	102340-08-000	EA	TIRE - 245/70R X 19.5F - GOODYEAR - FORD
1	091673-07-000	EA	TIRE - 225/70R19.5 LRF - MICHELIN XRV - W16/W18 16000/18000 GVWR WORKHORSE
1	102340-07-000	EA	TIRE - 245/70R X 19.5F - MICHELIN XRV - W20 20700 GVWR WORKHORSE
1	102340-09-000	EA	TIRE - 245/70R X 19.5G - GOODYEAR - W21 21200 GVWR WORKHORSE
1			WHEEL - FORD IS CHASSIS SUPPLIED
1	156482-01-000	EA	WHEEL - STEEL - 19.5" X 6" - 10 BOLT - W16/W18 16000/18000 GVWR WORKHORSE
1	118814-05-000	EA	WHEEL - STEEL - 19.5" X 6.75" - W/STEM - GRAY - W20/W21 20700/21200 GVWR GVWR WORKHORSE
2	134194-01-01A	EA	KNOB - HOLD DOWN/RECLINER - BLACK
3	148969-02-02B	EA	STRAP - SPARE TIRE - E-COATED
4	148982-01-02B	EA	BRACKET - SPARE TIRE - E-COATED
	051377-07-000	EA	VALVE STEM - 1.5" - W16/W18 16000/18000 GVWR WORKHORSE
	051377-01-000	EA	VALVE STEM - W20 20700 GVWR WORKHORSE
	051377-06-000	EA	VALVE STEM - .5" X 2 1/3" W/22 DEGREE BEND - W21 21200 GVWR WORKHORSE

CHASSIS GROUP (CONTINUED) HYDRAULIC LEVELING

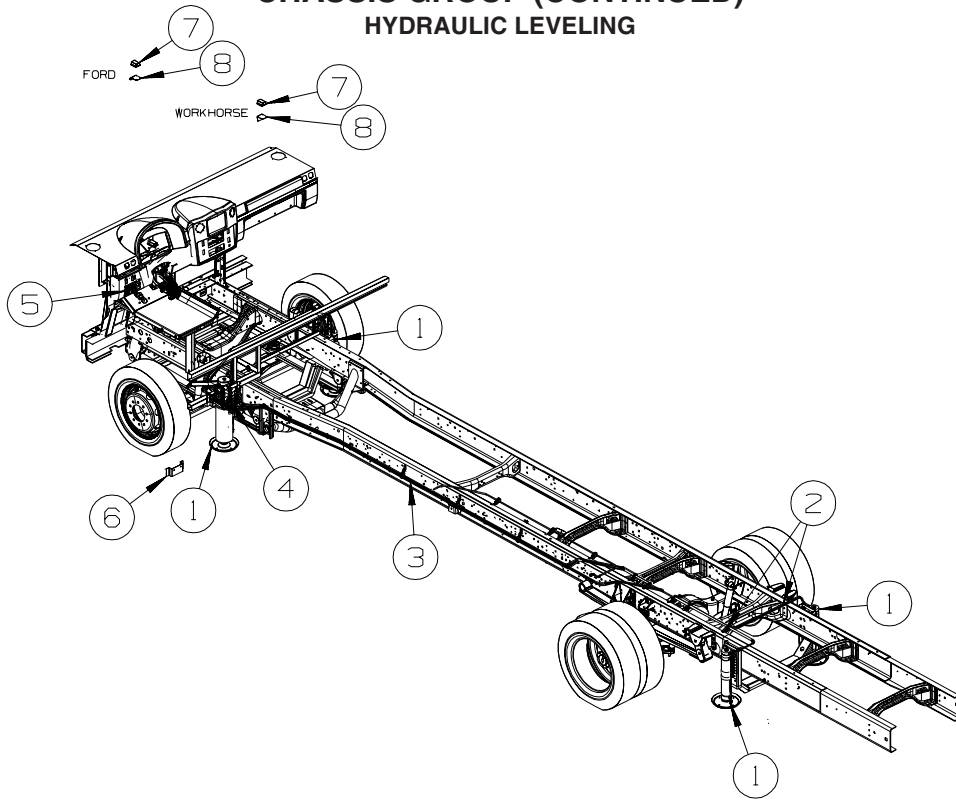

KEY	PART NUMBER	U/M	DESCRIPTION
1*	139641-09-000	EA	LEVELING SYSTEM-W/O PUMP-W/HARNESS/RMT SWITCH CAPABLE - FORD
1*	139641-10-000	EA	LEVELING SYSTEM-W/O PUMP-W/HARNESS/RMT SWITCH CAPABLE - WORKHORSE
2	126624-01-02B	EA	ANGLE - WIRE SUPPORT - E-COAT
3	139644-03-000	EA	HOSE KIT - LEVELING JACKS
4*	156056-02-000	EA	PUMP - F/AUTOMATIC LEVELING SYSTEM
5	139643-08-000	EA	CONTROL-LEVEL - AUTO SYST-W/SENSOR HARNESS/RMT SW CAPABLE
6	154816-01-02B	EA	BRACKET - PUMP/LEVELING - E-COATED
7	156057-01-000	EA	SENSOR - F/AUTOMATIC LEVELING SYSTEM
8	153870-01-02B	EA	BRACKET - SENSOR/LEVEL - E-COATED
8	153870-02-02B	EA	BRACKET - SENSOR/LEVEL - E-COATED - FORD

*COMPONENT PARTS LISTED LATER IN THIS GROUP

CHASSIS GROUP (CONTINUED)
COMPONENT PARTS FOR HYDRAULIC LEVELING

139641-09-000

KEY	PART NUMBER	U/M	DESCRIPTION	VENDOR NO.
	139641-01-701	EA	HARNESSE -AIR PUMP/WARN LIGHT	1809891
	139641-01-704	EA	SWITCH/SENSOR-JACK (UP/DOWN)	1812992
	139641-01-705	EA	FITTING HYD (1/4"X90 DEGREE)	1904500
	139641-01-706	EA	FITTING HYD (1/4" STRAIGHT)	1904510
	139641-01-709	EA	JACK - REAR 15"/10K	3700701
	139641-01-710	EA	CYLINDER ONLY - 15"/10K	1905200
	139641-01-715	EA	BOLT KIT(CROSS MBR/JK/PUMP)	3717794
	139641-01-720	EA	JACK - FRONT 15"/10K	3700702
	139641-01-723	EA	FOOT PAD - JACK	3700367
	139641-01-724	EA	BOLT/FOOT - 3/4-10 X 1 1/2"	1204645
	139641-01-725	EA	HARNESSE - EMERGENCY RETRACT	1809908
	139641-02-700	EA	HARNESSE F/READ SWITCH (FORD)	1809911
	139641-02-701	EA	BRACKET MTG (F53/W22 REAR)	3717742
	139641-02-703	EA	CROSS MEMBER/REAR (F53/W22)	3717795
	139641-09-700	EA	BRACKET/MOUNTING (F53 FRONT)	3717809
	139641-09-701	EA	BRACKET/FRONT X-MEMBER	3717808

139641-10-000

KEY	PART NUMBER	U/M	DESCRIPTION	VENDOR NO.
	139641-01-701	EA	HARNESSE -AIR PUMP/WARN LIGHT	1809891
	139641-01-704	EA	SWITCH/SENSOR-JACK (UP/DOWN)	1812992
	139641-01-705	EA	FITTING HYD (1/4"X90 DEGREE)	1904500
	139641-01-706	EA	FITTING HYD (1/4" STRAIGHT)	1904510
	139641-01-709	EA	JACK - REAR 15"/10K	3700701
	139641-01-710	EA	CYLINDER ONLY - 15"/10K	1905200
	139641-01-711	EA	BRACKET MTG (WORKHORSE REAR)	3717740
	139641-01-715	EA	BOLT KIT(CROSS MBR/JK/PUMP)	3717794
	139641-01-720	EA	JACK - FRONT 15"/10K	3700702
	139641-01-723	EA	FOOT PAD - JACK	3700367
	139641-01-724	EA	BOLT/FOOT - 3/4-10 X 1 1/2"	1204645
	139641-01-725	EA	HARNESSE - EMERGENCY RETRACT	1809908
	139641-02-700	EA	HARNESSE F/READ SWITCH (FORD)	1809911
	139641-02-701	EA	BRACKET MTG (F53/W22 REAR)	3717742
	139641-02-703	EA	CROSS MEMBER/REAR (F53/W22)	3717795
	139641-03-700	EA	CROSSMEMBER/FRONT (W22)	3717804

156056-02-000

KEY	PART NUMBER	U/M	DESCRIPTION	VENDOR NO.
	156056-02-700	EA	PRESSURE SWITCH - 1500 PSI	1812993

CHASSIS GROUP (CONTINUED)

WHEEL, TIRE, COVERS &/OR LINERS

KEY	PART NUMBER	U/M	DESCRIPTION
*	154672-01-000	EA	LINER - WHEEL - SET/4 - 19.5 - 10 BOLT - FORD
*	145580-06-000	EA	LINER - WHEEL (SET OF 4) - 19.5"/10 BOLT - 16,000 & 18,000 GVWR WORKHORSE
*	145580-03-000	EA	LINER - WHEEL (SET OF 4) - 19.5" - 8 BOLT/4 HAND HOLE - 20,700 GVWR WORKHORSE
	077030-10-000	EA	EXTENSION - VALVE STEM - .50" - METAL
	095012-10-000	EA	EXTENSION/VALVE STEM - LIVE - 8.5"
	095012-07-000	EA	STABILIZER/VALVE EXTENSION - LIVE - 4"

***COMPONENT PARTS LISTED LATER IN THIS GROUP**

COMPONENT PARTS FOR WHEEL, TIRE, COVERS &/OR LINERS

145580-03-000				
KEY	PART NUMBER	U/M	DESCRIPTION	VENDOR NO.
	110435-04-705	EA	DECAL-CTR HUB 2 3/4"	2 3/4 DECAL DIAMOND
	110435-05-700	EA	CAP-CENTER 4.50"D W/O DECAL	V22510-POC
	110435-12-700	EA	LINER - WHEEL - FRONT	V19580-FWC
	110435-12-701	EA	LINER - WHEEL - REAR	V19580-RWC
	145580-01-702	EA	COVER-LUG NUT/JAM NUT 22M	V19582-EJN
	145580-01-703	EA	TOOL-INSTALLATION	V22501-TOL

145580-06-000				
KEY	PART NUMBER	U/M	DESCRIPTION	VENDOR NO.
	110435-04-705	EA	DECAL-CTR HUB 2 3/4"	2 3/4 DECAL DIAMOND
	110435-10-702	EA	JAMB NUT/JAMB NUT COVER COMBINATION	
	110435-10-705	EA	TOOL/JAMB NUT INSTALLATION	V195P7-TOL
	145580-06-700	EA	LINER - WHEEL/FRONT - 1EA=1	V195W18-FWC
	145580-06-701	EA	LINER - WHEEL/REAR - 1EA=1	V195W18-RWC

154672-01-000				
KEY	PART NUMBER	U/M	DESCRIPTION	VENDOR NO.
	154672-01-700	EA	LINER - WHEEL - FRONT	V195F6-FWC
	154672-01-701	EA	LINER - WHEEL - REAR	V195F6-RWC

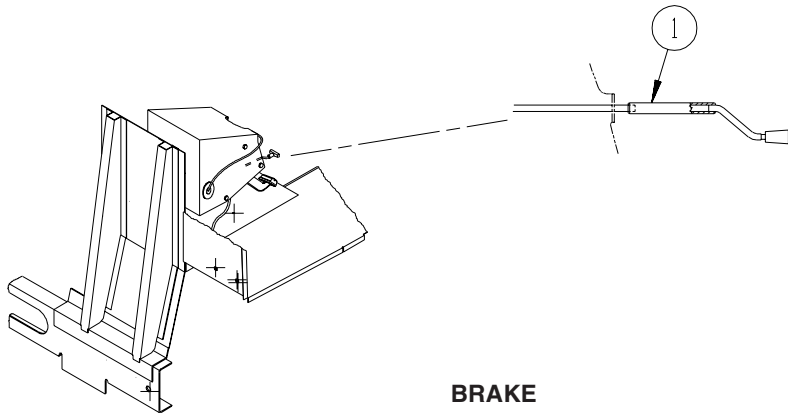

KEY	PART NUMBER	U/M	DESCRIPTION
1	113007-01-000	EA	PIN - SPRING - .375 X 3"

CURTAIN & CUSHION GROUP

NOTICE

IN ORDER TO ASSIST OUR PARTS SALES DEPT. IN PROVIDING INTERIOR SOFTWARE ITEMS, PLEASE INCLUDE THE SERIAL NUMBER AND THE COLOR CODE NUMBER FROM THE VEHICLE CERTIFICATION LABEL WHEN ORDERING. THIS LABEL IS LOCATED ON THE LEFT SIDEWALL AT THE END OF THE DASH (A-BODY), OR ON THE DRIVER'S DOOR LATCH PLATE (C-BODY).

AN EXAMPLE OF A COLOR CODE NUMBER IS B07, WHICH DESIGNATES AN OVERALL COLOR SCHEME OF A PARTICULAR UNIT. THE COLOR LISTED AFTER THE ITEM DESCRIPTION ON THE MICROFICHE, INDICATES THE OVERALL UNIT COLOR. ORDER THE ITEM YOU DESIRE ACCORDING TO UNIT COLOR CODE. IF ALL COLORS USE THE SAME ITEM NO COLOR CODE WILL BE NOTED.

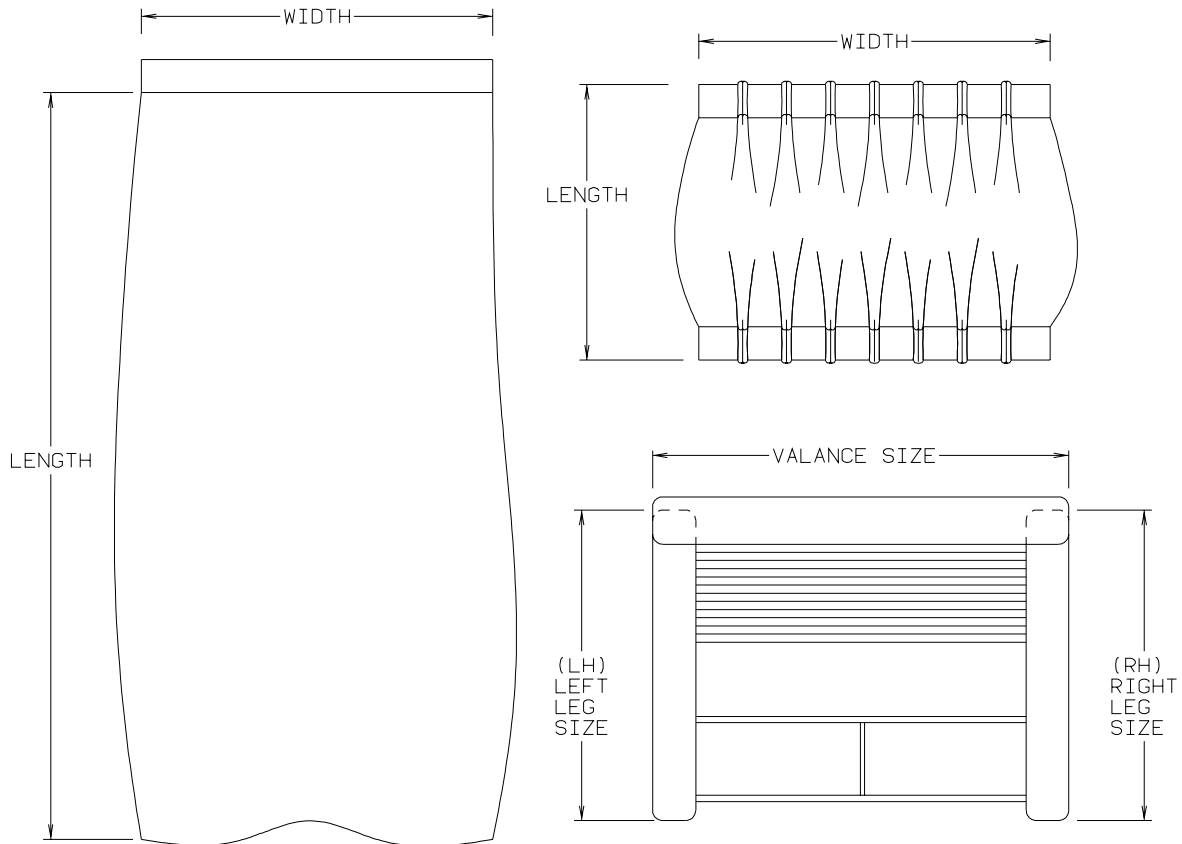

NOTE: USE THIS ILLUSTRATION WHEN DETERMINING LENGTH AND WIDTH MEASUREMENTS FOR CURTAINS. YOU WILL NOTE THE WIDTH MEASUREMENT IS TAKEN ON THE TOP OF THE CURTAIN WITH THE CURTAIN FULLY EXTENDED. THE LENGTH MEASUREMENT IS TAKEN FROM TOP TO BOTTOM. LEFT AND RIGHT WINDOW LEGS ARE DETERMINED WHEN FACING THE WINDOW.

CURTAIN & CUSHION GROUP (CONTINUED)

CUSHION LAYOUT

KEY	PART NUMBER	U/M	DESCRIPTION
1	135473-32-U51	EA	BUCKET SEAT - DRIVER/PASSENGER (U51, U52)
1	135473-31-U53	EA	BUCKET SEAT - DRIVER/PASSENGER (U53, U54)
1	135473-32-U55	EA	BUCKET SEAT - DRIVER/PASSENGER (U55, U56)
1	135473-33-U57	EA	BUCKET SEAT - DRIVER/PASSENGER - LEATHER (U51, U52, U53, U54) - ULTRA LEATHER
1	135473-33-U59	EA	BUCKET SEAT - DRIVER/PASSENGER - LEATHER (U55, U56) - ULTRA LEATHER
2	086120-01-U51	EA	PAD - MAP POCKET - 12" X 16" (U51, U52)
2	086120-01-U57	EA	PAD - MAP POCKET - 12" X 16" (U53, U54)
2	086120-01-U55	EA	PAD - MAP POCKET - 12" X 16" (U55, U56)

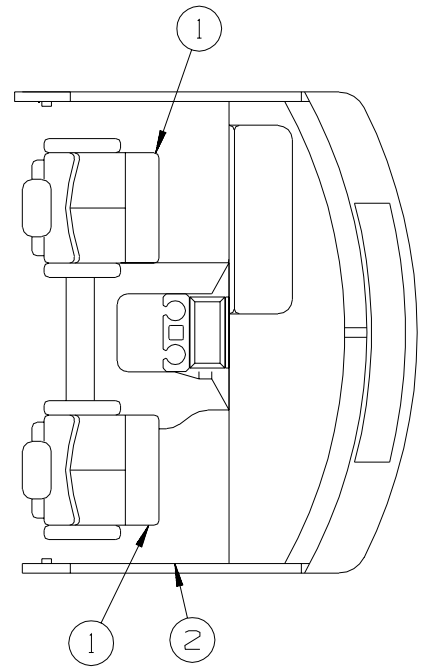

KEY	PART NUMBER	U/M	DESCRIPTION
1	145245-04-U51	EA	PILLOW - 17" W/1/4" WELT (U51, U52)
1	145245-04-U53	EA	PILLOW - 17" W/1/4" WELT (U53, U54)
1	145245-04-U55	EA	PILLOW - 17" W/1/4" WELT (U55, U56)
2	157947-02-U51	EA	CHAIR - GLIDER - W/SWIVEL HOOP (U51, U52)
2	157947-01-U53	EA	CHAIR - GLIDER - W/SWIVEL HOOP (U53, U54)
2	157947-01-U55	EA	CHAIR - GLIDER - W/SWIVEL HOOP (U55, U56)
2	157947-03-U37	EA	CHAIR - GLIDER - W/SWIVEL HOOP (U51, U52, U53, U54) - ULTRA LEATHER
2	157947-03-U55	EA	CHAIR - GLIDER - W/SWIVEL HOOP (U55, U56) - ULTRA LEATHER
3			SEE SOFA AREA FOR FRONT LEFT COUCH
4			SEE SOFA AREA FOR FRONT RIGHT COUCH
5	153519-13-U51	EA	PAD - TOP/LH - F/DINETTE BACK - W/TAB - FABRIC COVERED (U51, U52)
5	153519-08-U53	EA	PAD - TOP/LH - F/DINETTE BACK - W/TAB - FABRIC COVERED (U53, U54)
5	153519-13-U55	EA	PAD - TOP/LH - F/DINETTE BACK - W/TAB - FABRIC COVERED (U55, U56)
6	153519-14-U51	EA	PAD - TOP/RH - F/DINETTE BACK - W/TAB - FABRIC COVERED (U51, U52)
6	153519-07-U53	EA	PAD - TOP/RH - F/DINETTE BACK - W/TAB - FABRIC COVERED (U53, U54)
6	153519-14-U55	EA	PAD - TOP/RH - F/DINETTE BACK - W/TAB - FABRIC COVERED (U55, U56)
7	153671-04-U51	EA	CUSHION - SEAT - 21" X 42" X 5" (U51, U52)
7	153671-04-U57	EA	CUSHION - SEAT - 21" X 42" X 5" (U53, U54)
7	153671-04-U55	EA	CUSHION - SEAT - 21" X 42" X 5" (U55, U56)
	153671-A4-U51	EA	COVER/SEAT - 21" X 42" X 5" (U51, U52)
	153671-A4-U57	EA	COVER/SEAT - 21" X 42" X 5" (U53, U54)
	153671-A4-U55	EA	COVER/SEAT - 21" X 42" X 5" (U55, U56)
8	153672-04-U51	EA	CUSHION - SEAT BACK - 13.5" X 42" X 5" (U51, U52)
8	153672-01-T54	EA	CUSHION - SEAT BACK - 13.5" X 42" X 5" (U53, U54)
8	153672-04-U55	EA	CUSHION - SEAT BACK - 13.5" X 42" X 5" (U55, U56)
	P53672-04-U51	EA	COVER/BACK - 13.5" X 42" X 5" (U51, U52)
	P53672-01-T54	EA	COVER/BACK - 13.5" X 42" X 5" (U53, U54)
	P53672-04-U55	EA	COVER/BACK - 13.5" X 42" X 5" (U55, U56)

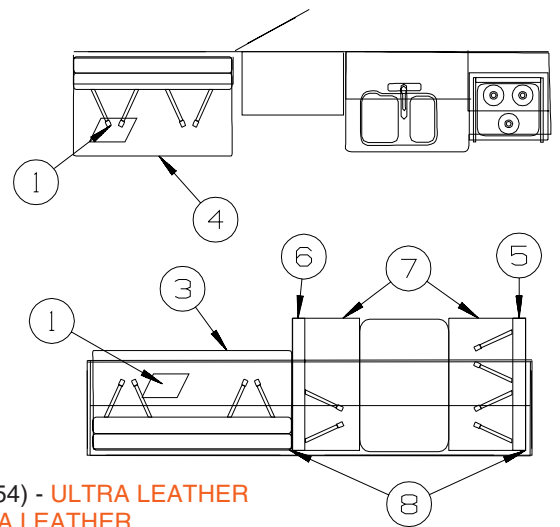

CURTAIN & CUSHION GROUP (CONTINUED)
CUSHION LAYOUT (LAYOUT)

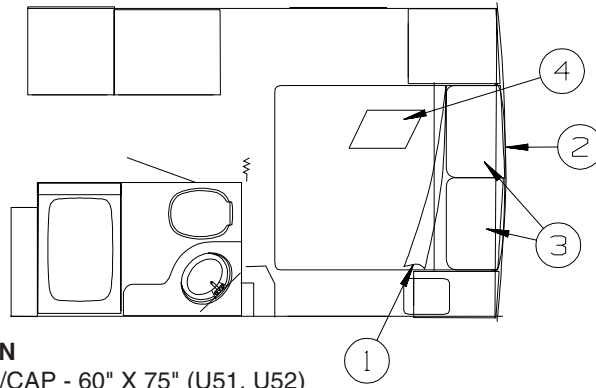

KEY	PART NUMBER	U/M	DESCRIPTION
1	132336-09-U21	EA	BEDSPREAD/CAP - 60" X 75" (U51, U52)
1	132336-09-U23	EA	BEDSPREAD/CAP - 60" X 75" (U53, U54)
1	132336-09-U55	EA	BEDSPREAD/CAP - 60" X 75" (U55, U56)
2	140489-04-U51	EA	HEADBOARD - CAMEO - FABRIC COVERED (U51, U52)
2	140489-04-U53	EA	HEADBOARD - CAMEO - FABRIC COVERED (U53, U54)
2	140489-04-U55	EA	HEADBOARD - CAMEO - FABRIC COVERED (U55, U56)
3	145244-01-U51	EA	PILLOW SHAM - DELMONT - 1/4" WELT (U51, U52)
3	145244-01-U53	EA	PILLOW SHAM - DELMONT - 1/4" WELT (U53, U54)
3	145244-01-U55	EA	PILLOW SHAM - DELMONT - 1/4" WELT (U55, U56)
4	150709-13-U51	EA	PILLOW - 15" X 24" (U51, U52)
4	150709-13-U53	EA	PILLOW - 15" X 24" (U53, U54)
4	150709-13-U55	EA	PILLOW - 15" X 24" (U55, U56)

CURTAIN & CUSHION GROUP (CONTINUED)

BUCKET SEATS

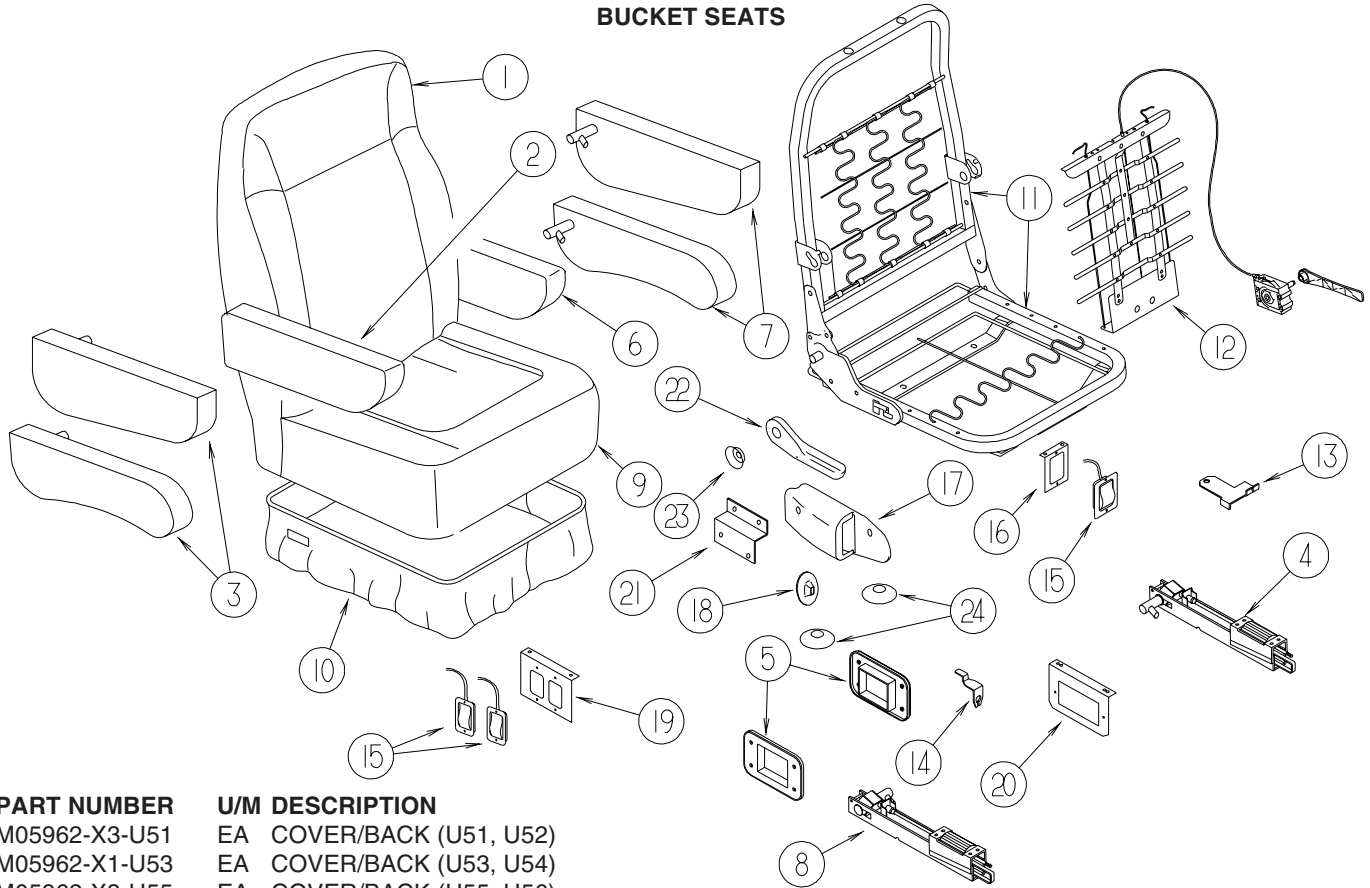

KEY	PART NUMBER	U/M	DESCRIPTION
1	M05962-X3-U51	EA	COVER/BACK (U51, U52)
1	M05962-X1-U53	EA	COVER/BACK (U53, U54)
1	M05962-X3-U55	EA	COVER/BACK (U55, U56)
1	M05962-X5-U57	EA	COVER/BACK (U51, U52, U53, U54) - ULTRA LEATHER
1	M05962-X5-U59	EA	COVER/BACK (U55, U56) - ULTRA LEATHER
2	148652-01-U51	EA	ARMREST - RIGHT (U51, U52)
2	148652-07-T54	EA	ARMREST - RIGHT (U53, U54)
2	148652-01-U55	EA	ARMREST - RIGHT (U55, U56)
2	148652-03-U51	EA	ARMREST - RIGHT (U51, U52, U53, U54) - ULTRA LEATHER
2	148652-03-S55	EA	ARMREST - RIGHT (U55, U56) - ULTRA LEATHER
	P48652-01-U51	EA	COVER/ARMREST - RIGHT (U51, U52)
	P48652-07-T54	EA	COVER/ARMREST - RIGHT (U53, U54)
	P48652-01-U55	EA	COVER/ARMREST - RIGHT (U55, U56)
	P48652-03-U51	EA	COVER/ARMREST - RIGHT (U51, U52, U53, U54) - ULTRA LEATHER
	P48652-03-S55	EA	COVER/ARMREST - RIGHT (U55, U56) - ULTRA LEATHER
3	130698-03-000	EA	ARMREST/MOLDED - RIGHT - W/O COVER
4	NOT USED		
5	NOT USED		
6	148652-02-U51	EA	ARMREST - LEFT (U51, U52)
6	148652-08-T54	EA	ARMREST - LEFT (U53, U54)
6	148652-02-U55	EA	ARMREST - LEFT (U55, U56)
6	148652-04-U51	EA	ARMREST - LEFT (U51, U52, U53, U54) - ULTRA LEATHER
6	148652-04-S55	EA	ARMREST - LEFT (U55, U56) - ULTRA LEATHER
	P48652-02-U51	EA	COVER/ARMREST - LEFT (U51, U52)
	P48652-08-T54	EA	COVER/ARMREST - LEFT (U53, U54)
	P48652-02-U55	EA	COVER/ARMREST - LEFT (U55, U56)
	P48652-04-U51	EA	COVER/ARMREST - LEFT (U51, U52, U53, U54) - ULTRA LEATHER
	P48652-04-S55	EA	COVER/ARMREST - LEFT (U55, U56) - ULTRA LEATHER
7	130698-04-000	EA	ARMREST/MOLDED - LEFT - W/O COVER
8	NOT USED		
9	M05962-X4-U51	EA	COVER/SEAT (U51, U52)
9	M05962-X2-U53	EA	COVER/SEAT (U53, U54)
9	M05962-X4-U55	EA	COVER/SEAT (U55, U56)
9	M05962-X6-U57	EA	COVER/SEAT (U51, U52, U53, U54) - ULTRA LEATHER
9	M05962-X6-U59	EA	COVER/SEAT (U55, U56) - ULTRA LEATHER
10	148630-01-U51	EA	SKIRT - W/SEAT BELT SLOT (U51, U52)
10	148630-14-T54	EA	SKIRT - W/SEAT BELT SLOT (U53, U54)
10	148630-01-U55	EA	SKIRT - W/SEAT BELT SLOT (U55, U56)

CURTAIN & CUSHION GROUP (CONTINUED)
BUCKET SEATS (CONTINUED)

KEY	PART NUMBER	U/M	DESCRIPTION
10	148630-02-S58	EA	SKIRT - W/SEAT BELT SLOT (U51, U52, U53, U54) - ULTRA LEATHER
10	148630-02-S55	EA	SKIRT - W/SEAT BELT SLOT (U55, U56) - ULTRA LEATHER
11	134532-01-000	EA	FRAME - SEAT/HIGH BACK
12	NOT USED		
13	117125-01-02B	EA	BRACKET - CABLE MOUNT - ADJUSTER W/LOCK
14	108049-02-000	EA	CLIP - CABLE/PEDESTAL
15	108049-04-000	EA	CABLE - W/MINI LEVER ACTION SWITCH - 28" SHEATH/30" CABLE
16	NOT USED		
17	NOT USED		
18	NOT USED		
19	127159-02-02B	EA	BRACKET - SEAT RELEASE - DUAL REMOTE - E-COATED
20	NOT USED		
21	NOT USED		
22	130802-02-000	EA	LEVER - RIGHT HAND
	130802-03-000	EA	SCREW F/LEVER
23	148668-01-01A	EA	CUP/WASHER COVER - F/LEVER - BLACK
24	NOT USED		
	152337-01-000	EA	PROTECTOR - SEAT - CLEAR VINYL

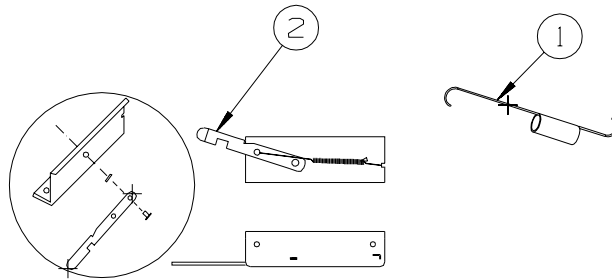

LOUNGE CHAIR

KEY	PART NUMBER	U/M	DESCRIPTION
	157947-A2-U51	EA	COVER/CHAIR - GLIDER (U51, U52)
	157947-A1-U53	EA	COVER/CHAIR - GLIDER (U53, U54)
	157947-A1-U55	EA	COVER/CHAIR - GLIDER (U55, U56)
	157947-A3-U37	EA	COVER/CHAIR - GLIDER - LEATHER (U51, U52, U53, U54) - ULTRALEATHER
	157947-A3-U55	EA	COVER/CHAIR - GLIDER - LEATHER (U55, U56) - ULTRALEATHER
	139208-01-000	EA	SUPPORT BAR - TALL - W/HOOP
1	139342-02-000	EA	SPRING - LOCK OUT
2	139342-03-000	EA	BRACKET - ROCKER LOCK - W/HANDLE
	133126-15-000	EA	BASE - SWIVEL/GLIDER - W/FLOOR RING

CURTAIN & CUSHION GROUP (CONTINUED)

SOFA

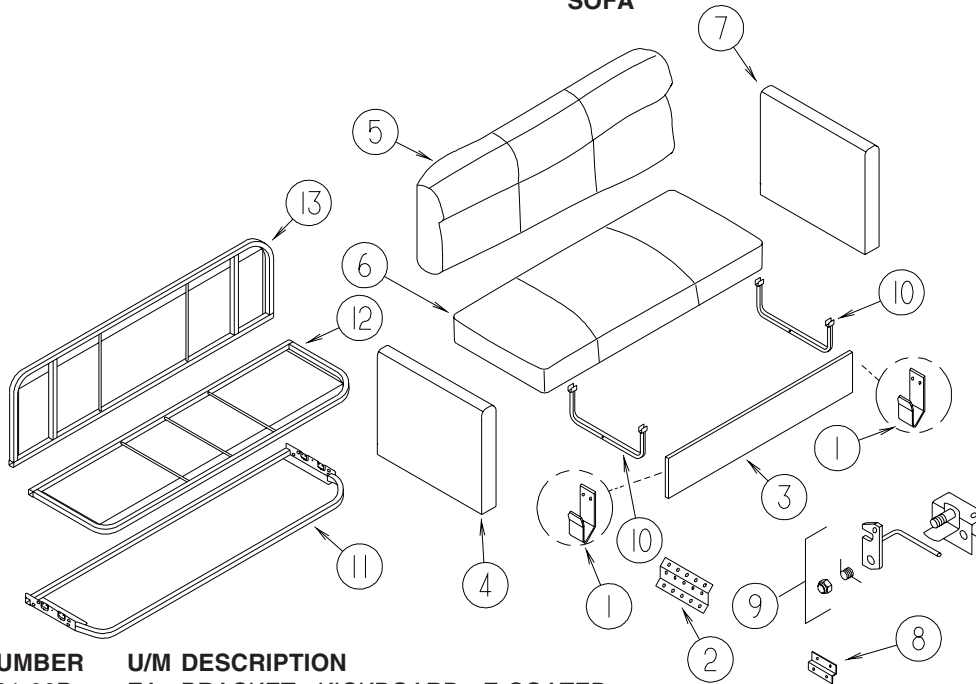

LEFT FRONT COUCH

KEY	PART NUMBER	U/M	DESCRIPTION
1	121906-01-02B	EA	BRACKET - KICKBOARD - E-COATED
2	116104-04-02B	EA	BRACKET - ZEE W/HOLES - 3.2" - E-COATED
3	120992-09-U51	EA	PANEL/FRONT KICK - SOFA/BED - 67.5" - FABRIC COVERED (U51, U52)
3	120992-09-T54	EA	PANEL/FRONT KICK - SOFA/BED - 67.5" - FABRIC COVERED (U53, U54)
3	120992-09-U55	EA	PANEL/FRONT KICK - SOFA/BED - 67.5" - FABRIC COVERED (U55, U56)
3	120992-41-U57	EA	PANEL/FRONT KICK - SOFA/BED - 67.5" (U51, U52, U53, U54) - ULTRA LEATHER/SEAT UPGRADE
3	120992-41-U59	EA	PANEL/FRONT KICK - SOFA/BED - 67.5" (U55, U56) - ULTRA LEATHER/SEAT UPGRADE
4	NOT USED		
5	135138-04-U51	EA	BACK - SOFA/BED - 67.5" (U51, U52)
5	135138-04-T54	EA	BACK - SOFA/BED - 67.5" (U53, U54)
5	135138-04-U55	EA	BACK - SOFA/BED - 67.5" (U55, U56)
5	161040-02-U51	EA	BACK - SOFA/BED - 67.5" (U51, U52, U53, U54) - ULTRA LEATHER SEAT UPGRADE
5	161040-02-U55	EA	BACK - SOFA/BED - 67.5" (U55, U56) - ULTRA LEATHER SEAT UPGRADE
5	135138-33-U51	EA	BACK - SOFA/BED - 67.5" - LEATHER (U51, U52, U53, U54) - ULTRA LEATHER
5	135138-33-U55	EA	BACK - SOFA/BED - 67.5" - LEATHER (U55, U56) - ULTRA LEATHER
	P35138-04-U51	EA	COVER/BACK - SOFA/BED - 67.5" (U51, U52)
	P35138-04-T54	EA	COVER/BACK - SOFA/BED - 67.5" (U53, U54)
	P35138-04-U55	EA	COVER/BACK - SOFA/BED - 67.5" (U55, U56)
	161040-A2-U51	EA	COVER/BACK - SOFA/BED - 67.5" (U51, U52, U53, U54) - ULTRA LEATHER SEAT UPGRADE
	161040-A2-U55	EA	COVER/BACK - SOFA/BED - 67.5" (U55, U56) - ULTRA LEATHER SEAT UPGRADE
	P35138-33-U51	EA	COVER/BACK - SOFA/BED - 67.5" - LEATHER (U51, U52, U53, U54) - ULTRA LEATHER
	P35138-33-U55	EA	COVER/BACK - SOFA/BED - 67.5" - LEATHER (U55, U56) - ULTRA LEATHER
6	135138-19-U51	EA	SEAT - SOFA/BED - 67.5" (U51, U52)
6	135138-19-T54	EA	SEAT - SOFA/BED - 67.5" (U53, U54)
6	135138-19-U55	EA	SEAT - SOFA/BED - 67.5" (U55, U56)
6	135138-34-U51	EA	SEAT - SOFA/BED - 67.5" (U51, U52, U53, U54) - ULTRA LEATHER/SEAT UPGRADE
6	135138-34-U55	EA	SEAT - SOFA/BED - 67.5" (U55, U56) - ULTRA LEATHER/SEAT UPGRADE
	P35138-19-U51	EA	COVER/SEAT - SOFA/BED (U51, U52)
	P35138-19-T54	EA	COVER/SEAT - SOFA/BED (U53, U54)
	P35138-19-U55	EA	COVER/SEAT - SOFA/BED (U55, U56)
	P35138-34-U51	EA	COVER/SEAT - SOFA/BED - 67.5" (U51, U52, U53, U54) - ULTRA LEATHER/SEAT UPGRADE
	P35138-34-U55	EA	COVER/SEAT - SOFA/BED - 67.5" (U55, U56) - ULTRA LEATHER/SEAT UPGRADE
7	155316-01-U51	EA	PANEL/END CAP - SOFA - FABRIC COVERED (U51, U52)
7	155316-01-T54	EA	PANEL/END CAP - SOFA - FABRIC COVERED (U53, U54)
7	155316-01-U55	EA	PANEL/END CAP - SOFA - FABRIC COVERED (U55, U56)
7	155316-03-U51	EA	PANEL/END CAP - SOFA (U51, U52, U53, U54) - ULTRA LEATHER/SEAT UPGRADE
7	155316-03-U55	EA	PANEL/END CAP - SOFA (U55, U56) - ULTRA LEATHER/SEAT UPGRADE
8	116104-04-02B	EA	BRACKET - ZEE W/HOLES - 3.2" - E-COATED
9	NOT USED		
10	127335-07-000	EA	LEG - SOFA/BED - 8"
11	151290-20-000	EA	FRAME - BASE - 27.25" X 67.5"
12	151290-05-000	EA	FRAME - SEAT - 67.5"
13	127335-05-000	EA	FRAME/BASE - (BACK) - 67.5"

CURTAIN & CUSHION GROUP (CONTINUED)
SOFA (CONTINUED)

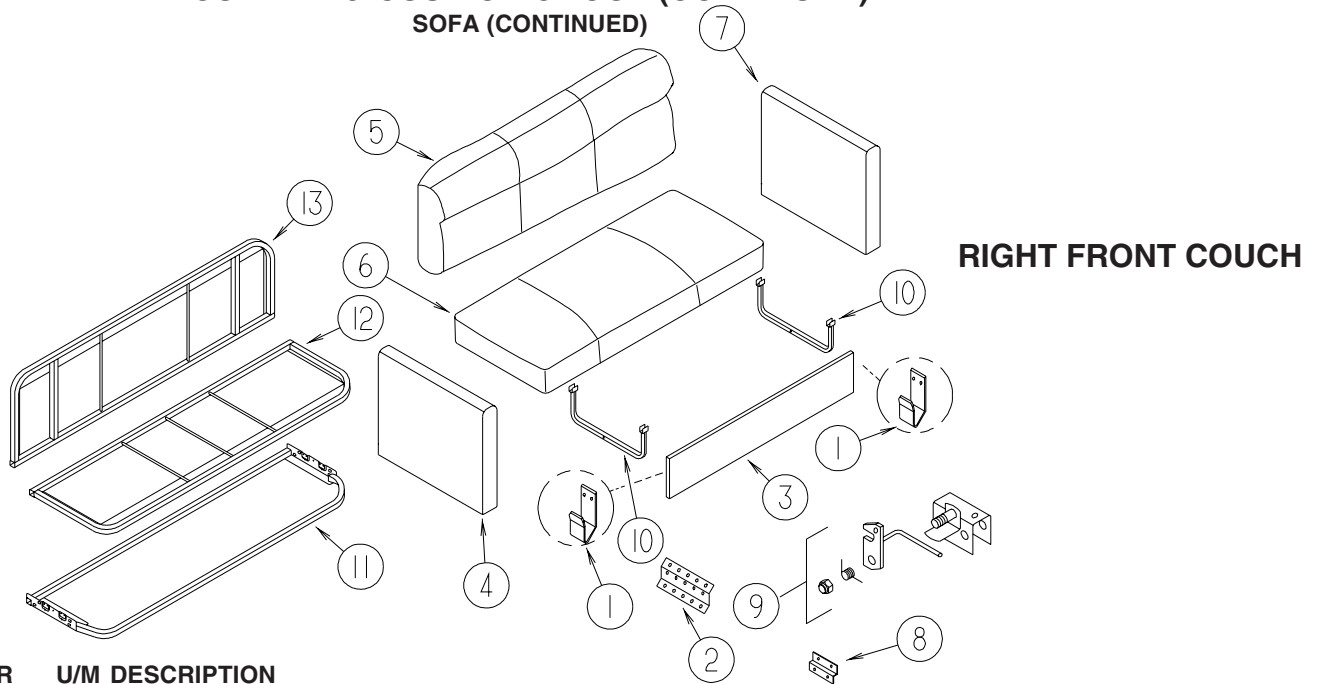

KEY	PART NUMBER	U/M	DESCRIPTION
1	121906-01-02B	EA	BRACKET - KICKBOARD - E-COATED
2	NOT USED		
3	155857-03-U51	EA	PANEL/FRONT KICK - SOFA/BED - 57" - FABRIC COVERED (U51, U52)
3	155857-03-T54	EA	PANEL/FRONT KICK - SOFA/BED - 57" - FABRIC COVERED (U53, U54)
3	155857-03-U55	EA	PANEL/FRONT KICK - SOFA/BED - 57" - FABRIC COVERED (U55, U56)
3	155857-04-U51	EA	PANEL/FRONT KICK - SOFA/BED - FABRIC COVERED - 57" (U51, U52, U53, U54) - ULTRA LEATHER
3	155857-04-U55	EA	PANEL/FRONT KICK - SOFA/BED - FABRIC COVERED - 57" (U55, U56) - ULTRA LEATHER
4	134282-01-U51	EA	PANEL - RIGHT END/SHORT - SOFA/BED - FABRIC COVERED (U51, U52)
4	134282-01-T12	EA	PANEL - RIGHT END/SHORT - SOFA/BED - FABRIC COVERED (U53, U54)
4	134282-01-U55	EA	PANEL - RIGHT END/SHORT - SOFA/BED - FABRIC COVERED (U55, U56)
4	134282-30-U51	EA	PANEL/RIGHT END/SHORT - SOFA/BED - LEATHER (U51, U52, U53, U54) - ULTRA LEATHER
4	134282-30-U55	EA	PANEL/RIGHT END/SHORT - SOFA/BED - LEATHER (U55, U56) - ULTRA LEATHER
5	157039-01-U51	EA	BACK - SOFA/BED - 56" (U51, U52)
5	157039-01-T54	EA	BACK - SOFA/BED - 56" (U53, U54)
5	157039-01-U55	EA	BACK - SOFA/BED - 56" (U55, U56)
5	161040-05-U51	EA	BACK - SOFA/BED - 56" - LEATHER (U51, U52, U53, U54) - ULTRA LEATHER
5	161040-05-U55	EA	BACK - SOFA/BED - 56" - LEATHER (U55, U56) - ULTRA LEATHER
	157039-A1-U51	EA	COVER/BACK - SOFA/BED - 56" (U51, U52)
	157039-A1-T54	EA	COVER/BACK - SOFA/BED - 56" (U53, U54)
	157039-A1-U55	EA	COVER/BACK - SOFA/BED - 56" (U55, U56)
	161040-A5-U51	EA	COVER/BACK - SOFA/BED - 56" - LEATHER (U51, U52, U53, U54) - ULTRA LEATHER
	161040-A5-U55	EA	COVER/BACK - SOFA/BED - 56" - LEATHER (U55, U56) - ULTRA LEATHER
6	157042-01-U51	EA	SEAT - SOFA/BED - 56" (U51, U52)
6	157042-01-T54	EA	SEAT - SOFA/BED - 56" (U53, U54)
6	157042-01-U55	EA	SEAT - SOFA/BED - 56" (U55, U56)
6	157042-02-U51	EA	SEAT - SOFA/BED - 56" - LEATHER (U51, U52, U53, U54) - ULTRA LEATHER
6	157042-02-U55	EA	SEAT - SOFA/BED - 56" - LEATHER (U55, U56) - ULTRA LEATHER
	157042-A1-U51	EA	COVER/SEAT - SOFA/BED - 56" (U51, U52)
	157042-A1-T54	EA	COVER/SEAT - SOFA/BED - 56" (U53, U54)
	157042-A1-U55	EA	COVER/SEAT - SOFA/BED - 56" (U55, U56)
	157042-A2-U51	EA	COVER/SEAT - SOFA/BED - 56" - LEATHER (U51, U52, U53, U54) - ULTRA LEATHER
	157042-A2-U55	EA	COVER/SEAT - SOFA/BED - 56" - LEATHER (U55, U56) - ULTRA LEATHER
7	134282-05-U51	EA	PANEL - LEFT END/TALL - SOFA/BED - FABRIC COVERED (U51, U52)
7	134282-05-T54	EA	PANEL - LEFT END/TALL - SOFA/BED - FABRIC COVERED (U53, U54)
7	134282-05-U55	EA	PANEL - LEFT END/TALL - SOFA/BED - FABRIC COVERED (U55, U56)
7	134282-32-U51	EA	PANEL/LEFT END/TALL - SOFA/BED - LEATHER (U51, U52, U53, U54) - ULTRA LEATHER
7	134282-32-U55	EA	PANEL/LEFT END/TALL - SOFA/BED - LEATHER (U55, U56) - ULTRA LEATHER
8	116104-04-02B	EA	BRACKET - ZEE W/HOLES - 3.2" - E-COATED
9	NOT USED		
10	127335-12-000	EA	LEG - SOFA/BED - 10"
11	151290-23-000	EA	FRAME - BASE - 27.25" X 56"
12	151290-24-000	EA	FRAME - SEAT - 26.25" X 56"
13	151290-25-000	EA	FRAME - BACK - 14.5" X 56"

CURTAIN & CUSHION GROUP (CONTINUED)
WINDOW TREATMENT

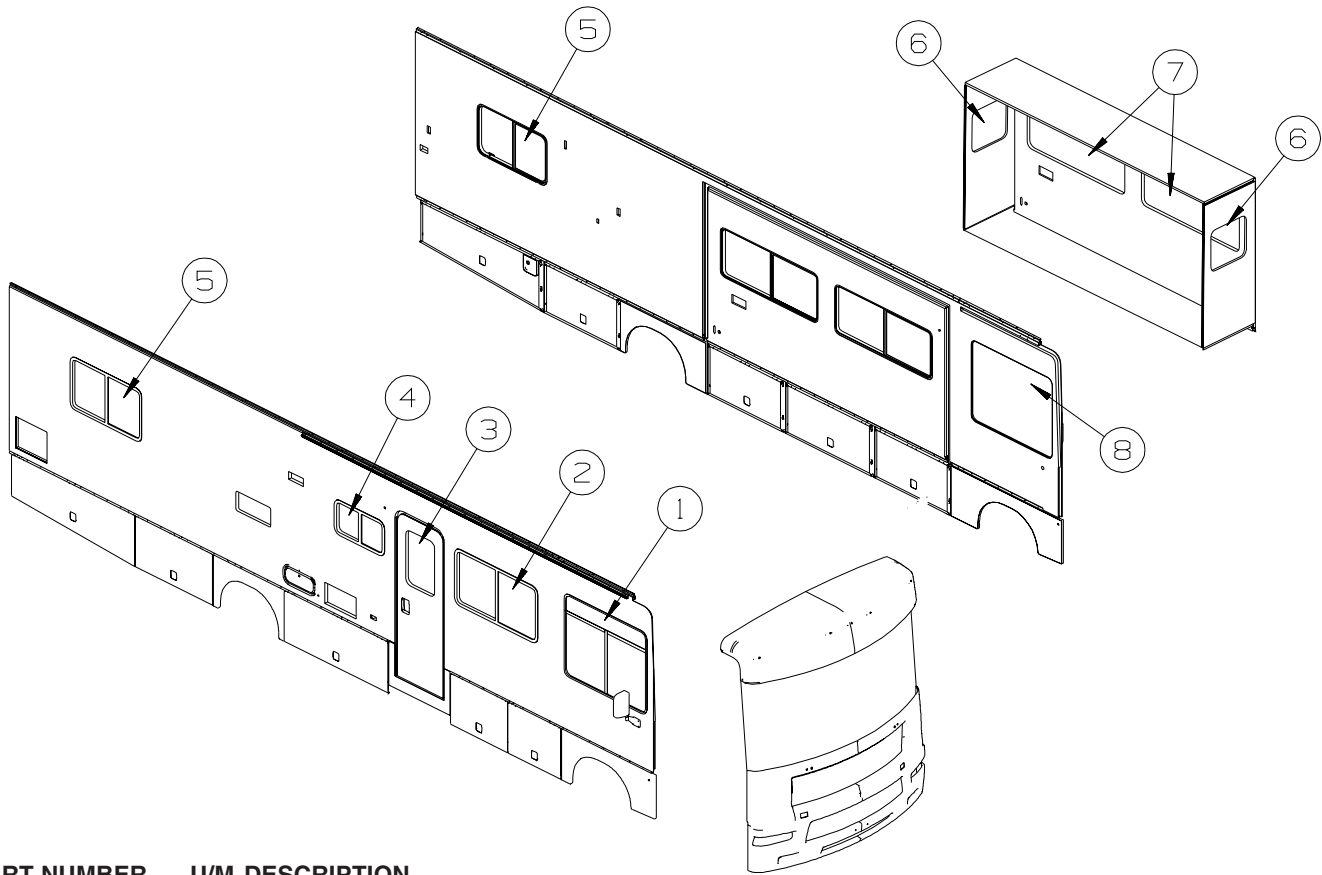

KEY	PART NUMBER	U/M	DESCRIPTION
1	101668-71-U51	EA	CURTAIN - RIGHT HAND - TAPE TOP - 40.5" X 110" (U51, U52)
1	101668-71-U53	EA	CURTAIN - RIGHT HAND - TAPE TOP - 40.5" X 110" (U53, U54)
1	101668-71-U55	EA	CURTAIN - RIGHT HAND - TAPE TOP - 40.5" X 110" (U55, U56)
1	073260-42-U51	EA	TIEBACK - 6" X 18" (U51, U52)
1	073260-42-U53	EA	TIEBACK - 6" X 18" (U53, U54)
1	073260-42-U55	EA	TIEBACK - 6" X 18" (U55, U56)
2	142210-59-U51	EA	VALANCE - FLANDER - 53" (U51, U52)
2	142210-60-U53	EA	VALANCE - FLANDER - 53" (U53, U54)
2	142210-61-U55	EA	VALANCE - FLANDER - 53" (U55, U56)
2	152445-13-U21	EA	LEG - RIGHT - 25" (U51, U52)
2	152445-13-U53	EA	LEG - RIGHT - 25" (U53, U54)
2	152445-05-U55	EA	LEG - RIGHT - 25" (U55, U56)
2	152445-14-U21	EA	LEG - LEFT - 25" (U51, U52)
2	152445-14-U53	EA	LEG - LEFT - 25" (U53, U54)
2	152445-06-U55	EA	LEG - LEFT - 25" (U55, U56)
2	109041-31-02A	EA	BLIND - MINI - 49" X 30"
2	140789-42-S34	EA	BLIND - DAY/NIGHTER - 49" X 29" - WINDOW COVERING EXCHANGE
3	153643-60-U51	EA	VALANCE - MODERATE - 12" X 32" (U51, U52)
3	153643-61-U53	EA	VALANCE - MODERATE - 12" X 32" (U53, U54)
3	153643-60-U55	EA	VALANCE - MODERATE - 12" X 32" (U55, U56)
3	084755-57-P37	EA	SHADE - PULL - 27.25"
4	109041-44-02A	EA	BLIND - 30.5" X 18"
5	142210-51-U51	EA	VALANCE - FLANDER - 47" (U51, U52)
5	142210-48-U53	EA	VALANCE - FLANDER - 47" (U53, U54)
5	142210-48-U55	EA	VALANCE - FLANDER - 47" (U55, U56)
5	152664-23-U51	EA	LEG - RIGHT - 26" (U51, U52)
5	152664-29-U53	EA	LEG - RIGHT - 26" (U53, U54)
5	152664-29-U55	EA	LEG - RIGHT - 26" (U55, U56)
5	152664-24-U51	EA	LEG - LEFT - 26" (U51, U52)
5	152664-30-U53	EA	LEG - LEFT - 26" (U53, U54)
5	152664-30-U55	EA	LEG - LEFT - 26" (U55, U56)
5	109802-64-N21	EA	BLIND - PLEATED - 43" X 28"
5	140789-02-N02	EA	BLIND - DAY/NIGHTER - 43" X 28" WINDOW COVERING EXCHANGE

CURTAIN & CUSHION GROUP (CONTINUED)
WINDOW TREATMENT (CONTINUED)

KEY	PART NUMBER	U/M	DESCRIPTION
6	142210-53-U51	EA	VALANCE - FLANDER - 26.5" (U51, U52)
6	142210-54-U53	EA	VALANCE - FLANDER - 26.5" (U53, U54)
6	142210-55-U55	EA	VALANCE - FLANDER - 26.5" (U55, U56)
6	152664-49-U51	EA	LEG - RIGHT - 21.5" (U51, U52)
6	152664-49-U53	EA	LEG - RIGHT - 21.5" (U53, U54)
6	152664-11-U55	EA	LEG - RIGHT - 21.5" (U55, U56)
6	152664-50-U51	EA	LEG - LEFT - 21.5" (U51, U52)
6	152664-50-U53	EA	LEG - LEFT - 21.5" (U53, U54)
6	152664-12-U55	EA	LEG - LEFT - 21.5" (U55, U56)
6	109041-73-02A	EA	BLIND - MINI - 22.5" X 23"
6	140789-07-N02	EA	BLIND - DAY/NIGHTER - 22.5" X 23" - WINDOW COVERING EXCHANGE
7	142210-42-U51	EA	VALANCE - FLANDER - 62.5" (U51, U52)
7	142210-44-U53	EA	VALANCE - FLANDER - 62.5" (U53, U54)
7	142210-52-U55	EA	VALANCE - FLANDER - 62.5" (U55, U56)
7	152445-13-U21	EA	LEG - RIGHT - 25" (U51, U52)
7	152445-13-U53	EA	LEG - RIGHT - 25" (U53, U54)
7	152445-05-U55	EA	LEG - RIGHT - 25" (U55, U56)
7	152445-14-U21	EA	LEG - LEFT - 25" (U51, U52)
7	152445-14-U53	EA	LEG - LEFT - 25" (U53, U54)
7	152445-06-U55	EA	LEG - LEFT - 25" (U55, U56)
7	109041-66-02A	EA	BLIND - MINI - 59" X 26"
7	140789-08-N02	EA	BLIND - DAY/NIGHTER - 59" X 26.5" - WINDOW COVERING EXCHANGE
8	101668-72-U51	EA	CURTAIN - LEFT HAND - TAPE TOP - 40.5" X 110" (U51, U52)
8	101668-72-U53	EA	CURTAIN - LEFT HAND - TAPE TOP - 40.5" X 110" (U53, U54)
8	101668-72-U55	EA	CURTAIN - LEFT HAND - TAPE TOP - 40.5" X 110" (U55, U56)
8	073260-42-U51	EA	TIEBACK - 6" X 18" (U51, U52)
8	073260-42-U53	EA	TIEBACK - 6" X 18" (U53, U54)
8	073260-42-U55	EA	TIEBACK - 6" X 18" (U55, U56)

CURTAIN & CUSHION GROUP (CONTINUED)

HARDWARE



KEY	PART NUMBER	U/M	DESCRIPTION
1A	029155-01-000	EA	CAP - SNAP - 5/32" OUTSIDE DIAMETER OF PIN
2A	029156-01-000	EA	SOCKET - SNAP - 9/16" O.D.
3A	046867-02-000	EA	WASHER - HANDY BUTTON #3
4A	046867-03-000	EA	GROMMET - HANDY BUTTON #3
5A	075943-10-000	EA	BRACE - VALANCE - 20" - OFF WHITE
6A	083170-01-000	EA	BRACKET/BLIND - LEFT SIDE WHEN FACING WINDOW - CLEAR
7A	083170-02-000	EA	BRACKET/BLIND - RIGHT SIDE WHEN FACING WINDOW - CLEAR
8A	084434-01-000	EA	BRACKET - MOUNTING - ROLLER SHADE - 1 3/8"
9A	094896-02-000	EA	GROMMET - CORD/PLEATED BLIND - NYLON - GRAY
10A	094907-02-000	EA	END CAP - PLEATED BLIND/TOP - RH/LH - GRAY PLASTIC
11A	094907-04-000	EA	END CAP - PLEATED BLIND/BOTTOM - RH/LH
12A	094907-09-000	EA	END CAP/BLIND - CENTER RAIL - RH/LH
13A	097564-03-000	EA	HANDLE - KNOB - E-Z LIFT SHADE - TAN
	097593-02-000	FT	CORD - BLIND - PLEATED - GRAY
	097593-10-000	FT	CORD - BLIND - PLEATED - VANILLA
14A	097565-01-000	EA	BRACKET - MOUNTING - PLEATED BLIND
15A	097591-01-000	EA	SPRING - EXTENSION - PLEATED BLIND
15A	155748-01-000	EA	SPRING - EXTENSION - DAY/NIGHTER BLIND
16A	101031-01-000	YD	TAPE/GLIDE - 4.25" SPACING
17A	102555-03-000	EA	BRACKET - (CLEAT TYPE) - F/BLIND HOLDOWN - MILKY WHITE

CURTAIN & CUSHION GROUP (CONTINUED)
HARDWARE (CONTINUED)

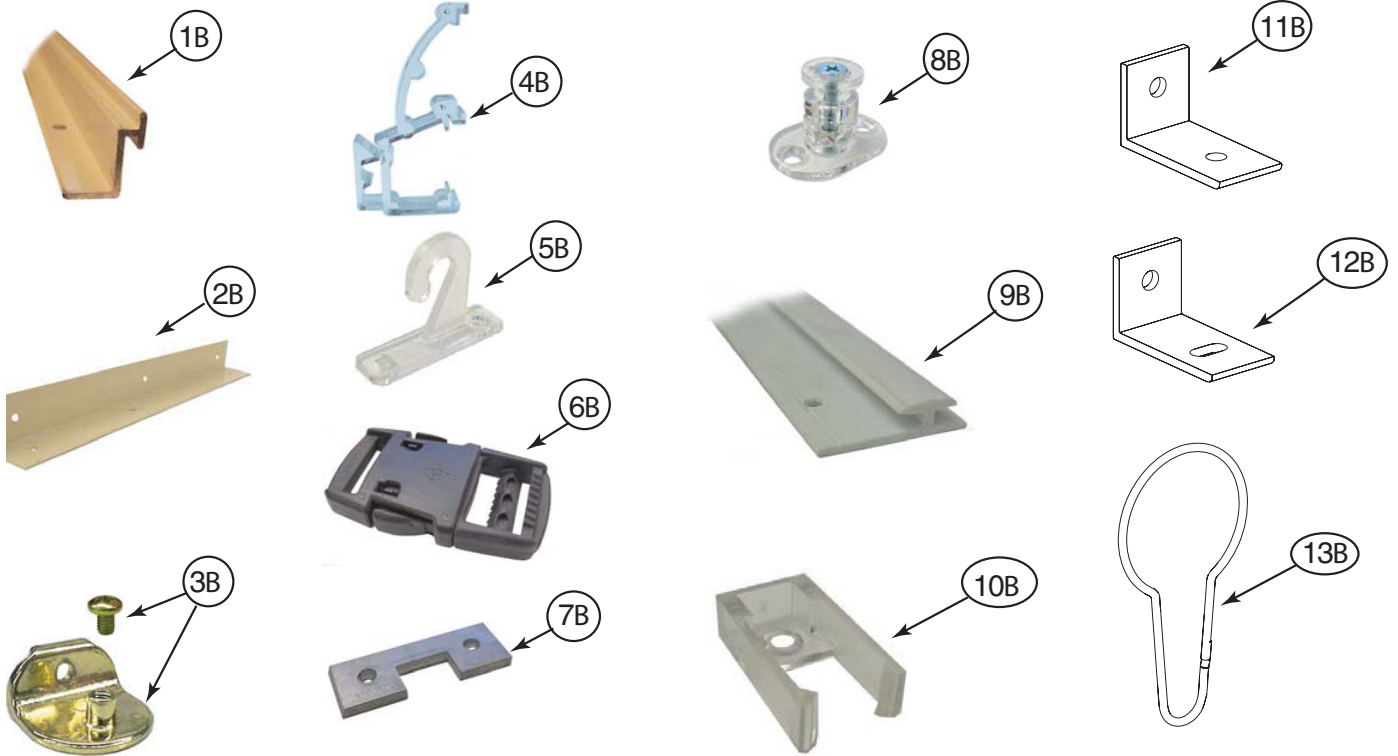

KEY	PART NUMBER	U/M	DESCRIPTION
1B	105450-14-01A	EA	TRACK-90"-OW - FRT BUNK PRIVACY OUTLOOK/SPIRIT 300-SERIES, ACCESS/IMPULSE 200-SERIES
2B	105648-01-02A	EA	BRACE - VALANCE - 14" - OFF WHITE
2B	105648-02-02A	EA	BRACE - VALANCE - 8.5" - OFF WHITE
3B	106544-01-000	EA	PULL - SHADE/BRASS
3B	106544-01-001	EA	SCREW - SHADE/BRASS
3B	106544-02-000	EA	PULL-SHADE - NICKEL
4B	109353-04-000	EA	CLIP - VALANCE SLAT MOUNTING - CLEAR PLASTIC
5B	109441-01-000	EA	BRACKET/HOOK - BLIND HOLD DOWN
	109441-02-000	EA	SPACER/BRACKET - BLIND HOLD DOWN
6B	129491-01-000	EA	CATCH - SNAP HOOK - 1"
7B	130549-01-01A	EA	STOP - CURTAIN TRACK
8B	141634-01-000	EA	BRACKET-(BOBBIN TYPE) 7/8"H HOLDUPBASE(OVAL)-2 HOLE-CLEAR
9B	156172-01-01A	EA	TRACK/WALL - 75" - BONE
9B	156172-02-01A	EA	TRACK/WALL - 32" - BONE
9B	156172-03-01A	EA	TRACK/WALL - 21" - BONE
10B	156172-04-01A	EA	END CAP - WALL TRACK - CLEAR
11B	154316-01-01A	EA	BRACE/ANGLE - W/HOLE - CASHMERE
12B	154316-02-01A	EA	BRACE/ANGLE - W/SLOT - CASHMERE
13B	159702-01-01A	EA	HOOK/RING - CURTAIN/SHOWER - NICKEL

CURTAIN & CUSHION GROUP (CONTINUED)

ACCESSORIES

KEY	PART NUMBER	U/M	DESCRIPTION
	070578-02-N30	EA	BUTTON - SCREW - STUD - #30 VINYL

FABRICS

U51, U52

137813-R9-000	FABRIC - DRAPERY, MAIN
148797-L6-000	FABRIC - UPHOLSTERY - MAIN
148797-L8-000	FABRIC - UPHOLSTERY - PLAIN ACCENT
148797-L8-000	FABRIC - DRAWER, FACE WRAP
148797-M0-000	FABRIC - UPHOLSTERY - PATTERN ACCENT
148797-M0-000	FABRIC - O/H CABINET, DINETTE & LOUNGE
137813-U6-000	FABRIC - UPHOLSTERY, BEDSPREAD - MAIN
137813-R9-000	FABRIC - UPHOLSTERY, BEDSPREAD, PATTERN ACCENT
137813-R9-000	FABRIC - O/H CABINET BEDROOM
148797-20-000	FABRIC - SPEAKER COVER
103907-01-01A	VINYL - DINETTE CUSHION
142523-04-000	VINYL - CABINET ENDS
079680-42-000	VINYL - ACCENT TRIM - COACH AREA
079680-47-000	FABRIC - UPHOLSTERY, ACCENT PLAIN
079680-47-000	FABRIC - UPHOLSTERY - SEAT INSERT
113979-09-01A	CARPET - HEADLINER - CEILING
113979-10-01A	CARPET - HEADLINER, SLIDEOUT

U53, U54

137813-Y1-000	FABRIC - DRAPERY, MAIN
137813-Y1-000	FABRIC - UPHOLSTERY, BEDSPREAD, PATTERN ACCENT
148797-70-000	FABRIC - UPHOLSTERY - MAIN
148797-H9-000	FABRIC - UPHOLSTERY - PLAIN ACCENT
148797-H9-000	FABRIC - DRAWER, FACE WRAP
148797-71-000	FABRIC - UPHOLSTERY - PATTERN ACCENT
148797-71-000	FABRIC - SPEAKER COVER
148797-71-000	FABRIC - O/H CABINET, DINETTE & LOUNGE
137813-Y0-000	FABRIC - UPHOLSTERY, BEDSPREAD - MAIN
137813-Y0-000	FABRIC - O/H CABINET BEDROOM
103907-01-01A	VINYL - DINETTE CUSHION
142523-04-000	VINYL - CABINET ENDS
079680-42-000	VINYL - ACCENT TRIM - COACH AREA
079680-47-000	FABRIC - UPHOLSTERY, ACCENT PLAIN
079680-47-000	FABRIC - UPHOLSTERY - SEAT INSERT
113979-09-01A	CARPET - HEADLINER - CEILING
113979-10-01A	CARPET - HEADLINER, SLIDEOUT

U55, U56

137813-X5-000	FABRIC - DRAPERY, MAIN
137813-X5-000	FABRIC - UPHOLSTERY, BEDSPREAD, PATTERN ACCENT
148797-R5-000	FABRIC - UPHOLSTERY - MAIN
148797-R6-000	FABRIC - UPHOLSTERY - PLAIN ACCENT
	FROM: 00-00-00 THRU: 07-20-06
148797-CM-000	FABRIC - UPHOLSTERY - PLAIN ACCENT
	FROM: 07-21-06 THRU: 99-99-99
148797-R6-000	FABRIC - DRAWER, FACE WRAP
	FROM: 00-00-00 THRU: 07-20-06
148797-CM-000	FABRIC - DRAWER, FACE WRAP
	FROM: 07-21-06 THRU: 99-99-99
148797-R7-000	FABRIC - UPHOLSTERY - PATTERN ACCENT
148797-R7-000	FABRIC - O/H CABINET, DINETTE & LOUNGE
126883-W9-000	FABRIC - SPEAKER COVER
137813-M4-000	FABRIC - UPHOLSTERY, BEDSPREAD - MAIN
137813-S5-000	FABRIC - O/H CABINET BEDROOM
103907-01-01A	VINYL - DINETTE CUSHION
142523-03-000	VINYL - CABINET ENDS
079680-42-000	VINYL - ACCENT TRIM - COACH AREA
142523-02-000	FABRIC - UPHOLSTERY, ACCENT PLAIN
142523-02-000	FABRIC - UPHOLSTERY - SEAT INSERT
113979-09-01A	CARPET - HEADLINER - CEILING
113979-10-01A	CARPET - HEADLINER, SLIDEOUT

DRIVERS COMPARTMENT GROUP DASH

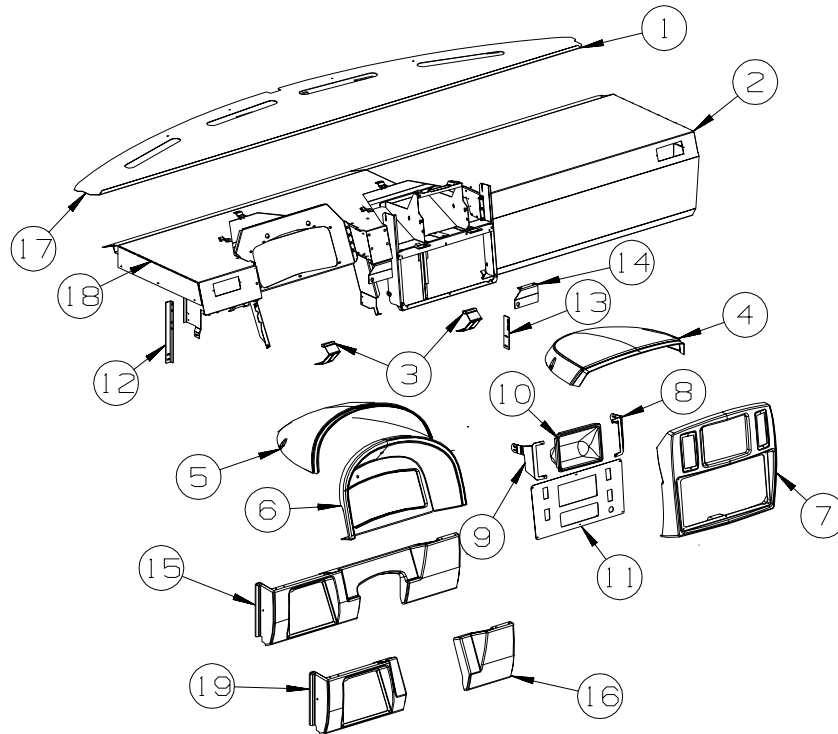

KEY	PART NUMBER	U/M	DESCRIPTION
1	154741-02-02B	EA	PANEL - DASH TOP - E-COATED
2	156677-01-02B	EA	DASH - W/O VINYL - E-COATED
3	110530-01-000	FT	SEAL - SPONGE - .31" X .62"
4	156682-01-20A	EA	DASH POD - CENTER - CASHMERE
4	156682-01-19A	EA	DASH POD - CENTER - RIVERSTONE
4	156682-02-20A	EA	DASH POD - CENTER - CASHMERE - REARVIEW MONITOR SYSTEM W/AUDIO
4	156682-02-19A	EA	DASH POD - CENTER - RIVERSTONE - REARVIEW MONITOR SYSTEM W/AUDIO
5	155700-01-20A	EA	POD - INSTRUMENT PANEL - CASHMERE
5	155700-01-19A	EA	POD - INSTRUMENT PANEL - RIVERSTONE
6	155698-06-U57	EA	BEZEL - INSTRUMENT PANEL - WORKHORSE - CASHMERE
6	155698-06-U59	EA	BEZEL - INSTRUMENT PANEL - WORKHORSE - RIVERSTONE
	155698-05-20A	EA	BEZEL - INSTRUMENT PANEL - WORKHORSE - CASHMERE
	155698-05-19A	EA	BEZEL - INSTRUMENT PANEL - WORKHORSE - RIVERSTONE
6	155699-06-U57	EA	BEZEL - INSTRUMENT PANEL - FORD - CASHMERE
6	155699-06-U59	EA	BEZEL - INSTRUMENT PANEL - FORD - RIVERSTONE
	155699-05-20A	EA	BEZEL - INSTRUMENT PANEL - FORD - CASHMERE
	155699-05-19A	EA	BEZEL - INSTRUMENT PANEL - FORD - RIVERSTONE
6	155698-04-U57	EA	BEZEL - INSTRUMENT PANEL - WORKHORSE - CASHMERE - HYDRAULIC LEVEL JACKS-AUTO
6	155698-04-U59	EA	BEZEL - INSTRUMENT PANEL - WORKHORSE - RIVERSTONE - HYDRAULIC LEVEL JACKS-AUTO
	155698-03-20A	EA	BEZEL - INSTRUMENT PANEL - WORKHORSE - CASHMERE
	155698-03-19A	EA	BEZEL - INSTRUMENT PANEL - WORKHORSE - RIVERSTONE
6	155699-04-U57	EA	BEZEL - INSTRUMENT PANEL - FORD - HYDRAULIC LEVEL JACKS-AUTO
6	155699-04-U59	EA	BEZEL - INSTRUMENT PANEL - FORD - HYDRAULIC LEVEL JACKS-AUTO
	155699-03-20A	EA	BEZEL - INSTRUMENT PANEL - FORD - CASHMERE
	155699-03-19A	EA	BEZEL - INSTRUMENT PANEL - FORD - RIVERSTONE
7	156681-01-20A	EA	BEZEL - DASH/CENTER - CASHMERE
7	156681-01-19A	EA	BEZEL - DASH/CENTER - RIVERSTONE
8	157043-01-02B	EA	RETAINER - LOUVER/RIGHT - E-COATED
9	157043-02-02B	EA	RETAINER - LOUVER/LEFT - E-COATED
10	111350-02-20A	EA	POCKET - INSTRUMENT PANEL - UPPER/RIGHT - CASHMERE
10	111350-02-19A	EA	POCKET - INSTRUMENT PANEL - UPPER/RIGHT - RIVERSTONE
11	156051-02-02B	EA	PANEL - BEZEL - CENTER DASH - E-COATED
12	128692-01-02B	EA	ANGLE - FORMED - DASH SUPPORT - E-COATED
13	139603-01-02B	EA	STRAP - DASH SUPPORT - CENTER - E-COATED
14	155948-01-02B	EA	SUPPORT - PARK BRAKE SWITCH - E-COATED

DRIVERS COMPARTMENT GROUP (CONTINUED)
DASH (CONTINUED)

KEY	PART NUMBER	U/M	DESCRIPTION
15	156253-01-02A	EA	PANEL/TRIM - DASH/LOWER - DRIVER/RIGHT - CASHMERE - FORD
15	156253-01-01A	EA	PANEL/TRIM - DASH/LOWER - DRIVER/RIGHT - RIVERSTONE - FORD
16	155129-01-02A	EA	PANEL/TRIM - DASH/LOWER LEFT - CASHMERE - WORKHORSE
16	155129-01-01A	EA	PANEL/TRIM - DASH/LOWER LEFT - RIVERSTONE - WORKHORSE
17	106569-07-09A	EA	VINYL - LAMINATE - 1/4" X 17" X 100" - DRIFTWOOD (U51, U52, U53, U54)
17	106569-07-08A	EA	VINYL - LAMINATE - 1/4" X 17" X 100" - PUTTY (U55, U56)
18	106569-17-09A	EA	VINYL - LAMINATE - 1/4" X 40" X 100" - DRIFTWOOD (U51, U52, U53, U54)
18	106569-17-08A	EA	VINYL - LAMINATE - 1/4" X 40" X 100" - PUTTY (U55, U56)
19	156254-01-02A	EA	PANEL/TRIM - DASH/LOWER - DRIVER/LEFT - CASHMERE - FORD
19	156254-01-01A	EA	PANEL/TRIM - DASH/LOWER - DRIVER/LEFT - RIVERSTONE - FORD

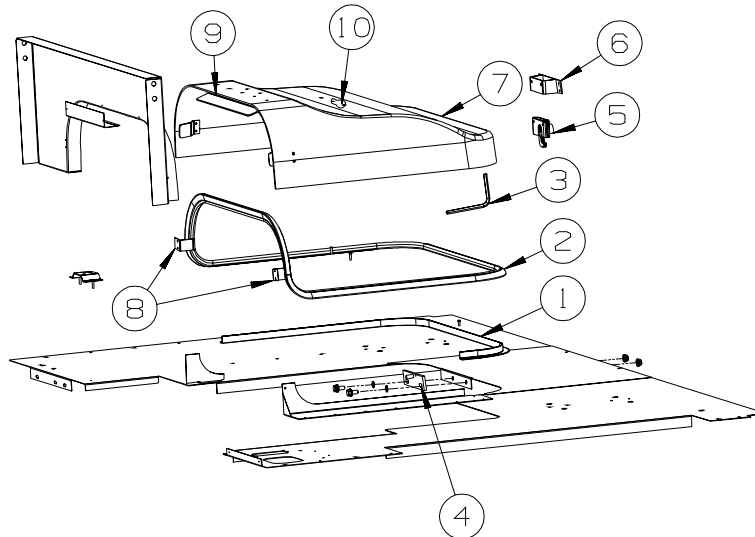

MOTOR COVER

KEY	PART NUMBER	U/M	DESCRIPTION
1	115860-06-01A	EA	TRIM - MOTOR COVER - FORD - MILL FINISH
2	039623-01-000	FT	SEAL - MOTOR COVER - RUBBER BULB TYPE
3	116833-01-02B	EA	WRENCH - HEX MOTOR COVER - E-COATED
4	115852-01-02B	EA	STRIKE - LATCH - MOTOR COVER - E-COATED
5	116581-01-000	EA	LATCH - W/O STRIKE - MOTOR COVER
6	115850-01-02B	EA	RETAINER - LATCH - MOTOR COVER - RIGHT HAND - E-COATED
7	156754-02-U57	EA	COVER - MOTOR - W/CARPET - FORD (U51, U52, U55, U56)
7	156754-02-U59	EA	COVER - MOTOR - W/CARPET - FORD (U53, U54)
	153970-02-01A	EA	COVER - MOTOR - W/O CARPET
8	115855-04-02B	EA	RETAINER - MOTOR COVER/SIDE - E-COATED
9	115855-01-02B	EA	RETAINER - MOTOR COVER/TOP - E-COATED
10	134497-01-000	SF	FOIL/ALUMINUM - REINFORCED

FORD

DRIVERS COMPARTMENT GROUP (CONTINUED)

MOTOR COVER (CONTINUED)

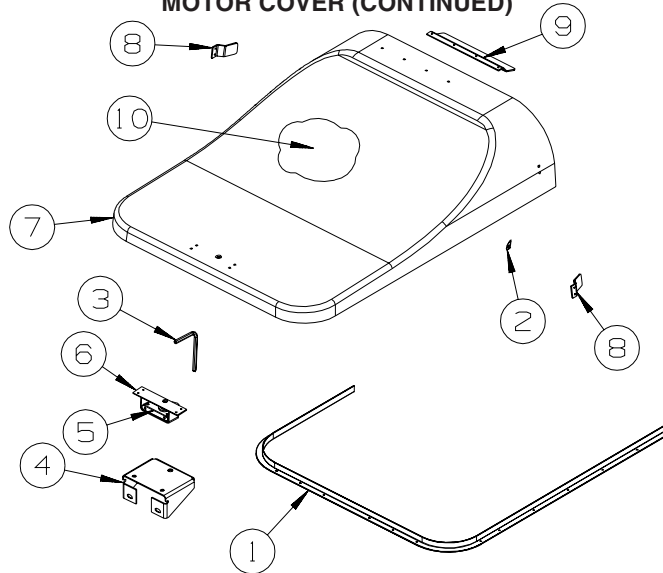

WORKHORSE

KEY	PART NUMBER	U/M	DESCRIPTION
1	137332-01-01A	EA	TRIM - MOTOR COVER
2	039623-01-000	FT	SEAL - MOTOR COVER - RUBBER BULB TYPE
3	116833-01-02B	EA	WRENCH - HEX MOTOR COVER - E-COATED
4	137305-02-02B	EA	BRACKET - STRIKE SUPPORT - E-COATED
5	116581-01-000	EA	LATCH - W/O STRIKE - MOTOR COVER
6	115850-01-02B	EA	RETAINER - LATCH - MOTOR COVER - RIGHT HAND - E-COATED
7	137097-01-U57	EA	COVER - MOTOR - W/CARPET (U51, U52)
7	137097-01-T53	EA	COVER - MOTOR - W/CARPET (U53, U54)
7	137097-01-T55	EA	COVER - MOTOR - W/CARPET (U55, U56)
	137096-01-01A	EA	COVER - MOTOR - W/O CARPET
8	115855-04-02B	EA	RETAINER - MOTOR COVER/SIDE - E-COATED
9	115855-03-02B	EA	RETAINER - MOTOR COVER/TOP - E-COATED
10	NOT USED		

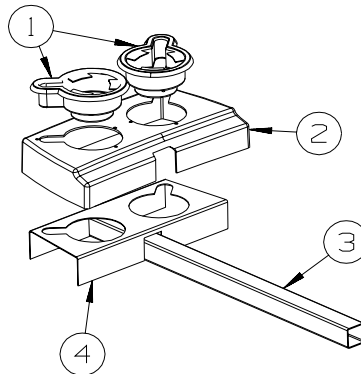

BEVERAGE TRAY

KEY	PART NUMBER	U/M	DESCRIPTION
1	133831-01-01A	EA	HOLDER - CUP W/THREE CENTERLINE RUBBER FINGERS
2	156018-01-20A	EA	TRAY - BEVERAGE - CASHMERE
2	156018-01-19A	EA	TRAY - BEVERAGE - RIVERSTONE
3	156047-01-02B	EA	SUPPORT - BEVERAGE TRAY - E-COATED
4	156016-01-01B	EA	BRACKET - BEVERAGE TRAY - E-COATED

DRIVERS COMPARTMENT GROUP (CONTINUED)

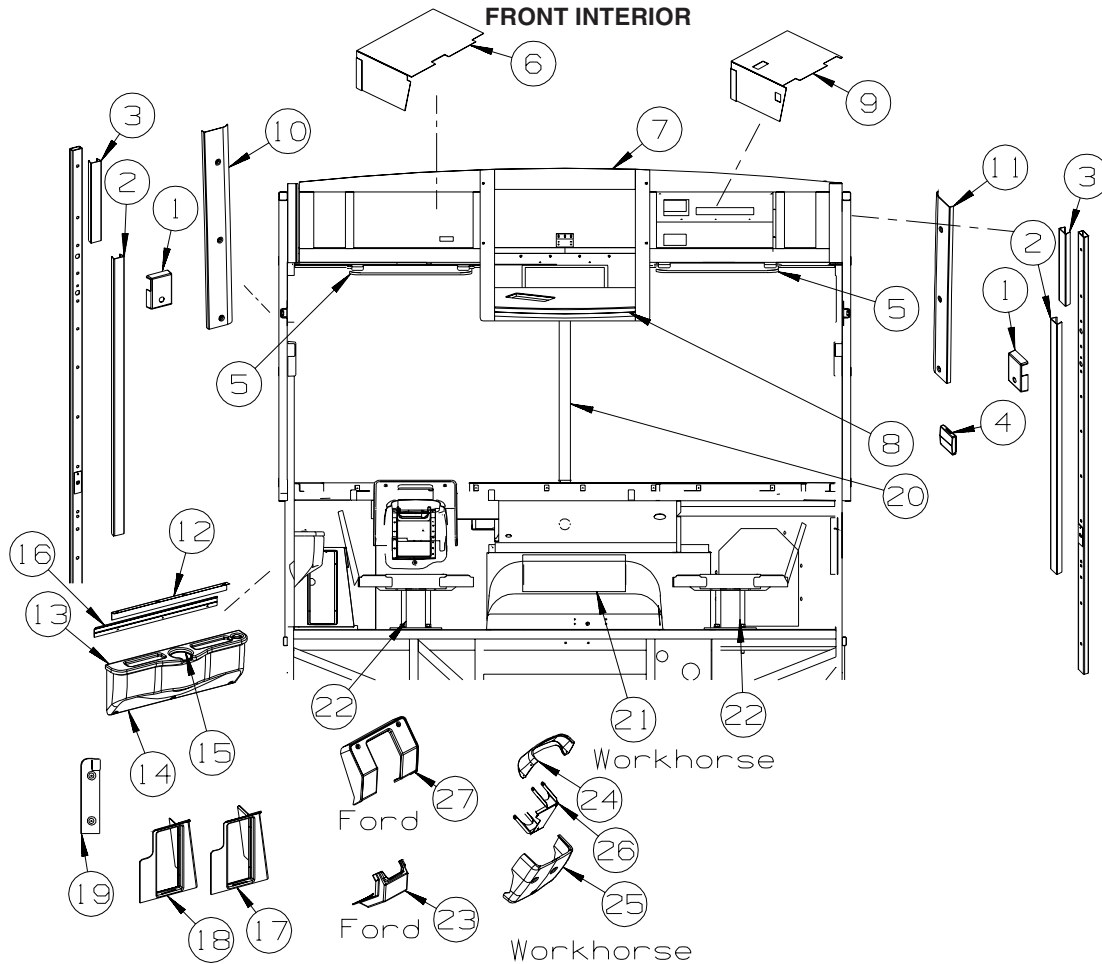

KEY	PART NUMBER	U/M	DESCRIPTION
1	103961-03-01A	EA	COVER - BRACKET - SEATBELT/OFF WHITE FROM: 00-00-00 THRU: 07-31-06
1	103961-03-02A	EA	COVER - BRACKET - SEATBELT/BLACK FROM: 08-01-06 THRU: 99-99-99
2	024700-38-000	EA	COVER - ROLL BAR - SIDEWALL - 15.3" - OFF WHITE FROM: 00-00-00 THRU: 07-31-06
2	024700-76-000	EA	COVER - ROLL BAR - SIDEWALL - 15.3" - MEDIUM OAK FROM: 08-01-06 THRU: 08-13-06
2	024700-71-000	EA	COVER - ROLL BAR - SIDEWALL - 16.5" - MEDIUM OAK FROM: 08-14-06 THRU: 99-99-99
3	024700-44-000	EA	COVER - ROLL BAR - SIDEWALL - 53" - OFF WHITE FROM: 00-00-00 THRU: 07-31-06
3	024700-75-000	EA	COVER - ROLL BAR - SIDEWALL - 53" - MEDIUM OAK FROM: 08-01-06 THRU: 99-99-99
4	118718-01-02A	EA	HOLDER/DRINK - COLLAPSIBLE MUG - WHITE PLASTIC
5	123298-04-09A	EA	SUNVISOR - 10.5" X 21" - DRIVER/PASSENGER - CASHMERE
5	123298-04-08A	EA	SUNVISOR - 10.5" X 21" - DRIVER/PASSENGER - RIVERSTONE
6	136422-05-T53	EA	PANEL - FABRIC COVERED
7	144351-07-U57	EA	CABINET - FRAME/TV - W/O DOORS/HARDWARE - PORTSMOUTH OAK
7	144351-07-U58	EA	CABINET - FRAME/TV - W/O DOORS/HARDWARE - SIERRA MAPLE
8	144278-03-U57	EA	CABINET/BASE - TV - W/O DOORS/HARDWARE
9	136422-03-R28	EA	PANEL - FABRIC COVERED
10	136351-05-20A	EA	TRIM - A-PILLAR - INTERIOR/PASSENGER - CASHMERE
10	136351-05-19A	EA	TRIM - A-PILLAR - INTERIOR/PASSENGER - RIVERSTONE
11	136351-06-20A	EA	TRIM - A-PILLAR - INTERIOR/DRIVER - CASHMERE
11	136351-06-19A	EA	TRIM - A-PILLAR - INTERIOR/DRIVER - RIVERSTONE
12	132595-02-02B	EA	BRACKET - BEVERAGE TRAY HOLDER - E-COATED
13	132297-03-06A	EA	PANEL-TRIM - BEVERAGE TRAY
14	132354-05-20A	EA	PANEL/TRIM - INNER - W/O BEVERAGE TRAY - CASHMERE
14	132354-05-19A	EA	PANEL/TRIM - INNER - W/O BEVERAGE TRAY - RIVERSTONE

DRIVERS COMPARTMENT GROUP (CONTINUED)
FRONT INTERIOR (CONTINUED)

KEY	PART NUMBER	U/M	DESCRIPTION
14	132354-06-20A	EA	PANEL/TRIM - INNER - W/O BEVERAGE TRAY - CASHMERE - MIRRORS-EXTERIOR W/DEFROST FROM: 00-00-00 THRU: 11-05-06
14	132354-08-20A	EA	PANEL/TRIM - INNER - W/O BEVERAGE TRAY - CASHMERE - MIRRORS-EXTERIOR W/DEFROST FROM: 11-06-06 THRU: 99-99-99
14	132354-06-19A	EA	PANEL/TRIM - INNER - W/O BEVERAGE TRAY - RIVERSTONE - MIRRORS-EXTERIOR W/DEFROST FROM: 00-00-00 THRU: 11-05-06
14	132354-08-19A	EA	PANEL/TRIM - INNER - W/O BEVERAGE TRAY - RIVERSTONE - MIRRORS-EXTERIOR W/DEFROST FROM: 11-06-06 THRU: 99-99-99
	122717-07-01A	EA	PAD - NON-SKID - PSA - 3.2" X 8.3"
15	134566-01-01A	EA	HOLDER - CUP - TWO STEP - BLACK
16	130034-11-02B	EA	CLIP - TRIM - E-COATED
17	148824-01-20A	EA	PANEL/TRIM - FUSE PANEL/LEFT HAND - CASHMERE
17	148824-01-19A	EA	PANEL/TRIM - FUSE PANEL/LEFT HAND - RIVERSTONE
17	148824-02-20A	EA	PANEL/TRIM - FUSE PANEL/LEFT HAND - CASHMERE - FORD
17	148824-02-19A	EA	PANEL/TRIM - FUSE PANEL/LEFT HAND - RIVERSTONE - FORD
18	148826-01-20A	EA	PANEL/DOOR - FUSE PANEL/LEFT HAND - CASHMERE
18	148826-01-19A	EA	PANEL/DOOR - FUSE PANEL/LEFT HAND - RIVERSTONE
19	127901-01-20A	EA	PANEL - TOEKICK/LEFT HAND - CASHMERE
19	127901-01-19A	EA	PANEL - TOEKICK/LEFT HAND - RIVERSTONE
20	118452-10-20A	EA	TRIM - WINDSHIELD/CENTER - CASHMERE
20	118452-10-19A	EA	TRIM - WINDSHIELD/CENTER - RIVERSTONE
21	156018-01-20A	EA	TRAY - BEVERAGE - CASHMERE
21	156018-01-19A	EA	TRAY - BEVERAGE - RIVERSTONE
22	133408-01-000	EA	PEDESTAL - SEAT - DRIVER/PASSENGER - 9 3/4"
23	125795-01-20A	EA	COVER - STEERING COLUMN/LOWER - FORD - CASHMERE
23	125795-01-19A	EA	COVER - STEERING COLUMN/LOWER - FORD - RIVERSTONE
24	155934-01-20A	EA	COVER - STEERING COMUMN - UPPER - WORKHORSE - CASHMERE
24	155934-01-19A	EA	COVER - STEERING COMUMN - UPPER - WORKHORSE - RIVERSTONE
25	155935-01-20A	EA	COVER - STEERING COLUMN - LOWER - WORKHORSE - CASHMERE
25	155935-01-19A	EA	COVER - STEERING COLUMN - LOWER - WORKHORSE - RIVERSTONE
26	148806-01-02B	EA	MOUNT - STEERING COVE - E-COATED
27	148815-02-20A	EA	COVER - STEERING COLUMN - LOWER - FORD - CASHMERE
27	148815-02-19A	EA	COVER - STEERING COLUMN - LOWER - FORD - RIVERSTONE

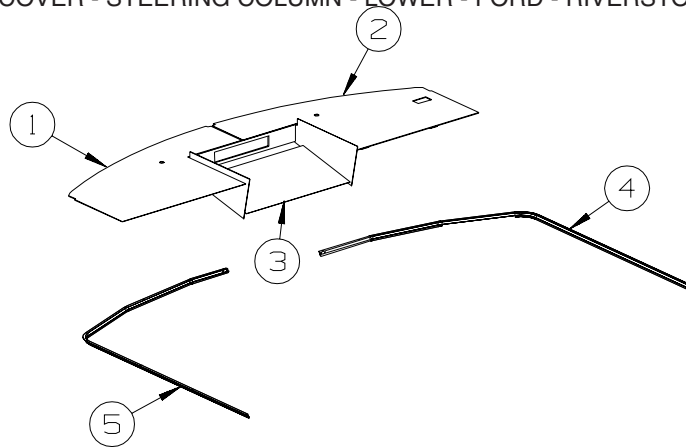

KEY	PART NUMBER	U/M	DESCRIPTION
1	134146-06-U57	EA	PANEL - OVERHEAD/FRONT/BOTTOM/LEFT HAND
2	134146-05-U57	EA	PANEL - OVERHEAD/FRONT/BOTTOM/RIGHT HAND
3	P34142-04-U57	EA	COVER - TV - OVERHEAD/BOTTOM - VINYL COVERED - CASHMERE
3	P34142-04-U59	EA	COVER - TV - OVERHEAD/BOTTOM - VINYL COVERED - RIVERSTONE
4	127254-14-20A	EA	TRACK/WRAPAROUND - PASSENGER - CASHMERE
4	127254-14-19A	EA	TRACK/WRAPAROUND - PASSENGER - RIVERSTONE
5	127254-04-20A	EA	TRACK/WRAPAROUND - DRIVER - CASHMERE
5	127254-04-19A	EA	TRACK/WRAPAROUND - DRIVER - RIVERSTONE

DRIVERS COMPARTMENT GROUP (CONTINUED)
FRONT INTERIOR (CONTINUED)

DRIVER MANUAL

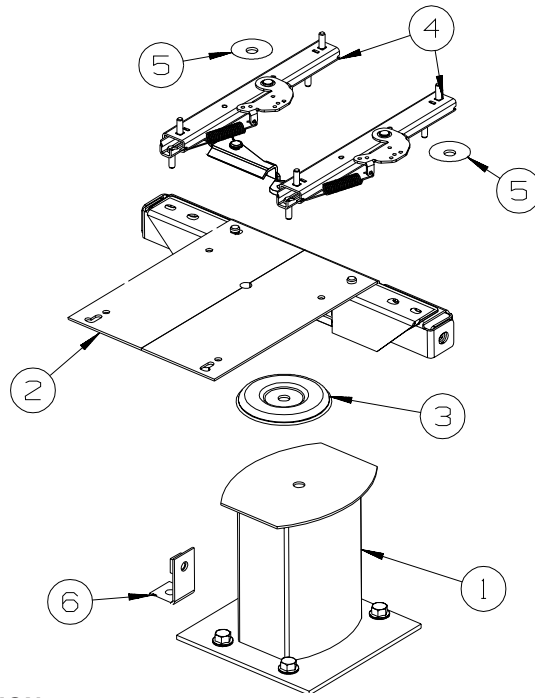

KEY	PART NUMBER	U/M	DESCRIPTION
1	133408-01-000	EA	PEDESTAL - SEAT/DRIVER - 9 3/4"
2	133408-19-000	EA	TOP PLATE - DRIVERS - W/ANCHOR
3	107921-06-000	EA	BEARING KIT - PEDESTAL
4	131566-04-000	EA	SLIDE/SEAT - HEAVY DUTY LOCKING - 5"
	119952-07-000	EA	WIRE - LATCH RELEASE/ROTARY
5	131566-05-000	EA	WASHER - SLIDE SPACER
6	133408-04-000	EA	BRACKET - ANCHOR/FLOOR

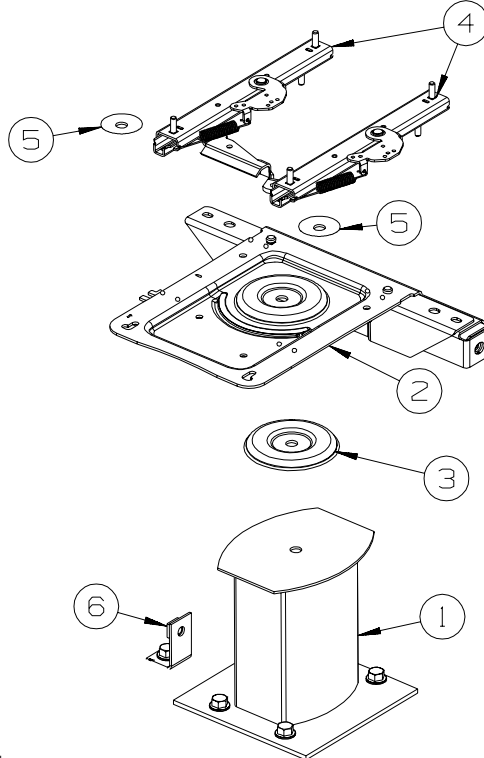

**PASSENGER
MANUAL**

KEY	PART NUMBER	U/M	DESCRIPTION
1	133408-01-000	EA	PEDESTAL - SEAT - DRIVER/PASSENGER - 9 3/4"
2	133408-20-000	EA	TOP PLATE - PASSENGER - W/ANCHOR
3	107921-06-000	EA	BEARING KIT - PEDESTAL
4	131566-04-000	EA	SLIDE/SEAT - HEAVY DUTY LOCKING - 5"
	119952-07-000	EA	WIRE - LATCH RELEASE/ROTARY
5	131566-05-000	EA	WASHER - SLIDE SPACER
6	133408-04-000	EA	BRACKET - ANCHOR/FLOOR

DRIVERS COMPARTMENT GROUP (CONTINUED)
FRONT INTERIOR (CONTINUED)

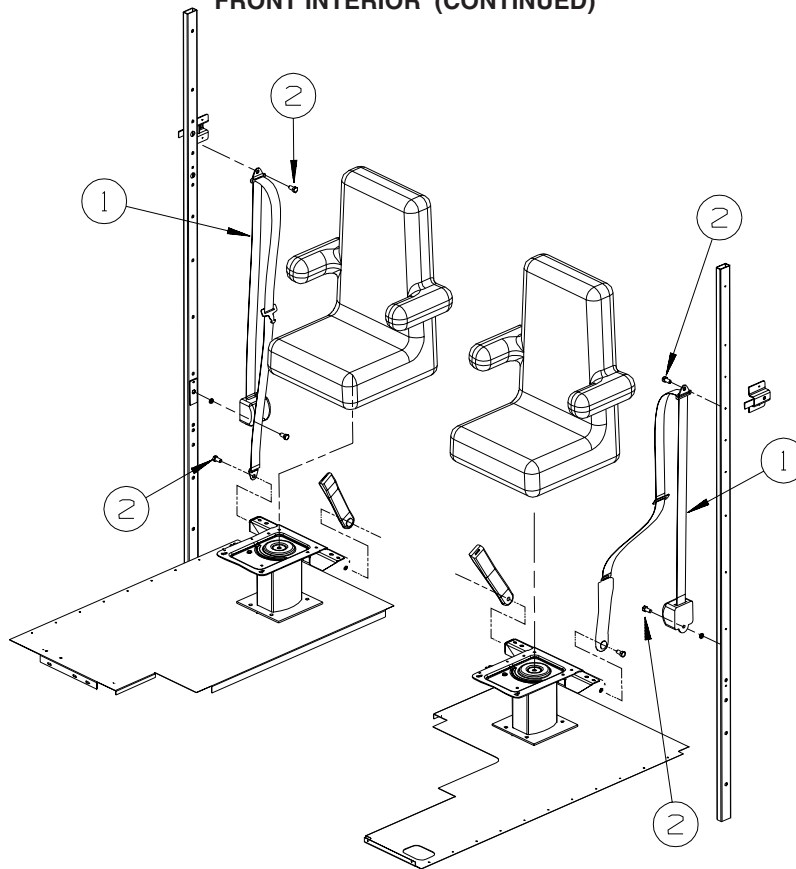

KEY	PART NUMBER	U/M	DESCRIPTION
1*	091990-04-01A	EA	SEAT BELT/SHOULDER HARNESS - DRIVERS/PASSENGER - BLACK
2	109146-01-000	EA	BOLT - SHOULDER/SEAT BELT

*COMPONENT PARTS LISTED LATER IN THIS GROUP

COMPONENT PARTS FOR FRONT INTERIOR

091990-04-01A

KEY	PART NUMBER	U/M	DESCRIPTION	VENDOR NO.
	091990-01-701	EA	EXTENDER 9" FOR A8408 3 PT	I-1331-02
	091990-01-703	EA	RECEIVER/FEMALE END-SEATBELT	I-1159-02
	091990-05-700	EA	SLEEVE/BUCKLE COVER-PLASTIC	209S-2
	091990-05-701	EA	CAP/COVER - BOLT HOLE COVER	209SC-02
	091990-05-702	EA	SLEEVE/RETRACTABLE COVER	309C-02
	091990-05-703	EA	EXTENDER 12"	I-1442-02

DRIVERS COMPARTMENT GROUP (CONTINUED)

CABINETS

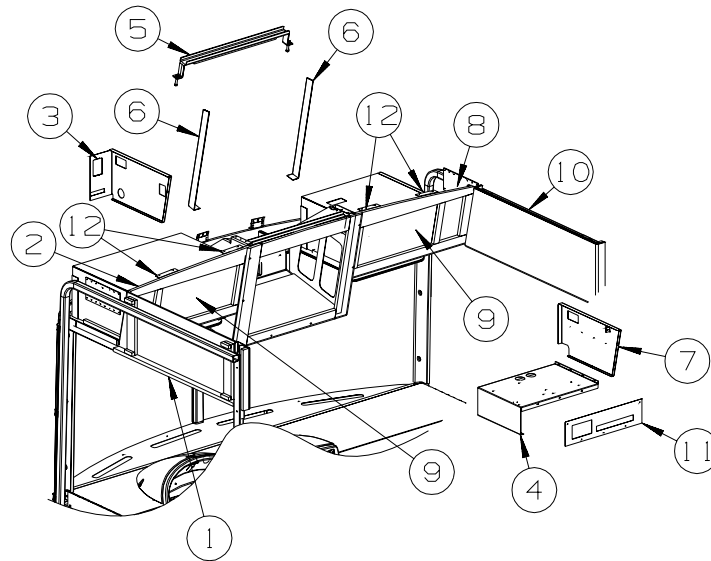

KEY	PART NUMBER	U/M	DESCRIPTION
1	138258-13-P31	EA	PANEL - FRONT/OVERHEAD - LEFT HAND
2	148442-02-U51	EA	CABINET - OVERHEAD/FRONT/LEFT HAND - W/O DOORS/HARDWARE (U51)
2	148442-02-U52	EA	CABINET - OVERHEAD/FRONT/LEFT HAND - W/O DOORS/HARDWARE (U52)
2	148442-02-T54	EA	CABINET - OVERHEAD/FRONT/LEFT HAND - W/O DOORS/HARDWARE (U53)
2	148442-02-TL1	EA	CABINET - OVERHEAD/FRONT/LEFT HAND - W/O DOORS/HARDWARE (U54)
2	148442-02-U55	EA	CABINET - OVERHEAD/FRONT/LEFT HAND - W/O DOORS/HARDWARE (U55)
2	148442-02-U56	EA	CABINET - OVERHEAD/FRONT/LEFT HAND - W/O DOORS/HARDWARE (U56)
3	134147-05-02B	EA	PANEL/SHELF - LEFT HAND - E-COATED
4	155345-01-02B	EA	BRACKET/SUPPORT - E-COATED
FROM: 00-00-00 THRU: 05-07-06			
5	160735-02-02B	EA	STRAP - TIEDOWN/TV - 31" - E-COATED
6	127842-01-01A	EA	SEAL - SIGHT SHIELD - 2" BLACK
7	134147-04-02B	EA	PANEL/SHELF - RIGHT HAND - E-COATED
8	148442-01-U51	EA	CABINET - OVERHEAD/FRONT/RIGHT HAND - W/O DOORS/HARDWARE (U51)
8	148442-01-U52	EA	CABINET - OVERHEAD/FRONT/RIGHT HAND - W/O DOORS/HARDWARE (U52)
8	148442-01-T54	EA	CABINET - OVERHEAD/FRONT/RIGHT HAND - W/O DOORS/HARDWARE (U53)
8	148442-01-U54	EA	CABINET - OVERHEAD/FRONT/RIGHT HAND - W/O DOORS/HARDWARE (U54)
8	148442-01-U55	EA	CABINET - OVERHEAD/FRONT/RIGHT HAND - W/O DOORS/HARDWARE (U55)
8	148442-01-U56	EA	CABINET - OVERHEAD/FRONT/RIGHT HAND - W/O DOORS/HARDWARE (U56)
9	146028-54-T54	EA	DOOR - GLASS INSERT/OGEE EDGE - 12" X 21.8" - W/O HDW - PORTSMOUTH OAK
9	146028-54-TL1	EA	DOOR - GLASS INSERT/OGEE EDGE - 12" X 21.8" - W/O HDW - SIERRA MAPLE
10	138258-12-R65	EA	PANEL - FRONT/OVERHEAD - RIGHT HAND
11	144923-03-U57	EA	PANEL/SHELF - W/CUTOUTS - VINYL COVERED (U51, U52, U53, U54)
FROM: 00-00-00 THRU: 05-07-06			
11	144923-07-U57	EA	PANEL/SHELF - W/CUTOUTS - VINYL COVERED (U51, U52, U53, U54)
FROM: 05-08-06 THRU: 99-99-99			
11	144923-03-U59	EA	PANEL/SHELF - W/CUTOUTS - VINYL COVERED (U55, U56)
FROM: 00-00-00 THRU: 05-07-06			
11	144923-07-U59	EA	PANEL/SHELF - W/CUTOUTS - VINYL COVERED (U55, U56)
FROM: 05-08-06 THRU: 99-99-99			
11	144923-04-U57	EA	PANEL/SHELF - W/CUTOUTS F/VIDEO/INVERTER (U51, U52, U53, U54)- INVERTER-DC/AC, 300 WATT
FROM: 00-00-00 THRU: 05-07-06			
11	144923-06-U57	EA	PANEL - W/CUTOUTS F/VIDEO/INVERTER (U51, U52, U53, U54)- INVERTER-DC/AC, 300 WATT
FROM: 05-08-06 THRU: 99-99-99			
11	144923-04-U59	EA	PANEL/SHELF - W/CUTOUTS F/VIDEO/INVERTER (U55, U56)- INVERTER-DC/AC, 300 WATT
FROM: 00-00-00 THRU: 05-07-06			
11	144923-06-U59	EA	PANEL - W/CUTOUTS F/VIDEO/INVERTER (U55, U56)- INVERTER-DC/AC, 300 WATT
FROM: 05-08-06 THRU: 99-99-99			
12	106699-01-01A	EA	BRACKET F/TV INSTALLATION - OVERHEAD CABINET

ELECTRICAL GROUP 110V BODY WIRING

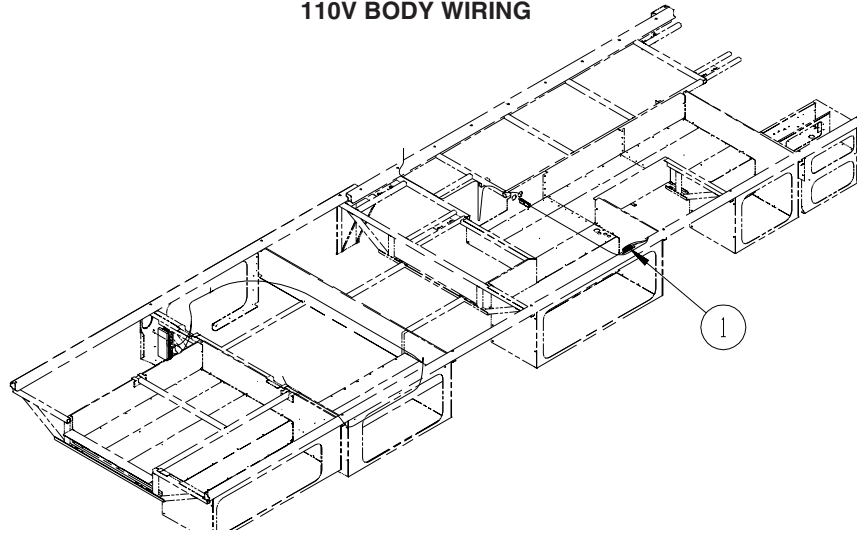

KEY	PART NUMBER	U/M	DESCRIPTION
1	058708-01-000	EA	RECEPTACLE - ELECTRIC - DOUBLE - BROWN

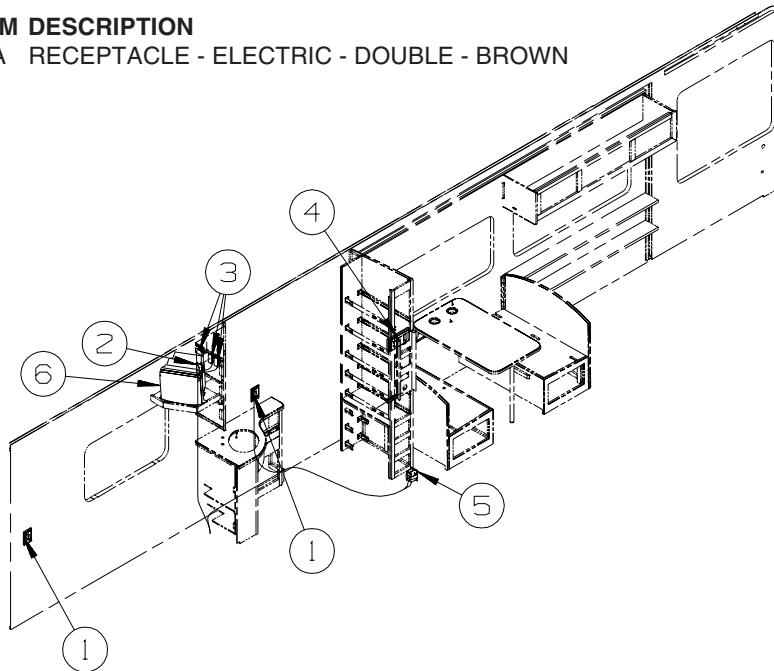

KEY	PART NUMBER	U/M	DESCRIPTION
1	058708-01-000	EA	RECEPTACLE - ELECTRIC - DOUBLE - BROWN
1	133713-01-08A	EA	SPACER/RECEPTACLE - VINYL - PORTSMOUTH OAK
1	133713-01-22A	EA	SPACER/RECEPTACLE - VINYL - SIERRA MAPLE
2	058708-01-000	EA	RECEPTACLE - ELECTRIC - DOUBLE - BROWN
3	058707-02-000	EA	RECEPTACLE - BLANK - JUNCTION BOX
4	058708-01-000	EA	RECEPTACLE - ELECTRIC - DOUBLE - BROWN
4	133713-06-08A	EA	SPACER/RECEPTACLE - PHONE - VINYL - PORTSMOUTH OAK
4	133713-06-22A	EA	SPACER/RECEPTACLE - PHONE - VINYL - SIERRA MAPLE
5	147446-01-02A	EA	RECEPTACLE - GFCI - 15A 125V - BROWN
			FROM: 00-00-00 THRU: 12-20-06
5	163319-01-02A	EA	RECEPTACLE - GFCI - 15A 125V - BROWN
			FROM: 12-21-06 THRU: 99-99-99
6	162051-01-000	EA	TV - 13" - COLOR/REMOTE - SANSUI #TVM1316E - US ONLY - TV-13" AC, COLOR W/REMOTE
6	162171-01-02B	EA	BRACKET - TV - E-COATED - TV-13" AC, COLOR W/REMOTE
6	162468-01-02B	EA	BRACKET - TV - E-COATED - TV-13" AC W/REMOTE

ELECTRICAL GROUP (CONTINUED)
110V BODY WIRING (CONTINUED)

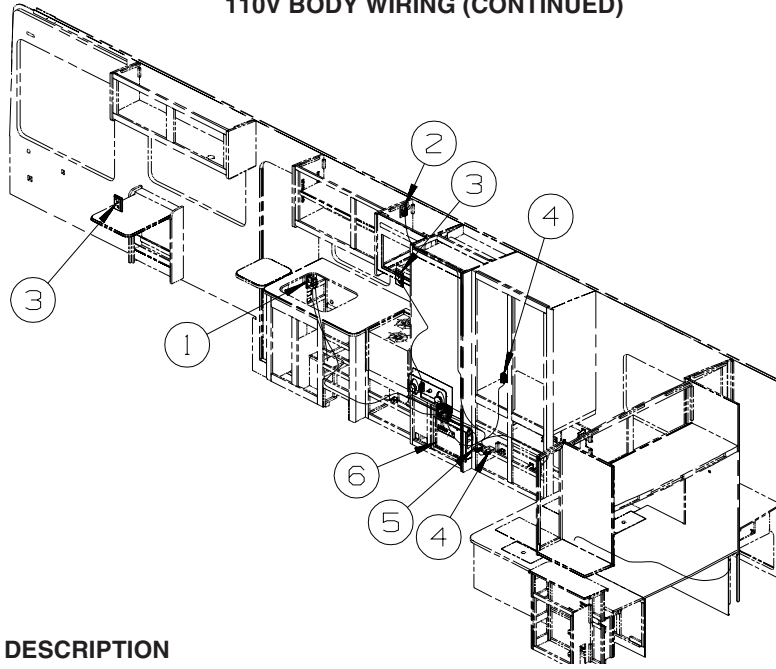

KEY	PART NUMBER	U/M	DESCRIPTION
1	147446-01-02A	EA	RECEPTACLE - GFCI - 15A 125V - BROWN FROM: 00-00-00 THRU: 12-20-06
1	163319-01-02A	EA	RECEPTACLE - GFCI - 15A 125V - BROWN FROM: 12-21-06 THRU: 99-99-99
2	058708-05-000	EA	RECEPTACLE - ELECTRICAL - SINGLE - BROWN
3	058708-01-000	EA	RECEPTACLE - ELECTRIC - DOUBLE - BROWN
3	133713-01-08A	EA	SPACER/RECEPTACLE - VINYL - PORTSMOUTH OAK
3	133713-01-22A	EA	SPACER/RECEPTACLE - VINYL - SIERRA MAPLE
4	058707-01-000	EA	RECEPTACLE - ELECTRIC - SINGLE - BROWN
5	058707-02-000	EA	RECEPTACLE - BLANK - JUNCTION BOX
6	095721-31-000	EA	LABEL - CONTROL CENTER - 30 AMP - US

ELECTRICAL GROUP (CONTINUED)

12V BODY WIRING

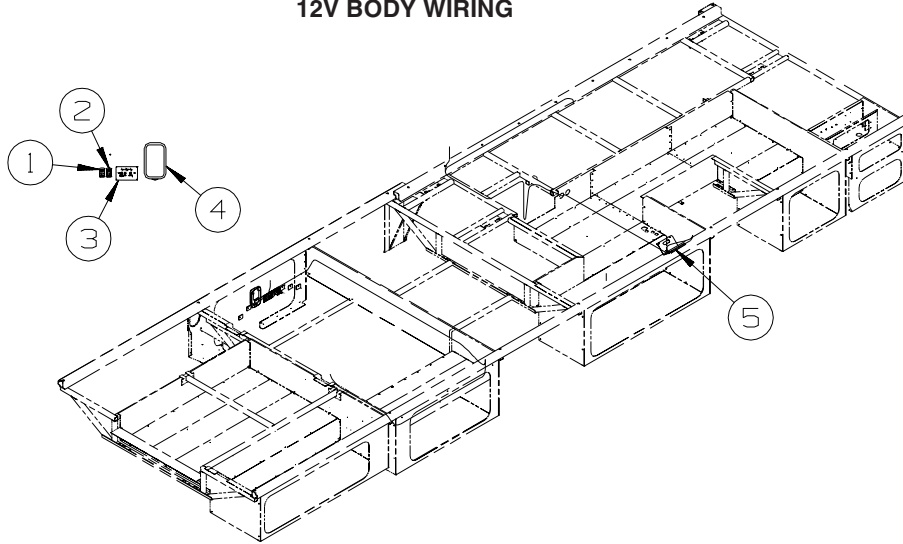

KEY	PART NUMBER	U/M	DESCRIPTION
1	108357-15-000	EA	SWITCH - ROCKER - DPDT - ON/NONE/ON - W/LIGHT W/O COVER
1	108356-04-01A	EA	COVER/ACTUATOR SWITCH - 2 ROWS DIMPLES W/LENS - BLACK
1	108355-01-000	EA	HOUSING - SWITCH
2	108357-18-000	EA	SWITCH - ROCKER - DPDT - MOM/OFF/MOM - W/O COVER - HYDRAULIC LEVEL JACKS-AUTO
2	108356-04-01A	EA	COVER/ACTUATOR SWITCH - 2 ROWS DIMPLES W/LENS - BLACK - HYDRAULIC LEVEL JACKS-AUTO
2	108355-01-000	EA	HOUSING - SWITCH - HYDRAULIC LEVEL JACKS-AUTO
2	096241-03-000	EA	SWITCH - BLANK - BLACK
3	149557-02-01A	EA	PLATE/WALL - PHONE/DUAL COAXIAL/HORIZONTAL - WHITE
4*	137417-01-01A	EA	LIGHT - DOME - SINGLE - W/SWITCH/FROSTED LENS - WHITE
5	082134-01-000	EA	ADAPTER - TV - CABLE TO CABLE
5	082136-01-000	EA	NUT - HEX JAM - 3/8-32
5	157486-01-02A	EA	LABEL - TV/EXTERIOR

***COMPONENT PARTS LISTED LATER IN THIS GROUP**

ELECTRICAL GROUP (CONTINUED)
12V BODY WIRING (CONTINUED)

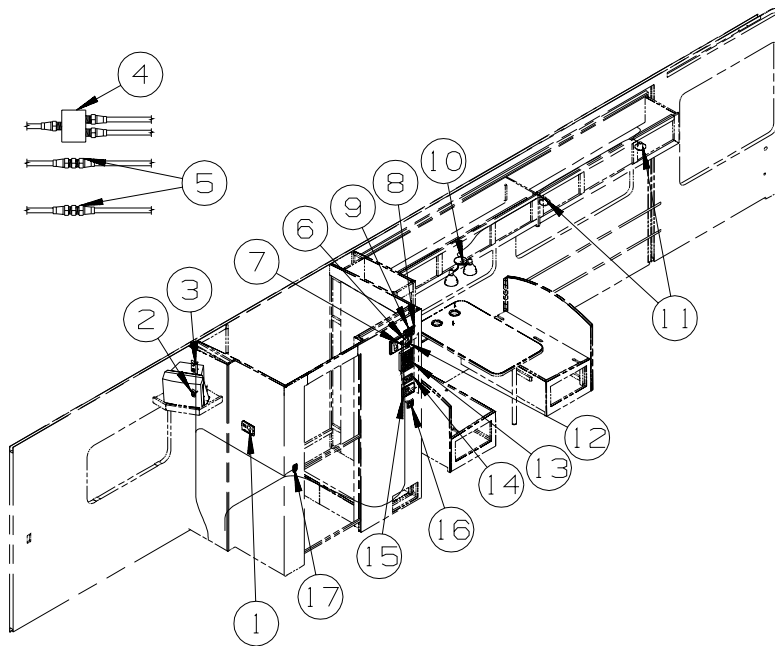

KEY	PART NUMBER	U/M	DESCRIPTION
1	135618-04-01A	EA	THERMOSTAT - ROOF A/C ONLY - WHITE - A/C ROOF-HI EFF (2) W/EMS
1	135618-03-01A	EA	THERMOSTAT - ROOF A/C & FURNACE - WHITE - AC HEAT PUMP-2 HI EFFICIENCY
2	135740-01-01A	EA	SWITCH - ROCKER - SPST - ON/OFF - BROWN
2	135741-01-01A	EA	SWITCH - BASE - SINGLE - BROWN
2	135742-45-02A	EA	BEZEL - SWITCH - TV - BROWN
3	076319-09-000	EA	WALLPLATE - TV CABLE RECEPTACLE - SINGLE - BROWN
3	076319-27-000	EA	WALLPLATE/RECEPTACLE - WHITE
4	086756-01-000	EA	SPLITTER - TV/2 WAY
5	082134-01-000	EA	ADAPTER - TV - CABLE TO CABLE
6	093253-01-02A	EA	PLATE - WALL - TELEPHONE - BROWN
7	132958-01-000	EA	RECEPTACLE - 12 VOLT - MOUNTING FLANGE - BLACK
8	138173-04-000	EA	CONTROL PANEL (TOUCH PAD) - ELECTRIC SLIDEOUT - #1802931
9	116549-01-000	EA	LABEL - WARNING - SLIDEOUT
10	093575-47-01A	EA	LIGHT - CEILING/DOUBLE - BRUSHED NICKEL
11	132427-01-02A	EA	LIGHT - READING/SWIVEL - ROUND - NICKEL
12	135740-06-01A	EA	SWITCH - ROCKER - ON/OFF - LIGHTED - RED
12	135741-01-01A	EA	SWITCH - BASE - SINGLE - BROWN
12	135742-35-02A	EA	BEZEL - SWITCH - WATER HEATER/110 VOLT - BROWN
13*	134940-06-01A	EA	PANEL - MONITOR - 2 TANK - W/GENERATOR SWITCH
14	127002-10-000	EA	PANEL/MONITOR - ENERGY MANAGEMENT SYSTEMS CTRL - W/3 PLUG
15	135618-03-01A	EA	THERMOSTAT - ROOF A/C & FURNACE - WHITE - A/C ROOF-HI EFF (2) W/EMS
15	135618-01-01A	EA	THERMOSTAT - HEAT PUMP/FURNACE - WHITE - AC HEAT PUMP-2 HI EFFICIENCY
16	135740-01-01A	EA	SWITCH - ROCKER - SPST - ON/OFF - BROWN
16	135740-02-01A	EA	SWITCH - ROCKER - SPDT - ON/ON - BROWN
16	135741-02-01A	EA	SWITCH - BASE - DOUBLE - BROWN
16	135742-16-02A	EA	BEZEL - SWITCH - CEILING/HALL - BROWN
17	135740-01-01A	EA	SWITCH - ROCKER - SPST - ON/OFF - BROWN
17	135741-01-01A	EA	SWITCH - BASE - SINGLE - BROWN
17	135742-07-02A	EA	BEZEL - SWITCH - CEILING - BROWN

*COMPONENT PARTS LISTED LATER IN THIS GROUP

ELECTRICAL GROUP (CONTINUED)

12V BODY WIRING (CONTINUED)

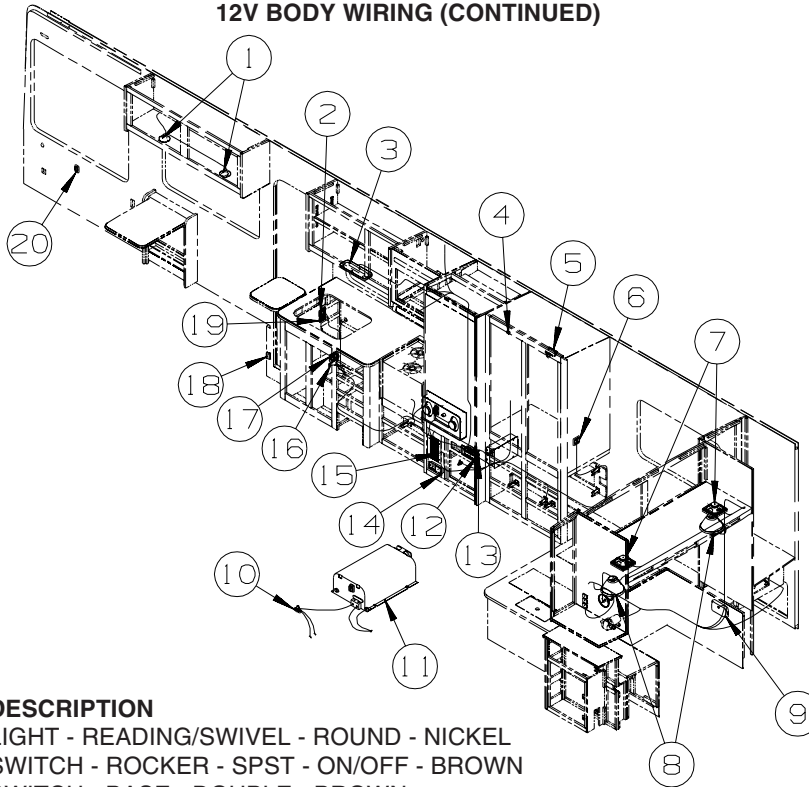

KEY	PART NUMBER	U/M	DESCRIPTION
1	132427-01-02A	EA	LIGHT - READING/SWIVEL - ROUND - NICKEL
2	135740-01-01A	EA	SWITCH - ROCKER - SPST - ON/OFF - BROWN
2	135741-02-01A	EA	SWITCH - BASE - DOUBLE - BROWN
2	135742-19-02A	EA	BEZEL - SWITCH - CEILING/PORCH - BROWN
3*	137417-05-01A	EA	LIGHT - DOME - DOUBLE - W/SWITCH/OPTIC LENS - WHITE
4	056264-01-000	EA	SWITCH - LEAF ACTUATOR
5*	087694-01-000	EA	LIGHT - WARDROBE/CLOSET - W/SWITCH
6	135740-01-01A	EA	SWITCH - ROCKER - SPST - ON/OFF - BROWN
6	135740-02-01A	EA	SWITCH - ROCKER - SPDT - ON/ON - BROWN
6	135741-02-01A	EA	SWITCH - BASE - DOUBLE - BROWN
6	135742-16-02A	EA	BEZEL - SWITCH - CEILING/HALL - BROWN
7	094097-01-000	EA	SPEAKER - RADIO/TV - W/O GRILLE - 5.25" DIAMETER
7	089340-02-000	EA	GRILLE - SPEAKER - 6.5" SQUARE
8	119258-55-01A	EA	LAMP - WALL - UL/CSA - BRUSHED NICKEL
8	119257-25-01A	EA	SHADE - LAMP - IVORY
9*	137417-01-01A	EA	LIGHT - DOME - SINGLE - W/SWITCH/FROSTED LENS - WHITE
10	086233-01-000	EA	STUD - ISOLATED - 3/8" X 7/8" LONG
11	123058-02-000	EA	CONVERTER - 45 AMP - ELECTRONIC - 4 1/8"H X 7"W X 12 3/8"L
12	092547-06-000	EA	LABEL - CIRCUIT BREAKER
13	139067-01-02B	EA	PLATE - CIRCUIT BREAKER/HOUSE - E-COATED
14	150138-01-02A	EA	DETECTOR - LP GAS - BROWN
14	150138-01-01A	EA	DETECTOR - LP GAS - WHITE
15	124884-01-000	EA	SPEAKER - 6" X 9" - SUB-WOOFER - W/O GRILLE - HOME THEATER SOUND SYSTEM
15	151844-01-01A	EA	GRILLE - SPEAKER - 6" X 9" - SUB WOOFER - BLACK - HOME THEATER SOUND SYSTEM
16	061424-01-000	EA	LIGHT - AISLE - 12 VOLT - RECTANGULAR
17	108357-06-000	EA	SWITCH - ROCKER - DPDT - MOM/OFF/MOM - 6 TERM - W/O COVER
17	108356-11-01A	EA	COVER/ACTUATOR SWITCH - 3 GROOVES - AUX BATT - BLACK
17	108355-01-000	EA	HOUSING - SWITCH
17	098351-22-02A	EA	PLATE/SWITCH - 2 GANG - CHROME
17	108357-18-000	EA	SWITCH - ROCKER - DPDT - MOM/OFF/MOM - W/O COVER - HYDRAULIC LEVEL JACKS-AUTO
17	108356-15-01A	EA	COVER/ACTUATOR SWITCH - 3 GROOVES-LEVEL JACKS/REMOTE - HYDRAULIC LEVEL JACKS-AUTO
17	108355-01-000	EA	HOUSING - SWITCH - HYDRAULIC LEVEL JACKS-AUTO
17	096241-03-000	EA	SWITCH - BLANK - BLACK
18	116995-02-000	EA	SWITCH/MAGNET - ELECTRIC STEP - BLACK/WHITE- NORMALLY OPEN
19	135740-01-01A	EA	SWITCH - ROCKER - SPST - ON/OFF - BROWN
19	135741-01-01A	EA	SWITCH - BASE - SINGLE - BROWN
19	135742-11-02A	EA	BEZEL - SWITCH - STEP - BROWN
20	135740-01-01A	EA	SWITCH - ROCKER - SPST - ON/OFF - BROWN
20	135741-01-01A	EA	SWITCH - BASE - SINGLE - BROWN
20	135742-01-01A	EA	BEZEL - SWITCH - SINGLE - BROWN

*COMPONENT PARTS LISTED LATER IN THIS GROUP

ELECTRICAL GROUP (CONTINUED)
12V BODY WIRING (CONTINUED)

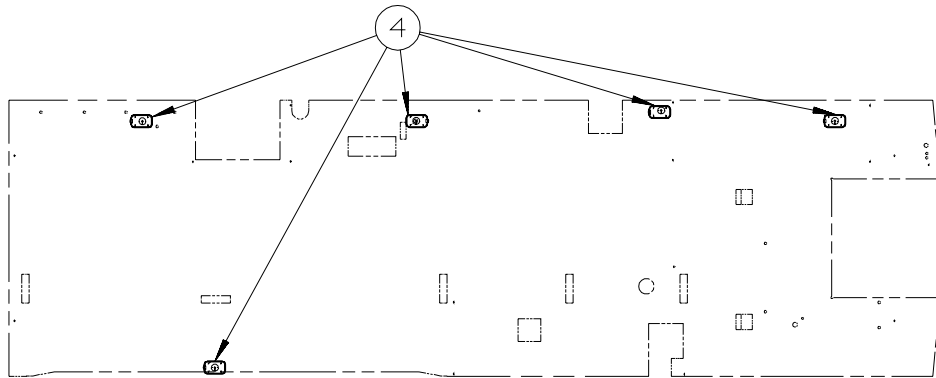
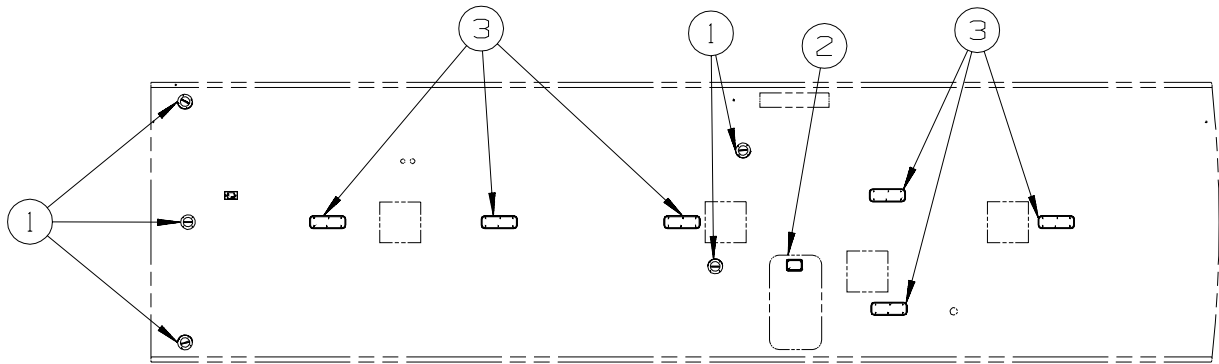

KEY	PART NUMBER	U/M	DESCRIPTION
1	151314-01-01A	EA	SPEAKER - CUBE/CEILING - WHITE - MAGNADYNE - LS3CM-WN FROM: 00-00-00 THRU: 07-09-06
1	160867-01-01A	EA	SPEAKER - ROUND/CEILING - CREAM - MAGNADYNE - LS3EYC-WN FROM: 07-10-06 THRU: 99-99-99
2*	121935-01-01A	EA	LIGHT - DOME - SHOWER - W/HOLE IN LENS
3*	137417-06-01A	EA	LIGHT - DOME - DOUBLE - W/O SWITCH - W/FROSTED LENS-WHITE
4*	137417-01-01A	EA	LIGHT - DOME - SINGLE - W/SWITCH/FROSTED LENS - WHITE

***COMPONENT PARTS LISTED LATER IN THIS GROUP**

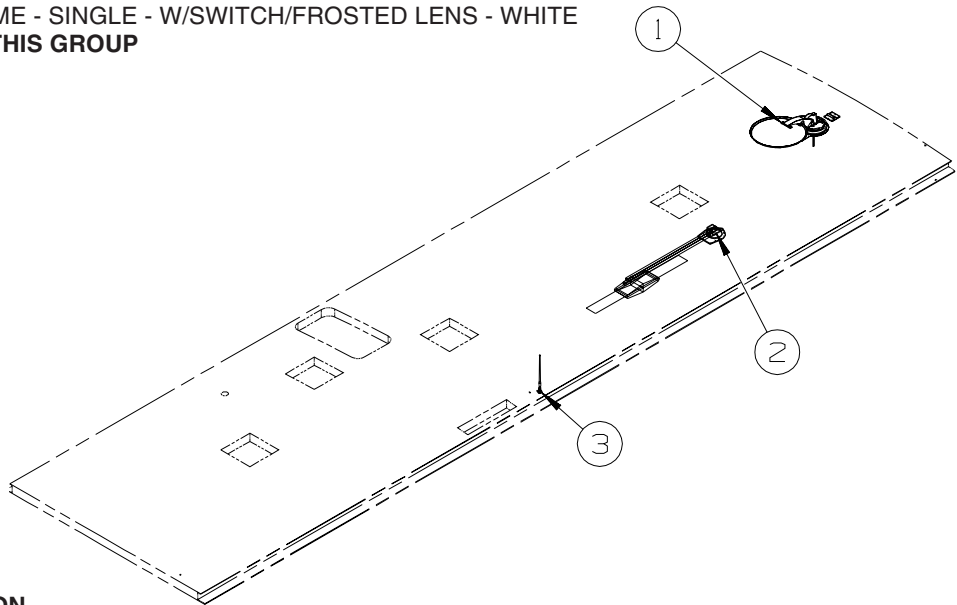

KEY	PART NUMBER	U/M	DESCRIPTION
1*	137135-02-000	EA	ANTENNA - SATELLITE DSS - W/SENSOR - SATELLITE DISH & ELEV.SENSOR
2*	076319-23-000	EA	ANTENNA - TV ROOF MOUNT - 44.5" MAST
2*	076319-25-000	EA	KIT - HARDWARE INTERIOR
2	069726-02-000	EA	BUMPER - .88" OD X .40" THICK - BLACK
3	090944-01-000	EA	ANTENNA - RADIO - 16" RUBBER - W/72" LEAD WIRE
3	109889-04-000	EA	EXTENDER - ANTENNA SHAFT - 3.7"
3	147741-01-09B	EA	BRACKET - ANTENNA GROUND - GALVANIZED

***COMPONENT PARTS LISTED LATER IN THIS GROUP**

ELECTRICAL GROUP (CONTINUED)
12V BODY WIRING (CONTINUED)

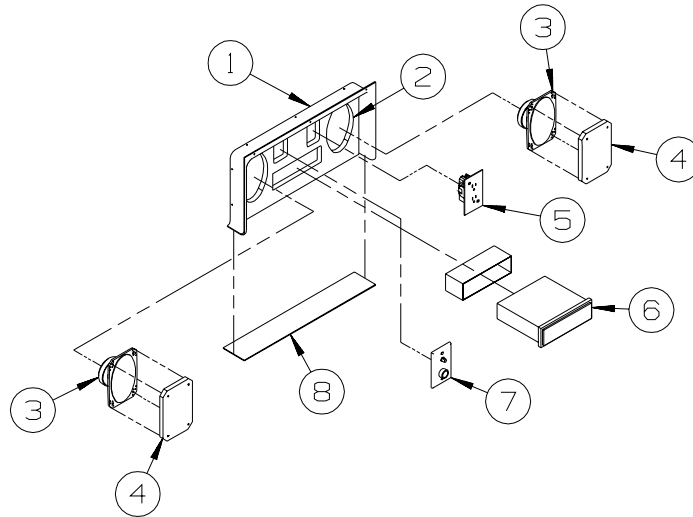

KEY	PART NUMBER	U/M	DESCRIPTION
1	124696-02-01A	EA	BOX-ENTERTAINMENT CTR/EXT-19.4"W X 10"H X 2.5"D - BRT WHT
	124696-01-01A	EA	BOX-ENTERTAINMENT CTR/EXT-19.4"W X 10"H X 10.2"D W/CUTOUTS
2	127409-03-U89	EA	PLATE - RADIO MOUNTING
3	110469-01-000	EA	SPEAKER - 4" X 6" OVAL - COAXIAL
4	110470-01-01A	EA	GRILLE - 4" X 6" - OVAL SPEAKER - BLACK
5	058708-01-000	EA	RECEPTACLE - ELECTRIC - DOUBLE - BROWN
6*	155619-01-000	EA	RADIO - AM/FM CD - W/REMOTE - MAGNADYNE M3200CD FROM: 00-00-00 THRU: 08-01-06
6	155619-02-000	EA	RADIO - AM/FM CD-W/O REMOTE/WIRE HARNESS-MAGNADYNE M3200CD FROM: 08-02-06 THRU: 99-99-99
	155619-03-000	EA	REMOTE - RADIO FROM: 08-02-06 THRU: 99-99-99
7	132958-01-000	EA	RECEPTACLE - 12 VOLT - MOUNTING FLANGE - BLACK
8	104898-01-02A	EA	PLATE - PLASTIC BOTTOM - BRIGHT WHITE

***COMPONENT PARTS LISTED LATER IN THIS GROUP**

ELECTRICAL GROUP (CONTINUED)
EXTERIOR LAMPS

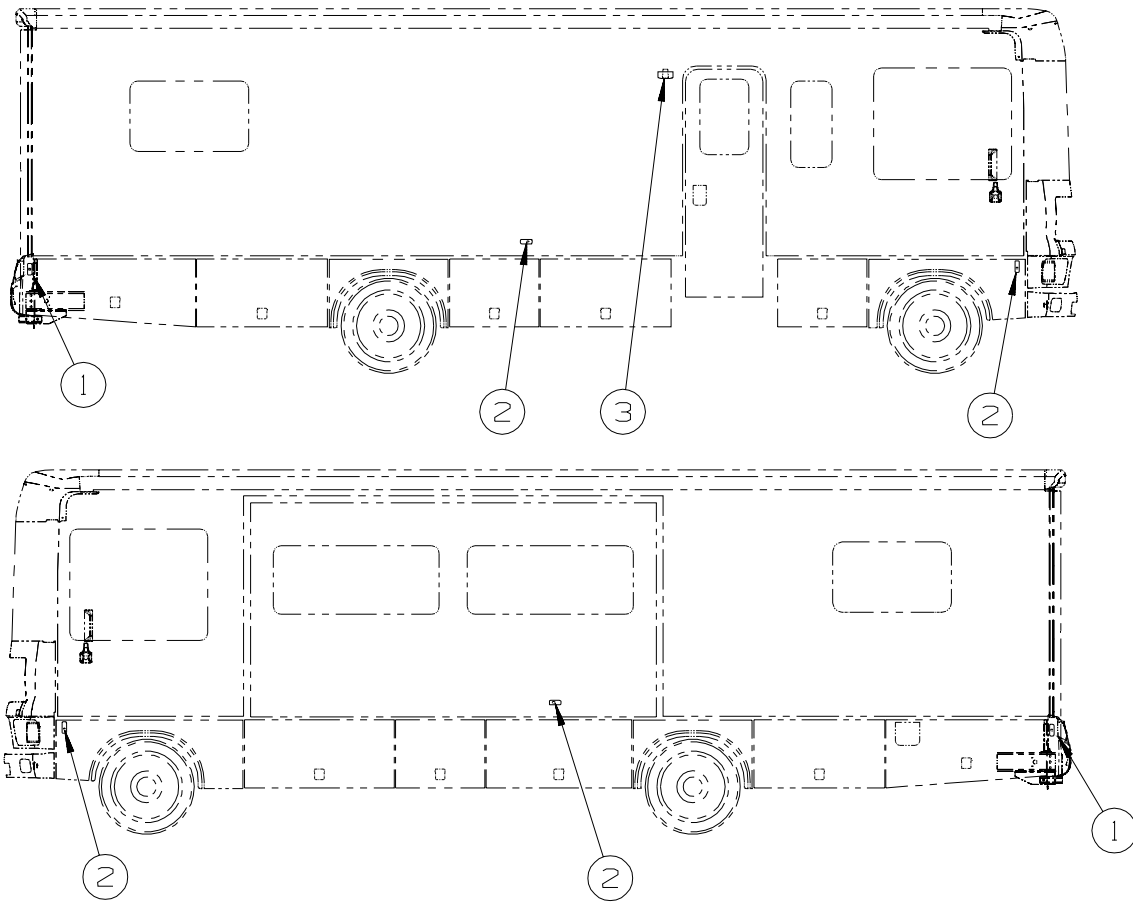

KEY	PART NUMBER	U/M	DESCRIPTION
1	147680-01-01A	EA	BASE - MARKER LAMP - WHITE
1	147680-03-01A	EA	LAMP - MARKER - LENS - RED
2	147680-01-01A	EA	BASE - MARKER LAMP - WHITE
2	147680-02-01A	EA	LAMP - MARKER - LENS - AMBER
3*	097917-01-06A	EA	LIGHT - PORCH - ENTRY DOOR - BRIGHT WHITE
	008215-01-000	EA	BULB - 12 VOLT - #1003 - .94 AMP

***COMPONENT PARTS LISTED LATER IN THIS GROUP**

ELECTRICAL GROUP (CONTINUED)
EXTERIOR LAMPS (CONTINUED)

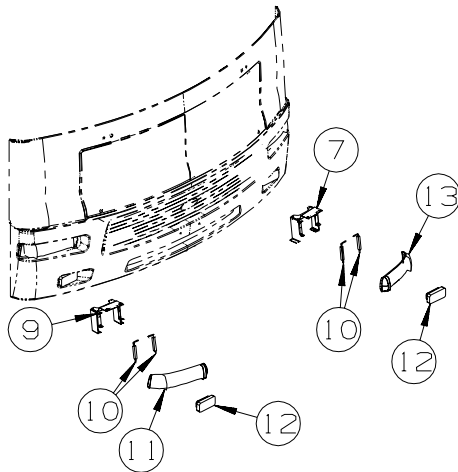
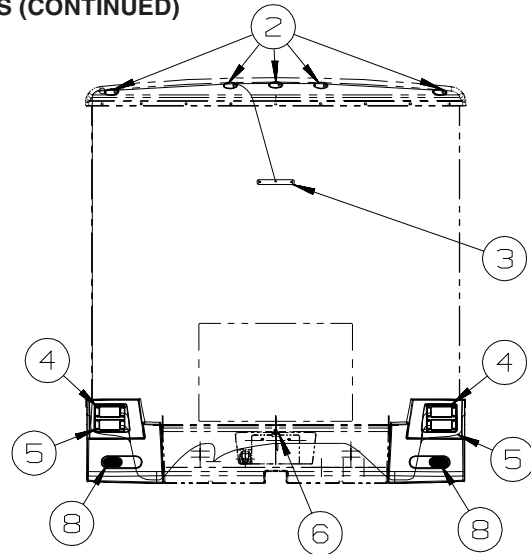
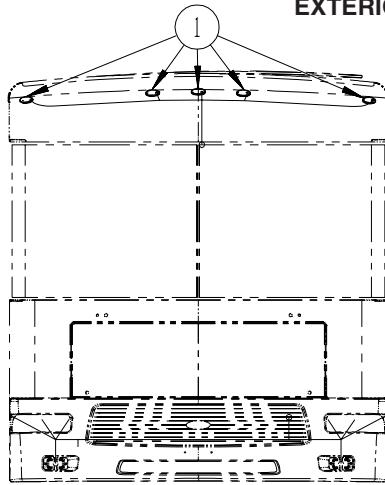

KEY	PART NUMBER	U/M	DESCRIPTION
1	147680-01-01A	EA	BASE - MARKER LAMP - WHITE
1	147680-02-01A	EA	LAMP - MARKER - LENS - AMBER
2	147680-01-01A	EA	BASE - MARKER LAMP - WHITE
2	147680-03-01A	EA	LAMP - MARKER - LENS - RED
3	136916-01-000	EA	LIGHT - BRAKE - CENTER MOUNT - RECTANGLE - 1.3" X 9.8"
4	152352-03-000	EA	LAMP - STOP/TURN/TAIL - RED
	037935-01-000	EA	BULB - 12V - #1157 OR #2057 - 2.1 AMP - CLEAR GLASS
5	152352-01-000	EA	LIGHT - BACKUP - CLEAR LENS - W/O SOCKET
	037934-01-000	EA	BULB - 12V - #1156 - 2.1 AMP - CLEAR GLASS
6	087201-01-000	EA	LIGHT - HALF ROUND - 1" X 1.7" - PLASTIC - BLACK OR WHITE
7	147901-02-02B	EA	BRACKET/HEADLAMP - DRIVER - E-COATED
			FROM: 00-00-00 THRU: 03-04-07
7	164261-02-02B	EA	BRACKET/HEADLAMP - DRIVER - E-COATED
			FROM: 03-05-07 THRU: 99-99-99
8	157998-01-000	EA	REFLECTOR - OVAL/RED - 1.9" X 4.3"
9	147901-01-02B	EA	BRACKET/HEADLAMP - PASSENGER - E-COATED
			FROM: 00-00-00 THRU: 03-04-07
9	164261-01-02B	EA	BRACKET/HEADLAMP - PASSENGER - E-COATED
			FROM: 03-05-07 THRU: 99-99-99
10	148111-01-01A	EA	PIN-MOUNT - HEADLAMP - BLACK
			FROM: 00-00-00 THRU: 03-04-07
11	148629-01-000	EA	HEADLAMP - PASSENGER/(HIGH/LOW) - W/BULB
	124187-01-000	EA	SOCKET/HOUSING
	124187-02-000	EA	SOCKET/HOUSING - HIGH BEAM HEADLAMP
12	159077-01-000	EA	LAMP - PARK/TURN - AMBER
13	148629-02-000	EA	HEADLAMP - DRIVER/(HIGH/LOW) - W/BULB
	124187-01-000	EA	SOCKET/HOUSING
	124187-02-000	EA	SOCKET/HOUSING - HIGH BEAM HEADLAMP
	157593-01-000	EA	CONNECTOR - PLUG - TRAILER - 7 SOCKET
	146246-01-000	EA	CONNECTOR/PLUG - TRAILER - 7 PIN

ELECTRICAL GROUP (CONTINUED) FRONT END

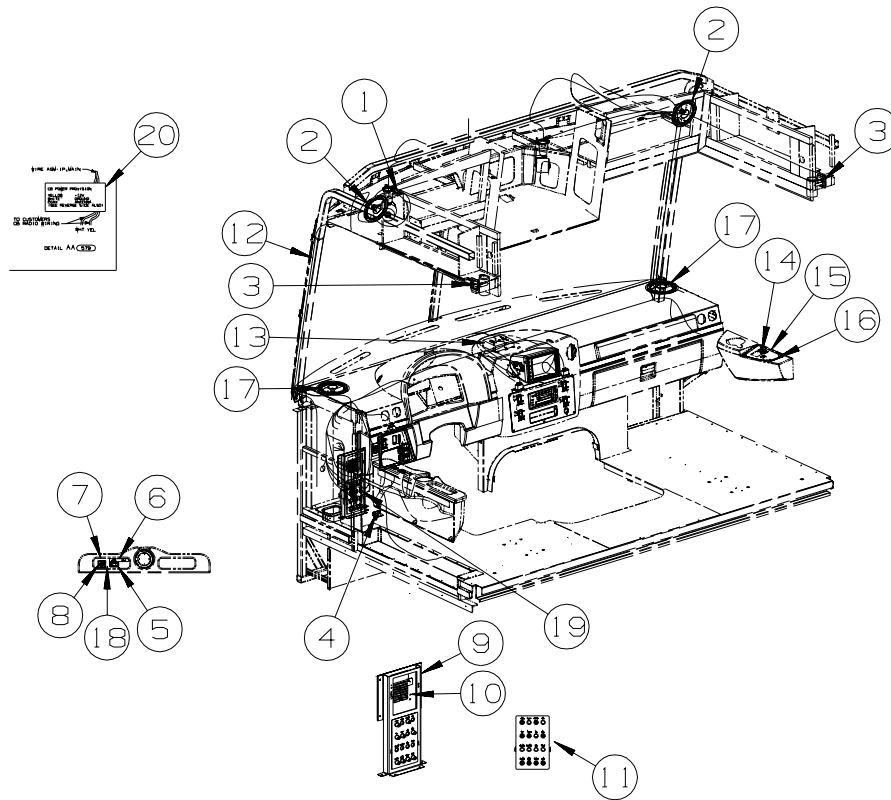

KEY	PART NUMBER	U/M	DESCRIPTION
1	122856-01-01A	EA	FAN-DEFROSTER-2 SPEED W/SWIVEL BASE/NON-OSCILLATING-CHROME
2	094097-01-000	EA	SPEAKER - RADIO/TV - W/O GRILLE - 5.25" DIAMETER
3	149590-01-02A	EA	LIGHT - READING/SWIVEL - W/O SWITCH - NICKEL
	123917-01-000	EA	BULB - 12V - HALOGEN SPOT
4	147428-01-02B	EA	BRACKET/ZEE - F/TEMPERATURE SENSOR - E-COATED - WORKHORSE
5	145638-02-01A	EA	SWITCH/ROCKER - SPST (ON/OFF) - LIGHTED - BLACK
6	133533-04-01A	EA	LABEL - WINDOW/MIRROR HEAT - BLACK/CLEAR
7	158280-01-02B	EA	PLATE - SWITCH - MIRROR/HEAT - E-COATED
8	088246-01-000	EA	SWITCH/REMOTE MIRROR - W/2PIN & 6 PIN CONNECTORS/PIGTAIL
9	149689-01-02B	EA	BRACKET - CIRCUIT BREAKER - E-COATED
10	149690-01-02B	EA	BRACKET - FUSE PANEL - E-COATED - WORKHORSE
10	149690-02-02B	EA	BRACKET - FUSE PANEL - E-COATED - FORD
11	093236-47-000	EA	LABEL - CIRCUIT BREAKER
12	158494-02-000	EA	CABLE/ANTENNA - SATELLITE RADIO SIRRUS
13	135420-20-000	EA	RECEIVER - SATELLITE RADIO
14	NOT USED		
15	NOT USED		
16	NOT USED		
17	NOT USED		
18	158280-01-02B	EA	PLATE - SWITCH - MIRROR/HEAT - E-COATED
19	NOT USED		
20	104678-01-000	EA	LABEL - CB PREP

CANADIAN DAY RUN LAMPS ON 2007 FORD CHASSIS

KEY	PART NUMBER	U/M	DESCRIPTION
	163912-01-000	EA	RESISITOR - DAYTIME RUNNING LIGHTS - FORD/CSA
	163913-01-000	EA	RELAY - DAYTIME RUNNING LIGHTS - FORD/CSA

ELECTRICAL GROUP (CONTINUED) FRONT END (CONTINUED)

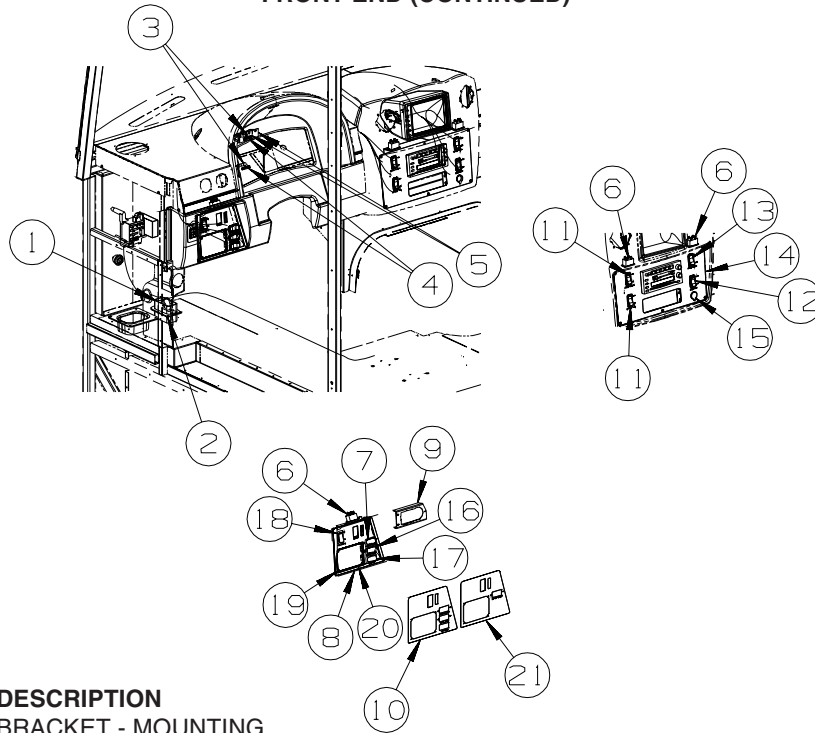

KEY	PART NUMBER	U/M	DESCRIPTION
1	118571-03-000	EA	BRACKET - MOUNTING
2	118571-04-000	EA	GASKET
3	150237-01-000	EA	LIGHT - INDICATOR - RED
4	133533-01-01A	EA	LABEL - JACKS DOWN - CLEAR W/WHITE LETTERING
5	063912-02-000	EA	RELAY - CANISTER - SPDT
6	157655-01-01A	EA	LIGHT - DASH/SWITCH - 2 LAMP INCANDESCANT - BLACK HOUSING
7	145638-04-01A	EA	SWITCH/ROCKER - SPDT (ON/ON) - BLACK
8	156292-10-01A	EA	APPLIQUE - DRIVERS/LEFT - FORD - DARK ANTELOPE
9	155516-01-02B	EA	MOUNT - HEADLAMP SWITCH - E-COATED
10	156292-08-01A	EA	APPLIQUE - DRIVERS/LEFT - WORKHORSE - DARK ANTELOPE
11	145638-03-01A	EA	SWITCH/ROCKER - SPDT (ON/OFF/ON) - BLACK
11	108355-02-000	EA	HOUSING - SWITCH - 12 POSITION
11	145754-01-01A	EA	SWITCH - BLANK - BLACK
12	NOT USED		
13	145638-07-01A	EA	SWITCH/ROCKER - DPDT (ON/ON) - BLACK
14	156292-07-01A	EA	APPLIQUE - BEZEL - CENTER - DARK ANTELOPE
15	111414-01-000	EA	RECEPTACLE/SOCKET - 12 VOLT
16	145638-01-01A	EA	SWITCH/ROCKER - SPST (ON/OFF) - BLACK - WORKHORSE
17	145638-14-01A	EA	SWITCH/ROCKER - DPDT (ON/OFF/ON) - BLACK - WORKHORSE
17	103603-01-000	EA	BULB - 12V - #74 - .12A WEDGE - GE 22-25 USED IN DASH
18	NOT USED		
19	134149-01-04B	EA	PLATE - COVER - LEVEL JACK CONTROL - BLACK
20	156292-11-01A	EA	APPLIQUE - COVER - LEVEL JACK - DARK ANTELOPE
21	156292-09-01A	EA	APPLIQUE - DRIVERS/LEFT - WORKHORSE - DARK ANTELOPE

ELECTRICAL GROUP (CONTINUED)

FRONT TV/VCR

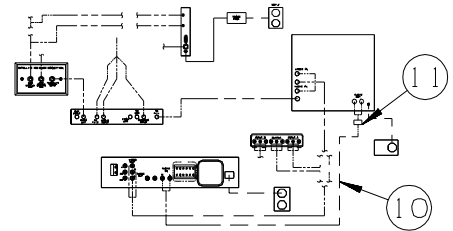
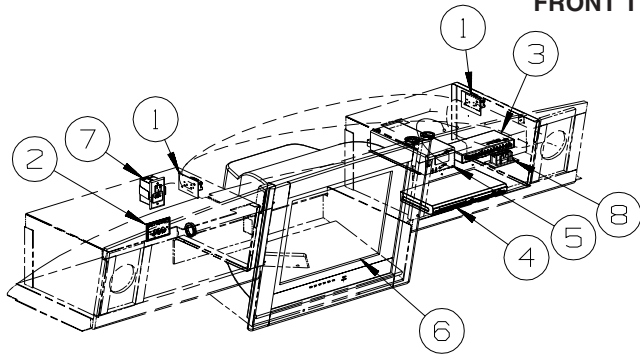

HOME THEATER SOUND SYSTEM

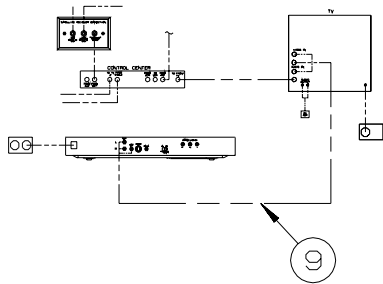

KEY	PART NUMBER	U/M	DESCRIPTION
1	058708-01-000	EA	RECEPTACLE - ELECTRIC - DOUBLE - BROWN
1	158542-02-01A	EA	LABEL - RECEPTACLE - ELECTRONICS - WHITE/BLACK - CANADIAN
2	149557-04-01A	EA	PLATE/WALL - TRIPLE COAXIAL/HORIZONTAL - WHITE
3	142258-01-000	EA	SWITCH - VIDEO/ANTENNA POWER SUPPLY - VIDEO SELECTION SYSTEM
4	159771-01-000	EA	DVD/MP3 PLAYER - PROGRESSIVE SCAN - MEMOREX MVD2022 - DVD PLAYER FROM: 00-00-00 THRU: 04-11-06
4	164584-01-000	EA	DVD/MP3 PLAYER - PROGRESSIVE SCAN - MEMOREX MVD2023 - DVD PLAYER FROM: 04-12-06 THRU: 99-99-99
4*	150089-01-000	EA	DVD/VCR PLAYER - RCA RTD300/SP - HOME THEATER SYSTEM FROM: 00-00-00 THRU: 03-12-06
4*	158836-01-000	EA	DVD - HOME THEATER - W/O SPEAKERS - MEMOREX STS71E-R - HOME THEATER SYSTEM FROM: 03-13-06 THRU: 99-99-99
5	099048-04-000	EA	INVERTER - 300 WATT
6	152441-03-000	EA	TV - 24" - STEREO/5 JACKS - RCA 24V412TAO
7	156676-01-000	EA	CONTROLLER/OUTLET - POWER/TV - AUTO SHUTOFF W/IGNITION
8	058708-01-000	EA	RECEPTACLE - ELECTRIC - DOUBLE - BROWN
9	136860-01-000	EA	CABLE - RCA - SHIELDED - 3 MALE TO MALE CONNECTORS - 12'
10	117420-02-000	EA	CABLE - W/MALE RCA ENDS - SHIELDED - 4'
11	123324-01-000	EA	FILTER - GROUND LOOP

*COMPONENT PARTS LISTED LATER IN THIS GROUP

ELECTRICAL GROUP (CONTINUED)
COMPONENT PARTS FOR WIRING

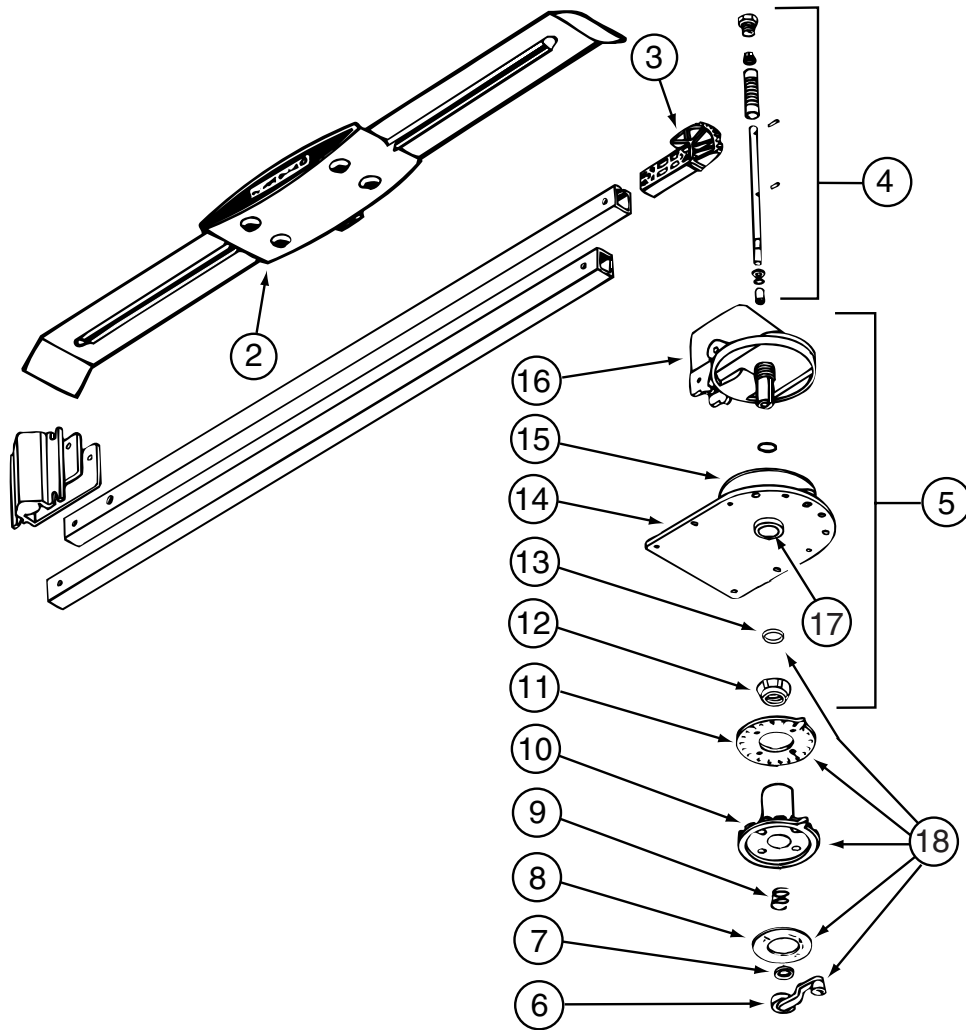

076319-23-000

KEY	PART NUMBER	U/M	DESCRIPTION	VENDOR NO.
2	076319-01-700	EA	HEAD-ANTENNA, AMPLIFIED	RVSA U/V
3	076319-01-701	EA	GEAR-ELEVATING, PLASTIC	2200046
4	076319-01-702	EA	SHAFT ASM-ELEVATING	RP-4000
5	076319-01-711	EA	BASE & LIFT ASM	2762802
7	076319-01-705	EA	GROMMET-NYLON, 7/8"ID	3200658
8	076319-01-708	EA	DECAL-CRANK	5413002
9	076319-01-707	EA	SPRING-HANDLE	2160822
11	076319-01-712	EA	PLATE - CEILING	3200608
12	076319-01-715	EA	NUT (GEAR HOUSING)	2200047
14	076319-01-713	EA	PLATE-BASE, STEEL	3100523
15	076319-01-703	EA	BEARING-NYLON, 5"OD	3200656
16	076319-01-714	EA	HOUSING, ROTATING GEAR	2200049
17	076319-01-704	EA	BEARING-NYLON, 1.25"OD	3200657
18	076319-01-709	EA	HANDLE-HEAD DIRECTIONAL	200644
	076319-01-716	EA	TUBING, ELEVATING	RP-2900

CONTACT WINNEBAGO PART SALES FOR UNLISTED COMPONENT(S)

076319-25-000

KEY	PART NUMBER	U/M	DESCRIPTION	VENDOR NO.
6	076319-01-706	EA	CRANK-W/SET SCREW UNIV/BEIGE	2750897
6	120233-01-710	EA	HANDLE-CRANK W/SCREW - WHITE	RP-6795
8	076319-01-708	EA	DECAL-CRANK	5413002
10	076319-25-700	EA	DIRECTIONAL HANDLE(WHITE)	3200612
11	076319-25-701	EA	PLATE - CEILING(WHITE)	3200609
13	120233-01-709	EA	WASHER-NYLON	RP-2658

CONTACT WINNEBAGO PART SALES FOR UNLISTED COMPONENT(S)

ELECTRICAL GROUP (CONTINUED)

COMPONENT PARTS FOR WIRING (CONTINUED)

083208-07-000

KEY	PART NUMBER	U/M DESCRIPTION	VENDOR NO.
	083208-06-701	EA CONVERTER ONLY (LOWER UNIT)	7345R

087694-01-000

KEY	PART NUMBER	U/M DESCRIPTION	VENDOR NO.
	087694-01-700	EA BULB	GE561

097917-01-06A

KEY	PART NUMBER	U/M DESCRIPTION	VENDOR NO.
	097917-01-700	EA LENS-LIGHT, CLEAR	30-78-021

121935-01-01A

KEY	PART NUMBER	U/M DESCRIPTION	VENDOR NO.
	121935-01-700	EA LENS ONLY	809511

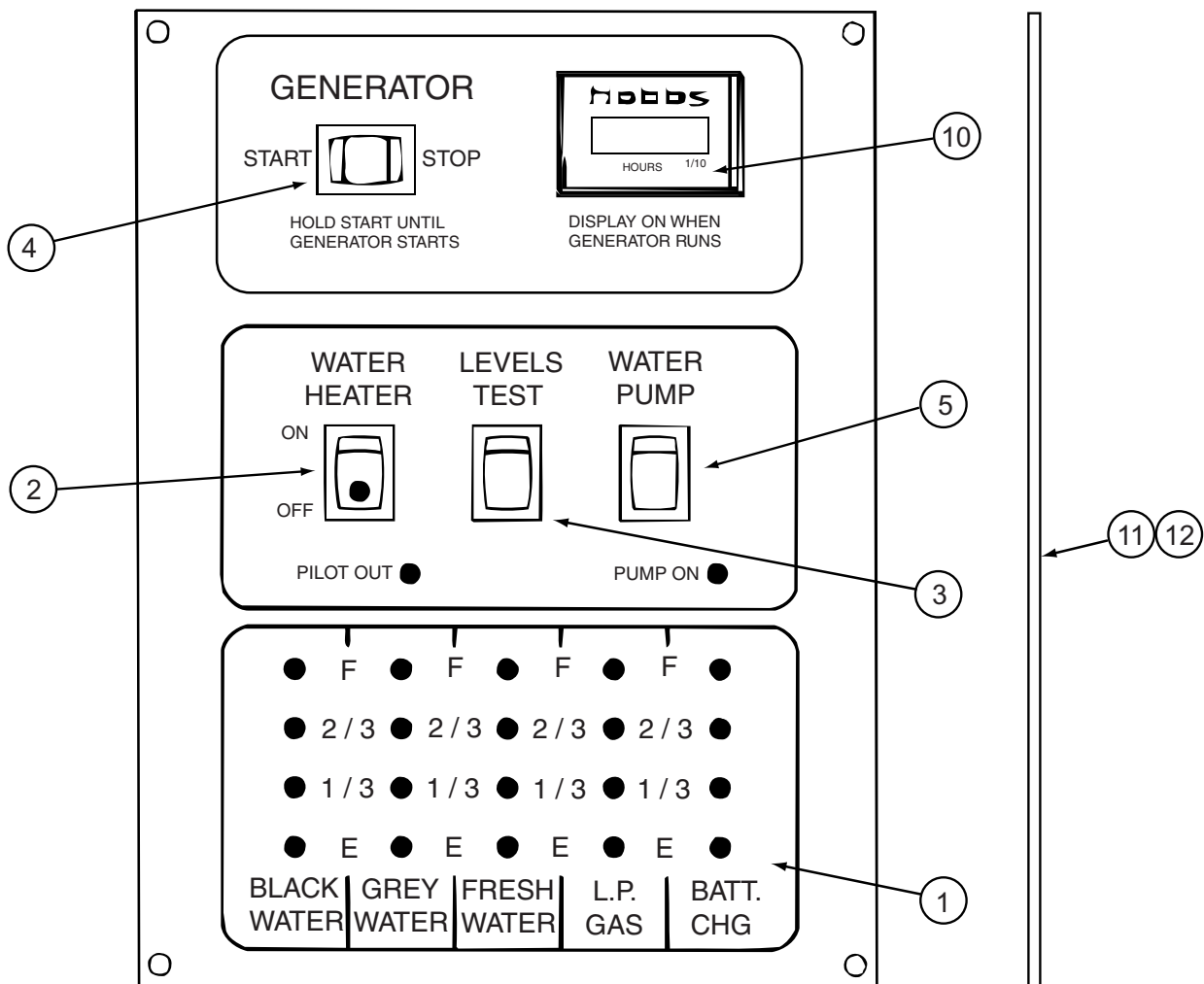

134940-06-01A

KEY	PART NUMBER	U/M DESCRIPTION	VENDOR NO.
1	134940-01-702	EA CHASSIS - SILKSCREENED	CC0558-00
2	134940-01-701	EA SWITCH-SPST/ON-OFF/BLK W/LGT	L0109
3	096983-01-701	EA SWITCH - SPST/MOM 2 TERMINAL	L0111-00
4	096983-01-702	EA SWITCH - MOM/OFF/MOM/3 TERM	L0112-00
5	096983-01-703	EA SWITCH - ON/ON	L0115-00
10	100258-10-701	EA GAUGE-HR METER ONLY (LCD)	L0775-00
11	134940-06-700	EA PC BOARD - SENSOR SYSTEM/RED	L5131-02

CONTACT WINNEBAGO PART SALES FOR UNLISTED COMPONENT(S)

ELECTRICAL GROUP (CONTINUED)
COMPONENT PARTS FOR WIRING (CONTINUED)

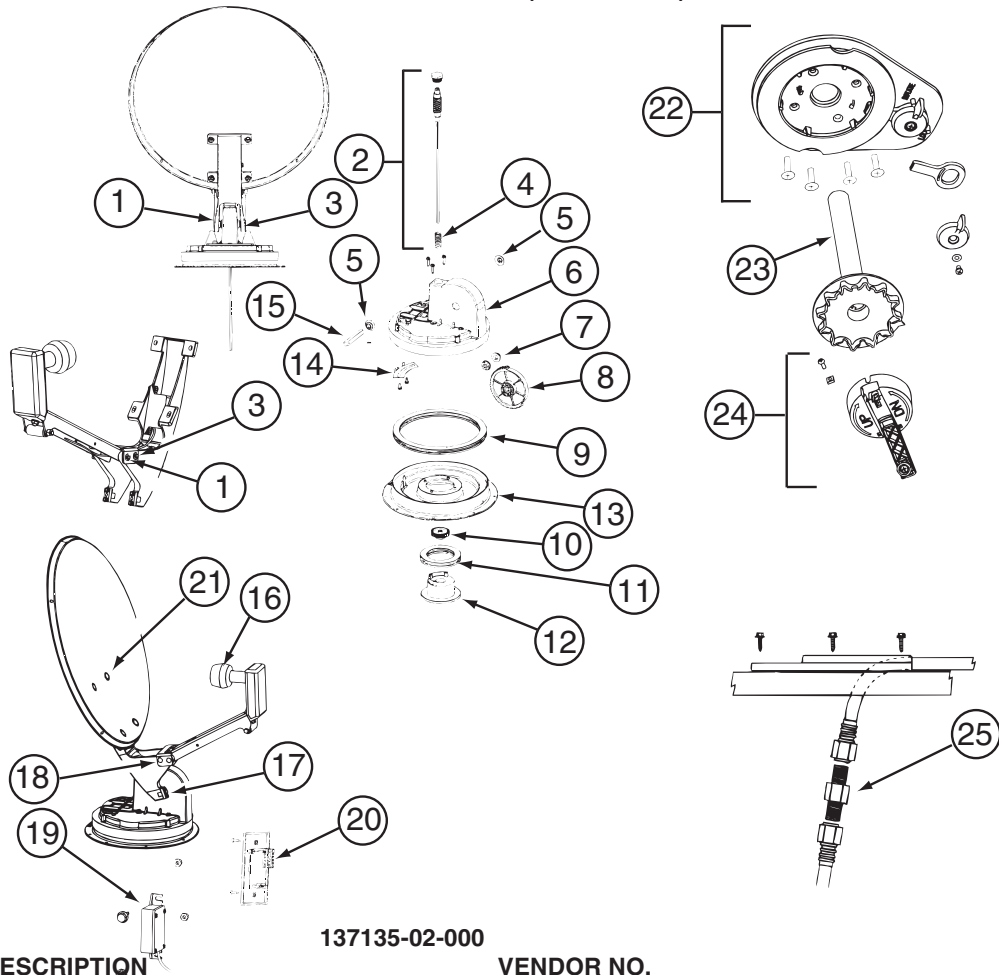

137135-02-000

KEY	PART NUMBER	U/M	DESCRIPTION	VENDOR NO.
1	120233-01-714	EA	CLIP-E	5160818
2	137135-01-703	EA	KIT ELEV - SHAFT/GEAR/SPRING	RP-4400
3	137135-01-704	EA	PIN - 1/4" X 3.25"	2160813
4	137135-01-705	EA	SPRING	2160818
5	137135-01-707	EA	SEAL - PIVOT SHAFT	2200852
6	137135-01-708	EA	TURRET	3100728
7	137135-01-709	EA	PIVOT BEARING	2200470
8	137135-01-711	EA	GEAR - ELEVATING	2200464
9	137135-01-712	EA	BEARING - OUTER	2590347
10	137135-01-714	EA	GEAR - ELEVATING SHAFT	2200465
11	137135-01-715	EA	BEARING - INNER	2590348
12	137135-01-716	EA	HUB	3100731
13	137135-01-713	EA	TURRET BASE	3100730
14	137135-01-710	EA	PLATE - ROTATE LIMIT	3720052
16	137135-02-703	EA	LOW NOISE BLOCK FILTER	LB-6000 - DUAL
17	137135-01-722	EA	CLAMP	2590343
18	137135-01-719	EA	BRACKET - PIVOT	2744945
19	137135-01-720	EA	DE-SENSOR UNIT W/43" CABLE	DM4000
20	137135-02-701	EA	BOX - SURFACE MOUNT	SM-100
21	137135-01-717	EA	BOLT - FLAT HEAD	2160362
22	120233-01-737	EA	PLATE/INT-W/DIRECTIONAL HDLE	RK-CEIL
23	120233-01-704	EA	DIAL/DIRECTIONAL 4"W/SPRING	3200364
24	120233-01-738	EA	HDW PKG-HANDLE/SPRING/WASHER	RK-HAND
25	137135-01-701	EA	CONNECTOR - F - MALE TO MALE	FS-8100
	120233-04-700	EA	KIT-WALL PLATE/CABLE - GRAY	DM4000
	137135-01-700	EA	ROOF WEDGE W/GASKET	RW-5000
	137135-01-706	EA	KIT-TURRET/SEAL/BEARING/GEAR	RP-RM30
	137135-01-718	EA	REFLECTOR/WHITE-46CM W/HDW	RP-35RM
	137135-02-700	EA	DE-SENSOR	2780096
	137135-02-704	EA	KIT-UPDATE DIRECTIONAL HDL	RP-RMDH
	137135-02-705	EA	KIT-TURRET & SHAFT COMPLETE	RP-RM46

CONTACT WINNEBAGO PART SALES FOR UNLISTED COMPONENT(S)

ELECTRICAL GROUP (CONTINUED)
COMPONENT PARTS FOR WIRING (CONTINUED)

137417-01-01A, 137417-03-01A

KEY	PART NUMBER	U/M	DESCRIPTION	VENDOR NO.
	137417-01-700	EA	LENS - SINGLE (FROSTED)	810868

137417-02-01A

KEY	PART NUMBER	U/M	DESCRIPTION	VENDOR NO.
	137417-02-700	EA	LENS - SINGLE OPTIC	810844

137417-05-01A

KEY	PART NUMBER	U/M	DESCRIPTION	VENDOR NO.
	137417-05-700	EA	LENS - DOUBLE OPTIC	810845

137417-06-01A

KEY	PART NUMBER	U/M	DESCRIPTION	VENDOR NO.
	137417-06-700	EA	LENS - DOUBLE WHITE	810867

150089-01-000

KEY	PART NUMBER	U/M	DESCRIPTION	VENDOR NO.
	150089-01-700	EA	REMOTE	265683

155619-01-000

KEY	PART NUMBER	U/M	DESCRIPTION	VENDOR NO.
	155619-01-700	EA	REMOTE	RC3200

158836-01-000

KEY	PART NUMBER	U/M	DESCRIPTION	VENDOR NO.
	158836-01-700	EA	REMOTE	STS71WREM

ELECTRICAL GROUP (CONTINUED)
CIRCUIT BREAKERS, FUSES & RELAYS

KEY	PART NUMBER	U/M	DESCRIPTION
	008235-01-000	EA	FUSE - 15 AMP/12VOLT - AUTOMOTIVE
	062901-02-000	EA	FUSE - 5 AMP - AUTOMOTIVE
	062901-04-000	EA	FUSE - 10 AMP - AUTOMOTIVE
	062901-05-000	EA	FUSE - 15 AMP - AUTOMOTIVE
	062901-06-000	EA	FUSE - 20 AMP - AUTOMOTIVE
	062901-07-000	EA	FUSE - 25 AMP - AUTOMOTIVE
	062901-08-000	EA	FUSE - 30 AMP - AUTOMOTIVE
	063910-01-000	EA	HOUSING - RELAY
	063912-02-000	EA	RELAY - CANISTER - SPDT
	083209-01-000	EA	CIRCUIT BREAKER - 15 AMP - 120 VOLT - CANADIAN
	083209-02-000	EA	CIRCUIT BREAKER - 15/15 AMP - 120 VOLT
	083209-03-000	EA	CIRCUIT BREAKER - 15/20 AMP - 120 VOLT
	083209-04-000	EA	CIRCUIT BREAKER - 30 AMP - 120 VOLT
	083209-05-000	EA	CIRCUIT BREAKER - 20 AMP - 120 VOLT
	083209-06-000	EA	CIRCUIT BREAKER - 30/15 AMP - 120 VOLT
	083209-07-000	EA	CIRCUIT BREAKER - 20/20 AMP - 120 VOLT
	083209-10-000	EA	CIRCUIT BREAKER - 20/30 AMP - 120 VOLT
	083209-11-000	EA	CIRCUIT BREAKER - 20/15 AMP - 120 VOLT
	092786-03-000	EA	BUSS BAR - 6.9" LONG
	092786-06-000	EA	BUSS BAR
	093654-01-000	EA	CIRCUIT BREAKER - 6 AMP - 12 VOLT - PUSH BUTTON - WHITE
	093654-02-000	EA	CIRCUIT BREAKER - 15 AMP - 12 VOLT - PUSH BUTTON - WHITE
	093654-03-000	EA	CIRCUIT BREAKER - 20 AMP - 12 VOLT - PUSH BUTTON - WHITE
	093655-01-000	EA	CIRCUIT BREAKER - 25 AMP - 12 VOLT - PUSH BUTTON - WHITE
	093655-02-000	EA	CIRCUIT BREAKER - 30 AMP - 12 VOLT - PUSH BUTTON - WHITE
	093655-03-000	EA	CIRCUIT BREAKER - 40 AMP - 12 VOLT - PUSH BUTTON - WHITE
	097611-01-000	EA	CIRCUIT BREAKER - 10 AMP
	100341-01-000	EA	FUSE HOLDER - IN LINE TYPE
	113482-01-000	EA	CIRCUIT BREAKER - 55 AMP - MANUAL
	115187-01-000	EA	FUSE - 300 AMP - NON-DELAY
	115187-02-000	EA	HOLDER - FUSE
	115187-03-000	EA	FUSE - 60 AMP - NON-DELAY
	122811-01-000	EA	CIRCUIT BREAKER - 20/50/50/20 AMP - 250V
	125986-02-000	EA	FUSE - 5 AMP - AUTO - MINI BLADE
	125986-05-000	EA	FUSE - 15 AMP - AUTO - MINI BLADE
	141789-01-000	EA	SPACER - CIRCUIT BREAKER

ELECTRICAL GROUP (CONTINUED)

CONVERTER, INVERTER, LOAD CENTERS

KEY	PART NUMBER	U/M	DESCRIPTION
	099048-04-000	EA	INVERTER - 300 WATT
	123058-02-000	EA	CONVERTER - 45 AMP - ELECTRONIC - 4 1/8"H X 7"W X 12 3/8"L
	024924-02-000	EA	RECEPTACLE - POWER CORD - W/PARTIAL PLATE

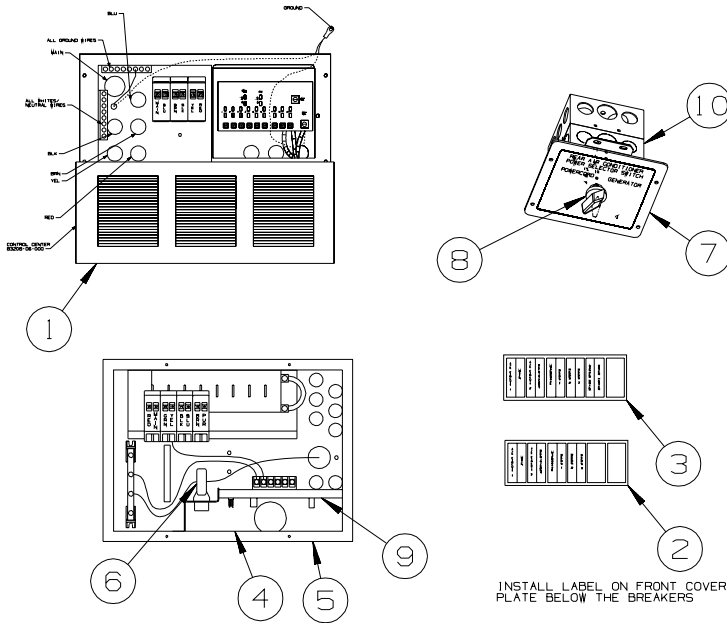

KEY	PART NUMBER	U/M	DESCRIPTION
1*	083208-07-000	EA	CONTROL CENTER - 45 AMP - 120V/12V - W/O BREAKERS
2	095721-27-000	EA	LABEL - CONTROL CENTER - 30 AMP
3	095721-31-000	EA	LABEL - CONTROL CENTER - 30 AMP - US - WTR HTR-6GAL/110/LP/MTR/AUTO
4	141258-01-000	EA	LOAD CENTER - 120/240 - 30/50 AMP
5	141258-02-000	EA	LOAD CENTER - COVER
6	127002-07-000	EA	SENSOR - CURRENT
7	121365-03-01A	EA	COVER - REAR A/C POWER SELECT SWITCH - POWERCORD/GENERATOR
8	073937-03-000	EA	SWITCH - ROTARY- AC - SELECTOR - 3 DECK
9	127002-11-000	EA	MODULE - EMS CENTER - W/REMOTE SENSOR
10	074890-01-000	EA	BOX - EXTENSION/STEEL - OPEN SIDES - 4" X 4" X 1 1/2"

*COMPONENT PARTS LISTED LATER IN THIS GROUP

ELECTRICAL GROUP (CONTINUED)

BOXES & CORDS

KEY	PART NUMBER	U/M	DESCRIPTION
	008054-01-000	EA	CORD - POWER - 10/3 WIRE - 30 AMP - 25'
	008289-01-000	EA	BOX - ELECTRIC/STEEL - 4" X 4" - 1/2" & 3/4" KNOCKOUTS
	008294-01-000	EA	COVER - ELECTRIC BOX - BLANK/STEEL - 4" X 4" - GRAY
	069238-01-000	EA	COVER - ELECTRICAL BOX - W/HOLE - 4" X 4" - GRAY
	115832-01-000	FT	CORD - HEAVY DUTY - 14-2 W/GROUND
	131679-01-000	EA	BOX/ELECTRIC-WATERPROOF-4" X 4" - W/4 3/4"OUTLETS-UL/CSA
	131680-01-000	EA	COVER - F/ELECTRIC BOX W/GASKET 4" X 4" - UL/CSA
	133070-01-000	EA	BOX - ELECTRIC/PLASTIC - 3" X 2" X 2.8" - UL
	133070-02-000	EA	BOX - ELECTRIC/PLASTIC - 3" X 2" X 2.8" - CSA

WIRE ASSEMBLIES

KEY	PART NUMBER	U/M	DESCRIPTION
	077069-02-000	EA	CABLE/EXTENSION - RADIO ANTENNA - 96"
	077069-03-000	EA	CABLE/EXTENSION - RADIO ANTENNA - 260"
	126030-01-000	EA	WIRE ASM-WIPER/WASHER
	125853-04-000	EA	WIRE LOOM - ENTERTAINMENT CENTER
	135420-16-000	EA	WIRE LOOM - RADIO
	137135-03-000	EA	WIRE LOOM - DIGITAL ELEVATION SENSOR
	137135-04-000	EA	WIRE HARNESS - POWER - DIGITAL ELEVATION SENSOR
	142258-02-000	EA	WIRE LOOM - VIDEO SWITCH/POWER SUPPLY
	144677-07-000	EA	WIRE - MONITOR - POWER - 3 PIN TO 6 PIN (3 WIRE)
	144677-09-000	EA	WIRE - MONITOR - POWER - 3 PIN/2 PIN
	145210-01-000	FT	CABLE - COAXIAL
	147313-01-000	EA	WIRE - OUTSIDE TEMP SENSOR - W/O SENSOR
	151316-01-000	EA	WIRE ASM - W/NON CONTACT SENSORS - GREY WATER - 3.9"
	151316-02-000	EA	WIRE ASM - W/NON CONTACT SENSORS - GREY WATER - 23.6"
	151316-03-000	EA	WIRE ASM - W/NON CONTACT SENSORS - GREY WATER - 43.2"
	151317-01-000	EA	WIRE ASM-W/NON CONTACT SENSORS-FRESH WATER/BLK TANK-3.9"
	151317-02-000	EA	WIRE ASM-W/NON CONTACT SENSORS-FRESH WATER/BLK TANK-23.6"
	155619-05-000	EA	WIRE ASSEMBLY - RADIO - 12 PIN

ELECTRICAL GROUP (CONTINUED)
CONNECTORS & CONDUIT

KEY	PART NUMBER	U/M	DESCRIPTION
	007940-01-000	EA	RECEPTACLE/SLIDE 16 TO 12 AWG - FEMALE END
	007940-02-000	EA	RECEPTACLE/SLIDE 10 AWG
	007954-01-000	EA	RECEPTACLE - HOUSING - 6 POSITION
	007956-05-000	EA	INSULATOR - SHRINK - 1/4"ID X 1 1/2"
	008058-01-000	EA	ADAPTER - POWER CORD - 30 AMP TO 15 AMP
	008311-01-000	EA	CONNECTOR - WIRE NUT - INSULATED - RED
	008312-01-000	EA	CONNECTOR - WIRE NUT - INSULATED - BLUE
	008313-01-000	EA	CONNECTOR - WIRE NUT - INSULATED - YELLOW
	008314-01-000	EA	CONNECTOR - WIRE NUT - INSULATED - GRAY
	008328-01-000	EA	TERMINAL - RING - 12/10 WIRE - #10 STUD FIT
	008331-01-000	EA	TERMINAL - RING - TONGUE - #4 WIRE - 3/8" STUD - COPPER
	008348-01-000	EA	TERMINAL - RING - 3/8" STUD 2 GA. WIRE
	008355-01-000	EA	CONNECTOR - CABLE CLAMPING - 3/4"
	008356-01-000	EA	CONNECTOR - PLASTIC - 3/8"
	008356-02-000	EA	CONNECTOR - PLASTIC - 21/32"
	008398-01-000	EA	CONNECTOR - 1/2" X 90 DEGREE - FLEX CONDUIT - UL & CSA
	035416-04-000	EA	TERMINAL - RING - #10 STUD FIT - INSULATED BARREL #16/14
	041953-01-000	FT	CONDUIT - CONVOLUTE SLIT - .5" ID - POLYETHYLENE
	041953-02-000	FT	CONDUIT - CONVOLUTE SLIT - .6" ID - POLYETHYLENE
	041953-03-000	FT	CONDUIT - CONVOLUTE SLIT - 1" ID (CLOTHES ROD COVER)
	041953-06-000	FT	CONDUIT - CONVOLUTE SLIT - .4" ID - POLYETHYLENE
	041953-07-000	FT	CONDUIT - CONVOLUTE SLIT - .25" ID - POLYETHYLENE
	041953-08-000	FT	CONDUIT - CONVOLUTE SLIT - 1.5" ID - POLYETHYLENE
	041953-09-000	FT	CONDUIT - CONVOLUTE SLIT - .5" ID - NYLON
	041953-10-000	FT	CONDUIT - CONVOLUTE SLIT - .75" ID - NYLON
	041953-11-000	FT	CONDUIT - CONVOLUTE SLIT - 1.06" ID - NYLON
	041953-12-000	FT	CONDUIT - CONVOLUTE SOLID - 1.1" ID - NYLON
	041953-13-000	FT	CONDUIT - CONVOLUTE SLIT - 1.25" ID
	041953-14-000	FT	CONDUIT - CONVOLUTE SLIT - 1.5" ID
	041953-15-000	FT	CONDUIT - CONVOLUTE SLIT - 2"
	041953-16-000	FT	CONDUIT - CONVOLUTE SLIT - 2"
	047441-01-000	EA	TERMINAL-BATTERY, HORIZONTAL LUG
	047443-01-000	EA	TERMINAL - .250 RECEPTACLE FIT - INSULATED - 16/14 AWG
	047443-02-000	EA	TERMINAL - .250 RECEPTACLE FIT - INSULATED - 12/10 AWG
	047443-05-000	EA	TERMINAL - .250 RECEPTACLE FIT - 18GA AWG
	058028-01-000	EA	CONNECTOR - ELECTRICAL PIGTAIL - NYLON - CLEAR
	062036-01-000	EA	TERMINAL - PACK - CON - 12/10 AWG
	076319-12-000	EA	CONNECTOR - COAXIAL - ONE PIECE
	077479-01-000	EA	BOOT - BATTERY TERMINAL - DOUBLE CABLE
	077479-02-000	EA	BOOT - BATTERY TERMINAL - SINGLE CABLE
	080015-02-000	EA	RECEPTACLE - FLAG - .185 - 16/14 GAUGE
	080015-03-000	EA	RECEPTACLE - FLAG - .250 - 14/16 GAUGE
	080015-04-000	EA	RECEPTACLE - FLAG - .187 - 16/14 GAUGE
	082109-01-000	EA	HOUSING - CONNECTOR - PACKARD
	082741-01-000	EA	CONNECTOR BODY - 2 CONNECTOR MALE
	087225-01-000	FT	SLEEVING - 1/2" - TYPE H
	088473-01-000	EA	HOUSING - PIN - 12 CAVITY (3 ROWS OF 4)
	088473-02-000	EA	HOUSING - PIN - 15 CAVITY (3 ROWS OF 5)
	088473-03-000	EA	HOUSING - PIN - 9 CAVITY (3 ROWS OF 3)
	088473-04-000	EA	HOUSING - PIN - 8 CAVITY IN-LINE
	088473-06-000	EA	HOUSING - PIN - 6 CAVITY (2 ROWS OF 3)
	088473-07-000	EA	HOUSING - PIN - 5 CAVITY - IN-LINE
	088473-08-000	EA	HOUSING - PIN - 4 CAVITY - IN-LINE
	088473-09-000	EA	HOUSING - PIN - 3 CAVITY - IN-LINE
	088473-10-000	EA	HOUSING - PIN - 2 CAVITY - IN-LINE
	088473-12-000	EA	HOUSING - PIN - 3 CAVITY - BLUE
	088473-13-000	EA	HOUSING - PIN - 3 CAVITY - GREEN
	088473-14-000	EA	HOUSING - PIN - 3 CAVITY - RED
	088474-01-000	EA	HOUSING - SOCKET - 12 CAVITY
	088474-02-000	EA	HOUSING - SOCKET - 15 CAVITY
	088474-03-000	EA	HOUSING - SOCKET - 9 CAVITY
	088474-06-000	EA	HOUSING - SOCKET - 6 CAVITY
	088474-07-000	EA	HOUSING - SOCKET - 5 CAVITY
	088474-08-000	EA	HOUSING - SOCKET - 4 CAVITY

ELECTRICAL GROUP (CONTINUED)
CONNECTORS & CONDUIT (CONTINUED)

KEY	PART NUMBER	U/M	DESCRIPTION
	088474-09-000	EA	HOUSING - SOCKET - 3 CAVITY
	088474-10-000	EA	HOUSING - SOCKET - 2 CAVITY
	088475-01-000	EA	PIN - CONNECTOR - 14-20 AWG
	088475-02-000	EA	PIN - CONNECTOR - 10-12 AWG
	088476-01-000	EA	TERMINAL - ELECTRICAL
	088476-02-000	EA	SOCKET - CONNECTOR - 12-10 GA - PRE-TIN
	098261-01-000	EA	SOCKET - CONNECTOR - WEATHERPACK - 12 AWG
	098261-02-000	EA	SOCKET - CONNECTOR - WEATHERPACK - 14-18 AWG
	098262-01-000	EA	SEAL - CONNECTOR - WEATHERPACK
	098264-01-000	EA	HOUSING - 2 PIN - WEATHER PACK - MALE W/FEMALE PINS
	098264-02-000	EA	HOUSING - 2 PIN - WEATHER PACK - FEMALE W/MALE PINS
	098265-02-000	EA	PIN - CONNECTOR - WEATHER PACK
	102777-02-000	EA	TERMINAL - RING - #6 STUD - 10 AWG
	103608-01-000	EA	SOCKET - WEDGE BASE W/LEADS
	104100-01-000	EA	HOUSING - 1 POSITION - 75 AMPS
	104100-03-000	EA	TERMINAL - 75 AMP
	106007-02-000	EA	TERMINAL - FEMALE - 10-12 AWG
	110178-01-000	EA	HOUSING - WIPER MOTOR
	112823-01-000	EA	SPLICE - REDUCER - 16-14 TO 18-22
	113072-02-000	EA	HOUSING - ELECTRICAL - BACK-UP/TAIL LAMP
	113072-03-000	EA	HOUSING - ELECTRICAL - STOP/MARKER TAILLAMP
	113073-01-000	EA	WEDGELOCK - HOUSING - TAIL LAMP
	113074-01-000	EA	TERMINAL - TAILLAMP
	113135-01-000	EA	TERMINAL - FEMALE - M/P - 14-16 - F/SEALED TERMINAL
	113308-01-000	EA	TERMINAL - FEMALE - M/P - 14-16 - 280
	113308-02-000	EA	TERMINAL - FEMALE - M/P - 14-18 - 280
	113468-01-000	EA	HOUSING - 2 POSITION-FEMALE-USED ON WIPER/WASHER WIRE ASM
	113468-02-000	EA	HOUSING - 2 POSITION - FEMALE
	115931-02-000	EA	COVER - CONNECTOR - 50 AMP W/LOCKING RING
	115932-02-000	EA	CONNECTOR - FEMALE - 50 AMP/240 VOLT
	116811-01-000	EA	TERMINAL - .110 RECEPTACLE - 16-14 AWG
	118571-01-000	EA	CONNECTOR - 3-WAY - MALE/SEALED
	118571-02-000	EA	CONNECTOR - 3-WAY - FEMALE/SEALED
	118571-05-000	EA	LOCK - SECONDARY - FEMALE
	118571-06-000	EA	LOCK - SECONDARY - MALE
	118599-02-000	EA	TERMINAL - MALE - M/P - 280/14-12
	118820-01-000	EA	INSULATOR - TERMINAL
	129233-01-000	EA	HOUSING - 2-POSITION/FEMALE - 280-SERIES
	129233-02-000	EA	HOUSING - 2-POSITION/FEMALE - 280-SERIES
	129233-03-000	EA	HOUSING - 2-POSITION/FEMALE - 280-SERIES
	131681-01-000	EA	CONNECTOR - 3/4" SO CORD - UL/CS
	137207-01-000	EA	HOUSING - PIN - 2 CAVITY/HIGH AMP
	137208-01-000	EA	HOUSING - SOCKET - 2 CAVITY/HIGH AMP
	137209-01-000	EA	PIN - CONNECTOR - 10AWG/HIGH AMP
	137210-01-000	EA	SOCKET - CONNECTOR - 10 AWG/HIGH AMP
	138996-04-000	EA	CONNECTOR - LAMP
	142520-01-000	EA	TERMINAL - FEMALE - MINI-FIT 16
	142522-01-000	EA	HOUSING - 4 PIN/MALE - MINI FIT
	142522-02-000	EA	HOUSING - 6 PIN/MALE - MINI FIT
	142522-03-000	EA	HOUSING - 8 PIN/MALE - MINI FIT
	142522-04-000	EA	HOUSING - 10 PIN/MALE - MINI FIT
	142522-05-000	EA	HOUSING - 12 PIN/MALE - MINI FIT
	142522-06-000	EA	HOUSING - 14 PIN/MALE - MINI FIT
	142524-01-000	EA	HOUSING - 4 PIN/FEMALE - WEATHER PACK
	142524-02-000	EA	HOUSING - 4 PIN/FEMALE - WEATHER PACK
	144283-01-000	EA	CONNECTOR - 110V - F/USE WITH SOW WIRE - BLUE
	144283-02-000	EA	CONNECTOR - 110V - F/USE WITH NM ROMEX WIRE - CLEAR
	145171-01-000	EA	CONNECTOR - COAXIAL
	148335-01-000	EA	HOUSING - 8-POSITION/MALE - 280-GT SERIES
	148335-02-000	EA	HOUSING - 4-POSITION/MALE - 280-GT SERIES
	148335-03-000	EA	HOUSING - 6-POSITION/MALE - 280-GT SERIES
	149683-01-000	EA	HOUSING - F/5 CAVITY RECEPTACLE - W/SQUARE GUIDE PIN
	149683-02-000	EA	HOUSING - F/5 CAVITY RECEPTACLE - W/ROUND GUIDE PIN
	149686-01-000	EA	TERMINAL - .250 RECEPTACLE

ELECTRICAL GROUP (CONTINUED)

CONNECTORS & CONDUIT (CONTINUED)

KEY	PART NUMBER	U/M	DESCRIPTION
	149687-01-000	EA	HOUSING - 2 POSITION/MALE - PACKARD
	149687-02-000	EA	LOCK - F/2 POSITION HOUSING - PACKARD
	149688-01-000	EA	TERMINAL - MALE - 16 GAUGE WIRE
	156035-01-000	EA	HOUSING - 12-POSITION/FEMALE - 280-GT SERIES
	156041-01-000	EA	TERMINAL - FEMALE - 16-12 - 280-GT SERIES
	156043-01-000	EA	HOUSING - 2-POSITION/FEMALE - 480-MP SERIES
	156043-02-000	EA	LOCK - F/2 POSITION HOUSING - 480 SERIES
	156044-01-000	EA	TERMINAL - FEMALE - 16-12 - 280-GT - F/SEALED HOUSING
	156045-01-000	EA	HOUSING - 10-POSITION/FEMALE - 280-GT SERIES
	156045-02-000	EA	HOUSING - 4-POSITION/FEMALE - 280-GT SERIES
	156045-03-000	EA	HOUSING - 8-POSITION/FEMALE - 280-GT SERIES
	156045-04-000	EA	HOUSING - 6-POSITION/FEMALE - 280-GT SERIES
	156207-01-000	EA	HOUSING - 6-POSITION/MALE - 150-GT SERIES
	156208-01-000	EA	TERMINAL - MALE - 18-16 - 150-GT SERIES
	157590-01-000	EA	TERMINAL - FEMALE - M/P - 10-12 - 630
	157592-01-000	EA	HOUSING - 7-POSITION/FEMAL - M/P
	157592-02-000	EA	LOCK - SECONDARY - F/7 POSITION HOUSING
	157656-01-01A	EA	CONNECTOR - DASH LIGHT - BLACK
	158357-01-000	EA	HOUSING - 3 PIN/MALE - MINI FIT
	158373-01-000	EA	HOUSING - SOCKET - 16 CAVITY - MINI MATE-N-LOCK
	158374-01-000	EA	SOCKET - 16-20 CAVITY - MINI MATE-N-LOCK

CHASSIS

KEY	PART NUMBER	U/M	DESCRIPTION
	065450-05-000	EA	TIEDOWN - BATTERY - 8.4" TUBE
			FROM: 00-00-00 THRU: 03-26-06
	160014-01-02B	EA	TIEDOWN - BATTERY - E-COATED
			FROM: 03-27-06 THRU: 99-99-99
	149825-01-000	EA	CONTROL MODULE - DIGISYNC/HIGH SPEED - F/C-BODY RAM
	138173-03-000	EA	MODULE - (CONTROL BOX) - SLIDEOUT CONTROL - #1802930
	142142-05-02B	EA	DOOR - ELECTRICAL BOX - E-COATED

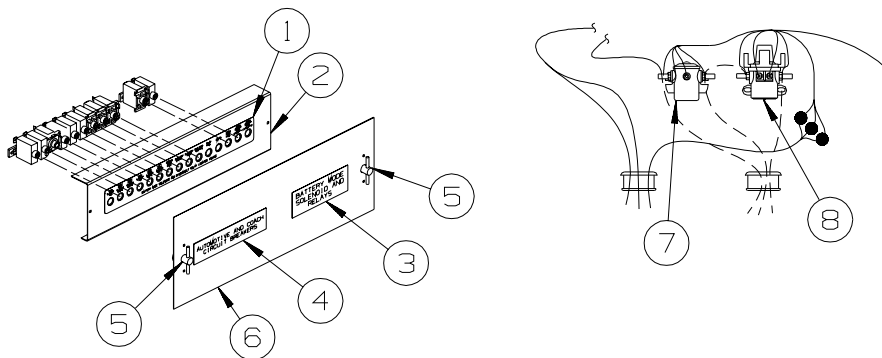

KEY	PART NUMBER	U/M	DESCRIPTION
1	093236-43-000	EA	LABEL - CIRCUIT BREAKER
2	118531-07-02B	EA	PLATE - CIRCUIT BREAKER - E-COATED
3	098379-04-000	EA	LABEL - ELECTRICAL BOX - SIDE
4	098379-01-000	EA	LABEL - CIRCUIT BREAKER - FRONT BOX
5	098196-01-000	EA	LATCH - 1/4 TURN - T-BAR
6	109925-04-000	EA	DOOR - ELECTRICAL BOX - 6.9" X 18.5" - GM/FORD
	092492-11-000	EA	SEAL - ELECTRIC BOX - 7" X 18.4"
7	008188-01-000	EA	SOLENOID - 3 POST - BATTERY CHANGE OVER
8	086273-01-000	EA	RELAY - BATTERY DISCONNECT

EXTERIOR BODY GROUP GRAPHICS & PAINT

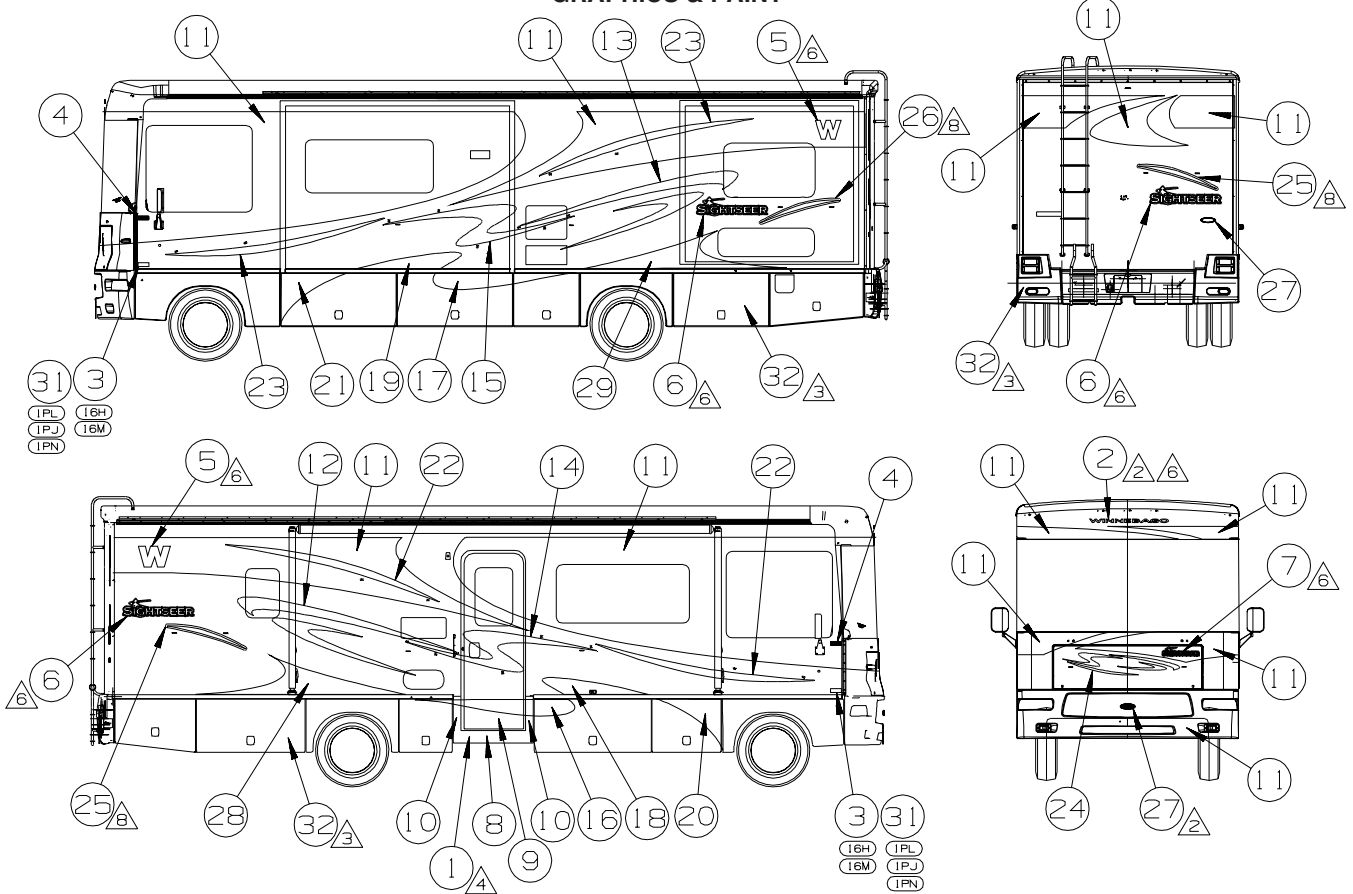

(27G) KEY	PART NUMBER	U/M	DESCRIPTION
1	109506-01-000	EA	FILM-URETHANE PROTECTANT
2	120702-03-CHT(153A)	EA	DECAL-LOGO WINNEBAGO - SUNSET
3	129922-02-CHT(01A)	EA	DECAL-EMBLEM TRITON V10 - BLACK/CHROME
4	132664-02-CHT(01A)	EA	DECAL-LOGO DOMED WINNEBAGO - CHROME/RED/BLACK
5	135381-02-CHT(113A)	EA	DECAL-LOGO W - SUNSET
6	135453-03-CHT(03A)	EA	DECAL-LOGO SIGHTSEER VYL LG - BRT WHITE/DP FOREST GREEN/MED PARCHEMENT/MYAN GREEN/CHARCOAL
7	135453-04-CHT(05A)	EA	DECAL-LOGO SIGHTSEER VYL SML - BRT WHITE/DP FOREST GREEN/MED PARCHEMENT/MYAN GREEN/CHARCOAL
8	138348-01-CHT(02A)	EA	DECAL-DOOR TRIM - MED PARCHEMENT
9	138349-01-CHT(02A)	EA	DECAL-DOOR - MED PARCHEMENT
10	139657-01-CHT(02A)	EA	DECAL-DOOR TRIM SIDE - MED PARCHEMENT
11	141599-42-000	GL	PAINT-DK TITANIUM - DUPONT #373-P765286
12	148521-03-CHT(01A)	EA	DECAL-SWIRL RH - MYAN GREEN/SUNSET
13	148521-04-CHT(01A)	EA	DECAL-SWIRL LH - MYAN GREEN/SUNSET
14	148523-03-CHT(01A)	EA	DECAL-S CURVE RH - CHARCOAL
15	148523-04-CHT(01A)	EA	DECAL-S CURVE LH - CHARCOAL
16	148524-01-CHT(01A)	EA	DECAL-PAINT LINE #3 RH - BRT WHITE
17	148524-02-CHT(01A)	EA	DECAL-PAINT LINE #3 LH - BRT WHITE
18	148525-01-CHT(02A)	EA	DECAL-PAINT LINE #2 RH - MED PARCHEMENT
19	148525-02-CHT(02A)	EA	DECAL-PAINT LINE #2 LH - MED PARCHEMENT
20	148526-01-CHT(01A)	EA	DECAL-PAINT LINE #1 RH - BRT WHITE
21	148526-02-CHT(01A)	EA	DECAL-PAINT LINE #1 LH - BRT WHITE
22	148528-03-CHT(01A)	EA	DECAL-SWEEP RH - OLYMPIC GOLD
23	148528-04-CHT(01A)	EA	DECAL-SWEEP LH - OLYMPIC GOLD
24	148531-02-CHT(01A)	EA	DECAL-HOOD - MYAN GREEN/CHARCOAL/SUNSET
25	148532-01-CHT(04A)	EA	DECAL-SWEEP SML RH - BRT WHITE/OLYMPIC GOLD
26	148532-02-CHT(04A)	EA	DECAL-SWEEP SML LH - BRT WHITE/OLYMPIC GOLD
27	151687-01-CHT(01A)	EA	DECAL-BEZEL DOMED NAMEPLATE WINNEBAGO - CHROME/RED
28	151687-02-CHT(01A)	EA	DECAL-PAINT LINE #4 RH - MED PARCHEMENT
29	151687-03-CHT(01A)	EA	DECAL-PAINT LINE #4 LH - MED PARCHEMENT
30	141599-27-000	GL	PAINT-IMRON CLEAR 55 GAL - DUPONT #3440S
31	EA	DECAL-EMBLEM - CHASSIS SUPPLIED
32	GL	COLORLED PLASTIC AND STEEL - MED PARCHEMENT

(92K) KEY	PART NUMBER	U/M	DESCRIPTION
1	109506-01-000	EA	FILM-URETHANE PROTECTANT
2	120702-03-CHT(152A)	EA	DECAL-LOGO WINNEBAGO - MOSS GREEN
3	129922-02-CHT(01A)	EA	DECAL-EMBLEM TRITON V10 - BLACK/CHROME
4	132664-02-CHT(01A)	EA	DECAL-LOGO DOMED WINNEBAGO - CHROME/RED/BLACK
5	135381-02-CHT(114A)	EA	DECAL-LOGO W - MOSS GREEN
6	135453-03-CHT(03A)	EA	DECAL-LOGO SIGHTSEER VYL LG - BRT WHITE/DP FOREST GREEN/MED PARCHEMENT/BURGUNDY/DK CHERRY
7	135453-04-CHT(03A)	EA	DECAL-LOGO SIGHTSEER VYL SML - BRT WHITE/DP FOREST GREEN/MED PARCHEMENT/BURGUNDY/DK CHERRY
8	138348-01-CHT(02A)	EA	DECAL-DOOR TRIM - MED PARCHEMENT
9	138349-01-CHT(02A)	EA	DECAL-DOOR - MED PARCHEMENT
10	139657-01-CHT(02A)	EA	DECAL-DOOR TRIM SIDE - MED PARCHEMENT
11	141599-31-000	GL	PAINT-METALLIC GOLD - DUPONT #P73-P7436
12	148521-03-CHT(02A)	EA	DECAL-SWIRL RH - BROWN/MOSS GREEN
13	148521-04-CHT(02A)	EA	DECAL-SWIRL LH - BROWN/MOSS GREEN
14	148523-03-CHT(02A)	EA	DECAL-S CURVE RH - BURGUNDY
15	148523-04-CHT(02A)	EA	DECAL-S CURVE LH - BURGUNDY
16	148524-01-CHT(01A)	EA	DECAL-PAINT LINE #3 RH - BRT WHITE
17	148524-02-CHT(01A)	EA	DECAL-PAINT LINE #3 LH - BRT WHITE
18	148525-01-CHT(02A)	EA	DECAL-PAINT LINE #2 RH - MED PARCHEMENT
19	148525-02-CHT(02A)	EA	DECAL-PAINT LINE #2 LH - MED PARCHEMENT
20	148526-01-CHT(01A)	EA	DECAL-PAINT LINE #1 RH - BRT WHITE
21	148526-02-CHT(01A)	EA	DECAL-PAINT LINE #1 LH - BRT WHITE
22	148528-03-CHT(02A)	EA	DECAL-SWEEP RH - DK CHERRY
23	148528-04-CHT(02A)	EA	DECAL-SWEEP LH - DK CHERRY
24	148531-02-CHT(02A)	EA	DECAL-HOOD - BROWN/BURGUNDY/MOSS GREEN
25	148532-01-CHT(05A)	EA	DECAL-SWEEP SML RH - BRT WHITE/DK CHERRY
26	148532-02-CHT(05A)	EA	DECAL-SWEEP SML LH - BRT WHITE/DK CHERRY
27	151687-01-CHT(01A)	EA	DECAL-BEZEL DOMED NAMEPLATE WINNEBAGO - CHROME/RED
28	148523-01-CHT(02A)	EA	DECAL-PAINT LINE #4 RH - MED PARCHEMENT
29	151687-02-CHT(01A)	EA	DECAL-PAINT LINE #4 LH - MED PARCHEMENT
30	141599-27-000	GL	PAINT-IMRON CLEAR 55 GAL - DUPONT #3440S
31	EA	DECAL-EMBLEM - CHASSIS SUPPLIED
32	GL	COLORLED PLASTIC AND STEEL - MED PARCHEMENT

- △ FILM TO PROTECT BOTTOM OF DOOR FROM SCUFF MARKS.
- △ PARTS BELOW FEATURE LINE WILL BE COLORED PRIOR TO ASSEMBLY.
- △ CENTER ON UNIT.
- 1. APPLY PROTECTOR 116424-01 TO WATER HEATER LATCH.

NOTES:

- △ DECAL NOT USED ON D34A.
- △ USE ALIGNMENT TABS ON DECAL FOR LOCATION.
- △ DECAL WILL NOT BE USED ON D26P SIDEWALL.
- △ LOGO IS TO BE HELD TO :1 MM ON A HORIZONTAL PLANE (END TO END).
- △ CLEAR COAT TO BE APPLIED ON PAINTED AREAS TO PROTECT PAINT.

- (1PN) WORKHORSE 20,700*
- (1PL) WORKHORSE 18,000* GVWR (W18)
- (1PJ) WORKHORSE 16,000* GVWR (W16)
- (16M) FORD CHASSIS 20,500*/V10 ENG
- (16H) FORD CHASSIS 18,000*/V10 ENG
- (26H) EXT GRAPHICS-DELUXE PKG #2
- (26F) EXT GRAPHICS-DELUXE, PKG #1
- (92K) EXTERIOR GRAPHICS PACKAGE #2
- (27G) EXTERIOR GRAPHICS PACKAGE #1

EXTERIOR BODY GROUP (CONTINUED)
GRAPHICS & PAINT (CONTINUED)

KEY	PART NUMBER	U/M	DESCRIPTION
	072882-01-000	GL	PAINT - LOW BAKE - OFF WHITE
	116424-01-000	EA	PROTECTOR - LATCH - WATER HEATER

**DUPONT COLOR CODES ARE NOW FOUND IN THE PAINT CODE MANUAL.
YOU CAN FIND THIS MANUAL ON YOUR DEALER INDEX WEBPAGE UNDER SERVICE.**

EXTERIOR BODY GROUP (CONTINUED)

PANELS & TRIMS

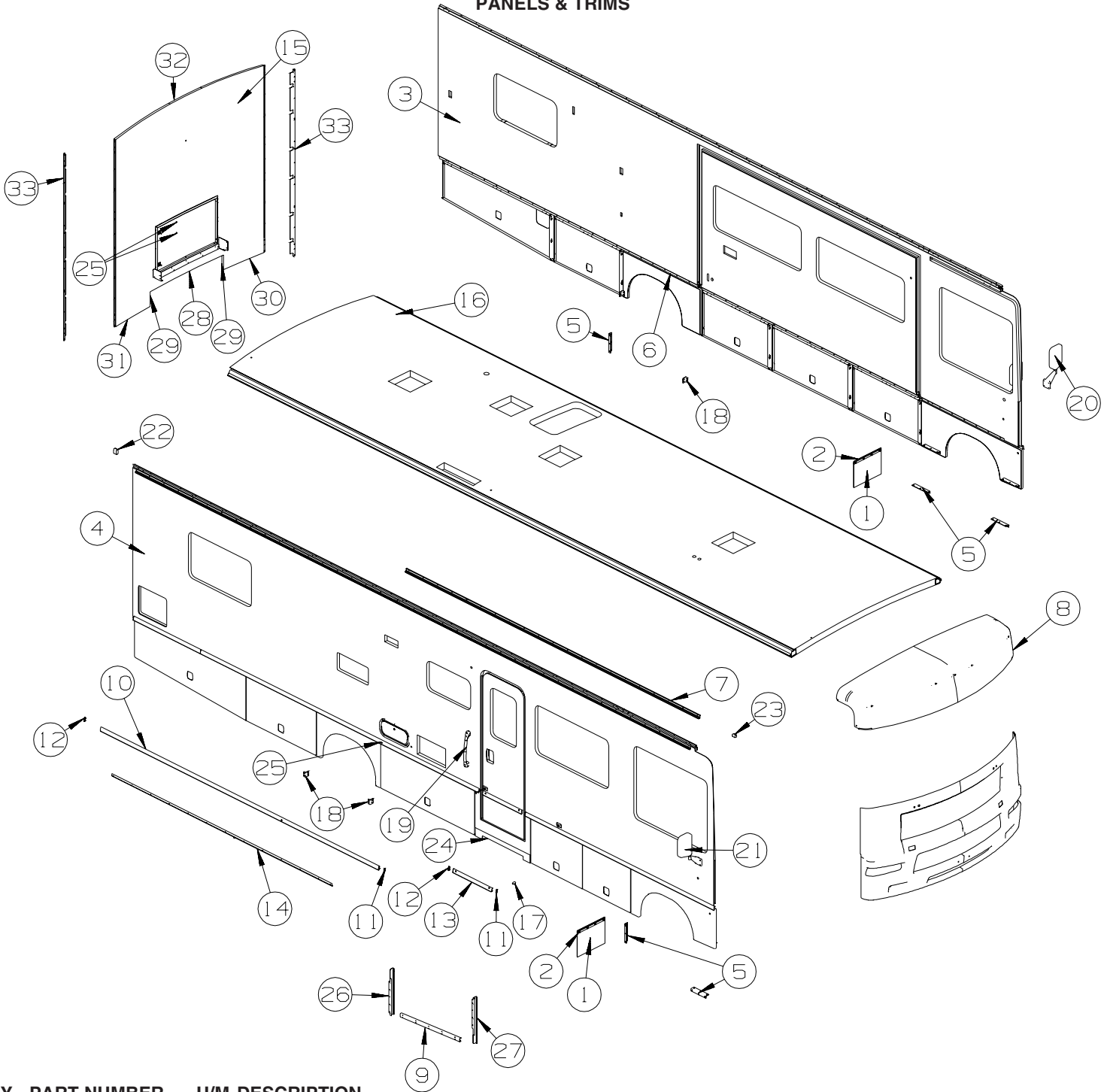

KEY	PART NUMBER	U/M	DESCRIPTION
1	017516-01-000	EA	MUD FLAP - 14"H X 18"W - W/O MOUNTING HOLES - BLACK
2	140922-01-02B	EA	PLATE - MUD FLAP - E-COATED
3	158768-01-U57	EA	SIDEWALL - DRIVER - W/O WINDOWS/TRIMS (U51, U52)
3	158768-01-U59	EA	SIDEWALL - DRIVER - W/O WINDOWS/TRIMS (U53, U54)
3	158768-01-U61	EA	SIDEWALL - DRIVER - W/O WINDOWS/TRIMS (U55, U56)
3	158768-02-U57	EA	SIDEWALL - DRIVER - W/O WINDOWS/TRIMS (U51, U52) - SIDEWALL-PREMIUM HIGH GLOSS
3	158768-02-U59	EA	SIDEWALL - DRIVER - W/O WINDOWS/TRIMS (U53, U54) - SIDEWALL-PREMIUM HIGH GLOSS
3	158768-02-U61	EA	SIDEWALL - DRIVER - W/O WINDOWS/TRIMS (U55, U56) - SIDEWALL-PREMIUM HIGH GLOSS
4	158767-01-U57	EA	SIDEWALL - PASSENGER - W/O WINDOWS/TRIMS (U51, U52)
4	158767-01-U59	EA	SIDEWALL - PASSENGER - W/O WINDOWS/TRIMS (U53, U54)
4	158767-01-U61	EA	SIDEWALL - PASSENGER - W/O WINDOWS/TRIMS (U55, U56)
4	158767-02-U57	EA	SIDEWALL - PASSENGER - W/O WINDOWS/TRIMS (U51, U52) - SIDEWALL-PREMIUM HIGH GLOSS
4	158767-02-U59	EA	SIDEWALL - PASSENGER - W/O WINDOWS/TRIMS (U53, U54) - SIDEWALL-PREMIUM HIGH GLOSS
4	158767-02-U61	EA	SIDEWALL - PASSENGER - W/O WINDOWS/TRIMS (U55, U56) - SIDEWALL-PREMIUM HIGH GLOSS
5	113904-18-02B	EA	ANGLE - ATTACHMENT/WHEEL LIP - E-COATED

EXTERIOR BODY GROUP (CONTINUED)
PANELS & TRIMS (CONTINUED)

KEY	PART NUMBER	U/M	DESCRIPTION
6	104692-01-000	FT	SEAL - ADHESIVE BACKED FOAM - 3/4" THICK X 3/4" WIDE X 25'
7	157284-01-01A	EA	RAIL - AWNING - 192" - BRIGHT WHITE
8	138017-02-N21	EA	CAP - ROOF/FRONT SECTION - W/O LIGHTS/VENTS - W/WIRING
9	137599-05-04A	EA	TRIM - SIDEWALL/LOWER - 35.9" - PARCHMENT
10	146550-01-03A	EA	TRIM - COVER - SIDEWALL
11	146576-01-01A	EA	CAP - END/TRIM - RIGHT HAND
12	146576-02-01A	EA	CAP - END/TRIM - LEFT HAND- BRIGHT WHITE
13	149822-01-01A	EA	TRIM - SIDEWALL/ENTRY DOOR - 25.3" - BRIGHT WHITE
14	146548-01-01A	EA	TRIM - RETAINER
15	P57687-01-U57	EA	BACKWALL - W/O WINDOW/TRIMS (U51, U52)
15	P57687-01-U59	EA	BACKWALL - W/O WINDOW/TRIMS (U53, U54)
15	P57687-01-U61	EA	BACKWALL - W/O WINDOW/TRIMS (U55, U56)
15	P57687-02-U57	EA	BACKWALL - W/O WINDOW/TRIMS (U51, U52) - SIDEWALL-PREMIUM HIGH GLOSS
15	P57687-02-U59	EA	BACKWALL - W/O WINDOW/TRIMS (U53, U54) - SIDEWALL-PREMIUM HIGH GLOSS
15	P57687-02-U61	EA	BACKWALL - W/O WINDOW/TRIMS (U55, U56) - SIDEWALL-PREMIUM HIGH GLOSS
16	158769-01-U57	EA	ROOF - W/O LIGHTS/VENTS - W/WIRING
17	120863-02-000	EA	BUMPER - RUBBER/RADIUS TOP - 1" X 1 1/2"
18	113904-19-02B	EA	ANGLE - ATTACHMENT/WHEEL LIP - E-COATED
19	152854-01-01A	EA	HANDLE - ASSIST - WHITE W/BLACK RUBBER GRIP - 18 5/8"
20*	106015-15-01A	EA	MIRROR - EXTERIOR ADJUSTABLE GLASS
20*	106015-13-01A	EA	MIRROR - EXTERIOR REMOTE/HEAT - MIRRORS-EXTERIOR W/DEFROST
21*	106015-14-01A	EA	MIRROR - EXTERIOR ADJUSTABLE GLASS
21*	106015-12-01A	EA	MIRROR - EXTERIOR REMOTE/HEAT - MIRRORS-EXTERIOR W/DEFROST
22	156094-01-000	EA	FOAM - PLUG - SIDEWALL TUBE
23	156094-02-000	EA	FOAM - PLUG - SIDEWALL TUBE
24	138021-05-18B	EA	PANEL-TRIM MED PARCH
25	153498-01-01A	EA	BUMPER - RUBBER - WHITE
26	133100-02-04A	EA	TRIM - SIDEWALL - 24.5" - PARCHMENT
27	133100-01-04A	EA	TRIM - SIDEWALL - 24.5" - PARCHMENT
28	158141-01-01A	EA	TRIM - BACKWALL/LOWER - 49.3"
29	158141-02-01A	EA	TRIM - BACKWALL/LOWER - 8.6"
30	158141-03-01A	EA	TRIM - BACKWALL/LOWER - 24.6"
31	158141-04-01A	EA	TRIM - BACKWALL/LOWER - 24.6"
32	114248-02-04A	EA	ANGLE - PLASTIC - .7" X .4" X 96.7" - BEIGE
33	135270-02-02B	EA	BRACKET/Z - BACKWALL MOUNT - E-COAT

*COMPONENT PARTS LISTED LATER IN THIS GROUP

EXTERIOR BODY GROUP (CONTINUED)
PANELS & TRIMS (CONTINUED)

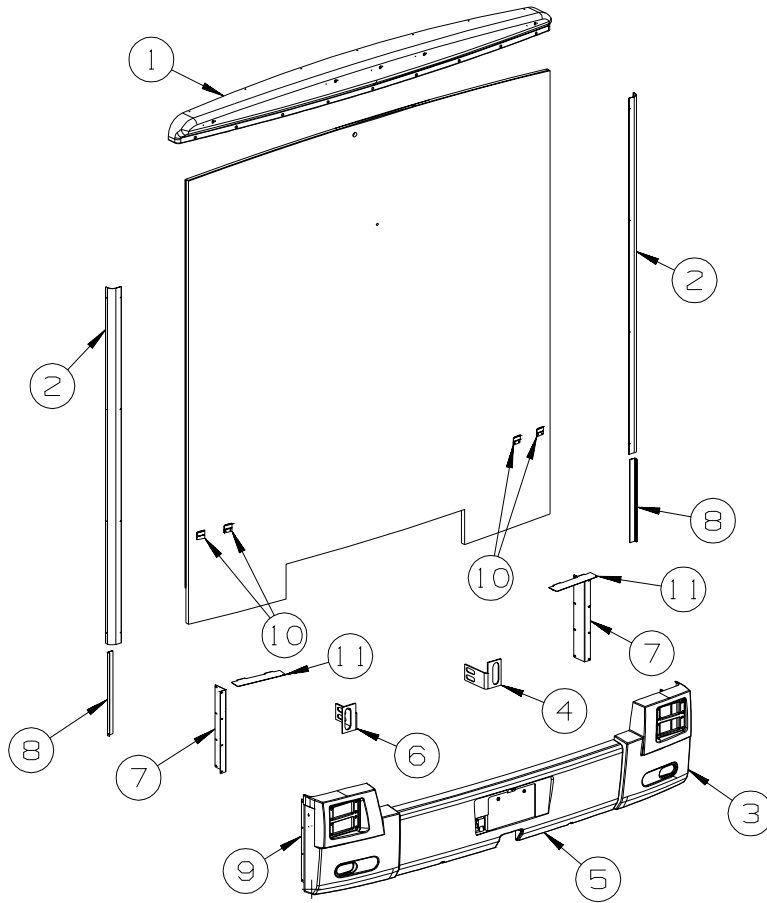

KEY	PART NUMBER	U/M	DESCRIPTION
1	137582-02-N21	EA	CAP - REAR/ROOF - W/O LIGHTS/VENTS - W/WIRING - BRIGHT WHT
2	139969-01-02A	EA	COVE - BACKWALL - BRIGHT WHITE
3	157713-03-U57	EA	TRIM/POD - BACKWALL/TAILLIGHT - LOWER/PASSENGER
4	138162-05-02B	EA	BRACKET/BUMPER - RR/RH HAND - 4.3"X 3.5"X 7.3" - E-COATED
5	P57727-02-U57	EA	PANEL - BUMPER/REAR - W/O HARDWARE
6	138162-06-02B	EA	BRACKET/BUMPER - RR/LH HAND - 4.3"X 3.5"X 7.3" - E-COATED
7	139811-01-02B	EA	SEAL PLANE/ANGLE MOUNT FILLER (SIDEWALL/BACKWALL ATTACH)
8	132721-02-02B	EA	BRACKET/MOUNT - TRIM - REAR - E-COATED
9	157713-04-U57	EA	TRIM/POD - BACKWALL/TAILLIGHT - LOWER/DRIVER
10	130034-07-02B	EA	CLIP - TRIM - E-COATED
11	159554-01-02B	EA	BRACKET/MOUNT - TRIM/POD - TAILLIGHT - E-COATED

EXTERIOR BODY GROUP (CONTINUED)
COMPONENT PARTS FOR PANELS & TRIMS

106015-12-01A

KEY	PART NUMBER	U/M	DESCRIPTION	VENDOR NO.
	106015-12-700	EA	MIRROR-FLAT-W/W/O HEAT	709448
	106015-12-701	EA	MIRROR-CONVEX - W/W/O HEAT	709449
	106015-12-702	EA	CAP/SCREW - (PKG OF 4) - BLK	748329 RND
	106015-12-703	EA	CONVEX GLASS/HANDSET/HOUSING	7095892
	106015-19-701	EA	GLASS/FLAT-W/BEZEL/HEAT/ANTI	709644
	119774-09-700	EA	PLATE-INNER SUPT/MIRROR HEAD	709418-7RH
	131431-01-701	EA	MOTOR	7475400

106015-13-01A

KEY	PART NUMBER	U/M	DESCRIPTION	VENDOR NO.
	106015-12-700	EA	MIRROR-FLAT-W/W/O HEAT	709448
	106015-12-701	EA	MIRROR-CONVEX - W/W/O HEAT	709449
	106015-12-702	EA	CAP/SCREW - (PKG OF 4) - BLK	748329 RND
	106015-12-703	EA	CONVEX GLASS/HANDSET/HOUSING	7095892
	106015-19-701	EA	GLASS/FLAT-W/BEZEL/HEAT/ANTI	709644
	119774-09-701	EA	PLATE INNER SUPT/MIRROR HEAD	709419-7LH
	131431-01-701	EA	MOTOR	7475400

106015-14-01A

KEY	PART NUMBER	U/M	DESCRIPTION	VENDOR NO.
	106015-12-700	EA	MIRROR-FLAT-W/W/O HEAT	709448
	106015-12-701	EA	MIRROR-CONVEX - W/W/O HEAT	709449
	106015-12-702	EA	CAP/SCREW - (PKG OF 4) - BLK	748329 RND
	106015-12-703	EA	CONVEX GLASS/HANDSET/HOUSING	7095892
	106015-19-701	EA	GLASS/FLAT-W/BEZEL/HEAT/ANTI	709644
	119774-09-700	EA	PLATE-INNER SUPT/MIRROR HEAD	709418-7RH

106015-15-01A

KEY	PART NUMBER	U/M	DESCRIPTION	VENDOR NO.
	106015-12-700	EA	MIRROR-FLAT-W/W/O HEAT	709448
	106015-12-701	EA	MIRROR-CONVEX - W/W/O HEAT	709449
	106015-12-702	EA	CAP/SCREW - (PKG OF 4) - BLK	748329 RND
	106015-12-703	EA	CONVEX GLASS/HANDSET/HOUSING	7095892
	106015-19-701	EA	GLASS/FLAT-W/BEZEL/HEAT/ANTI	709644
	119774-09-701	EA	PLATE INNER SUPT/MIRROR HEAD	709419-7LH

EXTERIOR BODY GROUP (CONTINUED)

FRONT END

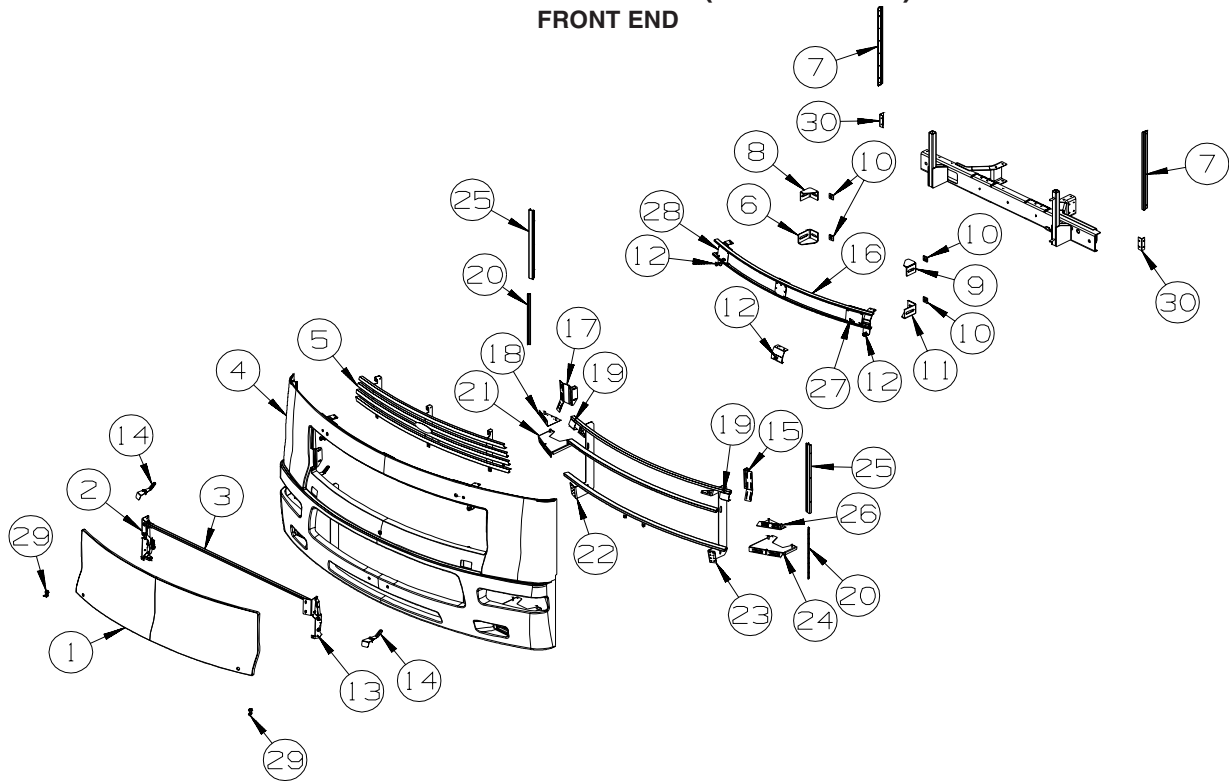

KEY	PART NUMBER	U/M	DESCRIPTION
1	137590-01-N21	EA	HOOD - FRONT
2	137072-13-01A	EA	HINGE - HOOD - PASSENGER - BLACK
3	137300-01-02B	EA	TUBE/TIMING - HOOD - 63.2" - E-COATED - WORKHORSE
3	154091-05-02B	EA	TUBE/TIMING - HOOD - E-COATED - FORD
4	147557-02-S28	EA	PANEL - FRONT/LOWER - BRIGHT WHITE
5	157957-01-U57	EA	GRILLE - FRONT
6	128455-02-02B	EA	BRACKET - BUMPER - E-COATED
7	092041-10-01A	EA	TRIM - FRONT/REAR CAP (SIDEWALL) - 25.2" - BRIGHT WHITE
7	091985-01-07A	FT	INSERT - TRIM - REAR CAP TO SIDEWALL - .66" - BRIGHT WHITE
8	128455-05-02B	EA	BRACKET - BUMPER - E-COATED
9	128455-06-02B	EA	BRACKET - BUMPER - E-COATED
10	116617-02-02B	EA	SPACER - BUMPER
11	128455-01-02B	EA	BRACKET - BUMPER - E-COATED
12	058786-01-000	EA	BOLT - HOOD ADJUSTMENT - 5/16"-18 X 1.5"-2"- W/BLACK PAD
13	137072-14-01A	EA	HINGE - HOOD - DRIVER - BLACK
14	141017-01-02B	EA	SUPPORT/HINGE - FRONT - E-COATED
15	134530-06-02B	EA	SUPPORT - HOOD LINK - E-COATED
16	149784-03-S46	EA	SUPPORT - WIPER
17	134530-05-02B	EA	SUPPORT - HOOD LINK - E-COATED
18	147894-02-02B	EA	BRACKET - HEADLAMP - E-COATED
19	137679-01-02B	EA	STRIKE - HOOD LATCH - E-COATED
20	134066-04-02B	EA	BRACKET - ZEE - W/HOLES - E-COATED
21	147895-02-02B	EA	BRACKET - HEADLAMP - E-COATED
22	137591-03-02B	EA	BRACKET - FRONT MOUNT/RIGHT HAND - E-COATED
23	137591-04-02B	EA	BRACKET - FRONT MOUNT/LEFT HAND - E-COATED
24	147895-04-02B	EA	BRACKET - HEADLAMP - E-COATED
25	132864-01-01A	EA	SUPPORT - FRONT/INNER PANEL TRIM
26	147894-04-02B	EA	BRACKET - HEADLAMP - E-COATED
27	149788-08-02B	EA	SUPPORT - PIVOT SHAFT - E-COATED
28	149788-06-02B	EA	SUPPORT - PIVOT SHAFT - E-COATED
29	102330-02-000	EA	LATCH - VISE ACTION/KEY OPERATED
29	102328-01-000	EA	KEY - BARREL - NICKEL PLATED
30	113041-10-02B	EA	ANGLE/MOUNT - BUMPER - E-COATED

EXTERIOR BODY GROUP (CONTINUED)

LADDER

KEY	PART NUMBER	U/M	DESCRIPTION
	152869-03-01A	EA	LADDER/FOLDING - 78.6"/141.5" - 11 STEP - BRUSHED ALUMINUM

STRUCTURAL COMPONENTS

KEY	PART NUMBER	U/M	DESCRIPTION
	089297-01-000	SF	PLYWOOD - LUAN - OVERLAY GRADE - 4' X 8'
	089297-03-000	SF	PLYWOOD - LUAN - OVERLAY GRADE - 4' X 8.3'
	100619-01-000	BF	FOAM - EXPANDED POLYSTYRENE - 1.34" X 48" X 96"
	100619-02-000	BF	FOAM - EXPANDED POLYSTYRENE - 1.5" X 48" X 96"
	100619-04-000	BF	FOAM - EXPANDED POLYSTYRENE - .5" X 48" X 96"
	100619-05-000	BF	FOAM - EXPANDED POLYSTYRENE - .75" X 48" X 96"-1.5"DENSITY
	100619-16-000	BF	FOAM - EXPANDED POLYSTYRENE - .75" X 48" X 96"-2" DENSITY
	100619-22-000	BF	FOAM - EXPANDED POLYSTYRENE - 1.34" X 48" X 120"
	120107-07-000	EA	FOAM - ROOF COVE
	152490-01-000	EA	FOAM - PLUG - ROOF TUBE
	116942-03-01A	LB	ALUMINUM - .7" X 40" X 158"
	108535-05-03A	SF	FIBERGLASS SHEET - 108" X 500' ROLL - BRIGHT WHITE
	128782-07-01A	EA	FIBERGLASS SHEET - 5/32" X 78.9" X 456" - HIGH GLOSS - B/W
	128782-09-01A	EA	FIBERGLASS SHEET - 31" X 68.2" - HIGH GLOSS - BRIGHT WHITE
	128782-14-01A	EA	FIBERGLASS SHEET - 102.4" X 99.2" - HIGH GLOSS - BRT WHITE
	128782-24-01A	EA	FIBERGLASS SHEET - 99.5" X 100.2" - HIGH GLOSS - BRT WHITE
	148884-12-01A	EA	FIBERGLASS SHEET - 31.1" X 68.2" - HIGH GLOSS-BRIGHT WHITE FROM: 00-00-00 THRU: 02-26-06
	159631-10-01A	EA	FIBERGLASS SHEET - 31.1" X 68.2" - BRIGHT WHITE FROM: 02-27-06 THRU: 01-14-07
	162931-10-01A	EA	FIBERGLASS SHEET - 31.1" X 68.2" - BRIGHT WHITE FROM: 01-15-07 THRU: 99-99-99
	159631-15-01A	EA	FIBERGLASS SHEET - 4" X 93.8" - BRIGHT WHITE FROM: 00-00-00 THRU: 01-14-07
	162931-15-01A	EA	FIBERGLASS SHEET - 4" X 93.8" - BRIGHT WHITE FROM: 01-15-07 THRU: 99-99-99
	148884-16-01A	EA	FIBERGLASS SHEET - 78.9" X 396.1" -HIGH GLOSS-BRIGHT WHITE FROM: 00-00-00 THRU: 02-26-06
	159631-13-01A	EA	FIBERGLASS SHEET - 78.9" X 396.1" - BRIGHT WHITE FROM: 02-27-06 THRU: 01-14-07
	162931-01-01A	EA	FIBERGLASS SHEET - 78.9" X 396.1" - BRIGHT WHITE FROM: 01-15-07 THRU: 99-99-99
	159631-19-01A	EA	FIBERGLASS SHEET - 25" X 47.9" - BRIGHT WHITE FROM: 00-00-00 THRU: 01-14-07
	148884-32-01A	EA	FIBERGLASS SHEET - 107.3" X 100.2" - BRIGHT WHITE FROM: 01-15-07 THRU: 99-99-99
	159631-24-01A	EA	FIBERGLASS SHEET - 107.3" X 100.2" - BRIGHT WHITE FROM: 00-00-00 THRU: 01-14-07
	162931-24-01A	EA	FIBERGLASS SHEET - 107.3" X 100.2" - BRIGHT WHITE FROM: 01-15-07 THRU: 99-99-99

AWNINGS

**ORDER AWNINGS & REPAIR PARTS FROM DOMETIC. CALL #800-366-3842.
THE DOMETIC AWNING INFORMATION YOU WILL NEED IS LOCATED ON THE MOTORHOME
NEAR THE TOP OF THE RAIL**

KEY	PART NUMBER	U/M	DESCRIPTION
	113874-11-01A	EA	SCREW/LAG - AWNING - 1/4" X 1" STAINLESS STEEL
	113874-12-01A	EA	SCREW/LAG - AWNING - 1/4" X 2 3/4" STAINLESS STEEL
	137054-01-02A	EA	BRACKET - AWNING - BRIGHT WHITE - D26P, D29R, D30B, D33T, D35J FROM: 00-00-00 THRU: 12-10-06
	161739-01-02A	EA	BRACKET - AWNING - BRIGHT WHITE - D26P, D29R, D30B, D33T, D35J FROM: 12-11-06 THRU: 99-99-99
	146457-02-03A	EA	BRACKET - AWNING - BRIGHT WHITE - D34A

EXTERIOR DOORS & COMPARTMENTS GROUP
DOOR & COMPARTMENT LAYOUT

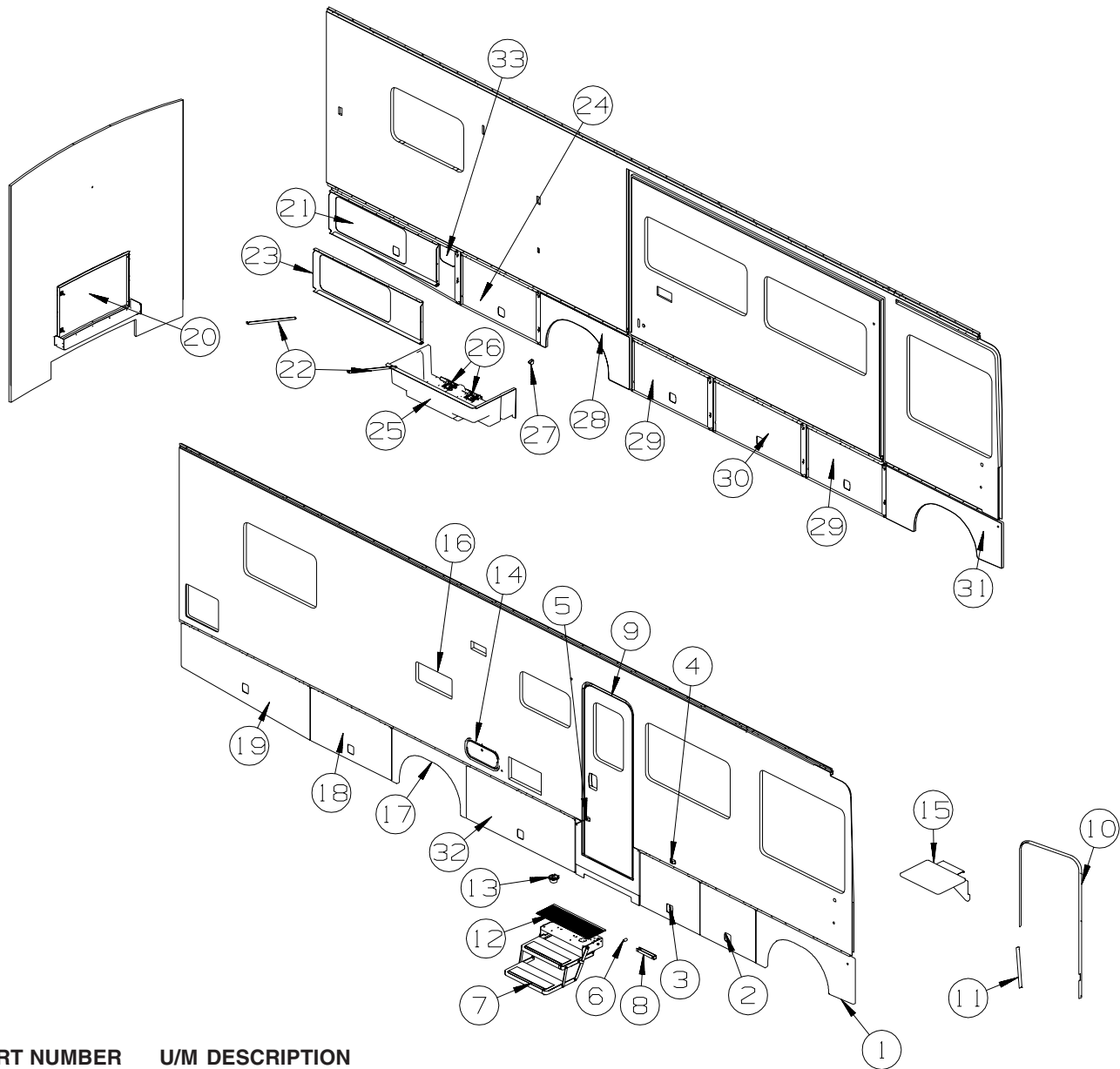

KEY	PART NUMBER	U/M	DESCRIPTION
1	147493-01-S28	EA	PANEL/WHEEL LIP - FRONT
	139793-03-01A	EA	HINGE - CENTER/VALANCE DOOR - W/O BALL STUD
2	141743-01-T53	EA	VALANCE/DOOR - W/O PADDLE LATCH/HDW - 31.2" X 24.3"
			FROM: 00-00-00 THRU: 04-02-06
2	159965-01-U57	EA	VALANCE/DOOR - W/O LATCH/HDW/NON LOCKING - 31.1"W X 24.3"H
			FROM: 04-03-06 THRU: 99-99-99
	132873-99-000	EA	ROD - LATCH - 9.4" W/3/4" DOG LEG
	135624-96-01B	EA	ROD - LATCH
	142569-12-000	EA	SPRING/GAS - 90 LB - 15" EXTENDED/9.5" COMPRESSED
	126263-02-02B	EA	BRACKET - GAS SPRING W/BALL STUD - E-COATED
	130053-02-01A	EA	STRIKER - LUGGAGE DOOR - OFF SET - BLACK
	143793-01-01A	EA	SHIM/STRIKER - LUGGAGE - 1.5" - BLACK
	120494-04-02B	EA	SHIM - STRIKER - LUGGAGE DOOR - 3/16" - E-COATED
	076767-15-000	EA	CABLE - STAINLESS STEEL - 9.8"
	132892-08-01A	FT	SEAL - BULB/SINGLE - W/U CHANNEL - BLACK
	099418-01-000	FT	SEAL - D-SECTION/ADHESIVE BACK - .44" X .44" - BLK RUBBER

EXTERIOR DOORS & COMPARTMENTS GROUP (CONTINUED)
DOOR & COMPARTMENT LAYOUT (CONTINUED)

KEY	PART NUMBER	U/M	DESCRIPTION	
3	141743-39-T53	EA	VALANCE/DOOR - W/O PADDLE LATCH/HDW - 33.6" X 24.3"	
				FROM: 00-00-00 THRU: 04-02-06
3	159965-26-U57	EA	VALANCE/DOOR - W/O PADDLE LATCH/HDW - 33.6"W X 24.3"H	
				FROM: 04-03-06 THRU: 99-99-99
	132873-H2-000	EA	ROD - LATCH - 10.7" W/3/4" DOG LEG	
	135624-C0-01B	EA	ROD - LATCH	
	142569-12-000	EA	SPRING/GAS - 90 LB - 15" EXTENDED/9.5" COMPRESSED	
	126263-02-02B	EA	BRACKET - GAS SPRING W/BALL STUD - E-COATED	
	126263-02-02B	EA	BRACKET - GAS SPRING W/BALL STUD - E-COATED	
	130053-02-01A	EA	STRIKER - LUGGAGE DOOR - OFF SET - BLACK	
	143793-01-01A	EA	SHIM/STRIKER - LUGGAGE - 1.5" - BLACK	
	120494-04-02B	EA	SHIM - STRIKER - LUGGAGE DOOR - 3/16" - E-COATED	
	132892-08-01A	FT	SEAL - BULB/SINGLE - W/U CHANNEL - BLACK	
	099418-01-000	FT	SEAL - D-SECTION/ADHESIVE BACK - .44" X .44" - BLK RUBBER	
4	104099-02-04A	EA	CATCH/RETAINER - DOOR HOLDER - BRIGHT WHITE	
5	104099-03-04A	EA	CATCH - DOOR HOLDER - STRIKE - 6" - BRIGHT WHITE	
6	120863-02-000	EA	BUMPER - RUBBER/RADIUS TOP - 1" X 1 1/2"	
7*	094707-04-01A	EA	STEP - ELECTRIC DOUBLE - KWIKEE	
	116975-01-01A	EA	LATCH - W/O STRIKE - BLACK - NEW STYLE	
8	138787-02-02B	EA	CHANNEL/MOUNT - E-COAT	
9	P32206-08-U51	EA	DOOR - ENTRY W/SCREEN DOOR - W/O WINDOW/LATCH (U51,U52)	
9	P32206-08-U53	EA	DOOR - ENTRY W/SCREEN DOOR - W/O WINDOW/LATCH (U53,U54)	
9	P32206-08-U55	EA	DOOR - ENTRY W/SCREEN DOOR - W/O WINDOW/LATCH (U55,U56)	
9	P32206-19-U51	EA	DOOR - ENTRY W/SCREEN DOOR - W/O WINDOW/LATCH (U51,U52)	PREMIUM HIGH GLOSS
9	P32206-19-U53	EA	DOOR - ENTRY W/SCREEN DOOR - W/O WINDOW/LATCH (U53,U54)	PREMIUM HIGH GLOSS
9	P32206-19-U55	EA	DOOR - ENTRY W/SCREEN DOOR - W/O WINDOW/LATCH (U55,U56)	PREMIUM HIGH GLOSS

ENTRY DOOR LOCK CYLINDERS

138287-11-000	EA	CYLINDER/LOCK - ENTRY DOOR - MASTER W/3M ICON - (3041)
138287-12-000	EA	CYLINDER/LOCK - ENTRY DOOR - MASTER W/3M ICON - (3042)
138287-13-000	EA	CYLINDER/LOCK - ENTRY DOOR - MASTER W/3M ICON - (3043)
138287-14-000	EA	CYLINDER/LOCK - ENTRY DOOR - MASTER W/3M ICON - (3044)
138287-15-000	EA	CYLINDER/LOCK - ENTRY DOOR - MASTER W/3M ICON - (3045)
138287-16-000	EA	CYLINDER/LOCK - ENTRY DOOR - MASTER W/3M ICON - (3046)
138287-17-000	EA	CYLINDER/LOCK - ENTRY DOOR - MASTER W/3M ICON - (3047)
138287-18-000	EA	CYLINDER/LOCK - ENTRY DOOR - MASTER W/3M ICON - (3048)
138287-19-000	EA	CYLINDER/LOCK - ENTRY DOOR - MASTER W/3M ICON - (3049)
138287-20-000	EA	CYLINDER/LOCK - ENTRY DOOR - MASTER W/3M ICON - (3050)
138292-01-000	EA	SEAL - LOCK CYLINDER

VALANCE DOOR LOCK CYLINDERS

138289-11-000	EA	CYLINDER/LOCK - ACCESS DOORS - REDUCED SENSITIVITY (3041)	
138289-12-000	EA	CYLINDER/LOCK - ACCESS DOORS - REDUCED SENSITIVITY (3042)	
138289-13-000	EA	CYLINDER/LOCK - ACCESS DOORS - REDUCED SENSITIVITY (3043)	
138289-14-000	EA	CYLINDER/LOCK - ACCESS DOORS - REDUCED SENSITIVITY (3044)	
138289-15-000	EA	CYLINDER/LOCK - ACCESS DOORS - REDUCED SENSITIVITY (3045)	
138289-16-000	EA	CYLINDER/LOCK - ACCESS DOORS - REDUCED SENSITIVITY (3046)	
138289-17-000	EA	CYLINDER/LOCK - ACCESS DOORS - REDUCED SENSITIVITY (3047)	
138289-18-000	EA	CYLINDER/LOCK - ACCESS DOORS - REDUCED SENSITIVITY (3048)	
138289-19-000	EA	CYLINDER/LOCK - ACCESS DOORS - REDUCED SENSITIVITY (3049)	
138289-20-000	EA	CYLINDER/LOCK - ACCESS DOORS - REDUCED SENSITIVITY (3050)	
138288-11-000	EA	KEY - REVERSIBLE - #3041 - T/M 16169-02-3041	
138288-12-000	EA	KEY - REVERSIBLE - #3042 - T/M 16169-02-3042	
138288-13-000	EA	KEY - REVERSIBLE - #3043 - T/M 16169-02-3043	
138288-14-000	EA	KEY - REVERSIBLE - #3044 - T/M 16169-02-3044	
138288-15-000	EA	KEY - REVERSIBLE - #3045 - T/M 16169-02-3045	
138288-16-000	EA	KEY - REVERSIBLE - #3046 - T/M 16169-02-3046	
138288-17-000	EA	KEY - REVERSIBLE - #3047 - T/M 16169-02-3047	
138288-18-000	EA	KEY - REVERSIBLE - #3048 - T/M 16169-02-3048	
138288-19-000	EA	KEY - REVERSIBLE - #3049 - T/M 16169-02-3049	
138288-20-000	EA	KEY - REVERSIBLE - #3050 - T/M 16169-02-3050	
10	139100-01-01A	EA	GARNISH/RADIUS - ENTRY DOOR - BRIGHT WHITE
11	139101-01-01A	EA	GARNISH/STRAIGHT - W/NOTCH - 36.31" - BRIGHT WHITE
12	133114-01-01A	EA	TREAD - STEP/RUBBER - 29.3" X 10.1" - TAUPE
13	009426-01-000	EA	HATCH - POWER CORD - WHITE

EXTERIOR DOORS & COMPARTMENTS GROUP (CONTINUED)
DOOR & COMPARTMENT LAYOUT (CONTINUED)

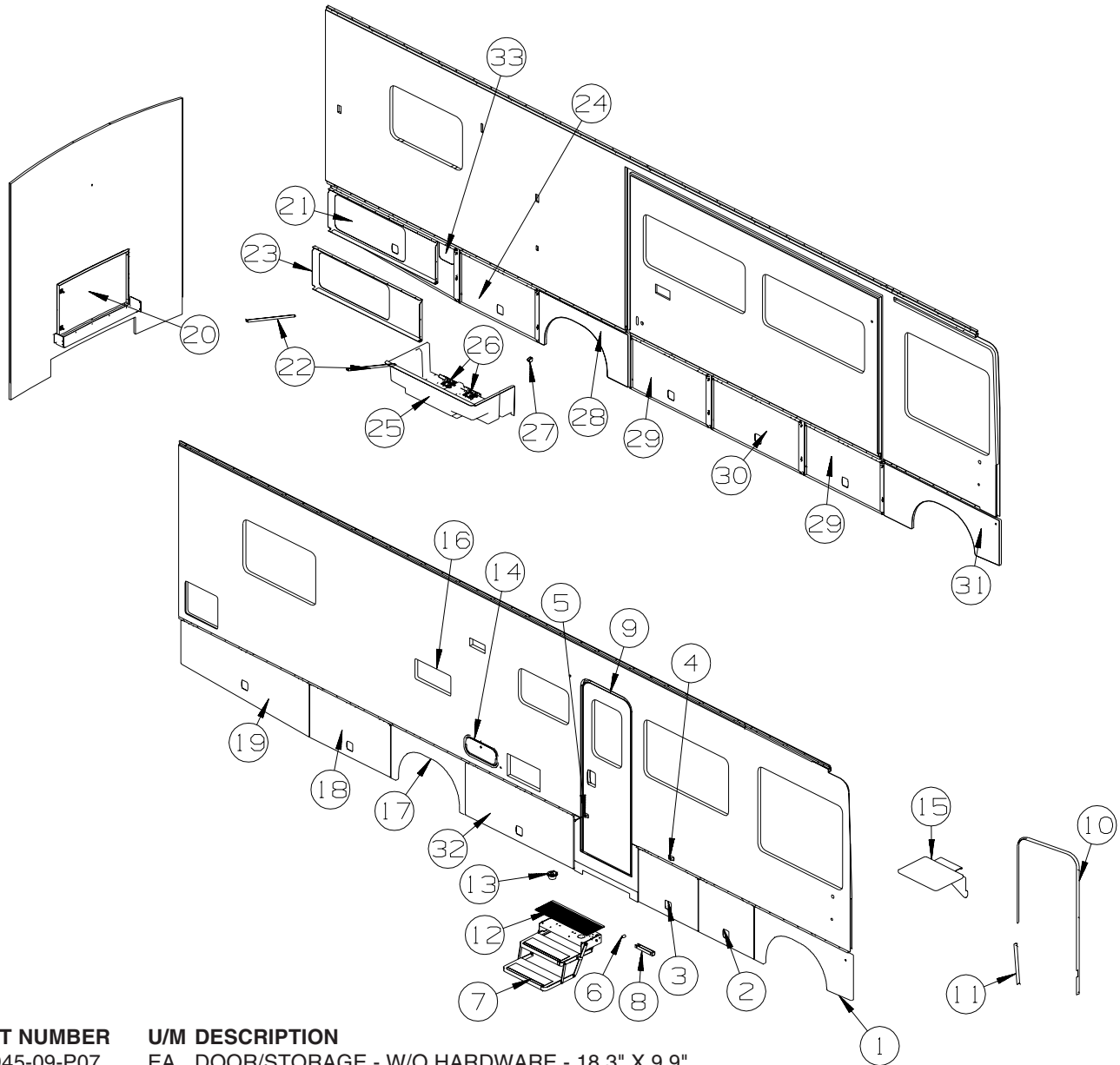

KEY	PART NUMBER	U/M	DESCRIPTION
14	126945-09-P07	EA	DOOR/STORAGE - W/O HARDWARE - 18.3" X 9.9"
15	142034-01-01A	EA	SHELF - F/EXTERIOR TV - BRIGHT WHITE
16*	084103-08-000	EA	DOOR - VENT - REFRIGERATOR - W/O JAMB - BRIGHT WHITE
16	084104-08-000	EA	JAMB - VENT DOOR/REFRIGERATOR - BRIGHT WHITE
17	147492-01-T53	EA	PANEL/WHEEL LIP - REAR
	139793-03-01A	EA	HINGE - CENTER/VALANCE DOOR - W/O BALL STUD
18	141743-03-T53	EA	VALANCE/DOOR - W/O PADDLE LATCH/HDW - 45.6" X 24.3"
			FROM: 00-00-00 THRU: 04-02-06
18	159965-03-U57	EA	VALANCE/DOOR - W/O PADDLE LATCH/HDW - 45.6"W X 24.3"H
			FROM: 04-03-06 THRU: 99-99-99
	132873-A3-000	EA	ROD - LATCH - 16.6" W/3/4" DOG LEG
	135624-97-01B	EA	ROD - LATCH
	142569-12-000	EA	SPRING/GAS - 90 LB - 15" EXTENDED/9.5" COMPRESSED
	126263-02-02B	EA	BRACKET - GAS SPRING W/BALL STUD - E-COATED
	130053-02-01A	EA	STRIKER - LUGGAGE DOOR - OFF SET - BLACK
	143793-01-01A	EA	SHIM/STRIKER - LUGGAGE - 1.5" - BLACK
	120494-04-02B	EA	SHIM - STRIKER - LUGGAGE DOOR - 3/16" - E-COATED
	132892-08-01A	FT	SEAL - BULB/SINGLE - W/U CHANNEL - BLACK
	099418-01-000	FT	SEAL - D-SECTION/ADHESIVE BACK - .44" X .44" - BLK RUBBER

EXTERIOR DOORS & COMPARTMENTS GROUP (CONTINUED)
DOOR & COMPARTMENT LAYOUT (CONTINUED)

KEY	PART NUMBER	U/M	DESCRIPTION
19	141743-42-T53	EA	VALANCE/DOOR - PASS W/O LATCH/HDW - 24.3" X 72.6" X 20.1" FROM: 00-00-00 THRU: 04-02-06
19	159965-29-U57	EA	VALANCE/DOOR - W/O PADDLE LATCH/HDW - 72.6"WX24.3"HX20.1"H FROM: 04-03-06 THRU: 99-99-99
	132873-H6-000	EA	ROD - LATCH - 30.2" W/3/4" DOG LEG
	135624-C2-01B	EA	ROD - LATCH
	142569-17-000	EA	SPRING/GAS - 90 LB - 12" EXTENDED/8.5" COMPRESSED
	126263-02-02B	EA	BRACKET - GAS SPRING W/BALL STUD - E-COATED
	130053-02-01A	EA	STRIKER - LUGGAGE DOOR - OFF SET - BLACK
	143793-01-01A	EA	SHIM/STRIKER - LUGGAGE - 1.5" - BLACK
	120494-04-02B	EA	SHIM - STRIKER - LUGGAGE DOOR - 3/16" - E-COATED
	132892-08-01A	FT	SEAL - BULB/SINGLE - W/U CHANNEL - BLACK
	099418-01-000	FT	SEAL - D-SECTION/ADHESIVE BACK - .44" X .44" - BLK RUBBER
20	158319-01-U57	EA	DOOR - STORAGE - 41.8" X 26.9" - W/O LOCK
20	158319-02-U57	EA	DOOR - STORAGE - 41.8" X 26.9" - W/O LOCK - PREMIUM HIGH GLOSS
21	141743-41-T53	EA	VALANCE/DOOR - DRVR W/O LATCH/HDW - 20.1" X 72.6" X 24.3" FROM: 00-00-00 THRU: 04-02-06
21	159965-28-U57	EA	VALANCE/DOOR - W/O PADDLE LATCH/HDW - 72.6"WX20.1"HX24.3"H FROM: 04-03-06 THRU: 99-99-99
	132873-H6-000	EA	ROD - LATCH - 30.2" W/3/4" DOG LEG
	135624-C2-01B	EA	ROD - LATCH
	142569-17-000	EA	SPRING/GAS - 90 LB - 12" EXTENDED/8.5" COMPRESSED
	126263-02-02B	EA	BRACKET - GAS SPRING W/BALL STUD - E-COATED
	130053-02-01A	EA	STRIKER - LUGGAGE DOOR - OFF SET - BLACK
	143793-01-01A	EA	SHIM/STRIKER - LUGGAGE - 1.5" - BLACK
	120494-04-02B	EA	SHIM - STRIKER - LUGGAGE DOOR - 3/16" - E-COATED
	132892-08-01A	FT	SEAL - BULB/SINGLE - W/U CHANNEL - BLACK
22	138075-01-02B	EA	ANGLE/SUPPORT - SEAL PLANE - E-COATED
23	137934-20-02B	EA	PLATE/SEAL - E-COATED
24	141743-03-T53	EA	VALANCE/DOOR - W/O PADDLE LATCH/HDW - 45.6" X 24.3" FROM: 00-00-00 THRU: 04-02-06
24	159965-03-U57	EA	VALANCE/DOOR - W/O PADDLE LATCH/HDW - 45.6"W X 24.3"H FROM: 04-03-06 THRU: 99-99-99
	132873-A3-000	EA	ROD - LATCH - 16.6" W/3/4" DOG LEG
	135624-97-01B	EA	ROD - LATCH
	142569-12-000	EA	SPRING/GAS - 90 LB - 15" EXTENDED/9.5" COMPRESSED
	126263-02-02B	EA	BRACKET - GAS SPRING W/BALL STUD - E-COATED
	130053-02-01A	EA	STRIKER - LUGGAGE DOOR - OFF SET - BLACK
	143793-01-01A	EA	SHIM/STRIKER - LUGGAGE - 1.5" - BLACK
	120494-04-02B	EA	SHIM - STRIKER - LUGGAGE DOOR - 3/16" - E-COATED
	107721-07-000	FT	SEAL - ACCESS DOOR - .9"WIDE X 1.1"HIGH
	099418-01-000	FT	SEAL - D-SECTION/ADHESIVE BACK - .44" X .44" - BLK RUBBER
25	144522-01-R28	EA	COMPARTMENT - ELECTRIC/DRAIN
	144574-01-01A	EA	COMPARTMENT - DRAINAGE - PLASTIC
26*	142226-02-01A	EA	HATCH - POWER
27	131383-03-02A	EA	BRACKET - SHOWER HEAD - WHITE
28	147492-04-T53	EA	PANEL/WHEEL LIP - REAR
	139793-03-01A	EA	HINGE - CENTER/VALANCE DOOR - W/O BALL STUD
29	141743-03-T53	EA	VALANCE/DOOR - W/O PADDLE LATCH/HDW - 45.6" X 24.3" FROM: 00-00-00 THRU: 04-02-06
29	159965-03-U57	EA	VALANCE/DOOR - W/O PADDLE LATCH/HDW - 45.6"W X 24.3"H FROM: 04-03-06 THRU: 99-99-99
	132873-A3-000	EA	ROD - LATCH - 16.6" W/3/4" DOG LEG
	135624-97-01B	EA	ROD - LATCH
	142569-12-000	EA	SPRING/GAS - 90 LB - 15" EXTENDED/9.5" COMPRESSED
	126263-02-02B	EA	BRACKET - GAS SPRING W/BALL STUD - E-COATED
	130053-01-01A	EA	STRIKER - LUGGAGE DOOR - FLUSH - BLACK
	130053-02-01A	EA	STRIKER - LUGGAGE DOOR - OFF SET - BLACK
	143793-01-01A	EA	SHIM/STRIKER - LUGGAGE - 1.5" - BLACK
	120494-04-02B	EA	SHIM - STRIKER - LUGGAGE DOOR - 3/16" - E-COATED
	132892-08-01A	FT	SEAL - BULB/SINGLE - W/U CHANNEL - BLACK
	099418-01-000	FT	SEAL - D-SECTION/ADHESIVE BACK - .44" X .44" - BLK RUBBER

EXTERIOR DOORS & COMPARTMENTS GROUP (CONTINUED)
DOOR & COMPARTMENT LAYOUT (CONTINUED)

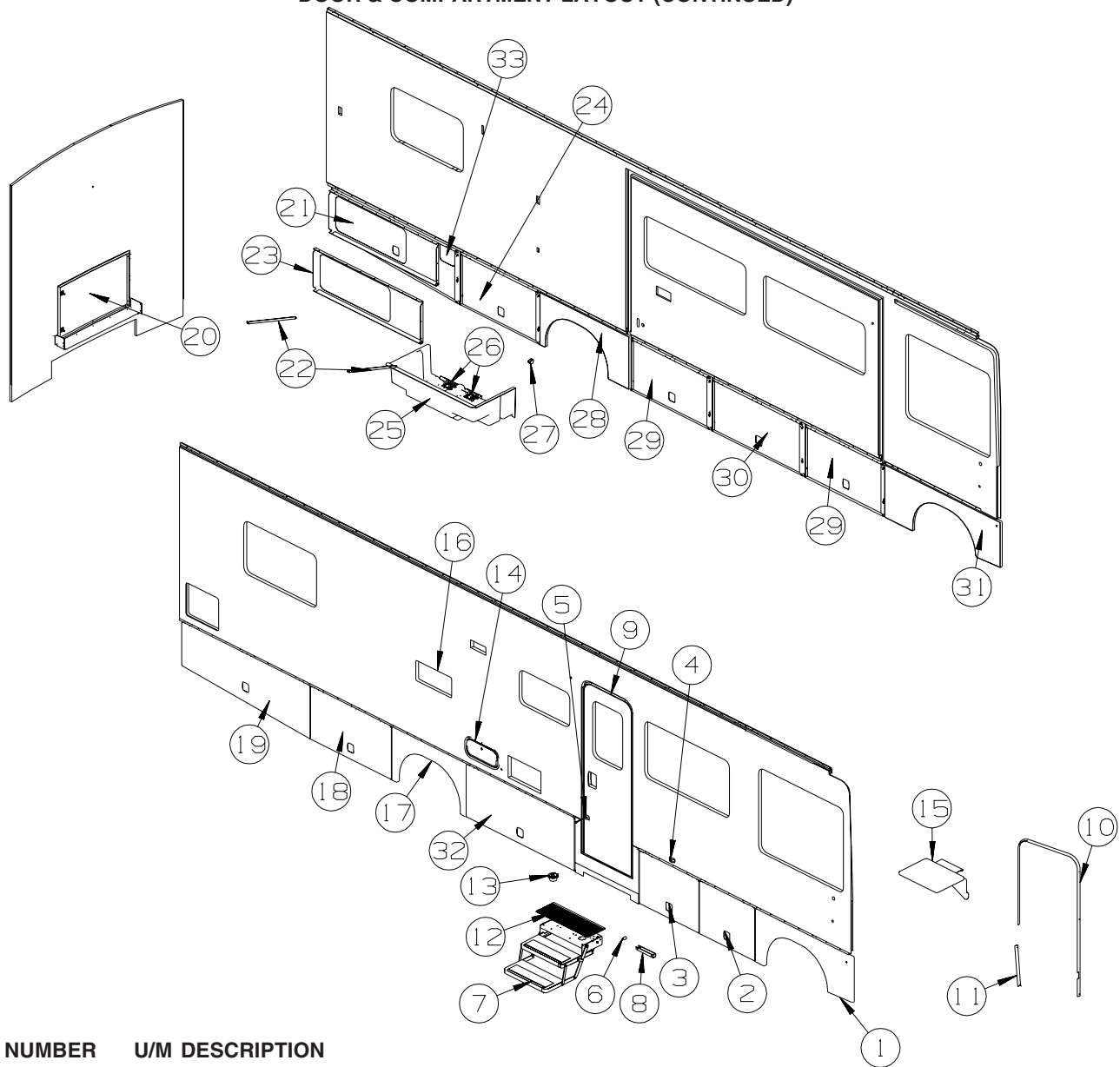

KEY	PART NUMBER	U/M	DESCRIPTION
30	141743-04-T53	EA	VALANCE/DOOR - W/O PADDLE LATCH/HDW - 52.2" X 24.3" FROM: 00-00-00 THRU: 04-02-06
30	159965-04-U57	EA	VALANCE/DOOR - W/O PADDLE LATCH/HDW - 52.1"W X 24.3"H FROM: 04-03-06 THRU: 99-99-99
	135624-98-01B	EA	ROD - LATCH
	132873-C7-000	EA	ROD - LATCH - 19.9" W/3/4" DOG LEG
	142569-12-000	EA	SPRING/GAS - 90 LB - 15" EXTENDED/9.5" COMPRESSED
	126263-02-02B	EA	BRACKET - GAS SPRING W/BALL STUD - E-COATED
	130053-02-01A	EA	STRIKER - LUGGAGE DOOR - OFF SET - BLACK
	143793-01-01A	EA	SHIM/STRIKER - LUGGAGE - 1.5" - BLACK
	120494-04-02B	EA	SHIM - STRIKER - LUGGAGE DOOR - 3/16" - E-COATED
	132892-08-01A	FT	SEAL - BULB/SINGLE - W/U CHANNEL - BLACK
	099418-01-000	FT	SEAL - D-SECTION/ADHESIVE BACK - .44" X .44" - BLK RUBBER
31	147493-02-S28	EA	PANEL/WHEEL LIP - FRONT
	139793-03-01A	EA	HINGE - CENTER/VALANCE DOOR - W/O BALL STUD

EXTERIOR DOORS & COMPARTMENTS GROUP (CONTINUED)
DOOR & COMPARTMENT LAYOUT (CONTINUED)

KEY	PART NUMBER	U/M	DESCRIPTION
32	141743-40-T53	EA	VALANCE/DOOR - W/O PADDLE LATCH/HDW - 61.1" X 24.3" FROM: 00-00-00 THRU: 04-02-06
32	159965-27-U57	EA	VALANCE/DOOR - W/O PADDLE LATCH/HDW - 61.1"W X 24.3"H FROM: 04-03-06 THRU: 99-99-99
	132873-H4-000	EA	ROD - LATCH - 24.5" W/3/4" DOG LEG
	135624-C1-01B	EA	ROD - LATCH
	142569-12-000	EA	SPRING/GAS - 90 LB - 15" EXTENDED/9.5" COMPRESSED
	126263-02-02B	EA	BRACKET - GAS SPRING W/BALL STUD - E-COATED
	130053-02-01A	EA	STRIKER - LUGGAGE DOOR - OFF SET - BLACK
	143793-01-01A	EA	SHIM/STRIKER - LUGGAGE - 1.5" - BLACK
	120494-04-02B	EA	SHIM - STRIKER - LUGGAGE DOOR - 3/16" - E-COATED
	132892-08-01A	FT	SEAL - BULB/SINGLE - W/U CHANNEL - BLACK
	076767-15-000	EA	CABLE - STAINLESS STEEL - 9.8"
	099418-01-000	FT	SEAL - D-SECTION/ADHESIVE BACK - .44" X .44" - BLK RUBBER
33	131905-03-T53	EA	PANEL/DOOR - FUEL FILL - W/O LOCK - PARCHMENT
*	110506-A2-000	EA	LOCK - TWIST - 26.45MM
	110506-51-000	EA	CASE/CYLINDER - TWIST LATCH - W/O CAM - 1" - 596669
	110506-78-000	EA	CAM - LATCHING - 2.3"
	153306-01-01A	EA	HINGE - PIANO - 1 1/2" X 5" - UNPAINTED

***COMPONENT PARTS LISTED LATER IN THIS GROUP**

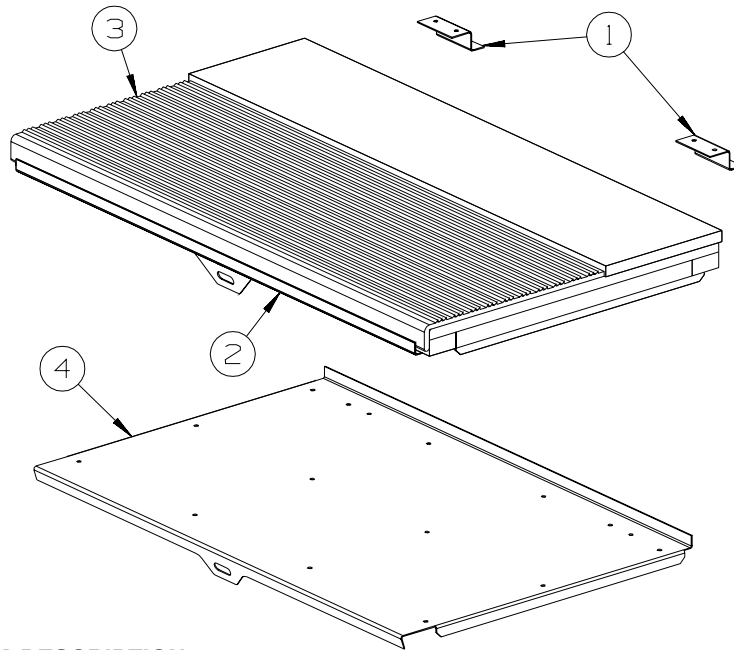

KEY	PART NUMBER	U/M	DESCRIPTION
1	101222-01-04A	EA	BRACKET - CATCH - LID - E-COATED
2	P20256-07-000	EA	LID/DOOR - ENTRY STEP - W/O CARPET/HARDWARE
3	133114-02-01A	EA	TREAD - STEP/RUBBER - W/LIP - 28.5" X 9.8" - TAUPE
4	123330-03-02B	EA	SUPPORT - ENTRY STEP - E-COATED

FLOORCOVERING-VINYL-THRU OUT

KEY	PART NUMBER	U/M	DESCRIPTION
1	101222-01-04A	EA	BRACKET - CATCH - LID - E-COATED
2	P20256-11-000	EA	LID/DOOR - ENTRY STEP - W/O CARPET/HARDWARE
3	133114-02-01A	EA	TREAD - STEP/RUBBER - W/LIP - 28.5" X 9.8" - TAUPE
4	123330-03-02B	EA	SUPPORT - ENTRY STEP - E-COATED

EXTERIOR DOORS & COMPARTMENTS GROUP (CONTINUED)

COMPONENT PARTS FOR DOOR & COMPARTMENT LAYOUT

084103-08-000

KEY	PART NUMBER	U/M	DESCRIPTION	VENDOR NO.
	084104-01-700	EA	LOCK-MALE, FASTENER	201-721-010
	084104-01-701	EA	LOCK-FEMALE, FASTENER	201-802-010

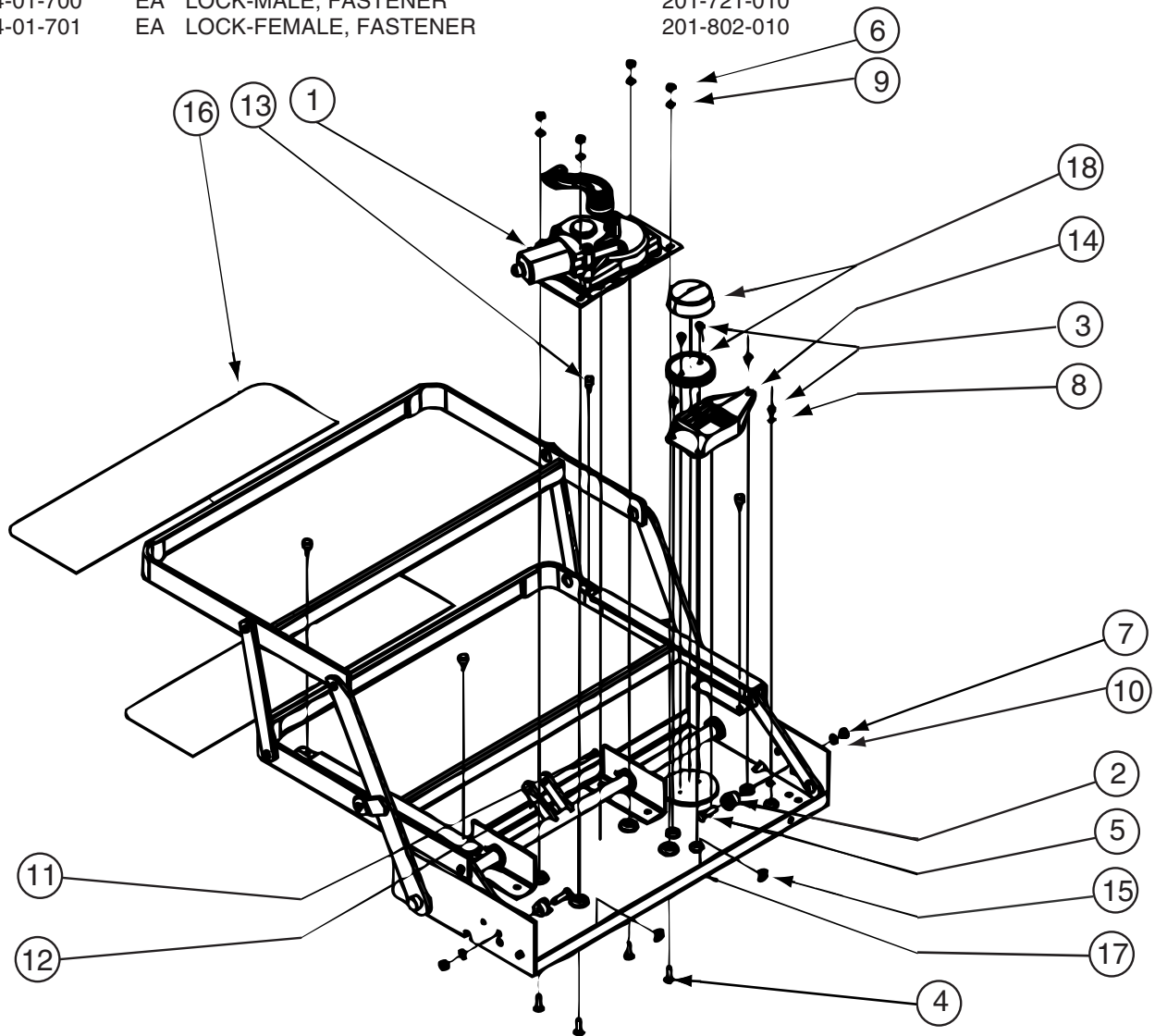

094707-04-01A

KEY	PART NUMBER	U/M	DESCRIPTION	VENDOR NO.
1	094707-04-701	EA	MOTOR "AM 214" F/IMGL STEPS	1101428
1	094707-04-703	EA	GEAR BOX W/LINKAGE-CURVED	1101425
2	143709-01-700	EA	CAM STOP	1102200
12	094707-04-702	EA	COTTOR PIN - W/CLEVIS PIN	905205000
13	143709-01-701	EA	BUMPER - BLACK (RUBBER STOP)	1602000
14	094707-04-700	EA	CONTROL UNIT W/OVERRIDE	909510000
16	143709-01-702	EA	TREAD/NON-SKID 6" X 21" BLK	1915260
17	094707-04-704	EA	FRAME W/DBL STEP-32REINF SRS	3202082
18	088746-01-705	EA	LIGHT-UNDER STEP	9004
	094707-03-701	EA	PLUG - 4-WAY - PACKARD	909306
	094707-04-711	EA	KWIKTEST - W/4-WAY PIGTAIL	909518000

CONTACT WINNEBAGO PART SALES FOR UNLISTED COMPONENT(S)

110506-A1-000, 110506-A2-000, 110506-26-000, 110506-27-000

KEY	PART NUMBER	U/M	DESCRIPTION	VENDOR NO .
	110506-40-700	EA	HARDWARE PACKAGE-CYLINDER/CASE	596950AAL

142226-02-01A

KEY	PART NUMBER	U/M	DESCRIPTION	VENDOR NO
	142226-02-700	EA	TAB/LOCKING - ESCAPE (RED)	9667709

EXTERIOR DOORS & COMPARTMENTS GROUP (CONTINUED)
COMPARTMENT DOOR PIECE PARTS

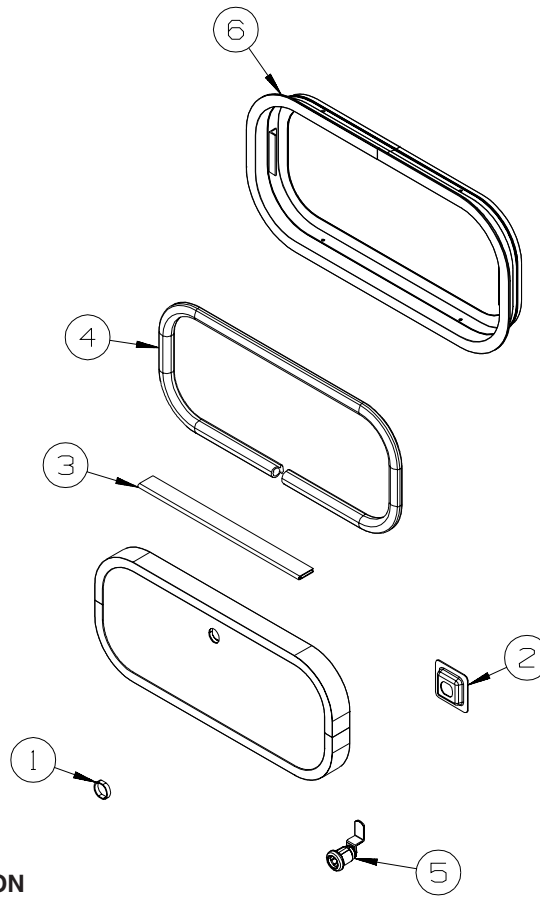

KEY	PART NUMBER	U/M	DESCRIPTION
1	139325-01-000	EA	SPACER - LOCK - 6MM
	139337-01-000	EA	GASKET - LOCK
2	097111-02-04A	EA	POCKET - LOCK - REAR DOOR - BLACK
2	097111-02-05A	EA	POCKET - LOCK - REAR DOOR - BRIGHT WHITE
3	081801-FN-000	EA	HINGE - DOOR - PIANO - 2" X 96" - BLACK
3	081801-V3-000	EA	HINGE - DOOR - PIANO - 2" X 96" - BRIGHT WHITE
4	156386-01-01A	FT	SEAL - BULB - W/ADHESIVE BACK
5	138290-02-000	EA	CASE - W/CAM - W/O CYLINDER/KEY
6	056795-01-000	FT	TAPE - SEAL - 1/8" X 3/8" WIDE - PRESS ON

EXTERIOR DOORS & COMPARTMENTS GROUP (CONTINUED)

COMPARTMENT DOOR PIECE PARTS (CONTINUED)

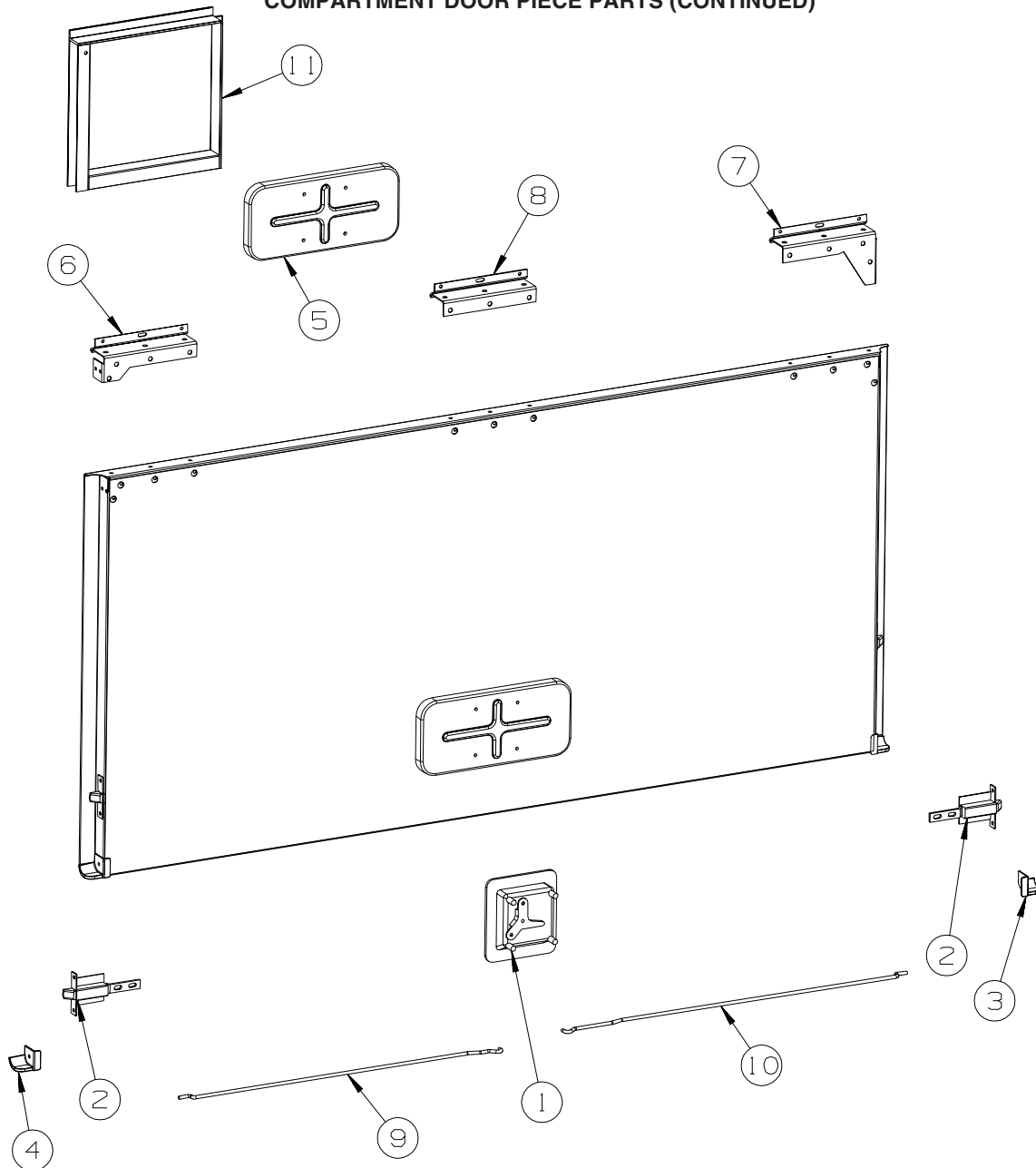

KEY	PART NUMBER	U/M DESCRIPTION
1	154900-01-01A	EA LATCH/PADDLE - LOCKING - COMPT DOOR - KEY ONE - BLACK
1	154900-02-01A	EA LATCH/PADDLE - NON LOCKING - COMPT DOOR - BLACK
2	121947-01-01A	EA BOLT - SLIDE W/PLASTIC PLUNGER
3	135276-01-03A	EA REINFORCEMENT - CORNER - LEFT HAND (FACING DOOR)-PARCHMENT
4	135276-02-03A	EA REINFORCEMENT - CORNER -RIGHT HAND (FACING DOOR)-PARCHMENT
5	137359-01-01A	EA COVER - LATCH - WHITE
6	139793-05-01A	EA HINGE - LEFT HAND/VALANCE DOOR - W/O BALL STUD
6	139793-02-01A	EA HINGE - VALANCE DOOR - W/BALL STUD - REAR PASSENGER
7	139793-01-01A	EA HINGE - RIGHT HAND/VALANCE DOOR - W/BALL STUD
7	139793-04-01A	EA HINGE - VALANCE DOOR - W/O BALL STUD - REAR PASSENGER
8	139793-03-01A	EA HINGE - CENTER/VALANCE DOOR - W/O BALL STUD
9	132873-01-000	EA ROD - LATCH (BLANK) - 37.3"
10	135624-71-01B	EA ROD - LATCH (BLANK) - 37.3"
11	133049-07-T53	EA TRIM - FUEL FILL

EXTERIOR DOORS & COMPARTMENTS GROUP (CONTINUED)
COMPARTMENT DOOR PIECE PARTS (CONTINUED)

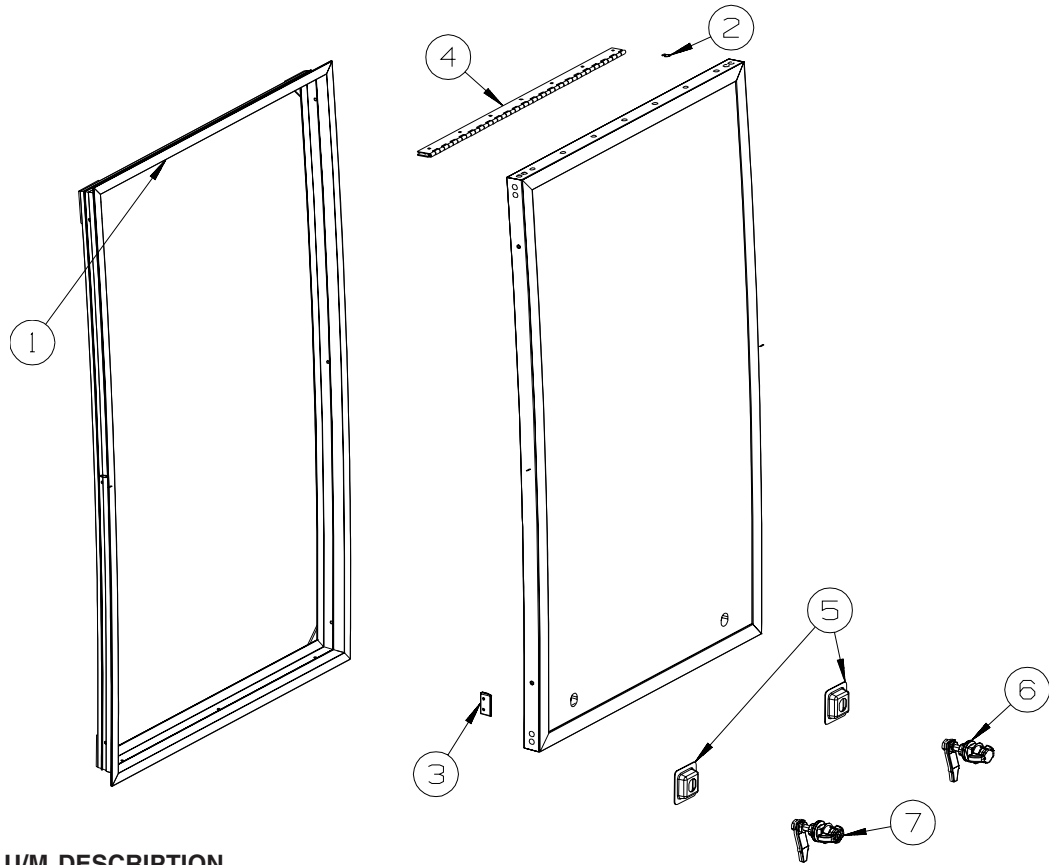

KEY	PART NUMBER	U/M	DESCRIPTION
1	056795-01-000	FT	TAPE-SEAL, 1/8~ X 3/8~ WIDE - PRESS ON
2	156386-01-01A	FT	SEAL - BULB - .4" X .5" - W/ADHESIVE BACK
3	159484-01-01A	EA	SUPPORT - DOOR/STORAGE - BRIGHT WHITE
4	158921-01-12B	EA	HINGE - PIANO - TRUNK DOOR - 2" X 21.9" - BRIGHT WHITE
5	097111-02-05A	EA	POCKET - LOCK - REAR DOOR - BRIGHT WHITE
			FROM: 00-00-00 THRU: 07-09-06
5	160652-01-02B	EA	POCKET - LATCH/TRUNK - E-COATED
			FROM: 07-10-06 THRU: 99-99-99
6	154066-02-01A	EA	LATCH - VISE ACTION/NON-LOCKING - BLACK
7	154066-01-01A	EA	LATCH - VISE ACTION/LOCKING-W/O CYLINDER/KEYS/HDW KIT-BLK
	154066-13-000	EA	HARDWARE KIT - W/PAWL/CAM - STRAIGHT
			FROM: 00-00-00 THRU: 05-21-06
	154066-14-000	EA	HARDWARE KIT - W/PAWL/CAM - OFFSET
			FROM: 05-22-06 THRU: 99-99-99
	154066-50-001	EA	CASE/CYLINDER - LOCKING
	154066-50-002	EA	CASE/CYLINDER - LOCKING
	154066-50-003	EA	CASE/CYLINDER - LOCKING
	154066-50-004	EA	CASE/CYLINDER - LOCKING
	154066-50-005	EA	CASE/CYLINDER - LOCKING
	154066-50-006	EA	CASE/CYLINDER - LOCKING
	154066-50-007	EA	CASE/CYLINDER - LOCKING
	154066-50-008	EA	CASE/CYLINDER - LOCKING
	154066-50-009	EA	CASE/CYLINDER - LOCKING
	154066-50-010	EA	CASE/CYLINDER - LOCKING
	154066-51-001	EA	KEYS - SET OF TWO
	154066-51-002	EA	KEYS - SET OF TWO
	154066-51-003	EA	KEYS - SET OF TWO
	154066-51-004	EA	KEYS - SET OF TWO
	154066-51-005	EA	KEYS - SET OF TWO
	154066-51-006	EA	KEYS - SET OF TWO
	154066-51-007	EA	KEYS - SET OF TWO
	154066-51-008	EA	KEYS - SET OF TWO
	154066-51-009	EA	KEYS - SET OF TWO
	154066-51-010	EA	KEYS - SET OF TWO

EXTERIOR DOORS & COMPARTMENTS GROUP (CONTINUED)

ENTRY

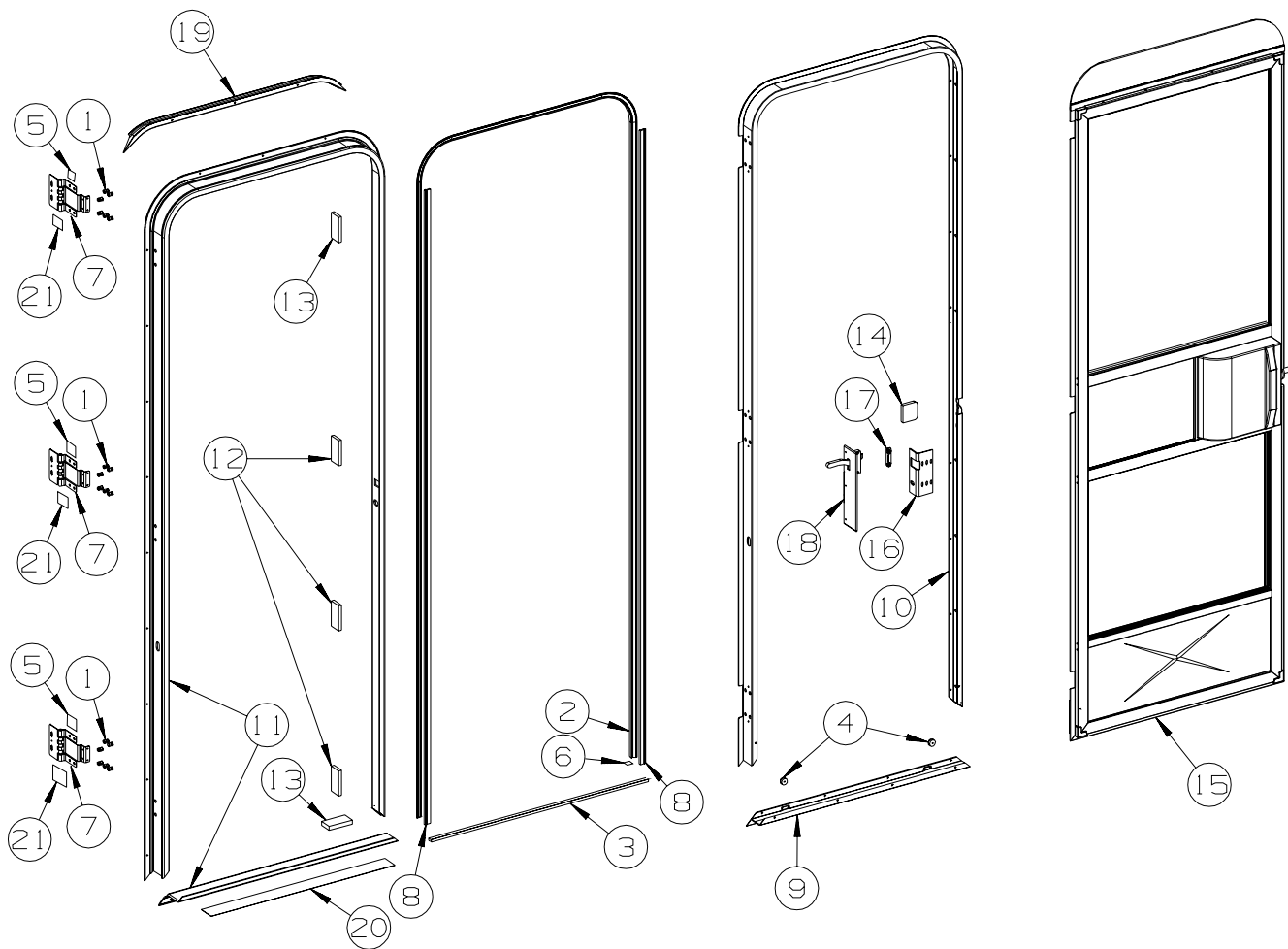

KEY	PART NUMBER	U/M	DESCRIPTION
1	039715-01-000	EA	NUT-SERT - 1/4" DIAMETER - 20 THREADS
2	075671-04-000	FT	SEAL - SPONGE - LAZY T - W/ADHESIVE STRIP - .5" WIDE
3	075673-05-000	FT	SEAL/PILE - .5" HIGH W/ADHESIVE BACK - BLACK
4	081914-02-000	EA	BUMPER - RUBBER - ROUND - 5/16" DIA. X 13/64" THICK
5	100128-02-000	FT	SEAL - FOAM/ADHESIVE BACK - .37" WIDE X .37" THICK
6	104692-01-000	FT	SEAL - ADHESIVE BACKED FOAM - 3/4" THICK X 3/4" WIDE X 25'
7	106719-01-05A	EA	HINGE - ENTRY DOOR - BRIGHT WHITE
8	118929-01-01A	FT	SEAL - PILE - PUSH ON
9	121893-03-02A	EA	FRAME - ENTRY DOOR/LOWER - BRIGHT WHITE
10	121894-27-01A	EA	FRAME - ENTRY DOOR - BRIGHT WHITE
11	121898-14-01A	EA	JAMB - DOOR/ENTRANCE - BRIGHT WHITE
12	125724-01-000	EA	SHIM - DOOR, ENTRANCE
13	125724-02-000	EA	SHIM - DOOR, ENTRANCE
14	130096-05-000	EA	FOAM - SCREEN DOOR, RETAINER
15	P32208-02-L32	EA	DOOR - SCREEN - W/O HARDWARE
16	137401-01-03B	EA	BRACKET - DOOR ANGLE - OFF WHITE
17	148364-01-12B	EA	STRIKE - SCREEN DOOR - BRIGHT WHITE
18	132915-01-01A	EA	LATCH - SCREEN DOOR - BLACK
19	139054-19-01A	EA	CAP - DRIP - JAMB MOUNTED - BRIGHT WHITE
20	038327-01-000	EA	TAPE - ANTI-SLIP - 2" X 60'
21	154585-01-01A	FT	SEAL - FOAM TAPE - ADHESIVE BACK - 3/8" X 3/8" - BLACK

EXTERIOR DOORS & COMPARTMENTS GROUP (CONTINUED)
SCREEN

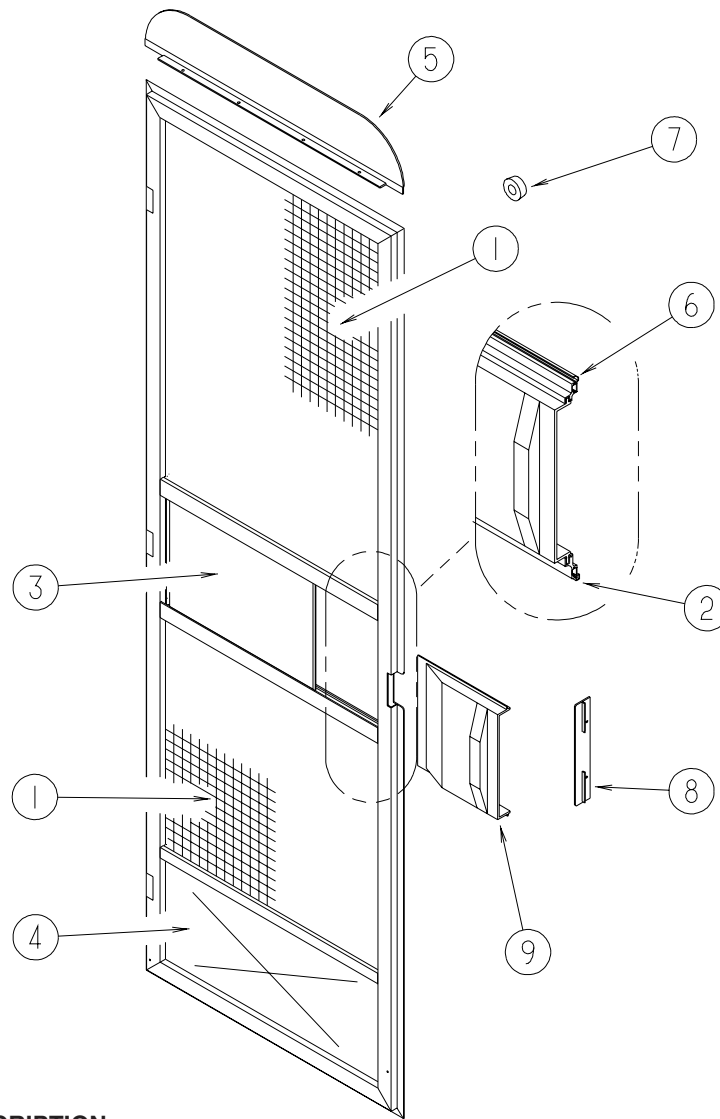

KEY	PART NUMBER	U/M	DESCRIPTION
1	002293-02-000	SF	SCREEN - 26" - CHARCOAL
2	002294-01-000	FT	SPLINE - SCREENING - .13" X .14"
3	016454-18-000	EA	INSERT/CENTER - SCREEN DOOR
4	078552-09-000	EA	INSERT - SCREEN DOOR - LOWER
5	078595-03-000	EA	PLATE - SCREEN DOOR
6	078777-08-000	FT	CHANNEL - SLIDER - 4 FOOT INCREMENTS
7	120863-09-000	EA	BUMPER - RUBBER/RADIUS TOP - 3/4" X 3/8" - LT GRAY
8	132081-01-01A	EA	STRIKE - SLIDER - SCREEN DOOR - BRIGHT WHITE
9	132082-01-01A	EA	SLIDER - SCREEN DOOR - BRIGHT WHITE

EXTERIOR DOORS & COMPARTMENTS GROUP (CONTINUED)

LATCH - ENTRY

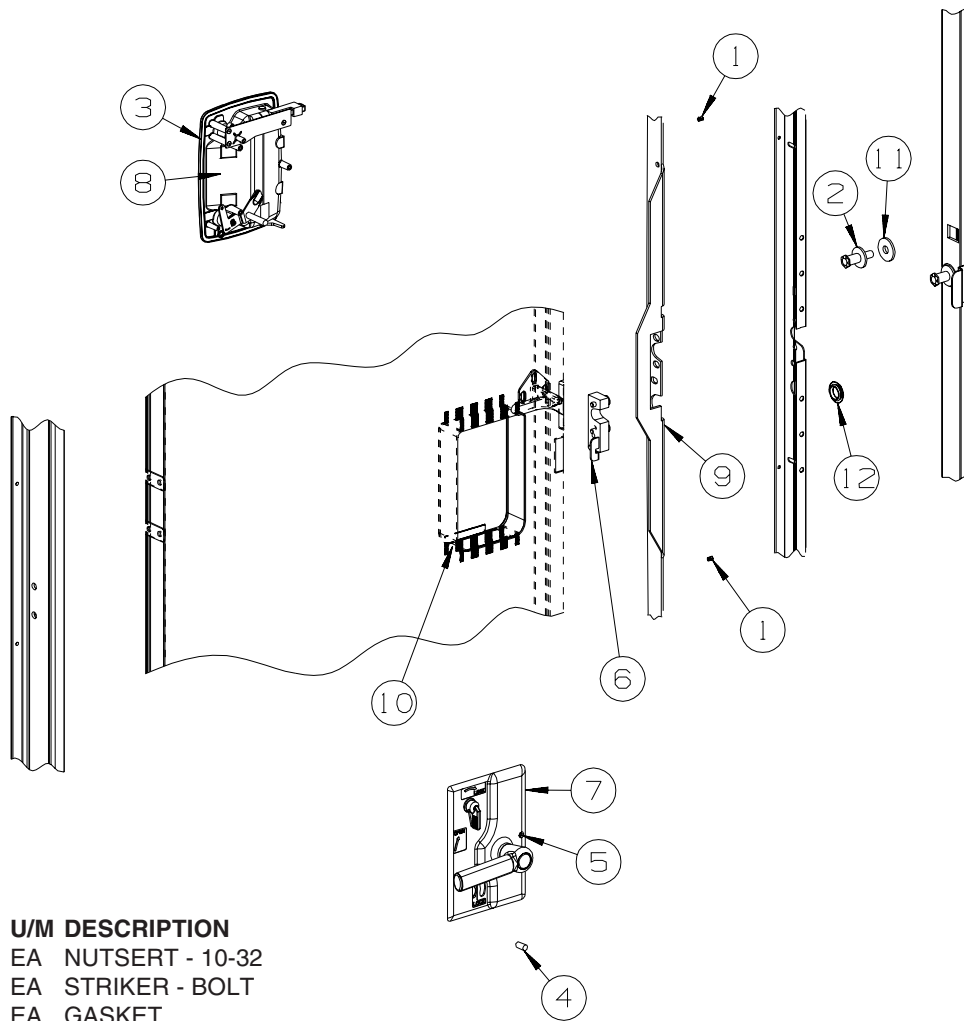

KEY	PART NUMBER	U/M	DESCRIPTION
1	072893-04-000	EA	NUTSERT - 10-32
2	092927-20-000	EA	STRIKER - BOLT
3	112782-04-01A	EA	GASKET
4	112782-05-01A	EA	CAP - VINYL - RED
5	112782-08-01A	EA	SCREW - MOUNTING/PLATE - ZINC
6	112782-22-01A	EA	LATCH - SINGLE ROTOR
7	112782-21-01A	EA	LATCH - INTERIOR PLATE
			FROM: 00-00-00 THRU: 05-28-06
7	112782-27-01A	EA	LATCH - INTERIOR PLATE - WHITE
			FROM: 05-29-06 THRU: 99-99-99
8	112782-20-01A	EA	LATCH - EXTERIOR - W/O LOCK CYLINDER W/ICON-REVERSIBLE KEY
9	132207-01-02B	EA	STIFFENER/DOOR - FORMED - E-COATED
10	137230-01-01A	EA	SPACER - NOTCHED, MILL
11	147900-01-01A	EA	SPACER - STRIKE BOLT, MILL
12	061420-14-000	EA	PLUG/PLASTIC - 7/8" DIAMETER - BLACK

EXTERIOR SLIDEOUT GROUP

FRONT LEFT

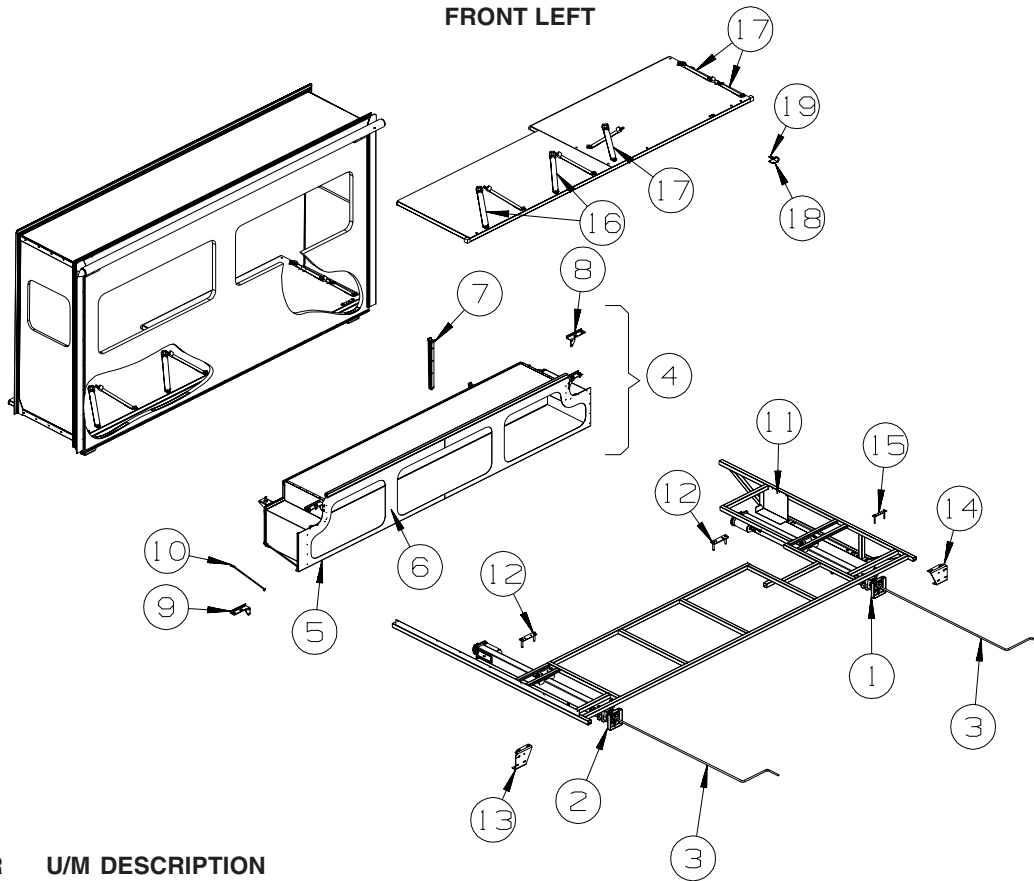

KEY	PART NUMBER	U/M	DESCRIPTION
1*	148875-01-000	EA	SLIDEOUT - ELECTRIC 30" - RIGHT HAND
2*	148875-02-000	EA	SLIDEOUT - ELECTRIC 30" - LEFT HAND
3	138173-06-000	EA	CRANK - SLIDEOUT
4	141162-15-U57	EA	COMPARTMENT - F/SLIDEOUT
5	126516-01-01A	FT	TRIM - VINYL/EXTRUDED - 8'
6	137064-11-02B	EA	SEAL PLANE - F/SLIDEOUT - E-COATED
7	126591-02-02B	EA	CARRIER - WIRE LOOM - F/SLIDEOUT ROOM - E-COATED
8	125888-05-02B	EA	BRACKET/SLIDEOUT COMPARTMENT - RIGHT HAND - E-COATED
9	125888-06-02B	EA	BRACKET/SLIDEOUT COMPARTMENT - LEFT HAND - E-COATED
10	107865-26-000	EA	ROD - SUPPORT - VALANCE PANEL - 18.9"
11	138777-02-02B	EA	COVER - MOTOR - F/SLIDEOUT - E-COATED
12	136995-03-02B	EA	PLATE W/BOLTS - 6.9" X 2" W/1/2" X 3" BOLTS
13	127030-07-02B	EA	BRACKET - INNER FRONT/MOUNT - E-COATED
14	127030-08-02B	EA	BRACKET - INNER REAR/MOUNT - E-COATED
15	136995-05-02B	EA	PLATE W/BOLTS - 5.9" X 1" W/7/16" X 3" BOLTS
16	160167-01-01A	EA	SEAT BELT - 2" X 102" - BLACK
17	160167-02-01A	EA	SEAT BELT - 2" X 90" - BLACK
18	150697-02-02B	EA	BRACKET - RESTRAINT/CHILD - E-COATED
19	150700-01-02B	EA	PLATE/MOUNTING - RESTRAINT/CHILD - 1" X 2.3" - E-COATED

*COMPONENT PARTS LISTED LATER IN THIS GROUP

EXTERIOR SLIDEOUT GROUP (CONTINUED)
FRONT LEFT (CONTINUED)

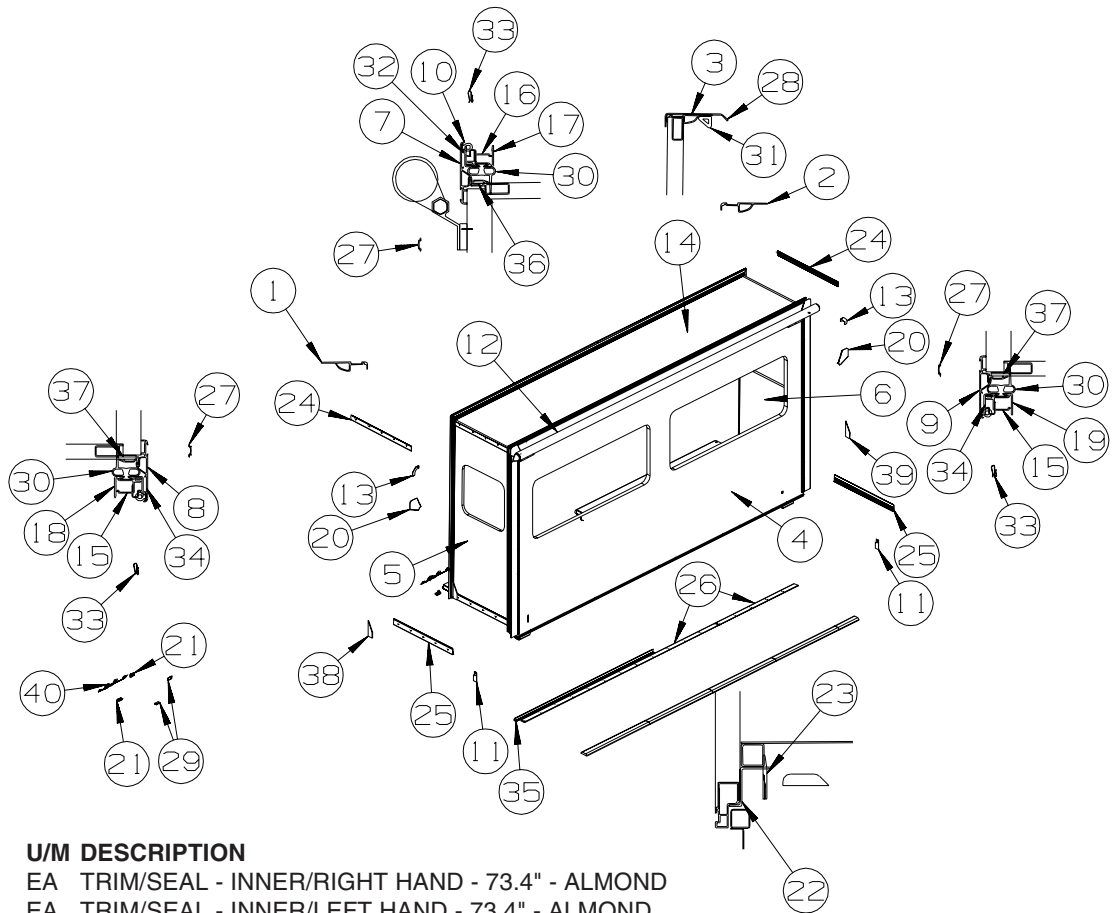

KEY	PART NUMBER	U/M	DESCRIPTION
1	139624-01-02A	EA	TRIM/SEAL - INNER/RIGHT HAND - 73.4" - ALMOND
2	139624-02-02A	EA	TRIM/SEAL - INNER/LEFT HAND - 73.4" - ALMOND
3	139624-06-02A	EA	TRIM/SEAL - INNER/TOP - 145.2" - ALMOND
4	158768-11-U57	EA	SLUG - F/SLIDEOUT (U51, U52)
4	158768-11-U59	EA	SLUG - F/SLIDEOUT (U53, U54)
4	158768-11-U61	EA	SLUG - F/SLIDEOUT (U55, U56)
4	158768-12-U57	EA	SLUG - F/SLIDEOUT (U51, U52) - SIDEWALL - PREMIUM
4	158768-12-U59	EA	SLUG - F/SLIDEOUT (U53, U54) - SIDEWALL - PREMIUM
4	158768-12-U61	EA	SLUG - F/SLIDEOUT (U55, U56) - SIDEWALL - PREMIUM
5	153296-07-U57	EA	PANEL END - F/SLIDEOUT (U51, U52)
5	153296-07-U59	EA	PANEL END - F/SLIDEOUT (U53, U54)
5	153296-07-U61	EA	PANEL END - F/SLIDEOUT (U55, U56)
5	153296-12-U57	EA	PANEL END - F/SLIDEOUT (U51, U52) - SIDEWALL - PREMIUM
5	153296-12-U59	EA	PANEL END - F/SLIDEOUT (U53, U54) - SIDEWALL - PREMIUM
5	153296-12-U61	EA	PANEL END - F/SLIDEOUT (U55, U56) - SIDEWALL - PREMIUM
6	153297-07-U57	EA	PANEL END - F/SLIDEOUT (U51, U52)
6	153297-07-U59	EA	PANEL END - F/SLIDEOUT (U53, U54)
6	153297-07-U61	EA	PANEL END - F/SLIDEOUT (U55, U56)
6	153297-12-U57	EA	PANEL END - F/SLIDEOUT (U51, U52) - SIDEWALL - PREMIUM
6	153297-12-U59	EA	PANEL END - F/SLIDEOUT (U53, U54) - SIDEWALL - PREMIUM
6	153297-12-U61	EA	PANEL END - F/SLIDEOUT (U55, U56) - SIDEWALL - PREMIUM
7	156417-04-01A	EA	TRIM/SEAL - W/MITERED ENDS - 143.6" - BRIGHT WHITE
8	156417-23-01A	EA	TRIM/SEAL - W/MITERED ENDS - 74.5" - BRIGHT WHITE
9	156417-24-01A	EA	TRIM/SEAL - W/MITERED ENDS - 74.5" - BRIGHT WHITE
10	158297-01-000	FT	SEAL - D-SECTION/BULB/TEE - ADHESIVE BACK - BLACK
11	126546-03-03A	EA	COVER - END/SIDEWALL - BLACK
12			SLIDEOUT AWNING

ORDER AWNINGS & REPAIR PARTS FROM DOMETIC. CALL #800-366-3842.
THE DOMETIC AWNING INFORMATION YOU WILL NEED IS LOCATED ON THE MOTOR HOME NEAR
THE TOP OF THE AWNING RAIL.

EXTERIOR SLIDEOUT GROUP (CONTINUED)
FRONT LEFT (CONTINUED)

KEY	PART NUMBER	U/M	DESCRIPTION
13	156416-01-12B	EA	BRACKET - CORNER TRIM/SLIDEOUT - 3.1"X 3.1" - BRIGHT WHITE FROM: 00-00-00 THRU: 01-06-07
13	156416-01-02B	EA	BRACKET - CORNER TRIM/SLIDEOUT - 3.1"X 3.1" - E-COATED FROM: 00-00-00 THRU: 01-06-07
13	160421-01-01A	EA	CORNER TRIM/SLIDEOUT - 3.1" X 3.1" - BLACK FROM: 01-07-07 THRU: 99-99-99
14	153716-04-T53	EA	ROOF - F/SLIDEOUT
15	142718-01-01A	EA	RETAINER - SIDEWALL/SLIDEOUT - 72.8"
16	142718-02-01A	EA	RETAINER - SIDEWALL/SLIDEOUT - 144.9" - MILL
17	151761-01-02A	EA	TRIM - SIDEWALL/SLIDEOUT/TOP - 146.4" - ALMOND
18	151760-04-02A	EA	TRIM - SIDEWALL/SLIDEOUT - 74.5" - ALMOND
19	151760-03-02A	EA	TRIM - SIDEWALL/SLIDEOUT - 74.5" - ALMOND
20	156151-01-02A	EA	PROTECTOR - CORNER - SLIDEOUT - BRIGHT WHITE
21	135619-02-01A	EA	PLATE - TIEDOWN - SLIDEOUT ROOM
22	128621-39-01A	EA	BRACKET/ZEE - SLIDEOUT - 140.4" - MILL
23	115075-03-000	FT	SEAL - WIPE - .25" X 2.9"
24	158375-01-01A	EA	TRIM - FEATURE STRIP - 29.6" - BRIGHT WHITE
25	158030-02-01A	EA	TRIM - FEATURE STRIP/LOWER - 2.3" X 29.1" - BRIGHT WHITE
26	152641-01-000	EA	SKID/GLIDE - SLIDEOUT ROOM - 1/4"X2"X95.5"- POLYETHYLENE
27	105312-01-07A	FT	INSERT - FEATURE STRIP - VINYL - BRIGHT WHITE
28	125466-02-04A	EA	SUPPORT - ROOF/INTERIOR - ALMOND
29	135622-01-02B	EA	PLATE - TIEDOWN - SLIDEOUT ROOM
30	136978-01-01A	FT	SEAL - SLIDEOUT - BLACK
31	146056-01-000	FT	SEAL - TRIANGLE - W/PSA
32	136824-05-01A	EA	TRIM - SIDEWALL/SLIDEOUT - 146.4" - BRIGHT WHITE
33	142549-01-000	EA	CLIP - "S" TYPE
34	136824-45-01A	EA	TRIM - SIDEWALL/SLIDEOUT - 74.4"
35	151282-05-01A	EA	TRIM - CARPET EDGE/F-ANGLE - 67.8" - BLACK
36	133954-07-01A	EA	TRIM/SEAL - 141.8" - BRIGHT WHITE - NOT ILLUSTRATED FROM: 00-00-00 THRU: 04-23-06
36	146606-07-01A	EA	TRIM/RETAINER - 141" - BRIGHT WHITE FROM: 04-24-06 THRU: 99-99-99
37	133954-05-01A	EA	TRIM/SEAL - 67.9" - BRIGHT WHITE - NOT ILLUSTRATED FROM: 00-00-00 THRU: 04-23-06
37	146606-05-01A	EA	TRIM/RETAINER - 69.5" - BRIGHT WHITE FROM: 04-24-06 THRU: 06-25-06
37	146606-48-01A	EA	TRIM/RETAINER - 69.3" - BRIGHT WHITE FROM: 06-26-06 THRU: 99-99-99
38	157809-01-01A	EA	SEAL - FOAM BLOCK/RIGHT SIDE - ADHESIVE BACK
39	157809-02-01A	EA	SEAL - FOAM BLOCK/LEFT SIDE - ADHESIVE BACK
40	135619-01-01A	EA	STRAP - TIEDOWN - SLIDEOUT ROOM

COMPONENT PARTS FOR FRONT LEFT

148875-01-000, 148875-02-000

KEY	PART NUMBER	U/M	DESCRIPTION	VENDOR NO.
	130294-04-700	EA	SCREW - 5/16"-18 X 1 1/2"	1202060
	131281-01-702	EA	PIN/CLEVIS-1/4" PLATED	1213190
	131281-01-704	EA	HAIRPIN/COTTER - 3/8" SPRING	1213460
	131682-01-700	EA	ROLLER - (BEARING)	1912040
	138173-01-701	EA	POP RIVET - SS 3/16"X1/4"	1214630
	138173-01-707	EA	WEAR PUCK - PLASTIC F/DRIVE	1612523
	140457-01-701	EA	BUSHING - 1" X 3/4" X 1/2"ID	1614006
	140457-01-704	EA	SHAFT/AXLE - REAR ROLLER	7204523
	148875-01-700	EA	PIN/COTTER - 3/32" X 1/2"	1213520
	148875-01-701	EA	PIN/ROLL - 3/16" X 3/4"	1213693
	148875-01-702	EA	PIN/ROLL - 1/4" X 1"	1213701
	148875-01-703	EA	NUT - PLASTIC - 1"	1612548
	148875-01-704	EA	END CARRIER - PLASTIC - 1"	1612549
	148875-01-705	EA	MOTOR/LINEAR - SLIDE ROOM	1820111
	148875-01-706	EA	DRIVE SCREW - SLIDE ROOM	1820401
	148875-01-707	EA	END GUIDE F/SCREW - 1"	1820450

**GENERATOR GROUP
GAS**

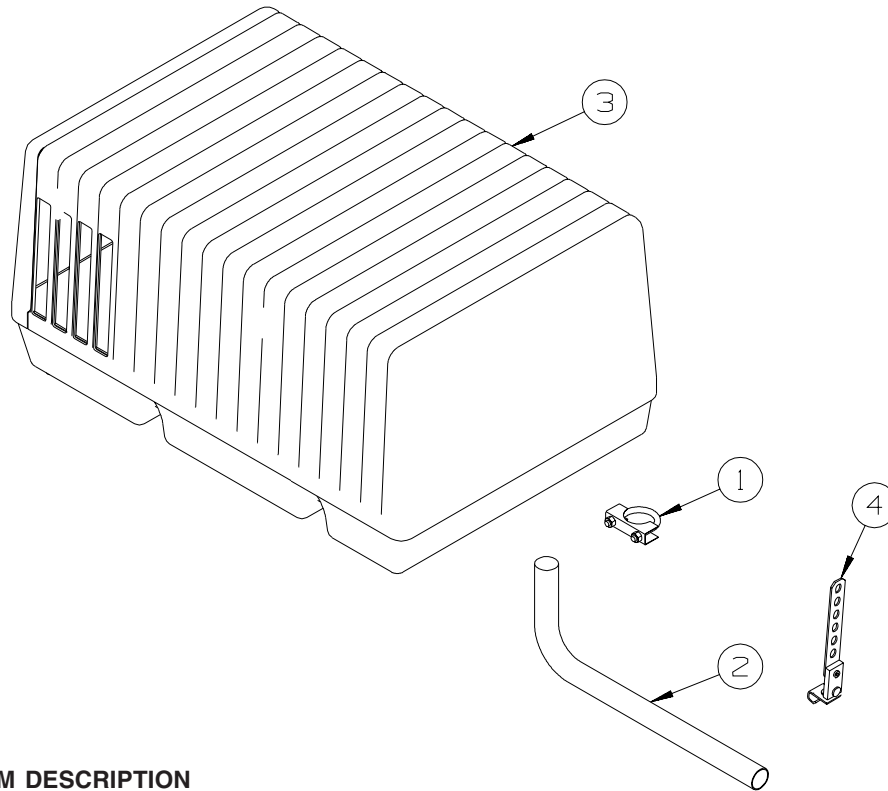

**MICROLITE
D26P, D29R, D30B**

KEY	PART NUMBER	U/M	DESCRIPTION
1	007125-04-000	EA	CLAMP - MUFFLER - 1.12" DIAMETER
2	158240-01-000	EA	PIPE - EXHAUST/GENERATOR
3	109982-03-000	EA	GENERATOR - 4.0 MICROLITE
4	007131-01-000	EA	HANGER - TAILPIPE - 6 SLOTS - D29R

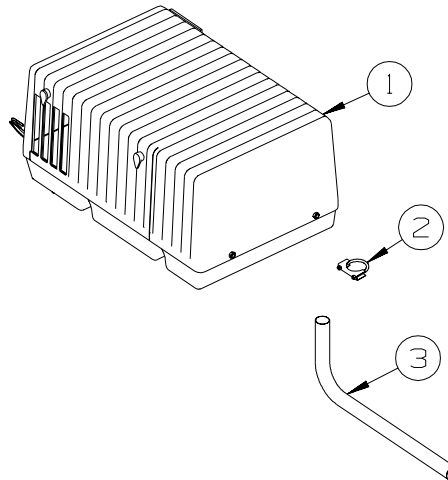

**MARQUIS GOLD
D33T, D34A, D35J**

KEY	PART NUMBER	U/M	DESCRIPTION
1	135707-07-000	EA	GENERATOR - 5.5 - 30/20 - GAS - MARQUIS GOLD
2	007125-03-000	EA	CLAMP - MUFFLER - 1.5" DIAMETER
3	105958-07-000	EA	PIPE - EXHAUST - 1.4" INLET X 1.5" O.D. - 4.9" X 20.1"

HEATING & A/C GROUP AUTOMOTIVE

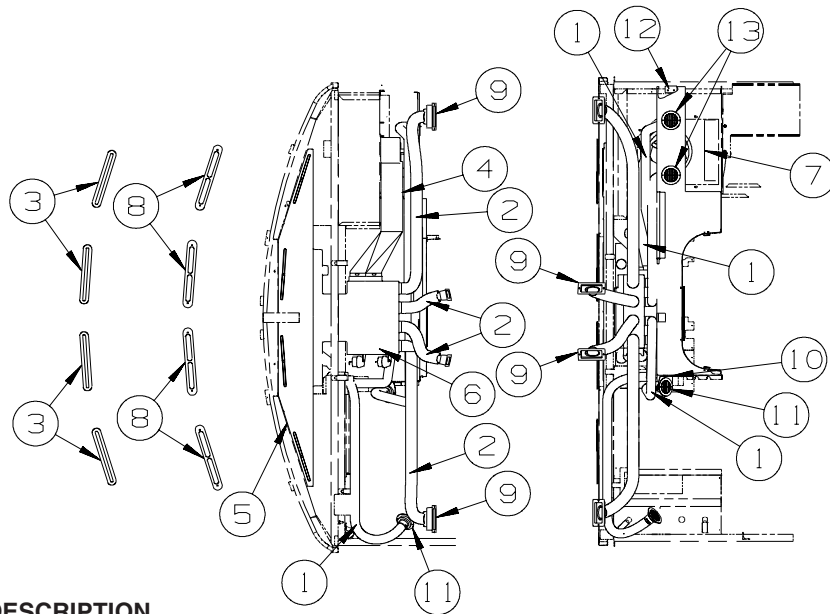

KEY	PART NUMBER	U/M	DESCRIPTION
1	007076-01-000	EA	HOSE - FLEXIBLE PVC - 2" ID - INCREMENTS OF 50'
2	007281-01-000	EA	HOSE - FLEXIBLE PVC - 2 1/2" ID X 50'
3	077075-01-000	EA	GASKET - INSTRUMENT PANEL/DEFROSTER PLENUM - .6" X 10.2"
4	103016-03-000	EA	PLENUM - TRANSITION
5	103017-03-000	EA	PLENUM - DEFROSTER
6*	103930-49-000	EA	CONTROL/PLENUM - LARGE ROTARY
7*	103930-55-000	EA	EVAPORATOR/HEATER - NONCHARGED - SINGLE OUTPUT
8	135265-01-06A	EA	VENT - DEFROSTER - PLASTIC - CASHMERE
8	135265-01-07A	EA	VENT - DEFROSTER - PLASTIC - RIVERSTONE
9	135803-02-01A	EA	LOUVER/A/C - ADJ W/MOUNT HOLES - 2.5" X 5.8" F/2.5" HOSE
10	136157-03-02B	EA	BRACKET - HEATER - E-COATED
11	157225-01-01A	EA	OUTLET - DEFROSTER - W/SWIVEL - 2" SLEEVE/4"OD - BLACK
12	156732-01-01A	EA	BRACE
13	157225-01-06A	EA	OUTLET - DEFROSTER - W/SWIVEL - 2" SLEEVE/4"OD - CASHMERE
13	157225-01-05A	EA	OUTLET - DEFROSTER - W/SWIVEL - 2" SLEEVE/4"OD - RIVERSTONE
	113452-02-000	FT	SEAL/TRIM - FRONT - VINYL W/WIRE CARRIER - .027" - WHERE WIRES & HOSES CROSS METAL

*COMPONENT PARTS LISTED LATER IN THIS GROUP

HEATING & A/C GROUP (CONTINUED) AUTOMOTIVE (CONTINUED)

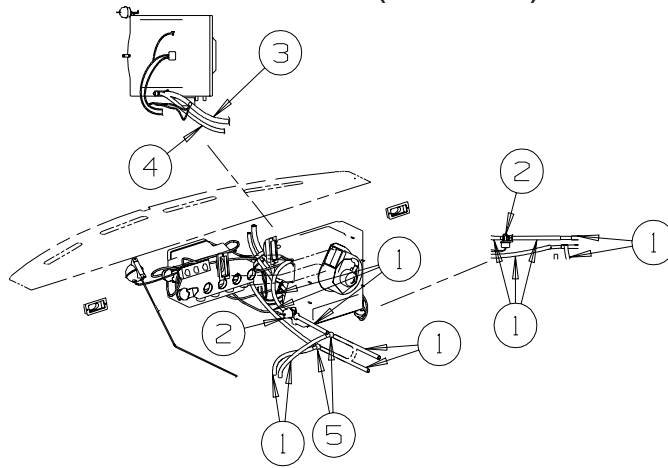

FORD

KEY	PART NUMBER	U/M	DESCRIPTION
1	007108-01-000	FT	HOSE - HEATER - 5/8"ID - HI-TEMP
2	103930-23-000	EA	VALVE/WATER - 2 PORT/VACUUM CONTROLLED - "NEW DESIGN"
3*	103930-44-000	EA	HOSE - EVAPORATOR/DRYER - #6
4*	103930-45-000	EA	HOSE - EVAPORATOR/COMPRESSOR - PRIOR TO 2007 FORD CHASSIS
4	103930-64-000	EA	HOSE - EVAPORATOR/COMPRESSOR - 2007 FORD CHASSIS
5	076776-01-000	EA	TEE - BEADED - 5/8" X 5/8" X 5/8"

***COMPONENT PARTS LISTED LATER IN THIS GROUP**

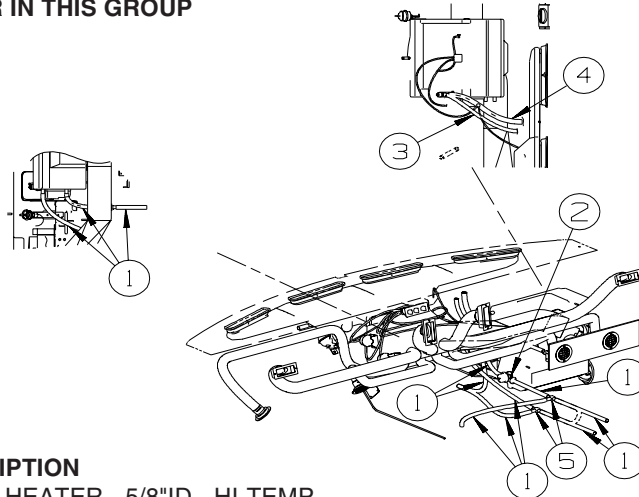

WORKHORSE

KEY	PART NUMBER	U/M	DESCRIPTION
1	007108-01-000	FT	HOSE - HEATER - 5/8"ID - HI-TEMP
2	103930-23-000	EA	VALVE/WATER - 2 PORT/VACUUM CONTROLLED - "NEW DESIGN"
3*	103930-46-000	EA	HOSE - EXPANSION BLOCK (EVAPORATOR) TO COMPRESSOR
4*	103930-47-000	EA	HOSE - EXPANSION VALVE (EVAPORATOR) TO DRIER
5	076776-01-000	EA	TEE - BEADED - 5/8" X 5/8" X 5/8"

***COMPONENT PARTS LISTED LATER IN THIS GROUP**

HEATING & A/C GROUP (CONTINUED)
COMPONENT PARTS FOR AUTOMOTIVE

103930-44-000

KEY	PART NUMBER	U/M	DESCRIPTION	VENDOR NO
	103930-29-701	EA	O'RING F/LOW PRESSURE SWITCH	045-0483
	103930-44-700	EA	HOSE ASSEMBLY #6	085-0462
	113245-01-711	EA	O'RING #6	045-0129

103930-45-000

KEY	PART NUMBER	U/M	DESCRIPTION	VENDOR NO.
	103930-17-702	EA	O'RING #10	045-0127
	103930-45-700	EA	HOSE - #10 EVAP/COMP - 3'	085-0463

103930-46-000

KEY	PART NUMBER	U/M	DESCRIPTION	VENDOR NO
	103930-17-702	EA	O'RING #10	045-0127
	103930-29-701	EA	O'RING F/LOW PRESSURE SWITCH	045-0483
	103930-46-700	EA	HOSE - #10 EVAP/COMP - 4.3'	085-0486

103930-47-000

KEY	PART NUMBER	U/M	DESCRIPTION	VENDOR NO
	103930-47-700	EA	HOSE - #6-EVAP/DRIER - 2.2'	085-0485
	113245-01-710	EA	O'RING, #12	045-0128

HEATING & A/C GROUP (CONTINUED)
COMPONENT PARTS FOR AUTOMOTIVE (CONTINUED)

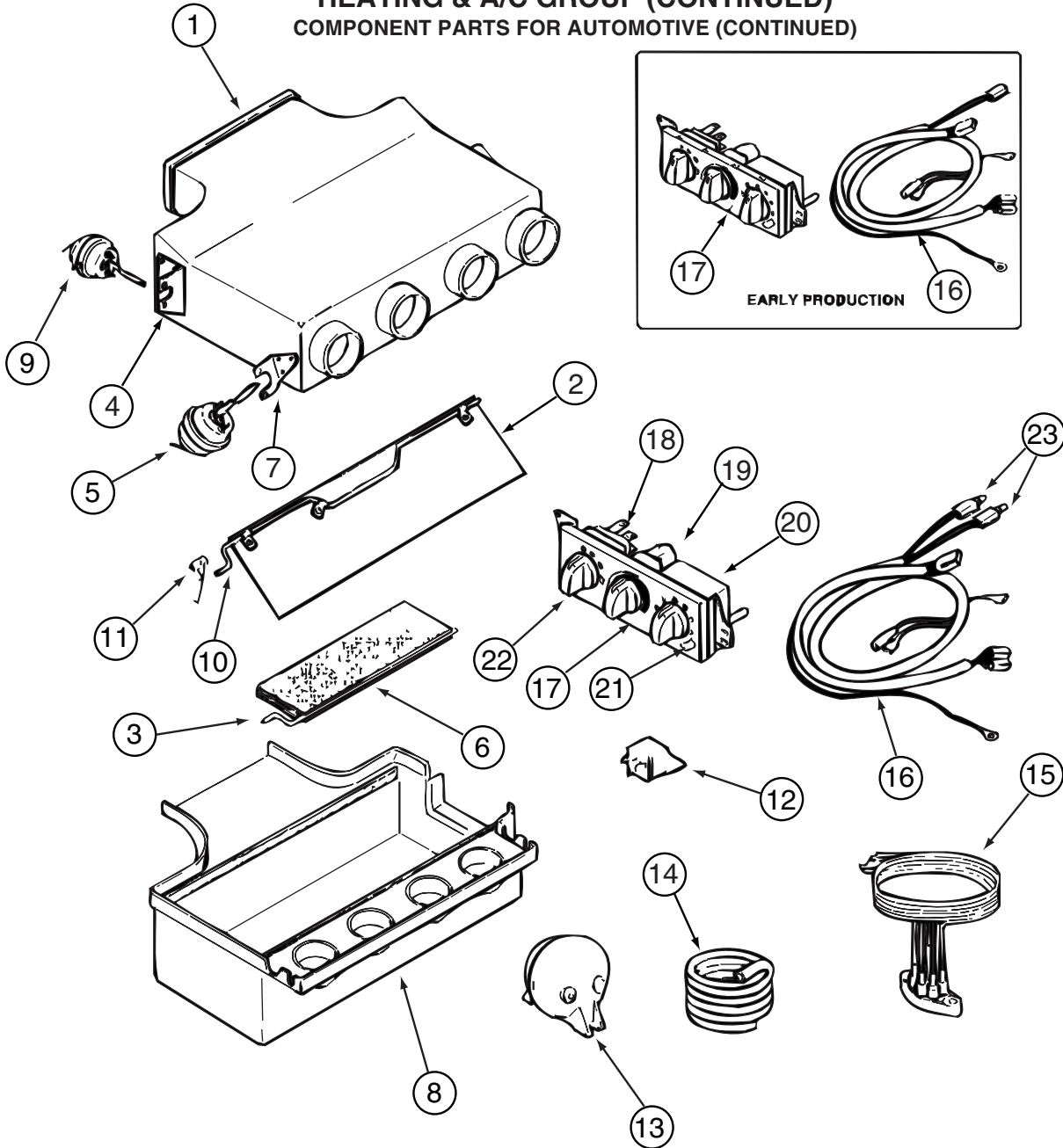

103930-49-000

HEATING & A/C GROUP (CONTINUED)
COMPONENT PARTS FOR AUTOMOTIVE (CONTINUED)

103930-49-000 (CONTINUED)

KEY	PART NUMBER	U/M	DESCRIPTION	VENDOR NO.
1	103930-39-705	EA	PLENUM - TOP	060-0482
2	103930-04-700	EA	DOOR - DEFROSTER-A/C	071-0149
3	103930-39-700	EA	ROD - DOOR - AC/HEAT	073-067
5	103930-02-708	EA	MOTOR-VACUUM SERVO, A/C	030-0025
6	103930-39-706	EA	PLATE - DOOR - A/C	071-0623
8	103930-39-707	EA	PLENUM - BOTTOM	060-0483
9	103930-33-701	EA	MOTOR - VACUUM, 3 STAGE	030-0105
10	103930-39-701	EA	ROD - DOOR - AC/DEFROST	073-0069
11	103930-39-704	EA	SPRING	022-0119
12	103930-02-707	EA	RELAY-BOSCH W/RESISTER	031-0001
13	103930-02-710	EA	CANISTER-VACUUM	054-0002
15	103930-33-703	EA	VACUUM HARNESS	036-0466
16	103930-49-700	EA	HARNESS - WIRE	036-556
16	103930-49-701	EA	HARNESS - WIRE W/BULBS	036-0557
17	103930-49-702	EA	CONTROL PANEL-RECESSED FACE	032-0054
17	103930-49-703	EA	CONTROL PANEL - NON RECESSED	083-0223
18	103930-49-704	EA	SWITCH - BLOWER	032-0332
19	103930-49-705	EA	POTENTIOMETER	032-0182
20	103930-49-706	EA	SWITCH - VACUUM	032-0185
21	103930-49-707	EA	DECAL CONTROL PANEL-N/RECESS	058-0144
22	103930-49-708	EA	KNOB - BLOWER - NONRECESSED	062-0620
23	103930-33-705	EA	LIGHT BULBS	035-0030
			CONTACT WINNEBAGO PART SALES FOR UNLISTED COMPONENT(S)	

HEATING & A/C GROUP (CONTINUED)
COMPONENT PARTS FOR AUTOMOTIVE (CONTINUED)

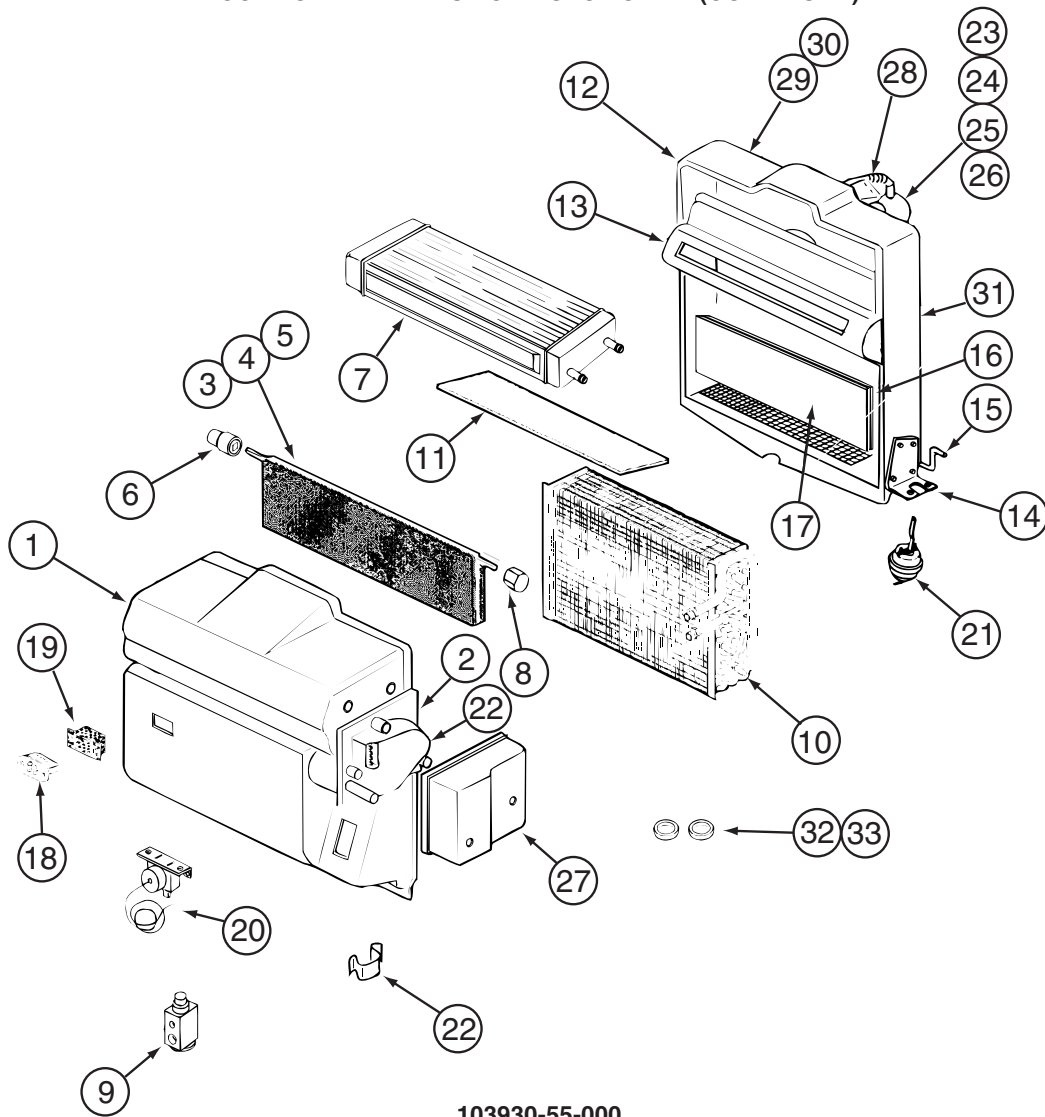

103930-55-000

KEY	PART NUMBER	U/M	DESCRIPTION	VENDOR NO.
1	103930-55-701	EA	CASE - FRONT	062-0658
2	103930-30-701	EA	PLATE - MOTOR MOUNT	062-0544
3	103930-55-705	EA	DOOR - BLEND AIR	071-0892
6	103930-30-702	EA	BUSHING/DRIVE (BLEND DOOR)	062-0168
7	103930-55-706	EA	CORE - HEATER - W/GASKET	084-0271
8	103930-30-709	EA	COUPLING - BLEND DOOR SHAFT	062-0634
9	103930-20-700	EA	VALVE-EXPANSION-BLOCK, 2 TON	034-0032
10	103930-55-700	EA	CORE-EVAPORATOR	041-00168
12	103930-55-702	EA	CASE-REAR	062-0657
14	103930-01-708	EA	BRACKET-VACUUM MOTOR	070-0113
15	103930-20-704	EA	ROD-DOOR-RECIRCULATING	073-0018
16	103930-55-707	EA	DOOR - RECIRCULATION	071-0891
18	103930-01-710	EA	RESISTOR-FUSED, A/C 4 TERM	035-0006
20	103930-01-711	EA	THERMOSTAT	033-0003
21	103930-02-708	EA	MOTOR-VACUUM SERVO, A/C	030-0025
22	103930-30-703	EA	MOTOR - SERVO	030-0104
23	103930-20-707	EA	HOUSING-BLOWER	062-0145
24	103930-55-703	EA	MOTOR-BLOWER W/O PIGTAIL	030-0137
25	103930-01-717	EA	WHEEL-BLOWER, CLOCKWISE	062-0010
26	103930-20-708	EA	CLIP-MOTOR SHAFT	022-0001
27	103930-30-704	EA	COVER - SERVO	062-0545
32	113245-01-707	EA	O'RING #8	045-0126
33	103930-17-702	EA	O'RING #10	045-0127
	103930-55-704	EA	CORE-HEATER	042-0059
	110279-01-703	EA	HOSE-VENT F/BLOWER MOTOR	051-0034

CONTACT WINNEBAGO PART SALES FOR UNLISTED COMPONENT(S)

HEATING & A/C GROUP (CONTINUED)
FURNACE

KEY	PART NUMBER	U/M	DESCRIPTION
*	139980-02-000	EA	FURNACE - 30000 BTU - SF QUIET - SUBURBAN SF-30 2321J - FURNACE-30,000BTU
*	143563-01-000	EA	FURNACE - 35000 BTU/HIGH QUIET - SUBURBAN SH-35 2322 - FURNACE-40,000 BTU
	138056-03-02B	EA	PANEL - FURNACE COMPARTMENT - E-COATED
	098668-26-000	EA	BOTTOM DUCT KIT - 40,000 BTU
	143563-06-000	EA	DUCT KIT - BOTTOM
	143563-05-000	EA	GASKET - FIBERGLASS - SUBURBAN #071018
	098668-23-000	EA	DOOR - ACCESS - FURNACE - BRIGHT WHITE
	056464-10-000	EA	REGISTER W/O DAMPER - 4" DIAMETER - PLASTIC - BEIGE
	130837-02-01A	EA	REGISTER - HEAT - W/DAMPER - DURA BEIGE
	137965-02-02A	EA	REGISTER - 11.2" X 3.6"(9.7 X 2.1"R/O) W/DAMPER - ANT PWTR
	093614-02-02A	EA	GRILLE - AIR RETURN - 9.9" X 9.9" - BEIGE
	009198-01-000	FT	DUCT - HEAT - FLEXIBLE - 4" ID X 25'
	134588-02-000	EA	GASKET - DUCT - 6.4" X 7.4" IS - 8.3" X 9.4" OS
	069636-02-000	EA	CONNECTOR - DUCT - 4" ID
	092776-01-000	EA	ADAPTER - DUCT - 2"
	009200-01-000	EA	TAPE - FURNACE - 1 1/2"
	105290-01-000	SF	INSULATION - AIR POCKET W/FOIL - 4' WIDE

***COMPONENT PARTS LISTED LATER IN THIS GROUP**

HEATING & A/C GROUP (CONTINUED)

COMPONENT PARTS FOR FURNACE

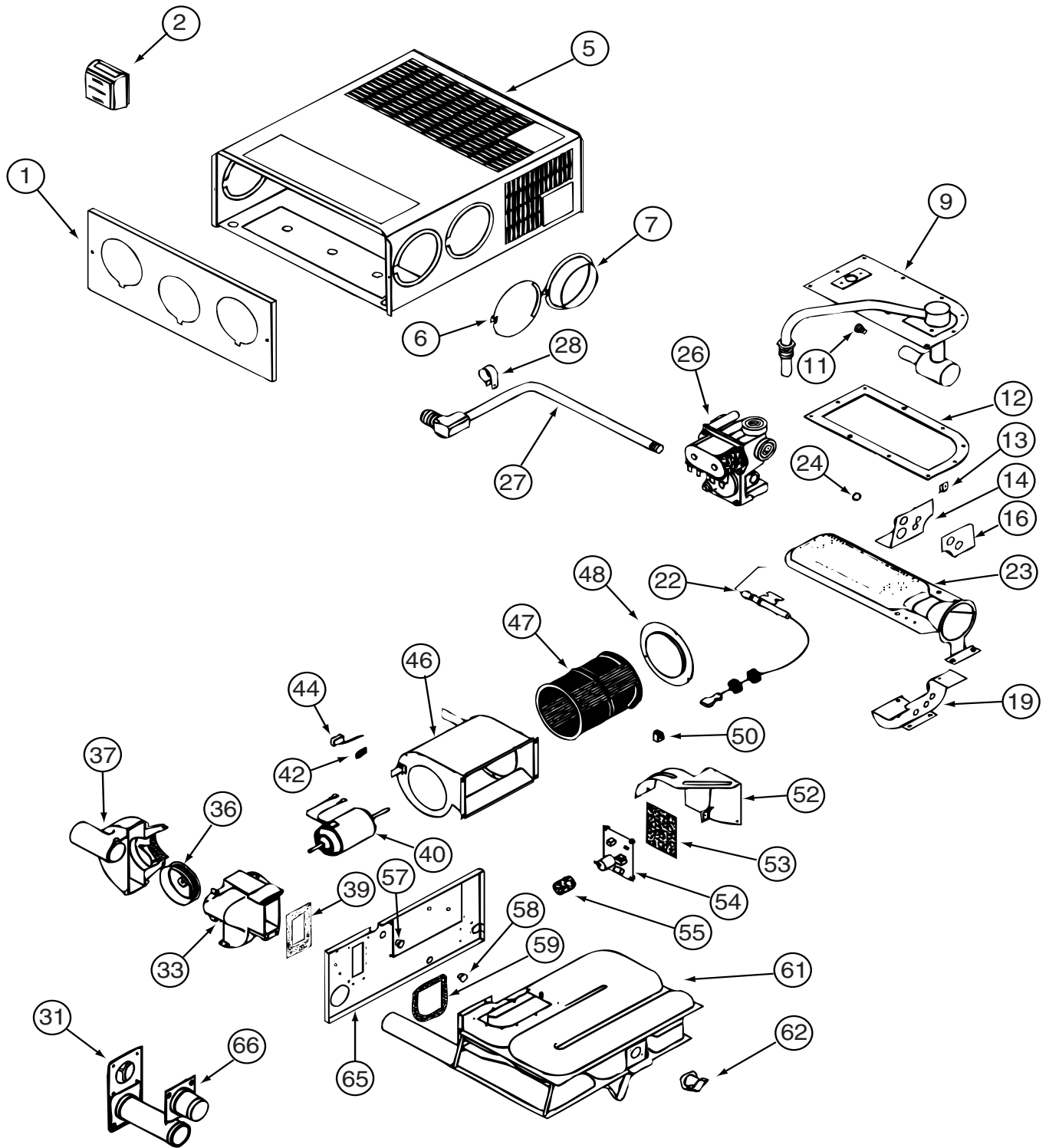

139980-02-000

HEATING & A/C GROUP (CONTINUED)
COMPONENT PARTS FOR FURNACE (CONTINUED)

139980-02-000 (CONTNUED)

KEY	PART NUMBER	U/M	DESCRIPTION	VENDOR NO.
9	139980-01-700	EA	MANIFOLD ASSEMBLY	171571
11	092300-02-701	EA	ORIFICE-MAIN BURNER (NT-30BW	180214
12	098668-22-703	EA	GASKET - BURNER ACCESS COVER	070811
22	139980-01-701	EA	ELECTRODE	232286
23	098668-02-700	EA	BURNER ASSEMBLY,SF-30 & SF35	010745
26	098668-01-718	EA	VALVE-GAS SF S.N.974903079	161122
27	139980-01-702	EA	PIPE ASSEMBLY/GAS INLET	171574
31	098668-01-707	EA	TUBE ASSEMBLY, EXHAUST W/CAP	260231
33	139980-01-703	EA	HOUSING/COMB. - FRONT/HALF	390852
36	098668-01-706	EA	WHEEL-COMBUSTION AIR	350184
37	139980-01-704	EA	HOUSING/COMB. - REAR/HALF	390848
39	139980-01-705	EA	GASKET/FIREWALL-COMB AIR	071084
40	139980-01-706	EA	MOTOR ASSEMBLY W/GASKET	232682
42	101990-01-714	EA	GASKET-MICROSWITCH	230877
44	098668-21-700	EA	SWITCH-MICRO-W/O FLAG 3 1/4"	232261
46	139980-01-708	EA	BLOWER ASSEMBLY - ROOM AIR	390739BK
47	098668-01-711	EA	WHEEL-BLOWER, ROOM AIR	350129
48	139980-01-709	EA	ORFICE RING	390696
50	139980-01-710	EA	SWITCH - ON/OFF	232351
52	139980-01-711	EA	PANEL ASSEMBLY-MODULE BD	101663
53	139980-01-712	EA	INSULATOR - MODULE BD	070807
54	098668-22-705	EA	MODULE BD W/RELAY TIME DELAY	520820
55	139980-01-713	EA	CAP/INSULATOR-MODULE BD	070973
57	139980-01-714	EA	BUSHING - UNIVERSAL	070362
58	139980-01-715	EA	BUSHING - STRAIN RELIEF	231809
59	098668-01-716	EA	GASKET-FIREWALL,CHAMBER SIDE	070808
61	139980-01-716	EA	CHAMBER ASSEMBLY - FINAL	021149BK
62	098668-21-701	EA	SWITCH - LIMIT	232504
66	098668-01-713	EA	TUBE ASSEMBLY, INTAKE	051248
	139980-02-700	EA	BLOWER ASM-1/2 HOUSING/OUTER	390851
	139980-02-701	EA	BLOWER ASM-1/2 HOUSING/INNER	390872
			CONTACT WINNEBAGO PART SALES FOR UNLISTED COMPONENT(S)	

HEATING & A/C GROUP (CONTINUED)
COMPONENT PARTS FOR FURNACE (CONTINUED)

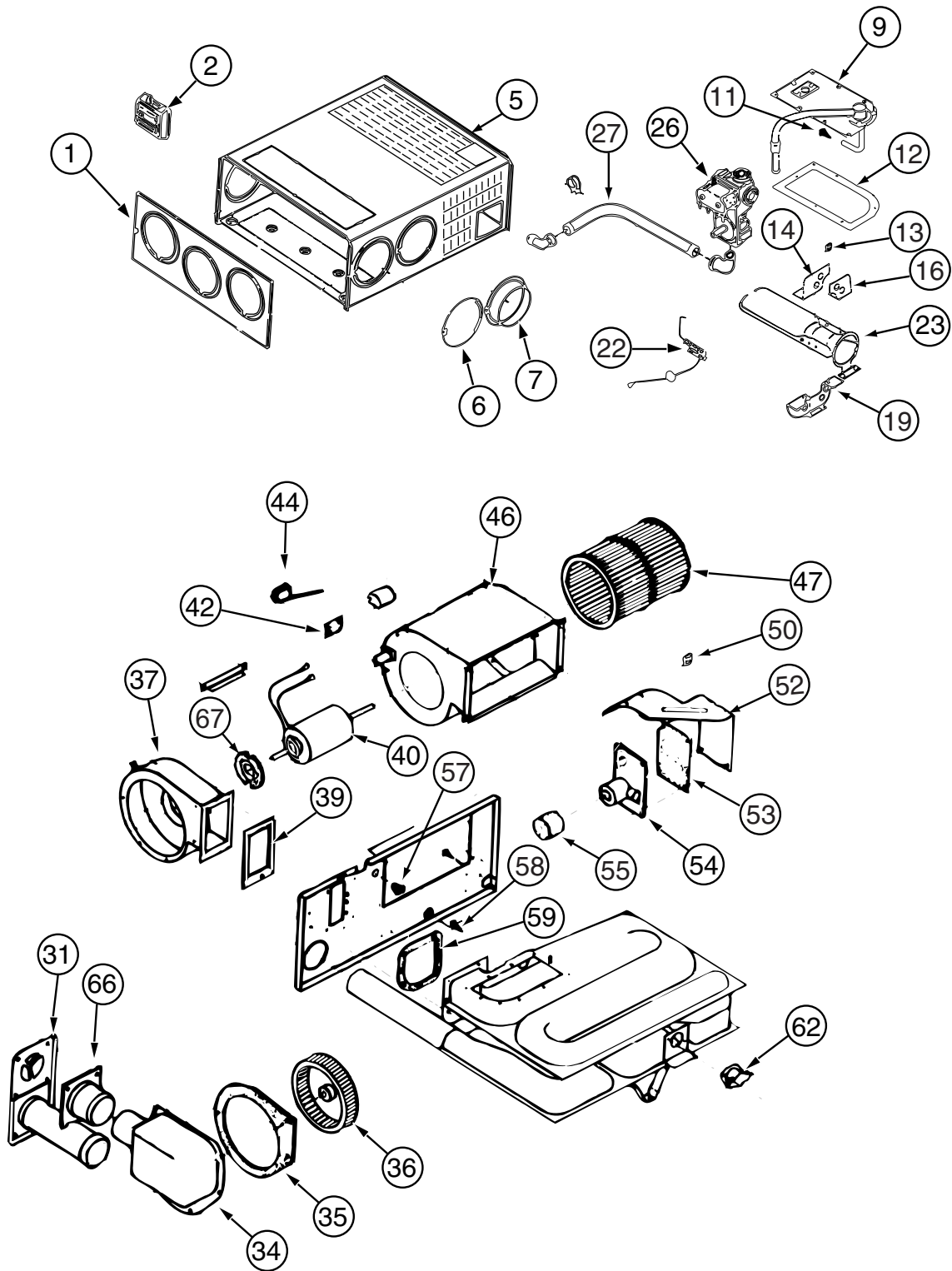

143563-01-000

HEATING & A/C GROUP (CONTINUED)
COMPONENT PARTS FOR FURNACE (CONTINUED)

143563-01-000 (CONTINUED)

KEY	PART NUMBER	U/M	DESCRIPTION	VENDOR NO.
1	143563-01-700	EA	CABINET - FRONT	101907
2			12 VOLT WIRING AREAS FOR CORRECT THERMOSTAT	
5	143563-01-701	EA	CABINET	101921
7	075696-02-703	EA	COLLAR - DUCT	050715
9	143563-01-702	EA	MANIFOLD ASSEMBLY	171599
11	143563-01-703	EA	ORFICE - MAIN BURNER	180308
12	098668-22-703	EA	GASKET - BURNER ACCESS COVER	070811
14	143563-01-704	EA	PLATE - SECONDARY AIR/TOP BACK	063199
16	143563-01-705	EA	PLATE - SECONDARY AIR/TOP FRT	062936
19	143563-01-706	EA	PLATE - SECONDARY AIR/BOTTOM	062938
22	139980-01-701	EA	ELECTRODE	232286
23	098668-02-700	EA	BURNER ASSEMBLY,SF-30 & SF35	010745
26	098668-01-718	EA	VALVE-GAS SF S.N.974903079	161122
27	143563-01-707	EA	PIPE ASSEMBLY (GAS INLET)	171603
31	098668-01-707	EA	TUBE ASSEMBLY, EXHAUST W/CAP	260231
34	143563-01-708	EA	BOX ASM (COMB. AIR INTAKE)	051430BK
35	143563-01-709	EA	GASKET (COMB. AIR HOUSING)	071108
36	143563-01-710	EA	WHEEL (COMBUSTION AIR)	350199
37	143563-01-711	EA	HOUSING (COMBUSTION AIR)	390862BK
39	143563-01-715	EA	GASKET-FIREWALL/COMB. AIR	071107
40	143563-01-712	EA	MOTOR ASSEMBLY	232727
42	101990-01-714	EA	GASKET-MICROSWITCH	230877
44	098668-21-700	EA	SWITCH-MICRO-W/O FLAG 3 1/4"	232261
46	143563-01-713	EA	BLOWER ASSEMBLY(ROOM AIR)	390867BK
47	143563-01-714	EA	WHEEL - ROOM AIR	350198
50	139980-01-710	EA	SWITCH - ON/OFF	232351
52	139980-01-711	EA	PANEL ASSEMBLY-MODULE BD	101663
53	139980-01-712	EA	INSULATOR - MODULE BD	070807
54	098668-22-705	EA	MODULE BD W/RELAY TIME DELAY	520820
55	139980-01-713	EA	CAP/INSULATOR-MODULE BD	070973
57	139980-01-714	EA	BUSHING - UNIVERSAL	070362
58	139980-01-715	EA	BUSHING - STRAIN RELIEF	231809
59	098668-01-716	EA	GASKET-FIREWALL,CHAMBER SIDE	070808
62	098668-21-701	EA	SWITCH - LIMIT	232504
66	098668-01-713	EA	TUBE ASSEMBLY, INTAKE	051248
67	075697-07-703	EA	GASKET - MOTOR	070448
	143563-01-716	EA	CHAMBER ASM. - FINAL	
			CONTACT WINNEBAGO PART SALES FOR UNLISTED COMPONENT(S)	

HEATING & A/C GROUP (CONTINUED)
REAR HEATER

KEY	PART NUMBER	U/M	DESCRIPTION
*	084405-01-000	EA	HEATER - REAR/DUCTED - W/MOTOR AID
	007108-01-000	FT	HOSE - HEATER - 5/8" ID - HI-TEMP
	079059-01-000	EA	HOSE - 90 DEGREE - 5/8"ID X 4" X 36"
			FROM: 00-00-00 THRU: 10-24-06
	079059-22-000	EA	HOSE - 90 DEGREE - 5/8"ID X 4" X 22"
			FROM: 10-25-06 THRU: 99-99-99
	079059-02-000	EA	HOSE - 90 DEGREE - .61" ID X 4" X 6"
	009198-01-000	FT	DUCT - HEAT - FLEXIBLE - 4" ID X 25
	069636-02-000	EA	CONNECTOR - DUCT - 4" ID
	118761-01-000	EA	REDUCER - 4"-2" - GALVANIZED
	076776-01-000	EA	TEE - BEADED - 5/8" X 5/8" X 5/8"
	056464-10-000	EA	REGISTER W/O DAMPER - 4" DIAMETER - PLASTIC - BEIGE

*COMPONENT PARTS LISTED LATER IN THIS GROUP

COMPONENT PARTS FOR REAR HEATER

084405-01-000

KEY	PART NUMBER	U/M	DESCRIPTION	VENDOR NO.
	084405-01-700	EA	CORE-HEATER	FT200229
	084405-01-701	EA	FAN BLADES	HV029931
	084405-01-702	EA	MOTOR ASSEMBLY, 12 VOLT	RV010348

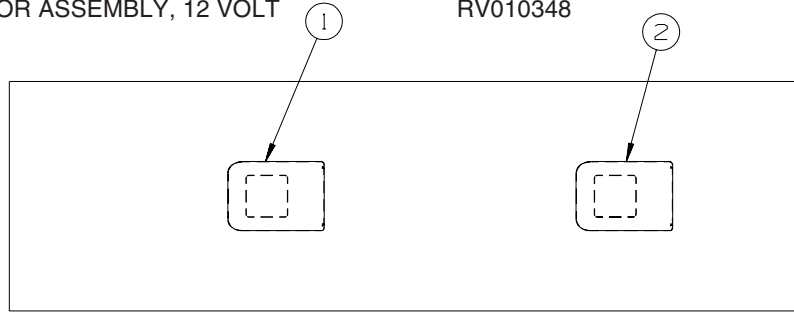

ROOF

KEY	PART NUMBER	U/M	DESCRIPTION
1	131184-02-01A	EA	BOARD - DIVIDER - SILVER
1*	131188-03-01A	EA	A/C/ROOF - 14,800 BTU/MACH 15 - NEW MODEL #8335B676 - WHT - D26P, D29R, D30B
			FROM: 00-00-00 THRU: 10-29-06
1	131188-05-01A	EA	A/C - ROOF - 14,800 BTU-MACH 15 - 2 PEICE SHROUD STYLE-WHT - D26P, D29R, D30B
			FROM: 10-30-06 THRU: 99-99-99
1*	131187-03-01A	EA	A/C - ROOF - MACH 3 POWER SAVER - WHITE - D33T, D34A, D35J
			FROM: 00-00-00 THRU: 08-13-06
1	131187-05-01A	EA	A/C - ROOF - MACH 3 POWER SAVER-2 PEICE SHROUD STYLE - WHT - D33T, D34A, D35J
			FROM: 10-30-06 THRU: 99-99-99
1*	131184-01-01A	EA	CEILING ASSEMBLY - A/C DUCTED - WHITE
1*	131188-04-01A	EA	A/C - ROOF - 14,800 BTU/HEAT PUMP - #8535B676- WHT - AC HEAT PUMP
			FROM: 00-00-00 THRU: 08-13-06
1	131188-06-01A	EA	A/C - ROOF-14,800 BTU-MACH 15/HEAT PUMP-2 PCE SHROUD STYLE
			FROM: 10-30-06 THRU: 99-99-99
1*	131187-04-01A	EA	A/C - ROOF - MACH 3 POWER SAVER - WHITE - AC HEAT PUMP-2 HI EFFICIENCY
			FROM: 00-00-00 THRU: 10-29-06
1	131187-06-01A	EA	A/C - ROOF - MACH 3 POWER SAVER-2 PEICE SHROUD STYLE - WHT
			FROM: 10-30-06 THRU: 99-99-99
1*	131184-05-01A	EA	CEILING ASSEMBLY - HEAT PUMP - WHITE - AC HEAT PUMP/AC HEAT PUMP-2 HI EFFICIENCY
2	131184-02-01A	EA	BOARD - DIVIDER - SILVER - D33T, D34A
2*	131186-02-01A	EA	A/C - ROOF - MACH 1 POWER SAVER - 9,600 BTU - WHITE - D33T, D34A, D35J
			FROM: 00-00-00 THRU: 10-29-06
2	131186-03-01A	EA	A/C - ROOF - MACH 1 PWR SAVER-11,000 BTU-2 PCE SHROUD-WHT - D33T, D34A, D35J
			FROM: 10-30-06 THRU: 99-99-99
2*	131184-01-01A	EA	CEILING ASSEMBLY - A/C DUCTED - WHITE - D33T, D34A
2*	131187-04-01A	EA	A/C - ROOF - MACH 3 POWER SAVER - WHITE - AC HEAT PUMP-2 HI EFFICIENCY
			FROM: 00-00-00 THRU: 10-29-06
2	131187-06-01A	EA	A/C - ROOF - MACH 3 POWER SAVER-2 PEICE SHROUD STYLE - WHT
			FROM: 10-30-06 THRU: 99-99-99
2*	131184-05-01A	EA	CEILING ASM - HT PMP - WHT - AC HEAT PUMP/AC HEAT PUMP-2 HI EFFICIENCY - D33T, D34A

*COMPONENT PARTS LISTED LATER IN THIS GROUP

HEATING & A/C GROUP (CONTINUED)

COMPONENT PARTS FOR ROOF

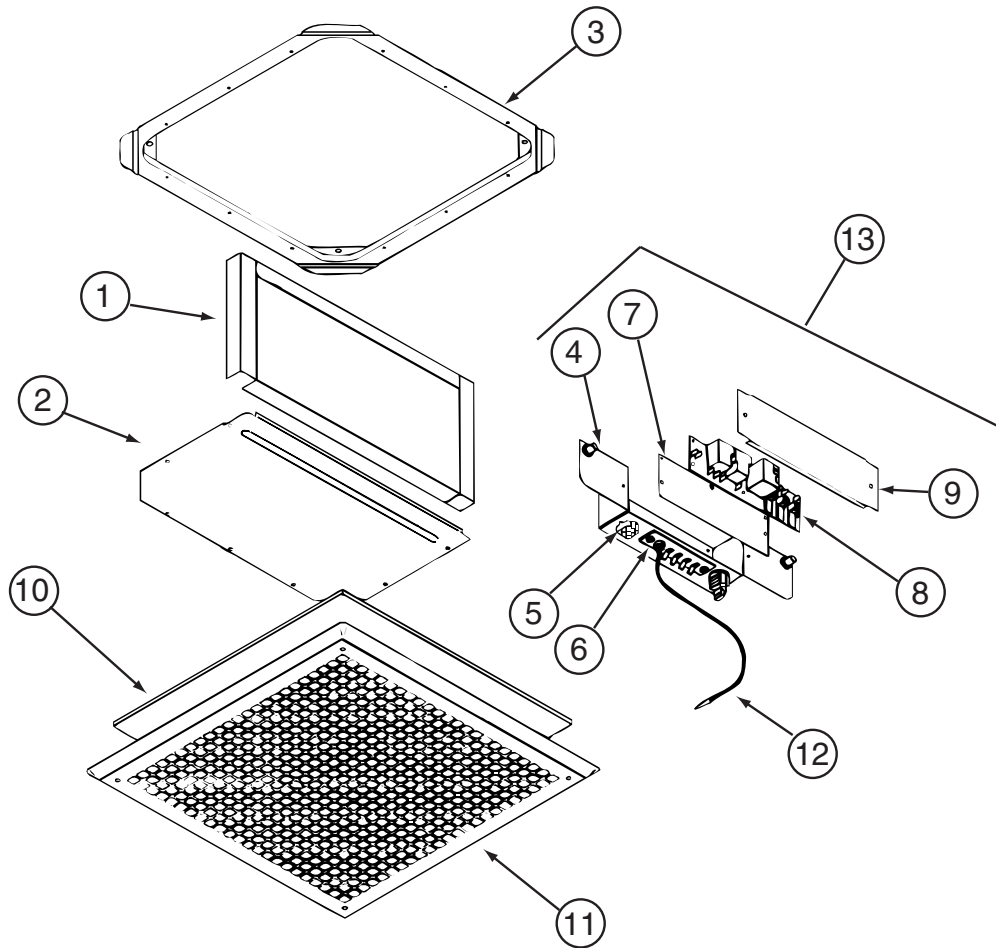

131184-01-01A

KEY	PART NUMBER	U/M	DESCRIPTION	VENDOR NO.
1	131184-01-707	EA	DUCT DIVIDER	8330-3501
5	131184-01-700	EA	PLUG ASSEMBLY	7330A389
6	131184-01-701	EA	TERMINAL BOARD	7330B3201
7	131184-01-702	EA	ISOLATOR - BLANK	7330C365
8	108892-01-702	EA	BOARD-P.C.	7330A3211
10	108892-01-703	EA	FILTER	6798A3761
11	108892-01-704	EA	GRILLE 16 3/8X16 3/8 RETURN	6798-3041
12	131184-01-704	EA	COIL SENSOR	7330-6111
13	131184-01-705	EA	JUNCTION BOX ASSEMBLY	7330B5551
	131184-01-703	EA	SMALL PARTS PKG	8330-5961

CONTACT WINNEBAGO PART SALES FOR UNLISTED COMPONENT(S)

HEATING & A/C GROUP (CONTINUED)
COMPONENT PARTS FOR ROOF (CONTINUED)

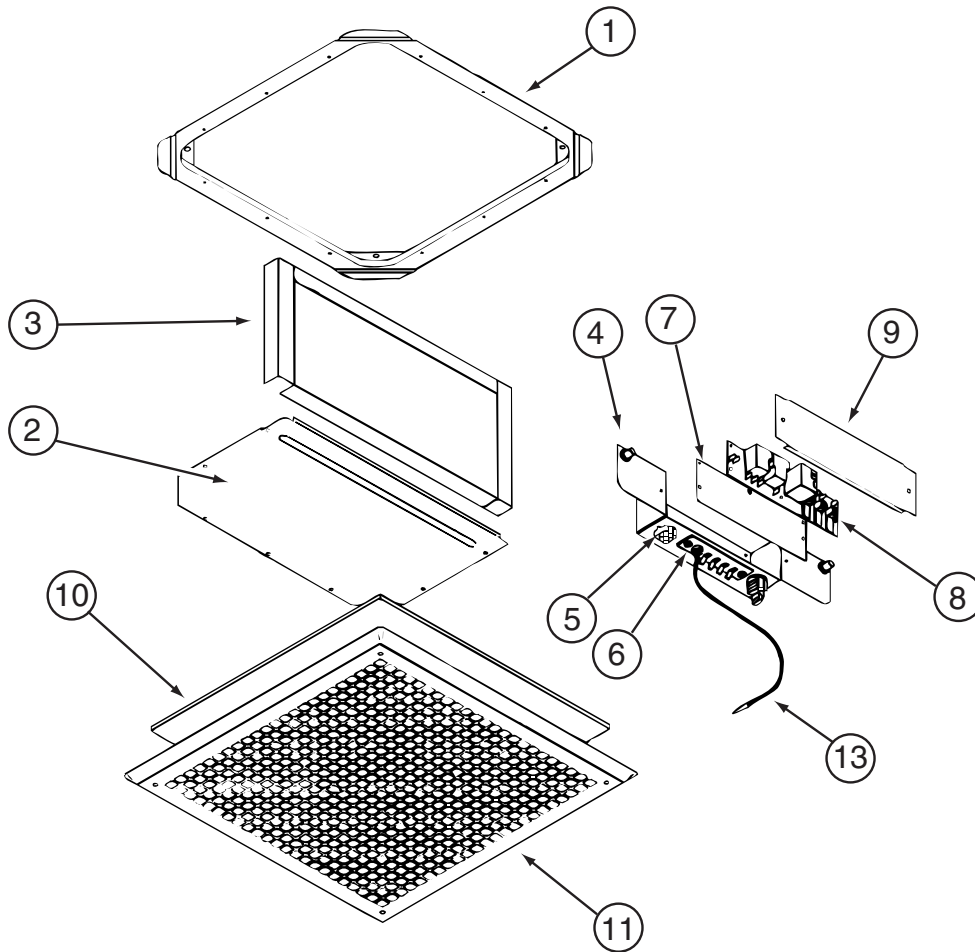

131184-05-01A

KEY	PART NUMBER	U/M	DESCRIPTION	VENDOR NO.
4	131184-05-700	EA	BOX - JUNCTION	8530-5091
5	131184-04-700	EA	PLUG ASSEMBLY	7530A340
6	131184-04-702	EA	BOARD - TERMINAL	7530B3201
7	131184-01-702	EA	ISOLATOR - BLANK	7330C365
8	131184-04-705	EA	BOARD - P.C.	7330B3311
10	108892-01-703	EA	FILTER	6798A3761
11	108892-01-704	EA	GRILLE 16 3/8X16 3/8 RETURN	6798-3041
13	105620-12-719	EA	COIL SENSOR	7330A3231
	131184-01-703	EA	SMALL PARTS PKG	8330-5961

CONTACT WINNEBAGO PART SALES FOR UNLISTED COMPONENT(S)

HEATING & A/C GROUP (CONTINUED)
COMPONENT PARTS FOR ROOF (CONTINUED)

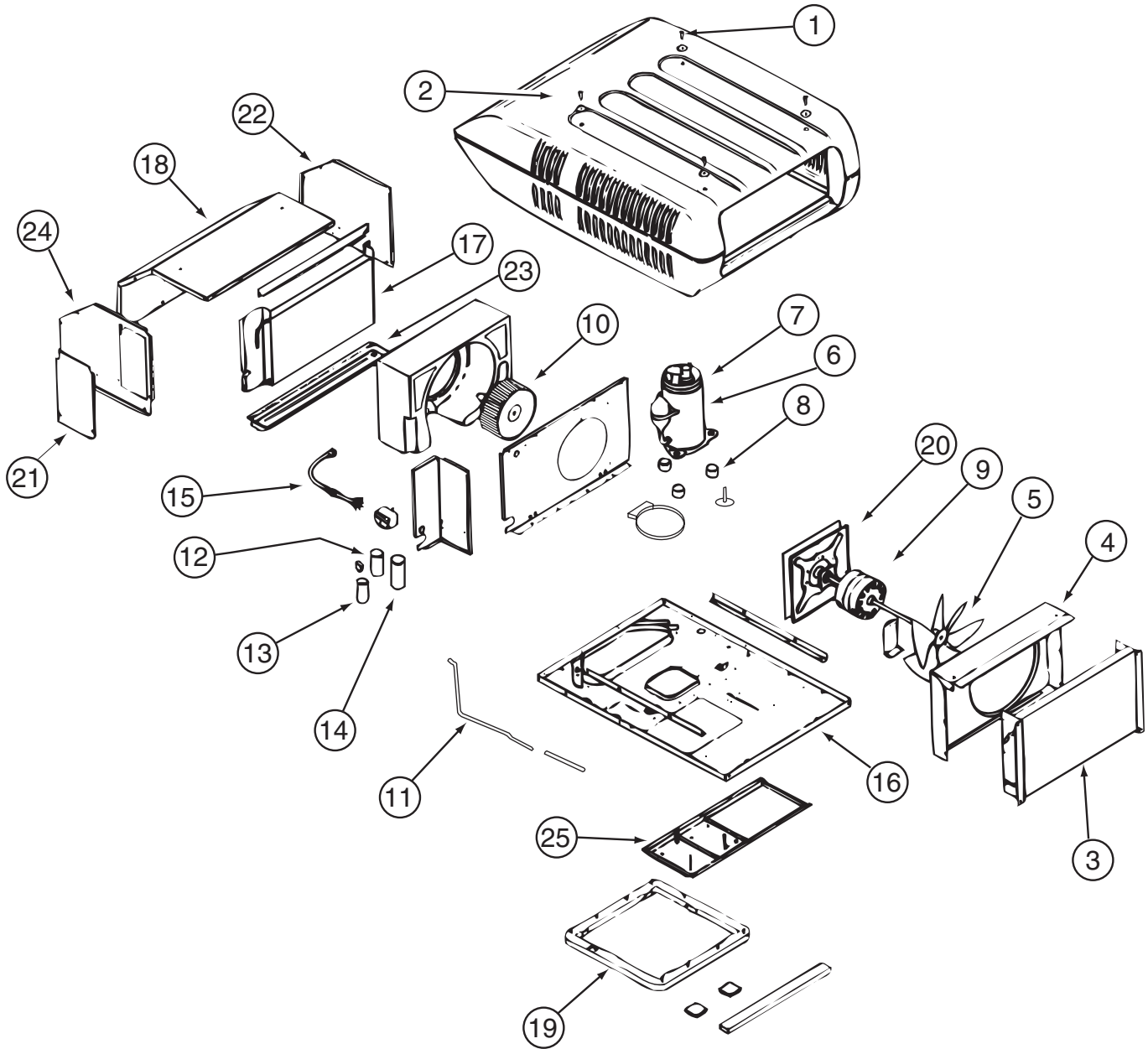

131186-02-01A

KEY	PART NUMBER	U/M	DESCRIPTION	VENDOR NO.
2	131185-03-700	EA	SHROUD - ROOF AIR	8333-4161
3	115219-01-700	EA	COIL-CONDENSER	1452A1321
5	093763-01-712	EA	BLADE-FAN-CONDENSER	6733-3221
6	126859-01-700	EA	COMPRESSOR RK124AT-001-A4Y	1450-2109
7	126859-01-701	EA	OVERLOAD PROTECTORMRA# 4761	1450-0061
8	105620-01-706	EA	MOUNTING PKG.,COMP., 3 PER	6759-3081
9	131186-01-700	EA	MOTOR - 115V, 60 HURTZ	1468-3109
10	131185-01-702	EA	BLOWER WHEEL PACKAGE	1472-1091
12	126859-01-703	EA	CAPACITOR - RUN	1499-5671
13	093763-01-704	EA	CAPACITOR-FAN	1499-5461
14	105620-10-704	EA	START COMPACITOR	1497-0861
15	105620-10-705	EA	PTCR (START DEVICE) - W/CAP.	8333A9021
18	131186-01-701	EA	EVAPORATOR COIL	1452-1521
21	131185-01-704	EA	MOTOR MOUNT & SEAL KIT	8333-5151
	093306-01-701	EA	DECAL PACKAGE, LEFT & RIGHT	6798B3591
	108889-01-710	EA	PAD-FILLER, CONDENSER SEAL	6759B3971
	126859-01-706	EA	LINE - SUCTION	7532A130

CONTACT WINNEBAGO PART SALES FOR UNLISTED COMPONENT

HEATING & A/C GROUP (CONTINUED)
COMPONENT PARTS FOR ROOF (CONTINUED)

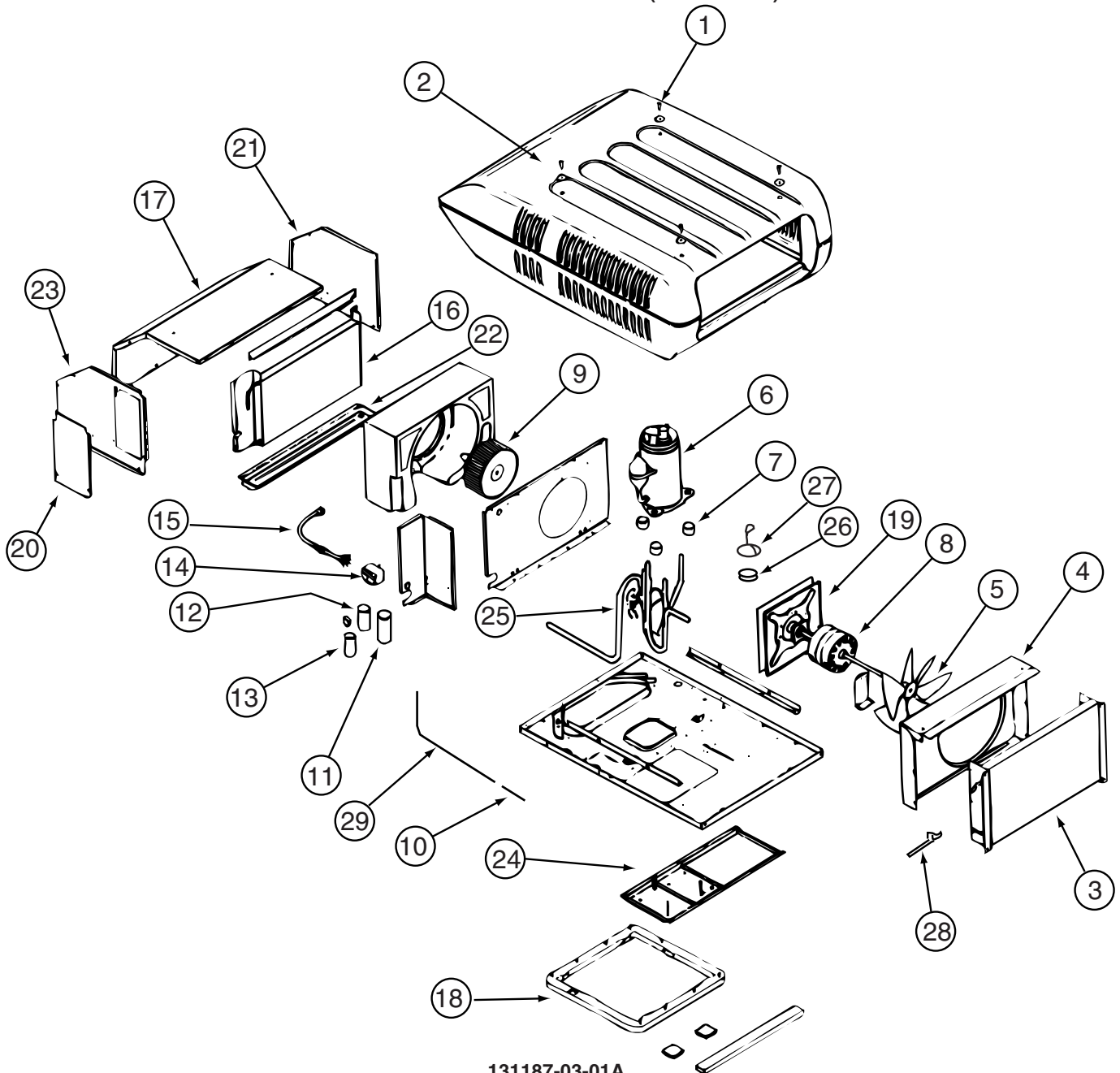

131187-03-01A

KEY	PART NUMBER	U/M	DESCRIPTION	VENDOR NO.
2	131185-03-700	EA	SHROUD - ROOF AIR	8333-4161
3	115219-01-700	EA	COIL-CONDENSER	1452A1321
5	093763-01-712	EA	BLADE-FAN-CONDENSER	6733-3221
6	126860-01-700	EA	COMPRESSOR RK136AT-002-A4Y	1450A2119
7	105620-01-706	EA	MOUNTING PKG.,COMP., 3 PER	6759-3081
8	131186-01-700	EA	MOTOR - 115V, 60 HURTZ	1468-3109
9	131185-01-702	EA	BLOWER WHEEL PACKAGE	1472-1091
11	126859-01-703	EA	CAPACITOR - RUN	1499-5671
12	105620-01-725	EA	CAPACITOR-BLOWER,I.D. 7.5MFD	1499-5461
13	105620-10-705	EA	PTCR (START DEVICE) - W/CAP.	8333A9021
16	131186-01-701	EA	EVAPORATOR COIL	1452-1521
19	131185-01-704	EA	MOTOR MOUNT & SEAL KIT	8333-5151
20	093306-01-701	EA	DECAL PACKAGE, LEFT & RIGHT	6798B3591
21	105620-10-704	EA	START CAPACITOR	1497-0861
22	108889-01-710	EA	PAD-FILLER, CONDENSER SEAL	6759B3971
23	126859-01-706	EA	LINE - SUCTION	7532A130
24	126860-01-701	EA	OVERLOAD PROTECTOR MRA# 1460	1450-0071

CONTACT WINNEBAGO PART SALES FOR UNLISTED COMPONENT

HEATING & A/C GROUP (CONTINUED)
COMPONENT PARTS FOR ROOF (CONTINUED)

131187-04-01A

KEY	PART NUMBER	U/M	DESCRIPTION	VENDOR NO.
2	131185-03-700	EA	SHROUD - ROOF AIR	8333-4161
3	131188-02-700	EA	CONDENSER COIL	1452-1441
5	093763-01-712	EA	BLADE-FAN-CONDENSER	6733-3221
6	126860-01-700	EA	COMPRESSOR RK136AT-002-A4Y	1450A2119
7	105620-01-706	EA	MOUNTING PKG.,COMP., 3 PER	6759-3081
8	131186-01-700	EA	MOTOR - 115V, 60 HURTZ	1468-3109
9	131185-01-702	EA	BLOWER WHEEL PACKAGE	1472-1091
10	105620-12-711	EA	RESTRICTOR - BY FLOW	1454-2521
11	126859-01-703	EA	CAPACITOR - RUN	1499-5671
12	093763-01-704	EA	CAPACITOR-FAN	1499-5461
13	105620-10-705	EA	PTCR (START DEVICE) - W/CAP.	8333A9021
16	131186-01-701	EA	EVAPORATOR COIL	1452-1521
18	037648-01-714	EA	GASKET PACKAGE	8332-3301
19	131185-01-704	EA	MOTOR MOUNT & SEAL KIT	8333-5151
25	131188-02-704	EA	VALVE/REVERSE ASSEMBLY	7535A5301
26	105620-12-708	EA	COIL - SOLENOID	1460-1081
27	131188-02-705	EA	WIRE HARNESS F/SOLENOID	7535-109
28	131188-02-706	EA	SWITCH - FREEZE	1460-2041
29	131188-02-707	EA	LIQUID LINE	7535-135

CONTACT WINNEBAGO PART SALES FOR UNLISTED COMPONENT

HEATING & A/C GROUP (CONTINUED)

COMPONENT PARTS FOR ROOF (CONTINUED)

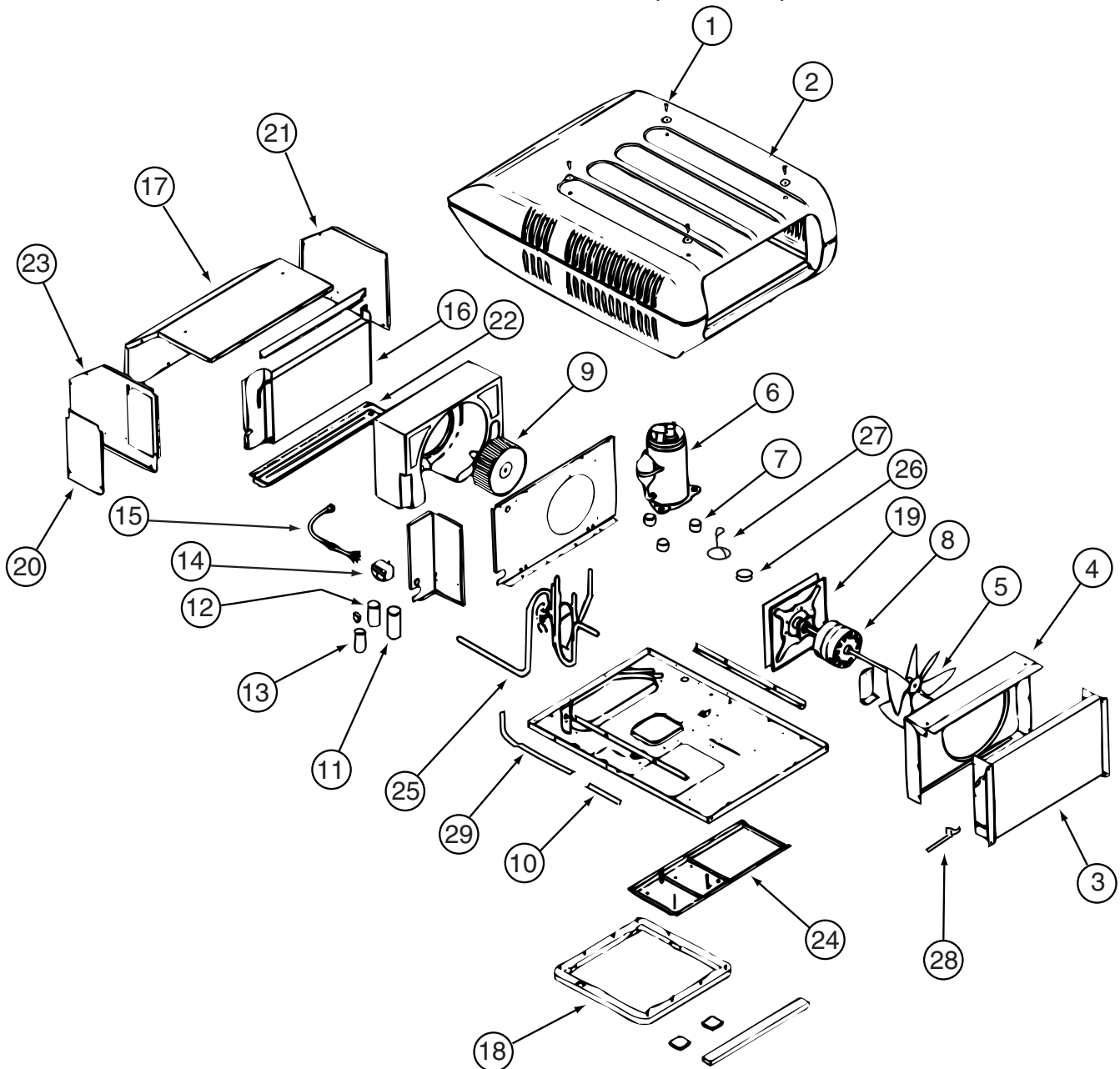

131188-03-01A

KEY	PART NUMBER	U/M	DESCRIPTION	VENDOR NO.
2	131185-03-700	EA	SHROUD-ROOF AIR W/HAIL GUARD	8333-4161
3	115219-01-700	EA	COIL-CONDENSER	1452A1321
5	093763-01-712	EA	BLADE-FAN-CONDENSER	6733-3221
6	131188-01-700	EA	COMPRESSOR - TECUMSEH	1450A2609
7	105620-01-706	EA	MOUNTING PKG.,COMP., 3 PER	6759-3081
8	131185-01-701	EA	MOTOR (115V, 60HZ)	1468-3069
9	131185-01-702	EA	BLOWER WHEEL PACKAGE	1472-1091
11	131188-01-701	EA	RUN CAP. (COMP-40MFD/370V)	1499-5721
12	108889-01-708	EA	CAPACITOR-FAN, 7.5MFD. 370U	1499-5461
13	126859-01-704	EA	CAPACITOR - START	1497-0871
14	091225-01-709	EA	RELAY-START	1497-4131
16	131186-01-701	EA	EVAPORATOR COIL	1452-1521
18	037648-01-714	EA	GASKET PACKAGE	8332-3301
19	131185-01-704	EA	MOTOR MOUNT & SEAL KIT	8333-5151
	093306-01-701	EA	DECAL PACKAGE, LEFT & RIGHT	6798B3591
	108889-01-710	EA	PAD-FILLER, CONDENSER SEAL	6759B3971
	131188-01-702	EA	LINE - SUCTION	7335A134
	131188-01-703	EA	LINE - DISCHARGE	7335A135

CONTACT WINNEBAGO PART SALES FOR UNLISTED COMPONENT(S)

HEATING & A/C GROUP (CONTINUED)
COMPONENT PARTS FOR ROOF (CONTINUED)

131188-04-01A

KEY	PART NUMBER	U/M	DESCRIPTION	VENDOR NO.
3	131188-02-700	EA	CONDENSER COIL	1452-1441
5	093763-01-712	EA	BLADE-FAN-CONDENSER	6733-3221
6	131188-02-701	EA	COMPRESSOR(TECUMSEH-RK225AT)	1450A2069
7	105620-01-706	EA	MOUNTING PKG.,COMP., 3 PER	6759-3081
8	131185-01-701	EA	MOTOR (115V, 60HZ)	1468-3069
9	131185-01-702	EA	BLOWER WHEEL PACKAGE	1472-1091
10	131188-02-702	EA	RESTRICTOR - BY FLOW	1454-2501
11	131188-01-701	EA	RUN CAP. (COMP-40MFD/370V)	1499-5721
12	093763-01-704	EA	CAPACITOR-FAN (INDOOR MOTOR)	1499-5461
13	131188-02-703	EA	CAPACITOR-START(21-25MFD)	1497-0211
14	091225-01-709	EA	RELAY-START	1497-4131
16	131186-01-701	EA	EVAPORATOR COIL	1452-1521
18	037648-01-714	EA	GASKET PACKAGE	8332-3301
19	131185-01-704	EA	MOTOR MOUNT & SEAL KIT	8333-5151
25	131188-02-704	EA	VALVE/REVERSE ASSEMBLY	7535A5301
26	105620-12-708	EA	COIL - SOLENOID	1460-1081
27	131188-02-705	EA	WIRE HARNESS F/SOLENOID	7535-109
28	131188-02-706	EA	SWITCH - FREEZE	1460-2041
29	131188-02-707	EA	LIQUID LINE	7535-135

CONTACT WINNEBAGO PART SALES FOR UNLISTED COMPONENT(S)

INTERIOR FINISH GROUP
MOLDINGS & TRIMS
PORTSMOUTH OAK-SIERRA MAPLE

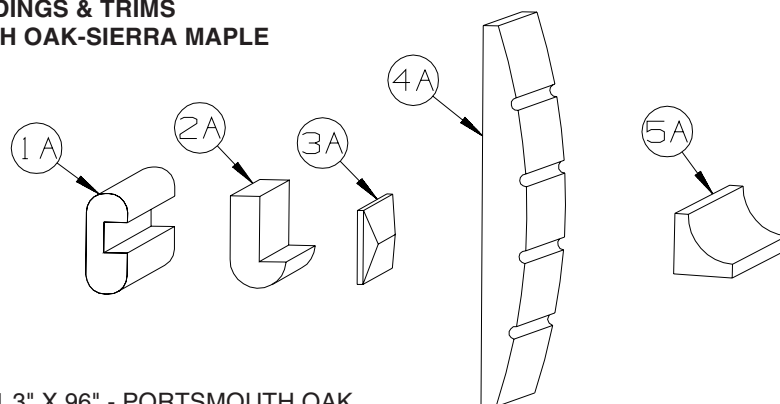

KEY	PART NUMBER	U/M	DESCRIPTION
1A	M09412-62-N42	EA	MOLDING/SHELF EDGE - .6" X 1.3" X 96" - PORTSMOUTH OAK
1A	M09412-62-M52	EA	MOLDING/SHELF EDGE - .6" X 1.3" X 96" - CHERRY - CONCERT CHERRY
1A	M09412-62-M62	EA	MOLDING/SHELF EDGE - .6" X 1.3" X 96" - WASHED MAPLE - WASHED MAPLE
1A	M09412-62-RC3	EA	MOLDING/SHELF EDGE - .6" X 1.3" X 96" - HONEY CHERRY - HONEY CHERRY
1A	M09412-62-SA3	EA	MOLDING/SHELF EDGE - .6" X 1.3" X 96" - MAPLE - SIERRA MAPLE
2A	M09450-77-PC0	EA	MOLDING - TRIM/HDWD W/LIP -.4"X3.2"X79.6" - PORTSMOUTH OAK
2A	M09450-77-PC1	EA	MOLDING - TRIM/HDWD W/LIP -.4"X3.2"X79.6" - CONCERT CHERRY
2A	M09450-77-PC2	EA	MOLDING - TRIM/HDWD W/LIP -.4"X3.2"X79.6" - WASHED MAPLE
2A	M09450-77-RC3	EA	MOLDING - TRIM/HDWD W/LIP -.4"X3.2"X79.6" - HONEY CHERRY
2A	M09501-32-TG1	EA	MOLDING/TRIM - W/NOTCH - .8" X 2.5" X 86.2"-CONCERT CHERRY
2A	M09501-32-TG2	EA	MOLDING/TRIM - W/NOTCH - .8" X 2.5" X 86.2" - WASHED MAPLE,
2A	M09501-32-TD3	EA	MOLDING/TRIM - W/NOTCH - .8" X 2.5" X 86.2" - SIERRA MAPLE
2A	M09503-52-T77	EA	MOLDING/TRIM - .75" X 1.2" X 86.5" - PORTSMOUTH OAK
2A	M09503-52-T78	EA	MOLDING/TRIM - .75" X 1.2" X 86.5" - CONCERT CHERRY
2A	M09503-52-T79	EA	MOLDING/TRIM - .75" X 1.2" X 86.5" - WASHED MAPLE
2A	M09503-52-T80	EA	MOLDING/TRIM - .75" X 1.2" X 86.5" - SIERRA MAPLE
2A	M09511-43-T78	EA	MOLDING - TRIM - W/NOTCH - .8" X 1.4" X 86.3" - CONCERT CHERRY
2A	M09525-80-UM1	EA	MOLDING - TRIM - W/NOTCH - .8"X 1.4"X 86.5" - CONCERT CHERRY
2A	M09511-43-T79	EA	MOLDING - TRIM - W/NOTCH - .8" X 1.4" X 86.3" - WASHED MAPLE
2A	M09525-80-U91	EA	MOLDING - TRIM - W/NOTCH - .8" X 1.4" X 86.5" - WASHED MAPLE
2A	M09511-43-T80	EA	MOLDING - TRIM - W/NOTCH - .8" X 1.4" X 86.3" - SIERRA MAPLE
2A	M09525-80-U92	EA	MOLDING - TRIM - W/NOTCH - .8" X 1.4" X 86.5" - SIERRA MAPLE
2A	M09438-25-RA3	EA	MOLDING - HARDWOOD-W/NOTCH - 1.4"X 80.2" - HONEY CHERRY
2A	M09515-72-TD1	EA	MOLDING/TRIM - .8" X 2.2" X 86.1" - CONCERT CHERRY
2A	M09515-72-TD2	EA	MOLDING/TRIM - .8" X 2.2" X 86.1" - WASHED MAPLE
2A	M09515-72-TD3	EA	MOLDING/TRIM - .8" X 2.2" X 86.1" - SIERRA MAPLE
3A	M09471-91-R69	EA	MOLDING - TRIM/VEE - .2" X 1" X 34.4" - CONCERT CHERRY
3A	M09471-91-R76	EA	MOLDING - TRIM/VEE - .2" X 1" X 34.4" - WASHED MAPLE
3A	M09471-91-SA3	EA	MOLDING - TRIM/VEE - .2" X 1" X 34.4" - SIERRA MAPLE
3A	M09477-88-S34	EA	MOLDING - TRIM/VEE - .2" X 1" X 19.9" - WASHED MAPLE
3A	M09477-88-S35	EA	MOLDING - TRIM/VEE - .2" X 1" X 19.9" - SIERRA MAPLE
3A	M09501-30-SD2	EA	MOLDING - TRIM/VEE - .2" X 1" X 35.1" - WASHED MAPLE
3A	M09501-30-SD3	EA	MOLDING - TRIM/VEE - .2" X 1" X 35.1" - HONEY CHERRY
3A	M09501-37-TG1	EA	MOLDING - TRIM/VEE - .2" X 1" X 19.2" - CONCERT CHERRY
3A	M09501-37-TG2	EA	MOLDING - TRIM/VEE - .2" X 1" X 19.2" - WASHED MAPLE
3A	M09501-37-TD3	EA	MOLDING - TRIM/VEE - .2" X 1" X 19.2" - SIERRA MAPLE
3A	M09501-37-TG3	EA	MOLDING - TRIM/VEE - .2" X 1" X 19.2" - HONEY CHERRY
3A	M09501-63-T78	EA	MOLDING - TRIM/VEE - .2" X 1" X 15" - CONCERT CHERRY
3A	M09501-63-T79	EA	MOLDING - TRIM/VEE - .2" X 1" X 15" - WASHED MAPLE
3A	M09501-63-T80	EA	MOLDING - TRIM/VEE - .2" X 1" X 15" - SIERRA MAPLE
3A	M09503-62-TG1	EA	MOLDING - TRIM/VEE - .2" X 1" X 26.3" - CONCERT CHERRY
3A	M09503-62-TG2	EA	MOLDING - TRIM/VEE - .2" X 1" X 26.3" - WASHED MAPLE
3A	M09503-62-TG3	EA	MOLDING - TRIM/VEE - .2" X 1" X 26.3" - HONEY CHERRY
3A	M09511-90-TG1	EA	MOLDING - TRIM/VEE - .2" X 1" X 42.1" - CONCERT CHERRY
3A	M09511-90-TG3	EA	MOLDING - TRIM/VEE - .2" X 1" X 42.1" - HONEY CHERRY
3A	M09511-90-TG2	EA	MOLDING - TRIM/VEE - .2" X 1" X 42.1" - WASHED MAPLE
3A	M09520-15-TD1	EA	MOLDING - TRIM/VEE - .2" X 1" X 15.3" - CONCERT CHERRY
3A	M09520-15-TD2	EA	MOLDING - TRIM/VEE - .2" X 1" X 15.3" - WASHED MAPLE
3A	M09520-15-TD3	EA	MOLDING - TRIM/VEE - .2" X 1" X 15.3" - SIERRA MAPLE
3A	M09520-96-T59	EA	MOLDING - TRIM/VEE - .2" X 1" X 32.7" - PORTSMOUTH OAK
3A	M09520-96-T60	EA	MOLDING - TRIM/VEE - .2" X 1" X 32.7" - CONCERT CHERRY
3A	M09520-96-T61	EA	MOLDING - TRIM/VEE - .2" X 1" X 32.7" - WASHED MAPLE
3A	M09520-96-TP0	EA	MOLDING - TRIM/VEE - .2" X 1" X 32.7" - SIERRA MAPLE

INTERIOR FINISH GROUP (CONTINUED)
MOLDINGS & TRIMS (CONTINUED)

KEY	PART NUMBER	U/M	DESCRIPTION
3A	M09525-96-TA0	EA	MOLDING - TRIM/VEE - .2" X 1" X 36.2" - PORTSMOUTH OAK
3A	M09525-96-TA1	EA	MOLDING - TRIM/VEE - .2" X 1" X 36.2" - CONCERT CHERRY
3A	M09525-96-TA2	EA	MOLDING - TRIM/VEE - .2" X 1" X 36.2" - WASHED MAPLE
3A	M09525-96-TA3	EA	MOLDING - TRIM/VEE - .2" X 1" X 36.2" - SIERRA MAPLE
3A	M09534-08-T01	EA	MOLDING - TRIM/VEE - .2" X 1" X 24.5" - SIERRA MAPLE
3A	M09534-08-T02	EA	MOLDING - TRIM/VEE - .2" X 1" X 24.5" - HONEY CHERRY
3A	M09511-32-T78	EA	MOLDING - TRIM/VEE - .4" X 1" X 26.8" - CONCERT CHERRY
3A	M09511-32-T79	EA	MOLDING - TRIM/VEE - .4" X 1" X 26.8" - WASHED MAPLE
3A	M09511-32-T80	EA	MOLDING - TRIM/VEE - .4" X 1" X 26.8" - SIERRA MAPLE
3A	M09511-86-T78	EA	MOLDING - TRIM/VEE - .4" X 1" X 28.3" - CONCERT CHERRY
3A	M09511-86-T79	EA	MOLDING - TRIM/VEE - .4" X 1" X 28.3" - WASHED MAPLE
3A	M09511-86-T80	EA	MOLDING - TRIM/VEE - .4" X 1" X 28.3" - SIERRA MAPLE
3A	M09477-63-S46	EA	MOLDING - TRIM/VEE - .4" X 1" X 64.1" - PORTSMOUTH OAK - BATH DOOR TRIM
3A	M09477-63-SR0	EA	MOLDING - TRIM/VEE - .4" X 1" X 64.1" - SIERRA MAPLE - BATH DOOR TRIM
3A	M09477-64-S46	EA	MOLDING - TRIM/VEE - .4" X 1" X 14.9" - PORTSMOUTH OAK - BATH DOOR TRIM
3A	M09477-64-SR0	EA	MOLDING - TRIM/VEE - .4" X 1" X 14.9" - SIERRA MAPLE - BATH DOOR TRIM
4A	M09462-54-R90	EA	MOLDING - FLUTED, CURVED - .6" X 6" X 82.7" - CONCERT CHERRY
4A	M09462-54-R91	EA	MOLDING - FLUTED, CURVED - .6" X 6" X 82.7" - WASHED MAPLE
4A	M09462-54-RE3	EA	MOLDING - FLUTED, CURVED - .6" X 6" X 82.7" - HONEY CHERRY
5A	M09471-79-R38	EA	MOLDING - TRIM/COVE - .8" X .8" X 95.8" - OAK/PORTS OAK - PORTSMOUTH OAK
5A	M09471-79-R39	EA	MOLDING - TRIM/COVE - .8" X .8" X 95.8" - CHERRY/CHERRY - CONCERT CHERRY
5A	M09471-79-R46	EA	MOLDING - TRIM/COVE - .8" X .8" X 95.8" - MAPLE/MAPLE - WASHED MAPLE
5A	M09471-79-RE0	EA	MOLDING - TRIM/COVE - .8" X .8" X 95.8" - HONEY/CHERRY- HONEY CHERRY
5A	M09471-79-SA3	EA	MOLDING - TRIM/COVE - .8" X .8" X 95.8" - HONEY/MAPLE - SIERRA MAPLE

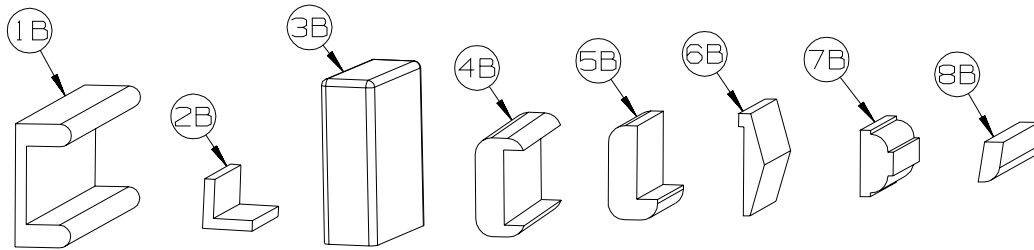

KEY	PART NUMBER	U/M	DESCRIPTION
1B	M09501-84-TG0	EA	MOLDING/TRIM - CAP/WALL - 2.2" X 85.9" - PORTSMOUTH OAK
1B	M09501-84-TG1	EA	MOLDING/TRIM - CAP/WALL - 2.2" X 85.9" - CONCERT CHERRY
1B	M09501-84-TG2	EA	MOLDING/TRIM - CAP/WALL - 2.2" X 85.9" - WASHED MAPLE
1B	M09520-07-TD3	EA	MOLDING/TRIM - CAP/WALL - 2.2" X 80.5" - SIERRA MAPLE
1B	M09501-84-TG3	EA	MOLDING/TRIM - CAP/WALL - 2.2" X 85.9" - HONEY CHERRY
2B	M09511-81-TA1	EA	MOLDING/TRIM - L SHAPE - .8"X .8"X 80.2" - CONCERT CHERRY
2B	M09511-81-TA2	EA	MOLDING/TRIM - L SHAPE - .8"X .8"X 80.2" - WASHED MAPLE
2B	M09511-81-TA3	EA	MOLDING/TRIM - L SHAPE - .8"X .8"X 80.2" - SIERRA MAPLE
3B	M09515-81-T01	EA	MOLDING/HARDWOOD STRAIGHT - 74.3" - WASHED MAPLE
3B	M09515-81-T02	EA	MOLDING/HARDWOOD STRAIGHT - 74.3" - HONEY CHERRY
4B	M09511-42-T77	EA	MOLDING - TRIM - W/NOTCH - 1.5" X 86.4" - PORTSMOUTH OAK
4B	M09511-42-T78	EA	MOLDING - TRIM - W/NOTCH - 1.5" X 86.4" - CONCERT CHERRY
4B	M09511-42-T79	EA	MOLDING - TRIM - W/NOTCH - 1.5" X 86.4" - WASHED MAPLE
4B	M09511-42-T80	EA	MOLDING - TRIM - W/NOTCH - 1.5" X 86.4" - SIERRA MAPLE
5B	M09515-18-T78	EA	MOLDING - HARDWOOD-W/NOTCH - 1.4"X 86.2" - CONCERT CHERRY
5B	M09515-18-T79	EA	MOLDING - HARDWOOD-W/NOTCH - 1.4"X 86.2" - WASHED MAPLE
5B	M09515-18-T80	EA	MOLDING - HARDWOOD-W/NOTCH - 1.4"X 86.2" - SIERRA MAPLE
6B	M09515-52-TG1	EA	MOLDING - TRIM/VEE - 1.5" X 73.9" - CONCERT CHERRY
6B	M09515-52-TG2	EA	MOLDING - TRIM/VEE - 1.5" X 73.9" - WASHED MAPLE
6B	M09515-52-TG3	EA	MOLDING - TRIM/VEE - 1.5" X 73.9" - HONEY CHERRY
7B	Y00076-32-438	EA	MOLDING/TRIM - .5" X 1" X 96" - CHERRY (UNSTAINED)
7B	Y00076-22-438	EA	MOLDING/TRIM - .5" X 1" X 96" - MAPLE (UNSTAINED)
8B	Y00086-72-438	EA	MOLDING - VINYL WRAP - .7" X 1.6" X 96" - PORTSMOUTH OAK - PORTSMOUTH OAK
8B	Y00086-62-438	EA	MOLDING - 96" - CONCERT CHERRY (U90/94/98/A1/A5/B1/C1/C5/D1/D5/E1/E5/F1/F5/G1/G5/H1/H5)
8B	Y00086-D2-438	EA	MOLDING - VINYL WRAP - .7" X 1.6" X 96" - CONCERT CHERRY (UM1 THRU UM9, UN1 THRU UN9)
8B	Y00086-A2-438	EA	MOLDING - VINYL WRAP - .7" X 1.6" X 96" - WASHED MAPLE
8B	Y00086-92-438	EA	MOLDING - VINYL WRAP - .7" X 1.6" X 96" - SIERRA MAPLE - SIERRA MAPLE

INTERIOR FINISH GROUP (CONTINUED)
MOLDINGS & TRIMS (CONTINUED)

KEY	PART NUMBER	U/M	DESCRIPTION
8B	Y00087-62-438	EA	MOLDING - 96" - CONCERT CHERRY (U90/94/98/A1/A5/B1/C1/C5/D1/D5/E1/E5/F1/F5/G1/G5/H1/H5)
8B	Y00087-D2-438	EA	MOLDING - VINYL WRAP - .7" X 2.9" X 96" - CONCERT CHERRY (UM1 THRU UM9, UN1 THRU UN9)
8B	Y00087-A2-438	EA	MOLDING - VINYL WRAP - .7" X 2.9" X 96" - WASHED MAPLE
8B	Y00087-92-438	EA	MOLDING - VINYL WRAP - .7" X 2.9" X 96" - SIERRA MAPLE
8B	Y00300-62-438	EA	MOLDING - 96" - CONCERT CHERRY (U90/94/98/A1/A5/B1/C1/C5/D1/D5/E1/E5/F1/F5/G1/G5/H1/H5)
8B	Y00300-D2-438	EA	MOLDING - VINYL WRAP - .3" X .6" X 96" - CONCERT CHERRY (UM1 THRU UM9, UN1 THRU UN9)
8B	Y00300-A2-438	EA	MOLDING - VINYL WRAP - .3" X .6" X 96" - WASHED MAPLE
8B	Y00300-92-438	EA	MOLDING - VINYL WRAP - .3" X .6" X 96" - SIERRA MAPLE

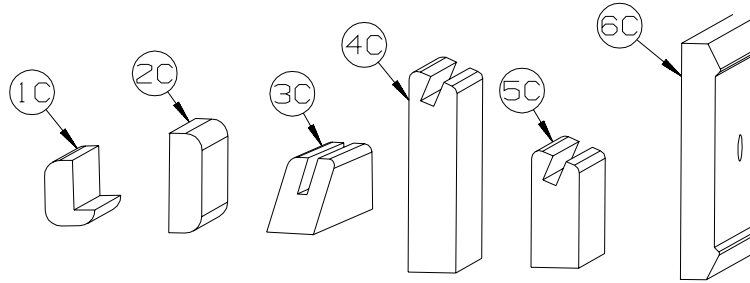

KEY	PART NUMBER	U/M	DESCRIPTION
1C	M09520-19-TD1	EA	MOLDING - TRIM - W/NOTCH - 1" X 86.3" - CONCERT CHERRY
1C	M09520-19-TD2	EA	MOLDING - TRIM - W/NOTCH - 1" X 86.3" - WASHED MAPLE
1C	M09520-19-TD3	EA	MOLDING - TRIM - W/NOTCH - 1" X 86.3" - HONEY CHERRY
1C	M09525-27-UF1	EA	MOLDING - HARDWOOD - .75" X 1.4" X 32.4" - CONCERT CHERRY
1C	M09525-27-UF2	EA	MOLDING - HARDWOOD - .75" X 1.4" X 32.4" - WASHED MAPLE
1C	M09525-27-UF3	EA	MOLDING - HARDWOOD - .75" X 1.4" X 32.4" - SIERRA MAPLE
2C	M09511-46-T77	EA	MOLDING/TRIM - .5" X 1.5" X 86.5" - PORTSMOUTH OAK
2C	M09511-46-T78	EA	MOLDING/TRIM - .5" X 1.5" X 86.5" - CONCERT CHERRY
2C	M09511-46-T79	EA	MOLDING/TRIM - .5" X 1.5" X 86.5" - WASHED MAPLE
2C	M09511-46-T80	EA	MOLDING/TRIM - .5" X 1.5" X 86.5" - SIERRA MAPLE
3C	Y00223-42-438	EA	MOLDING - HARDWOOD/OAK - .7" X 1" X 96"
3C	Y00223-32-438	EA	MOLDING - HARDWOOD/CHERRY - .7" X 1" X 96"
3C	Y00223-22-438	EA	MOLDING - HARDWOOD/MAPLE - .7" X 1" X 96"
4C	Y00054-62-438	EA	MOLDING- 96" - CONCERT CHERRY (U90/94/98/A1/A5/B1/C1/C5/D1/D5/E1/E5/F1/F5/G1/G5/H1/H5)
4C	Y00054-D2-438	EA	MOLDING/VYL WRP-BVLD-.73" X 3.1" X 96" - CONCERT CHERRY (UM1 THRU UM9, UN1 THRU UN9)
4C	Y00054-A2-438	EA	MOLDING/VINYL WRAP-BEVELED ENDS-.73"X3.1"X96" - WASHED MAPLE
4C	Y00054-92-438	EA	MOLDING/VINYL WRAP-BEVELED-.73" X 3.1" X 96" - SIERRA MAPLE
4C	Y00258-62-438	EA	MOLDING/VYL 96" - CONCERT CHERRY (U90/94/98/A1/A5/B1/C1/C5/D1/D5/E1/E5/F1/F5/G1/G5/H1/H5)
4C	Y00258-D2-438	EA	MOLDING/VINYL WRP-BVLD-.73" X 3.1" X 96" - CONCERT CHERRY (UM1 THRU UM9, UN1 THRU UN9)
4C	Y00258-A2-438	EA	MOLDING/VINYL WRAP-BEVELED ENDS-.73"X3.1"X96" - WASHED MAPLE
4C	Y00258-92-438	EA	MOLDING/VINYL WRAP-BEVELED-.73" X 3.1" X 96" - SIERRA MAPLE
5C	Y00259-62-438	EA	MOLDING/VYL 96" - CONCERT CHERRY (U90/94/98/A1/A5/B1/C1/C5/D1/D5/E1/E5/F1/F5/G1/G5/H1/H5)
5C	Y00259-D2-438	EA	MOLDING/VINYL WRP-BVLD-.73" X 1.8" X 96" - CONCERT CHERRY (UM1 THRU UM9, UN1 THRU UN9)
5C	Y00259-A2-438	EA	MOLDING/VINYL WRAP-BEVELED-.73"X1.8"X96" - WASHED MAPLE
5C	Y00259-92-438	EA	MOLDING/VINYL WRAP-BEVELED-.73"X1.8"X96" - SIERRA MAPLE
6C	Y00152-A2-438	EA	MOLDING/TRIM - VINYL - .6" X 3.5" X 96" - WASHED MAPLE
6C	Y00152-92-438	EA	MOLDING/TRIM - VINYL - .6" X 3.5" X 96" - SIERRA MAPLE

INTERIOR FINISH GROUP (CONTINUED)
MOLDINGS & TRIMS (CONTINUED)

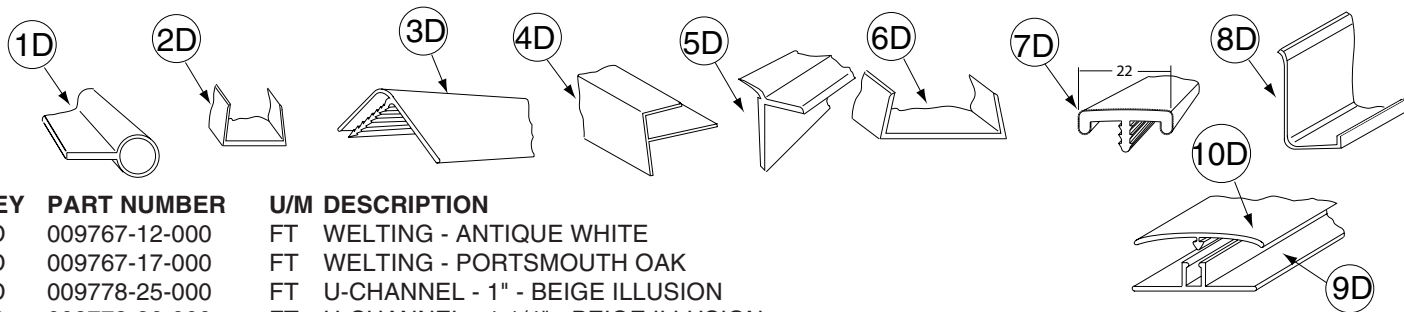

KEY	PART NUMBER	U/M	DESCRIPTION
1D	009767-12-000	FT	WELTING - ANTIQUE WHITE
1D	009767-17-000	FT	WELTING - PORTSMOUTH OAK
2D	009778-25-000	FT	U-CHANNEL - 1" - BEIGE ILLUSION
2D	009778-26-000	FT	U-CHANNEL - 1 1/4" - BEIGE ILLUSION
2D	009778-38-000	FT	U-CHANNEL - 1" - BONE
2D	009778-32-000	FT	U-CHANNEL - 1" - PORTSMOUTH OAK
2D	009778-34-000	FT	U-CHANNEL - 1" - CONCERT CHERRY
2D	009778-27-000	FT	U-CHANNEL - 1" - WASHED MAPLE
2D	009778-35-000	FT	U-CHANNEL - 1" - HONEY CHERRY
2D	009778-36-000	FT	U-CHANNEL - 1" - SIERRA MAPLE
3D	009809-30-000	EA	MOLDING - CORNER - OUTSIDE - 1" X 84" - BEIGE ILLUSION
3D	009809-37-000	EA	MOLDING - CORNER - OUTSIDE - 1" X 84" - BONE
3D	009809-32-000	EA	MOLDING - CORNER - OUTSIDE - 1" X 84" - PORTSMOUTH OAK
3D	009809-33-000	EA	MOLDING - CORNER - OUTSIDE - 1" X 84" - CONCERT CHERRY
3D	009809-31-000	EA	MOLDING - CORNER - OUTSIDE - 1" X 84" - WASHED MAPLE
3D	009809-34-000	EA	MOLDING - CORNER - OUTSIDE - 1" X 84" - HONEY CHERRY
3D	009809-35-000	EA	MOLDING - CORNER - OUTSIDE - 1" X 84" - SIERRA MAPLE
4D	009812-31-000	EA	MOLDING - CORNER - 1/2" W/1/4"CHAN X 84" - BEIGE ILLUSION
4D	009812-40-000	EA	MOLDING - CORNER - 1/2" W/1/4"CHAN X 84" - BONE
4D	009812-35-000	EA	MOLDING - CORNER - 1/2" W/1/4"CHAN X 84" - PORTSMOUTH OAK
4D	009812-36-000	EA	MOLDING - CORNER - 1/2" W/1/4"CHAN X 84" - CONCERT CHERRY
4D	009812-33-000	EA	MOLDING - CORNER - 1/2" W/1/4"CHAN X 84" - WASHED MAPLE
4D	009812-37-000	EA	MOLDING - CORNER - 1/2" W/1/4"CHAN X 84" - HONEY CHERRY
4D	009812-38-000	EA	MOLDING - CORNER - 1/2" W/1/4"CHAN X 84" - SIERRA MAPLE
5D	022992-11-000	FT	MOLDING - REVERSE COVE - T-SHAPED - IVORY
5D	022992-18-000	FT	MOLDING - REVERSE COVE - T-SHAPED - BONE
5D	022992-14-000	FT	MOLDING - REVERSE COVE - T-SHAPED - BRIGHT WHITE
6D	070504-42-000	FT	U-CHANNEL - PLASTIC - .13" X 84" - BEIGE ILLUSION
6D	070504-69-000	FT	U-CHANNEL - PLASTIC - .13" X 84" - BONE
6D	070504-43-000	FT	U-CHANNEL - PLASTIC - .9" X 96" - BEIGE ILLUSION
6D	070504-70-000	FT	U-CHANNEL - PLASTIC - .8" X 84" - BONE
6D	070504-57-000	FT	U-CHANNEL - PLASTIC - .13" X 84" - PORTSMOUTH OAK
6D	070504-58-000	FT	U-CHANNEL - PLASTIC - .9" X 84" - PORTSMOUTH OAK
6D	070504-60-000	FT	U-CHANNEL - PLASTIC - .13" X 84" - CONCERT CHERRY
6D	070504-61-000	FT	U-CHANNEL - PLASTIC - .9" X 84" - CONCERT CHERRY
6D	070504-50-000	FT	U-CHANNEL - PLASTIC - .13" X 96" - WASHED MAPLE
6D	070504-51-000	FT	U-CHANNEL - PLASTIC - .9" X 96" - WASHED MAPLE
6D	070504-62-000	FT	U-CHANNEL - PLASTIC - 1.65" X 84" - HONEY CHERRY
6D	070504-63-000	FT	U-CHANNEL - PLASTIC - .9" X 84" - HONEY CHERRY
6D	070504-65-000	FT	U-CHANNEL - PLASTIC - 1.65" X 84" - SIERRA MAPLE
6D	070504-66-000	FT	U-CHANNEL - PLASTIC - .9" X 84" - SIERRA MAPLE
7D	083620-15-000	FT	MOLDING-T - W/EDGE LIP - 7/8" FACE - BEIGE ILLUSION
7D	083620-25-000	FT	MOLDING-T - W/EDGE LIP - 7/8" FACE - BONE
7D	083620-20-000	FT	MOLDING-T - W/EDGE LIP - 7/8" FACE - PORTSMOUTH OAK
7D	083620-21-000	FT	MOLDING-T - W/EDGE LIP - 7/8" FACE - CONCERT CHERRY
7D	083620-19-000	FT	MOLDING-T - W/EDGE LIP - 7/8" FACE - WASHED MAPLE
7D	083620-24-000	FT	MOLDING-T - W/EDGE LIP - 7/8" FACE - HONEY CHERRY
7D	083620-22-000	FT	MOLDING-T - W/EDGE LIP - 7/8" FACE - SIERRA MAPLE
8D	085746-04-000	FT	TRIM-J - CARPET 1.2" X .5" ANGLE - 12' LONG - OFF WHITE
9D	086229-01-000	EA	RETAINER - BATTEN - .75" X 92.1" - ANY COLOR
10D	086229-20-000	EA	BATTEN - 1" X 96" - BEIGE

INTERIOR FINISH GROUP (CONTINUED)
MOLDINGS & TRIMS (CONTINUED)

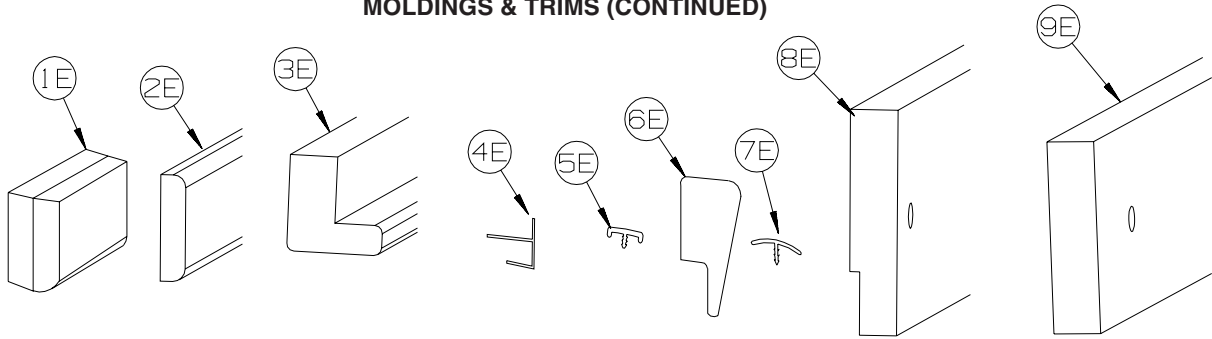

KEY	PART NUMBER	U/M	DESCRIPTION
1E	100659-30-N75	EA	MOLDING - TRIM - 8' - PORTSMOUTH OAK
1E	100659-30-N74	EA	MOLDING - TRIM - 8' - CONCERT CHERRY
1E	100659-30-M84	EA	MOLDING - TRIM - 8' - WASHED MAPLE
1E	100659-27-RA3	EA	MOLDING - TRIM - HONEY CHERRY
1E	100659-31-SA3	EA	MOLDING - TRIM - SIERRA MAPLE
2E	100818-01-12A	EA	MOLDING - VINYL WRAPPED - 1.6" X .4" X 84" - PORTSMOUTH OAK
2E	100818-01-13A	EA	MOLDING - VYL 84" - CONCERT CHERRY (U90/94/98/A1/A5/B1/C1/C5/D1/D5/E1/E5/F1/F5/G1/G5/H1/H5)
2E	100818-01-23A	EA	MOLDING - VINYL WRPPD - 1.6" X .4" X 84" - CONCERT CHERRY (UM1 THRU UM9, UN1 THRU UN9)
2E	100818-01-21A	EA	MOLDING - VINYL WRAPPED - 1.6" X .4" X 84" - WASHED MAPLE
2E	100818-01-14A	EA	MOLDING - VINYL WRAPPED - 1.6" X .4" X 84" - HONEY CHERRY
2E	100818-01-22A	EA	MOLDING - VINYL WRAPPED - 1.6" X .4" X 84" - SIERRA MAPLE
3E	100819-01-12A	EA	MOLDING - VINYL WRAPPED-L-SHAPED-1.5"X1.5"X84" - PORTSMOUTH OAK
3E	100819-01-13A	EA	MOLDING - VYL 84" - CONCERT CHERRY (U90/94/98/A1/A5/B1/C1/C5/D1/D5/E1/E5/F1/F5/G1/G5/H1/H5)
3E	100819-01-23A	EA	MOLDING - VYL WRPPD-L-SHPD-1.5"X1.5"X84" - CONCERT CHERRY (UM1 THRU UM9, UN1 THRU UN9)
3E	100819-01-21A	EA	MOLDING - VINYL WRAPPED-L-SHAPED-1.5"X1.5"X84" - WASHED MAPLE
3E	100819-01-14A	EA	MOLDING - VINYL WRAPPED-L-SHAPED-1.5"X1.5"X84" - HONEY CHERRY
3E	100819-01-22A	EA	MOLDING - VINYL WRAPPED-L-SHAPED-1.5"X1.5"X84" - SIERRA MAPLE
4E	103186-01-07A	FT	MOLDING/PLASTIC - 3/8" U-CHANNEL-3/4" FACE -BEIGE ILLUSION
4E	103186-01-09A	FT	MOLDING/PLASTIC - 3/8" U-CHAN'L-3/4" FACE - PORTSMOUTH OAK
4E	103186-01-10A	FT	MOLDING/PLASTIC - 3/8" U-CHAN'L-3/4" FACE - CONCERT CHERRY
4E	103186-01-08A	FT	MOLDING/PLASTIC - 3/8" U-CHANNEL-3/4"FACE-WASHED MAPLE 8' - WASHED MAPLE
4E	103186-01-11A	FT	MOLDING/PLASTIC - 3/8" U-CHAN'L-3/4" FACE - HONEY CHERRY
4E	103186-01-12A	FT	MOLDING/PLASTIC - 3/8" U-CHAN'L-3/4" FACE - SIERRA MAPLE
4E	103186-02-07A	FT	MOLDING/PLASTIC-1" U-CHAN'L-1 3/8" FACE - BEIGE ILLUSION
4E	103186-02-09A	FT	MOLDING/PLASTIC - 1" U-CHAN'L-1 3/8" FACE - PORTSMOUTH OAK
4E	103186-02-10A	FT	MOLDING/PLASTIC - 1" U-CHAN'L-1 3/8" FACE - CONCERT CHERRY
4E	103186-02-08A	FT	MOLDING/PLASTIC - 1" U-CHANNEL-1 3/8"FACE - WASHED MAPLE
4E	103186-02-11A	FT	MOLDING/PLASTIC - 1" U-CHAN'L-1 3/8" FACE - HONEY CHERRY
4E	103186-02-12A	FT	MOLDING/PLASTIC - 1" U-CHAN'L-1 3/8" FACE - SIERRA MAPLE
5E	104676-02-08A	FT	MOLDING-T - W/EDGE LIP - 11/16" FACE - PORTSMOUTH OAK
5E	104676-02-09A	FT	MOLDING-T - W/EDGE LIP - 11/16" FACE - CONCERT CHERRY
5E	104676-02-06A	FT	MOLDING-T - W/EDGE LIP - 11/16" FACE - WASHED MAPLE
5E	104676-02-10A	FT	MOLDING-T - W/EDGE LIP - 11/16" FACE - HONEY CHERRY
5E	104676-02-12A	FT	MOLDING-T - W/EDGE LIP - 11/16" FACE - SIERRA MAPLE
6E	105004-01-12A	EA	MOLDING - VINYL WRAPPED - 1" X 96" - PORTSMOUTH OAK
6E	105004-01-13A	EA	MOLDING - V W 8' - CONCERT CHERRY (U90/94/98/A1/A5/B1/C1/C5/D1/D5/E1/E5/F1/F5/G1/G5/H1/H5)
6E	105004-01-23A	EA	MOLDING - VINYL WRAPPD 1" X 8' - CONCERT CHERRY (UM1 THRU UM9, UN1 THRU UN9)
6E	105004-01-21A	EA	MOLDING - VINYL WRAPPED - 1" X 8' - WASHED MAPLE
6E	105004-01-24A	EA	MOLDING - VINYL WRAPPED - 1" X 8' - HONEY CHERRY
6E	105004-01-22A	EA	MOLDING - VINYL WRAPPED - 1" X 8' - SIERRA MAPLE
7E	105709-02-000	FT	MOLDING-T - W/EDGE LIP 3/4" FACE - BEIGE ILLUSION
8E	116951-45-R68	EA	MOLDING - TRIM - 3" X 30.3" - PORTSMOUTH OAK
8E	116951-45-R69	EA	MOLDING - TRIM - 3" X 30.3" - CONCERT CHERRY
8E	116951-45-R76	EA	MOLDING - TRIM - 3" X 30.3" - WASHED MAPLE
8E	116951-45-SA3	EA	MOLDING - TRIM - 3" X 30.3" - SIERRA MAPLE
9E	116951-37-R68	EA	MOLDING - TRIM - 3.5" X 38.6" - PORTSMOUTH OAK
9E	116951-37-R69	EA	MOLDING - TRIM - 3.5" X 38.6" - CONCERT CHERRY
9E	116951-37-R76	EA	MOLDING - TRIM - 3.5" X 38.6" - WASHED MAPLE
9E	116951-37-SA3	EA	MOLDING - TRIM - 3.5" X 38.6" - SIERRA MAPLE
9E	116951-51-SA0	EA	MOLDING - TRIM - 3.5" X 47.3" - PORTSMOUTH OAK
9E	116951-51-SA1	EA	MOLDING - TRIM - 3.5" X 47.3" - CONCERT CHERRY
9E	116951-51-SA2	EA	MOLDING - TRIM - 3.5" X 47.3" - WASHED MAPLE
9E	116951-51-SA3	EA	MOLDING - TRIM - 3.5" X 47.3" - SIERRA MAPLE

INTERIOR FINISH GROUP (CONTINUED)
MOLDINGS & TRIMS (CONTINUED)

KEY	PART NUMBER	U/M	DESCRIPTION
9E	116951-55-TD0	EA	MOLDING - TRIM - 4.5" X 52.3" - PORTSMOUTH OAK
9E	116951-55-TD1	EA	MOLDING - TRIM - 4.5" X 52.3" - CONCERT CHERRY
9E	116951-55-TD2	EA	MOLDING - TRIM - 4.5" X 52.3" - WASHED MAPLE
9E	116951-55-TD3	EA	MOLDING - TRIM - 4.5" X 52.3" - SIERRA MAPLE
9E	116951-56-TD0	EA	MOLDING - TRIM - 4.5" X 52.3" - PORTSMOUTH OAK
9E	116951-56-TD1	EA	MOLDING - TRIM - 4.5" X 52.3" - CONCERT CHERRY
9E	116951-56-TD2	EA	MOLDING - TRIM - 4.5" X 52.3" - WASHED MAPLE
9E	116951-56-TD3	EA	MOLDING - TRIM - 4.5" X 52.3" - SIERRA MAPLE

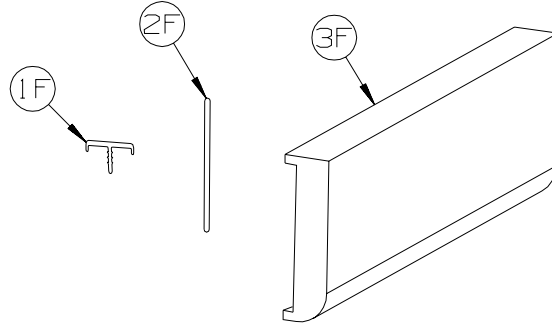

KEY	PART NUMBER	U/M	DESCRIPTION
1F	119520-01-01A	FT	MOLDING-T - OFFSET W/EDGE LIP - 1.3" FACE - OFF WHITE
1F	119520-03-03A	FT	MOLDING-T - OFFSET W/EDGE LIP - 1" FACE - WASHED MAPLE
1F	119520-03-06A	FT	MOLDING-T - OFFSET W/EDGE LIP - 1" FACE - HONEY CHERRY
2F	127842-01-01A	FT	SEAL - SIGHT SHIELD - 2" BLACK
	137885-A2-438	EA	LUMBER - VYL .75" - CONCERT CHERRY (U90/94/98/A1/A5/B1/C1/C5/D1/D5/E1/E5/F1/F5/G1/G5/H1/H5)
	160300-A2-438	EA	LUMBER - VINYL WRAPPED - .7" X .75" X 96" - CONCERT CHERRY (UM1 THRU UM9, UN1 THRU UN9)
	137885-D2-438	EA	LUMBER - VYL1.5" - CONCERT CHERRY (U90/94/98/A1/A5/B1/C1/C5/D1/D5/E1/E5/F1/F5/G1/G5/H1/H5)
	160300-D2-438	EA	LUMBER - VINYL WRAPPED - .7" X 1.5" X 96" - CONCERT CHERRY (UM1 THRU UM9, UN1 THRU UN9)
	137885-E2-438	EA	LUMBER - VYL2" -CONCERT CHERRY (U90/94/98/A1/A5/B1/C1/C5/D1/D5/E1/E5/F1/F5/G1/G5/H1/H5)
	160300-E2-438	EA	LUMBER - VINYL WRAPPED - .7" X 2" X 96" - CONCERT CHERRY (UM1 THRU UM9, UN1 THRU UN9)
	137885-F2-438	EA	LUMBER - VYL2.5" - CONCERT CHERRY (U90/94/98/A1/A5/B1/C1/C5/D1/D5/E1/E5/F1/F5/G1/G5/H1/H5)
	160300-F2-438	EA	LUMBER - VINYL WRAPPED - .7" X 2.5" X 96" - CONCERT CHERRY (UM1 THRU UM9, UN1 THRU UN9)
	137885-G2-438	EA	LUMBER - VYL3" - CONCERT CHERRY (U90/94/98/A1/A5/B1/C1/C5/D1/D5/E1/E5/F1/F5/G1/G5/H1/H5)
	160300-G2-438	EA	LUMBER - VINYL WRAPPED - .7" X 3" X 96" - CONCERT CHERRY (UM1 THRU UM9, UN1 THRU UN9)
	137885-H2-438	EA	LUMBER - VYL3.5" - CONCERT CHERRY (U90/94/98/A1/A5/B1/C1/C5/D1/D5/E1/E5/F1/F5/G1/G5/H1/H5)
	160300-H2-438	EA	LUMBER - VINYL WRAPPED - .7" X 3.5" X 96" - CONCERT CHERRY (UM1 THRU UM9, UN1 THRU UN9)
	137885-J2-438	EA	LUMBER - VYL5.5" - CONCERT CHERRY (U90/94/98/A1/A5/B1/C1/C5/D1/D5/E1/E5/F1/F5/G1/G5/H1/H5)
	160300-J2-438	EA	LUMBER - VINYL WRAPPED - .7" X 5.5" X 96" - CONCERT CHERRY (UM1 THRU UM9, UN1 THRU UN9)
	137885-J2-743	EA	LUMBER - VYL5.5" - CONCERT CHERRY (U90/94/98/A1/A5/B1/C1/C5/D1/D5/E1/E5/F1/F5/G1/G5/H1/H5)
	160300-J2-743	EA	LUMBER - VINYL WRAPPED - .7" X 5.5" X 108" - CONCERT CHERRY (UM1 THRU UM9, UN1 THRU UN9)
	137885-K2-438	EA	LUMBER - VYL3.9" - CONCERT CHERRY (U90/94/98/A1/A5/B1/C1/C5/D1/D5/E1/E5/F1/F5/G1/G5/H1/H5)
	160300-K2-438	EA	LUMBER - VINYL WRAPPED - .7" X 3.9" X 96" - CONCERT CHERRY (UM1 THRU UM9, UN1 THRU UN9)
	137885-R2-438	EA	LUMBER - VYL 3" - CONCERT CHERRY (U90/94/98/A1/A5/B1/C1/C5/D1/D5/E1/E5/F1/F5/G1/G5/H1/H5)
	160300-R2-438	EA	LUMBER - VINYL WRAPPED - .7" X 3" X 96" - CONCERT CHERRY (UM1 THRU UM9, UN1 THRU UN9)
3F	137887-D2-134	EA	MOLDING - 1.6" X 84"- CONCERT CHERRY (U90/94/98/A1/A5/B1/C1/C5/D1/D5/E1/E5/F1/F5/G1/G5/H1/H5)
3F	160301-D2-134	EA	MOLDING -VINYL WRAPPED - .7" X 1.6" X 84" - CONCERT CHERRY (UM1 THRU UM9, UN1 THRU UN9)
3F	137887-D2-743	EA	MLDG - 1.6" X 108" - CONCERT CHERRY (U90/94/98/A1/A5/B1/C1/C5/D1/D5/E1/E5/F1/F5/G1/G5/H1/H5)
3F	160301-D2-743	EA	MOLDING - VINYL WRAPPED- .7" X 1.6" X 108" - CONCERT CHERRY (UM1 THRU UM9, UN1 THRU UN9)
3F	137887-F2-134	EA	MLDNG - 2.5" X 84" - CONCERT CHERRY (U90/94/98/A1/A5/B1/C1/C5/D1/D5/E1/E5/F1/F5/G1/G5/H1/H5)
3F	160301-F2-134	EA	MOLDING - VINYL WRAPPED - .7" X 2.5" X 84" - CONCERT CHERRY (UM1 THRU UM9, UN1 THRU UN9)
3F	137887-F2-743	EA	MLDG - 2.5" X 108" - CONCERT CHERRY (U90/94/98/A1/A5/B1/C1/C5/D1/D5/E1/E5/F1/F5/G1/G5/H1/H5)
3F	160301-F2-743	EA	MOLDING - VINYL WRPPD - .7" X 2.5" X 108" - CONCERT CHERRY (UM1 THRU UM9, UN1 THRU UN9)
3F	137887-F2-438	EA	MLDG - 2.5" X 96" - CONCERT CHERRY (U90/94/98/A1/A5/B1/C1/C5/D1/D5/E1/E5/F1/F5/G1/G5/H1/H5)
3F	160301-F2-438	EA	MOLDING - VINYL WRPPD - .7" X 2.5" X 96" - CONCERT CHERRY (UM1 THRU UM9, UN1 THRU UN9)
	137894-A2-438	EA	LUMBER - VINYL WRAPPED - .7" X .75" X 96" - PORTSMOUTH OAK
	137894-D2-438	EA	LUMBER - VINYL WRAPPED - .7" X 1.5" X 96" - PORTSMOUTH OAK
	137894-E2-438	EA	LUMBER - VINYL WRAPPED - .7" X 2" X 96" - PORTSMOUTH OAK
	137894-F2-438	EA	LUMBER - VINYL WRAPPED - .7" X 2.5" X 96" - PORTSMOUTH OAK
	137894-G2-438	EA	LUMBER - VINYL WRAPPED - .7" X 3" X 96" - PORTSMOUTH OAK
	137894-H2-438	EA	LUMBER - VINYL WRAPPED - .7" X 3.5" X 96" - PORTSMOUTH OAK
	137894-J2-438	EA	LUMBER - VINYL WRAPPED - .7" X 5.5" X 80.2" - PORTSMOUTH OAK
	137894-J2-743	EA	LUMBER - VINYL WRAPPED - .7" X 5.5" X 96" - PORTSMOUTH OAK
	137894-K2-438	EA	LUMBER - VINYL WRAPPED - .7" X 3.9" X 96" - PORTSMOUTH OAK
	137894-R2-438	EA	LUMBER - VINYL WRAPPED - .7" X 3" X 96" - PORTSMOUTH OAK

INTERIOR FINISH GROUP (CONTINUED)
MOLDINGS & TRIMS (CONTINUED)

KEY	PART NUMBER	U/M	DESCRIPTION
3F	137895-D2-134	EA	MOLDING - VINYL WRAPPED - .7" X 1.6" X 84"-PORTSMOUTH OAK
3F	137895-D2-743	EA	MOLDING - VINYL WRAPPED - .7" X 1.6" X 108"-PORTSMOUTH OAK
3F	137895-F2-438	EA	MOLDING - VINYL WRAPPED - .7" X 2.5" X 96" - PORTSMOUTH OAK
3F	137895-F2-743	EA	MOLDING - VINYL WRAPPED - .7" X 2.5" X 108" - PORTSMOUTH OAK
	146419-A2-438	EA	LUMBER - VINYL WRAPPED - .7" X .75" X 96" - HONEY CHERRY
	146419-D2-438	EA	LUMBER - VINYL WRAPPED - .7" X 1.5" X 96" - HONEY CHERRY
	146419-E2-438	EA	LUMBER - VINYL WRAPPED - .7" X 2" X 96" - HONEY CHERRY
	146419-F2-438	EA	LUMBER - VINYL WRAPPED - .7" X 2.5" X 96" - HONEY CHERRY
	146419-G2-438	EA	LUMBER - VINYL WRAPPED - .7" X 3" X 96" - HONEY CHERRY
	146419-H2-438	EA	LUMBER - VINYL WRAPPED - .7" X 3.5" X 96" - HONEY CHERRY
	146419-J2-438	EA	LUMBER - VINYL WRAPPED - .7" X 5.5" X 96" - HONEY CHERRY
	146419-J2-743	EA	LUMBER - VINYL WRAPPED - .7" X 5.5" X 108" - HONEY CHERRY
	146419-K2-438	EA	LUMBER - VINYL WRAPPED - .7" X 3.9" X 96" - HONEY CHERRY
	146419-R2-438	EA	LUMBER - VINYL WRAPPED - .7" X 3" X 96" - HONEY CHERRY
	146419-S2-438	EA	LUMBER - VINYL WRAPPED/FULL - .7"X 3.5"X 96"- HONEY CHERRY
	146419-T2-438	EA	LUMBER - VINYL WRAPPED/FULL - .7"X 5.5"X 96"- HONEY CHERRY
3F	146425-D2-134	EA	MOLDING - VINYL WRAPPED - .7" X 1.6" X 83.9" - HONEY CHERRY
3F	146425-F2-438	EA	MOLDING - VINYL WRAPPED - .7" X 2.6" X 96" - HONEY CHERRY
	149325-A2-438	EA	LUMBER - VINYL WRAPPED - .7" X .75" X 96" - WASHED MAPLE
	149325-D2-438	EA	LUMBER - VINYL WRAPPED - .7" X 1.5" X 96" - WASHED MAPLE
	149325-E2-438	EA	LUMBER - VINYL WRAPPED - .7" X 2" X 96" - WASHED MAPLE
	149325-F2-438	EA	LUMBER - VINYL WRAPPED - .7" X 2.5" X 96" - WASHED MAPLE
	149325-G2-438	EA	LUMBER - VINYL WRAPPED - .7" X 3" X 96" - WASHED MAPLE
	149325-H2-438	EA	LUMBER - VINYL WRAPPED - .7" X 3.5" X 96" - WASHED MAPLE
	149325-J2-438	EA	LUMBER - VINYL WRAPPED - .7" X 5.5" X 96" - WASHED MAPLE
	149325-J2-743	EA	LUMBER - VINYL WRAPPED - .7" X 5.5" X 108" - WASHED MAPLE
	149325-K2-438	EA	LUMBER - VINYL WRAPPED - .7" X 3.9" X 96" - WASHED MAPLE
	149325-R2-438	EA	LUMBER - VINYL WRAPPED - .7" X 3" X 96" - WASHED MAPLE
3F	149326-D2-134	EA	MOLDING - VINYL WRAPPED - .7" X 1.5" X 83.9" - WASHED MAPLE
3F	149326-D2-743	EA	MOLDING - VINYL WRAPPED - .7" X 1.5" X 108" - WASHED MAPLE
3F	149326-F2-134	EA	MOLDING - VINYL WRAPPED - .7" X 2.5" X 83.9" - WASHED MAPLE
3F	149326-F2-438	EA	MOLDING - VINYL WRAPPED - .7" X 2.5" X 96" - WASHED MAPLE
3F	149326-F2-743	EA	MOLDING - VINYL WRAPPED - .7" X 2.5" X 108" - WASHED MAPLE
	149330-A2-438	EA	LUMBER - VINYL WRAPPED - .7" X .75" X 96" - SIERRA MAPLE
	149330-D2-438	EA	LUMBER - VINYL WRAPPED - .7" X 1.5" X 96" - SIERRA MAPLE
	149330-E2-438	EA	LUMBER - VINYL WRAPPED - .7" X 2" X 96" - SIERRA MAPLE
	149330-F2-438	EA	LUMBER - VINYL WRAPPED - .7" X 2.5" X 96" - SIERRA MAPLE
	149330-G2-438	EA	LUMBER - VINYL WRAPPED - .7" X 3" X 96" - SIERRA MAPLE
	149330-H2-438	EA	LUMBER - VINYL WRAPPED - .7" X 3.5" X 96" - SIERRA MAPLE
	149330-J2-438	EA	LUMBER - VINYL WRAPPED - .7" X 5.5" X 96" - SIERRA MAPLE
	149330-J2-743	EA	LUMBER - VINYL WRAPPED - .7" X 5.5" X 108" - SIERRA MAPLE
	149330-K2-438	EA	LUMBER - VINYL WRAPPED - .7" X 3.9" X 96" - SIERRA MAPLE
	149330-R2-438	EA	LUMBER - VINYL WRAPPED - .7" X 3" X 96" - SIERRA MAPLE
3F	149331-D2-134	EA	MOLDING - VINYL WRAPPED - .7" X 1.5" X 83.9" - SIERRA MAPLE
3F	149331-D2-743	EA	MOLDING - VINYL WRAP - .7" X 1.5" X 108" - SIERRA MAPLE
3F	149331-F2-134	EA	MOLDING - VINYL WRAPPED - .7" X 2.5" X 83.9" - SIERRA MAPLE
3F	149331-F2-438	EA	MOLDING - VINYL WRAPPED - .7" X 2.5" X 96" - SIERRA MAPLE
3F	149331-F2-743	EA	MOLDING - VINYL WRAPPED - .7" X 2.5" X 108" - SIERRA MAPLE

INTERIOR FINISH GROUP (CONTINUED)
MOLDINGS & TRIMS (CONTINUED)

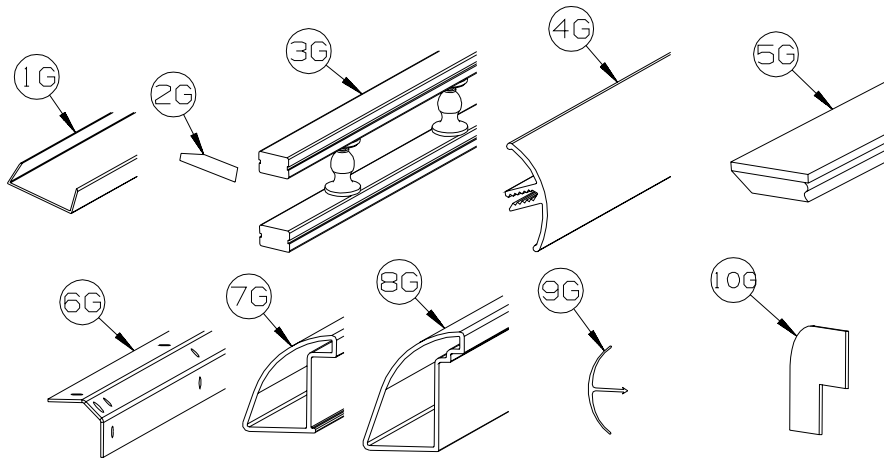

KEY	PART NUMBER	U/M	DESCRIPTION
1G	141260-01-01A	FT	U-CHANNEL - 1" - VILLAGE OAK
1G	141260-01-02A	FT	U-CHANNEL - 1" - GRADY BROWN
1G	141260-02-01A	FT	U-CHANNEL - 1 1/8" - VILLAGE OAK
1G	141260-02-02A	FT	U-CHANNEL - 1 1/8" - GRADY BROWN
2G	146306-01-01A	FT	TRANSITION - CARPET/TILE
3G	150167-01-07A	EA	RAIL - DECORATIVE - 96" W/O REVERSE SIDE GROOVE - PORTSMOUTH OAK
3G	150167-01-02A	EA	RAIL - DECORATIVE - 96" W/O REVERSE SIDE GROOVE - SALEM CHERRY - CONCERT CHERRY
3G	150167-01-03A	EA	RAIL - DECORATIVE - 96" W/O REVERSE SIDE GROOVE - WASHED MAPLE
3G	150167-01-09A	EA	RAIL - DECORATIVE - 96" W/O REVERSE SIDE GROOVE - SIERRA MAPLE
4G	151653-10-02A	EA	TRIM/RADIUS - CABINET CORNER - 79.6" - DULL METALLIC
4G	151653-13-02A	EA	TRIM/RADIUS - CABINET CORNER - 79.8" - DULL METALLIC
5G	151676-26-S46	EA	MOLDING/TRIM - .75" X 1.6" X 80.2" - PORTSMOUTH OAK
5G	151676-26-S47	EA	MOLDING/TRIM - .75" X 1.6" X 80.2" - CONCERT CHERRY
5G	151676-26-S48	EA	MOLDING/TRIM - .75" X 1.6" X 80.2" - WASHED MAPLE
5G	151676-26-SR0	EA	MOLDING/TRIM - .75" X 1.6" X 80.2" - SIERRA MAPLE
6G	151861-05-02B	EA	ANGLE - SUPPORT/CORNER - 1.4" X 78.6" - E-COATED
7G	151893-01-02A	EA	TRIM/RADIUS - CABINET BOTTOM - 72.6" - DULL METALLIC
8G	152077-01-02A	EA	TRIM/RADIUS - CABINET BOTTOM - 27.7" - DULL METALLIC
9G	156464-01-01A	FT	MOLDING - CORNER - RADIUS/PLASTIC - 8' - HONEY CHERRY
9G	156464-01-02A	FT	MOLDING - CORNER - RADIUS/PLASTIC - 8' - WASHED MAPLE
9G	156464-01-03A	FT	MOLDING - CORNER - RADIUS/PLASTIC - 8' - BONE
10G	160989-01-06A	FT	CAP - CORNER - RADIUS MOLDING - PLASTIC - WASHED MAPLE
10G	160989-01-07A	FT	CAP - CORNER - RADIUS MOLDING - PLASTIC - HONEY CHERRY

INTERIOR FINISH GROUP (CONTINUED)
PANELING & LAMINATES

KEY	PART NUMBER	U/M	DESCRIPTION
	076773-15-000	SF	PANELING - 2 SIDED/PORTSMOUTH OAK - 1/8" X 4' X 8'
	076773-19-000	SF	PANELING - 2 SIDED/SIERRA MAPLE - 1/8" X 4' X 8'
	074497-42-000	SF	PANELING - PORTSMOUTH OAK - 1/8" X 4' X 8'
	074497-48-000	SF	PANELING - SIERRA MAPLE - 1/8" X 4' X 8'
	088272-M9-000	SF	PANELING - WHITE THATCHED - 4' X 8'
	088272-M7-000	SF	PANELING - KURTA/CANVAS - 4' X 7.4' (U51, U52)
	088272-L8-000	SF	PANELING - D'VINCI ALMOND - 1/8" X 4' X 7' (U53, U54)
			FROM: 00-00-00 THRU: 03-27-07
	088272-M7-000	SF	PANELING - KURTA/CANVAS - 4' X 7.4' (U53, U54)
			FROM: 03-28-07 THRU: 99-99-99
	088272-M8-000	SF	PANELING - WISTERIA/DUNE - 4' X 7.4' (U55, U56)
	085284-G8-000	FT	BATT TAPE - ADHESIVE BACKED/PAPER WRAP - PORTSMOUTH OAK
	085284-J4-000	FT	BATT TAPE - ADHESIVE BACKED - DECORATIVE - SIERRA MAPLE
	085284-K9-000	FT	BATT TAPE - ADHESIVE BACKED - DECORATIVE - WHITE THATCHED
	085284-K7-000	FT	BATT TAPE - ADHESIVE BACKED - DECORATIVE - KURTA/CANVAS (U51, U52)
	085284-J3-000	FT	BATT TAPE - ADHESIVE BACKED - DECORATIVE - D'VINCI ALMOND (U53, U54)
			FROM: 00-00-00 THRU: 03-27-07
	085284-K7-000	FT	BATT TAPE - ADHESIVE BACKED - DECORATIVE - KURTA/CANVAS (U53, U54)
			FROM: 03-28-07 THRU: 99-99-99
	085284-K8-000	FT	BATT TAPE - ADHESIVE BACKED - DECORATIVE - WISTERIA/DUNE (U55, U56)
	074498-B9-000	SF	LAMINATE - PLASTIC - SUNSTONE - 5' X 8' (U51, U52)
	074498-B8-000	SF	LAMINATE - PLASTIC - CLASSIC ROCK - 5' X 8' (U53, U54)
	074498-A9-000	SF	LAMINATE - PLASTIC - KALAHARI/TOPAZ - 5' X 8' (U55, U56)
	076325-39-000	FT	MOLDING - EDGE BAND - 1 5/16" X .030" - ALMOND
	076325-40-000	FT	MOLDING - EDGE BAND - .93" X .024" - ALMOND
	000885-C3-000	SF	PARTICLE BOARD - 3/8" X 4' X 8' - WHITE THATCH EMB-1 SIDED
	000885-92-000	SF	PARTICLE BOARD - 3/8" X 4' X 8' - PORTSMOUTH OAK - 1 SIDED
	000885-B1-000	SF	PARTICLE BOARD - 3/8" X 4' X 8' - SIERRA MAPLE - 1 SIDED
	000885-93-000	SF	PARTICLE BOARD - 3/8" X 4' X 8' - PORTSMOUTH OAK - 2 SIDED
	000885-B0-000	SF	PARTICLE BOARD - 3/8" X 4' X 8' - SIERRA MAPLE - 2 SIDED
	000885-94-000	SF	PARTICLE BOARD - 1/2" X 4' X 8' - PORTSMOUTH OAK - 2 SIDED
	000885-B3-000	SF	PARTICLE BOARD - 1/2" X 4' X 8' - SIERRA MAPLE - 2 SIDED
	000885-95-000	SF	PARTICLE BOARD - 3/4" X 4' X 8' - PORTSMOUTH OAK - 2 SIDED
	000885-B2-000	SF	PARTICLE BOARD - 3/4" X 4' X 8' - SIERRA MAPLE - 2 SIDED
	057882-04-000	SF	TAMBOUR - 48" X 96" SHEET - UNFINISHED

INTERIOR FINISH GROUP (CONTINUED)

INTERIOR TRIM LAYOUT

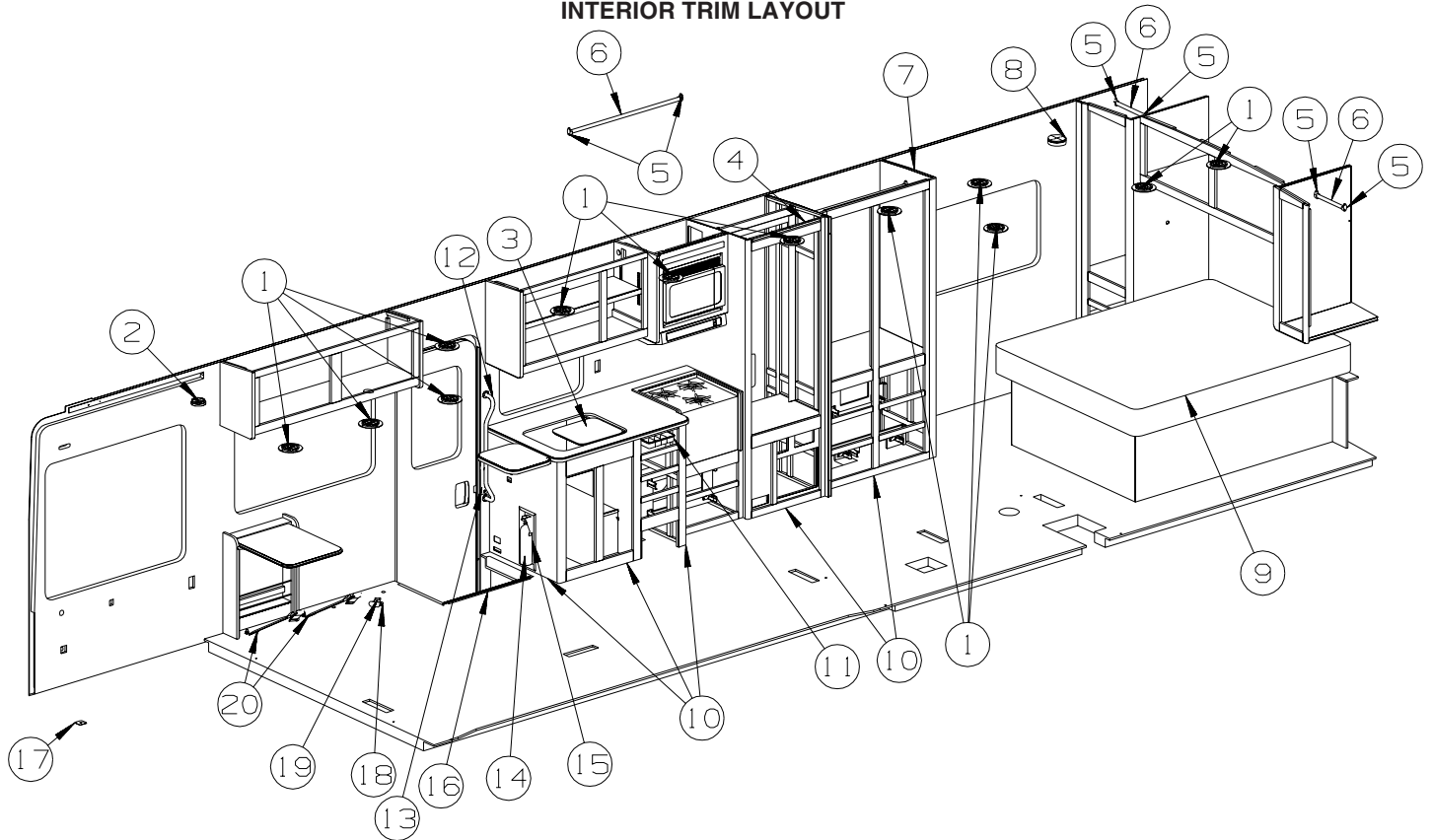

KEY	PART NUMBER	U/M	DESCRIPTION
1	120134-01-02A	EA	REGISTER - W/DAMPER - 4" PIPE/6.4" O.D. FACE - WHITE
2	072852-01-000	EA	DETECTOR - SMOKE - W/9 VOLT BATTERY - US
2	072852-02-000	EA	DETECTOR - SMOKE - W/9 VOLT BATTERY - CANADIAN
2	077956-01-000	EA	LABEL - WARNING/SMOKE DETECTOR
3	103610-04-U57	EA	COVER - SINK - 15.7" X 13.8" - SUNSTONE (U51)
			FROM: 00-00-00 THRU: 10-01-06
3	159542-01-U57	EA	COVER - SINK - 15.6" X 13.9" - PORTSMOUTH OAK (U51)
			FROM: 10-02-06 THRU: 99-99-99
3	103610-04-U57	EA	COVER - SINK - 15.7" X 13.8" - SUNSTONE (U52)
			FROM: 00-00-00 THRU: 10-01-06
3	159542-01-U58	EA	COVER - SINK - 15.6" X 13.9" - SIERRA MAPLE (U52)
			FROM: 10-02-06 THRU: 99-99-99
3	103610-04-U49	EA	COVER - SINK - 15.7" X 13.8" - CLASSIC ROCK (U53)
			FROM: 00-00-00 THRU: 10-02-06
3	159542-01-U57	EA	COVER - SINK - 15.6" X 13.9" - PORTSMOUTH OAK (U53)
			FROM: 10-02-06 THRU: 99-99-99
3	103610-04-U49	EA	COVER - SINK - 15.7" X 13.8" - CLASSIC ROCK (U54)
			FROM: 00-00-00 THRU: 10-02-06
3	159542-01-U58	EA	COVER - SINK - 15.6" X 13.9" - SIERRA MAPLE (U54)
			FROM: 10-02-06 THRU: 99-99-99
3	103610-04-U41	EA	COVER - SINK - 15.7" X 13.8" - KALAHARI/TOPAZ (U55)
			FROM: 00-00-00 THRU: 10-01-06
3	159542-01-U57	EA	COVER - SINK - 15.6" X 13.9" - PORTSMOUTH OAK (U55)
			FROM: 10-02-06 THRU: 99-99-99
3	103610-04-U41	EA	COVER - SINK - 15.7" X 13.8" - KALAHARI/TOPAZ (U56)
			FROM: 00-00-00 THRU: 10-01-06
3	159542-01-U58	EA	COVER - SINK - 15.6" X 13.9" - SIERRA MAPLE (U56)
			FROM: 10-02-06 THRU: 99-99-99
4	M09525-59-T53	EA	MOLDING - TRIM/VEE - .2" X 1" X 23.6" - PORTSMOUTH OAK
4	M09525-59-TL0	EA	MOLDING - TRIM/VEE - .2" X 1" X 23.6" - SIERRA MAPLE
5	152301-01-01A	EA	FLANGE - PLASTIC - 1" CLOTHES ROD HOLDER - WHITE
6	Y00136-21-218	EA	DOWEL - WOOD - CLOTHES ROD - 1"DIAMETER X 4'
	041953-12-000	FT	CONDUIT - CONVOLUTE SOLID - 1.1" ID - NYLON
7*	131595-01-01A	EA	DOOR/FOLDING-36.9"X 74.9"-4 CEILING BRKTS & STRAIGHT TRACK
	057534-03-000	EA	TIEBACK - CLEAR PLASTIC - 7.5"

INTERIOR FINISH GROUP (CONTINUED)
INTERIOR TRIM LAYOUT (CONTINUED)

KEY	PART NUMBER	U/M	DESCRIPTION
8	125136-02-000	EA	DETECTOR/CO - GAS MODEL - 9 VOLT
9	154430-01-000	EA	MATTRESS - INNERSPRING - 60" X 74.5"
10	M09471-79-R38	EA	MOLDING - TRIM/COVE - .8" X .8" X 96" - PORTSMOUTH OAK
10	M09471-79-SA3	EA	MOLDING - TRIM/COVE - .8" X .8" X 96" - SIERRA MAPLE
11	100081-01-01A	EA	TRAY - SILVERWARE - 9" X 13.3" RUBBERMAID ALMOND PLASTIC
12	137605-01-01A	EA	HAND RAIL - INTERIOR ENTRY DOOR - BLACK
13	148362-01-01A	EA	COVER - BRACKET/STRIKE - BRIGHT WHITE
			FROM: 00-00-00 THRU: 07-31-06
13	148362-01-02A	EA	COVER - BRACKET/STRIKE - MEDIUM OAK
			FROM: 08-01-06 THRU: 99-99-99
	140151-02-02A	EA	COVER - SCREW - BRIGHT WHITE
			FROM: 00-00-00 THRU: 07-31-06
	140151-02-03A	EA	COVER - SCREW - MEDIUM OAK
			FROM: 08-01-06 THRU: 99-99-99
14	094499-03-000	EA	EXTINGUISHER/FIRE - DRY - 10BC - W/GAUGE/BRACKET
14*	094499-02-000	EA	EXTINGUISHER/FIRE - DRY - 10BC - W/GAUGE - CANADIAN
15	094499-04-000	EA	STRAP - FIRE EXTINGUISHER MOUNTING - METAL
16	139955-06-02A	EA	TRIM - STEP/ENTRY - 29.3" - TITANIUM
17	134128-02-02B	EA	PLATE - W/HOLES - W/WELDNUT - E-COATED
18	134057-01-11B	EA	BRACKET - RECLINER - FLAT BLACK
19	137598-01-01A	EA	KNOB - HOLD DOWN - RECLINER
20	160167-01-01A	EA	SEAT BELT - 2" X 102" - BLACK

***COMPONENT PARTS LISTED LATER IN THIS GROUP**

INTERIOR FINISH GROUP (CONTINUED)
INTERIOR TRIM LAYOUT (CONTINUED)

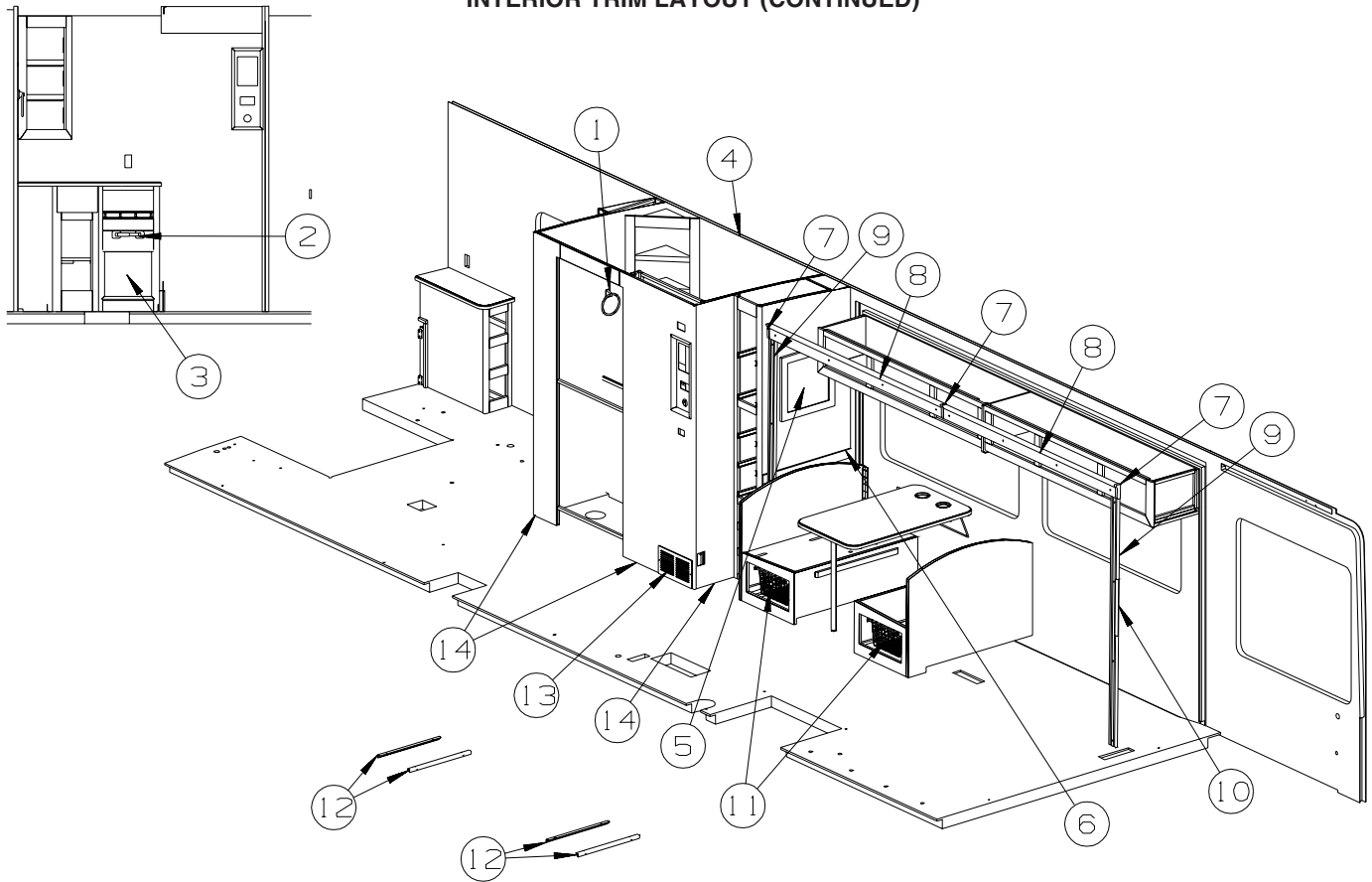

KEY	PART NUMBER	U/M	DESCRIPTION
1	145980-06-03A	EA	TOWEL RING - CHROME
2	145980-01-02A	EA	HOLDER - TOILET TISSUE - CHROME
3	137602-10-R89	EA	POCKET - MAGAZINE RACK - W/RAIL (PEWTER) - PORTSMOUTH OAK
3	137602-10-S79	EA	POCKET - MAGAZINE RACK - W/RAIL (PEWTER) - SIERRA MAPLE
4*	115011-03-02A	EA	DOOR SHOWER - SLIDING/BYPASS W/40" LOWER TRACK-CHROME/AQUA
4*	115011-03-03A	EA	DOOR SHOWER - SLIDING/BYPASS W/40" LOWER TRACK-NICKEL/AQUA
			FROM: 00-00-00 THRU: 04-23-06
			FROM: 04-24-06 THRU: 99-99-99
5	131493-09-01A	EA	PICTURE - DECORATIVE - 8" X 10" - HIGH ART II (U51, U52)
5	131493-05-04A	EA	PICTURE - DECORATIVE - 10" X 10" - ARCHITECTURAL (U53, U54)
5	131493-09-04A	EA	PICTURE - DECORATIVE - 8" X 10" - MINIATURE ROSETTE I (U55, U56)
			FROM: 00-00-00 THRU: 09-03-06
5	131493-02-36A	EA	PICTURE - DECORATIVE - 13" X 15" - BALSAM LEAF (U55, U56)
			FROM: 09-04-06 THRU: 99-99-99
6	100182-10-N47	EA	TRIM/WOOD - CHAIR RAIL - 2.5" X 8' - PORTSMOUTH OAK
			FROM: 00-00-00 THRU: 08-20-06
6	M09462-66-R74	EA	MOLDING - TRIM/RAIL - .6" X 2.4" X 96" - PORTSMOUTH OAK
			FROM: 08-21-06 THRU: 99-99-99
6	100182-10-S67	EA	TRIM/WOOD - CHAIR RAIL - 2.5" X 8' - SIERRA MAPLE
			FROM: 00-00-00 THRU: 08-20-06
6	M09462-66-SA3	EA	MOLDING - TRIM/RAIL - .6" X 2.4" X 96" - SIERRA MAPLE
			FROM: 08-21-06 THRU: 99-99-99
7	149151-01-S46	EA	MOLDING/BLOCK - PORTSMOUTH OAK
7	149151-01-SR0	EA	MOLDING/BLOCK - SIERRA MAPLE
8	Y00282-72-438	EA	MOLDING - SLIDEOUT/VINYL WRAP - 3.9"X 96" - PORTSMOUTH OAK
8	Y00282-92-438	EA	MOLDING - SLIDEOUT/VINYL WRAP - 3.9"X 96" - SIERRA MAPLE
9	132663-04-08A	EA	MOLDING-VINYL WRAP/PRE DRILLED-.6"X3"X70.2" - PORTS OAK
9	132663-04-22A	EA	MOLDING-VINYL WRAP/PRE DRILLED-.6"X3"X70.2" - SIERRA MAPLE
10	130262-05-000	EA	PROTECTOR - CORNER - .4" X .7"
11	149728-01-01A	EA	BASKET/DRAWER - WHITE - 12.9"W X 20.7"D X 7.3"H
12	149728-02-01A	EA	RUNNER/RAIL - F/BASKET - 21"DEEP
13	093614-11-01A	EA	GRILLE - AIR RETURN - 13.9" X 7.9" - BEIGE

*COMPONENT PARTS LISTED LATER IN THIS GROUP

INTERIOR FINISH GROUP (CONTINUED)
COMPONENT PARTS FOR INTERIOR TRIM LAYOUT

094499-02-000

KEY	PART NUMBER	U/M	DESCRIPTION	VENDOR NO
	094499-01-700	EA	BRACKET MTG. W/PLAS. STRAP	294039

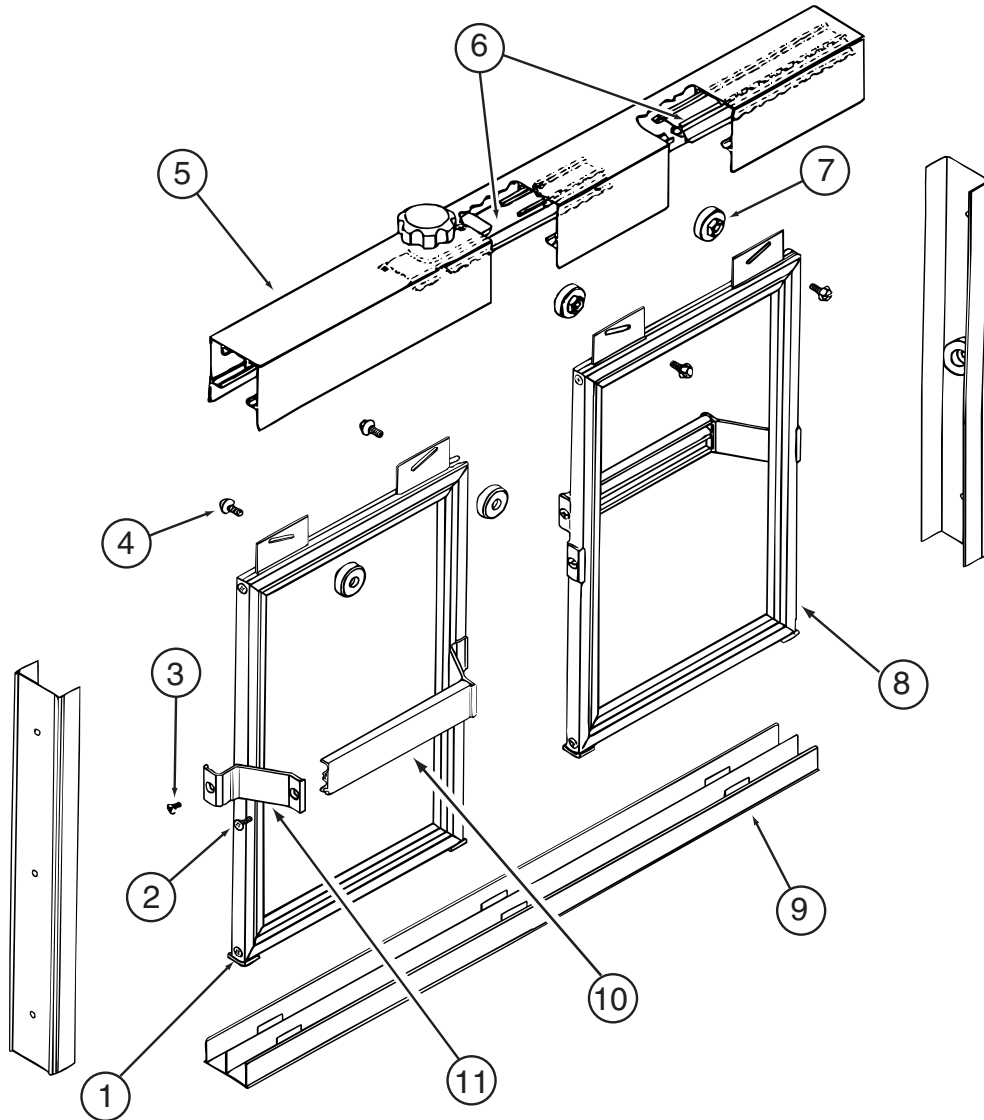

115011-03-02A

KEY	PART NUMBER	U/M	DESCRIPTION	VENDOR NO.
2	115011-03-700	EA	SCREW F/TOWEL BAR/HEADER	612F-B
3	115011-03-703	EA	SCREW F/TOWEL BAR BRKTS	638F-B CHROME
4	115011-01-705	EA	SCREW-ROLLER, (HEX HEAD)	832HEX
5	115011-03-705	EA	HEADER-W/O ANTI JUMP GUARD	120B - CHROME
6	115011-01-710	EA	HEADER(ANTI JUMP/LOCK)W/CLIP	130MIDDLE
6	115011-01-716	EA	GUARD-ANTI JUMP-W/O TENSION	130END
7	115011-01-704	EA	ROLLERS	PN193
8	115011-01-706	FT	GLAZING VINYL-BLACK	C169C
9	115011-03-704	EA	TRACK-BOTTOM- 50" CHROME	90B
10	115011-03-701	EA	BAR-TOWEL - SILVER	136B
11	115011-03-702	EA	BRACKET-TOWEL BAR - SILVER	135B
12	115011-03-706	EA	JAMB - WALL SHOWER DOOR	1268
	115011-01-711	EA	KNOB-TENSION,(HEADER W/BOLT)	1420K-1420S
	115011-01-714	EA	BUMPER - RATTLE/SHOWER DOOR	5168S
	115011-01-715	EA	PAD - FOAM	116R

CONTACT WINNEBAGO PART SALES FOR UNLISTED COMPONENT(S)

INTERIOR FINISH GROUP (CONTINUED)
COMPONENT PARTS FOR INTERIOR TRIM LAYOUT (CONTINUED)

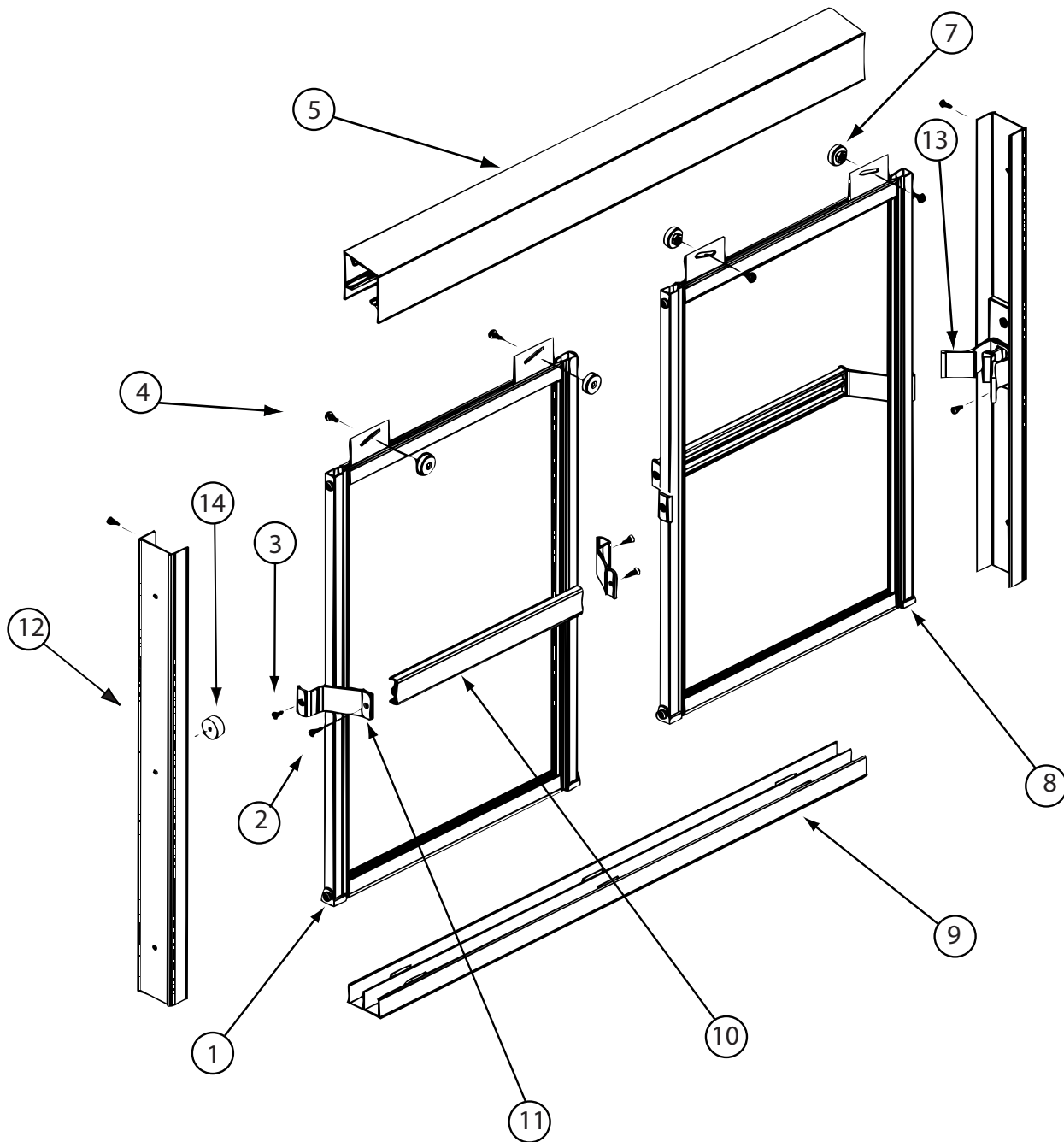

115011-03-02A

KEY	PART NUMBER	U/M	DESCRIPTION	VENDOR NO.
1	115011-03-708	EA	GUIDE/NYLON -F/DOOR BOTTOM	CP1105
2	115011-03-700	EA	SCREW F/TOWEL BAR/HEADER	612F-B
3	115011-03-703	EA	SCREW F/TOWEL BAR BRKTS	638F-B CHROME
4	115011-01-705	EA	SCREW-ROLLER, (HEX HEAD)	832HEX
5	115011-03-709	EA	HEADER - CHROME	45B
7	115011-01-704	EA	ROLLERS	PN193
8	115011-01-706	FT	GLAZING VINYL-BLACK	C154B
9	115011-03-704	EA	TRACK/BOTTOM - 50" CHROME	90B
10	115011-03-701	EA	TOWEL BAR - SILVER	136B - 17"
11	115011-03-702	EA	BRACKET-TOWEL BAR - SILVER	135B
12	115011-03-706	EA	JAMB - WALL SHOWER DOOR	126B
13	115011-03-707	EA	TRAVEL LATCH - BLACK	9733B
14	115011-01-714	EA	BUMPER - RATTLE/SHOWER DOOR	5168S
	115011-01-715	EA	PAD - FOAM	116R

CONTACT WINNEBAGO PART SALES FOR UNLISTED COMPONENT(S)

INTERIOR FINISH GROUP (CONTINUED)
COMPONENT PARTS FOR INTERIOR TRIM LAYOUT (CONTINUED)

KEY	PART NUMBER	U/M	DESCRIPTION	131595-01-01A, 131595-05-01A, 131595-10-01A	
				VENDOR NO.	
	117431-01-707	EA	CATCH/PIN - PLASTIC		
	131595-01-700	EA	END STOP ONLY		
	131595-01-701	EA	BRACKET/MOUNTING	908956	
	131595-01-702	EA	TRACK/STRAIGHT - 37"		

FLOOR COVERINGS

KEY	PART NUMBER	U/M	DESCRIPTION
	152251-05-07A	SY	CARPET - 4 SQUARE YARD INCREMENTS - RAFFIA (U51, U52, U55, U56)
	152251-05-02A	SY	CARPET - 4 SQUARE YARD INCREMENTS - BURLWOOD (U53, U54)
	093486-01-000	SY	CARPET - COMPARTMENT - 72" WIDE - DARK GRAY
	042720-38-000	SY	VINYL - FLOOR COVERING - BRIDGEWAY
	075233-01-000	SY	PAD - CARPET - 3/8" X 6'W ROLL - SOLD BY THE SQUARE YARD
	089275-02-000	FT	STRIP - 3/4" X 84" BLACK POLYETHYLENE

INTERIOR FINISH GROUP (CONTINUED)

HARDWARE

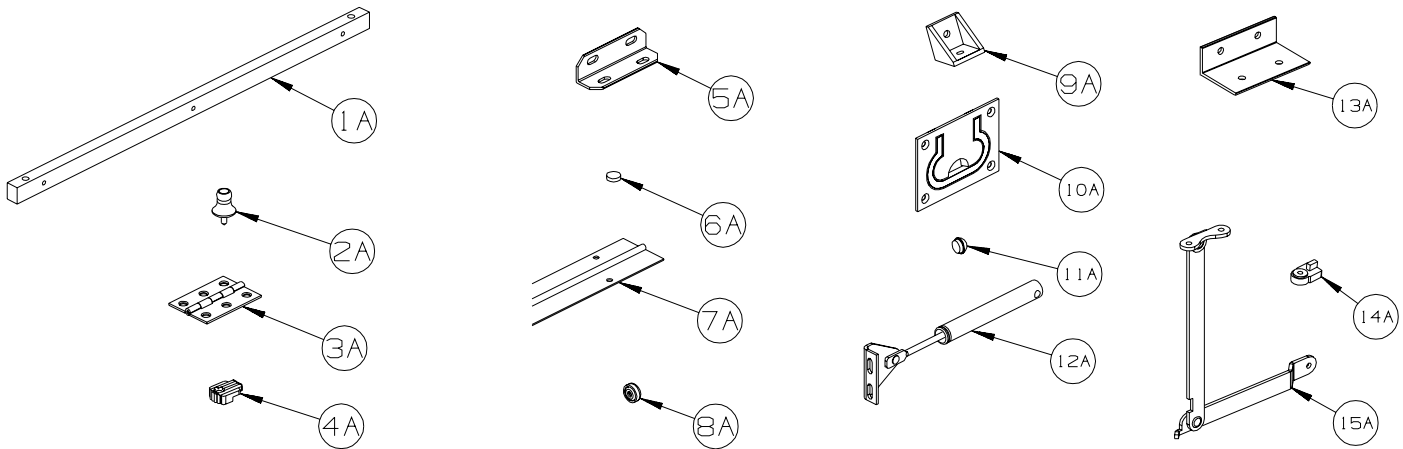

KEY	PART NUMBER	U/M	DESCRIPTION
1A	P34509-01-N01	EA	RAIL END - RH/LH - TOWEL RACK - PORTSMOUTH
1A	P34509-01-P14	EA	RAIL END - RH/LH - TOWEL RACK - CONCERT CHERRY
1A	P34509-01-J70	EA	RAIL END - RH/LH - TOWEL RACK - WASHED MAPLE
1A	P34509-01-RE0	EA	RAIL END - RH/LH - TOWEL RACK - HONEY CHERRY
1A	P34509-01-SA3	EA	RAIL END - RH/LH - TOWEL RACK - SIERRA MAPLE
2A	009013-01-000	EA	CATCH - BULLDOG - MALE/FEMALE
3A	009059-01-000	EA	HINGE - DOOR - 2" X 1.4" - BRASS
3A	009059-02-000	EA	HINGE - DOOR - 2" X 2.7" - BRASS
3A	009059-03-000	EA	HINGE - BRASS - 1.75"
3A	009059-04-000	EA	HINGE - 2" - ZINC
4A	009089-01-000	EA	CLIP - MIRROR
5A	016604-01-000	EA	BRACE - ANGLE - 2 1/2" - UNPAINTED METAL
5A	016604-05-000	EA	BRACE - ANGLE - 2 1/2" - OFF WHITE METAL
5A	016604-10-000	EA	BRACE - SEAT ANGLE - 2.5" - BLACK
6A	023320-01-000	EA	PAD - FELT 3/8" DIAMETER
7A	041389-19-000	EA	HINGE - PIANO - 1 1/2" X 71.9" - UNPAINTED
7A	041389-25-000	EA	HINGE - PIANO - 1 1/2" X 55" - UNPAINTED
7A	041389-32-000	EA	HINGE - PIANO - 68" - OFF WHITE
8A	057671-01-000	EA	COVER - SCREW - #8 - OFF WHITE
8A	057671-15-000	EA	COVER - SCREW - #8 - BRIGHT WHITE
8A	057671-16-000	EA	COVER - SCREW - #8 - SOFT WHITE
8A	057671-18-000	EA	COVER - SCREW - #8 - OFF WHITE
9A	065740-01-000	EA	BRACE - CABINET/CORNER - PLASTIC
10A	072871-01-000	EA	PULL - FLUSH - CHROME
11A	074045-13-000	EA	PLUG - OAK - 3/8" DOWEL-1/2" HEAD - PORTSMOUTH OAK
11A	074045-08-000	EA	PLUG - OAK - 3/8" DOWEL-1/2" HEAD - CONCERT CHERRY
11A	074045-12-000	EA	PLUG - OAK - 3/8" DOWEL-1/2" HEAD - WASHED MAPLE
11A	074045-14-000	EA	PLUG - OAK - 3/8" DOWEL-1/2" HEAD - HONEY CHERRY
11A	074045-15-000	EA	PLUG - OAK - 3/8" DOWEL-1/2" HEAD - SIERRA MAPLE
12A	074493-02-000	EA	SUPPORT - PISTON SPRING - CABINET DOOR - 26 LBS
12A	074493-03-000	EA	SUPPORT - PISTON SPRING - CABINET DOOR - 12 LBS
12A	074493-04-000	EA	SUPPORT - PISTON SPRING - CABINET DOOR - 32LBS
13A	156732-01-01A	EA	BRACE - ANGLE/COUCH - 2.5" - MILL
13A	156732-01-02A	EA	BRACE - ANGLE/COUCH - 2.5" - OFF WHITE
13A	156732-03-01A	EA	BRACE - ANGLE/COUCH - BLACK
14A	083204-03-000	EA	BUTTON - RETAINING MIRROR 5/16" TIP
15A	084412-01-000	EA	SUPPORT/HINGE KIT (LEFT & RIGHT HINGES)

INTERIOR FINISH GROUP (CONTINUED)

HARDWARE (CONTINUED)

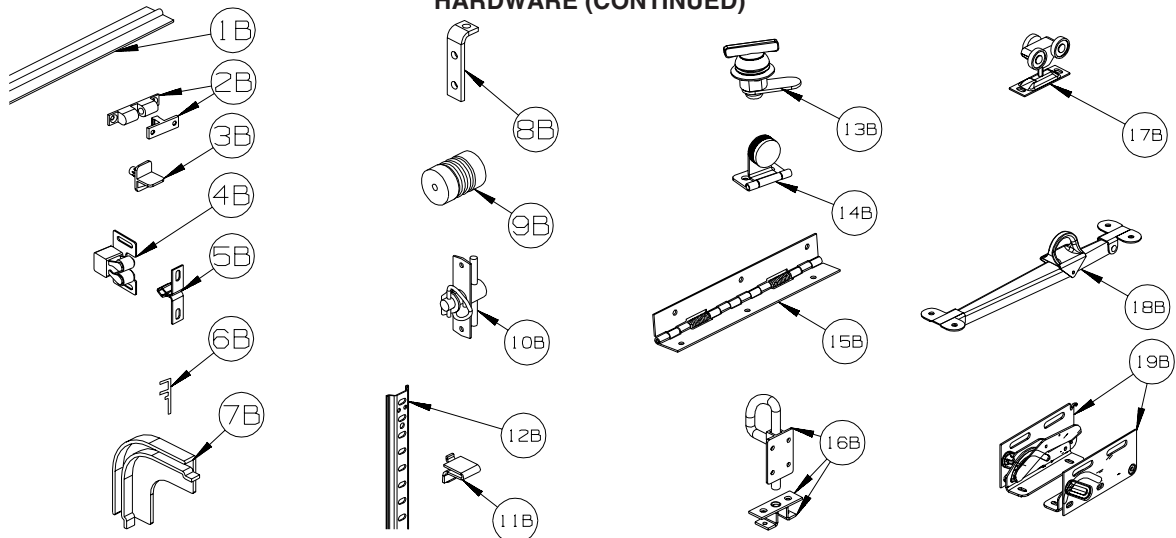

KEY	PART NUMBER	U/M	DESCRIPTION
1B	084413-01-000	EA	HINGE - 1" X 72" - ALUMINUM - W/HOLES
2B	084451-01-000	EA	CATCH & LATCH - 1.7" - BRASS
3B	092907-01-000	EA	SUPPORT - SHELF - PIN - 1/4" - CLEAR PLASTIC
4B	093586-03-000	EA	CATCH - SPRING ROLLER - .377"
4B	093586-06-000	EA	CATCH - SPRING ROLLER - .236"
5B	093586-04-000	EA	STRIKE - SPRING STEEL - 1.14"
6B	093622-01-000	EA	TRACK - DOOR - TAMBOUR - PLASTIC - 8' LENGTHS
7B	093623-01-000	EA	CORNER - TRACK - TAMBOUR DOOR
8B	096826-01-01A	EA	BRACE-CABINET E-COATED
9B	097872-04-000	EA	DOWEL - WOOD - 1" DIAMETER X 1.38" LONG - UNFINISHED
10B	098196-01-000	EA	LATCH - 1/4 TURN - T-BAR
11B	098979-01-000	EA	CLIP - ADJUSTABLE SHELF
12B	098980-01-000	EA	PILASTER - ADJUSTABLE SHELF - 18"
12B	098980-02-000	EA	PILASTER - ADJUSTABLE SHELF - 12"
12B	098980-03-000	EA	PILASTER - ADJUSTABLE SHELF - 9"
12B	098980-04-000	EA	PILASTER - ADJUSTABLE SHELF - 48"
12B	098980-05-000	EA	PILASTER - ADJUSTABLE SHELF - 15"
12B	098980-06-000	EA	PILASTER - ADJUSTABLE SHELF - 24"
13B	100710-01-02A	EA	LOCK - GLASS DOOR/TWIST TYPE - NICKEL
14B	100711-01-02A	EA	HINGE - GLASS DOOR - NICKEL
15B	102920-01-01A	EA	HINGE - SPRING LOADED - BRASS
15B	102920-01-02A	EA	HINGE - SPRING LOADED - NICKEL
15B	129753-01-01A	EA	HINGE - SPRING LOADED - 19" X 19" - BLACK
16B	103256-01-000	EA	LATCH COMPLETE (SLIDE)
17B	103874-01-000	EA	HANGER - SLIDING DOOR
18B	104181-01-01A	EA	SUPPORT - LEAF 5.3" EXTENDS TO 7.5" - SAFETY RING - METAL
19B	108126-01-000	EA	TRAY HINGE SET (QTY. 2 PER SET)

INTERIOR FINISH GROUP (CONTINUED) HARDWARE (CONTINUED)

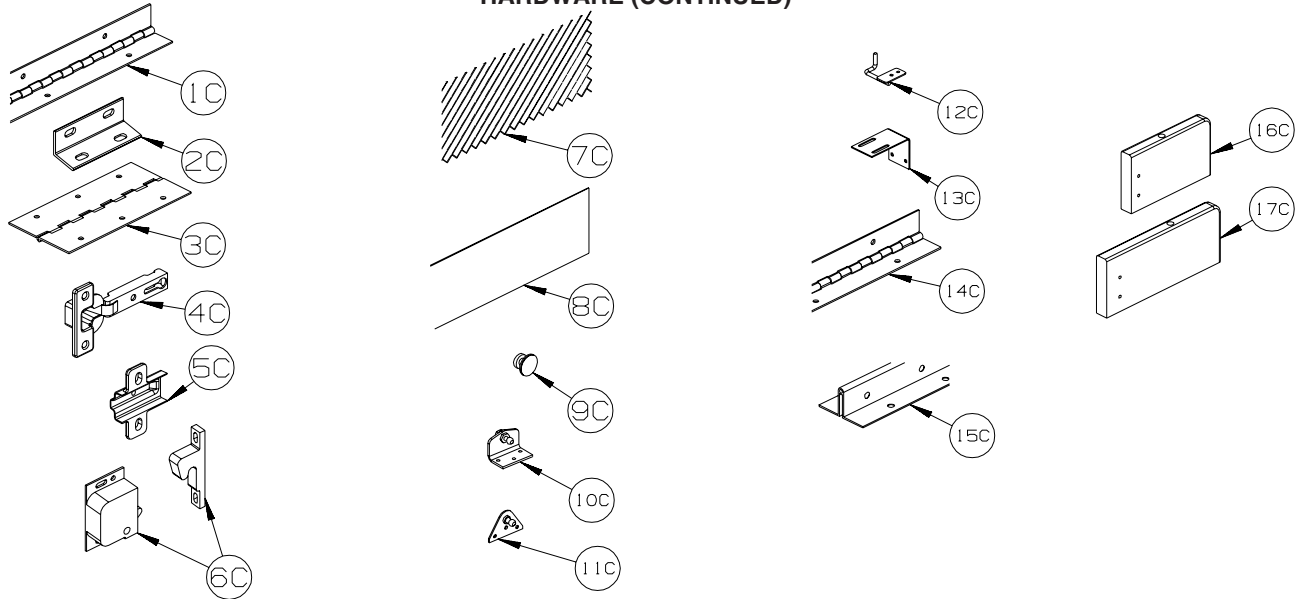

KEY	PART NUMBER	U/M	DESCRIPTION
1C	110496-01-01A	EA	HINGE - BRASS - 2" X 32"
1C	110496-01-02A	EA	HINGE - NICKEL - 2" X 32"
1C	110496-05-02A	EA	HINGE - NICKEL - 2" X 11.5"
1C	110496-06-02A	EA	HINGE - NICKEL - 2" X 9.5"
2C	111866-01-02A	EA	BRACE - SEAT - ANGLE - OFF WHITE
3C	114278-02-000	EA	HINGE - CONTINUOUS - 3" WIDE
4C	114443-02-01A	EA	HINGE - CABINET DOOR - W/O CLIP - SILVER
5C	114443-03-01A	EA	CLIP - HINGE/CABINET DOOR - SILVER
6C	117095-01-01A	EA	LATCH - DOOR - GRABBER W/KEEPER - PLASTIC - BLK-5 LB PULL
6C	117095-02-01A	EA	LATCH - DOOR - GRABBER W/KEEPER - PLASTIC - BLK-10 LB PULL
6C	117095-03-01A	EA	LATCH - DOOR - GRABBER W/KEEPER - PLASTIC - BLK-15 LB PULL
7C	118200-01-01A	SF	MESH - PLASTIC 1/2" - 48" X LENGTH = SF - BLACK
8C	122717-06-01A	FT	PAD - NON-SKID - PSA - 5"W
9C	125221-01-01A	EA	PULL - MIRROR - W/ROUND HANDLE
10C	126263-06-02B	EA	BRACKET - GAS SPRING W/INSIDE BALL STUD - E-COATED
11C	126263-05-02B	EA	BRACKET - GAS SPRING W/BALL STUD - E-COATED
11C	126263-08-02B	EA	BRACKET - GAS SPRING W/CENTERED BALL STUD - E-COATED
11C	126263-19-02B	EA	BRACKET - GAS SPRING W/BALL STUD - E-COATED
12C	130798-01-02B	EA	GUIDE - POCKET DOOR - E-COATED
13C	132871-02-02B	EA	BRACKET/L-ANGLE W/HOLES - 1.9" X 2.8" - E-COATED
14C	134099-01-02A	EA	HINGE - PIANO - WRAP AROUND - 15.7" - NICKEL PLATED
15C	135538-03-02A	EA	HINGE - PIANO - FULL WRAP - 15.7" - CHROME
16C	137445-02-P46	EA	STOP - F/SLIDING DOOR - CONCERT CHERRY
16C	137445-02-P56	EA	STOP - F/SLIDING DOOR - WASHED MAPLE
16C	137445-02-S67	EA	STOP - F/SLIDING DOOR - SIERRA MAPLE
17C	137445-03-T78	EA	STOP - F/SLIDING DOOR - CONCERT CHERRY
17C	137445-03-T79	EA	STOP - F/SLIDING DOOR - WASHED MAPLE
17C	137445-03-T80	EA	STOP - F/SLIDING DOOR - SIERRA MAPLE

INTERIOR FINISH GROUP (CONTINUED)

HARDWARE (CONTINUED)

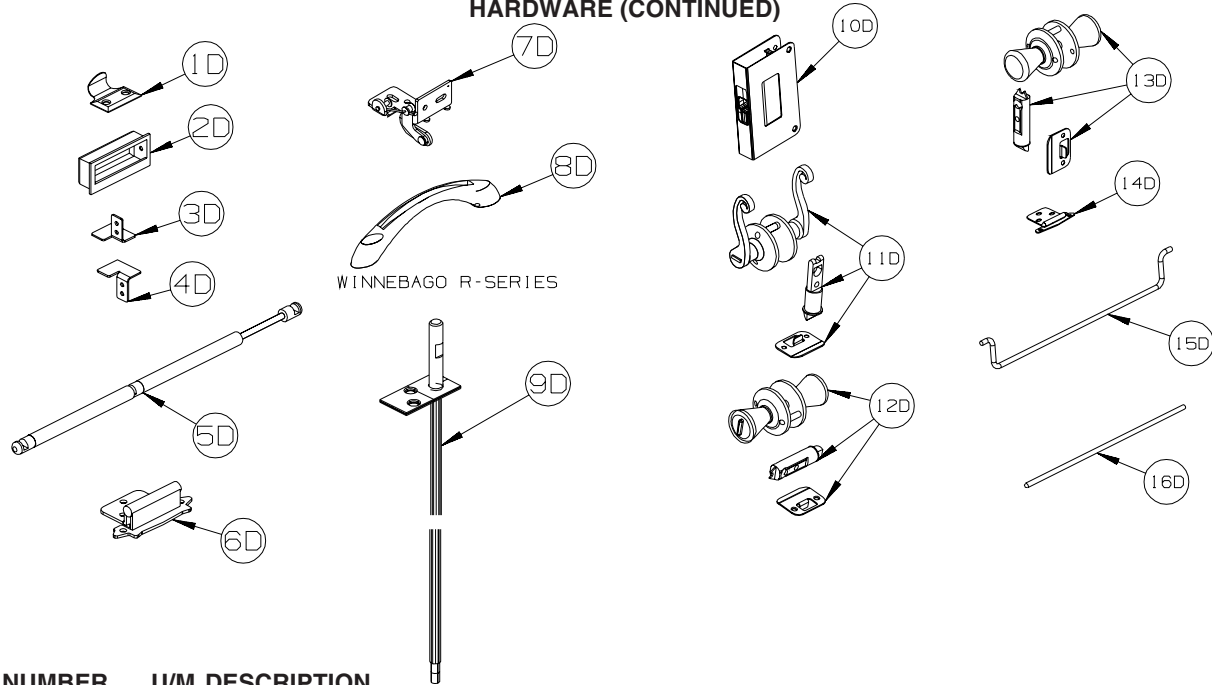

KEY	PART NUMBER	U/M	DESCRIPTION
1D	137463-01-02A	EA	LIFT - HOOK - PEWTER
2D	139136-01-02A	EA	HANDLE - .75" RECESSED - PEWTER
2D	139136-02-02A	EA	HANDLE - .35" RECESSED - PEWTER
3D	139264-01-02B	EA	STOP - DOOR - TAMBOUR/RH HAND - E-COATED
4D	139264-02-02B	EA	STOP - DOOR - TAMBOUR/LH HAND - E-COATED
5D	142569-07-000	EA	SPRING/GAS - 20 LB - 20" EXTENDED/12" COMPRESSED
5D	142569-15-000	EA	SPRING/GAS - 120 LB - 20" EXTENDED/12" COMPRESSED
5D	142569-16-000	EA	SPRING/GAS - 90 LB - 20" EXTENDED/12" COMPRESSED
5D	142569-29-000	EA	SPRING/GAS - 20 LB - 9.9" EXTENDED/5.9" COMPRESSED
6D	143468-02-03A	EA	HINGE - SELF CLOSING - SATIN NICKEL
7D	144488-01-02A	EA	HINGE - CABINET - NICKEL
8D	144917-01-01A	EA	PULL - DRAWER - SATIN NICKEL - TOUR R-SERIES
9D	145939-03-01A	EA	ROD/LATCH - AISLE DOOR - BRASS
			FROM: 00-00-00 THRU: 04-16-06
9D	145939-05-01A	EA	ROD/LATCH - AISLE DOOR - BRASS - NOT ILLUSTRATED
			FROM: 04-17-06 THRU: 07-30-06
9D	145939-05-02A	EA	ROD/LATCH - AISLE DOOR - NICKEL - NOT ILLUSTRATED
			FROM: 07-31-06 THRU: 99-99-99
10D	145939-04-02A	EA	LATCH/SLIDE - AISLE DOOR(1" THICK DOOR)-NICKEL/BLACK SLIDE
11D	146064-01-02A	EA	LOCK/PRIVACY (LOCKING) LEVER STYLE - SATIN PEWTER
12D	146064-05-01A	EA	LOCK/PRIVACY (LOCKING) KNOB STYLE - SATIN NICKEL
13D	146064-06-01A	EA	LOCK/PASSAGE (NON LOCKING) KNOB STYLE - SATIN NICKEL
14D	146553-01-01A	EA	HINGE - CABINET DOOR - BURNISHED BRASS
14D	146553-01-03A	EA	HINGE - CABINET DOOR - SATIN NICKEL
15D	146801-01-01A	EA	ROD/TOWEL BAR (OFFSET) - BRASS
15D	146801-01-02A	EA	ROD/TOWEL BAR (OFFSET) - PEWTER
16D	146840-03-01A	EA	ROD - .25" X 11.7" - BRASS
16D	146840-03-02A	EA	ROD - .25" X 11.7" - PEWTER
16D	146840-04-01A	EA	ROD - .25" X 13.1" - BRASS
16D	146840-04-02A	EA	ROD - .25" X 13.1" - PEWTER
16D	146840-05-01A	EA	ROD - .25" X 14.8" - BRASS
16D	146840-05-02A	EA	ROD - .25" X 14.8" - PEWTER
16D	146840-07-01A	EA	ROD - .25" X 4.2" - BRASS
16D	146840-07-02A	EA	ROD - .25" X 4.2" - PEWTER

INTERIOR FINISH GROUP (CONTINUED) HARDWARE (CONTINUED)

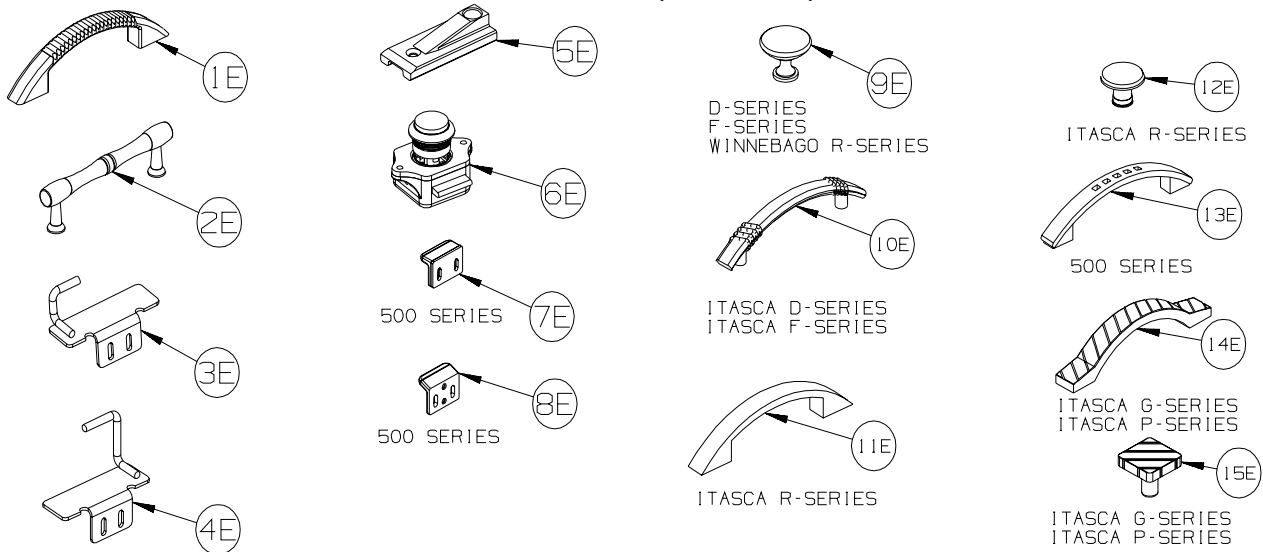

KEY	PART NUMBER	U/M	DESCRIPTION
1E	148816-01-02A	EA	PULL - CABINET DOOR - NICKEL - ASPECT, CAMBRIA 700-SERIES
2E	149090-01-02A	EA	PULL - CABINET DOOR - NICKEL - SIGHTSEER D-SERIES, VOYAGE F-SERIES
3E	149607-01-02B	EA	GUIDE - F/POCKET DOOR - 1.6" BENT ROD - E-COATED
3E	149607-03-02B	EA	GUIDE - F/POCKET DOOR - 2.9" BENT ROD - E-COATED
4E	149607-04-02B	EA	GUIDE - F/POCKET DOOR - E-COATED
5E	150983-01-01A	EA	STRIKE/BLOCK - WEDGE STYLE - F/SLIDE DOOR - 3" X 1.2" - BLACK
6E	151380-01-01A	EA	LATCH - CABINET DOOR - PUSH BUTTON - VIEW & NAVION 500-SERIES
7E	151380-02-01A	EA	STRIKE - CABINET DOOR - VIEW & NAVION 500-SERIES
8E	151380-03-01A	EA	STRIKE - CABINET DOOR - VIEW & NAVION 500-SERIES
9E	152080-01-01A	EA	PULL-NICKEL - SIGHTSEER & SUNOVA D-SERIES, VOYAGE & SUNRISE F-SERIES, TOUR R-SERIES
10E	152302-01-01A	EA	PULL - CABINET DOOR - SATIN NICKEL - SUNOVA D-SERIES, SUNRISE F-SERIES
11E	152304-01-01A	EA	PULL - CABINET DOOR - BRONZE - ELLIPSE R-SERIES
12E	152305-01-01A	EA	KNOB - DOOR/DRAWER - BRONZE - ELLIPSE R-SERIES
13E	152950-01-01A	EA	PULL - DOOR/DRAWER - BRUSHED NICKEL - VIEW & NAVION 500-SERIES
14E	152951-01-01A	EA	PULL - DOOR/DRAWER - PEWTER - SUNCRUISER G-SERIES, MERIDIAN P-SERIES
15E	152952-01-01A	EA	PULL - KNOB/DRAWER - PEWTER - SUNCRUISER G-SERIES, MERIDIAN P-SERIES

INTERIOR FINISH GROUP (CONTINUED) HARDWARE (CONTINUED)

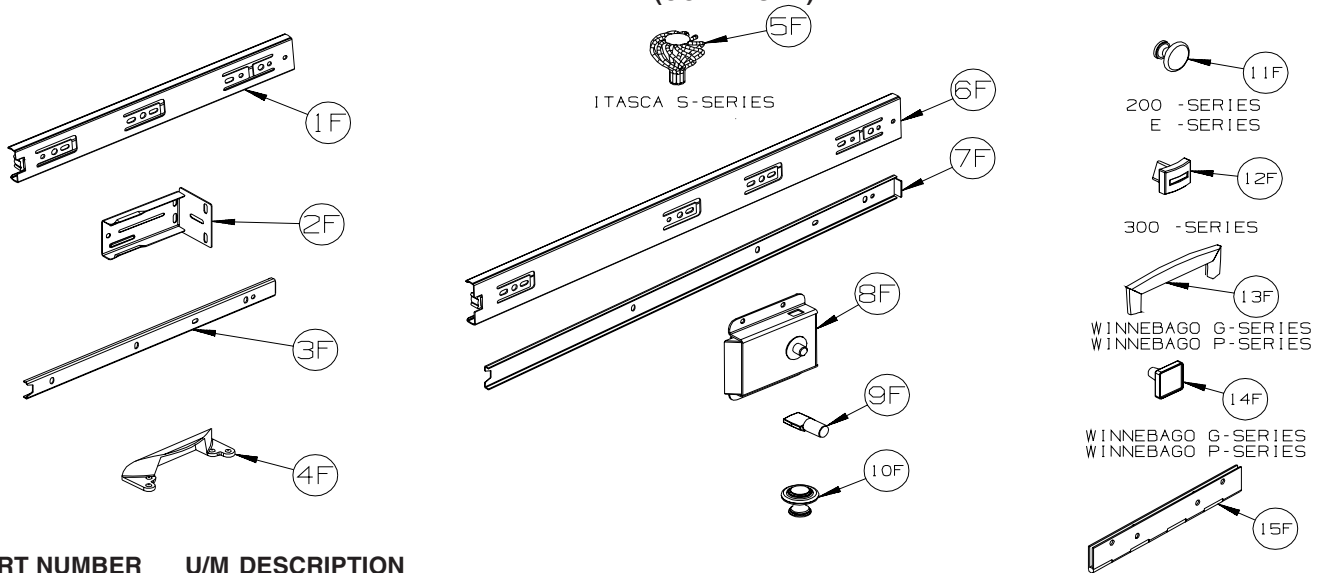

KEY	PART NUMBER	U/M	DESCRIPTION
1F	153000-01-01A	EA	SLIDE - CABINET MOUNT - 11.8"
1F	153000-03-01A	EA	SLIDE - CABINET MOUNT - 13.8"
1F	153000-05-01A	EA	SLIDE - CABINET MOUNT - 15.7"
1F	153000-07-01A	EA	SLIDE - CABINET MOUNT - 17.7"
1F	153000-09-01A	EA	SLIDE - CABINET MOUNT - 19.7"
1F	153000-11-01A	EA	SLIDE - CABINET MOUNT - 21.6"
1F	153000-14-01A	EA	SLIDE - CABINET MOUNT - 23.6"
1F	153000-18-01A	EA	SLIDE - CABINET MOUNT - 9.8"
1F	153000-20-01A	EA	SLIDE - CABINET MOUNT - 25.6"
2F	153000-13-01A	EA	BACKSOCKET - DRAWER SLIDE
3F	153000-02-01A	EA	SLIDE - DRAWER MOUNT - 11.8"
3F	153000-04-01A	EA	SLIDE - DRAWER MOUNT - 13.8"
3F	153000-06-01A	EA	SLIDE - DRAWER MOUNT - 15.7"
3F	153000-08-01A	EA	SLIDE - DRAWER MOUNT - 17.7"
3F	153000-10-01A	EA	SLIDE - DRAWER MOUNT - 19.7"
3F	153000-12-01A	EA	SLIDE - DRAWER MOUNT - 21.6"
3F	153000-15-01A	EA	SLIDE - DRAWER MOUNT - 23.4"
3F	153000-19-01A	EA	SLIDE - DRAWER MOUNT - 9.8"
3F	153000-21-01A	EA	SLIDE - DRAWER MOUNT - 25.4"
4F	153308-01-01A	EA	PULL - VANITY STOOL - SATIN NICKEL
5F	153335-01-02A	EA	PULL - KNOB - DOOR/DRAWER - FLAT BLACK - HORIZON S-SERIES
6F	153352-01-01A	EA	SLIDE - PANTRY - 19.7" - CABINET MOUNT
6F	153352-03-01A	EA	SLIDE - EXT ENTERTAINMENT CNTR - 13.8" - CABINET MOUNT
7F	153352-02-01A	EA	SLIDE - PANTRY - 19.5" - DRAWER MOUNT
7F	153352-04-01A	EA	SLIDE - EXT ENTERTAINMENT CNTR - 13.6" - DRAWER MOUNT
8F	153353-01-01A	EA	LATCH - SLIDING/FLUSH - BLACK
9F	154385-01-02A	EA	PIN - SUPPORT/GLASS DOOR - 1/4" - NICKEL
10F	155803-01-01A	EA	KNOB CABINET DOOR - WROUGHT IRON
11F	155925-01-01A	EA	KNOB - DOOR/DRAWER - SATIN NICKEL - ACCESS & IMPULSE 200-SERIES
12F	156579-01-01A	EA	KNOB - DOOR/DRAWER - PEWTER - OUTLOOK & SPIRIT 300-SERIES
13F	157246-01-01A	EA	PULL - CABINET DOOR/DRAWER - SATIN NICKEL - ADVENTURER G-SERIES, JOURNEY P-SERIES
14F	157246-02-01A	EA	KNOB - CABINET DOOR/DRAWER - SATIN NICKEL - ADVENTURER G-SERIES, JOURNEY P-SERIES
15F	158982-01-04B	EA	HINGE - CONTINUOUS - 2" X 8" - BLACK
	158982-01-01A	EA	HINGE - CONTINUOUS - 2" X 8" - ZINC

LABELS GROUP

ALTERNATE LABEL LOCATION

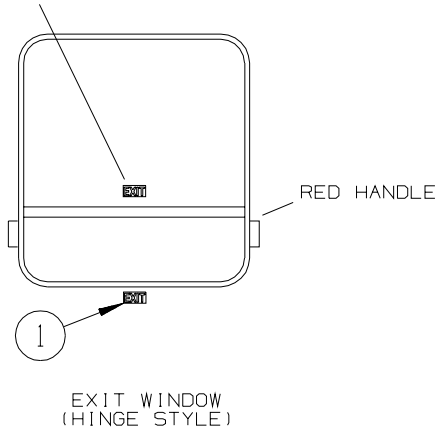

RED HANDLE

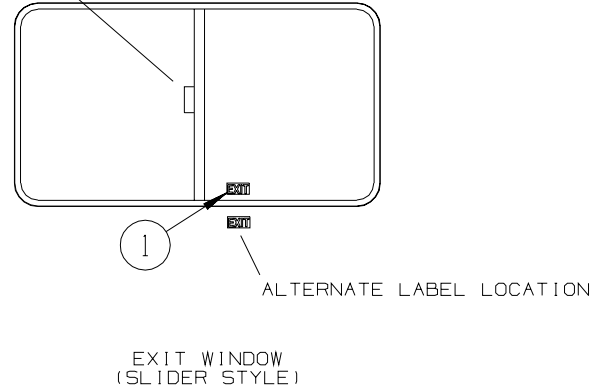

KEY	PART NUMBER	U/M DESCRIPTION
1	039290-01-000	EA LABEL - WARNING - EXIT

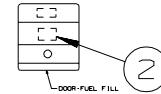
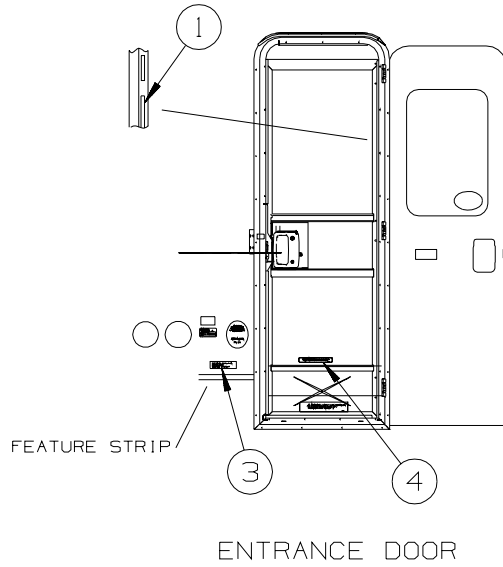

KEY	PART NUMBER	U/M DESCRIPTION
1	135869-01-01A	EA LABEL - MERCURY CONTENT - BLACK ON CLEAR
2	124519-01-01A	EA LABEL - WARNING/REFUELING - BLACK ON CLEAR
2	124519-02-01A	EA LABEL - WARNING/REFUELING - BLACK ON CLEAR - CSA
3	099509-01-000	EA LABEL - AWNING INSTALLATION
4	065748-01-000	EA LABEL - WARNING - BATTERY CHARGING - UL
4	065748-02-000	EA LABEL - WARNING - BATTERY CHARGING - CSA

LABELS GROUP (CONTINUED)

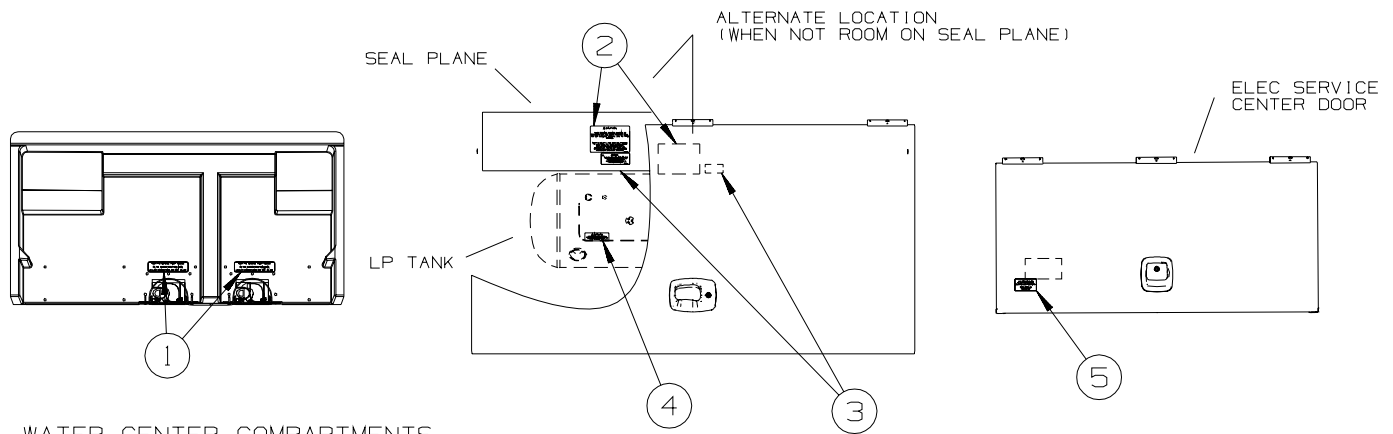

TYPICAL WATER CENTER COMPARTMENTS

KEY	PART NUMBER	U/M	DESCRIPTION
1	123562-01-000	EA	LABEL - SERVICE/UTILITY ACCESS
2	124520-01-01A	EA	LABEL - LP GAS ONLY - BLACK ON CLEAR
2	023769-01-000	EA	LABEL - WARNING - LPG - CANADIAN
3	124519-01-01A	EA	LABEL - WARNING/REFUELING - BLACK ON CLEAR
3	124519-02-01A	EA	LABEL - WARNING/REFUELING - BLACK ON CLEAR - CSA
4	079965-01-000	EA	LABEL - LPG - 80% CAPACITY
5	125306-01-01A	EA	LABEL - ELECTRICAL ENTRANCE - 110V 30 AMP - BLACK ON CLEAR
5	125306-04-01A	EA	LABEL - ELECTRICAL ENTRANCE-120/20V 50 AMP-BLACK ON CLEAR

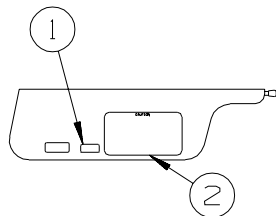

LABELS SHALL BE LOCATED ON OPPOSITE SIDE OF VISOR THAT THE AIR BAG LABEL IS INSTALLED ON

INSTRUMENT CLUSTER REF

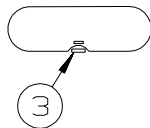

TYPICAL SEAT AND BELT CONFIGURATIONS

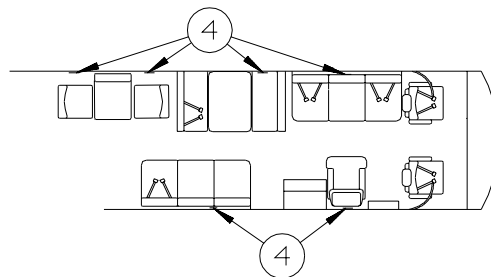

ATTACH LABEL ON OR NEXT TO:
 •ANY SINGLE CHAIR WITHOUT BELTS.
 •ANY DINETTE SEAT WITHOUT BELTS.
 •ANY COUCH WITHOUT BELTS OR ANY SEATING POSITION ON THAT COUCH.
 DO NOT ATTACH LABEL IF:
 •DINETTE SEAT HAS AT LEAST ONE SET OF BELTS INSTALLED.

KEY	PART NUMBER	U/M	DESCRIPTION
1	099689-01-000	EA	LABEL - WARNING - CANCER/TOXICITY
2	056259-01-000	EA	LABEL - SAFETY CHECK LIST
3	155692-01-02A	EA	LABEL - ODOMETER - READ IN MILE - WHITE/CLEAR
4	134538-01-01A	EA	LABEL - OCCUPANCY - NO SEAT BELT - BLACK ON CLEAR - US
4	134538-02-01A	EA	LABEL - OCCUPANCY - NO SEAT BELT - BLACK ON CLEAR - CSA

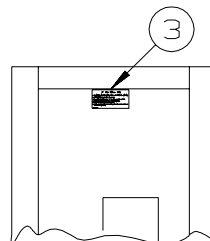
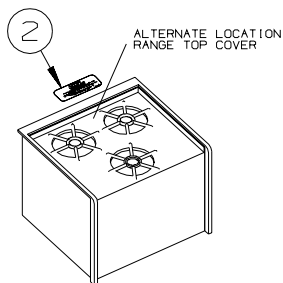
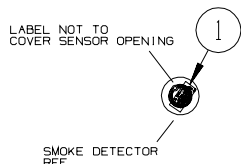

SLIDEOUT SWITCH

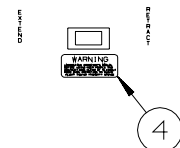

INSIDE OF GALLEY CABINET DOOR REF

KEY	PART NUMBER	U/M	DESCRIPTION
1	077956-01-000	EA	LABEL - WARNING/SMOKE DETECTOR
2	134539-01-01A	EA	LABEL - WARNING - STOVE/HEATING - US - BLACK ON CLEAR
2	134540-01-01A	EA	LABEL - WARNING - STOVE/HEATING - CSA - BLACK ON CLEAR
3	073998-01-000	EA	LABEL - LPG/ODOR WARNING
4	116549-02-000	EA	LABEL - WARNING - SLIDEOUT

LABELS GROUP (CONTINUED)

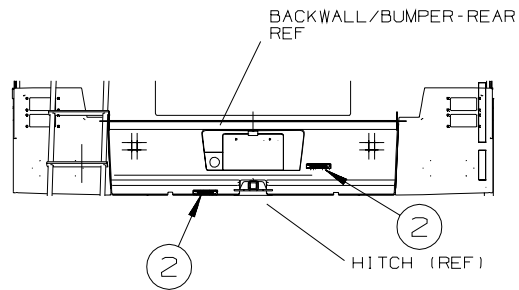
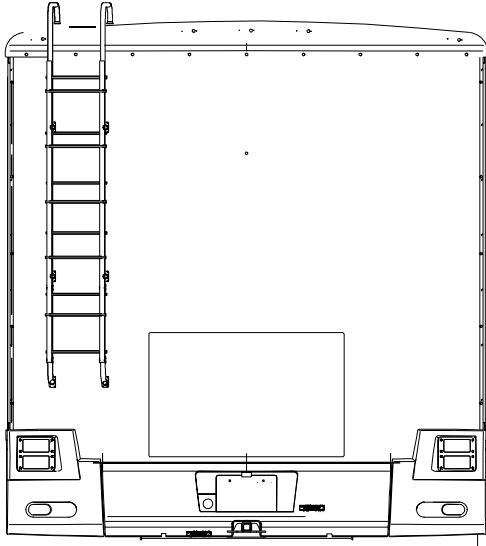
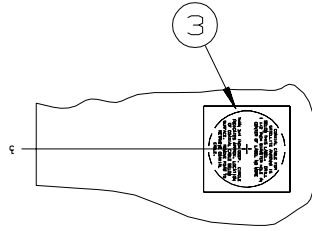
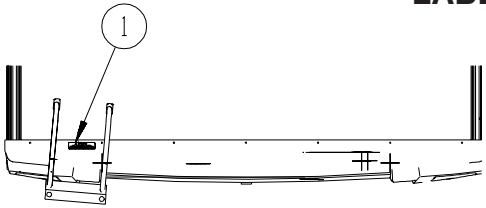

KEY	PART NUMBER	U/M DESCRIPTION
1	128218-01-01A	EA LABEL - WARNING - SLIPPERY ROOF
2	129669-02-01A	EA LABEL - HITCH/VEHICLE RATE - 500 - WHITE ON CLEAR
3	120431-01-000	EA LABEL - LOCATION - COAXIAL CABLE/SATELLITE ANTENNA

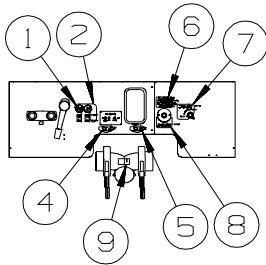

30B, 33T, 34A SERVICE PANEL

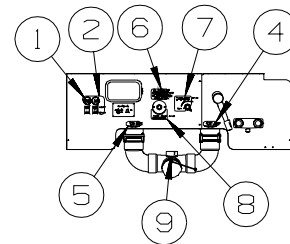

35J SERVICE PANEL

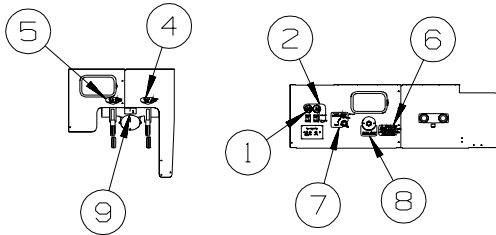

29R SERVICE PANEL

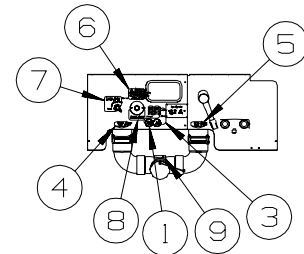

26P SERVICE PANEL

KEY	PART NUMBER	U/M DESCRIPTION
1	152544-03-01A	EA LABEL - SWITCHES - WATER PUMP
2	152544-07-01A	EA LABEL - SWITCHES - WTR PUMP/AUTO LVL-W/LVL/STORE DWN
3	152544-08-01A	EA LABEL - SWITCHES - WTR PUMP/AUTO LVL-W/LVL/STORE UP
4	152543-03-01A	EA LABEL - BLACK WASTE
5	152541-03-01A	EA LABEL - GRAY WASTE
6	154292-01-01A	EA LABEL - TANK FILL VALVE
7	152548-01-01A	EA LABEL - VALVE/FRESH
8	152538-01-01A	EA LABEL - FRESH WATER - PANTONE/CLEAR
9	144649-01-01A	EA LABEL - ADJUSTABLE VALVE - WHITE ON CLEAR

**LP GROUP
LP SYSTEM**

KEY	PART NUMBER	U/M	DESCRIPTION
	045703-03-000	EA	HOSE - LP - 3/8"ID X 18" - 3/8"MPT X 1/2"F SWIVEL - US
	045703-12-000	EA	HOSE - LP - 3/8"ID X 18" - 3/8"MPT X 1/2"F SWIVEL - CSA
	045703-15-000	EA	HOSE - LP - 3/8"ID X 142" - 1/2"F SWIVEL X 3/8"F SWIVEL
	045703-17-000	EA	HOSE - LP - 3/8"ID X 24" - 1/2"F SWIVEL X 3/8"F SWIVEL US
	106150-05-000	EA	REGULATOR - TWO STAGE
	144485-01-000	EA	COVER - LP REGULATOR
	040440-02-000	EA	TRANSMITTER - DIAL/BOLT-ON - 0-90 OHM 2 TERM(POWER/GROUND)
*	144116-04-000	EA	TANK - LP - 60 LB - 14"D X 29.75"L
	010589-01-000	EA	NIPPLE - PIPE - 1/2" X 1 1/2" - BLACK
	141090-01-02B	EA	SHIELD - HEAT - E-COATED
	010265-01-000	EA	ELBOW - BRASS - 90 DEGREE - 3/8"F X 1/2"FPT
	010323-01-000	EA	ADAPTER - 3/8"F X 1/2"MPT - BRASS
	010329-01-000	EA	ADAPTER - 1/2"F X 1/2"MPT - BRASS
	010377-02-000	EA	NUT - 3/8" FLARE - FORGED - BRASS
	010380-02-000	EA	NUT - 1/2" FLARE - FORGED - BRASS

***COMPONENT PARTS LISTED LATER IN THIS GROUP**

COMPONENT PARTS FOR LP SYSTEM

144116-04-000

KEY	PART NUMBER	U/M	DESCRIPTION	VENDOR NO.
	040421-01-712	EA	VALVE-SERV. W/O VAPOR RELIEF	V20373/V21202
	040421-01-713	EA	VALVE-RELIEF 1" W/SPRING 7"	V12560/V21207
	144116-01-700	EA	VALVE-OUTAGE(NO STEM REMOVE)	V20058
	144116-01-701	EA	VALVE/FILL 80 % W/YELLOW CAP	V13414
	144116-04-700	EA	FLOAT/SENDING UNIT W/O DIAL	G11530
	144116-04-701	EA	DIAL - TRANSMITER	G12845

SEALANTS & FASTENERS GROUP
SEALANTS & ADHESIVES

KEY	PART NUMBER	U/M	DESCRIPTION
	004001-02-000	EA	GUN - PLEXUS ADHESIVE - W/O NOZZLE
	004001-05-000	EA	ADHESIVE - SCOTCH-WELD - 3M DP100 - CLEAR - 50ML
	004011-01-000	EA	ADHESIVE-3M-4475 TUBE
	010405-02-000	EA	TAPE - THREAD SEALING - 3/8"
	064075-07-000	FT	SEAL - BULB - W/WIRED U CHANNEL - .3" X .5" CHANNEL-BLACK
	067788-01-000	EA	ADHESIVE - SPRAY - 3M - 19.5 OZ AEROSOL CAN
	069640-01-000	FT	SEALER - RIBBON - 1/4"DIAMETER X 30 FT - BLACK OR GRAY
	069640-02-000	FT	SEALER - TAPE - 1/8"THICK X 1/2"WIDE X 60 FT - GRAY
	069640-03-000	FT	SEALER - TAPE - 1/8"THICK X 3/4"WIDE X 60 FT - BLACK
	069640-07-000	FT	SEALER - TAPE - 3/32"THICK X 2"WIDE X 45 FT - GRAY
	069640-09-000	FT	SEALER - TAPE - 1/32"THICK X 2 1/2"WIDE X 80 FT - BRT WHT
	069640-10-000	FT	SEALER - TAPE - 1/32"THICK X 1 1/2"WIDE X 90 FT - BRT WHT
	069640-11-000	FT	SEALER - TAPE - 3/16"THICK X 3/8"WIDE X 40 FT - BLACK
	069640-13-000	FT	SEALER - TAPE - 3/32"THICK X 2"WIDE X 45 FT - BLACK
	069640-14-000	FT	SEALER - TAPE - 1/16"THICK X 1"WIDE X 100 FT - BLACK
	069640-15-000	FT	SEALER - TAPE - 1/16"THICK X 3/8"WIDE X 100 FT - BRT WHT
	069640-17-000	FT	SEALER - TAPE - 1/32"THICK X 1"WIDE X 150 FT - GRAY
	069640-18-000	FT	SEALER - TAPE - 1/8"THICK X 1/2"WIDE X 60 FT - BRT WHT
	069640-19-000	FT	SEALER - TAPE - 1/8"THICK X 3/4"WIDE X 60 FT - BRT WHT
	069640-20-000	FT	SEALER - TAPE - 1/8"THICK X 1/2"WIDE X 60 FT - BLACK
	069640-21-000	FT	SEALER - TAPE - 1/16"THICK X 1/2"WIDE X 100 FT - BRT WHT
	069640-22-000	FT	SEALER - TAPE - 1/32"THICK X 1/4"WIDE X 200 FT - BRT WHT
	069640-23-000	FT	SEALER - TAPE - 1/16"THICK X 3/4"WIDE X 100 FT - BRT WHT
	069640-27-000	FT	SEALER - TAPE - 1/16"THICK X 2 1/4"WIDE X 50 FT - BRT WHT
	069640-28-000	FT	SEALER - TAPE - 1/32"THICK X 1 7/8"WIDE X 90 FT - GRAY
	069640-30-000	FT	SEALER - TAPE - 1/32"THICK X 5/8"WIDE X 50 FT - GRAY
	069640-31-000	FT	SEALER - TAPE - 1/4"THICK X 3/4"WIDE X 15 FT - BLACK
	069640-32-000	FT	SEALER - TAPE - 1/16"THICK X 3/8"WIDE X 100 FT - BLACK
	069640-33-000	FT	SEALER - RIBBON - 3/8"DIAMETER X 20 FT - BLACK
	069640-34-000	FT	SEALER - RIBBON - 1/4"DIAMETER X 30 FT - BRIGHT WHITE
	072889-28-000	EA	SEALANT/URETHANE-10 OZ TUBE W/NOZZLE-SELF LEVELING-BRT WHT
	076322-01-000	FT	TAPE-DOUBLE COATED/ADHESIVE BK-.03"THK X .8"W X 216' - WHT
	076322-02-000	FT	TAPE-DOUBLE COATED/ADHESIVE BK-.05"THK X 1"W X 108' - WHT
	076322-03-000	FT	TAPE-DOUBLE COATED/ADHESIVE BK-.05"THK X .5"W X 108' - WHT
	076322-05-000	FT	TAPE-DOUBLE COATED/ADHESIVE BK-.05"THK X .8"W X 108' - WHT
	076322-07-000	FT	TAPE-DOUBLE COATED/ADHESIVE BK-.05"THK X .5"W X 200' - BLK
	076322-13-000	FT	TAPE - FOAM/DOUBLE COATED - .020"THK X .75"W - CLEAR
	076322-21-000	FT	TAPE - FOAM/DOUBLE COATED - .045"THK X .50"W
	076322-22-000	FT	TAPE - FOAM/DOUBLE COATED - .045"THK X .75"W
	076322-23-000	FT	TAPE - FOAM/DOUBLE COATED - .045"THK X 1"W
	076322-25-000	FT	TAPE - FOAM/DOUBLE COATED - .025"THK X .5"W
	086276-01-000	EA	TAPE - DOUBLE SIDED - 1/2" WIDE X 108' LONG (SOLD BY ROLL)
	088479-01-000	EA	TAPE - ALUMINUM - 3"
	090340-01-000	FT	SEAL - FOAM - CLOSED CELL - 1/4" X 1/2" X 50'
	091255-02-000	FT	SEAL - ADHESIVE BACKED/FOAM - 3/64"THICK X 3/16"W X 1000'
	091255-03-000	FT	SEAL - ADHESIVE BACKED/FOAM - 1/4" THICK X 1/4"W X 1000'
	094401-01-000	EA	SEALER - BODY SEAM - FLEXICLEAR
	094401-04-000	EA	SEALER - BODY SEAM - CLEAR
	094401-05-000	EA	SEALER - BODY SEAM - 20OZ BLACK
	094401-06-000	EA	SEALER - BODY SEAM - 12OZ BLACK
	094401-07-000	EA	SEALER - BODY SEAM - CLEAR
	098408-01-000	FT	SEAL - SPONGE RUBBER - CLOSED CELL
	099069-01-000	FT	SEAL - RUBBER - CLOSED SPONGE - .5" WIDE X .12" THICK-BLK
	099418-01-000	FT	SEAL - D-SECTION/ADHESIVE BACK - ..44" X .44" - BLK RUBBER
	107828-01-000	EA	SEALANT - SB - 190 EVERSEAL
	112864-01-000	FT	SEAL - FOAM/BUTYL COVERED - 3/8" X 35'
	112864-02-000	FT	FOAM - BUTYL COVERED - 5/16" X 44'
	112864-04-000	FT	FOAM - BUTYL COVERED - 3/8" X 1/8"
	112901-02-000	EA	ADHESIVE - PLEXUS - MA330 - 50ML - GRAY
	112901-03-000	EA	ADHESIVE - PLEXUS - MA300 - 50ML - WHITE
	112902-01-000	EA	NOZZLE - ELEMENT - 3/8" X 24
	112902-03-000	EA	MIXER NOZZLE - F/GUN #00400102000 - SCOTCH-WELD & PLEXUS
	112902-04-000	EA	NOZZLE - ELEMENT - 1/4" X 3.5"
	112902-05-000	EA	NOZZLE - BAYONET - 3/8" X 18

SEALANTS & FASTENERS GROUP (CONTINUED)
SEALANTS & ADHESIVES (CONTINUED)

KEY	PART NUMBER	U/M	DESCRIPTION
	112902-06-000	EA	NOZZLE - ELEMENT - 1/2" X 32
	113366-01-000	EA	ADHESIVE - INSTANT - 1 OZ
	120074-02-03A	EA	SILICONE - TUBE - W/O NOZZLE - LOW ODOR - SMOKEY WHITE
	120534-01-01A	EA	TAPE - SCOTCH - 3M - 1/2" FINE LINE
	123244-01-000	FT	TAPE - DOUBLE SIDED/FOAM - 5/64"THICK X 3/4"WIDE X 108'
	123816-01-000	FT	TAPE - DOUBLE SIDED - 1" X .020" X 200' - CLEAR
	123816-02-000	FT	TAPE - DOUBLE SIDED - 1/2" X .035" X 200' - CLEAR
	123816-03-000	FT	TAPE - DOUBLE SIDED - 1/2" X .020" X 200' - CLEAR
	123816-04-000	FT	TAPE - DOUBLE SIDED - 6" X .0035" X 750' - CLEAR
	123816-06-000	FT	TAPE - DOUBLE SIDED - 3/4" X 3/4" X 200' - CLEAR
	123816-07-000	FT	TAPE - DOUBLE SIDED - 1 3/4" X 200' - CLEAR
	126427-01-000	EA	ADHESIVE - ALL PURPOSE - ABS/PVC
	126427-02-000	EA	PRIMER - CLEANER - FLEX PIPING
	131264-01-11A	EA	SILICONE - TUBE - W/NOZZLE - BEIGE
	131264-01-12A	EA	SILICONE - TUBE - W/NOZZLE - BONE
	131264-01-13A	EA	SILICONE - TUBE - W/NOZZLE - TRANSLUCENT
	131264-02-01A	EA	SILICONE - TUBE - W/NOZZLE - VW GRAY - BATH ONLY
	131264-03-01A	EA	SILICONE - TUBE - W/O NOZZLE - SELF LEVELING -BRIGHT WHITE
	131264-04-01A	EA	SILICONE/SEALANT/ADHESIVE - FAST CURE F/GLASS/VINYL - B/W
	131264-04-02A	EA	SILICONE/SEALANT/ADHESIVE-FAST CURE F/GLASS/VINYL-SOFT WHT
	131264-05-01A	EA	SILICONE/SEALANT - ODORLESS - TUBE - W/NOZZLE - BLACK
	131264-05-02A	EA	SILICONE/SEALANT - ODORLESS - TUBE - W/NOZZLE - CLEAR
	131384-01-000	EA	ADHESIVE - JET WELD - 10 OZ CARTRIDGE
	132892-07-01A	FT	SEAL - BULB/SINGLE - W/U CHANNEL - .5" X 1" - BLACK
	152038-01-01A	EA	TAPE - PRESERVATION SEAL - 2" X 36YD ROLL - BLACK
	154585-01-01A	FT	SEAL - FOAM TAPE - ADHESIVE BACK - 3/8" X 3/8" - BLACK
	154585-02-01A	FT	SEAL - FOAM TAPE - ADHESIVE BACK - 3/4" X 1/2" - BLACK
	154585-03-01A	FT	SEAL - FOAM TAPE - ADHESIVE 2 SIDED - 1/8" X 3/4" - BLACK
	154585-04-01A	FT	SEAL - FOAM TAPE - ADHESIVE BACK - 5/8" X 1/8" - WHITE

BOLTS, NUTS AND WASHERS

KEY	PART NUMBER	U/M	DESCRIPTION
	0MD54F-06-000	EA	NUT - HEX W/SERATED FLANGE
	000C12-04-08B	EA	BOLT - HEX - 1/4-20 X 1/2 - GRADE #5 - ZINC
	000C12-04-40B	EA	BOLT - HEX - 1/4-20 X 2 1/2 - GRADE #5 ZINC
	000C12-04-20F	EA	BOLT - HEX - 1/4-20 X 1 1/4 - GRADE #5 - STAINLESS STEEL
	000C12-04-12A	EA	BOLT - HEX - 1/4-20 X 3/4 - PLAIN 5
	000C12-05-16B	EA	BOLT - HEX - 5/16 - 18X1 - GRADE #5 - ZINC
	000C12-05-40B	EA	BOLT - HEX - 5/16"-18 X 2.5" - GRADE #5 - ZINC
	000C12-06-28B	EA	BOLT-HEX-3/8-16X13/4 ZN 5 - 5185-01
	000C12-08-44B	EA	BOLT - HEX - 1/2-13 X 2 3/4 - GRADE #5 - ZINC
	000C12-08-24B	EA	BOLT - HEX - 1/2-13 X 1 1/2 - GRADE #5 - ZINC
	000C12-08-28B	EA	BOLT - HEX - 1/2-13 X 1 3/4 - GRADE #5 - ZINC
	000C13-07-40B	EA	BOLT - HEX - 7/16-20 X 2 1/2 - GRADE #5 - ZINC
	000C13-07-48B	EA	BOLT - HEX - 7/16-20 X 3 - GRADE #5 - ZINC
	000C13-07-72B	EA	BOLT - HEX - 7/16-20 X 4.5" - GRADE #5 - ZINC
	000C16-07-16B	EA	BOLT - CARRIAGE - ASSIST HANDLE - 7/16-14 X 1
	000C18-05-40A	EA	BOLT - ELEVATOR - 5/16-18 X 2 1/2 - PL
	000C26-04-18B	EA	BOLT - HEX - SERRATED FLANGE - 1/4-20 X 1 1/8 - ZINC
	000C26-04-14B	EA	BOLT - HEX - SERRATED FLANGE - 1/4-20 X 7/8 - ZINC
	000C26-04-12F	EA	BOLT - HEX - SERRATED FLANGE -1/4-20 X 3/4-STAINLESS STEEL
	000C26-04-10B	EA	BOLT - HEX - SERRATED FLANGE - 1/4-20 X 5/8 - ZINC
	000C26-04-40F	EA	BOLT - HEX - SERRATED FLANGE -1/4-20 X 2.5-STAINLESS STEEL
	000C26-05-12B	EA	BOLT - HEX - SERRATED FLANGE - 5/16-18 X 3/4 - ZINC
	000C26-06-12B	EA	BOLT - HEX - SERRATED FLANGE - 3/8-16 X 3/4 - ZINC
	000C26-06-20B	EA	BOLT - HEX - SERRATED FLANGE - 3/8-16 X 1 1/4 - ZINC
	000C26-06-28B	EA	BOLT - HEX - SERRATED FLANGE - 3/8-16 X 1 3/4 - ZINC
	000C26-06-40B	EA	BOLT - HEX - SERRATED FLANGE - 3/8-16 X 2 1/2 - ZINC
	000C26-08-28B	EA	BOLT - HEX - SERRATED FLANGE - 1/2-13 X 1 3/4 - ZINC
	000C26-08-24B	EA	BOLT - HEX - SERRATED FLANGE - 1/2-13 X 1 1/2 - ZINC
	000C26-08-40B	EA	BOLT - HEX - SERRATED FLANGE - 1/2-13 X 21/2-GRADE #5 ZINC
	000C27-08-48B	EA	BOLT-CARR 1/2-13X3.00 GR5 - 97 M-SERIES
	000C27-08-64B	EA	BOLT - CARRIAGE - 1/2-13 X 4 - GRADE 5
	000D16-07-00B	EA	NUT - HEX - 7/16-14 - ZINC

SEALANTS & FASTENERS GROUP (CONTINUED)
BOLTS, NUTS AND WASHERS (CONTINUED)

KEY	PART NUMBER	U/M	DESCRIPTION
	000D24-10-00B	EA	NUT - HEX - SELF LOCKING - 10-32 - ZINC
	000D27-05-00B	EA	NUT - HEX LOCK - 5-40 - ZINC
	000D28-10-00B	EA	NUT - HEX - W/NYLON LOCK - 10-32 - ZINC
	000D29-04-00F	EA	NUT - HEX - SELF LOCKING - 1/4 X 20 - STAINLESS STEEL
	000D29-04-00B	EA	NUT - HEX - SELF LOCKING - 1/4 X 20 - ZINC
	000D29-06-00B	EA	NUT - HEX - W/NYLON LOCK - 3/8-16 - ZINC
	000D29-09-00B	EA	NUT - HEX - SELF LOCKING - 9/16-12 - ZINC
	000D34-04-00B	EA	NUT - HEX - LOCKING - 1/4-20 - ZINC
	000D34-06-00B	EA	NUT - HEX - LOCKING - 3/8-16 GRADE C - ZINC
	000D39-04-00B	EA	NUT - HEX - LOCKING W/SERRATED FLANGE - 1/4-20 - ZINC
	000D39-05-00B	EA	NUT - HEX - LOCKING W/SERRATED FLANGE - 5/16-18 - ZINC
	000D39-06-00B	EA	NUT - HEX - LOCKING W/SERRATED FLANGE - 3/8-18 - ZINC
	000D39-06-00D	EA	NUT - HEX - LOCKING W/SERRATED FLANGE - 3/8"-16 BLACK
	000D39-07-00B	EA	NUT - HEX - LOCKING W/SERRATED FLANGE - 7/16-14 - ZINC
	000D39-08-00B	EA	NUT - HEX - LOCKING W/SERRATED FLANGE - 1/2-13 - ZINC
	000D39-09-00B	EA	NUT - HEX - LOCKING W/SERRATED FLANGE - 9/16-12 - ZINC
	000D44-04-00B	EA	NUT - HEX - LOCKING W/SERRATED FLANGE - 1/4-28 - ZINC
	000D44-07-00B	EA	NUT - HEX - LOCKING W/SERRATED FLANGE - 7/16-20 - ZINC
	000D44-08-00B	EA	NUT - HEX - LOCKING W/SERRATED FLANGE - 1/2-20 - ZINC
	000D46-04-00A	EA	NUT - HEX - WELD - 1/4-20 - PLAIN
	000D65-08-00B	EA	NUT - HEX - LOCKING W/SERRATED FLANGE - 8-32 - ZINC
	000D73-08-00C	EA	NUT - HEX FLANGE - 1/2-13
	000D75-09-00B	EA	NUT - HEX LOCKING - 9/16-12 - ZINC
	000D76-06-00B	EA	NUT - HEX FLANGE - 3/8-16
	000E11-04-00F	EA	WASHER - LOCKING - 1/4 MED SPLIT - STAINLESS STEEL
	000E11-07-00B	EA	WASHER - LOCKING - 7/16 MED SPLIT - ZINC
	000E11-08-00B	EA	WASHER - LOCKING - 1/2 MED SPLIT - ZINC
	000E13-17-00B	EA	WASHER - FLAT - 3/8 AR - ZINC
	000E13-18-00B	EA	WASHER - FLAT - 3/8 WIDE - ZINC
	000E13-20-00B	EA	WASHER - FLAT - 7/16 WIDE - ZINC
	000E13-22-00B	EA	WASHER - FLAT - 1/2 WIDE - ZINC
	000E13-26-00B	EA	WASHER - FLAT - 5/8 WIDE - ZINC
	000E14-10-00B	EA	WASHER - LOCKING - #10 EXTERNAL TOOTH - ZINC
	000E16-10-00B	EA	WASHER - HARDENED - 5/8 - FLAT - ZINC
	000G45-05-16B	EA	BOLT - LAG - 5/16-9 X 1 - ZINC
	005081-01-000	EA	NUT - SPEED - C-TYPE - #8 SCREW
	039715-01-000	EA	NUT-SERT - 1/4" DIAMETER - 20 THREADS
	040921-01-000	EA	NUT - SPEED - U TYPE - #10-24 - BLACK
	040921-03-000	EA	NUT - SPEED - U TYPE - #10
	040921-04-000	EA	NUT - SPEED - U TYPE - #8-.59" LENGTH X .44" WIDTH
	040921-05-000	EA	NUT - SPEED - U-TYPE - 8-.67" X .44" WIDE
	040921-11-000	EA	NUT - SPEED - U-TYPE - 8-.59" LENGTH X .44" WIDTH - BLACK
	041322-01-000	EA	WASHER - FLANGE - 15/32"ID X 2 3/8"OD - F/SEAT BELT MTG
	044364-02-000	EA	NUT - SPEED - FLAT - ROUND
	044533-01-000	EA	WASHER - 1 3/8"OD - FOR BUTTONS - PLASTIC
	051387-06-000	EA	BOLT - CARRIAGE W/O HOLE - 5/16-18 X 9 1/2 - ZINC
	058716-02-000	EA	WASHER - FLAT NYLON
	064081-03-000	EA	NUT - WING 3/8-16 - W/WELD NUT
	077071-01-000	EA	WASHER - FENDER - 3/16"ID X 1"OD
	087234-01-000	EA	NUT - JACK - 1/4 X 20 THD - MOLLY
	088787-12-000	EA	STUD - WELD - 1/4 - 20 X 1.0 LG - MN
	102540-02-000	EA	SEAL - SCREW
	106956-03-000	EA	BOLT - HEX TAP - 1/2-13NC X 3 - GRADE 5 - FULL THREAD/ZINC
	106956-10-000	EA	BOLT - HEX TAP - 9/16-12NC X 3 5/8 -GRD 5-FULL THREAD/ZINC
	106956-11-000	EA	BOLT - HEX TAP - 1/2-13NC X 2 1/2 - GRD 5-FULL THREAD/ZINC
	106956-13-000	EA	BOLT - HEX TAP - 1/2-20 X 2 1/2 - GRD 5-FULL THREAD/ZINC
	107397-01-000	EA	WASHER - FENDER - 3/4"ID X 1"OD
	108067-03-000	EA	STUD - WELD - 1/4 - 20 X 1/2 CD
	109917-03-000	EA	WASHER - 1" X .50"
	109917-04-000	EA	WASHER - 1" X .75"
	128444-01-000	EA	WASHER - SPRING - CONICAL
	135092-02-01A	EA	BOLT - HEX - SERRATED FLANGE - 1/2-20 X 2 1/2-GRADE 5 ZINC
	135092-05-01A	EA	BOLT - HEX - SERRATED FLANGE - 1/2-20 X 1 - GRADE 5 ZINC
	143399-01-01A	EA	NUT/RETAINING - 3/8"- 24 NFT

SEALANTS & FASTENERS GROUP (CONTINUED)
BOLTS, NUTS AND WASHERS (CONTINUED)

KEY	PART NUMBER	U/M	DESCRIPTION
	144904-01-01A	EA	BOLT - ADJUSTMENT - HEADLAMP
	147284-02-000	EA	NUT/SELF RETAINING - 5/16"-18
	148817-01-000	EA	WASHER/SPUR - LOCKING

SCREWS

KEY	PART NUMBER	U/M	DESCRIPTION
	0G1208-12-170	EA	SCREW - 8-18 X 3/4 POH - BRIGHT WHITE
	0G3908-08-170	EA	SCREW - SF/DR - 8-18 X 1/2 PPH - BRIGHT WHITE
	0G3908-08-410	EA	SCREW - SF/DR - 8-18 X 1/2 PPH - PARCHMENT
	0G3908-16-170	EA	SCREW - SF/DR - 8-18 X 1 PPH - BRIGHT WHITE
	0G3908-24-170	EA	SCREW - SF/DR - 8-18 X 1 1/2 PPH - BRIGHT WHITE
	0G3910-10-330	EA	SCREW - SF/DR - 20-16 X 5/8 PPH - PUTTY
	0G3910-12-170	EA	SCREW - SF/DR - 10-16 X 3/4 PPH - BRIGHT WHITE
	0G3910-12-240	EA	SCREW - SF/DR - 10-16 X .75 PPH - VW LIGHT GRAY
	0G3910-12-380	EA	SCREW - SF/DR - 10-16 X .75 PPH - CASHMERE
	0G3910-12-370	EA	SCREW - SF/DR - 10-16 X .75 PPH - RIVERSTONE
	0G3910-24-170	EA	SCREW - SF/DR - 10-16 X 1 1/2 PPH - BRIGHT WHITE
	0G3910-32-330	EA	SCREW - SF/DR - 10-16 X 2.00 PPH - PUTTY
	0G5508-08-380	EA	SCREW - SF/DR - 8-18 X .5 PWH - CASHMERE
	0G5508-08-370	EA	SCREW - SF/DR - 8-18 X .5 PWH - RIVERSTONE
	0G5508-12-170	EA	SCREW - SF/DR - 8-18 X 3/4 PWH - BRIGHT WHITE
	0G5508-12-320	EA	SCREW - SF/DR - 8-18 X 3/4 PWH - GLACIER
	0G5508-12-330	EA	SCREW - SF/DR - 8-18 X 3/4 PWH - PUTTY
	0G6008-16-170	EA	SCREW - SF/DR - 8-18 X 1 POH - BRIGHT WHITE
	0G5508-16-250	EA	SCREW - SF/DR - 8-18 X 1 PWH - VW DARK GRAY
	0G5508-16-330	EA	SCREW - SF/DR - 8-18 X 1 PWH - PUTTY
	0G5508-16-370	EA	SCREW - SF/DR - 8-18 X 1 PWH - RIVERSTONE
	0G5508-16-380	EA	SCREW - SF/DR - 8-18 X 1 PWH - CASHMERE
	0G5508-16-410	EA	SCREW - SF/DR - 8-18 X 1 PWH - MEDIUM PARCHMENT
	0G6012-32-170	EA	SCREW - SF/DR - 12-14 X 2 POH - BRIGHT WHITE
	0G6710-08-170	EA	SCREW - 10-12 X 1/2 PPH - BRIGHT WHITE
	0G6710-12-170	EA	SCREW - 10-12 X 3/4 PPH - BRIGHT WHITE
	0G6806-16-170	EA	SCREW - 6-18 X 1 POH - BRIGHT WHITE
	0G6810-24-280	EA	SCREW - 10-12 X 1 1/2 POH - SOFT WHITE
	000C20-06-24T	EA	SCREW - 3/8-16 X 1 1/2 - FLAT SOCKET
	000C28-05-24D	EA	CAPSCREW/BUTTON HEAD - 5/16-18 X 1 1/2 - #8-BLK PHOSPHATE
	000G11-06-08B	EA	SCREW - 6-20 X 1/2 PPH - ZINC
	000G11-06-10B	EA	SCREW - 6-20 X 5/8 PPH - ZINC
	000G11-06-10J	EA	SCREW - 6-20 X 5/8 PPH - BRASS
	000G11-07-08B	EA	SCREW - 7-19 X 1/2 PPH - ZINC
	000G11-08-06B	EA	SCREW - 8-18 X 3/8 PPH - ZINC
	000G11-08-08T	EA	SCREW - 8-18 X 1/2 PPH - FLUOROCARBON COATING
	000G11-08-12B	EA	SCREW - 8-18 X 3/4 PPH - ZINC
	000G11-08-12P	EA	SCREW - 8-18 X 3/4 PPH - DARK BROWN
	000G11-08-12S	EA	SCREW - 8-18 X 3/4 PPH - OFF WHITE
	000G11-08-12T	EA	SCREW - 8-18 X 3/4 PPH - BLACK MAGNESIUM
	000G11-08-20B	EA	SCREW - 8-18 X 1 1/4 PPH - ZINC
	000G11-08-20G	EA	SCREW - 8-18 X 1 1/4 - ANTIQUE BRASS
	000G11-10-12D	EA	SCREW - 10-16 X 3/4 PPH - BLACK
	000G12-06-08T	EA	SCREW - 6-20 X 1/2 POH - BLACK
	000G12-06-12J	EA	SCREW - 6-20 X .75 POH - BRASS
	000G12-10-16F	EA	SCREW - 10-16 X 1 POH - STAINLESS STEEL
	000G13-05-10B	EA	SCREW - 5-12 X 5/8 PFH - ZINC
	000G13-06-08B	EA	SCREW - 6-20 X 1/2 PFH - ZINC
	000G13-06-08G	EA	SCREW - 6-20 X 1/2 PFH - ANTIQUE BRASS
	000G13-06-10G	EA	SCREW - 6-20 X 5/8 PFH - ANTIQUE BRASS
	000G13-06-16J	EA	SCREW - 6-20 X 1 PFH - BRASS
	000G13-06-169	EA	SCREW - SF/DR - 6-20 X 1 PFH - SILVER
	000G13-06-24J	EA	SCREW - 6-20 X 1 1/2 PFH - BRASS
	000G13-07-10H	EA	SCREW - 7-19 X 5/8 PFH - BLACK
	000G13-07-12B	EA	SCREW - 7-19 X 3/4 PFH - ZINC
	000G13-08-109	EA	SCREW - 8-18 X 5/8 PFH
	000G13-08-10B	EA	SCREW - 8-18 X 5/8 PFH - ZINC
	000G13-08-16B	EA	SCREW - 8-18 X 1 PFH - ZINC

SEALANTS & FASTENERS GROUP (CONTINUED)
SCREWS (CONTINUED)

KEY	PART NUMBER	U/M	DESCRIPTION
	000G13-08-24B	EA	SCREW - 8-18 X 1 1/2 PFH - ZINC
	000G16-04-24B	EA	SCREW - MACHINE - 1/4-20 X 1 1/2 PPH
	000G18-08-12B	EA	SCREW - MACHINE - 8-32 X 3/4 PPH - ZINC
	000G18-08-16B	EA	SCREW - MACHINE - 8-32 X 1 PPH - ZINC
	000G18-08-24B	EA	SCREW - MACHINE - 8-32 X 1 1/2 PPH - ZINC
	000G18-08-22B	EA	SCREW - MACHINE - 8-32 X 1 3/8 PPH - ZINC
	000G19-10-08B	EA	SCREW - MACHINE - 10-32 X 1/2 PPH - ZINC
	000G19-10-10B	EA	SCREW - MACHINE - 10-32 X 5/8 - PPH - ZINC
	000G19-10-12F	EA	SCREW - MACHINE - 10-32 X 3/4 PPH - STAINLESS STEEL
	000G19-10-20B	EA	SCREW - MACHINE - 10-32 X 1 1/2 PPH - ZINC
	000G32-10-06B	EA	SCREW - 10-32 X 3/8 PPH - ZINC
	000G34-05-12B	EA	SCREW - HEX HEAD TAPPING - 5/16 X 3/4 LONG
	000G36-10-12T	EA	SCREW - 10-24X 3/4 PFH TYPE 23 - BLACK
	000G39-06-10T	EA	SCREW - SF/DR - 6-20 X 5/8 PPH - BLACK
	000G39-06-16T	EA	SCREW - SF/DR - 6-20 X 1 PPH - BLACK
	000G39-08-06B	EA	SCREW - SF/DR - 8-18 X 3/8 PPH - ZINC
	000G39-08-08B	EA	SCREW - SF/DR - 8-18 X 1/2 PPH - ZINC
	000G39-08-08S	EA	SCREW - SF/DR - 8-18 X 1/2 PPH - OFF WHITE
	000G39-08-08T	EA	SCREW - SF/DR - 8-18 X 1/2 PPH - BLACK
	000G39-08-12T	EA	SCREW - SF/DR - 8-18 X 3/4 PPH - BLACK
	000G39-08-16B	EA	SCREW - SF/DR - 8-18 X 1 PPH - ZINC
	000G39-08-16T	EA	SCREW - SF/DR - 6-20 X 1 PPH - BLACK
	000G39-08-24B	EA	SCREW - SF/DR - 8-18 X 1 1/2 PPH - ZINC
	000G39-08-24S	EA	SCREW - SF/DR - 8-18 X 1 1/2 - OFF WHITE
	000G39-08-24T	EA	SCREW - SF/DR - 8-18 X 1 1/2 PPH - BLACK
	000G39-08-32B	EA	SCREW - SF/DR - 8-18 X 2 PPH - ZINC
	000G39-10-08B	EA	SCREW - SF/DR - 10-16 X 1/2 PPH - ZINC
	000G39-10-10B	EA	SCREW - SF/DR - 10-16 X 5/8 PPH - ZINC
	000G39-10-12B	EA	SCREW - SF/DR - 10-16 X 3/4 PPH - ZINC
	000G39-10-129	EA	SCREW - SF/DR - 10-16 X 3/4 PPH - FLUOROCARBON SILVER
	000G39-10-169	EA	SCREW - SF/DR - 10-16 X 1 PPH - FLUOROCARBON SILVER
	000G39-10-20B	EA	SCREW - SF/DR - 10-16 X 1 1/4 PPH - ZINC
	000G39-10-20T	EA	SCREW - SF/DR - 10-16 X 1 1/4 PPH - BLACK
	000G39-10-24T	EA	SCREW - SF/DR - 10-16 X 1 1/2" PPH - BLACK
	000G39-10-28T	EA	SCREW - SF/DR - 10-16 X 1 3/4" PPH - BLACK
	000G39-10-32B	EA	SCREW - SF/DR - 10-16 X 2 - PPH - ZINC
	000G39-10-48B	EA	SCREW - SF/DR - 10-16 X 3 - PPH - ZINC
	000G39-10-48T	EA	SCREW - SF/DR - 10-16 X 3 PPH - BLACK
	000G42-04-16B	EA	SCREW - SF/DR - 1/4-14 X 1 HWH - ZINC
	000G42-04-24B	EA	SCREW - SF/DR - 1/4-14 X 1 1/2 - ZINC
	000G46-08-24T	EA	SCREW - MACHINE - 8-32 X 1 1/2 PFH - ZINC
	000G52-06-05B	EA	SCREW - MACHINE - 6-32 X 5/16 PTH - ZINC
	000G52-06-06B	EA	SCREW - MACHINE - 6-32 X 3/8 PTH - ZINC
	000G54-04-14B	EA	SCREW - 1/4-20 X 7/8 PTH - TYPE 23 - ZINC PLATED
	000G55-08-12T	EA	SCREW - SF/DR - 8-18 X 3/4 PWH - BLACK
	000G55-08-124	EA	SCREW - SF/DR - 8-18 X 3/4 PWH - ASH GRAY
	000G55-08-16T	EA	SCREW - SF/DR - 8-18 X 1 PWH - BLACK
	000G56-12-48B	EA	SCREW - WOOD - 12-11 X 3 POH - SPECIAL HARDENED
	000G57-14-64B	EA	SCREW - 14-10 X 4 PFH ZINC
	000G60-08-16E	EA	SCREW - SF/DR - 8-1 X 1 POH - CHROME
	000G60-08-20F	EA	SCREW - SF/DR - 8-19X1.25 POH
	000G60-08-22B	EA	SCREW - SF/DR - 8-18 X 1.38 POH - ZINC
	000G60-10-16J	EA	SCREW - SF/DR - 10-16 X 1 POH - BRIGHT BRASS
	000G60-10-20B	EA	SCREW - SF/DR - 10-16 X 1 1/4 POH - ZINC
	000G60-10-209	EA	SCREW - SF/DR - 10-16 X 1 1/4 POH - SILVER STALGAARD
	000G60-10-28T	EA	SCREW - SF/DR - 10-16 X 1 3/4 - BLACK
	000G62-06-24I	EA	SCREW - SF/DR - 8-18 X 1.5 PPH - BLACK
	000G62-06-249	EA	SCREW - SF/DR - 8-18 X 1.5 PPH - SILVER
	000G62-08-24B	EA	SCREW - SF/DR - 8-18 X 1 1/2 PFH
	000G67-08-32B	EA	SCREW - 8-15 X 2 PPH - ZINC
	000G67-10-08B	EA	SCREW - 10-12 X 1/2 PPH - ZINC
	000G67-10-08S	EA	SCREW - 10-12 X 1/2 PPH - OFF WHITE
	000G67-10-10B	EA	SCREW - 10-12 X 5/8 PPH - ZINC - TYPE A
	000G67-10-10S	EA	SCREW - 10-12 X 5/8 PPH - OFF WHITE

SEALANTS & FASTENERS GROUP (CONTINUED)
SCREWS (CONTINUED)

KEY	PART NUMBER	U/M	DESCRIPTION
	000G67-10-10T	EA	SCREW - 10-12 X 5/8 PPH - BLACK
	000G67-10-10P	EA	SCREW - 10-12 X 5/8 PPH - DARK BROWN
	000G67-10-12P	EA	SCREW - 10-12 X 3/4 PPH - DARK BROWN
	000G67-10-24B	EA	SCREW - 10-12 X 1 1/2 PPH - ZINC
	000G67-10-24S	EA	SCREW - 10-12 X 1 1/2 PPH - OFF WHITE
	000G67-10-32J	EA	SCREW-10-12X2 PPH - BRIGHT BRASS
	000G68-06-10J	EA	SCREW - 6-18 X 5/8 POH - BRASS
	000G68-06-12B	EA	SCREW - 6-18 X 3/4 POH - ZINC & CLEAR
	000G68-06-12J	EA	SCREW - 6-18 X 3/4 POH - BRASS
	000G68-06-12S	EA	SCREW - 6-18 X 3/4 POH
	029130-01-000	EA	SCREW - SNAP STUD - #8-16 X 5/8" LONG
	029130-03-000	EA	SCREW - SNAP STUD - #8-16 X 1" LONG
	049465-01-000	EA	SCREW - 10-16 PTH W/WASHER - DARK BROWN
	049465-03-000	EA	SCREW - 10-16 X 1 POH W/WASHER - OFF WHITE
	049465-13-000	EA	SCREW - 10-16 X 1 PTH W/WASHER - ASH GRAY
	049465-17-000	EA	SCREW - 10-16 X 1 POH W/WASHER - BRIGHT WHITE
	049465-18-000	EA	SCREW - 10-16 X 1 POH W/WASHER - VW GRAY
	054434-02-000	EA	SCREW - SF/DR - 10-16 X 2 - ZINC
	054434-03-000	EA	SCREW - SF/DR - 10-16 X 2 - PWH - ZINC
	075908-01-000	EA	SCREW - MACHINE - 10-32 X .56 PTH - EXTERNAL TOOTH - ZINC
	076790-01-000	EA	SCREW - 6-20 X 1 1/4 PPH - BLACK
	076790-05-000	EA	SCREW - 6-20 X 1/2 PPH - BLACK - THREAD CUTTING/WOOD
	083554-01-000	EA	SCREW - DRYWALL - 8 X 1 1/4
	083554-04-000	EA	SCREW - DRYWALL - 8 X 2 1/2
	087721-01-000	EA	SCREW - FLAT HEAD - TAPPING - 1/4" X 1 1/4" LONG - ZINC
	095772-01-000	EA	SOCKET-SNAP FASTNER1" SF/DR - SELF DRIVER
	097974-01-000	EA	SCREW - PARTICLE BOARD - 7-9 X 3/4 PPH
	097974-02-000	EA	SCREW-PART BD 8-9X.75 PFH - BEIGE
	101618-01-000	EA	SCREW - 1/4-20 X 3/4 HEX - TAPPING - STALGARD TYPE F
	113563-01-01A	EA	SCREW - 8 X 5/8 LONG SHOULDER/WASHER HEAD
	113563-01-02A	EA	SCREW - 8 X 5/8 LONG SHOULDER/WASHER HEAD - BRIGHT WHITE
	118383-01-09A	EA	RETAINER/RECESSED - F/.22" SCREW - GLACIER
	118383-01-12A	EA	RETAINER/RECESSED - F/.22" SCREW - RIVERSTONE
	118383-01-10A	EA	RETAINER/RECESSED - F/.22" SCREW - STORM GRAY
	118383-01-11A	EA	RETAINER/RECESSED - F/.22" SCREW - CASHMERE
	118383-02-10A	EA	RETAINER/RECESSED - F/.27" SCREW - RIVERSTONE
	118383-02-11A	EA	RETAINER/RECESSED - F/.27" SCREW - CASHMERE
	118383-02-13A	EA	RETAINER/RECESSED - F/.27" SCREW - OFF WHITE
	118383-03-09A	EA	RETAINER/RECESSED - F/.32" SCREW - GLACIER
	118383-04-04A	EA	CAP - F/RECESSED RETAINER - BRIGHT WHITE
	118383-04-09A	EA	CAP - F/RECESSED RETAINER - GLACIER
	118383-04-10A	EA	CAP - F/RECESSED RETAINER - RIVERSTONE
	118383-04-11A	EA	CAP - F/RECESSED RETAINER - CASHMERE
	118383-04-12A	EA	CAP - F/RECESSED RETAINER - STORM GRAY
	118383-04-13A	EA	CAP - F/RECESSED RETAINER - OFF WHITE
	134126-01-01A	EA	SCREW/NAIL - HEX HEAD - 3/4"
	140040-01-000	EA	SCREW - 1/4-20 X 1 - BUTTON HEAD/SOCKET - W/LOCTITE
	149753-01-01A	EA	RETAINER/RECESSED - F/.22" SCREW - BLACK
	149753-01-02A	EA	RETAINER/RECESSED - F/.22" SCREW - BRIGHT WHITE
	149753-02-01A	EA	CAP - F/RECESSED RETAINER - BLACK
	149753-02-02A	EA	CAP - F/RECESSED RETAINER - BRIGHT WHITE
	154938-01-01A	EA	SCREW - SF/DR - 10-16 X 3/4 PPH - W/SELF SEAL - BRIGHT WHITE
	154938-01-02A	EA	SCREW - SF/DR - 10-16 X 3/4 PPH - W/SELF SEAL - BLACK
	154938-02-01A	EA	SCREW - SF/DR - 8-18 X 1 PFH - W/SELF SEAL - BRIGHT WHITE
	154938-02-02A	EA	SCREW - SF/DR - 8-18 X 1 PFH - W/SELF SEAL - BLACK
	154938-02-03A	EA	SCREW - SF/DR - 8-18 X 1 PFH - W/SELF SEAL - SILVER
	154938-03-01A	EA	SCREW - SF/DR - 8-18 X 5/8 PFH - W/SELF SEAL - BRT WHT
	154935-03-02A	EA	SCREW - SF/DR - 8-18 X 5/8 PFH - W/SELF SEAL - BLACK
	154938-04-01A	EA	SCREW - SF/DR - 10-16 X 1" TPH - W/SELF SEAL - BRT WHT
	154938-04-02A	EA	SCREW - SF/DR - 10-16 X 1" TPH - W/SELF SEAL - BLACK
	154938-05-03A	EA	SCREW - SF/DR - 8-18 X 1.25" PFH - W/SELF SEAL - SILVER

SEALANTS & FASTENERS GROUP (CONTINUED)
CLAMPS, CLIPS, GROMMETS, RIVETS & PLUGS

KEY	PART NUMBER	U/M	DESCRIPTION
	000H16-04-06R	EA	RIVET - POP ALUMINUM - 1/8 X .313 - .375
	000H16-06-10R	EA	RIVET - POP ALUMINUM - 3/16 X .501 - .625
	007161-01-000	EA	CLAMP - HOSE - SPRING TYPE - 1/2"
	008386-01-000	EA	GROMMET - SNAP - 3/8" DIAMETER - NYLON
	010495-01-000	EA	CLAMP - CABLE - 9/16"ID - BLACK
	010495-02-000	EA	CLAMP - CABLE - 3/8"ID - BLACK
	010495-04-000	EA	CLAMP - CABLE - 11/16"ID - WHITE
	010497-01-000	EA	CLAMP - CLOSED - 5/8"ID
	010497-02-000	EA	CLAMP - CLOSED - 1.5"ID
	010497-03-000	EA	CLAMP - CLOSED - 1"ID - CUSHIONED
	010497-04-000	EA	CLAMP - CLOSED - 1 5/8"ID
	010497-05-000	EA	CLAMP - CLOSED - 1/2"ID
	010497-07-000	EA	CLAMP - CLOSED - 3/8"ID
	010497-09-000	EA	CLAMP - CLOSED - 5/16"ID
	010497-10-000	EA	CLAMP - CLOSED - 7/8"ID
	010499-01-000	EA	CLAMP - CLOSED - 3/8"ID
	016188-03-000	EA	GROMMET - LP LINE - 3/8"HOLE X 2 1/2"LONG - RUBBER
	016188-04-000	EA	GROMMET - LP LINE - 1/2"HOLE X 2 1/2"LONG - RUBBER
	016188-05-000	EA	GROMMET - LP LINE - 3/8"HOLE X 1 1/4"LONG - RUBBER
	016188-06-000	EA	GROMMET - LP LINE - 3/8"HOLE X 3 1/4"LONG - RUBBER
	016188-07-000	EA	GROMMET - L/P LINE - 1/2"HOLE X 3 1/4"LONG
	016188-08-000	EA	GROMMET - LP LINE - 1/2"HOLE X 1 1/4"LONG - RUBBER
	016188-09-000	EA	GROMMET - LP LINE - .68"HOLE X 1 1/4"LONG - RUBBER
	016188-10-000	EA	GROMMET - LP GAS - .68" X 2.5"
	023942-01-000	EA	GROMMET - RUBBER - 2"OD
	041930-11-000	EA	RIVET - POP ALUMINUM - 1/8 X .188 - .250 - BRIGHT WHITE
	061420-04-000	EA	PLUG/PLASTIC - 1 1/4" DIAMETER
	061420-05-000	EA	PLUG/PLASTIC - 1 1/2" DIAMETER
	061420-09-000	EA	PLUG/PLASTIC - 1.00" DIAMETER
	061420-10-000	EA	PLUG/PLASTIC - 1 1/2" DIAMETER - BLACK
	061420-12-000	EA	PLUG/PLASTIC - 1.50" DIAMETER - RED
	061420-13-000	EA	PLUG/PLASTIC - 3/8" - FLUSH
	061420-14-000	EA	PLUG/PLASTIC - 7/8" DIAMETER - BLACK
	061420-15-000	EA	PLUG/PLASTIC - 2" DIAMETER - BLACK
	061420-16-000	EA	PLUG/PLASTIC - 2 1/8" DIAMETER - BLACK
	062401-01-000	EA	CLAMP - HOSE - WORMGEAR - .25" - 1"
	062401-02-000	EA	CLAMP - HOSE - WORMGEAR - 1.56" - 2.5" ID
	062401-03-000	EA	CLAMP - HOSE - WORMGEAR - .22" - 1" ID
	062401-04-000	EA	CLAMP - HOSE - WORMGEAR - .69" - 1.25" ID
	062401-05-000	EA	CLAMP - HOSE - WORMGEAR - 2" - 3" ID
	062401-06-000	EA	CLAMP - HOSE - WORMGEAR - .22" - .62" ID
	062401-09-000	EA	CLAMP - HOSE - WORMGEAR - 2.8" - 3.75" ID
	062401-11-000	EA	CLAMP - HOSE - WORMGEAR - 3.50" - 4.50" ID
	062401-13-000	EA	CLAMP - HOSE - WORMGEAR
	063729-12-000	EA	RIVNUT - 5/16 - 18 UNCUT - FLATHEAD - STAINLESS
	071015-01-000	EA	GROMMET - RUBBER - .5"ID X 1"OD-W/.38" GROOVE - BLACK
	071015-11-000	EA	GROMMET - RUBBER - 1"ID FITS .12 MATERIAL - BLACK
	071015-13-000	EA	GROMMET - RUBBER - .62"ID X 1"OD W/.09" GROOVE - BLACK
	071015-22-000	EA	GROMMET - RUBBER - .62"ID X 1.12"OD W/.19" GROOVE - BLACK
	071015-26-000	EA	GROMMET - RUBBER - 1.5"ID X 2.1"OD W/.06" GROOVE - BLACK
	071015-29-000	EA	GROMMET - RUBBER - .3"ID X 1.3"OD W/.12" GROOVE - BLACK
	071015-30-000	EA	GROMMET - RUBBER - .3"ID X .81"OD W/.12" GROOVE - BLACK
	071015-39-000	EA	GROMMET - .75 ID FITS .06 MTL
	071015-41-000	EA	GROMMET - .125 ID FITS .188 MTL
	071015-42-000	EA	GROMMET - .25 ID FITS .06 MTL
	075148-02-000	EA	CLAMP - GROUNDING - BRONZE SCREWS
	077955-01-000	EA	CLIP/J - 3/8" - VINYL COATED
	080734-02-000	EA	CLIP - WIRE NYLON
	081211-01-000	EA	PLUG - PLASTIC - .31"DIA - BLACK
	081211-03-000	EA	PLUG - PLASTIC - .50"DIAMETER - TRUSS HEAD - BLACK
	081211-04-000	EA	PLUG - PLASTIC - .46"DIAMETER - TRUSS HEAD - BLACK
	083609-01-000	EA	CLAMP - WIRE - DUAL - EQUAL DIAMETERS - 5/8"
	083610-01-000	EA	CLAMP - WIRE - DUAL - UNEQUAL DIAMETERS - 3/4" & 1 1/4"
	083610-02-000	EA	CLAMP - WIRE - DUAL - UNEQUAL DIAMETERS - 3/4" & 2"

SEALANTS & FASTENERS GROUP (CONTINUED)
CLAMPS, CLIPS, GROMMETS, RIVETS & PLUGS (CONTINUED)

KEY	PART NUMBER	U/M	DESCRIPTION
	083610-03-000	EA	CLAMP - WIRE - DUAL - EQUAL DIAMETERS - 2"
	088756-01-000	EA	GROMMET - WEB - 1 1/8"ID
	089329-02-000	EA	CLIP - SPRING
	091952-01-000	EA	CLIP - GRIPPER - 1" - BLACK VINYL COATED
	091952-02-000	EA	CLIP - GRIPPER - 3/4" - BLACK VINYL COATED
	091952-03-000	EA	CLIP - GRIPPER - 1/2" - BLACK VINYL COATED
	094362-02-000	EA	CLIP - XMAS TREE - BINDER HEAD - .9" LONG/ANY COLOR
	094362-05-000	EA	CLIP - XMAS TREE - ROUND HEAD - 1.4" LONG/ANY COLOR
	113133-02-01A	EA	RIVET - POP - ALUMINUM - 3/16 X .252 - .504 - BLACK
	114208-05-000	EA	GROMMET - EDGE LINER - FITS 2"
	118626-01-02A	EA	RIVET/POP - ALUMINUM - 3/16 X .08 - .375
	118626-01-01A	EA	RIVET/POP - ALUMINUM - 3/16 X 1.2"(GRIP RANGE .1"-.4")
	118626-02-01A	EA	RIVET/POP - ALUMINUM - 3/16 X .500 - .750
	118626-03-01A	EA	RIVET/POP - STAINLESS STEEL - 3/16 X .500 - .750
	137014-01-02A	EA	GROMMET - CABLE - BROWN
	137014-01-01A	EA	GROMMET - CABLE - ALMOND
	137014-01-03A	EA	GROMMET - CABLE - BLACK
	139118-02-01A	EA	GROMMET - SCREW - PLASTIC
	155498-01-01A	EA	CLAMP - CLOSED - 7/8"ID - VINYL DIP/GALVONIZED - BLACK

MISCELLANEOUS FASTENERS

KEY	PART NUMBER	U/M	DESCRIPTION
	008343-01-000	EA	TIE - WIRE - 6"
	008343-02-000	EA	TIE - WIRE - 14"
	008343-03-000	EA	TIE - WIRE - 7 1/2" - BLACK
	029094-04-000	YD	VELCRO TAPE/LOOP - 1"WIDE - W/ADHESIVE BACK - BLACK
	029096-04-000	YD	VELCRO TAPE/HOOK - 1"WIDE - BLACK - W/ADHESIVE BACK (PSA)
	048394-02-000	YD	VELCRO TAPE - HOOK - ADHESIVE BACK - 3/4" WIDE - BEIGE
	085774-01-000	FT	FASTENER - DUAL LOCK - 1" WIDE - ADHESIVE BACK - BLACK
	085774-02-000	FT	FASTENER - DUAL HOOK - 1" WIDE - ADHESIVE BACK - BLACK
	088792-02-000	YD	VELCRO TAPE - LOOP - 3/4" - ADHESIVE BACK - BEIGE
	088792-04-000	YD	VELCRO TAPE - HOOK - 5/8" - NON-ADHESIVE BACK - WHITE
	088792-05-000	YD	VELCRO TAPE - LOOP - 5/8" - NON-ADHESIVE BACK - WHITE
	108046-02-000	EA	CABLE TIE - SCREW MOUNT 15"

WATER & SEWAGE GROUP DRAINAGE SYSTEM

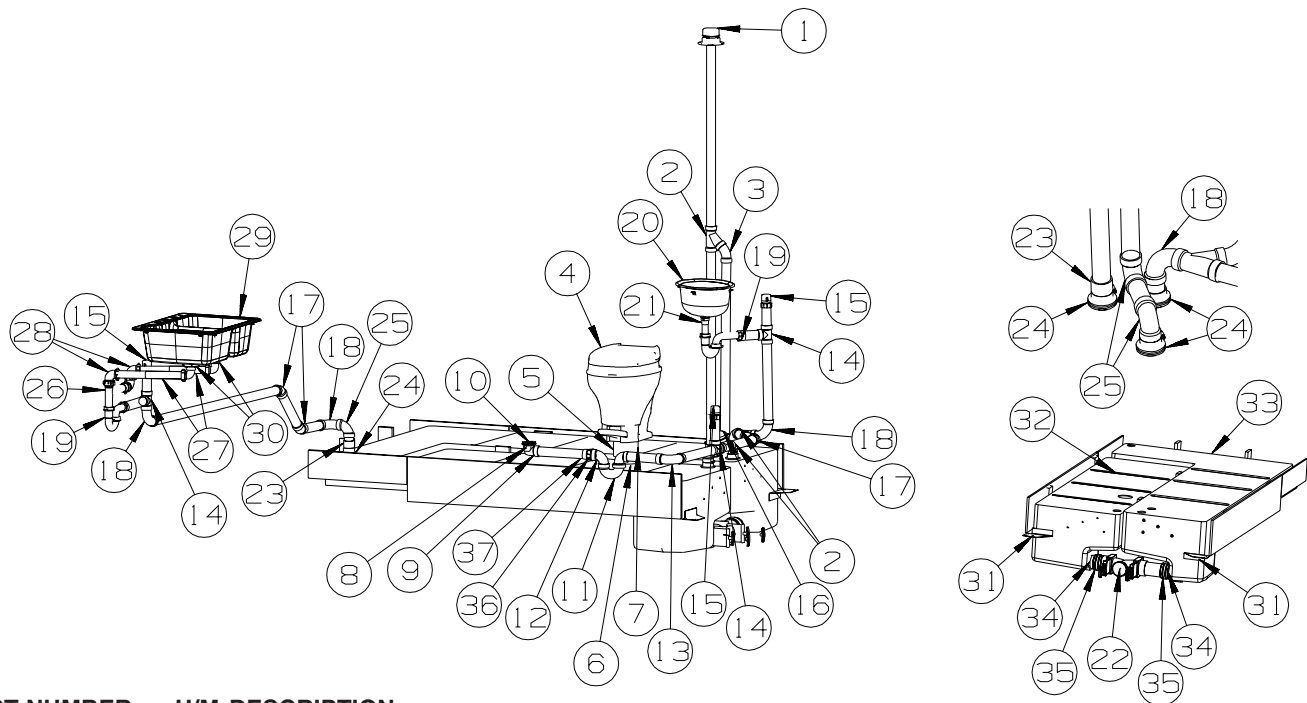

KEY	PART NUMBER	U/M	DESCRIPTION
1	083558-03-000	EA	VENT - W/COVER - F/PLUMBING STACK - OFF WHITE
2	010073-01-000	EA	WYE - 45 DEGREE - 1 1/2" HUB X HUB X HUB - PLASTIC
3	010051-01-000	EA	ELBOW - 45 DEGREE - 1 1/2" SPIGOT X HUB - PLASTIC
4*	147421-01-01A	EA	TOILET/AQUA MAGIC 5 (HIGH) FOOTFLUSH - W/SPRAY - WHITE
5	143289-01-000	EA	ADAPTER - DUCT - 5"
6	061607-02-000	EA	GROMMET - HOLDING TANK - 3" NPS
7	024676-01-000	EA	FLANGE/CLOSET - 4" X 3" - BLACK PLASTIC
8	130403-01-000	EA	NUT - SLIP - W/WINGS 1 1/2"
9	131486-01-000	EA	ELBOW - DRAIN 1 1/2" - LOW PROFILE - TUB DRAIN
10	066440-01-000	EA	STRAINER - SHOWER DRAIN - W/RUBBER WASHER
11	037763-01-000	EA	P-TRAP - PLASTIC - 1 1/2 HXH W/UNION
12	010009-01-000	EA	ELBOW - 90 DEGREE - 1/4 BEND - 1 1/2" - PLASTIC
13	010008-01-000	EA	ELBOW - 90 DEGREE - 1 1/2" HUB X HUB - PLASTIC
14	010071-01-000	EA	TEE - SANITARY - 1 1/2" HUB X HUB X HUB - PLASTIC
15	079968-01-000	EA	VENT - MECHANICAL/TRAP ARM - ANTI-SIPHON-2" X 7.3" PLASTIC
16	010122-01-000	EA	BUSHING/PLASTIC - REDUCER - 1 1/2"SMTH X 1 1/4"THD - BLACK
16	010166-01-000	EA	PLUG/THREADED - 1 1/4"MPT - PLASTIC - BLACK - UL
17	010006-01-000	EA	ELBOW - 45 DEGREE - 1 1/2" HUB X HUB - PLASTIC
18	033761-01-000	EA	ELBOW - 90 DEGREE - TURN - 1 1/2" HUB X 1 1/2" SPIGOT
19	152146-01-000	EA	CONNECTOR - 1 1/2"P X 1 1/2"MPT
19	107538-02-000	EA	P-TRAP - PLASTIC - 1 1/2" W/EXTENSION ARM
19	011071-01-000	EA	P-TRAP - 1 1/2" - CSA - PLASTIC - CANADIAN
20	156661-01-01A	EA	SINK - LAVATORY - OVAL - 15" X 12" X 6.5" - GLACIER WHITE
21	106116-01-02A	EA	STRAINER/PLASTIC - STOPPER/TAILPIECE/GASKET & NUT-LAVATORY
21	106116-02-01A	EA	GASKET - STRAINER
22	136143-01-000	EA	VALVE - DUAL - 3" X 3"
22	139513-01-000	EA	HOSE - SEWER - 3" X 10' - W/BAYONET TYPE ADAPTER
22	062416-01-000	EA	ADAPTER - SEWER HOSE TO 3" PIPE
23	010115-01-000	EA	COUPLING - 1 1/2" HUB X HUB - PLASTIC
24	061607-01-000	EA	GROMMET - HOLDING TANK - 1 1/2" NPS
25	034250-01-000	EA	ELBOW - 90 DEGREE - LONG TURN - 1 1/2" HUB X HUB - ABS
26	011091-02-000	EA	WASTE - CONTINUOUS - DOUBLE SINK
27	126588-01-000	EA	ARM - WASTE - 1 1/2" X 9 1/2" - FEMALE
28	125569-01-000	EA	ELBOW - 1 1/2" X 90 DEGREE - DOUBLE SLIP
29	148870-01-01A	EA	SINK/DOUBLE - LRG/SML BASIN - 25" X 19" X 7"
	127440-02-01A	EA	WASHER - RUBBER - 1.8" X .1"
30	092303-01-000	EA	STRAINER - W/BASKET - GALLEY SINK - 4" OD
31	139004-01-02B	EA	BRACKET/TIEDOWN - WATER TANK - E-COATED

WATER & SEWAGE GROUP (CONTINUED)
DRAINAGE SYSTEM (CONTINUED)

KEY	PART NUMBER	U/M	DESCRIPTION
32	133436-01-700	EA	TANK - HOLDING - 41 GALLON - W/3" NIPPLE - W/O FITTINGS
	049032-01-000	EA	PATCH - SPINWELD - 3/8" - PLASTIC
33	142301-01-700	EA	TANK - HOLDING - 57 GALLON - W/3" NIPPLE OUTLET
	049032-01-000	EA	PATCH - SPINWELD - 3/8" - PLASTIC
34	010129-03-000	EA	NIPPLE - 3" X 3" TOE - PLASTIC
35	078406-01-000	EA	COUPLER - 3" X 3" W/CLAMPS - RUBBER
36	126425-02-000	EA	ADAPTER - SWIVEL - 1 1/2 FPT X SPIGOT
37	126424-01-000	EA	ADAPTER - 1 1/2" MPT X 1 1/2" HUB

***COMPONENT PARTS LISTED LATER IN THIS GROUP**

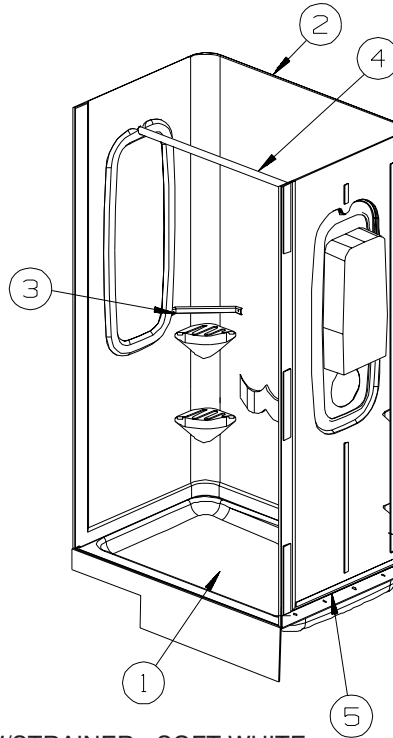

KEY	PART NUMBER	U/M	DESCRIPTION
1	M02630-80-R28	EA	SHOWER PAN - W/STRAINER - SOFT WHITE
2	147188-03-01A	EA	SURROUND/SHOWER - SOFT WHITE
3	113714-04-02A	EA	RETAINER - SHELF/SHOWER - SOFT WHITE
4	102075-18-02A	EA	ROD - SHOWER CURTAIN - 1" OD X 38.9" - SOFT WHITE
	081114-02-000	EA	CAP - INSERT/ROUND - 1" DIAMETER - WHITE PLASTIC
5	154585-03-01A	FT	SEAL - FOAM TAPE - ADHESIVE BACK - 1/8" X 3/4" - GRAY

WATER & SEWAGE GROUP (CONTINUED)
COMPONENT PARTS FOR DRAINAGE SYSTEM

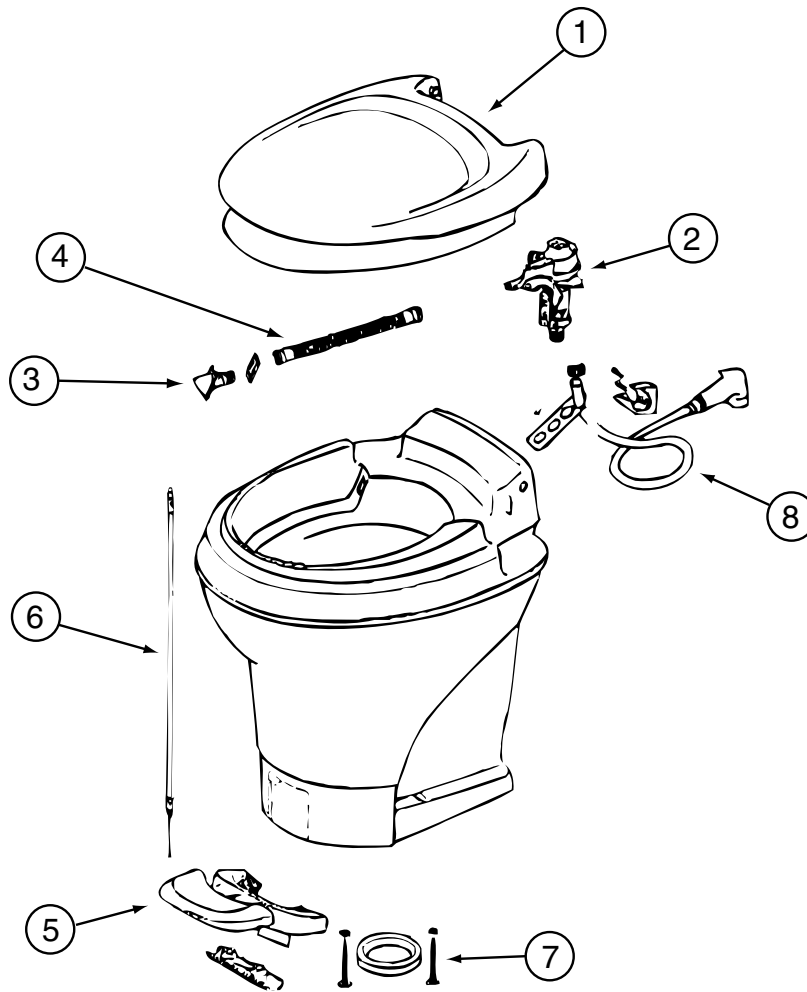

147421-01-01A, 147421-02-01A

KEY	PART NUMBER	U/M	DESCRIPTION	VENDOR NO.
1	147421-01-700	EA	SEAT & COVER ASSEMBLY(WHT)	31703
2	147421-01-701	EA	WATER MODULE ASSEMBLY	31705
3	147421-01-702	EA	NOZZLE ASSEMBLY	31706
4	147421-01-703	EA	LINK - WATER MODULE	31621
5	147421-01-704	EA	PEDAL - WHITE	31709
6	147421-01-705	EA	FOOT CABLE	31711
7	063740-01-706	EA	BOLT PACKAGE-FLOOR FLANGE	12524 THETFORD
8	147421-01-708	EA	HAND SPRAY KIT - WHITE HEAD	33226
	147421-01-706	EA	SEAL - BLADE	31708
	147421-01-707	EA	CAP (UNIVERSAL BOLT) - WHITE	31713

WATER & SEWAGE GROUP (CONTINUED)

WATER SYSTEM

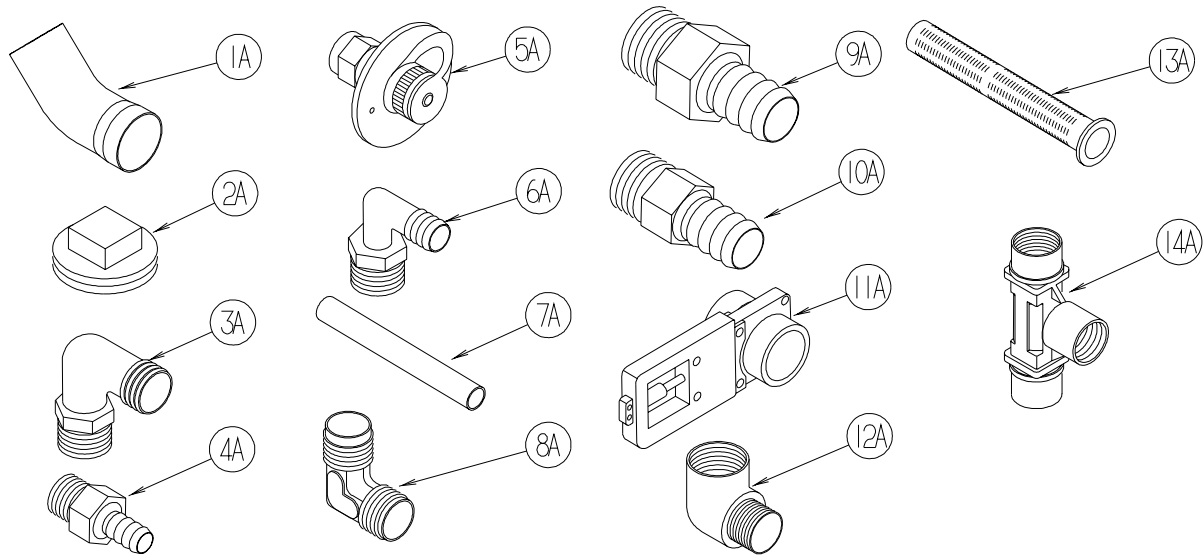

KEY	PART NUMBER	U/M	DESCRIPTION
1A	010009-01-000	EA	ELBOW - 90 DEGREE - 1/4 BEND - 1 1/2" PLASTIC
2A	010166-01-000	EA	PLUG/THREADED - 1 1/4"MPT - PLASTIC - BLACK - UL
3A	010219-01-000	EA	ELBOW - 1 1/4 MPT X 1 1/4 BARB - WATER FILL - PLASTIC
4A	010224-01-000	EA	ADAPTER - HOSE TO PIPE - 3/8 MPT X 3/8 BARB - PLASTIC
5A	010230-06-000	EA	FILL - CITY WATER - W/CHECK VALVE - MPT - BRUSHED ALUM
6A	035539-01-000	EA	ELBOW - 3/8 MPT X 3/8 BARB - PLASTIC
7A	039800-04-000	FT	TUBING - POLYBUTYL - 1/4"OD
7A	074462-02-000	FT	TUBING - VINYL - 3/8 ID X 20' - CLEAR
7A	112176-01-000	FT	TUBING - VINYL - REINFORCED - 1/2" ID
7A	124188-01-000	FT	TUBING - PEX - 1/2" ID X 20' - BLUE(COLD)
7A	124188-02-000	FT	TUBING - PEX - 1/2" ID X 20' - RED(HOT)
8A	039808-03-000	EA	ELBOW - 1/2" MPT X 1/2" MPT - PLASTIC
9A	044927-01-000	EA	ADAPTER - HOSE TO PIPE-1 1/4 MPTX1 1/4 BARB-BLACK PLASTIC
10A	044927-02-000	EA	ADAPTER - REDUCING - 1" MPT X 1.3" BARB - PLASTIC
11A	062421-03-000	EA	VALVE/DUMP W/O HANDLE - 1 1/2" X 1 1/2" HUB
	062421-05-000	EA	CABLE/ROD - F/DUMP VALVE - W/HANDLE - 48"
	062421-07-000	EA	CABLE/ROD - F/DUMP VALVE - W/HANDLE - 144"
	062421-08-000	EA	CABLE/ROD - F/DUMP VALVE - W/HANDLE - 108"
12A	065318-02-000	EA	ELBOW - 90 DEGREE - 3/8" MPT TO 3/8" FPT
13A	077954-02-000	EA	FILTER - WATER TANK - W/SCREEN IN TANK
14A	039798-01-000	EA	TEE - 1/2"MPT X 1/2"MPT X 1/2"MPT - PLASTIC

WATER & SEWAGE GROUP (CONTINUED)
WATER SYSTEM (CONTINUED)

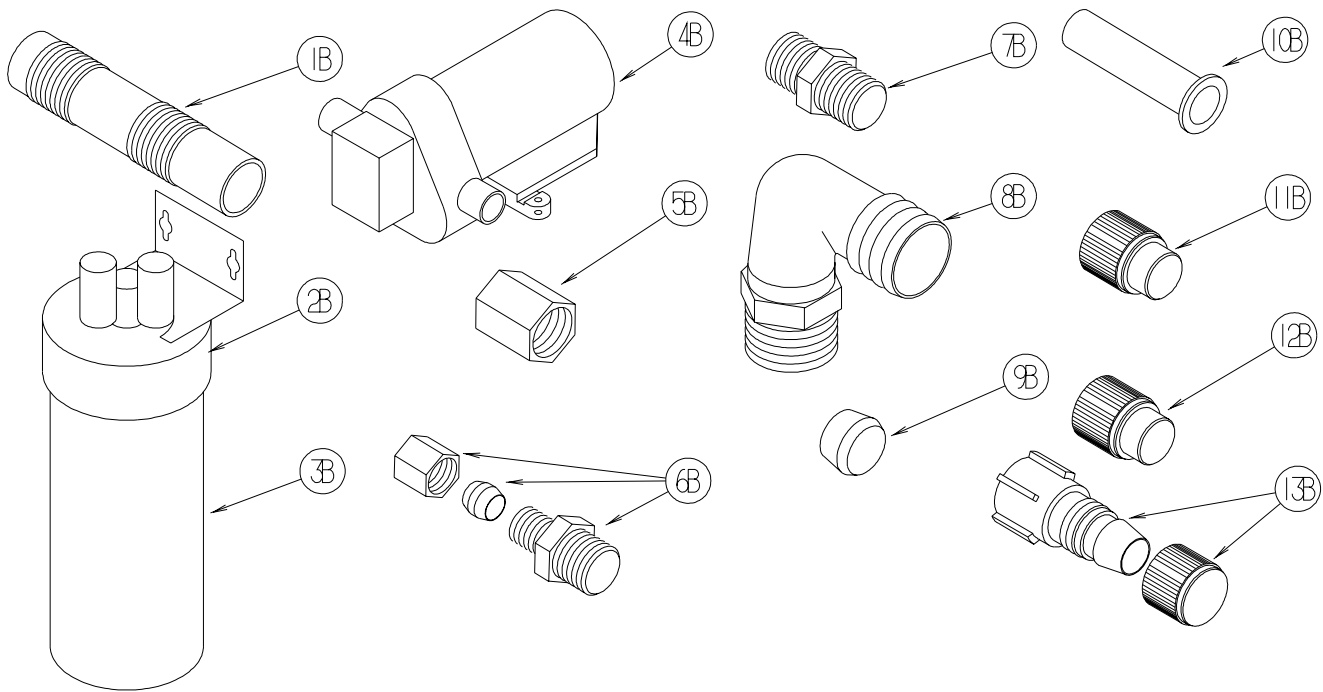

KEY	PART NUMBER	U/M	DESCRIPTION
1B	079381-01-000	FT	TUBING - RIBBED FLEXIBLE - WATER FILL - 1.4" ID
2B	087200-01-000	EA	FILTER-WATER PURIFICATION, EVERPURE QC2-AC
3B	087200-02-000	EA	CARTRIDGE-WATER FILTER,AC - EVERPURE 9601-11
4B*	098607-01-000	EA	PUMP - WATER - W/.5" MPT FITTING - FLOW 2.8 GPM
			FROM: 00-00-00 THRU: 06-21-06
4B	160702-01-000	EA	PUMP - WATER - 3.0 GPM - W/1/2" MPT
			FROM: 06-22-06 THRU: 99-99-99
5B	101814-01-000	EA	COUPLING - FEMALE - 1/2" X 1/2" FPT - GRAY
6B	103798-01-000	EA	CONNECTOR - 1/4 OD X 3/8 MPT
7B	110438-02-000	EA	VALVE - CHECK - BRASS - 1/2 MPT X 1/2 MPT
8B	111223-02-000	EA	ELBOW - 1/2" MPT X 3/8" BARB - PLASTIC
8B	111223-03-000	EA	ELBOW - 3/4" MPT X 1/2" BARB - PLASTIC
8B	111223-04-000	EA	ELBOW - 1/2" MPT X 1/2" BARB - PLASTIC
9B	111888-01-000	EA	FERRULE - PLASTIC - .250 ID X .375 OD
10B	111888-02-000	EA	INSERT - BRASS - 1/4 COMP
11B	113697-01-000	EA	CAP - 3/8"P
12B	114427-01-000	EA	CAP - 1/2"P
13B	114427-02-000	EA	PLUG - W/COMP NUT - 1/2" PLASTIC PIPE/1/2" FLAIR-IT

WATER & SEWAGE GROUP (CONTINUED)
WATER SYSTEM (CONTINUED)

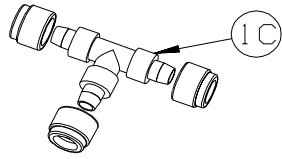

1C

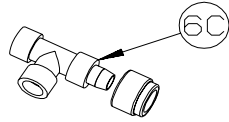

6C

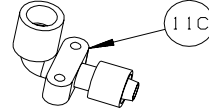

11C

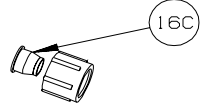

16C

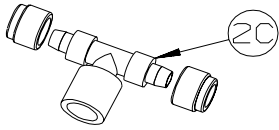

2C

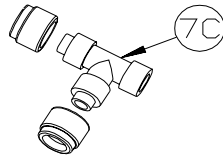

7C

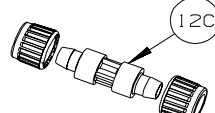

12C

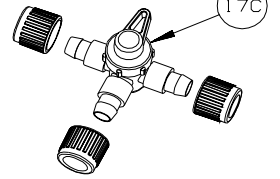

17C

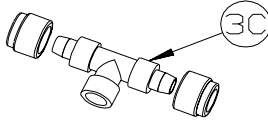

3C

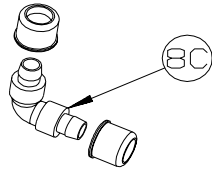

8C

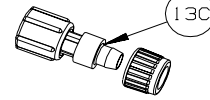

13C

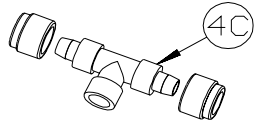

4C

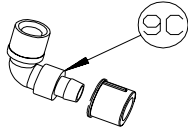

9C

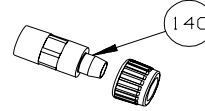

14C

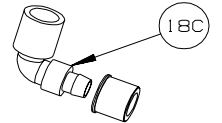

18C

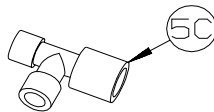

5C

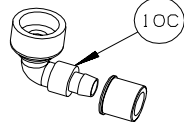

10C

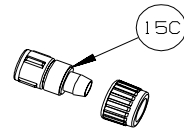

15C

KEY	PART NUMBER	U/M	DESCRIPTION
1C	114428-01-000	EA	TEE - 1/2"P X 1/2"P X 1/2"P
2C	114428-02-000	EA	TEE - SWIVEL - 1/2"P X 1/2"P X 1/2"FPT
3C	114428-03-000	EA	TEE - 1/2"P X 1/2"P X 1/2"MPT
4C	114428-04-000	EA	TEE - 1/2"P X 1/2"P X 1/8"FPT
5C	114428-05-000	EA	TEE - 1/2" SWIVEL X 1/2" MPT X 1/2" MPT
6C	114428-06-000	EA	TEE - 1/2" P X 1/2" MPT X 1/2" MPT
7C	114428-07-000	EA	TEE - 1/2" P X 1/2" MPT X 1/2" P
8C	114429-01-000	EA	ELBOW - 1/2"P X 1/2"P
9C	114429-02-000	EA	ELBOW - 1/2"P X 1/2"MPT
9C	114429-04-000	EA	ELBOW - 1/2"P X 3/8"MPT
9C	114429-05-000	EA	ELBOW - 1/2"P X 3/4"MPT
9C	114429-10-000	EA	ELBOW - SWIVEL - 1/2"MPT X 1/2"FPT
10C	114429-06-000	EA	ELBOW - SWIVEL - 1/2"P X 3/4"FPT
10C	114429-08-000	EA	ELBOW - SWIVEL - 1/2"P X 1/2"FPT
11C	114429-09-000	EA	ELBOW - 1/2"P X 1/2"FPT DROP EAR
12C	114430-01-000	EA	ADAPTER - 1/2"P X 1/2"P
13C	114430-02-000	EA	ADAPTER - SWIVEL - 1/2"P X 1/2"FPT
13C	114430-04-000	EA	ADAPTER - SWIVEL - 1/2"P X 3/8"MPT
14C	114430-03-000	EA	ADAPTER - 1/2"P X 1/2"MPT
15C	114430-06-000	EA	ADAPTER - 1/2"P X 3/8"FPT
15C	114430-09-000	EA	ADAPTER - 1/2"P X 1/2"FPT
16C	114430-10-000	EA	ADAPTER - NUT - PIPE CONNECTION - 1/2"
17C	114431-01-000	EA	VALVE - 180 DEGREE/CENTER DRAIN - 1/2"P - THREE WAY
18C	114429-11-000	EA	ELBOW - 1/2"P X 1/2"FPT

WATER & SEWAGE GROUP (CONTINUED)
WATER SYSTEM (CONTINUED)

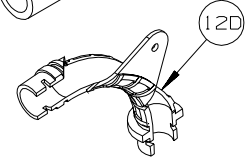
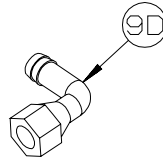
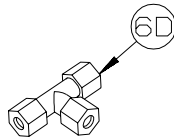
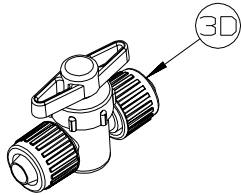
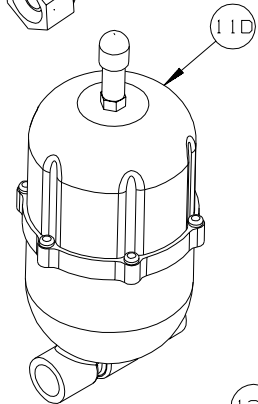
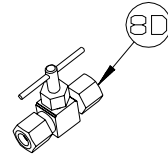
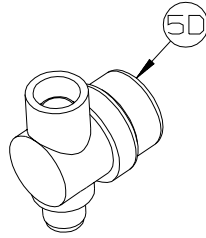
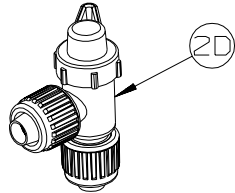
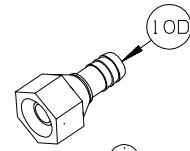
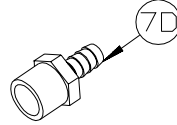
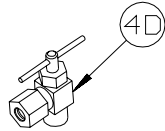
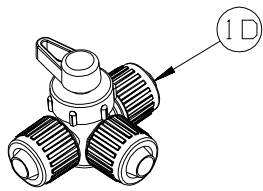

KEY	PART NUMBER	U/M	DESCRIPTION
1D	114431-02-000	EA	VALVE - WATER BYPASS - 1/2"P - THREE WAY (WATER HEATER)
2D	114431-03-000	EA	VALVE - 90 DEGREE DRAIN - 1/2"P
3D	114431-04-000	EA	VALVE - "INLINE SHUT-OFF" - 1/2"P
4D	114431-05-000	EA	VALVE - NEEDLE - 1/8" MPT X 1/4" COMPRESSION (ICE MAKER)
5D	152925-01-01A	EA	FILTER - IN LINE - TWIST ON - 1/2" - BLACK
6D	118423-01-000	EA	FITTING - BRASS-TEE - 1/4C X 1/4C X 1/4C
7D	118809-01-000	EA	ADAPTER - 1/2" MPT X 3/8" BARB - PLASTIC
7D	118809-02-000	EA	ADAPTER - 1/2" MPT X 1/2" BARB - PLASTIC
8D	120868-01-000	EA	VALVE - NEEDLE - 1/4" COMPRESSION X 1/4" COMPRESSION
9D	123150-01-000	EA	ELBOW - 1/2 FPT X 1/2 BARB - SWIVEL
10D	123152-01-000	EA	ADAPTER - 1/2 FPT X 1/2 BARB - SWIVEL
11D	123243-01-000	EA	TANK - ACCUMULATOR - 24 OZ
	123317-01-000	EA	TANK - ACCUMULATOR - 2 GALLON
12D	124184-01-000	EA	SUPPORT - WATER LINE - BEND

WATER & SEWAGE GROUP (CONTINUED)
WATER SYSTEM (CONTINUED)

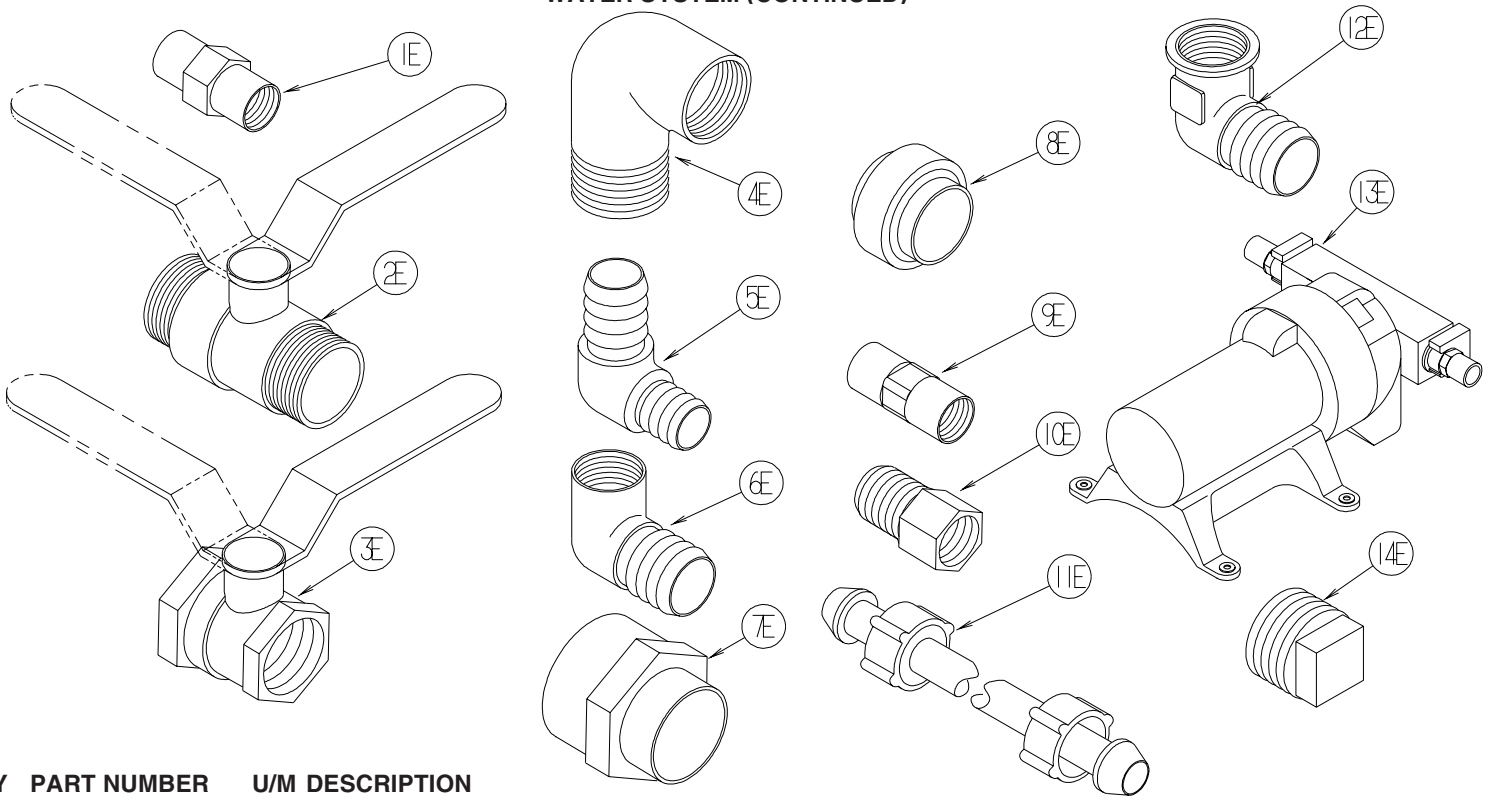

KEY	PART NUMBER	U/M	DESCRIPTION
1E	132148-01-000	EA	CONNECTOR - 1/2" X 1/2"MPT - BRASS
2E	132483-01-000	EA	VALVE/BALL - 1" - THREADED ENDS
3E	132483-02-000	EA	VALVE/BALL - 1/2" - BRASS - FPT
4E	132484-01-000	EA	ELBOW - 90 DEGREE - 1MPT X 1FPT - PLASTIC
5E	132781-01-000	EA	ELBOW - 1.3" BARB X 1.3" BARB - 90 DEGREE - PLASTIC
6E	132782-01-000	EA	ELBOW - 1"FPT X 1.3" BARB - 90 DEGREE - PLASTIC
7E	133835-01-000	EA	ADAPTER - REDUCING - 1 1/2" X 1 1/4"
8E	133889-01-000	EA	UNION - 1 1/2 DOUBLE SLIP - PVC
9E	135386-01-000	EA	NIPPLE - 1/2"
10E	136333-01-000	EA	ADAPTER - BRASS - 1/2"MPT X 1/2"FPT
11E	140821-01-000	EA	TUBE - WATER SUPPLY - 3/8" X 24"
11E	140821-02-000	EA	TUBE - WATER SUPPLY - 3/8" X 30"
11E	140821-03-000	EA	TUBE - WATER SUPPLY - 3/8" X 36"
11E	140821-04-000	EA	TUBE - WATER SUPPLY - 3/8" X 48"
11E	140821-05-000	EA	TUBE - WATER SUPPLY - 3/8" X 54"
11E	140821-06-000	EA	TUBE - WATER SUPPLY - 3/8" X 60"
11E	140821-07-000	EA	TUBE - WATER SUPPLY - 3/8" X 72"
11E	140821-08-000	EA	TUBE - WATER SUPPLY - 1/2" X 24"
11E	140821-09-000	EA	TUBE - WATER SUPPLY - 1/2" X 36"
11E	140821-10-000	EA	TUBE - WATER SUPPLY - 1/2" X 48"
12E	142812-01-000	EA	ELBOW - BRASS - 1/2"MPT X 1/2"FPT
13E*	144215-01-000	EA	PUMP - WATER - 5.7 GPM - W/1/2" MPT

FROM: 00-00-00 THRU: 02-05-06

14E 145609-01-000 EA PLUG - BRASS - 1/2" MPT/HEX HEAD

***COMPONENT PARTS LISTED LATER IN THIS GROUP**

WATER & SEWAGE GROUP (CONTINUED)
WATER SYSTEM (CONTINUED)

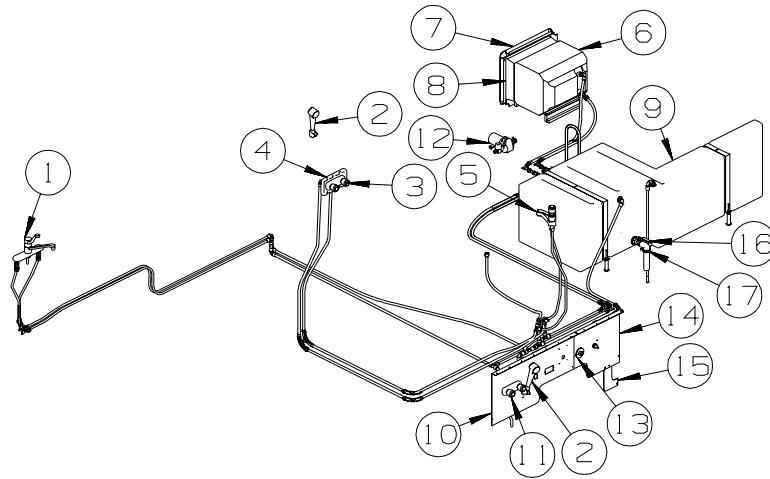

KEY	PART NUMBER	U/M	DESCRIPTION
1	149164-01-01A	EA	FAUCET - GALLEY - SINGLE CONTROL - CHROME
2	131383-01-02A	EA	SHOWER HEAD - W/60" HOSE & BRACKET - WHITE
3	163269-01-02A	EA	FAUCET/SHOWER - .5"MPT W/1.9" INLET PIPES- EXTERIOR/CHROME
4	075606-03-000	EA	PANEL - FAUCET SHOWER - SOFT WHITE
5	148886-01-01A	EA	FAUCET - LAVATORY/DUAL CONTROL/4" CENTER - CHROME
6*	051391-03-000	EA	WATER HEATER G6A-8E ELECTRONIC IGNITION - WATER HEATER-ELEC. IGNITION
6*	145541-02-000	EA	WATER HEATER-6 GAL-GAS/ELEC/120'-REM IGN-W/HEAT EXC-4E - WTR HTR-6GAL/110/LP/MTR/AUTO
7	052009-06-000	EA	DOOR - WATER HEATER - BRIGHT WHITE - 18" X 14.6"
	076767-03-000	EA	CABLE - STAINLESS STEEL - 18.5"
8	152239-01-01A	EA	FLANGE/MOUNTING/RECESSED - 19.3" X 15.8" - BRIGHT WHITE
9	158499-02-000	EA	TANK - WATER - 68 GALLON - W/FITTINGS
9	042989-08-000	EA	FITTING - SPINWELD - 1"FPT - PLASTIC
10	148582-02-12B	EA	PANEL - SERVICE CENTER - BRIGHT WHITE
11	163269-01-01A	EA	FAUCET/SHOWER - .5"MPT W/1.9" INLET PIPES- EXTERIOR/BRT WHT
12*	098607-01-000	EA	PUMP - WATER - W/.5" MPT FITTING - FLOW 2.8 GPM
			FROM: 00-00-00 THRU: 06-21-06
12	160702-01-000	EA	PUMP - WATER - 3.0 GPM - W/1/2" MPT
			FROM: 06-22-06 THRU: 99-99-99
13	010230-06-000	EA	FILL - CITY WATER - W/CHECK VALVE - MPT - BRUSHED ALUM
14	139549-02-12B	EA	PANEL - SERVICE CENTER - BRIGHT WHITE
15	159583-01-12B	EA	PANEL - SERVICE CENTER - BRIGHT WHITE
16	132483-01-000	EA	VALVE/BALL - 1" - THREADED ENDS
17	132782-01-000	EA	ELBOW - 1"FPT X 1.3" BARB - 90 DEGREE - PLASTIC

***COMPONENT PARTS LISTED LATER IN THIS GROUP**

WATER & SEWAGE GROUP (CONTINUED)
COMPONENT PARTS FOR WATER SYSTEM

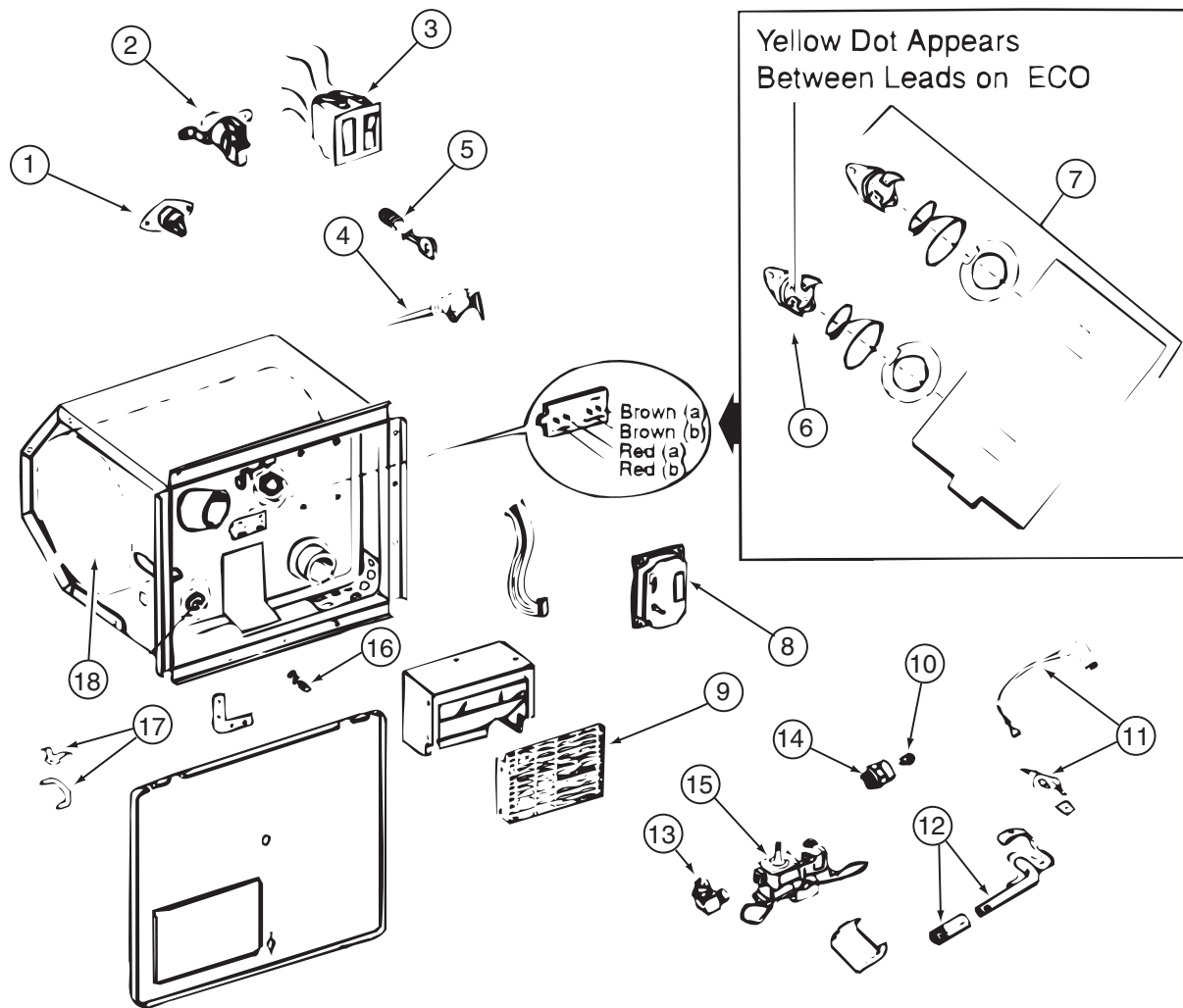

051391-03-000

KEY	PART NUMBER	U/M	DESCRIPTION	VENDOR NO.
3	051393-01-701	EA	SWITCH - REMOTE - W/LIGHT	91959
4	051391-01-704	EA	VALVE-RELIEF, 1/2" FITTING	91604
4	051391-03-701	EA	VALVE-RELIEF - 3/4" FITTING	90028
5	051391-01-705	EA	FASTENER-CAMLOCK	92609
6	051391-04-701	EA	THERMOSTAT 12V DC-120 PRESET	91470
7	051393-01-721	EA	THERMOSTAT W/ECO, 140 FRT MT	91447
9	051391-04-707	EA	KIT-EXHAUST, (FLUE & GASKET)	90960
10	051391-01-710	EA	ORIFICE-MAIN BURNER	92742
12	051391-04-703	EA	BURNER-MAIN/ELECTRONIC IG	91638
13	051391-01-714	EA	FITTING-ELBOW 45,3/8F X 3/8	MPT 1044
14	051391-03-700	EA	HOLDER-ORIFICE	91563
16	051391-01-715	EA	PLUG-DRAIN, 1 EA = 2 PER PKG	91857
17	051391-01-700	EA	HINGE KIT, (PIN & CLIP)	92568&92559
18	051391-04-706	EA	TANK-G6A-4E/6E/7E/8E-FRT.MT	91641 - INNER
	051391-01-717	EA	GRILLE-WATER HEATER DOOR	92640
	051393-01-723	EA	SWITCH - THERMAL CUTOUT 2/PK	93866 WAS 93853
	051393-01-724	EA	BOARD-CIRCUIT, SPADE TERMINAL	93865
	051393-01-725	EA	ELECTRODE-SGL SPADE CONNECT.	93868
	051393-01-726	EA	VALVE/SOLENOID - W/O BRACKET	93870
	111129-01-711	EA	BRACKET-CORNER, SET OF FOUR	91928

CONTACT WINNEBAGO PARTS SALES FOR UNLISTED COMPONENT(S)

WATER & SEWAGE GROUP (CONTINUED)
COMPONENT PARTS FOR WATER SYSTEM (CONTINUED)

098607-01-000

KEY	PART NUMBER	U/M	DESCRIPTION	VENDOR NO.
	098607-01-702	EA	DIAPHRAGM/DRIVE ASSEMBLY KIT	94-238-04
	098607-01-703	EA	VALVE KIT	94-232-00
	098607-01-705	EA	VALVE-CHECK, KIT	94-237-00
	098607-01-706	EA	HOUSING, W/SWITCH ONLY	94-231-20
	098607-01-707	EA	MOTOR W/BASEPLATE	11-148-04

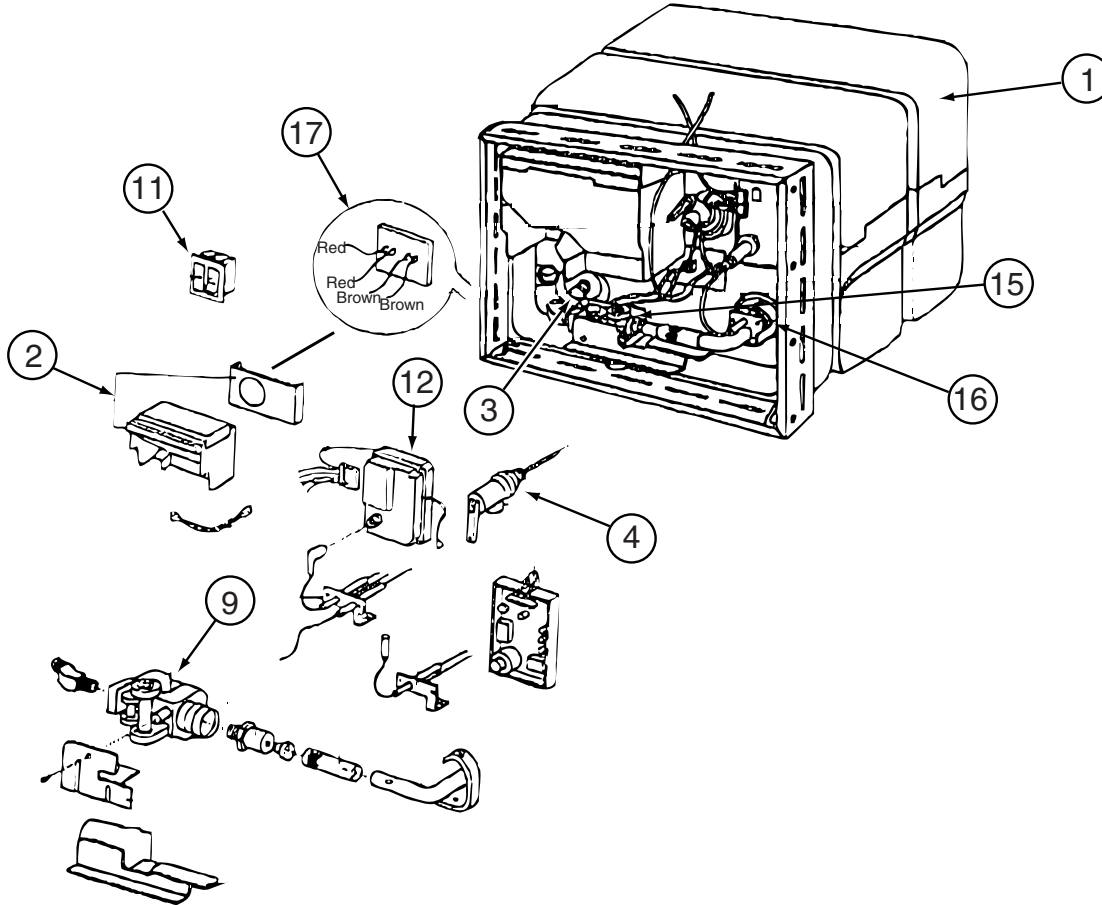

145541-02-000

KEY	PART NUMBER	U/M	DESCRIPTION	VENDOR NO.
1	145541-02-700	EA	TANK/SERVICE KIT PCS- 6 GAL	91053
2	051391-04-707	EA	KIT-EXHAUST, (FLUE & GASKET)	90960
3	051391-01-715	EA	PLUG-DRAIN, 1 EA = 2 PER PKG	91857
4	051391-01-704	EA	VALVE-RELIEF, 1/2" FITTING	91604
9	051393-01-726	EA	VALVE-SOLENOID - W/O BRACKET	93870
11	051393-01-701	EA	SWITCH - REMOTE - W/LIGHT	91959
11	145541-01-701	EA	SWITCH - ON/OFF - WHITE	91859
12	145541-01-702	EA	CIRCUIT BOARD	91226
15	145541-01-703	EA	SWITCH - THERMAL CUT OFF	93866
16	051393-01-725	EA	ELECTRODE-SGL SPADE CONNECT.	93868
17	051393-01-721	EA	THERMOSTAT W/ECO, 140 FRT MT	91447
	051391-05-706	EA	ELEMENT-HEATING 1500 WATT	92249 W/GASKET
	145541-01-704	EA	RELAY	90061
	145541-02-701	EA	JUNCTION BOX(PLASTIC) 6 GAL	91222

CONTACT WINNEBAGO PARTS SALES FOR UNLISTED COMPONENT(S)

WINDOW & VENTS GROUP

WINDOW & VENT LAYOUT

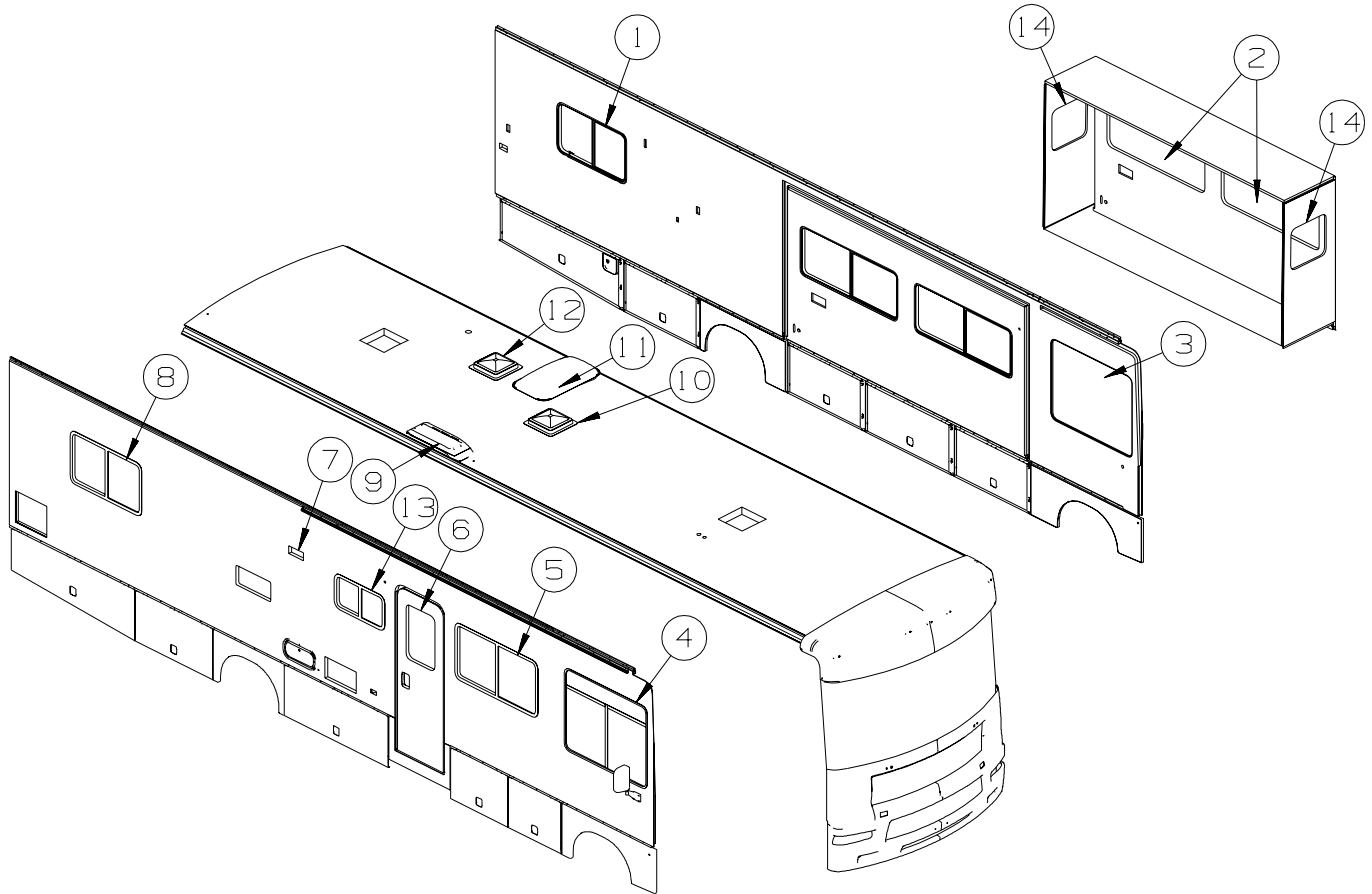

KEY	PART NUMBER	U/M	DESCRIPTION
1*	098647-63-01A	EA	WINDOW - DRIVER HORIZ SLIDER/EGRESS W/TRIM - 41" X 24.2"
1*	150648-12-01A	EA	WINDOW - HORIZ SLIDER/ESCAPE/FLUSH/THERMO/LH - 24.5" X 41.2" - DUAL PANE
2*	098647-47-02A	EA	WINDOW - DRIVER HORIZ SLIDER W/TRIM - TINTED - 57.4" X 23.6"
2*	150648-07-01A	EA	WINDOW - HORIZ SLIDER/FLUSH/THERMO/LH - 23.8" X 57.7" - DUAL PANE
3*	145573-06-01A	EA	WINDOW - CAB/DRIVER/RADIUS/3 GLASS - 39" X 47.9" - BLK
3*	151069-05-01A	EA	WINDOW - CAB/LEFT HAND/FLUSH/THERMO - 39" X 47.9" - DUAL PANE
4*	145573-05-01A	EA	WINDOW - CAB/PASSENGER/RADIUS/3 GLASS - 39" X 47.9" - BLK
4*	151069-04-01A	EA	WINDOW - CAB/RIGHT HAND/FLUSH/THERMO - 39" X 47.9" - DUAL PANE
5*	098647-69-01A	EA	WINDOW - PASSENGER HORIZ SLIDER W/TRIM - 26.3" X 47.9"
5*	150648-06-01A	EA	WINDOW - HORIZ SLIDER/FLUSH/THERMO/RH - 26.3" X 47.9" - DUAL PANE
6	117053-02-F36	EA	WINDOW - PICTURE - W/O TRIM - 60% TINTING - 26.4" X 17"
	002181-25-000	EA	GLASS - PICTURE WINDOW - 25.8"W X 16.4"H
	087561-01-000	FT	SEAL - GLASS - EXTERIOR - .5" WIDE - VINYL BLACK
6	117054-02-03A	EA	TRIM/RETAINER - INSIDE - 16.9" X 26.2" - BLACK
6*	150651-01-01A	EA	WINDOW - STATIONARY/FLUSH/THERMO - 26.3" X 17" - DUAL PANE
7	147821-01-01A	EA	VENT - RANGE - OUTER - BRIGHT WHITE
7	147821-01-02A	EA	VENT - EXHAUST/RANGE HOOD - BLACK - DELUXE GRAPHICS PACKAGE
7	147821-02-01A	EA	SHROUD - VENT - RANGE - BRIGHT WHITE
8*	098647-41-02A	EA	WINDOW - PASS HORIZ SLIDER W/TRIM - TINTED - 24.2" X 41"
8*	150648-11-01A	EA	WINDOW - HORIZ SLIDER/FLUSH/THERMO/RH - 24.5" X 41.2" - DUAL PANE
9	149508-01-02A	EA	CAP - ROOF/REFRIGERATOR VENT - WHITE
9	149508-02-02A	EA	BASE - ROOF/REFRIGERATOR VENT - BRIGHT WHITE
10*	122882-02-01A	EA	VENT - ROOF - W/FAN - W/O INSIDE GARNISH - UL
10*	122882-03-01A	EA	VENT - ROOF - W/FAN - W/O INSIDE GARNISH - CSA - CANADIAN
	009440-01-000	EA	GEAR/ARM - LIFT - ROOF VENT COVER
	048648-01-000	EA	MOTOR/ROOF VENT - W/RESISTER - 1/8"SHAFT - 12VOLT
	048649-01-000	EA	FAN BLADE - ROOF VENT - 6 BLADED - 6"RADIUS
10	122882-07-01A	EA	GARNISH - ROOF VENT - 2.5" TO 4.1"

WINDOW & VENTS GROUP (CONTINUED)
WINDOW & VENT LAYOUT (CONTINUED)

KEY	PART NUMBER	U/M	DESCRIPTION
11	122191-01-02A	EA	PANEL - SKYLIGHT - INNER W/LIGHT CUTOUT - 20.7" X 35.4"
11	138372-01-02B	EA	TRIM - CORNER - SKYLIGHT - E-COATED
11	138380-01-01A	EA	PANEL/SKYLIGHT - LARGE/OUTER - RECTANGULAR - WHITE
12*	122882-01-01A	EA	VENT - ROOF - NONPOWERED - W/O INSIDE GARNISH
	009440-01-000	EA	GEAR/ARM - LIFT - ROOF VENT COVER
12	122882-07-01A	EA	GARNISH - ROOF VENT - 2.5" TO 4.1"
12*	123780-03-01A	EA	FANTASTIC VENT-3"/4"ROOF-W/FAN-W/O THERM/PWR LIFT - POWERED VENTILATOR VENT
	009440-01-000	EA	GEAR/ARM - LIFT - ROOF VENT COVER
13*	098647-33-02A	EA	WINDOW - PASS HORIZ SLIDER W/TRIM - CLEAR - 28.5" X 15.7"
13*	150648-04-01A	EA	WINDOW-HORIZ SLIDER/FLUSH/THERMO/RH - 16" X 28.7" - DUAL PANE
14*	098644-13-01A	EA	WINDOW - VERTICAL SLIDER W/TRIM - 19.8" X 20.9"
14*	150649-07-01A	EA	WINDOW - VERT SLIDER/FLUSH/THERMO - 19.8" X 20.8" - DUAL PANE

***COMPONENT PARTS LISTED LATER IN THIS GROUP**

WINDOW & VENTS GROUP (CONTINUED)
COMPONENT PARTS FOR WINDOW & VENT LAYOUT

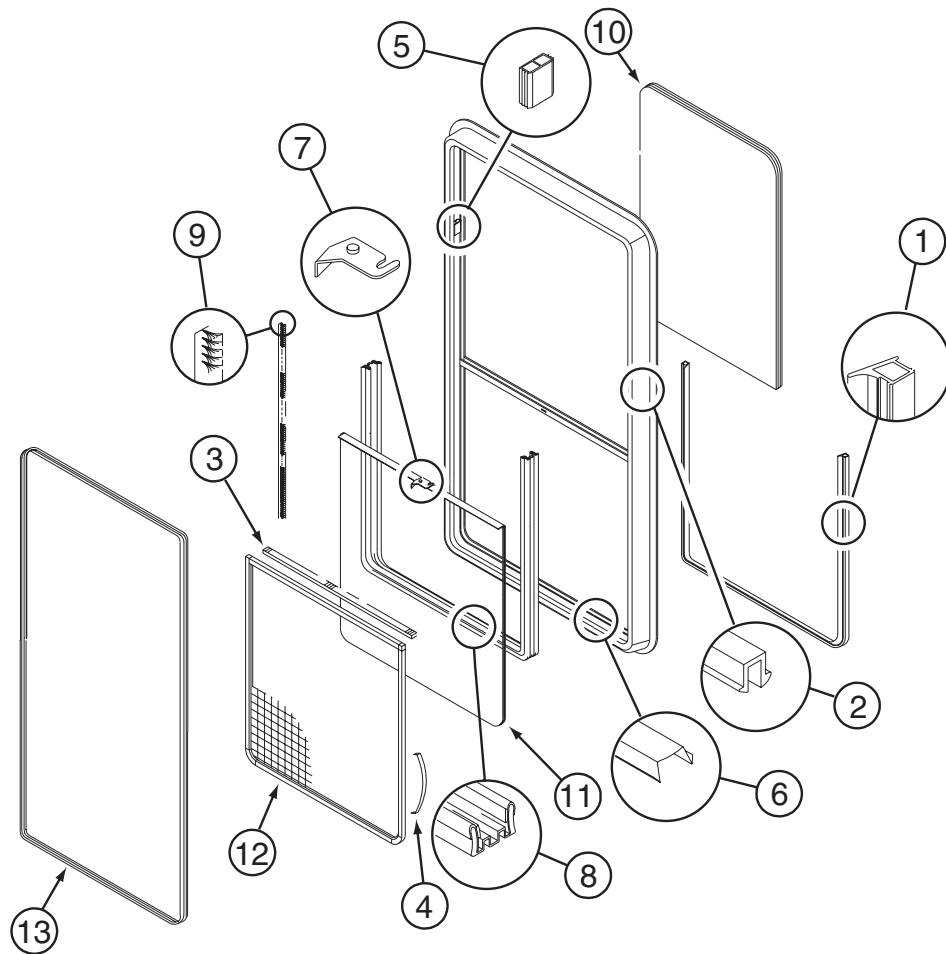

098644-13-01A

KEY	PART NUMBER	U/M	DESCRIPTION	VENDOR NO.
1	098644-01-716	FT	PLUG - FILLER	132-014470
2	098644-01-705	FT	GLAZING - STRIP	132-010231
3	098644-01-706	FT	WEATHERSTRIP - GLASS	171-010668
4	098644-01-713	EA	CLIP - SCREEN - METAL	226-016966
4	125582-01-701	EA	CLIP - SCREEN - PLASTIC	130-005153
5	098644-01-719	EA	STOP - SLIDER GLASS	132-014203
6	098644-01-710	FT	TRACK - SCREEN SPACER 12'	132-017135
7	098644-01-700	EA	LATCH - REPAIR KIT (BLACK)	B801-CK
7	098647-54-701	EA	LATCH - REPAIR KIT (RED)	B081-CK
8	098644-01-708	FT	CHANNEL - RUN PIERCED	122-016543
9	098644-01-711	FT	WEATHERSTRIP - SCREEN BLACK	171-016965
10	098644-13-700	EA	GLASS - STATIONARY	106-028698
11	098644-13-701	EA	GLASS - SLIDING W/SASH/LATCH	H702-G9
12	098644-13-702	EA	SCREEN ASM - W/SEALS/CLIPS	410-028663
13	098644-13-703	EA	RETAINER - TRIM	H702-60
	098644-01-717	FT	SPLINE - SCREEN	132-004716

WINDOW & VENTS GROUP (CONTINUED)
COMPONENT PARTS FOR WINDOWS & VENT LAYOUT (CONTINUED)

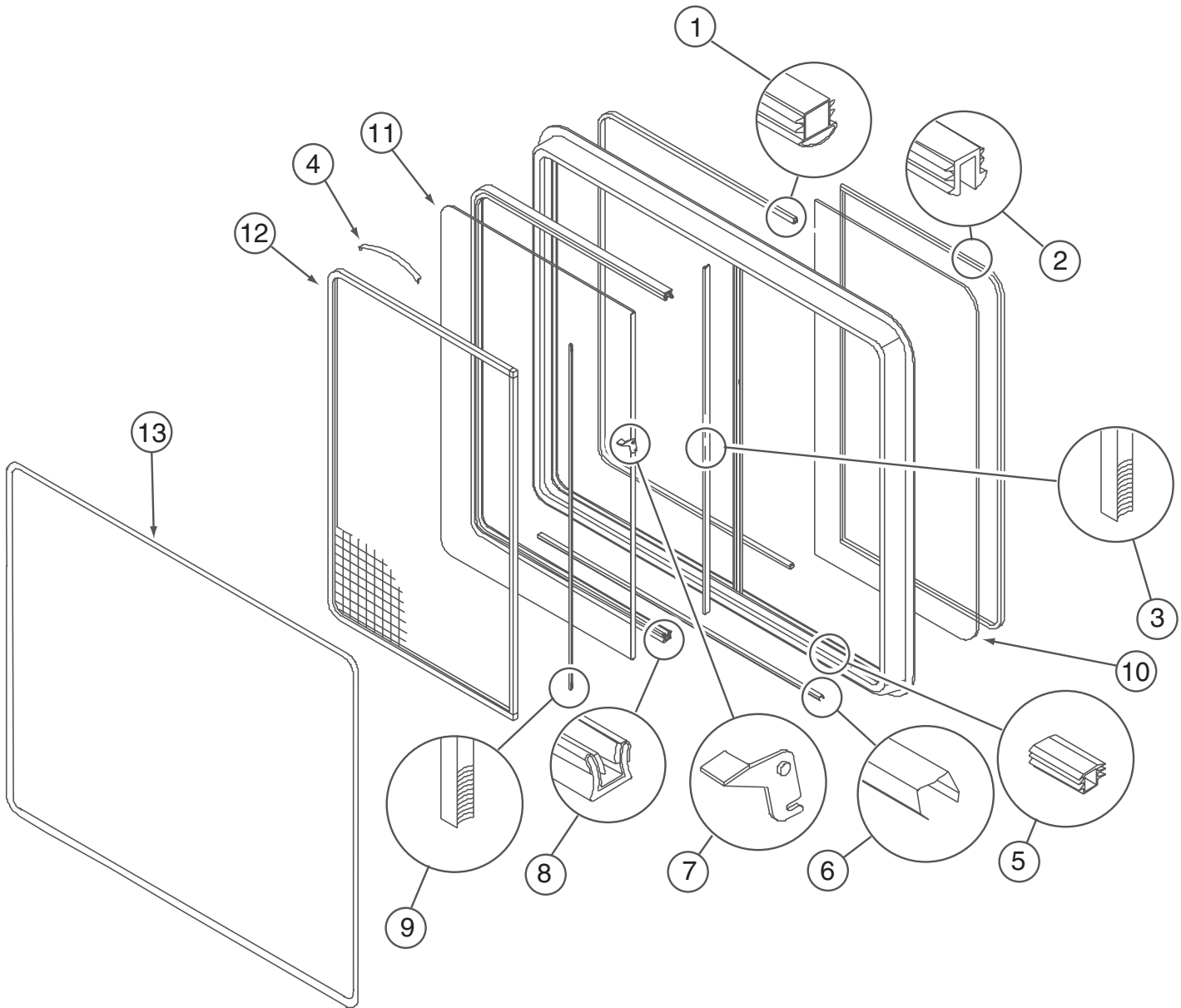

098647-33-02A

KEY	PART NUMBER	U/M	DESCRIPTION	VENDOR NO.
1	098644-01-716	FT	PLUG - FILLER	132-014470
2	098644-01-705	FT	GLAZING - STRIP	132-010231
3	098644-01-706	FT	WEATHERSTRIP - GLASS	171-010668
4	098644-01-713	EA	CLIP - SCREEN - METAL	226-016966
4	125582-01-701	EA	CLIP - SCREEN - PLASTIC	130-0
5	098644-01-719	EA	STOP - SLIDER GLASS	132-014203
6	098644-01-710	FT	TRACK - SCREEN SPACER 12'	132-017135
7	098647-54-701	EA	LATCH - REPAIR KIT (RED)	B081-CK
8	098644-01-708	FT	CHANNEL - RUN PIERCED	122-016543
9	098644-01-711	FT	WEATHERSTRIP - SCREEN BLACK	171-016965
10	098647-33-702	EA	GLASS - STATIONARY	106-019297
11	098647-33-703	EA	GLASS-SLIDING W/SASH & LATCH	H425-G9
12	098647-33-704	EA	SCREEN ASM - W/SEALS & CLIPS	410-019134
13	098647-31-705	EA	RETAINER - TRIM	CH29-66
	098644-01-717	FT	SPLINE - SCREEN	132-004716

WINDOW & VENTS GROUP (CONTINUED)
COMPONENT PARTS FOR WINDOWS & VENT LAYOUT (CONTINUED)

098647-41-02A

KEY	PART NUMBER	U/M	DESCRIPTION	VENDOR NO.
1	098644-01-716	FT	PLUG - FILLER	132-014470
2	098644-01-705	FT	GLAZING - STRIP	132-010231
3	098644-01-706	FT	WEATHERSTRIP - GLASS	171-010668
4	098644-01-713	EA	CLIP - SCREEN - METAL	226-016966
4	125582-01-701	EA	CLIP - SCREEN - PLASTIC	130-005153
5	098644-01-719	EA	STOP - SLIDER GLASS	132-014203
6	098644-01-710	FT	TRACK - SCREEN SPACER 12'	132-017135
7	098647-54-701	EA	LATCH - REPAIR KIT (RED)	B081-CK
8	098644-01-708	FT	CHANNEL - RUN PIERCED	122-016543
9	098644-01-711	FT	WEATHERSTRIP - SCREEN BLACK	171-016965
10	098647-41-701	EA	GLASS - STATIONARY	106-015474
11	098647-41-700	EA	GLASS-SLIDING W/SASH & LATCH	H172-G9
12	098647-29-704	EA	SCREEN ASM - W/SEALS & CLIPS	410-018864
13	098647-29-705	EA	RETAINER - TRIM	CH04-66
	098644-01-717	FT	SPLINE - SCREEN	132-004716

098647-47-02A

KEY	PART NUMBER	U/M	DESCRIPTION	VENDOR NO.
1	098644-01-716	FT	PLUG - FILLER	132-014470
2	098644-01-705	FT	GLAZING - STRIP	132-010231
3	098644-01-706	FT	WEATHERSTRIP - GLASS	171-010668
4	098644-01-713	EA	CLIP - SCREEN - METAL	226-016966
4	125582-01-701	EA	CLIP - SCREEN - PLASTIC	130-005153
5	098644-01-719	EA	STOP - SLIDER GLASS	132-014203
6	098644-01-710	FT	TRACK - SCREEN SPACER 12'	132-017135
7	098644-01-700	EA	LATCH - REPAIR KIT (BLACK)	B801-CK
7	098647-54-701	EA	LATCH - REPAIR KIT (RED)	B081-CK
8	098644-01-708	FT	CHANNEL - RUN PIERCED	122-016543
9	098644-01-711	FT	WEATHERSTRIP - SCREEN BLACK	171-016965
10	098647-47-700	EA	GLASS - STATIONARY	106-025224
11	098647-47-701	EA	GLASS-SLIDING W/SASH & LATCH	H493-G9
12	098647-47-702	EA	SCREEN ASM - W/SEALS & CLIPS	410-025226
13	098647-47-704	EA	RETAINER - TRIM	H493-66
	098644-01-717	FT	SPLINE - SCREEN	132-004716

098647-63-01A

KEY	PART NUMBER	U/M	DESCRIPTION	VENDOR NO.
1	098644-01-716	FT	PLUG - FILLER	132-014470
2	098644-01-705	FT	GLAZING - STRIP	132-010231
3	098644-01-706	FT	WEATHERSTRIP - GLASS	171-010668
4	098644-01-713	EA	CLIP - SCREEN - METAL	226-016966
4	125582-01-701	EA	CLIP - SCREEN - PLASTIC	130-0
5	098644-01-719	EA	STOP - SLIDER GLASS	132-014203
6	098644-01-710	FT	TRACK - SCREEN SPACER 12'	132-017135
7	098647-54-701	EA	LATCH - REPAIR KIT (RED)	B081-CK
8	098644-01-708	FT	CHANNEL - RUN PIERCED	122-016543
9	098644-01-711	FT	WEATHERSTRIP - SCREEN BLACK	171-016965
10	098647-56-700	EA	GLASS - STATIONARY	106-019401
11	098647-63-700	EA	GLASS-SLIDING W/SASH & LATCH	H422-G9
12	112795-62-702	EA	SCREEN ASSY - W/SEAL & CLIPS	410-018866
13	112795-62-704	EA	RETAINER - TRIM	H422-64
	098644-01-717	FT	SPLINE - SCREEN	132-004716

WINDOW & VENTS GROUP (CONTINUED)
COMPONENT PARTS FOR WINDOWS & VENT LAYOUT (CONTINUED)

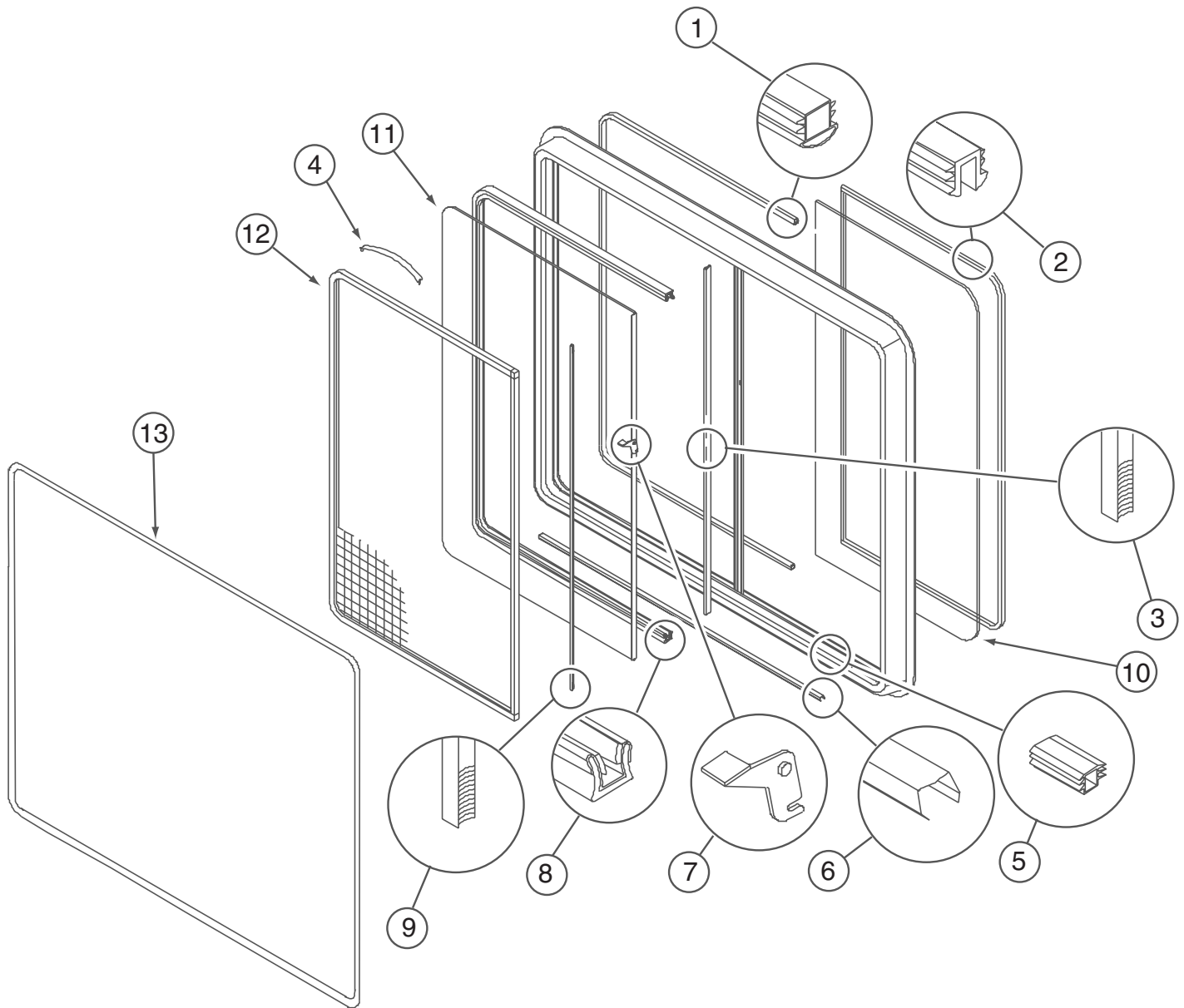

098647-69-01A

KEY	PART NUMBER	U/M	DESCRIPTION	VENDOR NO.
1	098644-01-716	FT	PLUG - FILLER	132-014470
2	098644-01-705	FT	GLAZING - STRIP	132-010231
3	098644-01-706	FT	WEATHERSTRIP - GLASS	171-010668
4	125582-01-701	EA	CLIP - SCREEN - PLASTIC	130-0
5	098644-01-719	EA	STOP - SLIDER GLASS	132-014203
6	098644-01-710	FT	TRACK - SCREEN SPACER 12'	132-017135
7	098644-01-700	EA	LATCH - REPAIR KIT (BLACK)	B801-CK
8	098644-01-708	FT	CHANNEL - RUN PIERCED	122-016543
9	098644-01-711	FT	WEATHERSTRIP - SCREEN BLACK	171-016965
10	098647-69-700	EA	GLASS - STATIONARY	106-018715
11	098647-69-701	EA	GLASS-SLIDING W/SASH & LATCH	H320G9
12	098647-38-704	EA	SCREEN ASM - W/SEALS & CLIPS	410-019063
13	098647-38-705	EA	RETAINER - TRIM	H303-66
	098644-01-717	FT	SPLINE - SCREEN	132-004716

WINDOW & VENTS GROUP (CONTINUED)
COMPONENT PARTS FOR WINDOWS & VENT LAYOUT (CONTINUED)

122882-01-01A

KEY	PART NUMBER	U/M	DESCRIPTION	VENDOR NO.
	064470-01-700	EA	COVER - VENT	J7291
	064470-01-701	EA	SLIDE BAR - VENT LID	JRP1291B
	122882-01-700	EA	HANDLE - CRANK - BLACK	90128
	122882-01-701	EA	SCREEN	JRP-1124-B
	122882-01-702	EA	HANDLE - CRANK - WHITE	JRP1031B

122882-02-01A, 122882-03-01A

KEY	PART NUMBER	U/M	DESCRIPTION	VENDOR NO.
	064470-01-700	EA	COVER - VENT	J7291
	064470-01-701	EA	SLIDE BAR - VENT LID	JRP1291B
	110051-03-700	EA	SWITCH-BLACK/PUSH BUTTON	27-0164
	122882-01-700	EA	HANDLE - CRANK - BLACK	90128
	122882-01-701	EA	SCREEN	JRP-1124-B
	122882-01-702	EA	HANDLE - CRANK - WHITE	JRP1031B

WINDOW & VENTS GROUP (CONTINUED)
COMPONENT PARTS FOR WINDOWS & VENT LAYOUT (CONTINUED)

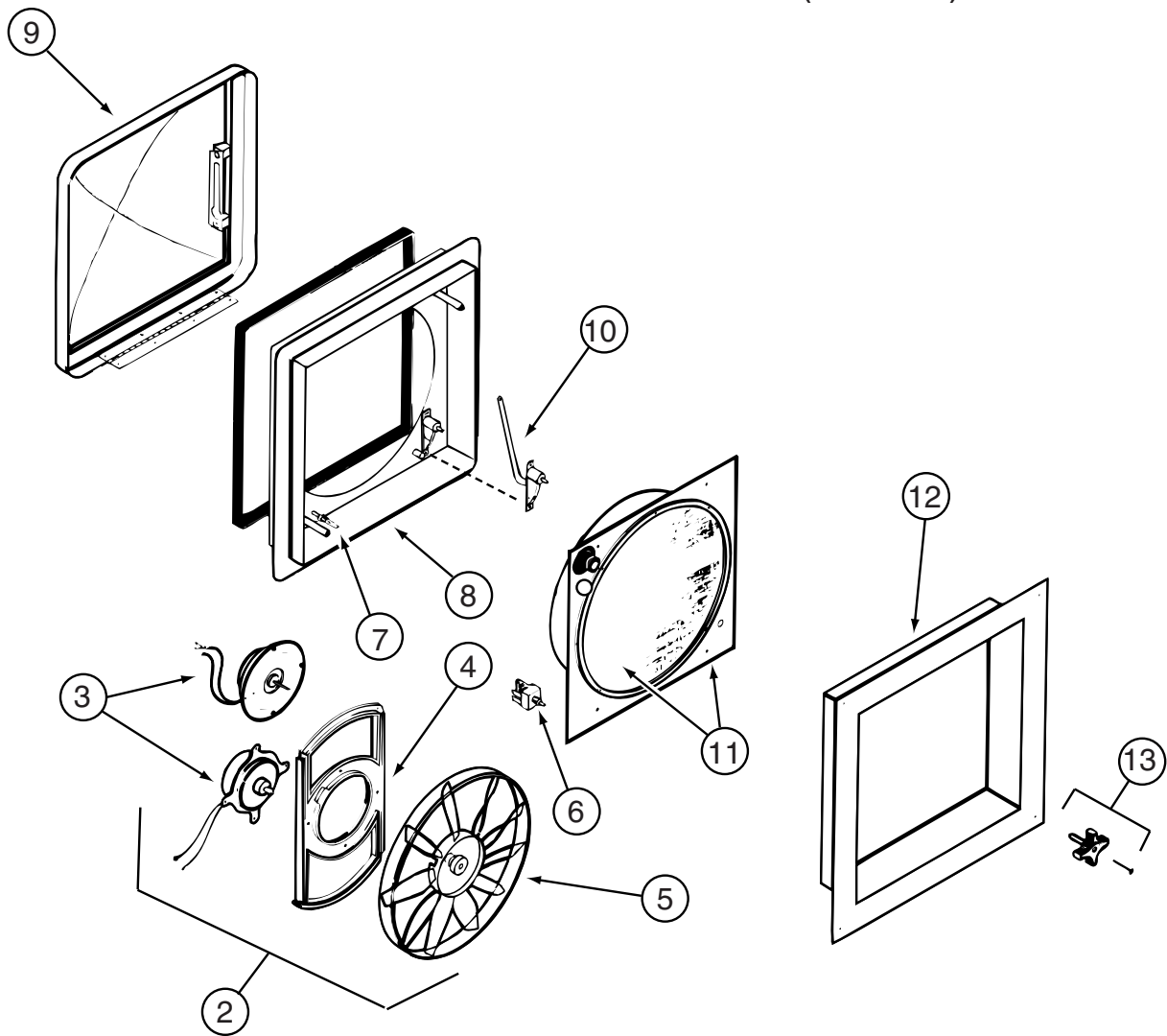

123780-03-01A

KEY	PART NUMBER	U/M	DESCRIPTION	VENDOR NO.
2	084079-11-700	EA	MOTOR & FAN BLADE W/BRACKET	K4017-09
3	084079-01-705	EA	MOTOR/EXT BRKT/FAN BLADE KIT	1080-00
4	084079-01-711	EA	MOTOR MOUNT (BOWTIE)	1015-00
5	084079-01-704	EA	BLADE-FAN	1138-00
6	084079-01-709	EA	SWITCH - MAIN - 3 SPEED	1031-05
7	084079-01-707	EA	SWITCH - SAFETY	1122-05
8	123780-05-700	EA	BASE/MAIN-BRT WHT W/GASKET	1010-81
9	123780-01-700	EA	COVER - VENT W/HINGE & SLIDE	1020K-81
10	009440-01-000	EA	GEAR-ARM-ROOF VENT	705221K38
11	123780-03-701	EA	SCREEN ASM 78-100MM W/SWITCH	1030BT-81
12	123780-03-700	EA	GARNISH - INT. 3"-4" BRT/WHT	2040-81
13	084079-01-703	EA	KNOB-LIFT	1140K-00
	084079-01-706	EA	PLUG, 12 VOLT	1090
	123780-01-702	EA	SCREEN INSERT (SCREEN RING)	K1035-81

CONTACT WINNEBAGO PART SALES FOR UNLISTED COMPONENT(S)

WINDOW & VENTS GROUP (CONTINUED)
COMPONENT PARTS FOR WINDOWS & VENT LAYOUT (CONTINUED)

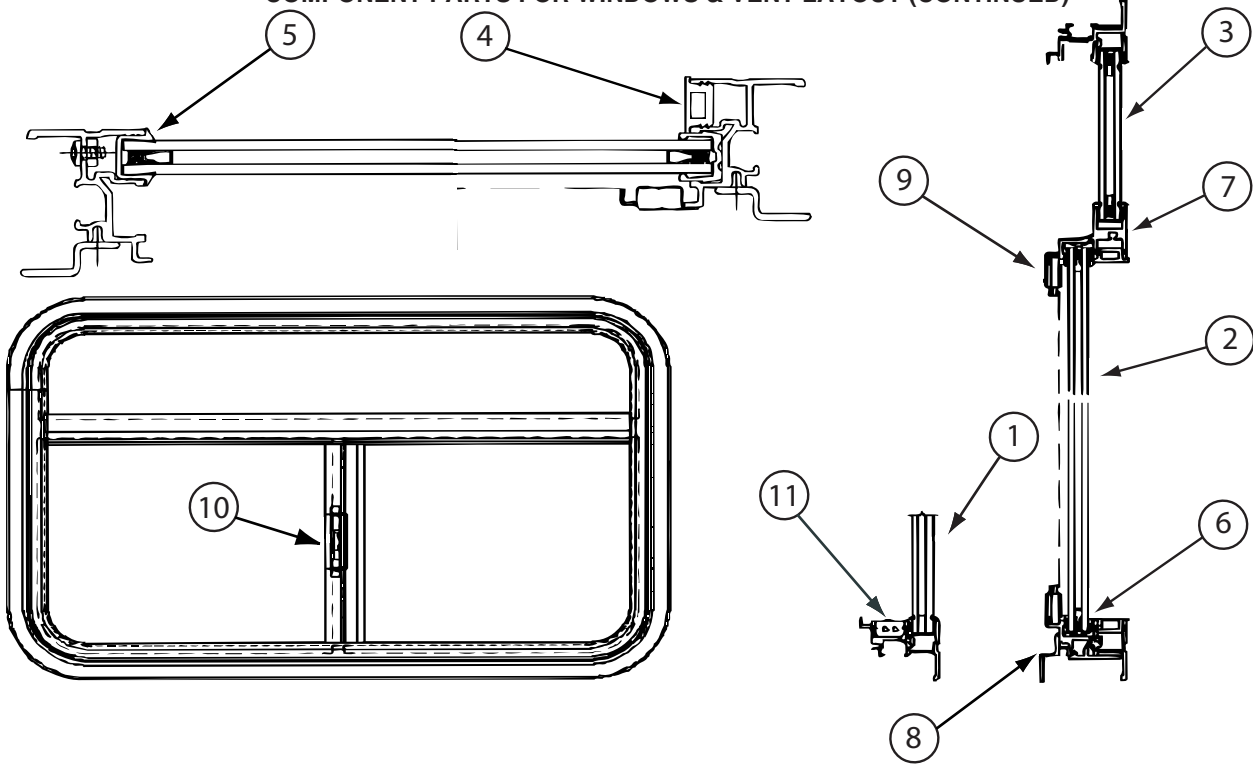

145573-05-01A

KEY	PART NUMBER	U/M	DESCRIPTION	VENDOR NO
1	145573-01-702	EA	GLASS - STATIONARY (LOWER)	106-030926
2	145573-01-703	EA	GLASS-SLIDING W/SASH & LATCH	H841-A9
3	145573-01-700	EA	GLASS - STATIONARY (TOP)	106-030654
4	098644-01-716	FT	PLUG - FILLER	132-014470
5	098644-01-705	FT	GLAZING - STRIP	132-010231
6	098644-01-708	FT	CHANNEL - RUN PIERCED	122-016543
7	145573-05-700	EA	WEATHERSTRIP F/LOCKING RAIL	H29219
8	112795-66-703	EA	RETAINER - TRIM	H611-66
9	145573-01-700	EA	SCREEN ASM - W/SEALS & CLIP	410-030660
10	098644-01-700	EA	LATCH - REPAIR KIT (BLACK)	B801-CK
11	098644-01-719	EA	STOP - SLIDER GLASS	132-014203

145573-06-01A

KEY	PART NUMBER	U/M	DESCRIPTION	VENDOR NO
1	145573-01-702	EA	GLASS - STATIONARY (LOWER)	106-030926
2	145573-02-701	EA	GLASS-SLIDING W/SASH & LATCH	H841-A9R
3	145573-01-701	EA	GLASS - STATIONARY (TOP)	106-030654
4	098644-01-716	FT	PLUG - FILLER	132-014470
5	098644-01-705	FT	GLAZING - STRIP	132-010231
6	098644-01-708	FT	CHANNEL - RUN PIERCED	122-016543
7	145573-05-700	EA	WEATHERSTRIP F/LOCKING RAIL	H29219
8	112795-66-703	EA	RETAINER - TRIM	H611-66
9	145573-01-700	EA	SCREEN ASM - W/SEALS & CLIP	410-030660
10	098644-01-700	EA	LATCH - REPAIR KIT (BLACK)	B801-CK
11	098644-01-719	EA	STOP - SLIDER GLASS	132-014203

WINDOW & VENTS GROUP (CONTINUED)
COMPONENT PARTS FOR WINDOW & VENT LAYOUT (CONTINUED)

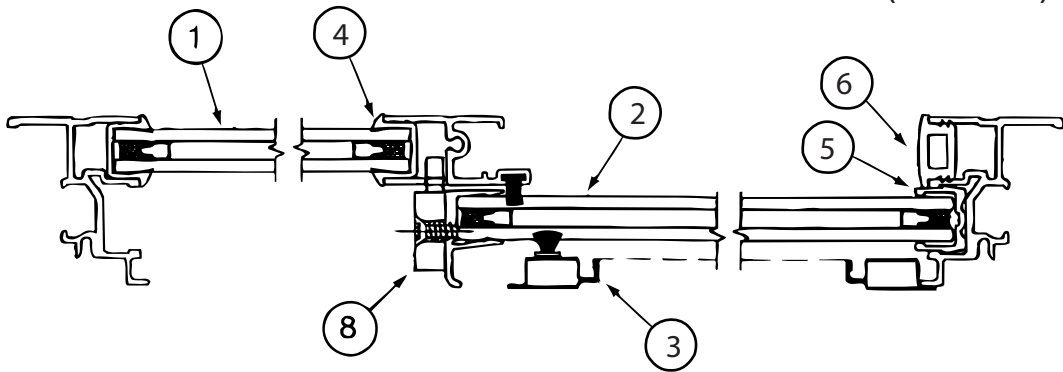

CROSS SECTION B-B

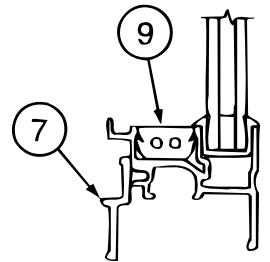
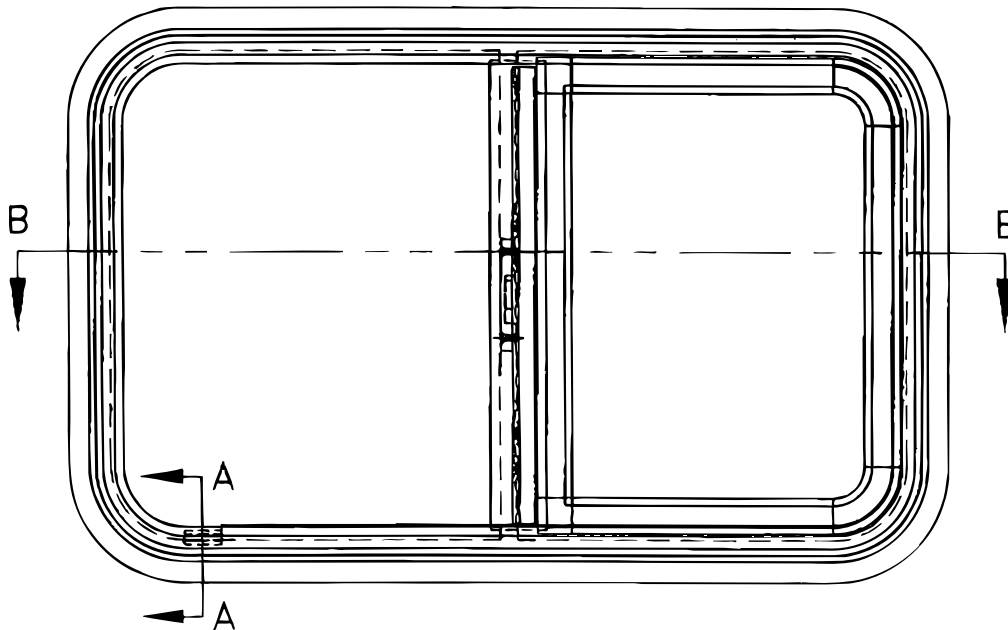

CROSS SECTION
A-A

150648-04-01A, 150648-05-01A

KEY	PART NUMBER	U/M	DESCRIPTION	VENDOR NO
1	112795-72-700	EA	GLASS - STATIONARY	390-028307
2	150648-04-700	EA	GLASS-SLIDING W/SASH & LATCH	FH3002G8
3	150648-05-700	EA	SCREEN ASM	410-031158
4	112795-01-705	FT	VINYL - GLAZING	132-027331
5	151069-01-700	EA	CHANNEL-RUN, SLIDING	122-030627
6	150648-01-703	EA	PLUG - FILLER	132-030308
7	150648-05-701	EA	RETAINER - TRIM	CH29-67
8	150648-01-700	EA	LATCH-HORIZONTAL SLIDE-BLK	FH3000-CK
8	150648-01-701	EA	LATCH-HORIZONTAL SLIDE-RED	FH3003-CK
9	150648-01-704	EA	SLIDE STOP	132-030866
	150648-05-702	FT	FIN SEAL-F/LOCKING RAIL-BLK	171-062348

WINDOW & VENTS GROUP (CONTINUED)
COMPONENT PARTS FOR WINDOW & VENT LAYOUT (CONTINUED)

150648-06-01A & 150648-35-01A

KEY	PART NUMBER	U/M	DESCRIPTION	VENDOR NO
1	112795-74-700	EA	GLASS - STATIONARY	390-028337
2	150648-06-700	EA	GLASS-SLIDING W/SASH & LATCH	FH3006G8
3	150648-06-701	EA	SCREEN ASM	410-035329
4	112795-01-705	FT	VINYL - GLAZING	132-027331
5	151069-01-700	EA	CHANNEL-RUN, SLIDING	122-030627
6	150648-01-703	EA	PLUG - FILLER	132-030308
7	150648-06-702	EA	RETAINER - TRIM	H303-67
8	150648-01-700	EA	LATCH-HORIZONTAL SLIDE-BLK	FH3000-CK
8	150648-01-701	EA	LATCH-HORIZONTAL SLIDE-RED	FH3003-CK
9	150648-01-704	EA	SLIDE STOP	132-030866
	150648-05-702	FT	FIN SEAL-F/LOCKING RAIL-BLK	171-062348

150648-07-01A, 150648-22-01A

KEY	PART NUMBER	U/M	DESCRIPTION	VENDOR NO
1	150648-07-701	EA	GLASS - STATIONARY	390-028314
2	150648-07-700	EA	GLASS-SLIDING W/SASH & LATCH	FH3000G8
3	150648-01-702	EA	SCREEN ASM	410-031156
4	112795-01-705	FT	VINYL - GLAZING	132-027331
5	151069-01-700	EA	CHANNEL-RUN, SLIDING	122-030627
6	150648-01-703	EA	PLUG - FILLER	132-030308
7	150648-01-707	EA	RETAINER - TRIM	H493-67
8	150648-01-700	EA	LATCH-HORIZONTAL SLIDE-BLK	FH3000-CK
8	150648-01-701	EA	LATCH-HORIZONTAL SLIDE-RED	FH3003-CK
9	150648-01-704	EA	SLIDE STOP	132-030866
	150648-05-702	FT	FIN SEAL-F/LOCKING RAIL-BLK	171-062348

150648-11-01A

KEY	PART NUMBER	U/M	DESCRIPTION	VENDOR NO
1	150648-11-700	EA	GLASS - STATIONARY	390-035650
2	150648-11-701	EA	GLASS-SLIDING W/SASH & LATCH	FH3057G8
3	150648-11-702	EA	SCREEN ASM	410-035635
4	112795-01-705	FT	VINYL - GLAZING	132-027331
5	151069-01-700	EA	CHANNEL-RUN, SLIDING	122-030627
6	150648-01-703	FT	PLUG - FILLER	132-030308
7	150648-11-703	EA	RETAINER - TRIM	CH04-67
8	150648-01-700	EA	LATCH-HORIZONTAL SLIDE-BLK	FH3000-CK
8	150648-01-701	EA	LATCH-HORIZONTAL SLIDE-RED	FH3003-CK
9	150648-01-704	EA	SLIDE STOP	132-030866
	150648-05-702	FT	FIN SEAL-F/LOCKING RAIL-BLK	171-06234

150648-12-01A & 150648-15-01A

KEY	PART NUMBER	U/M	DESCRIPTION	VENDOR NO
1	150648-15-700	EA	GLASS - STATIONARY	390-035689
2	150648-15-701	EA	GLASS-SLIDING W/SASH & LATCH	FH3060G8
3	150648-15-702	EA	SCREEN ASM	410-035691
4	112795-01-705	FT	VINYL - GLAZING	132-027331
5	151069-01-700	EA	CHANNEL-RUN, SLIDING	122-030627
6	150648-01-703	FT	PLUG - FILLER	132-030308
7	150648-15-703	EA	RETAINER - TRIM	FH814-60
8	150648-01-700	EA	LATCH-HORIZONTAL SLIDE-BLK	FH3000-CK
8	150648-01-701	EA	LATCH-HORIZONTAL SLIDE-RED	FH3003-CK
9	150648-01-704	EA	SLIDE STOP	132-030866
	150648-05-702	FT	FIN SEAL-F/LOCKING RAIL-BLK	171-062348
	112898-06-707	EA	HANDLE/RH - EGRESS (SLD) ESC-RED	182-025911
	112898-06-708	EA	HANDLE/LH - EGRESS (SLD) ESC-RED	182-025912

WINDOW & VENTS GROUP (CONTINUED)
COMPONENT PARTS FOR WINDOW & VENT LAYOUT (CONTINUED)

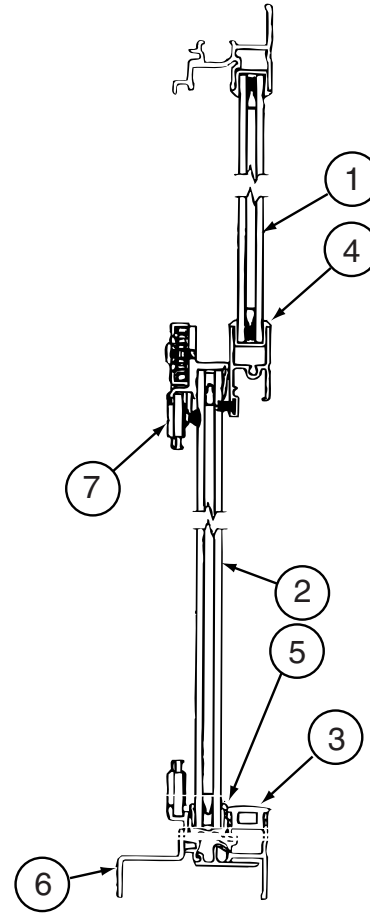
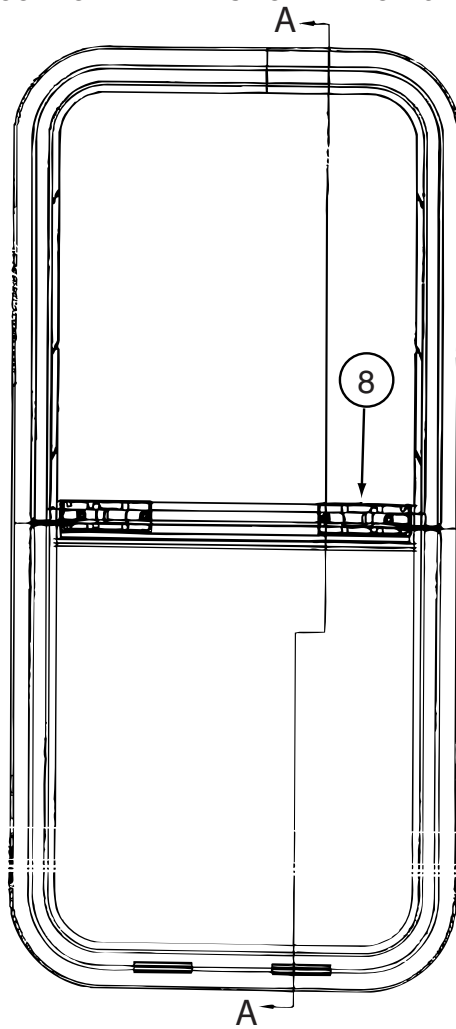

CROSS SECTION A-A

150649-07-01A

KEY	PART NUMBER	U/M	DESCRIPTION	VENDOR NO
1	150649-07-700	EA	GLASS - STATIONARY	390-028662
2	150649-07-702	EA	GLASS-SLIDING W/PULL & LATCH	FH3052G8
3	150648-01-703	FT	PLUG - FILLER	132-030308
4	112795-01-705	FT	VINYL - GLAZING	132-027331
5	151069-01-700	FT	CHANNEL-RUN, SLIDING	122-030627
6	150649-07-703	EA	RETAINER - TRIM	H702-61
7	150649-07-701	EA	SCREEN ASM	410-035475
8	150649-01-700	EA	LATCH-VERTICLE SLIDE-BLK	FH3016-CK

WINDOW & VENTS GROUP (CONTINUED)
COMPONENT PARTS FOR WINDOW & VENT LAYOUT (CONTINUED)

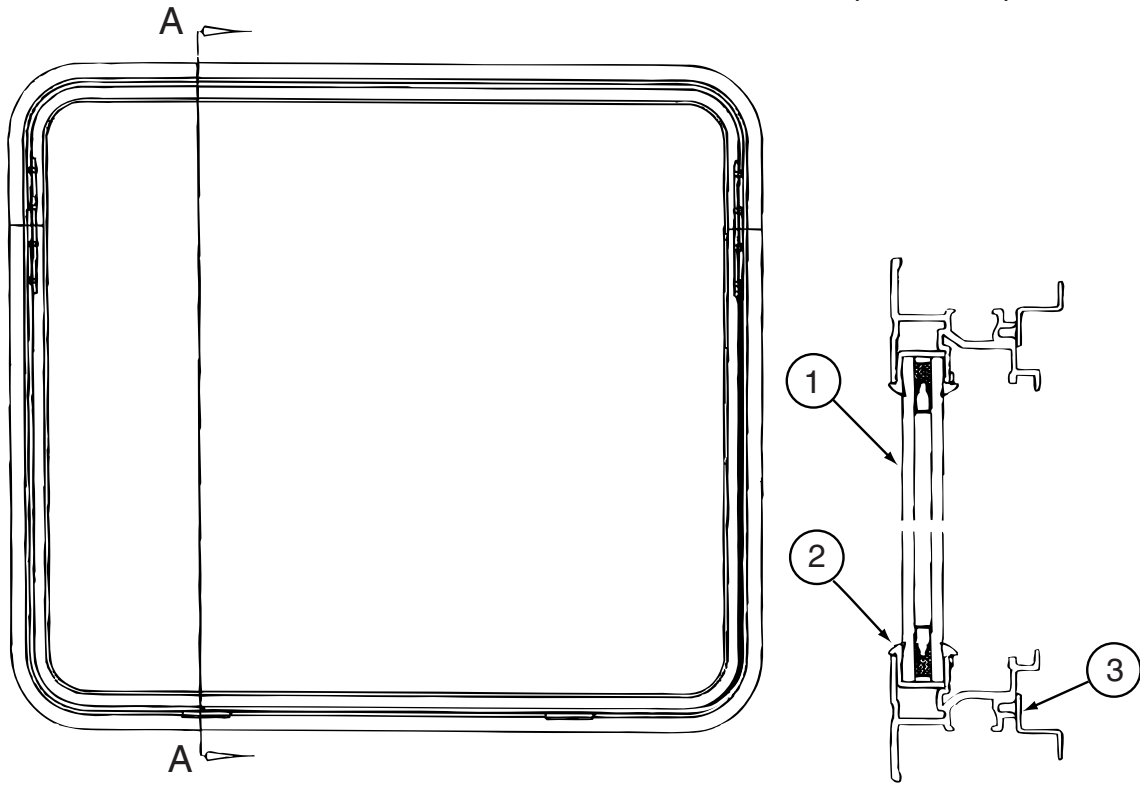

CROSS SECTION A-A

150651-01-01A

KEY	PART NUMBER	U/M	DESCRIPTION	VENDOR NO
1	113733-10-700	EA	GLASS-STATIONARY	390-028306
2	112795-01-705	FT	VINYL - GLAZING	132-027331
3	150651-01-700	EA	RETAINER - TRIM	H416-67

WINDOW & VENTS GROUP (CONTINUED)
COMPONENT PARTS FOR WINDOW & VENT LAYOUT (CONTINUED)

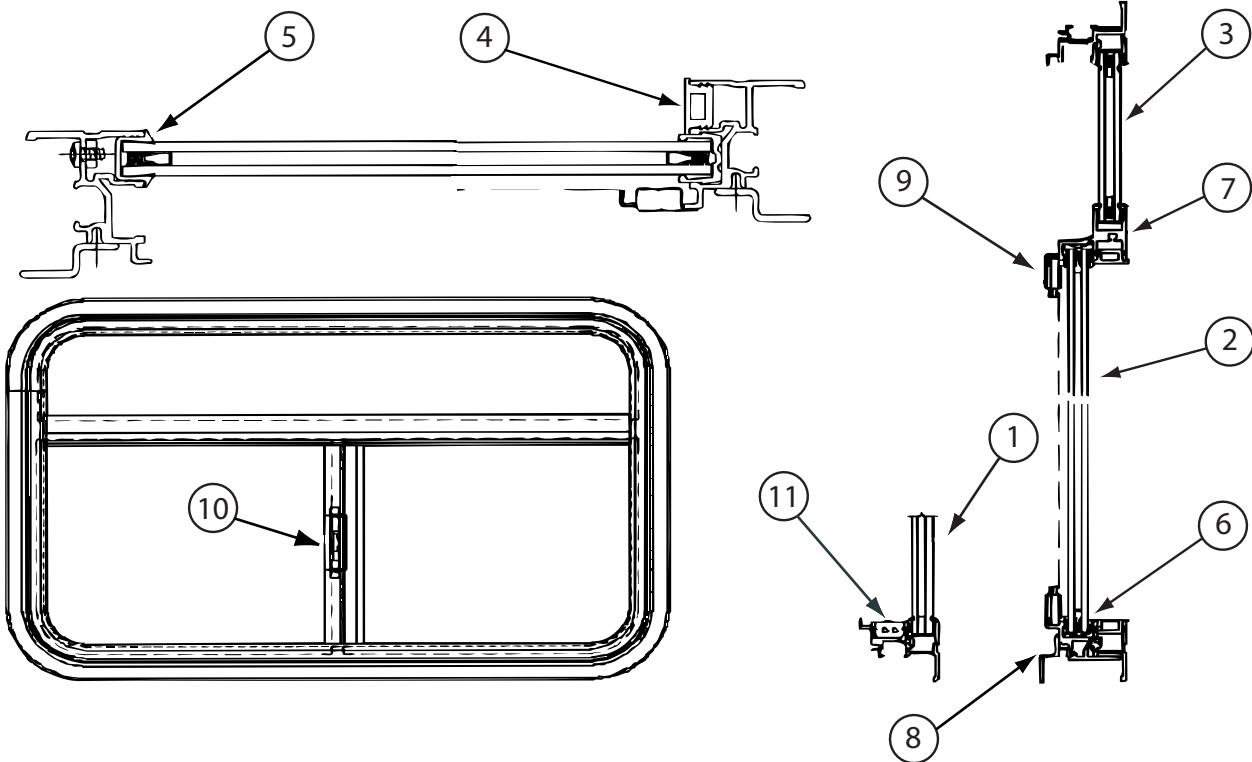

151069-04-01A

KEY	PART NUMBER	U/M	DESCRIPTION	VENDOR NO
1	145573-03-701	EA	GLASS - STATIONARY LWR RH	390-035011
2	151069-02-701	EA	GLASS-SLIDING W/SASH & LATCH	FH3059A9R
3	151069-05-700	EA	GLASS - STATIONARY - UPPER	390-036525
4	150648-01-703	FT	PLUG - FILLER	132-030308
5	112795-01-705	FT	VINYL - GLAZING	132-027331
6	151069-01-700	FT	CHANNEL-RUN, SLIDING	122-030627
7	151069-05-702	EA	WEATHERSTRIP F/LOCKING RAIL	FH305919
8	150648-16-702	EA	RETAINER - TRIM	H611-67
9	151069-02-700	EA	SCREEN ASM - RIGHT	410-035637 (RH)
10	150648-01-700	EA	LATCH-HORIZONTAL SLIDE-BLK	FH3000-CK
11	150648-01-704	EA	SLIDE STOP	132-030866

151069-05-01A

KEY	PART NUMBER	U/M	DESCRIPTION	VENDOR NO
1	145573-04-700	EA	GLASS - STATIONARY LWR	390-035010
2	151069-01-702	EA	GLASS-SLIDING W/SASH & LATCH	FH3059A9L
3	151069-05-700	EA	GLASS - STATIONARY - UPPER	390-036525
4	150648-01-703	FT	PLUG - FILLER	132-030308
5	151069-05-701	EA	VINYL GLAZING-PRE-CUT/FORMED	DH841-12 MITER/WELD
6	151069-01-700	FT	CHANNEL-RUN, SLIDING	122-030627
7	151069-05-702	EA	WEATHERSTRIP F/LOCKING RAIL	FH305919
8	151069-05-703	EA	RETAINER - TRIM	H611-67
9	151069-05-704	EA	SCREEN ASM	410-035641
10	150648-01-700	EA	LATCH-HORIZONTAL SLIDE-BLK	FH3000-CK
11	150648-01-704	EA	SLIDE STOP	132-030866

WINDSHIELD & WIPER GROUP

WINDSHIELD

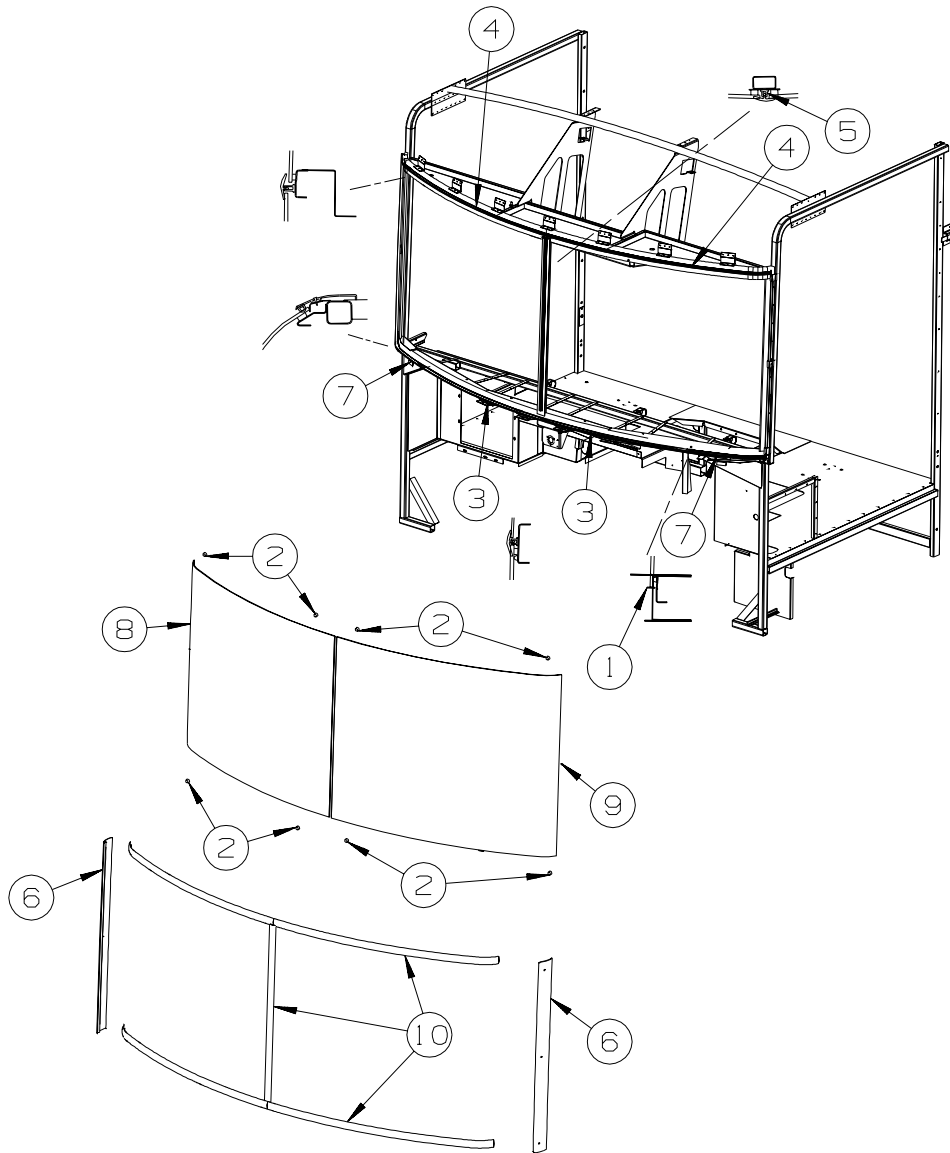

KEY	PART NUMBER	U/M	DESCRIPTION
1	002328-03-000	EA	BLOCK - WINDSHIELD - .125" X .5" X .98"
2	081914-02-000	EA	BUMPER - RUBBER - ROUND - 5/16" DIA. X 13/64" THICK
3	132375-04-000	EA	CARRIER/REVEAL - WINDSHIELD - 29.8"
4	127862-01-000	EA	CARRIER/REVEAL - WINDSHIELD - 47.2"
5	127862-09-000	EA	CARRIER/REVEAL - WINDSHIELD - 38.6"
6	129497-07-03A	EA	TRIM - WINDSHIELD/"A"-PILLAR - PASSENGER - BRIGHT WHITE
7	132375-01-000	EA	CARRIER/REVEAL - WINDSHIELD - 5.5"
8	137583-01-000	EA	WINDSHIELD - PASSENGER (CURVED) 52.4" X 40.5"
9	137583-02-000	EA	WINDSHIELD - DRIVER (CURVED) 52.4" X 40.5"
10	120533-01-000	FT	MOLDING - REVEAL - WINDSHIELD

WINDSHIELD & WIPER GROUP (CONTINUED)

WIPER

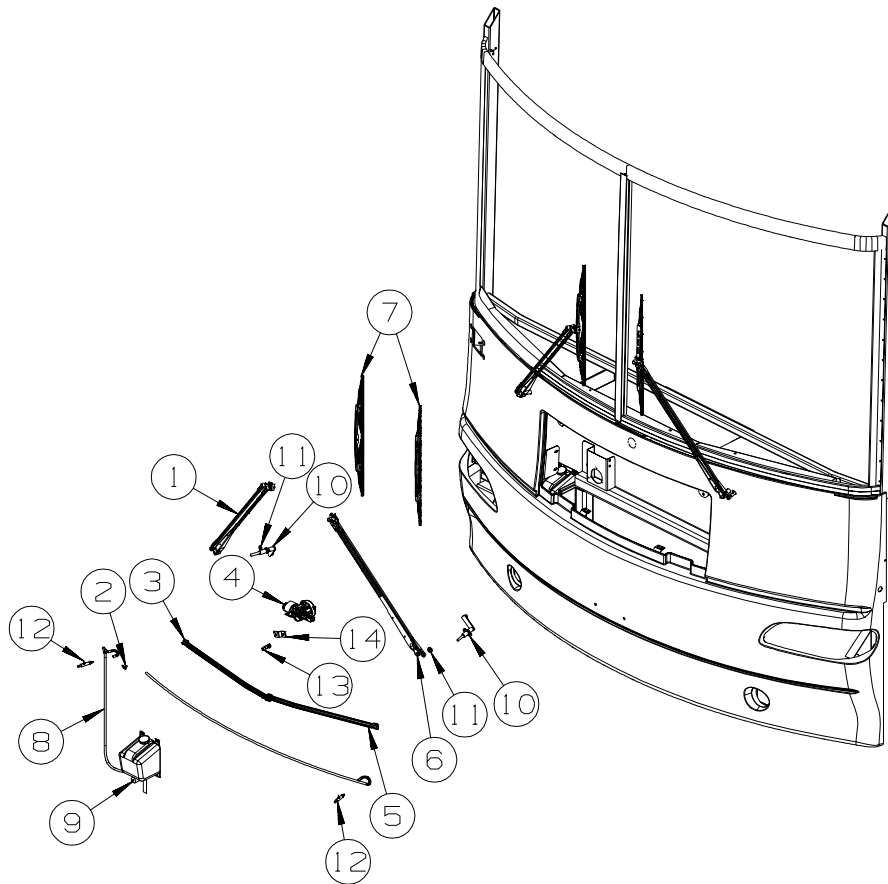

KEY	PART NUMBER	U/M	DESCRIPTION
1*	149402-03-000	EA	ARM - WINDSHIELD WIPER/PANTOGRAPH - RIGHT HAND - 28"
2	146486-01-000	EA	TEE - PLASTIC - 5/32" X 5/32" X 5/32" - ON LEFT SIDE OF WORKHORSE CHASSIS
3	149403-01-000	EA	LINK/CONNECTING-WINDSHIELD WIPER - CLOSED/CLOSED - 24"
4	149409-01-000	EA	MOTOR - WIPER - DYNAMIC PARK
5	149403-02-000	EA	LINK/CONNECTING-WINDSHIELD WIPER - OPEN/CLOSED GROMMET-24"
6*	149402-04-000	EA	ARM - WINDSHIELD WIPER/PANTOGRAPH - LEFT HAND - 28"
7	149399-01-000	EA	BLADE - WINDSHIELD WIPER - 24"
8	045794-01-000	FT	HOSE - WINDSHIELD WASHER - 5/32"ID - BLACK - ON LEFT SIDE OF WORKHORSE CHASSIS
9	117766-02-000	EA	RESERVOIR/PUMP - WINDSHIELD WASHER - ON LEFT SIDE OF WORKHORSE CHASSIS
10*	149401-03-000	EA	SHAFT/PIVOT - WINDSHIELD WIPER
11	110742-03-000	EA	GASKET - WIPER
12	145698-01-01A	EA	SHAFT/IDLER - PANTOGRAPH - W/WASHER DIVERTER - STAINLESS
13	149395-01-000	EA	STUD/DOUBLE BALL CRANK - WIPER MOTOR
14	149408-01-000	EA	ARM - DRIVE/WIPER MOTOR

*COMPONENT PARTS LISTED LATER IN THIS GROUP

COMPONENT PARTS FOR WIPER

149401-03-000

KEY	PART NUMBER	U/M	DESCRIPTION	VENDOR NO.
	096505-02-703	EA	NUT/ACORN - HD W/.687 BRL	51065-40-NT27WC
	149401-01-700	EA	HARDWARE PKG - F/SHAFT&PIVOT	PSHWKIT
	149401-01-701	EA	SEAL CAP/RUBBER GROMMET	300749

149402-03-000 & 149402-04-000

KEY	PART NUMBER	U/M	DESCRIPTION	VENDOR NO.
	149402-03-700	EA	WASHER NOZZLE KIT W/HDWR	19476
	149402-03-701	EA	COVER/CAP - BLACK	200342