

**2007**  
**OUTLOOK**  
**WF331H**  
**300-SERIES**  
**HONEY CHERRY**  
**U21 EMBER GLOW**  
**U23 GINGERSNAP**  
**U25 WOODMONT**  
**WASHED MAPLE**  
**U22 EMBER GLOW**  
**U24 GINGERSNAP**  
**U26 WOODMONT**

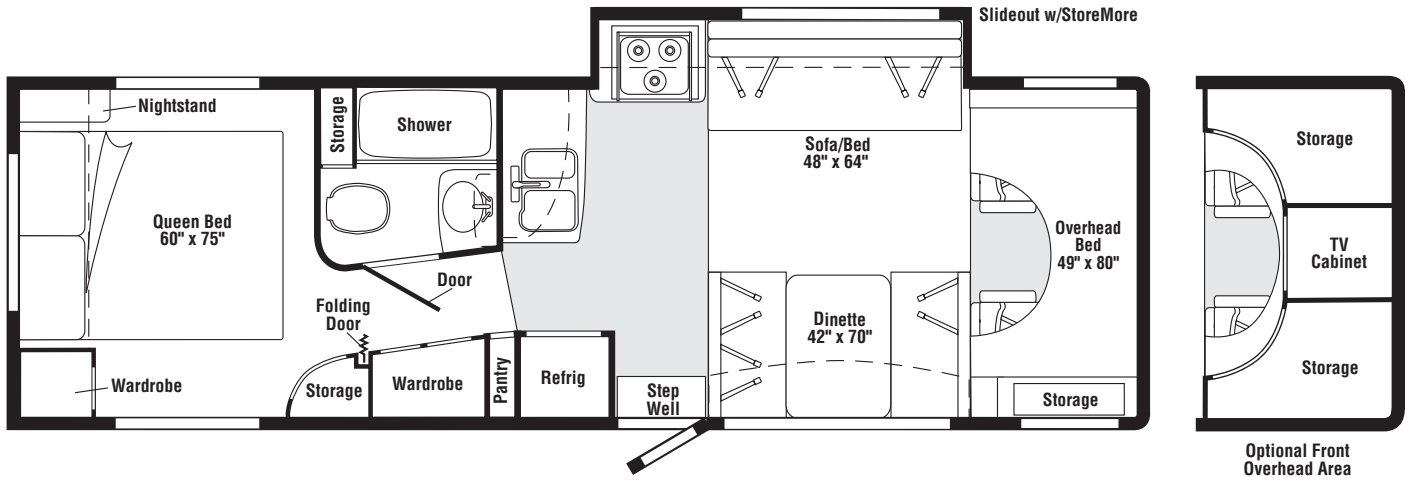

**FLOORPLANS**

# CONTENTS

<b>FLOORPLANS</b> .....	<b>1</b>
<b>ACCESSORIES GROUP</b> .....	<b>6</b>
OPERATORS MANUAL .....	6
<b>AUDIO VIDEO GROUP</b> .....	<b>7</b>
RADIO SYSTEM .....	7
COMPONENT PARTS FOR RADIO SYSTEM .....	7
135420-20-000 .....	7
REAR MONITOR .....	7
COMPONENT PARTS FOR REAR MONITOR .....	7
156930-02-01A .....	7
<b>CABINET &amp; APPLIANCE GROUP</b> .....	<b>8</b>
CABINET & APPLIANCE LAYOUT .....	8
COMPONENT PARTS FOR CABINET & APPLIANCE LAYOUT .....	14
121568-06-01A, 121568-07-01A, 121568-08-01A .....	14
157570-01-01A, 157570-02-01A .....	18
<b>CHASSIS GROUP</b> .....	<b>19</b>
FRAME .....	19
EXHAUST .....	19
HITCH .....	20
FUEL .....	20
SPARE TIRE .....	20
SUSPENSION .....	21
COMPONENT PARTS FOR SUSPENSION .....	21
144887-02-000 .....	21
156618-01-000 .....	21
WHEEL, TIRE, COVERS &/OR LINERS .....	22
COMPONENT PARTS FOR WHEEL, TIRE, COVERS &/OR LINERS .....	22
110435-13-000 .....	22
144647-01-000 .....	22
BRAKELINE .....	22
<b>CURTAIN &amp; CUSHION GROUP</b> .....	<b>23</b>
NOTICE .....	23
CUSHION LAYOUT .....	24
BUCKET SEATS .....	26
SOFA .....	27
WINDOW TREATMENT .....	28
HARDWARE .....	30
ACCESSORIES .....	31
FABRICS .....	32
<b>DRIVERS COMPARTMENT GROUP</b> .....	<b>33</b>
FRONT INTERIOR .....	33
CABINETS .....	36

# CONTENTS (CONTINUED)

<b>ELECTRICAL GROUP</b> .....	<b>37</b>
110V BODY WIRING .....	37
12V BODY WIRING .....	39
EXTERIOR LAMPS .....	45
FRONT END .....	46
FRONT TV/VCR .....	47
SIDE TV/VCR .....	48
COMPONENT PARTS FOR WIRING .....	49
076319-23-000 .....	49
076319-25-000 .....	49
087694-01-000 .....	50
097917-01-06A .....	50
120269-07-01A .....	50
121935-01-01A .....	50
134940-06-01A .....	51
134940-07-01A .....	51
137135-02-000 .....	52
137417-01-01A, 137417-03-01A .....	53
137417-02-01A .....	53
137417-05-01A .....	53
137417-06-01A .....	53
146298-02-000 .....	53
155619-01-000 .....	53
156413-01-01A .....	53
158703-01-000 .....	53
158836-01-000 .....	53
CIRCUIT BREAKERS, FUSES & RELAYS .....	54
CONVERTER, INVERTER, LOAD CENTERS .....	54
COMPONENT PARTS FOR CONVERTER, INVERTER, LOAD CENTERS .....	54
083208-07-000 .....	54
BOXES & CORDS .....	55
WIRE ASSEMBLIES .....	55
CONNECTORS & CONDUIT .....	56
CHASSIS .....	58
<b>EXTERIOR BODY GROUP</b> .....	<b>60</b>
GRAPHICS & PAINT .....	60
PANELS & TRIMS .....	61
COMPONENT PARTS FOR PANELS & TRIMS .....	64
133908-01 THRU 133908-08, 133908-10 THRU 133908-13, -01A/-02A/-03A .....	64
133908-09-01A .....	64
FRONT END .....	64
STRUCTURAL COMPONENTS .....	65
AWNINGS .....	65
COMPONENT PARTS FOR AWNINGS .....	65
113874-01-02A .....	65
<b>EXTERIOR DOORS &amp; COMPARTMENTS GROUP</b> .....	<b>66</b>
DOOR & COMPARTMENT LAYOUT .....	66
COMPONENT PARTS FOR DOOR & COMPARTMENT LAYOUT .....	69
084103-08-000 .....	69
094708-05-01A .....	70
COMPARTMENT DOOR PIECE PARTS .....	71
COMPONENT PARTS FOR COMPARTMENT DOOR PIECE PARTS .....	75
110506-A1-000, 110506-A2-000, 110506-26-000, 110506-27-000, 110506-36-000 .....	75
ENTRY .....	75
SCREEN .....	76
LATCH - ENTRY .....	77
<b>EXTERIOR SLIDEOUT GROUP</b> .....	<b>78</b>
FRONT LEFT .....	78
COMPONENT PARTS FOR FRONT SLIDEOUT .....	81
142598-01-000 .....	81
142598-02-000 .....	82

## CONTENTS (CONTINUED)

<b>GENERATOR GROUP</b> .....	<b>83</b>
<b>HEATING &amp; A/C GROUP</b> .....	<b>84</b>
FURNACE .....	84
COMPONENT PARTS FOR FURNACE .....	85
139980-02-000 .....	85
REAR HEATER .....	87
COMPONENT PARTS FOR REAR HEATER .....	87
084405-01-000 .....	87
ROOF .....	88
COMPONENT PARTS FOR ROOF .....	88
131184-01-01A .....	88
131184-05-01A .....	89
131185-03-01A .....	90
131188-03-01A .....	91
131188-04-01A .....	92
<b>INTERIOR FINISH GROUP</b> .....	<b>93</b>
MOLDINGS & TRIMS .....	93
PANELING & LAMINATES .....	101
INTERIOR TRIM LAYOUT .....	102
COMPONENT PARTS FOR INTERIOR TRIM LAYOUT .....	105
094499-02-000 .....	105
131595-01-01A, 131595-05-01A, 131595-10-01A .....	105
151578-02-01A .....	105
FLOOR COVERINGS .....	105
HARDWARE .....	106
<b>LABELS GROUP</b> .....	<b>112</b>
<b>LP GROUP</b> .....	<b>114</b>
LP SYSTEM .....	114
COMPONENT PARTS FOR LP SYSTEM .....	114
144116-04-000 .....	114
<b>SEALANTS &amp; FASTENERS GROUP</b> .....	<b>115</b>
SEALANTS & ADHESIVES .....	115
BOLTS, NUTS AND WASHERS .....	116
SCREWS .....	118
CLAMPS, CLIPS, GROMMETS, RIVETS & PLUGS .....	121
MISCELLANEOUS FASTENERS .....	122
<b>WATER &amp; SEWAGE GROUP</b> .....	<b>123</b>
DRAINAGE SYSTEM .....	123
COMPONENT PARTS FOR DRAINAGE SYSTEM .....	125
147421-01-01A, 147421-02-01A .....	125
WATER SYSTEM .....	126
COMPONENT PARTS FOR WATER SYSTEM .....	133
051391-03-000 .....	133
098607-01-000 .....	134
145541-02-000 .....	134
152311-01-01A .....	134

## CONTENTS (CONTINUED)

<b>WINDOW &amp; VENTS GROUP .....</b>	<b>135</b>
WINDOW & VENT LAYOUT .....	135
COMPONENT PARTS FOR WINDOW & VENT LAYOUT .....	136
098647-27-02A, 098647-28-02A .....	136
098647-29-02A, 098647-30-02A .....	137
098647-31-02A, 098647-32-02A .....	137
098647-74-01A .....	138
098647-78-01A, 098647-79-01A .....	139
122882-01-01A .....	140
122882-02-01A, 122882-03-01A .....	140
123780-03-01A .....	140
150648-02-01A, 150648-03-01A .....	141
150648-04-01A, 150648-05-01A .....	141
150648-07-01A, 150648-22-01A .....	142
150648-31-01A, 150648-32-01A .....	142
150651-01-01A .....	143
150651-03-01A .....	143
150656-03-01A .....	144
161452-01-01A .....	145

**ACCESSORIES GROUP**  
**OPERATORS MANUAL**

<b>KEY</b>	<b>PART NUMBER</b>	<b>U/M</b>	<b>DESCRIPTION</b>
	129079-01-01A	EA	CASE - VINYL/BLACK-EXPANDABLE ACCORDION SIDES-7"WX9"HX14"L FROM: 00-00-00 THRU: 07-09-06
	129079-04-01A	EA	CASE - VINYL/BLK-EXPANDABLE ACCORDION SIDES-11"WX9"HX14"L FROM: 07-10-06 THRU: 07-30-06
	159842-01-01A	EA	CASE - VINYL - F/MANUALS - W/SLEEVES - BLACK FROM: 07-31-06 THRU: 99-99-99
	132000-03-007	EA	MANUAL/OWNER - OUTLOOK - 2007
	158603-07-002	EA	MANUAL/OWNER - SUPPLEMENT - 300 SERIES - 2007
	156400-01-000	DW	TOP LEVEL-300,2007

## AUDIO VIDEO GROUP RADIO SYSTEM

KEY	PART NUMBER	U/M	DESCRIPTION
	135420-15-000	EA	RADIO-AM/FM/CD/SIRIUS SATELLITE READY-W/O REMOTES/WIRE ASM
	135420-05-000	EA	MOUNTING KIT - RADIO - FORD
	135420-19-000	EA	REMOTE CONTROL/RADIO (CREDIT CARD SIZE)
	135420-18-000	EA	REMOTE CONTROL/RADIO (STEERING WHEEL MOUNT)
	135420-14-000	EA	RECEIVER (EYE) - INFRARED

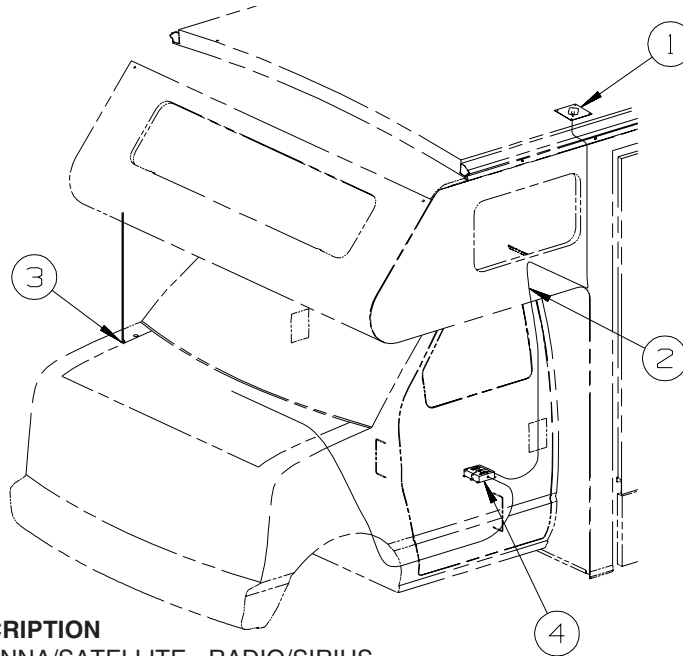

KEY	PART NUMBER	U/M	DESCRIPTION
1	158494-01-000	EA	ANTENNA/SATELLITE - RADIO/SIRIUS
2	158494-02-000	EA	CABLE/ANTENNA - SATELLITE RADIO SIRRUS
3	108137-01-000	EA	PLUG - ANTENNA
4*	135420-20-000	EA	RECEIVER - SATELLITE RADIO

\*COMPONENT PARTS LISTED LATER IN THIS GROUP

### COMPONENT PARTS FOR RADIO SYSTEM

135420-20-000

KEY	PART NUMBER	U/M	DESCRIPTION	VENDOR NO.
	135420-20-700	EA	CABLE-RECIEVER TO RADIO	M9CABLE

### REAR MONITOR

KEY	PART NUMBER	U/M	DESCRIPTION
	156442-01-01A	EA	COLOR MONITOR/LCD - 5.6" - NO AUDIO - PLAS POD MOUNT - TAN FROM: 00-00-00 THRU: 07-09-06
	156442-02-01A	EA	COLOR MONITOR/LCD - 5.6" - NO AUDIO-PLAS POD MOUNT-TAN/BLK FROM: 07-10-06 THRU: 99-99-99
	156930-01-01A	EA	MONITOR/LCD - 5.6" - NO AUDIO - PLASTIC POD MOUNT - TAN - CHEVY FROM: 00-00-00 THRU: 07-09-06
*	156930-02-01A	EA	MONITOR/LCD - 5.6" - NO AUDIO - PLASTIC POD MOUNT - TAN - CHEVY FROM: 07-10-06 THRU: 99-99-99
	144677-04-000	EA	CAMERA - REAR VIEW W/BACKET - BLACK & WHITE - VBCS150
	149227-01-02B	EA	BRACKET - CAMERA - E-COATED - ASPECT, CAMBRIA
	149237-01-01A	EA	SHROUD - CAMERA/OUTER - BRIGHT WHITE - ASPECT, CAMBRIA
	149237-01-02A	EA	SHROUD - CAMERA/OUTER - PRIMED - ASPECT, CAMBRIA / DLX GRAPHICS
	154189-04-02A	EA	COVER/TRIM - WIRING - 15.3" - ALMOND - ACCESS, IMPULSE 226A, 228P, 229T, 231C
	154189-06-02A	EA	COVER/TRIM - WIRING - 17.3" - ALMOND - ACCESS, IMPULSE 224V
	160883-01-02B	EA	BRACKET-MONITOR-E-COATED - ACCESS, IMPULSE / OUTLOOK, SPIRIT - FORD FROM: 06-12-06 THRU: 99-99-99

\*COMPONENT PARTS LISTED LATER IN THIS GROUP

### COMPONENT PARTS FOR REAR MONITOR

156930-02-01A

KEY	PART NUMBER	U/M	DESCRIPTION	VENDOR NO.
	156930-02-700	EA	SHROUD - REAR VIEW MONITOR	33200012
	156930-02-701	EA	BRACKET - REAR VIEW MONITOR	32300009

# CABINET & APPLIANCE GROUP

## CABINET & APPLIANCE LAYOUT

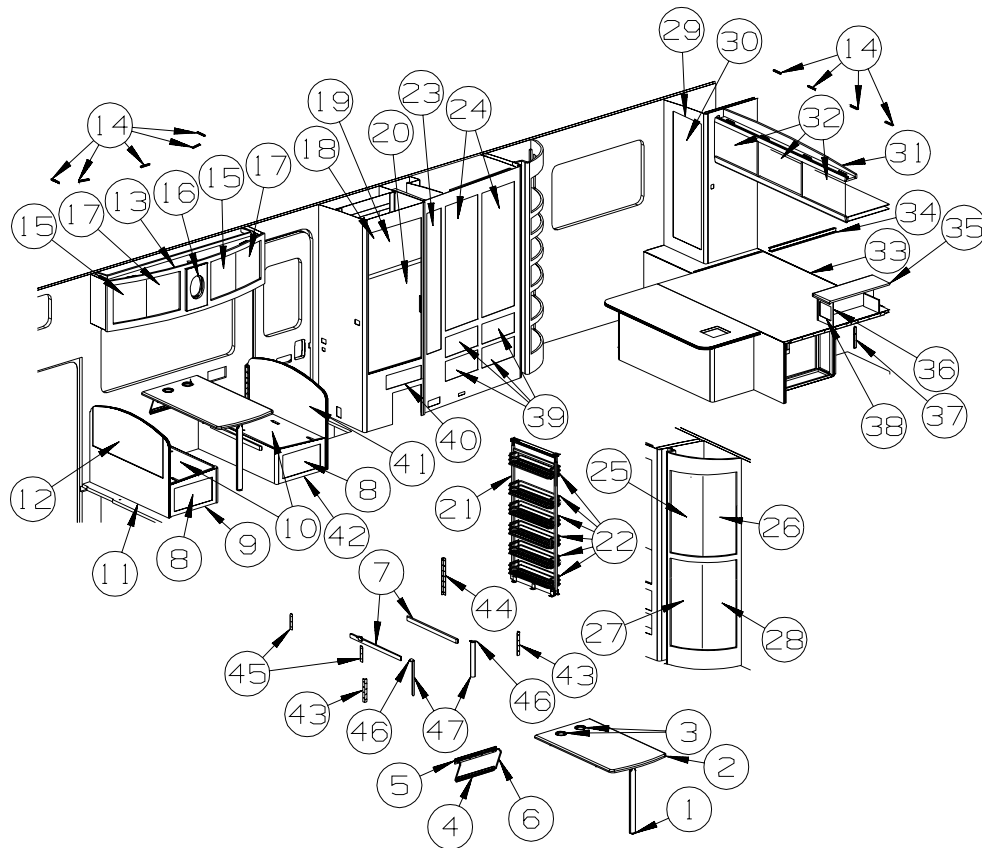

KEY	PART NUMBER	U/M	DESCRIPTION
1	143798-01-02A	EA	CATCH - FLOOR TO TABLE LEG - ALMOND
2	159010-01-U21	EA	TABLE - DINETTE - W/HANGER (U21, U22, U23, U24)
	157828-05-01A	EA	COUNTERTOP - TABLE - W/O HDW (U21, U22, U23, U24)
2	159010-01-U25	EA	TABLE - DINETTE - W/HANGER (U25, U26)
	157828-05-02A	EA	COUNTERTOP - TABLE - W/O HDW (U25, U26)
3	064781-06-000	EA	HOLDER/CUP - TWO STEP - OFF WHITE
4	024281-12-000	EA	BRACKET/WALL - TABLE LIFT - 17.1" - ALMOND
5	140921-02-02A	EA	BRACKET/TABLE SUPPORT - 18.5" - ALMOND
6	024275-16-000	EA	ROD - TABLE LIFT - W/ARMS 8" & BASE ROD 18.5" - ALMOND
7	081295-01-RE0	EA	SUPPORT - BED/DINETTE - 28" LONG - HONEY CHERRY
7	081295-01-T01	EA	SUPPORT - BED/DINETTE - 28" LONG - WASHED MAPLE
8	159216-08-U21	EA	DOOR - FLAT/SQUARE EDGE - 10" X 19.1" - W/O HDW - HONEY CHERRY
8	159216-08-U22	EA	DOOR - FLAT/SQUARE EDGE - 10" X 19.1" - W/O HDW - WASHED MAPLE
9	P55741-05-U21	EA	CABINET/SEAT BASE - LEFT HAND - W/O DOOR/DRAWER/HDW - HONEY CHERRY
9	P55741-05-U22	EA	CABINET/SEAT BASE - LEFT HAND - W/O DOOR/DRAWER/HDW - WASHED MAPLE
10	091261-01-000	FT	SLIPNOT - ANTISLIP - 1' WIDE X 12' - BLACK
11	155741-38-U21	EA	PANEL/BACK - DINETTE - LEFT HAND - W/O HINGED PORTION - HONEY CHERRY
11	155741-38-U22	EA	PANEL/BACK - DINETTE - LEFT HAND - W/O HINGED PORTION - WASHED MAPLE
12	155741-43-U21	EA	PANEL/BACK - DINETTE - HINGED PORTION - HONEY CHERRY
12	155741-43-U22	EA	PANEL/BACK - DINETTE - HINGED PORTION - WASHED MAPLE
13	157383-01-U21	EA	CABINET - OVERHEAD/DINETTE - W/O DOORS/HDW - HONEY CHERRY
13	157383-01-U22	EA	CABINET - OVERHEAD/DINETTE - W/O DOORS/HDW - WASHED MAPLE
13	157383-02-U21	EA	CABINET - OVHD/DINETTE - W/O DOORS/HDW - HONEY CHERRY - INTERIOR UPGRADE PACKAGE
13	157383-02-U22	EA	CABINET - OVHD/DINETTE - W/O DOORS/HDW - WASHED MAPLE - INTERIOR UPGRADE PACKAGE
14	146514-04-000	EA	CHANNEL/MOUNT - F/ROPE LIGHT
15	156092-03-U21	EA	DOOR - CURVED/VERTICLE - 13.8"W X 15.7"H - W/O HDW - HONEY CHERRY
15	156092-03-U22	EA	DOOR - CURVED/VERTICLE - 13.8"W X 15.7"H - W/O HDW - WASHED MAPLE
16	156100-02-U21	EA	COVER - SPEAKER - W/FABRIC
16	156100-02-U22	EA	COVER - SPEAKER - W/FABRIC
17	156092-04-U21	EA	DOOR - CURVED/VERTICLE - 13.8"W X 15.7"H - W/O HDW - HONEY CHERRY
17	156092-04-U22	EA	DOOR - CURVED/VERTICLE - 13.8"W X 15.7"H - W/O HDW - WASHED MAPLE
18*	121568-06-01A	EA	REFRIGERATOR - SMALL DBL DOOR-RH/2 WAY- 52.8"HX23.5"WX24"D
	090329-01-000	FT	SEAL - "T" - REFRIGERATOR CABINET
	116751-02-01A	EA	TRAY - REFRIGERATOR - BLACK
	054450-01-000	EA	LEVEL - REFRIGERATOR



**CABINET & APPLIANCE GROUP (CONTINUED)**  
**CABINET & APPLIANCE LAYOUT (CONTINUED)**

KEY	PART NUMBER	U/M	DESCRIPTION
19	103251-07-01A	EA	INSERT/REFRIGERATOR DOOR - 21.6" X 14.5" - BLACK ACRYLIC
19	158456-01-01A	EA	INSERT/REFRIGERATOR DOOR - 21.5"W X 14.5"H - TITANIUM SST - INTERIOR UPGRADE PACKAGE
20	103251-08-01A	EA	INSERT/REFRIGERATOR DOOR - 21.6" X 31.6" - BLACK ACRYLIC
20	158456-02-01A	EA	INSERT/REFRIGERATOR DOOR - 21.5"W X 31.6"H - TITANIUM SST - INTERIOR UPGRADE PACKAGE
21	148432-02-01A	EA	SLIDE FRAME - PANTRY - 22.1" DEEP X 49.8" TO 52.8" TALL
22	148432-10-01A	EA	PANTRY BASKET - 6" X 20.5" X 3.3"
23	159216-30-U21	EA	DOOR - FLAT/SQUARE EDGE - 7.9" X 53.9" - W/O HDW - HONEY CHERRY
23	159216-30-U22	EA	DOOR - FLAT/SQUARE EDGE - 7.9" X 53.9" - W/O HDW - WASHED MAPLE
24	159216-10-U21	EA	DOOR - FLAT/SQUARE EDGE - 16.7" X 48" - W/O HDW - HONEY CHERRY
24	159216-10-U22	EA	DOOR - FLAT/SQUARE EDGE - 16.7" X 48" - W/O HDW - WASHED MAPLE
25	159566-01-U21	EA	DOOR - CURVED - 12.6" X 21.8" - W/O HDW - HONEY CHERRY
			FROM: 00-00-00 THRU: 05-24-06
25	160251-01-U21	EA	DOOR - CURVED - 21.8" X 12.7" - W/O HDW - HONEY CHERRY
			FROM: 05-25-06 THRU: 99-99-99
25	159566-01-U22	EA	DOOR - CURVED - 12.6" X 21.8" - W/O HDW - WASHED MAPLE
			FROM: 00-00-00 THRU: 05-24-06
25	160251-01-U22	EA	DOOR - CURVED - 21.8" X 12.7" - W/O HDW - WASHED MAPLE
			FROM: 05-25-06 THRU: 99-99-99
26	159566-02-U21	EA	DOOR - CURVED - 12.6" X 21.8" - W/O HDW - HONEY CHERRY
			FROM: 00-00-00 THRU: 05-24-06
26	160251-02-U21	EA	DOOR - CURVED - 21.8" X 12.7" - W/O HDW - HONEY CHERRY
			FROM: 05-25-06 THRU: 99-99-99
26	159566-02-U22	EA	DOOR - CURVED - 12.6" X 21.8" - W/O HDW - WASHED MAPLE
			FROM: 00-00-00 THRU: 05-24-06
26	160251-02-U22	EA	DOOR - CURVED - 21.8" X 12.7" - W/O HDW - WASHED MAPLE
			FROM: 05-25-06 THRU: 99-99-99
27	159566-04-U21	EA	DOOR - CURVED - 12.6" X 43.6" - W/O HDW - HONEY CHERRY
			FROM: 00-00-00 THRU: 05-24-06
27	160251-04-U21	EA	DOOR - CURVED - 43.6" X 12.7" - W/O HDW - HONEY CHERRY
			FROM: 05-25-06 THRU: 99-99-99
27	159566-04-U22	EA	DOOR - CURVED - 12.6" X 43.6" - W/O HDW - WASHED MAPLE
			FROM: 00-00-00 THRU: 05-24-06
27	160251-04-U22	EA	DOOR - CURVED - 43.6" X 12.7" - W/O HDW - WASHED MAPLE
			FROM: 05-25-06 THRU: 99-99-99
28	159566-03-U21	EA	DOOR - CURVED - 12.6" X 43.6" - W/O HDW - HONEY CHERRY
			FROM: 00-00-00 THRU: 05-24-06
28	160251-03-U21	EA	DOOR - CURVED - 43.6" X 12.7" - W/O HDW - HONEY CHERRY
			FROM: 05-25-06 THRU: 99-99-99
28	159566-03-U22	EA	DOOR - CURVED - 12.6" X 43.6" - W/O HDW - WASHED MAPLE
			FROM: 00-00-00 THRU: 05-24-06
28	160251-03-U22	EA	DOOR - CURVED - 43.6" X 12.7" - W/O HDW - WASHED MAPLE
			FROM: 05-25-06 THRU: 99-99-99
29	159204-02-U21	EA	DOOR - MIRRORED - 16.7" X 48" - W/O HDW - HONEY CHERRY
29	159204-02-U22	EA	DOOR - MIRRORED - 16.7" X 48" - W/O HDW - WASHED MAPLE
30	140374-85-000	EA	MIRROR - SAFETY GLASS - 12.8" X 44"
31	155718-01-U21	EA	CABINET - OVERHEAD/REAR - W/O DOORS/HDW - HONEY CHERRY
31	155718-01-U22	EA	CABINET - OVERHEAD/REAR - W/O DOORS/HDW - WASHED MAPLE
32	159187-11-U21	EA	DOOR - CURVED - 16.9" X 24.1" - W/O HDW - HONEY CHERRY
32	159187-11-U22	EA	DOOR - CURVED - 16.9" X 24.1" - W/O HDW - WASHED MAPLE
33	155693-01-U21	EA	CABINET - BED BASE - QUEEN - W/O DOORS/DRAWERS/HDW - HONEY CHERRY
33	155693-01-U22	EA	CABINET - BED BASE - QUEEN - W/O DOORS/DRAWERS/HDW - WASHED MAPLE
34	158079-01-01A	EA	SUPPORT - BUNK/REAR - OFF WHITE
35	157828-04-01A	EA	COUNTERTOP - NIGHTSTAND (U21, U22, U23, U24)
35	157828-04-02A	EA	COUNTERTOP - NIGHTSTAND (U25, U26)
36	155695-01-U21	EA	CABINET - NIGHTSTAND/RH - W/O COUNTERTOP/DOORS/DRAWERS/HDW - HONEY CHERRY
36	155695-01-U22	EA	CABINET - NIGHTSTAND/RH - W/O COUNTERTOP/DOORS/DRAWERS/HDW - WASHED MAPLE
37	081521-02-007	EA	MOUNT - METAL MOLDING - F/RADIUS CORNER MOLDING - 151.5"
38	153121-HR-U21	EA	DRAWER - VENEER FACE - 5.3"W X 19.7"D - W/O SLIDES/HDW - HONEY CHERRY
38	153121-HR-U22	EA	DRAWER - VENEER FACE - 5.3"W X 19.7"D - W/O SLIDES/HDW - WASHED MAPLE
39	153121-KF-U21	EA	DRAWER - VENEER FACE - 14.7"W X 17.7"D - W/O SLIDES/HDW - HONEY CHERRY
39	153121-KF-U22	EA	DRAWER - VENEER FACE - 14.7"W X 17.7"D - W/O SLIDES/HDW - WASHED MAPLE
40	153121-KD-U21	EA	DRAWER - VENEER FACE - 14.7"W X 13.8"D - W/O SLIDES/HDW - HONEY CHERRY
40	153121-KD-U22	EA	DRAWER - VENEER FACE - 14.7"W X 13.8"D - W/O SLIDES/HDW - WASHED MAPLE

**CABINET & APPLIANCE GROUP (CONTINUED)**  
**CABINET & APPLIANCE LAYOUT (CONTINUED)**

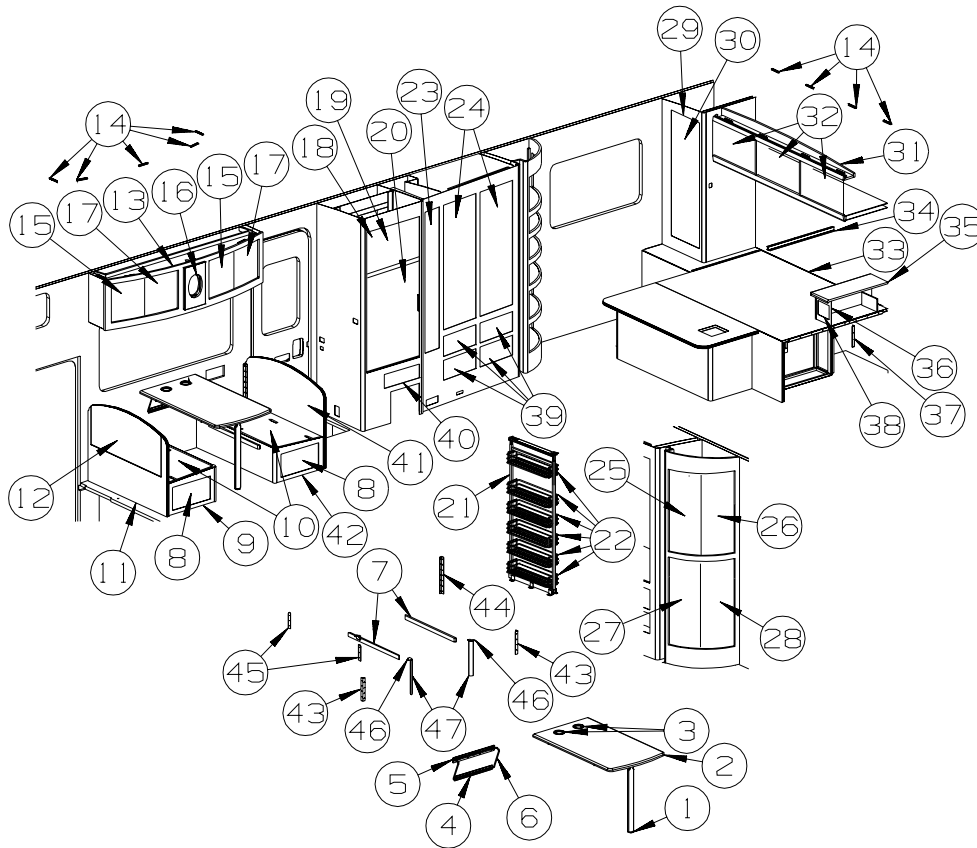

KEY	PART NUMBER	U/M	DESCRIPTION
41	155741-32-U21	EA	PANEL/BACK - DINETTE - RH - W/O HDW - HONEY CHERRY
41	155741-32-U22	EA	PANEL/BACK - DINETTE - RH - W/O HDW - WASHED MAPLE
41	155741-52-U21	EA	PANEL/BACK - DINETTE - RH - W/O HDW - HONEY CHERRY - <b>WTR HTR-6G/110/LP/MA</b>
41	155741-52-U22	EA	PANEL/BACK - DINETTE - RH - W/O HDW - WASHED MAPLE - <b>WTR HTR-6G/110/LP/MA</b>
42	P55741-06-U21	EA	CABINET/SEAT BASE - RH - W/O DOOR/DRWR/HDW - HONEY CHERRY
42	P55741-06-U22	EA	CABINET/SEAT BASE - RH - W/O DOOR/DRWR/HDW - WASHED MAPLE
42	P55741-09-U21	EA	CABINET/SEAT BASE - RH - W/O DOOR/DRWR/HDW - HONEY CHERRY - <b>WTR HTR-6G/110/LP/MA</b>
42	P55741-09-U22	EA	CABINET/SEAT BASE - RH - W/O DOOR/DRWR/HDW - WASHED MAPLE - <b>WTR HTR-6G/110/LP/MA</b>
43	122021-01-02A	EA	ANGLE - W/HOLES - 8.6" LONG - OFF WHITE
44	122021-02-02A	EA	ANGLE - W/HOLES - 13.7" LONG - OFF WHITE
45	111474-01-01A	EA	PLATE-STOP O/W
46	160989-01-07A	EA	CAP - CORNER - RADIUS MOLDING - PLASTIC - HONEY CHERRY
46	160989-01-06A	EA	CAP - CORNER - RADIUS MOLDING - PLASTIC - WASHED MAPLE
47	156464-01-01A	EA	MOLDING - CORNER - RADIUS/PLASTIC - 8' - HONEY CHERRY
47	156464-01-01A	EA	MOLDING - CORNER - RADIUS/PLASTIC - 8' - WASHED MAPLE

**\*COMPONENT PARTS LISTED LATER IN THIS GROUP**

**CABINET & APPLIANCE GROUP (CONTINUED)**  
**CABINET & APPLIANCE LAYOUT (CONTINUED)**

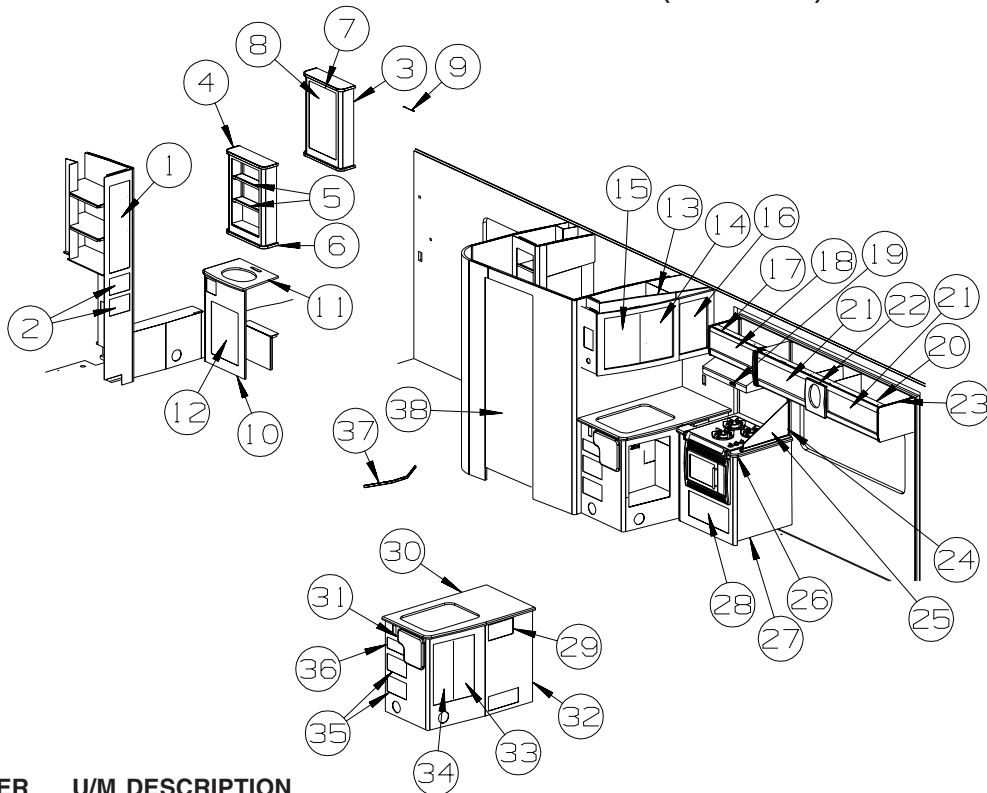

KEY	PART NUMBER	U/M	DESCRIPTION
1	159216-31-U21	EA	DOOR - FLAT/SQUARE EDGE - 9.8" X 33.4" - W/O HDW - HONEY CHERRY
1	159216-31-U22	EA	DOOR - FLAT/SQUARE EDGE - 9.8" X 33.4" - W/O HDW - WASHED MAPLE
2	153121-ME-U21	EA	DRAWER - VENEER FACE - 8"W X 13.8"D - W/O SLIDES/HDW - HONEY CHERRY
2	153121-ME-U22	EA	DRAWER - VENEER FACE - 8"W X 13.8"D - W/O SLIDES/HDW - WASHED MAPLE
3	157997-01-U21	EA	CABT - OVHD/MEDICINE - W/O DOORS/HDW - HONEY CHERRY
3	157997-01-U22	EA	CABT - OVHD/MEDICINE - W/O DOORS/HDW - WASHED MAPLE
4	158227-05-U21	EA	END CAP - OVERHEAD CABINET - HONEY CHERRY
4	158227-05-U22	EA	END CAP - OVERHEAD CABINET - WASHED MAPLE
5	157997-19-U21	EA	SHELF - W/PLASTIC EDGE MOLDING - HONEY CHERRY
5	157997-19-U22	EA	SHELF - W/PLASTIC EDGE MOLDING - WASHED MAPLE
6	158227-04-U21	EA	END CAP - OVERHEAD CABINET - HONEY CHERRY
6	158227-04-U22	EA	END CAP - OVERHEAD CABINET - WASHED MAPLE
7	145576-06-U21	EA	DOOR - W/MIRROR - 15.96" X 25.9" - W/O HARDWARE - HONEY CHERRY
7	145576-06-U22	EA	DOOR - W/MIRROR - 15.96" X 25.9" - W/O HARDWARE - WASHED MAPLE
8	093606-36-000	EA	MIRROR - BEVELED EDGE - 16" X 26"
9	076767-04-000	EA	CABLE - STAINLESS STEEL - 5.9"
10	157828-17-01A	EA	COUNTERTOP - LAVATORY CABT (U21, U22, U23, U24)
10	157828-17-02A	EA	COUNTERTOP - LAVATORY CABT (U25, U26)
11	157861-01-U21	EA	CABT - LAVATORY - W/O COUNTERTOP/DOORS/DRAWERS/HDW - HONEY CHERRY
11	157861-01-U22	EA	CABT - LAVATORY - W/O COUNTERTOP/DOORS/DRAWERS/HDW - WASHED MAPLE
12	159216-35-U21	EA	DOOR - FLAT/SQUARE EDGE - 15.7" X 20.4" - W/O HDW - HONEY CHERRY
12	159216-35-U22	EA	DOOR - FLAT/SQUARE EDGE - 15.7" X 20.4" - W/O HDW - WASHED MAPLE
13	158019-01-U21	EA	CABT - OVHD/GALLEY - W/O DOORS/HDW - HONEY CHERRY
13	158019-01-U22	EA	CABT - OVHD/GALLEY - W/O DOORS/HDW - WASHED MAPLE
13	158019-02-U21	EA	CABT - OVHD - W/O HDW - HONEY CHERRY - DRAIN SYST-HEATED OR WTR HTR-6G/110/LP/MA
13	158019-02-U22	EA	CABT - OVHD - W/O HDW - WASHED MAPLE - DRAIN SYST-HEATED OR WTR HTR-6G/110/LP/MA
13	158019-03-U21	EA	CABT - OVHD - W/O HDW - HONEY CHERRY - DRAIN SYST-HEATED/WTR HTR-6G/110/LP/MA
13	158019-03-U22	EA	CABT - OVHD - W/O HDW - WASHED MAPLE - DRAIN SYST-HEATED/WTR HTR-6G/110/LP/MA
13	158019-04-U21	EA	CABT - OVHD - W/O HDW - HONEY CHERRY - INTERIOR UPGRADE PKG
13	158019-04-U22	EA	CABT - OVHD - W/O HDW - WASHED MAPLE - INTERIOR UPGRADE PKG
13	158019-05-U21	EA	CABT - OVHD - W/O HDW - HONEY CHERRY - INTERIOR UPGRADE PKG/DRAINAGE SYST-HEATED OR WTR HTR-6G/110/LP/MA
13	158019-05-U22	EA	CABT - OVHD - W/O HDW - WASHED MAPLE - INTERIOR UPGRADE PKG/DRAINAGE SYST-HEATED OR WTR HTR-6G/110/LP/MA
13	158019-06-U21	EA	CABT - OVHD - W/O HDW - HONEY CHERRY - INTERIOR UPGRADE PKG/DRAINAGE SYST-HEATED/WTR HTR-6G/110/LP/MA
13	158019-06-U22	EA	CABT - OVHD - W/O HDW - WASHED MAPLE - INTERIOR UPGRADE PKG/DRAINAGE SYST-HEATED/WTR HTR-6G/110/LP/MA

**CABINET & APPLIANCE GROUP (CONTINUED)**  
**CABINET & APPLIANCE LAYOUT (CONTINUED)**

KEY	PART NUMBER	U/M	DESCRIPTION
14	156092-13-U21	EA	DOOR - CURVED/VERTICLE - 13.8"W X 19.9"H - W/O HDW - HONEY CHERRY
14	156092-13-U22	EA	DOOR - CURVED/VERTICLE - 13.8"W X 19.9"H - W/O HDW - WASHED MAPLE
15	156092-12-U21	EA	DOOR - CURVED/VERTICLE - 13.8"W X 19.9"H - W/O HDW - HONEY CHERRY
15	156092-12-U22	EA	DOOR - CURVED/VERTICLE - 13.8"W X 19.9"H - W/O HDW - WASHED MAPLE
16	159216-32-U21	EA	DOOR - FLAT/SQUARE EDGE - 12.6" X 19.9" - W/O HDW - HONEY CHERRY
16	159216-32-U22	EA	DOOR - FLAT/SQUARE EDGE - 12.6" X 19.9" - W/O HDW - WASHED MAPLE
17	157964-01-U21	EA	CABINET - OVERHEAD/RANGE - W/O DOORS/HDW - HONEY CHERRY
17	157964-01-U22	EA	CABINET - OVERHEAD/RANGE - W/O DOORS/HDW - WASHED MAPLE
18	159187-20-U29	EA	DOOR - CURVED - 9.8" X 26.9" - W/O HDW - HONEY CHERRY
18	159187-20-U30	EA	DOOR - CURVED - 9.8" X 26.9" - W/O HDW - WASHED MAPLE
19*	157570-01-01A	EA	HOOD - RANGE 24" - W/LIGHT/FAN - BLACK TEXTURED
19*	157570-02-01A	EA	HOOD - RANGE 24" - W/LIGHT/FAN - BLACK TEXTURED - <b>CANADIAN</b>
20	157963-01-U21	EA	CABINET - OVERHEAD/COUCH - W/O DOORS/HDW - HONEY CHERRY
20	157963-01-U22	EA	CABINET - OVERHEAD/COUCH - W/O DOORS/HDW - WASHED MAPLE
21	159187-10-U21	EA	DOOR - CURVED - 11.8" X 27.9" - W/O HDW - HONEY CHERRY
21	159187-10-U22	EA	DOOR - CURVED - 11.8" X 27.9" - W/O HDW - WASHED MAPLE
22	156100-01-U21	EA	COVER - SPEAKER - W/FABRIC
22	156100-01-U22	EA	COVER - SPEAKER - W/FABRIC
23	158227-01-U21	EA	END CAP - OVERHEAD CABINET - HONEY CHERRY
23	158227-01-U22	EA	END CAP - OVERHEAD CABINET - WASHED MAPLE
24	145211-03-U21	EA	SPLASHGUARD - HONEY CHERRY
24	145211-03-U22	EA	SPLASHGUARD - WASHED MAPLE
25	127117-03-01A	EA	GLASS - STATIONARY - SPLASHGUARD
26	157828-16-01A	EA	COUNTERTOP - GALLEY CABINET (U21, U22, U23, U24)
26	157828-16-02A	EA	COUNTERTOP - GALLEY CABINET (U25, U26)
27	P57955-01-U21	EA	CABINET - GALLEY - W/O COUNTERTOP/DOORS/DRAWERS/HDW - HONEY CHERRY
27	P57955-01-U22	EA	CABINET - GALLEY - W/O COUNTERTOP/DOORS/DRAWERS/HDW - WASHED MAPLE
28	153121-MA-U21	EA	DRAWER - VENEER FACE - 21"W X 19.7"D - W/O SLIDES/HDW - HONEY CHERRY
28	153121-MA-U22	EA	DRAWER - VENEER FACE - 21"W X 19.7"D - W/O SLIDES/HDW - WASHED MAPLE
29	153121-MB-U21	EA	DRAWER - VENEER FACE - 10"W X 19.7"D - W/O SLIDES/HDW - HONEY CHERRY
29	153121-MB-U22	EA	DRAWER - VENEER FACE - 10"W X 19.7"D - W/O SLIDES/HDW - WASHED MAPLE
30	157828-15-01A	EA	COUNTERTOP - GALLEY CABINET (U21, U22, U23, U24)
30	157828-15-02A	EA	COUNTERTOP - GALLEY CABINET (U25, U26)
31	157828-18-01A	EA	COUNTERTOP - EXTENSION/GALLEY (U21, U22, U23, U24)
31	157828-18-02A	EA	COUNTERTOP - EXTENSION/GALLEY (U25, U26)
32	P57895-01-U21	EA	CABINET - GALLEY - W/O COUNTERTOP/DOORS/DRAWERS/HDW - HONEY CHERRY
32	P57895-01-U22	EA	CABINET - GALLEY - W/O COUNTERTOP/DOORS/DRAWERS/HDW - WASHED MAPLE
33	159216-34-U21	EA	DOOR - FLAT/SQUARE EDGE - 9" X 26.5" - W/O HDW - HONEY CHERRY
33	159216-34-U22	EA	DOOR - FLAT/SQUARE EDGE - 9" X 26.5" - W/O HDW - WASHED MAPLE
34	159216-33-U21	EA	DOOR - FLAT/SQUARE EDGE - 9" X 26.5" - W/O HDW - HONEY CHERRY
34	159216-33-U22	EA	DOOR - FLAT/SQUARE EDGE - 9" X 26.5" - W/O HDW - WASHED MAPLE
35	153121-MC-U21	EA	DRAWER - VENEER FACE - 9.6"W X 15.7"D - W/O SLIDES/HDW - HONEY CHERRY
35	153121-MC-U22	EA	DRAWER - VENEER FACE - 9.6"W X 15.7"D - W/O SLIDES/HDW - WASHED MAPLE
36	153121-MD-U21	EA	DRAWER - VENEER FACE - 9.6"W X 15.7"D - W/O SLIDES/HDW - HONEY CHERRY
36	153121-MD-U22	EA	DRAWER - VENEER FACE - 9.6"W X 15.7"D - W/O SLIDES/HDW - WASHED MAPLE
37	158186-01-01A	EA	TRIM - TOILET PLATFORM - SOFT WHITE
38	144645-02-U21	EA	DOOR - BATH - W/O FRAME (PICTURE)/TOWEL RACK/HDW - HONEY CHERRY
38	144645-02-S48	EA	DOOR - BATH - W/O FRAME (PICTURE)/TOWEL RACK/HDW - WASHED MAPLE

**\*COMPONENT PARTS LISTED LATER IN THIS GROUP**

**CABINET & APPLIANCE GROUP (CONTINUED)**  
**CABINET & APPLIANCE LAYOUT (CONTINUED)**

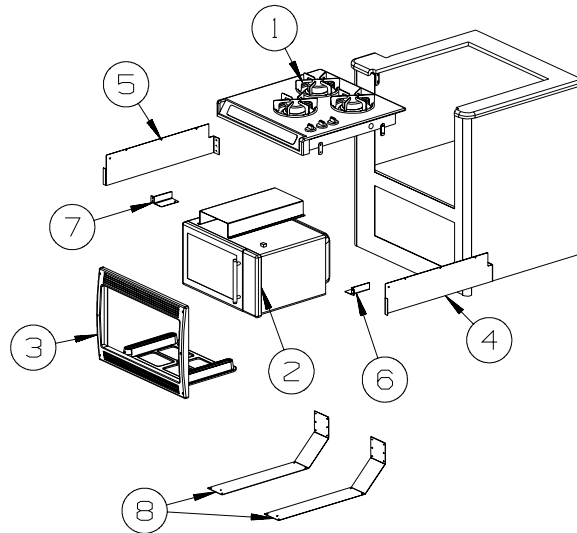

KEY	PART NUMBER	U/M	DESCRIPTION
1	156801-01-01A 115870-01-000	EA FT	RANGE - 3 BURNER - 8100 BTU - STAINLESS STEEL SEAL/EDGE - TRIM
2	156801-02-01A	EA	OVEN/MICROWAVE - 1 CU FT/TURN TABLE - STAINLESS STEEL FACE
3	156801-03-01A	EA	TRIM KIT - MICROWAVE - STAINLESS STEEL
4	156798-03-02B	EA	BRACKET/TIEDOWN - STOVE - E-COATED
5	156798-04-02B	EA	BRACKET/TIEDOWN - STOVE - E-COATED
6	156800-01-02B	EA	BRACKET - MICROWAVE - E-COATED
7	156800-02-02B	EA	BRACKET - MICROWAVE - E-COATED
8	156799-02-000	EA	BRACKET - MICROWAVE - E-COATED

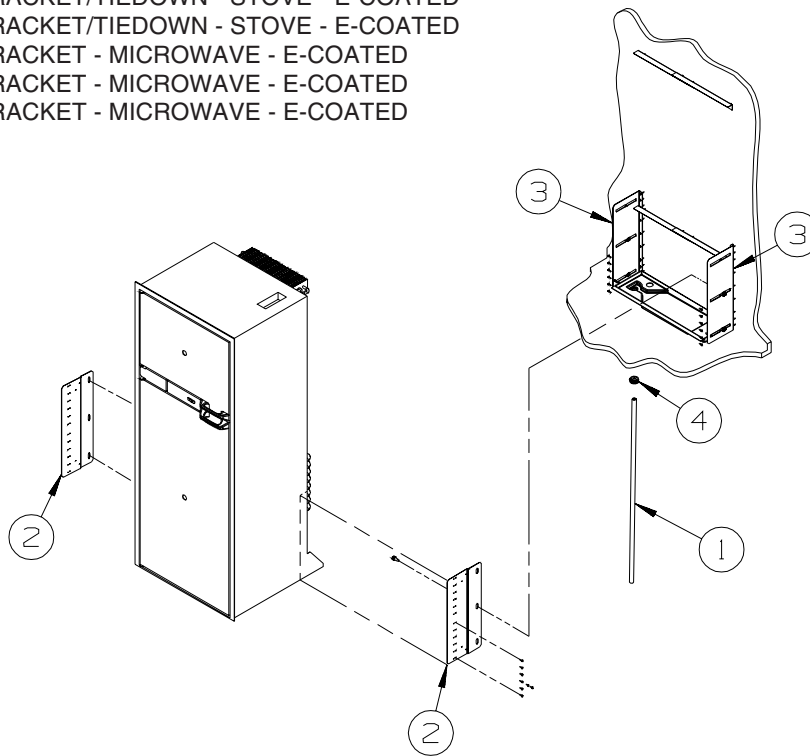

KEY	PART NUMBER	U/M	DESCRIPTION
1	112176-01-000	FT	TUBING - VINYL - REINFORCED - 1/2" ID
2	150740-01-02B	EA	BRACKET/TIEDOWN - REFRIGERATOR - E-COATED
3	150740-02-02B	EA	BRACKET/TIEDOWN - REFRIGERATOR - E-COATED
4	152417-01-01A	EA	CLAMP/RATCHET - F/REFRIGERATOR DRIP TRAY HOSE - BLACK

**CABINET & APPLIANCE GROUP (CONTINUED)**  
**COMPONENT PARTS FOR CABINET & APPLIANCE LAYOUT**

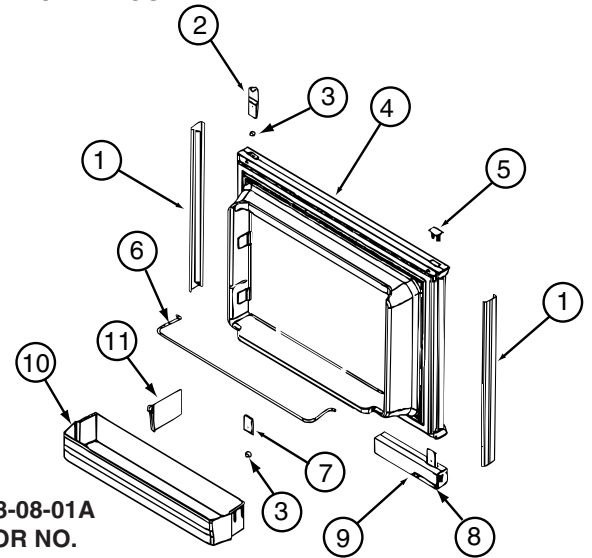

**121568-06-01A, 121568-07-01A, 121568-08-01A**

KEY	PART NUMBER	U/M	DESCRIPTION	VENDOR NO.
1	121568-03-700	EA	RETAINER-DOOR PNL/WAFFLE/BLK	619558-WDL-UPPER
2	120075-01-701	EA	HINGE-TOP RH/BOTTOM LH(DOOR)	618511
3	121568-03-701	EA	BUSHING - HINGE PIN/GRAY	619671
4	121568-03-702	EA	DOOR LINER-UPR/WAFFLED/BLACK	619627 - SMALL WDL
5	120075-01-702	EA	CAP, (HINGE PLUG)	618160
6	121568-01-700	EA	RAIL - DOOR UPPER	618618
7	120075-01-705	EA	HINGE-TOP LH/BOTTOM RH(DOOR)	618510
8	121568-03-705	EA	STORAGE LATCH - GRAY	619648
9	121568-03-721	EA	HANDLE/DOOR UPPER RH SWING	621465
9	121568-03-722	EA	HANDLE/DOOR LOWER RH SWING	621469
10	121568-01-701	EA	BIN - DOOR WHITE-WAFFLED LNR	618619 WDL

CONTACT WINNEBAGO PART SALES FOR UNLISTED COMPONENT(S)

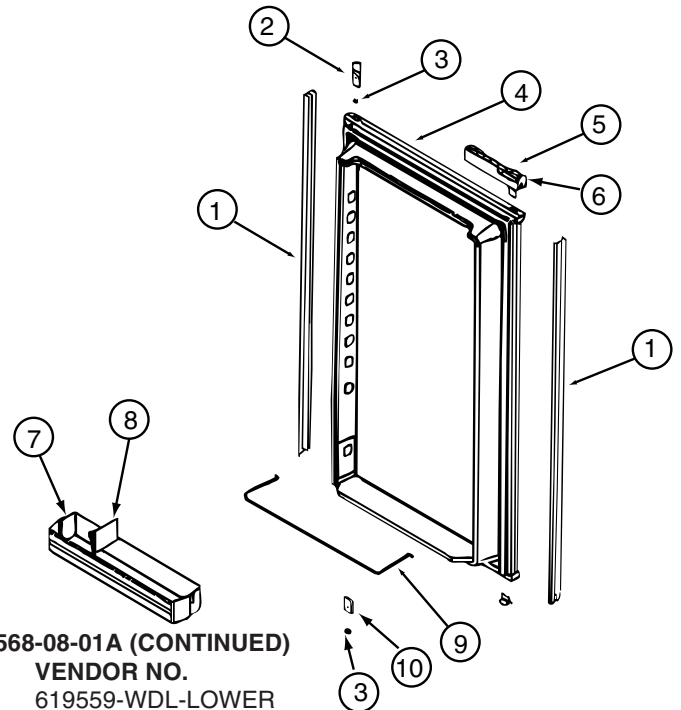

**121568-06-01A, 121568-07-01A, 121568-08-01A (CONTINUED)**

KEY	PART NUMBER	U/M	DESCRIPTION	VENDOR NO.
1	121568-03-706	EA	RETAINER-DOOR PNL/WAFFLE/BLK	619559-WDL-LOWER
2	120075-01-701	EA	HINGE-TOP RH/BOTTOM LH(DOOR)	618511
3	121568-03-701	EA	BUSHING - HINGE PIN/GRAY	619671
4	121568-03-707	EA	DOOR LINER-LWR/WAFFLED/B/TRM	619629
5	121568-03-721	EA	HANDLE/DOOR UPPER RH SWING	621465
5	121568-03-722	EA	HANDLE/DOOR LOWER RH SWING	621469
6	121568-03-705	EA	STORAGE LATCH - GRAY	619648
7	121568-01-701	EA	BIN - DOOR WHITE-WAFFLED LNR	618619 WDL
9	121568-01-704	EA	RAIL - DOOR LOWER	618578
10	120075-01-705	EA	HINGE-TOP LH/BOTTOM RH(DOOR)	618510

CONTACT WINNEBAGO PART SALES FOR UNLISTED COMPONENT(S)

**CABINET & APPLIANCE GROUP (CONTINUED)**  
**COMPONENT PARTS FOR CABINET & APPLIANCE LAYOUT (CONTINUED)**

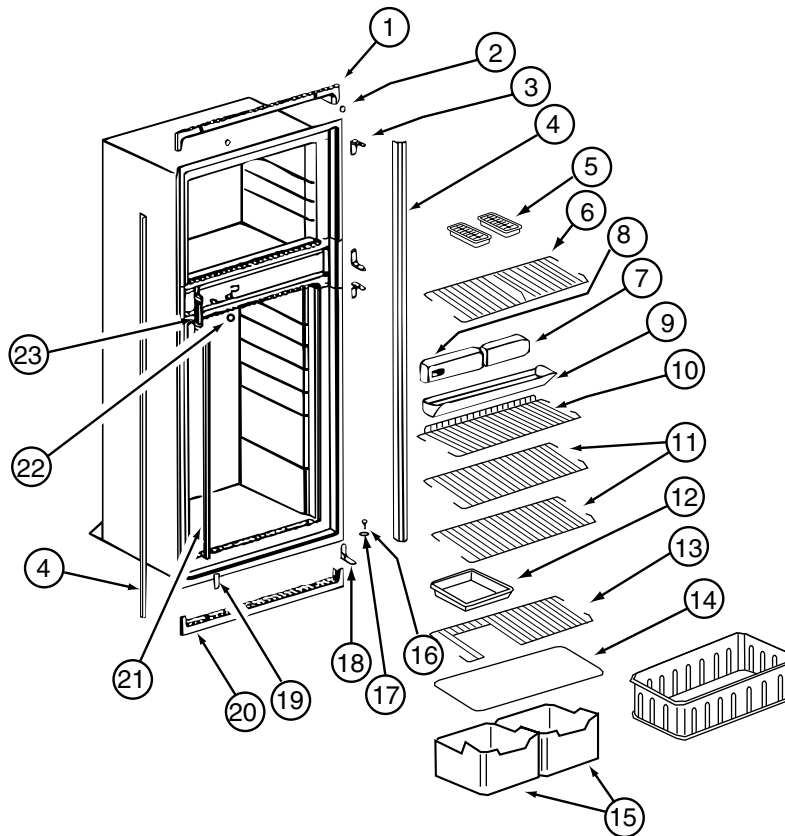

**121568-06-01A, 121568-07-01A, 121568-08-01A (CONTINUED)**

KEY	PART NUMBER	U/M	DESCRIPTION	VENDOR NO.
1	120075-01-713	EA	TRIM-TOP PIECE	619687
2	120075-01-714	EA	PLUG-HOLE (BLACK)	618170
3	121568-03-710	EA	HINGE/CABINET-TOP/RH-LWR/LH	619335 WAFFLED
4	121568-03-711	EA	TRIM - SIDE/BLACK	622295
6	121568-01-705	EA	SHELF - WIRE FREEZER	620250
7	121568-06-700	EA	FRONT BOX-N611	622002
8	121568-06-701	EA	CONTROL ASSY-OPTICAL/N611	621988
9	120075-01-720	EA	TRAY-DRIP	623250
9	120075-01-721	EA	LOUVER-DRIP TRAY	618176
11	121568-01-708	EA	SHELF - WIRE	620273
13	121568-01-707	EA	SHELF - WIRE - SHORT	620272
14	120075-01-725	EA	COVER-CRISPER - 18.5" WIDE	618158
15	121568-01-709	EA	CRISPER	618571
16	120075-01-727	EA	PIN-HINGE	618145
17	121568-03-701	EA	BUSHING - HINGE PIN/GRAY	619671
18	121568-03-715	EA	HINGE/CABINET-TOP/LH-LWR/RH	619336 WAFFLED
19	121568-03-716	EA	COVER - HINGE HOLES	619301
20	120075-01-729	EA	TRIM-BOTTOM PIECE	620958
21	121568-06-702	EA	CLIP - SHELF	61536522
22	121568-06-703	EA	HOLE PLUG - WHITE	620282
23	120075-01-732	EA	PLATE-STRIKE	618167

CONTACT WINNEBAGO PART SALES FOR UNLISTED COMPONENT(S)

**CABINET & APPLIANCE GROUP (CONTINUED)**  
**COMPONENT PARTS FOR CABINET & APPLIANCE LAYOUT (CONTINUED)**

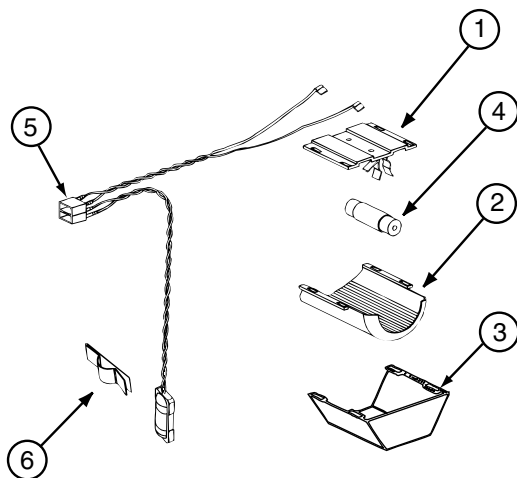

121568-03-01A, 121568-04-01A, 121568-05-01A, 121568-06-01A, 121568-07-01A, 121568-08-01A (CONTINUED)

KEY	PART NUMBER	U/M	DESCRIPTION	VENDOR NO.
1	084880-01-760	EA	CLIP (THERMISTER)	61689122
2	120075-01-735	EA	THERMISTER W/LAMP & WIRE/ASM	618548
3	084880-03-705	EA	BRACKET-LIGHT-INTERIOR	61629722
4	084880-03-706	EA	BULB-LAMP	61628922
6	084880-03-707	EA	COVER-LAMP, LENS	61627922

CONTACT WINNEBAGO PART SALES FOR UNLISTED COMPONENT(S)

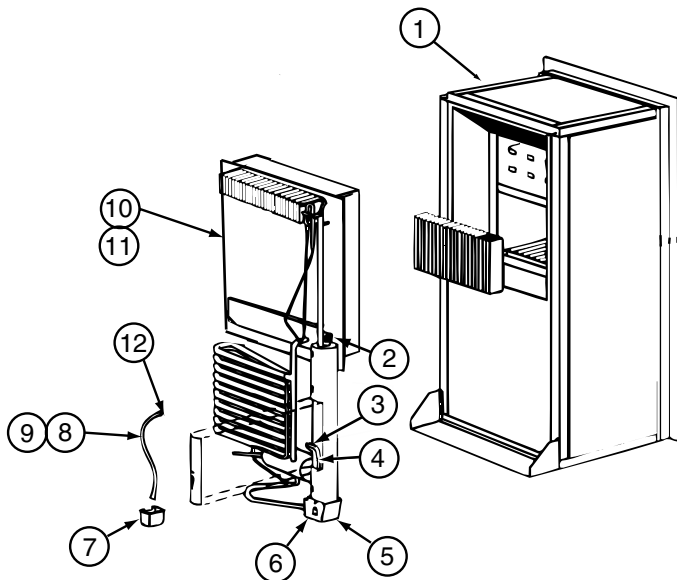

121568-06-01A, 121568-07-01A, 121568-08-01A (CONTINUED)

KEY	PART NUMBER	U/M	DESCRIPTION	VENDOR NO.
4	121568-06-704	EA	HEATER-AC/300W/120VAC	621702
10	120076-01-704	EA	COOLING UNIT, SERVICE PACK	618543

CONTACT WINNEBAGO PART SALES FOR UNLISTED COMPONENT(S)

121568-05-01A, 121568-07-01A, 121568-08-01A (CONTINUED)

KEY	PART NUMBER	U/M	DESCRIPTION	VENDOR NO.
	121568-05-700	EA	FAN 12V KIT DBLE SIDEWALL	619020



**CABINET & APPLIANCE GROUP (CONTINUED)**  
**COMPONENT PARTS FOR CABINET & APPLIANCE LAYOUT (CONTINUED)**

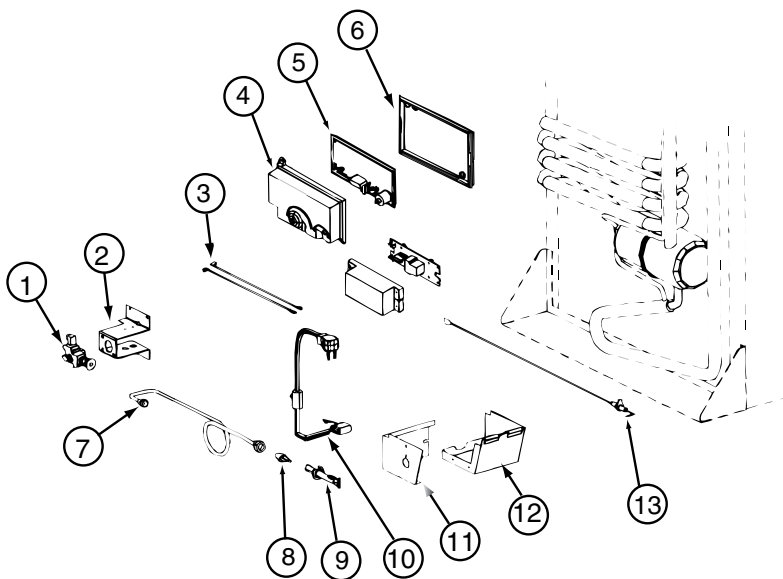

**121568-06-01A, 121568-07-01A, 121568-08-01A (CONTINUED)**

KEY	PART NUMBER	U/M	DESCRIPTION	VENDOR NO.
1	121568-06-705	EA	GAS VALVE/BRKT ASSY-COMBO	621439
1	121568-06-706	EA	GAS VALVE-COMBO/WRENCH FLAT	621329
4	120075-01-738	EA	COVER-POWER BOARD	618185
5	121568-06-707	EA	BOARD/POWER-N611	621991 = 621991001
6	120075-01-740	EA	BASE - POWER BOARD	618186
8	121568-06-708	EA	BURNER/ORFICE-ADAPTER KIT	621957
13	104137-06-715	EA	ELECTRODE-SPARK/SENSOR, SGL	61692222
	121569-08-704	EA	TUBE/BURNER - N8/N6	624682

CONTACT WINNEBAGO PART SALES FOR UNLISTED COMPONENT(S)

**CABINET & APPLIANCE GROUP (CONTINUED)**  
**COMPONENT PARTS FOR CABINET & APPLIANCE LAYOUT (CONTINUED)**

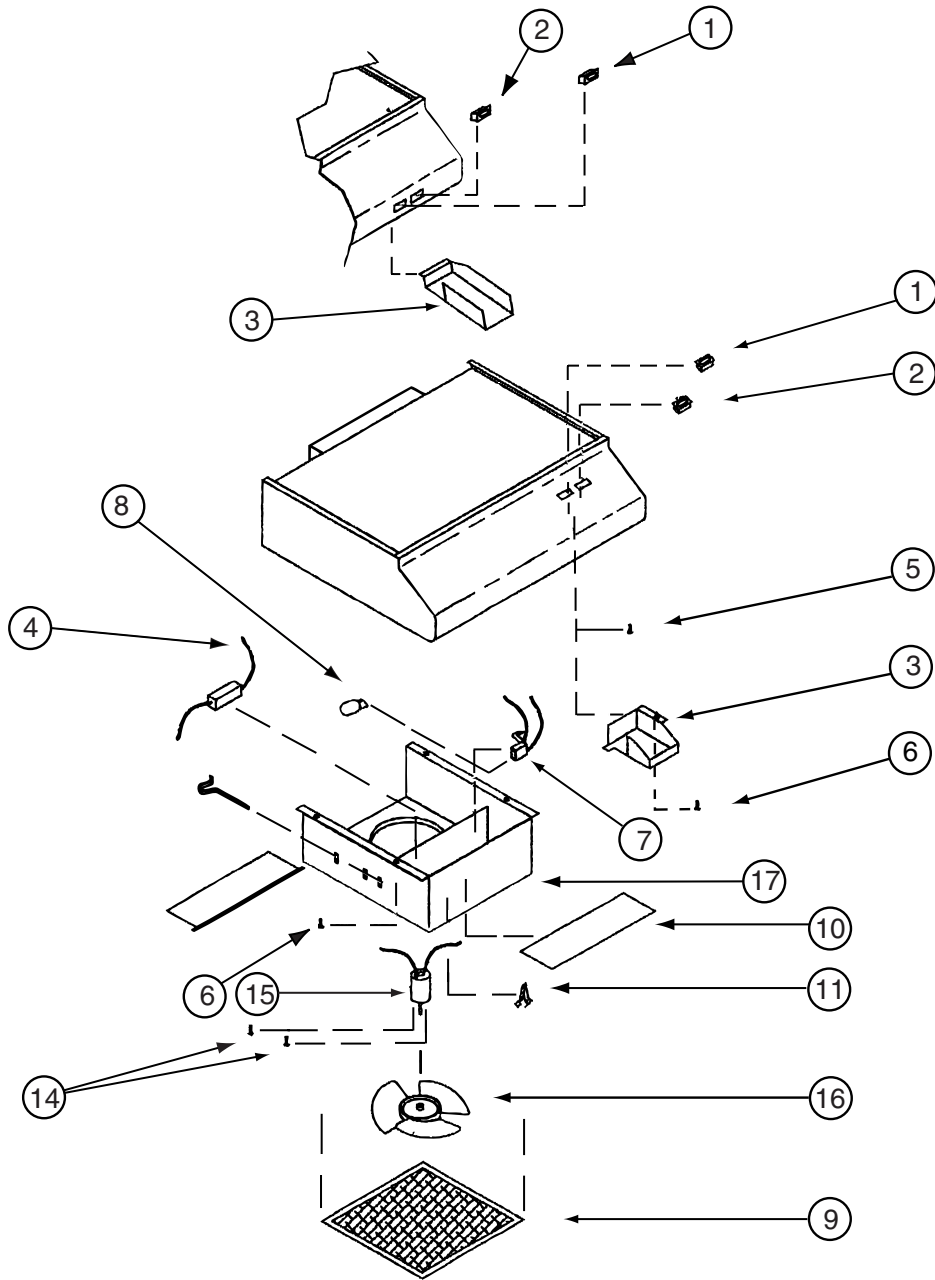

157570-01-01A, 157570-02-01A

KEY	PART NUMBER	U/M	DESCRIPTION	VENDOR NO.
1	157570-01-700	EA	SWITCH - LAMP/BLACK	L1196-00
2	157570-01-701	EA	SWITCH - FAN/BLACK	L1194-00
9	096983-01-707	EA	FILTER-MESH	CC0246-00
10	092696-02-701	EA	LENS-LAMP	CC0179
15	157570-01-702	EA	MOTOR-12 VOLT	VD0218-00
16	136354-05-701	EA	BLADE-FAN 7" DIA	VD0216-00

CONTACT WINNEBAGO PART SALES FOR UNLISTED COMPONENT(S)

## CHASSIS GROUP

### FRAME

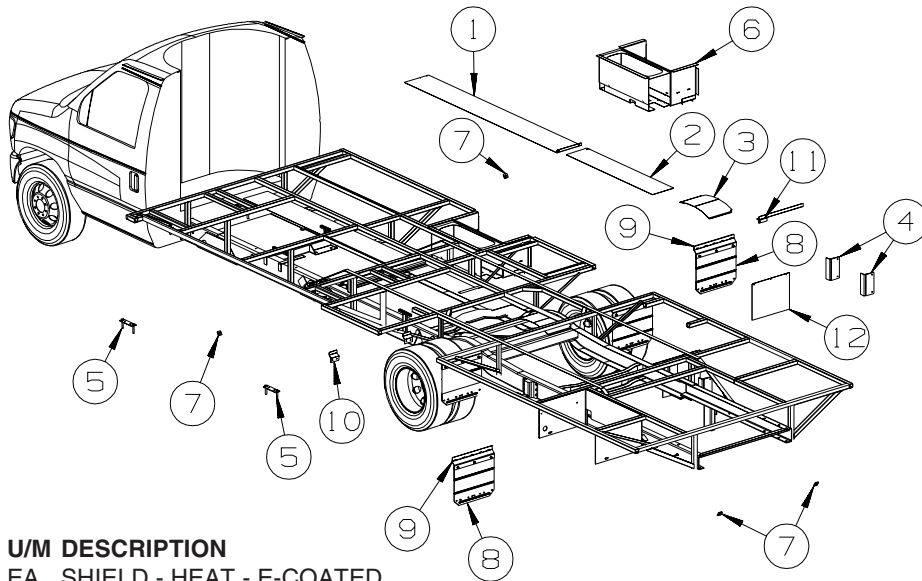

KEY	PART NUMBER	U/M	DESCRIPTION
1	135676-05-02B	EA	SHIELD - HEAT - E-COATED
2	145027-03-02B	EA	SHIELD - HEAT - E-COATED
2	145027-01-02B	EA	SHIELD - HEAT - E-COATED
3	158704-01-02B	EA	SHIELD/HEAT - E-COATED
4	136042-01-02B	EA	BRACKET - LP SUPPORT - E-COATED
5	136995-03-02B	EA	PLATE W/BOLTS - 6.9" X 2" W/1/2" X 3" BOLTS
6	135458-04-02B	EA	BOX - ENTRY STEP - E-COATED - <b>NOT ILLUSTRATED</b>
6	162352-01-02B	EA	BOX - ENTRY STEP - E-COATED
7	141901-02-02B	EA	PLATE - TIE DOWN - E-COATED
8	136391-02-02B	EA	GUARD/ROCK - STEEL - W/ANGLE - 18"W X 15"H - E-COATED
9	157464-01-02B	EA	BRACKET/MOUNTING - MUD GUARD - E-COATED
10	141003-01-02B	EA	PLATE - VALVE - AIR SPRING - E-COATED
11	143817-01-02B	EA	BRACKET - ROCK GUARD - E-COATED
12	111848-03-02B	EA	SHIELD - E-COAT

FROM: 00-00-00 THRU: 06-11-06

FROM: 06-12-06 THRU: 99-99-99

FROM: 00-00-00 THRU: 12-03-06

FROM: 12-04-06 THRU: 99-99-99

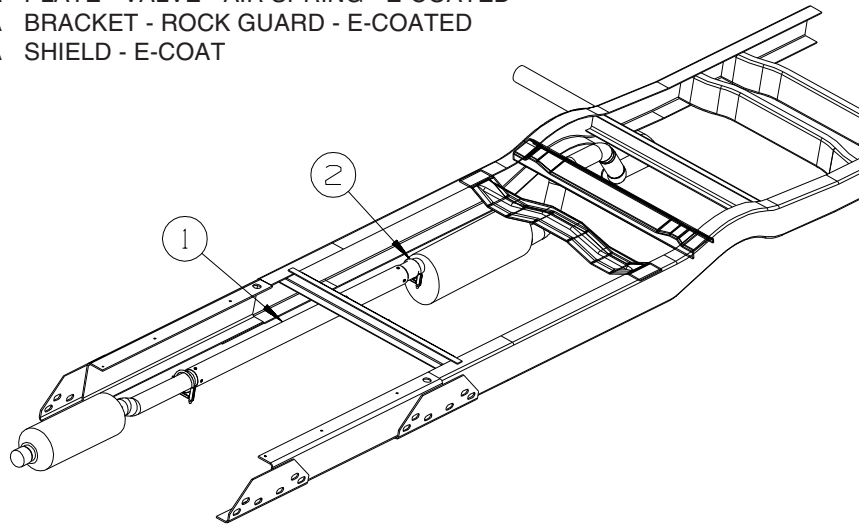

### EXHAUST

KEY	PART NUMBER	U/M	DESCRIPTION
1	111478-06-000	EA	EXHAUST PIPE - DOUBLE WALL STAINLESS STEEL - 58.9"
2	094918-06-000	EA	CLAMP - EXHAUST - 3" - HEAVY DUTY

## CHASSIS GROUP (CONTINUED)

### HITCH

KEY	PART NUMBER	U/M	DESCRIPTION
	154054-03-01A	EA	HITCH RECEIVER - BOLT ON CLASS III - BLACK
	140441-01-02B	EA	PLATE - SKID - E-COATED

FROM: 00-00-00 THRU: 01-29-06

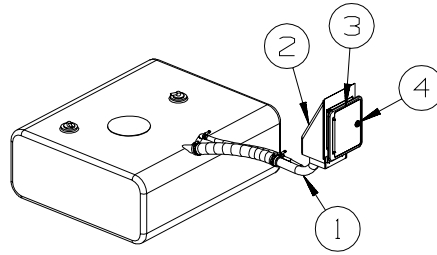

### FUEL

KEY	PART NUMBER	U/M	DESCRIPTION
1	148789-01-000	EA	NECK - FUEL FILL
2	135557-05-01A	EA	SHROUD - FUEL FILL - UPPER - 12.7" X 8.2"
3	147587-01-01A	EA	DOOR - FUEL FILL
4	138290-03-000	EA	CASE - W/CAM - W/O CYLINDER/KEY

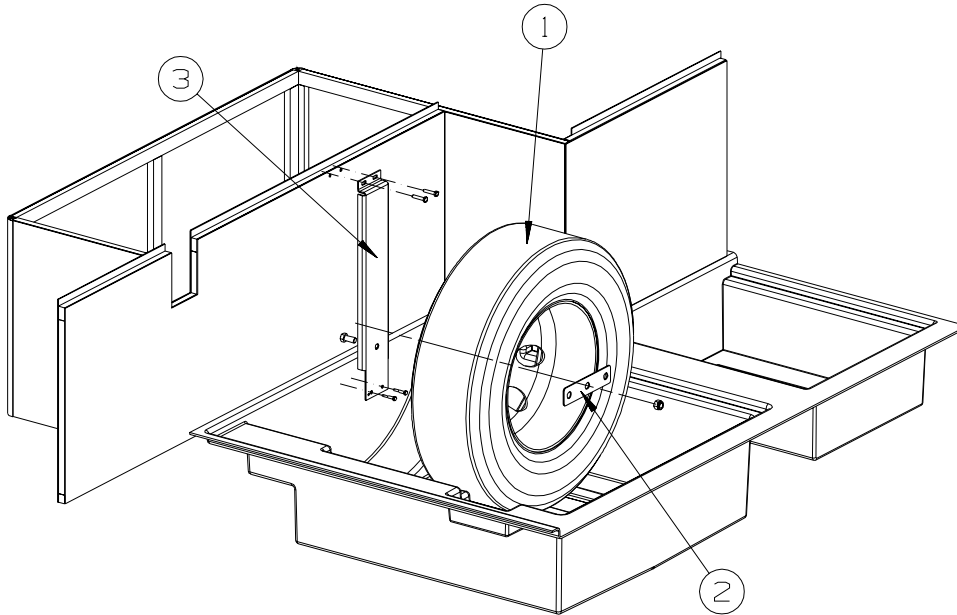

### SPARE TIRE

KEY	PART NUMBER	U/M	DESCRIPTION
1	083425-14-000	EA	TIRE - LT225/75R16 LRE - MICHELIN LTX M/S - FORD
1	144388-02-000	EA	TIRE - LT225/75R16 LRE - UNIROYAL LAREDO - CHEVY
1	083617-05-000	EA	WHEEL - STEEL - 6" X 16" - FORD W/6 VENT HOLES
1	164137-01-01A	EA	WHEEL - STEEL - 6" X 16" - 4 VENT HOLES/OVAL - FORD W/4 VENT HOLES
1	144386-02-000	EA	WHEEL - STEEL - 6.5" X 16" - 8 BOLT - CHEVY
2	143547-01-02B	EA	RETAINER - SPARE TIRE - E-COATED
3	157324-01-01B	EA	BRACKET - SPARE TIRE
	051377-07-000	EA	VALVE STEM - FORD W/6 VENT HOLES
	051377-09-000	EA	VALVE STEM - 1.8" - FORD W/4 VENT HOLES
	155645-01-000	EA	VALVE STEM - 1.25" - CHEVY

**CHASSIS GROUP (CONTINUED)**  
**SUSPENSION**

<b>KEY</b>	<b>PART NUMBER</b>	<b>U/M</b>	<b>DESCRIPTION</b>
*	144887-02-000	EA	AIRSPRING - 4" DIAMETER/TWIN BAG SYSTEM - FIRESTONE - FORD
*	156618-01-000	EA	AIRSPRING - AIR BAG KIT - GMT610/14050 CHEVY - FIRESTONE - CHEVY

**\*COMPONENT PARTS LISTED LATER IN THIS GROUP**

**COMPONENT PARTS FOR SUSPENSION**

**144887-02-000**

<b>KEY</b>	<b>PART NUMBER</b>	<b>U/M</b>	<b>DESCRIPTION</b>	<b>VENDOR NO.</b>
	084086-05-704	EA	BRACKET CLAMP	5086
	084086-05-706	EA	VALVE-INFLATION,PUSH TO CONN	3032
	144887-02-700	EA	AIRSPRING - BAG ONLY	9000
	144887-02-701	EA	BRACKET - LEFT UPPER	5390
	144887-02-702	EA	BRACKET - RIGHT UPPER	5389
	144887-02-703	EA	BRACKET - LOWER RH/LH	5391
	144887-02-704	EA	DISK	5204
	144887-02-705	EA	TUBING/AIR LINE - 18'	0937

**156618-01-000**

<b>KEY</b>	<b>PART NUMBER</b>	<b>U/M</b>	<b>DESCRIPTION</b>	<b>VENDOR NO.</b>
	084086-01-709	EA	SHIELD-HEAT-224 CR SYSTEM	21-1004
	084086-01-713	EA	BRACKET-AXLE STRAP, 4"	21-1163
	156618-01-700	EA	BAG - AIR SPRING - 1 ONLY	6762
	156618-01-701	EA	BRACKET - LEFT UPPER	5478
	156618-01-702	EA	BRACKET - RIGHT UPPER	5221
	156618-01-703	EA	BRACKET - LOWER RH/LH	5472

**CHASSIS GROUP (CONTINUED)**  
**WHEEL, TIRE, COVERS &/OR LINERS**

<b>KEY</b>	<b>PART NUMBER</b>	<b>U/M</b>	<b>DESCRIPTION</b>
	112358-02-000	EA	WRENCH - LUG - 7/8" - L-SHAPE
	080208-02-000	EA	BAR/LEVERAGE - LUG WRENCH - 13/16" DIA - ALUMINUM WHEELS
	080208-06-000	EA	LUG WRENCH - 1"/1.1" SOCKETS X 16.4" LONG - ALUMINUM WHEELS
	077030-01-000	EA	EXTENSION - VALVE STEM - 1.25" - METAL
	077030-10-000	EA	EXTENSION - VALVE STEM - .50" - METAL
	095012-05-000	EA	EXTENSION/VALVE STEM - LIVE - 5"
	095012-06-000	EA	STABILIZER/VALVE EXTENSION - LIVE - 2"
	095012-07-000	EA	STABILIZER/VALVE EXTENSION - LIVE - 4"
	095012-09-000	EA	EXTENSION/VALVE STEM - LIVE - 7.7"
*	110435-13-000	EA	LINER - WHEEL - SET OF 4 - 16" (8 HOLE) - FORD W/ STEEL WHEEL W/6 SLOTS
*	144647-01-000	EA	LINER - WHEEL SET (SET=4) 16" - FORD W/ STEEL WHEEL W/4 SLOTS/CHEVY
	149749-01-000	EA	WHEEL - ALUMINUM - 6" X 16" - FRONT - FORD E450 - ALUMINUM WHEELS
	149749-02-000	EA	WHEEL - ALUMINUM - 6" X 16" - REAR - FORD E450 - ALUMINUM WHEELS
	156797-01-000	EA	WHEEL - ALUMINUM/FRONT - 16" X 6.5" - 8 BOLT - CHEVY ALUMINUM WHEELS
	156797-02-000	EA	WHEEL - ALUMINUM/REAR - 16" X 6.5" - 8 BOLT - CHEVY ALUMINUM WHEELS
	156797-03-000	EA	COVER/HUB - FRONT - ALUMINUM WHEEL - ALUMINUM WHEELS
	156797-04-000	EA	COVER/HUB - FRONT - ALUMINUM WHEEL - ALUMINUM WHEELS
	149749-05-000	EA	COVER/NUT - ALUMINUM WHEELS
	149749-06-000	EA	NUT/WHEEL - 9/16"-18 - LOW PROFILE - FORD E450 - FORD ALUMINUM WHEELS
	156797-06-000	EA	NUT/LUG - 14MM X 1.5 - ALUMINUM WHEEL - CHEVY ALUMINUM WHEELS

\*COMPONENT PARTS LISTED LATER IN THIS GROUP

**COMPONENT PARTS FOR WHEEL, TIRE, COVERS &/OR LINERS**

**110435-13-000**

<b>KEY</b>	<b>PART NUMBER</b>	<b>U/M</b>	<b>DESCRIPTION</b>	<b>VENDOR NO.</b>
	110435-01-711	EA	DECAL-CENTER CAP, 2"	2" DECAL
	110435-10-705	EA	TOOL/JAMB NUT INSTALLATION	V195P7-TOL
	110435-13-700	EA	LINER - WHEEL - FRONT	V160F7-FWC
	110435-13-701	EA	LINER - WHEEL - REAR	V160F7-RWC
	110435-13-702	EA	JAMB NUT W/COVER - 9/16"	V160F7-EJN

**144647-01-000**

<b>KEY</b>	<b>PART NUMBER</b>	<b>U/M</b>	<b>DESCRIPTION</b>	<b>VENDOR NO.</b>
	110435-01-711	EA	DECAL-CENTER CAP, 2"	2" DECAL
	144647-01-700	EA	WHEEL COVER - FRONT/1 PIECE	FL60-FWC
	144647-01-701	EA	WHEEL COVER - REAR/1 PIECE	FL60-RWC

**BRAKELINE**

<b>KEY</b>	<b>PART NUMBER</b>	<b>U/M</b>	<b>DESCRIPTION</b>
	088498-01-000	EA	UNION - INVERTED FLARE - BRASS - 3/16 - FORD CHASSIS

## CURTAIN & CUSHION GROUP

### NOTICE

IN ORDER TO ASSIST OUR PARTS SALES DEPT. IN PROVIDING INTERIOR SOFTWARE ITEMS, PLEASE INCLUDE THE SERIAL NUMBER AND THE COLOR CODE NUMBER FROM THE VEHICLE CERTIFICATION LABEL WHEN ORDERING. THIS LABEL IS LOCATED ON THE LEFT SIDEWALL AT THE END OF THE DASH (A-BODY), OR ON THE DRIVER'S DOOR LATCH PLATE (C-BODY).

AN EXAMPLE OF A COLOR CODE NUMBER IS B07, WHICH DESIGNATES AN OVERALL COLOR SCHEME OF A PARTICULAR UNIT. THE COLOR LISTED AFTER THE ITEM DESCRIPTION ON THE MICROFICHE, INDICATES THE OVERALL UNIT COLOR. ORDER THE ITEM YOU DESIRE ACCORDING TO UNIT COLOR CODE. IF ALL COLORS USE THE SAME ITEM NO COLOR CODE WILL BE NOTED.

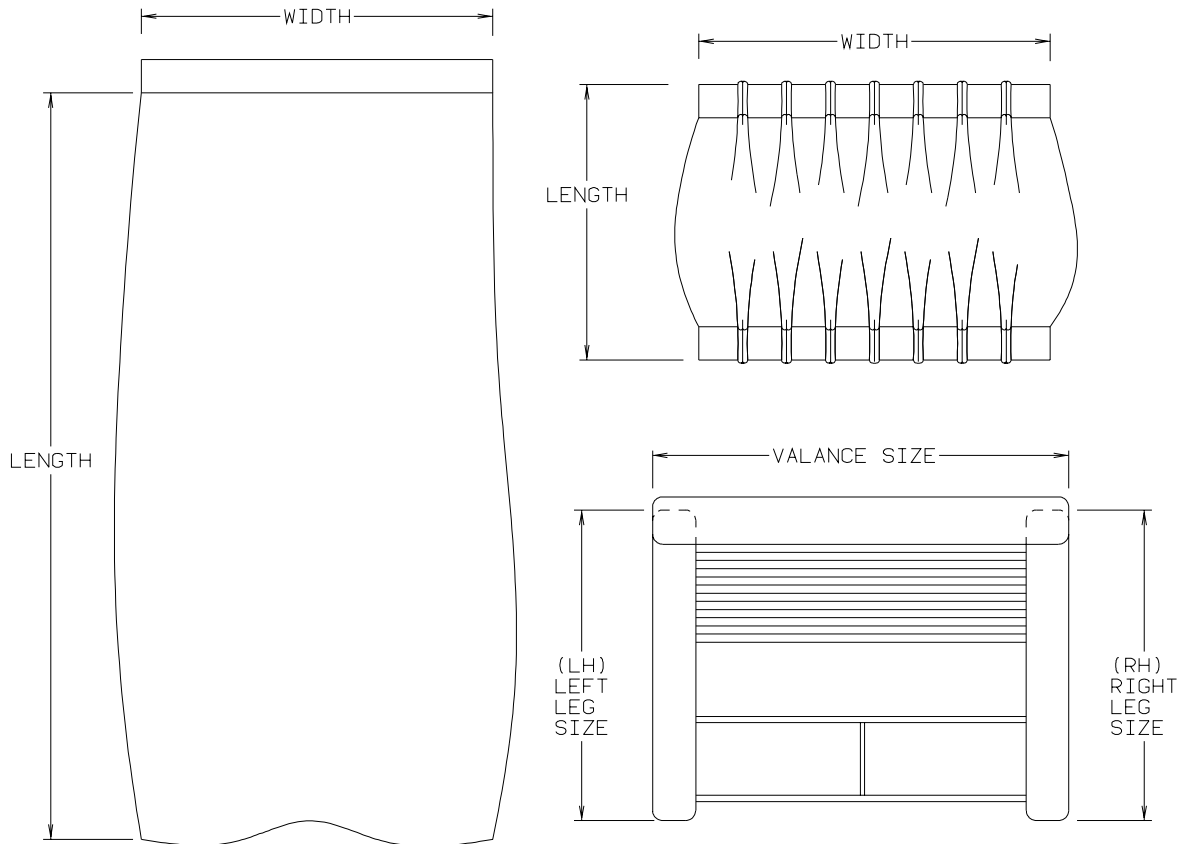

NOTE: USE THIS ILLUSTRATION WHEN DETERMINING LENGTH AND WIDTH MEASUREMENTS FOR CURTAINS. YOU WILL NOTE THE WIDTH MEASUREMENT IS TAKEN ON THE TOP OF THE CURTAIN WITH THE CURTAIN FULLY EXTENDED. THE LENGTH MEASUREMENT IS TAKEN FROM TOP TO BOTTOM. LEFT AND RIGHT WINDOW LEGS ARE DETERMINED WHEN FACING THE WINDOW.

**CURTAIN & CUSHION GROUP (CONTINUED)**  
**CUSHION LAYOUT**

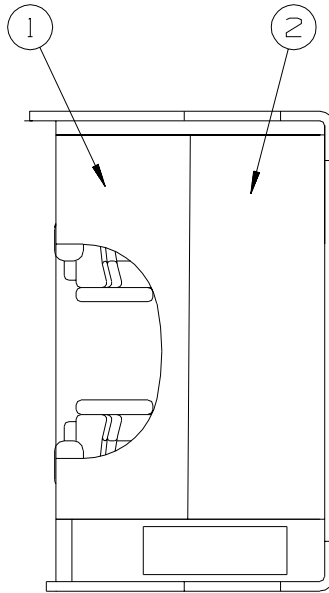

KEY	PART NUMBER	U/M	DESCRIPTION
1	157657-02-U21	EA	CUSHION - OVERHEAD BUNK/REAR - 27" X 76" X 5" (U21, U22)
1	157657-02-U23	EA	CUSHION - OVERHEAD BUNK/REAR - 27" X 76" X 5" (U23, U24)
1	157657-04-U25	EA	CUSHION - OVERHEAD BUNK/REAR - 27" X 80" X 5" (U25, U26)
	157657-A2-U21	EA	COVER - CUSHION/OVERHEAD BUNK/REAR - 27" X 76" X 5" (U21, U22)
	157657-A2-U23	EA	COVER - CUSHION/OVERHEAD BUNK/REAR - 27" X 76" X 5" (U23, U24)
	157657-A4-U25	EA	COVER - CUSHION/OVERHEAD BUNK/REAR - 27" X 80" X 5" (U25, U26)
2	157657-10-U21	EA	CUSHION - OVERHEAD BUNK/FRONT - 22" X 80" X 6" (U21, U22)
2	157657-10-U23	EA	CUSHION - OVERHEAD BUNK/FRONT - 22" X 80" X 6" (U23, U24)
2	157657-09-U25	EA	CUSHION - OVERHEAD BUNK/FRONT - 22" X 80" X 6" (U25, U26)
	157657-B0-U21	EA	COVER - CUSHION/OVERHEAD/FRONT BUNK -22"X80"X6"-DBL ANGLED (U21, U22)
	157657-B0-U23	EA	COVER - CUSHION/OVERHEAD/FRONT BUNK -22"X80"X6"-DBL ANGLED (U23, U24)
	157657-A9-U25	EA	COVER - CUSHION/OVERHEAD/FRONT BUNK -22"X80"X6"-DBL ANGLED (U25, U26)

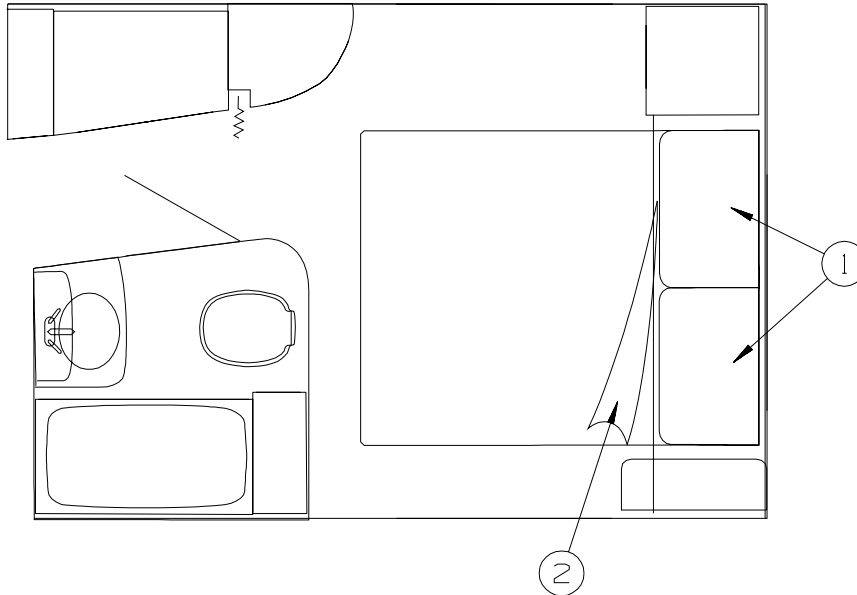

KEY	PART NUMBER	U/M	DESCRIPTION
1	104176-04-U21	EA	PILLOW SHAM - 30" (U21, U22)
1	104176-09-U23	EA	PILLOW SHAM - 30" (U23, U24)
1	104176-04-U25	EA	PILLOW SHAM - 30" (U25, U26)
2	132336-09-U21	EA	BEDSPREAD/CAP - 60" X 75" (U21, U22)
2	132336-09-U23	EA	BEDSPREAD/CAP - 60" X 75" (U23, U24)
2	132336-09-U25	EA	BEDSPREAD/CAP - 60" X 75" (U25, U26)



**CURTAIN & CUSHION GROUP (CONTINUED)**  
**CUSHION LAYOUT (CONTINUED)**

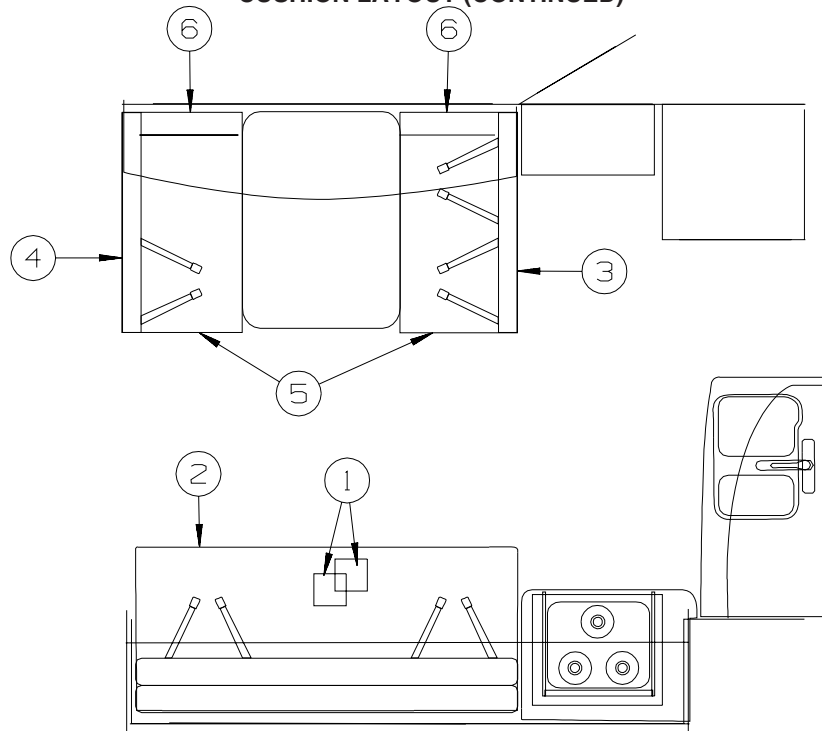

KEY	PART NUMBER	U/M	DESCRIPTION
1	158190-01-U21	EA	PILLOW - 18" - W/WELT (U21, U22)
1	158190-02-U23	EA	PILLOW - 18" - W/WELT (U23, U24)
1	158190-02-U25	EA	PILLOW - 18" - W/WELT (U25, U26)
2			SEE SOFA AREA
3	153071-05-U21	EA	CUSHION/DINETTE - BACK/RH - 15" X 44" X 5" (U21, U22)
3	153071-07-U23	EA	CUSHION/DINETTE - BACK/RH - 15" X 44" X 5" (U23, U24)
3	153071-07-U25	EA	CUSHION/DINETTE - BACK/RH - 15" X 44" X 5" (U25, U26)
	P53071-05-U21	EA	COVER/BACK/RIGHT - 15" X 44" X 5" (U21, U22)
	P53071-07-U23	EA	COVER/BACK/RIGHT - 15" X 44" X 5" (U23, U24)
	P53071-07-U25	EA	COVER/BACK/RIGHT - 15" X 44" X 5" (U25, U26)
4	153071-06-U21	EA	CUSHION/DINETTE - BACK/LH - 15" X 44" X 5" (U21, U22)
4	153071-08-U23	EA	CUSHION/DINETTE - BACK/LH - 15" X 44" X 5" (U23, U24)
4	153071-08-U25	EA	CUSHION/DINETTE - BACK/LH - 15" X 44" X 5" (U25, U26)
	P53071-06-U21	EA	COVER/BACK/LEFT - 15" X 44" X 5" (U21, U22)
	P53071-08-U23	EA	COVER/BACK/LEFT - 15" X 44" X 5" (U23, U24)
	P53071-08-U25	EA	COVER/BACK/LEFT - 15" X 44" X 5" (U25, U26)
5	153671-10-U21	EA	CUSHION - SEAT - 23" X 44" X 5" (U21, U22)
5	153671-11-U23	EA	CUSHION - SEAT - 23" X 44" X 5" (U23, U24)
5	153671-11-U25	EA	CUSHION - SEAT - 23" X 44" X 5" (U25, U26)
	P53671-10-U21	EA	COVER/SEAT - 23" X 44" X 5" (U21, U22)
	P53671-11-U23	EA	COVER/SEAT - 23" X 44" X 5" (U23, U24)
	P53671-11-U25	EA	COVER/SEAT - 23" X 44" X 5" (U25, U26)
6	157487-04-U21	EA	CUSHION - FILLER - 7" X 21" X 5" (U21, U22)
6	157487-05-U23	EA	CUSHION - FILLER - 7" X 21" X 5" (U23, U24)
6	157487-05-U25	EA	CUSHION - FILLER - 7" X 21" X 5" (U25, U26)
	157487-A4-U21	EA	COVER/CUSHION - FILLER - 7" X 21" X 5" (U21, U22)
	157487-A5-U23	EA	COVER/CUSHION - FILLER - 7" X 21" X 5" (U23, U24)
	157487-A5-U25	EA	COVER/CUSHION - FILLER - 7" X 21" X 5" (U25, U26)

## CURTAIN & CUSHION GROUP (CONTINUED)

### BUCKET SEATS

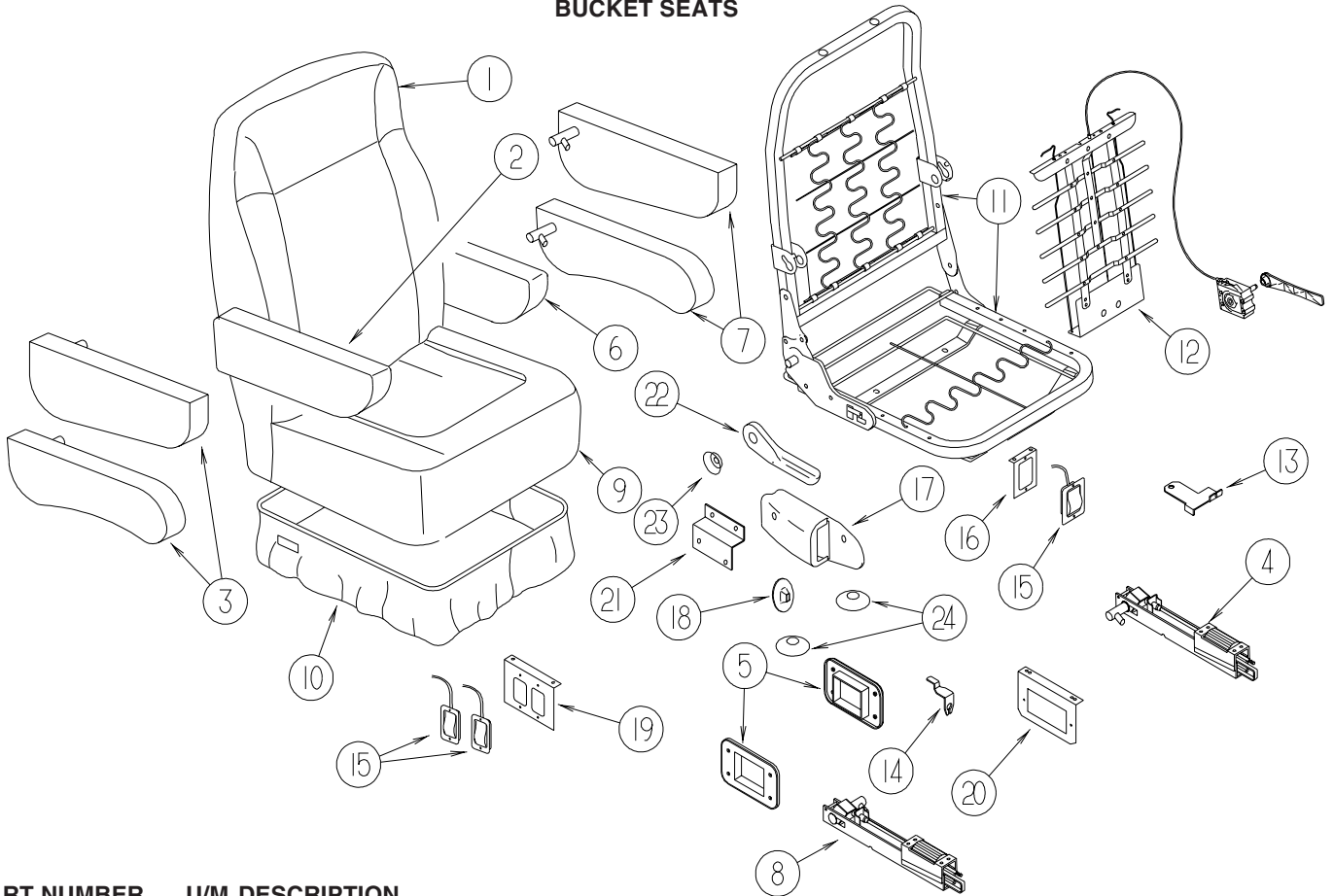

KEY	PART NUMBER	U/M	DESCRIPTION
1	158708-03-U21	EA	COVER - BACK (U21, U22, U23, U24) - FORD - ULTRALEATHER
1	158708-03-U25	EA	COVER - BACK (U25, U26) - FORD - ULTRALEATHER
1	159513-03-U21	EA	COVER - BACK (U21, U22, U23, U24) - CHEVY - ULTRALEATHER
1	159513-03-U25	EA	COVER - BACK (U25, U26) - CHEVY - ULTRALEATHER
2	158708-05-U21	EA	COVER - ARMREST/DRIVER (U21, U22, U23, U24) - FORD - ULTRALEATHER
2	158708-05-U25	EA	COVER - ARMREST/DRIVER (U25, U26) - FORD - ULTRALEATHER
2	159513-05-U21	EA	COVER - ARMREST/DRIVER (U21, U22, U23, U24) - CHEVY - ULTRALEATHER
2	159513-05-U25	EA	COVER - ARMREST/DRIVER (U25, U26) - CHEVY - ULTRALEATHER
3	NOT USED		
4	NOT USED		
5	NOT USED		
6	158708-06-U21	EA	COVER - ARMREST/PASSENGER (U21, U22, U23, U24) - FORD - ULTRALEATHER
6	158708-06-U25	EA	COVER - ARMREST/PASSENGER (U25, U26) - FORD - ULTRALEATHER
6	159513-06-U21	EA	COVER - ARMREST/PASSENGER (U21, U22, U23, U24) - CHEVY - ULTRALEATHER
6	159513-06-U25	EA	COVER - ARMREST/PASSENGER (U25, U26) - CHEVY - ULTRALEATHER
7	NOT USED		
8	NOT USED		
9	158708-04-U21	EA	COVER - SEAT (U21, U22, U23, U24) - DRIVER, FORD - ULTRALEATHER
9	158708-04-U25	EA	COVER - SEAT (U25, U26) - DRIVER, FORD - ULTRALEATHER
9	158708-07-U21	EA	COVER - SEAT (U21, U22, U23, U24) - PASSENGER, FORD - ULTRALEATHER
9	158708-07-U25	EA	COVER - SEAT (U25, U26) - PASSENGER, FORD - ULTRALEATHER
9	159513-04-U21	EA	COVER - SEAT (U21, U22, U23, U24) - CHEVY - ULTRALEATHER
9	159513-04-U25	EA	COVER - SEAT (U25, U26) - CHEVY - ULTRALEATHER
10	NOT USED		
11	NOT USED		
12	NOT USED		
13	NOT USED		
14	NOT USED		
15	NOT USED		
16	NOT USED		
17	NOT USED		
18	NOT USED		
19	NOT USED		
20	NOT USED		

## CURTAIN & CUSHION GROUP (CONTINUED)

### BUCKET SEATS (CONTINUED)

KEY	PART NUMBER	U/M DESCRIPTION
21	NOT USED	
22	NOT USED	
23	NOT USED	
24	NOT USED	

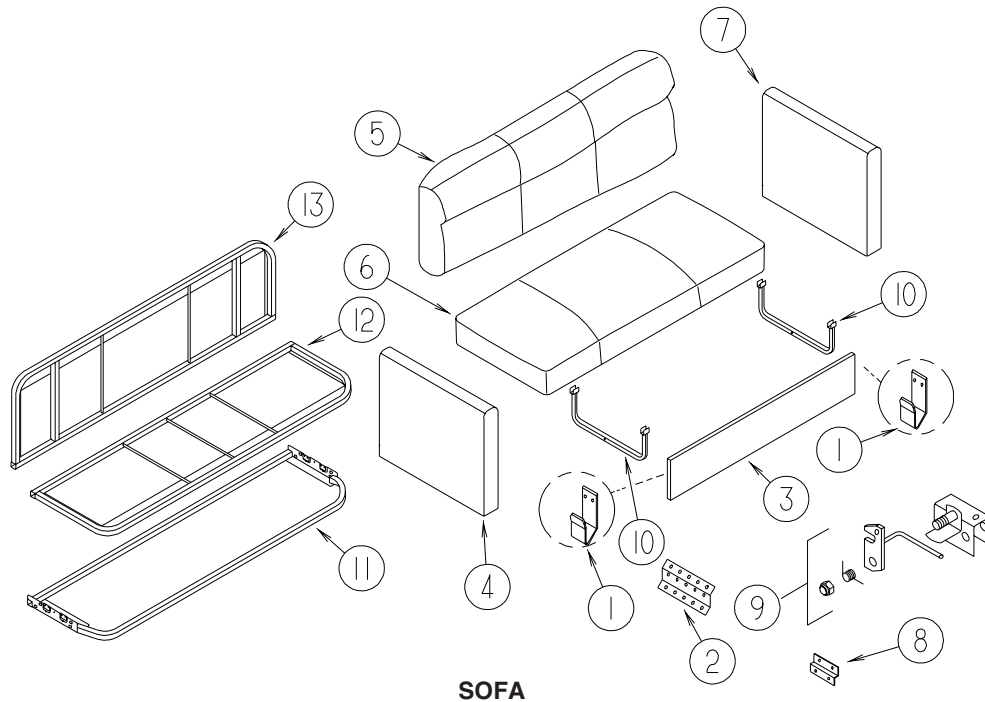

KEY	PART NUMBER	U/M DESCRIPTION
1	121906-01-02B	EA BRACKET - KICKBOARD - E-COATED
2	NOT USED	
3	159380-01-U21	EA PANEL/FRONT KICK - SOFA/BED - FABRIC COVERED - 64" (U21,U22)
3	159380-01-U23	EA PANEL/FRONT KICK - SOFA/BED - FABRIC COVERED - 64" (U23,U24)
3	159380-01-U25	EA PANEL/FRONT KICK - SOFA/BED - FABRIC COVERED - 64" (U25,U26)
4	134282-08-U21	EA PANEL - RIGHT END/FILLER - SOFA/BED - FABRIC COVERED (U21,U22)
4	134282-08-U23	EA PANEL - RIGHT END/FILLER - SOFA/BED - FABRIC COVERED (U23,U24)
4	134282-08-U25	EA PANEL - RIGHT END/FILLER - SOFA/BED - FABRIC COVERED (U25,U26)
5	153676-10-U21	EA BACK - SOFA/BED - 64" (U21,U22)
5	153676-10-U23	EA BACK - SOFA/BED - 64" (U23,U24)
5	153676-12-U25	EA BACK - SOFA/BED - 64" (U25,U26)
	P53676-10-U21	EA COVER/BACK - SOFA/BED - 64" (U21,U22)
	P53676-10-U23	EA COVER/BACK - SOFA/BED - 64" (U23,U24)
	P53676-12-U25	EA COVER/BACK - SOFA/BED - 64" (U25,U26)
6	153676-11-U21	EA SEAT - SOFA/BED - 64" (U21,U22)
6	153676-11-U23	EA SEAT - SOFA/BED - 64" (U23,U24)
6	153676-13-U25	EA SEAT - SOFA/BED - 64" (U25,U26)
	P53676-11-U21	EA COVER/SEAT - SOFA/BED - 64" (U21,U22)
	P53676-11-U23	EA COVER/SEAT - SOFA/BED - 64" (U23,U24)
	P53676-13-U25	EA COVER/SEAT - SOFA/BED - 64" (U25,U26)
7	134282-09-U21	EA PANEL - LEFT END/FILLER - SOFA/BED - FABRIC COVERED (U21,U22)
7	134282-09-T54	EA PANEL - LEFT END/FILLER - SOFA/BED - FABRIC COVERED (U23,U24)
7	134282-09-U25	EA PANEL - LEFT END/FILLER - SOFA/BED - FABRIC COVERED (U25,U26)
8	101926-01-02A	EA BRACKET - ZEE - 2" - BLACK
9	NOT USED	
10	127335-07-000	EA LEG - SOFA/BED - 8"
11	151290-19-000	EA FRAME - BASE - 27.25" X 64"
12	151290-17-000	EA FRAME - SEAT - 26.5" X 64"
13	151290-18-000	EA FRAME - BACK - 14.5" X 64"

**CURTAIN & CUSHION GROUP (CONTINUED)**  
**WINDOW TREATMENT**

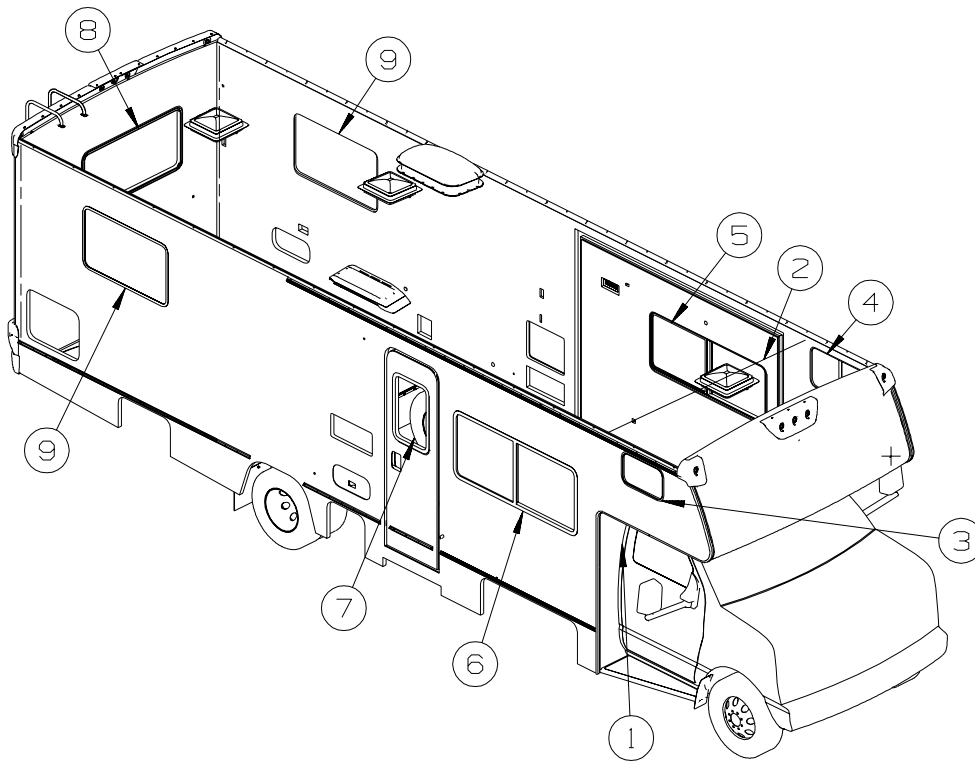

KEY	PART NUMBER	U/M	DESCRIPTION
1	076892-30-U21	EA	CURTAIN - CAB PRIVACY - 47.5" X 74" (U21, U22)
1	076892-36-U23	EA	CURTAIN - CAB PRIVACY - 47.5" X 74" (U23, U24)
1	076892-30-U25	EA	CURTAIN - CAB PRIVACY - 47.5" X 74" (U25, U26)
1	076892-29-U21	EA	CURTAIN - CAB PRIVACY - 47.5" X 74" (U21, U22) - CAB OVER ENTERTAINMENT CTR
1	076892-41-U23	EA	CURTAIN - CAB PRIVACY - 47.5" X 74" (U23, U24) - CAB OVER ENTERTAINMENT CTR
1	076892-29-U25	EA	CURTAIN - CAB PRIVACY - 47.5" X 74" (U25, U26) - CAB OVER ENTERTAINMENT CTR
1	073260-23-U21	EA	TIEBACK - 3" X 18" (U21, U22)
1	073260-23-U23	EA	TIEBACK - 3" X 18" (U23, U24)
1	073260-23-U25	EA	TIEBACK - 3" X 18" (U25, U26)
2	101668-80-U21	EA	CURTAIN - TAPE TOP - 27" X 90" (U21, U22)
2	101668-80-U23	EA	CURTAIN - TAPE TOP - 27" X 90" (U23, U24)
2	101668-80-U25	EA	CURTAIN - TAPE TOP - 27" X 90" (U25, U26)
3	101034-17-U21	EA	CURTAIN - PRIVACY - 16" X 25" (U21, U22)
3	101034-17-U23	EA	CURTAIN - PRIVACY - 16" X 25" (U23, U24)
3	101034-17-U25	EA	CURTAIN - PRIVACY - 16" X 25" (U25, U26)
4	101034-72-U21	EA	CURTAIN - PRIVACY - 19.5" X 34" (U21, U22)
4	101034-72-U23	EA	CURTAIN - PRIVACY - 19.5" X 34" (U23, U24)
4	101034-72-U25	EA	CURTAIN - PRIVACY - 19.5" X 34" (U25, U26)
5	158006-01-U21	EA	VALANCE - DENTON - 63" (U21, U22)
5	158006-02-U23	EA	VALANCE - DENTON - 63" (U23, U24)
5	158006-03-U25	EA	VALANCE - DENTON - 63" (U25, U26)
5	152445-11-U21	EA	LEG - RIGHT - 23.5" (U21, U22)
5	152445-11-U23	EA	LEG - RIGHT - 23.5" (U23, U24)
5	152445-11-U25	EA	LEG - RIGHT - 23.5" (U25, U26)
5	152445-12-U21	EA	LEG - LEFT - 23.5" (U21, U22)
5	152445-12-U23	EA	LEG - LEFT - 23.5" (U23, U24)
5	152445-12-U25	EA	LEG - LEFT - 23.5" (U25, U26)
5	157506-02-T12	EA	BLIND - PLEATED - 59" X 26.5" (U21, U22, U23, U24)
5	157506-02-TR0	EA	BLIND - PLEATED - 59" X 26.5" (U25, U26)
5	140789-08-T12	EA	BLIND - DAY/NIGHTER - 59" X 26.5" (U21, U22, U23, U24) - INTERIOR UPGRADE PKG
5	140789-08-N02	EA	BLIND - DAY/NIGHTER - 59" X 26.5" (U25, U26) - INTERIOR UPGRADE PKG

**CURTAIN & CUSHION GROUP (CONTINUED)**  
**WINDOW TREATMENT (CONTINUED)**

<b>KEY</b>	<b>PART NUMBER</b>	<b>U/M</b>	<b>DESCRIPTION</b>
6	158006-08-U21	EA	VALANCE - DENTON - 65" (U21, U22)
6	158006-09-U23	EA	VALANCE - DENTON - 65" (U23, U24)
6	158006-10-U25	EA	VALANCE - DENTON - 65" (U25, U26)
6	152445-13-U21	EA	LEG - RIGHT - 25" (U21, U22)
6	152445-13-T54	EA	LEG - RIGHT - 25" (U23, U24)
6	152445-13-U25	EA	LEG - RIGHT - 25" (U25, U26)
6	152445-14-U21	EA	LEG - LEFT - 25" (U21, U22)
6	152445-14-T54	EA	LEG - LEFT - 25" (U23, U24)
6	152445-14-U25	EA	LEG - LEFT - 25" (U25, U26)
6	157506-03-T12	EA	BLIND - PLEATED - 61" X 28.5" (U21, U22, U23, U24)
6	157506-03-TR0	EA	BLIND - PLEATED - 61" X 28.5" (U25, U26)
6	140789-14-T12	EA	BLIND - DAY/NIGHTER - 61" X 28.5" (U21, U22, U23, U24) - INTERIOR UPGRADE PKG
6	140789-14-N02	EA	BLIND - DAY/NIGHTER - 61" X 28.5" (U25, U26) - INTERIOR UPGRADE PKG
7	153643-70-U21	EA	VALANCE - MODERATE - 10" X 29" (U21, U22)
7	153643-71-U23	EA	VALANCE - MODERATE - 29" (U23, U24)
7	153643-72-U25	EA	VALANCE - MODERATE - 10" X 29" (U25, U26)
7	084755-57-P37	EA	SHADE - PULL - 27.25"
8	158006-04-U21	EA	VALANCE - DENTON - 54" (U21, U22)
8	158006-05-U23	EA	VALANCE - DENTON - 54" (U23, U24)
8	158006-04-U25	EA	VALANCE - DENTON - 54" (U25, U26)
8	157506-07-T12	EA	BLIND - PLEATED - 51" X 27" (U21, U22, U23, U24)
8	157506-07-TR0	EA	BLIND - PLEATED - 51" X 27" (U25, U26)
8	140789-03-T54	EA	BLIND - DAY/NIGHTER - 51" X 27" (U21, U22, U23, U24) - INTERIOR UPGRADE PKG
8	140789-03-N02	EA	BLIND - DAY/NIGHTER - 51" X 27" (U25, U26) - INTERIOR UPGRADE PKG
9	158006-06-U21	EA	VALANCE - DENTON - 46" (U21, U22)
9	158006-07-U23	EA	VALANCE - DENTON - 46" (U23, U24)
9	158006-06-U25	EA	VALANCE - DENTON - 46" (U25, U26)
9	157506-04-T12	EA	BLIND - PLEATED - 43" X 28" (U21, U22, U23, U24)
9	157506-04-TR0	EA	BLIND - PLEATED - 43" X 28" (U25, U26)
9	140789-02-T12	EA	BLIND - DAY/NIGHTER - 43" X 28" (U21, U22, U23, U24) - INTERIOR UPGRADE PKG
9	140789-02-N02	EA	BLIND - DAY/NIGHTER - 43" X 28" (U25, U26) - INTERIOR UPGRADE PKG

## CURTAIN & CUSHION GROUP (CONTINUED) HARDWARE

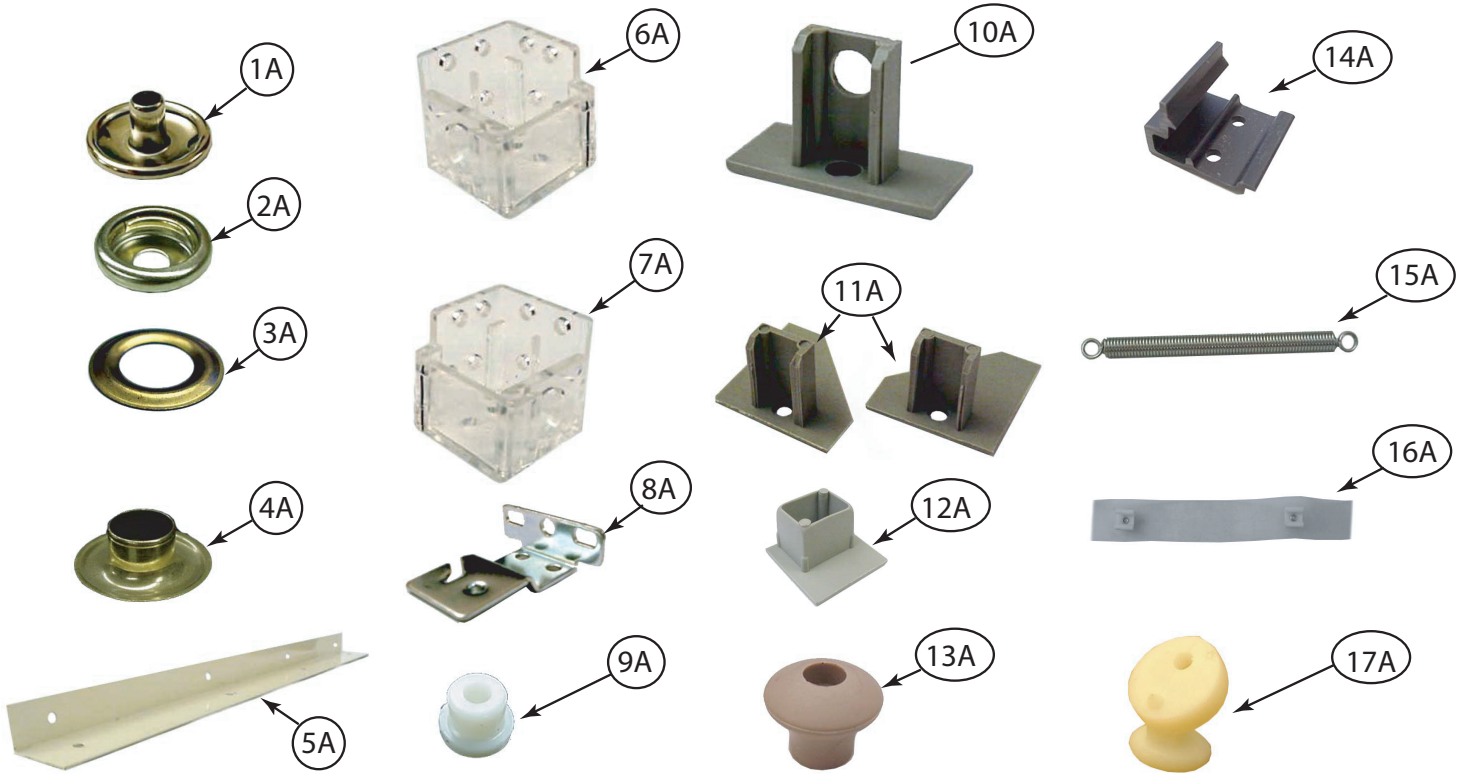

KEY	PART NUMBER	U/M	DESCRIPTION
1A	029155-01-000	EA	CAP - SNAP - 5/32" OUTSIDE DIAMETER OF PIN
2A	029156-01-000	EA	SOCKET - SNAP - 9/16" O.D.
3A	046867-02-000	EA	WASHER - HANDY BUTTON #3
4A	046867-03-000	EA	GROMMET - HANDY BUTTON #3
5A	075943-10-000	EA	BRACE - VALANCE - 20" - OFF WHITE
6A	083170-01-000	EA	BRACKET/BLIND - LEFT SIDE WHEN FACING WINDOW - CLEAR
7A	083170-02-000	EA	BRACKET/BLIND - RIGHT SIDE WHEN FACING WINDOW - CLEAR
8A	084434-01-000	EA	BRACKET - MOUNTING - ROLLER SHADE - 1 3/8"
9A	094896-02-000	EA	GROMMET - CORD/PLEATED BLIND - NYLON - GRAY
10A	094907-02-000	EA	END CAP - PLEATED BLIND/TOP - RH/LH - GRAY PLASTIC
11A	094907-04-000	EA	END CAP - PLEATED BLIND/BOTTOM - RH/LH
12A	094907-09-000	EA	END CAP/BLIND - CENTER RAIL - RH/LH
13A	097564-03-000	EA	HANDLE - KNOB - E-Z LIFT SHADE - TAN
	097593-02-000	FT	CORD - BLIND - PLEATED - GRAY
	097593-10-000	FT	CORD - BLIND - PLEATED - VANILLA
14A	097565-01-000	EA	BRACKET - MOUNTING - PLEATED BLIND
15A	097591-01-000	EA	SPRING - EXTENSION - PLEATED BLIND
15A	155748-01-000	EA	SPRING - EXTENSION - DAY/NIGHTER BLIND
16A	101031-01-000	YD	TAPE/GLIDE - 4.25" SPACING
17A	102555-03-000	EA	BRACKET - (CLEAT TYPE) - F/BLIND HOLDOWN - MILKY WHITE

**CURTAIN & CUSHION GROUP (CONTINUED)**  
**HARDWARE (CONTINUED)**

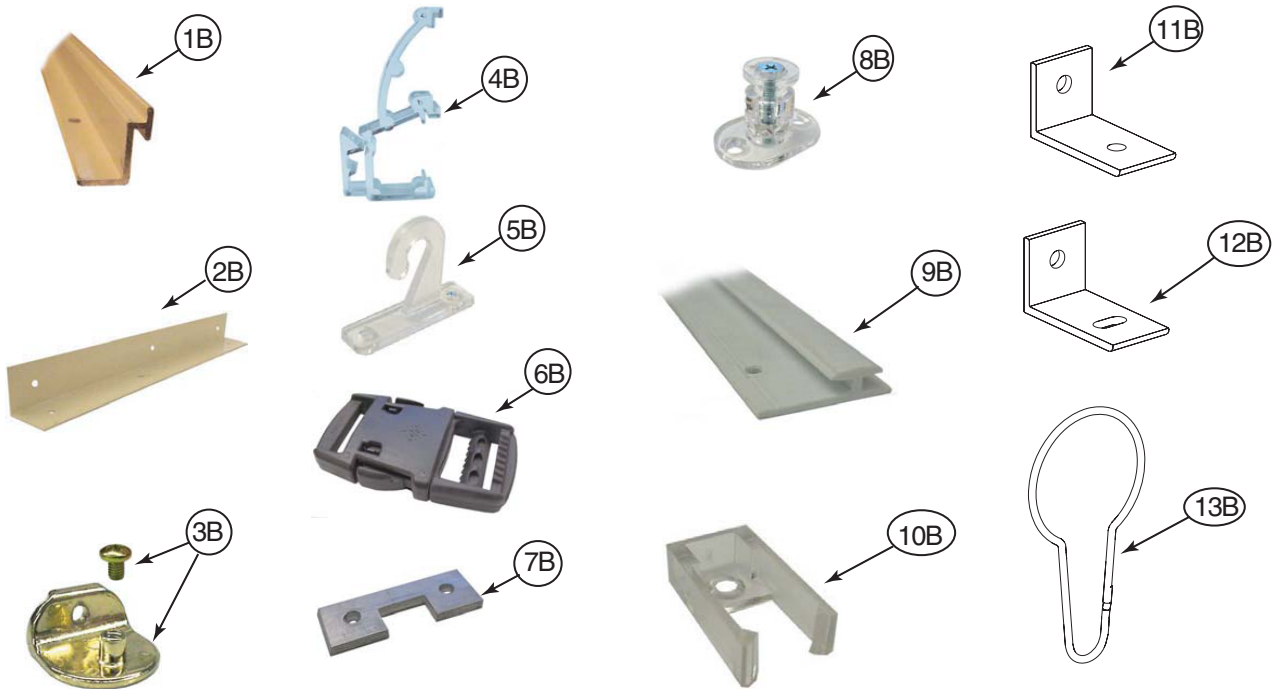

KEY	PART NUMBER	U/M	DESCRIPTION
1B	105450-14-01A	EA	TRACK-90"-OW - FRT BUNK PRIVACY OUTLOOK/SPIRIT 300-SERIES, ACCESS/IMPULSE 200-SERIES
2B	105648-01-02A	EA	BRACE - VALANCE - 14" - OFF WHITE
2B	105648-02-02A	EA	BRACE - VALANCE - 8.5" - OFF WHITE
3B	106544-01-000	EA	PULL - SHADE/BRASS
3B	106544-01-001	EA	SCREW - SHADE/BRASS
3B	106544-02-000	EA	PULL-SHADE - NICKEL
4B	109353-04-000	EA	CLIP - VALANCE SLAT MOUNTING - CLEAR PLASTIC
5B	109441-01-000	EA	BRACKET/HOOK - BLIND HOLD DOWN
	109441-02-000	EA	SPACER/BRACKET - BLIND HOLD DOWN
6B	129491-01-000	EA	CATCH - SNAP HOOK - 1"
7B	130549-01-01A	EA	STOP - CURTAIN TRACK
8B	141634-01-000	EA	BRACKET-(BOBBIN TYPE) 7/8"H HOLDUPBASE(OVAL)-2 HOLE-CLEAR
9B	156172-01-01A	EA	TRACK/WALL - 75" - BONE
9B	156172-02-01A	EA	TRACK/WALL - 32" - BONE
9B	156172-03-01A	EA	TRACK/WALL - 21" - BONE
10B	156172-04-01A	EA	END CAP - WALL TRACK - CLEAR
11B	154316-01-01A	EA	BRACE/ANGLE - W/HOLE - CASHMERE
12B	154316-02-01A	EA	BRACE/ANGLE - W/SLOT - CASHMERE
13B	159702-01-01A	EA	HOOK/RING - CURTAIN/SHOWER - NICKEL

**ACCESSORIES**

KEY	PART NUMBER	U/M	DESCRIPTION
	057534-01-000	EA	TIEBACK - CLEAR PLASTIC - 6"

## **CURTAIN & CUSHION GROUP (CONTINUED)**

### **FABRICS**

#### **U21, U22 EMBER GLOW**

113979-09-01A CARPET-HEADLINER (SY) - CEILING  
113979-10-01A CARPET-HEADLINER - SLDOUT (SY) - CEILING  
113979-11-01A CARPET-HEADLINER - SLDOUT (SY) - CEILING  
137813-R9-000 FABRIC-DRAPERY - MAIN  
148797-L6-000 FABRIC-UPHOSTERY MAIN ONE - MAIN  
148797-L8-000 FABRIC-UPHLSTRY - PLAIN ACCENT  
148797-M0-000 FABRIC-UPHLSTRY ACCENT - PATTERN  
137813-U6-000 FABRIC-UPHOSTERY - BEDSPREAD  
142523-04-000 FABRIC-UPHOSTERY - ACCEN PLAIN  
079680-47-000 FABRIC-UPHL - SEAT INSERT  
137813-R9-000 FABRIC-UPHOSTERY - BEDSPREAD  
148797-L8-000 FABRIC-HDLR/PAD/BUNK-TRANS PANEL  
148797-L8-000 FABRIC-SPEAKER COVER  
137813-R9-000 FABRIC-O/H CABT - DIN/LOUNGE  
137813-R9-000 FABRIC-O/H CABT - BEDROOM  
137813-L8-000 FABRIC-DINETTE WRAP - DINETTES  
142523-05-000 VINYL-BUCKET SEATS  
103907-01-01A VINYL-FILM DRAPERY - BUNK CUSHIONS  
142523-08-000 VINYL-HEADLINERS/BUNKS - CAB AREA  
142523-08-000 VINYL-ACCENT TRIMS - CAB AREA

#### **U23, U24 GINGERSNAP**

113979-09-01A CARPET-HEADLINER (SY) - CEILING  
113979-10-01A CARPET-HEADLINER - SLDOUT (SY) - CEILING  
113979-11-01A CARPET-HEADLINER - SLDOUT (SY) - CEILING  
137813-Y0-000 FABRIC-DRAPERY - MAIN  
148797-70-000 FABRIC-UPHOSTERY MAIN ONE - MAIN  
137813-58-000 FABRIC-UPHLSTRY -PLAIN ACCENT  
148797-71-000 FABRIC-UPHLSTRY ACCENT - PATTERN  
137813-Y0-000 FABRIC-UPHOSTERY -BEDSPREAD  
142523-04-000 FABRIC-UPHOSTERY -ACCEN PLAIN  
079680-47-000 FABRIC-UPHL -SEAT INSERT  
137813-Y1-000 FABRIC-UPHOSTERY -BEDSPREAD  
137813-58-000 FABRIC-HDLR/PAD/BUNK-TRANS PANEL  
137813-58-000 FABRIC-SPEAKER COVER  
137813-Y0-000 FABRIC-O/H CABT -DIN/LOUNGE  
137813-Y0-000 FABRIC-O/H CABT -BEDROOM  
137813-58-000 FABRIC-DINETTE WRAP - DINETTES  
142523-05-000 VINYL-BUCKET SEATS  
103907-01-01A VINYL-FILM DRAPERY - BUNK CUSHIONS  
142523-08-000 VINYL-HEADLINERS/BUNKS - CAB AREA  
142523-08-000 VINYL-ACCENT TRIMS - CAB AREA

#### **U25, U26 WOODMONT**

113979-09-01A CARPET-HEADLINER (SY) - CEILING  
113979-10-01A CARPET-HEADLINER - SLDOUT (SY) - CEILING  
113979-11-01A CARPET-HEADLINER - SLDOUT (SY) - CEILING  
137813-U8-000 FABRIC-DRAPERY - MAIN  
148797-L7-000 FABRIC-UPHOSTERY MAIN ONE  
148797-L9-000 FABRIC-UPHLSTRY -PLAIN ACCENT  
148797-D8-000 FABRIC-UPHOLSTERY ACCENT - PATTERN  
137813-U7-000 FABRIC-UPHOSTERY -BEDSPREAD  
142523-03-000 FABRIC-UPHOSTERY -ACCEN PLAIN  
142523-02-000 FABRIC-UPHL -SEAT INSERT  
137813-U8-000 FABRIC-UPHOSTERY -BEDSPREAD  
148797-L9-000 FABRIC-HDLR/PAD/BUNK-TRANS PANEL  
148797-L9-000 FABRIC-SPEAKER COVER  
137813-U8-000 FABRIC-O/H CABT -DIN/LOUNGE  
137813-U8-000 FABRIC-O/H CABT -BEDROOM  
148797-L9-000 FABRIC-DINETTE WRAP - DINETTES  
142523-05-000 VINYL-BUCKET SEATS  
103907-01-01A VINYL-FILM DRAPERY - BUNK CUSHIONS  
142523-08-000 VINYL-HEADLINERS/BUNKS - CAB AREA  
142523-08-000 VINYL-ACCENT TRIMS - CAB AREA



## DRIVERS COMPARTMENT GROUP FRONT INTERIOR

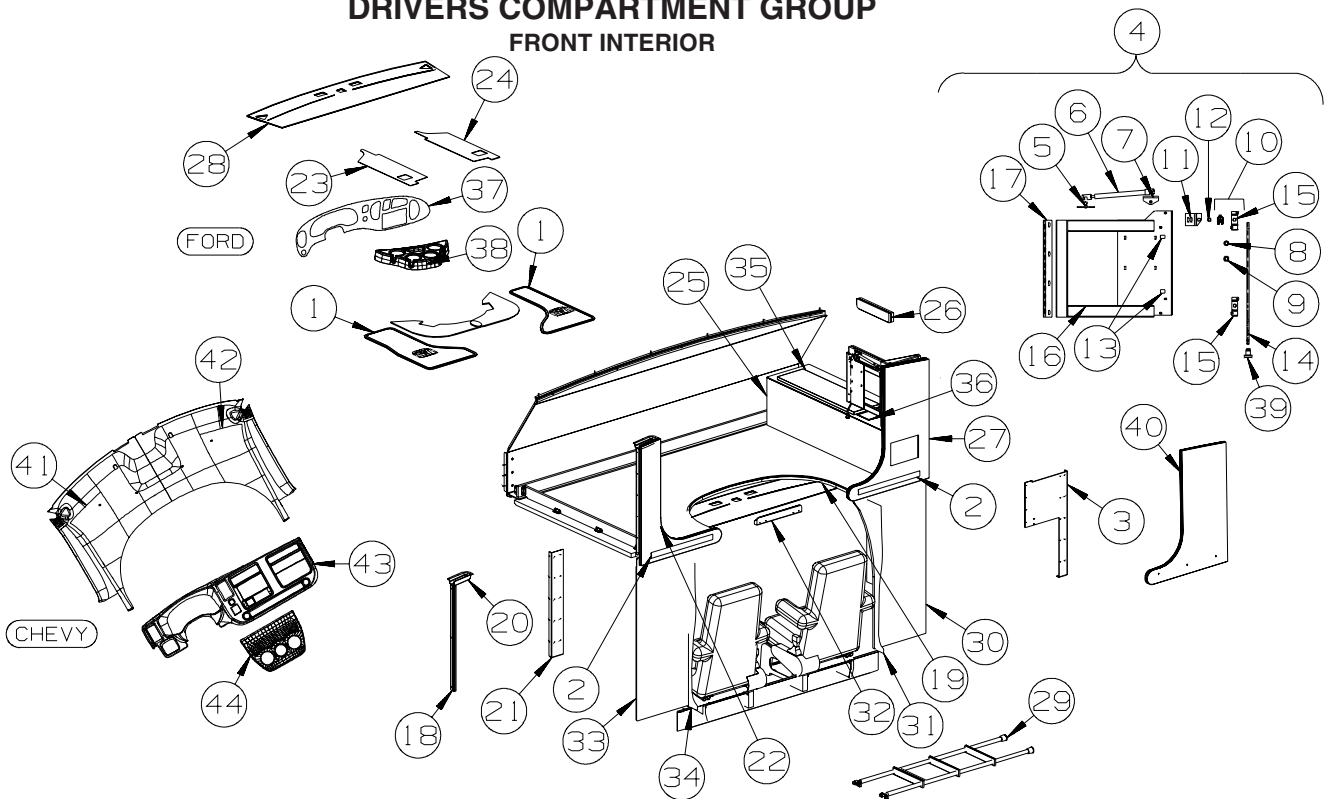

KEY	PART NUMBER	U/M	DESCRIPTION
1	155266-02-01A	EA	MAT - FLOOR - FRONT DRIVER - "W" - PEBBLE BROWN - FORD - INTERIOR UPGRADE PKG FROM: 00-00-00 THRU: 06-11-06
1	155266-01-01A	EA	MAT - FLOOR - FRONT PASSENGER - "W" - PEBBLE BROWN - FORD - INTERIOR UPGRADE PKG FROM: 00-00-00 THRU: 06-11-06
1	155266-05-01A	EA	MAT - FLOOR - SET - "W" - FORD - PEBBLE BROWN/BLACK - FORD - INTERIOR UPGRADE PKG FROM: 06-12-06 THRU: 99-99-99
2	M09525-61-U21	EA	MOLDING - TRIM/VEE - 1.5" X 20.6" - HONEY CHERRY
2	M09525-61-U22	EA	MOLDING - TRIM/VEE - 1.5" X 20.6" - WASHED MAPLE
3	109709-09-03B	EA	BRACKET - WINGWALL - OFF WHITE
3	109709-11-03B	EA	BRACKET - WINGWALL - OFF WHITE - ENTERTAINMENT CENTER-CABOVER
4	159840-01-U21	EA	SUPPORT - TV - COMPLETE
5	126263-08-02B	EA	BRACKET - GAS SPRING W/CENTERED BALL STUD - E-COATED
6	142569-31-000	EA	SPRING/GAS - 30 LB - 11.8" EXTENDED/7.3" COMPRESSED
7	126263-03-02B	EA	BRACKET - GAS SPRING W/BALL STUD - E/COATED
8	150082-06-000	EA	NUT - F/TV LATCH-KEEPER
9	150082-07-000	EA	WASHER - F/TV LATCH-KEEPER
10	150082-02-000	EA	LATCH/TV - W/O KEEPER/BACKET/ROD
11	150214-01-02B	EA	BRACKET/KEEPER - TV/SWINGOUT - E-COATED FROM: 00-00-00 THRU: 04-01-07
11	150214-02-02B	EA	BRACKET/KEEPER - TV/SWINGOUT - E-COATED FROM: 04-02-07 THRU: 99-99-99
12	150082-03-000	EA	KEEPER - W/O TV LATCH
13	099418-01-000	FT	SEAL - D-SECTION/ADHESIVE BACK - .44" X .44" - BLK RUBBER
14	150082-08-000	EA	ROD - F/TV LATCH-KEEPER
15	150082-04-000	EA	BRACKET - F/TV LATCH-KEEPER
16	156922-01-02B	EA	SUPPORT - TV - E-COATED
17	158921-02-01A	EA	HINGE - PIANO - TRUNK DOOR - 2" X 12.6"
18	154189-01-02A	EA	COVER/TRIM - WIRING - ALMOND
19	158191-01-01A	FT	MOLDING-T - W/EDGE LIP - OFF WHITE
20	153474-01-11A	EA	COVER/WIRE - SATELLITE RADIO - BRIGHT WHITE
21	109709-11-03B	EA	BRACKET - WINGWALL - OFF WHITE
21	109709-10-03B	EA	BRACKET - WINGWALL - OFF WHITE - ENTERTAINMENT CENTER-CABOVER
22	158629-03-U21	EA	PANEL - END CAP - HONEY CHERRY
22	158629-03-U22	EA	PANEL - END CAP - WASHED MAPLE
23	106477-10-T11	EA	TRIM - CAB DOOR - UPPER/LEFT HAND - FORD
24	106477-09-T11	EA	TRIM - CAB DOOR - UPPER/RIGHT HAND - FORD

**DRIVERS COMPARTMENT GROUP (CONTINUED)**  
**FRONT INTERIOR (CONTINUED)**

KEY	PART NUMBER	U/M	DESCRIPTION
25	156101-01-U21	EA	CABINET - HAMPER/STORAGE - W/O DOORS/DRAWERS/HDW
25	156101-01-U22	EA	CABINET - HAMPER/STORAGE - W/O DOORS/DRAWERS/HDW
25	156101-01-U23	EA	CABINET - HAMPER/STORAGE - W/O DOORS/DRAWERS/HDW
25	156101-01-U24	EA	CABINET - HAMPER/STORAGE - W/O DOORS/DRAWERS/HDW
25	156101-01-U25	EA	CABINET - HAMPER/STORAGE - W/O DOORS/DRAWERS/HDW
25	156101-01-U26	EA	CABINET - HAMPER/STORAGE - W/O DOORS/DRAWERS/HDW
25	156101-03-U21	EA	CABINET - HAMPER/STORAGE - W/O DOORS/DRAWERS/HDW - TV-20"AC,LCD,STEREO/CD/DVD
25	156101-03-U22	EA	CABINET - HAMPER/STORAGE - W/O DOORS/DRAWERS/HDW - TV-20"AC,LCD,STEREO/CD/DVD
25	156101-03-U23	EA	CABINET - HAMPER/STORAGE - W/O DOORS/DRAWERS/HDW - TV-20"AC,LCD,STEREO/CD/DVD
25	156101-03-U24	EA	CABINET - HAMPER/STORAGE - W/O DOORS/DRAWERS/HDW - TV-20"AC,LCD,STEREO/CD/DVD
25	156101-03-U25	EA	CABINET - HAMPER/STORAGE - W/O DOORS/DRAWERS/HDW - TV-20"AC,LCD,STEREO/CD/DVD
25	156101-03-U26	EA	CABINET - HAMPER/STORAGE - W/O DOORS/DRAWERS/HDW - TV-20"AC,LCD,STEREO/CD/DVD
26	156101-02-U21	EA	CABINET-TOP-HMPR/STORAGE-W/O LATCH/HDW-HONEY CHERRY - TV-20"AC,LCD,STEREO/CD/DVD FROM: 00-00-00 THRU: 07-02-06
26	161007-01-U21	EA	CABINET - SUPPORT/TV - TV-20"AC,LCD,STEREO/CD/DVD FROM: 07-03-06 THRU: 99-99-99
26	156101-02-U22	EA	CABINET-TOP-HMPR/STORAGE-W/O LATCH/HDW-WASHED MAPLE - TV-20"AC,LCD,STEREO/CD/DVD FROM: 00-00-00 THRU: 07-02-06
26	161007-01-U22	EA	CABINET - SUPPORT/TV - TV-20"AC,LCD,STEREO/CD/DVD FROM: 07-03-06 THRU: 99-99-99
27	158629-01-U21	EA	PANEL - END CAP - HONEY CHERRY - TV-20"AC,LCD,CD/DVD
27	158629-01-U22	EA	PANEL - END CAP - WASHED MAPLE - TV-20"AC,LCD,CD/DVD
28	106448-07-T11	EA	HEADLINER - W/VINYL - FORD
28	156218-01-T11	EA	HEADLINER - W/VINYL - CHEVY
29	106025-02-01A	EA	LADDER - BUNK - 52" - BLACK FROM: 00-00-00 THRU: 09-03-06
29	106025-05-01A	EA	LADDER - BUNK - 52.8" - BLACK FROM: 09-04-06 THRU: 99-99-99
	162356-01-000	EA	STRAP/TIEDOWN - LADDER FROM: 10-16-06 THRU: 99-99-99
30	157047-01-U21	EA	WINGWALL - INNER/LOWER (U21, U22)
30	157047-01-U23	EA	WINGWALL - INNER/LOWER (U23, U24)
30	157047-01-U25	EA	WINGWALL - INNER/LOWER (U25, U26)
	070578-19-U21	EA	BUTTON - #30 - SCREW/STUD - VINYL COVERED (U21, U22)
	070578-19-U23	EA	BUTTON - #30 - SCREW/STUD - VINYL COVERED (U23, U24)
	070578-19-U25	EA	BUTTON - #30 - SCREW/STUD - VINYL COVERED (U25, U26)
	049465-18-000	EA	SCREW - 10-16 X 1 POH W/WASHER - VW GRAY
31	125031-01-T11	EA	TRIM - CAB - B-PILLAR - PASSENGER SIDE
32	094658-04-T02	EA	HANDLE - BUNK - 1.1" X 2" X 14.9" - HONEY CHERRY
32	094658-04-T25	EA	HANDLE - BUNK - 1.1" X 2" X 14.9" - WASHED MAPLE
33	157047-02-U21	EA	WINGWALL - INNER/LOWER (U21, U22)
33	157047-02-U23	EA	WINGWALL - INNER/LOWER (U23, U24)
33	157047-02-U25	EA	WINGWALL - INNER/LOWER (U25, U26)
	070578-19-U21	EA	BUTTON - #30 - SCREW/STUD - VINYL COVERED (U21, U22)
	070578-19-U23	EA	BUTTON - #30 - SCREW/STUD - VINYL COVERED (U23, U24)
	070578-19-U25	EA	BUTTON - #30 - SCREW/STUD - VINYL COVERED (U25, U26)
	049465-18-000	EA	SCREW - 10-16 X 1 POH W/WASHER - VW GRAY
34	125031-02-T11	EA	TRIM - CAB - B-PILLAR - DRIVER SIDE
35	159216-AA-U21	EA	DOOR - FLAT/SQUARE EDGE - 8.7" X 31.5" - W/O HDW - HONEY CHERRY
35	159216-AA-U22	EA	DOOR - FLAT/SQUARE EDGE - 8.7" X 31.5" - W/O HDW - WASHED MAPLE
36	156101-19-U21	EA	PANEL/ACCESS - W/HOLE CUTOUT - HONEY CHERRY
36	156101-19-U22	EA	PANEL/ACCESS - W/HOLE CUTOUT - WASHED MAPLE
37	150974-01-04A	EA	APPLIQUE - BEZEL - INSTR PANEL - LEATHER LASER WAVE - INTERIOR UPGRADE PKG
38	150974-05-04A	EA	APPLIQUE - BEZEL - MOTOR COVER - FORD -LEATHER LASER WAVE - INTERIOR UPGRADE PKG
39	150109-01-01A	EA	KNOB - F/TV SWINGOUT - BLACK
40	158629-08-U21	EA	PANEL - END CAP - HONEY CHERRY
40	158629-08-U22	EA	PANEL - END CAP - WASHED MAPLE
41	156218-02-T11	EA	HEADLINER - W/VINYL - LEFT HAND - CHEVY
42	156218-03-T11	EA	HEADLINER - W/VINYL - RIGHT HAND - CHEVY
43	150974-03-04A	EA	APPLIQUE - BEZEL - INSTR PANEL - LEATHER LASER WAVE - INTERIOR UPGRADE PKG - CHEVY

## DRIVERS COMPARTMENT GROUP (CONTINUED)

### FRONT INTERIOR (CONTINUED)

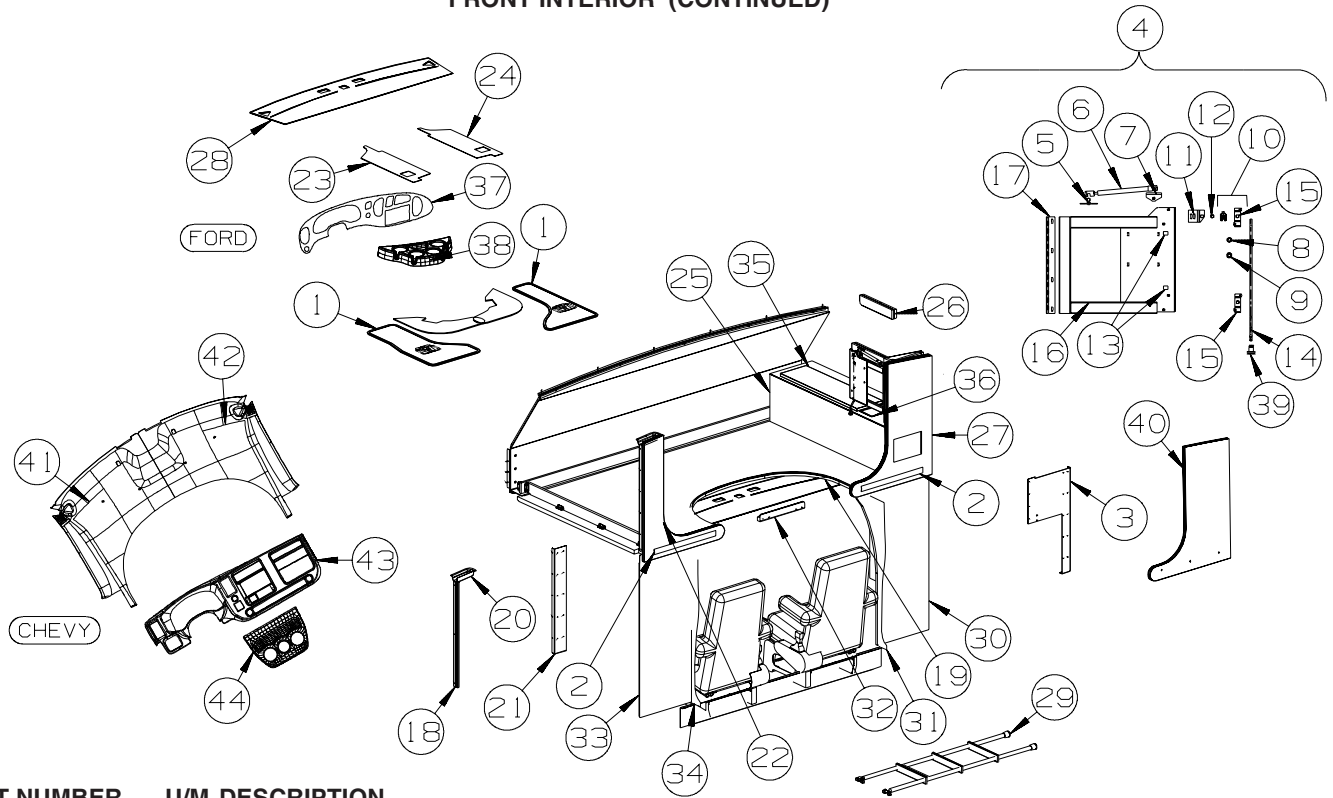

KEY	PART NUMBER	U/M	DESCRIPTION
44	150974-04-04A	EA	APPLIQUE - BEZEL - MOTOR COVER - LEATHER LASER WAVE - <b>INTERIOR UPGRADE PKG - CHEVY</b>
	147623-01-02A	EA	TRAY - BEVERAGE - W/LOWER POCKET (TRIMLINE CONSOLE) PEBBLE FROM: 00-00-00 THRU: 05-07-06
	151391-01-01A	EA	PAD/TRAY - BEVERAGE TRAY FROM: 00-00-00 THRU: 05-07-06
	151391-02-01A	EA	PAD/CUP - BEVERAGE TRAY FROM: 00-00-00 THRU: 05-07-06
	147623-01-02A	EA	TRAY - BEVERAGE - W/LOWER POCKET (TRIMLINE CONSOLE) PEBBLE - <b>331C</b> FROM: 00-00-00 THRU: 04-16-06
	151391-01-01A	EA	PAD/TRAY - BEVERAGE TRAY - <b>331C</b>

## DRIVERS COMPARTMENT GROUP (CONTINUED)

### CABINETS

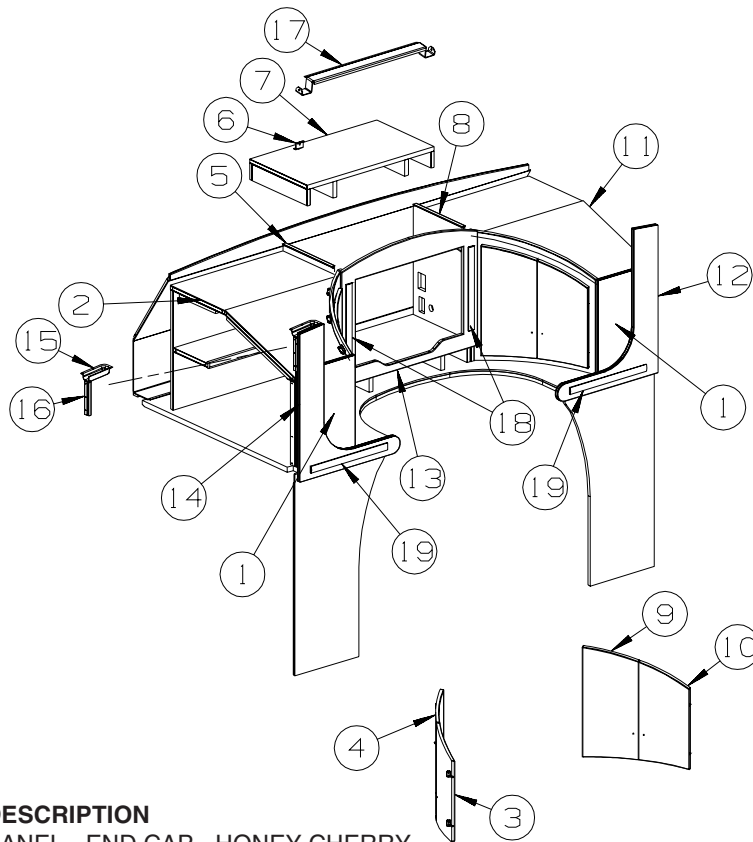

KEY	PART NUMBER	U/M	DESCRIPTION
1	158629-05-U21	EA	PANEL - END CAP - HONEY CHERRY
1	158629-05-U22	EA	PANEL - END CAP - WASHED MAPLE
2	157595-01-U21	EA	CABINET - ENTERTAINMENT CENTER/LEFT HAND - W/O DOORS/HDW - HONEY CHERRY
2	157595-01-U22	EA	CABINET - ENTERTAINMENT CENTER/LEFT HAND - W/O DOORS/HDW - WASHED MAPLE
3	157639-04-U21	EA	DOOR - CURVED/ARCHED - 11.7" X 22.2" - W/O HDW - HONEY CHERRY
3	157639-04-U22	EA	DOOR - CURVED/ARCHED - 11.7" X 22.2" - W/O HDW - WASHED MAPLE
4	157639-02-U21	EA	DOOR - CURVED/ARCHED - 11.7" X 24.8" - W/O HDW - HONEY CHERRY
4	157639-02-U22	EA	DOOR - CURVED/ARCHED - 11.7" X 24.8" - W/O HDW - WASHED MAPLE
5	158227-08-U21	EA	END CAP - OVERHEAD CABINET - HONEY CHERRY
5	158227-08-U22	EA	END CAP - OVERHEAD CABINET - WASHED MAPLE
6	152944-02-02B	EA	BRACKET - TIEDOWN/TV - E-COATED
7	157616-01-U21	EA	CABINET - SHELF/TV
8	158227-09-U21	EA	END CAP - OVERHEAD CABINET - HONEY CHERRY
8	158227-09-U22	EA	END CAP - OVERHEAD CABINET - WASHED MAPLE
9	157639-01-U21	EA	DOOR - CURVED/ARCHED - 11.7" X 24.8" - W/O HDW - HONEY CHERRY
9	157639-01-U22	EA	DOOR - CURVED/ARCHED - 11.7" X 24.8" - W/O HDW - WASHED MAPLE
10	157639-03-U21	EA	DOOR - CURVED/ARCHED - 11.7" X 22.2" - W/O HDW - HONEY CHERRY
10	157639-03-U22	EA	DOOR - CURVED/ARCHED - 11.7" X 22.2" - W/O HDW - WASHED MAPLE
11	157595-02-U21	EA	CABINET - ENTERTAINMENT CENTER/RIGHT HAND - W/O DOORS/HDW - HONEY CHERRY
11	157595-02-U22	EA	CABINET - ENTERTAINMENT CENTER/RIGHT HAND - W/O DOORS/HDW - WASHED MAPLE
12	158629-04-U21	EA	PANEL - END CAP - HONEY CHERRY
12	158629-04-U22	EA	PANEL - END CAP - WASHED MAPLE
13	158935-01-U21	EA	FACE/FRAME (PICTURE) - TV CABINET - W/O HDW - HONEY CHERRY
13	158935-01-U22	EA	FACE/FRAME (PICTURE) - TV CABINET - W/O HDW - WASHED MAPLE
14	158629-03-U21	EA	PANEL - END CAP - HONEY CHERRY
14	158629-03-U22	EA	PANEL - END CAP - WASHED MAPLE
15	153474-01-11A	EA	COVER/WIRE - SATELLITE RADIO - BRIGHT WHITE
16	154189-03-02A	EA	COVER/TRIM - WIRING - ALMOND
17	155313-02-02B	EA	BRACKET - MOUNTING/TV - E-COATED
18	M09525-60-U21	EA	MOLDING - TRIM/VEE - 1.5" X 18.9" - HONEY CHERRY
18	M09525-60-U22	EA	MOLDING - TRIM/VEE - 1.5" X 18.9" - WASHED MAPLE
19	M09525-61-U21	EA	MOLDING - TRIM/VEE - 1.5" X 20.6" - HONEY CHERRY
19	M09525-61-U22	EA	MOLDING - TRIM/VEE - 1.5" X 20.6" - WASHED MAPLE

## ELECTRICAL GROUP 110V BODY WIRING

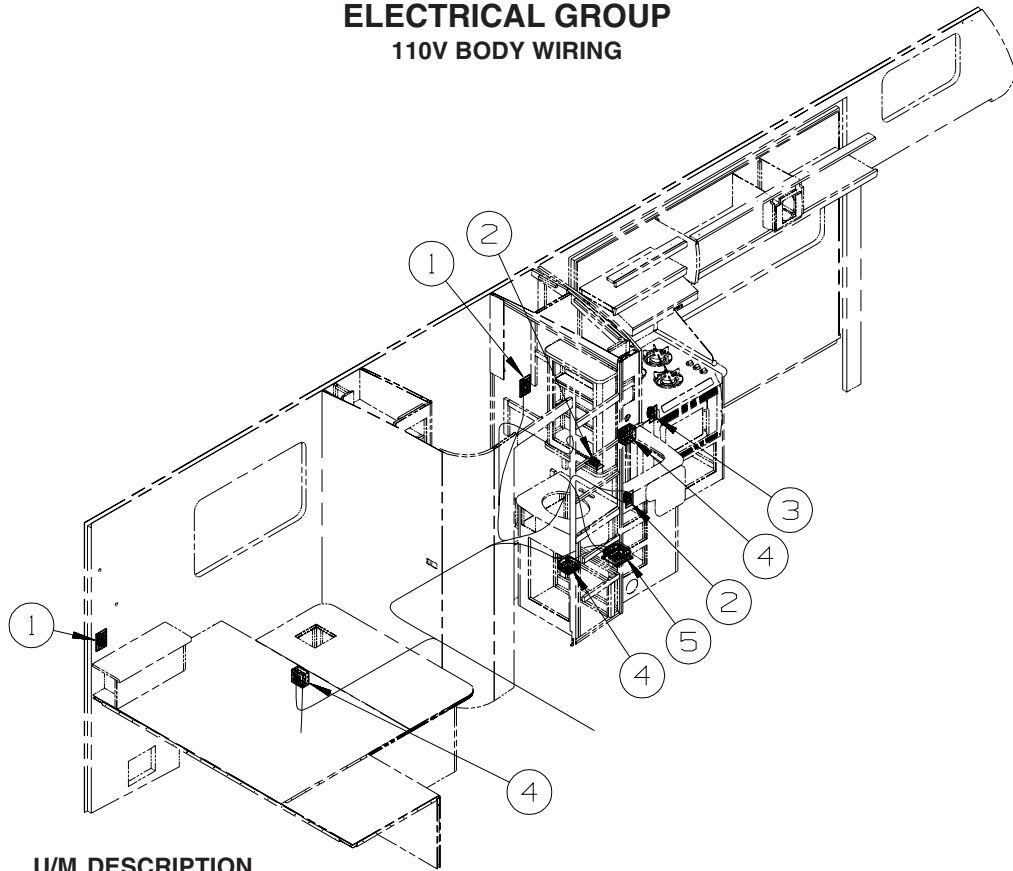

KEY	PART NUMBER	U/M	DESCRIPTION
1	133713-01-23A	EA	SPACER/RECEPTACLE - VINYL - HONEY CHERRY
1	133713-01-21A	EA	SPACER/RECEPTACLE - VINYL - WASHED MAPLE
1	133713-01-20A	EA	SPACER/RECEPTACLE - VINYL - WHITE
1	058708-01-000	EA	RECEPTACLE - ELECTRIC - DOUBLE - BROWN
1	058708-06-000	EA	RECEPTACLE - DUPLEX - WHITE
2	058708-01-000	EA	RECEPTACLE - ELECTRIC - DOUBLE - BROWN
2	058708-06-000	EA	RECEPTACLE - DUPLEX - WHITE
3	157360-01-000	EA	RECEPTACLE - 20 AMP - SINGLE - SURFACE MOUNT - BROWN
4	008289-01-000	EA	BOX - ELECTRIC/STEEL - 4" X 4" - 1/2" & 3/4" KNOCKOUTS
4	008294-01-000	EA	COVER - ELECTRIC BOX - BLANK/STEEL - 4" X 4" - GRAY
5	136481-01-000	EA	MODULE - AUTO ENERGY SELECTOR

**ELECTRICAL GROUP (CONTINUED)**  
**110V BODY WIRING (CONTINUED)**

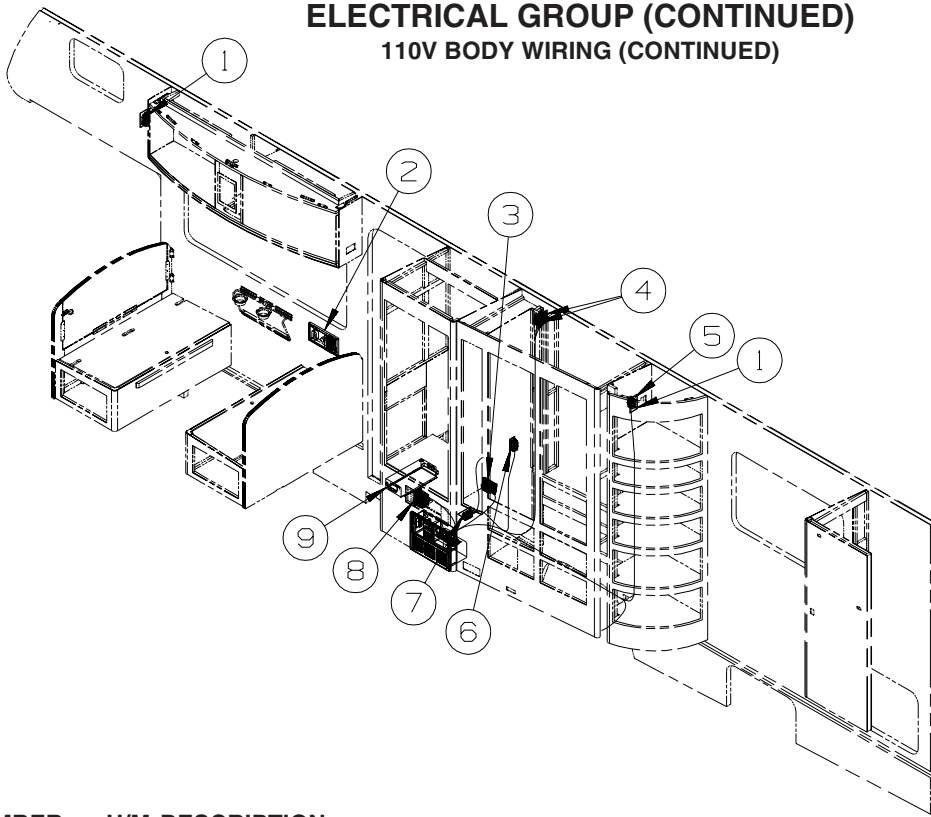

KEY	PART NUMBER	U/M	DESCRIPTION
1	058708-01-000	EA	RECEPTACLE - ELECTRIC - DOUBLE - BROWN - <b>BUNK FRONT OVERHEAD-SINGLE</b>
1	058708-06-000	EA	RECEPTACLE - DUPLEX - WHITE - <b>BUNK FRONT OVERHEAD-SINGLE</b>
2	133713-06-23A	EA	SPACER/RECEPTACLE - PHONE - VINYL - HONEY CHERRY
2	133713-06-21A	EA	SPACER/RECEPTACLE - PHONE - VINYL - WASHED MAPLE
2	133713-06-20A	EA	SPACER/RECEPTACLE - PHONE - VINYL - WHITE
2	058708-01-000	EA	RECEPTACLE - ELECTRIC - DOUBLE - BROWN
2	058708-06-000	EA	RECEPTACLE - DUPLEX - WHITE
3	131826-01-01A	EA	RECEPTACLE - EXTERIOR - W/COVER/GASKET - WHITE
4	058707-02-000	EA	RECEPTACLE - BLANK - JUNCTION BOX
5	158542-02-01A	EA	LABEL - RECEPTACLE - ELECTRONICS - WHITE/BLACK - <b>CANADIAN</b>
6	058707-01-000	EA	RECEPTACLE - ELECTRIC - SINGLE - BROWN
7	058707-02-000	EA	RECEPTACLE - BLANK - JUNCTION BOX
7	058708-05-000	EA	RECEPTACLE - ELECTRICAL - SINGLE - BROWN - <b>INVERTER-DC/AC, 300 WATT</b>
8	147446-01-01A	EA	RECEPTACLE - GFCI - 15A 125V - WHITE
			FROM: 00-00-00 THRU: 03-25-07
8	163319-01-01A	EA	RECEPTACLE - GFCI - 15A 125V - WHITE
			FROM: 03-26-07 THRU: 99-99-99
9	099048-04-000	EA	INVERTER - 300 WATT

## ELECTRICAL GROUP (CONTINUED)

### 12V BODY WIRING

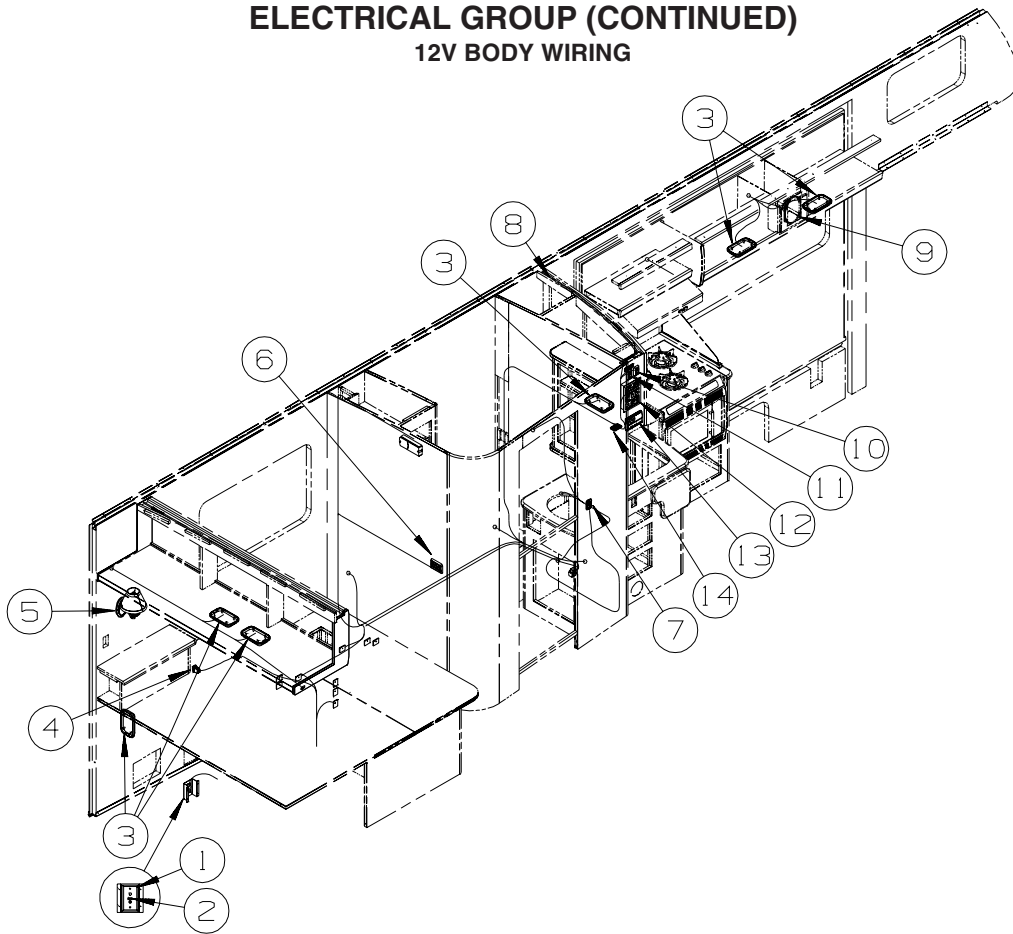

KEY	PART NUMBER	U/M	DESCRIPTION
1	130686-01-01A	EA	PLATE - WALL - TELEPHONE/COAX - WHITE
2	087236-01-000	EA	LABEL - CABLE - INPUT
3*	137417-02-01A	EA	LIGHT - DOME - SINGLE - W/SWITCH/OPTIC LENS - WHITE
4	108357-15-000	EA	SWITCH - ROCKER - DPDT - ON/NONE/ON - W/LIGHT W/O COVER
4	108356-04-01A	EA	COVER/ACTUATOR SWITCH - 2 ROWS DIMPLES W/LENS - BLACK
4	108355-01-000	EA	HOUSING - SWITCH
5	119258-55-01A	EA	LAMP - WALL - UL/CSA - BRUSHED NICKEL
5	119257-25-01A	EA	SHADE - LAMP - IVORY
6	135740-01-02A	EA	SWITCH - ROCKER - SPST - ON/OFF - WHITE
6	135740-01-01A	EA	SWITCH - ROCKER - SPST - ON/OFF - BROWN
6	135740-02-02A	EA	SWITCH - ROCKER - SPDT - ON/ON - WHITE
6	135740-02-01A	EA	SWITCH - ROCKER - SPDT - ON/ON - BROWN
6	135741-03-02A	EA	SWITCH - BASE - TRIPLE - WHITE
6	135741-03-01A	EA	SWITCH - BASE - TRIPLE - BROWN
6	135742-25-01A	EA	BEZEL - SWITCH - CEILING/AISLE/HALL - WHITE
6	135742-25-02A	EA	BEZEL - SWITCH - CEILING/AISLE/HALL - BROWN
7	135740-01-02A	EA	SWITCH - ROCKER - SPST - ON/OFF - WHITE
7	135740-01-01A	EA	SWITCH - ROCKER - SPST - ON/OFF - BROWN
7	135741-01-02A	EA	SWITCH - BASE - SINGLE - WHITE
7	135741-01-01A	EA	SWITCH - BASE - SINGLE - BROWN
7	135742-07-01A	EA	BEZEL - SWITCH - CEILING - WHITE
7	135742-07-02A	EA	BEZEL - SWITCH - CEILING - BROWN
8	146514-02-000	EA	CONNECTOR - LIGHT
8	146514-03-000	FT	LIGHT - FLEX - ROPE/ROUND - W/O MOUNT CHANNEL
8	146514-04-000	EA	CHANNEL/MOUNT - F/ROPE LIGHT
9	110465-01-000	EA	SPEAKER KIT,4 5X7 SPEAKERS

**ELECTRICAL GROUP (CONTINUED)**  
**12V BODY WIRING (CONTINUED)**

KEY	PART NUMBER	U/M	DESCRIPTION
10	135740-06-01A	EA	SWITCH - ROCKER - ON/OFF - LIGHTED - RED - WTR HTR-6GAL/110/LP/MTR/AUTO
10	135741-01-02A	EA	SWITCH - BASE - SINGLE - WHITE - WTR HTR-6GAL/110/LP/MTR/AUTO
10	135741-01-01A	EA	SWITCH - BASE - SINGLE - BROWN - WTR HTR-6GAL/110/LP/MTR/AUTO
10	135742-35-01A	EA	BEZEL - SWITCH - WATER HEATER/110 VOLT - WHITE - WTR HTR-6GAL/110/LP/MTR/AUTO
10	135742-35-02A	EA	BEZEL - SWITCH - WATER HEATER/110 VOLT - BROWN - WTR HTR-6GAL/110/LP/MTR/AUTO
11	135740-06-01A	EA	SWITCH - ROCKER - ON/OFF - LIGHTED - RED - DRAINAGE SYSTEM-HEATED
11	135741-01-02A	EA	SWITCH - BASE - SINGLE - WHITE - DRAINAGE SYSTEM-HEATED
11	135741-01-01A	EA	SWITCH - BASE - SINGLE - BROWN - DRAINAGE SYSTEM-HEATED
11	135742-01-02A	EA	BEZEL - SWITCH - SINGLE - WHITE - DRAINAGE SYSTEM-HEATED
11	135742-01-01A	EA	BEZEL - SWITCH - SINGLE - BROWN - DRAINAGE SYSTEM-HEATED
11	134563-01-01A	EA	LABEL - SWITCH - HEATER - WHITE/BLACK - DRAINAGE SYSTEM-HEATED FROM: 00-00-00 THRU: 06-25-06
11	134563-01-02A	EA	LABEL - SWITCH - HEATER - BLACK/WHITE - DRAINAGE SYSTEM-HEATED FROM: 06-26-06 THRU: 99-99-99
12*	134940-06-01A	EA	PANEL - MONITOR - 2 TANK - W/GENERATOR SWITCH - GEN-4.0KW-ONANGAS-MICROQUIET
12*	134940-07-01A	EA	PANEL - MONITOR - 2 TANK
13	135618-03-01A	EA	THERMOSTAT - ROOF A/C & FURNACE - WHITE
13	135618-01-01A	EA	THERMOSTAT - HEAT PUMP/FURNACE - WHITE
14	135740-01-02A	EA	SWITCH - ROCKER - SPST - ON/OFF - WHITE - INTERIOR UPGRADE PACKAGE
14	135740-01-01A	EA	SWITCH - ROCKER - SPST - ON/OFF - BROWN - INTERIOR UPGRADE PACKAGE
14	135741-01-02A	EA	SWITCH - BASE - SINGLE - WHITE - INTERIOR UPGRADE PACKAGE
14	135741-01-01A	EA	SWITCH - BASE - SINGLE - BROWN - INTERIOR UPGRADE PACKAGE
14	135742-50-01A	EA	BEZEL - SWITCH - ACCENT - WHITE - INTERIOR UPGRADE PACKAGE
14	135742-50-02A	EA	BEZEL - SWITCH - ACCENT - WHITE - INTERIOR UPGRADE PACKAGE

\*COMPONENT PARTS LISTED LATER IN THIS GROUP



## ELECTRICAL GROUP (CONTINUED) 12V BODY WIRING (CONTINUED)

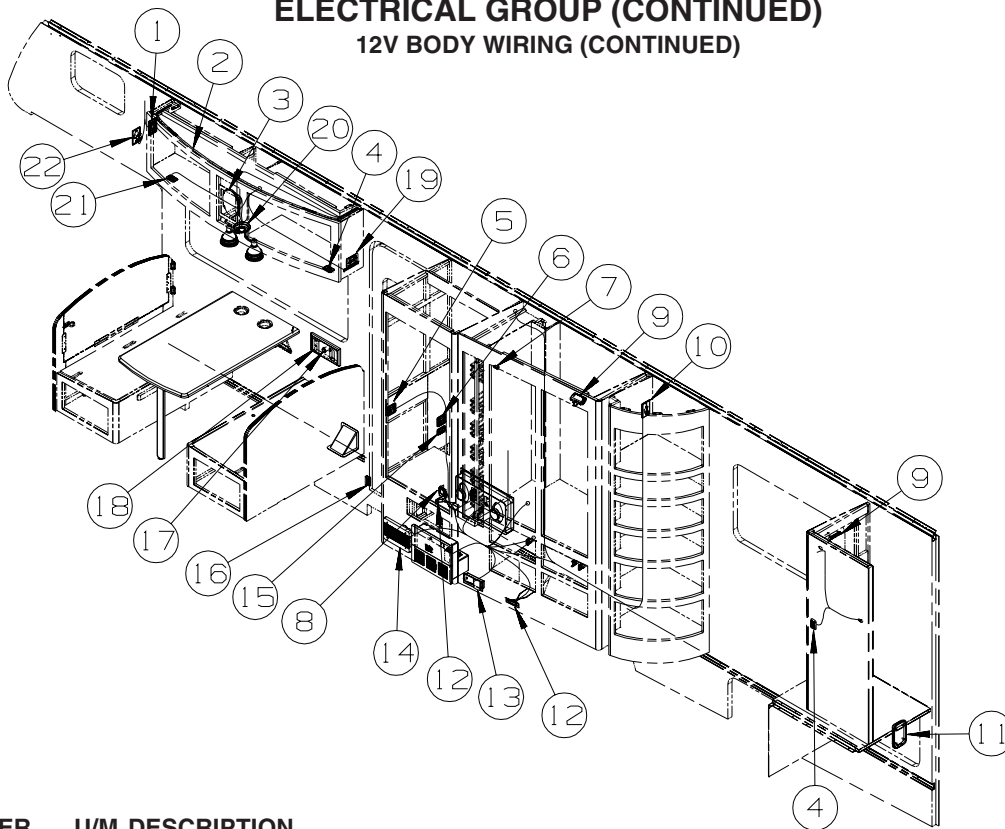

KEY	PART NUMBER	U/M	DESCRIPTION
1	149557-05-01A	EA	PLATE/WALL-DUAL COAXIAL/HORIZ-WHT-TV-20"AC,LCD,STEREO/CD/DVD/BUNKFRONTOVHD-SINGLE
2	146514-02-000	EA	CONNECTOR - LIGHT - INTERIOR UPGRADE PACKAGE
2	146514-03-000	FT	LIGHT - FLEX - ROPE/ROUND - W/O MOUNT CHANNEL - INTERIOR UPGRADE PACKAGE
2	146514-04-000	EA	CHANNEL/MOUNT - F/ROPE LIGHT - INTERIOR UPGRADE PACKAGE
3	110465-01-000	EA	SPEAKER KIT,4 5X7 SPEAKERS
4	135740-01-02A	EA	SWITCH - ROCKER - SPST - ON/OFF - WHITE - INTERIOR UPGRADE PACKAGE
4	135740-01-01A	EA	SWITCH - ROCKER - SPST - ON/OFF - BROWN - INTERIOR UPGRADE PACKAGE
4	135741-01-02A	EA	SWITCH - BASE - SINGLE - WHITE - INTERIOR UPGRADE PACKAGE
4	135741-01-01A	EA	SWITCH - BASE - SINGLE - BROWN - INTERIOR UPGRADE PACKAGE
4	135742-50-01A	EA	BEZEL - SWITCH - ACCENT - WHITE - INTERIOR UPGRADE PACKAGE
4	135742-50-02A	EA	BEZEL - SWITCH - ACCENT - WHITE - INTERIOR UPGRADE PACKAGE
5	135740-01-02A	EA	SWITCH - ROCKER - SPST - ON/OFF - WHITE
5	135740-01-01A	EA	SWITCH - ROCKER - SPST - ON/OFF - BROWN
5	135740-02-02A	EA	SWITCH - ROCKER - SPDT - ON/ON - WHITE
5	135740-02-01A	EA	SWITCH - ROCKER - SPDT - ON/ON - BROWN
5	135741-02-02A	EA	SWITCH - BASE - DOUBLE - WHITE
5	135741-02-01A	EA	SWITCH - BASE - DOUBLE - BROWN
5	135742-16-01A	EA	BEZEL - SWITCH - CEILING/HALL - WHITE
5	135742-16-02A	EA	BEZEL - SWITCH - CEILING/HALL - BROWN
6	135740-01-02A	EA	SWITCH - ROCKER - SPST - ON/OFF - WHITE
6	135740-01-01A	EA	SWITCH - ROCKER - SPST - ON/OFF - BROWN
6	135741-02-02A	EA	SWITCH - BASE - DOUBLE - WHITE
6	135741-02-01A	EA	SWITCH - BASE - DOUBLE - BROWN
6	135742-19-01A	EA	BEZEL - SWITCH - CEILING/PORCH - WHITE
6	135742-19-02A	EA	BEZEL - SWITCH - CEILING/PORCH - BROWN
7	056264-01-000	EA	SWITCH - LEAF ACTUATOR
8	108357-06-000	EA	SWITCH - ROCKER - DPDT - MOM/OFF/MOM - 6 TERM - W/O COVER
8	108356-11-01A	EA	COVER/ACTUATOR SWITCH - 3 GROOVES - AUX BATT - BLACK
8	108355-01-000	EA	HOUSING - SWITCH
9*	087694-01-000	EA	LIGHT - WARDROBE/CLOSET - W/SWITCH
10	076319-09-000	EA	WALLPLATE - TV CABLE RECEPTACLE - SINGLE - BROWN
11*	137417-02-01A	EA	LIGHT - DOME - SINGLE - W/SWITCH/OPTIC LENS - WHITE
12	061424-01-000	EA	LIGHT - AISLE - 12 VOLT - RECTANGULAR
13	150138-01-02A	EA	DETECTOR - LP GAS - BROWN
13	150138-01-01A	EA	DETECTOR - LP GAS - WHITE
14	124884-01-000	EA	SPEAKER-6"X9"-SUB-WOOFER-TV-20"AC,LCD,STEREO/CD/DVD/ENTER. CENTER-CABOVER
14	151844-01-01A	EA	GRILL-SPKER-6"X9"-SUB WOOFER-BLACK-TV-20"AC,LCD,STEREO/CD/DVD/ENTER. CENTER-CABOVER

## ELECTRICAL GROUP (CONTINUED)

### 12V BODY WIRING (CONTINUED)

KEY	PART NUMBER	U/M	DESCRIPTION
15	135740-01-02A	EA	SWITCH - ROCKER - SPST - ON/OFF - WHITE - ENTRANCE STEP-ELEC.
15	135740-01-01A	EA	SWITCH - ROCKER - SPST - ON/OFF - BROWN - ENTRANCE STEP-ELEC.
15	135741-01-02A	EA	SWITCH - BASE - SINGLE - WHITE - ENTRANCE STEP-ELEC.
15	135741-01-01A	EA	SWITCH - BASE - SINGLE - BROWN - ENTRANCE STEP-ELEC.
15	135742-11-01A	EA	BEZEL - SWITCH - STEP - WHITE - ENTRANCE STEP-ELEC.
15	135742-11-02A	EA	BEZEL - SWITCH - STEP - BROWN - ENTRANCE STEP-ELEC.
16	116995-02-000	EA	SWITCH/MAGNET - ELECTRIC STEP - BLACK/WHITE- NORMALLY OPEN
17	132958-01-000	EA	RECEPTACLE - 12 VOLT - MOUNTING FLANGE - BLACK
18	093253-01-03A	EA	PLATE - WALL - TELEPHONE - WHITE
18	093253-01-02A	EA	PLATE - WALL - TELEPHONE - BROWN
19	138173-04-000	EA	CONTROL PANEL (TOUCH PAD) - ELECTRIC SLIDEOUT - #1802931
19	116549-01-000	EA	LABEL - WARNING - SLIDEOUT
20	093575-47-01A	EA	LIGHT - CEILING/DOUBLE - BRUSHED NICKEL
21	135740-02-02A	EA	SWITCH - ROCKER - SPDT - ON/ON - WHITE
21	135740-02-01A	EA	SWITCH - ROCKER - SPDT - ON/ON - BROWN
21	135741-01-02A	EA	SWITCH - BASE - SINGLE - WHITE
21	135741-01-01A	EA	SWITCH - BASE - SINGLE - BROWN
21	135742-06-01A	EA	BEZEL - SWITCH - AISLE - WHITE
21	135742-06-02A	EA	BEZEL - SWITCH - AISLE - BROWN
22	086777-02-000	EA	WALL PL/TV CABLE W/ANT SW/BOOSTER-TV-20"AC,LCD,STEREO/CD/DVD/BUNKFRONTOVHD-SINGLE

\*COMPONENT PARTS LISTED LATER IN THIS GROUP

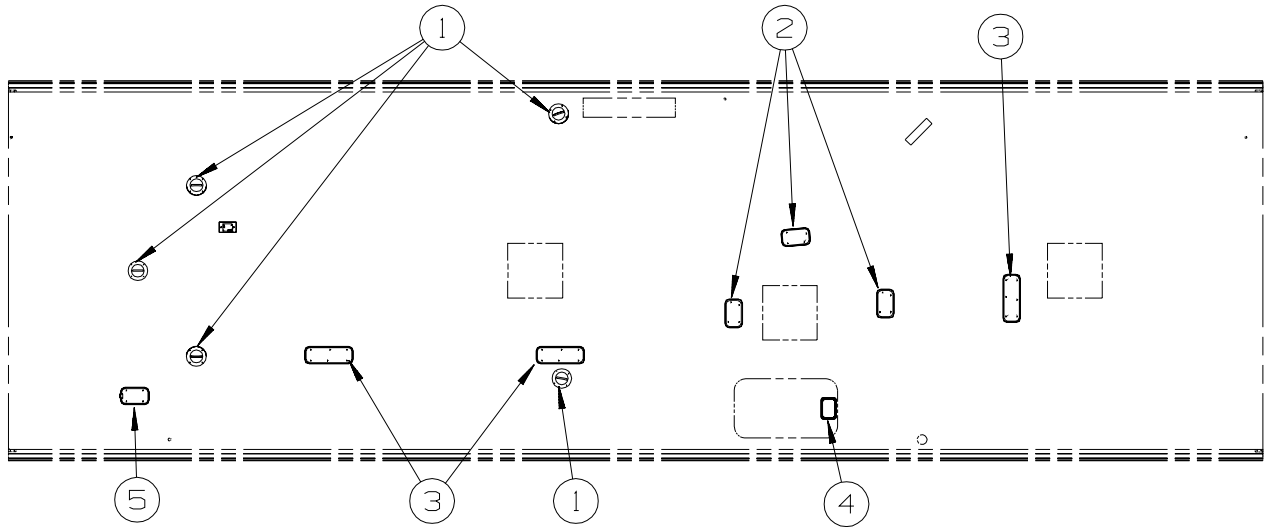

KEY	PART NUMBER	U/M	DESCRIPTION
1	151314-01-01A	EA	SPEAKER - CUBE/CEILING - WH - MAGNADYNE - LS3CM-WN - ENTERTAINMENT CENTER-CABOVER FROM: 00-00-00 THRU: 07-16-06
1	160867-01-01A	EA	SPEAKER-ROUND/CEILING-CREAM-MAGNADYNE-LS3EYC-WN-ENTERTAINMENT CENTER-CABOVER FROM: 07-17-06 THRU: 99-99-99
2*	137417-03-01A	EA	LIGHT - DOME - SINGLE - W/O SWITCH - W/FROSTED LENS-WHITE
3*	137417-06-01A	EA	LIGHT - DOME - DOUBLE - W/O SWITCH - W/FROSTED LENS-WHITE
4*	121935-01-01A	EA	LIGHT - DOME - SHOWER - W/HOLE IN LENS
5*	137417-01-01A	EA	LIGHT - DOME - SINGLE - W/SWITCH/FROSTED LENS - WHITE

\*COMPONENT PARTS LISTED LATER IN THIS GROUP

**ELECTRICAL GROUP (CONTINUED)**  
**12V BODY WIRING (CONTINUED)**

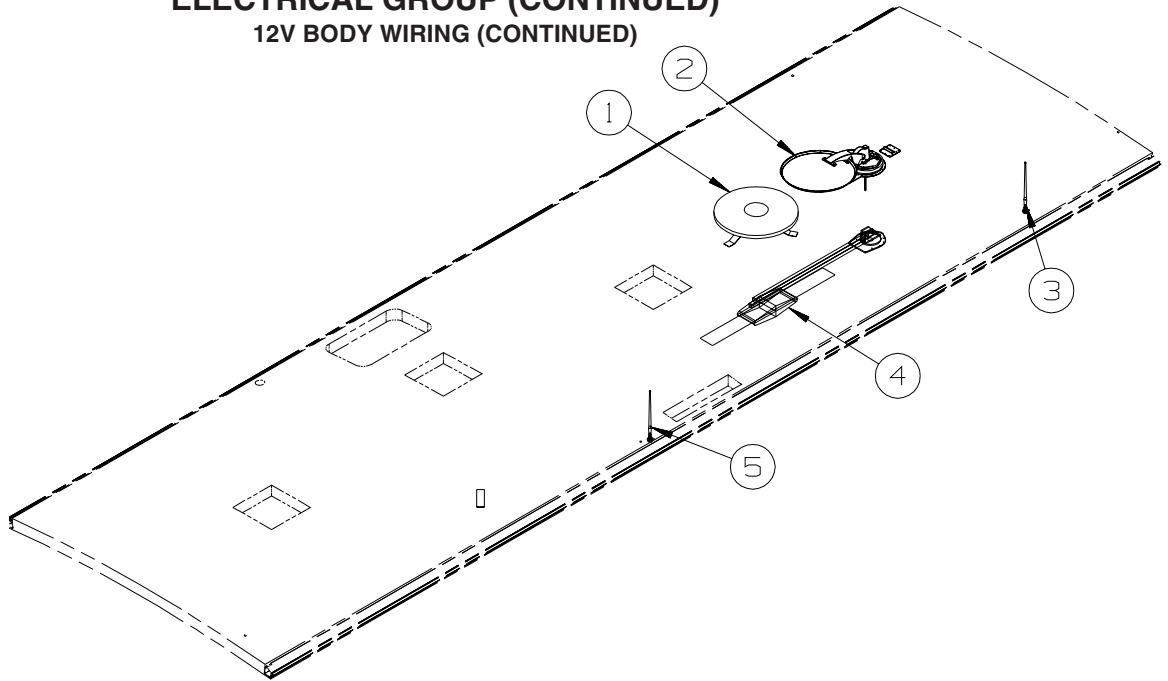

KEY	PART NUMBER	U/M	DESCRIPTION
1	132935-01-000	EA	ANTENNA - TV ROOF MOUNT - ROUND - W/O POWER SUPPLY
1	146488-01-000	EA	PLATE - ROOF - CABLE ENTRY
1	082134-01-000	EA	ADAPTER - TV - CABLE TO CABLE
2*	137135-02-000	EA	ANTENNA - SATELLITE DSS - W/SENSOR - <b>SATELLITE DISH &amp; ELEV.SENSOR</b>
3	090944-01-000	EA	ANTENNA - RADIO - 16" RUBBER - W/72" LEAD WIRE - <b>TV-20"AC,LCD,STEREO/CD/DVD</b>
3	109889-04-000	EA	EXTENDER - ANTENNA SHAFT - 3.7" - <b>TV-20"AC,LCD,STEREO/CD/DVD</b>
3	147741-01-09B	EA	BRACKET - ANTENNA GROUND - GALVANIZED - <b>TV-20"AC,LCD,STEREO/CD/DVD</b>
4*	076319-23-000	EA	ANTENNA - TV ROOF MOUNT - 44.5" MAST
4*	076319-25-000	EA	KIT - HARDWARE INTERIOR
4	069726-02-000	EA	BUMPER - .88" OD X .40" THICK - BLACK
5	090944-01-000	EA	ANTENNA - RADIO - 16" RUBBER - W/72" LEAD WIRE - <b>ENTERTAINMENT CENTR/EXT W/CD</b>
5	109889-04-000	EA	EXTENDER - ANTENNA SHAFT - 3.7" - <b>ENTERTAINMENT CENTR/EXT W/CD</b>
5	147741-01-09B	EA	BRACKET - ANTENNA GROUND - GALVANIZED - <b>ENTERTAINMENT CENTR/EXT W/CD</b>

**\*COMPONENT PARTS LISTED LATER IN THIS GROUP**

**ELECTRICAL GROUP (CONTINUED)**  
**12V BODY WIRING (CONTINUED)**

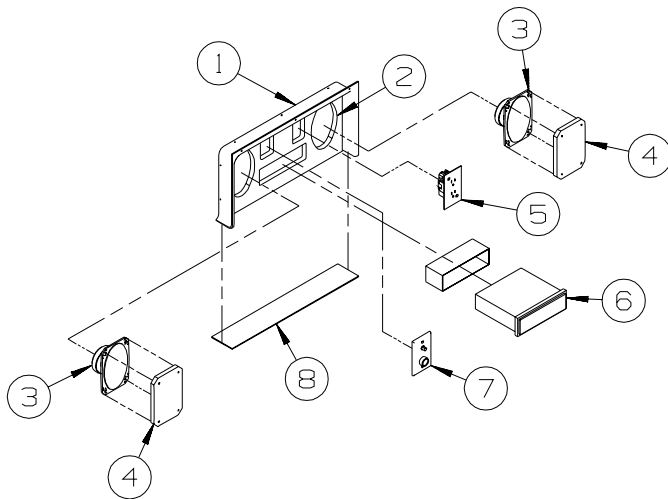

KEY	PART NUMBER	U/M	DESCRIPTION
1	124696-02-01A	EA	BOX-ENTERTAINMENT CTR/EXT-19.4"W X 10"H X 2.5"D - BRT WHT
	124696-01-01A	EA	BOX-ENTERTAINMENT CTR/EXT-19.4"W X 10"H X 10.2"D W/CUTOUTS
2	127409-02-L15	EA	PLATE - RADIO MOUNTING
3	110469-01-000	EA	SPEAKER - 4" X 6" OVAL - COAXIAL
4	110470-01-01A	EA	GRILLE - 4" X 6" - OVAL SPEAKER - BLACK
5	058708-01-000	EA	RECEPTACLE - ELECTRIC - DOUBLE - BROWN
6*	155619-01-000	EA	RADIO - AM/FM CD - W/REMOTE - MAGNADYNE M3200CD
			FROM: 00-00-00 THRU: 08-01-06
6	155619-02-000	EA	RADIO - AM/FM CD-W/O REMOTE/WIRE HARNESS-MAGNADYNE M3200CD
			FROM: 08-02-06 THRU: 99-99-99
	155619-03-000	EA	REMOTE - RADIO
			FROM: 08-02-06 THRU: 99-99-99
7	076319-09-000	EA	WALLPLATE - TV CABLE RECEPTACLE - SINGLE - BROWN
8	104898-01-02A	EA	PLATE - PLASTIC BOTTOM - BRIGHT WHITE

**\*COMPONENT PARTS LISTED LATER IN THIS GROUP**

# ELECTRICAL GROUP (CONTINUED)

## EXTERIOR LAMPS

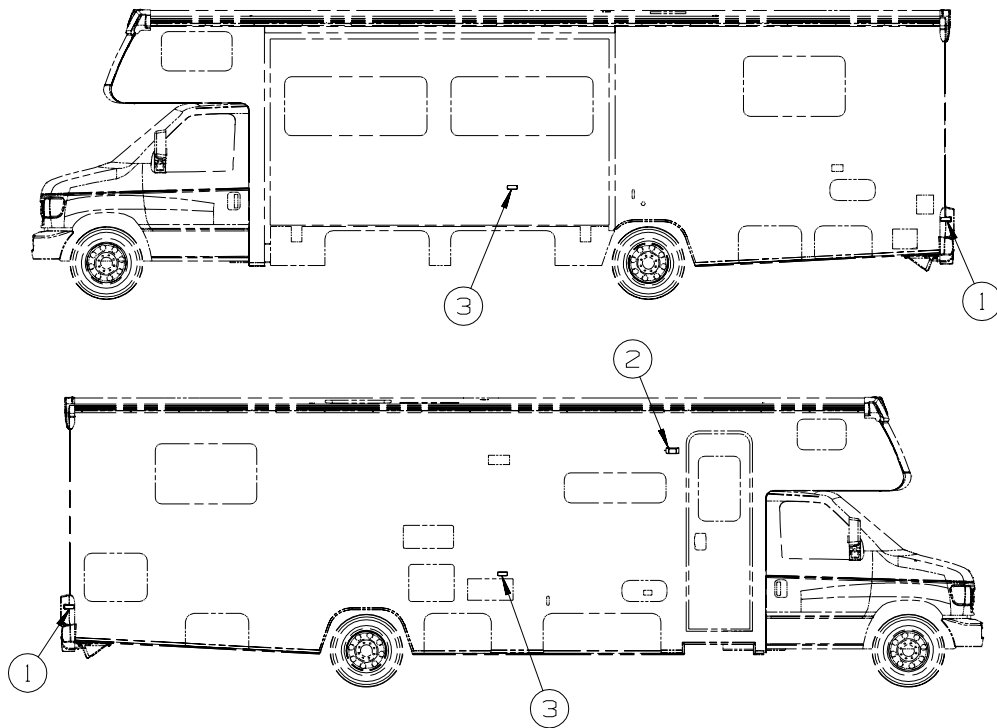

KEY	PART NUMBER	U/M	DESCRIPTION
1	111102-01-000	EA	BASE - MARKER LAMP
	036196-01-000	EA	BULB - 12V - #194 - .27 AMP - BAYONETTE
1	111102-03-000	EA	LENS - RED - MARKER LAMP
2*	097917-01-06A	EA	LIGHT - PORCH - ENTRY DOOR - BRIGHT WHITE
	008215-01-000	EA	BULB - 12 VOLT - #1003 - .94 AMP
3	111102-01-000	EA	BASE - MARKER LAMP
	036196-01-000	EA	BULB - 12V - #194 - .27 AMP - BAYONETTE
3	111102-02-000	EA	LENS - AMBER - MARKER LAMP

\*COMPONENT PARTS LISTED LATER IN THIS GROUP

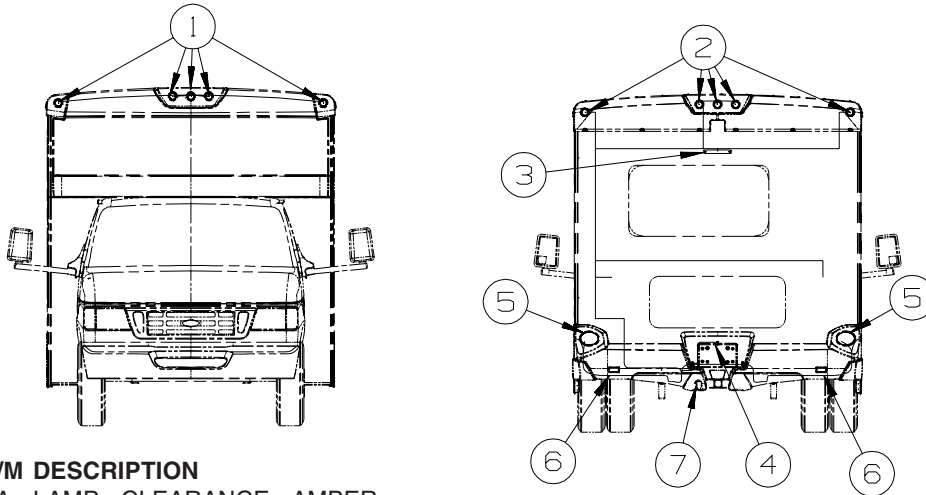

KEY	PART NUMBER	U/M	DESCRIPTION
1	138996-01-000	EA	LAMP - CLEARANCE - AMBER
1	138996-03-000	EA	BRACKET - CLEARANCE LIGHT
1	036196-01-000	EA	BULB - 12V - #194 - .27 AMP - BAYONETTE
2	138996-02-000	EA	LAMP - CLEARANCE - RED
2	138996-03-000	EA	BRACKET - CLEARANCE LIGHT
2	036196-01-000	EA	BULB - 12V - #194 - .27 AMP - BAYONETTE
3	136916-01-000	EA	LIGHT - BRAKE - CENTER MOUNT - RECTANGLE - 1.3" X 9.8"
4	087201-01-000	EA	LIGHT - HALF ROUND - 1" X 1.7" - PLASTIC - BLACK OR WHITE
5	152070-03-000	EA	LIGHT - STOP/TAIL/BACK UP
6	106646-02-000	EA	REFLECTOR - STICK ON - RED
7	146246-01-000	EA	CONNECTOR/PLUG - TRAILER - 7 PIN
7	157593-01-000	EA	CONNECTOR - PLUG - TRAILER - 7 SOCKET

**ELECTRICAL GROUP (CONTINUED)**  
**FRONT END**

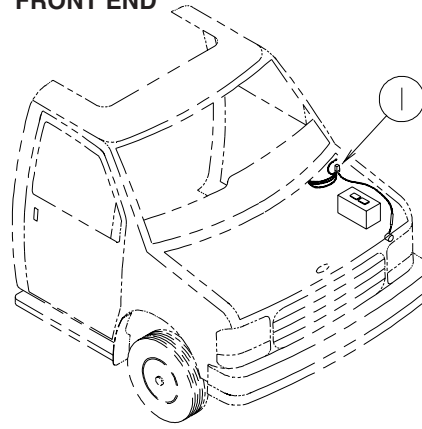

KEY	PART NUMBER	U/M DESCRIPTION
1	100138-01-000	EA MODULE - DAYTIME/RUNNING LIGHT - HAMSAR DRL #H8005B



**DRIVERS DOOR**

KEY	PART NUMBER	U/M DESCRIPTION
*	120269-07-01A	EA PANEL - W/ELECTRIC MIRROR/HEAT SWITCH - F/#L28X OPTION - MIRRORS-EXTERIOR W/DEFROST
*	133908-09-01A	EA PANEL - F/ELECTRIC MIRROR ONLY - L28X OPTION - MIRRORS-EXTERIOR W/DEFROST - CHEVY

**\*COMPONENT PARTS LISTED LATER IN THIS GROUP**

## ELECTRICAL GROUP (CONTINUED)

### FRONT TV/VCR

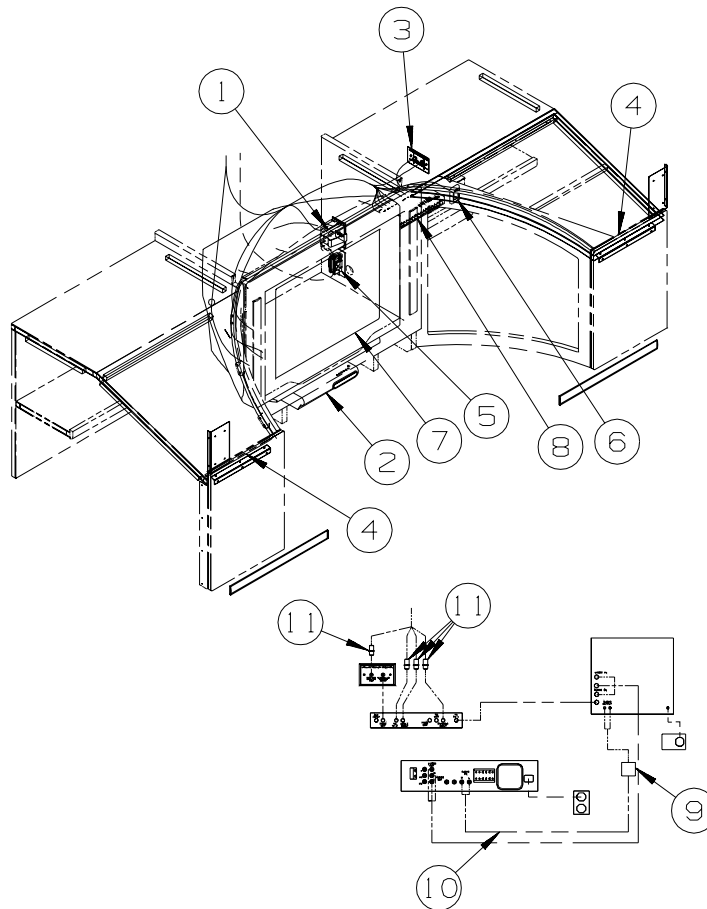

KEY	PART NUMBER	U/M	DESCRIPTION
1	156676-01-000	EA	CONTROLLER/OUTLET - POWER/TV - AUTO SHUTOFF W/IGNITION
2*	158836-01-000	EA	DVD - HOME THEATER - W/O SPEAKERS - MEMOREX STS71E-R
3	149557-05-01A	EA	PLATE/WALL - DUAL COAXIAL/HORIZONTAL - WHITE
4	146514-03-000	FT	LIGHT - FLEX - ROPE/ROUND - W/O MOUNT CHANNEL
4	146514-01-000	FT	LIGHT - FLEX - ROPE/ROUND - W/STRIP FROM: 00-00-00 THRU: 04-30-06
4	146514-02-000	EA	CONNECTOR - LIGHT FROM: 05-01-06 THRU: 99-99-99
5	058708-01-000	EA	RECEPTACLE - ELECTRIC - DOUBLE - BROWN
5	158542-02-01A	EA	LABEL - RECEPTACLE - ELECTRONICS - WHITE/BLACK - <b>CANADIAN</b>
6	135740-01-01A	EA	SWITCH - ROCKER - SPST - ON/OFF - BROWN
6	135741-01-01A	EA	SWITCH - BASE - SINGLE - BROWN
6	135742-50-02A	EA	BEZEL - SWITCH - ACCENT - BROWN
7*	146298-02-000	EA	TV - 27" STEREO W/5 JACKS - SONY 27FS120
8	142258-01-000	EA	SWITCH - VIDEO/ANTENNA POWER SUPPLY
9	123324-01-000	EA	FILTER - GROUND LOOP - <b>ENTERTAINMENT CENTER-CABOVER</b>
10	117420-02-000	EA	CABLE - W/MALE RCA ENDS - SHIELDED - 4' - <b>ENTERTAINMENT CENTER-CABOVER</b>
11	082134-01-000	EA	ADAPTER - TV - CABLE TO CABLE - <b>ENTERTAINMENT CENTER-CABOVER</b>

\*COMPONENT PARTS LISTED LATER IN THIS GROUP

## ELECTRICAL GROUP (CONTINUED)

### SIDE TV/VCR

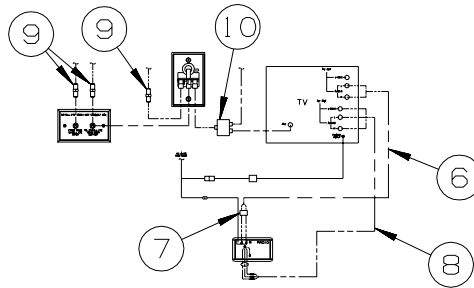
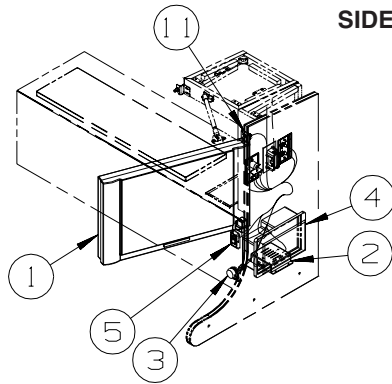

KEY	PART NUMBER	U/M	DESCRIPTION
1*	158703-01-000	EA	TV - 20" - LCD 4:3 - SIDE SPEAKER - JENSEN JE2043
2	150140-01-000	EA	CROSSOVER BOX - STANDARD STEREO TO DELUXE SOUND
3	150140-02-000	EA	CROSSOVER COIL - F/SUBWOOFER SPEAKER/LOW FREQUENCY
4*	156413-01-01A	EA	RADIO - WALL MOUNT - DVD/CD - W/ALARM - JENSEN AWM950
			FROM: 00-00-00 THRU: 01-01-07
4	163031-01-01A	EA	RADIO - WALL MOUNT - DVD/CD - W/ALARM - JENSEN AWM960
			FROM: 01-02-07 THRU: 99-99-99
5	135740-01-01A	EA	SWITCH - ROCKER - SPST - ON/OFF - BROWN
5	135741-01-01A	EA	SWITCH - BASE - SINGLE - BROWN
5	135742-45-02A	EA	BEZEL - SWITCH - TV - BROWN
6	117420-02-000	EA	CABLE - W/MALE RCA ENDS - SHIELDED - 4'
7	123324-01-000	EA	FILTER - GROUND LOOP
8	136860-01-000	EA	CABLE - RCA - SHIELDED - 3 MALE TO MALE CONNECTORS - 12'
9	082134-01-000	EA	ADAPTER - TV - CABLE TO CABLE
10	086756-01-000	EA	SPLITTER - TV/2 WAY
11	159814-01-000	EA	SWITCH - PLUNGER - SPST - OFF/ON
			FROM: 06-14-06 THRU: 99-99-99

**\*COMPONENT PARTS LISTED LATER IN THIS GROUP**



**ELECTRICAL GROUP (CONTINUED)**  
**COMPONENT PARTS FOR WIRING**

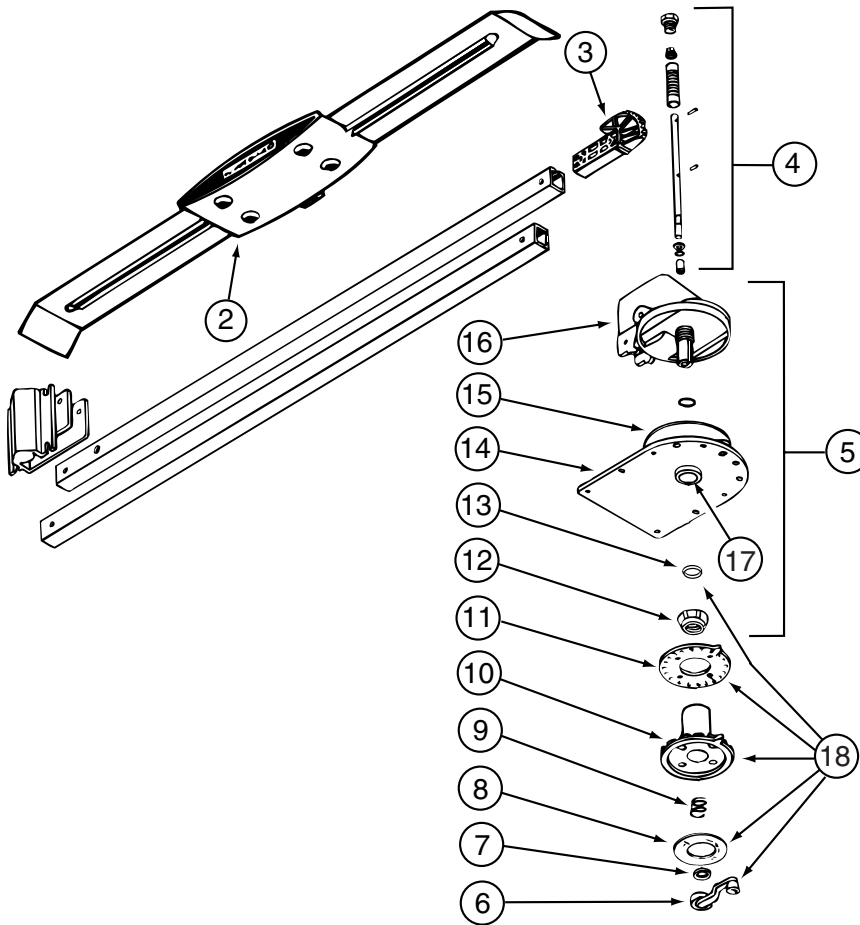

**076319-23-000**

KEY	PART NUMBER	U/M	DESCRIPTION	VENDOR NO.
2	076319-01-700	EA	HEAD-ANTENNA, AMPLIFIED	RVSA U/V
3	076319-01-701	EA	GEAR-ELEVATING, PLASTIC	2200046
4	076319-01-702	EA	SHAFT ASM-ELEVATING	RP-4000
5	076319-01-711	EA	BASE & LIFT ASM	2762802
7	076319-01-705	EA	GROMMET-NYLON, 7/8"ID	3200658
8	076319-01-708	EA	DECAL-CRANK	5413002
9	076319-01-707	EA	SPRING-HANDLE	2160822
11	076319-01-712	EA	PLATE - CEILING	3200608
12	076319-01-715	EA	NUT (GEAR HOUSING)	2200047
14	076319-01-713	EA	PLATE-BASE, STEEL	3100523
15	076319-01-703	EA	BEARING-NYLON, 5"OD	3200656
16	076319-01-714	EA	HOUSING, ROTATING GEAR	2200049
17	076319-01-704	EA	BEARING-NYLON, 1.25"OD	3200657
18	076319-01-709	EA	HANDLE-HEAD DIRECTIONAL	200644
	076319-01-716	EA	TUBING, ELEVATING	RP-2900

CONTACT WINNEBAGO PART SALES FOR UNLISTED COMPONENT(S)

**076319-25-000**

KEY	PART NUMBER	U/M	DESCRIPTION	VENDOR NO.
6	076319-01-706	EA	CRANK-W/SET SCREW UNIV/BEIGE	2750897
6	120233-01-710	EA	HANDLE-CRANK W/SCREW - WHITE	RP-6795
8	076319-01-708	EA	DECAL-CRANK	5413002
10	076319-25-700	EA	DIRECTIONAL HANDLE(WHITE)	3200612
11	076319-25-701	EA	PLATE - CEILING(WHITE)	3200609
13	120233-01-709	EA	WASHER-NYLON	RP-2658

CONTACT WINNEBAGO PART SALES FOR UNLISTED COMPONENT(S)

**ELECTRICAL GROUP (CONTINUED)**  
**COMPONENT PARTS FOR WIRING (CONTINUED)**

<b>087694-01-000</b>			
<b>KEY</b>	<b>PART NUMBER</b>	<b>U/M DESCRIPTION</b>	<b>VENDOR NO.</b>
	087694-01-700	EA BULB	GE561
<b>097917-01-06A</b>			
<b>KEY</b>	<b>PART NUMBER</b>	<b>U/M DESCRIPTION</b>	<b>VENDOR NO.</b>
	097917-01-700	EA LENS-LIGHT, CLEAR	30-78-021
<b>120269-07-01A</b>			
<b>KEY</b>	<b>PART NUMBER</b>	<b>U/M DESCRIPTION</b>	<b>VENDOR NO.</b>
	120269-07-700	EA SWITCH - REMOTE	7475720
	133908-09-700	EA SWITCH - MIRROR HEATER	7475150
<b>121935-01-01A</b>			
<b>KEY</b>	<b>PART NUMBER</b>	<b>U/M DESCRIPTION</b>	<b>VENDOR NO.</b>
	121935-01-700	EA LENS ONLY	809511

**ELECTRICAL GROUP (CONTINUED)  
COMPONENT PARTS FOR WIRING (CONTINUED)**

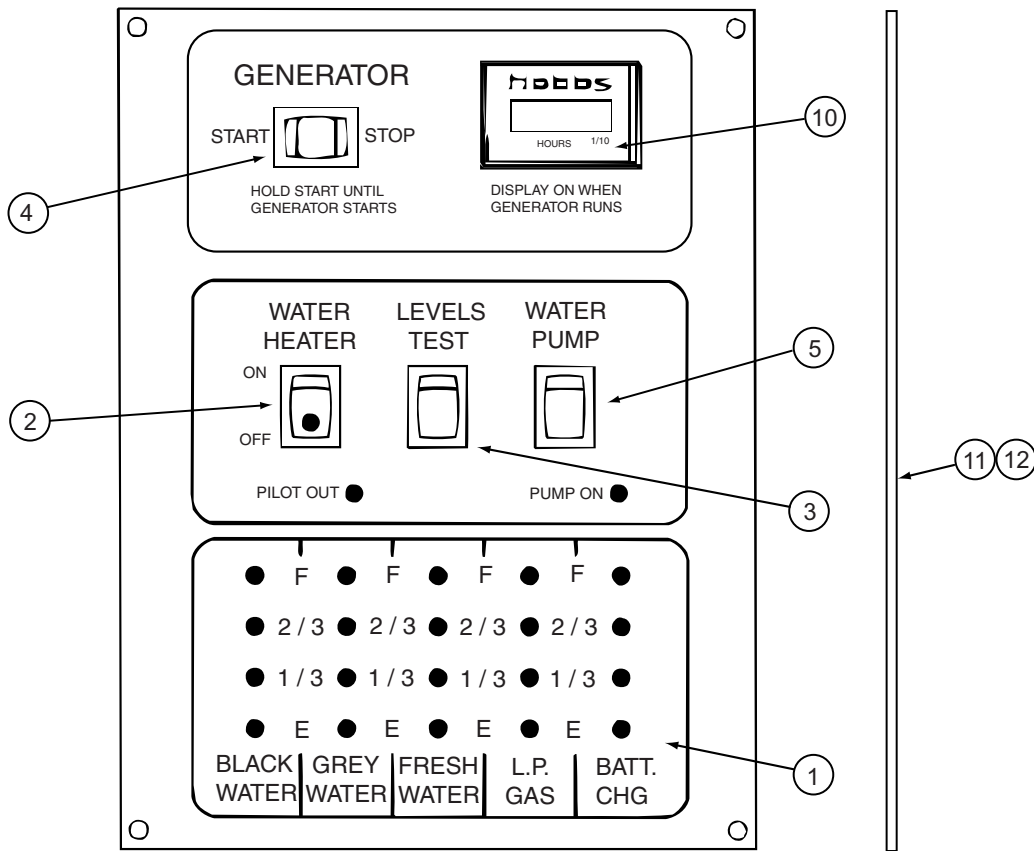

**134940-06-01A**

KEY	PART NUMBER	U/M	DESCRIPTION	VENDOR NO.
1	134940-01-702	EA	CHASSIS - SILKSCREENED	CC0558-00
2	134940-01-701	EA	SWITCH-SPST/ON-OFF/BLK W/LGT	L0109
3	096983-01-701	EA	SWITCH - SPST/MOM 2 TERMINAL	L0111-00
4	096983-01-702	EA	SWITCH - MOM/OFF/MOM/3 TERM	L0112-00
5	096983-01-703	EA	SWITCH - ON/ON	L0115-00
10	100258-10-701	EA	GAUGE-HR METER ONLY (LCD)	L0775-00
11	134940-06-700	EA	PC BOARD - SENSOR SYSTEM/RED	L5131-02

CONTACT WINNEBAGO PART SALES FOR UNLISTED COMPONENT(S)

**134940-07-01A**

KEY	PART NUMBER	U/M	DESCRIPTION	VENDOR NO.
1	134940-01-702	EA	CHASSIS - SILKSCREENED	CC0558-00
2	134940-01-701	EA	SWITCH-SPST/ON-OFF/BLK W/LGT	L0109
3	096983-01-701	EA	SWITCH - SPST/MOM 2 TERMINAL	L0111-00
4	096983-01-703	EA	SWITCH - ON/ON	L0115-00
5	134940-02-700	EA	SWITCH - DUMMY	L0118
11	134940-06-700	EA	PC BOARD - SENSOR SYSTEM/RED	L5131-02

CONTACT WINNEBAGO PART SALES FOR UNLISTED COMPONENT(S)

**ELECTRICAL GROUP (CONTINUED)**  
**COMPONENT PARTS FOR WIRING (CONTINUED)**

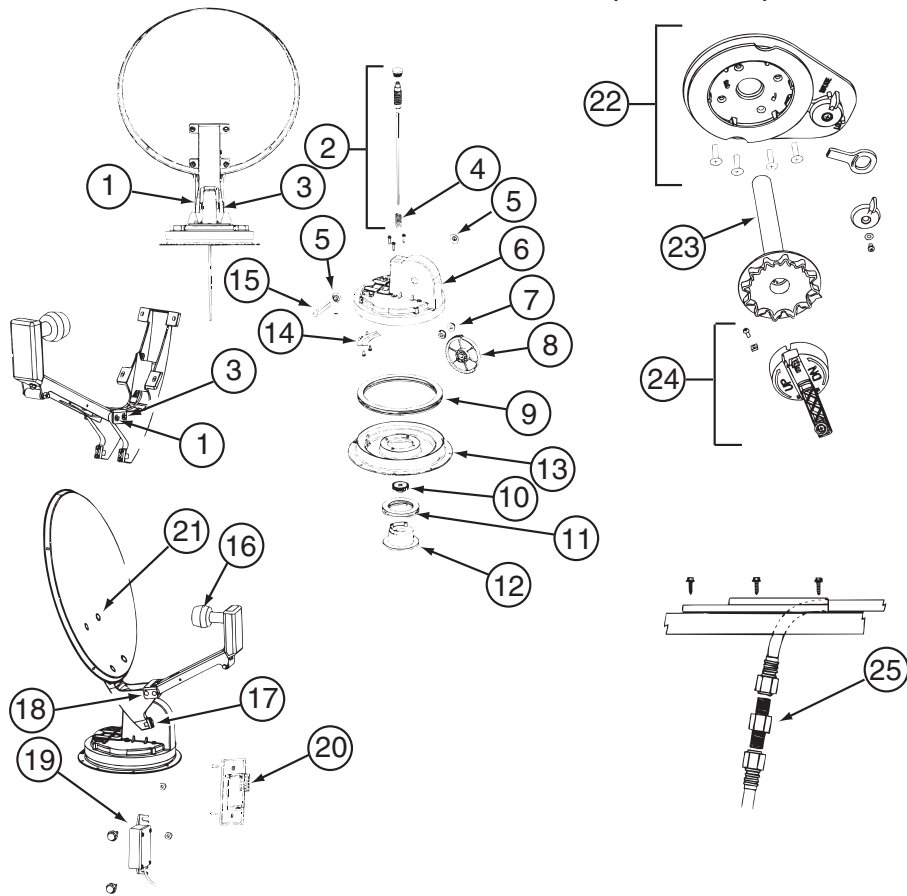

137135-02-000

KEY	PART NUMBER	U/M	DESCRIPTION	VENDOR NO.
1	120233-01-714	EA	CLIP-E	5160818
2	137135-01-703	EA	KIT ELEV - SHAFT/GEAR/SPRING	RP-4400
3	137135-01-704	EA	PIN - 1/4" X 3.25"	2160813
4	137135-01-705	EA	SPRING	2160818
5	137135-01-707	EA	SEAL - PIVOT SHAFT	2200852
6	137135-01-708	EA	TURRET	3100728
7	137135-01-709	EA	PIVOT BEARING	2200470
8	137135-01-711	EA	GEAR - ELEVATING	2200464
9	137135-01-712	EA	BEARING - OUTER	2590347
10	137135-01-714	EA	GEAR - ELEVATING SHAFT	2200465
11	137135-01-715	EA	BEARING - INNER	2590348
12	137135-01-716	EA	HUB	3100731
13	137135-01-713	EA	TURRET BASE	3100730
14	137135-01-710	EA	PLATE - ROTATE LIMIT	3720052
16	137135-02-703	EA	LOW NOISE BLOCK FILTER	LB-6000 - DUAL
17	137135-01-722	EA	CLAMP	2590343
18	137135-01-719	EA	BRACKET - PIVOT	2744945
19	137135-01-720	EA	DE-SENSOR UNIT W/43" CABLE	DM4000
20	137135-02-701	EA	BOX - SURFACE MOUNT	SM-100
21	137135-01-717	EA	BOLT - FLAT HEAD	2160362
22	120233-01-737	EA	PLATE/INT-W/DIRECTIONAL HDLE	RK-CEIL
23	120233-01-704	EA	DIAL/DIRECTIONAL 4"W/SPRING	3200364
24	120233-01-738	EA	HDW PKG-HANDLE/SPRING/WASHER	RK-HAND
25	137135-01-701	EA	CONNECTOR - F - MALE TO MALE	FS-8100
	120233-04-700	EA	KIT-WALL PLATE/CABLE - GRAY	DM4000
	137135-01-700	EA	ROOF WEDGE W/GASKET	RW-5000
	137135-01-706	EA	KIT-TURRET/SEAL/BEARING/GEAR	RP-RM30
	137135-01-718	EA	REFLECTOR/WHITE-46CM W/HDW	RP-35RM
	137135-02-700	EA	DE-SENSOR	2780096
	137135-02-704	EA	KIT-UPDATE DIRECTIONAL HDL	RP-RMDH
	137135-02-705	EA	KIT-TURRET & SHAFT COMPLETE	RP-RM46

CONTACT WINNEBAGO PART SALES FOR UNLISTED COMPONENT(S)

**ELECTRICAL GROUP (CONTINUED)**  
**COMPONENT PARTS FOR WIRING (CONTINUED)**

<b>137417-01-01A, 137417-03-01A</b>			
<b>KEY</b>	<b>PART NUMBER</b>	<b>U/M DESCRIPTION</b>	<b>VENDOR NO.</b>
	137417-01-700	EA LENS - SINGLE (FROSTED)	810868
<b>137417-02-01A</b>			
<b>KEY</b>	<b>PART NUMBER</b>	<b>U/M DESCRIPTION</b>	<b>VENDOR NO.</b>
	137417-02-700	EA LENS - SINGLE OPTIC	810844
<b>137417-05-01A</b>			
<b>KEY</b>	<b>PART NUMBER</b>	<b>U/M DESCRIPTION</b>	<b>VENDOR NO.</b>
	137417-05-700	EA LENS - DOUBLE OPTIC	810845
<b>137417-06-01A</b>			
<b>KEY</b>	<b>PART NUMBER</b>	<b>U/M DESCRIPTION</b>	<b>VENDOR NO.</b>
	137417-06-700	EA LENS - DOUBLE WHITE	810867
<b>146298-02-000</b>			
<b>KEY</b>	<b>PART NUMBER</b>	<b>U/M DESCRIPTION</b>	<b>VENDOR NO.</b>
	146298-02-700	EA REMOTE - TV	1-478-707-11
<b>155619-01-000</b>			
<b>KEY</b>	<b>PART NUMBER</b>	<b>U/M DESCRIPTION</b>	<b>VENDOR NO.</b>
	155619-01-700	EA REMOTE	RC3200
<b>156413-01-01A</b>			
<b>KEY</b>	<b>PART NUMBER</b>	<b>U/M DESCRIPTION</b>	<b>VENDOR NO.</b>
	156413-01-700	EA REMOTE	REMAWM950
<b>158703-01-000</b>			
<b>KEY</b>	<b>PART NUMBER</b>	<b>U/M DESCRIPTION</b>	<b>VENDOR NO.</b>
	158703-01-700	EA REMOTE	PSVCJE2043
<b>158836-01-000</b>			
<b>KEY</b>	<b>PART NUMBER</b>	<b>U/M DESCRIPTION</b>	<b>VENDOR NO.</b>
	158836-01-700	EA REMOTE	STS71WREM

## ELECTRICAL GROUP (CONTINUED)

### CIRCUIT BREAKERS, FUSES & RELAYS

KEY	PART NUMBER	U/M	DESCRIPTION
	008235-01-000	EA	FUSE - 15 AMP/12VOLT - AUTOMOTIVE
	062901-02-000	EA	FUSE - 5 AMP - AUTOMOTIVE
	062901-04-000	EA	FUSE - 10 AMP - AUTOMOTIVE
	062901-05-000	EA	FUSE - 15 AMP - AUTOMOTIVE
	062901-06-000	EA	FUSE - 20 AMP - AUTOMOTIVE
	062901-07-000	EA	FUSE - 25 AMP - AUTOMOTIVE
	062901-08-000	EA	FUSE - 30 AMP - AUTOMOTIVE
	063910-01-000	EA	HOUSING - RELAY
	063912-02-000	EA	RELAY - CANISTER - SPDT
	083209-01-000	EA	CIRCUIT BREAKER - 15 AMP - 120 VOLT - CANADIAN
	083209-02-000	EA	CIRCUIT BREAKER - 15/15 AMP - 120 VOLT
	083209-03-000	EA	CIRCUIT BREAKER - 15/20 AMP - 120 VOLT
	083209-04-000	EA	CIRCUIT BREAKER - 30 AMP - 120 VOLT
	083209-05-000	EA	CIRCUIT BREAKER - 20 AMP - 120 VOLT
	083209-06-000	EA	CIRCUIT BREAKER - 30/15 AMP - 120 VOLT
	083209-07-000	EA	CIRCUIT BREAKER - 20/20 AMP - 120 VOLT
	083209-10-000	EA	CIRCUIT BREAKER - 20/30 AMP - 120 VOLT
	083209-11-000	EA	CIRCUIT BREAKER - 20/15 AMP - 120 VOLT
	092786-03-000	EA	BUSS BAR - 6.9" LONG
	092786-06-000	EA	BUSS BAR
	093654-01-000	EA	CIRCUIT BREAKER - 6 AMP - 12 VOLT - PUSH BUTTON - WHITE
	093654-02-000	EA	CIRCUIT BREAKER - 15 AMP - 12 VOLT - PUSH BUTTON - WHITE
	093654-03-000	EA	CIRCUIT BREAKER - 20 AMP - 12 VOLT - PUSH BUTTON - WHITE
	093655-01-000	EA	CIRCUIT BREAKER - 25 AMP - 12 VOLT - PUSH BUTTON - WHITE
	093655-02-000	EA	CIRCUIT BREAKER - 30 AMP - 12 VOLT - PUSH BUTTON - WHITE
	093655-03-000	EA	CIRCUIT BREAKER - 40 AMP - 12 VOLT - PUSH BUTTON - WHITE
	097611-01-000	EA	CIRCUIT BREAKER - 10 AMP
	100341-01-000	EA	FUSE HOLDER - IN LINE TYPE
	113482-01-000	EA	CIRCUIT BREAKER - 55 AMP - MANUAL
	115187-01-000	EA	FUSE - 300 AMP - NON-DELAY
	115187-02-000	EA	HOLDER - FUSE
	115187-03-000	EA	FUSE - 60 AMP - NON-DELAY
	122811-01-000	EA	CIRCUIT BREAKER - 20/50/50/20 AMP - 250V
	125986-02-000	EA	FUSE - 5 AMP - AUTO - MINI BLADE
	125986-05-000	EA	FUSE - 15 AMP - AUTO - MINI BLADE
	141789-01-000	EA	SPACER - CIRCUIT BREAKER

### CONVERTER, INVERTER, LOAD CENTERS

KEY	PART NUMBER	U/M	DESCRIPTION
	099048-04-000	EA	INVERTER - 300 WATT

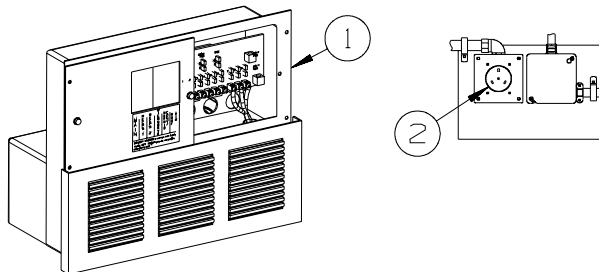

KEY	PART NUMBER	U/M	DESCRIPTION
1*	083208-07-000	EA	CONTROL CENTER - 45 AMP - 120V/12V - W/O BREAKERS
2	024924-02-000	EA	RECEPTACLE - POWER CORD - W/PARTIAL PLATE

\*COMPONENT PARTS LISTED LATER IN THIS GROUP

### COMPONENT PARTS FOR CONVERTER, INVERTER, LOAD CENTERS

**083208-07-000**

KEY	PART NUMBER	U/M	DESCRIPTION	VENDOR NO.
	083208-06-701	EA	CONVERTER ONLY (LOWER UNIT)	7345R

## ELECTRICAL GROUP (CONTINUED)

### BOXES & CORDS

KEY	PART NUMBER	U/M	DESCRIPTION
	008054-01-000	EA	CORD - POWER - 10/3 WIRE - 30 AMP - 25'
	115832-01-000	FT	CORD - HEAVY DUTY - 14-2 W/GROUND
	008289-01-000	EA	BOX - ELECTRIC/STEEL - 4" X 4" - 1/2" & 3/4" KNOCKOUTS
	091910-01-000	EA	BOX - ELECTRIC - 3.8" X 3.5" X 1.8" - PLASTIC
	091910-02-000	EA	BOX - ELECTRIC - 2.2" X 3.5" X 1.8" - PLASTIC
	131679-01-000	EA	BOX/ELECTRIC-WATERPROOF-4" X 4" - W/4 3/4"OUTLETS-UL/CSA
	133070-01-000	EA	BOX - ELECTRIC/PLASTIC - 3" X 2" X 2.8" - UL
	133070-02-000	EA	BOX - ELECTRIC/PLASTIC - 3" X 2" X 2.8" - CSA
	008294-01-000	EA	COVER - ELECTRIC BOX - BLANK/STEEL - 4" X 4" - GRAY
	069238-01-000	EA	COVER - ELECTRICAL BOX - W/HOLE - 4" X 4" - GRAY
	131680-01-000	EA	COVER - F/ELECTRIC BOX W/GASKET 4" X 4" - UL/CSA

### WIRE ASSEMBLIES

KEY	PART NUMBER	U/M	DESCRIPTION
	077069-02-000	EA	CABLE/EXTENSION - RADIO ANTENNA - 96"
	077069-03-000	EA	CABLE/EXTENSION - RADIO ANTENNA - 260"
	106851-01-000	EA	WIRE ASSEMBLY - RUNNING LIGHTS - FUSE
	116894-01-000	EA	WIRE ASSEMBLY - SPEED SENSOR EXTENDED
			FROM: 00-00-00 THRU: 12-20-06
	116894-01-000	EA	WIRE ASSEMBLY - SPEED SENSOR EXTENDED
			FROM: 12-21-06 THRU: 99-99-99
	134551-06-000	EA	WIRE ASSEMBLY - HEATER/TANKS - 3 PAD -196.5"(LONGEST WIRE)
	134551-08-000	EA	WIRE ASSEMBLY - HEATER/TANKS - 2 PAD -216.2"(LONGEST WIRE)
	134551-10-000	EA	WIRE ASSEMBLY - HEATER/TANKS - 2 PAD -167.1"(LONGEST WIRE)
	151316-03-000	EA	WIRE ASM - W/NON CONTACT SENSORS - GREY WATER - 43.2"
	151316-04-000	EA	WIRE ASM - W/NON CONTACT SENSORS - GREY WATER - 62.9"
	151316-06-000	EA	WIRE ASM - W/NON CONTACT SENSORS - GREY WATER - 78.6"
	151317-01-000	EA	WIRE ASM-W/NON CONTACT SENSORS-FRESH WATER/BLK TANK-3.9"
	151317-02-000	EA	WIRE ASM-W/NON CONTACT SENSORS-FRESH WATER/BLK TANK-23.6"
	151317-03-000	EA	WIRE ASM-W/NON CONTACT SENSORS-FRESH WATER/BLK TANK-43.2"
	155619-05-000	EA	WIRE ASSEMBLY - RADIO - 12 PIN
			FROM: 08-02-06 THRU: 99-99-99
	157475-01-000	EA	WIRE ASSEMBLY - CLEARANCE LAMPS
	157476-01-000	EA	WIRE ASSEMBLY - TAILLAMPS
	120269-08-000	EA	HARNESS/WIRE - F/ELECTRIC MIRRORS
	137135-04-000	EA	WIRE HARNESS - POWER - DIGITAL ELEVATION SENSOR
	125853-04-000	EA	WIRE LOOM - ENTERTAINMENT CENTER
	137135-03-000	EA	WIRE LOOM - DIGITAL ELEVATION SENSOR
	142258-02-000	EA	WIRE LOOM - VIDEO SWITCH/POWER SUPPLY
	135420-17-000	EA	WIRE - RADIO - C FORD - 4 PIN
	145210-01-000	FT	CABLE - COAXIAL

**ELECTRICAL GROUP (CONTINUED)**  
**CONNECTORS & CONDUIT**

KEY	PART NUMBER	U/M	DESCRIPTION
	007940-01-000	EA	RECEPTACLE/SLIDE 16 TO 12 AWG - FEMALE END
	007940-02-000	EA	RECEPTACLE/SLIDE 10 AWG
	007954-01-000	EA	RECEPTACLE - HOUSING - 6 POSITION
	007956-05-000	EA	INSULATOR - SHRINK - 1/4"ID X 1 1/2"
	008058-01-000	EA	ADAPTER - POWER CORD - 30 AMP TO 15 AMP
	008311-01-000	EA	CONNECTOR - WIRE NUT - INSULATED - RED
	008312-01-000	EA	CONNECTOR - WIRE NUT - INSULATED - BLUE
	008313-01-000	EA	CONNECTOR - WIRE NUT - INSULATED - YELLOW
	008314-01-000	EA	CONNECTOR - WIRE NUT - INSULATED - GRAY
	008328-01-000	EA	TERMINAL - RING - 12/10 WIRE - #10 STUD FIT
	008331-01-000	EA	TERMINAL - RING - TONGUE - #4 WIRE - 3/8" STUD - COPPER
	008348-01-000	EA	TERMINAL - RING - 3/8" STUD 2 GA. WIRE
	008355-01-000	EA	CONNECTOR - CABLE CLAMPING - 3/4"
	008356-01-000	EA	CONNECTOR - PLASTIC - 3/8"
	008356-02-000	EA	CONNECTOR - PLASTIC - 21/32"
	008398-01-000	EA	CONNECTOR - 1/2" X 90 DEGREE - FLEX CONDUIT - UL & CSA
	035416-04-000	EA	TERMINAL - RING - #10 STUD FIT - INSULATED BARREL #16/14
	041953-01-000	FT	CONDUIT - CONVOLUTE SLIT - .5" ID - POLYETHYLENE
	041953-02-000	FT	CONDUIT - CONVOLUTE SLIT - .6" ID - POLYETHYLENE
	041953-03-000	FT	CONDUIT - CONVOLUTE SLIT - 1" ID (CLOTHES ROD COVER)
	041953-06-000	FT	CONDUIT - CONVOLUTE SLIT - .4" ID - POLYETHYLENE
	041953-07-000	FT	CONDUIT - CONVOLUTE SLIT - .25" ID - POLYETHYLENE
	041953-08-000	FT	CONDUIT - CONVOLUTE SLIT - 1.5" ID - POLYETHYLENE
	041953-09-000	FT	CONDUIT - CONVOLUTE SLIT - .5" ID - NYLON
	041953-10-000	FT	CONDUIT - CONVOLUTE SLIT - .75" ID - NYLON
	041953-11-000	FT	CONDUIT - CONVOLUTE SLIT - 1.06" ID - NYLON
	041953-12-000	FT	CONDUIT - CONVOLUTE SOLID - 1.1" ID - NYLON
	041953-13-000	FT	CONDUIT - CONVOLUTE SLIT - 1.25" ID
	041953-14-000	FT	CONDUIT - CONVOLUTE SLIT - 1.5" ID
	041953-15-000	FT	CONDUIT - CONVOLUTE SLIT - 2"
	041953-16-000	FT	CONDUIT - CONVOLUTE SLIT - 2"
	047441-01-000	EA	TERMINAL-BATTERY, HORIZONTAL LUG
	047443-01-000	EA	TERMINAL - .250 RECEPTACLE FIT - INSULATED - 16/14 AWG
	047443-02-000	EA	TERMINAL - .250 RECEPTACLE FIT - INSULATED - 12/10 AWG
	047443-05-000	EA	TERMINAL - .250 RECEPTACLE FIT - 18GA AWG
	058028-01-000	EA	CONNECTOR - ELECTRICAL PIGTAIL - NYLON - CLEAR
	062036-01-000	EA	TERMINAL - PACK - CON - 12/10 AWG
	076319-12-000	EA	CONNECTOR - COAXIAL - ONE PIECE
	077479-01-000	EA	BOOT - BATTERY TERMINAL - DOUBLE CABLE
	077479-02-000	EA	BOOT - BATTERY TERMINAL - SINGLE CABLE
	080015-02-000	EA	RECEPTACLE - FLAG - .185 - 16/14 GAUGE
	080015-03-000	EA	RECEPTACLE - FLAG - .250 - 14/16 GAUGE
	080015-04-000	EA	RECEPTACLE - FLAG - .187 - 16/14 GAUGE
	082109-01-000	EA	HOUSING - CONNECTOR - PACKARD
	082741-01-000	EA	CONNECTOR BODY - 2 CONNECTOR MALE
	087225-01-000	FT	SLEEVING - 1/2" - TYPE H
	088473-01-000	EA	HOUSING - PIN - 12 CAVITY (3 ROWS OF 4)
	088473-02-000	EA	HOUSING - PIN - 15 CAVITY (3 ROWS OF 5)
	088473-03-000	EA	HOUSING - PIN - 9 CAVITY (3 ROWS OF 3)
	088473-04-000	EA	HOUSING - PIN - 8 CAVITY IN-LINE
	088473-06-000	EA	HOUSING - PIN - 6 CAVITY (2 ROWS OF 3)
	088473-07-000	EA	HOUSING - PIN - 5 CAVITY - IN-LINE
	088473-08-000	EA	HOUSING - PIN - 4 CAVITY - IN-LINE
	088473-09-000	EA	HOUSING - PIN - 3 CAVITY - IN-LINE
	088473-10-000	EA	HOUSING - PIN - 2 CAVITY - IN-LINE
	088473-12-000	EA	HOUSING - PIN - 3 CAVITY - BLUE
	088473-13-000	EA	HOUSING - PIN - 3 CAVITY - GREEN
	088473-14-000	EA	HOUSING - PIN - 3 CAVITY - RED
	088474-01-000	EA	HOUSING - SOCKET - 12 CAVITY
	088474-02-000	EA	HOUSING - SOCKET - 15 CAVITY
	088474-03-000	EA	HOUSING - SOCKET - 9 CAVITY
	088474-06-000	EA	HOUSING - SOCKET - 6 CAVITY
	088474-07-000	EA	HOUSING - SOCKET - 5 CAVITY
	088474-08-000	EA	HOUSING - SOCKET - 4 CAVITY



**ELECTRICAL GROUP (CONTINUED)**  
**CONNECTORS & CONDUIT (CONTINUED)**

KEY	PART NUMBER	U/M	DESCRIPTION
	088474-09-000	EA	HOUSING - SOCKET - 3 CAVITY
	088474-10-000	EA	HOUSING - SOCKET - 2 CAVITY
	088475-01-000	EA	PIN - CONNECTOR - 14-20 AWG
	088475-02-000	EA	PIN - CONNECTOR - 10-12 AWG
	088476-01-000	EA	TERMINAL - ELECTRICAL
	088476-02-000	EA	SOCKET - CONNECTOR - 12-10 GA - PRE-TIN
	098261-01-000	EA	SOCKET - CONNECTOR - WEATHERPACK - 12 AWG
	098261-02-000	EA	SOCKET - CONNECTOR - WEATHERPACK - 14-18 AWG
	098262-01-000	EA	SEAL - CONNECTOR - WEATHERPACK
	098264-01-000	EA	HOUSING - 2 PIN - WEATHER PACK - MALE W/FEMALE PINS
	098264-02-000	EA	HOUSING - 2 PIN - WEATHER PACK - FEMALE W/MALE PINS
	098265-02-000	EA	PIN - CONNECTOR - WEATHER PACK
	102777-02-000	EA	TERMINAL - RING - #6 STUD - 10 AWG
	103608-01-000	EA	SOCKET - WEDGE BASE W/LEADS
	104100-01-000	EA	HOUSING - 1 POSITION - 75 AMPS
	104100-03-000	EA	TERMINAL - 75 AMP
	106007-02-000	EA	TERMINAL - FEMALE - 10-12 AWG
	110178-01-000	EA	HOUSING - WIPER MOTOR
	112823-01-000	EA	SPLICE - REDUCER - 16-14 TO 18-22
	113072-02-000	EA	HOUSING - ELECTRICAL - BACK-UP/TAIL LAMP
	113072-03-000	EA	HOUSING - ELECTRICAL - STOP/MARKER TAILLAMP
	113073-01-000	EA	WEDGELOCK - HOUSING - TAIL LAMP
	113074-01-000	EA	TERMINAL - TAILLAMP
	113135-01-000	EA	TERMINAL - FEMALE - M/P - 14-16 - F/SEALED TERMINAL
	113308-01-000	EA	TERMINAL - FEMALE - M/P - 14-16 - 280
	113308-02-000	EA	TERMINAL - FEMALE - M/P - 14-18 - 280
	113468-01-000	EA	HOUSING - 2 POSITION-FEMALE-USED ON WIPER/WASHER WIRE ASM
	113468-02-000	EA	HOUSING - 2 POSITION - FEMALE
	115931-02-000	EA	COVER - CONNECTOR - 50 AMP W/LOCKING RING
	115932-02-000	EA	CONNECTOR - FEMALE - 50 AMP/240 VOLT
	116811-01-000	EA	TERMINAL - .110 RECEPTACLE - 16-14 AWG
	118571-01-000	EA	CONNECTOR - 3-WAY - MALE/SEALED
	118571-02-000	EA	CONNECTOR - 3-WAY - FEMALE/SEALED
	118571-05-000	EA	LOCK - SECONDARY - FEMALE
	118571-06-000	EA	LOCK - SECONDARY - MALE
	118599-02-000	EA	TERMINAL - MALE - M/P - 280/14-12
	118820-01-000	EA	INSULATOR - TERMINAL
	129233-01-000	EA	HOUSING - 2-POSITION/FEMALE - 280-SERIES
	129233-02-000	EA	HOUSING - 2-POSITION/FEMALE - 280-SERIES
	129233-03-000	EA	HOUSING - 2-POSITION/FEMALE - 280-SERIES
	131681-01-000	EA	CONNECTOR - 3/4" SO CORD - UL/CS
	137207-01-000	EA	HOUSING - PIN - 2 CAVITY/HIGH AMP
	137208-01-000	EA	HOUSING - SOCKET - 2 CAVITY/HIGH AMP
	137209-01-000	EA	PIN - CONNECTOR - 10AWG/HIGH AMP
	137210-01-000	EA	SOCKET - CONNECTOR - 10 AWG/HIGH AMP
	138996-04-000	EA	CONNECTOR - LAMP
	142520-01-000	EA	TERMINAL - FEMALE - MINI-FIT 16
	142522-01-000	EA	HOUSING - 4 PIN/MALE - MINI FIT
	142522-02-000	EA	HOUSING - 6 PIN/MALE - MINI FIT
	142522-03-000	EA	HOUSING - 8 PIN/MALE - MINI FIT
	142522-04-000	EA	HOUSING - 10 PIN/MALE - MINI FIT
	142522-05-000	EA	HOUSING - 12 PIN/MALE - MINI FIT
	142522-06-000	EA	HOUSING - 14 PIN/MALE - MINI FIT
	142524-01-000	EA	HOUSING - 4 PIN/FEMALE - WEATHER PACK
	142524-02-000	EA	HOUSING - 4 PIN/FEMALE - WEATHER PACK
	144283-01-000	EA	CONNECTOR - 110V - F/USE WITH SOW WIRE - BLUE
	144283-02-000	EA	CONNECTOR - 110V - F/USE WITH NM ROMEX WIRE - CLEAR
	145171-01-000	EA	CONNECTOR - COAXIAL
	148335-01-000	EA	HOUSING - 8-POSITION/MALE - 280-GT SERIES
	148335-02-000	EA	HOUSING - 4-POSITION/MALE - 280-GT SERIES
	148335-03-000	EA	HOUSING - 6-POSITION/MALE - 280-GT SERIES
	149683-01-000	EA	HOUSING - F/5 CAVITY RECEPTACLE - W/SQUARE GUIDE PIN
	149683-02-000	EA	HOUSING - F/5 CAVITY RECEPTACLE - W/ROUND GUIDE PIN
	149686-01-000	EA	TERMINAL - .250 RECEPTACLE

## ELECTRICAL GROUP (CONTINUED)

### CONNECTORS & CONDUIT (CONTINUED)

KEY	PART NUMBER	U/M	DESCRIPTION
	149687-01-000	EA	HOUSING - 2 POSITION/MALE - PACKARD
	149687-02-000	EA	LOCK - F/2 POSITION HOUSING - PACKARD
	149688-01-000	EA	TERMINAL - MALE - 16 GAUGE WIRE
	156035-01-000	EA	HOUSING - 12-POSITION/FEMALE - 280-GT SERIES
	156041-01-000	EA	TERMINAL - FEMALE - 16-12 - 280-GT SERIES
	156043-01-000	EA	HOUSING - 2-POSITION/FEMALE - 480-MP SERIES
	156043-02-000	EA	LOCK - F/2 POSITION HOUSING - 480 SERIES
	156044-01-000	EA	TERMINAL - FEMALE - 16-12 - 280-GT - F/SEALED HOUSING
	156045-01-000	EA	HOUSING - 10-POSITION/FEMALE - 280-GT SERIES
	156045-02-000	EA	HOUSING - 4-POSITION/FEMALE - 280-GT SERIES
	156045-03-000	EA	HOUSING - 8-POSITION/FEMALE - 280-GT SERIES
	156045-04-000	EA	HOUSING - 6-POSITION/FEMALE - 280-GT SERIES
	156207-01-000	EA	HOUSING - 6-POSITION/MALE - 150-GT SERIES
	156208-01-000	EA	TERMINAL - MALE - 18-16 - 150-GT SERIES
	157590-01-000	EA	TERMINAL - FEMALE - M/P - 10-12 - 630
	157592-01-000	EA	HOUSING - 7-POSITION/FEMAL - M/P
	157592-02-000	EA	LOCK - SECONDARY - F/7 POSITION HOUSING
	157656-01-01A	EA	CONNECTOR - DASH LIGHT - BLACK
	158357-01-000	EA	HOUSING - 3 PIN/MALE - MINI FIT
	158373-01-000	EA	HOUSING - SOCKET - 16 CAVITY - MINI MATE-N-LOCK
	158374-01-000	EA	SOCKET - 16-20 CAVITY - MINI MATE-N-LOCK

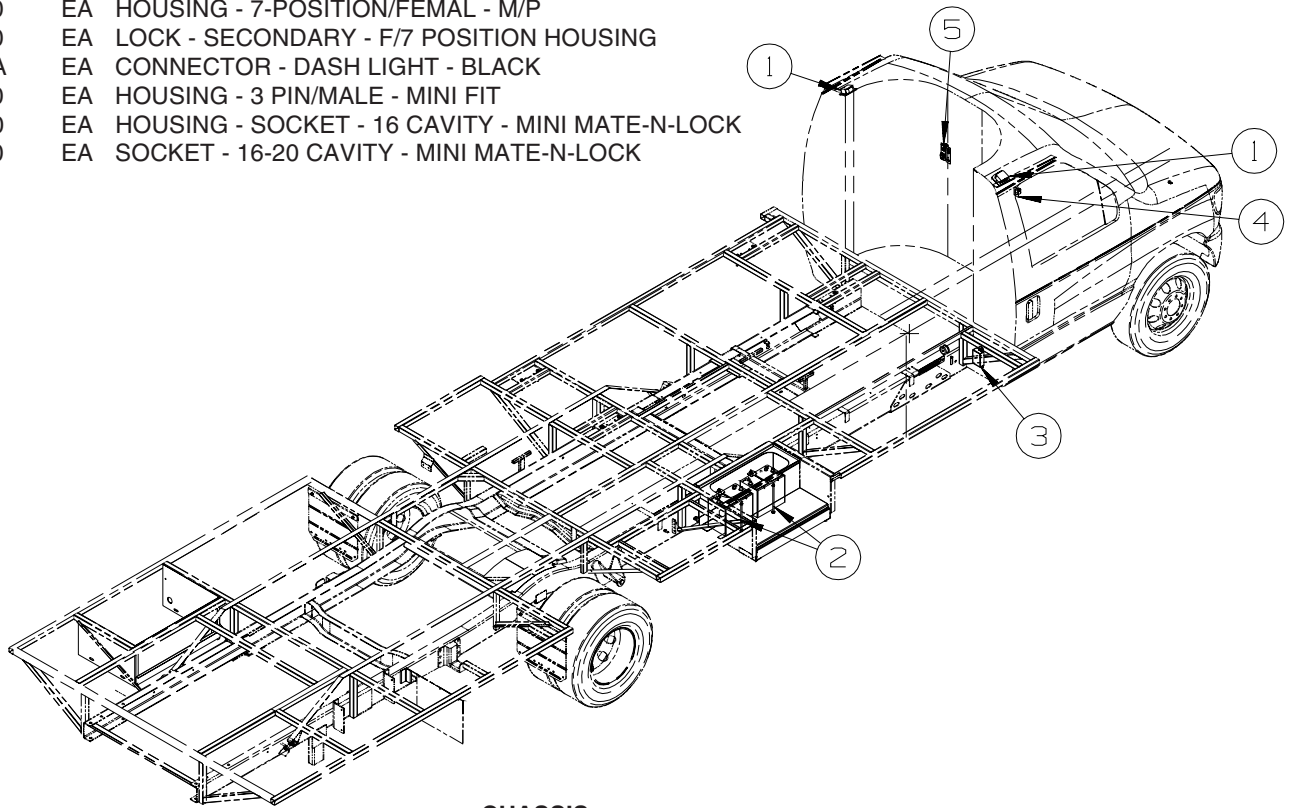

**CHASSIS**

KEY	PART NUMBER	U/M	DESCRIPTION
1	112642-01-06A	EA	TRIM RING - SINGLE LIGHT - BLACK
1	112643-01-000	EA	LIGHT - SINGLE - SWIVEL
2	160014-01-02B	EA	TIEDOWN - BATTERY - E-COATED
3	138173-03-000	EA	MODULE - (CONTROL BOX) - SLIDEOUT CONTROL - #1802930
3	078040-04-000	EA	SHROUD - 8.2"W X 12.6"H X 5.1"D - BLACK
4	145731-03-01A	EA	LABEL - SWITCH - REAR AUTO HEATER - <b>WTR HTR-6GAL/110/LP/MTR/AUTO</b>
4	108357-03-000	EA	SWITCH - ROCKER - SPDT - ON/OFF/ON - 3 TERM - W/O COVER - <b>WTR HTR-6GAL/110/LP/MTR/AUTO</b>
4	108356-02-01A	EA	COVER/ACTUATOR SWITCH - 2 ROWS DIMPLES - BLACK - <b>WTR HTR-6GAL/110/LP/MTR/AUTO</b>
4	108355-01-000	EA	HOUSING - SWITCH - <b>WTR HTR-6GAL/110/LP/MTR/AUTO</b>
4	144363-07-04B	EA	PLATE - SWITCH - BLACK - <b>WTR HTR-6GAL/110/LP/MTR/AUTO</b>
5	145731-01-01A	EA	LABEL - SWITCH - RADIO/BATTERY - BLACK
5	108357-08-000	EA	SWITCH - ROCKER - DPDT - 0N/NONE/ON - 6 TERM - W/O COVER
5	108356-02-01A	EA	COVER/ACTUATOR SWITCH - 2 ROWS DIMPLES - BLACK
5	108355-01-000	EA	HOUSING - SWITCH
5	144363-12-04B	EA	PLATE - SWITCH - BLACK
5	108357-09-000	EA	SWITCH - ROCKER - SPDT - ON/NONE/MOM - 3 TERM - W/O COVER
5	108356-02-01A	EA	COVER/ACTUATOR SWITCH - 2 ROWS DIMPLES - BLACK
5	108355-01-000	EA	HOUSING - SWITCH

**ELECTRICAL GROUP (CONTINUED)**  
**CHASSIS (CONTINUED)**

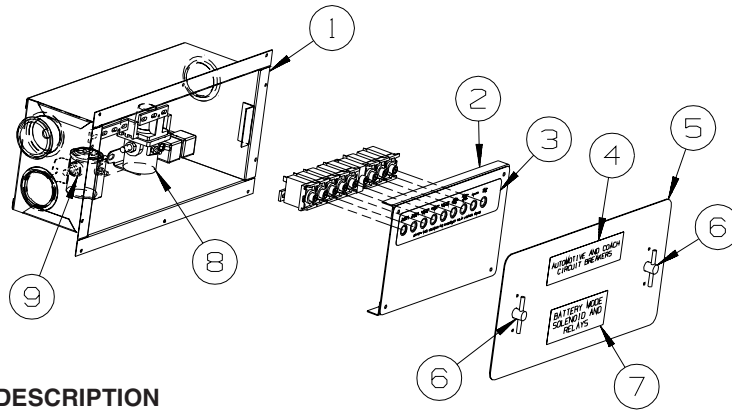

KEY	PART NUMBER	U/M	DESCRIPTION
1	141272-01-02B	EA	BOX - ELECTRICAL - E-COATED
2	139067-04-02B	EA	PLATE - CIRCUIT BREAKER/HOUSE - E-COATED
3	093236-38-000	EA	LABEL - CIRCUIT BREAKER
4	098379-01-000	EA	LABEL - CIRCUIT BREAKER - FRONT BOX
5	141273-01-02B	EA	COVER - ELECTRICAL BOX - E-COATED
5	092492-16-000	EA	SEAL - ELECTRICAL BOX
6	098196-01-000	EA	LATCH - 1/4 TURN - T-BAR
7	098379-04-000	EA	LABEL - ELECTRICAL BOX - SIDE
8	086273-01-000	EA	RELAY - BATTERY DISCONNECT
9	008188-01-000	EA	SOLENOID - 3 POST - BATTERY CHANGE OVER

# EXTERIOR BODY GROUP GRAPHICS & PAINT

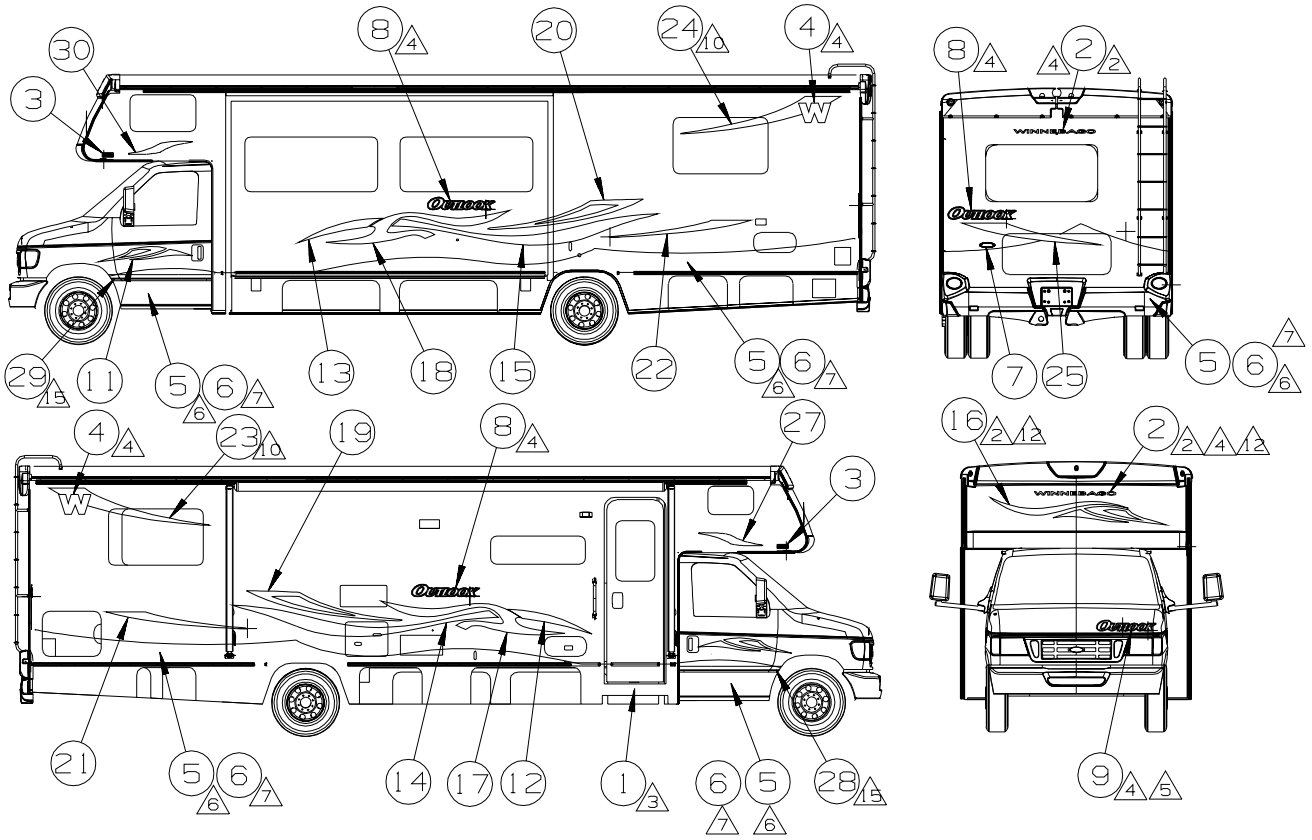

KEY	PART NUMBER	U/M	DESCRIPTION
	109506-01-000	EA	FILM-URETHANE PROTECTANT
	120702-03-CHT (61A)	EA	DECAL-LOGO WINNEBAGO SML - IVY GREEN
	132664-02-CHT (01A)	EA	DECAL-LOGO DOMED WINNEBAGO - CHROME/RED/BLACK
	135361-06-CHT (01A)	EA	DECAL-LOGO W - BRT WHITE/IVY GREEN
△△△ (16H)	.....	EA	PAINT-METALLIC GOLD - SHERWIN WILLIAMS #97757 OR 141599-31-000 DUPONT #373-P7436
△△△ (16F) △△△ (14)	.....	GL	PAINT-CATALINA BLUE MET - SHERWIN WILLIAMS #64136 OR 141599-48-000 DUPONT #373-P758414
6	151687-01-CHT (01A)	EA	DECAL-BEZEL DOMED NAMEPLATE WINNEBAGO - CHROME/RED
7	152952-01-CHT (02A)	EA	DECAL-OUTLOOK LG - BRT WHITE/SLATE GREY/SUNSET
8	152952-02-CHT (01A)	EA	DECAL-OUTLOOK SML - BRT WHITE/SLATE GREY/SUNSET
9	156709-01-CHT (01A)	EA	DECAL-CAB SWEEP RH - IVY GREEN/SUNSET
10	156709-02-CHT (01A)	EA	DECAL-CAB SWEEP LH - IVY GREEN/SUNSET
11	156710-01-CHT (01A)	EA	DECAL-TIP RH - MDR BLUE
12	156710-02-CHT (01A)	EA	DECAL-TIP LH - MDR BLUE
13	156711-01-CHT (01A)	EA	DECAL-SWEEP RH - MDR BLUE
14	156711-02-CHT (01A)	EA	DECAL-SWEEP LH - MDR BLUE
15	156712-01-CHT (01A)	EA	DECAL-OVHD - MDR BLUE/SUNSET/IVY GREEN
16	156713-01-CHT (01A)	EA	DECAL-MID RH - IVY GREEN
17	156713-02-CHT (01A)	EA	DECAL-MID LH - IVY GREEN
18	156714-01-CHT (01A)	EA	DECAL-ARC RH - SUNSET
19	156714-02-CHT (01A)	EA	DECAL-ARC LH - SUNSET
20	156715-01-CHT (01A)	EA	DECAL-ARC LWR RH - GOLD
21	156715-02-CHT (01A)	EA	DECAL-ARC LWR LH - GOLD
22	156716-01-CHT (01A)	EA	DECAL-ARC UPPER RH - GOLD/SUNSET
23	156716-02-CHT (01A)	EA	DECAL-ARC UPPER LH - GOLD/SUNSET
24	156717-01-CHT (01A)	EA	DECAL-ARC RR - GOLD/SUNSET
25	.....	GL	PAINT-CLEAR COAT - SHERWIN WILLIAMS
26	160518-01-CHT (01A)	EA	DECAL-OVERHEAD RH - MED DK ROYAL BLUE
27	160732-01-CHT (01A)	EA	DECAL-PAINT PROTECT FILM WINGALL FORD RH - CLEAR
28	160732-02-CHT (01A)	EA	DECAL-PAINT PROTECT FILM WINGALL FORD LH - CLEAR
29	160518-02-CHT (01A)	EA	DECAL-OVERHEAD LH - MED DK ROYAL BLUE
30	160732-03-CHT (01A)	EA	DECAL-PAINT PROTECT FILM WINGALL CHEVY RH - CLEAR
31	160732-04-CHT (01A)	EA	DECAL-PAINT PROTECT FILM WINGALL CHEVY LH - CLEAR
32	.....	EA	DECAL-PAINT PROTECT FILM WINGALL CHEVY LH - CLEAR

△△ DO NOT INSTALL WINNEBAGO DECALS ON FRONT BUNK FOR FEATURE #645. PUT IN BULK PACKAGE AND SHIP TO DEALERSHIP. MOTURIS DECALS SUPPLIED BY DEALER WILL BE INSTALLED IN THEIR PLACE. ALL OTHER PARTS ARE THE SAME AS OUTLOOK.

△△ ADD MOTURIS DECALS, SUPPLIED BY DEALER, FOR FEATURE #645. LOCATE ON REAR OF UNIT NEXT TO WINDOW (RIGHT SIDE).

△△ USE FLAT STRAIGHT EDGE OF DECAL WITH FLAT STRAIGHT EDGE OF FEATURE TRIM, TO ALIGN DECAL VERTICALLY. (3RD DIM WILL NOT BE NEEDED).

9. NO VINYL OR PAINT ON SLIDEOUT ROOM END PANELS.

△△ OPTIONAL PAINT.

△△ PAINTED AREA IS TO BE BELOW FEATURE STRIP FOR OPTIONAL PAINTED MODELS & CONTINUES ON CAB DOORS TO WHEEL WELL.

△△ CLEAR COAT TO BE APPLIED ON PAINTED AREAS TO PROTECT PAINT.

△△ LOCATE DECAL 120 MM LEFT OF HOOD EDGE AND 60 MM UP FROM FRONT EDGE OF HOOD.

△△ LOGO IS TO BE ±1 MM ON A HORIZONTAL PLANE (END TO END).

△△ FILM TO PROTECT BOTTOM OF DOOR FROM SCUFF MARKS.

△△ CENTERED ON UNIT.

1. APPLY PROTECTOR 116424-01-000 TO WATER HEATER DOOR LATCH.

△△△ (64B) RENTAL - MOTURIS

(16F) EXT PAINT #1 W/FBGLS BOARDS

(16H) EXT PAINT #2 W/FBGLS BOARDS

(276) EXTERIOR GRAPHICS PACKAGE #1

△△ UNITS WITH OPT PAINT WILL USE PAINT MASK, UNITS BUILT IN C.C. CDI PAINT MASK WILL BE CUT FROM RAW MATERIAL; UNITS BUILT IN F.C. CDI WILL SUPPLY PAINT MASK CUT FROM RAW MATERIAL.

△△ REFER TO UNIT BUILD SCHEDULE TO DETERMINE BRAND OF PAINT TO BE USED. WHEN BUILT IN CC CDI PAINT USED IS SHERWIN WILLIAMS. WHEN BUILT IN FC PAINT USED IS DUPONT.

13. ENTIRE RUNNING BOARD WHEEL WELL TRIM IS TO BE PAINTED ON OPT PAINT UNITS.

**DUPONT COLOR CODES ARE NOW FOUND IN THE PAINT CODE MANUAL.  
YOU CAN FIND THIS MANUAL ON YOUR DEALER INDEX WEBPAGE UNDER SERVICE.**

# EXTERIOR BODY GROUP (CONTINUED)

## PANELS & TRIMS

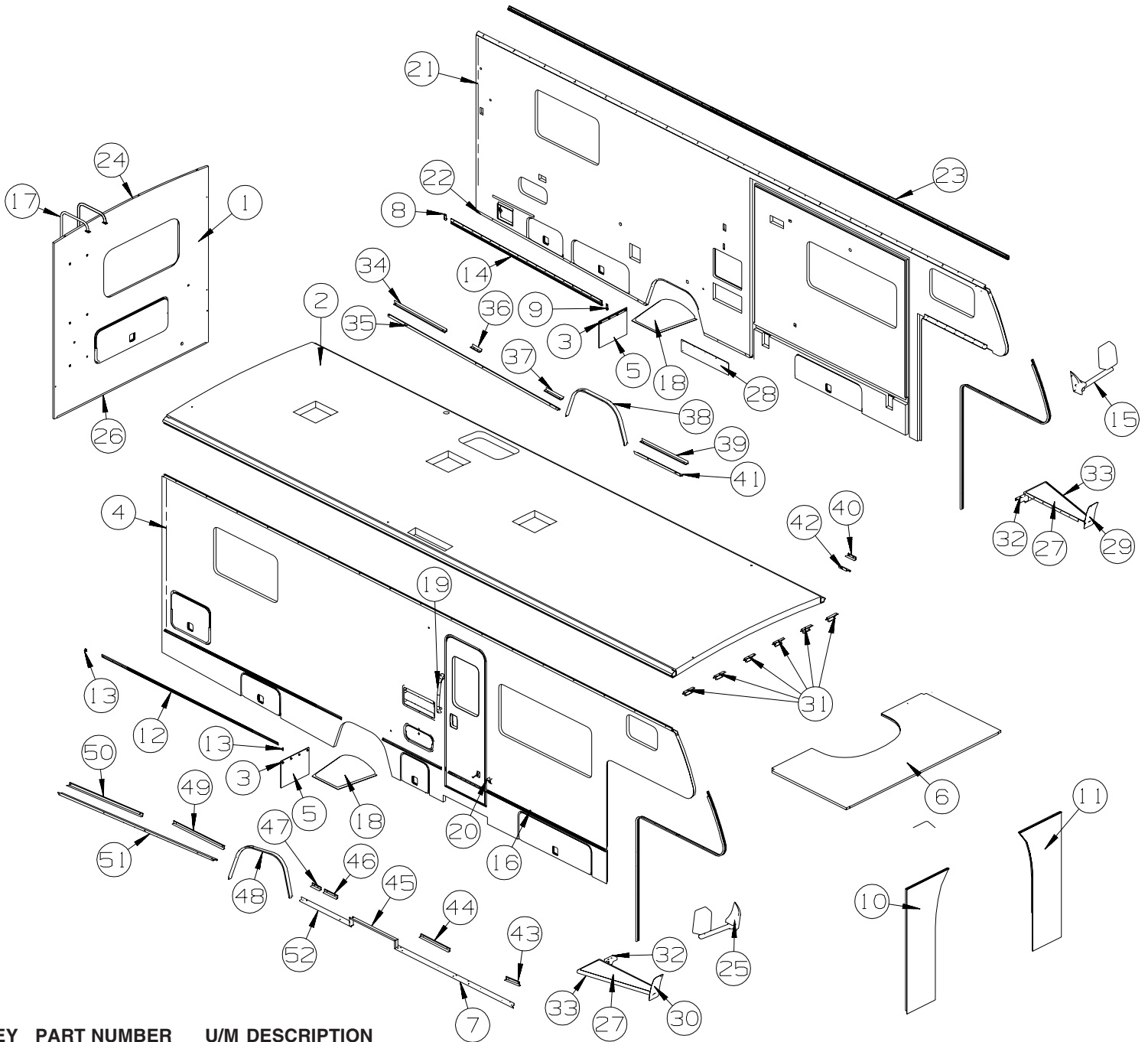

KEY	PART NUMBER	U/M	DESCRIPTION
1	155683-01-U21	EA	BACKWALL - W/O WINDOW/TRIMS (U21, U22)
1	155683-01-U23	EA	BACKWALL - W/O WINDOW/TRIMS (U23, U24)
1	155683-01-U25	EA	BACKWALL - W/O WINDOW/TRIMS (U25, U26)
1	155683-02-U21	EA	BACKWALL - W/O WINDOW/TRIMS (U21, U22) - DUAL PANE WINDOW
1	155683-02-U23	EA	BACKWALL - W/O WINDOW/TRIMS (U23, U24) - DUAL PANE WINDOW
1	155683-02-U25	EA	BACKWALL - W/O WINDOW/TRIMS (U25, U26) - DUAL PANE WINDOW
2	158409-01-U21	EA	ROOF - W/O LIGHTS/VENTS - W/WIRING
3	140922-01-02B	EA	RETAINER - MUD FLAP - 1" X 17.7" - E-COATED/BLACK
4	P57214-01-U21	EA	SIDEWALL - PASSENGER - W/O WINDOWS/TRIMS (U21, U22)
4	P57214-01-U23	EA	SIDEWALL - PASSENGER - W/O WINDOWS/TRIMS (U23, U24)
4	P57214-01-U25	EA	SIDEWALL - PASSENGER - W/O WINDOWS/TRIMS (U25, U26)
5	017516-01-000	EA	MUD FLAP - 14"H X 18"W - W/O MOUNTING HOLES - RUBBER - BLK
	107865-02-000	EA	ROD - SUPPORT - VALANCE PANEL - 13.2" - NOT ILLUSTRATED
6	156387-01-U21	EA	SLEEPERBOARD
7	148760-53-01A	EA	TRIM - ROCKER - NOTCHED - 75.6" - BRIGHT WHITE
8	151219-01-01A	EA	CAP - TRIM/SIDEWALL - RIGHT HAND - MILL FINISH
9	151219-02-01A	EA	CAP - TRIM/SIDEWALL - LEFT HAND - MILL FINISH

FROM: 00-00-00 THRU: 10-16-06

**EXTERIOR BODY GROUP (CONTINUED)**  
**PANELS & TRIMS (CONTINUED)**

KEY	PART NUMBER	U/M	DESCRIPTION
10	159600-01-T11	EA	WINGWALL
11	159600-02-T11	EA	WINGWALL
12	108688-06-03A	EA	STRIP - FEATURE - W/O INSERT/END CAPS - 96.9" - BRIGHT WHT
13	108651-01-01A	EA	END CAP - FEATURE STRIP
14	150188-02-01A	EA	TRIM/HINGE - SIDEWALL - 135.4" - BRIGHT WHITE
15*	133908-11-01A	EA	MIRROR/DRVR - 102" C BODY/FORD 4-BOLT MT - BRIGHT WHITE
15*	133908-13-01A	EA	MIRROR/DRVR - 102" C BODY/FORD 4-BOLT MT-HEATED/RMT-B/W - MIRRORS-EXTER W/DEFROST
16	153498-01-01A	EA	BUMPER - RUBBER - WHITE
17	152869-02-01A	EA	LADDER/FOLDING - 78.6"/129.7" - 10 STEP - BRUSHED ALUMINUM
18	112435-03-000	EA	WHEELWELL
19	152854-01-01A	EA	HANDLE - ASSIST - WHITE W/BLACK RUBBER GRIP - 18 5/8"
20	117046-02-000	EA	BUMPER - RUBBER/ROUND END - 1.5"
21	P57213-01-U21	EA	SIDEWALL - DRIVER - W/O WINDOWS/TRIMS (U21, U22)
21	P57213-01-U23	EA	SIDEWALL - DRIVER - W/O WINDOWS/TRIMS (U23, U24)
21	P57213-01-U25	EA	SIDEWALL - DRIVER - W/O WINDOWS/TRIMS (U25, U26)
22	104692-01-000	FT	SEAL - ADHESIVE BACKED FOAM - 3/4" THICK X 3/4" WIDE X 25'
23	157284-01-01A	EA	RAIL - AWNING - 192" - BRIGHT WHITE
24	114248-02-04A	EA	ANGLE - PLASTIC - .7" X .4" X 96.7" - BEIGE
25*	133908-10-01A	EA	MIRROR/PASS - 102" C BODY/FORD 4-BOLT MT - BRIGHT WHITE
25*	133908-12-01A	EA	MIRROR/PASS - 102" C BODY/FORD 4 BOLT MT-HEATED/RMT-B/W - MIRRORS-EXTER W/DEFROST
26	103335-05-02A	EA	TRIM - BACKWALL - LOWER - 96.3" - BRIGHT WHITE
27	146515-01-01A	EA	MAT - ANTI SLIP - RIGHT HAND - BLACK
27	146515-03-01A	EA	MAT - ANTI SLIP - RIGHT HAND - BLACK - LOWER BODY PAINT
27	146515-02-01A	EA	MAT - ANTI SLIP - LEFT HAND- BLACK
27	146515-04-01A	EA	MAT - ANTI SLIP - LEFT HAND - BLACK - LOWER BODY PAINT
28	121948-02-000	EA	SHIELD - SIGHT
29	146148-04-01A	EA	GUARD - MUD FLAP/LEFT - BLACK
29	149604-08-01A	EA	WHEEL LIP - FIBERGLASS - DRIVER - FORD - PRIMED - LOWER BODY PAINT - NOT ILLUSTRATED
	149604-09-000	EA	HARDWARE KIT (RUNNING BOARD INSTALL) - FORD
30	146148-03-01A	EA	GUARD - MUD FLAP/RIGHT - BLACK
30	149604-07-01A	EA	WHEEL LIP - FIBERGLASS - PASSNGR - FORD - PRIMED - LOWER BODY PAINT - NOT ILLUSTRATED
	149604-09-000	EA	HARDWARE KIT (RUNNING BOARD INSTALL) - FORD
31	134774-01-02B	EA	BRACKET - CAB ATTACHMENT - E-COATED
32	146180-01-02B	EA	BRACKET - RUNNING BOARD - E-COATED
33	146148-02-01A	EA	BOARD - RUNNING - LEFT HAND/TAPPERED - BLACK
33	149604-02-01A	EA	RUNNING BOARD/WEDGE - DRIVER - FORD - PRIMED - LOWER BODY PAINT - NOT ILLUSTRATED
33	146148-01-01A	EA	BOARD - RUNNING - RIGHT HAND/TAPPERED - BLACK
33	149604-01-01A	EA	RUNNING BOARD/WEDGE - PASS - FORD - PRIMED - LOWER BODY PAINT - NOT ILLUSTRATED
34	148759-B5-01A	EA	TRIM - SIDEWALL/LOWER - 33.7" - BRIGHT WHITE
35	148760-49-01A	EA	TRIM - SIDEWALL/LOWER - W/O MITER/NOTCH - 13.8"
36	148759-B6-01A	EA	TRIM - SIDEWALL/LOWER - 5.9" - BRIGHT WHITE
37	148759-B4-01A	EA	TRIM - SIDEWALL/LOWER - 11.1" - BRIGHT WHITE
38	127848-01-01A	EA	TRIM - WHEELWELL - BRIGHT WHITE
39	148759-B7-01A	EA	TRIM - SIDEWALL/LOWER - 29.6" - BRIGHT WHITE
40	148759-59-01A	EA	TRIM - SIDEWALL/LOWER - W/LH NOTCH - 6.1"
41	148760-50-01A	EA	TRIM - ROCKER - NOTCHED - 29.6" - BRIGHT WHITE
42	148760-24-01A	EA	TRIM - ROCKER - LH NOTCHED - 6.1" - BRIGHT WHITE
43	148759-C1-01A	EA	TRIM - SIDEWALL/LOWER - 8.3" - BRIGHT WHITE
44	148759-C2-01A	EA	TRIM - SIDEWALL/LOWER - 19" - BRIGHT WHITE
45	128732-19-U21	EA	TRIM - PASSENGER SIDEWALL W/ENTRY DOOR NOTCH - 137.3"
46	148759-B9-01A	EA	TRIM - SIDEWALL/LOWER - 8.6" - BRIGHT WHITE
			FROM: 00-00-00 THRU: 05-21-06
46	148759-C4-01A	EA	TRIM - SIDEWALL/LOWER - 8.3" - BRIGHT WHITE
			FROM: 05-22-06 THRU: 99-99-99
47	148759-B8-01A	EA	TRIM - SIDEWALL/LOWER - 6" - BRIGHT WHITE
48	127848-01-01A	EA	TRIM - WHEELWELL - BRIGHT WHITE
49	148759-53-01A	EA	TRIM - SIDEWALL/LOWER - MITERED ENDS - 34.3"
			FROM: 00-00-00 THRU: 05-21-06
49	148759-C5-01A	EA	TRIM - SIDEWALL/LOWER - 33.8" - BRIGHT WHITE
			FROM: 05-22-06 THRU: 99-99-99
50	148759-C0-01A	EA	TRIM - SIDEWALL/LOWER - 50.8" - BRIGHT WHITE
51	148760-51-01A	EA	TRIM - ROCKER - NOTCHED - 110.4" - BRIGHT WHITE
52	148760-52-01A	EA	TRIM - ROCKER - NOTCHED - 33.7" - BRIGHT WHITE

\*COMPONENT PARTS LISTED LATER IN THIS GROUP

## EXTERIOR BODY GROUP (CONTINUED)

### PANELS & TRIMS (CONTINUED)

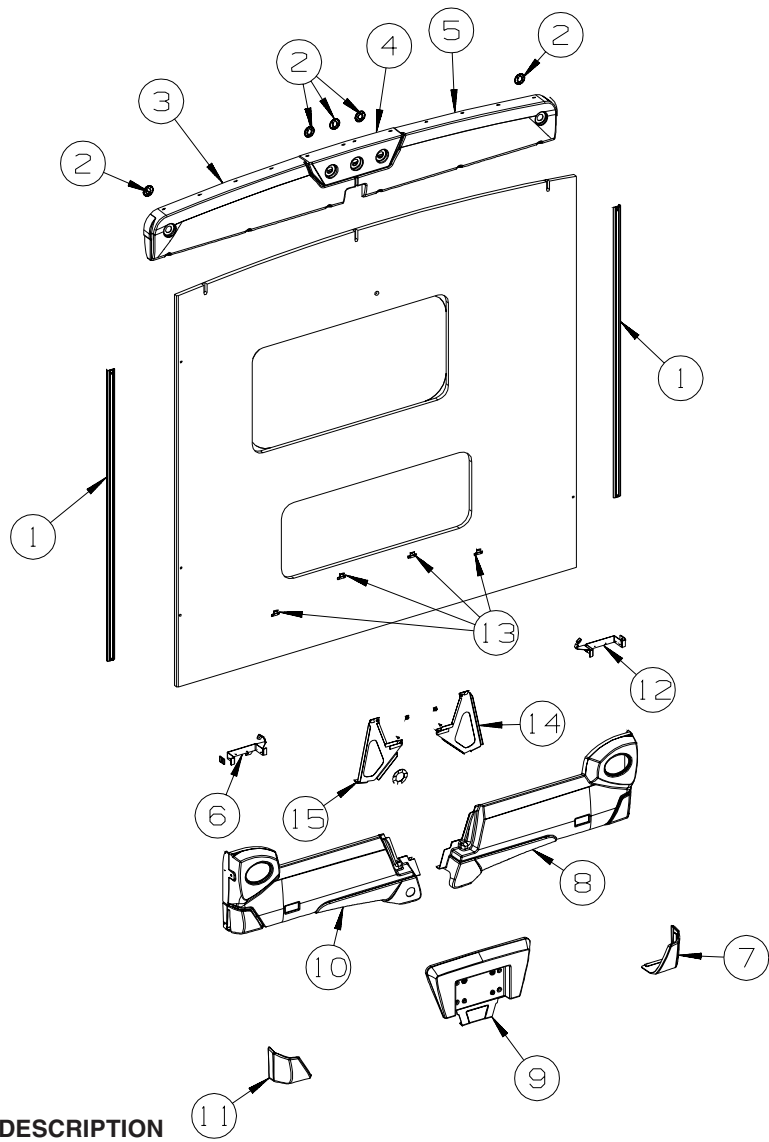

KEY	PART NUMBER	U/M	DESCRIPTION
1	158150-01-01A	EA	TRIM - CONTOUR - 66.8" - BRIGHT WHITE
1	158107-01-01A	EA	INSERT - FEATURE STRIP - VINYL - BRIGHT WHITE
2	138996-03-000	EA	BRACKET - CLEARANCE LIGHT
3	156058-06-U21	EA	TRIM - BACKWALL - TOP/DRIVER
4	156058-04-U21	EA	TRIM - BACKWALL - TOP/CENTER
5	156058-02-U21	EA	TRIM - BACKWALL - TOP/PASSENGER
6	156312-02-02B	EA	BRACKET/TAILLAMP - DRIVER - E-COATED
7	156059-07-10A	EA	TRIM/CAP - BACKWALL - LOWER/PASSENGER - BLACK
7	156059-07-25A	EA	TRIM/CAP - BACKWALL - LOWER/PASSENGER - SILVER
8	156059-02-U21	EA	TRIM - BACKWALL - LOWER/PASSENGER
8	156059-02-AA1	EA	TRIM - BACKWALL - LOWER/PASSENGER - LOWER EXTERIOR PAINT
9	156059-04-U21	EA	TRIM - BACKWALL - LOWER/CENTER
9	156059-04-AA1	EA	TRIM - BACKWALL - LOWER/CENTER - LOWER EXTERIOR PAINT
10	156059-06-U21	EA	TRIM - BACKWALL - LOWER/DRIVER
10	156059-06-AA1	EA	TRIM - BACKWALL - LOWER/DRIVER - LOWER EXTERIOR PAINT
11	156059-08-10A	EA	TRIM/CAP - BACKWALL - LOWER/DRIVER - BLACK
11	156059-08-25A	EA	TRIM/CAP - BACKWALL - LOWER/DRIVER - SILVER
12	156312-01-02B	EA	BRACKET/TAILLAMP - PASSENGER - E-COATED
13	073050-04-000	EA	CLIP/MOUNTING - VALANCE PANEL
14	156314-01-02B	EA	BRACKET - BUMPER - PASSENGER - E-COATED
15	156314-02-02B	EA	BRACKET - BUMPER - DRIVER - E-COATED

## EXTERIOR BODY GROUP (CONTINUED)

### COMPONENT PARTS FOR PANELS & TRIMS

133908-01 THRU 133908-08, 133908-10 THRU 133908-13, -01A/-02A/-03A

KEY	PART NUMBER	U/M	DESCRIPTION	VENDOR NO.
	117051-01-700	EA	MIRROR-CONVEX	723068-4
	120269-05-701	EA	GLASS-HTD/REM RH/LH W/CONVEX	709411
	133908-03-700	EA	CAP - RECT/BLACK-W/O LIGHT	709557
	133908-04-700	EA	CAP-MIRROR/ROUND - W/O LIGHT	7095470

133908-09-01A

KEY	PART NUMBER	U/M	DESCRIPTION	VENDOR NO.
	133908-09-700	EA	SWITCH-MIRROR HEATER	7475150

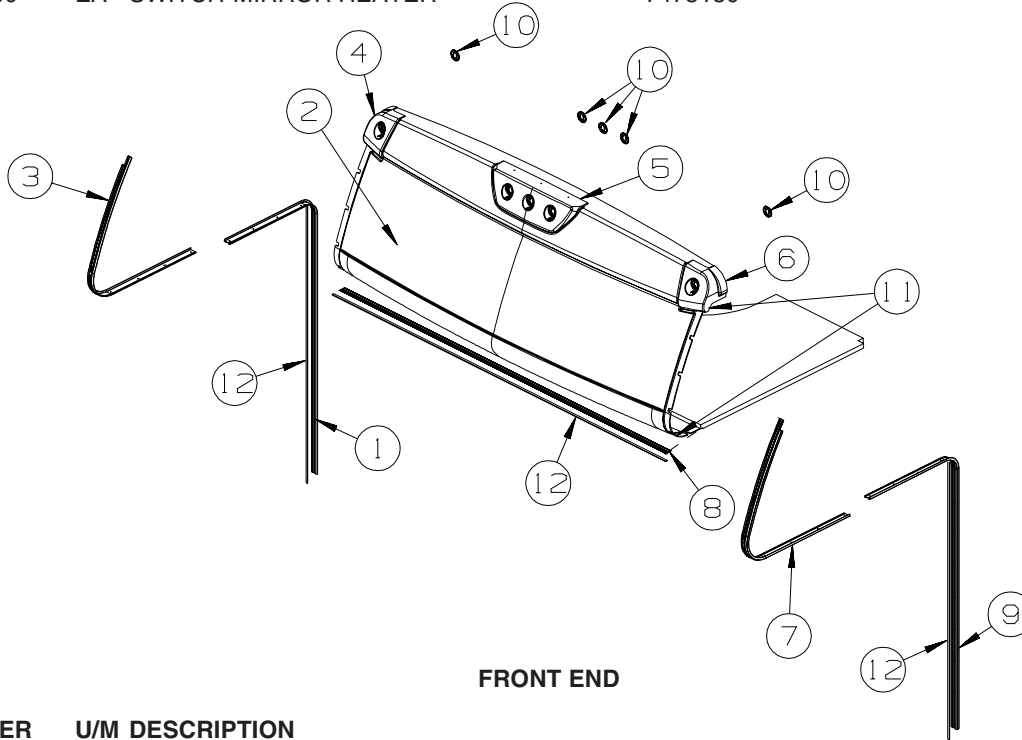

KEY	PART NUMBER	U/M	DESCRIPTION
1	158149-01-01A	EA	TRIM - CONTOUR/FRONT - PASSENGER - BRIGHT WHITE
2	157215-01-U21	EA	CAP - ROOF/FRONT - W/O LIGHTS/WIRING
3	158148-01-01A	EA	TRIM - CONTOUR/PASSENGER - 60.9" - BRIGHT WHITE
4	156849-02-U21	EA	TRIM - FRONT CAP/SIDEWALL - TOP/PASSENGER
5	156849-04-U21	EA	TRIM - FRONT CAP - TOP/CENTER
6	156849-06-U21	EA	TRIM - FRONT CAP/SIDEWALL - TOP/DRIVER
7	158148-02-01A	EA	TRIM - CONTOUR/DRIVER - 60.9" - BRIGHT WHITE
8	158152-01-01A	EA	TRIM - CONTOUR - 96.1" - BRIGHT WHITE
9	158149-02-01A	EA	TRIM - CONTOUR/FRONT - DRIVER - BRIGHT WHITE
10	138996-03-000	EA	BRACKET - CLEARANCE LIGHT
11	105290-01-000	SF	INSULATION - AIR POCKET W/FOIL - 4' WIDE
12	158107-01-01A	EA	INSERT - FEATURE STRIP - VINYL - BRIGHT WHITE



**EXTERIOR BODY GROUP (CONTINUED)**  
**STRUCTURAL COMPONENTS**

KEY	PART NUMBER	U/M	DESCRIPTION
	002365-03-006	EA	U-CHANNEL - EXTRUDED - 1" X 192" - BRIGHT WHITE
	002726-01-001	EA	GARNISH - U-CHANNEL - 1.38" X 19' - SERRATED
	002766-01-001	EA	ANGLE - EXTRUDED - 1" X 1 1/2" X 17'
	089297-01-000	SF	PLYWOOD - LUAN - OVERLAY GRADE - 4' X 8'
	089297-02-000	SF	PLYWOOD - LUAN - OVERLAY GRADE - 4' X 9'
	089297-03-000	SF	PLYWOOD - LUAN - OVERLAY GRADE - 4' X 8.3'
	100619-01-000	BF	FOAM - EXPANDED POLYSTYRENE - 1.34" X 48" X 96"
	100619-02-000	BF	FOAM - EXPANDED POLYSTYRENE - 1.5" X 48" X 96"
	100619-04-000	BF	FOAM - EXPANDED POLYSTYRENE - .5" X 48" X 96"
	100619-05-000	BF	FOAM - EXPANDED POLYSTYRENE - .75" X 48" X 96"-1.5"DENSITY
	100619-16-000	BF	FOAM - EXPANDED POLYSTYRENE - .75" X 48" X 96"-2" DENSITY
	100619-27-000	BF	FOAM - EXPANDED POLYSTYRENE - 3" X 48" X 92.8"
	116942-03-01A	LB	ALUMINUM - .7" X 40" X 158"
	120107-01-000	EA	FOAM - ROOF COVE - 2.8" X 48" LONG
	120107-02-000	EA	FOAM - PLUG - ROOF TUBE - 2.2" X 2.9" X 1.8" LONG
	120107-03-000	EA	FOAM - PLUG - SIDEWALL TUBE - 1.2" X 2.1" X 1.8" LONG
	108535-05-03A	SF	FIBERGLASS SHEET - 108" X 500' ROLL - BRIGHT WHITE
	159631-04-01A	EA	FIBERGLASS SHEET - 99.5" X 100.2" - BRIGHT WHITE
	159631-06-01A	EA	FIBERGLASS SHEET - 56.4" X 99.8" - BRIGHT WHITE
	159631-10-01A	EA	FIBERGLASS SHEET - 31.1" X 68.2" - BRIGHT WHITE
	159631-10-01A	EA	FIBERGLASS SHEET - 31.1" X 68.2" - BRIGHT WHITE
	159631-15-01A	EA	FIBERGLASS SHEET - 4" X 93.8" - BRIGHT WHITE
	159631-02-01A	EA	FIBERGLASS SHEET - 96.7" X 355.7" - BRIGHT WHITE

**AWNINGS**

**ORDER AWNINGS & REPAIR PARTS FROM DOMETIC. CALL #800-366-3842.**  
**THE DOMETIC AWNING INFORMATION YOU WILL NEED IS LOCATED ON THE MOTOR**  
**HOME NEAR THE TOP OF THE AWNING RAIL.**

KEY	PART NUMBER	U/M	DESCRIPTION
*	113874-01-02A	EA	HARDWARE KIT - AWNING - W/O STANDOFF BRACKET-BRIGHT WHITE
	113874-11-01A	EA	SCREW/LAG - AWNING - 1/4" X 1" STAINLESS STEEL
	113874-12-01A	EA	SCREW/LAG - AWNING - 1/4" X 2 3/4" STAINLESS STEEL
	127647-02-01A	EA	ROD/AWNING GUARD - ENTRY DOOR - 12.7" LONG
	137054-01-02A	EA	BRACKET - AWNING - BRIGHT WHITE
	127960-01-01A	EA	RETAINER - EYE - 3/8" - STAINLESS STEEL - 325F, 327L, 331C

**\*COMPONENT PARTS LISTED LATER IN THIS GROUP**

**COMPONENT PARTS FOR AWNINGS**

**113874-01-02A**

KEY	PART NUMBER	U/M	DESCRIPTION	VENDOR NO.
1	113874-01-714	EA	RAFTER - MAIN RH/LH BRT/WHT	830295.536F
2	113874-01-715	EA	RAFTER - SECONDARY BRT/WHT	830463.511F
3	113874-01-702	EA	KNOB - ADJUSTING	3105421.014
4	113874-01-706	EA	LOCK - TRAVEL	830587.001
5	113874-01-707	EA	HANDLE - LIFT W/RIVETS	830644
6	113874-01-712	EA	FOOT - PATIO	730366-001
7	113874-01-710	EA	PLUG-STOP KIT	830456
8	113874-01-717	EA	ARM - ADJUSTABLE BRT/WHT	830467.517/F
9	113874-01-709	EA	NAIL-SPIKE, 8"	113006
10	113874-01-716	EA	ARM - MAIN SUPPORT BRT/WHT	3104502.293/F
11	113874-01-703	EA	ROD-CENTER PULL W/ACCESSORY	830152.102

# EXTERIOR DOORS & COMPARTMENTS GROUP

## DOOR & COMPARTMENT LAYOUT

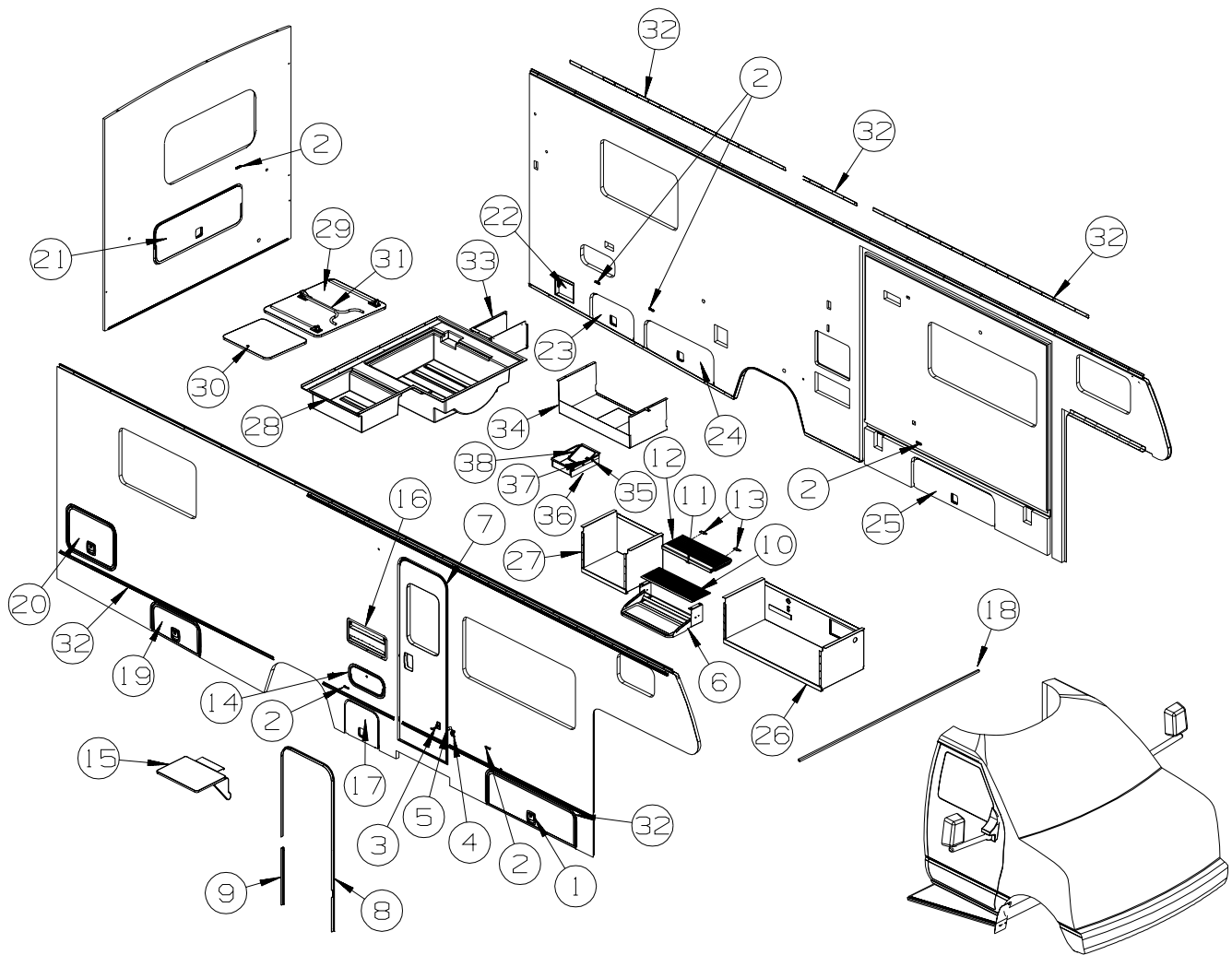

KEY	PART NUMBER	U/M	DESCRIPTION
1	148660-06-S01	EA	DOOR/STORAGE - W/O HDW/PADDLE LATCH - 47.3" X 16"
1	148660-06-AA1	EA	DOOR/STORAGE - W/O HDW/PADDLE LATCH - 47.3" X 16" - LOWER EXTERIOR PAINT
	056795-01-000	FT	TAPE-SEAL, 1/8" X 3/8" WIDE - PRESS ON
	107721-08-000	FT	SEAL - ACCESS DOOR - .9"WIDE X .9"HIGH
2	102768-01-000	EA	HOLDER - COMPARTMENT/ENTRY DOOR - METAL - MILL FINISH
3	104099-01-04A	EA	CATCH - DOOR HOLDER - STRIKE - 3.9" - BRIGHT WHITE
4	104099-02-04A	EA	CATCH/RETAINER - DOOR HOLDER - BRIGHT WHITE
5	117046-02-000	EA	BUMPER - RUBBER/ROUND END - 1.5"
6	139748-02-04B	EA	STEP/PULLOUT - W/BRACKETS - BLACK
			FROM: 00-00-00 THRU: 05-28-06
6	139748-04-04B	EA	STEP/PULLOUT - W/BRACKETS - BLACK
			FROM: 05-29-06 THRU: 99-99-99
	102569-04-000	EA	MAT - ANTI SLIP
6*	094708-03-01A	EA	STEP - ELECTRIC - SINGLE - BLACK CONTROL BOX - KWIKEE - ENTRANCE STEP-ELECTRIC
			FROM: 00-00-00 THRU: 08-07-05
6*	094708-05-01A	EA	STEP - ELECTRIC - SINGLE - BLACK - KWIKEE - ENTRANCE STEP-ELECTRIC
			FROM: 08-08-05 THRU: 99-99-99
7	P32206-18-TR0	EA	DOOR - ENTRY W/SCREEN DOOR - W/O WINDOW/LATCH (U21,U22)
7	P32206-18-U23	EA	DOOR - ENTRY W/SCREEN DOOR - W/O WINDOW/LATCH (U23,U24)
7	P32206-18-U25	EA	DOOR - ENTRY W/SCREEN DOOR - W/O WINDOW/LATCH (U25,U26)

**EXTERIOR DOORS & COMPARTMENTS GROUP (CONTINUED)**  
**DOOR & COMPARTMENT LAYOUT (CONTINUED)**

**KEY PART NUMBER U/M DESCRIPTION**

**ENTRY DOOR LOCK CYLINDERS**

138287-11-000	EA	CYLINDER/LOCK - ENTRY DOOR - MASTER W/3M ICON - (3041)
138287-12-000	EA	CYLINDER/LOCK - ENTRY DOOR - MASTER W/3M ICON - (3042)
138287-13-000	EA	CYLINDER/LOCK - ENTRY DOOR - MASTER W/3M ICON - (3043)
138287-14-000	EA	CYLINDER/LOCK - ENTRY DOOR - MASTER W/3M ICON - (3044)
138287-15-000	EA	CYLINDER/LOCK - ENTRY DOOR - MASTER W/3M ICON - (3045)
138287-16-000	EA	CYLINDER/LOCK - ENTRY DOOR - MASTER W/3M ICON - (3046)
138287-17-000	EA	CYLINDER/LOCK - ENTRY DOOR - MASTER W/3M ICON - (3047)
138287-18-000	EA	CYLINDER/LOCK - ENTRY DOOR - MASTER W/3M ICON - (3048)
138287-19-000	EA	CYLINDER/LOCK - ENTRY DOOR - MASTER W/3M ICON - (3049)
138287-20-000	EA	CYLINDER/LOCK - ENTRY DOOR - MASTER W/3M ICON - (3050)
138292-01-000	EA	SEAL - LOCK CYLINDER

**VALANCE DOOR & WATER FILL DOOR LOCK CYLINDERS**

138289-11-000	EA	CYLINDER/LOCK - ACCESS DOORS - REDUCED SENSITIVITY (3041)
138289-12-000	EA	CYLINDER/LOCK - ACCESS DOORS - REDUCED SENSITIVITY (3042)
138289-13-000	EA	CYLINDER/LOCK - ACCESS DOORS - REDUCED SENSITIVITY (3043)
138289-14-000	EA	CYLINDER/LOCK - ACCESS DOORS - REDUCED SENSITIVITY (3044)
138289-15-000	EA	CYLINDER/LOCK - ACCESS DOORS - REDUCED SENSITIVITY (3045)
138289-16-000	EA	CYLINDER/LOCK - ACCESS DOORS - REDUCED SENSITIVITY (3046)
138289-17-000	EA	CYLINDER/LOCK - ACCESS DOORS - REDUCED SENSITIVITY (3047)
138289-18-000	EA	CYLINDER/LOCK - ACCESS DOORS - REDUCED SENSITIVITY (3048)
138289-19-000	EA	CYLINDER/LOCK - ACCESS DOORS - REDUCED SENSITIVITY (3049)
138289-20-000	EA	CYLINDER/LOCK - ACCESS DOORS - REDUCED SENSITIVITY (3050)
138288-11-000	EA	KEY - REVERSIBLE - #3041 - T/M 16169-02-3041
138288-12-000	EA	KEY - REVERSIBLE - #3042 - T/M 16169-02-3042
138288-13-000	EA	KEY - REVERSIBLE - #3043 - T/M 16169-02-3043
138288-14-000	EA	KEY - REVERSIBLE - #3044 - T/M 16169-02-3044
138288-15-000	EA	KEY - REVERSIBLE - #3045 - T/M 16169-02-3045
138288-16-000	EA	KEY - REVERSIBLE - #3046 - T/M 16169-02-3046
138288-17-000	EA	KEY - REVERSIBLE - #3047 - T/M 16169-02-3047
138288-18-000	EA	KEY - REVERSIBLE - #3048 - T/M 16169-02-3048
138288-19-000	EA	KEY - REVERSIBLE - #3049 - T/M 16169-02-3049
138288-20-000	EA	KEY - REVERSIBLE - #3050 - T/M 16169-02-3050
8	139100-02-01A	EA GARNISH/RADIUS - ENTRY DOOR - BRIGHT WHITE
9	139101-02-01A	EA GARNISH/STRAIGHT - 35.31" - W/O NOTCHES - BRIGHT WHITE
10	133114-03-01A	EA TREAD - STEP/RUBBER - 27.1" X 10.1" - TAUPE
11	123330-05-02B	EA SUPPORT - ENTRY STEP - E-COATED
12	147781-01-01A	EA TREAD/STEP - RUBBER - TAUPE
13	146747-01-02B	EA BRACKET/CATCH - E-COATED
	116975-01-01A	EA LATCH - W/O STRIKE - BLACK - NEW STYLE
14	126945-09-P07	EA DOOR/STORAGE - W/O HARDWARE - 18.3" X 9.9"
15	142034-01-01A	EA SHELF - F/EXTERIOR TV - BRIGHT WHITE
16*	084103-08-000	EA DOOR - VENT - REFRIGERATOR - W/O JAMB - BRIGHT WHITE
16	084104-08-000	EA JAMB - VENT DOOR/REFRIGERATOR - BRIGHT WHITE
17	148660-03-S01	EA DOOR/STORAGE - W/O HDW/PADDLE LATCH - 18.2" X 16"
17	148660-03-AA1	EA DOOR/STORAGE - W/O HDW/PADDLE LATCH - 18.2" X 16" - LOWER EXTERIOR PAINT
	150657-03-01B	EA ROD/WIRE - LATCH
	150657-07-01B	EA ROD/WIRE - LATCH
	056795-01-000	FT TAPE-SEAL, 1/8" X 3/8" WIDE - PRESS ON
	107721-08-000	FT SEAL - ACCESS DOOR - .9"WIDE X .9"HIGH
18	098408-01-000	FT SEAL - SPONGE RUBBER - CLOSED CELL
19	148661-33-U01	EA DOOR/STORAGE - PASS W/O HDW/LATCH - 13.1" X 25.3" X 14.3"
19	148661-33-AA1	EA DOOR/STORAGE - PASS W/O HDW/LATCH - 13.1" X 25.3" X 14.3" - LOWER EXTERIOR PAINT
	150657-10-01B	EA ROD/WIRE - LATCH
	150657-13-01B	EA ROD/WIRE - LATCH
	056795-01-000	FT TAPE-SEAL, 1/8" X 3/8" WIDE - PRESS ON
20	150246-06-U21	EA DOOR/STORAGE - W/O HARDWARE - 25.2" X 19.3"
	150657-13-01B	EA ROD/WIRE - LATCH
	150657-42-01B	EA ROD/WIRE - LATCH
	056795-01-000	FT TAPE-SEAL, 1/8" X 3/8" WIDE - PRESS ON
21	150246-07-U21	EA DOOR/STORAGE - W/O HARDWARE - 46.9" X 17.4"
	150657-25-01B	EA ROD/WIRE - LATCH
	150657-43-01B	EA ROD/WIRE - LATCH
	056795-01-000	FT TAPE-SEAL, 1/8" X 3/8" WIDE - PRESS ON

**EXTERIOR DOORS & COMPARTMENTS GROUP (CONTINUED)**  
**DOOR & COMPARTMENT LAYOUT (CONTINUED)**

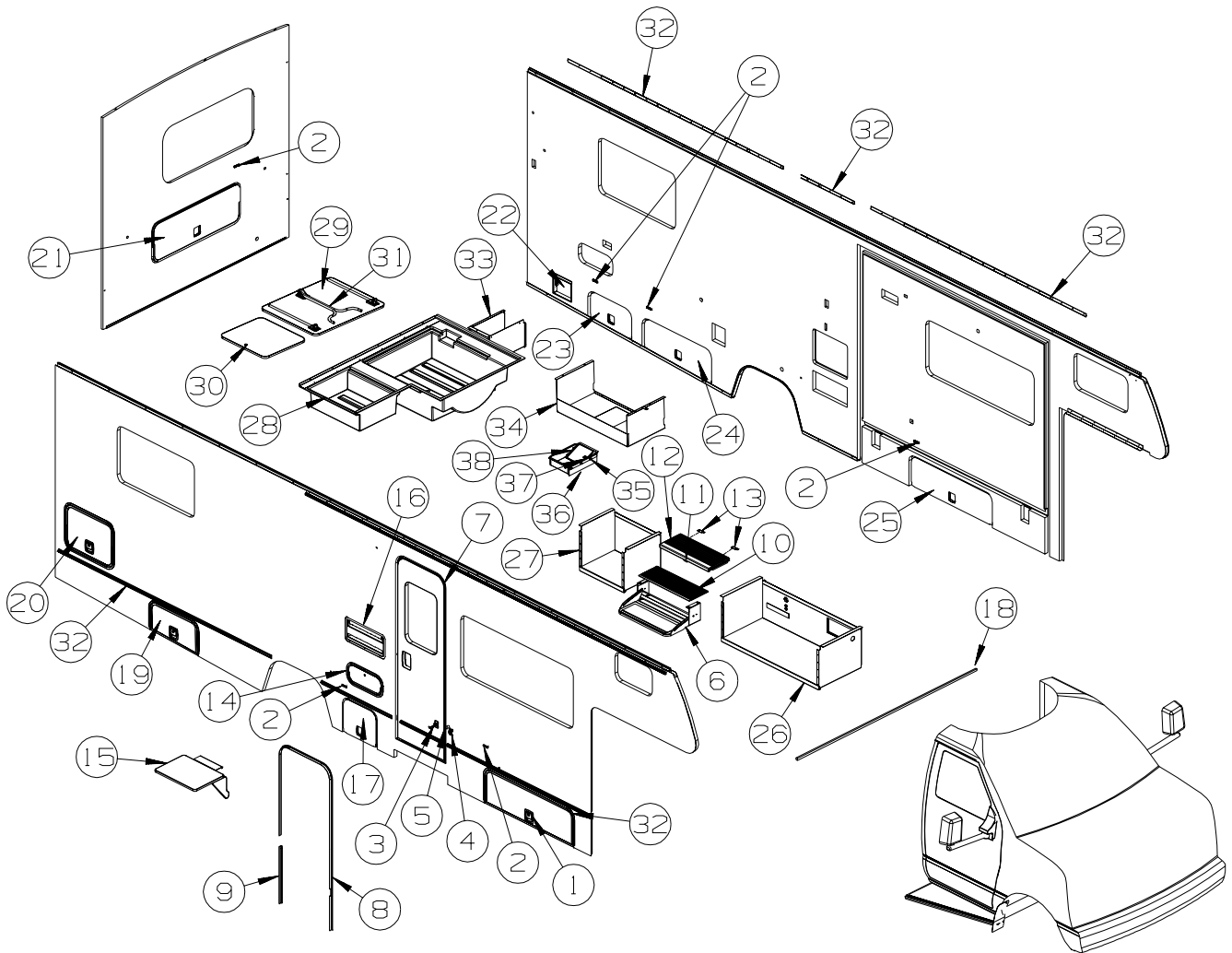

KEY	PART NUMBER	U/M	DESCRIPTION
	22	142894-01-01A	EA DOOR/POWER CORD - W/HATCH - W/LOCK - BRIGHT WHITE
	23	148661-32-U01	EA DOOR/STORAGE - DRVR W/O HDW/LATCH - 13.4" X 22.9" X 12.3"
	23	148661-32-AA1	EA DOOR/STORAGE - DRVR W/O HDW/LATCH - 13.4" X 22.9" X 12.3" - LOWER EXTERIOR PAINT
		150657-09-01B	EA ROD/WIRE - LATCH
		150657-11-01B	EA ROD/WIRE - LATCH
		056795-01-000	FT TAPE-SEAL, 1/8" X 3/8" WIDE - PRESS ON
		107721-08-000	FT SEAL - ACCESS DOOR - .9"WIDE X .9"HIGH
	24	148661-31-U01	EA DOOR/STORAGE - DRVR W/O HDW/LATCH - 15.3" X 36.6" X 13.6"
	24	148661-31-AA1	EA DOOR/STORAGE - DRVR W/O HDW/LATCH - 15.3" X 36.6" X 13.6" - LOWER EXTERIOR PAINT
		150657-10-01B	EA ROD/WIRE - LATCH
		150657-13-01B	EA ROD/WIRE - LATCH
		056795-01-000	FT TAPE-SEAL, 1/8" X 3/8" WIDE - PRESS ON
		107721-08-000	FT SEAL - ACCESS DOOR - .9"WIDE X .9"HIGH
	25	148660-09-S01	EA DOOR/STORAGE - W/O HDW/PADDLE LATCH - 44" X 14.2"
	25	148660-09-AA1	EA DOOR/STORAGE - W/O HDW/PADDLE LATCH - 44" X 14.2" - LOWER EXTERIOR PAINT
		150657-23-01B	EA ROD/WIRE - LATCH
		150657-26-01B	EA ROD/WIRE - LATCH
		056795-01-000	FT TAPE-SEAL, 1/8" X 3/8" WIDE - PRESS ON
		107721-08-000	FT SEAL - ACCESS DOOR - .9"WIDE X .9"HIGH
	26	137554-46-U21	EA COMPARTMENT - LUGGAGE - MOTOR AID
	26	137554-16-N01	EA COMPARTMENT - LUGGAGE - PATIO AWNING
	27	137554-23-R07	EA COMPARTMENT - LUGGAGE
	28	156199-01-01A	EA COMPARTMENT - TRUNK
		111848-08-02B	EA SHIELD - HEAT - EXHAUST - E-COATED - NOT ILLUSTRATED

**EXTERIOR DOORS & COMPARTMENTS GROUP (CONTINUED)**  
**DOOR & COMPARTMENT LAYOUT (CONTINUED)**

<b>KEY</b>	<b>PART NUMBER</b>	<b>U/M</b>	<b>DESCRIPTION</b>
29	158154-01-U01	EA	TABLE - 36.6" X 30.7" - W/O HDW FROM: 00-00-00 THRU: 07-23-06
29	160884-01-U01	EA	TABLE - 36.6" X 30.7" - W/FOLDING LEG/HDW FROM: 07-24-06 THRU: 99-99-99
	158154-01-U01	EA	TABLE - 36.6" X 30.7" - W/O HDW
	160875-01-01A	EA	LEG - TABLE/FOLDING - 1 DOUBLE/2 SINGLES - W/HDW
30	158154-03-U21	EA	TABLE - 25.6" X 21.6" - W/O HDW
31	158093-01-01A	EA	LEG/TABLE - FOLDING/26.9" - W/BRACKETS/TIE STRAP - WHITE - <b>NOT ILLUSTRATED</b> FROM: 00-00-00 THRU: 07-23-06
31	160875-01-01A	EA	LEG - TABLE/FOLDING - 1 DOUBLE/2 SINGLES - W/HDW FROM: 07-24-06 THRU: 99-99-99
32	105312-01-07A	FT	INSERT - FEATURE STRIP - VINYL - BRIGHT WHITE
33	140662-01-02B	EA	COMPARTMENT - POWER CORD - E-COATED
34	140482-03-02B	EA	COMPARTMENT - DRAINAGE - E-COATED
35	140922-02-02B	EA	RETAINER - MUD FLAP - 1" X 14.5" - E-COATED
36	017516-10-000	EA	MUD FLAP - 3.9"H X 14.9"W - RUBBER - BLACK
37	153718-01-01A	EA	LATCH - HOLD DOWN PANEL - STAINLESS STEEL
38	153529-01-02B	EA	DOOR - SUMP - E-COATED
	104692-01-000	FT	SEAL - ADHESIVE BACKED FOAM - 3/4" THICK X 3/4" WIDE X 25'

**\*COMPONENT PARTS LISTED LATER IN THIS GROUP**

**COMPONENT PARTS FOR DOOR & COMPARTMENT LAYOUT**

**084103-08-000**

<b>KEY</b>	<b>PART NUMBER</b>	<b>U/M</b>	<b>DESCRIPTION</b>	<b>VENDOR NO.</b>
	084104-01-700	EA	LOCK-MALE, FASTENER	201-721-010
	084104-01-701	EA	LOCK-FEMALE, FASTENER	201-802-010

**EXTERIOR DOORS & COMPARTMENTS GROUP (CONTINUED)**  
**COMPONENT PARTS FOR DOOR & COMPARTMENT LAYOUT (CONTINUED)**

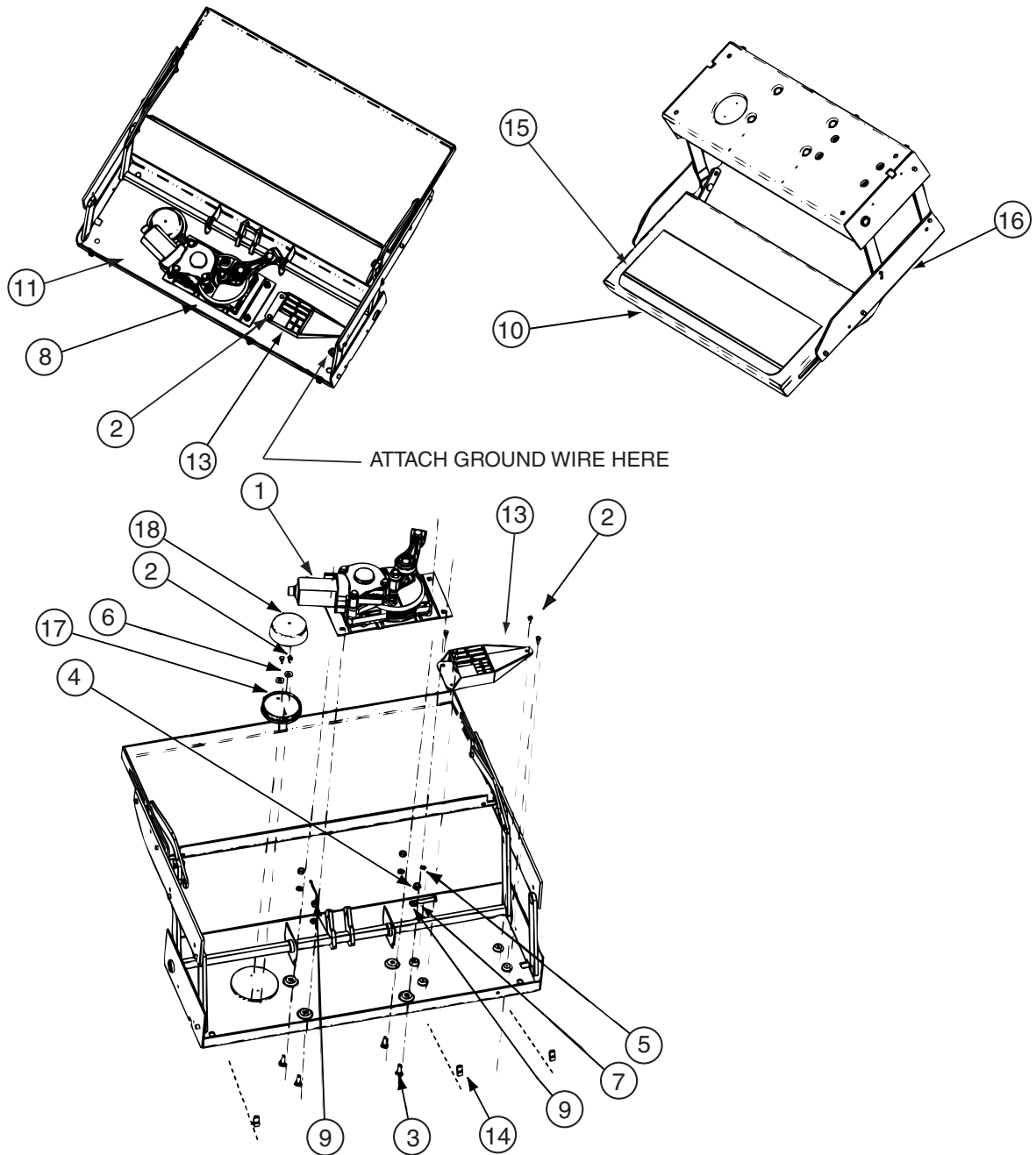

**094708-05-01A**

KEY	PART NUMBER	U/M	DESCRIPTION	VENDOR NO.
1	094707-04-701	EA	MOTOR "AM 214" F/IMGL STEPS	1101428
13	094707-04-700	EA	CONTROL UNIT W/OVERRIDE	909510000
15	143709-01-702	EA	TREAD/NON-SKID 6" X 21" BLK	1915260
16	094708-05-701	EA	FRAME W/SGL STEP,28 SERIES	908028000
17	088746-01-705	EA	LIGHT-UNDER STEP	9004
	094707-03-701	EA	PLUG - 4-WAY - PACKARD	909306
	094707-04-702	EA	COTTER PIN - W/CLEVIS PIN	905205000
	094707-04-711	EA	KWIKTEST - W/4-WAY PIGTAIL	909518000
	094708-05-700	EA	GEAR BOX W/LINKAGE-STRAIGHT	1101426
			CONTACT WINNEBAGO PART SALES FOR UNLISTED COMPONENT(S)	

**EXTERIOR DOORS & COMPARTMENTS GROUP (CONTINUED)**  
**COMPARTMENT DOOR PIECE PARTS**

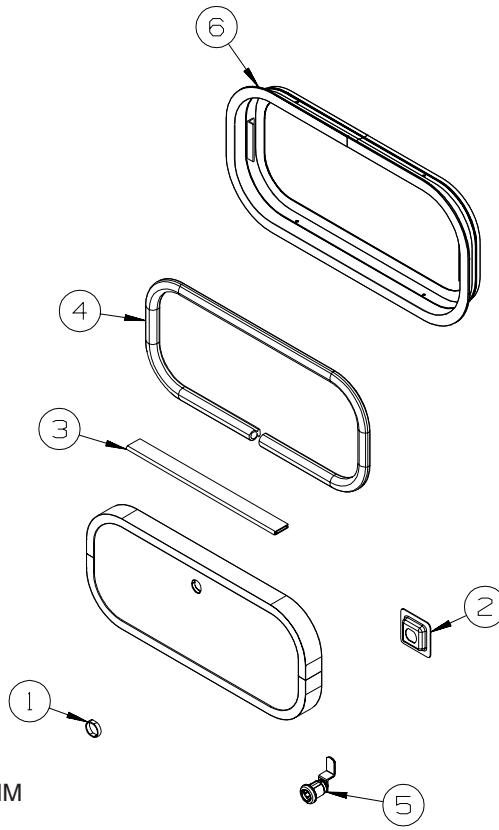

KEY	PART NUMBER	U/M	DESCRIPTION
1	139325-01-000	EA	SPACER - LOCK - 6MM
	139337-01-000	EA	GASKET - LOCK
2	097111-02-04A	EA	POCKET - LOCK - REAR DOOR - BLACK
2	097111-02-05A	EA	POCKET - LOCK - REAR DOOR - BRIGHT WHITE
3	081801-FN-000	EA	HINGE - DOOR - PIANO - 2" X 96" - BLACK
3	081801-V3-000	EA	HINGE - DOOR - PIANO - 2" X 96" - BRIGHT WHITE
4	156386-01-01A	FT	SEAL - BULB - W/ADHESIVE BACK
5	138290-02-000	EA	CASE - W/CAM - W/O CYLINDER/KEY
6	056795-01-000	FT	TAPE - SEAL - 1/8" X 3/8" WIDE - PRESS ON

**EXTERIOR DOORS & COMPARTMENTS GROUP (CONTINUED)**  
**COMPARTMENT DOOR PIECE PARTS (CONTINUED)**

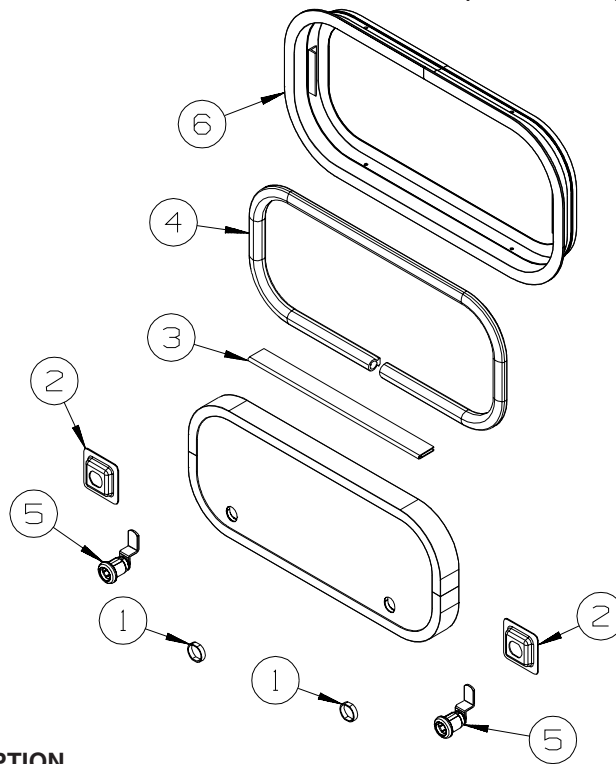

KEY	PART NUMBER	U/M	DESCRIPTION
1	144734-01-000	EA	SPACER - COMPARTMENT DOOR LOCK - 9/16" DEEP - TWIST LOCK/STRATTEC LOCKS
1	139325-01-000	EA	SPACER - LOCK - 6MM - TRI/MARK LOCKS
	139337-01-000	EA	GASKET - LOCK - TRI/MARK LOCKS
2	097111-02-04A	EA	POCKET - LOCK - REAR DOOR - BLACK
3	081801-V3-000	EA	HINGE - DOOR - PIANO - 2" X 96" - BRIGHT WHITE
3	081801-FN-000	EA	HINGE - DOOR - PIANO - 2" X 96" - BLACK
4	156386-01-01A	FT	SEAL - BULB - .4" X .5" - W/ADHESIVE BACK
5*	110506-27-000	EA	LOCK - TWIST - 1.6" - TWIST LOCK
	110506-55-000	EA	CASE/CYLINDER - TWIST LOCK - W/O CAM - 1.25" - 597312AA1 - TWIST LOCK
	110506-66-000	EA	CAM - LATCHING - DOG LEG - 1.5" LONG - TWIST LOCK
5	138637-04-000	EA	LOCK ASM. - KEYED - 1.5" CASE (CYLINDER/CAM/HDWR PKG) - KEYED LOCK/ STRATTEC
	144474-01-000	EA	ADAPTER - LOCK - 180 DEGREE
	138637-63-000	EA	CAM - LATCHING - DOG LEG - 1 1/2" LONG
	138637-53-000	EA	CASE/CYLINDER - LOCKING - W/O CAM/KEY - 1.5"
	138637-53-001	EA	CASE/CYLINDER - LOCKING - W/O CAM/KEY - 1.5"
	138637-53-002	EA	CASE/CYLINDER - LOCKING - W/O CAM/KEY - 1.5"
	138637-53-003	EA	CASE/CYLINDER - LOCKING - W/O CAM/KEY - 1.5"
	138637-53-004	EA	CASE/CYLINDER - LOCKING - W/O CAM/KEY - 1.5"
	138637-53-005	EA	CASE/CYLINDER - LOCKING - W/O CAM/KEY - 1.5"
	138637-53-006	EA	CASE/CYLINDER - LOCKING - W/O CAM/KEY - 1.5"
	138637-53-007	EA	CASE/CYLINDER - LOCKING - W/O CAM/KEY - 1.5"
	138637-53-008	EA	CASE/CYLINDER - LOCKING - W/O CAM/KEY - 1.5"
	138637-53-009	EA	CASE/CYLINDER - LOCKING - W/O CAM/KEY - 1.5"
5	138290-02-000	EA	CASE - W/CAM - W/O CYLINDER/KEY - KEYED ALIKE TRIMARK LOCK LISTED IN LAYOUT
6	056795-01-000	FT	TAPE-SEAL, 1/8~ X 3/8~ WIDE - PRESS ON

\*COMPONENT PARTS LISTED LATER IN THIS GROUP



**EXTERIOR DOORS & COMPARTMENTS GROUP (CONTINUED)**  
**COMPARTMENT DOOR PIECE PARTS (CONTINUED)**

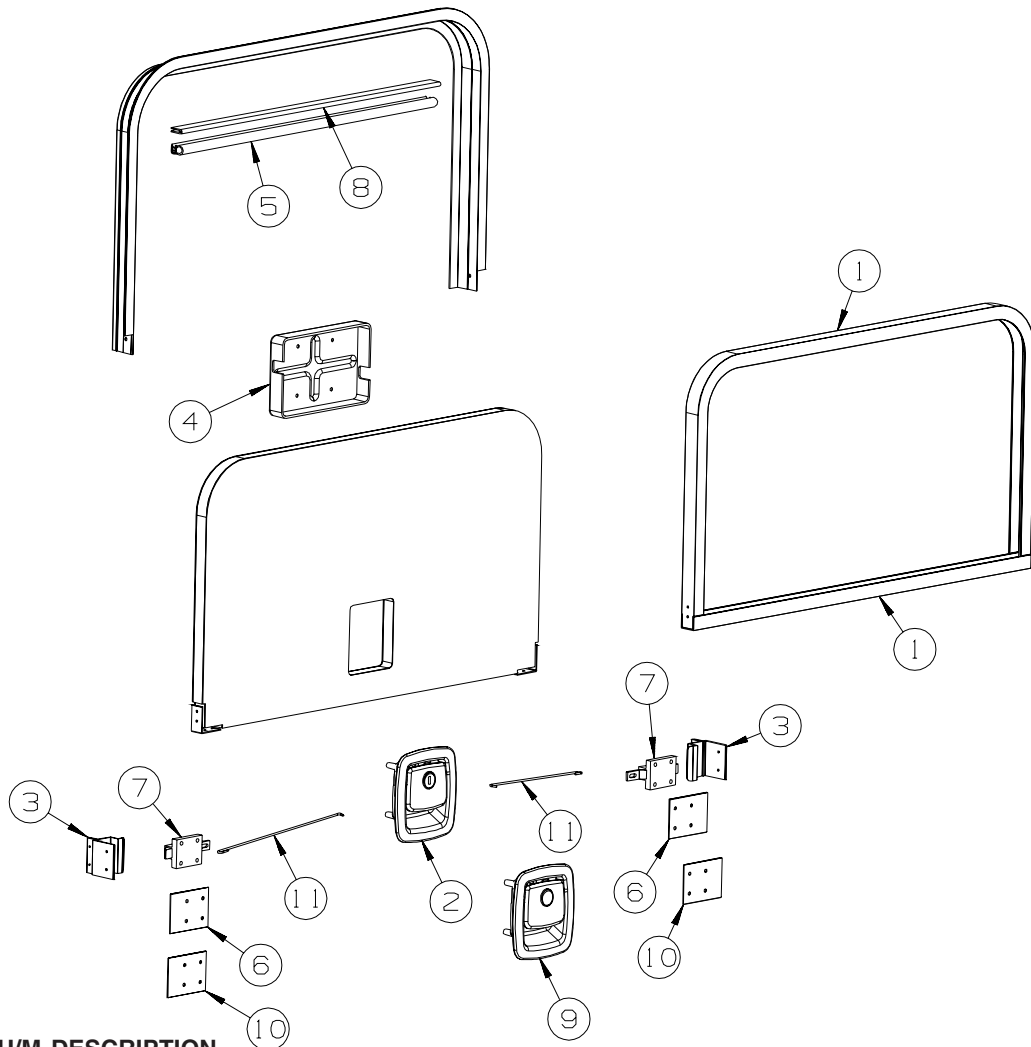

KEY	PART NUMBER	U/M DESCRIPTION
1	096217-55-006	EA U-CHANNEL - 210" - BRIGHT WHITE
1	096217-55-009	EA U-CHANNEL - 210" - BLACK - LOWER EXTERIOR PAINT
2	154900-01-02A	EA LATCH/PADDLE - LOCKING - COMPT DOOR - KEY ONE - WHITE
2	154900-01-01A	EA LATCH/PADDLE - LOCKING - COMPT DOOR - KEY ONE - BLACK - LOWER EXTERIOR PAINT
3	150789-01-S01	EA STRIKER - STORAGE DOOR
4	122277-06-02A	EA COVER - LATCH - WHITE
5	151104-01-01A	FT SEAL - BULB - W/WIRED U CHANNEL - .3" X .5" CHANNEL-BLACK
6	121577-07-01A	EA STRAP/PLATE - W/HOLE - 2.25" X 3" - BRIGHT WHITE
7	149741-01-01A	EA BOLT - SLIDE/LATCH
8	151229-06-01A	EA HINGE - CONTINUOUS - 1.5" X 72.4" - BRIGHT WHITE
8	151229-06-02A	EA HINGE - CONTINUOUS - 1.5" X 72.4" - BLACK - LOWER EXTERIOR PAINT
9	154900-02-02A	EA LATCH/PADDLE - NON LOCKING - COMPT DOOR - WHITE
9	154900-02-01A	EA LATCH/PADDLE - NON LOCKING - COMPT DOOR - BLACK - LOWER EXTERIOR PAINT
10	149738-01-01A	EA SPACER - SLIDE BOLT
11	150150-01-000	EA ROD - LATCH (BLANK) - 27.5" - STAINLESS STEEL

**EXTERIOR DOORS & COMPARTMENTS GROUP (CONTINUED)**  
**COMPARTMENT DOOR PIECE PARTS (CONTINUED)**

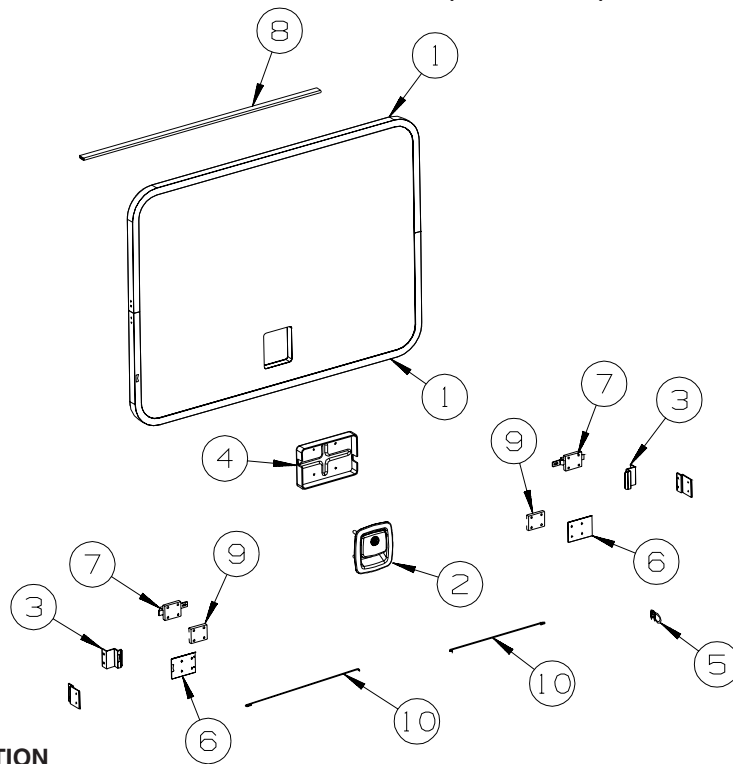

KEY	PART NUMBER	U/M	DESCRIPTION
1	096217-55-006	EA	U-CHANNEL - 210" - BRIGHT WHITE
2	154900-01-02A	EA	LATCH/PADDLE - LOCKING - COMPT DOOR - KEY ONE - WHITE
2	154900-01-01A	EA	LATCH/PADDLE - LOCKING - COMPT DOOR - KEY ONE - BLACK
3	150789-01-S01	EA	STRIKER - STORAGE DOOR
4	122277-06-02A	EA	COVER - LATCH - WHITE
5	151104-01-01A	FT	SEAL - BULB - W/WIRED U CHANNEL - .3" X .5" CHANNEL-BLACK
6	121577-07-01A	EA	PLATE - W/HOLE - BRIGHT WHITE
	035648-51-001	EA	STRAP - EXTRUSION - 2.25" X 80.6"
7	149741-01-01A	EA	BOLT - SLIDE/LATCH
8	151229-06-01A	EA	HINGE - CONTINUOUS - 1.5" X 72.4" - BRIGHT WHITE
9	149738-01-01A	EA	SPACER - SLIDE BOLT
10	150150-01-000	EA	ROD - LATCH (BLANK) - 27.5" - STAINLESS STEEL

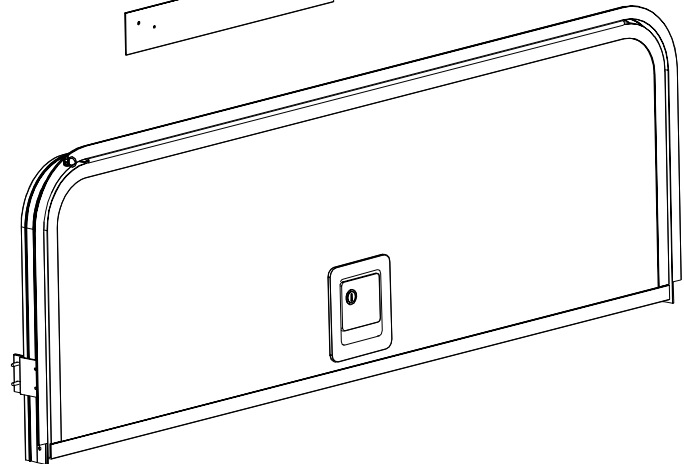
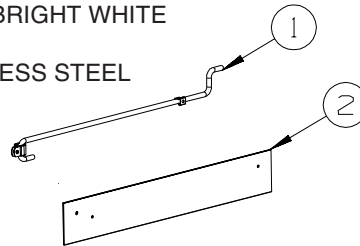

KEY	PART NUMBER	U/M	DESCRIPTION
1	155346-03-04B	EA	PROP ROD - 10.6" - BLACK
1	155346-04-04B	EA	PROP ROD - 15.3" - BLACK
1	155346-07-04B	EA	PROP ROD - 17.3" - BLACK
2	121577-02-01A	EA	STRAP/PLATE - W/HOLE - 2.25" X 11.8" - BRIGHT WHITE
2	121577-06-01A	EA	STRAP/PLATE - W/HOLE - 2.25" X 15.8" - BRIGHT WHITE
2	121577-07-01A	EA	STRAP/PLATE - W/HOLE - 2.25" X 3" - BRIGHT WHITE
2	121577-08-01A	EA	STRAP/PLATE - W/HOLE - 2.25" X 10" - BRIGHT WHITE
	035648-51-001	EA	STRAP - EXTRUSION - 2.25" X 80.6"

# EXTERIOR DOORS & COMPARTMENTS GROUP (CONTINUED)

## COMPONENT PARTS FOR COMPARTMENT DOOR PIECE PARTS

110506-A1-000, 110506-A2-000, 110506-26-000, 110506-27-000, 110506-36-000

KEY PART NUMBER  
110506-40-700

U/M DESCRIPTION  
EA HDWE KIT

VENDOR NO.  
596950AAL

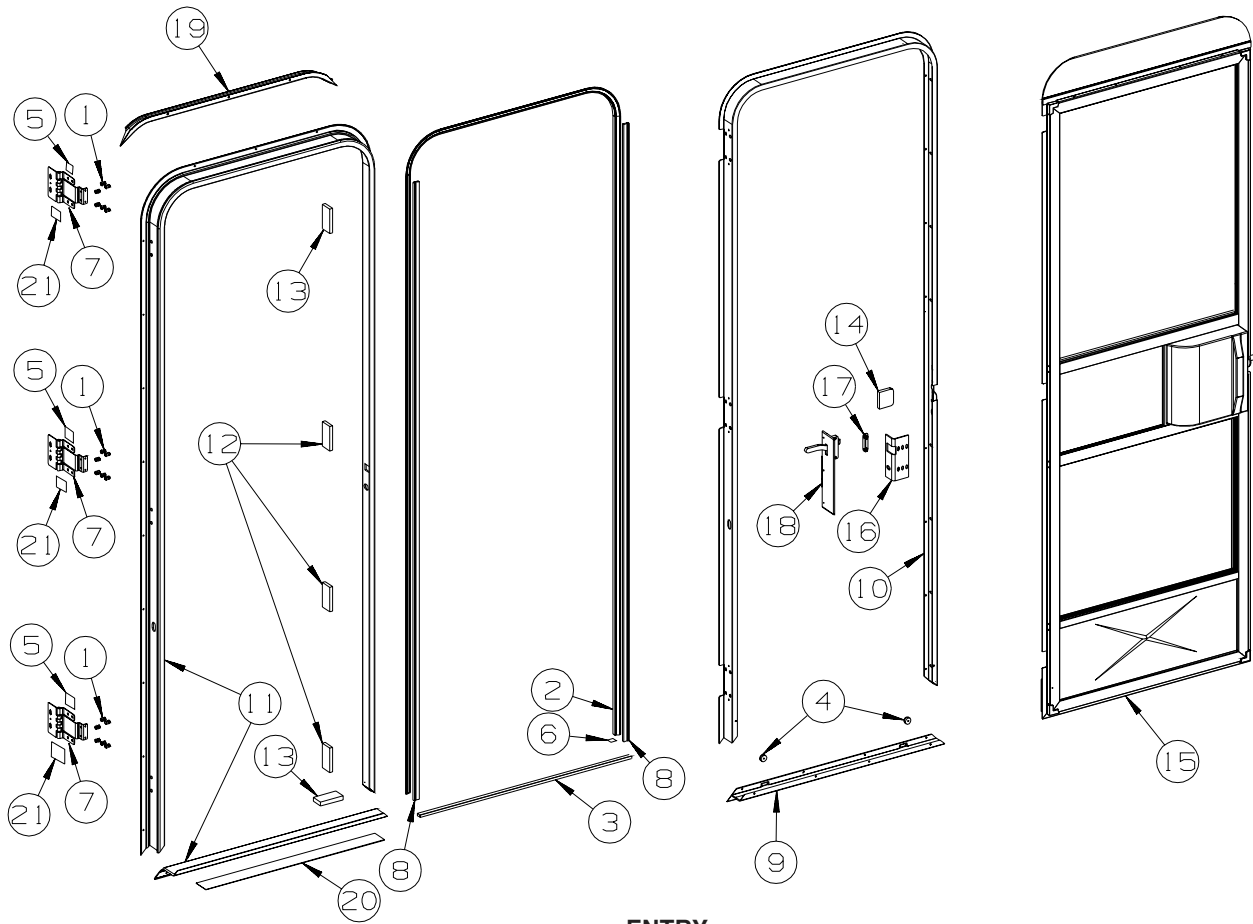

ENTRY

KEY PART NUMBER

U/M DESCRIPTION

1	039715-01-000	EA NUT-SERT - 1/4" DIAMETER - 20 THREADS
2	075671-04-000	FT SEAL - SPONGE - LAZY T - W/ADHESIVE STRIP - .5" WIDE
3	075673-05-000	FT SEAL/PILE - .5" HIGH W/ADHESIVE BACK - BLACK
4	081914-02-000	EA BUMPER - RUBBER - ROUND - 5/16" DIA. X 13/64" THICK
5	100128-02-000	FT SEAL - FOAM/ADHESIVE BACK - .37" WIDE X .37" THICK
6	104692-01-000	FT SEAL - ADHESIVE BACKED FOAM - 3/4" THICK X 3/4" WIDE X 25'
7	106719-01-05A	EA HINGE - ENTRY DOOR - BRIGHT WHITE
8	118929-01-01A	FT SEAL - PILE - PUSH ON
9	121893-01-01A	EA FRAME - ENTRY DOOR/LOWER - BRIGHT WHITE
10	121894-30-01A	EA FRAME - ENTRY DOOR - BRIGHT WHITE
11	121898-18-01A	EA JAMB - DOOR/ENTRANCE - BRIGHT WHITE
12	125724-01-000	EA SHIM - DOOR, ENTRANCE
13	125724-02-000	EA SHIM - DOOR, ENTRANCE
14	130096-05-000	EA FOAM - SCREEN DOOR, RETAINER
15	P32208-04-L07	EA DOOR - SCREEN - W/O HARDWARE
16	137401-01-03B	EA BRACKET - DOOR ANGLE - OFF WHITE
17	148364-01-12B	EA STRIKE - SCREEN DOOR - BRIGHT WHITE
18	132915-01-01A	EA LATCH - SCREEN DOOR - BLACK
19	139054-01-01A	EA CAP - DRIP - JAMB MOUNTED - BRIGHT WHITE
20	038327-01-000	EA TAPE - ANTI-SLIP - 2" X 60'
21	154585-01-01A	FT SEAL - FOAM TAPE - ADHESIVE BACK - 3/8" X 3/8" - BLACK

**EXTERIOR DOORS & COMPARTMENTS GROUP (CONTINUED)**  
**SCREEN**

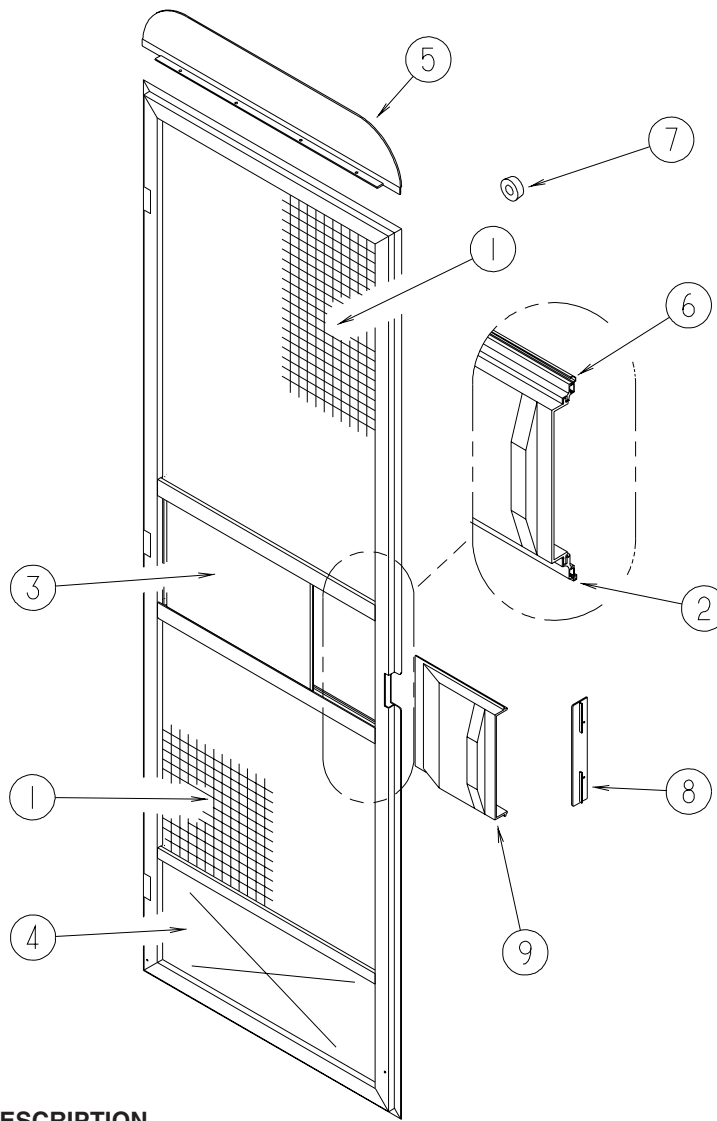

KEY	PART NUMBER	U/M	DESCRIPTION
1	002293-02-000	SF	SCREEN - 26" - CHARCOAL
2	002294-01-000	FT	SPLINE - SCREENING - .13" X .14"
3	016454-21-000	EA	INSERT/CENTER - SCREEN DOOR
4	078552-03-000	EA	KICK PANEL - SCREEN DOOR - LOWER INSERT - UNPAINTED
5	078595-01-000	EA	TOP PLATE - SCREEN DOOR - CURVED TOP - 4.7" X 25.35"
6	078777-08-000	FT	CHANNEL - SLIDER - 4 FOOT INCREMENTS
7	120863-09-000	EA	BUMPER - RUBBER/RADIUS TOP - 3/4" X 3/8" - LT GRAY
8	132081-01-01A	EA	STRIKE - SLIDER - SCREEN DOOR - BRIGHT WHITE
9	132082-01-01A	EA	SLIDER - SCREEN DOOR - BRIGHT WHITE

# EXTERIOR DOORS & COMPARTMENTS GROUP (CONTINUED)

## LATCH - ENTRY

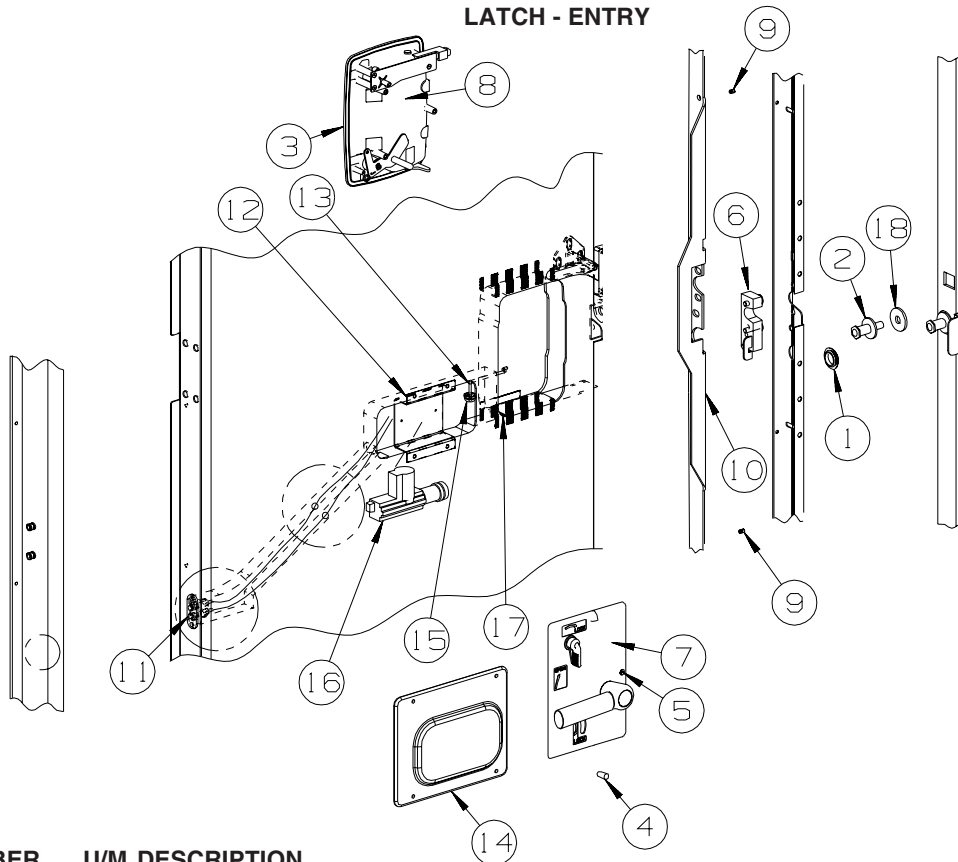

KEY	PART NUMBER	U/M	DESCRIPTION
1	061420-14-000	EA	PLUG/PLASTIC - 7/8" DIAMETER - BLACK
2	092927-20-000	EA	STRIKER - BOLT
3	112782-04-01A	EA	GASKET
4	112782-05-01A	EA	CAP - VINYL - RED
5	112782-08-01A	EA	SCREW - MOUNTING/PLATE - ZINC
6	112782-22-01A	EA	LATCH - SINGLE ROTOR
7	112782-21-01A	EA	LATCH - INTERIOR PLATE
			FROM: 00-00-00 THRU: 04-30-06
7	112782-27-01A	EA	LATCH - INTERIOR PLATE
			FROM: 05-01-06 THRU: 99-99-99
8	112782-20-01A	EA	LATCH - EXTERIOR - W/O LOCK CYLINDER W/ICON-REVERSIBLE KEY
9	072893-04-000	EA	NUTSERT - 10-32
10	132207-01-02B	EA	STIFFENER/DOOR - FORMED - E-COATED - <b>OUTLOOK, SPIRIT, SIGHTSEER, SUNOVA</b>
10	132207-03-02B	EA	STIFFENER/DOOR - FORMED - E-COATED - <b>VIEW, ASPECT, NAVION, CAMBRIA</b>
11	138897-01-000	EA	SWITCH - 2 PIN/SPRING LOADED CONTACTS (EA=1 SWITCH)
12	113650-02-02B	EA	BRACKET - ACTUATOR - ELECTRIC - E-COATED
13	113651-01-01A	EA	ROD - CONTROL - MOTOR/LOCK
14	113960-01-01A	EA	COVER - ACTUATOR - POWER LOCK
15	114209-01-01A	EA	PUSHNUT - CAP - 1/8" - WHITE
16	138898-01-000	EA	ACTUATOR/LOCK - ELECTRIC
17	137230-01-01A	EA	SPACER- NOTCHED, MILL
18	147900-01-01A	EA	SPACER-STRIKE BOLT, MILL

# EXTERIOR SLIDEOUT GROUP

FRONT LEFT

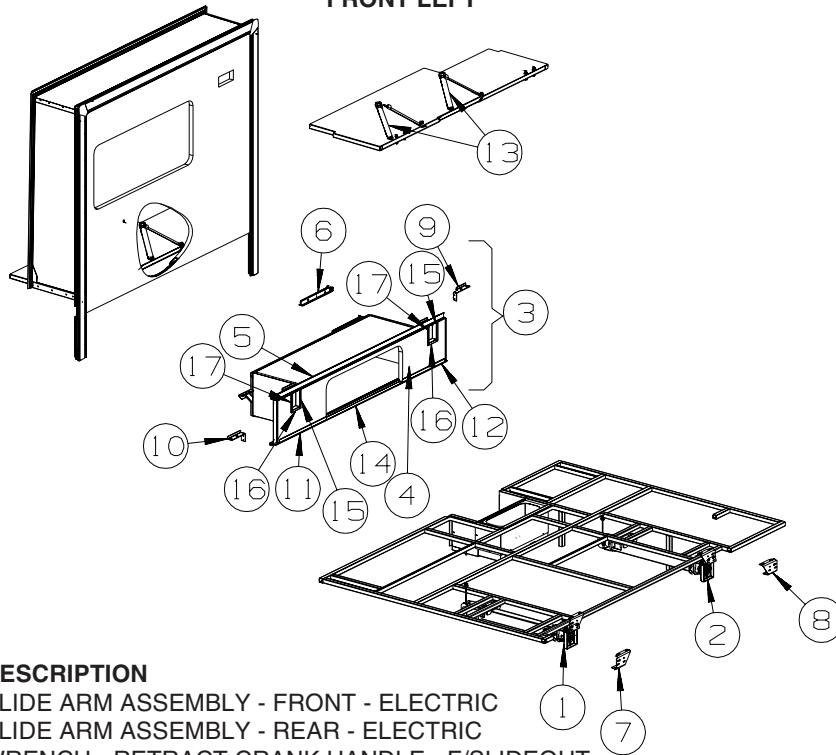

KEY	PART NUMBER	U/M	DESCRIPTION
1*	142598-01-000	EA	SLIDE ARM ASSEMBLY - FRONT - ELECTRIC
2*	142598-02-000	EA	SLIDE ARM ASSEMBLY - REAR - ELECTRIC
	138173-05-000	EA	WRENCH - RETRACT CRANK HANDLE - F/SLIDEOUT
3	140962-02-R07	EA	COMPARTMENT - SLIDEOUT
4	157262-01-U21	EA	PANEL/SEAL PLANE (U21, U22)
4	157262-01-U23	EA	PANEL/SEAL PLANE (U23, U24)
4	157262-01-U25	EA	PANEL/SEAL PLANE (U25, U26)
5	140976-06-01A	EA	JAMB - UPPER - BRIGHT WHITE
6	126591-01-02B	EA	CARRIER/EXTENSION - F/SLIDEOUT-F/WIRE/HOSES - E-COATED
7	127030-03-02B	EA	BRACKET - UPR FRT/MOUNT - OUTSIDE WALL/SLIDEOUT - E-COATED
8	127030-04-02B	EA	BRACKET - UPR REAR/MOUNT - OUTSIDE WALL/SLIDEOUT-E-COATED
9	127828-05-02B	EA	BRACKET - F/SLIDEOUT COMPARTMENT - E-COATED
10	127828-04-02B	EA	BRACKET - F/SLIDEOUT COMPARTMENT - E-COATED
11	148759-55-01A	EA	TRIM - SIDEWALL/LOWER - W/O MITER/NOTCH - 27.4"
12	148759-83-01A	EA	TRIM - SIDEWALL/LOWER - MITERED ENDS - 109.7"
13	160167-01-01A	EA	SEAT BELT - 2" X 102" - BLACK
14	140981-05-01A	EA	JAMB - LOWER - BRIGHT WHITE
15	137970-06-01A	EA	TRIM - SIDEWALL - 6.9"
16	137970-08-01A	EA	TRIM - SIDEWALL - 5.7"
17	137970-09-01A	EA	TRIM - SIDEWALL - 6.9"

\*COMPONENT PARTS LISTED LATER IN THIS GROUP

**EXTERIOR SLIDEOUT GROUP (CONTINUED)**  
**FRONT LEFT (CONTINUED)**

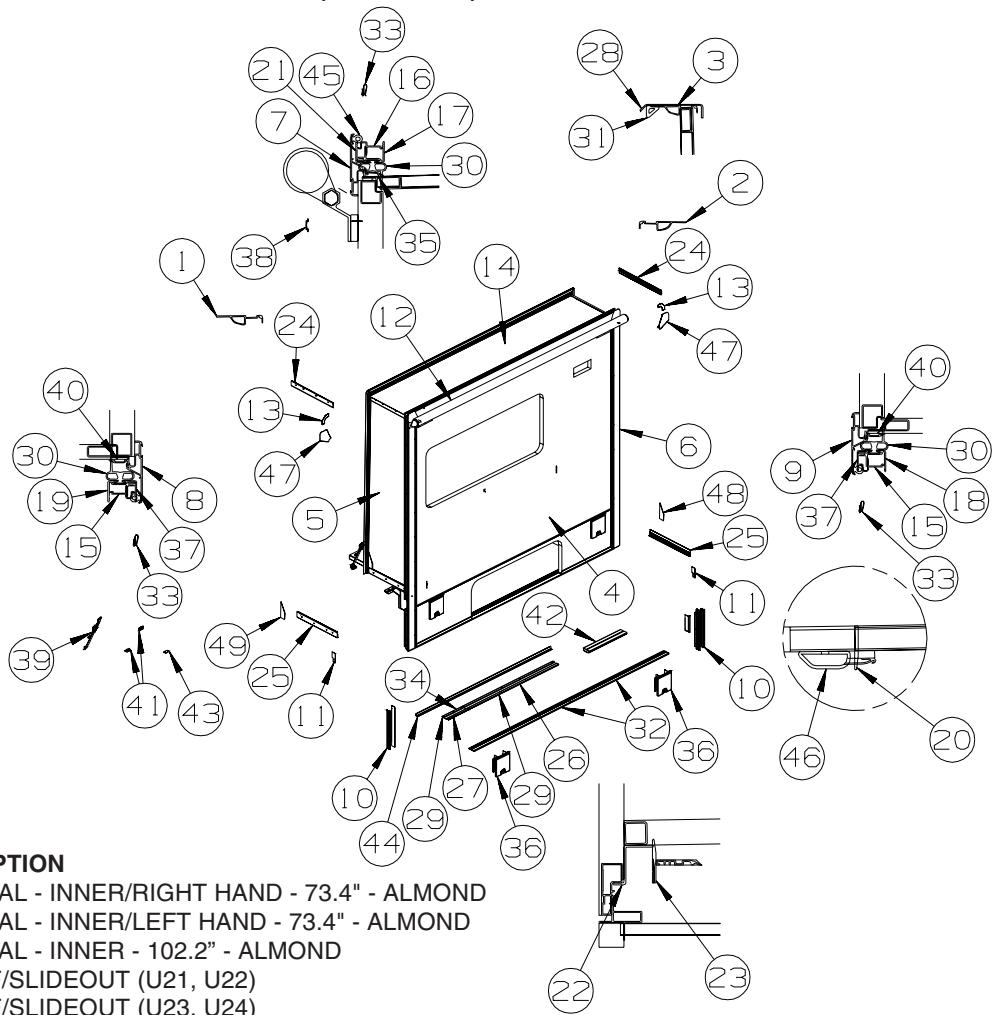

KEY	PART NUMBER	U/M	DESCRIPTION
1	139624-01-02A	EA	TRIM/SEAL - INNER/RIGHT HAND - 73.4" - ALMOND
2	139624-02-02A	EA	TRIM/SEAL - INNER/LEFT HAND - 73.4" - ALMOND
3	139624-56-02A	EA	TRIM/SEAL - INNER - 102.2" - ALMOND
4	157213-11-U21	EA	SLUG - F/SLIDEOUT (U21, U22)
4	157213-11-U23	EA	SLUG - F/SLIDEOUT (U23, U24)
4	157213-11-U25	EA	SLUG - F/SLIDEOUT (U25, U26)
5	158161-01-U21	EA	PANEL END - F/SLIDEOUT (U21, U22)
5	158161-01-U23	EA	PANEL END - F/SLIDEOUT (U23, U24)
5	158161-01-U25	EA	PANEL END - F/SLIDEOUT (U25, U26)
6	158162-01-U21	EA	PANEL END - F/SLIDEOUT (U21, U22)
6	158162-01-U23	EA	PANEL END - F/SLIDEOUT (U23, U24)
6	158162-01-U25	EA	PANEL END - F/SLIDEOUT (U25, U26)
7	156417-38-01A	EA	TRIM/SEAL - W/MITERED ENDS - 78.4" - BRIGHT WHITE - <b>NOT ILLUSTRATED</b>
			FROM: 00-00-00 THRU: 10-22-06
7	162052-38-01A	EA	TRIM/SEAL - W/MITERED ENDS - 78.4" - BRIGHT WHITE
			FROM: 10-23-06 THRU: 99-99-99
8	156417-05-01A	EA	TRIM/SEAL - W/MITERED ENDS - 93.1" - BRIGHT WHITE - <b>NOT ILLUSTRATED</b>
			FROM: 00-00-00 THRU: 10-22-06
8	162052-05-01A	EA	TRIM/SEAL - W/MITERED ENDS - 93.1" - BRIGHT WHITE
			FROM: 10-23-06 THRU: 99-99-99
9	156417-21-01A	EA	TRIM/SEAL - W/MITERED ENDS - 93.1" - BRIGHT WHITE - <b>NOT ILLUSTRATED</b>
			FROM: 00-00-00 THRU: 10-22-06
9	162052-21-01A	EA	TRIM/SEAL - W/MITERED ENDS - 93.1" - BRIGHT WHITE
			FROM: 10-23-06 THRU: 99-99-99
10	142718-27-01A	EA	RETAINER - SIDEWALL/SLIDEOUT - 15.2"
11	126546-03-03A	EA	COVER - END/SIDEWALL - BLACK
12			SLIDEOUT AWNING

**ORDER AWNINGS & REPAIR PARTS FROM DOMETIC. CALL #800-366-3842.**  
**THE DOMETIC AWNING INFORMATION YOU WILL NEED IS LOCATED ON THE**  
**MOTOR HOME NEAR THE TOP OF THE AWNING RAIL.**

**EXTERIOR SLIDEOUT GROUP (CONTINUED)**  
**FRONT LEFT (CONTINUED)**

KEY	PART NUMBER	U/M	DESCRIPTION
13	156416-01-12B	EA	BRACKET - CORNER TRIM/SLIDEOUT - 3.1"X 3.1" - BRIGHT WHITE FROM: 00-00-00 THRU: 01-06-07
13	156416-01-02B	EA	BRACKET - CORNER TRIM/SLIDEOUT - 3.1"X 3.1" - E-COATED FROM: 00-00-00 THRU: 01-06-07
13	160421-01-01A	EA	CORNER TRIM/SLIDEOUT - 3.1" X 3.1" - BLACK - <b>NOT ILLUSTRATED</b> FROM: 01-07-07 THRU: 99-99-99
14	157303-01-U21	EA	ROOF - F/SLIDEOUT
15	142718-01-01A	EA	RETAINER - SIDEWALL/SLIDEOUT - 72.8"
16	142718-45-01A	EA	RETAINER - SIDEWALL/SLIDEOUT - 101.4"
17	151761-21-02A	EA	TRIM - SIDEWALL/SLIDEOUT/TOP - 103.1" - ALMOND
18	158013-04-02A	EA	TRIM - SIDEWALL/SLIDEOUT - 93.3" - ALMOND
19	158013-02-02A	EA	TRIM - SIDEWALL/SLIDEOUT - 93.3" - ALMOND
20	115075-02-000	FT	SEAL - WIPE - .25" X 2.9"
21	136824-56-01A	EA	TRIM - SIDEWALL/SLIDEOUT - 103.2" - BRIGHT WHITE
22	128621-52-01A	EA	BRACKET/ZEE - SLIDEOUT - 97.2" - MILL
23	115075-03-000	FT	SEAL - WIPE - .25" X 2.9"
24	158375-03-01A	EA	TRIM - FEATURE STRIP - 20.6" - BRIGHT WHITE
25	158030-01-01A	EA	TRIM - FEATURE STRIP/LOWER - 2.3" X 20" - BRIGHT WHITE FROM: 00-00-00 THRU: 10-22-06
25	158030-06-01A	EA	TRIM - FEATURE STRIP/LOWER - 2.3" X 19.8" - BRIGHT WHITE FROM: 10-23-06 THRU: 99-99-99
26	115325-07-01A	EA	RAIL - FLOOR/SLIDEOUT ROOM - 44.4" LONG - BLACK
27	115325-16-01A	EA	RAIL - FLOOR/SLIDEOUT ROOM - 9.8" LONG - BLACK
28	125466-12-04A	EA	SUPPORT - ROOF/INTERIOR - ALMOND
29	115661-01-000	FT	SHOE/GLIDE - SLIDEOUT ROOM - 1/16" X 3" - POLYETHYLENE
30	136978-01-01A	FT	SEAL - SLIDEOUT - BLACK
31	146056-01-000	FT	SEAL - TRIANGLE - W/PSA
32	134837-01-01A	EA	RAMP - SLIDEOUT - BLACK PVC - <b>VINYL FLOOR THRU OUT</b>
33	142549-01-000	EA	CLIP - "S" TYPE
34	134756-02-I76	EA	RAMP - FABRIC COVERED - SLIDEOUT - 51.2" - <b>VINYL FLOOR THRU OUT</b>
35	133954-68-01A	EA	TRIM/SEAL - 98.5" - BRIGHT WHITE - <b>NOT ILLUSTRATED</b> FROM: 00-00-00 THRU: 05-07-06
35	146606-68-01A	EA	TRIM/RETAINER - 98.5" - BRIGHT WHITE FROM: 05-08-06 THRU: 99-99-99
36	154963-01-01A	EA	COVER - RAM - 6.8" X 7.6" - BRIGHT WHITE
37	136824-26-01A	EA	TRIM - SIDEWALL/SLIDEOUT - 93.3" - BRIGHT WHITE
38	105312-01-07A	FT	INSERT - FEATURE STRIP - VINYL - BRIGHT WHITE
39	135619-01-01A	EA	STRAP - TIEDOWN - SLIDEOUT ROOM
40	133954-11-01A	EA	TRIM/SEAL - 92" - BRIGHT WHITE - <b>NOT ILLUSTRATED</b> FROM: 00-00-00 THRU: 05-07-06
40	146606-11-01A	EA	TRIM/RETAINER - 89.9" - BRIGHT WHITE FROM: 05-08-06 THRU: 99-99-99
41	135619-02-01A	EA	PLATE - TIEDOWN - SLIDEOUT ROOM
42	134756-03-M30	EA	RAMP - FABRIC COVERED - SLIDEOUT - 18.3" - <b>VINYL FLOOR THRU OUT</b>
43	135622-01-02B	EA	PLATE - TIEDOWN - SLIDEOUT ROOM
44	151282-15-01A	EA	TRIM - CARPET EDGE/F-ANGLE - 66.4" - BLACK FROM: 00-00-00 THRU: 08-20-06
44	151282-13-01A	EA	TRIM - CARPET EDGE/F-ANGLE - 66" - BLACK FROM: 08-21-06 THRU: 99-99-99
45	158297-01-000	FT	SEAL - D-SECTION/BULB/TEE - ADHESIVE BACK - BLACK
46	134756-01-L76	EA	RAMP - FABRIC COVERED - F/SLIDEOUT - 66.9" - <b>VINYL FLOOR THRU OUT</b>
47	156151-01-02A	EA	PROTECTOR - CORNER - SLIDEOUT - BRIGHT WHITE
48	157809-01-01A	EA	SEAL - FOAM BLOCK/RIGHT SIDE - ADHESIVE BACK
49	157809-02-01A	EA	SEAL - FOAM BLOCK/LEFT SIDE - ADHESIVE BACK



**EXTERIOR SLIDEOUT GROUP (CONTINUED)**  
**COMPONENT PARTS FOR FRONT SLIDEOUT**

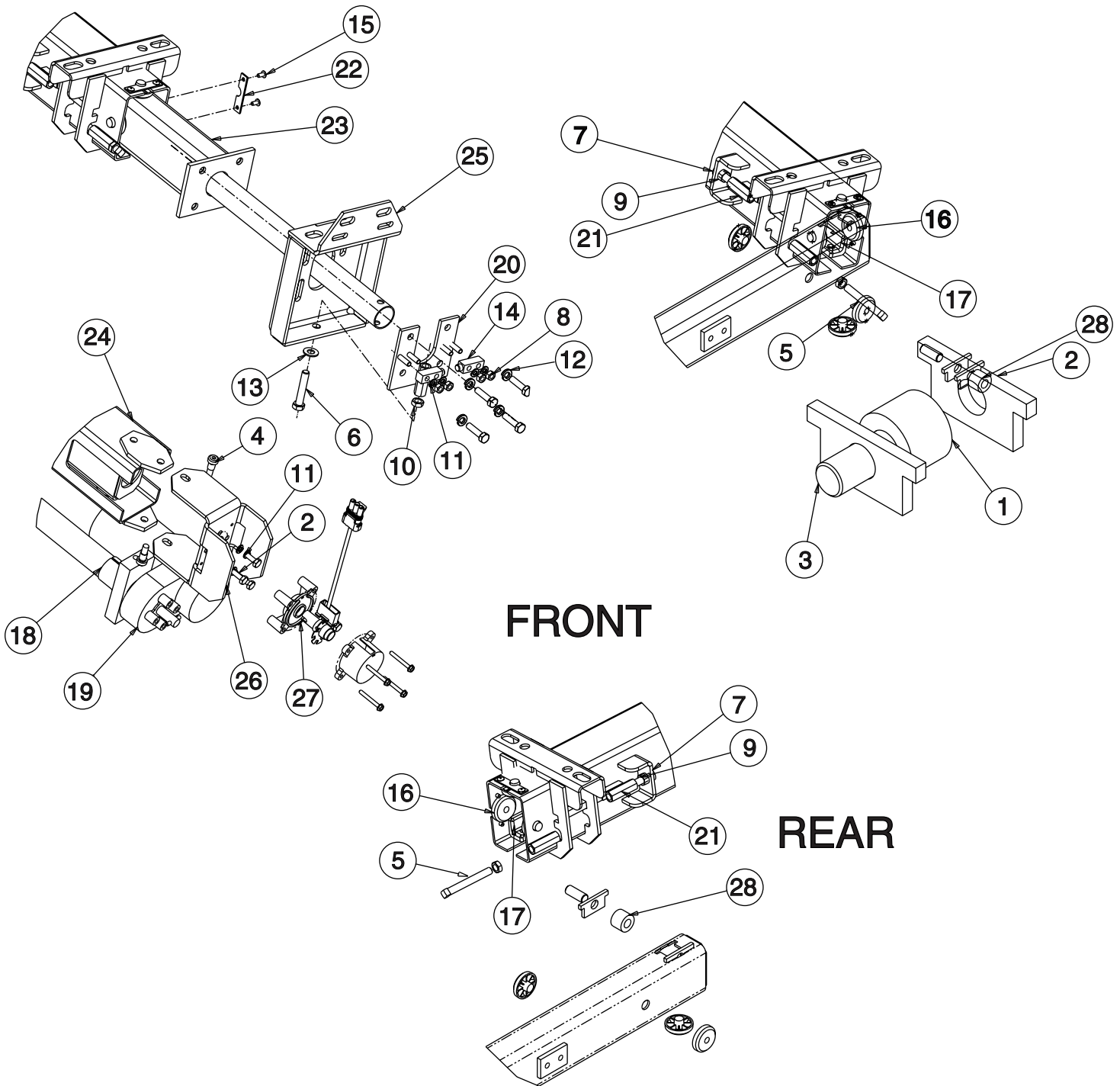

**FRONT**

**REAR**

142598-01-000

KEY	PART NUMBER	U/M	DESCRIPTION	VENDOR NO.
1	140457-01-701	EA	BUSHING - 1" X 3/4" X 1/2"ID	1614006
3	140457-01-704	EA	SHAFT/AXLE - REAR ROLLER	7204523
10	138173-01-710	EA	MOUNT PLATE W/STUDS	7201098
10	142958-01-700	EA	TUBE/OUTER -RH (FRONT)	7201155
10	142958-01-701	EA	TUBE/INNER - RH & LH	7201154
14	138173-01-700	EA	PIN/CLEVIS - PLATED/FRONT	1213810
15	138173-01-701	EA	POP RIVET - SS 3/16"X1/4"	1214630
16	138173-01-707	EA	WEAR PUCK - PLASTIC F/DRIVE	1612523
17	138173-01-705	EA	WEAR PAD - PLASTIC	1612531
19	138173-01-706	EA	MOTOR - DRIVE W/WORM SHAFT	1820106
	138173-01-704	EA	HOUSING/ENCODER-MAIN ASSY	7200055
	138173-01-711	EA	BOLT/SHOULDER 3/8 X 1/2	1203734

CONTACT WINNEBAGO PART SALES FOR UNLISTED COMPONENT(S)

**EXTERIOR SLIDEOUT GROUP (CONTINUED)**  
**COMPONENT PARTS FOR FRONT SLIDEOUT (CONTINUED)**

142598-02-000

KEY	PART NUMBER	U/M	DESCRIPTION	VENDOR NO.
1	140457-01-701	EA	BUSHING - 1" X 3/4" X 1/2"ID	1614006
3	140457-01-704	EA	SHAFT/AXLE - REAR ROLLER	7204523
10	142958-01-701	EA	TUBE/INNER - RH & LH	7201154
10	142958-02-700	EA	TUBE/OUTER -LH (REAR)	7201150
14	138173-01-700	EA	PIN/CLEVIS - PLATED/Front	1213810
15	138173-01-701	EA	POP RIVET - SS 3/16"X1/4"	1214630
16	138173-01-707	EA	WEAR PUCK - PLASTIC F/DRIVE	1612523
17	138173-01-705	EA	WEAR PAD - PLASTIC	1612531
19	138173-01-706	EA	MOTOR - DRIVE W/WORM SHAFT	1820106
	138173-01-704	EA	HOUSING/ENCODER-MAIN ASSY	7200055
			CONTACT WINNEBAGO PART SALES FOR UNLISTED COMPONENT(S)	

# GENERATOR GROUP

GAS

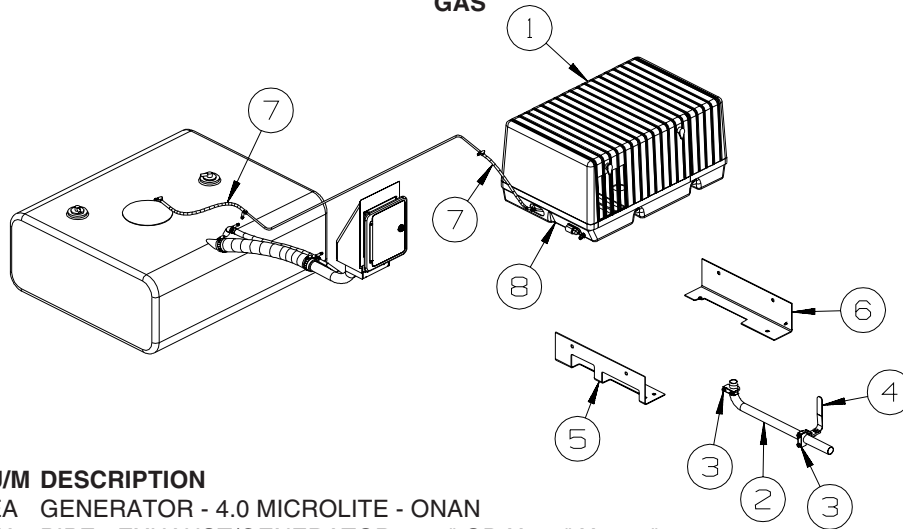

331H

KEY	PART NUMBER	U/M	DESCRIPTION
1	109982-03-000	EA	GENERATOR - 4.0 MICROLITE - ONAN
2	105958-08-000	EA	PIPE - EXHAUST/GENERATOR - 1.5" OD X 3.1" X 19.7"
3	007125-04-000	EA	CLAMP - MUFFLER - 1.12"DIAMETER
4	007131-01-000	EA	HANGER - TAILPIPE - 6 SLOTS
5	114070-02-02B	EA	SUPPORT - GENERATOR - LEFT
6	114071-02-02B	EA	SUPPORT - GENERATOR - RIGHT
7	128139-03-000	FT	HOSE - FUEL - LOW PERMEABILITY - 1/4" DIAMETER
8	084884-01-000	EA	PLUG - BRASS - 3/8"

**HEATING & A/C GROUP**  
**FURNACE**

<b>KEY</b>	<b>PART NUMBER</b>	<b>U/M</b>	<b>DESCRIPTION</b>
*	139980-02-000	EA	FURNACE-30000BTU-SF QUIET-SBRBN SF-30 2321J
	098668-23-000	EA	DOOR - ACCESS - FURNACE - BRIGHT WHITE
	009198-01-000	FT	DUCT - HEAT - FLEXIBLE - 4" ID X 25'
	009198-02-000	FT	DUCT - HEAT - FLEXIBLE - 2" ID X 25'
	056464-10-000	EA	REGISTER W/O DAMPER - 4" DIAMETER - PLASTIC - BEIGE
	069636-02-000	EA	CONNECTOR - DUCT - 4" ID
	009200-01-000	EA	TAPE - FURNACE - 1 1/2"
	089367-01-000	EA	TEE - 4" OD - 7" LONG - METAL
	089367-02-000	EA	TEE - 4" X 2" X 4"
	093614-01-02A	EA	GRILLE - AIR RETURN - 15.9" X 7.9" - BEIGE
	093614-02-02A	EA	GRILLE - AIR RETURN - 9.9" X 9.9" - BEIGE

**\*COMPONENT PARTS LISTED LATER IN THIS GROUP**

**HEATING & A/C GROUP (CONTINUED)**  
**COMPONENT PARTS FOR FURNACE**

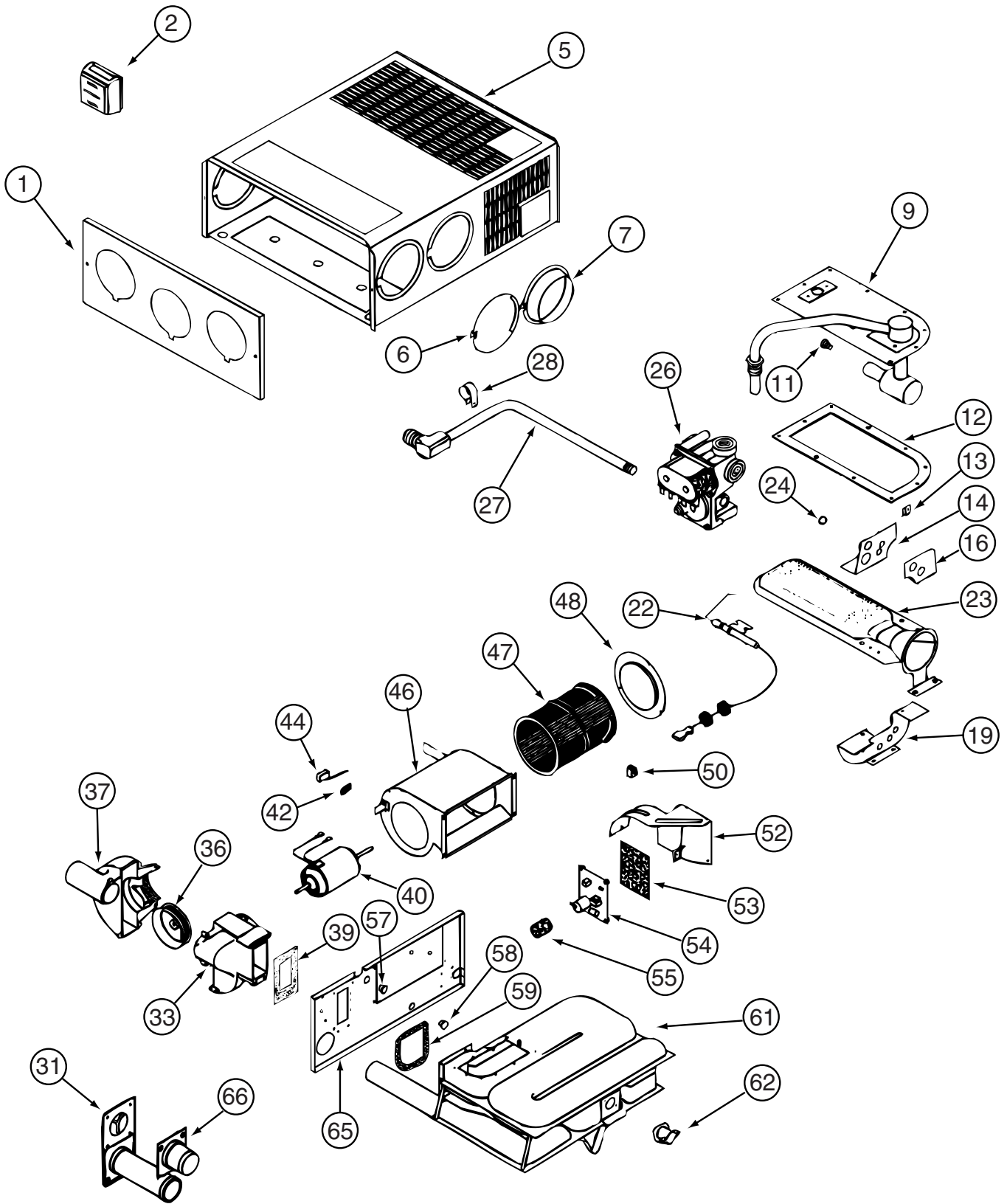

139980-02-000

**HEATING & A/C GROUP (CONTINUED)**  
**COMPONENT PARTS FOR FURNACE (CONTINUED)**

139980-02-000 (CONTNUED)

KEY	PART NUMBER	U/M	DESCRIPTION	VENDOR NO.
9	139980-01-700	EA	MANIFOLD ASSEMBLY	171571
11	092300-02-701	EA	ORIFICE-MAIN BURNER (NT-30BW	180214
12	098668-22-703	EA	GASKET - BURNER ACCESS COVER	070811
22	139980-01-701	EA	ELECTRODE	232286
23	098668-02-700	EA	BURNER ASSEMBLY,SF-30 & SF35	010745
26	098668-01-718	EA	VALVE-GAS SF S.N.974903079	161122
27	139980-01-702	EA	PIPE ASSEMBLY/GAS INLET	171574
31	098668-01-707	EA	TUBE ASSEMBLY, EXHAUST W/CAP	260231
33	139980-01-703	EA	HOUSING/COMB. - FRONT/HALF	390852
36	098668-01-706	EA	WHEEL-COMBUSTION AIR	350184
37	139980-01-704	EA	HOUSING/COMB. - REAR/HALF	390848
39	139980-01-705	EA	GASKET/FIREWALL-COMB AIR	071084
40	139980-01-706	EA	MOTOR ASSEMBLY W/GASKET	232682
42	101990-01-714	EA	GASKET-MICROSWITCH	230877
44	098668-21-700	EA	SWITCH-MICRO-W/O FLAG 3 1/4"	232261
46	139980-01-708	EA	BLOWER ASSEMBLY - ROOM AIR	390739BK
47	098668-01-711	EA	WHEEL-BLOWER, ROOM AIR	350129
48	139980-01-709	EA	ORFICE RING	390696
50	139980-01-710	EA	SWITCH - ON/OFF	232351
52	139980-01-711	EA	PANEL ASSEMBLY-MODULE BD	101663
53	139980-01-712	EA	INSULATOR - MODULE BD	070807
54	098668-22-705	EA	MODULE BD W/RELAY TIME DELAY	520820
55	139980-01-713	EA	CAP/INSULATOR-MODULE BD	070973
57	139980-01-714	EA	BUSHING - UNIVERSAL	070362
58	139980-01-715	EA	BUSHING - STRAIN RELIEF	231809
59	098668-01-716	EA	GASKET-FIREWALL,CHAMBER SIDE	070808
61	139980-01-716	EA	CHAMBER ASSEMBLY - FINAL	021149BK
62	098668-21-701	EA	SWITCH - LIMIT	232504
66	098668-01-713	EA	TUBE ASSEMBLY, INTAKE	051248
	139980-02-700	EA	BLOWER ASM-1/2 HOUSING/OUTER	390851
	139980-02-701	EA	BLOWER ASM-1/2 HOUSING/INNER	390872
			CONTACT WINNEBAGO PART SALES FOR UNLISTED COMPONENT(S)	

**HEATING & A/C GROUP (CONTINUED)**  
**REAR HEATER**

<b>KEY</b>	<b>PART NUMBER</b>	<b>U/M</b>	<b>DESCRIPTION</b>
*	084405-01-000	EA	HEATER - REAR/DUCTED - W/MOTOR AID
	007108-01-000	FT	HOSE - HEATER - 5/8"ID - HI-TEMP
	076776-01-000	EA	TEE - BEADED - 5/8" X 5/8" X 5/8"
	079059-01-000	EA	HOSE - 90 DEGREE - 5/8"ID X 4" X 36"
	079059-02-000	EA	HOSE - 90 DEGREE - .61" ID X 4" X 6"

**\*COMPONENT PARTS LISTED LATER IN THIS GROUP**

**COMPONENT PARTS FOR REAR HEATER**

<b>KEY</b>	<b>PART NUMBER</b>	<b>U/M</b>	<b>DESCRIPTION</b>	<b>084405-01-000</b>	<b>VENDOR NO.</b>
	084405-01-700	EA	CORE-HEATER		FT200229
	084405-01-701	EA	FAN BLADES		HV029931
	084405-01-702	EA	MOTOR ASSEMBLY, 12 VOLT		RV010348

## HEATING & A/C GROUP (CONTINUED)

### ROOF

KEY	PART NUMBER	U/M	DESCRIPTION
*	131188-03-01A	EA	A/C/ROOF - 14,800 BTU/MACH 15 - NEW MODEL #8335B676 - WHT
*	131188-04-01A	EA	A/C/ROOF - 14,800 BTU/HEAT PUMP - NEW MODEL #8535B676- WHT - <b>HEAT PUMP-ROOF AIR</b>
*	131184-01-01A	EA	CEILING ASSEMBLY - A/C DUCTED - WHITE
	131184-02-01A	EA	BOARD - DIVIDER - SILVER
*	131184-05-01A	EA	CEILING ASSEMBLY - HEAT PUMP - WHITE

**\*COMPONENT PARTS LISTED LATER IN THIS GROUP**

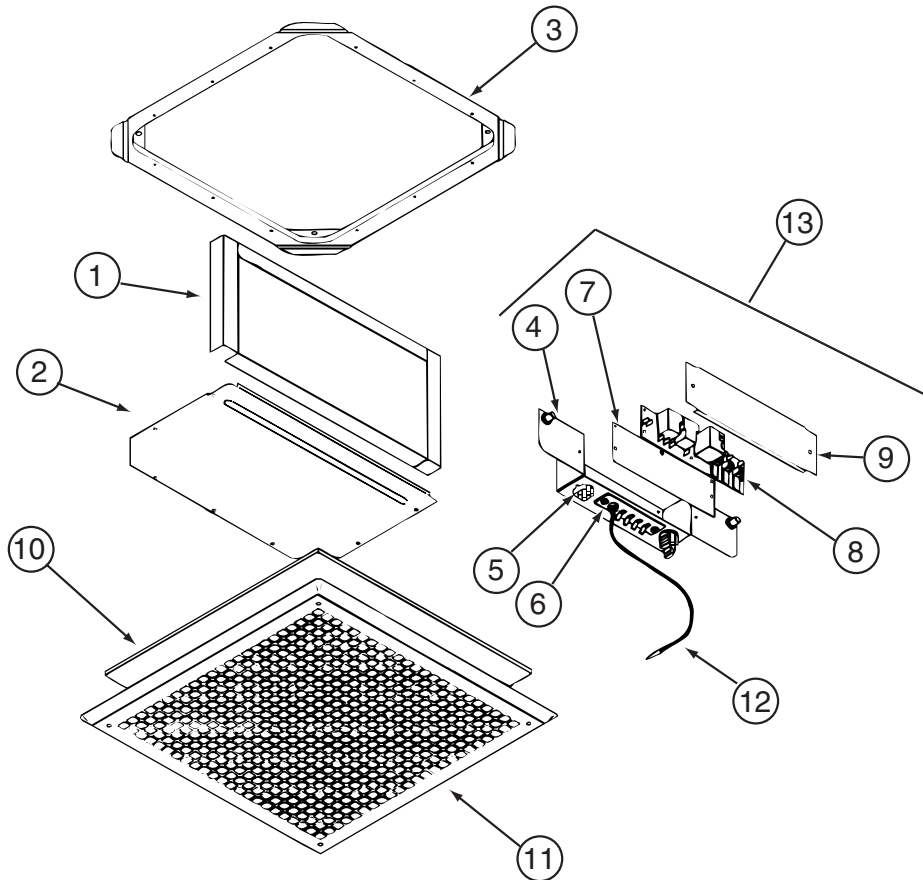

### COMPONENT PARTS FOR ROOF

131184-01-01A

KEY	PART NUMBER	U/M	DESCRIPTION	VENDOR NO.
1	131184-01-707	EA	DUCT DIVIDER	8330-3501
5	131184-01-700	EA	PLUG ASSEMBLY	7330A389
6	131184-01-701	EA	TERMINAL BOARD	7330B3201
7	131184-01-702	EA	ISOLATOR - BLANK	7330C365
8	108892-01-702	EA	BOARD-P.C.	7330A3211
10	108892-01-703	EA	FILTER	6798A3761
11	108892-01-704	EA	GRILLE 16 3/8X16 3/8 RETURN	6798-3041
12	131184-01-704	EA	COIL SENSOR	7330-6111
13	131184-01-705	EA	JUNCTION BOX ASSEMBLY	7330B5551
	131184-01-703	EA	SMALL PARTS PKG	8330-5961

CONTACT WINNEBAGO PART SALES FOR UNLISTED COMPONENT(S)



**HEATING & A/C GROUP (CONTINUED)**  
**COMPONENT PARTS FOR ROOF (CONTINUED)**

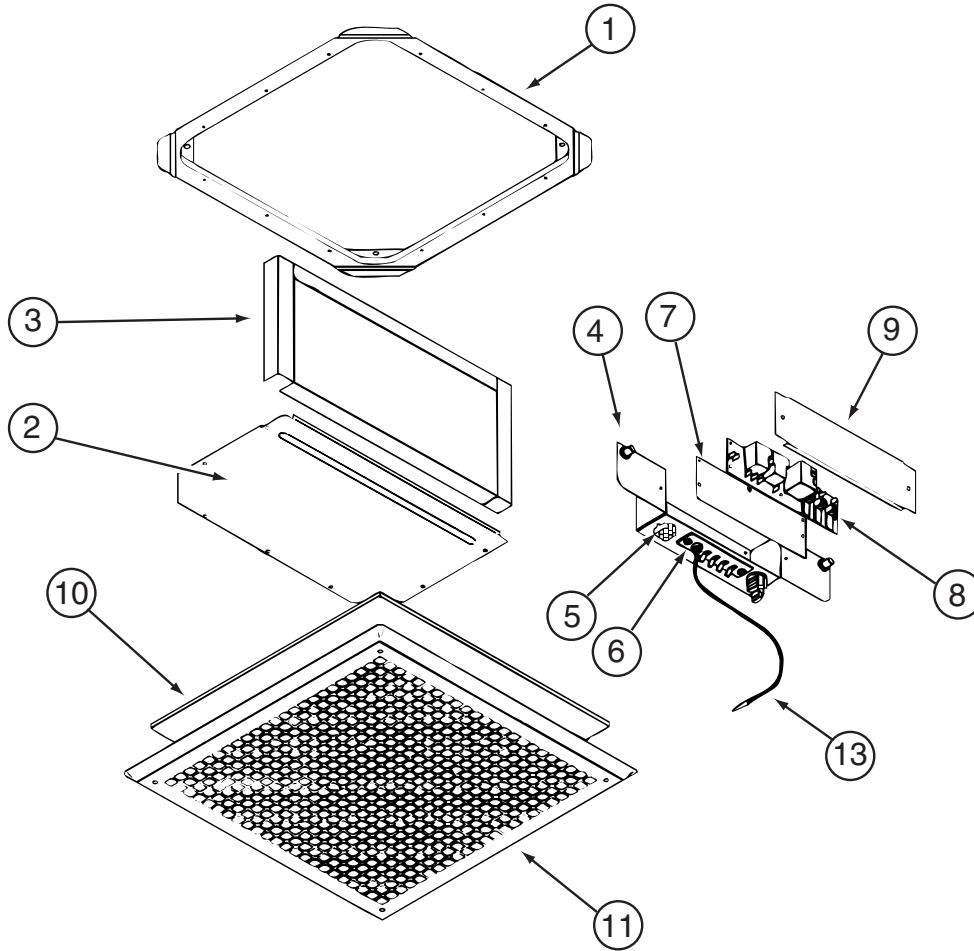

131184-05-01A

KEY	PART NUMBER	U/M	DESCRIPTION	VENDOR NO.
4	131184-05-700	EA	BOX - JUNCTION	8530-5091
5	131184-04-700	EA	PLUG ASSEMBLY	7530A340
6	131184-04-702	EA	BOARD - TERMINAL	7530B3201
7	131184-01-702	EA	ISOLATOR - BLANK	7330C365
8	131184-04-705	EA	BOARD - P.C.	7330B3311
10	108892-01-703	EA	FILTER	6798A3761
11	108892-01-704	EA	GRILLE 16 3/8X16 3/8 RETURN	6798-3041
13	105620-12-719	EA	COIL SENSOR	7330A3231
	131184-01-703	EA	SMALL PARTS PKG	8330-5961

CONTACT WINNEBAGO PART SALES FOR UNLISTED COMPONENT(S)

## HEATING & A/C GROUP (CONTINUED)

### COMPONENT PARTS FOR ROOF (CONTINUED)

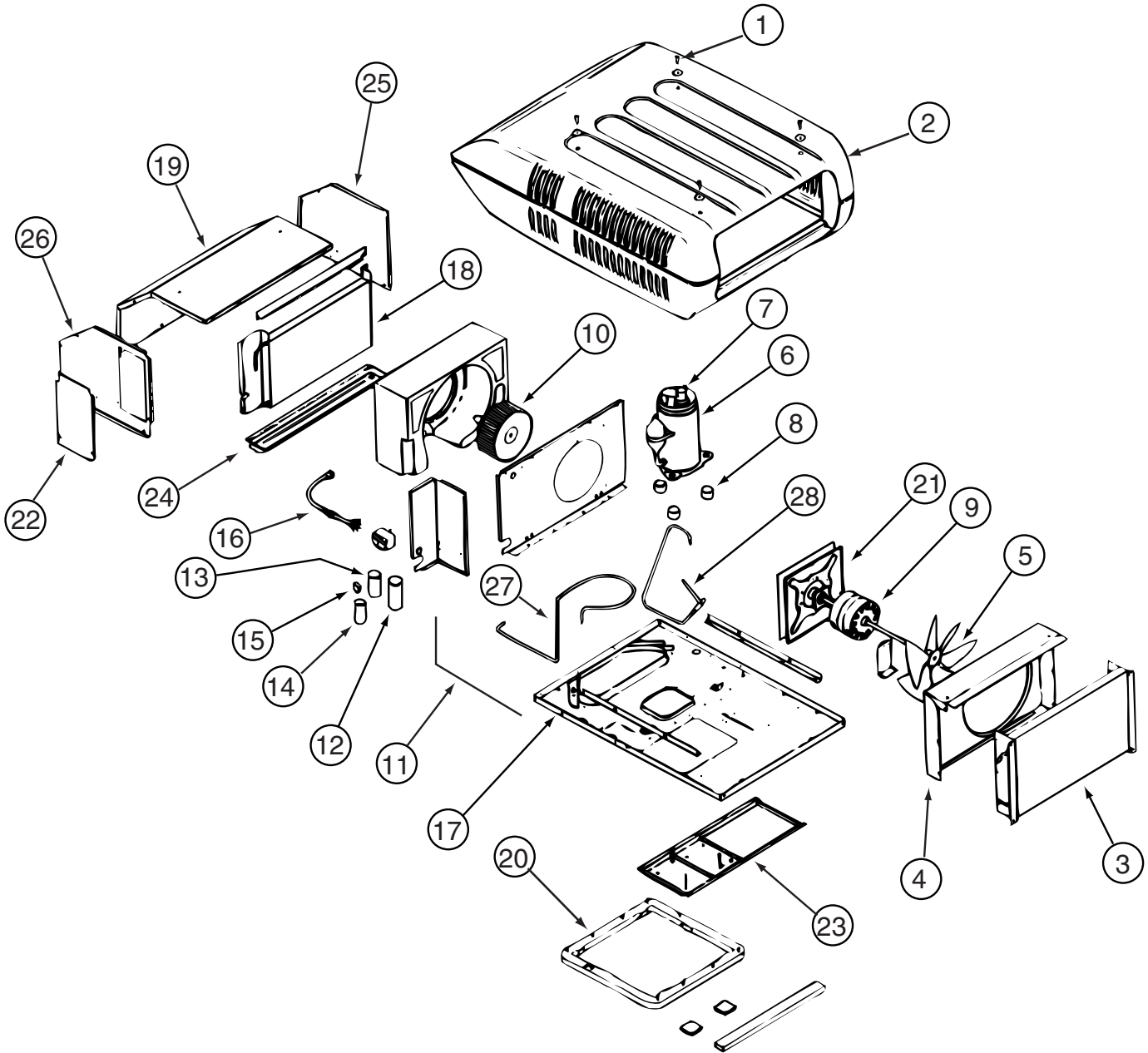

131185-03-01A

KEY	PART NUMBER	U/M	DESCRIPTION	VENDOR NO.
2	131185-03-700	EA	SHROUD-ROOF AIR W/HAIL GUARD	8333-4161
3	131185-01-700	EA	CONDENSER COIL	1452A1451
5	093763-01-712	EA	BLADE-FAN-CONDENSER	6733-3221
6	105620-01-706	EA	MOUNTING PKG.,COMP., 3 PER	6759-3081
6	131185-03-701	EA	COMPRESSOR - (PANASONIC)	1450A2059
7	131185-03-702	EA	OVERLOAD	1450-0141
9	131185-01-701	EA	MOTOR (115V, 60HZ)	1468-3069
10	131185-01-702	EA	BLOWER WHEEL PACKAGE	1472-1091
12	105620-12-725	EA	COMPRESSOR RUN CAPACITOR	1499-5731
13	108889-01-708	EA	CAPACITOR-FAN, 7.5MFD. 370U	1499-5461
15	105620-10-704	EA	START COMPACITOR	1497-0861
15	105620-10-705	EA	PTCR (START DEVICE) - W/CAP.	8333A9021
18	131185-01-703	EA	EVAPORATOR COIL	1452A1491
20	037648-01-714	EA	GASKET PACKAGE	8332-3301
21	131185-01-704	EA	MOTOR MOUNT & SEAL KIT	8333-5151
27	131185-03-704	EA	LINE - SUCTION	8333B530
28	131185-03-705	EA	LINE - DISCHARGE	8333-131
	093306-01-701	EA	DECAL PACKAGE, LEFT & RIGHT	6798B3591
	131185-03-703	EA	PAD/FILLER (COND AIR SEAL)	8332-3301

CONTACT WINNEBAGO PART SALES FOR UNLISTED COMPONENT(S)

## HEATING & A/C GROUP (CONTINUED)

### COMPONENT PARTS FOR ROOF (CONTINUED)

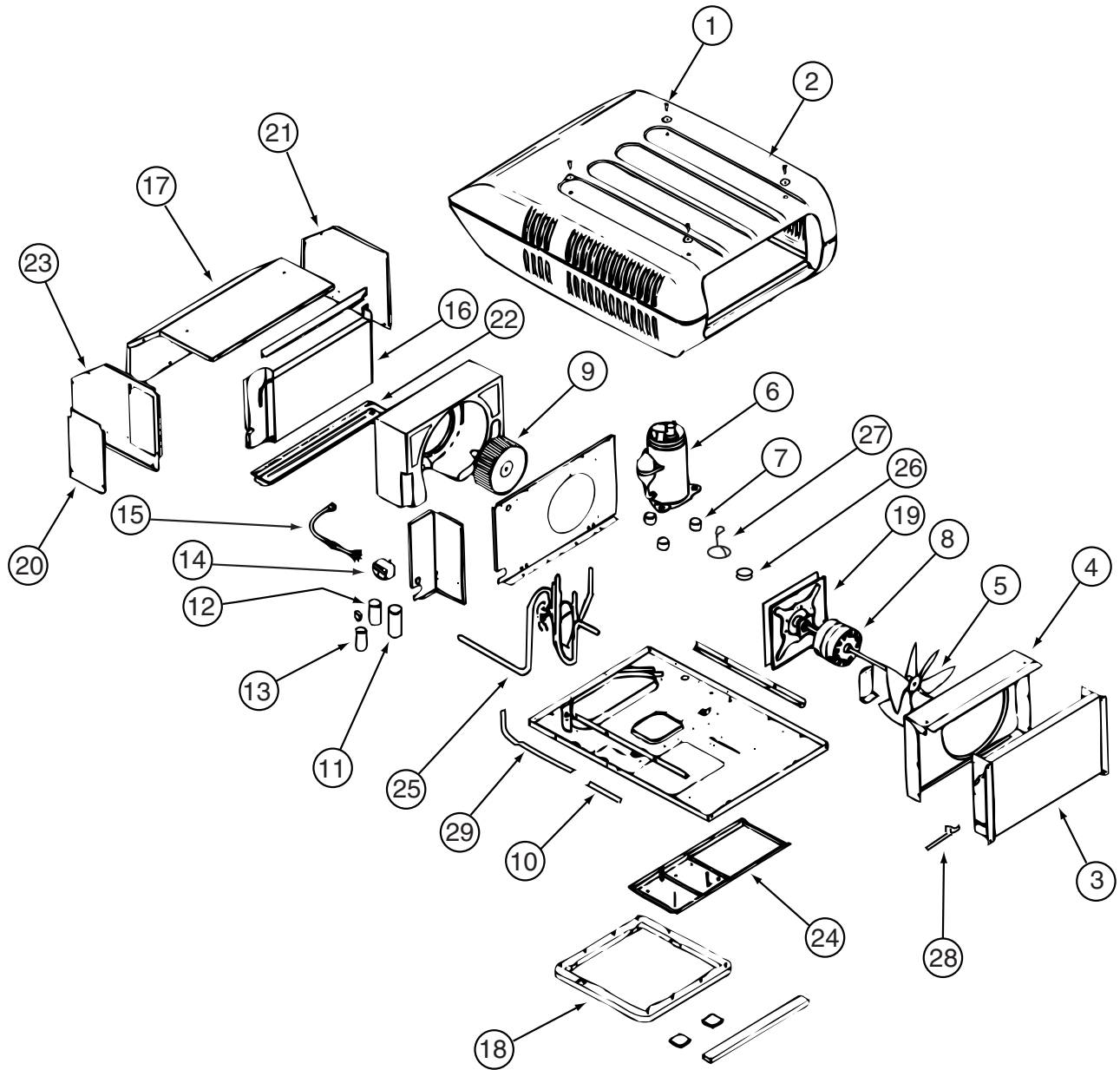

131188-03-01A

KEY	PART NUMBER	U/M	DESCRIPTION	VENDOR NO.
2	131185-03-700	EA	SHROUD-ROOF AIR W/HAIL GUARD	8333-4161
3	115219-01-700	EA	COIL-CONDENSER	1452A1321
5	093763-01-712	EA	BLADE-FAN-CONDENSER	6733-3221
6	131188-01-700	EA	COMPRESSOR - TECUMSEH	1450A2609
7	105620-01-706	EA	MOUNTING PKG.,COMP., 3 PER	6759-3081
8	131185-01-701	EA	MOTOR (115V, 60HZ)	1468-3069
9	131185-01-702	EA	BLOWER WHEEL PACKAGE	1472-1091
11	131188-01-701	EA	RUN CAP. (COMP-40MFD/370V)	1499-5721
12	108889-01-708	EA	CAPACITOR-FAN, 7.5MFD. 370U	1499-5461
13	126859-01-704	EA	CAPACITOR - START	1497-0871
14	091225-01-709	EA	RELAY-START	1497-4131
16	131186-01-701	EA	EVAPORATOR COIL	1452-1521
18	037648-01-714	EA	GASKET PACKAGE	8332-3301
19	131185-01-704	EA	MOTOR MOUNT & SEAL KIT	8333-5151
	093306-01-701	EA	DECAL PACKAGE, LEFT & RIGHT	6798B3591
	108889-01-710	EA	PAD-FILLER, CONDENSER SEAL	6759B3971
	131188-01-702	EA	LINE - SUCTION	7335A134
	131188-01-703	EA	LINE - DISCHARGE	7335A135

CONTACT WINNEBAGO PART SALES FOR UNLISTED COMPONENT(S)

**HEATING & A/C GROUP (CONTINUED)**  
**COMPONENT PARTS FOR ROOF (CONTINUED)**

131188-04-01A

<b>KEY</b>	<b>PART NUMBER</b>	<b>U/M</b>	<b>DESCRIPTION</b>	<b>VENDOR NO.</b>
3	131188-02-700	EA	CONDENSER COIL	1452-1441
5	093763-01-712	EA	BLADE-FAN-CONDENSER	6733-3221
6	131188-02-701	EA	COMPRESSOR(TECUMSEH-RK225AT)	1450A2069
7	105620-01-706	EA	MOUNTING PKG.,COMP., 3 PER	6759-3081
8	131185-01-701	EA	MOTOR (115V, 60HZ)	1468-3069
9	131185-01-702	EA	BLOWER WHEEL PACKAGE	1472-1091
10	131188-02-702	EA	RESTRICTOR - BY FLOW	1454-2501
11	131188-01-701	EA	RUN CAP. (COMP-40MFD/370V)	1499-5721
12	093763-01-704	EA	CAPACITOR-FAN (INDOOR MOTOR)	1499-5461
13	131188-02-703	EA	CAPACITOR-START(21-25MFD)	1497-0211
14	091225-01-709	EA	RELAY-START	1497-4131
16	131186-01-701	EA	EVAPORATOR COIL	1452-1521
18	037648-01-714	EA	GASKET PACKAGE	8332-3301
19	131185-01-704	EA	MOTOR MOUNT & SEAL KIT	8333-5151
25	131188-02-704	EA	VALVE/REVERSE ASSEMBLY	7535A5301
26	105620-12-708	EA	COIL - SOLENOID	1460-1081
27	131188-02-705	EA	WIRE HARNESS F/SOLENOID	7535-109
28	131188-02-706	EA	SWITCH - FREEZE	1460-2041
29	131188-02-707	EA	LIQUID LINE	7535-135
			CONTACT WINNEBAGO PART SALES FOR UNLISTED COMPONENT(S)	

# INTERIOR FINISH GROUP

## MOLDINGS & TRIMS

### HONEY CHERRY

### WASHED MAPLE

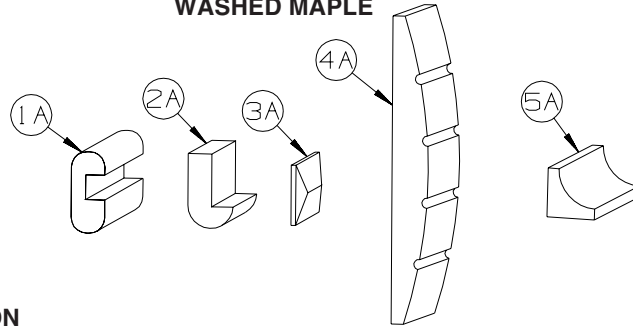

KEY	PART NUMBER	U/M	DESCRIPTION
1A	M09412-62-N42	EA	MOLDING/SHELF EDGE - .6" X 1.3" X 96" - PORTSMOUTH OAK
1A	M09412-62-M52	EA	MOLDING/SHELF EDGE - .6" X 1.3" X 96" - CHERRY - CONCERT CHERRY
1A	M09412-62-M62	EA	MOLDING/SHELF EDGE - .6" X 1.3" X 96" - WASHED MAPLE - WASHED MAPLE
1A	M09412-62-RC3	EA	MOLDING/SHELF EDGE - .6" X 1.3" X 96" - HONEY CHERRY - HONEY CHERRY
1A	M09412-62-SA3	EA	MOLDING/SHELF EDGE - .6" X 1.3" X 96" - MAPLE - SIERRA MAPLE
2A	M09450-77-PC0	EA	MOLDING - TRIM/HDWD W/LIP -.4"X3.2"X79.6" - PORTSMOUTH OAK
2A	M09450-77-PC1	EA	MOLDING - TRIM/HDWD W/LIP -.4"X3.2"X79.6" - CONCERT CHERRY
2A	M09450-77-PC2	EA	MOLDING - TRIM/HDWD W/LIP -.4"X3.2"X79.6" - WASHED MAPLE
2A	M09450-77-RC3	EA	MOLDING - TRIM/HDWD W/LIP -.4"X3.2"X79.6" - HONEY CHERRY
2A	M09501-32-TG1	EA	MOLDING/TRIM - W/NOTCH - .8" X 2.5" X 86.2"-CONCERT CHERRY
2A	M09501-32-TG2	EA	MOLDING/TRIM - W/NOTCH - .8" X 2.5" X 86.2" - WASHED MAPLE,
2A	M09501-32-TD3	EA	MOLDING/TRIM - W/NOTCH - .8" X 2.5" X 86.2" - SIERRA MAPLE
2A	M09503-52-T77	EA	MOLDING/TRIM - .75" X 1.2" X 86.5" - PORTSMOUTH OAK
2A	M09503-52-T78	EA	MOLDING/TRIM - .75" X 1.2" X 86.5" - CONCERT CHERRY
2A	M09503-52-T79	EA	MOLDING/TRIM - .75" X 1.2" X 86.5" - WASHED MAPLE
2A	M09503-52-T80	EA	MOLDING/TRIM - .75" X 1.2" X 86.5" - SIERRA MAPLE
2A	M09511-43-T78	EA	MOLDING - TRIM - W/NOTCH - .8" X 1.4" X 86.3" - CONCERT CHERRY
2A	M09525-80-UM1	EA	MOLDING - TRIM - W/NOTCH - .8"X 1.4"X 86.5" - CONCERT CHERRY
2A	M09511-43-T79	EA	MOLDING - TRIM - W/NOTCH - .8" X 1.4" X 86.3" - WASHED MAPLE
2A	M09525-80-U91	EA	MOLDING - TRIM - W/NOTCH - .8" X 1.4" X 86.5" - WASHED MAPLE
2A	M09511-43-T80	EA	MOLDING - TRIM - W/NOTCH - .8" X 1.4" X 86.3" - SIERRA MAPLE
2A	M09525-80-U92	EA	MOLDING - TRIM - W/NOTCH - .8" X 1.4" X 86.5" - SIERRA MAPLE
2A	M09438-25-RA3	EA	MOLDING - HARDWOOD-W/NOTCH - 1.4"X 80.2" - HONEY CHERRY
2A	M09515-72-TD1	EA	MOLDING/TRIM - .8" X 2.2" X 86.1" - CONCERT CHERRY
2A	M09515-72-TD2	EA	MOLDING/TRIM - .8" X 2.2" X 86.1" - WASHED MAPLE
2A	M09515-72-TD3	EA	MOLDING/TRIM - .8" X 2.2" X 86.1" - SIERRA MAPLE
3A	M09471-91-R69	EA	MOLDING - TRIM/VEE - .2" X 1" X 34.4" - CONCERT CHERRY
3A	M09471-91-R76	EA	MOLDING - TRIM/VEE - .2" X 1" X 34.4" - WASHED MAPLE
3A	M09471-91-SA3	EA	MOLDING - TRIM/VEE - .2" X 1" X 34.4" - SIERRA MAPLE
3A	M09477-88-S34	EA	MOLDING - TRIM/VEE - .2" X 1" X 19.9" - WASHED MAPLE
3A	M09477-88-S35	EA	MOLDING - TRIM/VEE - .2" X 1" X 19.9" - SIERRA MAPLE
3A	M09501-30-SD2	EA	MOLDING - TRIM/VEE - .2" X 1" X 35.1" - WASHED MAPLE
3A	M09501-30-SD3	EA	MOLDING - TRIM/VEE - .2" X 1" X 35.1" - HONEY CHERRY
3A	M09501-37-TG1	EA	MOLDING - TRIM/VEE - .2" X 1" X 19.2" - CONCERT CHERRY
3A	M09501-37-TG2	EA	MOLDING - TRIM/VEE - .2" X 1" X 19.2" - WASHED MAPLE
3A	M09501-37-TD3	EA	MOLDING - TRIM/VEE - .2" X 1" X 19.2" - SIERRA MAPLE
3A	M09501-37-TG3	EA	MOLDING - TRIM/VEE - .2" X 1" X 19.2" - HONEY CHERRY
3A	M09501-63-T78	EA	MOLDING - TRIM/VEE - .2" X 1" X 15" - CONCERT CHERRY
3A	M09501-63-T79	EA	MOLDING - TRIM/VEE - .2" X 1" X 15" - WASHED MAPLE
3A	M09501-63-T80	EA	MOLDING - TRIM/VEE - .2" X 1" X 15" - SIERRA MAPLE
3A	M09503-62-TG1	EA	MOLDING - TRIM/VEE - .2" X 1" X 26.3" - CONCERT CHERRY
3A	M09503-62-TG2	EA	MOLDING - TRIM/VEE - .2" X 1" X 26.3" - WASHED MAPLE
3A	M09503-62-TG3	EA	MOLDING - TRIM/VEE - .2" X 1" X 26.3" - HONEY CHERRY
3A	M09511-90-TG1	EA	MOLDING - TRIM/VEE - .2" X 1" X 42.1" - CONCERT CHERRY
3A	M09511-90-TG3	EA	MOLDING - TRIM/VEE - .2" X 1" X 42.1" - HONEY CHERRY
3A	M09511-90-TG2	EA	MOLDING - TRIM/VEE - .2" X 1" X 42.1" - WASHED MAPLE
3A	M09520-15-TD1	EA	MOLDING - TRIM/VEE - .2" X 1" X 15.3" - CONCERT CHERRY
3A	M09520-15-TD2	EA	MOLDING - TRIM/VEE - .2" X 1" X 15.3" - WASHED MAPLE
3A	M09520-15-TD3	EA	MOLDING - TRIM/VEE - .2" X 1" X 15.3" - SIERRA MAPLE
3A	M09520-96-T59	EA	MOLDING - TRIM/VEE - .2" X 1" X 32.7" - PORTSMOUTH OAK
3A	M09520-96-T60	EA	MOLDING - TRIM/VEE - .2" X 1" X 32.7" - CONCERT CHERRY
3A	M09520-96-T61	EA	MOLDING - TRIM/VEE - .2" X 1" X 32.7" - WASHED MAPLE
3A	M09520-96-TP0	EA	MOLDING - TRIM/VEE - .2" X 1" X 32.7" - SIERRA MAPLE

**INTERIOR FINISH GROUP (CONTINUED)**  
**MOLDINGS & TRIMS (CONTINUED)**

KEY	PART NUMBER	U/M	DESCRIPTION
3A	M09525-96-TA0	EA	MOLDING - TRIM/VEE - .2" X 1" X 36.2" - PORTSMOUTH OAK
3A	M09525-96-TA1	EA	MOLDING - TRIM/VEE - .2" X 1" X 36.2" - CONCERT CHERRY
3A	M09525-96-TA2	EA	MOLDING - TRIM/VEE - .2" X 1" X 36.2" - WASHED MAPLE
3A	M09525-96-TA3	EA	MOLDING - TRIM/VEE - .2" X 1" X 36.2" - SIERRA MAPLE
3A	M09534-08-T01	EA	MOLDING - TRIM/VEE - .2" X 1" X 24.5" - SIERRA MAPLE
3A	M09534-08-T02	EA	MOLDING - TRIM/VEE - .2" X 1" X 24.5" - HONEY CHERRY
3A	M09511-32-T78	EA	MOLDING - TRIM/VEE - .4" X 1" X 26.8" - CONCERT CHERRY
3A	M09511-32-T79	EA	MOLDING - TRIM/VEE - .4" X 1" X 26.8" - WASHED MAPLE
3A	M09511-32-T80	EA	MOLDING - TRIM/VEE - .4" X 1" X 26.8" - SIERRA MAPLE
3A	M09511-86-T78	EA	MOLDING - TRIM/VEE - .4" X 1" X 28.3" - CONCERT CHERRY
3A	M09511-86-T79	EA	MOLDING - TRIM/VEE - .4" X 1" X 28.3" - WASHED MAPLE
3A	M09511-86-T80	EA	MOLDING - TRIM/VEE - .4" X 1" X 28.3" - SIERRA MAPLE
3A	M09477-63-S46	EA	MOLDING - TRIM/VEE - .4" X 1" X 64.1" - PORTSMOUTH OAK - BATH DOOR TRIM
3A	M09477-63-SR0	EA	MOLDING - TRIM/VEE - .4" X 1" X 64.1" - SIERRA MAPLE - BATH DOOR TRIM
3A	M09477-64-S46	EA	MOLDING - TRIM/VEE - .4" X 1" X 14.9" - PORTSMOUTH OAK - BATH DOOR TRIM
3A	M09477-64-SR0	EA	MOLDING - TRIM/VEE - .4" X 1" X 14.9" - SIERRA MAPLE - BATH DOOR TRIM
4A	M09462-54-R90	EA	MOLDING - FLUTED, CURVED - .6" X 6" X 82.7" - CONCERT CHERRY
4A	M09462-54-R91	EA	MOLDING - FLUTED, CURVED - .6" X 6" X 82.7" - WASHED MAPLE
4A	M09462-54-RE3	EA	MOLDING - FLUTED, CURVED - .6" X 6" X 82.7" - HONEY CHERRY
5A	M09471-79-R38	EA	MOLDING - TRIM/COVE - .8" X .8" X 95.8" - OAK/PORTS OAK - PORTSMOUTH OAK
5A	M09471-79-R39	EA	MOLDING - TRIM/COVE - .8" X .8" X 95.8" - CHERRY/CHERRY - CONCERT CHERRY
5A	M09471-79-R46	EA	MOLDING - TRIM/COVE - .8" X .8" X 95.8" - MAPLE/MAPLE - WASHED MAPLE
5A	M09471-79-RE0	EA	MOLDING - TRIM/COVE - .8" X .8" X 95.8" - HONEY/CHERRY- HONEY CHERRY
5A	M09471-79-SA3	EA	MOLDING - TRIM/COVE - .8" X .8" X 95.8" - HONEY/MAPLE - SIERRA MAPLE

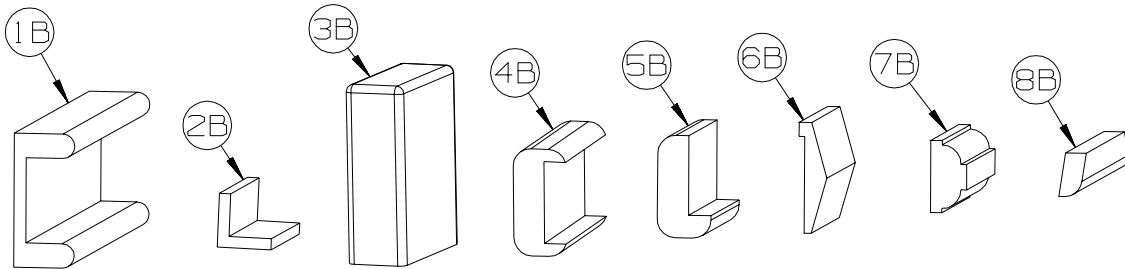

KEY	PART NUMBER	U/M	DESCRIPTION
1B	M09501-84-TG0	EA	MOLDING/TRIM - CAP/WALL - 2.2" X 85.9" - PORTSMOUTH OAK
1B	M09501-84-TG1	EA	MOLDING/TRIM - CAP/WALL - 2.2" X 85.9" - CONCERT CHERRY
1B	M09501-84-TG2	EA	MOLDING/TRIM - CAP/WALL - 2.2" X 85.9" - WASHED MAPLE
1B	M09520-07-TD3	EA	MOLDING/TRIM - CAP/WALL - 2.2" X 80.5" - SIERRA MAPLE
1B	M09501-84-TG3	EA	MOLDING/TRIM - CAP/WALL - 2.2" X 85.9" - HONEY CHERRY
2B	M09511-81-TA1	EA	MOLDING/TRIM - L SHAPE - .8"X .8"X 80.2" - CONCERT CHERRY
2B	M09511-81-TA2	EA	MOLDING/TRIM - L SHAPE - .8"X .8"X 80.2" - WASHED MAPLE
2B	M09511-81-TA3	EA	MOLDING/TRIM - L SHAPE - .8"X .8"X 80.2" - SIERRA MAPLE
3B	M09515-81-T01	EA	MOLDING/HARDWOOD STRAIGHT - 74.3" - WASHED MAPLE
3B	M09515-81-T02	EA	MOLDING/HARDWOOD STRAIGHT - 74.3" - HONEY CHERRY
4B	M09511-42-T77	EA	MOLDING - TRIM - W/NOTCH - 1.5" X 86.4" - PORTSMOUTH OAK
4B	M09511-42-T78	EA	MOLDING - TRIM - W/NOTCH - 1.5" X 86.4" - CONCERT CHERRY
4B	M09511-42-T79	EA	MOLDING - TRIM - W/NOTCH - 1.5" X 86.4" - WASHED MAPLE
4B	M09511-42-T80	EA	MOLDING - TRIM - W/NOTCH - 1.5" X 86.4" - SIERRA MAPLE
5B	M09515-18-T78	EA	MOLDING - HARDWOOD-W/NOTCH - 1.4"X 86.2" - CONCERT CHERRY
5B	M09515-18-T79	EA	MOLDING - HARDWOOD-W/NOTCH - 1.4"X 86.2" - WASHED MAPLE
5B	M09515-18-T80	EA	MOLDING - HARDWOOD-W/NOTCH - 1.4"X 86.2" - SIERRA MAPLE
6B	M09515-52-TG1	EA	MOLDING - TRIM/VEE - 1.5" X 73.9" - CONCERT CHERRY
6B	M09515-52-TG2	EA	MOLDING - TRIM/VEE - 1.5" X 73.9" - WASHED MAPLE
6B	M09515-52-TG3	EA	MOLDING - TRIM/VEE - 1.5" X 73.9" - HONEY CHERRY
7B	Y00076-32-438	EA	MOLDING/TRIM - .5" X 1" X 96" - CHERRY (UNSTAINED)
7B	Y00076-22-438	EA	MOLDING/TRIM - .5" X 1" X 96" - MAPLE (UNSTAINED)
8B	Y00086-72-438	EA	MOLDING - VINYL WRAP - .7" X 1.6" X 96" - PORTSMOUTH OAK - PORTSMOUTH OAK
8B	Y00086-62-438	EA	MOLDING - 96" - CONCERT CHERRY (U90/94/98/A1/A5/B1/C1/C5/D1/D5/E1/E5/F1/F5/G1/G5/H1/H5)
8B	Y00086-D2-438	EA	MOLDING - VINYL WRAP - .7" X 1.6" X 96" - CONCERT CHERRY (UM1 THRU UM9, UN1 THRU UN9)
8B	Y00086-A2-438	EA	MOLDING - VINYL WRAP - .7" X 1.6" X 96" - WASHED MAPLE
8B	Y00086-92-438	EA	MOLDING - VINYL WRAP - .7" X 1.6" X 96" - SIERRA MAPLE - SIERRA MAPLE

**INTERIOR FINISH GROUP (CONTINUED)**  
**MOLDINGS & TRIMS (CONTINUED)**

KEY	PART NUMBER	U/M	DESCRIPTION
8B	Y00087-62-438	EA	MOLDING - 96" - CONCERT CHERRY (U90/94/98/A1/A5/B1/C1/C5/D1/D5/E1/E5/F1/F5/G1/G5/H1/H5)
8B	Y00087-D2-438	EA	MOLDING - VINYL WRAP - .7" X 2.9" X 96" - CONCERT CHERRY (UM1 THRU UM9, UN1 THRU UN9)
8B	Y00087-A2-438	EA	MOLDING - VINYL WRAP - .7" X 2.9" X 96" - WASHED MAPLE
8B	Y00087-92-438	EA	MOLDING - VINYL WRAP - .7" X 2.9" X 96" - SIERRA MAPLE
8B	Y00300-62-438	EA	MOLDING - 96" - CONCERT CHERRY (U90/94/98/A1/A5/B1/C1/C5/D1/D5/E1/E5/F1/F5/G1/G5/H1/H5)
8B	Y00300-D2-438	EA	MOLDING - VINYL WRAP - .3" X .6" X 96" - CONCERT CHERRY (UM1 THRU UM9, UN1 THRU UN9)
8B	Y00300-A2-438	EA	MOLDING - VINYL WRAP - .3" X .6" X 96" - WASHED MAPLE
8B	Y00300-92-438	EA	MOLDING - VINYL WRAP - .3" X .6" X 96" - SIERRA MAPLE

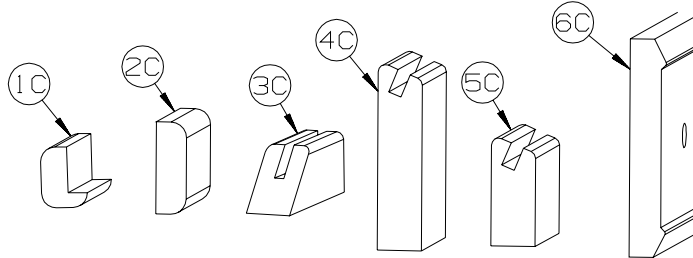

KEY	PART NUMBER	U/M	DESCRIPTION
1C	M09520-19-TD1	EA	MOLDING - TRIM - W/NOTCH - 1" X 86.3" - CONCERT CHERRY
1C	M09520-19-TD2	EA	MOLDING - TRIM - W/NOTCH - 1" X 86.3" - WASHED MAPLE
1C	M09520-19-TD3	EA	MOLDING - TRIM - W/NOTCH - 1" X 86.3" - HONEY CHERRY
1C	M09525-27-UF1	EA	MOLDING - HARDWOOD - .75" X 1.4" X 32.4" - CONCERT CHERRY
1C	M09525-27-UF2	EA	MOLDING - HARDWOOD - .75" X 1.4" X 32.4" - WASHED MAPLE
1C	M09525-27-UF3	EA	MOLDING - HARDWOOD - .75" X 1.4" X 32.4" - SIERRA MAPLE
2C	M09511-46-T77	EA	MOLDING/TRIM - .5" X 1.5" X 86.5" - PORTSMOUTH OAK
2C	M09511-46-T78	EA	MOLDING/TRIM - .5" X 1.5" X 86.5" - CONCERT CHERRY
2C	M09511-46-T79	EA	MOLDING/TRIM - .5" X 1.5" X 86.5" - WASHED MAPLE
2C	M09511-46-T80	EA	MOLDING/TRIM - .5" X 1.5" X 86.5" - SIERRA MAPLE
3C	Y00223-42-438	EA	MOLDING - HARDWOOD/OAK - .7" X 1" X 96"
3C	Y00223-32-438	EA	MOLDING - HARDWOOD/CHERRY - .7" X 1" X 96"
3C	Y00223-22-438	EA	MOLDING - HARDWOOD/MAPLE - .7" X 1" X 96"
4C	Y00054-62-438	EA	MOLDING- 96" - CONCERT CHERRY (U90/94/98/A1/A5/B1/C1/C5/D1/D5/E1/E5/F1/F5/G1/G5/H1/H5)
4C	Y00054-D2-438	EA	MOLDING/VYL WRP-BVLD-.73" X 3.1" X 96" - CONCERT CHERRY (UM1 THRU UM9, UN1 THRU UN9)
4C	Y00054-A2-438	EA	MOLDING/VINYL WRAP-BEVELED ENDS-.73"X3.1"X96" - WASHED MAPLE
4C	Y00054-92-438	EA	MOLDING/VINYL WRAP-BEVELED-.73" X 3.1" X 96" - SIERRA MAPLE
4C	Y00258-62-438	EA	MOLDING/VYL 96" - CONCERT CHERRY (U90/94/98/A1/A5/B1/C1/C5/D1/D5/E1/E5/F1/F5/G1/G5/H1/H5)
4C	Y00258-D2-438	EA	MOLDING/VINYL WRP-BVLD-.73" X 3.1" X 96" - CONCERT CHERRY (UM1 THRU UM9, UN1 THRU UN9)
4C	Y00258-A2-438	EA	MOLDING/VINYL WRAP-BEVELED ENDS-.73"X3.1"X96" - WASHED MAPLE
4C	Y00258-92-438	EA	MOLDING/VINYL WRAP-BEVELED-.73" X 3.1" X 96" - SIERRA MAPLE
5C	Y00259-62-438	EA	MOLDING/VYL 96" - CONCERT CHERRY (U90/94/98/A1/A5/B1/C1/C5/D1/D5/E1/E5/F1/F5/G1/G5/H1/H5)
5C	Y00259-D2-438	EA	MOLDING/VINYL WRP-BVLD-.73" X 1.8" X 96" - CONCERT CHERRY (UM1 THRU UM9, UN1 THRU UN9)
5C	Y00259-A2-438	EA	MOLDING/VINYL WRAP-BEVELED-.73"X1.8"X96" - WASHED MAPLE
5C	Y00259-92-438	EA	MOLDING/VINYL WRAP-BEVELED-.73"X1.8"X96" - SIERRA MAPLE
6C	Y00152-A2-438	EA	MOLDING/TRIM - VINYL - .6" X 3.5" X 96" - WASHED MAPLE
6C	Y00152-92-438	EA	MOLDING/TRIM - VINYL - .6" X 3.5" X 96" - SIERRA MAPLE

## INTERIOR FINISH GROUP (CONTINUED)

### MOLDINGS & TRIMS (CONTINUED)

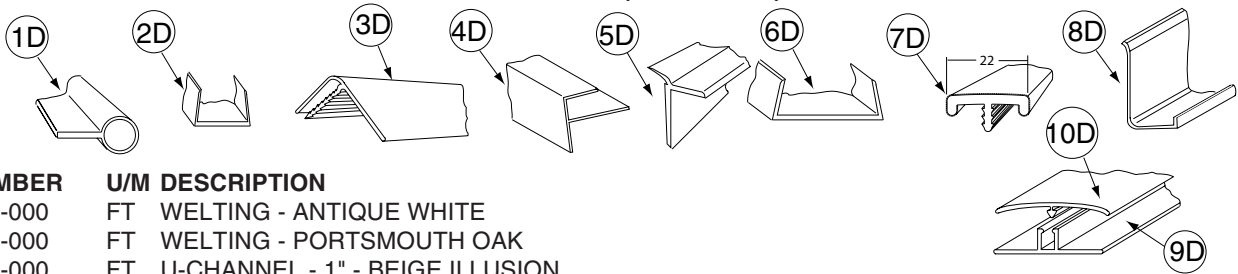

KEY	PART NUMBER	U/M	DESCRIPTION
1D	009767-12-000	FT	WELTING - ANTIQUE WHITE
1D	009767-17-000	FT	WELTING - PORTSMOUTH OAK
2D	009778-25-000	FT	U-CHANNEL - 1" - BEIGE ILLUSION
2D	009778-26-000	FT	U-CHANNEL - 1 1/4" - BEIGE ILLUSION
2D	009778-38-000	FT	U-CHANNEL - 1" - BONE
2D	009778-32-000	FT	U-CHANNEL - 1" - PORTSMOUTH OAK
2D	009778-34-000	FT	U-CHANNEL - 1" - CONCERT CHERRY
2D	009778-27-000	FT	U-CHANNEL - 1" - WASHED MAPLE
2D	009778-35-000	FT	U-CHANNEL - 1" - HONEY CHERRY
2D	009778-36-000	FT	U-CHANNEL - 1" - SIERRA MAPLE
3D	009809-30-000	EA	MOLDING - CORNER - OUTSIDE - 1" X 84" - BEIGE ILLUSION
3D	009809-37-000	EA	MOLDING - CORNER - OUTSIDE - 1" X 84" - BONE
3D	009809-32-000	EA	MOLDING - CORNER - OUTSIDE - 1" X 84" - PORTSMOUTH OAK
3D	009809-33-000	EA	MOLDING - CORNER - OUTSIDE - 1" X 84" - CONCERT CHERRY
3D	009809-31-000	EA	MOLDING - CORNER - OUTSIDE - 1" X 84" - WASHED MAPLE
3D	009809-34-000	EA	MOLDING - CORNER - OUTSIDE - 1" X 84" - HONEY CHERRY
3D	009809-35-000	EA	MOLDING - CORNER - OUTSIDE - 1" X 84" - SIERRA MAPLE
4D	009812-31-000	EA	MOLDING - CORNER - 1/2" W/1/4"CHAN X 84" - BEIGE ILLUSION
4D	009812-40-000	EA	MOLDING - CORNER - 1/2" W/1/4"CHAN X 84" - BONE
4D	009812-35-000	EA	MOLDING - CORNER - 1/2" W/1/4"CHAN X 84" - PORTSMOUTH OAK
4D	009812-36-000	EA	MOLDING - CORNER - 1/2" W/1/4"CHAN X 84" - CONCERT CHERRY
4D	009812-33-000	EA	MOLDING - CORNER - 1/2" W/1/4"CHAN X 84" - WASHED MAPLE
4D	009812-37-000	EA	MOLDING - CORNER - 1/2" W/1/4"CHAN X 84" - HONEY CHERRY
4D	009812-38-000	EA	MOLDING - CORNER - 1/2" W/1/4"CHAN X 84" - SIERRA MAPLE
5D	022992-11-000	FT	MOLDING - REVERSE COVE - T-SHAPED - IVORY
5D	022992-18-000	FT	MOLDING - REVERSE COVE - T-SHAPED - BONE
5D	022992-14-000	FT	MOLDING - REVERSE COVE - T-SHAPED - BRIGHT WHITE
6D	070504-42-000	FT	U-CHANNEL - PLASTIC - .13" X 84" - BEIGE ILLUSION
6D	070504-69-000	FT	U-CHANNEL - PLASTIC - .13" X 84" - BONE
6D	070504-43-000	FT	U-CHANNEL - PLASTIC - .9" X 96" - BEIGE ILLUSION
6D	070504-70-000	FT	U-CHANNEL - PLASTIC - .8" X 84" - BONE
6D	070504-57-000	FT	U-CHANNEL - PLASTIC - .13" X 84" - PORTSMOUTH OAK
6D	070504-58-000	FT	U-CHANNEL - PLASTIC - .9" X 84" - PORTSMOUTH OAK
6D	070504-60-000	FT	U-CHANNEL - PLASTIC - .13" X 84" - CONCERT CHERRY
6D	070504-61-000	FT	U-CHANNEL - PLASTIC - .9" X 84" - CONCERT CHERRY
6D	070504-50-000	FT	U-CHANNEL - PLASTIC - .13" X 96" - WASHED MAPLE
6D	070504-51-000	FT	U-CHANNEL - PLASTIC - .9" X 96" - WASHED MAPLE
6D	070504-62-000	FT	U-CHANNEL - PLASTIC - 1.65" X 84" - HONEY CHERRY
6D	070504-63-000	FT	U-CHANNEL - PLASTIC - .9" X 84" - HONEY CHERRY
6D	070504-65-000	FT	U-CHANNEL - PLASTIC - 1.65" X 84" - SIERRA MAPLE
6D	070504-66-000	FT	U-CHANNEL - PLASTIC - .9" X 84" - SIERRA MAPLE
7D	083620-15-000	FT	MOLDING-T - W/EDGE LIP - 7/8" FACE - BEIGE ILLUSION
7D	083620-25-000	FT	MOLDING-T - W/EDGE LIP - 7/8" FACE - BONE
7D	083620-20-000	FT	MOLDING-T - W/EDGE LIP - 7/8" FACE - PORTSMOUTH OAK
7D	083620-21-000	FT	MOLDING-T - W/EDGE LIP - 7/8" FACE - CONCERT CHERRY
7D	083620-19-000	FT	MOLDING-T - W/EDGE LIP - 7/8" FACE - WASHED MAPLE
7D	083620-24-000	FT	MOLDING-T - W/EDGE LIP - 7/8" FACE - HONEY CHERRY
7D	083620-22-000	FT	MOLDING-T - W/EDGE LIP - 7/8" FACE - SIERRA MAPLE
8D	085746-04-000	FT	TRIM-J - CARPET 1.2" X .5" ANGLE - 12' LONG - OFF WHITE
9D	086229-01-000	EA	RETAINER - BATTEN - .75" X 92.1" - ANY COLOR
10D	086229-20-000	EA	BATTEN - 1" X 96" - BEIGE



**INTERIOR FINISH GROUP (CONTINUED)**  
**MOLDINGS & TRIMS (CONTINUED)**

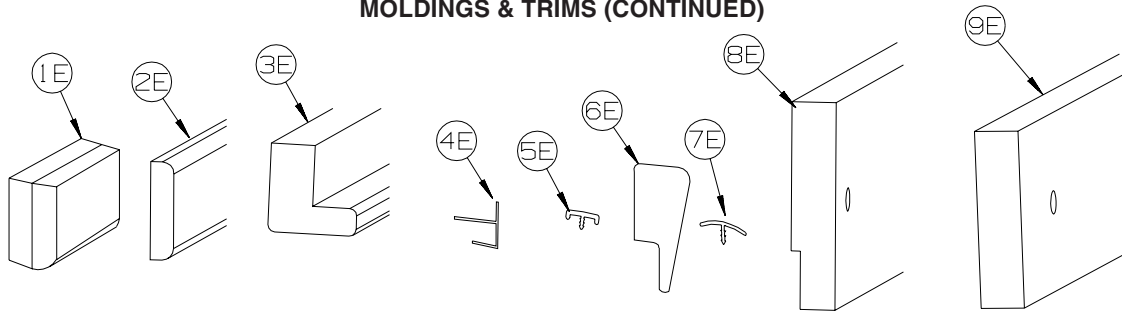

KEY	PART NUMBER	U/M	DESCRIPTION
1E	100659-30-N75	EA	MOLDING - TRIM - 8' - PORTSMOUTH OAK
1E	100659-30-N74	EA	MOLDING - TRIM - 8' - CONCERT CHERRY
1E	100659-30-M84	EA	MOLDING - TRIM - 8' - WASHED MAPLE
1E	100659-27-RA3	EA	MOLDING - TRIM - HONEY CHERRY
1E	100659-31-SA3	EA	MOLDING - TRIM - SIERRA MAPLE
2E	100818-01-12A	EA	MOLDING - VINYL WRAPPED - 1.6" X .4" X 84" - PORTSMOUTH OAK
2E	100818-01-13A	EA	MOLDING - VYL 84" - CONCERT CHERRY (U90/94/98/A1/A5/B1/C1/C5/D1/D5/E1/E5/F1/F5/G1/G5/H1/H5)
2E	100818-01-23A	EA	MOLDING - VINYL WRPPD - 1.6" X .4" X 84" - CONCERT CHERRY (UM1 THRU UM9, UN1 THRU UN9)
2E	100818-01-21A	EA	MOLDING - VINYL WRAPPED - 1.6" X .4" X 84" - WASHED MAPLE
2E	100818-01-14A	EA	MOLDING - VINYL WRAPPED - 1.6" X .4" X 84" - HONEY CHERRY
2E	100818-01-22A	EA	MOLDING - VINYL WRAPPED - 1.6" X .4" X 84" - SIERRA MAPLE
3E	100819-01-12A	EA	MOLDING - VINYL WRAPPED-L-SHAPED-1.5"X1.5"X84" - PORTSMOUTH OAK
3E	100819-01-13A	EA	MOLDING - VYL 84" - CONCERT CHERRY (U90/94/98/A1/A5/B1/C1/C5/D1/D5/E1/E5/F1/F5/G1/G5/H1/H5)
3E	100819-01-23A	EA	MOLDING - VYL WRPPD-L-SHPD-1.5"X1.5"X84" - CONCERT CHERRY (UM1 THRU UM9, UN1 THRU UN9)
3E	100819-01-21A	EA	MOLDING - VINYL WRAPPED-L-SHAPED-1.5"X1.5"X84" - WASHED MAPLE
3E	100819-01-14A	EA	MOLDING - VINYL WRAPPED-L-SHAPED-1.5"X1.5"X84" - HONEY CHERRY
3E	100819-01-22A	EA	MOLDING - VINYL WRAPPED-L-SHAPED-1.5"X1.5"X84" - SIERRA MAPLE
4E	103186-01-07A	FT	MOLDING/PLASTIC - 3/8" U-CHANNEL-3/4" FACE -BEIGE ILLUSION
4E	103186-01-09A	FT	MOLDING/PLASTIC - 3/8" U-CHAN'L-3/4" FACE - PORTSMOUTH OAK
4E	103186-01-10A	FT	MOLDING/PLASTIC - 3/8" U-CHAN'L-3/4" FACE - CONCERT CHERRY
4E	103186-01-08A	FT	MOLDING/PLASTIC - 3/8" U-CHANNEL-3/4"FACE-WASHED MAPLE 8' - WASHED MAPLE
4E	103186-01-11A	FT	MOLDING/PLASTIC - 3/8" U-CHAN'L-3/4" FACE - HONEY CHERRY
4E	103186-01-12A	FT	MOLDING/PLASTIC - 3/8" U-CHAN'L-3/4" FACE - SIERRA MAPLE
4E	103186-02-07A	FT	MOLDING/PLASTIC-1" U-CHAN'L-1 3/8" FACE - BEIGE ILLUSION
4E	103186-02-09A	FT	MOLDING/PLASTIC - 1" U-CHAN'L-1 3/8" FACE - PORTSMOUTH OAK
4E	103186-02-10A	FT	MOLDING/PLASTIC - 1" U-CHAN'L-1 3/8" FACE - CONCERT CHERRY
4E	103186-02-08A	FT	MOLDING/PLASTIC - 1" U-CHANNEL-1 3/8"FACE - WASHED MAPLE
4E	103186-02-11A	FT	MOLDING/PLASTIC - 1" U-CHAN'L-1 3/8" FACE - HONEY CHERRY
4E	103186-02-12A	FT	MOLDING/PLASTIC - 1" U-CHAN'L-1 3/8" FACE - SIERRA MAPLE
5E	104676-02-08A	FT	MOLDING-T - W/EDGE LIP - 11/16" FACE - PORTSMOUTH OAK
5E	104676-02-09A	FT	MOLDING-T - W/EDGE LIP - 11/16" FACE - CONCERT CHERRY
5E	104676-02-06A	FT	MOLDING-T - W/EDGE LIP - 11/16" FACE - WASHED MAPLE
5E	104676-02-10A	FT	MOLDING-T - W/EDGE LIP - 11/16" FACE - HONEY CHERRY
5E	104676-02-12A	FT	MOLDING-T - W/EDGE LIP - 11/16" FACE - SIERRA MAPLE
6E	105004-01-12A	EA	MOLDING - VINYL WRAPPED - 1" X 96" - PORTSMOUTH OAK
6E	105004-01-13A	EA	MOLDING - V W 8' - CONCERT CHERRY (U90/94/98/A1/A5/B1/C1/C5/D1/D5/E1/E5/F1/F5/G1/G5/H1/H5)
6E	105004-01-23A	EA	MOLDING - VINYL WRAPPD 1" X 8' - CONCERT CHERRY (UM1 THRU UM9, UN1 THRU UN9)
6E	105004-01-21A	EA	MOLDING - VINYL WRAPPED - 1" X 8' - WASHED MAPLE
6E	105004-01-24A	EA	MOLDING - VINYL WRAPPED - 1" X 8' - HONEY CHERRY
6E	105004-01-22A	EA	MOLDING - VINYL WRAPPED - 1" X 8' - SIERRA MAPLE
7E	105709-02-000	FT	MOLDING-T - W/EDGE LIP 3/4" FACE - BEIGE ILLUSION
8E	116951-45-R68	EA	MOLDING - TRIM - 3" X 30.3" - PORTSMOUTH OAK
8E	116951-45-R69	EA	MOLDING - TRIM - 3" X 30.3" - CONCERT CHERRY
8E	116951-45-R76	EA	MOLDING - TRIM - 3" X 30.3" - WASHED MAPLE
8E	116951-45-SA3	EA	MOLDING - TRIM - 3" X 30.3" - SIERRA MAPLE
9E	116951-37-R68	EA	MOLDING - TRIM - 3.5" X 38.6" - PORTSMOUTH OAK
9E	116951-37-R69	EA	MOLDING - TRIM - 3.5" X 38.6" - CONCERT CHERRY
9E	116951-37-R76	EA	MOLDING - TRIM - 3.5" X 38.6" - WASHED MAPLE
9E	116951-37-SA3	EA	MOLDING - TRIM - 3.5" X 38.6" - SIERRA MAPLE
9E	116951-51-SA0	EA	MOLDING - TRIM - 3.5" X 47.3" - PORTSMOUTH OAK
9E	116951-51-SA1	EA	MOLDING - TRIM - 3.5" X 47.3" - CONCERT CHERRY
9E	116951-51-SA2	EA	MOLDING - TRIM - 3.5" X 47.3" - WASHED MAPLE
9E	116951-51-SA3	EA	MOLDING - TRIM - 3.5" X 47.3" - SIERRA MAPLE

**INTERIOR FINISH GROUP (CONTINUED)**  
**MOLDINGS & TRIMS (CONTINUED)**

KEY	PART NUMBER	U/M	DESCRIPTION
9E	116951-55-TD0	EA	MOLDING - TRIM - 4.5" X 52.3" - PORTSMOUTH OAK
9E	116951-55-TD1	EA	MOLDING - TRIM - 4.5" X 52.3" - CONCERT CHERRY
9E	116951-55-TD2	EA	MOLDING - TRIM - 4.5" X 52.3" - WASHED MAPLE
9E	116951-55-TD3	EA	MOLDING - TRIM - 4.5" X 52.3" - SIERRA MAPLE
9E	116951-56-TD0	EA	MOLDING - TRIM - 4.5" X 52.3" - PORTSMOUTH OAK
9E	116951-56-TD1	EA	MOLDING - TRIM - 4.5" X 52.3" - CONCERT CHERRY
9E	116951-56-TD2	EA	MOLDING - TRIM - 4.5" X 52.3" - WASHED MAPLE
9E	116951-56-TD3	EA	MOLDING - TRIM - 4.5" X 52.3" - SIERRA MAPLE

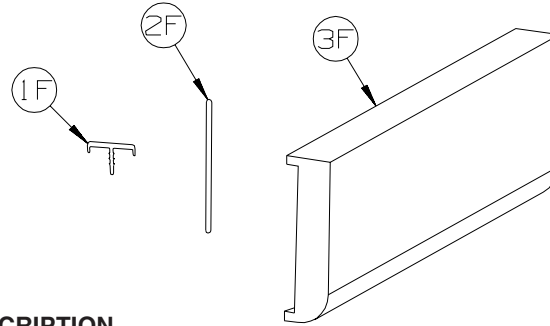

KEY	PART NUMBER	U/M	DESCRIPTION
1F	119520-01-01A	FT	MOLDING-T - OFFSET W/EDGE LIP - 1.3" FACE - OFF WHITE
1F	119520-03-03A	FT	MOLDING-T - OFFSET W/EDGE LIP - 1" FACE - WASHED MAPLE
1F	119520-03-06A	FT	MOLDING-T - OFFSET W/EDGE LIP - 1" FACE - HONEY CHERRY
2F	127842-01-01A	FT	SEAL - SIGHT SHIELD - 2" BLACK
	137885-A2-438	EA	LUMBER - VYL .75" - CONCERT CHERRY (U90/94/98/A1/A5/B1/C1/C5/D1/D5/E1/E5/F1/F5/G1/G5/H1/H5)
	160300-A2-438	EA	LUMBER - VINYL WRAPPED - .7" X .75" X 96" - CONCERT CHERRY (UM1 THRU UM9, UN1 THRU UN9)
	137885-D2-438	EA	LUMBER - VYL1.5" - CONCERT CHERRY (U90/94/98/A1/A5/B1/C1/C5/D1/D5/E1/E5/F1/F5/G1/G5/H1/H5)
	160300-D2-438	EA	LUMBER - VINYL WRAPPED - .7" X 1.5" X 96" - CONCERT CHERRY (UM1 THRU UM9, UN1 THRU UN9)
	137885-E2-438	EA	LUMBER - VYL2" -CONCERT CHERRY (U90/94/98/A1/A5/B1/C1/C5/D1/D5/E1/E5/F1/F5/G1/G5/H1/H5)
	160300-E2-438	EA	LUMBER - VINYL WRAPPED - .7" X 2" X 96" - CONCERT CHERRY (UM1 THRU UM9, UN1 THRU UN9)
	137885-F2-438	EA	LUMBER - VYL2.5" - CONCERT CHERRY (U90/94/98/A1/A5/B1/C1/C5/D1/D5/E1/E5/F1/F5/G1/G5/H1/H5)
	160300-F2-438	EA	LUMBER - VINYL WRAPPED - .7" X 2.5" X 96" - CONCERT CHERRY (UM1 THRU UM9, UN1 THRU UN9)
	137885-G2-438	EA	LUMBER - VYL3" - CONCERT CHERRY (U90/94/98/A1/A5/B1/C1/C5/D1/D5/E1/E5/F1/F5/G1/G5/H1/H5)
	160300-G2-438	EA	LUMBER - VINYL WRAPPED - .7" X 3" X 96" - CONCERT CHERRY (UM1 THRU UM9, UN1 THRU UN9)
	137885-H2-438	EA	LUMBER - VYL3.5" - CONCERT CHERRY (U90/94/98/A1/A5/B1/C1/C5/D1/D5/E1/E5/F1/F5/G1/G5/H1/H5)
	160300-H2-438	EA	LUMBER - VINYL WRAPPED - .7" X 3.5" X 96" - CONCERT CHERRY (UM1 THRU UM9, UN1 THRU UN9)
	137885-J2-438	EA	LUMBER - VYL5.5" - CONCERT CHERRY (U90/94/98/A1/A5/B1/C1/C5/D1/D5/E1/E5/F1/F5/G1/G5/H1/H5)
	160300-J2-438	EA	LUMBER - VINYL WRAPPED - .7" X 5.5" X 96" - CONCERT CHERRY (UM1 THRU UM9, UN1 THRU UN9)
	137885-J2-743	EA	LUMBER - VYL5.5" - CONCERT CHERRY (U90/94/98/A1/A5/B1/C1/C5/D1/D5/E1/E5/F1/F5/G1/G5/H1/H5)
	160300-J2-743	EA	LUMBER - VINYL WRAPPED - .7" X 5.5" X 108" - CONCERT CHERRY (UM1 THRU UM9, UN1 THRU UN9)
	137885-K2-438	EA	LUMBER - VYL3.9" - CONCERT CHERRY (U90/94/98/A1/A5/B1/C1/C5/D1/D5/E1/E5/F1/F5/G1/G5/H1/H5)
	160300-K2-438	EA	LUMBER - VINYL WRAPPED - .7" X 3.9" X 96" - CONCERT CHERRY (UM1 THRU UM9, UN1 THRU UN9)
	137885-R2-438	EA	LUMBER - VYL 3" - CONCERT CHERRY (U90/94/98/A1/A5/B1/C1/C5/D1/D5/E1/E5/F1/F5/G1/G5/H1/H5)
	160300-R2-438	EA	LUMBER - VINYL WRAPPED - .7" X 3" X 96" - CONCERT CHERRY (UM1 THRU UM9, UN1 THRU UN9)
3F	137887-D2-134	EA	MOLDING - 1.6" X 84"- CONCERT CHERRY (U90/94/98/A1/A5/B1/C1/C5/D1/D5/E1/E5/F1/F5/G1/G5/H1/H5)
3F	160301-D2-134	EA	MOLDING -VINYL WRAPPED - .7" X 1.6" X 84" - CONCERT CHERRY (UM1 THRU UM9, UN1 THRU UN9)
3F	137887-D2-743	EA	MLDG - 1.6" X 108" - CONCERT CHERRY (U90/94/98/A1/A5/B1/C1/C5/D1/D5/E1/E5/F1/F5/G1/G5/H1/H5)
3F	160301-D2-743	EA	MOLDING - VINYL WRAPPED- .7" X 1.6" X 108" - CONCERT CHERRY (UM1 THRU UM9, UN1 THRU UN9)
3F	137887-F2-134	EA	MLDNG - 2.5" X 84" - CONCERT CHERRY (U90/94/98/A1/A5/B1/C1/C5/D1/D5/E1/E5/F1/F5/G1/G5/H1/H5)
3F	160301-F2-134	EA	MOLDING - VINYL WRAPPED - .7" X 2.5" X 84" - CONCERT CHERRY (UM1 THRU UM9, UN1 THRU UN9)
3F	137887-F2-743	EA	MLDG - 2.5" X 108" - CONCERT CHERRY (U90/94/98/A1/A5/B1/C1/C5/D1/D5/E1/E5/F1/F5/G1/G5/H1/H5)
3F	160301-F2-743	EA	MOLDING - VINYL WRPPD - .7" X 2.5" X 108" - CONCERT CHERRY (UM1 THRU UM9, UN1 THRU UN9)
3F	137887-F2-438	EA	MLDG - 2.5" X 96" - CONCERT CHERRY (U90/94/98/A1/A5/B1/C1/C5/D1/D5/E1/E5/F1/F5/G1/G5/H1/H5)
3F	160301-F2-438	EA	MOLDING - VINYL WRPPD - .7" X 2.5" X 96" - CONCERT CHERRY (UM1 THRU UM9, UN1 THRU UN9)
	137894-A2-438	EA	LUMBER - VINYL WRAPPED - .7" X .75" X 96" - PORTSMOUTH OAK
	137894-D2-438	EA	LUMBER - VINYL WRAPPED - .7" X 1.5" X 96" - PORTSMOUTH OAK
	137894-E2-438	EA	LUMBER - VINYL WRAPPED - .7" X 2" X 96" - PORTSMOUTH OAK
	137894-F2-438	EA	LUMBER - VINYL WRAPPED - .7" X 2.5" X 96" - PORTSMOUTH OAK
	137894-G2-438	EA	LUMBER - VINYL WRAPPED - .7" X 3" X 96" - PORTSMOUTH OAK
	137894-H2-438	EA	LUMBER - VINYL WRAPPED - .7" X 3.5" X 96" - PORTSMOUTH OAK
	137894-J2-438	EA	LUMBER - VINYL WRAPPED - .7" X 5.5" X 80.2" - PORTSMOUTH OAK
	137894-J2-743	EA	LUMBER - VINYL WRAPPED - .7" X 5.5" X 96" - PORTSMOUTH OAK
	137894-K2-438	EA	LUMBER - VINYL WRAPPED - .7" X 3.9" X 96" - PORTSMOUTH OAK
	137894-R2-438	EA	LUMBER - VINYL WRAPPED - .7" X 3" X 96" - PORTSMOUTH OAK

**INTERIOR FINISH GROUP (CONTINUED)**  
**MOLDINGS & TRIMS (CONTINUED)**

KEY	PART NUMBER	U/M	DESCRIPTION
3F	137895-D2-134	EA	MOLDING - VINYL WRAPPED - .7" X 1.6" X 84"-PORTSMOUTH OAK
3F	137895-D2-743	EA	MOLDING - VINYL WRAPPED - .7" X 1.6" X 108"-PORTSMOUTH OAK
3F	137895-F2-438	EA	MOLDING - VINYL WRAPPED - .7" X 2.5" X 96" - PORTSMOUTH OAK
3F	137895-F2-743	EA	MOLDING - VINYL WRAPPED - .7" X 2.5" X 108" - PORTSMOUTH OAK
	146419-A2-438	EA	LUMBER - VINYL WRAPPED - .7" X .75" X 96" - HONEY CHERRY
	146419-D2-438	EA	LUMBER - VINYL WRAPPED - .7" X 1.5" X 96" - HONEY CHERRY
	146419-E2-438	EA	LUMBER - VINYL WRAPPED - .7" X 2" X 96" - HONEY CHERRY
	146419-F2-438	EA	LUMBER - VINYL WRAPPED - .7" X 2.5" X 96" - HONEY CHERRY
	146419-G2-438	EA	LUMBER - VINYL WRAPPED - .7" X 3" X 96" - HONEY CHERRY
	146419-H2-438	EA	LUMBER - VINYL WRAPPED - .7" X 3.5" X 96" - HONEY CHERRY
	146419-J2-438	EA	LUMBER - VINYL WRAPPED - .7" X 5.5" X 96" - HONEY CHERRY
	146419-J2-743	EA	LUMBER - VINYL WRAPPED - .7" X 5.5" X 108" - HONEY CHERRY
	146419-K2-438	EA	LUMBER - VINYL WRAPPED - .7" X 3.9" X 96" - HONEY CHERRY
	146419-R2-438	EA	LUMBER - VINYL WRAPPED - .7" X 3" X 96" - HONEY CHERRY
	146419-S2-438	EA	LUMBER - VINYL WRAPPED/FULL - .7"X 3.5"X 96"- HONEY CHERRY
	146419-T2-438	EA	LUMBER - VINYL WRAPPED/FULL - .7"X 5.5"X 96"- HONEY CHERRY
3F	146425-D2-134	EA	MOLDING - VINYL WRAPPED - .7" X 1.6" X 83.9" - HONEY CHERRY
3F	146425-F2-438	EA	MOLDING - VINYL WRAPPED - .7" X 2.6" X 96" - HONEY CHERRY
	149325-A2-438	EA	LUMBER - VINYL WRAPPED - .7" X .75" X 96" - WASHED MAPLE
	149325-D2-438	EA	LUMBER - VINYL WRAPPED - .7" X 1.5" X 96" - WASHED MAPLE
	149325-E2-438	EA	LUMBER - VINYL WRAPPED - .7" X 2" X 96" - WASHED MAPLE
	149325-F2-438	EA	LUMBER - VINYL WRAPPED - .7" X 2.5" X 96" - WASHED MAPLE
	149325-G2-438	EA	LUMBER - VINYL WRAPPED - .7" X 3" X 96" - WASHED MAPLE
	149325-H2-438	EA	LUMBER - VINYL WRAPPED - .7" X 3.5" X 96" - WASHED MAPLE
	149325-J2-438	EA	LUMBER - VINYL WRAPPED - .7" X 5.5" X 96" - WASHED MAPLE
	149325-J2-743	EA	LUMBER - VINYL WRAPPED - .7" X 5.5" X 108" - WASHED MAPLE
	149325-K2-438	EA	LUMBER - VINYL WRAPPED - .7" X 3.9" X 96" - WASHED MAPLE
	149325-R2-438	EA	LUMBER - VINYL WRAPPED - .7" X 3" X 96" - WASHED MAPLE
3F	149326-D2-134	EA	MOLDING - VINYL WRAPPED - .7" X 1.5" X 83.9" - WASHED MAPLE
3F	149326-D2-743	EA	MOLDING - VINYL WRAPPED - .7" X 1.5" X 108" - WASHED MAPLE
3F	149326-F2-134	EA	MOLDING - VINYL WRAPPED - .7" X 2.5" X 83.9" - WASHED MAPLE
3F	149326-F2-438	EA	MOLDING - VINYL WRAPPED - .7" X 2.5" X 96" - WASHED MAPLE
3F	149326-F2-743	EA	MOLDING - VINYL WRAPPED - .7" X 2.5" X 108" - WASHED MAPLE
	149330-A2-438	EA	LUMBER - VINYL WRAPPED - .7" X .75" X 96" - SIERRA MAPLE
	149330-D2-438	EA	LUMBER - VINYL WRAPPED - .7" X 1.5" X 96" - SIERRA MAPLE
	149330-E2-438	EA	LUMBER - VINYL WRAPPED - .7" X 2" X 96" - SIERRA MAPLE
	149330-F2-438	EA	LUMBER - VINYL WRAPPED - .7" X 2.5" X 96" - SIERRA MAPLE
	149330-G2-438	EA	LUMBER - VINYL WRAPPED - .7" X 3" X 96" - SIERRA MAPLE
	149330-H2-438	EA	LUMBER - VINYL WRAPPED - .7" X 3.5" X 96" - SIERRA MAPLE
	149330-J2-438	EA	LUMBER - VINYL WRAPPED - .7" X 5.5" X 96" - SIERRA MAPLE
	149330-J2-743	EA	LUMBER - VINYL WRAPPED - .7" X 5.5" X 108" - SIERRA MAPLE
	149330-K2-438	EA	LUMBER - VINYL WRAPPED - .7" X 3.9" X 96" - SIERRA MAPLE
	149330-R2-438	EA	LUMBER - VINYL WRAPPED - .7" X 3" X 96" - SIERRA MAPLE
3F	149331-D2-134	EA	MOLDING - VINYL WRAPPED - .7" X 1.5" X 83.9" - SIERRA MAPLE
3F	149331-D2-743	EA	MOLDING - VINYL WRAP - .7" X 1.5" X 108" - SIERRA MAPLE
3F	149331-F2-134	EA	MOLDING - VINYL WRAPPED - .7" X 2.5" X 83.9" - SIERRA MAPLE
3F	149331-F2-438	EA	MOLDING - VINYL WRAPPED - .7" X 2.5" X 96" - SIERRA MAPLE
3F	149331-F2-743	EA	MOLDING - VINYL WRAPPED - .7" X 2.5" X 108" - SIERRA MAPLE

**INTERIOR FINISH GROUP (CONTINUED)**  
**MOLDINGS & TRIMS (CONTINUED)**

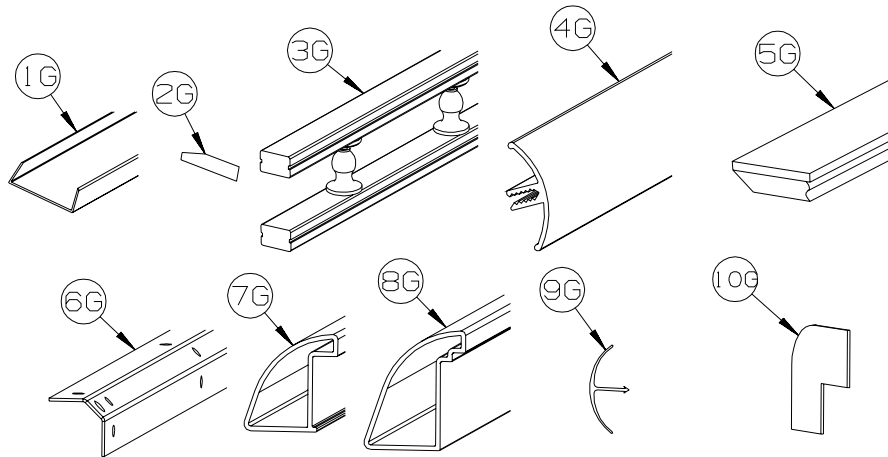

KEY	PART NUMBER	U/M	DESCRIPTION
	141260-01-01A	FT	U-CHANNEL - 1" - VILLAGE OAK
1G	141260-01-02A	FT	U-CHANNEL - 1" - GRADY BROWN
1G	141260-02-01A	FT	U-CHANNEL - 1 1/8" - VILLAGE OAK
1G	141260-02-02A	FT	U-CHANNEL - 1 1/8" - GRADY BROWN
2G	146306-01-01A	FT	TRANSITION - CARPET/TILE
3G	150167-01-07A	EA	RAIL - DECORATIVE - 96" W/O REVERSE SIDE GROOVE - PORTSMOUTH OAK
3G	150167-01-02A	EA	RAIL - DECORATIVE - 96" W/O REVERSE SIDE GROOVE - SALEM CHERRY - CONCERT CHERRY
3G	150167-01-03A	EA	RAIL - DECORATIVE - 96" W/O REVERSE SIDE GROOVE - WASHED MAPLE
3G	150167-01-09A	EA	RAIL - DECORATIVE - 96" W/O REVERSE SIDE GROOVE - SIERRA MAPLE
4G	151653-10-02A	EA	TRIM/RADIUS - CABINET CORNER - 79.6" - DULL METALLIC
4G	151653-13-02A	EA	TRIM/RADIUS - CABINET CORNER - 79.8" - DULL METALLIC
5G	151676-26-S46	EA	MOLDING/TRIM - .75" X 1.6" X 80.2" - PORTSMOUTH OAK
5G	151676-26-S47	EA	MOLDING/TRIM - .75" X 1.6" X 80.2" - CONCERT CHERRY
5G	151676-26-S48	EA	MOLDING/TRIM - .75" X 1.6" X 80.2" - WASHED MAPLE
5G	151676-26-SR0	EA	MOLDING/TRIM - .75" X 1.6" X 80.2" - SIERRA MAPLE
6G	151861-05-02B	EA	ANGLE - SUPPORT/CORNER - 1.4" X 78.6" - E-COATED
7G	151893-01-02A	EA	TRIM/RADIUS - CABINET BOTTOM - 72.6" - DULL METALLIC
8G	152077-01-02A	EA	TRIM/RADIUS - CABINET BOTTOM - 27.7" - DULL METALLIC
9G	156464-01-01A	FT	MOLDING - CORNER - RADIUS/PLASTIC - 8' - HONEY CHERRY
9G	156464-01-02A	FT	MOLDING - CORNER - RADIUS/PLASTIC - 8' - WASHED MAPLE
9G	156464-01-03A	FT	MOLDING - CORNER - RADIUS/PLASTIC - 8' - BONE
10G	160989-01-06A	FT	CAP - CORNER - RADIUS MOLDING - PLASTIC - WASHED MAPLE
10G	160989-01-07A	FT	CAP - CORNER - RADIUS MOLDING - PLASTIC - HONEY CHERRY

**INTERIOR FINISH GROUP (CONTINUED)**  
**PANELING & LAMINATES**

<b>KEY</b>	<b>PART NUMBER</b>	<b>U/M</b>	<b>DESCRIPTION</b>
	000885-A7-000	SF	PARTICLE BOARD - 3/4" X 4' X 8' - HONEY CHERRY - 2 SIDED - HONEY CHERRY
	000885-A8-000	SF	PARTICLE BOARD - 3/8" X 4' X 8' - HONEY CHERRY - 1 SIDED - HONEY CHERRY
	000885-A9-000	SF	PARTICLE BOARD - 3/8" X 4' X 8' - HONEY CHERRY - 2 SIDED - HONEY CHERRY
	000885-B4-000	SF	PARTICLE BOARD - 3/8" X 4' X 8' - WASHED MAPLE - 2 SIDED - WASHED MAPLE
	000885-B5-000	SF	PARTICLE BOARD - 3/8" X 4' X 8' - WASHED MAPLE - 1 SIDED - WASHED MAPLE
	000885-B6-000	SF	PARTICLE BOARD - 3/4" X 4' X 8' - WASHED MAPLE - 2 SIDED - WASHED MAPLE
	000885-C3-000	SF	PARTICLE BOARD - 3/8" X 4' X 8' - WHITE THATCH EMB-1 SIDED
	074497-47-000	SF	PANELING - HONEY CHERRY - 1/8" X 4' X 8' - HONEY CHERRY
	074497-49-000	SF	PANELING - WASHED MAPLE - 1/8" X 4' X 8' - WASHED MAPLE
	088272-M7-000	SF	PANELING - KURTA/CANVAS - 4' X 7.4' (U21, U22)
	088272-L8-000	SF	PANELING - D'VINCI/ALMOND - 4' X 7' (U23, U24)
	088272-M8-000	SF	PANELING - WISTERIA/DUNE - 4' X 7.4' (U25, U26)
	088272-M9-000	SF	PANELING - WHITE THATCHED - 4' X 8'
	074498-A2-000	SF	LAMINATE - PLASTIC - PHANTOM GRAY - 5' X 8'
	074498-A6-000	SF	LAMINATE - PLASTIC - HARDROCK MAPLE - 5' X 8' - WASHED MAPLE
	074498-A7-000	SF	LAMINATE - PLASTIC - GRAND ISLE - 5' X 8' - HONEY CHERRY
	076325-71-000	FT	MOLDING - EDGE BAND - 1 5/16" X .038" - GRAY
	069733-91-000	EA	BATT STRIP - WOODGRAINED/WASHED MAPLE - 8' - WASHED MAPLE
	088263-J2-000	EA	BATT STRIP - DECORATIVE - NEAT/WASHED MAPLE - WASHED MAPLE
	088263-K5-000	EA	BATT STRIP - DECORATIVE - WHITE THATCHED - 8'
	088263-K3-000	EA	BATT STRIP - DECORATIVE - KURTA/CANVAS - 8' (U21, U22)
	088263-J0-000	EA	BATT STRIP - DECORATIVE - D'VINCI ALMOND (U23, U24)
	088263-K4-000	EA	BATT STRIP - DECORATIVE - WISTERIA/DUNE - 8' (U25, U26)
	085284-J6-000	FT	BATT TAPE - ADHESIVE BACKED - DECORATIVE - HONEY CHERRY
	085284-K9-000	FT	BATT TAPE - ADHESIVE BACKED - DECORATIVE-NEAT/WASHED MAPLE - WASHED MAPLE
	085284-J5-000	FT	BATT TAPE - ADHESIVE BACKED - DECORATIVE-NEAT/WASHED MAPLE - WASHED MAPLE
	085284-K7-000	FT	BATT TAPE - ADHESIVE BACKED - DECORATIVE - KURTA/CANVAS (U21, U22)
	085284-J3-000	FT	BATT TAPE - ADHESIVE BACKED - DECORATIVE - D'VINCI ALMOND (U21, U22)
			FROM: 00-00-00 THRU: 03-27-07
	085284-K7-000	FT	BATT TAPE - ADHESIVE BACKED - DECORATIVE - KURTA/CANVAS (U21, U22)
			FROM: 03-28-07 THRU: 99-99-99
	085284-K8-000	FT	BATT TAPE - ADHESIVE BACKED - DECORATIVE - WISTERIA/DUNE (U25, U26)
	057882-06-700	EA	DOOR - TAMBOUR - 4' X 4'-CHERRY/HONEY/PRE-FINISHED - HONEY CHERRY
	057882-05-700	EA	DOOR - TAMBOUR - 4' X 4'-MAPLE/HONEY/PRE-FINISHED - WASHED MAPLE
	P26866-14-U21	EA	HANDLE - DOOR/TAMBOUR - 11.6" - HONEY CHERRY
	P26866-14-U22	EA	HANDLE - DOOR/TAMBOUR - 11.6" - WASHED MAPLE
	P26866-10-K09	EA	HANDLE - DOOR/TAMBOUR - 11.6" - MAPLE/WASHED MAPLE - WASHED MAPLE
	126339-01-000	SF	BOARD - WHEAT - 60" X 72"

## INTERIOR FINISH GROUP (CONTINUED)

### INTERIOR TRIM LAYOUT

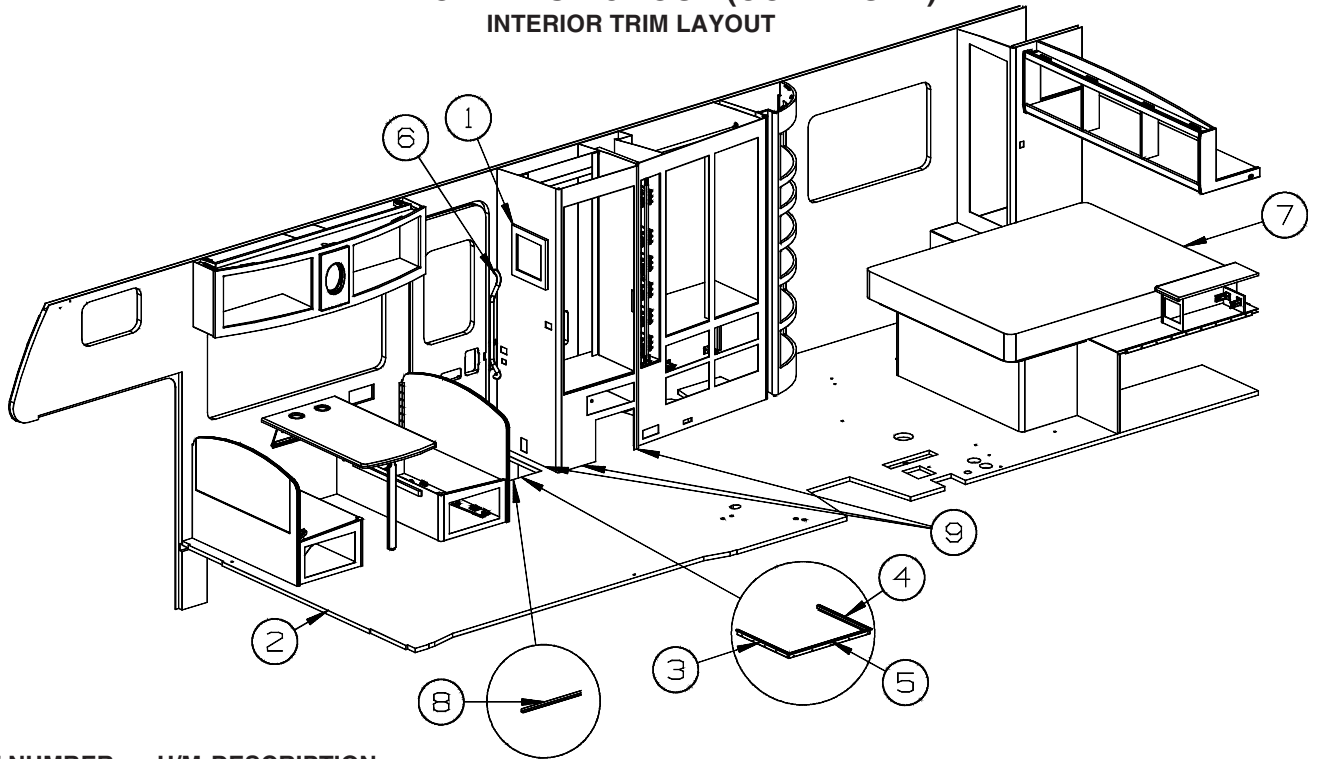

KEY	PART NUMBER	U/M	DESCRIPTION
1	131493-09-01A	EA	PICTURE - DECORATIVE - 8" X 10" - HIGH ART II (U21, U22) - <b>INTERIOR UPGRADE PKG</b>
1	131493-05-04A	EA	PICTURE - DECORATIVE - 10" X 10" - ARCHITECTURAL (U23, U24) - <b>INTERIOR UPGRADE PKG</b>
1	131493-09-04A	EA	PICTURE - DECORATIVE - 8" X 10" - MINIATURE ROSETTE I (U25, U26) - <b>INTERIOR UPGRADE PKG</b>
	130120-01-01A	EA	BRACKET/MOUNTING - MIRROR
2	139955-18-03A	EA	TRIM - STEP/ENTRY - 62.3" - TITANIUM - <b>VINYL FLOOR COVERING</b>
3	139955-15-01A	EA	TRIM - STEP/ENTRY - 21.7" - MILL
4	139955-16-01A	EA	TRIM - STEP/ENTRY - 21.7" - MILL
5	139955-17-01A	EA	TRIM - STEP/ENTRY - 28" - MILL
6	137605-02-01A	EA	HAND RAIL - INTERIOR ENTRY DOOR - BLACK
7	154430-01-000	EA	MATTRESS - INNERSPRING - 60" X 74.5"
8	139955-14-04A	EA	TRIM - STEP/ENTRY - 26.7" - TITANIUM
9	M09471-79-R46	EA	MOLDING - TRIM/COVE - .8" X .8" X 96" - WASHED MAPLE
9	M09471-79-RE0	EA	MOLDING - TRIM/COVE - .8" X .8" X 96" - HONEY CHERRY

**INTERIOR FINISH GROUP (CONTINUED)**  
**INTERIOR TRIM LAYOUT (CONTINUED)**

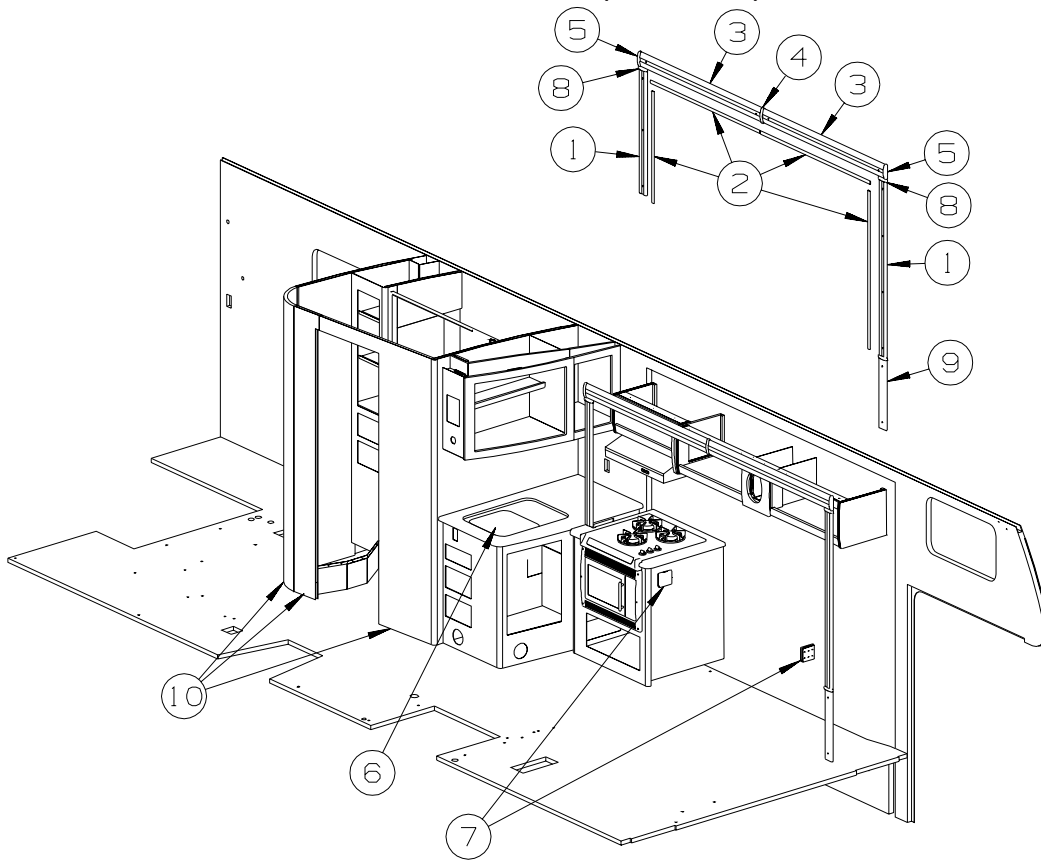

KEY	PART NUMBER	U/M	DESCRIPTION
1	Y00360-A2-438	EA	MOLDING - VINYL/CURVED - 3" X 96" - WASHED MAPLE
1	Y00360-82-438	EA	MOLDING - VINYL/CURVED - 3" X 96" - HONEY CHERRY
2	M09520-83-U21	EA	MOLDING/TRIM - .3" X 1" X 78.9" - WASHED MAPLE
2	M09520-83-U22	EA	MOLDING/TRIM - .3" X 1" X 78.9" - HONEY CHERRY
3	Y00361-A2-438	EA	MOLDING - VINYL/CURVED - 3.9" X 96" - WASHED MAPLE
3	Y00361-82-438	EA	MOLDING - VINYL/CURVED - 3.9" X 96" - HONEY CHERRY
4	156636-06-U21	EA	MOLDING/BLOCK - .8" X 3.1" - HONEY CHERRY
5	156636-05-U21	EA	MOLDING/BLOCK - .8" X 4" - HONEY CHERRY
6	159542-01-U21	EA	COVER - SINK - 15.6" X 13.9" - HONEY CHERRY
6	159542-01-U22	EA	COVER - SINK - 15.6" X 13.9" - WASHED MAPLE
7	118718-01-01A	EA	HOLDER/DRINK - COLLAPSIBLE MUG - BLACK PLASTIC
7	118718-01-02A	EA	HOLDER/DRINK - COLLAPSIBLE MUG - WHITE PLASTIC
8	156636-04-U21	EA	MOLDING/BLOCK - .8" X 3.1" - HONEY CHERRY
9	153973-02-U21	EA	MOLDING - CROWN/BLOCK - 3.1" X 20.4" - HONEY CHERRY
9	153973-02-U22	EA	MOLDING - CROWN/BLOCK - 3.1" X 20.4" - WASHED MAPLE
10	M09471-79-R46	EA	MOLDING - TRIM/COVE - .8" X .8" X 96" - WASHED MAPLE
10	M09471-79-RE0	EA	MOLDING - TRIM/COVE - .8" X .8" X 96" - HONEY CHERRY

**INTERIOR FINISH GROUP (CONTINUED)**  
**INTERIOR TRIM LAYOUT (CONTINUED)**

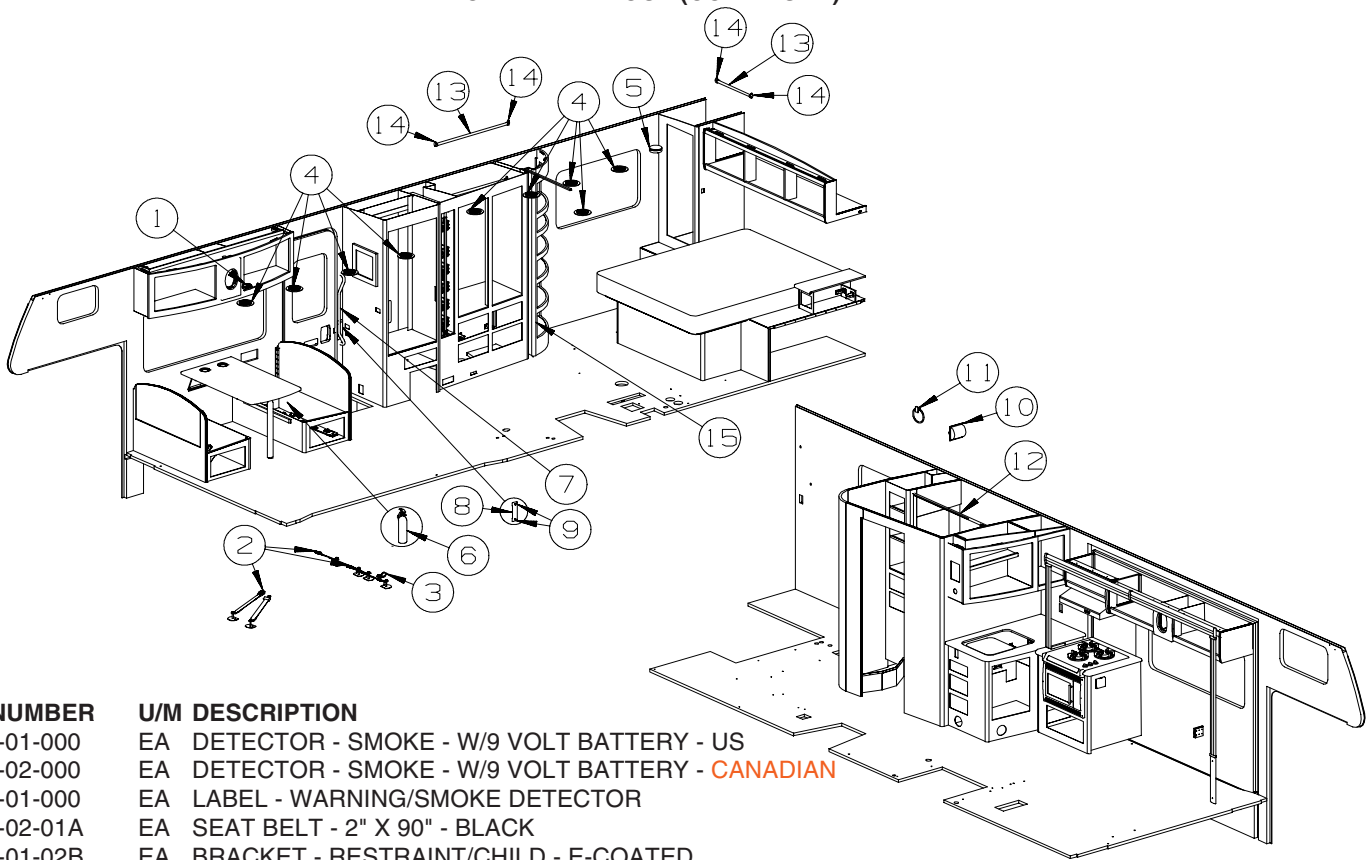

KEY	PART NUMBER	U/M	DESCRIPTION
1	072852-01-000	EA	DETECTOR - SMOKE - W/9 VOLT BATTERY - US
1	072852-02-000	EA	DETECTOR - SMOKE - W/9 VOLT BATTERY - <b>CANADIAN</b>
1	077956-01-000	EA	LABEL - WARNING/SMOKE DETECTOR
2	160167-02-01A	EA	SEAT BELT - 2" X 90" - BLACK
3	150697-01-02B	EA	BRACKET - RESTRAINT/CHILD - E-COATED
4	120134-01-02A	EA	REGISTER - W/DAMPER - 4" PIPE/6.4" O.D. FACE - WHITE
5	125136-02-000	EA	DETECTOR/CO - GAS MODEL - 9 VOLT
6	094499-03-000	EA	EXTINGUISHER/FIRE - DRY - 10BC - W/GAUGE/BRACKET
6*	094499-02-000	EA	EXTINGUISHER/FIRE - DRY - 10BC - W/GAUGE - <b>CANADIAN</b>
6	094499-04-000	EA	STRAP - FIRE EXTINGUISHER MOUNTING - METAL
7	137605-02-01A	EA	HAND RAIL - INTERIOR ENTRY DOOR - BLACK
8	148362-01-01A	EA	COVER - BRACKET/STRIKE - BRIGHT WHITE
			FROM: 00-00-00 THRU: 07-31-06
8	148362-01-02A	EA	COVER - BRACKET/STRIKE - MEDIUM OAK
			FROM: 08-01-06 THRU: 99-99-99
9	140151-02-02A	EA	COVER - SCREW - BRIGHT WHITE
			FROM: 00-00-00 THRU: 07-31-06
9	140151-02-03A	EA	COVER - SCREW - MEDIUM OAK
			FROM: 08-01-06 THRU: 99-99-99
10	145980-02-02A	EA	HOLDER - TOILET TISSUE - RECESSED - NICKEL
11	145980-06-03A	EA	TOWEL RING - CHROME
12*	151578-02-01A	EA	DOOR - SHOWER - 47.9" X 59.9" - WHT OPAQUE SCREEN/WHITE
13	Y00136-21-218	EA	DOWEL - WOOD - CLOTHES ROD - 1"DIAMETER X 4'
14	152301-01-01A	EA	FLANGE - PLASTIC - 1" CLOTHES ROD HOLDER - WHITE
15*	131595-01-01A	EA	DOOR/FOLDING-36.9"X 74.9"-4 CEILING BRKTS & STRAIGHT TRACK
	057534-03-000	EA	TIEBACK - CLEAR PLASTIC - 7.5"
			FROM: 00-00-00 THRU: 08-27-06

\*COMPONENT PARTS LISTED LATER IN THIS GROUP



**INTERIOR FINISH GROUP (CONTINUED)**  
**COMPONENT PARTS FOR INTERIOR TRIM LAYOUT**

**094499-02-000**

<b>KEY</b>	<b>PART NUMBER</b>	<b>U/M</b>	<b>DESCRIPTION</b>	<b>VENDOR NO</b>
	094499-01-700	EA	BRACKET MTG. W/PLAS. STRAP	294039

**131595-01-01A, 131595-05-01A, 131595-10-01A**

<b>KEY</b>	<b>PART NUMBER</b>	<b>U/M</b>	<b>DESCRIPTION</b>	<b>VENDOR NO.</b>
	117431-01-707	EA	CATCH/PIN - PLASTIC	
	131595-01-700	EA	END STOP ONLY	
	131595-01-701	EA	BRACKET/MOUNTING	908956
	131595-01-702	EA	TRACK/STRAIGHT - 37"	

**151578-02-01A**

<b>KEY</b>	<b>PART NUMBER</b>	<b>U/M</b>	<b>DESCRIPTION</b>	<b>VENDOR NO.</b>
	151578-02-700	EA	UPPER/LOWER TRACK, 36" WHITE	

**FLOOR COVERINGS**

<b>KEY</b>	<b>PART NUMBER</b>	<b>U/M</b>	<b>DESCRIPTION</b>
	042720-38-000	SY	VINYL - FLOOR COVERING - BRIDGEWAY
	089275-02-000	FT	STRIP - 3/4" X 84" BLACK POLYETHYLENE
	075233-01-000	SY	PAD - CARPET - 3/8" X 6'W ROLL - SOLD BY THE SQUARE YARD
	093486-01-000	SY	CARPET - COMPARTMENT - 72" WIDE - DARK GRAY
	152251-05-07A	SY	CARPET - 4 SQUARE YARD INCREMENTS - RAFFIA (U21, U22, U25, U26)
	152251-05-02A	EA	CARPET - 4 SQUARE YARD INCREMENTS - BURLWOOD (U23, U24)

## INTERIOR FINISH GROUP (CONTINUED)

### HARDWARE

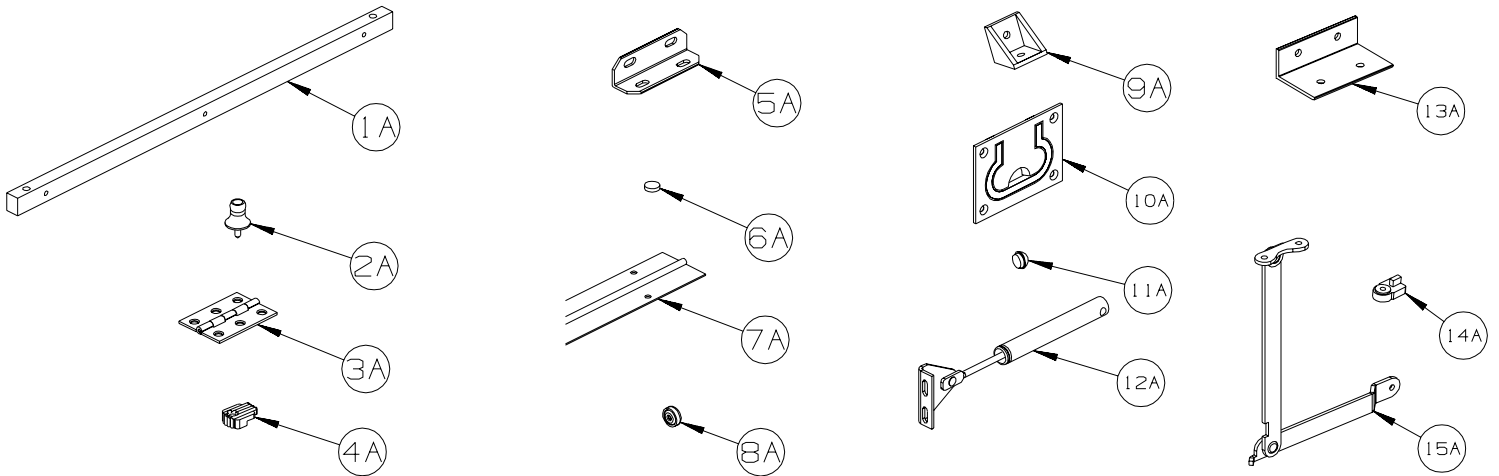

KEY	PART NUMBER	U/M	DESCRIPTION
1A	P34509-01-N01	EA	RAIL END - RH/LH - TOWEL RACK - PORTSMOUTH
1A	P34509-01-P14	EA	RAIL END - RH/LH - TOWEL RACK - CONCERT CHERRY
1A	P34509-01-J70	EA	RAIL END - RH/LH - TOWEL RACK - WASHED MAPLE
1A	P34509-01-RE0	EA	RAIL END - RH/LH - TOWEL RACK - HONEY CHERRY
1A	P34509-01-SA3	EA	RAIL END - RH/LH - TOWEL RACK - SIERRA MAPLE
2A	009013-01-000	EA	CATCH - BULLDOG - MALE/FEMALE
3A	009059-01-000	EA	HINGE - DOOR - 2" X 1.4" - BRASS
3A	009059-02-000	EA	HINGE - DOOR - 2" X 2.7" - BRASS
3A	009059-03-000	EA	HINGE - BRASS - 1.75"
3A	009059-04-000	EA	HINGE - 2" - ZINC
4A	009089-01-000	EA	CLIP - MIRROR
5A	016604-01-000	EA	BRACE - ANGLE - 2 1/2" - UNPAINTED METAL
5A	016604-05-000	EA	BRACE - ANGLE - 2 1/2" - OFF WHITE METAL
5A	016604-10-000	EA	BRACE - SEAT ANGLE - 2.5" - BLACK
6A	023320-01-000	EA	PAD - FELT 3/8" DIAMETER
7A	041389-19-000	EA	HINGE - PIANO - 1 1/2" X 71.9" - UNPAINTED
7A	041389-25-000	EA	HINGE - PIANO - 1 1/2" X 55" - UNPAINTED
7A	041389-32-000	EA	HINGE - PIANO - 68" - OFF WHITE
8A	057671-01-000	EA	COVER - SCREW - #8 - OFF WHITE
8A	057671-15-000	EA	COVER - SCREW - #8 - BRIGHT WHITE
8A	057671-16-000	EA	COVER - SCREW - #8 - SOFT WHITE
8A	057671-18-000	EA	COVER - SCREW - #8 - OFF WHITE
9A	065740-01-000	EA	BRACE - CABINET/CORNER - PLASTIC
10A	072871-01-000	EA	PULL - FLUSH - CHROME
11A	074045-13-000	EA	PLUG - OAK - 3/8" DOWEL-1/2" HEAD - PORTSMOUTH OAK
11A	074045-08-000	EA	PLUG - OAK - 3/8" DOWEL-1/2" HEAD - CONCERT CHERRY
11A	074045-12-000	EA	PLUG - OAK - 3/8" DOWEL-1/2" HEAD - WASHED MAPLE
11A	074045-14-000	EA	PLUG - OAK - 3/8" DOWEL-1/2" HEAD - HONEY CHERRY
11A	074045-15-000	EA	PLUG - OAK - 3/8" DOWEL-1/2" HEAD - SIERRA MAPLE
12A	074493-02-000	EA	SUPPORT - PISTON SPRING - CABINET DOOR - 26 LBS
12A	074493-03-000	EA	SUPPORT - PISTON SPRING - CABINET DOOR - 12 LBS
12A	074493-04-000	EA	SUPPORT - PISTON SPRING - CABINET DOOR - 32LBS
13A	156732-01-01A	EA	BRACE - ANGLE/COUCH - 2.5" - MILL
13A	156732-01-02A	EA	BRACE - ANGLE/COUCH - 2.5" - OFF WHITE
13A	156732-03-01A	EA	BRACE - ANGLE/COUCH - BLACK
14A	083204-03-000	EA	BUTTON - RETAINING MIRROR 5/16" TIP
15A	084412-01-000	EA	SUPPORT/HINGE KIT (LEFT & RIGHT HINGES)

## INTERIOR FINISH GROUP (CONTINUED) HARDWARE (CONTINUED)

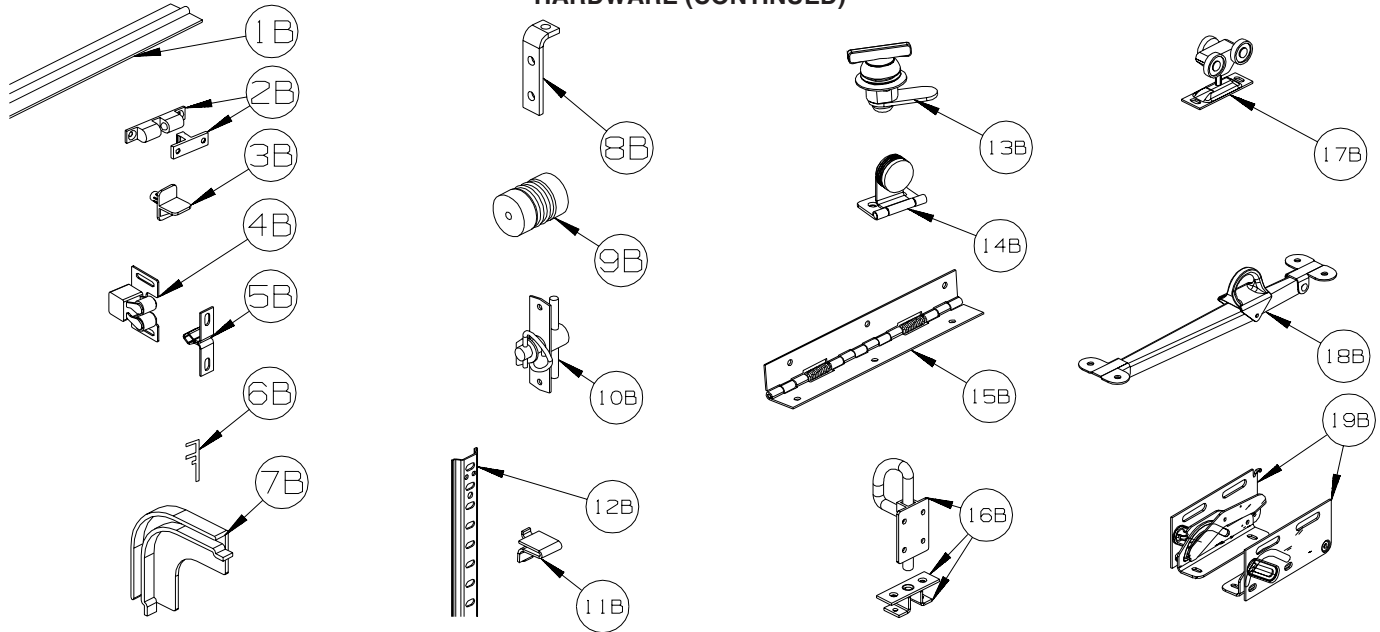

KEY	PART NUMBER	U/M	DESCRIPTION
1B	084413-01-000	EA	HINGE - 1" X 72" - ALUMINUM - W/HOLES
2B	084451-01-000	EA	CATCH & LATCH - 1.7" - BRASS
3B	092907-01-000	EA	SUPPORT - SHELF - PIN - 1/4" - CLEAR PLASTIC
4B	093586-03-000	EA	CATCH - SPRING ROLLER - .377"
4B	093586-06-000	EA	CATCH - SPRING ROLLER - .236"
5B	093586-04-000	EA	STRIKE - SPRING STEEL - 1.14"
6B	093622-01-000	EA	TRACK - DOOR - TAMBOUR - PLASTIC - 8' LENGTHS
7B	093623-01-000	EA	CORNER - TRACK - TAMBOUR DOOR
8B	096826-01-01A	EA	BRACE-CABINET E-COATED
9B	097872-04-000	EA	DOWEL - WOOD - 1" DIAMETER X 1.38" LONG - UNFINISHED
10B	098196-01-000	EA	LATCH - 1/4 TURN - T-BAR
11B	098979-01-000	EA	CLIP - ADJUSTABLE SHELF
12B	098980-01-000	EA	PILASTER - ADJUSTABLE SHELF - 18"
12B	098980-02-000	EA	PILASTER - ADJUSTABLE SHELF - 12"
12B	098980-03-000	EA	PILASTER - ADJUSTABLE SHELF - 9"
12B	098980-04-000	EA	PILASTER - ADJUSTABLE SHELF - 48"
12B	098980-05-000	EA	PILASTER - ADJUSTABLE SHELF - 15"
12B	098980-06-000	EA	PILASTER - ADJUSTABLE SHELF - 24"
13B	100710-01-02A	EA	LOCK - GLASS DOOR/TWIST TYPE - NICKEL
14B	100711-01-02A	EA	HINGE - GLASS DOOR - NICKEL
15B	102920-01-01A	EA	HINGE - SPRING LOADED - BRASS
15B	102920-01-02A	EA	HINGE - SPRING LOADED - NICKEL
15B	129753-01-01A	EA	HINGE - SPRING LOADED - 19" X 19" - BLACK
16B	103256-01-000	EA	LATCH COMPLETE (SLIDE)
17B	103874-01-000	EA	HANGER - SLIDING DOOR
18B	104181-01-01A	EA	SUPPORT - LEAF 5.3" EXTENDS TO 7.5" - SAFETY RING - METAL
19B	108126-01-000	EA	TRAY HINGE SET (QTY. 2 PER SET)

**INTERIOR FINISH GROUP (CONTINUED)**  
**HARDWARE (CONTINUED)**

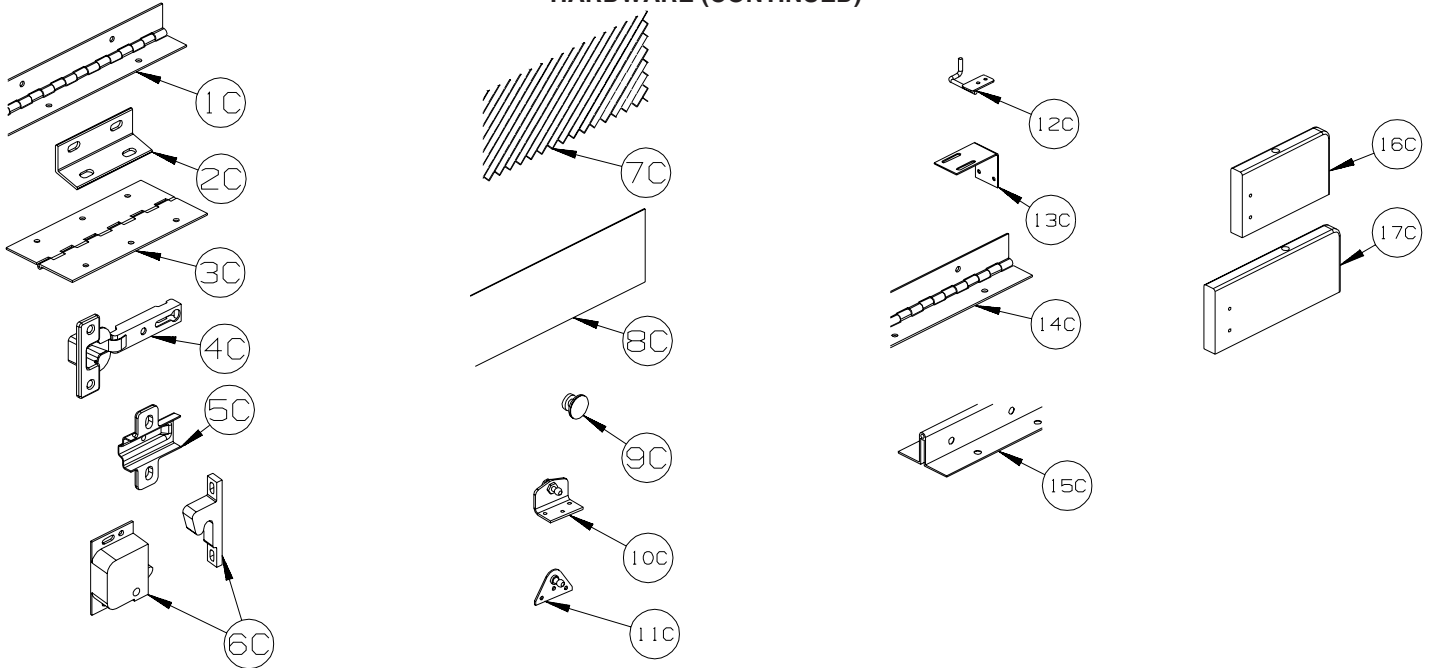

KEY	PART NUMBER	U/M	DESCRIPTION
1C	110496-01-01A	EA	HINGE - BRASS - 2" X 32"
1C	110496-01-02A	EA	HINGE - NICKEL - 2" X 32"
1C	110496-05-02A	EA	HINGE - NICKEL - 2" X 11.5"
1C	110496-06-02A	EA	HINGE - NICKEL - 2" X 9.5"
2C	111866-01-02A	EA	BRACE - SEAT - ANGLE - OFF WHITE
3C	114278-02-000	EA	HINGE - CONTINUOUS - 3" WIDE
4C	114443-02-01A	EA	HINGE - CABINET DOOR - W/O CLIP - SILVER
5C	114443-03-01A	EA	CLIP - HINGE/CABINET DOOR - SILVER
6C	117095-01-01A	EA	LATCH - DOOR - GRABBER W/KEEPER - PLASTIC - BLK-5 LB PULL
6C	117095-02-01A	EA	LATCH - DOOR - GRABBER W/KEEPER - PLASTIC - BLK-10 LB PULL
6C	117095-03-01A	EA	LATCH - DOOR - GRABBER W/KEEPER - PLASTIC - BLK-15 LB PULL
7C	118200-01-01A	SF	MESH - PLASTIC 1/2" - 48" X LENGTH = SF - BLACK
8C	122717-06-01A	FT	PAD - NON-SKID - PSA - 5"W
9C	125221-01-01A	EA	PULL - MIRROR - W/ROUND HANDLE
10C	126263-06-02B	EA	BRACKET - GAS SPRING W/INSIDE BALL STUD - E-COATED
11C	126263-05-02B	EA	BRACKET - GAS SPRING W/BALL STUD - E-COATED
11C	126263-08-02B	EA	BRACKET - GAS SPRING W/CENTERED BALL STUD - E-COATED
11C	126263-19-02B	EA	BRACKET - GAS SPRING W/BALL STUD - E-COATED
12C	130798-01-02B	EA	GUIDE - POCKET DOOR - E-COATED
13C	132871-02-02B	EA	BRACKET/L-ANGLE W/HOLES - 1.9" X 2.8" - E-COATED
14C	134099-01-02A	EA	HINGE - PIANO - WRAP AROUND - 15.7" - NICKEL PLATED
15C	135538-03-02A	EA	HINGE - PIANO - FULL WRAP - 15.7" - CHROME
16C	137445-02-P46	EA	STOP - F/SLIDING DOOR - CONCERT CHERRY
16C	137445-02-P56	EA	STOP - F/SLIDING DOOR - WASHED MAPLE
16C	137445-02-S67	EA	STOP - F/SLIDING DOOR - SIERRA MAPLE
17C	137445-03-T78	EA	STOP - F/SLIDING DOOR - CONCERT CHERRY
17C	137445-03-T79	EA	STOP - F/SLIDING DOOR - WASHED MAPLE
17C	137445-03-T80	EA	STOP - F/SLIDING DOOR - SIERRA MAPLE

## INTERIOR FINISH GROUP (CONTINUED) HARDWARE (CONTINUED)

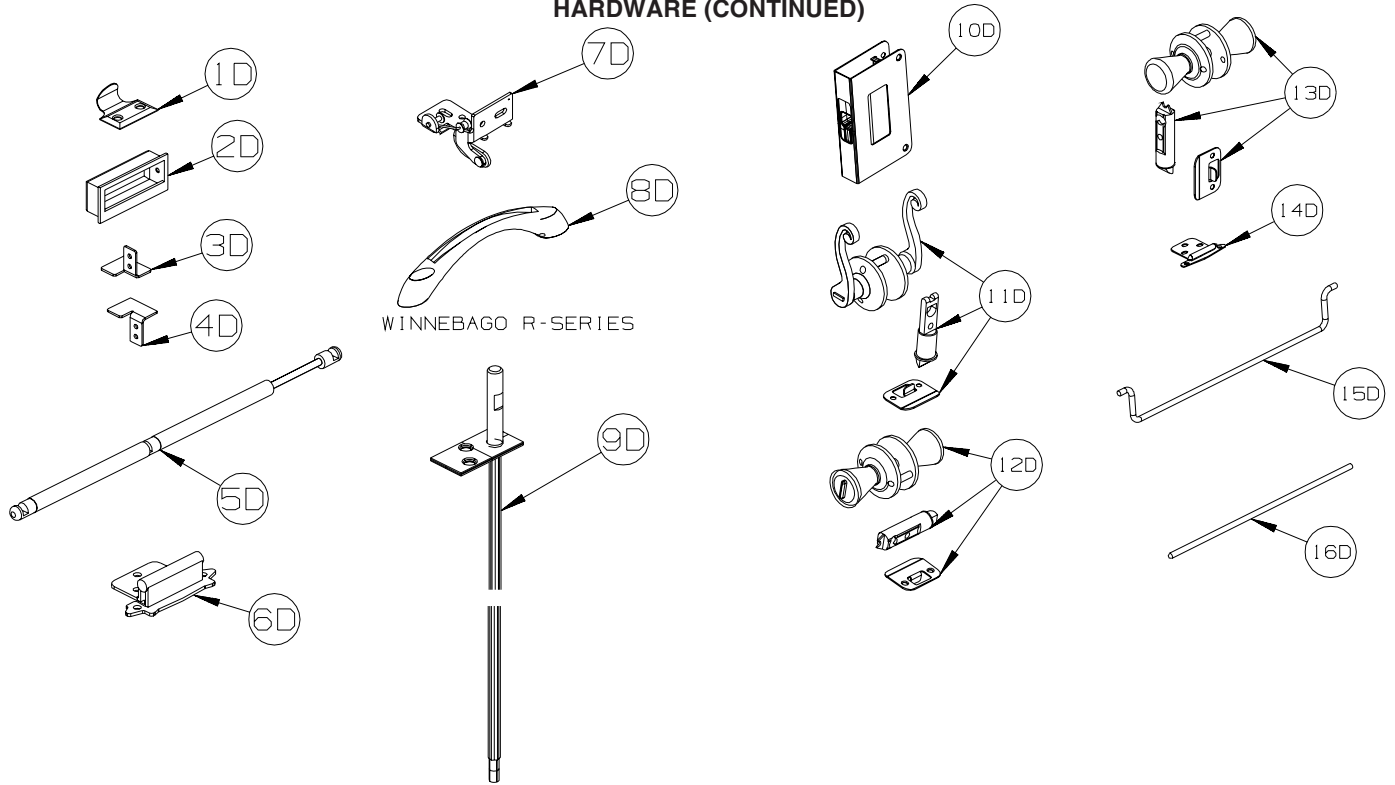

KEY	PART NUMBER	U/M	DESCRIPTION
1D	137463-01-02A	EA	LIFT - HOOK - PEWTER
2D	139136-01-02A	EA	HANDLE - .75" RECESSED - PEWTER
2D	139136-02-02A	EA	HANDLE - .35" RECESSED - PEWTER
3D	139264-01-02B	EA	STOP - DOOR - TAMBOUR/RH HAND - E-COATED
4D	139264-02-02B	EA	STOP - DOOR - TAMBOUR/LH HAND - E-COATED
5D	142569-07-000	EA	SPRING/GAS - 20 LB - 20" EXTENDED/12" COMPRESSED
5D	142569-15-000	EA	SPRING/GAS - 120 LB - 20" EXTENDED/12" COMPRESSED
5D	142569-16-000	EA	SPRING/GAS - 90 LB - 20" EXTENDED/12" COMPRESSED
5D	142569-29-000	EA	SPRING/GAS - 20 LB - 9.9" EXTENDED/5.9" COMPRESSED
6D	143468-02-03A	EA	HINGE - SELF CLOSING - SATIN NICKEL
7D	144488-01-02A	EA	HINGE - CABINET - NICKEL
8D	144917-01-01A	EA	PULL - DRAWER - SATIN NICKEL - <b>TOUR R-SERIES</b>
9D	145939-03-01A	EA	ROD/LATCH - AISLE DOOR - BRASS
9D	145939-05-01A	EA	ROD/LATCH - AISLE DOOR - BRASS - <b>NOT ILLUSTRATED</b>
			FROM: 00-00-00 THRU: 04-16-06
9D	145939-05-02A	EA	ROD/LATCH - AISLE DOOR - NICKEL - <b>NOT ILLUSTRATED</b>
			FROM: 04-17-06 THRU: 07-30-06
			FROM: 07-31-06 THRU: 99-99-99
10D	145939-04-02A	EA	LATCH/SLIDE - AISLE DOOR(1" THICK DOOR)-NICKEL/BLACK SLIDE
11D	146064-01-02A	EA	LOCK/PRIVACY (LOCKING) LEVER STYLE - SATIN PEWTER
12D	146064-05-01A	EA	LOCK/PRIVACY (LOCKING) KNOB STYLE - SATIN NICKEL
13D	146064-06-01A	EA	LOCK/PASSAGE (NON LOCKING) KNOB STYLE - SATIN NICKEL
14D	146553-01-01A	EA	HINGE - CABINET DOOR - BURNISHED BRASS
14D	146553-01-03A	EA	HINGE - CABINET DOOR - SATIN NICKEL
15D	146801-01-01A	EA	ROD/TOWEL BAR (OFFSET) - BRASS
15D	146801-01-02A	EA	ROD/TOWEL BAR (OFFSET) - PEWTER
16D	146840-03-01A	EA	ROD - .25" X 11.7" - BRASS
16D	146840-03-02A	EA	ROD - .25" X 11.7" - PEWTER
16D	146840-04-01A	EA	ROD - .25" X 13.1" - BRASS
16D	146840-04-02A	EA	ROD - .25" X 13.1" - PEWTER
16D	146840-05-01A	EA	ROD - .25" X 14.8" - BRASS
16D	146840-05-02A	EA	ROD - .25" X 14.8" - PEWTER
16D	146840-07-01A	EA	ROD - .25" X 4.2" - BRASS
16D	146840-07-02A	EA	ROD - .25" X 4.2" - PEWTER

## INTERIOR FINISH GROUP (CONTINUED) HARDWARE (CONTINUED)

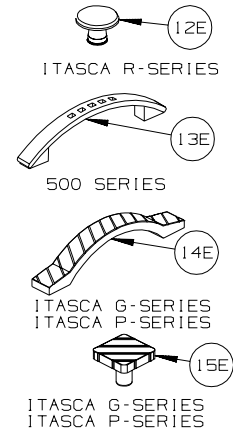
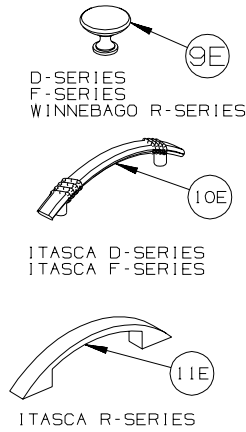
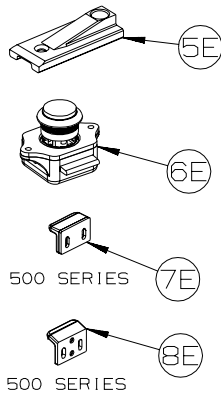
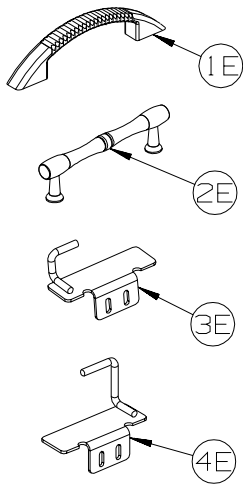

KEY	PART NUMBER	U/M	DESCRIPTION
1E	148816-01-02A	EA	PULL - CABINET DOOR - NICKEL - ASPECT, CAMBRIA 700-SERIES
2E	149090-01-02A	EA	PULL - CABINET DOOR - NICKEL - SIGHTSEER D-SERIES, VOYAGE F-SERIES
3E	149607-01-02B	EA	GUIDE - F/POCKET DOOR - 1.6" BENT ROD - E-COATED
3E	149607-03-02B	EA	GUIDE - F/POCKET DOOR - 2.9" BENT ROD - E-COATED
4E	149607-04-02B	EA	GUIDE - F/POCKET DOOR - E-COATED
5E	150983-01-01A	EA	STRIKE/BLOCK - WEDGE STYLE - F/SLIDE DOOR - 3" X 1.2" - BLACK
6E	151380-01-01A	EA	LATCH - CABINET DOOR - PUSH BUTTON - VIEW & NAVION 500-SERIES
7E	151380-02-01A	EA	STRIKE - CABINET DOOR - VIEW & NAVION 500-SERIES
8E	151380-03-01A	EA	STRIKE - CABINET DOOR - VIEW & NAVION 500-SERIES
9E	152080-01-01A	EA	PULL-NICKEL - SIGHTSEER & SUNOVA D-SERIES, VOYAGE & SUNRISE F-SERIES, TOUR R-SERIES
10E	152302-01-01A	EA	PULL - CABINET DOOR - SATIN NICKEL - SUNOVA D-SERIES, SUNRISE F-SERIES
11E	152304-01-01A	EA	PULL - CABINET DOOR - BRONZE- ELLIPSE R-SERIES
12E	152305-01-01A	EA	KNOB - DOOR/DRAWER - BRONZE - ELLIPSE R-SERIES
13E	152950-01-01A	EA	PULL - DOOR/DRAWER - BRUSHED NICKEL - VIEW & NAVION 500-SERIES
14E	152951-01-01A	EA	PULL - DOOR/DRAWER - PEWTER - SUNCRUISER G-SERIES, MERIDIAN P-SERIES
15E	152952-01-01A	EA	PULL - KNOB/DRAWER - PEWTER - SUNCRUISER G-SERIES, MERIDIAN P-SERIES

## INTERIOR FINISH GROUP (CONTINUED) HARDWARE (CONTINUED)

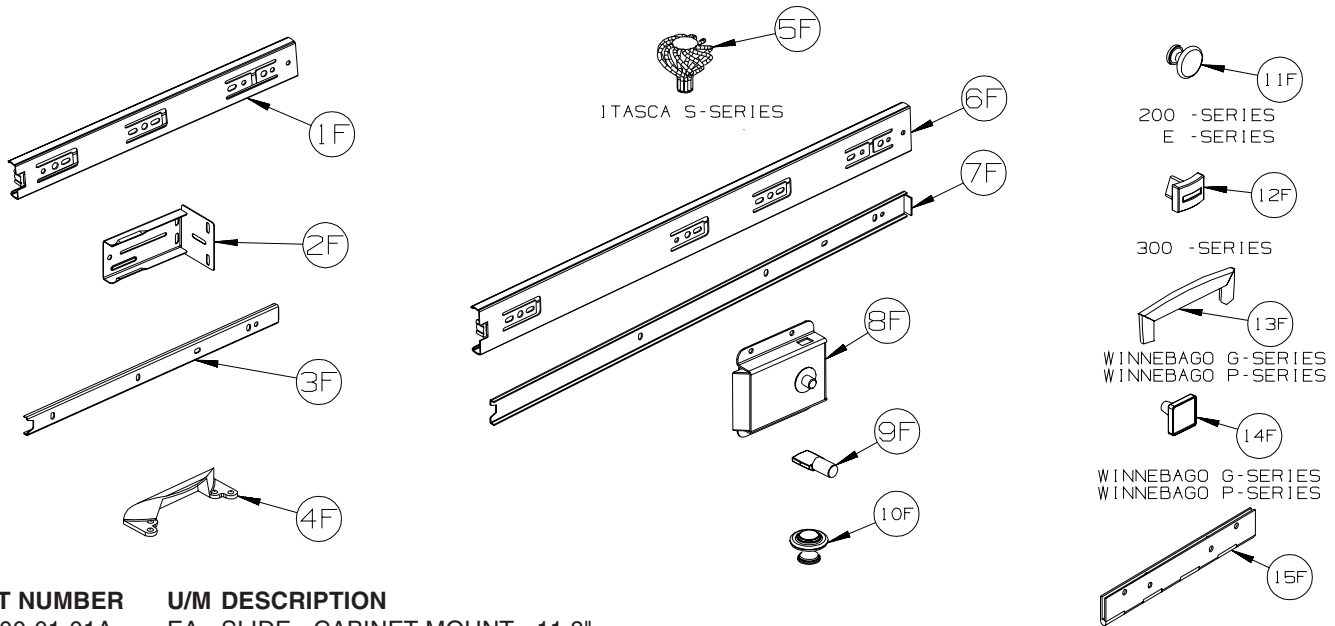

KEY	PART NUMBER	U/M	DESCRIPTION
1F	153000-01-01A	EA	SLIDE - CABINET MOUNT - 11.8"
1F	153000-03-01A	EA	SLIDE - CABINET MOUNT - 13.8"
1F	153000-05-01A	EA	SLIDE - CABINET MOUNT - 15.7"
1F	153000-07-01A	EA	SLIDE - CABINET MOUNT - 17.7"
1F	153000-09-01A	EA	SLIDE - CABINET MOUNT - 19.7"
1F	153000-11-01A	EA	SLIDE - CABINET MOUNT - 21.6"
1F	153000-14-01A	EA	SLIDE - CABINET MOUNT - 23.6"
1F	153000-18-01A	EA	SLIDE - CABINET MOUNT - 9.8"
1F	153000-20-01A	EA	SLIDE - CABINET MOUNT - 25.6"
2F	153000-13-01A	EA	BACKSOCKET - DRAWER SLIDE
3F	153000-02-01A	EA	SLIDE - DRAWER MOUNT - 11.8"
3F	153000-04-01A	EA	SLIDE - DRAWER MOUNT - 13.8"
3F	153000-06-01A	EA	SLIDE - DRAWER MOUNT - 15.7"
3F	153000-08-01A	EA	SLIDE - DRAWER MOUNT - 17.7"
3F	153000-10-01A	EA	SLIDE - DRAWER MOUNT - 19.7"
3F	153000-12-01A	EA	SLIDE - DRAWER MOUNT - 21.6"
3F	153000-15-01A	EA	SLIDE - DRAWER MOUNT - 23.4"
3F	153000-19-01A	EA	SLIDE - DRAWER MOUNT - 9.8"
3F	153000-21-01A	EA	SLIDE - DRAWER MOUNT - 25.4"
4F	153308-01-01A	EA	PULL - VANITY STOOL - SATIN NICKEL
5F	153335-01-02A	EA	PULL - KNOB - DOOR/DRAWER - FLAT BLACK - <b>HORIZON S-SERIES</b>
6F	153352-01-01A	EA	SLIDE - PANTRY - 19.7" - CABINET MOUNT
6F	153352-03-01A	EA	SLIDE - EXT ENTERTAINMENT CNTR - 13.8" - CABINET MOUNT
7F	153352-02-01A	EA	SLIDE - PANTRY - 19.5" - DRAWER MOUNT
7F	153352-04-01A	EA	SLIDE - EXT ENTERTAINMENT CNTR - 13.6" - DRAWER MOUNT
8F	153353-01-01A	EA	LATCH - SLIDING/FLUSH - BLACK
9F	154385-01-02A	EA	PIN - SUPPORT/GLASS DOOR - 1/4" - NICKEL
10F	155803-01-01A	EA	KNOB CABINET DOOR - WROUGHT IRON
11F	155925-01-01A	EA	KNOB - DOOR/DRAWER - SATIN NICKEL - <b>ACCESS &amp; IMPULSE 200-SERIES</b>
12F	156579-01-01A	EA	KNOB - DOOR/DRAWER - PEWTER - <b>OUTLOOK &amp; SPIRIT 300-SERIES</b>
13F	157246-01-01A	EA	PULL - CABINET DOOR/DRAWER - SATIN NICKEL - <b>ADVENTURER G-SERIES, JOURNEY P-SERIES</b>
14F	157246-02-01A	EA	KNOB - CABINET DOOR/DRAWER - SATIN NICKEL - <b>ADVENTURER G-SERIES, JOURNEY P-SERIES</b>
15F	158982-01-04B	EA	HINGE - CONTINUOUS - 2" X 8" - BLACK
	158982-01-01A	EA	HINGE - CONTINUOUS - 2" X 8" - ZINC

## LABELS GROUP

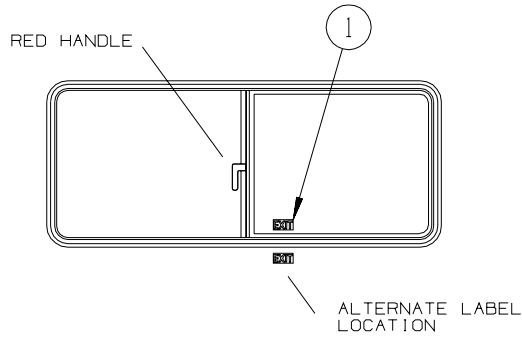

EXIT WINDOW  
(SLIDER STYLE)

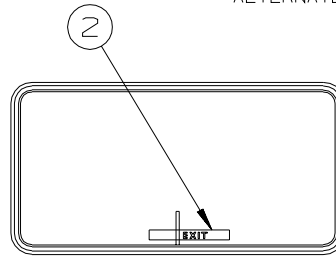

EXIT WINDOW  
(POP-OUT STYLE)

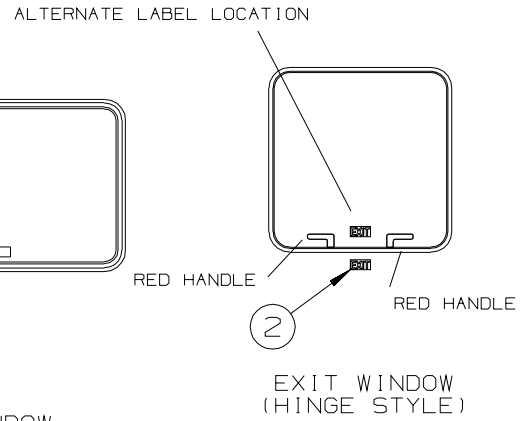

EXIT WINDOW  
(HINGE STYLE)

KEY	PART NUMBER	U/M	DESCRIPTION
1	039290-01-000	EA	LABEL - WARNING - EXIT
2	107571-01-000	EA	LABEL - EXIT/ESCAPE WINDOW

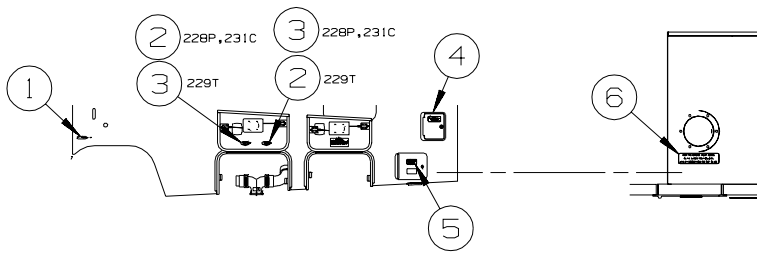

SERVICE COMPARTMENTS

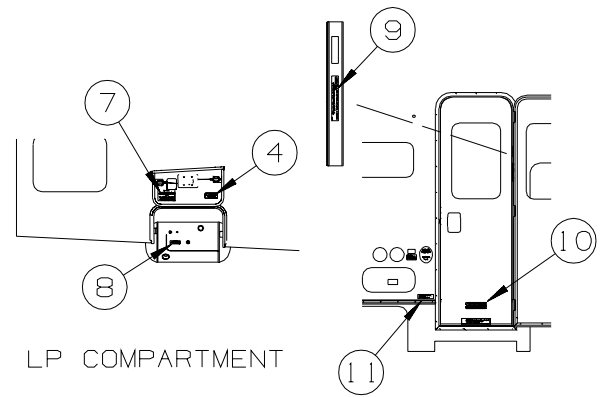

LP COMPARTMENT

ENTRANCE DOOR

KEY	PART NUMBER	U/M	DESCRIPTION
1	136360-01-01A	EA	LABEL - AIR BAGS
1	136360-02-01A	EA	LABEL - AIR BAGS - BLACK/CLEAR
2	152543-03-01A	EA	LABEL - BLACK WASTE
3	152541-03-01A	EA	LABEL - GRAY WASTE
4	124519-01-01A	EA	LABEL - WARNING/REFUELING - BLACK ON CLEAR
4	124519-02-01A	EA	LABEL - WARNING/REFUELING - BLACK ON CLEAR - CANADIAN
5	125306-01-01A	EA	LABEL - ELECTRICAL ENTRANCE - 110V 30 AMP - BLACK ON CLEAR
6	123562-01-000	EA	LABEL - SERVICE/UTILITY ACCESS
7	124520-01-01A	EA	LABEL - LP GAS ONLY - BLACK ON CLEAR
7	023769-01-000	EA	LABEL - WARNING - LPG - CANADIAN
8	079965-01-000	EA	LABEL - LPG - 80% CAPACITY
9	135869-01-01A	EA	LABEL - MERCURY CONTENT - BLACK ON CLEAR
10	065748-01-000	EA	LABEL - WARNING - BATTERY CHARGING - UL
10	065748-02-000	EA	LABEL - WARNING - BATTERY CHARGING - CANADIAN
11	099509-01-000	EA	LABEL - AWNING INSTALLATION

TYPICAL SEAT AND BELT CONFIGURATIONS

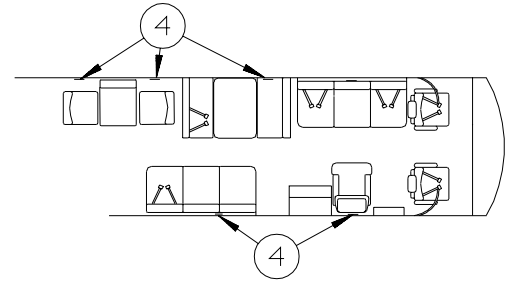
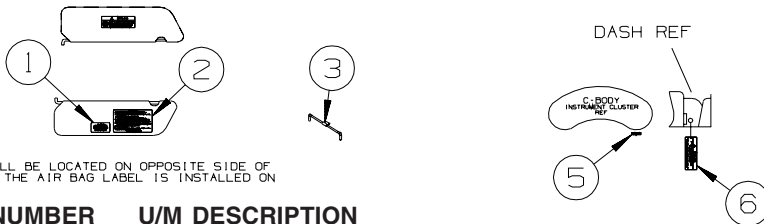

LABELS SHALL BE LOCATED ON OPPOSITE SIDE OF VISOR THAT THE AIR BAG LABEL IS INSTALLED ON

KEY	PART NUMBER	U/M	DESCRIPTION
1	099689-01-000	EA	LABEL - WARNING - CANCER/TOXICITY
2	056259-01-000	EA	LABEL - SAFETY CHECK LIST
3	128658-01-000	EA	LABEL - PROP ROD - ENTRY DOOR
4	134538-01-01A	EA	LABEL - OCCUPANCY - NO SEAT BELT - BLACK ON CLEAR - US
4	134538-02-01A	EA	LABEL - OCCUPANCY - NO SEAT BELT - BLACK ON CLEAR - CANADIAN
5	155692-01-02A	EA	LABEL - ODOMETER - READ IN MILE - WHITE/CLEAR
6	126612-01-000	EA	LABEL - HANG TAG - AIR BAG - DASH



## LABELS GROUP (CONTINUED)

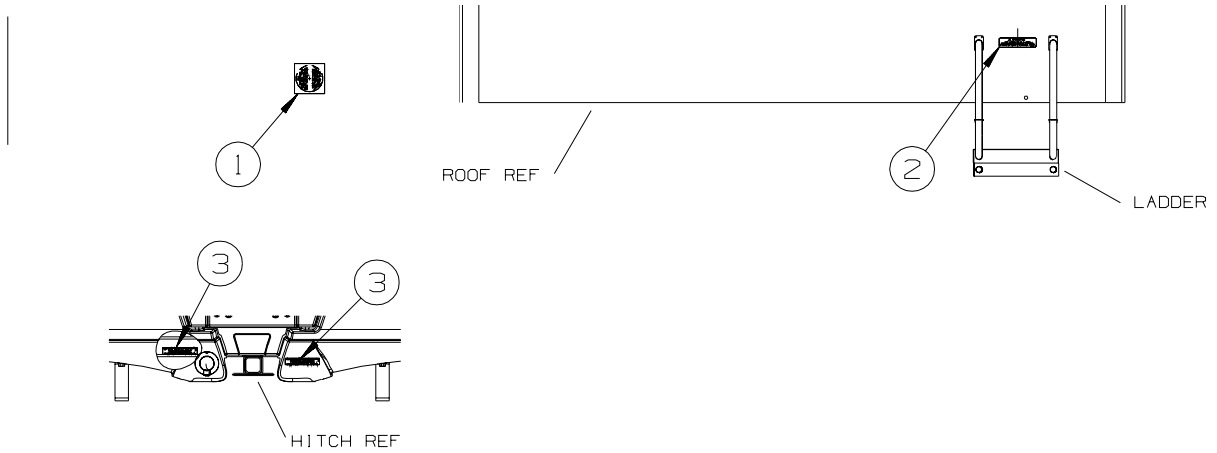

KEY	PART NUMBER	U/M DESCRIPTION
1	120431-01-000	EA LABEL - LOCATION - COAXIAL CABLE/SATELLITE ANTENNA
2	128218-01-01A	EA LABEL - WARNING - SLIPPERY ROOF
3	129669-01-01A	EA LABEL - HITCH/VEHICLE RATE - 350 - WHITE ON CLEAR
3	129669-01-02A	EA LABEL - HITCH/VEHICLE RATE - 350 - BLACK ON CLEAR

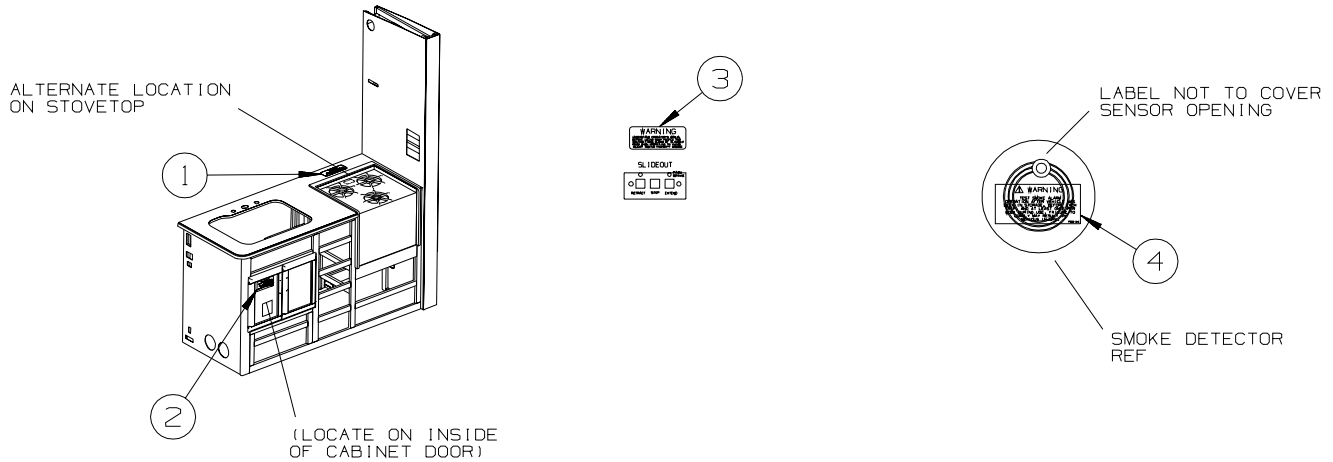

KEY	PART NUMBER	U/M DESCRIPTION
1	134539-01-01A	EA LABEL - WARNING - STOVE/HEATING - US - BLACK ON CLEAR
1	134540-01-01A	EA LABEL - WARNING - STOVE/HEATING - CSA - BLACK ON CLEAR - <b>CANADIAN</b>
2	073998-01-000	EA LABEL - LPG/ODOR WARNING
3	116549-02-000	EA LABEL - WARNING - SLIDEOUT
4	077956-01-000	EA LABEL - WARNING/SMOKE DETECTOR

**LP GROUP**  
**LP SYSTEM**

<b>KEY</b>	<b>PART NUMBER</b>	<b>U/M</b>	<b>DESCRIPTION</b>
	010329-01-000	EA	ADAPTER - 1/2"F X 1/2"MPT - BRASS
	010323-01-000	EA	ADAPTER - 3/8"F X 1/2"MPT - BRASS
	024250-01-000	EA	ADAPTER - BRASS - 3/8"F X 1/2"FPT
	010326-01-000	EA	ADAPTER - FLARE - W/CONE GASKET - 3/8"F X 1/2"F
	045703-13-000	EA	HOSE - LP - 3/8"ID X 120" - 3/8"F SWIVEL X 1/2"F SWIVEL US FROM: 00-00-00 THRU: 06-11-06
	045703-15-000	EA	HOSE - LP - 3/8"ID X 142" - 1/2"F SWIVEL X 3/8"F SWIVEL FROM: 06-12-06 THRU: 99-99-99
	045703-03-000	EA	HOSE - LP - 3/8"ID X 18" - 3/8"MPT X 1/2"F SWIVEL - US
	045703-12-000	EA	HOSE - LP - 3/8"ID X 18" - 3/8"MPT X 1/2"F SWIVEL - CANADIAN
	045703-05-000	EA	HOSE - LP - 3/8"ID X 28" - 3/8"MPT X 1/2"F SWIVEL - US
	045703-06-000	EA	HOSE - LP - 3/8"ID X 28" - 3/8"MPT X 1/2"F SWIVEL - CANADIAN
	045703-22-000	EA	HOSE - LP - 3/8"ID X 60" - 1/2"F SWIVEL X 1/2"F SWIVEL US/CSA - 331H
	010589-01-000	EA	NIPPLE - PIPE - 1/2" X 1 1/2" - BLACK
	010589-03-000	EA	NIPPLE - PIPE - 1/2" X 2 1/2" - BLACK
	010380-02-000	EA	NUT - 1/2" FLARE - FORGED - BRASS
	010377-02-000	EA	NUT - 3/8" FLARE - FORGED - BRASS
	137828-05-02B	EA	PANEL - ROCKGUARD/LP - E-COATED - 325F
	106150-05-000	EA	REGULATOR - TWO STAGE
	144485-01-000	EA	COVER - LP REGULATOR
*	144116-04-000	EA	TANK - LP - 60 LB - 14"D X 29.75"L
	040440-02-000	EA	TRANSMITTER - DIAL/BOLT-ON - 0-90 OHM 2 TERM(POWER/GROUND)

**\*COMPONENT PARTS LISTED LATER IN THIS GROUP**

**COMPONENT PARTS FOR LP SYSTEM**

**144116-04-000**

<b>KEY</b>	<b>PART NUMBER</b>	<b>U/M</b>	<b>DESCRIPTION</b>	<b>VENDOR NO.</b>
	040421-01-712	EA	VALVE-SERV. W/O VAPOR RELIEF	V20373/V21202
	040421-01-713	EA	VALVE-RELIEF 1" W/SPRING 7"	V12560/V21207
	144116-01-700	EA	VALVE-OUTAGE(NO STEM REMOVE)	V20058
	144116-01-701	EA	VALVE/FILL 80 % W/YELLOW CAP	V13414
	144116-04-700	EA	FLOAT/SENDING UNIT W/O DIAL	G11530
	144116-04-701	EA	DIAL - TRANSMITER	G12845

**SEALANTS & FASTENERS GROUP**  
**SEALANTS & ADHESIVES**

KEY	PART NUMBER	U/M	DESCRIPTION
	004001-02-000	EA	GUN - PLEXUS ADHESIVE - W/O NOZZLE
	004001-05-000	EA	ADHESIVE - SCOTCH-WELD - 3M DP100 - CLEAR - 50ML
	004011-01-000	EA	ADHESIVE-3M-4475 TUBE
	010405-02-000	EA	TAPE - THREAD SEALING - 3/8"
	064075-07-000	FT	SEAL - BULB - W/WIRED U CHANNEL - .3" X .5" CHANNEL-BLACK
	067788-01-000	EA	ADHESIVE - SPRAY - 3M - 19.5 OZ AEROSOL CAN
	069640-01-000	FT	SEALER - RIBBON - 1/4"DIAMETER X 30 FT - BLACK OR GRAY
	069640-02-000	FT	SEALER - TAPE - 1/8"THICK X 1/2"WIDE X 60 FT - GRAY
	069640-03-000	FT	SEALER - TAPE - 1/8"THICK X 3/4"WIDE X 60 FT - BLACK
	069640-07-000	FT	SEALER - TAPE - 3/32"THICK X 2"WIDE X 45 FT - GRAY
	069640-09-000	FT	SEALER - TAPE - 1/32"THICK X 2 1/2"WIDE X 80 FT - BRT WHT
	069640-10-000	FT	SEALER - TAPE - 1/32"THICK X 1 1/2"WIDE X 90 FT - BRT WHT
	069640-11-000	FT	SEALER - TAPE - 3/16"THICK X 3/8"WIDE X 40 FT - BLACK
	069640-13-000	FT	SEALER - TAPE - 3/32"THICK X 2"WIDE X 45 FT - BLACK
	069640-14-000	FT	SEALER - TAPE - 1/16"THICK X 1"WIDE X 100 FT - BLACK
	069640-15-000	FT	SEALER - TAPE - 1/16"THICK X 3/8"WIDE X 100 FT - BRT WHT
	069640-17-000	FT	SEALER - TAPE - 1/32"THICK X 1"WIDE X 150 FT - GRAY
	069640-18-000	FT	SEALER - TAPE - 1/8"THICK X 1/2"WIDE X 60 FT - BRT WHT
	069640-19-000	FT	SEALER - TAPE - 1/8"THICK X 3/4"WIDE X 60 FT - BRT WHT
	069640-20-000	FT	SEALER - TAPE - 1/8"THICK X 1/2"WIDE X 60 FT - BLACK
	069640-21-000	FT	SEALER - TAPE - 1/16"THICK X 1/2"WIDE X 100 FT - BRT WHT
	069640-22-000	FT	SEALER - TAPE - 1/32"THICK X 1/4"WIDE X 200 FT - BRT WHT
	069640-23-000	FT	SEALER - TAPE - 1/16"THICK X 3/4"WIDE X 100 FT - BRT WHT
	069640-27-000	FT	SEALER - TAPE - 1/16"THICK X 2 1/4"WIDE X 50 FT - BRT WHT
	069640-28-000	FT	SEALER - TAPE - 1/32"THICK X 1 7/8"WIDE X 90 FT - GRAY
	069640-30-000	FT	SEALER - TAPE - 1/32"THICK X 5/8"WIDE X 50 FT - GRAY
	069640-31-000	FT	SEALER - TAPE - 1/4"THICK X 3/4"WIDE X 15 FT - BLACK
	069640-32-000	FT	SEALER - TAPE - 1/16"THICK X 3/8"WIDE X 100 FT - BLACK
	069640-33-000	FT	SEALER - RIBBON - 3/8"DIAMETER X 20 FT - BLACK
	069640-34-000	FT	SEALER - RIBBON - 1/4"DIAMETER X 30 FT - BRIGHT WHITE
	072889-28-000	EA	SEALANT/URETHANE-10 OZ TUBE W/NOZZLE-SELF LEVELING-BRT WHT
	076322-01-000	FT	TAPE-DOUBLE COATED/ADHESIVE BK-.03"THK X .8"W X 216' - WHT
	076322-02-000	FT	TAPE-DOUBLE COATED/ADHESIVE BK-.05"THK X 1"W X 108' - WHT
	076322-03-000	FT	TAPE-DOUBLE COATED/ADHESIVE BK-.05"THK X .5"W X 108' - WHT
	076322-05-000	FT	TAPE-DOUBLE COATED/ADHESIVE BK-.05"THK X .8"W X 108' - WHT
	076322-07-000	FT	TAPE-DOUBLE COATED/ADHESIVE BK-.05"THK X .5"W X 200' - BLK
	076322-13-000	FT	TAPE - FOAM/DOUBLE COATED - .020"THK X .75"W - CLEAR
	076322-21-000	FT	TAPE - FOAM/DOUBLE COATED - .045"THK X .50"W
	076322-22-000	FT	TAPE - FOAM/DOUBLE COATED - .045"THK X .75"W
	076322-23-000	FT	TAPE - FOAM/DOUBLE COATED - .045"THK X 1"W
	076322-25-000	FT	TAPE - FOAM/DOUBLE COATED - .025"THK X .5"W
	086276-01-000	EA	TAPE - DOUBLE SIDED - 1/2" WIDE X 108' LONG (SOLD BY ROLL)
	088479-01-000	EA	TAPE - ALUMINUM - 3"
	090340-01-000	FT	SEAL - FOAM - CLOSED CELL - 1/4" X 1/2" X 50'
	091255-02-000	FT	SEAL - ADHESIVE BACKED/FOAM - 3/64"THICK X 3/16"W X 1000'
	091255-03-000	FT	SEAL - ADHESIVE BACKED/FOAM - 1/4" THICK X 1/4"W X 1000'
	094401-01-000	EA	SEALER - BODY SEAM - FLEXICLEAR
	094401-04-000	EA	SEALER - BODY SEAM - CLEAR
	094401-05-000	EA	SEALER - BODY SEAM - 20OZ BLACK
	094401-06-000	EA	SEALER - BODY SEAM - 12OZ BLACK
	094401-07-000	EA	SEALER - BODY SEAM - CLEAR
	098408-01-000	FT	SEAL - SPONGE RUBBER - CLOSED CELL
	099069-01-000	FT	SEAL - RUBBER - CLOSED SPONGE - .5" WIDE X .12" THICK-BLK
	099418-01-000	FT	SEAL - D-SECTION/ADHESIVE BACK - ..44" X .44" - BLK RUBBER
	107828-01-000	EA	SEALANT - SB - 190 EVERSEAL
	112864-01-000	FT	SEAL - FOAM/BUTYL COVERED - 3/8" X 35'
	112864-02-000	FT	FOAM - BUTYL COVERED - 5/16" X 44'
	112864-04-000	FT	FOAM - BUTYL COVERED - 3/8" X 1/8"
	112901-02-000	EA	ADHESIVE - PLEXUS - MA330 - 50ML - GRAY
	112901-03-000	EA	ADHESIVE - PLEXUS - MA300 - 50ML - WHITE
	112902-01-000	EA	NOZZLE - ELEMENT - 3/8" X 24
	112902-03-000	EA	MIXER NOZZLE - F/GUN #00400102000 - SCOTCH-WELD & PLEXUS
	112902-04-000	EA	NOZZLE - ELEMENT - 1/4" X 3.5"
	112902-05-000	EA	NOZZLE - BAYONET - 3/8" X 18

## SEALANTS & FASTENERS GROUP (CONTINUED)

### SEALANTS & ADHESIVES (CONTINUED)

KEY	PART NUMBER	U/M	DESCRIPTION
	112902-06-000	EA	NOZZLE - ELEMENT - 1/2" X 32
	113366-01-000	EA	ADHESIVE - INSTANT - 1 OZ
	120074-02-03A	EA	SILICONE - TUBE - W/O NOZZLE - LOW ODOR - SMOKEY WHITE
	120534-01-01A	EA	TAPE - SCOTCH - 3M - 1/2" FINE LINE
	123244-01-000	FT	TAPE - DOUBLE SIDED/FOAM - 5/64"THICK X 3/4"WIDE X 108'
	123816-01-000	FT	TAPE - DOUBLE SIDED - 1" X .020" X 200' - CLEAR
	123816-02-000	FT	TAPE - DOUBLE SIDED - 1/2" X .035" X 200' - CLEAR
	123816-03-000	FT	TAPE - DOUBLE SIDED - 1/2" X .020" X 200' - CLEAR
	123816-04-000	FT	TAPE - DOUBLE SIDED - 6" X .0035" X 750' - CLEAR
	123816-06-000	FT	TAPE - DOUBLE SIDED - 3/4" X 3/4" X 200' - CLEAR
	123816-07-000	FT	TAPE - DOUBLE SIDED - 1 3/4" X 200' - CLEAR
	126427-01-000	EA	ADHESIVE - ALL PURPOSE - ABS/PVC
	126427-02-000	EA	PRIMER - CLEANER - FLEX PIPING
	131264-01-11A	EA	SILICONE - TUBE - W/NOZZLE - BEIGE
	131264-01-12A	EA	SILICONE - TUBE - W/NOZZLE - BONE
	131264-01-13A	EA	SILICONE - TUBE - W/NOZZLE - TRANSLUCENT
	131264-02-01A	EA	SILICONE - TUBE - W/NOZZLE - VW GRAY - BATH ONLY
	131264-03-01A	EA	SILICONE - TUBE - W/O NOZZLE - SELF LEVELING -BRIGHT WHITE
	131264-04-01A	EA	SILICONE/SEALANT/ADHESIVE - FAST CURE F/GLASS/VINYL - B/W
	131264-04-02A	EA	SILICONE/SEALANT/ADHESIVE-FAST CURE F/GLASS/VINYL-SOFT WHT
	131264-05-01A	EA	SILICONE/SEALANT - ODORLESS - TUBE - W/NOZZLE - BLACK
	131264-05-02A	EA	SILICONE/SEALANT - ODORLESS - TUBE - W/NOZZLE - CLEAR
	131384-01-000	EA	ADHESIVE - JET WELD - 10 OZ CARTRIDGE
	132892-07-01A	FT	SEAL - BULB/SINGLE - W/U CHANNEL - .5" X 1" - BLACK
	152038-01-01A	EA	TAPE - PRESERVATION SEAL - 2" X 36YD ROLL - BLACK
	154585-01-01A	FT	SEAL - FOAM TAPE - ADHESIVE BACK - 3/8" X 3/8" - BLACK
	154585-02-01A	FT	SEAL - FOAM TAPE - ADHESIVE BACK - 3/4" X 1/2" - BLACK
	154585-03-01A	FT	SEAL - FOAM TAPE - ADHESIVE 2 SIDED - 1/8" X 3/4" - BLACK
	154585-04-01A	FT	SEAL - FOAM TAPE - ADHESIVE BACK - 5/8" X 1/8" - WHITE

### BOLTS, NUTS AND WASHERS

KEY	PART NUMBER	U/M	DESCRIPTION
	0MD54F-06-000	EA	NUT - HEX W/SERATED FLANGE
	000C12-04-08B	EA	BOLT - HEX - 1/4-20 X 1/2 - GRADE #5 - ZINC
	000C12-04-40B	EA	BOLT - HEX - 1/4-20 X 2 1/2 - GRADE #5 ZINC
	000C12-04-20F	EA	BOLT - HEX - 1/4-20 X 1 1/4 - GRADE #5 - STAINLESS STEEL
	000C12-04-12A	EA	BOLT - HEX - 1/4-20 X 3/4 - PLAIN 5
	000C12-05-16B	EA	BOLT - HEX - 5/16 - 18X1 - GRADE #5 - ZINC
	000C12-05-40B	EA	BOLT - HEX - 5/16"-18 X 2.5" - GRADE #5 - ZINC
	000C12-06-28B	EA	BOLT-HEX-3/8-16X13/4 ZN 5 - 5185-01
	000C12-08-44B	EA	BOLT - HEX - 1/2-13 X 2 3/4 - GRADE #5 - ZINC
	000C12-08-24B	EA	BOLT - HEX - 1/2-13 X 1 1/2 - GRADE #5 - ZINC
	000C12-08-28B	EA	BOLT - HEX - 1/2-13 X 1 3/4 - GRADE #5 - ZINC
	000C13-07-40B	EA	BOLT - HEX - 7/16-20 X 2 1/2 - GRADE #5 - ZINC
	000C13-07-48B	EA	BOLT - HEX - 7/16-20 X 3 - GRADE #5 - ZINC
	000C13-07-72B	EA	BOLT - HEX - 7/16-20 X 4.5" - GRADE #5 - ZINC
	000C16-07-16B	EA	BOLT - CARRIAGE - ASSIST HANDLE - 7/16-14 X 1
	000C18-05-40A	EA	BOLT - ELEVATOR - 5/16-18 X 2 1/2 - PL
	000C26-04-18B	EA	BOLT - HEX - SERRATED FLANGE - 1/4-20 X 1 1/8 - ZINC
	000C26-04-14B	EA	BOLT - HEX - SERRATED FLANGE - 1/4-20 X 7/8 - ZINC
	000C26-04-12F	EA	BOLT - HEX - SERRATED FLANGE -1/4-20 X 3/4-STAINLESS STEEL
	000C26-04-10B	EA	BOLT - HEX - SERRATED FLANGE - 1/4-20 X 5/8 - ZINC
	000C26-04-40F	EA	BOLT - HEX - SERRATED FLANGE -1/4-20 X 2.5-STAINLESS STEEL
	000C26-05-12B	EA	BOLT - HEX - SERRATED FLANGE - 5/16-18 X 3/4 - ZINC
	000C26-06-12B	EA	BOLT - HEX - SERRATED FLANGE - 3/8-16 X 3/4 - ZINC
	000C26-06-20B	EA	BOLT - HEX - SERRATED FLANGE - 3/8-16 X 1 1/4 - ZINC
	000C26-06-28B	EA	BOLT - HEX - SERRATED FLANGE - 3/8-16 X 1 3/4 - ZINC
	000C26-06-40B	EA	BOLT - HEX - SERRATED FLANGE - 3/8-16 X 2 1/2 - ZINC
	000C26-08-28B	EA	BOLT - HEX - SERRATED FLANGE - 1/2-13 X 1 3/4 - ZINC
	000C26-08-24B	EA	BOLT - HEX - SERRATED FLANGE - 1/2-13 X 1 1/2 - ZINC
	000C26-08-40B	EA	BOLT - HEX - SERRATED FLANGE - 1/2-13 X 2 1/2-GRADE #5 ZINC
	000C27-08-48B	EA	BOLT-CARR 1/2-13X3.00 GR5 - 97 M-SERIES
	000C27-08-64B	EA	BOLT - CARRIAGE - 1/2-13 X 4 - GRADE 5
	000D16-07-00B	EA	NUT - HEX - 7/16-14 - ZINC

**SEALANTS & FASTENERS GROUP (CONTINUED)**  
**BOLTS, NUTS AND WASHERS (CONTINUED)**

KEY	PART NUMBER	U/M	DESCRIPTION
	000D24-10-00B	EA	NUT - HEX - SELF LOCKING - 10-32 - ZINC
	000D27-05-00B	EA	NUT - HEX LOCK - 5-40 - ZINC
	000D28-10-00B	EA	NUT - HEX - W/NYLON LOCK - 10-32 - ZINC
	000D29-04-00F	EA	NUT - HEX - SELF LOCKING - 1/4 X 20 - STAINLESS STEEL
	000D29-04-00B	EA	NUT - HEX - SELF LOCKING - 1/4 X 20 - ZINC
	000D29-06-00B	EA	NUT - HEX - W/NYLON LOCK - 3/8-16 - ZINC
	000D29-09-00B	EA	NUT - HEX - SELF LOCKING - 9/16-12 - ZINC
	000D34-04-00B	EA	NUT - HEX - LOCKING - 1/4-20 - ZINC
	000D34-06-00B	EA	NUT - HEX - LOCKING - 3/8-16 GRADE C - ZINC
	000D39-04-00B	EA	NUT - HEX - LOCKING W/SERRATED FLANGE - 1/4-20 - ZINC
	000D39-05-00B	EA	NUT - HEX - LOCKING W/SERRATED FLANGE - 5/16-18 - ZINC
	000D39-06-00B	EA	NUT - HEX - LOCKING W/SERRATED FLANGE - 3/8-18 - ZINC
	000D39-06-00D	EA	NUT - HEX - LOCKING W/SERRATED FLANGE - 3/8"-16 BLACK
	000D39-07-00B	EA	NUT - HEX - LOCKING W/SERRATED FLANGE - 7/16-14 - ZINC
	000D39-08-00B	EA	NUT - HEX - LOCKING W/SERRATED FLANGE - 1/2-13 - ZINC
	000D39-09-00B	EA	NUT - HEX - LOCKING W/SERRATED FLANGE - 9/16-12 - ZINC
	000D44-04-00B	EA	NUT - HEX - LOCKING W/SERRATED FLANGE - 1/4-28 - ZINC
	000D44-07-00B	EA	NUT - HEX - LOCKING W/SERRATED FLANGE - 7/16-20 - ZINC
	000D44-08-00B	EA	NUT - HEX - LOCKING W/SERRATED FLANGE - 1/2-20 - ZINC
	000D46-04-00A	EA	NUT - HEX - WELD - 1/4-20 - PLAIN
	000D65-08-00B	EA	NUT - HEX - LOCKING W/SERRATED FLANGE - 8-32 - ZINC
	000D73-08-00C	EA	NUT - HEX FLANGE - 1/2-13
	000D75-09-00B	EA	NUT - HEX LOCKING - 9/16-12 - ZINC
	000D76-06-00B	EA	NUT - HEX FLANGE - 3/8-16
	000E11-04-00F	EA	WASHER - LOCKING - 1/4 MED SPLIT - STAINLESS STEEL
	000E11-07-00B	EA	WASHER - LOCKING - 7/16 MED SPLIT - ZINC
	000E11-08-00B	EA	WASHER - LOCKING - 1/2 MED SPLIT - ZINC
	000E13-17-00B	EA	WASHER - FLAT - 3/8 AR - ZINC
	000E13-18-00B	EA	WASHER - FLAT - 3/8 WIDE - ZINC
	000E13-20-00B	EA	WASHER - FLAT - 7/16 WIDE - ZINC
	000E13-22-00B	EA	WASHER - FLAT - 1/2 WIDE - ZINC
	000E13-26-00B	EA	WASHER - FLAT - 5/8 WIDE - ZINC
	000E14-10-00B	EA	WASHER - LOCKING - #10 EXTERNAL TOOTH - ZINC
	000E16-10-00B	EA	WASHER - HARDENED - 5/8 - FLAT - ZINC
	000G45-05-16B	EA	BOLT - LAG - 5/16-9 X 1 - ZINC
	005081-01-000	EA	NUT - SPEED - C-TYPE - #8 SCREW
	039715-01-000	EA	NUT-SERT - 1/4" DIAMETER - 20 THREADS
	040921-01-000	EA	NUT - SPEED - U TYPE - #10-24 - BLACK
	040921-03-000	EA	NUT - SPEED - U TYPE - #10
	040921-04-000	EA	NUT - SPEED - U TYPE - #8-.59" LENGTH X .44" WIDTH
	040921-05-000	EA	NUT - SPEED - U-TYPE - 8-.67" X .44" WIDE
	040921-11-000	EA	NUT - SPEED - U-TYPE - 8-.59" LENGTH X .44" WIDTH - BLACK
	041322-01-000	EA	WASHER - FLANGE - 15/32"ID X 2 3/8"OD - F/SEAT BELT MTG
	044364-02-000	EA	NUT - SPEED - FLAT - ROUND
	044533-01-000	EA	WASHER - 1 3/8"OD - FOR BUTTONS - PLASTIC
	051387-06-000	EA	BOLT - CARRIAGE W/O HOLE - 5/16-18 X 9 1/2 - ZINC
	058716-02-000	EA	WASHER - FLAT NYLON
	064081-03-000	EA	NUT - WING 3/8-16 - W/WELD NUT
	077071-01-000	EA	WASHER - FENDER - 3/16"ID X 1"OD
	087234-01-000	EA	NUT - JACK - 1/4 X 20 THD - MOLLY
	088787-12-000	EA	STUD - WELD - 1/4 - 20 X 1.0 LG - MN
	102540-02-000	EA	SEAL - SCREW
	106956-03-000	EA	BOLT - HEX TAP - 1/2-13NC X 3 - GRADE 5 - FULL THREAD/ZINC
	106956-10-000	EA	BOLT - HEX TAP - 9/16-12NC X 3 5/8 -GRD 5-FULL THREAD/ZINC
	106956-11-000	EA	BOLT - HEX TAP - 1/2-13NC X 2 1/2 - GRD 5-FULL THREAD/ZINC
	106956-13-000	EA	BOLT - HEX TAP - 1/2-20 X 2 1/2 - GRD 5-FULL THREAD/ZINC
	107397-01-000	EA	WASHER - FENDER - 3/4"ID X 1"OD
	108067-03-000	EA	STUD - WELD - 1/4 - 20 X 1/2 CD
	109917-03-000	EA	WASHER - 1" X .50"
	109917-04-000	EA	WASHER - 1" X .75"
	128444-01-000	EA	WASHER - SPRING - CONICAL
	135092-02-01A	EA	BOLT - HEX - SERRATED FLANGE - 1/2-20 X 2 1/2-GRADE 5 ZINC
	135092-05-01A	EA	BOLT - HEX - SERRATED FLANGE - 1/2-20 X 1 - GRADE 5 ZINC
	143399-01-01A	EA	NUT/RETAINING - 3/8"- 24 NFT

**SEALANTS & FASTENERS GROUP (CONTINUED)**  
**BOLTS, NUTS AND WASHERS (CONTINUED)**

KEY	PART NUMBER	U/M	DESCRIPTION
	144904-01-01A	EA	BOLT - ADJUSTMENT - HEADLAMP
	147284-02-000	EA	NUT/SELF RETAINING - 5/16"-18
	148817-01-000	EA	WASHER/SPUR - LOCKING

**SCREWS**

KEY	PART NUMBER	U/M	DESCRIPTION
	0G1208-12-170	EA	SCREW - 8-18 X 3/4 POH - BRIGHT WHITE
	0G3908-08-170	EA	SCREW - SF/DR - 8-18 X 1/2 PPH - BRIGHT WHITE
	0G3908-08-410	EA	SCREW - SF/DR - 8-18 X 1/2 PPH - PARCHMENT
	0G3908-16-170	EA	SCREW - SF/DR - 8-18 X 1 PPH - BRIGHT WHITE
	0G3908-24-170	EA	SCREW - SF/DR - 8-18 X 1 1/2 PPH - BRIGHT WHITE
	0G3910-10-330	EA	SCREW - SF/DR - 20-16 X 5/8 PPH - PUTTY
	0G3910-12-170	EA	SCREW - SF/DR - 10-16 X 3/4 PPH - BRIGHT WHITE
	0G3910-12-240	EA	SCREW - SF/DR - 10-16 X .75 PPH - VW LIGHT GRAY
	0G3910-12-380	EA	SCREW - SF/DR - 10-16 X .75 PPH - CASHMERE
	0G3910-12-370	EA	SCREW - SF/DR - 10-16 X .75 PPH - RIVERSTONE
	0G3910-24-170	EA	SCREW - SF/DR - 10-16 X 1 1/2 PPH - BRIGHT WHITE
	0G3910-32-330	EA	SCREW - SF/DR - 10-16 X 2.00 PPH - PUTTY
	0G5508-08-380	EA	SCREW - SF/DR - 8-18 X .5 PWH - CASHMERE
	0G5508-08-370	EA	SCREW - SF/DR - 8-18 X .5 PWH - RIVERSTONE
	0G5508-12-170	EA	SCREW - SF/DR - 8-18 X 3/4 PWH - BRIGHT WHITE
	0G5508-12-320	EA	SCREW - SF/DR - 8-18 X 3/4 PWH - GLACIER
	0G5508-12-330	EA	SCREW - SF/DR - 8-18 X 3/4 PWH - PUTTY
	0G6008-16-170	EA	SCREW - SF/DR - 8-18 X 1 POH - BRIGHT WHITE
	0G5508-16-250	EA	SCREW - SF/DR - 8-18 X 1 PWH - VW DARK GRAY
	0G5508-16-330	EA	SCREW - SF/DR - 8-18 X 1 PWH - PUTTY
	0G5508-16-370	EA	SCREW - SF/DR - 8-18 X 1 PWH - RIVERSTONE
	0G5508-16-380	EA	SCREW - SF/DR - 8-18 X 1 PWH - CASHMERE
	0G5508-16-410	EA	SCREW - SF/DR - 8-18 X 1 PWH - MEDIUM PARCHMENT
	0G6012-32-170	EA	SCREW - SF/DR - 12-14 X 2 POH - BRIGHT WHITE
	0G6710-08-170	EA	SCREW - 10-12 X 1/2 PPH - BRIGHT WHITE
	0G6710-12-170	EA	SCREW - 10-12 X 3/4 PPH - BRIGHT WHITE
	0G6806-16-170	EA	SCREW - 6-18 X 1 POH - BRIGHT WHITE
	0G6810-24-280	EA	SCREW - 10-12 X 1 1/2 POH - SOFT WHITE
	000C20-06-24T	EA	SCREW - 3/8-16 X 1 1/2 - FLAT SOCKET
	000C28-05-24D	EA	CAPSCREW/BUTTON HEAD - 5/16-18 X 1 1/2 - #8-BLK PHOSPHATE
	000G11-06-08B	EA	SCREW - 6-20 X 1/2 PPH - ZINC
	000G11-06-10B	EA	SCREW - 6-20 X 5/8 PPH - ZINC
	000G11-06-10J	EA	SCREW - 6-20 X 5/8 PPH - BRASS
	000G11-07-08B	EA	SCREW - 7-19 X 1/2 PPH - ZINC
	000G11-08-06B	EA	SCREW - 8-18 X 3/8 PPH - ZINC
	000G11-08-08T	EA	SCREW - 8-18 X 1/2 PPH - FLUOROCARBON COATING
	000G11-08-12B	EA	SCREW - 8-18 X 3/4 PPH - ZINC
	000G11-08-12P	EA	SCREW - 8-18 X 3/4 PPH - DARK BROWN
	000G11-08-12S	EA	SCREW - 8-18 X 3/4 PPH - OFF WHITE
	000G11-08-12T	EA	SCREW - 8-18 X 3/4 PPH - BLACK MAGNESIUM
	000G11-08-20B	EA	SCREW - 8-18 X 1 1/4 PPH - ZINC
	000G11-08-20G	EA	SCREW - 8-18 X 1 1/4 - ANTIQUE BRASS
	000G11-10-12D	EA	SCREW - 10-16 X 3/4 PPH - BLACK
	000G12-06-08T	EA	SCREW - 6-20 X 1/2 POH - BLACK
	000G12-06-12J	EA	SCREW - 6-20 X .75 POH - BRASS
	000G12-10-16F	EA	SCREW - 10-16 X 1 POH - STAINLESS STEEL
	000G13-05-10B	EA	SCREW - 5-12 X 5/8 PFH - ZINC
	000G13-06-08B	EA	SCREW - 6-20 X 1/2 PFH - ZINC
	000G13-06-08G	EA	SCREW - 6-20 X 1/2 PFH - ANTIQUE BRASS
	000G13-06-10G	EA	SCREW - 6-20 X 5/8 PFH - ANTIQUE BRASS
	000G13-06-16J	EA	SCREW - 6-20 X 1 PFH - BRASS
	000G13-06-169	EA	SCREW - SF/DR - 6-20 X 1 PFH - SILVER
	000G13-06-24J	EA	SCREW - 6-20 X 1 1/2 PFH - BRASS
	000G13-07-10H	EA	SCREW - 7-19 X 5/8 PFH - BLACK
	000G13-07-12B	EA	SCREW - 7-19 X 3/4 PFH - ZINC
	000G13-08-109	EA	SCREW - 8-18 X 5/8 PFH
	000G13-08-10B	EA	SCREW - 8-18 X 5/8 PFH - ZINC
	000G13-08-16B	EA	SCREW - 8-18 X 1 PFH - ZINC

**SEALANTS & FASTENERS GROUP (CONTINUED)**  
**SCREWS (CONTINUED)**

KEY	PART NUMBER	U/M	DESCRIPTION
	000G13-08-24B	EA	SCREW - 8-18 X 1 1/2 PFH - ZINC
	000G16-04-24B	EA	SCREW - MACHINE - 1/4-20 X 1 1/2 PPH
	000G18-08-12B	EA	SCREW - MACHINE - 8-32 X 3/4 PPH - ZINC
	000G18-08-16B	EA	SCREW - MACHINE - 8-32 X 1 PPH - ZINC
	000G18-08-24B	EA	SCREW - MACHINE - 8-32 X 1 1/2 PPH - ZINC
	000G18-08-22B	EA	SCREW - MACHINE - 8-32 X 1 3/8 PPH - ZINC
	000G19-10-08B	EA	SCREW - MACHINE - 10-32 X 1/2 PPH - ZINC
	000G19-10-10B	EA	SCREW - MACHINE - 10-32 X 5/8 - PPH - ZINC
	000G19-10-12F	EA	SCREW - MACHINE - 10-32 X 3/4 PPH - STAINLESS STEEL
	000G19-10-20B	EA	SCREW - MACHINE - 10-32 X 1 1/2 PPH - ZINC
	000G32-10-06B	EA	SCREW - 10-32 X 3/8 PPH - ZINC
	000G34-05-12B	EA	SCREW - HEX HEAD TAPPING - 5/16 X 3/4 LONG
	000G36-10-12T	EA	SCREW - 10-24X 3/4 PFH TYPE 23 - BLACK
	000G39-06-10T	EA	SCREW - SF/DR - 6-20 X 5/8 PPH - BLACK
	000G39-06-16T	EA	SCREW - SF/DR - 6-20 X 1 PPH - BLACK
	000G39-08-06B	EA	SCREW - SF/DR - 8-18 X 3/8 PPH - ZINC
	000G39-08-08B	EA	SCREW - SF/DR - 8-18 X 1/2 PPH - ZINC
	000G39-08-08S	EA	SCREW - SF/DR - 8-18 X 1/2 PPH - OFF WHITE
	000G39-08-08T	EA	SCREW - SF/DR - 8-18 X 1/2 PPH - BLACK
	000G39-08-12T	EA	SCREW - SF/DR - 8-18 X 3/4 PPH - BLACK
	000G39-08-16B	EA	SCREW - SF/DR - 8-18 X 1 PPH - ZINC
	000G39-08-16T	EA	SCREW - SF/DR - 6-20 X 1 PPH - BLACK
	000G39-08-24B	EA	SCREW - SF/DR - 8-18 X 1 1/2 PPH - ZINC
	000G39-08-24S	EA	SCREW - SF/DR - 8-18 X 1 1/2 - OFF WHITE
	000G39-08-24T	EA	SCREW - SF/DR - 8-18 X 1 1/2 PPH - BLACK
	000G39-08-32B	EA	SCREW - SF/DR - 8-18 X 2 PPH - ZINC
	000G39-10-08B	EA	SCREW - SF/DR - 10-16 X 1/2 PPH - ZINC
	000G39-10-10B	EA	SCREW - SF/DR - 10-16 X 5/8 PPH - ZINC
	000G39-10-12B	EA	SCREW - SF/DR - 10-16 X 3/4 PPH - ZINC
	000G39-10-129	EA	SCREW - SF/DR - 10-16 X 3/4 PPH - FLUOROCARBON SILVER
	000G39-10-169	EA	SCREW - SF/DR - 10-16 X 1 PPH - FLUOROCARBON SILVER
	000G39-10-20B	EA	SCREW - SF/DR - 10-16 X 1 1/4 PPH - ZINC
	000G39-10-20T	EA	SCREW - SF/DR - 10-16 X 1 1/4 PPH - BLACK
	000G39-10-24T	EA	SCREW - SF/DR - 10-16 X 1 1/2" PPH - BLACK
	000G39-10-28T	EA	SCREW - SF/DR - 10-16 X 1 3/4" PPH - BLACK
	000G39-10-32B	EA	SCREW - SF/DR - 10-16 X 2 - PPH - ZINC
	000G39-10-48B	EA	SCREW - SF/DR - 10-16 X 3 - PPH - ZINC
	000G39-10-48T	EA	SCREW - SF/DR - 10-16 X 3 PPH - BLACK
	000G42-04-16B	EA	SCREW - SF/DR - 1/4-14 X 1 HWH - ZINC
	000G42-04-24B	EA	SCREW - SF/DR - 1/4-14 X 1 1/2 - ZINC
	000G46-08-24T	EA	SCREW - MACHINE - 8-32 X 1 1/2 PFH - ZINC
	000G52-06-05B	EA	SCREW - MACHINE - 6-32 X 5/16 PTH - ZINC
	000G52-06-06B	EA	SCREW - MACHINE - 6-32 X 3/8 PTH - ZINC
	000G54-04-14B	EA	SCREW - 1/4-20 X 7/8 PTH - TYPE 23 - ZINC PLATED
	000G55-08-12T	EA	SCREW - SF/DR - 8-18 X 3/4 PWH - BLACK
	000G55-08-124	EA	SCREW - SF/DR - 8-18 X 3/4 PWH - ASH GRAY
	000G55-08-16T	EA	SCREW - SF/DR - 8-18 X 1 PWH - BLACK
	000G56-12-48B	EA	SCREW - WOOD - 12-11 X 3 POH - SPECIAL HARDENED
	000G57-14-64B	EA	SCREW - 14-10 X 4 PFH ZINC
	000G60-08-16E	EA	SCREW - SF/DR - 8-1 X 1 POH - CHROME
	000G60-08-20F	EA	SCREW - SF/DR - 8-19X1.25 POH
	000G60-08-22B	EA	SCREW - SF/DR - 8-18 X 1.38 POH - ZINC
	000G60-10-16J	EA	SCREW - SF/DR - 10-16 X 1 POH - BRIGHT BRASS
	000G60-10-20B	EA	SCREW - SF/DR - 10-16 X 1 1/4 POH - ZINC
	000G60-10-209	EA	SCREW - SF/DR - 10-16 X 1 1/4 POH - SILVER STALGAARD
	000G60-10-28T	EA	SCREW - SF/DR - 10-16 X 1 3/4 - BLACK
	000G62-06-24I	EA	SCREW - SF/DR - 8-18 X 1.5 PPH - BLACK
	000G62-06-249	EA	SCREW - SF/DR - 8-18 X 1.5 PPH - SILVER
	000G62-08-24B	EA	SCREW - SF/DR - 8-18 X 1 1/2 PFH
	000G67-08-32B	EA	SCREW - 8-15 X 2 PPH - ZINC
	000G67-10-08B	EA	SCREW - 10-12 X 1/2 PPH - ZINC
	000G67-10-08S	EA	SCREW - 10-12 X 1/2 PPH - OFF WHITE
	000G67-10-10B	EA	SCREW - 10-12 X 5/8 PPH - ZINC - TYPE A
	000G67-10-10S	EA	SCREW - 10-12 X 5/8 PPH - OFF WHITE

**SEALANTS & FASTENERS GROUP (CONTINUED)**  
**SCREWS (CONTINUED)**

<b>KEY</b>	<b>PART NUMBER</b>	<b>U/M</b>	<b>DESCRIPTION</b>
	000G67-10-10T	EA	SCREW - 10-12 X 5/8 PPH - BLACK
	000G67-10-10P	EA	SCREW - 10-12 X 5/8 PPH - DARK BROWN
	000G67-10-12P	EA	SCREW - 10-12 X 3/4 PPH - DARK BROWN
	000G67-10-24B	EA	SCREW - 10-12 X 1 1/2 PPH - ZINC
	000G67-10-24S	EA	SCREW - 10-12 X 1 1/2 PPH - OFF WHITE
	000G67-10-32J	EA	SCREW-10-12X2 PPH - BRIGHT BRASS
	000G68-06-10J	EA	SCREW - 6-18 X 5/8 POH - BRASS
	000G68-06-12B	EA	SCREW - 6-18 X 3/4 POH - ZINC & CLEAR
	000G68-06-12J	EA	SCREW - 6-18 X 3/4 POH - BRASS
	000G68-06-12S	EA	SCREW - 6-18 X 3/4 POH
	029130-01-000	EA	SCREW - SNAP STUD - #8-16 X 5/8" LONG
	029130-03-000	EA	SCREW - SNAP STUD - #8-16 X 1" LONG
	049465-01-000	EA	SCREW - 10-16 PTH W/WASHER - DARK BROWN
	049465-03-000	EA	SCREW - 10-16 X 1 POH W/WASHER - OFF WHITE
	049465-13-000	EA	SCREW - 10-16 X 1 PTH W/WASHER - ASH GRAY
	049465-17-000	EA	SCREW - 10-16 X 1 POH W/WASHER - BRIGHT WHITE
	049465-18-000	EA	SCREW - 10-16 X 1 POH W/WASHER - VW GRAY
	054434-02-000	EA	SCREW - SF/DR - 10-16 X 2 - ZINC
	054434-03-000	EA	SCREW - SF/DR - 10-16 X 2 - PWH - ZINC
	075908-01-000	EA	SCREW - MACHINE - 10-32 X .56 PTH - EXTERNAL TOOTH - ZINC
	076790-01-000	EA	SCREW - 6-20 X 1 1/4 PPH - BLACK
	076790-05-000	EA	SCREW - 6-20 X 1/2 PPH - BLACK - THREAD CUTTING/WOOD
	083554-01-000	EA	SCREW - DRYWALL - 8 X 1 1/4
	083554-04-000	EA	SCREW - DRYWALL - 8 X 2 1/2
	087721-01-000	EA	SCREW - FLAT HEAD - TAPPING - 1/4" X 1 1/4" LONG - ZINC
	095772-01-000	EA	SOCKET-SNAP FASTNER1" SF/DR - SELF DRIVER
	097974-01-000	EA	SCREW - PARTICLE BOARD - 7-9 X 3/4 PPH
	097974-02-000	EA	SCREW-PART BD 8-9X.75 PFH - BEIGE
	101618-01-000	EA	SCREW - 1/4-20 X 3/4 HEX - TAPPING - STALGARD TYPE F
	113563-01-01A	EA	SCREW - 8 X 5/8 LONG SHOULDER/WASHER HEAD
	113563-01-02A	EA	SCREW - 8 X 5/8 LONG SHOULDER/WASHER HEAD - BRIGHT WHITE
	118383-01-09A	EA	RETAINER/RECESSED - F/.22" SCREW - GLACIER
	118383-01-12A	EA	RETAINER/RECESSED - F/.22" SCREW - RIVERSTONE
	118383-01-10A	EA	RETAINER/RECESSED - F/.22" SCREW - STORM GRAY
	118383-01-11A	EA	RETAINER/RECESSED - F/.22" SCREW - CASHMERE
	118383-02-10A	EA	RETAINER/RECESSED - F/.27" SCREW - RIVERSTONE
	118383-02-11A	EA	RETAINER/RECESSED - F/.27" SCREW - CASHMERE
	118383-02-13A	EA	RETAINER/RECESSED - F/.27" SCREW - OFF WHITE
	118383-03-09A	EA	RETAINER/RECESSED - F/.32" SCREW - GLACIER
	118383-04-04A	EA	CAP - F/RECESSED RETAINER - BRIGHT WHITE
	118383-04-09A	EA	CAP - F/RECESSED RETAINER - GLACIER
	118383-04-10A	EA	CAP - F/RECESSED RETAINER - RIVERSTONE
	118383-04-11A	EA	CAP - F/RECESSED RETAINER - CASHMERE
	118383-04-12A	EA	CAP - F/RECESSED RETAINER - STORM GRAY
	118383-04-13A	EA	CAP - F/RECESSED RETAINER - OFF WHITE
	134126-01-01A	EA	SCREW/NAIL - HEX HEAD - 3/4"
	140040-01-000	EA	SCREW - 1/4-20 X 1 - BUTTON HEAD/SOCKET - W/LOCTITE
	149753-01-01A	EA	RETAINER/RECESSED - F/.22" SCREW - BLACK
	149753-01-02A	EA	RETAINER/RECESSED - F/.22" SCREW - BRIGHT WHITE
	149753-02-01A	EA	CAP - F/RECESSED RETAINER - BLACK
	149753-02-02A	EA	CAP - F/RECESSED RETAINER - BRIGHT WHITE
	154938-01-01A	EA	SCREW - SF/DR - 10-16 X 3/4 PPH - W/SELF SEAL - BRIGHT WHITE
	154938-01-02A	EA	SCREW - SF/DR - 10-16 X 3/4 PPH - W/SELF SEAL - BLACK
	154938-02-01A	EA	SCREW - SF/DR - 8-18 X 1 PFH - W/SELF SEAL - BRIGHT WHITE
	154938-02-02A	EA	SCREW - SF/DR - 8-18 X 1 PFH - W/SELF SEAL - BLACK
	154938-02-03A	EA	SCREW - SF/DR - 8-18 X 1 PFH - W/SELF SEAL - SILVER
	154938-03-01A	EA	SCREW - SF/DR - 8-18 X 5/8 PFH - W/SELF SEAL - BRT WHT
	154935-03-02A	EA	SCREW - SF/DR - 8-18 X 5/8 PFH - W/SELF SEAL - BLACK
	154938-04-01A	EA	SCREW - SF/DR - 10-16 X 1" TPH - W/SELF SEAL - BRT WHT
	154938-04-02A	EA	SCREW - SF/DR - 10-16 X 1" TPH - W/SELF SEAL - BLACK
	154938-05-03A	EA	SCREW - SF/DR - 8-18 X 1.25" PFH - W/SELF SEAL - SILVER



## SEALANTS & FASTENERS GROUP (CONTINUED)

### CLAMPS, CLIPS, GROMMETS, RIVETS & PLUGS

KEY	PART NUMBER	U/M	DESCRIPTION
	000H16-04-06R	EA	RIVET - POP ALUMINUM - 1/8 X .313 - .375
	000H16-06-10R	EA	RIVET - POP ALUMINUM - 3/16 X .501 - .625
	007161-01-000	EA	CLAMP - HOSE - SPRING TYPE - 1/2"
	008386-01-000	EA	GROMMET - SNAP - 3/8" DIAMETER - NYLON
	010495-01-000	EA	CLAMP - CABLE - 9/16"ID - BLACK
	010495-02-000	EA	CLAMP - CABLE - 3/8"ID - BLACK
	010495-04-000	EA	CLAMP - CABLE - 11/16"ID - WHITE
	010497-01-000	EA	CLAMP - CLOSED - 5/8"ID
	010497-02-000	EA	CLAMP - CLOSED - 1.5"ID
	010497-03-000	EA	CLAMP - CLOSED - 1"ID - CUSHIONED
	010497-04-000	EA	CLAMP - CLOSED - 1 5/8"ID
	010497-05-000	EA	CLAMP - CLOSED - 1/2"ID
	010497-07-000	EA	CLAMP - CLOSED - 3/8"ID
	010497-09-000	EA	CLAMP - CLOSED - 5/16"ID
	010497-10-000	EA	CLAMP - CLOSED - 7/8"ID
	010499-01-000	EA	CLAMP - CLOSED - 3/8"ID
	016188-03-000	EA	GROMMET - LP LINE - 3/8"HOLE X 2 1/2"LONG - RUBBER
	016188-04-000	EA	GROMMET - LP LINE - 1/2"HOLE X 2 1/2"LONG - RUBBER
	016188-05-000	EA	GROMMET - LP LINE - 3/8"HOLE X 1 1/4"LONG - RUBBER
	016188-06-000	EA	GROMMET - LP LINE - 3/8"HOLE X 3 1/4"LONG - RUBBER
	016188-07-000	EA	GROMMET - L/P LINE - 1/2"HOLE X 3 1/4"LONG
	016188-08-000	EA	GROMMET - LP LINE - 1/2"HOLE X 1 1/4"LONG - RUBBER
	016188-09-000	EA	GROMMET - LP LINE - .68"HOLE X 1 1/4"LONG - RUBBER
	016188-10-000	EA	GROMMET - LP GAS - .68" X 2.5"
	023942-01-000	EA	GROMMET - RUBBER - 2"OD
	041930-11-000	EA	RIVET - POP ALUMINUM - 1/8 X .188 - .250 - BRIGHT WHITE
	061420-04-000	EA	PLUG/PLASTIC - 1 1/4" DIAMETER
	061420-05-000	EA	PLUG/PLASTIC - 1 1/2" DIAMETER
	061420-09-000	EA	PLUG/PLASTIC - 1.00" DIAMETER
	061420-10-000	EA	PLUG/PLASTIC - 1 1/2" DIAMETER - BLACK
	061420-12-000	EA	PLUG/PLASTIC - 1.50" DIAMETER - RED
	061420-13-000	EA	PLUG/PLASTIC - 3/8" - FLUSH
	061420-14-000	EA	PLUG/PLASTIC - 7/8" DIAMETER - BLACK
	061420-15-000	EA	PLUG/PLASTIC - 2" DIAMETER - BLACK
	061420-16-000	EA	PLUG/PLASTIC - 2 1/8" DIAMETER - BLACK
	062401-01-000	EA	CLAMP - HOSE - WORMGEAR - .25" - 1"
	062401-02-000	EA	CLAMP - HOSE - WORMGEAR - 1.56" - 2.5" ID
	062401-03-000	EA	CLAMP - HOSE - WORMGEAR - .22" - 1" ID
	062401-04-000	EA	CLAMP - HOSE - WORMGEAR - .69" - 1.25" ID
	062401-05-000	EA	CLAMP - HOSE - WORMGEAR - 2" - 3" ID
	062401-06-000	EA	CLAMP - HOSE - WORMGEAR - .22" - .62" ID
	062401-09-000	EA	CLAMP - HOSE - WORMGEAR - 2.8" - 3.75" ID
	062401-11-000	EA	CLAMP - HOSE - WORMGEAR - 3.50" - 4.50" ID
	062401-13-000	EA	CLAMP - HOSE - WORMGEAR
	063729-12-000	EA	RIVNUT - 5/16 - 18 UNCUT - FLATHEAD - STAINLESS
	071015-01-000	EA	GROMMET - RUBBER - .5"ID X 1"OD-W/.38" GROOVE - BLACK
	071015-11-000	EA	GROMMET - RUBBER - 1"ID FITS .12 MATERIAL - BLACK
	071015-13-000	EA	GROMMET - RUBBER - .62"ID X 1"OD W/.09" GROOVE - BLACK
	071015-22-000	EA	GROMMET - RUBBER - .62"ID X 1.12"OD W/.19" GROOVE - BLACK
	071015-26-000	EA	GROMMET - RUBBER - 1.5"ID X 2.1"OD W/.06" GROOVE - BLACK
	071015-29-000	EA	GROMMET - RUBBER - .3"ID X 1.3"OD W/.12" GROOVE - BLACK
	071015-30-000	EA	GROMMET - RUBBER - .3"ID X .81"OD W/.12" GROOVE - BLACK
	071015-39-000	EA	GROMMET - .75 ID FITS .06 MTL
	071015-41-000	EA	GROMMET - .125 ID FITS .188 MTL
	071015-42-000	EA	GROMMET - .25 ID FITS .06 MTL
	075148-02-000	EA	CLAMP - GROUNDING - BRONZE SCREWS
	077955-01-000	EA	CLIP/J - 3/8" - VINYL COATED
	080734-02-000	EA	CLIP - WIRE NYLON
	081211-01-000	EA	PLUG - PLASTIC - .31"DIA - BLACK
	081211-03-000	EA	PLUG - PLASTIC - .50"DIAMETER - TRUSS HEAD - BLACK
	081211-04-000	EA	PLUG - PLASTIC - .46"DIAMETER - TRUSS HEAD - BLACK
	083609-01-000	EA	CLAMP - WIRE - DUAL - EQUAL DIAMETERS - 5/8"
	083610-01-000	EA	CLAMP - WIRE - DUAL - UNEQUAL DIAMETERS - 3/4" & 1 1/4"
	083610-02-000	EA	CLAMP - WIRE - DUAL - UNEQUAL DIAMETERS - 3/4" & 2"

**SEALANTS & FASTENERS GROUP (CONTINUED)**  
**CLAMPS, CLIPS, GROMMETS, RIVETS & PLUGS (CONTINUED)**

<b>KEY</b>	<b>PART NUMBER</b>	<b>U/M</b>	<b>DESCRIPTION</b>
	083610-03-000	EA	CLAMP - WIRE - DUAL - EQUAL DIAMETERS - 2"
	088756-01-000	EA	GROMMET - WEB - 1 1/8"ID
	089329-02-000	EA	CLIP - SPRING
	091952-01-000	EA	CLIP - GRIPPER - 1" - BLACK VINYL COATED
	091952-02-000	EA	CLIP - GRIPPER - 3/4" - BLACK VINYL COATED
	091952-03-000	EA	CLIP - GRIPPER - 1/2" - BLACK VINYL COATED
	094362-02-000	EA	CLIP - XMAS TREE - BINDER HEAD - .9" LONG/ANY COLOR
	094362-05-000	EA	CLIP - XMAS TREE - ROUND HEAD - 1.4" LONG/ANY COLOR
	113133-02-01A	EA	RIVET - POP - ALUMINUM - 3/16 X .252 - .504 - BLACK
	114208-05-000	EA	GROMMET - EDGE LINER - FITS 2"
	118626-01-02A	EA	RIVET/POP - ALUMINUM - 3/16 X .08 - .375
	118626-01-01A	EA	RIVET/POP - ALUMINUM - 3/16 X 1.2"(GRIP RANGE .1"-.4")
	118626-02-01A	EA	RIVET/POP - ALUMINUM - 3/16 X .500 - .750
	118626-03-01A	EA	RIVET/POP - STAINLESS STEEL - 3/16 X .500 - .750
	137014-01-02A	EA	GROMMET - CABLE - BROWN
	137014-01-01A	EA	GROMMET - CABLE - ALMOND
	137014-01-03A	EA	GROMMET - CABLE - BLACK
	139118-02-01A	EA	GROMMET - SCREW - PLASTIC
	155498-01-01A	EA	CLAMP - CLOSED - 7/8"ID - VINYL DIP/GALVONIZED - BLACK

**MISCELLANEOUS FASTENERS**

<b>KEY</b>	<b>PART NUMBER</b>	<b>U/M</b>	<b>DESCRIPTION</b>
	008343-01-000	EA	TIE - WIRE - 6"
	008343-02-000	EA	TIE - WIRE - 14"
	008343-03-000	EA	TIE - WIRE - 7 1/2" - BLACK
	029094-04-000	YD	VELCRO TAPE/LOOP - 1"WIDE - W/ADHESIVE BACK - BLACK
	029096-04-000	YD	VELCRO TAPE/HOOK - 1"WIDE - BLACK - W/ADHESIVE BACK (PSA)
	048394-02-000	YD	VELCRO TAPE - HOOK - ADHESIVE BACK - 3/4" WIDE - BEIGE
	085774-01-000	FT	FASTENER - DUAL LOCK - 1" WIDE - ADHESIVE BACK - BLACK
	085774-02-000	FT	FASTENER - DUAL HOOK - 1" WIDE - ADHESIVE BACK - BLACK
	088792-02-000	YD	VELCRO TAPE - LOOP - 3/4" - ADHESIVE BACK - BEIGE
	088792-04-000	YD	VELCRO TAPE - HOOK - 5/8" - NON-ADHESIVE BACK - WHITE
	088792-05-000	YD	VELCRO TAPE - LOOP - 5/8" - NON-ADHESIVE BACK - WHITE
	108046-02-000	EA	CABLE TIE - SCREW MOUNT 15"

## WATER & SEWAGE GROUP DRAINAGE SYSTEM

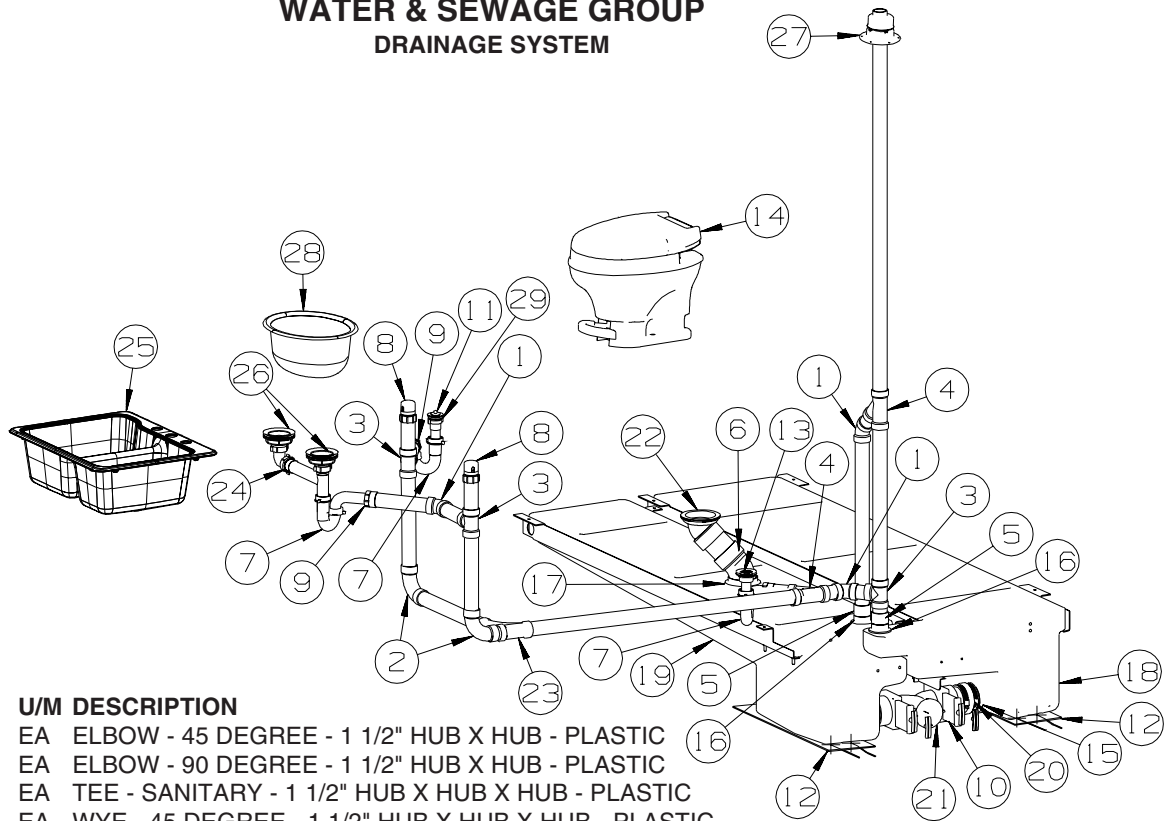

KEY	PART NUMBER	U/M	DESCRIPTION
1	010006-01-000	EA	ELBOW - 45 DEGREE - 1 1/2" HUB X HUB - PLASTIC
2	010008-01-000	EA	ELBOW - 90 DEGREE - 1 1/2" HUB X HUB - PLASTIC
3	010071-01-000	EA	TEE - SANITARY - 1 1/2" HUB X HUB X HUB - PLASTIC
4	010073-01-000	EA	WYE - 45 DEGREE - 1 1/2" HUB X HUB X HUB - PLASTIC
5	010115-01-000	EA	COUPLING - 1 1/2" HUB X HUB - PLASTIC
6	010061-01-000	EA	ELBOW - 45 DEGREE ST - 3" SPIGOT & HUB - PLASTIC
7	107538-02-000	EA	P-TRAP - PLASTIC - 1 1/2" W/EXTENSION ARM
7	011071-01-000	EA	P-TRAP - 1 1/2" - CSA - PLASTIC - <b>CANADIAN</b>
8	079968-01-000	EA	VENT - MECHANICAL/TRAP ARM - ANTI-SIPHON-2" X 7.3" PLASTIC
9	152146-01-000	EA	CONNECTOR - 1 1/2"P X 1 1/2"MPT
10	136143-01-000	EA	VALVE - DUAL - 3" X 3"
11	106116-01-02A	EA	STRAINER/PLASTIC - STOPPER/TAILPIECE/GASKET & NUT-LAVATORY
12	133972-04-000	EA	PAD/HEATER - HOLDING TANK - F/34 GALLON
13	066440-01-000	EA	STRAINER - SHOWER DRAIN - W/RUBBER WASHER
	130403-01-000	EA	NUT - SLIP - W/WINGS 1 1/2"
	127440-02-01A	EA	WASHER - RUBBER - 1.8" X .1"
	011069-02-000	EA	TAILPIECE - TUB/SHOWER - 1 1/2" X 1 1/4" X 4" - BRASS
14*	147421-02-01A	EA	TOILET/AQUA MAGIC 5 (LOW) FOOTFLUSH - W/SPRAY - WHITE
15	010129-03-000	EA	NIPPLE - 3" X 3" TOE - PLASTIC
16	061607-01-000	EA	GROMMET - HOLDING TANK - 1 1/2" NPS
17	061607-02-000	EA	GROMMET - HOLDING TANK - 3" NPS
18	157730-01-700	EA	TANK - HOLDING W/3" NIPPLE
	010129-03-000	EA	NIPPLE - 3" X 3" TOE - PLASTIC
	049032-01-000	EA	PATCH - SPINWELD - 3/8" - PLASTIC
19	157729-01-700	EA	TANK - HOLDING W/3" NIPPLE
	010129-03-000	EA	NIPPLE - 3" X 3" TOE - PLASTIC
	049032-01-000	EA	PATCH - SPINWELD - 3/8" - PLASTIC
20	078406-01-000	EA	COUPLER - 3" X 3" W/CLAMPS - RUBBER
21	139513-01-000	EA	HOSE - SEWER - 3" X 10' - W/BAYONET TYPE ADAPTER
	062416-01-000	EA	ADAPTER - SEWER HOSE TO 3" PIPE
22	151541-01-000	EA	FLANGE - CLOSET - ELBOW/SWIVEL - 4" X 3"
23	031365-02-000	EA	TEE - 1 1/2" EXTRA LONG TURN - PLASTIC
24	011091-02-000	EA	WASTE - CONTINUOUS - DOUBLE SINK
25	148870-04-01A	EA	SINK/DOUBLE - LRG/SML BASIN - 25" X 19" X 7" W/LT/RR NOTCH, FROM: 00-00-00 THRU: 05-01-06
25	148870-01-01A	EA	SINK/DOUBLE - LRG/SML BASIN - 25" X 19" X 7" FROM: 05-02-06 THRU: 99-99-99
26	092303-01-000	EA	STRAINER - W/BASKET - GALLEY SINK - 4" OD
27	083558-03-000	EA	VENT - W/COVER - F/PLUMBING STACK - OFF WHITE
28	156661-01-01A	EA	SINK - LAVATORY - OVAL - 15" X 12" X 6.5" - GLACIER WHITE
	091255-02-000	FT	SEAL - ADHESIVE BACKED/FOAM - 3/64"THICK X 3/16"W X 1000'
29	106116-02-01A	EA	GASKET - STRAINER

\*COMPONENT PARTS LISTED LATER IN THIS GROUP

**WATER & SEWAGE GROUP (CONTINUED)**  
**DRAINAGE SYSTEM (CONTINUED)**

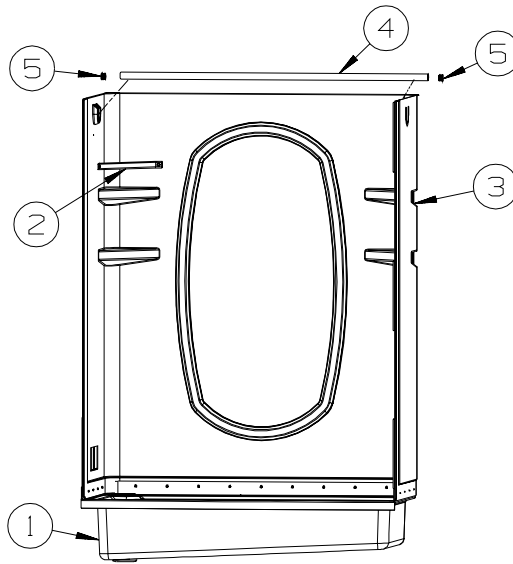

KEY	PART NUMBER	U/M	DESCRIPTION
1	M09530-01-U21	EA	SHOWER PAN - W/STRAINER
2	113714-02-02A	EA	RETAINER - SHELF/SHOWER - 10.6" - SOFT WHITE
3	158103-01-01A	EA	SURROUND - SHOWER/TUB - SOFT WHITE
4	102075-10-02A	EA	ROD - SHOWER CURTAIN - 1" OD X 46.3" - SOFT WHITE
5	081114-02-000	EA	CAP - INSERT/ROUND - 1" DIAMETER - WHITE PLASTIC

**WATER & SEWAGE GROUP (CONTINUED)**  
**COMPONENT PARTS FOR DRAINAGE SYSTEM**

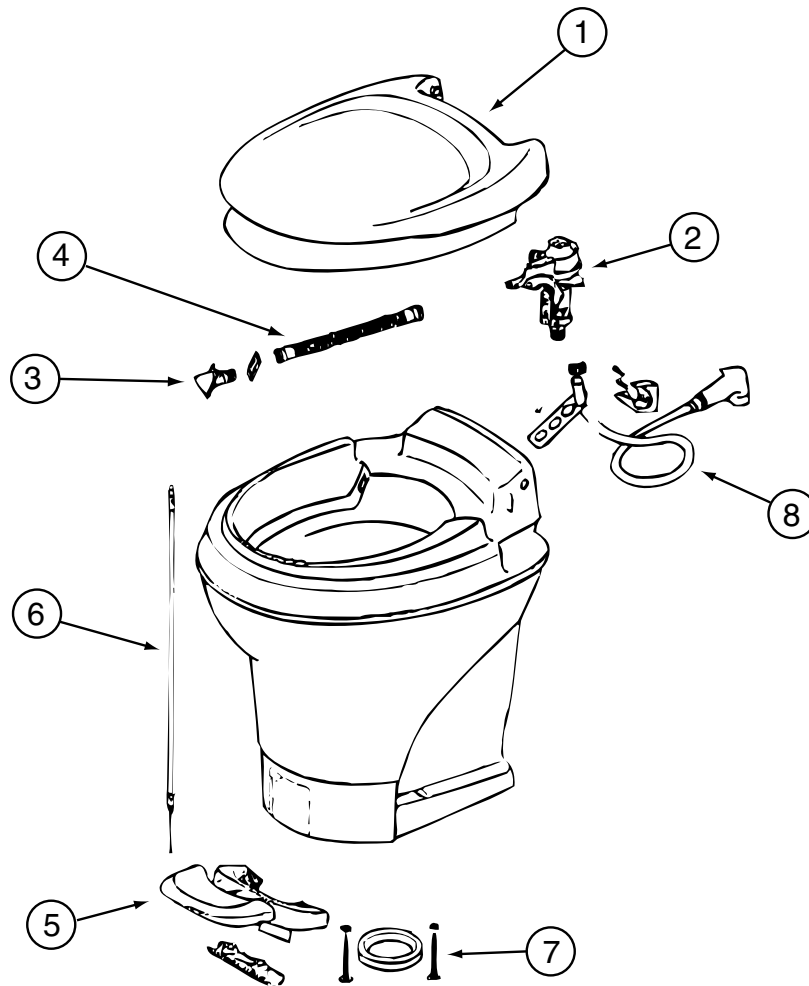

147421-01-01A, 147421-02-01A

KEY	PART NUMBER	U/M	DESCRIPTION	VENDOR NO.
1	147421-01-700	EA	SEAT & COVER ASSEMBLY(WHT)	31703
2	147421-01-701	EA	WATER MODULE ASSEMBLY	31705
3	147421-01-702	EA	NOZZLE ASSEMBLY	31706
4	147421-01-703	EA	LINK - WATER MODULE	31621
5	147421-01-704	EA	PEDAL - WHITE	31709
6	147421-01-705	EA	FOOT CABLE	31711
7	063740-01-706	EA	BOLT PACKAGE-FLOOR FLANGE	12524 THETFORD
8	147421-01-708	EA	HAND SPRAY KIT - WHITE HEAD	33226
	147421-01-706	EA	SEAL - BLADE	31708
	147421-01-707	EA	CAP (UNIVERSAL BOLT) - WHITE	31713

**WATER & SEWAGE GROUP (CONTINUED)**  
**WATER SYSTEM**

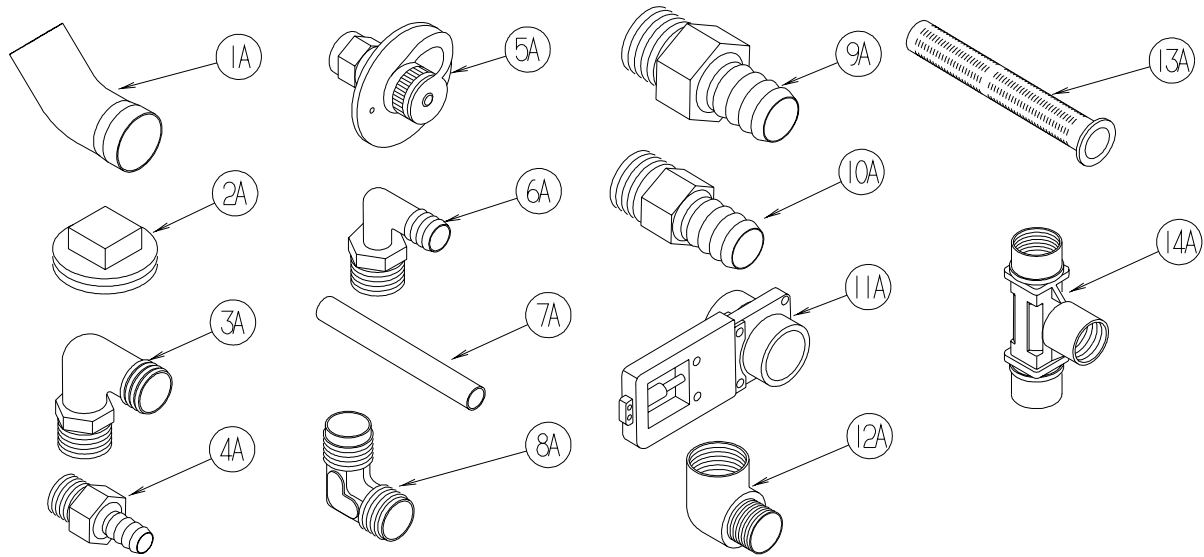

KEY	PART NUMBER	U/M	DESCRIPTION
1A	010009-01-000	EA	ELBOW - 90 DEGREE - 1/4 BEND - 1 1/2" PLASTIC
2A	010166-01-000	EA	PLUG/THREADED - 1 1/4"MPT - PLASTIC - BLACK - UL
3A	010219-01-000	EA	ELBOW - 1 1/4 MPT X 1 1/4 BARB - WATER FILL - PLASTIC
4A	010224-01-000	EA	ADAPTER - HOSE TO PIPE - 3/8 MPT X 3/8 BARB - PLASTIC
5A	010230-06-000	EA	FILL - CITY WATER - W/CHECK VALVE - MPT - BRUSHED ALUM
6A	035539-01-000	EA	ELBOW - 3/8 MPT X 3/8 BARB - PLASTIC
7A	039800-04-000	FT	TUBING - POLYBUTYL - 1/4"OD
7A	074462-02-000	FT	TUBING - VINYL - 3/8 ID X 20' - CLEAR
7A	112176-01-000	FT	TUBING - VINYL - REINFORCED - 1/2" ID
7A	124188-01-000	FT	TUBING - PEX - 1/2" ID X 20' - BLUE(COLD)
7A	124188-02-000	FT	TUBING - PEX - 1/2" ID X 20' - RED(HOT)
8A	039808-03-000	EA	ELBOW - 1/2" MPT X 1/2" MPT - PLASTIC
9A	044927-01-000	EA	ADAPTER - HOSE TO PIPE-1 1/4 MPTX1 1/4 BARB-BLACK PLASTIC
10A	044927-02-000	EA	ADAPTER - REDUCING - 1" MPT X 1.3" BARB - PLASTIC
11A	062421-03-000	EA	VALVE/DUMP W/O HANDLE - 1 1/2" X 1 1/2" HUB
	062421-05-000	EA	CABLE/ROD - F/DUMP VALVE - W/HANDLE - 48"
	062421-07-000	EA	CABLE/ROD - F/DUMP VALVE - W/HANDLE - 144"
	062421-08-000	EA	CABLE/ROD - F/DUMP VALVE - W/HANDLE - 108"
12A	065318-02-000	EA	ELBOW - 90 DEGREE - 3/8" MPT TO 3/8" FPT
13A	077954-02-000	EA	FILTER - WATER TANK - W/SCREEN IN TANK
14A	039798-01-000	EA	TEE - 1/2"MPT X 1/2"MPT X 1/2"MPT - PLASTIC

**WATER & SEWAGE GROUP (CONTINUED)**  
**WATER SYSTEM (CONTINUED)**

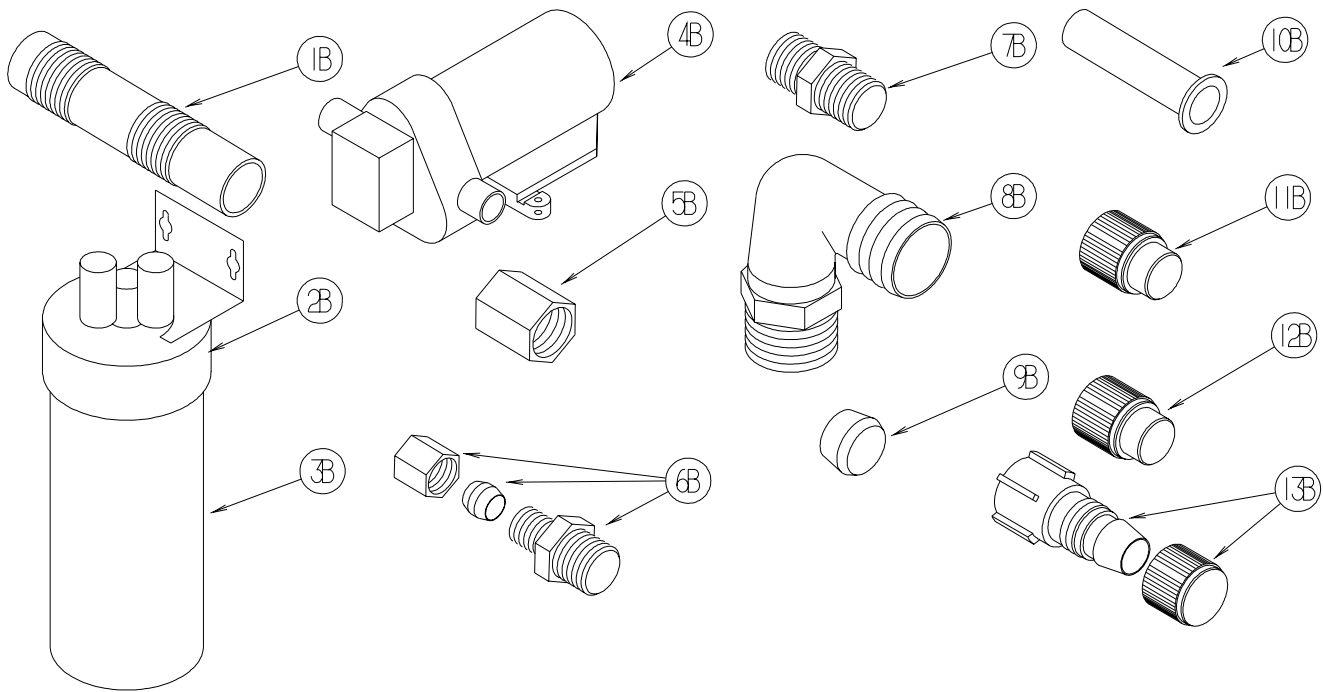

KEY	PART NUMBER	U/M	DESCRIPTION
1B	079381-01-000	FT	TUBING - RIBBED FLEXIBLE - WATER FILL - 1.4" ID
2B	087200-01-000	EA	FILTER-WATER PURIFCATION, EVERPURE QC2-AC
3B	087200-02-000	EA	CARTRIDGE-WATER FILTER,AC - EVERPURE 9601-11
4B*	098607-01-000	EA	PUMP - WATER - W/.5" MPT FITTING - FLOW 2.8 GPM
			FROM: 00-00-00 THRU: 06-21-06
4B	160702-01-000	EA	PUMP - WATER - 3.0 GPM - W/1/2" MPT
			FROM: 06-22-06 THRU: 99-99-99
5B	101814-01-000	EA	COUPLING - FEMALE - 1/2" X 1/2" FPT - GRAY
6B	103798-01-000	EA	CONNECTOR - 1/4 OD X 3/8 MPT
7B	110438-02-000	EA	VALVE - CHECK - BRASS - 1/2 MPT X 1/2 MPT
8B	111223-02-000	EA	ELBOW - 1/2" MPT X 3/8" BARB - PLASTIC
8B	111223-03-000	EA	ELBOW - 3/4" MPT X 1/2" BARB - PLASTIC
8B	111223-04-000	EA	ELBOW - 1/2" MPT X 1/2" BARB - PLASTIC
9B	111888-01-000	EA	FERRULE - PLASTIC - .250 ID X .375 OD
10B	111888-02-000	EA	INSERT - BRASS - 1/4 COMP
11B	113697-01-000	EA	CAP - 3/8"P
12B	114427-01-000	EA	CAP - 1/2"P
13B	114427-02-000	EA	PLUG - W/COMP NUT - 1/2" PLASTIC PIPE/1/2" FLAIR-IT

**WATER & SEWAGE GROUP (CONTINUED)**  
**WATER SYSTEM (CONTINUED)**

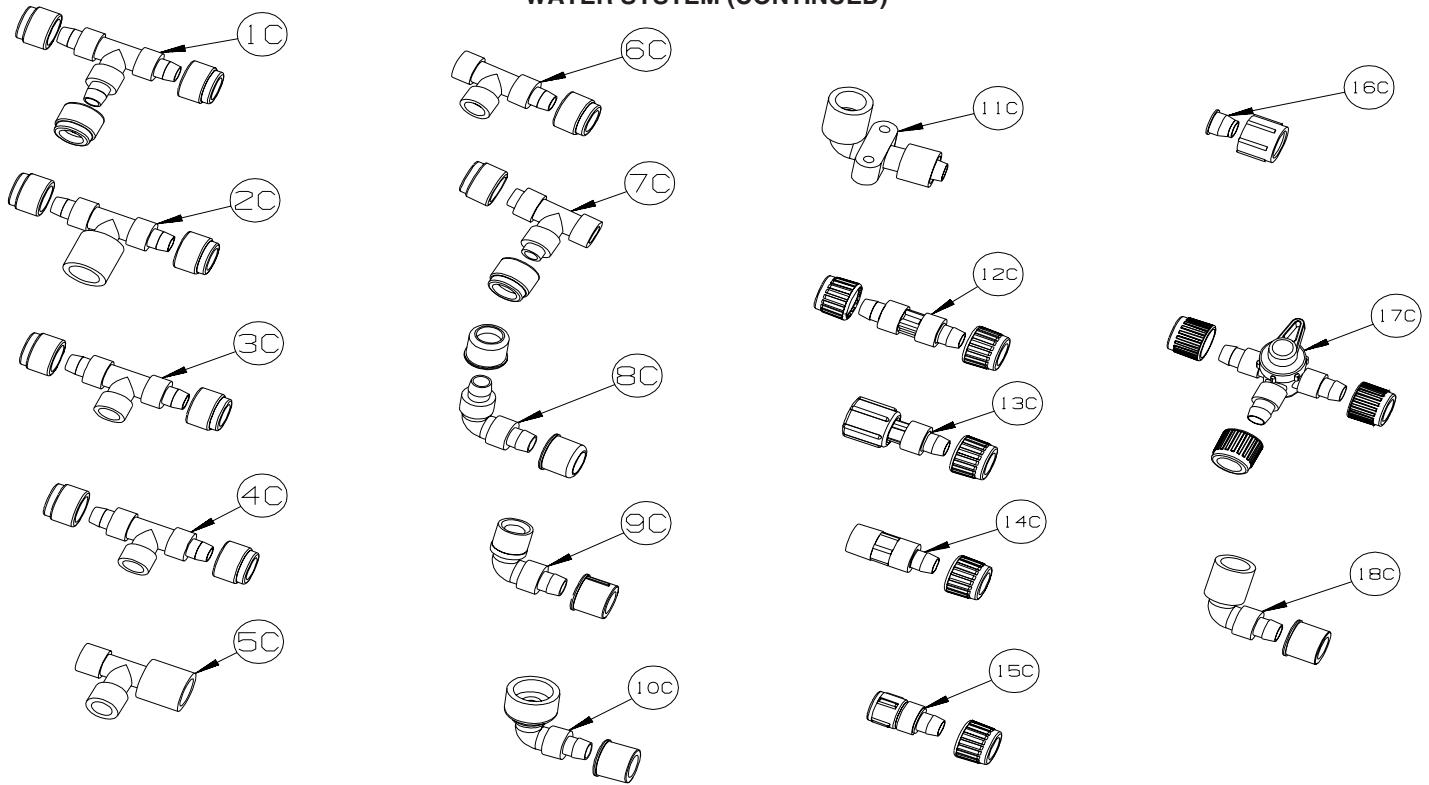

KEY	PART NUMBER	U/M	DESCRIPTION
1C	114428-01-000	EA	TEE - 1/2"P X 1/2"P X 1/2"P
2C	114428-02-000	EA	TEE - SWIVEL - 1/2"P X 1/2"P X 1/2"FPT
3C	114428-03-000	EA	TEE - 1/2"P X 1/2"P X 1/2"MPT
4C	114428-04-000	EA	TEE - 1/2"P X 1/2"P X 1/8"FPT
5C	114428-05-000	EA	TEE - 1/2" SWIVEL X 1/2" MPT X 1/2" MPT
6C	114428-06-000	EA	TEE - 1/2" P X 1/2" MPT X 1/2" MPT
7C	114428-07-000	EA	TEE - 1/2" P X 1/2" MPT X 1/2" P
8C	114429-01-000	EA	ELBOW - 1/2"P X 1/2"P
9C	114429-02-000	EA	ELBOW - 1/2"P X 1/2"MPT
9C	114429-04-000	EA	ELBOW - 1/2"P X 3/8"MPT
9C	114429-05-000	EA	ELBOW - 1/2"P X 3/4"MPT
9C	114429-10-000	EA	ELBOW - SWIVEL - 1/2"MPT X 1/2"FPT
10C	114429-06-000	EA	ELBOW - SWIVEL - 1/2"P X 3/4"FPT
10C	114429-08-000	EA	ELBOW - SWIVEL - 1/2"P X 1/2"FPT
11C	114429-09-000	EA	ELBOW - 1/2"P X 1/2"FPT DROP EAR
12C	114430-01-000	EA	ADAPTER - 1/2"P X 1/2"P
13C	114430-02-000	EA	ADAPTER - SWIVEL - 1/2"P X 1/2"FPT
13C	114430-04-000	EA	ADAPTER - SWIVEL - 1/2"P X 3/8"MPT
14C	114430-03-000	EA	ADAPTER - 1/2"P X 1/2"MPT
15C	114430-06-000	EA	ADAPTER - 1/2"P X 3/8"FPT
15C	114430-09-000	EA	ADAPTER - 1/2"P X 1/2"FPT
16C	114430-10-000	EA	ADAPTER - NUT - PIPE CONNECTION - 1/2"
17C	114431-01-000	EA	VALVE - 180 DEGREE/CENTER DRAIN - 1/2"P - THREE WAY
18C	114429-11-000	EA	ELBOW - 1/2"P X 1/2"FPT



**WATER & SEWAGE GROUP (CONTINUED)**  
**WATER SYSTEM (CONTINUED)**

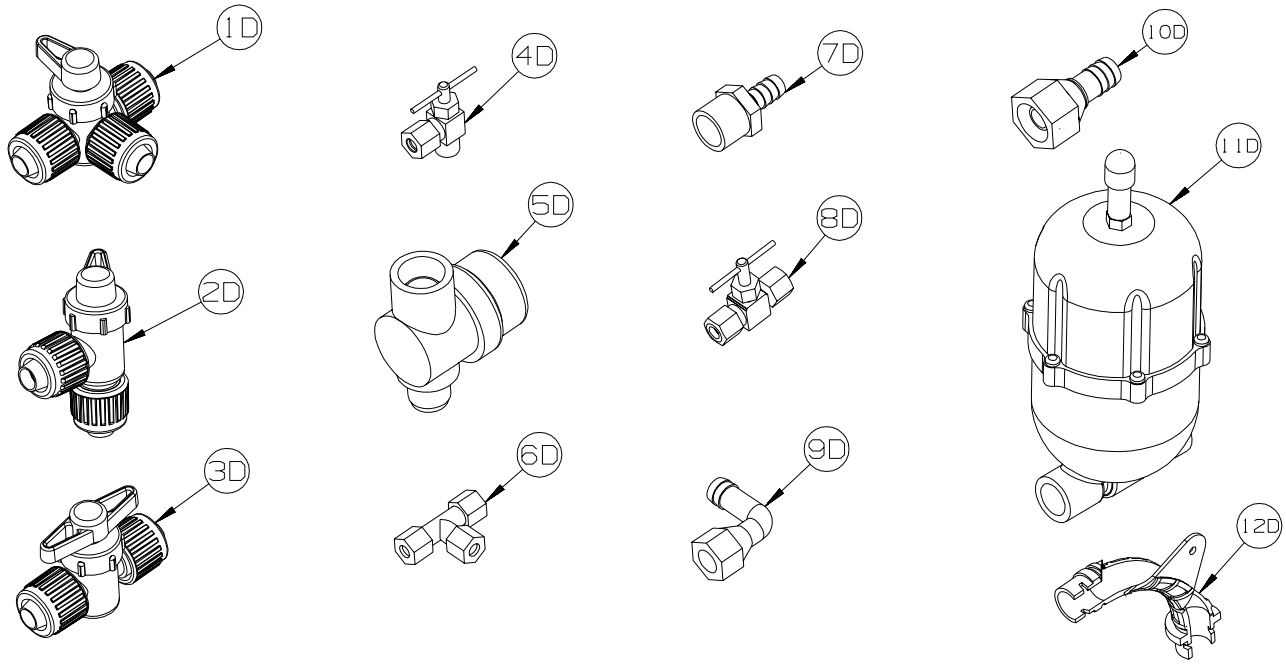

KEY	PART NUMBER	U/M	DESCRIPTION
1D	114431-02-000	EA	VALVE - WATER BYPASS - 1/2"P - THREE WAY (WATER HEATER)
2D	114431-03-000	EA	VALVE - 90 DEGREE DRAIN - 1/2"P
3D	114431-04-000	EA	VALVE - "INLINE SHUT-OFF" - 1/2"P
4D	114431-05-000	EA	VALVE - NEEDLE - 1/8" MPT X 1/4" COMPRESSION (ICE MAKER)
5D	152925-01-01A	EA	FILTER - IN LINE - TWIST ON - 1/2" - BLACK
6D	118423-01-000	EA	FITTING - BRASS-TEE - 1/4C X 1/4C X 1/4C
7D	118809-01-000	EA	ADAPTER - 1/2" MPT X 3/8" BARB - PLASTIC
7D	118809-02-000	EA	ADAPTER - 1/2" MPT X 1/2" BARB - PLASTIC
8D	120868-01-000	EA	VALVE - NEEDLE - 1/4" COMPRESSION X 1/4" COMPRESSION
9D	123150-01-000	EA	ELBOW - 1/2 FPT X 1/2 BARB - SWIVEL
10D	123152-01-000	EA	ADAPTER - 1/2 FPT X 1/2 BARB - SWIVEL
11D	123243-01-000	EA	TANK - ACCUMULATOR - 24 OZ
11D	123317-01-000	EA	TANK - ACCUMULATOR - 2 GALLON
12D	124184-01-000	EA	SUPPORT - WATER LINE - BEND

**WATER & SEWAGE GROUP (CONTINUED)**  
**WATER SYSTEM (CONTINUED)**

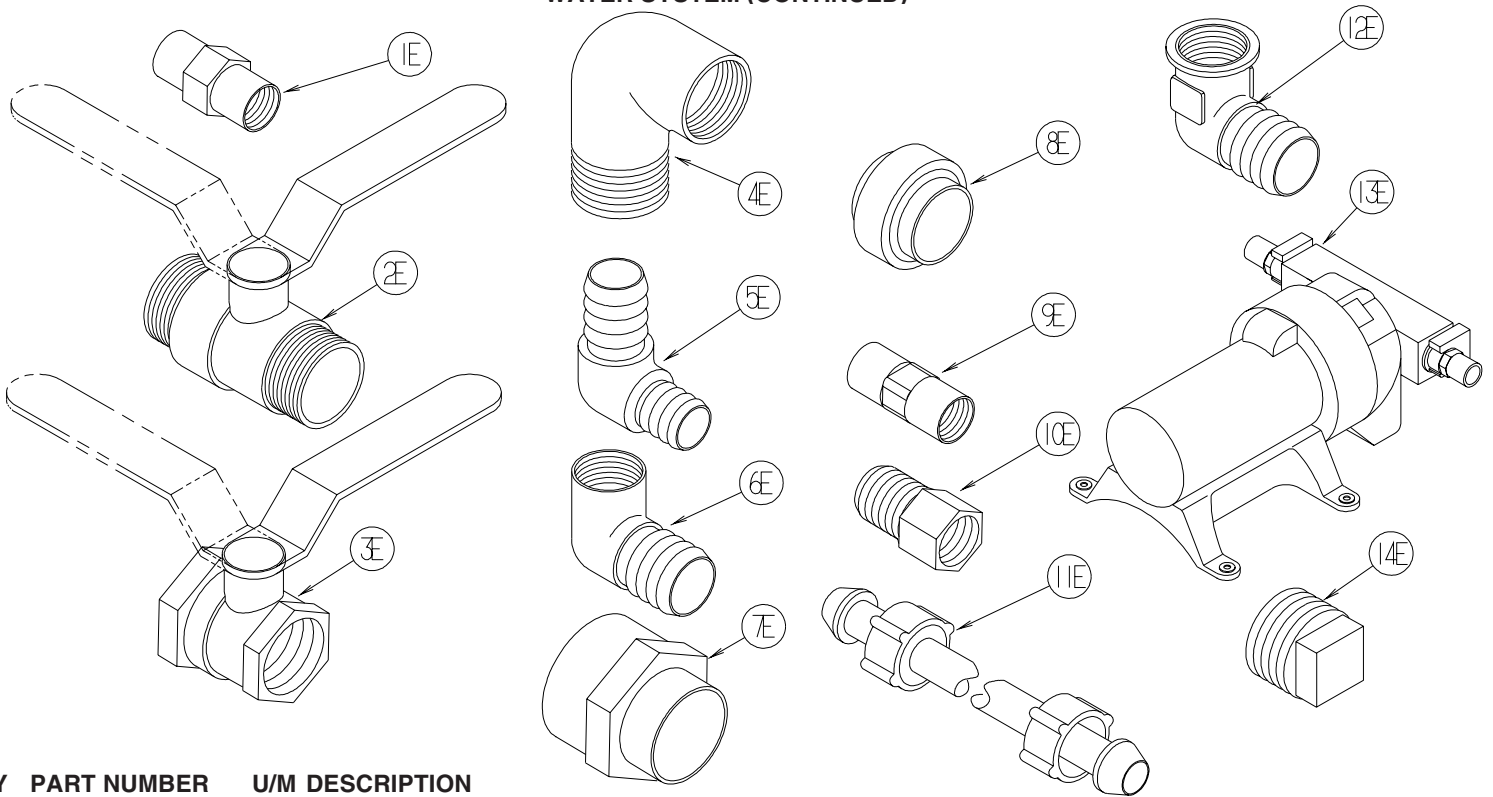

KEY	PART NUMBER	U/M	DESCRIPTION
1E	132148-01-000	EA	CONNECTOR - 1/2" X 1/2"MPT - BRASS
2E	132483-01-000	EA	VALVE/BALL - 1" - THREADED ENDS
3E	132483-02-000	EA	VALVE/BALL - 1/2" - BRASS - FPT
4E	132484-01-000	EA	ELBOW - 90 DEGREE - 1MPT X 1FPT - PLASTIC
5E	132781-01-000	EA	ELBOW - 1.3" BARB X 1.3" BARB - 90 DEGREE - PLASTIC
6E	132782-01-000	EA	ELBOW - 1"FPT X 1.3" BARB - 90 DEGREE - PLASTIC
7E	133835-01-000	EA	ADAPTER - REDUCING - 1 1/2" X 1 1/4"
8E	133889-01-000	EA	UNION - 1 1/2 DOUBLE SLIP - PVC
9E	135386-01-000	EA	NIPPLE - 1/2"
10E	136333-01-000	EA	ADAPTER - BRASS - 1/2"MPT X 1/2"FPT
11E	140821-01-000	EA	TUBE - WATER SUPPLY - 3/8" X 24"
11E	140821-02-000	EA	TUBE - WATER SUPPLY - 3/8" X 30"
11E	140821-03-000	EA	TUBE - WATER SUPPLY - 3/8" X 36"
11E	140821-04-000	EA	TUBE - WATER SUPPLY - 3/8" X 48"
11E	140821-05-000	EA	TUBE - WATER SUPPLY - 3/8" X 54"
11E	140821-06-000	EA	TUBE - WATER SUPPLY - 3/8" X 60"
11E	140821-07-000	EA	TUBE - WATER SUPPLY - 3/8" X 72"
11E	140821-08-000	EA	TUBE - WATER SUPPLY - 1/2" X 24"
11E	140821-09-000	EA	TUBE - WATER SUPPLY - 1/2" X 36"
11E	140821-10-000	EA	TUBE - WATER SUPPLY - 1/2" X 48"
12E	142812-01-000	EA	ELBOW - BRASS - 1/2"MPT X 1/2"FPT
13E*	144215-01-000	EA	PUMP - WATER - 5.7 GPM - W/1/2" MPT

FROM: 00-00-00 THRU: 02-05-06

14E 145609-01-000 EA PLUG - BRASS - 1/2" MPT/HEX HEAD

**\*COMPONENT PARTS LISTED LATER IN THIS GROUP**

**WATER & SEWAGE GROUP (CONTINUED)**  
**WATER SYSTEM (CONTINUED)**

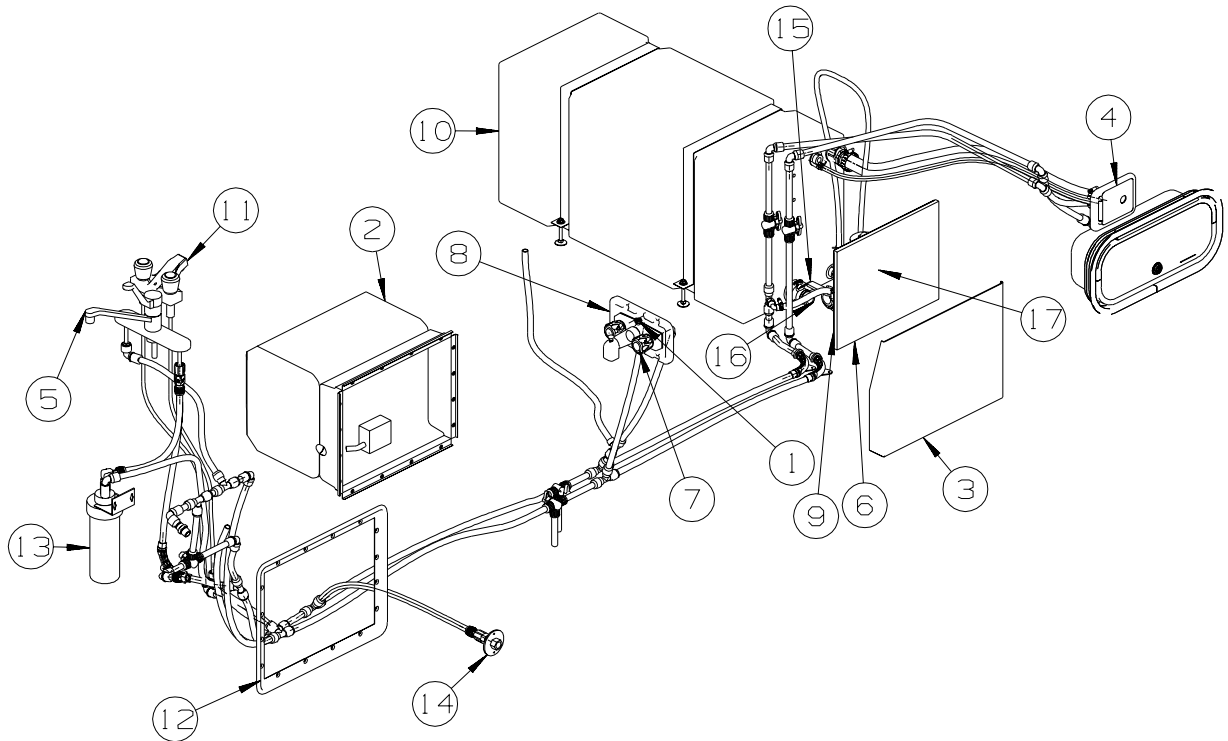

KEY	PART NUMBER	U/M	DESCRIPTION
1	131383-01-02A	EA	SHOWER HEAD - W/60" HOSE & BRACKET - WHITE
2*	051391-03-000	EA	WATER HEATER G6A-8E ELECTRONIC IGNITION
2*	145541-02-000	EA	WATER HEATER-6 GAL-GAS/ELEC/120'-REM IGN-W/HEAT EXC-4E - <b>WTR HTR-6GAL/110/LP/MTR/AUTO</b>
3	156298-02-02B	EA	BRACKET/MOUNTING - WATER PUMP - E-COATED
4	137169-01-01A	EA	WATER FILL/GRAVITY - W/DOOR - W/O LOCK - BRIGHT WHITE
	138290-03-000	EA	CASE - W/CAM - W/O CYLINDER/KEY
5	149164-01-01A	EA	FAUCET - GALLEY - SINGLE CONTROL - CHROME
6	149477-03-02B	EA	PANEL - WATER PUMP - E-COATED
7	156638-01-01A	EA	FAUCET - TUB/SHOWER - DUAL - 4" SPOUT W/DIVERTER - CHROME
8	075606-03-000	EA	PANEL - FAUCET SHOWER - SOFT WHITE
9	140364-05-01A	EA	FOAM - PAD - .5" X 12" X 15"
10	156167-02-000	EA	TANK - WATER - 36 GALLON - W/FITTINGS
	042989-03-000	EA	FITTING - SPINWELD - 1 1/4"NPT - PLASTIC
	042989-04-000	EA	FITTING - SPINWELD - 3/8"FPT - PLASTIC
	042989-05-000	EA	FITTING - SPINWELD - 1/2"FPT - PLASTIC
	042989-08-000	EA	FITTING - SPINWELD - 1"FPT - PLASTIC
	049032-01-000	EA	PATCH - SPINWELD - 3/8" - PLASTIC
11	148886-01-01A	EA	FAUCET - LAVATORY/DUAL CONTROL/4" CENTER - CHROME
11*	152311-01-01A	EA	FAUCET - LAVATORY - SINGLE CONTROL - CHROME - <b>INTERIOR UPGRADE PACKAGE</b>
12	052009-06-000	EA	DOOR - WATER HEATER - BRIGHT WHITE - 18" X 14.6"
12	152239-01-01A	EA	FLANGE/MOUNTING/RECESSED - 19.3" X 15.8" - BRIGHT WHITE
13	087200-01-000	EA	FILTER - WATER PURIFICATION
13	087200-02-000	EA	CARTRIDGE - WATER FILTER
14	010230-06-000	EA	FILL - CITY WATER - W/CHECK VALVE - MPT - BRUSHED ALUM
15	132483-01-000	EA	VALVE/BALL - 1" - THREADED ENDS
16	132484-01-000	EA	ELBOW - 90 DEGREE - 1MPT X 1FPT - PLASTIC
17*	098607-01-000	EA	PUMP - WATER - W/.5" MPT FITTING - FLOW 2.8 GPM - <b>NOT ILLUSTRATED</b>
			FROM: 00-00-00 THRU: 06-21-06
17	160702-01-000	EA	PUMP - WATER - 3.0 GPM - W/1/2" MPT
			FROM: 06-22-06 THRU: 99-99-99

\*COMPONENT PARTS LISTED LATER IN THIS GROUP

**WATER & SEWAGE GROUP (CONTINUED)**  
**WATER SYSTEM (CONTINUED)**

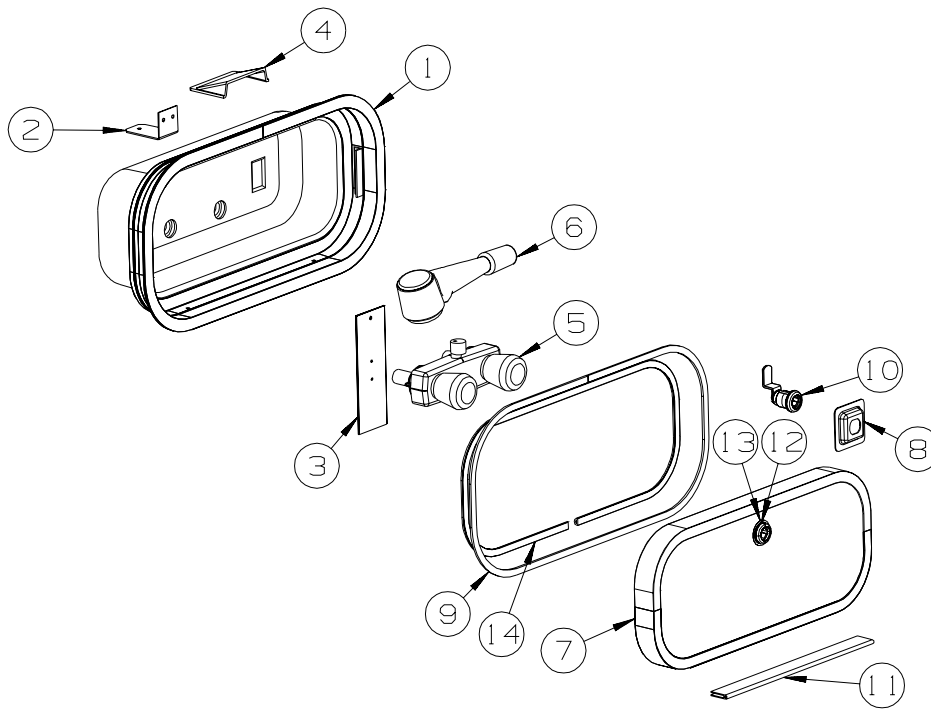

KEY	PART NUMBER	U/M	DESCRIPTION
1	106208-01-02A	EA	COMPARTMENT - EXTERIOR SHOWER - BRIGHT WHITE
2	131732-01-12B	EA	BRACKET - SQUEEGEE - BRIGHT WHITE
3	121577-04-01A	EA	STRAP/PLATE - W/HOLE - 2.25" X 6.5" - BRIGHT WHITE
4	054250-09-000	EA	SUPPORT - DIMMER SWITCH - BRIGHT WHITE
5*	075241-06-000	EA	FAUCET/SHOWER -.5"MPT W/1.9" INLET PIPES- EXTERIOR/BRT WHT
6	131383-01-02A	EA	SHOWER HEAD - W/60" HOSE & BRACKET - WHITE
7	126945-11-T11	EA	DOOR/STORAGE - W/O HARDWARE - 18" X 8.3"
8	097111-02-04A	EA	POCKET - LOCK - REAR DOOR - BLACK
9	056795-01-000	EA	TAPE-SEAL, 1/8~ X 3/8~ WIDE - PRESS ON
10	138290-02-000	EA	CASE - W/CAM - W/O CYLINDER/KEY
11	081801-V3-000	EA	HINGE - DOOR - PIANO - 2" X 96" - BRIGHT WHITE
12	139325-01-000	EA	SPACER - LOCK - 6MM
13	139337-01-000	EA	GASKET - LOCK
14	112160-02-000	FT	SEAL - D SECTION - .2 X .3" - FOAM RUBBER

**\*COMPONENT PARTS LISTED LATER IN THIS GROUP**

**WATER & SEWAGE GROUP (CONTINUED)**  
**COMPONENT PARTS FOR WATER SYSTEM**

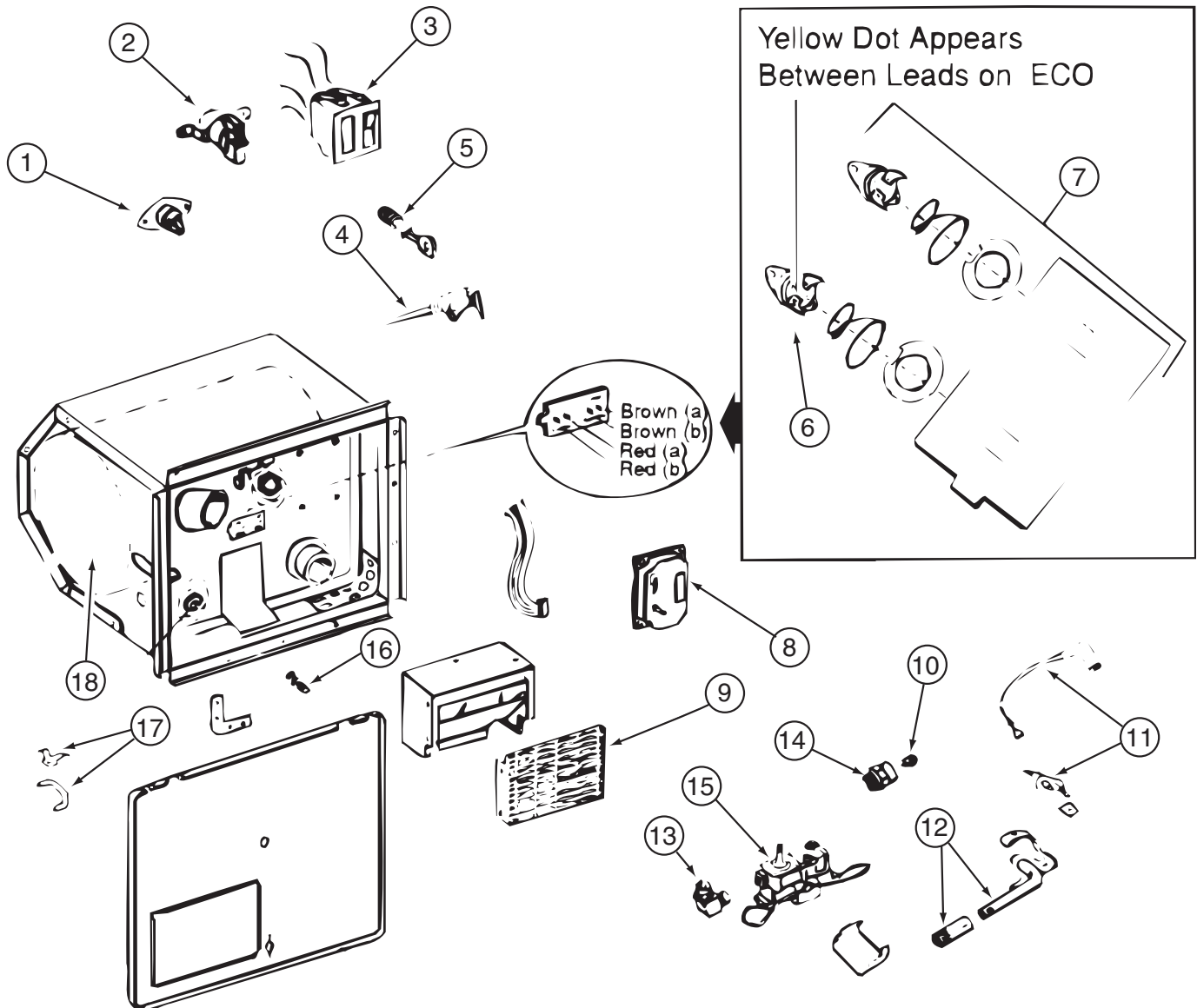

051391-03-000

KEY	PART NUMBER	U/M	DESCRIPTION	VENDOR NO.
3	051393-01-701	EA	SWITCH - REMOTE - W/LIGHT	91959
4	051391-01-704	EA	VALVE-RELIEF, 1/2" FITTING	91604
4	051391-03-701	EA	VALVE-RELIEF - 3/4" FITTING	90028
5	051391-01-705	EA	FASTENER-CAMLOCK	92609
6	051391-04-701	EA	THERMOSTAT 12V DC-120 PRESET	91470
7	051393-01-721	EA	THERMOSTAT W/ECO, 140 FRT MT	91447
9	051391-04-707	EA	KIT-EXHAUST, (FLUE & GASKET)	90960
10	051391-01-710	EA	ORIFICE-MAIN BURNER	92742
12	051391-04-703	EA	BURNER-MAIN/ELECTRONIC IG	91638
13	051391-01-714	EA	FITTING-ELBOW 45,3/8F X 3/8	MPT 1044
14	051391-03-700	EA	HOLDER-ORIFICE	91563
16	051391-01-715	EA	PLUG-DRAIN, 1 EA = 2 PER PKG	91857
17	051391-01-700	EA	HINGE KIT, (PIN & CLIP)	92568&92559
18	051391-04-706	EA	TANK-G6A-4E/6E/7E/8E-FRT.MT	91641 - INNER
	051391-01-717	EA	GRILLE-WATER HEATER DOOR	92640
	051393-01-723	EA	SWITCH - THERMAL CUTOUT 2/PK	93866 WAS 93853
	051393-01-724	EA	BOARD-CIRCUIT, SPADE TERMINAL	93865
	051393-01-725	EA	ELECTRODE-SGL SPADE CONNECT.	93868
	051393-01-726	EA	VALVE/SOLENOID - W/O BRACKET	93870
	111129-01-711	EA	BRACKET-CORNER, SET OF FOUR	91928

CONTACT WINNEBAGO PARTS SALES FOR UNLISTED COMPONENT(S)

**WATER & SEWAGE GROUP (CONTINUED)**  
**COMPONENT PARTS FOR WATER SYSTEM (CONTINUED)**

098607-01-000

KEY	PART NUMBER	U/M	DESCRIPTION	VENDOR NO.
	098607-01-702	EA	DIAPHRAGM/DRIVE ASSEMBLY KIT	94-238-04
	098607-01-703	EA	VALVE KIT	94-232-00
	098607-01-705	EA	VALVE-CHECK, KIT	94-237-00
	098607-01-706	EA	HOUSING, W/SWITCH ONLY	94-231-20
	098607-01-707	EA	MOTOR W/BASEPLATE	11-148-04

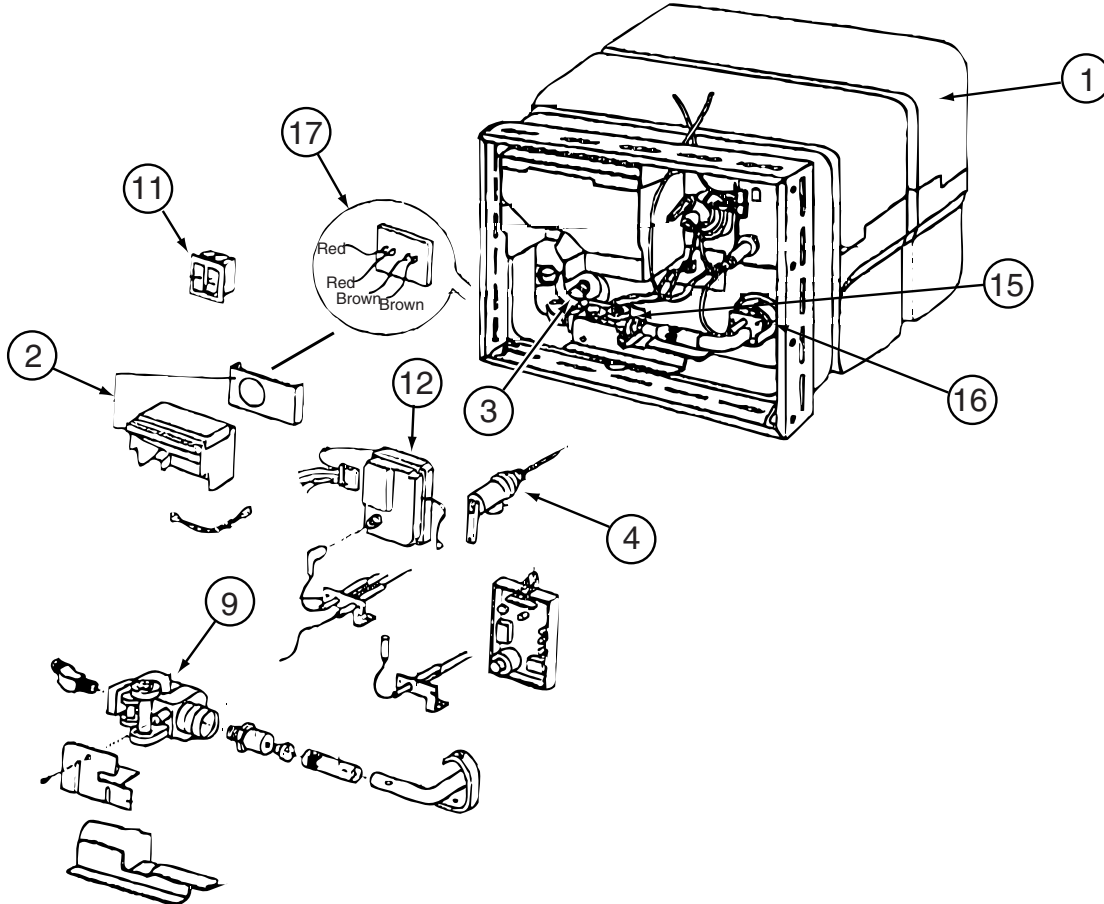

145541-02-000

KEY	PART NUMBER	U/M	DESCRIPTION	VENDOR NO.
1	145541-02-700	EA	TANK/SERVICE KIT PCS- 6 GAL	91053
2	051391-04-707	EA	KIT-EXHAUST, (FLUE & GASKET)	90960
3	051391-01-715	EA	PLUG-DRAIN, 1 EA = 2 PER PKG	91857
4	051391-01-704	EA	VALVE-RELIEF, 1/2" FITTING	91604
9	051393-01-726	EA	VALVE-SOLENOID - W/O BRACKET	93870
11	051393-01-701	EA	SWITCH - REMOTE - W/LIGHT	91959
11	145541-01-701	EA	SWITCH - ON/OFF - WHITE	91859
12	145541-01-702	EA	CIRCUIT BOARD	91226
15	145541-01-703	EA	SWITCH - THERMAL CUT OFF	93866
16	051393-01-725	EA	ELECTRODE-SGL SPADE CONNECT.	93868
17	051393-01-721	EA	THERMOSTAT W/ECO, 140 FRT MT	91447
	051391-05-706	EA	ELEMENT-HEATING 1500 WATT	92249 W/GASKET
	145541-01-704	EA	RELAY	90061
	145541-02-701	EA	JUNCTION BOX(PLASTIC) 6 GAL	91222

CONTACT WINNEBAGO PARTS SALES FOR UNLISTED COMPONENT(S)

152311-01-01A

KEY	PART NUMBER	U/M	DESCRIPTION	VENDOR NO.
	152311-01-700	EA	KNOB - CONTROL	AF-0908-HANDLE

## WINDOW & VENTS GROUP

### WINDOW & VENT LAYOUT

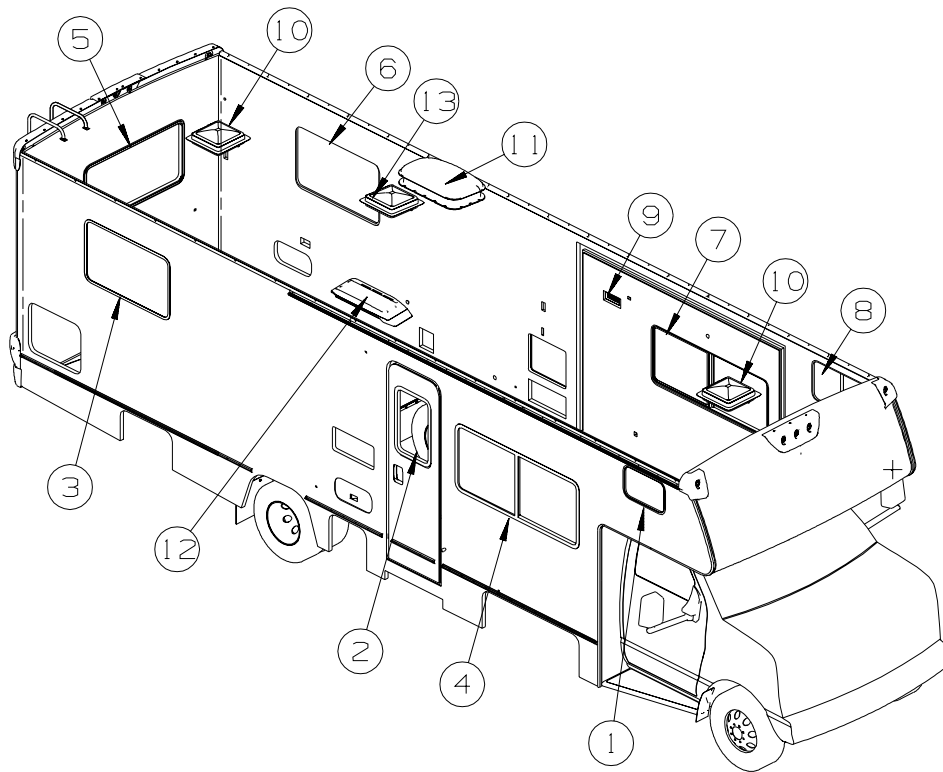

KEY	PART NUMBER	U/M	DESCRIPTION
1*	098647-78-01A	EA	WINDOW - PASS HORIZ SLIDER W/TRIM - 12.5" X 19.9" - BLACK
1*	150648-31-01A	EA	WINDOW-HORIZ SLIDER/FLUSH/THERMO/RH - 12.3" X 19.7" - BLK - <b>DUAL PANE</b>
2	117053-04-FB1	EA	WINDOW - PICTURE/CLEAR - W/O TRIM - 17" X 26.4"
	002181-27-000	EA	GLASS - PICTURE WINDOW - 25.8"W X 16.4"H - CLEAR
	087561-01-000	FT	SEAL - GLASS - EXTERIOR - .5" WIDE - VINYL BLACK
	117054-02-03A	EA	TRIM/RETAINER - INSIDE - 16.9" X 26.2" - BLACK
2*	150651-01-01A	EA	WINDOW - STATIONARY/FLUSH/THERMO - 26.3" X 17" - BLACK - <b>DUAL PANE</b>
3*	098647-29-02A	EA	WINDOW - PASS HORIZ SLIDER W/TRIM - CLEAR - 24.2" X 41"
3*	150648-03-01A	EA	WINDOW-HORIZ SLIDER/FLUSH/THERMO/RH - 26.3" X 59.9" - BLK - <b>DUAL PANE</b>
			FROM: 00-00-00 THRU: 10-01-06
3*	161452-01-01A	EA	WINDOW - TIPOUT/FLUSH/THERMO - 24.5" X 41.2" - <b>DUAL PANE</b>
			FROM: 10-02-06 THRU: 99-99-99
4*	098647-27-02A	EA	WINDOW - PASS HORIZ SLIDER W/TRIM - CLEAR - 26.1" X 59.7"
4*	150648-03-01A	EA	WINDOW - TIPOUT/FLUSH/THERMO - 24.5" X 41.2" - <b>DUAL PANE</b>
5	078528-07-F15	EA	WINDOW - ESCAPE W/O INSIDE TRIM - CLEAR - 24.5" X 48.5"
	002282-09-000	EA	WEATHERSTRIP - WINDOW - .125" X 130.5" - BLACK
	002285-01-000	FT	FILLER - WEATHERSTRIP - RUBBER - BLACK
	076337-13-000	EA	GLASS - EGRESS - 45.5" X 21.5"
5	074816-16-000	EA	FRAME - WINDOW - INSIDE ESCAPE - BLACK
5*	150651-03-01A	EA	WINDOW - STATIONARY/FLUSH/ESCAPE/THERMO - 24.7"X 48.7"-BLK - <b>DUAL PANE</b>
6*	098647-30-02A	EA	WINDOW - DRVR HORIZ SLIDER W/TRIM - CLEAR - 24.2" X 41"
6*	150656-03-01A	EA	WINDOW - TIPOUT/FLUSH/THERMO - 24.5" X 41.2" - <b>DUAL PANE</b>
			FROM: 00-00-00 THRU: 10-01-06
6*	161452-01-01A	EA	WINDOW - TIPOUT/FLUSH/THERMO - 24.5" X 41.2" - <b>DUAL PANE</b>
			FROM: 10-02-06 THRU: 99-99-99
7*	098647-74-01A	EA	WINDOW - DRIVER HORIZ SLIDER W/TRIM - 23.6" X 57.5"
7*	150648-07-01A	EA	WINDOW-HORIZ SLIDER/FLUSH/THERMO/LH - 23.8" X 57.7" - <b>DUAL PANE</b>
8*	098647-32-02A	EA	WINDOW - DRVR HORIZ SLIDER W/TRIM - CLEAR- 15.7" X 28.5"
8*	150648-05-01A	EA	WINDOW-HORIZ SLIDER/FLUSH/THERMO/LH - 16" X 28.7" - BLACK - <b>DUAL PANE</b>
9	147821-01-01A	EA	VENT - EXHAUST/RANGE HOOD - BRIGHT WHITE
9	147821-02-01A	EA	SHROUD - EXHAUST VENT/RANGE HOOD - BRIGHT WHITE
10*	122882-01-01A	EA	VENT - ROOF - NONPOWERED - W/O INSIDE GARNISH
	009440-01-000	EA	GEAR/ARM - LIFT - ROOF VENT COVER
10	122882-07-01A	EA	GARNISH - ROOF VENT - 2.5" TO 4.1"
10*	123780-03-01A	EA	FANTASTIC VENT-3"/4"ROOF-W/FAN-W/O THERM/PWR LIFT/WHT CVR - <b>VENT-POWER VENTILATOR</b>
	009440-01-000	EA	GEAR/ARM - LIFT - ROOF VENT COVER
11	122193-01-02A	EA	PANEL - SKYLITE - INNER - W/LIGHT INDENTATION
11	138372-01-02B	EA	TRIM - CORNER - SKYLIGHT - E-COATED

**WINDOW & VENTS GROUP (CONTINUED)**  
**WINDOW & VENT LAYOUT (CONTINUED)**

KEY	PART NUMBER	U/M	DESCRIPTION
11	138379-02-01A	EA	PANEL/SKYLIGHT OTR - RECT/4"H CTR DOME - 18.4"X 29.5"- WHT
12	149508-01-02A	EA	CAP - ROOF/REFRIGERATOR VENT - WHITE
12	149508-02-02A	EA	BASE - ROOF/REFRIGERATOR VENT - BRIGHT WHITE
13*	122882-02-01A	EA	VENT - ROOF - W/FAN - W/O INSIDE GARNISH - UL
13*	122882-03-01A	EA	VENT - ROOF - W/FAN - W/O INSIDE GARNISH - <b>CANADIAN</b>
	009440-01-000	EA	GEAR/ARM - LIFT - ROOF VENT COVER
	048648-01-000	EA	MOTOR/ROOF VENT - W/RESISTER - 1/8"SHAFT - 12VOLT
	048649-01-000	EA	FAN BLADE - ROOF VENT - 6 BLADED - 6"RADIUS
13	122882-07-01A	EA	GARNISH - ROOF VENT - 2.5" TO 4.1"

**\*COMPONENT PARTS LISTED LATER IN THIS GROUP**

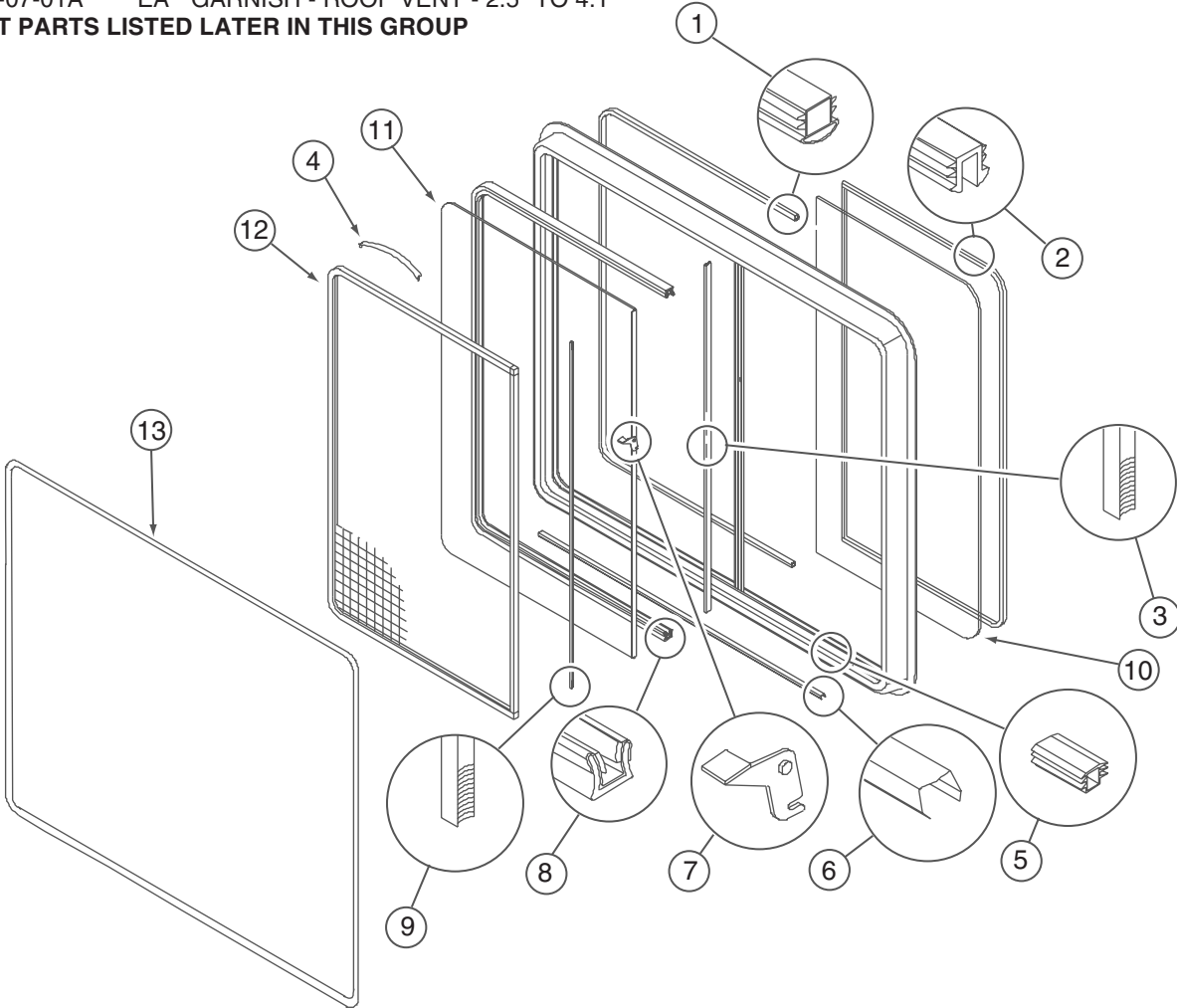

**COMPONENT PARTS FOR WINDOW & VENT LAYOUT**

098647-27-02A, 098647-28-02A

KEY	PART NUMBER	U/M	DESCRIPTION	VENDOR NO.
1	098644-01-716	FT	PLUG - FILLER	132-014470
2	098644-01-705	FT	GLAZING - STRIP	132-010231
3	098644-01-706	FT	WEATHERSTRIP - GLASS	171-010668
4	098644-01-713	EA	CLIP - SCREEN - METAL	226-016966
4	125582-01-701	EA	CLIP - SCREEN - PLASTIC	130-005153
5	098644-01-719	EA	STOP - SLIDER GLASS	132-014203
6	098644-01-710	FT	TRACK - SCREEN SPACER 12'	132-017135
7	098644-01-700	EA	LATCH - REPAIR KIT (BLACK)	B801-CK
7	098647-54-701	EA	LATCH - REPAIR KIT (RED)	B081-CK
8	098644-01-708	FT	CHANNEL - RUN PIERCED	122-016543
9	098644-01-711	FT	WEATHERSTRIP - SCREEN BLACK	171-016965
10	098647-27-702	EA	GLASS - STATIONARY	096-017868
11	098647-27-703	EA	GLASS-SLIDING W/SASH & LATCH	H287-C8
12	098647-23-704	EA	SCREEN ASM - W/SEALS & CLIPS	410-019066
13	098647-27-704	EA	RETAINER - TRIM	H287-66
	098644-01-717	FT	SPLINE - SCREEN	132-004716



**WINDOW & VENTS GROUP (CONTINUED)**  
**COMPONENT PARTS FOR WINDOW & VENT LAYOUT (CONTINUED)**

**098647-29-02A, 098647-30-02A**

<b>KEY</b>	<b>PART NUMBER</b>	<b>U/M</b>	<b>DESCRIPTION</b>	<b>VENDOR NO.</b>
1	098644-01-716	FT	PLUG - FILLER	132-014470
2	098644-01-705	FT	GLAZING - STRIP	132-010231
3	098644-01-706	FT	WEATHERSTRIP - GLASS	171-010668
4	098644-01-713	EA	CLIP - SCREEN - METAL	226-016966
4	125582-01-701	EA	CLIP - SCREEN - PLASTIC	130-005153
5	098644-01-719	EA	STOP - SLIDER GLASS	132-014203
6	098644-01-710	FT	TRACK - SCREEN SPACER 12'	132-017135
7	098644-01-700	EA	LATCH - REPAIR KIT (BLACK)	B801-CK
7	098647-54-701	EA	LATCH - REPAIR KIT (RED)	B081-CK
8	098644-01-708	FT	CHANNEL - RUN PIERCED	122-016543
9	098644-01-711	FT	WEATHERSTRIP - SCREEN BLACK	171-016965
10	098647-29-702	EA	GLASS - STATIONARY	096-019295
11	098647-29-703	EA	GLASS-SLIDING W/SASH & LATCH	H172-C8
12	098647-29-704	EA	SCREEN ASM - W/SEALS & CLIPS	410-018864
13	098647-29-705	EA	RETAINER - TRIM	CH04-66
	098644-01-717	FT	SPLINE - SCREEN	132-004716

**098647-31-02A, 098647-32-02A**

<b>KEY</b>	<b>PART NUMBER</b>	<b>U/M</b>	<b>DESCRIPTION</b>	<b>VENDOR NO.</b>
1	098644-01-716	FT	PLUG - FILLER	132-014470
2	098644-01-705	FT	GLAZING - STRIP	132-010231
3	098644-01-706	FT	WEATHERSTRIP - GLASS	171-010668
4	098644-01-713	EA	CLIP - SCREEN - METAL	226-016966
4	125582-01-701	EA	CLIP - SCREEN - PLASTIC	130-005153
5	098644-01-719	EA	STOP - SLIDER GLASS	132-014203
6	098644-01-710	FT	TRACK - SCREEN SPACER 12'	132-017135
7	098644-01-700	EA	LATCH - REPAIR KIT (BLACK)	B801-CK
7	098647-54-701	EA	LATCH - REPAIR KIT (RED)	B081-CK
8	098644-01-708	FT	CHANNEL - RUN PIERCED	122-016543
9	098644-01-711	FT	WEATHERSTRIP - SCREEN BLACK	171-016965
10	098647-31-702	EA	GLASS - STATIONARY	096-019299
11	098647-31-703	EA	GLASS-SLIDING W/SASH & LATCH	H425-C8
12	098647-31-704	EA	SCREEN ASM - W/SEALS & CLIPS	410-019128
13	098647-31-705	EA	RETAINER - TRIM	CH29-66
	098644-01-717	FT	SPLINE - SCREEN	132-004716

**WINDOW & VENTS GROUP (CONTINUED)**  
**COMPONENT PARTS FOR WINDOW & VENT LAYOUT (CONTINUED)**

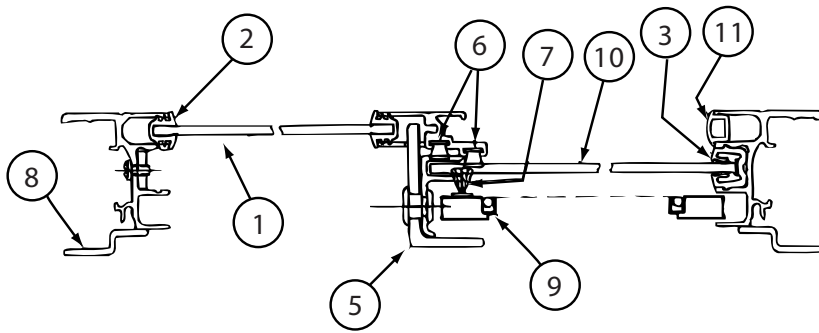

CROSS SECTION B-B

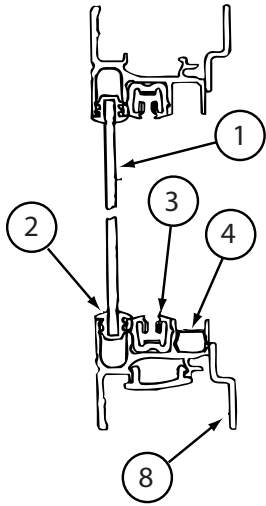

CROSS SECTION A-A

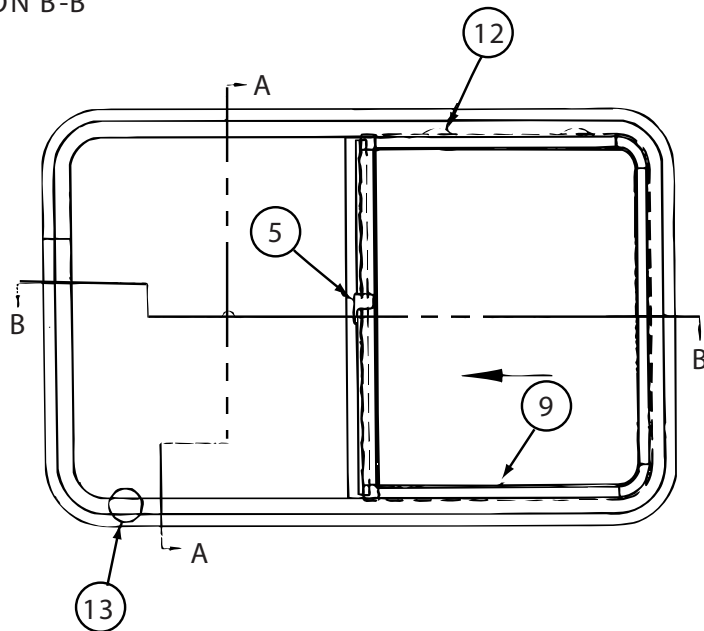

098647-74-01A

KEY	PART NUMBER	U/M	DESCRIPTION	VENDOR NO.
1	098647-68-701	EA	GLASS - STATIONARY	096-029585
2	098644-01-705	FT	GLAZING - STRIP	132-010231
3	098644-01-708	FT	CHANNEL - RUN PIERCED	122-016543
4	098644-01-710	FT	TRACK - SCREEN SPACER 12'	132-017135
5	098644-01-700	EA	LATCH - REPAIR KIT (BLACK)	B801-CK
6	098644-01-706	FT	WEATHERSTRIP - GLASS	171-010668
7	098644-01-711	FT	WEATHERSTRIP - SCREEN BLACK	171-016965
8	098647-47-704	EA	RETAINER - TRIM	H493-66
9	098647-47-702	EA	SCREEN ASM - W/SEALS & CLIPS	410-025226
10	098647-74-700	EA	GLASS SLIDING W/SASH & LATCH	H493C8
11	098644-01-716	FT	PLUG - FILLER	132-014470
12	125582-01-701	EA	CLIP - SCREEN - PLASTIC	130-005153
13	098644-01-719	EA	STOP - SLIDER GLASS	132-014203

**WINDOW & VENTS GROUP (CONTINUED)**  
**COMPONENT PARTS FOR WINDOW & VENT LAYOUT (CONTINUED)**

098647-78-01A, 098647-79-01A

KEY	PART NUMBER	U/M	DESCRIPTION	VENDOR NO.
1	098647-78-700	EA	GLASS - STATIONARY	096-036830
2	098644-01-705	FT	GLAZING - STRIP	132-010231
3	098644-01-708	FT	CHANNEL - RUN PIERCED	122-016543
4	098644-01-710	FT	TRACK - SCREEN SPACER 12'	132-017135
5	098644-01-700	EA	LATCH - REPAIR KIT (BLACK)	B801-CK
6	098644-01-706	FT	WEATHERSTRIP - GLASS	171-010668
7	098644-01-711	FT	WEATHERSTRIP - SCREEN BLACK	171-016965
8	098647-78-701	EA	RETAINER - TRIM	H996-66
9	098647-78-702	EA	SCREEN ASM	410-036304
10	098647-78-703	EA	GLASS SLIDING W/SASH & LATCH	H996C8
11	098644-01-716	FT	PLUG - FILLER	132-014470
12	125582-01-701	EA	CLIP - SCREEN - PLASTIC	130-005153
13	098644-01-719	EA	STOP - SLIDER GLASS	132-014203

**WINDOW & VENTS GROUP (CONTINUED)**  
**COMPONENT PARTS FOR WINDOW & VENT LAYOUT (CONTINUED)**

122882-01-01A

KEY	PART NUMBER	U/M DESCRIPTION	VENDOR NO.
	064470-01-700	EA COVER - VENT	J7291
	064470-01-701	EA SLIDE BAR - VENT LID	JRP1291B
	122882-01-700	EA HANDLE - CRANK - BLACK	90128
	122882-01-701	EA SCREEN	JRP-1124-B
	122882-01-702	EA HANDLE - CRANK - WHITE	JRP1031B

122882-02-01A, 122882-03-01A

KEY	PART NUMBER	U/M DESCRIPTION	VENDOR NO.
	064470-01-700	EA COVER - VENT	J7291
	064470-01-701	EA SLIDE BAR - VENT LID	JRP1291B
	110051-03-700	EA SWITCH-BLACK/PUSH BUTTON	27-0164
	122882-01-700	EA HANDLE - CRANK - BLACK	90128
	122882-01-701	EA SCREEN	JRP-1124-B
	122882-01-702	EA HANDLE - CRANK - WHITE	JRP1031B

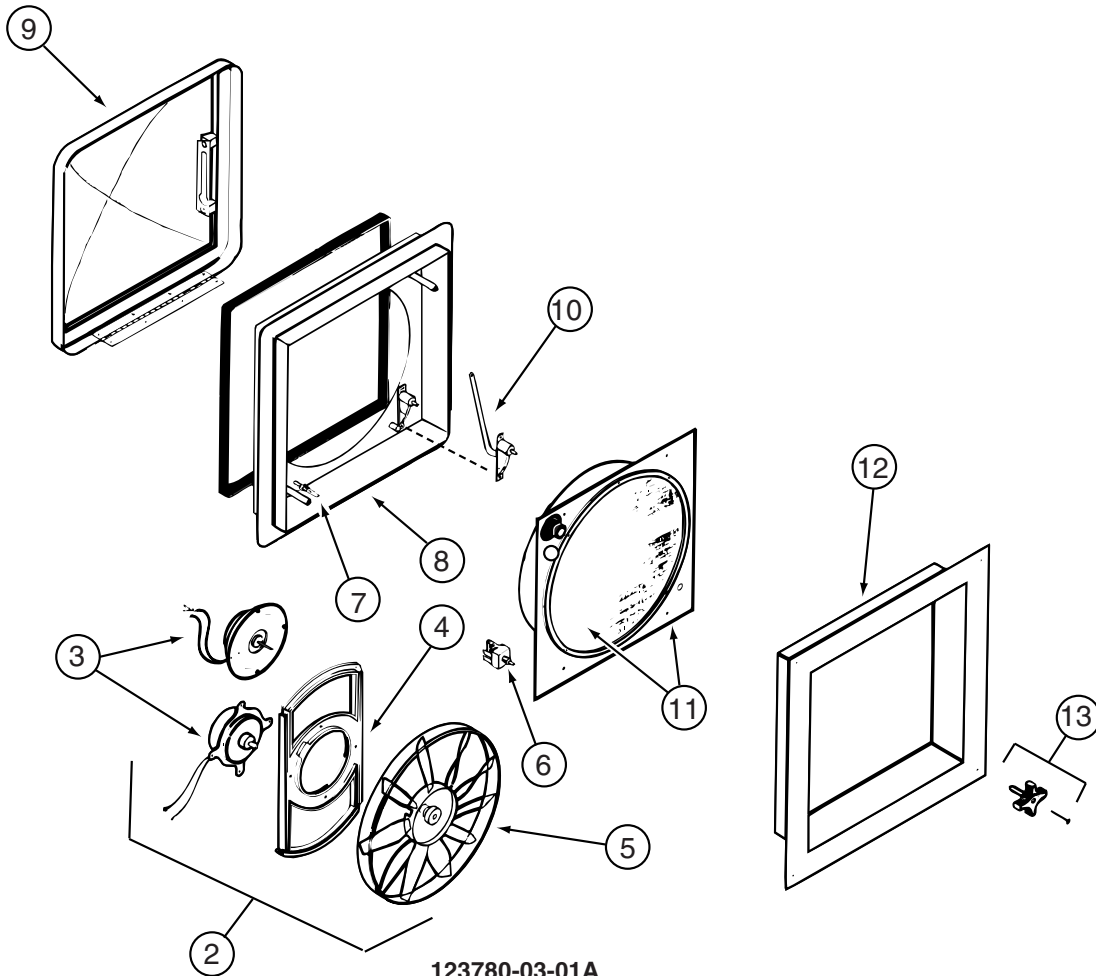

123780-03-01A

KEY	PART NUMBER	U/M DESCRIPTION	VENDOR NO.
2	084079-11-700	EA MOTOR & FAN BLADE W/BRACKET	K4017-09
3	084079-01-705	EA MOTOR/EXT BRKT/FAN BLADE KIT	1080-00
4	084079-01-711	EA MOTOR MOUNT (BOWTIE)	1015-00
5	084079-01-704	EA BLADE-FAN	1138-00
6	084079-01-709	EA SWITCH - MAIN - 3 SPEED	1031-05
7	084079-01-707	EA SWITCH - SAFETY	1122-05
8	123780-05-700	EA BASE/MAIN-BRT WHT W/GASKET	1010-81
9	123780-01-700	EA COVER - VENT W/HINGE & SLIDE	1020K-81
10	009440-01-000	EA GEAR-ARM-ROOF VENT	705221K38
11	123780-03-701	EA SCREEN ASM 78-100MM W/SWITCH	1030BT-81
12	123780-03-700	EA GARNISH - INT. 3"-4" BRT/WHT	2040-81
13	084079-01-703	EA KNOB-LIFT	1140K-00
	084079-01-706	EA PLUG, 12 VOLT	1090
	123780-01-702	EA SCREEN INSERT (SCREEN RING)	K1035-81

CONTACT WINNEBAGO PART SALES FOR UNLISTED COMPONENT(S)

**WINDOW & VENTS GROUP (CONTINUED)**  
**COMPONENT PARTS FOR WINDOW & VENT LAYOUT (CONTINUED)**

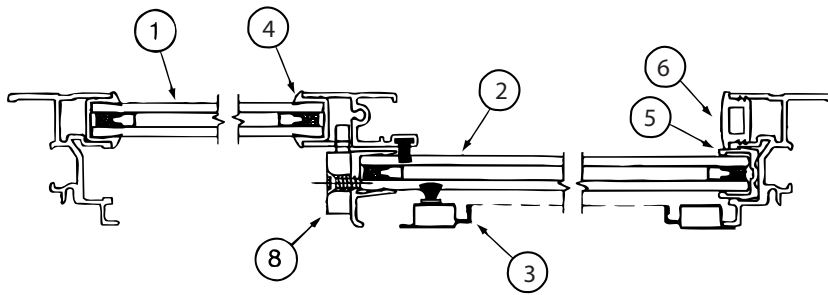

CROSS SECTION B-B

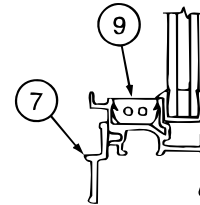
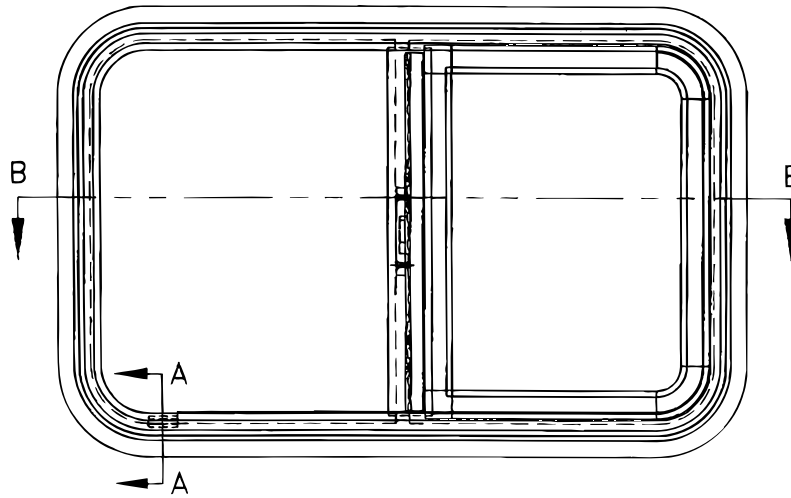

CROSS SECTION  
A-A

**150648-02-01A, 150648-03-01A**

KEY	PART NUMBER	U/M	DESCRIPTION	VENDOR NO
1	112795-68-700	EA	GLASS - STATIONARY	390-028353
2	150648-02-700	EA	GLASS-SLIDING W/SASH & LATCH	FH3009G8
3	150648-19-700	EA	SCREEN ASM	410-035332
4	112795-01-705	FT	VINYL - GLAZING	132-027331
5	151069-01-700	EA	CHANNEL-RUN, SLIDING	122-030627
6	150648-01-703	EA	PLUG - FILLER	132-030308
7	098647-22-701	EA	RETAINER - TRIM	H287-67
8	150648-01-700	EA	LATCH-HORIZONTAL SLIDE-BLK	FH3000-CK
8	150648-01-701	EA	LATCH-HORIZONTAL SLIDE-RED	FH3003-CK
9	150648-01-704	EA	SLIDE STOP	132-030866
	150648-05-702	FT	FIN SEAL-F/LOCKING RAIL-BLK	171-062348

**150648-04-01A, 150648-05-01A**

KEY	PART NUMBER	U/M	DESCRIPTION	VENDOR NO
1	112795-72-700	EA	GLASS - STATIONARY	390-028307
2	150648-04-700	EA	GLASS-SLIDING W/SASH & LATCH	FH3002G8
3	150648-05-700	EA	SCREEN ASM	410-031158
4	112795-01-705	FT	VINYL - GLAZING	132-027331
5	151069-01-700	EA	CHANNEL-RUN, SLIDING	122-030627
6	150648-01-703	EA	PLUG - FILLER	132-030308
7	150648-05-701	EA	RETAINER - TRIM	CH29-67
8	150648-01-700	EA	LATCH-HORIZONTAL SLIDE-BLK	FH3000-CK
8	150648-01-701	EA	LATCH-HORIZONTAL SLIDE-RED	FH3003-CK
9	150648-01-704	EA	SLIDE STOP	132-030866
	150648-05-702	FT	FIN SEAL-F/LOCKING RAIL-BLK	171-062348

**WINDOW & VENTS GROUP (CONTINUED)**  
**COMPONENT PARTS FOR WINDOW & VENT LAYOUT (CONTINUED)**

**150648-07-01A, 150648-22-01A**

<b>KEY</b>	<b>PART NUMBER</b>	<b>U/M</b>	<b>DESCRIPTION</b>	<b>VENDOR NO</b>
1	150648-07-701	EA	GLASS - STATIONARY	390-028314
2	150648-07-700	EA	GLASS-SLIDING W/SASH & LATCH	FH3000G8
3	150648-01-702	EA	SCREEN ASM	410-031156
4	112795-01-705	FT	VINYL - GLAZING	132-027331
5	151069-01-700	EA	CHANNEL-RUN, SLIDING	122-030627
6	150648-01-703	EA	PLUG - FILLER	132-030308
7	150648-01-707	EA	RETAINER - TRIM	H493-67
8	150648-01-700	EA	LATCH-HORIZONTAL SLIDE-BLK	FH3000-CK
8	150648-01-701	EA	LATCH-HORIZONTAL SLIDE-RED	FH3003-CK
9	150648-01-704	EA	SLIDE STOP	132-030866
	150648-05-702	FT	FIN SEAL-F/LOCKING RAIL-BLK	171-062348

**150648-31-01A, 150648-32-01A**

<b>KEY</b>	<b>PART NUMBER</b>	<b>U/M</b>	<b>DESCRIPTION</b>	<b>VENDOR NO</b>
1	150648-31-700	EA	GLASS - STATIONARY	390-036848
2	150648-31-701	EA	GLASS-SLIDING W/PULL & LATCH	FH3093G8
3	150648-31-702	EA	SCREEN ASM	410-036850
4	112795-01-705	FT	VINYL - GLAZING	132-027331
5	151069-01-700	FT	CHANNEL-RUN, SLIDING	122-030627
6	150648-01-703	FT	PLUG - FILLER	132-030308
7	150648-31-703	EA	RETAINER - TRIM	H3093-67
8	150658-01-700	EA	LATCH-HORIZONTAL SLIDE-BLK	FH3000-CK
8	150648-01-701	EA	LATCH-HORIZONTAL SLIDE-RED	FH3003-CK
9	150648-01-704	EA	SLIDE STOP	132-030866
	150648-05-702	FT	FIN SEAL-F/LOCKING RAIL-BLK	171-062348

**WINDOW & VENTS GROUP (CONTINUED)**  
**COMPONENT PARTS FOR WINDOW & VENT LAYOUT (CONTINUED)**

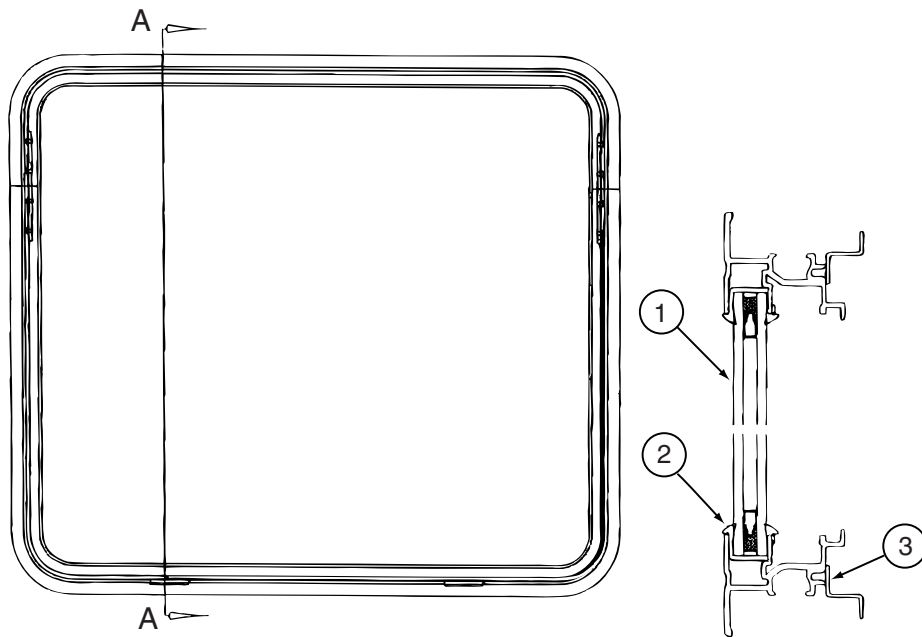

CROSS SECTION A-A

150651-01-01A

KEY	PART NUMBER	U/M	DESCRIPTION	VENDOR NO
1	113733-10-700	EA	GLASS-STATIONARY	390-028306
2	112795-01-705	FT	VINYL - GLAZING	132-027331
3	150651-01-700	EA	RETAINER - TRIM	H416-67

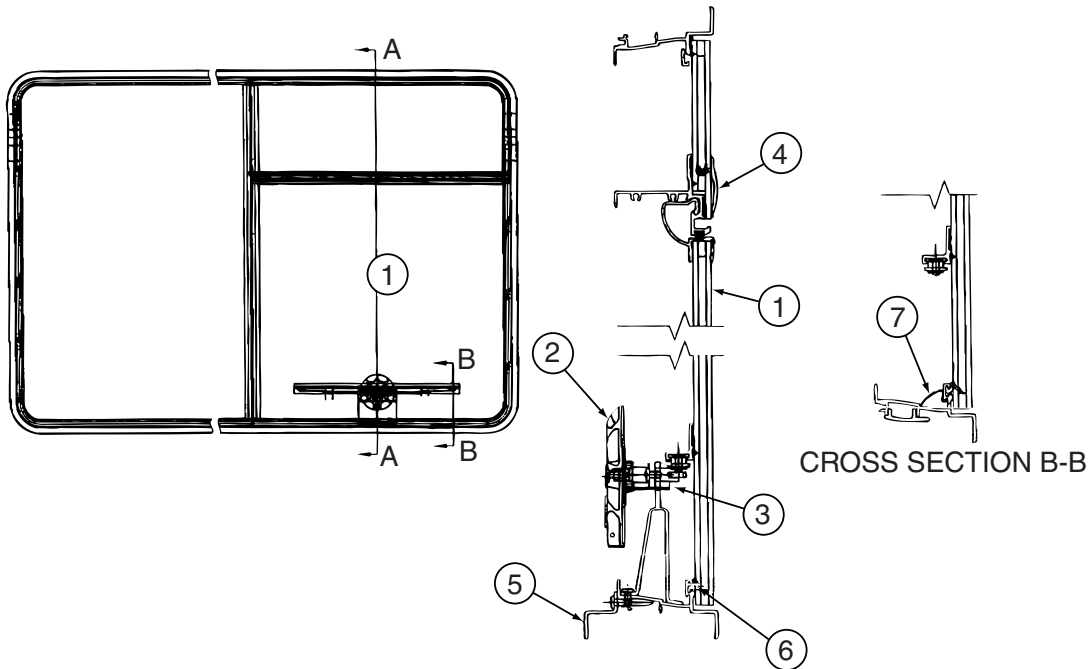

CROSS SECTION A-A

150651-03-01A

KEY	PART NUMBER	U/M	DESCRIPTION	VENDOR NO
1	150651-03-700	EA	GLASS-TIPOUT-W/HNG/GDE RAIL	DTH3049G8R RH F/INS
2	150656-02-702	EA	HANDLE-DIAL	410-016081E
3	150656-08-701	EA	OPERATOR - TIPOUT/LARGE	410-036141
4	150656-08-700	EA	SEAL/DUAL - WINDOW - 100"	132-030725
5	150651-03-701	EA	RETAINER - TRIM	DTH3049-50
6	100322-01-701	FT	SEAL-VENT	122-016071
7	150651-03-702	EA	COVER - DRAIN SLOT	132-030723

**WINDOW & VENTS GROUP (CONTINUED)**  
**COMPONENT PARTS FOR WINDOW & VENT LAYOUT (CONTINUED)**

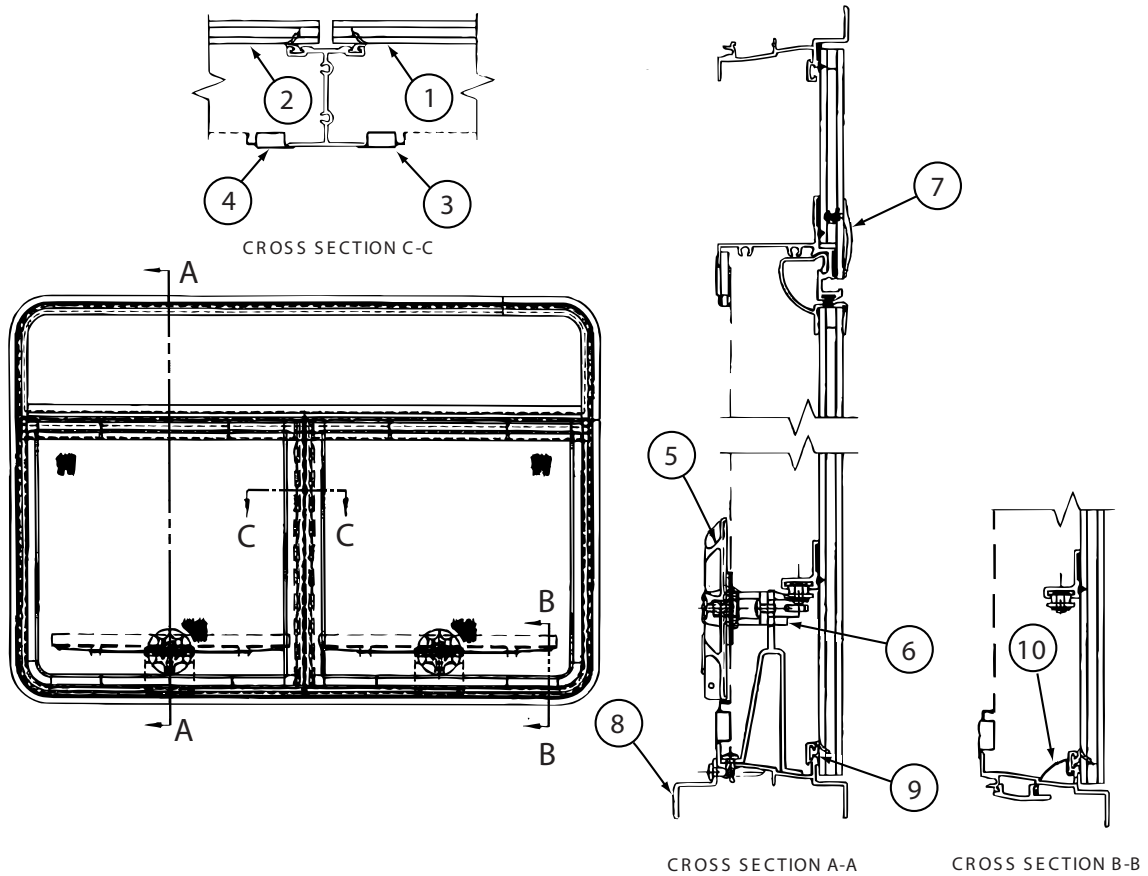

**150656-03-01A**

KEY	PART NUMBER	U/M	DESCRIPTION	VENDOR NO
1	150656-03-700	EA	GLASS-TIPOUT-RH-W/HNG/RAIL	DTH3023G8R RH F/INS
2	150656-03-701	EA	GLASS-TIPOUT-LH-W/HNG/RAIL	DTH3023G8L LH F/INS
3	150656-03-702	EA	SCREEN ASM - RIGHT	410-031152
4	150656-03-703	EA	SCREEN ASM - LEFT	410-031151
5	150656-02-702	EA	HANDLE-DIAL	410-016081E
6	150656-08-701	EA	OPERATOR - TIPOUT/LARGE	410-036141
7	150656-08-700	EA	SEAL/DUAL - WINDOW - 100"	132-030725
8	150656-03-704	EA	RETAINER - TRIM	DTH3023-56
9	100322-01-701	FT	SEAL-VENT	122-016071
10	150651-03-702	EA	COVER - DRAIN SLOT	132-030723



**WINDOW & VENTS GROUP (CONTINUED)**  
**COMPONENT PARTS FOR WINDOW & VENT LAYOUT (CONTINUED)**

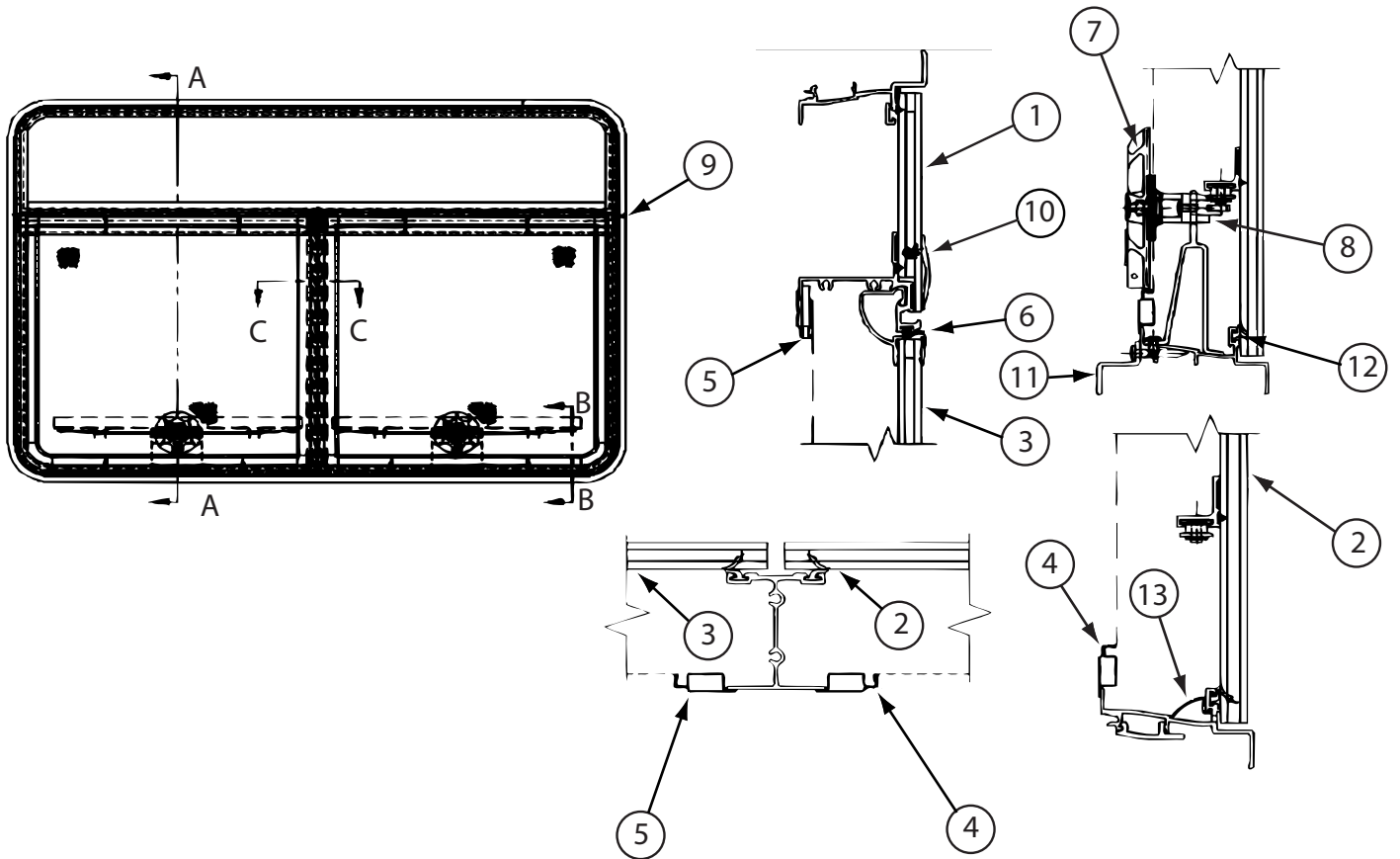

**161452-01-01A**

<b>KEY</b>	<b>PART NUMBER</b>	<b>U/M</b>	<b>DESCRIPTION</b>	<b>VENDOR NO.</b>
4	150656-03-702	EA	SCREEN ASM - RIGHT	410-031152
5	150656-03-703	EA	SCREEN ASM - LEFT	410-031151
6	098644-01-706	FT	WEATHERSTRIP - GLASS	171-010668
7	100322-01-718	EA	HANDLE-DIAL	410-016081
8	150656-08-701	EA	OPERATOR - TIPOUT/LARGE	410-036141
9	161452-01-700	FT	FELT SEAL	160-014688
11	150656-03-704	EA	RETAINER - TRIM	DTH3023-56
12	100322-01-701	FT	SEAL-VENT	122-016071
13	150651-03-702	FT	COVER - DRAIN SLOT	132-030723

CONTACT WINNEBAGO PART SALES FOR UNLISTED COMPONENT(S)