

# 2005 VOYAGE WFF36M F-SERIES

**PORTSMOUTH OAK**  
 S46 OAKWOOD - TAUPE  
 S49 ASPEN MIST - GREEN  
 S52 ALPINE BLUE - BLUE  
**CONCERT CHERRY**  
 S47 OAKWOOD - TAUPE  
 S50 ASPEN MIST - GREEN  
 S53 ALPINE BLUE - BLUE

**WASHED MAPLE**  
 S48 OAKWOOD - TAUPE  
 S51 ASPEN MIST - GREEN  
 S54 ALPINE BLUE - BLUE  
**SIERRA MAPLE**  
 SR0 OAKWOOD - TAUPE  
 SR1 ASPEN MIST - GREEN  
 SR2 ALPINE BLUE - BLUE

**DASH ACCENT COLORS**  
 S46, S47, S48, S49, S50, S51, SR0, SR1 - RIVERSTONE  
 S52, S53, S54, SR2 - CASHMERE

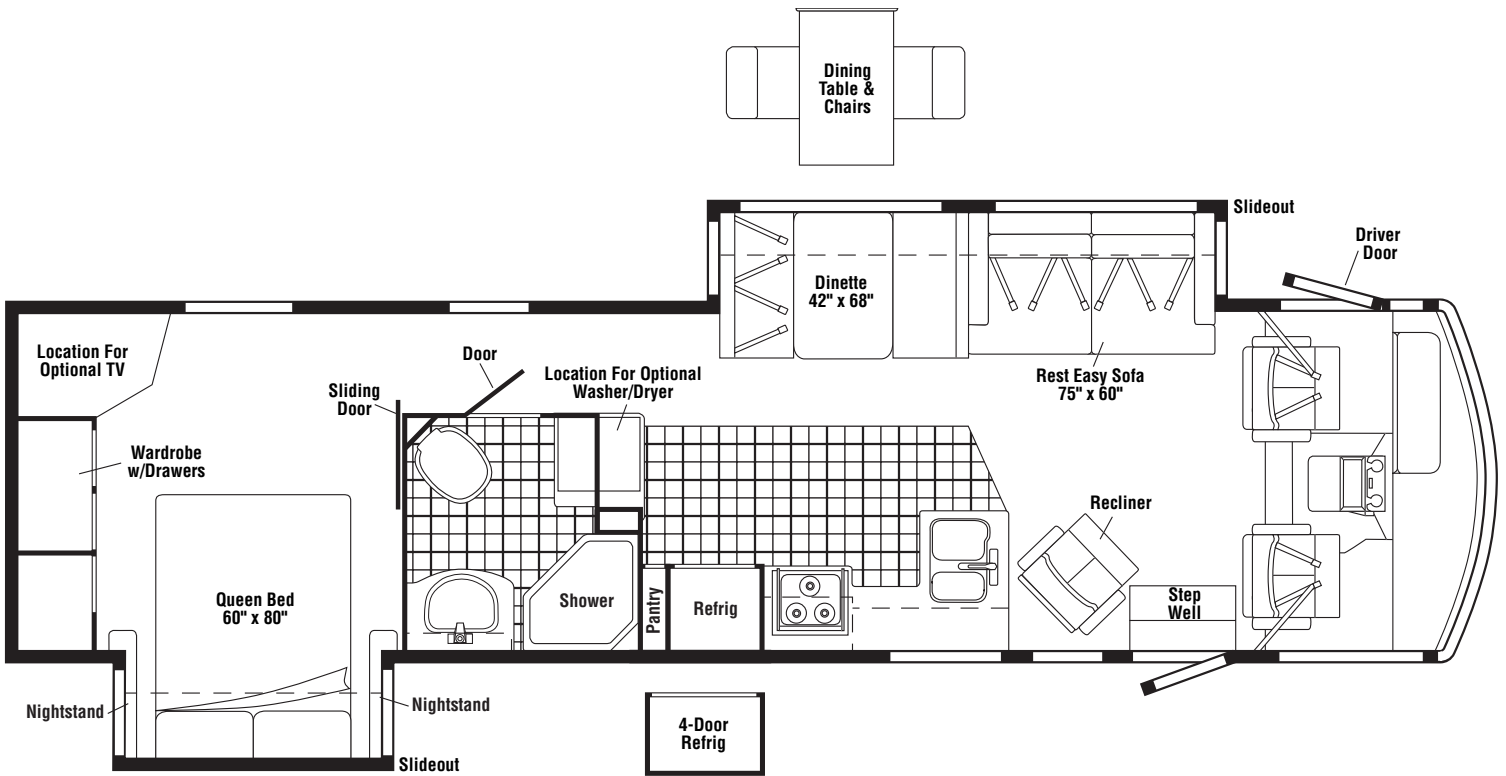

**FLOORPLAN**

# CONTENTS

<b>FLOORPLAN</b> .....	<b>1</b>
<b>ACCESSORIES GROUP</b> .....	<b>7</b>
OPERATORS MANUAL .....	7
<b>AUDIO VIDEO GROUP</b> .....	<b>8</b>
RADIO SYSTEM .....	8
REAR MONITOR .....	8
<b>CABINET &amp; APPLIANCE GROUP</b> .....	<b>9</b>
CABINET & APPLIANCE LAYOUT .....	9
APPLIANCES .....	9
COMPONENT PARTS FOR APPLIANCES .....	17
114030-02-01A, 114030-03-01A .....	17
114030-04-01A .....	18
119267-10-01A .....	19
119267-12-01A .....	19
119267-13-01A .....	19
119267-15-01A .....	19
120075-12-01A, 120075-13-01A, 120075-14-01A, 120075-15-01A .....	20
121569-05-01A, 121569-06-01A & 121569-07-01A .....	33
125242-02-01A .....	38
126022-01-01A, 126022-02-01A, 126022-03-01A .....	47
135065-03-01A, 135065-03-03A, 135065-04-01A .....	48
135066-03-01A, 135066-03-04A, 150778-01-01A .....	50
144972-01-01A .....	54
151277-03-01A, 151279-01-01A, 151279-02-01A/02A, 151279-03-01A .....	58
BATH .....	60
BEDROOM .....	62
DINETTE .....	65
GALLEY .....	69
LOUNGE .....	73
<b>CHASSIS GROUP</b> .....	<b>74</b>
FRAME .....	74
COMPONENT PARTS FOR FRAME .....	75
132643-01-01A, 132643-06-01A, 132643-07-01A, 132643-09-01A .....	75
149055-01-01A, 149055-02-01A .....	75
149055-03-01A .....	75
149055-04-01A .....	75
FRONT END .....	76
AIR INTAKE .....	82
DRIVETRAIN .....	82
EXHAUST .....	83
FUEL .....	88
SPARE TIRE .....	91
HYDRAULIC LEVELING .....	91
COMPONENT PARTS FOR HYDRAULIC LEVELING .....	93
139641-02-000 .....	93
139641-03-000 .....	94
WHEEL, TIRE, COVERS &/OR LINERS .....	95
COMPONENT PARTS FOR WHEEL, TIRE, COVERS &/OR LINERS .....	95
110435-20-000 .....	95
145580-02-000 .....	95
145580-03-000 .....	95
BRAKE .....	96
BRAKELINE .....	96

## CONTENTS (CONTINUED)

<b>CURTAIN &amp; CUSHION GROUP .....</b>	<b>97</b>
NOTICE .....	97
CUSHION LAYOUT .....	98
BUCKET SEATS .....	100
COMPONENT PARTS FOR BUCKET SEATS .....	101
122611-02-000 .....	101
LOUNGE CHAIR .....	102
SOFA .....	103
COMPONENT PARTS FOR SOFA .....	104
136534-13-000, 136534-15-000, 136534-28-000, 136534-29-000 .....	104
148226-01-000, 148226-02-000, 148226-03-000 .....	104
136534-07-000, 136534-17-000 .....	104
WINDOW TREATMENT .....	105
HARDWARE .....	107
ACCESSORIES .....	108
FABRICS .....	109
<b>DRIVERS COMPARTMENT GROUP .....</b>	<b>111</b>
DASH .....	111
MOTOR COVER .....	115
BEVERAGE TRAY .....	117
FRONT INTERIOR .....	118
COMPONENT PARTS FOR FRONT INTERIOR .....	121
091990-08-01A .....	121
CABINETS .....	122

# CONTENTS (CONTINUED)

<b>ELECTRICAL GROUP .....</b>	<b>124</b>
110V BODY WIRING .....	124
12V BODY WIRING .....	125
EXTERIOR LAMPS .....	131
FRONT END .....	133
GPS .....	135
FRONT TV/VCR .....	136
SIDE TV/VCR .....	137
<b>COMPONENT PARTS FOR WIRING .....</b>	<b>138</b>
076319-23-000 .....	138
076319-25-000 .....	138
086280-01-000 .....	139
087694-01-000 .....	139
091937-08-000 .....	139
093575-21-01A .....	139
097917-01-06A .....	139
108354-01-01A .....	139
113589-01-000 .....	139
113589-02-000 .....	139
121935-01-01A .....	139
126696-07-000 .....	139
134940-01-01A .....	140
134940-04-01A .....	141
134940-06-01A .....	142
134940-08-01A .....	142
137135-02-000 .....	143
137417-01-01A, 137417-03-01A .....	144
137417-02-01A .....	144
137417-05-01A .....	144
137417-06-01A .....	144
141454-03-01A .....	144
145641-02-000, 145641-04-000 .....	145
145641-03-000 .....	145
148113-01-000, 148113-03-000 .....	145
148158-01-000 .....	145
148230-01-000, 148230-02-000 .....	145
148231-01-000 .....	145
149040-02-000 .....	145
150089-01-000 .....	145
<b>CIRCUIT BREAKERS, FUSES &amp; RELAYS .....</b>	<b>146</b>
<b>CONVERTER, INVERTER, LOAD CENTERS .....</b>	<b>147</b>
<b>BOXES &amp; CORDS .....</b>	<b>148</b>
<b>WIRE ASSEMBLIES .....</b>	<b>148</b>
<b>CONNECTORS &amp; CONDUIT .....</b>	<b>149</b>
<b>CHASSIS .....</b>	<b>150</b>
<b>EXTERIOR BODY GROUP .....</b>	<b>152</b>
GRAPHICS & PAINT .....	152
PANELS & TRIMS .....	154
<b>COMPONENT PARTS FOR PANELS &amp; TRIMS .....</b>	<b>157</b>
106015-18-01A, 106015-19-01A .....	157
132442-01-01A .....	157
FRONT END .....	158
LADDER .....	160
STRUCTURAL COMPONENTS .....	160
AWNINGS .....	161
<b>COMPONENT PARTS FOR AWNINGS .....</b>	<b>162</b>
113874-01-02A .....	162

# CONTENTS (CONTINUED)

<b>EXTERIOR DOORS &amp; COMPARTMENTS GROUP</b> .....	<b>163</b>
DOOR & COMPARTMENT LAYOUT .....	163
COMPONENT PARTS FOR DOOR & COMPARTMENT LAYOUT .....	168
084103-08-000 .....	168
094707-03-01A .....	168
110506-A1-000, 110506-A2-000, 110506-26-000, 110506-27-000 .....	168
142226-02-01A .....	168
143709-01-01A .....	169
COMPARTMENT DOOR PIECE PARTS .....	170
DRIVERS .....	173
COMPONENT PARTS FOR DRIVERS .....	174
125581-09-01A .....	174
ENTRY .....	176
SCREEN .....	177
LATCH - ENTRY .....	178
<b>EXTERIOR SLIDEOUT GROUP</b> .....	<b>179</b>
FRONT LEFT .....	179
COMPONENT PARTS FOR FRONT SLIDEOUT .....	182
148875-01-000, 148875-02-000 .....	182
RIGHT REAR .....	183
COMPONENT PARTS FOR RIGHT REAR SLIDEOUT .....	186
149165-01-000 .....	186
<b>GENERATOR GROUP</b> .....	<b>187</b>
GAS .....	187
<b>HEATING &amp; A/C GROUP</b> .....	<b>188</b>
AUTOMOTIVE .....	188
COMPONENT PARTS FOR AUTOMOTIVE .....	190
103930-44-000 .....	190
103930-45-000 .....	190
103930-46-000 .....	190
103930-47-000 .....	190
103930-49-000 .....	190
103930-55-000 .....	192
FURNACE .....	193
COMPONENT PARTS FOR FURNACE .....	194
143563-01-000 .....	194
143563-02-000 .....	196
REAR HEATER .....	197
ROOF .....	198
COMPONENT PARTS FOR ROOF .....	198
131184-01-01A .....	198
131184-05-01A .....	199
131186-02-01A .....	200
131187-03-01A .....	201
131187-04-01A .....	202
131188-03-01A .....	203
131188-04-01A .....	204
<b>INTERIOR FINISH GROUP</b> .....	<b>205</b>
MOLDINGS & TRIMS .....	205
PANELING & LAMINATES .....	216
INTERIOR TRIM LAYOUT .....	217
COMPONENT PARTS FOR INTERIOR TRIM LAYOUT .....	219
139047-01-01A/02A, 139047-02-01A/02A, 139049-03-01A/02A/03A, 139047-04-02A/03A, 139047-05-01A .....	219
FLOOR COVERINGS .....	220
HARDWARE .....	221
<b>LABELS GROUP</b> .....	<b>228</b>

# CONTENTS (CONTINUED)

<b>LP GROUP</b> .....	<b>233</b>
LP SYSTEM .....	233
COMPONENT PARTS FOR LP SYSTEM .....	233
144116-01-000 .....	233
144116-02-000, 144116-06-000, 144116-07-000 & 144116-08-000 .....	233
<b>SEALANTS &amp; FASTENERS GROUP</b> .....	<b>234</b>
SEALANTS & ADHESIVES .....	234
BOLTS, NUTS AND WASHERS .....	235
SCREWS .....	237
CLAMPS, CLIPS, GROMMETS, RIVETS & PLUGS .....	240
MISCELLANEOUS FASTENERS .....	241
<b>WATER &amp; SEWAGE GROUP</b> .....	<b>243</b>
DRAINAGE SYSTEM .....	243
COMPONENT PARTS FOR DRAINAGE SYSTEM .....	245
140798-01-01A .....	245
WATER SYSTEM .....	246
COMPONENT PARTS FOR WATER SYSTEM .....	254
051393-01-000 .....	254
075240-05-000 .....	254
075241-04-000, 075241-05-000, 075241-06-000 .....	255
098607-01-000 .....	255
103635-01-000 .....	255
125420-01-02A, 125420-01-03A, 125420-03-03A, 125420-04-03A .....	255
129390-03-01A .....	255
144215-01-000 .....	255
144215-02-000 .....	255
144596-01-01A .....	255
144596-02-01A, 144596-03-01A .....	255
145541-01-000 .....	256
145541-02-000 .....	256
<b>WINDOW &amp; VENTS GROUP</b> .....	<b>257</b>
WINDOW & VENT LAYOUT .....	257
COMPONENT PARTS FOR WINDOW & VENT LAYOUT .....	259
098644-04-03A .....	259
098644-13-01A .....	260
098647-33-02A .....	261
098647-47-02A .....	262
112463-03-02A .....	263
113500-06-02A .....	264
113733-10-01A .....	264
122882-01-01A .....	264
122882-02-01A, 122882-03-01A .....	265
123780-03-01A .....	265
125582-01-01A .....	266
125584-01-01A .....	267
125586-01-01A .....	267
150648-04-01A .....	267
150648-07-01A .....	267
150649-07-01A .....	267
150651-01-01A .....	267
150656-02-01A .....	267
151072-01-01A .....	267
<b>WINDSHIELD &amp; WIPER GROUP</b> .....	<b>268</b>
WINDSHIELD .....	268
WIPER .....	269
COMPONENT PARTS FOR WIPER .....	270
149401-01-000 .....	270
149402-01-000, 149402-02-000, 149402-03-000, 149402-04-000 .....	270

**ACCESSORIES GROUP**  
**OPERATORS MANUAL**

<b>KEY</b>	<b>PART NUMBER</b>	<b>U/M</b>	<b>DESCRIPTION</b>
	148451-01-000	DW	TOP LEVEL-F,2005
	129079-01-01A	EA	CASE - VINYL/BLACK-EXPANDABLE ACCORDION SIDES-7"WX9"HX14"L
	129079-04-01A	EA	CASE - VINYL/BLK-EXPANDABLE ACCORDION SIDES-11"WX9"HX14"L
	132000-05-005	EA	MANUAL/OWNER - VOYAGE - 2005

## AUDIO VIDEO GROUP RADIO SYSTEM

KEY	PART NUMBER	U/M	DESCRIPTION
	135420-07-000	EA	MOUNTING KIT - RADIO - A-BODY
	135420-09-000	EA	RADIO-AM/FM/CASS/CD COMBO-AUX/CD CHANGER INPUT-REMOTE COMP FROM: 00-00-00 THRU: 05-02-04
	135420-13-000	EA	RADIO-AM/FM/CASS/CD COMBO-AUX/CD CHANGER INPUT-IR REMOTE FROM: 05-03-04 THRU: 99-99-99
	135420-10-000	EA	REMOTE CONTROL/RADIO (CREDIT CARD SIZE)
	135420-11-000	EA	REMOTE CONTROL/RADIO (STEERING WHEEL MOUNT) FROM: 05-05-04 THRU: 99-99-99
	135420-12-000	EA	REMOTE CONTROL/RADIO(STEERING WHEEL MT W/BUTTON CD CHANGER - <b>CD CHANGER</b> ) FROM: 05-05-04 THRU: 99-99-99
	135420-14-000	EA	RECEIVER - INFRARED FROM: 05-03-04 THRU: 99-99-99
	148134-01-000	EA	CHANGER - COMPACT DISC - SANYO EAX-510

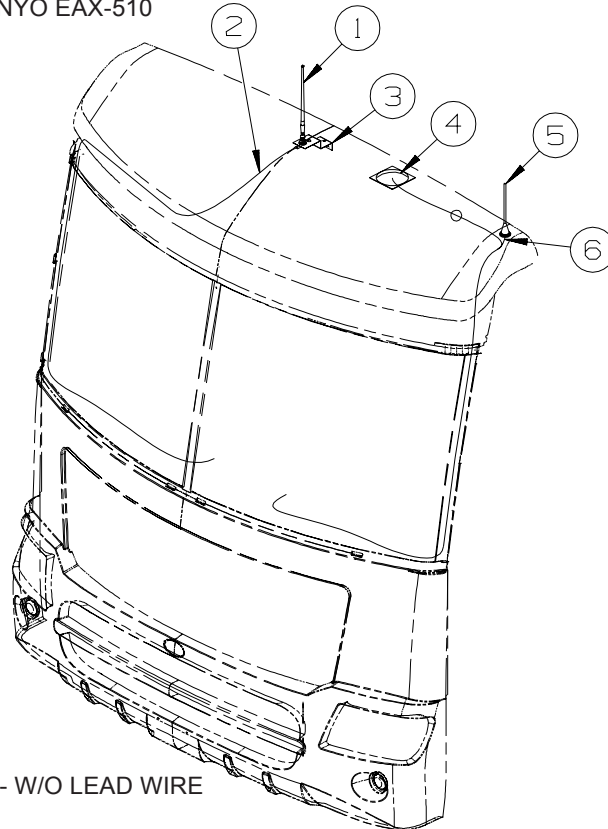

KEY	PART NUMBER	U/M	DESCRIPTION
1	090944-02-000	EA	ANTENNA - RADIO - 16" RUBBER - W/O LEAD WIRE
2	090944-03-000	EA	CABLE - ANTENNA
3	115916-01-01B	EA	BRACKET - ANTENNA MOUNT
4	147190-01-000	EA	ANTENNA/SATELLITE-RADIO/SIRIUS-W/GRD PLANE PLATE/6" LEAD FROM: 00-00-00 THRU: 09-03-04
4	152780-01-000	EA	ANTENNA/SATELLITE - RADIO/SIRIUS FROM: 09-04-04 THRU: 99-99-99
5	123256-01-000	EA	ANTENNA - CB - W/O CABLE
6	123256-02-000	EA	CABLE - CB - COAX

### REAR MONITOR

KEY	PART NUMBER	U/M	DESCRIPTION
	144677-06-000	EA	MONITOR/BLACK & WHITE - 7" - 3 PIN/MECH CONTROLS - RESIZED
	143363-01-000	EA	MONITOR/REAR - COLOR - W/BRACKET - SONY VCB-MH1 - <b>GPS NAVIGATION SYS</b>
	136514-02-000	EA	CABLE - MONITOR/CAMERA
	143363-03-000	EA	CABLE - MONITOR/CAMERA - COLOR - SONY VCB-MHC20 - <b>GPS NAVIGATION SYS</b>
	144677-04-000	EA	CAMERA - REAR VIEW W/BRACKET - BLACK & WHITE - VBBS150
	143363-05-000	EA	CAMERA - REAR - COLOR W/BRACKET - SONY VCB-MH3 - <b>GPS NAVIGATION SYS</b>
	137919-03-01A	EA	SHROUD - CAMERA/OUTER - BRIGHT WHITE
	137919-02-01A	EA	SHROUD - CAMERA - OUTER - BRIGHT WHITE - <b>GPS NAVIGATION SYS</b>
	098819-01-000	EA	SPEAKER - 4" - 2 WATT - 8 OHM
	093214-01-03A	EA	GRILLE - SPEAKER - 4" - GLACIER

**SEE 12V BODY WIRING IN THE ELECTRICAL GROUP FOR LOCATION OF OTHER  
AUDIO VIDEO COMPONENTS**



# CABINET & APPLIANCE GROUP

## CABINET & APPLIANCE LAYOUT

### APPLIANCES

KEY	PART NUMBER	U/M	DESCRIPTION
	126022-05-01A	EA	COVER/RANGE - BI-FOLD - 22" - NEW GRATES
*	126022-01-01A	EA	COVER - RANGE/BI-FOLD - 16" & 22" - BLACK TEXTURED - 38J, 35A
	130816-06-03A	EA	COUNTERTOP/STOVE LID - 1/4" VENDURA - ALMONDINE - 38J, 35A
	149094-02-02A	EA	COVER/STOVE TOP - 1/2" VENDURA - ALMONDINE - 38J
	149094-04-02A	EA	COVER/STOVE TOP - 1/4" VENDURA - ALMONDINE - 35A
			FROM: 00-00-00 THRU: 10-19-04
	149094-05-02A	EA	COVER/STOVE TOP - 1/4" VENDURA - ALMONDINE - 35A
			FROM: 10-20-04 THRU: 99-99-99
*	114030-04-01A	EA	RANGE - 3 BRNR TOP/NEW STYLE KNOBS/GRATES-W/O OVEN-BLK - RANGE TOP, 31W,33V,35D,36M
*	135065-03-01A	EA	RANGE - 3 BURNER (SEALED) - W/O OVEN-NEW STYLE KNOBS-BLACK GLASS - RANGE TOP, 38J, 35A
*	135065-04-01A	EA	RANGE - 3 BURNER (SEALED) - W/O OVEN - CSA - BLACK TOP - RANGE TOP/CANADIAN, 38J, 35A
*	144972-01-01A	EA	RANGE - 22" - 3 BURNER/LARGE KNOB/GRATES - BLACK - RANGE W/OVEN
			FROM: 00-00-00 THRU: 05-13-04
*	151277-03-01A	EA	RANGE-22"-3 BURNER - MERCURY FREE - BLK DOOR/TEXTURED - RANGE W/OVEN
			FROM: 05-14-04 THRU: 99-99-99
*	135066-03-01A	EA	RANGE - 3 BURNER W/OVEN - 22" BLACK GLASS DOOR - RANGE W/OVEN, 38J
			FROM: 00-00-00 THRU: 06-14-04
*	151279-02-01A	EA	RANGE-22"-3 BURNER/SEALED-MERCURY FREE-BLK DOOR/GLASS - RANGE W/OVEN, 38J, 35A
			FROM: 06-15-04 THRU: 99-99-99
*	150778-01-01A	EA	RANGE - 3 BURNER (SEALED) - W/OVEN - BLACK - CSA - RANGE W/OVEN/CANADIAN , 38J
			FROM: 00-00-00 THRU: 06-06-04
*	151279-03-01A	EA	RANGE-3 BRNR/SEALED-MERCURY FREE-BLK DR/GLASS-CSA - RANGE W/OVEN/CANADIAN, 38J, 35A
			FROM: 06-07-04 THRU: 99-99-99
	142139-17-02B	EA	BRACKET/TIEDOWN - STOVE - E-COATED - RANGE TOP, 31W
	142139-18-02B	EA	BRACKET/TIEDOWN - STOVE - E-COATED - RANGE TOP, 31W
	142139-03-02B	EA	BRACKET/TIEDOWN - STOVE - E-COATED - RANGE TOP, 33V, 35D, 36M
	142139-04-02B	EA	BRACKET/TIEDOWN - STOVE - E-COATED - RANGE TOP, 33V, 35D, 36M
	106936-42-04B	EA	BRACKET - STOVE TIEDOWN/FRONT - BLACK - RANGE TOP, 38J
	106936-22-04B	EA	BRACKET - STOVE TIEDOWN/REAR - BLACK - RANGE TOP, 38J
	106936-45-04B	EA	BRACKET - TIEDOWN - RANGE/FRONT - BLACK - RANGE TOP, 35A
	106936-46-04B	EA	BRACKET - TIEDOWN - RANGE/REAR - BLACK - RANGE TOP, 35A
	140176-03-02B	EA	BRACKET/STOVE TIEDOWN - E-COATED - RANGE W/OVEN
	140176-04-02B	EA	BRACKET/STOVE TIEDOWN - E-COATED - RANGE W/OVEN
	136382-12-04B	EA	BRACKET/TIEDOWN - OVEN - FRONT - BLACK - RANGE W/OVEN, 38J
	136382-02-04B	EA	BRACKET - TIEDOWN/OVEN - REAR - BLACK - RANGE W/OVEN, 38J
	136382-17-04B	EA	BRACKET - TIEDOWN - OVEN/FRONT - BLACK - RANGE W/OVEN, 35A
	136382-18-04B	EA	BRACKET - TIEDOWN - OVEN/REAR - BLACK - RANGE W/OVEN, 35A

\*COMPONENT PARTS LISTED LATER IN THIS GROUP

**CABINET & APPLIANCE GROUP (CONTINUED)**  
**CABINET & APPLIANCE LAYOUT (CONTINUED)**

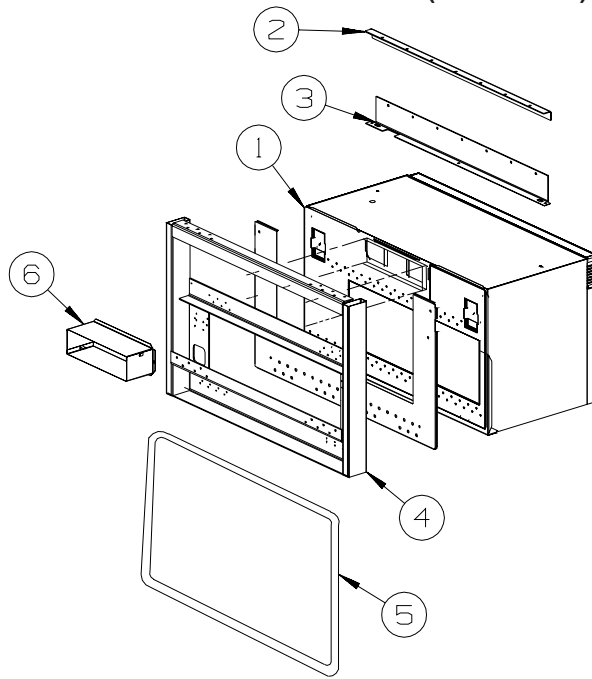

**APPLIANCES (CONTINUED)**

**33V**

<b>KEY</b>	<b>PART NUMBER</b>	<b>U/M</b>	<b>DESCRIPTION</b>
1*	119267-12-01A	EA	OVEN - MICROWAVE W/HOOD US - #R-1875 - CONVECTION/U.S.
1*	119267-13-01A	EA	OVEN - MICROWAVE W/HOOD CSA - #R-1875A - CONVECTION/CANADIAN
1*	119267-15-01A	EA	OVEN - MICROWAVE/NON/CONVECTION W/HOOD US - OVEN W/FAN
	119267-14-000	EA	VENT - KIT - F/1510 - OVEN W/FAN
2	NOT USED		
3	NOT USED		
4	NOT USED		
5	NOT USED		
6	NOT USED		

**31W, 35A, 35D, 36M & 38J**

<b>KEY</b>	<b>PART NUMBER</b>	<b>U/M</b>	<b>DESCRIPTION</b>
1*	119267-12-01A	EA	OVEN - MICROWAVE W/HOOD US - #R-1875 - CONVECTION/U.S.
1*	119267-13-01A	EA	OVEN - MICROWAVE W/HOOD CSA - #R-1875A - CONVECTION/CANADIAN
1*	119267-15-01A	EA	OVEN - MICROWAVE/NON/CONVECTION W/HOOD US - OVEN W/FAN
	119267-14-000	EA	VENT - KIT - F/1510 - OVEN W/FAN
2	129836-02-02B	EA	ANGLE - W/HOLES - .7" X 1" X 28.3" - E-COATED - LH
3	129836-07-02B	EA	ANGLE - W/HOLES - E-COATED
4	137824-06-02B	EA	BRACKET - MICROWAVE - E-COATED
5	NOT USED		
6	140093-06-02B	EA	DUCT - E-COATED

**\*COMPONENT PARTS LISTED LATER IN THIS GROUP**

**CABINET & APPLIANCE GROUP (CONTINUED)**  
**CABINET & APPLIANCE LAYOUT (CONTINUED)**

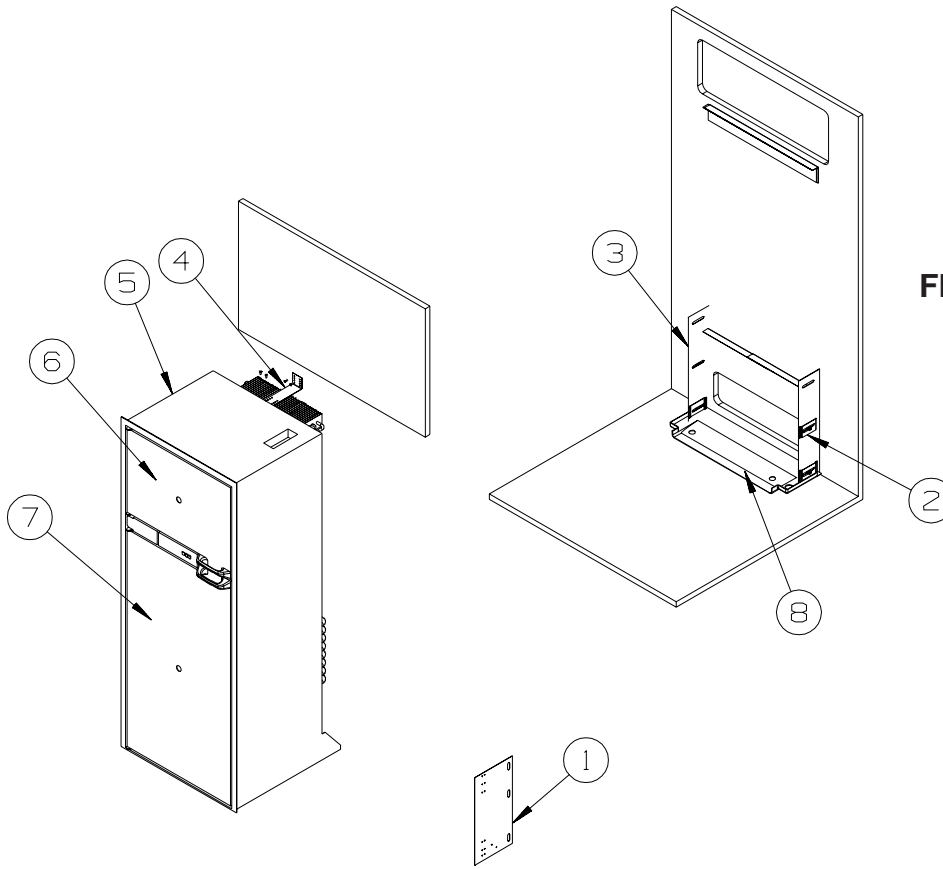

**FROM: 00-00-00 THRU: 08-17-04**

**APPLIANCES (CONTINUED)**

KEY	PART NUMBER	U/M	DESCRIPTION
1	141975-04-02B	EA	PLATE - TIEDOWN/REFRIGERATOR
2	141550-01-02B	EA	BRACKET - TIEDOWN/REFRIGERATOR - RIGHT HAND
3	141550-02-02B	EA	BRACKET - TIEDOWN/REFRIGERATOR - LEFT HAND
4	145445-02-02B	EA	STRAP - REFRIGERATOR
5*	120075-12-01A	EA	REFRIGERATOR - LARGE DOUBLE DOOR/RH - 2-WAY - HANDLE FROM: 00-00-00 THRU: 04-25-04
5*	121569-05-01A	EA	REFRIGERATOR-LARGE DBL DOOR/2 WAY/NON-FLUSH HANDLE-BLK RH FROM: 04-26-04 THRU: 99-99-99
5*	120075-13-01A	EA	REFRIGERATOR-LARGE DOUBLE DOOR/RH - 2-WAY -ICE MAKER-BLACK - <b>W/ICE MAKER</b>
6	P34457-03-N47	EA	PANEL - INSERT RAISED MEMBRANE - 21.5" X 14.5" - PORTSMOUTH OAK
6	P34457-03-L85	EA	PANEL - INSERT RAISED MEMBRANE - 21.5" X 14.5" - CONCERT CHERRY
6	P34457-03-L94	EA	PANEL - INSERT RAISED MEMBRANE - 21.5" X 14.5" - WASHED MAPLE
6	P34457-03-SA3	EA	PANEL - INSERT RAISED MEMBRANE - 21.5" X 14.5" - SIERRA MAPLE
7	P34457-04-N47	EA	PANEL - INSERT RAISED MEMBRANE - 21.5" X 38.5" - PORTSMOUTH OAK
7	P34457-04-L85	EA	PANEL - INSERT RAISED MEMBRANE - 21.5" X 38.5" - CONCERT CHERRY
7	P34457-04-L94	EA	PANEL - INSERT RAISED MEMBRANE - 21.5" X 38.5" - WASHED MAPLE
7	P34457-04-SA3	EA	PANEL - INSERT RAISED MEMBRANE - 21.5" X 38.5" - SIERRA MAPLE
8	112176-01-000	FT	TUBING - VINYL - REINFORCED - 1/2" ID
	116751-05-01A	EA	TRAY - REFRIGERATOR - BLACK
	116751-02-01A	EA	TRAY - REFRIGERATOR - BLACK - <b>F36M ONLY</b>
	090329-01-000	FT	SEAL/T - REFRIGERATOR CABINET
	054450-01-000	EA	LEVEL - REFRIGERATOR

**\*COMPONENT PARTS LISTED LATER IN THIS GROUP**

**CABINET & APPLIANCE GROUP (CONTINUED)**  
**CABINET & APPLIANCE LAYOUT (CONTINUED)**

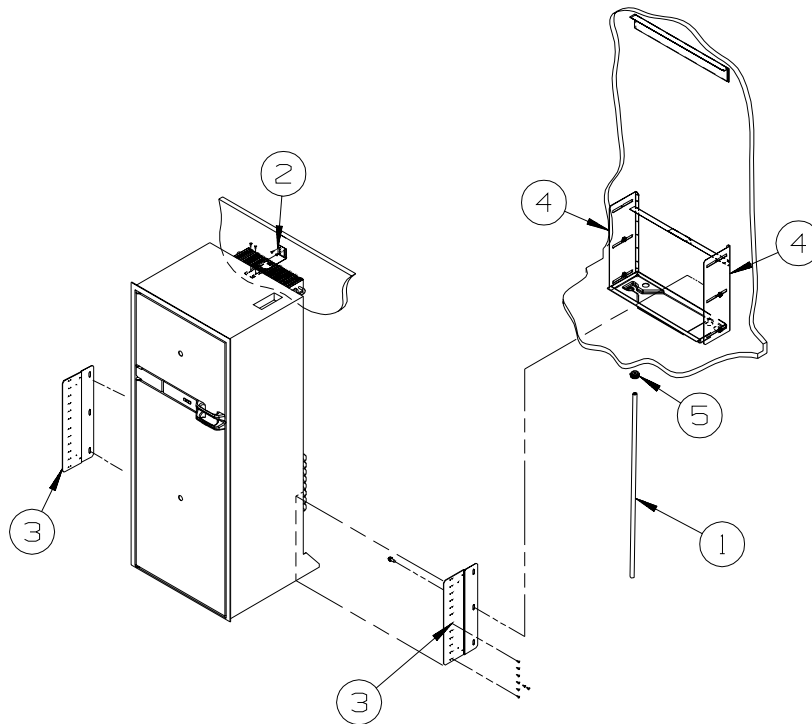

**FROM: 08-18-04 THRU: 99-99-99**

**APPLIANCES (CONTINUED)**

KEY	PART NUMBER	U/M	DESCRIPTION
1	112176-01-000	FT	TUBING - VINYL - REINFORCED - 1/2" ID
2	145445-02-02B	EA	STRAP - REFRIGERATOR - E-COATED
3	150740-01-02B	EA	BRACKET - REFRIGERATOR - E-COATED
4	150740-02-02B	EA	BRACKET - REFRIGERATOR - E-COATED
5	152417-01-01A	EA	CLAMP/RATCHET - F/REFRIDGERATOR DRIP TRAY HOSE - BLACK
*	121569-05-01A	EA	REFRIGERATOR-LARGE DBL DOOR/2 WAY/NON-FLUSH HANDLE-BLK RH FROM: 04-26-04 THRU: 99-99-99
*	121569-06-01A	EA	REFRIGERATOR - LARGE DBL DOOR/2 WAY - BLACK - <b>F35A ONLY</b>
*	120075-13-01A	EA	REFRIGERATOR-LARGE DOUBLE DOOR/RH - 2-WAY -ICE MAKER-BLACK - <b>W/ICE MAKER</b>
*	120075-23-01A	EA	REFRIGERATOR-LGE DBL DR-2-WAY/LH/ICE MAKER/FLUSH HDL-BLACK - <b>F35A ONLY</b>
	P34457-03-N47	EA	PANEL - INSERT RAISED MEMBRANE - 21.5" X 14.5" - PORTSMOUTH OAK
	P34457-03-L85	EA	PANEL - INSERT RAISED MEMBRANE - 21.5" X 14.5" - CONCERT CHERRY
	P34457-03-L94	EA	PANEL - INSERT RAISED MEMBRANE - 21.5" X 14.5" - WASHED MAPLE
	P34457-03-SA3	EA	PANEL - INSERT RAISED MEMBRANE - 21.5" X 14.5" - SIERRA MAPLE
	P34457-04-N47	EA	PANEL - INSERT RAISED MEMBRANE - 21.5" X 38.5" - PORTSMOUTH OAK
	P34457-04-L85	EA	PANEL - INSERT RAISED MEMBRANE - 21.5" X 38.5" - CONCERT CHERRY
	P34457-04-L94	EA	PANEL - INSERT RAISED MEMBRANE - 21.5" X 38.5" - WASHED MAPLE
	P34457-04-SA3	EA	PANEL - INSERT RAISED MEMBRANE - 21.5" X 38.5" - SIERRA MAPLE
	116751-05-01A	EA	TRAY - REFRIGERATOR - BLACK
	116751-02-01A	EA	TRAY - REFRIGERATOR - BLACK - <b>F36M ONLY</b>
	090329-01-000	FT	SEAL/T - REFRIGERATOR CABINET
	054450-01-000	EA	LEVEL - REFRIGERATOR

**\*COMPONENT PARTS LISTED LATER IN THIS GROUP**

**CABINET & APPLIANCE GROUP (CONTINUED)**  
**CABINET & APPLIANCE LAYOUT (CONTINUED)**

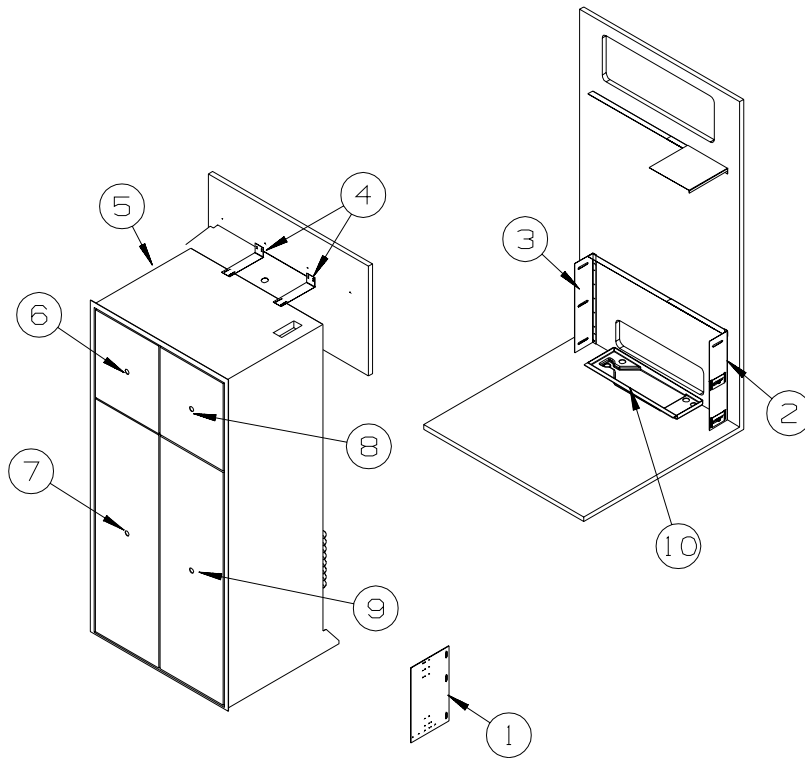

**FROM: 00-00-00 THRU: 08-17-04**

**APPLIANCES (CONTINUED)**

KEY	PART NUMBER	U/M	DESCRIPTION
1	141975-01-02B	EA	PLATE - TIEDOWN/REFRIGERATOR
2	141550-01-02B	EA	BRACKET - TIEDOWN/REFRIGERATOR - RIGHT HAND
3	141550-02-02B	EA	BRACKET - TIEDOWN/REFRIGERATOR - LEFT HAND
4	145445-02-02B	EA	STRAP - REFRIGERATOR
5*	125242-02-01A	EA	REFRIGERATOR-4 DR-W/ICE MKR-W/CONTOURED HANDLE-NORCOLD1201
6	P34457-01-N75	EA	PANEL - INSERT RAISED MEMBRANE - 16.1" X 18.3" - PORTSMOUTH OAK
6	P34457-01-LQ1	EA	PANEL - INSERT RAISED MEMBRANE - 16.1" X 18.3" - CONCERT CHERRY
6	P34457-01-L94	EA	PANEL - INSERT RAISED MEMBRANE - 16.1" X 18.3" - WASHED MAPLE
6	P34457-01-SA3	EA	PANEL - INSERT RAISED MEMBRANE - 16.1" X 18.3" - SIERRA MAPLE
7	P34457-02-N75	EA	PANEL - INSERT RAISED MEMBRANE - 16.1" X 41.1" - PORTSMOUTH OAK
7	P34457-02-LQ1	EA	PANEL - INSERT RAISED MEMBRANE - 16.1" X 41.1" - CONCERT CHERRY
7	P34457-02-L94	EA	PANEL - INSERT RAISED MEMBRANE - 16.1" X 41.1" - WASHED MAPLE
7	P34457-02-SA3	EA	PANEL - INSERT RAISED MEMBRANE - 16.1" X 41.1" - SIERRA MAPLE
8	P34457-01-N75	EA	PANEL - INSERT RAISED MEMBRANE - 16.1" X 18.3" - PORTSMOUTH OAK
8	P34457-01-LQ1	EA	PANEL - INSERT RAISED MEMBRANE - 16.1" X 18.3" - CONCERT CHERRY
8	P34457-01-L94	EA	PANEL - INSERT RAISED MEMBRANE - 16.1" X 18.3" - WASHED MAPLE
8	P34457-01-SA3	EA	PANEL - INSERT RAISED MEMBRANE - 16.1" X 18.3" - SIERRA MAPLE
9	P34457-02-N75	EA	PANEL - INSERT RAISED MEMBRANE - 16.1" X 41.1" - PORTSMOUTH OAK
9	P34457-02-LQ1	EA	PANEL - INSERT RAISED MEMBRANE - 16.1" X 41.1" - CONCERT CHERRY
9	P34457-02-L94	EA	PANEL - INSERT RAISED MEMBRANE - 16.1" X 41.1" - WASHED MAPLE
9	P34457-02-SA3	EA	PANEL - INSERT RAISED MEMBRANE - 16.1" X 41.1" - SIERRA MAPLE
10	112176-01-000	FT	TUBING - VINYL - REINFORCED - 1/2" ID
	090329-01-000	FT	SEAL/T - REFRIGERATOR CABINET
	054450-01-000	EA	LEVEL - REFRIGERATOR
	118871-02-01A	EA	TRAY - REFRIGERATOR - SIDE/SIDE - BLACK - 34.4" LONG - 38J
	118871-03-01A	EA	TRAY - REFRIGERATOR - SIDE/SIDE - BLACK - 34.4" LONG - 35D, 36M

**\*COMPONENT PARTS LISTED LATER IN THIS GROUP**

**CABINET & APPLIANCE GROUP (CONTINUED)**  
**CABINET & APPLIANCE LAYOUT (CONTINUED)**

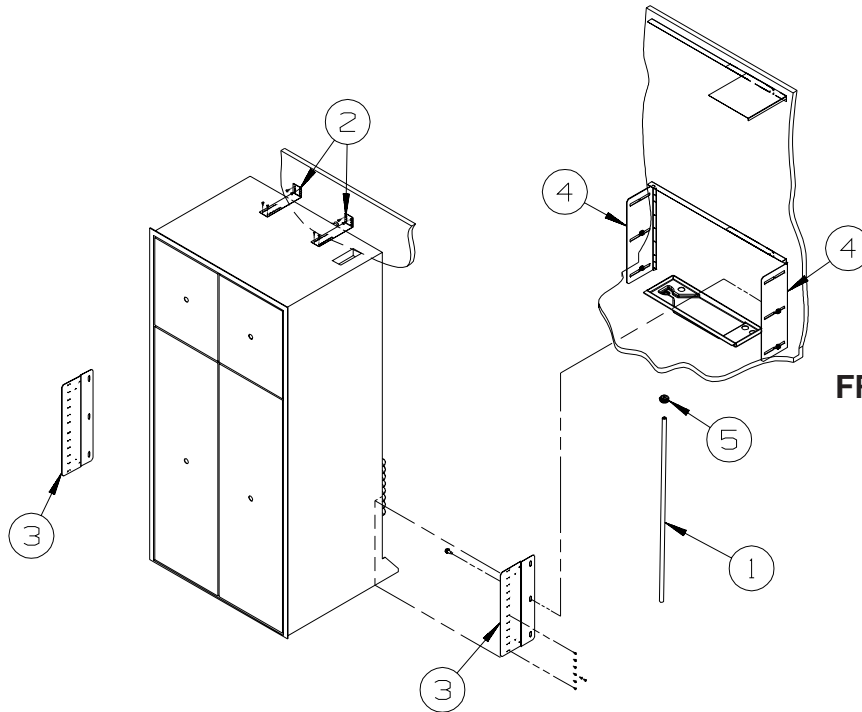

**FROM: 08-18-04 THRU: 99-99-99**

**APPLIANCES (CONTINUED)**

KEY	PART NUMBER	U/M	DESCRIPTION
1	112176-01-000	FT	TUBING - VINYL - REINFORCED - 1/2" ID
2	145445-02-02B	EA	STRAP - REFRIGERATOR - E-COATED
3	150740-01-02B	EA	BRACKET - REFRIGERATOR - E-COATED
4	150740-02-02B	EA	BRACKET - REFRIGERATOR - E-COATED
5	152417-01-01A	EA	CLAMP/RATCHET - F/REFRIDGERATOR DRIP TRAY HOSE - BLACK
*	125242-02-01A	EA	REFRIGERATOR-4 DR-W/ICE MKR-W/CONTOURED HANDLE-NORCOLD1201
	P34457-01-N75	EA	PANEL - INSERT RAISED MEMBRANE - 16.1" X 18.3" - PORTSMOUTH OAK
	P34457-01-LQ1	EA	PANEL - INSERT RAISED MEMBRANE - 16.1" X 18.3" - CONCERT CHERRY
	P34457-01-L94	EA	PANEL - INSERT RAISED MEMBRANE - 16.1" X 18.3" - WASHED MAPLE
	P34457-01-SA3	EA	PANEL - INSERT RAISED MEMBRANE - 16.1" X 18.3" - SIERRA MAPLE
	P34457-02-N75	EA	PANEL - INSERT RAISED MEMBRANE - 16.1" X 41.1" - PORTSMOUTH OAK
	P34457-02-LQ1	EA	PANEL - INSERT RAISED MEMBRANE - 16.1" X 41.1" - CONCERT CHERRY
	P34457-02-L94	EA	PANEL - INSERT RAISED MEMBRANE - 16.1" X 41.1" - WASHED MAPLE
	P34457-02-SA3	EA	PANEL - INSERT RAISED MEMBRANE - 16.1" X 41.1" - SIERRA MAPLE
	090329-01-000	FT	SEAL/T - REFRIGERATOR CABINET
	054450-01-000	EA	LEVEL - REFRIGERATOR
	118871-02-01A	EA	TRAY - REFRIGERATOR - SIDE/SIDE - BLACK - 34.4" LONG - 38J, 35A
	118871-03-01A	EA	TRAY - REFRIGERATOR - SIDE/SIDE - BLACK - 34.4" LONG - 35D, 36M

**\*COMPONENT PARTS LISTED LATER IN THIS GROUP**

**CABINET & APPLIANCE GROUP (CONTINUED)**  
**CABINET & APPLIANCE LAYOUT (CONTINUED)**

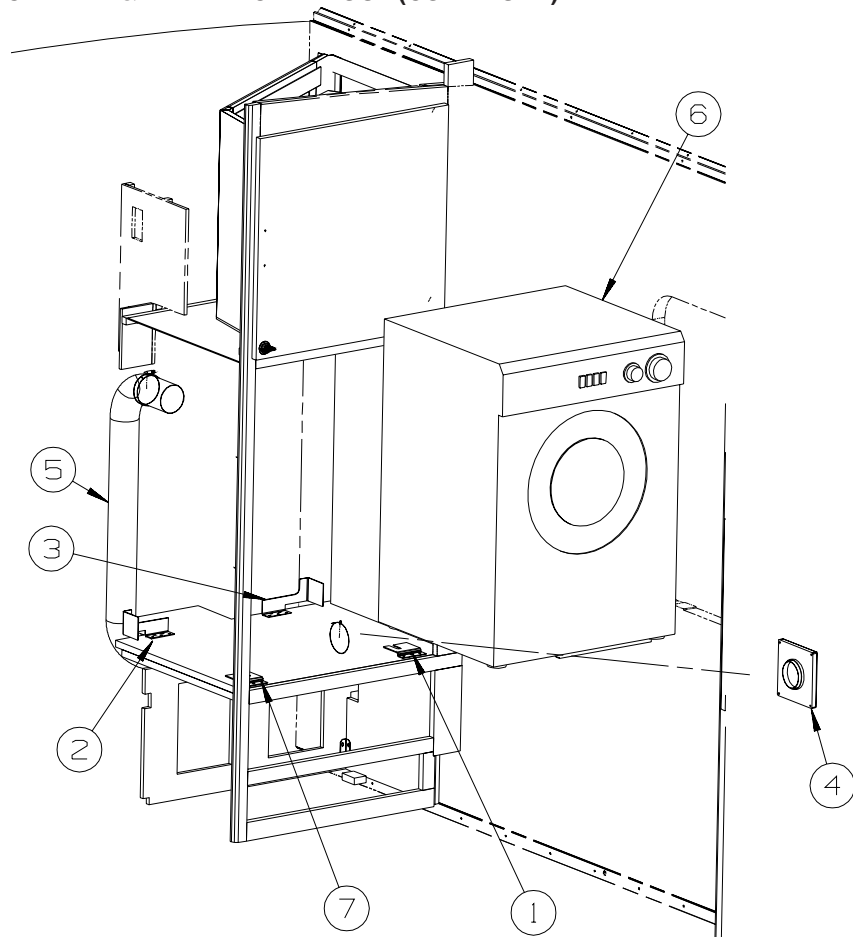

**F35D**

**APPLIANCES (CONTINUED)**

KEY	PART NUMBER	U/M	DESCRIPTION
1	111913-02-04B	EA	BRACKET/WASHER - TIE DOWN - BLACK
2	113795-03-02B	EA	BRACKET - WASHER - E-COATED
3	113795-04-02B	EA	BRACKET - WASHER - E-COATED
4	146292-01-01A	EA	COVER - DRYER VENT - BRIGHT WHITE
4	146292-02-01A	EA	DRYER VENT - INNER - BRIGHT WHITE
5	116653-02-000	FT	DUCT - FLEXIBLE - 3' COMPRESSED/8' EXTENDED
6	107753-04-01A	EA	WASHER - DRYER - VENTED - UL/CSA - WHITE
			FROM: 00-00-00 THRU: 11-21-04
6	107753-05-01A	EA	WASHER - DRYER - VENTED - UL/CSA - WHITE
			FROM: 11-22-04 THRU: 99-99-99
7	111913-03-04B	EA	BRACKET/WASHER - TIE DOWN - BLACK
	141523-01-01A	EA	LABEL - WASHER/DRYER BRACKETS - BLACK/WHITE

**CABINET & APPLIANCE GROUP (CONTINUED)**  
**CABINET & APPLIANCE LAYOUT (CONTINUED)**

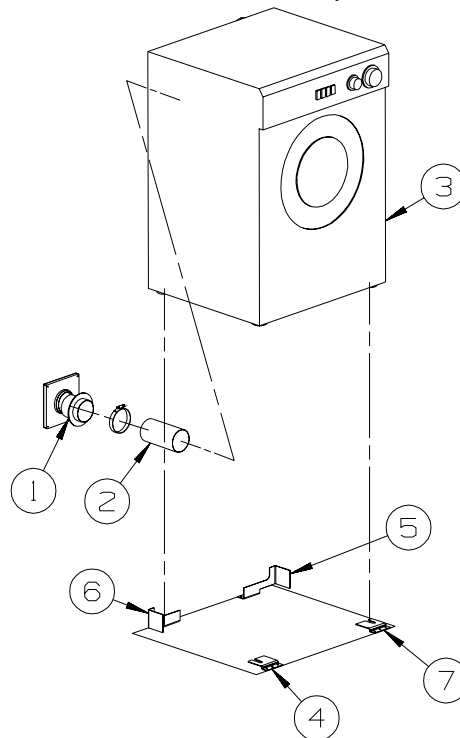

**APPLIANCES (CONTINUED)**

**F38J, F35A**

KEY	PART NUMBER	U/M	DESCRIPTION
1	146292-01-01A	EA	VENT - DRYER - 3" - BRIGHT WHITE
1	146292-01-02A	EA	VENT - DRYER - 3" - BLACK
1	146292-02-01A	EA	DRYER VENT - INNER - BRIGHT WHITE
1	146292-02-02A	EA	DRYER VENT - INNER - BLACK
2	116653-02-000	FT	DUCT - FLEXIBLE - 3' COMPRESSED/8' EXTENDED
3	107753-04-01A	EA	WASHER - DRYER - VENTED - UL/CSA - WHITE
			FROM: 00-00-00 THRU: 11-21-04
3	107753-05-01A	EA	WASHER - DRYER - VENTED - UL/CSA - WHITE
			FROM: 11-22-04 THRU: 99-99-99
4	111913-02-04B	EA	BRACKET/WASHER - TIE DOWN - BLACK
5	113795-03-02B	EA	BRACKET - WASHER - E-COATED
			FROM: 00-00-00 THRU: 11-21-04
5	113795-01-02B	EA	BRACKET - WASHER - E-COATED
			FROM: 11-22-04 THRU: 99-99-99
6	113795-04-02B	EA	BRACKET - WASHER - E-COATED
			FROM: 00-00-00 THRU: 11-21-04
6	113795-02-02B	EA	BRACKET - WASHER - E-COATED
			FROM: 11-22-04 THRU: 99-99-99
7	111913-03-04B	EA	BRACKET/WASHER - TIE DOWN - BLACK
	141523-01-01A	EA	LABEL - WASHER/DRYER BRACKETS - BLACK/WHITE

**F36M**

KEY	PART NUMBER	U/M	DESCRIPTION
1	146292-01-01A	EA	VENT - DRYER - 3" - BRIGHT WHITE
1	146292-01-02A	EA	VENT - DRYER - 3" - BLACK
1	146292-02-01A	EA	DRYER VENT - INNER - BRIGHT WHITE
1	146292-02-02A	EA	DRYER VENT - INNER - BLACK
2	116653-02-000	FT	DUCT - FLEXIBLE - 3' COMPRESSED/8' EXTENDED
3	107753-04-01A	EA	WASHER - DRYER - VENTED - UL/CSA - WHITE
			FROM: 00-00-00 THRU: 11-21-04
3	107753-05-01A	EA	WASHER - DRYER - VENTED - UL/CSA - WHITE
			FROM: 11-22-04 THRU: 99-99-99
4	111913-03-04B	EA	BRACKET/WASHER - TIE DOWN - BLACK
5	113795-03-02B	EA	BRACKET - WASHER - E-COATED
6	113795-04-02B	EA	BRACKET - WASHER - E-COATED
7	111913-02-04B	EA	BRACKET/WASHER - TIE DOWN - BLACK



**CABINET & APPLIANCE GROUP (CONTINUED)**  
**COMPONENT PARTS FOR APPLIANCES**

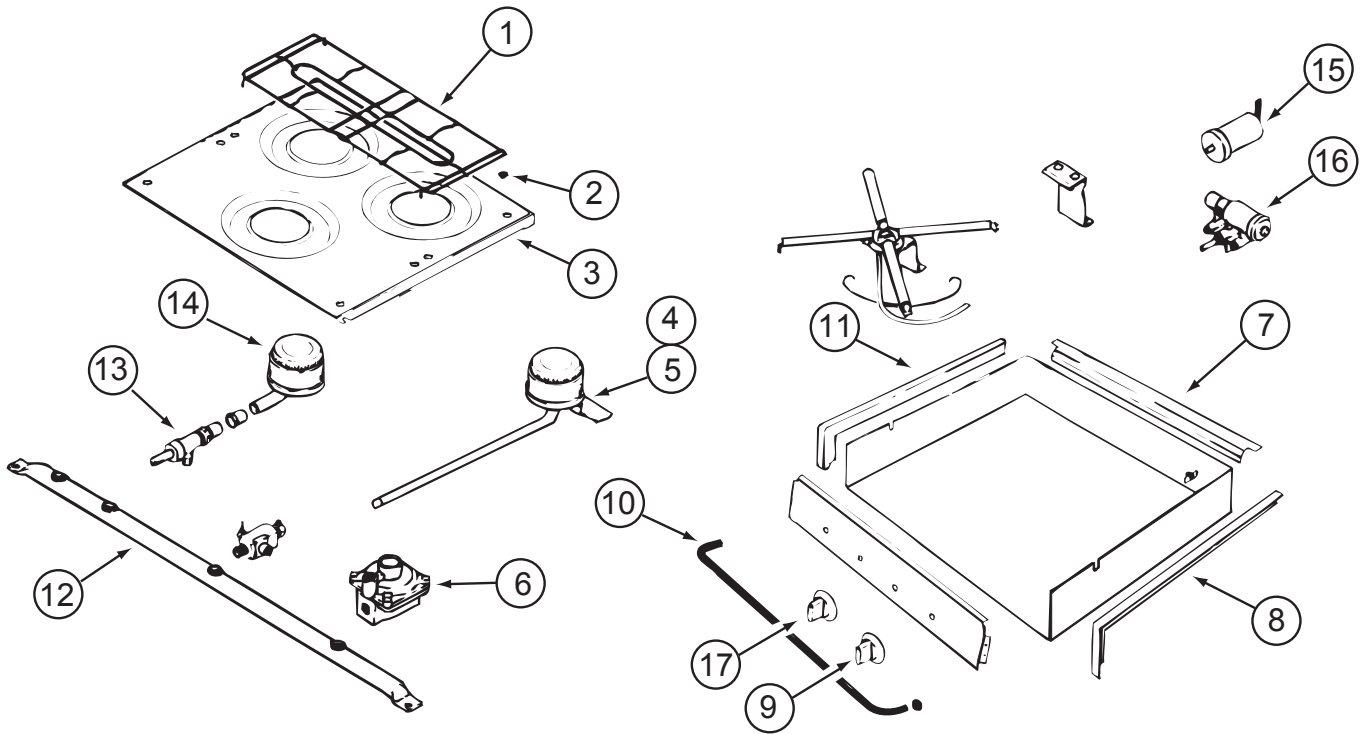

114030-02-01A, 114030-03-01A

KEY	PART NUMBER	U/M	DESCRIPTION	VENDOR NO.
1	126023-01-703	EA	GRATE - TOP	74003358
2	102020-01-709	EA	BUMPER - GRATE	8007-P020-60
3	126023-01-706	EA	TOP - MAIN (WHITE)	74003322
3	126023-01-707	EA	TOP - MAIN (BLACK)	74003323
3	126023-01-708	EA	TOP - MAIN (ALMOND)	74003324
4	126023-01-700	EA	BURNER - TOP (RT-REAR)	7505P195-60
5	126023-01-701	EA	BURNER - TOP (LT-REAR)	7505P196-60
6	102020-01-729	EA	REGULATOR - PRESSURE	7510P043-60
7	114030-01-706	EA	TRIM - REAR/BLACK TEXTURED	74002841
8	114030-01-704	EA	TRIM - RIGHT/BLACK TEXTURED	74002839
9	126023-01-720	EA	KNOB - IGNITER	74002414
10	114030-02-700	EA	GUARD/FABRIC - TOWEL BAR	3609F006-70
11	114030-01-705	EA	TRIM - LEFT/BLACK TEXTURED	74002840
12	126023-01-705	EA	PIPE - MANIFOLD	7513P161-60
13	126023-01-709	EA	VALVE - BURNER (REAR)	74003348
13	126023-01-710	EA	VALVE - BURNER (FRONT)	74003349
14	126023-01-702	EA	BURNER - TOP (FRONT)	7505P144-60
15	126023-01-711	EA	ELECTRODE - IGNITER	7432P077-60
16	126023-01-719	EA	IGNITER - TOP BURNER	74002413
17	112881-01-705	EA	KNOB - TOP BURNER	733P072-60
17	112881-01-718	EA	KNOB - TOP BURNER HI-OUTPUT	74001794
	126023-01-735	EA	KIT-IGNITOR TOP BRNER & KNOB	12001296=74002413&
	128728-01-703	EA	T-NUT - F/HINGE	7103P109-60

**CABINET & APPLIANCE GROUP (CONTINUED)**  
**COMPONENT PARTS FOR APPLIANCES (CONTINUED)**

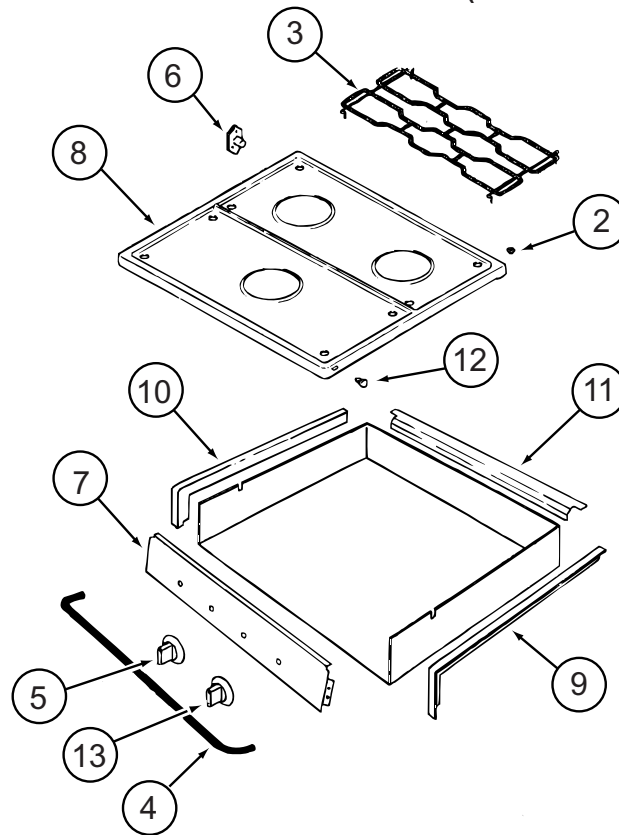

114030-04-01A

KEY	PART NUMBER	U/M	DESCRIPTION	VENDOR NO.
2	102020-01-709	EA	BUMPER-GRATE	8007P020-60
3	112881-04-702	EA	GRATE - BLACK	74007277
4	114030-02-700	EA	GUARD/FABRIC - TOWEL BAR	3609F006-70
5	128728-01-701	EA	KNOB - BURNER - REAR	74003941 (1 PER)
5	128728-01-702	EA	KNOB - BURNER - FRONT	74003942 (2 PER)
6	128728-01-703	EA	PIN/T-NUT F/HINGE	7103P109-60
7	114030-04-700	EA	PANEL - MANIFOLD - BLACK	74007325
8	126023-01-728	EA	TOP - MAIN (BLACK)	74003323
9	114030-01-704	EA	TRIM - RIGHT/BLACK TEXTURED	74002839
10	114030-01-705	EA	TRIM - LEFT/BLACK TEXTURED	74002840
11	114030-01-706	EA	TRIM - REAR/BLACK TEXTURED	74002841
12	102020-01-724	EA	BUMPER - MAIN TOP	8003P008-60
13	128728-01-707	EA	KNOB - IGNITER	74003944

CONTACT WINNEBAGO PART SALES FOR UNLISTED COMPONENT(S)

**CABINET & APPLIANCE GROUP (CONTINUED)**  
**COMPONENT PARTS FOR APPLIANCES (CONTINUED)**

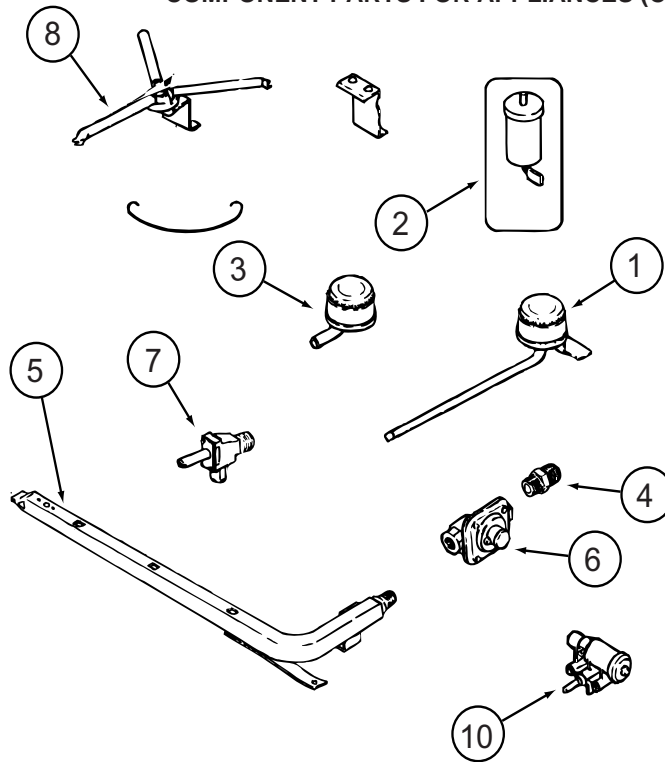

**114030-04-01A (CONTINUED)**

KEY	PART NUMBER	U/M	DESCRIPTION	VENDOR NO.
1	112881-04-700	EA	BURNER - TOP /LEFT - REAR	74004584
1	126023-01-700	EA	BURNER - TOP (RT-REAR) 5100 BTU	74004583
2	112881-04-705	EA	PUSH RING (ELECTRODE MTG)	7104P002-60
2	126023-01-711	EA	ELECTRODE - IGNITER (ONLY)	7432P077-60
3	112881-04-701	EA	BURNER - TOP/FRONT	74004582
4	135065-03-700	EA	FITTING - HALF UNION	74004234
5	126023-01-702	EA	PIPE/MANIFOLD	74004642
6	126023-02-702	EA	PIPE - MANIFOLD	74004360
7	126023-02-705	EA	VALVE - BURNER - REAR	74004362
7	126023-02-706	EA	VALVE - BURNER - FRONT	74004363
8	126023-01-736	EA	FLASH TUBE EXTENSION (REAR)	74003326
8	126023-01-737	EA	FLASH TUBE EXTENSION (FRONT)	74003327
10	126023-01-719	EA	IGNITER HEAD - TOP BURNER	74002413

CONTACT WINNEBAGO PART SALES FOR UNLISTED COMPONENT(S)

**119267-10-01A**

KEY	PART NUMBER	U/M	DESCRIPTION	VENDOR NO.
	119267-04-700	EA	FILTER-GREASE	BOO2
	119267-10-700	EA	BRACKET/MOUNTING	FANGTB005MRY0

**119267-12-01A**

KEY	PART NUMBER	U/M	DESCRIPTION	VENDOR NO.
	119267-04-700	EA	FILTER-GREASE	BOO2
	119267-04-703	EA	PLATE - MOUNTING	FANGTB003MRY0
	119267-04-704	EA	LIGHT COVER-F/MOD R1480/1850	FANGKB009MRYO
	119267-12-700	EA	LOUVER-EXHAUST	PDIF-BO32MRFO

**119267-13-01A**

KEY	PART NUMBER	U/M	DESCRIPTION	VENDOR NO.
	119267-04-700	EA	FILTER-GREASE	BOO2

**119267-15-01A**

KEY	PART NUMBER	U/M	DESCRIPTION	VENDOR NO.
	119267-15-700	EA	SUPPORT - F/GLASS TRAY	FROLPB025MRKO
	119267-15-701	EA	TRAY - GLASS	NTNT-A10WREZ

**CABINET & APPLIANCE GROUP (CONTINUED)**  
**COMPONENT PARTS FOR APPLIANCES (CONTINUED)**

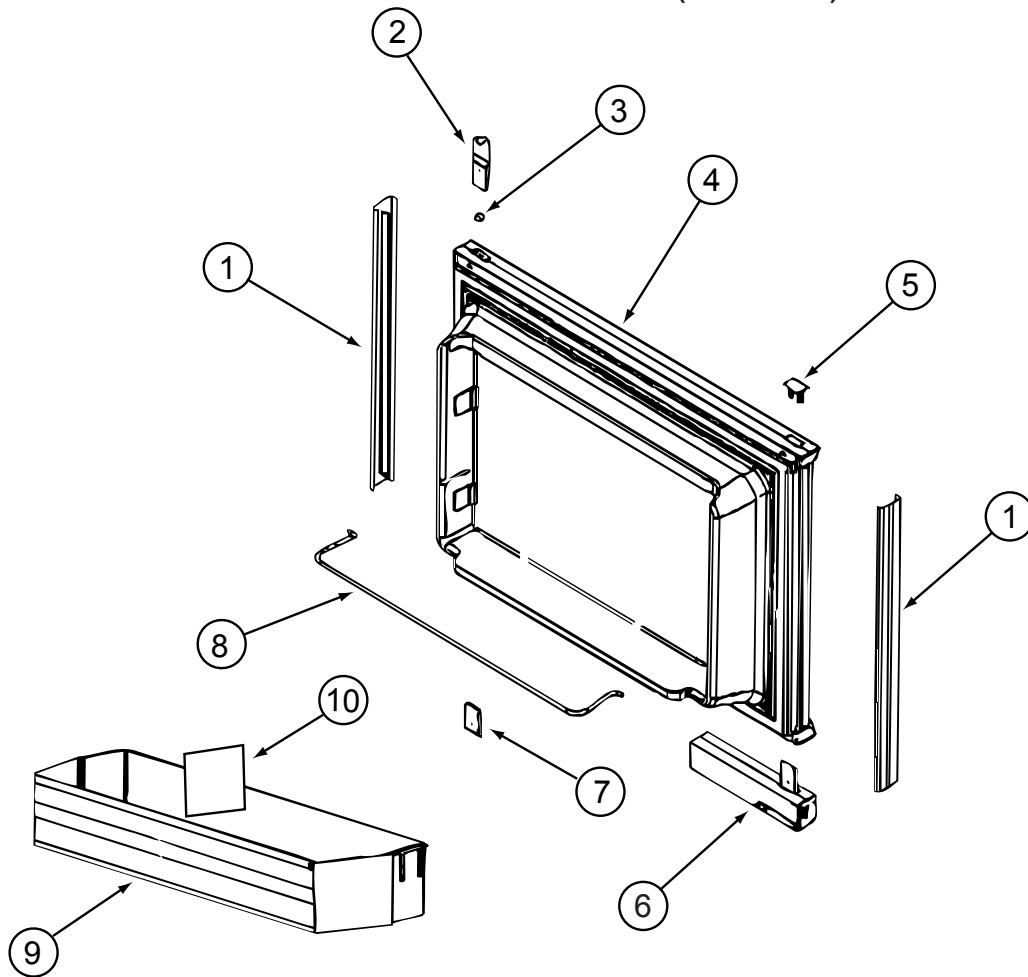

120075-12-01A, 120075-13-01A, 120075-14-01A, 120075-15-01A

KEY	PART NUMBER	U/M	DESCRIPTION	VENDOR NO.
1	121568-03-700	EA	RETAINER - DOOR PANEL/BLACK	619558
2	120075-01-701	EA	HINGE-TOP RH/BOTTOM LH(DOOR)	618511
3	121568-03-701	EA	BUSHING - HINGE PIN/GRAY	619671
4	121568-03-702	EA	DOOR LINER - W/TRIM/BLACK	619627 - SMALL DOOR
5	120075-01-702	EA	CAP, (HINGE PLUG)	618160
6	120075-12-700	EA	HANDLE(CONTOUR)TOP LH/BTM RH	621105
	120075-12-702	EA	HANDLE/HOUSING-TOP-LH/BTM RH	618159GEN
6	120075-12-701	EA	HANDLE(CONTOUR)TOP RH/BTM LH	621104
	120075-12-707	EA	LATCH	619648
	120075-12-709	EA	HANDLE/HOUSING-BTM LH/TOP RH	618122GEN
6	121568-03-703	EA	HANDLE/FLUSH-TOP/RH-LWR/LH	619865
6	121568-03-708	EA	HANDLE/FLUSH-TOP/LH-LWR/RH	619866
7	120075-01-705	EA	HINGE-TOP LH/BOTTOM RH(DOOR)	618510
8	121568-01-700	EA	RAIL - DOOR UPPER	618618
9	120075-07-700	EA	DOOR BIN - CLEAR	619006
10	120075-07-701	EA	DIVIDER/DOOR BIN CLEAR	619008
	121568-03-704	EA	TRAVEL LATCH - GRAY	619647
	121568-03-705	EA	STORAGE LATCH - GRAY	619648

**CABINET & APPLIANCE GROUP (CONTINUED)**  
**COMPONENT PARTS FOR APPLIANCES (CONTINUED)**

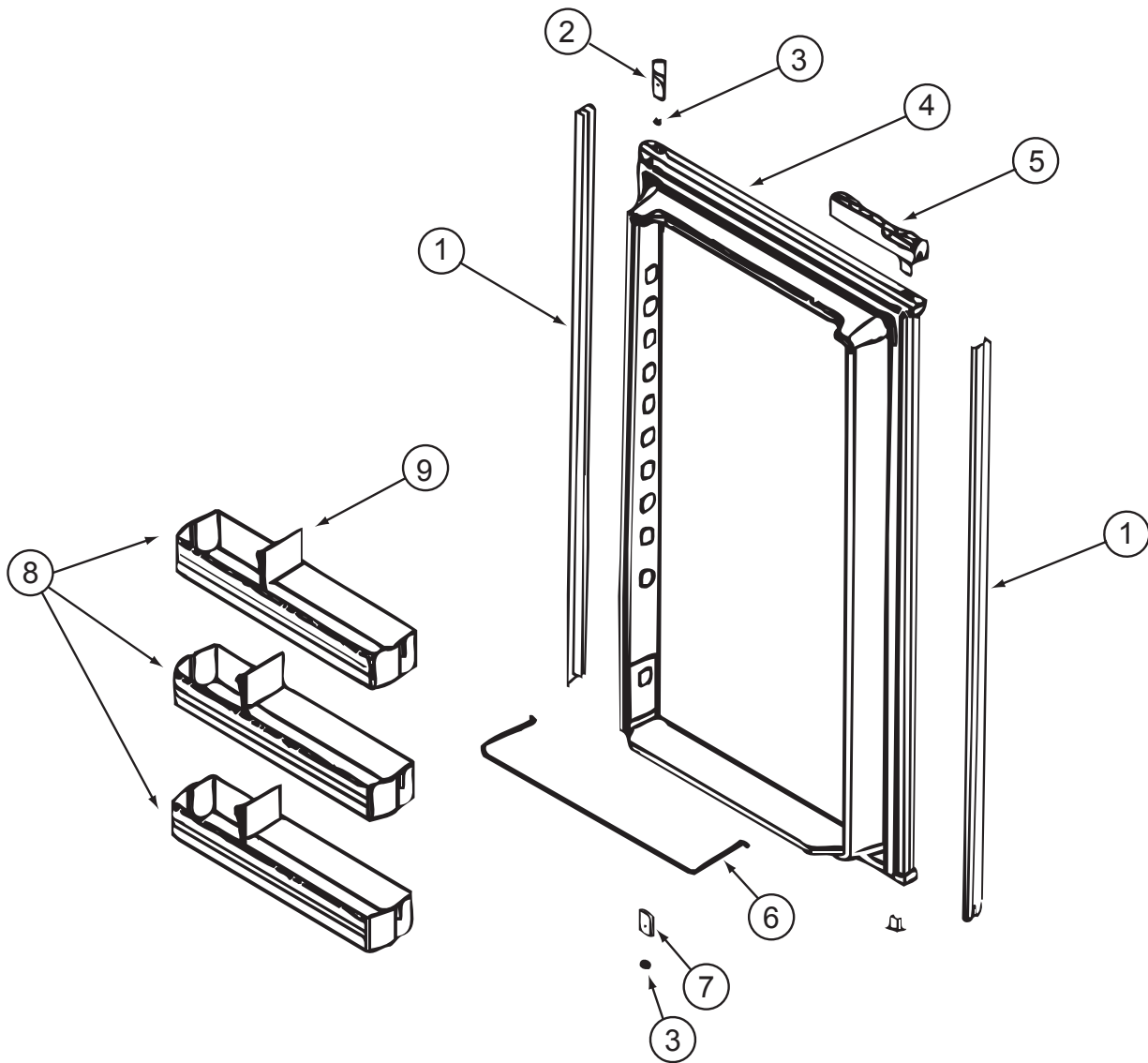

**120075-12-01A, 120075-13-01A, 120075-14-01A, 120075-15-01A (CONTINUED)**

KEY	PART NUMBER	U/M	DESCRIPTION	VENDOR NO.
1	120075-07-702	EA	RETAINER - DOOR PANEL/BLACK	619560
2	120075-01-701	EA	HINGE-TOP RH/BOTTOM LH(DOOR)	618511
3	121568-03-701	EA	BUSHING - HINGE PIN/GRAY	619671
4	120075-07-703	EA	DOOR LINER - BLACK	619631 - LARGE DOOR
5	120075-12-700	EA	HANDLE(CONTOUR)TOP LH/BTM RH	621105
	120075-12-702	EA	HANDLE/HOUSING-TOP-LH/BTM RH	618159GEN
5	120075-12-701	EA	HANDLE(CONTOUR)TOP RH/BTM LH	621104
	120075-12-707	EA	LATCH	619648
	120075-12-709	EA	HANDLE/HOUSING-BTM LH/TOP RH	618122GEN
5	121568-03-703	EA	HANDLE/FLUSH-TOP/RH-LWR/LH	619865
5	121568-03-708	EA	HANDLE/FLUSH-TOP/LH-LWR/RH	619866
6	121568-01-704	EA	RAIL - DOOR LOWER	618578
7	120075-01-705	EA	HINGE-TOP LH/BOTTOM RH(DOOR)	618510
8	120075-07-700	EA	DOOR BIN - CLEAR	619006
8	120075-07-704	EA	DOOR BIN - LARGE/CLEAR	619005
9	120075-07-701	EA	DIVIDER/DOOR BIN CLEAR	619008
	121568-03-704	EA	TRAVEL LATCH - GRAY	619647
	121568-03-705	EA	STORAGE LATCH - GRAY	619648

**CABINET & APPLIANCE GROUP (CONTINUED)**  
**COMPONENT PARTS FOR APPLIANCES (CONTINUED)**

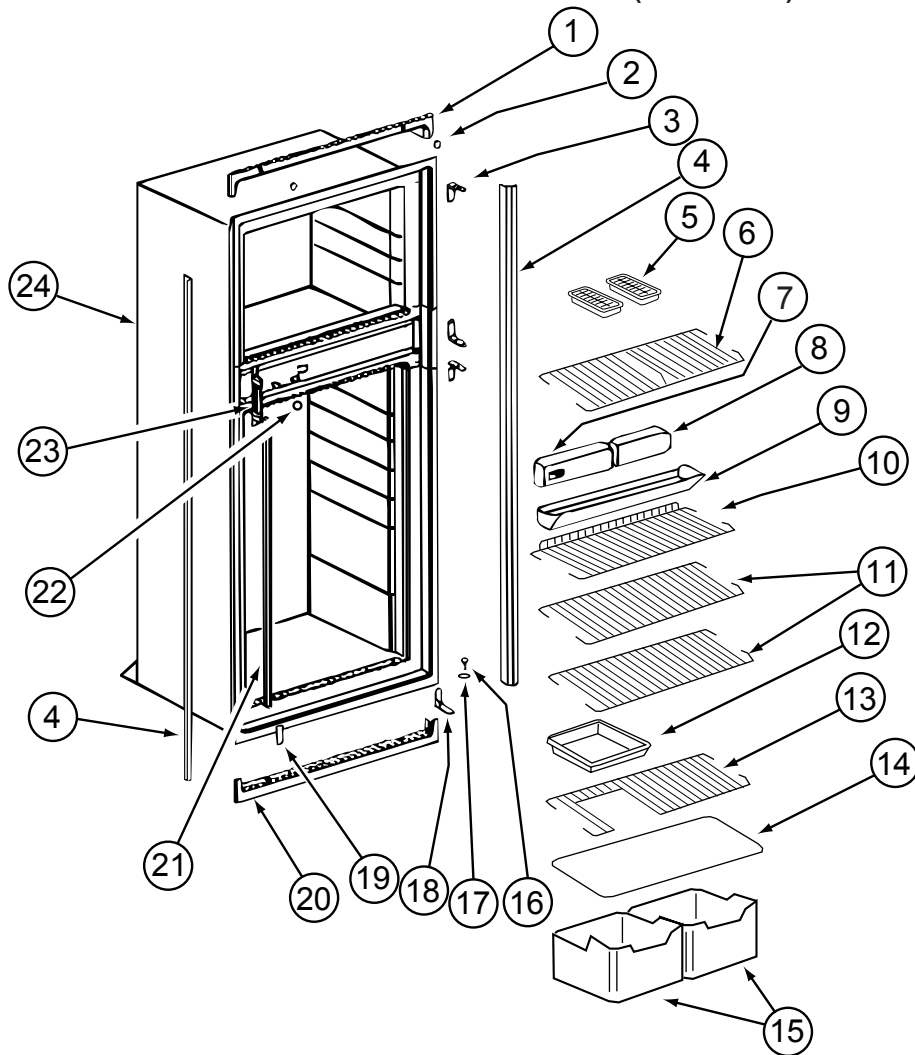

**120075-12-01A, 120075-13-01A, 120075-14-01A, 120075-15-01A (CONTINUED)**

KEY	PART NUMBER	U/M DESCRIPTION	VENDOR NO.
1	121568-03-709	EA TRIM - TOP/BLACK	619687
2	120075-01-714	EA PLUG-HOLE (BLACK)	618170
3	121568-03-710	EA HINGE/CABINET-TOP/RH-LWR/LH	619335
4	120075-07-705	EA TRIM - SIDE - BLACK	622296
5	104137-06-724	EA ICE TRAY	61630422
6	120075-07-706	EA SHELF - WIRE/FREEZER	620249
7	120075-07-707	EA CONTROL BOX - BLACK	619665
8	121568-03-713	EA FRONT BOX/DECORATIVE-BLACK	619282
9	120075-01-720	EA TRAY-DRIP	618137
10	120075-01-722	EA SHELF-WIRE, SHORT	620269
11	120075-01-723	EA SHELF-WIRE	620270
12	104137-06-718	EA SHELF-TRAY, WHITE, W/CUTOUT	617756
13	120075-01-724	EA SHELF-WIRE, W/CUTOUT	618177
14	120075-01-725	EA COVER-CRISPER	618158
15	120075-07-708	EA CRISPER/ICE BIN	619007
16	120075-01-727	EA PIN-HINGE	618145
17	121568-03-701	EA BUSHING - HINGE PIN/GRAY	619671
18	121568-03-715	EA HINGE/CABINET-TOP/LH-LWR/RH	619336
19	121568-03-716	EA COVER - HINGE HOLES	619301
20	120075-01-729	EA TRIM-BOTTOM PIECE	620958
21	120075-01-730	EA RETAINER-SHELF(SER#926684 DN	618181
22	121568-03-717	EA HOLE PLUG - WHITE	619561
23	120075-01-732	EA PLATE-STRIKE	618167
24	120075-09-700	EA CABINET - FOAMED	619660
	120075-01-721	EA LOUVER-DRIP TRAY	618176

**CABINET & APPLIANCE GROUP (CONTINUED)**  
**COMPONENT PARTS FOR APPLIANCES (CONTINUED)**

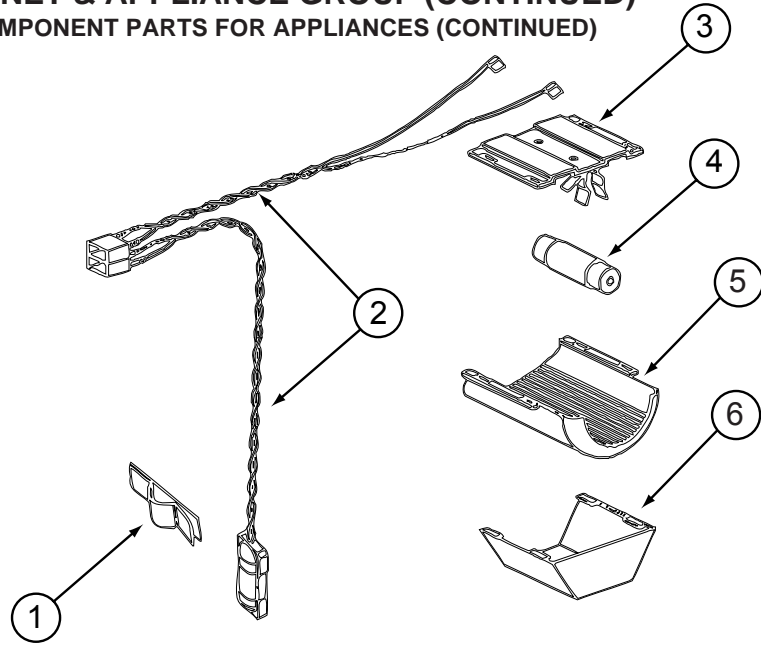

**120075-12-01A, 120075-13-01A, 120075-14-01A, 120075-15-01A (CONTINUED)**

KEY	PART NUMBER	U/M DESCRIPTION	VENDOR NO.
1	084880-01-760	EA CLIP (THERMISTER)	61689122
2	120075-01-735	EA THERMISTER W/LAMP & WIRE/ASM	618548
3	084880-03-705	EA BRACKET-LIGHT-INTERIOR	61629722
4	084880-03-706	EA BULB-LAMP	61628922
5	120075-01-734	EA COVER-LENS	618190
6	084880-03-707	EA COVER-LAMP, LENS	61627922

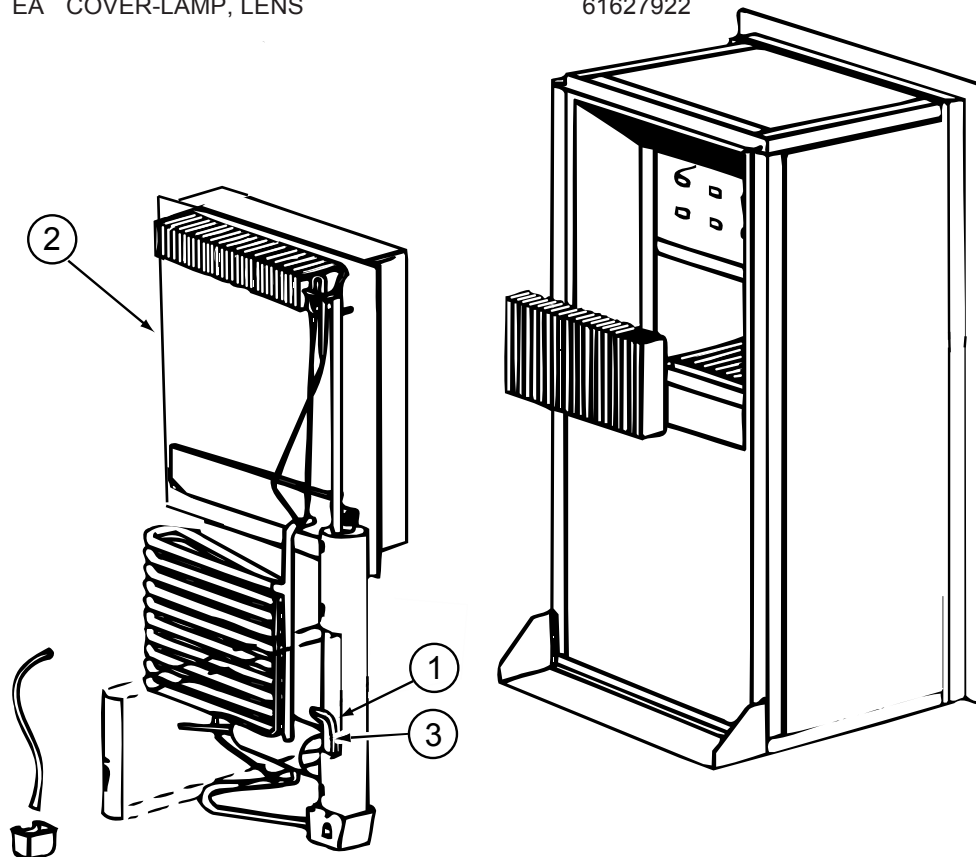

**120075-12-01A, 120075-13-01A, 120075-14-01A, 120075-15-01A (CONTINUED)**

KEY	PART NUMBER	U/M DESCRIPTION	VENDOR NO.
1	088248-01-710	EA HEATER DC (HORIZONTAL)	61562822
2	120075-01-736	EA COOLING UNIT, SERVICE PACK	618542
3	088248-01-709	EA HEATER-AC (HORIZONTAL)	61562722

**CABINET & APPLIANCE GROUP (CONTINUED)**  
**COMPONENT PARTS FOR APPLIANCES (CONTINUED)**

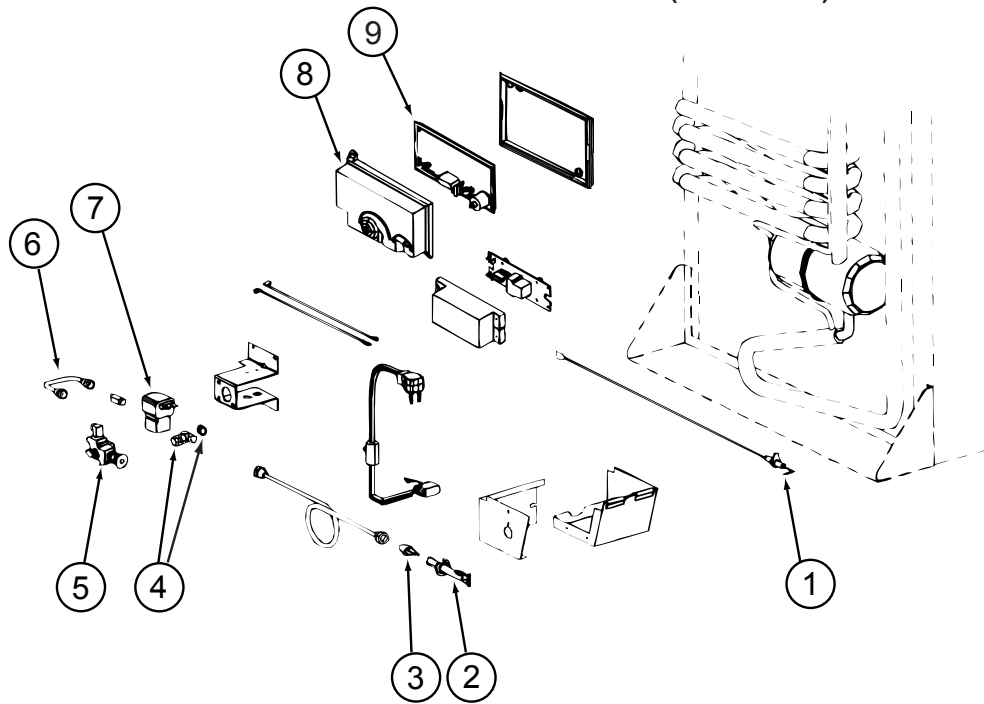

**120075-12-01A, 120075-13-01A, 120075-14-01A, 120075-15-01A (CONTINUED)**

KEY	PART NUMBER	U/M	DESCRIPTION	VENDOR NO.
1	104137-06-715	EA	ELECTRODE-SPARK/SENSOR, SGL	61692222
2	104137-06-714	EA	BURNER ASSEMBLY, 5-SLOT	61705222
3	120075-01-737	EA	ORIFICE - JEWEL - .0155	618284
4	113737-01-702	EA	PLUG 1/8" F/PRESSURE TAP	61445322
4	113737-01-716	EA	TAP-PRESSURE	61594422
5	104137-06-734	EA	VALVE-SHUT OFF/MAN-NEW STYLE	618696
6	113737-01-750	EA	TUBE-UNION	61694622
7	084880-01-718	EA	VALVE-GAS, (ASCO)	621447
8	120075-01-738	EA	COVER-POWER BOARD	618185
9	120075-07-710	EA	POWER - BOARD - 2-WAY	619360 = 621269
	120075-01-744	EA	KIT - GAS VALVE/BURNER TUBE	620609



**CABINET & APPLIANCE GROUP (CONTINUED)**  
**COMPONENT PARTS FOR APPLIANCES (CONTINUED)**

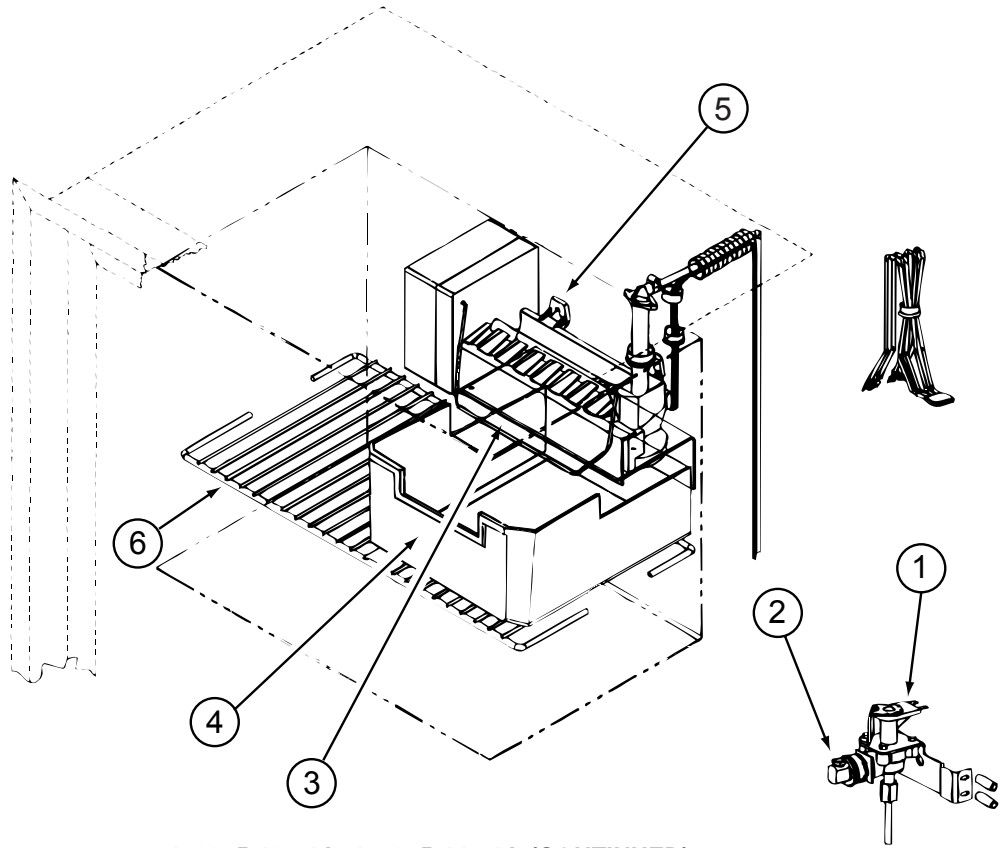

**120075-13-01A, 120075-14-01A (CONTINUED)**

KEY	PART NUMBER	U/M	DESCRIPTION	VENDOR NO.
1	120075-09-701	EA	WATER VALVE W/BRACKET	618253
2	120075-03-702	EA	NUT/COMPRESSION - FITTING	61678722
3	120075-03-703	EA	ARM-SHUT OFF	61656922
4	120075-03-704	EA	BIN-ICE CUBE	618154
5	094039-07-706	EA	ICE MAKER W/O PLATES	61656522
6	120075-01-717	EA	SHELF-FREEZER, WIRE	618172

**CABINET & APPLIANCE GROUP (CONTINUED)**  
**COMPONENT PARTS FOR APPLIANCES (CONTINUED)**

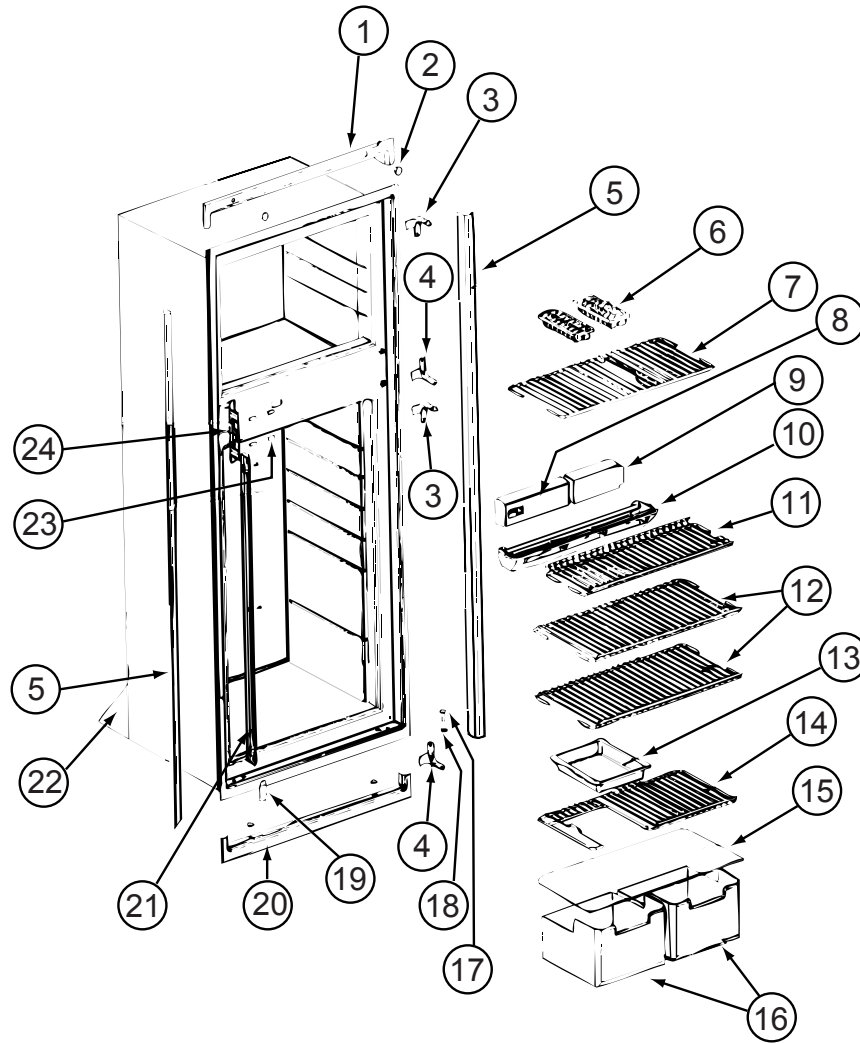

**120075-16, 120075-17, 120075-18, 120075-19, 120075-20, 120075-21, 120075-22, 120075-23-01A (CONTINUED)**

KEY	PART NUMBER	U/M	DESCRIPTION	VENDOR NO.
1	120075-20-700	EA	TRIM/TOP ASM W/INSERTS-BLACK	622319
2	120075-01-714	EA	PLUG-HOLE (BLACK)	618170
3	121568-03-710	EA	HINGE/CABINET-TOP/RH-LWR/LH	619335
4	121568-03-715	EA	HINGE/CABINET-TOP/LH-LWR/RH	619336
5	120075-07-705	EA	TRIM - SIDE - BLACK	622296
6	104137-06-724	EA	ICE TRAY	61630422
7	121568-03-712	EA	SHELF-WIRE FREEZER	620250
7	120075-07-706	EA	SHELF-WIRE F/ICEMAKER MODELS	620250
8	120075-07-707	EA	CONTROL BOX - BLACK	619665
9	121568-03-713	EA	FRONT BOX/DECORATIVE-BLACK	619282
10	120075-20-701	EA	TRAY/DRIP(INSIDE 1 PC)LOUVER	623250
11	120075-01-722	EA	SHELF-WIRE, SHORT	620269
12	120075-01-723	EA	SHELF-WIRE	620270
13	104137-06-718	EA	SHELF-TRAY, WHITE, W/CUTOUT	617756
14	120075-20-703	EA	SHELF - WIRE W/CUTOUT	620268
15	120075-01-725	EA	COVER-CRISPER	618158
16	120075-07-708	EA	CRISPER/ICE BIN	619007
17	120075-01-727	EA	PIN-HINGE	618145
18	121568-03-701	EA	BUSHING - HINGE PIN/GRAY	619671
19	121568-03-716	EA	COVER - HINGE HOLES	619301
20	120075-20-702	EA	TRIM PC(FOAM/TAPE)BTM BLACK	622323
21	120075-01-730	EA	RETAINER-SHELF(SER#926684 DN)	618181
21	125242-02-720	EA	RETAINER/SHELF(SER#926685 UP)	622033
23	121568-06-703	EA	HOLE PLUG - WHITE	620282
24	120075-01-732	EA	PLATE-STRIKE	618167

CONTACT WINNEBAGO PART SALES FOR UNLISTED COMPONENT(S)

**CABINET & APPLIANCE GROUP (CONTINUED)**  
**COMPONENT PARTS FOR APPLIANCES (CONTINUED)**

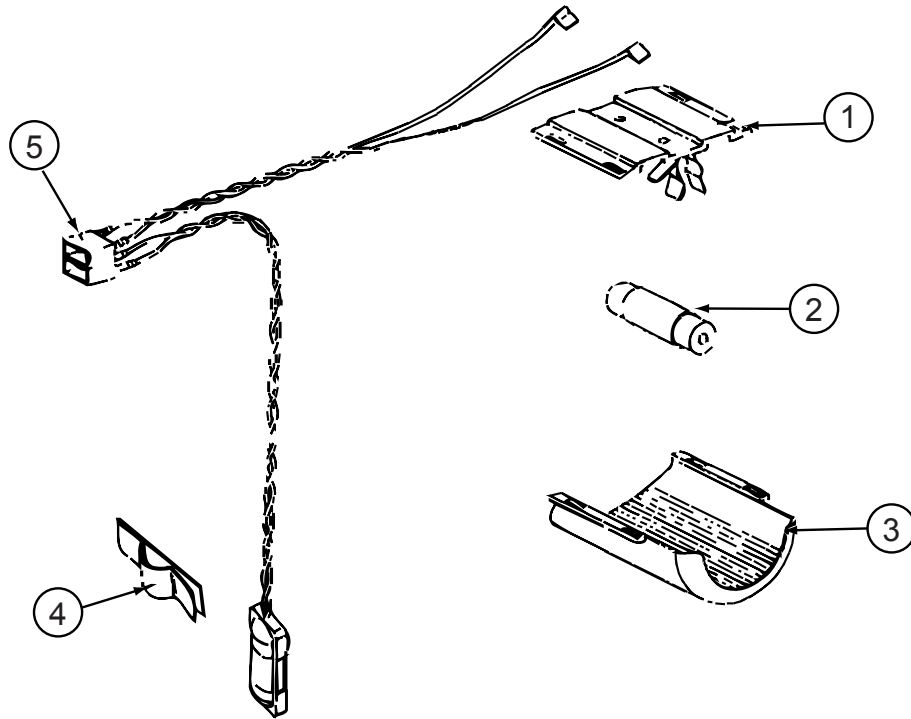

120075-16, 120075-17, 120075-18, 120075-19, 120075-20, 120075-21, 120075-22, 120075-23-01A (CONTINUED)

KEY	PART NUMBER	U/M	DESCRIPTION	VENDOR NO.
1	084880-03-705	EA	BRACKET-LIGHT-INTERIOR	61629722
2	084880-03-706	EA	BULB-LAMP	61628922
3	125242-02-708	EA	COVER/LAMP BRACKET	621827
4	084880-01-760	EA	CLIP (THERMISTER)	61689122
5	120075-01-735	EA	THERMISTER W/LAMP & WIRE/ASM	618548

**CABINET & APPLIANCE GROUP (CONTINUED)**  
**COMPONENT PARTS FOR APPLIANCES (CONTINUED)**

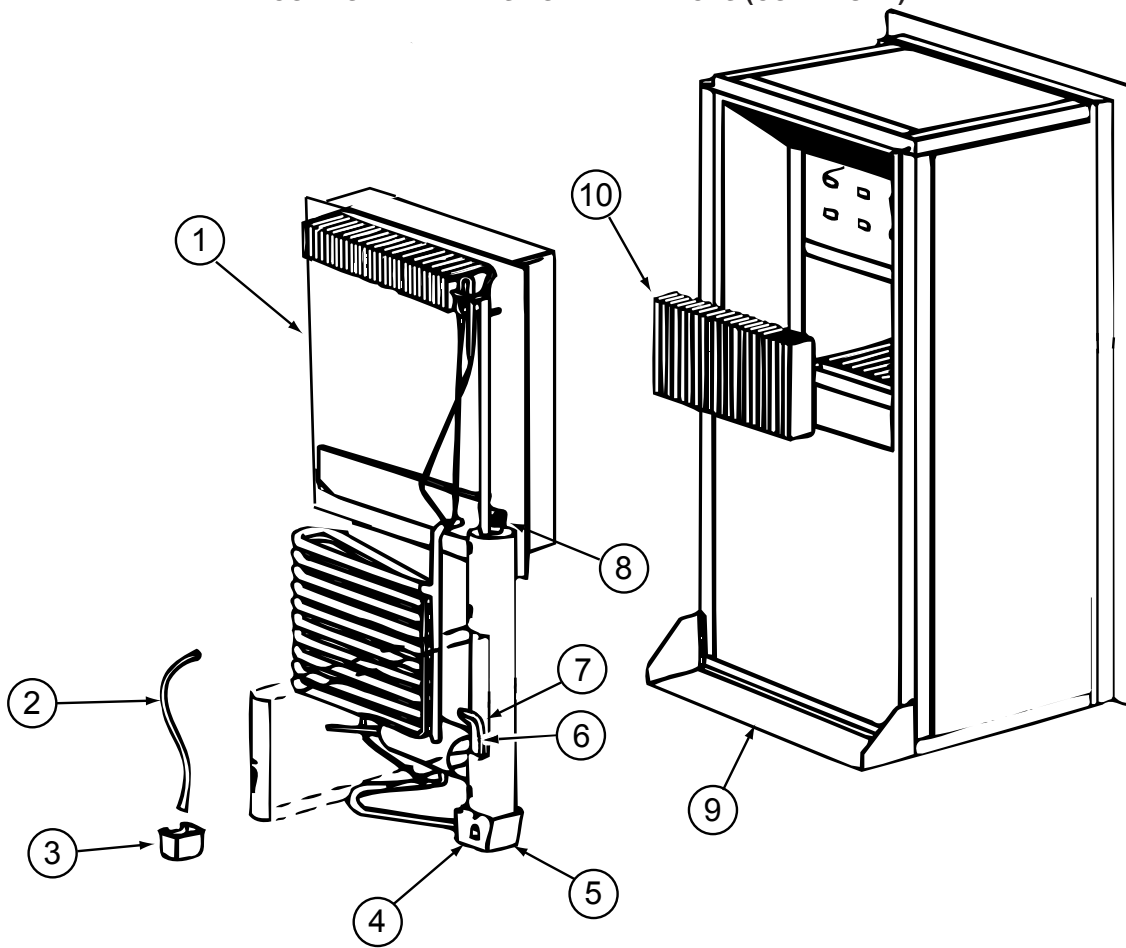

120075-16, 120075-17, 120075-18, 120075-19, 120075-20, 120075-21, 120075-22, 120075-23-01A (CONTINUED)

KEY	PART NUMBER	U/M	DESCRIPTION	VENDOR NO.
1	120075-01-736	EA	COOLING UNIT, SERVICE PACK	618542
6	121568-06-704	EA	HEATER-AC/300W/120VAC	621702

CONTACT WINNEBAGO PART SALES FOR UNLISTED COMPONENT(S)

**CABINET & APPLIANCE GROUP (CONTINUED)**  
**CABINET & APPLIANCE LAYOUT (CONTINUED)**

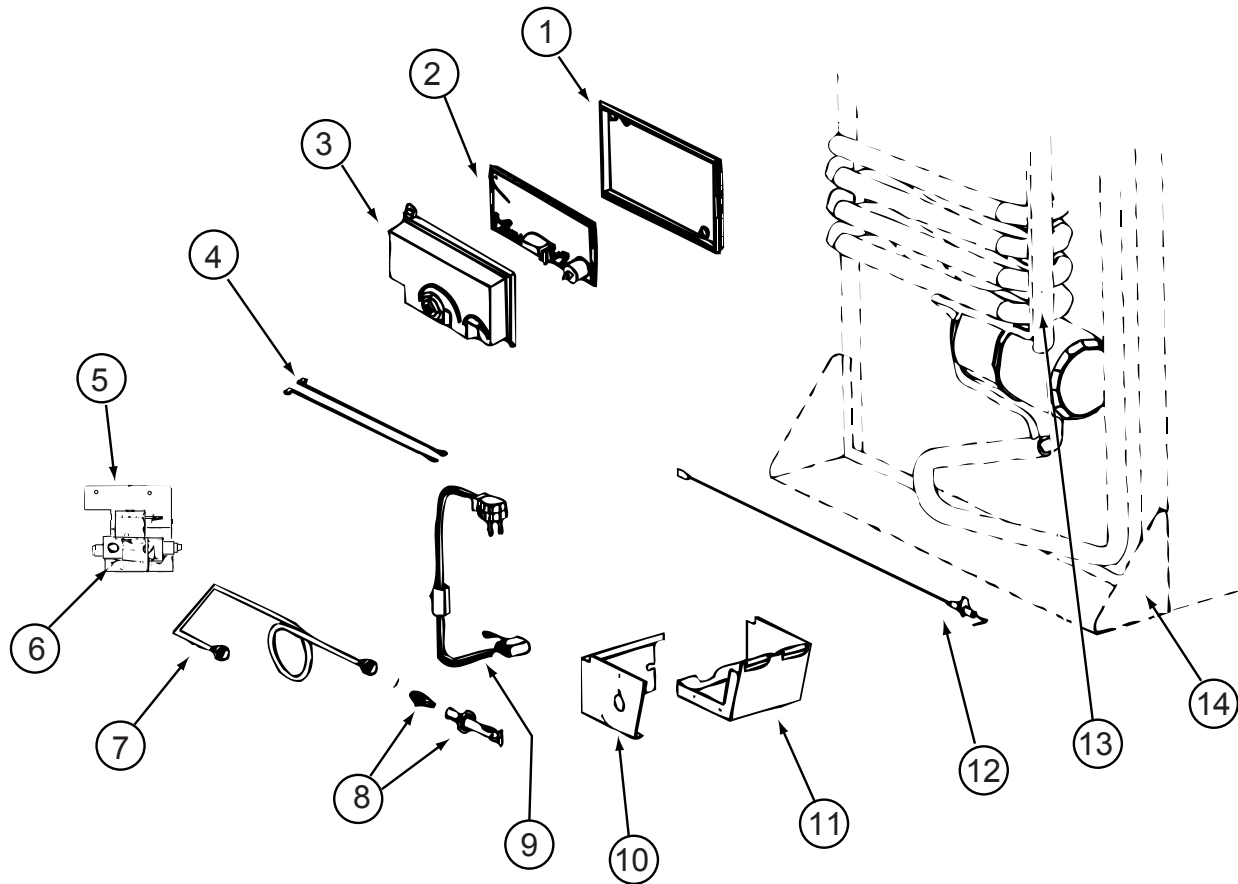

**COMPONENT PARTS FOR APPLIANCES (CONTINUED)**

120075-16, 120075-17, 120075-18, 120075-19, 120075-20, 120075-21, 120075-22, 120075-23-01A (CONTINUED)

KEY	PART NUMBER	U/M	DESCRIPTION	VENDOR NO.
1	120075-01-740	EA	COVER-BASE, POWER BOARD	618186
2	120075-20-704	EA	KIT-POWER BOARD/EG2-2 WAY	621269001
3	120075-01-738	EA	COVER-POWER BOARD	618185
4	125242-02-709	EA	WIRE/WHITE/9"/GAS VALVE	621448
5	125242-02-710	EA	GAS VALVE/BRKT/WIRES COMB.	621334
6	121568-06-706	EA	GAS VALVE-COMBO/WRENCH FLAT	621329
7	120075-20-705	EA	TUBE/BURNER - N8/N6	620033
8	121568-06-708	EA	BURNER/ORFICE-ADAPTER KIT	621957
12	104137-06-715	EA	ELECTRODE-SPARK/SENSOR, SGL	61692222

CONTACT WINNEBAGO PART SALES FOR UNLISTED COMPONENT(S)

**CABINET & APPLIANCE GROUP (CONTINUED)**  
**COMPONENT PARTS FOR APPLIANCES (CONTINUED)**

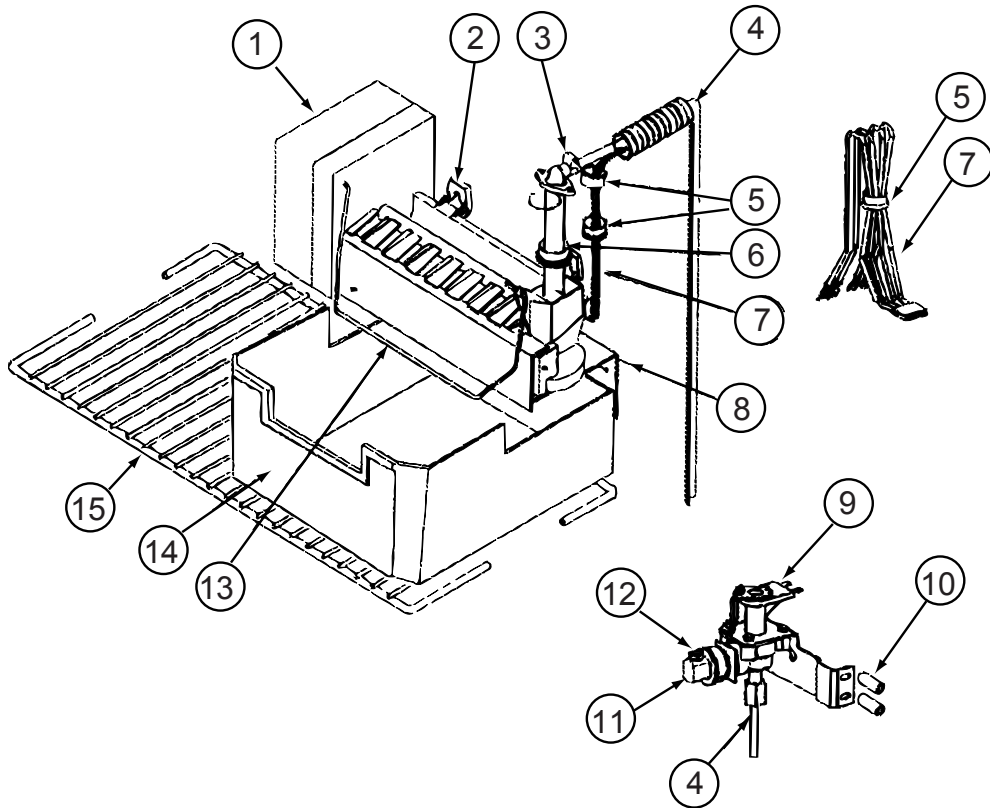

120075-16-01A, 120075-17-01A, 120075-18-01A, 120075-19-01A, 120075-20-01A, 120075-23-01A (CONTINUED)

KEY	PART NUMBER	U/M	DESCRIPTION	VENDOR NO.
2	094039-07-706	EA	ICE MAKER W/O PLATES	61656522
9	120075-03-701	EA	VALVE ASM., WATER, W/BRACKET	618253
13	120075-03-703	EA	ARM-SHUT OFF	61656922
14	120075-07-708	EA	CRISPER/ICE BIN	619007
15	120075-07-706	EA	SHELF-WIRE F/ICEMAKER MODELS	620249

CONTACT WINNEBAGO PART SALES FOR UNLISTED COMPONENT(S)

**CABINET & APPLIANCE GROUP (CONTINUED)**  
**COMPONENT PARTS FOR APPLIANCES (CONTINUED)**

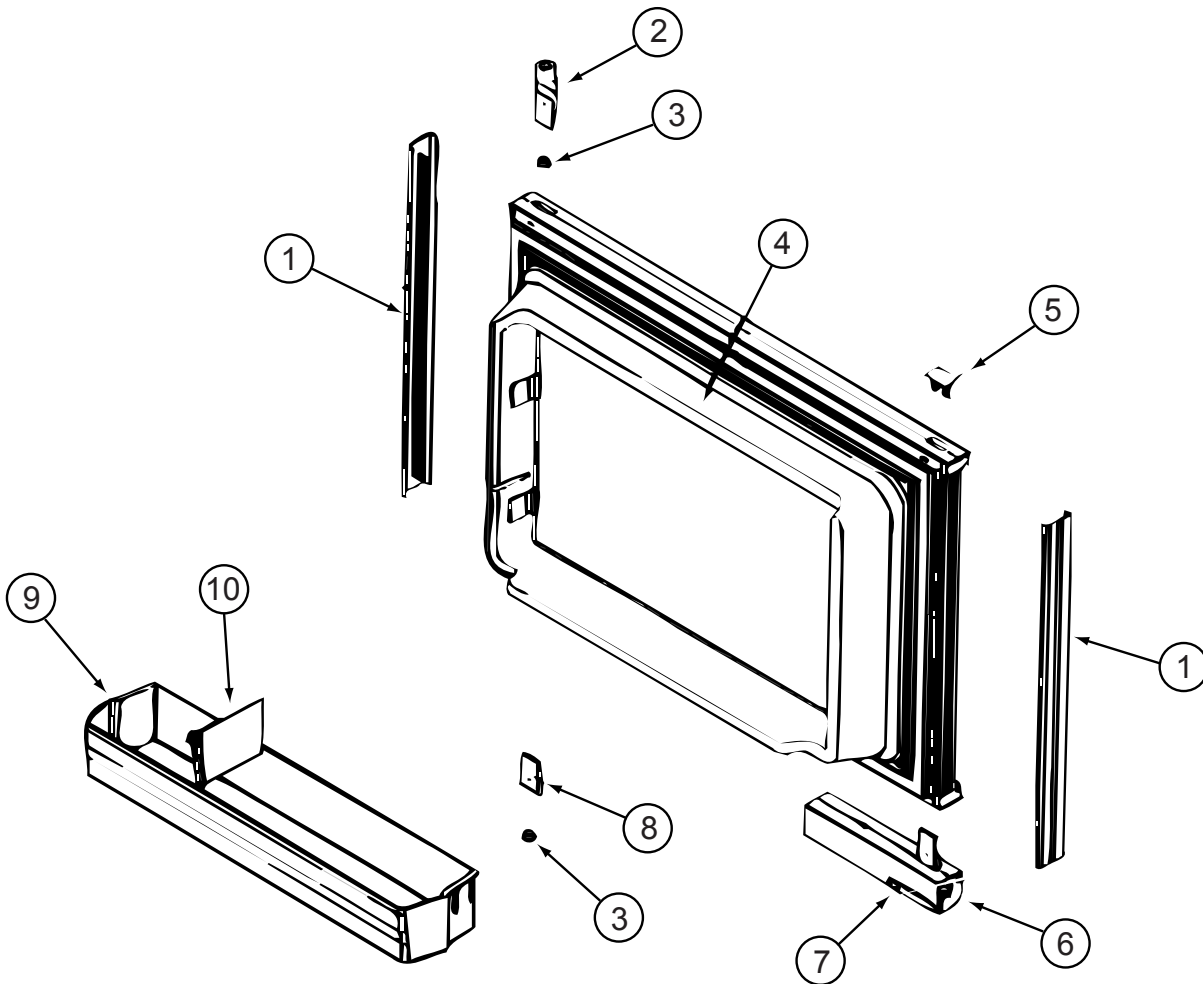

120075-23-01A

KEY	PART NUMBER	U/M	DESCRIPTION	VENDOR NO.
1	121568-03-700	EA	RETAINER - DOOR PANEL/BLACK	619558
2	120075-01-701	EA	HINGE-TOP RH/BOTTOM LH(DOOR)	618511
3	121568-03-701	EA	BUSHING - HINGE PIN/GRAY	619671
4	121568-03-702	EA	DOOR LINER - W/TRIM/BLACK	619627 - SMALL DOOR
5	120075-01-702	EA	CAP, (HINGE PLUG)	618160
6	120075-12-700	EA	HANDLE(CONTOUR)TOP LH/BTM RH	621105
6	120075-12-701	EA	HANDLE(CONTOUR)TOP RH/BTM LH	621104
7	121568-03-705	EA	STORAGE LATCH - GRAY	619648
8	120075-01-705	EA	HINGE-TOP LH/BOTTOM RH(DOOR)	618510
9	120075-07-700	EA	DOOR BIN - SMALL/CLEAR	619006
10	120075-07-701	EA	DIVIDER/DOOR BIN CLEAR	619008

**CABINET & APPLIANCE GROUP (CONTINUED)**  
**COMPONENT PARTS FOR APPLIANCES (CONTINUED)**

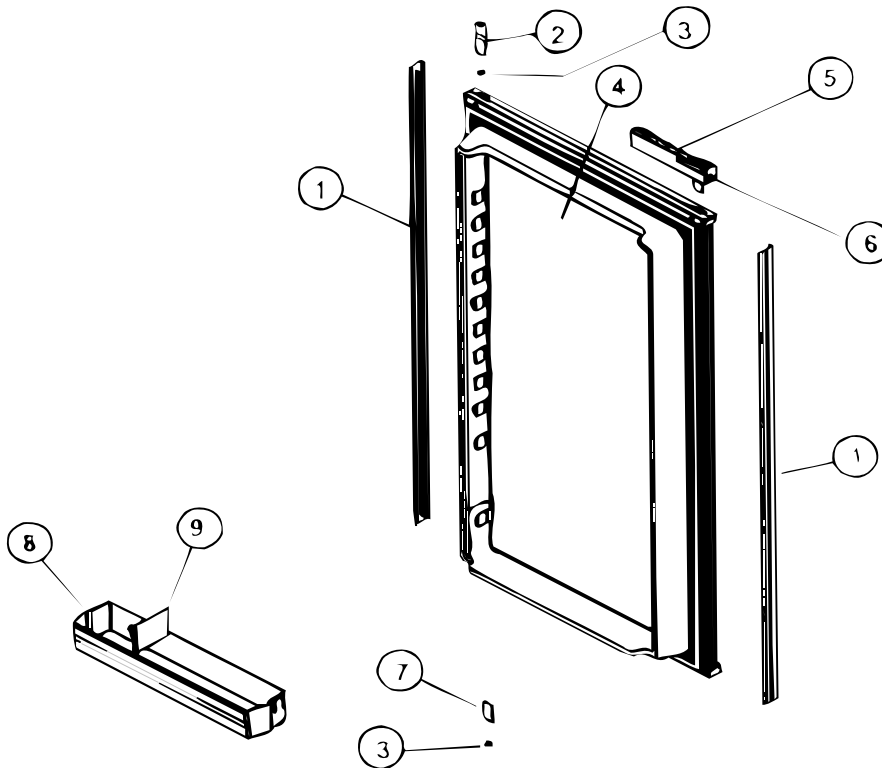

**120075-23-01A (CONTINUED)**

KEY	PART NUMBER	U/M	DESCRIPTION	VENDOR NO.
1	120075-07-702	EA	RETAINER - DOOR PANEL/BLACK	619560
2	120075-01-701	EA	HINGE-TOP RH/BOTTOM LH(DOOR)	618511
3	121568-03-701	EA	BUSHING - HINGE PIN/GRAY	619671
4	120075-07-703	EA	DOOR LINER - BLACK	619631 - LARGE DOOR
5	120075-12-700	EA	HANDLE(CONTOUR)TOP LH/BTM RH	621105
5	120075-12-701	EA	HANDLE(CONTOUR)TOP RH/BTM LH	621104
6	121568-03-705	EA	STORAGE LATCH - GRAY	619648
7	120075-01-705	EA	HINGE-TOP LH/BOTTOM RH(DOOR)	618510
8	120075-07-700	EA	DOOR BIN - SMALL/CLEAR	619006
8	120075-07-704	EA	DOOR BIN - LARGE/CLEAR	619005
9	120075-07-701	EA	DIVIDER/DOOR BIN CLEAR	619008



**CABINET & APPLIANCE GROUP (CONTINUED)**  
**COMPONENT PARTS FOR APPLIANCES (CONTINUED)**

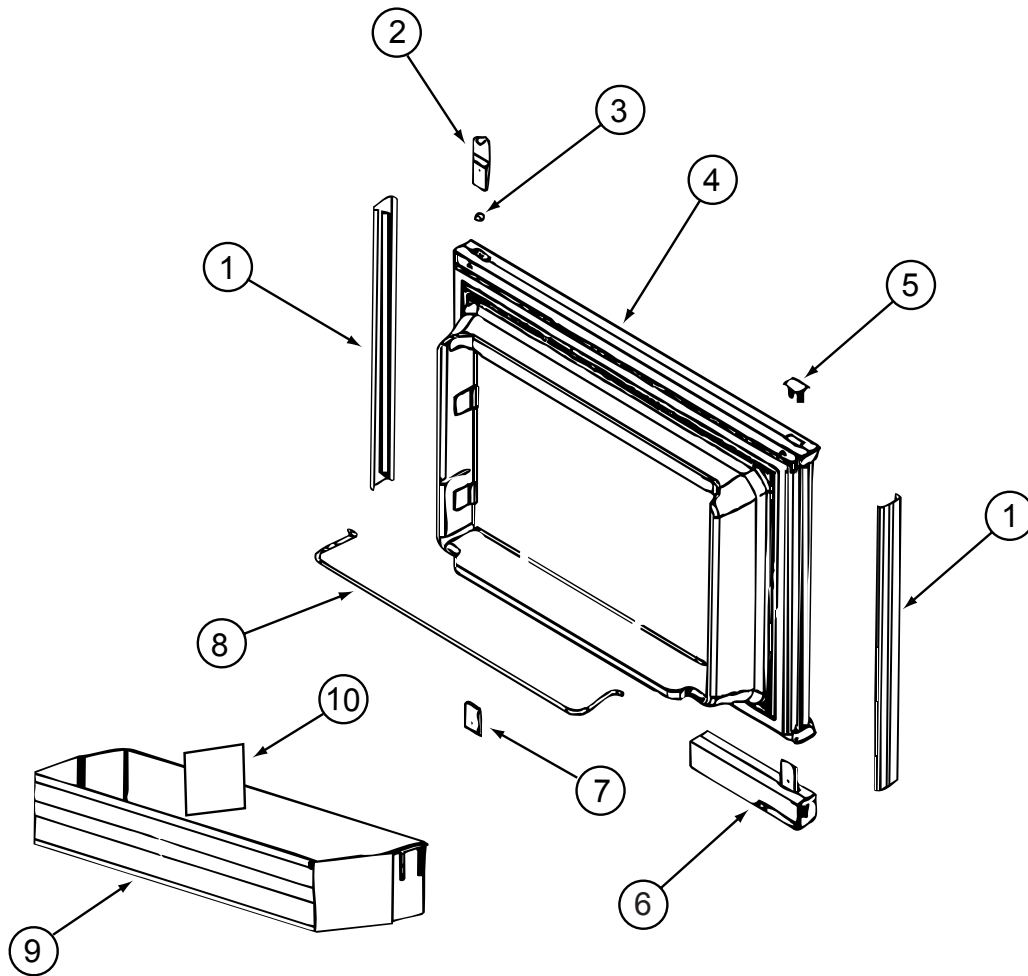

121569-05-01A, 121569-06-01A & 121569-07-01A

KEY	PART NUMBER	U/M	DESCRIPTION	VENDOR NO.
1	121568-03-700	EA	RETAINER - DOOR PANEL/BLACK	619558
2	120075-01-701	EA	HINGE-TOP RH/BOTTOM LH(DOOR)	618511
3	121568-03-701	EA	BUSHING - HINGE PIN/GRAY	619671
4	121568-03-702	EA	DOOR LINER - W/TRIM/BLACK	619627 - SMALL DOOR
5	120075-01-702	EA	CAP, (HINGE PLUG)	618160
6	120075-12-700	EA	HANDLE(CONTOUR)TOP LH/BTM RH	621105
7	120075-01-705	EA	HINGE-TOP LH/BOTTOM RH(DOOR)	618510
8	121568-01-700	EA	RAIL - DOOR UPPER	618618
9	120075-07-700	EA	DOOR BIN - CLEAR	619006
10	120075-07-701	EA	DIVIDER/DOOR BIN CLEAR	619008
	121568-03-705	EA	STORAGE LATCH - GRAY	619648

**CABINET & APPLIANCE GROUP (CONTINUED)**  
**COMPONENT PARTS FOR CABINET & APPLIANCE LAYOUT (CONTINUED)**

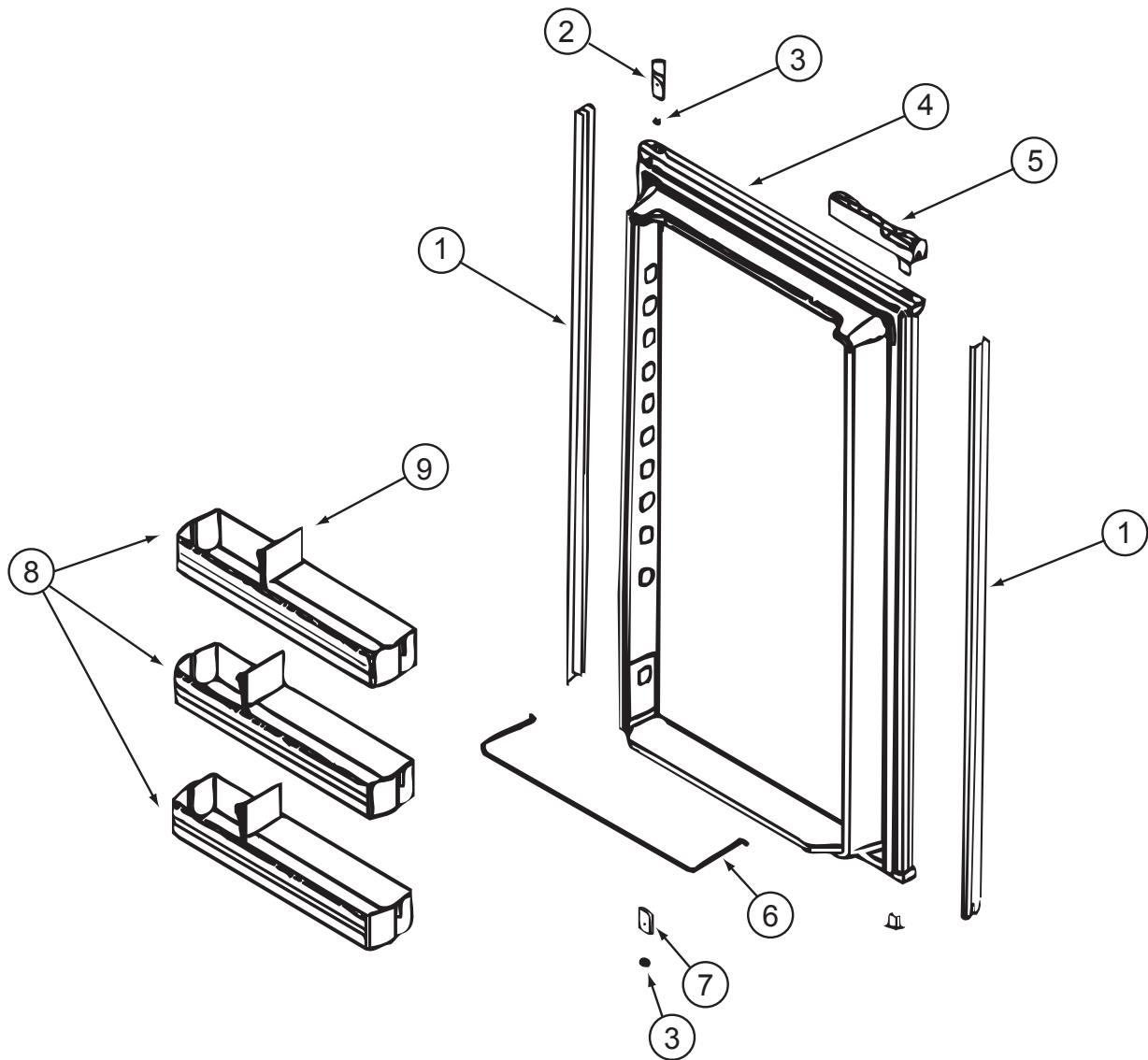

**121569-05-01A, 121569-06-01A, 121569-07-01A (CONTINUED)**

KEY	PART NUMBER	U/M	DESCRIPTION	VENDOR NO.
1	120075-07-702	EA	RETAINER - DOOR PNL/WAFFLE/BLK	619560 -WDL-LOWER
2	120075-01-701	EA	HINGE-TOP RH/BOTTOM LH(DOOR)	618511
3	121568-03-701	EA	BUSHING - HINGE PIN/GRAY	619671
4	120075-07-703	EA	DOOR LINER-LWR/WAFFLED/BLACK	619631 LARGE WDL
5	120075-12-701	EA	HANDLE(CONTOUR)TOP RH/BTM LH	621104
6	121568-01-704	EA	RAIL - DOOR LOWER	618578
7	120075-01-705	EA	HINGE-TOP LH/BOTTOM RH(DOOR)	618510
8	121568-01-701	EA	BIN - DOOR WHITE-WAFFLED LNR	618619 WDL
9	120075-07-701	EA	DIVIDER/DOOR BIN CLEAR	619008 WDL & SDL
	121568-03-705	EA	STORAGE LATCH - GRAY	619648

**CABINET & APPLIANCE GROUP (CONTINUED)**  
**COMPONENT PARTS FOR APPLIANCES (CONTINUED)**

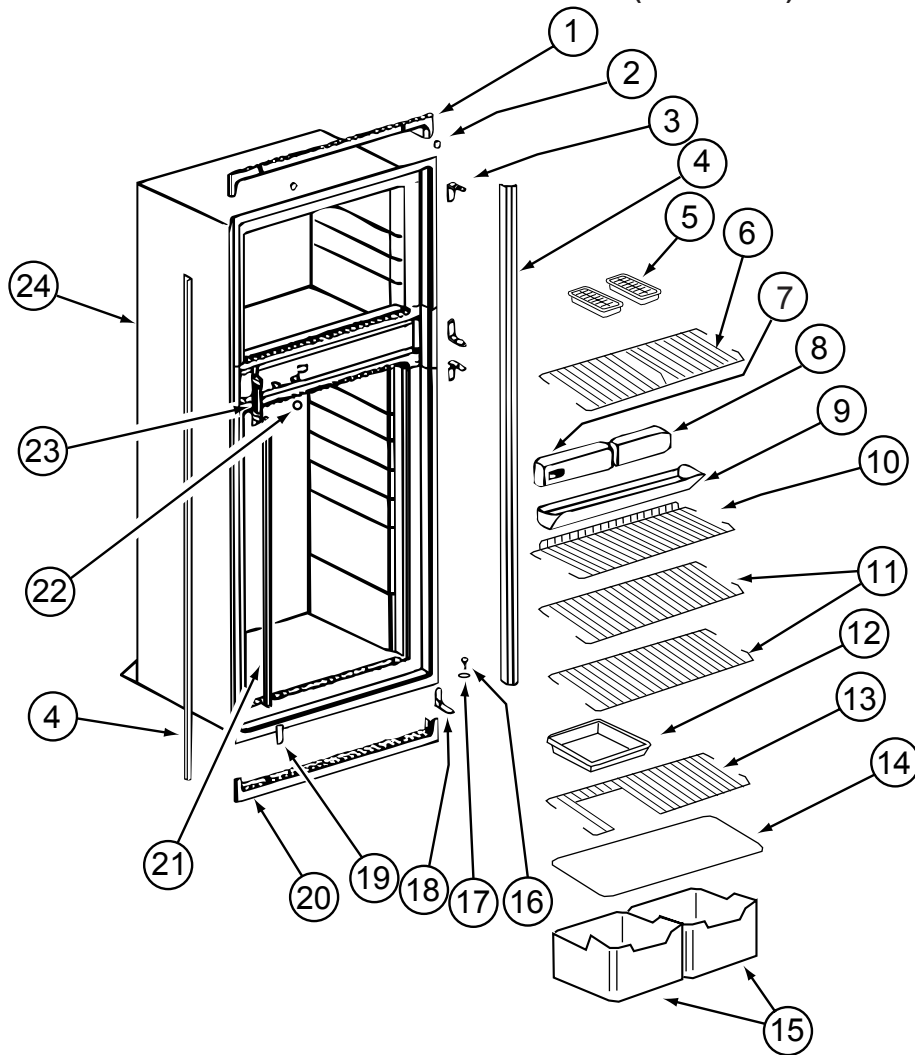

**121569-05-01A, 121569-06-01A & 121569-07-01A (CONTINUED)**

KEY	PART NUMBER	U/M	DESCRIPTION	VENDOR NO.
1	121568-03-709	EA	TRIM - TOP/BLACK	619687
2	120075-01-714	EA	PLUG-HOLE	618170
3	121568-03-710	EA	HINGE/CABINET-TOP/RH-LWR/LH	619335
4	120075-07-705	EA	TRIM - SIDE - BLACK	619802
6	121568-03-712	EA	SHELF - WIRE/FREEZER	620250
7	121568-03-714	EA	CONTROL ASM - 2 WAY BLACK	619350
8	121568-03-713	EA	FRONT BOX/DECORATIVE-BLACK	619282
9	120075-01-720	EA	TRAY-DRIP	618137
10	121568-01-707	EA	SHELF - WIRE - SHORT	618624
11	121568-01-708	EA	SHELF - WIRE	618589
14	120075-01-725	EA	COVER-CRISPER	618158
15	121568-01-709	EA	CRISPER	618571
16	120075-01-727	EA	PIN-HINGE	618145
18	121568-03-715	EA	HINGE/CABINET-TOP/LH-LWR/RH	619336
19	121568-03-716	EA	COVER - HINGE HOLES	619301
20	120075-01-729	EA	TRIM-BOTTOM PIECE	618136
21	120075-01-730	EA	RETAINER-SHELF	618181
22	121568-03-717	EA	HOLE PLUG - WHITE	619561
23	120075-01-732	EA	PLATE-STRIKE	618167
24	120075-07-709	EA	CABINET - FOAMED	619347
	120075-01-721	EA	LOUVER-DRIP TRAY	618176

CONTACT WINNEBAGO PART SALES FOR UNLISTED COMPONENTS

**CABINET & APPLIANCE GROUP (CONTINUED)**  
**COMPONENT PARTS FOR APPLIANCES (CONTINUED)**

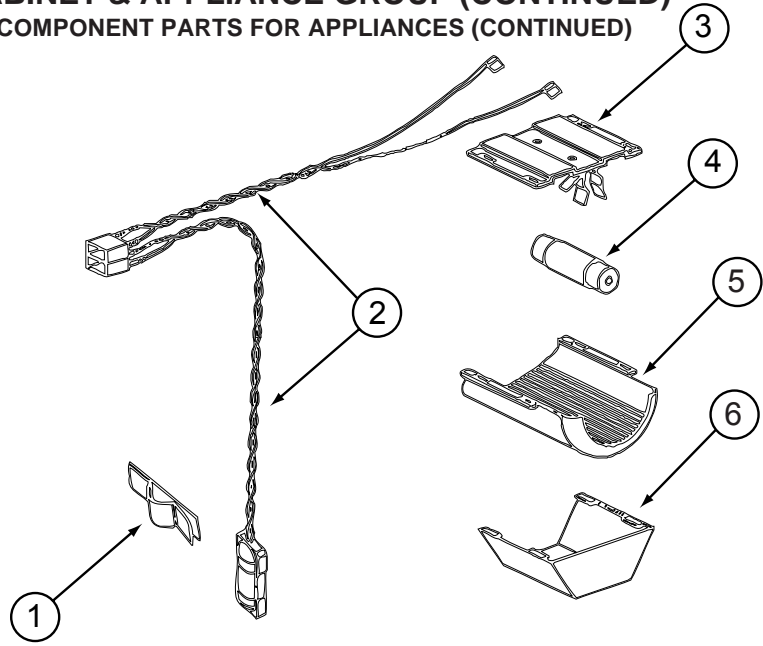

**121569-05-01A, 121569-06-01A & 121569-07-01A (CONTINUED)**

KEY	PART NUMBER	U/M	DESCRIPTION	VENDOR NO.
1	084880-01-760	EA	CLIP (THERMISTER)	61689122
2	120075-01-735	EA	THERMISTER W/LAMP & WIRE/ASM	618548
3	084880-03-705	EA	BRACKET-LIGHT-INTERIOR	61629722
4	084880-03-706	EA	BULB-LAMP	61628922
6	084880-03-707	EA	COVER-LAMP, LENS	61627922

CONTACT WINNEBAGO PART SALES FOR UNLISTED COMPONENTS

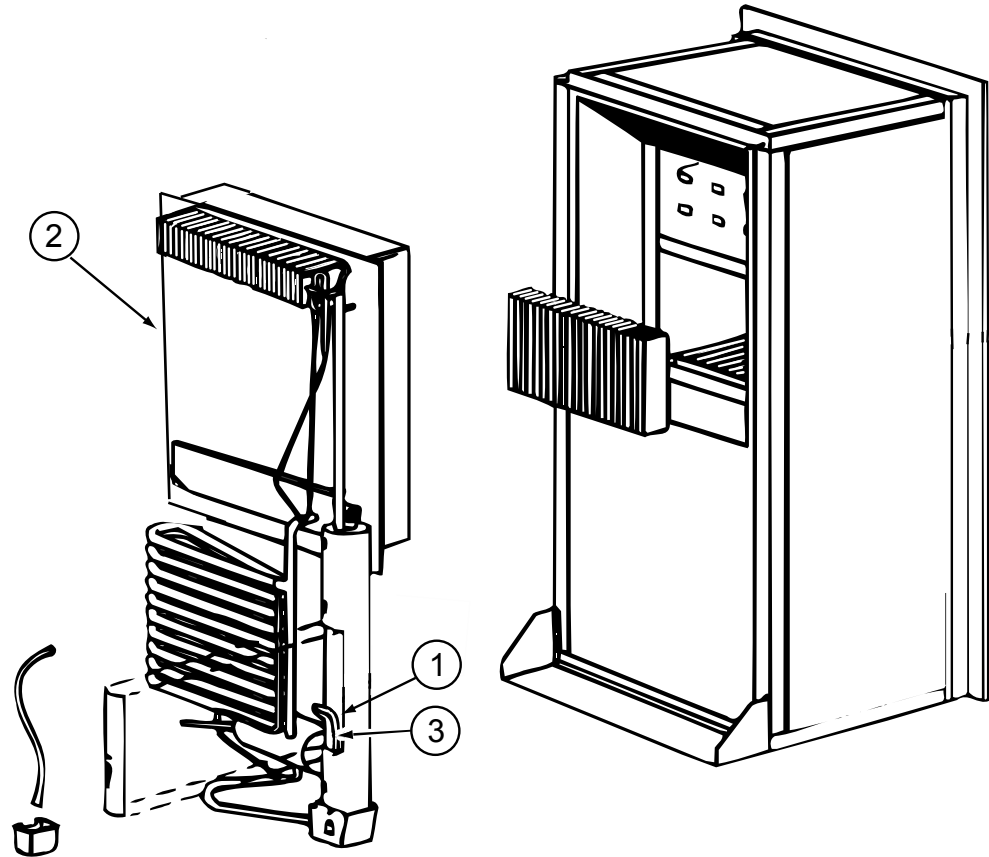

**121569-05-01A, 121569-06-01A & 121569-07-01A (CONTINUED)**

KEY	PART NUMBER	U/M	DESCRIPTION	VENDOR NO.
2	120075-01-736	EA	COOLING UNIT, SERVICE PACK	618542
3	088248-01-709	EA	HEATER-AC (HORIZONTAL)	61562722
	120075-01-744	EA	KIT - GAS VALVE/BURNER TUBE	620609

CONTACT WINNEBAGO PART SALES FOR UNLISTED COMPONENTS

**CABINET & APPLIANCE GROUP (CONTINUED)**  
**COMPONENT PARTS FOR APPLIANCES (CONTINUED)**

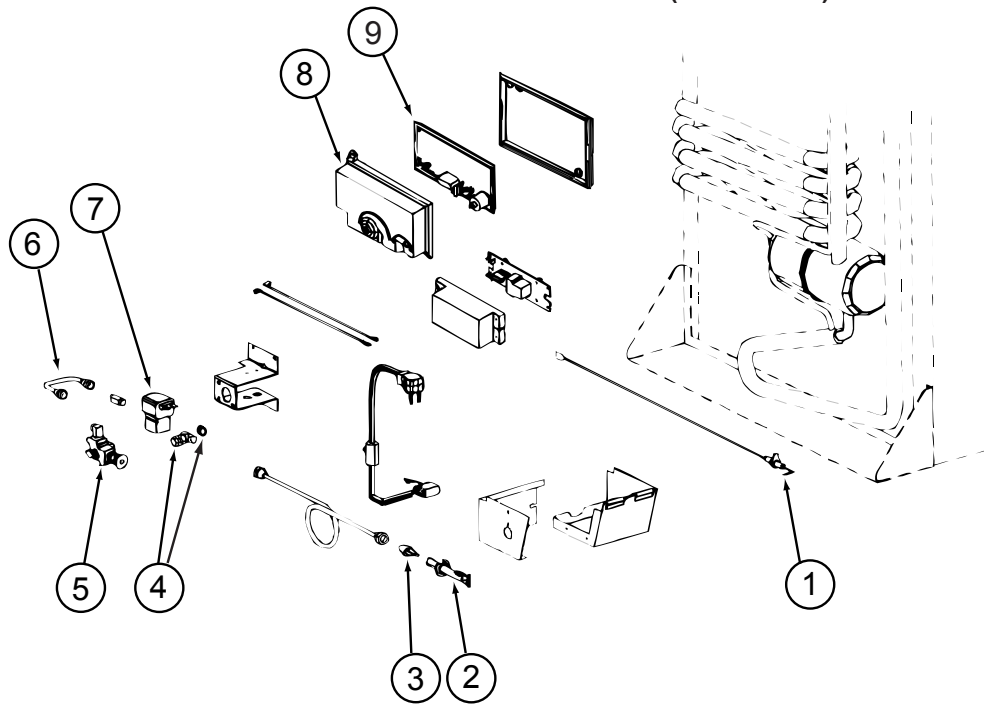

**121569-05-01A, 121569-06-01A & 121569-07-01A (CONTINUED)**

KEY	PART NUMBER	U/M	DESCRIPTION	VENDOR NO.
1	104137-06-715	EA	ELECTRODE-SPARK/SENSOR, SGL	61692222
2	104137-06-714	EA	BURNER ASSEMBLY, 5-SLOT	61705222
3	120075-01-737	EA	ORIFICE - JEWEL - .0155	618284
4	113737-01-702	EA	PLUG 1/8" F/PRESSURE TAP	61445322
4	113737-01-716	EA	TAP-PRESSURE	61594422
6	113737-01-750	EA	TUBE-UNION	61694622
7	084880-01-718	EA	VALVE-GAS, (ASCO)	61551822
8	120075-01-738	EA	COVER-POWER BOARD	618185
9	121568-03-719	EA	POWER - BOARD - 2-WAY	619353
	121568-03-720	EA	VALVE/SHUT OF-MANUAL ELECT.	618696

CONTACT WINNEBAGO PART SALES FOR UNLISTED COMPONENTS

**CABINET & APPLIANCE GROUP (CONTINUED)**  
**COMPONENT PARTS FOR APPLIANCES (CONTINUED)**

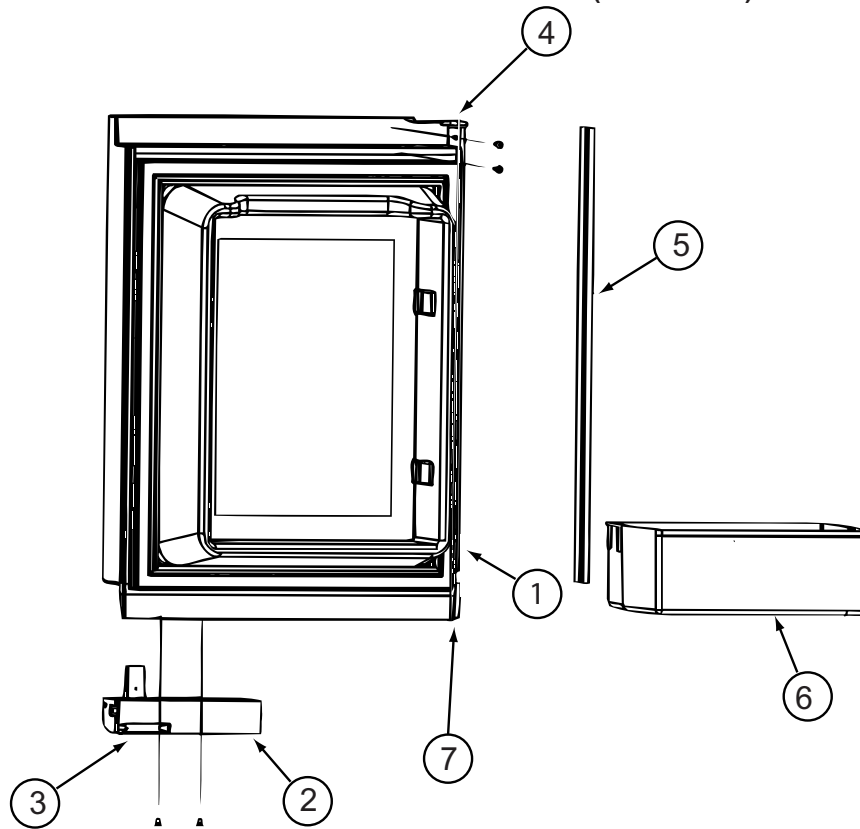

125242-02-01A

KEY	PART NUMBER	U/M	DESCRIPTION	VENDOR NO.
1	125242-01-762	EA	LINER/FOAMED-UPPER/LH-WHITE	619839
1	125242-02-734	EA	LINER/FOAMED-UPPER/LH-BLACK	625212 AFT #1291390
2	125242-02-700	EA	HANDLE(CONTOUR)TOP LH BTM RH	621107
3	125242-02-722	EA	LATCH-STORAGE DR/BLK POINTED	619374
4	125242-02-724	EA	HINGE - DOOR	618792
5	125242-02-723	EA	RETAINER/PANEL-UPPER DOOR	623166
6	125242-03-704	EA	DOOR BIN	622831
7	125242-01-704	EA	BUSHING-HINGE MIDDLE	618746
	125242-02-725	EA	DOOR ASM/UPR LH/WHITE GASKET	621148
	125242-02-735	EA	DOOR ASM/UPR LH/BLACK GASKET	625220 AFT #1291390
	125242-01-719	EA	RETAINER-UPPER PANEL	618825 = 623166

**CABINET & APPLIANCE GROUP (CONTINUED)**  
**COMPONENT PARTS FOR APPLIANCES (CONTINUED)**

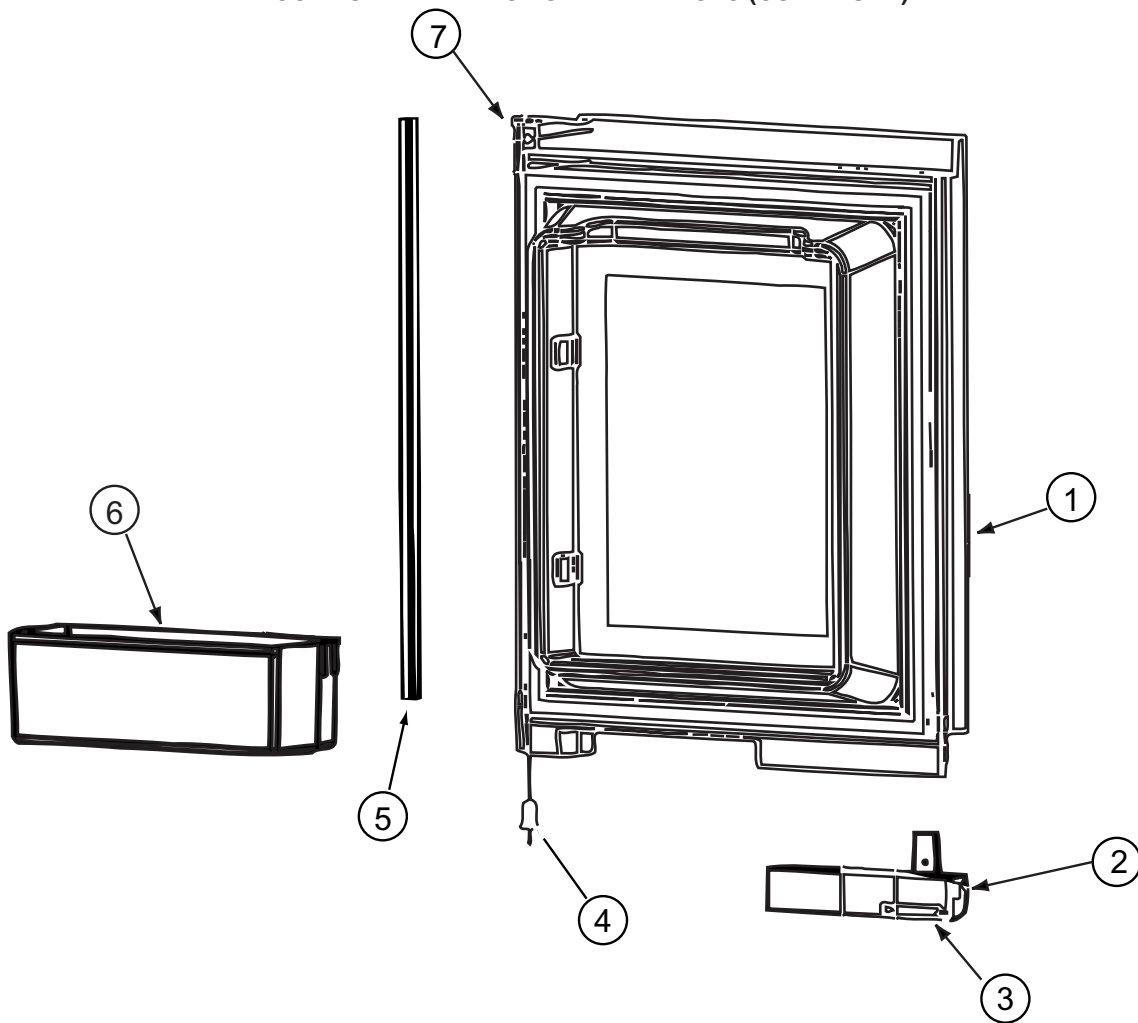

**125242-02-01A (CONTINUED)**

KEY	PART NUMBER	U/M	DESCRIPTION	VENDOR NO.
1	125242-01-763	EA	LINER/FOAMED-UPPER/RH-WHITE	619840
1	125242-02-733	EA	LINER/FOAMED-UPPER/RH-BLACK	625213 1291391 & UP
2	125242-02-701	EA	HANDLE(CONTOUR)TOP RH LWR LH	621106
3	125242-02-722	EA	LATCH-STORAGE DR/BLK POINTED	619374
4	125242-01-704	EA	BUSHING-HINGE MIDDLE	618746
5	125242-02-723	EA	RETAINER/PANEL-UPPER DOOR	623166
6	125242-03-704	EA	BIN - DOOR SHELF	622831
7	125242-02-724	EA	HINGE - DOOR	618792
	125242-02-721	EA	DOOR ASM-UPR/RH/WHITE GASKET	621149
	125242-02-732	EA	DOOR ASM-UPR/RH/BLACK GASKET	625221 1291391 & UP
	125242-01-719	EA	RETAINER-UPPER PANEL	618825 = 623166

**CABINET & APPLIANCE GROUP (CONTINUED)**  
**COMPONENT PARTS FOR APPLIANCES (CONTINUED)**

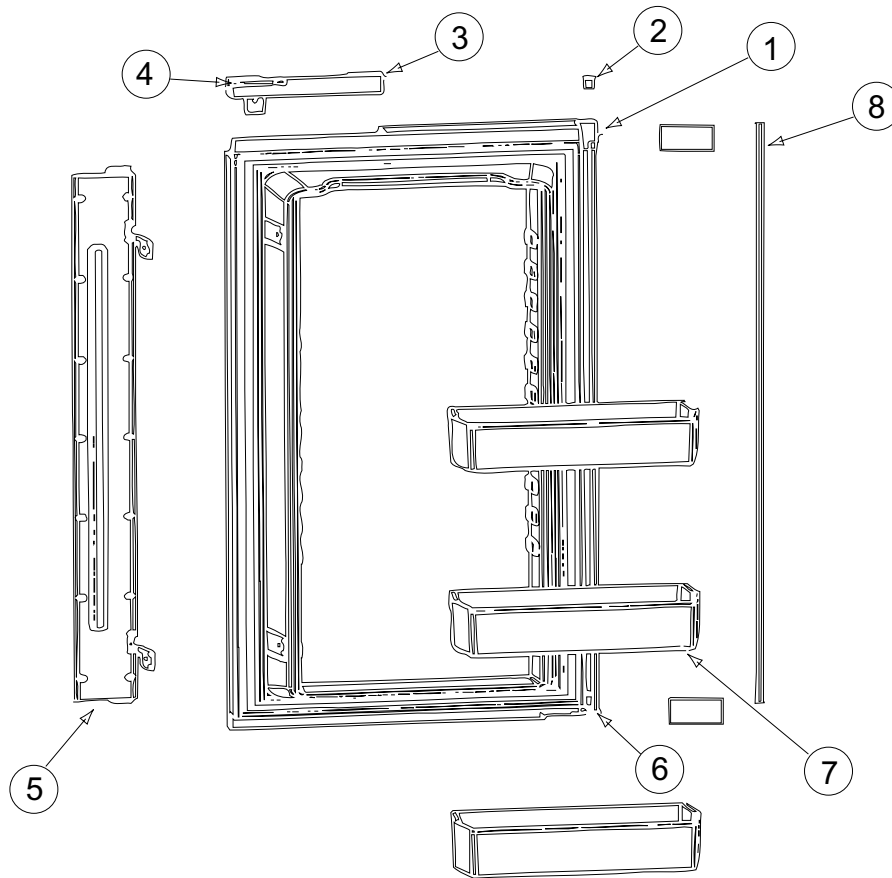

**125242-02-01A (CONTINUED)**

KEY	PART NUMBER	U/M	DESCRIPTION	VENDOR NO.
1	125242-01-765	EA	LINER/FOAMED-LOWER-LH-WHITE	619837
1	125242-02-739	EA	LINER/FOAMED-LOWER-LH-BLACK	625214 1291390 & UP
2	125242-01-704	EA	BUSHING-HINGE MIDDLE	618746
3	125242-02-701	EA	HANDLE(CONTOUR)TOP RH LWR LH	621106
4	125242-02-722	EA	LATCH-STORAGE DR/BLK POINTED	619374
5	125242-02-727	EA	FLAPPER/DBL POLE (SER#540295) UP	619845
5	125242-02-740	EA	FLAPPER/DBL POLE SER#1291391	623887 1291391 & UP
6	125242-02-724	EA	HINGE - DOOR	618792
7	125242-03-704	EA	BIN - DOOR SHELF	622831
8	125242-02-728	EA	RETAINER/PANEL - LOWER	623167
	125242-02-726	EA	DOOR ASM-LWR LH/WHITE GASKET	621150
	125242-02-738	EA	DOOR ASM-LWR LH/BLACK GASKET	625222 1291390 & UP
	125242-02-716	EA	GUIDE ASM LWR(SER#540294 DN)	620042
	125242-02-717	EA	GUIDE ASM LWR(SER#540295 UP)	620043
	125242-03-706	EA	PROBE - CONTACT/LARGE	620689



**CABINET & APPLIANCE GROUP (CONTINUED)**  
**COMPONENT PARTS FOR APPLIANCES (CONTINUED)**

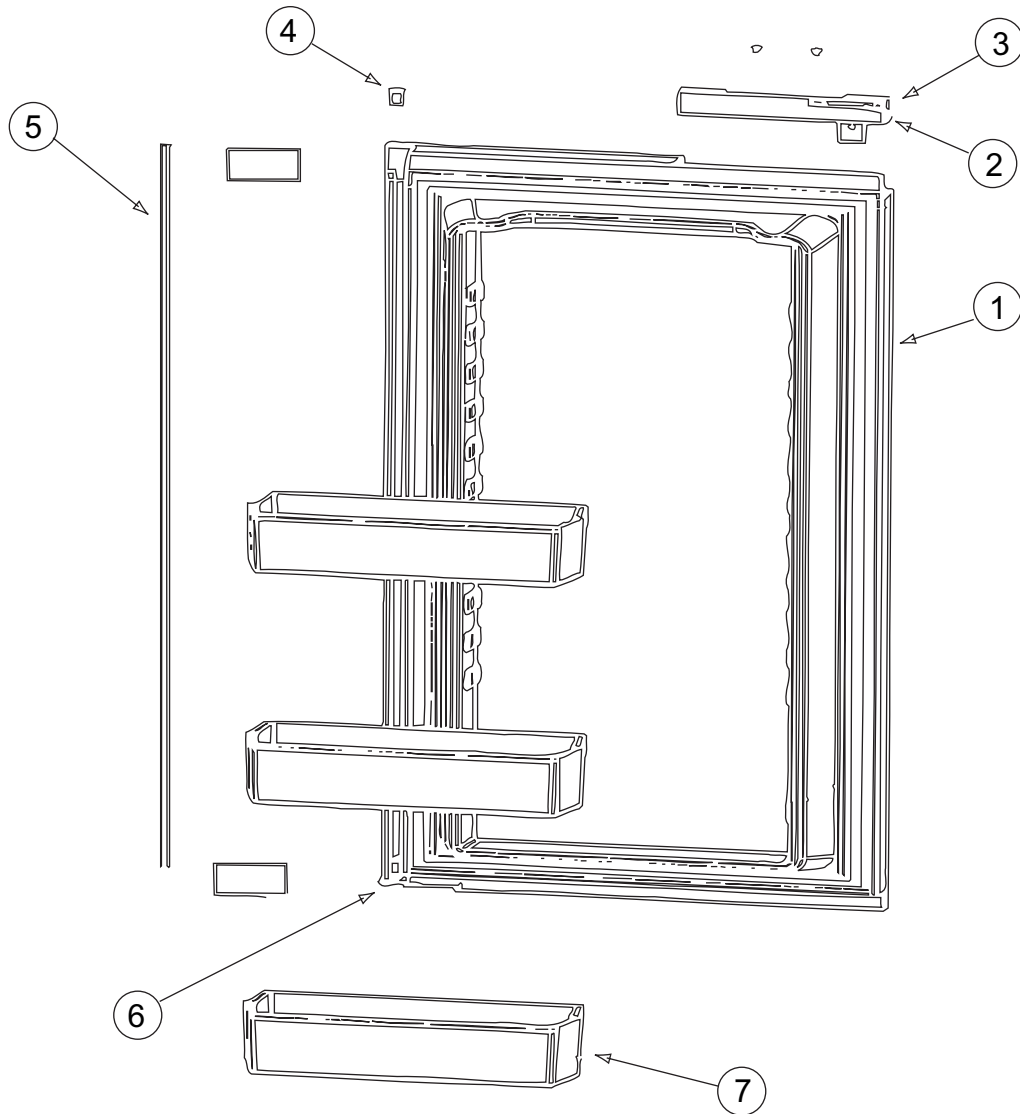

**125242-02-01A (CONTINUED)**

KEY	PART NUMBER	U/M	DESCRIPTION	VENDOR NO.
1	125242-01-764	EA	LINER/FOAMED-LOWER/RH-WHITE	619838
1	125242-02-737	EA	LINER/FOAMED-LOWER/RH-BLACK	625215 F/1291391&UP
2	125242-02-700	EA	HANDLE(CONTOUR)TOP LH BTM RH	621107
3	125242-02-722	EA	LATCH-STORAGE DR/BLK POINTED	619374
4	125242-01-704	EA	BUSHING-HINGE MIDDLE	618746
5	125242-02-728	EA	RETAINER/PANEL - LOWER	623167
6	125242-02-724	EA	HINGE - DOOR	618792
7	125242-03-704	EA	BIN - DOOR SHELF	622831
	125242-02-729	EA	DOOR ASM-LWR RH/WHITE GASKET	621151
	125242-02-736	EA	DOOR ASM-LWR RH/BLACK GASKET	625223 F/1291391&UP
	125242-02-716	EA	GUIDE ASM LWR(SER#540294 DN)	620042
	125242-02-717	EA	GUIDE ASM LWR(SER#540295 UP)	620043

**CABINET & APPLIANCE GROUP (CONTINUED)**  
**COMPONENT PARTS FOR APPLIANCES (CONTINUED)**

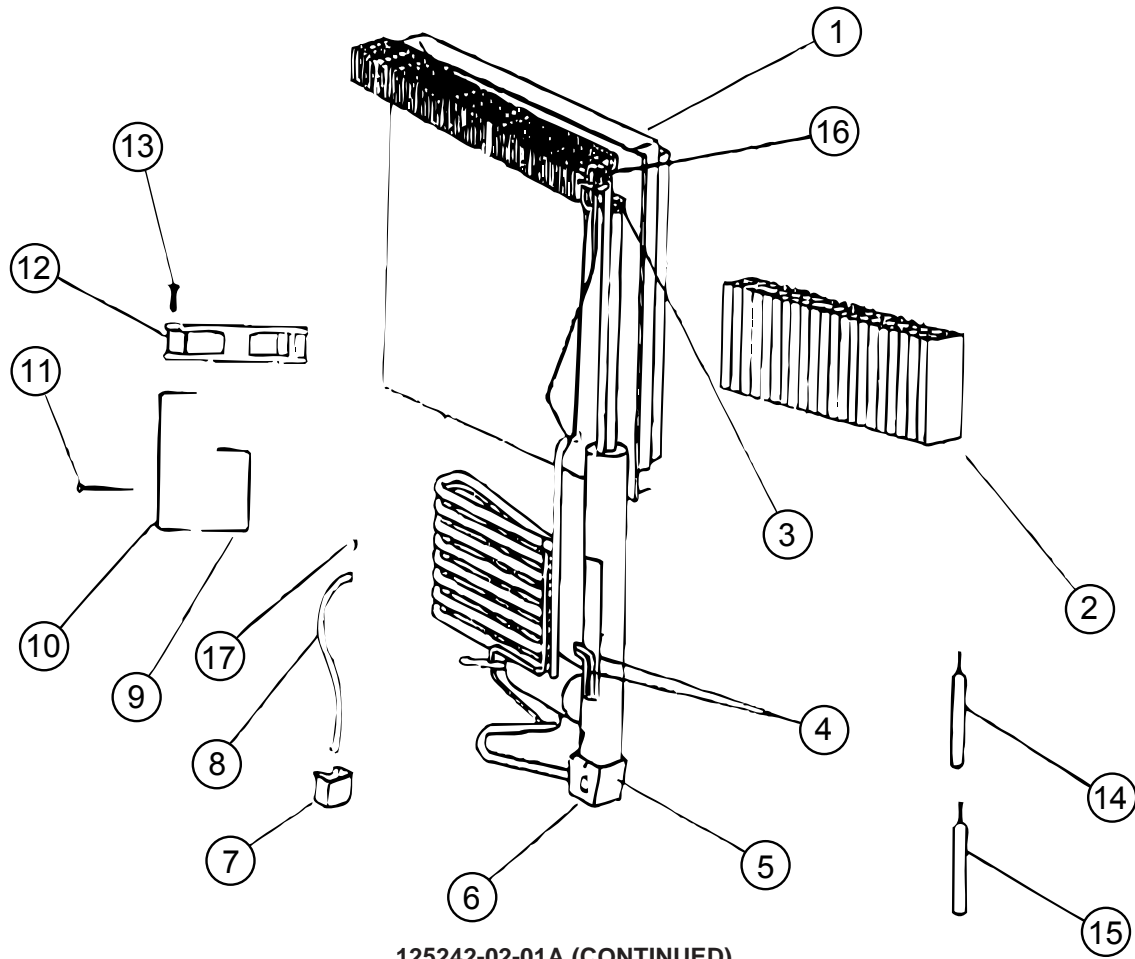

**125242-02-01A (CONTINUED)**

KEY	PART NUMBER	U/M	DESCRIPTION	VENDOR NO.
1	125242-01-746	EA	COOLING UNIT - 1200	618964
4	125242-01-732	EA	HEATER AC - 225W/110VAC	618872
5	125242-01-739	EA	BASE-BURNER BOX	618902
6	125242-01-740	EA	COVER-BURNER BOX	618910
9	125242-01-730	EA	BRACKET-DC FAN	618857
10	125242-01-741	EA	SUPPORT-DC FAN	618912
12	125242-01-729	EA	FAN-EXTERNAL DC	618856
16	113737-01-754	EA	THERMOSTAT (FAN 12V DC)	618093

CONTACT WINNEBAGO PART SALES FOR UNLISTED COMPONENTS

**CABINET & APPLIANCE GROUP (CONTINUED)**  
**COMPONENT PARTS FOR APPLIANCES (CONTINUED)**

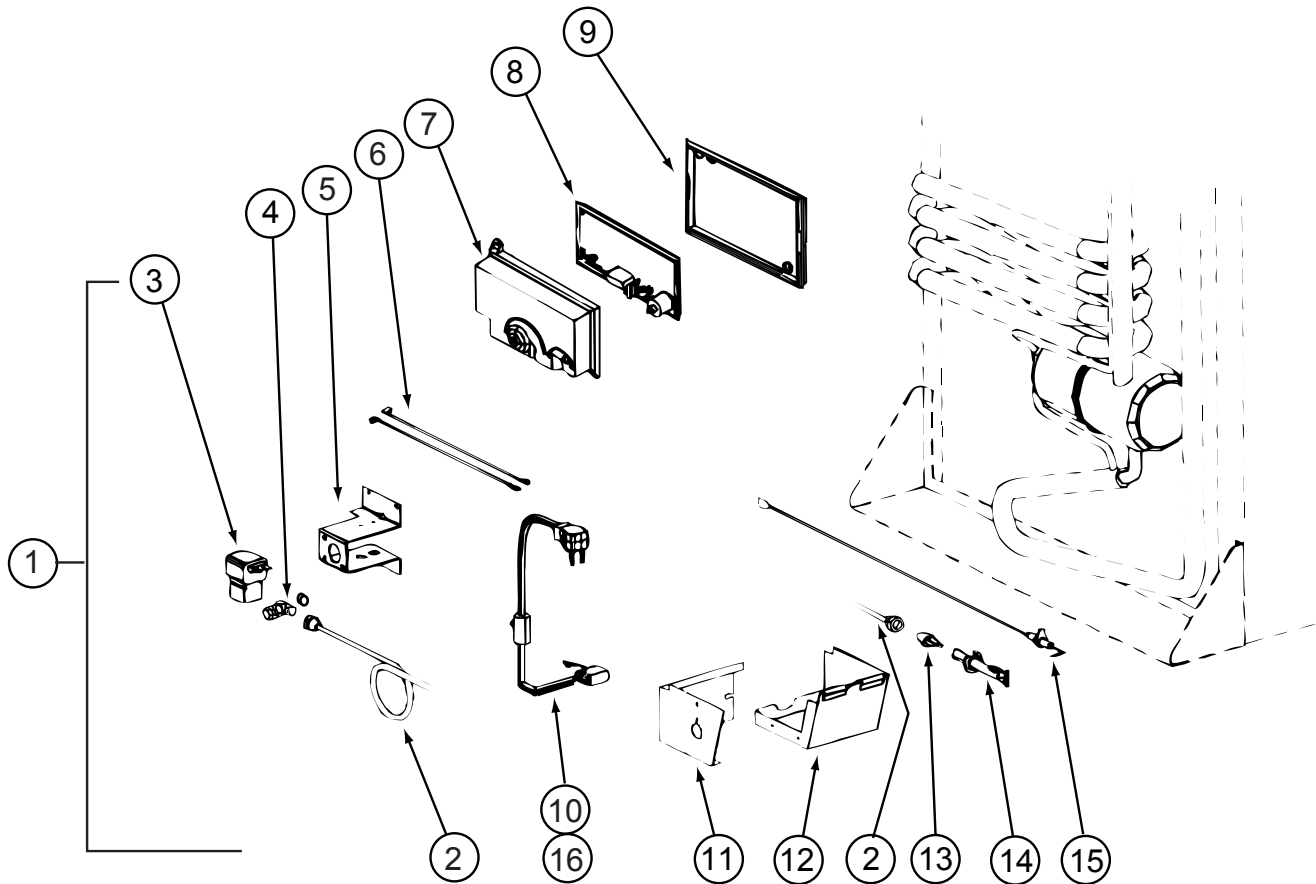

**125242-02-01A (CONTINUED)**

KEY	PART NUMBER	U/M	DESCRIPTION	VENDOR NO.
1	125242-01-753	EA	KIT-GAS VALVE/SOLENOID/TUBE	621445
2	125242-01-744	EA	BURNER TUBE	618937
4	113737-01-716	EA	TAP-PRESSURE	61594422
7	120075-01-738	EA	COVER-POWER BOARD	618185
8	125242-02-703	EA	POWER BOARD (SER #832171 UP)	621271
9	120075-01-740	EA	COVER-BASE, POWER BOARD	618186
11	125242-01-740	EA	COVER-BURNER BOX	618910
12	125242-01-739	EA	BASE-BURNER BOX	618902
13	125242-01-717	EA	ORIFICE-JEWEL	618814
14	125242-01-743	EA	BURNER - 8 SLOT	618932
15	104137-06-715	EA	ELECTRODE-SPARK/SENSOR, SGL	61692222

CONTACT WINNEBAGO PART SALES FOR UNLISTED COMPONENT(S)

**CABINET & APPLIANCE GROUP (CONTINUED)**  
**COMPONENT PARTS FOR APPLIANCES (CONTINUED)**

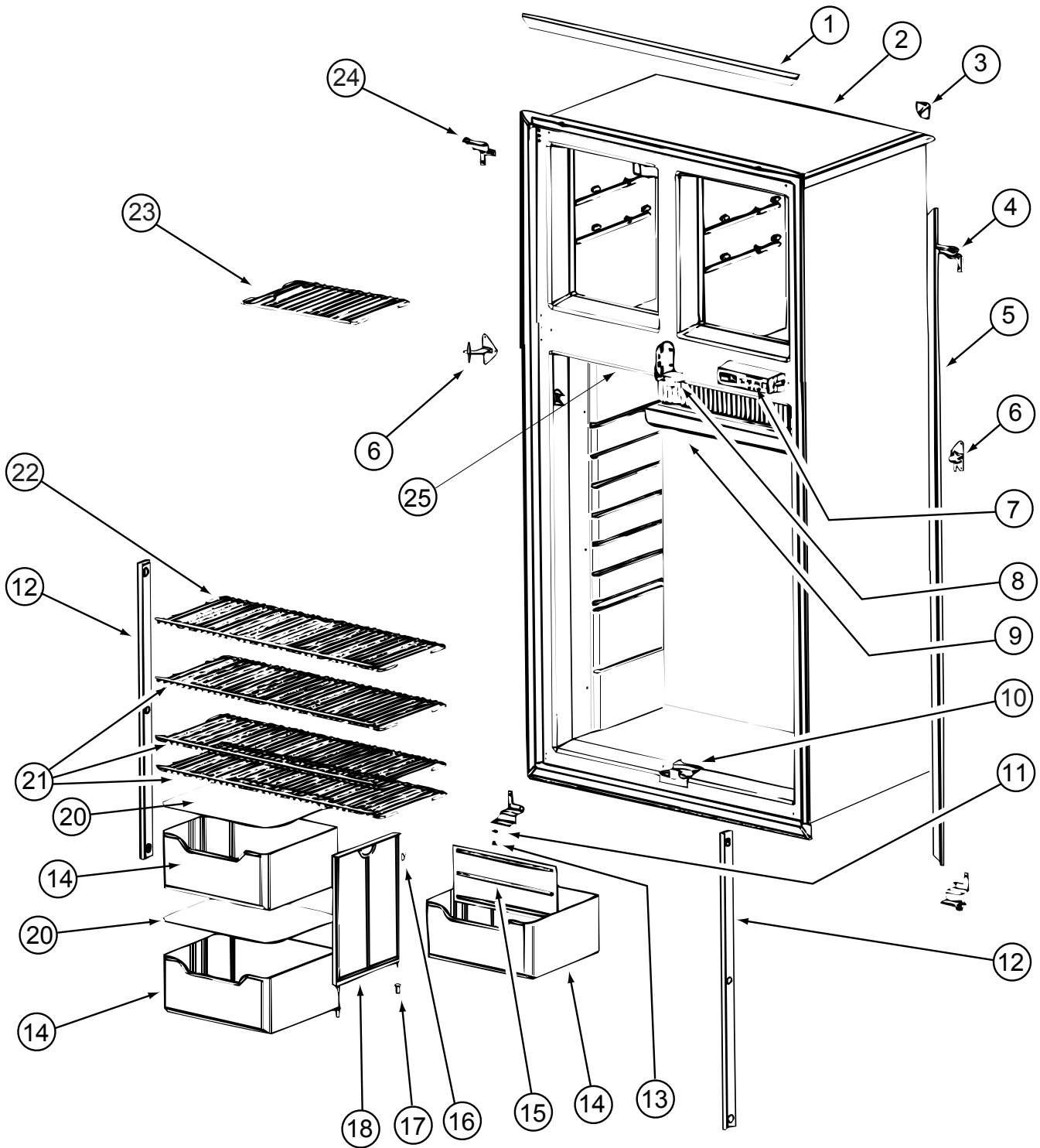

125242-02-01A (CONTINUED)

**CABINET & APPLIANCE GROUP (CONTINUED)**  
**COMPONENT PARTS FOR APPLIANCES (CONTINUED)**

**125242-02-01A (CONTINUED)**

<b>KEY</b>	<b>PART NUMBER</b>	<b>U/M</b>	<b>DESCRIPTION</b>	<b>VENDOR NO.</b>
1	125242-01-723	EA	TRIM-HORIZONTAL-FRT SNAP ON	618845
1	125242-02-730	EA	TRIM - TOP/BOTTOM - SCREW ON	623255
2	125242-01-748	EA	CABINET/FOAMED ASSEMBLY	618748
3	125242-01-722	EA	TRIM-CORNER	618844
3	125242-01-767	EA	KIT INSTALL(U TRIM PCS)HDW	623528
4	125242-01-715	EA	HINGE - TOP RH/BOTTOM LH	618798
5	125242-01-724	EA	TRIM-LT/RT-FRT VERT SNAPON	618846
5	125242-01-766	EA	TRIM-LT/RT HAND-SCREW ON	623254
6	125242-01-713	EA	HINGE-MIDDLE (PAINTED)	618794
7	125242-02-704	EA	DISPLAY ASM (SER#832172) UP	621188
8	125242-01-751	EA	BLOCK - GUIDE - UPPER	618789
9	125242-01-712	EA	DRIP TRAY	618774
10	125242-01-752	EA	BLOCK - GUIDE - LOWER	618788
11	120075-01-708	EA	BUSHING-DOOR HINGE	618144
12	120075-01-730	EA	RETAINER-SHELF(SER#926684 DN	618181
12	125242-02-720	EA	RETAINER/SHELF(SER#926685 UP	622033
13	120075-01-727	EA	PIN-HINGE	618145
14	125242-01-734	EA	CRISPER/BOTTLE BIN	618878
15	125242-01-733	EA	DIVIDER-BOTTLE CRISPER	618877
16	125242-01-750	EA	CLIP	61409622
17	113737-01-701	EA	BUSHING-HINGE	61742022
18	125242-01-749	EA	SUPPORT - WALL	618840
20	125242-01-706	EA	COVER-CRISPER	618757
21	125242-01-726	EA	SHELF-WIRE (LONG)	618848
22	125242-01-727	EA	SHELF-WIRE (SHORT)	618849
23	125242-01-725	EA	SHELF-FREEZER (WIRE)	618847
24	125242-01-714	EA	HINGE - TOP LH/BOTTOM RH	618796
25	125242-01-735	EA	SWITCH - DOOR LIGHT	618884
25	125242-01-768	EA	SWITCH - DOOR LIGHT	623918
	120075-01-714	EA	PLUG-HOLE (BLACK)	618170
	125242-01-728	EA	CAP-SCREW WHITE	618853

**CABINET & APPLIANCE GROUP (CONTINUED)**  
**COMPONENT PARTS FOR APPLIANCES (CONTINUED)**

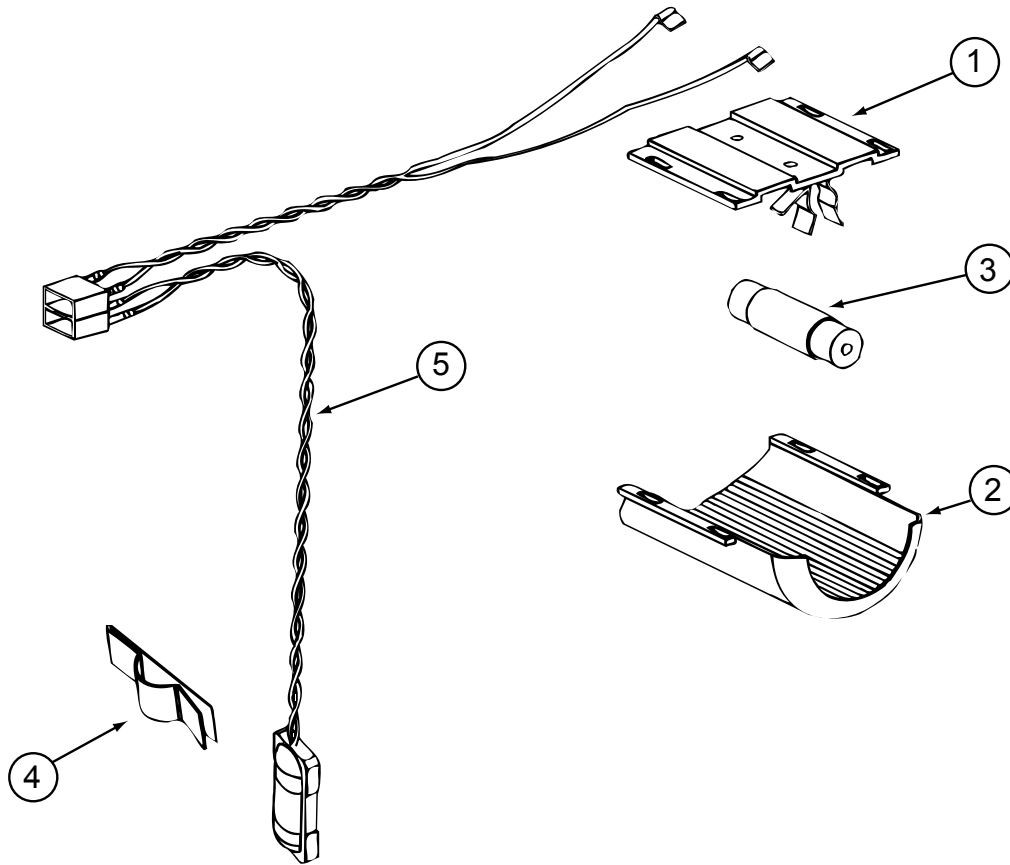

**125242-02-01A (CONTINUED)**

KEY	PART NUMBER	U/M	DESCRIPTION	VENDOR NO.
1	084880-03-705	EA	BRACKET-LIGHT-INTERIOR	61629722
2	120075-01-734	EA	COVER-LENS	618190
3	084880-03-706	EA	BULB-LAMP	61628922
4	084880-01-760	EA	CLIP (THERMISTER)	61689122
5	120075-01-735	EA	THERMISTER W/LAMP & WIRE/ASM	618548
	125242-02-706	EA	LAMP/WIRE ASM/SER#849677 UP	620871
	125242-02-707	EA	LAMP/WIRE ASM SER#849677 DWN	621742

**CABINET & APPLIANCE GROUP (CONTINUED)**  
**COMPONENT PARTS FOR APPLIANCES (CONTINUED)**

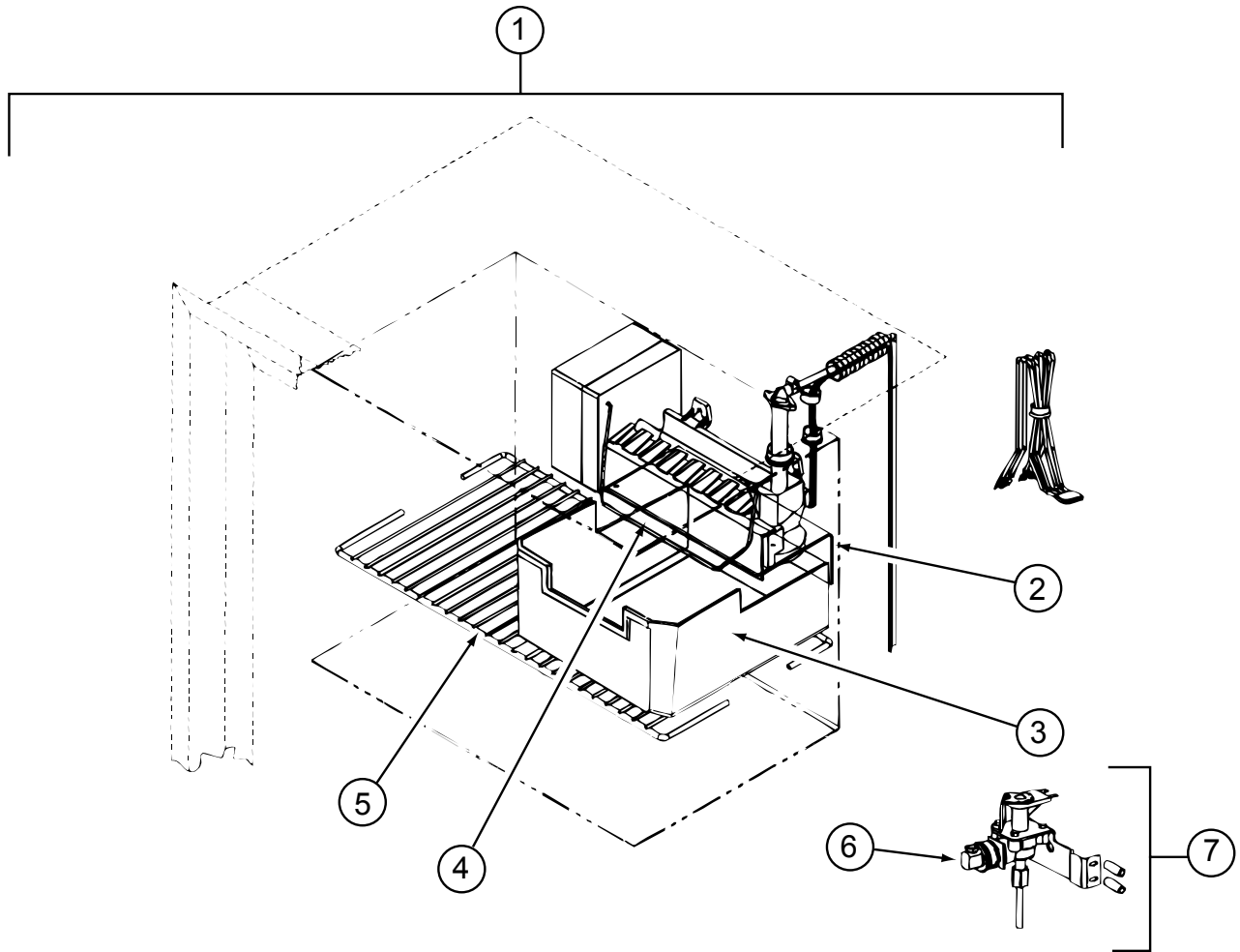

**125242-02-01A (CONTINUED)**

KEY	PART NUMBER	U/M	DESCRIPTION	VENDOR NO.
1	094039-07-706	EA	ICE MAKER W/O PLATES	61656522
2	125242-01-737	EA	BRACKET-MOUNTING (ICE MAKER)	618894/620890
3	125242-01-716	EA	ICE BIN	618803
4	120075-03-703	EA	ARM-SHUT OFF	61656922
5	125242-01-725	EA	SHELF-FREEZER (WIRE)	618847
6	120075-03-702	EA	NUT/COMPRESSION - FITTING	61678722
7	120075-03-701	EA	VALVE ASM., WATER, W/BRACKET	618253

**126022-01-01A, 126022-02-01A, 126022-03-01A**

KEY	PART NUMBER	U/M	DESCRIPTION	VENDOR NO.
	114030-01-707	EA	PLUG BUTTON BLACK	74002628
	126022-01-700	EA	BUMPER - RANGE BIFOLD COVER	MAGIC 8003P007-60
	126022-01-701	EA	HINGE-RANGE BIFOLD COVER-22"	MAGIC 3418F067-34

**CABINET & APPLIANCE GROUP (CONTINUED)**  
**COMPONENT PARTS FOR APPLIANCES (CONTINUED)**

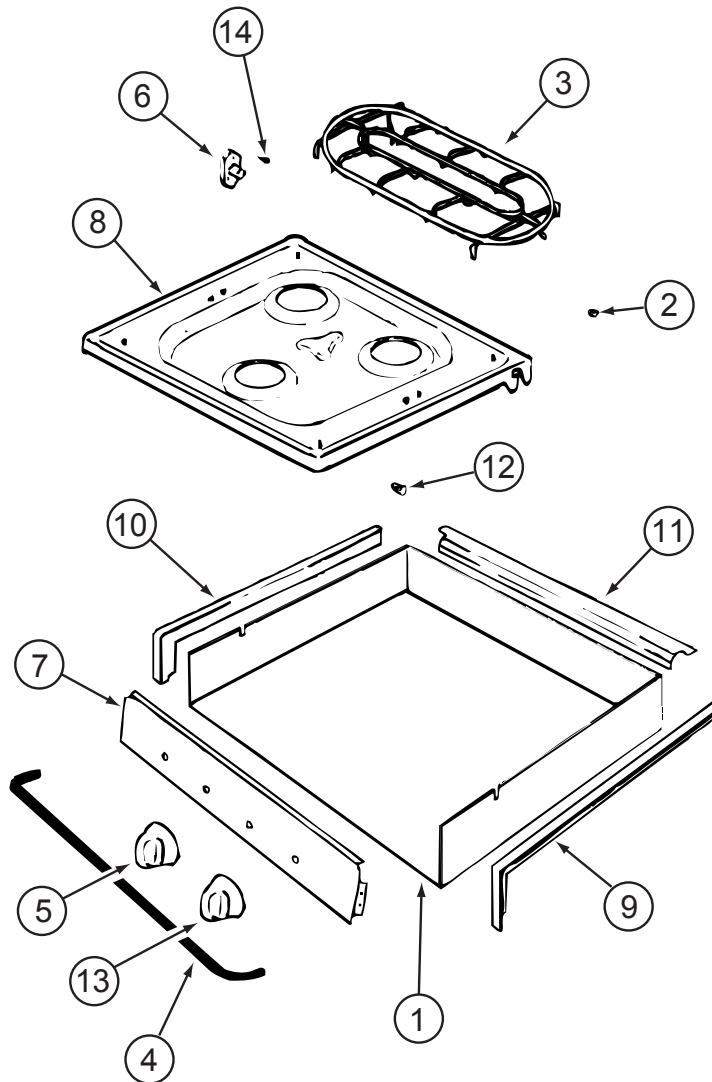

135065-03-01A, 135065-03-03A, 135065-04-01A

KEY	PART NUMBER	U/M	DESCRIPTION	VENDOR NO.
2	102020-01-709	EA	BUMPER-GRATE	8007-P020-60
3	135065-03-703	EA	GRATE - BLACK(SEALED BURNER)	74007304
4	114030-02-700	EA	GUARD/FABRIC - TOWEL BAR	3609F006-70
5	128728-01-701	EA	KNOB - BURNER - REAR	74003941
5	128728-01-702	EA	KNOB - BURNER - FRONT	74003942
6	128728-01-703	EA	PIN/T-NUT F/HINGE	7103P109-60
7	135065-03-704	EA	PANEL - MANIFOLD (BLACK)	74007330
8	128728-01-705	EA	TOP - MAIN - BLACK	74003928
8	135065-03-715	EA	TOP - MAIN - STAINLESS STEEL	74007299
9	114030-01-704	EA	TRIM - RIGHT/BLACK TEXTURED	74002839
10	114030-01-705	EA	TRIM - LEFT/BLACK TEXTURED	74002840
11	114030-01-706	EA	TRIM - REAR/BLACK TEXTURED	74002841
12	102020-01-724	EA	BUMPER-MAIN TOP	8003P008-60
13	128728-01-707	EA	KNOB - IGNITOR	74003944

CONTACT WINNEBAGO PART SALES FOR UNLISTED COMPONENT(S)



**CABINET & APPLIANCE GROUP (CONTINUED)**  
**COMPONENT PARTS FOR APPLIANCES (CONTINUED)**

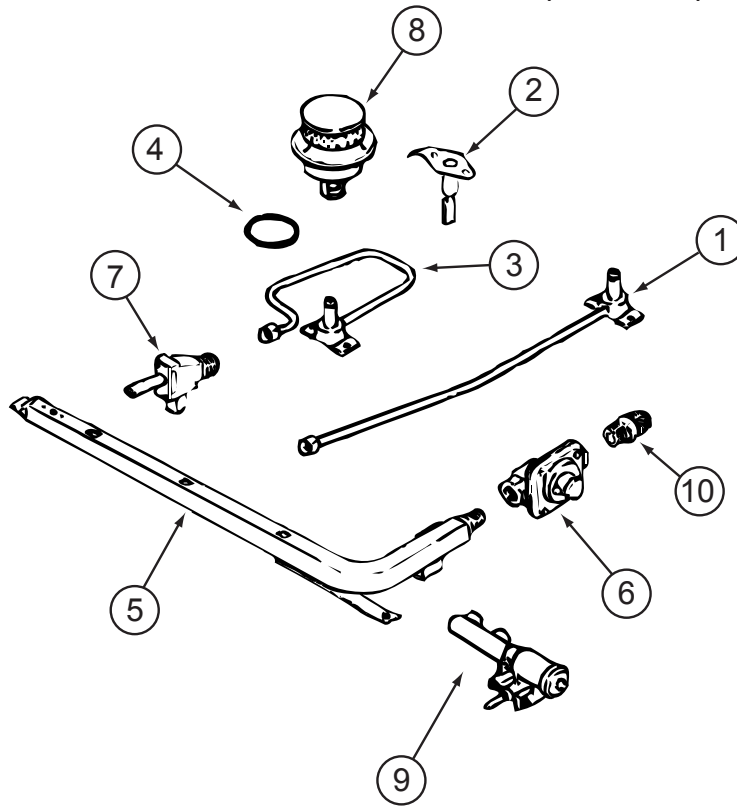

**135065-03-01A, 135065-03-03A, 135065-04-01A (CONTINUED)**

KEY	PART NUMBER	U/M	DESCRIPTION	VENDOR NO.
1	128728-01-708	EA	FITTING W/ORFICE/TUBE - REAR	74003931
2	135065-01-701	EA	IGNITOR/PORCELAIN-TOP BURNER	74004053
3	128728-01-710	EA	FITTING W/ORFICE/TUBE - FRT	74003930
4	135065-03-700	EA	FITTING - HALF UNION	74004234
5	135065-01-702	EA	PIPE/MANIFOLD	74004642
6	126023-02-703	EA	REGULATOR - PRESSURE	74004235
7	135065-01-703	EA	VALVE/BURNER - REAR	74004643
7	135065-01-704	EA	VALVE/BURNER-FRT-HI	74004644
7	135065-03-701	EA	SCREW - VALVE	71003231
8	135065-03-702	EA	SEALED BURNER ASM.(BLACK) RV	74003967
9	128728-01-716	EA	BURNER - IGNITOR	74003946
9	128728-01-717	EA	WIRES - IGNITOR	74003947

**CABINET & APPLIANCE GROUP (CONTINUED)**  
**COMPONENT PARTS FOR APPLIANCES (CONTINUED)**

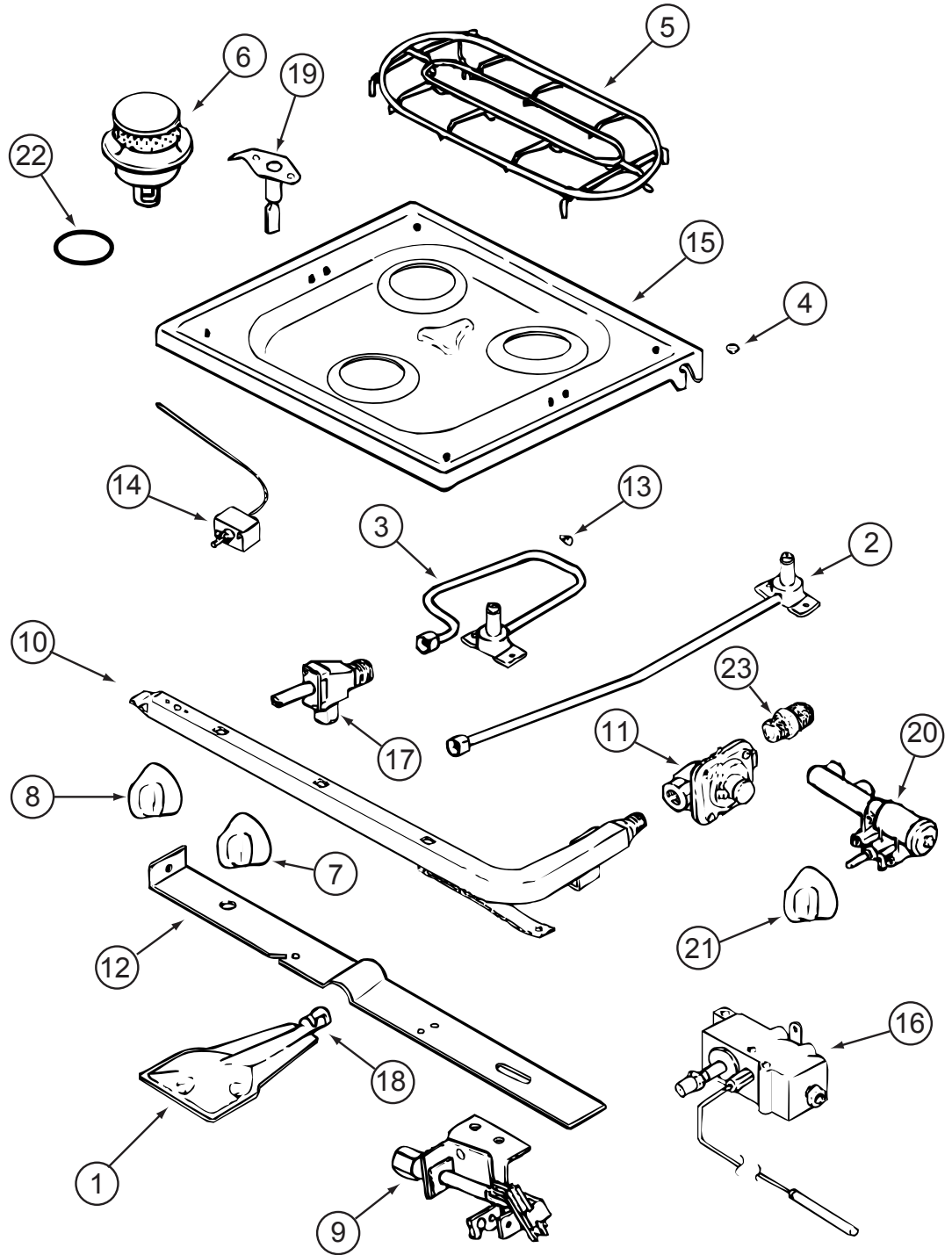

135066-03-01A, 135066-03-04A, 150778-01-01A

**CABINET & APPLIANCE GROUP (CONTINUED)**  
**COMPONENT PARTS FOR APPLIANCES (CONTINUED)**

135066-03-01A, 135066-03-04A, 150778-01-01A (CONTINUED)

KEY	PART NUMBER	U/M	DESCRIPTION	VENDOR NO.
1	126023-01-717	EA	BURNER - OVEN	74003343
2	128728-01-708	EA	FITTING W/ORFICE/TUBE - REAR	74003931
3	128728-01-710	EA	FITTING W/ORFICE/TUBE - FRT	74003930
4	102020-01-709	EA	BUMPER-GRATE	8007-P020-60
5	135065-03-703	EA	GRATE - BLACK(SEALED BURNER)	74007304
6	135065-03-702	EA	SEALED BURNER ASM.(BLACK) RV	74003967
7	128728-01-701	EA	KNOB - BURNER - REAR	74003941
7	128728-01-702	EA	KNOB - BURNER - FRONT	74003942
8	112881-04-703	EA	KNOB - THERMOSTAT - BLACK	74004645
9	112881-04-706	EA	PILOT - OVEN	74006334
10	126023-02-702	EA	PIPE - MANIFOLD	74004360
11	126023-02-703	EA	REGULATOR - PRESSURE	74004235
13	102020-01-724	EA	BUMPER-MAIN TOP	8003P008-60
14	126023-01-734	EA	THERMOSTAT/OVEN SERIES #11	74006332
15	128728-01-705	EA	TOP - MAIN - BLACK	74003928
15	135065-03-705	EA	TOP - MAIN - BLACK F/1512790201A ONLY	74007300
15	135065-03-715	EA	TOP - MAIN - STAINLESS STEEL	74007299
16	112881-04-704	EA	VALVE - OVEN	74006333
17	135065-01-703	EA	VALVE/BURNER - REAR	74004643
17	135065-01-704	EA	VALVE/BURNER-FRT-HI	74004644
17	135065-03-701	EA	SCREW - VALVE	71003231
18	135656-01-701	EA	MIXER/AIR	3411F003-34
19	135065-01-701	EA	IGNITOR/PORCELAIN-TOP BURNER	74004053
20	128728-01-716	EA	BURNER - IGNITOR	74003946
20	128728-01-717	EA	WIRES - IGNITOR	74003947
21	128728-01-707	EA	KNOB - IGNITOR	74003944
22	135065-03-700	EA	FITTING - HALF UNION	74004234

CONTACT WINNEBAGO PART SALES FOR UNLISTED COMPONENTS

**CABINET & APPLIANCE GROUP (CONTINUED)**  
**COMPONENT PARTS FOR APPLIANCES (CONTINUED)**

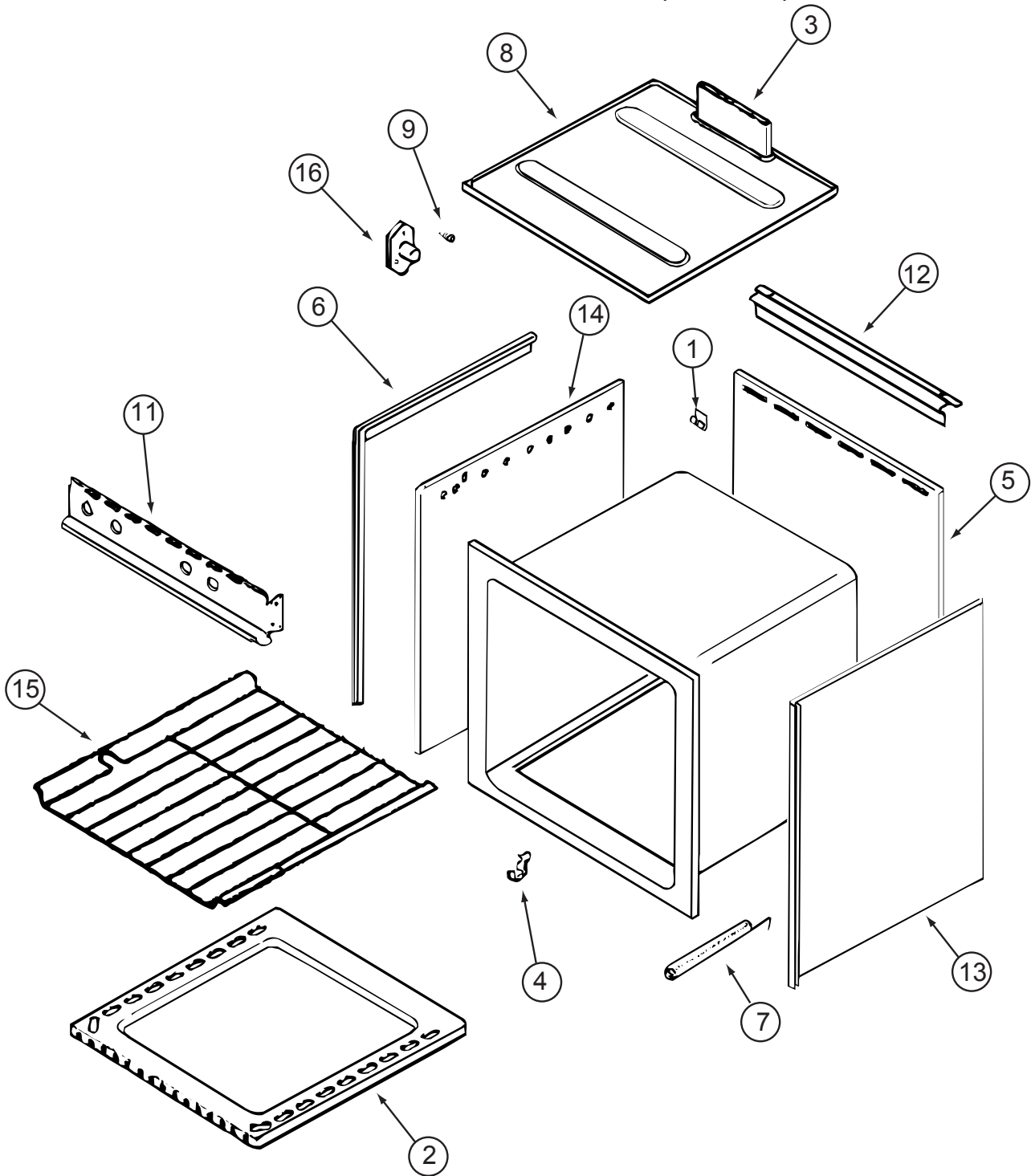

135066-03-01A/04A, 150778-01-01A, 151277-03-01A, 151279-02-01A/02A, 151279-03-01A (CONTINUED)

KEY	PART NUMBER	U/M	DESCRIPTION	VENDOR NO.
1	112881-03-702	EA	CLIP - MAIN TOP	74003998
2	126023-01-731	EA	BOTTOM - OVEN	2205F016-19
3	126023-01-718	EA	FLUE BOX ASSEMBLY	4006W075-80
6	126023-01-713	EA	TRIM - SIDE (RIGHT)	74002827
6	126023-01-714	EA	TRIM - SIDE (LEFT)	74002828
7	135066-03-708	EA	SPRING - OVEN DOOR	7803P053-60
9	128728-01-703	EA	PIN/T-NUT F/HINGE	7103P109-60
11	135066-03-701	EA	PANEL - MANIFOLD - BLACK	74007306
12	112881-01-721	EA	DEFLECTOR/FLUE-BLK-SEALED BR	74002829
15	126023-01-716	EA	RACK - OVEN	74003106

CONTACT WINNEBAGO PART SALES FOR UNLISTED COMPONENT(S)

**CABINET & APPLIANCE GROUP (CONTINUED)**  
**COMPONENT PARTS FOR APPLIANCES (CONTINUED)**

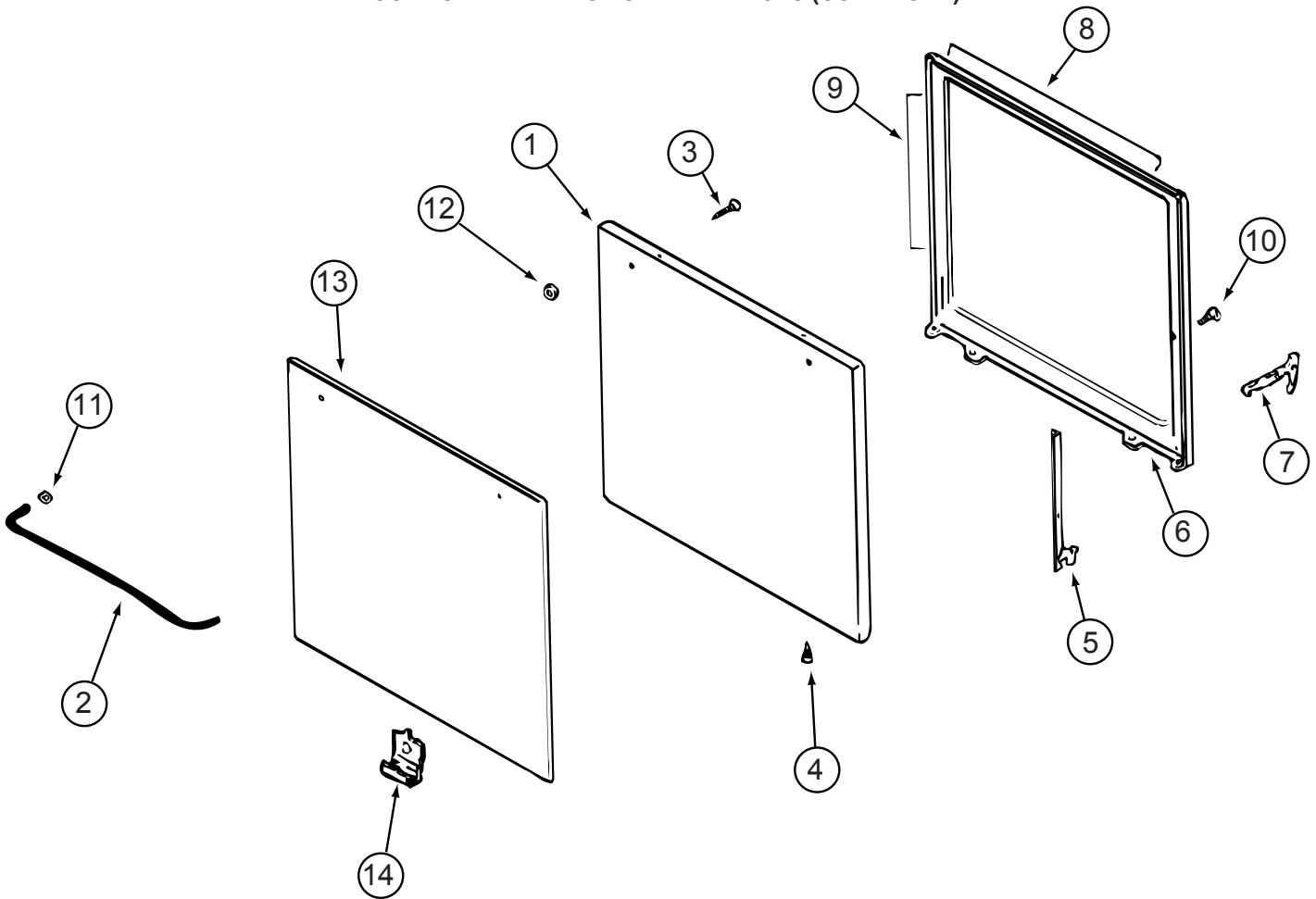

135066-03-01A, 135066-03-04A (CONTINUED)

KEY	PART NUMBER	U/M	DESCRIPTION	VENDOR NO.
1	126023-01-712	EA	PANEL - DOOR (BLACK)	74001190
1	135066-03-702	EA	PANEL - DOOR - STAINLESS STEEL	74007313
2	102020-01-701	EA	HANDLE,DOOR	7701P092-60
8	126023-01-732	EA	SEAL/OVEN DR TOP	7212P014-60
9	126023-01-733	EA	SEAL/OVEN DR SIDES(2PCS)	7212P038-60
13	102020-01-725	EA	GLASS OUTER	7902P266-60

CONTACT WINNEBAGO PART SALES FOR UNLISTED COMPONENT(S)

**CABINET & APPLIANCE GROUP (CONTINUED)**  
**CABINET & APPLIANCE LAYOUT (CONTINUED)**

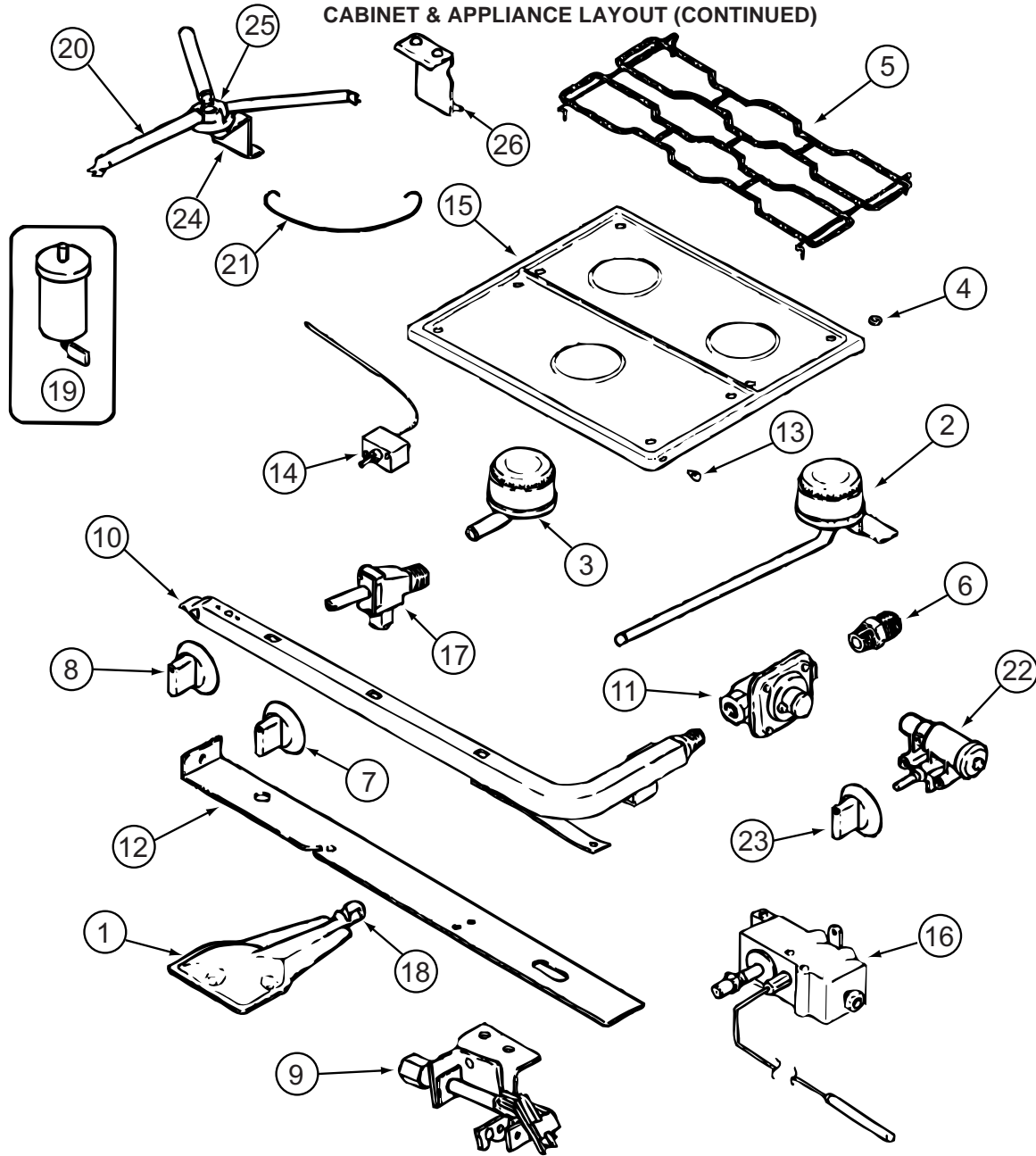

144972-01-01A

KEY	PART NUMBER	U/M	DESCRIPTION	VENDOR NO.
1	126023-01-717	EA	BURNER - OVEN	74003343
2	112881-04-700	EA	BURNER - TOP/LEFT REAR	74004584
2	126023-01-700	EA	BURNER-TOP (RT-REAR) 5100BTU	74004583
3	112881-04-701	EA	BURNER - TOP/FRONT	74004582
4	102020-01-709	EA	BUMPER-GRATE	8007-P020-60
5	112881-04-702	EA	GRATE - BLACK	74007277
6	135065-03-700	EA	FITTING - HALF UNION	74004234
7	128728-01-701	EA	KNOB - BURNER - REAR	74003941
7	128728-01-702	EA	KNOB - BURNER - FRONT	74003942
8	112881-04-703	EA	KNOB - THERMOSTAT - BLACK	74004645
9	112881-04-706	EA	PILOT - OVEN	74006334
10	126023-02-702	EA	PIPE - MANIFOLD	74004360
11	126023-02-703	EA	REGULATOR - PRESSURE	74004235
13	102020-01-724	EA	BUMPER-MAIN TOP	8003P008-60
14	126023-01-734	EA	THERMOSTAT/OVEN SERIES #11	74006332
15	135065-03-705	EA	TOP - MAIN (BLACK)	74007300
16	112881-04-704	EA	VALVE - OVEN	74006333

**CABINET & APPLIANCE GROUP (CONTINUED)**  
**COMPONENT PARTS FOR APPLIANCES (CONTINUED)**

KEY	PART NUMBER	U/M	DESCRIPTION	VENDOR NO.
17	126023-02-705	EA	VALVE - BURNER - REAR	74004362
17	126023-02-706	EA	VALVE - BURNER - FRONT	74004363
17	135065-03-701	EA	SCREW - VALVE	71003231
18	135656-01-701	EA	MIXER/AIR	3411F003-34
19	112881-04-705	EA	PUSH RING (ELECTRODE MTG)	7104P002-60
19	126023-01-711	EA	ELECTRODE - IGNITER (ONLY)	7432P077-60
20	126023-01-736	EA	FLASH TUBE EXTENSION (REAR)	74003326
20	126023-01-737	EA	FLASH TUBE EXTENSION (FRONT)	74003327
22	126023-01-719	EA	IGNITER HEAD - TOP BURNER	74002413
23	128728-01-707	EA	KNOB - IGNITOR	74003944

CONTACT WINNEBAGO PART SALES FOR UNLISTED COMPONENTS

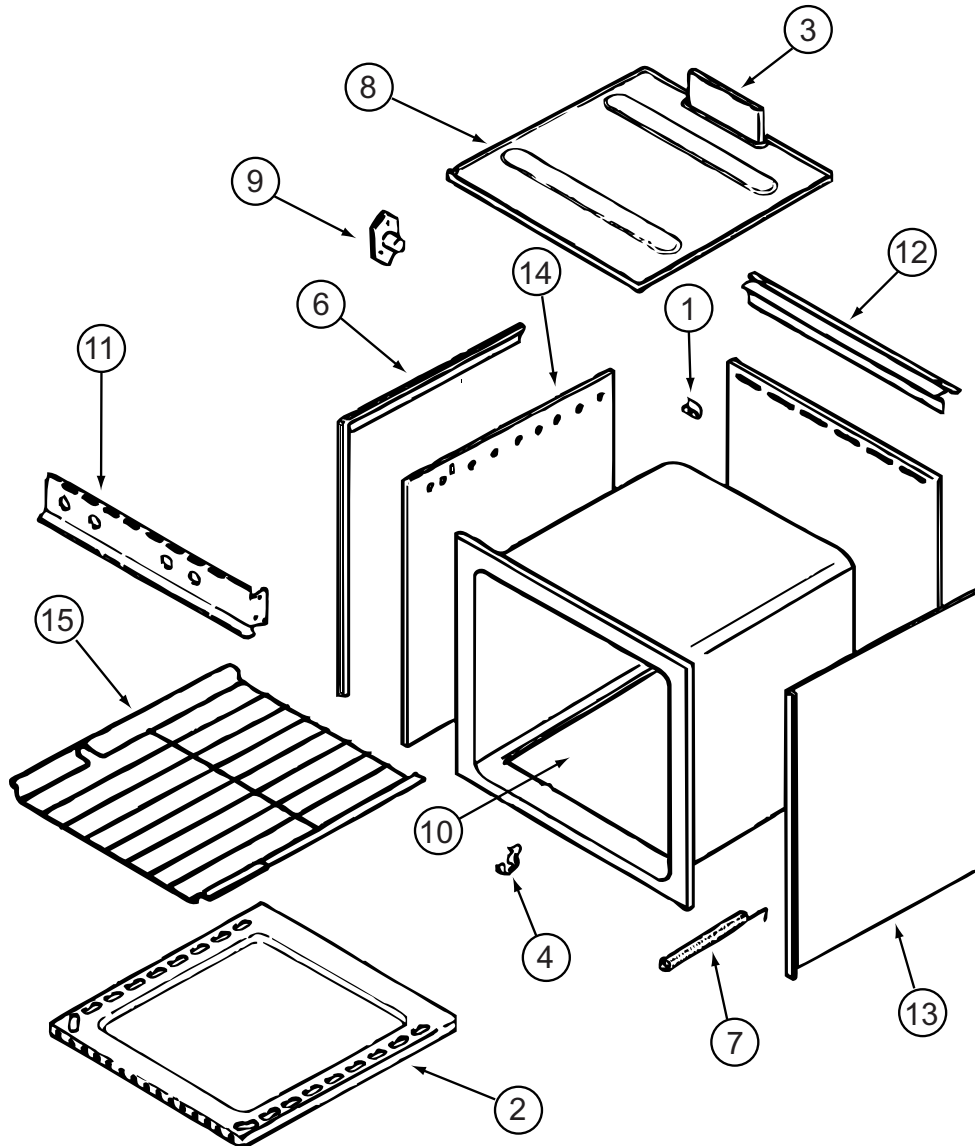

**144972-01-01A (CONTINUED)**

KEY	PART NUMBER	U/M	DESCRIPTION	VENDOR NO.
1	112881-03-702	EA	CLIP - MAIN TOP	74003998
2	126023-01-731	EA	BOTTOM - OVEN	2205F016-19
3	126023-01-718	EA	FLUE BOX ASSEMBLY	4006W075-80
6	126023-01-713	EA	TRIM - SIDE (RIGHT)	74002827
6	126023-01-714	EA	TRIM - SIDE (LEFT)	74002828
7	135066-03-700	EA	SPRING - OVEN DOOR	74001835
9	128728-01-703	EA	PIN/T-NUT F/HINGE	7103P109-60
11	144972-01-700	EA	MANIFOLD - BLACK	74002809
12	112881-01-721	EA	DEFLECTOR/FLUE-BLK-SEALED BR	74002829
15	126023-01-716	EA	RACK - OVEN	74003106

CONTACT WINNEBAGO PART SALES FOR UNLISTED COMPONENTS

**CABINET & APPLIANCE GROUP (CONTINUED)**  
**COMPONENT PARTS FOR APPLIANCES (CONTINUED)**

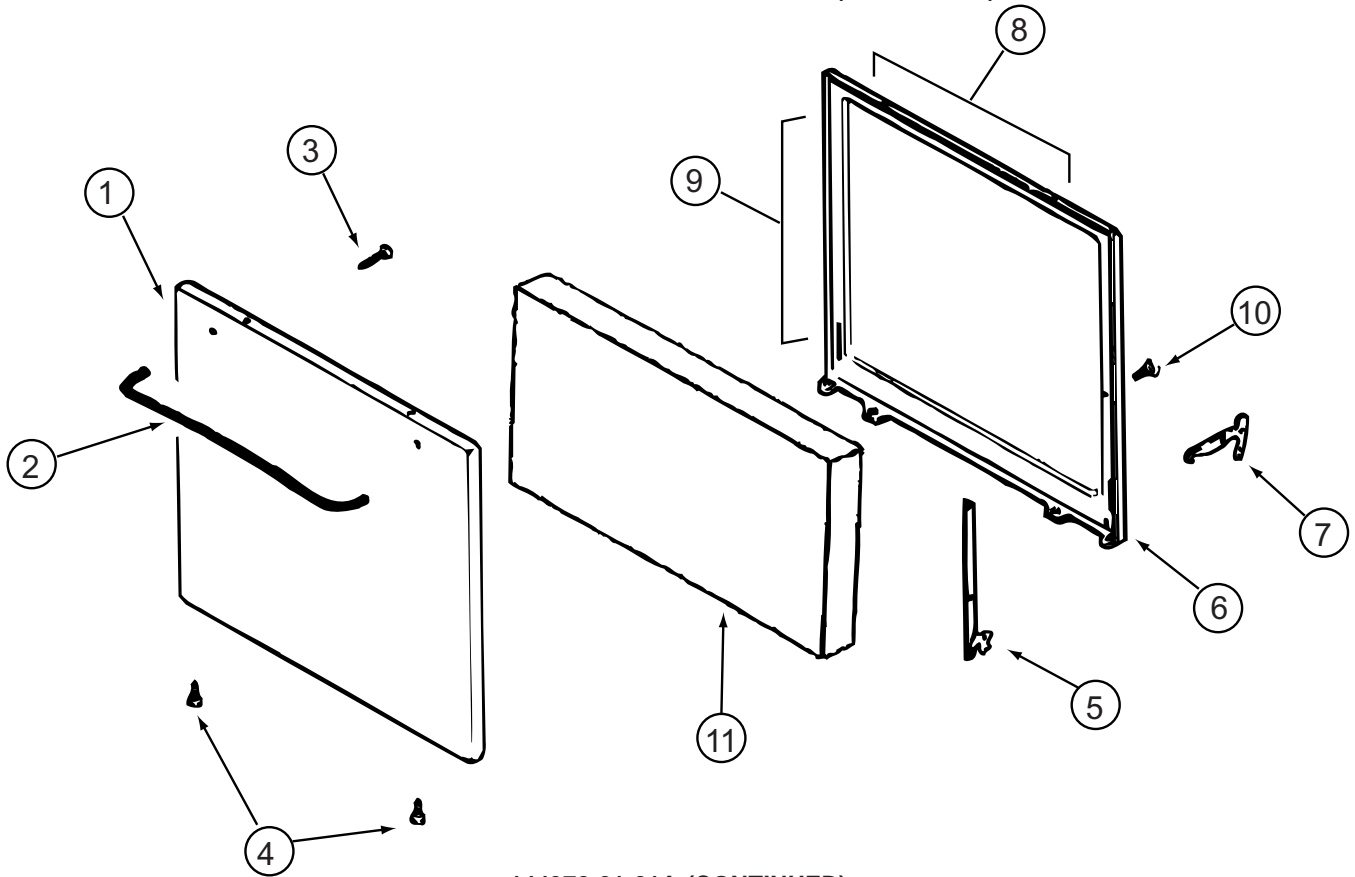

**144972-01-01A (CONTINUED)**

KEY	PART NUMBER	U/M	DESCRIPTION	VENDOR NO.
1	144972-01-701	EA	PANEL (DOOR) BLACK	2401F127-70
2	128727-01-701	EA	HANDLE - OVEN DOOR	74003929
8	126023-01-732	EA	SEAL/OVEN DR TOP	7212P014-60
9	126023-01-733	EA	SEAL/OVEN DR SIDES(2PCS)	7212P038-60

CONTACT WINNEBAGO PART SALES FOR UNLISTED COMPONENTS



**CABINET & APPLIANCE GROUP (CONTINUED)**  
**COMPONENT PARTS FOR APPLIANCES (CONTINUED)**

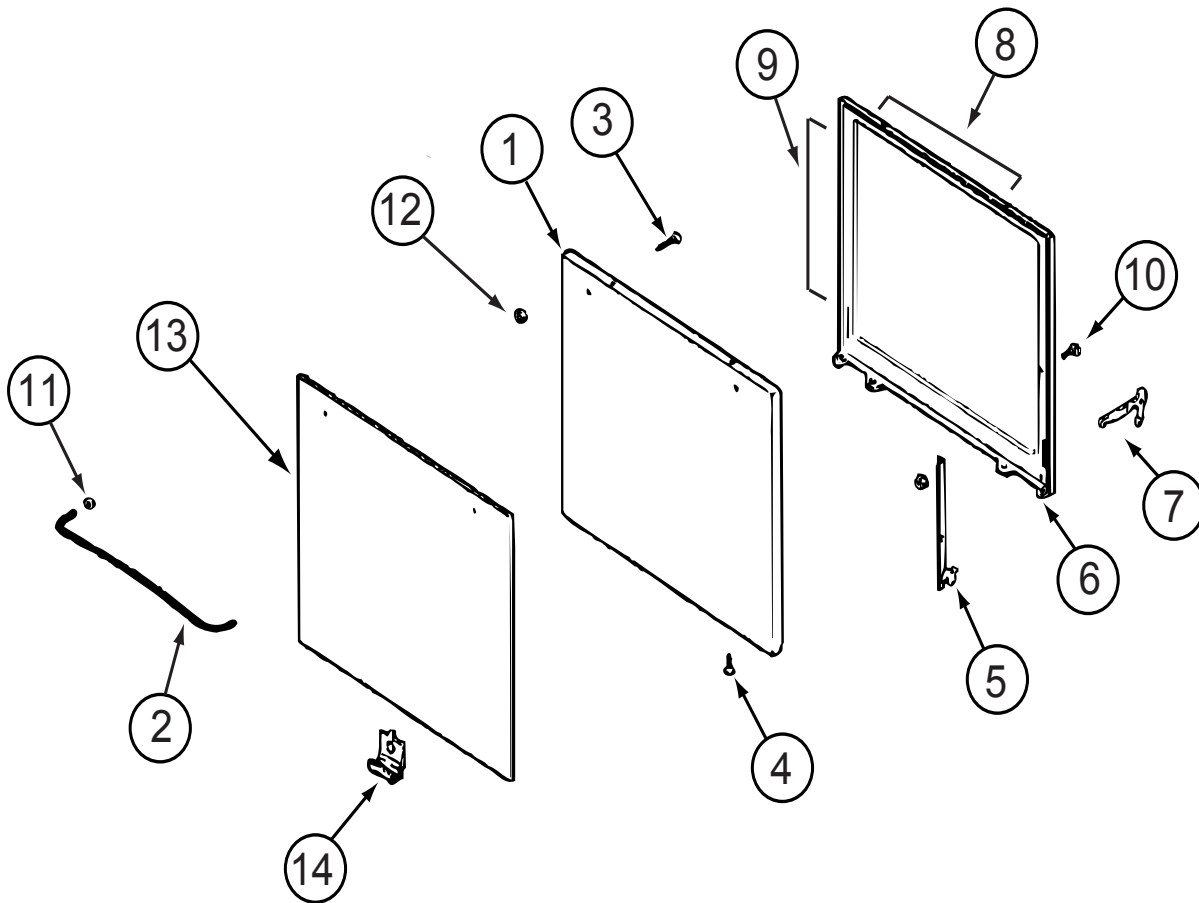

150778-01-01A, 151277-03-01A, 151279-02-01A, 151279-03-01A (CONTINUED)

KEY	PART NUMBER	U/M	DESCRIPTION	VENDOR NO.
1	126023-01-712	EA	PANEL - DOOR (BLACK)	74001190
2	128727-01-701	EA	HANDLE - OVEN DOOR	74003929
5	151277-01-704	EA	HINGE KIT-OVEN DR/LT	12400028
5	151277-01-705	EA	HINGE KIT-OVEN DR/RT	12400029
8	126023-01-732	EA	SEAL/OVEN DR TOP	7212P014-60
9	135066-03-714	EA	SEAL - OVEN DOOR SIDES	7212P039-60
13	102020-01-725	EA	GLASS OUTER	7902P266-60
14	126023-01-738	EA	CLIP - GLASS OVEN/BLACK	7112P093-60

CONTACT WINNEBAGO PART SALES FOR UNLISTED COMPONENT(S)

**CABINET & APPLIANCE GROUP (CONTINUED)**  
**COMPONENT PARTS FOR APPLIANCES (CONTINUED)**

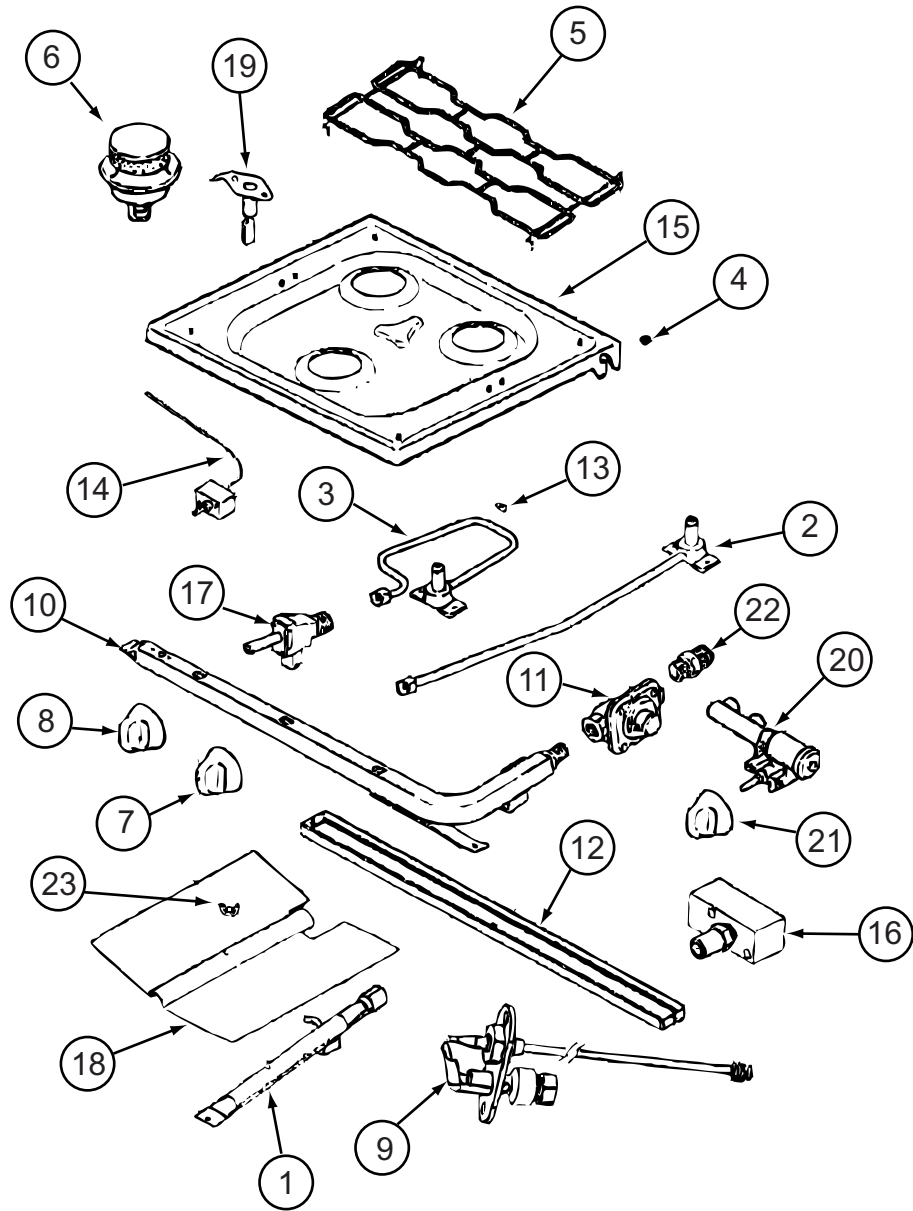

151277-03-01A, 151279-01-01A, 151279-02-01A/02A, 151279-03-01A

## CABINET & APPLIANCE GROUP (CONTINUED)

### COMPONENT PARTS FOR APPLIANCES (CONTINUED)

151277-03-01A, 151279-01-01A, 151279-02-01A/02A, 151279-03-01A (CONTINUED)

KEY	PART NUMBER	U/M DESCRIPTION	VENDOR NO.
1	151279-02-700	EA BURNER - OVEN - W/SHUTTER	74009853
2	128728-01-708	EA FITTING W/ORFICE/TUBE - REAR	74003931
3	128728-01-710	EA FITTING W/ORFICE/TUBE - FRT	74003930
4	102020-01-709	EA BUMPER-GRATE	8007P020-60
5	135065-03-703	EA GRATE - BLACK(SEALED BURNER)	74007304
6	135065-03-702	EA SEALED BURNER ASM.(BLACK) RV	74003967
7	128728-01-701	EA KNOB - BURNER - REAR	74003941 (1 PER)
7	128728-01-702	EA KNOB - BURNER - FRONT	74003942 (2 PER)
8	151279-02-701	EA KNOB - THERMOSTAT - BLACK	74009858
9	112881-04-706	EA PILOT-OVEN (151279-01-01A ONLY)	74006334
9	151279-01-700	EA PILOT-BURNER- 16" (151279-01-01A ONLY)	74009852
9	151279-02-705	EA PILOT - OVEN - 22" SERIES	74010544
10	151279-02-702	EA PIPE - MANIFOLD	74009856
11	126023-02-703	EA REGULATOR - PRESSURE	74004235
11	112881-03-701	EA REGULATOR KIT W/FITTINGS	12001285
13	102020-01-724	EA BUMPER-MAIN TOP	8003P008-60
14	151279-02-703	EA THERMOSTAT	74009855
15	128728-01-705	EA TOP - MAIN - BLACK	74003928
15	135065-03-715	EA TOP - MAIN - STAINLESS STEEL	74007299
16	151279-02-704	EA ELBOW BLOCK ASM (VALVE-OVEN)	74009864
17	135065-01-703	EA VALVE/BURNER - REAR	74004643
17	135065-01-704	EA VALVE/BURNER-FRT-HI	74004644
18	135656-01-701	EA MIXER/AIR	3411F003-34
19	135065-01-701	EA IGNITOR/PORCELAIN-TOP BURNER	74004053
20	128728-01-716	EA IGNITOR - F/BURNERS	74003946
20	128728-01-717	EA WIRES - IGNITOR	74003947
21	128728-01-707	EA KNOB - IGNITOR	74003944
22	135065-03-700	EA FITTING - HALF UNION	74004234

CONTACT WINNEBAGO PART SALES FOR UNLISTED COMPONENT(S)

**CABINET & APPLIANCE GROUP (CONTINUED)**  
**CABINET & APPLIANCE LAYOUT (CONTINUED)**

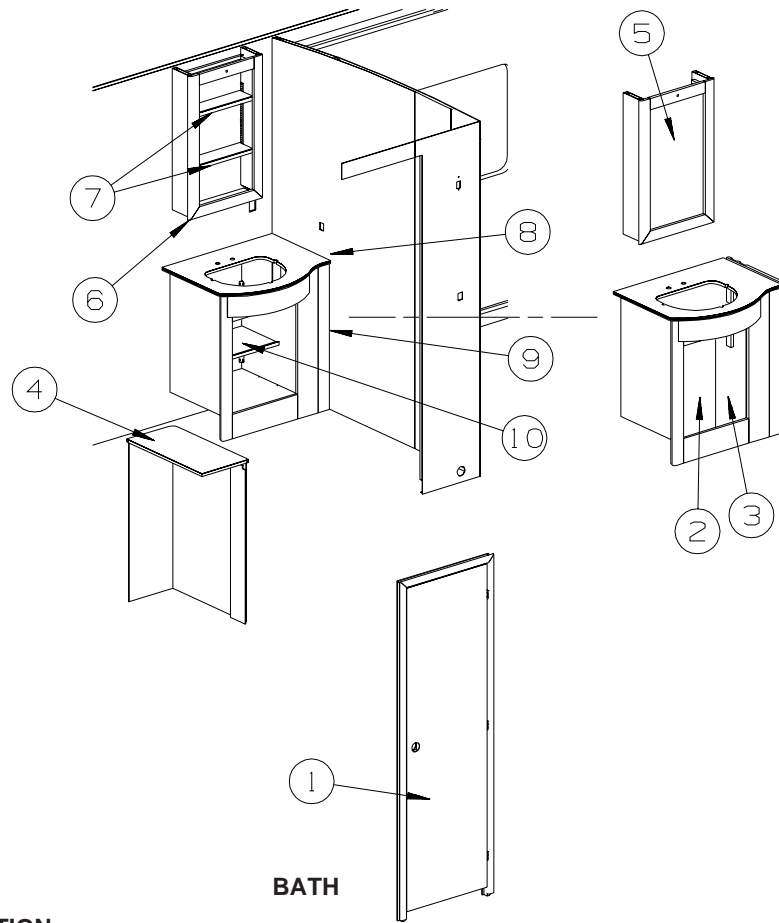

KEY	PART NUMBER	U/M	DESCRIPTION
1	144645-02-R32	EA	DOOR - BATH - W/O TOWEL RACK/HARDWARE - PORTSMOUTH OAK
1	144645-02-S47	EA	DOOR - BATH - W/O TOWEL RACK/HARDWARE - CONCERT CHERRY
1	144645-02-S48	EA	DOOR - BATH - W/O TOWEL RACK/HARDWARE - WASHED MAPLE
1	144645-02-S88	EA	DOOR - BATH - W/O TOWEL RACK/HARDWARE - SIERRA MAPLE
2	136918-08-S46	EA	DOOR - FLAT/OGEE EDGE - 9.2" X 21.8" - W/O HARDWARE - PORTSMOUTH OAK
2	136918-08-S47	EA	DOOR - FLAT/OGEE EDGE - 9.2" X 21.8" - W/O HARDWARE - CONCERT CHERRY
2	136918-08-S48	EA	DOOR - FLAT/OGEE EDGE - 9.2" X 21.8" - W/O HARDWARE - WASHED MAPLE
2	136918-08-SR0	EA	DOOR - FLAT/OGEE EDGE - 9.2" X 21.8" - W/O HARDWARE - SIERRA MAPLE
3	136918-09-S28	EA	DOOR - FLAT/OGEE EDGE - 9.2" X 21.8" - W/O HARDWARE - PORTSMOUTH OAK
3	136918-09-S47	EA	DOOR - FLAT/OGEE EDGE - 9.2" X 21.8" - W/O HARDWARE - CONCERT CHERRY
3	136918-09-S48	EA	DOOR - FLAT/OGEE EDGE - 9.2" X 21.8" - W/O HARDWARE - WASHED MAPLE
3	136918-09-SR0	EA	DOOR - FLAT/OGEE EDGE - 9.2" X 21.8" - W/O HARDWARE - SIERRA MAPLE
4	133654-18-S46	EA	COUNTERTOP - LAMINATED - ROCKY MT HIGH/PORTSMOUTH OAK (S46)
4	133654-18-S47	EA	COUNTERTOP - LAMINATED - ROCKY MT HIGH/CONCERT CHERRY (S47)
4	133654-18-S48	EA	COUNTERTOP - LAMINATED - ROCKY MT HIGH/WASHED MAPLE (S48)
4	133654-18-R32	EA	COUNTERTOP - LAMINATED - LINO FRIEZE/PORTSMOUTH OAK (S49)
4	133654-18-S50	EA	COUNTERTOP - LAMINATED - LINO FRIEZE/CONCERT CHERRY (S50)
4	133654-18-S51	EA	COUNTERTOP - LAMINATED - LINO FRIEZE/WASHED MAPLE (S51)
4	133654-18-N30	EA	COUNTERTOP - LAMINATED - GRAY TRANQUILITY/PORTSMOUTH OAK (S52)
4	133654-18-S53	EA	COUNTERTOP - LAMINATED - GRAY TRANQUILITY/CONCERT CHERRY (S53)
4	133654-18-S54	EA	COUNTERTOP - LAMINATED - GRAY TRANQUILITY/WASHED MAPLE (S54)
4	133654-18-SR0	EA	COUNTERTOP - LAMINATED - ROCKY MT HIGH/SIERRA MAPLE (SR0)
4	133654-18-SR1	EA	COUNTERTOP - LAMINATED - LINO FRIEZE/SIERRA MAPLE (SR1)
4	133654-18-SR2	EA	COUNTERTOP - LAMINATED - GRAY TRANQUILITY/SIERRA MAPLE (SR2)
5	141506-06-S28	EA	DOOR - MIRRORED/OGEE EDGE - 15.7" X 27.9" - W/O HARDWARE - PORTSMOUTH OAK
5	141506-06-S47	EA	DOOR - MIRRORED/OGEE EDGE - 15.7" X 27.9" - W/O HARDWARE - CONCERT CHERRY
5	141506-06-S48	EA	DOOR - MIRRORED/OGEE EDGE - 15.7" X 27.9" - W/O HARDWARE - WASHED MAPLE
5	141506-06-SR0	EA	DOOR - MIRRORED/OGEE EDGE - 15.7" X 27.9" - W/O HARDWARE - SIERRA MAPLE
6	139023-01-N30	EA	CABINET - OVERHEAD/MEDICINE - W/O DOORS/HARDWARE - PORTSMOUTH OAK
6	139023-01-S47	EA	CABINET - OVERHEAD/MEDICINE - W/O DOORS/HARDWARE - CONCERT CHERRY
6	139023-01-S48	EA	CABINET - OVERHEAD/MEDICINE - W/O DOORS/HARDWARE - WASHED MAPLE
6	139023-01-SR0	EA	CABINET - OVERHEAD/MEDICINE - W/O DOORS/HARDWARE - SIERRA MAPLE

## CABINET & APPLIANCE GROUP (CONTINUED)

### CABINET & APPLIANCE LAYOUT (CONTINUED)

#### BATH (CONTINUED)

KEY	PART NUMBER	U/M	DESCRIPTION
7	139023-12-N30	EA	SHELF - W/PLASTIC EDGE MOLDING - PORTSMOUTH OAK
7	139023-12-S47	EA	SHELF - W/PLASTIC EDGE MOLDING - CONCERT CHERRY
7	139023-12-S48	EA	SHELF - W/PLASTIC EDGE MOLDING - WASHED MAPLE
7	139023-12-SR0	EA	SHELF - W/PLASTIC EDGE MOLDING - SIERRA MAPLE
8	133654-19-S46	EA	COUNTERTOP - LAMINATED - ROCKY MT HIGH/PORTSMOUTH OAK (S46)
8	133654-19-S47	EA	COUNTERTOP - LAMINATED - ROCKY MT HIGH/CONCERT CHERRY (S47)
8	133654-19-S48	EA	COUNTERTOP - LAMINATED - ROCKY MT HIGH/WASHED MAPLE (S48)
8	133654-19-R32	EA	COUNTERTOP - LAMINATED - LINO FRIEZE/PORTSMOUTH OAK (S49)
8	133654-19-S50	EA	COUNTERTOP - LAMINATED - LINO FRIEZE/CONCERT CHERRY (S50)
8	133654-19-S51	EA	COUNTERTOP - LAMINATED - LINO FRIEZE/WASHED MAPLE (S51)
8	133654-19-N30	EA	COUNTERTOP - LAMINATED - GRAY TRANQUILITY/PORTSMOUTH OAK (S52)
8	133654-19-S53	EA	COUNTERTOP - LAMINATED - GRAY TRANQUILITY/CONCERT CHERRY (S53)
8	133654-19-S54	EA	COUNTERTOP - LAMINATED - GRAY TRANQUILITY/WASHED MAPLE (S54)
8	133654-19-SR0	EA	COUNTERTOP - LAMINATED - ROCKY MT HIGH/SIERRA MAPLE (SR0)
8	133654-19-SR1	EA	COUNTERTOP - LAMINATED - LINO FRIEZE/SIERRA MAPLE (SR1)
8	133654-19-SR2	EA	COUNTERTOP - LAMINATED - GRAY TRANQUILITY/SIERRA MAPLE (SR2)
9	139449-01-N30	EA	CABINET - LAVATORY - W/O COUNTERTOP/DOORS/DRAWERS/HARDWARE - PORTSMOUTH OAK
9	139449-01-N52	EA	CABINET - LAVATORY - W/O COUNTERTOP/DOORS/DRAWERS/HARDWARE - CONCERT CHERRY
9	139449-01-S48	EA	CABINET - LAVATORY - W/O COUNTERTOP/DOORS/DRAWERS/HARDWARE - WASHED MAPLE
9	139449-01-SR0	EA	CABINET - LAVATORY - W/O COUNTERTOP/DOORS/DRAWERS/HARDWARE - SIERRA MAPLE
10	139449-19-N30	EA	SHELF ASM - PORTSMOUTH OAK
10	139449-19-N52	EA	SHELF ASM - CONCERT CHERRY
10	139449-19-N62	EA	SHELF ASM - WASHED MAPLE
10	139449-19-SR0	EA	SHELF ASM - SIERRA MAPLE

# CABINET & APPLIANCE GROUP (CONTINUED)

## CABINET & APPLIANCE LAYOUT (CONTINUED)

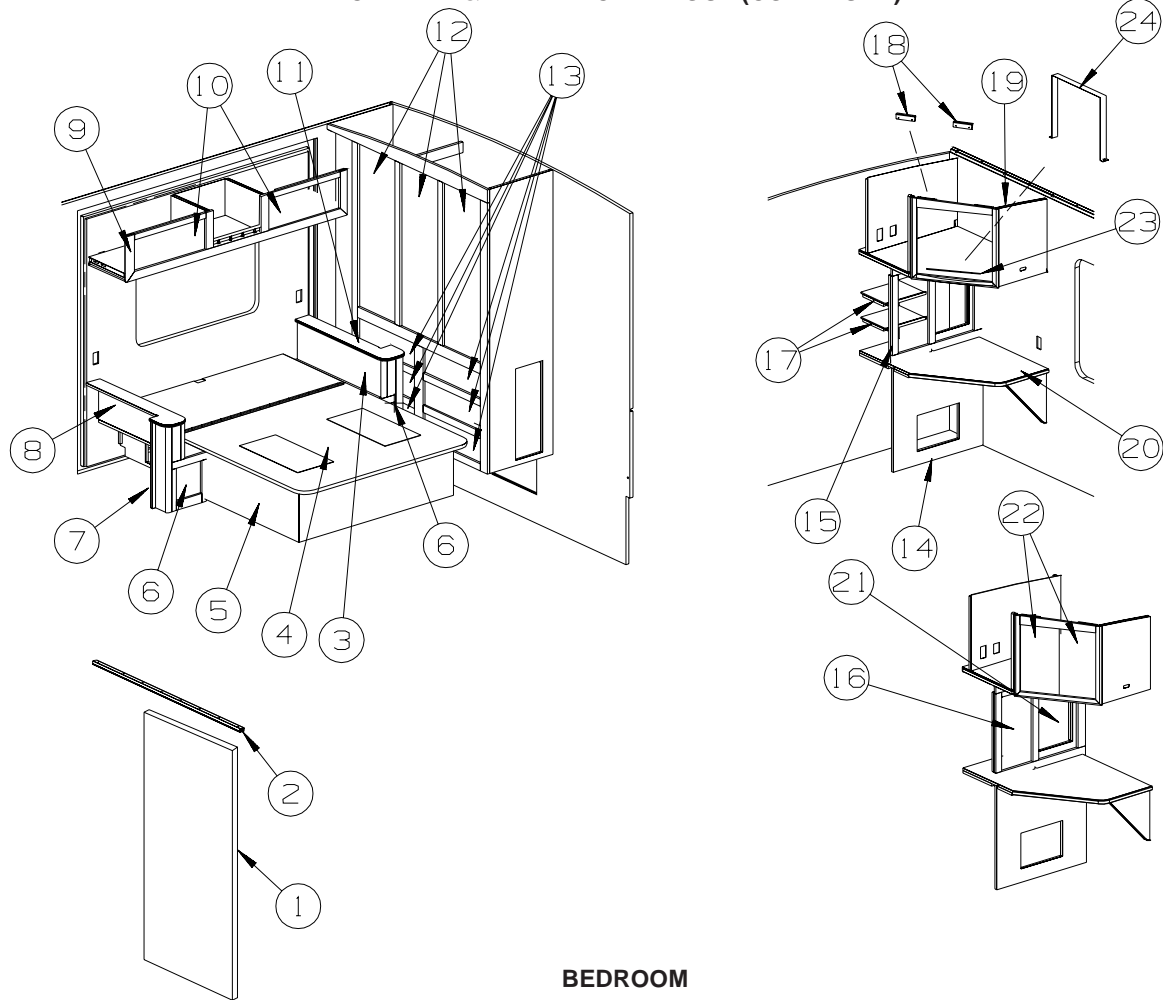

### BEDROOM

KEY	PART NUMBER	U/M	DESCRIPTION
1	140629-07-S46	EA	DOOR - SLIDING - W/O HARDWARE - PORTSMOUTH OAK K
1	140629-07-S47	EA	DOOR - SLIDING - W/O HARDWARE - CONCERT CHERRY
1	140629-07-S48	EA	DOOR - SLIDING - W/O HARDWARE - WASHED MAPLE
1	140629-07-SR0	EA	DOOR - SLIDING - W/O HARDWARE - SIERRA MAPLE
2	137422-10-01A	EA	TRACK/DOOR - OFF WHITE
3	136885-04-N47	EA	CABINET - NIGHTSTAND/RH - W/O COUNTERTOP/DOOR/DRAWER/HDW - PORTSMOUTH OAK
3	136885-04-N52	EA	CABINET - NIGHTSTAND/RH - W/O COUNTERTOP/DOOR/DRAWER/HDW - CONCERT CHERRY
3	136885-04-RW4	EA	CABINET - NIGHTSTAND/RH - W/O COUNTERTOP/DOOR/DRAWER/HDW - WASHED MAPLE
3	136885-04-S67	EA	CABINET - NIGHTSTAND/RH - W/O COUNTERTOP/DOOR/DRAWER/HDW - SIERRA MAPLE
4	137406-04-N52	EA	BEDBOARD - W/HINGE/T-MOLDING/SLIPNOT - FLIP-UP
5	137388-03-S46	EA	CABINET/BASE - W/O DOOR/DRAWER/HARDWARE - F/QUEEN BED - PORTSMOUTH OAK
5	137388-03-S47	EA	CABINET/BASE - W/O DOOR/DRAWER/HARDWARE - F/QUEEN BED - CONCERT CHERRY
5	137388-03-S48	EA	CABINET/BASE - W/O DOOR/DRAWER/HARDWARE - F/QUEEN BED - WASHED MAPLE
5	137388-03-SR0	EA	CABINET/BASE - W/O DOOR/DRAWER/HARDWARE - F/QUEEN BED - SIERRA MAPLE
6	145492-G4-R38	EA	DRAWER - OGEE EDGE - 7.6"W X 23.6"D - W/O SLIDES/HDW - PORTSMOUTH OAK
6	145492-G4-R39	EA	DRAWER - OGEE EDGE - 7.6"W X 23.6"D - W/O SLIDES/HDW - CONCERT CHERRY
6	145492-G4-S48	EA	DRAWER - OGEE EDGE - 7.6"W X 23.6"D - W/O SLIDES/HDW - WASHED MAPLE
6	145492-G4-S67	EA	DRAWER - OGEE EDGE - 7.6"W X 23.6"D - W/O SLIDES/HDW - SIERRA MAPLE
7	136885-03-N42	EA	CABINET - NIGHTSTAND/LH - W/O COUNTERTOP/DOOR/DRAWER/HDW - PORTSMOUTH OAK
7	136885-03-N52	EA	CABINET - NIGHTSTAND/LH - W/O COUNTERTOP/DOOR/DRAWER/HDW - CONCERT CHERRY
7	136885-03-RW4	EA	CABINET - NIGHTSTAND/LH - W/O COUNTERTOP/DOOR/DRAWER/HDW - WASHED MAPLE
7	136885-03-S67	EA	CABINET - NIGHTSTAND/LH - W/O COUNTERTOP/DOOR/DRAWER/HDW - SIERRA MAPLE
8	133655-25-S46	EA	COUNTERTOP - LAMINATED - ROCKY MT HIGH/PORTSMOUTH OAK (S46)
8	133655-25-S47	EA	COUNTERTOP - LAMINATED - ROCKY MT HIGH/CONCERT CHERRY (S47)
8	133655-25-S48	EA	COUNTERTOP - LAMINATED - ROCKY MT HIGH/WASHED MAPLE (S48)
8	133655-25-R32	EA	COUNTERTOP - LAMINATED - LINO FRIEZE/PORTSMOUTH OAK (S49)
8	133655-25-S50	EA	COUNTERTOP - LAMINATED - LINO FRIEZE/CONCERT CHERRY (S50)
8	133655-25-S51	EA	COUNTERTOP - LAMINATED - LINO FRIEZE/WASHED MAPLE (S51)
8	133655-25-N44	EA	COUNTERTOP - LAMINATED - GRAY TRANQUILITY/PORTSMOUTH OAK (S52)

# CABINET & APPLIANCE GROUP (CONTINUED)

## CABINET & APPLIANCE LAYOUT (CONTINUED)

### BEDROOM (CONTINUED)

KEY	PART NUMBER	U/M	DESCRIPTION
8	133655-25-P50	EA	COUNTERTOP - LAMINATED - GRAY TRANQUILITY/CONCERT CHERRY (S53)
8	133655-25-S54	EA	COUNTERTOP - LAMINATED - GRAY TRANQUILITY/WASHED MAPLE (S54)
8	133655-25-SR0	EA	COUNTERTOP - LAMINATED - ROCKY MT HIGH/SIERRA MAPLE (SR0)
8	133655-25-SR1	EA	COUNTERTOP - LAMINATED - LINO FRIEZE/SIERRA MAPLE (SR1)
8	133655-25-SR2	EA	COUNTERTOP - LAMINATED - GRAY TRANQUILITY/SIERRA MAPLE (SR2)
9	149264-01-S64	EA	CABINET - OVERHEAD/REAR/RIGHT HAND - W/O DOORS/HARDWARE - PORTSMOUTH OAK
9	149264-01-S65	EA	CABINET - OVERHEAD/REAR/RIGHT HAND - W/O DOORS/HARDWARE - CONCERT CHERRY
9	149264-01-S66	EA	CABINET - OVERHEAD/REAR/RIGHT HAND - W/O DOORS/HARDWARE - WASHED MAPLE
9	149264-01-S67	EA	CABINET - OVERHEAD/REAR/RIGHT HAND - W/O DOORS/HARDWARE - SIERRA MAPLE
10	136954-25-S28	EA	DOOR - RAISED PANEL/OGEE EDGE - 10" X 25.2" - W/O HDW - PORTSMOUTH OAK
10	136954-25-S08	EA	DOOR - RAISED PANEL/OGEE EDGE - 10" X 25.2" - W/O HDW - CONCERT CHERRY
10	136954-25-S09	EA	DOOR - RAISED PANEL/OGEE EDGE - 10" X 25.2" - W/O HDW - WASHED MAPLE
10	136954-25-S88	EA	DOOR - RAISED PANEL/OGEE EDGE - 10" X 25.2" - W/O HDW - SIERRA MAPLE
11	133655-26-S46	EA	COUNTERTOP - LAMINATED - ROCKY MT HIGH/PORTSMOUTH OAK (S46)
11	133655-26-S47	EA	COUNTERTOP - LAMINATED - ROCKY MT HIGH/CONCERT CHERRY (S47)
11	133655-26-S48	EA	COUNTERTOP - LAMINATED - ROCKY MT HIGH/WASHED MAPLE (S48)
11	133655-26-R32	EA	COUNTERTOP - LAMINATED - LINO FRIEZE/PORTSMOUTH OAK (S49)
11	133655-26-S50	EA	COUNTERTOP - LAMINATED - LINO FRIEZE/CONCERT CHERRY (S50)
11	133655-26-S51	EA	COUNTERTOP - LAMINATED - LINO FRIEZE/WASHED MAPLE (S51)
11	133655-26-N44	EA	COUNTERTOP - LAMINATED - GRAY TRANQUILITY/PORTSMOUTH OAK (S52)
11	133655-26-P50	EA	COUNTERTOP - LAMINATED - GRAY TRANQUILITY/CONCERT CHERRY (S53)
11	133655-26-S54	EA	COUNTERTOP - LAMINATED - GRAY TRANQUILITY/WASHED MAPLE (S54)
11	133655-26-SR0	EA	COUNTERTOP - LAMINATED - ROCKY MT HIGH/SIERRA MAPLE (SR0)
11	133655-26-SR1	EA	COUNTERTOP - LAMINATED - LINO FRIEZE/SIERRA MAPLE (SR1)
11	133655-26-SR2	EA	COUNTERTOP - LAMINATED - GRAY TRANQUILITY/SIERRA MAPLE (SR2)
12	141506-03-S52	EA	DOOR - MIRRORED/OGEE EDGE - 16.7" X 48" - W/O HARDWARE - PORTSMOUTH OAK
12	141506-03-S47	EA	DOOR - MIRRORED/OGEE EDGE - 16.7" X 48" - W/O HARDWARE - CONCERT CHERRY
12	141506-03-S48	EA	DOOR - MIRRORED/OGEE EDGE - 16.7" X 48" - W/O HARDWARE - WASHED MAPLE
12	141506-03-S88	EA	DOOR - MIRRORED/OGEE EDGE - 16.7" X 48" - W/O HARDWARE - SIERRA MAPLE
12	076767-04-000	EA	CABLE - STAINLESS STEEL - 5.9"
13	145492-S9-S46	EA	DRAWER - OGEE EDGE - 22.5"W X 15.7"D - W/O SLIDES/HDW - PORTSMOUTH OAK
13	145492-S9-S47	EA	DRAWER - OGEE EDGE - 22.5"W X 15.7"D - W/O SLIDES/HDW - CONCERT CHERRY
13	145492-S9-S48	EA	DRAWER - OGEE EDGE - 22.5"W X 15.7"D - W/O SLIDES/HDW - WASHED MAPLE
13	145492-S9-SR0	EA	DRAWER - OGEE EDGE - 22.5"W X 15.7"D - W/O SLIDES/HDW - SIERRA MAPLE
14	140034-01-N30	EA	CABINET - VANITY - W/O DOORS/HARDWARE - PORTSMOUTH OAK
14	140034-01-S47	EA	CABINET - VANITY - W/O DOORS/HARDWARE - CONCERT CHERRY
14	140034-01-S48	EA	CABINET - VANITY - W/O DOORS/HARDWARE - WASHED MAPLE
14	140034-01-SR0	EA	CABINET - VANITY - W/O DOORS/HARDWARE - SIERRA MAPLE
15	151480-01-S46	EA	CABINET - WALL/REAR/LEFT HAND - W/O DOORS/HARDWARE - PORTSMOUTH OAK
15	151480-01-S47	EA	CABINET - WALL/REAR/LEFT HAND - W/O DOORS/HARDWARE - CONCERT CHERRY
15	151480-01-S48	EA	CABINET - WALL/REAR/LEFT HAND - W/O DOORS/HARDWARE - WASHED MAPLE
15	151480-01-SR0	EA	CABINET - WALL/REAR/LEFT HAND - W/O DOORS/HARDWARE - SIERRA MAPLE
16	136954-58-S07	EA	DOOR - RAISED PANEL/OGEE EDGE - 11.4" X 21.8" - W/O HDW - PORTSMOUTH OAK
16	136954-58-S08	EA	DOOR - RAISED PANEL/OGEE EDGE - 11.4" X 21.8" - W/O HDW - CONCERT CHERRY
16	136954-58-S09	EA	DOOR - RAISED PANEL/OGEE EDGE - 11.4" X 21.8" - W/O HDW - WASHED MAPLE
16	136954-58-SW0	EA	DOOR - RAISED PANEL/OGEE EDGE - 11.4" X 21.8" - W/O HDW - SIERRA MAPLE
17	151480-16-S46	EA	SHELF - W/PLASTIC EDGE MOLDING - PORTSMOUTH OAK
17	151480-16-S47	EA	SHELF - W/PLASTIC EDGE MOLDING - CONCERT CHERRY
17	151480-16-S48	EA	SHELF - W/PLASTIC EDGE MOLDING - WASHED MAPLE
17	151480-16-SR0	EA	SHELF - W/PLASTIC EDGE MOLDING - SIERRA MAPLE
18	106699-01-01A	EA	BRACKET F/TV INSTALLATION - OVERHEAD CABINET
19	151462-01-S46	EA	CABINET - OVERHEAD/TV/REAR - W/O DOORS/HARDWARE - PORTSMOUTH OAK
19	151462-01-S47	EA	CABINET - OVERHEAD/TV/REAR - W/O DOORS/HARDWARE - CONCERT CHERRY
19	151462-01-S48	EA	CABINET - OVERHEAD/TV/REAR - W/O DOORS/HARDWARE - WASHED MAPLE
19	151462-01-SR0	EA	CABINET - OVERHEAD/TV/REAR - W/O DOORS/HARDWARE - SIERRA MAPLE
19	151462-02-S46	EA	CABINET - OVERHEAD/TV/REAR - W/O DOORS/HDW - PORTSMOUTH OAK - 20" REAR STEREO TV
19	151462-02-S47	EA	CABINET - OVERHEAD/TV/REAR - W/O DOORS/HDW - CONCERT CHERRY - 20" REAR STEREO TV
19	151462-02-S48	EA	CABINET - OVERHEAD/TV/REAR - W/O DOORS/HDW - WASHED MAPLE - 20" REAR STEREO TV
19	151462-02-SR0	EA	CABINET - OVERHEAD/TV/REAR - W/O DOORS/HDW - SIERRA MAPLE - 20" REAR STEREO TV

**CABINET & APPLIANCE GROUP (CONTINUED)**  
**CABINET & APPLIANCE LAYOUT (CONTINUED)**

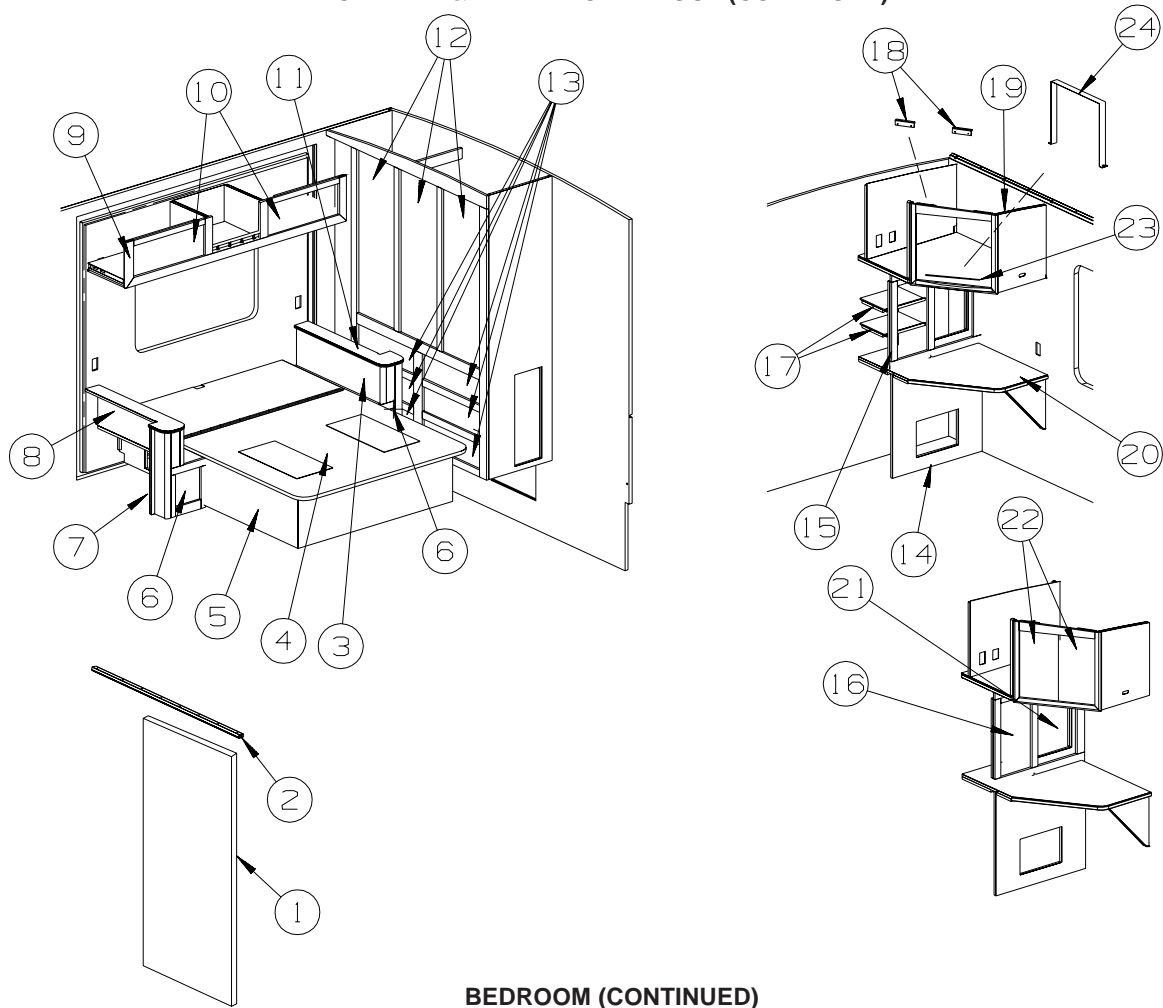

**BEDROOM (CONTINUED)**

KEY	PART NUMBER	U/M	DESCRIPTION
20	133655-59-S46	EA	COUNTERTOP - LAMINATED - ROCKY MT HIGH/PORTSMOUTH OAK (S46)
20	133655-59-S47	EA	COUNTERTOP - LAMINATED - ROCKY MT HIGH/CONCERT CHERRY (S47)
20	133655-59-S48	EA	COUNTERTOP - LAMINATED - ROCKY MT HIGH/WASHED MAPLE (S48)
20	133655-59-R32	EA	COUNTERTOP - LAMINATED - LINO FRIEZE/PORTSMOUTH OAK (S49)
20	133655-59-S50	EA	COUNTERTOP - LAMINATED - LINO FRIEZE/CONCERT CHERRY (S50)
20	133655-59-S51	EA	COUNTERTOP - LAMINATED - LINO FRIEZE/WASHED MAPLE (S51)
20	133655-59-N30	EA	COUNTERTOP - LAMINATED - GRAY TRANQUILITY/PORTSMOUTH OAK (S52)
20	133655-59-S53	EA	COUNTERTOP - LAMINATED - GRAY TRANQUILITY/CONCERT CHERRY (S53)
20	133655-59-S54	EA	COUNTERTOP - LAMINATED - GRAY TRANQUILITY/WASHED MAPLE (S54)
20	133655-59-SR0	EA	COUNTERTOP - LAMINATED - ROCKY MT HIGH/SIERRA MAPLE (SR0)
20	133655-59-SR1	EA	COUNTERTOP - LAMINATED - LINO FRIEZE/SIERRA MAPLE (SR1)
20	133655-59-SR2	EA	COUNTERTOP - LAMINATED - GRAY TRANQUILITY/SIERRA MAPLE (SR2)
21	136954-A6-S01	EA	DOOR - RAISED PANEL/OGEE EDGE - 14.4" X 21.9" - W/O HDW - PORTSMOUTH OAK
21	136954-A6-S47	EA	DOOR - RAISED PANEL/OGEE EDGE - 14.4" X 21.9" - W/O HDW - CONCERT CHERRY
21	136954-A6-S48	EA	DOOR - RAISED PANEL/OGEE EDGE - 14.4" X 21.9" - W/O HDW - WASHED MAPLE
21	136954-A6-S88	EA	DOOR - RAISED PANEL/OGEE EDGE - 14.4" X 21.9" - W/O HDW - SIERRA MAPLE
22	136954-40-S01	EA	DOOR - RAISED PANEL/OGEE EDGE - 10.8" X 21.8" - W/O HDW - PORTSMOUTH OAK
22	136954-40-S47	EA	DOOR - RAISED PANEL/OGEE EDGE - 10.8" X 21.8" - W/O HDW - CONCERT CHERRY
22	136954-40-S48	EA	DOOR - RAISED PANEL/OGEE EDGE - 10.8" X 21.8" - W/O HDW - WASHED MAPLE
22	136954-40-S88	EA	DOOR - RAISED PANEL/OGEE EDGE - 10.8" X 21.8" - W/O HDW - SIERRA MAPLE
23	123655-01-000	FT	SEAL - CLOSED CELL/FOAM
24	148247-05-02B	EA	STRAP/TIEDOWN - TV - E-COATED



**CABINET & APPLIANCE GROUP (CONTINUED)**  
**CABINET & APPLIANCE LAYOUT (CONTINUED)**

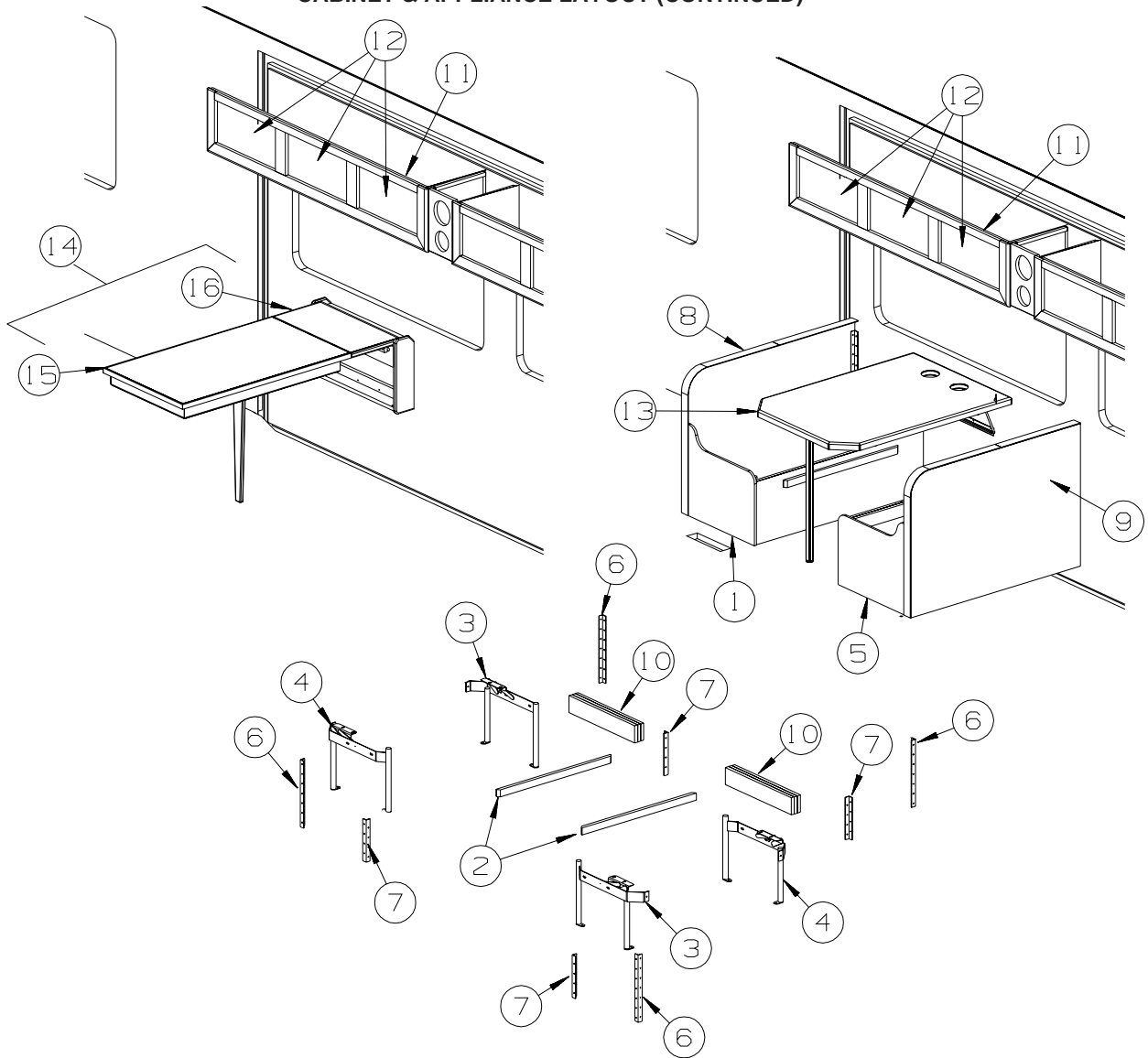

**DINETTE**

KEY	PART NUMBER	U/M	DESCRIPTION
1	142046-03-S46	EA	CABINET/BASE - DINETTE W/O BACK-F/FLIP UP CUSHION - LH (S46)
1	142046-03-S47	EA	CABINET/BASE - DINETTE W/O BACK-F/FLIP UP CUSHION - LH (S47)
1	142046-03-S48	EA	CABINET/BASE - DINETTE W/O BACK-F/FLIP UP CUSHION - LH (S48)
1	142046-03-P21	EA	CABINET/BASE - DINETTE W/O BACK-F/FLIP UP CUSHION - LH (S49)
1	142046-03-P22	EA	CABINET/BASE - DINETTE W/O BACK-F/FLIP UP CUSHION - LH (S50)
1	142046-03-S51	EA	CABINET/BASE - DINETTE W/O BACK-F/FLIP UP CUSHION - LH (S51)
1	142046-03-R34	EA	CABINET/BASE - DINETTE W/O BACK-F/FLIP UP CUSHION - LH (S52)
1	142046-03-S53	EA	CABINET/BASE - DINETTE W/O BACK-F/FLIP UP CUSHION - LH (S53)
1	142046-03-S54	EA	CABINET/BASE - DINETTE W/O BACK-F/FLIP UP CUSHION - LH (S54)
1	142046-03-SR0	EA	CABINET/BASE - DINETTE W/O BACK-F/FLIP UP CUSHION - LH (SR0)
1	142046-03-SR1	EA	CABINET/BASE - DINETTE W/O BACK-F/FLIP UP CUSHION - LH (SR1)
1	142046-03-SR2	EA	CABINET/BASE - DINETTE W/O BACK-F/FLIP UP CUSHION - LH (SR2)
2	081295-01-N70	EA	SUPPORT - BED/DINETTE - 28" LONG - PORTSMOUTH OAK
2	081295-01-M52	EA	SUPPORT - BED/DINETTE - 28" LONG - CONCERT CHERRY
2	081295-01-H37	EA	SUPPORT - BED/DINETTE - 28" LONG - WASHED MAPLE
2	081295-01-RE0	EA	SUPPORT - BED/DINETTE - 28" LONG - SIERRA MAPLE
3	142033-01-000	EA	BRACKET - DINETTE - RIGHT HAND
4	142033-02-000	EA	BRACKET - DINETTE - LEFT HAND

# CABINET & APPLIANCE GROUP (CONTINUED)

## CABINET & APPLIANCE LAYOUT (CONTINUED)

### DINETTE (CONTINUED)

KEY	PART NUMBER	U/M	DESCRIPTION
5	142046-05-S46	EA	CABINET/BASE - DINETTE W/O BACK-F/FLIP UP CUSHION - RH (S46)
5	142046-05-S47	EA	CABINET/BASE - DINETTE W/O BACK-F/FLIP UP CUSHION - RH (S47)
5	142046-05-S48	EA	CABINET/BASE - DINETTE W/O BACK-F/FLIP UP CUSHION - RH (S48)
5	142046-05-P21	EA	CABINET/BASE - DINETTE W/O BACK-F/FLIP UP CUSHION - RH (S49)
5	142046-05-P22	EA	CABINET/BASE - DINETTE W/O BACK-F/FLIP UP CUSHION - RH (S50)
5	142046-05-RW2	EA	CABINET/BASE - DINETTE W/O BACK-F/FLIP UP CUSHION - RH (S51)
5	142046-05-R34	EA	CABINET/BASE - DINETTE W/O BACK-F/FLIP UP CUSHION - RH (S52)
5	142046-05-S53	EA	CABINET/BASE - DINETTE W/O BACK-F/FLIP UP CUSHION - RH (S53)
5	142046-05-S54	EA	CABINET/BASE - DINETTE W/O BACK-F/FLIP UP CUSHION - RH (S54)
5	142046-05-SR0	EA	CABINET/BASE - DINETTE W/O BACK-F/FLIP UP CUSHION - RH (SR0)
5	142046-05-SR1	EA	CABINET/BASE - DINETTE W/O BACK-F/FLIP UP CUSHION - RH (SR1)
5	142046-05-SR2	EA	CABINET/BASE - DINETTE W/O BACK-F/FLIP UP CUSHION - RH (SR2)
6	122021-02-02A	EA	ANGLE - W/HOLES - 13.7" LONG - OFF WHITE
7	122021-01-02A	EA	ANGLE - W/HOLES - 8.6" LONG - OFF WHITE
8	142046-65-S46	EA	PANEL/BACK - DINETTE SEAT - LEFT HAND (S46)
8	142046-65-S47	EA	PANEL/BACK - DINETTE SEAT - LEFT HAND (S47)
8	142046-65-S48	EA	PANEL/BACK - DINETTE SEAT - LEFT HAND (S48)
8	142046-65-P21	EA	PANEL/BACK - DINETTE SEAT - LEFT HAND (S49)
8	142046-65-P22	EA	PANEL/BACK - DINETTE SEAT - LEFT HAND (S50)
8	142046-65-S51	EA	PANEL/BACK - DINETTE SEAT - LEFT HAND (S51)
8	142046-65-R34	EA	PANEL/BACK - DINETTE SEAT - LEFT HAND (S52)
8	142046-65-S53	EA	PANEL/BACK - DINETTE SEAT - LEFT HAND (S53)
8	142046-65-S54	EA	PANEL/BACK - DINETTE SEAT - LEFT HAND (S54)
8	142046-65-SR0	EA	PANEL/BACK - DINETTE SEAT - LEFT HAND (SR0)
8	142046-65-SR1	EA	PANEL/BACK - DINETTE SEAT - LEFT HAND (SR1)
8	142046-65-SR2	EA	PANEL/BACK - DINETTE SEAT - LEFT HAND (SR2)
9	142046-69-S46	EA	PANEL/BACK - DINETTE SEAT - RIGHT HAND (S46)
9	142046-69-S47	EA	PANEL/BACK - DINETTE SEAT - RIGHT HAND (S47)
9	142046-69-S48	EA	PANEL/BACK - DINETTE SEAT - RIGHT HAND (S48)
9	142046-69-P21	EA	PANEL/BACK - DINETTE SEAT - RIGHT HAND (S49)
9	142046-69-P22	EA	PANEL/BACK - DINETTE SEAT - RIGHT HAND (S50)
9	142046-69-RW2	EA	PANEL/BACK - DINETTE SEAT - RIGHT HAND (S51)
9	142046-69-R34	EA	PANEL/BACK - DINETTE SEAT - RIGHT HAND (S52)
9	142046-69-S53	EA	PANEL/BACK - DINETTE SEAT - RIGHT HAND (S53)
9	142046-69-S54	EA	PANEL/BACK - DINETTE SEAT - RIGHT HAND (S54)
9	142046-69-SR0	EA	PANEL/BACK - DINETTE SEAT - RIGHT HAND (SR0)
9	142046-69-SR1	EA	PANEL/BACK - DINETTE SEAT - RIGHT HAND (SR1)
9	142046-69-SR2	EA	PANEL/BACK - DINETTE SEAT - RIGHT HAND (SR2)
10	142046-63-S46	EA	SPACER/BASE - DINETTE SEAT (S46, S47, S48, SR0)
10	142046-63-P21	EA	SPACER/BASE - DINETTE SEAT (S49, S50, S51, SR1)
10	142046-63-R34	EA	SPACER/BASE - DINETTE SEAT (S52, S53, S54, SR2)
11	139122-04-S46	EA	CABINET - OVERHEAD/DINETTE - W/O DOORS/HARDWARE - PORTSMOUTH OAK
11	139122-04-S47	EA	CABINET - OVERHEAD/DINETTE - W/O DOORS/HARDWARE - CONCERT CHERRY
11	139122-04-S48	EA	CABINET - OVERHEAD/DINETTE - W/O DOORS/HARDWARE - WASHED MAPLE
11	139122-04-SR0	EA	CABINET - OVERHEAD/DINETTE - W/O DOORS/HARDWARE - SIERRA MAPLE
12	136954-22-S28	EA	DOOR - RAISED PANEL/OGEE EDGE - 10" X 19.1" - W/O HDW - PORTSMOUTH OAK
12	136954-22-S08	EA	DOOR - RAISED PANEL/OGEE EDGE - 10" X 19.1" - W/O HDW - CONCERT CHERRY
12	136954-22-S09	EA	DOOR - RAISED PANEL/OGEE EDGE - 10" X 19.1" - W/O HDW - WASHED MAPLE
12	136954-22-SJ0	EA	DOOR - RAISED PANEL/OGEE EDGE - 10" X 19.1" - W/O HDW - SIERRA MAPLE
13	149294-03-S46	EA	TABLE/DINETTE - W/LEG - 24"W X 41.6"D
13	149294-03-S47	EA	TABLE/DINETTE - W/LEG - 24"W X 41.6"D
13	149294-03-S48	EA	TABLE/DINETTE - W/LEG - 24"W X 41.6"D
13	149294-03-S49	EA	TABLE/DINETTE - W/LEG - 24"W X 41.6"D
13	149294-03-S50	EA	TABLE/DINETTE - W/LEG - 24"W X 41.6"D
13	149294-03-S51	EA	TABLE/DINETTE - W/LEG - 24"W X 41.6"D
13	149294-03-S52	EA	TABLE/DINETTE - W/LEG - 24"W X 41.6"D
13	149294-03-S53	EA	TABLE/DINETTE - W/LEG - 24"W X 41.6"D
13	149294-03-S54	EA	TABLE/DINETTE - W/LEG - 24"W X 41.6"D
13	149294-03-SR0	EA	TABLE/DINETTE - W/LEG - 24"W X 41.6"D
13	149294-03-SR1	EA	TABLE/DINETTE - W/LEG - 24"W X 41.6"D
13	149294-03-SR2	EA	TABLE/DINETTE - W/LEG - 24"W X 41.6"D

**CABINET & APPLIANCE GROUP (CONTINUED)**  
**CABINET & APPLIANCE LAYOUT (CONTINUED)**

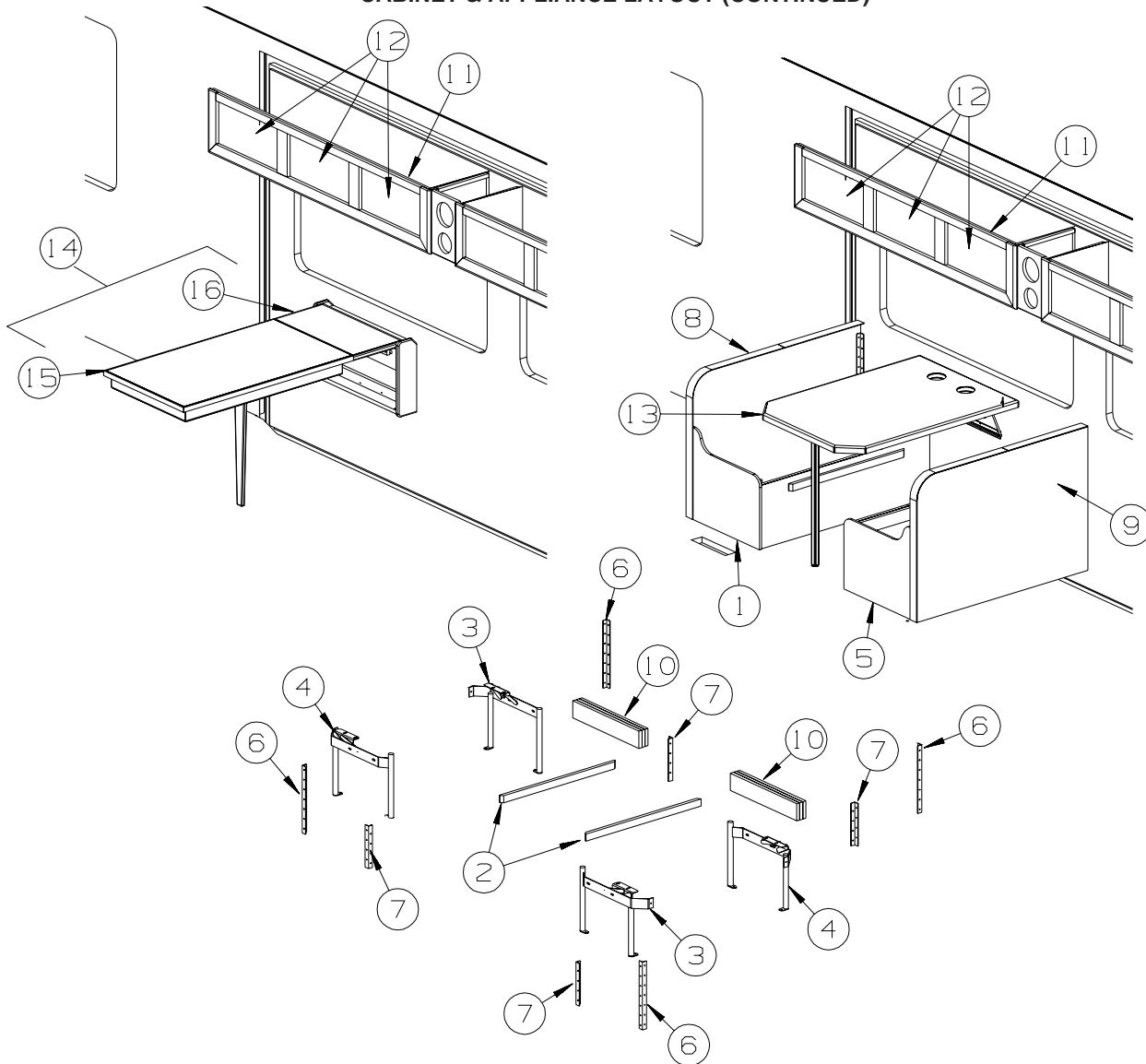

**DINETTE (CONTINUED)**

KEY	PART NUMBER	U/M	DESCRIPTION
14	133856-01-N42	EA	CABINET/WALL - W/FOLD DOWN TABLE/LEG - PORTSMOUTH OAK
14	133856-01-L52	EA	CABINET/WALL - W/FOLD DOWN TABLE/LEG - CONCERT CHERRY
14	133856-01-RW4	EA	CABINET/WALL - W/FOLD DOWN TABLE/LEG - WASHED MAPLE
14	133856-01-SA3	EA	CABINET/WALL - W/FOLD DOWN TABLE/LEG - SIERRA MAPLE
15	133856-11-N42	EA	TABLE TOP - LARGE SECTION - LAMINATED - PORTSMOUTH OAK
15	133856-11-L52	EA	TABLE TOP - LARGE SECTION - LAMINATED - CONCERT CHERRY
15	133856-11-RW4	EA	TABLE TOP - LARGE SECTION - LAMINATED - WASHED MAPLE
15	133856-11-SA3	EA	TABLE TOP - LARGE SECTION - LAMINATED - SIERRA MAPLE
16	133856-12-N42	EA	TABLE TOP - SMALL HINGED SECTION-LAMINATED - PORTSMOUTH OAK
16	133856-12-L52	EA	TABLE TOP - SMALL HINGED SECTION - LAMINATED - CONCERT CHERRY
16	133856-12-RW4	EA	TABLE TOP - SMALL HINGED SECTION-LAMINATED - WASHED MAPLE
16	133856-12-SA3	EA	TABLE TOP - SMALL HINGED SECTION-LAMINATED - SIERRA MAPLE

**CABINET & APPLIANCE GROUP (CONTINUED)**  
**CABINET & APPLIANCE LAYOUT (CONTINUED)**

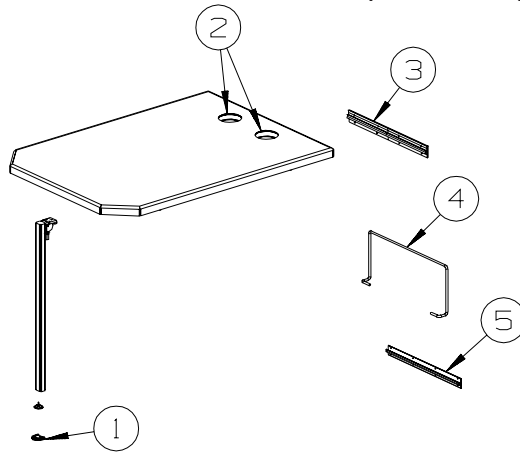

**DINETTE (CONTINUED)**

KEY	PART NUMBER	U/M	DESCRIPTION
1	143798-01-01A	EA	CATCH - FLOOR TO TABLE LEG - BRIGHT WHITE
2	064781-06-000	EA	HOLDER/CUP - TWO STEP - OFF WHITE
3	140921-02-01A	EA	BRACKET/TABLE SUPPORT - 18.5" - OFF WHITE
4	024275-13-000	EA	ROD - TABLE LIFT - OFF/WHITE
5	024281-15-000	EA	BRACKET/TABLE - LIFT ROD/LOWER WALL MOUNTED - 17.1"

**CABINET & APPLIANCE GROUP (CONTINUED)**  
**CABINET & APPLIANCE LAYOUT (CONTINUED)**

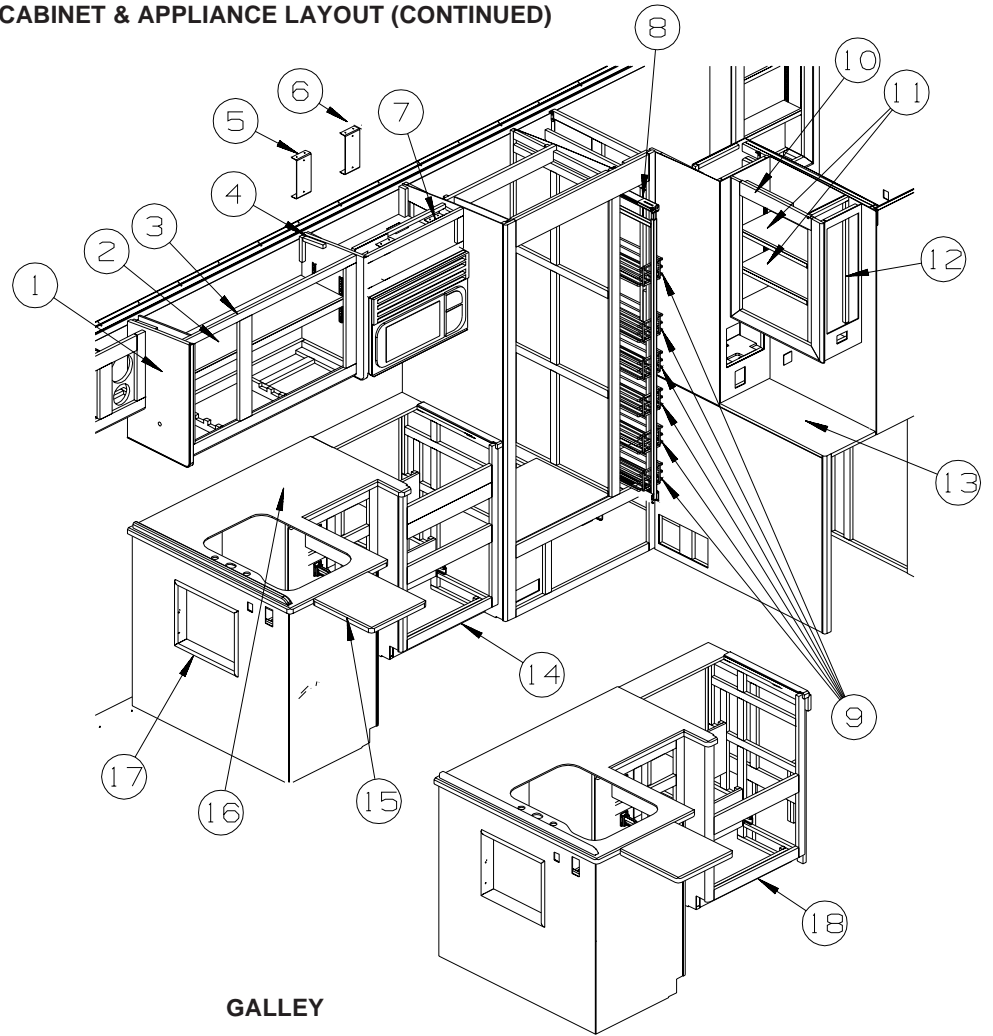

**GALLEY**

KEY	PART NUMBER	U/M	DESCRIPTION
1	103128-89-R32	EA	END CAP - OVERHEAD CABINET - RIGHT HAND - PORTSMOUTH OAK
1	103128-89-S47	EA	END CAP - OVERHEAD CABINET - RIGHT HAND - CONCERT CHERRY
1	103128-89-S48	EA	END CAP - OVERHEAD CABINET - RIGHT HAND - WASHED MAPLE
1	103128-89-SR0	EA	END CAP - OVERHEAD CABINET - RIGHT HAND - SIERRA MAPLE
2	144287-14-R32	EA	SHELF - W/PLASTIC EDGE MOLDING - PORTSMOUTH OAK
2	144287-14-S47	EA	SHELF - W/PLASTIC EDGE MOLDING - CONCERT CHERRY
2	144287-14-S48	EA	SHELF - W/PLASTIC EDGE MOLDING - WASHED MAPLE
2	144287-14-SR0	EA	SHELF - W/PLASTIC EDGE MOLDING - SIERRA MAPLE
3	144287-02-R32	EA	CABINET - OVERHEAD/GALLEY - W/O DOORS/HARDWARE - PORTSMOUTH OAK
3	144287-02-S47	EA	CABINET - OVERHEAD/GALLEY - W/O DOORS/HARDWARE - CONCERT CHERRY
3	144287-02-S48	EA	CABINET - OVERHEAD/GALLEY - W/O DOORS/HARDWARE - WASHED MAPLE
3	144287-02-SR0	EA	CABINET - OVERHEAD/GALLEY - W/O DOORS/HARDWARE - SIERRA MAPLE
4	103128-47-M42	EA	END CAP - OVERHEAD CABINET - RIGHT HAND - PORTSMOUTH OAK
4	103128-47-M52	EA	END CAP - OVERHEAD CABINET - RIGHT HAND - CONCERT CHERRY
4	103128-47-S48	EA	END CAP - OVERHEAD CABINET - RIGHT HAND - WASHED MAPLE
4	103128-47-SR0	EA	END CAP - OVERHEAD CABINET - RIGHT HAND - SIERRA MAPLE
5	130736-03-02B	EA	BRACKET - MICROWAVE - E-COATED
6	130736-04-02B	EA	BRACKET - MICROWAVE - E-COATED
7	141733-02-P45	EA	CABINET - OVERHEAD/MICROWAVE - W/O DOORS/HARDWARE - PORTSMOUTH OAK
7	141733-02-P46	EA	CABINET - OVERHEAD/MICROWAVE - W/O DOORS/HARDWARE - CONCERT CHERRY
7	141733-02-RW4	EA	CABINET - OVERHEAD/MICROWAVE - W/O DOORS/HARDWARE - WASHED MAPLE
7	141733-02-S67	EA	CABINET - OVERHEAD/MICROWAVE - W/O DOORS/HARDWARE - SIERRA MAPLE
8	148432-01-01A	EA	SLIDE FRAME - PANTRY - 22.1" DEEP X 56.6" TO 59.4" TALL
9	148432-10-01A	EA	PANTRY BASKET - 6" X 20.5" X 3.3"
10	140181-01-N30	EA	CABINET - OVERHEAD/GALLEY/REAR - W/O DOORS/HARDWARE - PORTSMOUTH OAK
10	140181-01-S47	EA	CABINET - OVERHEAD/GALLEY/REAR - W/O DOORS/HARDWARE - CONCERT CHERRY
10	140181-01-S48	EA	CABINET - OVERHEAD/GALLEY/REAR - W/O DOORS/HARDWARE - WASHED MAPLE
10	140181-01-SR0	EA	CABINET - OVERHEAD/GALLEY/REAR - W/O DOORS/HARDWARE - SIERRA MAPLE

## CABINET & APPLIANCE GROUP (CONTINUED)

### CABINET & APPLIANCE LAYOUT (CONTINUED)

#### GALLEY (CONTINUED)

KEY	PART NUMBER	U/M	DESCRIPTION
11	140181-12-N30	EA	SHELF - W/PLASTIC EDGE MOLDING - PORTSMOUTH OAK
11	140181-12-S47	EA	SHELF - W/PLASTIC EDGE MOLDING - CONCERT CHERRY
11	140181-12-S48	EA	SHELF - W/PLASTIC EDGE MOLDING - WASHED MAPLE
11	140181-12-SR0	EA	SHELF - W/PLASTIC EDGE MOLDING - SIERRA MAPLE
12	137602-04-N30	EA	POCKET - MONITOR PANEL - PORTSMOUTH OAK
12	137602-04-S47	EA	POCKET - MONITOR PANEL - CONCERT CHERRY
12	137602-04-S48	EA	POCKET - MONITOR PANEL - WASHED MAPLE
12	137602-04-SJ0	EA	POCKET - MONITOR PANEL - SIERRA MAPLE
13	133131-10-S46	EA	COUNTERTOP - LAMINATED (S46)
13	133131-10-S47	EA	COUNTERTOP - LAMINATED (S47)
13	133131-10-S48	EA	COUNTERTOP - LAMINATED (S48)
13	133131-10-R32	EA	COUNTERTOP - LAMINATED - LINO FRIEZE/PORTSMOUTH OAK (S49)
13	133131-10-S50	EA	COUNTERTOP - LAMINATED (S50)
13	133131-10-S51	EA	COUNTERTOP - LAMINATED (S51)
13	133131-10-N30	EA	COUNTERTOP - LAMINATED - GRAY TRANQUILITY (S52)
13	133131-10-S53	EA	COUNTERTOP - LAMINATED (S53)
13	133131-10-S54	EA	COUNTERTOP - LAMINATED (S54)
13	133131-10-SR0	EA	COUNTERTOP - LAMINATED (SR0)
13	133131-10-SR1	EA	COUNTERTOP - LAMINATED (SR1)
13	133131-10-SR2	EA	COUNTERTOP - LAMINATED (SR2)
14	P51525-01-S46	EA	CABINET - GALLEY - W/O CTRTP/DRS/DWR/HDW - PORTSMOUTH OAK - TWO-WAY RADIOS
14	P51525-01-S47	EA	CABINET - GALLEY - W/O CTRTP/DRS/DWR/HDW - CONCERT CHERRY - TWO-WAY RADIOS
14	P51525-01-S48	EA	CABINET - GALLEY - W/O CTRTP/DRS/DWR/HDW - WASHED MAPLE - TWO-WAY RADIOS
14	P51525-01-SR0	EA	CABINET - GALLEY - W/O CTRTP/DRS/DWR/HDW - SIERRA MAPLE - TWO-WAY RADIOS
14	P51525-03-S46	EA	CABINET - GALLEY - W/O COUNTERTOP/DOORS/DRAWERS/HDW - PORTSMOUTH OAK
14	P51525-03-S47	EA	CABINET - GALLEY - W/O COUNTERTOP/DOORS/DRAWERS/HDW - CONCERT CHERRY
14	P51525-03-S48	EA	CABINET - GALLEY - W/O COUNTERTOP/DOORS/DRAWERS/HDW - WASHED MAPLE
14	P51525-03-SR0	EA	CABINET - GALLEY - W/O COUNTERTOP/DOORS/DRAWERS/HDW - SIERRA MAPLE
15	141784-02-02A	EA	COUNTERTOP - EXTENSION - 1/4" VENDURA - ALMONDINE
16	137475-24-02A	EA	COUNTERTOP - 1/4" VENDURA - ALMONDINE
17	137602-05-N42	EA	POCKET - MAGAZINE - PORTSMOUTH OAK
17	137602-05-N94	EA	POCKET - MAGAZINE - CONCERT CHERRY
17	137602-05-RW4	EA	POCKET - MAGAZINE - WASHED MAPLE
17	137602-05-S88	EA	POCKET - MAGAZINE - SIERRA MAPLE
18	P51525-02-S46	EA	CABINET - GALLEY - W/O CTRTP/DRS/DWR/HDW - PORTSMOUTH OAK - TWO-WAY RADIOS
18	P51525-02-S47	EA	CABINET - GALLEY - W/O CTRTP/DRS/DWR/HDW - CONCERT CHERRY - TWO-WAY RADIOS
18	P51525-02-S48	EA	CABINET - GALLEY - W/O CTRTP/DRS/DWR/HDW - WASHED MAPLE - TWO-WAY RADIOS
18	P51525-02-SR0	EA	CABINET - GALLEY - W/O CTRTP/DRS/DWR/HDW - SIERRA MAPLE - TWO-WAY RADIOS
18	P51525-04-S46	EA	CABINET - GALLEY - W/O COUNTERTOP/DOORS/DRAWERS/HARDWARE - PORTSMOUTH OAK
18	P51525-04-S47	EA	CABINET - GALLEY - W/O COUNTERTOP/DOORS/DRAWERS/HARDWARE - CONCERT CHERRY
18	P51525-04-S48	EA	CABINET - GALLEY - W/O COUNTERTOP/DOORS/DRAWERS/HARDWARE - WASHED MAPLE
18	P51525-04-SR0	EA	CABINET - GALLEY - W/O COUNTERTOP/DOORS/DRAWERS/HARDWARE - SIERRA MAPLE

**CABINET & APPLIANCE GROUP (CONTINUED)**  
**CABINET & APPLIANCE LAYOUT (CONTINUED)**

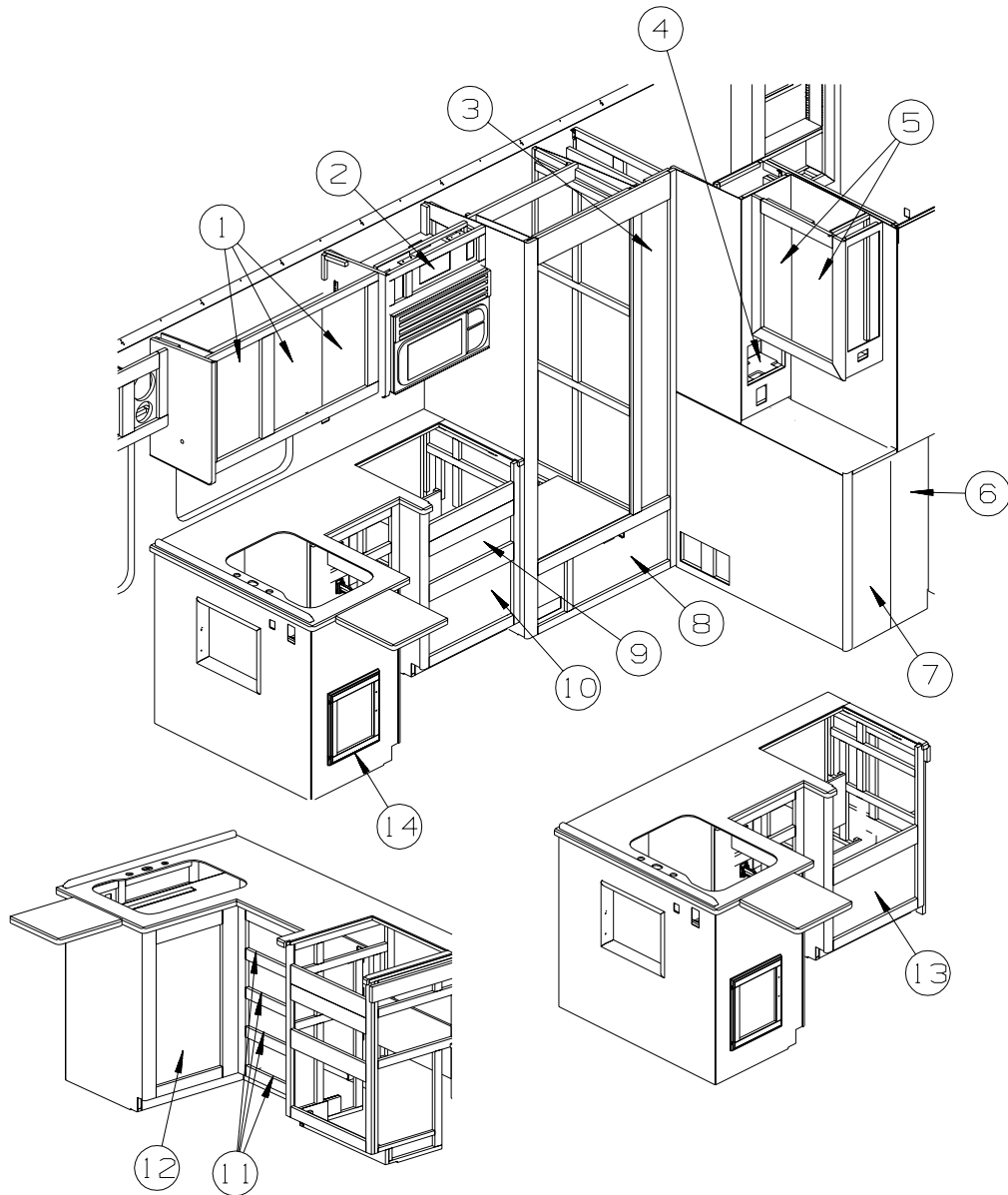

**GALLEY (CONTINUED)**

KEY	PART NUMBER	U/M	DESCRIPTION
1	136954-40-S01	EA	DOOR - RAISED PANEL/OGEE EDGE - 10.8" X 21.8" - W/O HDW - PORTSMOUTH OAK
1	136954-40-S47	EA	DOOR - RAISED PANEL/OGEE EDGE - 10.8" X 21.8" - W/O HDW - CONCERT CHERRY
1	136954-40-S48	EA	DOOR - RAISED PANEL/OGEE EDGE - 10.8" X 21.8" - W/O HDW - WASHED MAPLE
1	136954-40-S88	EA	DOOR - RAISED PANEL/OGEE EDGE - 10.8" X 21.8" - W/O HDW - SIERRA MAPLE
2	136954-28-S28	EA	DOOR - RAISED PANEL/OGEE EDGE - 10" X 29.5" - W/O HDW - PORTSMOUTH OAK
2	136954-28-S47	EA	DOOR - RAISED PANEL/OGEE EDGE - 10" X 29.5" - W/O HDW - CONCERT CHERRY
2	136954-28-S48	EA	DOOR - RAISED PANEL/OGEE EDGE - 10" X 29.5" - W/O HDW - WASHED MAPLE
2	136954-28-S88	EA	DOOR - RAISED PANEL/OGEE EDGE - 10" X 29.5" - W/O HDW - SIERRA MAPLE
3	136954-01-S46	EA	DOOR - RAISED PANEL/OGEE EDGE - 8.1" X 60.8" - W/O HDW - PORTSMOUTH OAK
3	136954-01-S47	EA	DOOR - RAISED PANEL/OGEE EDGE - 8.1" X 60.8" - W/O HDW - CONCERT CHERRY
3	136954-01-S48	EA	DOOR - RAISED PANEL/OGEE EDGE - 8.1" X 60.8" - W/O HDW - WASHED MAPLE
3	136954-01-SR0	EA	DOOR - RAISED PANEL/OGEE EDGE - 8.1" X 60.8" - W/O HDW - SIERRA MAPLE
4	131995-Y1-N30	EA	DOOR - RAIL/SOLID PANEL - 10.2" X 9.2" - W/O HARDWARE - PORTSMOUTH OAK
4	131995-Y1-L52	EA	DOOR - RAIL/SOLID PANEL - 10.2" X 9.2" - W/O HARDWARE - CONCERT CHERRY
4	131995-Y1-L58	EA	DOOR - RAIL/SOLID PANEL - 10.2" X 9.2" - W/O HARDWARE - WASHED MAPLE
4	131995-Y1-SR0	EA	DOOR - RAIL/SOLID PANEL - 10.2" X 9.2" - W/O HARDWARE - SIERRA MAPLE
5	136954-25-S28	EA	DOOR - RAISED PANEL/OGEE EDGE - 10" X 25.2" - W/O HDW - PORTSMOUTH OAK
5	136954-25-S08	EA	DOOR - RAISED PANEL/OGEE EDGE - 10" X 25.2" - W/O HDW - CONCERT CHERRY
5	136954-25-S09	EA	DOOR - RAISED PANEL/OGEE EDGE - 10" X 25.2" - W/O HDW - WASHED MAPLE
5	136954-25-S88	EA	DOOR - RAISED PANEL/OGEE EDGE - 10" X 25.2" - W/O HDW - SIERRA MAPLE

## CABINET & APPLIANCE GROUP (CONTINUED)

### CABINET & APPLIANCE LAYOUT (CONTINUED)

#### GALLEY (CONTINUED)

KEY	PART NUMBER	U/M	DESCRIPTION
6	140283-02-S46	EA	DOOR - HINGED - OGEE EDGE - 12.4" X 32.2" - W/O HARDWARE - PORTSMOUTH OAK
6	140283-02-S47	EA	DOOR - HINGED - OGEE EDGE - 12.4" X 32.2" - W/O HARDWARE - CONCERT CHERRY
6	140283-02-S48	EA	DOOR - HINGED - OGEE EDGE - 12.4" X 32.2" - W/O HARDWARE - WASHED MAPLE
6	140283-02-SR0	EA	DOOR - HINGED - OGEE EDGE - 12.4" X 32.2" - W/O HARDWARE - SIERRA MAPLE
6	139560-02-11B	EA	MESH - GRILLE - FLAT BLACK
7	140283-03-S46	EA	DOOR - HINGED - OGEE EDGE - 12.4" X 32.2" - W/O HARDWARE - PORTSMOUTH OAK
7	140283-03-S47	EA	DOOR - HINGED - OGEE EDGE - 12.4" X 32.2" - W/O HARDWARE - CONCERT CHERRY
7	140283-03-S48	EA	DOOR - HINGED - OGEE EDGE - 12.4" X 32.2" - W/O HARDWARE - WASHED MAPLE
7	140283-03-SR0	EA	DOOR - HINGED - OGEE EDGE - 12.4" X 32.2" - W/O HARDWARE - SIERRA MAPLE
7	139560-02-11B	EA	MESH - GRILLE - FLAT BLACK
8	145492-E8-R32	EA	DRAWER - OGEE EDGE - 22.9"W X 13.8"D - W/O SLIDES/HDW - PORTSMOUTH OAK
8	145492-E8-S47	EA	DRAWER - OGEE EDGE - 22.9"W X 13.8"D - W/O SLIDES/HDW - CONCERT CHERRY
8	145492-E8-S48	EA	DRAWER - OGEE EDGE - 22.9"W X 13.8"D - W/O SLIDES/HDW - WASHED MAPLE
8	145492-E8-SR0	EA	DRAWER - OGEE EDGE - 22.9"W X 13.8"D - W/O SLIDES/HDW - SIERRA MAPLE
9	145492-C1-R32	EA	DRAWER - OGEE EDGE - 19.8"W X 17.7"D - W/O SLIDES/HDW - PORTSMOUTH OAK
9	145492-C1-S47	EA	DRAWER - OGEE EDGE - 19.8"W X 17.7"D - W/O SLIDES/HDW - CONCERT CHERRY
9	145492-C1-S48	EA	DRAWER - OGEE EDGE - 19.8"W X 17.7"D - W/O SLIDES/HDW - WASHED MAPLE
9	145492-C1-S35	EA	DRAWER - OGEE EDGE - 19.8"W X 17.7"D - W/O SLIDES/HDW - SIERRA MAPLE
10	145492-G0-R32	EA	DRAWER - OGEE EDGE - 19.8"W X 13.8"D - W/O SLIDES/HDW - PORTSMOUTH OAK
10	145492-G0-S47	EA	DRAWER - OGEE EDGE - 19.8"W X 13.8"D - W/O SLIDES/HDW - CONCERT CHERRY
10	145492-G0-S48	EA	DRAWER - OGEE EDGE - 19.8"W X 13.8"D - W/O SLIDES/HDW - WASHED MAPLE
10	145492-G0-SR0	EA	DRAWER - OGEE EDGE - 19.8"W X 13.8"D - W/O SLIDES/HDW - SIERRA MAPLE
11	145492-F9-R32	EA	DRAWER - OGEE EDGE - 15.5"W X 11.8"D - W/O SLIDES/HDW - PORTSMOUTH OAK
11	145492-F9-S47	EA	DRAWER - OGEE EDGE - 15.5"W X 11.8"D - W/O SLIDES/HDW - CONCERT CHERRY
11	145492-F9-S48	EA	DRAWER - OGEE EDGE - 15.5"W X 11.8"D - W/O SLIDES/HDW - WASHED MAPLE
11	145492-F9-SR0	EA	DRAWER - OGEE EDGE - 15.5"W X 11.8"D - W/O SLIDES/HDW - SIERRA MAPLE
12	136918-D5-S28	EA	DOOR - FLAT/OGEE EDGE - 15.7" X 27.9" - W/O HARDWARE - PORTSMOUTH OAK
12	136918-D5-S47	EA	DOOR - FLAT/OGEE EDGE - 15.7" X 27.9" - W/O HARDWARE - CONCERT CHERRY
12	136918-D5-S48	EA	DOOR - FLAT/OGEE EDGE - 15.7" X 27.9" - W/O HARDWARE - WASHED MAPLE
12	136918-D5-SR0	EA	DOOR - FLAT/OGEE EDGE - 15.7" X 27.9" - W/O HARDWARE - SIERRA MAPLE
13	145492-P9-R32	EA	DRAWER - OGEE EDGE - 19.8"W X 13.8"D - W/O SLIDES/HDW - PORTSMOUTH OAK
13	145492-P9-S47	EA	DRAWER - OGEE EDGE - 19.8"W X 13.8"D - W/O SLIDES/HDW - CONCERT CHERRY
13	145492-P9-S48	EA	DRAWER - OGEE EDGE - 19.8"W X 13.8"D - W/O SLIDES/HDW - WASHED MAPLE
13	145492-P9-SR0	EA	DRAWER - OGEE EDGE - 19.8"W X 13.8"D - W/O SLIDES/HDW - SIERRA MAPLE
14	136918-81-S46	EA	DOOR - FLAT/OGEE EDGE - 12.4" X 14.3" - W/O HARDWARE - PORTSMOUTH OAK
14	136918-81-S47	EA	DOOR - FLAT/OGEE EDGE - 12.4" X 14.3" - W/O HARDWARE - CONCERT CHERRY
14	136918-81-S48	EA	DOOR - FLAT/OGEE EDGE - 12.4" X 14.3" - W/O HARDWARE - WASHED MAPLE
14	136918-81-SR0	EA	DOOR - FLAT/OGEE EDGE - 12.4" X 14.3" - W/O HARDWARE - SIERRA MAPLE



**CABINET & APPLIANCE GROUP (CONTINUED)**  
**CABINET & APPLIANCE LAYOUT (CONTINUED)**

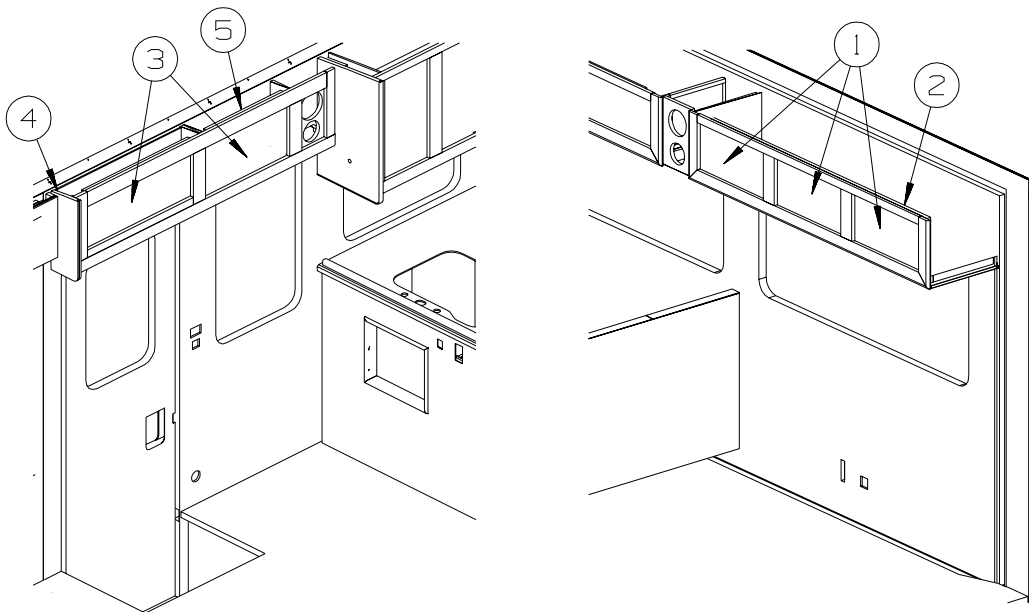

**LOUNGE**

KEY	PART NUMBER	U/M	DESCRIPTION
1	136954-22-S28	EA	DOOR - RAISED PANEL/OGEE EDGE - 10" X 19.1" - W/O HDW - PORTSMOUTH OAK
1	136954-22-S08	EA	DOOR - RAISED PANEL/OGEE EDGE - 10" X 19.1" - W/O HDW - CONCERT CHERRY
1	136954-22-S09	EA	DOOR - RAISED PANEL/OGEE EDGE - 10" X 19.1" - W/O HDW - WASHED MAPLE
1	136954-22-SJ0	EA	DOOR - RAISED PANEL/OGEE EDGE - 10" X 19.1" - W/O HDW - SIERRA MAPLE
2	139026-01-N30	EA	CABINET - OVERHEAD/COUCH - W/O DOORS/HARDWARE - PORTSMOUTH OAK
2	139026-01-S47	EA	CABINET - OVERHEAD/COUCH - W/O DOORS/HARDWARE - CONCERT CHERRY
2	139026-01-S48	EA	CABINET - OVERHEAD/COUCH - W/O DOORS/HARDWARE - WASHED MAPLE
2	139026-01-SR0	EA	CABINET - OVERHEAD/COUCH - W/O DOORS/HARDWARE - SIERRA MAPLE
3	136954-58-S07	EA	DOOR - RAISED PANEL/OGEE EDGE - 11.4" X 21.8" - W/O HDW - PORTSMOUTH OAK
3	136954-58-S08	EA	DOOR - RAISED PANEL/OGEE EDGE - 11.4" X 21.8" - W/O HDW - CONCERT CHERRY
3	136954-58-S09	EA	DOOR - RAISED PANEL/OGEE EDGE - 11.4" X 21.8" - W/O HDW - WASHED MAPLE
3	136954-58-SW0	EA	DOOR - RAISED PANEL/OGEE EDGE - 11.4" X 21.8" - W/O HDW - SIERRA MAPLE
4	103128-65-M53	EA	END CAP - OVERHEAD CABINET - LEFT HAND - PORTSMOUTH OAK
4	103128-65-M52	EA	END CAP - OVERHEAD CABINET - LEFT HAND - CONCERT CHERRY
4	103128-65-S48	EA	END CAP - OVERHEAD CABINET - LEFT HAND - WASHED MAPLE
4	103128-65-SR0	EA	END CAP - OVERHEAD CABINET - LEFT HAND - SIERRA MAPLE
5	145429-01-S46	EA	CABINET - OVERHEAD/ENTRY DOOR - W/O DOORS/HARDWARE (S46)
5	145429-01-S47	EA	CABINET - OVERHEAD/ENTRY DOOR - W/O DOORS/HARDWARE (S47)
5	145429-01-S48	EA	CABINET - OVERHEAD/ENTRY DOOR - W/O DOORS/HARDWARE (S48)
5	145429-01-S49	EA	CABINET - OVERHEAD/ENTRY DOOR - W/O DOORS/HARDWARE (S49)
5	145429-01-S50	EA	CABINET - OVERHEAD/ENTRY DOOR - W/O DOORS/HARDWARE (S50)
5	145429-01-S51	EA	CABINET - OVERHEAD/ENTRY DOOR - W/O DOORS/HARDWARE (S51)
5	145429-01-R34	EA	CABINET - OVERHEAD/ENTRY DOOR - W/O DOORS/HARDWARE (S52)
5	145429-01-S53	EA	CABINET - OVERHEAD/ENTRY DOOR - W/O DOORS/HARDWARE (S53)
5	145429-01-S54	EA	CABINET - OVERHEAD/ENTRY DOOR - W/O DOORS/HARDWARE (S54)
5	145429-01-SR0	EA	CABINET - OVERHEAD/ENTRY DOOR - W/O DOORS/HARDWARE (SR0)
5	145429-01-SR1	EA	CABINET - OVERHEAD/ENTRY DOOR - W/O DOORS/HARDWARE (SR1)
5	145429-01-SR2	EA	CABINET - OVERHEAD/ENTRY DOOR - W/O DOORS/HARDWARE (SR2)

# CHASSIS GROUP FRAME

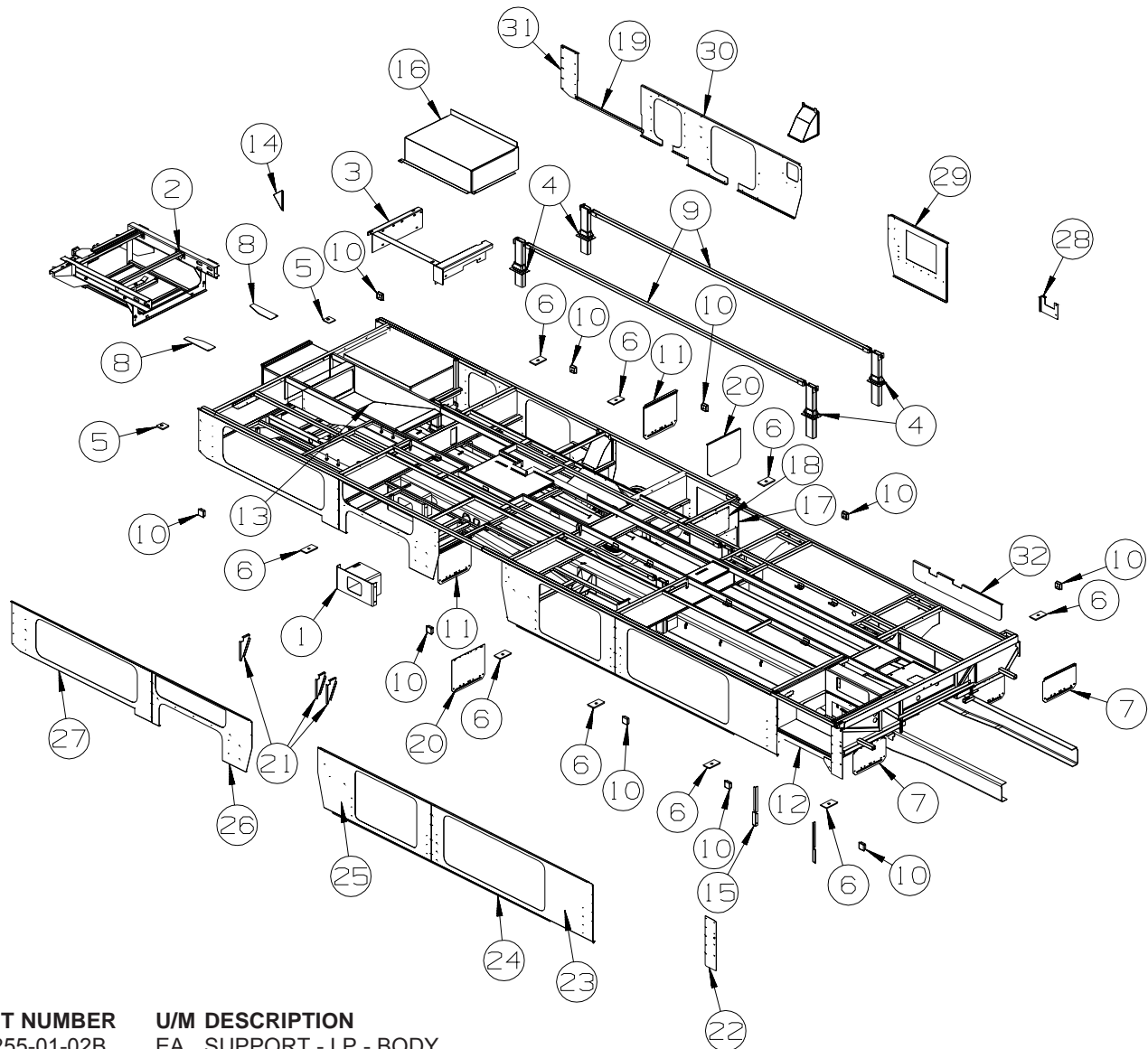

KEY	PART NUMBER	U/M	DESCRIPTION
1	139255-01-02B	EA	SUPPORT - LP - BODY
2*	149055-01-01A	EA	CLIP/REAR EXTENSION RAIL - W/HITCH/TIRE CARRIER
2*	149055-03-01A	EA	CLIP/REAR EXTENSION RAIL - W/HITCH-W/O TIRE CARRIER
3	138113-01-02B	EA	OUTRIGGER/GENERATOR - E-COATED
4	139724-01-01A	EA	BOOT - TOWER - BLACK
5	135712-02-02B	EA	PLATE - BODY MOUNT - E-COATED
6	135712-01-02B	EA	PLATE - BODY MOUNT - E-COATED
7	136391-01-02B	EA	GUARD/ROCK - STEEL - W/ANGLE - 18"W X 11"H - E-COATED
7	136388-01-02B	EA	GUARD/ROCK - STEEL - 18" X 11" - E-COATED FROM: 00-00-00 THRU: 07-23-04
7	136388-07-02B	EA	GUARD/ROCK - STEEL - 18" X 11" - E-COATED FROM: 07-24-04 THRU: 08-06-04 FROM: 08-07-04 THRU: 99-99-99
8	133095-01-02B	EA	PLATE - CLIP - E-COATED
9	150924-06-02B	EA	TUBE - TENSION - E-COATED
10	119845-01-01A	EA	PLUG/PLASTIC - 1 1/2" SQUARE - BLACK
11	136391-02-02B	EA	GUARD/ROCK - STEEL - W/ANGLE - 18"W X 15"H - E-COATED
12	132607-13-02B	EA	BOX/ENTRANCE STEP - E-COATED
13	144746-06-02B	EA	COMPARTMENT - FURNACE - E-COATED
14	123440-07-02B	EA	SUPPORT - PANEL - 8.7" X 4.7" - E-COATED
15	136814-02-02B	EA	ANGLE/FILLER - STEP/LH HAND - E-COATED
16	140930-02-02B	EA	COMPARTMENT - GENERATOR - E-COATED
17	138765-05-02B	EA	PANEL - CLOSEOUT - E-COATED
18	134316-01-02B	EA	PANEL - ACCESS - E-COATED
19	133612-05-02B	EA	ZEE/SEAL PLANE - BOTTOM - E-COATED

**CHASSIS GROUP (CONTINUED)**  
**FRAME (CONTINUED)**

<b>KEY</b>	<b>PART NUMBER</b>	<b>U/M</b>	<b>DESCRIPTION</b>	
20	134191-01-02B	EA	GUARD/ROCK - STEEL - W/BEND - 18"W X 14.9"H - E-COATED	
21	123440-02-02B	EA	SUPPORT - PANEL - 9.9"/7.6" X 4.7" - E-COATED	
22	132606-03-02B	EA	PLATE/SEAL - E-COATED	
23	144365-13-02B	EA	PLATE/SEAL - E-COATED	
24	126516-01-01A	FT	TRIM - VINYL/EXTRUDED - 8'	
25	144365-14-02B	EA	PLATE/SEAL - E-COATED	
26	137098-12-02B	EA	PLATE/SEAL - E-COATED	
27	137098-13-02B	EA	PLATE/SEAL - E-COATED	
28	132606-01-02B	EA	PLATE/SEAL - E-COATED	
				FROM: 00-00-00 THRU: 07-09-04
28	132606-04-02B	EA	PLATE/SEAL - E-COATED	
				FROM: 07-10-04 THRU: 99-99-99
29	144365-15-02B	EA	PLATE/SEAL - E-COATED	
29	144365-53-02B	EA	PLATE/SEAL - E-COATED - WASHER/DRYER - WATER HEATER/MOTOR-AID	
30	137103-21-02B	EA	PLATE/SEAL - E-COATED	
31	137103-03-02B	EA	PLATE/SEAL - E-COATED	
32	140219-04-02B	EA	SHIELD - HEAT/EXHAUST - E-COATED	
				FROM: 00-00-00 THRU: 07-16-04
33	136814-01-02B	EA	ANGLE/FILLER - STEPRH HAND - E-COATED	

**\*COMPONENT PARTS LISTED LATER IN THIS GROUP**

**COMPONENT PARTS FOR FRAME**

**132643-01-01A, 132643-06-01A, 132643-07-01A, 132643-09-01A**

<b>KEY</b>	<b>PART NUMBER</b>	<b>U/M</b>	<b>DESCRIPTION</b>	<b>VENDOR NO.</b>
	132643-01-700	EA	HITCH/RECEIVER WELDED ASM.	72430-47
	132643-01-701	EA	TIRE CARRIER COMPLETE	56610-47
	132643-01-702	EA	RETAINER KIT/SPARE TIRE	55290-47
	132643-01-703	EA	BOLT IN CROSSMEMBER W/SPARE	4132-03

**149055-01-01A, 149055-02-01A**

<b>KEY</b>	<b>PART NUMBER</b>	<b>U/M</b>	<b>DESCRIPTION</b>	<b>VENDOR NO.</b>
	132643-01-701	EA	TIRE CARRIER COMPLETE	56610-47
	132643-01-702	EA	RETAINER KIT/SPARE TIRE	55290-47
	132643-01-703	EA	BOLT IN CROSSMEMBER W/SPARE	4132-03
	149055-01-702	EA	HITCH/RECEIVER WELDED ASM.	2352-01

**149055-03-01A**

<b>KEY</b>	<b>PART NUMBER</b>	<b>U/M</b>	<b>DESCRIPTION</b>	<b>VENDOR NO.</b>
	149055-01-702	EA	HITCH/RECEIVER WELDED ASM.	2352-01

**149055-04-01A**

<b>KEY</b>	<b>PART NUMBER</b>	<b>U/M</b>	<b>DESCRIPTION</b>	<b>VENDOR NO.</b>
	132643-01-702	EA	RETAINER KIT/SPARE TIRE	55290-47
	132643-01-703	EA	BOLT IN CROSSMEMBER W/SPARE	4132-03
	149055-01-700	EA	TIRE CARRIER COMPLETE	181606
	149055-01-701	EA	HITCH/RECEIVER-WELDED ASM	1823-05

# CHASSIS GROUP (CONTINUED)

## FRONT END

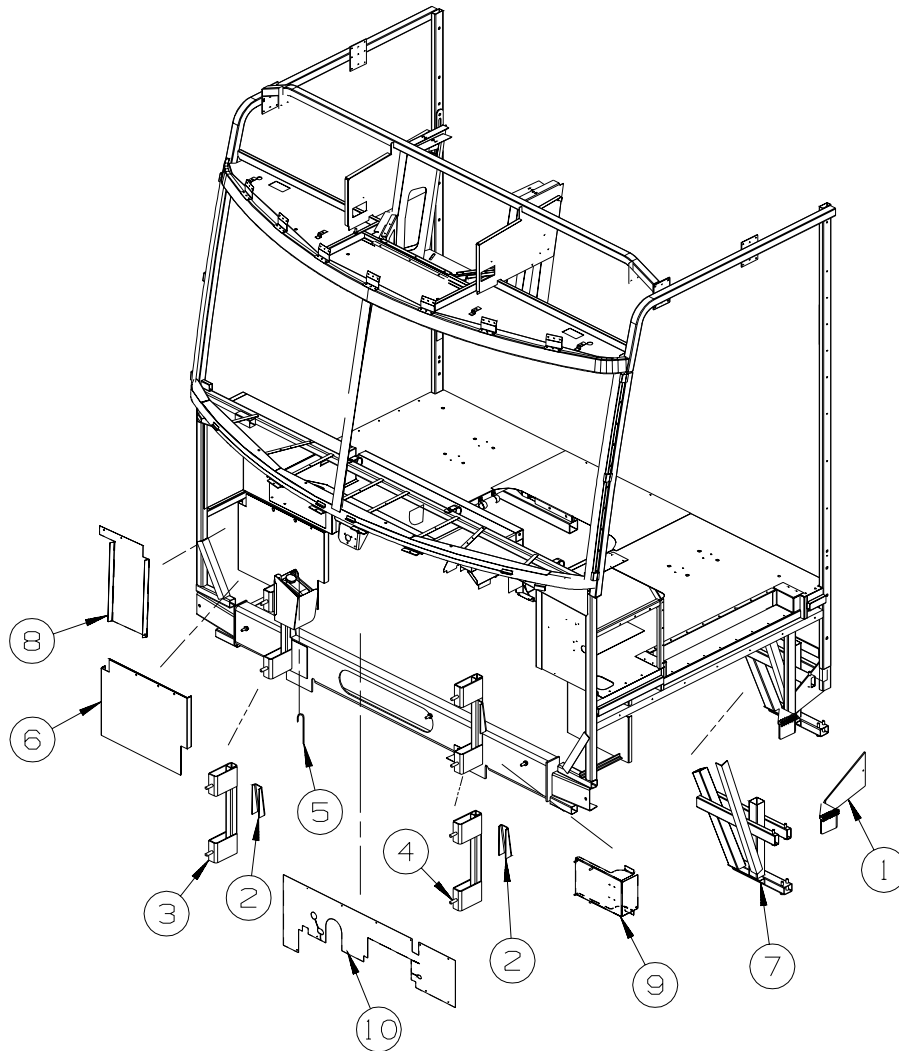

2004  
FORD

KEY	PART NUMBER	U/M	DESCRIPTION
1	128255-03-04B	EA	STEP - DRIVER DOOR - BLACK
2	117622-01-02B	EA	BRACE - TUBE/BUMPER - VERTICAL - E-COATED
3	134807-03-02B	EA	SUPPORT - FRONT - E-COATED
4	134807-04-02B	EA	SUPPORT - FRONT - E-COATED
5	NOT USED		
6	144679-02-02B	EA	SHIELD/SPLASH - HEADLIGHT - E-COATED
7	138340-02-02B	EA	SUPPORT/STEP - DRIVER - E-COATED - F36M ONLY
8	NOT USED		
9	NOT USED		
10	NOT USED		

**CHASSIS GROUP (CONTINUED)**  
**FRONT END (CONTINUED)**

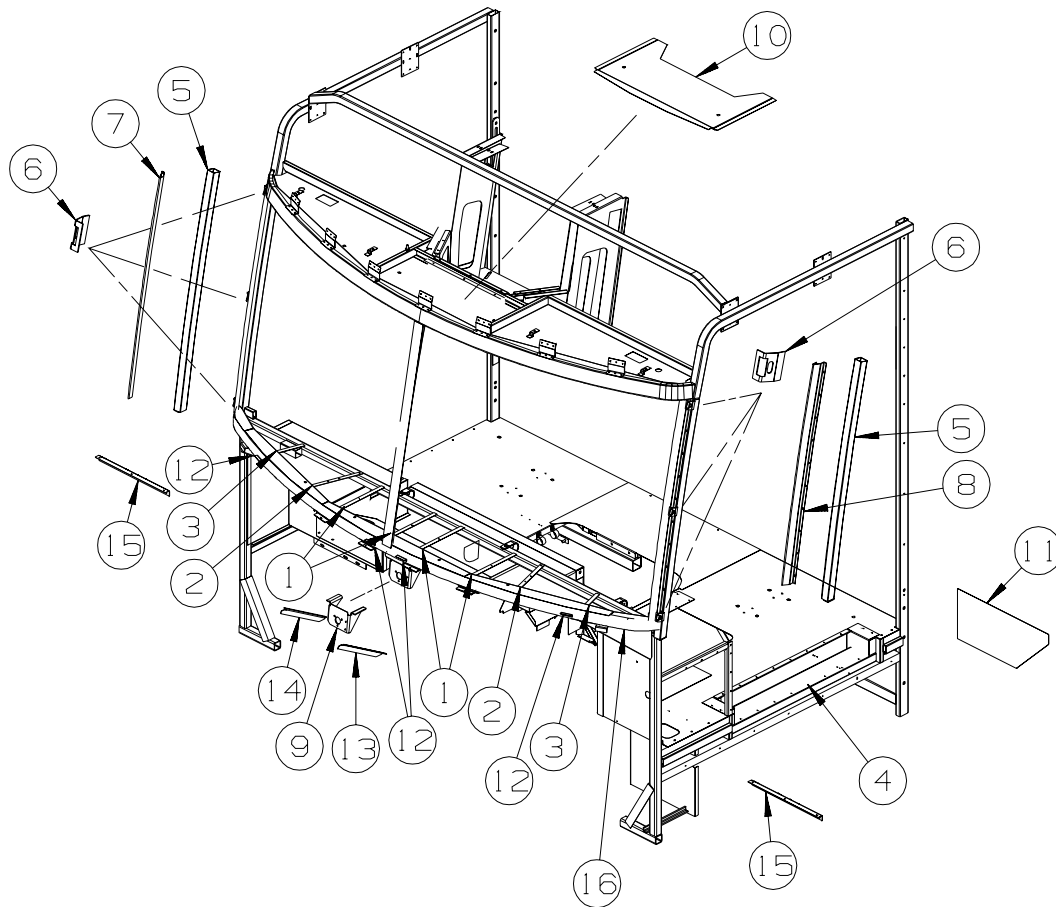

**2004  
 FORD**

KEY	PART NUMBER	U/M	DESCRIPTION
1	137047-04-01B	EA	STRAP - DEFROSTER PLENUM
2	137047-05-01B	EA	STRAP - DEFROSTER PLENUM
3	137047-06-01B	EA	STRAP - DEFROSTER PLENUM
4	146492-02-01B	EA	PANEL - STEPWELL
5	117273-01-01A	EA	TUBE - SUPPORT - A-PILLAR
6	120363-01-01B	EA	BRACKET - WINDSHIELD
			FROM: 00-00-00 THRU: 05-14-04
6	148935-01-01B	EA	BRACKET - WINDSHIELD
			FROM: 05-15-04 THRU: 99-99-99
7	121269-05-01B	EA	FRAME - WINDSHIELD - A-PILLAR - MILL
8	121269-06-01B	EA	FRAME - WINDSHIELD - A-PILLAR - MILL
9	134506-02-01B	EA	BRACKET - WIPER MOTOR
10	124904-05-01B	EA	HEADER/WINDSHIELD - CENTER - 27.5"
11	NOT USED		
12	126289-65-01B	EA	ANGLE - FORMED - 4 USED
13	134371-01-01B	EA	ANGLE/MOUNT - WIPER MOTOR
14	134371-02-01B	EA	ANGLE/MOUNT - WIPER MOTOR
15	152540-02-02B	EA	SUPPORT - DIRT GUARD - E-COATED
			FROM: 07-24-04 THRU: 99-99-99
16	124974-01-01B	EA	SUPPORT - WINDSHIELD, LOWER, MILL FINISH

**CHASSIS GROUP (CONTINUED)**  
**FRONT END (CONTINUED)**

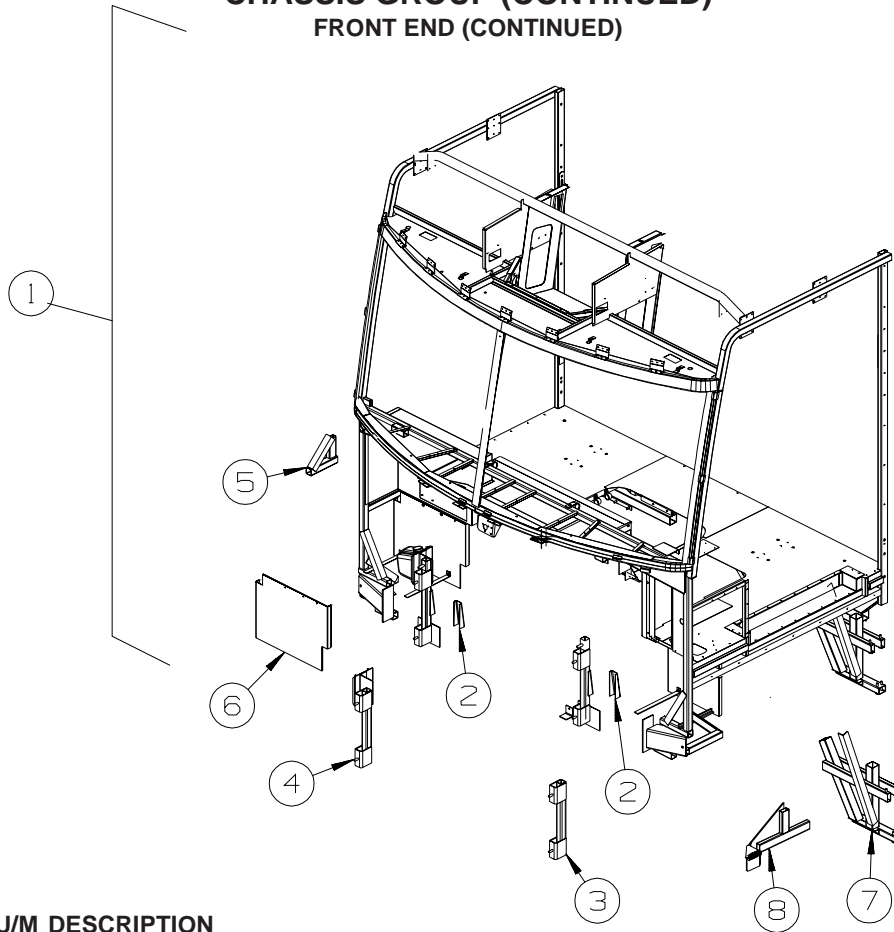

**2006  
 FORD**

KEY	PART NUMBER	U/M	DESCRIPTION
1	153180-04-02B	EA	FRONT END ASM - (20,500) GVWR CHASSIS
1	153180-03-02B	EA	FRONT END ASM - (22,000) GVWR CHASSIS
2	117622-01-02B	EA	BRACE - TUBE/BUMPER - VERTICAL - E-COATED
3	152916-01-02B	EA	SUPPORT - FRONT - E-COATED
4	152916-02-02B	EA	SUPPORT - FRONT - E-COATED
5	152725-02-02B	EA	SUPPORT - WHEEL LIP - E-COATED
6	144679-02-02B	EA	SHIELD/SPLASH - HEADLIGHT - E-COATED
7	138340-02-02B	EA	SUPPORT/STEP - DRIVER - E-COATED - (22,000) GVWR CHASSIS
8	152131-01-02B	EA	SUPPORT/STEP - DRIVER - E-COATED - (20,500) GVWR CHASSIS

**CHASSIS GROUP (CONTINUED)**  
**FRONT END (CONTINUED)**

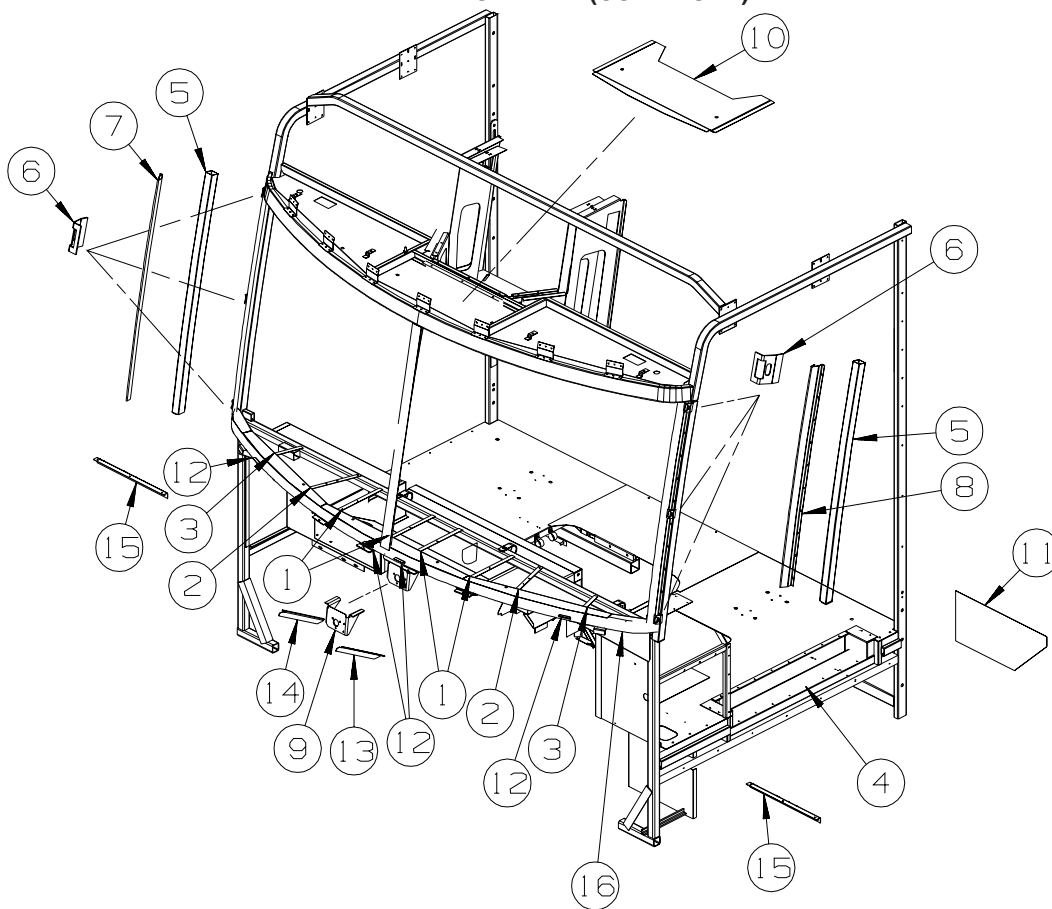

**2006  
FORD**

KEY	PART NUMBER	U/M	DESCRIPTION	
1	137047-04-01B	EA	STRAP - DEFROSTER PLENUM	
2	137047-05-01B	EA	STRAP - DEFROSTER PLENUM	
3	137047-06-01B	EA	STRAP - DEFROSTER PLENUM	
4	146492-02-01B	EA	PANEL - STEPWELL	
5	117273-01-01A	EA	TUBE - SUPPORT - A-PILLAR	
6	120363-01-01B	EA	BRACKET - WINDSHIELD	
6	148935-01-01B	EA	BRACKET - WINDSHIELD	FROM: 00-00-00 THRU: 05-14-04
7	121269-05-01B	EA	FRAME - WINDSHIELD - A-PILLAR - MILL	FROM: 05-15-04 THRU: 99-99-99
8	121269-06-01B	EA	FRAME - WINDSHIELD - A-PILLAR - MILL	
9	134506-02-01B	EA	BRACKET - WIPER MOTOR	
10	124904-05-01B	EA	HEADER/WINDSHIELD - CENTER - 27.5"	
11	NOT USED			
12	126289-65-01B	EA	ANGLE - FORMED - 4 USED	
13	134371-01-01B	EA	ANGLE/MOUNT - WIPER MOTOR	
14	134371-02-01B	EA	ANGLE/MOUNT - WIPER MOTOR	
15	152540-02-02B	EA	SUPPORT - DIRT GUARD - E-COATED	FROM: 07-24-04 THRU: 99-99-99
16	124974-01-01B	EA	SUPPORT - WINDSHIELD, LOWER, MILL FINISH	

## CHASSIS GROUP (CONTINUED) FRONT END (CONTINUED)

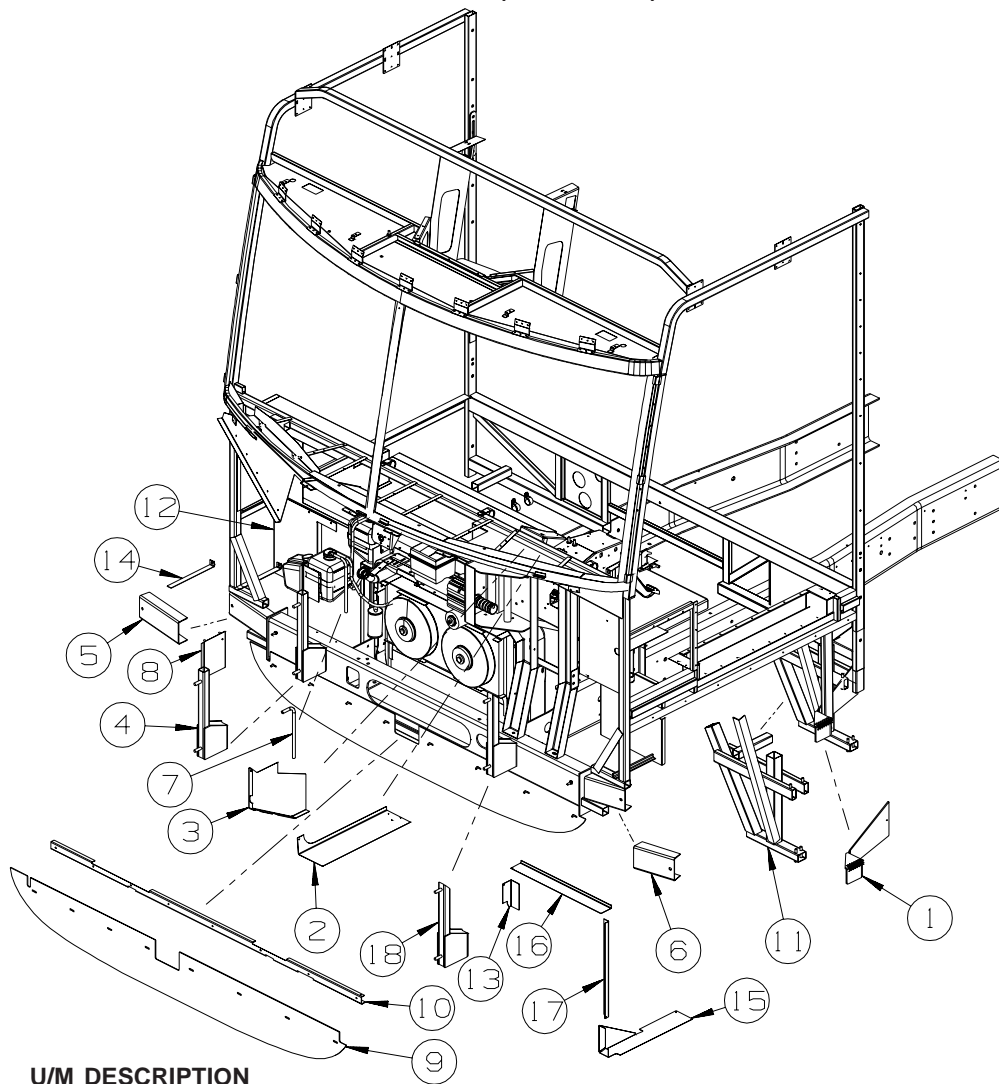

**WORKHORSE**

KEY	PART NUMBER	U/M	DESCRIPTION
1	128255-03-04B	EA	STEP - DRIVER DOOR - BLACK
2	137041-01-02B	EA	ANGLE - MOTOR COVER - E-COATED
3	150565-01-02B	EA	PANEL - CLOSE OUT - CAB - E-COATED
4	134807-01-02B	EA	SUPPORT - FRONT - E-COATED
			FROM: 00-00-00 THRU: 04-08-04
4	134807-11-02B	EA	SUPPORT - FRONT - E-COATED
			FROM: 04-09-04 THRU: 99-99-99
5	137048-02-02B	EA	CHANNEL - SUPPORT - FRONT - E-COATED
6	137048-01-02B	EA	CHANNEL/SUPPORT - FRONT - E-COATED
7	044317-01-000	FT	HOSE - FUEL - 3/8" ID
8	119656-02-02B	EA	BRACKET - RESERVOIR/WASHER - E-COATED
			FROM: 00-00-00 THRU: 04-08-04
8	134807-11-02B	EA	SUPPORT - FRONT - E-COATED - <b>INCLUDES RESERVOIR BRACKET</b>
			FROM: 04-09-04 THRU: 99-99-99
9	140782-02-01A	EA	SHIELD/SIGHT - PLASTIC
10	140790-01-02B	EA	ANGLE - SIGHT SHIELD - E-COATED
11	138340-01-02B	EA	SUPPORT/STEP - DRIVER - E-COATED - <b>CHASSIS W/22.5 TIRE - F35A, F36M, F38J</b>
11	138340-02-02B	EA	SUPPORT/STEP - DRIVER - E-COATED - <b>CHASSIS W/19.5 TIRE - F36M</b>
12	121962-02-02B	EA	SHIELD/SPLASH - HEADLIGHT - E-COATED
13	139131-01-02B	EA	ANGLE - W/NOTCHSTEEL
14	139119-01-02B	EA	STRAP - BENT, W/HOLE
15	137045-01-02B	EA	PANEL - FILLER, BULKHEAD
16	137037-01-02B	EA	ANGLE - FILLER, BULKHEAD
17	137037-02-02B	EA	ANGLE - FILLER, BULKHEAD
18	134807-01-02B	EA	SUPPORT - FRONT - E-COATED
			FROM: 00-00-00 THRU: 04-08-04
18	134807-12-02B	EA	SUPPORT - FRONT - E-COATED
			FROM: 04-09-04 THRU: 99-99-99



**CHASSIS GROUP (CONTINUED)**  
**FRONT END (CONTINUED)**

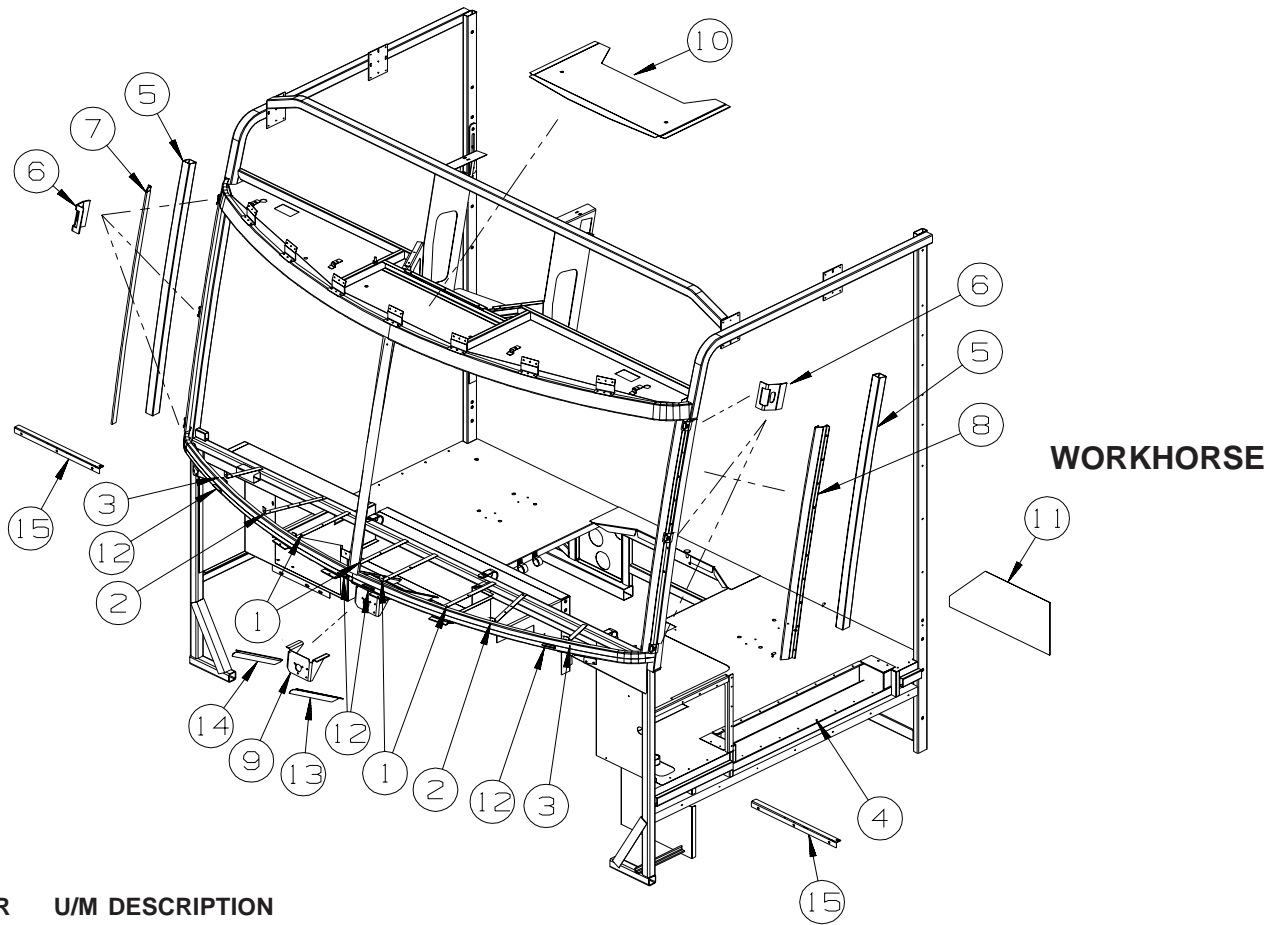

KEY	PART NUMBER	U/M	DESCRIPTION
1	137047-04-01B	EA	STRAP - DEFROSTER PLENUM
2	137047-05-01B	EA	STRAP - DEFROSTER PLENUM
3	137047-06-01B	EA	STRAP - DEFROSTER PLENUM
4	146492-02-01B	EA	PANEL - STEPWELL
5	117273-01-01A	EA	TUBE - SUPPORT - A-PILLAR
6	120363-01-01B	EA	BRACKET - WINDSHIELD
6	148935-01-01B	EA	BRACKET - WINDSHIELD
7	121269-05-01B	EA	FRAME - WINDSHIELD - A-PILLAR - MILL
8	121269-06-01B	EA	FRAME - WINDSHIELD - A-PILLAR - MILL
9	134506-02-01B	EA	BRACKET - WIPER MOTOR
10	124904-05-01B	EA	HEADER/WINDSHIELD - CENTER - 27.5"
11	137496-01-01B	EA	PANEL - SPLASH GUARD - F36M, F38J
12	126289-65-01B	EA	ANGLE - FORMED
13	134371-01-01B	EA	ANGLE/MOUNT - WIPER MOTOR
14	134371-02-01B	EA	ANGLE/MOUNT - WIPER MOTOR
15	152540-02-02B	EA	SUPPORT - DIRT GUARD - E-COATED

FROM: 00-00-00 THRU: 05-14-04

FROM: 05-15-04 THRU: 99-99-99

FROM: 07-24-04 THRU: 99-99-99

## CHASSIS GROUP (CONTINUED)

### AIR INTAKE

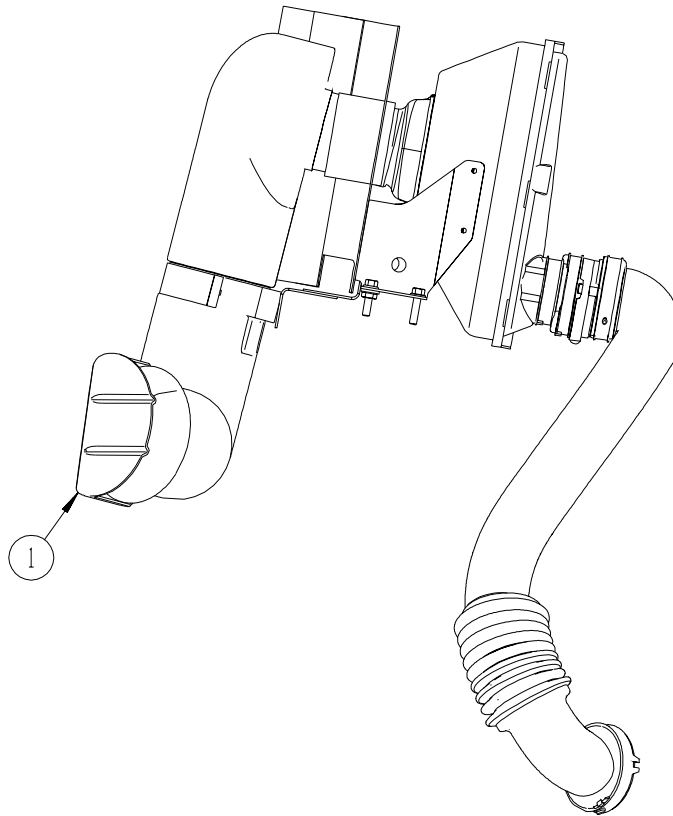

KEY	PART NUMBER	U/M DESCRIPTION
1	154181-01-10A	EA DEFLECTOR - AIR INTAKE - WORKHORSE - BLACK

### DRIVETRAIN

#### WORKHORSE, F35D & F38J

KEY	PART NUMBER	U/M DESCRIPTION
	128528-03-000	EA BOLT - U-JOINT - 3/8-24 X 3/4
	128528-04-000	EA STRAP - BEARING - 1480 JOINT
	138616-01-02B	EA BRACKET/BEARING MOUNT - FRONT/248" W B - E-COATED - 228 STRECH TO 248, 24000 GVWR
	138616-02-02B	EA BRACKET/BEARING MOUNT - MID-RR/248" W B - E-COATED - 228 STRECH TO 248, 24000 GVWR
	138616-06-02B	EA BRACKET/BEARING MOUNT - FRONT/220" W B - E-COATED - 208 STRECH TO 220, 22000 GVWR
	138126-02-000	EA DRIVESHAFT ASM-4 BALANCED - WH W22, 248"WB - 228 STRECH TO 248, 24000 GVWR FROM: 00-00-00 THRU: 05-21-04
	138126-05-000	EA DRIVESHAFT-BAL-4 SEC-WH W2 -248" WB - 228 STRECH TO 248, 24000 GVWR W/DISC PARK BRAKE FROM: 05-22-04 THRU: 99-99-99
	140691-07-000	EA DRIVESHAFT - BALANCED - 3 SECTION - WH W20 - 220" WB - 208 STRECH TO 220, 22000 GVWR

#### FORD, F35D & F36M

KEY	PART NUMBER	U/M DESCRIPTION
	128528-03-000	EA BOLT - U-JOINT - 3/8-24 X 3/4
	128528-04-000	EA STRAP - BEARING - 1480 JOINT
	149203-01-000	EA DRIVESHAFT-BALANCE -190" WB -04 F53FD-20,500 GVW -208 CHASSIS SHRINK TO 190 WHEEL BASE
	115043-03-000	EA BUSHING - DRIVESHAFT
	149203-03-000	EA DRIVESHAFT - BALANCED - 220" WB - 04 F53FD - 20,500 GVWR-208 STRETCH TO 220 WHEEL BASE

## CHASSIS GROUP (CONTINUED)

### EXHAUST

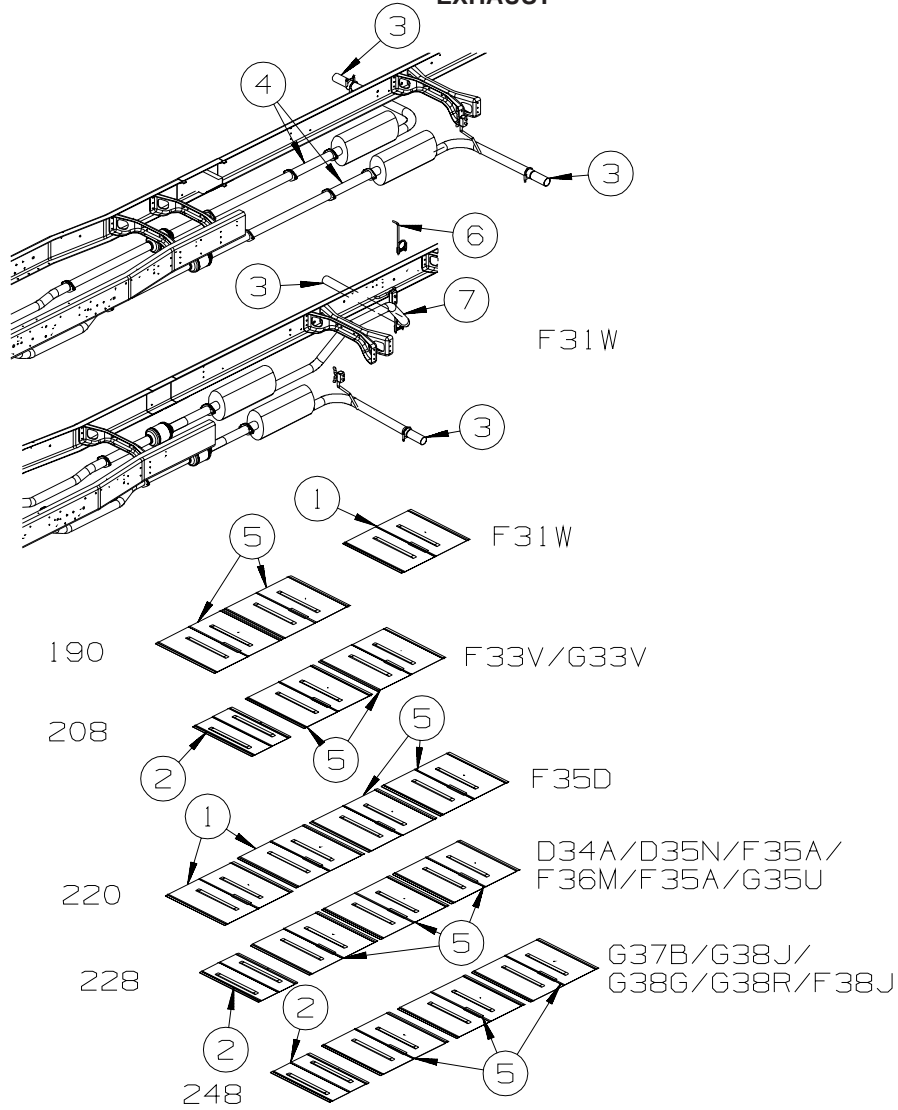

**WORKHORSE  
2004 CHASSIS**

KEY	PART NUMBER	U/M DESCRIPTION
1	143712-02-02B	EA SHIELD - HEAT/EXHAUST - E-COATED
2	143712-01-02B	EA SHIELD - HEAT/EXHAUST - E-COATED
3	098762-05-000	EA EXTENSION - EXHAUST - STRAIGHT - 3" O.D X 7.9" LONG - SST
	094918-01-000	EA CLAMP - EXHAUST - 3" - GUILLOTINE STYLE
4	137652-03-000	EA PIPE - EXHAUST - W/FLANGES - 208"-220" STRETCH F35D
4	137652-01-000	EA PIPE - EXHAUST - W/FLANGES - 228"-248" STRETCH F38J
5	143712-05-02B	EA SHIELD - HEAT/EXHAUST - E-COATED
6	122392-13-02B	EA HANGER - TAILPIPE - E-COATED
7	137925-04-000	EA PIPE - EXHAUST - RIGHT HAND

# CHASSIS GROUP (CONTINUED)

## EXHAUST (CONTINUED)

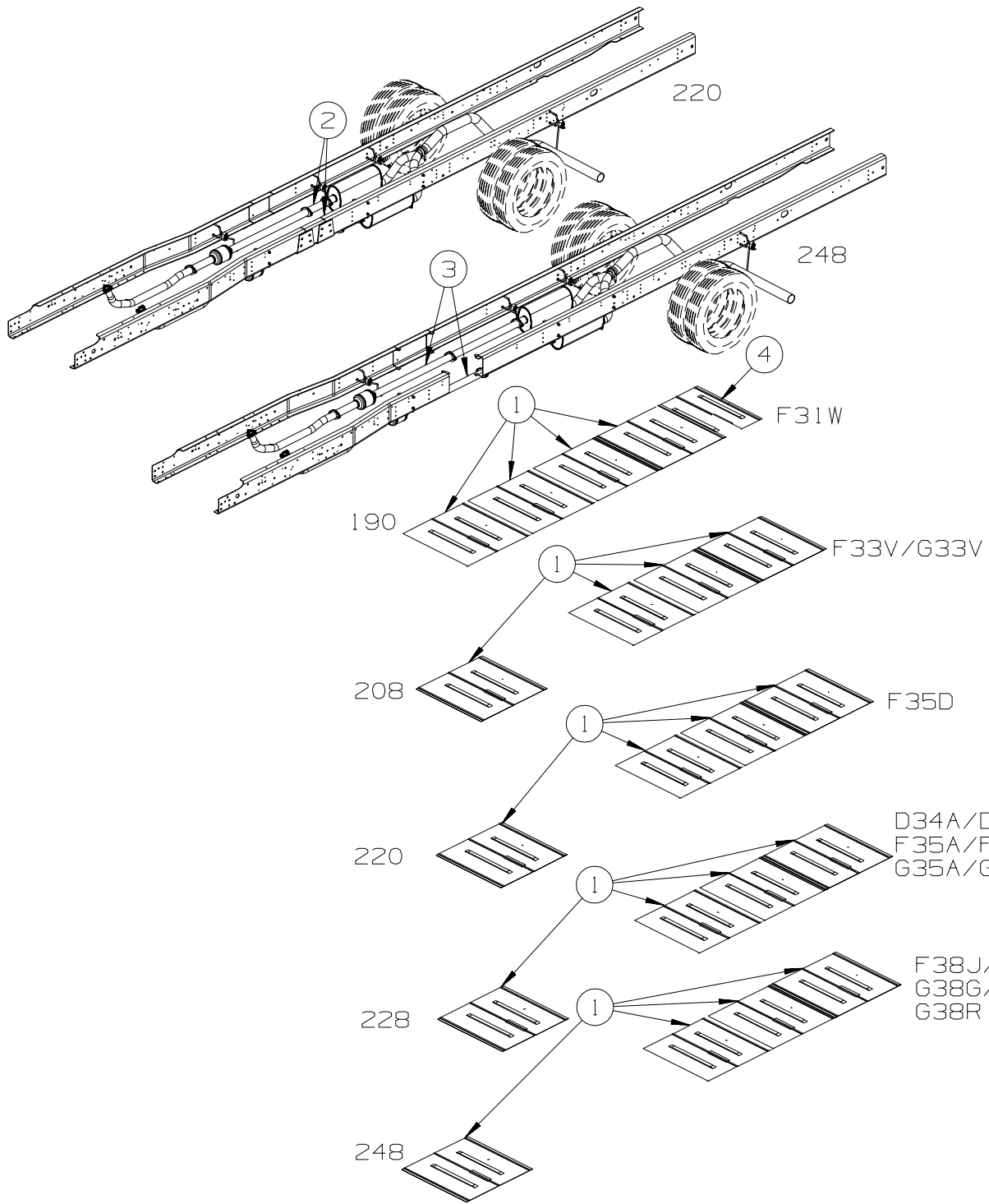

**WORKHORSE  
2005 CHASSIS  
W/SINGLE  
TAILPIPE**

KEY	PART NUMBER	U/M	DESCRIPTION
1	143712-02-02B	EA	SHIELD/HEAT - EXHAUST - E-COATED
2	137652-03-000	EA	PIPE - EXHAUST - W/FLANGES - 208"-220" STRETCH F35D
3	137652-01-000	EA	PIPE - EXHAUST - W/FLANGES - 228"-248" STRETCH F38J
4	143712-01-02B	EA	SHIELD/HEAT - EXHAUST - E-COATED

**CHASSIS GROUP (CONTINUED)**  
**EXHAUST (CONTINUED)**

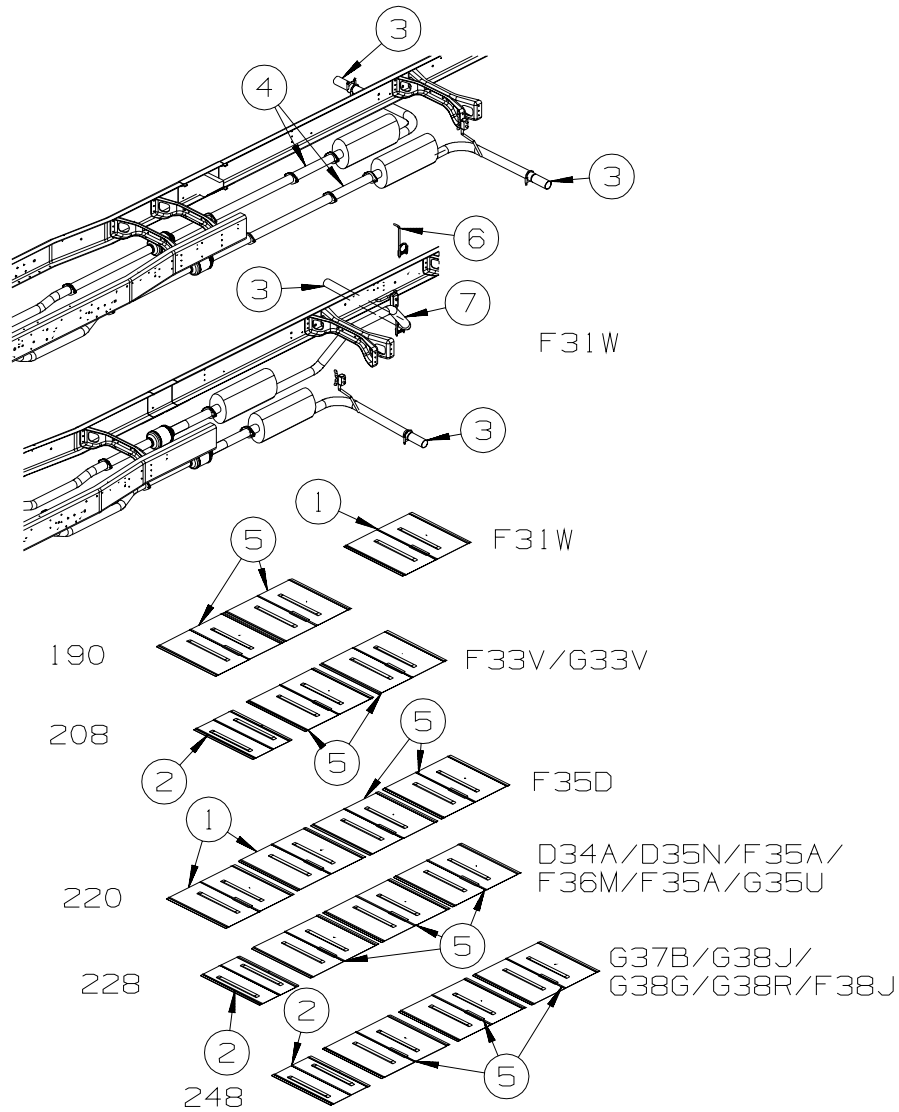

**WORKHORSE  
 2005 CHASSIS  
 W/DUAL TAILPIPE  
 UP TO 02-09-05**

KEY	PART NUMBER	U/M DESCRIPTION
1	143712-02-02B	EA SHIELD - HEAT/EXHAUST - E-COATED
2	143712-01-02B	EA SHIELD - HEAT/EXHAUST - E-COATED
3	098762-05-000	EA EXTENSION - EXHAUST - STRAIGHT - 3" O.D X 7.9" LONG - SST
	094918-01-000	EA CLAMP - EXHAUST - 3" - GUILLOTINE STYLE
4	137652-03-000	EA PIPE - EXHAUST - W/FLANGES - 208"-220" STRETCH F35D
4	137652-01-000	EA PIPE - EXHAUST - W/FLANGES - 228"-248" STRETCH F38J
5	143712-05-02B	EA SHIELD - HEAT/EXHAUST - E-COATED
6	122392-13-02B	EA HANGER - TAILPIPE - E-COATED
7	137925-04-000	EA PIPE - EXHAUST - RIGHT HAND

**CHASSIS GROUP (CONTINUED)**  
**EXHAUST (CONTINUED)**

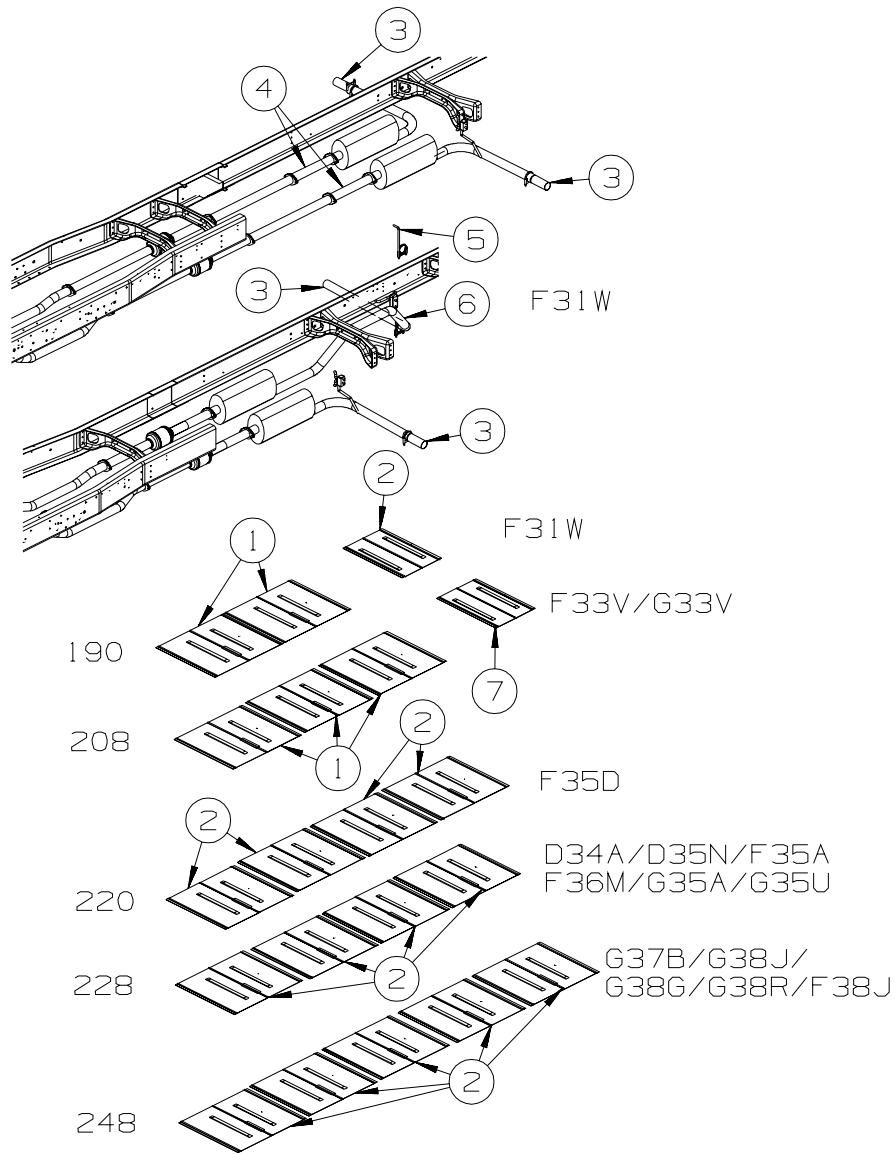

**WORKHORSE  
2005 CHASSIS  
W/DUAL TAILPIPE  
FROM 02-10-05**

KEY	PART NUMBER	U/M DESCRIPTION
1	143712-05-02B	EA SHIELD - HEAT/EXHAUST - E-COATED
2	143712-02-02B	EA SHIELD - HEAT/EXHAUST - E-COATED
3	098762-05-000	EA EXTENSION - EXHAUST - STRAIGHT - 3" O.D X 7.9" LONG - SST
3	142985-01-000	EA PIPE - EXHAUST - DRIVER SIDE F33V ONLY
	094918-01-000	EA CLAMP - EXHAUST - 3" - GUILLOTINE STYLE
4	137652-03-000	EA PIPE - EXHAUST - W/FLANGES - 208"-220" STRETCH F35D
4	137652-01-000	EA PIPE - EXHAUST - W/FLANGES - 228"-248" STRETCH F38J
5	122392-13-02B	EA HANGER - TAILPIPE - E-COATED
6	137925-04-000	EA PIPE - EXHAUST - RIGHT HAND
7	143712-07-02B	EA SHIELD - HEAT/EXHAUST - E-COATED

FROM: 03-01-05 THRU: 99-99-99

## CHASSIS GROUP (CONTINUED) EXHAUST (CONTINUED)

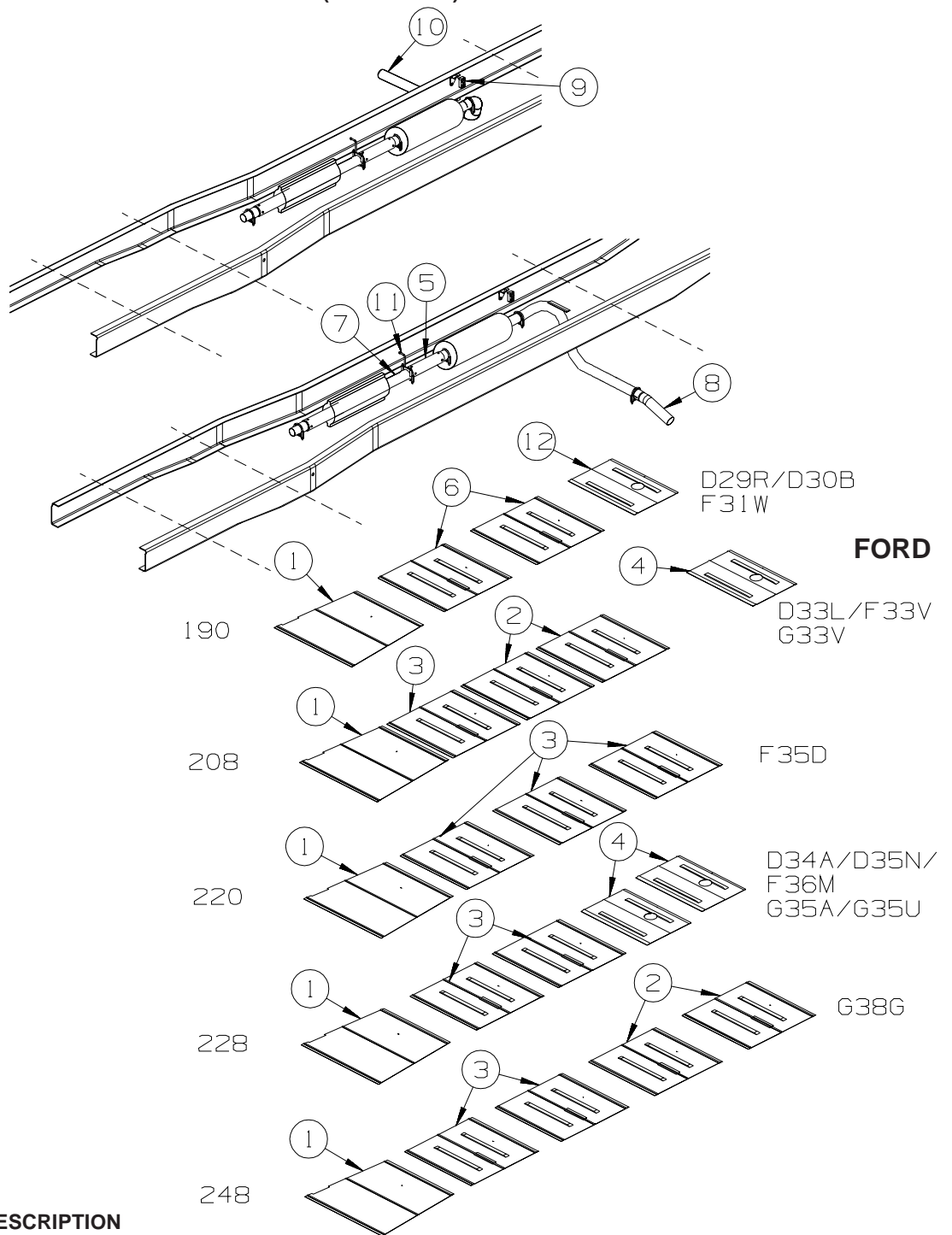

KEY	PART NUMBER	U/M DESCRIPTION
1	128756-01-02B	EA SHIELD - HEAT/EXHAUST - 33.9" X 16.9" - E-COATED
2	143712-02-02B	EA SHIELD - HEAT/EXHAUST - E-COATED
3	143712-05-02B	EA SHIELD - HEAT/EXHAUST - E-COATED - 208 WHEELBASE
3	143712-02-02B	EA SHIELD - HEAT/EXHAUST - E-COATED - 208 WHEELBASE
3	143712-05-02B	EA SHIELD - HEAT/EXHAUST - E-COATED - 220, 228 & 248 WHEELBASE
4	143712-07-02B	EA SHIELD - HEAT/EXHAUST - E-COATED - 228 WHEELBASE
4	143712-07-02B	EA SHIELD - HEAT/EXHAUST - E-COATED - 208 WHEELBASE
5	112012-02-000	EA PIPE - EXHAUST - 3" DIAMETER - FORD CHASSIS - 208"-220" STRETCH - F35D
5	094918-06-000	EA CLAMP - EXHAUST - 3" - HEAVY DUTY
6	143712-01-02B	EA SHIELD/HEAT - EXHAUST - E-COATED - 2 USED
6	143712-02-02B	EA SHIELD/HEAT - EXHAUST - E-COATED - 1 USED

## CHASSIS GROUP (CONTINUED) EXHAUST (CONTINUED)

KEY	PART NUMBER	U/M	DESCRIPTION
6	143712-02-02B	EA	SHIELD/HEAT - EXHAUST - E-COATED - <b>2 USED</b> FROM: 08-14-04 THRU: 09-17-04
6	143712-05-02B	EA	SHIELD/HEAT - EXHAUST - E-COATED - <b>2 USED</b> FROM: 09-18-04 THRU: 99-99-99
7	112012-09-000	EA	PIPE - EXHAUST - 3" DIAMETER - 7.5" LONG - <b>208"-190" SHRINK - F31W</b>
8	142985-01-000	EA	PIPE - EXHAUST
9	NOT USED		
10	NOT USED		
11	NOT USED		
12	143712-07-02B	EA	SHIELD/HEAT - EXHAUST - E-COATED FROM: 04-01-05 THRU: 99-99-99

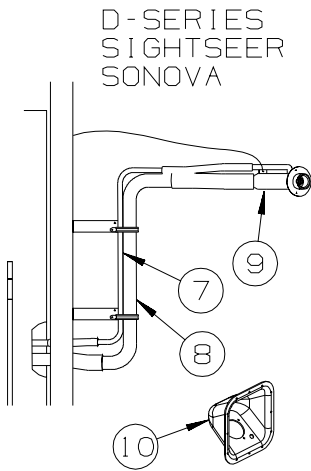

### FUEL

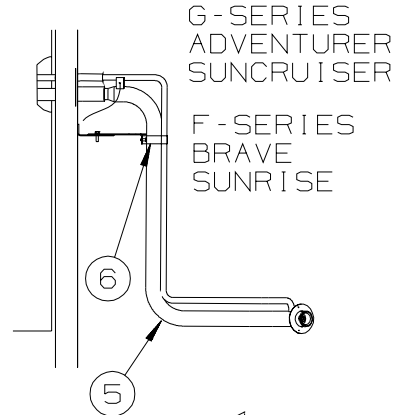

**2004  
FORD**

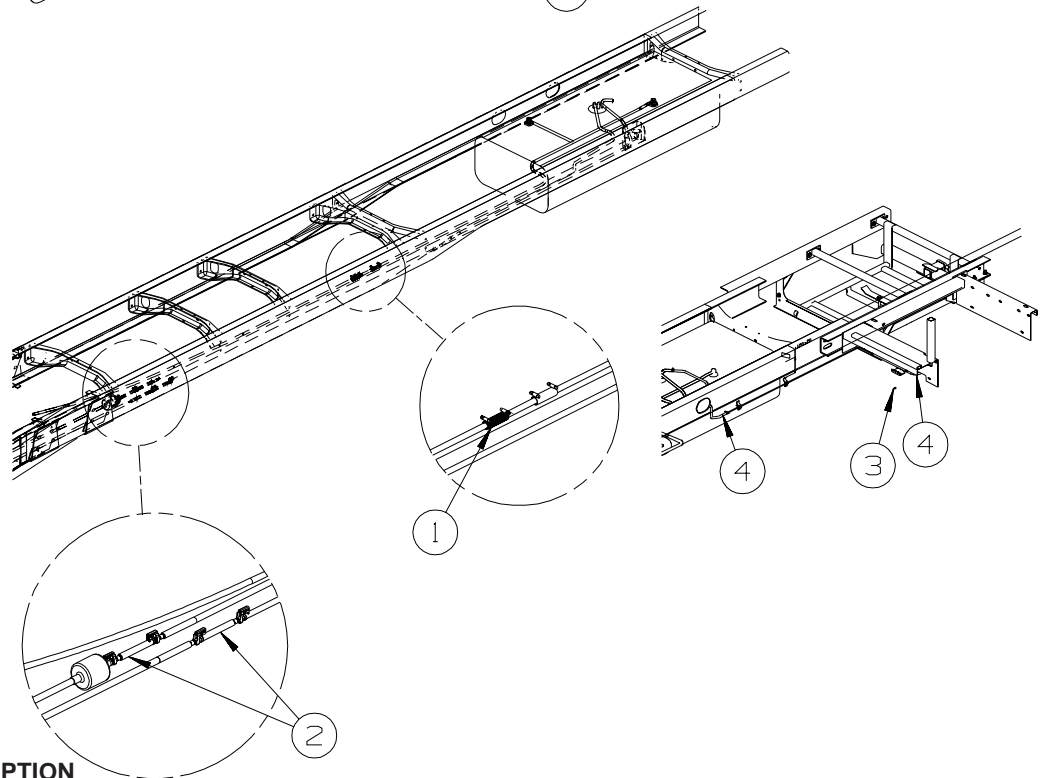

KEY	PART NUMBER	U/M	DESCRIPTION
1	128139-02-000	FT	HOSE - FUEL - LOW PERMEABILITY - 5/8" DIAMETER - <b>208"-220" STRETCH F35D</b>
2	129494-02-000	EA	FUEL LINE - 5/16" X 34.9" - FORD CHASSIS - <b>208"-220" STRETCH F35D</b>
3	084884-01-000	EA	PLUG - BRASS - 3/8"
4	128139-03-000	FT	HOSE - FUEL - LOW PERMEABILITY - 1/4" DIAMETER
5	135801-01-000	EA	NECK - FUEL FILL
6	140728-02-02B	EA	BRACKET - FUEL FILL - E-COATED
7	NOT USED		
8	NOT USED		
9	NOT USED		
10	NOT USED		



**CHASSIS GROUP (CONTINUED)**  
**FUEL (CONTINUED)**

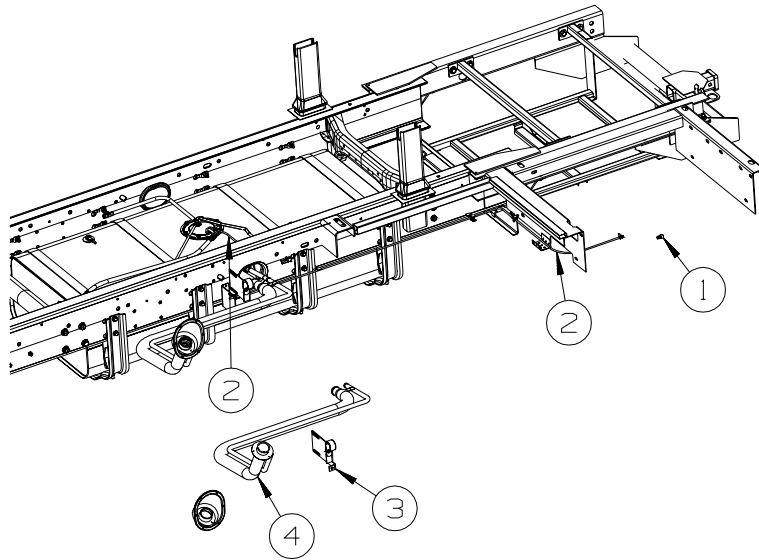

**2006  
 FORD**

KEY	PART NUMBER	U/M	DESCRIPTION
1	084884-01-000	EA	PLUG - BRASS - 3/8"
2	128139-03-000	FT	HOSE - FUEL - LOW PERMEABILITY - 1/4" DIAMETER
3	140728-02-02B	EA	BRACKET - FUEL FILL - E-COATED
4	153027-01-000	EA	NECK - FUEL

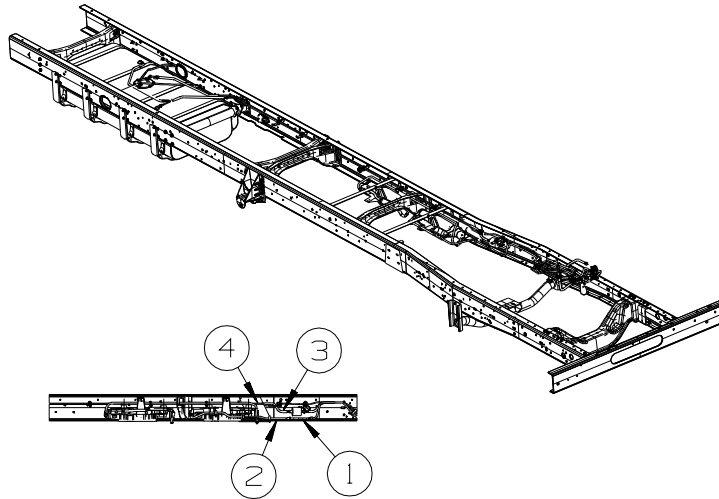

**2006  
 FORD**

190" WHEELBASE  
 208" SHRINK TO 190"

KEY	PART NUMBER	U/M	DESCRIPTION
1	155359-03-000	EA	EXTENSION - TUBE/VAPOR 1/2" - EMISSION CANISTER
2	155382-01-000	EA	TUBE/VAPOR - PURGE - CANISTER
3	155383-01-000	EA	TUBE - FUEL SUPPLY
4	155384-01-000	EA	TUBE/VAPOR - TANK

**CHASSIS GROUP (CONTINUED)**  
**FUEL (CONTINUED)**

**WORKHORSE**

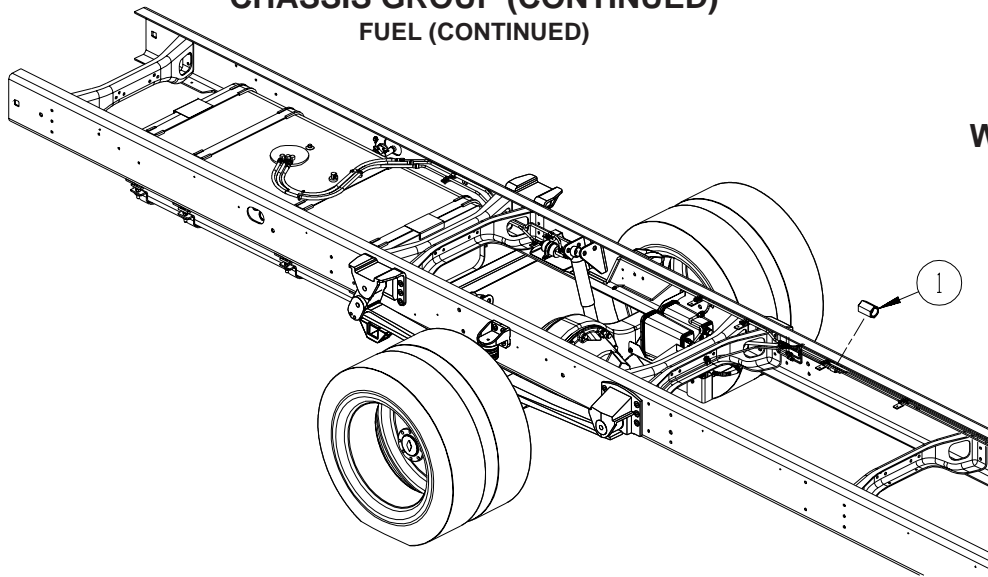

KEY	PART NUMBER	U/M	DESCRIPTION
1	098779-02-000	EA	COUPLER - FUEL LINE - 1.2" LONG X 16MM THREAD - <b>STRETCHED CHASSIS ONLY</b>

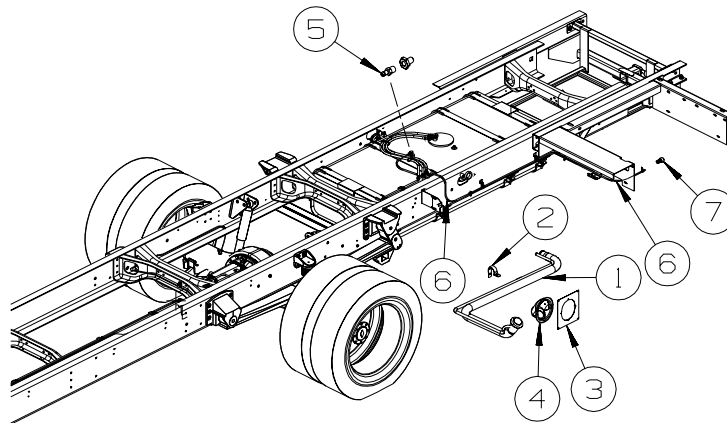

**WORKHORSE**

KEY	PART NUMBER	U/M	DESCRIPTION
1	136300-02-000	EA	NECK - FUEL FILL
2	140728-01-02B	EA	BRACKET - FUEL FILL - E-COATED
			FROM: 00-00-00 THRU: 04-15-04
2	140728-02-02B	EA	BRACKET - FUEL FILL - E-COATED
			FROM: 04-16-04 THRU: 99-99-99
3	139138-01-02B	EA	PLATE - FUEL FILL - E-COATED
4			CHASSIS SUPPLIED
5	068382-06-000	EA	BUSHING - BRASS - 3/8" MPT X 1/8" FPT
5	114254-01-000	EA	ADAPTER - 1/4 BARB X 1/8 MPT
6	128139-03-000	FT	HOSE - FUEL - LOW PERMEABILITY - 1/4" DIAMETER
7	084884-01-000	EA	PLUG - BRASS - 3/8"

## CHASSIS GROUP (CONTINUED)

### SPARE TIRE

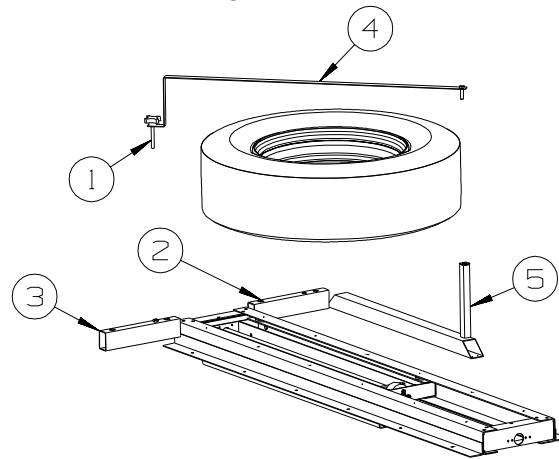

**F31W  
WORKHORSE**

KEY	PART NUMBER	U/M	DESCRIPTION
1	134194-01-01A	EA	KNOB - HOLD DOWN/RECLINER - BLACK
2	148968-01-02B	EA	TUBE - STEEL, W/HOLES
3	148968-02-02B	EA	TUBE - STEEL, W/HOLES
4	148969-02-02B	EA	STRAP - SPARE TIRE - E-COATED
5	148982-01-02B	EA	BRACKET - SPARE TIRE - E-COATED

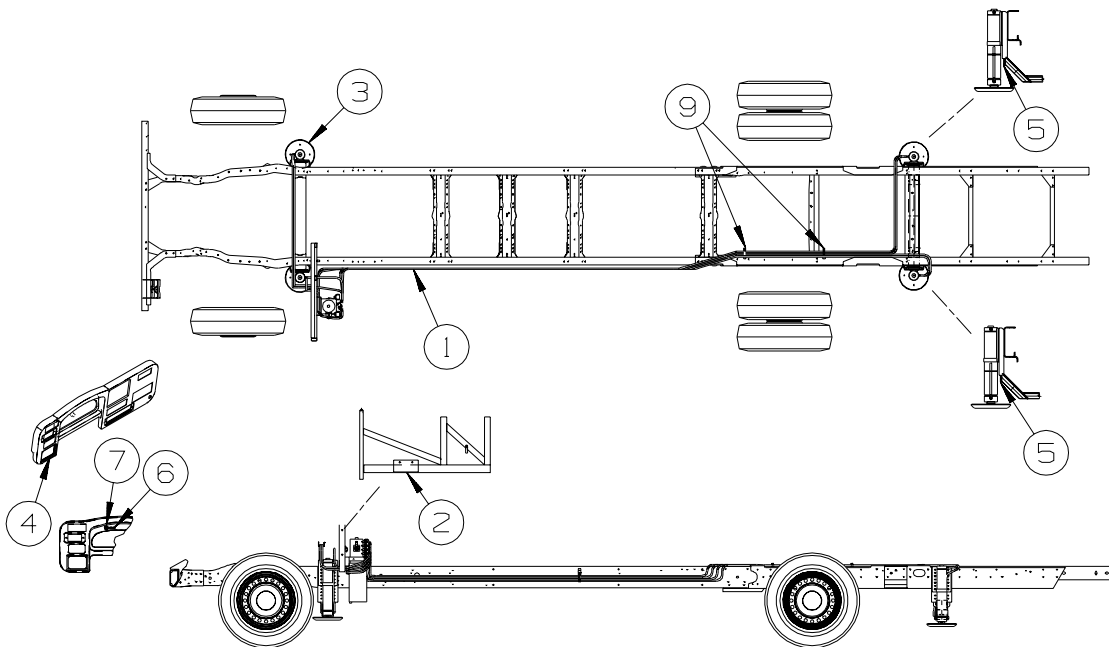

**F31W, F33V, F35D, F36M**

### HYDRAULIC LEVELING

KEY	PART NUMBER	U/M	DESCRIPTION
1	139644-03-000	EA	HOSE KIT - LEVELING JACKS
2	149803-01-02B	EA	BRACKET - PUMP/LEVELING
2	154816-01-02B	EA	BRACKET - PUMP/LEVELING - E-COATED
			FROM: 00-00-00 THRU: 01-16-05
			FROM: 01-17-05 THRU: 99-99-99
3*	139641-02-000	EA	LEVELING SYSTEM (LEVEL BEST) - F/53 - KWIKEE - <b>FORD</b>
3*	139641-03-000	EA	LEVELING SYSTEM (LEVEL BEST) - WORKHORSE W22 - KWIKEE - <b>WORKHORSE</b>
4	139643-02-000	EA	CONTROL - LEVEL W/O INDIVIDUAL CONTROLS - RECTANGLE BOX
5	126624-01-02B	EA	ANGLE - WIRE SUPPORT - E-COAT
6	133533-01-01A	EA	LABEL - JACKS DOWN - CLEAR W/WHITE LETTERING
7	133534-01-000	EA	LIGHT - RED INDICATOR WITH 1/4" TERMINALS

**\*COMPONENT PARTS LISTED LATER IN THIS GROUP**

**CHASSIS GROUP (CONTINUED)**  
**HYDRAULIC LEVELING (CONTINUED)**

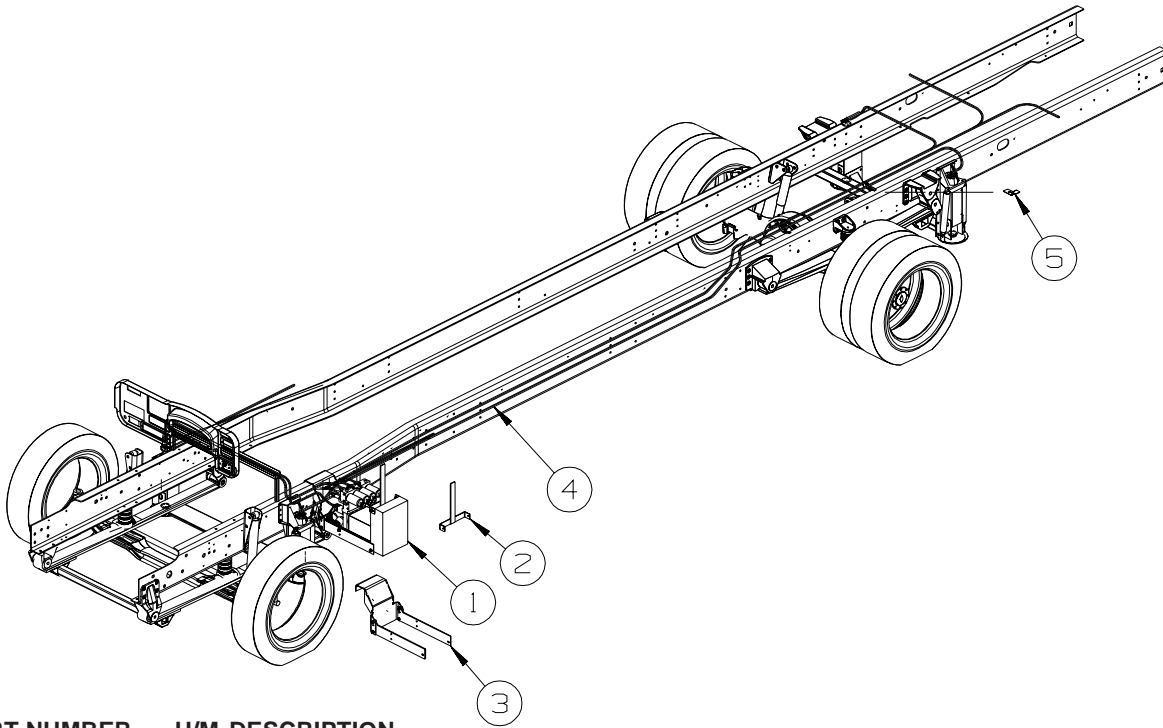

**F35A & F38J**

KEY	PART NUMBER	U/M	DESCRIPTION
1	144226-32-000	EA	LEVELING SYSTEM - W/3 SIDEOUT ROOMS
2	149900-01-02B	EA	BRACKET - PUMP/LEVELING SYSTEM - E-COATED
3	150001-01-02B	EA	BRACKET - PUMP/LEVELING SYSTEM - E-COATED
4	100536-60-000	EA	HOSE KIT - LEVELING JACKS - <b>F35A</b>
4	100536-57-000	EA	HOSE KIT - LEVELING JACKS - <b>F38J</b>
5	126624-01-02B	EA	ANGLE - WIRE SUPPORT - E-COAT

# CHASSIS GROUP (CONTINUED)

## COMPONENT PARTS FOR HYDRAULIC LEVELING

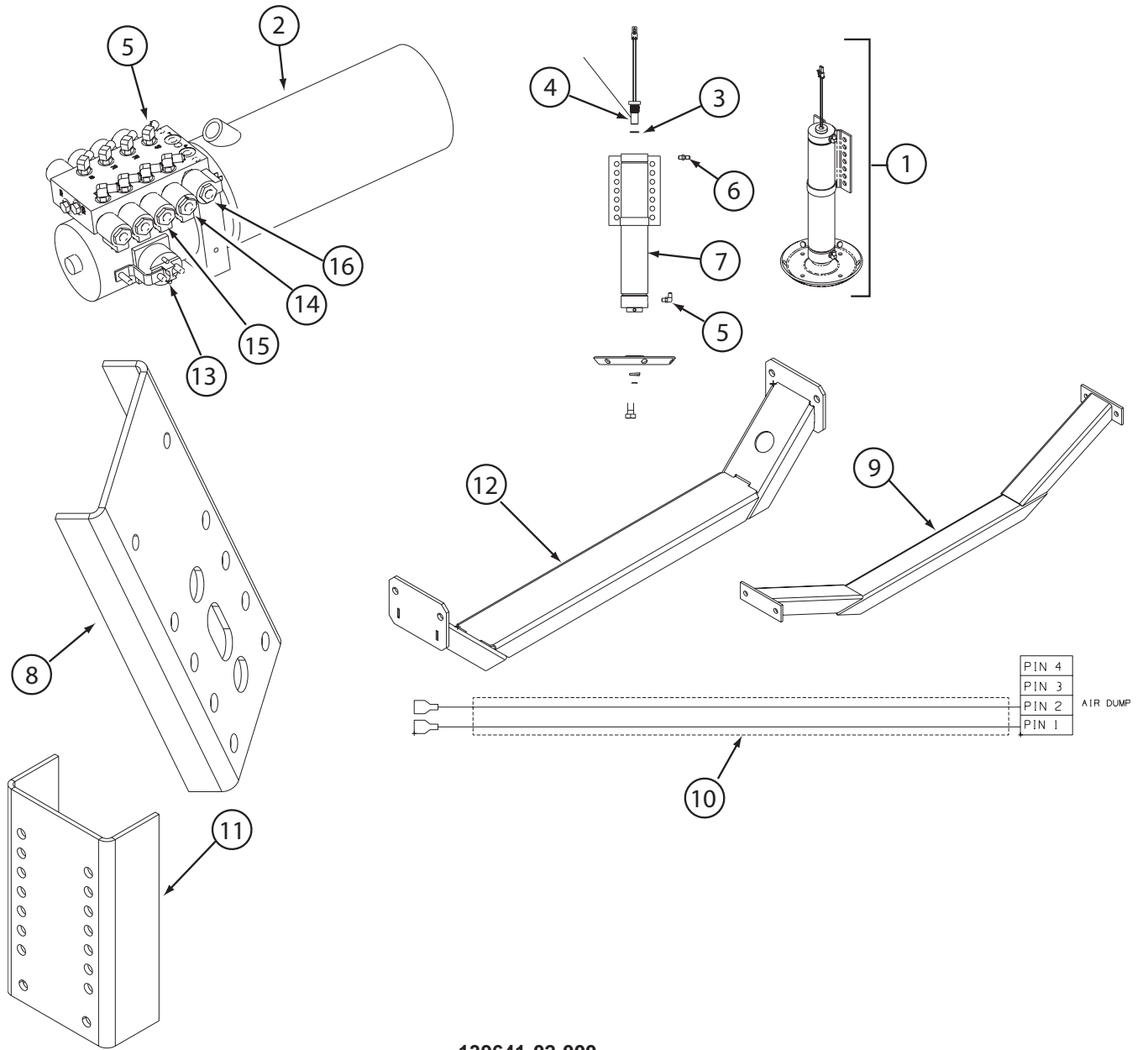

139641-02-000

**CHASSIS GROUP (CONTINUED)**  
**COMPONENT PARTS FOR HYDRAULIC LEVELING (CONTINUED)**

**139641-02-000 (CONTINUED)**

KEY	PART NUMBER	U/M	DESCRIPTION	VENDOR NO.
1	139641-01-720	EA	JACK - FRONT 15"/10K	3700702
2	139641-01-708	EA	PUMP ASM.(WATER TIGHT) W/HDW	370090
3	139641-01-700	EA	O-RING 3-912N70 .924IDX.116W	1612040
4	139641-01-704	EA	SWITCH(HERMETIC)CYLINDER TOP	1812992
5	139641-01-705	EA	FITTING HYD (1/4"X90 DEGREE)	1904500
6	139641-01-706	EA	FITTING HYD (1/4" STRAIGHT)	1904510
7	139641-01-710	EA	CYLINDER - REPLACEMENT	1905200
8	139641-02-701	EA	BRACKET MTG (FORD REAR)	3717742
9	139641-02-702	EA	CROSS MEMBER-FRONT (F53)	3717786
10	139641-01-701	EA	HARNES (AIR DUMP) CONTROL	180981
11	139641-02-704	EA	BRACKET FRT MT(3.5"DEEP F53)	1717787
12	139641-02-703	EA	CROSS MEMBER-REAR (F53)	3717795
13	139641-01-718	EA	PUMP KIT (SOLENOID 4 POST)	906900250
14	139641-01-719	EA	VALVE KIT (COIL W/PACKARD)	906963010
15	139641-01-721	EA	SOLENOID VALVE - 2-WAY	906965000
16	139641-01-722	EA	SOLENOID VALVE - 4-WAY	906964000
	139641-02-700	EA	HARNES F/READ SWITCH (FORD)	1809911
	139641-01-702	EA	HARNES - PUMP (WATER TIGHT)	1809912
	139641-01-703	EA	HARNES (CONTROL PUMP) 10'	1809913
	139641-01-707	EA	LEVEL (BUBBLE)	1906200
	139641-01-709	EA	JACK ASM.(ST 15" RR 10K)	3700701
	139641-01-715	EA	BOLT KIT(CROSS MBR/JK/PUMP)	3717794
	139641-01-717	EA	HOSE KIT (WINNEBAGO D30B)	906935521
	139641-01-723	EA	FOOT PAD - JACK	3700367
	139641-01-725	EA	HARNES - EMERGENCY RETRACT	1809908

**139641-03-000**

KEY	PART NUMBER	U/M	DESCRIPTION	VENDOR NO.
	139641-01-700	EA	O-RING 3-912N70 .924IDX.116W	1612040
	139641-01-701	EA	HARNES -AIR PUMP/WARN LIGHT	1809891
	139641-01-702	EA	HARNES - PUMP (WATER TIGHT)	1809912
	139641-01-703	EA	HARNES (CONTROL PUMP) 10'	1809913
	139641-01-704	EA	SWITCH/SENSOR-JACK (UP/DOWN)	1812992
	139641-01-705	EA	FITTING HYD (1/4"X90 DEGREE)	1904500
	139641-01-706	EA	FITTING HYD (1/4" STRAIGHT)	1904510
	139641-01-707	EA	LEVEL (BUBBLE)	1906200
	139641-01-708	EA	PUMP ASM. - W/SOLENOIDS/WIRE	3700690
	139641-01-709	EA	JACK - REAR 15"/10K	3700701
	139641-01-710	EA	CYLINDER ONLY - 15"/10K	1905200
	139641-01-711	EA	BRACKET MTG (WORKHORSE REAR)	3717740
	139641-01-713	EA	CROSS MEMBER-FRONT(P32/P42)	3717791
	139641-01-715	EA	BOLT KIT(CROSS MBR/JK/PUMP)	3717794
	139641-01-718	EA	SOLENOID - 4 POST ELECTRICAL	906900250
	139641-01-719	EA	VALVE KIT (COIL W/PACKARD)	906963010
	139641-01-720	EA	JACK - FRONT 15"/10K	3700702
	139641-01-710	EA	CYLINDER ONLY - 15"/10K	1905200
	139641-01-721	EA	SOLENOID VALVE - 2-WAY	906965000
	139641-01-722	EA	SOLENOID VALVE - 4-WAY	906964000
	139641-01-723	EA	FOOT PAD - JACK	3700367
	139641-01-724	EA	BOLT/FOOT - 3/4-10 X 1 1/2"	1204645
	139641-02-700	EA	HARNES F/READ SWITCH (FORD)	1809911
	139641-02-701	EA	BRACKET MTG (F53/W22 REAR)	3717742
	139641-02-703	EA	CROSS MEMBER/REAR (F53/W22)	3717795
	139641-03-700	EA	CROSSMEMBER/FRONT (W22)	3717797

## CHASSIS GROUP (CONTINUED)

### WHEEL, TIRE, COVERS &/OR LINERS

KEY	PART NUMBER	U/M	DESCRIPTION
	118814-05-000	EA	WHEEL - STEEL - 19.5" X 6.75" - W/STEM - GRAY - WORKHORSE W/19.5 TIRE
	102340-07-000	EA	TIRE - 245/70R X 19.5 - LOAD RANGE F - MICHELIN XRV - WORKHORSE W/19.5 TIRE
	102340-08-000	EA	TIRE - 245/70R X 19.5F - GOODYEAR - FORD
*	145580-03-000	EA	LINER - WHEEL(SET OF 4) - 19.5"/10 BOLT - WORKHORSE W/19.5 TIRE
*	145580-02-000	EA	LINER - WHEEL(SET OF 4) - 22.5"/10 BOLT - WORKHORSE W/22.5 TIRE
*	110435-20-000	EA	LINER - WHEEL - SET OF 4 - 19.5" - 8 BOLT - 2004 FORD CHASSIS W/19.5 TIRE
	154672-01-000	EA	LINER - WHEEL - SET/4 - 19.5 - 10 BOLT - 2006 FORD CHASSIS W/19.5 TIRE
	110435-21-000	EA	JAMB NUT W/CHROME NUT COVER - METRIC THREAD - 2003 FORD - FORD
	051377-01-000	EA	VALVE STEM
	051377-06-000	EA	VALVE STEM - .5" X 2 1/3" W/W22 DEGREE BEND
	077030-01-000	EA	EXTENSION - VALVE STEM - 1.25" - METAL
	077030-10-000	EA	EXTENSION - VALVE STEM - .50" - METAL
	095012-09-000	EA	EXTENSION - VALVE STEM - LIVE - 7.7"
	095012-10-000	EA	EXTENSION/VALVE STEM - LIVE - 8.5"
	095012-07-000	EA	STABILIZER - VALVE EXTENSION - LIVE - 4"
	080208-05-000	EA	BAR - LEVERAGE - LUG WRENCH - .75"DIA. - WORKHORSE
	080208-04-000	EA	LUG WRENCH - 1 3/16" - OSHKOSH/SPARTAN - WORKHORSE

\*COMPONENT PARTS LISTED LATER IN THIS GROUP

### COMPONENT PARTS FOR WHEEL, TIRE, COVERS &/OR LINERS

#### 110435-20-000

KEY	PART NUMBER	U/M	DESCRIPTION	VENDOR NO.
	110435-04-705	EA	DECAL-CTR HUB 2 3/4" DIAMOND	
	110435-10-705	EA	TOOL/JAMB NUT INSTALLATION	V195P7-TOL
	110435-15-700	EA	LINER - WHEEL - FRONT	V195F9-FWC
	110435-15-701	EA	LINER - WHEEL - REAR	V195F9-RWC
	110435-15-702	EA	JAMB NUT W/COVER - CRS THRD	V195F9-EJN
	110435-20-700	EA	LNC W/ENCL M14X1.5 JAM NUT	V195F9-EJN-MF

#### 145580-02-000

KEY	PART NUMBER	U/M	DESCRIPTION	VENDOR NO.
	110435-04-705	EA	DECAL-CTR HUB 2 3/4" DIAMO	2 3/4 DECAL DIAMOND
	110435-05-700	EA	CAP-CENTER, POP-OUT 4 1/2"	V22510-POC
	145580-01-702	EA	COVER-LUG NUT/JAM NUT 22M	V22501-EJN
	145580-01-703	EA	TOOL-INSTALLATION	V22501-TOL
	145580-02-700	EA	LINER - WHEEL/FRONT - 1EA=1	V22569-FWC
	145580-02-701	EA	LINER - WHEEL/REAR - 1EA=1	V22569-RWC

#### 145580-03-000

KEY	PART NUMBER	U/M	DESCRIPTION	VENDOR NO.
	110435-04-705	EA	DECAL-CTR HUB 2 3/4"	2 3/4 DECAL DIAMOND
	110435-05-700	EA	CAP-CENTER 4.50"D W/O DECAL	V22510-POC
	110435-12-700	EA	LINER - WHEEL - FRONT	V19580-FWC
	110435-12-701	EA	LINER - WHEEL - REAR	V19580-RWC
	145580-01-702	EA	COVER-LUG NUT/JAM NUT 22M	V19582-EJN
	145580-01-703	EA	TOOL-INSTALLATION	V22501-TOL

**CHASSIS GROUP (CONTINUED)**  
**BRAKE**

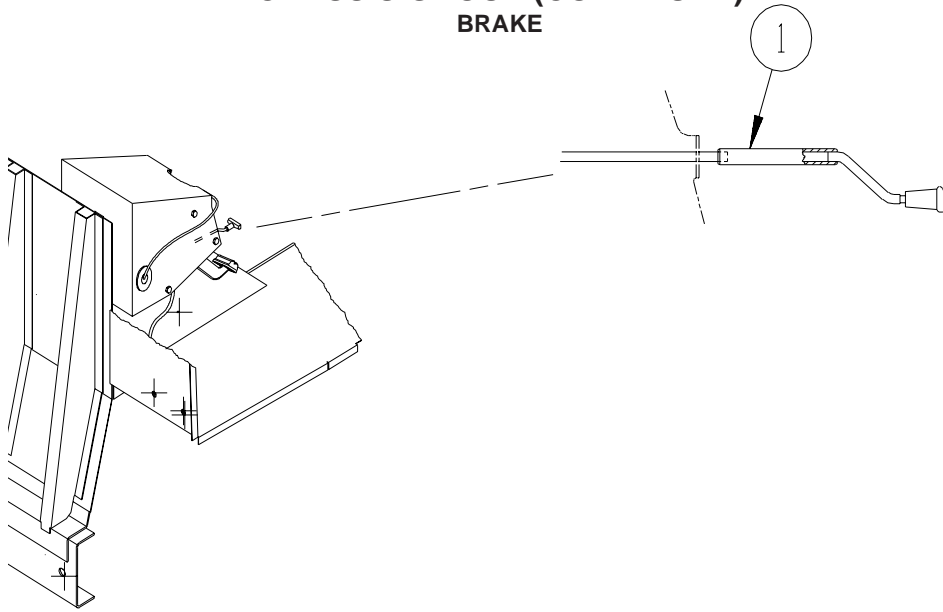

**FORD**

<b>KEY</b>	<b>PART NUMBER</b>	<b>U/M</b>	<b>DESCRIPTION</b>
1	113007-01-000	EA	PIN - SPRING - .375 X 3"

**BRAKELINE**

<b>KEY</b>	<b>PART NUMBER</b>	<b>U/M</b>	<b>DESCRIPTION</b>
	075466-01-000	EA	UNION - INVERTED FLAIR - 1/4"



## CURTAIN & CUSHION GROUP

### NOTICE

IN ORDER TO ASSIST OUR PARTS SALES DEPT. IN PROVIDING INTERIOR SOFTWARE ITEMS, PLEASE INCLUDE THE SERIAL NUMBER AND THE COLOR CODE NUMBER FROM THE VEHICLE CERTIFICATION LABEL WHEN ORDERING. THIS LABEL IS LOCATED ON THE LEFT SIDEWALL AT THE END OF THE DASH (A-BODY), OR ON THE DRIVER'S DOOR LATCH PLATE (C-BODY).

AN EXAMPLE OF A COLOR CODE NUMBER IS B07, WHICH DESIGNATES AN OVERALL COLOR SCHEME OF A PARTICULAR UNIT. THE COLOR LISTED AFTER THE ITEM DESCRIPTION ON THE MICROFICHE, INDICATES THE OVERALL UNIT COLOR. ORDER THE ITEM YOU DESIRE ACCORDING TO UNIT COLOR CODE. IF ALL COLORS USE THE SAME ITEM NO COLOR CODE WILL BE NOTED.

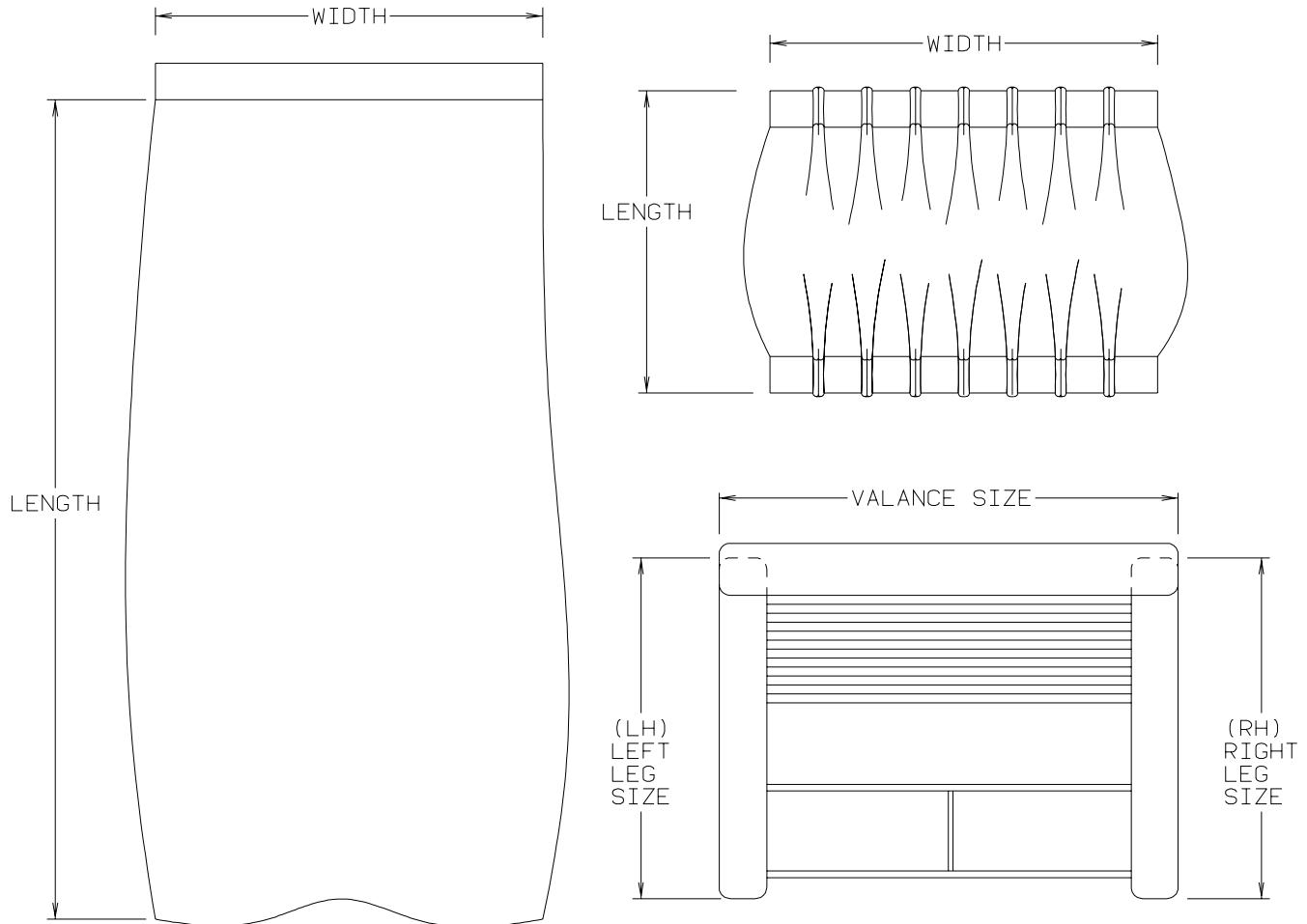

NOTE: USE THIS ILLUSTRATION WHEN DETERMINING LENGTH AND WIDTH MEASUREMENTS FOR CURTAINS. YOU WILL NOTE THE WIDTH MEASUREMENT IS TAKEN ON THE TOP OF THE CURTAIN WITH THE CURTAIN FULLY EXTENDED. THE LENGTH MEASUREMENT IS TAKEN FROM TOP TO BOTTOM. LEFT AND RIGHT WINDOW LEGS ARE DETERMINED WHEN FACING THE WINDOW.

## CURTAIN & CUSHION GROUP (CONTINUED)

### CUSHION LAYOUT

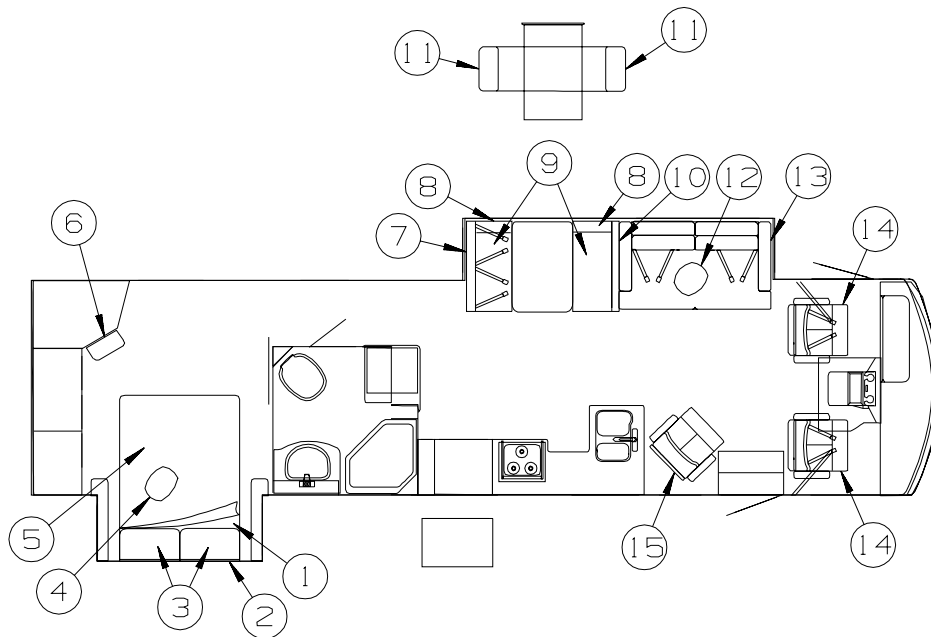

KEY	PART NUMBER	U/M	DESCRIPTION
1	123015-07-000	EA	MATTRESS - INNERSPRING - 60" X 79.5" FROM: 00-00-00 THRU: 01-02-05
1	154430-01-000	EA	MATTRESS - INNERSPRING - 60" X 74.5" FROM: 01-03-05 THRU: 02-20-05
1	154430-02-000	EA	MATTRESS - INNERSPRING - 60" X 79.5" FROM: 02-21-05 THRU: 99-99-99
2	150164-01-S46	EA	HEADBOARD - REMINGTON - FABRIC COVERED (S46, S47, S48, SR0)
2	150164-01-S49	EA	HEADBOARD - REMINGTON - FABRIC COVERED (S49, S50, S51, SR1)
2	150164-01-S52	EA	HEADBOARD - REMINGTON - FABRIC COVERED (S52, S53, S54, SR2)
3	119555-04-S46	EA	PILLOW SHAM - 20" X 33" (S46, S47, S48, SR0)
3	119555-04-S49	EA	PILLOW SHAM - 20" X 33" (S49, S50, S51, SR1)
3	119555-04-S52	EA	PILLOW SHAM - 20" X 33" (S52, S53, S54, SR2)
4	149930-01-S46	EA	PILLOW - 17" - W/CORD (S46, S47, S48, SR0)
4	149930-01-S49	EA	PILLOW - 17" - W/CORD (S49, S50, S51, SR1)
4	149930-01-S52	EA	PILLOW - 17" - W/CORD (S52, S53, S54, SR2)
5	132336-03-S46	EA	BEDSPREAD/CAP - 60" X 80" (S46, S47, S48, SR0)
5	132336-03-S49	EA	BEDSPREAD/CAP - 60" X 80" (S49, S50, S51, SR1)
5	132336-03-S52	EA	BEDSPREAD/CAP - 60" X 80" (S52, S53, S54, SR2)
6	135600-R6-000	EA	CHAIR - FOLDING - SKYLINE/PORTSMOUTH OAK (S46) FROM: 00-00-00 THRU: 07-18-04
6	135600-R7-000	EA	CHAIR - FOLDING - SKYLINE/CONCERT CHERRY (S47) FROM: 00-00-00 THRU: 07-18-04
6	135600-R8-000	EA	CHAIR - FOLDING - SKYLINE/WASHED MAPLE (S48) FROM: 00-00-00 THRU: 07-18-04
6	150547-01-S46	EA	CHAIR - VANITY (S46, S47, S48, SR0) FROM: 07-19-04 THRU: 99-99-99
6	135600-R9-000	EA	CHAIR - FOLDING - PEBBLE/PORTSMOUTH OAK (S49) FROM: 00-00-00 THRU: 07-18-04
6	135600-S0-000	EA	CHAIR - FOLDING - PEBBLE/CONCERT CHERRY (S50) FROM: 00-00-00 THRU: 07-18-04
6	135600-S1-000	EA	CHAIR - FOLDING - PEBBLE/WASHED MAPLE (S51) FROM: 00-00-00 THRU: 07-18-04
6	150547-01-S49	EA	CHAIR - VANITY (S49, S50, S51, SR1) FROM: 07-19-04 THRU: 99-99-99
6	135600-S2-000	EA	CHAIR - FOLDING - MADARA/PORTSMOUTH OAK (S52) FROM: 00-00-00 THRU: 07-18-04
6	135600-S3-000	EA	CHAIR - FOLDING - MADARA/CONERT CHERRY (S53) FROM: 00-00-00 THRU: 07-18-04
6	135600-S4-000	EA	CHAIR - FOLDING - MADARA/WASHED MAPLE (S46) FROM: 00-00-00 THRU: 07-18-04
6	150547-01-S52	EA	CHAIR - VANITY (S52, S53, S54, SR2) FROM: 07-19-04 THRU: 99-99-99

**CURTAIN & CUSHION GROUP (CONTINUED)**  
**CUSHION LAYOUT (CONTINUED)**

KEY	PART NUMBER	U/M	DESCRIPTION
7	142291-14-S46	EA	BACK - DINETTE CUSHION - LEFT - 11" X 42" (S46, S47, S48, SR0)
7	142291-14-S49	EA	BACK - DINETTE CUSHION - LEFT - 11" X 42" (S49, S50, S51, SR1)
7	142291-14-S52	EA	BACK - DINETTE CUSHION - LEFT - 11" X 42" (S52, S53, S54, SR2)
	P42291-14-S46	EA	COVER/BACK - DINETTE CUSHION - LEFT - 11" X 42" (S46, S47, S48, SR0)
	P42291-14-S49	EA	COVER/BACK - DINETTE CUSHION - LEFT - 11" X 42" (S49, S50, S51, SR1)
	P42291-14-S52	EA	COVER/BACK - DINETTE CUSHION - LEFT - 11" X 42" (S52, S53, S54, SR2)
8	151856-01-S46	EA	CUSHION - FILLER - DINETTE (S46, S47, S48, SR0)
8	151856-01-S49	EA	CUSHION - FILLER - DINETTE (S49, S50, S51, SR1)
8	151856-01-S52	EA	CUSHION - FILLER - DINETTE (S52, S53, S54, SR2)
9	142292-01-S46	EA	SEAT - DINETTE CUSHION (SPRUNG) - 22" X 37" (S46, S47, S48, SR0)
9	142292-01-S49	EA	SEAT - DINETTE CUSHION (SPRUNG) - 22" X 37" (S49, S50, S51, SR1)
9	142292-01-R34	EA	SEAT - DINETTE CUSHION (SPRUNG) - 22" X 37" (S52, S53, S54, SR2)
	P42292-01-S46	EA	COVER/SEAT - DINETTE CUSHION (SPRUNG) - 22" X 37" (S46, S47, S48, SR0)
	P42292-01-S49	EA	COVER/SEAT - DINETTE CUSHION (SPRUNG) - 22" X 37" (S49, S50, S51, SR1)
	P42292-01-R34	EA	COVER/SEAT - DINETTE CUSHION (SPRUNG) - 22" X 37" (S52, S53, S54, SR2)
	142366-03-000	EA	FRAME - SPRUNG - DINETTE SEAT
	143730-01-000	EA	CAP - F/DINETTE BRACKET TUBE - PLASTIC
10	142291-13-S46	EA	BACK - DINETTE CUSHION - RIGHT - 11" X 42" (S46, S47, S48, SR0)
10	142291-13-S49	EA	BACK - DINETTE CUSHION - RIGHT - 11" X 42" (S49, S50, S51, SR1)
10	142291-13-S52	EA	BACK - DINETTE CUSHION - RIGHT - 11" X 42" (S52, S53, S54, SR2)
	P42291-13-S46	EA	COVER/BACK - DINETTE CUSHION - RIGHT - 11" X 42" (S46, S47, S48, SR0)
	P42291-13-S49	EA	COVER/BACK - DINETTE CUSHION - RIGHT - 11" X 42" (S49, S50, S51, SR1)
	P42291-13-S52	EA	COVER/BACK - DINETTE CUSHION - RIGHT - 11" X 42" (S52, S53, S54, SR2)
11	149983-01-S46	EA	CHAIR - DINING
11	149983-01-S47	EA	CHAIR - DINING
11	149983-01-S48	EA	CHAIR - DINING
11	149983-01-S49	EA	CHAIR - DINING
11	149983-01-S50	EA	CHAIR - DINING
11	149983-01-S51	EA	CHAIR - DINING
11	149983-01-S52	EA	CHAIR - DINING
11	149983-01-S53	EA	CHAIR - DINING
11	149983-01-S54	EA	CHAIR - DINING
11	149983-01-SR0	EA	CHAIR - DINING
11	149983-01-SR1	EA	CHAIR - DINING
11	149983-01-SR2	EA	CHAIR - DINING
	135600-R6-000	EA	CHAIR - FOLDING - SKYLINE/PORTSMOUTH OAK (S46)
	135600-R7-000	EA	CHAIR - FOLDING - SKYLINE/CONCERT CHERRY (S47)
	135600-R8-000	EA	CHAIR - FOLDING - SKYLINE/WASHED MAPLE (S48)
	135600-Y0-000	EA	CHAIR - FOLDING - SKYLINE/SIERRA MAPLE (SR0)
	135600-R9-000	EA	CHAIR - FOLDING - PEBBLE/PORTSMOUTH OAK (S49)
	135600-S0-000	EA	CHAIR - FOLDING - PEBBLE/CONCERT CHERRY (S50)
	135600-S1-000	EA	CHAIR - FOLDING - PEBBLE/WASHED MAPLE (S51)
	135600-Y1-000	EA	CHAIR - FOLDING - PEBBLE/SIERRA MAPLE (SR1)
	135600-S2-000	EA	CHAIR - FOLDING - MADARA/PORTSMOUTH OAK (S52)
	135600-S3-000	EA	CHAIR - FOLDING - MADARA/CONERT CHERRY (S53)
	135600-S4-000	EA	CHAIR - FOLDING - MADARA/WASHED MAPLE (S54)
	135600-Y2-000	EA	CHAIR - FOLDING - MADARA/SIERRA MAPLE (SR2)
12	149993-01-S46	EA	PILLOW - 18" - W/FRINGE (S46, S47, S48, SR0)
12	149993-01-S49	EA	PILLOW - 18" - W/FRINGE (S49, S50, S51, SR1)
12	149993-01-S52	EA	PILLOW - 18" - W/FRINGE (S52, S53, S54, SR2)
13	135822-19-S46	EA	SOFA/SLEEPER - REST EASY #800/#800 ARM - 30" (S46, S47, S48, SR0)
13	135822-19-S49	EA	SOFA/SLEEPER - REST EASY #800/#800 ARM - 30" (S49, S50, S51, SR1)
13	135822-15-R34	EA	SOFA/SLEEPER - REST EASY #800/#800 ARM - 30" (S52, S53, S54, SR2)
14	145491-03-S46	EA	SEAT - BUCKET - W/LUMBAR (S46, S47, S48, SR0)
14	145491-03-S49	EA	SEAT - BUCKET - W/LUMBAR (S49, S50, S51, SR1)
14	145491-01-S52	EA	SEAT - BUCKET - MANUAL RECLINE (S52, S53, S54, SR2)
14	145491-04-S46	EA	SEAT - BUCKET - W/LUMBAR (S46, S47, S48, S49, S50, S51, SR0, SR1) - SEATS-CAB-LEATHER FACED
14	145491-04-S52	EA	SEAT - BUCKET - W/LUMBAR (S52, S53, S54, SR2) - SEATS-CAB-LEATHER FACED
15	135477-10-S46	EA	CHAIR - RECLINER/SWIVEL/ROCKER - W/FOOTREST (S46, S47, S48, SR0)
15	135477-10-S49	EA	CHAIR - RECLINER/SWIVEL/ROCKER - W/FOOTREST (S49, S50, S51, SR1)
15	135477-11-S52	EA	CHAIR - RECLINER/SWIVEL/ROCKER - W/FOOTREST (S52, S53, S54, SR2)

## CURTAIN & CUSHION GROUP (CONTINUED)

### BUCKET SEATS

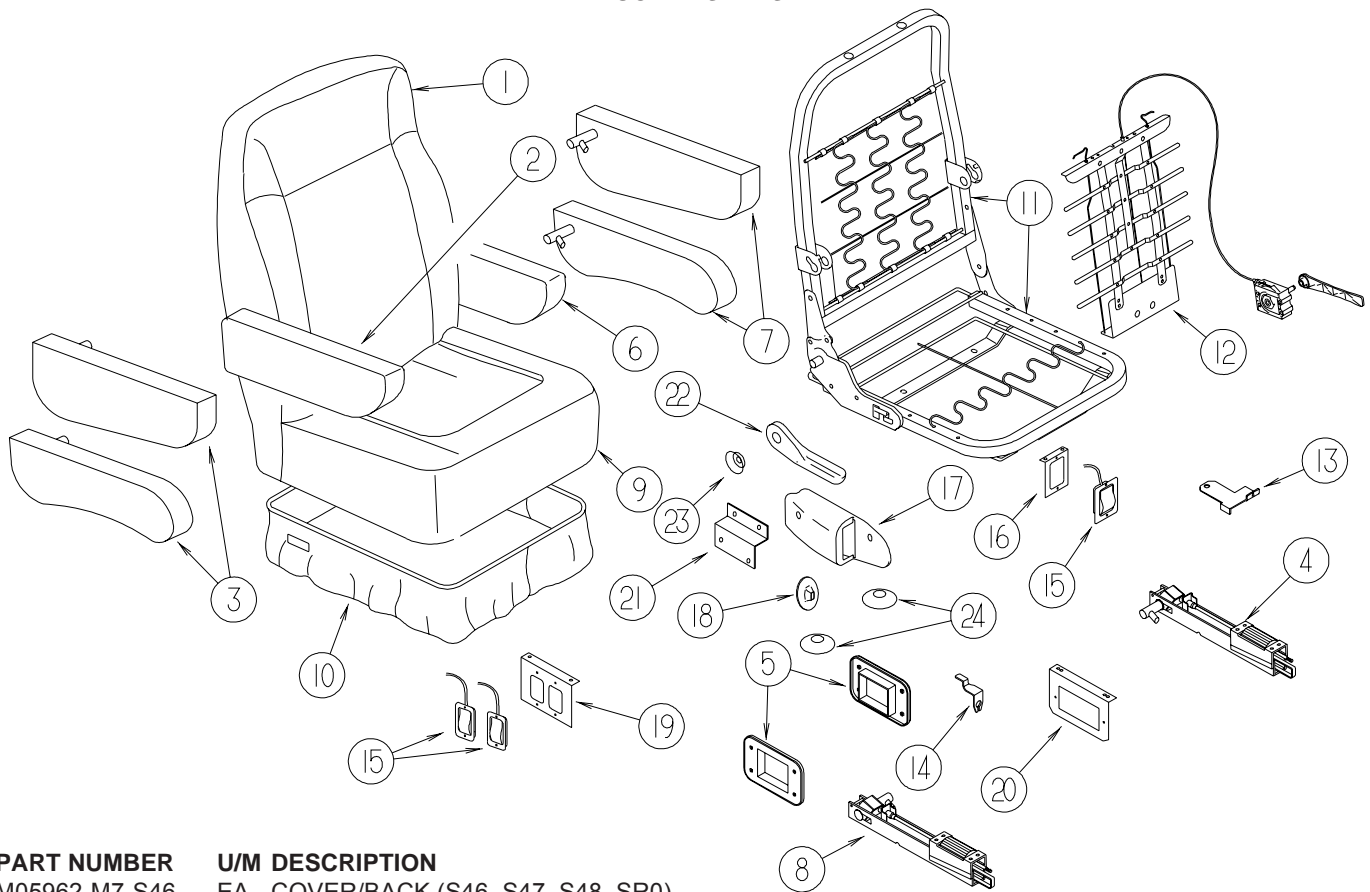

KEY	PART NUMBER	U/M	DESCRIPTION
1	M05962-M7-S46	EA	COVER/BACK (S46, S47, S48, SR0)
1	M05962-M7-S49	EA	COVER/BACK (S49, S50, S51, SR1)
1	M05962-H3-S52	EA	COVER/BACK (S52, S53, S54, SR2)
1	M05962-N7-S46	EA	COVER/BACK (S46, S47, S48, SR0, S49, S50, S51, SR1) - SEATS-CAB, LEATHER FACED
1	M05962-N7-S52	EA	COVER/BACK (S52, S53, S54, SR2) - SEATS-CAB, LEATHER FACED
2	148652-01-S46	EA	ARMREST - RIGHT (S46, S47, S48, SR0)
2	148652-01-S49	EA	ARMREST - RIGHT (S49, S50, S51, SR1)
2	148652-01-S61	EA	ARMREST - RIGHT (S52, S53, S54, SR2)
2	148652-03-S46	EA	ARMREST - RT- LEATHER (S46, S47, S48, SR0, S49, S50, S51, SR1) - SEATS-CAB, LEATHER FACED
2	148652-03-S52	EA	ARMREST - RIGHT - LEATHER (S52, S53, S54, SR2) - SEATS-CAB, LEATHER FACED
	P48652-01-S46	EA	COVER/ARMREST - RIGHT (S46, S47, S48, SR0)
	P48652-01-S49	EA	COVER/ARMREST - RIGHT (S49, S50, S51, SR1)
	P48652-01-S61	EA	COVER/ARMREST - RIGHT (S52, S53, S54, SR2)
	P48652-03-S46	EA	COVER/ARMREST-RT- LTHR (S46, S47, S48, SR0, S49, S50, S51, SR1) - SEATS-CAB, LEATHER FACED
	P48652-03-S52	EA	COVER/ARMREST - RIGHT - LEATHER (S52, S53, S54, SR2) - SEATS-CAB, LEATHER FACED
3	130698-03-000	EA	ARMREST/MOLDED - RIGHT - W/O COVER
4	NOT USED		
5	NOT USED		
6	148652-02-S46	EA	ARMREST - LEFT (S46, S47, S48, SR0)
6	148652-02-S49	EA	ARMREST - LEFT (S49, S50, S51, SR1)
6	148652-02-S61	EA	ARMREST - LEFT (S52, S53, S54, SR2)
6	148652-04-S46	EA	ARMREST - LEFT - LEATHER (S46, S47, S48, SR0, S49, S50, S51, SR1) - SEATS-CAB, LEATHER FACED
6	148652-04-S52	EA	ARMREST - LEFT - LEATHER (S52, S53, S54, SR2) - SEATS-CAB, LEATHER FACED
	P48652-02-S46	EA	COVER/ARMREST - LEFT (S46, S47, S48, SR0)
	P48652-02-S49	EA	COVER/ARMREST - LEFT (S49, S50, S51, SR1)
	P48652-02-S61	EA	COVER/ARMREST - LEFT (S52, S53, S54, SR2)
	P48652-04-S46	EA	COVER/ARMREST-LT- LTHR (S46, S47, S48, SR0, S49, S50, S51, SR1) - SEATS-CAB, LEATHER FACED
	P48652-04-S52	EA	COVER/ARMREST - LEFT - LEATHER (S52, S53, S54, SR2) - SEATS-CAB, LEATHER FACED
7	130698-04-000	EA	ARMREST/MOLDED - LEFT - W/O COVER
8	NOT USED		
9	M05962-M8-S46	EA	COVER/SEAT (S46, S47, S48, SR0)
9	M05962-M8-S49	EA	COVER/SEAT (S49, S50, S51, SR1)
9	M05962-H4-S52	EA	COVER/SEAT (S52, S53, S54, SR2)
9	M05962-N8-S46	EA	COVER/SEAT (S46, S47, S48, S49, S50, S51) - SEATS-CAB, LEATHER FACED
9	M05962-N8-S52	EA	COVER/SEAT (S52, S53, S54, SR2) - SEATS-CAB, LEATHER FACED

**CURTAIN & CUSHION GROUP (CONTINUED)**  
**BUCKET SEATS (CONTINUED)**

<b>KEY</b>	<b>PART NUMBER</b>	<b>U/M</b>	<b>DESCRIPTION</b>
10	148630-01-S46	EA	SKIRT - W/SEAT BELT SLOT (S46, S47, S48, SR0)
10	148630-01-S49	EA	SKIRT - W/SEAT BELT SLOT (S49, S50, S51, SR1)
10	148630-01-S52	EA	SKIRT - W/SEAT BELT SLOT (S52, S53, S54, SR2)
10	148630-02-S72	EA	SKIRT - W/ BELT SLOT - LTHR(S46, S47, S48, SR0, S49, S50, S51, SR1) - SEATS-CAB, LEATHER FACED
10	148630-02-SA0	EA	SKIRT - W/SEAT BELT SLOT - LEATHER (S52, S53, S54, SR2) - SEATS-CAB, LEATHER FACED
11	134532-01-000	EA	FRAME - SEAT/HIGH BACK
12*	122611-02-000	EA	LUMBAR - W/LEVER
13	117125-01-02B	EA	BRACKET - CABLE MOUNT - ADJUSTER W/LOCK
14	108049-02-000	EA	CLIP - CABLE/PEDESTAL
15	108049-04-000	EA	CABLE - W/MINI LEVER ACTION SWITCH - 28" SHEATH/30" CABLE
16	127159-01-02B	EA	BRACKET - SEAT RELEASE - SINGLE REMOTE - E-COATED
17	NOT USED		
18	NOT USED		
19	127159-02-02B	EA	BRACKET - SEAT RELEASE - DUAL REMOTE - E-COATED
20	128699-01-02B	EA	BRACKET - SEAT SWITCH - E-COATED
21	147457-01-02B	EA	BRACKET - ZEE W/HOLES - 2.8" - E-COATED
22	130802-02-000	EA	LEVER - RIGHT HAND
23	130802-03-000	EA	SCREW F/LEVER
	148668-01-01A	EA	CUP/TRIM COVER - F/LEVER - BLACK
24	NOT USED		

\*COMPONENT PARTS LISTED LATER IN THIS GROUP

**COMPONENT PARTS FOR BUCKET SEATS**

<b>KEY</b>	<b>PART NUMBER</b>	<b>U/M</b>	<b>DESCRIPTION</b>	<b>VENDOR NO.</b>
			<b>122611-02-000</b>	
	122611-02-701	EA	LUMBAR - LEVER	412
	122611-02-702	EA	LUMBAR MECHANISM	24395-FLEXSTEEL

**CURTAIN & CUSHION GROUP (CONTINUED)**  
**LOUNGE CHAIR**

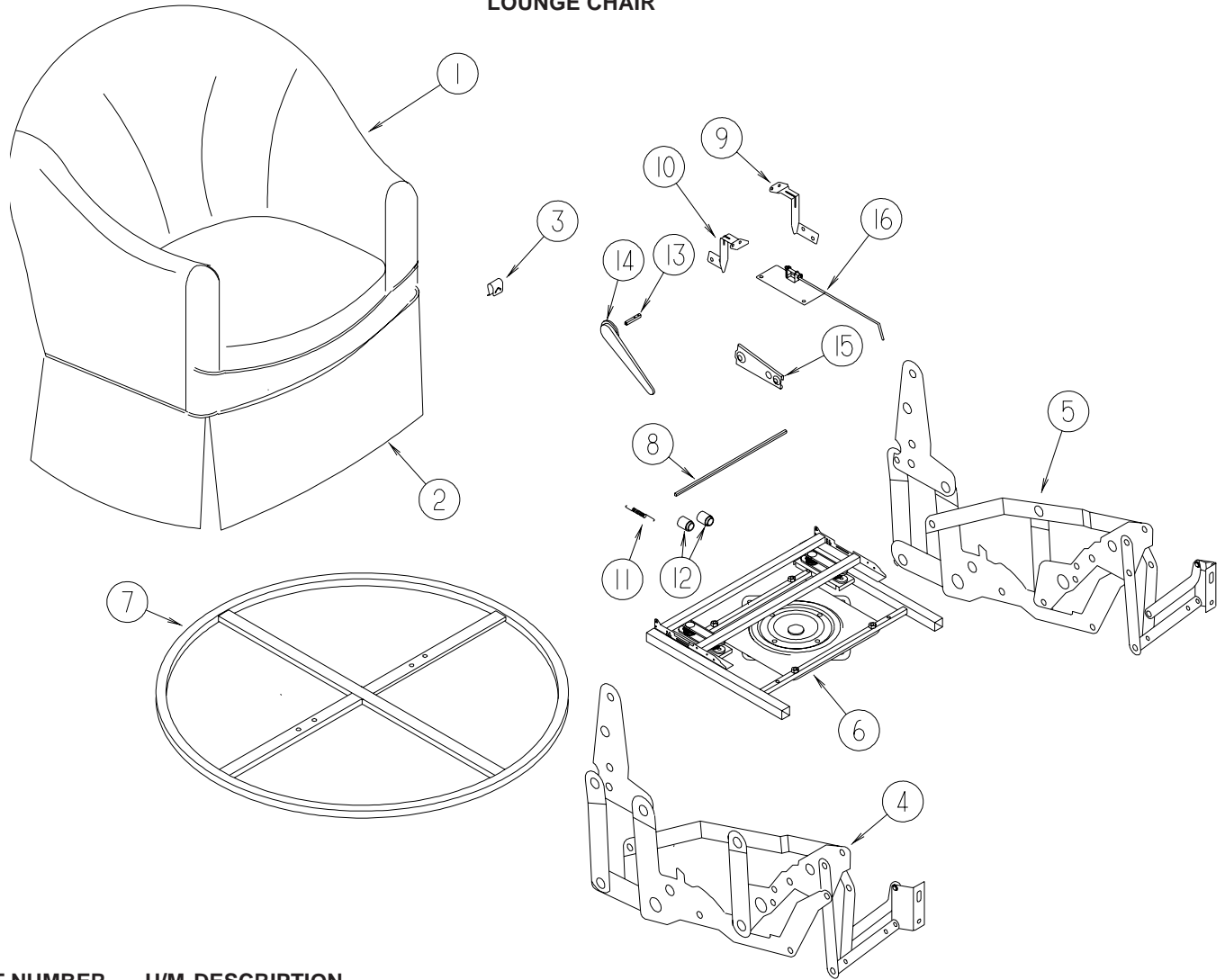

KEY	PART NUMBER	U/M	DESCRIPTION
1	P35477-10-S46	EA	COVER - RECLINER/SWIVEL/ROCKER - W/FOOTREST (S46, S47, S48, SR0)
1	P35477-10-S49	EA	COVER - RECLINER/SWIVEL/ROCKER - W/FOOTREST (S49, S50, S51, SR1)
1	P35477-11-S52	EA	COVER - RECLINER/SWIVEL/ROCKER - W/FOOTREST (S52, S53, S54, SR2)
2	NOT USED		
3	029134-01-000	EA	CLIP - FINISH - UPHOLSTERY
4	133126-01-000	EA	RECLINER MECHANISM - RIGHT HAND (WHEN SITTING IN CHAIR)
5	133126-02-000	EA	RECLINER MECHANISM - LEFT HAND (WHEN SITTING IN CHAIR)
6	133126-03-000	EA	BASE - SWIVEL/ROCKER - W/O FLOOR RING
7	133126-04-000	EA	FLOOR RING - 24" DIAMETER
8	133126-05-000	EA	HANDLE TUBE/DRIVE - 23.3" LONG (JOINS OPERATORS)
9	133126-06-000	EA	BRACKET - OTTOMAN/FIXED MID - RIGHT HAND
10	133126-07-000	EA	BRACKET - OTTOMAN/FIXED MID - LEFT HAND
11	133126-08-000	EA	SPRING/LOCKING
12	133126-09-000	EA	BUSHING - F/HANDLE TUBE - PLASTIC
13	133126-10-000	EA	HANDLE MOUNTING TUBE - 3.3" LONG
14	133126-11-000	EA	HANDLE/RECLINE - PLASTIC
15	133126-12-000	EA	BRACKET - BACK SLEEVE
16	147314-01-000	EA	LOCKOUT - ROCKER/RECLINER

# CURTAIN & CUSHION GROUP (CONTINUED)

## SOFA

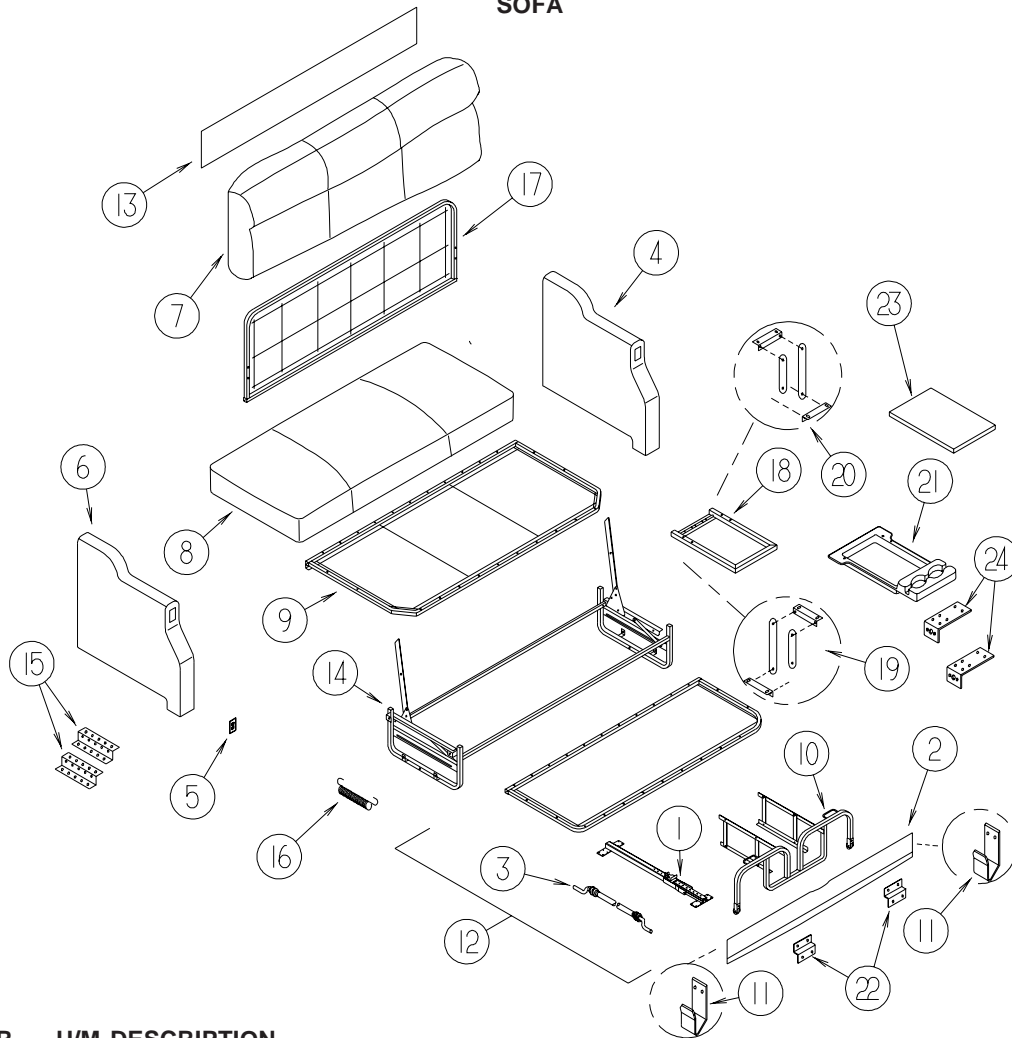

KEY	PART NUMBER	U/M	DESCRIPTION
1*	148226-02-000	EA	SLIDE RAIL - W/LATCH MECH/PLATES/STOP F/30" RAISED FLOOR
2	135824-13-S46	EA	PANEL/FRONT KICK - SOFA/SLEEPER - 59.5" - FABRIC COVERED (S46, S47, S48, SR0)
2	135824-13-S49	EA	PANEL/FRONT KICK - SOFA/SLEEPER - 59.5" - FABRIC COVERED (S49, S50, S51, SR1)
2	135824-07-R34	EA	PANEL/FRONT KICK - SOFA/SLEEPER - 59.5" - FABRIC COVERED (S52, S53, S54, SR2)
3	148225-01-000	EA	CABLE ONLY - REMOTE - 31.9" W/Z-ENDS
4	135823-34-S46	EA	ARMREST - LEFT HAND (S46, S47, S48, SR0)
4	135823-34-S49	EA	ARMREST - LEFT HAND (S49, S50, S51, SR1)
4	135823-08-R34	EA	ARMREST - LEFT HAND (S52, S53, S54, SR2)
	P35823-34-S46	EA	COVER/ARMREST - LEFT HAND (S46, S47, S48, SR0)
	P35823-34-S49	EA	COVER/ARMREST - LEFT HAND (S49, S50, S51, SR1)
	P35823-08-R34	EA	COVER/ARMREST - LEFT HAND (S52, S53, S54, SR2)
5	136118-01-000	EA	SWITCH - SOFA/RECLINER
6	135823-33-S46	EA	ARMREST - RIGHT HAND - W/SWITCH (S46, S47, S48, SR0)
6	135823-33-S49	EA	ARMREST - RIGHT HAND - W/SWITCH (S49, S50, S51, SR1)
6	135823-07-R34	EA	ARMREST - RIGHT HAND (S52, S53, S54, SR2)
	P35823-33-S46	EA	COVER/ARMREST - RIGHT HAND (S46, S47, S48, SR0)
	P35823-33-S49	EA	COVER/ARMREST - RIGHT HAND (S49, S50, S51, SR1)
	P35823-07-R34	EA	COVER/ARMREST - RIGHT HAND (S52, S53, S54, SR2)
7	135822-16-S46	EA	BACK - SOFA/SLEEPER (S46, S47, S48, SR0)
7	135822-16-S49	EA	BACK - SOFA/SLEEPER (S49, S50, S51, SR1)
7	135822-16-R34	EA	BACK - SOFA/SLEEPER (S52, S53, S54, SR2)
	P35822-16-S46	EA	COVER/BACK - SOFA/SLEEPER - RECLINER/POWERED (S46, S47, S48, SR0)
	P35822-16-S49	EA	COVER/BACK - SOFA/SLEEPER - RECLINER/POWERED (S49, S50, S51, SR1)
	P35822-16-R34	EA	COVER/BACK - SOFA/SLEEPER - RECLINER/POWERED (S52, S53, S54, SR2)
8	135822-20-S46	EA	SEAT - SOFA/SLEEPER (S46, S47, S48, SR0)
8	135822-20-S49	EA	SEAT - SOFA/SLEEPER (S49, S50, S51, SR1)
8	135822-24-S52	EA	SEAT - SOFA/SLEEPER (S52, S53, S54, SR2)
	P35822-03-S46	EA	COVER/SEAT - SOFA/SLEEPER - RECLINER/POWERED (S46, S47, S48, SR0)
	P35822-03-S49	EA	COVER/SEAT - SOFA/SLEEPER - RECLINER/POWERED (S49, S50, S51, SR1)
	P35822-03-R34	EA	COVER/SEAT - SOFA/SLEEPER - RECLINER/POWERED (S52, S53, S54, SR2)

**CURTAIN & CUSHION GROUP (CONTINUED)**  
**SOFA (CONTINUED)**

<b>KEY</b>	<b>PART NUMBER</b>	<b>U/M</b>	<b>DESCRIPTION</b>
9	151290-04-000	EA	FRAME - SEAT - 60"
10*	136534-17-000	EA	TRUNDLE FRAME - 17.5" X 55" - W/LINKAGE, LATCH & HANDLE
11	121906-01-02B	EA	BRACKET - KICKBOARD - E-COATED
12	135822-17-S46	EA	TRUNDLE - SOFA/SLEEPER (S46, S47, S48, SR0)
12	135822-17-S49	EA	TRUNDLE - SOFA/SLEEPER (S49, S50, S51, SR1)
12	135822-17-R34	EA	TRUNDLE - SOFA/SLEEPER (S52, S53, S54, SR2)
	P35822-17-S46	EA	COVER/TRUNDLE - SOFA/SLEEPER (S46, S47, S48, SR0)
	P35822-17-S49	EA	COVER/TRUNDLE - SOFA/SLEEPER (S49, S50, S51, SR1)
	P35822-17-R34	EA	COVER/TRUNDLE - SOFA/SLEEPER (S52, S53, S54, SR2)
13	139716-01-S46	EA	SIGHT SHIELD - 58" - FULL BACK (S46, S47, S48, SR0)
13	139716-01-S49	EA	SIGHT SHIELD - 58" - FULL BACK (S49, S50, S51, SR1)
13	139716-01-R34	EA	SIGHT SHIELD - 58" - FULL BACK (S52, S53, S54, SR2)
14*	136534-13-000	EA	BASE - 27.25" X 60" - POWERED
15	116104-04-02B	EA	BRACKET - ZEE W/HOLES - 3.2" - E-COATED
16	136534-33-000	EA	SPRING/ASSIST - 1/2" X 7" W/HOOK ENDS - REST EASY SOFAS
17	136534-18-000	EA	FRAME/BACK - 16.5" X 60"
18	NOT USED		
19	NOT USED		
20	NOT USED		
21	NOT USED		
22	NOT USED		
23	NOT USED		
24	152034-01-02B	EA	BRACKET - HOLD DOWN/COUCH - E-COATED

\*COMPONENT PARTS LISTED LATER IN THIS GROUP

**COMPONENT PARTS FOR SOFA**

**RESTEASY SOFAS**

**136534-13-000, 136534-15-000, 136534-28-000, 136534-29-000**

<b>KEY</b>	<b>PART NUMBER</b>	<b>U/M</b>	<b>DESCRIPTION</b>	<b>VENDOR NO.</b>
	136534-02-700	EA	MOTOR	9PL-MO-W/T-1
	136534-02-701	EA	CABLE/DRV MTR-REST EASY SOFA	9PL-FCA27.75

**148226-01-000, 148226-02-000, 148226-03-000**

<b>KEY</b>	<b>PART NUMBER</b>	<b>U/M</b>	<b>DESCRIPTION</b>	<b>VENDOR NO.</b>
	148226-01-700	EA	BUSHING/GUIDE - F/MECHANISM	9TN-SLD-GR-1
	148226-01-701	EA	SLIDE MECHANISM ASM W/LATCH	PTN-SLD-BUSH1

**DUAL RESTEASY SOFA ONLY**

**136534-07-000, 136534-17-000**

<b>KEY</b>	<b>PART NUMBER</b>	<b>U/M</b>	<b>DESCRIPTION</b>	<b>VENDOR NO.</b>
	136534-07-701	EA	WHEEL - NYLON - 1 5/8", 9WHEEL-1.62	



## CURTAIN & CUSHION GROUP (CONTINUED)

### WINDOW TREATMENT

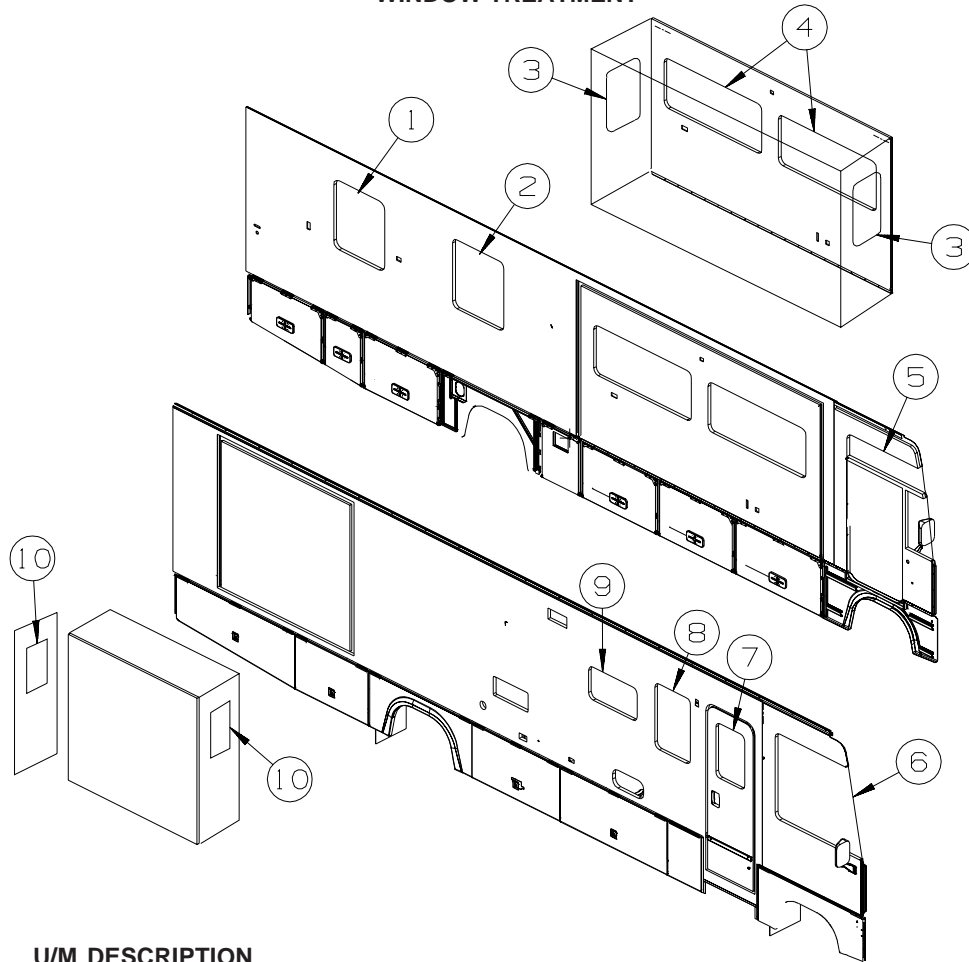

KEY	PART NUMBER	U/M	DESCRIPTION
1	149911-17-S46	EA	VALANCE - REMINGTON - 35" (S46, S47, S48, SR0)
1	149911-17-S49	EA	VALANCE - REMINGTON - 35" (S49, S50, S51, SR1)
1	149911-17-S52	EA	VALANCE - REMINGTON - 35" (S52, S53, S54, SR2)
1	136988-29-N42	EA	LEG - RIGHT - 35" (S46, S47, S48, SR0)
1	136988-29-R38	EA	LEG - RIGHT - 35" (S49, S50, S51, SR1)
1	136988-29-R34	EA	LEG - RIGHT - 35" (S52, S53, S54, SR2)
1	136988-30-N42	EA	LEG - LEFT - 35" (S46, S47, S48, SR0)
1	136988-30-R38	EA	LEG - LEFT - 35" (S49, S50, S51, SR1)
1	136988-30-R34	EA	LEG - LEFT - 35" (S52, S53, S54, SR2)
1	140789-22-S46	EA	BLIND - DAY/NIGHTER - 32" X 36"
2	149911-15-S46	EA	VALANCE - REMINGTON - 35" (S46, S47, S48, SR0)
2	149911-15-S49	EA	VALANCE - REMINGTON - 35" (S49, S50, S51, SR1)
2	149911-16-S52	EA	VALANCE - REMINGTON - 35" (S52, S53, S54, SR2)
2	136988-F4-S46	EA	LEG - RIGHT - 35" (S46, S47, S48, SR0)
2	136988-F4-S49	EA	LEG - RIGHT - 35" (S49, S50, S51, SR1)
2	136988-F2-S52	EA	LEG - RIGHT - 35" (S52, S53, S54, SR2)
2	136988-F5-S46	EA	LEG - LEFT - 35" (S46, S47, S48, SR0)
2	136988-F5-S49	EA	LEG - LEFT - 35" (S49, S50, S51, SR1)
2	136988-F3-S52	EA	LEG - LEFT - 35" (S52, S53, S54, SR2)
2	140789-22-S46	EA	BLIND - DAY/NIGHTER - 32" X 36"
3	149911-03-S46	EA	VALANCE - REMINGTON - 26" (S46, S47, S48, SR0)
3	149911-03-S49	EA	VALANCE - REMINGTON - 26" (S49, S50, S51, SR1)
3	149911-09-S52	EA	VALANCE - REMINGTON - 26" (S52, S53, S54, SR2)
3	136988-41-S46	EA	LEG - RIGHT - 21.5" (S46, S47, S48, SR0)
3	136988-41-S49	EA	LEG - RIGHT - 21.5" (S49, S50, S51, SR1)
3	136988-21-S52	EA	LEG - RIGHT - 21.5" (S52, S53, S54, SR2)
3	136988-42-S46	EA	LEG - LEFT - 21.5" (S46, S47, S48, SR0)
3	136988-42-S49	EA	LEG - LEFT - 21.5" (S49, S50, S51, SR1)
3	136988-22-S52	EA	LEG - LEFT - 21.5" (S52, S53, S54, SR2)
3	140789-07-S46	EA	BLIND - DAY/NIGHTER - 22.5" X 23"

**CURTAIN & CUSHION GROUP (CONTINUED)**  
**WINDOW TREATMENT (CONTINUED)**

KEY	PART NUMBER	U/M	DESCRIPTION
4	149911-02-S46	EA	VALANCE - REMINGTON - 63" (S46, S47, S48, SR0)
4	149911-02-S49	EA	VALANCE - REMINGTON - 63" (S49, S50, S51, SR1)
4	149911-08-S52	EA	VALANCE - REMINGTON - 63" (S52, S53, S54, SR2)
4	127017-47-S46	EA	LEG - RIGHT - 23.5" (S46, S47, S48, SR0)
4	127017-47-S49	EA	LEG - RIGHT - 23.5" (S49, S50, S51, SR1)
4	127017-41-S52	EA	LEG - RIGHT - 23.5" (S52, S53, S54, SR2)
4	127017-48-S46	EA	LEG - LEFT - 23.5" (S46, S47, S48, SR0)
4	127017-48-S49	EA	LEG - LEFT - 23.5" (S49, S50, S51, SR1)
4	127017-42-S52	EA	LEG - LEFT - 23.5" (S52, S53, S54, SR2)
4	140789-08-S46	EA	BLIND - DAY/NIGHTER - 59" X 26.5"
5	101668-68-J22	EA	CURTAIN - LEFT HAND - 42" X 110"
6	101668-67-J22	EA	CURTAIN - RIGHT HAND/LEFT HAND - 42" X 110"
	073260-42-M22	EA	TIEBACK - 6" X 18"
7	084755-57-P37	EA	SHADE - PULL - 27.25"
8	149911-03-S46	EA	VALANCE - REMINGTON - 26" (S46, S47, S48, SR0)
8	149911-03-S49	EA	VALANCE - REMINGTON - 26" (S49, S50, S51, SR1)
8	149911-09-S52	EA	VALANCE - REMINGTON - 26" (S52, S53, S54, SR2)
8	136988-A0-S46	EA	LEG - RIGHT - 35" (S46, S47, S48, SR0)
8	136988-A0-S49	EA	LEG - RIGHT - 35" (S49, S50, S51, SR1)
8	136988-H4-S52	EA	LEG - RIGHT - 35" (S52, S53, S54, SR2)
8	136988-A1-S46	EA	LEG - LEFT - 35" (S46, S47, S48, SR0)
8	136988-A1-S49	EA	LEG - LEFT - 35" (S49, S50, S51, SR1)
8	136988-H5-S52	EA	LEG - LEFT - 35" (S52, S53, S54, SR2)
9	109041-58-04A	EA	BLIND - MINI - 30.5" X 17"
10	149911-06-S46	EA	VALANCE - REMINGTON - 26" (S46, S47, S48, SR0)
10	149911-06-S49	EA	VALANCE - REMINGTON - 26" (S49, S50, S51, SR1)
10	149911-06-S52	EA	VALANCE - REMINGTON - 26" (S52, S53, S54, SR2)
10	136988-85-S46	EA	LEG - RIGHT - 21.5" (S46, S47, S48, SR0)
10	136988-85-R72	EA	LEG - RIGHT - 22" (S49, S50, S51, SR1)
10	136988-85-R34	EA	LEG - RIGHT - 22" (S52, S53, S54, SR2)
10	136988-86-S46	EA	LEG - LEFT - 21.5" (S46, S47, S48, SR0)
10	136988-86-R72	EA	LEG - LEFT - 22" (S49, S50, S51, SR1)
10	136988-86-R34	EA	LEG - LEFT - 22" (S52, S53, S54, SR2)
10	140789-07-S46	EA	BLIND - DAY/NIGHTER - 22.5" X 23"

## CURTAIN & CUSHION GROUP (CONTINUED)

### HARDWARE

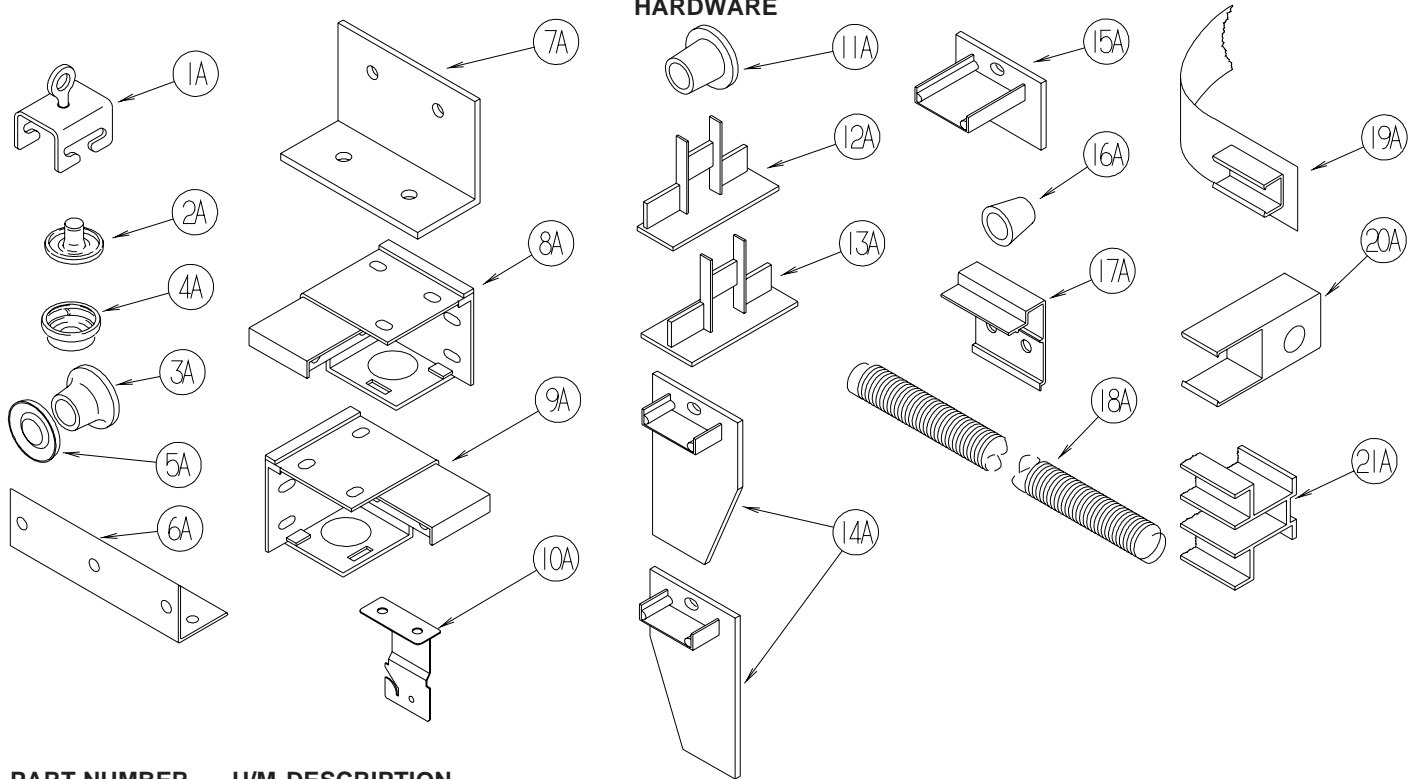

KEY	PART NUMBER	U/M	DESCRIPTION
1A	009702-01-000	EA	END STOP - CURTAIN CARRIER - L ROD
2A	029155-01-000	EA	CAP - SNAP - 5/32" OUTSIDE DIAMETER OF PIN
3A	029156-01-000	EA	SOCKET - SNAP - 9/16" O.D.
4A	046867-02-000	EA	WASHER - HANDY BUTTON #3
5A	046867-03-000	EA	GROMMET - HANDY BUTTON #3
6A	075943-10-000	EA	BRACE - VALANCE - 20" - OFF WHITE
7A	083125-08-000	EA	BRACE - WINDOW MOUNT - .75" - OFF WHITE
8A	083170-01-000	EA	BRACKET/BLIND - LEFT SIDE WHEN FACING WINDOW - CLEAR
9A	083170-02-000	EA	BRACKET/BLIND - RIGHT SIDE WHEN FACING WINDOW - CLEAR
10A	084434-01-000	EA	BRACKET - MOUNTING - ROLLER SHADE - 1 3/8"
11A	094896-02-000	EA	GROMMET - CORD/PLEATED BLIND - NYLON - GRAY
12A	094907-02-000	EA	END CAP - PLEATED BLIND/TOP - RH/LH - GRAY PLASTIC
13A	094907-04-000	EA	END CAP - PLEATED BLIND/BOTTOM - RH/LH
14A	094907-05-000	EA	END CAP - PLEATED BLIND/BOTTOM - PULL TYPE - PLASTIC
15A	094907-06-000	EA	END CAP/BLIND - TOP RH/LH
	094907-09-000	EA	END CAP/BLIND - CENTER RAIL - RH/LH
16A	097564-03-000	EA	HANDLE - KNOB - E-Z LIFT SHADE - TAN
16A	097564-06-000	EA	HANDLE - KNOB - E-Z LIFT SHADE - ALABASTER
	097593-02-000	FT	CORD - BLIND - PLEATED - GRAY
	097593-06-000	FT	CORD - BLIND - PLEATED - PEWTER
	097593-10-000	FT	CORD - BLIND - PLEATED - VANILLA
	109353-09-01A	EA	BLIND - SLAT - 21' - ALABASTER PEARL
17A	097565-01-000	EA	BRACKET - MOUNTING - PLEATED BLIND
18A	097591-01-000	EA	SPRING - EXTENSION - PLEATED BLIND
19A	101031-01-000	YD	TAPE/GLIDE - 4.25" SPACING
20A	101033-02-000	EA	END CAP - LOW PROFILE TRACK - CLEAR
21A	101033-08-000	EA	TRACK/WALL - 75" - <b>FRT BUNK WINDOW MINNIE/SPIRIT 300-SERIES</b>
21A	101033-09-000	EA	TRACK/WALL - 32" - <b>SIDE BUNK WINDOW MINNIE/SPIRIT 300-SERIES</b>

## CURTAIN & CUSHION GROUP (CONTINUED)

### HARDWARE (CONTINUED)

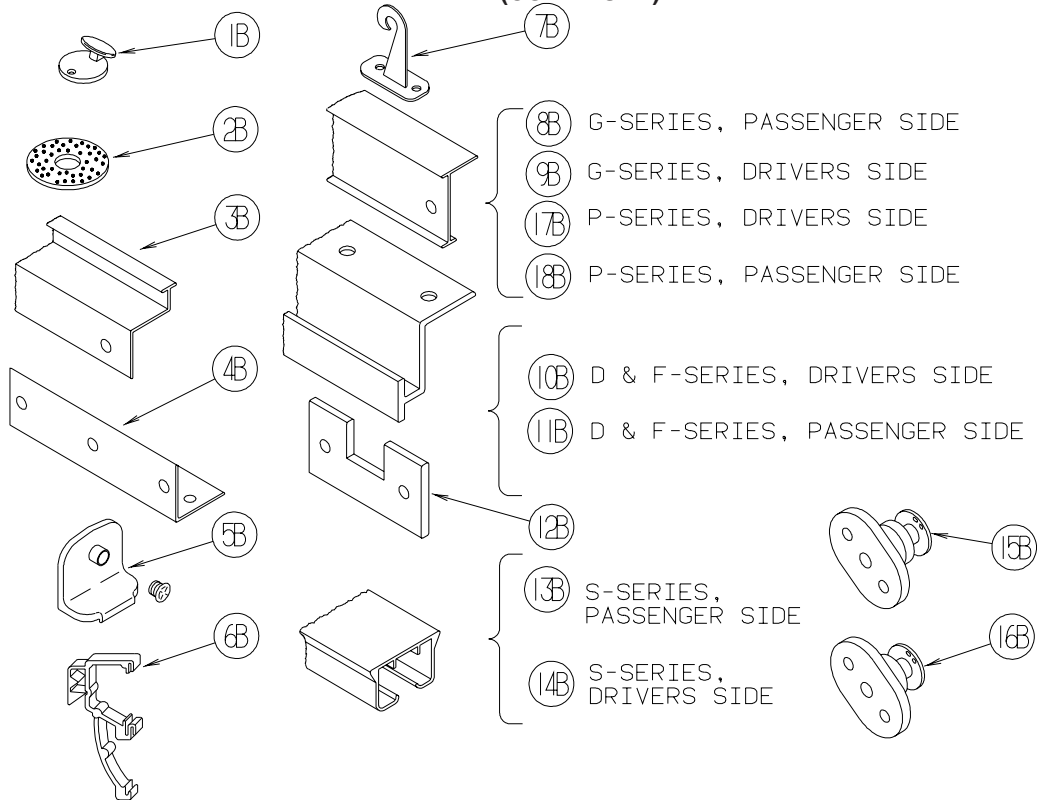

KEY	PART NUMBER	U/M	DESCRIPTION
1B	102555-03-000	EA	BRACKET - (CLEAT TYPE) - F/BLIND HOLDOWN - MILKY WHITE
2B	103242-01-000	EA	VELCRO HOOK - BEIGE 7/8" ROUND W/CENTER HOLE
2B	103242-02-000	EA	VELCRO HOOK - BLACK 7/8" ROUND W/CENTER HOLE
3B	105450-14-01A	EA	TRACK - CURTAIN - 90" - OFF WHITE - <b>FRONT BUNK PRIVACY MINNIE/SPIRIT 300-SERIES</b>
4B	105648-01-02A	EA	BRACE - VALANCE - OFF/WHITE - 14"
5B	106544-01-000	EA	PULL - SHADE/BRASS
5B	106544-01-001	EA	SCREW - SHADE/BRASS
5B	106544-02-000	EA	PULL-SHADE - NICKEL
6B	109353-04-000	EA	CLIP - VALANCE SLAT MOUNTING - CLEAR PLASTIC
7B	109441-03-000	EA	BRACKET/HOOK - BLIND HOLD DOWN - NEW DESIGN/CLEAR
8B	126456-03-04A	EA	TRACK/WRAPAROUND - PASSENGER - GLACIER - <b>ADVENTURER/SUNCRUISER G-SERIES</b>
9B	126456-04-04A	EA	TRACK/WRAPAROUND - DRIVER - GLACIER - <b>ADVENTURER/SUNCRUISER G-SERIES</b>
10B	127254-04-05A	EA	TRACK/WRAPAROUND-DRVR-GLACIER - <b>SIGHTSEER/SUNOVA D-SERIES, BRAVE/SUNRISE F-SERIES</b>
11B	127254-14-03A	EA	TRACK/WRAPAROUND-PASS-GLACIER - <b>SIGHTSEER/SUNOVA D-SERIES, BRAVE/SUNRISE F-SERIES</b>
12B	130549-01-01A	EA	STOP - CURTAIN TRACK
13B	138460-07-02A	EA	TRACK/CURTAIN - PASSENGER - W/BRACKET/CARRIER/PULLEY - WHT - <b>VECTRA/HORIZON S-SERIES</b>
14B	138460-08-02A	EA	TRACK/CURTAIN - DRIVER - W/BRACKET/CARRIER/PULLEY - WHT - <b>VECTRA/HORIZON S-SERIES</b>
15B	141634-01-000	EA	BRACKET-(BOBBIN TYPE) 7/8"H HOLDUPBASE(OVAL)-2 HOLE-CLEAR
16B	143805-01-000	EA	BRACKET-(BOBBIN TYPE) 1/2"H HOLDUPBASE(OVAL)-2 HOLES CLEAR
17B	146591-01-01A	EA	TRACK - CURTAIN - LEFT HAND - GLACIER - <b>JOURNEY/MERIDIAN P-SERIES</b>
18B	146591-02-01A	EA	TRACK - CURTAIN - RIGHT HAND - GLACIER - <b>JOURNEY/MERIDIAN P-SERIES</b>

### ACCESSORIES

KEY	PART NUMBER	U/M	DESCRIPTION
	057534-01-000	EA	TIEBACK - CLEAR PLASTIC - 6"
	057534-03-000	EA	TIEBACK - CLEAR PLASTIC - 7.5"
	070578-02-N30	EA	BUTTON - SCREW - STUD - #30 VINYL
	105402-03-000	EA	STRAP - DINING CHAIR/TIEDOWN - 18"

**CURTAIN & CUSHION GROUP (CONTINUED)**  
FABRICS

<b>FAMILY</b>	<b>S46/S47/S48/SR0 OAKWOOD</b>	<b>S49/S50/S51/SR1 ASPEN MIST</b>	<b>S52/S53/S54/SR2 ALPINE BLUE</b>
<b>VOYAGE BUCKET</b>	578 VL	578 VL	578 VL
	126883-X3-000 (BUCKET)	126883-K9-000 (BUCKET)	126883-V4-000 (BUCKET)
	137813-58-000 (WELT)	137813-58-000 (WELT)	126883-V4-000 (WELT)
	*OPT. LEATH. DR&PASS W/LUMBAR	*OPT. LEATH. DR&PASS W/LUMBAR	*OPT. LEATH. DR&PASS W/LUMBAR
	142523-03-000	142523-03-000	142523-04-000
<b>DINETTE</b>	735-1 CLUB W/RADIUS - SPRUNG	735-1 CLUB W/RADIUS - SPRUNG	735-1 CLUB W/RADIUS - SPRUNG
	<b>2-TONE BACK</b>	<b>2-TONE BACK</b>	<b>2-TONE BACK</b>
	126883-X2/INSERT 126883-X3	126883-X4/INSERT 126883-K9	126883-V2/INSERT 126883-V4
	<b>SEAT</b> 126883-X2-000	<b>SEAT</b> 126883-X4-000	<b>SEAT</b> 126883-V2-000
<b>DINETTE WRAP</b>	126883-X3-000	126883-K9-000	126883-V4-000
<b>DINETTE AND FOLDING CHAIRS</b>	REM FC703 & REM FC200	REM FC703 & REM FC200	REM FC703 & REM FC200
	126883-X2-000	126883-X4-000	126883-V2-000
<b>SOFA</b>	800 REST EASY	800 REST EASY	800 REST EASY
	*F31W 695 SOFA	*F31W 695 SOFA	*F31W 695 SOFA
	SOFA 126883-X2-000	SOFA 126883-X4-000	SOFA 126883-V2-000
	WELT 137813-58-000	WELT 137813-58-000	WELT 126883-V2-000
<b>LOUNGE CHAIR</b>	455-2 W/ HOOP	455-2 W/ HOOP	455-2 W/ HOOP
	CHAIR 126883-X3-000	CHAIR 126883-K9-000	CHAIR 126883-V4-000
	WELT 137813-58-000	WELT 137813-58-000	WELT 126883-V4-000
<b>LOUNGE PILLOW 2 PER SOFA</b>	18X18	18X18	18X18
	FACE - 126883-X2-000	FACE - 126883-X4-000	FACE - 126883-V2-000
	BACK - 126883-X3-000	BACK - 126883-K9-000	BACK - 126883-V4-000
	FRINGE - 139041-38-000	FRINGE - 139041-40-000	FRINGE - 139041-42-000
<b>LOUNGE WINDOWS</b>	REMINGTON STYLE	REMINGTON STYLE	REMINGTON STYLE
	UNDERLAY & LEGS 126883-X3-000	UNDERLAY 126883-K9-000	UNDER, TOP OVERLAY & LEGS
	TOP OVERLAY 126883-X2-000	TOP OVERLAY 126883-X4-000	123883-V2-000
	CENTER OVERLAY 137813-58-000	CENTER OVERLAY 137813-58-000	CENTER OVERLAY 126883-V4-000
	1/4" SELF WELT RUN ALONG BTM	1/4" SELF WELT RUN ALONG BTM	1/4" SELF WELT RUN ALONG BTM
	OF VALANCE & BETWEEN LEGS	OF VALANCE & BETWEEN LEGS	OF VALANCE & BETWEEN LEGS
<b>LGE. OVHD. INSERTS</b>	126883-X3-000	126883-K9-000	126883-V4-000
<b>GALLEY BLIND</b>	260 BEIGE	260 BEIGE	260 BEIGE

**CURTAIN & CUSHION GROUP (CONTINUED)**  
**FABRICS (CONTINUED)**

<b>FAMILY</b>	<b>S46/S47/S48/SR0 OAKWOOD</b>	<b>S49/S50/S51/SR1 ASPEN MIST</b>	<b>S52/S53/S54/SR2 ALPINE BLUE</b>
<b>VOYAGE</b>			
<b>BEDSPREAD</b>	BEDCAP W/BRAID TRIM. 137813-A4-000/139041-39-000	BEDCAP W/BRAID TRIM. 137813-67-000/139041-41-000	BEDCAP W/BRAID TRIM. 105745-Y1-000/139041-43-000
<b>QUILT PATTERN</b>	6" CHANNEL QUILT	6" CHANNEL QUILT	6" CHANNEL QUILT
<b>HEADBOARD</b>	REMINGTON STYLE BODY 105745-X6-000 OVERLAY 137813-A4-000 BRAID 139041-39-000	REMINGTON STYLE BODY 137813-83-000 OVERLAY 137813-67-000 BRAID 139041-41-000	REMINGTON STYLE BODY 126883-V3-000 OVERLAY 105745-Y1-000 BRAID 139041-43-000
<b>SHAMS</b>	WITH BRAID 137813-A4-000/139041-39-000	WITH BRAID 137813-67-000/139041-41-000	WITH BRAID 105745-Y1-000/139041-43-000
<b>BEDRM. PILLOW 1 PER MATTRESS</b>	18X18 REMINGTON STYLE BACK OF PILLOW TOP & BOTTOM INSERTS 137813-A4-000 CENTER INSERT 105745-X6-000 FRINGE 139041-38-000	18X18 REMINGTON STYLE BACK OF PILLOW TOP & BOTTOM INSERTS 137813-67-000 CENTER INSERT 137813-83-000 FRINGE 139041-40-000	18X18 REMINGTON STYLE BACK OF PILLOW TOP & BOTTOM INSERTS 105745-Y1-000 CENTER INSERT 126883-V3-000 FRINGE 139041-42-000
<b>BEDROOM WINDOWS</b>	REMINGTON STYLE W/FLUSH LEGS TOP & BOTTOM OVERLAY & WELT 137813-A4-000 CENTER OVERLAY & FLUSH LEG 105745-X6-000 self welt runs along btm of valance between layers (ALL)	REMINGTON STYLE W/FLUSH LEGS TOP & BOTTOM OVERLAY & WELT 137813-67-000 CENTER OVERLAY & FLUSH LEG 137813-83-000	REMINGTON STYLE W/FLUSH LEGS TOP & BOTTOM OVERLAY & WELT 105745-Y1-000 CENTER OVERLAY & FLUSH LEG 126883-V3-000
<b>BEDRM. OVHD. INSERTS</b>	105745-X6-000	137813-83-000	126883-V3-000
<b>DAY-NITERS LGE. &amp; BEDROOM</b>	DESERT/PEARL 094911-63-000/094911-64-000	DESERT/PEARL 094911-63-000/094911-64-000	DESERT/PEARL 094911-63-000/094911-64-000
<b>FRONT WRAP</b>	CLOUDS MUSHROOM 072333-85-000	CLOUDS MUSHROOM 072333-85-000	CLOUDS MUSHROOM 072333-85-000
<b>SUNVISORS</b>	DOESKIN 079680-50-000	DOESKIN 079680-50-000	DOESKIN 079680-50-000
<b>FLOOR MATS</b>	096060-H1-000 CARPET 102695-12-000 TAPE	139056-21-000 CARPET 102695-28-000 TAPE	139056-24-000 CARPET 102695-24-000 TAPE
<b>CEILING FABRIC</b>	113979-12-01A SOFT CLOUD	113979-12-01A SOFT CLOUD	113979-12-01A SOFT CLOUD

# DRIVERS COMPARTMENT GROUP

DASH

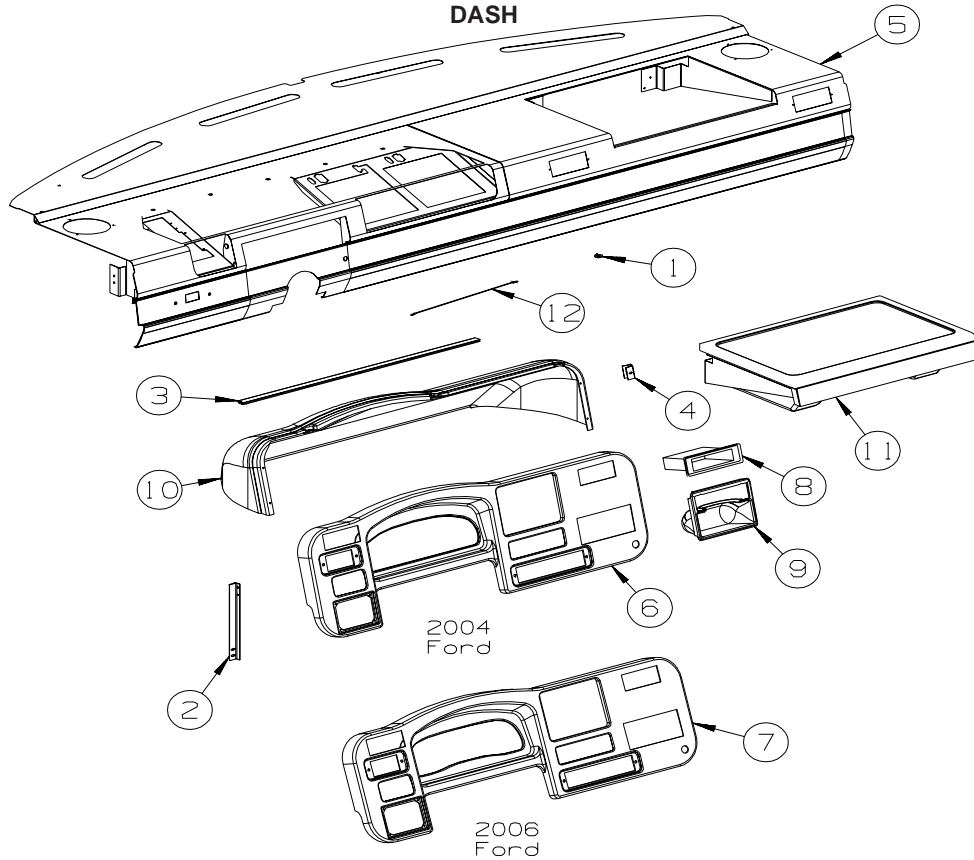

FORD

KEY	PART NUMBER	U/M	DESCRIPTION
1	049176-01-000	EA	HEDLOCK II - 3/4 DIAMETER SCREW MOUNT
2	128692-01-02B	EA	ANGLE-FORMED,DASH SUPPORT,EC - *98 F&G-SERIES
3	129813-02-02A	EA	HINGE - DASH POD - GLACIER
4	134257-02-02B	EA	CLIP - RETAINER - BEZEL - E-COATED
5	132426-09-S46	EA	DASH COMPLETE - RIVERSTONE
5	132426-09-S52	EA	DASH COMPLETE - CASHMERE
5	135095-09-S46	EA	DASH COMPLETE - RIVERSTONE - <b>WORK STATION</b>
5	135095-09-S52	EA	DASH COMPLETE - CASHMERE - <b>WORK STATION</b>
6	138611-02-04A	EA	BEZEL - INSTRUMENT PANEL - FORD - RIVERSTONE - <b>2004 CHASSIS</b>
6	138611-02-05A	EA	BEZEL - INSTRUMENT PANEL - FORD - CASHMERE - <b>2004 CHASSIS</b>
7	153719-01-04A	EA	BEZEL - INSTRUMENT PANEL - FORD - RIVERSTONE - <b>2006 CHASSIS</b>
7	153719-01-05A	EA	BEZEL - INSTRUMENT PANEL - FORD - CASHMERE - <b>2006 CHASSIS</b>
8	096776-03-000	EA	STORAGE BOX - CD'S - 4 DISC HOLDER
9	111350-01-19A	EA	POCKET - INSTRUMENT PANEL - UPPER - RIVERSTONE
9	111350-01-20A	EA	POCKET - INSTRUMENT PANEL - UPPER - CASHMERE
10	132080-01-19A	EA	POD - INSTRUMENT PANEL - W/O HOLE - RIVERSTONE
10	132080-01-20A	EA	POD - INSTRUMENT PANEL - W/O HOLE - CASHMERE
10	132080-02-19A	EA	POD - INSTRUMENT PANEL - W/O HOLE - RIVERSTONE - <b>REAR MONITOR</b>
10	132080-02-20A	EA	POD - INSTRUMENT PANEL - W/O HOLE - CASHMERE - <b>REAR MONITOR</b>
11	135298-02-R32	EA	TABLE COMPLETE - WORKSTATION
12	076767-05-000	EA	CABLE - STAINLESS STEEL - 15.5"

**DRIVERS COMPARTMENT GROUP (CONTINUED)**  
**DASH (CONTINUED)**

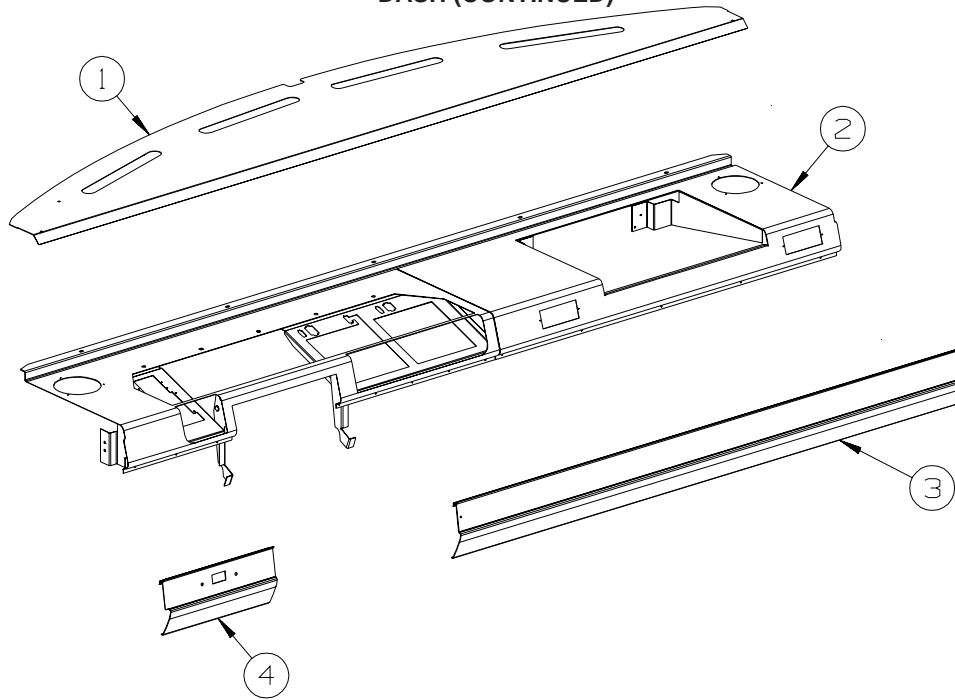

**FORD**

KEY	PART NUMBER	U/M	DESCRIPTION
1	132126-02-02B	EA	PANEL - DASH TOP - E-COATED
	106569-11-05A	EA	VINYL - LAMINATE - 1/4" X 25" X 100" - ALLANTE DOESKIN
2	132128-01-02B	EA	DASH - E-COATED
2	135096-01-02B	EA	DASH - E-COAT - <b>WORK STATION</b>
3	111528-10-19A	EA	TRIM - DASH/LOWER - PASSENGER - RIVERSTONE
3	111528-10-20A	EA	TRIM - DASH/LOWER - PASSENGER - CASHMERE
4	111528-13-19A	EA	TRIM - DASH/LOWER - DRIVER - RIVERSTONE
4	111528-13-20A	EA	TRIM - DASH/LOWER - DRIVER - CASHMERE



**DRIVERS COMPARTMENT GROUP (CONTINUED)**  
**DASH (CONTINUED)**

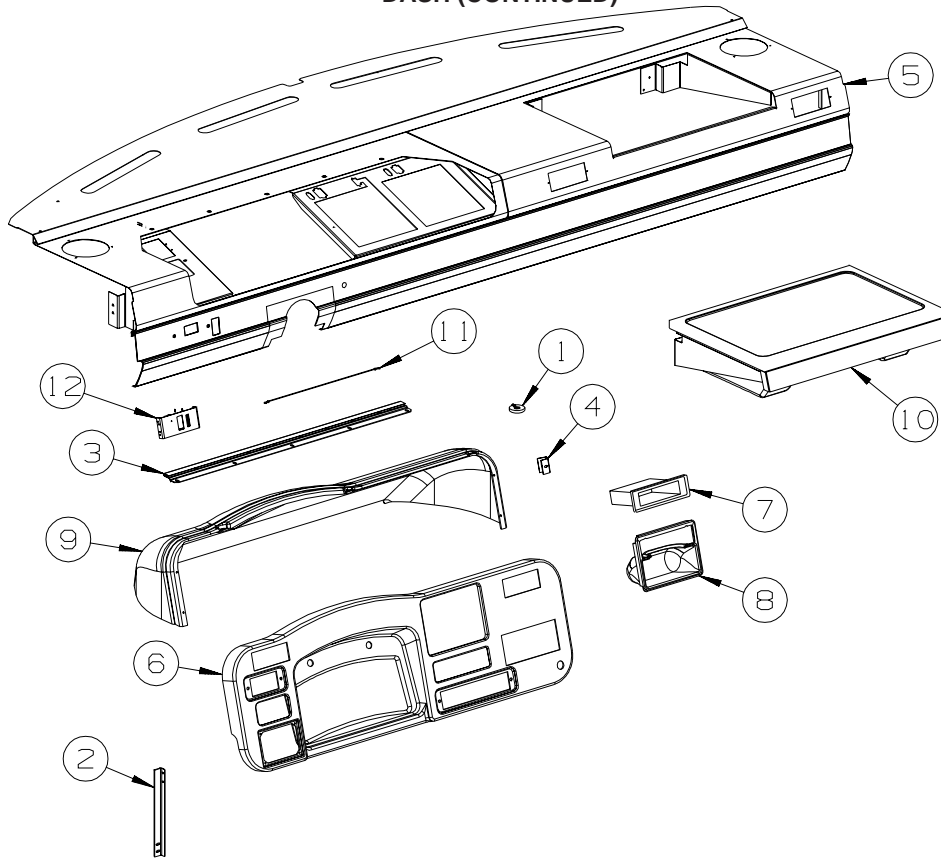

**WORKHORSE**

KEY	PART NUMBER	U/M	DESCRIPTION
1	049176-01-000	EA	HEDLOCK II - 3/4 DIAMETER SCREW MOUNT
2	128692-01-02B	EA	ANGLE-FORMED,DASH SUPPORT,EC - *98 F&G-SERIES
3	129813-02-02A	EA	HINGE - DASH POD - GLACIER
4	134257-02-02B	EA	CLIP - RETAINER - BEZEL - E-COATED
5	142960-07-S46	EA	DASH COMPLETE - RIVERSTONE
5	142960-07-S52	EA	DASH COMPLETE - CASHMERE
5	142960-08-S46	EA	DASH COMPLETE - RIVERSTONE - <b>WORK STATION</b>
5	142960-08-S52	EA	DASH COMPLETE - CASHMERE - <b>WORK STATION</b>
5	142960-11-S46	EA	DASH COMPLETE - RIVERSTONE - <b>F38J</b>
5	142960-11-S52	EA	DASH COMPLETE - CASHMERE - <b>F38J</b>
5	142960-12-S46	EA	DASH COMPLETE - RIVERSTONE - <b>WORK STATION, F38J</b>
5	142960-12-S52	EA	DASH COMPLETE - CASHMERE - <b>WORK STATION, F38J</b>
6	142956-01-04A	EA	BEZEL - INSTRUMENT PANEL - WORKHORSE - RIVERSTONE
6	142956-01-05A	EA	BEZEL - INSTRUMENT PANEL - WORKHORSE - CASHMERE
7	096776-03-000	EA	STORAGE BOX - CD'S - 4 DISC HOLDER
8	111350-01-19A	EA	POCKET - INSTRUMENT PANEL - UPPER - RIVERSTONE
8	111350-01-20A	EA	POCKET - INSTRUMENT PANEL - UPPER - CASHMERE
9	132080-01-19A	EA	POD - INSTRUMENT PANEL - W/O HOLE - RIVERSTONE
9	132080-01-20A	EA	POD - INSTRUMENT PANEL - W/O HOLE - CASHMERE
9	132080-02-19A	EA	POD - INSTRUMENT PANEL - W/O HOLE - RIVERSTONE - <b>REAR MONITOR</b>
9	132080-02-20A	EA	POD - INSTRUMENT PANEL - W/O HOLE - CASHMERE - <b>REAR MONITOR</b>
10	135298-02-R32	EA	TABLE COMPLETE - WORKSTATION
11	076767-05-000	EA	CABLE - STAINLESS STEEL - 15.5"
12	133849-01-02B	EA	MOUNT - HEADLAMP SWITCH - E-COATED

**DRIVERS COMPARTMENT GROUP (CONTINUED)**  
**DASH (CONTINUED)**

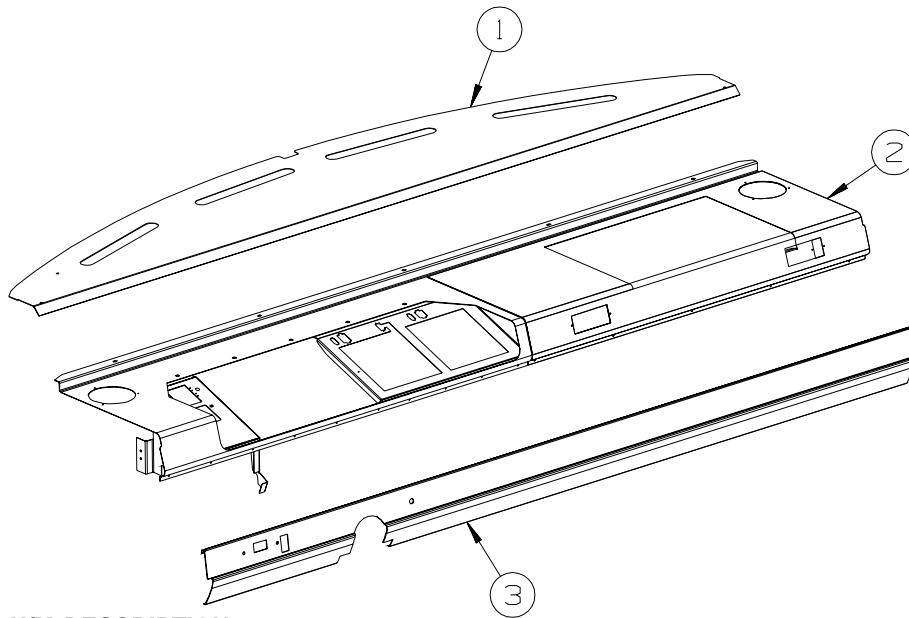

**WORKHORSE**

KEY	PART NUMBER	U/M	DESCRIPTION
1	132126-02-02B	EA	PANEL - DASH TOP - E-COATED
	106569-11-05A	EA	VINYL - LAMINATE - 1/4" X 25" X 100" - ALLANTE DOESKIN
2	142962-03-02B	EA	DASH - E-COATED
2	142962-04-02B	EA	DASH - E-COATED - <b>WORK STATION</b>
3	137928-03-07A	EA	TRIM - DASH - LOWER - RIVERSTONE
3	137928-03-06A	EA	TRIM - DASH - LOWER - CASHMERE
	137928-03-01A	EA	TRIM - DASH - LOWER - MILL
3	137928-04-07A	EA	TRIM - DASH - LOWER - RIVERSTONE - <b>F38J ONLY</b>
3	137928-04-06A	EA	TRIM - DASH - LOWER - CASHMERE - <b>F38J ONLY</b>
	137928-04-01A	EA	TRIM - DASH - LOWER - MILL - <b>F38J ONLY</b>

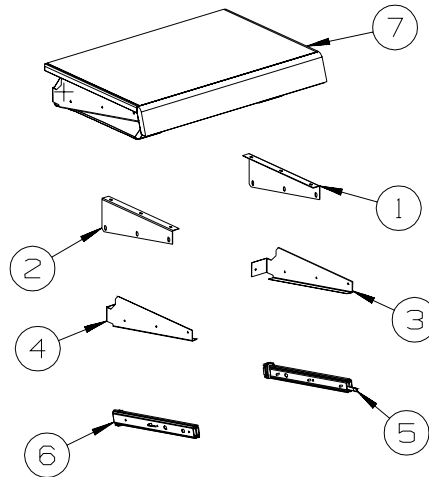

**WORKSTATION**

KEY	PART NUMBER	U/M	DESCRIPTION
1	135132-03-02B	EA	ANGLE-SLIDE,RH
2	135132-04-02B	EA	ANGLE-SLIDE,LH
3	135228-01-02B	EA	ANGLE - SLIDE - TRAY/RIGHT HAND - E-COATED
4	135228-02-02B	EA	ANGLE - SLIDE - TRAY/LEFT HAND - E-COATED
5	135314-01-01A	EA	SLIDE - DASH WORK STATION - RIGHT HAND
6	135314-02-01A	EA	SLIDE - DASH WORK STATION - LEFT HAND
7	135122-02-R32	EA	TABLE TOP - PULLOUT/WORKSTATION

## DRIVERS COMPARTMENT GROUP (CONTINUED)

### MOTOR COVER

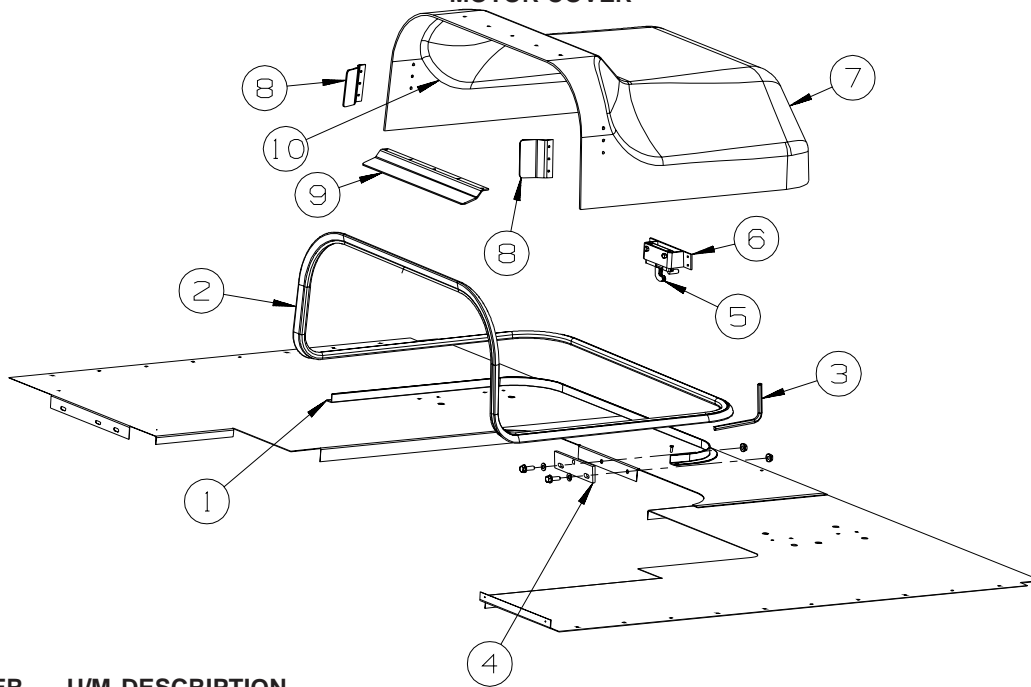

2004  
FORD

KEY	PART NUMBER	U/M	DESCRIPTION
1	115860-05-01A	EA	TRIM - MOTOR COVER - MILL FINISH
2	039623-01-000	FT	SEAL - MOTOR COVER - RUBBER BULB TYPE
3	116833-01-02B	EA	WRENCH - HEX MOTOR COVER - E-COATED
4	115852-01-02B	EA	STRIKE - LATCH - MOTOR COVER - E-COATED
5	116581-01-000	EA	LATCH - W/O STRIKE - MOTOR COVER
6	115850-01-02B	EA	RETAINER - LATCH - MOTOR COVER - RIGHT HAND - E-COATED
7	129099-04-01A	EA	COVER - MOTOR - W/O CARPET
8	115855-02-02B	EA	RETAINER - MOTOR COVER/SIDE - E-COATED
9	115855-01-02B	EA	RETAINER - MOTOR COVER/TOP - E-COATED
10	NOT USED		

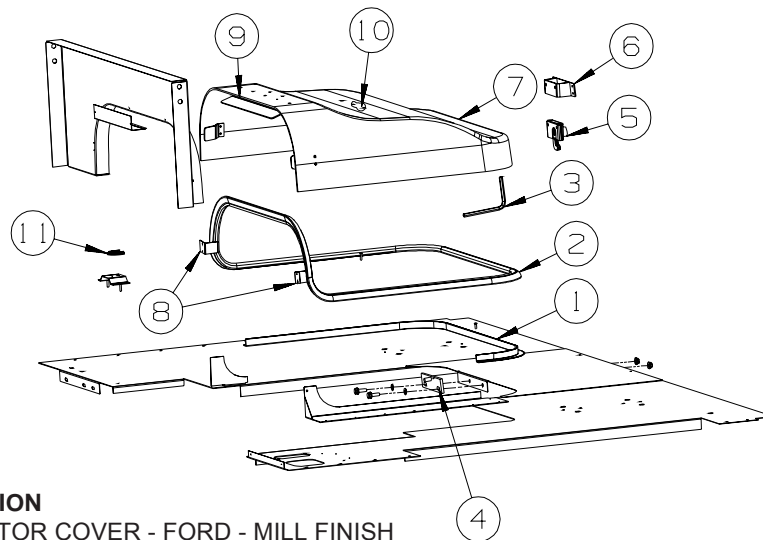

2006  
FORD

KEY	PART NUMBER	U/M	DESCRIPTION
1	115860-06-01A	EA	TRIM - MOTOR COVER - FORD - MILL FINISH
2	039623-01-000	FT	SEAL - MOTOR COVER - RUBBER BULB TYPE
3	116833-01-02B	EA	WRENCH - HEX MOTOR COVER - E-COATED
4	115852-01-02B	EA	STRIKE - LATCH - MOTOR COVER - E-COATED
5	116581-01-000	EA	LATCH - W/O STRIKE - MOTOR COVER
6	115850-01-02B	EA	RETAINER - LATCH - MOTOR COVER - RIGHT HAND - E-COATED
7	153971-01-T54	EA	COVER - MOTOR - W/CARPET (S46, S47, S48, SR0)
7	153971-01-T56	EA	COVER - MOTOR - W/CARPET (S49, S50, S51, SR1)
7	153971-01-S52	EA	COVER - MOTOR - W/CARPET (S52, S53, S54, SR2)
	153970-01-01A	EA	COVER - MOTOR - W/O CARPET - FORD
8	115855-04-02B	EA	RETAINER - MOTOR COVER/SIDE - E-COATED
9	115855-01-02B	EA	RETAINER - MOTOR COVER/TOP - E-COATED
10	134497-01-000	SF	FOIL/ALUMINUM - REINFORCED
11	143798-01-01A	EA	CATCH - FLOOR TO TABLE LEG - BRIGHT WHITE

**DRIVERS COMPARTMENT GROUP (CONTINUED)**  
**MOTOR COVER (CONTINUED)**

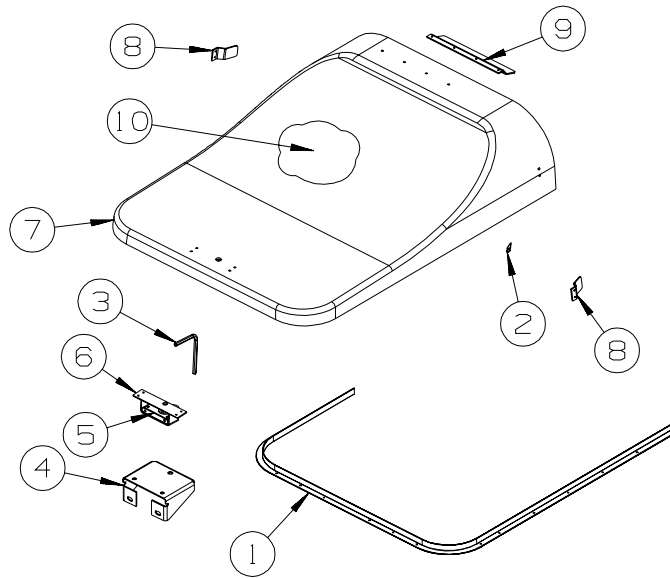

**WORKHORSE**

KEY	PART NUMBER	U/M DESCRIPTION
1	137332-01-01A	EA TRIM - MOTOR COVER
2	039623-01-000	FT SEAL - MOTOR COVER - RUBBER BULB TYPE
3	116833-01-02B	EA WRENCH - HEX MOTOR COVER - E-COATED
4	137305-02-02B	EA BRACKET - STRIKE SUPPORT - E-COATED
5	116581-01-000	EA LATCH - W/O STRIKE - MOTOR COVER
6	115850-01-02B	EA RETAINER - LATCH - MOTOR COVER - RIGHT HAND - E-COATED
7	137097-01-M43	EA COVER - MOTOR W/CARPET (S46, S47, S48, SR0)
7	137097-01-S49	EA COVER - MOTOR W/CARPET (S49, S50, S51, SR1)
7	137097-01-S52	EA COVER - MOTOR W/CARPET (S52, S53, S54, SR2)
	137096-01-01A	EA COVER - MOTOR - W/O CARPET
8	115855-04-02B	EA RETAINER - MOTOR COVER/SIDE - E-COATD
9	115855-03-02B	EA RETAINER - MOTOR COVER/TOP - E-COATED
10	NOT USED	

## DRIVERS COMPARTMENT GROUP (CONTINUED)

### BEVERAGE TRAY

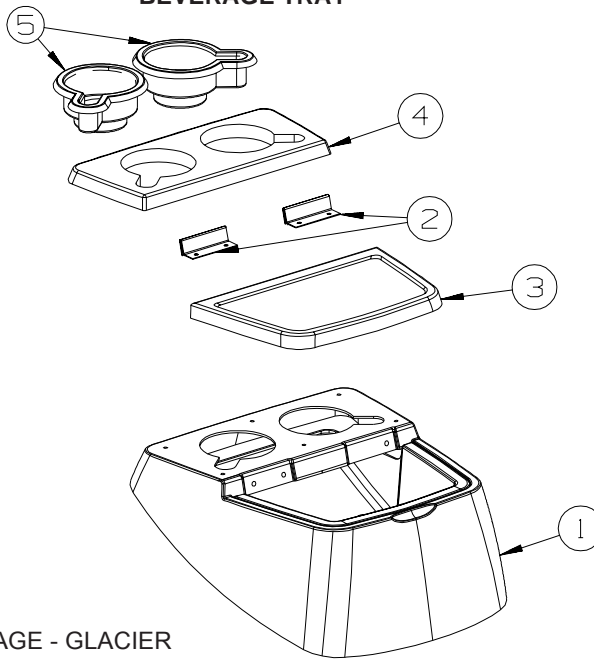

**WORKHORSE**

KEY	PART NUMBER	U/M DESCRIPTION
1	139268-01-01A	EA TRAY - BEVERAGE - GLACIER
2	139279-01-04B	EA HINGE - BLACK
3	139285-01-03A	EA LID/DOOR - SANDSTONE
4	139296-01-03A	EA LID - BEVERAGE TRAY - SANDSTONE
5	133831-01-01A	EA HOLDER - CUP W/THREE CENTERLINE RUBBER FINGERS

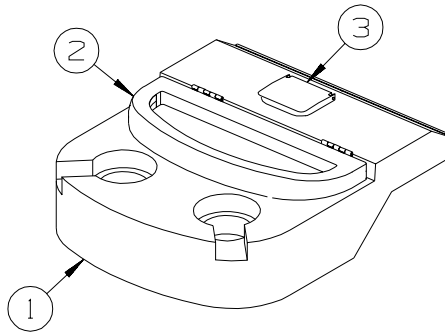

**2004  
FORD**

KEY	PART NUMBER	U/M DESCRIPTION
1	128114-01-04A	EA TRAY/BEVERAGE - GLACIER
2	128113-01-N21	EA LID - BEVERAGE TRAY
3	118719-01-01A	EA ASHTRAY - TOP MOUNT - BLACK PLASTIC

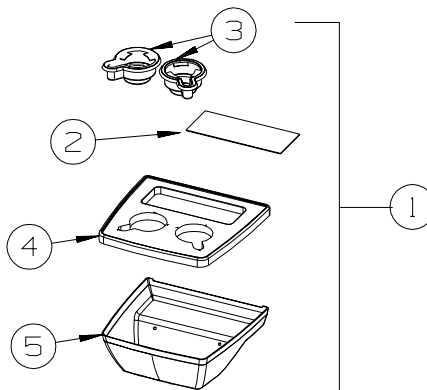

**2006  
FORD**

KEY	PART NUMBER	U/M DESCRIPTION
1	149301-01-S28	EA TRAY - BEVERAGE - W/CONVENIENCE TRAY - GLACIER
2	122717-11-01A	EA PAD - NON-SKID - PSA - 4.5" X 11"
3	133831-01-01A	EA HOLDER - CUP W/THREE CENTERLINE RUBBER FINGERS
4	148918-01-01A	EA TRAY - BEVERAGE CENTER - SANDSTONE
5	149256-01-04A	EA COVER - BEVERAGE TRAY BOTTOM - GLACIER

# DRIVERS COMPARTMENT GROUP (CONTINUED)

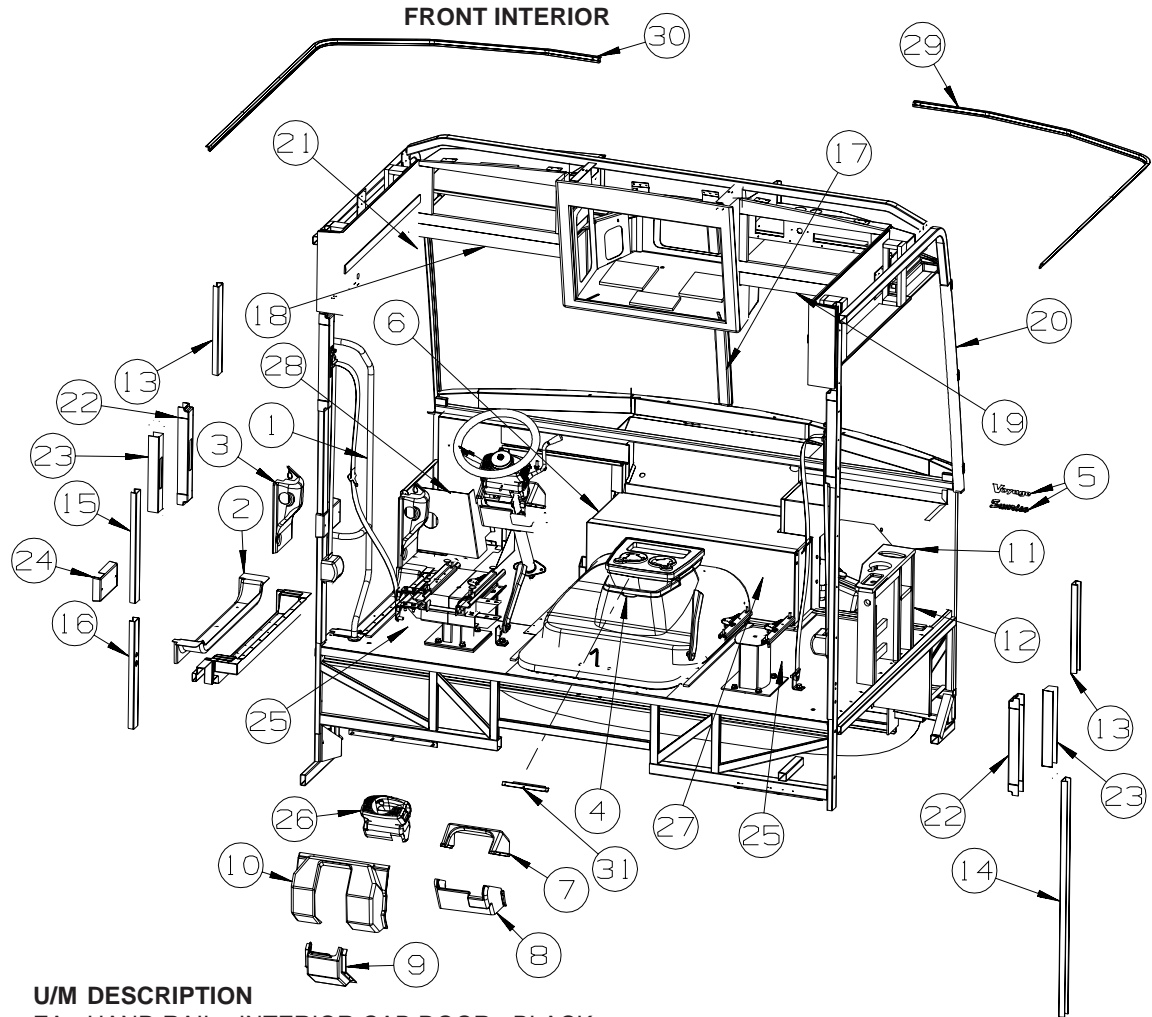

KEY	PART NUMBER	U/M	DESCRIPTION
1	131058-04-02A	EA	HAND RAIL - INTERIOR CAB DOOR - BLACK
2	131849-02-01A	EA	TRIM/STEP - DRIVER DOOR - GLACIER
	102569-02-000	EA	MAT - ANTI SLIP - LOWER
3	132296-02-04A	EA	PANEL/TRIM - DASH/CAB DOOR - F/ELECTRIC MIRRORS - GLACIER
	132296-01-04A	EA	PANEL/TRIM - DASH/CAB DOOR - LOW MOUNT MIRRORS - GLACIER
4	139275-01-R32	EA	TRAY - BEVERAGE - <b>WORKHORSE</b>
4	126008-02-N21	EA	TRAY - BEVERAGE - <b>FORD</b>
5	126340-07-01A	EA	DECAL - LOGO - "VOYAGE" - 3-D - CHAMPAGNE BEIGE
6	134455-04-000	EA	INSULATION/RADIATOR COVER - LEFT HAND
7	137851-01-19A	EA	COVER - STEERING COLUMN - RIVERSTONE - <b>WORKHORSE</b>
7	137851-01-20A	EA	COVER - STEERING COLUMN - CASHMERE - <b>WORKHORSE</b>
8	137878-02-19A	EA	COVER - STEERING COLUMN - FRONT - RIVERSTONE - <b>WORKHORSE</b>
8	137878-02-20A	EA	COVER - STEERING COLUMN - FRONT - CASHMERE - <b>WORKHORSE</b>
9	125795-01-19A	EA	COVER - STEERING COLUMN/LOWER - RIVERSTONE - <b>FORD</b>
9	125795-01-20A	EA	COVER - STEERING COLUMN/LOWER - CASHMERE - <b>FORD</b>
10	131804-04-19A	EA	COVER - STEERING COLUMN - RIVERSTONE - <b>FORD</b>
10	131804-04-20A	EA	COVER - STEERING COLUMN - CASHMERE - <b>FORD</b>
11	137643-03-02A	EA	COUNTERTOP - ARMREST CABINET - SANDSTONE
12	137644-01-N30	EA	CABINET/ARMREST - RIGHT HAND - PORTSMOUTH OAK
12	137644-01-S47	EA	CABINET/ARMREST - RIGHT HAND - CONCERT CHERRY
12	137644-01-S48	EA	CABINET/ARMREST - RIGHT HAND - WASHED MAPLE
12	137644-01-SR0	EA	CABINET/ARMREST - RIGHT HAND - SIERRA MAPLE
13	024700-58-000	EA	COVER - ROLL BAR - SIDEWALL - 16.5" - OFF WHITE
14	024700-59-000	EA	COVER - ROLL BAR - SIDEWALL - 44.1" - OFF WHITE
15	024700-66-000	EA	COVER - ROLL BAR - SIDEWALL - 20.6" - OFF WHITE
16	024700-67-000	EA	COVER - ROLL BAR - SIDEWALL - 20.1" - OFF WHITE
17	118452-04-03A	EA	TRIM - WINDSHIELD - CENTER - GLACIER
18	118453-03-03A	EA	TRIM - WINDSHIELD - INNER/TOP/PASSENGER - GLACIER
19	118453-04-03A	EA	TRIM - WINDSHIELD - INNER/TOP/DRIVER - GLACIER
20	125508-01-03A	EA	TRIM - A-PILLAR - PASSENGER/INTERIOR - GLACIER
21	125508-02-03A	EA	TRIM - A-PILLAR - DRIVER/INTERIOR - GLACIER
22	140151-01-01A	EA	COVER - SEAT BELT - OFF WHITE

## DRIVERS COMPARTMENT GROUP (CONTINUED)

### FRONT INTERIOR (CONTINUED)

KEY	PART NUMBER	U/M DESCRIPTION
23	140151-03-01A	EA COVER - SLIDING - F/SEATBELT - BLACK
24	141072-01-01A	EA COVER - BRACKET/LATCH - OFF WHITE
	140151-02-01A	EA COVER - SCREW - OFF WHITE
	141395-03-01A	EA CLIP - U, #6-20
25	105924-01-P41	EA MAT/FLOOR - 18" X 27" (S46, S47, S48, SR0)
25	105924-01-S49	EA MAT/FLOOR - 18" X 27" (S49, S50, S51, SR1)
25	105924-01-S52	EA MAT/FLOOR - 18" X 27" (S52, S53, S54, SR2)
26	103498-09-000	EA BOOT - STEERING COLUMN - W/1/2 CIRCLE - 18,000 GVWR WORKHORSE
27	134455-03-000	EA INSULATION/RADIATOR COVER - MAIN - FORD 2004 CHASSIS
27	140168-02-000	EA INSULATION/RADIATOR COVER - MAIN - FORD 2006 CHASSIS
27	140168-02-000	EA INSULATION/RADIATOR COVER - MAIN - WORKHORSE
28	139991-02-02B	EA PANEL - COVER
29	127254-14-03A	EA TRACK/WRAPAROUND - PASSENGER - GLACIER
30	127254-04-05A	EA TRACK/WRAPAROUND - DRIVER - GLACIER
31	155496-01-02B	EA BRACKET - BEVERAGE TRAY - E-COATED - 2006 FORD

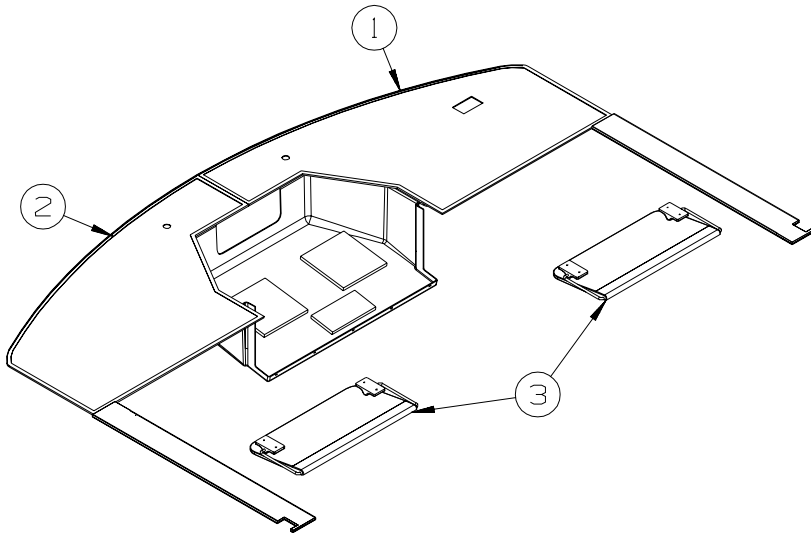

**WITH FRONT TV**

KEY	PART NUMBER	U/M DESCRIPTION
1	126440-27-S46	EA PANEL - OVERHEAD/FRONT/BOTTOM/RIGHT HAND - VINYL COVERED
2	126440-28-S46	EA PANEL - OVERHEAD/FRONT/BOTTOM/LEFT HAND - VINYL COVERED
3	123298-04-05A	EA SUNVISOR - 10.5" X 21" - DRIVER/PASSENGER - GLACIER

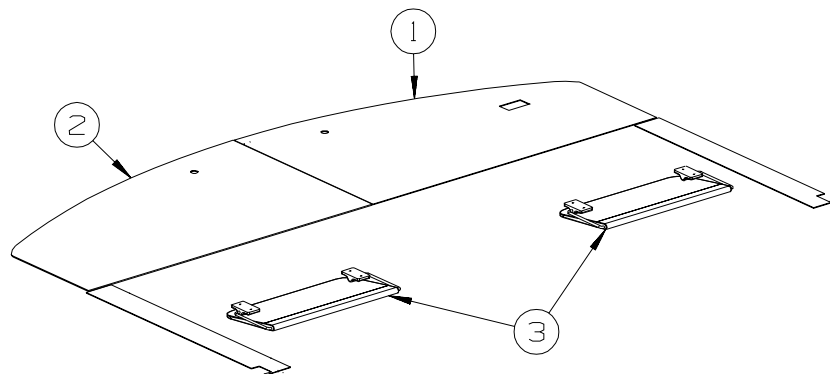

**WITHOUT FRONT TV**

KEY	PART NUMBER	U/M DESCRIPTION
1	126440-29-S46	EA PANEL - OVERHEAD/FRONT/BOTTOM/RIGHT HAND - VINYL COVERED
2	126440-30-S46	EA PANEL - OVERHEAD/FRONT/BOTTOM/LEFT HAND - VINYL COVERED
3	123298-04-05A	EA SUNVISOR - 10.5" X 21" - DRIVER/PASSENGER - GLACIER

**DRIVERS COMPARTMENT GROUP (CONTINUED)**  
**FRONT INTERIOR (CONTINUED)**

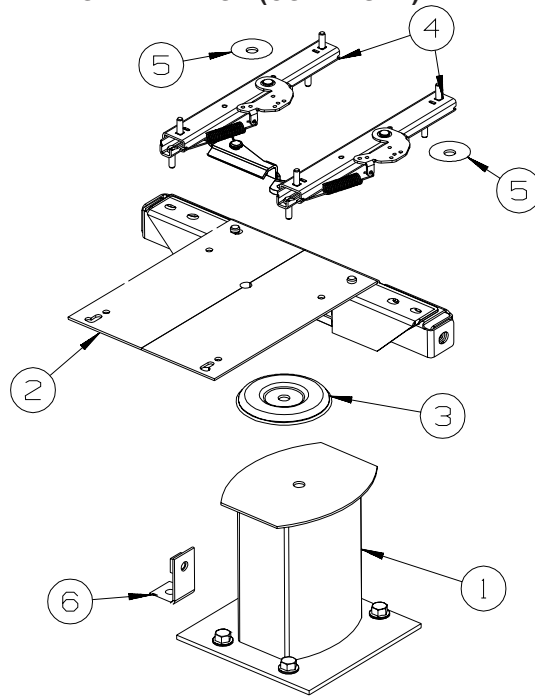

**DRIVER MANUAL**

KEY	PART NUMBER	U/M	DESCRIPTION
1	133408-01-000	EA	PEDESTAL - SEAT/DRIVER - 9 3/4"
2	133408-19-000	EA	TOP PLATE - DRIVERS - W/ANCHOR
3	107921-06-000	EA	BEARING KIT - PEDESTAL
4	131566-04-000	EA	SLIDE/SEAT - HEAVY DUTY LOCKING - 5"
	119952-07-000	EA	WIRE - LATCH RELEASE/ROTARY
5	131566-05-000	EA	WASHER - SLIDE SPACER
6	133408-04-000	EA	BRACKET - ANCHOR/FLOOR

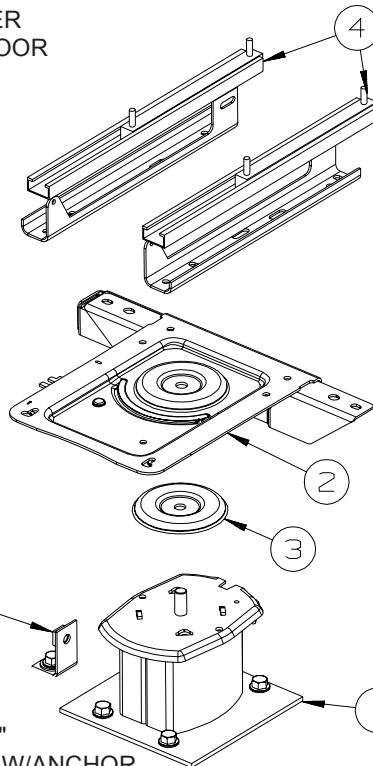

**DRIVER POWERED**

KEY	PART NUMBER	U/M	DESCRIPTION
1	133408-05-000	EA	PEDESTAL - SEAT - 5.75"
2	133408-19-000	EA	TOP PLATE - DRIVERS - W/ANCHOR
3	107921-06-000	EA	BEARING KIT - PEDESTAL
4	147767-01-000	EA	SEAT - POWER - 6-WAY - DRIVER
5	133408-04-000	EA	BRACKET - ANCHOR/FLOOR



## DRIVERS COMPARTMENT GROUP (CONTINUED) FRONT INTERIOR (CONTINUED)

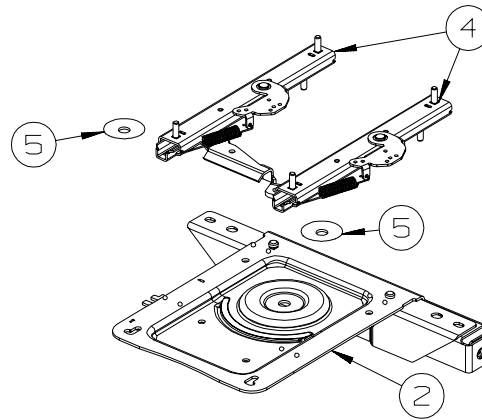

**PASSENGER MANUAL**

KEY	PART NUMBER	U/M	DESCRIPTION
1	133408-01-000	EA	PEDESTAL - SEAT - DRIVER/PASSENGER - 9 3/4"
2	133408-20-000	EA	TOP PLATE - PASSENGER - W/ANCHOR
3	107921-06-000	EA	BEARING KIT - PEDESTAL
4	131566-04-000	EA	SLIDE/SEAT - HEAVY DUTY LOCKING - 5"
	119952-07-000	EA	WIRE - LATCH RELEASE/ROTARY
5	131566-05-000	EA	WASHER - SLIDE SPACER
6	133408-04-000	EA	BRACKET - ANCHOR/FLOOR

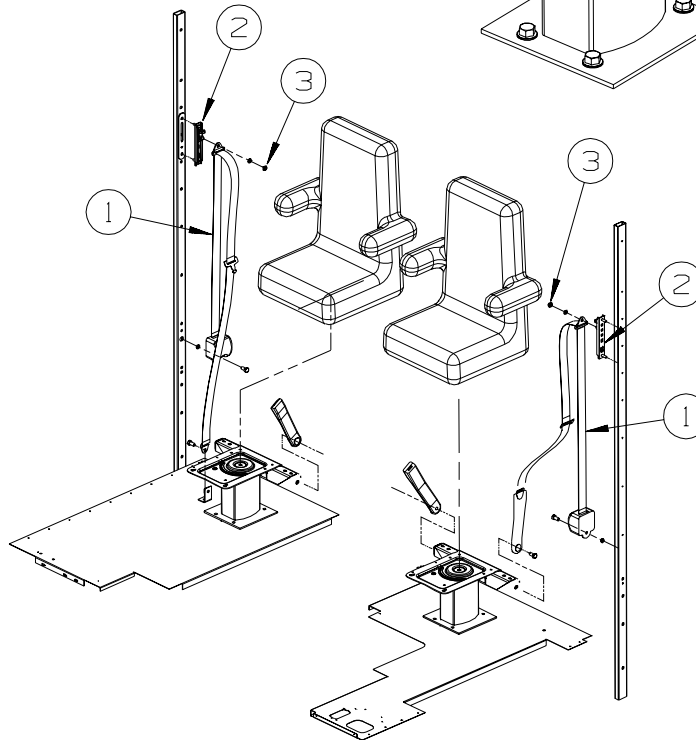
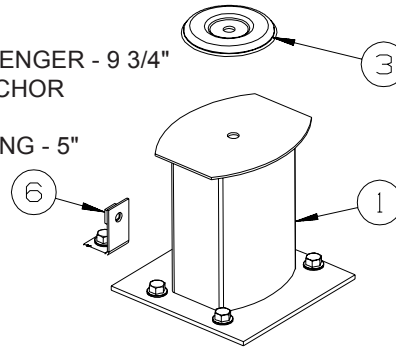

KEY	PART NUMBER	U/M	DESCRIPTION
1*	091990-08-01A	EA	SEAT BELT - 3 POINT - .766" DIAMETER HOLE IN D-LOOP BRKT
2	127598-01-01A	EA	ADJUSTER - SEATBELT - D-LOOP
3	127598-02-000	EA	NUT - HEX FLANGE - M10 X 1.5 - CLASS 10

**\*COMPONENT PARTS LISTED LATER IN THIS GROUP**

### COMPONENT PARTS FOR FRONT INTERIOR

**091990-08-01A**

KEY	PART NUMBER	U/M	DESCRIPTION	VENDOR NO.
	091990-01-701	EA	EXTENDER 9" FOR A8408 3 PT	I-1331-02
	091990-01-703	EA	RECEIVER/FEMALE END-SEATBELT	I-1159-02
	091990-05-700	EA	SLEEVE/BUCKLE COVER-PLASTIC	209S-2
	091990-05-701	EA	CAP/COVER - BOLT HOLE COVER	209SC-02
	091990-05-702	EA	SLEEVE/RETRACTABLE COVER	309C-02

# DRIVERS COMPARTMENT GROUP (CONTINUED)

## CABINETS

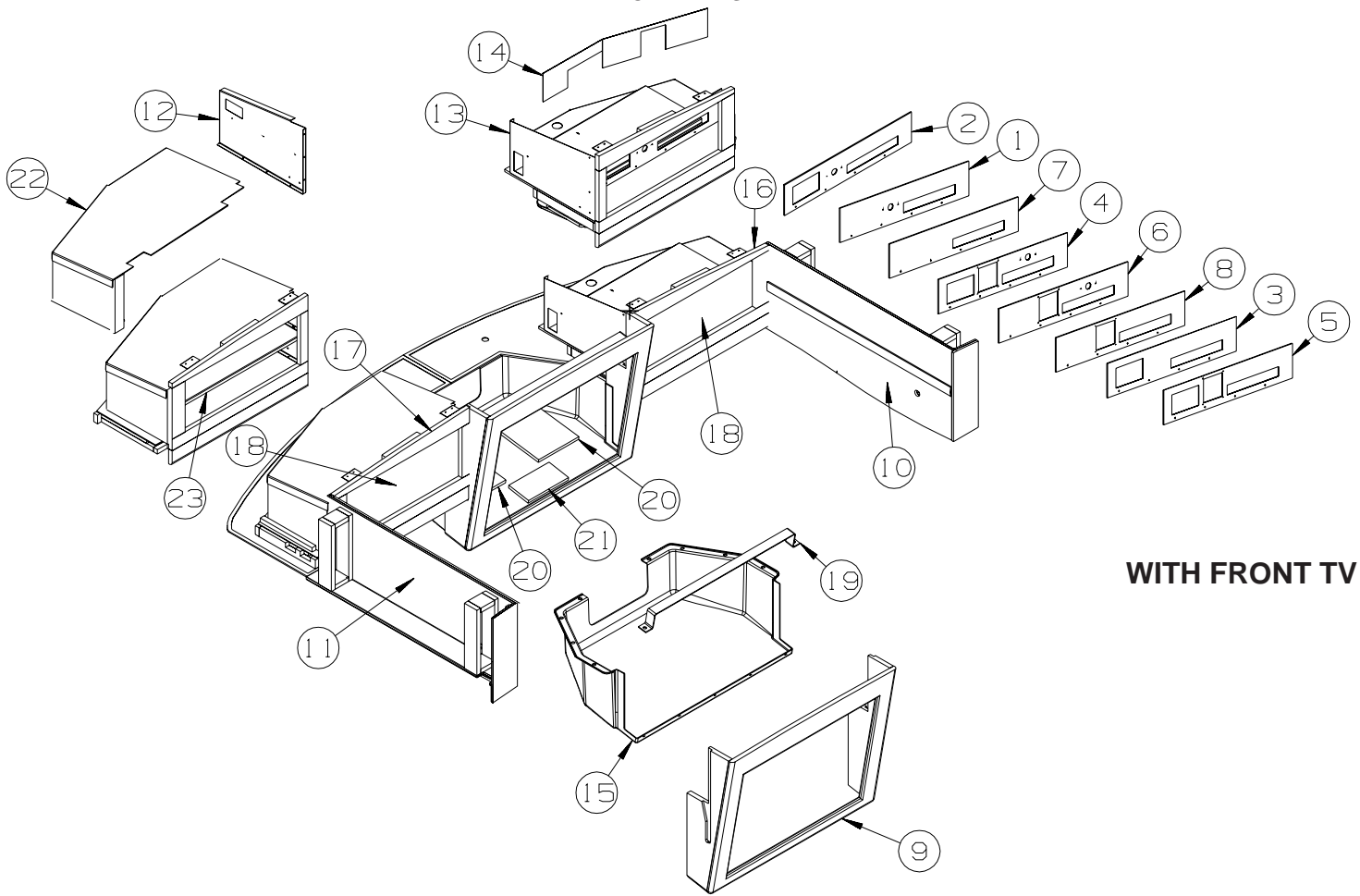

WITH FRONT TV

KEY	PART NUMBER	U/M	DESCRIPTION
1	144652-02-R38	EA	PANEL/VINYL COVERED - WIRE HOLE CUT
2	144652-01-R38	EA	PANEL/VINYL COVERED - WIRE HOLE CUT - DC/AC INVERTER
3	144652-10-S64	EA	PANEL/VINYL COVERED - WIRE HOLE CUT - DC/AC INVERTER/HOME THEATER SYS
4	144652-04-R68	EA	PANEL/VINYL COVERED - WIRE HOLE CUT - DC/AC INVERTER/AUTOMATIC SATELLITE DISH
5	144652-11-S64	EA	PANEL/VINYL COVERED - DC/AC INVERTER/HOME THEATER SYS/AUTOMATIC SATELLITE DISH
6	144652-05-R68	EA	PANEL/VINYL COVERED-WIRE HOLE CUT - AUTOMATIC SATELLITE DISH
7	144652-03-R83	EA	PANEL/VINYL COVERED - WIRE HOLE CUT - HOME THEATER SYS
8	144652-08-R83	EA	PANEL/VINYL COVERED - WIRE HOLE CUT - AUTOMATIC SATELLITE DISH/HOME THEATER SYS
9	148894-01-S46	EA	CABINET - FRONT/TV FACE - W/O DOORS/HARDWARE - PORTSMOUTH OAK FROM: 00-00-00 THRU: 09-05-04
9	148894-02-S46	EA	CABINET - FRONT/TV FACE - W/O DOORS/HARDWARE - PORTSMOUTH OAK FROM: 09-06-04 THRU: 99-99-99
9	148894-01-S47	EA	CABINET - FRONT/TV FACE - W/O DOORS/HARDWARE - CONCERT CHERRY FROM: 00-00-00 THRU: 09-05-04
9	148894-02-S47	EA	CABINET - FRONT/TV FACE - W/O DOORS/HARDWARE - CONCERT CHERRY FROM: 09-06-04 THRU: 99-99-99
9	148894-01-S48	EA	CABINET - FRONT/TV FACE - W/O DOORS/HARDWARE - WASHED MAPLE FROM: 00-00-00 THRU: 09-05-04
9	148894-02-S48	EA	CABINET - FRONT/TV FACE - W/O DOORS/HARDWARE - WASHED MAPLE FROM: 09-06-04 THRU: 99-99-99
9	148894-01-SR0	EA	CABINET - FRONT/TV FACE - W/O DOORS/HARDWARE - SIERRA MAPLE FROM: 00-00-00 THRU: 09-05-04
9	148894-02-SR0	EA	CABINET - FRONT/TV FACE - W/O DOORS/HARDWARE - SIERRA MAPLE FROM: 09-06-04 THRU: 99-99-99
10	149043-01-S46	EA	PANEL - OVERHEAD/FRONT - RIGHT HAND - VINYL COVERED
11	149043-02-S46	EA	PANEL - OVERHEAD/FRONT - LEFT HAND - VINYL COVERED
12	126079-07-02B	EA	PANEL ASM - SHELF
13	126275-07-02B	EA	SHELF - OVERHEAD/FRONT - E-COATED
14	132909-09-S46	EA	PANEL - VINYL COVERED - HOME THEATER SYS
14	132909-06-S46	EA	PANEL - VINYL COVERED
15	148888-01-01A	EA	COVER - FRONT TV/OVERHEAD - GLACIER

## DRIVERS COMPARTMENT GROUP (CONTINUED)

### CABINETS (CONTINUED)

KEY	PART NUMBER	U/M	DESCRIPTION
16	148971-01-S46	EA	CABINET - OVERHEAD/FRONT - PASSENGER - W/O DOORS/HARDWARE - PORTSMOUTH OAK
16	148971-01-S47	EA	CABINET - OVERHEAD/FRONT - PASSENGER - W/O DOORS/HARDWARE - CONCERT CHERRY
16	148971-01-S48	EA	CABINET - OVERHEAD/FRONT - PASSENGER - W/O DOORS/HARDWARE - WASHED MAPLE
16	148971-01-SR0	EA	CABINET - OVERHEAD/FRONT - PASSENGER - W/O DOORS/HARDWARE - SIERRA MAPLE
17	148971-02-S46	EA	CABINET - OVERHEAD/FRONT - DRIVER - W/O DOORS/HARDWARE - PORTSMOUTH OAK
17	148971-02-S47	EA	CABINET - OVERHEAD/FRONT - DRIVER - W/O DOORS/HARDWARE - CONCERT CHERRY
17	148971-02-S48	EA	CABINET - OVERHEAD/FRONT - DRIVER - W/O DOORS/HARDWARE - WASHED MAPLE
17	148971-02-SR0	EA	CABINET - OVERHEAD/FRONT - DRIVER - W/O DOORS/HARDWARE - SIERRA MAPLE
18	146028-43-S46	EA	DOOR - GLASS INSERT/OGEE EDGE - 10.8" X 23.8" - W/O HDW - PORTSMOUTH OAK
18	146028-43-S47	EA	DOOR - GLASS INSERT/OGEE EDGE - 10.8" X 23.8" - W/O HDW - CONCERT CHERRY
18	146028-43-S48	EA	DOOR - GLASS INSERT/OGEE EDGE - 10.8" X 23.8" - W/O HDW - WASHED MAPLE
18	146028-43-SR0	EA	DOOR - GLASS INSERT/OGEE EDGE - 10.8" X 23.8" - W/O HDW - SIERRA MAPLE
	100708-21-000	EA	DOOR/GLASS - TV CABINET - 8.1" X 22" - W/O HARDWARE
19	133790-28-02B	EA	STRAP - TIEDOWN - TV - E-COATED
			FROM: 00-00-00 THRU: 09-06-04
19	144148-05-02B	EA	BRACKET - TIEDOWN/TV - E-COATED
			FROM: 09-07-04 THRU: 99-99-99
20	140364-01-01A	EA	FOAM - PAD - .5" X 8" X 8"
21	140364-03-01A	EA	FOAM - PAD - .5" X 4" X 8"
22	P26457-10-000	EA	PANEL/CLOSEOUT - OVERHEAD - FRONT
23	137572-04-02B	EA	PANEL - SHELF

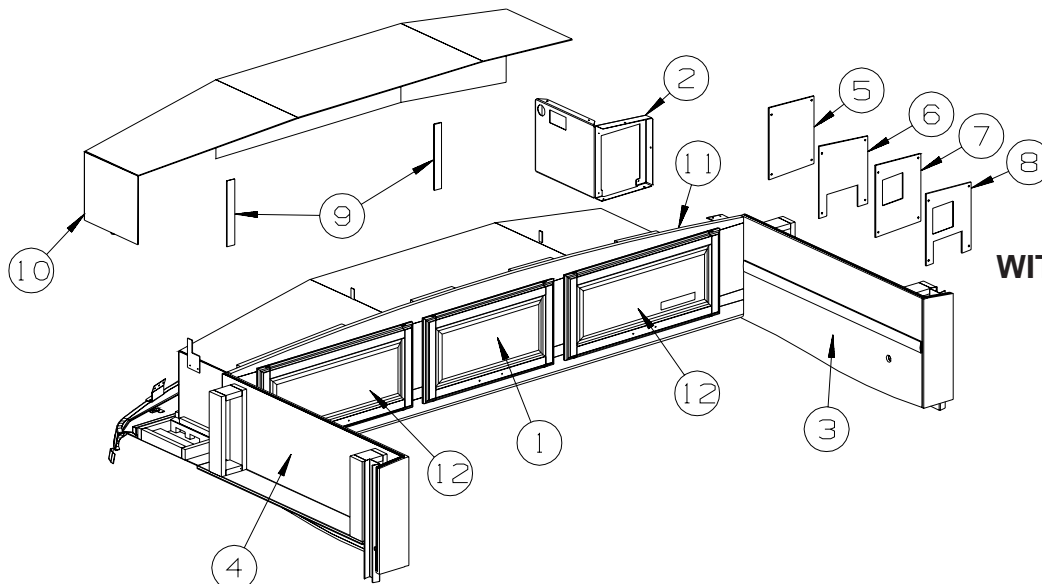

KEY	PART NUMBER	U/M	DESCRIPTION
1	136954-67-S28	EA	DOOR - RAISED PANEL/OGEE EDGE - 12" X 21.9" - W/O HDW - PORTSMOUTH OAK
1	136954-67-S08	EA	DOOR - RAISED PANEL/OGEE EDGE - 12" X 21.9" - W/O HDW - CONCERT CHERRY
1	136954-67-S09	EA	DOOR - RAISED PANEL/OGEE EDGE - 12" X 21.9" - W/O HDW - WASHED MAPLE
1	136954-67-SJ0	EA	DOOR - RAISED PANEL/OGEE EDGE - 12" X 21.9" - W/O HDW - SIERRA MAPLE
2	149953-01-02B	EA	PANEL - END - CLOSEOUT
3	149043-01-S46	EA	PANEL - OVERHEAD/FRONT - RIGHT HAND - VINYL COVERED
4	149043-02-S46	EA	PANEL - OVERHEAD/FRONT - LEFT HAND - VINYL COVERED
5	148681-06-R38	EA	PANEL/VINYL COVERED
6	148681-01-R38	EA	PANEL/VINYL COVERED - <b>DC/AC INVERTER</b>
7	148681-03-R38	EA	PANEL/VINYL COVERED - <b>AUTOMATIC SATELLITE DISH</b>
8	148681-02-R38	EA	PANEL/VINYL COVERED - <b>DC/AC INVERTER/AUTOMATIC SATELLITE DISH</b>
9	118608-16-R38	EA	PANEL-HEADLINER
10	140015-04-S46	EA	PANEL ASM-CLOSEOUT,OVHD FRT
11	149899-01-S46	EA	CABINET - OVERHEAD/FRONT - W/O DOORS/HARDWARE - PORTSMOUTH OAK
11	149899-01-S47	EA	CABINET - OVERHEAD/FRONT - W/O DOORS/HARDWARE - CONCERT CHERRY
11	149899-01-S48	EA	CABINET - OVERHEAD/FRONT - W/O DOORS/HARDWARE - WASHED MAPLE
11	149899-01-SR0	EA	CABINET - OVERHEAD/FRONT - W/O DOORS/HARDWARE - SIERRA MAPLE
12	136954-70-S01	EA	DOOR - RAISED PANEL/OGEE EDGE - 12" X 26" - W/O HDW - PORTSMOUTH OAK
12	136954-70-S08	EA	DOOR - RAISED PANEL/OGEE EDGE - 12" X 26" - W/O HDW - CONCERT CHERRY
12	136954-70-S09	EA	DOOR - RAISED PANEL/OGEE EDGE - 12" X 26" - W/O HDW - WASHED MAPLE
12	136954-70-S88	EA	DOOR - RAISED PANEL/OGEE EDGE - 12" X 26" - W/O HDW - SIERRA MAPLE

## ELECTRICAL GROUP 110V BODY WIRING

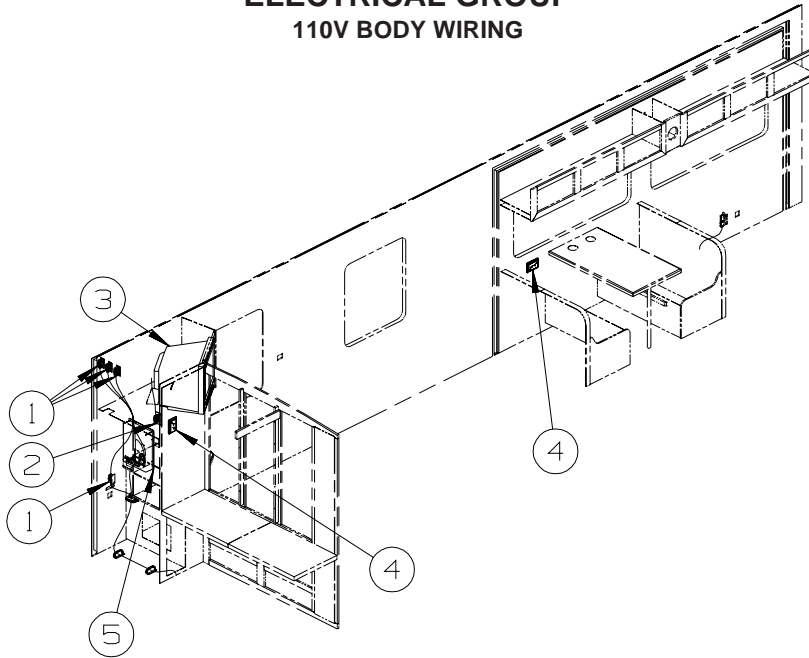

KEY	PART NUMBER	U/M	DESCRIPTION
1	058707-02-000	EA	RECEPTACLE - BLANK - JUNCTION BOX
2	058708-05-000	EA	RECEPTACLE - ELECTRIC - SINGLE - BROWN
3*	149040-02-000	EA	TV - 20" FLAT SCREEN/STEREO - RCA 20F410T
4	133713-01-20A	EA	SPACER/RECEPTACLE - WHITE VINYL
4	058708-06-000	EA	RECEPTACLE - DUPLEX - WHITE
5	095721-31-000	EA	LABEL - CONTROL CENTER - 30 AMP - US
5	095721-33-000	EA	LABEL - CONTROL CENTER - 50 AMP - US

\*COMPONENT PARTS LISTED LATER IN THIS GROUP

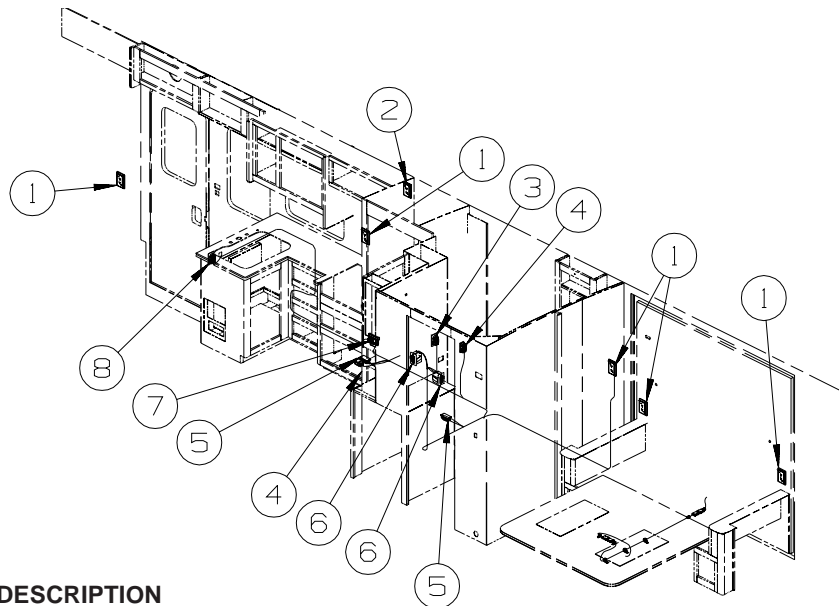

KEY	PART NUMBER	U/M	DESCRIPTION
1	133713-01-20A	EA	SPACER/RECEPTACLE - WHITE VINYL
1	058708-06-000	EA	RECEPTACLE - DUPLEX - WHITE
2	133713-01-20A	EA	SPACER/RECEPTACLE - WHITE VINYL
2	058708-07-000	EA	RECEPTACLE - ELECTRICAL - SINGLE - WHITE
3	058708-05-000	EA	RECEPTACLE - ELECTRIC - SINGLE - BROWN
4	058707-01-000	EA	RECEPTACLE - ELECTRIC - SINGLE - BROWN
5	058707-02-000	EA	RECEPTACLE - BLANK - JUNCTION BOX
6	147446-01-02A	EA	RECEPTACLE - GFCI - 15A 125V - BROWN
7	131826-01-01A	EA	RECEPTACLE - EXTERIOR - W/COVER/GASKET - WHITE
8	058708-01-000	EA	RECEPTACLE - ELECTRIC - DOUBLE - BROWN

# ELECTRICAL GROUP (CONTINUED)

## 12V BODY WIRING

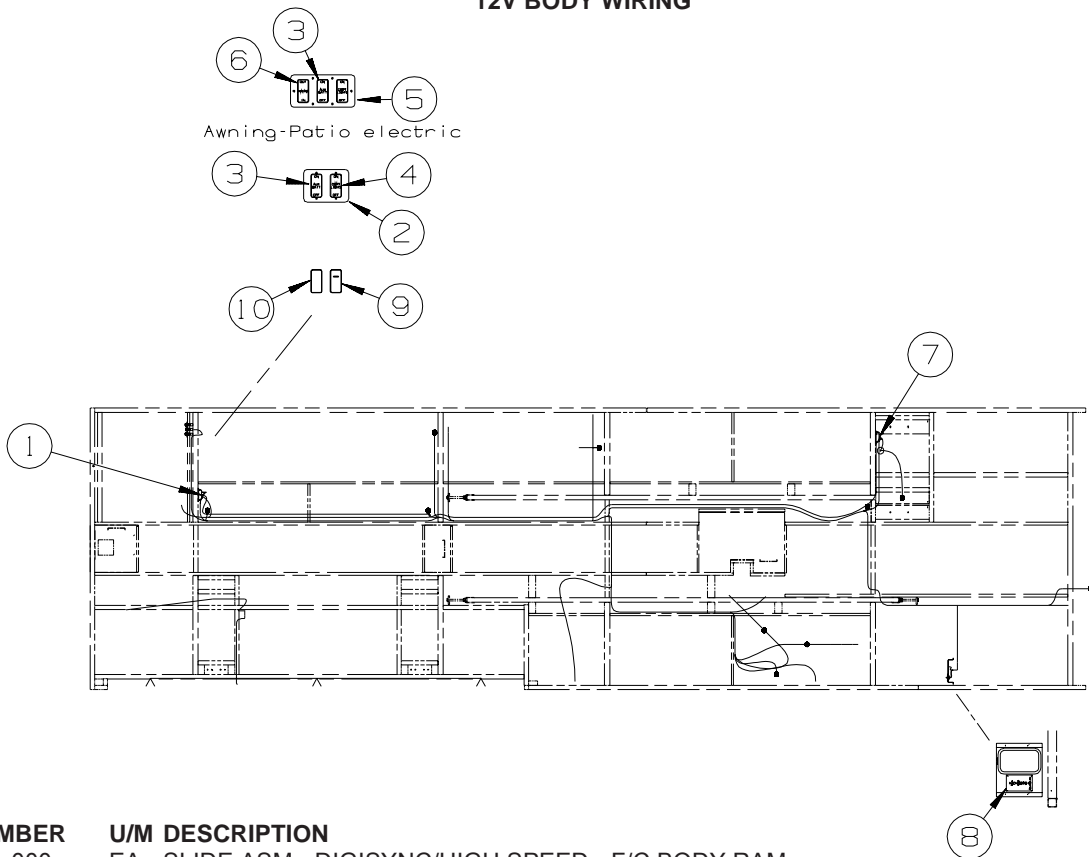

KEY	PART NUMBER	U/M	DESCRIPTION
1	149825-01-000	EA	SLIDE ASM - DIGISYNC/HIGH SPEED - F/C BODY RAM
2	098351-22-01A	EA	PLATE/SWITCH - 2 GANG - POLISHED BRASS
3	108357-06-000	EA	SWITCH - ROCKER - DPDT - MOM/OFF/MOM - 6 TERM - W/O COVER
3	108356-11-01A	EA	COVER/ACTUATOR SWITCH - 3 GROOVES - AUX BATT - BLACK
3	108355-01-000	EA	HOUSING - SWITCH
4	108357-01-000	EA	SWITCH - ROCKER - SPST - ON/OFF - 2 TERMINAL - W/O COVER
4	108356-14-01A	EA	COVER/ACTUATOR SWITCH - 3 GROOVES - COMPT LIGHTS
4	108355-01-000	EA	HOUSING - SWITCH
5	098351-23-01A	EA	PLATE/SWITCH - 3 GANG - POLISHED BRASS
6	108357-07-000	EA	SWITCH - ROCKER - SPDT - MOM/OFF/MOM - 3 TERM - W/O COVER
6	108356-12-01A	EA	COVER/ACTUATOR SWITCH - 3 GROOVES - AWNING/IN/OUT
6	108355-01-000	EA	HOUSING - SWITCH
7	149828-01-000	EA	SLIDE ASM - SINGLE/HIGH SPEED
8	149557-01-01A	EA	PLATE/WALL - PHONE/DUAL COAXIAL/VERTICAL - WHITE
9	108357-15-000	EA	SWITCH - ROCKER - DPDT - ON/NONE/ON - W/LIGHT W/O COVER
9	108356-04-01A	EA	COVER/ACTUATOR SWITCH - 2 ROWS DIMPLES W/LENS - BLACK
9	108355-01-000	EA	HOUSING - SWITCH
10	108357-01-000	EA	SWITCH - ROCKER - SPST - ON/OFF - 2 TERMINAL - W/O COVER
10	108356-02-01A	EA	COVER/ACTUATOR SWITCH - 2 ROWS DIMPLES - BLACK
10	108355-01-000	EA	HOUSING - SWITCH

## ELECTRICAL GROUP (CONTINUED)

### 12V BODY WIRING (CONTINUED)

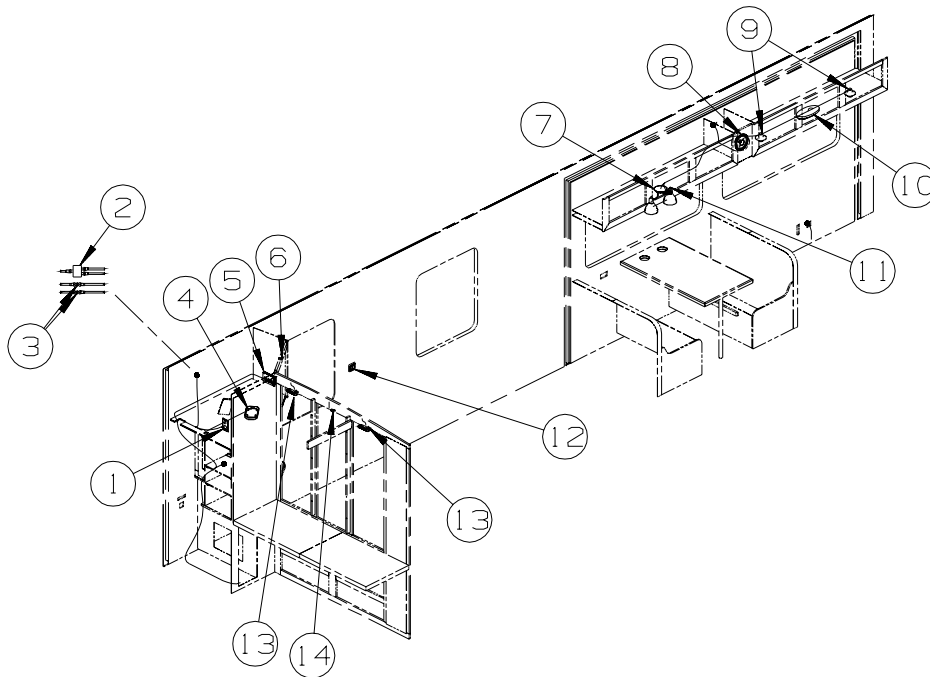

KEY	PART NUMBER	U/M	DESCRIPTION
1	076319-09-000	EA	WALLPLATE - TV CABLE RECEPTACLE - SINGLE - BROWN
2	086756-01-000	EA	SPLITTER - TV/2 WAY
3	082134-01-000	EA	ADAPTER - TV - CABLE TO CABLE
4*	137417-01-01A	EA	LIGHT - DOME - SINGLE - W/SWITCH/FROSTED LENS - WHITE
5	135618-04-01A	EA	THERMOSTAT - ROOF A/C ONLY - WHITE - A/C ROOF-HI EFF (2) W/EMS
5	135618-03-01A	EA	THERMOSTAT - ROOF A/C & FURNACE - WHITE - A/C ROOF-HI EFF (2) W/EMS
6	149750-01-000	EA	RECEIVER - (INFRA RED SIGNAL) - W/6"LEAD/PLUG - TV (REAR)-20"COLOR, STEREO
7*	093575-21-01A	EA	LIGHT - CEILING/DOUBLE - UL/CSA
7	117805-01-000	EA	BULB - 12V - #921F - 1.4 AMPS
8	094097-01-000	EA	SPEAKER - RADIO/TV - W/O GRILLE - 5.25" DIAMETER
9	132427-01-01A	EA	LIGHT - READING/SWIVEL - ROUND - BRASS
9	123917-01-000	EA	BULB - 12V - HALOGEN SPOT
10	093575-26-02A	EA	LIGHT - CEILING/OVAL - BRASS
10	117805-02-000	EA	BULB - 12V - #921 - 1.4 AMPS
11	135740-01-02A	EA	SWITCH - ROCKER - SPST - ON/OFF - WHITE
11	135741-01-02A	EA	SWITCH - BASE - SINGLE - WHITE
11	135742-01-02A	EA	BEZEL - SWITCH - SINGLE - WHITE
12	135740-01-02A	EA	SWITCH - ROCKER - SPST - ON/OFF - WHITE - CEILING
12	135740-02-02A	EA	SWITCH - ROCKER - SPDT - ON/ON - WHITE - HALL
12	135741-02-02A	EA	SWITCH - BASE - DOUBLE - WHITE
12	135742-16-01A	EA	BEZEL - SWITCH - CEILING/HALL - WHITE
13*	087694-01-000	EA	LIGHT - WARDROBE/CLOSET - W/SWITCH
14	056264-01-000	EA	SWITCH - LEAF ACTUATOR

\*COMPONENT PARTS LISTED LATER IN THIS GROUP

## ELECTRICAL GROUP (CONTINUED)

### 12V BODY WIRING (CONTINUED)

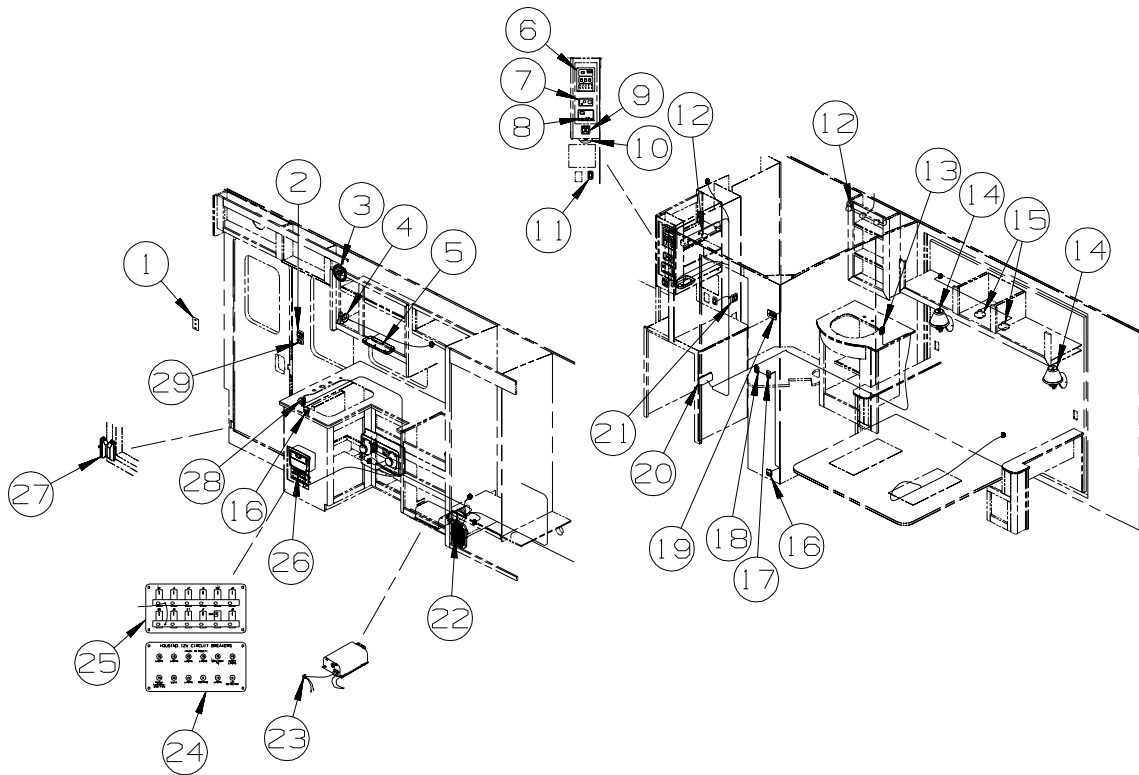

KEY	PART NUMBER	U/M	DESCRIPTION
1	093253-01-03A	EA	PLATE - WALL - TELEPHONE - WHITE
2	135740-01-01A	EA	SWITCH - ROCKER - SPST - ON/OFF - BROWN
2	135741-02-01A	EA	SWITCH - BASE - DOUBLE - BROWN
2	135742-19-02A	EA	BEZEL - SWITCH - CEILING/PORCH - BROWN
3	094097-01-000	EA	SPEAKER - RADIO/TV - W/O GRILLE - 5.25" DIAMETER
4	128786-02-01A	EA	LIGHT - READING/SWIVEL - W/O SWITCH - BRASS
5*	137417-05-01A	EA	LIGHT - DOME - DOUBLE - W/SWITCH/OPTIC LENS - WHITE
6*	134940-01-01A	EA	PANEL - MONITOR - 2 TANK - W/GENERATOR SWITCH/HOUR METER FROM: 00-00-00 THRU: 05-02-04
6*	134940-06-01A	EA	PANEL - MONITOR - 2 TANK - W/GENERATOR SWITCH FROM: 05-03-04 THRU: 99-99-99
6*	134940-04-01A	EA	PANEL - MONITOR - 2 TANK-W/GENERATOR SWITCH/SOLAR CHARGER - SOLAR PANEL-10 WATT FROM: 00-00-00 THRU: 05-02-04
6*	134940-08-01A	EA	PANEL - MONITOR - 2 TANK-W/GENERATOR SWITCH/SOLAR CHARGER - SOLAR PANEL-10 WATT FROM: 05-03-04 THRU: 99-99-99
7	127002-05-000	EA	PANEL/MONITOR - ENERGY MANAGEMENT SYSTEMS CTRL - W/PLUG FROM: 00-00-00 THRU: 11-07-04
7	127002-10-000	EA	PANEL/MONITOR - ENERGY MANAGEMENT SYSTEMS CTRL - W/3 PLUG FROM: 11-08-04 THRU: 99-99-99
8	135618-01-01A	EA	THERMOSTAT - HEAT PUMP/FURNACE - WHITE - AC HEAT PUMP-2 HI EFFICIENCY
8	135618-03-01A	EA	THERMOSTAT - ROOF A/C & FURNACE - WHITE - A/C ROOF-HI EFF (2) W/EMS
9	135740-01-02A	EA	SWITCH - ROCKER - SPST - ON/OFF - WHITE - CEILING
9	135740-02-02A	EA	SWITCH - ROCKER - SPDT - ON/ON - WHITE - HALL
9	135741-02-02A	EA	SWITCH - BASE - DOUBLE - WHITE
9	135742-16-01A	EA	BEZEL - SWITCH - CEILING/HALL - WHITE

**ELECTRICAL GROUP (CONTINUED)**  
**12V BODY WIRING (CONTINUED)**

KEY	PART NUMBER	U/M	DESCRIPTION
10*	137417-01-01A	EA	LIGHT - DOME - SINGLE - W/SWITCH/FROSTED LENS - WHITE
11	135740-06-01A	EA	SW-ROCKER-ON/OFF-LT-RED-WTR HTR-6GAL/ELE/LP/MOTORAIID-WTR HTR-10GAL/ELEC/LP/MTRAIID
11	135741-01-01A	EA	SW- BASE - SINGLE - BROWN-WTR HTR-6GAL/ELE/LP/MOTORAIID-WTR HTR-10GAL/ELEC/LP/MTRAIID
11	135742-35-02A	EA	BZL-SW-WAT HEAT/110 V-BRN-WTR HTR-6GAL/ELE/LP/MOTORAIID-WTR HTR-10GAL/ELEC/LP/MTRAIID
12	138116-01-01A	EA	LIGHT/MAKE UP - 3 BULB - CURVED - W/O BULB - BRASS
	123918-01-000	EA	BULB - 12V - MAKEUP - WHITE
13	135740-01-02A	EA	SWITCH - ROCKER - SPST - ON/OFF - WHITE
13	135741-01-02A	EA	SWITCH - BASE - SINGLE - WHITE
13	135742-08-01A	EA	BEZEL - SWITCH - MAKEUP - WHITE
14	119258-29-01A	EA	LAMP - WALL - UL/CSA
14	119257-15-01A	EA	SHADE - LAMP - LINEN SILKARA
14	067479-01-000	EA	BULB - 12V - #1076 - 1.80 AMP
15	132427-01-01A	EA	LIGHT - READING/SWIVEL - ROUND - BRASS
15	123917-01-000	EA	BULB - 12V - HALOGEN SPOT
16*	108354-01-01A	EA	LIGHT - COURTESY
17	135740-01-02A	EA	SWITCH - ROCKER - SPST - ON/OFF - WHITE
17	135741-01-02A	EA	SWITCH - BASE - SINGLE - WHITE
17	135742-06-01A	EA	BEZEL - SWITCH - AISLE - WHITE
18	135740-01-02A	EA	SWITCH - ROCKER - SPST - ON/OFF - WHITE
18	135741-01-02A	EA	SWITCH - BASE - SINGLE - WHITE
18	135742-07-01A	EA	BEZEL - SWITCH - CEILING - WHITE
19	138173-04-000	EA	CONTROL PANEL (TOUCH PAD) - ELECTRIC SLIDEOUT - #1802931
19	116549-01-000	EA	LABEL - WARNING - SLIDEOUT
20	150138-01-01A	EA	DETECTOR - LP GAS - WHITE
21	135740-01-02A	EA	SWITCH - ROCKER - SPST - ON/OFF - WHITE
21	135741-02-02A	EA	SWITCH - BASE - DOUBLE - WHITE
21	135742-20-01A	EA	BEZEL - SWITCH - SHOWER/MAKEUP - WHITE
22	150090-01-000	EA	SPEAKER - 6" X 9" - SUB-WOOFER - MAGNADYNE LS69W - HOME THEATER SOUND SYSTEM
22	124885-01-000	EA	GRILLE - SPEAKER - 6" X 9" - SUB WOOFER - HOME THEATER SOUND SYSTEM FROM: 00-00-00 THRU: 08-10-04
22	151569-01-01A	EA	GRILLE - SPEAKER - 6" X 9" - SUB WOOFER - BLACK - HOME THEATER SOUND SYSTEM FROM: 08-11-04 THRU: 99-99-99
23	086233-01-000	EA	STUD - ISOLATED - 3/8" X 7/8" LONG
24	092547-10-000	EA	LABEL - CIRCUIT BREAKER
25	139067-02-02B	EA	PLATE - CIRCUIT BREAKER/HOUSE - E-COATED
26	141679-03-000	EA	CHARGER/DOCK STATION ONLY - FOR #GMRS100 TWO-WAY RADIO
26	141679-04-000	EA	RADIO/TWO-WAY W/BATTERY (EACH = 1) - 5 MILE - ASA GMRS100
27	116995-02-000	EA	SWITCH/MAGNET - ELECTRIC STEP - BLACK/WHITE- NORMALLY OPEN
28	135740-01-02A	EA	SWITCH - ROCKER - SPST - ON/OFF - WHITE
28	135741-01-02A	EA	SWITCH - BASE - SINGLE - WHITE
28	135742-01-02A	EA	BEZEL - SWITCH - SINGLE - WHITE
29	135740-01-02A	EA	SWITCH - ROCKER - SPST - ON/OFF - WHITE
29	135741-01-02A	EA	SWITCH - BASE - SINGLE - WHITE
29	135742-11-01A	EA	BEZEL - SWITCH - STEP - WHITE

\*COMPONENT PARTS LISTED LATER IN THIS GROUP



**ELECTRICAL GROUP (CONTINUED)**  
**12V BODY WIRING (CONTINUED)**

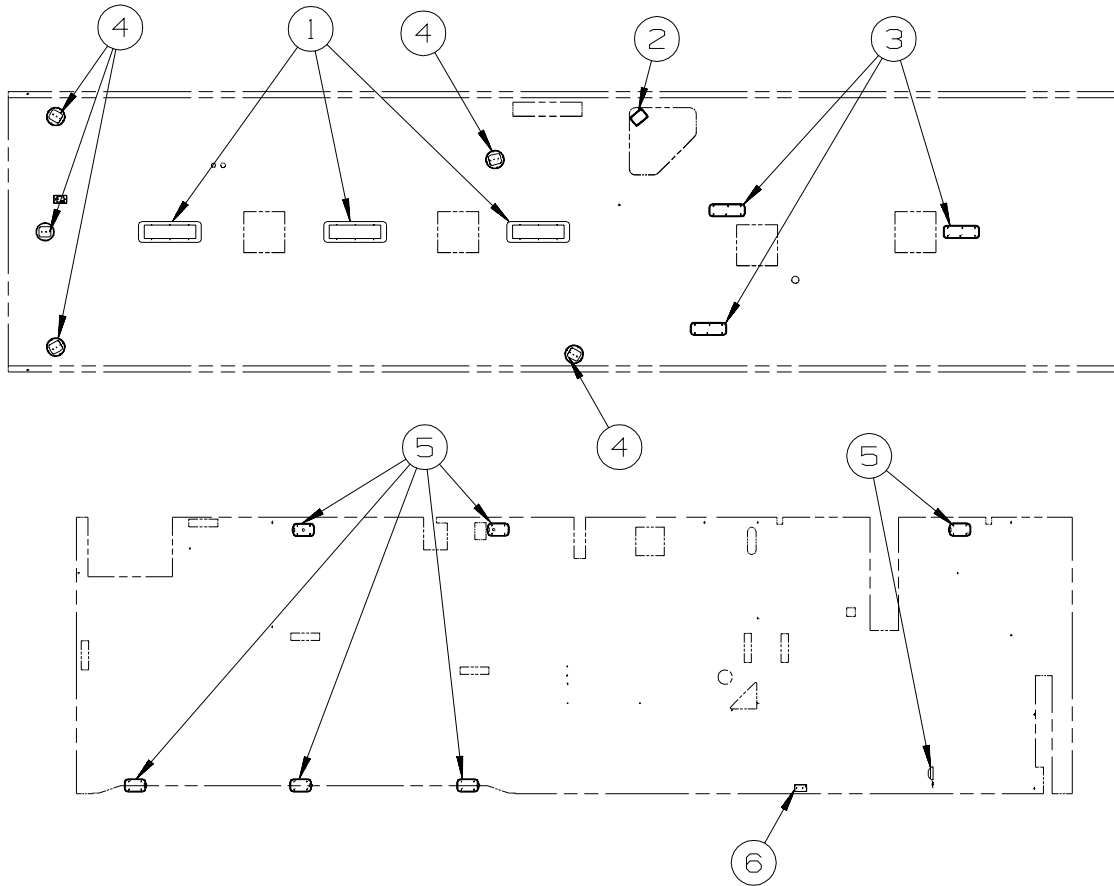

KEY	PART NUMBER	U/M	DESCRIPTION
1*	091937-08-000	EA	LIGHT-FLOURESCENT-12V/30W-RECESSED-7.3" X 21.8" W/O SWITCH FROM: 00-00-00 THRU: 11-07-04
1	091937-03-000	EA	BULB - FLUORESCENT LIGHT - 12 VOLT FROM: 00-00-00 THRU: 11-07-04
1	153464-03-01A	EA	LIGHT-FLUORESCENT 18" - RECESSED/CURVED-NO SWITCH - WHITE FROM: 11-08-04 THRU: 99-99-99
2*	121935-01-01A	EA	LIGHT - DOME - SHOWER
3*	137417-06-01A	EA	LIGHT - DOME - DOUBLE - W/O SWITCH - W/FROSTED LENS-WHITE
4	150091-01-01A	EA	SPEAKER - CUBE - W/ADJ BRACKET - SILVER - MAGNADYNE LS3S FROM: 00-00-00 THRU: 05-16-04
4	151314-01-01A	EA	SPEAKER - CUBE/CEILING - WHITE - MAGNADYNE - LS3CM-WN FROM: 05-17-04 THRU: 99-99-99
5*	137417-01-01A	EA	LIGHT - DOME - SINGLE - W/SWITCH/FROSTED LENS - WHITE
6*	086280-01-000	EA	LIGHT - SURFACE MOUNT - 12 VOLT

**\*COMPONENT PARTS LISTED LATER IN THIS GROUP**

## ELECTRICAL GROUP (CONTINUED)

### 12V BODY WIRING (CONTINUED)

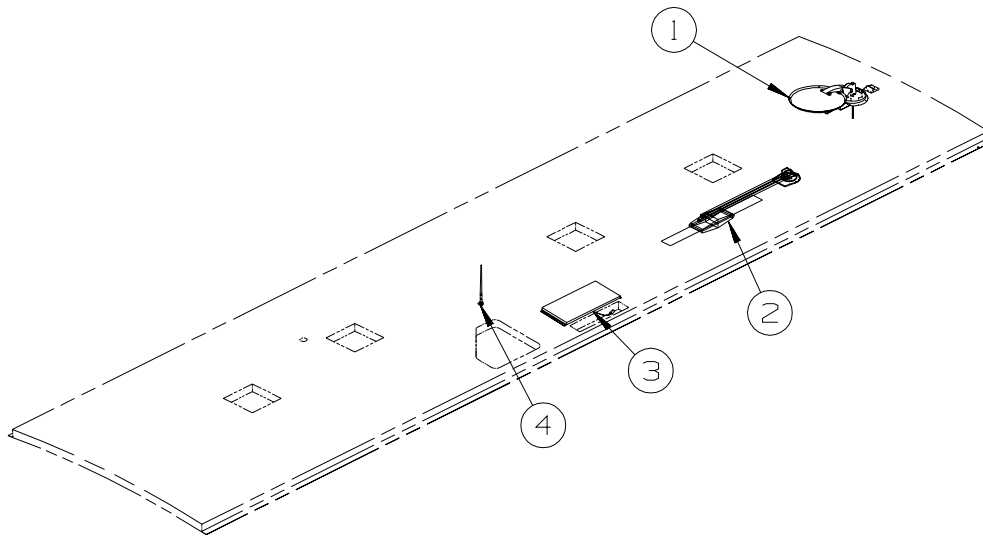

KEY	PART NUMBER	U/M	DESCRIPTION
1*	141454-03-01A	EA	ANTENNA/SATELLITE - "AUTO SEARCH WHILE PARKED/GPS SYSTEM"
1*	137135-02-000	EA	ANTENNA - SATELLITE DSS - W/SENSOR
2*	076319-23-000	EA	ANTENNA - TV ROOF MOUNT - 44.5" MAST
2*	076319-25-000	EA	KIT - HARDWARE INTERIOR
3	151647-01-000	EA	PANEL - SOLAR 10 WATT
4	090944-01-000	EA	ANTENNA - RADIO - 16" RUBBER - W/72" LEAD WIRE
4	109889-04-000	EA	EXTENDER - ANTENNA SHAFT - 3.7"
4	147741-01-09B	EA	BRACKET - ANTENNA GROUND - GALVANIZED

**\*COMPONENT PARTS LISTED LATER IN THIS GROUP**

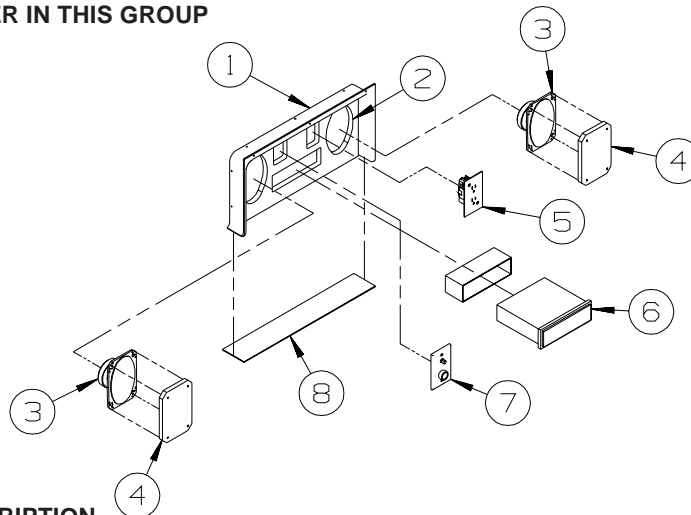

KEY	PART NUMBER	U/M	DESCRIPTION
1	124696-02-01A	EA	BOX-19.4"W X 10"H X 2.5"D - BRT WHT
	124696-01-01A	EA	BOX-19.4"W X 10"H X 10.2"D W/CUTOUTS
2	127409-02-L15	EA	PLATE - RADIO MOUNTING
3	110469-01-000	EA	SPEAKER - 4" X 6" OVAL - COAXIAL
4	110470-01-01A	EA	GRILLE - 4" X 6" - OVAL SPEAKER - BLACK
5	058708-01-000	EA	RECEPTACLE - ELECTRIC - DOUBLE - BROWN
6*	148231-01-000	EA	RADIO - AM/FM CD W/REMOTE - MAGNADYNE M3100CD
			FROM: 00-00-00 THRU: 04-11-05
6*	155619-01-000	EA	RADIO - AM/FM CD - W/REMOTE - MAGNADYNE M3200CD
			FROM: 04-12-05 THRU: 99-99-99
7	076319-09-000	EA	WALLPLATE - TV CABLE RECEPTACLE - SINGLE - BROWN
8	104898-01-02A	EA	PLATE - PLASTIC BOTTOM - BRIGHT WHITE

**\*COMPONENT PARTS LISTED LATER IN THIS GROUP**

## ELECTRICAL GROUP (CONTINUED)

### EXTERIOR LAMPS

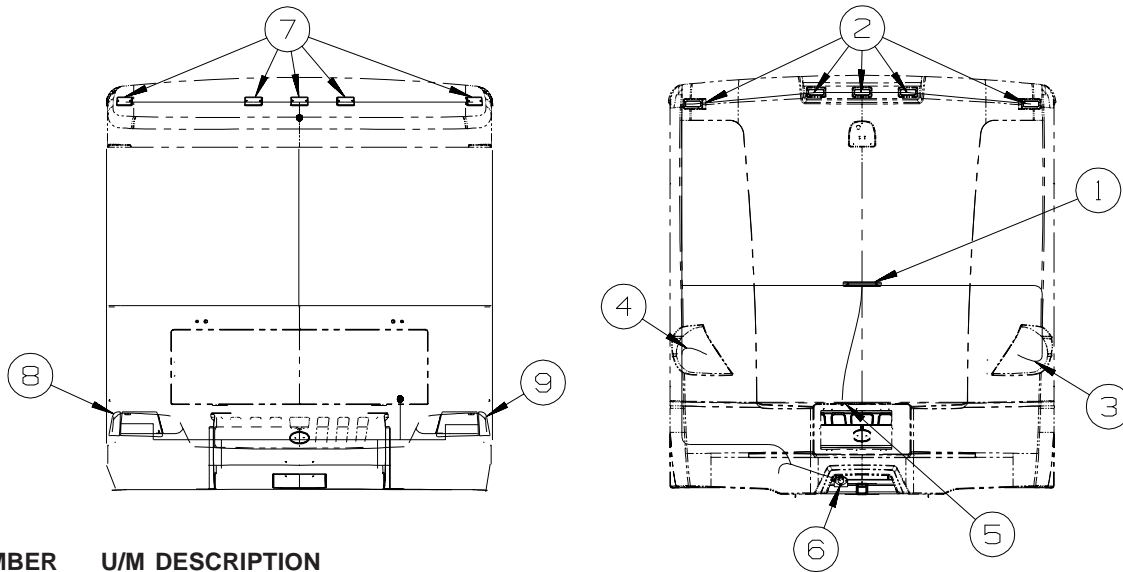

KEY	PART NUMBER	U/M	DESCRIPTION
1	136916-01-000	EA	LIGHT - CENTER BRAKE - L.E.D.
2	102520-02-000	EA	LIGHT - CLEARANCE - W/O SOCKET/HOUSING - RED
2	102541-01-000	EA	GASKET - CLEARANCE LIGHT
2	067789-02-000	EA	SOCKET - LAMP
3	148658-01-000	EA	TAILLAMP - PASSENGER/REAR
4	148658-02-000	EA	TAILLAMP - DRIVER/REAR
5	087201-01-000	EA	LIGHT - HALF ROUND - 1" X 1.7" - PLASTIC - BLACK OR WHITE
6*	113589-01-000	EA	CONNECTOR - PLUG - TRAILER
6*	113589-02-000	EA	CONNECTOR - SOCKET - TRAILER
7	102520-01-000	EA	LIGHT - CLEARANCE - W/O SOCKET/HOUSING - AMBER
7	102541-01-000	EA	GASKET - CLEARANCE LIGHT
7	036196-01-000	EA	BULB - 12V - #194 - .27 AMP - BAYONETTE
8	148657-01-000	EA	HEADLAMP - PASSENGER - W/PARK&TURN
8	112708-02-000	EA	BULB - 12 VOLT - #3157NA
8	148657-05-000	EA	SOCKET - F/LAMP
8	148657-03-000	EA	LAMP - PASSENGER SIDEMARKER/AMBER
8	067789-02-000	EA	SOCKET - LAMP - <b>SIDE MARKER</b>
			FROM: 00-00-00 THRU: 05-04-04
8	151289-01-000	EA	SOCKET - SIDE MARKER
			FROM: 05-05-04 THRU: 99-99-99
8	036196-01-000	EA	BULB - 12V - #194 - .27 AMP - BAYONETTE - <b>SIDE MARKER</b>
8	148078-01-01A	EA	RETAINER - HEADLAMP - OUTSIDE - BLACK
8	148078-02-01A	EA	RETAINER - HEADLAMP - INSIDE - BLACK
8	067789-02-000	EA	SOCKET - LAMP
8	088758-01-000	EA	HOUSING - HEADLAMP - CONNECTOR TERMINAL W/3 WIRES
9	148657-02-000	EA	HEADLAMP - DRIVER - W/PARK&TURN
9	112708-02-000	EA	BULB - 12 VOLT - #3157NA
9	148657-05-000	EA	SOCKET - F/LAMP
9	148657-04-000	EA	LAMP - DRIVER SIDEMARKER/AMBER
9	067789-02-000	EA	SOCKET - LAMP - <b>SIDE MARKER</b>
			FROM: 00-00-00 THRU: 05-04-04
9	151289-01-000	EA	SOCKET - SIDE MARKER
			FROM: 05-05-04 THRU: 99-99-99
9	036196-01-000	EA	BULB - 12V - #194 - .27 AMP - BAYONETTE - <b>SIDE MARKER</b>
9	148078-01-01A	EA	RETAINER - HEADLAMP - OUTSIDE - BLACK
9	148078-02-01A	EA	RETAINER - HEADLAMP - INSIDE - BLACK
9	067789-02-000	EA	SOCKET - LAMP
9	088758-01-000	EA	HOUSING - HEADLAMP - CONNECTOR TERMINAL W/3 WIRES

**\*COMPONENT PARTS LISTED LATER IN THIS GROUP**

**ELECTRICAL GROUP (CONTINUED)**  
**EXTERIOR LAMPS (CONTINUED)**

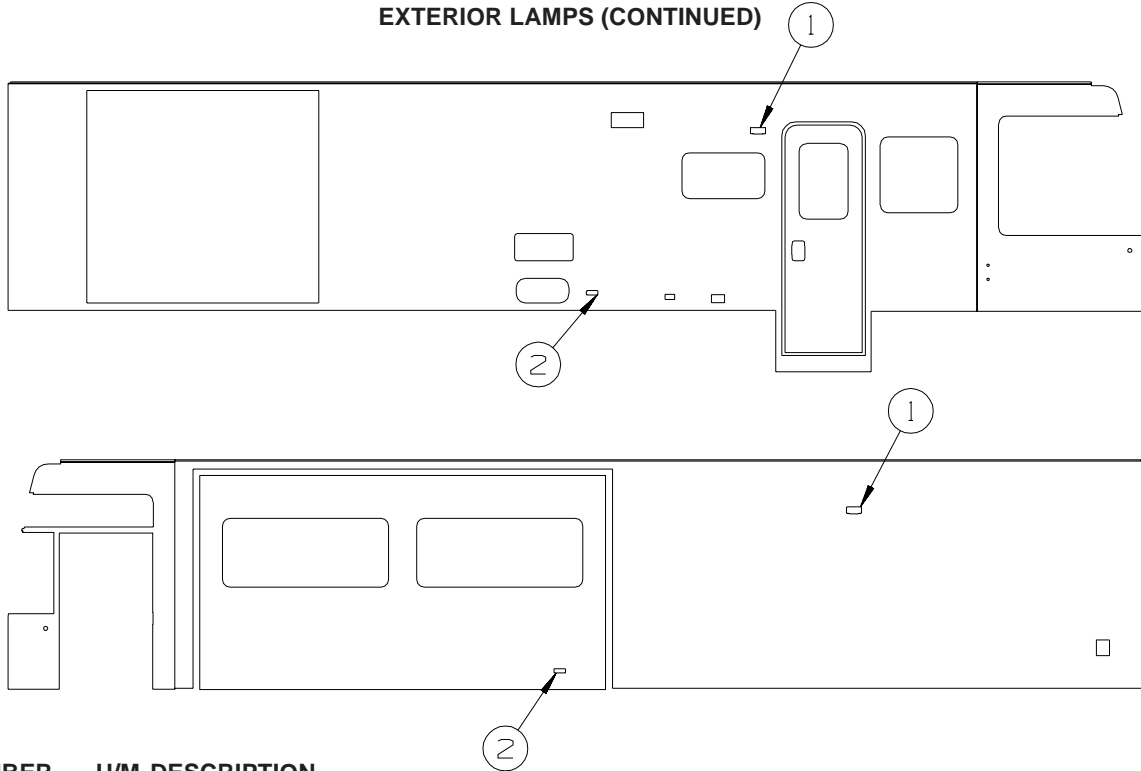

KEY	PART NUMBER	U/M	DESCRIPTION
1*	097917-01-06A	EA	LIGHT - PORCH - BRIGHT WHITE
	008215-01-000	EA	BULB - 12 VOLT - #1003 - .94 AMP
2	111102-02-000	EA	LENS - AMBER - MARKER LAMP
2	111102-01-000	EA	BASE - MARKER LAMP
2	036196-01-000	EA	BULB - 12V - #194 - .27 AMP - BAYONETTE

**\*COMPONENT PARTS LISTED LATER IN THIS GROUP**

# ELECTRICAL GROUP (CONTINUED)

## FRONT END

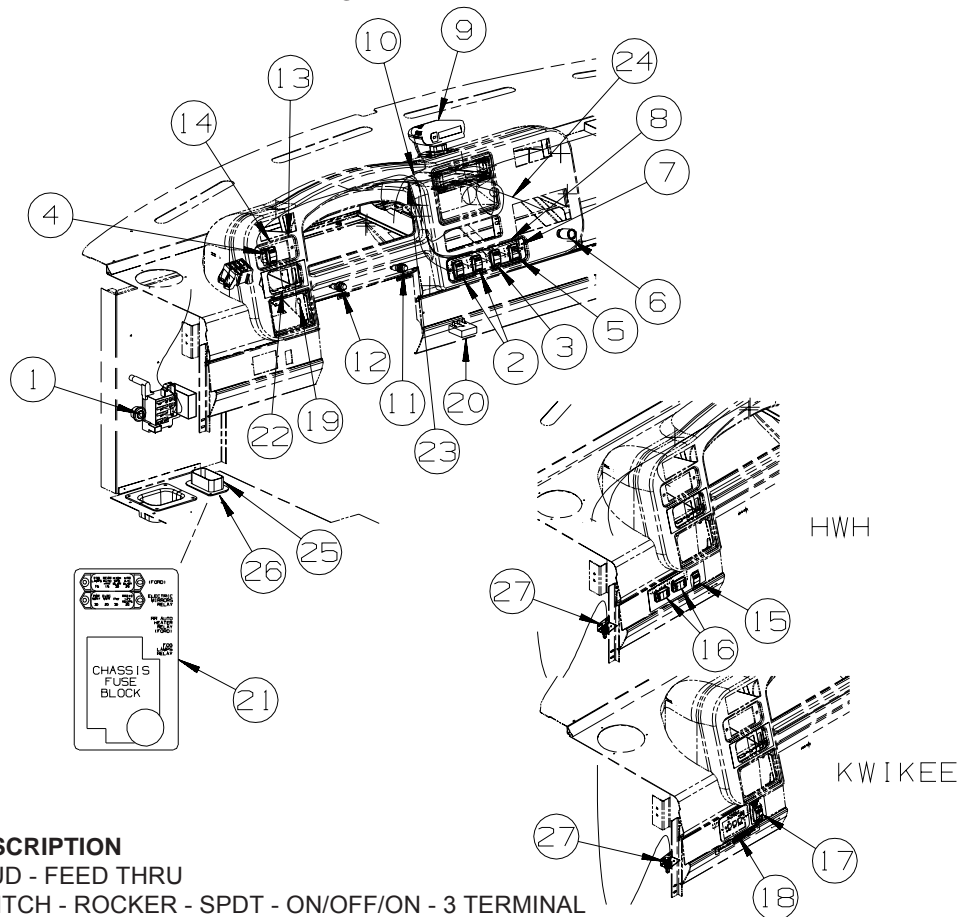

KEY	PART NUMBER	U/M	DESCRIPTION
1	118499-01-000	EA	STUD - FEED THRU
2	108357-03-000	EA	SWITCH - ROCKER - SPDT - ON/OFF/ON - 3 TERMINAL
2	108356-02-01A	EA	COVER/ACTUATOR SWITCH - 2 ROWS DIMPLES- CONTURA II - BLACK
2	108355-01-000	EA	HOUSING - SWITCH
2	096241-03-000	EA	SWITCH - BLANK - BLACK
3	108357-08-000	EA	SWITCH - ROCKER - DPDT - 0N/NONE/ON - 6 TERMINAL
3	108356-02-01A	EA	COVER/ACTUATOR SWITCH - 2 ROWS DIMPLES- CONTURA II - BLACK
3	108355-01-000	EA	HOUSING - SWITCH
4	108357-08-000	EA	SWITCH - ROCKER - DPDT - 0N/NONE/ON - 6 TERMINAL - <b>WORKHORSE</b>
4	108356-02-01A	EA	COVER/ACTUATOR SWITCH - 2 ROWS DIMPLES- CONTURA II - BLACK - <b>WORKHORSE</b>
4	108355-01-000	EA	HOUSING - SWITCH - <b>WORKHORSE</b>
5	108357-10-000	EA	SWITCH - ROCKER - SPDT - W/LIGHT - MOM/NONE/MOM-5 TERMINAL
5	108356-04-01A	EA	COVER/ACTUATOR SWITCH - 2 ROWS DIMPLES W/LENS-CONTURA-BLK
5	108355-01-000	EA	HOUSING - SWITCH
6	089294-01-000	EA	LIGHTER - CIGARETTE - W/SOCKET & WIRE
7	132954-01-01A	EA	APPLIQUE - SWITCH - HEATER/RADIO/GENERATOR
8	132047-02-02B	EA	INSERT - DASH/SWITCH-AUX FANS/RR HTR/RADIO PWR/GEN SW
9*	148113-01-000	EA	RADIO/TUNER - SATELLITE/SIRIUS - W/REMOTE-W/O ANTENNA FROM: 00-00-00 THRU: 06-04-04
9*	148113-03-000	EA	RADIO - SATELLITE - SIRIUS - KENWOOD KTC-H2A1-SU FROM: 06-05-04 THRU: 99-99-99
9	148113-02-000	EA	CRADLE - RADIO - W/O BUILT IN FM TRANSMITTER - KENWOOD FROM: 00-00-00 THRU: 06-04-04
9	148113-04-000	EA	DOCKING KIT-W/FM TRANSMITTER/ANTENNA/CRADLE/WIRING/SCREWS FROM: 06-05-04 THRU: 99-99-99
10	147190-03-000	EA	CABLE/ANTENNA-SAT RADIO SIRIUS-22'W/O RADIO END CONNECTOR FROM: 00-00-00 THRU: 09-01-04
10	152780-02-000	EA	CABLE/ANTENNA - SATELLITE RADIO SIRIUS FROM: 09-02-04 THRU: 99-99-99
11	133534-02-000	EA	LIGHT - AMBER INDICATOR WITH 1/4" TERMINALS
11	133533-02-01A	EA	LABEL - CHECK ANTENNA - CLEAR W/WHITE LETTERING
12	133534-01-000	EA	LIGHT - RED INDICATOR WITH 1/4" TERMINALS
12	133533-01-01A	EA	LABEL - JACKS DOWN - CLEAR W/WHITE LETTERING
13	132048-02-04B	EA	INSERT ASM - SWITCH - DASH - LH
14	132954-07-01A	EA	APPLIQUE - SWITCH - BLANK - BLACK - <b>FORD</b>
14	132954-05-01A	EA	APPLIQUE - SWITCH - OVER/DRIVE - BLACK - <b>WORKHORSE</b>

## ELECTRICAL GROUP (CONTINUED)

### FRONT END (CONTINUED)

KEY	PART NUMBER	U/M	DESCRIPTION
15	108357-09-000	EA	SWITCH - ROCKER - SPDT - ON/NONE/MOM - 3 TERMINAL - HWH (HYDRAULIC) SLIDEOUT ROOM
15	108356-02-01A	EA	COVER/ACTUATOR SWITCH - 2 ROWS DMPLS - BLK - HWH (HYDRAULIC) SLIDEOUT ROOM
15	108355-01-000	EA	HOUSING - SWITCH - HWH (HYDRAULIC) SLIDEOUT ROOM
16	108357-06-000	EA	SWITCH - ROCKER - DPDT - MOM/OFF/MOM - 6 TERMINAL - HWH (HYDRAULIC) SLIDEOUT ROOM
16	108356-02-01A	EA	COVER/ACTUATOR SWITCH - 2 ROWS DIMPLES - BLK - HWH (HYDRAULIC) SLIDEOUT ROOM
16	108355-01-000	EA	HOUSING - SWITCH - HWH (HYDRAULIC) SLIDEOUT ROOM
16	132946-07-01A	EA	APPLIQUE - SWITCH - F/SLIDEOUT - BLACK - HWH (HYDRAULIC) SLIDEOUT ROOM
17	108357-09-000	EA	SWITCH - ROCKER - SPDT - ON/NONE/MOM - 3 TERMINAL - KWIKEE (ELECTRIC) SLIDEOUT ROOM
17	108356-02-01A	EA	COVER/ACTUATOR SWITCH - 2 ROWS DIMPLES - BLK - KWIKEE (ELECTRIC) SLIDEOUT ROOM
17	108355-01-000	EA	HOUSING - SWITCH - KWIKEE (ELECTRIC) SLIDEOUT ROOM
17	132946-06-01A	EA	APPLIQUE - SWITCH - F/SLIDEOUT - BLACK - KWIKEE (ELECTRIC) SLIDEOUT ROOM
18	138173-04-000	EA	CONTROL PANEL - (TOUCH PAD) - ELC SLIDEOUT - #1802931 - KWIKEE (ELECTRIC) SLIDEOUT ROOM
18	116549-01-000	EA	LABEL - WARNING - SLIDEOUT - KWIKEE (ELECTRIC) SLIDEOUT ROOM
19	134149-01-04B	EA	PLATE - COVER - LEVEL JACK CONTROL - BLACK
20	133535-01-000	EA	MODULE - TIMER 20 SECOND - ANTENNA WARNING LIGHT - TS61120P
21	111537-09-000	EA	LABEL - FUSES
22	134088-01-01A	EA	APPLIQUE - SWITCH - HEADLAMP - BLACK - WORKHORSE
23	148115-01-000	EA	WIRE/POWER CABLE - RADIO - SATELLITE
24	148114-01-000	EA	CABLE - AUDIO - 1/8" TO RCA STEREO - RADIO - SATELLITE
25	118571-03-000	EA	BRACKET - MOUNTING
26	118571-04-000	EA	GASKET
27	111537-09-000	EA	BRACKET - ZEE - F/TEMPERATURE SENSOR - E-COATED
	077031-01-000	EA	FILM - BLACK - 1" X 1.75"
	077031-03-000	EA	FILM - WHITE - .75" X 1"

\*COMPONENT PARTS LISTED LATER IN THIS GROUP

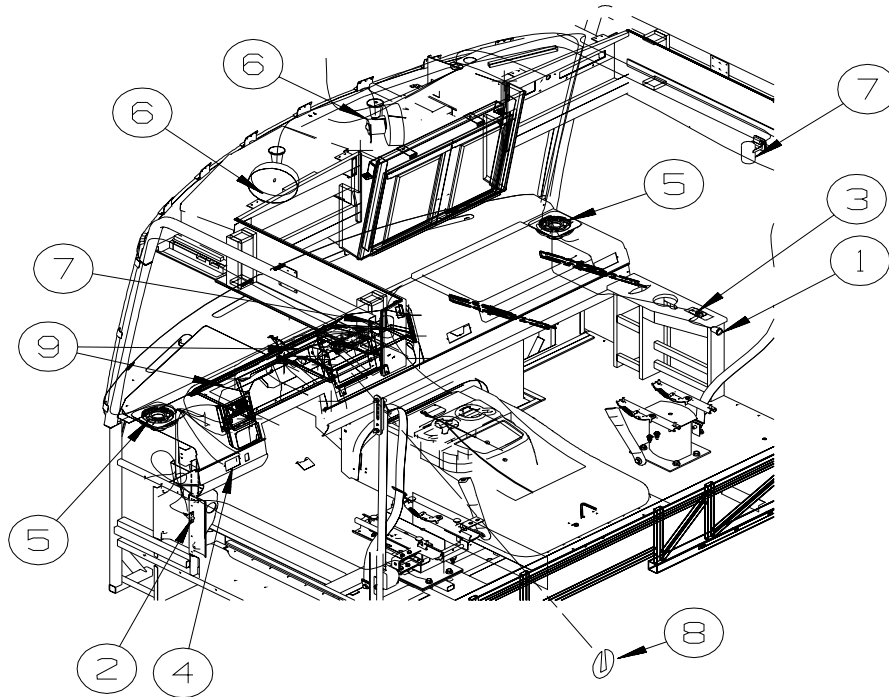

KEY	PART NUMBER	U/M	DESCRIPTION
1	132958-01-000	EA	RECEPTACLE - 12 VOLT - MOUNTING FLANGE - BLACK
2	041250-01-000	EA	SWITCH - PUSH BUTTON/DOOR JAMB - METAL - CHROME
3	132180-01-01A	EA	SWITCH - PADDLE - SPST - ON/OFF - BLACK
3	098351-01-01A	EA	PLATE/SWITCH - 1 GANG - POLISHED BRASS - W/O LABEL
4	104678-01-000	EA	LABEL - CB PREP
5	094097-01-000	EA	SPEAKER - RADIO/TV - W/O GRILLE - 5.25" DIAMETER
5	139111-01-02A	EA	GRILLE - SPEAKER - 6" ROUND - GLACIER
6	122856-01-01A	EA	FAN-DEFROSTER-2 SPEED W/SWIVEL BASE/NON-OSCILLATING-CHROME
7	149590-01-01A	EA	LIGHT - READING/SWIVEL - W/O SWITCH - BRASS
8	115870-01-000	FT	SEAL/EDGE - TRIM
			FROM: 00-00-00 THRU: 12-19-04
8	093305-01-01A	FT	TRIM - EDGE C-TYPE - WIRE CARRIER - .35" X .24" - VINYL
			FROM: 12-20-04 THRU: 99-99-99
9	115870-01-000	FT	SEAL/EDGE - TRIM

## ELECTRICAL GROUP (CONTINUED) FRONT END (CONTINUED)

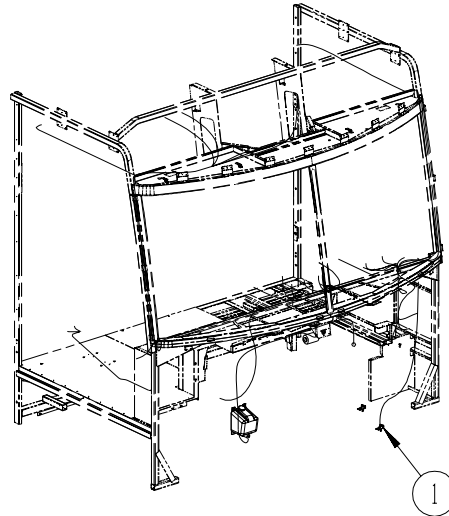

KEY	PART NUMBER	U/M DESCRIPTION
1	147428-01-02B	EA BRACKET/ZEE - F/TEMPERATURE SENSOR - E-COATED - <b>WORKHORSE</b>

### GPS

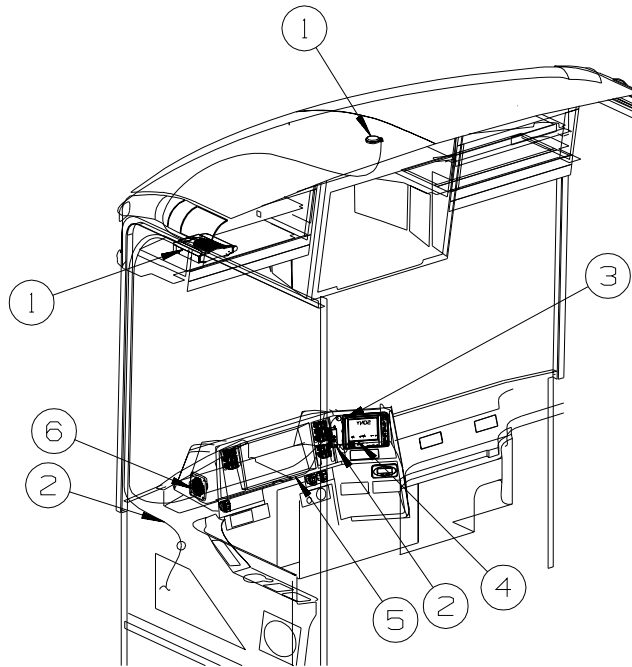

KEY	PART NUMBER	U/M DESCRIPTION
1*	148158-01-000	EA COMPUTER - GPS NAVIGATION SYS - (MAGELLAN MAGNK-01W) - <b>INCLUDES ANTENNA</b>
2	148158-02-000	EA CABLES - F/GPS NAVIGATION SYS - (MAGELLAN MAGNK-02W) - <b>INCLUDES MODULE, REMOTE EYE</b>
3	144734-03-000	EA SPACER
4	148112-01-000	EA CABLE - MONITOR - SONY AUX
5	148592-01-000	EA CABLE - RCA MALE-1/4 FEMALE SPADES - RIVER PARK SCB-RCA120
6	098819-01-000	EA SPEAKER - 4" - 2 WATT - 8 OHM
6	093214-01-01A	EA GRILLE - SPEAKER - 4" - BLACK

**\*COMPONENT PARTS LISTED LATER IN THIS GROUP**

## ELECTRICAL GROUP (CONTINUED)

### FRONT TV/VCR

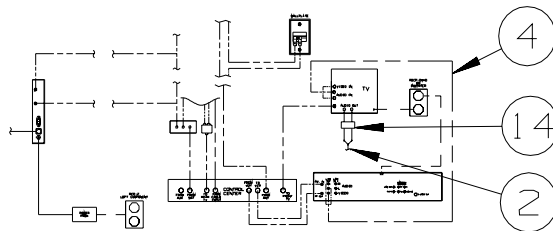
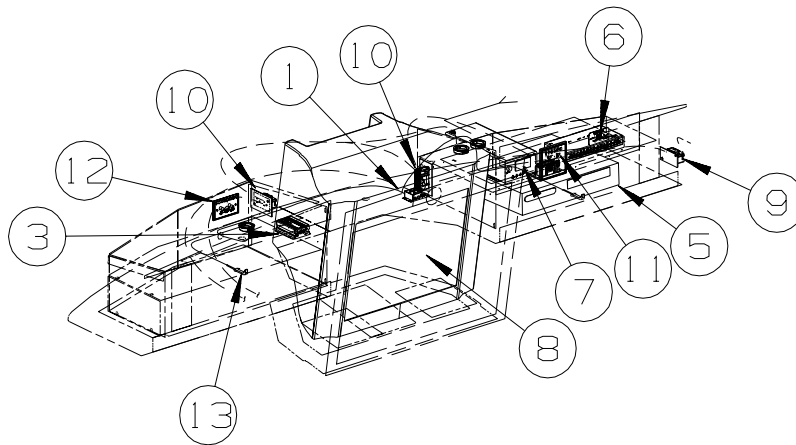

KEY	PART NUMBER	U/M	DESCRIPTION
1	149750-04-000	EA	MODULE/INTERFACE - INFRA RED (RECEIVER TO TRANSMITTER)
2	117420-01-000	EA	CABLE - W/MALE RCA ENDS - SHIELDED - 12"
3	147139-01-000	EA	AMPLIFIER - STEREO 2 CHANNEL
4	136860-01-000	EA	CABLE - RCA - #3 MALE TO #12F MALE CONNECTOR
5*	145641-03-000	EA	DVD/VCR PLAYER - RCA DRC6200N - <b>STEREO DVD/VCR</b> FROM: 00-00-00 THRU: 08-22-04
5*	145641-02-000	EA	DVD/VCR PLAYER - RCA DRC6100N - <b>STEREO DVD/VCR</b> FROM: 08-23-04 THRU: 10-17-04
5*	145641-04-000	EA	DVD/VCR PLAYER - RCA DRC6300N - <b>STEREO DVD/VCR</b> FROM: 10-18-04 THRU: 99-99-99
5*	150089-01-000	EA	DVD/VCR PLAYER - RCA RTD300/SP - <b>HOME THEATER SYSTEM</b>
6	142258-01-000	EA	SWITCH - VIDEO/ANTENNA POWER SUPPLY
7	099048-04-000	EA	INVERTER - 300 WATT
8*	148230-02-000	EA	TV - 24" - STEREO/5 JACKS - RCA 24F530T FROM: 00-00-00 THRU: 09-05-04
8	152440-01-000	EA	TV - 24" - STEREO/FLAT SCREEN/5 JACKS - RCA 24F650T FROM: 09-06-04 THRU: 99-99-99
9	058707-02-000	EA	RECEPTACLE - BLANK - JUNCTION BOX
10	058708-01-000	EA	RECEPTACLE - ELECTRIC - DOUBLE - BROWN
11	079364-04-000	EA	SWITCH - ON/OFF ROCKER - 2 TERMINAL - BLACK
11	098351-09-01A	EA	PLATE/SWITCH - 1 GANG - POLISHED BRASS - SPEAKER SELECT/TV
12	149557-04-01A	EA	PLATE/WALL - TRIPLE COAXIAL/HORIZONTAL - WHITE
13	149750-03-000	EA	TRANSMITTER - F/INFRA RED RECEIVER
14	123324-01-000	EA	FILTER - GROUND LOOP

\*COMPONENT PARTS LISTED LATER IN THIS GROUP



# ELECTRICAL GROUP (CONTINUED)

## SIDE TV/VCR

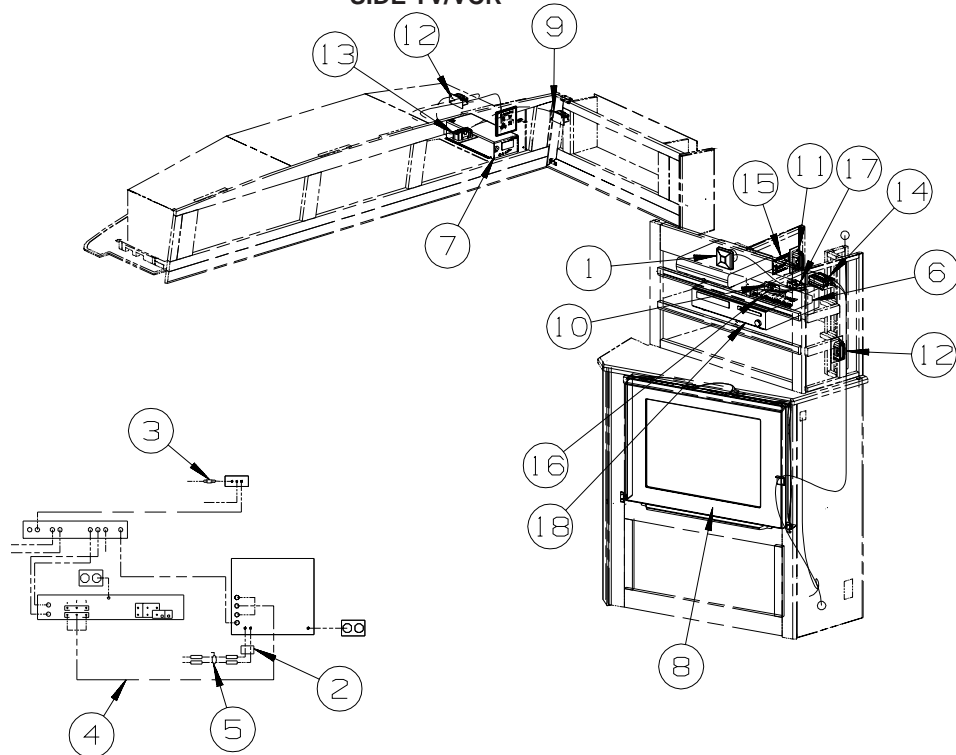

KEY	PART NUMBER	U/M	DESCRIPTION
1	148026-02-01A	EA	SPEAKER GRILLE - CUBE - SILVER
1	148026-03-01A	EA	SPEAKER - CUBE - W/O CASE
2	123324-01-000	EA	FILTER - GROUND LOOP
3	082134-01-000	EA	ADAPTER - TV - CABLE TO CABLE
4	136860-01-000	EA	CABLE - RCA - #3 MALE TO #12F MALE CONNECTOR
5	117420-03-000	EA	CABLE - W/MALE RCA ENDS - SHIELDED - 20'
6	142258-01-000	EA	SWITCH - VIDEO/ANTENNA POWER SUPPLY
7	099048-04-000	EA	INVERTER - 300 WATT
8	150933-01-000	EA	TV - 27" FLAT SCREEN/STEREO/5 JACK - RCA 27F530T
9	058707-02-000	EA	RECEPTACLE - BLANK - JUNCTION BOX
10	079364-04-000	EA	SWITCH - ON/OFF ROCKER - 2 TERMINAL - BLACK - HOME THEATER SYSTEM
10	098351-09-01A	EA	PLATE/SWITCH - 1 GANG - POLISHED BRASS - SPEAKER SELECT/TV - HOME THEATER SYSTEM
11	058708-01-000	EA	RECEPTACLE - ELECTRIC - DOUBLE - BROWN
12	058708-05-000	EA	RECEPTACLE - ELECTRIC - SINGLE - BROWN
13	058708-06-000	EA	RECEPTACLE - ELECTRIC - DOUBLE - WHITE
14	147139-01-000	EA	AMPLIFIER - STEREO 2 CHANNEL
15	149557-04-01A	EA	PLATE/WALL - TRIPLE COAXIAL/HORIZONTAL - WHITE
16	149750-03-000	EA	TRANSMITTER - F/INFRA RED RECEIVER
17	149750-04-000	EA	MODULE/INTERFACE - INFRA RED (RECEIVER TO TRANSMITTER)
18*	145641-03-000	EA	DVD/VCR PLAYER - RCA DRC6200N - STEREO DVD/VCR FROM: 00-00-00 THRU: 08-22-04
18*	145641-02-000	EA	DVD/VCR PLAYER - RCA DRC6100N - STEREO DVD/VCR FROM: 08-23-04 THRU: 10-17-04
18*	145641-04-000	EA	DVD/VCR PLAYER - RCA DRC6300N - STEREO DVD/VCR FROM: 10-18-04 THRU: 99-99-99
18*	150089-01-000	EA	DVD/VCR PLAYER - RCA RTD300/SP - HOME THEATER SYSTEM

\*COMPONENT PARTS LISTED LATER IN THIS GROUP

**ELECTRICAL GROUP (CONTINUED)**  
**COMPONENT PARTS FOR WIRING**

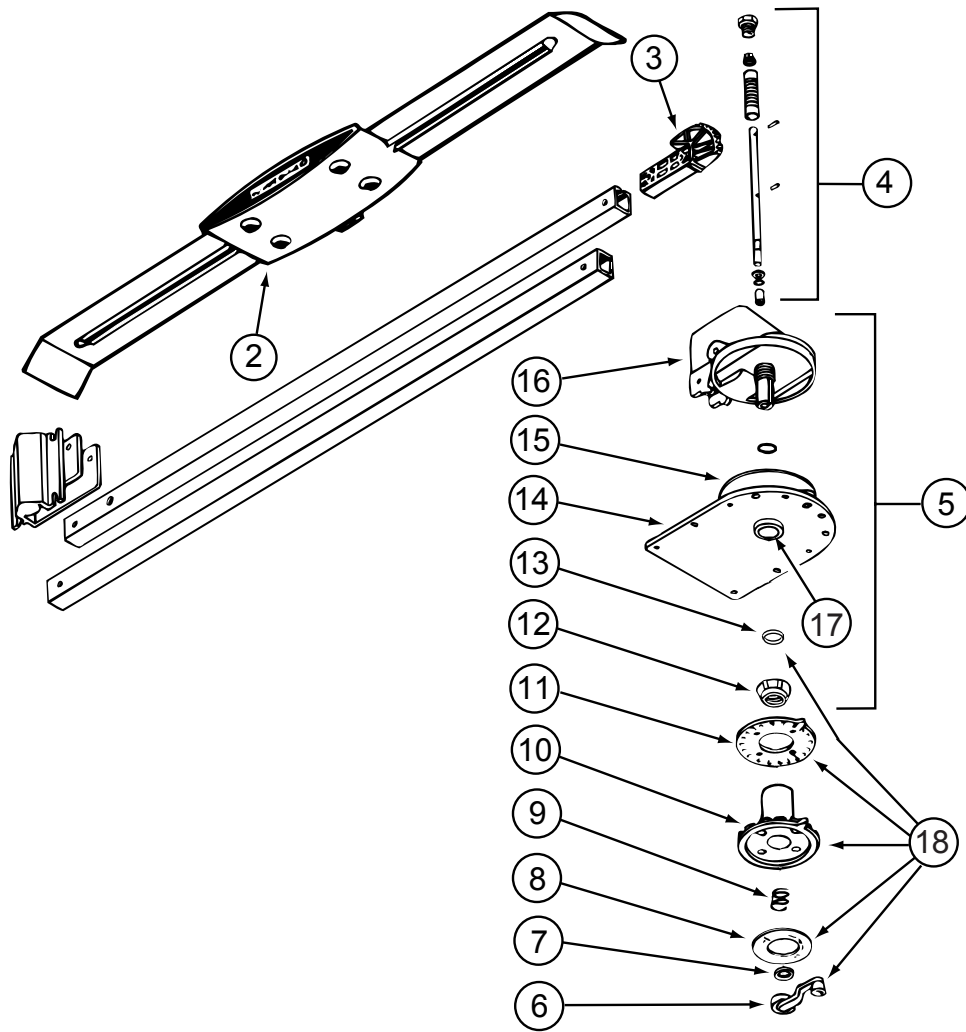

**076319-23-000**

KEY	PART NUMBER	U/M	DESCRIPTION	VENDOR NO.
2	076319-01-700	EA	HEAD-ANTENNA, AMPLIFIED	RVSA U/V
3	076319-01-701	EA	GEAR-ELEVATING, PLASTIC	2200046
4	076319-01-702	EA	SHAFT ASM-ELEVATING	RP-4000
5	076319-01-711	EA	BASE & LIFT ASM	2762802
7	076319-01-705	EA	GROMMET-NYLON, 7/8"ID	3200658
8	076319-01-708	EA	DECAL-CRANK	5413002
9	076319-01-707	EA	SPRING-HANDLE	2160822
11	076319-01-712	EA	PLATE - CEILING	3200608
12	076319-01-715	EA	NUT (GEAR HOUSING)	2200047
14	076319-01-713	EA	PLATE-BASE, STEEL	3100523
15	076319-01-703	EA	BEARING-NYLON, 5"OD	3200656
16	076319-01-714	EA	HOUSING, ROTATING GEAR	2200049
17	076319-01-704	EA	BEARING-NYLON, 1.25"OD	3200657
18	076319-01-709	EA	HANDLE-HEAD DIRECTIONAL	200644
	076319-01-716	EA	TUBING, ELEVATING	RP-2900

CONTACT WINNEBAGO PART SALES FOR UNLISTED COMPONENT(S)

**076319-25-000**

KEY	PART NUMBER	U/M	DESCRIPTION	VENDOR NO.
6	076319-01-706	EA	CRANK-W/SET SCREW UNIV/BEIGE	2750897
6	120233-01-710	EA	HANDLE-CRANK W/SCREW - WHITE	RP-6795
8	076319-01-708	EA	DECAL-CRANK	5413002
10	076319-25-700	EA	DIRECTIONAL HANDLE(WHITE)	3200612
11	076319-25-701	EA	PLATE - CEILING(WHITE)	3200609
13	120233-01-709	EA	WASHER-NYLON	RP-2658

CONTACT WINNEBAGO PART SALES FOR UNLISTED COMPONENT(S)

**ELECTRICAL GROUP (CONTINUED)**  
**COMPONENT PARTS FOR WIRING (CONTINUED)**

			<b>086280-01-000</b>	
<b>KEY</b>	<b>PART NUMBER</b>	<b>U/M DESCRIPTION</b>		<b>VENDOR NO.</b>
	086280-01-700	EA BULB,12V		ARP1089
			<b>087694-01-000</b>	
<b>KEY</b>	<b>PART NUMBER</b>	<b>U/M DESCRIPTION</b>		<b>VENDOR NO.</b>
	087694-01-700	EA BULB		GE561
			<b>091937-08-000</b>	
<b>KEY</b>	<b>PART NUMBER</b>	<b>U/M DESCRIPTION</b>		<b>VENDOR NO.</b>
	091937-08-700	EA LENS - LIGHT - FLUORESCENT		D-766
			<b>093575-21-01A</b>	
<b>KEY</b>	<b>PART NUMBER</b>	<b>U/M DESCRIPTION</b>		<b>VENDOR NO.</b>
	093575-21-700	EA GLOBE		9079
			<b>097917-01-06A</b>	
<b>KEY</b>	<b>PART NUMBER</b>	<b>U/M DESCRIPTION</b>		<b>VENDOR NO.</b>
	097917-01-700	EA LENS-LIGHT, CLEAR		30-78-021
			<b>108354-01-01A</b>	
<b>KEY</b>	<b>PART NUMBER</b>	<b>U/M DESCRIPTION</b>		<b>VENDOR NO.</b>
	108354-01-700	EA BULB-COURTESY LIGHT		395-B
			<b>113589-01-000</b>	
<b>KEY</b>	<b>PART NUMBER</b>	<b>U/M DESCRIPTION</b>		<b>VENDOR NO.</b>
	113589-01-700	EA ADAPTER, 4-WAY/6-WAY		5291
			<b>113589-02-000</b>	
<b>KEY</b>	<b>PART NUMBER</b>	<b>U/M DESCRIPTION</b>		<b>VENDOR NO.</b>
	113589-03-700	EA ADAPTER 7 RND SPADE/4 FLAT		5290
			<b>121935-01-01A</b>	
<b>KEY</b>	<b>PART NUMBER</b>	<b>U/M DESCRIPTION</b>		<b>VENDOR NO.</b>
	121935-01-700	EA LENS ONLY		809511
			<b>126696-07-000</b>	
<b>KEY</b>	<b>PART NUMBER</b>	<b>U/M DESCRIPTION</b>		<b>VENDOR NO.</b>
	133377-01-700	EA REMOTE		240961

**ELECTRICAL GROUP (CONTINUED)**  
**COMPONENT PARTS FOR WIRING (CONTINUED)**

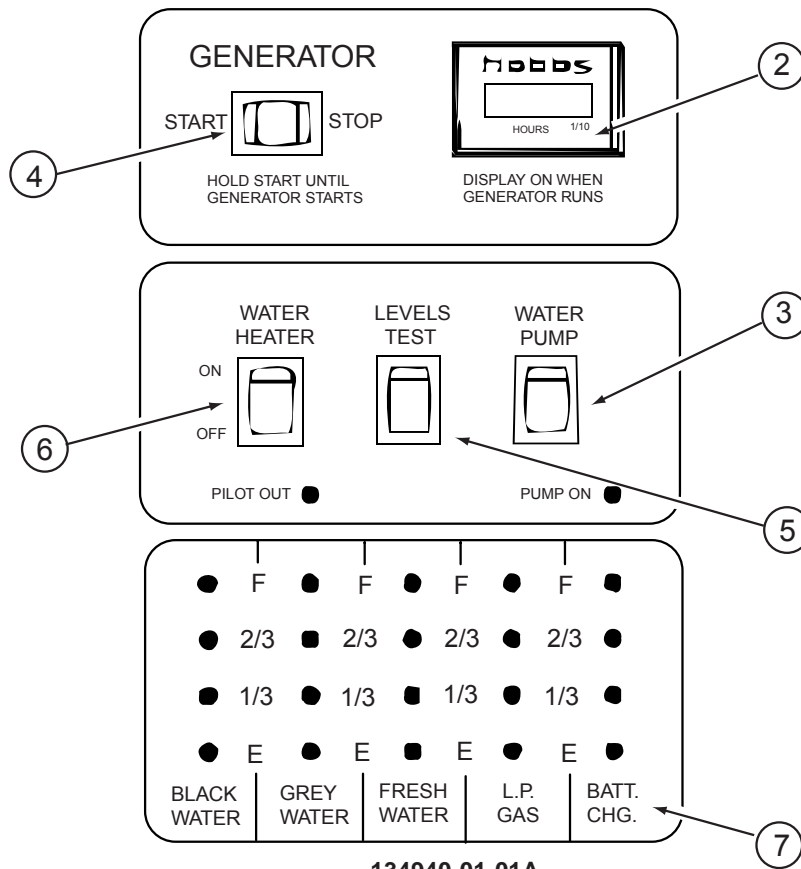

KEY	PART NUMBER	U/M	DESCRIPTION	VENDOR NO.
2	100258-10-701	EA	GAUGE-HR METER ONLY (LCD)	L0775-00
3	096983-01-703	EA	SWITCH - ON/ON	L0115-00
4	096983-01-702	EA	SWITCH - MOM/OFF/MOM/3 TERM	L0112-00
5	096983-01-701	EA	SWITCH - SPST/MOM 2 TERMINAL	L0111-00
6	134940-01-701	EA	SWITCH-SPST/ON-OFF/BLK W/LGT	L0109
7	134940-01-702	EA	CHASSIS - SILKSCREENED	CC0558-00
	100258-10-702	EA	HOUR METER(SNAP-IN)SW & WIRE	L4441-00
	134940-01-700	EA	BOARD - PC	L5118-01

**ELECTRICAL GROUP (CONTINUED)**  
**COMPONENT PARTS FOR WIRING (CONTINUED)**

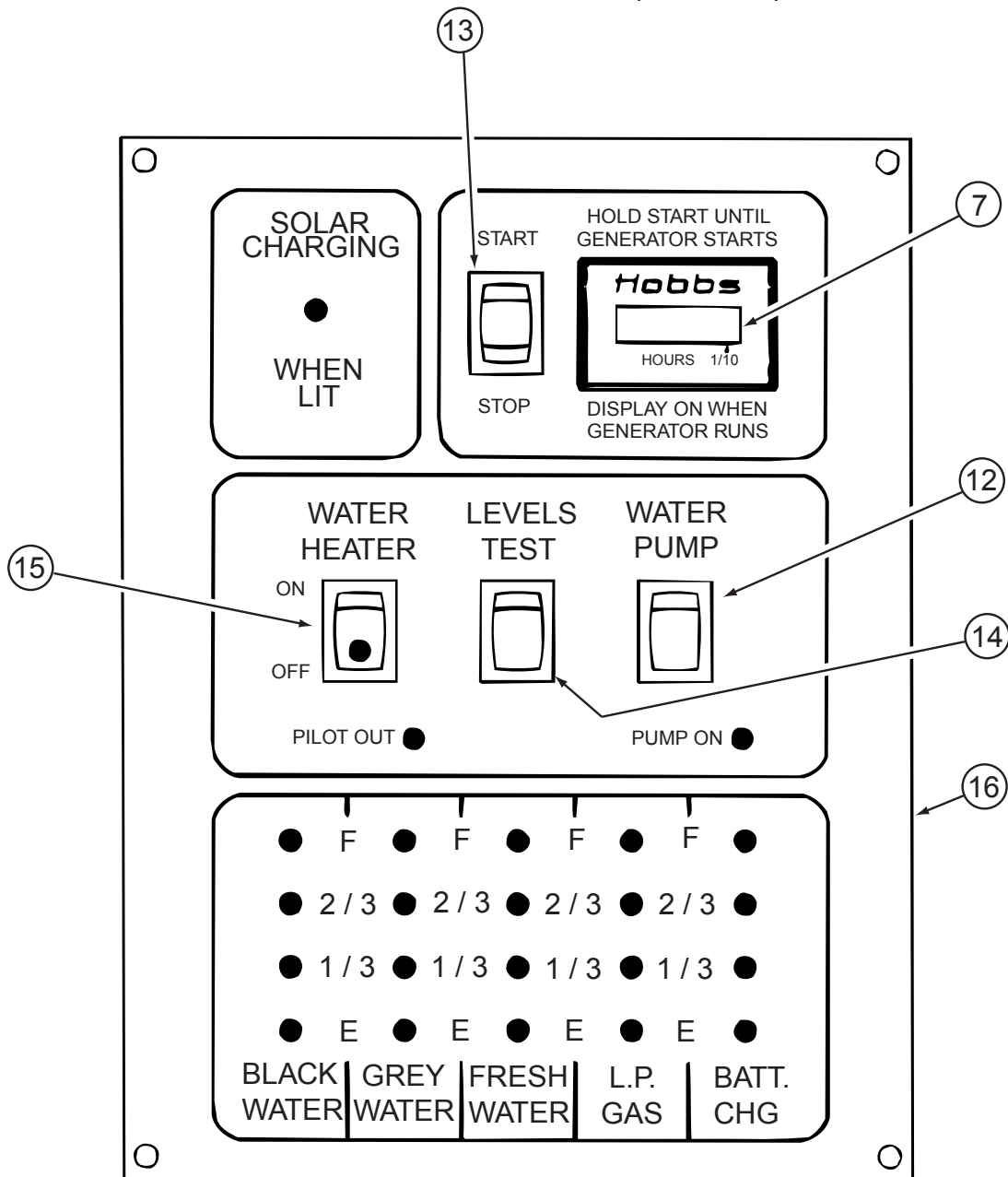

134940-04-01A

KEY	PART NUMBER	U/M	DESCRIPTION	VENDOR NO.
7	100258-10-701	EA	GAUGE/HOUR METER-CLIP ON LCD	L0775-00
12	096983-01-703	EA	SWITCH - ON/ON	L0115-00
13	096983-01-702	EA	SWITCH - MOM/OFF/MOM/3 TERM	L0112-00
14	096983-01-701	EA	SWITCH - SPST/MOM 2 TERMINAL	L0111-00
15	134940-01-701	EA	SWITCH-SPST/ON-OFF/BLK W/LGT	L0109
16	134940-04-700	EA	CHASSIS - SILKSCREENED	CE0136-00
	134940-04-701	EA	BOARD - PC - SOLAR LIGHT	L5121-01

**ELECTRICAL GROUP (CONTINUED)**  
**COMPONENT PARTS FOR WIRING (CONTINUED)**

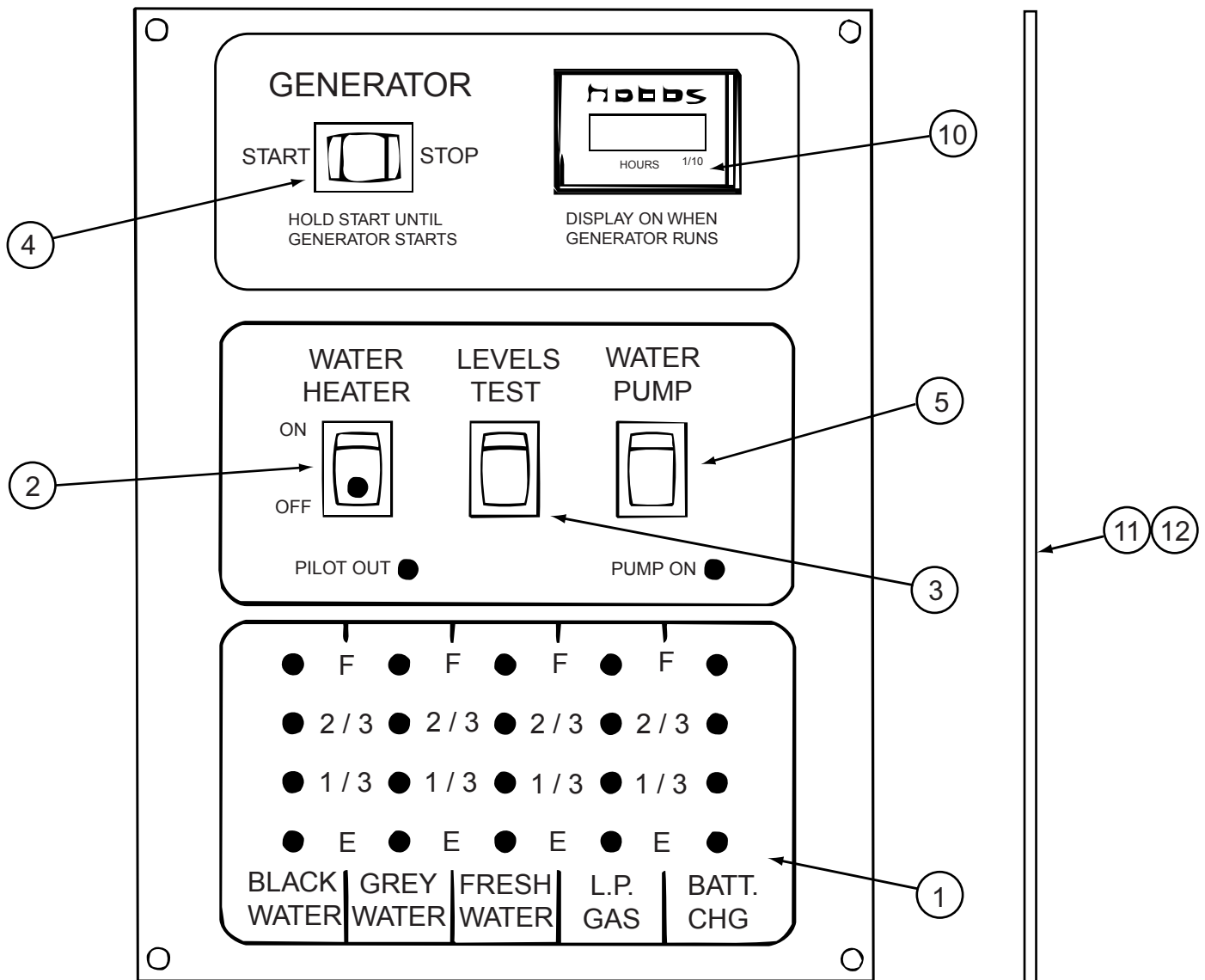

**134940-06-01A**

KEY	PART NUMBER	U/M	DESCRIPTION	VENDOR NO.
1	134940-01-702	EA	CHASSIS - SILKSCREENED	CC0558-00
2	134940-01-701	EA	SWITCH-SPST/ON-OFF/BLK W/LGT	L0109
3	096983-01-701	EA	SWITCH - SPST/MOM 2 TERMINAL	L0111-00
4	096983-01-702	EA	SWITCH - MOM/OFF/MOM/3 TERM	L0112-00
5	096983-01-703	EA	SWITCH - ON/ON	L0115-00
10	100258-10-701	EA	GAUGE-HR METER ONLY (LCD)	L0775-00
11	134940-06-700	EA	PC BOARD - SENSOR SYSTEM/RED	L5131-02

CONTACT WINNEBAGO PART SALES FOR UNLISTED COMPONENT(S)

**134940-08-01A**

KEY	PART NUMBER	U/M	DESCRIPTION	VENDOR NO.
1	134940-04-700	EA	CHASSIS - SILKSCREENED	CE0136-00
2	134940-01-701	EA	SWITCH-SPST/ON-OFF/BLK W/LGT	L0109
3	096983-01-701	EA	SWITCH - SPST/MOM 2 TERMINAL	L0111-00
4	096983-01-702	EA	SWITCH - MOM/OFF/MOM/3 TERM	L0112-00
5	096983-01-703	EA	SWITCH - ON/ON	L0115-00
10	100258-10-701	EA	GAUGE-HR METER ONLY (LCD)	L0775-00
11	134940-06-700	EA	PC BOARD - SENSOR SYSTEM/RED	L5131-02
12	134940-04-701	EA	BOARD - PC - SOLAR LIGHT	L5121-01

CONTACT WINNEBAGO PART SALES FOR UNLISTED COMPONENT(S)

**ELECTRICAL GROUP (CONTINUED)**  
**COMPONENT PARTS FOR WIRING (CONTINUED)**

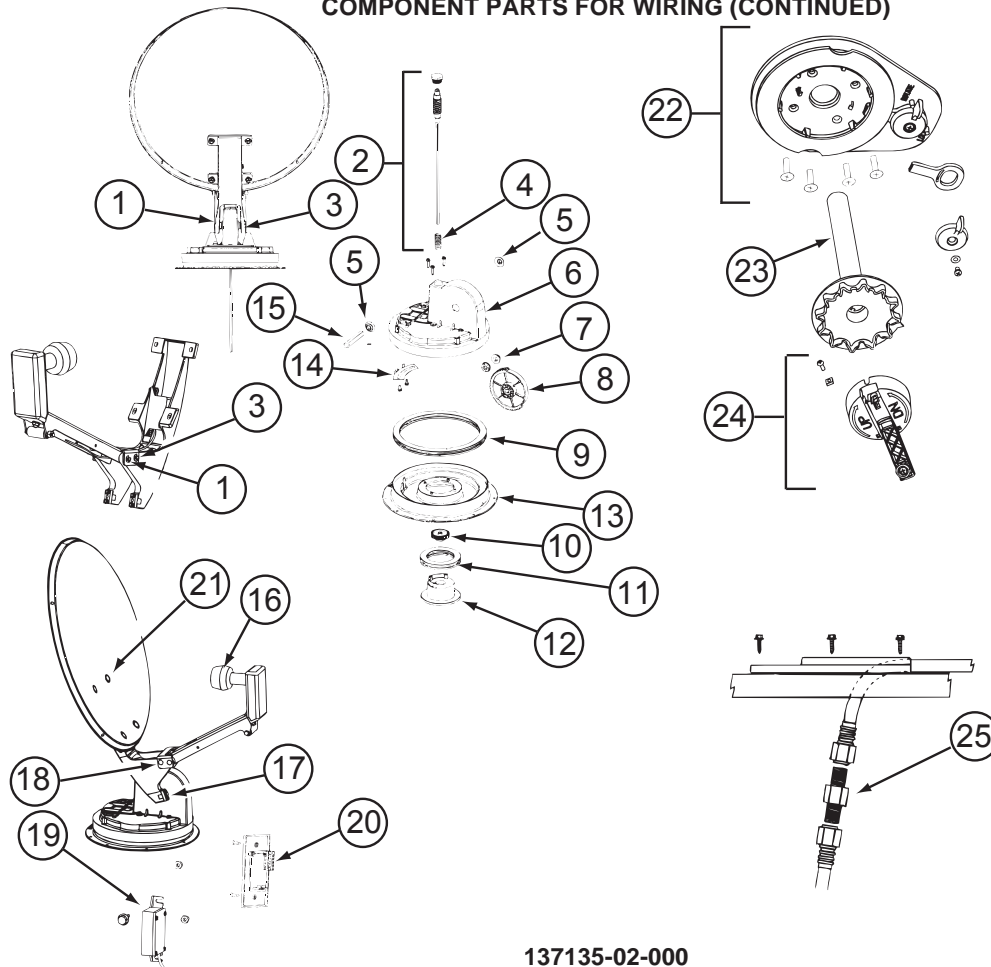

137135-02-000

KEY	PART NUMBER	U/M	DESCRIPTION	VENDOR NO.
1	120233-01-714	EA	CLIP-E	5160818
2	137135-01-703	EA	KIT ELEV - SHAFT/GEAR/SPRING	RP-4400
3	137135-01-704	EA	PIN - 1/4" X 3.25"	2160813
4	137135-01-705	EA	SPRING	2160818
5	137135-01-707	EA	SEAL - PIVOT SHAFT	2200852
6	137135-01-708	EA	TURRET	3100728
7	137135-01-709	EA	PIVOT BEARING	2200470
8	137135-01-711	EA	GEAR - ELEVATING	2200464
9	137135-01-712	EA	BEARING - OUTER	2590347
10	137135-01-714	EA	GEAR - ELEVATING SHAFT	2200465
11	137135-01-715	EA	BEARING - INNER	2590348
12	137135-01-716	EA	HUB	3100731
13	137135-01-713	EA	TURRET BASE	3100730
14	137135-01-710	EA	PLATE - ROTATE LIMIT	3720052
16	137135-02-703	EA	LOW NOISE BLOCK FILTER	LB-6000 - DUAL
17	137135-01-722	EA	CLAMP	2590343
18	137135-01-719	EA	BRACKET - PIVOT	2744945
19	137135-01-720	EA	DE-SENSOR UNIT W/43" CABLE	DM4000
20	137135-02-701	EA	BOX - SURFACE MOUNT	SM-100
21	137135-01-717	EA	BOLT - FLAT HEAD	2160362
22	120233-01-737	EA	PLATE/INT-W/DIRECTIONAL HDLE	RK-CEIL
23	120233-01-704	EA	DIAL/DIRECTIONAL 4"W/SPRING	3200364
24	120233-01-738	EA	HDW PKG-HANDLE/SPRING/WASHER	RK-HAND
25	137135-01-701	EA	CONNECTOR - F - MALE TO MALE	FS-8100
	120233-04-700	EA	KIT-WALL PLATE/CABLE - GRAY	DM4000
	137135-01-700	EA	ROOF WEDGE W/GASKET	RW-5000
	137135-01-706	EA	KIT-TURRET/SEAL/BEARING/GEAR	RP-RM30
	137135-01-718	EA	REFLECTOR/WHITE-46CM W/HDW	RP-35RM
	137135-02-700	EA	DE-SENSOR	2780096
	137135-02-704	EA	KIT-UPDATE DIRECTIONAL HDL	RP-RMDH
	137135-02-705	EA	KIT-TURRET & SHAFT COMPLETE	RP-RM46

CONTACT WINNEBAGO PART SALES FOR UNLISTED COMPONENT(S)

## ELECTRICAL GROUP (CONTINUED)

### COMPONENT PARTS FOR WIRING (CONTINUED)

137417-01-01A, 137417-03-01A

KEY	PART NUMBER	U/M	DESCRIPTION	VENDOR NO.
	137417-01-700	EA	LENS - SINGLE (FROSTED)	810868

137417-02-01A

<b>KEY</b>	<b>PART NUMBER</b>	<b>U/M</b>	<b>DESCRIPTION</b>	<b>VENDOR NO.</b>
	137417-02-700	EA	LENS - SINGLE OPTIC	810844

137417-05-01A

<b>KEY</b>	<b>PART NUMBER</b>	<b>U/M</b>	<b>DESCRIPTION</b>	<b>VENDOR NO.</b>
	137417-05-700	EA	LENS - DOUBLE OPTIC	810845

137417-06-01A

<b>KEY</b>	<b>PART NUMBER</b>	<b>U/M</b>	<b>DESCRIPTION</b>	<b>VENDOR NO.</b>
	137417-06-700	EA	LENS - DOUBLE WHITE	810867

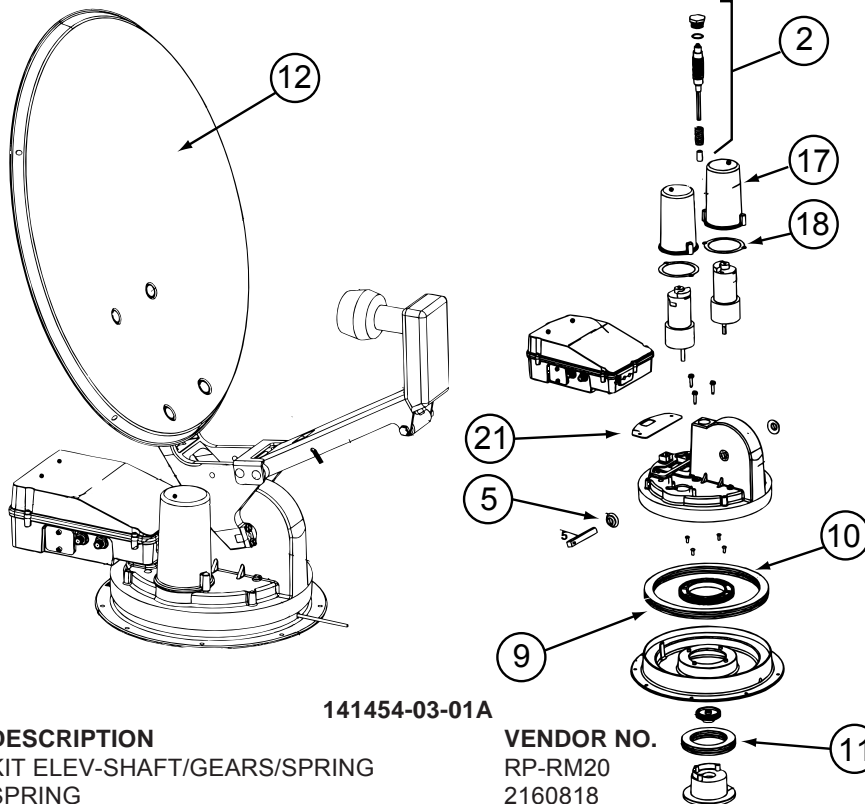

141454-03-01A

KEY	PART NUMBER	U/M	DESCRIPTION	VENDOR NO.
2	141454-01-700	EA	KIT ELEV-SHAFT/GEARS/SPRING	RP-RM20
4	137135-01-705	EA	SPRING	2160818
5	137135-01-707	EA	SEAL - PIVOT SHAFT	2200852
9	137135-01-712	EA	BEARING - OUTER	2590347
10	137135-01-714	EA	GEAR - ELEVATING SHAFT	2200465
10	141454-01-712	EA	GEAR - ROTATE	2200469
11	137135-01-715	EA	BEARING - INNER	2590348
12	137135-01-718	EA	REFLECTOR/WHITE-46CM W/HDWE	RP-35RM
13	137135-01-713	EA	TURRET BASE	3100730
17	141454-01-705	EA	HOUSING - MOTOR	3200260
18	141454-01-706	EA	GASKET - MOTOR HOUSING	2240054
21	141454-01-709	EA	GASKET	2240056
	120233-01-714	EA	CLIP-E	5160818
	137135-01-704	EA	PIN - 1/4" X 3.25"	2160813
	137135-01-719	EA	BRACKET - PIVOT	2744945
	137135-01-722	EA	CLAMP	2590343
	137135-01-723	EA	SUPPORT/FRAME-BACKUP-W/HDWE	RP-RM00
	137135-02-703	EA	LOW NOISE BLOCK FILTER	LB-6000 - DUAL
	141454-01-701	EA	KIT - GEAR/MOTOR-GEAR/ROTATE	RP-RM25
	141454-01-702	EA	HOUSING/ELECTRONICS - UPPER	RP-RM10
	141454-01-703	EA	HOUSING/ELECTRONICS - LOWER	RP-RM15
	141454-01-704	EA	KIT LIFT ASSEMBLY COMPLETE	RP-RM05
	141454-03-700	EA	MOTOR (AZIMUTH)	2665042
	141454-03-701	EA	MOTOR (ELEVATION)	2665041
	141454-03-702	EA	CIRCUIT BOARD(CONTROL BOARD)	RP-RM80
	141454-03-703	EA	CONTRL PANEL W/BOX (AS2003)	RP-AS85

CONTACT WINNEBAGO PART SALES FOR UNLISTED COMPONENT(S)



**ELECTRICAL GROUP (CONTINUED)**  
**COMPONENT PARTS FOR WIRING (CONTINUED)**

**145641-02-000, 145641-04-000**

<b>KEY</b>	<b>PART NUMBER</b>	<b>U/M DESCRIPTION</b>	<b>VENDOR NO.</b>
	145641-02-700	EA REMOTE	260607

**145641-03-000**

<b>KEY</b>	<b>PART NUMBER</b>	<b>U/M DESCRIPTION</b>	<b>VENDOR NO.</b>
	145641-03-700	EA REMOTE	RCR311DA1

**148113-01-000, 148113-03-000**

<b>KEY</b>	<b>PART NUMBER</b>	<b>U/M DESCRIPTION</b>	<b>VENDOR NO.</b>
	148113-01-700	EA REMOTE - SIRIUS RADIO	0111202P00

**148158-01-000**

<b>KEY</b>	<b>PART NUMBER</b>	<b>U/M DESCRIPTION</b>	<b>VENDOR NO.</b>
	148158-01-700	EA ANTENNA - F/GPS W/20' CABLE	DIS-CMP-ANTNGPS

**148230-01-000, 148230-02-000**

<b>KEY</b>	<b>PART NUMBER</b>	<b>U/M DESCRIPTION</b>	<b>VENDOR NO.</b>
	148230-01-700	EA REMOTE (TV)	260605

**148231-01-000**

<b>KEY</b>	<b>PART NUMBER</b>	<b>U/M DESCRIPTION</b>	<b>VENDOR NO.</b>
	148231-01-700	EA REMOTE	RC3100

**149040-02-000**

<b>KEY</b>	<b>PART NUMBER</b>	<b>U/M DESCRIPTION</b>	<b>VENDOR NO.</b>
	149040-02-700	EA REMOTE - TV	RCR311TBM1-RCA

**150089-01-000**

<b>KEY</b>	<b>PART NUMBER</b>	<b>U/M DESCRIPTION</b>	<b>VENDOR NO.</b>
	150089-01-700	EA REMOTE	265683

**ELECTRICAL GROUP (CONTINUED)**  
**CIRCUIT BREAKERS, FUSES & RELAYS**

KEY	PART NUMBER	U/M	DESCRIPTION
	008235-01-000	EA	FUSE - 15 AMP/12VOLT - AUTOMOTIVE
	033573-01-000	EA	CIRCUIT BREAKER W/MOUNT-20A, 12V - FASCO 1711-2026
	062901-02-000	EA	FUSE - 5 AMP - AUTOMOTIVE
	062901-04-000	EA	FUSE - 10 AMP - AUTOMOTIVE
	062901-05-000	EA	FUSE - 15 AMP - AUTOMOTIVE
	062901-06-000	EA	FUSE - 20 AMP - AUTOMOTIVE
	062901-07-000	EA	FUSE - 25 AMP - AUTOMOTIVE
	062901-08-000	EA	FUSE - 30 AMP - AUTOMOTIVE
	063910-01-000	EA	HOUSING - RELAY
	063912-02-000	EA	RELAY - CANISTER - SPDT
	083209-01-000	EA	CIRCUIT BREAKER - 15 AMP - 120 VOLT - CANADIAN
	083209-02-000	EA	CIRCUIT BREAKER - 15/15 AMP - 120 VOLT
	083209-03-000	EA	CIRCUIT BREAKER - 15/20 AMP - 120 VOLT
	083209-04-000	EA	CIRCUIT BREAKER - 30 AMP - 120 VOLT
	083209-05-000	EA	CIRCUIT BREAKER - 20 AMP - 120 VOLT
	083209-06-000	EA	CIRCUIT BREAKER - 30/15 AMP - 120 VOLT
	083209-07-000	EA	CIRCUIT BREAKER - 20/20 AMP - 120 VOLT
	083209-10-000	EA	CIRCUIT BREAKER - 20/30 AMP - 120 VOLT
	083209-11-000	EA	CIRCUIT BREAKER - 20/15 AMP - 120 VOLT
	092786-03-000	EA	BUSS BAR - 6.9" LONG
	092786-06-000	EA	BUSS BAR
	093654-01-000	EA	CIRCUIT BREAKER - 6 AMP - 12 VOLT - PUSH BUTTON - WHITE
	093654-02-000	EA	CIRCUIT BREAKER - 15 AMP - 12 VOLT - PUSH BUTTON - WHITE
	093654-03-000	EA	CIRCUIT BREAKER - 20 AMP - 12 VOLT - PUSH BUTTON - WHITE
	093654-11-000	EA	COVER - RESET BUTTON
	093655-01-000	EA	CIRCUIT BREAKER - 25 AMP - 12 VOLT - PUSH BUTTON - WHITE
	093655-02-000	EA	CIRCUIT BREAKER - 30 AMP - 12 VOLT - PUSH BUTTON - WHITE
	093655-03-000	EA	CIRCUIT BREAKER - 40 AMP - 12 VOLT - PUSH BUTTON - WHITE
	097611-01-000	EA	CIRCUIT BREAKER - 10 AMP
	097611-02-000	EA	CIRCUIT BREAKER - 30 AMP
	097611-03-000	EA	CIRCUIT BREAKER - 20 AMP
	097611-04-000	EA	CIRCUIT BREAKER - 25 AMP
	100341-01-000	EA	FUSE HOLDER - IN LINE TYPE
	106656-01-000	EA	FUSE BLOCK - 4 CAVITY - AUTOFUSE
	108567-01-000	EA	CIRCUIT BREAKER - 40 AMP - 12 VOLT - TYPE II
	111683-01-000	EA	FUSE - HOLDER - GLASS - 1/4" X 1 1/4"
	113482-01-000	EA	CIRCUIT BREAKER - 55 AMP - MANUAL
	115187-01-000	EA	FUSE - 300 AMP - NON-DELAY
	115187-02-000	EA	FUSE HOLDER - BUSS ANN/ANL BLOCK
	119930-01-000	EA	CAPACITOR - ELECTROLYTIC
	122811-01-000	EA	CIRCUIT BREAKER - 20/50/50/20 AMP - 250V
	125986-02-000	EA	FUSE - 5 AMP - AUTO - MINI BLADE
	125986-04-000	EA	FUSE - 10 AMP - AUTO - MINI BLADE
	125986-05-000	EA	FUSE - 15 AMP - AUTO - MINI BLADE
	125986-06-000	EA	FUSE - 20 AMP - AUTO - MINI BLADE
	125986-07-000	EA	FUSE - 25 AMP - AUTO - MINI BLADE
	134127-01-000	EA	CIRCUIT BREAKER - 10 AMP - MINI
	141789-01-000	EA	SPACER - CIRCUIT BREAKER

## ELECTRICAL GROUP (CONTINUED)

### CONVERTER, INVERTER, LOAD CENTERS

KEY	PART NUMBER	U/M	DESCRIPTION
	099048-04-000	EA	INVERTER - 300 WATT
	109677-01-000	EA	LOAD CENTER - 120 VOLT - 40 AMP - F31W
	123058-01-000	EA	CONVERTER - 55 AMP - ELECTRONIC - 4 1/8"H X 7"W X 12 3/8"L - F38J
	123058-02-000	EA	CONVERTER - 45 AMP - ELECTRONIC - 4 1/8"H X 7"W X 12 3/8"L
	141258-01-000	EA	LOAD CENTER - 120/240 - 50 AMP
	141258-02-000	EA	LOAD CENTER - COVER

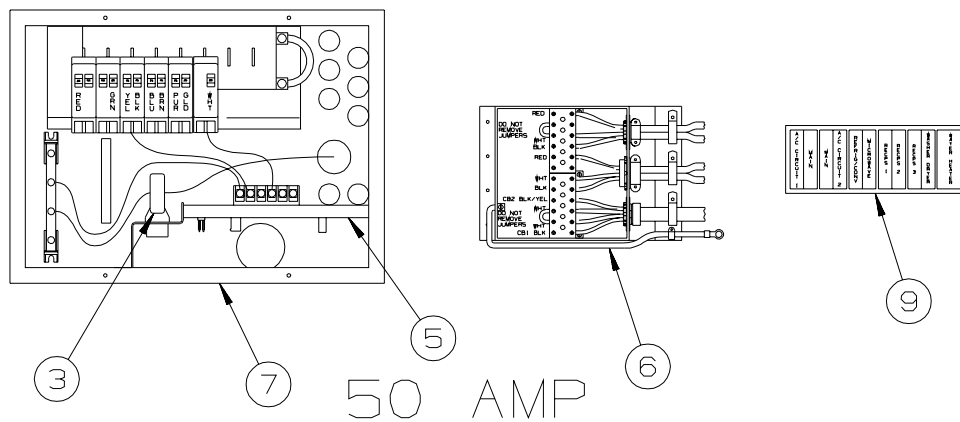
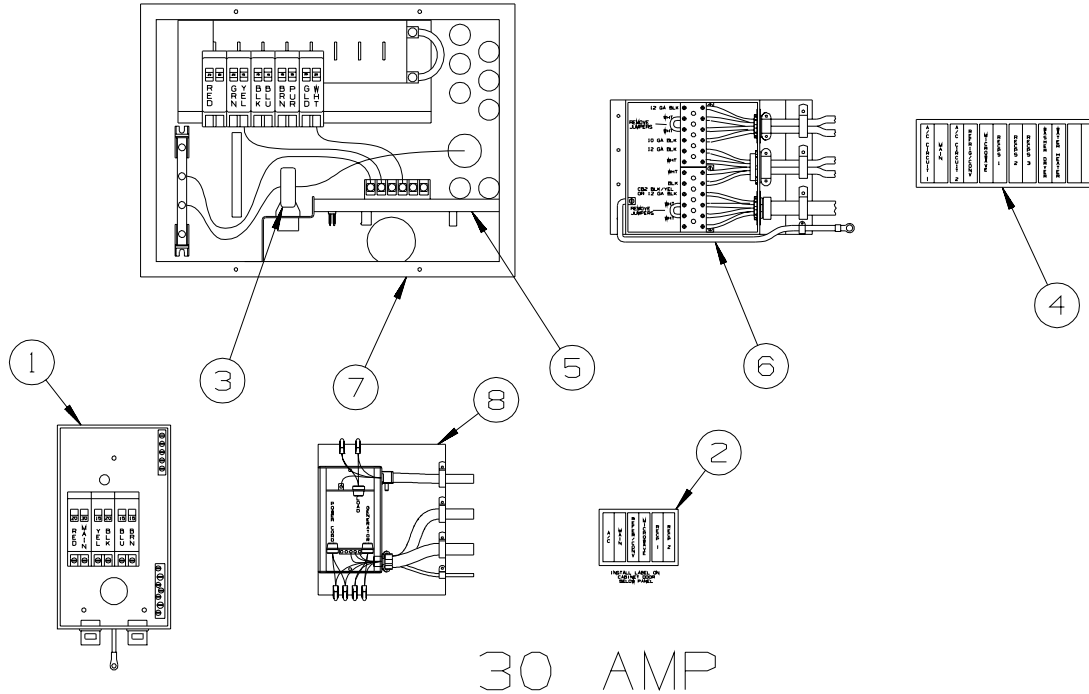

KEY	PART NUMBER	U/M	DESCRIPTION
1	109677-01-000	EA	LOAD CENTER - 120 VOLT - 40 AMP
2	095721-40-000	EA	LABEL - CONTROL CENTER
3	127002-07-000	EA	SENSOR - CURRENT
4	095721-31-000	EA	LABEL - CONTROL CENTER - 30 AMP - US
5	127002-08-000	EA	MODULE - EMS CENTER - W/REMOTE SENSOR
			FROM: 00-00-00 THRU: 11-07-04
5	127002-11-000	EA	MODULE - EMS CENTER - W/REMOTE SENSOR
			FROM: 11-08-04 THRU: 99-99-99
6	106071-06-000	EA	SWITCH - AUTOMATIC TRANSFER - PARALLAX 5070 - 50 AMP
7	141258-01-000	EA	LOAD CENTER - 120/240 - 50 AMP
7	141258-02-000	EA	LOAD CENTER - COVER
8	106071-01-000	EA	SWITCH - AUTOMATIC TRANSFER - 30 AMP - MAGNETEK
9	095721-33-000	EA	LABEL - CONTROL CENTER - 50 AMP - US

## ELECTRICAL GROUP (CONTINUED)

### BOXES & CORDS

KEY	PART NUMBER	U/M	DESCRIPTION
	008054-01-000	EA	CORD - POWER - 10/3 WIRE - 30 AMP - 25'
	008289-01-000	EA	BOX - ELECTRIC/STEEL - 4" X 4" - 1/2" & 3/4" KNOCKOUTS
	008294-01-000	EA	COVER - ELECTRIC BOX - BLANK/STEEL - 4" X 4" - GRAY
	092492-11-000	EA	SEAL - ELECTRIC BOX - 7" X 18.4"
	106071-01-000	EA	SWITCH - AUTOMATIC TRANSFER - 30 AMP - MAGNETEK
	106071-06-000	EA	SWITCH - AUTOMATIC TRANSFER - PARALLAX 5070 - 50 AMP
	115832-01-000	FT	CORD - HEAVY DUTY - 14-2 W/GROUND
	133070-01-000	EA	BOX - ELECTRIC/PLASTIC - 3" X 2" X 2.8" - UL
	133070-02-000	EA	BOX - ELECTRIC/PLASTIC - 3" X 2" X 2.8" - CSA
	108934-02-000	EA	CORD - POWER - 50 AMP - 4-WIRE - 36'
	131679-01-000	EA	BOX/ELECTRIC-WATERPROOF-4" X 4" - W/4 3/4"OUTLETS-UL/CSA
	131680-01-000	EA	COVER - F/ELECTRIC BOX W/GASKET 4" X 4" - UL/CSA

### WIRE ASSEMBLIES

KEY	PART NUMBER	U/M	DESCRIPTION
	125853-04-000	EA	WIRE LOOM - ENTERTAINMENT CENTER
	077069-02-000	EA	CABLE/EXTENSION - RADIO ANTENNA - 96"
	077069-03-000	EA	CABLE/EXTENSION - RADIO ANTENNA - 260"
	131279-02-000	EA	WIRE LOOM - POWER SEAT - DRIVER
	132668-01-000	EA	WIRE ASSEMBLY - AUXILIARY FANS
	132669-01-000	EA	WIRE ASSEMBLY - INSTRUMENT PANEL - AUXILARY FANS
	135420-02-000	EA	WIRE LOOM - RADIO
	136514-02-000	EA	CABLE - MONITOR/CAMERA
	137135-03-000	EA	WIRE LOOM - DIGITAL ELEVATION SENSOR
	137135-04-000	EA	WIRE HARNESS - POWER - DIGITAL ELEVATION SENSOR
	137626-01-000	EA	WIRE - OVERDRIVE SWITCH
	142258-02-000	EA	WIRE LOOM - VIDEO SWITCH/POWER SUPPLY
	143545-01-000	EA	WIRE ASSEMBLY - REAR MONITOR
	144677-07-000	EA	WIRE - MONITOR - POWER - 3 PIN
	147139-02-000	EA	WIRE - STEREO KIT - ASA 100ZXIHAR
	147313-01-000	EA	WIRE - OUTSIDE TEMP SENSOR - W/O SENSOR
	148657-06-000	EA	WIRE - F/SOCKET LAMP
	149750-02-000	EA	CABLE - (RECEIVER TO MODULE) - 45'
	151288-01-000	EA	WIRE ASSEMBLY - MARKER LIGHT
	096449-01-000	EA	WIRE ASSEMBLY - WATER TANK TO MONITOR PANEL
	151317-01-000	EA	WIRE ASM-W/NO CONTACT SENSORS - FRESH WATER/BLK TANK - MALE PLUG - 3.9" FROM: 00-00-00 THRU: 05-02-04
	096450-05-000	EA	WIRE F/SENSORS - BLACK WATER - 23.6" FROM: 05-03-04 THRU: 99-99-99
	151317-02-000	EA	WIRE ASM-W/NO CONTACT SENSORS - FRESH WATER/BLK TANK - MALE PLUG - 23.6" FROM: 00-00-00 THRU: 05-02-04
	096451-06-000	EA	WIRE F/SENSORS - GREY WATER - 23.6" FROM: 05-03-04 THRU: 99-99-99
	151316-02-000	EA	WIRE ASM - W/NO CONTACT SENSORS - GREY WATER - FEMALE PLUG - 23.6" FROM: 00-00-00 THRU: 05-02-04
	136028-01-000	EA	WIRE ASM-SOFA,REST EASY FROM: 05-03-04 THRU: 99-99-99

**ELECTRICAL GROUP (CONTINUED)**  
**CONNECTORS & CONDUIT**

KEY	PART NUMBER	U/M	DESCRIPTION
	007940-01-000	EA	RECEPTACLE/SLIDE 16 TO 12 AWG - FEMALE END
	007940-02-000	EA	RECEPTACLE-SLIDE 10 AWG - AMP 180351-2
	007954-01-000	EA	RECEPTACLE - HOUSING - 6 POSITION
	007956-05-000	EA	INSULATOR - SHRINK - 1/4"ID X 1 1/2"
	008058-01-000	EA	ADAPTER - POWER CORD - 30 AMP TO 15 AMP
	008311-01-000	EA	CONNECTOR - WIRE NUT - INSULATED - RED
	008312-01-000	EA	CONNECTOR - WIRE NUT - INSULATED - BLUE
	008313-01-000	EA	CONNECTOR - WIRE NUT - INSULATED - YELLOW
	008314-01-000	EA	CONNECTOR - WIRE NUT - INSULATED - GRAY
	008326-01-000	EA	TERMINAL - RING - 16/14 WIRE - 3/8" STUD
	008328-01-000	EA	TERMINAL - RING - 12/10 WIRE - #10 STUD FIT
	008331-01-000	EA	TERMINAL - RING - TONGUE - #4 WIRE - 3/8" STUD - COPPER
	008348-01-000	EA	TERMINAL - RING - 3/8" STUD 2 GA. WIRE
	008355-01-000	EA	CONNECTOR - CABLE CLAMPING - 3/4"
	008356-01-000	EA	CONNECTOR - PLASTIC - 3/8"
	008356-02-000	EA	CONNECTOR - PLASTIC - 21/32"
	008394-01-000	FT	CONDUIT - FLEXIBLE - 1/2"
	008398-01-000	EA	CONNECTOR - 1/2" X 90 DEGREE - FLEX CONDUIT - UL & CSA
	035416-04-000	EA	TERMINAL - RING - #10 STUD FIT - INSULATED BARREL #16/14
	041953-01-000	FT	CONDUIT - CONVOLUTE SLIT - .5" ID - POLYETHYLENE
	041953-03-000	FT	CONDUIT - CONVOLUTE SLIT - 1" ID (CLOTHES ROD COVER)
	041953-06-000	FT	CONDUIT - CONVOLUTE SLIT - .4" ID - POLYETHYLENE
	041953-07-000	FT	CONDUIT - CONVOLUTE SLIT - .25" ID - POLYETHYLENE
	041953-08-000	FT	CONDUIT - CONVOLUTE SLIT - 1.5" ID - POLYETHYLENE
	041953-09-000	FT	CONDUIT - CONVOLUTE SLIT - .5" ID - NYLON
	041953-10-000	FT	CONDUIT - CONVOLUTE SLIT - .75" ID - NYLON
	041953-11-000	FT	CONDUIT - CONVOLUTE SLIT - 1.06" ID - NYLON
	041953-12-000	FT	CONDUIT - CONVOLUTE SOLID - 1.1" ID - NYLON
	041953-13-000	FT	CONDUIT - CONVOLUTE SLIT - 1.25" ID
	041953-14-000	FT	CONDUIT - CONVOLUTE SLIT - 1.5" ID
	041953-15-000	FT	CONDUIT - CONVOLUTE SLIT - 2"
	041953-16-000	FT	CONDUIT - CONVOLUTE SLIT - 2"
	047443-01-000	EA	TERMINAL - .250 RECEPTACLE FIT - INSULATED - 16/14 AWG
	047443-02-000	EA	TERMINAL - .250 RECEPTACLE FIT - INSULATED - 12/10 AWG
	058028-01-000	EA	CONNECTOR - ELECTRICAL PIGTAIL - NYLON - CLEAR
	062036-01-000	EA	TERMINAL - PACK - CON - 12/10 AWG
	077479-01-000	EA	BOOT - BATTERY TERMINAL - DOUBLE CABLE
	077479-02-000	EA	BOOT - BATTERY TERMINAL - SINGLE CABLE
	080015-02-000	EA	RECEPTACLE - FLAG - .185 - 16/14 GAUGE
	080015-03-000	EA	RECEPTACLE - FLAG - .250 - 14/16 GAUGE
	082109-01-000	EA	HOUSING - CONNECTOR - PACKARD
	082741-01-000	EA	CONNECTOR BODY - 2 CONNECTOR MALE
	087225-01-000	FT	SLEEVEING - 1/2" - TYPE H
	087949-01-000	EA	BUSS BAR - 2 POSITION - .6" X 1.5"
	087949-03-000	EA	BUSS BAR - 4 POSITION
	088473-01-000	EA	HOUSING - PIN - 12 CAVITY (3 ROWS OF 4)
	088473-02-000	EA	HOUSING - PIN - 15 CAVITY (3 ROWS OF 5)
	088473-03-000	EA	HOUSING - PIN - 9 CAVITY (3 ROWS OF 3)
	088473-04-000	EA	HOUSING - PIN - 8 CAVITY IN-LINE
	088473-06-000	EA	HOUSING - PIN - 6 CAVITY (2 ROWS OF 3)
	088473-07-000	EA	HOUSING - PIN - 5 CAVITY - IN-LINE
	088473-08-000	EA	HOUSING - PIN - 4 CAVITY - IN-LINE
	088473-09-000	EA	HOUSING - PIN - 3 CAVITY - IN-LINE
	088473-10-000	EA	HOUSING - PIN - 2 CAVITY - IN LINE
	088474-01-000	EA	HOUSING - SOCKET - 12 CAVITY
	088474-02-000	EA	HOUSING - SOCKET - 15 CAVITY
	088474-03-000	EA	HOUSING - SOCKET - 9 CAVITY
	088474-06-000	EA	HOUSING - SOCKET - 6 CAVITY
	088474-07-000	EA	HOUSING - SOCKET - 5 CAVITY
	088474-08-000	EA	HOUSING - SOCKET - 4 CAVITY
	088474-09-000	EA	HOUSING - SOCKET - 3 CAVITY
	088474-10-000	EA	HOUSING - SOCKET - 2 CAVITY

**ELECTRICAL GROUP (CONTINUED)**  
**CONNECTORS & CONDUIT (CONTINUED)**

<b>KEY</b>	<b>PART NUMBER</b>	<b>U/M</b>	<b>DESCRIPTION</b>
	088475-01-000	EA	PIN - CONNECTOR - 14-20 AWG
	088475-02-000	EA	PIN - CONNECTOR - 10-12 AWG
	088476-01-000	EA	TERMINAL - ELECTRICAL
	088476-02-000	EA	SOCKET - CONNECTOR - 12-10 GA - PRE-TIN
	098261-01-000	EA	SOCKET - CONNECTOR - WEATHERPACK - 12 AWG
	098261-02-000	EA	SOCKET - CONNECTOR - WEATHERPACK - 14-18 AWG
	098262-01-000	EA	SEAL - CONNECTOR - WEATHERPACK
	098264-01-000	EA	HOUSING - 2 PIN - WEATHER PACK - MALE W/FEMALE PINS
	098264-02-000	EA	HOUSING - 2 PIN - WEATHER PACK - FEMALE W/MALE PINS
	098265-02-000	EA	PIN - CONNECTOR - WEATHER PACK
	102777-02-000	EA	TERMINAL - RING - #6 STUD - 10 AWG
	103608-01-000	EA	SOCKET - WEDGE BASE W/LEADS
	104100-01-000	EA	HOUSING - 1 POSITION - 75 AMPS
	104100-03-000	EA	TERMINAL - 75 AMP
	110178-01-000	EA	HOUSING - WIPER MOTOR
	112823-01-000	EA	SPLICE - REDUCER - 16-14 TO 18-22
	113135-01-000	EA	TERMINAL - FEMALE - M/P - 14-16 - F/SEALED TERMINAL
	113308-01-000	EA	TERMINAL - FEMALE - M/P - 14-16 - 280
	113468-01-000	EA	HOUSING - 2 POSITION-FEMALE-USED ON WIPER/WASHER WIRE ASM
	115931-02-000	EA	COVER - CONNECTOR - 50 AMP W/LOCKING RING
	115932-01-000	EA	CONNECTOR - FEMALE - 30 AMP/120 VOLT
	116811-01-000	EA	TERMINAL - .110 RECEPTACLE - 16-14 AWG
	118571-01-000	EA	CONNECTOR - 3-WAY - MALE/SEALED
	118571-02-000	EA	CONNECTOR - 3-WAY - FEMALE/SEALED
	118571-05-000	EA	LOCK - SECONDARY - FEMALE/SEALED
	118571-06-000	EA	LOCK - SECONDARY - MALE
	118599-02-000	EA	TERMINAL - MALE - M/P - 280/14-12
	118820-01-000	EA	INSULATOR - TERMINAL
	129233-01-000	EA	HOUSING - 2-POSITION/FEMALE - 280-SERIES
	129233-02-000	EA	HOUSING - 2-POSITION/FEMALE - 280-SERIES
	131681-01-000	EA	CONNECTOR - 3/4" SO CORD - UL/CS
	137207-01-000	EA	HOUSING - PIN - 2 CAVITY/HIGH AMP
	137208-01-000	EA	HOUSING - SOCKET - 2 CAVITY/HIGH AMP
	137209-01-000	EA	PIN - CONNECTOR - 10AWG/HIGH AMP
	137210-01-000	EA	SOCKET - CONNECTOR - 10 AWG/HIGH AMP
	138419-03-000	EA	SOCKET - TURN SIGNAL LAMP - 3 WIRE
	142520-01-000	EA	TERMINAL - FEMALE - MINI-FIT 16
	142522-01-000	EA	HOUSING - 4 PIN/MALE - MINI FIT
	142524-01-000	EA	HOUSING - 4 PIN/FEMALE - WEATHER PACK
	142524-02-000	EA	HOUSING - 4 PIN/FEMALE - WEATHER PACK
	144283-01-000	EA	CONNECTOR - 110V - F/USE WITH SOW WIRE - BLUE
	144283-02-000	EA	CONNECTOR - 110V - F/USE WITH NM ROMEX WIRE - CLEAR
	145171-01-000	EA	CONNECTOR - COAXIAL
	149687-01-000	EA	HOUSING - 2 POSITION/MALE - PACKARD
	149687-02-000	EA	LOCK - F/2 POSITION HOUSING - PACKARD
	149688-01-000	EA	TERMINAL - MALE - 16 GAUGE WIRE

**CHASSIS**

<b>KEY</b>	<b>PART NUMBER</b>	<b>U/M</b>	<b>DESCRIPTION</b>
	065450-05-000	EA	TIEDOWN - BATTERY - 8.4" TUBE
	065451-05-000	EA	BRACKET/TIEDOWN - BATTERY - 7.7" FROM BRKT TO BRKT
	086233-01-000	EA	STUD - ISOLATED - 3/8" X 7/8" LONG
	113452-02-000	FT	SEAL/TRIM - FRONT - VINYL W/WIRE CARRIER - .027"

## ELECTRICAL GROUP (CONTINUED)

### CHASSIS (CONTINUED)

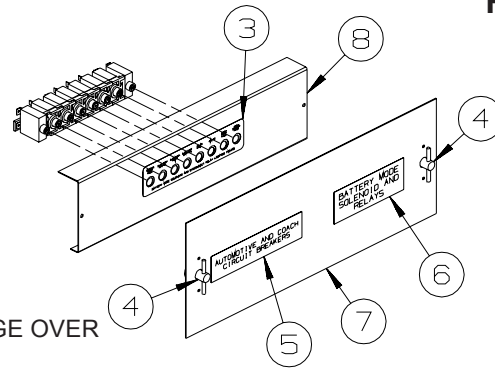
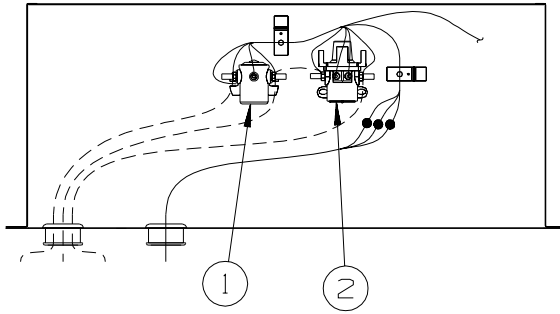

**F38J ONLY**

KEY	PART NUMBER	U/M	DESCRIPTION
1	008188-01-000	EA	SOLENOID - 3 POST - BATTERY CHANGE OVER
2	086273-01-000	EA	RELAY - BATTERY DISCONNECT
3	093236-35-000	EA	LABEL - CIRCUIT BREAKER
4	098196-01-000	EA	LATCH - 1/4 TURN - T-BAR
5	098379-01-000	EA	LABEL - CIRCUIT BREAKER - FRONT BOX
6	098379-04-000	EA	LABEL - ELECTRICAL BOX - SIDE
7	109925-04-000	EA	DOOR - ELECTRICAL BOX - 6.9" X 18.5" - GM/FORD
	092492-11-000	EA	SEAL - ELECTRIC BOX - 7" X 18.4"
8	118531-02-02B	EA	PLATE - CIRCUIT BREAKER - E COATED

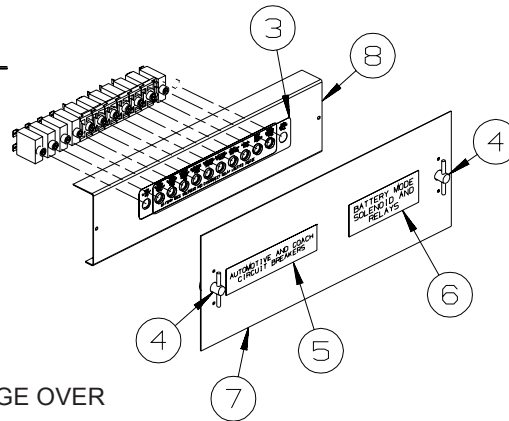
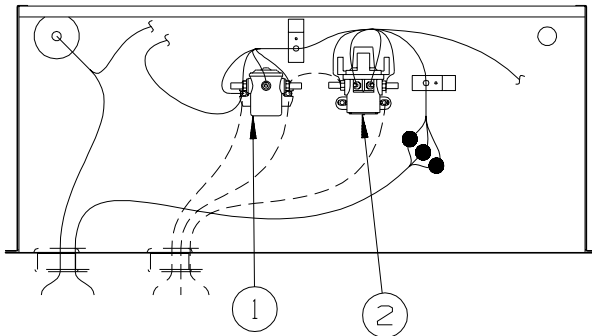

KEY	PART NUMBER	U/M	DESCRIPTION
1	008188-01-000	EA	SOLENOID - 3 POST - BATTERY CHANGE OVER
2	086273-01-000	EA	RELAY - BATTERY DISCONNECT
3	093236-39-000	EA	LABEL - CIRCUIT BREAKER
4	098196-01-000	EA	LATCH - 1/4 TURN - T-BAR
5	098379-01-000	EA	LABEL - CIRCUIT BREAKER - FRONT BOX
6	098379-04-000	EA	LABEL - ELECTRICAL BOX - SIDE
7	109925-04-000	EA	DOOR - ELECTRICAL BOX - 6.9" X 18.5" - GM/FORD
8	118531-06-02B	EA	PLATE - CIRCUIT BREAKER - E COATED

# EXTERIOR BODY GROUP GRAPHICS & PAINT

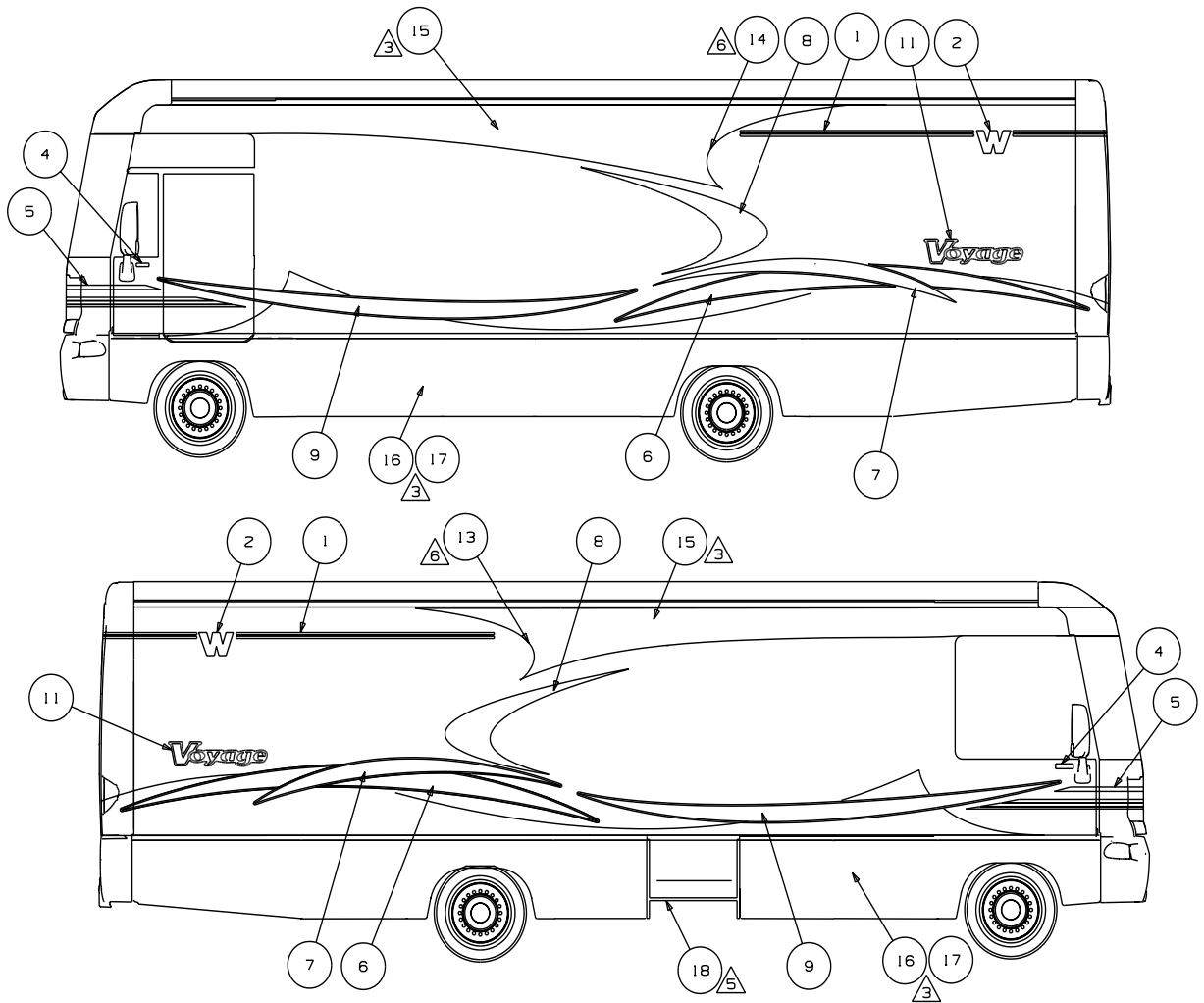

- PAINT MASK TO BE REMOVED AFTER PAINTED.
- FILM TO PROTECT BOTTOM OF DOOR FROM SCUFF MARKS.
- 4. CONTINUE MULTISTRIPIES ONTO SLIDEOUT WINGWALLS AND BACKWALLS.
- CLEAR COAT TO BE APPLIED ON PAINTED AREAS TO PROTECT PAINT.
- CENTER ON UNIT.

(92K) EXTERIOR GRAPHICS PACKAGE #2  
(276) EXTERIOR GRAPHICS PACKAGE #1

1. APPLY PROTECTOR 116424-01-000 TO WATER HEATER LATCH.

**NOTES:**

KEY	PART NUMBER	U/M	DESCRIPTION
1	105781-07-CHT(05A)	FT	MULTISTRIPE-50.8MM - PINE GREEN/GOLD STAR
1	105781-07-CHT(06A)	FT	MULTISTRIPE-50.8MM - DK BLUE POLY/BRIAR SMOKE
2	120700-10-CHT(04A)	EA	DECAL-W - PINE GREEN
2	120700-10-CHT(05A)	EA	DECAL-W - DK BLUE POLY
3	120702-03-CHT(44A)	EA	DECAL-WINNEBAGO,SML - PINE GREEN
3	120702-03-CHT(45A)	EA	DECAL-WINNEBAGO,SML - DK PLUE POLY
4	132664-01-CHT(01A)	EA	DECAL-WINNEBAGO DOMED - GOLD CHROME/BLACK
4	144258-02-CHT(01A)	FT	MULTISTRIPE - 187.3MM - GOLD STAR/CHAMPAGNE STAR/MED TITANIUM
5	144258-02-CHT(02A)	FT	MULTISTRIPE - 187.3MM - DK BLUE POLY/BRIAR SMOKE/DK BRIAR BROWN
6	49814-01-CHT(01A)	EA	DECAL-SLASH,#1,RH - CHAMPAGNE STAR
6	49814-01-CHT(02A)	EA	DECAL-SLASHES,RH - PINE GREEN/CHAMPAGNE STAR
6	49814-02-CHT(01A)	EA	DECAL-SLASH,#1,LH - DK BRIAR BROWN
6	49814-02-CHT(02A)	EA	DECAL-SLASH,#1,LH - CHAMPAGNE STAR
7	49815-01-CHT(01A)	EA	DECAL-SLASHES,RH - DK BLUE POLY/DK BRIAR BROWN
7	49815-02-CHT(01A)	EA	DECAL-SLASHES,LH - PINE GREEN/CHAMPAGNE STAR
7	49815-02-CHT(02A)	EA	DECAL-SLASHES,LH - DK BLUE POLY/DK BRIAR BROWN
8	49816-01-CHT(01A)	EA	DECAL-SLASH,#2,RH - MED TITANIUM
8	49816-01-CHT(02A)	EA	DECAL-SLASH,#2,RH - BRIAR SMOKE
8	49816-02-CHT(01A)	EA	DECAL-SLASH,#2,LH - MED TITANIUM
8	49816-02-CHT(02A)	EA	DECAL-SLASH,#2,LH - BRIAR SMOKE
9	49817-01-CHT(01A)	EA	DECAL-SLASH,#3,RH - PINE GREEN/GOLD STAR
9	49817-01-CHT(02A)	EA	DECAL-SLASH,#3,RH - DK BLUE POLY/DK BRIAR BROWN
9	49817-02-CHT(01A)	EA	DECAL-SLASH,#3,LH - PINE GREEN/GOLD STAR
9	49817-02-CHT(02A)	EA	DECAL-SLASH,#3,LH - DK BLUE POLY/DK BRIAR BROWN
10	49818-01-CHT(01A)	EA	DECAL-SLASHES,FRT & RR - BRT WHITE/PINE GREEN/MED TITANIUM
10	49818-01-CHT(02A)	EA	DECAL-SLASHES,FRT & RR - BRT WHITE/PINE GREEN/MED TITANIUM
11	49819-01-CHT(01A)	EA	DECAL-VOYAGE,LG - BRT WHITE/BLACK/SILVER/LT CHARCOAL
11	49819-02-CHT(01A)	EA	DECAL-VOYAGE,SML - BRT WHITE/BLACK/SILVER/LT CHARCOAL
12	49884-01-000	EA	DECAL-PAINT MASK,RH #16
13	149884-02-000	EA	DECAL-PAINT MASK,LH #16
14	141599-32-000	GL	PAINT - TITANIUM MET - DUPONT #373-P7435
15	141599-38-000	GL	PAINT - LUXOR BEIGE MET - DUPONT #373-P7434
16	141599-39-000	GL	PAINT - SPRUCE GREEN MET - DUPONT #373-P7443
17	109506-01-000	EA	FILM-URETHANE PROTECTION
18	137618-01-CHT(01A)	EA	DECAL/BEZEL-DOMED GRILLE LOGO - BLACK/GOLD



## EXTERIOR BODY GROUP (CONTINUED) GRAPHICS & PAINT (CONTINUED)

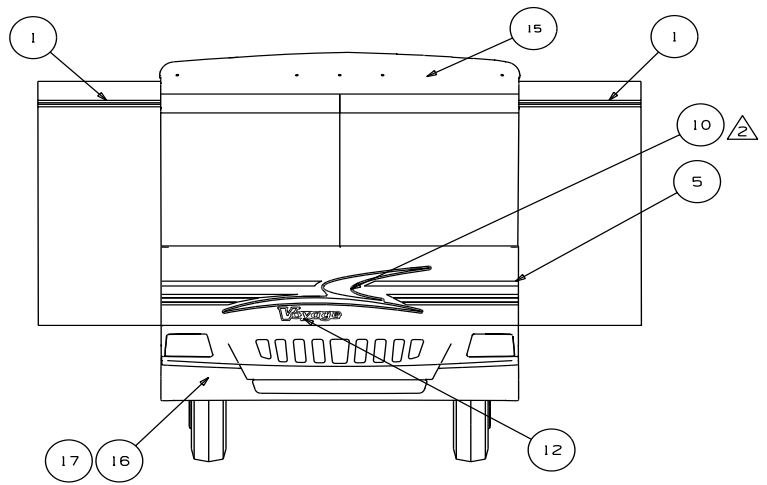
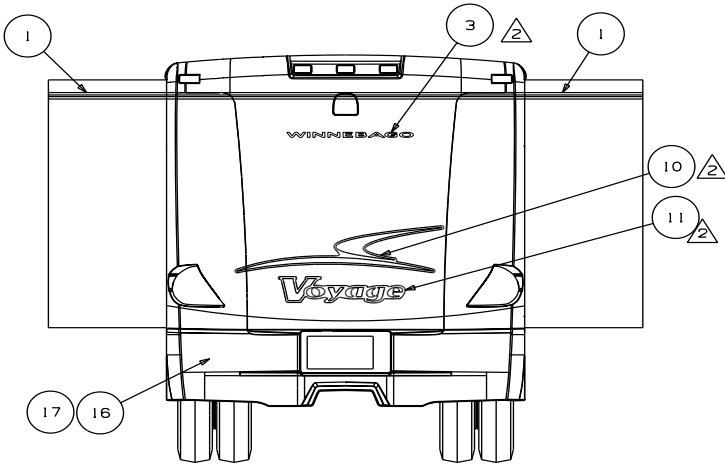

KEY	PART NUMBER	U/M	DESCRIPTION
27G	105781-07-CHT(05A)	FT	MULTISTRIPE-50.8MM - PINE GREEN/GOLD STAR
92K	105781-07-CHT(06A)	FT	MULTISTRIPE-50.8MM - DK BLUE POLY/BRIAR SMOKE
27G	120700-10-CHT(04A)	EA	DECAL-W - PINE GREEN
92K	120700-10-CHT(05A)	EA	DECAL-W - DK BLUE POLY
27G	120702-03-CHT(44A)	EA	DECAL-WINNEBAGO,SML - PINE GREEN
92K	120702-03-CHT(45A)	EA	DECAL-WINNEBAGO,SML - DK BLUE POLY
	132664-01-CHT(01A)	EA	DECAL-WINNEBAGO,DOMED - GOLD CHROME/BLACK
27G	144258-02-CHT(01A)	FT	MULTISTRIPE - 187.3MM - GOLD STAR/CHAMPAGNE STAR/MED TITANIUM
92K	144258-02-CHT(02A)	FT	MULTISTRIPE - 187.3MM - DK BLUE POLY/BRIAR SMOKE/DK BRIAR BROWN
27G	149814-01-CHT(01A)	EA	DECAL-SLASH,#1,RH - CHAMPAGNE STAR
92K	149814-01-CHT(02A)	EA	DECAL-SLASH,#1,RH - DK BRIAR BROWN
27G	149814-02-CHT(01A)	EA	DECAL-SLASH,#1,LH - CHAMPAGNE STAR
92K	149814-02-CHT(02A)	EA	DECAL-SLASH,#1,LH - DK BRIAR BROWN
27G	149815-01-CHT(01A)	EA	DECAL-SLASHES,RH - PINE GREEN/CHAMPAGNE STAR
92K	149815-01-CHT(02A)	EA	DECAL-SLASHES,RH - DK BLUE POLY/DK BRIAR BROWN
27G	149815-02-CHT(01A)	EA	DECAL-SLASHES,LH - PINE GREEN/CHAMPAGNE STAR
92K	149815-02-CHT(02A)	EA	DECAL-SLASHES,LH - DK BLUE POLY/DK BRIAR BROWN
27G	149816-01-CHT(01A)	EA	DECAL-SLASH,#2,RH - MED TITANIUM
92K	149816-01-CHT(02A)	EA	DECAL-SLASH,#2,RH - BRIAR SMOKE
27G	149816-02-CHT(01A)	EA	DECAL-SLASH,#2,LH - MED TITANIUM
92K	149816-02-CHT(02A)	EA	DECAL-SLASH,#2,LH - BRIAR SMOKE
27G	149817-01-CHT(01A)	EA	DECAL-SLASH,#3,RH - PINE GREEN/GOLD STAR
92K	149817-01-CHT(02A)	EA	DECAL-SLASH,#3,RH - DK BLUE POLY/DK BRIAR BROWN
27G	149817-02-CHT(01A)	EA	DECAL-SLASH,#3,LH - PINE GREEN/GOLD STAR
92K	149817-02-CHT(02A)	EA	DECAL-SLASH,#3,LH - DK BLUE POLY/DK BRIAR BROWN
27G	149818-01-CHT(01A)	EA	DECAL-SLASHES,FRT & RR - BRT WHITE/PINE GREEN/MED TITANIUM
92K	149818-01-CHT(02A)	EA	DECAL-SLASHES,FRT & RR - BRT WHITE/DK BLUE POLY/BRIAR SMOKE
27G	149819-01-CHT(01A)	EA	DECAL-VOYAGE,LG - BRT WHITE/BLACK/SILVER/LT CHARCOAL
92K	149819-02-CHT(01A)	EA	DECAL-VOYAGE,SML - BRT WHITE/BLACK/SILVER/LT CHARCOAL
27G	149884-01-000	EA	DECAL-PAINT MASK,RH #16
92K	149884-02-000	EA	DECAL-PAINT MASK,LH #16
27G	141599-32-000	GL	PAINT - TITANIUM MET - DUPONT #373-P7435
92K	141599-38-000	GL	PAINT - LUXOR BEIGE MET - DUPONT #373-P7434
27G	141599-39-000	GL	PAINT - SPRUCE GREEN MET - DUPONT #373-P7443
18	109506-01-000	EA	FILM-URETHANE PROTECTION
19	137618-01-CHT(01A)	EA	DECAL/BEZEL-DOMED GRILLE LOGO - BLACK/GOLD

KEY	PART NUMBER	U/M	DESCRIPTION
	093681-40-01A	FT	FILM - 2" - FLAT BLACK
	041561-03-000	EA	PAINT - 16 OUNCE SPRAY - OFF WHITE

**DUPONT COLOR CODES ARE NOW FOUND IN THE PAINT CODE MANUAL.  
YOU CAN FIND THIS MANUAL ON YOUR DEALER INDEX WEBPAGE UNDER SERVICE.**

## EXTERIOR BODY GROUP (CONTINUED)

### PANELS & TRIMS

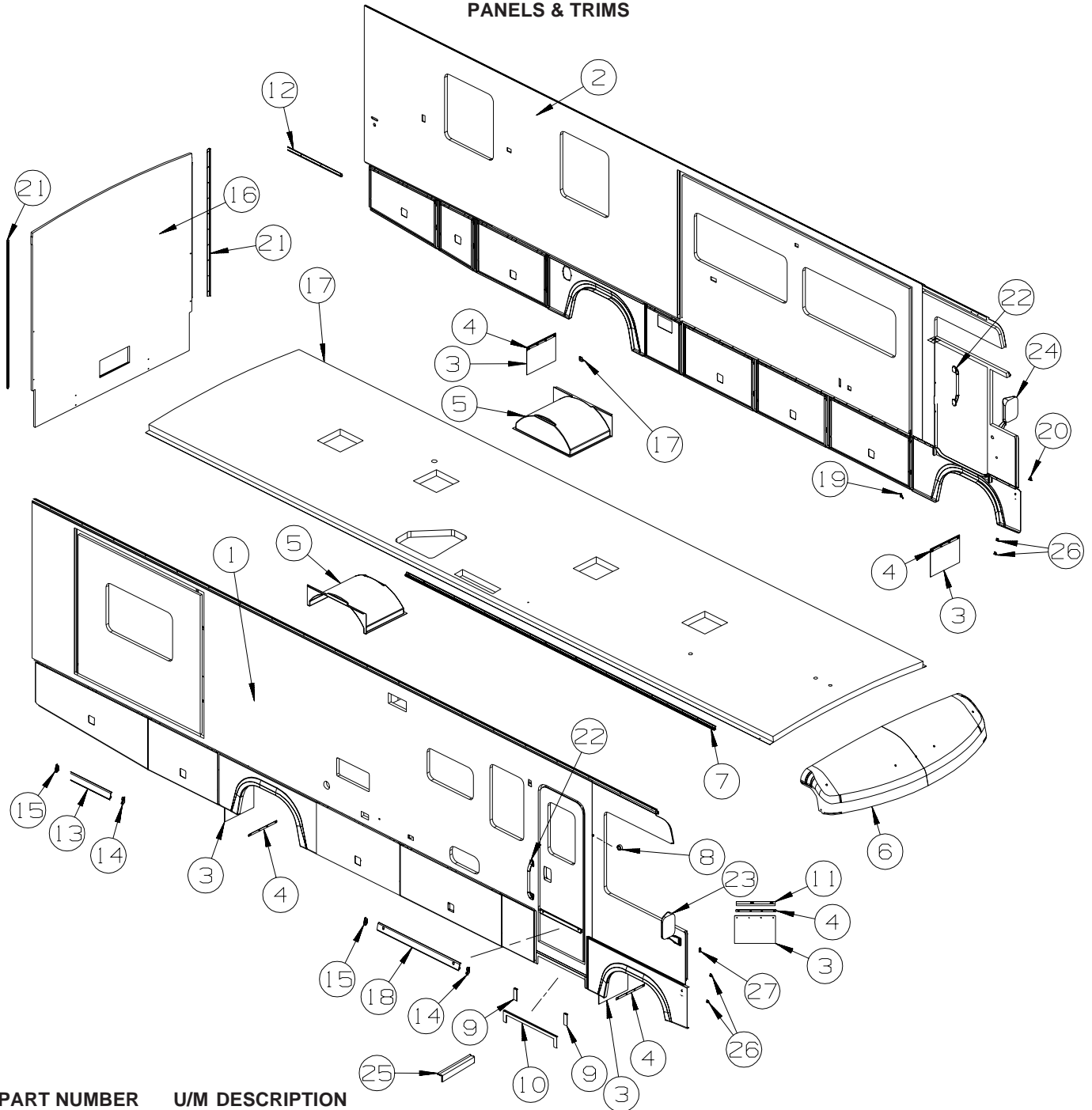

KEY	PART NUMBER	U/M	DESCRIPTION
1	151345-01-S46	EA	SIDEWALL - PASSENGER - W/O WINDOWS/TRIMS (S46, S47, S48, SR0)
1	151345-01-S49	EA	SIDEWALL - PASSENGER - W/O WINDOWS/TRIMS (S49, S50, S51, SR1)
1	151345-01-S52	EA	SIDEWALL - PASSENGER - W/O WINDOWS/TRIMS (S52, S53, S54, SR2)
2	151346-01-S46	EA	SIDEWALL - DRIVER - W/O WINDOWS/TRIMS (S46, S47, S48, SR0)
2	151346-01-S49	EA	SIDEWALL - DRIVER - W/O WINDOWS/TRIMS (S49, S50, S51, SR1)
2	151346-01-S52	EA	SIDEWALL - DRIVER - W/O WINDOWS/TRIMS (S52, S53, S54, SR2)
3	017516-01-000	EA	MUD FLAP - 14"H X 18"W - W/O MOUNTING HOLES - RUBBER - BLK
4	140922-01-02B	EA	RETAINER - MUD FLAP - 1" X 17.7" - E-COATED/BLACK
5	131365-01-000	EA	WHEELWELL - PLASTIC
6	125052-02-J20	EA	CAP - ROOF - W/O LIGHTS/WIRING
7	131483-01-01A	EA	RAIL - AWNING - 192" - BRIGHT WHITE
8	069726-02-000	EA	BUMPER - .88" OD X .40" THICK - BLACK
9	121117-05-02B	EA	ANGLE - W/O SLOTS - 5.7" X 2" - E-COATED
			FROM: 09-05-04 THRU: 99-99-99
10	138021-02-02B	EA	VALANCE/PANEL - ENTRY STEP/U-SHAPED - 33.2" X 4.1" E-COAT
11	132695-01-02B	EA	ANGLE - MUDFLAP - E-COATED
12	146548-01-01A	EA	TRIM - RETAINER
13	146550-01-02A	EA	TRIM COVER - SIDEWALL - 182" - BLACK

## EXTERIOR BODY GROUP (CONTINUED) PANELS & TRIMS (CONTINUED)

KEY	PART NUMBER	U/M	DESCRIPTION
14	146576-01-02A	EA	END CAP/TRIM - RIGHT HAND - BLACK
15	146576-02-02A	EA	END CAP/TRIM - LEFT HAND - BLACK
16	148412-01-S46	EA	BACKWALL - W/O WINDOW/TRIMS (S46, S47, S48, SR0)
16	148412-01-S49	EA	BACKWALL - W/O WINDOW/TRIMS (S49, S50, S51, SR1)
16	148412-01-S52	EA	BACKWALL - W/O WINDOW/TRIMS (S52, S53, S54, SR2)
17	151347-01-S46	EA	ROOF - W/O LIGHTS/VENTS - W/WIRING
18	149822-01-01A	EA	TRIM - SIDEWALL/ENTRY DOOR - 25.3" - BRIGHT WHITE
19	150742-01-02A	EA	CAP/TRIM - DRIVER DOOR - BLACK
			FROM: 07-12-04 THRU: 99-99-99
20	150742-02-02A	EA	CAP/TRIM - DRIVER DOOR - BLACK
			FROM: 07-12-04 THRU: 99-99-99
21	132273-01-02B	EA	BRACKET - REAR TRIM - E-COATED
22*	132442-01-01A	EA	HANDLE - ASSIST/WHITE METAL - 20" - W/WHITE ENDS
23*	106015-18-01A	EA	MIRROR - EXTERIOR/REMOTE/HEAT - PASSENGER
24*	106015-19-01A	EA	MIRROR - EXTERIOR/REMOTE/HEAT - DRIVER
25	093873-01-01A	EA	TRIM - CARPET - L-ANGLE 1.1" X 1.3" X 12' - GRAY VINYL
26	143143-01-01A	EA	ANGLE - SUPPORT/TRIM
27	132597-01-02B	EA	ANGLE/SUPPORT/TRIM - 2" - E-COATED
			FROM: 02-21-05 THRU: 99-99-99

**\*COMPONENT PARTS LISTED LATER IN THIS GROUP**

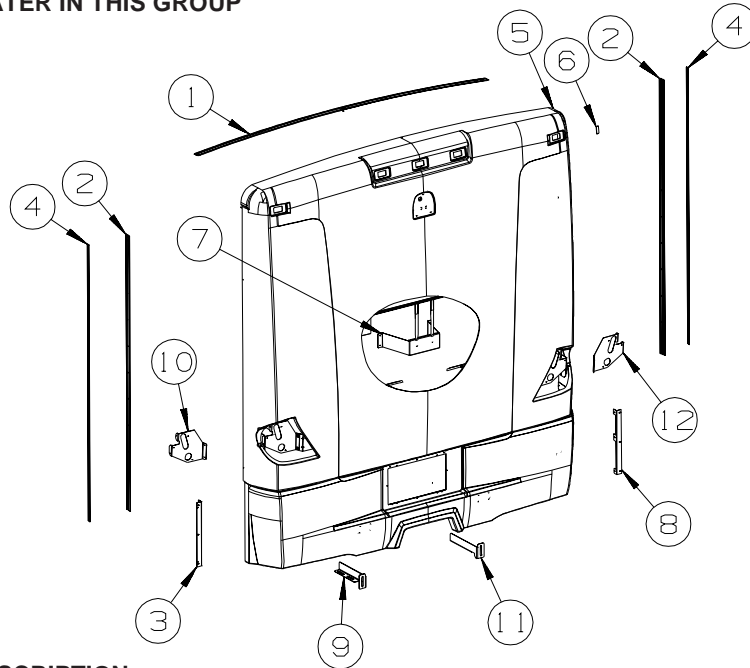

KEY	PART NUMBER	U/M	DESCRIPTION
1	083805-23-000	EA	TRIM - ROOF CAP - 92.1" - BRIGHT WHITE
2	092041-09-01A	EA	TRIM - FRONT/REAR CAP (SIDEWALL) - 77.3" - BRIGHT WHITE
3	138789-01-02B	EA	ANGLE/MOUNT - WHEEL LIP/BACKWALL - E-COATED
4	091985-01-07A	FT	INSERT - TRIM - REAR CAP TO SIDEWALL - .66" - BRIGHT WHITE
5	148999-04-S46	EA	PANEL - REAR CAP - F/UNITS W/O CAMERA
5	148999-03-S46	EA	PANEL - REAR CAP - F/UNITS W/CAMERA - REARVIEW MONITOR SYS W/AUDIO
6	104692-03-000	EA	SEAL - ADHESIVE BACKED FOAM - 1" THICK X 1 3/16"WIDE X 15'
7	150633-01-02B	EA	BRACE - REAR CAP, E-COATED
8	150703-01-02B	EA	ANGLE - MOUNT - SEAL PLANE - E-COATED
9	149152-02-02B	EA	BRACE - REAR CAP, LOWER, LH, E-COATED
10	149005-04-02B	EA	SUPPORT - TAIL LAMP - LEFT - E-COATED
11	149152-01-02B	EA	BRACE - REAR CAP, LOWER, RH, E-COATED
12	149005-03-02B	EA	SUPPORT - TAILLAMP - RIGHT - E-COATED

**EXTERIOR BODY GROUP (CONTINUED)**  
**PANELS & TRIMS (CONTINUED)**

**PASSENGER  
SIDEWALL**

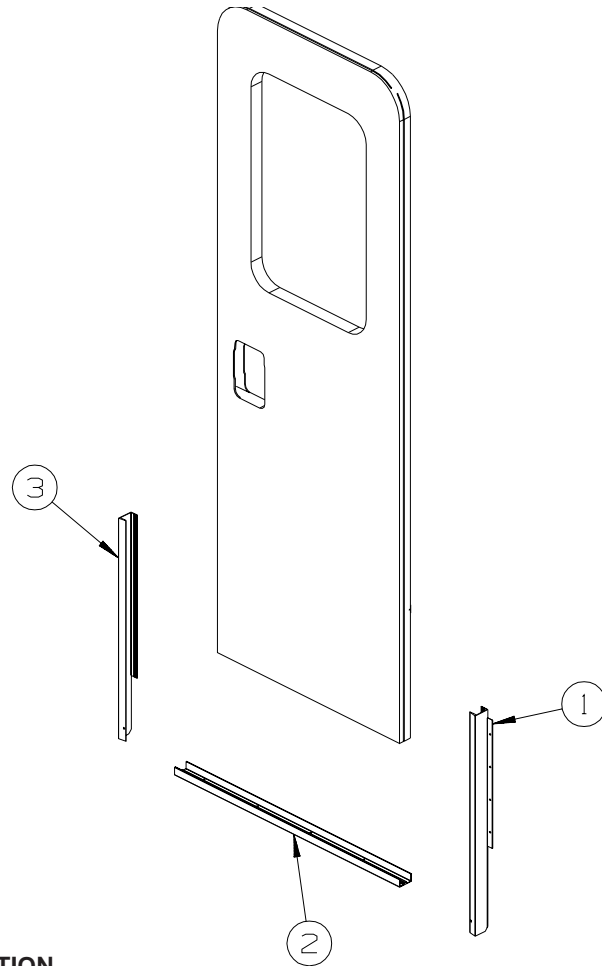

KEY	PART NUMBER	U/M	DESCRIPTION
1	133100-05-01A	EA	TRIM - SIDEWALL - 26.5" - BLACK
2	137599-01-01A	EA	TRIM - SIDEWALL/LOWER - 33.2" - BLACK
3	133100-06-01A	EA	TRIM - SIDEWALL - 26.5" - BLACK

**BACKWALL**

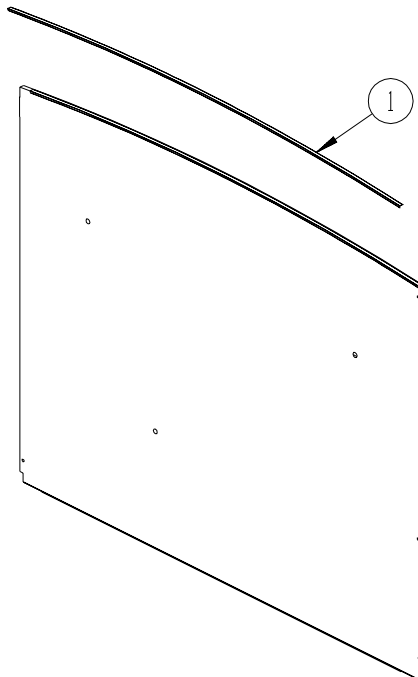

KEY	PART NUMBER	U/M	DESCRIPTION
1	114248-02-01A	EA	ANGLE - PLASTIC - 96.6"

## EXTERIOR BODY GROUP (CONTINUED)

### COMPONENT PARTS FOR PANELS & TRIMS

106015-18-01A, 106015-19-01A

KEY	PART NUMBER	U/M	DESCRIPTION	VENDOR NO.
	106015-12-702	EA	CAP/SCREW - (PKG OF 4) - BLK	748329 RND
	106015-16-700	EA	GLASS-FLAT W/HEAT ELEMENT	709450
	106015-18-700	EA	GLASS/CONVEX-KIT W/CLIP	709650
	106015-18-701	EA	ACTUATOR - CONVEX GLASS	7475410
	106015-18-702	EA	MOTOR - FLAT GLASS	747118
	106015-18-703	EA	CONVEX REBUILT KIT	709651
	106015-19-700	EA	VIBRATION KIT - MIRROR GLASS, VELVAC	709645

132442-01-01A

KEY	PART NUMBER	U/M	DESCRIPTION	VENDOR NO.
	132442-01-700	EA	BULB/ROPE - F/ASSIST HANDLE	ST012-0C/12MLX

# EXTERIOR BODY GROUP (CONTINUED)

## FRONT END

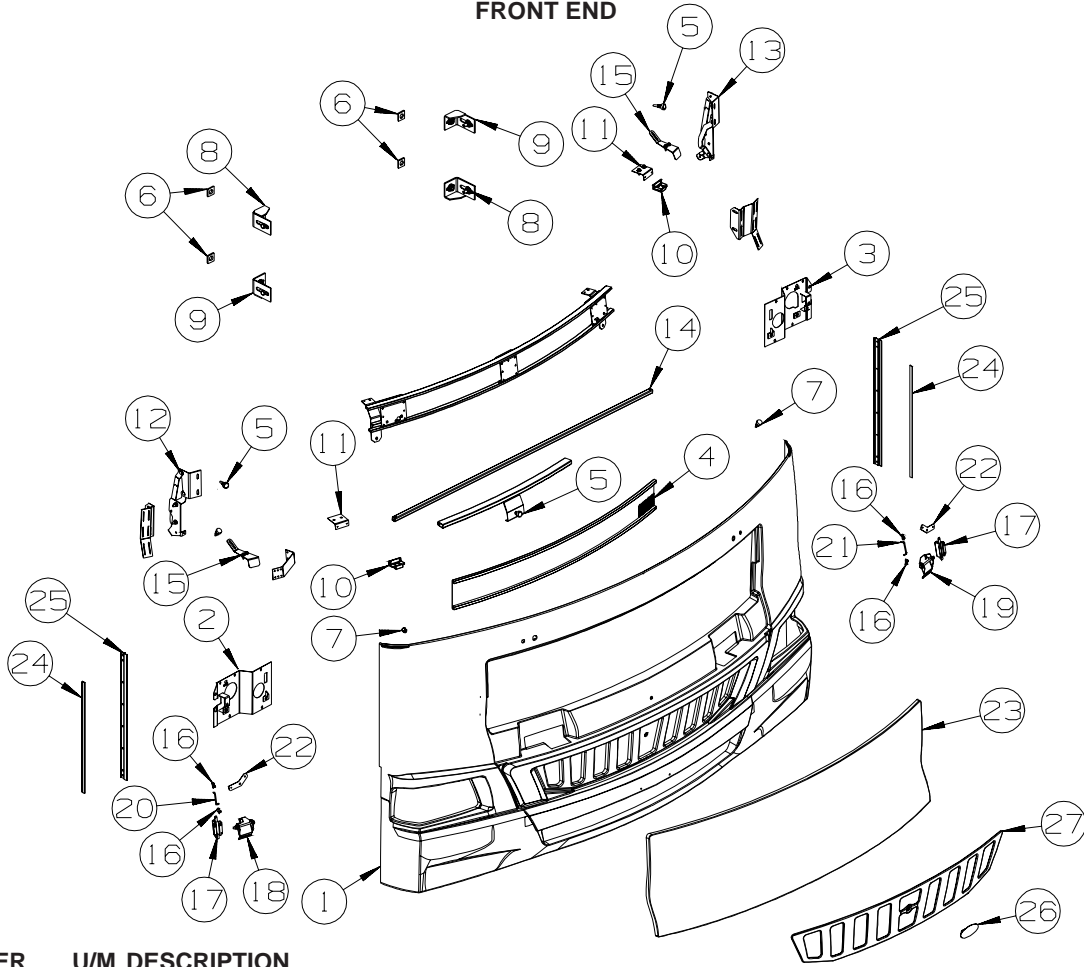

KEY	PART NUMBER	U/M	DESCRIPTION
1	147858-04-S46	EA	PANEL - FRONT/LOWER - W/O HOOD/GRILLE/LIGHTS
2	147920-01-02B	EA	SUPPORT ASM-HEADLAMP,RH,E-CT
3	147920-02-02B	EA	SUPPORT ASM-HEADLAMP,LH,E-CT
4	147960-01-02A	EA	MESH - GRILLE - BLACK - 5.7" X 50.1"
5	058786-01-000	EA	BOLT - HOOD ADJUSTMENT - 5/16"-18 X 1.5"-2" - W/BLACK PAD
6	116617-02-02B	EA	SPACER - BUMPER
7	117047-01-000	EA	BUMPER - RUBBER/WASHER INSERT
8	128455-07-02B	EA	BRACKET - BUMPER - E-COATED
9	128455-08-02B	EA	BRACKET - BUMPER - E-COATED
10	130053-02-01A	EA	STRIKER - LUGGAGE DOOR - OFF SET - BLACK
11	133802-02-02B	EA	BRACKET - LATCH - ADJUSTING - E-COATED
12	137072-03-01A	EA	HINGE - HOOD - RIGHT HAND - BLACK
13	137072-04-01A	EA	HINGE - HOOD - LEFT HAND - BLACK
14	137300-01-02B	EA	TUBE/TIMING - HOOD - 63.2" - E-COATED - WORKHORSE & 2004 FORD
14	154091-05-02B	EA	TUBE - TIMING - HOOD - E-COATED - 2006 FORD
15	141017-01-02B	EA	SUPPORT/HINGE - FRONT - E-COATED
16	102265-01-000	EA	CLIP/ROD END - 5/32" - BLACK PLASTIC
17	113908-02-000	EA	LATCH/PLUNGER - F/HOOD/REAR TRUNK/ENGINE DOOR
18	134415-01-02B	EA	LATCH/HOOD - PULL - RIGHT HAND - E-COATED
19	134415-02-02B	EA	LATCH/HOOD - PULL - LEFT HAND - E-COATED
20	134416-01-01A	EA	ROD/HOOD LATCH - STAINLESS STEEL - RIGHT HAND
21	134416-02-01A	EA	ROD/HOOD LATCH - STAINLESS STEEL - LEFT HAND
22	134418-08-02B	EA	PIVOT - LATCH/HOOD - RIGHT HAND/LEFT HAND - E-COATED
23	148081-01-S46	EA	PANEL/HOOD - W/O PADDLE LATCH/LATCHING MECHANISM
24	091985-01-07A	FT	INSERT - TRIM - .65" WIDE - BRIGHT WHITE
25	092041-10-01A	EA	TRIM - FRONT/REAR CAP (SIDEWALL) - 25.2" - BRIGHT WHITE
26	137933-03-02B	EA	PLATE - BEZEL
27	147971-01-01A	EA	GRILLE - FRONT/UPPER - BRIGHT BRUSHED STAINLESS STEEL

**EXTERIOR BODY GROUP (CONTINUED)**  
**FRONT END (CONTINUED)**

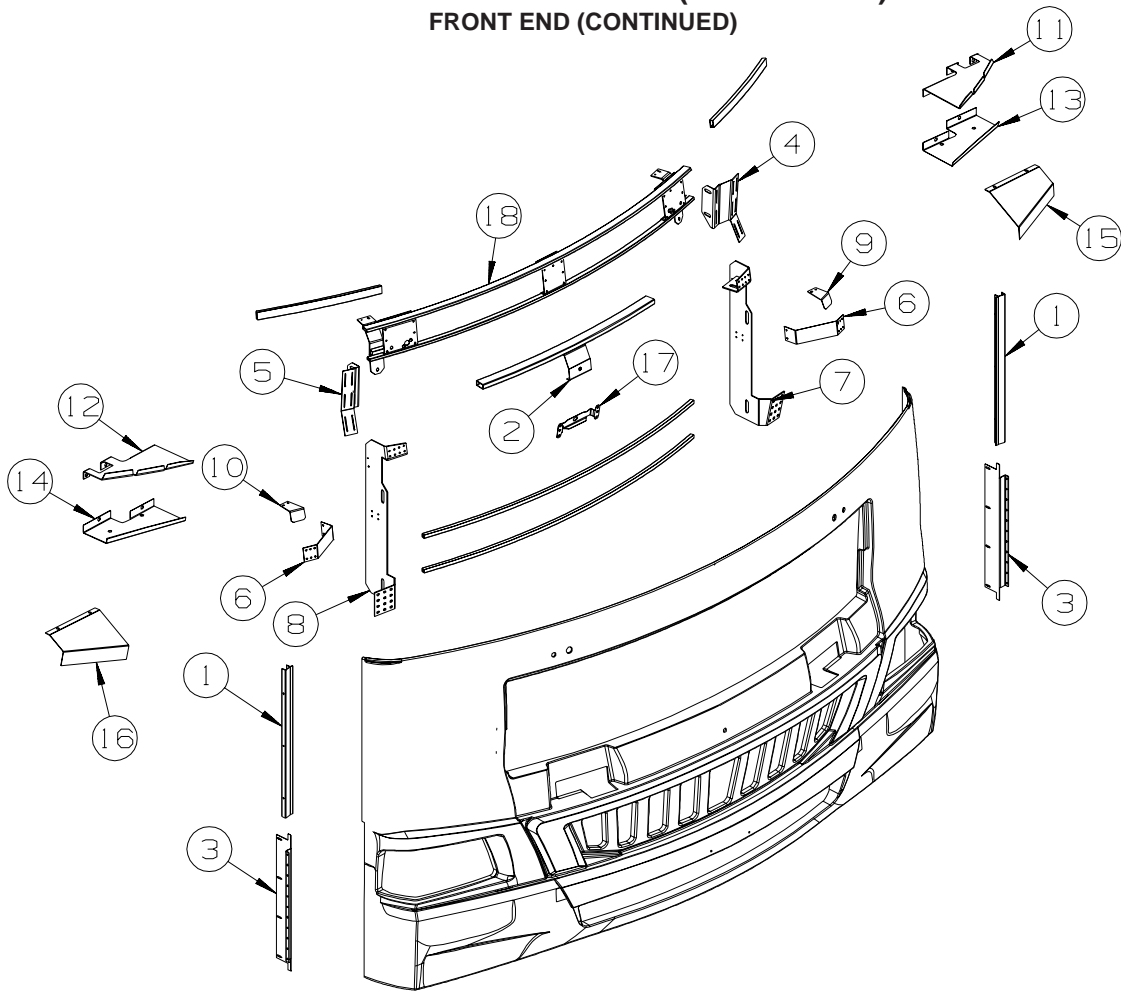

KEY	PART NUMBER	U/M	DESCRIPTION
1	132864-01-01A	EA	SUPPORT - FRONT/INNER PANEL TRIM
2	133770-02-02B	EA	BRACKET - HOOD SUPPORT - E-COATED
3	134066-01-02B	EA	BRACKET - ZEE - W/HOLES - E-COATED
			FROM: 00-00-00 THRU: 03-04-05
3	134066-04-02B	EA	BRACKET - ZEE - W/HOLES - E-COATED
			FROM: 03-05-05 THRU: 99-99-99
4	134530-05-02B	EA	SUPPORT - HOOD LINK - E-COATED
5	134530-06-02B	EA	SUPPORT - HOOD LINK - E-COATED
6	134562-01-02B	EA	SUPPORT - FRONT
7	137896-01-02B	EA	BRACKET - FRONT
8	137896-02-02B	EA	BRACKET - FRONT
9	141018-01-02B	EA	BRACKET/HINGE - FRONT/PASSENGER - E-COATED
10	141018-02-02B	EA	BRACKET/HINGE - FRONT/DRIVER - E-COATED
11	147934-03-02B	EA	SUPPORT ASM
12	147934-04-02B	EA	SUPPORT ASM
13	147935-03-02B	EA	SUPPORT ASM
14	147935-04-02B	EA	SUPPORT ASM
15	147941-01-02B	EA	BRACKET - HEADLAMP - RIGHT HAND - E-COATED
16	147941-02-02B	EA	BRACKET - HEADLAMP - LEFT HAND - E-COATED
17	148372-01-02B	EA	BRACKET - MOUNT
18	149784-03-S46	EA	SUPPORT - WIPER
	149788-06-02B	EA	SUPPORT - PIVOT SHAFT - E-COATED - PASSENGER SIDE
	149788-08-02B	EA	SUPPORT - PIVOT SHAFT - E-COATED - DRIVER SIDE

**EXTERIOR BODY GROUP (CONTINUED)**  
**LADDER**

<b>KEY</b>	<b>PART NUMBER</b>	<b>U/M</b>	<b>DESCRIPTION</b>
	129375-02-000	EA	SEAL - LADDER BRACKET
	149238-01-01A	EA	LADDER - UPPER - BRUSHED ALUMINUM
	150785-02-01A	EA	LADDER - LOWER - 35.6" / 3 STEP W/DOG LEG - HINGED STANDOFF

**STRUCTURAL COMPONENTS**

<b>KEY</b>	<b>PART NUMBER</b>	<b>U/M</b>	<b>DESCRIPTION</b>
	001054-01-011	EA	SHEET-ALUMINUM, 4' X 8' - FLAT - OFF WHITE
	002766-01-001	EA	ANGLE - EXTRUDED - 1" X 1 1/2" X 17'
	076054-Z3-000	EA	FIBERGLASS SHEET - 102" X 93.9" - ROOF/SIDEWALL - BRT WHT
	089297-01-000	SF	PLYWOOD - LUAN - OVERLAY GRADE - 4' X 8'
	100619-01-000	BF	FOAM - EXPANDED POLYSTYRENE - 1.34" X 48" X 96"
	100619-02-000	BF	FOAM - EXPANDED POLYSTYRENE - 1.5" X 48" X 96"
	100619-04-000	BF	FOAM - EXPANDED POLYSTYRENE - .5" X 48" X 96"
	100619-05-000	BF	FOAM - EXPANDED POLYSTYRENE - .75" X 48" X 96"-1.5"DENSITY
	100619-13-000	BF	FOAM - EXPANDED POLYSTYRENE-.34" X 34.7" X 96"-2" DENSITY
	100619-16-000	BF	FOAM - EXPANDED POLYSTYRENE - .75" X 48" X 96"-2" DENSITY
	100619-27-000	BF	FOAM - EXPANDED POLYSTYRENE - 3" X 48" X 92.8"
	105077-08-000	EA	FOAM - PLUG - ROOF CAP
	108535-05-03A	SF	FIBERGLASS SHEET - 108" X 500' ROLL - BRIGHT WHITE
	116942-03-01A	LB	ALUMINUM - .7" X 40" X 158"
	120107-02-000	EA	FOAM - PLUG - ROOF TUBE - 2.2" X 2.9" X 1.8" LONG
	120107-03-000	EA	FOAM - PLUG - SIDEWALL TUBE - 1.2" X 2.1" X 1.8" LONG
	120107-07-000	EA	FOAM - ROOF COVE
	128782-07-01A	EA	FIBERGLASS SHEET - 79" X 456" - HIGH GLOSS - BRIGHT WHITE
	128782-08-01A	EA	FIBERGLASS SHEET - 22" X 68.3" - HIGH GLOSS - BRIGHT WHITE
	128782-09-01A	EA	FIBERGLASS SHEET - 31" X 68.2" - HIGH GLOSS - BRIGHT WHITE
	128782-10-01A	EA	FIBERGLASS SHEET - 25" X 48" - HIGH GLOSS - BRIGHT WHITE
	128782-14-01A	EA	FIBERGLASS SHEET - 102.4" X 99.2" - HIGH GLOSS
	148884-20-01A	EA	FIBERGLASS SHEET - 4" X 93.8" - HIGH GLOSS - BRIGHT WHITE
	148884-22-01A	EA	FIBERGLASS SHEET - 47.9" X 95.8" - HIGH GLOSS-BRIGHT WHITE



## EXTERIOR BODY GROUP (CONTINUED)

### AWNINGS

#### PATIO AWNINGS

SERIES	MODEL	COLOR DESIGNATION	AWNING FABRIC	AWNING LENGTH	WEATHER WRAP(MANUAL)	PART # MANUAL	WEATHER WRAP(ELEC)	PART # ELECTRIC
VOYAGE (92K)	F31W	FAWN (EA)	VINYL	16'	VYL/BRT WHT	113874-06-53A	MTL/BRT WHT	143181-06-29A
	F33V	FAWN (EA)	VINYL	18'	VYL/BRT WHT	113874-07-53A	MTL/BRT WHT	143181-07-29A
	F35D	FAWN (EA)	VINYL	18'	VYL/BRT WHT	113874-07-53A	MTL/BRT WHT	143181-07-29A
	F35A	FAWN (EA)	VINYL	18'	VYL/BRT WHT	113874-07-53A	MTL/BRT WHT	143181-07-29A
	F36M	FAWN (EA)	VINYL	19'	VYL/BRT WHT	113874-08-53A	MTL/BRT WHT	143181-08-29A
VOYAGE (27G)	F31W	ALPINE GREEN (DY)	VINYL	16'	VYL/BRT WHT	113874-06-45A	MTL/BRT WHT	143181-06-28A
	F33V	ALPINE GREEN (DY)	VINYL	18'	VYL/BRT WHT	113874-07-45A	MTL/BRT WHT	143181-07-28A
	F35D	ALPINE GREEN (DY)	VINYL	18'	VYL/BRT WHT	113874-07-45A	MTL/BRT WHT	143181-07-28A
	F35A	ALPINE GREEN (DY)	VINYL	18'	VYL/BRT WHT	113874-07-45A	MTL/BRT WHT	143181-07-28A
	F36M	ALPINE GREEN (DY)	VINYL	19'	VYL/BRT WHT	113874-08-45A	MTL/BRT WHT	143181-08-28A

KEY	PART NUMBER	U/M DESCRIPTION
	113874-11-01A	EA SCREW/LAG - AWNING - 1/4" X 1" STAINLESS STEEL
*	113874-01-02A	EA HARDWARE KIT - AWNING - W/O STANDOFF BRACKET-BRIGHT WHITE - <b>MANUAL</b>
	113874-12-01A	EA SCREW/LAG - AWNING - 1/4" X 2 3/4" STAINLESS STEEL - <b>MANUAL</b>
	137054-01-02A	EA BRACKET - AWNING - BRIGHT WHITE - <b>MANUAL</b>
	143181-10-01A	EA AWNING/WEATHERPROOF - HARDWARE KIT - BRIGHT WHITE - <b>ELECTRIC</b>
	143181-11-01A	EA AWNING/WEATHERPROOF - SPACER KIT - BRIGHT WHITE - <b>ELECTRIC</b>
	143181-02-01A	EA ELECTRICAL KIT/AWNING - WEATHERPROOF - <b>ELECTRIC</b>
	146457-02-03A	EA BRACKET - AWNING - BRIGHT WHITE - <b>ELECTRIC</b>

\*COMPONENT PARTS LISTED LATER IN THIS GROUP

**EXTERIOR BODY GROUP (CONTINUED)**  
**COMPONENT PARTS FOR AWNINGS**

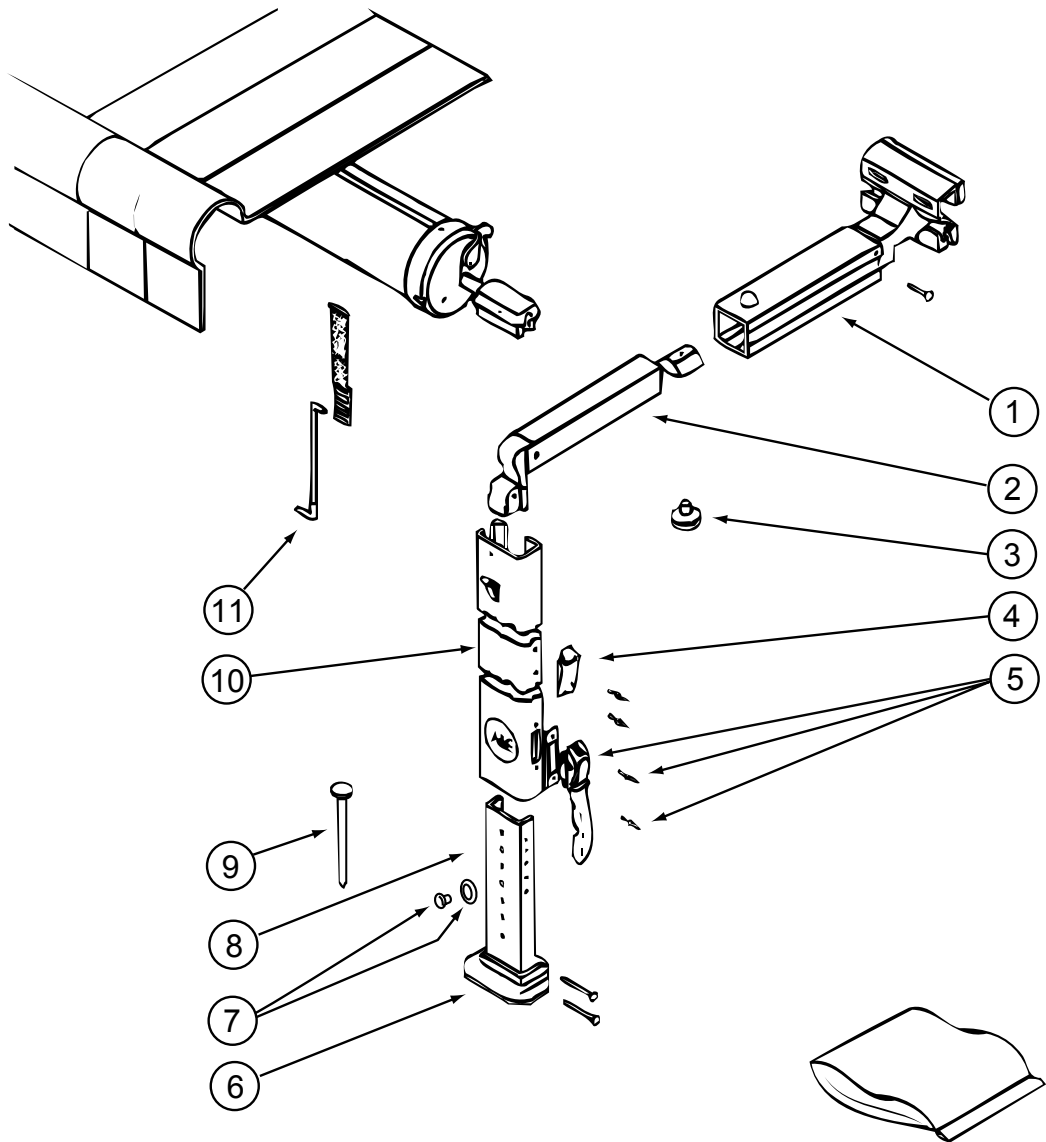

113874-01-02A

KEY	PART NUMBER	U/M	DESCRIPTION	VENDOR NO.
1	113874-01-714	EA	RAFTER - MAIN RH/LH BRT/WHT	830295.536F
2	113874-01-715	EA	RAFTER - SECONDARY BRT/WHT	830463.511F
3	113874-01-702	EA	KNOB - ADJUSTING	3105421.014
4	113874-01-706	EA	LOCK - TRAVEL	830587.001
5	113874-01-707	EA	HANDLE - LIFT W/RIVETS	830644
6	113874-01-712	EA	FOOT - PATIO	730366-001
7	113874-01-710	EA	PLUG-STOP KIT	830456
8	113874-01-717	EA	ARM - ADJUSTABLE BRT/WHT	830467.517/F
9	113874-01-709	EA	NAIL-SPIKE, 8"	113006
10	113874-01-716	EA	ARM - MAIN SUPPORT BRT/WHT	3104502.293/F
11	113874-01-703	EA	ROD-CENTER PULL W/ACCESSORY	830152.102

# EXTERIOR DOORS & COMPARTMENTS GROUP

## DOOR & COMPARTMENT LAYOUT

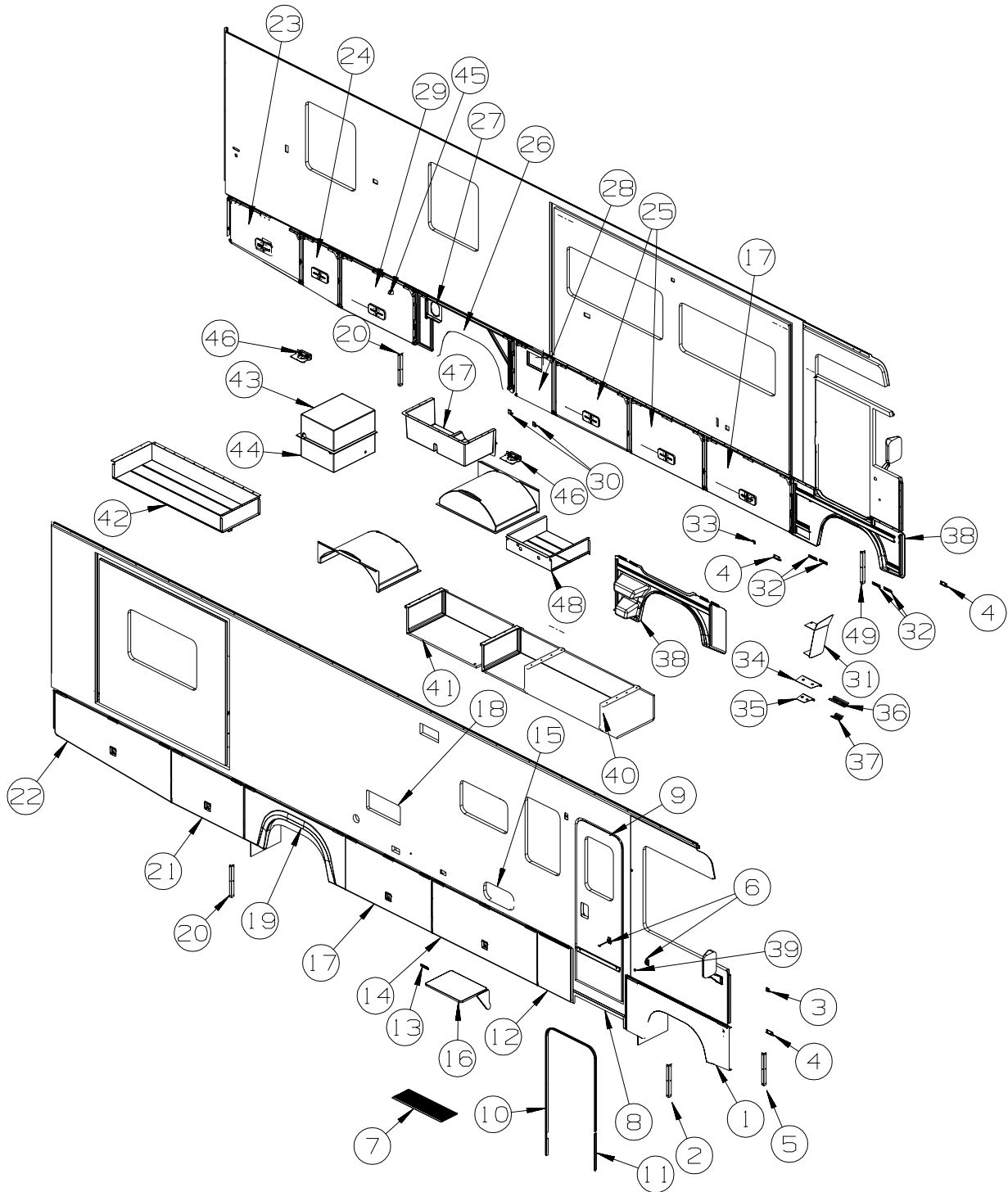

KEY	PART NUMBER	U/M	DESCRIPTION
1	141621-30-R35	EA	PANEL/WHEEL LIP - PASSENGER/FRONT - 61.2" - <b>WORKHORSE</b> - 19.5" TIRE - FORD
1	143492-32-S46	EA	PANEL/WHEEL LIP - PASSENGER/FRONT - <b>WORKHORSE</b> - 22.5" TIRE
	139793-03-01A	EA	HINGE - CENTER/VALANCE DOOR - W/O BALL STUD
2	113904-07-02B	EA	ANGLE - ATTACHMENT/WHEEL LIP - 8" - E-COAT
2	113904-18-02B	EA	ANGLE - ATTACHMENT/WHEEL LIP - 9.8" - E-COAT
3	143143-01-01A	EA	ANGLE - SUPPORT/TRIM
4	143143-02-01A	EA	ANGLE - SUPPORT/TRIM
5	113904-16-02B	EA	ANGLE - ATTACHMENT/WHEEL LIP - 5.1" - E-COAT
6	104099-02-04A	EA	CATCH/RETAINER - DOOR HOLDER - BRIGHT WHITE
6	104099-03-04A	EA	CATCH - DOOR HOLDER - STRIKE - 6" - BRIGHT WHITE
7	133114-01-01A	EA	TREAD - STEP/RUBBER - 29.3" X 10.1" - TAUPE (S46, S47, S48, S49, S50, S51, SR0, SR1)
7	133114-01-03A	EA	TREAD - STEP/RUBBER - 29.3" X 10.1" - GRAY (S52, S53, S54, SR2)
8*	143709-01-01A	EA	STEP - ELECTRIC - TRIPLE - BLACK - <b>WORKHORSE</b> - 22.5" TIRE

**EXTERIOR DOORS & COMPARTMENTS GROUP (CONTINUED)**  
**DOOR & COMPARTMENT LAYOUT (CONTINUED)**

KEY	PART NUMBER	U/M	DESCRIPTION
8*	094707-03-01A	EA	STEP - ELECTRIC DOUBLE - W/BLACK CONTROL BOX - KWIKEE - <b>WORKHORSE - 19.5" TIRE - FORD</b>
	116975-01-01A	EA	LATCH - W/O STRIKE - BLACK - NEW STYLE
	138787-02-02B	EA	CHANNEL/MOUNT - E-COAT - <b>WORKHORSE - 19.5" TIRE - FORD</b>
9	P32206-08-S29	EA	DOOR - ENTRY W/SCREEN DOOR - W/O WINDOW/LATCH (S46, S47, S48, SR0)
9	P32206-08-S28	EA	DOOR - ENTRY W/SCREEN DOOR - W/O WINDOW/LATCH (S49, S50, S51, SR1)
9	P32206-08-R34	EA	DOOR - ENTRY W/SCREEN DOOR - W/O WINDOW/LATCH (S52, S53, S54, SR2)
10	139100-01-01A	EA	GARNISH/RADIUS - ENTRY DOOR - BRIGHT WHITE
11	139101-01-01A	EA	GARNISH/STRAIGHT - W/NOTCH - 36.31" - BRIGHT WHITE
12	140983-02-P37	EA	VALANCE/PANEL - 19.7" X 26.5" - W/O HARDWARE
13	132654-01-01A	EA	SUPPORT - WHEEL LIP - BLACK - 17.6"
14	147682-03-R32	EA	VALANCE/DOOR - W/O PADDLE LATCH/HDWR - 62.9" X 26.3"
	132873-D3-000	EA	ROD - LATCH - 25.3" W/3/4" DOG LEG
	132873-D4-000	EA	ROD - LATCH - 27.1" W/3/4" DOG LEG
	142569-12-000	EA	SPRING/GAS - 90 LB - 15" EXTENDED/9.5" COMPRESSED
	132892-02-01A	FT	SEAL - BULB - W/WIRED U CHANNEL - 1.3" X 1" - BLACK FROM: 00-00-00 THRU: 01-23-05
	132892-08-01A	FT	SEAL - BULB/SINGLE - W/U CHANNEL - BLACK FROM: 01-24-04 THRU: 99-99-99
15	126945-09-N42	EA	DOOR/STORAGE - W/O HARDWARE - 18.3" X 9.9"
16	142034-01-01A	EA	SHELF - F/EXTERIOR TV - BRIGHT WHITE
17	147682-01-R32	EA	VALANCE/DOOR - W/O PADDLE LATCH/HDWR - 51.8" X 26.3"
	132873-D1-000	EA	ROD - LATCH - 19.7" W/3/4" DOG LEG
	132873-D2-000	EA	ROD - LATCH - 21.5" W/3/4" DOG LEG
	142569-12-000	EA	SPRING/GAS - 90 LB - 15" EXTENDED/9.5" COMPRESSED
	132892-02-01A	FT	SEAL - BULB - W/WIRED U CHANNEL - 1.3" X 1" - BLACK FROM: 00-00-00 THRU: 01-23-05
	132892-08-01A	FT	SEAL - BULB/SINGLE - W/U CHANNEL - BLACK FROM: 01-24-04 THRU: 99-99-99
18*	084103-08-000	EA	DOOR - VENT - REFRIGERATOR - W/O JAMB - BRIGHT WHITE
	084104-08-000	EA	JAMB - VENT DOOR/REFRIGERATOR - BRIGHT WHITE
19	143492-31-S46	EA	PANEL/WHEEL LIP - PASSENGER/REAR - <b>WORKHORSE - 22.5" TIRE</b>
19	141621-35-S46	EA	PANEL/WHEEL LIP - PASSENGER/REAR - 60.9" - <b>WORKHORSE - 19.5" TIRE - FORD</b>
	139793-03-01A	EA	HINGE - CENTER/VALANCE DOOR - W/O BALL STUD
20	113904-13-02B	EA	ANGLE - ATTACHMENT/WHEEL LIP - 15.7" - E-COAT
21	140982-08-P45	EA	VALANCE/DOOR - W/O LATCH/HINGE - 43.2" X 26.3"
	132873-29-000	EA	ROD - LATCH - 15.4" W/3/4" DOG LEG
	132873-30-000	EA	ROD - LATCH - 17.2" W/3/4" DOG LEG
	142569-12-000	EA	SPRING/GAS - 90 LB - 15" EXTENDED/9.5" COMPRESSED
	076767-14-000	EA	CABLE - STAINLESS STEEL - 14.9"
	132892-02-01A	FT	SEAL - BULB - W/WIRED U CHANNEL - 1.3" X 1" - BLACK FROM: 00-00-00 THRU: 01-23-05
	132892-08-01A	FT	SEAL - BULB/SINGLE - W/U CHANNEL - BLACK FROM: 01-24-04 THRU: 99-99-99
22	147682-10-R32	EA	VALANCE/DOOR - PASS W/O LATCH/HDWR - 26.3" X 69.5" X 21.3"
	132873-E2-000	EA	ROD - LATCH - 28.6" W/3/4" DOG LEG
	132873-E3-000	EA	ROD - LATCH - 30.4" W/3/4" DOG LEG
	142569-17-000	EA	SPRING/GAS - 90 LB - 12" EXTENDED/8.5" COMPRESSED
	076767-14-000	EA	CABLE - STAINLESS STEEL - 14.9"
	132892-02-01A	FT	SEAL - BULB - W/WIRED U CHANNEL - 1.3" X 1" - BLACK FROM: 00-00-00 THRU: 01-23-05
	132892-08-01A	FT	SEAL - BULB/SINGLE - W/U CHANNEL - BLACK FROM: 01-24-04 THRU: 99-99-99
23	147682-08-R32	EA	VALANCE/DOOR - DRVR W/O LATCH/HDWR - 24.4" X 43.1" X 21.3"
	132873-29-000	EA	ROD - LATCH - 15.4" W/3/4" DOG LEG
	132873-30-000	EA	ROD - LATCH - 17.2" W/3/4" DOG LEG
	142569-17-000	EA	SPRING/GAS - 90 LB - 12" EXTENDED/8.5" COMPRESSED
	132892-02-01A	FT	SEAL - BULB - W/WIRED U CHANNEL - 1.3" X 1" - BLACK FROM: 00-00-00 THRU: 01-23-05
	132892-08-01A	FT	SEAL - BULB/SINGLE - W/U CHANNEL - BLACK FROM: 01-24-04 THRU: 99-99-99

**EXTERIOR DOORS & COMPARTMENTS GROUP (CONTINUED)**  
**DOOR & COMPARTMENT LAYOUT (CONTINUED)**

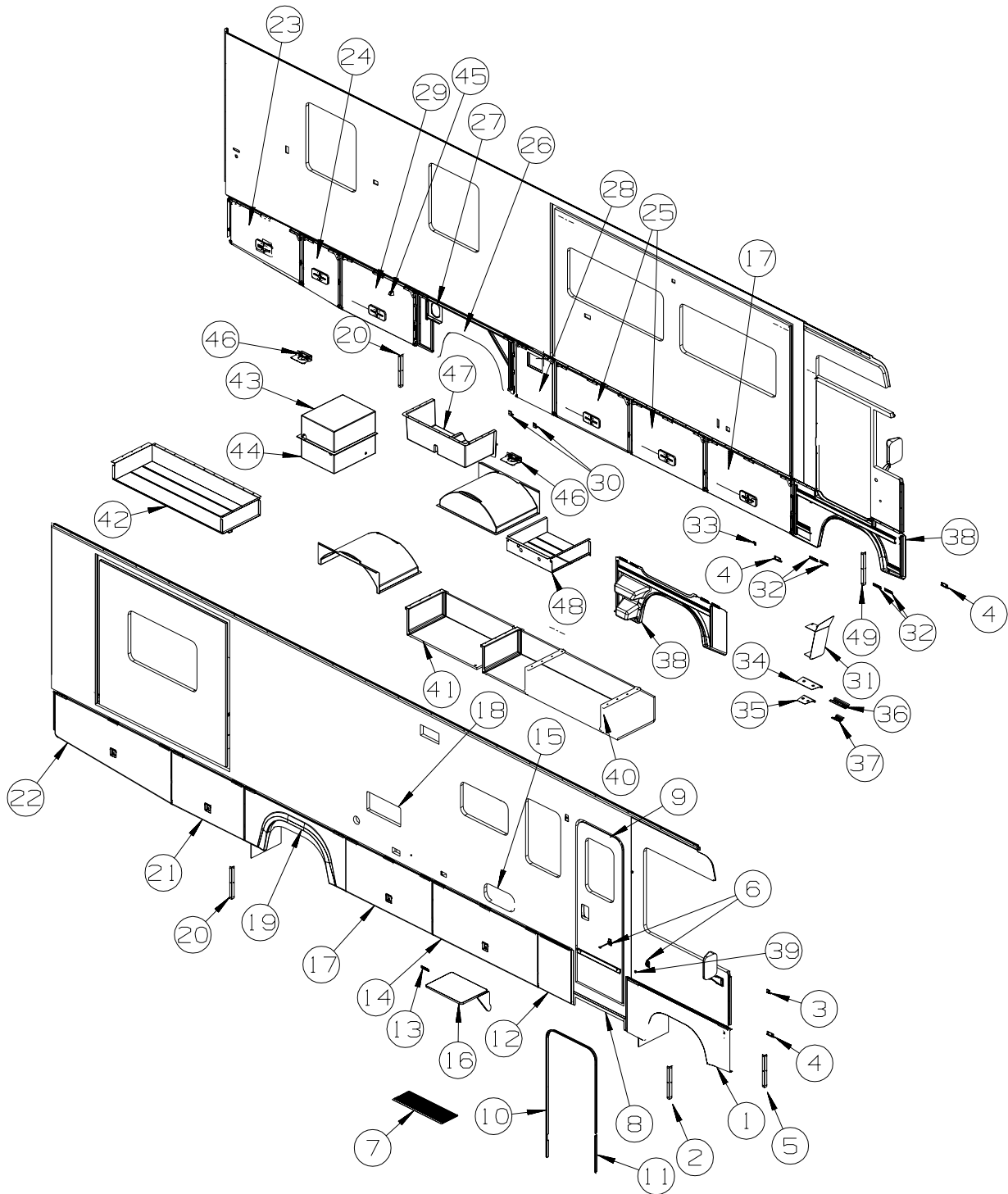

KEY	PART NUMBER	U/M DESCRIPTION
24	140982-19-P37	EA VALANCE/DOOR - DRVR W/O LATCH/HINGE- 26.3" X 22.9" X 24.4"
	132873-46-000	EA ROD - LATCH - 5.3" W/3/4" DOG LEG
	132873-47-000	EA ROD - LATCH - 7.1" W/3/4" DOG LEG
	142569-17-000	EA SPRING/GAS - 90 LB - 12" EXTENDED/8.5" COMPRESSED
	107721-08-000	FT SEAL - ACCESS DOOR - .9"WIDE X .9"HIGH
25	140982-09-P37	EA VALANCE/DOOR - W/O LATCH/HINGE - 45" X 26.3"
	132873-31-000	EA ROD - LATCH - 16.3" W/3/4" DOG LEG
	132873-32-000	EA ROD - LATCH - 18.1" W/3/4" DOG LEG
	142569-12-000	EA SPRING/GAS - 90 LB - 15" EXTENDED/9.5" COMPRESSED
	107721-08-000	FT SEAL - ACCESS DOOR - .9"WIDE X .9"HIGH
26	144686-16-S46	EA PANEL/WHEEL LIP - DRIVER/REAR - <b>WORKHORSE - 19.5" TIRE - FORD</b>
26	143492-30-S46	EA PANEL/WHEEL LIP - DRIVER/REAR - <b>WORKHORSE - 22.5" TIRE</b>
	139793-03-01A	EA HINGE - CENTER/VALANCE DOOR - W/O BALL STUD

**EXTERIOR DOORS & COMPARTMENTS GROUP (CONTINUED)**  
**DOOR & COMPARTMENT LAYOUT (CONTINUED)**

KEY	PART NUMBER	U/M	DESCRIPTION
27	131905-03-L32	EA	PANEL/DOOR - FUEL FILL - W/O LOCK - BLACK
*	110506-A2-000	EA	LOCK - TWIST - 26.45MM
	110506-51-000	EA	CASE/CYLINDER - TWIST LATCH - W/O CAM - 1" - 596669
	110506-78-000	EA	CAM - LOCK
	009065-01-000	EA	HINGE - ALUMINUM - 1 1/2" X 96" - UNPAINTED
			FROM: 00-00-00 THRU: 11-14-04
	153306-01-01A	EA	HINGE - PIANO - 1 1/2" X 5" - UNPAINTED
			FROM: 11-15-04 THRU: 99-99-99
28	147682-06-R32	EA	VALANCE/DOOR - W/O LATCH/HDWR - W/CUT-OUT - 23.5" X 26.4"
29	140982-09-P37	EA	VALANCE/DOOR - W/O LATCH/HINGE - 45" X 26.3"
	132873-31-000	EA	ROD - LATCH - 16.3" W/3/4" DOG LEG
	132873-32-000	EA	ROD - LATCH - 18.1" W/3/4" DOG LEG
	142569-12-000	EA	SPRING/GAS - 90 LB - 15" EXTENDED/9.5" COMPRESSED
	107721-08-000	FT	SEAL - ACCESS DOOR - .9"WIDE X .9"HIGH
30	119568-01-01A	EA	STANDOFF - VALANCE PANEL - BLACK
31	144919-01-02B	EA	DIRT GUARD - E-COATED - <b>WORKHORSE - 22.5" TIRE</b>
31	144919-02-02B	EA	DIRT GUARD - E-COATED - <b>WORKHORSE - 19.5" TIRE - FORD</b>
32	132654-07-01A	EA	SUPPORT - WHEEL LIP - BLACK - 4.5"
33	123512-04-02B	EA	BRACKET/VALANCE DOOR - E-COATED
34	138141-01-04B	EA	TREAD/STEP - DRIVER - BLACK
35	138141-02-04B	EA	TREAD/STEP - DRIVER - BLACK
36	138143-02-02B	EA	SUPPORT/STEP - DRIVER - E-COATED
37	138143-04-02B	EA	SUPPORT/STEP - DRIVER - E-COATED
38	141621-36-S46	EA	PANEL/WHEEL LIP - DRIVER/FRONT - 66.5" - <b>WORKHORSE - 19.5" TIRE - FORD</b>
	151892-01-01A	EA	PANEL/WHEEL LIP - DRIVER/FRONT - WORKHORSE - BLACK
38	143492-24-S46	EA	PANEL/WHEEL LIP - DRIVER/FRONT - <b>WORKHORSE - 22.5" TIRE</b>
	139793-03-01A	EA	HINGE - CENTER/VALANCE DOOR - W/O BALL STUD
39	120863-05-000	EA	BUMPER - RUBBER/RADIUS TOP - 3/4" X 3/8"
			FROM: 00-00-00 THRU: 11-07-04
40	144629-07-R32	EA	COMPARTMENT - LUGGAGE
41	144629-08-R32	EA	COMPARTMENT - LUGGAGE
			FROM: 00-00-00 THRU: 07-15-04
41	144629-28-S46	EA	COMPARTMENT - LUGGAGE
			FROM: 07-16-04 THRU: 99-99-99
42	118413-85-02B	EA	COMPARTMENT - LUGGAGE - E-COATED
43	132315-03-000	EA	COMPARTMENT - POWER CORD
44	144651-01-R32	EA	COMPARTMENT - POWER CORD - <b>GENERATOR</b>
	132315-06-000	EA	COMPARTMENT - POWER CORD
45	131383-03-02A	EA	BRACKET - SHOWER HEAD - WHITE
46*	142226-02-01A	EA	HATCH - POWER
47	144654-01-000	EA	COMPARTMENT - DRAINAGE
48	134319-03-02B	EA	COMPARTMENT - WATER HEATER - 6 GAL - E-COATED
48	134319-05-02B	EA	COMPARTMENT - WATER HEATER - E-COATED - <b>WASHER/DRYER - 10 GAL WATER HEATER</b>
			FROM: 00-00-00 THRU: 08-30-04
48	140829-05-02B	EA	COMPARTMENT - WATER HEATER - E-COATED - <b>WASHER/DRYER - 10 GAL WATER HEATER</b>
			FROM: 08-31-04 THRU: 99-99-99
49	113904-18-02B	EA	ANGLE - ATTACHMENT/WHEEL LIP - 2.6" - E-COAT

\*COMPONENT PARTS LISTED LATER IN THIS GROUP

**EXTERIOR DOORS & COMPARTMENTS GROUP (CONTINUED)**  
**DOOR & COMPARTMENT LAYOUT (CONTINUED)**

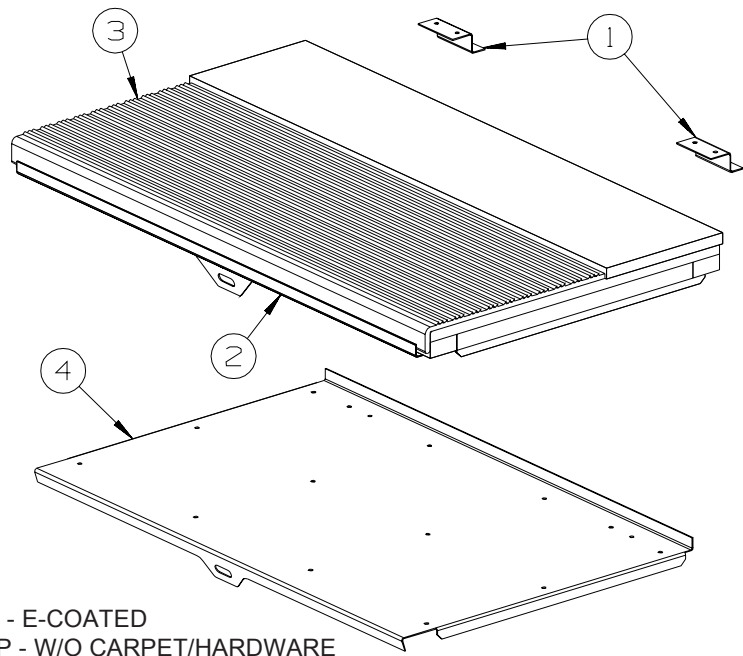

KEY	PART NUMBER	U/M	DESCRIPTION
1	101222-01-04A	EA	BRACKET - CATCH - LID - E-COATED
2	P20256-07-000	EA	LID/DOOR - ENTRY STEP - W/O CARPET/HARDWARE
3	133114-02-01A	EA	TREAD-STEP/RUBBER-28.5"-TAUPE (S46, S47, S48, S49, S50, S51,SR0, SR1)
3	133114-02-03A	EA	TREAD - STEP/RUBBER - 28.5" - GRAY (S52, S53, S54, SR2)
4	123330-03-02B	EA	SUPPORT - ENTRY STEP - E-COATED

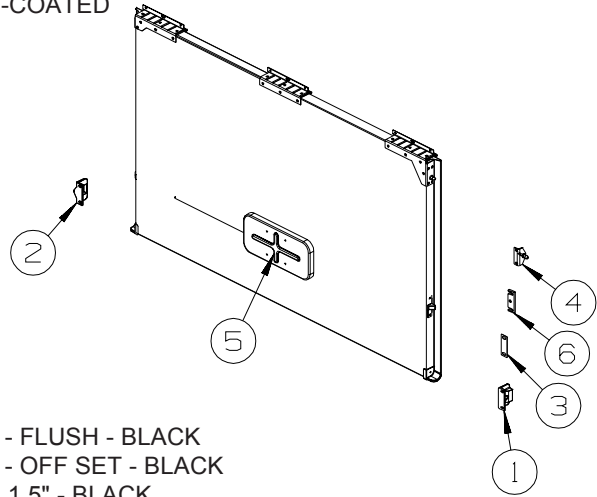

KEY	PART NUMBER	U/M	DESCRIPTION
1	130053-01-01A	EA	STRIKER - LUGGAGE DOOR - FLUSH - BLACK
2	130053-02-01A	EA	STRIKER - LUGGAGE DOOR - OFF SET - BLACK
3	143793-01-01A	EA	SHIM/STRIKER - LUGGAGE - 1.5" - BLACK
3	120494-04-02B	EA	SHIM - STRIKER - LUGGAGE DOOR - 3/16" - E-COATED - <b>F35A ONLY</b>
4	126263-02-02B	EA	BRACKET - GAS SPRING W/BALL STUD - E-COATED
5	138289-01-000	EA	CYLINDER - LOCKING
5	138289-02-000	EA	CYLINDER - LOCKING
5	138289-03-000	EA	CYLINDER - LOCKING
5	138289-04-000	EA	CYLINDER - LOCKING
5	138289-05-000	EA	CYLINDER - LOCKING
5	138289-06-000	EA	CYLINDER - LOCKING
5	138289-07-000	EA	CYLINDER - LOCKING
5	138289-08-000	EA	CYLINDER - LOCKING
5	138289-09-000	EA	CYLINDER - LOCKING
5	138289-10-000	EA	CYLINDER - LOCKING
	138288-01-000	EA	KEY - REVERSIBLE - #1151 - T/M 16169-02-1151
	138288-02-000	EA	KEY - REVERSIBLE - #1152 - T/M 16169-02-1152
	138288-03-000	EA	KEY - REVERSIBLE - #1153 - T/M 16169-02-1153
	138288-04-000	EA	KEY - REVERSIBLE - #1154 - T/M 16169-02-1154
	138288-05-000	EA	KEY - REVERSIBLE - #1155 - T/M 16169-02-1155
	138288-06-000	EA	KEY - REVERSIBLE - #1156 - T/M 16169-02-1156
	138288-07-000	EA	KEY - REVERSIBLE - #1157 - T/M 16169-02-1157
	138288-08-000	EA	KEY - REVERSIBLE - #1158 - T/M 16169-02-1158
	138288-09-000	EA	KEY - REVERSIBLE - #1159 - T/M 16169-02-1159
	138288-10-000	EA	KEY - REVERSIBLE - #1150 - T/M 16169-02-1150
6	NOT USED		

# EXTERIOR DOORS & COMPARTMENTS GROUP (CONTINUED)

## COMPONENT PARTS FOR DOOR & COMPARTMENT LAYOUT

084103-08-000

KEY	PART NUMBER	U/M DESCRIPTION	VENDOR NO.
	084104-01-700	EA LOCK-MALE, FASTENER	201-721-010
	084104-01-701	EA LOCK-FEMALE, FASTENER	201-802-010

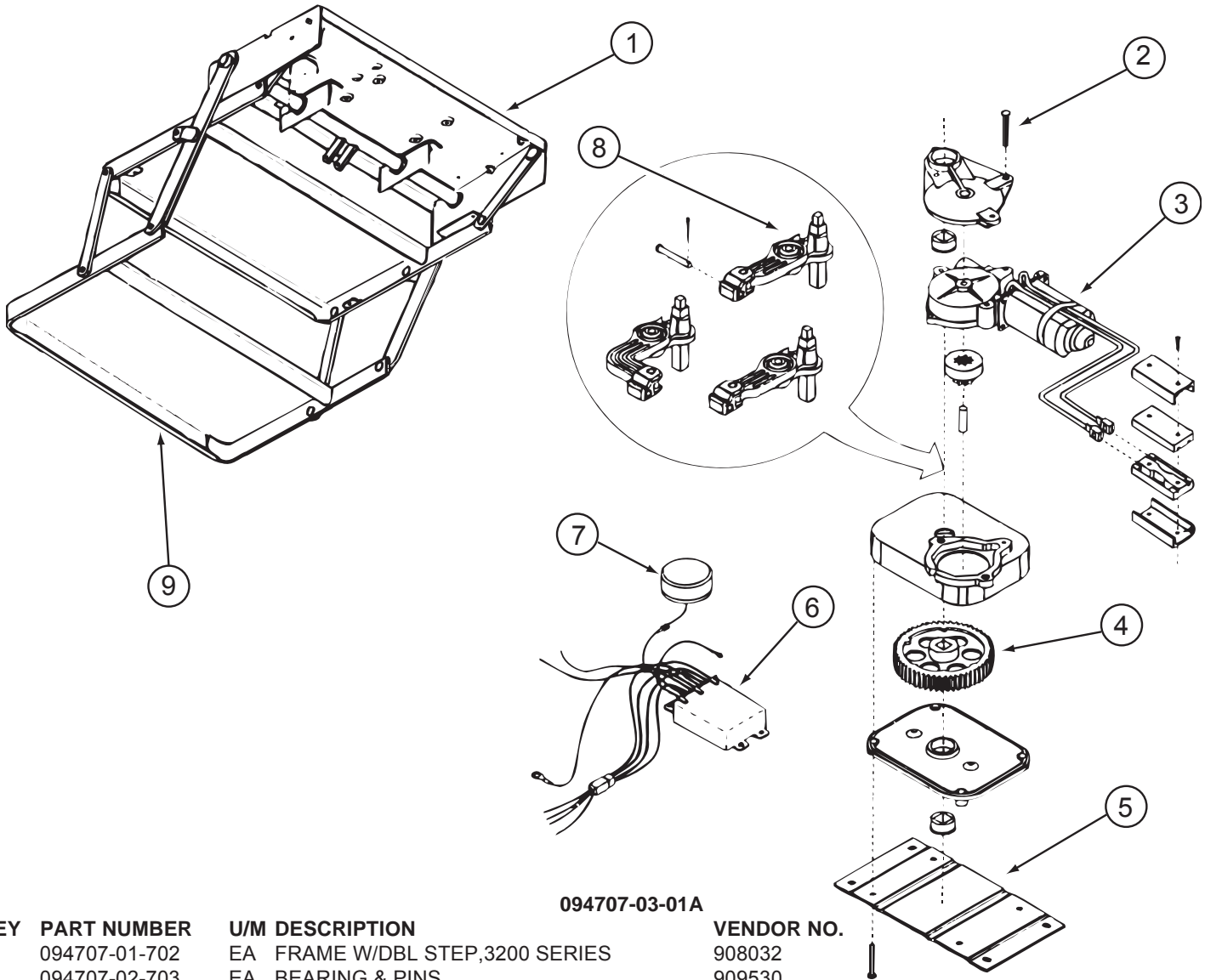

094707-03-01A

KEY	PART NUMBER	U/M DESCRIPTION	VENDOR NO.
1	094707-01-702	EA FRAME W/DBL STEP, 3200 SERIES	908032
2	094707-02-703	EA BEARING & PINS	909530
3	094707-02-700	EA MOTOR - "UT" ASM W/BRGS/PIN	909520
4	094707-02-702	EA GEAR KIT(GEAR-BEARING-PINS)	909525
5	094707-02-704	EA CONNECTOR-MOTOR ASM.W/PLATES	909537
6	094707-03-700	EA KIT CONTROL/SWITCH-RETROFIT	909506005
7	088746-01-705	EA LIGHT-UNDER STEP	9004
7	088733-01-700	EA BULB	9004
8	094707-02-701	EA LINKAGE ASM. W/BEARINGS-PINS	909534
9	094707-02-707	EA TREAD - NON-SKID - BLACK	909333
	094707-02-706	EA GEAR BOX ASM. W/O MOTOR	9524
	094707-02-708	EA TREAD - NON-SKID - YELLOW	909331
	094707-03-701	EA PLUG - 4-WAY - PACKARD	909306

110506-A1-000, 110506-A2-000, 110506-26-000, 110506-27-000

KEY	PART NUMBER	U/M DESCRIPTION	VENDOR NO .
	110506-40-700	EA HARDWARE PACKAGE-CYLINDER/CASE	596950AAL

142226-02-01A

KEY	PART NUMBER	U/M DESCRIPTION	VENDOR NO
	142226-02-700	EA TAB/LOCKING - ESCAPE (RED)	9667709



**EXTERIOR DOORS & COMPARTMENTS GROUP (CONTINUED)**  
**COMPONENT PARTS FOR DOOR & COMPARTMENT LAYOUT (CONTINUED)**

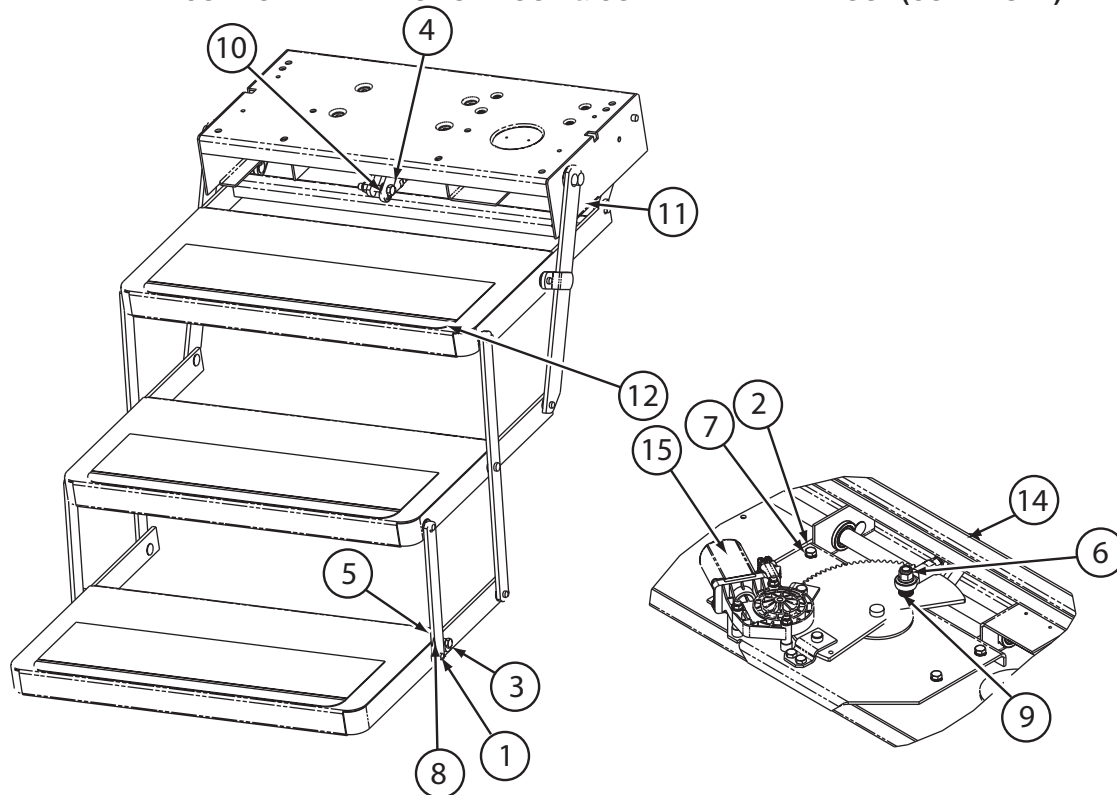

143709-01-01A

KEY	PART NUMBER	U/M	DESCRIPTION	VENDOR NO.
1	143709-01-700	EA	CAM STOP	1102200
10	143709-01-706	EA	CONTROL UNIT	909508003
11	143709-01-701	EA	BUMPER - BLACK (RUBBER STOP)	1602000
12	143709-01-702	EA	TREAD/NON-SKID _6" X 21" BLK	1915260
13	143709-01-703	EA	FRAME ONLY PAINTED BLACK 25	3202050
14	143709-01-704	EA	LINK ASM ELECTRIC STEP 24/25	3380050
15	143709-01-705	EA	MOTOR ASSEMBLY 24/25 STEP	3392151

CONTACT WINNEBAGO PART SALES FOR UNLISTED COMPONENT(S)

**EXTERIOR DOORS & COMPARTMENTS GROUP (CONTINUED)**  
**COMPARTMENT DOOR PIECE PARTS**

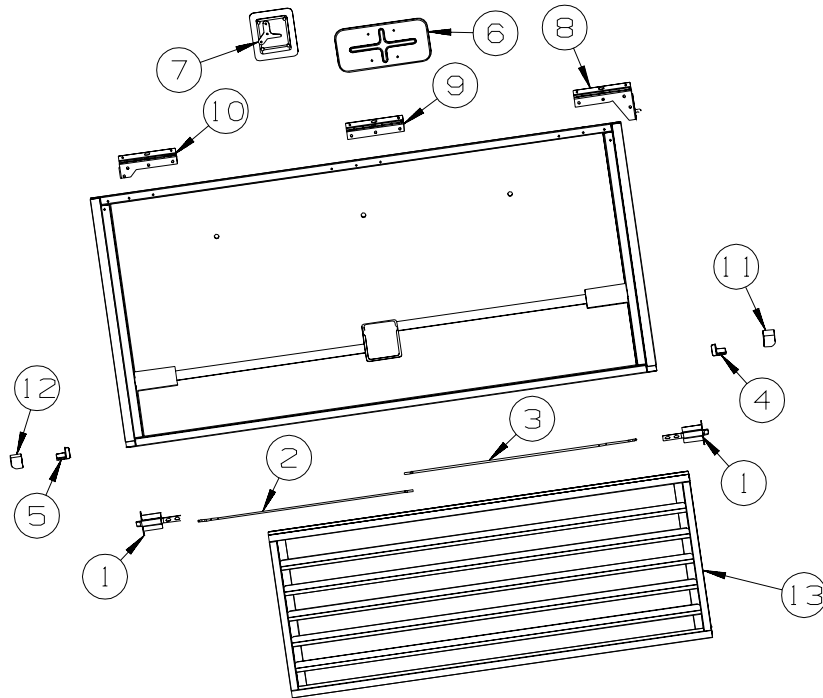

KEY	PART NUMBER	U/M	DESCRIPTION
1	121947-01-01A	EA	BOLT - SLIDE W/PLASTIC PLUNGER
2	132873-01-000	EA	ROD - LATCH (BLANK) - RIGHT HAND
3	132873-02-000	EA	ROD - LATCH (BLANK) - LEFT HAND
4	135276-01-01A	EA	REINFORCEMENT - CORNER - RIGHT HAND
5	135276-02-01A	EA	REINFORCEMENT - CORNER - LEFT HAND
6	137359-01-01A	EA	COVER - LATCH - WHITE
7	138277-01-01A	EA	LATCH/PADDLE - COMPARTMENT DOOR - BLACK - KEY ONE
7	112949-02-05A	EA	LATCH - PADDLE NON-LOCKING - BLACK
7	112949-02-04A	EA	LATCH - PADDLE NON-LOCKING - BRIGHT WHITE
8	139793-01-01A	EA	HINGE - RIGHT HAND/VALANCE DOOR - W/BALL STUD
8	139793-04-01A	EA	HINGE - RIGHT HAND/VALANCE DOOR - W/O BALL STUD
9	139793-03-01A	EA	HINGE - CENTER/VALANCE DOOR - W/O BALL STUD
10	139793-05-01A	EA	HINGE - LEFT HAND/VALANCE DOOR - W/O BALL STUD
11	141601-02-01A	EA	END CAP/VALANCE DOOR - LEFT HAND
12	141601-01-01A	EA	END CAP/VALANCE DOOR - RIGHT HAND
13	NOT USED		

**EXTERIOR DOORS & COMPARTMENTS GROUP (CONTINUED)**  
**COMPARTMENT DOOR PIECE PARTS (CONTINUED)**

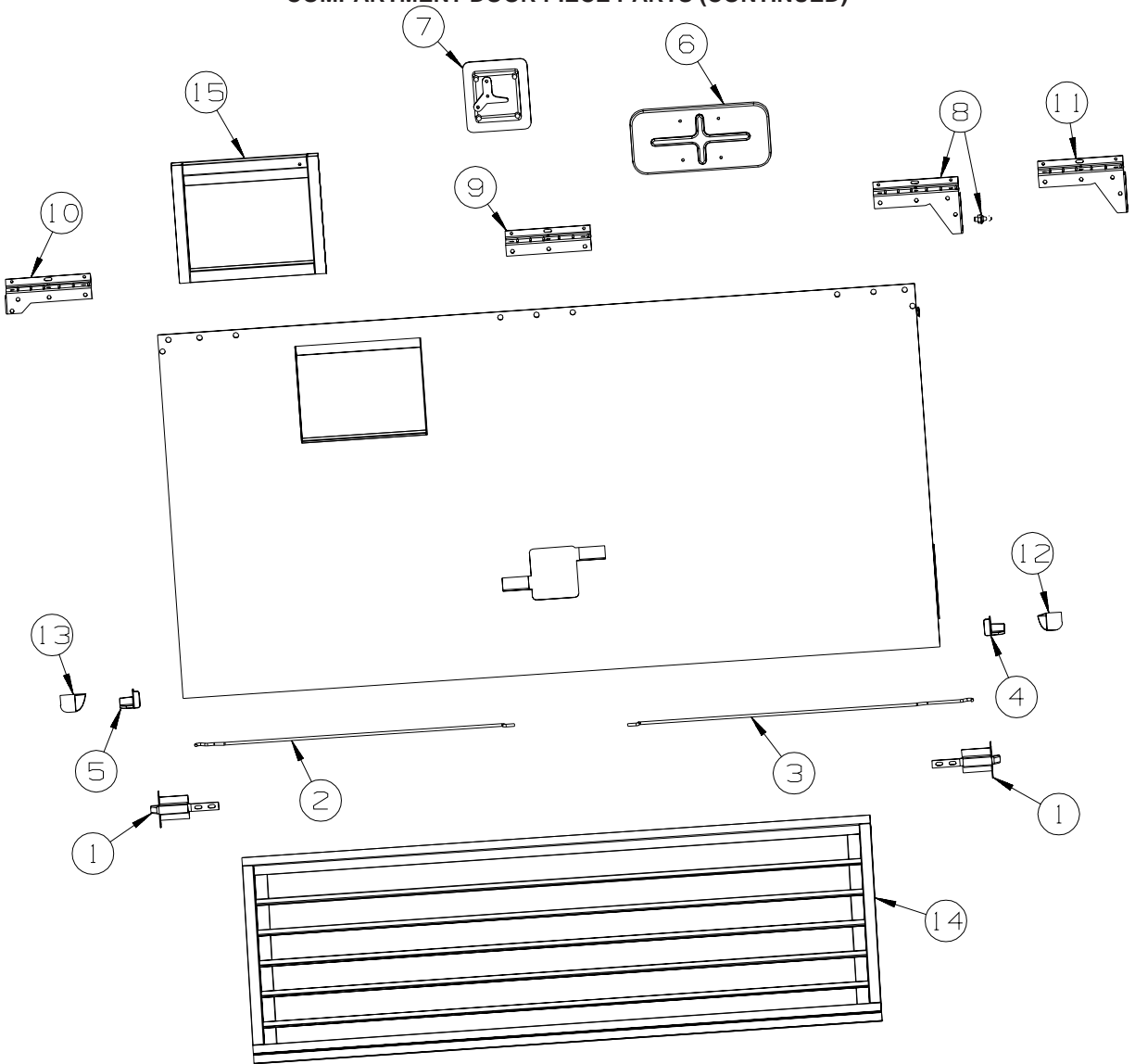

KEY	PART NUMBER	U/M	DESCRIPTION
1	121947-01-01A	EA	BOLT - SLIDE W/PLASTIC PLUNGER
2	132873-01-000	EA	ROD - LATCH (BLANK) - RIGHT HAND
3	132873-02-000	EA	ROD - LATCH (BLANK) - LEFT HAND
4	135276-01-01A	EA	REINFORCEMENT - CORNER - RIGHT HAND
5	135276-02-01A	EA	REINFORCEMENT - CORNER - LEFT HAND
6	137359-01-01A	EA	COVER - LATCH - WHITE
7	138277-01-01A	EA	LATCH/PADDLE - COMPARTMENT DOOR - BLACK - KEY ONE
7	112949-02-05A	EA	LATCH - PADDLE NON-LOCKING - BLACK
8	139793-01-01A	EA	HINGE - RIGHT HAND/VALANCE DOOR - W/BALL STUD
9	139793-03-01A	EA	HINGE - CENTER/VALANCE DOOR - W/O BALL STUD
10	139793-05-01A	EA	HINGE - LEFT HAND/VALANCE DOOR - W/O BALL STUD
11	139793-04-01A	EA	HINGE - RIGHT HAND/VALANCE DOOR - W/O BALL STUD
12	141601-02-01A	EA	END CAP/VALANCE DOOR - LEFT HAND
13	141601-01-01A	EA	END CAP/VALANCE DOOR - RIGHT HAND
14			NOT USED

**EXTERIOR DOORS & COMPARTMENTS GROUP (CONTINUED)**  
**COMPARTMENT DOOR PIECE PARTS (CONTINUED)**

KEY	PART NUMBER	U/M	DESCRIPTION
15	133049-02-L76	EA	TRIM - COVER/WATER HEATER - F31W, F33V, F35D FROM: 00-00-00 THRU: 01-31-05
15	133049-11-R32	EA	TRIM - COVER/WATER HEATER - F31W, F33V, F35D FROM: 02-01-05 THRU: 99-99-99
15	133049-02-L76	EA	TRIM - COVER/WATER HEATER - F35A, F36M FROM: 00-00-00 THRU: 02-16-05
15	133049-09-R32	EA	TRIM - COVER/WATER HEATER - F35A, F36M FROM: 02-17-05 THRU: 99-99-99
15	133049-02-L76	EA	TRIM - COVER/WATER HEATER - F38J FROM: 00-00-00 THRU: 02-28-05
15	133049-10-S64	EA	TRIM - COVER/WATER HEATER - F38J FROM: 03-01-05 THRU: 99-99-99

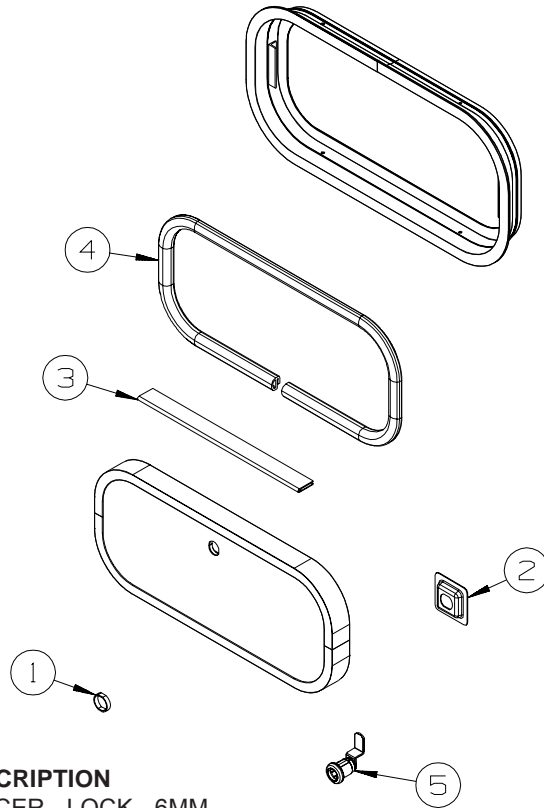

KEY	PART NUMBER	U/M	DESCRIPTION
1	139325-01-000	EA	SPACER - LOCK - 6MM
	139337-01-000	EA	GASKET - LOCK
2	097111-02-05A	EA	POCKET - LOCK - REAR DOOR - BRIGHT WHITE
2	097111-02-04A	EA	POCKET - LOCK - REAR DOOR - BLACK - FULL BODY OR LOWER EXT PAINT
3	081801-V3-000	EA	HINGE - DOOR - PIANO - 2" X 96" - BRIGHT WHITE
3	081801-FN-000	EA	HINGE - DOOR - PIANO - 2" X 96" - BLACK - FULL BODY OR LOWER EXT PAINT
4	106850-02-000	FT	SEAL-E - SPONGE RUBBER - .43" X .75"
5	138290-02-000	EA	CASE - W/CAM - W/O CYLINDER/KEY

## EXTERIOR DOORS & COMPARTMENTS GROUP (CONTINUED)

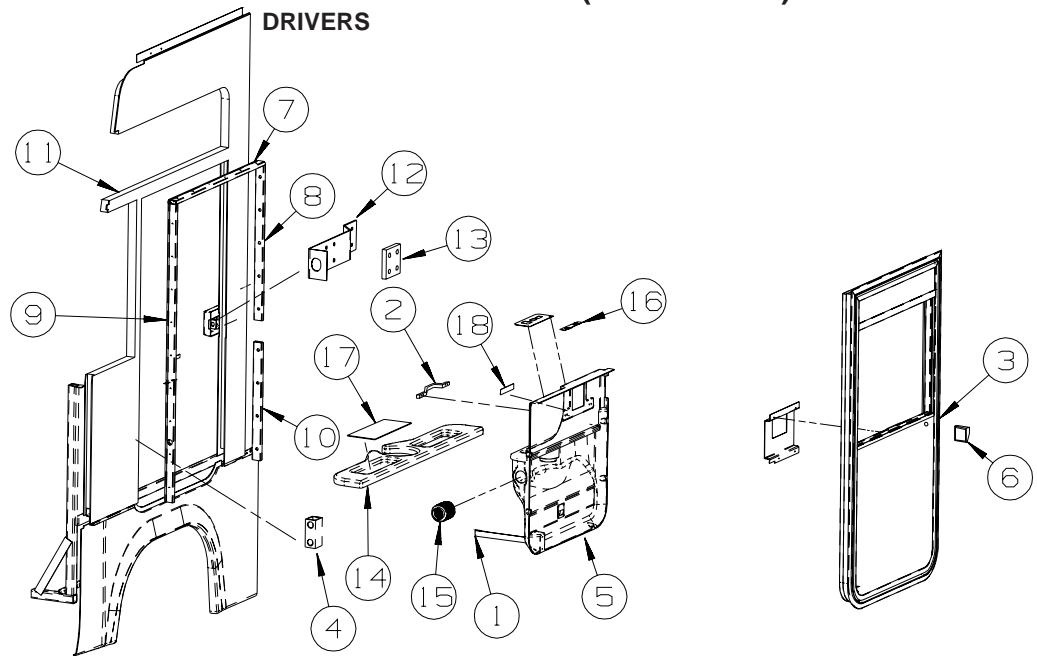

KEY	PART NUMBER	U/M	DESCRIPTION
1	109378-01-000	EA	STRAP - CHECK - DRIVER DOOR - 12.8"
2	110604-01-01A	EA	HANDLE - ASSIST - DRIVER DOOR - 10.8" LONG - BLACK
3*	125581-09-01A	EA	DOOR - DRIVER - POWER WINDOW/LOCK
4	128131-01-01A	EA	SPACER/SWITCH - DOME - BLACK
5	132298-05-04A	EA	PANEL/DOOR - INNER/DRIVER - W/O BEVERAGE TRAY - GLACIER
6	109235-01-05A	FT	COVER - SCREW - BRIGHT WHITE
6	109235-01-01A	FT	COVER - SCREW - MAT BLACK
7	125725-01-01A	EA	FRAME - DRIVER DOOR - 33.5" - BLACK
8	125725-03-01A	EA	FRAME - DRIVER DOOR - 27.8" - BLACK
9	125725-07-01A	EA	FRAME - DRIVER DOOR - 53.3" - BLACK
10	125725-08-01A	EA	FRAME - DRIVER DOOR - 21.4" - BLACK
11	125804-02-02B	EA	ANGLE - DOOR SUPPORT - E-COATED
12	126506-01-02B	EA	BRACKET - STRIKE - DRIVER DOOR - E-COATED
13	126534-01-02B	EA	SPACER - STRIKE - DRIVER DOOR - E-COATED
14	132297-03-06A	EA	PANEL/TRIM - W/BEVERAGE HOLDER - SANSTONE
15	117802-01-000	EA	GROMMET - CONVOLUTED - 2"
16	133533-04-01A	EA	LABEL - WINDOW/MIRROR HEAT - BLACK/CLEAR
17	122717-07-01A	EA	PAD - NON-SKID - PSA - 3.2" X 8.3"
18	133533-03-01A	EA	LABEL - LOCK/UNLOCK - BLACK/WHITE
	138288-01-000	EA	KEY - REVERSIBLE - #1151 - T/M 16169-02-3091
	138288-02-000	EA	KEY - REVERSIBLE - #1152 - T/M 16169-02-3092
	138288-03-000	EA	KEY - REVERSIBLE - #1153 - T/M 16169-02-3093
	138288-04-000	EA	KEY - REVERSIBLE - #1154 - T/M 16169-02-3094
	138288-05-000	EA	KEY - REVERSIBLE - #1155 - T/M 16169-02-3095
	138288-06-000	EA	KEY - REVERSIBLE - #1156 - T/M 16169-02-3096
	138288-07-000	EA	KEY - REVERSIBLE - #1157 - T/M 16169-02-3097
	138288-08-000	EA	KEY - REVERSIBLE - #1158 - T/M 16169-02-3098
	138288-09-000	EA	KEY - REVERSIBLE - #1159 - T/M 16169-02-3099
	138288-10-000	EA	KEY - REVERSIBLE - #1150 - T/M 16169-02-3100
	138289-01-000	EA	CYLINDER - LOCKING
	138289-02-000	EA	CYLINDER - LOCKING
	138289-03-000	EA	CYLINDER - LOCKING
	138289-04-000	EA	CYLINDER - LOCKING
	138289-05-000	EA	CYLINDER - LOCKING
	138289-06-000	EA	CYLINDER - LOCKING
	138289-07-000	EA	CYLINDER - LOCKING
	138289-08-000	EA	CYLINDER - LOCKING
	138289-09-000	EA	CYLINDER - LOCKING
	138289-10-000	EA	CYLINDER - LOCKING
	138292-01-000	EA	SEAL - LOCK CYLINDER

\*COMPONENT PARTS LISTED LATER IN THIS GROUP

# EXTERIOR DOORS & COMPARTMENTS GROUP (CONTINUED)

## COMPONENT PARTS FOR DRIVERS

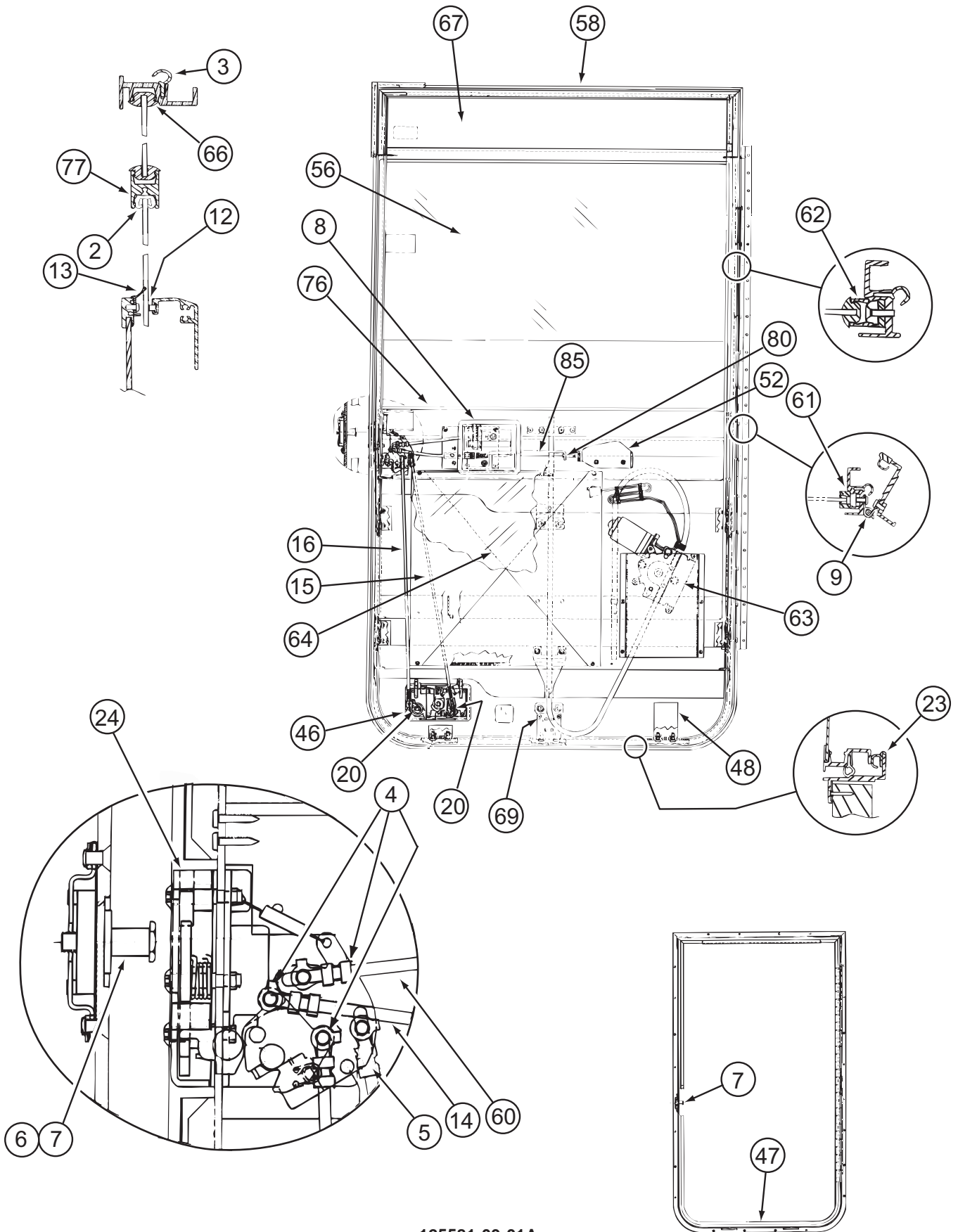

125581-09-01A

**EXTERIOR DOORS & COMPARTMENTS GROUP (CONTINUED)****COMPONENT PARTS FOR DRIVERS (CONTINUED)****125581-09-01A (CONTINUED)**

<b>KEY</b>	<b>PART NUMBER</b>	<b>U/M</b>	<b>DESCRIPTION</b>	<b>VENDOR NO.</b>
2	106469-01-705	FT	CHANNEL-RUN, SLIDING	122-010850
3	106469-01-702	EA	SEAL-DOOR FRAME (DOOR)EA=1	122-040984
4	106469-04-714	EA	ROD-CLIP, RH	80801
5	106469-04-713	EA	ROD-CLIP, LH	80802
6	106469-04-704	EA	NUT ASSEMBLY-CAGED W/STRIKER	11920-16
7	106469-04-703	EA	BOLT-STRIKER, W/WASHER	10335-16
8	106469-04-712	EA	HANDLE/DOOR-INNER W/HARDWARE	11297-01
9	106469-05-702	EA	HINGE - 42"	211-041194
12	106469-01-709	FT	WEATHERSTRIP FUZZY	171-040630
13	125581-03-703	EA	WEATHERSTRIP - BELTING	132-041069
13	125581-09-712	EA	WEATHERSTRIP/BELT - F/GLASS	490664
14	106469-04-711	EA	ROD-LOCK, HORIZONTAL	15508-01
15	125581-04-700	EA	ROD - LATCH/VERTICAL ADJUST.	203-041767
16	125581-04-701	EA	ROD - LOCK/VERTICAL ADJUST.	203-041768
20	128913-01-707	EA	NUT - HEX/NYLOCK - 1/4 - 20	233-062447
23	106469-01-723	EA	SEAL-BULB ASM. (DOOR JAMB)	171-040985
24	106469-05-706	EA	LATCH-ROTARY, W/LINKAGE	16512-01
46	125581-09-700	EA	PADDLE-W/O LOCK RH (REV KEY)	17191-02
46	125581-09-701	EA	LATCH/LOCK-DRVR DR (REV KEY)	PARTS DEPT
46	125581-09-702	EA	LATCH/LOCK-DRVR DR (REV KEY)	PARTS DEPT
46	125581-09-703	EA	LATCH/LOCK-DRVR DR (REV KEY)	PARTS DEPT
46	125581-09-704	EA	LATCH/LOCK-DRVR DR (REV KEY)	PARTS DEPT
46	125581-09-705	EA	LATCH/LOCK-DRVR DR (REV KEY)	PARTS DEPT
46	125581-09-706	EA	LATCH/LOCK-DRVR DR (REV KEY)	PARTS DEPT
46	125581-09-707	EA	LATCH/LOCK-DRVR DR (REV KEY)	PARTS DEPT
46	125581-09-708	EA	LATCH/LOCK-DRVR DR (REV KEY)	PARTS DEPT
46	125581-09-709	EA	LATCH/LOCK-DRVR DR (REV KEY)	PARTS DEPT
46	125581-09-710	EA	LATCH/LOCK-DRVR DR (REV KEY)	PARTS DEPT
46	125581-09-721	EA	LATCH/LOCK-DRVR DR (3041)	PARTS DEPT (3041)
46	125581-09-722	EA	LATCH/LOCK-DRVR DR (3042)	PARTS DEPT (3042)
46	125581-09-723	EA	LATCH/LOCK-DRVR DR (3043)	PARTS DEPT (3043)
46	125581-09-724	EA	LATCH/LOCK-DRVR DR (3044)	PARTS DEPT (3044)
46	125581-09-725	EA	LATCH/LOCK-DRVR DR (3045)	PARTS DEPT (3045)
46	125581-09-726	EA	LATCH/LOCK-DRVR DR (3046)	PARTS DEPT (3046)
46	125581-09-727	EA	LATCH/LOCK-DRVR DR (3047)	PARTS DEPT (3047)
46	125581-09-728	EA	LATCH/LOCK-DRVR DR (3048)	PARTS DEPT (3048)
46	125581-09-729	EA	LATCH/LOCK-DRVR DR (3049)	PARTS DEPT (3049)
46	125581-09-730	EA	LATCH/LOCK-DRVR DR (3050)	PARTS DEPT (3050)
47	125581-04-703	EA	FRAME - MOUNTING - BLACK	V180-35L
48	125581-07-703	EA	BRACKET-ALUMINUM "L"(INSIDE)	N135-55
56	125581-08-703	EA	GLASS-ROLL-UP 29.46"X29.37"	106-042081
56	125581-09-711	EA	GLASS-ROLL UP 24"H X 29.37"W	490207
58	125581-08-702	EA	FRAME/DOOR - SUB ASSY-BLACK	V220-98L
60	106469-04-705	EA	ROD-LATCH, HORIZONTAL	203-041139
61	125581-08-701	EA	CHANNEL/VERT ROLL UP-BLACK	V220-60
62	125581-08-700	EA	CHANNEL/VERT STA GLASS-BLACK	V220-61
63	125581-03-702	EA	REGULATOR-ELECTRIC-SPEC RH	410-040966
64	125581-06-700	EA	PANEL/INTERIOR	V164-97
66	125581-04-710	FT	VINYL - GLAZING	132-041484
67	125581-07-701	EA	GLASS-STATIONERY/4.95"X29.5"	106-042082
69	125581-04-711	EA	CHANNEL-GLASS - LIFT BRKT	N135-66
76	125581-03-701	EA	SILL - INNER - BLACK	V123-68L
77	125581-03-700	EA	MULLION RAIL- BLACK	V123-84
	106469-04-716	EA	LEVER-LOCKING-BLACK	80978-00
	125581-07-705	EA	BRACKET (L) F/SEAL PROTECT	490201
	125581-07-704	EA	BRACKET - STRAP/JAMB & DOOR	248-080394
	125581-10-701	EA	CLIP - CABLE	130-042047

CONTACT WINNEBAGO PART SALES FOR UNLISTED COMPONENT(S)

# EXTERIOR DOORS & COMPARTMENTS GROUP (CONTINUED)

## ENTRY

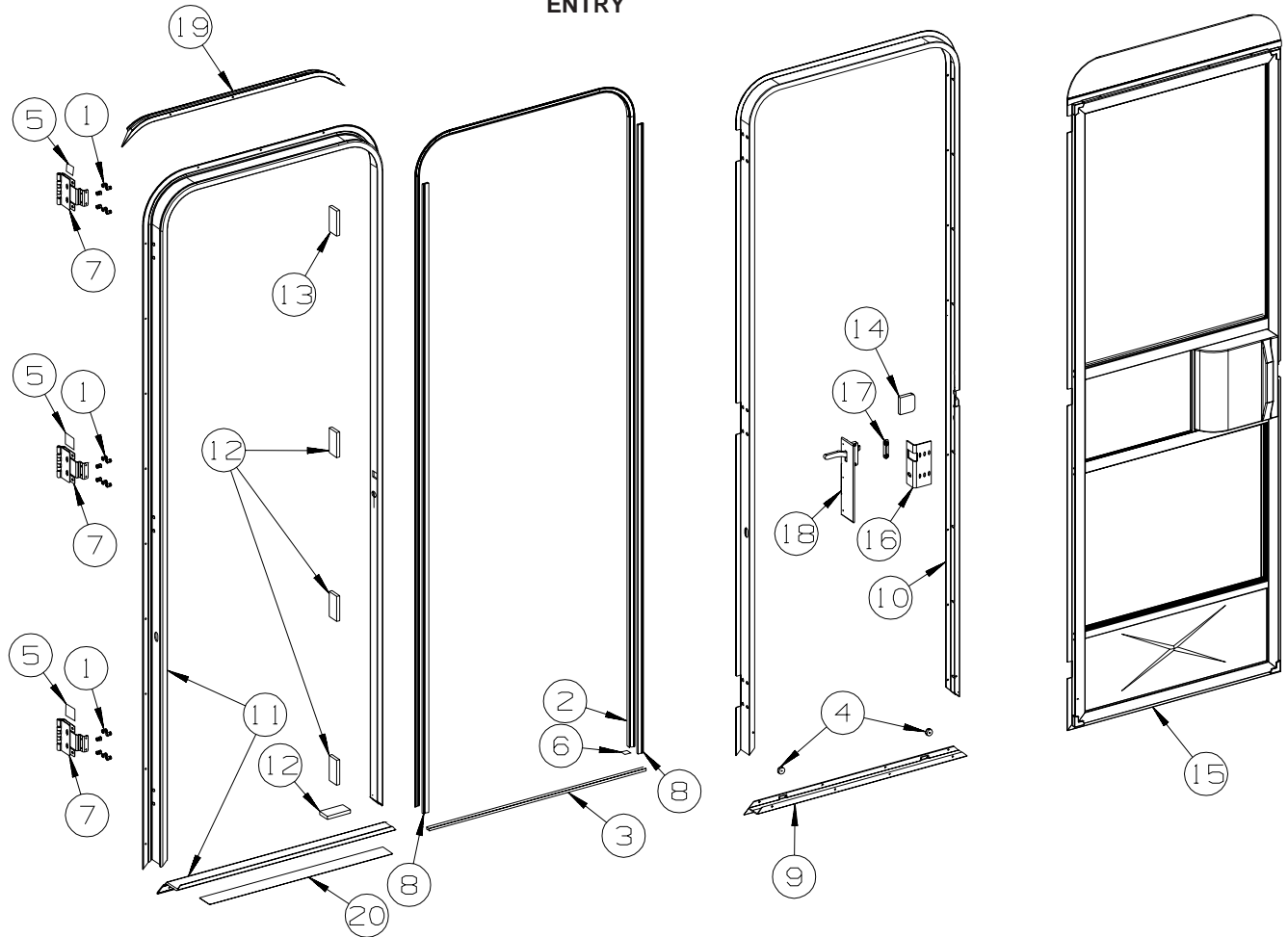

KEY	PART NUMBER	U/M	DESCRIPTION
1	039715-01-000	EA	NUT-SERT - 1/4" DIAMETER - 20 THREADS
2	075671-04-000	FT	SEAL - SPONGE - LAZY T - W/ADHESIVE STRIP - .5" WIDE
3	075673-05-000	FT	SEAL/PILE - .5" HIGH W/ADHESIVE BACK - BLACK
4	081914-02-000	EA	BUMPER - RUBBER - ROUND - 5/16" DIA. X 13/64" THICK
5	100128-02-000	FT	SEAL - FOAM/ADHESIVE BACK - .37" WIDE X .37" THICK
6	104692-01-000	FT	SEAL - ADHESIVE BACKED FOAM - 3/4" THICK X 3/4" WIDE X 25'
7	106719-01-05A	EA	HINGE - ENTRY DOOR - BRIGHT WHITE
8	118929-01-01A	FT	SEAL - PILE - PUSH ON
9	121893-03-02A	EA	FRAME - ENTRY DOOR/LOWER - BRIGHT WHITE
10	121894-27-01A	EA	FRAME - ENTRY DOOR - BRIGHT WHITE
11	121898-14-01A	EA	JAMB - DOOR/ENTRANCE - BRIGHT WHITE
12	125724-01-000	EA	SHIM - DOOR, ENTRANCE
13	125724-02-000	EA	SHIM - DOOR, ENTRANCE
14	130096-05-000	EA	FOAM - SCREEN DOOR, RETAINER
15	132208-02-L32	EA	DOOR - SCREEN - W/O HARDWARE
16	137401-01-03B	EA	BRACKET - DOOR ANGLE - OFF WHITE
17	148364-01-12B	EA	STRIKE - SCREEN DOOR - BRIGHT WHITE
	138287-01-000	EA	CYLINDER/LOCK - ENTRY DOOR (MASTER)
	138287-02-000	EA	CYLINDER/LOCK - ENTRY DOOR (MASTER)
	138287-03-000	EA	CYLINDER/LOCK - ENTRY DOOR (MASTER)
	138287-04-000	EA	CYLINDER/LOCK - ENTRY DOOR (MASTER)
	138287-05-000	EA	CYLINDER/LOCK - ENTRY DOOR (MASTER)
	138287-06-000	EA	CYLINDER/LOCK - ENTRY DOOR (MASTER)
	138287-07-000	EA	CYLINDER/LOCK - ENTRY DOOR (MASTER)
	138287-08-000	EA	CYLINDER/LOCK - ENTRY DOOR (MASTER)
	138287-09-000	EA	CYLINDER/LOCK - ENTRY DOOR (MASTER)
	138287-10-000	EA	CYLINDER/LOCK - ENTRY DOOR (MASTER)
	138288-01-000	EA	KEY - REVERSIBLE - #1151 - T/M 16169-02-1151
	138288-02-000	EA	KEY - REVERSIBLE - #1152 - T/M 16169-02-1152
	138288-03-000	EA	KEY - REVERSIBLE - #1153 - T/M 16169-02-1153
	138288-04-000	EA	KEY - REVERSIBLE - #1154 - T/M 16169-02-1154



**EXTERIOR DOORS & COMPARTMENTS GROUP (CONTINUED)**  
**ENTRY (CONTINUED)**

KEY	PART NUMBER	U/M	DESCRIPTION
	138288-05-000	EA	KEY - REVERSIBLE - #1155 - T/M 16169-02-1155
	138288-06-000	EA	KEY - REVERSIBLE - #1156 - T/M 16169-02-1156
	138288-07-000	EA	KEY - REVERSIBLE - #1157 - T/M 16169-02-1157
	138288-08-000	EA	KEY - REVERSIBLE - #1158 - T/M 16169-02-1158
	138288-09-000	EA	KEY - REVERSIBLE - #1159 - T/M 16169-02-1159
	138288-10-000	EA	KEY - REVERSIBLE - #1150 - T/M 16169-02-1150
18	132915-01-01A	EA	LATCH - SCREEN DOOR - BLACK
	138292-01-000	EA	SEAL - LOCK CYLINDER
19	139054-19-01A	EA	CAP - DRIP - JAMB MOUNTED - BRIGHT WHITE
20	038327-01-000	EA	TAPE - ANTI-SLIP - 2" X 60'

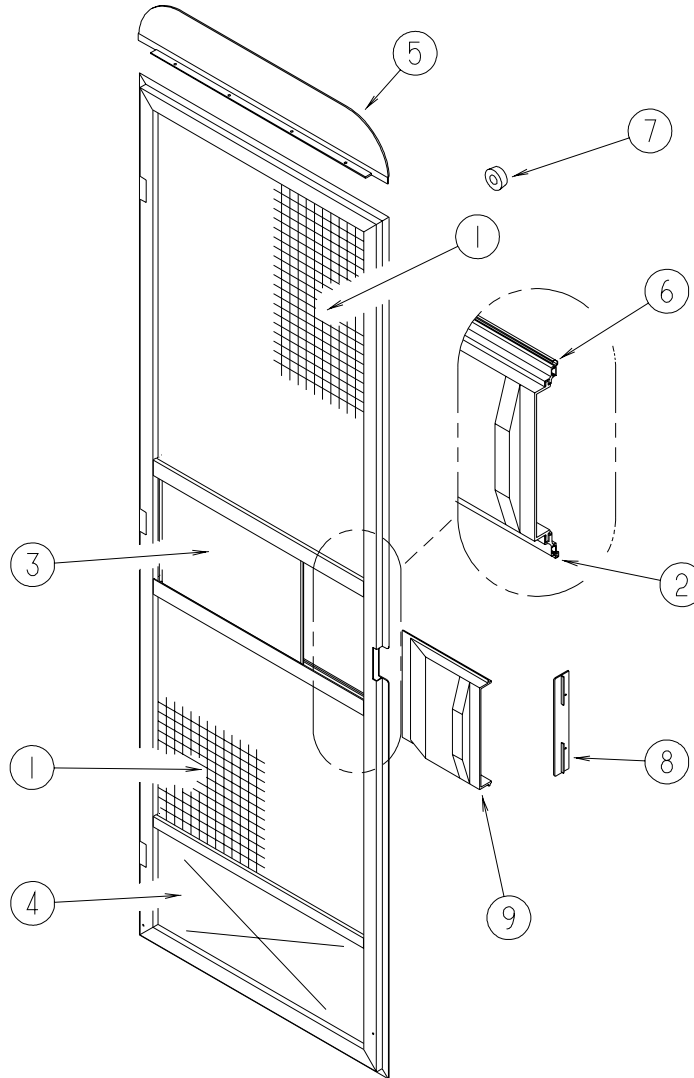

**SCREEN**

KEY	PART NUMBER	U/M	DESCRIPTION
1	002293-02-000	SF	SCREEN - 26" - CHARCOAL
2	002294-01-000	FT	SPLINE - SCREENING - .13" X .14"
3	016454-18-000	EA	INSERT/CENTER - SCREEN DOOR
4	078552-09-000	EA	INSERT - SCREEN DOOR - LOWER
5	078595-03-000	EA	PLATE - SCREEN DOOR
6	078777-08-000	FT	CHANNEL - SLIDER - 4 FOOT INCREMENTS
7	120863-06-000	EA	BUMPER - RUBBER/RADIUS TOP - 3/4" X 3/8" - LT GRAY FROM: 00-00-00 THRU: 06-26-05
7	120863-09-000	EA	BUMPER - RUBBER/RADIUS TOP - 3/4" X 3/8" - LT GRAY FROM: 06-27-05 THRU: 99-99-99
8	132081-01-01A	EA	STRIKE - SLIDER - SCREEN DOOR - BRIGHT WHITE
9	132082-01-01A	EA	SLIDER - SCREEN DOOR - BRIGHT WHITE

# EXTERIOR DOORS & COMPARTMENTS GROUP (CONTINUED)

## LATCH - ENTRY

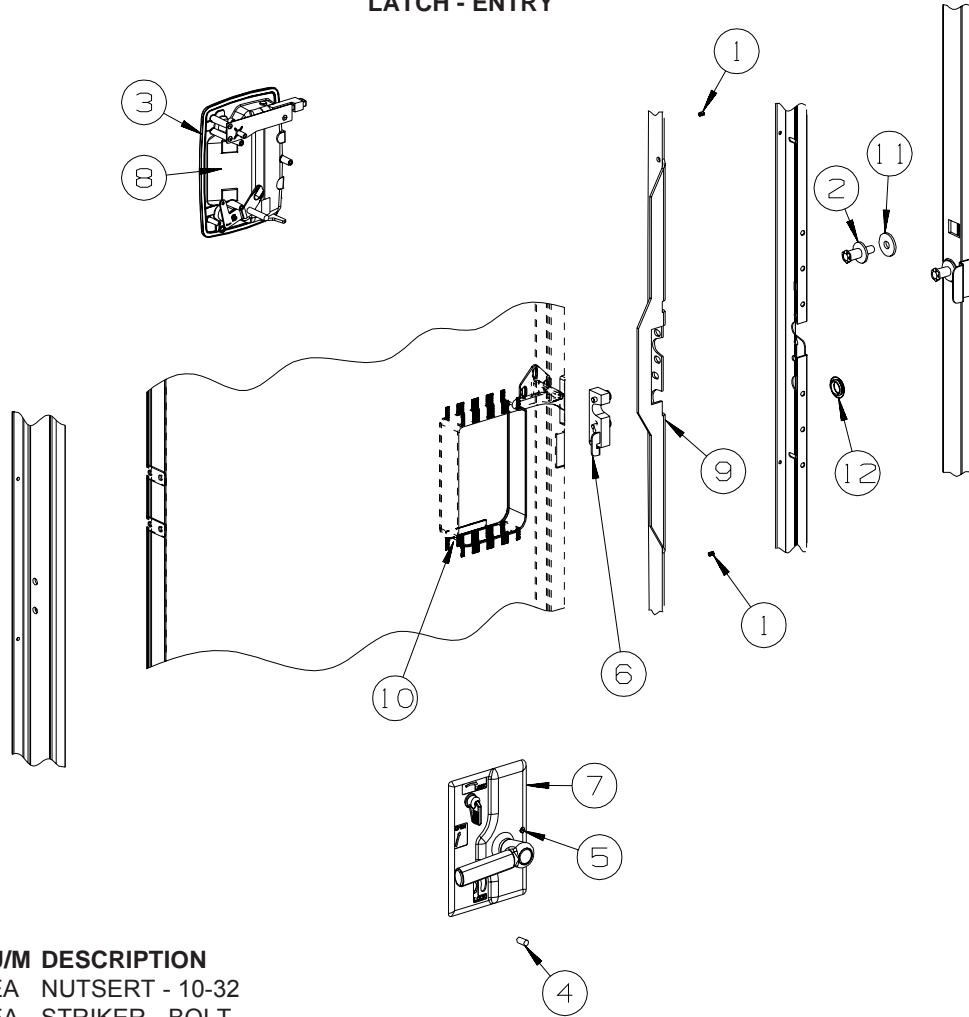

KEY	PART NUMBER	U/M	DESCRIPTION	
1	072893-04-000	EA	NUTSERT - 10-32	
2	092927-15-000	EA	STRIKER - BOLT	
3	112782-04-01A	EA	GASKET	
4	112782-05-01A	EA	CAP - VINYL - RED	
5	112782-08-01A	EA	SCREW - MOUNTING/PLATE - ZINC	
6	112782-15-01A	EA	LATCH - SINGLE ROTOR	
6	112782-22-01A	EA	LATCH - SINGLE ROTOR	FROM: 00-00-00 THRU: 05-30-04
7	112782-16-01A	EA	LATCH - INTERIOR PLATE	FROM: 05-31-04 THRU: 99-99-99
7	112782-21-01A	EA	LATCH - INTERIOR PLATE	FROM: 00-00-00 THRU: 05-30-04
8	112782-18-01A	EA	LATCH - EXTERIOR - W/O LOCK CYLINDER W/ICON-REVERSIBLE KEY	FROM: 05-31-04 THRU: 99-99-99
8	112782-20-01A	EA	LATCH - EXTERIOR - W/O LOCK CYLINDER W/ICON-REVERSIBLE KEY	FROM: 00-00-00 THRU: 05-30-04
9	132207-01-02B	EA	STIFFENER/DOOR - FORMED - E-COATED	FROM: 05-31-04 THRU: 99-99-99
10	137230-01-01A	EA	SPACER - NOTCHED, MILL	
11	147900-01-01A	EA	SPACER - STRIKE BOLT, MILL	
12	061420-14-000	EA	PLUG/PLASTIC - 7/8" DIAMETER - BLACK	

# EXTERIOR SLIDEOUT GROUP

## FRONT LEFT

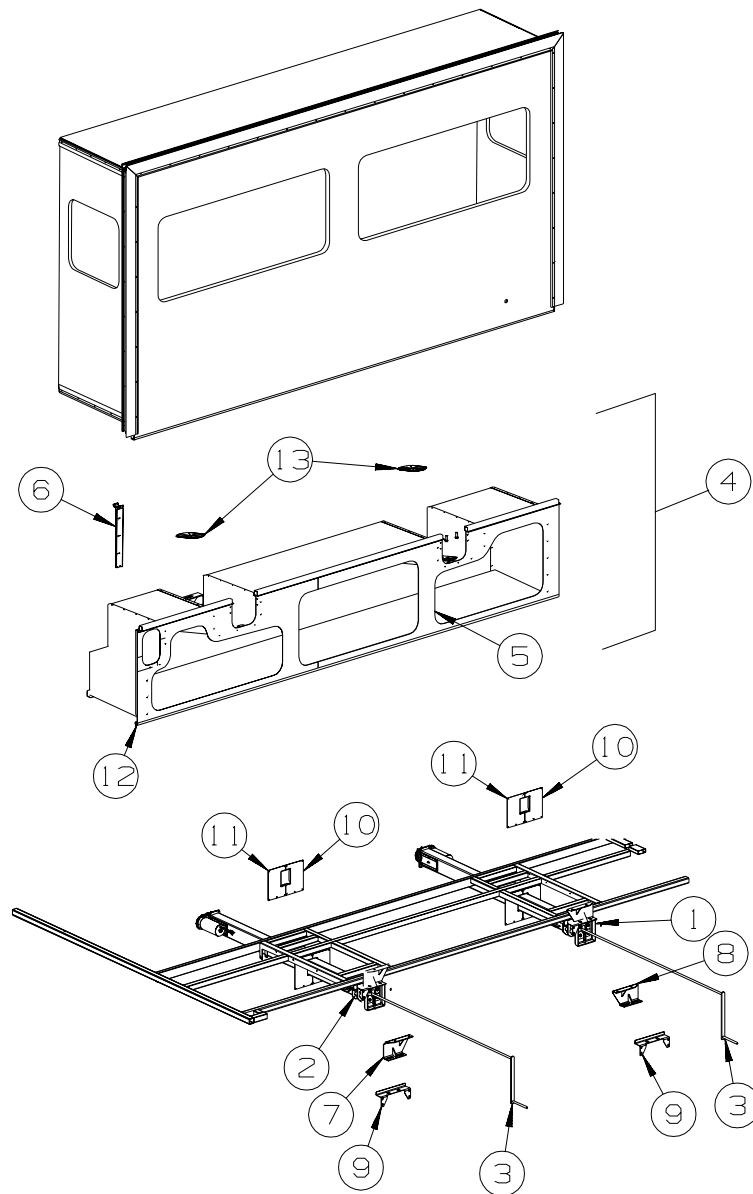

KEY	PART NUMBER	U/M	DESCRIPTION
1*	148875-01-000	EA	SLIDEOUT - ELECTRIC 30" - RIGHT HAND
2*	148875-02-000	EA	SLIDEOUT - ELECTRIC 30" - LEFT HAND
3	138173-05-000	EA	WRENCH - RETRACT CRANK HANDLE - F/SLIDEOUT
			FROM: 00-00-00 THRU: 11-11-04
3	138173-06-000	EA	CRANK - SLIDEOUT
			FROM: 11-12-04 THRU: 99-99-99
4	144137-26-S46	EA	COMPARTMENT - F/SLIDEOUT
			FROM: 00-00-00 THRU: 10-22-04
4	144137-32-S46	EA	COMPARTMENT - F/SLIDEOUT
			FROM: 10-23-04 THRU: 99-99-99
5	144138-25-02B	EA	SEAL PLANE - F/SLIDEOUT - E-COATED
			FROM: 00-00-00 THRU: 10-22-04
5	144138-31-02B	EA	SEAL PLANE - F/SLIDEOUT - E-COATED
			FROM: 10-23-04 THRU: 99-99-99
6	126591-01-02B	EA	CARRIER/EXTENSION - F/SLIDEOUT-F/WIRE/HOSES - E-COATED
7	145328-02-02B	EA	BRACKET/MOUNT - SLIDEOUT - E-COATED
8	145328-01-02B	EA	BRACKET/MOUNT - SLIDEOUT - E-COATED
9	128386-01-02B	EA	BRACKET - SLIDEOUT/COMPARTMENT - E-COATED
10	125828-05-02B	EA	FILLER/STEEL - SLIDEOUT - E-COATED
11	125828-06-02B	EA	FILLER/STEEL - SLIDEOUT - E-COATED
12	126516-01-01A	FT	TRIM - VINYL/EXTRUDED - 8'
13	148331-01-01A	EA	PLUG - OVAL/LARGE - BLACK

**\*COMPONENT PARTS LISTED LATER IN THIS GROUP**

**EXTERIOR SLIDEOUT GROUP (CONTINUED)**  
**FRONT LEFT (CONTINUED)**

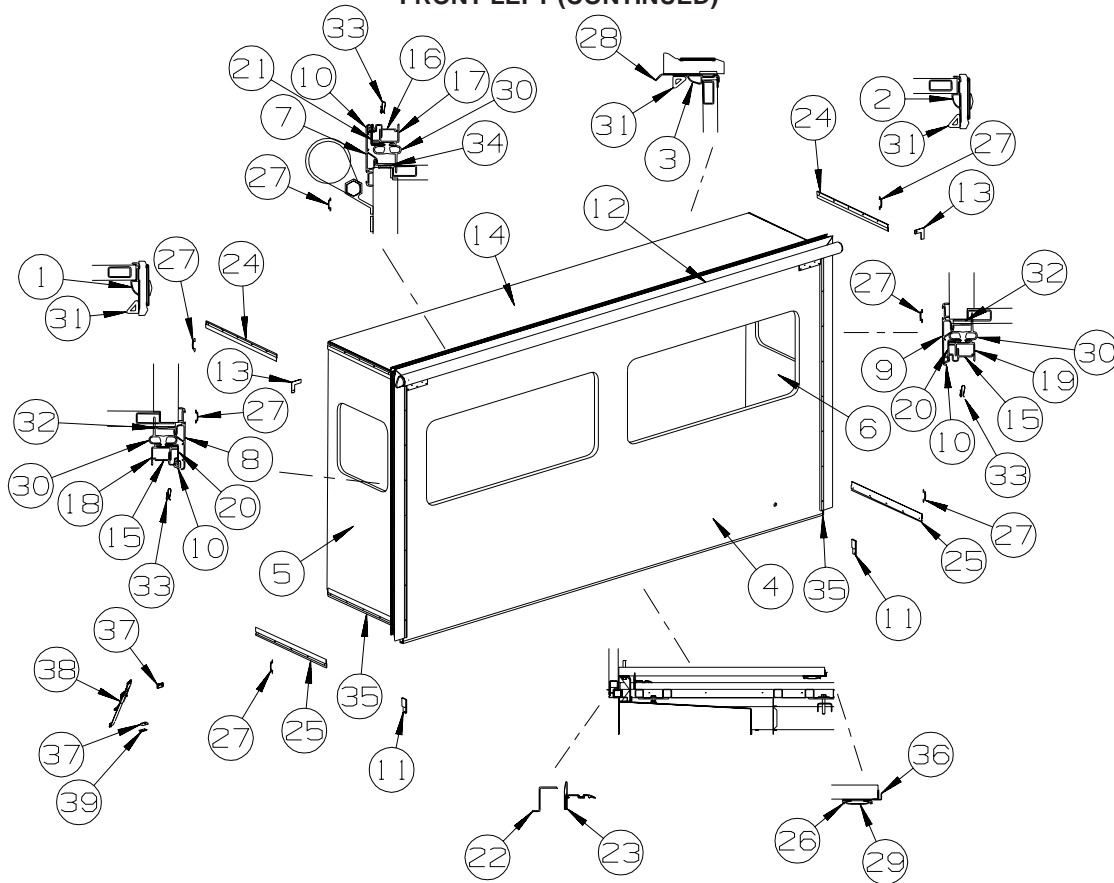

KEY	PART NUMBER	U/M DESCRIPTION
1	139624-01-01A	EA TRIM/SEAL - INNER/RIGHT HAND - 73.4" - BRIGHT WHITE
2	139624-02-01A	EA TRIM/SEAL - INNER/LEFT HAND - 73.4" - BRIGHT WHITE
3	139624-06-01A	EA TRIM/SEAL - INNER/TOP - 145.2" - BRIGHT WHITE
4	151346-11-S46	EA SLUG - F/SLIDEOUT (S46, S47, S48, SR0)
4	151346-11-S49	EA SLUG - F/SLIDEOUT (S49, S50, S51, SR1)
4	151346-11-S52	EA SLUG - F/SLIDEOUT (S52, S53, S54, SR2)
5	143066-01-S46	EA PANEL END - F/SLIDEOUT (S46, S47, S48, SR0)
5	143066-01-S49	EA PANEL END - F/SLIDEOUT (S49, S50, S51, SR1)
5	143066-01-R34	EA PANEL END - F/SLIDEOUT (S52, S53, S54, SR2)
6	143067-01-S46	EA PANEL END - F/SLIDEOUT (S46, S47, S48, SR0)
6	143067-01-S49	EA PANEL END - F/SLIDEOUT (S49, S50, S51, SR1)
6	143067-01-R34	EA PANEL END - F/SLIDEOUT (S52, S53, S54, SR2)
7	139625-06-01A	EA TRIM/SEAL - TOP/W/MITERED ENDS - 147" - BRIGHT WHITE
8	139625-42-01A	EA TRIM/SEAL - W/RH MITERED END - 76.2" - BRIGHT WHITE
9	139625-43-01A	EA TRIM/SEAL - W/LH MITERED END - 76.2" - BRIGHT WHITE
10	099418-01-000	FT SEAL - D-SECTION/ADHESIVE BACK - .44" X .44" - BLK RUBBER
11	126546-01-02A	EA COVER - END/SIDEWALL SLIDEOUT - BRIGHT WHITE
12	122977-07-03A	EA AWNING/SLIDEOUT W/COVER - 147" - WHITE - VINYL/VINYL WRAP
13	116444-04-12B	EA TRIM/KEY CORNER - SLIDEOUT - 3.1"X3.1" - BRT WHT
14	137383-01-N42	EA ROOF - F/SLIDEOUT
15	142718-01-01A	EA RETAINER - SIDEWALL/SLIDEOUT - 72.8"
16	142718-02-01A	EA RETAINER - SIDEWALL/SLIDEOUT - 144.9" - MILL
17	142719-01-01A	EA TRIM/SIDEWALL - TOP/SLIDEOUT - 146.7" - BRIGHT WHITE
18	142720-08-01A	EA TRIM - SIDEWALL/SLIDEOUT - 74.4" - BRIGHT WHITE
19	142720-06-01A	EA TRIM - SIDEWALL/SLIDEOUT - 74.4" - BRIGHT WHITE
20	136824-45-01A	EA TRIM - SIDEWALL/SLIDEOUT - 74.4"
21	136824-05-01A	EA TRIM - SIDEWALL/SLIDEOUT - 146.4" - BRIGHT WHITE
22	128621-25-01A	EA BRACKET/ZEE - SLIDEOUT - 140.6" - MILL
23	115075-03-000	FT SEAL - WIPE - .25" X 2.9"
24	138659-01-01A	EA TRIM/FEATURE STRIP - 181.7" - BRIGHT WHITE
25	125051-03-01A	EA TRIM - FEATURE STRIP/LOWER - 29.3" - BRIGHT WHITE
26	115325-04-02A	EA RAIL - FLOOR/SLIDEOUT ROOM - 134.2" LONG - BLACK
27	105312-01-07A	FT INSERT - FEATURE STRIP - VINYL - BRIGHT WHITE

**EXTERIOR SLIDEOUT GROUP (CONTINUED)**  
**FRONT LEFT (CONTINUED)**

KEY	PART NUMBER	U/M	DESCRIPTION
28	125466-02-02A	EA	SUPPORT - ROOF/INTERIOR - BRIGHT WHITE
29	115661-01-000	FT	SHOE/GLIDE - SLIDEOUT ROOM - 1/16" X 3" - POLYETHYLENE
30	136978-01-01A	FT	SEAL - SLIDEOUT - BLACK
31	146056-01-000	FT	SEAL - TRIANGLE - W/PSA
32	133954-09-01A	EA	TRIM/SEAL - 71.6" - BRIGHT WHITE
33	142549-01-000	EA	CLIP - "S" TYPE
34	133954-07-01A	EA	TRIM/SEAL - 141.8" - BRIGHT WHITE
35	075673-05-000	FT	SEAL - PILE - ADHESIVE BACK - BLACK
36	151282-03-01A	EA	TRIM - CARPET EDGE/F-ANGLE - 69.6" - BLACK
37	135619-02-01A	EA	PLATE - TIEDOWN - SLIDEOUT ROOM
38	135619-01-01A	EA	STRAP - TIEDOWN - SLIDEOUT ROOM
39	135622-01-02B	EA	PLATE - TIEDOWN - SLIDEOUT ROOM

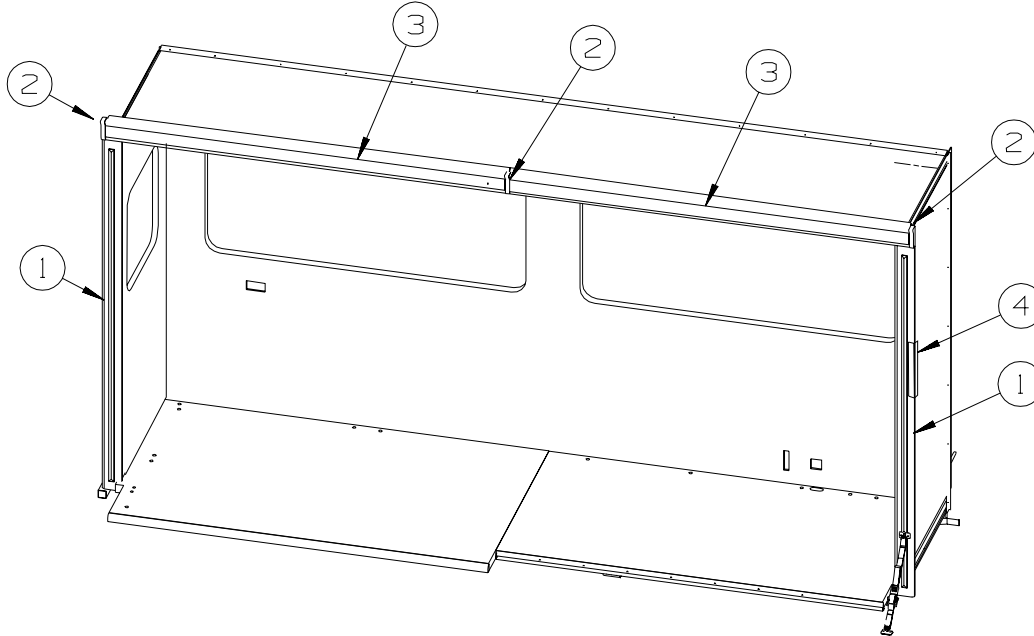

KEY	PART NUMBER	U/M	DESCRIPTION
1	Y00152-72-438	EA	MOLDING/TRIM - VINYL - .6" X 3.5" X 96" - PORTSMOUTH OAK
1	Y00152-62-438	EA	MOLDING/TRIM - VINYL - .6" X 3.5" X 96" - CONCERT CHERRY
1	Y00152-A2-438	EA	MOLDING/TRIM - VINYL - .6" X 3.5" X 96" - WASHED MAPLE
1	Y00152-92-438	EA	MOLDING/TRIM - VINYL - .6" X 3.5" X 96" - SIERRA MAPLE
1	149496-15-S46	EA	TRIM - DECORATIVE - 1.7" X 74.5" - FABRIC COVERED (S46, S47, S48, SR0) FROM: 00-00-00 THRU: 07-15-04
1	149496-39-S46	EA	TRIM - DECORATIVE - 2.6" X 70.2" - FABRIC COVERED (S46, S47, S48, SR0) FROM: 07-16-04 THRU: 99-99-99
1	149496-15-S49	EA	TRIM - DECORATIVE - 1.7" X 74.5" - FABRIC COVERED (S49, S50, S51, SR1) FROM: 00-00-00 THRU: 07-15-04
1	149496-39-S49	EA	TRIM - DECORATIVE - 2.6" X 70.2" - FABRIC COVERED (S49, S50, S51, SR1) FROM: 07-16-04 THRU: 99-99-99
1	149496-15-S52	EA	TRIM - DECORATIVE - 1.7" X 74.5" - FABRIC COVERED (S52, S53, S54, SR2) FROM: 00-00-00 THRU: 07-15-04
1	149496-39-S52	EA	TRIM - DECORATIVE - 2.6" X 70.2" - FABRIC COVERED (S52, S53, S54, SR2) FROM: 07-16-04 THRU: 99-99-99
2	149151-01-S46	EA	MOLDING/BLOCK - PORTSMOUTH OAK
2	149151-01-S47	EA	MOLDING/BLOCK - CHERRY IV - CONCERT CHERRY
2	149151-01-S48	EA	MOLDING/BLOCK - WASHED MAPLE
2	149151-01-SR0	EA	MOLDING/BLOCK - SIERRA MAPLE
3	Y00282-72-438	EA	MOLDING - SLIDEOUT/VINYL WRAP - 3.9" X 96" - PORTSMOUTH OAK
3	Y00282-62-438	EA	MOLDING - SLIDEOUT/VINYL WRAP - 3.9" X 96" - CONCERT CHERRY
3	Y00282-A2-438	EA	MOLDING - SLIDEOUT/VINYL WRAP - 3.9" X 96" - WASHED MAPLE
3	Y00282-92-438	EA	MOLDING - SLIDEOUT/VINYL WRAP - 3.9" X 96" - SIERRA MAPLE
4	130262-04-000	EA	PROTECTOR - CORNER SAVER - .4" X .7" X 48"

**EXTERIOR SLIDEOUT GROUP (CONTINUED)**  
**COMPONENT PARTS FOR FRONT SLIDEOUT**

148875-01-000, 148875-02-000

KEY	PART NUMBER	U/M	DESCRIPTION	VENDOR NO.
	130294-04-700	EA	SCREW - 5/16"-18 X 1 1/2"	1202060
	131281-01-702	EA	PIN/CLEVIS-1/4" PLATED	1213190
	131281-01-704	EA	HAIRPIN/COTTER - 3/8" SPRING	1213460
	131682-01-700	EA	ROLLER - (BEARING)	1912040
	138173-01-701	EA	POP RIVET - SS 3/16"X1/4"	1214630
	138173-01-707	EA	WEAR PUCK - PLASTIC F/DRIVE	1612523
	140457-01-701	EA	BUSHING - 1" X 3/4" X 1/2"ID	1614006
	140457-01-704	EA	SHAFT/AXLE - REAR ROLLER	7204523
	148875-01-700	EA	PIN/COTTER - 3/32" X 1/2"	1213520
	148875-01-701	EA	PIN/ROLL - 3/16" X 3/4"	1213693
	148875-01-702	EA	PIN/ROLL - 1/4" X 1"	1213701
	148875-01-703	EA	NUT - PLASTIC - 1"	1612548
	148875-01-704	EA	END CARRIER - PLASTIC - 1"	1612549
	148875-01-705	EA	MOTOR/LINEAR - SLIDE ROOM	1820111
	148875-01-706	EA	DRIVE SCREW - SLIDE ROOM	1820401
	148875-01-707	EA	END GUIDE F/SCREW - 1"	1820450

**EXTERIOR SLIDEOUT GROUP (CONTINUED)**  
**RIGHT REAR**

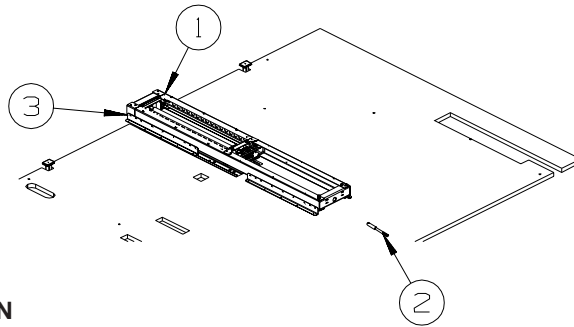
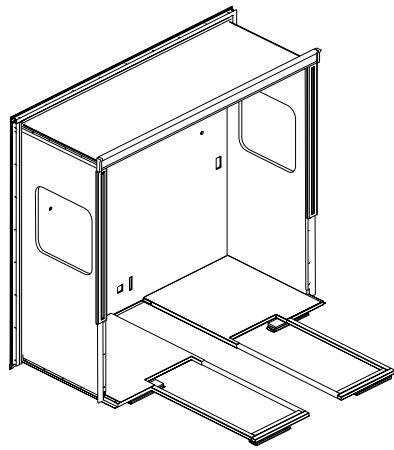

KEY	PART NUMBER	U/M	DESCRIPTION
1*	149165-01-000	EA	SLIDEOUT - ELECTRIC/REAR/SINGLE
2	140464-03-000	EA	WRENCH - SLIDE ROOM RETRACT - RATCHET W/2 EXTENSIONS
3	104692-03-000	FT	SEAL - ADHESIVE BACKED FOAM - 1" THICK X 1 3/16"WIDE X 15'

**\*COMPONENT PARTS LISTED LATER IN THIS GROUP**

**EXTERIOR SLIDEOUT GROUP (CONTINUED)**  
**RIGHT REAR (CONTINUED)**

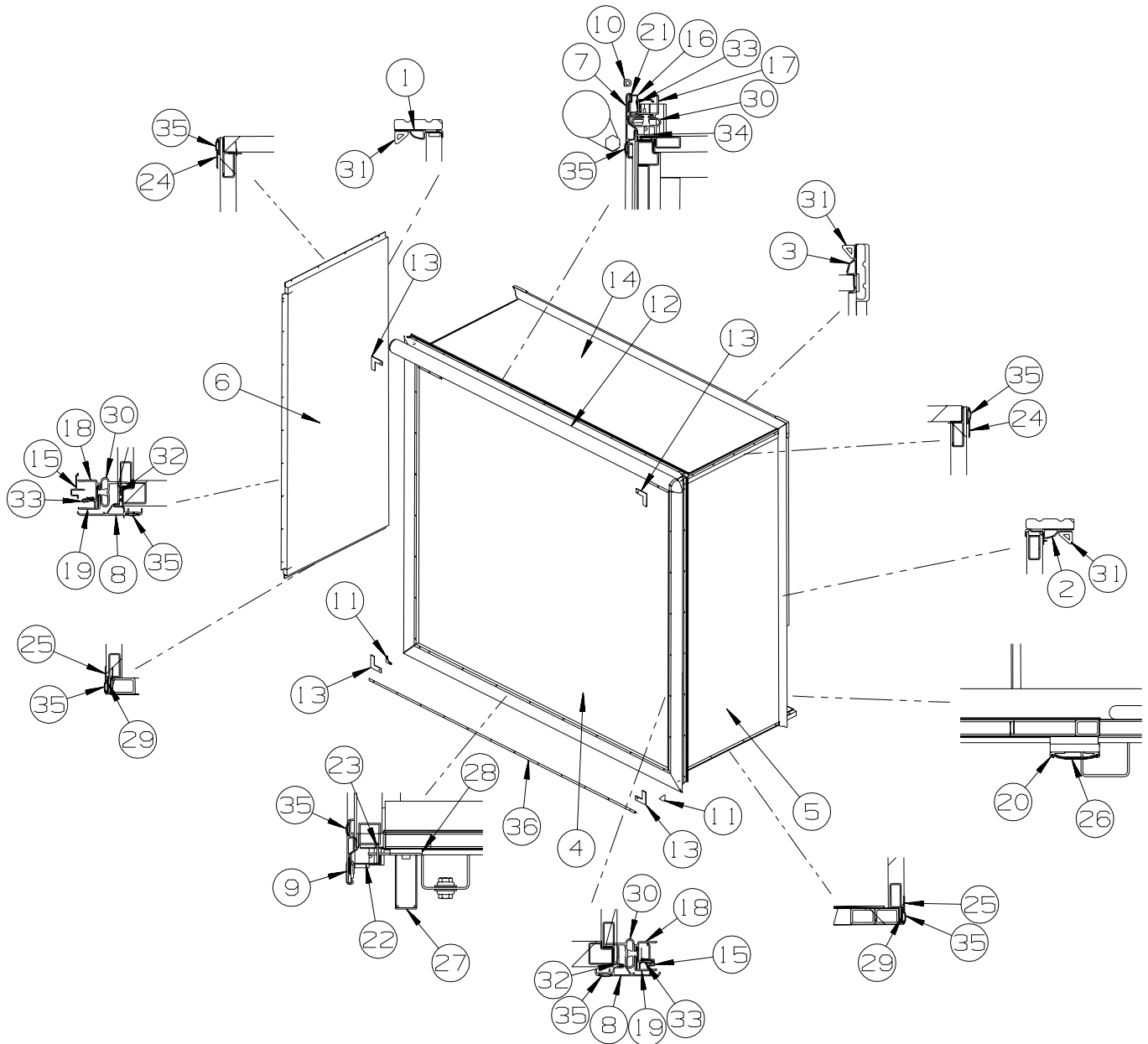

KEY	PART NUMBER	U/M	DESCRIPTION
1	139624-15-01A	EA	TRIM/SEAL - INNER/RIGHT HAND - 72.9" - BRIGHT WHITE
2	139624-16-01A	EA	TRIM/SEAL - INNER/LEFT HAND - 72.9" - BRIGHT WHITE
3	139624-04-01A	EA	TRIM/SEAL - INNER/TOP - 80.2" - BRIGHT WHITE
4	151345-11-S46	EA	SLUG - F/SLIDEOUT (S46, S47, S48, SR0)
4	151345-11-S49	EA	SLUG - F/SLIDEOUT (S49, S50, S51, SR1)
4	151345-11-S52	EA	SLUG - F/SLIDEOUT (S52, S53, S54, SR2)
5	142890-01-S46	EA	PANEL END - F/SLIDEOUT (S46, S47, S48, SR0)
5	142890-01-S49	EA	PANEL END - F/SLIDEOUT (S49, S50, S51, SR1)
5	142890-01-R42	EA	PANEL END - F/SLIDEOUT (S52, S53, S54, SR2)
6	142891-01-S46	EA	PANEL END - F/SLIDEOUT (S46, S47, S48, SR0)
6	142891-01-S49	EA	PANEL END - F/SLIDEOUT (S49, S50, S51, SR1)
6	142891-01-S52	EA	PANEL END - F/SLIDEOUT (S52, S53, S54, SR2)
7	139625-03-01A	EA	TRIM/SEAL - W/MITERED ENDS - 82" - BRIGHT WHITE
8	139625-11-01A	EA	TRIM/SEAL - W/MITERED ENDS - 75.9" - BRIGHT WHITE
9	142233-04-01A	EA	TRIM/SEAL - W/MITERED ENDS - 82" - BRIGHT WHITE
10	099418-01-000	FT	SEAL - D-SECTION/ADHESIVE BACK - .44" X .44" - BLK RUBBER
11	135275-01-01A	EA	PROTECTOR - CORNER - SLIDEOUT - WHITE
12	122977-12-03A	EA	AWNING/SLIDEOUT W/COVER - 81.8" - WHITE - VINYL/VINYL WRAP
13	116444-04-12B	EA	TRIM/KEY CORNER - SLIDEOUT - 3.1" X 3.1" - BRT WHITE



**EXTERIOR SLIDEOUT GROUP (CONTINUED)**  
**RIGHT REAR (CONTINUED)**

KEY	PART NUMBER	U/M	DESCRIPTION
14	137400-01-N42	EA	ROOF - F/SLIDEOUT
15	142718-01-01A	EA	RETAINER - SIDEWALL/SLIDEOUT - 72.8"
16	142718-23-01A	EA	RETAINER - SIDEWALL/SLIDEOUT - 79.9"
17	142719-05-01A	EA	TRIM/SIDEWALL - TOP/SLIDEOUT - 81.3" - BRIGHT WHITE
18	142720-11-01A	EA	TRIM - SIDEWALL/SLIDEOUT - 72.9" - BRIGHT WHITE
19	136824-16-01A	EA	TRIM - SIDEWALL/SLIDEOUT - 72.7" - BRIGHT WHITE
20	115325-08-01A	EA	RAIL - FLOOR/SLIDEOUT ROOM - 12" LONG - BLACK
21	136824-02-01A	EA	TRIM - SIDEWALL/SLIDEOUT - 81.2" - BRIGHT WHITE
22	141174-01-02A	EA	TRIM/ZEE - SIDEWALL - 81.4" - BRIGHT WHITE
23	123012-01-000	FT	SEAL - SLIDEOUT - .09"/.13" THICK X 1.3" - W/ADHESIVE
24	138659-01-01A	EA	TRIM/FEATURE STRIP - 181.7" - BRIGHT WHITE
25	141435-03-01A	EA	TRIM - FEATURE - LOWER - 29.1" - BRIGHT WHITE
26	115661-01-000	FT	SHOE/GLIDE - SLIDEOUT ROOM - 1/16" X 3" - POLYETHYLENE
27	126313-10-02B	EA	SUPPORT - ROLLER - SLIDE-OUT ROOM - E-COATED
28	128599-03-000	EA	PAD - F/SLIDEOUT
29	075673-05-000	FT	SEAL - PILE - ADHESIVE BACK - BLACK
30	136978-01-01A	FT	SEAL - SLIDEOUT - BLACK
31	146056-01-000	FT	SEAL - TRIANGLE - W/PSA
32	133954-46-01A	EA	TRIM/SEAL - W/MITERED ENDS - 68.8" - BRIGHT WHITE
33	142549-01-000	EA	CLIP - "S" TYPE
34	133954-18-01A	EA	TRIM/SEAL - 76.5" - BRIGHT WHITE
35	105312-01-07A	FT	INSERT - FEATURE STRIP - VINYL - BRIGHT WHITE
36	149821-01-02A	EA	TRIM/ANGLE - SIDEWALL - BRIGHT WHITE - 1/2" X 1/2" X 77.9" FROM: 00-00-00 THRU: 10-24-04
36	149821-01-01A	EA	TRIM/ANGLE - SIDEWALL - BLACK - 1/2" X 1/2" X 77.9" FROM: 10-25-04 THRU: 99-99-99

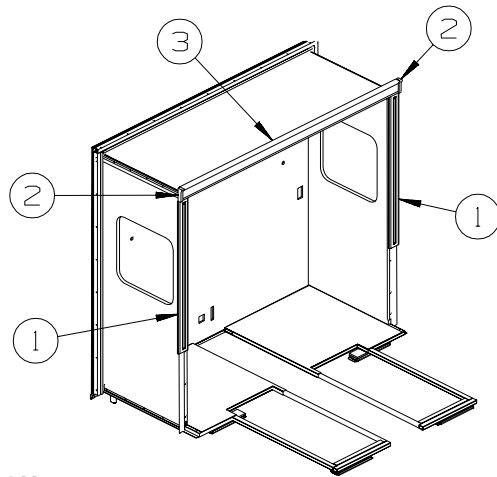

KEY	PART NUMBER	U/M	DESCRIPTION
1	Y00152-72-438	EA	MOLDING/TRIM - VINYL - .6" X 3.5" X 96" - PORTSMOUTH OAK
1	Y00152-62-438	EA	MOLDING/TRIM - VINYL - .6" X 3.5" X 96" - CONCERT CHERRY
1	Y00152-A2-438	EA	MOLDING/TRIM - VINYL - .6" X 3.5" X 96" - WASHED MAPLE
1	Y00152-92-438	EA	MOLDING/TRIM - VINYL - .6" X 3.5" X 96" - SIERRA MAPLE
1	149496-06-S46	EA	TRIM - DECORATIVE - 2.7" X 45.8" - FABRIC COVERED (S46, S47, S48, SR0)
1	149496-06-S49	EA	TRIM - DECORATIVE - 2.7" X 45.8" - FABRIC COVERED (S49, S50, S51, SR1)
1	149496-06-S52	EA	TRIM - DECORATIVE - 2.7" X 45.8" - FABRIC COVERED (S52, S53, S54, SR2)
2	149151-01-S46	EA	MOLDING/BLOCK - PORTSMOUTH OAK
2	149151-01-S47	EA	MOLDING/BLOCK - CHERRY IV - CONCERT CHERRY
2	149151-01-S48	EA	MOLDING/BLOCK - WASHED MAPLE
2	149151-01-SR0	EA	MOLDING/BLOCK - SIERRA MAPLE
3	Y00282-72-438	EA	MOLDING - SLIDEOUT/VINYL WRAP - 3.9" X 96" - PORTSMOUTH OAK
3	Y00282-62-438	EA	MOLDING - SLIDEOUT/VINYL WRAP - 3.9" X 96" - CONCERT CHERRY
3	Y00282-A2-438	EA	MOLDING - SLIDEOUT/VINYL WRAP - 3.9" X 96" - WASHED MAPLE
3	Y00282-92-438	EA	MOLDING - SLIDEOUT/VINYL WRAP - 3.9" X 96" - SIERRA MAPLE

**EXTERIOR SLIDEOUT GROUP (CONTINUED)**  
**COMPONENT PARTS FOR RIGHT REAR SLIDEOUT**

149165-01-000

<b>KEY</b>	<b>PART NUMBER</b>	<b>U/M</b>	<b>DESCRIPTION</b>	<b>VENDOR NO.</b>
	131281-01-702	EA	PIN/CLEVIS-1/4" PLATED	1213190
	131281-01-704	EA	HAIRPIN/COTTER - 3/8" SPRING	1213460
	138173-01-701	EA	POP RIVET - SS 3/16"X1/4"	1214630
	138173-01-707	EA	WEAR PUCK - PLASTIC F/DRIVE	1612523
	148875-01-703	EA	NUT - PLASTIC - 1"	1612548
	148875-01-705	EA	MOTOR/LINEAR - SLIDE ROOM	1820111
	149165-01-700	EA	BEARING - 5/8" ID	1102015
	149165-01-701	EA	PIN/CLEVIS - 1/4" X 2"	1213204
	149165-01-702	EA	SEAL/RUBBER - LOWER ROOM "Z"	1611999
	149165-01-703	EA	SEAL/RUBBER - INNER FRAME	1612007
	149165-01-704	EA	SEAL/LOWER ROOM - "Z"	1612009

## GENERATOR GROUP GAS

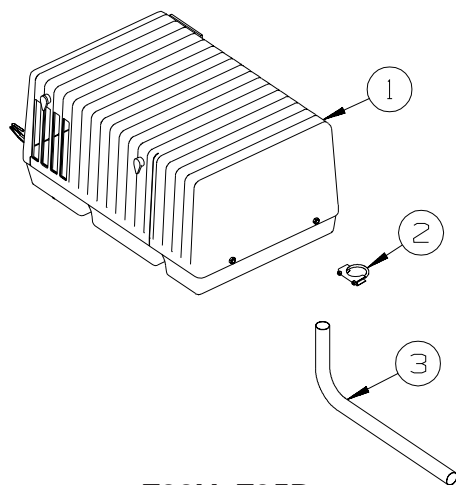

### F33V, F35D

KEY	PART NUMBER	U/M	DESCRIPTION
1	135707-02-000	EA	GENERATOR - 7.0 - 30/20 - GAS - MARQUIS GOLD - 7.0 KW ONAN - 30 AMP
1	135707-01-000	EA	GENERATOR - 7.0 - 30/30 - GAS - MARQUIS GOLD - 7.0 KW ONAN - 50 AMP
1	135707-07-000	EA	GENERATOR - 5.5 - 30/20 - GAS - MARQUIS GOLD - 5.5 KW ONAN - 30 AMP
1	135707-06-000	EA	GENERATOR - 5.5 - 30/30 - GAS - MARQUIS GOLD - 5.5 KW ONAN - 50 AMP
2	007125-03-000	EA	CLAMP - MUFFLER - 1.5" DIAMETER
3	105958-30-000	EA	PIPE - EXHAUST/GENERATOR

### F31W, F35A, F36M, F38J

KEY	PART NUMBER	U/M	DESCRIPTION
1	135707-02-000	EA	GENERATOR - 7.0 - 30/20 - GAS - MARQUIS GOLD - 7.0 KW ONAN - 30 AMP
1	135707-01-000	EA	GENERATOR - 7.0 - 30/30 - GAS - MARQUIS GOLD - 7.0 KW ONAN - 50 AMP
1	135707-07-000	EA	GENERATOR - 5.5 - 30/20 - GAS - MARQUIS GOLD - 5.5 KW ONAN - 30 AMP
1	135707-06-000	EA	GENERATOR - 5.5 - 30/30 - GAS - MARQUIS GOLD - 5.5 KW ONAN - 50 AMP
2	007125-03-000	EA	CLAMP - MUFFLER - 1.5" DIAMETER
3	105958-30-000	EA	PIPE - EXHAUST/GENERATOR

FROM: 00-00-00 THRU: 10-19-04

3	105958-27-000	EA	PIPE - EXHAUST/GENERATOR
---	---------------	----	--------------------------

FROM: 10-20-04 THRU: 99-99-99

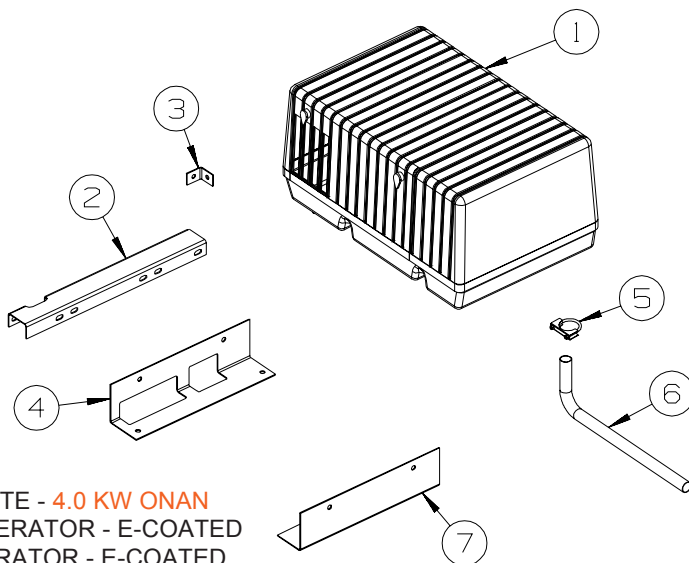

KEY	PART NUMBER	U/M	DESCRIPTION
1	109982-03-000	EA	GENERATOR - 4.0 MICROLITE - 4.0 KW ONAN
2	135825-01-02B	EA	CHANNEL - SPACER - GENERATOR - E-COATED
3	135826-01-02B	EA	ANGLE - SUPPORT - GENERATOR - E-COATED
4	114070-02-02B	EA	SUPPORT - GENERATOR - LEFT
5	007125-04-000	EA	CLAMP - MUFFLER - 1.12" DIAMETER
6	105958-10-000	EA	PIPE - GENERATOR EXHAUST - 1.3" OD X 5.9" X 19.7"
			FROM: 00-00-00 THRU: 08-01-04
6	105958-31-000	EA	PIPE - EXHAUST/GENERATOR
			FROM: 08-02-04 THRU: 03-06-05
6	105958-17-000	EA	PIPE - EXHAUST/GENERATOR - 1.5" OD X 4.9" X 24"
			FROM: 03-07-05 THRU: 99-99-99
7	114071-02-02B	EA	SUPPORT - GENERATOR - RIGHT

## HEATING & A/C GROUP AUTOMOTIVE

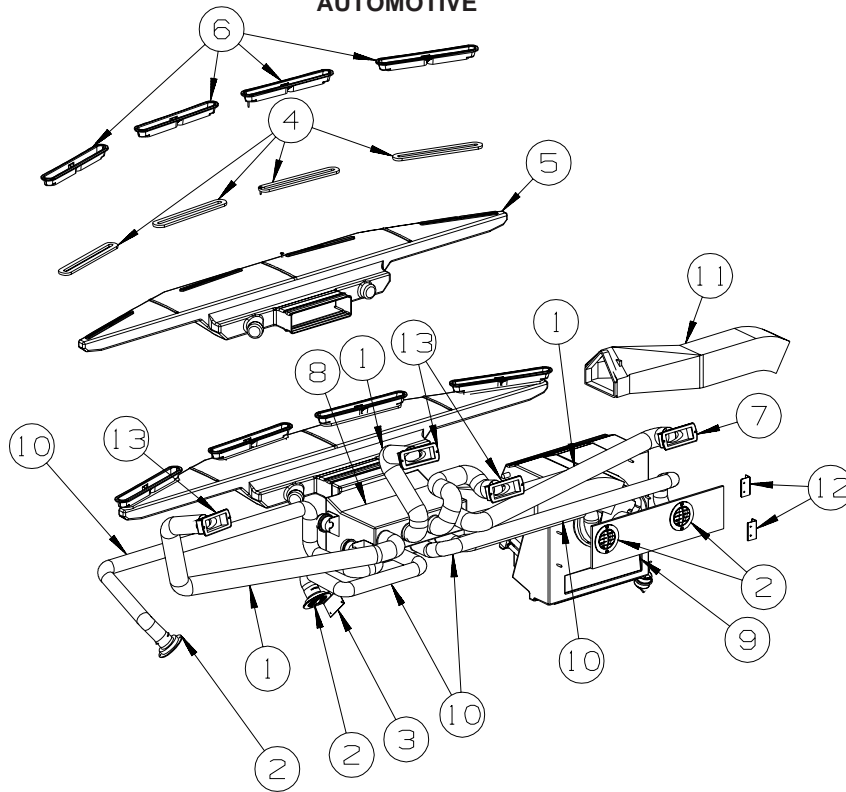

KEY	PART NUMBER	U/M	DESCRIPTION
1	007281-01-000	EA	HOSE - FLEXIBLE PVC - 2 1/2" ID X 50'
2	024990-05-000	EA	OUTLET - DEFROSTER - W/SWIVEL - 2" SLEEVE/4" OD - BLACK
3	136157-03-02B	EA	BRACKET - HEATER - E-COATED
4	077075-01-000	EA	GASKET - INSTRUMENT PANEL/DEFROSTER PLENUM - .6" X 10.2"
5	103017-03-000	EA	PLENUM - DEFROSTER
6	135265-01-04A	EA	VENT - DEFROSTER - PLASTIC - GLACIER
7	135803-01-01A	EA	LOUVER - A/C - 2.5" X 5.2" - BLACK
8*	103930-49-000	EA	CONTROL/PLENUM - LARGE ROTARY
9*	103930-55-000	EA	EVAPORATOR/HEATER - NONCHARGED - SINGLE OUTPUT
10	007076-01-000	EA	HOSE - FLEXIBLE PVC - 2" ID - INCREMENTS OF 50'
11	103016-03-000	EA	PLENUM - TRANSITION
12	083125-02-000	EA	BRACE
13	135803-02-01A	EA	LOUVER/A/C - ADJ W/MOUNT HOLES - 2.5" X 5.8" F/2.5" HOSE
	113452-02-000	FT	SEAL/TRIM - FRONT - VINYL W/WIRE CARRIER - .027" - <b>WHERE HOSES CROSS METAL</b>
	103930-54-000	EA	MANUAL - OWNERS - HEATER/AC

**\*COMPONENT PARTS LISTED LATER IN THIS GROUP**

## HEATING & A/C GROUP (CONTINUED)

### AUTOMOTIVE (CONTINUED)

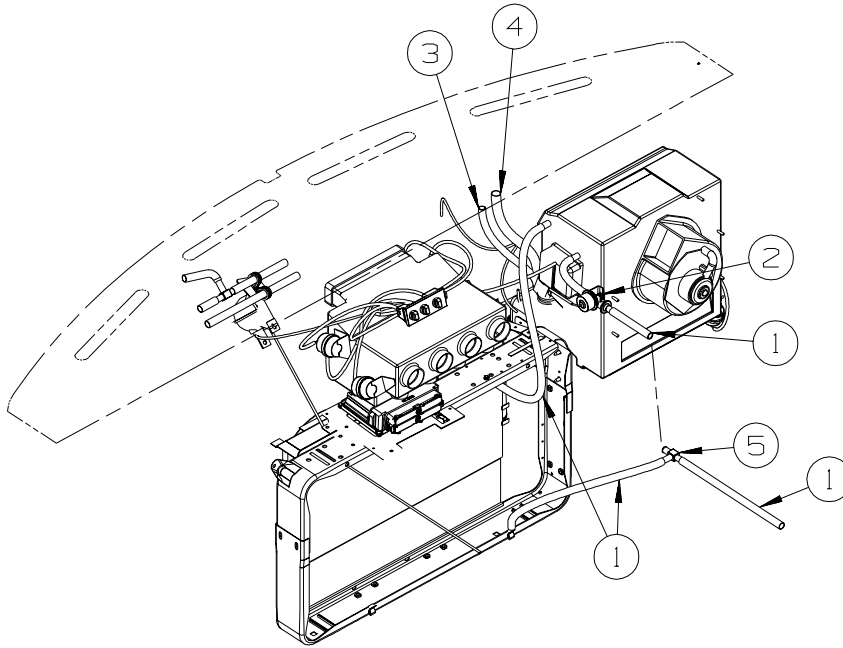

KEY	PART NUMBER	U/M	DESCRIPTION
1	007108-01-000	FT	HOSE - HEATER - 5/8" ID - HI-TEMP
2	103930-23-000	EA	VALVE/WATER - 2 PORT/VACUUM CONTROLLED - "NEW DESIGN"
3*	103930-46-000	EA	HOSE - EXPANSION BLOCK (EVAPORATOR) TO COMPRESSOR
4*	103930-47-000	EA	HOSE - EXPANSION VALVE (EVAPORATOR) TO DRIER
5	076776-01-000	EA	TEE - BEADED - 5/8" X 5/8" X 5/8"

**\*COMPONENT PARTS LISTED LATER IN THIS GROUP**

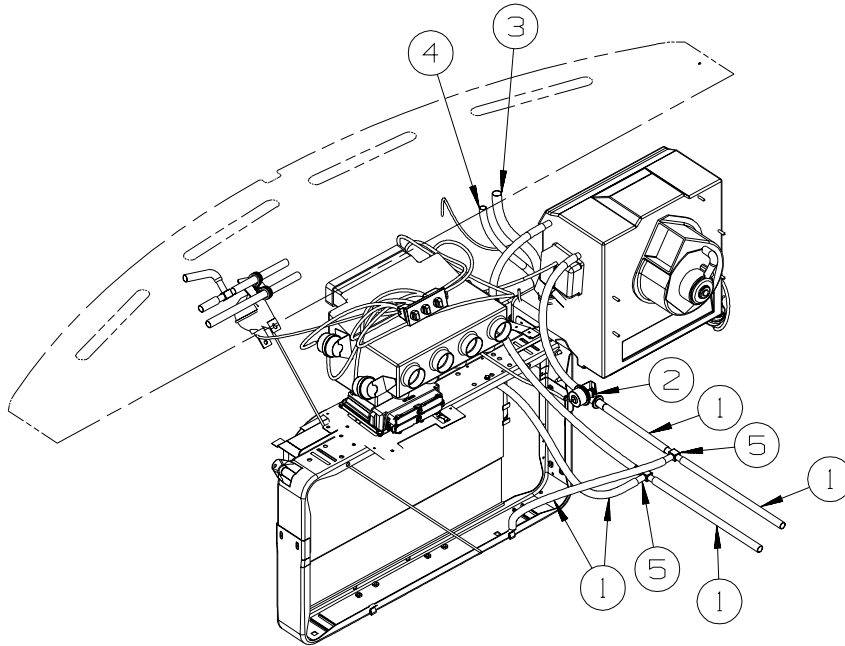

KEY	PART NUMBER	U/M	DESCRIPTION
1	007108-01-000	FT	HOSE - HEATER - 5/8" ID - HI-TEMP
2	103930-23-000	EA	VALVE/WATER - 2 PORT/VACUUM CONTROLLED - "NEW DESIGN"
3*	103930-44-000	EA	HOSE - EVAPORATOR/DRYER - #6
4*	103930-45-000	EA	HOSE - EVAPORATOR/COMPRESSOR - FORD
5	076776-01-000	EA	TEE - BEADED - 5/8" X 5/8" X 5/8"

**\*COMPONENT PARTS LISTED LATER IN THIS GROUP**

# HEATING & A/C GROUP (CONTINUED)

## COMPONENT PARTS FOR AUTOMOTIVE

### 103930-44-000

KEY	PART NUMBER	U/M	DESCRIPTION	VENDOR NO
	103930-29-701	EA	O'RING F/LOW PRESSURE SWITCH	045-0483
	103930-44-700	EA	HOSE ASSEMBLY #6	085-0462
	113245-01-711	EA	O'RING #6	045-0129

### 103930-45-000

KEY	PART NUMBER	U/M	DESCRIPTION	VENDOR NO.
	103930-17-702	EA	O'RING #10	045-0127
	103930-45-700	EA	HOSE - #10 EVAP/COMP - 3'	085-0463

### 103930-46-000

KEY	PART NUMBER	U/M	DESCRIPTION	VENDOR NO
	103930-17-702	EA	O'RING #10	045-0127
	103930-29-701	EA	O'RING F/LOW PRESSURE SWITCH	045-0483
	103930-46-700	EA	HOSE - #10 EVAP/COMP - 4.3'	085-0486

### 103930-47-000

KEY	PART NUMBER	U/M	DESCRIPTION	VENDOR NO
	103930-47-700	EA	HOSE - #6-EVAP/DRIER - 2.2'	085-0485
	113245-01-710	EA	O'RING, #12	045-0128

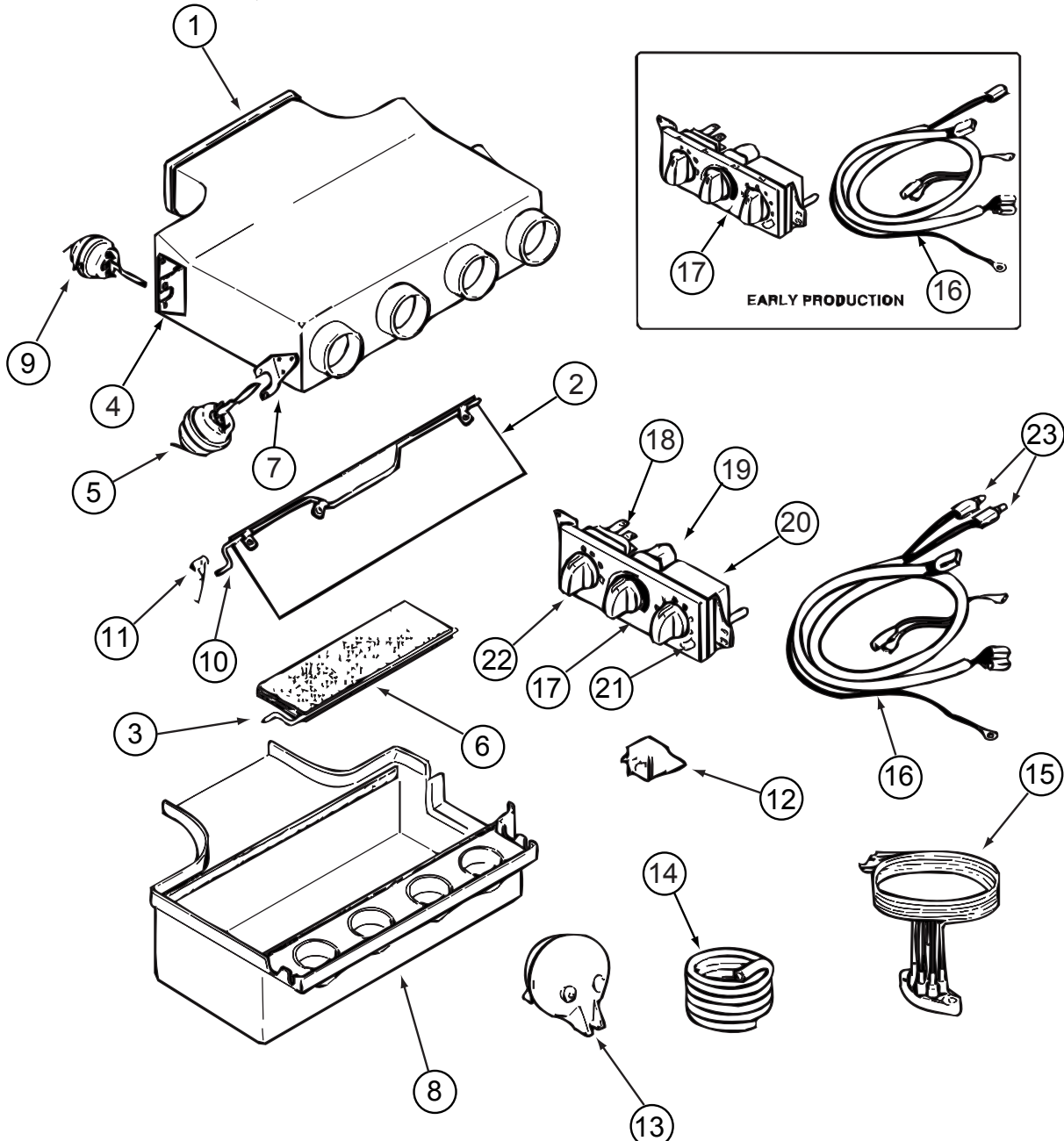

### 103930-49-000

**HEATING & A/C GROUP (CONTINUED)**  
**COMPONENT PARTS FOR AUTOMOTIVE (CONTINUED)**

**103930-49-000 (CONTINUED)**

<b>KEY</b>	<b>PART NUMBER</b>	<b>U/M</b>	<b>DESCRIPTION</b>	<b>VENDOR NO.</b>
1	103930-39-705	EA	PLENUM - TOP	060-0482
2	103930-04-700	EA	DOOR - DEFROSTER-A/C	071-0149
3	103930-39-700	EA	ROD - DOOR - AC/HEAT	073-067
5	103930-02-708	EA	MOTOR-VACUUM SERVO, A/C	030-0025
6	103930-39-706	EA	PLATE - DOOR - A/C	071-0623
8	103930-39-707	EA	PLENUM - BOTTOM	060-0483
9	103930-33-701	EA	MOTOR - VACUUM, 3 STAGE	030-0105
10	103930-39-701	EA	ROD - DOOR - AC/DEFROST	073-0069
11	103930-39-704	EA	SPRING	022-0119
12	103930-02-707	EA	RELAY-BOSCH W/RESISTER	031-0001
13	103930-02-710	EA	CANISTER-VACUUM	054-0002
15	103930-33-703	EA	VACUUM HARNESS	036-0466
16	103930-49-700	EA	HARNESS - WIRE	036-556
16	103930-49-701	EA	HARNESS - WIRE W/BULBS	036-0557
17	103930-49-702	EA	CONTROL PANEL-RECESSED FACE	032-0054
17	103930-49-703	EA	CONTROL PANEL - NON RECESSED	083-0223
18	103930-49-704	EA	SWITCH - BLOWER	032-0332
19	103930-49-705	EA	POTENTIOMETER	032-0182
20	103930-49-706	EA	SWITCH - VACUUM	032-0185
21	103930-49-707	EA	DECAL CONTROL PANEL-N/RECESS	058-0144
22	103930-49-708	EA	KNOB - BLOWER - NONRECESSED	062-0620
23	103930-33-705	EA	LIGHT BULBS	035-0030

CONTACT WINNEBAGO PART SALES FOR UNLISTED COMPONENT(S)

**HEATING & A/C GROUP (CONTINUED)**  
**COMPONENT PARTS FOR AUTOMOTIVE (CONTINUED)**

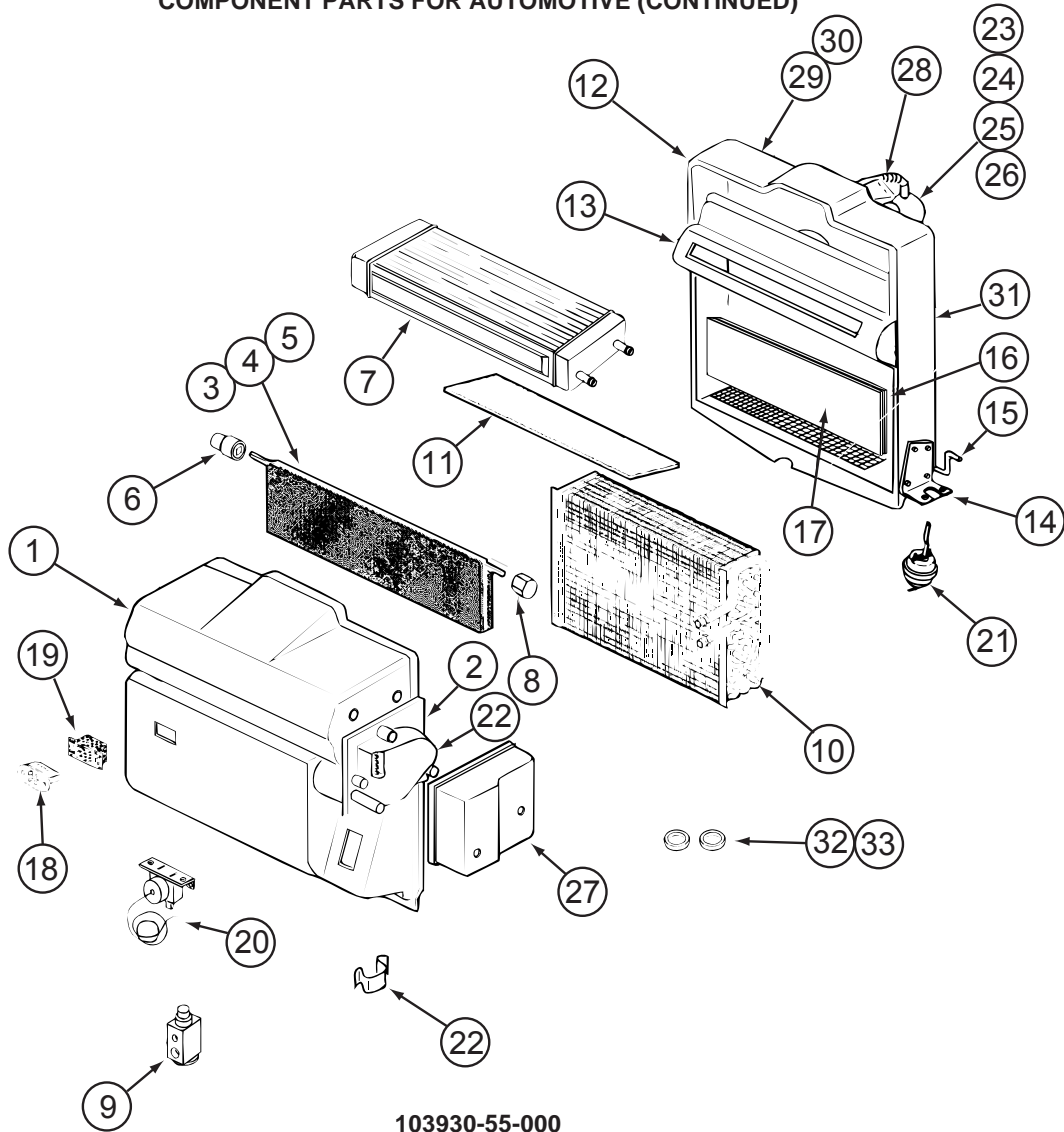

103930-55-000

KEY	PART NUMBER	U/M DESCRIPTION	VENDOR NO.
1	103930-55-701	EA CASE - FRONT	062-0658
2	103930-30-701	EA PLATE - MOTOR MOUNT	062-0544
3	103930-55-705	EA DOOR - BLEND AIR	071-0892
6	103930-30-702	EA BUSHING/DRIVE (BLEND DOOR)	062-0168
7	103930-55-706	EA CORE - HEATER - W/GASKET	084-0271
8	103930-30-709	EA COUPLING - BLEND DOOR SHAFT	062-0634
9	103930-20-700	EA VALVE-EXPANSION-BLOCK, 2 TON	034-0032
10	103930-55-700	EA CORE-EVAPORATOR	041-00168
12	103930-55-702	EA CASE-REAR	062-0657
14	103930-01-708	EA BRACKET-VACUUM MOTOR	070-0113
15	103930-20-704	EA ROD-DOOR-RECIRCULATING	073-0018
16	103930-55-707	EA DOOR - RECIRCULATION	071-0891
18	103930-01-710	EA RESISTOR-FUSED, A/C 4 TERM	035-0006
20	103930-01-711	EA THERMOSTAT	033-0003
21	103930-02-708	EA MOTOR-VACUUM SERVO, A/C	030-0025
22	103930-30-703	EA MOTOR - SERVO	030-0104
23	103930-20-707	EA HOUSING-BLOWER	062-0145
24	103930-55-703	EA MOTOR-BLOWER W/O PIGTAIL	030-0137
25	103930-01-717	EA WHEEL-BLOWER, CLOCKWISE	062-0010
26	103930-20-708	EA CLIP-MOTOR SHAFT	022-0001
27	103930-30-704	EA COVER - SERVO	062-0545
32	113245-01-707	EA O'RING #8	045-0126
33	103930-17-702	EA O'RING #10	045-0127
	103930-55-704	EA CORE-HEATER	042-0059
	110279-01-703	EA HOSE-VENT F/BLOWER MOTOR	051-0034

CONTACT WINNEBAGO PART SALES FOR UNLISTED COMPONENT(S)



## HEATING & A/C GROUP (CONTINUED)

### FURNACE

KEY	PART NUMBER	U/M	DESCRIPTION
*	143563-01-000	EA	FURNACE - 35000 BTU/HIGH QUIET - SUBURBAN SH-35 2322 - F33V, F31W
*	143563-02-000	EA	FURNACE - 40000 BTU HIGH QUIET - SUBURBAN SH-40 2322 - F35D, F38J, F35A, F36M
	093614-11-02A	EA	GRILLE - AIR RETURN - 15.9" X 11.9" - BEIGE - F36M
	093614-13-02A	EA	GRILLE - AIR RETURN - 15.9" X 11.9" - BEIGE - F33V, F31W, F36M
	137965-01-01A	EA	REGISTER - 11.2" X 3.6"(9.7 X 2.1"R/O) W/O DAMPER- ANTIQUE BRASS
	137965-02-01A	EA	REGISTER - 11.2" X 3.6"(9.7 X 2.1"R/O) W/DAMPER - ANTIQUE BRASS
	126693-05-02B	EA	PANEL - EXHAUST/FURNACE - E-COATED
	141194-03-02B	EA	PANEL/FURNACE CLOSEOUT - E-COATED
	134651-01-000	FT	SEAL - 1/2" X 3/4" PSA 1 SIDE
	139980-05-000	EA	VENT - INTAKE
	139980-06-000	EA	VENT CAP
	141337-01-01A	EA	GASKET - FURNACE
	143563-04-000	EA	PLATE END - COLLAR
	143563-05-000	EA	GASKET - FIBERGLASS - SUBURBAN #071018
	143563-03-01A	EA	DOOR/ACCESS - FURNACE - W/FRAME - WHITE
			FROM: 00-00-00 THRU: 10-17-04
	143563-03-02A	EA	DOOR/ACCESS - FURNACE - W/FRAME - BLACK
			FROM: 10-18-04 THRU: 99-99-99
	009198-02-000	FT	DUCT - HEAT - FLEXIBLE - 2" ID X 25' - F35D, F38J, F35A
	092776-01-000	EA	ADAPTER - DUCT - 2" - F35D, F38J, F35A
	024990-05-000	EA	OUTLET - DEFROSTER - W/SWIVEL - 2" SLEEVE/4"OD - BLACK - F35A
	024990-12-000	EA	OUTLET - DEFROSTER - W/SWIVEL - 2" SLEEVE/4"OD - GLACIER - F35D, F38J

**\*COMPONENT PARTS LISTED LATER IN THIS GROUP**

**HEATING & A/C GROUP (CONTINUED)**  
**COMPONENT PARTS FOR FURNACE**

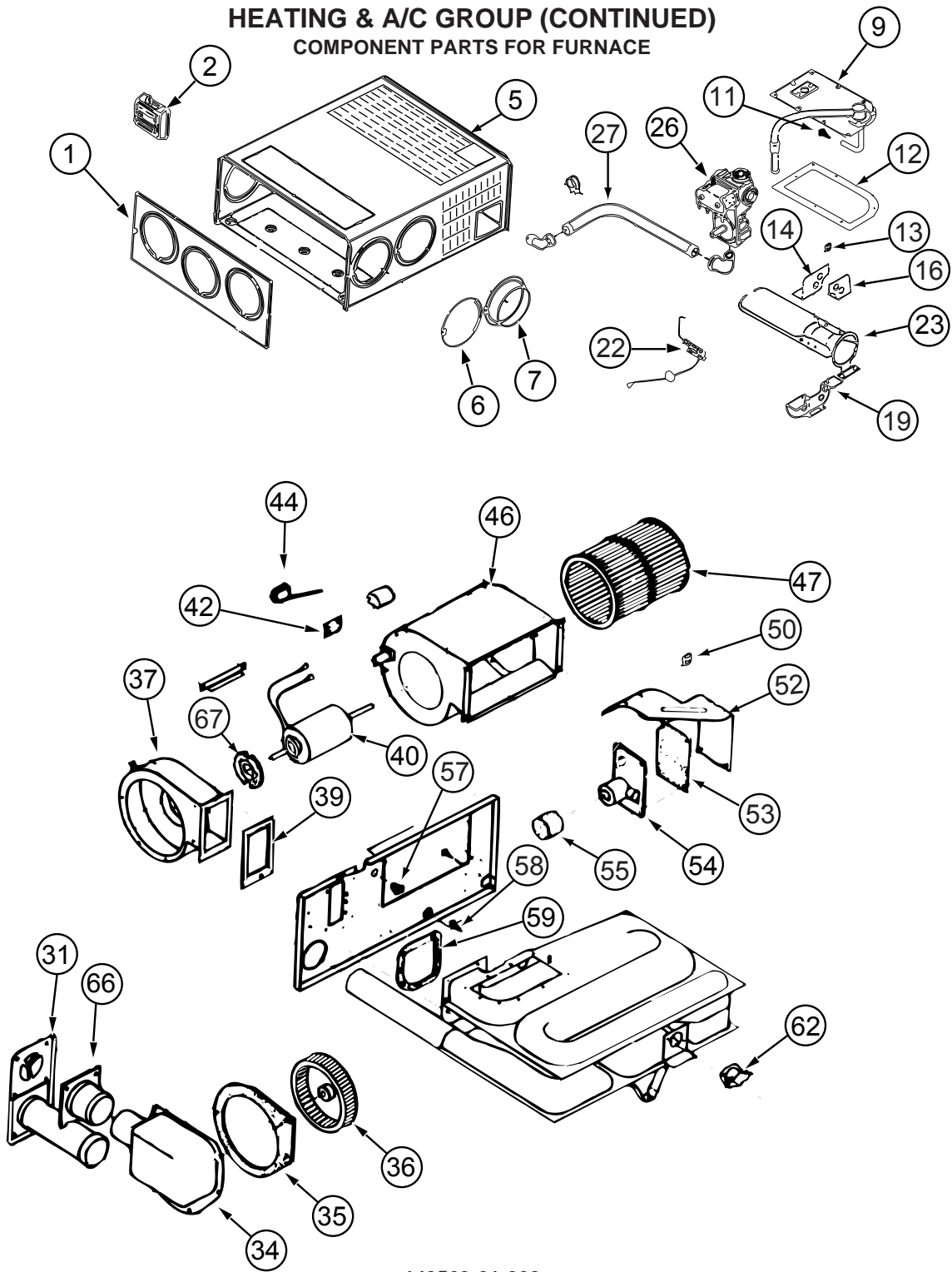

143563-01-000

**HEATING & A/C GROUP (CONTINUED)**  
**COMPONENT PARTS FOR FURNACE (CONTINUED)**  
**143563-01-000 (CONTINUED)**

KEY	PART NUMBER	U/M	DESCRIPTION	VENDOR NO.
1	143563-01-700	EA	CABINET - FRONT	101907
2			12 VOLT WIRING AREAS FOR CORRECT THERMOSTAT	
5	143563-01-701	EA	CABINET	101921
7	075696-02-703	EA	COLLAR - DUCT	050715
9	143563-01-702	EA	MANIFOLD ASSEMBLY	171599
11	143563-01-703	EA	ORFICE - MAIN BURNER	180308
12	098668-22-703	EA	GASKET - BURNER ACCESS COVER	070811
14	143563-01-704	EA	PLATE - SECONDARY AIR/TOP BACK	063199
16	143563-01-705	EA	PLATE - SECONDARY AIR/TOP FRT	062936
19	143563-01-706	EA	PLATE - SECONDARY AIR/BOTTOM	062938
22	139980-01-701	EA	ELECTRODE	232286
23	098668-02-700	EA	BURNER ASSEMBLY,SF-30 & SF35	010745
26	098668-01-718	EA	VALVE-GAS SF S.N.974903079	161122
27	143563-01-707	EA	PIPE ASSEMBLY (GAS INLET)	171603
31	098668-01-707	EA	TUBE ASSEMBLY, EXHAUST W/CAP	260231
34	143563-01-708	EA	BOX ASM (COMB. AIR INTAKE)	051430BK
35	143563-01-709	EA	GASKET (COMB. AIR HOUSING)	071108
36	143563-01-710	EA	WHEEL (COMBUSTION AIR)	350199
37	143563-01-711	EA	HOUSING (COMBUSTION AIR)	390862BK
39	143563-01-715	EA	GASKET-FIREWALL/COMB. AIR	071107
40	143563-01-712	EA	MOTOR ASSEMBLY	232727
42	101990-01-714	EA	GASKET-MICROSWITCH	230877
44	098668-21-700	EA	SWITCH-MICRO-W/O FLAG 3 1/4"	232261
46	143563-01-713	EA	BLOWER ASSEMBLY(ROOM AIR)	390867BK
47	143563-01-714	EA	WHEEL - ROOM AIR	350198
50	139980-01-710	EA	SWITCH - ON/OFF	232351
52	139980-01-711	EA	PANEL ASSEMBLY-MODULE BD	101663
53	139980-01-712	EA	INSULATOR - MODULE BD	070807
54	098668-22-705	EA	MODULE BD W/RELAY TIME DELAY	520820
55	139980-01-713	EA	CAP/INSULATOR-MODULE BD	070973
57	139980-01-714	EA	BUSHING - UNIVERSAL	070362
58	139980-01-715	EA	BUSHING - STRAIN RELIEF	231809
59	098668-01-716	EA	GASKET-FIREWALL,CHAMBER SIDE	070808
62	098668-21-701	EA	SWITCH - LIMIT	232504
66	098668-01-713	EA	TUBE ASSEMBLY, INTAKE	051248
67	075697-07-703	EA	GASKET - MOTOR	070448
	143563-01-716	EA	CHAMBER ASM. - FINAL	
			CONTACT WINNEBAGO PART SALES FOR UNLISTED COMPONENT(S)	

**HEATING & A/C GROUP (CONTINUED)**  
**COMPONENT PARTS FOR FURNACE (CONTINUED)**

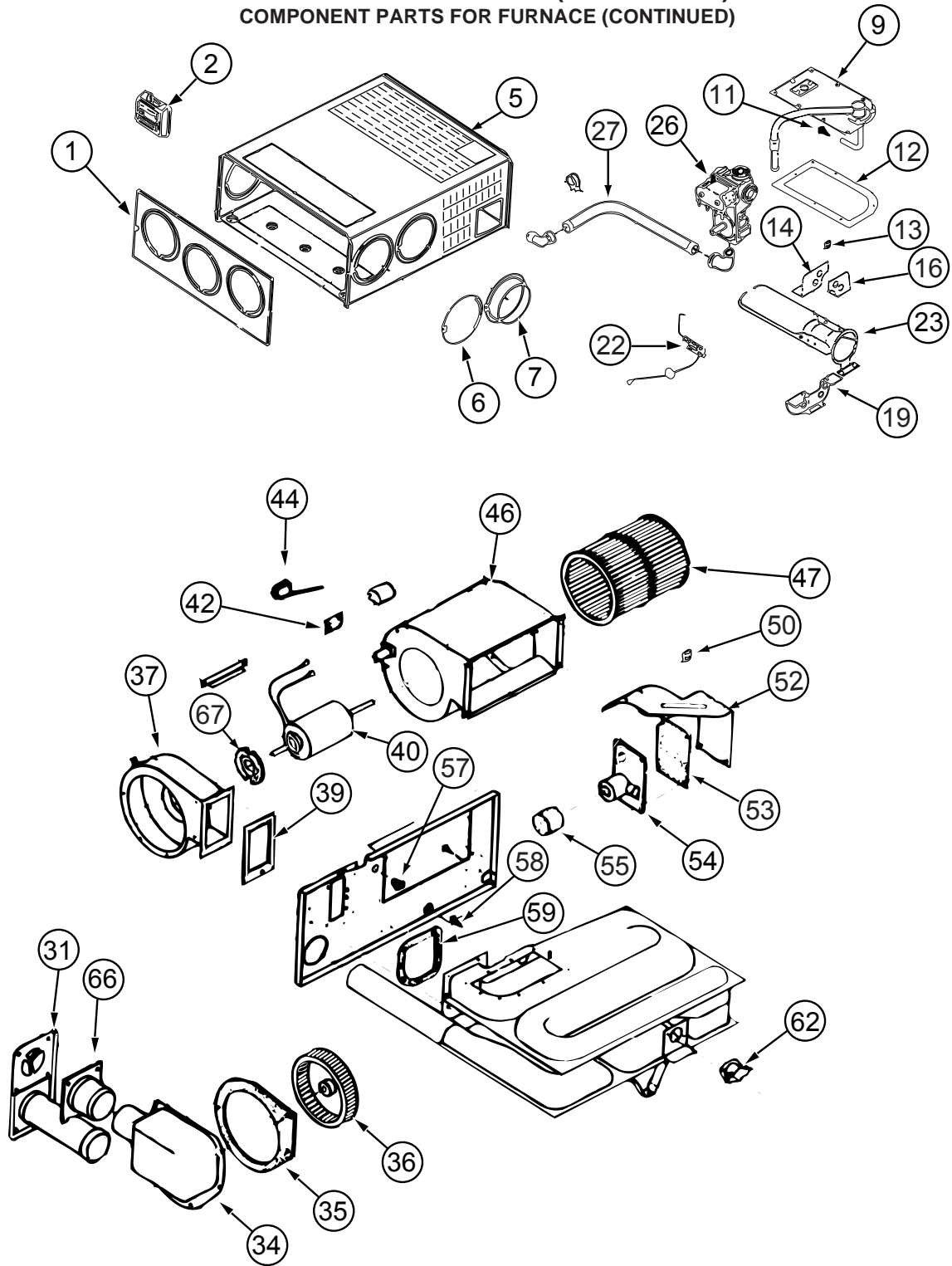

143563-02-000

**HEATING & A/C GROUP (CONTINUED)**  
**COMPONENT PARTS FOR FURNACE (CONTINUED)**  
**143563-02-000 (CONTINUED)**

KEY	PART NUMBER	U/M	DESCRIPTION	VENDOR NO.
1	143563-01-700	EA	CABINET - FRONT	101907
2			SEE 12 VOLT WIRING AREAS FOR CORRECT THERMOSTAT	
5	143563-02-700	EA	CABINET	101915
7	075696-02-703	EA	COLLAR - DUCT	050715
9	143563-01-702	EA	MANIFOLD ASSEMBLY	171599
11	143563-02-701	EA	ORFICE - MAIN BURNER	180309
12	098668-22-703	EA	GASKET - BURNER ACCESS COVER	070811
14	143563-02-702	EA	PLATE - SECONDARY AIR/TOP BACK	063198
16	143563-02-703	EA	PLATE - SECONDARY AIR/TOP FRT	062933
19	143563-02-704	EA	PLATE - SECONDARY AIR/BOTTOM	062935
22	139980-01-701	EA	ELECTRODE	232286
23	098668-11-701	EA	BURNER ASSEMBLY, SF-42F	010799
26	098668-01-718	EA	VALVE-GAS SF S.N.974903079	161122
27	143563-01-707	EA	PIPE ASSEMBLY (GAS INLET)	171603
31	098668-01-707	EA	TUBE ASSEMBLY, EXHAUST W/CAP	260231
34	143563-01-708	EA	BOX ASM (COMB. AIR INTAKE)	051430BK
35	143563-01-709	EA	GASKET (COMB. AIR HOUSING)	071108
36	143563-01-710	EA	WHEEL (COMBUSTION AIR)	350199
37	143563-01-711	EA	HOUSING (COMBUSTION AIR)	390862BK
39	143563-01-715	EA	GASKET-FIREWALL/COMB. AIR	071107
40	143563-02-705	EA	MOTOR ASSEMBLY	232726
42	101990-01-714	EA	GASKET-MICROSWITCH	230877
44	098668-21-700	EA	SWITCH-MICRO-W/O FLAG 3 1/4"	232261
46	143563-01-713	EA	BLOWER ASSEMBLY(ROOM AIR)	390867BK
47	143563-01-714	EA	WHEEL - ROOM AIR	350198
50	139980-01-710	EA	SWITCH - ON/OFF	232351
52	139980-01-711	EA	PANEL ASSEMBLY-MODULE BD	101663
53	139980-01-712	EA	INSULATOR - MODULE BD	070807
54	098668-22-705	EA	MODULE BD W/RELAY TIME DELAY	520820
55	139980-01-713	EA	CAP/INSULATOR-MODULE BD	070973
57	139980-01-714	EA	BUSHING - UNIVERSAL	070362
58	139980-01-715	EA	BUSHING - STRAIN RELIEF	231809
59	098668-01-716	EA	GASKET-FIREWALL,CHAMBER SIDE	070808
62	143563-02-706	EA	SWITCH - LIMIT	232735
66	098668-01-713	EA	TUBE ASSEMBLY, INTAKE	051248
67	075697-07-703	EA	GASKET - MOTOR	070448
	143563-02-707	EA	CHAMBER ASM. - FINAL	021172BK

CONTACT WINNEBAGO PART SALES FOR UNLISTED COMPONENT(S)

**REAR HEATER**

KEY	PART NUMBER	U/M	DESCRIPTION
	147610-01-000	EA	HEATER - AUTO/AUX
	147610-02-000	EA	HEATER - AUTO/AUX - <b>F38J ONLY</b>
	007108-01-000	FT	HOSE - HEATER - 5/8" ID - HI-TEMP
	079059-01-000	EA	HOSE - 90 DEGREE - 5/8"ID X 4" X 36"
	079059-13-000	EA	HOSE - 90 DEGREE - .61"ID X 4" X 48"
	137965-01-01A	EA	REGISTER - 11.2" X 3.6"(9.7 X 2.1"R/O) W/O DAMPER- ANT BRS

## HEATING & A/C GROUP (CONTINUED)

### ROOF

KEY	PART NUMBER	U/M	DESCRIPTION
	131184-02-01A	EA	BOARD - DIVIDER - SILVER
*	131184-01-01A	EA	CEILING ASSEMBLY - A/C DUCTED - WHITE - <b>ONE 14,800 A/C ROOF OR HI EFF2/EMS A/C ROOF</b>
*	131184-05-01A	EA	CEILING ASSEMBLY - HEAT PUMP - WHITE - <b>1 A/C HEAT PUMP OR 2 HI EF AC HEAT PUMP</b>
*	131186-02-01A	EA	A/C - ROOF - MACH 1 POWER SAVER - 9,600 BTU - WHITE - <b>HI EFF2/EMS A/C ROOF</b>
*	131187-03-01A	EA	A/C - ROOF - MACH 3 POWER SAVER - WHITE - <b>HI EFF2/EMS A/C ROOF</b>
*	131187-04-01A	EA	A/C - ROOF - MACH 3 POWER SAVER - WHITE - <b>2 HI EF AC HEAT PUMP</b>
*	131188-03-01A	EA	A/C/ROOF - 14,800 BTU/MACH 15 - #8335B676 - WHT - <b>ONE 14,800 A/C ROOF</b>
*	131188-04-01A	EA	A/C/ROOF - 14,800 BTU/HEAT PUMP - #8535B676- WHT - <b>1 A/C HEAT PUMP</b>

\*COMPONENT PARTS LISTED LATER IN THIS GROUP

### COMPONENT PARTS FOR ROOF

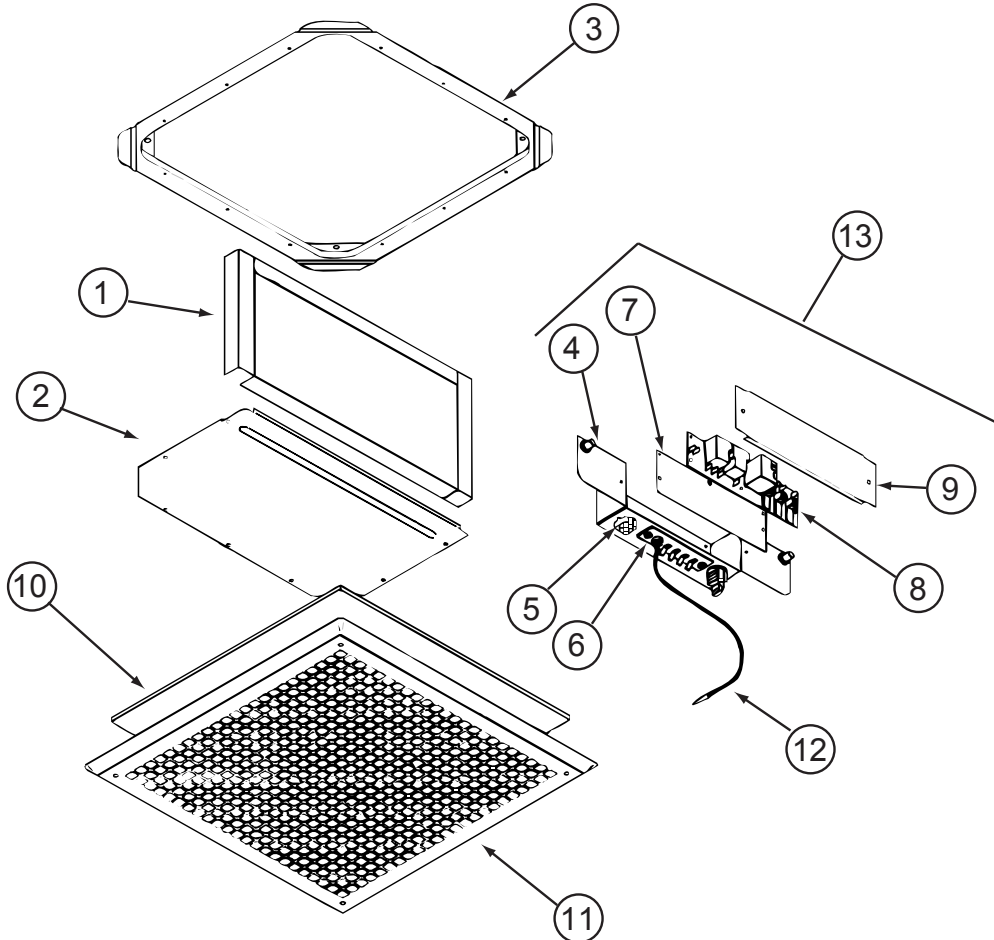

131184-01-01A

KEY	PART NUMBER	U/M	DESCRIPTION	VENDOR NO.
1	131184-01-707	EA	DUCT DIVIDER	8330-3501
5	131184-01-700	EA	PLUG ASSEMBLY	7330A389
6	131184-01-701	EA	TERMINAL BOARD	7330B3201
7	131184-01-702	EA	ISOLATOR - BLANK	7330C365
8	108892-01-702	EA	BOARD-P.C.	7330A3211
10	108892-01-703	EA	FILTER	6798A3761
11	108892-01-704	EA	GRILLE 16 3/8X16 3/8 RETURN	6798-3041
12	131184-01-704	EA	COIL SENSOR	7330-6111
13	131184-01-705	EA	JUNCTION BOX ASSEMBLY	7330B5551
	131184-01-703	EA	SMALL PARTS PKG	8330-5961

CONTACT WINNEBAGO PART SALES FOR UNLISTED COMPONENT(S)

**HEATING & A/C GROUP (CONTINUED)**  
**COMPONENT PARTS FOR ROOF (CONTINUED)**

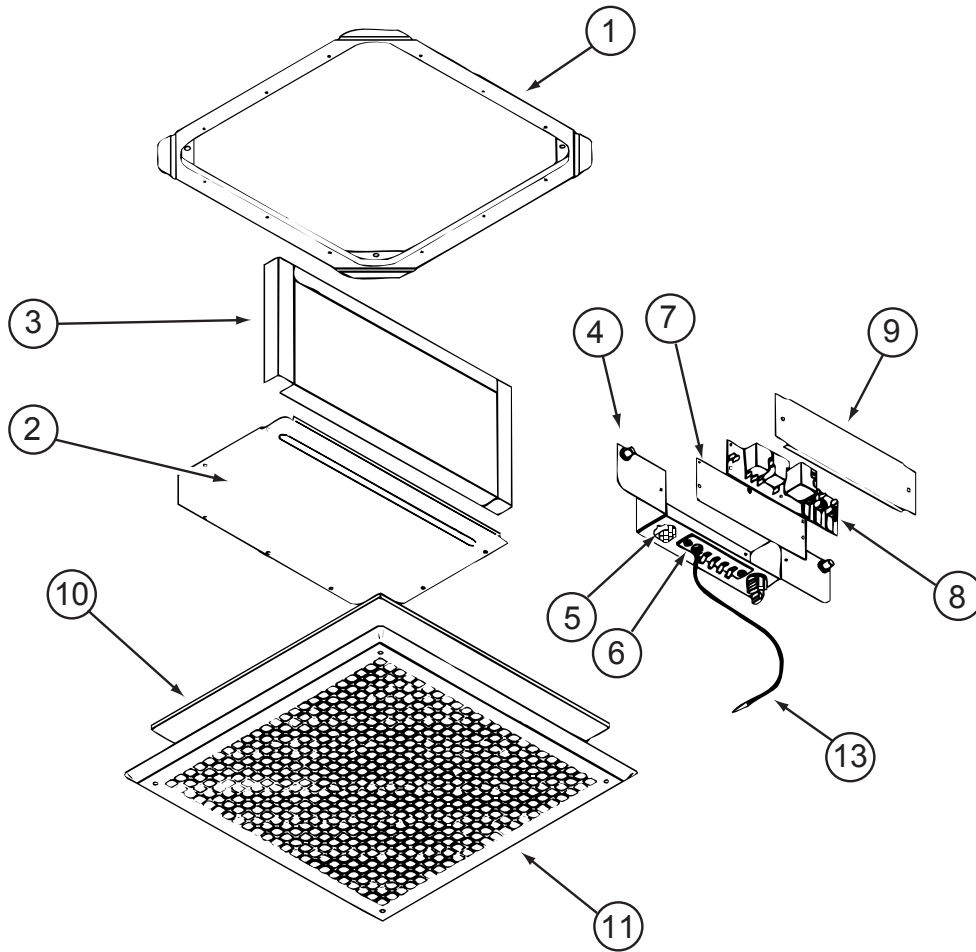

**131184-05-01A**

KEY	PART NUMBER	U/M	DESCRIPTION	VENDOR NO.
4	131184-05-700	EA	BOX - JUNCTION	8530-5091
5	131184-04-700	EA	PLUG ASSEMBLY	7530A340
6	131184-04-702	EA	BOARD - TERMINAL	7530B3201
7	131184-01-702	EA	ISOLATOR - BLANK	7330C365
8	131184-04-705	EA	BOARD - P.C.	7330B3311
10	108892-01-703	EA	FILTER	6798A3761
11	108892-01-704	EA	GRILLE 16 3/8X16 3/8 RETURN	6798-3041
13	105620-12-719	EA	COIL SENSOR	7330A3231
	131184-01-703	EA	SMALL PARTS PKG	8330-5961

CONTACT WINNEBAGO PART SALES FOR UNLISTED COMPONENT(S)

**HEATING & A/C GROUP (CONTINUED)**  
**COMPONENT PARTS FOR ROOF (CONTINUED)**

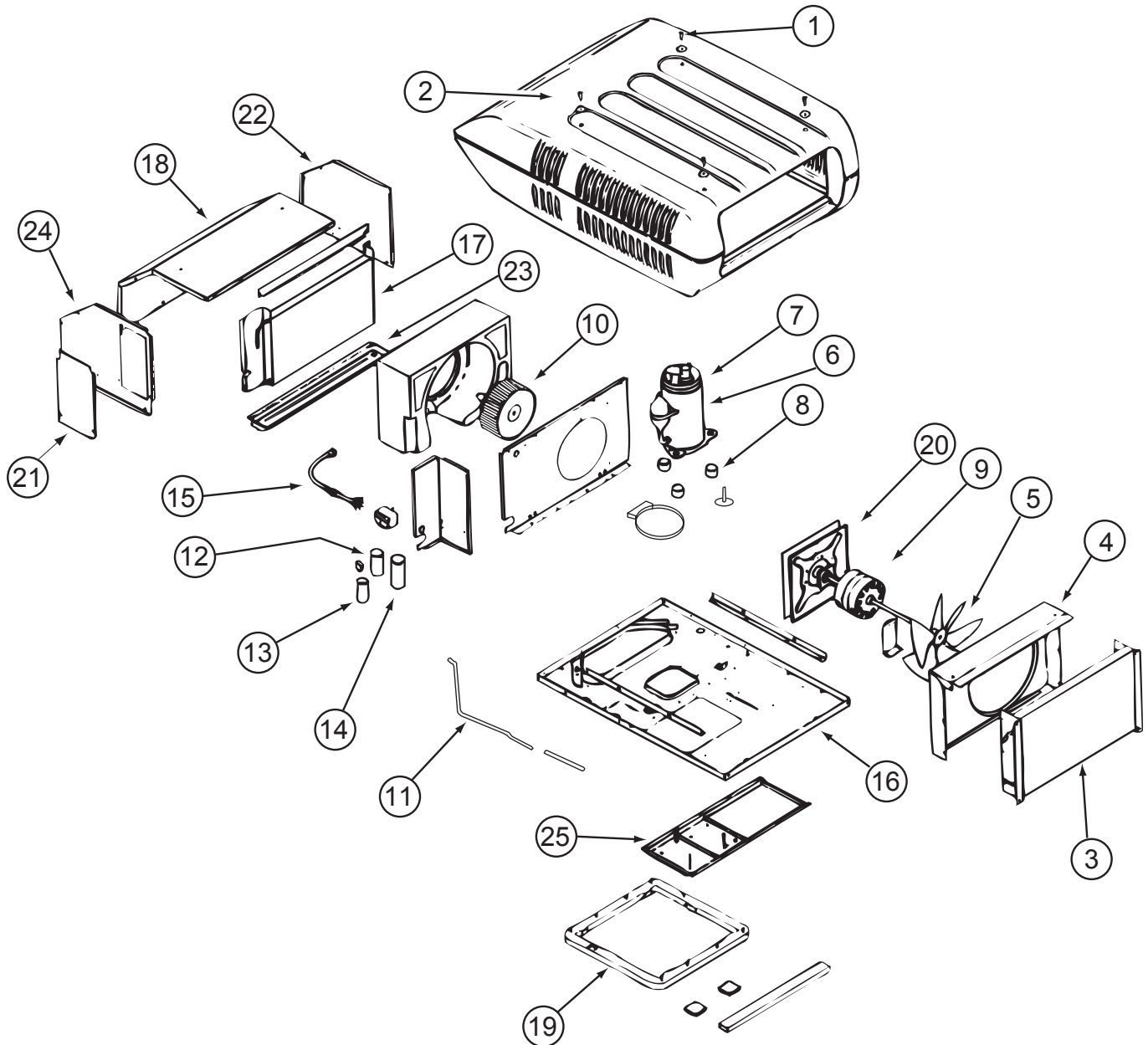

131186-02-01A

KEY	PART NUMBER	U/M	DESCRIPTION	VENDOR NO.
2	131185-03-700	EA	SHROUD - ROOF AIR	8333-4161
3	115219-01-700	EA	COIL-CONDENSER	1452A1321
5	093763-01-712	EA	BLADE-FAN-CONDENSER	6733-3221
6	126859-01-700	EA	COMPRESSOR RK124AT-001-A4Y	1450-2109
7	126859-01-701	EA	OVERLOAD PROTECTORMRA# 4761	1450-0061
8	105620-01-706	EA	MOUNTING PKG.,COMP., 3 PER	6759-3081
9	131186-01-700	EA	MOTOR - 115V, 60 HURTZ	1468-3109
10	131185-01-702	EA	BLOWER WHEEL PACKAGE	1472-1091
12	126859-01-703	EA	CAPACITOR - RUN	1499-5671
13	093763-01-704	EA	CAPACITOR-FAN	1499-5461
14	105620-10-704	EA	START COMPACITOR	1497-0861
15	105620-10-705	EA	PTCR (START DEVICE) - W/CAP.	8333A9021
18	131186-01-701	EA	EVAPORATOR COIL	1452-1521
21	131185-01-704	EA	MOTOR MOUNT & SEAL KIT	8333-5151
	093306-01-701	EA	DECAL PACKAGE, LEFT & RIGHT	6798B3591
	108889-01-710	EA	PAD-FILLER, CONDENSER SEAL	6759B3971
	126859-01-706	EA	LINE - SUCTION	7532A130

CONTACT WINNEBAGO PART SALES FOR UNLISTED COMPONENT



## HEATING & A/C GROUP (CONTINUED)

### COMPONENT PARTS FOR ROOF (CONTINUED)

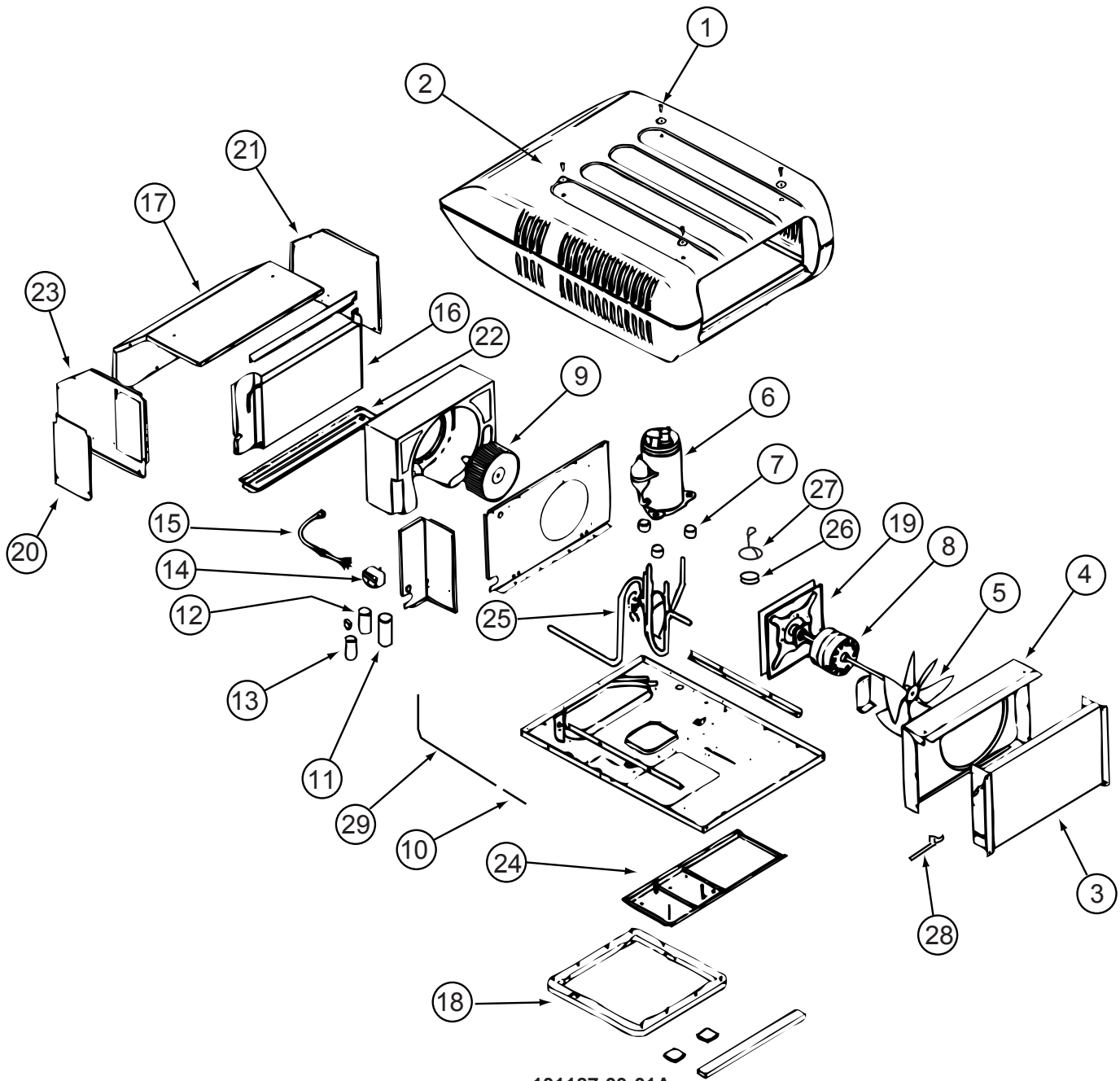

131187-03-01A

KEY	PART NUMBER	U/M	DESCRIPTION	VENDOR NO.
2	131185-03-700	EA	SHROUD - ROOF AIR	8333-4161
3	115219-01-700	EA	COIL-CONDENSER	1452A1321
5	093763-01-712	EA	BLADE-FAN-CONDENSER	6733-3221
6	126860-01-700	EA	COMPRESSOR RK136AT-002-A4Y	1450A2119
7	105620-01-706	EA	MOUNTING PKG.,COMP., 3 PER	6759-3081
8	131186-01-700	EA	MOTOR - 115V, 60 HURTZ	1468-3109
9	131185-01-702	EA	BLOWER WHEEL PACKAGE	1472-1091
11	126859-01-703	EA	CAPACITOR - RUN	1499-5671
12	105620-01-725	EA	CAPACITOR-BLOWER,I.D. 7.5MFD	1499-5461
13	105620-10-705	EA	PTCR (START DEVICE) - W/CAP.	8333A9021
16	131186-01-701	EA	EVAPORATOR COIL	1452-1521
19	131185-01-704	EA	MOTOR MOUNT & SEAL KIT	8333-5151
	093306-01-701	EA	DECAL PACKAGE, LEFT & RIGHT	6798B3591
	105620-10-704	EA	START COMPACITOR	1497-0861
	108889-01-710	EA	PAD-FILLER, CONDENSER SEAL	6759B3971
	126859-01-706	EA	LINE - SUCTION	7532A130
	126860-01-701	EA	OVERLOAD PROTECTOR MRA# 1460	1450-0071

CONTACT WINNEBAGO PART SALES FOR UNLISTED COMPONENT

**HEATING & A/C GROUP (CONTINUED)**  
**COMPONENT PARTS FOR ROOF (CONTINUED)**

131187-04-01A

<b>KEY</b>	<b>PART NUMBER</b>	<b>U/M</b>	<b>DESCRIPTION</b>	<b>VENDOR NO.</b>
2	131185-03-700	EA	SHROUD - ROOF AIR	8333-4161
3	131188-02-700	EA	CONDENSER COIL	1452-1441
5	093763-01-712	EA	BLADE-FAN-CONDENSER	6733-3221
6	126860-01-700	EA	COMPRESSOR RK136AT-002-A4Y	1450A2119
7	105620-01-706	EA	MOUNTING PKG.,COMP., 3 PER	6759-3081
8	131186-01-700	EA	MOTOR - 115V, 60 HURTZ	1468-3109
9	131185-01-702	EA	BLOWER WHEEL PACKAGE	1472-1091
10	105620-12-711	EA	RESTRICTOR - BY FLOW	1454-2521
11	126859-01-703	EA	CAPACITOR - RUN	1499-5671
12	093763-01-704	EA	CAPACITOR-FAN	1499-5461
13	105620-10-705	EA	PTCR (START DEVICE) - W/CAP.	8333A9021
16	131186-01-701	EA	EVAPORATOR COIL	1452-1521
18	037648-01-714	EA	GASKET PACKAGE	8332-3301
19	131185-01-704	EA	MOTOR MOUNT & SEAL KIT	8333-5151
25	131188-02-704	EA	VALVE/REVERSE ASSEMBLY	7535A5301
26	105620-12-708	EA	COIL - SOLENOID	1460-1081
27	131188-02-705	EA	WIRE HARNESS F/SOLENOID	7535-109
28	131188-02-706	EA	SWITCH - FREEZE	1460-2041
29	131188-02-707	EA	LIQUID LINE	7535-135

CONTACT WINNEBAGO PART SALES FOR UNLISTED COMPONENT

## HEATING & A/C GROUP (CONTINUED)

### COMPONENT PARTS FOR ROOF (CONTINUED)

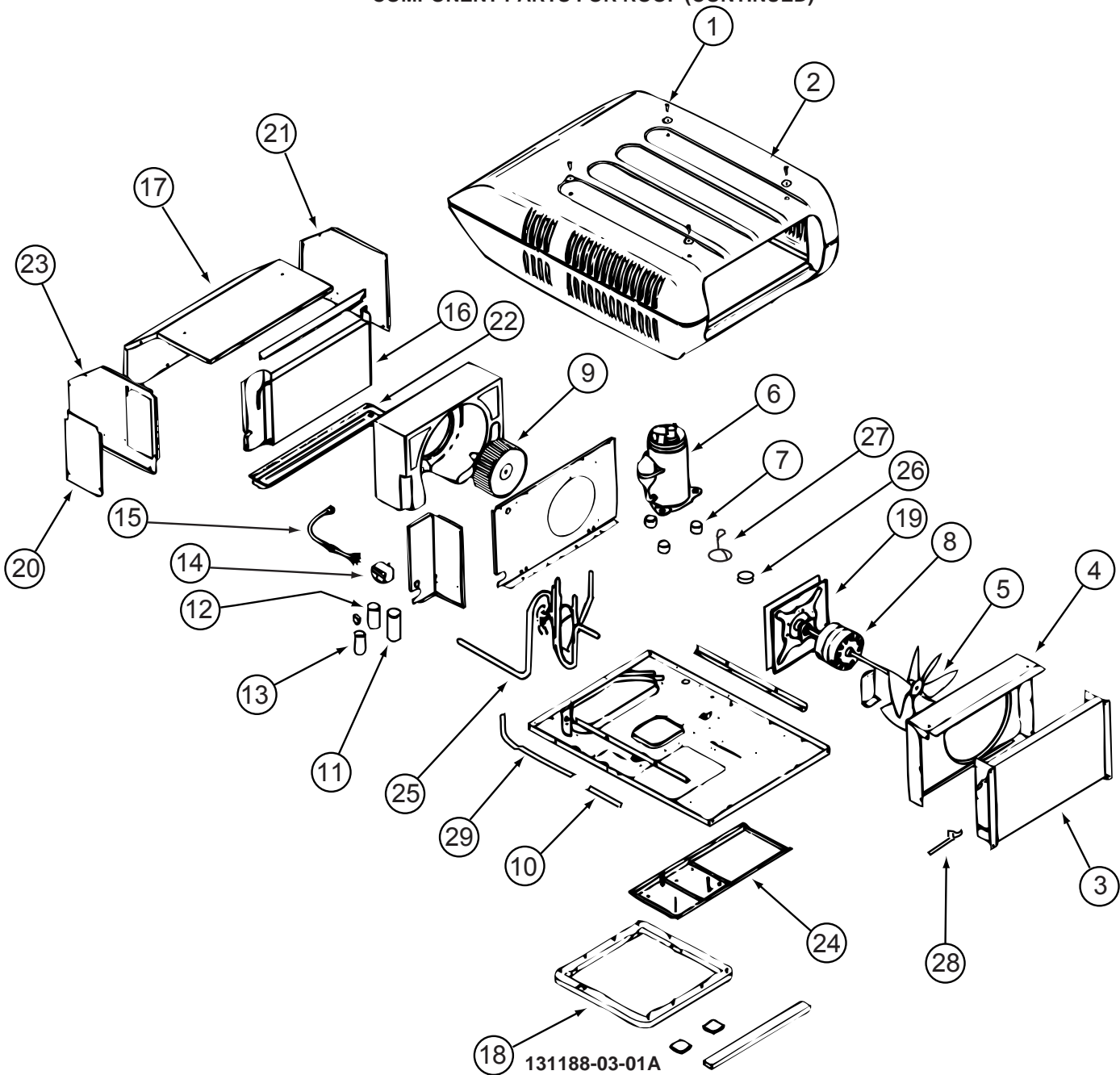

KEY	PART NUMBER	U/M	DESCRIPTION	VENDOR NO.
2	131185-03-700	EA	SHROUD-ROOF AIR W/HAIL GUARD	8333-4161
3	115219-01-700	EA	COIL-CONDENSER	1452A1321
5	093763-01-712	EA	BLADE-FAN-CONDENSER	6733-3221
6	131188-01-700	EA	COMPRESSOR - TECUMSEH	1450A2609
7	105620-01-706	EA	MOUNTING PKG.,COMP., 3 PER	6759-3081
8	131185-01-701	EA	MOTOR (115V, 60HZ)	1468-3069
9	131185-01-702	EA	BLOWER WHEEL PACKAGE	1472-1091
11	131188-01-701	EA	RUN CAP. (COMP-40MFD/370V)	1499-5721
12	108889-01-708	EA	CAPACITOR-FAN, 7.5MFD. 370U	1499-5461
13	126859-01-704	EA	CAPACITOR - START	1497-0871
14	091225-01-709	EA	RELAY-START	1497-4131
16	131186-01-701	EA	EVAPORATOR COIL	1452-1521
18	037648-01-714	EA	GASKET PACKAGE	8332-3301
19	131185-01-704	EA	MOTOR MOUNT & SEAL KIT	8333-5151
	093306-01-701	EA	DECAL PACKAGE, LEFT & RIGHT	6798B3591
	108889-01-710	EA	PAD-FILLER, CONDENSER SEAL	6759B3971
	131188-01-702	EA	LINE - SUCTION	7335A134
	131188-01-703	EA	LINE - DISCHARGE	7335A135

CONTACT WINNEBAGO PART SALES FOR UNLISTED COMPONENT(S)

**HEATING & A/C GROUP (CONTINUED)**  
**COMPONENT PARTS FOR ROOF (CONTINUED)**

131188-04-01A

<b>KEY</b>	<b>PART NUMBER</b>	<b>U/M</b>	<b>DESCRIPTION</b>	<b>VENDOR NO.</b>
3	131188-02-700	EA	CONDENSER COIL	1452-1441
5	093763-01-712	EA	BLADE-FAN-CONDENSER	6733-3221
6	131188-02-701	EA	COMPRESSOR(TECUMSEH-RK225AT)	1450A2069
7	105620-01-706	EA	MOUNTING PKG.,COMP., 3 PER	6759-3081
8	131185-01-701	EA	MOTOR (115V, 60HZ)	1468-3069
9	131185-01-702	EA	BLOWER WHEEL PACKAGE	1472-1091
10	131188-02-702	EA	RESTRICTOR - BY FLOW	1454-2501
11	131188-01-701	EA	RUN CAP. (COMP-40MFD/370V)	1499-5721
12	093763-01-704	EA	CAPACITOR-FAN (INDOOR MOTOR)	1499-5461
13	131188-02-703	EA	CAPACITOR-START(21-25MFD)	1497-0211
14	091225-01-709	EA	RELAY-START	1497-4131
16	131186-01-701	EA	EVAPORATOR COIL	1452-1521
18	037648-01-714	EA	GASKET PACKAGE	8332-3301
19	131185-01-704	EA	MOTOR MOUNT & SEAL KIT	8333-5151
25	131188-02-704	EA	VALVE/REVERSE ASSEMBLY	7535A5301
26	105620-12-708	EA	COIL - SOLENOID	1460-1081
27	131188-02-705	EA	WIRE HARNESS F/SOLENOID	7535-109
28	131188-02-706	EA	SWITCH - FREEZE	1460-2041
29	131188-02-707	EA	LIQUID LINE	7535-135
			CONTACT WINNEBAGO PART SALES FOR UNLISTED COMPONENT(S)	

**INTERIOR FINISH GROUP**  
**MOLDINGS & TRIMS**  
**PORTSMOUTH OAK, CONCERT CHERRY, WASHED MAPLE & SIERRA MAPLE**

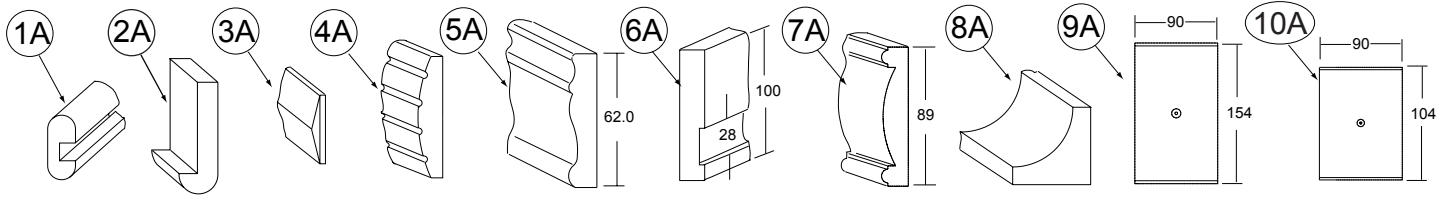

KEY	PART NUMBER	U/M	DESCRIPTION
1A	M09412-62-N42	EA	MOLDING/SHELF EDGE - .6" X 1.3" X 96" - PORTSMOUTH OAK
1A	M09412-62-M52	EA	MOLDING/SHELF EDGE - .6" X 1.3" X 96" - CHERRY - CONCERT CHERRY
1A	M09412-62-M62	EA	MOLDING/SHELF EDGE - .6" X 1.3" X 96" - WASHED MAPLE - WASHED MAPLE
1A	M09412-62-RC3	EA	MOLDING/SHELF EDGE - .6" X 1.3" X 96" - HONEY CHERRY - HONEY CHERRY
1A	M09412-62-SA3	EA	MOLDING/SHELF EDGE - .6" X 1.3" X 96" - MAPLE - SIERRA MAPLE
2A	M09438-25-N95	EA	MOLDING - HARDWOOD-W/NOTCH - 1.4"X 80.2" - OAK/PORTS OAK - PORTSMOUTH OAK
2A	M09438-25-N94	EA	MOLDING - HARDWOOD-W/NOTCH - 1.4"X 80.2" - CHERRY/CHERRY IV - CONCERT CHERRY
2A	M09438-25-NQ0	EA	MOLDING - HARDWOOD-W/NOTCH - 1.4"X 80.2" - MAPLE/WASHED MP - WASHED MAPLE
2A	M09438-25-RA3	EA	MOLDING - HARDWOOD-W/NOTCH - 1.4"X 80.2" - CHERRY/HONEY - HONEY CHERRY
2A	M09454-33-PC0	EA	MOLDING - HARDWOOD-W/NOTCH - 1"X 77.6" - OAK/PORTS OAK - PORTSMOUTH OAK
2A	M09454-33-PC1	EA	MOLDING - HARDWOOD-W/NOTCH - 1"X 77.6" - CHERRY/CHERRY IV - CONCERT CHERRY
2A	M09454-33-PC2	EA	MOLDING - HARDWOOD-W/NOTCH - 1"X 77.6" - MAPLE/WASHED MP - WASHED MAPLE
2A	M09454-33-RA3	EA	MOLDING - HARDWOOD-W/NOTCH - 1"X 77.6" - CHERRY/HONEY - HONEY CHERRY
3A	M09454-62-P54	EA	MOLDING - TRIM/VEE - .2" X 1" X 3.5" - OAK - PORTSMOUTH OAK
3A	M09454-62-P55	EA	MOLDING - TRIM/VEE - .2" X 1" X 3.5" - CHERRY - CONCERT CHERRY
3A	M09454-62-P56	EA	MOLDING - TRIM/VEE - .2" X 1" X 3.5" - MAPLE - WASHED MAPLE
3A	M09454-62-RE0	EA	MOLDING - TRIM/VEE - .2" X 1" X 3.5" - CHERRY - HONEY CHERRY
3A	M09462-50-R74	EA	MOLDING - TRIM/VEE - .2" X 1" X 93.5" - PORTSMOUTH OAK
3A	M09462-50-R75	EA	MOLDING - TRIM/VEE - .2" X 1" X 93.5" - CHERRY/CHERRY - CONCERT CHERRY
3A	M09462-50-R76	EA	MOLDING - TRIM/VEE - .2" X 1" X 93.5" - MAPLE/MAPLE - WASHED MAPLE
3A	M09462-50-SD3	EA	MOLDING - TRIM/VEE - .2" X 1" X 93.5" - HONEY/CHERRY - HONEY CHERRY
3A	M09462-50-S67	EA	MOLDING - TRIM/VEE - .2" X 1" X 93.5" - SIERRA/MAPLE - SIERRA MAPLE
4A	M09462-54-R89	EA	MOLDING - FLUTED, CURVED - .6" X 6" X 82.7" - PORTSMOUTH OAK
4A	M09462-54-R90	EA	MOLDING - FLUTED, CURVED - .6" X 6" X 82.7" - CONCERT CHERRY
4A	M09462-54-R91	EA	MOLDING - FLUTED, CURVED - .6" X 6" X 82.7" - WASHED MAPLE
4A	M09462-54-RE3	EA	MOLDING - FLUTED, CURVED - .6" X 6" X 82.7" - HONEY CHERRY
4A	M09471-09-R89	EA	MOLDING - STAINED - 4" X 8' - PORTSMOUTH OAK
4A	M09471-09-R90	EA	MOLDING - STAINED - 4" X 8' - CONCERT CHERRY
4A	M09471-09-R91	EA	MOLDING - STAINED - 4" X 8' - WASHED MAPLE
4A	M09471-09-RE3	EA	MOLDING - STAINED - 4" X 8' - HONEY CHERRY
4A	Y00202-42-438	EA	MOLDING - FLUTED - .75" X 3.5" X 96" - UNSTAINED - OAK
4A	Y00202-32-438	EA	MOLDING - FLUTED - .75" X 3.5" X 96" - UNSTAINED - CHERRY
4A	Y00202-22-438	EA	MOLDING - FLUTED - .75" X 3.5" X 96" - UNSTAINED - MAPLE
5A	M09462-66-R74	EA	TRIM - RAIL - .5" X 2.4" X 96" - PORTSMOUTH OAK
5A	M09462-66-R75	EA	TRIM - RAIL - .5" X 2.4" X 96" - CONCERT CHERRY
5A	M09462-66-R76	EA	TRIM - RAIL - .5" X 2.4" X 96" - WASHED MAPLE
5A	M09462-66-RE0	EA	TRIM - RAIL - .5" X 2.4" X 96" - HONEY CHERRY
5A	M09462-66-SA3	EA	TRIM - RAIL - .5" X 2.4" X 96" - SIERRA MAPLE
6A	M09471-20-R83	EA	MOLDING - STAINED - .75" X 4" X 74.6" - PORTSMOUTH OAK
6A	M09471-20-R84	EA	MOLDING - STAINED - .75" X 4" X 74.6" - CONCERT CHERRY
6A	M09471-20-R91	EA	MOLDING - STAINED - .75" X 4" X 74.6" - WASHED MAPLE
6A	M09471-20-RE0	EA	MOLDING - STAINED - .75" X 4" X 74.6" - HONEY CHERRY
7A	M09471-40-R83	EA	MOLDING - STAINED - .7" X 3.5" X 70.4" - PORTSMOUTH OAK
7A	M09471-40-R84	EA	MOLDING - STAINED - .7" X 3.5" X 70.4" - CONCERT CHERRY
7A	M09471-40-SD2	EA	MOLDING - STAINED - .7" X 3.5" X 70.4" - WASHED MAPLE
7A	M09471-40-RE0	EA	MOLDING - STAINED - .7" X 3.5" X 70.4" - HONEY CHERRY
8A	M09471-79-R38	EA	MOLDING - TRIM/COVE - .8" X .8" X 95.8" - OAK/PORTS OAK - PORTSMOUTH OAK
8A	M09471-79-R39	EA	MOLDING - TRIM/COVE - .8" X .8" X 95.8" - CHERRY/CHERRY - CONCERT CHERRY
8A	M09471-79-R46	EA	MOLDING - TRIM/COVE - .8" X .8" X 95.8" - MAPLE/MAPLE - WASHED MAPLE
8A	M09471-79-RE0	EA	MOLDING - TRIM/COVE - .8" X .8" X 95.8" - HONEY/CHERRY - HONEY CHERRY
8A	M09471-79-SA3	EA	MOLDING - TRIM/COVE - .8" X .8" X 95.8" - HONEY/MAPLE - SIERRA MAPLE
9A	P49186-01-SA0	EA	MOLDING/BLOCK - PORTSMOUTH OAK
9A	P49186-01-SA1	EA	MOLDING/BLOCK - CONCERT CHERRY
9A	P49186-01-SA2	EA	MOLDING/BLOCK - WASHED MAPLE
9A	P49186-01-SA3	EA	MOLDING/BLOCK - SIERRA MAPLE

## INTERIOR FINISH GROUP (CONTINUED)

### MOLDINGS & TRIMS (CONTINUED)

KEY	PART NUMBER	U/M	DESCRIPTION
10A	P49186-02-SA0	EA	MOLDING/BLOCK - PORTSMOUTH OAK
10A	P49186-02-SA1	EA	MOLDING/BLOCK - CONCERT CHERRY
10A	P49186-02-SA2	EA	MOLDING/BLOCK - WASHED MAPLE
10A	P49186-02-SA3	EA	MOLDING/BLOCK - SIERRA MAPLE

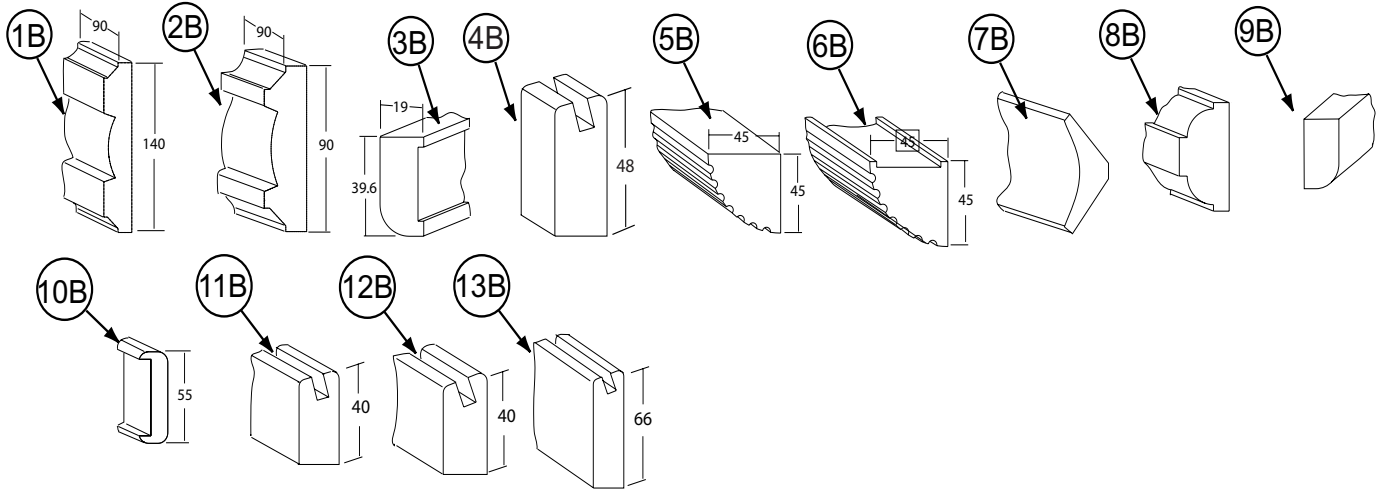

KEY	PART NUMBER	U/M	DESCRIPTION
1B	P49188-01-SA0	EA	MOLDING/BLOCK - PORTSMOUTH OAK
1B	P49188-01-SA1	EA	MOLDING/BLOCK - CONCERT CHERRY
1B	P49188-01-SA2	EA	MOLDING/BLOCK - WASHED MAPLE
1B	P49188-01-SA3	EA	MOLDING/BLOCK - SIERRA MAPLE
2B	P49188-02-SA0	EA	MOLDING/BLOCK - PORTSMOUTH OAK
2B	P49188-02-SA1	EA	MOLDING/BLOCK - CONCERT CHERRY
2B	P49188-02-SA2	EA	MOLDING/BLOCK - WASHED MAPLE
2B	P49188-02-SA3	EA	MOLDING/BLOCK - SIERRA MAPLE
3B	Y00007-42-438	EA	MOLDING - 12.7 RADIUS OAK - UNSTAINED
3B	Y00007-32-438	EA	MOLDING - 12.7 RADIUS CHERRY - UNSTAINED
3B	Y00007-22-438	EA	MOLDING - 12.7 RADIUS MAPLE - UNSTAINED
3B	Y00287-42-438	EA	MOLDING - 6.0 RADIUS OAK - UNSTAINED
3B	Y00287-32-438	EA	MOLDING - 6.0 RADIUS CHERRY - UNSTAINED
3B	Y00287-22-438	EA	MOLDING - 6.0 RADIUS MAPLE - UNSTAINED
4B	Y00054-72-438	EA	MOLDING - VINYL - W/SLOT - .7" X 1.9" X 96" - PORTSMOUTH OAK
4B	Y00054-62-438	EA	MOLDING - VINYL - W/SLOT - .7" X 1.9" X 96" - CONCERT CHERRY
4B	Y00054-A2-438	EA	MOLDING - VINYL - W/SLOT - .7" X 1.9" X 96" - WASHED MAPLE
4B	Y00054-92-438	EA	MOLDING - VINYL - W/SLOT - .7" X 1.9" X 96" - SIERRA MAPLE
5B	Y00070-42-438	EA	MOLDING/FLUTED - OAK - 96"
5B	Y00070-32-438	EA	MOLDING/FLUTED - CHERRY - 96"
5B	Y00070-22-438	EA	MOLDING/FLUTED - MAPLE - 96"
6B	Y00071-42-438	EA	MOLDING/FLUTED - W/NOTCH - OAK/UNSTAINED - 96"
6B	Y00071-32-438	EA	MOLDING/FLUTED - W/NOTCH - CHERRY/UNSTAINED - 96"
6B	Y00071-22-438	EA	MOLDING/FLUTED - W/NOTCH - MAPLE/UNSTAINED - 96"
7B	Y00074-72-438	EA	MOLDING/CROWN - VINYL WRAPPED - PORTSMOUTH OAK - 96" - PORTSMOUTH OAK
7B	Y00074-62-438	EA	MOLDING/CROWN - VINYL WRAPPED - CONCERT CHERRY - 96" - CONCERT CHERRY
7B	Y00074-A2-438	EA	MOLDING/CROWN - VINYL WRAPPED - MAPLE - 96" - WASHED MAPLE
7B	Y00074-92-438	EA	MOLDING/CROWN - VINYL WRAPPED - SIERRA MAPLE - 96" - SIERRA MAPLE
8B	Y00076-42-438	EA	MOLDING/TRIM - .5" X 1" X 96" - OAK (UNSTAINED)
8B	Y00076-32-438	EA	MOLDING/TRIM - .5" X 1" X 96" - CHERRY (UNSTAINED)
8B	Y00076-22-438	EA	MOLDING/TRIM - .5" X 1" X 96" - MAPLE (UNSTAINED)
9B	Y00086-72-438	EA	MOLDING - VINYL WRAP - .7" X 1.6" X 96" - PORTSMOUTH OAK - PORTSMOUTH OAK
9B	Y00086-62-438	EA	MOLDING - VINYL WRAP - .7" X 1.6" X 96" - CHERRY - CONCERT CHERRY
9B	Y00086-A2-438	EA	MOLDING - VINYL WRAP - .7" X 1.6" X 96" - WASHED MAPLE
9B	Y00086-82-438	EA	MOLDING - VINYL WRAP - .7" X 1.6" X 96" - HONEY CHERRY - HONEY CHERRY
9B	Y00086-92-438	EA	MOLDING - VINYL WRAP - .7" X 1.6" X 96" - SIERRA MAPLE - SIERRA MAPLE
9B	Y00087-A2-438	EA	MOLDING - VINYL WRAP - .7" X 2.9" X 96" - WASHED MAPLE
9B	Y00087-62-438	EA	MOLDING - VINYL WRAP - .7" X 2.9" X 96" - CONCERT CHERRY
9B	Y00087-72-438	EA	MOLDING - VINYL WRAP - .7" X 2.9" X 96" - PORTSMOUTH OAK
9B	Y00087-82-438	EA	MOLDING - VINYL WRAP - .7" X 2.9" X 96" - HONEY CHERRY
9B	Y00087-92-438	EA	MOLDING - VINYL WRAP - .7" X 2.9" X 96" - SIERRA MAPLE
9B	Y00267-72-438	EA	MOLDING - VINYL WRAP/MITERED - .6" X 96" - PORTSMOUTH OAK

**INTERIOR FINISH GROUP (CONTINUED)**  
**MOLDINGS & TRIMS (CONTINUED)**

KEY	PART NUMBER	U/M	DESCRIPTION
9B	Y00267-62-438	EA	MOLDING - VINYL WRAP/MITERED - .6" X 96" - CONCERT CHERRY
9B	Y00267-A2-438	EA	MOLDING - VINYL WRAP/MITERED - .6" X 96" - WASHED MAPLE
9B	Y00267-A2-438	EA	MOLDING - VINYL WRAP/MITERED - .6" X 96" - SIERRA MAPLE
10B	Y00103-42-438	EA	MOLDING - STRAIGHT - .75" X 2.16" X 96" - UNSTAINED - OAK
10B	Y00103-32-438	EA	MOLDING - STRAIGHT - .75" X 2.16" X 96" - UNSTAINED - CHERRY
10B	Y00103-22-438	EA	MOLDING - STRAIGHT - .75" X 2.16" X 96" - UNSTAINED - MAPLE
11B	Y00203-72-438	EA	MOLDING - VINYL/BEVELED - 96" - PORTSMOUT OAK
11B	Y00203-62-438	EA	MOLDING - VINYL/BEVELED - 96" - CONCERT CHERRY
11B	Y00203-A2-438	EA	MOLDING - VINYL/BEVELED - 96" - WASHED MAPLE
11B	Y00203-82-438	EA	MOLDING - VINYL/BEVELED - 96" - HONEY CHERRY
12B	Y00204-72-438	EA	MOLDING - VINYL/BEVELED - 96" - PORTSMOUT OAK
12B	Y00204-62-438	EA	MOLDING - VINYL/BEVELED - 96" - CONCERT CHERRY
12B	Y00204-A2-438	EA	MOLDING - VINYL/BEVELED - 96" - WASHED MAPLE
12B	Y00204-82-438	EA	MOLDING - VINYL/BEVELED - 96" - HONEY CHERRY
13B	Y00205-72-438	EA	MOLDING - VINYL/BEVELED - 96" - PORTSMOUT OAK
13B	Y00205-62-438	EA	MOLDING - VINYL/BEVELED - 96" - CONCERT CHERRY
13B	Y00205-A2-438	EA	MOLDING - VINYL/BEVELED - WASHED MAPLE
13B	Y00205-82-438	EA	MOLDING - VINYL/BEVELED - 96" - HONEY CHERRY

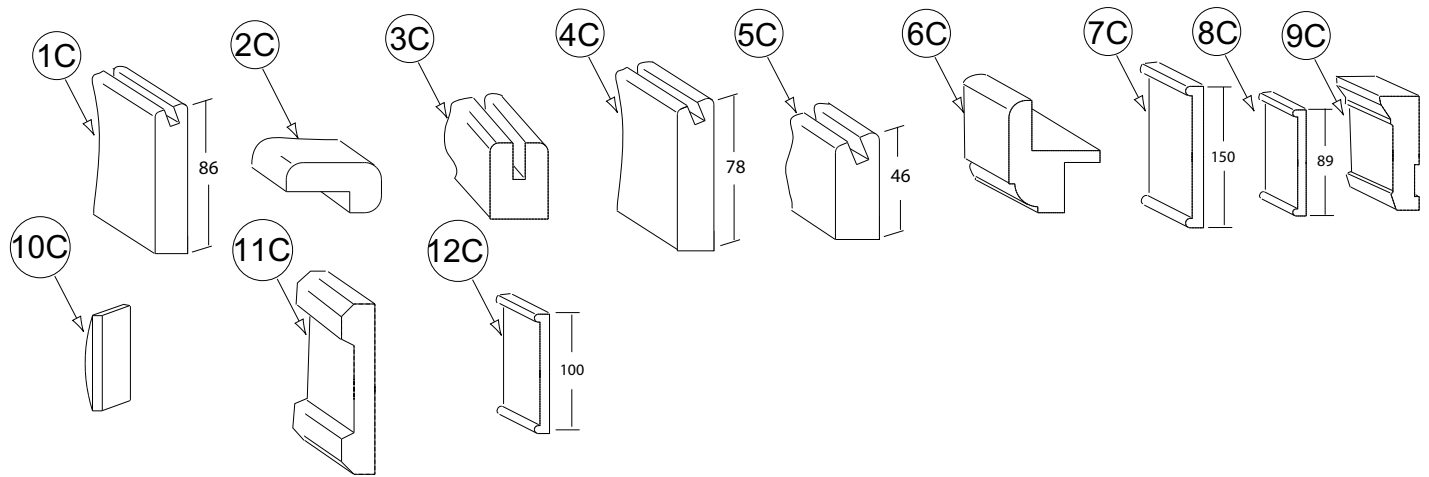

KEY	PART NUMBER	U/M	DESCRIPTION
1C	Y00206-72-438	EA	MOLDING - VINYL/BEVELED - 96" - PORTSMOUT OAK
1C	Y00206-62-438	EA	MOLDING - VINYL/BEVELED - 96" - CONCERT CHERRY
1C	Y00206-A2-438	EA	MOLDING - VINYL/BEVELED - 96" - WASHED MAPLE
1C	Y00206-82-438	EA	MOLDING - VINYL/BEVELED - 96" - HONEY CHERRY
2C	M09494-38-SD0	EA	MOLDING - TRIM - W/NOTCH - 1" X 79.6" - OAK/PORTSMOUTH OAK - PORTSMOUTH OAK
2C	M09494-38-SD1	EA	MOLDING - TRIM - W/NOTCH - 1" X 79.6" - CHERRY/CHERRY - CONCERT CHERRY
2C	M09494-38-SD2	EA	MOLDING - TRIM - W/NOTCH - 1" X 79.6" - MAPLE/WASHED MAPLE - WASHED MAPLE
2C	M09494-38-SD3	EA	MOLDING - TRIM - W/NOTCH - 1" X 79.6" - HONEY/CHERRY - HONEY CHERRY
2C	Y00207-42-438	EA	MOLDING - .75" X 1.4" X 96" - UNSTAINED OAK
2C	Y00207-32-438	EA	MOLDING - .75" X 1.4" X 96" - UNSTAINED CHERRY
2C	Y00207-22-438	EA	MOLDING - .75" X 1.4" X 96" - UNSTAINED MAPLE
3C	Y00223-42-438	EA	MOLDING - HARDWOOD/OAK - .7" X 1" X 96"
3C	Y00223-32-438	EA	MOLDING - HARDWOOD/CHERRY - .7" X 1" X 96"
3C	Y00223-22-438	EA	MOLDING - HARDWOOD/MAPLE - .7" X 1" X 96"
4C	Y00258-72-438	EA	MOLDING/VINYL WRAP-BEVELED-.73" X 3.1" X 96" - PORTSMOUTH OAK
4C	Y00258-62-438	EA	MOLDING/VINYL WRAP-BEVELED-.73" X 3.1" X 96" - CONCERT CHERRY
4C	Y00258-A2-438	EA	MOLDING/VINYL WRAP-BEVELED ENDS-.73"X3.1"X96" - WASHED MAPLE
4C	Y00258-92-438	EA	MOLDING/VINYL WRAP-BEVELED-.73" X 3.1" X 96" - SIERRA MAPLE
5C	Y00259-72-438	EA	MOLDING/VINYL WRAP-BEVELED-.73" X 1.8" X 96" - PORTSMOUTH OAK
5C	Y00259-62-438	EA	MOLDING/VINYL WRAP-BEVELED-.73" X 1.8" X 96" - CONCERT CHERRY
5C	Y00259-A2-438	EA	MOLDING/VINYL WRAP-BEVELED-.73"X1.8"X96" - WASHED MAPLE
5C	Y00259-92-438	EA	MOLDING/VINYL WRAP-BEVELED-.73"X1.8"X96" - SIERRA MAPLE
6C	Y00266-42-438	EA	MOLDING - .75" X 1.5" X 96" OAK - .7" X 1" X 96"
6C	Y00266-32-438	EA	MOLDING - .75" X 1.5" X 96" CHERRY - .7" X 1" X 96"
6C	Y00266-22-438	EA	MOLDING - .75" X 1.5" X 96" MAPLE - .7" X 1" X 96"
7C	Y00280-74-174	EA	MOLDING/TRIM - VINYL - F/SLIDEOUT - 164.1" - PORTSMOUTH OAK
7C	Y00280-64-174	EA	MOLDING/TRIM - VINYL - F/SLIDEOUT - 164.1" - CONCERT CHERRY

**INTERIOR FINISH GROUP (CONTINUED)**  
**MOLDINGS & TRIMS (CONTINUED)**

KEY	PART NUMBER	U/M	DESCRIPTION
7C	Y00280-A4-174	EA	MOLDING/TRIM - VINYL - F/SLIDEOUT - 164.1" - WASHED MAPLE
7C	Y00280-94-174	EA	MOLDING/TRIM - VINYL - F/SLIDEOUT - 164.1" - SIERRA MAPLE
8C	Y00281-72-438	EA	MOLDING/TRIM - VINYL - F/SLIDEOUT - 96" - PORTSMTH OAK
8C	Y00281-62-438	EA	MOLDING/TRIM - VINYL - F/SLIDEOUT - 96" - CONCERT CHERRY
8C	Y00281-A2-438	EA	MOLDING/TRIM - VINYL - F/SLIDEOUT - 96" - WASHED MAPLE
8C	Y00281-92-438	EA	MOLDING/TRIM - VINYL - F/SLIDEOUT - 96" - SIERRA MAPLE
9C	Y00282-72-438	EA	MOLDING - SLIDEOUT/VINYL WRAP - 3.9" X 96" - PORTSMOUTH OAK
9C	Y00282-62-438	EA	MOLDING - SLIDEOUT/VINYL WRAP - 3.9" X 96" - CONCERT CHERRY
9C	Y00282-A2-438	EA	MOLDING - SLIDEOUT/VINYL WRAP - 3.9" X 96" - WASHED MAPLE
10C	Y00284-42-438	EA	MOLDING - STRAIGHT - .2" X 1.5" X 96" - UNSTAINED OAK
10C	Y00284-32-438	EA	MOLDING - STRAIGHT - .2" X 1.5" X 96" - UNSTAINED CHERRY
10C	Y00284-22-438	EA	MOLDING - STRAIGHT - .2" X 1.5" X 96" - UNSTAINED MAPLE
11C	Y00285-42-438	EA	MOLDING - STRAIGHT - .63" X 3.2" X 96" - UNSTAINED OAK
11C	Y00285-32-438	EA	MOLDING - STRAIGHT - .63" X 3.2" X 96" - UNSTAINED CHERRY
11C	Y00285-22-438	EA	MOLDING - STRAIGHT - .63" X 3.2" X 96" - UNSTAINED MAPLE
12C	Y00291-72-438	EA	MOLDING - VINYL WRAPPED - 4" X 96" - PORTSMTH OAK
12C	Y00291-62-438	EA	MOLDING - VINYL WRAPPED - 4" X 96" - CONCERT CHERRY
12C	Y00291-A2-438	EA	MOLDING - VINYL WRAPPED - 4" X 96" - WASHED MAPLE
12C	Y00291-92-438	EA	MOLDING - VINYL WRAPPED - 4" X 96" - SIERRA MAPLE

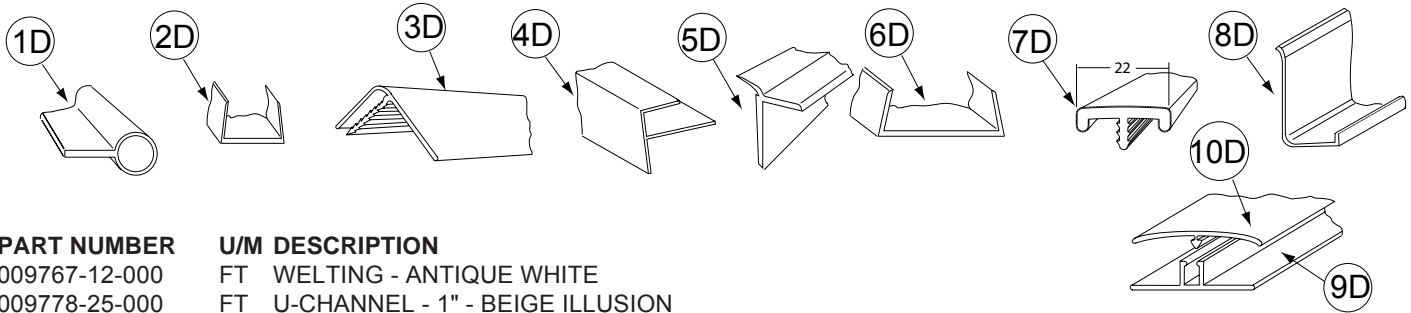

KEY	PART NUMBER	U/M	DESCRIPTION
1D	009767-12-000	FT	WELTING - ANTIQUE WHITE
2D	009778-25-000	FT	U-CHANNEL - 1" - BEIGE ILLUSION
2D	009778-32-000	FT	U-CHANNEL - 1" - PORTSMOUTH OAK
2D	009778-34-000	FT	U-CHANNEL - 1" - CONCERT CHERRY
2D	009778-35-000	FT	U-CHANNEL - 1" - HONEY CHERRY
2D	009778-36-000	FT	U-CHANNEL - 1" - SIERRA MAPLE
2D	009778-27-000	FT	U-CHANNEL - 1" - WASHED MAPLE
3D	009809-30-000	EA	MOLDING - CORNER - OUTSIDE - 1" X 84" - BEIGE ILLUSION
3D	009809-32-000	EA	MOLDING - CORNER - OUTSIDE - 1" X 84" - PORTSMOUTH OAK
3D	009809-33-000	EA	MOLDING - CORNER - OUTSIDE - 1" X 84" - CONCERT CHERRY
3D	009809-35-000	EA	MOLDING - CORNER - OUTSIDE - 1" X 84" - SIERRA MAPLE
3D	009809-34-000	EA	MOLDING - CORNER - OUTSIDE - 1" X 84" - HONEY CHERRY
3D	009809-31-000	EA	MOLDING - CORNER - OUTSIDE - 1" X 84" - WASHED MAPLE
4D	009812-31-000	EA	MOLDING - CORNER - 1/2" W/1/4"CHAN X 84" - BEIGE ILLUSION
4D	009812-34-000	EA	MOLDING - CORNER - 1/2" W/1/4"CHAN X 84" - VW LIGHT GRAY
4D	009812-35-000	EA	MOLDING - CORNER - 1/2" W/1/4"CHAN X 84" - PORTSMOUTH OAK
4D	009812-36-000	EA	MOLDING - CORNER - 1/2" W/1/4"CHAN X 84" - CONCERT CHERRY
4D	009812-37-000	EA	MOLDING - CORNER - 1/2" W/1/4"CHAN X 84" - HONEY CHERRY
4D	009812-38-000	EA	MOLDING - CORNER - 1/2" W/1/4"CHAN X 84" - SIERRA MAPLE
4D	009812-33-000	EA	MOLDING - CORNER - 1/2" W/1/4"CHAN X 84" - WASHED MAPLE
5D	022992-11-000	FT	MOLDING - REVERSE COVE - T-SHAPED - IVORY
5D	022992-14-000	FT	MOLDING - REVERSE COVE - T-SHAPED - BRIGHT WHITE
5D	022992-15-000	FT	MOLDING - REVERSE COVE - T-SHAPED - VW GRAY
6D	070504-42-000	FT	U-CHANNEL - PLASTIC - .13" X 84" - BEIGE ILLUSION
6D	070504-43-000	FT	U-CHANNEL - PLASTIC - .9" X 96" - BEIGE ILLUSION
6D	070504-57-000	FT	U-CHANNEL - PLASTIC - .13" X 84" - PORTSMOUTH OAK
6D	070504-58-000	FT	U-CHANNEL - PLASTIC - .9" X 84" - PORTSMOUTH OAK
6D	070504-60-000	FT	U-CHANNEL - PLASTIC - .13" X 84" - CONCERT CHERRY
6D	070504-61-000	FT	U-CHANNEL - PLASTIC - .9" X 84" - CONCERT CHERRY
6D	070504-62-000	FT	U-CHANNEL - PLASTIC - 1.65" X 84" - HONEY CHERRY
6D	070504-63-000	FT	U-CHANNEL - PLASTIC - .9" X 84" - HONEY CHERRY
6D	070504-65-000	FT	U-CHANNEL - PLASTIC - 1.65" X 84" - SIERRA MAPLE
6D	070504-66-000	FT	U-CHANNEL - PLASTIC - .9" X 84" - SIERRA MAPLE
6D	070504-50-000	FT	U-CHANNEL - PLASTIC - .13" X 96" - WASHED MAPLE
6D	070504-51-000	FT	U-CHANNEL - PLASTIC - .9" X 96" - WASHED MAPLE



**INTERIOR FINISH GROUP (CONTINUED)**  
**MOLDINGS & TRIMS (CONTINUED)**

KEY	PART NUMBER	U/M	DESCRIPTION
7D	083620-15-000	FT	MOLDING-T - W/EDGE LIP - 7/8" FACE - BEIGE ILLUSION
7D	083620-20-000	FT	MOLDING-T - W/EDGE LIP - 7/8" FACE - PORTSMOUTH OAK
7D	083620-21-000	FT	MOLDING-T - W/EDGE LIP - 7/8" FACE - CONCERT CHERRY/HONEY CHERRY
7D	083620-22-000	FT	MOLDING-T - W/EDGE LIP - 7/8" FACE - SIERRA MAPLE
7D	083620-19-000	FT	MOLDING-T - W/EDGE LIP - 7/8" FACE - WASHED MAPLE
8D	085746-04-000	FT	TRIM-J - CARPET 1.2" X .5" ANGLE - 12' LONG - OFF WHITE
9D	086229-01-000	EA	RETAINER - BATTEN - .75" X 92.1" - ANY COLOR
10D	086229-20-000	EA	BATTEN - 1" X 96" - BEIGE

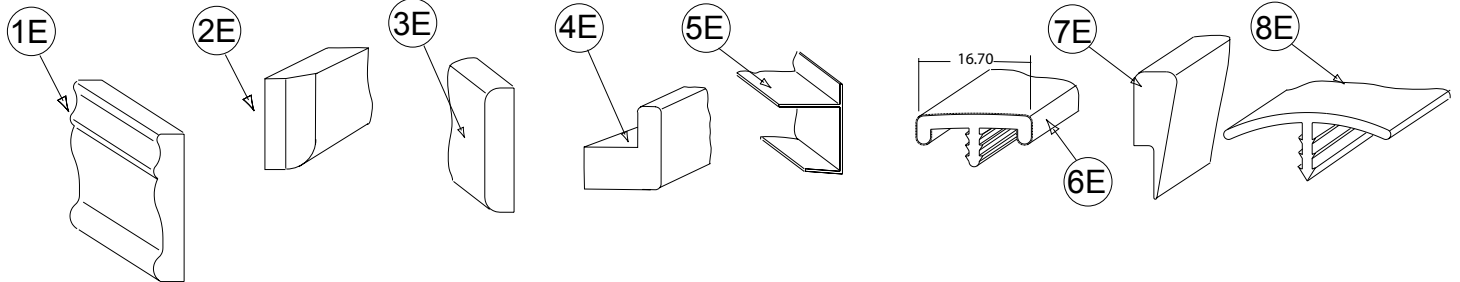

KEY	PART NUMBER	U/M	DESCRIPTION
1E	100182-10-N47	EA	TRIM/WOOD - CHAIR RAIL - 2.5" X 8' - PORTSMOUTH OAK
1E	100182-10-P85	EA	TRIM/WOOD - CHAIR RAIL - 2.5" X 8' - CONCERT CHERRY
1E	100182-10-J70	EA	TRIM/WOOD - CHAIR RAIL - 2.5" X 8' - WASHED MAPLE
1E	100182-10-RA3	EA	TRIM/WOOD - CHAIR RAIL - 2.5" X 8' - HONEY CHERRY
1E	100182-10-S67	EA	TRIM/WOOD - CHAIR RAIL - 2.5" X 8' - SIERRA MAPLE
2E	100659-30-N75	EA	MOLDING - TRIM - 8' - PORTSMOUTH OAK
2E	100659-30-N74	EA	MOLDING - TRIM - 8' - CONCERT CHERRY
2E	100659-30-M84	EA	MOLDING - TRIM - 8' - WASHED MAPLE
2E	100659-27-RA3	EA	MOLDING - TRIM - HONEY CHERRY
2E	100659-31-SA3	EA	MOLDING - TRIM - SIERRA MAPLE
3E	100818-01-12A	EA	MOLDING - VINYL WRAPPED - 1.6" X .4" X 84" - PORTSMOUTH OAK
3E	100818-01-13A	EA	MOLDING - VINYL WRAPPED - 1.6" X .4" X 84" - CONCERT CHERRY
3E	100818-01-14A	EA	MOLDING - VINYL WRAPPED - 1.6" X .4" X 84" - HONEY CHERRY
3E	100818-01-21A	EA	MOLDING - VINYL WRAPPED - 1.6" X .4" X 84" - WASHED MAPLE
3E	100818-01-22A	EA	MOLDING - VINYL WRAPPED - 1.6" X .4" X 84" - SIERRA MAPLE
4E	100819-01-12A	EA	MOLDING - VINYL WRAPPED-L-SHAPED-1.5"X1.5"X84" - PORTSMOUTH OAK
4E	100819-01-13A	EA	MOLDING - VINYL WRAPPED-L-SHAPED-1.5"X1.5"X84" - CONCERT CHERRY
4E	100819-01-14A	EA	MOLDING - VINYL WRAPPED-L-SHAPED-1.5"X1.5"X84" - HONEY CHERRY
4E	100819-01-21A	EA	MOLDING - VINYL WRAPPED-L-SHAPED-1.5"X1.5"X84" - WASHED MAPLE
4E	100819-01-22A	EA	MOLDING - VINYL WRAPPED-L-SHAPED-1.5"X1.5"X84" - SIERRA MAPLE
5E	103186-01-07A	FT	MOLDING/PLASTIC - 3/8" U-CHANNEL-3/4" FACE -BEIGE ILLUSION
5E	103186-01-09A	FT	MOLDING/PLASTIC - 3/8" U-CHAN'L-3/4" FACE - PORTSMOUTH OAK
5E	103186-01-10A	FT	MOLDING/PLASTIC - 3/8" U-CHAN'L-3/4" FACE - CONCERT CHERRY
5E	103186-01-11A	FT	MOLDING/PLASTIC - 3/8" U-CHAN'L-3/4" FACE - HONEY CHERRY
5E	103186-01-12A	FT	MOLDING/PLASTIC - 3/8" U-CHAN'L-3/4" FACE - SIERRA MAPLE
5E	103186-01-08A	FT	MOLDING/PLASTIC - 3/8" U-CHANNEL-3/4"FACE-WASHED MAPLE 8' - WASHED MAPLE
5E	103186-02-07A	FT	MOLDING/PLASTIC-1" U-CHAN'L-1 3/8" FACE - BEIGE ILLUSION
5E	103186-02-09A	FT	MOLDING/PLASTIC - 1" U-CHAN'L-1 3/8" FACE - PORTSMOUTH OAK
5E	103186-02-10A	FT	MOLDING/PLASTIC - 1" U-CHAN'L-1 3/8" FACE - CONCERT CHERRY
5E	103186-02-11A	FT	MOLDING/PLASTIC - 1" U-CHAN'L-1 3/8" FACE - HONEY CHERRY
5E	103186-02-12A	FT	MOLDING/PLASTIC - 1" U-CHAN'L-1 3/8" FACE - SIERRA MAPLE
5E	103186-02-08A	FT	MOLDING/PLASTIC - 1" U-CHANNEL-1 3/8"FACE - WASHED MAPLE
6E	104676-02-08A	FT	MOLDING-T - W/EDGE LIP - 11/16" FACE - PORTSMOUTH OAK
6E	104676-02-09A	FT	MOLDING-T - W/EDGE LIP - 11/16" FACE - CONCERT CHERRY
6E	104676-02-10A	FT	MOLDING-T - W/EDGE LIP - 11/16" FACE - HONEY CHERRY
6E	104676-02-06A	FT	MOLDING-T - W/EDGE LIP - 11/16" FACE - WASHED MAPLE
6E	104676-02-12A	FT	MOLDING-T - W/EDGE LIP - 11/16" FACE - SIERRA MAPLE
7E	105004-01-12A	EA	MOLDING - VINYL WRAPPED - 1" X 96" - PORTSMOUTH OAK
7E	105004-01-13A	EA	MOLDING - VINYL WRAPPED 1" X 8' - CONCERT CHERRY/HONEY CHERRY
7E	105004-01-21A	EA	MOLDING - VINYL WRAPPED - 1" X 8' - WASHED MAPLE
7E	105004-01-22A	EA	MOLDING - VINYL WRAPPED - 1" X 8' - SIERRA MAPLE
8E	105709-02-000	FT	MOLDING-T - W/EDGE LIP 3/4" FACE - BEIGE ILLUSION

## INTERIOR FINISH GROUP (CONTINUED)

### MOLDINGS & TRIMS (CONTINUED)

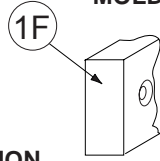

KEY	PART NUMBER	U/M	DESCRIPTION
1F	116951-11-N95	EA	MOLDING - TRIM - 3.5" X 75.9" - PORTSMOUTH
1F	116951-11-KQ1	EA	MOLDING - TRIM - 3.5" X 75.9" - CONCERT CHERRY
1F	116951-11-RE0	EA	MOLDING - TRIM - 3.5" X 75.8" - HONEY CHERRY
1F	116951-23-R83	EA	MOLDING - TRIM - 3.5" X 74.6" - PORTSMOUTH OAK
1F	116951-23-R84	EA	MOLDING - TRIM - 3.5" X 74.6" - CONCERT CHERRY
1F	116951-23-R91	EA	MOLDING - TRIM - 3.5" X 74.6" - WASHED MAPLE
1F	116951-23-RE0	EA	MOLDING - TRIM - 3.5" X 74.6" - HONEY CHERRY
1F	116951-24-R83	EA	MOLDING - TRIM - 3.5" X 74.6" - PORTSMOUTH OAK
1F	116951-24-R84	EA	MOLDING - TRIM - 3.5" X 74.6" - CONCERT CHERRY
1F	116951-24-R91	EA	MOLDING - TRIM - 3.5" X 74.6" - WASHED MAPLE
1F	116951-24-RE0	EA	MOLDING - TRIM - 3.5" X 74.6" - HONEY CHERRY
1F	116951-25-SD0	EA	MOLDING - TRIM - 5.5" X 69.8" - PORTSMOUTH OAK
1F	116951-25-SD1	EA	MOLDING - TRIM - 5.5" X 69.8" - CONCERT CHERRY
1F	116951-25-SD2	EA	MOLDING - TRIM - 5.5" X 69.8" - WASHED MAPLE
1F	116951-25-SD3	EA	MOLDING - TRIM - 5.5" X 69.8" - HONEY CHERRY
1F	116951-27-N75	EA	MOLDING - TRIM - 3.5" X 46.8" - PORTSMOUTH OAK
1F	116951-27-N85	EA	MOLDING - TRIM - 3.5" X 46.8" - CONCERT CHERRY
1F	116951-27-N84	EA	MOLDING - TRIM - 3.5" X 46.8" - WASHED MAPLE
1F	116951-28-N75	EA	MOLDING - TRIM - 3.5" X 79.4" - PORTSMOUTH OAK
1F	116951-28-N85	EA	MOLDING - TRIM - 3.5" X 79.4" - CONCERT CHERRY
1F	116951-28-N84	EA	MOLDING - TRIM - 3.5" X 79.4" - WASHED MAPLE
1F	116951-29-N70	EA	MOLDING - TRIM - 5.5" X 30.4" - PORTSMOUTH OAK
1F	116951-29-N85	EA	MOLDING - TRIM - 5.5" X 30.4" - CONCERT CHERRY
1F	116951-29-N84	EA	MOLDING - TRIM - 5.5" X 30.4" - WASHED MAPLE
1F	116951-29-RC3	EA	MOLDING - TRIM - 5.5" X 30.4" - HONEY CHERRY
1F	116951-29-SA3	EA	MOLDING - TRIM - 5.5" X 30.4" - SIERRA MAPLE
1F	116951-32-P75	EA	MOLDING - TRIM - 1.5" X 33.4" - PORTSMOUTH OAK
1F	116951-32-P25	EA	MOLDING - TRIM - 1.5" X 33.4" - CONCERT CHERRY
1F	116951-32-P28	EA	MOLDING - TRIM - 1.5" X 33.4" - WASHED MAPLE
1F	116951-32-RE0	EA	MOLDING - TRIM - 1.5" X 33.4" - HONEY CHERRY
1F	116951-34-P78	EA	MOLDING - TRIM - 3.5" X 44.3" - PORTSMOUTH OAK
1F	116951-34-P79	EA	MOLDING - TRIM - 3.5" X 44.3" - CONCERT CHERRY
1F	116951-34-P28	EA	MOLDING - TRIM - 3.5" X 44.3" - WASHED MAPLE
1F	116951-34-RE0	EA	MOLDING - TRIM - 3.5" X 44.3" - HONEY CHERRY
1F	116951-35-P78	EA	MOLDING - TRIM - 3.5" X 96" - PORTSMOUTH OAK
1F	116951-35-P79	EA	MOLDING - TRIM - 3.5" X 96" - CONCERT CHERRY
1F	116951-35-P28	EA	MOLDING - TRIM - 3.5" X 96" - WASHED MAPLE
1F	116951-35-RE0	EA	MOLDING - TRIM - 3.5" X 96" - HONEY CHERRY
1F	116951-36-R68	EA	MOLDING - TRIM - 3.5" X 48.8" - PORTSMOUTH OAK
1F	116951-36-R69	EA	MOLDING - TRIM - 3.5" X 48.8" - CONCERT CHERRY
1F	116951-36-R76	EA	MOLDING - TRIM - 3.5" X 48.8" - WASHED MAPLE
1F	116951-37-R68	EA	MOLDING - TRIM - 3.5" X 38.6" - PORTSMOUTH OAK
1F	116951-37-R69	EA	MOLDING - TRIM - 3.5" X 38.6" - CONCERT CHERRY
1F	116951-37-R76	EA	MOLDING - TRIM - 3.5" X 38.6" - WASHED MAPLE
1F	116951-38-R83	EA	MOLDING - TRIM - 3.5" X 82.6" - PORTSMOUTH OAK
1F	116951-38-R84	EA	MOLDING - TRIM - 3.5" X 82.6" - CONCERT CHERRY
1F	116951-38-R91	EA	MOLDING - TRIM - 3.5" X 82.6" - WASHED MAPLE
1F	116951-38-RE0	EA	MOLDING - TRIM - 3.5" X 82.6" - HONEY CHERRY
1F	116951-39-R83	EA	MOLDING - TRIM - 3.5" X 73.9" - PORTSMOUTH OAK
1F	116951-39-R84	EA	MOLDING - TRIM - 3.5" X 73.9" - CONCERT CHERRY
1F	116951-39-R91	EA	MOLDING - TRIM - 3.5" X 73.9" - WASHED MAPLE
1F	116951-39-RE0	EA	MOLDING - TRIM - 3.5" X 73.9" - HONEY CHERRY
1F	116951-40-R83	EA	MOLDING - TRIM - 4.5" X 81.9" - PORTSMOUTH OAK
1F	116951-40-R84	EA	MOLDING - TRIM - 4.5" X 81.9" - CONCERT CHERRY
1F	116951-40-R91	EA	MOLDING - TRIM - 4.5" X 81.9" - WASHED MAPLE
1F	116951-40-RE0	EA	MOLDING - TRIM - 4.5" X 81.9" - HONEY CHERRY
1F	116951-41-R83	EA	MOLDING - TRIM - 3.5" X 36.8" - PORTSMOUTH OAK
1F	116951-41-R84	EA	MOLDING - TRIM - 3.5" X 36.8" - CONCERT CHERRY
1F	116951-41-R91	EA	MOLDING - TRIM - 3.5" X 36.8" - WASHED MAPLE
1F	116951-41-RE0	EA	MOLDING - TRIM - 3.5" X 36.8" - HONEY CHERRY

**INTERIOR FINISH GROUP (CONTINUED)**  
**MOLDINGS & TRIMS (CONTINUED)**

KEY	PART NUMBER	U/M	DESCRIPTION
1F	116951-42-R83	EA	MOLDING - TRIM - 3.5" X 46.8" - PORTSMOUTH OAK
1F	116951-42-R84	EA	MOLDING - TRIM - 3.5" X 46.8" - CONCERT CHERRY
1F	116951-42-R91	EA	MOLDING - TRIM - 3.5" X 46.8" - WASHED MAPLE
1F	116951-42-RE0	EA	MOLDING - TRIM - 3.5" X 46.8" - HONEY CHERRY
1F	116951-43-R83	EA	MOLDING - TRIM - 3.5" X 86.5" - PORTSMOUTH OAK
1F	116951-43-R84	EA	MOLDING - TRIM - 3.5" X 86.5" - CONCERT CHERRY
1F	116951-43-R91	EA	MOLDING - TRIM - 3.5" X 86.5" - WASHED MAPLE
1F	116951-43-RE0	EA	MOLDING - TRIM - 3.5" X 86.5" - HONEY CHERRY
1F	116951-44-R83	EA	MOLDING - TRIM - 3.5" X 76.1" - PORTSMOUTH OAK
1F	116951-44-R84	EA	MOLDING - TRIM - 3.5" X 76.1" - CONCERT CHERRY
1F	116951-44-R91	EA	MOLDING - TRIM - 3.5" X 76.1" - WASHED MAPLE
1F	116951-44-RE0	EA	MOLDING - TRIM - 3.5" X 76.1" - HONEY CHERRY
1F	116951-45-R68	EA	MOLDING - TRIM - 3" X 30.3" - PORTSMOUTH OAK
1F	116951-45-R69	EA	MOLDING - TRIM - 3" X 30.3" - CONCERT CHERRY
1F	116951-45-R76	EA	MOLDING - TRIM - 3" X 30.3" - WASHED MAPLE
1F	116951-46-R83	EA	MOLDING - TRIM - 4.5" X 72.3" - PORTSMOUTH OAK
1F	116951-46-R84	EA	MOLDING - TRIM - 4.5" X 72.3" - CONCERT CHERRY
1F	116951-46-R91	EA	MOLDING - TRIM - 4.5" X 72.3" - WASHED MAPLE
1F	116951-46-RE0	EA	MOLDING - TRIM - 4.5" X 72.3" - HONEY CHERRY
1F	116951-48-R83	EA	MOLDING - TRIM - 4.5" X 76.1" - PORTSMOUTH OAK
1F	116951-48-R84	EA	MOLDING - TRIM - 4.5" X 76.1" - CONCERT CHERRY
1F	116951-48-R91	EA	MOLDING - TRIM - 4.5" X 76.1" - WASHED MAPLE
1F	116951-48-RE0	EA	MOLDING - TRIM - 4.5" X 76.1" - HONEY CHERRY
1F	116951-49-R83	EA	MOLDING - TRIM - 4.5" X 69.8" - PORTSMOUTH OAK
1F	116951-49-R84	EA	MOLDING - TRIM - 4.5" X 69.8" - CONCERT CHERRY
1F	116951-49-R91	EA	MOLDING - TRIM - 4.5" X 69.8" - WASHED MAPLE
1F	116951-49-RE0	EA	MOLDING - TRIM - 4.5" X 69.8" - HONEY CHERRY
1F	116951-51-SA3	EA	MOLDING - TRIM - 3.5" X 47.3" - SIERRA MAPLE
1F	116951-51-SA2	EA	MOLDING - TRIM - 3.5" X 47.3" - WASHED MAPLE
1F	116951-51-SA0	EA	MOLDING - TRIM - 3.5" X 47.3" - PORTSMOUTH OAK
1F	116951-51-SA1	EA	MOLDING - TRIM - 3.5" X 47.3" - CONCERT CHERRY
1F	116951-52-SD0	EA	MOLDING - TRIM - 4.5" X 73.3" - PORTSMOUTH OAK
1F	116951-52-SD1	EA	MOLDING - TRIM - 4.5" X 73.3" - CONCERT CHERRY
1F	116951-52-SD2	EA	MOLDING - TRIM - 4.5" X 73.3" - WASHED MAPLE
1F	116951-52-SD3	EA	MOLDING - TRIM - 4.5" X 73.3" - HONEY CHERRY
1F	116951-53-SD0	EA	MOLDING - TRIM - 4.5" X 53.4" - PORTSMOUTH OAK
1F	116951-53-SD1	EA	MOLDING - TRIM - 4.5" X 53.4" - CONCERT CHERRY
1F	116951-53-SD2	EA	MOLDING - TRIM - 4.5" X 53.4" - WASHED MAPLE
1F	116951-53-SD3	EA	MOLDING - TRIM - 4.5" X 53.4" - HONEY CHERRY

**INTERIOR FINISH GROUP (CONTINUED)**  
**MOLDINGS & TRIMS (CONTINUED)**

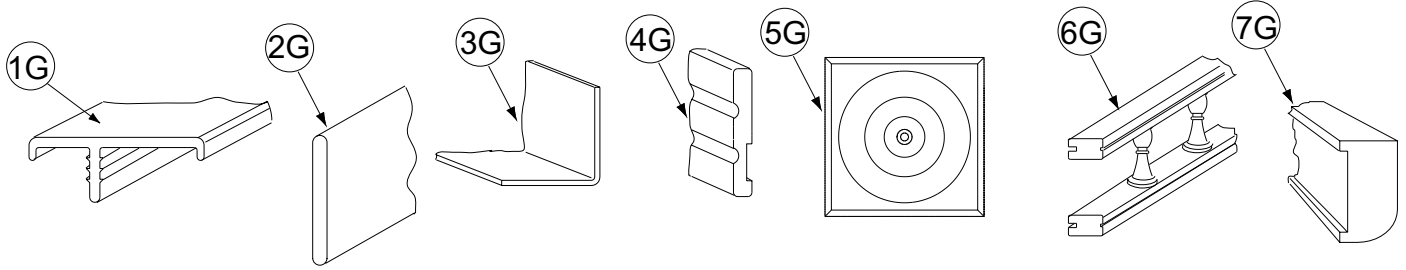

KEY	PART NUMBER	U/M	DESCRIPTION
1G	119520-01-01A	FT	MOLDING-T/OFFSET - W/EDGE LIP - 1"FACE - OFF WHITE
1G	119520-01-04A	FT	MOLDING-T - OFFSET W/EDGE LIP - 1"FACE - PORTSMOUTH OAK
1G	119520-01-02A	FT	MOLDING-T - OFFSET W/EDGE LIP - 1"FACE - CONCERT CHERRY/HONEY CHERRY
1G	119520-01-03A	FT	MOLDING-T - OFFSET W/EDGE LIP - 1"FACE - WASHED MAPLE
2G	127842-01-01A	FT	SEAL - SIGHT SHIELD - 2" BLACK
3G	130262-01-000	EA	PROTECTOR - CORNER SAVER - .7" X .7" X 48"
3G	130262-03-000	EA	PROTECTOR - CORNER - .75" X .75"
3G	130262-04-000	EA	PROTECTOR - CORNER SAVER - .4" X .7" X 48"
4G	132663-03-08A	EA	MOLDING-VINYL WRAP/PRE DRILLED-.6"X3.8"X150.6" - PORTSMOUTH OAK
4G	132663-11-07A	EA	MOLDING-VINYL WRAP/PRE DRILLED-.6"X3.8"X110.5" - CONCERT CHERRY/HONEY CHERRY
4G	132663-11-21A	EA	MOLDING-VINYL WRAP/PRE DRILLED-.6"X3.4"X57.9" - WASHED MAPLE
4G	132663-11-22A	EA	MOLDING-VINYL WRAP/PRE DRILLED-.6"X3.4"X57.9" - SIERRA MAPLE
4G	132663-09-08A	EA	MOLDING-VINYL WRAP/PRE DRILLED-.6"X3.4"X96.5" - PORTSMOUTH OAK
4G	132663-09-07A	EA	MOLDING-VINYL WRAP/PRE DRILLED-.6"X3.4"X96.5" - CONCERT CHERRY/ HONEY CHERRY
4G	132663-18-21A	EA	MOLDING-VINYL WRAP/PRE DRILLED-.6" X 3.4" X 73.1" - WASHED MAPLE
4G	132663-18-22A	EA	MOLDING-VINYL WRAP/PRE DRILLED-.6" X 3.4" X 73.1" - SIERRA MAPLE
4G	132663-15-08A	EA	MOLDING-VINYL WRAP/PRE DRILLED-.6"X3"X96" - PORTSMOUTH OAK
4G	132663-15-07A	EA	MOLDING-VINYL WRAP/PRE DRILLED-.6"X3"X96" - CONCERT CHERRY/HONEY CHERRY
4G	132663-04-21A	EA	MOLDING-VINYL WRAP/PRE DRILLED - .6" X 3" X 70.2" - WASHED MAPLE
4G	132663-04-22A	EA	MOLDING-VINYL WRAP/PRE DRILLED - .6" X 3" X 70.2" - SIERRA MAPLE
5G	132844-01-08A	EA	BLOCK - CORNER - 3.9" X 3.9" - PORTSMOUTH OAK
5G	132844-01-02A	EA	BLOCK - CORNER - 3.9" X 3.9" - CONCERT CHERRY/HONEY CHERRY
5G	132844-01-21A	EA	BLOCK - CORNER - 3.9" X 3.9" - WASHED MAPLE
5G	132844-01-22A	EA	BLOCK - CORNER - 3.9" X 3.9" - SIERRA MAPLE
5G	132844-02-08A	EA	BLOCK - CORNER - 3.5" X 3.5" - PORTSMOUTH OAK
5G	132844-02-02A	EA	BLOCK - CORNER - 3.5" X 3.5" - CONCERT CHERRY/HONEY CHERRY
5G	132844-02-21A	EA	BLOCK - CORNER - 3.5" X 3.5" - WASHED MAPLE
5G	132844-02-22A	EA	BLOCK - CORNER - 3.5" X 3.5" - SIERRA MAPLE
6G	137108-01-07A	EA	RAIL - DECORATIVE - 96" - PORTSMOUTH OAK
6G	137108-01-02A	EA	RAIL - DECORATIVE - 96" - CONCERT CHERRY
6G	137108-01-03A	EA	RAIL - DECORATIVE - 96" - WASHED MAPLE
6G	137108-01-08A	EA	RAIL - DECORATIVE - 96" - HONEY CHERRY
6G	137108-01-09A	EA	RAIL - DECORATIVE - 96" W/O REVERSE SIDE GROOVE - SIERRA MAPLE
6G	150167-01-07A	EA	RAIL - DECORATIVE - 96" W/O REVERSE SIDE GROOVE - PORTSMOUTH OAK
6G	150167-01-02A	EA	RAIL - DECORATIVE - 96" W/O REVERSE SIDE GROOVE - SALEM CHERRY - CONCERT CHERRY
6G	150167-01-03A	EA	RAIL - DECORATIVE - 96" W/O REVERSE SIDE GROOVE - WASHED MAPLE
6G	150167-01-09A	EA	RAIL - DECORATIVE - 96" W/O REVERSE SIDE GROOVE - SIERRA MAPLE
	137885-A2-438	EA	LUMBER - VINYL WRAPPED - .7" X .75" X 96" - CONCERT CHERRY
	137885-D2-438	EA	LUMBER - VINYL WRAPPED - .7" X 1.5" X 96" - CONCERT CHERRY
	137885-E2-438	EA	LUMBER - VINYL WRAPPED - .7" X 2" X 96" - CONCERT CHERRY
	137885-F2-438	EA	LUMBER - VINYL WRAPPED - .7" X 2.5" X 96" - CONCERT CHERRY
	137885-G2-438	EA	LUMBER - VINYL WRAPPED - .7" X 3" X 96" - CONCERT CHERRY
	137885-H2-438	EA	LUMBER - VINYL WRAPPED - .7" X 3.5" X 96" - CONCERT CHERRY
	137885-J2-438	EA	LUMBER - VINYL WRAPPED - .7" X 5.5" X 96" - CONCERT CHERRY
	137885-J2-743	EA	LUMBER - VINYL WRAPPED - .7" X 5.5" X 108" - CONCERT CHERRY
	137885-K2-438	EA	LUMBER - VINYL WRAPPED - .7" X 3.9" X 96" - CONCERT CHERRY
	137885-R2-438	EA	LUMBER - VINYL WRAPPED - .7" X 3" X 96" - CONCERT CHERRY
7G	137887-D2-134	EA	MOLDING - VINYL WRAPPED - .7" X 1.6" X 84" - CONCERT CHERRY
7G	137887-D2-743	EA	MOLDING - VINYL WRAPPED - .7" X 1.6" X 108" - CONCERT CHERRY
7G	137887-F2-134	EA	MOLDING - VINYL WRAPPED - .7" X 2.5" X 84" - CONCERT CHERRY
7G	137887-F2-743	EA	MOLDING - VINYL WRAPPED - .7" X 2.5" X 108" - CONCERT CHERRY
7G	137887-F2-438	EA	MOLDING - VINYL WRAPPED - .7" X 2.5" X 96" - CONCERT CHERRY

**INTERIOR FINISH GROUP (CONTINUED)**  
**MOLDINGS & TRIMS (CONTINUED)**

KEY	PART NUMBER	U/M	DESCRIPTION
	137894-A2-438	EA	LUMBER - VINYL WRAPPED - .7" X .75" X 96" - PORTSMOUTH OAK
	137894-D2-438	EA	LUMBER - VINYL WRAPPED - .7" X 1.5" X 96" - PORTSMOUTH OAK
	137894-E2-438	EA	LUMBER - VINYL WRAPPED - .7" X 2" X 96" - PORTSMOUTH OAK
	137894-F2-438	EA	LUMBER - VINYL WRAPPED - .7" X 2.5" X 96" - PORTSMOUTH OAK
	137894-G2-438	EA	LUMBER - VINYL WRAPPED - .7" X 3" X 96" - PORTSMOUTH OAK
	137894-H2-438	EA	LUMBER - VINYL WRAPPED - .7" X 3.5" X 96" - PORTSMOUTH OAK
	137894-J2-438	EA	LUMBER - VINYL WRAPPED - .7" X 5.5" X 96" - PORTSMOUTH OAK
	137894-J2-743	EA	LUMBER - VINYL WRAPPED - .7" X 5.5" X 96" - PORTSMOUTH OAK
	137894-K2-438	EA	LUMBER - VINYL WRAPPED - .7" X 3.9" X 96" - PORTSMOUTH OAK
	137894-R2-438	EA	LUMBER - VINYL WRAPPED - .7" X 3" X 96" - PORTSMOUTH OAK
7G	137895-D2-134	EA	MOLDING - VINYL WRAPPED - .7" X 1.6" X 84"-PORTSMOUTH OAK
7G	137895-D2-743	EA	MOLDING - VINYL WRAPPED - .7" X 1.6" X 108"-PORTSMOUTH OAK
7G	137895-F2-743	EA	MOLDING - VINYL WRAPPED - .7" X 2.5" X 108" - PORTSMOUTH OAK
	146419-A2-438	EA	LUMBER - VINYL WRAPPED - .7" X .75" X 96" - HONEY CHERRY
	146419-D2-438	EA	LUMBER - VINYL WRAPPED - .7" X 1.5" X 96" - HONEY CHERRY
	146419-E2-438	EA	LUMBER - VINYL WRAPPED - .7" X 2" X 96" - HONEY CHERRY
	146419-F2-438	EA	LUMBER - VINYL WRAPPED - .7" X 2.5" X 96" - HONEY CHERRY
	146419-G2-438	EA	LUMBER - VINYL WRAPPED - .7" X 3" X 96" - HONEY CHERRY
	146419-H2-438	EA	LUMBER - VINYL WRAPPED - .7" X 3.5" X 96" - HONEY CHERRY
	146419-J2-438	EA	LUMBER - VINYL WRAPPED - .7" X 5.5" X 96" - HONEY CHERRY
	146419-J2-743	EA	LUMBER - VINYL WRAPPED - .7" X 5.5" X 108" - HONEY CHERRY
	146419-K2-438	EA	LUMBER - VINYL WRAPPED - .7" X 3.9" X 96" - HONEY CHERRY
	146419-R2-438	EA	LUMBER - VINYL WRAPPED - .7" X 3" X 96" - HONEY CHERRY
7G	146425-D2-134	EA	MOLDING - VINYL WRAPPED - .7" X 1.6" X 96" - HONEY CHERRY
7G	146425-F2-134	EA	MOLDING - VINYL WRAPPED - .7" X 2.5" X 84" - HONEY CHERRY
7G	146425-F2-134	EA	MOLDING - VINYL WRAPPED - .7" X 2.5" X 96" - HONEY CHERRY
7G	146425-F2-743	EA	MOLDING - VINYL WRAPPED - .7" X 2.5" X 108" - HONEY CHERRY
	149325-A2-438	EA	LUMBER - VINYL WRAPPED - .7" X .75" X 96" - WASHED MAPLE
	149325-D2-438	EA	LUMBER - VINYL WRAPPED - .7" X 1.5" X 96" - WASHED MAPLE
	149325-E2-438	EA	LUMBER - VINYL WRAPPED - .7" X 2" X 96" - WASHED MAPLE
	149325-F2-438	EA	LUMBER - VINYL WRAPPED - .7" X 2.5" X 96" - WASHED MAPLE
	149325-G2-438	EA	LUMBER - VINYL WRAPPED - .7" X 3" X 96" - WASHED MAPLE
	149325-H2-438	EA	LUMBER - VINYL WRAPPED - .7" X 3.5" X 96" - WASHED MAPLE
	149325-J2-438	EA	LUMBER - VINYL WRAPPED - .7" X 5.5" X 96" - WASHED MAPLE
	149325-J2-743	EA	LUMBER - VINYL WRAPPED - .7" X 5.5" X 108" - WASHED MAPLE
	149325-K2-438	EA	LUMBER - VINYL WRAPPED - .7" X 3.9" X 96" - WASHED MAPLE
	149325-R2-438	EA	LUMBER - VINYL WRAPPED - .7" X 3" X 96" - WASHED MAPLE
7G	149326-D2-134	EA	MOLDING - VINYL WRAPPED - .7" X 1.6" X 84" - WASHED MAPLE
7G	149326-F2-134	EA	MOLDING - VINYL WRAPPED - .7" X 2.5" X 84" - WASHED MAPLE
7G	149326-F2-438	EA	MOLDING - VINYL WRAPPED - .7" X 2.5" X 96" - WASHED MAPLE
7G	149326-F2-743	EA	MOLDING - VINYL WRAPPED - .7" X 2.5" X 108" - WASHED MAPLE
	149330-A2-438	EA	LUMBER - VINYL WRAPPED - .7" X .75" X 96" - SIERRA MAPLE
	149330-D2-438	EA	LUMBER - VINYL WRAPPED - .7" X 1.5" X 96" - SIERRA MAPLE
	149330-E2-438	EA	LUMBER - VINYL WRAPPED - .7" X 2" X 96" - SIERRA MAPLE
	149330-F2-438	EA	LUMBER - VINYL WRAPPED - .7" X 2.5" X 96" - SIERRA MAPLE
	149330-G2-438	EA	LUMBER - VINYL WRAPPED - .7" X 3" X 96" - SIERRA MAPLE
	149330-H2-438	EA	LUMBER - VINYL WRAPPED - .7" X 3.5" X 96" - SIERRA MAPLE
	149330-J2-438	EA	LUMBER - VINYL WRAPPED - .7" X 5.5" X 96" - SIERRA MAPLE
	149330-J2-743	EA	LUMBER - VINYL WRAPPED - .7" X 5.5" X 108" - SIERRA MAPLE
	149330-K2-438	EA	LUMBER - VINYL WRAPPED - .7" X 3.9" X 96" - SIERRA MAPLE
	149330-R2-438	EA	LUMBER - VINYL WRAPPED - .7" X 3" X 96" - SIERRA MAPLE
7G	149331-D2-134	EA	MOLDING - VINYL WRAPPED - .7" X 1.6" X 96" - SIERRA MAPLE
7G	149331-F2-134	EA	MOLDING - VINYL WRAPPED - .7" X 2.5" X 84" - SIERRA MAPLE
7G	149331-F2-439	EA	MOLDING - VINYL WRAPPED - .7" X 2.5" X 96" - SIERRA MAPLE
7G	149331-F2-743	EA	MOLDING - VINYL WRAPPED - .7" X 2.5" X 108" - SIERRA MAPLE

**INTERIOR FINISH GROUP (CONTINUED)**  
**MOLDINGS & TRIMS (CONTINUED)**

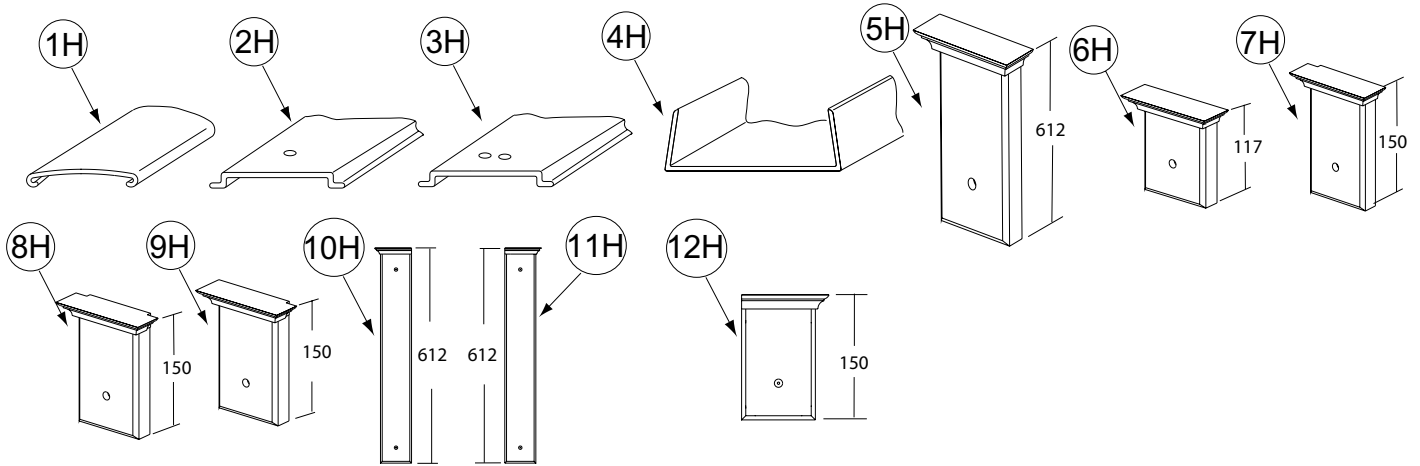

KEY	PART NUMBER	U/M	DESCRIPTION
1H	138359-01-01A	FT	COVER - ROOF BREAK - PEARL CREAM/PLASTIC - 96"
2H	138403-01-01A	EA	TRIM - ROOF - MILL
3H	138403-03-01A	EA	TRIM - ROOF - MILL
4H	141260-01-01A	FT	U-CHANNEL - 1" - VILLAGE OAK - PORTSMOUTH OAK/WASHED MAPLE/SIERRA MAPLE
4H	141260-01-02A	FT	U-CHANNEL - 1" - GRADY BROWN - CONCERT CHERRY/HONEY CHERRY
5H	141303-02-N53	EA	MOLDING - CROWN/BLOCK - PORTSMOUTH OAK
5H	141303-02-N52	EA	MOLDING - CROWN/BLOCK - CONCERT CHERRY
5H	141303-02-N62	EA	MOLDING - CROWN/BLOCK - WASHED MAPLE
5H	141303-02-RA3	EA	MOLDING - CROWN/BLOCK - HONEY CHERRY
6H	141303-03-N53	EA	MOLDING - CROWN/BLOCK - PORTSMOUTH OAK
6H	141303-03-N52	EA	MOLDING - CROWN/BLOCK - CONCERT CHERRY
6H	141303-03-N62	EA	MOLDING - CROWN/BLOCK - WASHED MAPLE
6H	141303-03-RA3	EA	MOLDING - CROWN/BLOCK - HONEY CHERRY
7H	141303-05-R89	EA	MOLDING - CROWN/BLOCK - PORTSMOUTH OAK
7H	141303-05-R91	EA	MOLDING - CROWN/BLOCK - WASHED MAPLE
7H	141303-05-R90	EA	MOLDING - CROWN/BLOCK - CONCERT CHERRY
7H	141303-05-RE3	EA	MOLDING - CROWN/BLOCK - HONEY CHERRY
8H	141303-06-R89	EA	MOLDING - CROWN/BLOCK - PORTSMOUTH OAK
8H	141303-06-R90	EA	MOLDING - CROWN/BLOCK - CONCERT CHERRY
8H	141303-06-R91	EA	MOLDING - CROWN/BLOCK - WASHED MAPLE
8H	141303-06-RE3	EA	MOLDING - CROWN/BLOCK - HONEY CHERRY
9H	141303-07-R89	EA	MOLDING - CROWN/BLOCK - PORTSMOUTH OAK
9H	141303-07-R90	EA	MOLDING - CROWN/BLOCK - CONCERT CHERRY
9H	141303-07-R91	EA	MOLDING - CROWN/BLOCK - WASHED MAPLE
9H	141303-07-RE3	EA	MOLDING - CROWN/BLOCK - HONEY CHERRY
10H	141303-08-R83	EA	MOLDING - CROWN/BLOCK - PORTSMOUTH OAK
10H	141303-08-R84	EA	MOLDING - CROWN/BLOCK - CONCERT CHERRY
10H	141303-08-R91	EA	MOLDING - CROWN/BLOCK - WASHED MAPLE
10H	141303-08-RE0	EA	MOLDING - CROWN/BLOCK - HONEY CHERRY
11H	141303-09-R83	EA	MOLDING - CROWN/BLOCK - PORTSMOUTH OAK
11H	141303-09-R84	EA	MOLDING - CROWN/BLOCK - CONCERT CHERRY
11H	141303-09-R91	EA	MOLDING - CROWN/BLOCK - WASHED MAPLE
11H	141303-09-RE0	EA	MOLDING - CROWN/BLOCK - HONEY CHERRY
12H	141303-10-R89	EA	MOLDING - CROWN/BLOCK - PORTSMOUTH OAK
12H	141303-10-R90	EA	MOLDING - CROWN/BLOCK - CONCERT CHERRY
12H	141303-10-R91	EA	MOLDING - CROWN/BLOCK - WASHED MAPLE
12H	141303-10-RE3	EA	MOLDING - CROWN/BLOCK - HONEY CHERRY

**INTERIOR FINISH GROUP (CONTINUED)**  
**MOLDINGS & TRIMS (CONTINUED)**

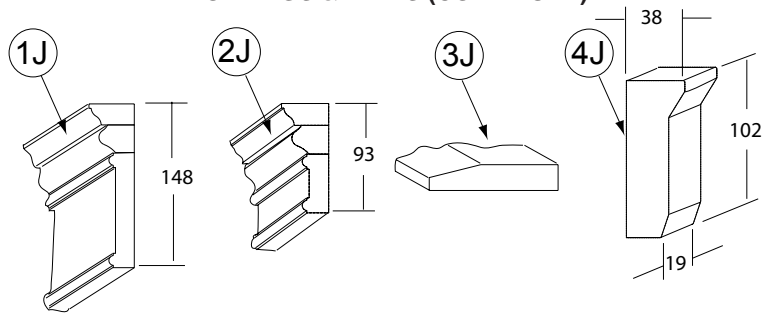

KEY	PART NUMBER	U/M	DESCRIPTION
1J	144885-14-R83	EA	MOLDING - F/SLIDEOUT - 86.5" - PORTSMOUTH OAK
1J	144885-14-R84	EA	MOLDING - F/SLIDEOUT - 86.5" - CHERRY
1J	144885-14-RE0	EA	MOLDING - F/SLIDEOUT - 86.5" - HONEY CHERRY
1J	144885-07-SD2	EA	MOLDING - F/SLIDEOUT - 82.5" - WASHED MAPLE
2J	145379-01-R83	EA	MOLDING/TRIM - 47.48" - PORTSMOUTH OAK
2J	145379-01-R84	EA	MOLDING/TRIM - 47.48" - CONCERT CHERRY
2J	145379-01-RE0	EA	MOLDING/TRIM - 47.48" - HONEY CHERRY
2J	145379-01-SD2	EA	MOLDING/TRIM - 47.48" - WASHED MAPLE
2J	145379-02-R83	EA	MOLDING/TRIM - 7.87" W/RIGHT SIDE ANGLE CUT - PORTSMOUTH OAK
2J	145379-02-R84	EA	MOLDING/TRIM - 7.87" W/RIGHT SIDE ANGLE CUT - CONCERT CHERRY
2J	145379-02-RE0	EA	MOLDING/TRIM - 7.87" W/RIGHT SIDE ANGLE CUT - HONEY CHERRY
2J	145379-02-SD2	EA	MOLDING/TRIM - 7.87" W/RIGHT SIDE ANGLE CUT - WASHED MAPLE
2J	145379-03-R83	EA	MOLDING/TRIM - 7.87" W/LEFT SIDE ANGLE CUT - PORTSMOUTH OAK
2J	145379-03-R84	EA	MOLDING/TRIM - 7.87" W/LEFT SIDE ANGLE CUT - CONCERT CHERRY
2J	145379-03-RE0	EA	MOLDING/TRIM - 7.87" W/LEFT SIDE ANGLE CUT - HONEY CHERRY
2J	145379-03-SD2	EA	MOLDING/TRIM - 7.87" W/LEFT SIDE ANGLE CUT - WASHED MAPLE
2J	145379-05-R83	EA	MOLDING/TRIM - 102.75" - PORTSMOUTH OAK
2J	145379-05-R84	EA	MOLDING/TRIM - 102.75" - CONCERT CHERRY
2J	145379-05-SD2	EA	MOLDING/TRIM - 102.75" - WASHED MAPLE
2J	145379-05-RE0	EA	MOLDING/TRIM - 102.75" - HONEY CHERRY
3J	146306-01-01A	FT	TRANSITION - CARPET/TILE
4J	149151-01-S46	EA	MOLDING - BLOCK - PORTSMOUTH OAK
4J	149151-01-S47	EA	MOLDING - BLOCK - CONCERT CHERRY
4J	149151-01-S48	EA	MOLDING - BLOCK - WASHED MAPLE

**INTERIOR FINISH GROUP (CONTINUED)**  
**PANELING & LAMINATES**

KEY	PART NUMBER	U/M	DESCRIPTION
	000885-A5-000	SF	PARTICLE BOARD - 3/8" X 4' X 8' - WHITE PEB EMB - 1 SIDED
	000885-93-000	SF	PARTICLE BOARD - 3/8" X 4' X 8' - PORTSMOUTH OAK - 2 SIDED - PORTSMOUTH OAK
	000885-94-000	SF	PARTICLE BOARD - 1/2" X 4' X 8' - PORTSMOUTH OAK - 2 SIDED - PORTSMOUTH OAK
	000885-95-000	SF	PARTICLE BOARD - 3/4" X 4' X 8' - PORTSMOUTH OAK - 2 SIDED - PORTSMOUTH OAK
	000885-B8-000	SF	PARTICLE BOARD - 3/8" X 4' X 8'- NEW CONC CHERRY - 2 SIDED - CONCERT CHERRY
	000885-C1-000	SF	PARTICLE BOARD - 1/2" X 4' X 8'- NEW CONC CHERRY - 2 SIDED - CONCERT CHERRY
	000885-C0-000	SF	PARTICLE BOARD - 3/4" X 4' X 8'- NEW CONC CHERRY - 2 SIDED - CONCERT CHERRY
	000885-B4-000	SF	PARTICLE BOARD - 3/8" X 4' X 8'- WASHED MAPLE - 2 SIDED - WASHED MAPLE
	000885-B5-000	SF	PARTICLE BOARD - 3/8" X 4' X 8'- WASHED MAPLE - 1 SIDED - WASHED MAPLE
	000885-B6-000	SF	PARTICLE BOARD - 3/4" X 4' X 8'- WASHED MAPLE - 2 SIDED - WASHED MAPLE
	000885-B7-000	SF	PARTICLE BOARD - 1/2" X 4' X 8'- WASHED MAPLE - 2 SIDED - WASHED MAPLE
	000885-B1-000	SF	PARTICLE BOARD - 3/8" X 4' X 8' - SIERRA MAPLE - 1-SIDED - SIERRA MAPLE
	000885-B0-000	SF	PARTICLE BOARD - 3/8" X 4' X 8' - SIERRA MAPLE - 2-SIDED - SIERRA MAPLE
	000885-B2-000	SF	PARTICLE BOARD - 3/4" X 4' X 8' - SIERRA MAPLE - 2-SIDED - SIERRA MAPLE
	074497-42-000	SF	PANELING - PORTSMOUTH OAK - 1/8" X 4' X 8' - PORTSMOUTH OAK
	074497-50-000	SF	PANELING - NEW CONCERT CHERRY - 1/8" X 4' X 8' - CONCERT CHERRY
	074497-49-000	SF	PANELING - WASHED MAPLE - 1/8" X 4' X 8' - WASHED MAPLE
	074497-48-000	SF	PANELING - SIERRA MAPLE - 4' X 8' - SIERRA MAPLE
	088272-H9-000	SF	PANELING - PEBBLE EMBOSSED - WHITE - 4' X 7'
	088272-K7-000	SF	PANELING - STONE - 4' X 7' (S46, S47, S48, SR0)
	088272-K6-000	SF	PANELING - CYPRESS - 4' X 7' (S49, S50, S51, SR1)
	088272-K5-000	SF	PANELING - SILVERADO - 4' X 7' (S52, S53, S54, SR2)
	076773-15-000	SF	PANELING - 2 SIDED/PORTSMOUTH OAK - 1/8" X 4' X 8' - PORTSMOUTH OAK
	076773-21-000	SF	PANELING - 2 SIDED/NEW CONC CHERRY - 1/8" X 4' X 8' - CONCERT CHERRY
	076773-20-000	SF	PANELING - 2 SIDED/WASHED MAPLE - 1/8" X 4' X 8' - WASHED MAPLE
	076773-19-000	SF	PANELING - 2 SIDED/SIERRA MAPLE - 1/8" X 4' X 8' - SIERRA MAPLE
	080215-14-000	SF	PANELING - 2 SIDED/PORTSMOUTH OAK - 3/16" X 4' X 8' - PORTSMOUTH OAK
	080215-17-000	SF	PANELING - PAPER WRAP - 2 SIDED/N CON CHERRY - 3/16" X 4' X 8' - CONCERT CHERRY
	080215-18-000	SF	PANELING/PAPER WRAP - 2 SIDED/WASHED MAPLE - 3/16" X 4' X 8' - WASHED MAPLE
	080215-19-000	SF	PANELING - 2 SIDED/SIERRA MAPLE - 3/16" X 4' X 8' - SIERRA MAPLE
	057882-04-000	SF	TAMBOUR - 48" X 96" SHEET - UNFINISHED (S46, S49, S52, SR0)
	057882-06-000	SF	TAMBOUR - 48" X 96" SHEET - UNFINISHED (S47, S50, S53, SR1)
	057882-05-000	SF	TAMBOUR - 48" X 96" SHEET - UNFINISHED (S48, S51, S54, SR2)
	126339-01-000	SF	BOARD - WHEAT - 60" X 72"
	069733-87-000	EA	BATT STRIP - WOODGRAINED/PORTSMOUTH OAK - 8'- PORTSMOUTH OAK
	088263-J3-000	EA	BATT STRIP - DECORATIVE - NEAT CONCERT CHERRY - CONCERT CHERRY
	088263-J2-000	EA	BATT STRIP - DECORATIVE - NEAT/WASHED MAPLE - WASHED MAPLE
	088263-J1-000	EA	BATT STRIP - DECORATIVE - SIERRA MAPLE
	088263-G1-000	EA	BATT STRIP - DECORATIVE - PEBBLE EMBOSSED - 8' LONG
	088263-H6-000	EA	BATT STRIP - DECORATIVE - STONE (S46, S47, S48, SR0)
	088263-H5-000	EA	BATT STRIP - DECORATIVE - CYPRESS (S49, S50, S51, SR1)
	088263-H4-000	EA	BATT STRIP - DECORATIVE - ROCKET SILVERADO (S52, S53, S54, SR2)
	085284-F7-000	FT	TAPE/STRIP - TRUE GRIP - 1 1/2" WIDE - ADHESIVE BACKED
	085284-F9-000	FT	BATT TAPE - ADHESIVE BACKED - PEBBLE EMBOSSED
	085284-G8-000	FT	BATT TAPE - ADHESIVE BACKED/PAPER WRAP - PORTSMOUTH OAK
	085284-J7-000	FT	BATT TAPE - ADHESIVE BACKED - DECORATIVE - CONCERT CHERRY
	085284-J5-000	FT	BATT TAPE - ADHESIVE BACKED - DECORATIVE-NEAT/WASHED MAPLE - WASHED MAPLE
	085284-J4-000	FT	BATT TAPE - ADHESIVE BACKED - DECORATIVE - SIERRA MAPLE
	085284-H0-000	FT	BATT TAPE - ADHESIVE BACKED - DECORATIVE - STONE (S46,S47,S48, SR0)
	085284-H9-000	FT	BATT TAPE - ADHESIVE BACKED - DECORATIVE - CYPRESS (S49, S50, S51, SR1)
	085284-H8-000	FT	BATT TAPE - ADHESIVE BACKED - DECORATIVE-ROCKET SILVERADO (S52, S53, S54, SR2)
	074498-40-000	SF	LAMINATE - PLASTIC - OFF WHITE - 4' X 8'
	074498-A0-000	SF	LAMINATE - PLASTIC - ROCKY MOUNTAIN HIGH - 4' X 8' (S46, S47, S48, SR0)
	074498-A1-000	SF	LAMINATE - PLASTIC - LINO FRIEZE - 5' X 8' (S49, S50, S51, SR1)
	074498-97-000	SF	LAMINATE - PLASTIC - GRAY TRANQUILITY - 4' X 8' (S52, S53, S54, SR2)
	074498-95-000	SF	LAMINATE - PLASTIC - PORTSMOUTH OAK - 4' X 8' - PORTSMOUTH OAK
	074498-96-000	SF	LAMINATE - PLASTIC - CHERRY - 4' X 8' - CONCERT CHERRY
	074498-A6-000	SF	LAMINATE - PLASTIC - HARDROCK MAPLE - 5' X 8' - WASHED MAPLE
	074498-A8-000	SF	LAMINATE - PLASTIC - SIERRA MAPLE - 4' X 8' - SIERRA MAPLE
	076325-77-000	FT	MOLDING - EDGE BAND - 1 5/16" X .030" - PORTSMOUTH - PORTSMOUTH OAK
	076325-80-000	FT	MOLDING - EDGE BAND - 1 5/16" X .30" - CONCERT CHERRY - CONCERT CHERRY
	076325-81-000	FT	MOLDING - EDGE BAND - 1 5/16" X .30" - NEAT/WASHED MAPLE - WASHED MAPLE
	076325-83-000	FT	MOLDING - EDGE BAND - .93" X .024" - SIERRA MAPLE
	076325-73-000	FT	MOLDING - EDGE BAND - .93" X .024" - OFF WHITE



## INTERIOR FINISH GROUP (CONTINUED)

### PANELING & LAMINATES (CONTINUED)

KEY	PART NUMBER	U/M	DESCRIPTION
	132610-06-14A	FT	WALLPAPER - BORDER - 5 1/4" - SELF-ADHESIVE (S46, S47, S48, SR0)
	132610-05-26A	FT	WALLPAPER - BORDER - 7" - SELF-ADHESIVE (S49, S50, S51, SR1)
	132610-05-27A	FT	WALLPAPER - BORDER - 7" - SELF ADHESIVE (S52, S53, S54, SR2)

#### INTERIOR TRIM LAYOUT

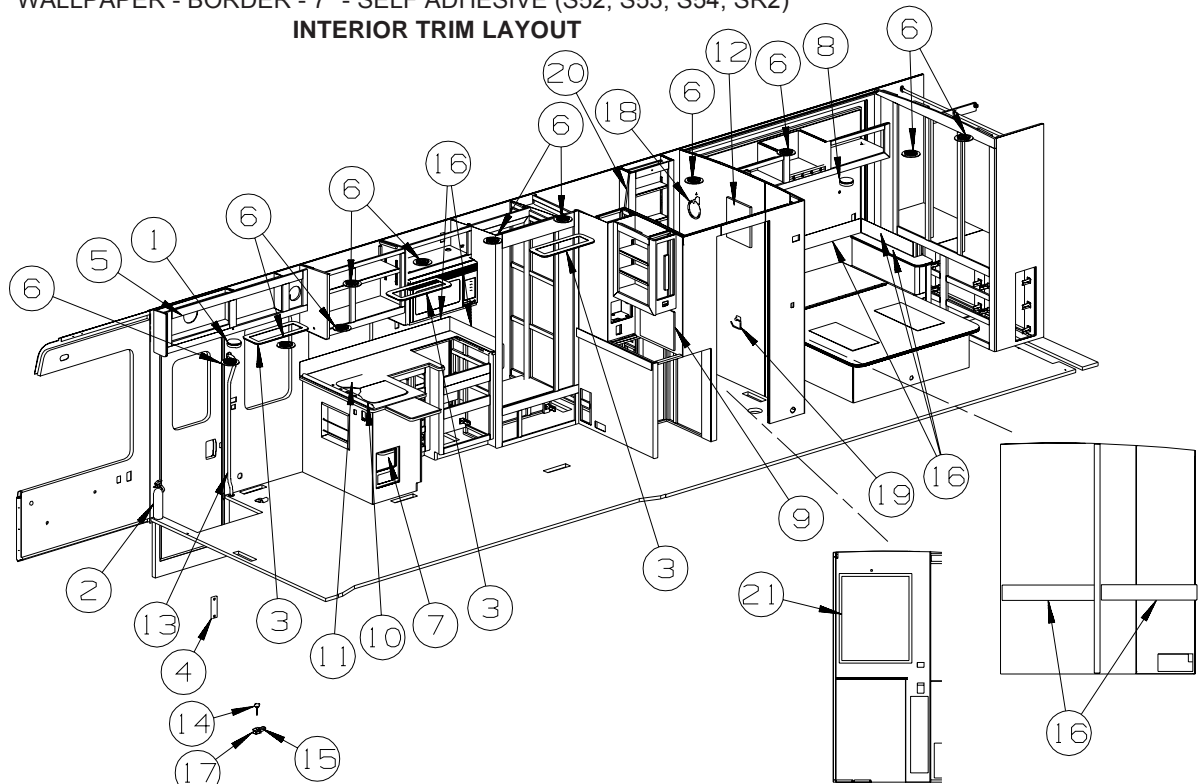

KEY	PART NUMBER	U/M	DESCRIPTION
1	072852-01-000	EA	DETECTOR - SMOKE - W/9 VOLT BATTERY - US
1	072852-02-000	EA	DETECTOR - SMOKE - W/9 VOLT BATTERY - CANADIAN
1	077956-01-000	EA	LABEL - WARNING/SMOKE DETECTOR
2	094499-03-000	EA	EXTINGUISHER/FIRE - DRY - 10BC - W/GAUGE/BRACKET
2	094499-02-000	EA	EXTINGUISHER/FIRE - DRY - 10BC - W/GAUGE - CANADIAN
2	094499-04-000	EA	STRAP - FIRE EXTINGUISHER MOUNTING - METAL
3	149160-01-05A	EA	TRIM - LIGHT RING - PORTSMOUTH OAK
3	149160-01-01A	EA	TRIM - LIGHT RING - CONCERT CHERRY
3	149160-01-03A	EA	TRIM - LIGHT RING - WASHED MAPLE
3	149160-01-04A	EA	TRIM - LIGHT RING - SIERRA MAPLE
4	148362-01-01A	EA	COVER - BRACKET/STRIKE - BRIGHT WHITE
4	140151-02-02A	EA	COVER - SCREW - BRIGHT WHITE
5	142368-01-01A	EA	CLOCK - 8" ROUND - BRASS
6	120134-01-02A	EA	REGISTER - W/DAMPER - 4" PIPE/6.4" O.D. FACE - WHITE
7	130818-02-01A	EA	TRASH CONTAINER - 20 QUART ALMOND
8	125136-02-000	EA	DETECTOR/CO - GAS MODEL - 9 VOLT
9	088742-16-000	EA	MIRROR - BEVELED/SAFETY GLASS - 14.4" X 18.5"
10	137489-01-02A	EA	COVER - SINK/LARGE - 13.8"X17"X1/4" - VENDURA/ALMONDINE
11	137489-02-02A	EA	COVER - SINK/SMALL - 9.6"X15.7"X1/4" - VENDURA/ALMONDINE
12	131493-01-01A	EA	PICTURE - 10" X 16" - BOTANICA (S46,S47,S48,SR0)
12	131493-02-22A	EA	PICTURE - DECORATIVE - 13" X 15" - HEATH FERN (S49,S50,S51,SR1)
12	131493-02-12A	EA	PICTURE - DECORATIVE - 13" X 15" - AFRICAN LILY (S52,S53,S54,SR2)
13	131058-03-02A	EA	HAND RAIL - INTERIOR ENTRY DOOR - BLACK
14	134194-01-01A	EA	KNOB - HOLD DOWN/RECLINER - BLACK
15	134057-01-11B	EA	BRACKET - RECLINER - FLAT BLACK
16	132610-06-14A	FT	WALLPAPER - BORDER - 5 1/4" - SELF-ADHESIVE (S46,S47,S48,SR0)
16	132610-05-26A	FT	WALLPAPER - BORDER - 7" - SELF-ADHESIVE (S49,S50,S51,SR1)
16	132610-05-27A	FT	WALLPAPER - BORDER - 7" - SELF-ADHESIVE (S52,S53,S54,SR2)
17	134128-02-02B	EA	PLATE - W/HOLES - W/WELDNUT - E-COATED
18	145980-06-01A	EA	TOWEL RING - BRASS
19	145980-03-01A	EA	HOLDER - TOILET TISSUE - EURO - BRASS
20*	139047-03-01A	EA	DOOR - SHOWER - NEO ANGLE - GOLD/AQUA - 66.4" TALL
21	140374-61-000	EA	MIRROR - SAFETY GLASS - 24" X 30"

\*COMPONENT PARTS LISTED LATER IN THIS GROUP

**INTERIOR FINISH GROUP (CONTINUED)**  
**INTERIOR TRIM LAYOUT (CONTINUED)**

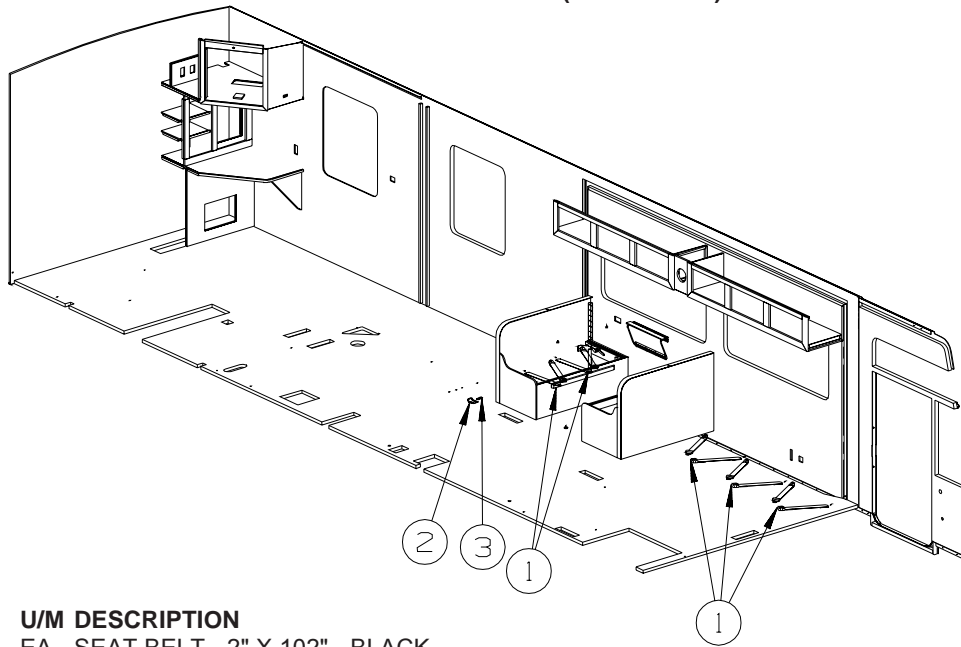

KEY	PART NUMBER	U/M	DESCRIPTION	
1	056271-01-000	EA	SEAT BELT - 2" X 102" - BLACK	FROM: 00-00-00 THRU: 02-14-05
1	007021-01-000	EA	SEAT BELT - 2" X 90" - BLACK	FROM: 02-15-05 THRU: 99-99-99
2	150697-02-02B	EA	BRACKET - RESTRAINT/CHILD - E-COATED	
3	150700-01-02B	EA	PLATE/MOUNTING - RESTRAINT/CHILD - 1" X 2.3" - E-COATED	

**INTERIOR FINISH GROUP (CONTINUED)**  
**COMPONENT PARTS FOR INTERIOR TRIM LAYOUT**

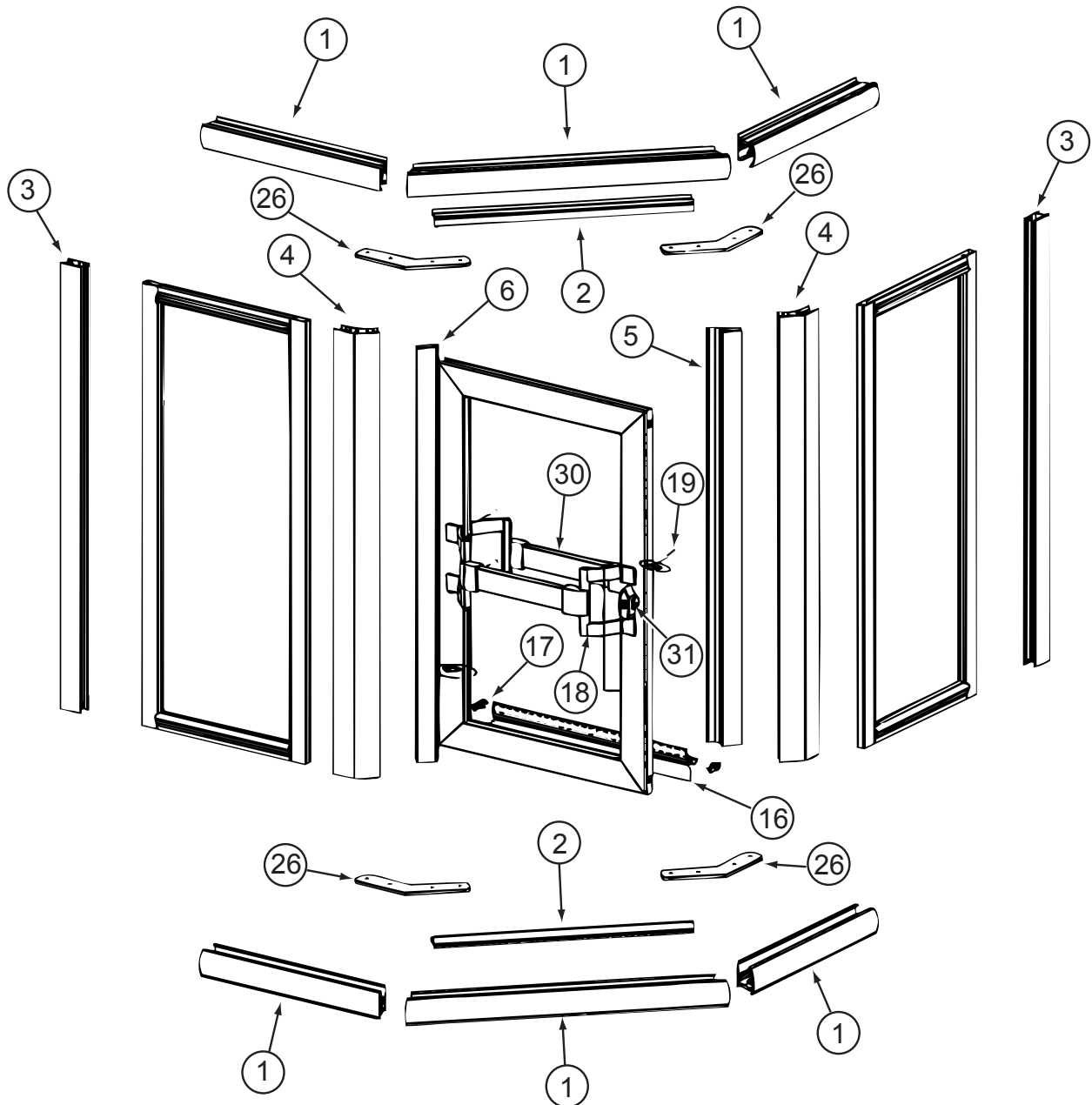

139047-01-01A/02A, 139047-02-01A/02A, 139049-03-01A/02A/03A, 139047-04-02A/03A, 139047-05-01A

KEY	PART NUMBER	U/M	DESCRIPTION	VENDOR NO.
1	139047-01-700	EA	HEADER/SILL - 30" (PAIR)	900
2	139047-01-701	EA	DAM STRIP-TOP/BOTTOM-35.4"	901
3	139047-01-702	EA	JAMB - WALL - 65.9"	903
4	139047-01-703	EA	CORNER POST-45 DEGREE- 65.9"	909
5	139047-01-704	EA	STRIKE - JAMB - 64.6"	926
6	139047-01-705	EA	HINGE/POST - DOOR - 64.5"	920
16	139047-01-710	EA	VINYL SWEEP	C176G
17	139047-01-711	EA	PLUG - DRIP CAP (SET)	CP933
18	092574-01-701	EA	BRACKET-DOOR PULL/TOWEL BAR	8141G
19	092574-01-710	EA	SCREW-GOLD, FOR TOWEL BAR	83212G
26	139047-01-712	EA	HEADER - CORNER BRACKET	313.45C
30	116814-01-700	EA	BAR-TOWEL 17 5/16"	68G
31	089318-01-707	EA	LATCH/CATCH - SAFETY - BLACK	9730N
	139047-01-706	EA	HINGE PINS	CP932
	139047-01-707	EA	WASHERS - HINGE	CP148TW
	139047-01-708	EA	HINGE - SLEEVE - 61.5"	C921B
	139047-01-709	EA	STRIP - MAGNETIC- 55"	98-42
	139047-01-713	EA	RAIL DRIP - 31.6"	927G

CONTACT WINNEBAGO PART SALES FOR UNLISTED COMPONENT(S)

**INTERIOR FINISH GROUP (CONTINUED)**  
**FLOOR COVERINGS**

<b>KEY</b>	<b>PART NUMBER</b>	<b>U/M</b>	<b>DESCRIPTION</b>
	075233-01-000	SY	PAD - CARPET - 3/8" X 6' ROLL
	089275-02-000	FT	STRIP - 3/4" X 84" BLACK POLYETHYLENE
	093486-01-000	SY	CARPET - COMPARTMENT - 72" WIDE - DARK GRAY
	096060-H1-000	SY	CARPET - TAPIOCA - INCREMENTS OF 4 SQ YARDS (S46, S47, S48, SR0) FROM: 00-00-00 THRU: 12-19-04
	152251-06-01A	EA	CARPET - 4 SQUARE YARD INCREMENTS - WHEAT (S46, S47, S48, SR0) FROM: 12-20-04 THRU: 99-99-99
	096060-F0-000	SY	CARPET - PALE SAGE - INCREMENTS OF 4 SQ YARDS (S49, S50, S51, SR1) FROM: 00-00-00 THRU: 11-14-04
	152251-05-01A	SY	CARPET - 4 SQUARE YARD INCREMENTS - SAGE (S49, S50, S51, SR1) FROM: 11-15-04 THRU: 99-99-99
	096060-E6-000	SY	CARPET - OASIS - INCREMENTS OF 4 SQ YARDS (S52, S53, S54, SR2) FROM: 00-00-00 THRU: 11-07-04
	152251-05-03A	SY	CARPET - 4 SQUARE YARD INCREMENTS - CLOUD BURST (S52, S53, S54, SR2) FROM: 11-08-04 THRU: 99-99-99
	042720-31-000	SY	VINYL - FLOOR COVERING - HAMPTON

## INTERIOR FINISH GROUP (CONTINUED)

### HARDWARE

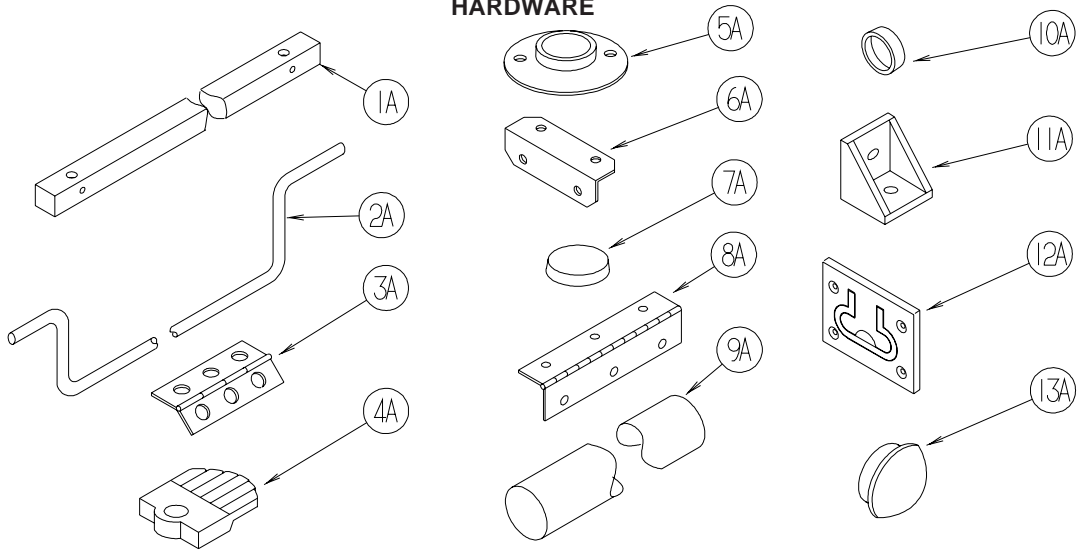

KEY	PART NUMBER	U/M	DESCRIPTION
1A	P34509-01-N01	EA	RAIL END - RH/LH - TOWEL RACK - PORTSMOUTH
1A	P34509-01-P14	EA	RAIL END - RH/LH - TOWEL RACK - CONCERT CHERRY
1A	P34509-01-J70	EA	RAIL END - RH/LH - TOWEL RACK - WASHED MAPLE
1A	P34509-01-RE0	EA	RAIL END - RH/LH - TOWEL RACK - HONEY CHERRY
1A	P34509-01-SA3	EA	RAIL END - RH/LH - TOWEL RACK - SIERRA MAPLE
2A	146801-01-01A	EA	ROD/TOWEL BAR (OFFSET) - BRASS
2A	146801-01-02A	EA	ROD/TOWEL BAR (OFFSET) - PEWTER
3A	009059-01-000	EA	HINGE - DOOR - 2" X 1.4" - BRASS
3A	009059-02-000	EA	HINGE - DOOR - 2" X 2.7" - BRASS
3A	009059-03-000	EA	HINGE - BRASS - 1.75"
3A	009059-04-000	EA	HINGE - 2" - ZINC
4A	009089-01-000	EA	CLIP - MIRROR
5A	009112-01-000	EA	FLANGE - PLASTIC - 1" CLOTHES ROD - OFF WHITE
5A	152301-01-01A	EA	FLANGE - PLASTIC - 1" CLOTHES ROD HOLDER - WHITE
6A	016604-05-000	EA	BRACE - ANGLE - 2 1/2" - OFF WHITE METAL
6A	016604-10-000	EA	BRACE - SEAT ANGLE - 2.5" - BLACK
7A	023320-01-000	EA	PAD - FELT 3/8" DIAMETER
8A	041389-25-000	EA	HINGE - PIANO - 1 1/2" X 55" - UNPAINTED
9A	042438-02-000	EA	DOWEL - WOOD - 2" DIAMETER X 2'
10A	057671-01-000	EA	COVER - SCREW - #8 - OFF WHITE
10A	057671-15-000	EA	COVER - SCREW - #8 - BRIGHT WHITE
10A	057671-16-000	EA	COVER - SCREW - #8 - SOFT WHITE
10A	057671-17-000	EA	COVER - SCREW - VW LT GRAY - #8
11A	065740-01-000	EA	BRACE - CABINET/CORNER - PLASTIC
12A	072871-01-000	EA	PULL - FLUSH - CHROME
13A	074045-08-000	EA	PLUG - OAK - 3/8" DOWEL-1/2" HEAD - CONCERT CHERRY
13A	074045-12-000	EA	PLUG - OAK - 3/8" DOWEL-1/2" HEAD - WASHED MAPLE
13A	074045-13-000	EA	PLUG - OAK - 3/8" DOWEL-1/2" HEAD - PORTSMOUTH OAK
13A	074045-14-000	EA	PLUG - OAK - 3/8" DOWEL-1/2" HEAD - HONEY CHERRY
13A	074045-15-000	EA	PLUG - OAK - 3/8" DOWEL-1/2" HEAD - SIERRA MAPLE

## INTERIOR FINISH GROUP (CONTINUED)

### HARDWARE (CONTINUED)

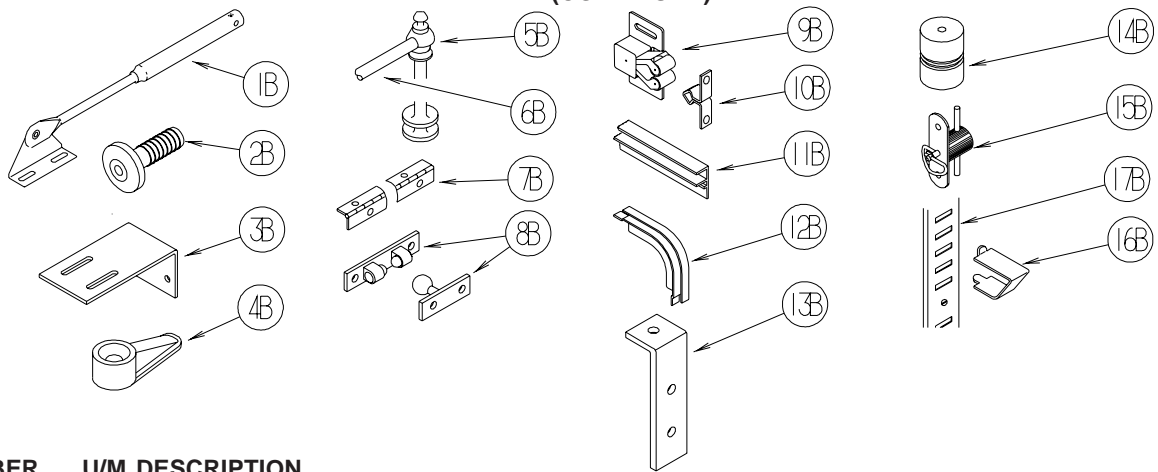

KEY	PART NUMBER	U/M	DESCRIPTION
1B	074493-02-000	EA	SUPPORT - PISTON SPRING - CABINET DOOR - 26 LBS
1B	074493-03-000	EA	SUPPORT - PISTON SPRING - CABINET DOOR - 12 LBS
2B	079921-01-000	EA	ROLLER - NYLON - W/STEEL SHAFT - BARBED
3B	083125-07-000	EA	BRACE - ANGLE/COUCH - 2.5" - OFF WHITE
4B	083204-03-000	EA	BUTTON - RETAINING MIRROR 5/16" TIP
5B	084070-03-000	EA	POST - END - 2.4" - SHINY BRASS
6B	084071-20-000	EA	ROD - BRASS - 9.8"
6B	146840-03-01A	EA	ROD - .25" DIAMETER - BRASS
6B	146840-03-02A	EA	ROD - .25" DIAMETER - PEWTER
6B	146840-04-01A	EA	ROD - .25" DIAMETER - BRASS
6B	146840-04-02A	EA	ROD - .25" DIAMETER - PEWTER
6B	146840-05-01A	EA	ROD - .25" DIAMETER - BRASS
6B	146840-05-02A	EA	ROD - .25" DIAMETER - PEWTER
7B	084413-01-000	EA	HINGE - 1" X 72" - ALUMINUM - W/HOLES
8B	084451-01-000	EA	CATCH & LATCH - 1.7" - BRASS
9B	093586-03-000	EA	CATCH - SPRING ROLLER - .377"
9B	093586-06-000	EA	CATCH - SPRING ROLLER - .236"
10B	093586-04-000	EA	STRIKE - SPRING STEEL - 1.14"
10B	093586-05-000	EA	STRIKE - SPRING STEEL - .943"
11B	093622-01-000	EA	TRACK - DOOR - TAMBOUR - PLASTIC - 8' LENGTHS
12B	093623-01-000	EA	CORNER - TRACK - TAMBOUR DOOR
13B	096826-01-01A	EA	BRACE-CABINET E-COATED
14B	097872-04-000	EA	DOWEL - WOOD - 1" DIAMETER X 1.38" LONG - UNFINISHED
15B	098196-01-000	EA	LATCH - 1/4 TURN - T-BAR
16B	098979-01-000	EA	CLIP - ADJUSTABLE SHELF
17B	098980-01-000	EA	PILASTER - ADJUSTABLE SHELF - 18"
17B	098980-02-000	EA	PILASTER - ADJUSTABLE SHELF - 12"
17B	098980-03-000	EA	PILASTER - ADJUSTABLE SHELF - 9"
17B	098980-04-000	EA	PILASTER - ADJUSTABLE SHELF - 48"
17B	098980-05-000	EA	PILASTER - ADJUSTABLE SHELF - 15"
17B	098980-06-000	EA	PILASTER - ADJUSTABLE SHELF - 24"

**INTERIOR FINISH GROUP (CONTINUED)**  
**HARDWARE (CONTINUED)**

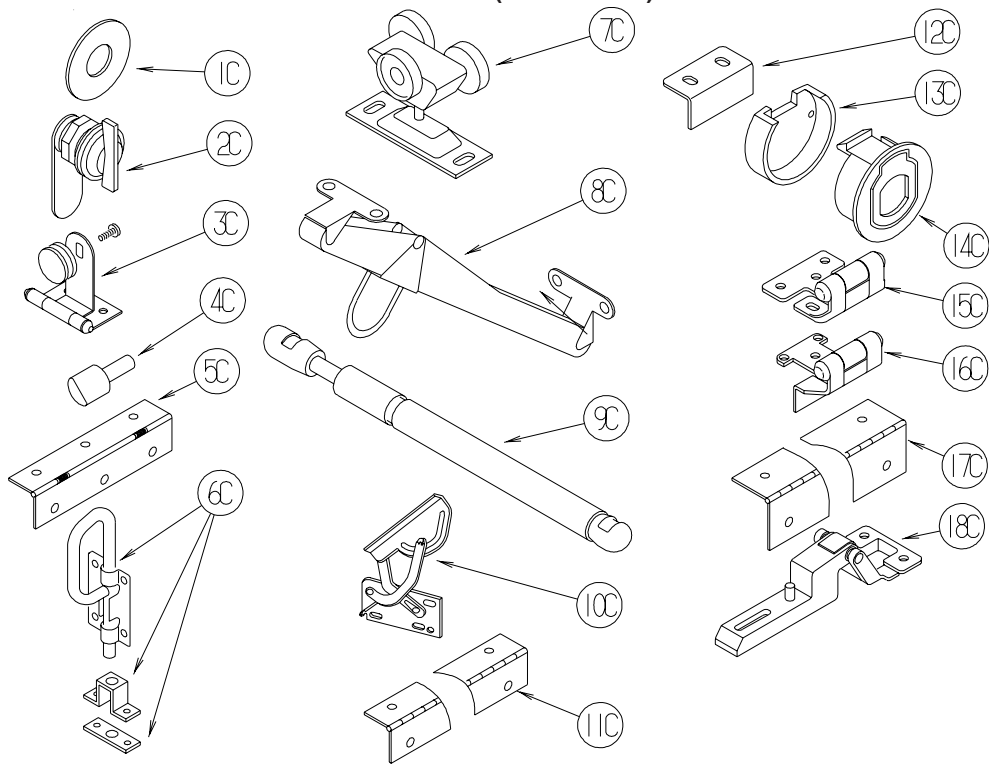

KEY	PART NUMBER	U/M	DESCRIPTION
1C	100707-01-000	EA	SPACER - GLASS DOOR - .8" DIA - .3" HOLE - PLASTIC
2C	100710-01-01A	EA	LOCK - GLASS DOOR/TWIST TYPE - BRASS
3C	100711-01-01A	EA	HINGE - GLASS DOOR
4C	101766-01-000	EA	PIN - SUPPORT/GLASS DOOR
5C	102920-01-01A	EA	HINGE - SPRING LOADED - BRASS
6C	103256-01-000	EA	LATCH COMPLETE (SLIDE)
7C	103874-01-000	EA	HANGER - SLIDING DOOR
8C	104181-01-01A	EA	SUPPORT - LEAF 5.3" EXTENDS TO 7.5" - SAFETY RING - METAL
9C	142569-15-000	EA	SPRING/GAS - 12" COMPRESSED/20" EXTENDED - 120 LB.
9C	142569-16-000	EA	SPRING/GAS - 12" COMPRESSED/20" EXTENDED - 90 LB
10C	108126-01-000	EA	TRAY HINGE SET (QTY. 2 PER SET)
11C	110496-01-01A	EA	HINGE - BRASS
12C	113375-02-01A	EA	STRIKE - DOOR - CHROME
13C	113375-05-01A	EA	LATCH - SLAM - BACK - .8" THICK
14C	113375-06-01A	EA	LATCH - SLAM - FACE - .7" THICK
15C	113676-01-01A	EA	HINGE - OVERLAY - VARIABLE - BURNISHED BRASS
16C	113677-01-01A	EA	HINGE - SELF CLOSING
17C	114278-02-000	EA	HINGE - CONTINUOUS - 3" WIDE
18C	114443-01-01A	EA	HINGE - CABINET DOOR

## INTERIOR FINISH GROUP (CONTINUED)

### HARDWARE (CONTINUED)

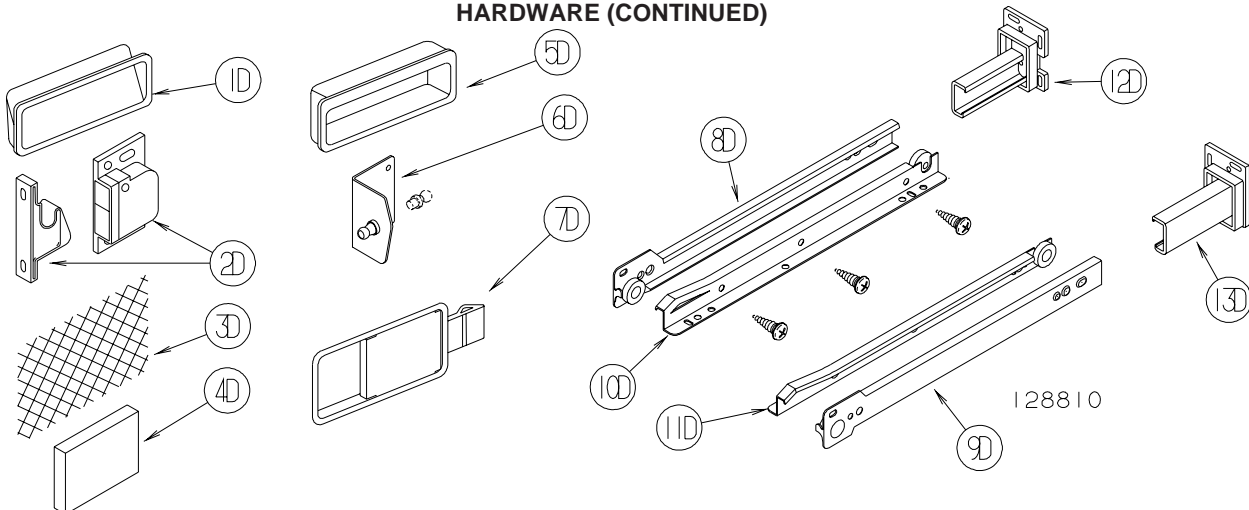

KEY	PART NUMBER	U/M	DESCRIPTION
1D	115994-01-01A	EA	HANDLE - POCKET
2D	117095-01-01A	EA	LATCH - DOOR - GRABBER W/KEEPER - PLASTIC - BLK-5 LB PULL
2D	117095-02-01A	EA	LATCH - DOOR - GRABBER W/KEEPER - PLASTIC - BLK-10 LB PULL
3D	118200-01-01A	SF	MESH - PLASTIC 1/2" - 48" X LENGTH = SF - BLACK
4D	122717-06-01A	FT	PAD - NON-SKID - PSA - 5"W
5D	124311-01-01A	EA	HANDLE - RECESSED - BRASS
6D	126263-06-02B	EA	BRACKET - GAS SPRING W/INSIDE BALL STUD - E-COATED
	057460-02-000	EA	BALL STUD - F/GAS SPRING .39" - 5/16" - 18
6D	126263-08-02B	EA	BRACKET - GAS SPRING W/CENTERED BALL STUD - E-COATED
7D	127349-01-01A	EA	LATCH - PADDLE

**FROM: 00-00-00 THRU: 01-03-05**

8D	128810-01-01A	EA	SLIDE - DRAWER - 12" - LEFT CABINET
8D	128810-05-01A	EA	SLIDE - DRAWER - 14" - LEFT CABINET
8D	128810-09-01A	EA	SLIDE - DRAWER - 16" - LEFT CABINET
8D	128810-13-01A	EA	SLIDE - DRAWER - 18" - LEFT CABINET
8D	128810-17-01A	EA	SLIDE - DRAWER - 20" - LEFT CABINET
8D	128810-21-01A	EA	SLIDE - DRAWER - 22" - LEFT CABINET
8D	128810-25-01A	EA	SLIDE - DRAWER - 24" - LEFT CABINET
9D	128810-02-01A	EA	SLIDE - DRAWER - 12" - RIGHT CABINET
9D	128810-06-01A	EA	SLIDE - DRAWER - 14" - RIGHT CABINET
9D	128810-10-01A	EA	SLIDE - DRAWER - 16" - RIGHT CABINET
9D	128810-14-01A	EA	SLIDE - DRAWER - 18" - RIGHT CABINET
9D	128810-18-01A	EA	SLIDE - DRAWER - 20" - RIGHT CABINET
9D	128810-22-01A	EA	SLIDE - DRAWER - 22" - RIGHT CABINET
9D	128810-26-01A	EA	SLIDE - DRAWER - 24" - RIGHT CABINET
10D	128810-03-01A	EA	SLIDE - DRAWER - 12" - LEFT DRAWER
10D	128810-07-01A	EA	SLIDE - DRAWER - 14" - LEFT DRAWER
10D	128810-11-01A	EA	SLIDE - DRAWER - 16" - LEFT DRAWER
10D	128810-15-01A	EA	SLIDE - DRAWER - 18" - LEFT DRAWER
10D	128810-19-01A	EA	SLIDE - DRAWER - 20" - LEFT DRAWER
10D	128810-23-01A	EA	SLIDE - DRAWER - 22" - LEFT DRAWER
10D	128810-27-01A	EA	SLIDE - DRAWER - 24" - LEFT DRAWER
11D	128810-04-01A	EA	SLIDE - DRAWER - 12" - RIGHT DRAWER
11D	128810-08-01A	EA	SLIDE - DRAWER - 14" - RIGHT DRAWER
11D	128810-12-01A	EA	SLIDE - DRAWER - 16" - RIGHT DRAWER
11D	128810-16-01A	EA	SLIDE - DRAWER - 18" - RIGHT DRAWER
11D	128810-20-01A	EA	SLIDE - DRAWER - 20" - RIGHT DRAWER
11D	128810-24-01A	EA	SLIDE - DRAWER - 22" - RIGHT DRAWER
11D	128810-28-01A	EA	SLIDE - DRAWER - 24" - RIGHT DRAWER
12D	128811-01-02A	EA	BACKSOCKET - ADJUSTABLE - LEFT
13D	128811-02-02A	EA	BACKSOCKET - ADJUSTABLE - RIGHT

**FROM: 01-04-05 THRU: 99-99-99**

153000-01-01A	EA	SLIDE - CABINET MOUNT - 11.8"
153000-02-01A	EA	SLIDE - DRAWER MOUNT - 11.8"
153000-03-01A	EA	SLIDE - CABINET MOUNT - 13.8"
153000-04-01A	EA	SLIDE - DRAWER MOUNT - 13.8"
153000-05-01A	EA	SLIDE - CABINET MOUNT - 15.7"
153000-06-01A	EA	SLIDE - DRAWER MOUNT - 15.7"



# INTERIOR FINISH GROUP (CONTINUED)

## HARDWARE (CONTINUED)

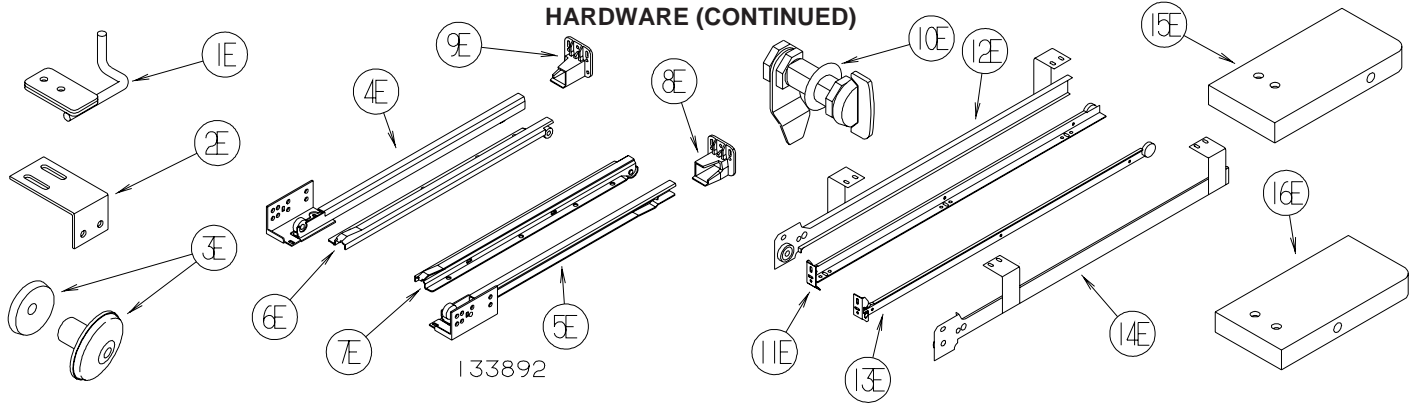

KEY	PART NUMBER	U/M	DESCRIPTION
	153000-07-01A	EA	SLIDE - CABINET MOUNT - 17.7"
	153000-08-01A	EA	SLIDE - DRAWER MOUNT - 17.7"
	153000-09-01A	EA	SLIDE - CABINET MOUNT - 19.7"
	153000-10-01A	EA	SLIDE - DRAWER MOUNT - 19.7"
	153000-11-01A	EA	SLIDE - CABINET MOUNT - 21.6"
	153000-12-01A	EA	SLIDE - DRAWER MOUNT - 21.6"
	153000-14-01A	EA	SLIDE - CABINET MOUNT - 23.6"
	153000-15-01A	EA	SLIDE - DRAWER MOUNT - 23.4"
	153000-16-01A	EA	SLIDE - CABINET MOUNT - 7.9"
	153000-17-01A	EA	SLIDE - DRAWER MOUNT - 7.7"
	153000-18-01A	EA	SLIDE - CABINET MOUNT - 9.8"
	153000-19-01A	EA	SLIDE - DRAWER MOUNT - 9.6"
	153000-13-01A	EA	BACKSOCKET - DRAWER SLIDE

KEY	PART NUMBER	U/M	DESCRIPTION
1E	130798-01-02B	EA	GUIDE - POCKET DOOR - E-COATED
2E	132871-02-02B	EA	BRACKET/L-ANGLE W/HOLES - 1.9" X 2.8" - E-COATED
3E	133313-01-02A	EA	PULL - DOOR/DRAWER - BRIGHT BRASS - MINNIE, MINNIE WINNIE, BRAVE & SPIRIT
3E	133313-01-03A	EA	PULL - DOOR/DWR - CHROME/BRASS - SUNDANCER AND SUNRISE
4E	133892-01-01A	EA	SLIDE - DRAWER - 16" - LEFT CABINET
4E	133892-06-01A	EA	SLIDE - DRAWER - 22" - LEFT CABINET
4E	133892-10-01A	EA	SLIDE - DRAWER - 12" - LEFT CABINET
4E	133892-14-01A	EA	SLIDE - DRAWER - 18" - LEFT CABINET
5E	133892-02-01A	EA	SLIDE - DRAWER - 16" - RIGHT CABINET
5E	133892-07-01A	EA	SLIDE - DRAWER - 22" - RIGHT CABINET
5E	133892-11-01A	EA	SLIDE - DRAWER - 12" - RIGHT CABINET
5E	133892-15-01A	EA	SLIDE - DRAWER - 18" - RIGHT CABINET
6E	133892-03-01A	EA	SLIDE - DRAWER - 16" - LEFT DRAWER
6E	133892-08-01A	EA	SLIDE - DRAWER - 22" - LEFT DRAWER
6E	133892-12-01A	EA	SLIDE - DRAWER - 12" - LEFT DRAWER
6E	133892-16-01A	EA	SLIDE - DRAWER - 18" - LEFT DRAWER
7E	133892-04-01A	EA	SLIDE - DRAWER - 16" - RIGHT DRAWER
7E	133892-09-01A	EA	SLIDE - DRAWER - 22" - RIGHT DRAWER
7E	133892-13-01A	EA	SLIDE - DRAWER - 12" - RIGHT DRAWER
7E	133892-17-01A	EA	SLIDE - DRAWER - 18" - RIGHT DRAWER
8E	133907-01-01A	EA	BACKSOCKET - RIGHT HAND
9E	133907-02-01A	EA	BACKSOCKET - LEFT HAND
10E	135231-01-01A	EA	LATCH - COMPRESSION - BLACK
11E	136944-01-01A	EA	SLIDE - DRAWER/RIGHT HAND - 13.8"
12E	136944-02-01A	EA	SLIDE - CABINET/RIGHT HAND - 13.8"
13E	136944-03-01A	EA	SLIDE - DRAWER/LEFT HAND - 13.8"
14E	136944-04-01A	EA	SLIDE - CABINET/LEFT HAND - 13.8"
15E	137445-01-N42	EA	STOP - F/SLIDING DOOR - PORTSMOUTH OAK
15E	137445-01-P46	EA	STOP - F/SLIDING DOOR - CONCERT CHERRY
15E	137445-01-P56	EA	STOP - F/SLIDING DOOR - WASHED MAPLE
15E	137445-01-S67	EA	STOP - F/SLIDING DOOR - HONEY CHERRY
16E	137445-02-P45	EA	STOP - F/SLIDING DOOR - PORTSMOUTH OAK
16E	137445-02-P46	EA	STOP - F/SLIDING DOOR - CONCERT CHERRY
16E	137445-02-P56	EA	STOP - F/SLIDING DOOR - WASHED MAPLE
16E	137445-02-S67	EA	STOP - F/SLIDING DOOR - HONEY CHERRY

# INTERIOR FINISH GROUP (CONTINUED)

## HARDWARE (CONTINUED)

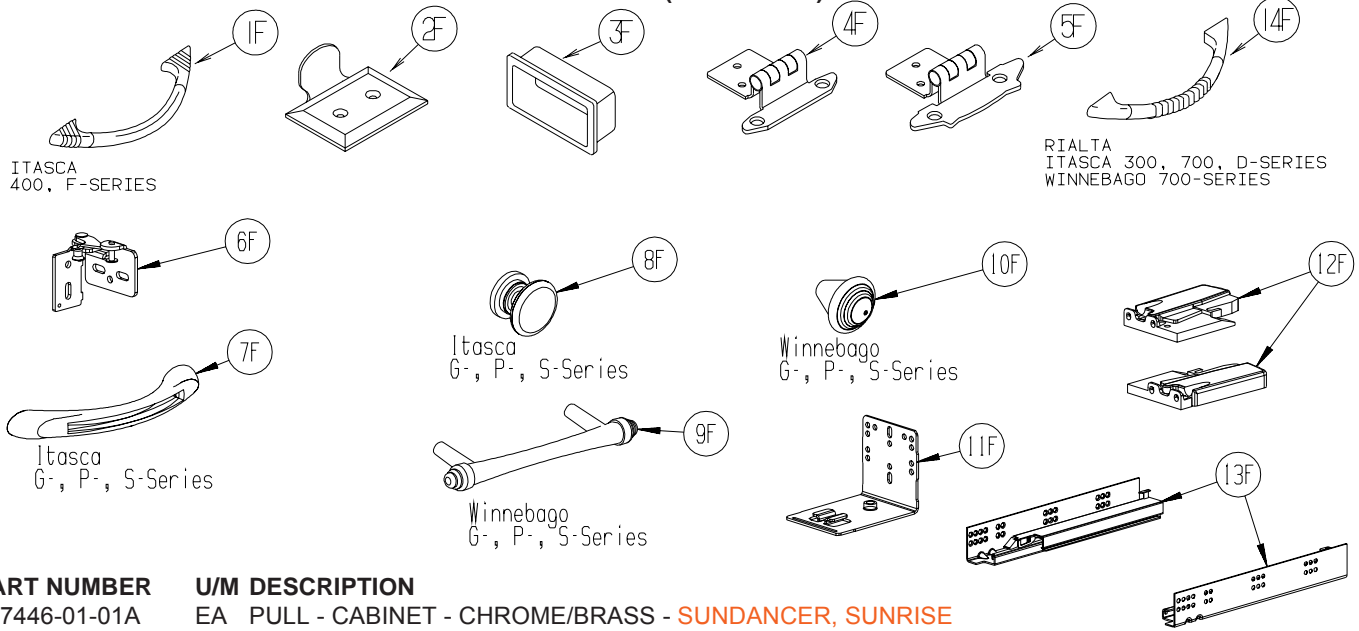

KEY	PART NUMBER	U/M	DESCRIPTION
1F	137446-01-01A	EA	PULL - CABINET - CHROME/BRASS - <b>SUNDANCER, SUNRISE</b>
2F	137463-01-01A	EA	LIFT - HOOK - SATIN BRASS
2F	137463-01-02A	EA	LIFT - HOOK - PEWTER
3F	139136-01-01A	EA	HANDLE - RECESSED .7" - BRASS
3F	139136-02-01A	EA	HANDLE - RECESSED .35" - BRASS
3F	139136-02-02A	EA	HANDLE - RECESSED .35" - PEWTER
4F	143468-01-02A	EA	HINGE - SELF CLOSING - POLISHED BRASS
5F	143468-02-03A	EA	HINGE - SELF CLOSING - SATIN NICKEL
6F	144488-01-02A	EA	HINGE - CABINET - NICKEL - <b>HORIZON</b>
7F	144917-01-01A	EA	PULL - DRAWER - SATIN NICKEL - <b>SUNCRUISER, MERIDIAN, HORIZON</b>
8F	144918-01-01A	EA	PULL - DRAWER/KNOB - SATIN NICKEL - <b>SUNCRUISER, MERIDIAN, HORIZON</b>
9F	145172-01-01A	EA	PULL - CABINET DOOR - BRASS - <b>ADVENTURER, JOURNEY, VECTRA</b>
9F	145172-01-02A	EA	PULL - CABINET DOOR - CHROME - <b>ADVENTURER, JOURNEY, VECTRA</b>
10F	145172-02-01A	EA	KNOB - CABINET DOOR - BRASS - <b>ADVENTURER, JOURNEY, VECTRA</b>
10F	145172-02-02A	EA	KNOB - CABINET DOOR - CHROME - <b>ADVENTURER, JOURNEY, VECTRA</b>
11F	145739-01-000	EA	BRACKET - REAR MOUNT
12F	145739-02-000	EA	LOCKING MECHANISM - LEFT
12F	145739-03-000	EA	LOCKING MECHANISM - RIGHT
13F	145739-04-000	EA	SLIDE - DRAWER - 12"
14F	148816-01-01A	EA	PULL - CABINET DOOR - BRASS - <b>RIALTA, SUNDANCER, SUNOVA</b>
14F	148816-01-02A	EA	PULL - CABINET DOOR - NICKEL - <b>ASPECT, CAMBRIA</b>

**INTERIOR FINISH GROUP (CONTINUED)**  
**HARDWARE (CONTINUED)**

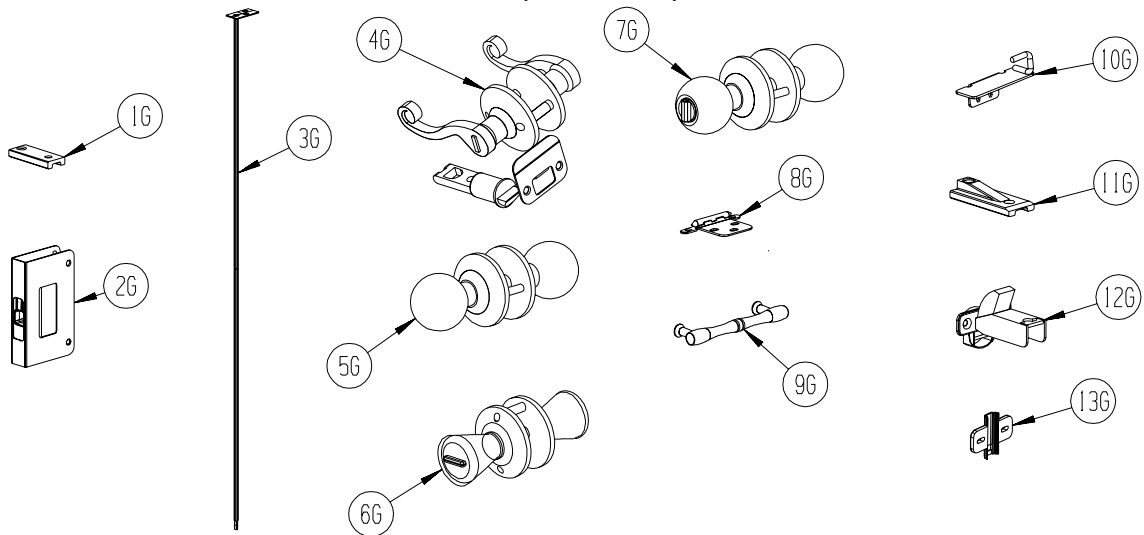

KEY	PART NUMBER	U/M	DESCRIPTION
1G	145815-01-000	EA	BLOCK - DOOR TRACK - 3" X 1.2" - BLACK
2G	145939-01-01A	EA	LATCH - SLIDE - AISLE DOOR(1" THICK DOOR) - BRASS
2G	145939-01-02A	EA	LATCH - SLIDE - AISLE DOOR(1" THICK DOOR) - NICKEL
3G	145939-03-01A	EA	ROD/LATCH - AISLE DOOR - BRASS
3G	145939-03-02A	EA	ROD/LATCH - AISLE DOOR - NICKEL
4G	146064-01-01A	EA	LOCK/PRIVACY (LOCKING) LEVER STYLE - POLISHED BRASS
4G	146064-01-02A	EA	LOCK/PRIVACY (LOCKING) LEVER STYLE - SATIN PEWTER
5G	146064-04-01A	EA	LOCK/PASSAGE (NON LOCKING) KNOB STYLE - POLISHED BRASS
6G	146064-05-01A	EA	LOCK/PRIVACY (LOCKING) KNOB STYLE - SATIN NICKEL
7G	146064-06-01A	EA	LOCK/PASSAGE (NON LOCKING) KNOB STYLE - SATIN NICKEL
8G	146553-01-01A	EA	HINGE - CABINET DOOR - BURNISHED BRASS
8G	146553-01-02A	EA	HINGE - CABINET DOOR - BRIGHT BRASS
8G	146553-01-03A	EA	HINGE - CABINET DOOR - SATIN NICKEL
9G	149090-01-01A	EA	PULL - CABINET DOOR - BRASS - <b>MINNIE, MINNIE WINNIE, BRAVE, SIGHTSEER</b>
10G	149607-01-02B	EA	GUIDE - F/POCKET DOOR - 1.6" BENT ROD - E-COATED
10G	149607-03-02B	EA	GUIDE - F/POCKET DOOR - 2.9" BENT ROD - E-COATED
11G	150983-01-01A	EA	BLOCK - DOOR TRACK - 3" X 1.2" - BLACK
12G	151305-01-01A	EA	HINGE - CONCEALED/SELF CLOSING - BRASS
13G	151305-02-01A	EA	PLATE/MOUNTING - F/HINGE - WHITE

# LABELS GROUP

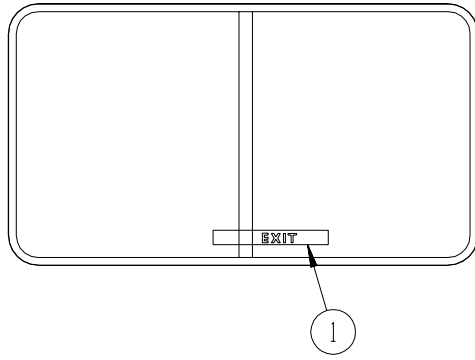

EXIT WINDOW (POP-OUT STYLE)

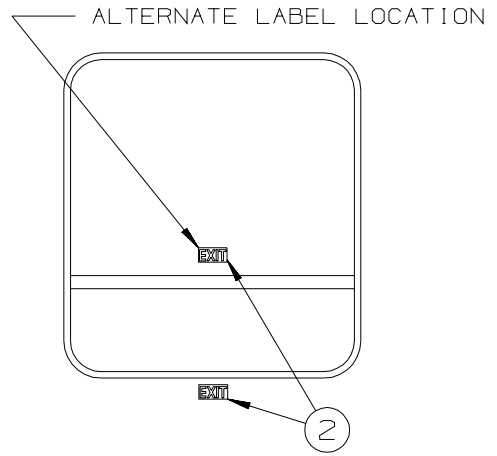

EXIT WINDOW (HINGE STYLE)

KEY	PART NUMBER	U/M DESCRIPTION
1	107571-01-000	EA LABEL - EXIT/ESCAPE WINDOW
2	039290-01-000	EA LABEL - WARNING - EXIT

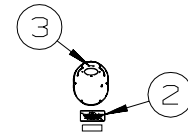

FUEL FILL

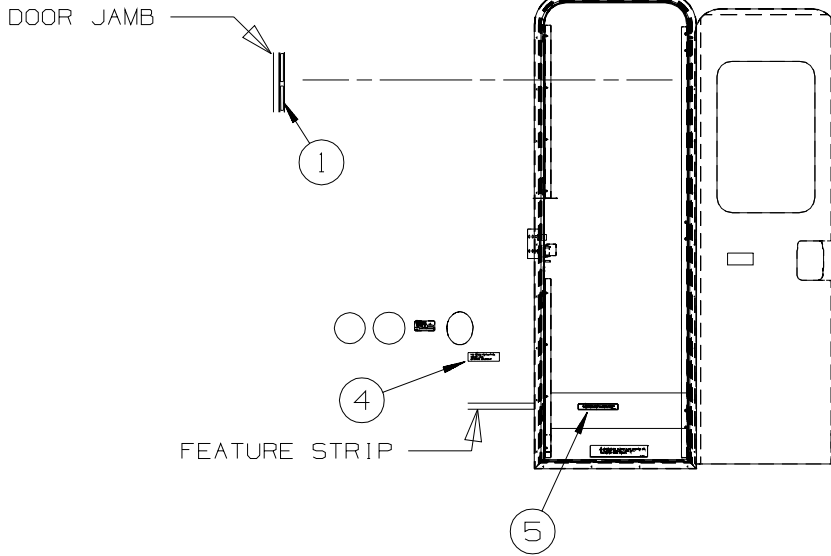

ENTRANCE DOOR

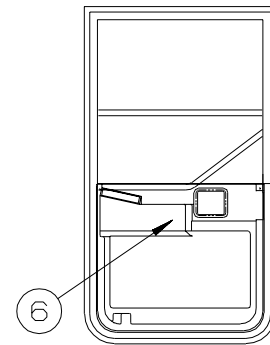

DRIVER'S DOOR

KEY	PART NUMBER	U/M DESCRIPTION
1	135869-01-01A	EA LABEL - MERCURY CONTENT - BLACK ON CLEAR
2	124519-01-02A	EA LABEL - WARNING/REFUELING - WHITE ON CLEAR
2	124519-02-01A	EA LABEL - WARNING/REFUELING - BLACK ON CLEAR - CSA
3	087207-05-000	EA LABEL - FUEL CAP REMOVAL
4	099509-01-000	EA LABEL - AWNING INSTALLATION
5	065748-01-000	EA LABEL - WARNING - BATTERY CHARGING - UL
5	065748-02-000	EA LABEL - WARNING - BATTERY CHARGING - CSA
6	116775-01-000	EA LABEL/CAUTION - TRAVEL LATCH

## LABELS GROUP (CONTINUED)

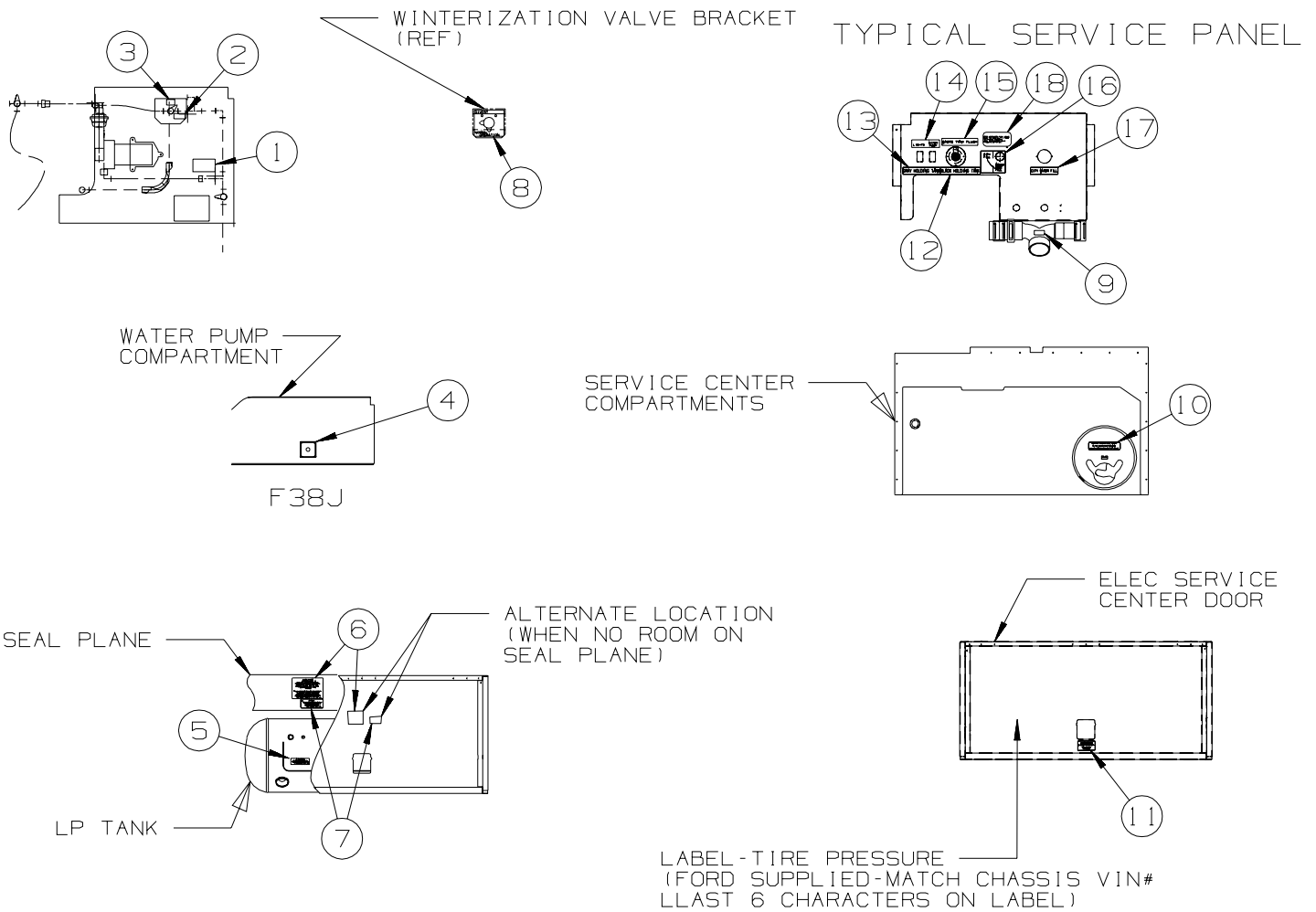

KEY	PART NUMBER	U/M	DESCRIPTION
1	133423-01-01A	EA	LABEL - DRAIN
2	133424-02-01A	EA	LABEL - NORMAL OPERATION
3	133424-03-01A	EA	LABEL - WATER HEATER BYPASS - BLACK/CLEAR
4	127170-01-000	EA	LABEL - WATER TANK DRAIN
5	079965-01-000	EA	LABEL - LPG - 80% CAPACITY
6	023769-01-000	EA	LABEL - WARNING - LPG - CANADIAN
6	124520-01-01A	EA	LABEL - LP GAS ONLY - BLACK ON CLEAR
7	124519-01-02A	EA	LABEL - WARNING/REFUELING - WHITE ON CLEAR
7	124519-02-01A	EA	LABEL - WARNING/REFUELING - BLACK ON CLEAR - CSA
8	137997-01-01A	EA	LABEL - WINTERIZATION VALVE - BLACK/CLEAR
9	144649-01-01A	EA	LABEL - ADJUSTABLE VALVE - WHITE ON CLEAR
10	123562-01-000	EA	LABEL - SERVICE/UTILITY ACCESS
11	125306-01-01A	EA	LABEL - ELECTRICAL ENTRANCE - 110V 30 AMP - BLACK ON CLEAR
11	125306-04-01A	EA	LABEL - ELECTRICAL ENTRANCE - 120/20V 50 AMP-BLACK ON CLEAR
12	126247-06-000	EA	LABEL - BLACK HOLDING TANK-BLACK LETTERS/CLEAR BACKGROUND
13	126247-05-000	EA	LABEL - GRAY HOLDING TANK-BLACK LETTERS/CLEAR BACKGROUND
14	130170-02-000	EA	LABEL - SWITCH PANEL - BLK/CLEAR BACKGROUND- 1.4"H X 3.9"L
15	130168-01-000	EA	LABEL - WASTE TANK FLUSH
16	117629-04-000	EA	LABEL - CITY WATER/TANK FILL
17	126249-03-000	EA	LABEL - CITY WATER FILL-BLK LETTERS/CLEAR BACKGROUND .31"
18	154292-01-000	EA	LABEL - TANK FILL VALVE

## LABELS GROUP (CONTINUED)

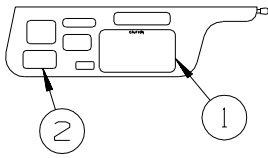

LABELS SHALL BE LOCATED ON OPPOSITE SIDE OF VISOR THAT THE AIR BAG LABEL IS INSTALLED ON.

### 3 TYPICAL SEAT AND BELT CONFIGURATIONS

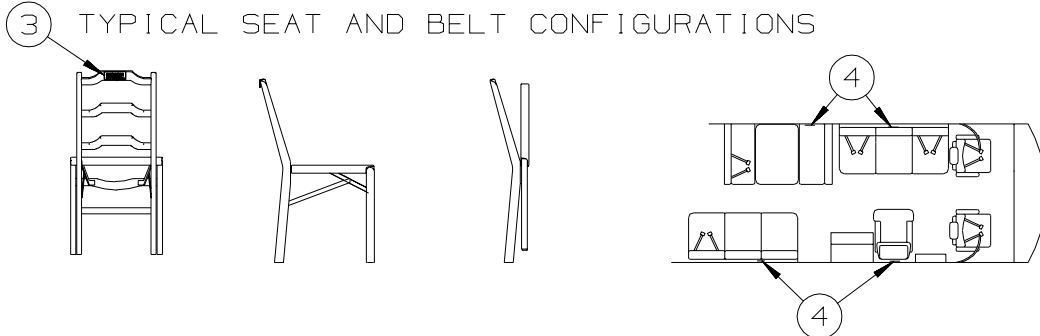

ATTACH LABEL ON OR NEXT TO:  
 +ANY SINGLE CHAIR WITHOUT BELTS.  
 +ANY DINETTE SEAT WITHOUT BELTS.  
 +ANY COUCH WITHOUT BELTS OR ANY SEATING POSITION ON THE  
 DO NOT ATTACH LABEL IF:  
 +DINETTE SEAT HAS AT LEAST ONE SET OF BELTS INSTALLED.

KEY	PART NUMBER	U/M	DESCRIPTION
1	056259-01-000	EA	LABEL - SAFETY CHECK LIST
2	111802-01-000	EA	LABEL - CFC WARNING
3	134537-01-01A	EA	LABEL - OCCUPANCY - CHAIR - US
3	134537-02-01A	EA	LABEL - OCCUPANCY - CHAIR - CSA
4	134538-01-01A	EA	LABEL - OCCUPANCY - NO SEAT BELT - BLACK ON CLEAR - US
4	134538-02-01A	EA	LABEL - OCCUPANCY - NO SEAT BELT - BLACK ON CLEAR - CSA

## LABELS GROUP (CONTINUED)

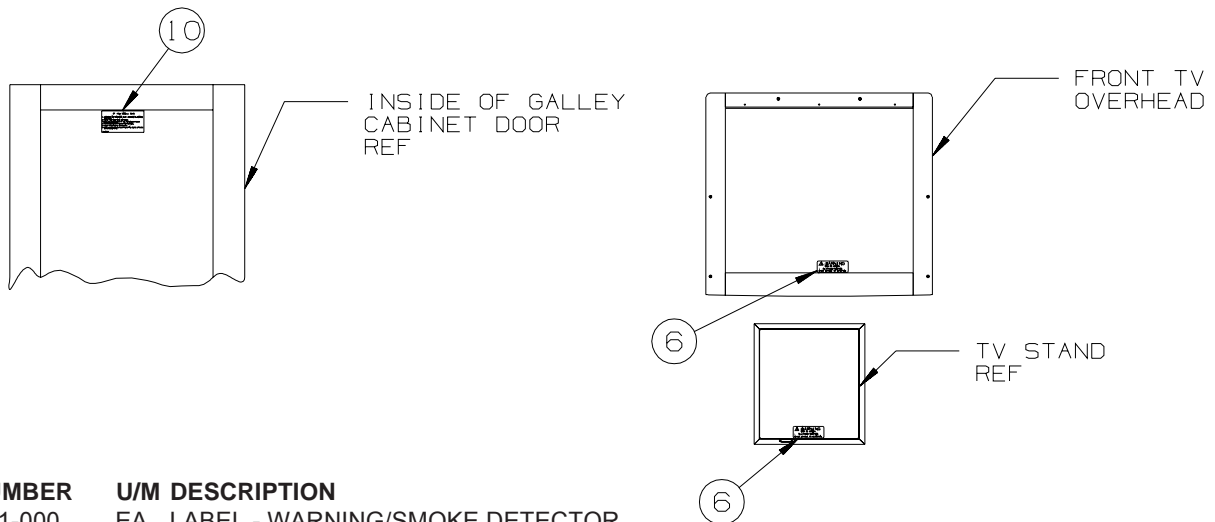
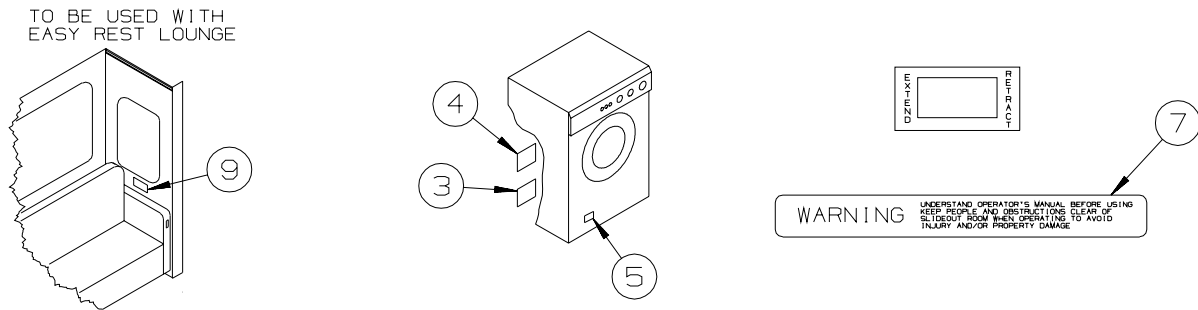
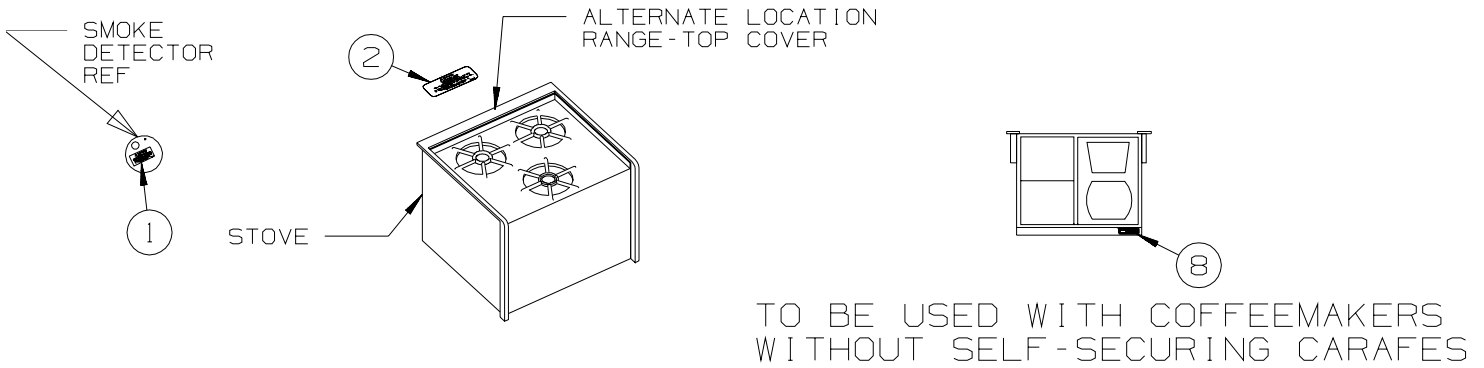

KEY	PART NUMBER	U/M DESCRIPTION
1	077956-01-000	EA LABEL - WARNING/SMOKE DETECTOR
2	134539-01-01A	EA LABEL - WARNING - STOVE/HEATING - US - BLACK ON CLEAR
2	134540-01-01A	EA LABEL - WARNING - STOVE/HEATING - CSA - BLACK ON CLEAR
3	147524-01-000	EA LABEL - DRYER VENTING
4	147525-01-000	EA LABEL - DRYER VENT CUTOUT
5	130670-01-01A	EA LABEL - CAUTION DRYER VENTING - BLACK ON CLEAR
6	079966-01-000	EA LABEL - WARNING - STOWED - MOTION
7	116549-01-000	EA LABEL - WARNING - SLIDEOUT
8	116829-02-000	EA LABEL - COFFEEMAKER
9	137260-01-01A	EA LABEL - WARNING - REST EASY SOFA - BLACK ON CLEAR
10	073998-01-000	EA LABEL - LPG/ODOR WARNING

## LABELS GROUP (CONTINUED)

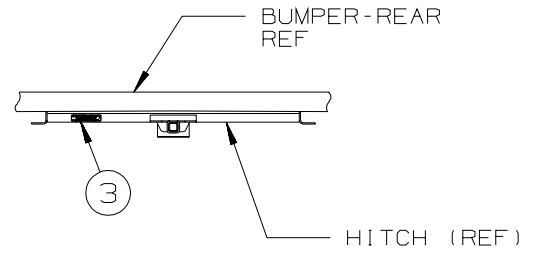
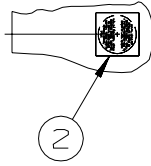
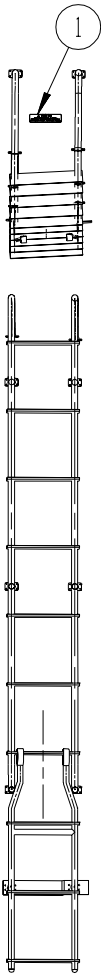

KEY	PART NUMBER	U/M	DESCRIPTION
1	128218-01-01A	EA	LABEL - WARNING - SLIPPERY ROOF
2	120431-01-000	EA	LABEL - LOCATION - COAXIAL CABLE/SATELLITE ANTENNA
3	129669-02-02A	EA	LABEL - HITCH/VEHICLE RATE - 500 - BLACK ON CLEAR



**LP GROUP  
LP SYSTEM**

KEY	PART NUMBER	U/M	DESCRIPTION
	010265-01-000	EA	ELBOW - BRASS - 90 DEGREE - 3/8"F X 1/2"FPT
	010323-01-000	EA	ADAPTER - 3/8"F X 1/2"MPT - BRASS
	010326-01-000	EA	ADAPTER - FLARE - W/CONE GASKET - 3/8"F X 1/2"F
	010329-01-000	EA	ADAPTER - 1/2"F X 1/2"MPT - BRASS
	010377-02-000	EA	NUT - 3/8" FLARE - FORGED - BRASS
	010380-02-000	EA	NUT - 1/2" FLARE - FORGED - BRASS
	010589-01-000	EA	NIPPLE - PIPE - 1/2" X 1 1/2" - BLACK
	024250-01-000	EA	ADAPTER - BRASS - 3/8"F X 1/2"FPT
	040440-03-000	EA	TRANSMITTER - DIAL/SNAP-ON - 0-90 OHM 2 TERM(POWER/GROUND)
	045703-01-000	EA	HOSE - LP - 3/8"ID X 24" - 3/8"MPT X 1/2"F SWIVEL - U.S.
	045703-02-000	EA	HOSE - LP - 3/8"ID X 24" - 3/8"MPT X 1/2"F SWIVEL - CSA
	045703-03-000	EA	HOSE - LP - 3/8"ID X 18" - 3/8"MPT X 1/2"F SWIVEL - US
	045703-12-000	EA	HOSE - LP - 3/8"ID X 18" - 3/8"MPT X 1/2"F SWIVEL - CSA
	045703-15-000	EA	HOSE - LP - 3/8"ID X 142" - 1/2"F SWIVEL X 3/8"F SWIVEL
	045703-25-000	EA	HOSE - LP - 3/8"ID X 177" - 1/2"F SWIVEL X 3/8"M FL US/CSA
	106150-05-000	EA	REGULATOR - TWO STAGE
	144485-01-000	EA	COMPARTMENT - LP REGULATOR
*	144116-01-000	EA	TANK - LP - 100 LB - 14"D X 47"L
*	144116-06-000	EA	TANK - LP - 80 LB - 16"D X 30.75"L - F31W ONLY

\*COMPONENT PARTS LISTED LATER IN THIS GROUP

**COMPONENT PARTS FOR LP SYSTEM  
144116-01-000**

KEY	PART NUMBER	U/M	DESCRIPTION	VENDOR NO.
	040421-01-712	EA	VALVE-SERV. W/O VAPOR RELIEF	29000853
	040421-01-713	EA	VALVE-RELIEF 1" W/SPRING 7"	V-20479
	088253-09-700	EA	SENDING UNIT-F/SNAP ON DIAL	SG14C0001466
	144116-01-700	EA	VALVE-OUTAGE(NO STEM REMOVE)	V20058
	144116-01-701	EA	VALVE/FILL 80 % W/YELLOW CAP	V13414

**144116-02-000, 144116-06-000, 144116-07-000 & 144116-08-000**

KEY	PART NUMBER	U/M	DESCRIPTION	VENDOR NO.
	040421-01-712	EA	VALVE-SERV. W/O VAPOR RELIEF	29000853
	040421-01-713	EA	VALVE-RELIEF 1" W/SPRING 7"	V-20479
	088253-01-702	EA	FLOAT/SCREW IN-SNAP ON DIAL	SG16C0001442
	144116-01-700	EA	VALVE-OUTAGE(NO STEM REMOVE)	V20058
	144116-01-701	EA	VALVE/FILL 80 % W/YELLOW CAP	V13414

**SEALANTS & FASTENERS GROUP**  
**SEALANTS & ADHESIVES**

KEY	PART NUMBER	U/M	DESCRIPTION
	004001-02-000	EA	GUN - PLEXUS ADHESIVE - W/O NOZZLE
	004001-05-000	EA	ADHESIVE - SCOTCH-WELD - 3M DP100 - CLEAR - 50ML
	004001-06-000	EA	FASTWELD PIN TIPS
	004011-01-000	EA	ADHESIVE-3M-4475 TUBE
	010405-02-000	EA	TAPE - THREAD SEALING - 3/8"
	034552-06-000	EA	SILICONE - TUBE - W/O NOZZLE - OFF WHITE
	034552-15-000	EA	SILICONE - TUBE - W/O NOZZLE - BRIGHT WHITE
	063642-01-000	FT	TAPE - ADHESIVE - .4" X 1.5" X 180'
	064075-07-000	FT	SEAL - BULB - W/WIRED U CHANNEL - .3" X .5" CHANNEL-BLACK
	067788-01-000	EA	ADHESIVE - SPRAY - 3M - 19.5 OZ AEROSOL CAN
	069640-01-000	FT	SEALER - TAPE - .25" DIAMETER X 30' - BLACK OR GRAY
	069640-02-000	FT	SEALER - TAPE - .13" THICK X .5" WIDE X 60' - GRAY
	069640-03-000	FT	SEALER - TAPE - .13" THICK X .75" WIDE X 60' - BLACK
	069640-07-000	FT	SEALER - TAPE - .09" THICK X 2" WIDE X 45' - GRAY
	069640-09-000	FT	SEALER - TAPE - .03" THICK X 2.50" WIDE X 80' - GRAY
	069640-10-000	FT	SEALER - TAPE - .03" THICK X 1.50" WIDE X 90' - GRAY
	069640-11-000	FT	SEALER - TAPE - .19" THICK X .38" WIDE X 40' - BLACK
	069640-13-000	FT	SEALER - TAPE - .03" THICK X 2" WIDE X 45' - BLACK
	069640-14-000	FT	SEALER - TAPE - .06" THICK X 1" WIDE X 100' - GRAY
	069640-15-000	FT	SEALER - TAPE - .06" THICK X .38" WIDE X 100' - GRAY
	069640-17-000	FT	SEALER - TAPE - .03" THICK X 1" WIDE X 90' - GRAY
	069640-18-000	FT	SEALER - TAPE - .50" THICK X .13" WIDE X 60' - BRT WHITE
	069640-19-000	FT	SEALER - TAPE - .75" THICK X .13" WIDE X 60' - BRT WHITE
	069640-20-000	FT	SEALER - TAPE - .50" THICK X .5" WIDE X 60' - BLACK
	069640-21-000	FT	SEALER - TAPE - .50" THICK X .06" WIDE X 100' - BRT WHITE
	069640-22-000	FT	SEALER - TAPE - 1/32"THICK X 1/4"WIDE X 200 FT - BRT WHT
	069640-23-000	FT	SEALER - TAPE - 1/16"THICK X 3/4"WIDE X 100 FT - BRT WHT
	069640-27-000	FT	SEALER - TAPE - .06" THICK X 2.25" WIDE - BRIGHT WHITE
	069640-28-000	FT	SEALER - TAPE - .25" THICK X 1.86" WIDE X 90' - GRAY
	069640-30-000	FT	SEALER - TAPE - .03" THICK X .625" WIDE X 50' - GRAY
	069640-31-000	FT	SEALER - TAPE - .25"THICK X .75" WIDE X 15' - BLACK
	069640-32-000	FT	SEALER - RIBBON - 1/16" X 3/8" X 100' - BLACK
	069640-33-000	FT	SEALER - RIBBON - 3/8"DIAMETER X 20' - BLACK
	072889-01-000	EA	SEALANT - URETHANE - BLACK - TUBE W/NOZZLE TIP
	072889-10-000	EA	SEALANT - URETHANE - BRIGHT WHITE - TUBE W/NOZZLE TIP
	072889-27-000	EA	SEALANT - URETHANE - SILVER - 10 OZ TUBE W/NOZZLE TIP
	076322-01-000	FT	TAPE-DOUBLE COATED/ADHESIVE BK-.03"THK X .8"W X 216'- WHT
	076322-02-000	FT	TAPE-DOUBLE COATED/ADHESIVE BK-.05"THK X 1"W X 108' - WHT
	076322-03-000	FT	TAPE-DOUBLE COATED/ADHESIVE BK-.05"THK X .5"W X 108' - WHT
	076322-04-000	FT	TAPE-DOUBLE COATED/ADHESIVE BK-.05"THK X .8"W X 108' - WHT
	076322-05-000	FT	TAPE-DOUBLE COATED/ADHESIVE BK-.05"THK X .8"W X 108' - WHT
	076322-07-000	FT	TAPE-DOUBLE COATED/ADHESIVE BK-.05"THK X .5"W X 200' - BLK
	076322-11-000	FT	TAPE-DOUBLE COATED/ADHESIVE BK-.02"THK X 1"W X 216' - CLR
	076322-21-000	FT	TAPE - FOAM/DOUBLE COATED - .5"
	076322-22-000	FT	TAPE - FOAM/DOUBLE COATED - .045" X .75"
	076322-23-000	FT	TAPE - FOAM/DOUBLE COATED - .045" X 1"
	076322-24-000	FT	TAPE - FOAM/DOUBLE COATED - .025" X 1"
	076322-25-000	FT	TAPE - FOAM/DOUBLE COATED - .025" X .5"
	076813-02-000	FT	SEAL-D BULB, .5" X .7" - MEDIUM SPONGE RUBBER - BLACK
	086276-01-000	EA	TAPE - DOUBLE SIDED - 1/2" WIDE X 108' LONG (SOLD BY ROLL)
	088479-01-000	EA	TAPE - ALUMINUM - 3"
	090340-01-000	FT	SEAL - FOAM - CLOSED CELL - 1/4" X 1/2" X 50'
	091255-02-000	FT	SEAL - ADHESIVE BACKED/FOAM - 3/64" THICK X 3/16"W X 1000'
	091255-03-000	FT	SEAL - ADHESIVE BACKED/FOAM - 1/4" THICK X 1/4"W X 1000'
	094401-01-000	EA	SEALER - BODY SEAM - FLEXICLEAR
	094401-03-000	EA	SEALER - BODY SEAM - BLACK
	094401-04-000	EA	SEALER - BODY SEAM - CLEAR
	094401-05-000	EA	SEALER - BODY SEAM - 20OZ BLACK
	094401-06-000	EA	SEALER - BODY SEAM - 12OZ BLACK
	098408-01-000	FT	SEAL - SPONGE RUBBER - CLOSED CELL
	099069-01-000	FT	SEAL - RUBBER - CLOSED SPONGE - .5" WIDE X .12" THICK -BLK
	099418-01-000	FT	SEAL - D-SECTION/ADHESIVE BACK - .44" X .44"- BLK RUBBER
	099418-02-000	FT	SEAL - D-SECTION/ADHESIVE BACK - .44" X .44"- WHITE RUBBER
	100128-02-000	FT	SEAL - FOAM/ADHESIVE BACK - .37" WIDE X .37" THICK

## SEALANTS & FASTENERS GROUP (CONTINUED)

### SEALANTS & ADHESIVES (CONTINUED)

KEY	PART NUMBER	U/M	DESCRIPTION
	104692-01-000	FT	SEAL - ADHESIVE BACKED FOAM - 3/4" THICK X 3/4" WIDE X 25'
	104692-03-000	FT	SEAL - ADHESIVE BACKED FOAM - 1" THICK X 1 3/16"WIDE X 15'
	107828-01-000	EA	SEALANT - SB - 190 EVERSEAL
	109506-01-000	EA	FILM - URETHANE - PROTECTANT - 4.25" X 26.75"
	109506-12-000	EA	FILM/ABRASION-RESISTANT - TRANSPARENT - 1" DIA.
	109506-13-000	EA	FILM/ABRASION-RESISTANT - TRANSPARENT - 1" DIA.
	110274-01-000	FT	TAPE - DOUBLE SIDED/FOAM - .45" X 1" X 216' - BLACK
	112481-02-000	EA	ADHESIVE - PLEXUS ETHACRYLATE - CARTRIDGE
	112864-01-000	FT	SEAL - FOAM/BUTYL COVERED - 3/8" X 35'
	112864-02-000	FT	FOAM - BUTYL COVERED - 5/16" X 44'
	112864-04-000	FT	FOAM - BUTYL COVERED - 3/8" X 1/8"
	112901-02-000	EA	ADHESIVE - PLEXUS - MA330 - 50ML - GRAY
	112901-03-000	EA	ADHESIVE - PLEXUS - MA300 - 50ML - WHITE
	112902-01-000	EA	NOZZLE - ELEMENT - 3/8 X 24
	112902-03-000	EA	MIXER NOZZLE - F/GUN #00400102000 - SCOTCH-WELD & PLEXUS
	112902-04-000	EA	NOZZLE - ELEMENT - 1/4" X 3.5"
	113366-01-000	EA	ADHESIVE - INSTANT - 1 OZ
	113452-02-000	FT	SEAL/TRIM - FRONT - VINYL W/WIRE CARRIER - .027"
	115933-01-000	FT	TAPE - 1/64" X 3/8" X 100'
	120074-02-03A	EA	SILICONE - TUBE - W/O NOZZLE - LOW ODOR - SMOKEY WHITE
	120074-02-02A	EA	SILICONE - TUBE - W/O NOZZLE - LOW ODOR - SOFT WHITE
	120534-01-01A	EA	TAPE - SCOTCH - 3M - 1/2" FINE LINE
	123244-01-000	FT	TAPE - DOUBLE SIDED/FOAM - 5/64" THICK X 3/4" WIDE X 108'
	123816-01-000	FT	TAPE - DOUBLE SIDED - 1" X 3/4" X 200'
	123816-02-000	FT	TAPE - DOUBLE SIDED - 1/2" X 1 1/3" X 200'
	123816-03-000	FT	TAPE - DOUBLE SIDED - 1/2" X 3/4" X 200'
	123816-04-000	FT	TAPE - DOUBLE SIDED - 6" X 750'
	126427-01-000	EA	ADHESIVE - ALL PURPOSE - ABS/PVC
	126427-02-000	EA	PRIMER - CLEANER - FLEX PIPING
	131264-01-02A	EA	SILICONE - TUBE - W/O NOZZLE - CLEAR
	131264-01-01A	EA	SILICONE - TUBE - W/O NOZZLE - BLACK
	131264-02-01A	EA	SILICONE - TUBE - W/O NOZZLE - VW GRAY - BATH ONLY
	131264-03-01A	EA	SILICONE - TUBE - W/O NOZZLE- SELF LEVELING - BRIGHT WHITE
	131264-04-01A	EA	SILICONE/SEALANT/ADHESIVE - FAST CURE F/GLASS/VINYL - B/W
	131264-05-01A	EA	SILICONE/SEALANT - ODORLESS - TUBE - W/NOZZLE - BLACK
	131264-05-02A	EA	SILICONE/SEALANT - ODORLESS - TUBE - W/NOZZLE - CLEAR
	131384-01-000	EA	ADHESIVE - JET WELD
	134651-01-000	FT	SEAL - 1/2" X 3/4" PSA 1 SIDE
	900390-01-000	EA	NOZZLE - SILICONE TUBE - 2.5" LONG - W/EXTERNAL THREADS
	900390-03-000	EA	NOZZLE - SILICONE TUBE - 4.3" LONG W/INTERNAL THREADS
	900563-17-000	EA	TAPE - 2 SIDED, 2" X 36 YDS

### BOLTS, NUTS AND WASHERS

KEY	PART NUMBER	U/M	DESCRIPTION
	OMC05K-08-055	EA	BOLT - HEX - M08 X 1.25 X 2.2
	OMD16K-10-000	EA	NUT - HEX PREV TORQUE M10 X 1 1/2 CLASS 8
	OMD39K-12-000	EA	NUT - HEX W/NYLON LOCK - M12 X 1 3/4
	OMD40K-14-000	EA	NUT - HEX W/NYLON LOCK - M14 X 2
	OMD54F-06-000	EA	NUT-HEX SER FLG M6X1,0 SS - DIN6923A2M6
	OME06K-14-280	EA	WASHER - FLAT - 14 ID X 28 OD
	000C12-04-08B	EA	BOLT - HEX - 1/4-20 X 1/2 - GRADE #5 - ZINC
	000C12-04-12A	EA	BOLT - HEX - 1/4-20 X 3/4 - PLAIN 5
	000C12-04-40B	EA	BOLT - HEX - 1/4-20 X 2 1/2 - GRADE #5 ZINC
	000C12-05-16B	EA	BOLT - HEX - 5/16 - 18X1 - GRADE #5 - ZINC
	000C12-05-40B	EA	BOLT - HEX - 5/16"-18 X 2.5" - GRADE #5 - ZINC
	000C12-06-44B	EA	BOLT - HEX - 3/8-16 X 2 3/4 - GRADE 5 - ZINC
	000C12-06-16B	EA	BOLT - HEX - 3/8 - 16X1 - GRADE #5 - ZINC
	000C12-08-28B	EA	BOLT - HEX - 1/2-13 X 1 3/4 - GRADE #5 - ZINC
	000C12-08-24B	EA	BOLT - HEX - 1/2 - 13X1 1/2 - GRADE #5 - ZINC
	000C12-08-16B	EA	BOLT - HEX - 1/2-13 X 1 - GRADE #5 - ZINC
	000C12-10-24B	EA	BOLT - HEX - 5/8 - 11X1 1/2 - GRADE #5 - ZINC
	000C13-07-48B	EA	BOLT - HEX - 7/16-20 X 3 - GRADE #5 - ZINC
	000C13-07-40B	EA	BOLT - HEX - 7/16-20 X 2 1/2 - GRADE #5 - ZINC
	000C14-07-28B	EA	BOLT - HEX - 7/16-14 X 1 3/4 - GRADE #8 - ZINC

**SEALANTS & FASTENERS GROUP (CONTINUED)**  
**BOLTS, NUTS AND WASHERS (CONTINUED)**

KEY	PART NUMBER	U/M	DESCRIPTION
	000C14-10-32K	EA	BOLT - HEX - 5/8-11 X 2 - GRADE #8 - ZINC
	000C16-07-16B	EA	BOLT - CARRIAGE - ASSIST HANDLE - 7/16-14 X 1
	000C18-05-40A	EA	BOLT - ELEVATOR - 5/16-18 X 2 1/2 - PL
	000C26-04-10B	EA	BOLT - HEX - SERRATED FLANGE - 1/4-20 X 5/8 - ZINC
	000C26-04-18B	EA	BOLT - HEX - SERRATED FLANGE - 1/4-20 X 1 1/8 - ZINC
	000C26-04-14B	EA	BOLT - HEX - SERRATED FLANGE - 1/4-20 X 7/8 - ZINC
	000C26-05-20B	EA	BOLT - HEX - SERRATED FLANGE - 5/16-18 X 1 1/4 - ZINC
	000C26-05-12B	EA	BOLT - HEX - SERRATED FLANGE - 5/16-18 X 3/4 - ZINC
	000C26-06-40B	EA	BOLT - HEX - SERRATED FLANGE - 3/8-16 X 2 1/2 - ZINC
	000C26-06-28B	EA	BOLT - HEX - SERRATED FLANGE - 3/8-16 X 1 3/4 - ZINC
	000C26-06-20B	EA	BOLT - HEX - SERRATED FLANGE - 3/8-16 X 1 1/4 - ZINC
	000C26-06-12B	EA	BOLT - HEX - SERRATED FLANGE - 3/8-16 X 3/4 - ZINC
	000C26-08-24B	EA	BOLT - HEX - SERRATED FLANGE - 1/2-13 X 1 1/2 - ZINC
	000C27-04-40B	EA	BOLT - CARRIAGE - 1/4-20 X 2 1/2 - ZINC
	000C27-07-40B	EA	BOLT - CARRIAGE - 7/16-14 X 2 1/2 - GRADE #5
	000C27-08-48B	EA	BOLT - CARRIAGE - 1/2-13 X 3 - GRADE #5
	000D16-07-00B	EA	NUT - HEX - 7/16-14 - ZINC
	000D20-07-00B	EA	NUT - ACORN - ASSIST HANDLE - 7/16 - 14
	000D23-04-00B	EA	NUT - HEX SF/LK #4-40
	000D24-10-00B	EA	NUT - HEX - SELF LOCKING - 10-32 - ZINC
	000D25-06-00B	EA	NUT-3/8" W/BURR - FASTENER HOUSE
	000D28-10-00B	EA	NUT - HEX - W/NYLON LOCK - 10-32 ZINC
	000D29-04-00B	EA	NUT - HEX - SELF LOCKING - 1/4 X 20 - ZINC
	000D29-06-00B	EA	NUT - HEX - W/NYLON LOCK - 3/8-16 - ZINC
	000D29-09-00B	EA	NUT - HEX - SELF LOCKING - 9/16-12 - ZINC
	000D30-07-00B	EA	NUT - HEX LOCK - NYLON 7/16 X 20
	000D34-04-00B	EA	NUT - HEX - LOCKING - 1/4-20 - ZINC
	000D34-06-00B	EA	NUT - HEX - LOCKING - 3/8-16 GRADE C - ZINC
	000D39-04-00B	EA	NUT - HEX - LOCKING W/SERRATED FLANGE - 1/4-20 - ZINC
	000D39-05-00B	EA	NUT - HEX - LOCKING W/SERRATED FLANGE - 5/16-18 - ZINC
	000D39-06-00B	EA	NUT - HEX - LOCKING W/SERRATED FLANGE - 3/8-18 - ZINC
	000D39-07-00B	EA	NUT - HEX - LOCKING W/SERRATED FLANGE - 7/16-14 - ZINC
	000D39-08-00B	EA	NUT - HEX - LOCKING W/SERRATED FLANGE - 1/2-13 - ZINC
	000D44-04-00B	EA	NUT - HEX - LOCKING W/SERRATED FLANGE - 1/4-28 - ZINC
	000D44-07-00B	EA	NUT - HEX - LOCKING W/SERRATED FLANGE - 7/16-20 - ZINC
	000D44-08-00B	EA	NUT - HEX - LOCKING W/SERRATED FLANGE - 1/2-20 - ZINC
	000D46-04-00A	EA	NUT - HEX - WELD - 1/4-20 - PLAIN
	000D58-06-00A	EA	NUT - HEX - WELD 3/8-16 - PLAIN
	000D65-08-00B	EA	NUT - HEX - LOCKING W/SERRATED FLANGE - 8-32 - ZINC
	000D67-10-00B	EA	NUT - HEX - LOCK - 5/8-11 - ZINC
	000D73-08-00C	EA	NUT - HEX FLANGE - 1/2-13
	000D75-09-00B	EA	NUT - HEX LOCKING - 9/16-12 - ZINC
	000D76-06-00B	EA	NUT - HEX FLANGE - 3/8-16
	000E11-04-00F	EA	WASHER - LOCKING - 1/4 MED SPLIT - STAINLESS STEEL
	000E11-07-00B	EA	WASHER - LOCKING - 7/16 MED SPLIT - ZINC
	000E11-08-00B	EA	WASHER - LOCKING - 1/2 MED SPLIT - ZINC
	000E13-17-00B	EA	WASHER - FLAT - 3/8 AR - ZINC
	000E13-18-00B	EA	WASHER - FLAT - 3/8 WIDE - ZINC
	000E13-20-00B	EA	WASHER - FLAT - 7/16 WIDE - ZINC
	000E13-22-00B	EA	WASHER - FLAT - 1/2 WIDE - ZINC
	000E13-26-00B	EA	WASHER - FLAT - 5/8 WIDE - ZINC
	000E14-10-00B	EA	WASHER - LOCKING - #10 EXTERNAL TOOTH - ZINC
	000E16-10-00B	EA	WASHER - HARDENED - 5/8 - FLAT - ZINC
	000G45-05-16B	EA	BOLT - LAG - 5/16-9 X 1 - ZINC
	002329-01-000	EA	WASHER-FLAT, 9/32" ID X 5/8" OD - NYLON
	005081-01-000	EA	NUT - SPEED - C-TYPE - #8 SCREW
	040921-01-000	EA	NUT - SPEED - U TYPE - #10-24 - BLACK
	040921-03-000	EA	NUT - SPEED - U TYPE - #10
	040921-04-000	EA	NUT - SPEED - U TYPE - #8-.59" LENGTH X .44" WIDTH
	040921-05-000	EA	NUT - SPEED - U-TYPE - 8-.67" X .44" WIDE
	041322-01-000	EA	WASHER - FLANGE - 15/32 ID X 2 3/8 OD - F/SEAT BELT MTG
	044364-02-000	EA	NUT - SPEED - FLAT - ROUND
	044533-01-000	EA	WASHER - 1 3/8"OD - FOR BUTTONS - PLASTIC
	051387-06-000	EA	BOLT - CARRIAGE W/O HOLE - 5/16-18 X 9 1/2 - ZINC

**SEALANTS & FASTENERS GROUP (CONTINUED)**  
**BOLTS, NUTS AND WASHERS (CONTINUED)**

KEY	PART NUMBER	U/M	DESCRIPTION
	058716-02-000	EA	WASHER - FLAT NYLON
	064081-03-000	EA	NUT - WING 3/8-16 - W/WELD NUT
	077071-01-000	EA	WASHER - FENDER - 3/16"ID X 1"OD
	084406-01-000	EA	NUT - CAPPED - CROSS RECESSED - BLACK - 1/4-20 THD
	087234-01-000	EA	NUT - JACK - 1/4 X 20 THD - MOLLY
	087718-01-000	EA	MONOBOLT - STEEL - 3/16 DIAMETER
	088787-12-000	EA	STUD - WELD - 1/4 - 20 X 1.0 LG - MN
	102333-01-06A	EA	BOLT - CARRIAGE - 7/16-14 STAINLESS STEEL CAP
	103020-02-000	EA	BOLT-U - #8-32 - GRADE 5 ZINC
	106956-03-000	EA	BOLT - HEX TAP - 1/2-12NC X 3 - GRADE 5 - FULL THREAD/ZINC
	107397-01-000	EA	WASHER - FENDER - 3/4"ID X 1"OD
	108067-03-000	EA	STUD - WELD - 1/4 - 20 X 1/2 CD
	109917-01-000	EA	WASHER - 1.5" X 1.25"
	109917-03-000	EA	WASHER - 1" X .50"
	109917-04-000	EA	WASHER - 1" X .75"
	110794-01-000	EA	WASHER - FLAT - 1"ID X 1 3/4"OD
	113985-02-000	EA	BOLT - FLANGE - M10-1 1/2 X 30CL 10.9
	114259-05-000	EA	BOLT - 7/16-20 X 1 1/4 W/WASHER
	128444-01-000	EA	WASHER - SPRING - CONICAL
	131377-01-000	EA	NUT-HEX HEAD W/WASHER-1/4-20 X 2" STEEL W/3/4" OD WASHER
	135092-02-01A	EA	BOLT - HEX - SERRATED FLANGE - 1/2-20 X 2 1/2-GRADE 5 ZINC
	143399-01-01A	EA	NUT/RETAINING - 3/8"- 24 NFT
	144904-01-01A	EA	BOLT - ADJUSTMENT - HEADLAMP
	147284-01-000	EA	NUT/SELF RETAINING - 3/8"-16
	147284-02-000	EA	NUT/SELF RETAINING - 5/16"-18
	148817-01-000	EA	WASHER/SPUR - LOCKING

**SCREWS**

KEY	PART NUMBER	U/M	DESCRIPTION
	0G1106-06-160	EA	SCREW - 6-20 X 3/8 PPH
	0G1106-08-240	EA	SCREW - 6-20 X 1/2 PPH - VW LIGHT GRAY
	0G1208-12-170	EA	SCREW - 8-18 X 3/4 POH - BRIGHT WHITE
	0G3804-22-180	EA	SCREW - MACHINE - 1/4-20 X 1 3/8 PFH - BLACK
	0G3908-08-170	EA	SCREW - SF/DR - 8-18 X 1/2 PPH - BRIGHT WHITE
	0G3908-08-160	EA	SCREW - SF/DR - 8-18 X 1/2 PPH - VW WHITE
	0G3908-12-250	EA	SCREW - SF/DR - 8-18 X 3/4 PPH - DARK GRAY
	0G3908-16-170	EA	SCREW - SF/DR - 8-18 X 1 PPH - BRIGHT WHITE
	0G3908-24-170	EA	SCREW - SF/DR - 8-18 X 1 1/2 PPH - BRIGHT WHITE
	0G3910-10-330	EA	SCREW - SF/DR - 20-16 X 5/8 PPH - PUTTY
	0G3910-10-320	EA	SCREW - SF/DR - 10-16 X 5/8 PPH - GLACIER
	0G3910-12-240	EA	SCREW - SF/DR - 10-16 X .75 PPH - VW LIGHT GRAY
	0G3910-12-170	EA	SCREW - SF/DR - 10-16 X 3/4 PPH - BRIGHT WHITE
	0G3910-12-320	EA	SCREW - SF/DR - 10-16 X 3/4 PPH - GLACIER
	0G5508-08-380	EA	SCREW - SF/DR - 8-18 X .5 PWH - CASHMERE
	0G5508-08-370	EA	SCREW - SF/DR - 8-18 X .5 PWH - RIVERSTONE
	0G5508-12-240	EA	SCREW - SF/DR - 8-18 X 3/4 PWH - VW LIGHT GRAY
	0G5508-12-170	EA	SCREW - SF/DR - 8-18 X 3/4 PWH - BRIGHT WHITE
	0G5508-12-330	EA	SCREW - SF/DR - 8-18 X 3/4 PWH - PUTTY
	0G5508-12-320	EA	SCREW - SF/DR - 8-18 X 3/4 PWH - GLACIER
	0G5508-12-270	EA	SCREW - SF/DR - 8-18 X 3/4 PWH - TITANIUM
	0G5508-16-250	EA	SCREW - SF/DR - 8-18 X 1 PWH - VW DARK GRAY
	0G5508-16-320	EA	SCREW - SF/DR - 8-18 X 1 PWH - GLACIER
	0G6008-16-170	EA	SCREW - SF/DR - 8-18 X 1 POH - BRIGHT WHITE
	0G6710-08-130	EA	SCREW - 10-12 X 1/2 PPH - TAUPE
	0G6710-08-170	EA	SCREW - 10-12 X 1/2 PPH - BRIGHT WHITE
	0G6710-08-240	EA	SCREW - 10-12 X 1/2 PPH - VW LIGHT GRAY
	0G6710-12-170	EA	SCREW - 10-12 X 3/4 PPH - BRIGHT WHITE
	0G6806-16-170	EA	SCREW - 6-18 X 1 POH - BRIGHT WHITE
	0G6810-24-280	EA	SCREW - 10-12 X 1 1/2 POH - SOFT WHITE
	000C20-05-28F	EA	SCREW - 5/16-18 X 1 3/4 FLAT SOC - STAINLESS STEEL
	000C20-06-24T	EA	SCREW - 3/8-16 X 1 1/2 - FLAT SOCKET
	000G11-06-10J	EA	SCREW - 6-20 X 5/8 PPH - BRASS

**SEALANTS & FASTENERS GROUP (CONTINUED)**  
**SCREWS (CONTINUED)**

KEY	PART NUMBER	U/M	DESCRIPTION
	000G11-06-08B	EA	SCREW - 6-20 X 1/2 PPH - ZINC
	000G11-06-10B	EA	SCREW - 6-20 X 5/8 PPH - ZINC
	000G11-07-08B	EA	SCREW - 7-19 X 1/2 PPH - ZINC
	000G11-08-20G	EA	SCREW - 8-18 X 1 1/4 - ANTIQUE BRASS
	000G11-08-20B	EA	SCREW - 8-18 X 1 1/4 PPH - ZINC
	000G11-08-12T	EA	SCREW - 8-18 X 3/4 PPH - BLACK MAGNESIUM
	000G11-08-12P	EA	SCREW - 8-18 X 3/4 PPH - DARK BROWN
	000G11-08-12S	EA	SCREW - 8-18 X 3/4 PPH - OFF WHITE
	000G11-08-12B	EA	SCREW - 8-18 X 3/4 PPH - ZINC
	000G11-08-08T	EA	SCREW - 8-18 X 1/2 PPH - FLUOROCARBON COATING
	000G11-08-06B	EA	SCREW - 8-18 X 3/8 PPH - ZINC
	000G11-10-12D	EA	SCREW - 10-16 X 3/4 PPH - BLACK
	000G12-06-12J	EA	SCREW - 6-20 X .75 POH - BRASS
	000G12-06-08T	EA	SCREW - 6-20 X 1/2 POH - BLACK
	000G13-05-10B	EA	SCREW - 5-12 X 5/8 PFH - ZINC
	000G13-06-08G	EA	SCREW - 6-20 X 1/2 PFH - ANTIQUE BRASS
	000G13-06-08B	EA	SCREW - 6-20 X 1/2 PFH - ZINC
	000G13-06-06I	EA	SCREW - 6-20 X 3/8 PFH - BLACK ZINC
	000G13-06-24J	EA	SCREW - 6-20 X 1 1/2 PFH - BRASS
	000G13-06-16J	EA	SCREW - 6-20 X 1 PFH - BRASS
	000G13-06-10J	EA	SCREW - 6-20 X 5/8 PFH - BRASS
	000G13-06-10G	EA	SCREW - 6-20 X 5/8 PFH - ANTIQUE BRASS
	000G13-07-10H	EA	SCREW - 7-19 X 5/8 PFH - BLACK
	000G13-07-12B	EA	SCREW - 7-19 X 3/4 PFH - ZINC
	000G13-08-16B	EA	SCREW - 8-18 X 1 PFH - ZINC
	000G13-08-109	EA	SCREW - 8-18 X 5/8 PFH
	000G13-08-10B	EA	SCREW - 8-18 X 5/8 PFH - ZINC
	000G13-08-24B	EA	SCREW - 8-18 X 1 1/2 PFH - ZINC
	000G16-04-24B	EA	SCREW - MACHINE - 1/4-20 X 1 1/2 PPH
	000G18-04-12B	EA	SCREW - MACHINE - 4-40 X 3/4 PPH - ZINC
	000G18-08-12B	EA	SCREW - MACHINE - 8-32 X 3/4 PPH - ZINC
	000G18-08-16B	EA	SCREW - MACHINE - 8-32 X 1 PPH - ZINC
	000G18-08-24B	EA	SCREW - MACHINE - 8-32 X 1 1/2 PPH - ZINC
	000G18-08-22B	EA	SCREW - MACHINE - 8-32 X 1 3/8 PPH - ZINC
	000G19-10-10B	EA	SCREW - MACHINE - 10-32 X 5/8 - PPH - ZINC
	000G19-10-08B	EA	SCREW - MACHINE - 10-32 X 1/2 PPH - ZINC
	000G19-10-20B	EA	SCREW - MACHINE - 10-32 X 1 1/2 PPH - ZINC
	000G19-10-40B	EA	SCREW-MACH,10-32X2.50 PPH ZN
	000G19-10-12F	EA	SCREW - MACHINE - 10-32 X 3/4 PPH - STAINLESS STEEL
	000G32-10-06B	EA	SCREW - 10-32 X 3/8 PPH - ZINC
	000G36-10-12T	EA	SCREW - 10-24X 3/4 PFH TYPE 23 - BLACK
	000G39-06-06J	EA	SCREW - 6-20 X 3/8 PPH - BRASS
	000G39-06-10T	EA	SCREW - SF/DR - 6-20 X 5/8 PPH - BLACK
	000G39-06-16T	EA	SCREW - SF/DR - 6-20 X 1 PPH - BLACK
	000G39-08-08S	EA	SCREW - SF/DR - 8-18 X 1/2 PPH - OFF WHITE
	000G39-08-08B	EA	SCREW - SF/DR - 8-18 X 1/2 PPH - ZINC
	000G39-08-08T	EA	SCREW - SF/DR - 8-18 X 1/2 PPH - BLACK
	000G39-08-06B	EA	SCREW - SF/DR - 8-18 X 3/8 PPH - ZINC
	000G39-08-32B	EA	SCREW - SF/DR - 8-18 X 2 PPH - ZINC
	000G39-08-24T	EA	SCREW - SF/DR - 8-18 X 1 1/2 PPH - BLACK
	000G39-08-24S	EA	SCREW - SF/DR - 8-18 X 1 1/2 - OFF WHITE
	000G39-08-24B	EA	SCREW - SF/DR - 8-18 X 1 1/2 PPH - ZINC
	000G39-08-16T	EA	SCREW - SF/DR - 6-20 X 1 PPH - BLACK
	000G39-08-16B	EA	SCREW - SF/DR - 8-18 X 1 PPH - ZINC
	000G39-08-12B	EA	SCREW - SF/DR - 8-18 X 3/4 PPH - ZINC
	000G39-08-12T	EA	SCREW - SF/DR - 8-18 X 3/4 PPH - BLACK
	000G39-10-48T	EA	SCREW - SF/DR - 10-16 X 3 PPH - BLACK
	000G39-10-48B	EA	SCREW - SF/DR - 10-16 X 3 - PPH - ZINC
	000G39-10-40D	EA	SCREW - SF/DR - 10-16 X 2 1/2 PPH - BLACK
	000G39-10-32B	EA	SCREW - SF/DR - 10-16 X 2 - PPH - ZINC
	000G39-10-20T	EA	SCREW - SF/DR - 10-16 X 1 1/4 PPH - BLACK
	000G39-10-20B	EA	SCREW - SF/DR - 10-16 X 1 1/4 PPH - ZINC
	000G39-10-169	EA	SCREW - SF/DR - 10-16 X 1 PPH - FLUOROCARBON SILVER
	000G39-10-129	EA	SCREW - SF/DR - 10-16 X 3/4 PPH - FLUOROCARBON SILVER

**SEALANTS & FASTENERS GROUP (CONTINUED)**  
**SCREWS (CONTINUED)**

KEY	PART NUMBER	U/M	DESCRIPTION
	000G39-10-12T	EA	SCREW - SF/DR - 10-16 X 3/4 - BLACK
	000G39-10-10T	EA	SCREW - SF/DR - 10-16 X 5/8 - BLACK
	000G39-10-10B	EA	SCREW - SF/DR - 10-16 X 5/8 PPH - ZINC
	000G39-10-08B	EA	SCREW - SF/DR - 10-16 X 1/2 PPH - ZINC
	000G39-12-12E	EA	SCREW - SF/DR - 12 - 14 X 3/4 PPH - CHROME
	000G42-04-24B	EA	SCREW - SF/DR - 1/4-14 X 1 1/2 - ZINC
	000G42-04-16B	EA	SCREW - SF/DR - 1/4-14 X 1 HWH - ZINC
	000G42-04-24B	EA	SCREW - SF/DR - 1/4-14 X 1 1/2 - ZINC
	000G46-08-24T	EA	SCREW - MACHINE - 8-32 X 1 1/2 PFH - BLACK
	000G50-04-08B	EA	SCREW - MACHINE - 1/4-20 X 1/2 PTH - ZINC
	000G52-06-05B	EA	SCREW - MACHINE - 6-32 X 5/16 PTH ZINC
	000G52-06-06B	EA	SCREW - MACHINE - 6-32 X 3/8 PIN - ZINC
	000G54-04-14B	EA	SCREW - 1/4-20 X 7/8 PTH - TYPE 23 - ZINC PLATED
	000G55-08-124	EA	SCREW - SF/DR - 8-18 X 3/4 PWH - ASH GRAY
	000G55-08-16T	EA	SCREW - SF/DR - 8-18 X 1 PWH - BLACK
	000G56-12-48B	EA	SCREW - WOOD - 12-11 X 3 POH - SPECIAL HARDENED
	000G57-14-64B	EA	SCREW - 14-10 X 4 PFH ZINC
	000G60-08-20F	EA	SCREW - SF/DR - 8-19X1.25 POH
	000G60-08-16E	EA	SCREW - SF/DR - 8-1 X 1 POH - CHROME
	000G60-08-22B	EA	SCREW - SF/DR - 8-18 X 1.38 POH - ZINC
	000G60-10-209	EA	SCREW - SF/DR - 10-16 X 1 1/4 POH - SILVER STALGAARD
	000G60-10-20B	EA	SCREW - SF/DR - 10-16 X 1 1/4 POH - ZINC
	000G60-10-16J	EA	SCREW - SF/DR - 10-16 X 1 POH - BRIGHT BRASS
	000G60-10-28T	EA	SCREW - SF/DR - 10-16 X 1 3/4 - BLACK
	000G62-08-24B	EA	SCREW - SF/DR - 8-18 X 1 1/2 PFH
	000G67-08-32B	EA	SCREW - 8-15 X 2 PPH - ZINC
	000G67-10-08B	EA	SCREW - 10-12 X 1/2 PPH - ZINC
	000G67-10-32J	EA	SCREW-10-12X2 PPH - BRIGHT BRASS
	000G67-10-24S	EA	SCREW - 10-12 X 1 1/2 PPH - OFF WHITE
	000G67-10-24B	EA	SCREW - 10-12 X 1 1/2 PPH - ZINC
	000G67-10-20D	EA	SCREW - 10-12 X 1 1/4 PPH - BLACK
	000G67-10-12P	EA	SCREW - 10-12 X 3/4 PPH - DARK BROWN
	000G67-10-12B	EA	SCREW - 10-12 X 3/4 PPH - ZINC
	000G67-10-10T	EA	SCREW - 10-12 X 5/8 PPH - BLACK
	000G67-10-10S	EA	SCREW - 10-12 X 5/8 PPH - OFF WHITE
	000G67-10-10P	EA	SCREW - 10-12 X 5/8 PPH - DARK BROWN
	000G67-10-10B	EA	SCREW - 10-12 X 5/8 PPH - ZINC - TYPE A
	000G67-10-08S	EA	SCREW - 10-12 X 1/2 PPH - OFF WHITE
	000G68-06-12B	EA	SCREW - 6-18 X 3/4 POH - ZINC & CLEAR
	000G68-06-10J	EA	SCREW - 6-18 X 5/8 POH - BRASS
	000G68-06-10G	EA	SCREW - 6-18 X 5/8 POH - ANTIQUE BRASS
	000G68-06-12J	EA	SCREW - 6-18 X 3/4 POH - BRASS
	029130-01-000	EA	SCREW - SNAP STUD - #8-16 X 5/8" LONG
	029130-03-000	EA	SCREW - SNAP STUD - #8-16 X 1" LONG
	049465-01-000	EA	SCREW - 10-16 PTH W/WASHER - DARK BROWN
	049465-03-000	EA	SCREW - 10-16 X 1 POH W/WASHER - OFF WHITE
	049465-04-000	EA	SCREW - 10-16 X 1 PTH W/WASHER - BEIGE
	049465-13-000	EA	SCREW-10+16X1 PTH W/WASHER - *ASH GRAY
	049465-17-000	EA	SCREW - 10-16 X 1 POH W/WASHER - BRIGHT WHITE
	054434-03-000	EA	SCREW - SF/DR - 10-16 X 2 - PWH - ZINC
	075908-01-000	EA	SCREW - MACHINE - 10-32 X .56 PTH - EXTERNAL TOOTH - ZINC
	076790-01-000	EA	SCREW - 6-20 X 1 1/4 PPH - BLACK
	076790-05-000	EA	SCREW - 6-20 X 1/2 PPH - BLACK - THREAD CUTTING/WOOD
	083554-01-000	EA	SCREW - DRYWALL - 8 X 1 1/4
	083554-04-000	EA	SCREW - DRYWALL - 8 X 2 1/2
	087721-01-000	EA	SCREW - FLAT HEAD - TAPPING - 1/4 X 1 1/4 LONG - ZINC
	087721-02-000	EA	SCREW - FLAT HEAD - TAPPING - 1/4" X 2 1/4" LONG - ZINC
	090033-02-000	EA	SCREW - 1/4-20 X 5/8 - ROUND WASHER HEAD - OFF/WHITE
	097974-01-000	EA	SCREW - PARTICLE BOARD - 7-9 X 3/4 PPH
	101618-01-000	EA	SCREW - 1/4-20 X 3/4 HEX - TAPPING - STALGARD TYPE F
	109235-01-05A	FT	COVER - SCREW - BRIGHT WHITE
	109235-01-01A	FT	COVER - SCREW - MAT BLACK
	113563-01-01A	EA	SCREW - 8 X 5/8 LONG SHOULDER/WASHER HEAD
	116111-02-01A	EA	SCREW - TAPTITE - 1/4-20 X 3/8 PPH - ZINC

**SEALANTS & FASTENERS GROUP (CONTINUED)**  
**SCREWS (CONTINUED)**

KEY	PART NUMBER	U/M	DESCRIPTION
	117478-01-04A	EA	SCREW - 8-18 X 3/4 PPH W/WASHER - VW LIGHT GRAY
	118383-01-09A	EA	RETAINER/RECESSED - F/.22" SCREW - GLACIER
	118383-01-06A	EA	RETAINER/RECESSED - F/.22" SCREW - ALLANTE ANTELOPE
	118383-01-04A	EA	RETAINER/RECESSED - F/.22" SCREW - BRIGHT WHITE
	118383-02-09A	EA	RETAINER/RECESSED - F/.27" SCREW - GLACIER
	118383-02-05A	EA	RETAINER/RECESSED - F/.27" SCREW - VW LIGHT GRAY
	118383-02-10A	EA	RETAINER/RECESSED - F/.27" SCREW - RIVERSTONE
	118383-02-11A	EA	RETAINER/RECESSED - F/.27" SCREW - CASHMERE
	118383-03-09A	EA	RETAINER/RECESSED - F/.32" SCREW - GLACIER
	118383-04-04A	EA	CAP - F/RECESSED RETAINER - BRIGHT WHITE
	118383-04-08A	EA	CAP - F/RECESSED RETAINER - CADDY CREAM
	118383-04-05A	EA	CAP - F/RECESSED RETAINER - VW LIGHT GRAY
	118383-04-11A	EA	CAP - F/RECESSED RETAINER - CASHMERE
	118383-04-10A	EA	CAP - F/RECESSED RETAINER - RIVERSTONE
	118383-04-09A	EA	CAP - F/RECESSED RETAINER - GLACIER
	134126-01-01A	EA	SCREW/NAIL - HEX HEAD - 3/4"
	140040-01-000	EA	SCREW - 1/4-20 X 1 - BUTTON HEAD/SOCKET - W/LOCTITE
	144078-01-01A	EA	SCREW - HEX/FLANGE HEAD CAP-1" W/.75" THREAD LENGTH-ZINC
	149753-01-02A	EA	RETAINER/RECESSED - F/.22" SCREW - BRIGHT WHITE
	149753-01-01A	EA	RETAINER/RECESSED - F/.22" SCREW - BLACK
	149753-02-02A	EA	CAP - F/RECESSED RETAINER - BRIGHT WHITE
	149753-02-01A	EA	CAP - F/RECESSED RETAINER - BLACK

**CLAMPS, CLIPS, GROMMETS, RIVETS & PLUGS**

KEY	PART NUMBER	U/M	DESCRIPTION
	000F10-06-32B	EA	PIN - COTTER - 3/16" X 2" - ZINC
	000H14-06-06R	EA	RIVET-MANDREL BLIND,3/16 AL - CHERRY BSP-66
	000H16-04-06R	EA	RIVET - POP ALUMINUM - 1/8 X .313 - .375
	000H16-06-10R	EA	RIVET - POP ALUMINUM - 3/16 X .501 - .625
	007161-01-000	EA	CLAMP - HOSE - SPRING TYPE - 1/2"
	008386-01-000	EA	GROMMET - SNAP - 3/8" DIAMETER - NYLON
	010495-01-000	EA	CLAMP - CABLE - 9/16"ID - BLACK
	010495-02-000	EA	CLAMP - CABLE - 3/8"ID - BLACK
	010495-04-000	EA	CLAMP - CABLE - 11/16"ID - WHITE
	010497-01-000	EA	CLAMP - CLOSED - 5/8"ID
	010497-02-000	EA	CLAMP - CLOSED - 1.5"ID
	010497-03-000	EA	CLAMP - CLOSED - 1"ID - CUSHIONED
	010497-04-000	EA	CLAMP - CLOSED - 1 5/8"ID
	010497-05-000	EA	CLAMP - CLOSED - 1/2"ID
	010497-07-000	EA	CLAMP - CLOSED - 3/8"ID
	010497-09-000	EA	CLAMP - CLOSED - 5/16"ID
	010497-10-000	EA	CLAMP - CLOSED - 7/8"ID
	010499-01-000	EA	CLAMP - CLOSED - 3/8"ID
	016188-03-000	EA	GROMMET - LP LINE - 3/8"HOLE X 2 1/2"LONG - RUBBER
	016188-04-000	EA	GROMMET - LP LINE - 1/2"HOLE X 2 1/2"LONG - RUBBER
	016188-05-000	EA	GROMMET - LP LINE - 3/8"HOLE X 1 1/4"LONG - RUBBER
	016188-06-000	EA	GROMMET - L/P LINE - 3/8"HOLE X 3 1/4"LONG - RUBBER
	016188-08-000	EA	GROMMET - LP LINE - 1/2"HOLE X 1 1/4"LONG - RUBBER
	016188-09-000	EA	GROMMET - LP LINE - .68"HOLE X 1 1/4"LONG - RUBBER
	016188-10-000	EA	GROMMET - LP LINE - .68"HOLE X 2.5"LONG - RUBBER
	023942-01-000	EA	GROMMET - RUBBER - 2" OD
	034141-02-000	EA	PLUG/NYLON - .38" - BLACK
	061420-01-000	EA	PLUG/PLASTIC - 1 3/4" DIAMETER - BROWN
	061420-04-000	EA	PLUG/PLASTIC - 1 1/4" DIAMETER
	061420-05-000	EA	PLUG/PLASTIC - 1 1/2" DIAMETER
	061420-08-000	EA	PLUG/PLASTIC - 2 1/2" DIAMETER
	061420-09-000	EA	PLUG/PLASTIC - 1.00" - DIAMETER
	061420-10-000	EA	PLUG/PLASTIC - 1 1/2" DIAMETER - BLACK
	061420-14-000	EA	PLUG/PLASTIC - 7/8" DIAMETER - BLACK
	061420-15-000	EA	PLUG/PLASTIC - 2" DIAMETER - BLACK
	062401-01-000	EA	CLAMP - HOSE - WORMGEAR - .25" - 1"
	062401-02-000	EA	CLAMP - HOSE - WORMGEAR - 1.56" - 2.5"
	062401-03-000	EA	CLAMP - HOSE - WORMGEAR - .22" - 1"
	062401-04-000	EA	CLAMP - HOSE - WORMGEAR - .69" - 1.25"



**SEALANTS & FASTENERS GROUP (CONTINUED)**  
**CLAMPS, CLIPS, GROMMETS, RIVETS & PLUGS (CONTINUED)**

KEY	PART NUMBER	U/M	DESCRIPTION
	062401-05-000	EA	CLAMP - HOSE - WORMGEAR - 2" - 3" ID
	062401-06-000	EA	CLAMP - HOSE - WORMGEAR - .22" - .62" ID
	062401-09-000	EA	CLAMP - HOSE - WORMGEAR - 2.8" - 3.75"
	062401-11-000	EA	CLAMP - HOSE - WORMGEAR - 3.50" - 4.50"
	062401-12-000	EA	CLAMP - HOSE - WORMGEAR - .79" X 1.26"
	062401-13-000	EA	CLAMP - HOSE - WORMGEAR
	071015-01-000	EA	GROMMET - RUBBER - .5"ID X 1"OD-W/.38" GROOVE - BLACK
	071015-11-000	EA	GROMMET - RUBBER - 1 ID - FITS .12 MATERIAL - BLACK
	071015-13-000	EA	GROMMET - RUBBER - .62 ID - FITS .09 GROOVE - BLACK
	071015-19-000	EA	GROMMET - RUBBER - .38 ID - FITS .06 MATERIAL - BLACK
	071015-26-000	EA	GROMMET - RUBBER - 1.5" ID X 2.1" OD W/.06" GROOVE-BLACK
	071015-29-000	EA	GROMMET - RUBBER - .3"ID X 1.3"OD W/.12" GROOVE - BLACK
	071015-30-000	EA	GROMMET - RUBBER - .3"ID X .81"OD W/.12" GROOVE - BLACK
	071015-32-000	EA	GROMMET - RUBBER - .75"ID X 1.375"OD W/.187" GROOVE-BLK
	071015-37-000	EA	GROMMET - .81 ID FITS .56 MTL
	071015-39-000	EA	GROMMET - .75 ID FITS .06 MTL
	071015-40-000	EA	GROMMET - .38 ID FITS .09 MTL
	071015-41-000	EA	GROMMET - .125 ID FITS .188 MTL
	071015-42-000	EA	GROMMET - RUBBER - .25 ID - FITS .06 MATERIAL - BLACK
	075148-02-000	EA	CLAMP - GROUNDING - BRONZE SCREWS
	077955-01-000	EA	CLIP/J - 3/8" - VINYL COATED
	080211-03-000	EA	CLIP - XMAS TREE W/PANEL RETAINING HEAD - 3/4" SHANK
	080734-02-000	EA	CLIP - WIRE NYLON
	081211-01-000	EA	PLUG - PLASTIC - .31"DIA - BLACK
	081211-03-000	EA	PLUG/PLASTIC - .50" DIAMETER - TRUSS HEAD - BLACK
	081211-04-000	EA	PLUG/PLASTIC - .46 DIAMETER - TRUSS HEAD - BLACK
	083609-01-000	EA	CLAMP - WIRE - DUAL - EQUAL DIAMETERS - 5/8"
	083610-01-000	EA	CLAMP - WIRE - DUAL - UNEQUAL DIAMETERS - 3/4" & 1 1/4"
	083610-02-000	EA	CLAMP - WIRE - DUAL - UNEQUAL DIAMETERS - 3/4" & 2"
	083610-03-000	EA	CLAMP - WIRE - DUAL - EQUAL DIAMETERS - 2"
	088756-01-000	EA	GROMMET - WEB - 1 1/8 " I.D.
	089329-02-000	EA	CLIP - SPRING
	091952-01-000	EA	CLIP - GRIPPER - 1"
	091952-02-000	EA	CLIP - GRIPPER - 3/4"
	091952-03-000	EA	CLIP - GRIPPER - 1/2" - BLACK VINYL COATED
	094362-02-000	EA	CLIP - XMAS TREE - BINDER HEAD - .9" LONG
	094362-05-000	EA	CLIP - XMAS TREE - ROUND HEAD - 1.4" LONG
	113133-02-01A	EA	RIVET - POP - ALUMINUM - 3/16 X .252 - .504 - BLACK
	114208-01-000	EA	GROMMET - EDGE LINER - FITS 1 3/4"
	114208-05-000	EA	GROMMET - EDGE LINER - FITS 2"
	115361-01-01A	EA	PLUG/PLASTIC - 1/2" DIAMETER
	118626-01-02A	EA	RIVET - POP - ALUMINUM - 3/16 X .08 - .375
	118626-01-01A	EA	RIVET - POP - ALUMINUM - 3/16 X .08 - .375
	137014-01-02A	EA	GROMMET - CABLE - BROWN
	137014-01-01A	EA	GROMMET - CABLE - ALMOND
	137014-01-03A	EA	GROMMET - CABLE - BLACK
	139118-02-01A	EA	GROMMET - SCREW - PLASTIC
	140171-01-000	EA	CLAMP - HOSE - STEPLESS EAR - .312

**MISCELLANEOUS FASTENERS**

KEY	PART NUMBER	U/M	DESCRIPTION
	008343-01-000	EA	TIE - WIRE - 6"
	008343-02-000	EA	TIE - WIRE - 14"
	008343-03-000	EA	TIE - WIRE - 7 1/2" - BLACK
	029094-04-000	YD	VELCRO TAPE - LOOP - 1" WIDE - BLACK
	029096-03-000	YD	VELCRO TAPE - HOOK - 1" WIDE - BLACK
	029096-04-000	YD	VELCRO TAPE/HOOK - 1" WIDE - BLACK - W/ADHESIVE BACK (PSA)
	048394-02-000	YD	VELCRO TAPE - HOOK - ADHESIVE BACK - 3/4" WIDE - BEIGE
	085774-01-000	FT	FASTENER - DUAL LOCK - 1" WIDE - ADHESIVE BACK - BLACK
	085774-02-000	FT	FASTENER - DUAL HOOK - 1" WIDE - ADHESIVE BACK - BLACK
	085774-03-000	FT	FASTENER - DUAL LOCK - 1/2" WIDE - ADHESIVE BACK - BLACK
	085774-04-000	FT	FASTENER - DUAL HOOK - 1/2" WIDE - ADHESIVE BACK - BLACK
	088792-02-000	YD	VELCRO TAPE - LOOP - 3/4" - ADHESIVE BACK - BEIGE
	088792-04-000	YD	VELCRO TAPE - HOOK - 5/8" - NON-ADHESIVE BACK - WHITE

**SEALANTS & FASTENERS GROUP (CONTINUED)**  
**MISCELLANEOUS FASTENERS (CONTINUED)**

<b>KEY</b>	<b>PART NUMBER</b>	<b>U/M</b>	<b>DESCRIPTION</b>
	088792-05-000	YD	VELCRO TAPE - LOOP - 5/8" - NON-ADHESIVE BACK - WHITE
	108046-01-000	EA	CABLE TIE - SCREW MOUNT 8"
	108046-02-000	EA	CABLE TIE - SCREW MOUNT 15"
	110943-01-000	FT	FELT STRIP - 3/8" - ADHESIVE BACK - BLACK - 75' PER ROLL
	110943-02-000	FT	FELT STRIP - 3/8" - ADHESIVE BACK - WHITE
	127960-01-01A	EA	RETAINER - 3/8" - STAINLESS STEEL

# WATER & SEWAGE GROUP DRAINAGE SYSTEM

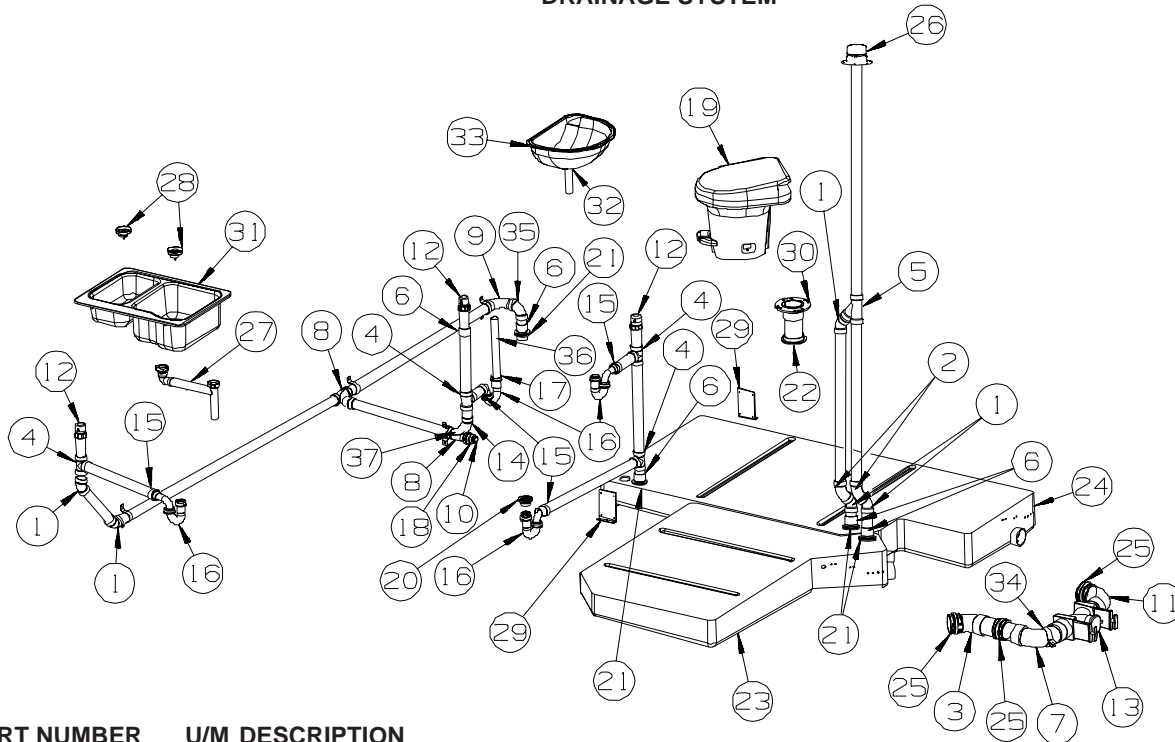

KEY	PART NUMBER	U/M	DESCRIPTION
1	010006-01-000	EA	ELBOW - 45 DEGREE - 1 1/2" HUB X HUB - PLASTIC
2	010051-01-000	EA	ELBOW - 45 DEGREE - 1 1/2" SPIGOT X HUB - PLASTIC
3	010061-01-000	EA	ELBOW - 45 DEGREE ST - 3" SPIGOT & HUB - PLASTIC
4	010071-01-000	EA	TEE - SANITARY - 1 1/2" HUB X HUB X HUB - PLASTIC
5	010073-01-000	EA	WYE - 45 DEGREE - 1 1/2" HUB X HUB X HUB - PLASTIC
6	010115-01-000	EA	COUPLING - 1 1/2" HUB X HUB - PLASTIC
7	031126-01-000	EA	ELBOW - 1/4 BEND - 3" X 90" XLT - BLACK PLASTIC
8	031365-02-000	EA	TEE - PLASTIC - 1 1/2" EXTRA LONG TURN
9	033761-01-000	EA	ELBOW - 90 DEGREE - TURN - 1 1/2" HUB X 1 1/2" SPIGOT
10	010166-01-000	EA	PLUG/THREADED - 1 1/4"MPT - PLASTIC - BLACK - <b>CANADIAN</b>
11	041956-01-000	EA	ELBOW - 3" STREET - 90 DEGREE PLASTIC
12	079968-01-000	EA	VENT - MECHANICAL/TRAP ARM - ANTI-SIPHON-2" X 7.3" PLASTIC
13	136143-01-000	EA	VALVE - DUAL - 3" X 3"
	139513-01-000	EA	HOSE - SEWER - 3" X 10' - W/ADAPTER
	062416-01-000	EA	ADAPTER - SEWER HOSE TO 3" PIPE
14	010008-01-000	EA	ELBOW - 90 DEGREE - 1 1/2" HUB X HUB - PLASTIC
15	109571-01-000	EA	ADAPTER - P-TRAP - 1 1/2"P X 1 1/4"MPT
			FROM: 00-00-00 THRU: 10-12-04
15	152146-01-000	EA	CONNECTOR - 1 1/2"P X 1 1/2"MPT
			FROM: 10-13-04 THRU: 99-99-99
16	107538-01-000	EA	P-TRAP - PLASTIC - 1 1/4" W/EXTENSION ARM - <b>USA</b>
			FROM: 00-00-00 THRU: 10-18-04
16	107538-02-000	EA	P-TRAP - PLASTIC - 1 1/2" W/EXTENSION ARM - <b>USA</b>
			FROM: 10-19-04 THRU: 99-99-99
16	011071-01-000	EA	P-TRAP - 1 1/2" - CSA - PLASTIC - <b>CANADIAN</b>
17	061420-10-000	EA	PLUG/PLASTIC - 1 1/2" DIAMETER - BLACK
18	010122-01-000	EA	BUSHING/PLASTIC - REDUCER - 1 1/2"SMTH X 1 1/4"THD - BLACK - <b>CANADIAN</b>
19*	140798-01-01A	EA	TOILET - TRAVELER LITE - TALL - WHITE
20	066440-01-000	EA	STRAINER - SHOWER DRAIN - W/RUBBER WASHER
	011069-06-000	EA	TAILPIECE - 1 1/2" X 1 1/4" X 2 1/2"
	127440-02-01A	EA	WASHER - RUBBER - 1.8" X .1"
	130403-01-000	EA	NUT - SLIP - W/WINGS 1 1/2"
21	061607-01-000	EA	GROMMET - HOLDING TANK - 1 1/2" NPS
22	061607-02-000	EA	GROMMET - HOLDING TANK - 3" NPS
23	134216-01-000	EA	TANK - HOLDING - 45 GALLON - W/O FITTINGS
	114429-02-000	EA	ELBOW - 1/2"P X 1/2"MPT
	125697-02-000	EA	NOZZLE - WELD-A-FLUSH
24	134217-01-000	EA	TANK - HOLDING - 67 GALLON - W/O FITTINGS

**WATER & SEWAGE GROUP (CONTINUED)**  
**DRAINAGE SYSTEM (CONTINUED)**

<b>KEY</b>	<b>PART NUMBER</b>	<b>U/M</b>	<b>DESCRIPTION</b>
25	078406-01-000	EA	COUPLER - 3" X 3" W/CLAMPS - RUBBER
26	083558-03-000	EA	VENT W/COVER F/PLUMBING STACK - OFF WHITE
27	011091-02-000	EA	WASTE - CONTINUOUS - DOUBLE SINK
28	092303-01-000	EA	STRAINER - W/BASKET - GALLEY SINK - 4" OD
	127440-02-01A	EA	WASHER - RUBBER - 1.8" X .1"
29	094756-02-01A	EA	BRACKET - L - 6.1" LONG X 3.9" WIDE - STEEL
30	116644-01-000	EA	FLANGE/CLOSET - 3" FEMALE - 4 BOLT
31	148870-01-01A	EA	SINK/DOUBLE - LGE/SML BASIN-25"X19"X7"
32	106116-01-02A	EA	STRAINER/PLASTIC - STOPPER/TAILPIECE/GASKET & NUT-LAVATORY
	011069-02-000	EA	TAILPIECE - TUB/SHOWER - 1 1/2" X 1 1/4" X 4" - BRASS
	106116-02-01A	EA	GASKET - STRAINER
	127440-02-01A	EA	WASHER - RUBBER - 1.8" X .1"
	130403-01-000	EA	NUT - SLIP - W/WINGS 1 1/2"
33	142285-01-01A	EA	SINK - LAVATORY
34	141443-01-02B	EA	HOLDER - RING - 3.6" DIAMETER - METAL
35	034250-01-000	EA	ELBOW - 90 DEGREE - LONG TURN - 1 1/2" HUB X HUB - ABS
36	126588-02-000	EA	ARM - WASTE - 1 1/2 X 20" - FEMALE
37	010008-01-000	EA	ELBOW - 90 DEGREE - 1 1/2" HUB X HUB - PLASTIC - USA

**\*COMPONENT PARTS LISTED LATER IN THIS GROUP**

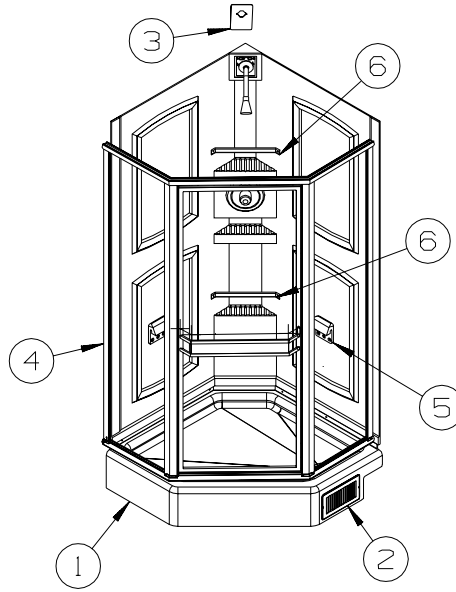

<b>KEY</b>	<b>PART NUMBER</b>	<b>U/M</b>	<b>DESCRIPTION</b>
1	M02630-58-N30	EA	SHOWER PAN - W/STRAINER
2	089326-02-000	EA	GRILLE - FLOOR - HEATING - 9.3" X 5.3" - SOFT WHITE
3	131549-01-01A	EA	PLATE-COVER,SHOWER HEAD
4	131311-01-01A	EA	ENCLOSURE - SHOWER - SIDES/BACK - 1 PIECE
5	135607-03-01A	EA	SEAT - SHOWER/FOLDING(FOR REPLACEMENT OR OPTION INST ONLY)
6	113714-02-02A	EA	RETAINER - SHELF/SHOWER - 10.6" - SOFT WHITE

**WATER & SEWAGE GROUP (CONTINUED)**  
**COMPONENT PARTS FOR DRAINAGE SYSTEM**

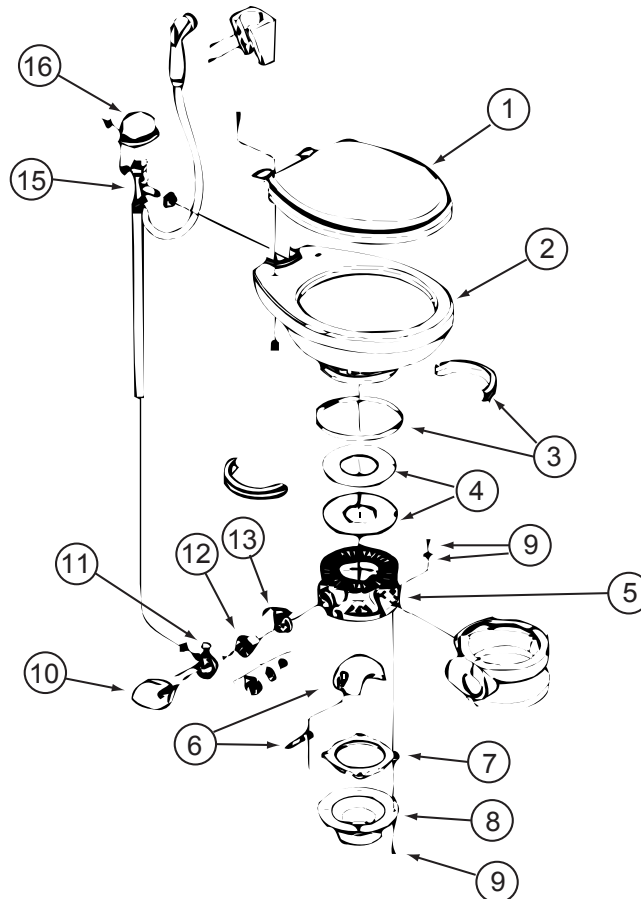

**140798-01-01A**

KEY	PART NUMBER	U/M	DESCRIPTION	VENDOR NO.
1	140798-01-700	EA	SEAT ASSEMBLY - WHITE	344089
2	140798-01-701	EA	BOWL/CHINA - WHITE	310790
3	140798-01-702	EA	RING & HALF CLAMP KIT-WHITE	310025
4	140798-01-703	EA	TEFLON & RUBBER SEAL KIT	316140
5	140798-01-714	EA	BASE KIT - WHITE	385310792
6	140798-01-705	EA	BALL/SHAFT/CARTRIDGE KIT	318162
7	140798-01-712	EA	SEAL - FLOOR FLANGE	600343938
8	085330-01-716	EA	FLANGE-FLOOR, 3" MPT	345889
9	140798-01-715	EA	FLOOR BOLT MOUNTING PACKAGE	385310794
10	140798-01-713	EA	FLUSH PEDAL KIT - WHITE	385310682
11	140798-01-707	EA	WATER VALVE KIT	314349
12	140798-01-708	EA	SPRING CARTRIDGE KIT	236096
15	140798-01-710	EA	VACUUM BREAKER KIT W/O SPRAY	310687
16	140798-01-711	EA	VACUUM BREAKER COVER KIT WHT	310795
	085330-04-701	EA	HAND SPRAY W/HOSE(500 & 900)	340683
	085330-06-701	EA	BREAKER-VACUUM/DIVERTER(900)	230335

## WATER & SEWAGE GROUP (CONTINUED)

### WATER SYSTEM

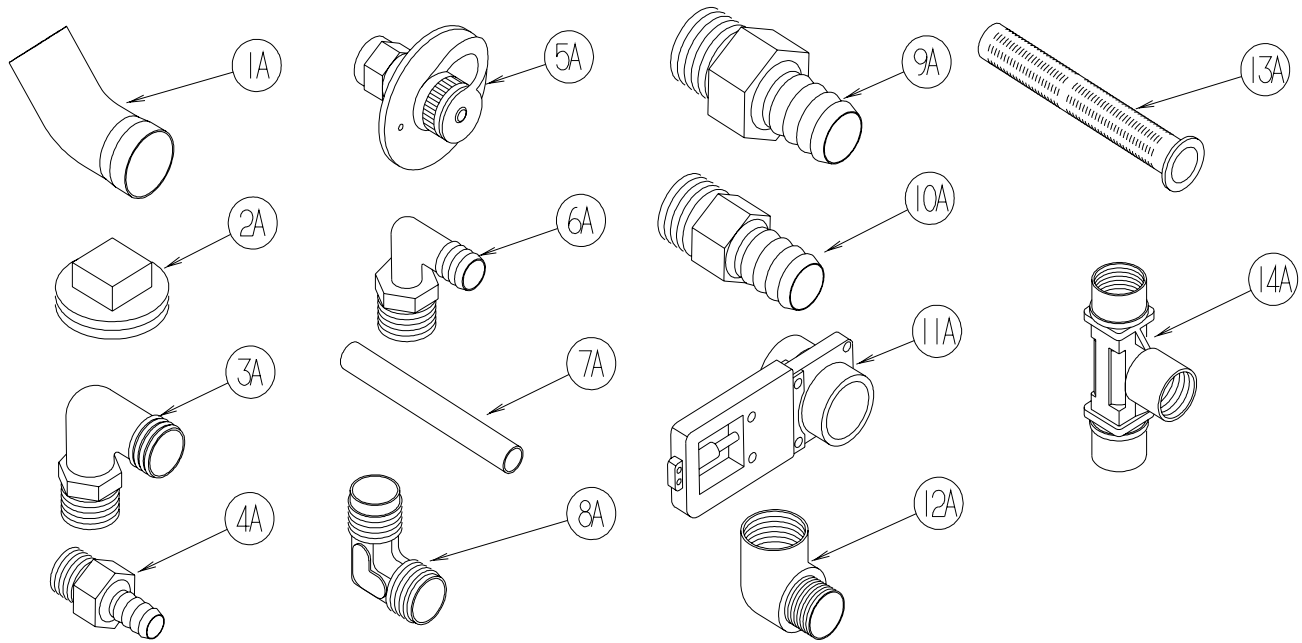

KEY	PART NUMBER	U/M	DESCRIPTION
1A	010009-01-000	EA	ELBOW - 90 DEGREE - 1/4 BEND - 1 1/2" PLASTIC
2A	010166-01-000	EA	PLUG/THREADED - 1 1/4"MPT - PLASTIC - BLACK - UL
3A	010219-01-000	EA	ELBOW - 1 1/4 MPT X 1 1/4 BARB - WATER FILL - PLASTIC
4A	010224-01-000	EA	ADAPTER - HOSE TO PIPE - 3/8 MPT X 3/8 BARB - PLASTIC
5A	010230-06-000	EA	FILL - CITY WATER - W/CHECK VALVE - MPT - BRUSHED ALUM
6A	035539-01-000	EA	ELBOW - 3/8 MPT X 3/8 BARB - PLASTIC
7A	039800-04-000	FT	TUBING - POLYBUTYL - 1/4"OD
7A	074462-02-000	FT	TUBING - VINYL - 3/8 ID X 20' - CLEAR
7A	112176-01-000	FT	TUBING - VINYL - REINFORCED - 1/2" ID
7A	124188-01-000	FT	TUBING - PEX - 1/2" ID X 20' - BLUE(COLD)
7A	124188-02-000	FT	TUBING - PEX - 1/2" ID X 20' - RED(HOT)
8A	039808-03-000	EA	ELBOW - 1/2" MPT X 1/2" MPT - PLASTIC
9A	044927-01-000	EA	ADAPTER - HOSE TO PIPE-1 1/4 MPTX1 1/4 BARB-BLACK PLASTIC
10A	044927-02-000	EA	ADAPTER - REDUCING - 1" MPT X 1.3" BARB - PLASTIC
11A	062421-03-000	EA	VALVE/DUMP W/O HANDLE - 1 1/2" X 1 1/2" HUB
	062421-05-000	EA	CABLE/ROD - F/DUMP VALVE - W/HANDLE - 48"
	062421-07-000	EA	CABLE/ROD - F/DUMP VALVE - W/HANDLE - 144"
	062421-08-000	EA	CABLE/ROD - F/DUMP VALVE - W/HANDLE - 108"
12A	065318-02-000	EA	ELBOW - 90 DEGREE - 3/8" MPT TO 3/8" FPT
13A	077954-02-000	EA	FILTER - WATER TANK - W/SCREEN IN TANK
14A	039798-01-000	EA	TEE - 1/2"MPT X 1/2"MPT X 1/2"MPT - PLASTIC

**WATER & SEWAGE GROUP (CONTINUED)**  
**WATER SYSTEM (CONTINUED)**

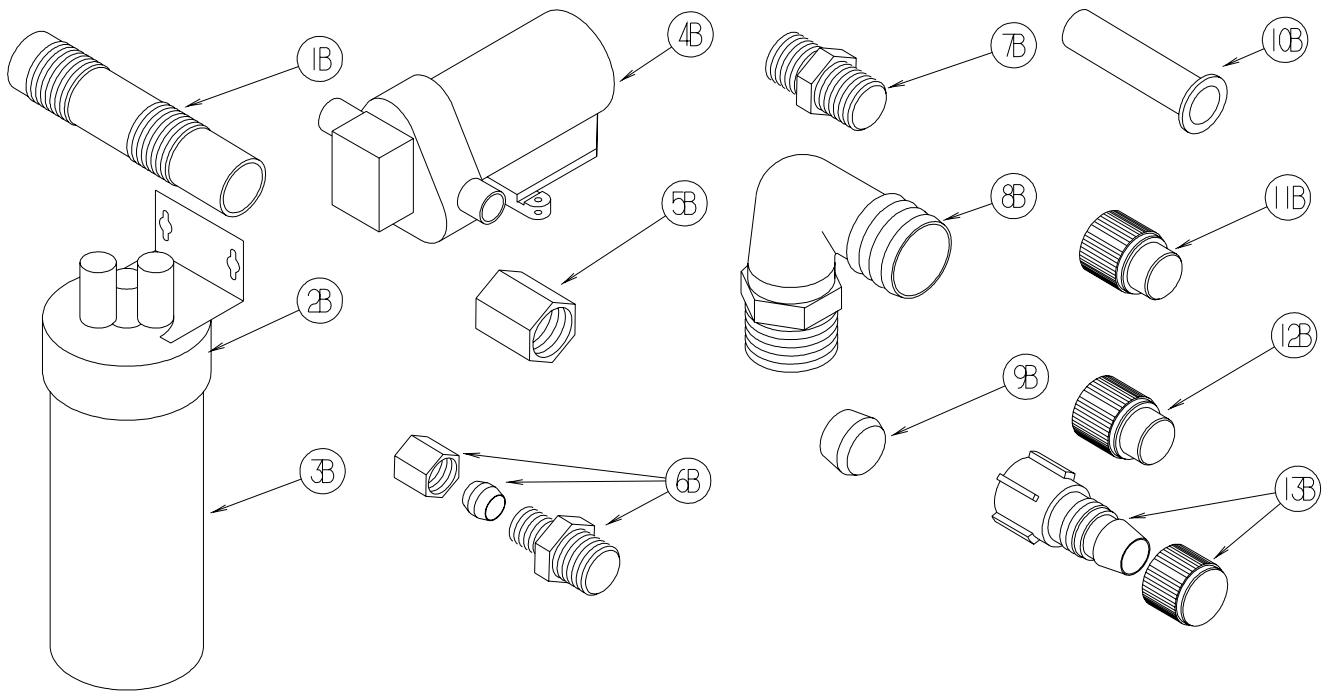

KEY	PART NUMBER	U/M	DESCRIPTION
1B	079381-01-000	FT	TUBING - RIBBED FLEXIBLE - WATER FILL - 1.4" ID
2B	087200-01-000	EA	FILTER-WATER PURIFICATION, EVERPURE QC2-AC
3B	087200-02-000	EA	CARTRIDGE-WATER FILTER,AC - EVERPURE 9601-11
4B*	098607-01-000	EA	PUMP - WATER - W/.5" MPT FITTING - FLOW 2.8 GPM
5B	101814-01-000	EA	COUPLING - FEMALE - 1/2" X 1/2" FPT - GRAY
6B	103798-01-000	EA	CONNECTOR - 1/4 OD X 3/8 MPT
7B	110438-02-000	EA	VALVE - CHECK - BRASS - 1/2 MPT X 1/2 MPT
8B	111223-02-000	EA	ELBOW - 1/2" MPT X 3/8" BARB - PLASTIC
8B	111223-03-000	EA	ELBOW - 3/4" MPT X 1/2" BARB - PLASTIC
8B	111223-04-000	EA	ELBOW - 1/2" MPT X 1/2" BARB - PLASTIC
9B	111888-01-000	EA	FERRULE - PLASTIC - .250 ID X .375 OD
10B	111888-02-000	EA	INSERT - BRASS - 1/4 COMP
11B	113697-01-000	EA	CAP - 3/8"P
12B	114427-01-000	EA	CAP - 1/2"P
13B	114427-02-000	EA	PLUG - W/COMP NUT - 1/2" PLASTIC PIPE/1/2" FLAIR-IT

**WATER & SEWAGE GROUP (CONTINUED)**  
**WATER SYSTEM (CONTINUED)**

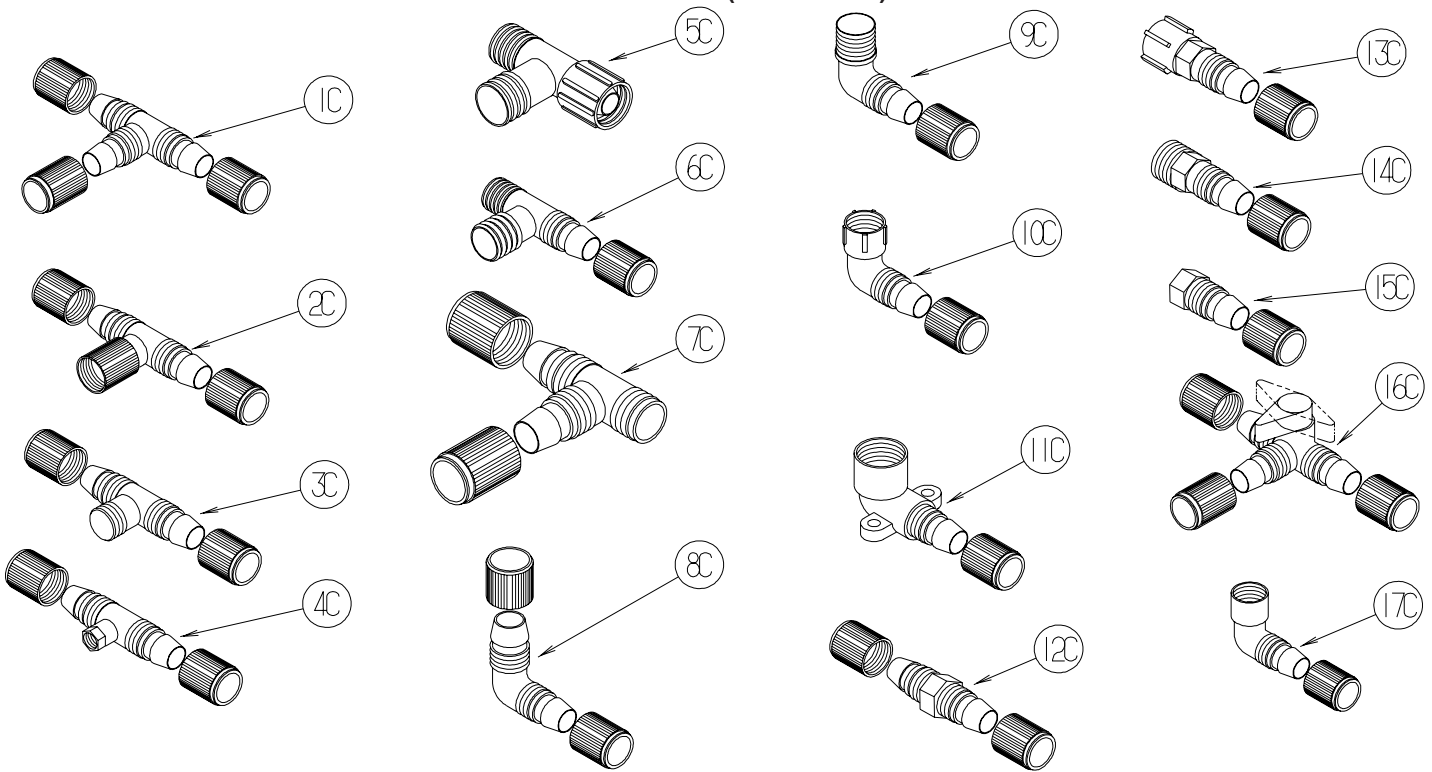

KEY	PART NUMBER	U/M	DESCRIPTION
1C	114428-01-000	EA	TEE - 1/2"P X 1/2"P X 1/2"P
2C	114428-02-000	EA	TEE - SWIVEL - 1/2"P X 1/2"P X 1/2"FPT
3C	114428-03-000	EA	TEE - 1/2"P X 1/2"P X 1/2"MPT
4C	114428-04-000	EA	TEE - 1/2"P X 1/2"P X 1/8"FPT
5C	114428-05-000	EA	TEE - 1/2" SWIVEL X 1/2" MPT X 1/2" MPT
6C	114428-06-000	EA	TEE - 1/2" P X 1/2" MPT X 1/2" MPT
7C	114428-07-000	EA	TEE - 1/2" P X 1/2" MPT X 1/2" P
8C	114429-01-000	EA	ELBOW - 1/2"P X 1/2"P
9C	114429-02-000	EA	ELBOW - 1/2"P X 1/2"MPT
9C	114429-04-000	EA	ELBOW - 1/2"P X 3/8"MPT
9C	114429-05-000	EA	ELBOW - 1/2"P X 3/4"MPT
9C	114429-10-000	EA	ELBOW - SWIVEL - 1/2"MPT X 1/2"FPT
10C	114429-06-000	EA	ELBOW - SWIVEL - 1/2"P X 3/4"FPT
10C	114429-08-000	EA	ELBOW - SWIVEL - 1/2"P X 1/2"FPT
11C	114429-09-000	EA	ELBOW - 1/2"P X 1/2"FPT DROP EAR
12C	114430-01-000	EA	ADAPTER - 1/2"P X 1/2"P
13C	114430-02-000	EA	ADAPTER - SWIVEL - 1/2"P X 1/2"FPT
13C	114430-04-000	EA	ADAPTER - SWIVEL - 1/2"P X 3/8"MPT
14C	114430-03-000	EA	ADAPTER - 1/2"P X 1/2"MPT
15C	114430-06-000	EA	ADAPTER - 1/2"P X 3/8"FPT
15C	114430-09-000	EA	ADAPTER - 1/2"P X 1/2"FPT
16C	114431-01-000	EA	VALVE - 180 DEGREE/CENTER DRAIN - 1/2"P - THREE WAY
17C	114429-11-000	EA	ELBOW - 1/2"P X 1/2"FPT



**WATER & SEWAGE GROUP (CONTINUED)**  
**WATER SYSTEM (CONTINUED)**

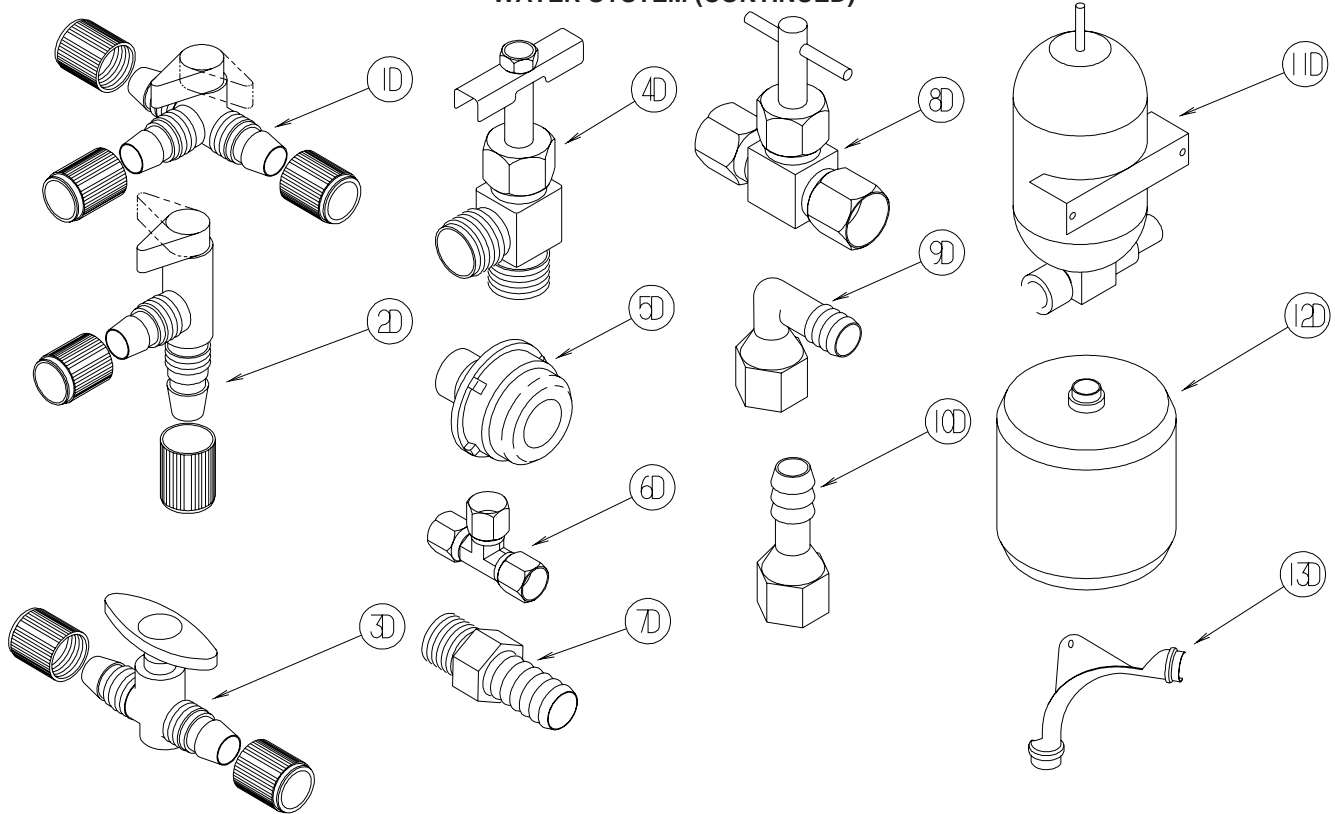

KEY	PART NUMBER	U/M	DESCRIPTION
1D	114431-02-000	EA	VALVE - WATER BYPASS - 1/2"P - THREE WAY (WATER HEATER)
2D	114431-03-000	EA	VALVE - 90 DEGREE DRAIN - 1/2"P
3D	114431-04-000	EA	VALVE - "INLINE SHUT-OFF" - 1/2"P
4D	114431-05-000	EA	VALVE - NEEDLE - 1/8" MPT X 1/4" COMPRESSION (ICE MAKER)
5D	114966-01-000	EA	FILTER - IN LINE - TWIST ON - 1/2"
			FROM: 00-00-00 THRU: 09-26-04
5D	152925-01-01A	EA	FILTER - IN LINE - TWIST ON - 1/2" - BLACK
			FROM: 09-27-04 THRU: 99-99-99
6D	118423-01-000	EA	FITTING - BRASS-TEE - 1/4C X 1/4C X 1/4C
7D	118809-01-000	EA	ADAPTER - 1/2" MPT X 3/8" BARB - PLASTIC
7D	118809-02-000	EA	ADAPTER - 1/2" MPT X 1/2" BARB - PLASTIC
8D	120868-01-000	EA	VALVE - NEEDLE - 1/4" COMPRESSION X 1/4" COMPRESSION
9D	123150-01-000	EA	ELBOW - 1/2 FPT X 1/2 BARB - SWIVEL
10D	123152-01-000	EA	ADAPTER - 1/2 FPT X 1/2 BARB - SWIVEL
11D	123243-01-000	EA	TANK - ACCUMULATOR - 24 OZ
12D	123317-01-000	EA	TANK - ACCUMULATOR - 2 GALLON
13D	124184-01-000	EA	SUPPORT - WATER LINE - BEND

**WATER & SEWAGE GROUP (CONTINUED)**  
**WATER SYSTEM (CONTINUED)**

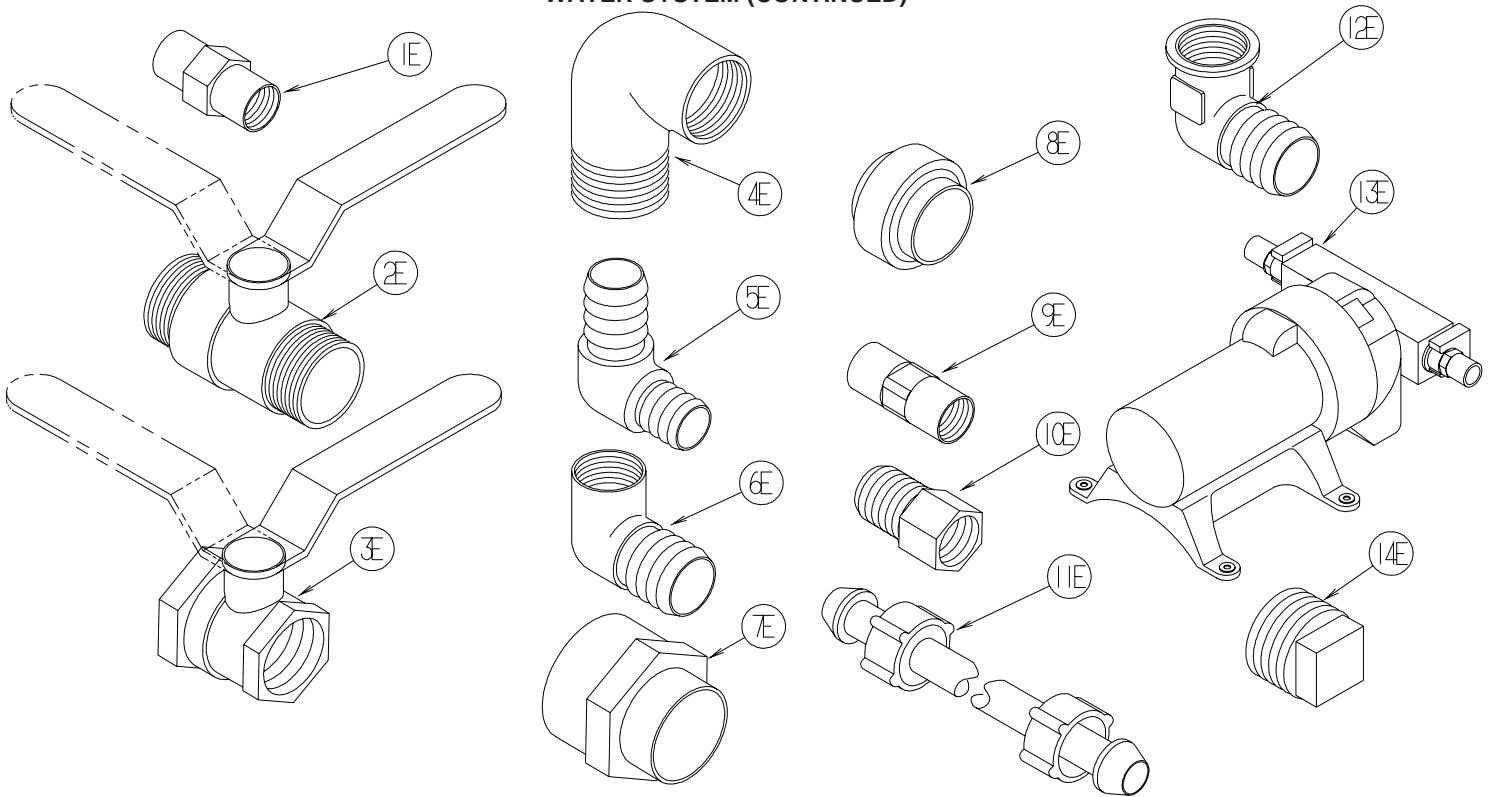

KEY	PART NUMBER	U/M	DESCRIPTION
1E	132148-01-000	EA	CONNECTOR - 1/2" X 1/2" MPT - BRASS
2E	132483-01-000	EA	VALVE/BALL - 1" - THREADED ENDS
3E	132483-02-000	EA	VALVE/BALL - 1/2" - BRASS - FPT
4E	132484-01-000	EA	ELBOW - 90 DEGREE - 1 MPT X 1 FPT - PLASTIC
5E	132781-01-000	EA	ELBOW - 1.3" BARB X 1.3" BARB - 90 DEGREE - PLASTIC
6E	132782-01-000	EA	ELBOW - 1" FPT X 1.3" BARB - 90 DEGREE - PLASTIC
7E	133835-01-000	EA	ADAPTER - REDUCING - 1 1/2" X 1 1/4"
8E	133889-01-000	EA	UNION - 1 1/2" DOUBLE SLIP - PVC
9E	135386-01-000	EA	NIPPLE - 1/2"
10E	136333-01-000	EA	ADAPTER - BRASS - 1/2" MPT X 1/2" FPT
11E	140821-01-000	EA	TUBE - WATER SUPPLY - 3/8" X 24"
11E	140821-02-000	EA	TUBE - WATER SUPPLY - 3/8" X 30"
11E	140821-03-000	EA	TUBE - WATER SUPPLY - 3/8" X 36"
11E	140821-04-000	EA	TUBE - WATER SUPPLY - 3/8" X 48"
11E	140821-05-000	EA	TUBE - WATER SUPPLY - 3/8" X 54"
11E	140821-06-000	EA	TUBE - WATER SUPPLY - 3/8" X 60"
11E	140821-07-000	EA	TUBE - WATER SUPPLY - 3/8" X 72"
12E	142812-01-000	EA	ELBOW - BRASS - 1/2" MPT X 1/2" FPT
13E*	144215-01-000	EA	PUMP - WATER - 5.7 GPM - W/1/2" MPT
*	144215-02-000	EA	STRAINER - WATER PUMP
14E	145609-01-000	EA	PLUG - BRASS - 1/2" MPT/HEX HEAD

**\*COMPONENT PARTS LISTED LATER IN THIS GROUP**

**WATER & SEWAGE GROUP (CONTINUED)**  
**WATER SYSTEM (CONTINUED)**

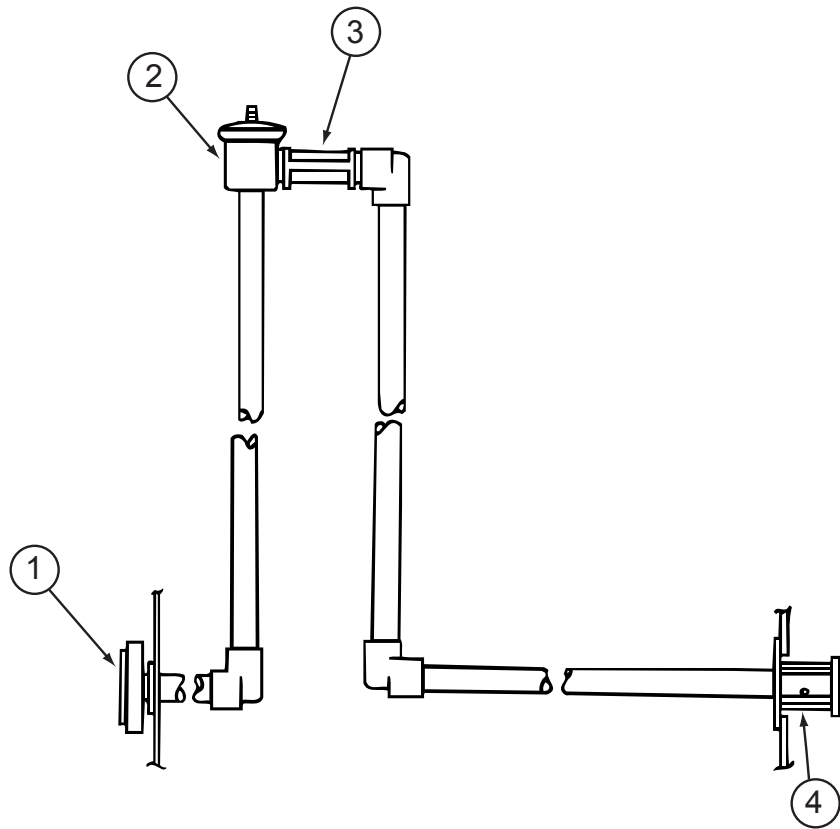

KEY	PART NUMBER	U/M	DESCRIPTION
1	125697-05-000	EA	INLET/WATER - F/FLUSHING SYSTEM
2	125697-04-000	EA	BREAKER/VACUUM - F/FLUSHING SYSTEM
3	125697-03-000	EA	CHECK VALVE - F/FLUSHING SYSTEM
4	125697-02-000	EA	NOZZLE - WELD-A-FLUSH
	125697-06-000	EA	INSTRUCTIONS - USER - F/FLUSHING SYSTEM
	125697-07-000	EA	LABEL - CAUTION - F/FLUSHING SYSTEM

**WATER & SEWAGE GROUP (CONTINUED)**  
**WATER SYSTEM (CONTINUED)**

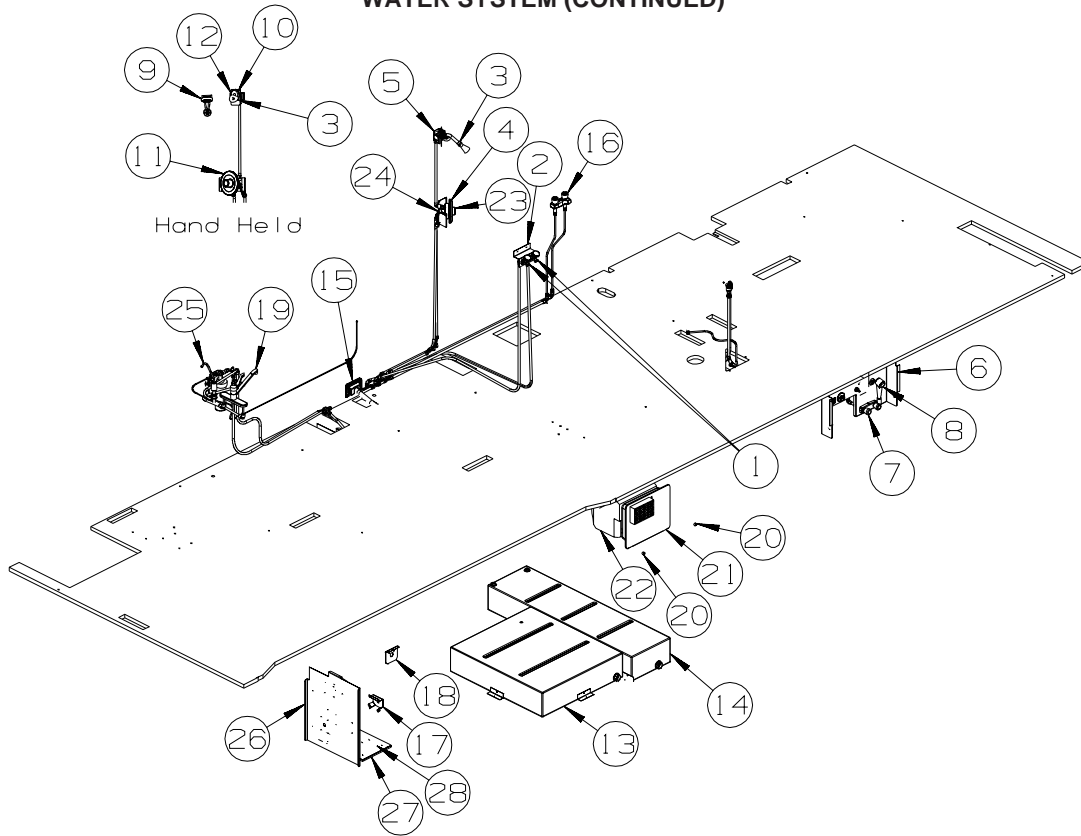

KEY	PART NUMBER	U/M	DESCRIPTION
1	098419-01-000	EA	FAUCET - 90 DEGREE
2	134472-01-02B	EA	BRACKET - FAUCET - WASHER - E-COATED
3	128974-01-01A	EA	VALVE - SHOWER HEAD/WATER SAVER (ON/OFF) - BRIGHT BRASS
4*	144596-03-01A	EA	TRIM KIT - (KNOB-HANDLE/PLATE/SHOWER HEAD & ARM) - BRASS
5	131551-01-02B	EA	BRACKET - SHOWER HEAD
6	136034-10-12B	EA	PANEL - SERVICE CENTER - BRIGHT WHITE
7*	075241-06-000	EA	FAUCET - SHOWER/BRIGHT WHITE - .5" MPT W/1.9" INLET PIPES
8	131383-01-02A	EA	SHOWER HEAD - W/60" HOSE & BRACKET - WHITE
9*	129390-03-01A	EA	SHOWER HEAD - W/HOSE & BRACKET - BRASS
10	130041-03-18A	EA	SPACER/SHOWER HEAD
11*	144596-02-01A	EA	TRIM KIT - (KNOB & PLATE) - CHATEAU - POLISHED BRASS
12	135028-01-01A	EA	DROP ELL - F/HAND HELD SHOWER HEAD - 1/2"IPS - BRASS
			FROM: 00-00-00 THRU: 09-19-04
12	135028-02-01A	EA	DROP ELL - F/HAND HELD SHOWER HEAD/OVAL - 1/2"IP-BRASS
			FROM: 09-20-04 THRU: 99-99-99
13	132224-01-000	EA	TANK - WATER - 40 GALLONS - W/O FITTINGS
13	132224-16-000	EA	TANK - WATER - 40 GALLONS - W/FITTINGS
	042989-03-000	EA	FITTING - SPINWELD - 1 1/4"NPT - PLASTIC
	042989-05-000	EA	FITTING - SPINWELD - 1/2"FPT - PLASTIC
	049032-01-000	EA	PATCH - SPINWELD - 3/8" - PLASTIC
14	137377-01-000	EA	TANK - WATER - 30 GALLON
14	137377-05-000	EA	TANK - WATER - 30 GALLONS - W/FITTINGS
	042989-03-000	EA	FITTING - SPINWELD - 1 1/4"NPT - PLASTIC
	042989-05-000	EA	FITTING - SPINWELD - 1/2"FPT - PLASTIC
	042989-08-000	EA	FITTING - SPINWELD - 1"FPT - PLASTIC
	049032-01-000	EA	PATCH - SPINWELD - 3/8" - PLASTIC

**WATER & SEWAGE GROUP (CONTINUED)**  
**WATER SYSTEM (CONTINUED)**

KEY	PART NUMBER	U/M	DESCRIPTION
15	137169-01-01A	EA	WATER FILL/GRAVITY - W/DOOR - W/O LOCK - BRIGHT WHITE
	138290-03-000	EA	CASE - W/CAM - W/O CYLINDER/KEY
	138289-01-000	EA	CYLINDER - LOCKING
	138289-02-000	EA	CYLINDER - LOCKING
	138289-03-000	EA	CYLINDER - LOCKING
	138289-04-000	EA	CYLINDER - LOCKING
	138289-05-000	EA	CYLINDER - LOCKING
	138289-06-000	EA	CYLINDER - LOCKING
	138289-07-000	EA	CYLINDER - LOCKING
	138289-08-000	EA	CYLINDER - LOCKING
	138289-09-000	EA	CYLINDER - LOCKING
	138289-10-000	EA	CYLINDER - LOCKING
16*	075240-05-000	EA	FAUCET - LAVATORY/BRASS - W/CLEAR KNOBS
17	138618-01-12B	EA	COVER - VALVE - BYPASS - BRIGHT WHITE
18	137410-01-12B	EA	BRACKET - VALVE - WINTERIZATION - BRIGHT WHITE
19	149164-01-01A	EA	FAUCET - GALLEY - SINGLE CONTROL - CHROME
20	117047-02-000	EA	BUMPER - RUBBER/WASHER INSERT
21*	125420-04-03A	EA	DOOR - WATER HEATER - 18" X 14.6" - BLACK
21*	125420-03-03A	EA	DOOR - WATER HEATER - 18" X 17.7" - BLACK-WASHER/DRYER,WTR HTR-10GL/ELEC/LP/MTRAIID
22*	051393-01-000	EA	WATER HEATER - GH6-8E - ELECTRONIC IGNITION W/MOTOR AID - WTR HTR-AUX AUTO/MOTORAIID
22*	145541-02-000	EA	WATER HEATER-6 GAL-GAS/ELEC/120'-REM IGN-W/HEAT EXC-4E -WTR HTR-6GAL/ELE/LP/MOTORAIID
22*	145541-01-000	EA	WTR HTR/MOTOR AID-GAS/ELECT IGN—10 GL-WASHER/DRYER,WTR HTR-10GL/ELEC/LP/MTRAIID
23*	144596-01-01A	EA	FAUCET/VALVE ONLY - SHOWER - W/TEMP LIMIT STOP(MOEN 62300)
24	131554-01-02B	EA	BRACKET/SHOWER CONTROL - E-COATED
25*	103635-01-000	EA	FAUCET - SINGLE CONTROL/DRINKING WATER
26	149497-01-12B	EA	PANEL - F/VALVE BYPASS - BRIGHT WHITE
27	149477-01-02B	EA	PANEL - WATER PUMP - E-COATED
28	140364-04-01A	EA	FOAM - PAD - .5" X 12" X 18"

**\*COMPONENT PARTS LISTED LATER IN THIS GROUP**

**WATER & SEWAGE GROUP (CONTINUED)**  
**COMPONENT PARTS FOR WATER SYSTEM**

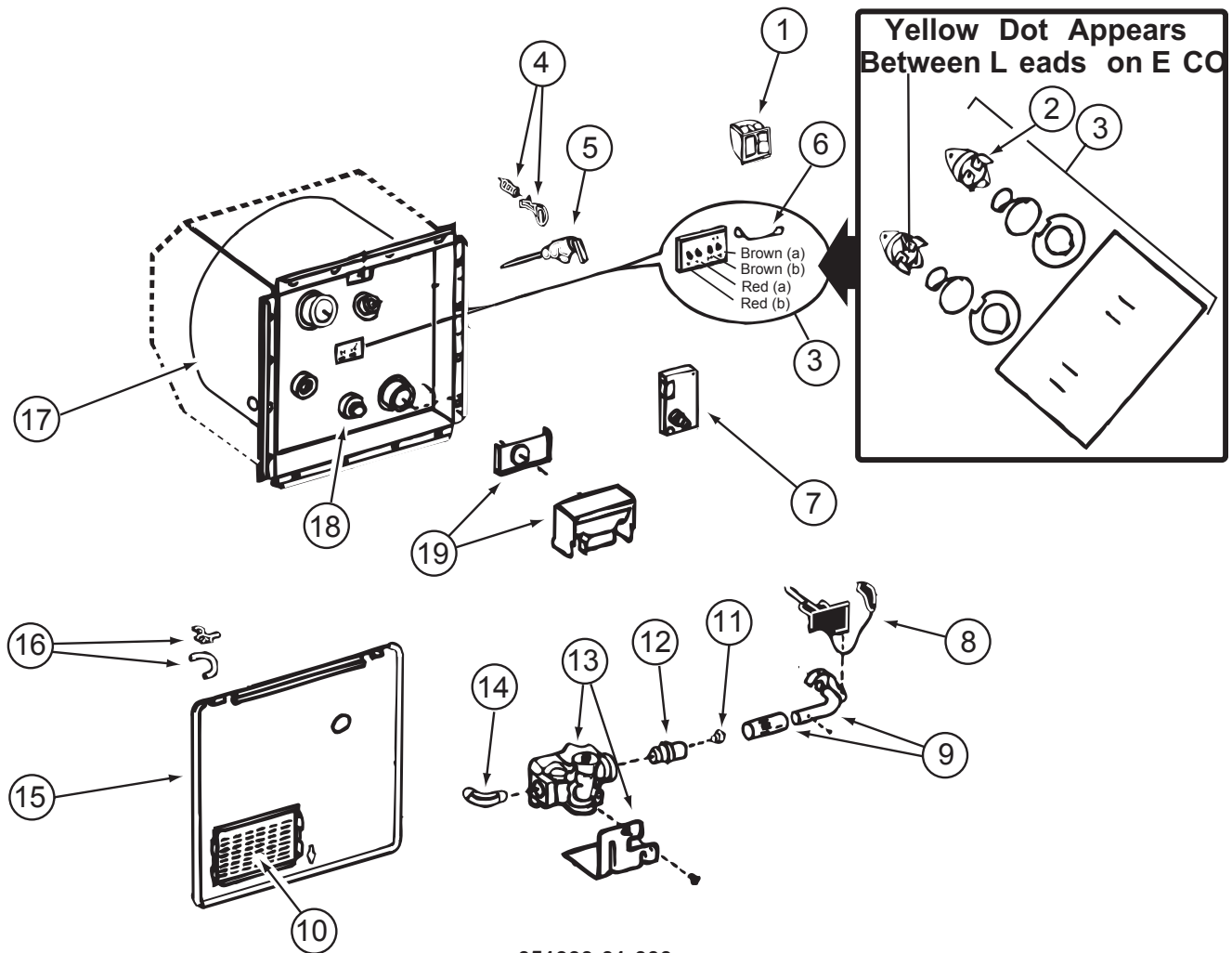

**051393-01-000**

KEY	PART NUMBER	U/M	DESCRIPTION	VENDOR NO.
1	051393-01-701	EA	SWITCH PACKAGE	91959
2	051391-04-701	EA	THERMOSTAT 12V DC-120 PRESET	91470
3	051393-01-721	EA	ECO & THERMOSTAT ASM - FRT MT - 140°	91447
4	051391-01-705	EA	FASTENER - CAMLOC	92609
5	051391-01-704	EA	VALVE - RELIEF - 1/2" FITTING	91604
6	051393-01-723	EA	SWITCH - ENERGY CUT-OFF	93866
7	051393-01-724	EA	CIRCUIT BOARD - W/ SPADE TERMINAL	93867
8	051393-01-725	EA	ELECTRODE - SINGLE SPADE CNT	93868
9	051391-04-703	EA	BURNER - MAIN	91638
10	051391-01-717	EA	GRILLE	92640
11	051391-01-710	EA	ORIFICE - MAIN BURNER	92742
12	051391-03-700	EA	ORIFICE HOLDER	91563
13	051393-01-726	EA	SOLENOID VALVE & BRACKET	93870
14	051391-01-714	EA	ELBOW - 45 DEGREE - 3/8" F X 3/8" MPT	91044
15		EA	DOOR-WATER HEATER - SEE EXTERIOR DOOR & COMPARTMENT GROUP BY MODEL	
16	051391-01-700	EA	HINGE KIT - W/CLIP	92568 & 92559
17	051391-04-704	EA	TANK - INNER	91642
18	051391-01-715	EA	DRAIN PLUG	91857
19	051391-04-707	EA	FLUE & GASKET	90960
	111129-01-711	EA	BRACKET-CORNER, SET OF FOUR	91928

**075240-05-000**

KEY	PART NUMBER	U/M	DESCRIPTION	VENDOR NO.
	075240-05-700	EA	CARTRIDGE - WASHERLESS	9-P42

**WATER & SEWAGE GROUP (CONTINUED)**  
**COMPONENT PARTS FOR WATER SYSTEM (CONTINUED)**

075241-04-000, 075241-05-000, 075241-06-000

KEY	PART NUMBER	U/M DESCRIPTION	VENDOR NO.
	075240-05-700	EA CARTRIDGE - WASHERLESS	9-P42

098607-01-000

KEY	PART NUMBER	U/M DESCRIPTION	VENDOR NO.
	098607-01-702	EA DIAPHRAGM/DRIVE ASSEMBLY KIT	94-238-04
	098607-01-703	EA VALVE KIT	94-232-00
	098607-01-705	EA VALVE-CHECK, KIT	94-237-00
	098607-01-706	EA HOUSING, W/SWITCH ONLY	94-231-20
	098607-01-707	EA MOTOR W/BASEPLATE	11-148-04

103635-01-000

KEY	PART NUMBER	U/M DESCRIPTION	VENDOR NO.
	103635-01-703	EA CARTRIDGE - 10"	ADC-959201

125420-01-02A, 125420-01-03A, 125420-03-03A, 125420-04-03A

KEY	PART NUMBER	U/M DESCRIPTION	VENDOR NO.
	051391-01-705	EA FASTENER - CAMLOCK	92609

129390-03-01A

KEY	PART NUMBER	U/M DESCRIPTION	VENDOR NO.
	129390-03-700	EA BRACKET-HANGAR/SHOWER HEAD	5001-210PK
	129390 03 701	EA CONNECTOR-SWIVE	4002-210PK

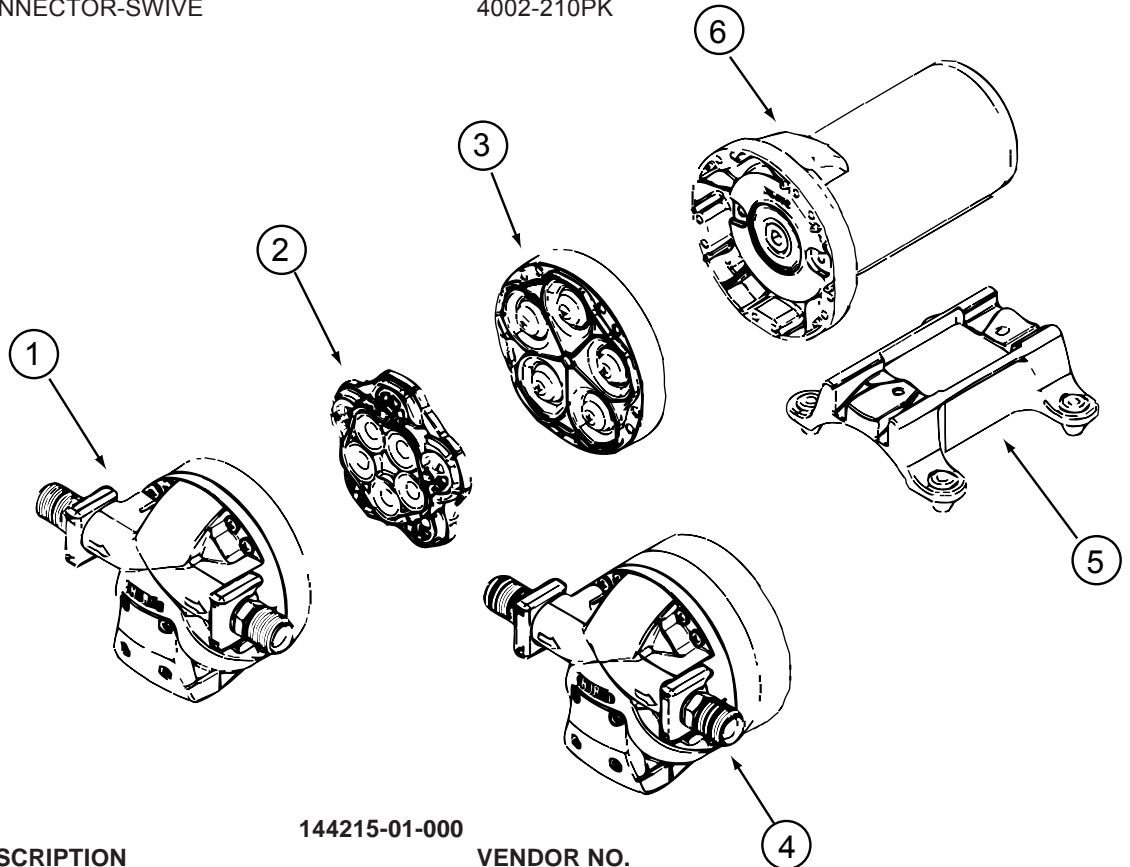

144215-01-000

KEY	PART NUMBER	U/M DESCRIPTION	VENDOR NO.
2	144215-01-700	EA VALVE ASSEMBLY	94-030-01
3	144215-01-701	EA DRIVE ASSEMBLY	94-030-02
	144215-01-702	EA FITTING KIT - W/ORINGS	94-615-06

CONTACT WINNEBAGO PARTS SALES FOR UNLISTED COMPONENT(S)

144215-02-000

KEY	PART NUMBER	U/M DESCRIPTION	VENDOR NO.
	144215-02-700	EA FITTING KIT- COUPLER W/ORING	94-637-00

144596-01-01A

KEY	PART NUMBER	U/M DESCRIPTION	VENDOR NO.
	144596-01-700	EA CARTRIDGE (REPLACEMENT)	1222

144596-02-01A, 144596-03-01A

KEY	PART NUMBER	U/M DESCRIPTION	VENDOR NO.
	144596-03-700	EA KNOB (INSERT KIT) WHITE/GOLD	M0-91754

**WATER & SEWAGE GROUP (CONTINUED)**  
**COMPONENT PARTS FOR WATER SYSTEM (CONTINUED)**

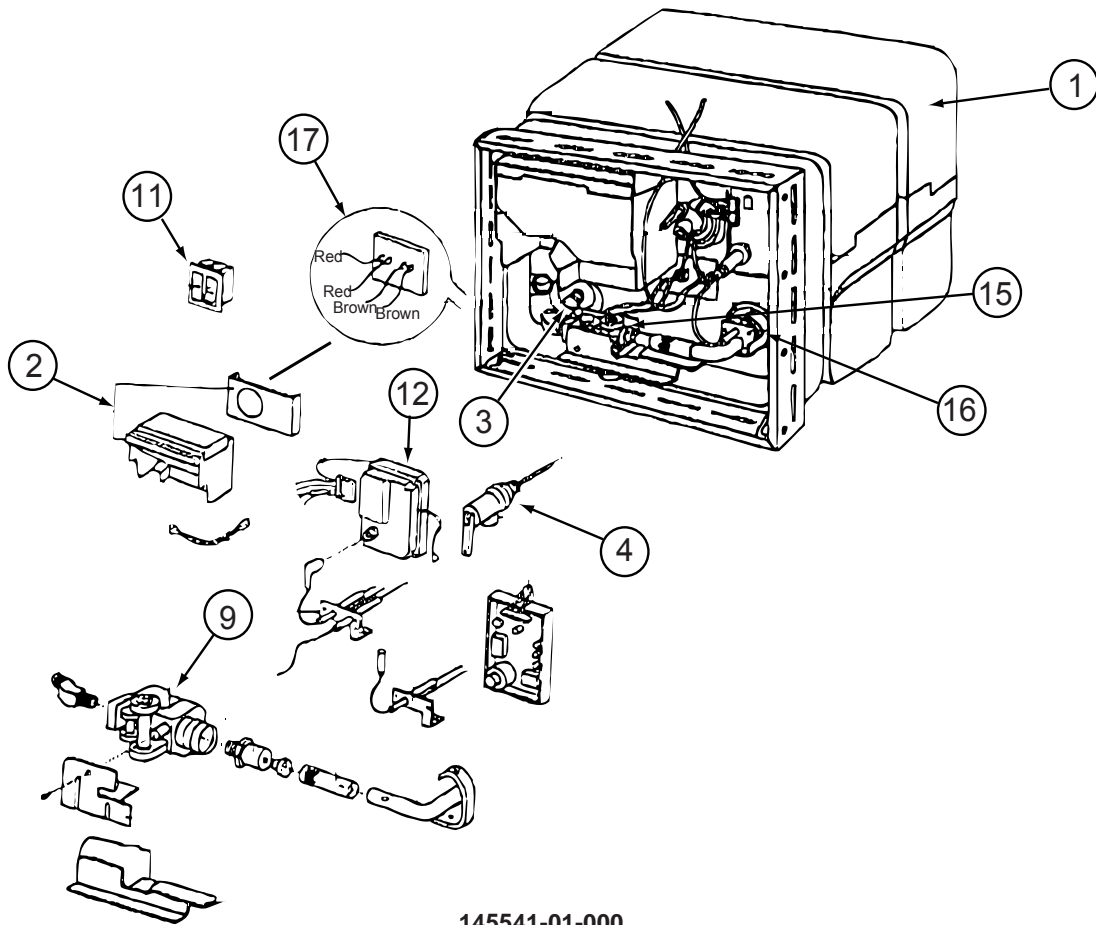

**145541-01-000**

KEY	PART NUMBER	U/M	DESCRIPTION	VENDOR NO.
1	145541-01-700	EA	TANK - W/INSULATION - 10 GAL	91028
2	051391-04-707	EA	KIT-EXHAUST, (FLUE & GASKET)	90960
3	051391-01-715	EA	PLUG-DRAIN, 1 EA = 2 PER PKG	91857
4	051391-01-704	EA	VALVE-RELIEF, 1/2" FITTING	91604
9	051393-01-726	EA	VALVE/SOLENOID - W/O BRACKET	93870
11	145541-01-701	EA	SWITCH - ON/OFF - WHITE	91859
12	145541-01-702	EA	CIRCUIT BOARD	91226
15	145541-01-703	EA	SWITCH - THERMAL CUT OFF	93866
16	051393-01-725	EA	ELECTRODE-SGL SPADE CONNECT.	93868
17	051393-01-721	EA	THERMOSTAT W/ECO, 140 FRT MT	91447
	051391-05-706	EA	ELEMENT-HEATING 1500 WATT	92249 W/GASKET
	051393-01-701	EA	SWITCH - REMOTE - W/LIGHT	91959
	145541-01-704	EA	RELAY	90061
	145541-01-705	EA	JUNCTION BOX(PLASTIC) 10 GAL	91224

CONTACT WINNEBAGO PARTS SALES FOR UNLISTED COMPONENT(S)

**145541-02-000**

KEY	PART NUMBER	U/M	DESCRIPTION	VENDOR NO.
1	145541-02-700	EA	TANK/SERVICE KIT PCS- 6 GAL	91053
2	051391-04-707	EA	KIT-EXHAUST, (FLUE & GASKET)	90960
3	051391-01-715	EA	PLUG-DRAIN, 1 EA = 2 PER PKG	91857
4	051391-01-704	EA	VALVE-RELIEF, 1/2" FITTING	91604
9	051393-01-726	EA	VALVE-SOLENOID - W/O BRACKET	93870
11	051393-01-701	EA	SWITCH - REMOTE - W/LIGHT	91959
11	145541-01-701	EA	SWITCH - ON/OFF - WHITE	91859
12	145541-01-702	EA	CIRCUIT BOARD	91226
15	145541-01-703	EA	SWITCH - THERMAL CUT OFF	93866
16	051393-01-725	EA	ELECTRODE-SGL SPADE CONNECT.	93868
17	051393-01-721	EA	THERMOSTAT W/ECO, 140 FRT MT	91447
	051391-05-706	EA	ELEMENT-HEATING 1500 WATT	92249 W/GASKET
	145541-01-704	EA	RELAY	90061
	145541-02-701	EA	JUNCTION BOX(PLASTIC) 6 GAL	91222

CONTACT WINNEBAGO PARTS SALES FOR UNLISTED COMPONENT(S)



## WINDOW & VENTS GROUP

### WINDOW & VENT LAYOUT

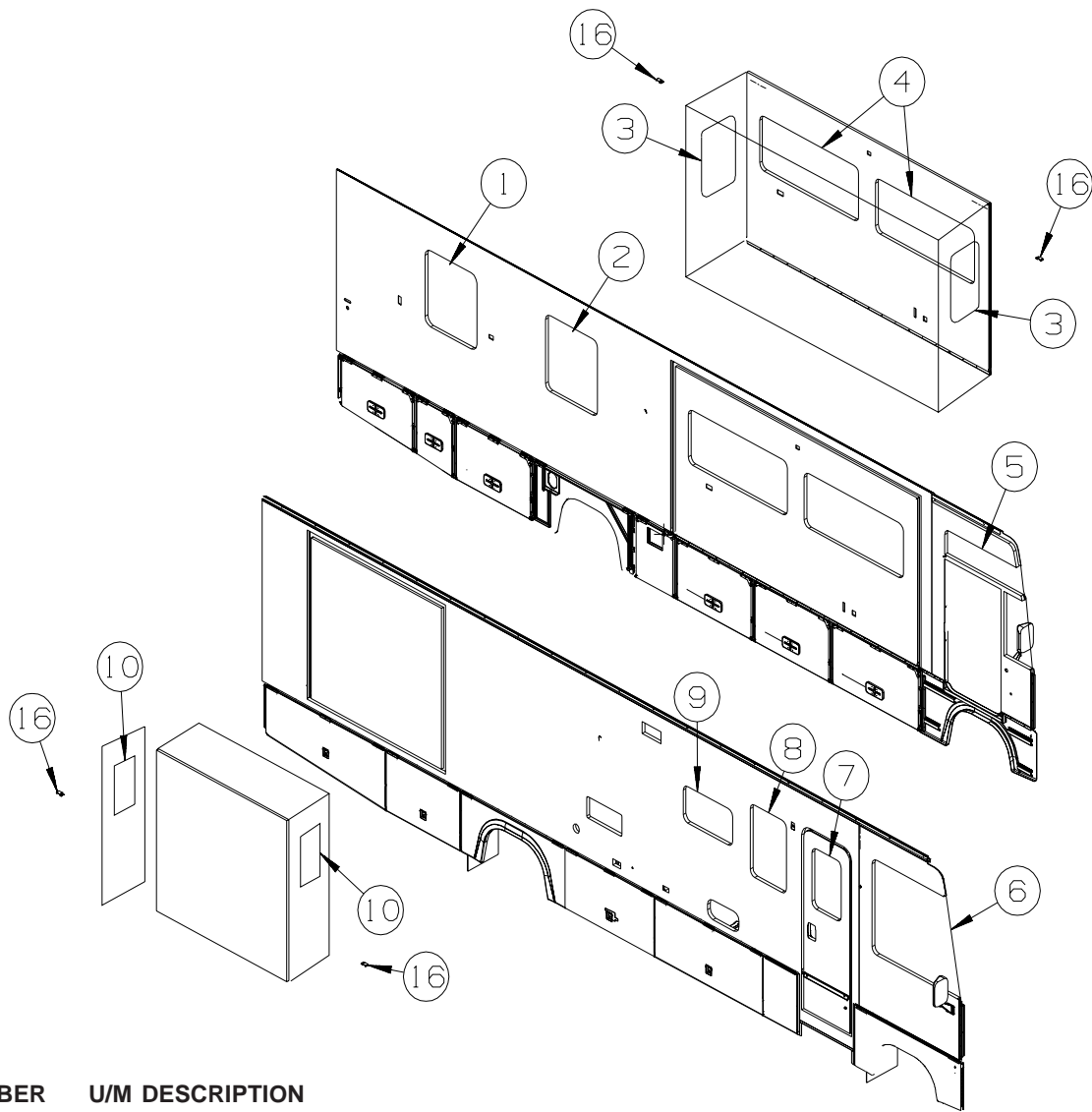

KEY	PART NUMBER	U/M	DESCRIPTION
1*	113500-06-02A	EA	WINDOW - DBL TIPOUT/ESCAPE W/TRIM - TINTED - 33.2" X 30.2"
1*	150656-02-01A	EA	WINDOW - TIPOUT/FLUSH/ESCAPE/THERMO - 33.2" X 30.2" - <b>WINDOWS-COACH-DUAL PANE</b>
2*	112463-03-02A	EA	WINDOW - TIPOUT W/RETAINER - 33.3" X 30.2"
2	150656-01-01A	EA	WINDOW - TIPOUT/FLUSH/THERMO - 33.2" X 30.2" - <b>WINDOWS-COACH-DUAL PANE</b>
10*	098644-13-01A	EA	WINDOW - VERTICAL SLIDER W/TRIM - 19.8" X 20.9"
10*	150649-07-01A	EA	WINDOW - VERT SLIDER/FLUSH/THERMO - 19.8" X 20.8" - <b>WINDOWS-COACH-DUAL PANE</b>
4*	098647-47-02A	EA	WINDOW - DRVR HORIZ SLIDER W/TRIM - TINTED - 57.4" X 23.6"
4*	150648-07-01A	EA	WINDOW-HORIZ SLIDER/FLUSH/THERMO/LH - 23.8" X 57.7" - <b>WINDOWS-COACH-DUAL PANE</b>
5*	125586-01-01A	EA	WINDOW - VISTA
5	151074-01-01A	EA	WINDOW - CAB/VISTA/FLUSH/THERMO - 11.3" X 44.7"/41.8" - <b>WINDOWS-COACH-DUAL PANE</b>
17*	125584-01-01A	EA	WINDOW/WING - DRIVER W/TRIM - 11.6" X 29.2" X 16.8"
17	151073-01-01A	EA	WINDOW - CAB/FRT SLANT/FLUSH/THERMO - 28.1" X 19.7"/6.6" - <b>WINDOWS-COACH-DUAL PANE</b>
6*	125582-01-01A	EA	WINDOW - PASSENGER CAB/3 WINDOW - 42.9"T X 42.6"H X 51.2"B
6*	151072-01-01A	EA	WINDOW - CAB/RIGHT HAND/FLUSH/THERMO - 41.5" X 50.2"/41.8" - <b>WINDOWS-COACH-DUAL PANE</b>
7	117053-02-F36	EA	WINDOW - PICTURE - W/O TRIM - 60% TINTING - 26.4" X 17"
	002181-25-000	EA	GLASS - PICTURE WINDOW - 25.8"W X 16.4"H
	087561-01-000	FT	SEAL - GLASS - EXTERIOR - .5" WIDE - VINYL BLACK
7	117054-02-02A	EA	TRIM/RETAINER - INSIDE - 16.9" X 26.2" - BRIGHT WHITE FROM: 00-00-00 THRU: 11-28-04
7	117054-02-03A	EA	TRIM/RETAINER - INSIDE - 16.9" X 26.2" - BLACK FROM: 11-29-04 THRU: 99-99-99
7*	113733-10-01A	EA	WINDOW - STATIONARY W/TRIM - THERMO/EURO - 26.3" X 17" - <b>WINDOWS-COACH-DUAL PANE</b> FROM: 00-00-00 THRU: 05-02-04
7*	150651-01-01A	EA	WINDOW - STATIONARY/FLUSH/THERMO - 26.3" X 17" - BLACK - <b>WINDOWS-COACH-DUAL PANE</b> FROM: 05-03-04 THRU: 99-99-99
8*	098644-04-03A	EA	WINDOW - VERTICAL SLIDER W/TRIM - TINTED - 31.7" X 21.1"

**WINDOW & VENTS GROUP (CONTINUED)**  
**WINDOW & VENT LAYOUT (CONTINUED)**

KEY	PART NUMBER	U/M	DESCRIPTION
8*	150649-10-01A	EA	WINDOW - VERT SLIDER/FLUSH/THERMO - 31.7" X 21.1" - <b>WINDOWS-COACH-DUAL PANE</b>
9*	098647-33-02A	EA	WINDOW - PASS HORIZ SLIDER W/TRIM - CLEAR - 28.5" X 15.7"
9*	150648-04-01A	EA	WINDOW-HORIZ SLIDER/FLUSH/THERMO/RH - 16" X 28.7" - <b>WINDOWS-COACH-DUAL PANE</b>
11	138983-01-01A	EA	VENT - MICROWAVE/OUTER - BRIGHT WHITE
	138983-03-01A	EA	COVER - VENT MICROWAVE/OUTER - BRIGHT WHITE
12	149508-01-02A	EA	CAP - ROOF/REFRIGERATOR VENT - WHITE
12	149508-02-02A	EA	BASE - ROOF/REFRIGERATOR VENT - BRIGHT WHITE
13	122214-01-02A	EA	PANEL - SKYLITE - INNER - W/ANGLED CORNER - WHITE
13	138372-01-02B	EA	TRIM - CORNER - SKYLIGHT - E-COATED
13	139411-01-01A	EA	PANEL/SKYLITE - OUTER - NEO ANGLE - WHITE
14*	122882-02-01A	EA	VENT - ROOF - W/FAN - W/O INSIDE GARNISH - UL - <b>U.S. - POWER VENT</b>
14*	122882-03-01A	EA	VENT - ROOF - W/FAN - W/O INSIDE GARNISH - CSA - <b>CANADIAN - POWER VENT</b>
	009440-01-000	EA	GEAR/ARM - LIFT - ROOF VENT COVER
	048648-01-000	EA	MOTOR/ROOF VENT - W/RESISTER - 1/8"SHAFT - 12VOLT
	048649-01-000	EA	FAN BLADE - ROOF VENT - 6 BLADED - 6"RADIUS
14	122882-07-01A	EA	GARNISH - ROOF VENT - 2.5" TO 4.1"
15*	122882-01-01A	EA	VENT - ROOF - NONPOWERED - W/O INSIDE GARNISH - <b>NON-POWERED</b>
	009440-01-000	EA	GEAR/ARM - LIFT - ROOF VENT COVER
15	122882-07-01A	EA	GARNISH - ROOF VENT - 2.5" TO 4.1"
15*	123780-03-01A	EA	VENT-3"/4"ROOF-W/FAN-W/O THERM/PWR LIFT/WHT CVR - <b>POWERED VENT W/VENTILATOR</b>
	009440-01-000	EA	GEAR/ARM - LIFT - ROOF VENT COVER
16	151905-01-01A	EA	CLIP/BRACKET - SCREEN RETAINER - BLACK

**\*COMPONENT PARTS LISTED LATER IN THIS GROUP**

**WINDOW & VENTS GROUP (CONTINUED)**  
**COMPONENT PARTS FOR WINDOW & VENT LAYOUT**

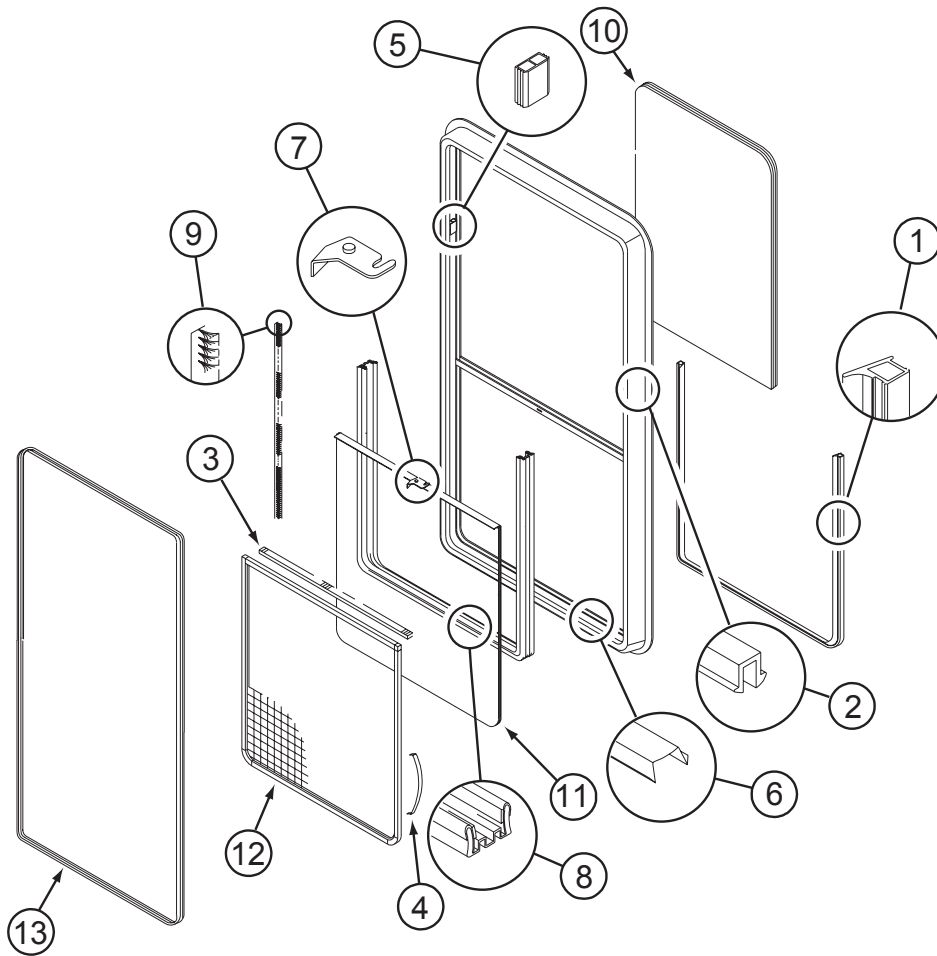

**098644-04-03A**

KEY	PART NUMBER	U/M	DESCRIPTION	VENDOR NO.
1	098644-01-716	FT	PLUG - FILLER	132-014470
2	098644-01-705	FT	GLAZING - STRIP	132-010231
3	098644-01-706	FT	WEATHERSTRIP - GLASS	171-010668
4	098644-01-713	EA	CLIP - SCREEN - METAL	226-016966
4	125582-01-701	EA	CLIP - SCREEN - PLASTIC	130-005153
5	098644-01-719	EA	STOP - SLIDER GLASS	132-014203
6	098644-01-710	FT	TRACK - SCREEN SPACER 12'	132-017135
7	098647-54-701	EA	LATCH - REPAIR KIT (RED)	B081-CK
8	098644-01-708	FT	CHANNEL - RUN PIERCED	122-016543
9	098644-01-711	FT	WEATHERSTRIP - SCREEN BLACK	171-016965
	098644-01-717	FT	SPLINE - SCREEN	132-004716
10	098644-04-701	EA	GLASS - STATIONARY	106-017953
11	098644-04-702	EA	GLASS-SLIDING W/SASH & LATCH	H332-G9
12	098644-04-703	EA	SCREEN ASM - W/SEALS & CLIPS	410-017955
13	098644-04-704	EA	RETAINER - TRIM	H332-67

**WINDOW & VENTS GROUP (CONTINUED)**  
**COMPONENT PARTS FOR WINDOW & VENT LAYOUT (CONTINUED)**

098644-13-01A

KEY	PART NUMBER	U/M	DESCRIPTION	VENDOR NO.
1	098644-01-716	FT	PLUG - FILLER	132-014470
2	098644-01-705	FT	GLAZING - STRIP	132-010231
3	098644-01-706	FT	WEATHERSTRIP - GLASS	171-010668
4	098644-01-713	EA	CLIP - SCREEN - METAL	226-016966
4	125582-01-701	EA	CLIP - SCREEN - PLASTIC	130-005153
5	098644-01-719	EA	STOP - SLIDER GLASS	132-014203
6	098644-01-710	FT	TRACK - SCREEN SPACER 12'	132-017135
7	098644-01-700	EA	LATCH - REPAIR KIT (BLACK)	B801-CK
7	098647-54-701	EA	LATCH - REPAIR KIT (RED)	B081-CK
8	098644-01-708	FT	CHANNEL - RUN PIERCED	122-016543
9	098644-01-711	FT	WEATHERSTRIP - SCREEN BLACK	171-016965
10	098644-13-700	EA	GLASS - STATIONARY	106-028698
11	098644-13-701	EA	GLASS - SLIDING W/SASH/LATCH	H702-G9
12	098644-13-702	EA	SCREEN ASM - W/SEALS/CLIPS	410-028663
13	098644-13-703	EA	RETAINER - TRIM	H702-60
	098644-01-717	FT	SPLINE - SCREEN	132-004716

**WINDOW & VENTS GROUP (CONTINUED)**  
**COMPONENT PARTS FOR WINDOW & VENT LAYOUT (CONTINUED)**

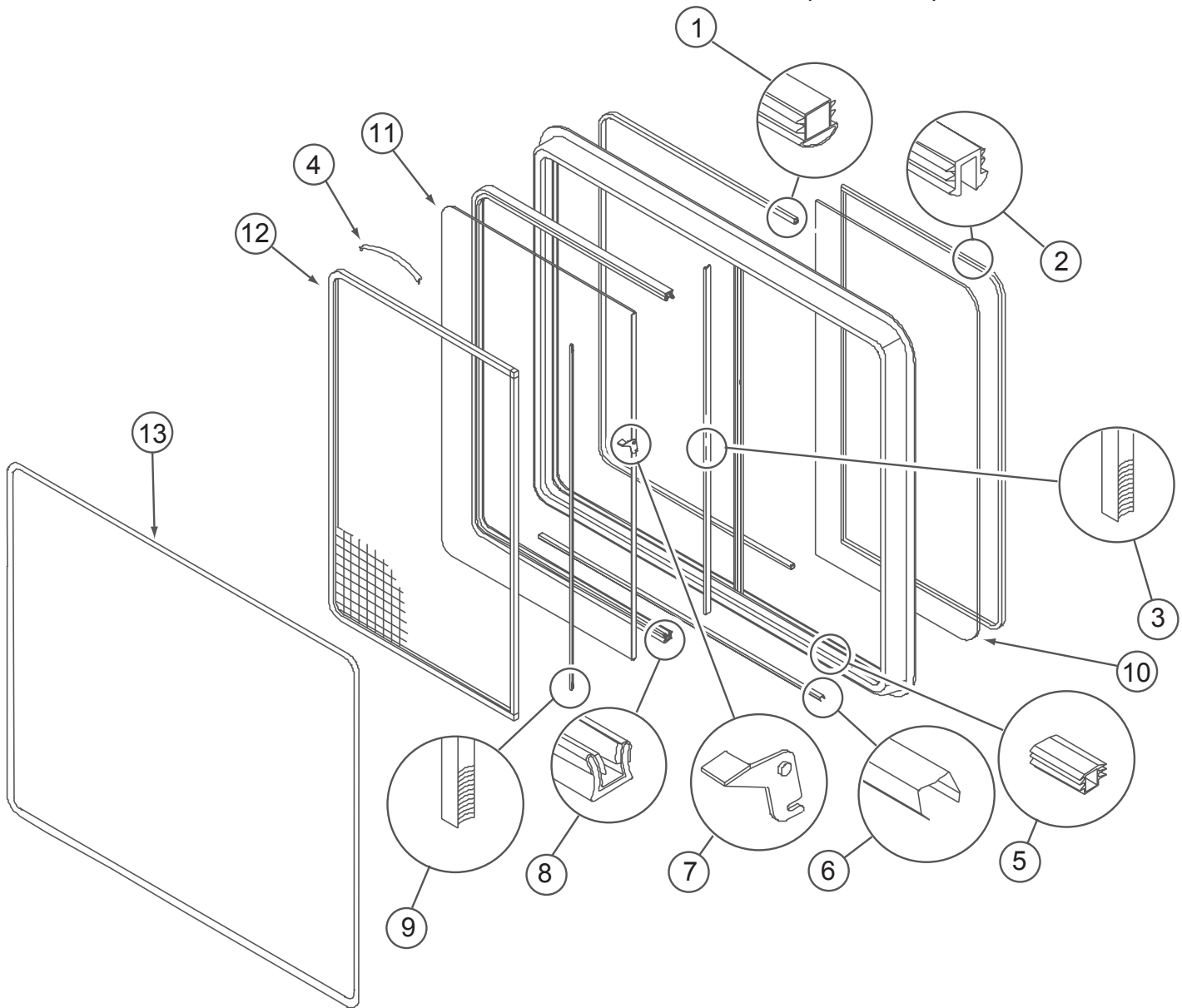

**098647-33-02A**

<b>KEY</b>	<b>PART NUMBER</b>	<b>U/M</b>	<b>DESCRIPTION</b>	<b>VENDOR NO.</b>
1	098644-01-716	FT	PLUG - FILLER	132-014470
2	098644-01-705	FT	GLAZING - STRIP	132-010231
3	098644-01-706	FT	WEATHERSTRIP - GLASS	171-010668
4	098644-01-713	EA	CLIP - SCREEN - METAL	226-016966
4	125582-01-701	EA	CLIP - SCREEN - PLASTIC	130-0
5	098644-01-719	EA	STOP - SLIDER GLASS	132-014203
6	098644-01-710	FT	TRACK - SCREEN SPACER 12'	132-017135
7	098647-54-701	EA	LATCH - REPAIR KIT (RED)	B081-CK
8	098644-01-708	FT	CHANNEL - RUN PIERCED	122-016543
9	098644-01-711	FT	WEATHERSTRIP - SCREEN BLACK	171-016965
10	098647-33-702	EA	GLASS - STATIONARY	106-019297
11	098647-33-703	EA	GLASS-SLIDING W/SASH & LATCH	H425-G9
12	098647-33-704	EA	SCREEN ASM - W/SEALS & CLIPS	410-019134
13	098647-31-705	EA	RETAINER - TRIM	CH29-66
	098644-01-717	FT	SPLINE - SCREEN	132-004716

**WINDOW & VENTS GROUP (CONTINUED)**  
**COMPONENT PARTS FOR WINDOW & VENT LAYOUT (CONTINUED)**

098647-47-02A

KEY	PART NUMBER	U/M	DESCRIPTION	VENDOR NO.
1	098644-01-716	FT	PLUG - FILLER	132-014470
2	098644-01-705	FT	GLAZING - STRIP	132-010231
3	098644-01-706	FT	WEATHERSTRIP - GLASS	171-010668
4	098644-01-713	EA	CLIP - SCREEN - METAL	226-016966
4	125582-01-701	EA	CLIP - SCREEN - PLASTIC	130-005153
5	098644-01-719	EA	STOP - SLIDER GLASS	132-014203
6	098644-01-710	FT	TRACK - SCREEN SPACER 12'	132-017135
7	098644-01-700	EA	LATCH - REPAIR KIT (BLACK)	B801-CK
7	098647-54-701	EA	LATCH - REPAIR KIT (RED)	B081-CK
8	098644-01-708	FT	CHANNEL - RUN PIERCED	122-016543
9	098644-01-711	FT	WEATHERSTRIP - SCREEN BLACK	171-016965
10	098647-47-700	EA	GLASS - STATIONARY	106-025224
11	098647-47-701	EA	GLASS-SLIDING W/SASH & LATCH	H493-G9
12	098647-47-702	EA	SCREEN ASM - W/SEALS & CLIPS	410-025226
13	098647-47-704	EA	RETAINER - TRIM	H493-66
	098644-01-717	FT	SPLINE - SCREEN	132-004716

**WINDOW & VENTS GROUP (CONTINUED)**  
**COMPONENT PARTS FOR WINDOW & VENT LAYOUT (CONTINUED)**

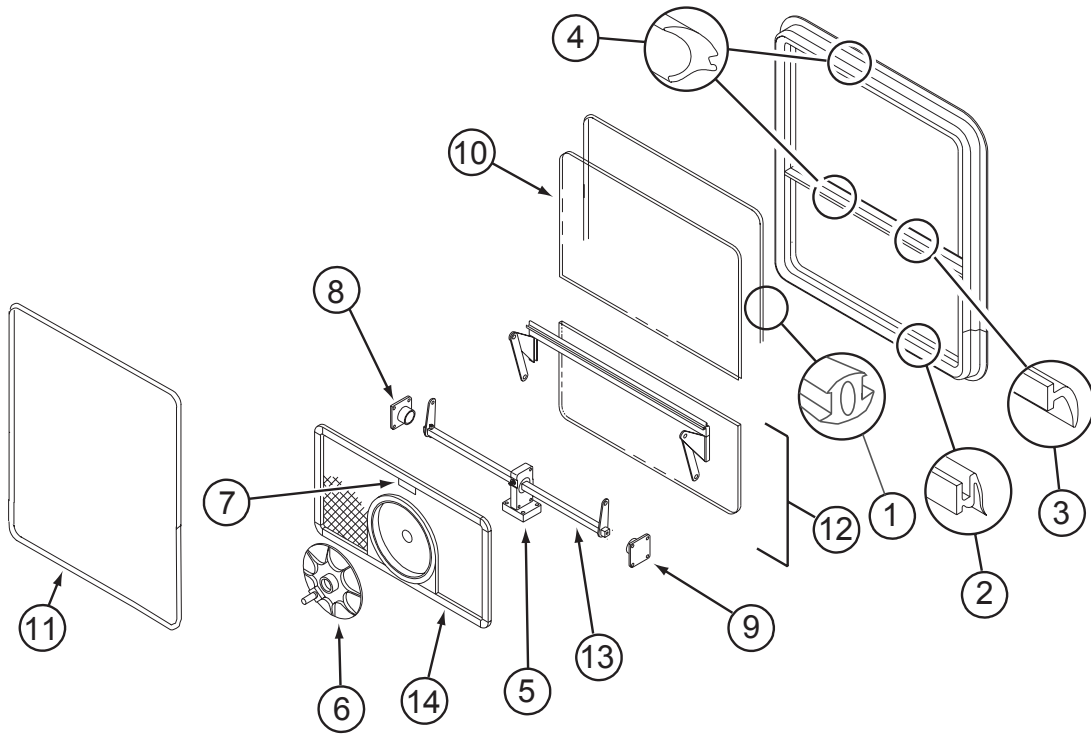

112463-03-02A

KEY	PART NUMBER	U/M	DESCRIPTION	VENDOR NO.
1	116976-01-702	FT	FILLER PLUG	132-016065
2	100322-01-701	FT	SEAL-VENT	122-016071
3	100322-01-702	EA	WEATHERSTRIP-HORIZ RAIL-148"	132-019631
4	100322-01-703	FT	VINYL-GLAZING, BUTYL	132-010723
5	100322-01-716	EA	SUPPORT-TORQUE BAR, CTR RAIL	130-015980
6	100322-01-718	EA	HANDLE-DIAL	410-016081
7	112519-01-706	EA	CLIP-SCREEN	CH21-50
8	113500-01-707	EA	SUPPORT - TORQUE BAR RH	130-015979
9	113500-01-708	EA	SUPPORT - TORQUE BAR LH	130-015978
10	112463-03-701	EA	GLASS - STATIONARY	106-025377
11	112463-03-704	EA	RETAINER - TRIM	CB100-59
12	112463-03-700	EA	VENT ASSEMBLY	CH100-G9
13	113500-05-703	EA	OPERATOR & BAR ASSEMBLY	CH10-15
14	112463-03-703	EA	SCREEN ASM - W/SEALS & CLIPS	410-018439
	100322-01-717	EA	E-RING	245-015975

**WINDOW & VENTS GROUP (CONTINUED)**  
**COMPONENT PARTS FOR WINDOW & VENT LAYOUT (CONTINUED)**

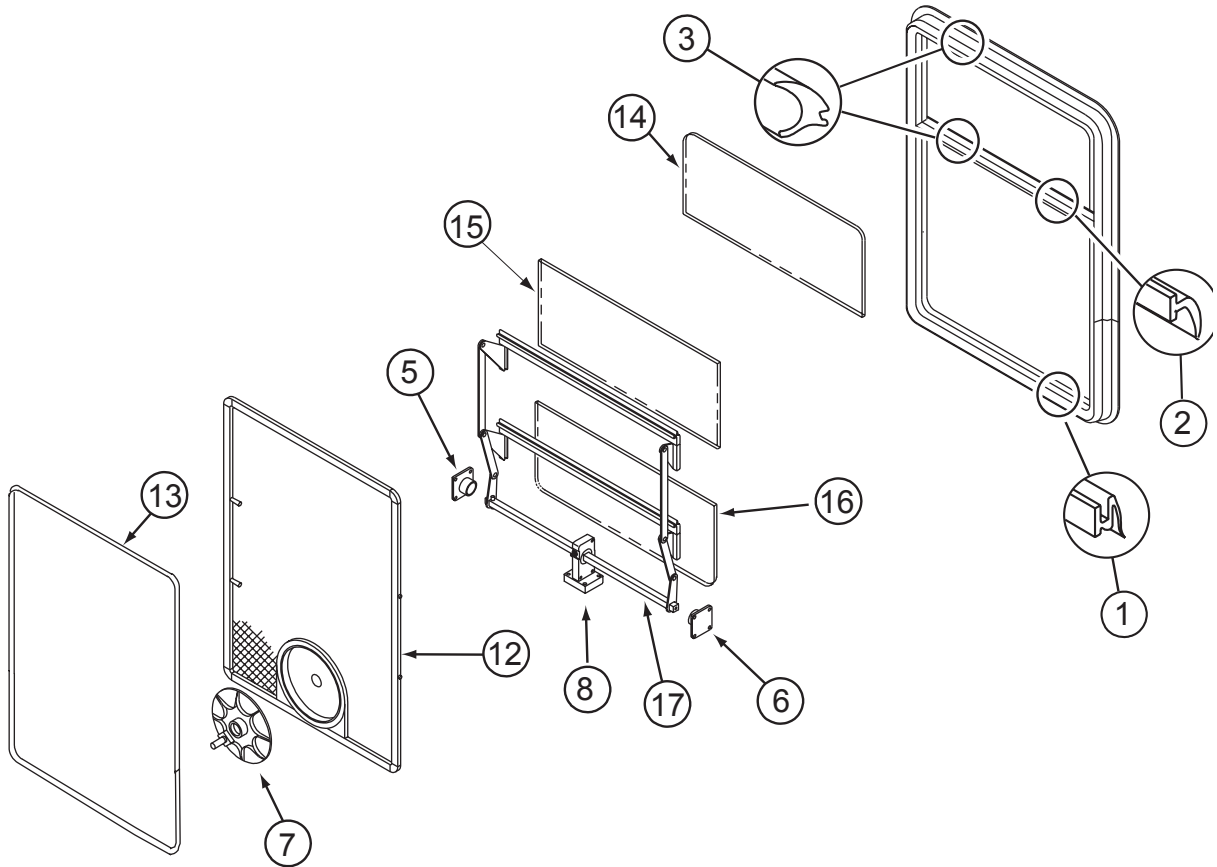

**113500-06-02A**

KEY	PART NUMBER	U/M	DESCRIPTION	VENDOR NO.
1	116976-01-702	FT	FILLER PLUG	132-016065
2	100322-01-701	FT	SEAL-VENT	122-016071
3	100322-01-702	EA	WEATHERSTRIP-HORIZ RAIL-148"	132-019631
5	100322-01-714	EA	SUPPORT-TORQUE BAR, LH	130-015978
6	100322-01-715	EA	SUPPORT-TORQUE BAR, RH	130-015979
7	100322-01-718	EA	HANDLE-DIAL	410-016081
8	112519-01-702	EA	TORQUE-CTR SUPPORT (4 HOLE)	410-016123
12	113500-06-704	EA	SCREEN ASM - W/SEALS & CLIPS	410-025661
13	112463-05-704	EA	RETAINER - TRIM	CB101-59
14	113500-06-700	EA	GLASS - STATIONARY	106-025658
15	113500-06-701	EA	VENT ASM (UPPER)	CH105-D7
16	113500-06-702	EA	VENT ASM (LOWER)	CH105-D9
17	113500-06-703	EA	OPERATOR BAR ASSEMBLY	CH65-15
	100322-01-703	FT	VINYL-GLAZING, BUTYL	132-010723
	100322-01-717	EA	E-RING	245-015975
	112463-02-706	FT	SEAL - FOAM RUBBER	140-014727
	112898-06-704	EA	HANDLE/RH-(TIPOUT)ESCAPE-RED	182-11293
	112898-06-705	EA	HANDLE-LH-(TIPOUT)ESCAPE-RED	182-11294

CONTACT WINNEBAGO PART SALES FOR UNLISTED COMPONENT(S)

**113733-10-01A**

KEY	PART NUMBER	U/M	DESCRIPTION	VENDOR NO.
	112795-01-705	FT	VINYL - GLAZING	132-025736
	113733-10-700	EA	GLASS-STATIONARY	390-028306
	113733-10-701	EA	RETAINER-TRIM	H416-66

**122882-01-01A**

KEY	PART NUMBER	U/M	DESCRIPTION	VENDOR NO.
	009440-01-000	EA	GEAR-ARM-ROOF VENT	705221K38
	064470-01-700	EA	COVER - VENT	J7291
	064470-01-701	EA	SLIDE BAR - VENT LID	JRP1291B
	122882-01-700	EA	HANDLE - CRANK - BLACK	90128
	122882-01-701	EA	SCREEN	JRP-1124-B
	122882-01-702	EA	HANDLE - CRANK - WHITE	JRP1031B



**WINDOW & VENTS GROUP (CONTINUED)**  
**COMPONENT PARTS FOR WINDOW & VENT LAYOUT (CONTINUED)**

122882-02-01A, 122882-03-01A

KEY	PART NUMBER	U/M	DESCRIPTION	VENDOR NO.
	064470-01-700	EA	COVER - VENT	J7291
	064470-01-701	EA	SLIDE BAR - VENT LID	JRP1291B
	110051-03-700	EA	SWITCH-BLACK/PUSH BUTTON	27-0164
	122882-01-700	EA	HANDLE - CRANK - BLACK	90128
	122882-01-701	EA	SCREEN	JRP-1124-B
	122882-01-702	EA	HANDLE - CRANK - WHITE	JRP1031B

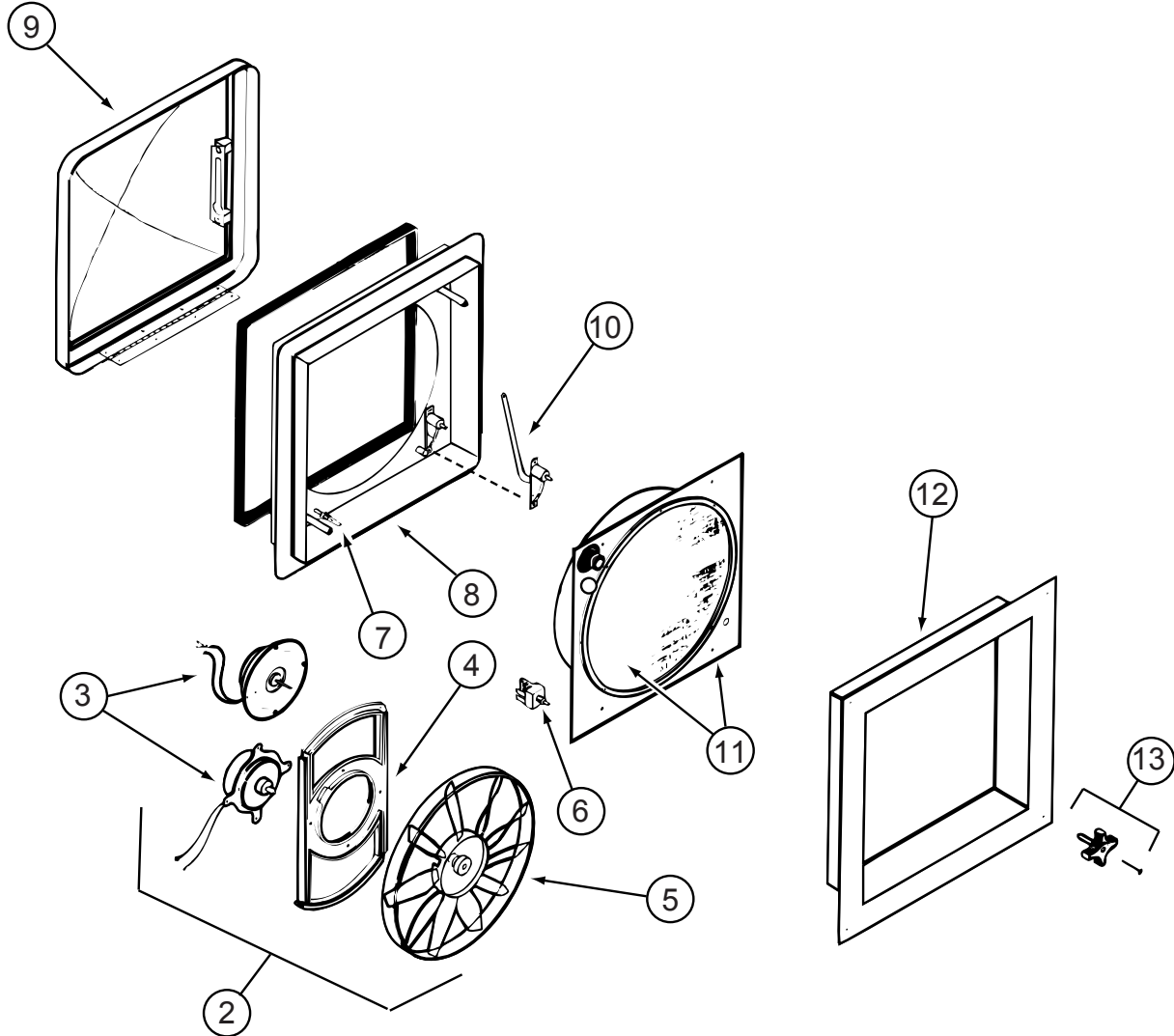

123780-03-01A

KEY	PART NUMBER	U/M	DESCRIPTION	VENDOR NO.
2	084079-11-700	EA	MOTOR & FAN BLADE W/BRACKET	K4017-09
3	084079-01-705	EA	MOTOR/EXT BRKT/FAN BLADE KIT	1080-00
4	084079-01-711	EA	MOTOR MOUNT (BOWTIE)	1015-00
5	084079-01-704	EA	BLADE-FAN	1138-00
6	084079-01-709	EA	SWITCH - MAIN - 3 SPEED	1031-05
7	084079-01-707	EA	SWITCH - SAFETY	1122-05
8	123780-05-700	EA	BASE/MAIN-BRT WHT W/GASKET	1010-81
9	123780-01-700	EA	COVER - VENT W/HINGE & SLIDE	1020K-81
11	123780-03-701	EA	SCREEN ASM 78-100MM W/SWITCH	1030BT-81
12	123780-03-700	EA	GARNISH - INT. 3"-4" BRT/WHT	2040-81
13	084079-01-703	EA	KNOB-LIFT	1140K-00
	084079-01-706	EA	PLUG, 12 VOLT	1090
	123780-01-702	EA	SCREEN INSERT (SCREEN RING)	K1035-81

CONTACT WINNEBAGO PART SALES FOR UNLISTED COMPONENT(S)

**WINDOW & VENTS GROUP (CONTINUED)**  
**COMPONENT PARTS FOR WINDOW & VENT LAYOUT (CONTINUED)**

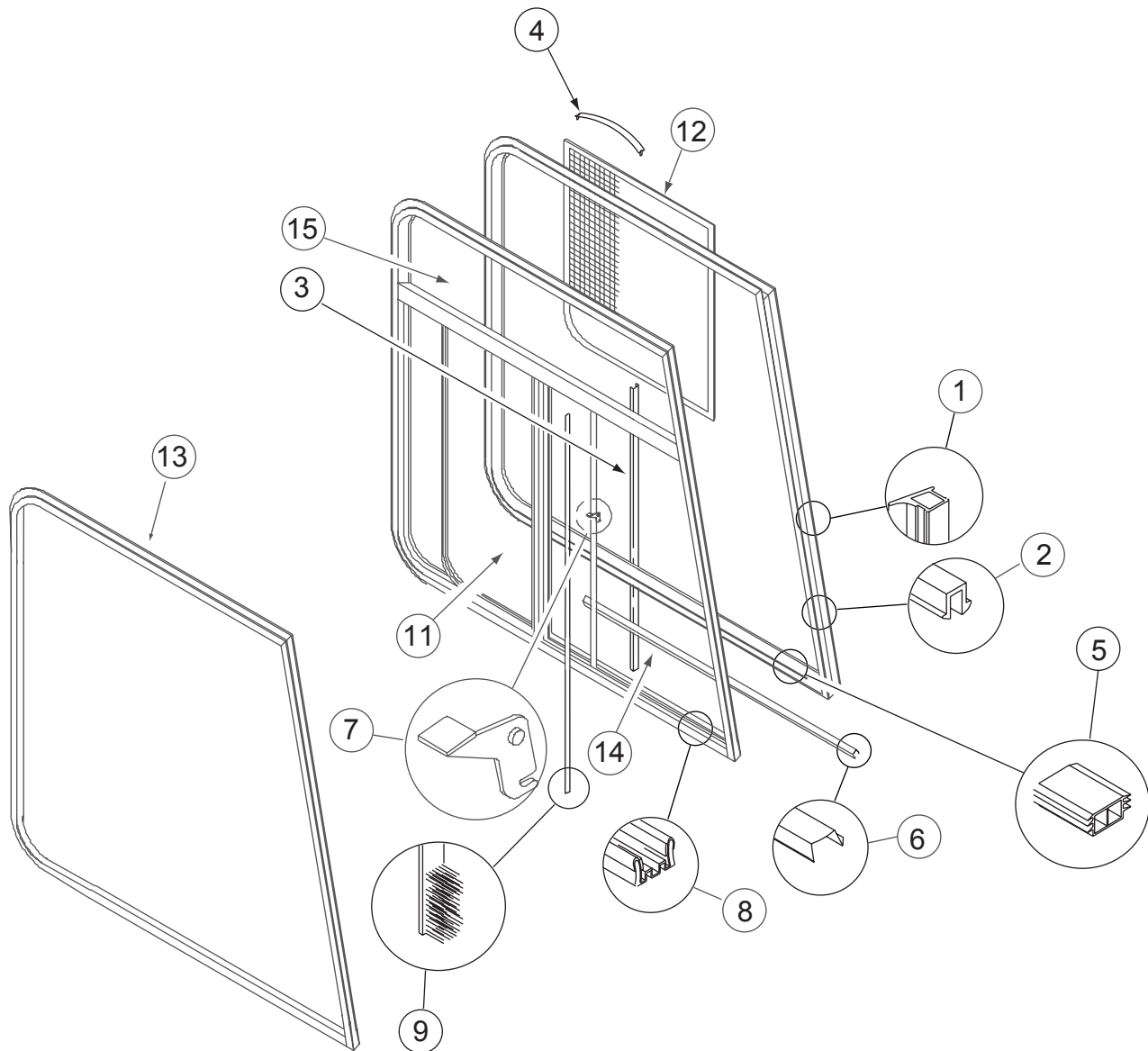

125582-01-01A

KEY	PART NUMBER	U/M	DESCRIPTION	VENDOR NO.
1	098644-01-716	FT	PLUG - FILLER	132-014470
2	098644-01-705	FT	GLAZING - STRIP	132-010231
3	098644-01-706	FT	WEATHERSTRIP - GLASS	171-010668
4	098644-01-713	EA	CLIP - SCREEN - METAL	226-016966
4	125582-01-701	EA	CLIP - SCREEN - PLASTIC	130-005153
5	098644-01-719	EA	STOP - SLIDER GLASS	132-014203
6	098644-01-710	FT	TRACK - SCREEN SPACER 12'	132-017135
7	098644-01-700	EA	LATCH - REPAIR KIT (BLACK)	B801-CK
8	098644-01-708	FT	CHANNEL - RUN PIERCED	122-016543
9	098644-01-711	FT	WEATHERSTRIP - SCREEN BLACK	171-016965
11	125582-01-704	EA	GLASS-SLIDING W/SASH & LATCH	H573-A9R
12	125582-01-705	EA	SCREEN - PASSENGER - W/SEALS & CLIPS	410-026545
13	125582-01-706	EA	RETAINER - TRIM	H573-27R
14	125582-01-703	EA	GLASS - STATIONARY - LOWER	106-026083
15	125582-01-702	EA	GLASS - STATIONARY - UPPER	106-026082
	098644-01-717	FT	SPLINE - SCREEN	132-004716
	112520-01-706	EA	WEATHERSTRIP-SCREEN, (FUZZY)	171-017245
	125582-01-708	EA	WEEPHOLE COVER - RIGHT HAND	130-026598
	125582-01-709	EA	WEEPHOLE COVER - LEFT HAND	130-026599

**WINDOW & VENTS GROUP (CONTINUED)**  
**COMPONENT PARTS FOR WINDOW & VENT LAYOUT (CONTINUED)**

**125584-01-01A**

KEY	PART NUMBER	U/M	DESCRIPTION	VENDOR NO.
	125584-01-700	EA	GLASS - STATIONARY	106026078
	100322-01-703	EA	VINYL - GLAZING, BUTYL	132-010723
	125584-01-701	EA	RETAINER - TRIM	H56927L B969 GRL

**125586-01-01A**

KEY	PART NUMBER	U/M	DESCRIPTION	VENDOR NO.
	125586-01-700	EA	GLASS - STATIONARY	106026079
	100322-01-703	EA	VINYL - GLAZING, BUTYL	132-010723
	125586-01-701	EA	RETAINER - TRIM	H57027L

**150648-04-01A**

KEY	PART NUMBER	U/M	DESCRIPTION	VENDOR NO
	151069-01-700	EA	CHANNEL-RUN, SLIDING	122-030627

**150648-07-01A**

KEY	PART NUMBER	U/M	DESCRIPTION	VENDOR NO
	112795-01-705	FT	VINYL - GLAZING	132-027331
	150648-01-700	EA	LATCH-HORIZONTAL SLIDE-BLK	FH3000-CK
	150648-01-702	EA	SCREEN ASM	410-031156
	150648-07-700	EA	GLASS-SLIDING W/SASH & LATCH	FH3000G8
	151069-01-700	FT	CHANNEL-RUN, SLIDING	122-030627

**150649-07-01A**

KEY	PART NUMBER	U/M	DESCRIPTION	VENDOR NO
	112898-04-703	EA	VERTICAL LATCH/HOLD UP/OPEN	DH343-CK
	150649-01-700	EA	LATCH-VERTICLE SLIDE-BLK	FH3016-CK
	150649-07-700	EA	GLASS - STATIONARY	390-028662
	150649-07-701	EA	SCREEN ASM	410-035475

**150651-01-01A**

KEY	PART NUMBER	U/M	DESCRIPTION	VENDOR NO
	112795-01-705	FT	VINYL - GLAZING	132-027331

**150656-02-01A**

KEY	PART NUMBER	U/M	DESCRIPTION	VENDOR NO
	100322-01-718	EA	HANDLE-DIAL	410-016081
	150656-02-700	EA	GLASS-STATIONARY	390-035654
	150656-02-701	EA	GLASS-TIPOUT	DTH3017G8
	150656-07-700	EA	SCREEN ASM	DTH3045-06

**151072-01-01A**

KEY	PART NUMBER	U/M	DESCRIPTION	VENDOR NO
	150648-01-703	EA	PLUG - FILLER	132-030308
	151069-01-700	EA	CHANNEL-RUN, SLIDING	122-030627
	151069-03-705	EA	VINYL GLAZING - F/STATIONARY	DH567-12 MITER/WELD
	151069-03-706	EA	VINYL GLAZING - F/STATIONARY	DH373-12 MITER/WELD
	151072-01-700	EA	SCREEN ASM	410-035507
	151072-01-701	EA	GLASS-SLIDING W/SASH & LATCH	FH3040A9R
	151072-01-702	EA	GLASS - STATIONARY - UPPER	390-036521

# WINDSHIELD & WIPER GROUP

## WINDSHIELD

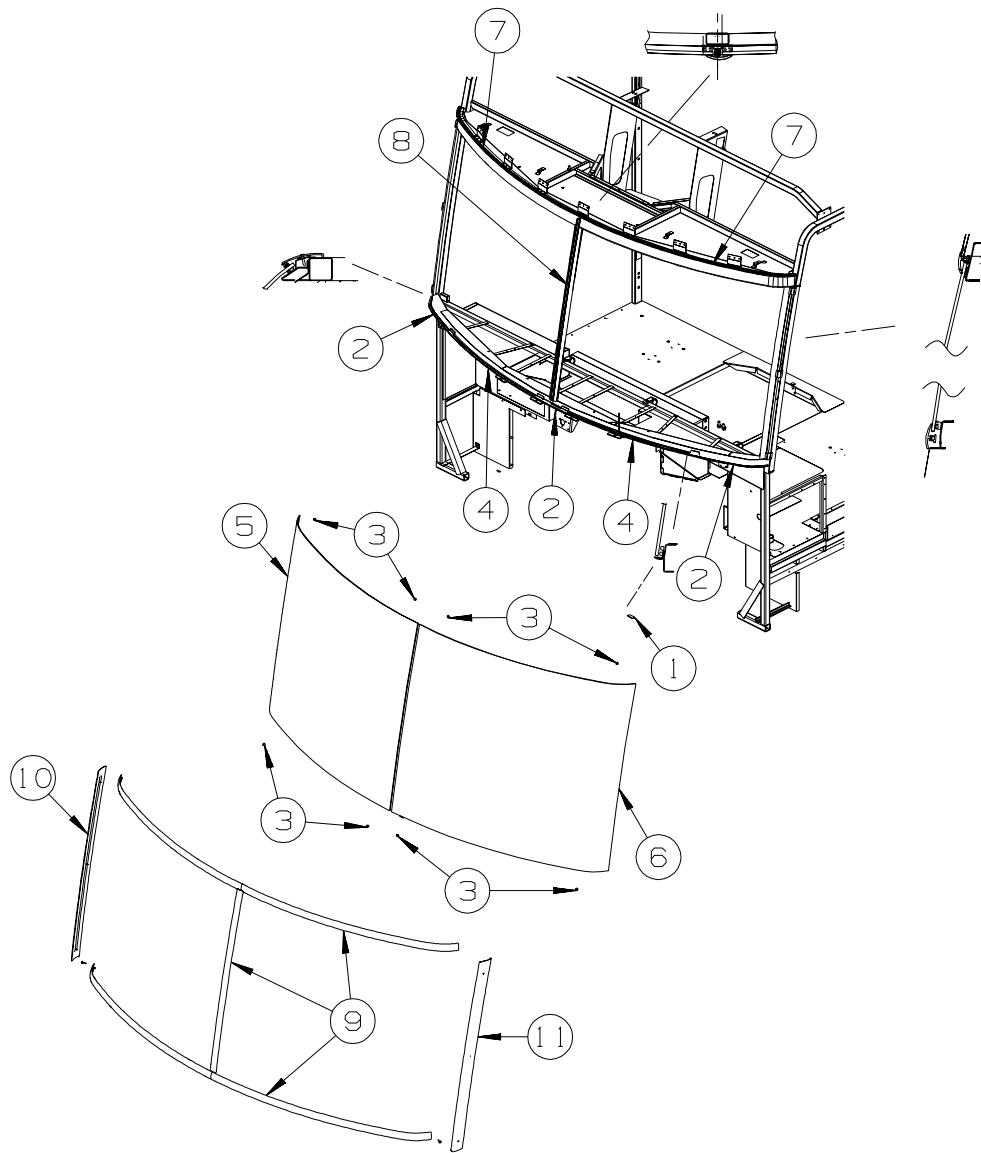

KEY	PART NUMBER	U/M	DESCRIPTION
1	002328-02-000	EA	BLOCK - WINDSHIELD - .062" X .5" X .98"
2	142036-01-000	EA	CARRIER/REVEAL - WINDSHIELD
3	081914-02-000	EA	BUMPER - RUBBER - ROUND - 5/16" DIA. X 13/64" THICK
4	132375-04-000	EA	CARRIER/REVEAL - WINDSHIELD - 29.8"
5	124328-01-000	EA	WINDSHIELD - PASSENGER - 52" X 41" (CURVED)
6	124328-02-000	EA	WINDSHIELD - DRIVER - 52" X 41" (CURVED)
7	127862-01-000	EA	CARRIER/REVEAL - WINDSHIELD - 47.2"
8	127862-09-000	EA	CARRIER/REVEAL - WINDSHIELD - 38.6"
9	FT	MOLDING - REVEAL - WINDSHIELD	
10	125384-01-02A	EA	TRIM - WINDSHIELD - A-PILLAR - PASSENGER - BLACK
11	125384-02-02A	EA	TRIM - WINDSHIELD - A-PILLAR - DRIVER - BLACK

# WINDSHIELD & WIPER GROUP (CONTINUED)

## WIPER

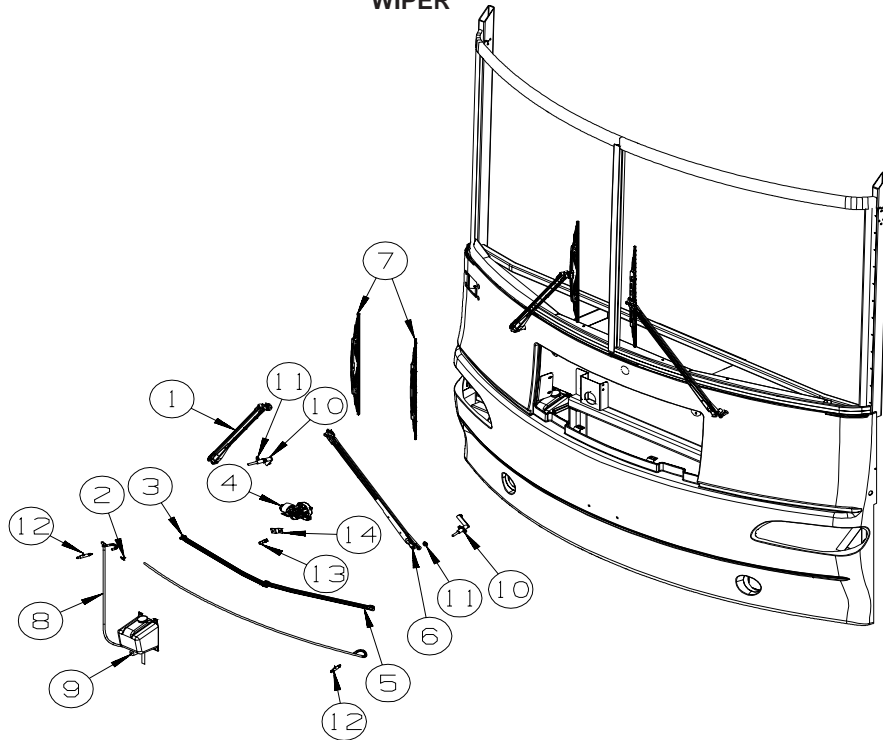

KEY	PART NUMBER	U/M	DESCRIPTION
1*	149402-01-000	EA	ARM - WINDSHIELD WIPER/PANTOGRAPH - RIGHT HAND - 28" FROM: 00-00-00 THRU: 03-18-05
1*	149402-03-000	EA	ARM - WINDSHIELD WIPER/PANTOGRAPH - RIGHT HAND - 28" FROM: 03-19-05 THRU: 99-99-99
2	146486-01-000	EA	TEE - PLASTIC - 5/32" X 5/32" X 5/32" - <b>ON LEFT SIDE OF WORKHORSE CHASSIS</b>
3	149403-01-000	EA	LINK/CONNECTING-WINDSHIELD WIPER - CLOSED/CLOSED - 24"
4	149409-01-000	EA	MOTOR - WIPER - DYNAMIC PARK
4	149409-02-000	EA	MOTOR - WIPER - COAST TO PARK - <b>WORKHORSE P32 (15,000/18,000) CHASSIS</b>
5	149403-02-000	EA	LINK/CONNECTING-WINDSHIELD WIPER - OPEN/CLOSED GROMMET-24"
6*	149402-02-000	EA	ARM - WINDSHIELD WIPER/PANTOGRAPH - LEFT HAND - 28" FROM: 00-00-00 THRU: 03-18-05
6*	149402-04-000	EA	ARM - WINDSHIELD WIPER/PANTOGRAPH - LEFT HAND - 28" FROM: 03-19-05 THRU: 99-99-99
7	149399-01-000	EA	BLADE - WINDSHIELD WIPER - 24"
8	045794-01-000	FT	HOSE - WINDSHIELD WASHER - 5/32"ID - BLACK - <b>ON LEFT SIDE OF WORKHORSE CHASSIS</b>
9	117766-02-000	EA	RESERVOIR/PUMP - WINDSHIELD WASHER - <b>ON LEFT SIDE OF WORKHORSE CHASSIS</b>
10*	149401-01-000	EA	SHAFT & PIVOT ASM. - WINDSHIELD WIPER FROM: 00-00-00 THRU: 04-15-05
10	149401-02-000	EA	SHAFT & PIVOT ASM. - WINDSHIELD WIPER FROM: 04-16-05 THRU: 99-99-99
11	110742-03-000	EA	GASKET - WIPER
12	145698-01-01A	EA	SHAFT/IDLER - PANTOGRAPH - W/WASHER DIVERTER - STAINLESS
13	149395-01-000	EA	STUD/DOUBLE BALL CRANK - WIPER MOTOR
14	149408-01-000	EA	ARM - DRIVE/WIPER MOTOR

\*COMPONENT PARTS LISTED LATER IN THIS GROUP

# WINDSHIELD & WIPER GROUP (CONTINUED))

## COMPONENT PARTS FOR WIPER

### 149401-01-000

KEY	PART NUMBER	U/M	DESCRIPTION	VENDOR NO.
	096505-02-703	EA	NUT/ACORN - HD W/.687 BRL	51065-40-NT27WC
	149401-01-700	EA	HARDWARE PKG - F/SHAFT&PIVOT	PSHWKIT

### 149402-01-000, 149402-02-000, 149402-03-000, 149402-04-000

KEY	PART NUMBER	U/M	DESCRIPTION	VENDOR NO.
	096931-01-705	EA	CAP-PLASTIC	52699-40-CP27WC
	149402-01-700	EA	WASHER NOZZLE KIT - W/HDWR	5219140