

**2005
SIGHTSEER
WFD30B
D-SERIES**

- PORTSMOUTH OAK**
S28 RIVERSIDE SAGE - GREEN
S29 ROCKFORD DUSK - GRAY
S30 STONE BROOK - BLUE
SX2 BLEACHED SAND
SX4 SAGEBRUSH
SY4 GREENGAGE
SY6 CILANTRO
SY8 ESTATE GREEN
SIERRA MAPLE
SJ0 RIVERSIDE SAGE - GREEN
SJ1 ROCKFORD DUSK - GRAY
SJ2 STONE BROOK - BLUE
SX3 BLEACHED SAND
SX5 SAGEBRUSH
SY5 GREENGAGE
SY7 CILANTRO
SY9 ESTATE GREEN

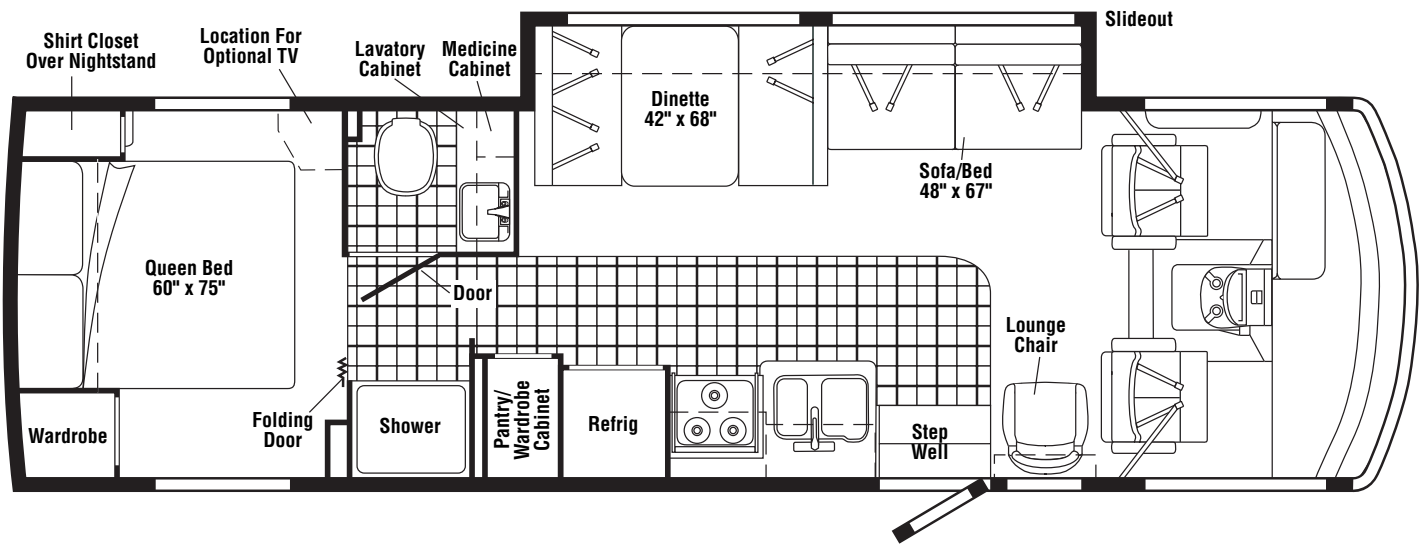

FLOORPLAN

CONTENTS

FLOORPLAN	1
ACCESSORIES GROUP	6
OPERATORS MANUAL	6
AUDIO VIDEO GROUP	7
RADIO SYSTEM	7
REAR VIEW MONITOR	7
CABINET & APPLIANCE GROUP	8
CABINET & APPLIANCE LAYOUT	8
APPLIANCES	8
COMPONENT PARTS FOR APPLIANCES	16
112881-04-01A, 112881-05-01A	16
114030-04-01A	19
121568-06-01A, 121568-07-01A, 121568-08-01A	21
128527-09-000, 128527-10-000, 128527-13-000	25
136354-01-01A, 136354-02-01A	26
136354-05-01A	27
136354-06-01A	27
151277-01-01A, 151277-02-01A	28
BATH	31
BEDROOM	32
DINETTE	33
GALLEY	35
LOUNGE	38
CHASSIS GROUP	39
FRAME	39
COMPONENT PARTS FOR FRAME	40
132643-05-01A	40
FRONT END	41
EXHAUST	43
HITCH	49
FUEL	50
HYDRAULIC LEVELING	53
COMPONENT PARTS FOR HYDRAULIC LEVELING	54
139641-01-000	54
139641-02-000	55
139641-03-000	56
SPARE TIRE	57
SUSPENSION	57
COMPONENT PARTS FOR SUSPENSION	57
122756-04-000	57
WHEEL, TIRE, COVERS &/OR LINERS	58
COMPONENT PARTS FOR WHEEL, TIRE, COVERS &/OR LINERS	58
109443-05-000	58
109443-06-000	58
109443-08-000	58
110435-20-000	58
145580-03-000	58
145580-04-000	59
BRAKE	59
BRAKELINE	59
CURTAIN & CUSHION GROUP	60
NOTICE	60
CUSHION LAYOUT	61
BUCKET SEATS	65
LOUNGE CHAIR	69
SOFA	70
WINDOW TREATMENT	72
HARDWARE	77
ACCESSORIES	78
FABRICS	79

CONTENTS (CONTINUED)

DRIVERS COMPARTMENT GROUP	83
DASH	83
MOTOR COVER	84
BEVERAGE TRAY	86
FRONT INTERIOR	88
COMPONENT PARTS FOR FRONT INTERIOR	90
091990-04-01A	90
CABINETS	91
ELECTRICAL GROUP	93
110V BODY WIRING	93
12V BODY WIRING	94
EXTERIOR LAMPS	98
FRONT END	100
FRONT TV/VCR	102
COMPONENT PARTS FOR WIRING	103
076319-23-000	103
076319-25-000	103
086231-10-000	104
097917-01-06A	104
113589-01-000	104
115632-03-01A	104
121935-01-01A	104
134940-01-01A	104
134940-06-01A	105
137135-02-000	106
137417-01-01A, 137417-03-01A	107
137417-05-01A	107
137417-06-01A	107
145641-02-000, 145641-04-000	107
145641-03-000	107
148230-01-000, 148230-02-000	107
148230-03-000	107
148231-01-000	107
150089-01-000	107
CIRCUIT BREAKERS & FUSES	108
CONVERTER, INVERTER, LOAD CENTERS	109
BOXES & CORDS	110
WIRE ASSEMBLIES	110
CONNECTORS & CONDUIT	111
CHASSIS	113
EXTERIOR BODY GROUP	114
GRAPHICS & PAINT	114
PANELS & TRIMS	116
COMPONENT PARTS FOR PANELS & TRIMS	119
106015-12-01A, 106015-14-01A	119
106015-13-01A, 106015-15-01A	119
FRONT END	120
LADDER	122
STRUCTURAL COMPONENTS	122
AWNINGS	122
COMPONENT PARTS FOR AWNINGS	123
113874-01-02A	123

CONTENTS (CONTINUED)

EXTERIOR DOORS & COMPARTMENTS GROUP	124
DOOR & COMPARTMENT LAYOUT	124
COMPONENT PARTS FOR DOOR & COMPARTMENT LAYOUT	129
084103-08-000	129
094707-03-01A	129
110506-A1-000, 110506-A2-000, 110506-26-000, 110506-27-000	129
142226-02-01A	129
COMPARTMENT DOOR PIECE PARTS	130
ENTRY	132
SCREEN	133
LATCH - ENTRY	134
EXTERIOR SLIDEOUT GROUP	135
FRONT	135
COMPONENT PARTS FOR FRONT	138
142599-01-000, 142599-02-000	138
GENERATOR GROUP	139
GAS	139
HEATING & A/C GROUP	140
AUTOMOTIVE	140
COMPONENT PARTS FOR AUTOMOTIVE	142
103930-39-000	142
103930-44-000	143
103930-45-000	143
103930-46-000	143
103930-47-000	143
103930-55-000	144
FURNACE	145
COMPONENT PARTS FOR FURNACE	146
139980-02-000	146
143563-01-000	148
143563-02-000	150
REAR HEATER	152
COMPONENT PARTS FOR REAR HEATER	152
084405-01-000	152
ROOF	152
COMPONENT PARTS FOR ROOF	153
131184-01-01A	153
131184-05-01A	154
131186-02-01A	155
131187-03-01A	156
131187-04-01A	157
131188-03-01A	158
131188-04-01A	159
INTERIOR FINISH GROUP	160
MOLDINGS & TRIMS	160
PANELING & LAMINATES	171
INTERIOR TRIM LAYOUT	172
COMPONENT PARTS FOR INTERIOR TRIM LAYOUT	175
089318-01-000	175
094499-02-000	176
131595-01-01A, 131595-05-01A, 131595-10-01A	176
FLOOR COVERINGS	176
HARDWARE	177

CONTENTS (CONTINUED)

LABELS GROUP	184
LP GROUP	188
LP SYSTEM	188
COMPONENT PARTS FOR LP SYSTEM	188
144116-04-000	188
SEALANTS & FASTENERS GROUP	189
SEALANTS & ADHESIVES	189
BOLTS, NUTS AND WASHERS	190
SCREWS	192
CLAMPS, CLIPS, GROMMETS, RIVETS & PLUGS	195
MISCELLANEOUS FASTENERS	196
WATER & SEWAGE GROUP	198
DRAINAGE SYSTEM	198
COMPONENT PARTS FOR DRAINAGE SYSTEM	199
096927-01-02A	199
147421-01-01A, 147421-02-01A	200
WATER SYSTEM	201
COMPONENT PARTS FOR WATER SYSTEM	207
051391-03-000	207
051393-01-000	208
075240-05-000	209
075241-04-000, 075241-05-000, 075241-06-000	209
098607-01-000	209
104114-05-01A	209
144215-01-000	209
144215-02-000	209
WINDOW & VENTS GROUP	210
WINDOW & VENT LAYOUT	210
COMPONENT PARTS FOR WINDOWS & VENT LAYOUT	212
098644-07-02A	212
098647-41-02A	213
098647-47-02A	214
098647-63-01A	214
112795-21-02A	215
112795-54-02A	216
112795-90-01A	216
112898-04-02A	217
113733-01-02A	218
122882-01-01A	218
122882-02-01A, 122882-03-01A	218
123780-03-01A	219
145573-01-01A	220
145573-02-01A	221
145573-03-01A	221
145573-04-01A	221
150648-11-01A	222
150648-12-01A	222
150649-01-01A	222
150651-01-01A	222
151069-01-01A	222
151069-02-01A	222
150648-07-01A	222
WINDSHIELD & WIPER GROUP	223
WINDSHIELD	223
WIPER	224
COMPONENT PARTS FOR WIPER	224
149401-01-000	224
149402-01-000, 149402-02-000, 149402-03-000, 149402-04-000	224

ACCESSORIES GROUP
OPERATORS MANUAL

KEY	PART NUMBER	U/M	DESCRIPTION
	132000-17-005	EA	MANUAL/OWNER - SIGHTSEER - 2005
	129079-01-01A	EA	CASE - VINYL/BLACK-EXPANDABLE ACCORDION SIDES-7"WX9"HX14"L
	147501-01-000	DW	TOP LEVEL - D, 2005

AUDIO VIDEO GROUP RADIO SYSTEM

KEY	PART NUMBER	U/M	DESCRIPTION
	135420-09-000	EA	RADIO-AM/FM/CASS/CD COMBO-AUX/CD CHANGER INPUT-REMOTE COMP - DASH FROM: 00-00-00 THRU: 05-02-04
	135420-13-000	EA	RADIO-AM/FM/CASS/CD COMBO-AUX/CD CHANGER INPUT-IR REMOTE - DASH FROM: 05-03-04 THRU: 99-99-99
	135420-10-000	EA	REMOTE CONTROL/RADIO (CREDIT CARD SIZE) MAGNAD M9999-CCR. - DASH
	135420-11-000	EA	REMOTE CONTROL/RADIO (STEERING WHEEL MOUNT) FROM: 05-05-04 THRU: 99-99-99
	135420-14-000	EA	RECEIVER - INFRARED FROM: 05-03-04 THRU: 99-99-99
	135420-07-000	EA	RADIO - MOUNTING KIT - A-BODY

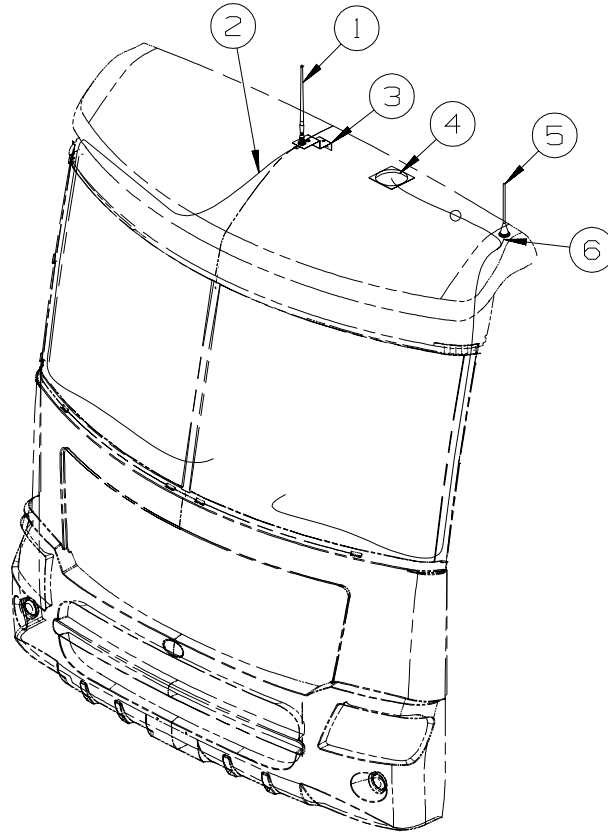

KEY	PART NUMBER	U/M	DESCRIPTION
1	090944-02-000	EA	ANTENNA - RADIO - 16" RUBBER - W/O LEAD WIRE
2	090944-03-000	EA	CABLE - ANTENNA
3	115916-01-01B	EA	BRACKET - ANTENNA MOUNT
4	147190-01-000	EA	ANTENNA/SATELLITE-RADIO/SIRIUS-W/GRD PLANE PLATE/6" LEAD FROM: 00-00-00 THRU: 09-03-04
4	152780-01-000	EA	ANTENNA/SATELLITE - RADIO/SIRIUS FROM: 09-04-04 THRU: 99-99-99
5	123256-01-000	EA	ANTENNA - CB - W/O CABLE
6	123256-02-000	EA	CABLE - CB - COAX

REAR VIEW MONITOR

KEY	PART NUMBER	U/M	DESCRIPTION
	144677-05-000	EA	MONITOR/BLACK & WHITE - 7" - 3 PIN/MECH CONTROLS FROM: 00-00-00 THRU: 04-25-04
	144677-06-000	EA	MONITOR/BLACK & WHITE - 7" - 3 PIN/MECH CONTROLS - RESIZED FROM: 04-26-04 THRU: 99-99-99
	144677-04-000	EA	CAMERA - REAR VIEW W/BRACKET
	136514-02-000	EA	CABLE - MONITOR/CAMERA

**SEE 12V BODY WIRING IN THE ELECTRICAL GROUP FOR LOCATION OF OTHER
AUDIO VIDEO COMPONENTS**

CABINET & APPLIANCE GROUP

CABINET & APPLIANCE LAYOUT

APPLIANCES

KEY	PART NUMBER	U/M	DESCRIPTION
*	114030-04-01A	EA	RANGE - 3 BRNR TOP/NEW STYLE KNOBS/GRATES-W/O OVEN-BLK
*	112881-04-01A	EA	RANGE-16"-3 BRNR/NEW STYLE KNOBS/GRATE/HDL-BLK DOOR/TOP FROM: 00-00-00 THRU: 05-23-04
*	151277-01-01A	EA	RANGE-16"-3 BURNER - MERCURY FREE - BLACK DOOR/TEXTURED FROM: 05-24-04 THRU: 99-99-99
*	151277-02-01A	EA	RANGE-16"-3 BURNER - BLACK DOOR/TEXTURED - CANADIAN FROM: 05-24-04 THRU: 99-99-99
	140111-01-02B	EA	BRACKET/TIEDOWN - STOVE - RIGHT HAND - E-COATED - W/OVEN - D27C, D30B, D33L
	140111-02-02B	EA	BRACKET/TIEDOWN - STOVE - LEFT HAND - E-COATED - W/OVEN - D27C, D30B, D33L
	140176-03-02B	EA	BRACKET/TIEDOWN - STOVE - E-COATED - D35N
	140176-04-02B	EA	BRACKET/TIEDOWN - STOVE - E-COATED - D35N
	149374-01-02B	EA	BRACKET/RANGE TIEDOWN - E-COATED - D29R FROM: 00-00-00 THRU: 10-03-04
	140176-03-02B	EA	BRACKET/TIEDOWN - STOVE - E-COATED - D29R FROM: 10-04-04 THRU: 99-99-99
	140176-04-02B	EA	BRACKET/TIEDOWN - STOVE - E-COATED - D29R FROM: 10-04-04 THRU: 99-99-99
	140176-11-02B	EA	BRACKET/STOVE TIEDOWN - E-COATED - W/OVEN - D34A FROM: 00-00-00 THRU: 07-25-04
	136382-21-01B	EA	BRACKET/STOVE TIEDOWN - W/OVEN - D34A FROM: 07-26-04 THRU: 99-99-99
	140176-12-02B	EA	BRACKET/STOVE TIEDOWN - E-COATED - W/OVEN - D34A FROM: 00-00-00 THRU: 07-25-04
	136382-22-01B	EA	BRACKET/STOVE TIEDOWN - W/OVEN - D34A FROM: 07-26-04 THRU: 99-99-99
	142139-03-02B	EA	BRACKET/TIEDOWN - STOVE - E-COATED - RANGE TOP 3 BURNER
	142139-04-02B	EA	BRACKET/TIEDOWN - STOVE - E-COATED - RANGE TOP 3 BURNER
*	136354-01-01A	EA	HOOD - RANGE - W/LITE/FAN - US/VENTED - TEXTURED BLK - W/OVEN - U.S.
*	136354-02-01A	EA	HOOD - RANGE - W/LITE/FAN - CSA/VENTED - TEXTURED BLK - W/OVEN - CANADIAN
*	136354-05-01A	EA	HOOD - RANGE - W/LITE/FAN - BLACK TEXTURED - UL
	117806-01-000	EA	BULB - 12V - #912 - 1.0 AMP
*	136354-06-01A	EA	HOOD - RANGE - W/LITE/FAN - BLACK TEXTURED - CSA
	117806-01-000	EA	BULB - 12V - #912 - 1.0 AMP

***COMPONENT PARTS LISTED LATER IN THIS GROUP**

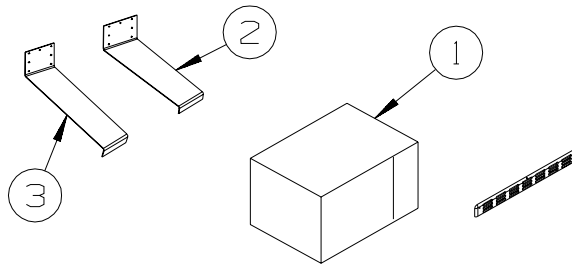

KEY	PART NUMBER	U/M	DESCRIPTION
1*	128527-09-000	EA	OVEN/MICROWAVE W/TRIM KIT - 1.1 CUBIC FT - NON CONVECTION FROM: 00-00-00 THRU: 09-30-04
1*	128527-13-000	EA	OVEN/MICROWAVE W/TRIM KIT - 1.0 CUBIC FT - NON CONVECTION FROM: 10-01-04 THRU: 99-99-99
1*	128527-10-000	EA	OVEN/MICROWAVE W/TRIM KIT - 1.1 CUBIC FT - NON CONVECTION - CANADIAN FROM: 00-00-00 THRU: 11-07-04
1	128527-14-000	EA	OVEN/MICROWAVE W/TRIM KIT - 1.0 CUBIC FT - NON CONV - CANADIAN FROM: 11-08-04 THRU: 99-99-99
2	143759-06-02B	EA	BRACKET - MICROWAVE - E-COATED
3	143759-06-02B	EA	BRACKET - MICROWAVE - E-COATED

***COMPONENT PARTS LISTED LATER IN THIS GROUP**

CABINET & APPLIANCE GROUP (CONTINUED)
CABINET & APPLIANCE LAYOUT (CONTINUED)

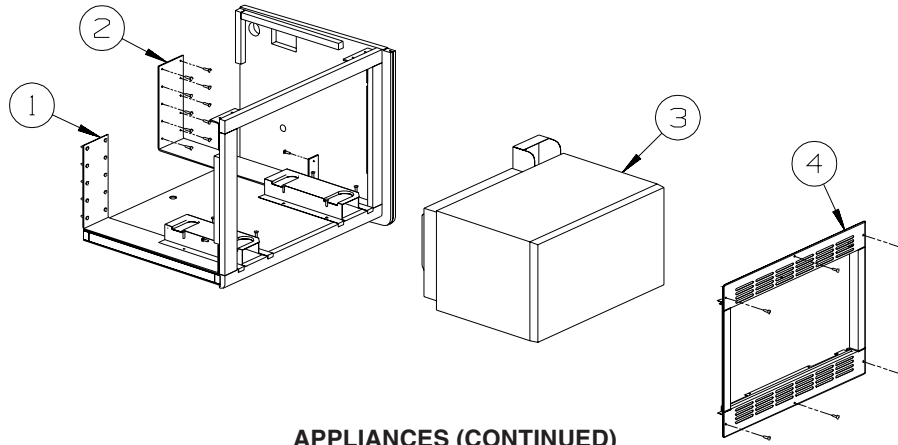

CONVECTION

APPLIANCES (CONTINUED)

D29R, D34A

KEY	PART NUMBER	U/M	DESCRIPTION
1	149418-02-02B	EA	BRACKET - MICROWAVE - E-COATED
2	149418-01-02B	EA	BRACKET - MICROWAVE - E-COATED
3	128527-11-000	EA	OVEN/MICROWAVE W/O TRIM KIT - 1.0 CUBIC FT - CONVECTION FROM: 00-00-00 THRU: 01-03-05
3	128527-15-000	EA	OVEN/MICROWAVE W/O TRIM KIT - 1.0 CUBIC FT - CONVECTION FROM: 01-04-05 THRU: 99-99-99
4	128527-12-000	EA	MOUNTING FRAME/RAILS-W/TRIM KIT (SASH) 1.0 FT - CONVECTION

D27C, D30B, D33L, D35N

KEY	PART NUMBER	U/M	DESCRIPTION
1	149418-04-02B	EA	BRACKET - MICROWAVE - E-COATED
2	149418-01-02B	EA	BRACKET - MICROWAVE - E-COATED
3	150606-01-01A	EA	OVEN - MICROWAVE/CONVECTION/BLACK - 1.5 CU FT - #R-930AK
4	150606-02-01A	EA	TRIM KIT - MICROWAVE 1.5 CU FT - BLACK - SHARP #RK-66A

CABINET & APPLIANCE GROUP (CONTINUED)
CABINET & APPLIANCE LAYOUT (CONTINUED)

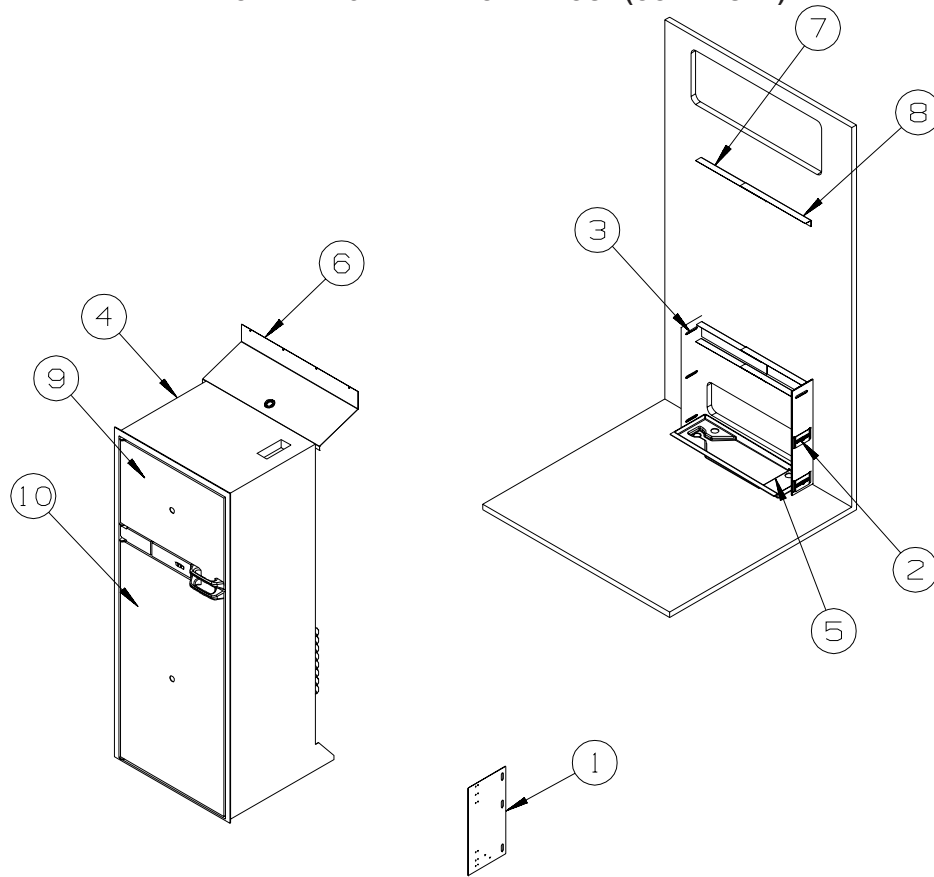

D27C

FROM: 00-00-00
THRU: 08-17-04

APPLIANCES (CONTINUED)

KEY	PART NUMBER	U/M	DESCRIPTION
1	141975-04-02B	EA	PLATE - TIEDOWN/REFRIGERATOR
2	141550-01-02B	EA	BRACKET - TIEDOWN/REFRIGERATOR - RIGHT HAND
3	141550-02-02B	EA	BRACKET - TIEDOWN/REFRIGERATOR - LEFT HAND
4*	121568-08-01A	EA	REFRIGERATOR - SMALL DBL DOOR-LH/2 WAY- 52.8"HX23.5"WX24"D
5	112176-01-000	FT	TUBING - VINYL - REINFORCED - 1/2" ID
6	136966-04-02B	EA	BAFFLE - REFRIGERATOR - E-COATED
7	143195-01-02B	EA	BAFFLE - REFRIGERATOR - E-COATED
8	143195-02-02B	EA	BAFFLE - REFRIGERATOR - E-COATED
9	NOT USED		USE WOODGRAIN PANELING
10	NOT USED		USE WOODGRAIN PANELING
	054450-01-000	EA	LEVEL - REFRIGERATOR
	090329-01-000	FT	SEAL/T - REFRIGERATOR CABINET
	116751-01-01A	EA	TRAY - REFRIGERATOR - BLACK

***COMPONENT PARTS LISTED LATER IN THIS GROUP**

CABINET & APPLIANCE GROUP (CONTINUED)
CABINET & APPLIANCE LAYOUT (CONTINUED)

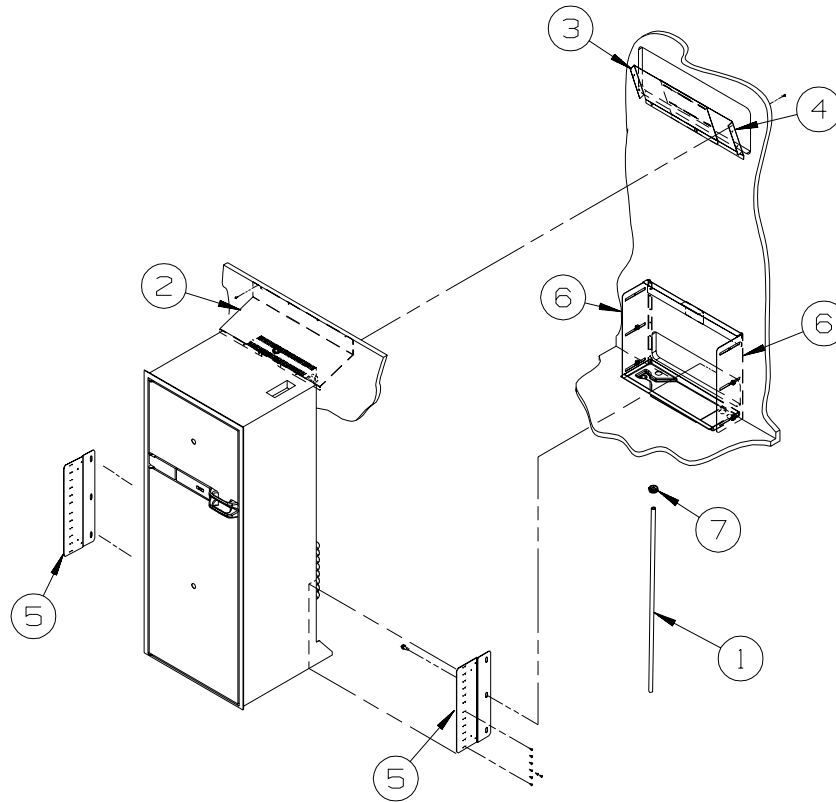

D27C

FROM: 08-18-04
THRU: 99-99-99

APPLIANCES (CONTINUED)

KEY	PART NUMBER	U/M	DESCRIPTION
1	112176-01-000	FT	TUBING - VINYL - REINFORCED - 1/2" ID
2	136966-04-02B	EA	BAFFLE - REFRIGERATOR - E-COATED
3	143195-01-02B	EA	BAFFLE - REFRIGERATOR - E-COATED
4	143195-02-02B	EA	BAFFLE - REFRIGERATOR - E-COATED
5	150740-01-02B	EA	BRACKET - REFRIGERATOR - E-COATED
6	150740-02-02B	EA	BRACKET - REFRIGERATOR - E-COATED
7	152417-01-01A	EA	CLAMP/RATCHET - F/REFRIDGERATOR DRIP TRAY HOSE - BLACK
*	121568-08-01A	EA	REFRIGERATOR - SMALL DBL DOOR-LH/2 WAY- 52.8"HX23.5"WX24"D
	054450-01-000	EA	LEVEL - REFRIGERATOR
	090329-01-000	FT	SEAL/T - REFRIGERATOR CABINET
	116751-01-01A	EA	TRAY - REFRIGERATOR - BLACK

***COMPONENT PARTS LISTED LATER IN THIS GROUP**

CABINET & APPLIANCE GROUP (CONTINUED)
CABINET & APPLIANCE LAYOUT (CONTINUED)

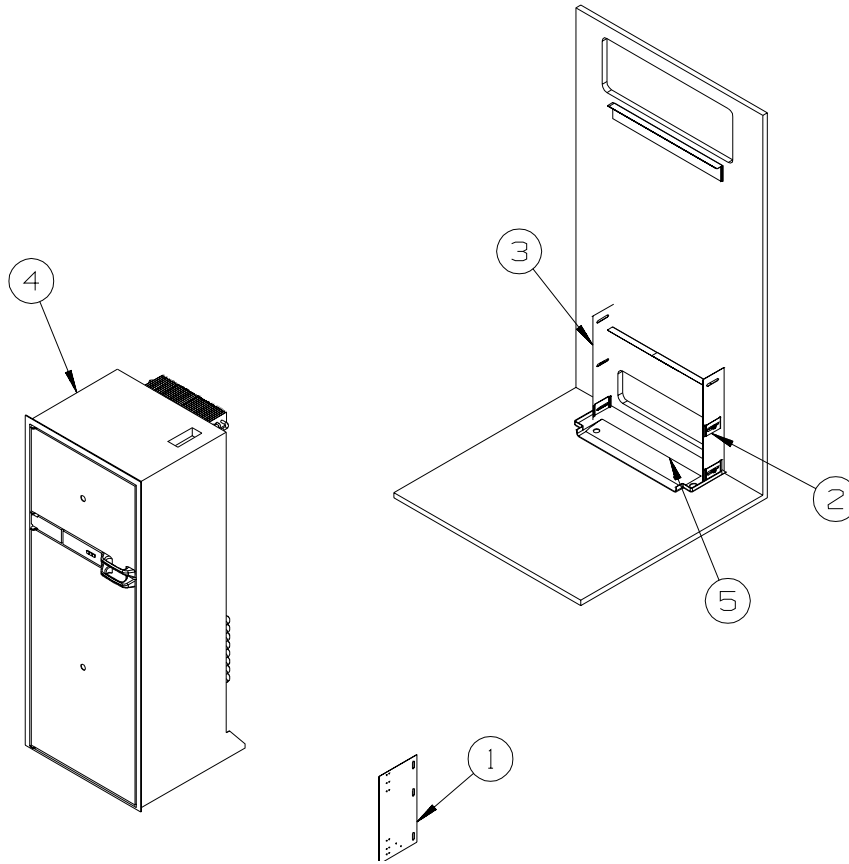

D30B, D33L

FROM: 00-00-00
THRU: 08-17-04

APPLIANCES (CONTINUED)

KEY	PART NUMBER	U/M	DESCRIPTION
1	141975-04-02B	EA	PLATE - TIEDOWN/REFRIGERATOR
2	141550-03-02B	EA	BRACKET - TIEDOWN/RIGHT HAND - REFRIGERATOR
3	141550-04-02B	EA	BRACKET - TIEDOWN/LEFT HAND - REFRIGERATOR
4*	121568-06-01A	EA	REFRIGERATOR - SMALL DBL DOOR-RH/2 WAY- 52.8"HX23.5"WX24"D
5	112176-01-000	FT	TUBING - VINYL - REINFORCED - 1/2" ID
	090329-01-000	FT	SEAL/T - REFRIGERATOR CABINET
	054450-01-000	EA	LEVEL - REFRIGERATOR
	116751-01-01A	EA	TRAY - REFRIGERATOR - BLACK - D33L
	116751-02-01A	EA	TRAY - REFRIGERATOR - BLACK - D30B

***COMPONENT PARTS LISTED LATER IN THIS GROUP**

CABINET & APPLIANCE GROUP (CONTINUED)
CABINET & APPLIANCE LAYOUT (CONTINUED)

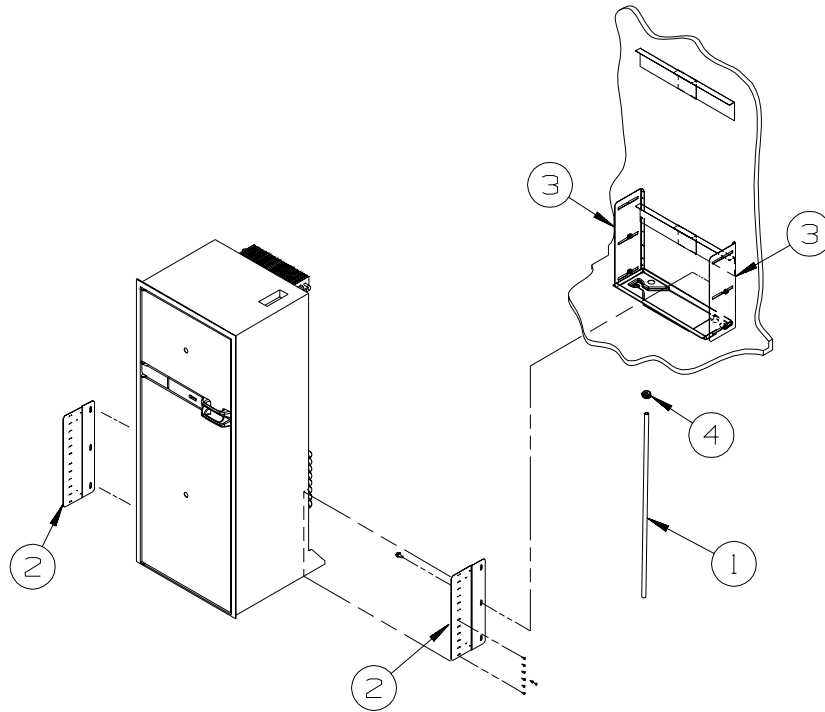

D30B, D33L

FROM: 08-18-04
THRU: 99-99-99

APPLIANCES (CONTINUED)

KEY	PART NUMBER	U/M	DESCRIPTION
1	112176-01-000	FT	TUBING - VINYL - REINFORCED - 1/2" ID
2	150740-01-02B	EA	BRACKET - REFRIGERATOR - E-COATED
3	150740-02-02B	EA	BRACKET - REFRIGERATOR - E-COATED
4	152417-01-01A	EA	CLAMP/RATCHET - F/REFRIDGERATOR DRIP TRAY HOSE - BLACK
*	121568-06-01A	EA	REFRIGERATOR - SMALL DBL DOOR-RH/2 WAY- 52.8"HX23.5"WX24"D
	090329-01-000	FT	SEAL/T - REFRIGERATOR CABINET
	054450-01-000	EA	LEVEL - REFRIGERATOR
	116751-01-01A	EA	TRAY - REFRIGERATOR - BLACK - D33L
	116751-02-01A	EA	TRAY - REFRIGERATOR - BLACK - D30B

***COMPONENT PARTS LISTED LATER IN THIS GROUP**

CABINET & APPLIANCE GROUP (CONTINUED)
CABINET & APPLIANCE LAYOUT (CONTINUED)

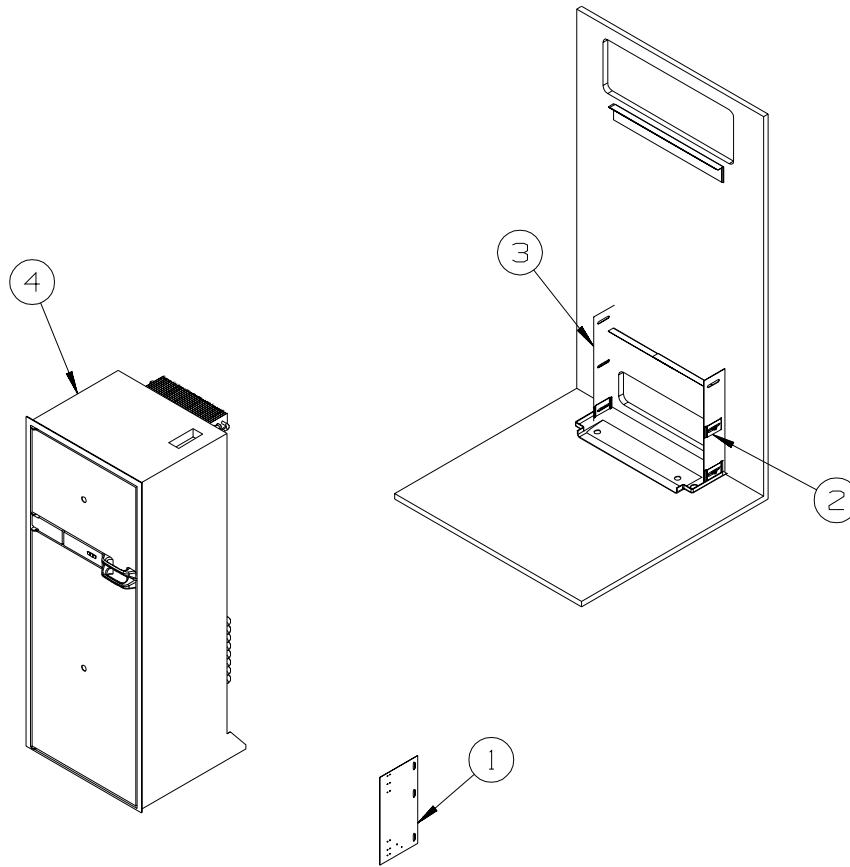

D29R, D34A, D35N

FROM: 00-00-00
THRU: 08-17-04

APPLIANCES (CONTINUED)

KEY	PART NUMBER	U/M	DESCRIPTION
1	141975-04-02B	EA	PLATE/TIEDOWN - REFRIGERATOR - E-COATED
2	141550-01-02B	EA	BRACKET/TIEDOWN - REFRIGERATOR - E-COATED
3	141550-02-02B	EA	BRACKET/TIEDOWN - REFRIGERATOR - E-COATED
4*	121568-06-01A	EA	REFRIGERATOR - SMALL DBL DOOR-RH/2 WAY- 52.8"HX23.5"WX24"D
	112176-01-000	FT	TUBING - VINYL - REINFORCED - 1/2" ID
	090329-01-000	FT	SEAL/T - REFRIGERATOR CABINET
	116751-02-01A	EA	TRAY - REFRIGERATOR - BLACK - D29R
	116751-01-01A	EA	TRAY - REFRIGERATOR - BLACK - D34A, D35N
	054450-01-000	EA	LEVEL - REFRIGERATOR

***COMPONENT PARTS LISTED LATER IN THIS GROUP**

CABINET & APPLIANCE GROUP (CONTINUED)
CABINET & APPLIANCE LAYOUT (CONTINUED)

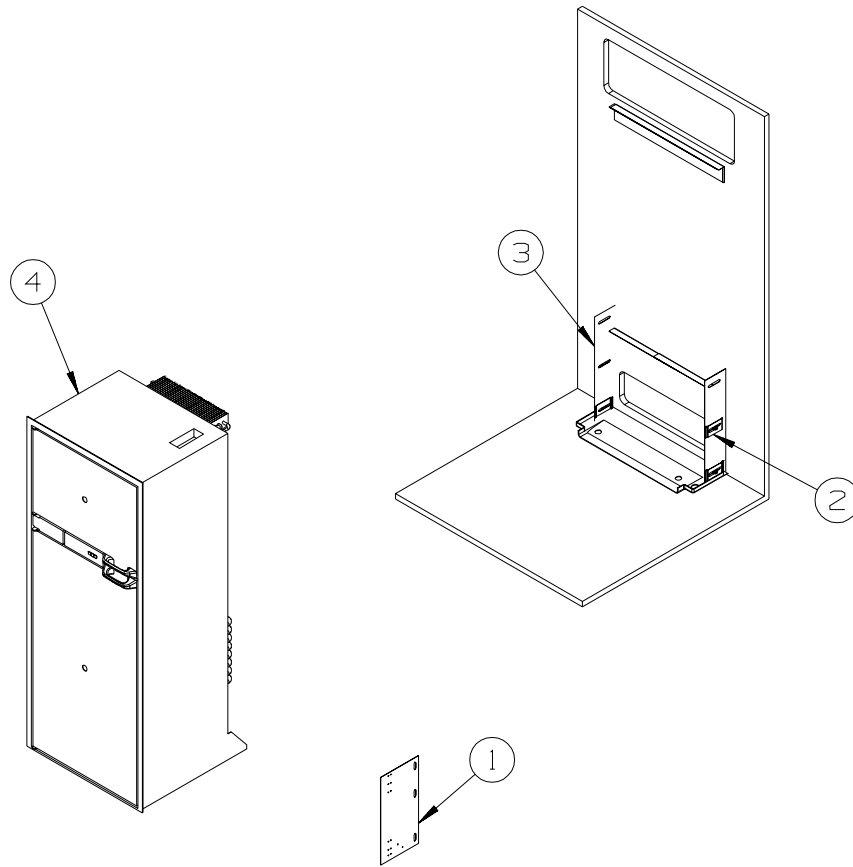

D29R, D34A, D35N

FROM: 00-00-00

THRU: 08-17-04

APPLIANCES (CONTINUED)

KEY	PART NUMBER	U/M	DESCRIPTION
1	141975-04-02B	EA	PLATE/TIEDOWN - REFRIGERATOR - E-COATED
2	141550-01-02B	EA	BRACKET/TIEDOWN - REFRIGERATOR - E-COATED
3	141550-02-02B	EA	BRACKET/TIEDOWN - REFRIGERATOR - E-COATED
4*	121568-06-01A	EA	REFRIGERATOR - SMALL DBL DOOR-RH/2 WAY- 52.8"HX23.5"WX24"D
	112176-01-000	FT	TUBING - VINYL - REINFORCED - 1/2" ID
	090329-01-000	FT	SEAL/T - REFRIGERATOR CABINET
	116751-02-01A	EA	TRAY - REFRIGERATOR - BLACK - D29R
	116751-01-01A	EA	TRAY - REFRIGERATOR - BLACK - D34A, D35N
	054450-01-000	EA	LEVEL - REFRIGERATOR

***COMPONENT PARTS LISTED LATER IN THIS GROUP**

CABINET & APPLIANCE GROUP (CONTINUED)
CABINET & APPLIANCE LAYOUT (CONTINUED)

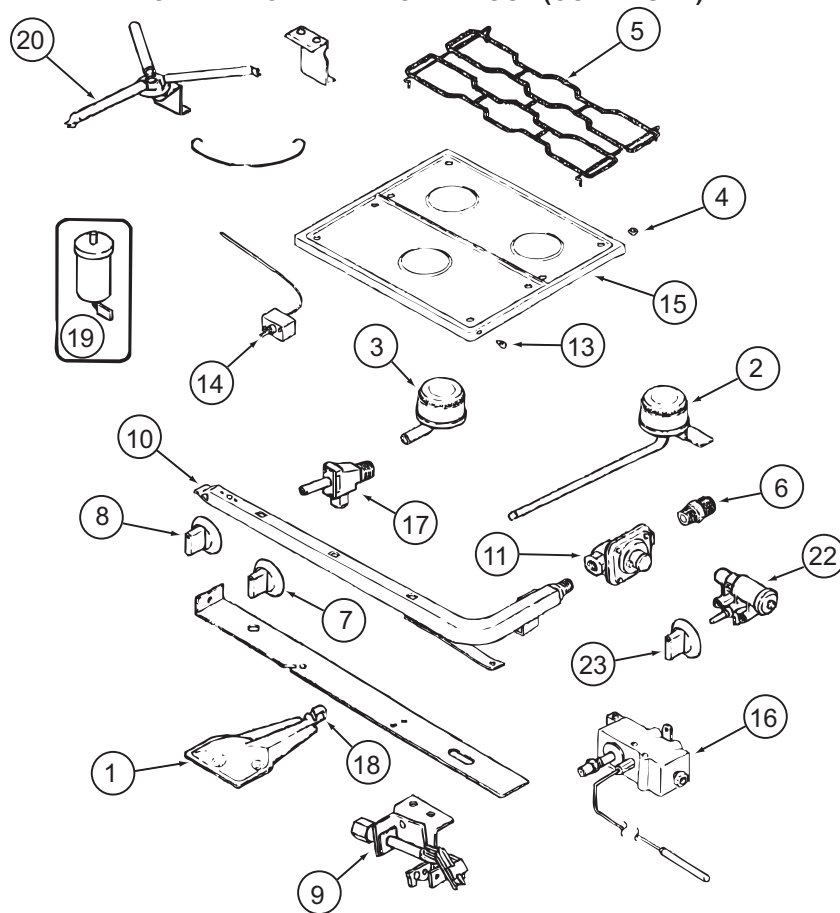

COMPONENT PARTS FOR APPLIANCES

112881-04-01A, 112881-05-01A

KEY	PART NUMBER	U/M	DESCRIPTION	VENDOR NO.
1	126023-01-717	EA	BURNER - OVEN	74003343
2	112881-04-700	EA	BURNER - TOP/LEFT REAR	74004584
2	126023-01-700	EA	BURNER-TOP (RT-REAR) 5100BTU	74004583
3	112881-04-701	EA	BURNER - TOP/FRONT	74004582
4	102020-01-709	EA	BUMPER-GRATE	8007P020-60
5	112881-04-702	EA	GRATE - BLACK	74007277
6	135065-03-700	EA	FITTING - HALF UNION	74004234
7	128728-01-701	EA	KNOB - BURNER - REAR	74003941 (1 PER)
7	128728-01-702	EA	KNOB - BURNER - FRONT	74003942 (2 PER)
8	112881-04-703	EA	KNOB - THERMOSTAT - BLACK	74004645
9	112881-04-706	EA	PILOT - OVEN	74006334
10	126023-02-702	EA	PIPE - MANIFOLD	74004360
11	126023-02-703	EA	REGULATOR - PRESSURE	74004235
13	102020-01-724	EA	BUMPER-MAIN TOP	8003P008-60
14	126023-01-734	EA	THERMOSTAT OVEN SER#10/11&14	74006332
15	126023-01-728	EA	TOP - MAIN (BLACK)	74003323
16	112881-04-704	EA	VALVE - OVEN	74006333
17	126023-02-705	EA	VALVE - BURNER - REAR	74004362
17	126023-02-706	EA	VALVE - BURNER - FRONT	74004363
17	135065-03-701	EA	SCREW - VALVE	71003231
18	135656-01-701	EA	MIXER/AIR	3411F003-34
19	126023-01-711	EA	ELECTRODE - IGNITER (ONLY)	7432P077-60
20	126023-01-736	EA	FLASH TUBE EXTENSION (REAR)	74003326
20	126023-01-737	EA	FLASH TUBE EXTENSION (FRONT)	74003327
21	112881-04-708	EA	CLIP-FLASH TUBE	7112P068-60
22	126023-01-719	EA	IGNITER HEAD - TOP BURNER	74002413
23	128728-01-707	EA	KNOB - IGNITOR	74003944
26	112881-04-709	EA	SHIELD-SPARK	3604F211-45

CONTACT WINNEBAGO PART SALES FOR UNLISTED COMPONENT(S)

CABINET & APPLIANCE GROUP (CONTINUED)
CABINET & APPLIANCE LAYOUT (CONTINUED)

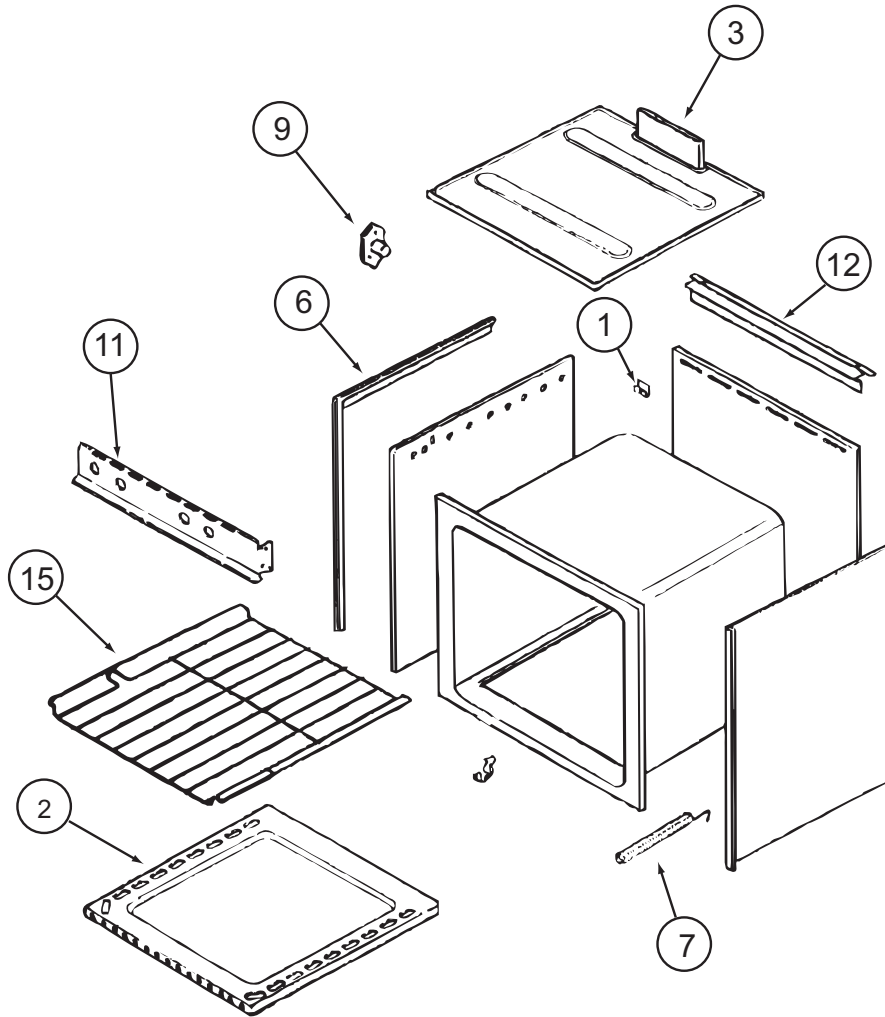

COMPONENT PARTS FOR APPLIANCE (CONTINUED)

112881-04-01A, 112881-05-01A, 151277-02-01A (CONTINUED)

KEY	PART NUMBER	U/M	DESCRIPTION	VENDOR NO.
1	112881-03-702	EA	CLIP - MAIN TOP	74003998
2	126023-01-731	EA	BOTTOM - OVEN	2205F016-19
3	126023-01-718	EA	FLUE BOX ASSEMBLY	4006W075-80
6	112881-01-719	EA	TRIM-FLAT LH BLACK TEXTURED	74002813
6	112881-01-720	EA	TRIM-FLAT RH BLACK TEXTURED	74002812
7	112881-02-702	EA	SPRING - OVEN DOOR F/1631 MOD	7803P051-60
9	128728-01-703	EA	PIN/T-NUT F/HINGE	7103P109-60
11	112881-04-707	EA	MANIFOLD - BLACK	74007296
12	112881-01-723	EA	DEFLECTOR/FLUE-BLK-NON SEAL	74002809
15	126023-01-716	EA	RACK - OVEN	74003106

CONTACT WINNEBAGO PART SALES FOR UNLISTED COMPONENT(S)

CABINET & APPLIANCE GROUP (CONTINUED)
CABINET & APPLIANCE LAYOUT (CONTINUED)

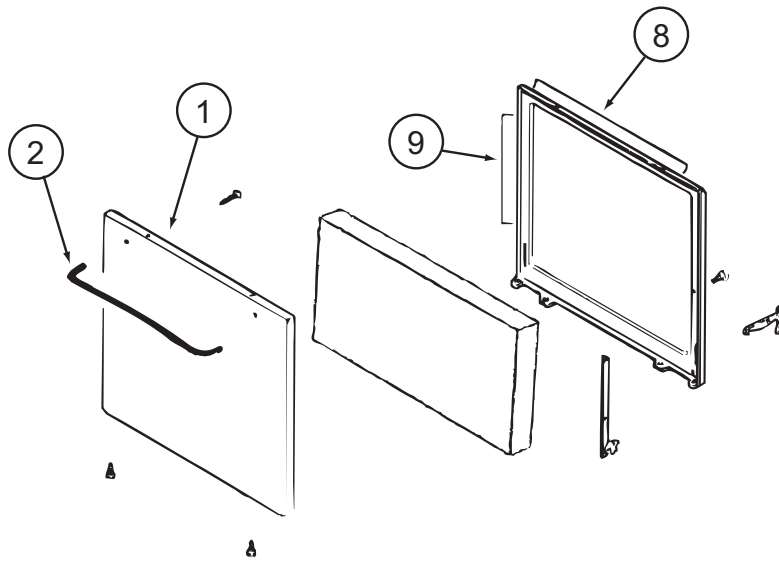

COMPONENT PARTS FOR APPLIANCE (CONTINUED)

112881-04-01A, 112881-05-01A, 151277-02-01A (CONTINUED)

KEY	PART NUMBER	U/M	DESCRIPTION	VENDOR NO.
1	112881-01-713	EA	DR-TXT/BLK NO WNDW (112881-05/151277)	2401F126-70
1	112881-02-705	EA	DOOR-TXT/BLK-F/WINDOW (112881-04)	74001273
2	128727-01-701	EA	HANDLE - OVEN DOOR	74003929
8	126023-01-732	EA	SEAL/OVEN DR TOP	7212P014-60
9	126023-01-733	EA	SEAL/OVEN DR SIDES(2PCS)	7212P038-60

CONTACT WINNEBAGO PART SALES FOR UNLISTED COMPONENT(S)

CABINET & APPLIANCE GROUP (CONTINUED)
CABINET & APPLIANCE LAYOUT (CONTINUED)

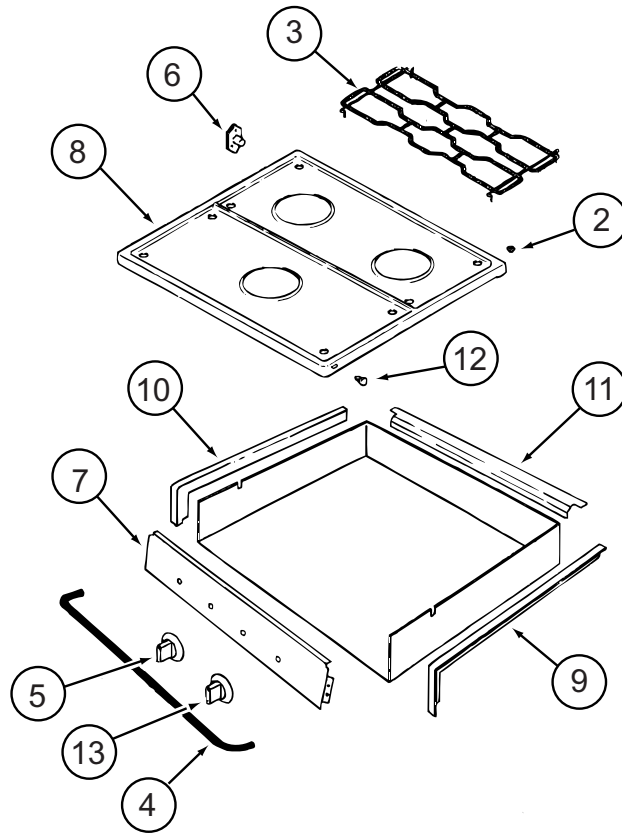

COMPONENT PARTS FOR APPLIANCE (CONTINUED)

114030-04-01A

KEY	PART NUMBER	U/M	DESCRIPTION	VENDOR NO.
2	102020-01-709	EA	BUMPER-GRATE	8007P020-60
3	112881-04-702	EA	GRATE - BLACK	74007277
4	114030-02-700	EA	GUARD/FABRIC - TOWEL BAR	3609F006-70
5	128728-01-701	EA	KNOB - BURNER - REAR	74003941 (1 PER)
5	128728-01-702	EA	KNOB - BURNER - FRONT	74003942 (2 PER)
6	128728-01-703	EA	PIN/T-NUT F/HINGE	7103P109-60
7	114030-04-700	EA	PANEL - MANIFOLD - BLACK	74007325
8	126023-01-728	EA	TOP - MAIN (BLACK)	74003323
9	114030-01-704	EA	TRIM - RIGHT/BLACK TEXTURED	74002839
10	114030-01-705	EA	TRIM - LEFT/BLACK TEXTURED	74002840
11	114030-01-706	EA	TRIM - REAR/BLACK TEXTURED	74002841
12	102020-01-724	EA	BUMPER - MAIN TOP	8003P008-60
13	128728-01-707	EA	KNOB - IGNITER	74003944

CONTACT WINNEBAGO PART SALES FOR UNLISTED COMPONENT(S)

CABINET & APPLIANCE GROUP (CONTINUED)
CABINET & APPLIANCE LAYOUT (CONTINUED)

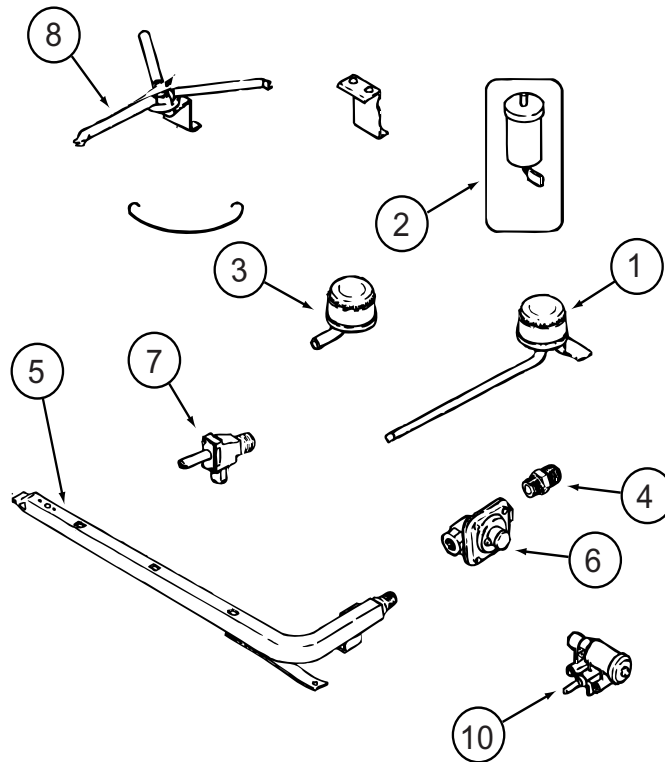

COMPONENT PARTS FOR APPLIANCE (CONTINUED)

114030-04-01A (CONTINUED)

KEY	PART NUMBER	U/M	DESCRIPTION	VENDOR NO.
1	112881-04-700	EA	BURNER - TOP /LEFT - REAR	74004584
1	126023-01-700	EA	BURNER - TOP (RT-REAR) 5100 BTU	74004583
2	112881-04-705	EA	PUSH RING (ELECTRODE MTG)	7104P002-60
2	126023-01-711	EA	ELECTRODE - IGNITER (ONLY)	7432P077-60
3	112881-04-701	EA	BURNER - TOP/FRONT	74004582
4	135065-03-700	EA	FITTING - HALF UNION	74004234
5	126023-01-702	EA	PIPE/MANIFOLD	74004642
6	126023-02-702	EA	PIPE - MANIFOLD	74004360
7	126023-02-705	EA	VALVE - BURNER - REAR	74004362
7	126023-02-706	EA	VALVE - BURNER - FRONT	74004363
8	126023-01-736	EA	FLASH TUBE EXTENSION (REAR)	74003326
8	126023-01-737	EA	FLASH TUBE EXTENSION (FRONT)	74003327
10	126023-01-719	EA	IGNITER HEAD - TOP BURNER	74002413

CONTACT WINNEBAGO PART SALES FOR UNLISTED COMPONENT(S)

CABINET & APPLIANCE GROUP (CONTINUED)
CABINET & APPLIANCE LAYOUT (CONTINUED)

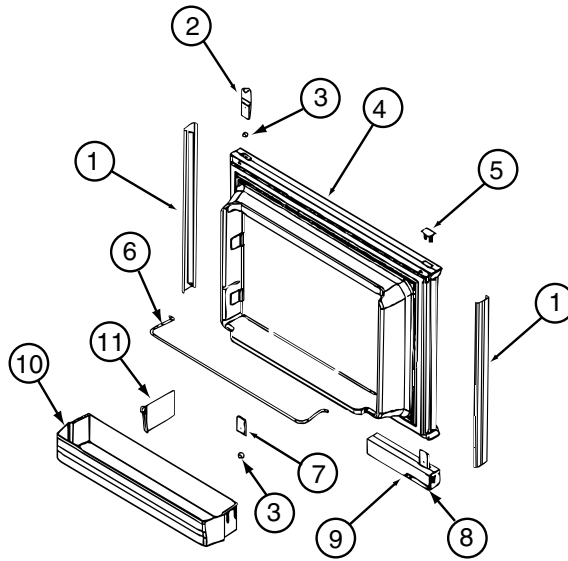

COMPONENT PARTS FOR APPLIANCE (CONTINUED)

121568-06-01A, 121568-07-01A, 121568-08-01A

KEY	PART NUMBER	U/M	DESCRIPTION	VENDOR NO.
1	121568-03-700	EA	RETAINER - DOOR PANEL/BLACK	619559
2	120075-01-701	EA	HINGE-TOP RH/BOTTOM LH(DOOR)	618511
3	121568-03-701	EA	BUSHING - HINGE PIN/GRAY	619671
4	121568-03-702	EA	DOOR LINER - W/BLACK TRIM	619627
5	120075-01-702	EA	CAP, (HINGE PLUG)	618160
6	121568-01-700	EA	RAIL - DOOR UPPER	618618
7	120075-01-705	EA	HINGE-TOP LH/BOTTOM RH(DOOR)	618510
8	121568-03-705	EA	STORAGE LATCH - GRAY	619648
9	121568-03-721	EA	HANDLE/DOOR TOP LH/LWR RH	621465
9	121568-03-722	EA	HANDLE/DOOR LWR RH/TOP LH	621469
10	121568-01-701	EA	BIN - DOOR WHITE	618619

CONTACT WINNEBAGO PART SALES FOR UNLISTED COMPONENT(S)

CABINET & APPLIANCE GROUP (CONTINUED)
CABINET & APPLIANCE LAYOUT (CONTINUED)

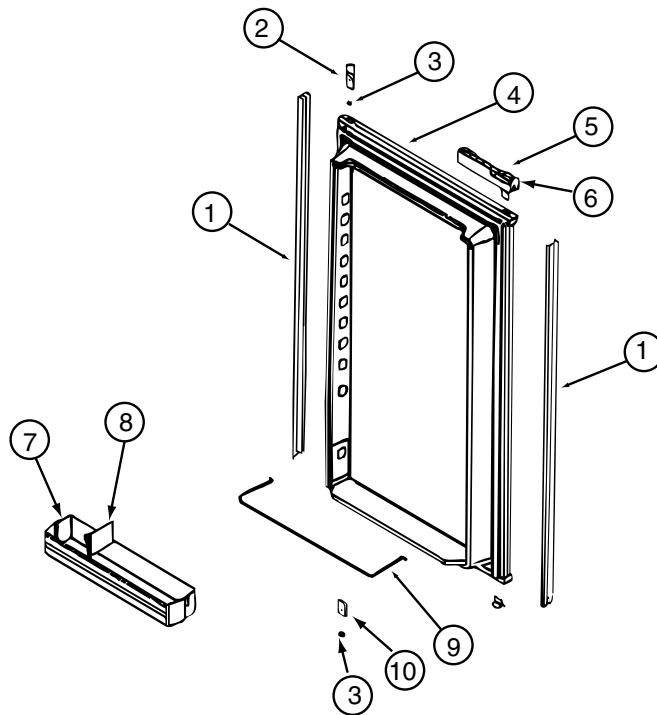

COMPONENT PARTS FOR APPLIANCE (CONTINUED)

121568-06-01A, 121568-07-01A, 121568-08-01A (CONTINUED)

KEY	PART NUMBER	U/M	DESCRIPTION	VENDOR NO.
1	121568-03-706	EA	RETAINER - DOOR PANEL/BLACK	619559
2	120075-01-701	EA	HINGE-TOP RH/BOTTOM LH(DOOR)	618511
3	121568-03-701	EA	BUSHING - HINGE PIN/GRAY	619671
4	121568-03-707	EA	DOOR LINER - W/BLACK TRIM	619629
5	121568-03-721	EA	HANDLE/DOOR TOP LH/LWR RH	621465
5	121568-03-722	EA	HANDLE/DOOR LWR RH/TOP LH	621469
6	121568-03-705	EA	STORAGE LATCH - GRAY	619648
7	121568-01-701	EA	BIN - DOOR WHITE	618619
9	121568-01-704	EA	RAIL - DOOR LOWER	618578
10	120075-01-705	EA	HINGE-TOP LH/BOTTOM RH(DOOR)	618510

CONTACT WINNEBAGO PART SALES FOR UNLISTED COMPONENT(S)

CABINET & APPLIANCE GROUP (CONTINUED)
CABINET & APPLIANCE LAYOUT (CONTINUED)

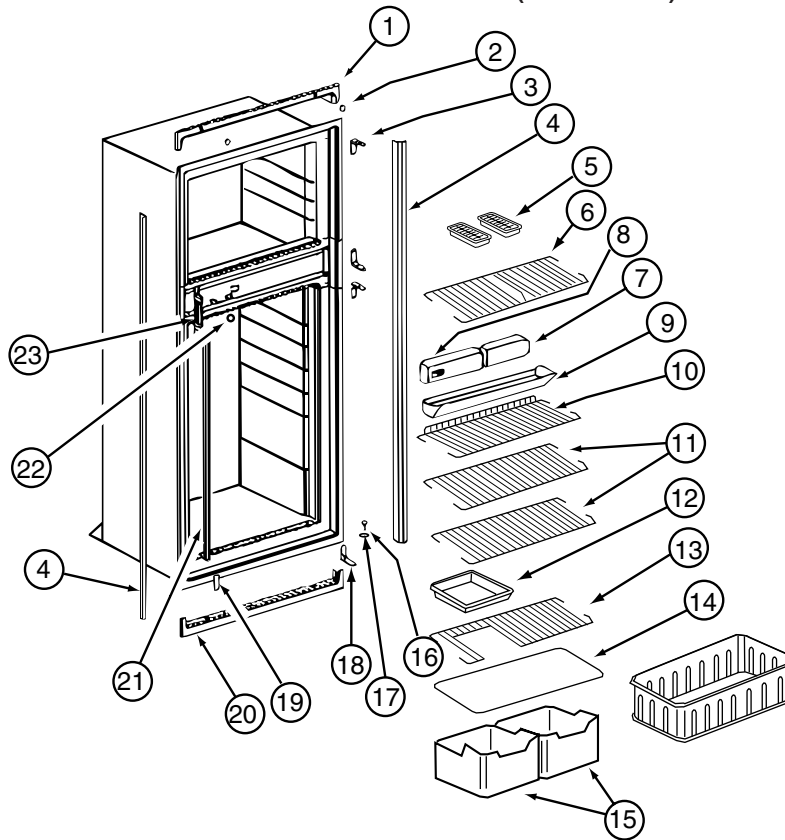

COMPONENT PARTS FOR APPLIANCE (CONTINUED)

121568-06-01A, 121568-07-01A, 121568-08-01A (CONTINUED)

KEY	PART NUMBER	U/M	DESCRIPTION	VENDOR NO.
1	120075-01-713	EA	TRIM-TOP PIECE	619687
2	120075-01-714	EA	PLUG-HOLE (BLACK)	618170
3	121568-03-710	EA	HINGE/CABINET-TOP/RH-LWR/LH	619335
4	121568-03-711	EA	TRIM - SIDE/BLACK	622295
6	121568-01-705	EA	SHELF - WIRE FREEZER	620250
7	121568-06-700	EA	FRONT BOX-N611	622002
8	121568-06-701	EA	CONTROL ASSEMBLY-OPTICAL/N611	621988
9	120075-01-720	EA	TRAY-DRIP	618137
9	120075-01-721	EA	LOUVER-DRIP TRAY	618176
11	121568-01-708	EA	SHELF - WIRE	620273
13	121568-01-707	EA	SHELF - WIRE - SHORT	620272
14	120075-01-725	EA	COVER-CRISPER	618158
15	121568-01-709	EA	CRISPER	618571
16	120075-01-727	EA	PIN-HINGE	618145
17	121568-03-701	EA	BUSHING - HINGE PIN/GRAY	619671
18	121568-03-715	EA	HINGE/CABINET-TOP/LH-LWR/RH	619336
19	121568-03-716	EA	COVER - HINGE HOLES	619301
20	120075-01-729	EA	TRIM-BOTTOM PIECE	620958
21	121568-06-702	EA	CLIP - SHELF	61536522
22	121568-06-703	EA	HOLE PLUG - WHITE	620282
23	120075-01-732	EA	PLATE-STRIKE	618167

CONTACT WINNEBAGO PART SALES FOR UNLISTED COMPONENT(S)

CABINET & APPLIANCE GROUP (CONTINUED)
CABINET & APPLIANCE LAYOUT (CONTINUED)

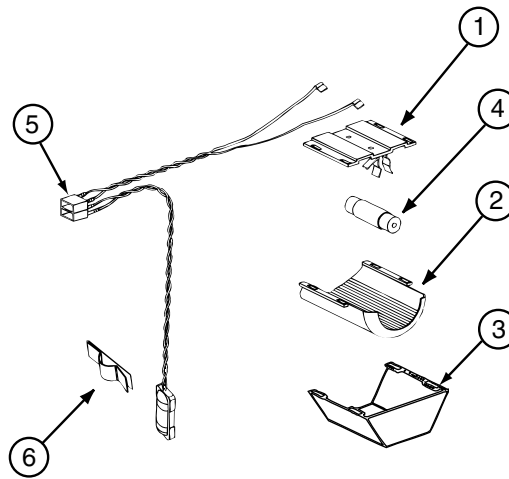

COMPONENT PARTS FOR APPLIANCE (CONTINUED)

121568-06-01A, 121568-07-01A, 121568-08-01A (CONTINUED)

KEY	PART NUMBER	U/M	DESCRIPTION	VENDOR NO.
1	084880-01-760	EA	CLIP (THERMISTER)	61689122
2	120075-01-735	EA	THERMISTER W/LAMP & WIRE/ASM	618548
3	084880-03-705	EA	BRACKET-LIGHT-INTERIOR	61629722
4	084880-03-706	EA	BULB-LAMP	61628922
6	084880-03-707	EA	COVER-LAMP, LENS	61627922

CONTACT WINNEBAGO PART SALES FOR UNLISTED COMPONENT(S)

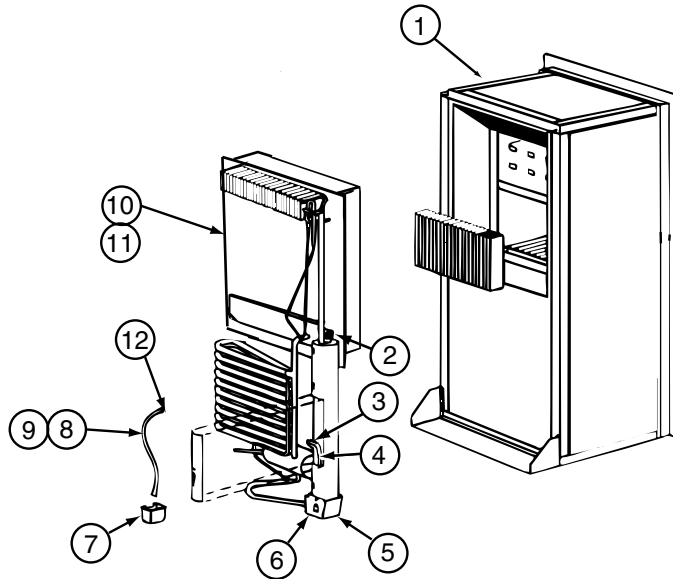

121568-06-01A, 121568-07-01A, 121568-08-01A (CONTINUED)

KEY	PART NUMBER	U/M	DESCRIPTION	VENDOR NO.
4	121568-06-704	EA	HEATER-AC/300W/120VAC	621702
10	120076-01-704	EA	COOLING UNIT, SERVICE PACK	618543

CONTACT WINNEBAGO PART SALES FOR UNLISTED COMPONENT(S)

CABINET & APPLIANCE GROUP (CONTINUED)
CABINET & APPLIANCE LAYOUT (CONTINUED)

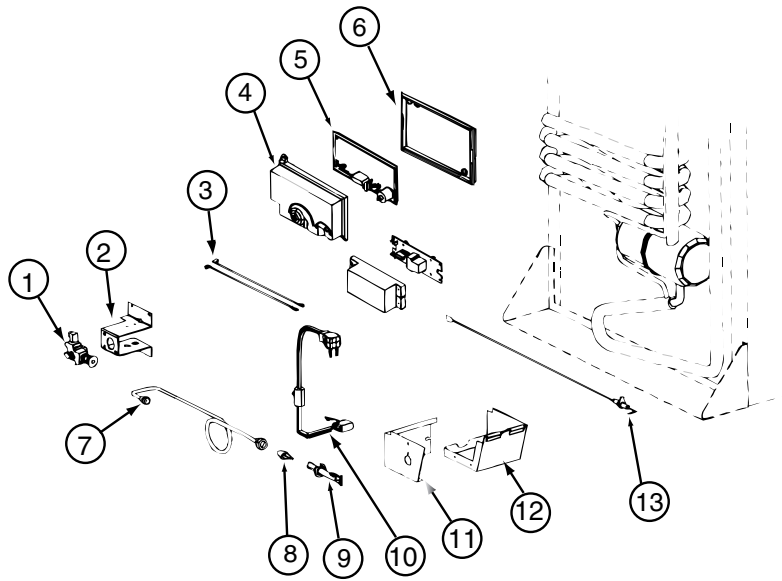

COMPONENT PARTS FOR APPLIANCE (CONTINUED)

121568-06-01A, 121568-07-01A, 121568-08-01A (CONTINUED)

KEY	PART NUMBER	U/M	DESCRIPTION	VENDOR NO.
1	121568-06-705	EA	GAS VALVE/BRKT ASSY-COMBO	621439
1	121568-06-706	EA	GAS VALVE-COMBO/WRENCH FLAT	621329
4	120075-01-738	EA	COVER-POWER BOARD	618185
5	121568-06-707	EA	BOARD/POWER-N611	621991
6	120075-01-740	EA	COVER-BASE, POWER BOARD	618186
8	121568-06-708	EA	BURNER/ORFICE-ADAPTER KIT	621957
13	104137-06-715	EA	ELECTRODE-SPARK/SENSOR, SGL	61692222

CONTACT WINNEBAGO PART SALES FOR UNLISTED COMPONENT(S)

121568-06-01A, 121568-07-01A, 121568-08-01A (CONTINUED)

KEY	PART NUMBER	U/M	DESCRIPTION	VENDOR NO.
	121568-05-700	EA	FAN 12V KIT DBLE SIDEWALL	619020

128527-09-000, 128527-10-000, 128527-13-000

KEY	PART NUMBER	U/M	DESCRIPTION	VENDOR NO.
	128527-08-700	EA	TRIM RING-F/1.0 NON CONV	MR10BB

CABINET & APPLIANCE GROUP (CONTINUED)
CABINET & APPLIANCE LAYOUT (CONTINUED)

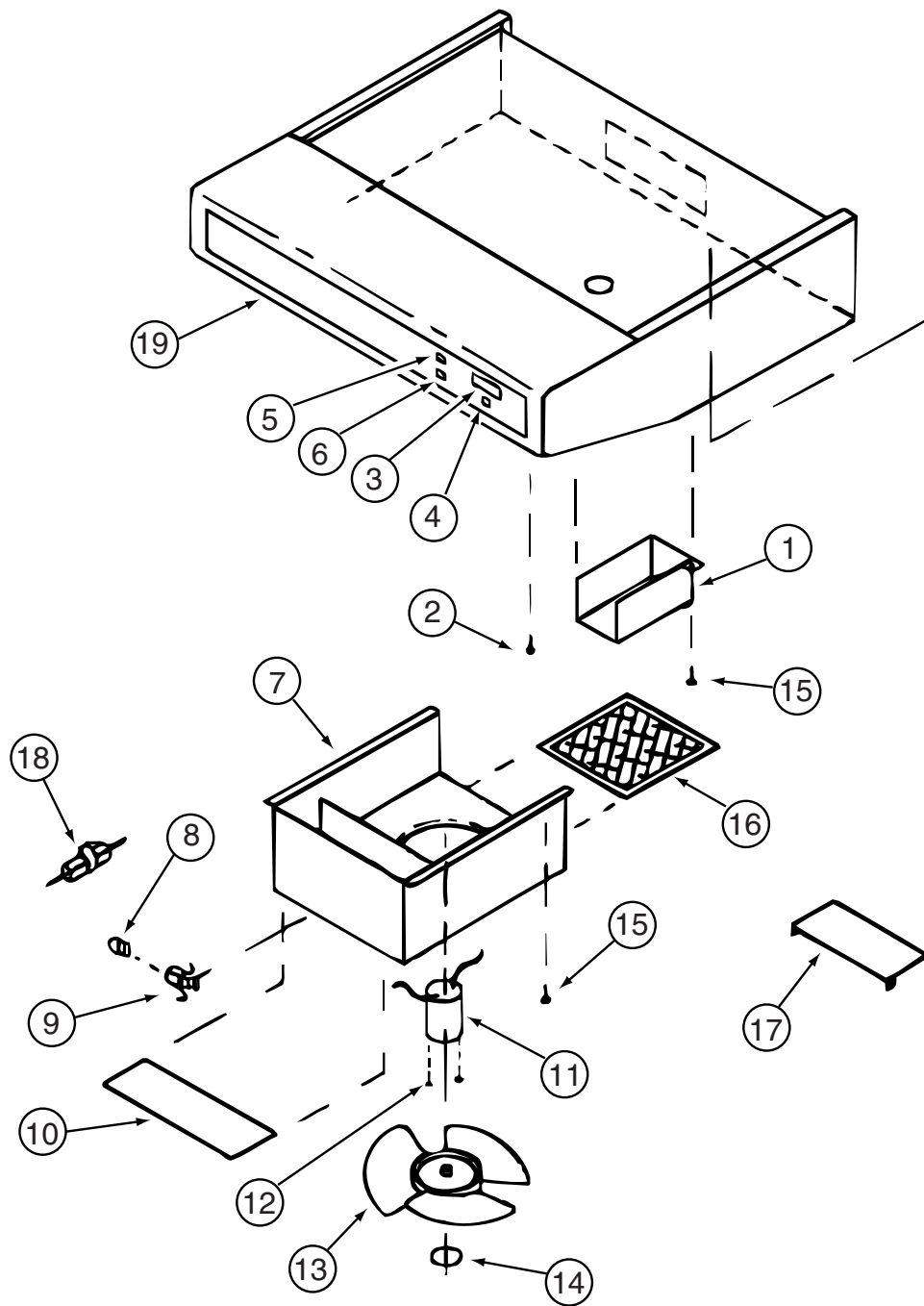

COMPONENT PARTS FOR APPLIANCE (CONTINUED)

136354-01-01A, 136354-02-01A

KEY	PART NUMBER	U/M	DESCRIPTION	VENDOR NO.
3	100258-10-700	EA	GAUGE-HOUR METER, SCREW ON	L0150-00 WAS 150
4	096983-01-702	EA	SWITCH - MOM/OFF/MOM/3 TERM	L0112-00
6	096983-01-700	EA	SWITCH/1 SPEED -ON/OFF- BLK	00108-00
8	092696-01-709	EA	LAMP #912	VA415
9	092696-01-710	EA	HOLDER-LAMP	CB267-2
10	092696-02-701	EA	LENS-LAMP	CC179-2
11	090973-01-700	EA	MOTOR-12 VOLT, CSA & UL	CA508-1
13	090973-01-702	EA	BLADE-FAN	VA183-1
16	096983-01-707	EA	FILTER-MESH	CC246
17	100258-01-701	EA	DAMPER ASSEMBLY (METAL FLAP)	CAO-565-00
19	100258-01-700	EA	LABEL-HOOD NOSE	CC0428-00

CONTACT WINNEBAGO PART SALES FOR UNLISTED COMPONENT(S)

CABINET & APPLIANCE GROUP (CONTINUED)

CABINET & APPLIANCE LAYOUT (CONTINUED)

COMPONENT PARTS FOR APPLIANCE (CONTINUED)

136354-05-01A

KEY	PART NUMBER	U/M	DESCRIPTION	VENDOR NO.
3	100258-10-700	EA	GAUGE-HOUR METER, SCREW ON	L0150-00 WAS 150
4	096983-01-702	EA	SWITCH - MOM/OFF/MOM/3 TERM	L0112-00
5	096983-01-700	EA	SWITCH/1 SPEED -ON/OFF- BLK	L0108-00
9	092696-01-710	EA	HOLDER-LAMP	CB267-02
10	092696-02-701	EA	LENS-LAMP	CC179-2
11	136354-05-700	EA	MOTOR-12 VOLT	VC0536-02
13	136354-05-701	EA	BLADE-FAN 7" DIA	VD0216-00
16	096983-01-707	EA	FILTER-MESH	CC0246-00
17	100258-01-701	EA	DAMPER ASSEMBLY (METAL FLAP)	CA0-565-00
19	100258-01-700	EA	LABEL-HOOD NOSE	CC0428-00
			CONTACT WINNEBAGO PART SALES FOR UNLISTED COMPONENT(S)	

136354-06-01A

KEY	PART NUMBER	U/M	DESCRIPTION	VENDOR NO.
3	100258-10-700	EA	GAUGE-HOUR METER, SCREW ON	L0150-00 WAS 150
4	096983-01-702	EA	SWITCH - MOM/OFF/MOM/3 TERM	L0112-00
5	096983-01-700	EA	SWITCH/1 SPEED -ON/OFF- BLK	L0108-00
9	092696-01-710	EA	HOLDER-LAMP	CB0267-02
10	096983-01-708	EA	LENS-LAMP	CC0179
11	136354-06-700	EA	MOTOR - FAN (CSA)	VC0535-02
13	136354-05-701	EA	BLADE-FAN 7" DIA	VD0216-00
16	096983-01-707	EA	FILTER-MESH	CC0246-00
17	100258-01-701	EA	DAMPER ASSEMBLY (METAL FLAP)	CA0565-00
19	100258-01-700	EA	LABEL-HOOD NOSE	CC0428-00
			CONTACT WINNEBAGO PART SALES FOR UNLISTED COMPONENT(S)	

CABINET & APPLIANCE GROUP (CONTINUED)
CABINET & APPLIANCE LAYOUT (CONTINUED)

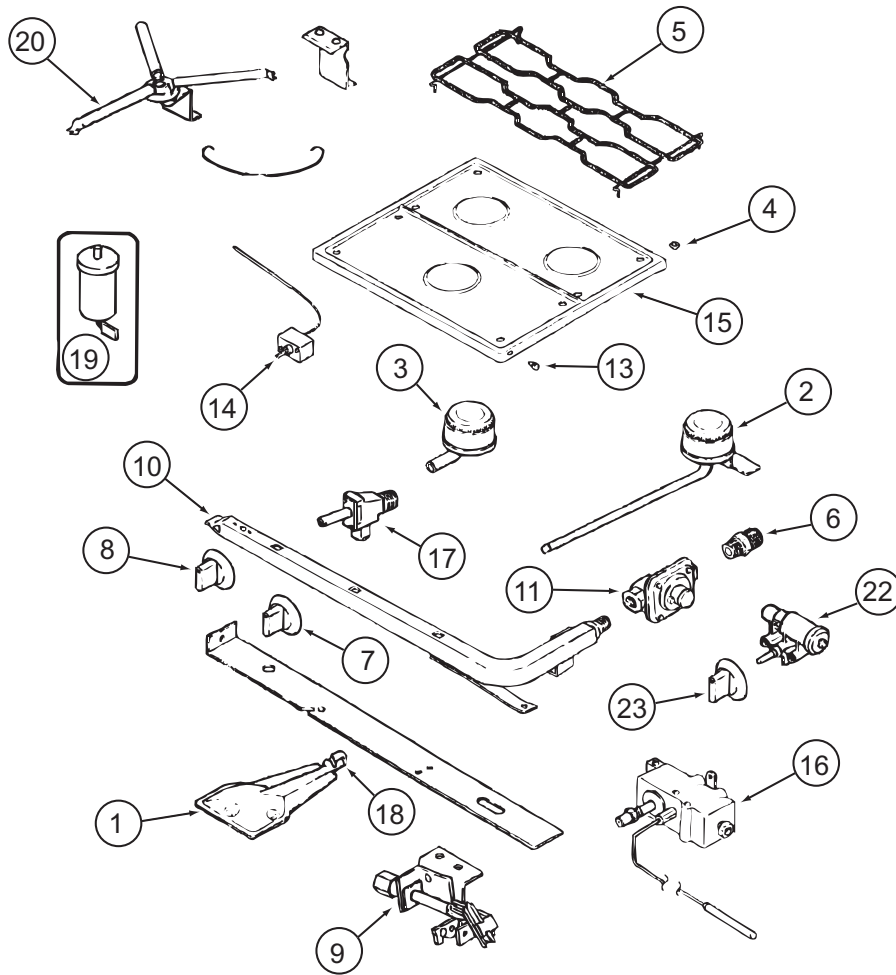

COMPONENT PARTS FOR APPLIANCE (CONTINUED)

151277-01-01A, 151277-02-01A

KEY	PART NUMBER	U/M	DESCRIPTION	VENDOR NO.
1	151279-02-700	EA	BURNER - OVEN - W/SHUTTER	74009853
2	112881-04-700	EA	BURNER - TOP/LEFT REAR	74004584
2	126023-01-700	EA	BURNER-TOP (RT-REAR) 5100BTU	74004583
3	112881-04-701	EA	BURNER - TOP/FRONT	74004582
4	102020-01-709	EA	BUMPER-GRATE	8007P020-60
5	112881-04-702	EA	GRATE - BLACK	74007277
6	135065-03-700	EA	FITTING - HALF UNION	74004234
7	128728-01-701	EA	KNOB - BURNER - REAR	74003941 (1 PER)
7	128728-01-702	EA	KNOB - BURNER - FRONT	74003942 (2 PER)
8	151279-02-701	EA	KNOB - THERMOSTAT - BLACK	74009858
9	151279-01-700	EA	PILOT - BURNER - 16" SERIES	74009852
10	151279-02-702	EA	PIPE - MANIFOLD	74009856
11	112881-03-701	EA	REGULATOR KIT W/FITTINGS	12001285
13	102020-01-724	EA	BUMPER-MAIN TOP	8003P008-60
14	151279-02-703	EA	THERMOSTAT	74009855
15	151277-01-700	EA	TOP - MAIN (BLACK)	74007287
16	151279-02-704	EA	ELBOW BLOCK ASM (VALVE-OVEN)	74009864
17	151277-01-701	EA	VALVE/REAR - W/SET SCREW	12002254
17	151277-01-702	EA	VALVE/FRONT - W/SET SCREW	12002246
19	112881-04-705	EA	PUSH RING (ELECTRODE MTG)	7104P002-60
19	126023-01-711	EA	ELECTRODE - IGNITER (ONLY)	7432P077-60
20	126023-01-736	EA	FLASH TUBE EXTENSION (REAR)	74003326
20	126023-01-737	EA	FLASH TUBE EXTENSION (FRONT)	74003327
21	112881-04-708	EA	CLIP-FLASH TUBE	7112P068-60
22	126023-01-735	EA	KIT - IGNITOR TOP BRNER & KNOB	12001296=74002413&4
23	128728-01-707	EA	KNOB - IGNITOR	74003944
26	112881-04-709	EA	SHIELD-SPARK	3604F211-45

CONTACT WINNEBAGO PART SALES FOR UNLISTED COMPONENT(S)

CABINET & APPLIANCE GROUP (CONTINUED)
CABINET & APPLIANCE LAYOUT (CONTINUED)

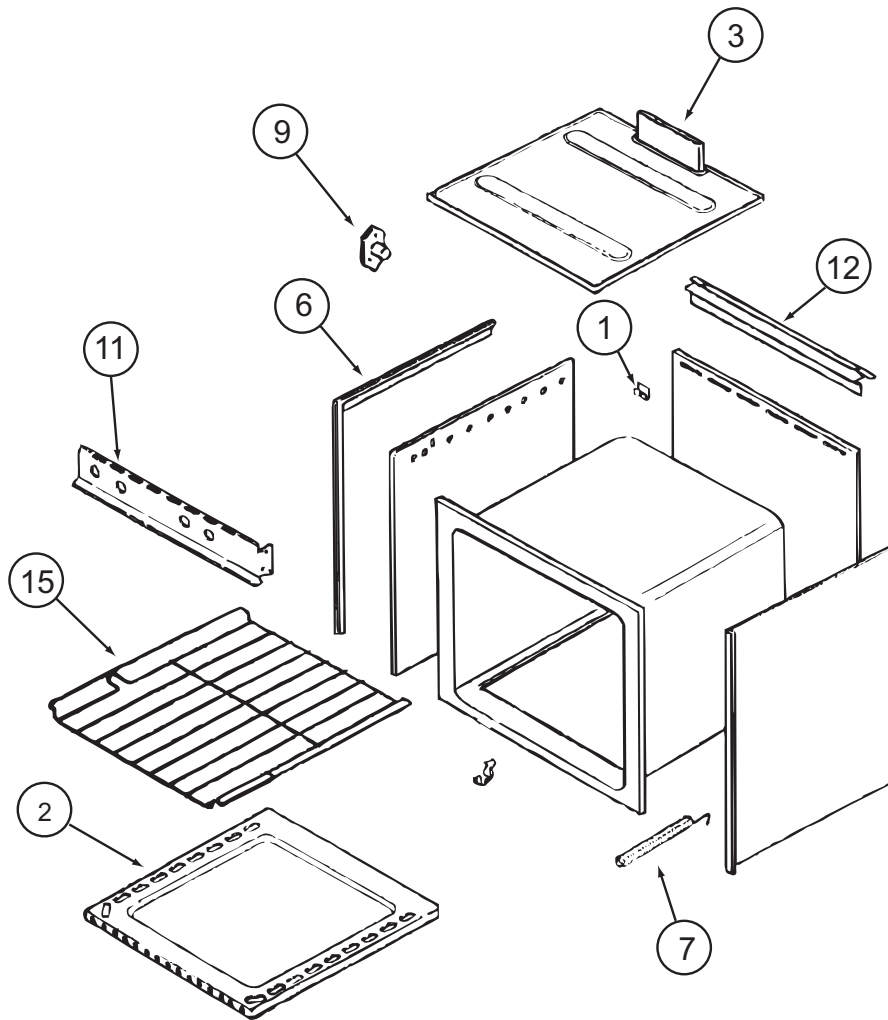

COMPONENT PARTS FOR APPLIANCE (CONTINUED)

151277-01-01A (CONTINUED)

KEY	PART NUMBER	U/M	DESCRIPTION	VENDOR NO.
1	112881-03-702	EA	CLIP - MAIN TOP	74003998
2	126023-01-731	EA	BOTTOM - OVEN	2205F016-19
3	126023-01-718	EA	FLUE BOX ASSEMBLY	4006W075-80
6	126023-01-713	EA	TRIM - SIDE (RIGHT) BLACK	74002827
6	126023-01-714	EA	TRIM - SIDE (LEFT) BLACK	74002828
7	135066-03-700	EA	SPRING - OVEN DOOR	74001835
9	128728-01-703	EA	PIN/T-NUT F/HINGE	7103P109-60
11	112881-04-707	EA	MANIFOLD - BLACK	74007296
12	112881-01-721	EA	DEFLECTOR/FLUE-BLK-SEALED BR	74002829
15	126023-01-716	EA	RACK - OVEN	74003106

CONTACT WINNEBAGO PART SALES FOR UNLISTED COMPONENT(S)

CABINET & APPLIANCE GROUP (CONTINUED)
CABINET & APPLIANCE LAYOUT (CONTINUED)

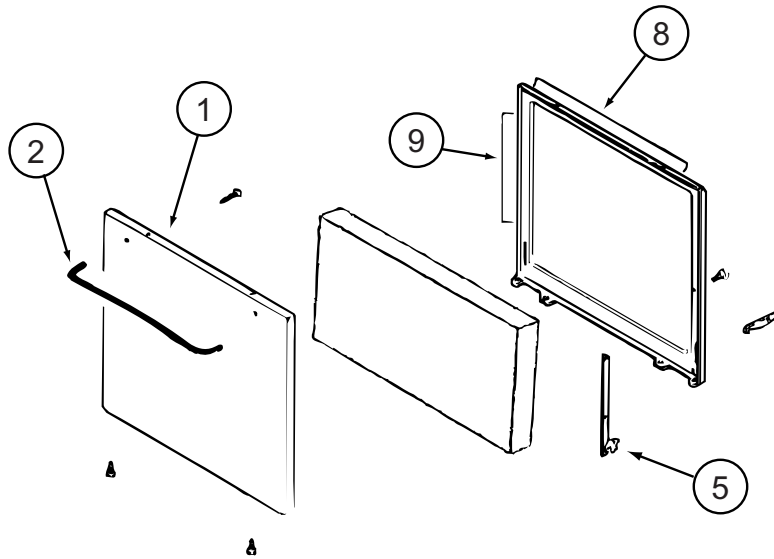

COMPONENT PARTS FOR APPLIANCE (CONTINUED)

151277-01-01A (CONTINUED)

KEY	PART NUMBER	U/M	DESCRIPTION	VENDOR NO.
1	102022-01-704	EA	GLASS-OUTER	7902P261-60
1	112881-01-713	EA	DOOR/OVEN-TEXT/BLK NO WINDOW	2401F126-70
2	128727-01-701	EA	HANDLE - OVEN DOOR	74003929
5	151277-01-704	EA	HINGE KIT-OVEN DR/LT	12400028
5	151277-01-705	EA	HINGE KIT-OVEN DR/RT	12400029
8	126023-01-732	EA	SEAL/OVEN DR TOP	7212P014-60
9	135066-03-714	EA	SEAL - OVEN DOOR SIDES	7212P039-60

CONTACT WINNEBAGO PART SALES FOR UNLISTED COMPONENT(S)

CABINET & APPLIANCE GROUP (CONTINUED)
CABINET & APPLIANCE LAYOUT (CONTINUED)

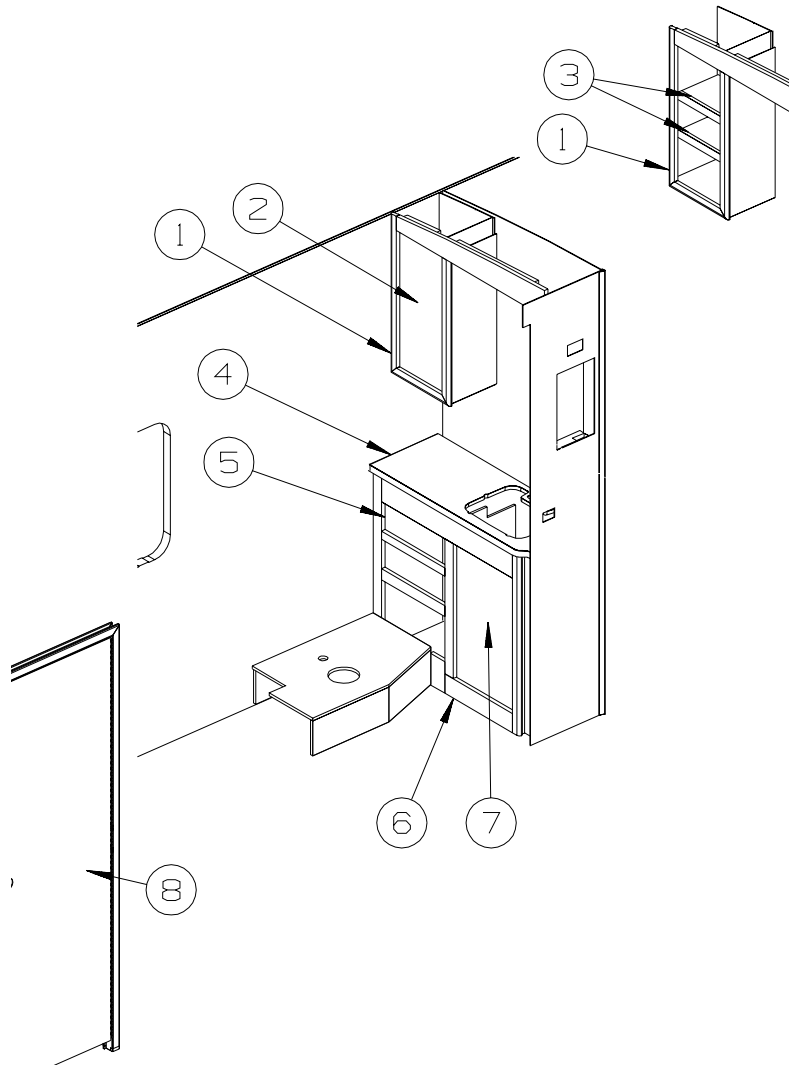

BATH

KEY	PART NUMBER	U/M	DESCRIPTION
1	138026-01-N21	EA	CABINET - MEDICINE - W/O DOORS/HARDWARE - PORTSMOUTH OAK
1	138026-01-SJ0	EA	CABINET - MEDICINE - W/O DOORS/HARDWARE - SIERRA MAPLE
2	136918-70-S28	EA	DOOR - FLAT/OGEE EDGE - 12" X 25.9" - W/O HARDWARE - PORTSMOUTH OAK
2	136918-70-S28	EA	DOOR - FLAT/OGEE EDGE - 12" X 25.9" - W/O HARDWARE - SIERRA MAPLE
3	138026-25-N21	EA	SHELF - W/PLASTIC EDGE - PORTSMOUTH OAK
3	138026-25-SJ0	EA	SHELF - W/PLASTIC EDGE - SIERRA MAPLE
4	133654-01-R28	EA	CTRTP - LAMINATED - LINO FRIEZE/PORTSMOUTH OAK (S28, SX2, SX4, SX6, SY4, SY6, SY8)
4	133654-01-P31	EA	CTRTP - LAMINATED - EGGHELL/PORTSMOUTH OAK (S29)
4	133654-01-R98	EA	CTRTP - LAMINATED - GRAY TRANQUILITY/PORTSMOUTH OAK (S30)
4	133654-01-SJ0	EA	CTRTP - LAMINATED - LINO FRIEZE/SIERRA MAPLE (SJ0, SX3, SX5, SX7, SY5, SY7, SY9)
4	133654-01-SJ1	EA	CTRTP - LAMINATED - EGGHELL/SIERRA MAPLE (SJ1)
4	133654-01-SJ2	EA	CTRTP - LAMINATED - GRAY TRANQUILITY/SIERRA MAPLE (SJ2)
5	145492-R9-R28	EA	DRAWER - OGEE EDGE - 13.9"W X 11.8"D - W/O SLIDES/HDW - PORTSMOUTH OAK
5	145492-R9-SJ0	EA	DRAWER - OGEE EDGE - 13.9"W X 11.8"D - W/O SLIDES/HDW - SIERRA MAPLE
6	138027-01-N21	EA	CABINET - LAVATORY - W/O CTRTP/DOORS/DRAWERS/HARDWARE - PORTSMOUTH OAK
6	138027-01-SJ0	EA	CABINET - LAVATORY - W/O CTRTP/DOORS/DRAWERS/HARDWARE - SIERRA MAPLE
7	136918-C2-S28	EA	DOOR - FLAT/OGEE EDGE - 15.3" X 25.6" - W/O HARDWARE - PORTSMOUTH OAK
7	136918-C2-S28	EA	DOOR - FLAT/OGEE EDGE - 15.3" X 25.6" - W/O HARDWARE - SIERRA MAPLE
8	144645-03-R28	EA	DOOR - BATH - W/O TOWEL RACK/HARDWARE - PORTSMOUTH OAK
8	144645-03-SJ0	EA	DOOR - BATH - W/O TOWEL RACK/HARDWARE - SIERRA MAPLE

SEE DRAINAGE AREA IN THE WATER & SEWAGE GROUP FOR SHOWER

CABINET & APPLIANCE GROUP (CONTINUED)
CABINET & APPLIANCE LAYOUT (CONTINUED)

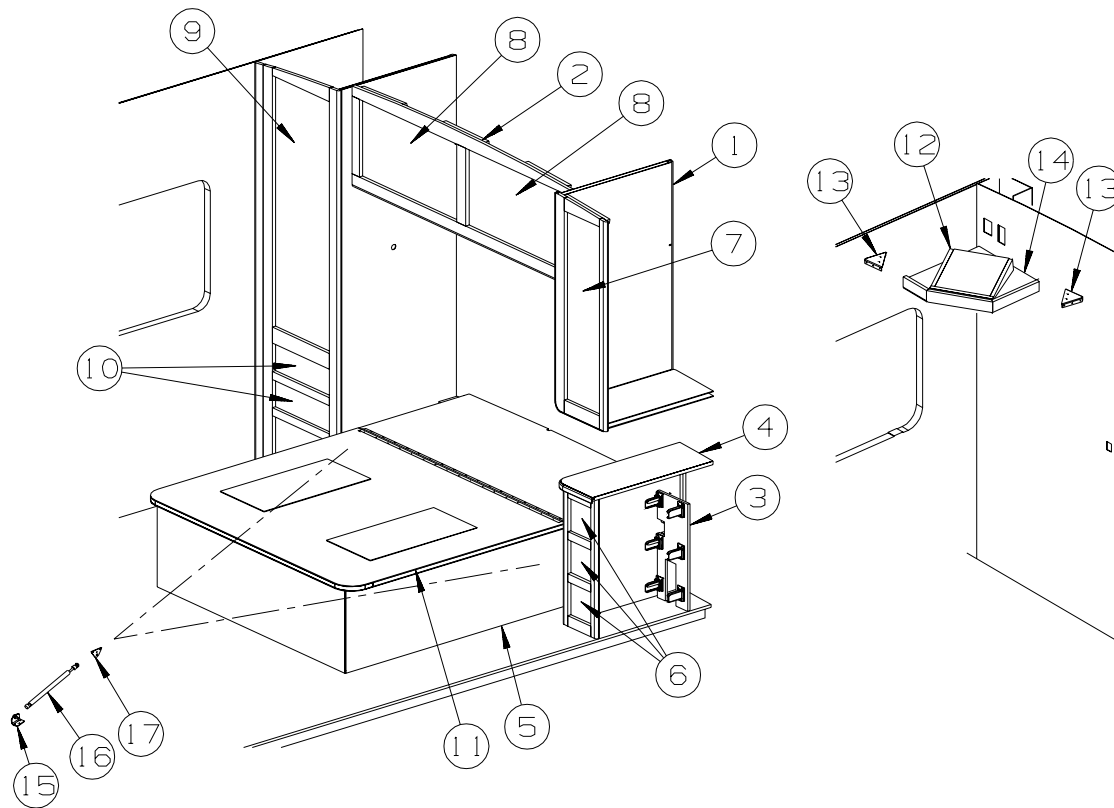

BEDROOM

KEY	PART NUMBER	U/M	DESCRIPTION
1	137960-01-N21	EA	CABINET - OVERHEAD/SHIRT/LEFT HAND - W/O DOORS/HARDWARE - PORTSMOUTH OAK
1	137960-01-SJ0	EA	CABINET - OVERHEAD/SHIRT/LEFT HAND - W/O DOORS/HARDWARE - SIERRA MAPLE
2	137983-01-N21	EA	CABINET - OVERHEAD/REAR - W/O DOORS/HARDWARE - PORTSMOUTH OAK
2	137983-01-SJ0	EA	CABINET - OVERHEAD/REAR - W/O DOORS/HARDWARE - SIERRA MAPLE
3	131843-02-N21	EA	CABINET - NIGHTSTAND - W/O COUNTERTOP/DOOR/DRAWER/HARDWARE - PORTSMOUTH OAK
3	131843-02-SJ0	EA	CABINET - NIGHTSTAND - W/O COUNTERTOP/DOOR/DRAWER/HARDWARE - SIERRA MAPLE
4	133655-32-R28	EA	COUNTERTOP - LAMINATED - LINO FRIEZE/PORTSMOUTH OAK (S28, SX2, SX4, SX6, SY4, SY6, SY8)
4	133655-32-P31	EA	COUNTERTOP - LAMINATED - EGGHELL/PORTSMOUTH OAK (S29)
4	133655-32-R98	EA	COUNTERTOP - LAMINATED - GRAY TRANQUILITY/PORTSMOUTH OAK (S30)
4	133655-32-SJ0	EA	COUNTERTOP - LAMINATED - LINO FRIEZE/SIERRA MAPLE (SJ0, SX3, SX5, SX7, SY5, SY7, SY9)
4	133655-32-SJ1	EA	COUNTERTOP - LAMINATED - EGGHELL/SIERRA MAPLE (SJ1)
4	133655-32-SJ2	EA	COUNTERTOP - LAMINATED - GRAY TRANQUILITY/SIERRA MAPLE (SJ2)
5	P48212-01-S28	EA	CABINET - BASE - QUEEN BED - W/O DOORS/DRAWERS/HDW - PORTSMOUTH OAK
5	P48212-01-SJ0	EA	CABINET - BASE - QUEEN BED - W/O DOORS/DRAWERS/HDW - SIERRA MAPLE
5	P48212-02-S28	EA	CAB/BASE- W/O HDW-QN BED-W/MTR AID-PORTSMOUTH OAK - WTR HEATER AUX AUTO/MOTORAID
5	P48212-02-SJ0	EA	CAB/BASE-W/O HDW-QN BED-W/MTR AID - SIERRA MAPLE - WTR HEATER AUX AUTO/MOTORAID
6	145492-C3-R68	EA	DRAWER - OGEE EDGE - 5.2"W X 19.7"D - W/O SLIDES/HARDWARE - PORTSMOUTH OAK
6	145492-C3-SA3	EA	DRAWER - OGEE EDGE - 5.2"W X 19.7"D - W/O SLIDES/HARDWARE - SIERRA MAPLE
7	136918-49-S28	EA	DOOR - FLAT/OGEE EDGE - 10.8" X 36.4" - W/O HARDWARE - PORTSMOUTH OAK
7	136918-49-S88	EA	DOOR - FLAT/OGEE EDGE - 10.8" X 36.4" - W/O HARDWARE - SIERRA MAPLE
8	136918-D3-S28	EA	DOOR - FLAT/OGEE EDGE - 15.7" X 27.9" - W/O HARDWARE - PORTSMOUTH OAK
8	136918-D3-SJ0	EA	DOOR - FLAT/OGEE EDGE - 15.7" X 27.9" - W/O HARDWARE - SIERRA MAPLE
9	141506-03-S52	EA	DOOR - MIRRORED/OGEE EDGE - 16.7" X 48" - W/O HDW - PORTSMOUTH OAK
9	141506-03-S88	EA	DOOR - MIRRORED/OGEE EDGE - 16.7" X 48" - W/O HDW - SIERRA MAPLE
10	145492-B4-R28	EA	DRAWER - OGEE EDGE - 14.6"W X 17.7"D - W/O SLIDES/HDW - PORTSMOUTH OAK
10	145492-B4-S88	EA	DRAWER - OGEE EDGE - 14.6"W X 17.7"D - W/O SLIDES/HDW - SIERRA MAPLE
11	137406-03-N21	EA	BEDBOARD - W/HINGE/T-MOLDING/SLIPNOT - FLIP-UP
12	133023-07-R28	EA	WEDGE - TV - PORTSMOUTH OAK
12	133023-07-SJ0	EA	WEDGE - TV - SIERRA MAPLE
13	146782-01-02B	EA	BRACKET - TV SHELF - E-COATED
14	146774-01-R28	EA	CABINET - TV SHELF/LEFT HAND - W/O DOORS/HARDWARE - PORTSMOUTH OAK
14	146774-01-SJ0	EA	CABINET - TV SHELF/LEFT HAND - W/O DOORS/HARDWARE - SIERRA MAPLE
15	126263-06-02B	EA	BRACKET - GAS SPRING W/BALL STUD - E-COATED
16	142569-15-000	EA	SPRING/GAS - 120 LB - 20" EXTENDED/12" COMPRESSED
17	126263-08-02B	EA	BRACKET - GAS SPRING W/CENTERED BALL STUD - E-COATED

CABINET & APPLIANCE GROUP (CONTINUED)
CABINET & APPLIANCE LAYOUT (CONTINUED)

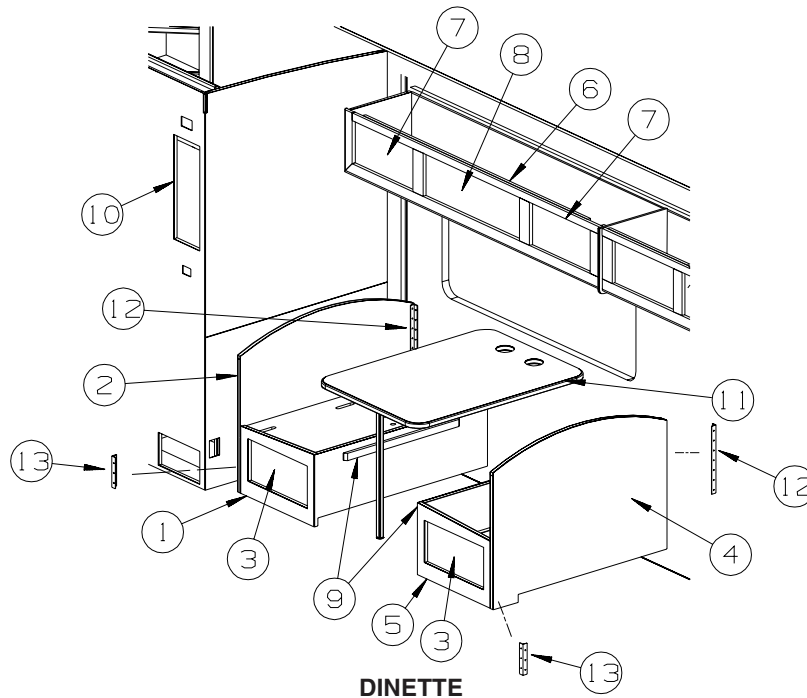

KEY	PART NUMBER	U/M	DESCRIPTION
1	P37092-16-P31	EA	CABINET/SEAT BASE - W/O DOOR/DRAWER/HARDWARE - PORTSMOUTH OAK
1	P37092-16-SJ0	EA	CABINET/SEAT BASE - W/O DOOR/DRAWER/HARDWARE - SIERRA MAPLE
	091261-01-000	FT	SLIPNOT - ANTISLIP - 1' WIDE X 12' - BLACK
2	137092-C6-P31	EA	DINETTE SEATBACK - W/O HARDWARE - PORTSMOUTH OAK
2	137092-C6-SJ0	EA	DINETTE SEAT BACK - W/O HARDWARE - SIERRA MAPLE
3	131995-G4-N01	EA	DOOR - RAIL/SOLID PANEL - 10" X 19.1" - W/O HARDWARE
			FROM: 00-00-00 THRU: 04-25-04
3	147084-07-S01	EA	DOOR - FLAT PANEL/OGEE EDGE - 10" X 19.1" - W/O HDW - PORTSMOUTH OAK
			FROM: 04-26-04 THRU: 99-99-99
3	147084-07-S88	EA	DOOR - FLAT PANEL/OGEE EDGE - 10" X 19.1" - W/O HDW - SIERRA MAPLE
			FROM: 04-26-04 THRU: 99-99-99
4	137092-D0-P31	EA	PANEL - BACK - F/DINETTE - PORTSMOUTH OAK
4	137092-D0-SJ0	EA	PANEL - BACK - F/DINETTE - SIERRA MAPLE
5	P37092-15-P31	EA	CABINET/SEATBASE - W/O DOOR/DRAWER/HARDWARE - PORTSMOUTH OAK
5	P37092-15-SJ0	EA	CABINET/SEAT BASE - W/O DOOR/DRAWER/HARDWARE - SIERRA MAPLE
	091261-01-000	FT	SLIPNOT - ANTISLIP - 1' WIDE X 12' - BLACK
6	148603-01-S28	EA	CABINET - OVERHEAD/DINETTE - W/O DOORS/HARDWARE - PORTSMOUTH OAK
6	148603-01-SJ0	EA	CABINET - OVERHEAD/DINETTE - W/O DOORS/HARDWARE - SIERRA MAPLE
7	136954-22-S28	EA	DOOR - RAISED PANEL/OGEE EDGE - 10" X 19.1" - W/O HDW - PORTSMOUTH OAK
	136954-22-SJ0	EA	DOOR - RAISED PANEL/OGEE EDGE - 10" X 19.1" - W/O HDW - SIERRA MAPLE
8	136954-25-S28	EA	DOOR - RAISED PANEL/OGEE EDGE - 10" X 25.2" - W/O HDW - PORTSMOUTH OAK
	136954-25-S88	EA	DOOR - RAISED PANEL/OGEE EDGE - 10" X 25.2" - W/O HDW - SIERRA MAPLE
9	081295-01-N70	EA	SUPPORT - BED/DINETTE - 28" LONG - PORTSMOUTH OAK
9	081295-01-RE0	EA	SUPPORT - BED/DINETTE - 28" LONG - SIERRA MAPLE
10	131096-51-N25	EA	POCKET - MONITOR PANEL - PORTSMOUTH OAK
			FROM: 00-00-00 THRU: 09-19-04
10	137602-E6-S28	EA	POCKET - MONITOR PANEL - PORTSMOUTH OAK
			FROM: 09-20-04 THRU: 99-99-99
10	131096-51-SJ0	EA	POCKET - MONITOR PANEL - SIERRA MAPLE
			FROM: 00-00-00 THRU: 09-19-04
10	137602-E6-SJ0	EA	POCKET - MONITOR PANEL - SIERRA MAPLE
			FROM: 09-20-04 THRU: 99-99-99
11	144605-06-R28	EA	TABLE - 41.6"X24" - LINO FRIEZE/PORTSMOUTH OAK (S28, SX2, SX4, SX6, SY4, SY6, SY8)
11	144605-06-P31	EA	TABLE - 41.6"X24" - EGGHELL/PORTSMOUTH OAK (S29)
11	144605-06-R98	EA	TABLE - 41.6"X24" - GRAY TRANQUILITY/PORTSMOUTH OAK (S30)
11	144605-06-SJ0	EA	TABLE - 41.6"X24" - LINO FRIEZE/SIERRA MAPLE (SJ0, SX3, SX5, SX7, SY5, SY7, SY9)
11	144605-06-SJ1	EA	TABLE - 41.6"X24" - EGGHELL/SIERRA MAPLE (SJ1)
11	144605-06-SJ2	EA	TABLE - 41.6"X24" - GRAY TRANQUILITY/SIERRA MAPLE (SJ2)
12	122021-02-02A	EA	ANGLE - W/HOLES - 13.7" LONG - OFF WHITE
13	122021-09-02A	EA	ANGLE - W/HOLES - 6.3" LONG - OFF WHITE

CABINET & APPLIANCE GROUP (CONTINUED)
CABINET & APPLIANCE LAYOUT (CONTINUED)

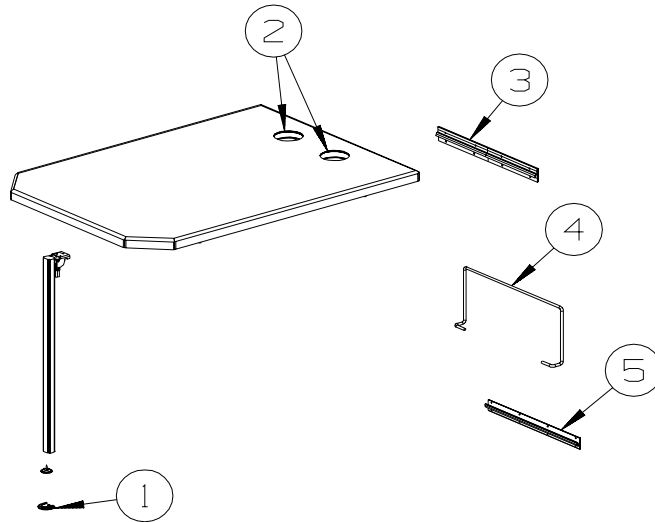

DINETTE (CONTINUED)

KEY	PART NUMBER	U/M	DESCRIPTION
1	143798-01-01A	EA	CATCH - FLOOR TO TABLE LEG - BRIGHT WHITE
2	064781-06-000	EA	HOLDER/CUP - TWO STEP - OFF WHITE
3	140921-02-01A	EA	BRACKET/TABLE SUPPORT - 18.5" - OFF WHITE
4	024275-13-000	EA	ROD - TABLE LIFT - OFF/WHITE
5	024281-15-000	EA	BRACKET/TABLE - LIFT ROD/LOWER WALL MOUNTED - 17.1"

CABINET & APPLIANCE GROUP (CONTINUED)
CABINET & APPLIANCE LAYOUT (CONTINUED)

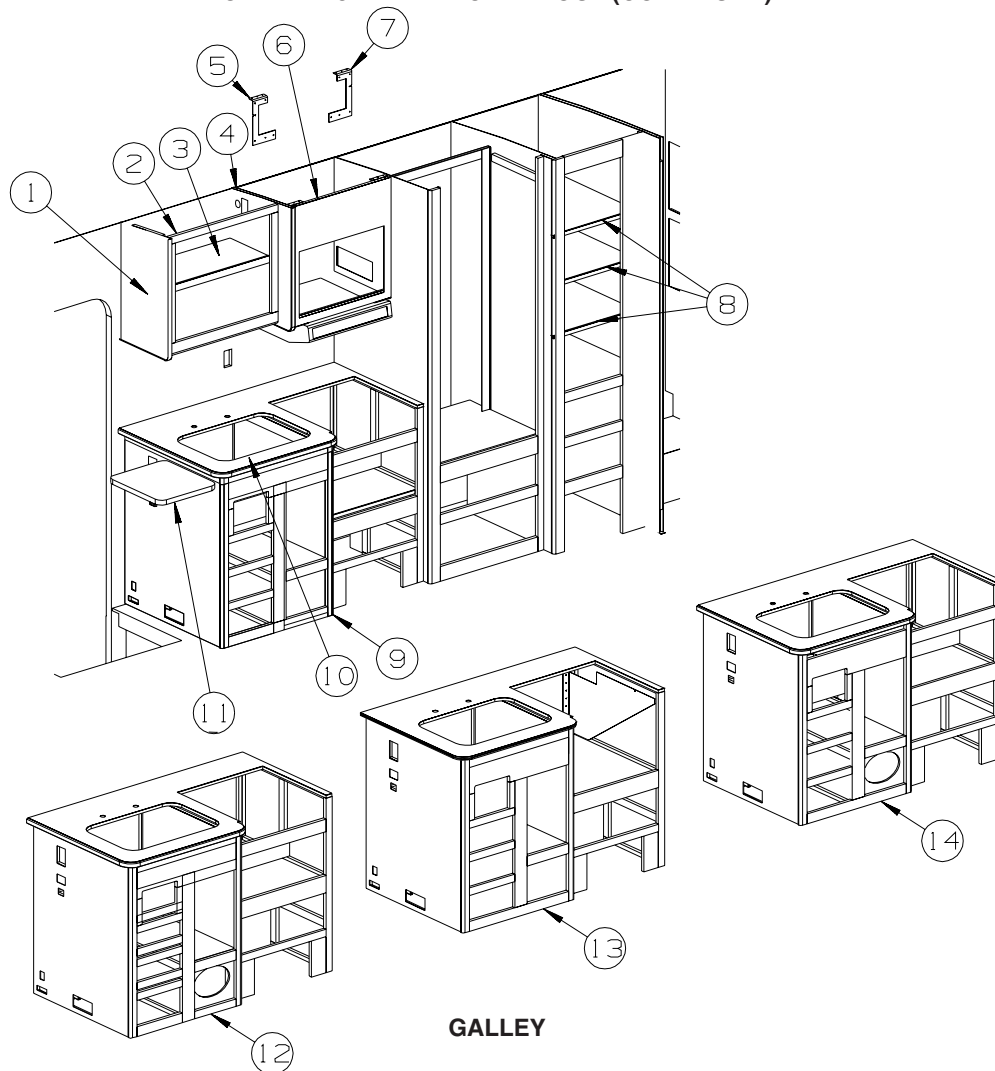

GALLEY

KEY	PART NUMBER	U/M	DESCRIPTION
1	081319-20-M24	EA	END CAP - OVHD CABINET - PORTSMOUTH OAK
1	081319-20-SJ0	EA	END CAP - OVHD CABINET - SIERRA MAPLE
2	144618-01-R28	EA	CABINET-OVHD/GALLEY-W/O DOORS/HDW - PORTSMOUTH OAK
2	144618-01-SJ0	EA	CABINET-OVHD/GALLEY-W/O DOORS/HDW - SIERRA MAPLE
2	144618-02-R28	EA	CABINET-OVHD/GALLEY-W/O DOORS/HDW - PORTSMOUTH OAK - MICROWAVE/CONVECTION OVEN
2	144618-02-SJ0	EA	CABINET-OVHD/GALLEY-W/O DOORS/HDW - SIERRA MAPLE - MICROWAVE/CONVECTION OVEN
3	144618-13-R28	EA	SHELF - W/PLASTIC EDGE MOLDING - PORTSMOUTH OAK
3	144618-13-SJ0	EA	SHELF - W/PLASTIC EDGE MOLDING - SIERRA MAPLE
3	144618-21-R28	EA	SHELF - W/PLASTIC EDGE MOLDING - PORTSMOUTH OAK - MICROWAVE/CONVECTION OVEN
3	144618-21-SJ0	EA	SHELF - W/PLASTIC EDGE MOLDING - SIERRA MAPLE - MICROWAVE/CONVECTION OVEN
4	081319-14-M24	EA	END CAP - OVHD CABINET - PORTSMOUTH OAK
4	081319-14-SJ0	EA	END CAP - OVHD CABINET - SIERRA MAPLE
4	140307-40-R13	EA	END CAP - OVERHEAD CABINET - PORTSMOUTH OAK - MICROWAVE/CONVECTION OVEN
4	140307-40-SJ0	EA	END CAP - OVERHEAD CABINET - SIERRA MAPLE - MICROWAVE/CONVECTION OVEN
5	098916-33-02B	EA	BRACE - MICROWAVE CABINET - LEFT HAND - E-COATED
5	149420-06-02B	EA	BRACE - MICROWAVE - E-COATED - LEFT HAND - MICROWAVE/CONVECTION OVEN
6	145568-01-R28	EA	CABINET - OVERHEAD/MICROWAVE - W/O DOORS/HARDWARE - PORTSMOUTH OAK
6	145568-01-SJ0	EA	CABINET - OVERHEAD/MICROWAVE - W/O DOORS/HARDWARE - SIERRA MAPLE
6	150460-01-R28	EA	CABINET - OVHD /MICROWAVE - W/O HDW- PORTSMOUTH OAK- MICROWAVE/CONVECTION OVEN
6	150460-01-SJ0	EA	CABINET - OVHD /MICROWAVE - W/O HDW- SIERRA MAPLE- MICROWAVE/CONVECTION OVEN
7	098916-34-02B	EA	BRACE - MICROWAVE CABINET - RIGHT HAND - E-COATED
7	149420-05-02B	EA	BRACE - MICROWAVE - E-COATED - RIGHT HAND - MICROWAVE/CONVECTION OVEN
8	144700-18-R28	EA	SHELF - W/PLASTIC EDGE MOLDING - PORTSMOUTH OAK
8	144700-18-SJ0	EA	SHELF - W/PLASTIC EDGE MOLDING - SIERRA MAPLE
9	P50320-05-S28	EA	CABINET-GALLEY-W/O CTRTP/HDW- PORTSMOUTH OAK - RANGE TOP 3-BURNER
9	P50320-05-SJ0	EA	CABINET-GALLEY-W/O CTRTP/HDW- SIERRA MAPLE - RANGE TOP 3-BURNER
9	P50320-06-S28	EA	CABINET-GALLEY-W/O CTRTP/HDW- PORTSMOUTH OAK - RANGE TOP 3-BURNER/RADIOS TWO-WAY
9	P50320-06-SJ0	EA	CABINET-GALLEY-W/O CTRTP/HDW- SIERRA MAPLE - RANGE TOP 3-BURNER/RADIOS TWO-WAY

CABINET & APPLIANCE GROUP (CONTINUED)

CABINET & APPLIANCE LAYOUT (CONTINUED)

GALLEY (CONTINUED)

KEY	PART NUMBER	U/M	DESCRIPTION
10	133653-23-R28	EA	COUNTERTOP - LAMINATED - LINO FRIEZE/PORTSMOUTH OAK (S28, SX2, SX4, SX6, SY4, SY6, SY8)
10	133653-23-P31	EA	COUNTERTOP - LAMINATED - EGGSHELL/PORTSMOUTH OAK (S29)
10	133653-23-R98	EA	COUNTERTOP - LAMINATED - GRAY TRANQUILITY/PORTSMOUTH OAK (S30)
10	133653-23-SJ0	EA	COUNTERTOP - LAMINATED - LINO FRIEZE/SIERRA MAPLE (SJ0, SX3, SX5, SX7, SY5, SY7, SY9)
10	133653-23-SJ1	EA	COUNTERTOP - LAMINATED - EGGSHELL/SIERRA MAPLE (SJ1)
10	133653-23-SJ2	EA	COUNTERTOP - LAMINATED - GRAY TRANQUILITY/SIERRA MAPLE (SJ2)
11	129503-04-R28	EA	EXTENSION - GALLEY COUNTERTOP - W/O HDW (S28, SX2, SX4, SX6, SY4, SY6, SY8)
11	129503-04-P31	EA	EXTENSION - GALLEY COUNTERTOP - W/O HDW (S29)
11	129503-04-P13	EA	EXTENSION - GALLEY COUNTERTOP - W/O HDW (S30)
11	129503-04-SJ0	EA	EXTENSION - GALLEY COUNTERTOP - W/O HDW (SJ0, SX3, SX5, SX7, SY5, SY7, SY9)
11	129503-04-SJ1	EA	EXTENSION - GALLEY COUNTERTOP - W/O HDW (SJ1)
11	129503-04-SJ2	EA	EXTENSION - GALLEY COUNTERTOP - W/O HDW (SJ2)
12	P50320-07-S28	EA	CABINET-W/O CTRTP/HDW - PORTSMOUTH OAK- RANGE TOP 3-BURNER/HOME THEATER SYSTEM
12	P50320-07-SJ0	EA	CABINET-W/O CTRTP/HDW - SIERRA MAPLE- RANGE TOP 3-BURNER/HOME THEATER SYSTEM
12	P50320-08-S28	EA	CABINET-W/O CTRTP/HDW - PORTSMOUTH OAK - RANGE TOP/RADIOS TWO-WAY/HOME THEATER
12	P50320-08-SJ0	EA	CABINET-W/O CTRTP/HDW - SIERRA MAPLE - RANGE TOP/RADIOS TWO-WAY/HOME THEATER
13	P50320-01-S28	EA	CABINET-W/O CTRTP/HDW - PORTSMOUTH OAK
13	P50320-01-SJ0	EA	CABINET-W/O CTRTP/HDW - SIERRA MAPLE
13	P50320-02-S28	EA	CABINET-W/O CTRTP/HDW - PORTSMOUTH OAK- RADIOS TWO-WAY
13	P50320-02-SJ0	EA	CABINET-W/O CTRTP/HDW - SIERRA MAPLE- RADIOS TWO-WAY
14	P50320-03-S28	EA	CABINET-W/O CTRTP/HDW - PORTSMOUTH OAK - HOME THEATER SYSTEM
14	P50320-03-SJ0	EA	CABINET-W/O CTRTP/HDW - SIERRA MAPLE - HOME THEATER SYSTEM
14	P50320-04-S28	EA	CABINET-W/O CTRTP/HDW - PORTSMOUTH OAK - RADIOS TWO-WAY/HOME THEATER SYSTEM
14	P50320-04-SJ0	EA	CABINET-W/O CTRTP/HDW - SIERRA MAPLE - RADIOS TWO-WAY/HOME THEATER SYSTEM

CABINET & APPLIANCE GROUP (CONTINUED)
CABINET & APPLIANCE LAYOUT (CONTINUED)

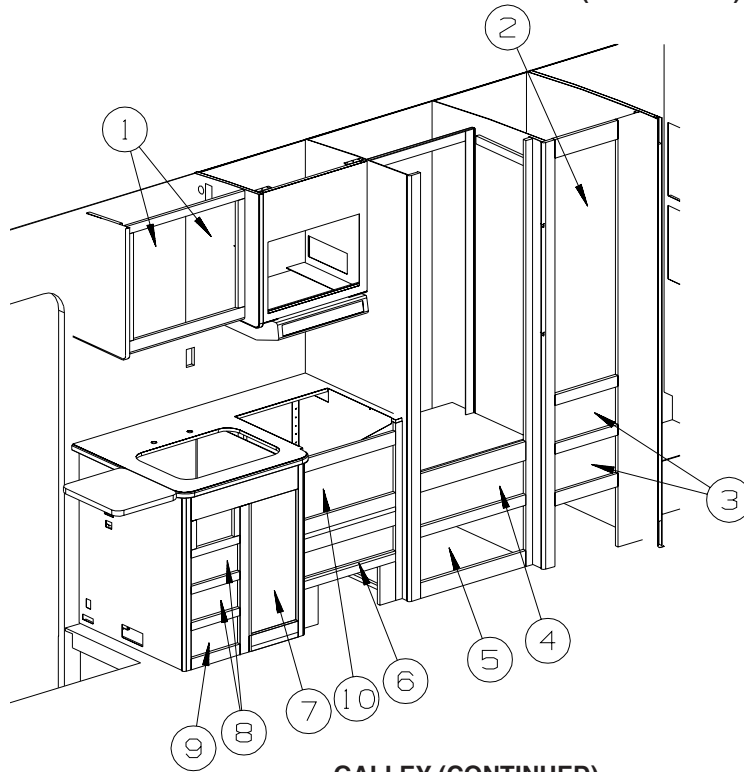

GALLEY (CONTINUED)

KEY	PART NUMBER	U/M	DESCRIPTION
1	136954-67-S28	EA	DOOR - RSD PANEL/OGEE - 12" X 21.9" - W/O HDW - PORTSMOUTH OAK
1	136954-67-SJ0	EA	DOOR - RSD PANEL/OGEE - 12" X 21.9" - W/O HDW - SIERRA MAPLE
1	136954-31-S28	EA	DOOR - RSD PANEL/OGEE - 10.2" X 21.5" - PORTSMOUTH OAK - MICROWAVE/CONVECTION OVEN
1	136954-31-SJ0	EA	DOOR - RSD PANEL/OGEE - 10.2" X 21.5" - SIERRA MAPLE - MICROWAVE/CONVECTION OVEN
2	136918-C7-S28	EA	DOOR - FLAT/OGEE - 15.5" X 45.4" - W/O HARDWARE - PORTSMOUTH OAK
2	136918-C7-SJ0	EA	DOOR - FLAT/OGEE - 15.5" X 45.4" - W/O HARDWARE - SIERRA MAPLE
3	145492-K2-R28	EA	DRAWER - OGEE EDGE - 13.1"W X 23.6"D - W/O SLIDES/HDW - PORTSMOUTH OAK
3	145492-K2-SJ0	EA	DRAWER - OGEE EDGE - 13.1"W X 23.6"D - W/O SLIDES/HDW - SIERRA MAPLE
4	145492-E7-R68	EA	DRAWER - OGEE EDGE - 22.5"W X 17.7"D - W/O SLIDES/HDW - PORTSMOUTH OAK
4	145492-E7-SA3	EA	DRAWER - OGEE EDGE - 22.5"W X 17.7"D - W/O SLIDES/HDW - SIERRA MAPLE
5	145492-M7-R28	EA	DRAWER - OGEE EDGE - 22.5"W X 17.7"D - W/O SLIDES/HDW - PORTSMOUTH OAK
5	145492-M7-SJ0	EA	DRAWER - OGEE EDGE - 22.5"W X 17.7"D - W/O SLIDES/HDW - SIERRA MAPLE
6	145492-L2-R28	EA	DRAWER - OGEE EDGE - 19.8"W X 19.7"D - W/O SLIDES/HDW - PORTSMOUTH OAK
6	145492-L2-SJ0	EA	DRAWER - OGEE EDGE - 19.8"W X 19.7"D - W/O SLIDES/HDW - SIERRA MAPLE
7	136918-54-S28	EA	DOOR - FLAT/OGEE EDGE - 11.2" X 19.7" - W/O HARDWARE - PORTSMOUTH OAK
7	136918-54-SJ0	EA	DOOR - FLAT/OGEE EDGE - 11.2" X 19.7" - W/O HARDWARE - SIERRA MAPLE
8	145492-F0-R28	EA	DRAWER - OGEE EDGE - 9.9"W X 19.7"D - W/O SLIDES/HDW - PORTSMOUTH OAK
8	145492-F0-SJ0	EA	DRAWER - OGEE EDGE - 9.9"W X 19.7"D - W/O SLIDES/HDW - SIERRA MAPLE
9	145492-M5-R28	EA	DRAWER - OGEE EDGE - 9.9"W X 19.7"D - W/O SLIDES/HDW - PORTSMOUTH OAK
9	145492-M5-SJ0	EA	DRAWER - OGEE EDGE - 9.9"W X 19.7"D - W/O SLIDES/HDW - SIERRA MAPLE
10	145492-X6-R28	EA	DRAWER - OGEE - 19.8"W X 11.8"D - W/O SLIDES/HDW - PORTSMOUTH OAK - RANGE TOP 3 BURNER
10	145492-X6-S35	EA	DRAWER - OGEE - 19.8"W X 11.8"D - W/O SLIDES/HDW - SIERRA MAPLE - RANGE TOP 3 BURNER

CABINET & APPLIANCE GROUP (CONTINUED)
CABINET & APPLIANCE LAYOUT (CONTINUED)

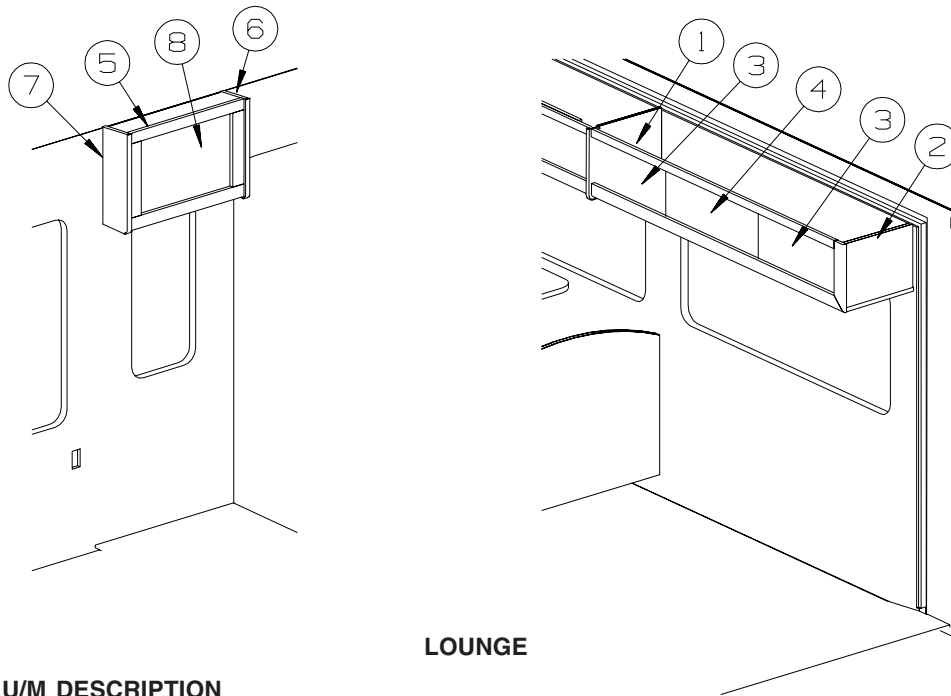

KEY	PART NUMBER	U/M	DESCRIPTION
1	139373-01-N21	EA	CABINET - OVERHEAD/COUCH - W/O DOORS/HDW - PORTSMOUTH OAK
1	139373-01-SJ0	EA	CABINET - OVERHEAD/COUCH - W/O DOORS/HDW - SIERRA MAPLE
2	109908-B7-M07	EA	END CAP - OVERHEAD COUCH - PORTSMOUTH OAK
2	109908-B7-S88	EA	END CAP - OVERHEAD COUCH - SIERRA MAPLE
3	136954-22-S28	EA	DOOR - RAISED PANEL/OGEE EDGE - 10" X 19.1" - W/O HDW - PORTSMOUTH OAK
3	136954-22-SJ0	EA	DOOR - RAISED PANEL/OGEE EDGE - 10" X 19.1" - W/O HDW - SIERRA MAPLE
4	136954-25-S28	EA	DOOR - RAISED PANEL/OGEE EDGE - 10" X 25.2" - W/O HDW - PORTSMOUTH OAK
4	136954-25-S88	EA	DOOR - RAISED PANEL/OGEE EDGE - 10" X 25.2" - W/O HDW - SIERRA MAPLE
5	138178-01-N21	EA	CABINET - OVERHEAD/FRONT/RH - W/O DOORS/HDW - PORTSMOUTH OAK
5	138178-01-SJ0	EA	CABINET - OVERHEAD/FRONT/RH - W/O DOORS/HDW - SIERRA MAPLE
6	103128-82-N21	EA	END CAP - OVERHEAD CABINET - RH - PORTSMOUTH OAK
6	103128-82-SJ0	EA	END CAP - OVERHEAD CABINET - RH - SIERRA MAPLE
7	103128-83-N21	EA	END CAP - OVERHEAD CABINET - LH - PORTSMOUTH OAK
7	103128-83-SJ0	EA	END CAP - OVERHEAD CABINET - LH - SIERRA MAPLE
8	136954-B8-S28	EA	DOOR - RAISED PANEL/OGEE EDGE - 9.3" X 21.9" - W/O HDW - PORTSMOUTH OAK
8	136954-B8-SJ0	EA	DOOR - RAISED PANEL/OGEE EDGE - 9.3" X 21.9" - W/O HDW - SIERRA MAPLE

CHASSIS GROUP FRAME

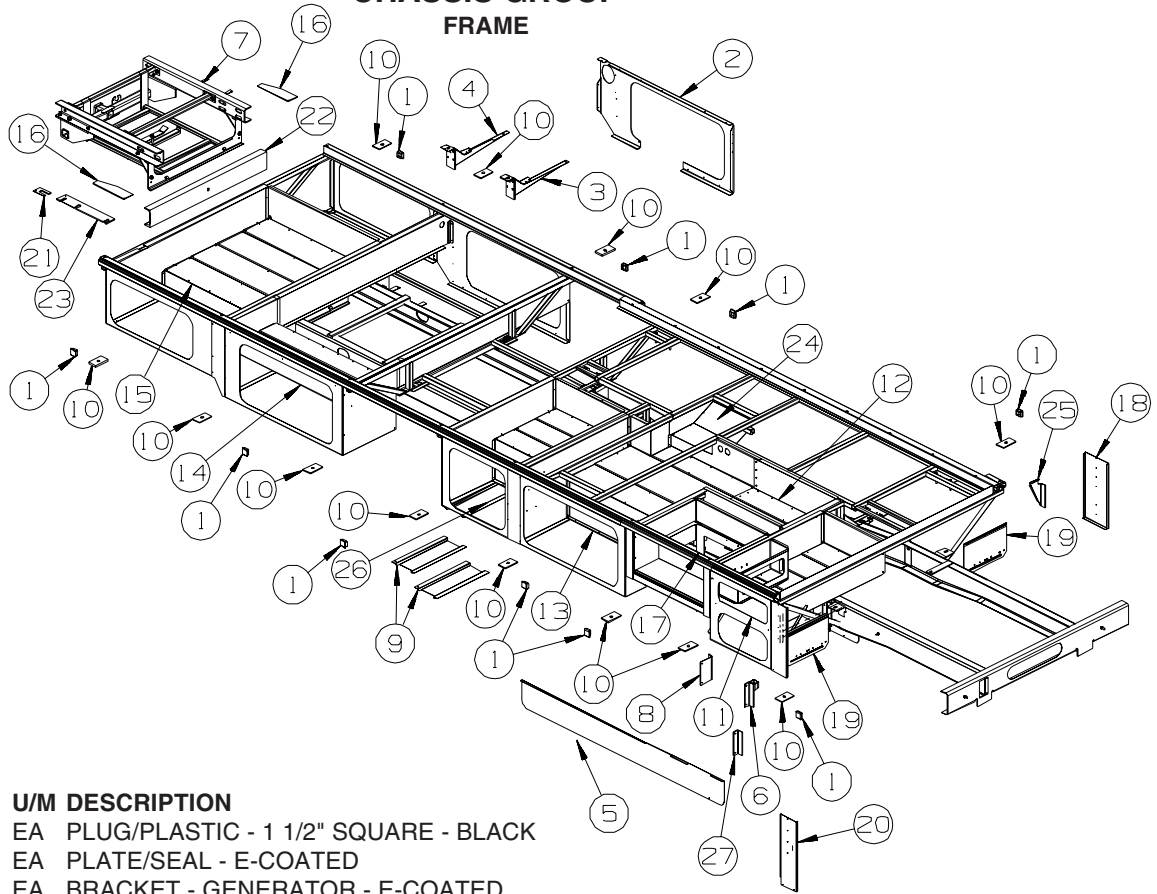

KEY	PART NUMBER	U/M	DESCRIPTION
1	119845-01-01A	EA	PLUG/PLASTIC - 1 1/2" SQUARE - BLACK
2	142221-02-02B	EA	PLATE/SEAL - E-COATED
3	135575-01-02B	EA	BRACKET - GENERATOR - E-COATED
3	152901-01-02B	EA	OUTRIGGER - GENERATOR - E-COATED FROM: 00-00-00 THRU: 08-30-04
3	152901-01-02B	EA	OUTRIGGER - GENERATOR - E-COATED FROM: 08-31-04 THRU: 99-99-99
4	135575-02-02B	EA	BRACKET - GENERATOR - E-COATED FROM: 00-00-00 THRU: 05-12-04
4	135575-04-02B	EA	BRACKET - GENERATOR - E-COATED FROM: 05-13-04 THRU: 08-30-04
4	152901-01-02B	EA	OUTRIGGER - GENERATOR - E-COATED FROM: 08-31-04 THRU: 99-99-99
5	134325-01-02B	EA	SHIELD - HEAT/EXHAUST - E-COATED
6	139189-01-02B	EA	BRACKET - LP SUPPORT - E-COATED
7*	132643-05-01A	EA	CLIP/REAR EXTENSION RAIL - W/HITCH/TIRE CARRIER
8	139188-01-02B	EA	BRACKET - LP SUPPORT
9	140963-01-02B	EA	SHIELD - EXHAUST - E-COATED
10	135712-01-02B	EA	PLATE - BODY MOUNT - E-COATED
11	137815-02-02B	EA	COMPARTMENT - RIGHT/FRONT - E-COATED
12	137814-02-02B	EA	COMPARTMENT - RIGHT - E-COATED
13	137814-01-02B	EA	COMPARTMENT - RIGHT - E-COATED
14	138044-02-02B	EA	COMPARTMENT - DRAINAGE - RIGHT HAND - E-COATED
15	133977-02-02B	EA	COMPARTMENT - REAR - E-COATED FROM: 00-00-00 THRU: 09-13-04
15	153020-03-02B	EA	COMPARTMENT - REAR - E-COATED FROM: 09-14-04 THRU: 99-99-99
16	133095-01-02B	EA	PLATE - CLIP - E-COATED
17	132607-08-02B	EA	BOX/ENTRANCE STEP - E-COATED
18	139843-02-02B	EA	PANEL - CLOSEOUT - E-COATED
19	136391-01-02B	EA	GUARD/ROCK - STEEL - W/ANGLE - 18"W X 11"H - E-COATED
20	139843-01-02B	EA	PANEL - CLOSEOUT/LP - E-COATED
21	128310-01-02B	EA	SHIM - BODY MOUNT - 11 GAUGE - E-COAT
22	134072-01-02B	EA	CHANNEL-SPARE TIRE,E-COAT
23	136538-01-02B	EA	SHIM - HITCH - E-COATED
24	138056-04-02B	EA	PANEL ASM-FURNACE COMPT,E-CT
25	123440-14-02B	EA	SUPPORT - PANEL - 9.9"/7.6" X 4.8" - E-COATED
26	138726-01-02B	EA	COMPARTMENT - MIDDLE - E-COATED
27	142128-02-02B	EA	BRACKET - LP SUPPORT - E-COATED

*COMPONENT PARTS LISTED LATER IN THIS GROUP

EXTERIOR SLIDEOUT GROUP (CONTINUED)
COMPONENT PARTS FOR FRAME

132643-05-01A

KEY	PART NUMBER	U/M	DESCRIPTION	VENDOR NO.
	132643-01-701	EA	TIRE CARRIER COMPLETE	56610-47
	132643-01-702	EA	RETAINER KIT/SPARE TIRE	55290-47

CHASSIS GROUP (CONTINUED)

FRONT END

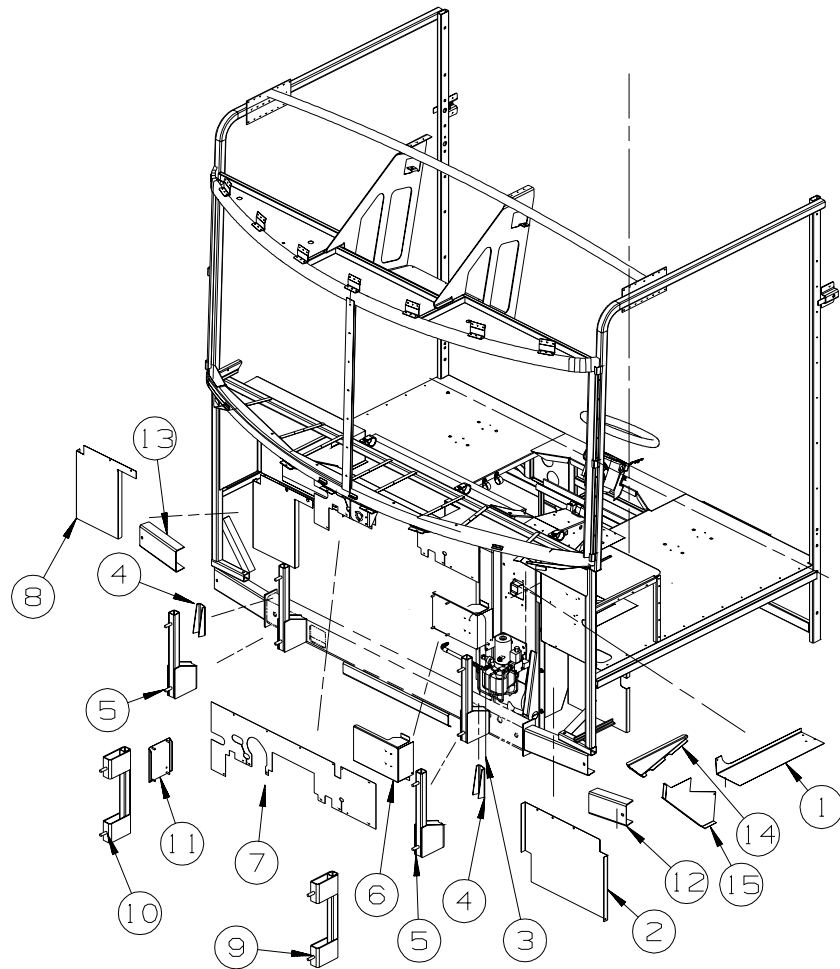

KEY	PART NUMBER	U/M	DESCRIPTION
1	137041-01-02B	EA	ANGLE/FILLER - MOTOR COVER - E-COATED - WORKHORSE
2	121962-02-02B	EA	SHIELD/SPLASH - HEADLIGHT - E-COATED - WORKHORSE
3	044317-01-000	FT	HOSE - FUEL - 3/8" ID - 15,000 & 18,000 GVWR WORKHORSE
4	117622-01-02B	EA	BRACE - TUBE/BUMPER - VERTICAL - E-COATED - FORD
5	134807-01-02B	EA	SUPPORT - FRONT - E-COATED - WORKHORSE
			FROM: 00-00-00 THRU: 07-30-04
5	134807-11-02B	EA	SUPPORT - FRONT - E-COATED - LH - WORKHORSE
			FROM: 07-31-04 THRU: 99-99-99
5	134807-12-02B	EA	SUPPORT - FRONT - E-COATED - RH - WORKHORSE
			FROM: 07-31-04 THRU: 99-99-99
5	152916-01-02B	EA	SUPPORT - FRONT - E-COATED - LH - FORD
5	152916-02-02B	EA	SUPPORT - FRONT - E-COATED - RH - FORD
6	137355-02-02B	EA	BRACKET - RESERVOIR/WASHER - E-COATED - 15,000 & 18,000 GVWR WORKHORSE
7	117749-03-000	EA	BAFFLE - RADIATOR - TOP/P32 - 15,000 & 18,000 GVWR WORKHORSE
8	144679-02-02B	EA	SHIELD/SPLASH - HEADLIGHT - E-COATED - FORD
9	134807-04-02B	EA	SUPPORT - FRONT - E-COATED - FORD
10	134807-03-02B	EA	SUPPORT - FRONT - E-COATED - FORD
11	119656-02-02B	EA	BRACKET - RESERVOIR/WASHER - E-COATED - 20,700 GVWR WORKHORSE
			FROM: 00-00-00 THRU: 07-30-04
12	137048-01-02B	EA	CHANNEL/SUPPORT - FRONT END - E-COATED - 20,700 GVWR WORKHORSE
13	137048-02-02B	EA	CHANNEL/SUPPORT - FRONT END - E-COATED - 20,700 GVWR WORKHORSE
14	137306-01-02B	EA	FILLER/BRACKET - LEFT HAND - E-COATED - 20,700 GVWR WORKHORSE
			FROM: 00-00-00 THRU: 02-11-04
15	137043-01-02B	EA	PANEL/FILLER - E-COATED - 20,700 GVWR WORKHORSE
			FROM: 00-00-00 THRU: 02-11-04
15	150565-01-02B	EA	PANEL-CLOSEOUT - CAB - E-COATED - 20,700 GVWR WORKHORSE
			FROM: 02-12-04 THRU: 99-99-99

CHASSIS GROUP (CONTINUED) FRONT END (CONTINUED)

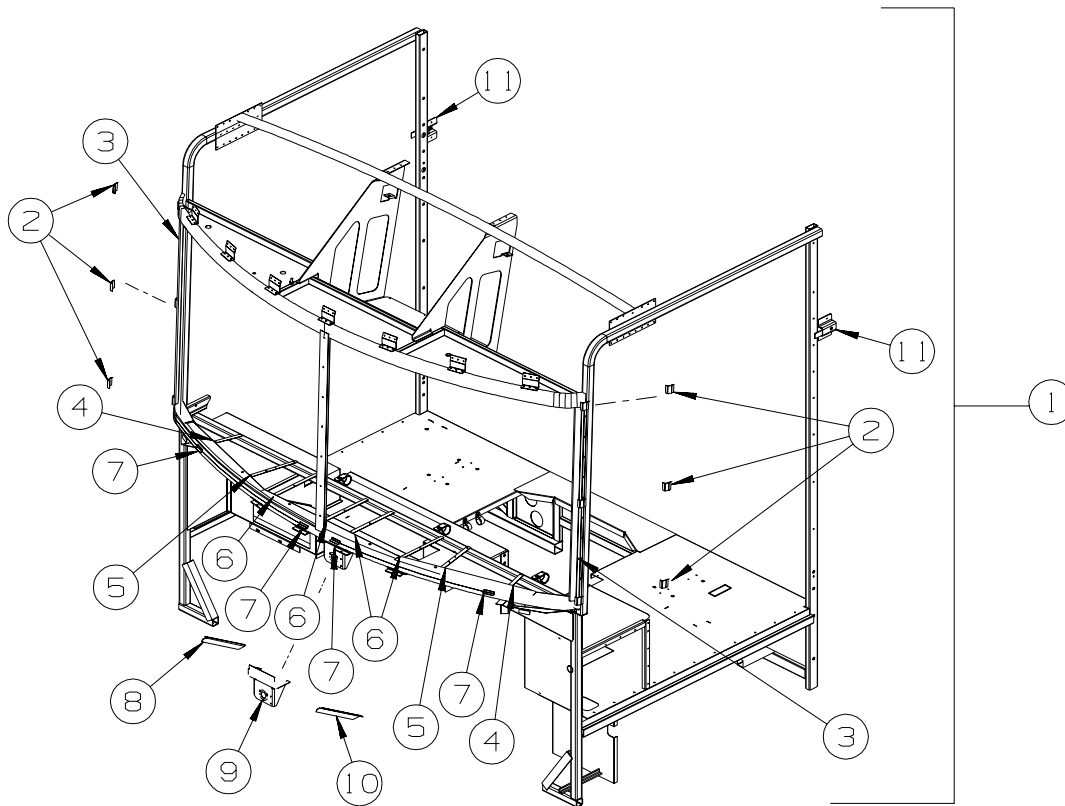

KEY	PART NUMBER	U/M	DESCRIPTION	
1	148388-01-02B	EA	FRONT END - WORKHORSE	
1	148388-03-02B	EA	FRONT END - WORKHORSE - 20,700	
1	148388-02-02B	EA	FRONT END - FORD	FROM: 00-00-00 THRU: 01-30-05
1	153443-01-02B	EA	FRONT END - FORD	FROM: 01-31-05 THRU: 99-99-99
2	120363-01-01B	EA	BRACKET - WINDSHIELD	FROM: 00-00-00 THRU: 05-14-04
2	148935-01-01B	EA	BRACKET - WINDSHIELD	FROM: 05-15-04 THRU: 99-99-99
3	137584-01-01B	EA	FRAME/PILLAR - WINDSHIELD	
4	137047-04-01B	EA	STRAP - DEFROSTER PLENUM	
5	137047-05-01B	EA	STRAP - DEFROSTER PLENUM	
6	137047-06-01B	EA	STRAP - DEFROSTER PLENUM	
7	126289-65-01B	EA	ANGLE - FORMED	
8	134371-02-01B	EA	ANGLE/MOUNT - WIPER MOTOR	
9	134506-01-01B	EA	BRACKET - WIPER MOTOR	
10	134371-01-01B	EA	ANGLE/MOUNT - WIPER MOTOR	
11	140387-02-01B	EA	MOUNT - SEATBELT/WALL - E-COATED	

CHASSIS GROUP (CONTINUED)

EXHAUST

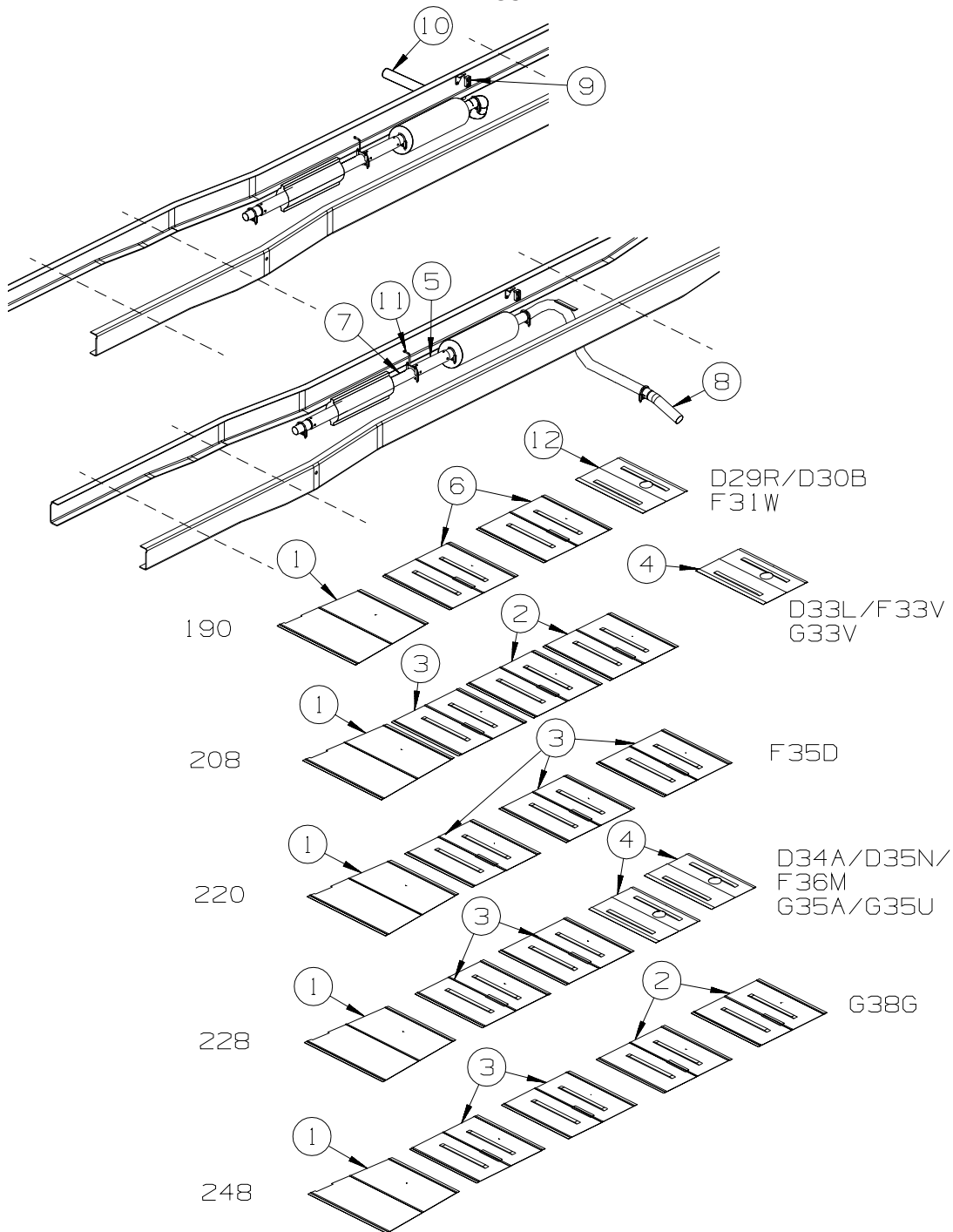

FORD

KEY	PART NUMBER	U/M	DESCRIPTION
1	128756-01-02B	EA	SHIELD - HEAT/EXHAUST - 33.9" X 16.9" - E-COATED
2	143712-02-02B	EA	SHIELD/HEAT - EXHAUST - E-COATED
3	143712-05-02B	EA	SHIELD - HEAT/EXHAUST - E-COATED - 208 WHEELBASE FROM: 00-00-00 THRU: 01-20-05
3	143712-02-02B	EA	SHIELD - HEAT/EXHAUST - E-COATED - 208 WHEELBASE FROM: 01-21-05 THRU: 99-99-99
3	143712-05-02B	EA	SHIELD - HEAT/EXHAUST - E-COATED - 220, 228 & 248 WHEELBASE
4	143712-07-02B	EA	SHIELD/HEAT - EXHAUST - E-COATED
4	143712-07-02B	EA	SHIELD - HEAT/EXHAUST - E-COATED - 208 WHEELBASE FROM: 02-24-05 THRU: 99-99-99
5	NOT USED		
6	143712-01-02B	EA	SHIELD/HEAT - EXHAUST - E-COATED - 2 USED FROM: 00-00-00 THRU: 08-13-04
6	143712-02-02B	EA	SHIELD/HEAT - EXHAUST - E-COATED - 1 USED FROM: 00-00-00 THRU: 08-13-04

CHASSIS GROUP (CONTINUED)
EXHAUST (CONTINUED)

KEY	PART NUMBER	U/M	DESCRIPTION
6	143712-02-02B	EA	SHIELD/HEAT - EXHAUST - E-COATED - 2 USED FROM: 08-14-04 THRU: 09-17-04
6	143712-05-02B	EA	SHIELD/HEAT - EXHAUST - E-COATED - 2 USED FROM: 09-18-04 THRU: 99-99-99
7	112012-11-000	EA	PIPE - EXHAUST - 3" DIAMETER X 20" LONG - 190" - 208" STRETCH - D33L
	094918-06-000	EA	CLAMP - EXHAUST - 3" - HEAVY DUTY
8	142985-01-000	EA	PIPE - EXHAUST
8	142985-01-000	EA	PIPE - EXHAUST - 190" - 208" STRETCH - D33L FROM: 00-00-00 THRU: 01-20-05
9	122392-02-02B	EA	HANGER - TAILPIPE - E-COATED - 190" - D30B - 2004 CHASSIS FROM: 00-00-00 THRU: 03-30-05
9	122392-16-02B	EA	HANGER - TAILPIPE - E-COATED - 190" - D30B - 2006 CHASSIS FROM: 03-31-05 THRU: 99-99-99
10	122529-03-000	EA	PIPE - EXHAUST - 190" - D30B
11	122392-12-02B	EA	HANGER - TAILPIPE - E-COATED - 190" - 208" STRETCH - D33L
12	143712-07-02B	EA	SHIELD/HEAT - EXHAUST - E-COATED FROM: 04-01-05 THRU: 99-99-99

CHASSIS GROUP (CONTINUED) EXHAUST (CONTINUED)

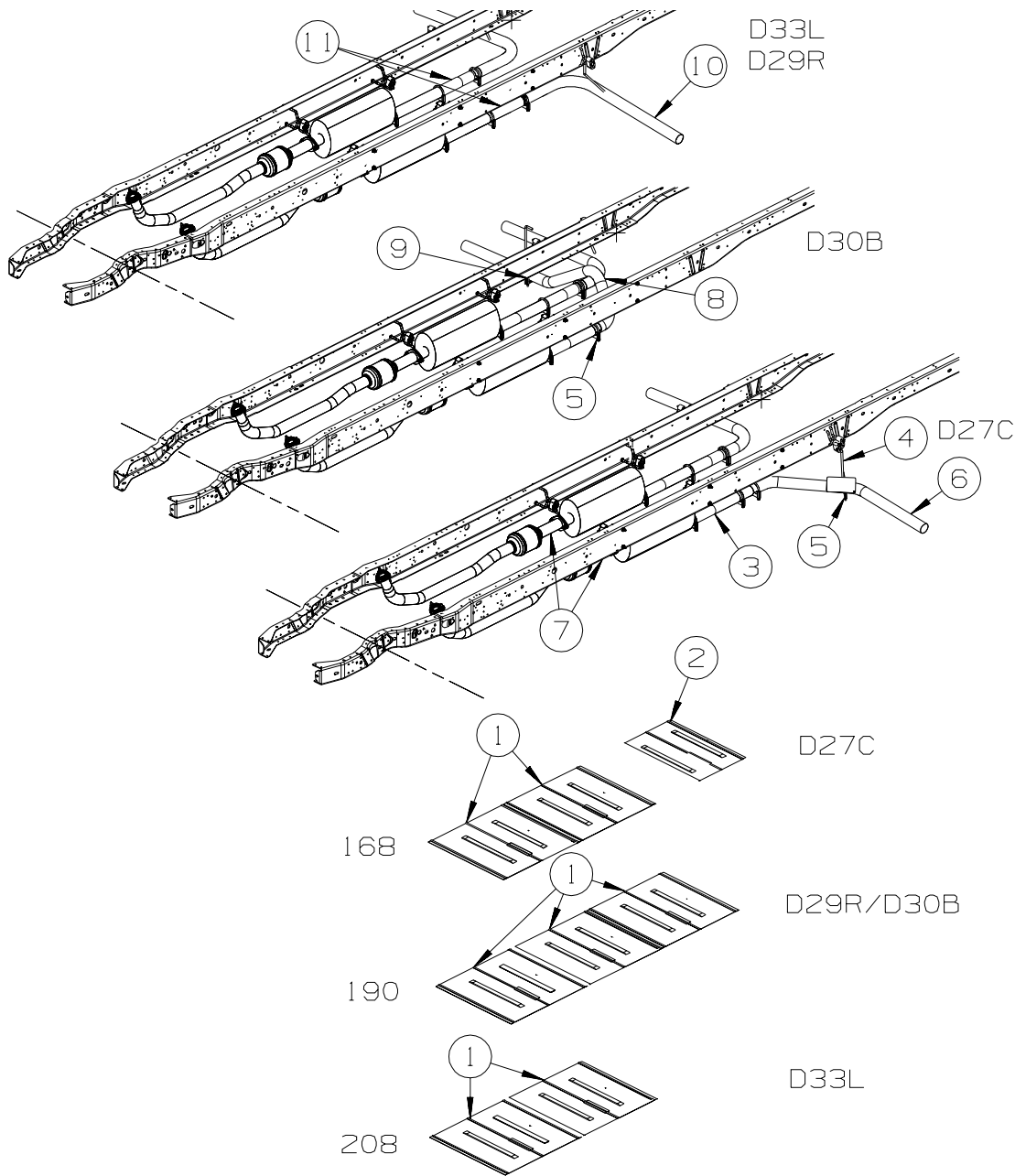

**D27C, D29R, D30B
WORKHORSE**

KEY	PART NUMBER	U/M	DESCRIPTION
1	143712-02-02B	EA	SHIELD - HEAT/EXHAUST - E-COATED
2	143712-01-02B	EA	SHIELD - HEAT/EXHAUST - E-COATED
			FROM: 00-00-00 THRU: 06-06-04
2	143712-02-02B	EA	SHIELD - HEAT/EXHAUST - E-COATED
			FROM: 06-07-04 THRU: 99-99-99
3	098762-06-000	EA	PIPE - EXHAUST - STRAIGHT
			FROM: 00-00-00 THRU: 06-06-04
3	142985-02-000	EA	PIPE - EXHAUST
			FROM: 06-07-04 THRU: 99-99-99
4	122392-08-02B	EA	HANGER - TAILPIPE - E-COATED
5	094918-06-000	EA	CLAMP - EXHAUST - 3" - HEAVY DUTY
6	137925-02-000	EA	PIPE - EXHAUST - LEFT HAND
			FROM: 00-00-00 THRU: 06-06-04
6	137925-05-000	EA	PIPE - EXHAUST - LEFT HAND
			FROM: 06-07-04 THRU: 99-99-99
	094918-06-000	EA	CLAMP - EXHAUST - 3" - HEAVY DUTY

CHASSIS GROUP (CONTINUED)
EXHAUST (CONTINUED)

KEY	PART NUMBER	U/M	DESCRIPTION
7	137652-04-000	EA	PIPE - EXHAUST - W/FLANGES
	127598-02-000	EA	NUT - HEX FLANGE - M10 X 1.5 - CLASS 10
	138037-01-000	EA	GASKET - FLANGE - EXHAUST - GM-15027074
8	141412-01-000	EA	PIPE - EXHAUST
9	122392-09-02B	EA	HANGER - TAILPIPE - E-COATED
	094918-06-000	EA	CLAMP - EXHAUST - 3" - HEAVY DUTY
10	129726-02-000	EA	PIPE - EXHAUST
			FROM: 00-00-00 THRU: 08-08-04
10	129726-03-000	EA	PIPE - EXHAUST
			FROM: 08-09-04 THRU: 99-99-99
11	098762-05-000	EA	EXTENSION - EXHAUST - STRAIGHT - 3" O.D X 7.9" LONG - SST - D29R
			FROM: 00-00-00 THRU: 06-08-04
	094918-06-000	EA	CLAMP - EXHAUST - 3" - HEAVY DUTY
11	129726-02-000	EA	PIPE - EXHAUST - D29R
			FROM: 06-09-04 THRU: 08-13-04
11	129726-03-000	EA	PIPE - EXHAUST - D29R
			FROM: 08-14-04 THRU: 99-99-99

CHASSIS GROUP (CONTINUED)
EXHAUST (CONTINUED)

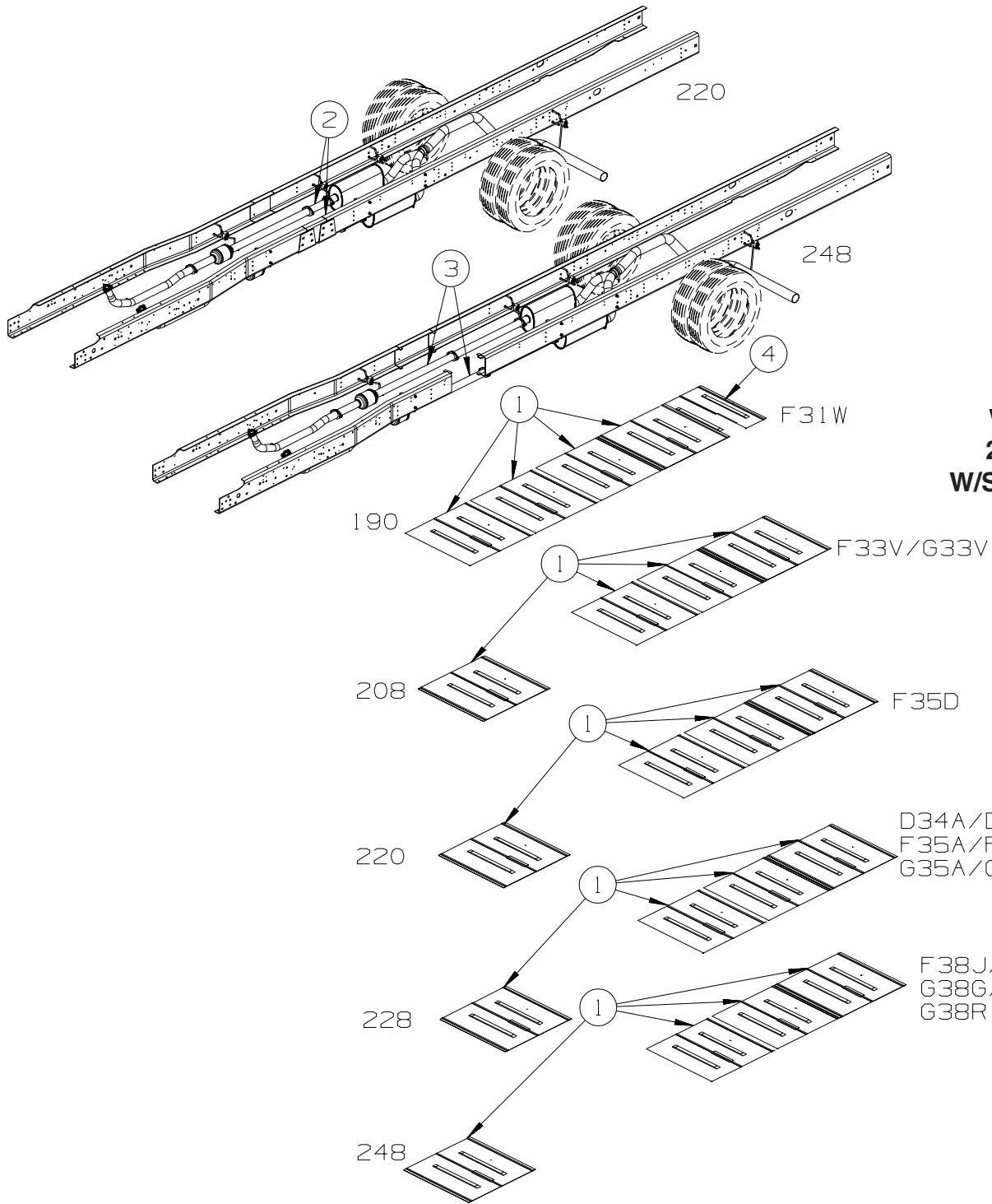

**D34A, D35N
 WORKHORSE
 2005 CHASSIS
 W/SINGLE TAILPIPE**

KEY	PART NUMBER	U/M DESCRIPTION
1	143712-02-02B	EA SHIELD - HEAT/EXHAUST - E-COATED
2	NOT USED	
3	NOT USED	

CHASSIS GROUP (CONTINUED)
EXHAUST (CONTINUED)

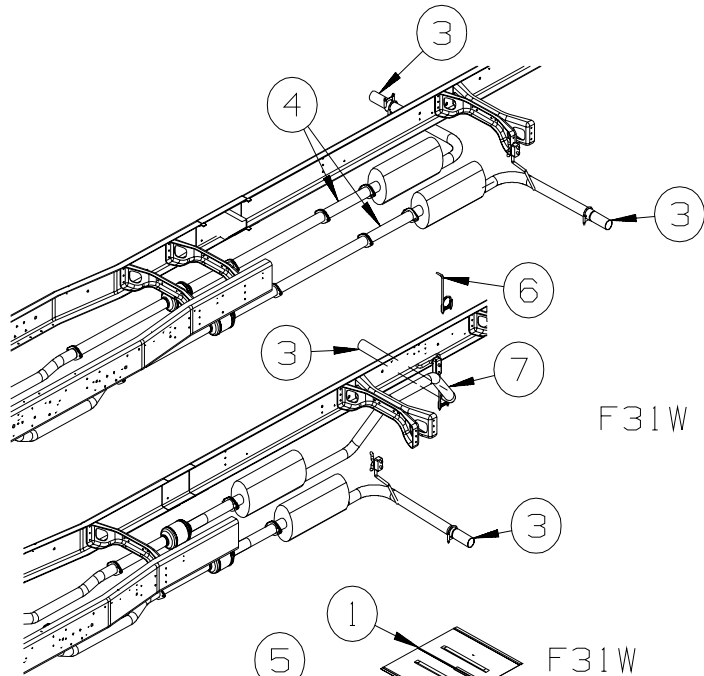

F31W

**WORKHORSE
 2005 CHASSIS
 W/DUAL TAILPIPE
 UP TO 02-09-05**

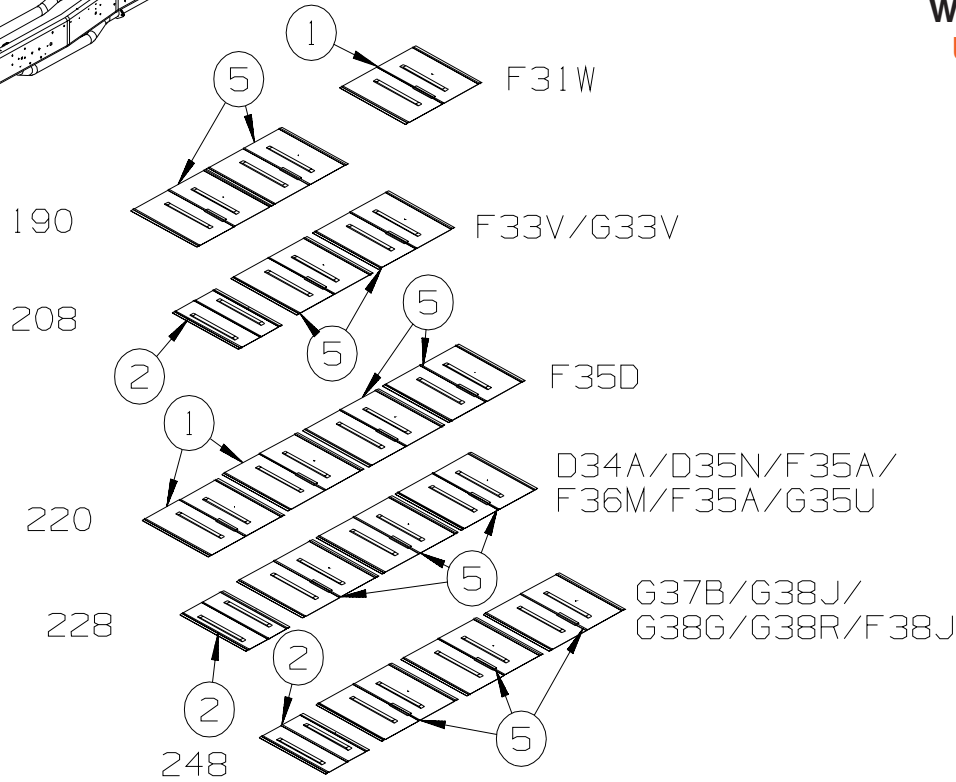

KEY	PART NUMBER	U/M DESCRIPTION
1	NOT USED	
2	143712-01-02B	EA SHIELD - HEAT/EXHAUST - E-COATED
3	098762-05-000	EA EXTENSION - EXHAUST - STRAIGHT - 3" O.D X 7.9" LONG - SST
3	129726-02-000	EA PIPE - EXHAUST - PASSENGER SIDE ON D34A ONLY
	094918-01-000	EA CLAMP - EXHAUST - 3" - GUILLOTINE STYLE
4	NOT USED	
5	143712-05-02B	EA SHIELD - HEAT/EXHAUST - E-COATED
6	NOT USED	
7	NOT USED	

CHASSIS GROUP (CONTINUED)
EXHAUST (CONTINUED)

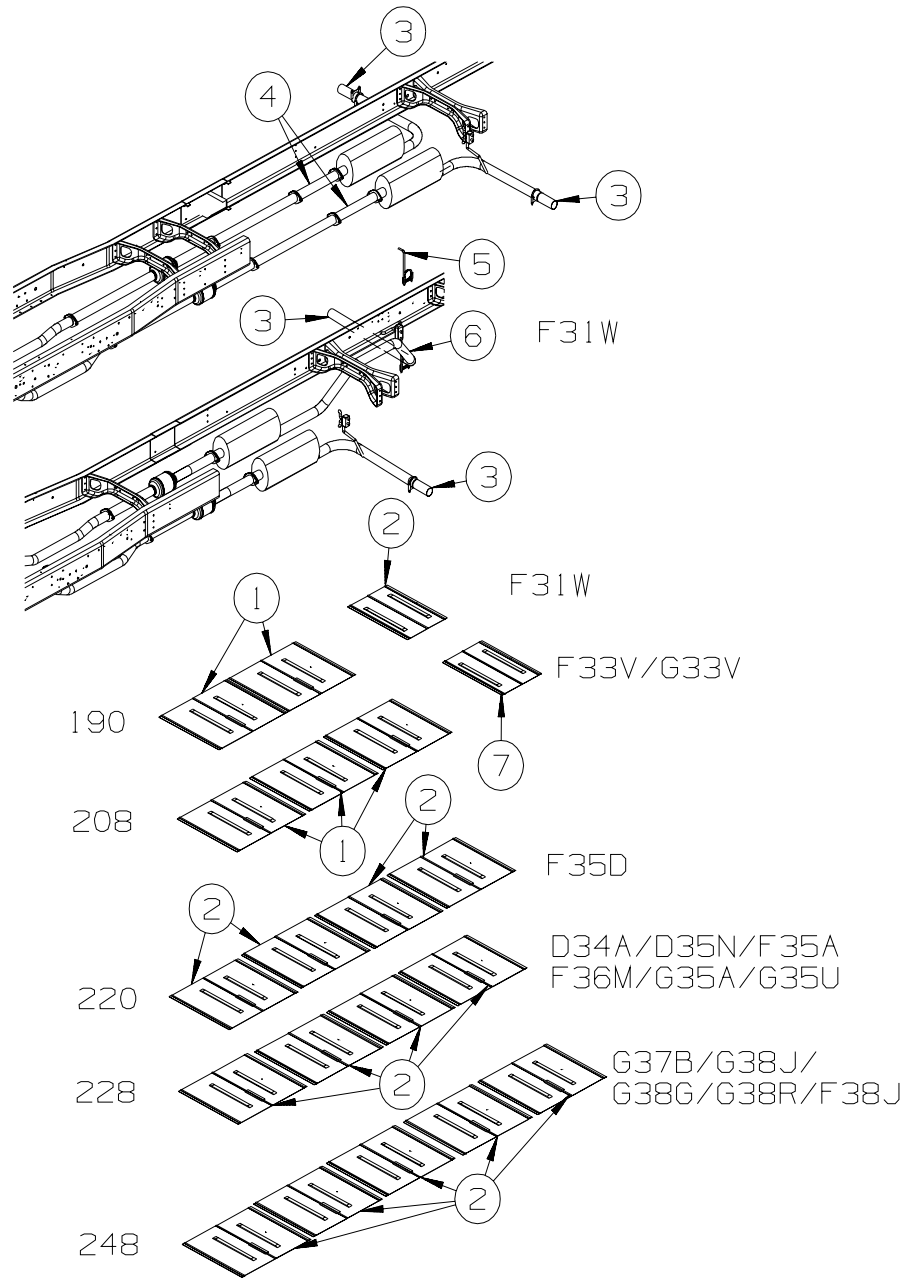

**WORKHORSE
 2005 CHASSIS
 W/DUAL TAILPIPE
 FROM 02-10-05 ON**

KEY	PART NUMBER	U/M	DESCRIPTION
1	NOT USED		
2	143712-02-02B	EA	SHIELD - HEAT/EXHAUST - E-COATED
3	129726-02-000	EA	PIPE - EXHAUST
3	098762-05-000	EA	EXTENSION - EXHAUST - STRAIGHT - 3" O.D X 7.9" LONG - SST
	094918-01-000	EA	CLAMP - EXHAUST - 3" - GUILLOTINE STYLE
4	129726-02-000	EA	PIPE - EXHAUST
5	NOT USED		
6	NOT USED		

HITCH

KEY	PART NUMBER	U/M	DESCRIPTION
	130339-08-000	EA	DRAWBAR ASSEMBLY - HITCH - CLASS 3
	140441-01-02B	EA	PLATE - SKID - E-COATED
	140441-03-02B	EA	PLATE - SKID - E-COATED - D29R FORD

CHASSIS GROUP (CONTINUED)

FUEL

D-SERIES
SIGHTSEER
SONOVA

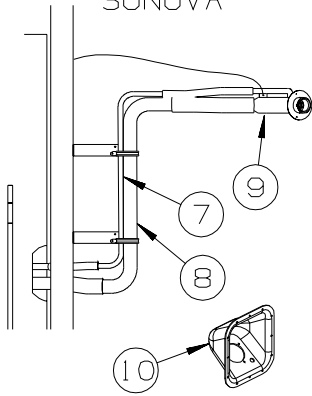

G-SERIES
ADVENTURER
SUNCRUISER

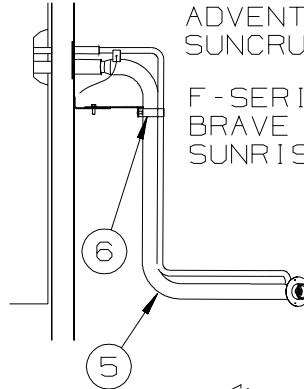

F-SERIES
BRAVE
SUNRISE

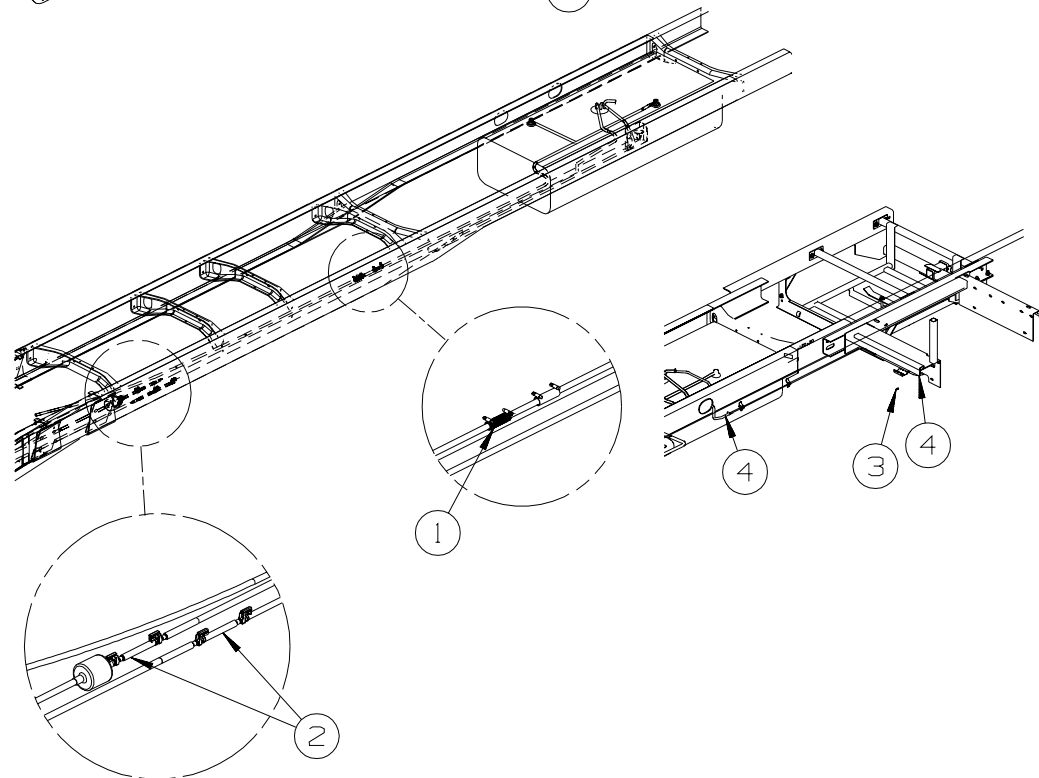

FORD

KEY	PART NUMBER	U/M	DESCRIPTION
1	128139-02-000	FT	HOSE - FUEL - LOW PERMEABILITY - 5/8" DIAMETER - 190" - 208" STRETCH D33L
1	007108-01-000	FT	HOSE - HEATER - 5/8" ID - HI-TEMP - 190" - 208" STRETCH, D33L
2	129494-03-000	EA	FUEL LINE - 5/16" X 21.2" - FORD CHASSIS - 190" - 208" STRETCH D33L
3	084884-01-000	EA	PLUG - BRASS - 3/8"
4	128139-03-000	FT	HOSE - FUEL - LOW PERMEABILITY - 1/4" DIAMETER
5	NOT USED	EA	
6	NOT USED	EA	
7	129320-06-000	EA	PIPE - VENT - FILL - 190" D30B, 190" - 208" STRETCH D33L, 228" D34A, D35N
7	129320-13-000	EA	PIPE - VENT - FILL - 190" D29R
8	129321-06-000	EA	TUBE - FUEL INLET - 190" D30B, 190" - 208" STRETCH D33L, 228" D34A, D35N
8	129321-14-000	EA	TUBE - FUEL INLET - 190" D29R
9	138884-01-000	EA	NECK - FUEL FILL - FORD
10	128299-02-01A	EA	SHROUD - FUEL FILL

CHASSIS GROUP (CONTINUED) FUEL (CONTINUED)

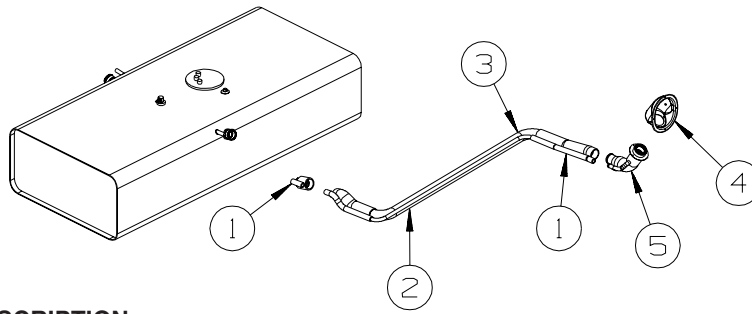

WORKHORSE

KEY	PART NUMBER	U/M	DESCRIPTION
1	128139-02-000	FT	HOSE - FUEL - LOW PERMEABILITY - 5/8" DIAMETER
2	128524-05-000	EA	PIPE - VENT - FUEL FILL - D27C
2	128524-01-000	EA	PIPE - VENT - FUEL FILL - D30B - D33L
2	128524-06-000	EA	PIPE - VENT - FUEL FILL - D34A/D35N
2	128524-07-000	EA	PIPE - VENT - FUEL FILL - D29R
3	124327-04-000	EA	TUBE - FUEL INLET - D30B - D33L
3	124327-10-000	EA	TUBE - FUEL INLET - D27C
3	124327-11-000	EA	TUBE - FUEL INLET - D34A/D35N
3	124327-12-000	EA	TUBE - FUEL INLET - D29R
4			CHASSIS SUPPLIED
5	127301-05-000	EA	NECK - FUEL FILL - UNLEADED

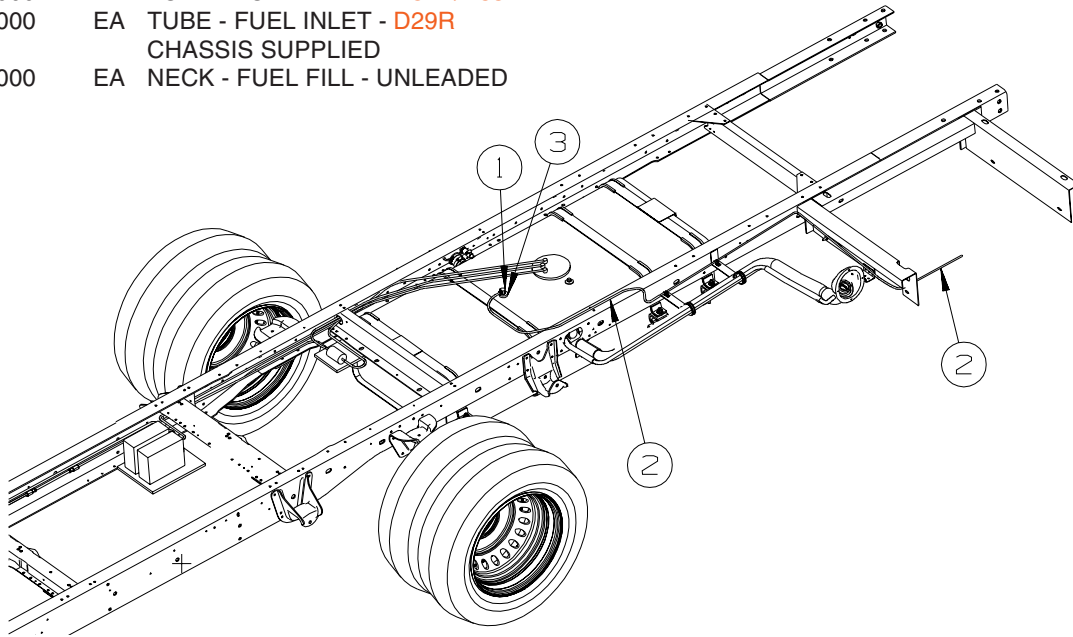

WORKHORSE

KEY	PART NUMBER	U/M	DESCRIPTION
1	114254-01-000	EA	ADAPTER - 1/4" BARB X 1/8" MPT
2	128139-03-000	FT	HOSE - FUEL - LOW PERMEABILITY - 1/4" DIAMETER
3	068382-06-000	EA	BUSHING - 3/8" MPT X 1/8" FPT - BRASS

CHASSIS GROUP (CONTINUED)
FUEL (CONTINUED)

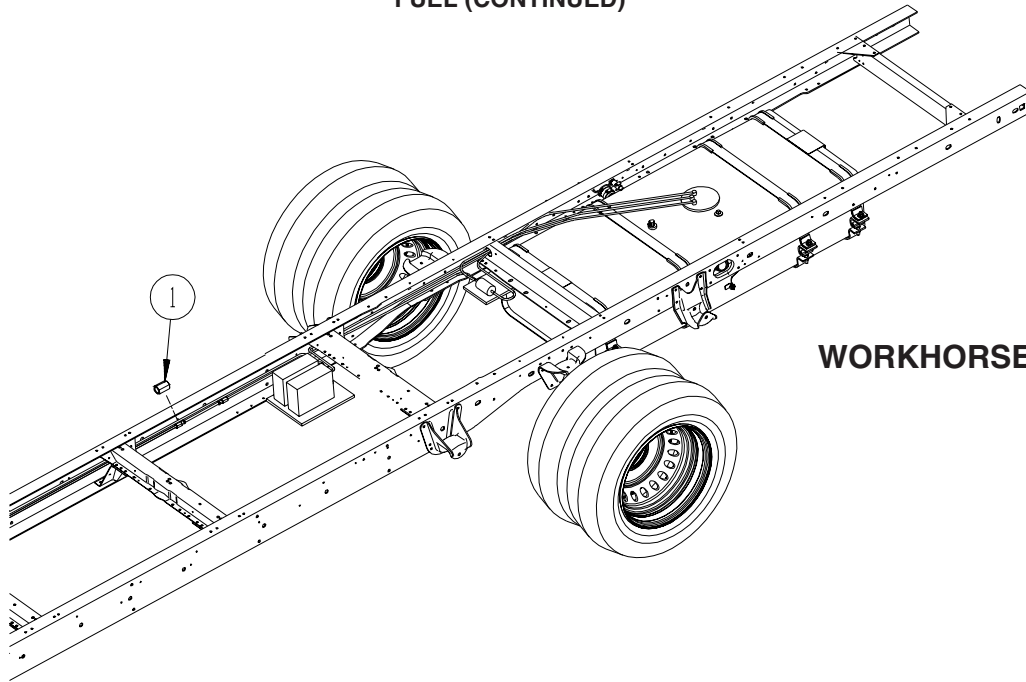

WORKHORSE - P32 CHASSIS

KEY	PART NUMBER	U/M DESCRIPTION
1	098779-02-000	EA COUPLER - FUEL LINE - 1.2" LONG X .63" THREAD

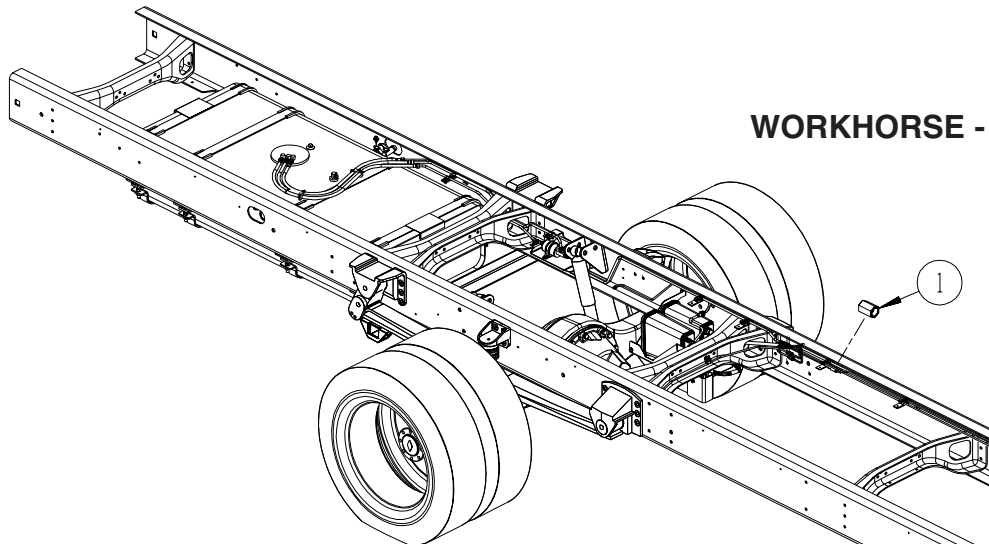

WORKHORSE - W20/22 CHASSIS

KEY	PART NUMBER	U/M DESCRIPTION
1	098779-02-000	EA COUPLER - FUEL LINE - 1.2" LONG X 16MM THREAD - STRETCHED CHASSIS ONLY

CHASSIS GROUP (CONTINUED)

HYDRAULIC LEVELING

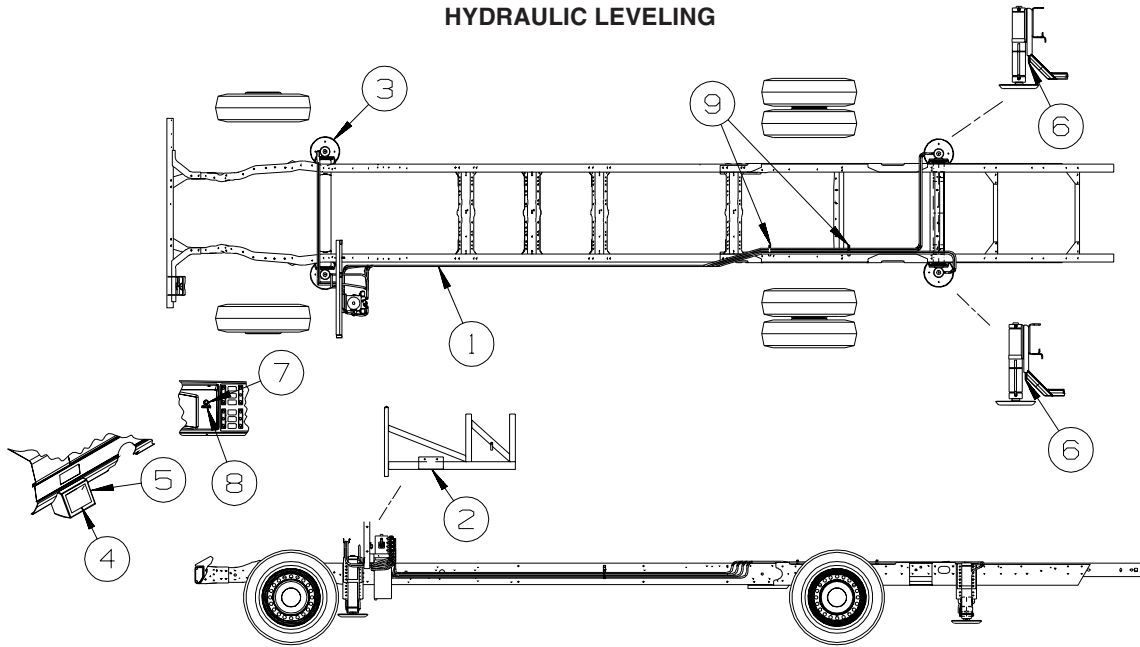

KEY	PART NUMBER	U/M	DESCRIPTION
1	139644-03-000	EA	HOSE KIT - LEVELING JACKS
2	149803-01-02B	EA	BRACKET - PUMP/LEVELING
			FROM: 00-00-00 THRU: 01-16-05
2	154816-01-02B	EA	BRACKET - PUMP/LEVELING - E-COATED
			FROM: 01-17-05 THRU: 99-99-99
3*	139641-01-000	EA	LEVELING SYSTEM (LEVEL BEST) - P32/P42 - KWIKEE - WORKHORSE - D27C, D29R, D30B, D33L
3*	139641-02-000	EA	LEVELING SYSTEM (LEVEL BEST) - F/53 - KWIKEE - FORD - D29R, D30B, D33L, D34A, D35N
3*	139641-03-000	EA	LEVELING SYSTEM (LEVEL BEST) - WORKHORSE W22 - KWIKEE - D35N, D34A
4	139643-02-000	EA	CONTROL - LEVEL W/O INDIVIDUAL CONTROLS - RECTANGLE BOX
5	139369-02-N21	EA	BEZEL - MONITOR - LEVELING
	139350-02-01A	EA	BEZEL - MONITOR - LEVELING
6	140083-01-000	EA	SPACER - JACK/CROSSMEMBER - WORKHORSE - 18,000 GVWR D29R, D30B, D33L
7	133534-01-000	EA	LIGHT - RED INDICATOR WITH 1/4" TERMINALS
8	133533-01-01A	EA	LABEL - JACKS DOWN - CLEAR W/WHITE LETTERING
9	126624-01-02B	EA	ANGLE - WIRE SUPPORT - E-COAT

*COMPONENT PARTS LISTED LATER IN THIS GROUP

CHASSIS GROUP (CONTINUED)
COMPONENT PARTS FOR HYDRAULIC LEVELING

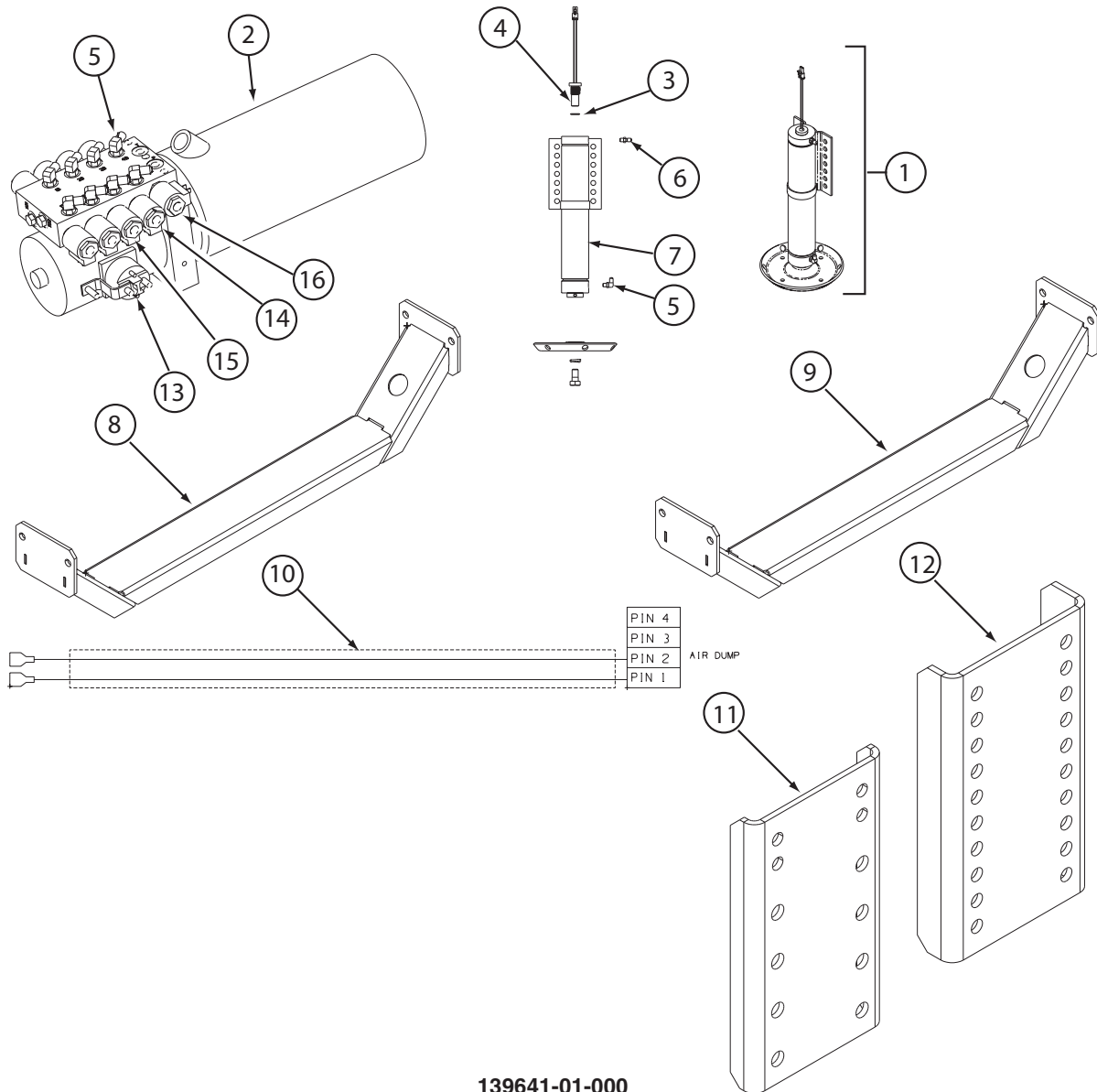

139641-01-000

KEY	PART NUMBER	U/M	DESCRIPTION	VENDOR NO.
1	139641-01-720	ea	JACK - FRONT 15"/10K	3700702
2*	139641-01-708	EA	PUMP ASM.(WATER TIGHT) W/HDW	370090
3	139641-01-700	EA	O-RING 3-912N70 .924IDX.116W	1612040
4	139641-01-704	EA	SWITCH(HERMETIC)CYLINDER TOP	1812992
5	139641-01-705	EA	FITTING HYD (1/4"X90 DEGREE)	1904500
6	139641-01-706	EA	FITTING HYD (1/4" STRAIGHT)	1904510
7	139641-01-710	EA	CYLINDER - REPLACEMENT	1905200
8	139641-01-713	EA	CROSS MEMBER-FRONT(P32/P42)	317791
9	139641-01-714	EA	CROSS MEMBER-REAR (P32/P42)	3717793
10	139641-01-701	EA	HARNES (AIR DUMP) CONTROL	180981
11	139641-01-711	EA	BRACKET MTG (WORKHORSE REAR)	3717740
12	139641-01-712	EA	BRACKET MTG (WORKHORSE FRT)	3717741
13	139641-01-718	EA	PUMP KIT (SOLENOID 4 POST)	906900250
14	139641-01-719	EA	VALVE KIT (COIL W/PACKARD)	906963010
15	139641-01-721	EA	SOLENOID VALVE - 2-WAY	906965000
16	139641-01-722	EA	SOLENOID VALVE - 4-WAY	906964000
	139641-01-702	EA	HARNES - PUMP (WATER TIGHT)	1809912
	139641-01-703	EA	HARNES (CONTROL PUMP) 10'	1809913
	139641-01-707	EA	LEVEL (BUBBLE)	1906200
	139641-01-709	EA	JACK ASM.(ST 15" RR 10K)	3700701
	139641-01-715	EA	BOLT KIT(CROSS MBR/JK/PUMP)	3717794
	139641-01-717	EA	HOSE KIT (WINNEBAGO D30B)	906935521
	139641-01-723	EA	FOOT PAD - JACK	3700367

CHASSIS GROUP (CONTINUED)
COMPONENT PARTS FOR HYDRAULIC LEVELING (CONTINUED)

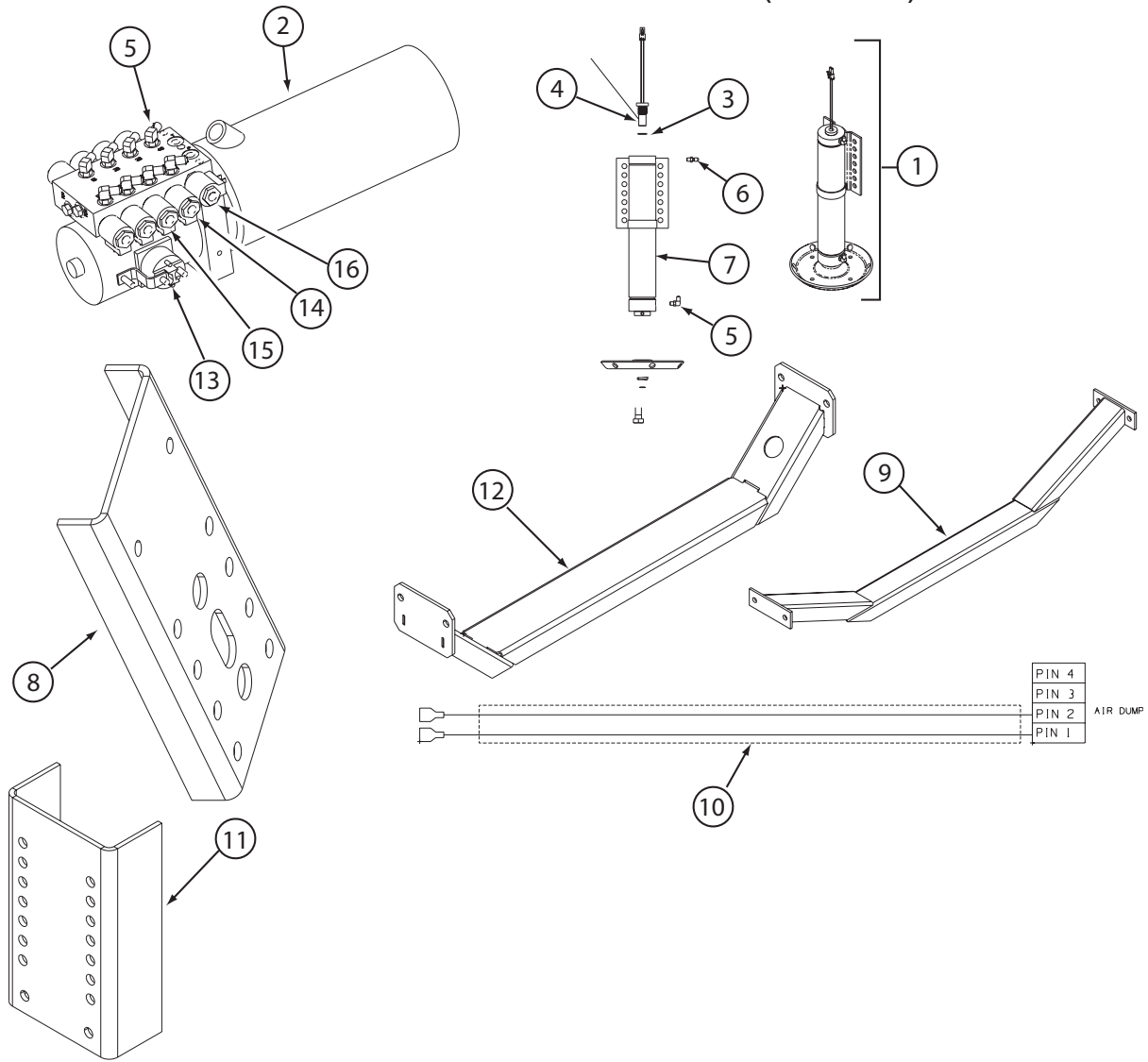

139641-02-000

KEY	PART NUMBER	U/M	DESCRIPTION	VENDOR NO.
1	139641-01-720	EA	JACK - FRONT 15"/10K	3700702
2	139641-01-708	EA	PUMP ASM.(WATER TIGHT) W/HDW	370090
3	139641-01-700	EA	O-RING 3-912N70 .924IDX.116W	1612040
4	139641-01-704	EA	SWITCH(HERMETIC)CYLINDER TOP	1812992
5	139641-01-705	EA	FITTING HYD (1/4"X90 DEGREE)	1904500
6	139641-01-706	EA	FITTING HYD (1/4" STRAIGHT)	1904510
7	139641-01-710	EA	CYLINDER - REPLACEMENT	1905200
8	139641-02-701	EA	BRACKET MTG (FORD REAR)	3717742
9	139641-02-702	EA	CROSS MEMBER-FRONT (F53)	3717786
10	139641-01-701	EA	HARNESS (AIR DUMP) CONTROL	180981
11	139641-02-704	EA	BRACKET FRT MT(3.5"DEEP F53)	1717787
12	139641-02-703	EA	CROSS MEMBER-REAR (F53)	3717795
13	139641-01-718	EA	PUMP KIT (SOLENOID 4 POST)	906900250
14	139641-01-719	EA	VALVE KIT (COIL W/PACKARD)	906963010
15	139641-01-721	EA	SOLENOID VALVE - 2-WAY	906965000
16	139641-01-722	EA	SOLENOID VALVE - 4-WAY	906964000
	139641-02-700	EA	HARNESS F/READ SWITCH (FORD)	1809911
	139641-01-702	EA	HARNESS - PUMP (WATER TIGHT)	1809912
	139641-01-703	EA	HARNESS (CONTROL PUMP) 10'	1809913
	139641-01-707	EA	LEVEL (BUBBLE)	1906200
	139641-01-709	EA	JACK ASM.(ST 15" RR 10K)	3700701
	139641-01-715	EA	BOLT KIT(CROSS MBR/JK/PUMP)	3717794
	139641-01-717	EA	HOSE KIT (WINNEBAGO D30B)	906935521
	139641-01-723	EA	FOOT PAD - JACK	3700367
	139641-01-725	EA	HARNESS - EMERGENCY RETRACT	1809908

CHASSIS GROUP (CONTINUED)
COMPONENT PARTS FOR HYDRAULIC LEVELING (CONTINUED)

139641-03-000

KEY	PART NUMBER	U/M	DESCRIPTION	VENDOR NO.
	139641-01-700	EA	O-RING 3-912N70 .924IDX.116W	1612040
	139641-01-701	EA	HARNESS -AIR PUMP/WARN LIGHT	1809891
	139641-01-702	EA	HARNESS - PUMP (WATER TIGHT)	1809912
	139641-01-703	EA	HARNESS (CONTROL PUMP) 10'	1809913
	139641-01-704	EA	SWITCH/SENSOR-JACK (UP/DOWN)	1812992
	139641-01-705	EA	FITTING HYD (1/4"X90 DEGREE)	1904500
	139641-01-706	EA	FITTING HYD (1/4" STRAIGHT)	1904510
	139641-01-707	EA	LEVEL (BUBBLE)	1906200
	139641-01-708	EA	PUMP ASM. - W/SOLENOIDS/WIRE	3700690
	139641-01-709	EA	JACK - REAR 15"/10K	3700701
	139641-01-710	EA	CYLINDER ONLY - 15"/10K	1905200
	139641-01-711	EA	BRACKET MTG (WORKHORSE REAR)	3717740
	139641-01-713	EA	CROSS MEMBER-FRONT(P32/P42)	3717791
	139641-01-715	EA	BOLT KIT(CROSS MBR/JK/PUMP)	3717794
	139641-01-718	EA	SOLENOID - 4 POST ELECTRICAL	906900250
	139641-01-719	EA	VALVE KIT (COIL W/PACKARD)	906963010
	139641-01-720	EA	JACK - FRONT 15"/10K	3700702
	139641-01-710	EA	CYLINDER ONLY - 15"/10K	1905200
	139641-01-721	EA	SOLENOID VALVE - 2-WAY	906965000
	139641-01-722	EA	SOLENOID VALVE - 4-WAY	906964000
	139641-01-723	EA	FOOT PAD - JACK	3700367
	139641-01-724	EA	BOLT/FOOT - 3/4-10 X 1 1/2"	1204645
	139641-02-700	EA	HARNESS F/READ SWITCH (FORD)	1809911
	139641-02-701	EA	BRACKET MTG (F53/W22 REAR)	3717742
	139641-02-703	EA	CROSS MEMBER/REAR (F53/W22)	3717795
	139641-03-700	EA	CROSSMEMBER/FRONT (W22)	3717797

CHASSIS GROUP (CONTINUED)
SPARE TIRE

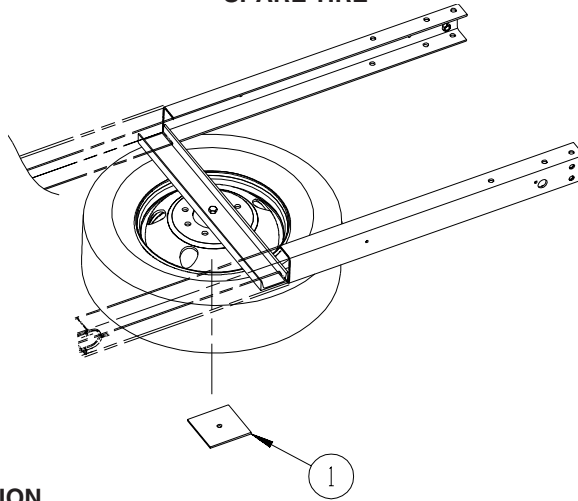

**D27C, D30B, D33L, D34A, D35N
WORKHORSE**

KEY	PART NUMBER	U/M	DESCRIPTION
1	111685-01-000	EA	PLATE - SPARE TIRE

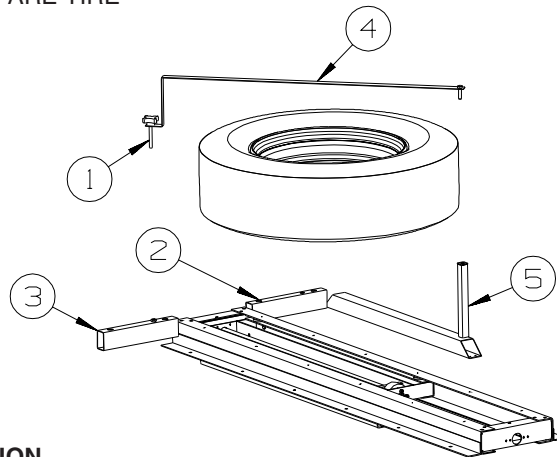

**D29R
WORKHORSE/FORD**

KEY	PART NUMBER	U/M	DESCRIPTION
1	134194-01-01A	EA	KNOB - HOLD DOWN/RECLINER - BLACK
2	148968-01-02B	EA	TUBE - STEEL, W/HOLES
3	148968-02-02B	EA	TUBE - STEEL, W/HOLES
4	148969-02-02B	EA	STRAP - SPARE TIRE - E-COATED
5	148982-01-02B	EA	BRACKET - SPARE TIRE - E-COATED

SUSPENSION

KEY	PART NUMBER	U/M	DESCRIPTION
*	122756-04-000	EA	SHOCK & STABILIZER KIT - WORKHORSE/WIDE BODY CHASSIS

***COMPONENT PARTS LISTED LATER IN THIS GROUP**

COMPONENT PARTS FOR SUSPENSION

122756-04-000

KEY	PART NUMBER	U/M	DESCRIPTION	VENDOR NO.
	122756-02-707	EA	DAMPNER - STEERING	T818SD
	122756-02-708	EA	BOOT - DAMPNER	T818SDB
	122756-02-709	EA	BUSHING PKG-STEERING DAMPNER	T818SDBSH
	122756-02-710	EA	BOLT PKG - STEERING DAMPNER	T818BSD
	122756-03-702	EA	SHOCK	557003
	122756-04-700	EA	BRACKET ASSEMBLY - DRIVER	T818L-WW
	122756-04-701	EA	BRACKET ASSEMBLY - PASSENGER	T818R-WW
	122756-04-702	EA	BOLT PACKAGE KIT	T818B-WW

CHASSIS GROUP (CONTINUED)
WHEEL, TIRE, COVERS &/OR LINERS

KEY	PART NUMBER	U/M	DESCRIPTION
	064963-03-000	EA	WHEEL - STEEL - 6" X 19.5" - WORKHORSE P32 (15,000/18,000)CHASSIS
	118814-05-000	EA	WHEEL - STEEL - 19.5" X 6.75" - W/STEM - GRAY - WORKHORSE W20 (20,700) CHASSIS
	091673-07-000	EA	TIRE - 225/70R19.5 LRF - MICHELIN XRUV - WORKHORSE P32 (15,000/18,000) CHASSIS
	102340-07-000	EA	TIRE - 245/70R X 19.5 - RANGE F - MICHELIN XRV - WORKHORSE W20 (20,700) CHASSIS
	102340-08-000	EA	TIRE - 245/70R X 19.5F - GOODYEAR - FORD
*	109443-06-000	EA	WHEEL COVER - 4/SET - 19.5" - GM/WORKHORSE - WORKHORSE P32 (15,000/18,000) CHASSIS
*	109443-08-000	EA	WHEEL COVER - 4/SET - 19.5" - FORD "F53" CHASSIS - FORD
*	145580-04-000	EA	LINER - WHEEL(SET OF 4) - 19.5"/10 BOLT - WORKHORSE P32 (15,000/18,000) CHASSIS
*	145580-03-000	EA	LINER - WHEEL(SET OF 4) - 19.5" - 8 BOLT - WORKHORSE W20 (20,700) CHASSIS
*	110435-20-000	EA	LINER - WHEEL - SET OF 4 - 19.5" - 8 BOLT - 2004 FORD CHASSIS W/19.5 TIRE
	154672-01-000	EA	LINER - WHEEL - SET/4 - 19.5 - 10 BOLT - 2006 FORD CHASSIS W/19.5 TIRE
	051377-01-000	EA	VALVE STEM
	051377-06-000	EA	VALVE STEM - .5" X 2 1/3" W/W22 DEGREE BEND
	077030-01-000	EA	EXTENSION - VALVE STEM - 1.25"
	077030-10-000	EA	EXTENSION - VALVE STEM
	095012-09-000	EA	EXTENSION/VALVE STEM - LIVE - 7.7"
	095012-07-000	EA	STABILIZER/VALVE EXTENSION - LIVE - 4"
	080208-02-000	EA	BAR - LEVERAGE - LUG WRENCH - CHEVY/OSHKOSH - WORKHORSE P32 (15,000/18,000) CHASSIS
	080208-05-000	EA	BAR - LEVERAGE - LUG WRENCH - .75"DIA. - WORKHORSE W20 (20,700) CHASSIS
	080208-06-000	EA	LUG WRENCH - 1" X 1.06" W/DEEP SOCKET ENDS - WORKHORSE P32 (15,000/18,000) CHASSIS
	080208-04-000	EA	LUG WRENCH - 1 3/16" - WORKHORSE W20 (20,700) CHASSIS

***COMPONENT PARTS LISTED LATER IN THIS GROUP**

COMPONENT PARTS FOR WHEEL, TIRE, COVERS &/OR LINERS

KEY	PART NUMBER	U/M	DESCRIPTION	VENDOR NO.
109443-05-000				
	098532-01-700	EA	COVER-LUG NUT (CHROME)	SHAU-LNC
	109443-05-700	EA	COVER-WHEEL, 16" SS EA=1	SHFM16-CVR
109443-06-000				
KEY	PART NUMBER	U/M	DESCRIPTION	VENDOR NO.
	109443-01-700	EA	COVER-WHEEL 19.5 FRT/RR EA=1	SHAG95
	109443-01-701	EA	BRACKET-RET FRT 1EA=1 SET	SHAG95-FBS
	109443-01-703	EA	CAP-CENTER, HUB - DICOR	SHAU95-CAP
	109443-01-704	EA	CLIP-RETAINER	V160GM-PNT
	109443-06-701	EA	BRACKET-RET RR 1EA=1 SET	SHG795-RBS
109443-08-000				
KEY	PART NUMBER	U/M	DESCRIPTION	VENDOR NO.
	109443-01-703	EA	CAP-CENTER, HUB - DICOR	SHAU95-CAP
	109443-07-700	EA	COVER/WHEEL-FRONT/REAR 8 LUG	SHAF95-COV
	109443-08-700	EA	BRACKET-RET FRT 1EA=1 SET	SHAF95M-FBS
	109443-08-701	EA	BRACKET-RET RR 1EA=1 SET	SHAF95M-RBS
110435-20-000				
KEY	PART NUMBER	U/M	DESCRIPTION	VENDOR NO.
	110435-04-705	EA	DECAL-CTR HUB 2 3/4" DIAMOND	
	110435-10-705	EA	TOOL/JAMB NUT INSTALLATION	V195P7-TOL
	110435-15-700	EA	LINER - WHEEL - FRONT	V195F9-FWC
	110435-15-701	EA	LINER - WHEEL - REAR	V195F9-RWC
	110435-15-702	EA	JAMB NUT W/COVER - CRS THRD	V195F9-EJN
	110435-20-700	EA	LNC W/ENCL M14X1.5 JAM NUT	V195F9-EJN-MF
145580-03-000				
KEY	PART NUMBER	U/M	DESCRIPTION	VENDOR NO.
	110435-04-705	EA	DECAL-CTR HUB 2 3/4"	2 3/4 DECAL DIAMOND
	110435-05-700	EA	CAP-CENTER 4.50"D W/O DECAL	V22510-POC
	110435-12-700	EA	LINER - WHEEL - FRONT	V19580-FWC
	110435-12-701	EA	LINER - WHEEL - REAR	V19580-RWC
	145580-01-702	EA	COVER-LUG NUT/JAM NUT 22M	V19582-EJN
	145580-01-703	EA	TOOL-INSTALLATION	V22501-TOL

CHASSIS GROUP (CONTINUED)
COMPONENT PARTS FOR WHEEL, TIRE, COVERS &/OR LINERS (CONTINUED)

145580-04-000

KEY	PART NUMBER	U/M DESCRIPTION	VENDOR NO.
	110435-04-705	EA DECAL-CTR HUB 2 3/4"	2 3/4 DECAL DIAMOND
	110435-10-701	EA LINER - WHEEL - REAR - 1 PC.	V195P7-RWC
	110435-10-702	EA JAMB NUT W/JAMB NUT COVER	V195P7-EJN
	110435-10-703	EA STUD - PLASTIC	V195P7-PST
	110435-10-704	EA COVER-LUG NUT/PLASTIC JB NUT	V195P7-PJN
	110435-10-705	EA TOOL/JAMB NUT INSTALLATION	V195P7-TOL
	145580-04-700	EA LINER - WHEEL/FRONT - 1EA=1	V195P72-FWC

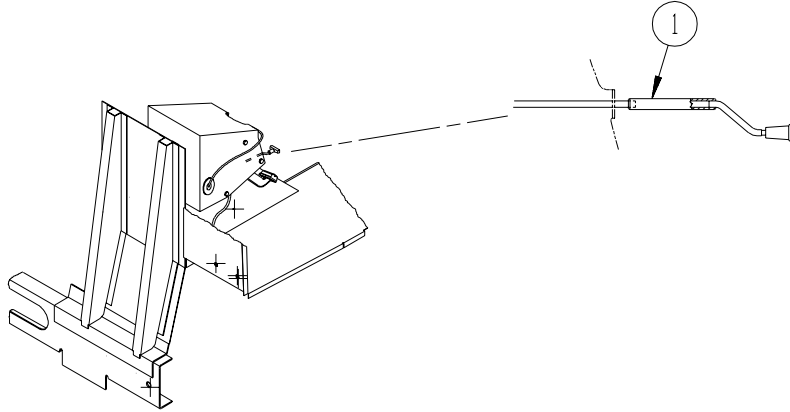

BRAKE

KEY	PART NUMBER	U/M DESCRIPTION
1	113007-01-000	EA PIN - SPRING - .375 X 3"

BRAKELINE

KEY	PART NUMBER	U/M DESCRIPTION
	075466-01-000	EA UNION - INVERTED FLAIR - 1/4"

CURTAIN & CUSHION GROUP

NOTICE

IN ORDER TO ASSIST OUR PARTS SALES DEPT. IN PROVIDING INTERIOR SOFTWARE ITEMS, PLEASE INCLUDE THE SERIAL NUMBER AND THE COLOR CODE NUMBER FROM THE VEHICLE CERTIFICATION LABEL WHEN ORDERING. THIS LABEL IS LOCATED ON THE LEFT SIDEWALL AT THE END OF THE DASH (A-BODY), OR ON THE DRIVER'S DOOR LATCH PLATE (C-BODY).

AN EXAMPLE OF A COLOR CODE NUMBER IS B07, WHICH DESIGNATES AN OVERALL COLOR SCHEME OF A PARTICULAR UNIT. THE COLOR LISTED AFTER THE ITEM DESCRIPTION ON THE MICROFICHE, INDICATES THE OVERALL UNIT COLOR. ORDER THE ITEM YOU DESIRE ACCORDING TO UNIT COLOR CODE. IF ALL COLORS USE THE SAME ITEM NO COLOR CODE WILL BE NOTED.

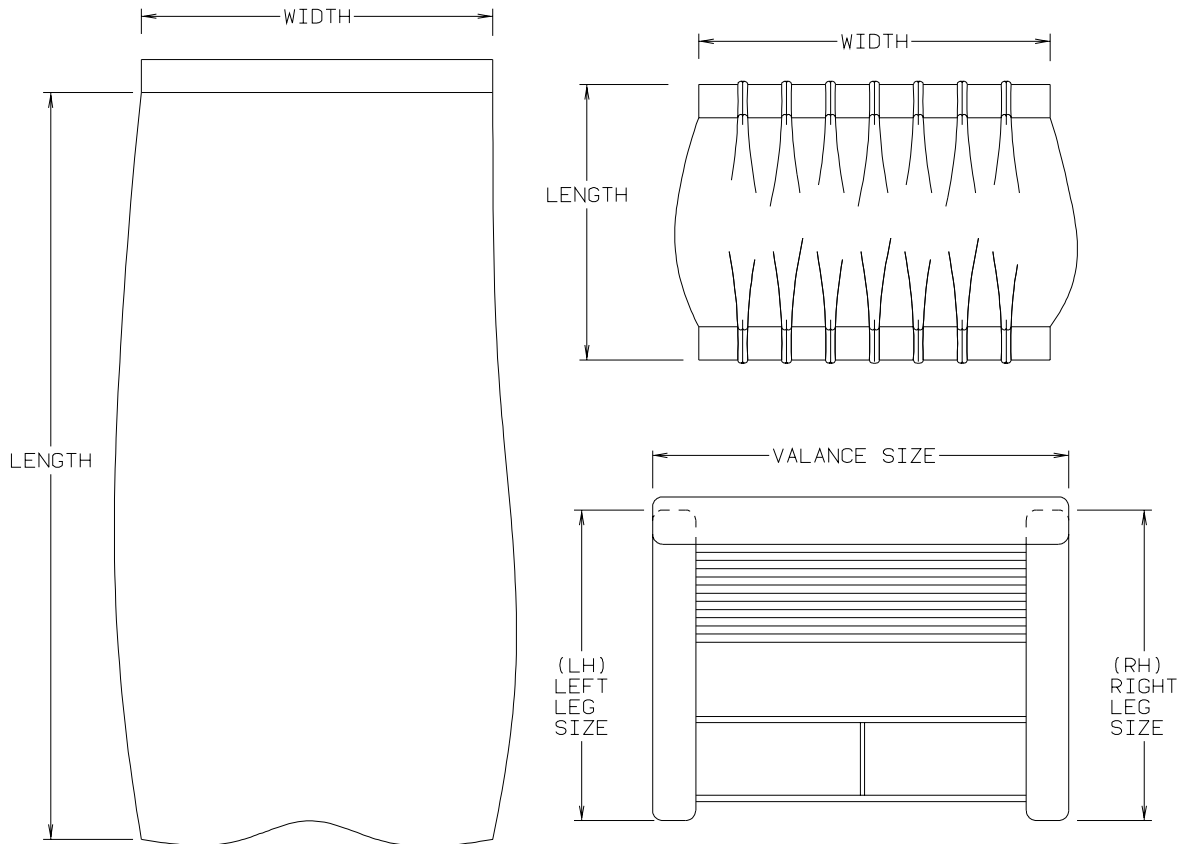

NOTE: USE THIS ILLUSTRATION WHEN DETERMINING LENGTH AND WIDTH MEASUREMENTS FOR CURTAINS. YOU WILL NOTE THE WIDTH MEASUREMENT IS TAKEN ON THE TOP OF THE CURTAIN WITH THE CURTAIN FULLY EXTENDED. THE LENGTH MEASUREMENT IS TAKEN FROM TOP TO BOTTOM. LEFT AND RIGHT WINDOW LEGS ARE DETERMINED WHEN FACING THE WINDOW.

CURTAIN & CUSHION GROUP (CONTINUED)
CUSHION LAYOUT

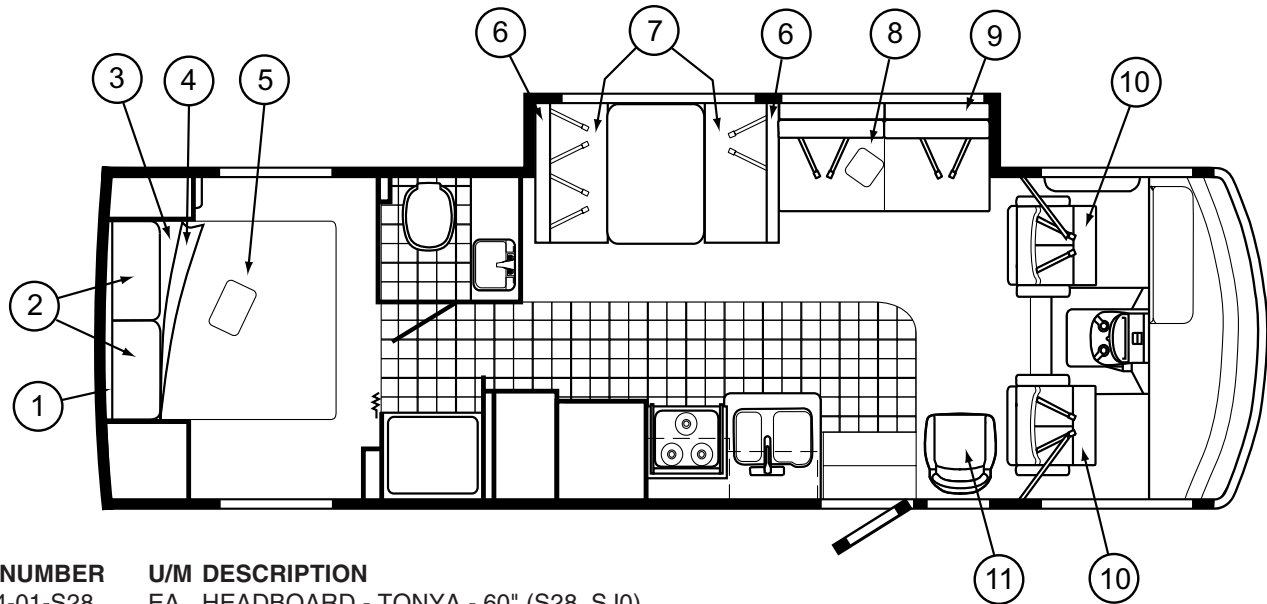

KEY	PART NUMBER	U/M	DESCRIPTION	
1	149184-01-S28	EA	HEADBOARD - TONYA - 60" (S28, SJ0)	
1	149184-01-S29	EA	HEADBOARD - TONYA - 60" (S29, SJ1, SX6, SX7)	
1	149184-01-S30	EA	HEADBOARD - TONYA - 60" (S30, SJ2)	
1	149184-01-SX2	EA	HEADBOARD - TONYA - 60" (S30, SJ2)	
1	149184-01-SX4	EA	HEADBOARD - TONYA - 60" (SX4, SX5)	
1	149184-01-S4X	EA	HEADBOARD - TONYA - 60" (SX4, SX5)	FROM: 00-00-00 THRU: 11-14-04
1	149184-01-SY4	EA	HEADBOARD - TONYA - 60" (SY4, SY5)	FROM: 11-15-04 THRU: 99-99-99
1	149184-01-S4Y	EA	HEADBOARD - TONYA - 60" (SY4, SY5)	FROM: 00-00-00 THRU: 11-17-04
1	149184-01-SY5	EA	HEADBOARD - TONYA - 60" (SY4, SY5)	FROM: 11-18-04 THRU: 12-08-04
1	149184-01-SY6	EA	HEADBOARD - TONYA - 60" (SY4, SY5)	FROM: 12-09-04 THRU: 99-99-99
1	149184-01-SY6	EA	HEADBOARD - TONYA - 60" (SY6, SY7)	
1	149184-01-SY8	EA	HEADBOARD - TONYA - 60" (SY8, SY9)	
2	104176-04-R28	EA	PILLOW SHAM - 30" (S28, SJ0)	
2	104176-04-R29	EA	PILLOW SHAM - 30" (S29, SJ1, SX6, SX7)	
2	104176-04-S30	EA	PILLOW SHAM - 30" (S30, SJ2)	
2	104176-04-S06	EA	PILLOW SHAM - 30" (SX2, SX3)	
2	104176-04-SX0	EA	PILLOW SHAM - 30" (SX4, SX5)	
2	104176-04-P10	EA	PILLOW SHAM - 30" (SY4, SY5)	
2	104176-04-SY6	EA	PILLOW SHAM - 30" (SY6, SY7)	
2	104176-04-SY8	EA	PILLOW SHAM - 30" (SY8, SY9)	
3	123015-06-000	EA	MATTRESS - INNERSPRING - 60" X 74.5"	
3	154430-01-000	EA	MATTRESS - INNERSPRING - 60" X 74.5"	FROM: 00-00-00 THRU: 01-02-05
4	132336-06-S28	EA	BEDSPREAD/CAP - 60" X 75" (S28, SJ0)	
4	132336-06-S29	EA	BEDSPREAD/CAP - 60" X 75" (S29, SJ1, SX6, SX7)	
4	132336-06-S30	EA	BEDSPREAD/CAP - 60" X 75" (S30, SJ2)	
4	132336-06-SX2	EA	BEDSPREAD/CAP - 60" X 75" (SX2, SX3)	
4	132336-06-SX4	EA	BEDSPREAD/CAP - 60" X 75" (SX4, SX5)	
4	132336-06-S4X	EA	BEDSPREAD/CAP - 60" X 75" (SX4, SX5)	FROM: 00-00-00 THRU: 11-14-04
4	132336-06-SY4	EA	BEDSPREAD/CAP - 60" X 75" (SY4, SY5)	FROM: 11-15-04 THRU: 99-99-99
4	132336-06-S4Y	EA	BEDSPREAD/CAP - 60" X 75" (SY4, SY5)	FROM: 00-00-00 THRU: 11-17-04
4	132336-06-SY6	EA	BEDSPREAD/CAP - 60" X 75" (SY4, SY5)	FROM: 11-18-04 THRU: 99-99-99
4	132336-06-SY6	EA	BEDSPREAD/CAP - 60" X 75" (SY6, SY7)	
4	132336-06-SY8	EA	BEDSPREAD/CAP - 60" X 75" (SY8, SY9)	
5	149228-02-S28	EA	PILLOW - TONYA - 18" (WELTED) (S28, SJ0)	
5	149228-02-S29	EA	PILLOW - TONYA - 18" (WELTED) (S29, SJ1, SX6, SX7)	

CURTAIN & CUSHION GROUP (CONTINUED)
CUSHION LAYOUT (CONTINUED)

KEY	PART NUMBER	U/M	DESCRIPTION
5	149228-02-S30	EA	PILLOW - TONYA - 18" (WELTED) (S30, SJ2)
5	149228-02-SX2	EA	PILLOW - TONYA - 18" (WELTED) (SX2, SX3)
5	149228-02-SX4	EA	PILLOW - TONYA - 18" (WELTED) (SX4, SX5)
			FROM: 00-00-00 THRU: 11-14-04
5	149228-02-S4X	EA	PILLOW - TONYA - 18" (WELTED) (SX4, SX5)
			FROM: 11-15-04 THRU: 99-99-99
5	149228-02-SY4	EA	PILLOW - TONYA - 18" (WELTED) (SY4, SY5)
			FROM: 00-00-00 THRU: 11-14-04
5	149228-02-S4Y	EA	PILLOW - TONYA - 18" (WELTED) (SY4, SY5)
			FROM: 11-15-04 THRU: 12-08-04
5	149228-02-SY5	EA	PILLOW - TONYA - 18" (WELTED) (SY4, SY5)
			FROM: 12-09-04 THRU: 99-99-99
5	149228-02-SY6	EA	PILLOW - TONYA - 18" (WELTED) (SY6, SY7)
5	149228-02-SY8	EA	PILLOW - TONYA - 18" (WELTED) (SY8, SY9)
6	111897-05-R28	EA	CUSHION - BACK - 13.5" X 42" X 5" (S28, SJ0)
6	111897-05-R29	EA	CUSHION - BACK - 13.5" X 42" X 5" (S29, SJ1)
6	111897-05-S30	EA	CUSHION - BACK - 13.5" X 42" X 5" (S30, SJ2)
6	111897-05-SX2	EA	CUSHION - BACK - 13.5" X 42" X 5" (SX2, SX3)
			FROM: 00-00-00 THRU: 11-30-04
6	111897-05-SX3	EA	CUSHION - BACK - 13.5" X 42" X 5" (SX2, SX3)
			FROM: 12-01-04 THRU: 99-99-99
6	111897-05-SX4	EA	CUSHION - BACK - 13.5" X 42" X 5" (SX4, SX5)
6	111897-05-SX6	EA	CUSHION - BACK - 13.5" X 42" X 5" (SX6, SX7)
6	111897-05-SY4	EA	CUSHION - BACK - 13.5" X 42" X 5" (SY4, SY5)
			FROM: 00-00-00 THRU: 11-30-04
6	111897-05-SY5	EA	CUSHION - BACK - 13.5" X 42" X 5" (SY4, SY5)
			FROM: 12-01-04 THRU: 99-99-99
6	111897-05-P34	EA	CUSHION - BACK - 13.5" X 42" X 5" (SY6, SY7)
6	111897-05-SY8	EA	CUSHION - BACK - 13.5" X 42" X 5" (SY8, SY9)
	P11897-05-R28	EA	COVER - BACK - 13.5" X 42" X 5" (S28, SJ0)
	P11897-05-R29	EA	COVER - BACK - 13.5" X 42" X 5" (S29, SJ1)
	P11897-05-S30	EA	COVER - BACK - 13.5" X 42" X 5" (S30, SJ2)
	P11897-05-SX2	EA	COVER - BACK - 13.5" X 42" X 5" (SX2, SX3)
			FROM: 00-00-00 THRU: 11-30-04
	P11897-05-SX3	EA	COVER - BACK - 13.5" X 42" X 5" (SX2, SX3)
			FROM: 12-01-04 THRU: 99-99-99
	P11897-05-SX4	EA	COVER - BACK - 13.5" X 42" X 5" (SX4, SX5)
	P11897-05-SX6	EA	COVER - BACK - 13.5" X 42" X 5" (SX6, SX7)
	P11897-05-SY4	EA	COVER - BACK - 13.5" X 42" X 5" (SY4, SY5)
			FROM: 00-00-00 THRU: 11-30-04
	P11897-05-SY5	EA	COVER - BACK - 13.5" X 42" X 5" (SY4, SY5)
			FROM: 12-01-04 THRU: 99-99-99
	P11897-05-P34	EA	COVER - BACK - 13.5" X 42" X 5" (SY6, SY7)
	P11897-05-SY8	EA	COVER - BACK - 13.5" X 42" X 5" (SY8, SY9)
7	105603-23-R28	EA	CUSHION - SEAT - 21" X 42" X 5" (S28, SJ0)
7	105603-23-S29	EA	CUSHION - SEAT - 21" X 42" X 5" (S29, SJ1)
7	105603-23-S30	EA	CUSHION - SEAT - 21" X 42" X 5" (S30, SJ2)
7	105603-23-SX2	EA	CUSHION - SEAT - 21" X 42" X 5" (SX2, SX3)
			FROM: 00-00-00 THRU: 11-30-04
7	105603-23-SX3	EA	CUSHION - SEAT - 21" X 42" X 5" (SX2, SX3)
			FROM: 12-01-04 THRU: 99-99-99
7	105603-23-P07	EA	CUSHION - SEAT - 21" X 42" X 5" (SX4, SX5)
7	105603-23-R09	EA	CUSHION - SEAT - 21" X 42" X 5" (SX6, SX7)
7	105603-23-P10	EA	CUSHION - SEAT - 21" X 42" X 5" (SY4, SY5)
			FROM: 00-00-00 THRU: 11-30-04
7	105603-23-SY5	EA	CUSHION - SEAT - 21" X 42" X 5" (SY4, SY5)
			FROM: 12-01-04 THRU: 99-99-99
7	105603-23-P34	EA	CUSHION - SEAT - 21" X 42" X 5" (SY6, SY7)
7	105603-23-SY8	EA	CUSHION - SEAT - 21" X 42" X 5" (SY8, SY9)
	P05603-23-R28	EA	COVER - SEAT - 21" X 42" X 5" (S28, SJ0)
	P05603-23-S29	EA	COVER - SEAT - 21" X 42" X 5" (S29, SJ1)
	P05603-23-S30	EA	COVER - SEAT - 21" X 42" X 5" (S30, SJ2)

CURTAIN & CUSHION GROUP (CONTINUED)
CUSHION LAYOUT (CONTINUED)

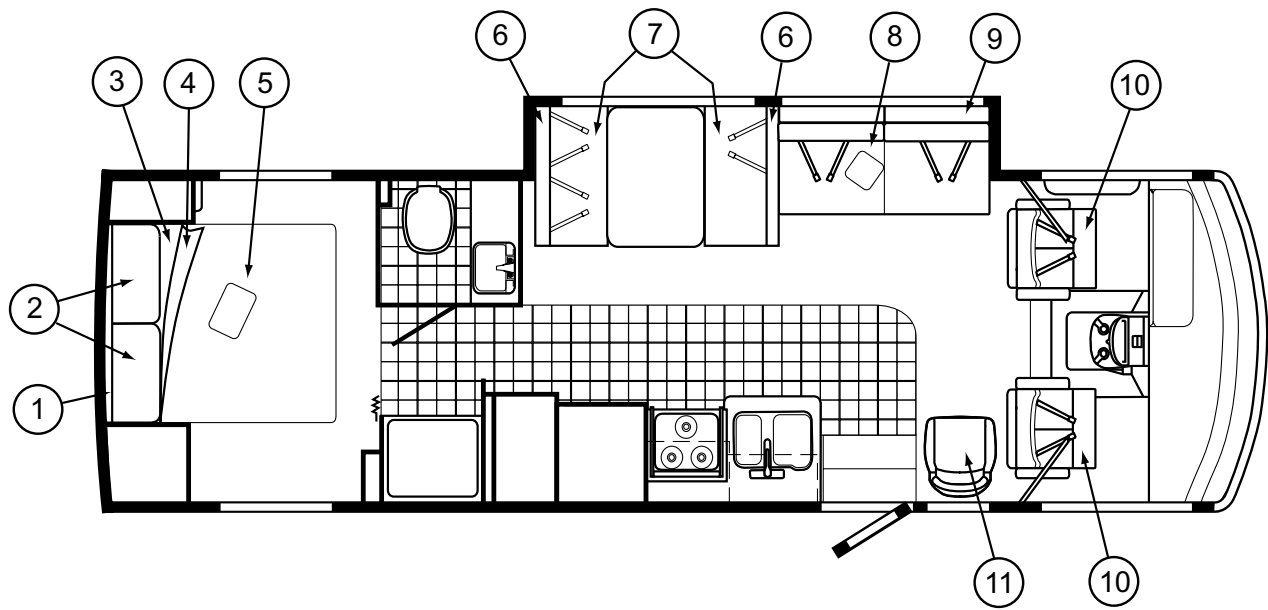

KEY	PART NUMBER	U/M	DESCRIPTION
	P05603-23-SX2	EA	COVER - SEAT - 21" X 42" X 5" (SX2, SX3) FROM: 00-00-00 THRU: 11-30-04
	P05603-23-SX3	EA	COVER - SEAT - 21" X 42" X 5" (SX2, SX3) FROM: 12-01-04 THRU: 99-99-99
	P05603-23-P07	EA	COVER - SEAT - 21" X 42" X 5" (SX4, SX5)
	P05603-23-R09	EA	COVER - SEAT - 21" X 42" X 5" (SX6, SX7)
	P05603-23-P10	EA	COVER - SEAT - 21" X 42" X 5" (SY4, SY5) FROM: 00-00-00 THRU: 11-30-04
	P05603-23-SY5	EA	COVER - SEAT - 21" X 42" X 5" (SY4, SY5) FROM: 12-01-04 THRU: 99-99-99
	P05603-23-P34	EA	COVER - SEAT - 21" X 42" X 5" (SY6, SY7)
	P05603-23-SY8	EA	COVER - SEAT - 21" X 42" X 5" (SY8, SY9)
8	149228-01-S28	EA	PILLOW - TONYA - 18" (BRAIDED) (S28, SJ0)
8	149228-01-S29	EA	PILLOW - TONYA - 18" (BRAIDED) (S29, SJ1)
8	149228-01-S30	EA	PILLOW - TONYA - 18" (BRAIDED) (S30, SJ2)
8	149228-03-SX2	EA	PILLOW - TONYA - 18" (WELTED) (SX2, SX3) FROM: 00-00-00 THRU: 11-30-04
8	149228-03-SX3	EA	PILLOW - TONYA - 18" (WELTED) (SX2, SX3) FROM: 12-01-04 THRU: 99-99-99
8	149228-03-SX4	EA	PILLOW - TONYA - 18" (WELTED) (SX4, SX5) FROM: 00-00-00 THRU: 11-16-04
8	149228-03-S4X	EA	PILLOW - TONYA - 18" (WELTED) (SX4, SX5) FROM: 11-17-04 THRU: 99-99-99
8	149228-03-SX6	EA	PILLOW - TONYA - 18" (WELTED) (SX6, SX7) FROM: 00-00-00 THRU: 11-15-04
8	149228-03-SX7	EA	PILLOW - TONYA - 18" (WELTED) (SX6, SX7) FROM: 11-16-04 THRU: 99-99-99
8	149228-03-SY4	EA	PILLOW - TONYA - 18" (WELTED) (SY4, SY5) FROM: 00-00-00 THRU: 11-11-04
8	149228-03-SY5	EA	PILLOW - TONYA - 18" (WELTED) (SY4, SY5) FROM: 11-12-04 THRU: 99-99-99
8	149228-03-SY6	EA	PILLOW - TONYA - 18" (WELTED) (SY6, SY7) FROM: 00-00-00 THRU: 12-08-04
8	149228-03-SY7	EA	PILLOW - TONYA - 18" (WELTED) (SY6, SY7) FROM: 12-09-04 THRU: 99-99-99
8	149228-03-SY8	EA	PILLOW - TONYA - 18" (WELTED) (SY8, SY9)
9			SOFA - SEE SOFA AREA
10	135473-22-R28	EA	BUCKET SEAT - DRIVER/PASSENGER (S28, SJ0)
10	135473-22-R29	EA	BUCKET SEAT - DRIVER/PASSENGER (S29, SJ1)
10	135473-22-S30	EA	BUCKET SEAT - DRIVER/PASSENGER (S30, SJ2)
10	135473-22-SX2	EA	BUCKET SEAT - DRIVER/PASSENGER (SX2, SX3)

CURTAIN & CUSHION GROUP (CONTINUED)
CUSHION LAYOUT (CONTINUED)

KEY	PART NUMBER	U/M	DESCRIPTION
10	135473-22-SX4	EA	BUCKET SEAT - DRIVER/PASSENGER (SX4,SX5) FROM: 00-00-00 THRU: 11-16-04
10	135473-22-S4X	EA	BUCKET SEAT - DRIVER/PASSENGER (SX4,SX5) FROM: 11-17-04 THRU: 99-99-99
10	135473-22-SX6	EA	BUCKET SEAT - DRIVER/PASSENGER (SX6,SX7) FROM: 00-00-00 THRU: 11-30-04
10	135473-22-S6X	EA	BUCKET SEAT - DRIVER/PASSENGER (SX6,SX7) FROM: 12-01-04 THRU: 99-99-99
10	135473-22-SY4	EA	BUCKET SEAT - DRIVER/PASSENGER (SY4, SY5)
10	135473-22-SY6	EA	BUCKET SEAT - DRIVER/PASSENGER (SY6, SY7) FROM: 00-00-00 THRU: 12-08-04
10	135473-22-SY7	EA	BUCKET SEAT - DRIVER/PASSENGER (SY6, SY7) FROM: 12-09-04 THRU: 99-99-99
10	135473-22-SY8	EA	BUCKET SEAT - DRIVER/PASSENGER (SY8, SY9)
	152337-01-000	EA	PROTECTOR - SEAT - CLEAR VINYL
11	138523-01-R28	EA	CHAIR - GLIDER - W/SWIVEL & HOOP (S28, SJ0, SY8, SY9)
11	138523-01-R29	EA	CHAIR - GLIDER - W/SWIVEL & HOOP (S29, SJ1)
11	138523-01-S30	EA	CHAIR - GLIDER - W/SWIVEL & HOOP (S30, SJ2)
11	138523-01-SX2	EA	CHAIR - GLIDER - W/SWIVEL & HOOP (SX2, SX3)
11	138523-01-P38	EA	CHAIR - GLIDER - W/SWIVEL & HOOP (SX4,SX5)
11	138523-01-SX6	EA	CHAIR - GLIDER - W/SWIVEL & HOOP (SX6,SX7)
11	138523-01-SY4	EA	CHAIR - GLIDER - W/SWIVEL & HOOP (SY4, SY5)
11	138523-01-P34	EA	CHAIR - GLIDER - W/SWIVEL & HOOP (SY6, SY7)

CURTAIN & CUSHION GROUP (CONTINUED)

BUCKET SEATS

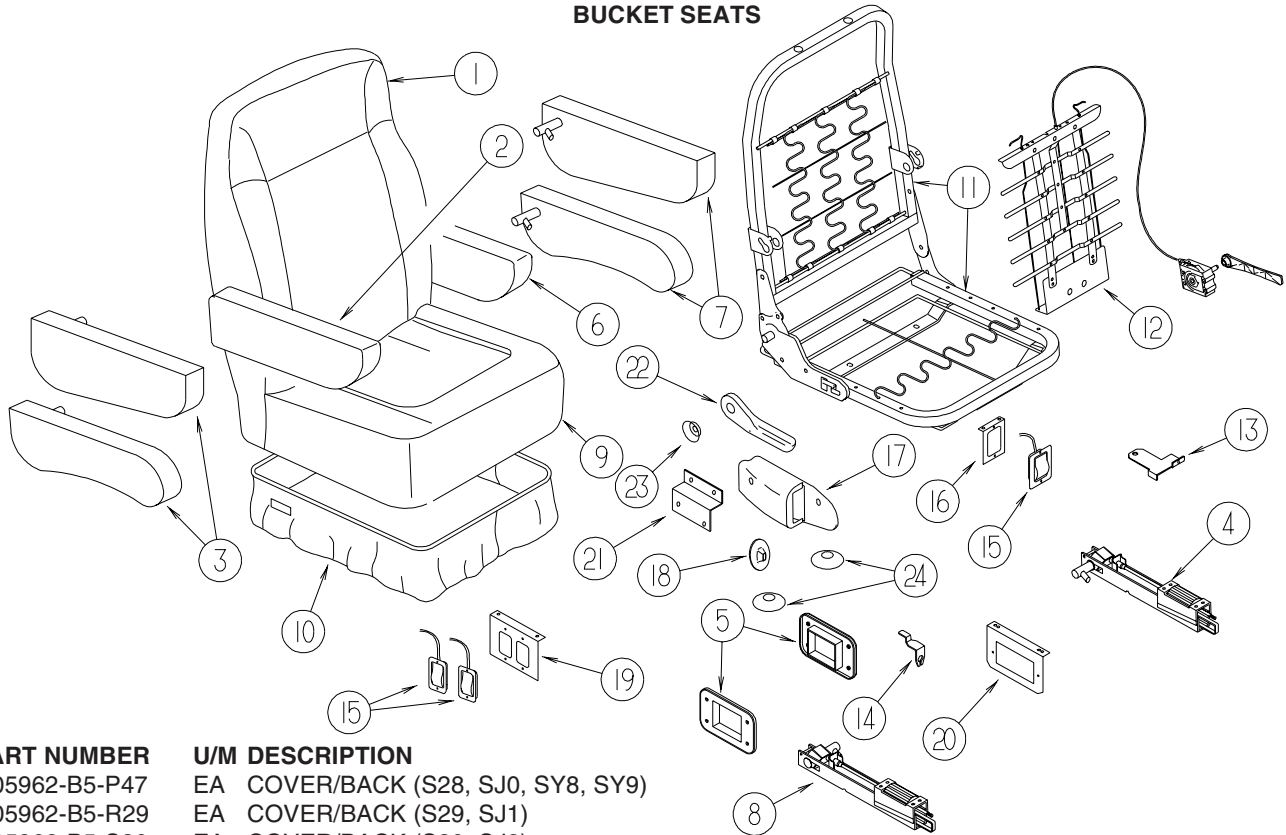

KEY	PART NUMBER	U/M	DESCRIPTION	
1	M05962-B5-P47	EA	COVER/BACK (S28, SJ0, SY8, SY9)	
1	M05962-B5-R29	EA	COVER/BACK (S29, SJ1)	
1	M05962-B5-S30	EA	COVER/BACK (S30, SJ2)	
1	M05962-B5-SX2	EA	COVER/BACK (SX2, SX3)	
1	M05962-B5-SX4	EA	COVER/BACK (SX4, SX5)	
1	M05962-B5-S4X	EA	COVER/BACK (SX4, SX5)	FROM: 00-00-00 THRU: 11-16-04
1	M05962-B5-SX6	EA	COVER/BACK (SX6, SX7)	FROM: 11-17-04 THRU: 99-99-99
1	M05962-B5-S6X	EA	COVER/BACK (SX6, SX7)	FROM: 00-00-00 THRU: 11-30-04
1	M05962-B5-SY4	EA	COVER/BACK (SY4, SY5)	FROM: 12-01-04 THRU: 99-99-99
1	M05962-B5-SY5	EA	COVER/BACK (SY4, SY5)	FROM: 00-00-00 THRU: 11-11-04
1	M05962-B5-R30	EA	COVER/BACK (SY6, SY7)	FROM: 11-12-04 THRU: 99-99-99
1	M05962-B5-SY7	EA	COVER/BACK (SY6, SY7)	FROM: 00-00-00 THRU: 12-08-04
1	M05962-B5-SY7	EA	COVER/BACK (SY6, SY7)	FROM: 12-09-04 THRU: 99-99-99
2	129666-07-R28	EA	ARMREST - RIGHT HAND (S28, SJ0)	
2	129666-07-R29	EA	ARMREST - RIGHT HAND (S29, SJ1)	
2	129666-07-S30	EA	ARMREST - RIGHT HAND (S30, SJ2)	
2	148652-01-SX2	EA	ARMREST - RIGHT HAND (SX2, SX3)	
2	129666-07-P07	EA	ARMREST - RIGHT HAND (SX4, SX5)	
2	148652-01-S4X	EA	ARMREST - RIGHT HAND (SX4, SX5)	FROM: 00-00-00 THRU: 11-16-04
2	129666-07-R35	EA	ARMREST - RIGHT HAND (SX6, SX7)	FROM: 11-17-04 THRU: 99-99-99
2	129666-07-S6X	EA	ARMREST - RIGHT HAND (SX6, SX7)	FROM: 00-00-00 THRU: 11-30-04
2	129666-07-P10	EA	ARMREST - RIGHT HAND (SY4, SY5)	FROM: 12-01-04 THRU: 99-99-99
2	129666-07-SY5	EA	ARMREST - RIGHT HAND (SY4, SY5)	FROM: 00-00-00 THRU: 11-11-04
2	129666-07-SY5	EA	ARMREST - RIGHT HAND (SY4, SY5)	FROM: 11-12-04 THRU: 99-99-99
2	148652-01-SY6	EA	ARMREST - RIGHT HAND (SY6, SY7)	FROM: 00-00-00 THRU: 12-08-04
2	148652-01-SY7	EA	ARMREST - RIGHT HAND (SY6, SY7)	FROM: 12-09-04 THRU: 99-99-99

CURTAIN & CUSHION GROUP (CONTINUED)
BUCKET SEATS (CONTINUED)

KEY	PART NUMBER	U/M	DESCRIPTION
2	148652-01-SY8	EA	ARMREST - RIGHT (SY8, SY9)
	P29666-07-R28	EA	COVER/ARMREST - RIGHT HAND (S28, SJ0)
	P29666-07-R29	EA	COVER/ARMREST - RIGHT HAND (S29, SJ1)
	P29666-07-S30	EA	COVER/ARMREST - RIGHT HAND (S30, SJ2)
	P48652-01-SX2	EA	COVER/ARMREST - RIGHT HAND (SX2, SX3)
	P29666-07-P07	EA	COVER/ARMREST - RIGHT HAND (SX4, SX5)
			FROM: 00-00-00 THRU: 11-16-04
	P48652-01-S4X	EA	COVER/ARMREST - RIGHT HAND (SX4, SX5)
			FROM: 11-17-04 THRU: 99-99-99
	P29666-07-R35	EA	COVER/ARMREST - RIGHT HAND (SX6, SX7)
			FROM: 00-00-00 THRU: 11-30-04
	P29666-07-S6X	EA	COVER/ARMREST - RIGHT HAND (SX6, SX7)
			FROM: 12-01-04 THRU: 99-99-99
	P29666-07-P10	EA	COVER/ARMREST - RIGHT HAND (SY4, SY5)
			FROM: 00-00-00 THRU: 11-11-04
	P29666-07-SY5	EA	COVER/ARMREST - RIGHT HAND (SY4, SY5)
			FROM: 11-12-04 THRU: 99-99-99
	P48652-01-SY6	EA	COVER/ARMREST - RIGHT HAND (SY6, SY7)
			FROM: 00-00-00 THRU: 12-08-04
	P48652-01-SY7	EA	COVER/ARMREST - RIGHT HAND (SY6, SY7)
			FROM: 12-09-04 THRU: 99-99-99
	P48652-01-SY8	EA	COVER/ARMREST - RIGHT HAND (SY8, SY9)
3	130698-01-000	EA	ARMREST/MOLDED - RIGHT HAND - W/O COVER
4	NOT USED		
5	NOT USED		
6	129666-08-R28	EA	ARMREST - LEFT HAND (S28, SJ0)
6	129666-08-R29	EA	ARMREST - LEFT HAND (S29, SJ1)
6	129666-08-S30	EA	ARMREST - LEFT HAND (S30, SJ2)
6	148652-02-SX2	EA	ARMREST - LEFT HAND (SX2, SX3)
6	129666-08-P07	EA	ARMREST - LEFT HAND (SX4, SX5)
			FROM: 00-00-00 THRU: 11-16-04
6	148652-02-S4X	EA	ARMREST - LEFT HAND (SX4, SX5)
			FROM: 11-17-04 THRU: 99-99-99
6	129666-08-R35	EA	ARMREST - LEFT HAND (SX6, SX7)
			FROM: 00-00-00 THRU: 11-30-04
6	129666-08-S6X	EA	ARMREST - LEFT HAND (SX6, SX7)
			FROM: 12-01-04 THRU: 99-99-99
6	129666-08-P10	EA	ARMREST - LEFT HAND (SY4, SY5)
			FROM: 00-00-00 THRU: 11-11-04
6	129666-08-SY5	EA	ARMREST - LEFT HAND (SY4, SY5)
			FROM: 11-12-04 THRU: 99-99-99
6	148652-02-SY6	EA	ARMREST - LEFT HAND (SY6, SY7)
			FROM: 00-00-00 THRU: 12-08-04
6	148652-02-SY7	EA	ARMREST - LEFT HAND (SY6, SY7)
			FROM: 12-09-04 THRU: 99-99-99
6	148652-02-SY8	EA	ARMREST - LEFT (SY8, SY9)
	P29666-08-R28	EA	COVER/ARMREST - LEFT HAND (S28, SJ0, SY8, SY9)
	P29666-08-R29	EA	COVER/ARMREST - LEFT HAND (S29, SJ1)
	P29666-08-S30	EA	COVER/ARMREST - LEFT HAND (S30, SJ2)
	P48652-02-SX2	EA	COVER/ARMREST - LEFT HAND (SX2, SX3)
	P29666-08-P07	EA	COVER/ARMREST - LEFT HAND (SX4, SX5)
			FROM: 00-00-00 THRU: 11-16-04
	P48652-02-S4X	EA	COVER/ARMREST - LEFT HAND (SX4, SX5)
			FROM: 11-17-04 THRU: 99-99-99
	P29666-08-R35	EA	COVER/ARMREST - LEFT HAND (SX6, SX7)
			FROM: 00-00-00 THRU: 11-30-04
	P29666-08-S6X	EA	COVER/ARMREST - LEFT HAND (SX6, SX7)
			FROM: 12-01-04 THRU: 99-99-99
	P29666-08-P10	EA	COVER/ARMREST - LEFT HAND (SY4, SY5)
			FROM: 00-00-00 THRU: 11-11-04
	P29666-08-SY5	EA	COVER/ARMREST - LEFT HAND (SY4, SY5)
			FROM: 11-12-04 THRU: 99-99-99
	P48652-02-SY6	EA	COVER/ARMREST - LEFT HAND (SY6, SY7)
			FROM: 00-00-00 THRU: 12-08-04

CURTAIN & CUSHION GROUP (CONTINUED)
BUCKET SEATS (CONTINUED)

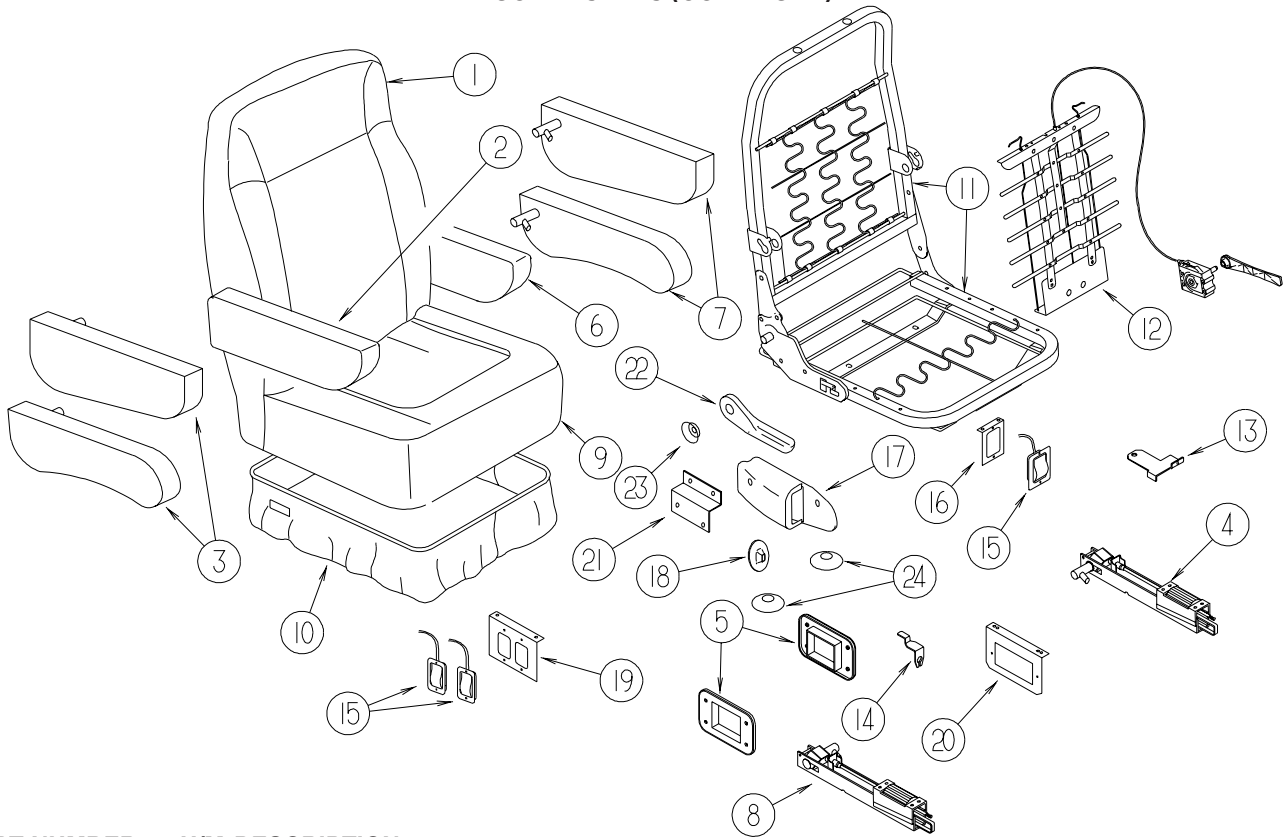

KEY	PART NUMBER	U/M	DESCRIPTION
	P48652-02-SY7	EA	COVER/ARMREST - LEFT HAND (SY6, SY7) FROM: 12-09-04 THRU: 99-99-99
	P48652-02-SY8	EA	COVER/ARMREST - LEFT HAND (SY8, SY9)
7	130698-02-000	EA	ARMREST/MOLDED - LEFT HAND - W/O COVER
8			NOT USED
9	M05962-B6-P47	EA	COVER/SEAT (S28, SJ0)
9	M05962-B6-R29	EA	COVER/SEAT (S29, SJ1)
9	M05962-B6-S30	EA	COVER/SEAT (S30, SJ2)
9	M05962-B6-SX2	EA	COVER/SEAT (SX2, SX3)
9	M05962-B6-SX4	EA	COVER/SEAT (SX4, SX5) FROM: 00-00-00 THRU: 11-16-04
9	M05962-B6-S4X	EA	COVER/SEAT (SX4, SX5) FROM: 11-17-04 THRU: 99-99-99
9	M05962-B6-SX6	EA	COVER/SEAT (SX6, SX7) FROM: 00-00-00 THRU: 11-30-04
9	M05962-B6-S6X	EA	COVER/SEAT (SX6, SX7) FROM: 12-01-04 THRU: 99-99-99
9	M05962-B6-SY4	EA	COVER/SEAT (SY4, SY5) FROM: 00-00-00 THRU: 11-11-04
9	M05962-B6-SY5	EA	COVER/SEAT (SY4, SY5) FROM: 11-12-04 THRU: 99-99-99
9	M05962-B6-SY6	EA	COVER/SEAT (SY6, SY7) FROM: 00-00-00 THRU: 12-08-04
9	M05962-B6-SY7	EA	COVER/SEAT (SY6, SY7) FROM: 12-09-04 THRU: 99-99-99
9	M05962-B6-SY8	EA	COVER/SEAT (SY8, SY9)
10	148630-01-R40	EA	SKIRT - W/SEAT BELT SLOT (S28, SJ0, SY8, SY9)
10	148630-01-R29	EA	SKIRT - W/SEAT BELT SLOT (S29, SJ1)
10	148630-01-S30	EA	SKIRT - W/SEAT BELT SLOT (S30, SJ2)
10	148630-01-SX2	EA	SKIRT - W/SEAT BELT SLOT (SX2, SX3)
10	148630-01-R33	EA	SKIRT - W/SEAT BELT SLOT (SX4, SX5) FROM: 00-00-00 THRU: 11-16-04
10	148630-01-S4X	EA	SKIRT - W/SEAT BELT SLOT (SX4, SX5) FROM: 11-17-04 THRU: 99-99-99
10	148630-01-R35	EA	SKIRT - W/SEAT BELT SLOT (SX6, SX7)
10	148630-01-R36	EA	SKIRT - W/SEAT BELT SLOT (SY4, SY5)

CURTAIN & CUSHION GROUP (CONTINUED)
BUCKET SEATS (CONTINUED)

KEY	PART NUMBER	U/M	DESCRIPTION
10	148630-01-R30	EA	SKIRT - W/SEAT BELT SLOT (SY6, SY7) FROM: 00-00-00 THRU: 12-08-04
10	148630-01-SY7	EA	SKIRT - W/SEAT BELT SLOT (SY6, SY7) FROM: 12-09-04 THRU: 99-99-99
11	134532-01-000	EA	FRAME - SEAT/HIGH BACK
12	NOT USED		
13	117125-01-02B	EA	BRACKET - CABLE MOUNT - ADJUSTER W/LOCK
14	108049-02-000	EA	CLIP - CABLE/PEDESTAL
15	108049-04-000	EA	CABLE - W/MINI LEVER ACTION SWITCH - 28" SHEATH/30" CABLE
16	NOT USED		
17	NOT USED		
18	NOT USED		
19	127159-02-02B	EA	BRACKET - SEAT RELEASE - DUAL REMOTE - E-COATED
20	NOT USED		
21	NOT USED		
22	130802-02-000	EA	LEVER - RIGHT HAND
23	130802-03-000	EA	SCREW F/LEVER
	148668-01-01A	EA	CUP/TRIM COVER - F/LEVER - BLACK
24	NOT USED		

CURTAIN & CUSHION GROUP (CONTINUED)
LOUNGE CHAIR

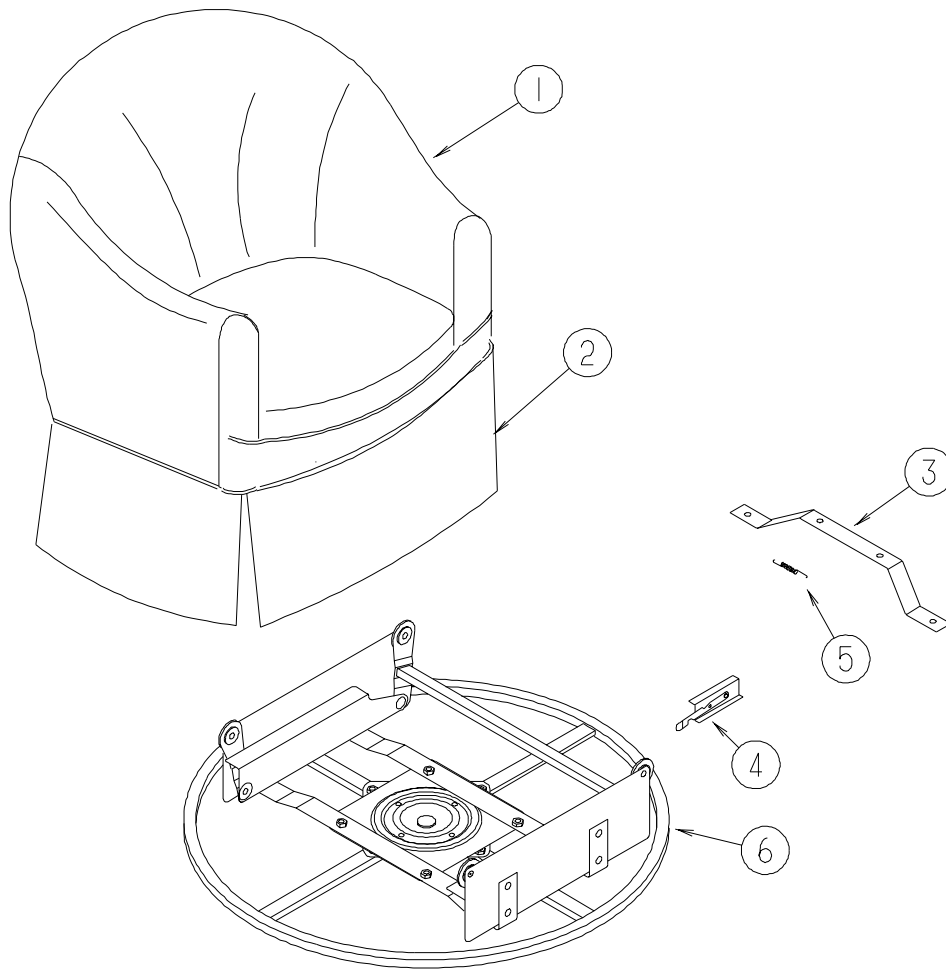

KEY	PART NUMBER	U/M	DESCRIPTION
1	P38523-01-R28	EA	COVER/CHAIR - W/SPRUNG SEAT (S28, SJ0, SY8, SY9)
1	P38523-01-R29	EA	COVER/CHAIR - W/SPRUNG SEAT (S29, SJ1)
1	P38523-01-S30	EA	COVER/CHAIR - W/SPRUNG SEAT (S30, SJ2)
1	P38523-01-SX2	EA	COVER/CHAIR - W/SPRUNG SEAT (SX2, SX3)
1	P38523-01-P38	EA	COVER/CHAIR - W/SPRUNG SEAT (SX4, SX5)
1	P38523-01-R12	EA	COVER/CHAIR - W/SPRUNG SEAT (SX6, SX7)
1	P38523-01-P10	EA	COVER/CHAIR - W/SPRUNG SEAT (SY4, SY5)
1	P38523-01-P34	EA	COVER/CHAIR - W/SPRUNG SEAT (SY6, SY7)
2	139083-01-R28	EA	SKIRT - F/GLIDER CHAIR (S28, SJ0, SY8, SY9)
2	139083-01-R29	EA	SKIRT - F/GLIDER CHAIR (S29, SJ1)
2	139083-01-S30	EA	SKIRT - F/GLIDER CHAIR (S30, SJ2)
2	139083-01-SX2	EA	SKIRT - F/GLIDER CHAIR (SX2, SX3)
2	139083-01-P38	EA	SKIRT - F/GLIDER CHAIR (SX4, SX5)
2	139083-01-SX6	EA	SKIRT - F/GLIDER CHAIR (SX6, SX7)
2	139083-01-SY4	EA	SKIRT - F/GLIDER CHAIR (SY4, SY5)
2	139083-01-SY5	EA	SKIRT - F/GLIDER CHAIR (SY4, SY5)
			FROM: 00-00-00 THRU: 11-11-04
			FROM: 11-12-04 THRU: 99-99-99
2	139083-01-P34	EA	SKIRT - F/GLIDER CHAIR (SY6, SY7)
3	139208-01-000	EA	SUPPORT BAR - TALL - W/HOOP
4	139342-01-000	EA	BRACKET - ROCKERLOCK
5	139342-02-000	EA	SPRING-#9GL-SPRING,LOCK OUT - SHROCK
6	133126-15-000	EA	BASE - SWIVEL/GLIDER - W/FLOOR RING

CURTAIN & CUSHION GROUP (CONTINUED)

SOFA

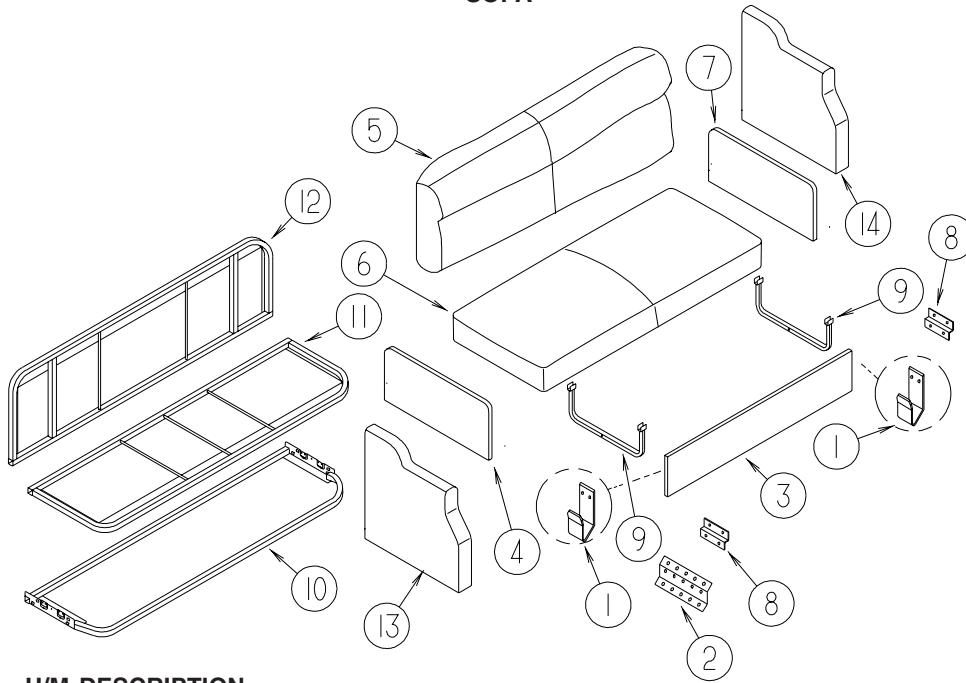

KEY	PART NUMBER	U/M	DESCRIPTION
1	121906-01-02B	EA	BRACKET - KICKBOARD - E-COATED
2	116104-04-02B	EA	BRACKET - ZEE W/HOLES - 3.2" - E-COATED - MOUNTS ARM TO FLOOR
3	120992-09-R28	EA	PANEL/FRONT KICK W/SKIRT - SOFA/BED - 67.5"/FABRIC COVERED (S28, SJ0)
3	120992-09-R29	EA	PANEL/FRONT KICK W/SKIRT - SOFA/BED - 67.5"/FABRIC COVERED (S29, SJ1)
3	120992-09-S30	EA	PANEL/FRONT KICK W/SKIRT - SOFA/BED - 67.5"/FABRIC COVERED (S30, SJ2)
3	120992-09-SX2	EA	PANEL/FRONT KICK W/SKIRT - SOFA/BED - 67.5"/FABRIC COVERED (SX2, SX3) FROM: 00-00-00 THRU: 11-30-04
3	120992-09-SX3	EA	PANEL/FRONT KICK W/SKIRT - SOFA/BED - 67.5"/FABRIC COVERED (SX2, SX3) FROM: 12-01-04 THRU: 99-99-99
3	120992-09-P38	EA	PANEL/FRONT KICK W/SKIRT - SOFA/BED - 67.5"/FABRIC COVERED (SX4, SX5)
3	120992-09-P37	EA	PANEL/FRONT KICK W/SKIRT - SOFA/BED - 67.5"/FABRIC COVERED (SX6, SX7)
3	120992-09-P42	EA	PANEL/FRONT KICK W/SKIRT - SOFA/BED - 67.5"/FABRIC COVERED (SY4, SY5) FROM: 00-00-00 THRU: 11-30-04
3	120992-09-SY5	EA	PANEL/FRONT KICK W/SKIRT - SOFA/BED - 67.5"/FABRIC COVERED (SY4, SY5) FROM: 12-01-04 THRU: 99-99-99
3	120992-09-P34	EA	PANEL/FRONT KICK W/SKIRT - SOFA/BED - 67.5"/FABRIC COVERED (SY6, SY7)
3	120992-09-SY8	EA	PANEL/FRONT KICK W/SKIRT - SOFA/BED - 67.5"/FABRIC COVERED (SY8, SY9)
4			NOT USED
5	135138-04-R28	EA	BACK - SOFA/BED - 67.5" (S28, SJ0)
5	135138-04-R29	EA	BACK - SOFA/BED - 67.5" (S29, SJ1)
5	135138-04-S30	EA	BACK - SOFA/BED - 67.5" (S30, SJ2)
5	135138-04-SX2	EA	BACK - SOFA/BED - 67.5" (SX2, SX3) FROM: 00-00-00 THRU: 11-30-04
5	135138-04-SX3	EA	BACK - SOFA/BED - 67.5" (SX2, SX3) FROM: 12-01-04 THRU: 99-99-99
5	135138-04-R33	EA	BACK - SOFA/BED - 67.5" (SX4, SX5)
5	135138-04-P37	EA	BACK - SOFA/BED - 67.5" (SX6, SX7)
5	135138-04-P42	EA	BACK - SOFA/BED - 67.5" (SY4, SY5) FROM: 00-00-00 THRU: 11-30-04
5	135138-04-SY5	EA	BACK - SOFA/BED - 67.5" (SY4, SY5) FROM: 12-01-04 THRU: 99-99-99
5	135138-04-P34	EA	BACK - SOFA/BED - 67.5" (SY6, SY7)
5	135138-04-SY8	EA	BACK - SOFA/BED - 67.5" (SY8, SY9)
	P35138-04-R28	EA	COVER/BACK - SOFA/BED - 67.5" (S28, SJ0)
	P35138-04-R29	EA	COVER/BACK - SOFA/BED - 67.5" (S29, SJ1)
	P35138-04-S30	EA	COVER/BACK - SOFA/BED - 67.5" (S30, SJ2)
	P35138-04-SX2	EA	COVER/BACK - SOFA/BED - 67.5" (SX2, SX3) FROM: 00-00-00 THRU: 11-30-04
	P35138-04-SX3	EA	COVER/BACK - SOFA/BED - 67.5" (SX2, SX3) FROM: 12-01-04 THRU: 99-99-99
	P35138-04-P38	EA	COVER/BACK - SOFA/BED - 67.5" (SX4, SX5)
	P35138-04-P37	EA	COVER/BACK - SOFA/BED - 67.5" (SX6, SX7)

CURTAIN & CUSHION GROUP (CONTINUED)
SOFA (CONTINUED)

KEY	PART NUMBER	U/M	DESCRIPTION
	P35138-04-P42	EA	BACK - SOFA/BED - 67.5" (SY4, SY5) FROM: 00-00-00 THRU: 11-30-04
	P35138-04-SY5	EA	BACK - SOFA/BED - 67.5" (SY4, SY5) FROM: 12-01-04 THRU: 99-99-99
	P35138-04-P34	EA	COVER/BACK - SOFA/BED - 67.5" (SY6, SY7)
	P35138-04-SY8	EA	COVER/BACK - SOFA/BED - 67.5" (SY8, SY9)
6	135138-19-S28	EA	SEAT - SOFA/BED - 67.5" (S28, SJ0)
6	135138-19-S29	EA	SEAT - SOFA/BED - 67.5" (S29, SJ1)
6	135138-19-S30	EA	SEAT - SOFA/BED - 67.5" (S30, SJ2)
6	135138-19-SX2	EA	SEAT - SOFA/BED - 67.5" (SX2, SX3) FROM: 00-00-00 THRU: 11-30-04
6	135138-19-SX3	EA	SEAT - SOFA/BED - 67.5" (SX2, SX3) FROM: 12-01-04 THRU: 99-99-99
6	135138-19-SX4	EA	SEAT - SOFA/BED - 67.5" (SX4, SX5)
6	135138-19-SX6	EA	SEAT - SOFA/BED - 67.5" (SX6, SX7)
6	135138-19-SY4	EA	SEAT - SOFA/BED - 67.5" (SY4, SY5)
6	135138-19-SY6	EA	SEAT - SOFA/BED - 67.5" (SY6, SY7)
6	135138-19-SY8	EA	SEAT - SOFA/BED - 67.5" (SY8, SY9)
	P35138-19-S28	EA	COVER/SEAT - SOFA/BED (S28, SJ0)
	P35138-19-S29	EA	COVER/SEAT - SOFA/BED (S29, SJ1)
	P35138-19-S30	EA	COVER/SEAT - SOFA/BED (S30, SJ2)
	P35138-19-SX2	EA	COVER/SEAT - SOFA/BED (SX2, SX3) FROM: 00-00-00 THRU: 11-30-04
	P35138-19-SX3	EA	COVER/SEAT - SOFA/BED (SX2, SX3) FROM: 12-01-04 THRU: 99-99-99
	P35138-19-SX4	EA	COVER/SEAT - SOFA/BED (SX4, SX5)
	P35138-19-SX6	EA	COVER/SEAT - SOFA/BED (SX6, SX7)
	P35138-19-SY4	EA	COVER/SEAT - SOFA/BED (SY4, SY5)
	P35138-19-SY6	EA	COVER/SEAT - SOFA/BED (SY6, SY7)
	P35138-19-SY8	EA	COVER/SEAT - SOFA/BED (SY8, SY9)
7	134282-09-R28	EA	PANEL - LEFT END/FILLER - SOFA/BED - FABRIC COVERED (S28, SJ0)
7	134282-09-R29	EA	PANEL - LEFT END/FILLER - SOFA/BED - FABRIC COVERED (S29, SJ1)
7	134282-09-S30	EA	PANEL - LEFT END/FILLER - SOFA/BED - FABRIC COVERED (S30, SJ2)
7	134282-09-SX2	EA	PANEL - LEFT END/FILLER - SOFA/BED - FABRIC COVERED (SX2, SX3) FROM: 00-00-00 THRU: 11-30-04
7	134282-09-SX3	EA	PANEL - LEFT END/FILLER - SOFA/BED - FABRIC COVERED (SX2, SX3) FROM: 12-01-04 THRU: 99-99-99
7	134282-09-SX4	EA	PANEL - LEFT END/FILLER - SOFA/BED - FABRIC COVERED (SX4, SX5)
7	134282-09-SX6	EA	PANEL - LEFT END/FILLER - SOFA/BED - FABRIC COVERED (SX6, SX7)
7	134282-09-SY4	EA	PANEL - LEFT END/FILLER - SOFA/BED - FABRIC COVERED (SY4, SY5) FROM: 00-00-00 THRU: 11-30-04
7	134282-09-SY5	EA	PANEL - LEFT END/FILLER - SOFA/BED - FABRIC COVERED (SY4, SY5) FROM: 12-01-04 THRU: 99-99-99
7	134282-09-P34	EA	PANEL - LEFT END/FILLER - SOFA/BED - FABRIC COVERED (SY6, SY7)
7	134282-09-SY8	EA	PANEL - LEFT END/FILLER - SOFA/BED - FABRIC COVERED (SY8, SY9)
8	NOT USED		
9	127335-07-000	EA	LEG - SOFA/BED - 8"
10	127335-04-000	EA	FRAME/BASE - (SEAT) - 67.5" FROM: 00-00-00 THRU: 03-24-05
10	151290-20-000	EA	FRAME - BASE - 27.25" X 67.5" FROM: 03-25-05 THRU: 99-99-99
	136534-15-001	EA	MOTOR - DRIVE - REST EASY SOFA
11	151290-05-000	EA	FRAME - SEAT - 67.5"
12	127335-05-000	EA	FRAME/BASE - (BACK) - 67.5"
13	NOT USED		
14	NOT USED		

CURTAIN & CUSHION GROUP (CONTINUED)
WINDOW TREATMENT

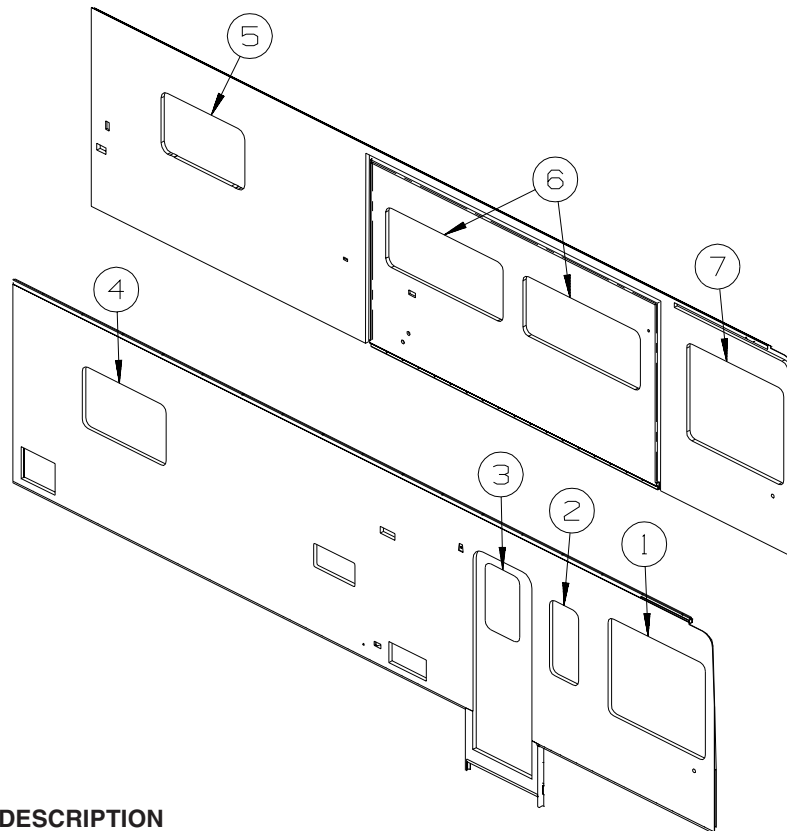

KEY	PART NUMBER	U/M	DESCRIPTION
1	101668-71-R28	EA	CURTAIN - RIGHT HAND - TAPE TOP - 40.5" X 110" (S28, SJ0)
1	101668-71-RA7	EA	CURTAIN - RIGHT HAND - TAPE TOP - 40.5" X 110" (S29, SJ1, SX6, SX7)
1	101668-71-R98	EA	CURTAIN - RIGHT HAND - TAPE TOP - 40.5" X 110" (S30, SJ2)
1	101668-71-SX2	EA	CURTAIN - RIGHT HAND - TAPE TOP - 40.5" X 110" (SX2, SX3, SY6, SY7)
1	101668-71-SY0	EA	CURTAIN - RIGHT HAND - TAPE TOP - 40.5" X 110" (SX4, SX5)
1	101668-71-SY4	EA	CURTAIN - RIGHT HAND - TAPE TOP - 40.5" X 110" (SY4, SY5)
			FROM: 00-00-00 THRU: 11-17-04
1	101668-71-S4Y	EA	CURTAIN - RIGHT HAND - TAPE TOP - 40.5" X 110" (SY4, SY5)
			FROM: 11-18-04 THRU: 12-08-04
1	101668-71-SY5	EA	CURTAIN - RIGHT HAND - TAPE TOP - 40.5" X 110" (SY4, SY5)
			FROM: 12-09-04 THRU: 99-99-99
1	101668-71-SY8	EA	CURTAIN - RIGHT HAND - TAPE TOP - 40.5" X 110" (SY8, SY9)
1	073260-42-R28	EA	TIEBACK - 6" X 18" (S28, SJ0)
1	073260-42-RA7	EA	TIEBACK - 6" X 18" (S29, SJ1, SX6, SX7)
1	073260-42-R98	EA	TIEBACK - 6" X 18" (S30, SJ2)
1	073260-42-SX2	EA	TIEBACK - 6" X 18" (SX2, SX3, SY6, SY7)
1	073260-42-SY0	EA	TIEBACK - 6" X 18" (SX4, SX5)
1	073260-42-SY4	EA	TIEBACK - 6" X 18" (SY4, SY5)
			FROM: 00-00-00 THRU: 11-17-04
1	073260-42-S4Y	EA	TIEBACK - 6" X 18" (SY4, SY5)
			FROM: 11-18-04 THRU: 12-08-04
1	073260-42-SY5	EA	TIEBACK - 6" X 18" (SY4, SY5)
			FROM: 12-09-04 THRU: 99-99-99
1	073260-42-SY8	EA	TIEBACK - 6" X 18" (SY8, SY9)
2	149201-03-S28	EA	VALANCE - TONYA - 18.5" (S28, SJ0)
2	149201-03-S29	EA	VALANCE - TONYA - 18.5" (S29, SJ1)
2	149201-03-S30	EA	VALANCE - TONYA - 18.5" (S30, SJ2)
2	149201-14-SX2	EA	VALANCE - TONYA - 18.5" (SX2, SX3)
			FROM: 00-00-00 THRU: 11-30-04
2	149201-14-SX3	EA	VALANCE - TONYA - 18.5" (SX2, SX3)
			FROM: 12-01-04 THRU: 99-99-99
2	149201-14-SX4	EA	VALANCE - TONYA - 18.5" (SX4, SX5)
			FROM: 00-00-00 THRU: 11-16-04
2	149201-14-S4X	EA	VALANCE - TONYA - 18.5" (SX4, SX5)
			FROM: 11-17-04 THRU: 99-99-99
2	149201-14-SX6	EA	VALANCE - TONYA - 18.5" (SX6, SX7)
			FROM: 00-00-00 THRU: 11-10-04

CURTAIN & CUSHION GROUP (CONTINUED)
WINDOW TREATMENT (CONTINUED)

KEY	PART NUMBER	U/M	DESCRIPTION
2	149201-14-S6X	EA	VALANCE - TONYA - 18.5" (SX6, SX7) FROM: 11-11-04 THRU: 99-99-99
2	149201-14-SY4	EA	VALANCE - TONYA - 18.5" (SY4, SY5) FROM: 00-00-00 THRU: 11-11-04
2	149201-14-SY5	EA	VALANCE - TONYA - 18.5" (SY4, SY5) FROM: 11-12-04 THRU: 99-99-99
2	149201-14-SY6	EA	VALANCE - TONYA - 18.5" (SY6, SY7) FROM: 00-00-00 THRU: 12-08-04
2	149201-14-SY7	EA	VALANCE - TONYA - 18.5" (SY6, SY7) FROM: 12-09-04 THRU: 99-99-99
2	149201-14-SY8	EA	VALANCE - TONYA - 18.5" (SY8, SY9)
2	109041-62-01A	EA	BLIND - MINI - 17" X 32"
2	140789-31-P31	EA	BLIND - DAY/NIGHTER - 17" X 32" - WINDOW COVERING EXCHANGE
3	121410-E4-S28	EA	VALANCE - MODERATE - 32" (S28, SJ0)
3	121410-E4-S29	EA	VALANCE - MODERATE - 32" (S29, SJ1)
3	121410-E4-S30	EA	VALANCE - MODERATE - 32" (S30, SJ2)
3	153643-04-SX2	EA	VALANCE - MODERATE - 32" (SX2, SX3)
3	153643-04-SX4	EA	VALANCE - MODERATE - 32" (SX4, SX5) FROM: 00-00-00 THRU: 11-16-04
3	153643-04-S4X	EA	VALANCE - MODERATE - 32" (SX4, SX5) FROM: 11-17-04 THRU: 99-99-99
3	153643-04-SX6	EA	VALANCE - MODERATE - 32" (SX6, SX7) FROM: 00-00-00 THRU: 11-10-04
3	153643-04-S6X	EA	VALANCE - MODERATE - 32" (SX6, SX7) FROM: 11-11-04 THRU: 99-99-99
3	153643-04-SY4	EA	VALANCE - MODERATE - 32" (SY4, SY5) FROM: 00-00-00 THRU: 11-11-04
3	153643-04-SY5	EA	VALANCE - MODERATE - 32" (SY4, SY5) FROM: 11-12-04 THRU: 99-99-99
3	153643-04-SY6	EA	VALANCE - MODERATE - 32" (SY6, SY7) FROM: 00-00-00 THRU: 12-08-04
3	153643-04-SY7	EA	VALANCE - MODERATE - 32" (SY6, SY7) FROM: 12-09-04 THRU: 99-99-99
3	153643-04-SY8	EA	VALANCE - MODERATE - 32" (SY8, SY9)
3	084755-57-P37	EA	SHADE - PULL - 27.25"
4	149201-04-S28	EA	VALANCE - TONYA - 46" (S28, SJ0)
4	149201-04-S29	EA	VALANCE - TONYA - 46" (S29, SJ1)
4	149201-04-S30	EA	VALANCE - TONYA - 46" (S30, SJ2)
4	149201-12-SX2	EA	VALANCE - TONYA - 46" (SX2, SX3)
4	149201-12-SX4	EA	VALANCE - TONYA - 46" (SX4, SX5) FROM: 00-00-00 THRU: 11-14-04
4	149201-12-S4X	EA	VALANCE - TONYA - 46" (SX4, SX5) FROM: 11-15-04 THRU: 99-99-99
4	149201-12-SX6	EA	VALANCE - TONYA - 46" (SX6, SX7)
4	149201-12-SY4	EA	VALANCE - TONYA - 46" (SY4, SY5) FROM: 00-00-00 THRU: 11-17-04
4	149201-12-S4Y	EA	VALANCE - TONYA - 46" (SY4, SY5) FROM: 11-18-04 THRU: 12-08-04
4	149201-12-SY5	EA	VALANCE - TONYA - 46" (SY4, SY5) FROM: 12-09-04 THRU: 99-99-99
4	149201-12-SY6	EA	VALANCE - TONYA - 46" (SY6, SY7)
4	149201-12-SY8	EA	VALANCE - TONYA - 46" (SY8, SY9)
4	136988-15-R28	EA	LEG - RIGHT - 26" (S28, SJ0)
4	136988-15-R29	EA	LEG - RIGHT - 26" (S29, SJ1, SX6, SX7)
4	136988-15-P08	EA	LEG - RIGHT - 26" (S30, SJ2)
4	136988-15-SX2	EA	LEG - RIGHT - 26" (SX2, SX3, SY6, SY7)
4	136988-15-SY0	EA	LEG - RIGHT - 26" (SX4, SX5)
4	136988-15-N47	EA	LEG - RIGHT - 26" (SY4, SY5)
4	136988-15-SY8	EA	LEG - RIGHT - 26" (SY8, SY9)
4	136988-16-R28	EA	LEG - LEFT - 26" (S28, SJ0)
4	136988-16-R29	EA	LEG - LEFT - 26" (S29, SJ1, SX6, SX7)
4	136988-16-P08	EA	LEG - LEFT - 26" (S30, SJ2)
4	136988-16-SX2	EA	LEG - LEFT - 26" (SX2, SX3, SY6, SY7)
4	136988-16-SY0	EA	LEG - LEFT - 26" (SX4, SX5)

CURTAIN & CUSHION GROUP (CONTINUED)
WINDOW TREATMENT (CONTINUED)

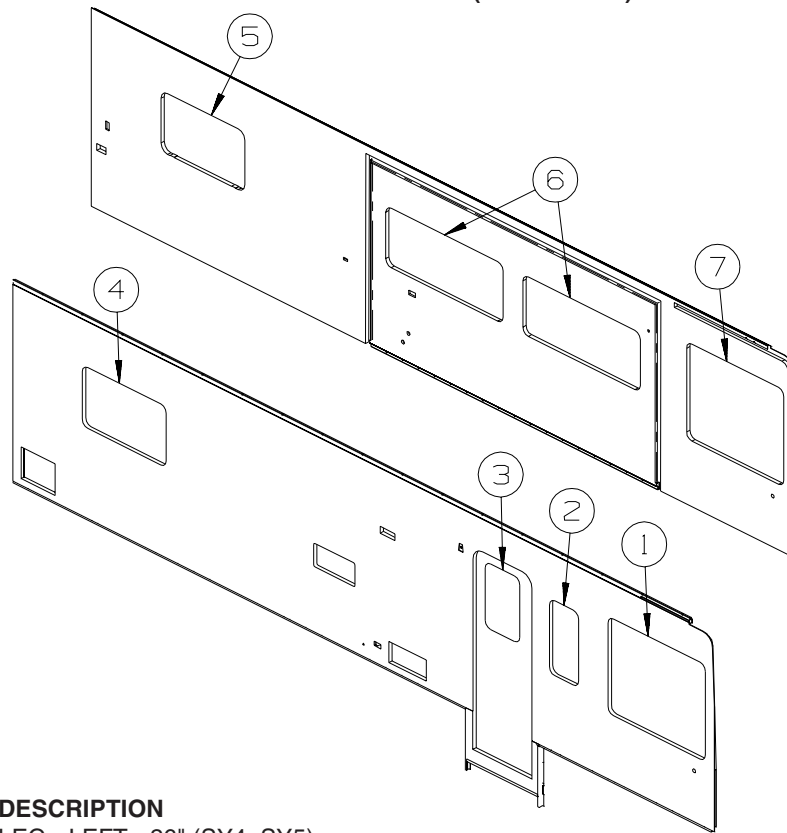

KEY	PART NUMBER	U/M	DESCRIPTION
4	136988-16-N47	EA	LEG - LEFT - 26" (SY4, SY5)
4	136988-16-SY8	EA	LEG - LEFT - 26" (SY8, SY9)
4	109802-64-N21	EA	BLIND - PLEATED - 43" X 28"
4	140789-02-N02	EA	BLIND - DAY/NIGHTER - 43" X 28" - WINDOW COVERING EXCHANGE
5	149201-04-S28	EA	VALANCE - TONYA - 46" (S28, SJ0)
5	149201-04-S29	EA	VALANCE - TONYA - 46" (S29, SJ1)
5	149201-04-S30	EA	VALANCE - TONYA - 46" (S30, SJ2)
5	149201-12-SX2	EA	VALANCE - TONYA - 46" (SX2, SX3)
5	149201-12-SX4	EA	VALANCE - TONYA - 46" (SX4, SX5)
5	149201-12-S4X	EA	VALANCE - TONYA - 46" (SX4, SX5)
			FROM: 00-00-00 THRU: 11-14-04
5	149201-12-SX6	EA	VALANCE - TONYA - 46" (SX6, SX7)
5	149201-12-SY4	EA	VALANCE - TONYA - 46" (SY4, SY5)
			FROM: 11-15-04 THRU: 99-99-99
5	149201-12-S4Y	EA	VALANCE - TONYA - 46" (SY4, SY5)
			FROM: 00-00-00 THRU: 11-17-04
5	149201-12-SY5	EA	VALANCE - TONYA - 46" (SY4, SY5)
			FROM: 11-18-04 THRU: 12-08-04
5	149201-12-SY6	EA	VALANCE - TONYA - 46" (SY6, SY7)
			FROM: 12-09-04 THRU: 99-99-99
5	149201-12-SY8	EA	VALANCE - TONYA - 46" (SY8, SY9)
5	136988-17-R28	EA	LEG - RIGHT - 26" (S28, SJ0)
5	136988-17-R29	EA	LEG - RIGHT - 26" (S29, SJ1, SX6, SX7)
5	136988-17-P08	EA	LEG - RIGHT - 26" (S30, SJ2)
5	136988-17-S06	EA	LEG - RIGHT - 26" (SX2, SX3, SY6, SY7)
5	136988-17-S42	EA	LEG - RIGHT - 26" (SX4, SX5)
5	136988-17-N47	EA	LEG - RIGHT - 26" (SY4, SY5)
5	136988-17-SY8	EA	LEG - RIGHT - 26" (SY8, SY9)
5	136988-18-R28	EA	LEG - LEFT - 26" (S28, SJ0)
5	136988-18-R29	EA	LEG - LEFT - 26" (S29, SJ1, SX6, SX7)
5	136988-18-P08	EA	LEG - LEFT - 26" (S30, SJ2)
5	136988-18-S06	EA	LEG - LEFT - 26" (SX2, SX3, SY6, SY7)
5	136988-18-S42	EA	LEG - LEFT - 26" (SX4, SX5)
5	136988-18-N47	EA	LEG - LEFT - 26" (SY4, SY5)
5	136988-18-SY8	EA	LEG - LEFT - 26" (SY8, SY9)
5	109802-64-N21	EA	BLIND - PLEATED - 43" X 28"
5	140789-02-N02	EA	BLIND - DAY/NIGHTER - 43" X 28" - WINDOW COVERING EXCHANGE

CURTAIN & CUSHION GROUP (CONTINUED)
WINDOW TREATMENT (CONTINUED)

KEY	PART NUMBER	U/M	DESCRIPTION	
6	149201-01-S28	EA	VALANCE - TONYA - 62.5" (S28, SJ0)	
6	149201-01-S29	EA	VALANCE - TONYA - 62.5" (S29, SJ1)	
6	149201-01-S30	EA	VALANCE - TONYA - 62.5" (S30, SJ2)	
6	149201-10-SX2	EA	VALANCE - TONYA - 62.5" (SX2, SX3)	FROM: 00-00-00 THRU: 11-30-04
6	149201-10-SX3	EA	VALANCE - TONYA - 62.5" (SX2, SX3)	FROM: 12-01-04 THRU: 99-99-99
6	149201-10-SX4	EA	VALANCE - TONYA - 62.5" (SX4, SX5)	FROM: 00-00-00 THRU: 11-16-04
6	149201-10-S4X	EA	VALANCE - TONYA - 62.5" (SX4, SX5)	FROM: 11-17-04 THRU: 99-99-99
6	149201-10-SX6	EA	VALANCE - TONYA - 62.5" (SX6, SX7)	FROM: 00-00-00 THRU: 11-10-04
6	149201-10-S6X	EA	VALANCE - TONYA - 62.5" (SX6, SX7)	FROM: 11-11-04 THRU: 99-99-99
6	149201-10-SY4	EA	VALANCE - TONYA - 62.5" (SY4, SY5)	FROM: 00-00-00 THRU: 11-11-04
6	149201-10-SY5	EA	VALANCE - TONYA - 62.5" (SY4, SY5)	FROM: 11-12-04 THRU: 99-99-99
6	149201-10-SY6	EA	VALANCE - TONYA - 62.5" (SY6, SY7)	FROM: 00-00-00 THRU: 12-08-04
6	149201-10-SY7	EA	VALANCE - TONYA - 62.5" (SY6, SY7)	FROM: 12-09-04 THRU: 99-99-99
4	149201-10-SY8	EA	VALANCE - TONYA - 62.5" (SY8, SY9)	
6	127017-13-R28	EA	LEG - RIGHT - 25" (S28, SJ0, SY8, SY9)	
6	127017-13-R29	EA	LEG - RIGHT - 25" (S29, SJ1)	
6	127017-13-S30	EA	LEG - RIGHT - 25" (S30, SJ2)	
6	127017-13-SX2	EA	LEG - RIGHT - 25" (SX2, SX3)	
6	127017-13-P07	EA	LEG - RIGHT - 25" (SX4, SX5)	FROM: 00-00-00 THRU: 11-16-04
6	127017-13-S4X	EA	LEG - RIGHT - 25" (SX4, SX5)	FROM: 11-17-04 THRU: 99-99-99
6	127017-13-R12	EA	LEG - RIGHT - 25" (SX6, SX7)	FROM: 00-00-00 THRU: 11-10-04
6	127017-13-S6X	EA	LEG - RIGHT - 25" (SX6, SX7)	FROM: 11-11-04 THRU: 99-99-99
6	127017-13-P10	EA	LEG - RIGHT - 25" (SY4, SY5)	FROM: 00-00-00 THRU: 11-11-04
6	127017-13-SY5	EA	LEG - RIGHT - 25" (SY4, SY5)	FROM: 11-12-04 THRU: 99-99-99
6	127017-13-R30	EA	LEG - RIGHT - 25" (SY6, SY7)	FROM: 00-00-00 THRU: 12-08-04
6	127017-13-SY7	EA	LEG - RIGHT - 25" (SY6, SY7)	FROM: 12-09-04 THRU: 99-99-99
6	127017-14-R28	EA	LEG - LEFT - 25" (S28, SJ0, SY8, SY9)	
6	127017-14-R29	EA	LEG - LEFT - 25" (S29, SJ1)	
6	127017-14-S30	EA	LEG - LEFT - 25" (S30, SJ2)	
6	127017-14-SX2	EA	LEG - LEFT - 25" (SX2, SX3)	
6	127017-14-P07	EA	LEG - LEFT - 25" (SX4, SX5)	FROM: 00-00-00 THRU: 11-16-04
6	127017-14-S4X	EA	LEG - LEFT - 25" (SX4, SX5)	FROM: 11-17-04 THRU: 99-99-99
6	127017-14-R12	EA	LEG - LEFT - 25" (SX6, SX7)	FROM: 00-00-00 THRU: 11-10-04
6	127017-14-S6X	EA	LEG - LEFT - 25" (SX6, SX7)	FROM: 11-11-04 THRU: 99-99-99
6	127017-14-P10	EA	LEG - LEFT - 25" (SY4, SY5)	FROM: 00-00-00 THRU: 11-11-04
6	127017-14-SY5	EA	LEG - LEFT - 25" (SY4, SY5)	FROM: 11-12-04 THRU: 99-99-99
6	127017-14-R30	EA	LEG - LEFT - 25" (SY6, SY7)	FROM: 00-00-00 THRU: 12-08-04
6	127017-14-SY7	EA	LEG - LEFT - 25" (SY6, SY7)	FROM: 12-09-04 THRU: 99-99-99

CURTAIN & CUSHION GROUP (CONTINUED)
WINDOW TREATMENT (CONTINUED)

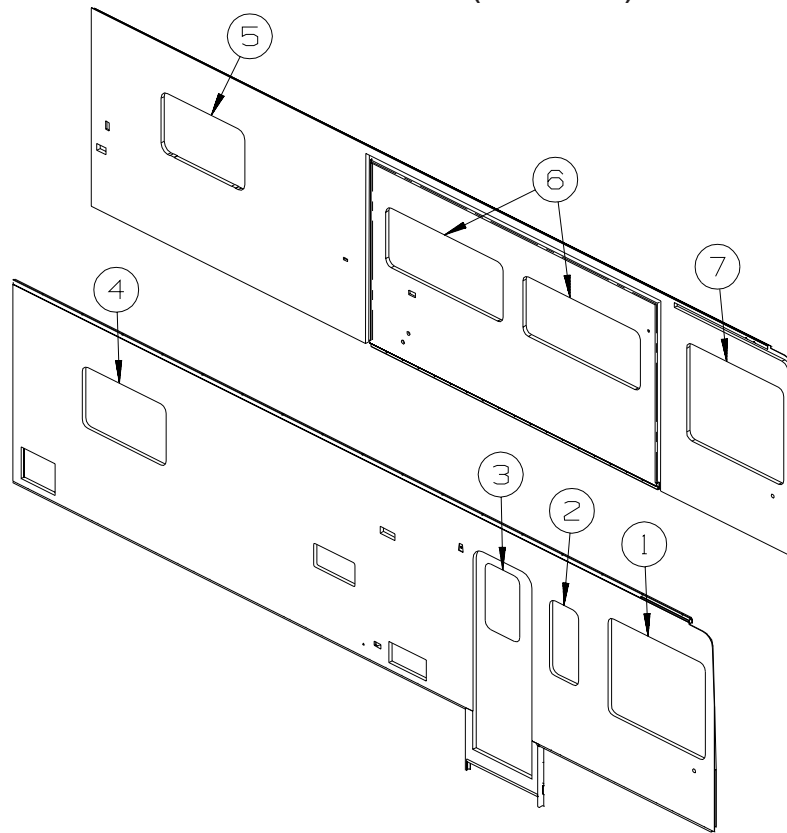

KEY	PART NUMBER	U/M	DESCRIPTION
6	109041-66-01A	EA	BLIND - MINI - 59"
6	140789-08-N02	EA	BLIND - DAY/NIGHTER - 59" X 26.5" - WINDOW COVERING EXCHANGE
7	101668-72-R28	EA	CURTAIN - LEFT HAND - TAPE TOP - 40.5" X 110" (S28, SJ0)
7	101668-72-RA7	EA	CURTAIN - LEFT HAND - TAPE TOP - 40.5" X 110" (S29, SJ1, SX6, SX7)
7	101668-72-R98	EA	CURTAIN - LEFT HAND - TAPE TOP - 40.5" X 110" (S30, SJ2)
7	101668-72-SX2	EA	CURTAIN - LEFT HAND - TAPE TOP - 40.5" X 110" (SX2, SX3, SY6, SY7)
7	101668-72-SY0	EA	CURTAIN - LEFT HAND - TAPE TOP - 40.5" X 110" (SX4, SX5)
7	101668-72-SY4	EA	CURTAIN - LEFT HAND - TAPE TOP - 40.5" X 110" (SY4, SY5) FROM: 00-00-00 THRU: 11-17-04
7	101668-72-S4Y	EA	CURTAIN - LEFT HAND - TAPE TOP - 40.5" X 110" (SY4, SY5) FROM: 11-18-04 THRU: 12-08-04
7	101668-72-SY5	EA	CURTAIN - LEFT HAND - TAPE TOP - 40.5" X 110" (SY4, SY5) FROM: 12-09-04 THRU: 99-99-99
7	101668-72-SY8	EA	CURTAIN - LEFT HAND - TAPE TOP - 40.5" X 110" (SY8, SY9)
7	073260-42-R28	EA	TIEBACK - 6" X 18" (S28, SJ0)
7	073260-42-RA7	EA	TIEBACK - 6" X 18" (S29, SJ1, SX6, SX7)
7	073260-42-R98	EA	TIEBACK - 6" X 18" (S30, SJ2)
7	073260-42-SX2	EA	TIEBACK - 6" X 18" (SX2, SX3, SY6, SY7)
7	073260-42-SY0	EA	TIEBACK - 6" X 18" (SX4, SX5)
7	073260-42-SY4	EA	TIEBACK - 6" X 18" (SY4, SY5) FROM: 00-00-00 THRU: 11-17-04
7	073260-42-S4Y	EA	TIEBACK - 6" X 18" (SY4, SY5) FROM: 11-18-04 THRU: 12-08-04
7	073260-42-SY5	EA	TIEBACK - 6" X 18" (SY4, SY5) FROM: 12-09-04 THRU: 99-99-99
7	073260-42-SY8	EA	TIEBACK - 6" X 18" (SY8, SY9)

CURTAIN & CUSHION GROUP (CONTINUED)

HARDWARE

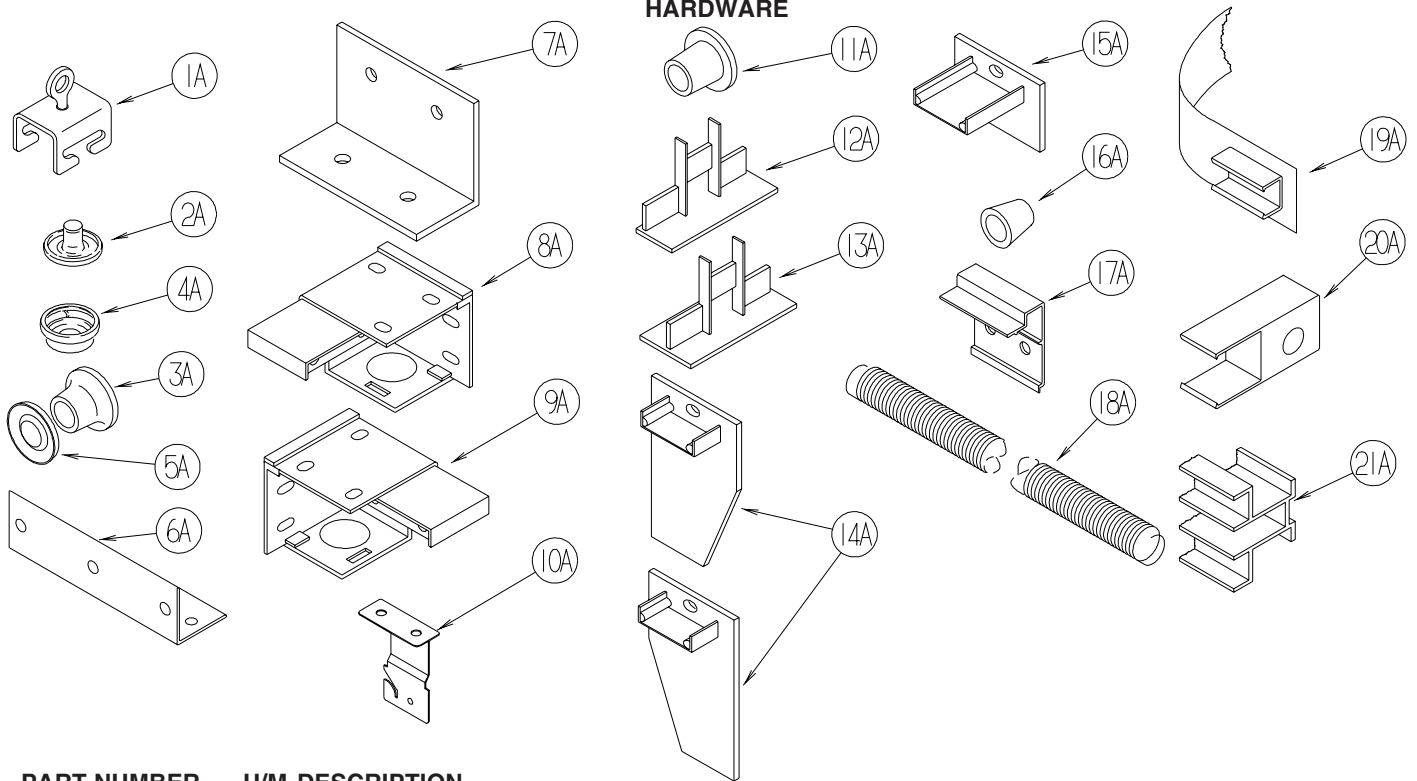

KEY	PART NUMBER	U/M	DESCRIPTION
1A	009702-01-000	EA	END STOP - CURTAIN CARRIER - L ROD
2A	029155-01-000	EA	CAP - SNAP - 5/32" OUTSIDE DIAMETER OF PIN
3A	029156-01-000	EA	SOCKET - SNAP - 9/16" O.D.
4A	046867-02-000	EA	WASHER - HANDY BUTTON #3
5A	046867-03-000	EA	GROMMET - HANDY BUTTON #3
6A	075943-10-000	EA	BRACE - VALANCE - 20" - OFF WHITE
7A	083125-08-000	EA	BRACE - WINDOW MOUNT - .75" - OFF WHITE
8A	083170-01-000	EA	BRACKET/BLIND - LEFT SIDE WHEN FACING WINDOW - CLEAR
9A	083170-02-000	EA	BRACKET/BLIND - RIGHT SIDE WHEN FACING WINDOW - CLEAR
10A	084434-01-000	EA	BRACKET - MOUNTING - ROLLER SHADE - 1 3/8"
11A	094896-02-000	EA	GROMMET - CORD/PLEATED BLIND - NYLON - GRAY
12A	094907-02-000	EA	END CAP - PLEATED BLIND/TOP - RH/LH - GRAY PLASTIC
13A	094907-04-000	EA	END CAP - PLEATED BLIND/BOTTOM - RH/LH
14A	094907-05-000	EA	END CAP - PLEATED BLIND/BOTTOM - PULL TYPE - PLASTIC
15A	094907-06-000	EA	END CAP/BLIND - TOP RH/LH
	094907-09-000	EA	END CAP/BLIND - CENTER RAIL - RH/LH
16A	097564-03-000	EA	HANDLE - KNOB - E-Z LIFT SHADE - TAN
16A	097564-06-000	EA	HANDLE - KNOB - E-Z LIFT SHADE - ALABASTER
	097593-02-000	FT	CORD - BLIND - PLEATED - GRAY
	097593-06-000	FT	CORD - BLIND - PLEATED - PEWTER
	097593-10-000	FT	CORD - BLIND - PLEATED - VANILLA
	109353-09-01A	EA	BLIND - SLAT - 21' - ALABASTER PEARL
17A	097565-01-000	EA	BRACKET - MOUNTING - PLEATED BLIND
18A	097591-01-000	EA	SPRING - EXTENSION - PLEATED BLIND
19A	101031-01-000	YD	TAPE/GLIDE - 4.25" SPACING
20A	101033-02-000	EA	END CAP - LOW PROFILE TRACK - CLEAR
21A	101033-08-000	EA	TRACK/WALL - 75" - FRT BUNK WINDOW MINNIE/SPIRIT 300-SERIES

CURTAIN & CUSHION GROUP (CONTINUED)
HARDWARE (CONTINUED)

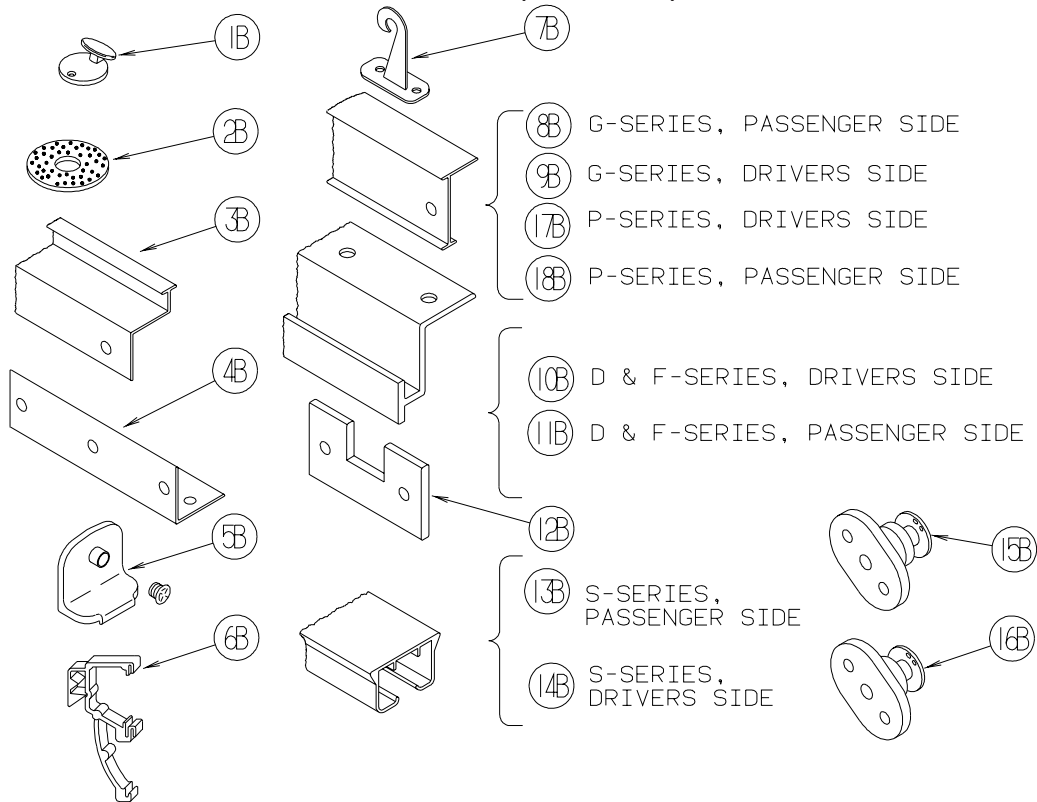

21A	101033-09-000	EA TRACK/WALL - 32" - SIDE BUNK WINDOW MINNIE/SPIRIT 300-SERIES
KEY	PART NUMBER	U/M DESCRIPTION
1B	102555-03-000	EA BRACKET - (CLEAT TYPE) - F/BLIND HOLDDOWN - MILKY WHITE
2B	103242-01-000	EA VELCRO HOOK - BEIGE 7/8" ROUND W/CENTER HOLE
2B	103242-02-000	EA VELCRO HOOK - BLACK 7/8" ROUND W/CENTER HOLE
3B	105450-14-01A	EA TRACK - CURTAIN - 90" - OFF WHITE - FRONT BUNK PRIVACY MINNIE/SPIRIT 300-SERIES
4B	105648-01-02A	EA BRACE - VALANCE - OFF/WHITE - 14"
5B	106544-01-000	EA PULL - SHADE/BRASS
5B	106544-01-001	EA SCREW - SHADE/BRASS
5B	106544-02-000	EA PULL-SHADE - NICKEL
6B	109353-04-000	EA CLIP - VALANCE SLAT MOUNTING - CLEAR PLASTIC
7B	109441-03-000	EA BRACKET/HOOK - BLIND HOLD DOWN - NEW DESIGN/CLEAR
8B	126456-03-04A	EA TRACK/WRAPAROUND - PASSENGER - GLACIER - ADVENTURER/SUNCRUISER G-SERIES
9B	126456-04-04A	EA TRACK/WRAPAROUND - DRIVER - GLACIER - ADVENTURER/SUNCRUISER G-SERIES
10B	127254-04-05A	EA TRACK/WRAPAROUND-DRVR-GLACIER - SIGHTSEER/SUNOVA D-SERIES, BRAVE/SUNRISE F-SERIES
11B	127254-14-03A	EA TRACK/WRAPAROUND-PASS-GLACIER - SIGHTSEER/SUNOVA D-SERIES, BRAVE/SUNRISE F-SERIES
12B	130549-01-01A	EA STOP - CURTAIN TRACK
13B	138460-07-02A	EA TRACK/CURTAIN - PASSENGER - W/BRACKET/CARRIER/PULLEY - WHT - VECTRA/HORIZON S-SERIES
14B	138460-08-02A	EA TRACK/CURTAIN - DRIVER - W/BRACKET/CARRIER/PULLEY - WHT - VECTRA/HORIZON S-SERIES
15B	141634-01-000	EA BRACKET-(BOBBIN TYPE) 7/8"H HOLDUPBASE(OVAL)-2 HOLE-CLEAR
16B	143805-01-000	EA BRACKET-(BOBBIN TYPE) 1/2"H HOLDUPBASE(OVAL)-2 HOLES CLEAR
17B	146591-01-01A	EA TRACK - CURTAIN - LEFT HAND - GLACIER - JOURNEY/MERIDIAN P-SERIES
18B	146591-02-01A	EA TRACK - CURTAIN - RIGHT HAND - GLACIER - JOURNEY/MERIDIAN P-SERIES

ACCESSORIES

KEY	PART NUMBER	U/M DESCRIPTION
	070578-02-N30	EA BUTTON - SCREW - STUD - #30 VINYL
	057534-03-000	EA TIEBACK - CLEAR PLASTIC - 7.5"

CURTAIN & CUSHION GROUP (CONTINUED)

FABRICS

	S28/SJ0 RIVERSIDE SAGE	S29/SJ1 ROCKFORD DUSK	S30/SJ2 STONEBROOK
2005 FAMILY BUCKET	580 WIDE MAN. REC. 126883-K2-000	580 WIDE MAN. REC. 126883-T1-000	580 WIDE MAN. REC. 126883-W9-000
DINETTE	CURVED CLUB 126883-S9-000	CURVED CLUB 126883-T0-000	CURVED CLUB 126883-W8-000
DINETTE PADS	126883-K2-000	126883-T1-000	126883-W9-000
SOFA	695 /K.E. JACK KNIFE 126883-S9-000	695 /K.E. JACK KNIFE 126883-T0-000	695 /K.E. JACK KNIFE 126883-W8-000
LOUNGE CHAIR	465 GLIDER CHAIR 126883-K2-000	465 GLIDER CHAIR 126883-T1-000	465 GLIDER CHAIR 126883-W9-000
LOUNGE WINDOWS	TONYA VALANCE BODY 126883-K2-000	TONYA VALANCE BODY 126883-T1-000	TONYA VALANCE BODY 126883-W9-000
	OVERLAY - 126883-S9-000	OVERLAY - 126883-T0-000	OVERLAY - 126883-W8-000
	LEGS - 126883-K2-000	LEGS - 126883-T1-000	LEGS - 126883-W9-000
	CORD139041-50-000	CORD139041-51-000	CORD139041-52-000
ENT. DOOR CLOCK	8" ROUND CLOCK	8" ROUND CLOCK	8" ROUND CLOCK
LOUNGE PILLOW	(1) TONYA STYLE BODY - 126883-K2-000	(1) TONYA STYLE BODY - 126883-T1-000	(1) TONYA STYLE BODY - 126883-W9-000
	"T" OVERLAY - 126883-S9-000	"T" OVERLAY - 126883-T0-000	"T" OVERLAY - 126883-W8-000
	CORD TRIM - 139041-50-000	CORD TRIM - 139041-51-000	CORD TRIM - 139041-52-000
FWA, BLACKOUT & PRIVACY CURTAIN	137813-75-000	137813-77-000	137813-27-000
DAY/NIGHTER	094911-53-000 COTTON	094911-53-000 COTTON	094911-53-000 COTTON
GALLEY BLINDS	386 SNOCAP	386 SNOCAP	386 SNOCAP
BEDROOM WDO TREATMENT	TONYA VALANCE BODY 137813-75-000	TONYA VALANCE BODY 137813-77-000	TONYA VALANCE BODY 137813-27-000
	OVERLAY 137813-74-000	OVERLAY 137813-76-000	OVERLAY 137813-A1-000
	LEGS - 137813-75-000	LEGS - 137813-77-000	LEGS - 137813-27-000
BEDCOVER	BEDCAP W/1/2" N-G WELT 137813-74-000	BEDCAP W/1/2" N-G WELT 137813-76-000	BEDCAP W/1/2" N-G WELT 137813-A1-000
QUILT PATTERN	6" CHANNEL	6" CHANNEL	6" CHANNEL
SHAMS	1/2" NON-GATH. WELT BODY 137813-74-000	1/2" NON-GATH. WELT BODY 137813-76-000	1/2" NON-GATH. WELT BODY 137813-A1-000
	WELT 137813-75-000	WELT 137813-77-000	WELT 137813-27-000

CURTAIN & CUSHION GROUP (CONTINUED)
FABRICS (CONTINUED)

	S28/SJ0 RIVERSIDE SAGE	S29/SJ1 ROCKFORD DUSK	S30/SJ2 STONEBROOK
BED PILLOW	(1) TONYA STYLE	(1) TONYA STYLE	(1) TONYA STYLE
	BODY & WELT - 137813-75-000	BODY & WELT - 137813-77-000	BODY & WELT - 137813-27-000
	"T" OVERLAY - 137813-74-000	"T" OVERLAY - 137813-76-000	"T" OVERLAY - 137813-A1-000
HEADBOARD	TONYA W/1/2" WELT	TONYA W/1/2" WELT	TONYA W/1/2" WELT
	BODY - 137813-75-000	BODY - 137813-77-000	BODY - 137813-27-000
	OVERLAY - 137813-74-000	OVERLAY - 137813-76-000	OVERLAY - 137813-A1-000
	WELT - 137813-74-000	WELT - 137813-76-000	WELT - 137813-A1-000
CARPET	139056-21-000	096060-J7-000	139056-26-000
	PALE SAGE	SAHARA DESERT	SKY BLUE
CARPET TAPE	102695-28-000	102695-12-000	102695-26-000

CURTAIN & CUSHION GROUP (CONTINUED)
FABRICS (CONTINUED)

2005 FAMILY	SX2/SX3 BLEACHED SAND	SX4/SX5 SAGEBRUSH	SX6/SX7 SANDFROST	SY4/SY5 GREENGAGE	SY6/SY7 CILANTRO	SY8/SY9 ESTATE GREEN
BUCKET	580 WIDE MAN. REC.	580 WIDE MAN. REC.	580 WIDE MAN. REC.	580 WIDE MAN. REC.	580 WIDE MAN. REC.	580 WIDE MAN. REC.
	126883-U9-000	126883-L3-000	126883-N3-000	126883-L7-000	126883-M1-000	126883-K2-000
DINETTE	CURVED CLUB	CURVED CLUB	CURVED CLUB	CURVED CLUB	CURVED CLUB	CURVED CLUB
	126883-Z0-000	126883-L2-000	126883-N1-000	126883-L6-000	126883-M0-000	126883-K1-000
DINETTE PADS	126883-U9-000	126883-L3-000	126883-N3-000	126883-L7-000	126883-M1-000	126883-K2-000
SOFA	695 /K.E. JACK KNIFE	695 /K.E. JACK KNIFE	695 /K.E. JACK KNIFE	695 /K.E. JACK KNIFE	695 /K.E. JACK KNIFE	695 /K.E. JACK KNIFE
	126883-Z0-000	126883-L2-000	126883-N1-000	126883-L6-000	126883-M0-000	126883-K1-000
LOUNGE CHAIR	465 GLIDER CHAIR	465 GLIDER CHAIR	465 GLIDER CHAIR	465 GLIDER CHAIR	465 GLIDER CHAIR	465 GLIDER CHAIR
	126883-U9-000	126883-L3-000	126883-N3-000	126883-L7-000	126883-M1-000	126883-K2-000
LOUNGE WINDOWS	TONYA VALANCE	TONYA VALANCE	TONYA VALANCE	TONYA VALANCE	TONYA VALANCE	TONYA VALANCE
	BODY 126883-U9-000	BODY 126883-L3-000	BODY 126883-N3-000	BODY 126883-L7-000	BODY 126883-M1-000	BODY 126883-K2-000
	OVERLAY - 126883-Z0-000	OVERLAY - 126883-L2-000	OVERLAY - 126883-N1-000	OVERLAY - 126883-L6-000	OVERLAY - 126883-M0-000	OVERLAY - 126883-K1-000
	LEGS - 126883-U9-000	LEGS - 126883-L3-000	LEGS - 126883-N3-000	LEGS - 126883-L7-000	LEGS - 126883-M1-000	LEGS - 126883-K2-000
ENT. DOOR CLOCK	8" ROUND CLOCK	8" ROUND CLOCK	8" ROUND CLOCK	8" ROUND CLOCK	8" ROUND CLOCK	8" ROUND CLOCK
LOUNGE PILLOW	(1) TONYA STYLE	(1) TONYA STYLE	(1) TONYA STYLE	(1) TONYA STYLE	(1) TONYA STYLE	(1) TONYA STYLE
	BODY 126883-U9-000	BODY 126883-L3-000	BODY 126883-N3-000	BODY 126883-L7-000	BODY 126883-M1-000	BODY 126883-K2-000
	"T" OVERLAY - 126883-Z0-000	"T" OVERLAY - 126883-L2-000	"T" OVERLAY - 126883-N1-000	"T" OVERLAY - 126883-L6-000	"T" OVERLAY - 126883-M0-000	"T" OVERLAY - 126883-K1-000
FWA, BLACKOUT & PRIVACY CURTAIN	137813-C1-000	137813-E4-000	137813-77-000	105745-Y0-000	137813-C1-000	137813-15-000
DAY/NIGHTER	094911-53-000	094911-53-000	094911-53-000	094911-53-000	094911-53-000	094911-53-000
	COTTON	COTTON	COTTON	COTTON	COTTON	COTTON
GALLEY BLINDS	386 SNOCAP	386 SNOCAP	386 SNOCAP	386 SNOCAP	386 SNOCAP	386 SNOCAP
BEDROOM WDO TREATMENT	TONYA VALANCE	TONYA VALANCE	TONYA VALANCE	TONYA VALANCE	TONYA VALANCE	TONYA VALANCE
	BODY 137813-C1-000	BODY 137813-E4-000	BODY 137813-77-000	BODY 105745-Y0-000	BODY 137813-C1-000	BODY 137813-15-000
	OVERLAY 137813-C0-000	OVERLAY 137813-F5-000	OVERLAY 137813-76-000	OVERLAY 105745-X9-000	OVERLAY 137813-B3-000	OVERLAY 137813-14-000
BEDCOVER	LEGS - 137813-C1-000	LEGS - 137813-E4-000	LEGS - 137813-77-000	LEGS - 105745-Y0-000	LEGS - 137813-C1-000	LEGS - 137813-15-000
	BEDCAP W/1/2" N-G WELT	BEDCAP W/1/2" N-G WELT	BEDCAP W/1/2" N-G WELT	BEDCAP W/1/2" N-G WELT	BEDCAP W/1/2" N-G WELT	BEDCAP W/1/2" N-G WELT
	137813-C0-000	137813-F5-000	137813-76-000	105745-X9-000	137813-B3-000	137813-14-000
QUILT PATTERN	6" CHANNEL	6" CHANNEL	6" CHANNEL	6" CHANNEL	6" CHANNEL	6" CHANNEL
SHAMS	1/2" NON-GATH. WELT	1/2" NON-GATH. WELT	1/2" NON-GATH. WELT	1/2" NON-GATH. WELT	1/2" NON-GATH. WELT	1/2" NON-GATH. WELT
	BODY 137813-C0-000	BODY 137813-F5-000	BODY 137813-76-000	BODY 105745-X9-000	BODY 137813-B3-000	BODY 137813-14-000
	WELT 137813-C1-000	WELT 137813-E4-000	WELT 137813-77-000	WELT 105745-Y0-000	WELT 137813-C1-000	WELT 137813-15-000

CURTAIN & CUSHION GROUP (CONTINUED)
FABRICS (CONTINUED)

	SX2/SX3	SX4/SX5	SX6/SX7	SY4/SY5	SY6/SY7	SY8/SY9
	BLEACHED SAND	SAGEBRUSH	SANDFROST	GREENGAGE	CILANTRO	ESTATE GREEN
BED PILLOW	(1) TONYA STYLE	(1) TONYA STYLE	(1) TONYA STYLE	(1) TONYA STYLE	(1) TONYA STYLE	(1) TONYA STYLE
	BODY & WELT - 137813-C1-00	BODY & WELT - 137813-E4-00	BODY & WELT - 137813-77-00	BODY & WELT - 105745-Y0-00	BODY & WELT - 137813-C1-00	BODY & WELT - 137813-15-00
	"T" OVERLAY - 137813-C0-00	"T" OVERLAY - 137813-F5-00	"T" OVERLAY - 137813-76-00	"T" OVERLAY - 105745-X9-00	"T" OVERLAY - 137813-B3-00	"T" OVERLAY - 137813-14-00
HEADBOARD	TONYA W/1/2" WELT	TONYA W/1/2" WELT	TONYA W/1/2" WELT	TONYA W/1/2" WELT	TONYA W/1/2" WELT	TONYA W/1/2" WELT
	BODY - 137813-C1-000	BODY - 137813-E4-000	BODY - 137813-77-000	BODY - 105474-Y0-000	BODY - 137813-C1-000	BODY - 137813-15-000
	OVERLAY - 137813-C0-000	OVERLAY - 137813-F5-000	OVERLAY - 137813-76-000	OVERLAY - 105745-X9-000	OVERLAY - 137813-B3-000	OVERLAY - 137813-14000
	WELT - 137813-C1-000	WELT - 137813-E4-000	WELT - 137813-77-000	WELT - 105474-Y0-000	WELT - 137813-C1-000	WELT - 137813-15-000
VANITY STOOL	TOP 137813-C0-000	TOP 137813-F5-000	TOP 137813-76-000	TOP 105745-X9-000	TOP 137813-B3-000	TOP 137813-14-000
29R ONLY	LOWER TRIM BAND & WELT	LOWER TRIM BAND & WELT	LOWER TRIM BAND & WELT	LOWER TRIM BAND & WELT	LOWER TRIM BAND & WELT	LOWER TRIM BAND & WELT
	137813-C1-000	137813-E4-000	137813-77-000	105745-Y0-000	137813-C1-000	137813-15-000
CARPET	096060-G8-000	096060-G9-000	096060-G8-000	096060-G9-000	096060-G9-000	096060-G9-000
	CAMEL	LAUREL GREEN	CAMEL	LAUREL GREEN	LAUREL GREEN	LAUREL GREEN
CARPET TAPE	102695-12-000	102695-20-000	102695-12-000	102695-20-000	102695-20-000	102695-20-000

DRIVERS COMPARTMENT GROUP

DASH

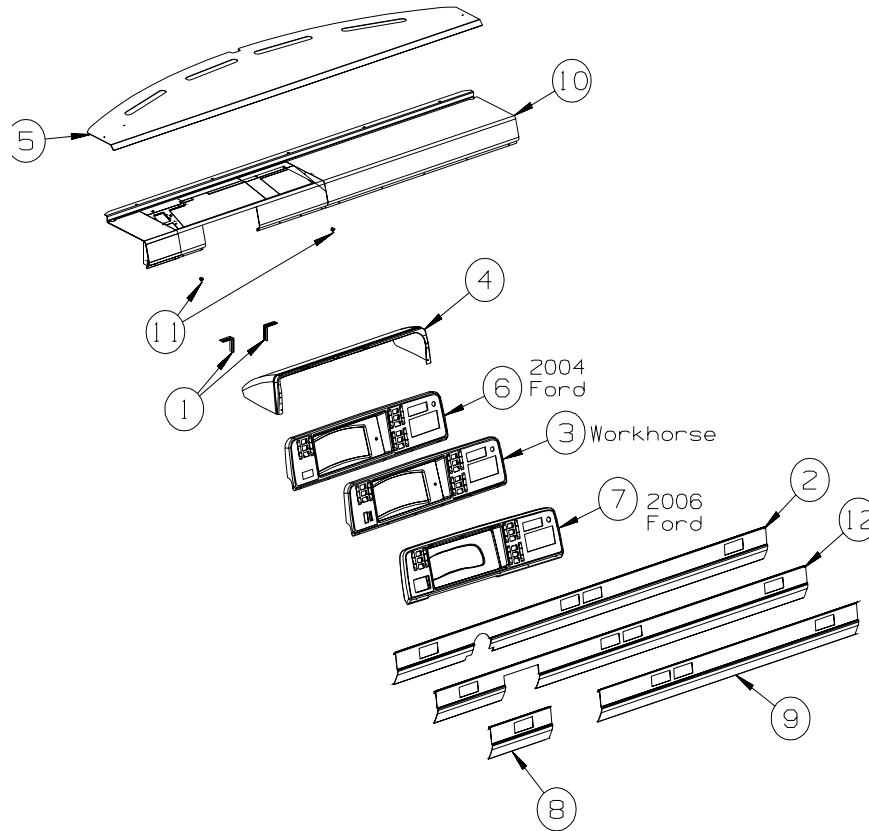

KEY	PART NUMBER	U/M	DESCRIPTION
1	143634-01-02B	EA	ANGLE/SUPPORT - DASH - E-COATED - FORD
2	114620-12-04A	EA	TRIM - LOWER DASH - 96" - GLACIER - WORKHORSE P32 (15,000/18,000) CHASSIS
3	143642-01-02A	EA	BEZEL - INSTRUMENT PANEL - GLACIER - WORK HORSE
4	125677-04-N21	EA	POD - INSTRUMENT PANEL - FORD
4	125677-02-N21	EA	POD - INSTRUMENT PANEL - WORKHORSE
5	140037-02-02B	EA	PANEL - DASH TOP - E-COATED
6	103662-16-02A	EA	BEZEL - INSTRUMENT PANEL - GLACIER - 2004 FORD
7	143642-02-02A	EA	BEZEL - INSTRUMENT PANEL - GLACIER - 2006 FORD
8	111528-08-04A	EA	TRIM - DASH/LOWER - PASSENGER - GLACIER - FORD
9	111528-04-06A	EA	TRIM - DASH/LOWER - DRIVER - GLACIER - FORD
10	140038-01-02B	EA	DASH - E-COATED - WORKHORSE
10	140038-02-02B	EA	DASH - E-COATED - FORD
	106569-11-05A	EA	VINYL - LAMINATE - ALLANTE DOESKIN - 1/4" X 25" X 100"
	076767-05-000	EA	CABLE - STAINLESS STEEL - 15.5"
11	049176-01-000	EA	HEDLOCK II - 3/4 DIAMETER SCREW MOUNT
12	114620-15-04A	EA	TRIM - LOWER DASH - GLACIER - WORKHORSE W20 (20,700) CHASSIS

DRIVERS COMPARTMENT GROUP (CONTINUED)

MOTOR COVER

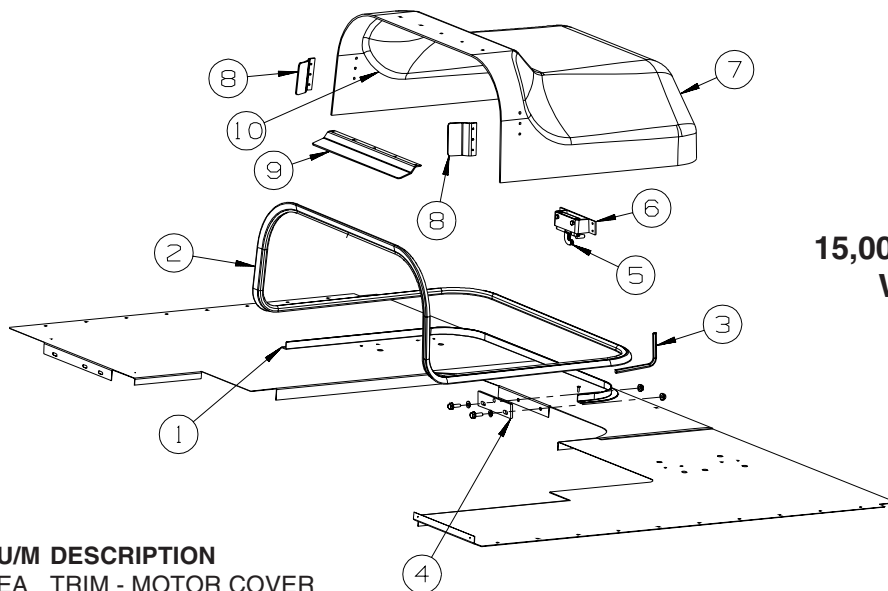

**15,000 & 18,000 GVWR
WORKHORSE**

KEY	PART NUMBER	U/M	DESCRIPTION
1	115860-04-01A	EA	TRIM - MOTOR COVER
2	039623-01-000	FT	SEAL - MOTOR COVER - RUBBER BULB TYPE
3	116833-01-02B	EA	WRENCH - HEX MOTOR COVER - E-COATED
4	115852-01-02B	EA	STRIKE - LATCH - MOTOR COVER - E-COATED
5	116581-01-000	EA	LATCH - W/O STRIKE - MOTOR COVER
6	115850-01-02B	EA	RETAINER - LATCH - MOTOR COVER - RIGHT HAND - E-COATED
7	129099-02-01A	EA	COVER - MOTOR - W/O CARPET - CHEVY P32 CHASSIS
7	129414-02-S28	EA	COVER - MOTOR - W/CARPET (S28, SJ0)
7	129414-02-R29	EA	COVER - MOTOR - W/CARPET (S29, SJ1)
7	129414-02-S30	EA	COVER - MOTOR - W/CARPET (S30, SJ2)
7	129414-02-SX2	EA	COVER - MOTOR - W/CARPET (SX2, SX3, SX6, SX7
7	129414-02-SX4	EA	COVER - MOTOR - W/CARPET (SX4, SX5, SY4, SY5, SY6, SY7, SY8, SY9)
8	115855-02-02B	EA	RETAINER - MOTOR COVER/SIDE - E-COATED
9	115855-01-02B	EA	RETAINER - MOTOR COVER/TOP - E-COATED
10	NOT USED		

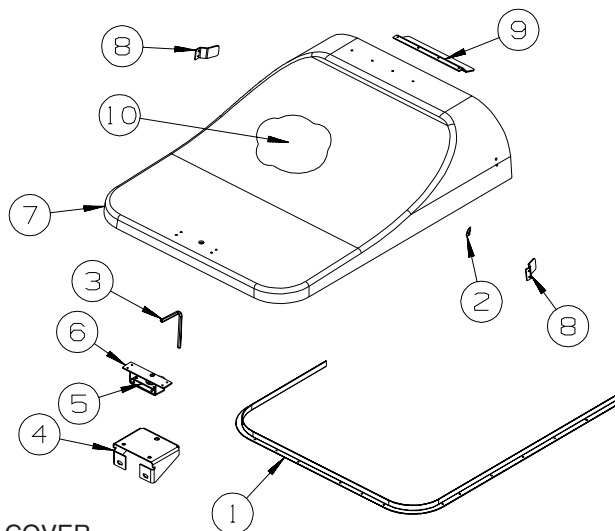

**20,700 GVWR
WORKHORSE**

KEY	PART NUMBER	U/M	DESCRIPTION
1	137332-01-01A	EA	TRIM - MOTOR COVER
2	039623-01-000	FT	SEAL - MOTOR COVER - RUBBER BULB TYPE
3	116833-01-02B	EA	WRENCH - HEX MOTOR COVER - E-COATED
4	137305-02-02B	EA	BRACKET - STRIKE SUPPORT - E-COATED
5	116581-01-000	EA	LATCH - W/O STRIKE - MOTOR COVER
6	115850-01-02B	EA	RETAINER - LATCH - MOTOR COVER - RIGHT HAND - E-COATED
7	137096-01-01A	EA	COVER - MOTOR - W/O CARPET
7	137097-02-S28	EA	COVER - MOTOR - W/CARPET (S28, SJ0)
7	137097-02-S29	EA	COVER - MOTOR - W/CARPET (S29, SJ1)
7	137097-02-P49	EA	COVER - MOTOR - W/CARPET (S30, SJ2)
8	115855-04-02B	EA	RETAINER - MOTOR COVER/SIDE - E-COATED
9	115855-03-02B	EA	RETAINER - MOTOR COVER/TOP - E-COATED
10	134497-01-000	SF	FOIL/ALUMINUM - REINFORCED
	140168-01-000	EA	INSULATION/ENGINE COVER

DRIVERS COMPARTMENT GROUP (CONTINUED)
MOTOR COVER (CONTINUED)

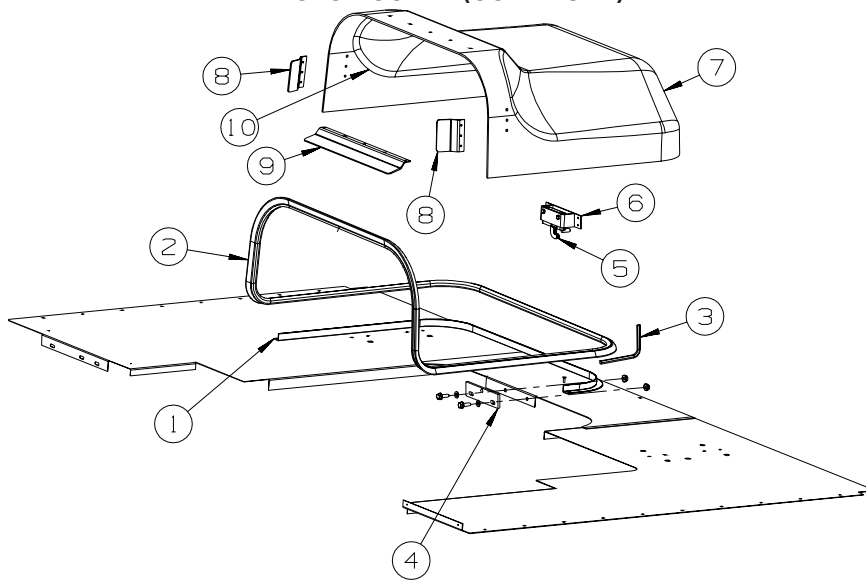

**2004
FORD**

KEY	PART NUMBER	U/M	DESCRIPTION
1	115860-05-01A	EA	TRIM - MOTOR COVER - MILL FINISH
2	039623-01-000	FT	SEAL - MOTOR COVER - RUBBER BULB TYPE
3	116833-01-02B	EA	WRENCH - HEX MOTOR COVER - E-COATED
4	115852-01-02B	EA	STRIKE - LATCH - MOTOR COVER - E-COATED
5	116581-01-000	EA	LATCH - W/O STRIKE - MOTOR COVER
6	115850-01-02B	EA	RETAINER - LATCH - MOTOR COVER - RIGHT HAND - E-COATED
7	129099-04-01A	EA	COVER - MOTOR - W/O CARPET
7	129414-06-S28	EA	COVER - MOTOR - W/CARPET (S28, SJ0)
7	129414-06-R29	EA	COVER - MOTOR - W/CARPET (S29, SJ1)
7	129414-06-S30	EA	COVER - MOTOR - W/CARPET (S30, SJ2)
7	129414-06-SX2	EA	COVER - MOTOR - W/CARPET (SX2, SX3, SX6, SX7)
7	129414-06-SX4	EA	COVER - MOTOR - W/CARPET (SX4, SX5, SY4, SY5, SY6, SY7, SY8, SY9)
8	115855-02-02B	EA	RETAINER - MOTOR COVER/SIDE - E-COATED
9	115855-01-02B	EA	RETAINER - MOTOR COVER/TOP - E-COATED
10	NOT USED		

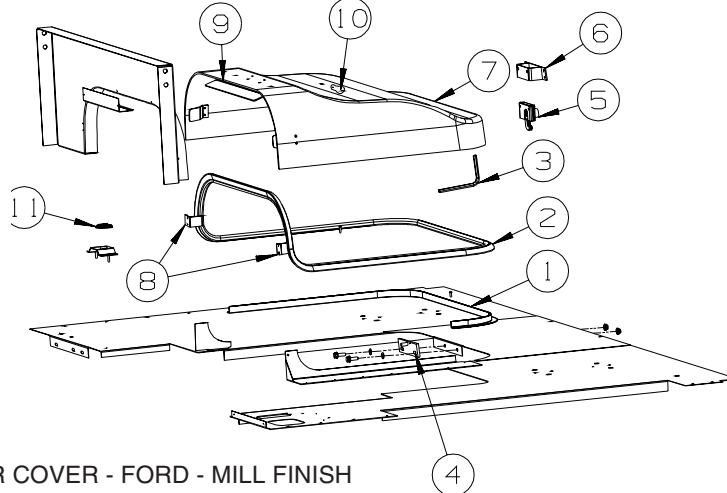

**2006
FORD**

KEY	PART NUMBER	U/M	DESCRIPTION
1	115860-06-01A	EA	TRIM - MOTOR COVER - FORD - MILL FINISH
2	039623-01-000	FT	SEAL - MOTOR COVER - RUBBER BULB TYPE
3	116833-01-02B	EA	WRENCH - HEX MOTOR COVER - E-COATED
4	115852-01-02B	EA	STRIKE - LATCH - MOTOR COVER - E-COATED
5	116581-01-000	EA	LATCH - W/O STRIKE - MOTOR COVER
6	115850-01-02B	EA	RETAINER - LATCH - MOTOR COVER - RIGHT HAND - E-COATED
7	153971-02-T56	EA	COVER - MOTOR - W/CARPET (S28, SJ0)
7	153971-02-T58	EA	COVER - MOTOR - W/CARPET (S29, SJ1)
7	153971-02-T55	EA	COVER - MOTOR - W/CARPET (S30, SJ2)
7	153971-02-SX2	EA	COVER - MOTOR - W/CARPET (SX2, SX3, SX6, SX7)
7	153971-02-SX4	EA	COVER - MOTOR - W/CARPET (SX4, SX5, SY4, SY5, SY6, SY7, SY8, SY9)
8	115855-04-02B	EA	RETAINER - MOTOR COVER/SIDE - E-COATED
9	115855-01-02B	EA	RETAINER - MOTOR COVER/TOP - E-COATED
10	134497-01-000	SF	FOIL/ALUMINUM - REINFORCED
11	143798-01-01A	EA	CATCH - FLOOR TO TABLE LEG - BRIGHT WHITE

DRIVERS COMPARTMENT GROUP (CONTINUED)
BEVERAGE TRAY

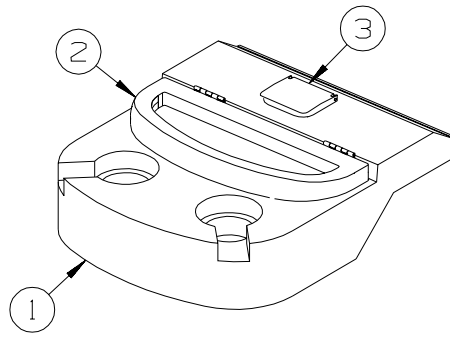

2004 FORD
UP TO: 01-30-05

KEY	PART NUMBER	U/M	DESCRIPTION
1	128114-01-04A	EA	TRAY/BEVERAGE - GLACIER
2	128113-01-N21	EA	LID - BEVERAGE TRAY
3	118719-01-01A	EA	ASHTRAY - TOP MOUNT - BLACK PLASTIC

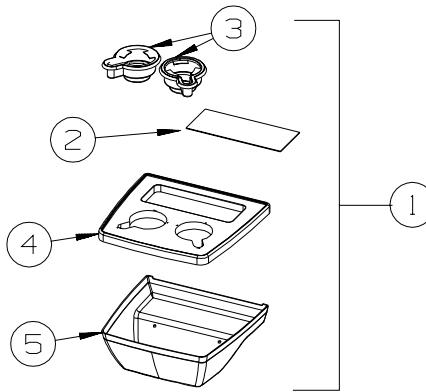

2006 FORD
FROM: 01-31-05 ON

KEY	PART NUMBER	U/M	DESCRIPTION
1	149301-01-S28	EA	TRAY - BEVERAGE - W/CONVENIENCE TRAY - GLACIER
2	122717-11-01A	EA	PAD - NON-SKID - PSA - 4.5" X 11"
3	133831-01-01A	EA	HOLDER - CUP W/THREE CENTERLINE RUBBER FINGERS
4	148918-01-01A	EA	TRAY - BEVERAGE CENTER - SANDSTONE
5	149256-01-04A	EA	COVER - BEVERAGE TRAY BOTTOM - GLACIER

DRIVERS COMPARTMENT GROUP (CONTINUED)
BEVERAGE TRAY (CONTINUED)

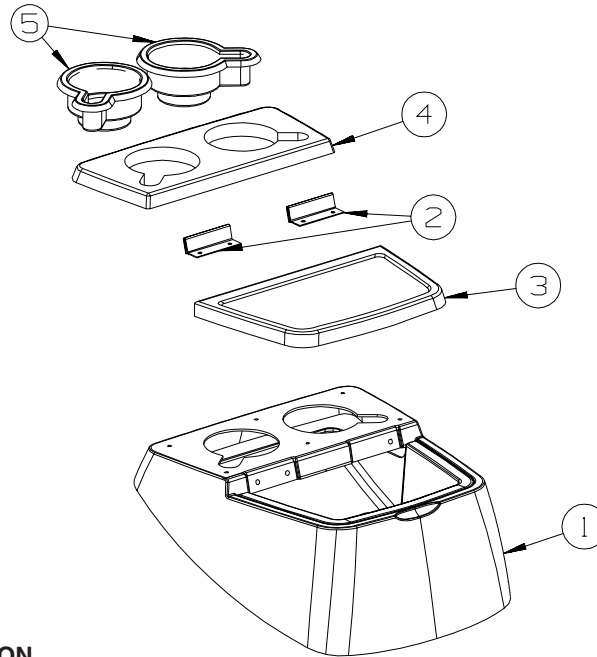

WORKHORSE

KEY	PART NUMBER	U/M	DESCRIPTION
1	139268-01-01A	EA	TRAY - BEVERAGE - GLACIER
2	139279-01-04B	EA	HINGE - BLACK
3	139285-01-03A	EA	LID/DOOR - SANDSTONE
4	139296-01-03A	EA	LID - BEVERAGE TRAY - SANDSTONE
5	133831-01-01A	EA	HOLDER - CUP W/THREE CENTERLINE RUBBER FINGERS

DRIVERS COMPARTMENT GROUP (CONTINUED)

FRONT INTERIOR

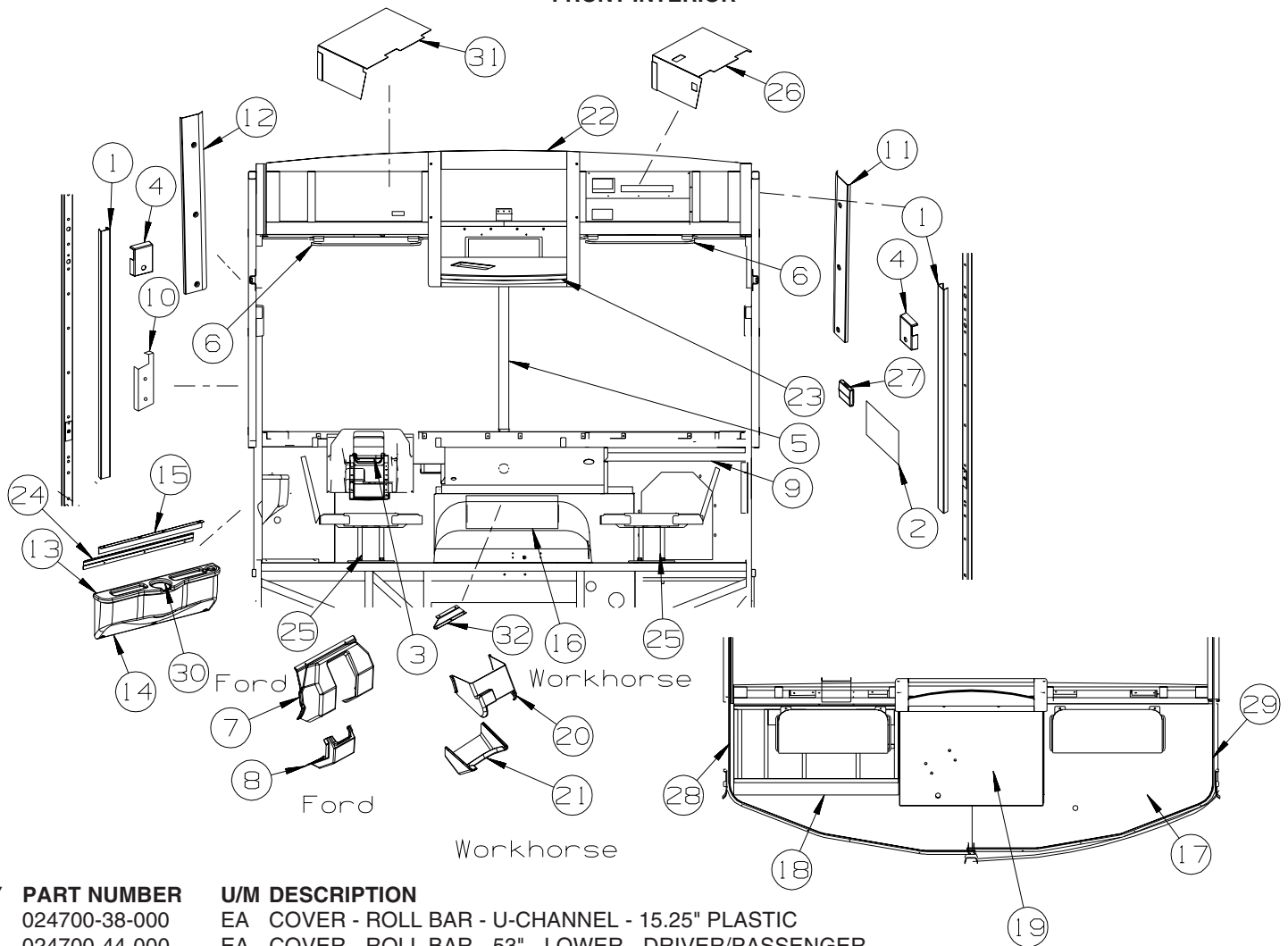

KEY	PART NUMBER	U/M	DESCRIPTION
1	024700-38-000	EA	COVER - ROLL BAR - U-CHANNEL - 15.25" PLASTIC
1	024700-44-000	EA	COVER - ROLL BAR - 53" - LOWER - DRIVER/PASSENGER
2	086120-01-R28	EA	PAD - MAP POCKET - 12" X 16" (S28, SJ0, SY8, SY9)
2	086120-01-R29	EA	PAD - MAP POCKET - 12" X 16" (S29, SJ1)
2	086120-01-S30	EA	PAD - MAP POCKET - 12" X 16" (S30, SJ2)
2	086120-01-SX2	EA	PAD - MAP POCKET - 12" X 16" (SX2, SX3)
2	086120-01-P01	EA	PAD - MAP POCKET - 12" X 16" (SX4, SX5)
2	086120-01-SX6	EA	PAD - MAP POCKET - 12" X 16" (SX6, SX7)
			FROM: 00-00-00 THRU: 11-30-04
2	086120-01-S6X	EA	PAD - MAP POCKET - 12" X 16" (SX6, SX7)
			FROM: 12-01-04 THRU: 99-99-99
2	086120-01-P04	EA	PAD - MAP POCKET - 12" X 16" (SY4, SY5)
2	086120-01-P34	EA	PAD - MAP POCKET - 12" X 16" (SY6, SY7)
3	103498-09-000	EA	BOOT - STEERING COLUMN - W/1/2 CIRCLE - WORKHORSE
4	103961-03-01A	EA	COVER - BRACKET - SEATBELT/OFF WHITE
5	118452-10-02A	EA	TRIM - WINDSHIELD/CENTER - GLACIER
6	123298-04-05A	EA	SUNVISOR - 10.5" X 21" - DRIVER/PASSENGER - GLACIER
7	131804-01-04A	EA	COVER - STEERING COLUMN - UPPER - GLACIER - FORD
8	125795-01-04A	EA	COVER - STEERING COLUMN/LOWER - GLACIER - FORD
9	126340-05-01A	EA	DECAL - LOGO - SIGHTSEER - 3D - CHAMPAGNE BEIGE
10	127901-01-03A	EA	PANEL - TOEKICK/LEFT HAND - GLACIER
11	136351-03-02A	EA	TRIM - A-PILLAR - INTERIOR/PASSENGER - GLACIER
12	136351-04-02A	EA	TRIM - A-PILLAR - INTERIOR/DRIVER - GLACIER
13	132297-06-04A	EA	PANEL-TRIM - BEVERAGE TRAY - PORTSMOUTH OAK
13	132297-06-05A	EA	PANEL-TRIM - BEVERAGE TRAY - SIERRA MAPLE
14	132354-05-04A	EA	PANEL/TRIM - INNER - W/O BEVERAGE TRAY - GLACIER
14	132354-06-04A	EA	PANEL/TRIM - INNER - W/O BEVERAGE TRAY - GLACIER - MIRRORS-EXTERIOR W/DEFROST
	142434-01-000	EA	LEVEL - BUBBLE - MOUNTED
	122717-06-01A	FT	PAD - NON-SKID - PSA - 5"W
15	132595-02-02B	EA	ANGLE/SUPPORT/TRIM PANEL - E-COATED

DRIVERS COMPARTMENT GROUP (CONTINUED)
FRONT INTERIOR (CONTINUED)

KEY	PART NUMBER	U/M	DESCRIPTION
16	126008-02-N21	EA	TRAY - BEVERAGE - W/DOOR - 15,000 & 18,000 GVWR WORKHORSE
16	139275-01-R32	EA	TRAY - BEVERAGE - W/DOOR - 20,700 GVWR WORKHORSE
16	126008-02-N21	EA	TRAY - BEVERAGE - W/DOOR - FORD FROM: 00-00-00 THRU: 01-30-05
16	149301-01-S28	EA	TRAY - BEVERAGE - W/CONVENIENCE TRAY - GLACIER - FORD FROM: 01-31-05 THRU: 04-14-05
16	149301-03-S28	EA	TRAY - BEVERAGE - W/CONVENIENCE TRAY - GLACIER - FORD FROM: 04-15-05 THRU: 99-99-99
17	134146-05-S28	EA	PANEL - OVERHEAD/FRONT/BOTTOM/RIGHT HAND
18	134146-06-S28	EA	PANEL - OVERHEAD/FRONT/BOTTOM/LEFT HAND
19	P34142-03-S28	EA	COVER - TV - OVERHEAD/BOTTOM - VINYL COVERED
	134142-03-000	EA	COVER - TV - OVERHEAD/BOTTOM
20	137851-01-04A	EA	COVER - STEERING COLUMN - GLACIER - WORKHORSE
21	137878-02-04A	EA	COVER - STEERING COLUMN - FRONT - GLACIER - WORKHORSE
22	144351-03-S28	EA	CABINET - FRAME/TV - W/O DOORS/HARDWARE - PORTSMOUTH OAK
22	144351-03-SJ0	EA	CABINET - FRAME/TV - W/O DOORS/HARDWARE - SIERRA MAPLE
23	144278-02-S28	EA	CABINET/BASE - TV - W/O DOORS/HARDWARE - PORTSMOUTH OAK
23	144278-02-SJ0	EA	CABINET/BASE - TV - W/O DOORS/HARDWARE - SIERRA MAPLE
24	130034-11-02B	EA	CLIP - TRIM - E-COATED
25	133408-01-000	EA	PEDESTAL - SEAT - DRIVER/PASSENGER - 9 3/4"
26	136422-03-R28	EA	PANEL - CLOSEOUT
27	118718-01-02A	EA	HOLDER/DRINK - COLLAPSIBLE MUG - WHITE PLASTIC
28	127254-14-03A	EA	TRACK/WRAPAROUND - PASSENGER - GLACIER
29	127254-04-05A	EA	TRACK/WRAPAROUND - DRIVER - GLACIER
30	134566-01-01A	EA	HOLDER - CUP - TWO STEP - BLACK
31	136422-04-R28	EA	PANEL - CLOSEOUT
32	126010-01-03A	EA	SPACER - BEVERAGE TRAY - GLACIER

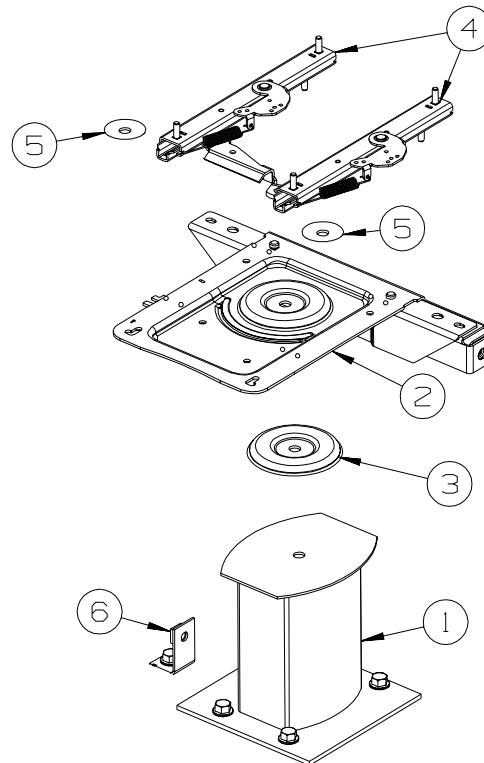

PASSENGER

KEY	PART NUMBER	U/M	DESCRIPTION
1	133408-01-000	EA	PEDESTAL - SEAT - DRIVER/PASSENGER - 9 3/4"
2	133408-20-000	EA	TOP PLATE - PASSENGER - W/ANCHOR
3	107921-06-000	EA	BEARING KIT - PEDESTAL
4	131566-04-000	EA	SLIDE/SEAT - HEAVY DUTY LOCKING - 5"
	119952-07-000	EA	WIRE - LATCH RELEASE/ROTARY
5	131566-05-000	EA	WASHER - SLIDE SPACER
6	133408-04-000	EA	BRACKET - ANCHOR/FLOOR

DRIVERS COMPARTMENT GROUP (CONTINUED)

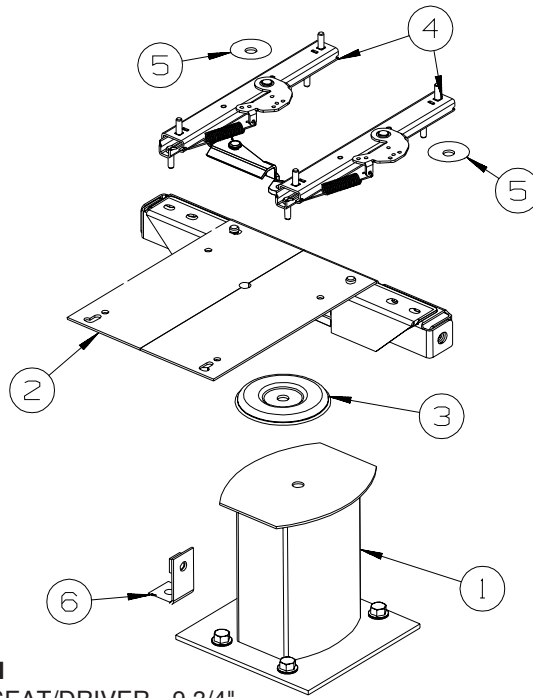

DRIVER

KEY	PART NUMBER	U/M	DESCRIPTION
1	133408-01-000	EA	PEDESTAL - SEAT/DRIVER - 9 3/4"
2	133408-19-000	EA	TOP PLATE - DRIVERS - W/ANCHOR
3	107921-06-000	EA	BEARING KIT - PEDESTAL
4	131566-04-000	EA	SLIDE/SEAT - HEAVY DUTY LOCKING - 5"
	119952-07-000	EA	WIRE - LATCH RELEASE/ROTARY
5	131566-05-000	EA	WASHER - SLIDE SPACER
6	133408-04-000	EA	BRACKET - ANCHOR/FLOOR

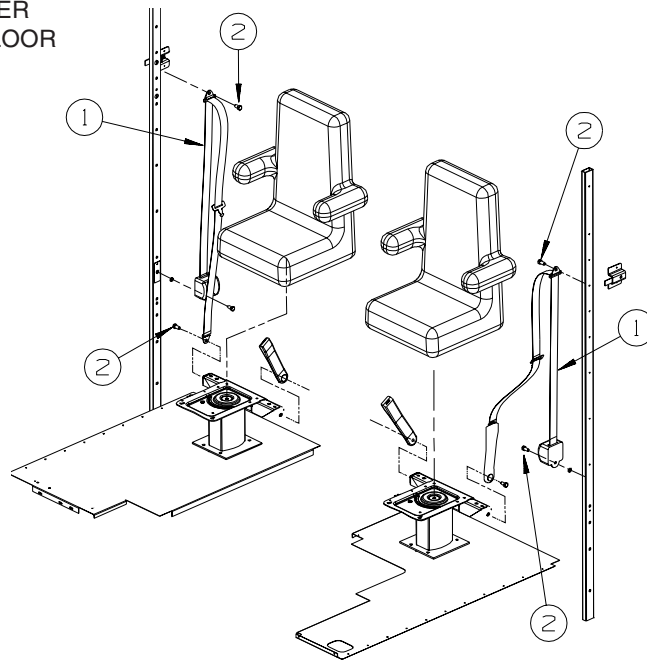

KEY	PART NUMBER	U/M	DESCRIPTION
1*	091990-04-01A	EA	SEAT BELT/SHOULDER HARNESS - DRIVERS/PASSENGER - BLACK
2	109146-01-000	EA	BOLT - SHOULDER/SEAT BELT

***COMPONENT PARTS LISTED LATER IN THIS GROUP**

COMPONENT PARTS FOR FRONT INTERIOR

091990-04-01A

KEY	PART NUMBER	U/M	DESCRIPTION	VENDOR NO.
	091990-01-701	EA	EXTENDER 9" FOR A8408 3 PT	I-1331-02
	091990-01-703	EA	RECEIVER/FEMALE END-SEATBELT	I-1159-02
	091990-05-700	EA	SLEEVE/BUCKLE COVER-PLASTIC	209S-2
	091990-05-701	EA	CAP/COVER - BOLT HOLE COVER	209SC-02
	091990-05-702	EA	SLEEVE/RETRACTABLE COVER	309C-02
	091990-05-703	EA	EXTENDER 12"	I-1442-02

DRIVERS COMPARTMENT GROUP (CONTINUED)

CABINETS

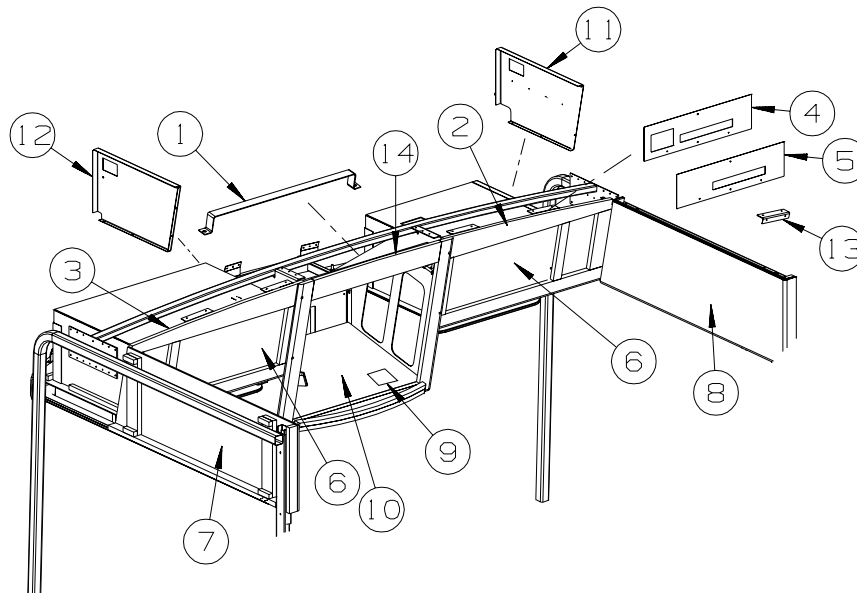

KEY	PART NUMBER	U/M	DESCRIPTION
1	133790-16-02B	EA	STRAP/TIEDOWN - TV - E-COATED
2	148442-01-S28	EA	CABINET - OVERHEAD/FRONT/RIGHT HAND - W/O DOORS/HARDWARE - PORTSMOUTH OAK (S28)
2	148442-01-S29	EA	CABINET - OVERHEAD/FRONT/RIGHT HAND - W/O DOORS/HARDWARE - PORTSMOUTH OAK (S29)
2	148442-01-S30	EA	CABINET - OVERHEAD/FRONT/RIGHT HAND - W/O DOORS/HARDWARE - PORTSMOUTH OAK (S30)
2	148442-01-SX2	EA	CABINET - OVERHEAD/FRONT/R HAND - W/O DOORS/HARDWARE - PORTSMOUTH OAK (SX2, SY6)
2	148442-01-SX4	EA	CABINET - OVERHEAD/FRONT/RIGHT HAND - W/O DOORS/HARDWARE - PORTSMOUTH OAK (SX4)
2	148442-01-SX6	EA	CABINET - OVERHEAD/FRONT/RIGHT HAND - W/O DOORS/HARDWARE - PORTSMOUTH OAK (SX6)
2	148442-01-SY4	EA	CABINET - OVERHEAD/FRONT/RIGHT HAND - W/O DOORS/HARDWARE - PORTSMOUTH OAK (SY4)
2	148442-01-SY8	EA	CABINET - OVERHEAD/FRONT/RIGHT HAND - W/O DOORS/HARDWARE - PORTSMOUTH OAK (SY8)
2	148442-01-SJ0	EA	CABINET - OVERHEAD/FRONT/RIGHT HAND - W/O DOORS/HARDWARE - SIERRA MAPLE (SJ0)
2	148442-01-SJ1	EA	CABINET - OVERHEAD/FRONT/RIGHT HAND - W/O DOORS/HARDWARE - SIERRA MAPLE (SJ1)
2	148442-01-SJ2	EA	CABINET - OVERHEAD/FRONT/RIGHT HAND - W/O DOORS/HARDWARE - SIERRA MAPLE (SJ2)
2	148442-01-SX3	EA	CABINET - OVERHEAD/FRONT/RIGHT HAND - W/O DOORS/HARDWARE - SIERRA MAPLE (SX3, SY7)
2	148442-01-SX5	EA	CABINET - OVERHEAD/FRONT/RIGHT HAND - W/O DOORS/HARDWARE - SIERRA MAPLE (SX5)
2	148442-01-SX7	EA	CABINET - OVERHEAD/FRONT/RIGHT HAND - W/O DOORS/HARDWARE - SIERRA MAPLE (SX7)
2	148442-01-SY5	EA	CABINET - OVERHEAD/FRONT/RIGHT HAND - W/O DOORS/HARDWARE - SIERRA MAPLE (SY5)
2	148442-01-SY9	EA	CABINET - OVERHEAD/FRONT/RIGHT HAND - W/O DOORS/HARDWARE - SIERRA MAPLE (SY9)
3	148442-02-S28	EA	CABINET - OVERHEAD/FRONT/RIGHT HAND - W/O DOORS/HARDWARE - PORTSMOUTH OAK (S28)
3	148442-02-S29	EA	CABINET - OVERHEAD/FRONT/RIGHT HAND - W/O DOORS/HARDWARE - PORTSMOUTH OAK (S29)
3	148442-02-S30	EA	CABINET - OVERHEAD/FRONT/RIGHT HAND - W/O DOORS/HARDWARE - PORTSMOUTH OAK (S30)
3	148442-02-SX2	EA	CABINET - OVERHEAD/FRONT/R HAND - W/O DOORS/HARDWARE - PORTSMOUTH OAK (SX2, SY6)
3	148442-02-SX4	EA	CABINET - OVERHEAD/FRONT/RIGHT HAND - W/O DOORS/HARDWARE - PORTSMOUTH OAK (SX4)
3	148442-02-SX6	EA	CABINET - OVERHEAD/FRONT/RIGHT HAND - W/O DOORS/HARDWARE - PORTSMOUTH OAK (SX6)
3	148442-02-SY4	EA	CABINET - OVERHEAD/FRONT/RIGHT HAND - W/O DOORS/HARDWARE - PORTSMOUTH OAK (SY4)
3	148442-02-SY8	EA	CABINET - OVERHEAD/FRONT/RIGHT HAND - W/O DOORS/HARDWARE - PORTSMOUTH OAK (SY8)
3	148442-02-SJ2	EA	CABINET - OVERHEAD/FRONT/RIGHT HAND - W/O DOORS/HARDWARE - SIERRA MAPLE (SJ2)
3	148442-02-SJ0	EA	CABINET - OVERHEAD/FRONT/RIGHT HAND - W/O DOORS/HARDWARE - SIERRA MAPLE (SJ0)
3	148442-02-SJ1	EA	CABINET - OVERHEAD/FRONT/RIGHT HAND - W/O DOORS/HARDWARE - SIERRA MAPLE (SJ1)
3	148442-02-SX3	EA	CABINET - OVERHEAD/FRONT/RIGHT HAND - W/O DOORS/HARDWARE - SIERRA MAPLE (SX3, SY7)
3	148442-02-SX5	EA	CABINET - OVERHEAD/FRONT/RIGHT HAND - W/O DOORS/HARDWARE - SIERRA MAPLE (SX5)
3	148442-02-SY5	EA	CABINET - OVERHEAD/FRONT/RIGHT HAND - W/O DOORS/HARDWARE - SIERRA MAPLE (SY5)
3	148442-02-SX7	EA	CABINET - OVERHEAD/FRONT/RIGHT HAND - W/O DOORS/HARDWARE - SIERRA MAPLE (SX7)
3	148442-02-SY9	EA	CABINET - OVERHEAD/FRONT/RIGHT HAND - W/O DOORS/HARDWARE - SIERRA MAPLE (SY9)
4	144923-04-S28	EA	PANEL/SHELF - W/CUTOUTS F/VIDEO/INVERTER- VINYL COVERED - INVERTER-DC/AC, 300 WATT
4	144923-05-S28	EA	PANEL/SHELF - W/CUTOUTS - INVERTER-DC/AC, 300 WATT/13" TV W/VIDEO SELECTION SYS
5	144923-03-R28	EA	PANEL/SHELF - W/CUTOUTS F/VIDEO/INVERTER- VINYL COVERED - INVERTER-DC/AC, 300 WATT
6	131995-BX-S28	EA	DOOR - RAIL/SOLID PANEL W/GLASS -10.8"X 21.8"-W/O HARDWARE - PORTSMOUTH OAK FROM: 00-00-00 THRU: 06-16-04
6	146028-44-S28	EA	DOOR - GLASS INSERT/OGEE EDGE - 10.8" X 21.8" - W/O HDW - PORTSMOUTH OAK FROM: 06-17-04 THRU: 99-99-99
6	146028-44-SJ0	EA	DOOR - GLASS INSERT/OGEE EDGE - 10.8" X 21.8" - W/O HDW - SIERRA MAPLE FROM: 06-17-04 THRU: 99-99-99

DRIVERS COMPARTMENT GROUP (CONTINUED)
CABINETS (CONTINUED)

KEY	PART NUMBER	U/M	DESCRIPTION
7	138258-13-P31	EA	PANEL - FRONT/OVERHEAD - LEFT HAND
8	138258-12-R65	EA	PANEL - FRONT/OVERHEAD - RIGHT HAND
9	140364-01-01A	EA	FOAM - PAD - .5" X 8" X 8"
10	091261-01-000	FT	SLIPNOT - ANTISLIP - 1' WIDE X 12' - BLACK
10	123816-01-000	FT	TAPE - DOUBLE SIDED - 1" X .020" X 200'
11	134147-01-02B	EA	PANEL/SHELF - RIGHT HAND - E-COATED
12	134147-03-02B	EA	PANEL/SHELF - RIGHT HAND - E-COATED
13	016604-05-000	EA	BRACE - ANGLE - 2 1/2" - OFF WHITE METAL
14	144351-05-S28	EA	CABINET - FRAME/TV - W/O DOORS/HARDWARE - PORTSMOUTH OAK
14	144351-05-SJ0	EA	CABINET - FRAME/TV - W/O DOORS/HARDWARE - SIERRA MAPLE

ELECTRICAL GROUP 110V BODY WIRING

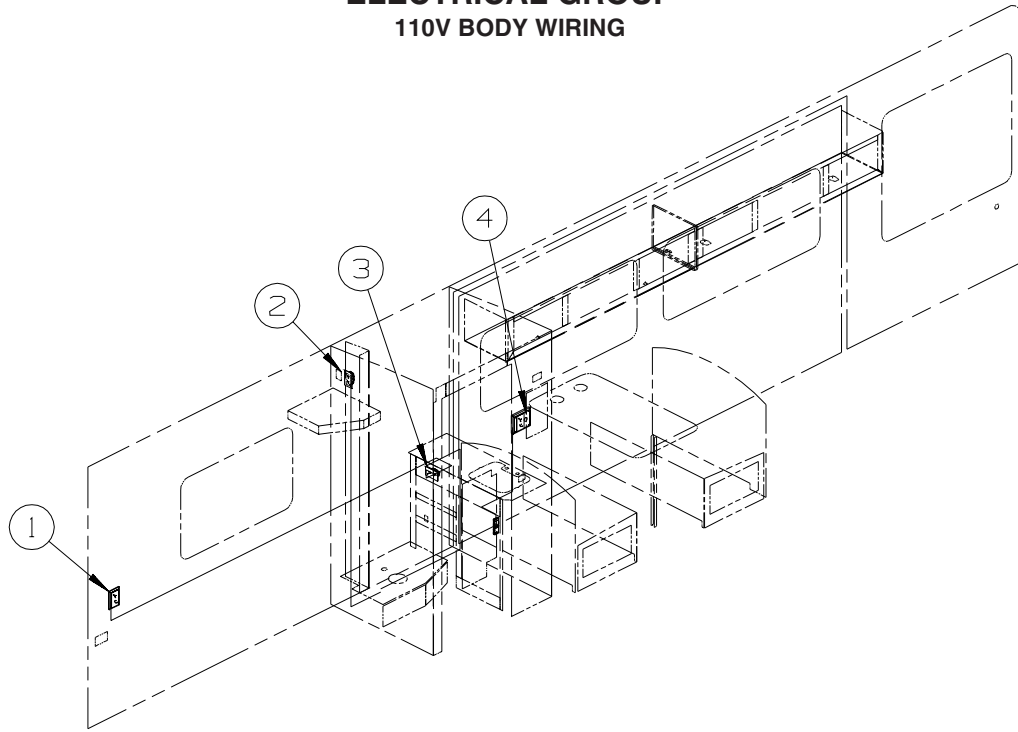

KEY	PART NUMBER	U/M	DESCRIPTION
1	133713-01-20A	EA	SPACER/RECEPTACLE - WHITE VINYL
1	058708-06-000	EA	RECEPTACLE - DUPLEX - WHITE
2	058708-01-000	EA	RECEPTACLE - ELECTRIC - DOUBLE - BROWN
3	058708-06-000	EA	RECEPTACLE - DUPLEX - WHITE
4	133713-04-20A	EA	SPACER/RECEPTACLE - WHITE VINYL
4	058708-06-000	EA	RECEPTACLE - DUPLEX - WHITE

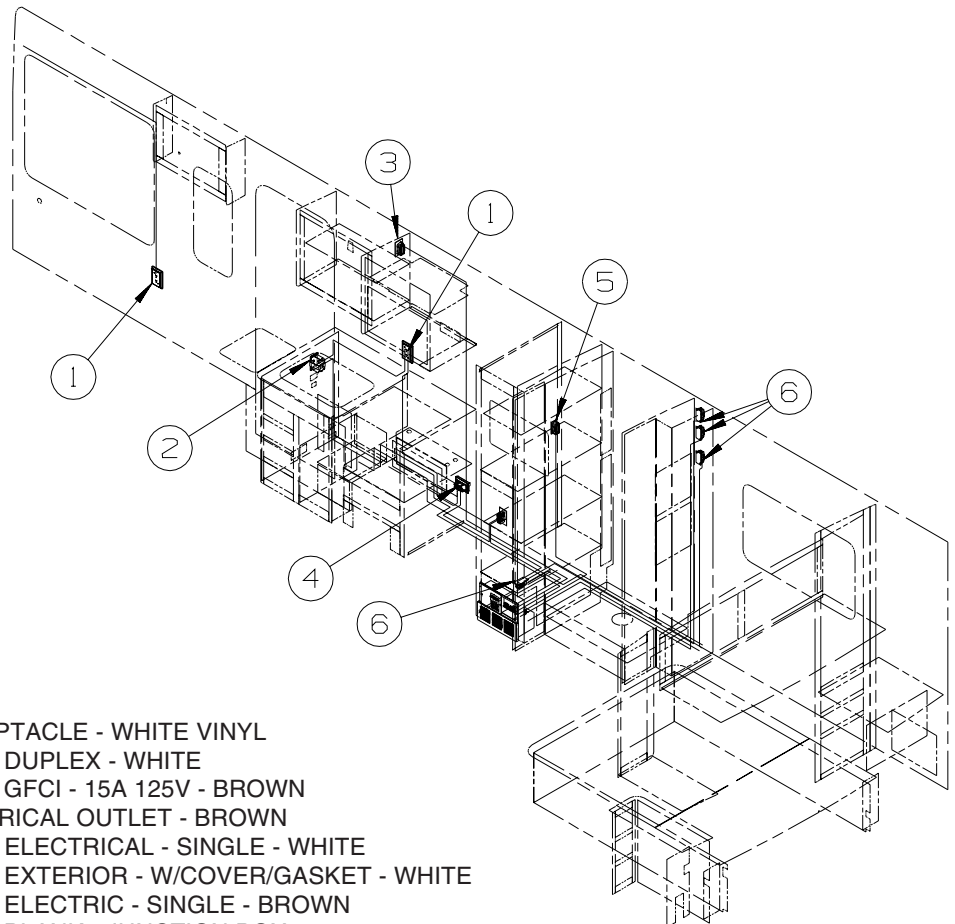

KEY	PART NUMBER	U/M	DESCRIPTION
1	133713-01-20A	EA	SPACER/RECEPTACLE - WHITE VINYL
1	058708-06-000	EA	RECEPTACLE - DUPLEX - WHITE
2	147446-01-02A	EA	RECEPTACLE - GFCI - 15A 125V - BROWN
2	147450-01-02A	EA	PLATE - ELECTRICAL OUTLET - BROWN
3	058708-07-000	EA	RECEPTACLE - ELECTRICAL - SINGLE - WHITE
4	131826-01-01A	EA	RECEPTACLE - EXTERIOR - W/COVER/GASKET - WHITE
5	058707-01-000	EA	RECEPTACLE - ELECTRIC - SINGLE - BROWN
6	058707-02-000	EA	RECEPTACLE - BLANK - JUNCTION BOX

ELECTRICAL GROUP (CONTINUED)

12V BODY WIRING

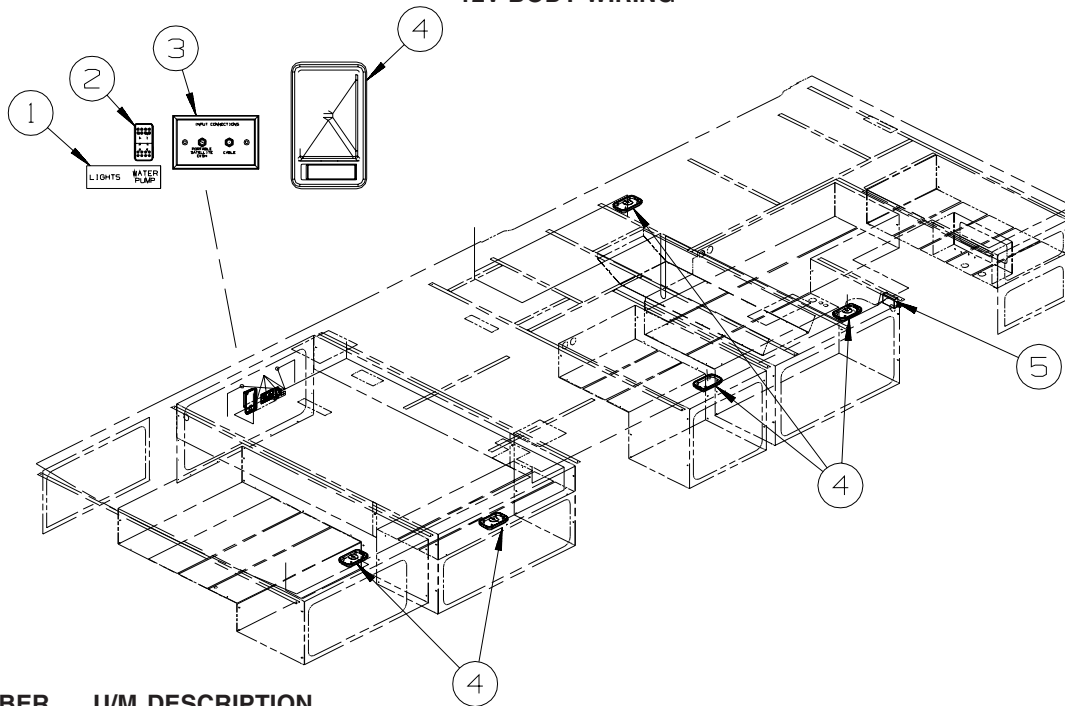

KEY	PART NUMBER	U/M	DESCRIPTION
1	117628-01-000	EA	LABEL - SWITCH - WATER PUMP/LIGHTS-BLACK/CLEAR BACKGROUND
2	108357-15-000	EA	SWITCH - ROCKER - DPDT - ON/NONE/ON - W/LIGHT W/O COVER
2	108356-04-01A	EA	COVER/ACTUATOR SWITCH - 2 ROWS DIMPLES W/LENS - BLACK
2	108355-01-000	EA	HOUSING - SWITCH
3	149557-03-01A	EA	PLATE/WALL - DUAL COAXIAL/HORIZONTAL - WHITE
4*	137417-01-01A	EA	LIGHT - DOME - SINGLE - W/SWITCH/FROSTED LENS - WHITE
5	138173-03-000	EA	MODULE - (CONTROL BOX) - SLIDEOUT CONTROL - #1802930

*COMPONENT PARTS LISTED LATER IN THIS GROUP

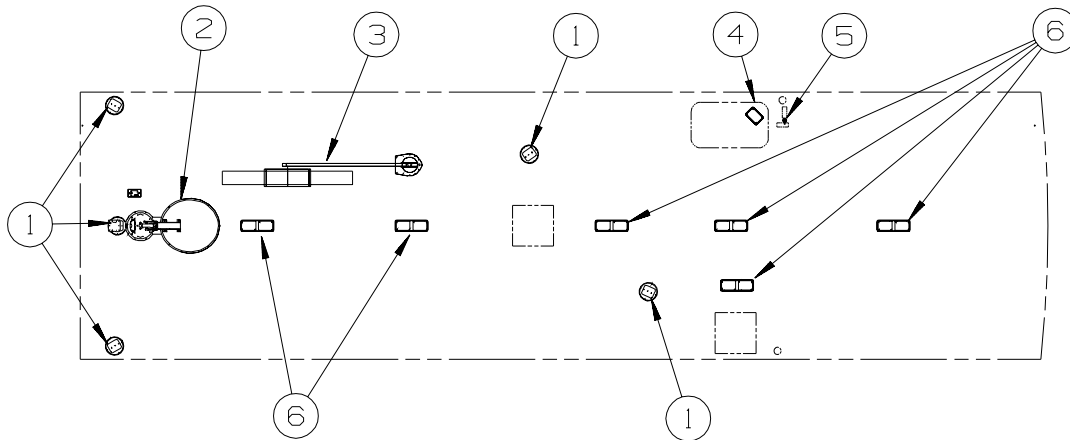

KEY	PART NUMBER	U/M	DESCRIPTION
1	150091-01-01A	EA	SPEAKER - CUBE - W/ADJ BRACKET - SILVER - MAGNADYNE LS3S FROM: 00-00-00 THRU: 05-09-04
1	151314-01-01A	EA	SPEAKER - CUBE/CEILING - WHITE - MAGNADYNE - LS3CM-WN FROM: 05-10-04 THRU: 99-99-99
2*	137135-02-000	EA	ANTENNA - SATELLITE DSS - W/SENSOR
3*	076319-23-000	EA	ANTENNA - TV ROOF MOUNT - 44.5" MAST
3*	076319-25-000	EA	KIT - HARDWARE INTERIOR
4*	121935-01-01A	EA	LIGHT - DOME - SHOWER
5	090944-01-000	EA	ANTENNA - RADIO - 16" RUBBER - W/72" LEAD WIRE
5	109889-04-000	EA	EXTENDER - ANTENNA SHAFT - 3.7"
5	147741-01-09B	EA	BRACKET - ANTENNA GROUND - GALVANIZED
6*	137417-06-01A	EA	LIGHT - DOME - DOUBLE - W/O SWITCH - W/FROSTED LENS-WHITE

*COMPONENT PARTS LISTED LATER IN THIS GROUP

ELECTRICAL GROUP (CONTINUED)
12V BODY WIRING (CONTINUED)

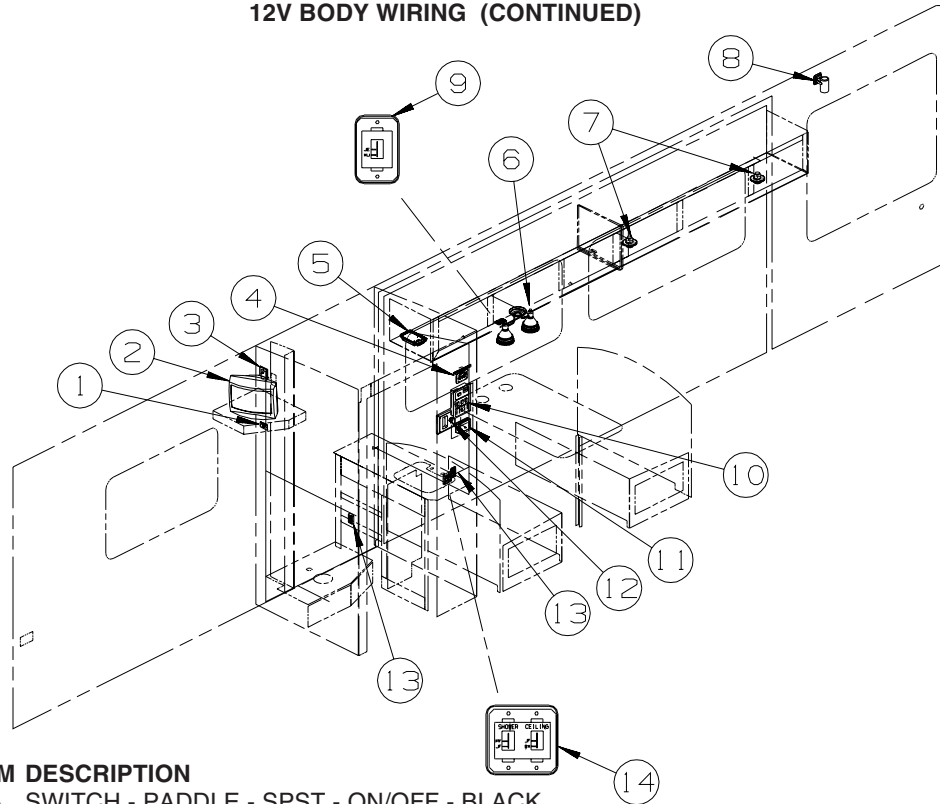

KEY	PART NUMBER	U/M	DESCRIPTION
1	132180-01-01A	EA	SWITCH - PADDLE - SPST - ON/OFF - BLACK
1	098351-14-01A	EA	PLATE/SWITCH - 1 GANG - POLISHED BRASS - TV
2*	086231-10-000	EA	TV - 13" COLOR - AUDIOVOX - FLEX VISION/AVT-1498/DC
2	144819-01-02B	EA	BRACKET - TV - E-COATED
3	076319-27-000	EA	WALLPLATE/RECEPTACLE - WHITE
4	138173-04-000	EA	CONTROL PANEL (TOUCH PAD) - ELECTRIC SLIDEOUT - #1802931
4	116549-01-000	EA	LABEL - WARNING - SLIDEOUT
5*	137417-01-01A	EA	LIGHT - DOME - SINGLE - W/SWITCH/FROSTED LENS - WHITE
6	093575-12-01A	EA	LIGHT - CEILING/DOUBLE - BRASS - UL/CSA
6	117805-01-000	EA	BULB - 12V - #921F - 1.4 AMPS
7	132427-01-01A	EA	LIGHT - READING/SWIVEL - ROUND - BRASS
	123917-01-000	EA	BULB - 12V - HALOGEN SPOT
8	149590-01-01A	EA	LIGHT - READING/SWIVEL - W/O SWITCH - BRASS
9	135740-01-02A	EA	SWITCH - ROCKER - SPST - ON/OFF - WHITE
9	135741-01-02A	EA	SWITCH - BASE - SINGLE - WHITE
9	135742-01-01A	EA	BEZEL - SWITCH - SINGLE - BROWN
10*	134940-01-01A	EA	PANEL - MONITOR - 2 TANK - W/GENERATOR SWITCH/HOUR METER FROM: 00-00-00 THRU: 05-02-04
10*	134940-06-01A	EA	PANEL - MONITOR - 2 TANK - W/GENERATOR SWITCH FROM: 05-03-04 THRU: 99-99-99
11	135618-03-01A	EA	THERMOSTAT - ROOF A/C & FURNACE - WHITE
11	135618-01-01A	EA	THERMOSTAT - HEAT PUMP/FURNACE - WHITE
12	132958-01-000	EA	RECEPTACLE - 12 VOLT - MOUNTING FLANGE - BLACK
13	135740-01-02A	EA	SWITCH - ROCKER - SPST - ON/OFF - WHITE
13	135741-01-02A	EA	SWITCH - BASE - SINGLE - WHITE
13	135742-07-01A	EA	BEZEL - SWITCH - CEILING - WHITE
14	135740-01-02A	EA	SWITCH - ROCKER - SPST - ON/OFF - WHITE
14	135741-02-02A	EA	SWITCH - BASE - DOUBLE - WHITE
14	135742-15-01A	EA	BEZEL - SWITCH - CEILING/SHOWER - WHITE

***COMPONENT PARTS LISTED LATER IN THIS GROUP**

ELECTRICAL GROUP (CONTINUED)

12V BODY WIRING (CONTINUED)

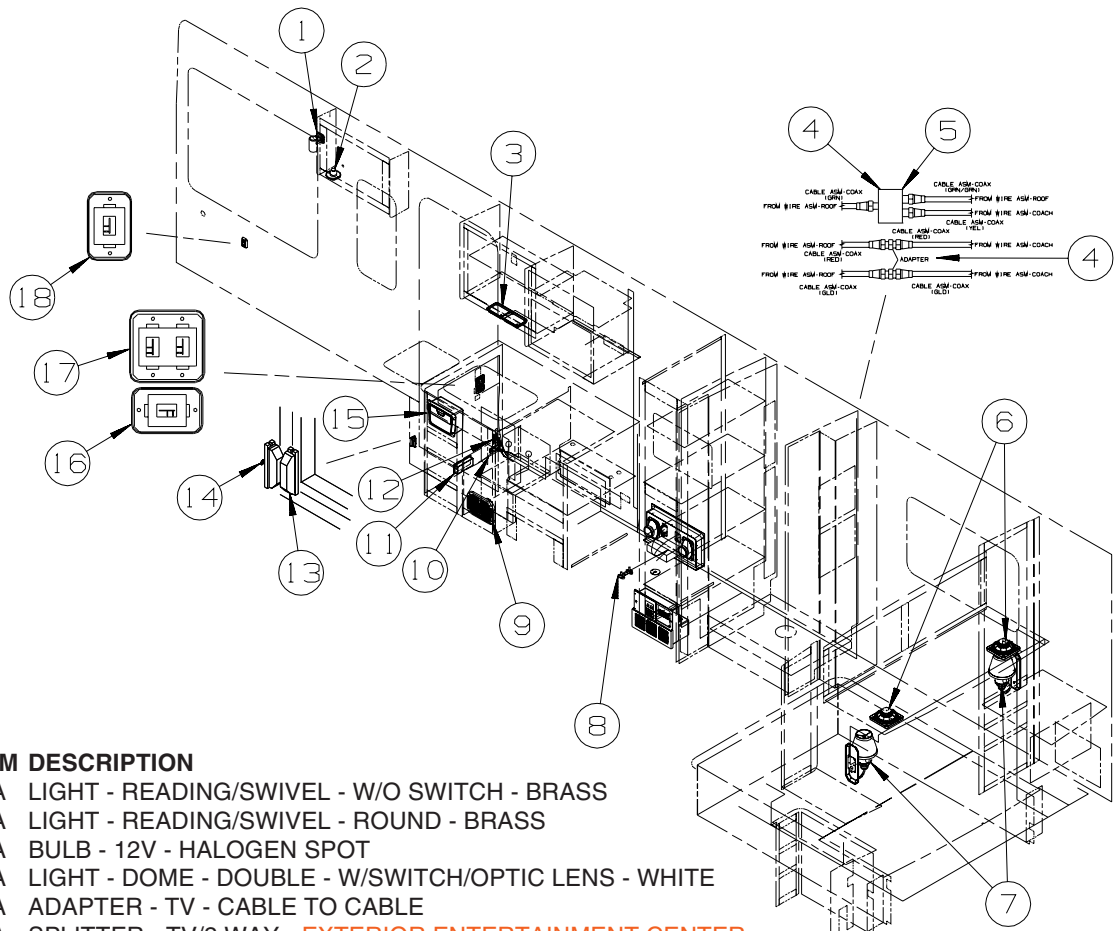

KEY	PART NUMBER	U/M	DESCRIPTION
1	149590-01-01A	EA	LIGHT - READING/SWIVEL - W/O SWITCH - BRASS
2	132427-01-01A	EA	LIGHT - READING/SWIVEL - ROUND - BRASS
	123917-01-000	EA	BULB - 12V - HALOGEN SPOT
3*	137417-05-01A	EA	LIGHT - DOME - DOUBLE - W/SWITCH/OPTIC LENS - WHITE
4	082134-01-000	EA	ADAPTER - TV - CABLE TO CABLE
5	086756-01-000	EA	SPLITTER - TV/2 WAY - EXTERIOR ENTERTAINMENT CENTER
6	094097-01-000	EA	SPEAKER - RADIO/TV - W/O GRILLE - 5.25" DIAMETER
6	089340-02-000	EA	GRILLE - SPEAKER - 6.5" SQUARE
7	119258-09-01A	EA	LAMP - WALL - BRASS - UL/CSA
7	119257-08-01A	EA	SHADE - LAMP - SHORT - CRYSTAL/SMALL DIAMOND
7	067479-01-000	EA	BULB - 12V - #1076 - 1.80 AMP
8	086233-01-000	EA	STUD - ISOLATED - 3/8" X 7/8" LONG
9	150090-01-000	EA	SPEAKER - 6" X 9" - SUB-WOOFER - MAGNADYNE LS69W
9	124885-01-000	EA	GRILLE - SPEAKER - 6" X 9" - SUB WOOFER
			FROM: 00-00-00 THRU: 05-09-04
9	151569-01-01A	EA	GRILLE - SPEAKER - 6" X 9" - SUB WOOFER - BLACK
			FROM: 05-10-04 THRU: 99-99-99
10	061424-01-000	EA	LIGHT - AISLE - 12 VOLT - RECTANGULAR
11	150138-01-01A	EA	DETECTOR - LP GAS - WHITE
11	150138-01-02A	EA	DETECTOR - LP GAS - BROWN
12	098351-07-01A	EA	PLATE/SWITCH - 1 GANG - POLISHED BRASS - GENERATOR
12	108357-06-000	EA	SWITCH - ROCKER - DPDT - MOM/OFF/MOM - 6 TERM - W/O COVER
12	108356-11-01A	EA	COVER/ACTUATOR SWITCH - 3 GROOVES - AUX BATT - BLACK
12	108355-01-000	EA	HOUSING - SWITCH
13	116995-02-000	EA	SWITCH/MAGNET - ELECTRIC STEP - BLACK/WHITE- NORMALLY OPEN
14	008386-01-000	EA	GROMMET - SNAP - 3/8" DIAMETER - NYLON
15	141679-03-000	EA	CHARGER/DOCK STATION ONLY - FOR #GMRS100 TWO-WAY RADIO
15	141679-04-000	EA	RADIO/TWO-WAY W/BATTERY (EACH = 1) - 5 MILE - ASA GMRS100
16	135740-01-02A	EA	SWITCH - ROCKER - SPST - ON/OFF - WHITE
16	135741-01-02A	EA	SWITCH - BASE - SINGLE - WHITE
16	135742-11-02A	EA	BEZEL - SWITCH - STEP - BROWN
17	135740-01-02A	EA	SWITCH - ROCKER - SPST - ON/OFF - WHITE
17	135741-02-02A	EA	SWITCH - BASE - DOUBLE - WHITE
17	135742-19-01A	EA	BEZEL - SWITCH - CEILING/PORCH - WHITE
17	135742-19-02A	EA	BEZEL - SWITCH - CEILING/PORCH - BROWN
18	135740-01-02A	EA	SWITCH - ROCKER - SPST - ON/OFF - WHITE
18	135741-01-02A	EA	SWITCH - BASE - SINGLE - WHITE
18	135742-01-01A	EA	BEZEL - SWITCH - SINGLE - BROWN

*COMPONENT PARTS LISTED LATER IN THIS GROUP

ELECTRICAL GROUP (CONTINUED)
12V BODY WIRING (CONTINUED)

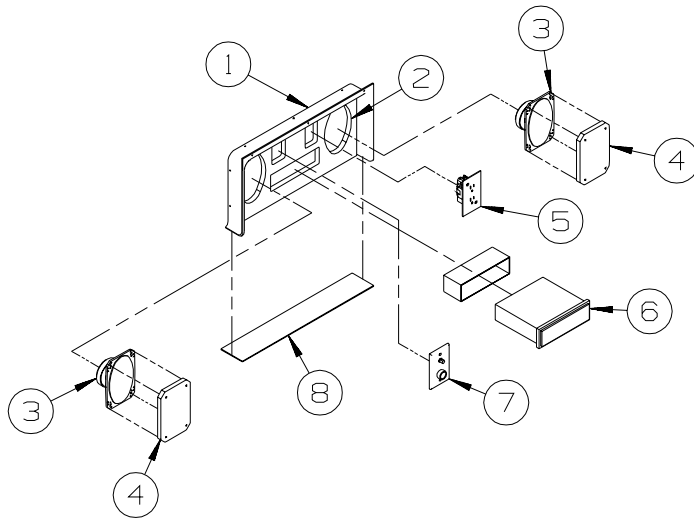

KEY	PART NUMBER	U/M	DESCRIPTION
1	124696-02-01A	EA	BOX-19.4"W X 10"H X 2.5"D - BRT WHT
	124696-01-01A	EA	BOX-19.4"W X 10"H X 10.2"D W/CUTOUTS
2	127409-02-L15	EA	PLATE - RADIO MOUNTING
3	110469-01-000	EA	SPEAKER - 4" X 6" OVAL - COAXIAL
4	110470-01-01A	EA	GRILLE - 4" X 6" - OVAL SPEAKER - BLACK
5	058708-01-000	EA	RECEPTACLE - ELECTRIC - DOUBLE - BROWN
6*	148231-01-000	EA	RADIO - AM/FM CD W/REMOTE - MAGNADYNE M3100CD
			FROM: 00-00-00 THRU: 04-11-05
6*	155619-01-000	EA	RADIO - AM/FM CD - W/REMOTE - MAGNADYNE M3200CD
			FROM: 04-12-05 THRU: 99-99-99
7	076319-09-000	EA	WALLPLATE - TV CABLE RECEPTACLE - SINGLE - BROWN
8	104898-01-02A	EA	PLATE - PLASTIC BOTTOM - BRIGHT WHITE

***COMPONENT PARTS LISTED LATER IN THIS GROUP**

ELECTRICAL GROUP (CONTINUED)
EXTERIOR LAMPS

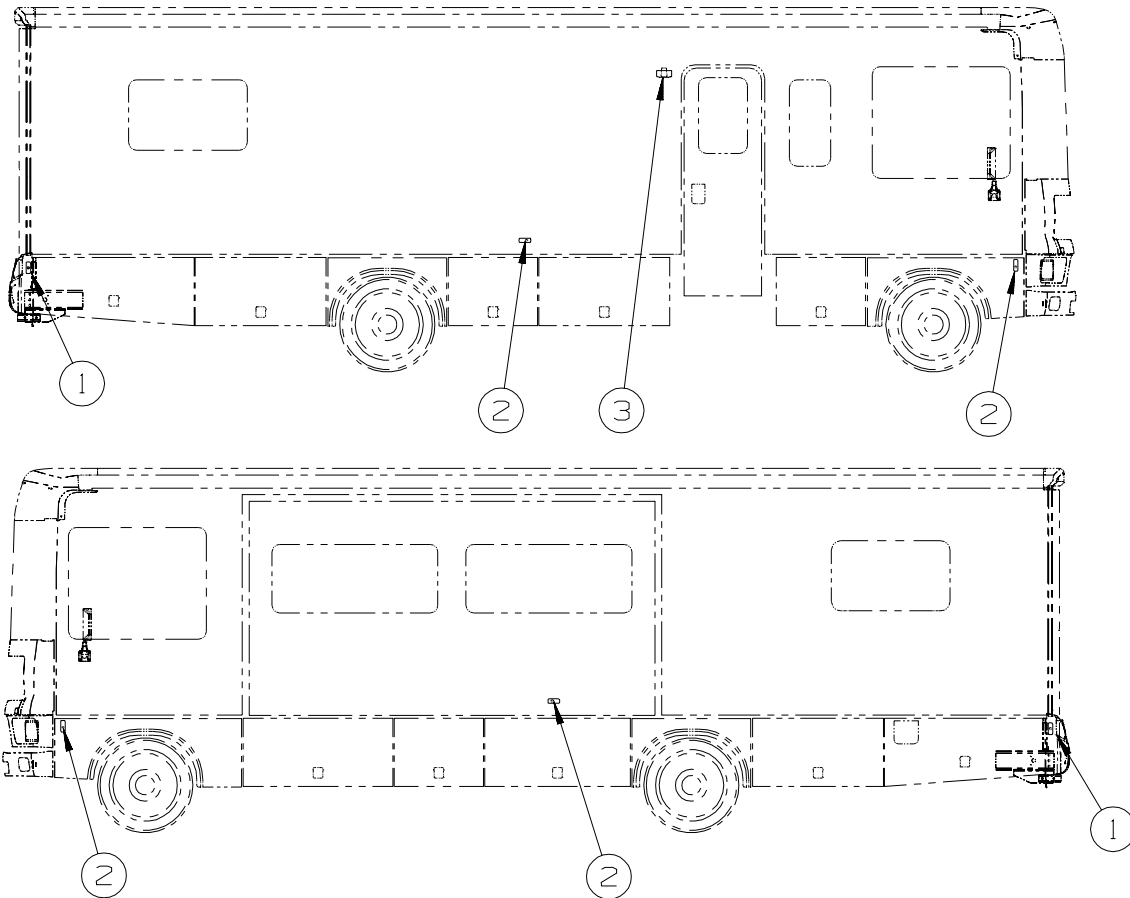

KEY	PART NUMBER	U/M	DESCRIPTION
1	111102-01-000	EA	BASE - MARKER LAMP
	036196-01-000	EA	BULB - 12V - #194 - .27 AMP - BAYONETTE
1	111102-03-000	EA	LENS - RED - MARKER LAMP
2	111102-01-000	EA	BASE - MARKER LAMP
	036196-01-000	EA	BULB - 12V - #194 - .27 AMP - BAYONETTE
2	111102-02-000	EA	LENS - AMBER - MARKER LAMP
3*	097917-01-06A	EA	LIGHT - PORCH - ENTRY DOOR - BRIGHT WHITE
	008215-01-000	EA	BULB - 12 VOLT - #1003 - .94 AMP

***COMPONENT PARTS LISTED LATER IN THIS GROUP**

ELECTRICAL GROUP (CONTINUED)

EXTERIOR LAMPS (CONTINUED)

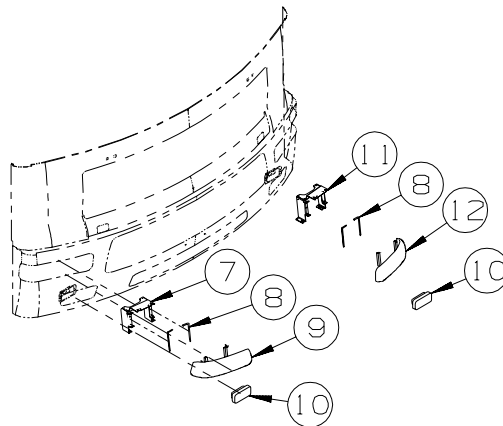
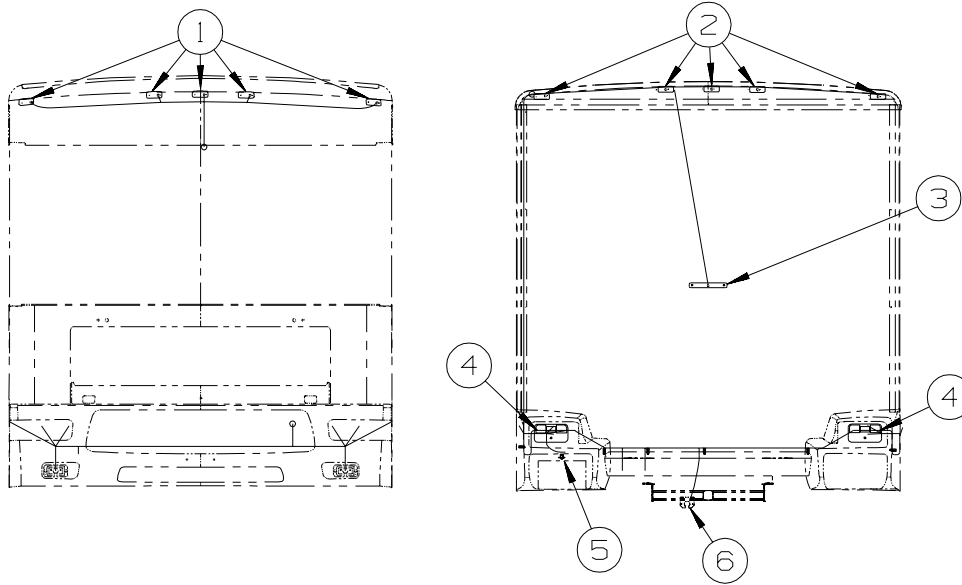

KEY	PART NUMBER	U/M DESCRIPTION
1	111102-01-000	EA BASE - MARKER LAMP
	036196-01-000	EA BULB - 12V - #194 - .27 AMP - BAYONETTE
1	111102-02-000	EA LENS - AMBER - MARKER LAMP
2	111102-01-000	EA BASE - MARKER LAMP
	036196-01-000	EA BULB - 12V - #194 - .27 AMP - BAYONETTE
2	111102-03-000	EA LENS - RED - MARKER LAMP
3	136916-01-000	EA LIGHT - BRAKE - CENTER MOUNT - RECTANGLE - 1.3" X 9.8"
4*	115632-03-01A	EA LIGHT - STOP/TAIL/BACKUP
5	087201-01-000	EA LIGHT - HALF ROUND - 1" X 1.7" - PLASTIC - BLACK OR WHITE
6*	113589-01-000	EA CONNECTOR - PLUG - TRAILER
6	113589-02-000	EA CONNECTOR - SOCKET - TRAILER
7	147901-01-02B	EA BRACKET/HEADLAMP - PASSENGER - E-COATED
7	147901-02-02B	EA BRACKET/HEADLAMP - DRIVER - E-COATED
8	148111-01-01A	EA PIN-MOUNT - HEADLAMP - BLACK
9	148629-01-000	EA HEADLAMP - PASSENGER/(HIGH/LOW) - W/BULB
9	148629-02-000	EA HEADLAMP - DRIVER/(HIGH/LOW) - W/BULB
9	124187-01-000	EA SOCKET/HOUSING - LOW BEAM HEADLAMP
9	124187-02-000	EA SOCKET/HOUSING - HIGH BEAM HEADLAMP
10	084901-01-000	EA LAMP - PARK/TURN - GM #916558 (BULB #2057)

*COMPONENT PARTS LISTED LATER IN THIS GROUP

ELECTRICAL GROUP (CONTINUED) FRONT END

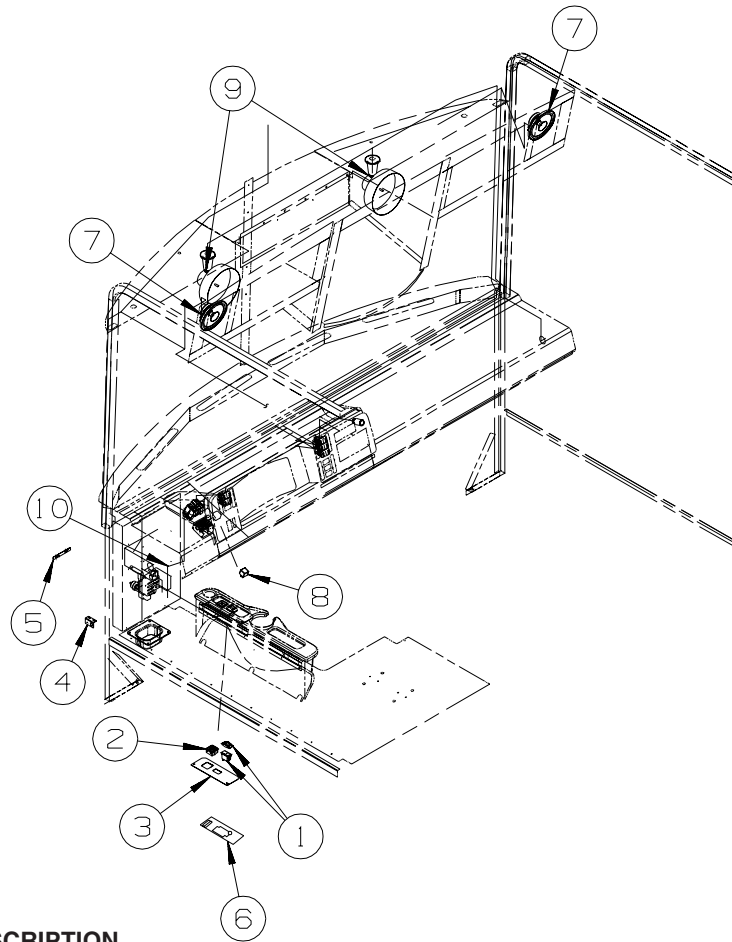

KEY	PART NUMBER	U/M	DESCRIPTION
1	108357-14-000	EA	SWITCH - ROCKER - SPST-ON/OFF - 4 TERM W/LIGHT W/O COVER
1	108356-03-01A	EA	COVER/ACTUATOR SWITCH - 3 GROOVES W/LIGHT-CONTURA III-BLK
2	088246-01-000	EA	SWITCH/REMOTE MIRROR - W/2PIN & 6 PIN CONNECTORS/PIGTAIL
3	132514-01-02B	EA	PLATE - SWITCH - HEATED MIRROR - E-COATED
4	147428-01-02B	EA	BRACKET - Z - TEMP SENSOR
5	133533-04-01A	EA	LABEL - WINDOW/MIRROR HEAT - BLACK/CLEAR
6	111537-08-000	EA	LABEL - FUSES
7	094097-01-000	EA	SPEAKER - RADIO/TV - W/O GRILLE - 5.25" DIAMETER
8	063912-02-000	EA	RELAY - CANISTER - SPDT
9	122856-01-01A	EA	FAN-DEFROSTER-2 SPEED W/SWIVEL BASE/NON-OSCILLATING-CHROME
10	104678-01-000	EA	LABEL - CB PREP

ELECTRICAL GROUP (CONTINUED) FRONT END (CONTINUED)

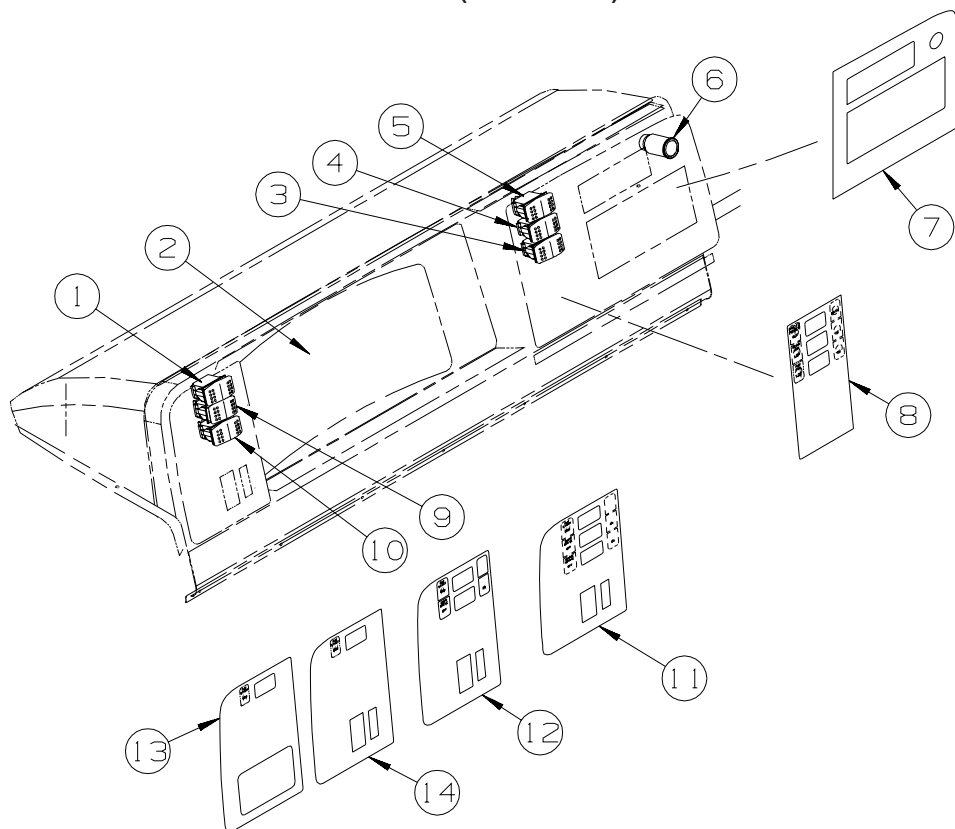

KEY	PART NUMBER	U/M	DESCRIPTION
1	108357-09-000	EA	SWITCH - ROCKER - SPDT - ON/NONE/MOM - 3 TERM - W/O COVER
1	108356-02-01A	EA	COVER/ACTUATOR SWITCH - 2 ROWS DIMPLES- CONTURA II - BLACK
1	108355-01-000	EA	HOUSING - SWITCH
1	103603-01-000	EA	BULB - 12V - #74 - .12A WEDGE - GE 22-25 USED IN DASH
2			SUPPLIED BY CHASSIS MANUFACTURER - U.S.
2	127244-10-000	EA	CLUSTER - INSTRUMENT PANEL - K/M - GAS - CANADIAN
3	108357-03-000	EA	SWITCH - ROCKER - SPDT - ON/OFF/ON - 3 TERMINAL- W/O COVER
3	108356-02-01A	EA	COVER/ACTUATOR SWITCH - 2 ROWS DIMPLES- CONTURA II - BLK
3	108355-01-000	EA	HOUSING - SWITCH
3	096241-03-000	EA	SWITCH - BLANK - BLACK
3	103603-01-000	EA	BULB - 12V - #74 - .12A WEDGE - GE 22-25 USED IN DASH
4	108357-03-000	EA	SWITCH - ROCKER - SPDT - ON/OFF/ON - 3 TERMINAL- W/O COVER
4	108356-02-01A	EA	COVER/ACTUATOR SWITCH - 2 ROWS DIMPLES- CONTURA II - BLACK
4	108355-01-000	EA	HOUSING - SWITCH
4	096241-03-000	EA	SWITCH - BLANK - BLACK
4	103603-01-000	EA	BULB - 12V - #74 - .12A WEDGE - GE 22-25 USED IN DASH
5	108357-08-000	EA	SWITCH - ROCKER - DPDT - 0N/NONE/ON - 6 TERM - W/O COVER
5	108356-02-01A	EA	COVER/ACTUATOR SWITCH - 2 ROWS DIMPLES- CONTURA II - BLACK
5	108355-01-000	EA	HOUSING - SWITCH
5	103603-01-000	EA	BULB - 12V - #74 - .12A WEDGE - GE 22-25 USED IN DASH
6	089294-01-000	EA	LIGHTER - CIGARETTE - W/SOCKET & WIRE
7	104056-54-02A	EA	APPLIQUE - BEZEL - PASSENGER - DRESS UP - DARK TITANIUM
8	104056-53-02A	EA	APPLIQUE - BEZEL/3 SWITCH - PASSENGER - DARK TITANIUM
	077031-01-000	EA	FILM - BLACK - 1" X 1.75"
	077031-03-000	EA	FILM - WHITE - .75" X 1"
9	108357-08-000	EA	SWITCH - ROCKER - DPDT - 0N/NONE/ON - 6 TERM - W/O COVER
9	108356-02-01A	EA	COVER/ACTUATOR SWITCH - 2 ROWS DIMPLES- CONTURA II
9	108355-01-000	EA	HOUSING - SWITCH
9	103603-01-000	EA	BULB - 12V - #74 - .12A WEDGE - GE 22-25 USED IN DASH
10	108356-02-01A	EA	COVER/ACTUATOR SWITCH - 2 ROWS DIMPLES- CONTURA II
10	103603-01-000	EA	BULB - 12V - #74 - .12A WEDGE - GE 22-25 USED IN DASH
11	104056-64-01A	EA	APPLIQUE - SWITCH BEZEL - DARK TITANIUM - 2005 20,700 # WORKHORSE CHASSIS
12	104056-55-02A	EA	APPLIQUE - BEZEL/SWITCH - DRIVER - DARK TITANIUM - 2004 20,700 # WORKHORSE CHASSIS
13	104056-49-02A	EA	APPLIQUE - BEZEL/SWITCH - DRIVER - DARK TITANIUM - FORD
14	104056-48-02A	EA	APPLIQUE - BEZEL - DRIVER - BLACK - 15,000 # & 18,000 # WORKHORSE

ELECTRICAL GROUP (CONTINUED)

FRONT TV/VCR

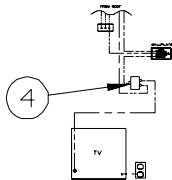
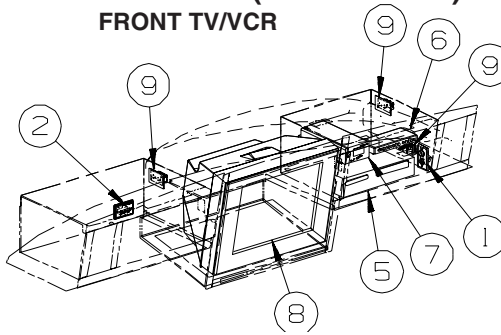

TV-24" color stereo

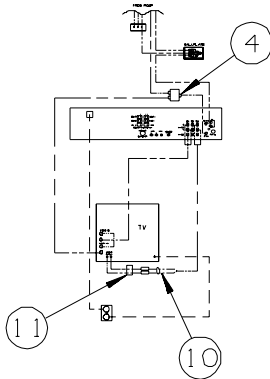

HOME THEATER SOUND SYSTEM

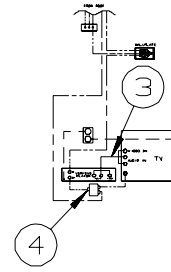

DVD/VCR STEREO W/REMOTE

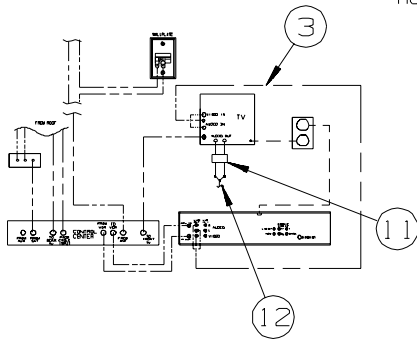

TV-13" W/VIDEO SELECTION SYSTEM
 DVD/VCR, STEREO W/REMOTE/TV 13" W/VIDEO SELECT SYSTEM
 VIDEO SELECTION SYSTEM
 TV-"RR" 19" VIDEO SELECTION
 TV-"RR" 19" VIDEO SELECTION/DVD/VCR, STEREO, W/REMOTE

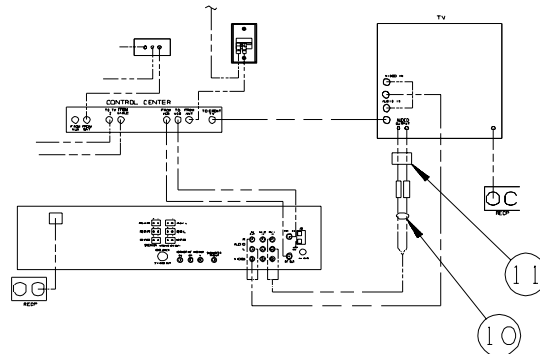

TV-13" W/VIDEO SELECTION SYSTEM/HOME THEATER SOUND SYSTEM
 HOME THEATER SOUND SYSTEM/TV"RR"19", VIDEO SELECTION

KEY	PART NUMBER	U/M	DESCRIPTION
1	086777-02-000	EA	WALLPLATE/TV CABLE W/ANTENNA SWITCH/BOOSTER - 2 TV - TV ANTENNA
1	086777-06-000	EA	WALLPLATE/TV CABLE - W/ANTENNA BOOSTER/1 OUTPUT
2	149557-04-01A	EA	PLATE/WALL - TRIPLE COAXIAL/HORIZONTAL - WHITE
3	136860-01-000	EA	CABLE - RCA - #3 MALE TO #12F MALE CONNECTOR
4	086756-01-000	EA	SPLITTER - TV/2 WAY
5*	145641-03-000	EA	DVD/VCR PLAYER - RCA DRC6100N - STEREO DVD/VCR FROM: 00-00-00 THRU: 08-22-04
5*	145641-02-000	EA	DVD/VCR PLAYER - RCA DRC6200N - STEREO DVD/VCR FROM: 08-23-04 THRU: 10-17-04
5*	145641-04-000	EA	DVD/VCR PLAYER - RCA DRC6300N - STEREO DVD/VCR FROM: 10-18-04 THRU: 99-99-99
5*	150089-01-000	EA	DVD/VCR PLAYER - RCA RTD300/SP - HOME THEATER SYSTEM
6	086757-04-000	EA	CONTROL CENTER - SWITCH - VCR/TV - 5 INPUTS
7	099048-04-000	EA	INVERTER - 300 WATT
8*	148230-03-000	EA	TV - 24" - STEREO/5 JACKS - RCA 24V510TAO FROM: 00-00-00 THRU: 09-19-04
8*	148230-01-000	EA	TV - 24" - STEREO/3 JACKS - RCA 24V510T FROM: 09-20-04 THRU: 01-02-05
8	152441-01-000	EA	TV - 24" - STEREO/3 JACKS - RCA 24V511T FROM: 01-03-05 THRU: 99-99-99
9	058708-01-000	EA	RECEPTACLE - ELECTRIC - DOUBLE - BROWN
10	117420-02-000	EA	CABLE - W/MALE RCA ENDS - SHIELDED - 4' - NOT USED HOME THEATER SYSTEM
11	123324-01-000	EA	FILTER - GROUND LOOP - NOT USED HOME THEATER SYSTEM
12	117420-01-000	EA	CABLE - W/MALE RCA ENDS - SHIELDED - 12'

*COMPONENT PARTS LISTED LATER IN THIS GROUP

ELECTRICAL GROUP (CONTINUED)

COMPONENT PARTS FOR WIRING

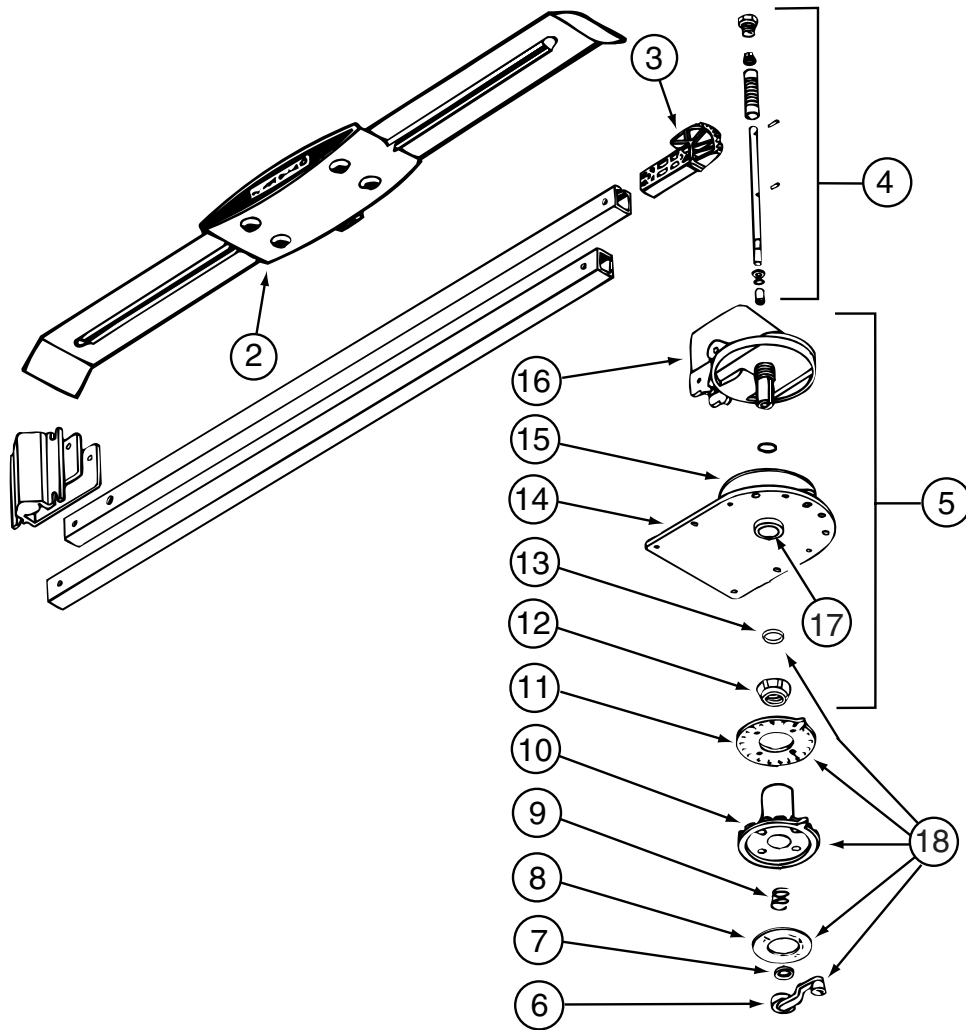

076319-23-000

KEY	PART NUMBER	U/M	DESCRIPTION	VENDOR NO.
2	076319-01-700	EA	HEAD-ANTENNA, AMPLIFIED	RVSA U/V
3	076319-01-701	EA	GEAR-ELEVATING, PLASTIC	2200046
4	076319-01-702	EA	SHAFT ASM-ELEVATING	RP-4000
5	076319-01-711	EA	BASE & LIFT ASM	2762802
7	076319-01-705	EA	GROMMET-NYLON, 7/8"ID	3200658
8	076319-01-708	EA	DECAL-CRANK	5413002
9	076319-01-707	EA	SPRING-HANDLE	2160822
11	076319-01-712	EA	PLATE - CEILING	3200608
12	076319-01-715	EA	NUT (GEAR HOUSING)	2200047
14	076319-01-713	EA	PLATE-BASE, STEEL	3100523
15	076319-01-703	EA	BEARING-NYLON, 5"OD	3200656
16	076319-01-714	EA	HOUSING, ROTATING GEAR	2200049
17	076319-01-704	EA	BEARING-NYLON, 1.25"OD	3200657
18	076319-01-709	EA	HANDLE-HEAD DIRECTIONAL	200644
	076319-01-716	EA	TUBING, ELEVATING	RP-2900
CONTACT WINNEBAGO PART SALES FOR UNLISTED COMPONENT(S)				

076319-25-000

KEY	PART NUMBER	U/M	DESCRIPTION	VENDOR NO.
6	076319-01-706	EA	CRANK-W/SET SCREW UNIV/BEIGE	2750897
6	120233-01-710	EA	HANDLE-CRANK W/SCREW - WHITE	RP-6795
8	076319-01-708	EA	DECAL-CRANK	5413002
10	076319-25-700	EA	DIRECTIONAL HANDLE(WHITE)	3200612
11	076319-25-701	EA	PLATE - CEILING(WHITE)	3200609
13	120233-01-709	EA	WASHER-NYLON	RP-2658
CONTACT WINNEBAGO PART SALES FOR UNLISTED COMPONENT(S)				

ELECTRICAL GROUP (CONTINUED)

COMPONENT PARTS FOR WIRING (CONTINUED)

086231-10-000

KEY	PART NUMBER	U/M	DESCRIPTION	VENDOR NO.
	086231-08-700	EA	REMOTE-UNIVERSAL	0892325
	086231-10-700	EA	ADAPTER WIRE - (CIGARETTE)	0894000
	086231-10-701	EA	CONVERTER/POWER SUP 110/12 V	0891412

097917-01-06A

KEY	PART NUMBER	U/M	DESCRIPTION	VENDOR NO.
	097917-01-700	EA	LENS-LIGHT, CLEAR	30-78-021

113589-01-000

KEY	PART NUMBER	U/M	DESCRIPTION	VENDOR NO.
	113589-01-700	EA	ADAPTER, 4-WAY/6-WAY	5291

115632-03-01A

KEY	PART NUMBER	U/M	DESCRIPTION	VENDOR NO.
	115632-03-700	EA	LENS - RED-(STOP/TAIL/BACK)	3092-704

121935-01-01A

KEY	PART NUMBER	U/M	DESCRIPTION	VENDOR NO.
	121935-01-700	EA	LENS ONLY	809511

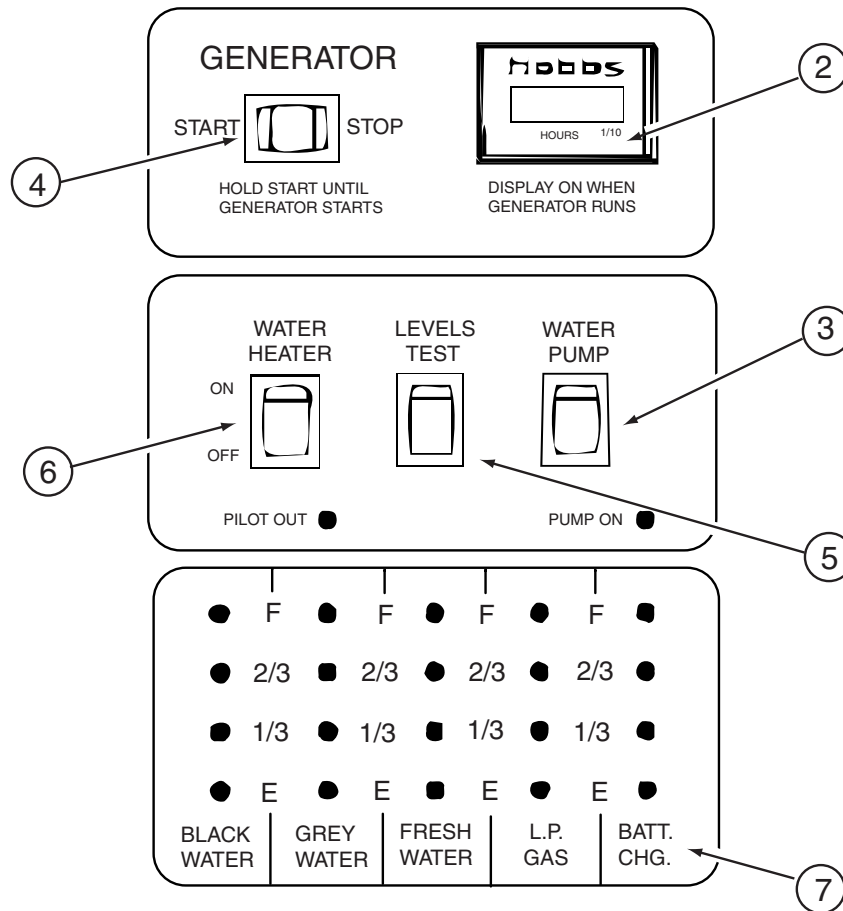

134940-01-01A

KEY	PART NUMBER	U/M	DESCRIPTION	VENDOR NO.
2	100258-10-701	EA	GAUGE-HR METER ONLY (LCD)	L0775-00
3	096983-01-703	EA	SWITCH - ON/ON	L0115-00
4	096983-01-702	EA	SWITCH - MOM/OFF/MOM/3 TERM	L0112-00
5	096983-01-701	EA	SWITCH - SPST/MOM 2 TERMINAL	L0111-00
6	134940-01-701	EA	SWITCH-SPST/ON-OFF/BLK W/LGT	L0109
7	134940-01-702	EA	CHASSIS - SILKSCREENED	CC0558-00
	100258-10-702	EA	HOUR METER(SNAP-IN)SW & WIRE	L4441-00
	134940-01-700	EA	BOARD - PC	L5118-01

ELECTRICAL GROUP (CONTINUED)
COMPONENT PARTS FOR WIRING (CONTINUED)

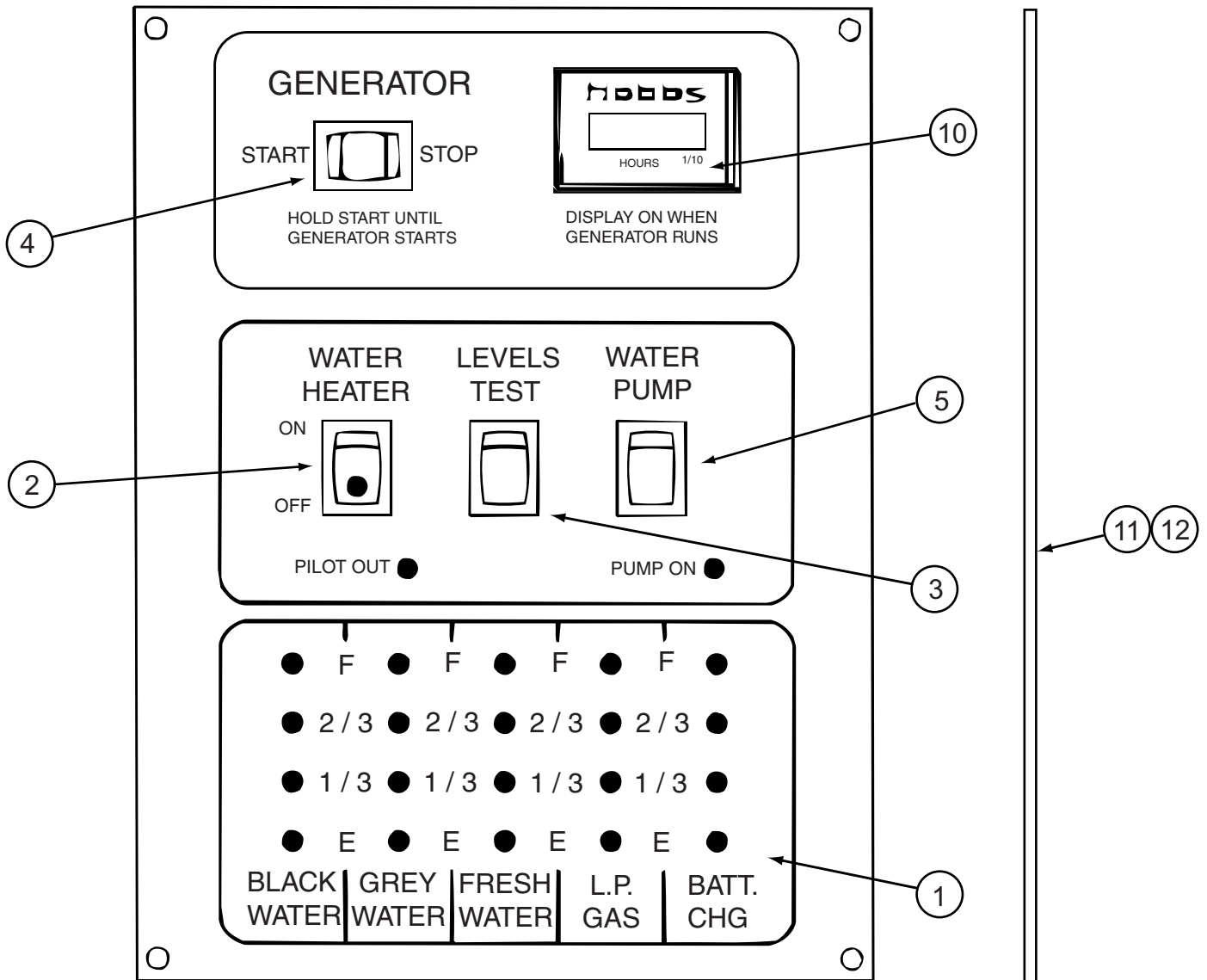

134940-06-01A

KEY	PART NUMBER	U/M	DESCRIPTION	VENDOR NO.
1	134940-01-702	EA	CHASSIS - SILKSCREENED	CC0558-00
2	134940-01-701	EA	SWITCH-SPST/ON-OFF/BLK W/LGT	L0109
3	096983-01-701	EA	SWITCH - SPST/MOM 2 TERMINAL	L0111-00
4	096983-01-702	EA	SWITCH - MOM/OFF/MOM/3 TERM	L0112-00
5	096983-01-703	EA	SWITCH - ON/ON	L0115-00
10	100258-10-701	EA	GAUGE-HR METER ONLY (LCD)	L0775-00
11	134940-06-700	EA	PC BOARD - SENSOR SYSTEM/RED	L5131-02

CONTACT WINNEBAGO PART SALES FOR UNLISTED COMPONENT(S)

ELECTRICAL GROUP (CONTINUED)
COMPONENT PARTS FOR WIRING (CONTINUED)

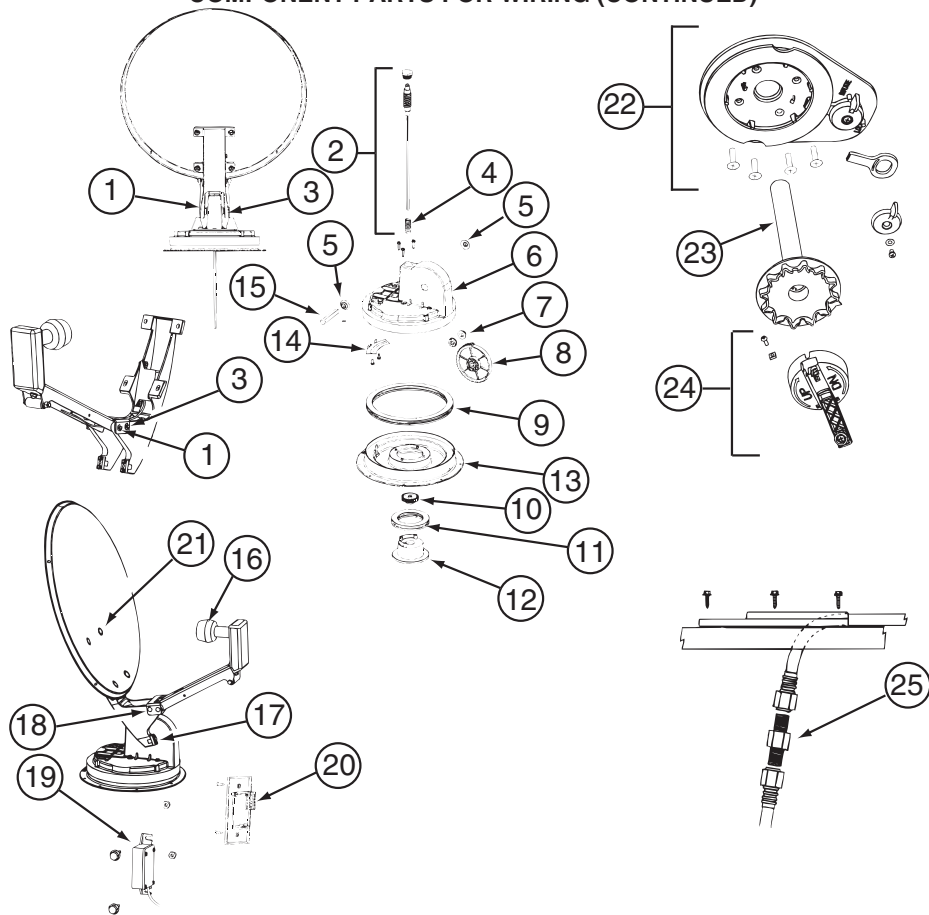

137135-02-000

KEY	PART NUMBER	U/M	DESCRIPTION	VENDOR NO.
1	120233-01-714	EA	CLIP-E	5160818
2	137135-01-703	EA	KIT ELEV - SHAFT/GEAR/SPRING	RP-4400
3	137135-01-704	EA	PIN - 1/4" X 3.25"	2160813
4	137135-01-705	EA	SPRING	2160818
5	137135-01-707	EA	SEAL - PIVOT SHAFT	2200852
6	137135-01-708	EA	TURRET	3100728
7	137135-01-709	EA	PIVOT BEARING	2200470
8	137135-01-711	EA	GEAR - ELEVATING	2200464
9	137135-01-712	EA	BEARING - OUTER	2590347
10	137135-01-714	EA	GEAR - ELEVATING SHAFT	2200465
11	137135-01-715	EA	BEARING - INNER	2590348
12	137135-01-716	EA	HUB	3100731
13	137135-01-713	EA	TURRET BASE	3100730
14	137135-01-710	EA	PLATE - ROTATE LIMIT	3720052
16	137135-02-703	EA	LOW NOISE BLOCK FILTER	LB-6000 - DUAL
17	137135-01-722	EA	CLAMP	2590343
18	137135-01-719	EA	BRACKET - PIVOT	2744945
19	137135-01-720	EA	DE-SENSOR UNIT W/43" CABLE	DM4000
20	137135-02-701	EA	BOX - SURFACE MOUNT	SM-100
21	137135-01-717	EA	BOLT - FLAT HEAD	2160362
22	120233-01-737	EA	PLATE/INT-W/DIRECTIONAL HDLE	RK-CEIL
23	120233-01-704	EA	DIAL/DIRECTIONAL 4"W/SPRING	3200364
24	120233-01-738	EA	HDW PKG-HANDLE/SPRING/WASHER	RK-HAND
25	137135-01-701	EA	CONNECTOR - F - MALE TO MALE	FS-8100
	120233-04-700	EA	KIT-WALL PLATE/CABLE - GRAY	DM4000
	137135-01-700	EA	ROOF WEDGE W/GASKET	RW-5000
	137135-01-706	EA	KIT-TURRET/SEAL/BEARING/GEAR	RP-RM30
	137135-01-718	EA	REFLECTOR/WHITE-46CM W/HDW	RP-35RM
	137135-02-700	EA	DE-SENSOR	2780096
	137135-02-704	EA	KIT-UPDATE DIRECTIONAL HDL	RP-RMDH
	137135-02-705	EA	KIT-TURRET & SHAFT COMPLETE	RP-RM46

CONTACT WINNEBAGO PART SALES FOR UNLISTED COMPONENT(S)

ELECTRICAL GROUP (CONTINUED)
COMPONENT PARTS FOR WIRING (CONTINUED)

137417-01-01A, 137417-03-01A

KEY	PART NUMBER	U/M DESCRIPTION	VENDOR NO.
	137417-01-700	EA LENS - SINGLE (FROSTED)	810868

137417-05-01A

KEY	PART NUMBER	U/M DESCRIPTION	VENDOR NO.
	137417-05-700	EA LENS - DOUBLE OPTIC	810845

137417-06-01A

KEY	PART NUMBER	U/M DESCRIPTION	VENDOR NO.
	137417-06-700	EA LENS - DOUBLE WHITE	810867

145641-02-000, 145641-04-000

KEY	PART NUMBER	U/M DESCRIPTION	VENDOR NO.
	145641-02-700	EA REMOTE	260607

145641-03-000

KEY	PART NUMBER	U/M DESCRIPTION	VENDOR NO.
	145641-03-700	EA REMOTE	RCR311DA1

148230-01-000, 148230-02-000

KEY	PART NUMBER	U/M DESCRIPTION	VENDOR NO.
	148230-01-700	EA REMOTE (TV)	260605

148230-03-000

KEY	PART NUMBER	U/M DESCRIPTION	VENDOR NO.
	149040-02-700	EA REMOTE (TV)	RCR311TBM1-RCA

148231-01-000

KEY	PART NUMBER	U/M DESCRIPTION	VENDOR NO.
	148231-01-700	EA REMOTE	RC3100

150089-01-000

KEY	PART NUMBER	U/M DESCRIPTION	VENDOR NO.
	150089-01-700	EA REMOTE	265683

ELECTRICAL GROUP (CONTINUED)
CIRCUIT BREAKERS & FUSES

KEY	PART NUMBER	U/M	DESCRIPTION
	008235-01-000	EA	FUSE - 15 AMP/12VOLT - AUTOMOTIVE
	033573-01-000	EA	CIRCUIT BREAKER W/MOUNT-20A, 12V - FASCO 1711-2026
	062901-02-000	EA	FUSE - 5 AMP - AUTOMOTIVE
	062901-04-000	EA	FUSE - 10 AMP - AUTOMOTIVE
	062901-05-000	EA	FUSE - 15 AMP - AUTOMOTIVE
	062901-06-000	EA	FUSE - 20 AMP - AUTOMOTIVE
	062901-07-000	EA	FUSE - 25 AMP - AUTOMOTIVE
	062901-08-000	EA	FUSE - 30 AMP - AUTOMOTIVE
	063910-01-000	EA	HOUSING - RELAY
	063912-02-000	EA	RELAY - CANISTER - SPDT
	083209-01-000	EA	CIRCUIT BREAKER - 15 AMP - 120 VOLT - CANADIAN
	083209-02-000	EA	CIRCUIT BREAKER - 15/15 AMP - 120 VOLT
	083209-03-000	EA	CIRCUIT BREAKER - 15/20 AMP - 120 VOLT
	083209-04-000	EA	CIRCUIT BREAKER - 30 AMP - 120 VOLT
	083209-05-000	EA	CIRCUIT BREAKER - 20 AMP - 120 VOLT
	083209-06-000	EA	CIRCUIT BREAKER - 30/15 AMP - 120 VOLT
	083209-07-000	EA	CIRCUIT BREAKER - 20/20 AMP - 120 VOLT
	083209-10-000	EA	CIRCUIT BREAKER - 20/30 AMP - 120 VOLT
	083209-11-000	EA	CIRCUIT BREAKER - 20/15 AMP - 120 VOLT
	092786-03-000	EA	BUSS BAR - 6.9" LONG
	092786-06-000	EA	BUSS BAR
	093654-01-000	EA	CIRCUIT BREAKER - 6 AMP - 12 VOLT - PUSH BUTTON - WHITE
	093654-02-000	EA	CIRCUIT BREAKER - 15 AMP - 12 VOLT - PUSH BUTTON - WHITE
	093654-03-000	EA	CIRCUIT BREAKER - 20 AMP - 12 VOLT - PUSH BUTTON - WHITE
	093654-11-000	EA	COVER - RESET BUTTON
	093655-01-000	EA	CIRCUIT BREAKER - 25 AMP - 12 VOLT - PUSH BUTTON - WHITE
	093655-02-000	EA	CIRCUIT BREAKER - 30 AMP - 12 VOLT - PUSH BUTTON - WHITE
	093655-03-000	EA	CIRCUIT BREAKER - 40 AMP - 12 VOLT - PUSH BUTTON - WHITE
	097611-01-000	EA	CIRCUIT BREAKER - 10 AMP
	097611-02-000	EA	CIRCUIT BREAKER - 30 AMP
	097611-03-000	EA	CIRCUIT BREAKER - 20 AMP
	097611-04-000	EA	CIRCUIT BREAKER - 25 AMP
	100341-01-000	EA	FUSE HOLDER - IN LINE TYPE
	106656-01-000	EA	FUSE BLOCK - 4 CAVITY - AUTOFUSE
	108567-01-000	EA	CIRCUIT BREAKER - 40 AMP - 12 VOLT - TYPE II
	111683-01-000	EA	FUSE - HOLDER - GLASS - 1/4" X 1 1/4"
	113482-01-000	EA	CIRCUIT BREAKER - 55 AMP - MANUAL
	115187-01-000	EA	FUSE - 300 AMP - NON-DELAY
	115187-02-000	EA	FUSE HOLDER - BUSS ANN/ANL BLOCK
	119930-01-000	EA	CAPACITOR - ELECTROLYTIC
	122811-01-000	EA	CIRCUIT BREAKER - 20/50/50/20 AMP - 250V
	125986-02-000	EA	FUSE - 5 AMP - AUTO - MINI BLADE
	125986-04-000	EA	FUSE - 10 AMP - AUTO - MINI BLADE
	125986-05-000	EA	FUSE - 15 AMP - AUTO - MINI BLADE
	125986-06-000	EA	FUSE - 20 AMP - AUTO - MINI BLADE
	125986-07-000	EA	FUSE - 25 AMP - AUTO - MINI BLADE
	134127-01-000	EA	CIRCUIT BREAKER - 10 AMP - MINI
	141789-01-000	EA	SPACER - CIRCUIT BREAKER

ELECTRICAL GROUP (CONTINUED)

CONVERTER, INVERTER, LOAD CENTERS

KEY	PART NUMBER	U/M	DESCRIPTION
	099048-03-000	EA	INVERTER - 130 WATT
	123058-02-000	EA	CONVERTER - 45 AMP - ELECTRONIC - 4 1/8"H X 7"W X 12 3/8"L - D33L, D35N

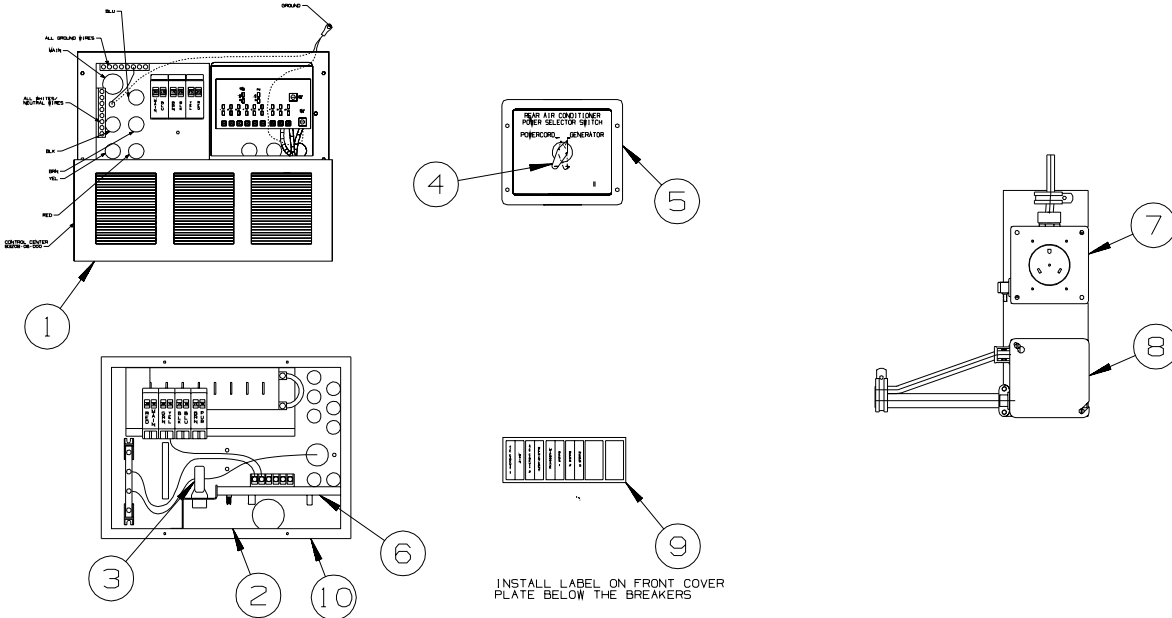

KEY	PART NUMBER	U/M	DESCRIPTION
1	083208-06-000	EA	CONTROL CENTER - 45 AMP/120V/12V - W/O BREAKERS - A/C HEAT PUMP/A/C ROOF (1) 14,800 BTU
2	141258-01-000	EA	LOAD CENTER - 120/240 - 50 AM - A/C HEAT PUMP 2 HIGH EFFICIENCY/A/C ROOF 2 HIGH EFF W/EMS
3	127002-07-000	EA	SENSOR - CURRENT
4	073937-03-000	EA	SWITCH - ROTARY- AC - SELECTOR - 3 DECK
5	121365-03-01A	EA	COVER - REAR A/C POWER SELECT SWITCH - POWERCORD/GENERATOR
6	127002-08-000	EA	MODULE - EMS CENTER - W/REMOTE SENSOR
			FROM: 00-00-00 THRU: 11-07-04
6	127002-11-000	EA	MODULE - EMS CENTER - W/REMOTE SENSOR
			FROM: 11-08-04 THRU: 99-99-99
7	024924-02-000	EA	RECEPTACLE - POWER CORD - W/PARTIAL PLATE
8	008289-01-000	EA	BOX - ELECTRIC/STEEL - 4" X 4" - 1/2" & 3/4" KNOCKOUTS
9	095721-27-000	EA	LABEL - CONTROL CENTER - 30 AMP
10	141258-02-000	EA	LOAD CENTER - COVER

ELECTRICAL GROUP (CONTINUED)
BOXES & CORDS

KEY	PART NUMBER	U/M	DESCRIPTION
	008289-01-000	EA	BOX - ELECTRIC/STEEL - 4" X 4" - 1/2" & 3/4" KNOCKOUTS
	074890-01-000	EA	BOX - EXTENSION/STEEL - OPEN SIDES - 4" X 4" X 1 1/2" - D33L, D35N
	091910-01-000	EA	BOX - ELECTRIC - 3.8" X 3.5" X 1.8" - PLASTIC - D27C
	091910-02-000	EA	BOX - ELECTRIC - 2.2" X 3.5" X 1.8" - PLASTIC - D27C
	133070-01-000	EA	BOX - ELECTRIC/PLASTIC - 3" X 2" X 2.8" - UL - D27C, D29R, D33L
	133070-02-000	EA	BOX - ELECTRIC/PLASTIC - 3" X 2" X 2.8" - CSA - D27C, D29R, D33L
	131679-01-000	EA	BOX/ELECTRIC-WATERPROOF-4" X 4" - W/4 3/4"OUTLETS-UL/CSA - D33L, D35N
	008294-01-000	EA	COVER - ELECTRIC BOX - BLANK/STEEL - 4" X 4" - GRAY
	069238-01-000	EA	COVER - ELECTRICAL BOX - W/HOLE - 4" X 4" - GRAY
	074897-01-000	EA	COVER - ELECTRICAL BOX W/HOLES - 4" X 4" - D30B, D35N
	131680-01-000	EA	COVER - F/ELECTRIC BOX W/GASKET 4" X 4" - UL/CSA - D33L, D35N
	008054-01-000	EA	CORD - POWER - 10/3 WIRE - 30 AMP - 25'
	115832-01-000	FT	CORD - HEAVY DUTY - 14-2W GROUND
	092492-11-000	EA	SEAL - ELECTRIC BOX - 7" X 18.4"
	109925-04-000	EA	DOOR - ELECTRICAL BOX - GM/FORD

WIRE ASSEMBLIES

KEY	PART NUMBER	U/M	DESCRIPTION
	096449-01-000	EA	WIRE ASSEMBLY - WATER TANK TO MONITOR PANEL
	096450-05-000	EA	WIRE F/SENSORS - BLACK WATER - 23.6" FROM: 00-00-00 THRU: 05-02-04
	151317-02-000	EA	WIRE ASM-W/NON CONTACT SENSORS - BLACK WATER - 23.6" FROM: 05-03-04 THRU: 99-99-99
	096451-05-000	EA	WIRE F/SENSORS - GREY WATER - 43.2" - D29R, D33L FROM: 00-00-00 THRU: 05-02-04
	096451-06-000	EA	WIRE F/SENSORS - GREY WATER - 23.6" - D35N FROM: 00-00-00 THRU: 05-02-04
	096451-07-000	EA	WIRE F/SENSORS - GREY WATER - 3.9" - D27C, D30B FROM: 00-00-00 THRU: 05-02-04
	151316-01-000	EA	WIRE ASM - W/NON CONTACT SENSORS - GREY WATER - 3.9" - D27C FROM: 05-03-04 THRU: 99-99-99
	151316-02-000	EA	WIRE ASM - W/NON CONTACT SENSORS - GREY WATER - 23.6" - D29R, D34A, D35N FROM: 05-03-04 THRU: 99-99-99
	151316-03-000	EA	WIRE ASM - W/NON CONTACT SENSORS - GREY WATER - 43.2" - D30B, D33L FROM: 05-03-04 THRU: 99-99-99
	077069-02-000	EA	CABLE/EXTENSION - RADIO ANTENNA - 96"
	077069-03-000	EA	CABLE/EXTENSION - RADIO ANTENNA - 260"
	125853-04-000	EA	WIRE LOOM - ENTERTAINMENT CENTER
	135420-02-000	EA	WIRE LOOM - RADIO
	137135-03-000	EA	WIRE LOOM - DIGITAL ELEVATION SENSOR
	137626-01-000	EA	WIRE - OVERDRIVE SWITCH - D35N
	144677-07-000	EA	WIRE - MONITOR - POWER - 3 PIN
	147313-01-000	EA	WIRE - OUTSIDE TEMP SENSOR - W/O SENSOR
	136514-02-000	EA	CABLE - MONITOR/CAMERA
	137135-03-000	EA	WIRE LOOM - DIGITAL ELEVATION SENSOR
	137135-04-000	EA	WIRE HARNESS - POWER - DIGITAL ELEVATION SENSOR
	137626-01-000	EA	WIRE - OVERDRIVE SWITCH - 20,700 GVWR WORKHORSE

ELECTRICAL GROUP (CONTINUED)
CONNECTORS & CONDUIT

KEY	PART NUMBER	U/M	DESCRIPTION
	007940-01-000	EA	RECEPTACLE/SLIDE 16 TO 12 AWG - FEMALE END
	007940-02-000	EA	RECEPTACLE-SLIDE 10 AWG - AMP 180351-2
	007954-01-000	EA	RECEPTACLE - HOUSING - 6 POSITION
	007956-05-000	EA	INSULATOR - SHRINK - 1/4"ID X 1 1/2"
	008058-01-000	EA	ADAPTER - POWER CORD - 30 AMP TO 15 AMP
	008311-01-000	EA	CONNECTOR - WIRE NUT - INSULATED - RED
	008312-01-000	EA	CONNECTOR - WIRE NUT - INSULATED - BLUE
	008313-01-000	EA	CONNECTOR - WIRE NUT - INSULATED - YELLOW
	008314-01-000	EA	CONNECTOR - WIRE NUT - INSULATED - GRAY
	008326-01-000	EA	TERMINAL - RING - 16/14 WIRE - 3/8" STUD
	008328-01-000	EA	TERMINAL - RING - 12/10 WIRE - #10 STUD FIT
	008331-01-000	EA	TERMINAL - RING - TONGUE - #4 WIRE - 3/8" STUD - COPPER
	008348-01-000	EA	TERMINAL - RING - 3/8" STUD 2 GA. WIRE
	008355-01-000	EA	CONNECTOR - CABLE CLAMPING - 3/4"
	008356-01-000	EA	CONNECTOR - PLASTIC - 3/8"
	008356-02-000	EA	CONNECTOR - PLASTIC - 21/32"
	008394-01-000	FT	CONDUIT - FLEXIBLE - 1/2"
	008398-01-000	EA	CONNECTOR - 1/2" X 90 DEGREE - FLEX CONDUIT - UL & CSA
	035416-04-000	EA	TERMINAL - RING - #10 STUD FIT - INSULATED BARREL #16/14
	041953-01-000	FT	CONDUIT - CONVOLUTE SLIT - .5" ID - POLYETHYLENE
	041953-03-000	FT	CONDUIT - CONVOLUTE SLIT - 1" ID (CLOTHES ROD COVER)
	041953-06-000	FT	CONDUIT - CONVOLUTE SLIT - .4" ID - POLYETHYLENE
	041953-07-000	FT	CONDUIT - CONVOLUTE SLIT - .25" ID - POLYETHYLENE
	041953-08-000	FT	CONDUIT - CONVOLUTE SLIT - 1.5" ID - POLYETHYLENE
	041953-09-000	FT	CONDUIT - CONVOLUTE SLIT - .5" ID - NYLON
	041953-10-000	FT	CONDUIT - CONVOLUTE SLIT - .75" ID - NYLON
	041953-11-000	FT	CONDUIT - CONVOLUTE SLIT - 1.06" ID - NYLON
	041953-12-000	FT	CONDUIT - CONVOLUTE SOLID - 1.1" ID - NYLON
	041953-13-000	FT	CONDUIT - CONVOLUTE SLIT - 1.25" ID
	041953-14-000	FT	CONDUIT - CONVOLUTE SLIT - 1.5" ID
	041953-15-000	FT	CONDUIT - CONVOLUTE SLIT - 2"
	041953-16-000	FT	CONDUIT - CONVOLUTE SLIT - 2"
	047443-01-000	EA	TERMINAL - .250 RECEPTACLE FIT - INSULATED - 16/14 AWG
	047443-02-000	EA	TERMINAL - .250 RECEPTACLE FIT - INSULATED - 12/10 AWG
	058028-01-000	EA	CONNECTOR - ELECTRICAL PIGTAIL - NYLON - CLEAR
	062036-01-000	EA	TERMINAL - PACK - CON - 12/10 AWG
	077479-01-000	EA	BOOT - BATTERY TERMINAL - DOUBLE CABLE
	077479-02-000	EA	BOOT - BATTERY TERMINAL - SINGLE CABLE
	080015-02-000	EA	RECEPTACLE - FLAG - .185 - 16/14 GAUGE
	080015-03-000	EA	RECEPTACLE - FLAG - .250 - 14/16 GAUGE
	082109-01-000	EA	HOUSING - CONNECTOR - PACKARD
	082741-01-000	EA	CONNECTOR BODY - 2 CONNECTOR MALE
	087225-01-000	FT	SLEEVEING - 1/2" - TYPE H
	087949-01-000	EA	BUSS BAR - 2 POSITION - .6" X 1.5"
	087949-03-000	EA	BUSS BAR - 4 POSITION
	088473-01-000	EA	HOUSING - PIN - 12 CAVITY (3 ROWS OF 4)
	088473-02-000	EA	HOUSING - PIN - 15 CAVITY (3 ROWS OF 5)
	088473-03-000	EA	HOUSING - PIN - 9 CAVITY (3 ROWS OF 3)
	088473-04-000	EA	HOUSING - PIN - 8 CAVITY IN-LINE
	088473-06-000	EA	HOUSING - PIN - 6 CAVITY (2 ROWS OF 3)
	088473-07-000	EA	HOUSING - PIN - 5 CAVITY - IN-LINE
	088473-08-000	EA	HOUSING - PIN - 4 CAVITY - IN-LINE
	088473-09-000	EA	HOUSING - PIN - 3 CAVITY - IN-LINE
	088473-10-000	EA	HOUSING - PIN - 2 CAVITY - IN LINE
	088474-01-000	EA	HOUSING - SOCKET - 12 CAVITY
	088474-02-000	EA	HOUSING - SOCKET - 15 CAVITY
	088474-03-000	EA	HOUSING - SOCKET - 9 CAVITY
	088474-06-000	EA	HOUSING - SOCKET - 6 CAVITY
	088474-07-000	EA	HOUSING - SOCKET - 5 CAVITY
	088474-08-000	EA	HOUSING - SOCKET - 4 CAVITY
	088474-09-000	EA	HOUSING - SOCKET - 3 CAVITY
	088474-10-000	EA	HOUSING - SOCKET - 2 CAVITY

ELECTRICAL GROUP (CONTINUED)
CONNECTORS & CONDUIT (CONTINUED)

KEY	PART NUMBER	U/M	DESCRIPTION
	088475-01-000	EA	PIN - CONNECTOR - 14-20 AWG
	088475-02-000	EA	PIN - CONNECTOR - 10-12 AWG
	088476-01-000	EA	TERMINAL - ELECTRICAL
	088476-02-000	EA	SOCKET - CONNECTOR - 12-10 GA - PRE-TIN
	098261-01-000	EA	SOCKET - CONNECTOR - WEATHERPACK - 12 AWG
	098261-02-000	EA	SOCKET - CONNECTOR - WEATHERPACK - 14-18 AWG
	098262-01-000	EA	SEAL - CONNECTOR - WEATHERPACK
	098264-01-000	EA	HOUSING - 2 PIN - WEATHER PACK - MALE W/FEMALE PINS
	098264-02-000	EA	HOUSING - 2 PIN - WEATHER PACK - FEMALE W/MALE PINS
	098265-02-000	EA	PIN - CONNECTOR - WEATHER PACK
	102777-02-000	EA	TERMINAL - RING - #6 STUD - 10 AWG
	103608-01-000	EA	SOCKET - WEDGE BASE W/LEADS
	104100-01-000	EA	HOUSING - 1 POSITION - 75 AMPS
	104100-03-000	EA	TERMINAL - 75 AMP
	110178-01-000	EA	HOUSING - WIPER MOTOR
	112823-01-000	EA	SPLICE - REDUCER - 16-14 TO 18-22
	113135-01-000	EA	TERMINAL - FEMALE - M/P - 14-16 - F/SEALED TERMINAL
	113308-01-000	EA	TERMINAL - FEMALE - M/P - 14-16 - 280
	113468-01-000	EA	HOUSING - 2 POSITION-FEMALE-USED ON WIPER/WASHER WIRE ASM
	115931-02-000	EA	COVER - CONNECTOR - 50 AMP W/LOCKING RING
	115932-01-000	EA	CONNECTOR - FEMALE - 30 AMP/120 VOLT
	116811-01-000	EA	TERMINAL - .110 RECEPTACLE - 16-14 AWG
	118571-01-000	EA	CONNECTOR - 3-WAY - MALE/SEALED
	118571-02-000	EA	CONNECTOR - 3-WAY - FEMALE/SEALED
	118571-05-000	EA	LOCK - SECONDARY - FEMALE/SEALED
	118571-06-000	EA	LOCK - SECONDARY - MALE
	118599-02-000	EA	TERMINAL - MALE - M/P - 280/14-12
	118820-01-000	EA	INSULATOR - TERMINAL
	129233-01-000	EA	HOUSING - 2-POSITION/FEMALE - 280-SERIES
	129233-02-000	EA	HOUSING - 2-POSITION/FEMALE - 280-SERIES
	131681-01-000	EA	CONNECTOR - 3/4" SO CORD - UL/CS
	137207-01-000	EA	HOUSING - PIN - 2 CAVITY/HIGH AMP
	137208-01-000	EA	HOUSING - SOCKET - 2 CAVITY/HIGH AMP
	137209-01-000	EA	PIN - CONNECTOR - 10AWG/HIGH AMP
	137210-01-000	EA	SOCKET - CONNECTOR - 10 AWG/HIGH AMP
	138419-03-000	EA	SOCKET - TURN SIGNAL LAMP - 3 WIRE
	142520-01-000	EA	TERMINAL - FEMALE - MINI-FIT 16
	142522-01-000	EA	HOUSING - 4 PIN/MALE - MINI FIT
	142524-01-000	EA	HOUSING - 4 PIN/FEMALE - WEATHER PACK
	142524-02-000	EA	HOUSING - 4 PIN/FEMALE - WEATHER PACK
	144283-01-000	EA	CONNECTOR - 110V - F/USE WITH SOW WIRE - BLUE
	144283-02-000	EA	CONNECTOR - 110V - F/USE WITH NM ROMEX WIRE - CLEAR
	145171-01-000	EA	CONNECTOR - COAXIAL
	149687-01-000	EA	HOUSING - 2 POSITION/MALE - PACKARD
	149687-02-000	EA	LOCK - F/2 POSITION HOUSING - PACKARD
	149688-01-000	EA	TERMINAL - MALE - 16 GAUGE WIRE

ELECTRICAL GROUP (CONTINUED)

CHASSIS

KEY	PART NUMBER	U/M	DESCRIPTION
	065450-05-000	EA	TIEDOWN - BATTERY - 8.4" TUBE
	065451-05-000	EA	BRACKET/TIEDOWN - BATTERY - 7.7" FROM BRKT TO BRKT
	086233-01-000	EA	STUD - ISOLATED - 3/8" X 7/8" LONG
	113452-02-000	FT	SEAL/TRIM - FRONT - VINYL W/WIRE CARRIER - .027"

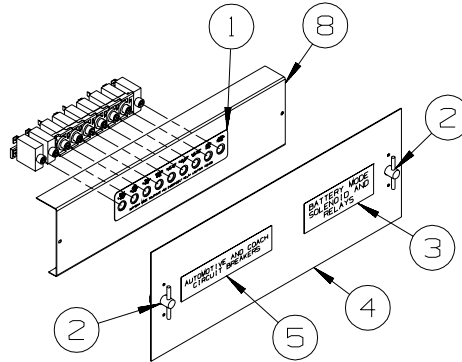
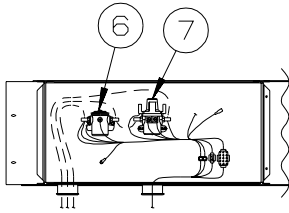

KEY	PART NUMBER	U/M	DESCRIPTION
1	093236-34-000	EA	LABEL - CIRCUIT BREAKER

FROM: 00-00-00 THRU: 03-14-04

1	093236-42-000	EA	LABEL - CIRCUIT BREAKER
---	---------------	----	-------------------------

FROM: 03-15-04 THRU: 99-99-99

2	098196-01-000	EA	LATCH - 1/4 TURN - T-BAR
3	098379-04-000	EA	LABEL - ELECTRICAL BOX - SIDE
4	109925-04-000	EA	DOOR - ELECTRICAL BOX - 6.9" X 18.5" - GM/FORD
5	098379-01-000	EA	LABEL - CIRCUIT BREAKER - FRONT BOX
6	008188-01-000	EA	SOLENOID - 3 POST - BATTERY CHANGE OVER
7	086273-01-000	EA	RELAY - BATTERY DISCONNECT
8	118531-02-02B	EA	PLATE - CIRCUIT BREAKER - E-COATED

FROM: 00-00-00 THRU: 03-14-04

8	118531-05-02B	EA	PLATE - CIRCUIT BREAKER - E-COATED
---	---------------	----	------------------------------------

FROM: 03-15-04 THRU: 99-99-99

EXTERIOR BODY GROUP GRAPHICS & PAINT

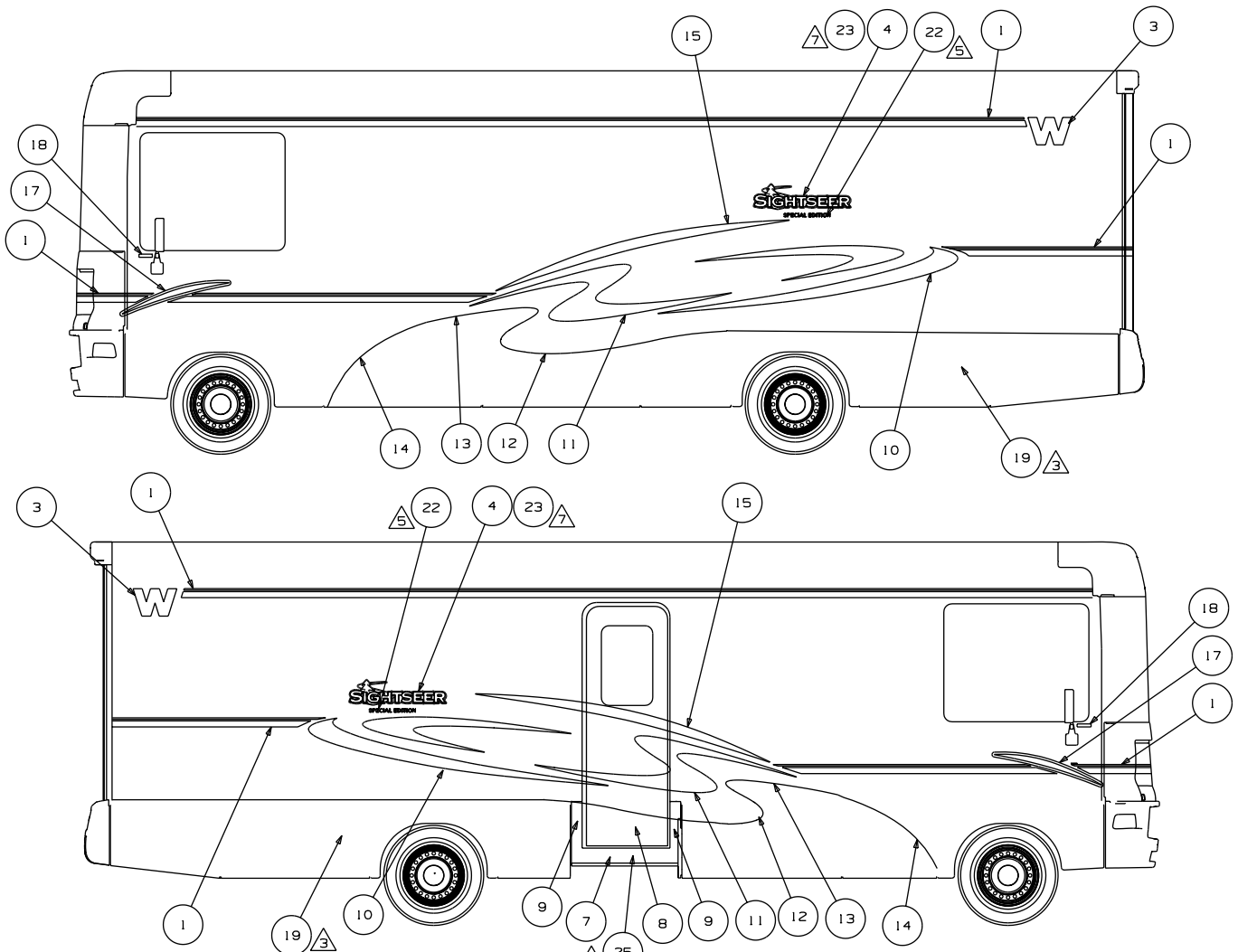

△6 CENTER BETWEEN LADDER AND OUTSIDE OF COACH.

△5 SPECIAL EDITION UNITS ONLY.

4. CONTINUE MULTISTRIPE ONTO WINGWALLS OF SLIDEOUT.

△3 PARTS BELOW FEATURE LINE WILL BE COLORED PRIOR TO ASSEMBLY.

△2 CENTER ON UNIT.

1. APPLY PROTECTOR 116424-01 TO WATER HEATER LATCH.

△8 FILM TO PROTECT BOTTOM OF DOOR FROM SCUFF MARKS.

△4 DECAL WILL BE USED ON CHALET RENTAL UNITS INSTEAD OF SIGHTSEER DECAL, ALL OTHER PARTS SAME AS SIGHTSEER.

• 2006 CHALET RENTAL PROGRAM

NOTES:

1	105781-99-CHT(01A)	FT
2	120702-03-CHT(11A)	EA
3	135391-02-CHT(03A)	EA
4	135453-03-CHT(02A)	EA
5	135453-04-CHT(02A)	EA
6	137618-01-CHT(01A)	EA
7	138348-01-CHT(01A)	EA
8	138349-01-CHT(01A)	EA
9	139657-01-CHT(01A)	EA
10	148521-01-CHT(01A)	EA
11	148521-02-CHT(01A)	EA
12	148523-01-CHT(01A)	EA
13	148523-02-CHT(01A)	EA
14	148524-01-CHT(01A)	EA
15	148524-02-CHT(01A)	EA
16	148525-01-CHT(01A)	EA
17	148525-02-CHT(01A)	EA
18	148526-01-CHT(01A)	EA
19	148526-02-CHT(01A)	EA
20	148528-01-CHT(01A)	EA
21	148528-02-CHT(01A)	EA
22	148531-01-CHT(01A)	EA
23	148532-01-CHT(01A)	EA
24	148532-02-CHT(01A)	EA
25	132664-01-CHT(01A)	EA
	XXXXXXXXXXXXXXXXXXXX	EA
	150691-01-CHT(01A)	EA
	150691-02-CHT(01A)	EA
	147534-01-CHT(01A)	EA
	129744-01-CHT(11A)	EA
	129744-02-CHT(11A)	EA
	109506-01-000	EA

MULTISTRIPE-76.2MM - STONE GRAY/MED DK ROYAL BLUE
DECAL-WINNEBAGO - MED DK ROYAL BLUE
DECAL-W - MED DK ROYAL BLUE
DECAL-SIGHTSEER, LG - BRT WHITE/DK BRT TEAL/STONE GRAY/BLAZER BLUE/MED DK ROYAL BLUE
DECAL-SIGHTSEER, SML - BRT WHITE/DK BRT TEAL/STONE GRAY/BLAZER BLUE/MED DK ROYAL BLUE
DECAL-BEZEL, DOMED GRILLE LOGO - GOLD/BLACK
DECAL-DOOR TRIM - SANDSTONE
DECAL-DOOR - SANDSTONE
DECAL-DOOR TRIM SIDE, RH - SANDSTONE
DECAL-SWIRL, RH - MED DK ROYAL BLUE/STONE GRAY
DECAL-SWIRL, LH - MED DK ROYAL BLUE/STONE GRAY
DECAL-S CURVE, RH - BLAZER BLUE
DECAL-S CURVE, LH - BLAZER BLUE
DECAL-PAINT LINE #3, RH - BRT WHITE
DECAL-PAINT LINE #3, LH - BRT WHITE
DECAL-PAINT LINE #2, RH - SANDSTONE
DECAL-PAINT LINE #2, LH - SANDSTONE
DECAL-PAINT LINE #1, RH - BRT WHITE
DECAL-PAINT LINE #1, LH - BRT WHITE
DECAL-SWEEP, RH - STONE GRAY
DECAL-SWEEP, LH - STONE GRAY
DECAL-HOOD & BACK - STONE GRAY/MED DK ROYAL BLUE/BLAZER BLUE
DECAL-SWEEP, SML, RH - BRT WHITE/BLAZER BLUE
DECAL-SWEEP, SML, LH - BRT WHITE/BLAZER BLUE
DECAL-WINNEBAGO, DOMED - GOLD/CHROME/BLACK
COLORLED PLASTIC AND STEEL - SANDSTONE - DUPONT #4949U
DECAL-FRT/RR STRIPE, RH - STONE GRAY/MED DK ROYAL BLUE
DECAL-FRT/RR STRIPE, LH - STONE GRAY/MED DK ROYAL BLUE
DECAL-SPECIAL EDITION - BLACK
DECAL-LOGO, CHALET, LG - BLAZER BLUE/MED DK ROYAL BLUE
DECAL-LOGO, CHALET, SML - BLAZER BLUE/MED DK ROYAL BLUE
FILM-URETHANE PROTECTION

EXTERIOR BODY GROUP (CONTINUED)

GRAPHICS & PAINT (CONTINUED)

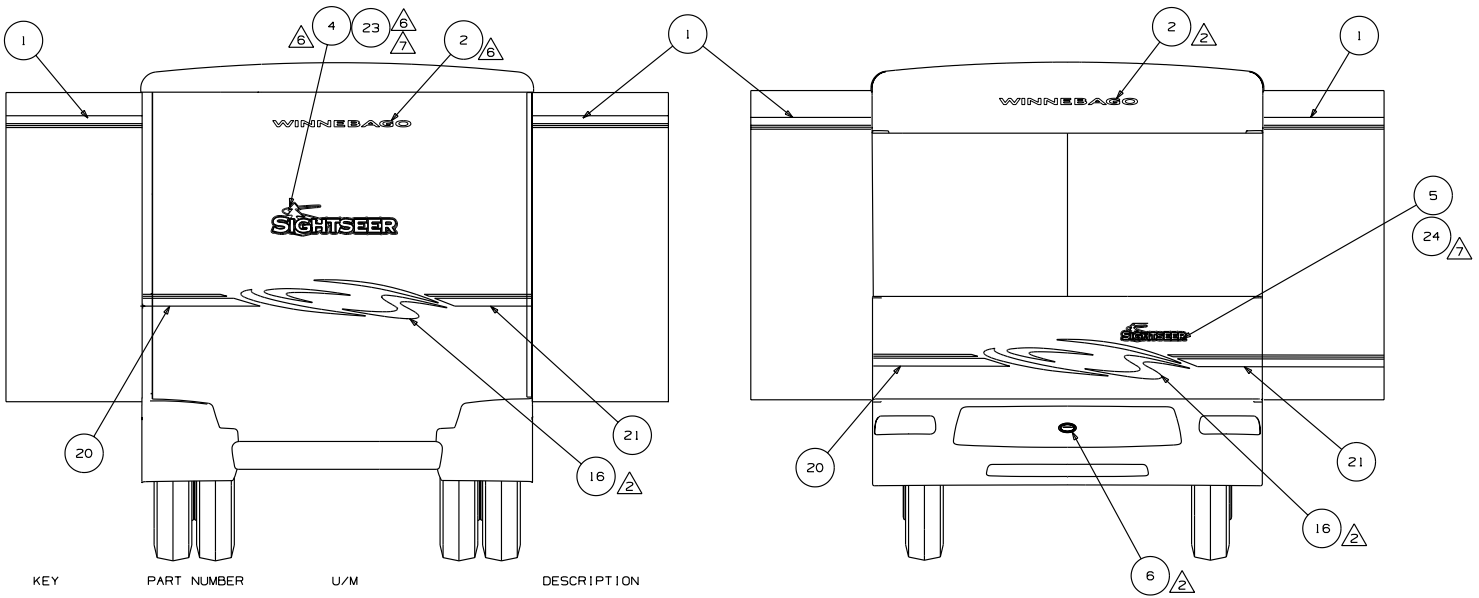

KEY	PART NUMBER	U/M	DESCRIPTION
1	105781-99-CHT(01A)	FT	MULTI STRIPE-76,2MM - STONF GRAY/MED DK ROYAL BLUE
2	120702-03-CHT(11A)	EA	DECAL-WINNEBAGO - MED DK ROYAL BLUE
3	135381-02-CHT(03A)	EA	DECAL-W - MED DK ROYAL BLUE
4	135451-03-CHT(02A)	EA	DECAL-SIGHTSEER,LG - BRT WHITE/DK BRT TEAL/STONE GRAY/BLAZER BLUE/MED DK ROYAL BLUE
5	135453-04-CHT(02A)	EA	DECAL-SIGHTSEER,SML - BRT WHITE/DK BRT TEAL/STONE GRAY/BLAZER BLUE/MED DK ROYAL BLUE
6	137618-01-CHT(01A)	EA	DECAL-BEZEL,DOMED GRILLE LOGO - GOLD/BLACK
7	138348-01-CHT(01A)	EA	DECAL-DOOR TRIM - SANDSTONE
8	138349-01-CHT(01A)	EA	DECAL-DOOR - SANDSTONE
9	139657-01-CHT(01A)	EA	DECAL-DOOR TRIM SIDE,RH - SANDSTONE
10	148521-01-CHT(01A)	EA	DECAL-SWIRL,RH - MED DK ROYAL BLUE/STONE GRAY
11	148521-02-CHT(01A)	EA	DECAL-SWIRL,LH - MED DK ROYAL BLUE/STONE GRAY
12	148523-01-CHT(01A)	EA	DECAL-S CURVE,RH - BLAZER BLUE
13	148523-02-CHT(01A)	EA	DECAL-S CURVE,LH - BLAZER BLUE
14	148524-01-CHT(01A)	EA	DECAL-PAINT LINE #3,RH - BRT WHITE
15	148524-02-CHT(01A)	EA	DECAL-PAINT LINE #3,LH - BRT WHITE
16	148525-01-CHT(01A)	EA	DECAL-PAINT LINE #2,RH - SANDSTONE
17	148525-02-CHT(01A)	EA	DECAL-PAINT LINE #2,LH - SANDSTONE
18	148526-01-CHT(01A)	EA	DECAL-PAINT LINE #1,RH - BRT WHITE
19	148526-02-CHT(01A)	EA	DECAL-PAINT LINE #1,LH - BRT WHITE
20	148528-01-CHT(01A)	EA	DECAL-SWEEP,RH - STONE GRAY
21	148528-02-CHT(01A)	EA	DECAL-SWEEP,LH - STONE GRAY
22	148531-01-CHT(01A)	EA	DECAL-HOOD & BACK - STONE GRAY/MED DK ROYAL BLUE/BLAZER BLUE
23	148532-01-CHT(01A)	EA	DECAL-SWEEP,SML,RH - BRT WHITE/BLAZER BLUE
24	148532-02-CHT(01A)	EA	DECAL-SWEEP,SML,LH - BRT WHITE/BLAZER BLUE
25	132664-01-CHT(01A)	EA	DECAL-WINNEBAGO,DOMED - GOLD/CHROME/BLACK
△	19	XXXXXXXXXXXXXXXXXX	COLORED PLASTIC AND STEEL - SANDSTONE - DUPONT #4949U
△	20	150691-01-CHT(01A)	DECAL-FRT/RR STRIPE,RH - STONE GRAY/MED DK ROYAL BLUE
△	21	150691-02-CHT(01A)	DECAL-FRT/RR STRIPE,LH - STONE GRAY/MED DK ROYAL BLUE
△	22	147534-01-CHT(01A)	DECAL-SPECIAL EDITION - BLACK
△	23	129744-01-CHT(11A)	DECAL-LOGO,CHALET,LG - BLAZER BLUE/MED DK ROYAL BLUE
△	24	129744-02-CHT(11A)	DECAL-LOGO,CHALET,SML - BLAZER BLUE/MED DK ROYAL BLUE
△	25	109506-01-000	FILM-URETHANE PROTECTION

KEY PART NUMBER U/M DESCRIPTION
 041561-03-000 EA PAINT - 16 OUNCE SPRAY - OFF WHITE

**DUPONT COLOR CODES ARE NOW FOUND IN THE PAINT CODE MANUAL.
 YOU CAN FIND THIS MANUAL ON YOUR DEALER INDEX WEBPAGE UNDER SERVICE.**

EXTERIOR BODY GROUP (CONTINUED)

PANELS & TRIMS

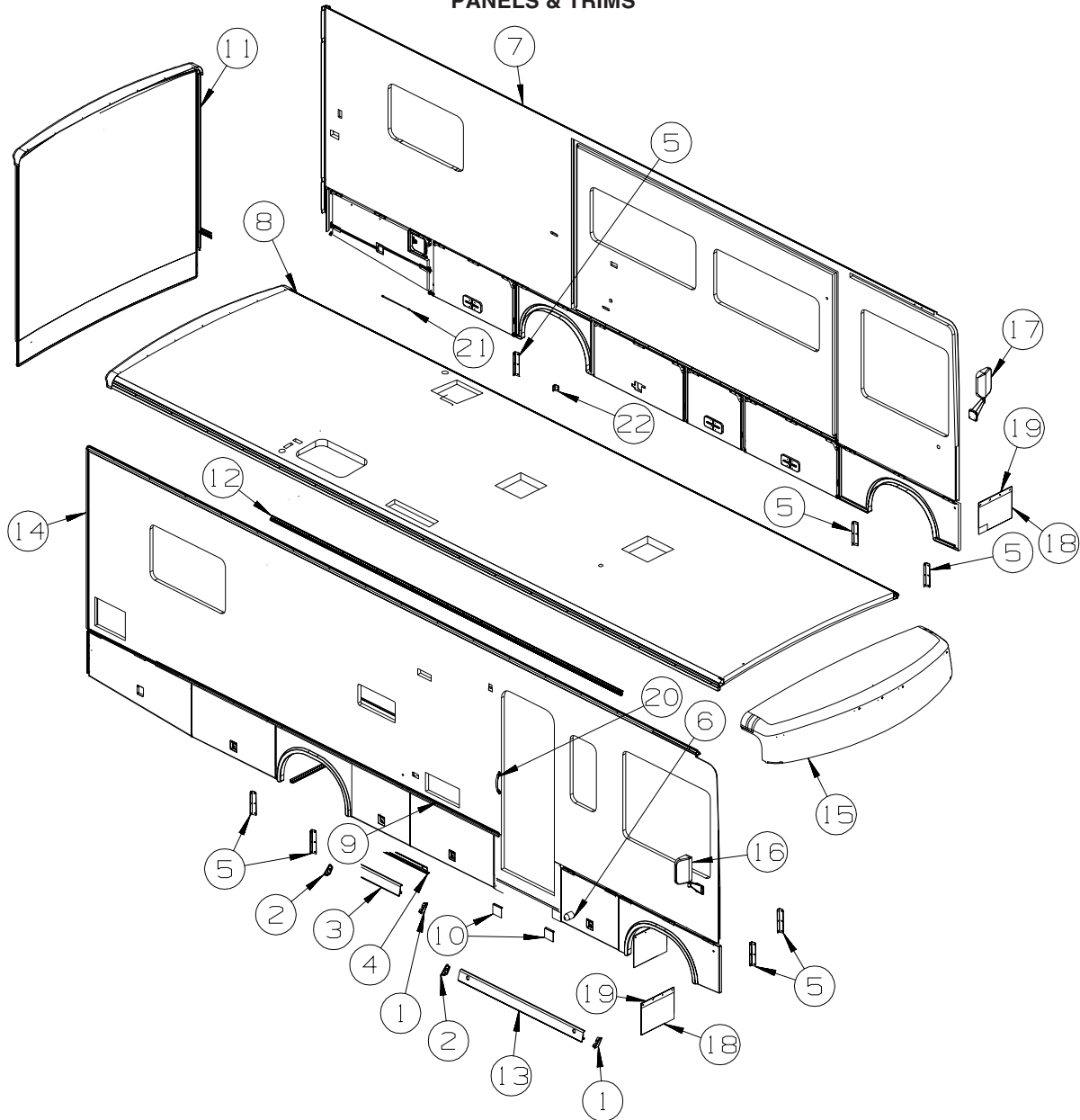

KEY	PART NUMBER	U/M	DESCRIPTION
1	146576-01-01A	EA	END CAP/TRIM - RIGHT HAND - BRIGHT WHITE
2	146576-02-01A	EA	END CAP/TRIM - LEFT HAND - BRIGHT WHITE
3	146550-01-03A	EA	TRIM COVER - SIDEWALL - 182" - BRIGHT WHITE
4	146548-01-01A	EA	TRIM - RETAINER
5	113904-18-02B	EA	ANGLE - ATTACHMENT/WHEEL LIP - E-COATED
6	120863-02-000	EA	BUMPER - RUBBER/RADIUS TOP - 1" X 1 1/2"
7	148267-01-S28	EA	SIDEWALL - DR (S28, SJ0, SX2, SX3, SX4, SX5, SX6, SX7, SY4, SY5, SY6, SY7, SY8, SY9)
7	148267-01-S29	EA	SIDEWALL - DRIVER - W/O WINDOWS/TRIMS (S29, SJ1)
7	148267-01-S30	EA	SIDEWALL - DRIVER - W/O WINDOWS/TRIMS (S30, SJ2)
8	148265-01-S28	EA	ROOF - W/O LIGHTS/VENTS - W/WIRING
9	153498-01-01A	EA	BUMPER - RUBBER - WHITE
10	121117-04-01A	EA	ANGLE - W/HOLES - SANDSTONE
11	P48262-01-S28	EA	BACKWALL (S28, SJ0, SX2, SX3, SX4, SX5, SX6, SX7, SY4, SY5, SY6, SY7, SY8, SY9)
11	P48262-01-S29	EA	BACKWALL - W/O WINDOW/TRIMS (S29, SJ1)
11	P48262-01-S30	EA	BACKWALL - W/O WINDOW/TRIMS (S30, SJ2)
12	131483-01-01A	EA	RAIL - AWNING - 192" - BRIGHT WHITE
13	149822-01-01A	EA	TRIM - SIDEWALL/ENTRY DOOR - 25.3" - BRIGHT WHITE
14	148266-01-S28	EA	SIDEWALL - PASS (S28, SJ0, SX2, SX3, SX4, SX5, SX6, SX7, SY4, SY5, SY6, SY7, SY8, SY9)
14	148266-01-S29	EA	SIDEWALL - PASSENGER - W/O WINDOWS/TRIMS (S29, SJ1)
14	148266-01-S30	EA	SIDEWALL - PASSENGER - W/O WINDOWS/TRIMS (S30, SJ2)
15	138017-02-N21	EA	CAP - ROOF/FRONT SECTION - W/O LIGHTS/VENTS - W/WIRING

EXTERIOR BODY GROUP (CONTINUED)
PANELS & TRIMS (CONTINUED)

KEY	PART NUMBER	U/M	DESCRIPTION
16*	106015-12-01A	EA	MIRROR - EXTERIOR REMOTE/HEAT - PASSENGER - MIRRORS-EXTERIOR W/DEFROST
16*	106015-14-01A	EA	MIRROR - EXTERIOR ADJUSTABLE GLASS - PASSENGER
17*	106015-13-01A	EA	MIRROR - EXTERIOR REMOTE/HEAT - DRIVER - MIRRORS-EXTERIOR W/DEFROST
17*	106015-15-01A	EA	MIRROR - EXTERIOR ADJUSTABLE GLASS - DRIVER
18	017516-01-000	EA	MUD FLAP - 14"H X 18"W - W/O MOUNTING HOLES - RUBBER - BLK
19	140922-01-02B	EA	RETAINER - MUD FLAP - 1" X 17.7" - E-COATED/BLACK
20	009126-03-000	EA	HANDLE - ASSIST - BLACK TEXTURED
21	107865-06-000	EA	ROD - SUPPORT - VALANCE PANEL - 15"
22	113904-19-02B	EA	ANGLE - ATTACHMENT/WHEEL LIP - E-COATED

***COMPONENT PARTS LISTED LATER IN THIS GROUP**

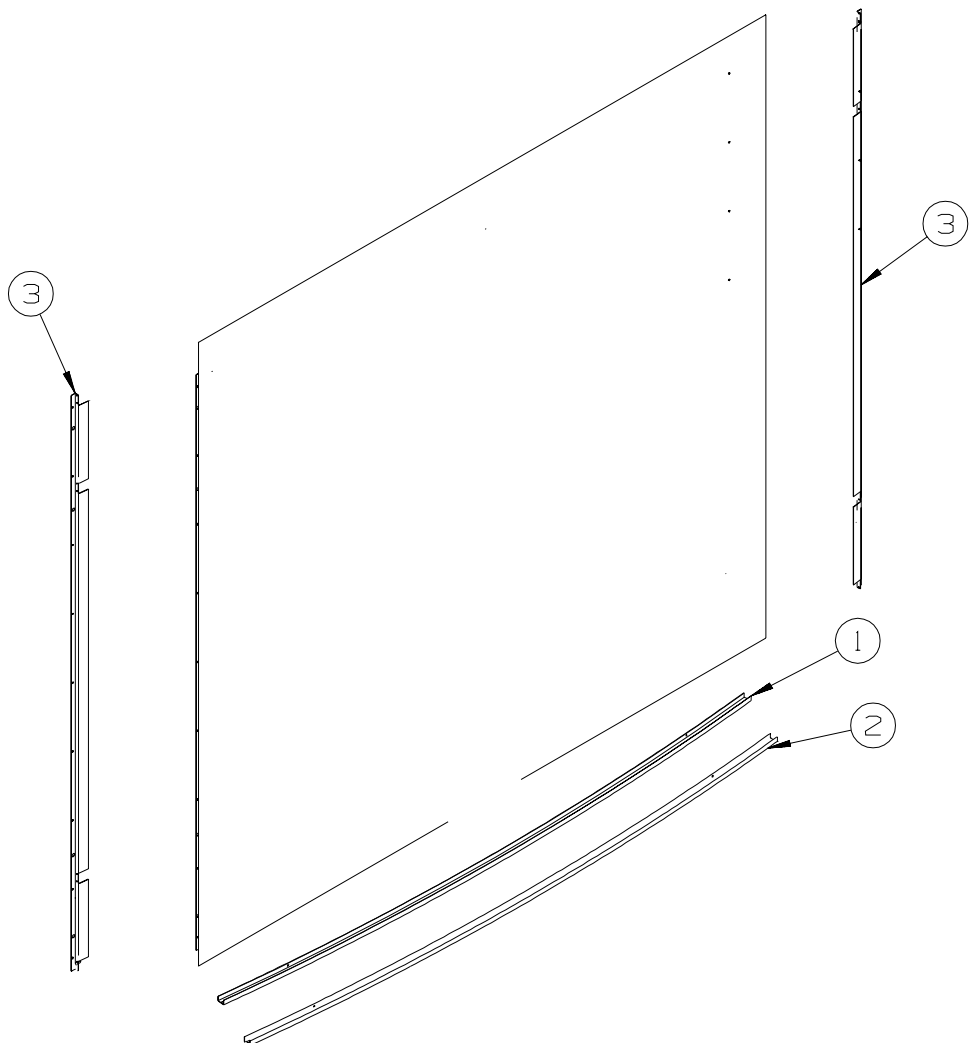

BACKWALL

KEY	PART NUMBER	U/M	DESCRIPTION
1	140118-01-01A	EA	TRIM - BACKWALL - LOWER - 98.3" - BRIGHT WHITE
2	114248-02-01A	EA	ANGLE - PLASTIC - 96.6"
3	135270-01-02B	EA	BRACKET/Z - BACKWALL MOUNT - E-COAT

EXTERIOR BODY GROUP (CONTINUED)
PANELS & TRIMS (CONTINUED)

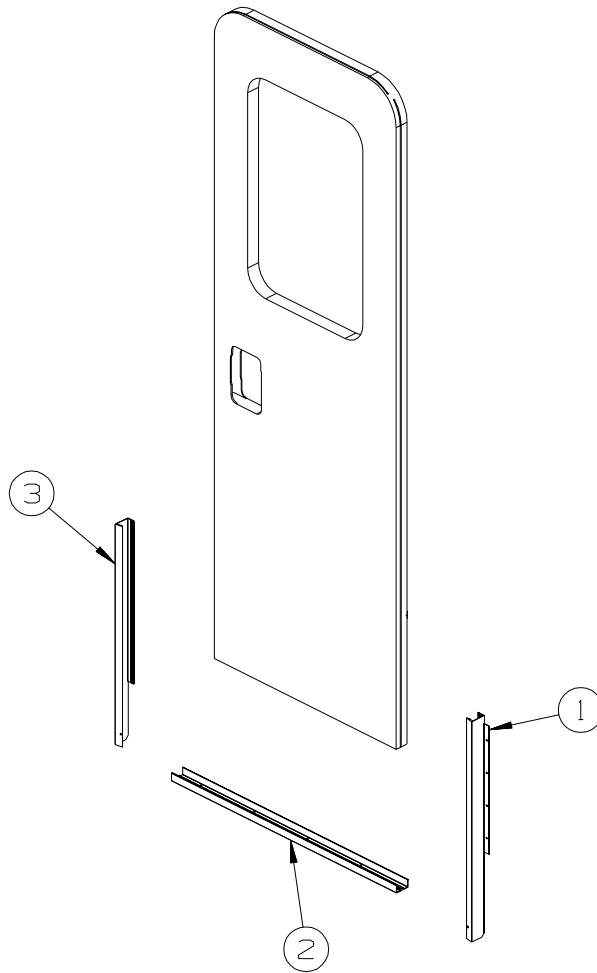

KEY	PART NUMBER	U/M	DESCRIPTION
1	133100-01-03A	EA	TRIM - SIDEWALL - 24.5" - SANDSTONE
2	137599-05-03A	EA	TRIM - SIDEWALL/LOWER - 35.9" - SANDSTONE
3	133100-02-03A	EA	TRIM - SIDEWALL - 24.5" - SANDSTONE

EXTERIOR BODY GROUP (CONTINUED)
PANELS & TRIMS (CONTINUED)

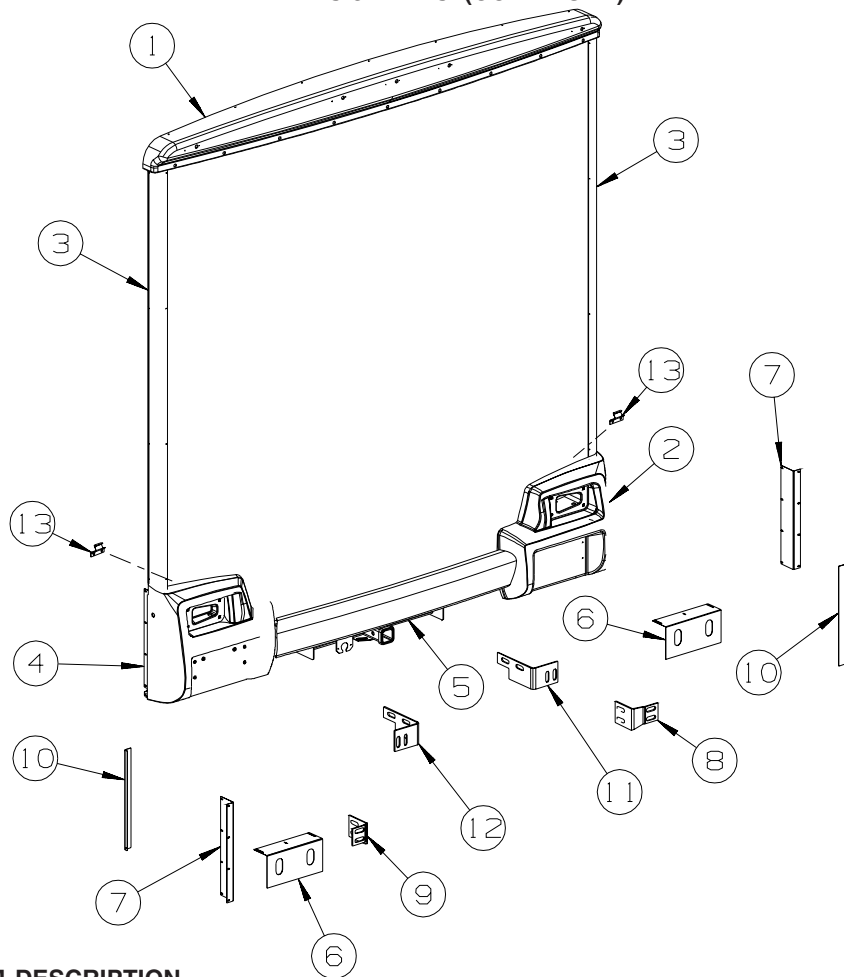

KEY	PART NUMBER	U/M	DESCRIPTION
1	137582-02-N21	EA	CAP - REAR/ROOF - W/O LIGHTS/VENTS - W/WIRING - BRIGHT WHT
2	138054-03-N21	EA	TRIM - BACKWALL - LOWER/RIGHT HAND
3	139969-01-02A	EA	COVE - BACKWALL - BRIGHT WHITE
4	138054-04-N21	EA	TRIM - BACKWALL - LOWER/LEFT HAND
5	138055-02-N21	EA	PANEL - BUMPER/REAR - W/O HARDWARE
6	139870-01-02B	EA	BRACKET - MOUNT - TRIM - LOWER - E-COATED
7	139811-01-02B	EA	SEAL PLANE/ANGLE MOUNT FILLER (SIDEWALL/BACKWALL ATTACH)
8	138162-01-02B	EA	BRACKET/BUMPER - REAR/RIGHT HAND - E-COATED - WORKHORSE
9	138162-02-02B	EA	BRACKET/BUMPER - REAR/LEFT HAND - E-COATED - WORKHORSE
10	132721-02-02B	EA	BRACKET/MOUNT - TRIM - REAR - E-COATED
11	138162-03-02B	EA	BRACKET/BUMPER - REAR/RIGHT HAND - E-COATED - FORD
12	138162-04-02B	EA	BRACKET/BUMPER - REAR/LEFT HAND - E-COATED - FORD
13	073050-04-000	EA	CLIP/MOUNTING - VALANCE PANEL

COMPONENT PARTS FOR PANELS & TRIMS

106015-12-01A, 106015-14-01A

KEY	PART NUMBER	U/M	DESCRIPTION	VENDOR NO.
	106015-12-700	EA	MIRROR-FLAT-W/W/O HEAT	709448
	106015-12-701	EA	MIRROR-CONVEX - W/W/O HEAT	709449
	106015-12-702	EA	CAP/SCREW - (PKG OF 4) - BLK	748329 RND
	106015-12-703	EA	CONVEX GLASS/HANDSET/HOUSING	7095892
	119774-09-700	EA	PLATE-INNER SUPT/MIRROR HEAD	709418-7RH

106015-13-01A, 106015-15-01A

KEY	PART NUMBER	U/M	DESCRIPTION	VENDOR NO.
	106015-12-700	EA	MIRROR-FLAT-W/W/O HEAT	709448
	106015-12-701	EA	MIRROR-CONVEX - W/W/O HEAT	709449
	106015-12-702	EA	CAP/SCREW - (PKG OF 4) - BLK	748329 RND
	106015-12-703	EA	CONVEX GLASS/HANDSET/HOUSING	7095892
	119774-09-701	EA	PLATE INNER SUPT/MIRROR HEAD	709419-7LH

EXTERIOR BODY GROUP (CONTINUED)

FRONT END

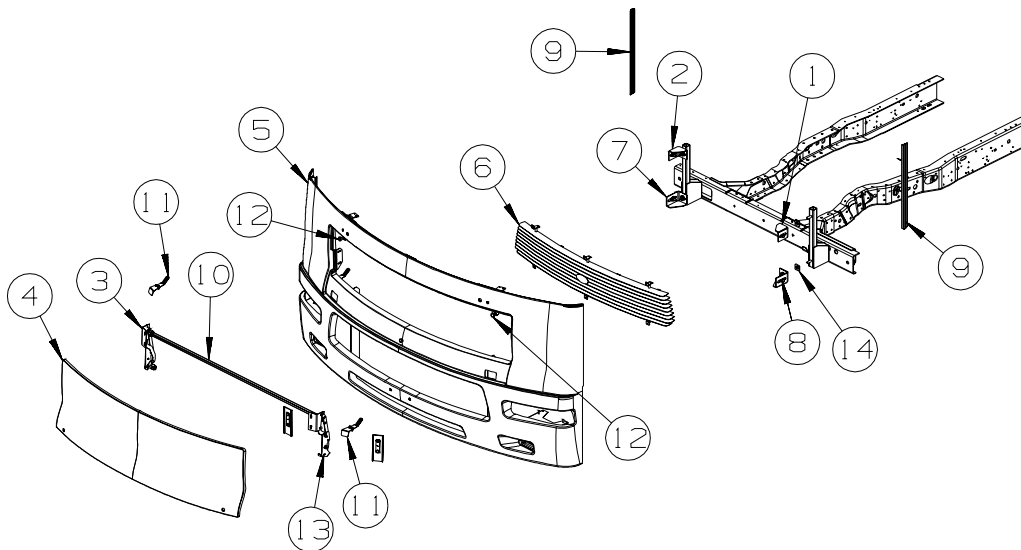

KEY	PART NUMBER	U/M	DESCRIPTION
1	128455-06-02B	EA	BRACKET - BUMPER - E-COATED
2	128455-05-02B	EA	BRACKET - BUMPER - E-COATED
3	137072-03-01A	EA	HINGE - HOOD - RIGHT HAND - BLACK
4	137590-01-N21	EA	HOOD - FRONT
5	147557-02-S28	EA	PANEL - FRONT/LOWER
6	137913-07-01A	EA	GRILLE - FRONT/UPPER
7	128455-02-02B	EA	BRACKET - BUMPER - E-COATED
8	128455-01-02B	EA	BRACKET - BUMPER - E-COATED
9	092041-10-01A	EA	TRIM - FRONT/REAR CAP (SIDEWALL) - 25.2" - BRIGHT WHITE
	091985-01-07A	FT	INSERT - TRIM - REAR CAP TO SIDEWALL - .66" - BRIGHT WHITE
10	137300-01-02B	EA	TUBE/TIMING - HOOD - 63.2" - E-COATED - WORKHORSE & 2004 FORD
10	154091-02-02B	EA	TUBE - TIMING - HOOD - E-COATED - 2006 FORD
11	141017-01-02B	EA	SUPPORT/HINGE - FRONT - E-COATED
12	058786-01-000	EA	BOLT - HOOD ADJUSTMENT - 5/16"-18 X 1.5"-2"- W/BLACK PAD
13	137072-04-01A	EA	HINGE - HOOD - LEFT HAND - BLACK
14	116617-02-02B	EA	SPACER - BUMPER

EXTERIOR BODY GROUP (CONTINUED)
FRONT END (CONTINUED)

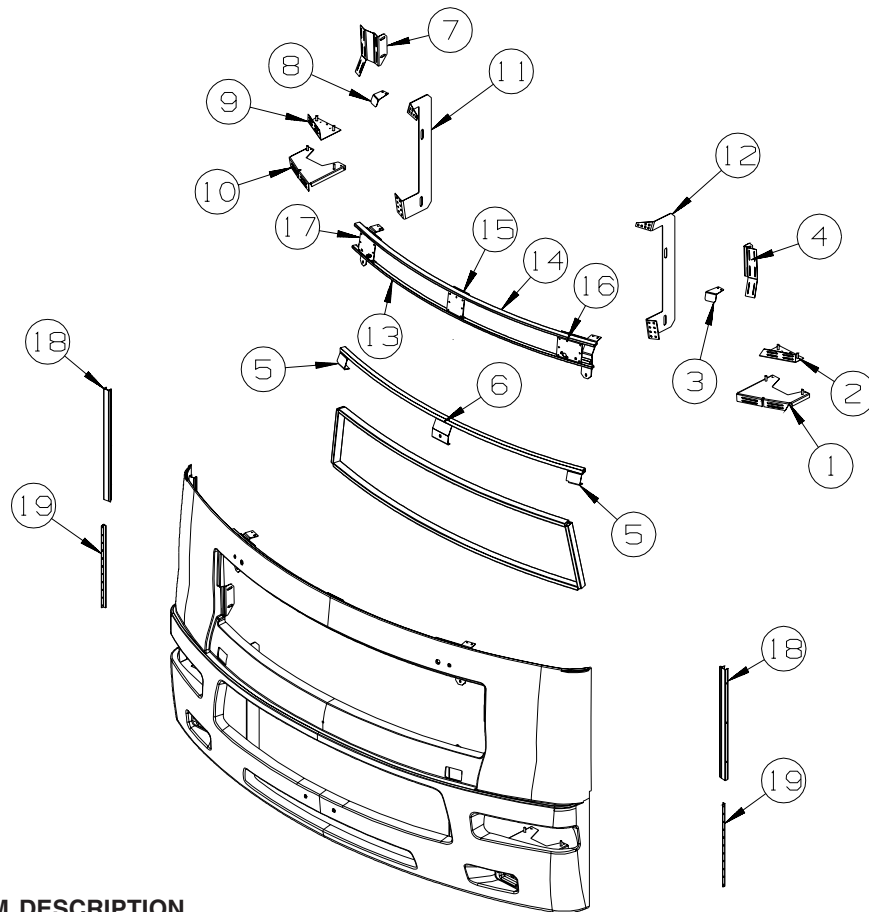

KEY	PART NUMBER	U/M	DESCRIPTION
1	147895-04-02B	EA	BRACKET - HEADLAMP - E-COAT
2	147894-04-02B	EA	BRACKET - HEADLAMP - E-COAT
3	141018-02-02B	EA	BRACKET/HINGE - FRONT/DRIVER - E-COATED
4	134530-06-02B	EA	SUPPORT - HOOD LINK - E-COATED
5	137679-01-02B	EA	STRIKE - HOOD LATCH - E-COATED
6	133770-02-02B	EA	BRACKET - HOOD SUPPORT - E-COATED
7	134530-05-02B	EA	SUPPORT - HOOD LINK - E-COATED
8	141018-01-02B	EA	BRACKET/HINGE - FRONT/PASSENGER - E-COATED
9	147894-02-02B	EA	BRACKET - HEADLAMP - E-COAT
10	147895-02-02B	EA	BRACKET - HEADLAMP - E-COAT
11	137591-03-02B	EA	BRACKET - FRONT MOUNT/RIGHT HAND - E-COATED
12	137591-04-02B	EA	BRACKET - FRONT MOUNT/LEFT HAND - E-COATED
13	149788-06-02B	EA	SUPPORT - PIVOT SHAFT - E-COATED
14	141004-05-S28	EA	SUPPORT - WIPER
			FROM: 00-00-00 THRU: 03-15-04
14	149784-03-S46	EA	SUPPORT - WIPER
			FROM: 03-16-04 THRU: 99-99-99
15	125847-10-02B	EA	SUPPORT/PIVOT SHAFT - E-COATED
16	149788-08-02B	EA	SUPPORT - PIVOT SHAFT - E-COATED
17	125849-02-02A	EA	BRACE-WIPER/HOOD - BLACK
18	132864-01-01A	EA	SUPPORT - FRONT/INNER PANEL TRIM
19	134066-04-02B	EA	BRACKET - ZEE - W/HOLES - E-COATED

EXTERIOR BODY GROUP (CONTINUED)

LADDER

KEY	PART NUMBER	U/M	DESCRIPTION
	129639-03-01A	EA	LADDER - 89" - 7 STEP - BRUSHED ALUMINUM
	130163-06-01A	EA	LADDER EXTENSION/LOWER - 24.4" - 2 STEP - BRUSHED ALUMINUM

STRUCTURAL COMPONENTS

KEY	PART NUMBER	U/M	DESCRIPTION
	002726-01-001	EA	GARNISH - U-CHANNEL - 1.38" X 19' - SERRATED
	076054-X9-000	EA	FIBERGLASS SHEET - 22.1" X 70.6" - BRIGHT WHITE
	077517-62-000	EA	FIBERGLASS SHEET - 48" X 96" - BRIGHT WHITE
	089297-01-000	SF	PLYWOOD - LUAN - OVERLAY GRADE - 4' X 8'
	089297-03-000	SF	PLYWOOD - LUAN - OVERLAY GRADE - 4' X 8.3'
	100619-01-000	BF	FOAM - EXPANDED POLYSTYRENE - 1.34" X 48" X 96"
	100619-02-000	BF	FOAM - EXPANDED POLYSTYRENE - 1.5" X 48" X 96"
	100619-04-000	BF	FOAM - EXPANDED POLYSTYRENE - .5" X 48" X 96"
	100619-05-000	BF	FOAM - EXPANDED POLYSTYRENE - .75" X 48" X 96"-1.5"DENSITY
	100619-16-000	BF	FOAM - EXPANDED POLYSTYRENE - .75" X 48" X 96"-2" DENSITY
	100619-27-000	BF	FOAM - EXPANDED POLYSTYRENE - 3" X 48" X 92.8"
	108535-05-03A	SF	FIBERGLASS SHEET - 108" X 500' ROLL - BRIGHT WHITE
	116942-03-01A	LB	ALUMINUM - .7" X 40" X 158"
	120107-01-000	EA	FOAM - ROOF COVE - 2.8" X 96" LONG
	120107-02-000	EA	FOAM - PLUG - ROOF TUBE - 2.2" X 2.9" X 1.8" LONG
	120107-03-000	EA	FOAM - PLUG - SIDEWALL TUBE - 1.2" X 2.1" X 1.8" LONG
	148884-03-01A	EA	FIBERGLASS SHEET - 96.7" X 355.7" - HIGH GLOSS
	148884-04-01A	EA	FIBERGLASS SHEET - 99.5" X 100.2" - HIGH GLOSS
	148884-10-01A	EA	FIBERGLASS SHEET - 22.1" X 68.2" - HIGH GLOSS-BRIGHT WHITE
	148884-11-01A	EA	FIBERGLASS SHEET - 26.1" X 68.2" - HIGH GLOSS
	148884-13-01A	EA	FIBERGLASS SHEET - 78.9" X 309.4" - HIGH GLOSS
	148884-15-01A	EA	FIBERGLASS SHEET - 78.9" X 372.1" - HIGH GLOSS
	148884-16-01A	EA	FIBERGLASS SHEET - 78.9" X 396.1" - HIGH GLOSS
	148884-20-01A	EA	FIBERGLASS SHEET - 4" X 93.8" - HIGH GLOSS - BRIGHT WHITE
	148884-22-01A	EA	FIBERGLASS SHEET - 47.9" X 95.8" - HIGH GLOSS-BRIGHT WHITE
	148884-27-01A	EA	FIBERGLASS SHEET - 25" X 48" - HIGH GLOSS
	148884-24-01A	EA	FIBERGLASS SHEET - 78.9" X 330.2" - HIGH GLOSS-BRIGHT WHITE

AWNINGS

PATIO AWNINGS

SERIES MODEL	COLOR DESIGNATION	AWNING FABRIC	AWNING LENGTH	WEATHER WRAP(MANUAL)	PART # MANUAL
SIGHTSEER					
D27C	GULF BLUE (DX)	VINYL	13'	VYL/BRT WHT	113874-04-50A
D29R	GULF BLUE (DX)	VINYL	16'	VYL/BRT WHT	113874-06-50A
D30B	GULF BLUE (DX)	VINYL	16'	VYL/BRT WHT	113874-06-50A
D33L	GULF BLUE (DX)	VINYL	16'	VYL/BRT WHT	113874-06-50A
D334A	GULF BLUE (DX)	VINYL	18'	VYL/BRT WHT	113874-02-50A
D35N	GULF BLUE (DX)	VINYL	16'	VYL/BRT WHT	113874-06-50A

KEY	PART NUMBER	U/M	DESCRIPTION
*	113874-01-02A	EA	HARDWARE KIT - AWNING - W/O STANDOFF BRACKET-BRIGHT WHITE
	153692-01-01A	EA	HARDWARE KIT - F/2 STEP (STANDARD) - BRIGHT WHITE - D34A
	113874-11-01A	EA	SCREW/LAG - AWNING - 1/4" X 1" STAINLESS STEEL
	113874-12-01A	EA	SCREW/LAG - AWNING - 1/4" X 2 3/4" STAINLESS STEEL
	137054-01-02A	EA	BRACKET - AWNING - BRIGHT WHITE
	146457-02-03A	EA	BRACKET - AWNING - BRIGHT WHITE - D34A
	143181-11-01A	EA	AWNING/WEATHERPROOF - SPACER KIT - BRIGHT WHITE - D34A

*COMPONENT PARTS LISTED LATER IN THIS GROUP

EXTERIOR BODY GROUP (CONTINUED)
COMPONENT PARTS FOR AWNINGS

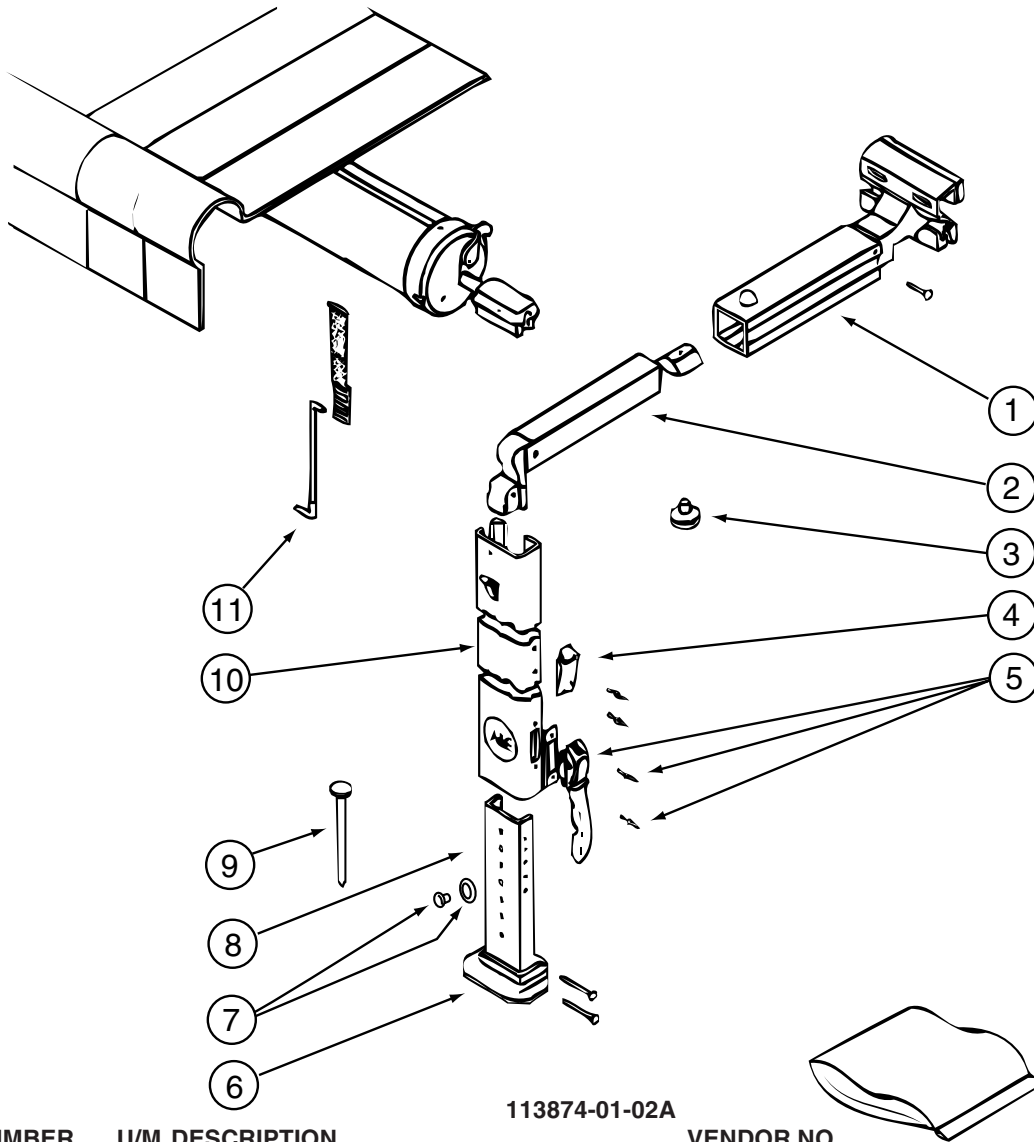

113874-01-02A

KEY	PART NUMBER	U/M	DESCRIPTION	VENDOR NO.
1	113874-01-714	EA	RAFTER - MAIN RH/LH BRT/WHT	830295.536F
2	113874-01-715	EA	RAFTER - SECONDARY BRT/WHT	830463.511F
3	113874-01-702	EA	KNOB - ADJUSTING	3105421.014
4	113874-01-706	EA	LOCK - TRAVEL	830587.001
5	113874-01-707	EA	HANDLE - LIFT W/RIVETS	830644
6	113874-01-712	EA	FOOT - PATIO	730366-001
7	113874-01-710	EA	PLUG-STOP KIT	830456
8	113874-01-717	EA	ARM - ADJUSTABLE BRT/WHT	830467.517/F
9	113874-01-709	EA	NAIL-SPIKE, 8"	113006
10	113874-01-716	EA	ARM - MAIN SUPPORT BRT/WHT	3104502.293/F
11	113874-01-703	EA	ROD-CENTER PULL W/ACCESSORY	830152.102

EXTERIOR DOORS & COMPARTMENTS GROUP
DOOR & COMPARTMENT LAYOUT

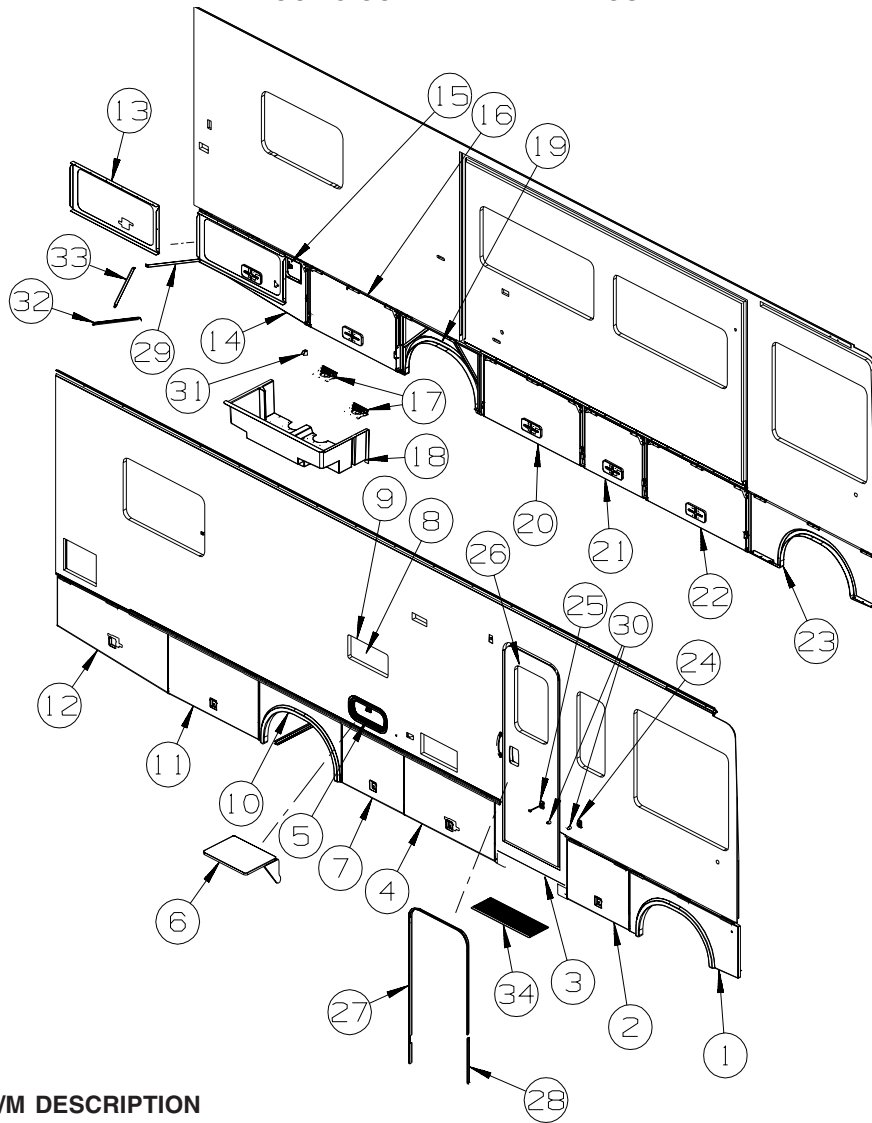

KEY	PART NUMBER	U/M	DESCRIPTION
1	147493-01-S28	EA	PANEL/WHEEL LIP - FRONT
	139793-03-01A	EA	HINGE - CENTER/VALANCE DOOR - W/O BALL STUD
2	141743-01-P31	EA	VALANCE/DOOR - W/O PADDLE LATCH/HDWR - 31.2" X 24.3"
	132873-A0-000	EA	ROD - LATCH - 11.3" W/3/4" DOG LEG
	132873-99-000	EA	ROD - LATCH - 9.4" W/3/4" DOG LEG
	142569-12-000	EA	SPRING/GAS - 90 LB. - 15" EXTENDED/9.5" COMPRESSED
	132892-02-01A	FT	SEAL - BULB - W/WIRED U CHANNEL - 1.3" X 1" - BLACK FROM: 00-00-00 THRU: 01-23-05
	132892-08-01A	FT	SEAL - BULB/SINGLE - W/U CHANNEL - BLACK FROM: 01-24-04 THRU: 99-99-99
3 *	094707-03-01A	EA	STEP - ELECTRIC DOUBLE - W/BLACK CONTROL BOX - KWIKEE
	116975-01-01A	EA	LATCH - W/O STRIKE - BLACK - NEW STYLE
4	141743-03-P31	EA	VALANCE/DOOR - W/O PADDLE LATCH/HDWR - 45.6" X 24.3"
	132873-A3-000	EA	ROD - LATCH - 16.6" W/3/4" DOG LEG
	132873-A4-000	EA	ROD - LATCH - 18.6" W/3/4" DOG LEG
	142569-12-000	EA	SPRING/GAS - 90 LB. - 15" EXTENDED/9.5" COMPRESSED
	076767-15-000	EA	CABLE - STAINLESS STEEL - 9.8"
	132892-02-01A	FT	SEAL - BULB - W/WIRED U CHANNEL - 1.3" X 1" - BLACK FROM: 00-00-00 THRU: 01-23-05
	132892-08-01A	FT	SEAL - BULB/SINGLE - W/U CHANNEL - BLACK FROM: 01-24-04 THRU: 99-99-99
5	126945-09-P07	EA	DOOR/STORAGE - W/O HARDWARE - 18" X 8.3"
6	142034-01-01A	EA	SHELF - F/EXTERIOR TV - BRIGHT WHITE
7	141743-11-P31	EA	VALANCE/DOOR - W/O PADDLE LATCH/HDWR - 31.2" X 24.3"
	132873-A0-000	EA	ROD - LATCH - 11.3" W/3/4" DOG LEG
	132873-99-000	EA	ROD - LATCH - 9.4" W/3/4" DOG LEG
	142569-12-000	EA	SPRING/GAS - 90 LB. - 15" EXTENDED/9.5" COMPRESSED

EXTERIOR DOORS & COMPARTMENTS GROUP (CONTINUED)
DOOR & COMPARTMENT LAYOUT (CONTINUED)

KEY	PART NUMBER	U/M	DESCRIPTION
8*	084103-08-000	EA	DOOR - VENT - REFRIGERATOR - W/O JAMB - BRIGHT WHITE
9	084104-08-000	EA	JAMB - VENT DOOR/REFRIGERATOR - BRIGHT WHITE
10	147492-01-S28	EA	PANEL/WHEEL LIP - REAR
	139793-03-01A	EA	HINGE - CENTER/VALANCE DOOR - W/O BALL STUD
11	141743-03-P31	EA	VALANCE/DOOR - W/O PADDLE LATCH/HDWR - 45.6" X 24.3"
	132873-A3-000	EA	ROD - LATCH - 16.6" W/3/4" DOG LEG
	132873-A4-000	EA	ROD - LATCH - 18.6" W/3/4" DOG LEG
	142569-12-000	EA	SPRING/GAS - 90 LB. - 15" EXTENDED/9.5" COMPRESSED
	132892-02-01A	FT	SEAL - BULB - W/WIRED U CHANNEL - 1.3" X 1" - BLACK FROM: 00-00-00 THRU: 01-23-05
	132892-08-01A	FT	SEAL - BULB/SINGLE - W/U CHANNEL - BLACK FROM: 01-24-04 THRU: 99-99-99
12	141743-19-P31	EA	VALANCE/DOOR - PASS W/O LATCH/HDWR - 24.3" X 55.9" X 20.1"
	132873-35-000	EA	ROD - LATCH - 21.8" W/3/4" DOG LEG
	132873-36-000	EA	ROD - LATCH - 23.6" W/3/4" DOG LEG
	142569-17-000	EA	SPRING/GAS - 90 LB - 12" EXTENDED/8.5" COMPRESSED
	132892-02-01A	FT	SEAL - BULB - W/WIRED U CHANNEL - 1.3" X 1" - BLACK FROM: 00-00-00 THRU: 01-23-05
	132892-08-01A	FT	SEAL - BULB/SINGLE - W/U CHANNEL - BLACK FROM: 01-24-04 THRU: 99-99-99
13	137934-10-02B	EA	PLATE/SEAL - E-COATED
14	141743-18-P31	EA	VALANCE/DOOR - DRVR W/O LATCH/HDWR - 24.3" X 55.9" X 20.1"
	132873-35-000	EA	ROD - LATCH - 21.8" W/3/4" DOG LEG
	132873-36-000	EA	ROD - LATCH - 23.6" W/3/4" DOG LEG
	142569-17-000	EA	SPRING/GAS - 90 LB - 12" EXTENDED/8.5" COMPRESSED
	132892-02-01A	FT	SEAL - BULB - W/WIRED U CHANNEL - 1.3" X 1" - BLACK FROM: 00-00-00 THRU: 01-23-05
	132892-08-01A	FT	SEAL - BULB/SINGLE - W/U CHANNEL - BLACK FROM: 01-24-04 THRU: 99-99-99
15	131905-03-P31	EA	PANEL/DOOR - FUEL FILL - W/O LOCK - SANDSTONE
*	110506-A2-000	EA	LOCK - TWIST - 26.45MM
	110506-51-000	EA	CASE/CYLINDER - TWIST LATCH - W/O CAM - 1" - 596669
	110506-78-000	EA	CAM - LOCK
	153306-01-01A	EA	HINGE - PIANO - 1 1/2" X 5" - UNPAINTED
16	141743-03-P31	EA	VALANCE/DOOR - W/O PADDLE LATCH/HDWR - 45.6" X 24.3"
	132873-A3-000	EA	ROD - LATCH - 16.6" W/3/4" DOG LEG
	132873-A4-000	EA	ROD - LATCH - 18.6" W/3/4" DOG LEG
	142569-12-000	EA	SPRING/GAS - 90 LB. - 15" EXTENDED/9.5" COMPRESSED
	107721-07-000	FT	SEAL - ACCESS DOOR - .9"WIDE X 1.1"HIGH
17*	142226-02-01A	EA	HATCH - POWER
18	144574-01-01A	EA	COMPARTMENT - DRAINAGE - PLASTIC
19	147492-02-S28	EA	PANEL/WHEEL LIP - REAR
	139793-03-01A	EA	HINGE - CENTER/VALANCE DOOR - W/O BALL STUD
20	141743-02-P31	EA	VALANCE/DOOR - W/O PADDLE LATCH/HDWR - 50.8" X 24.3"
	132873-A1-000	EA	ROD - LATCH - 19.2" W/3/4" DOG LEG
	132873-A2-000	EA	ROD - LATCH - 21.2" W/3/4" DOG LEG
	142569-12-000	EA	SPRING/GAS - 90 LB. - 15" EXTENDED/9.5" COMPRESSED
	132892-02-01A	FT	SEAL - BULB - W/WIRED U CHANNEL - 1.3" X 1" - BLACK FROM: 00-00-00 THRU: 01-23-05
	132892-08-01A	FT	SEAL - BULB/SINGLE - W/U CHANNEL - BLACK FROM: 01-24-04 THRU: 99-99-99
21	141743-11-P31	EA	VALANCE/DOOR - W/O PADDLE LATCH/HDWR - 31.2" X 24.3"
	132873-A0-000	EA	ROD - LATCH - 11.3" W/3/4" DOG LEG
	132873-99-000	EA	ROD - LATCH - 9.4" W/3/4" DOG LEG
	142569-12-000	EA	SPRING/GAS - 90 LB. - 15" EXTENDED/9.5" COMPRESSED
	132892-02-01A	FT	SEAL - BULB - W/WIRED U CHANNEL - 1.3" X 1" - BLACK FROM: 00-00-00 THRU: 01-23-05
	132892-08-01A	FT	SEAL - BULB/SINGLE - W/U CHANNEL - BLACK FROM: 01-24-04 THRU: 99-99-99

EXTERIOR DOORS & COMPARTMENTS GROUP (CONTINUED)
DOOR & COMPARTMENT LAYOUT (CONTINUED)

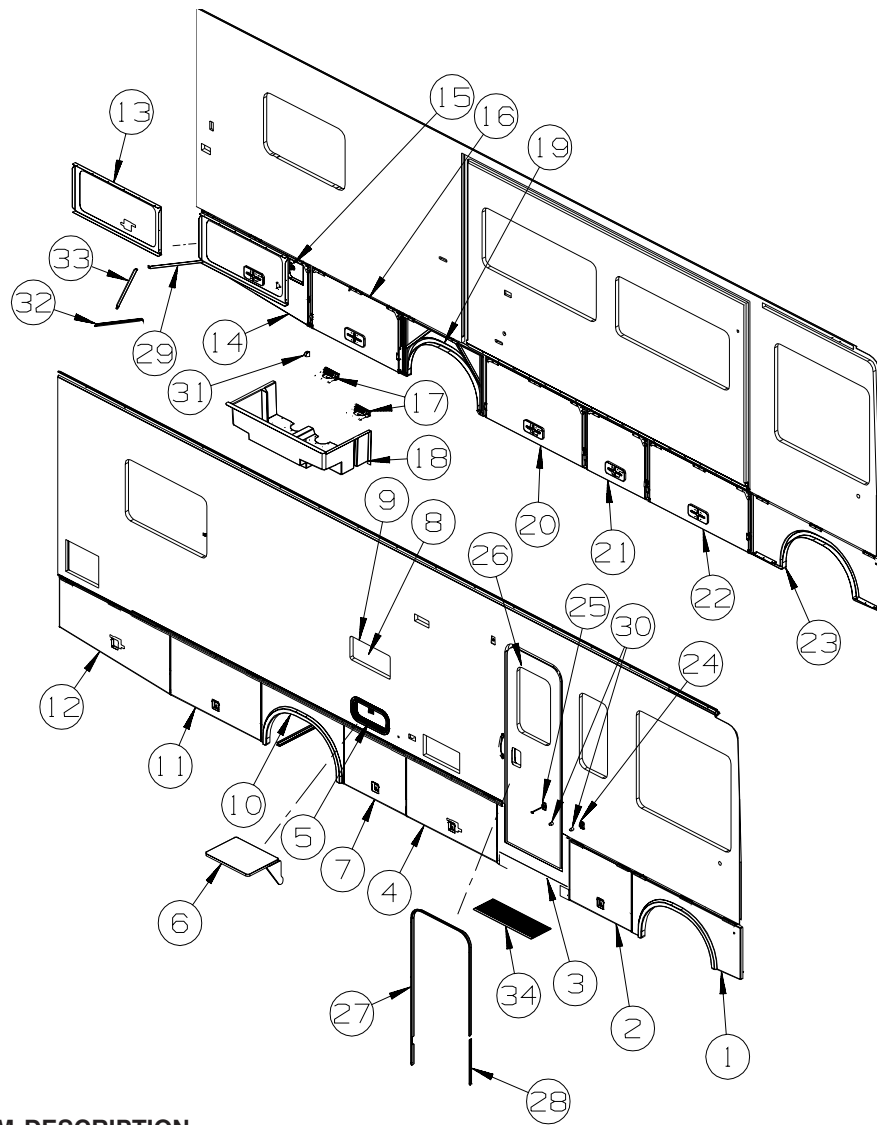

KEY	PART NUMBER	U/M	DESCRIPTION
22	141743-04-P31	EA	VALANCE/DOOR - W/O PADDLE LATCH/HDWR - 52.2" X 24.3"
	132873-A5-000	EA	ROD - LATCH - 21.9" W/3/4" DOG LEG
	132873-C7-000	EA	ROD - LATCH - 19.9" W/3/4" DOG LEG
	142569-12-000	EA	SPRING/GAS - 90 LB. - 15" EXTENDED/9.5" COMPRESSED
	132892-02-01A	FT	SEAL - BULB - W/WIRED U CHANNEL - 1.3" X 1" - BLACK FROM: 00-00-00 THRU: 01-23-05
	132892-08-01A	FT	SEAL - BULB/SINGLE - W/U CHANNEL - BLACK FROM: 01-24-04 THRU: 99-99-99
23	147493-02-S28	EA	PANEL/WHEEL LIP - FRONT
	139793-03-01A	EA	HINGE - CENTER/VALANCE DOOR - W/O BALL STUD
24	104099-02-04A	EA	CATCH/RETAINER - DOOR HOLDER - BRIGHT WHITE
25	104099-03-04A	EA	CATCH - DOOR HOLDER - STRIKE - 6" - BRIGHT WHITE
26	P32206-08-S28	EA	DOOR - ENTRY W/SCREEN DOOR (S28, SJ0, SX2, SX3, SX4, SX5, SX7, SY4, SY5, SY6, SY7, SY8, SY9)
26	P32206-08-R34	EA	DOOR - ENTRY W/SCREEN DOOR - W/O WINDOW/LATCH (S30, SJ2)
26	P32206-08-S29	EA	DOOR - ENTRY W/SCREEN DOOR - W/O WINDOW/LATCH (S29, J1)
27	139100-01-01A	EA	GARNISH/RADIUS - ENTRY DOOR - BRIGHT WHITE
28	139101-01-01A	EA	GARNISH/STRAIGHT - W/NOTCH - 36.31" - BRIGHT WHITE
29	138075-01-02B	EA	ANGLE/SUPPORT - SEAL PLANE - E-COATED
30	120863-02-000	EA	BUMPER - RUBBER/RADIUS TOP - 1" X 1 1/2"
31	131383-03-02A	EA	BRACKET - SHOWER HEAD - WHITE
32	138075-06-02B	EA	ANGLE/SUPPORT - GENERATOR
33	138075-07-02B	EA	ANGLE/SUPPORT - GENERATOR
34	133114-01-01A	EA	TREAD - STEP/RUBBER - 28.5" - TAUPE
34	133114-01-03A	EA	TREAD - STEP/RUBBER - 28.5" - GRAY

*COMPONENT PARTS LISTED LATER IN THIS GROUP

EXTERIOR DOORS & COMPARTMENTS GROUP (CONTINUED)
DOOR & COMPARTMENT LAYOUT (CONTINUED)

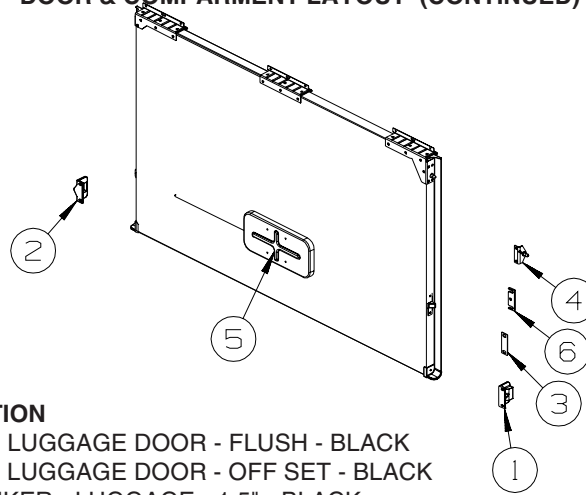

KEY	PART NUMBER	U/M	DESCRIPTION
1	130053-01-01A	EA	STRIKER - LUGGAGE DOOR - FLUSH - BLACK
2	130053-02-01A	EA	STRIKER - LUGGAGE DOOR - OFF SET - BLACK
3	143793-01-01A	EA	SHIM/STRIKER - LUGGAGE - 1.5" - BLACK
4	126263-02-02B	EA	BRACKET - GAS SPRING W/BALL STUD - E-COATED
5	138289-01-000	EA	CYLINDER - LOCKING
5	138289-02-000	EA	CYLINDER - LOCKING
5	138289-03-000	EA	CYLINDER - LOCKING
5	138289-04-000	EA	CYLINDER - LOCKING
5	138289-05-000	EA	CYLINDER - LOCKING
5	138289-06-000	EA	CYLINDER - LOCKING
5	138289-07-000	EA	CYLINDER - LOCKING
5	138289-08-000	EA	CYLINDER - LOCKING
5	138289-09-000	EA	CYLINDER - LOCKING
5	138289-10-000	EA	CYLINDER - LOCKING
	138288-01-000	EA	KEY - REVERSIBLE - #1151 - T/M 16169-02-3091
	138288-02-000	EA	KEY - REVERSIBLE - #1151 - T/M 16169-02-3091
	138288-03-000	EA	KEY - REVERSIBLE - #1151 - T/M 16169-02-3091
	138288-04-000	EA	KEY - REVERSIBLE - #1151 - T/M 16169-02-3091
	138288-05-000	EA	KEY - REVERSIBLE - #1151 - T/M 16169-02-3091
	138288-06-000	EA	KEY - REVERSIBLE - #1151 - T/M 16169-02-3091
	138288-07-000	EA	KEY - REVERSIBLE - #1151 - T/M 16169-02-3091
	138288-08-000	EA	KEY - REVERSIBLE - #1151 - T/M 16169-02-3091
	138288-09-000	EA	KEY - REVERSIBLE - #1151 - T/M 16169-02-3091
	138288-10-000	EA	KEY - REVERSIBLE - #1151 - T/M 16169-02-3091
6	120494-04-02B	EA	SHIM - STRIKER - LUGGAGE DOOR - .27 - E-COATED

EXTERIOR DOORS & COMPARTMENTS GROUP (CONTINUED)
DOOR & COMPARTMENT LAYOUT (CONTINUED)

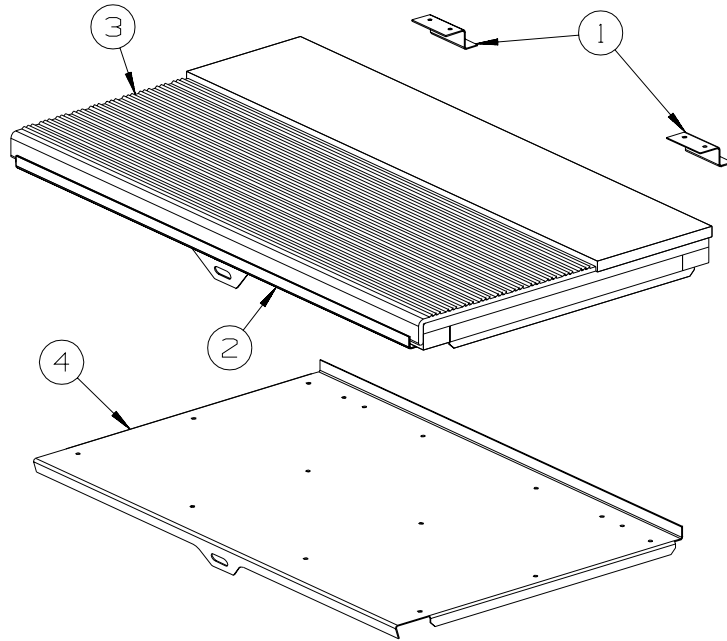

KEY	PART NUMBER	U/M	DESCRIPTION
1	101222-01-04A	EA	BRACKET - CATCH - LID - E-COATED
2	P20256-11-000	EA	LID/DOOR - ENTRY STEP - W/O CARPET/HARDWARE - VINYL FLOOR THROUGHOUT
2	P20256-12-000	EA	LID/DOOR - ENTRY STEP - W/O CARPET/HARDWARE - D34A
2	P20256-07-000	EA	LID/DOOR - ENTRY STEP - W/O CARPET/HARDWARE
3	133114-02-01A	EA	TREAD-STEP/RUBBER - 28.5"-TAUPE
3	133114-02-03A	EA	TREAD - STEP/RUBBER - 28.5" - GRAY
4	123330-03-02B	EA	SUPPORT - ENTRY STEP - E-COATED
4	123330-07-02B	EA	SUPPORT - ENTRY STEP - E-COATED - D34A

EXTERIOR DOORS & COMPARTMENTS GROUP (CONTINUED)

COMPONENT PARTS FOR DOOR & COMPARTMENT LAYOUT

084103-08-000

KEY	PART NUMBER	U/M	DESCRIPTION	VENDOR NO.
	084104-01-700	EA	LOCK-MALE, FASTENER	201-721-010
	084104-01-701	EA	LOCK-FEMALE, FASTENER	201-802-010

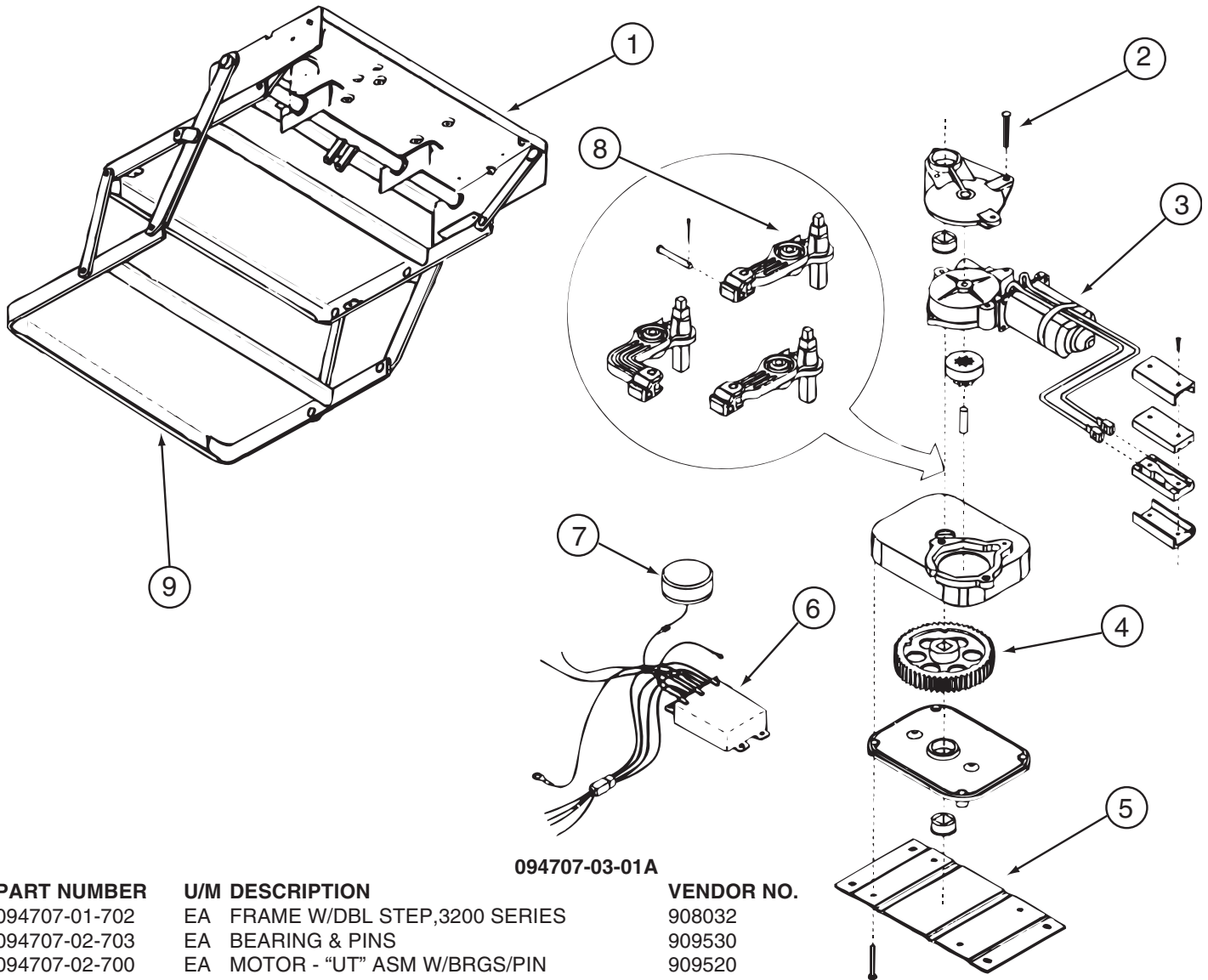

094707-03-01A

KEY	PART NUMBER	U/M	DESCRIPTION	VENDOR NO.
1	094707-01-702	EA	FRAME W/DBL STEP,3200 SERIES	908032
2	094707-02-703	EA	BEARING & PINS	909530
3	094707-02-700	EA	MOTOR - "UT" ASM W/BRGS/PIN	909520
4	094707-02-702	EA	GEAR KIT(GEAR-BEARING-PINS)	909525
5	094707-02-704	EA	CONNECTOR-MOTOR ASM.W/PLATES	909537
6	094707-03-700	EA	KIT CONTROL/SWITCH-RETROFIT	909506005
7	088746-01-705	EA	LIGHT-UNDER STEP	9004
7	088733-01-700	EA	BULB	9004
8	094707-02-701	EA	LINKAGE ASM. W/BEARINGS-PINS	909534
9	094707-02-707	EA	TREAD - NON-SKID - BLACK	909333
	094707-02-706	EA	GEAR BOX ASM. W/O MOTOR	9524
	094707-02-708	EA	TREAD - NON-SKID - YELLOW	909331
	094707-03-701	EA	PLUG - 4-WAY - PACKARD	909306

110506-A1-000, 110506-A2-000, 110506-26-000, 110506-27-000

KEY	PART NUMBER	U/M	DESCRIPTION	VENDOR NO .
	110506-40-700	EA	HARDWARE PACKAGE-CYLINDER/CASE	596950AAL

142226-02-01A

KEY	PART NUMBER	U/M	DESCRIPTION	VENDOR NO
	142226-02-700	EA	TAB/LOCKING - ESCAPE (RED)	9667709

EXTERIOR DOORS & COMPARTMENTS GROUP (CONTINUED)
COMPARTMENT DOOR PIECE PARTS

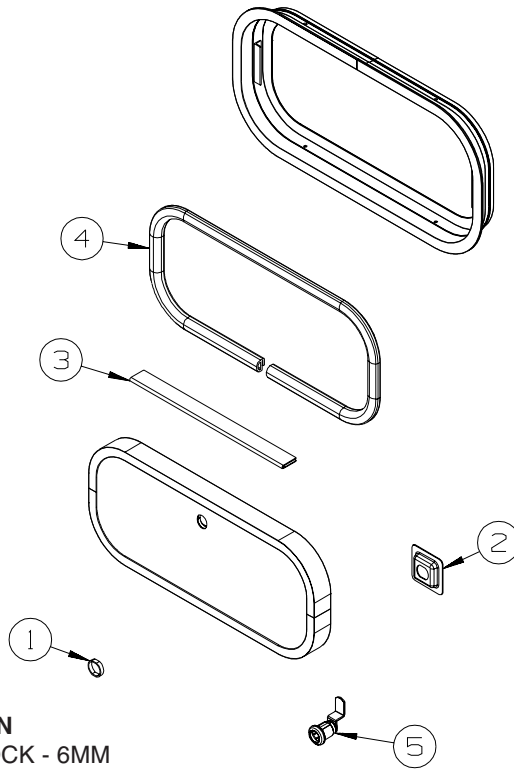

KEY	PART NUMBER	U/M	DESCRIPTION
1	139325-01-000	EA	SPACER - LOCK - 6MM
	139337-01-000	EA	GASKET - LOCK
2	097111-02-05A	EA	POCKET - LOCK - REAR DOOR - BRIGHT WHITE
2	097111-02-04A	EA	POCKET - LOCK - REAR DOOR - BLACK - FULL BODY OR LOWER EXT PAINT
3	081801-V3-000	EA	HINGE - DOOR - PIANO - 2" X 96" - BRIGHT WHITE
3	081801-FN-000	EA	HINGE - DOOR - PIANO - 2" X 96" - BLACK - FULL BODY OR LOWER EXT PAINT
4	106850-02-000	FT	SEAL-E - SPONGE RUBBER - .43" X .75"
5	138290-02-000	EA	CASE - W/CAM - W/O CYLINDER/KEY

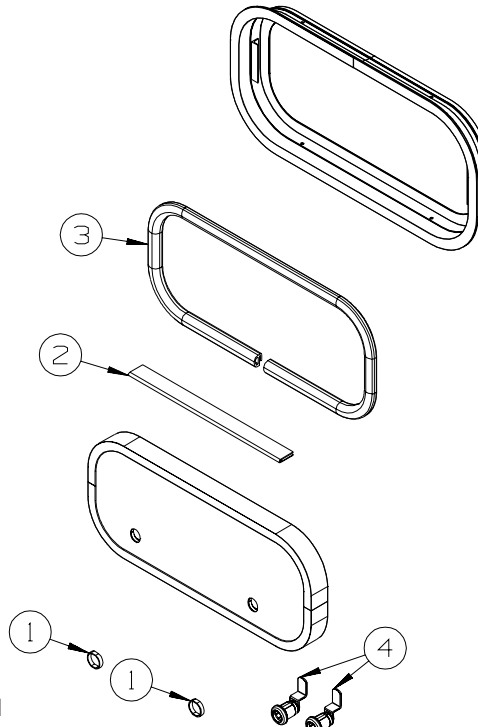

KEY	PART NUMBER	U/M	DESCRIPTION
1	144734-01-000	EA	SPACER
2	081801-V3-000	EA	HINGE - ALUMINUM - 2" X 96" - BRIGHT WHITE
3	106850-02-000	FT	SEAL-E - SPONGE RUBBER - .43" X .75"
	097111-02-05A	EA	POCKET - LOCK - REAR DOOR - BRIGHT WHITE
4	138290-02-000	EA	CASE - W/CAM - W/O CYLINDER/KEY

EXTERIOR DOORS & COMPARTMENTS GROUP (CONTINUED)

COMPARTMENT DOOR PIECE PARTS (CONTINUED)

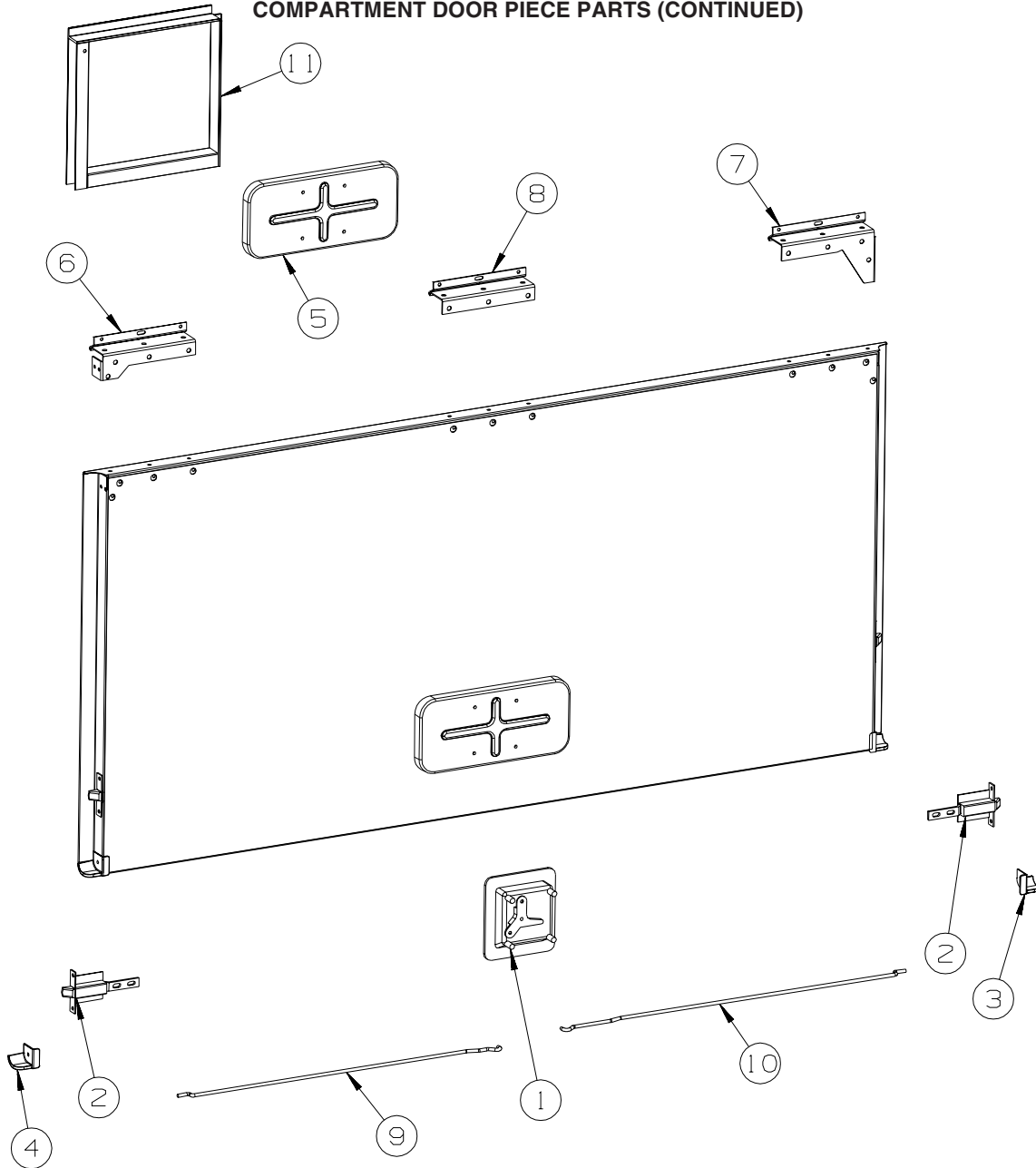

KEY	PART NUMBER	U/M DESCRIPTION
1	112949-02-05A	EA LATCH - PADDLE NON-LOCKING - BLACK
1	138277-01-01A	EA LATCH/PADDLE - COMPARTMENT DOOR - BLACK - KEY ONE
2	121947-01-01A	EA BOLT - SLIDE W/PLASTIC PLUNGER
3	135276-01-02A	EA REINFORCEMENT - CORNER - SANDSTONE
4	135276-02-02A	EA REINFORCEMENT - CORNER - SANDSTONE
5	137359-01-01A	EA COVER - LATCH - WHITE
6	139793-01-01A	EA HINGE - RIGHT HAND/VALANCE DOOR - W/BALL STUD
6	139793-04-01A	EA HINGE - RIGHT HAND/VALANCE DOOR - W/O BALL STUD - REAR PASSENGER
7	139793-05-01A	EA HINGE - LEFT HAND/VALANCE DOOR - W/O BALL STUD
7	139793-02-01A	EA HINGE - LEFT HAND/VALANCE DOOR - W/BALL STUD - REAR PASSENGER
8	139793-03-01A	EA HINGE - CENTER/VALANCE DOOR - W/O BALL STUD
9	132873-01-000	EA ROD - LATCH (BLANK) - RIGHT HAND
10	132873-02-000	EA ROD - LATCH (BLANK) - LEFT HAND
11	133049-07-R28	EA TRIM - FUEL FILL

EXTERIOR DOORS & COMPARTMENTS GROUP (CONTINUED)

ENTRY

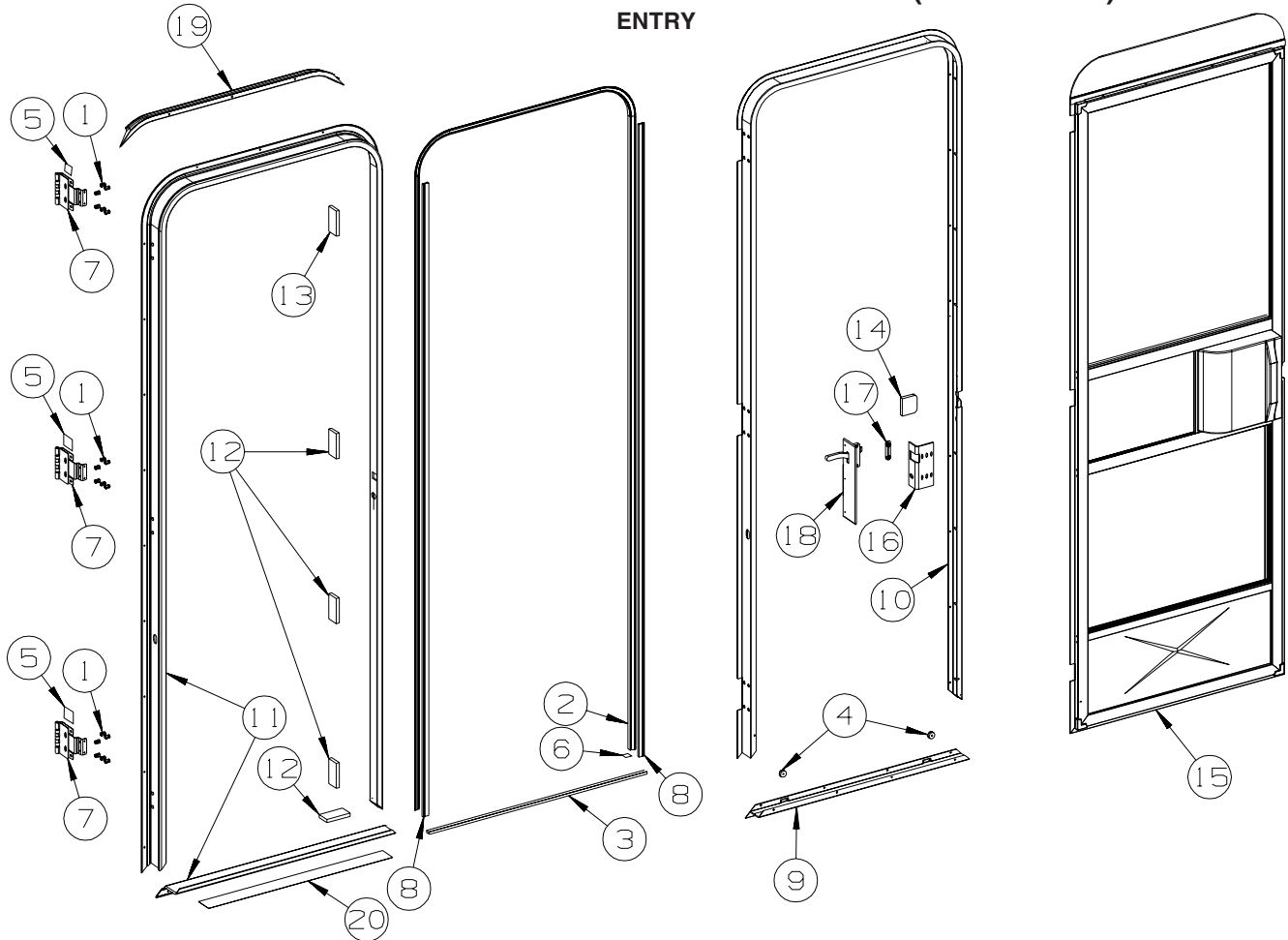

KEY	PART NUMBER	U/M	DESCRIPTION
1	039715-01-000	EA	NUT-SERT - 1/4" DIAMETER - 20 THREADS
2	075671-04-000	FT	SEAL - SPONGE - LAZY T - W/ADHESIVE STRIP - .5" WIDE
3	075673-05-000	FT	SEAL/PILE - .5" HIGH W/ADHESIVE BACK - BLACK
4	081914-02-000	EA	BUMPER - RUBBER - ROUND - 5/16" DIA. X 13/64" THICK
5	100128-02-000	FT	SEAL - FOAM/ADHESIVE BACK - .37" WIDE X .37" THICK
6	104692-01-000	FT	SEAL - ADHESIVE BACKED FOAM - 3/4" THICK X 3/4" WIDE X 25'
7	106719-01-05A	EA	HINGE - ENTRY DOOR - BRIGHT WHITE
8	118929-01-01A	FT	SEAL - PILE - PUSH ON
9	121893-03-02A	EA	FRAME - ENTRY DOOR/LOWER - BRIGHT WHITE
10	121894-16-01A	EA	FRAME - ENTRY DOOR - BRIGHT WHITE
			FROM: 00-00-00 THRU: 06-22-04
10	121894-27-01A	EA	FRAME - ENTRY DOOR - BRIGHT WHITE
			FROM: 06-23-04 THRU: 99-99-99
11	121898-14-01A	EA	JAMB - DOOR/ENTRANCE - BRIGHT WHITE
12	125724-01-000	EA	SHIM - DOOR, ENTRANCE
13	125724-02-000	EA	SHIM - DOOR, ENTRANCE
14	130096-05-000	EA	FOAM - SCREEN DOOR, RETAINER
15	132208-02-L32	EA	DOOR - SCREEN - W/O HARDWARE
16	137401-01-03B	EA	BRACKET - DOOR ANGLE - OFF WHITE
17	148364-01-02A	EA	STRIKE - SCREEN DOOR - BRIGHT WHITE
			FROM: 00-00-00 THRU: 02-11-04
17	148364-01-12B	EA	STRIKE - SCREEN DOOR - BRIGHT WHITE
			FROM: 02-12-04 THRU: 99-99-99
	138287-01-000	EA	CYLINDER/LOCK - ENTRY DOOR (MASTER)
	138287-02-000	EA	CYLINDER/LOCK - ENTRY DOOR (MASTER)
	138287-03-000	EA	CYLINDER/LOCK - ENTRY DOOR (MASTER)
	138287-04-000	EA	CYLINDER/LOCK - ENTRY DOOR (MASTER)
	138287-05-000	EA	CYLINDER/LOCK - ENTRY DOOR (MASTER)
	138287-06-000	EA	CYLINDER/LOCK - ENTRY DOOR (MASTER)
	138287-07-000	EA	CYLINDER/LOCK - ENTRY DOOR (MASTER)
	138287-08-000	EA	CYLINDER/LOCK - ENTRY DOOR (MASTER)
	138287-09-000	EA	CYLINDER/LOCK - ENTRY DOOR (MASTER)

EXTERIOR DOORS & COMPARTMENTS GROUP (CONTINUED)
ENTRY (CONTINUED)

KEY	PART NUMBER	U/M	DESCRIPTION
	138287-10-000	EA	CYLINDER/LOCK - ENTRY DOOR (MASTER)
	138288-01-000	EA	KEY - REVERSIBLE - #1151 - T/M 16169-02-1151
	138288-02-000	EA	KEY - REVERSIBLE - #1152 - T/M 16169-02-1152
	138288-03-000	EA	KEY - REVERSIBLE - #1153 - T/M 16169-02-1153
	138288-04-000	EA	KEY - REVERSIBLE - #1154 - T/M 16169-02-1154
	138288-05-000	EA	KEY - REVERSIBLE - #1155 - T/M 16169-02-1155
	138288-06-000	EA	KEY - REVERSIBLE - #1156 - T/M 16169-02-1156
	138288-07-000	EA	KEY - REVERSIBLE - #1157 - T/M 16169-02-1157
	138288-08-000	EA	KEY - REVERSIBLE - #1158 - T/M 16169-02-1158
	138288-09-000	EA	KEY - REVERSIBLE - #1159 - T/M 16169-02-1159
	138288-10-000	EA	KEY - REVERSIBLE - #1150 - T/M 16169-02-1150
18	132915-01-01A	EA	LATCH - SCREEN DOOR - BLACK
	138292-01-000	EA	SEAL - LOCK CYLINDER
19	139054-19-01A	EA	CAP - DRIP - JAMB MOUNTED - BRIGHT WHITE
20	038327-01-000	EA	TAPE - ANTI-SLIP - 2" X 60'

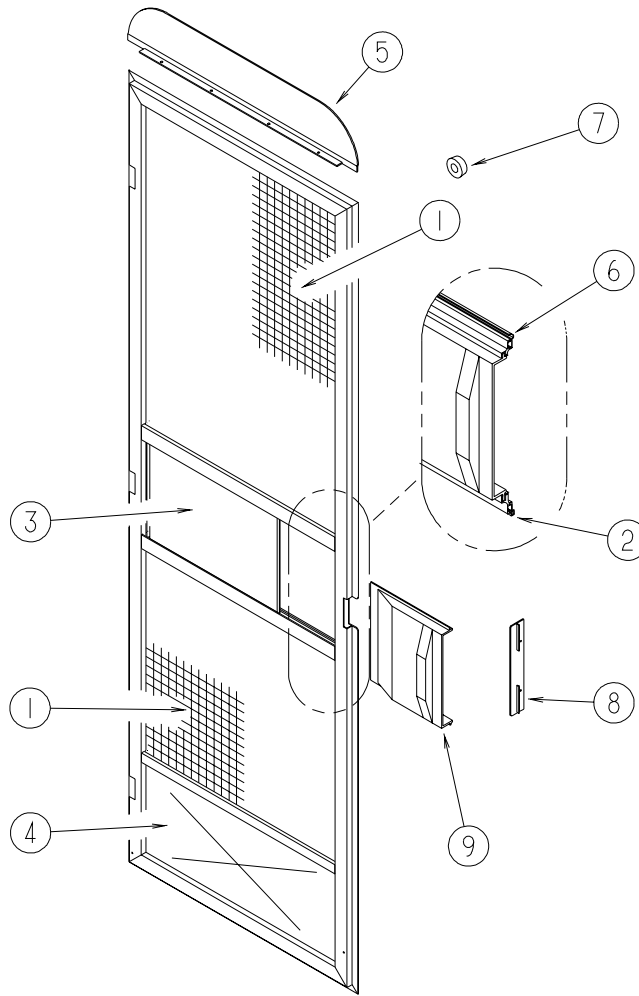

SCREEN

KEY	PART NUMBER	U/M	DESCRIPTION
1	002293-02-000	SF	SCREEN - 26" - CHARCOAL
2	002294-01-000	FT	SPLINE - SCREENING - .13" X .14"
3	016454-18-000	EA	INSERT/CENTER - SCREEN DOOR
4	078552-09-000	EA	INSERT - SCREEN DOOR - LOWER
5	078595-03-000	EA	PLATE - SCREEN DOOR
6	078777-08-000	FT	CHANNEL - SLIDER - 4 FOOT INCREMENTS
7	120863-06-000	EA	BUMPER - RUBBER/RADIUS TOP - 3/4" X 3/8" - LT GRAY
			FROM: 00-00-00 THRU: 06-26-05
7	120863-09-000	EA	BUMPER - RUBBER/RADIUS TOP - 3/4" X 3/8" - LT GRAY
			FROM: 06-27-05 THRU: 99-99-99
8	132081-01-01A	EA	STRIKE - SLIDER - SCREEN DOOR - BRIGHT WHITE
9	132082-01-01A	EA	SLIDER - SCREEN DOOR - BRIGHT WHITE

EXTERIOR DOORS & COMPARTMENTS GROUP (CONTINUED)

LATCH - ENTRY

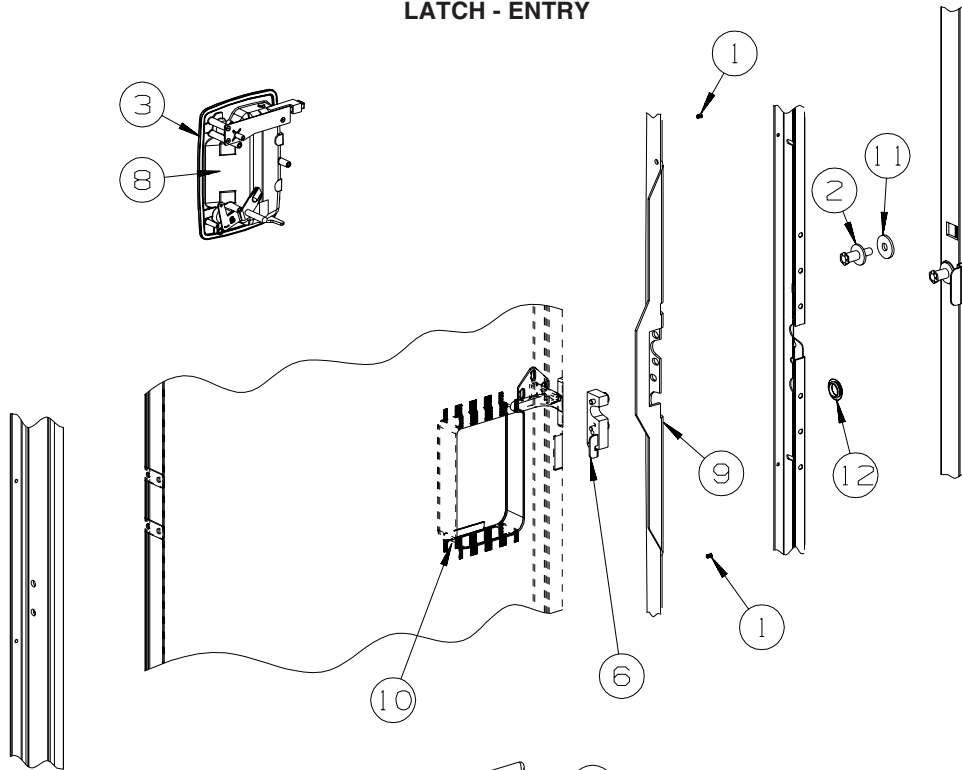

KEY	PART NUMBER	U/M	DESCRIPTION	
1	072893-04-000	EA	NUTSERT - 10-32	
2	092927-15-000	EA	STRIKER - BOLT	
3	112782-04-01A	EA	GASKET	
4	112782-05-01A	EA	CAP - VINYL - RED	
5	112782-08-01A	EA	SCREW - MOUNTING/PLATE - ZINC	
6	112782-15-01A	EA	LATCH - SINGLE ROTOR	
6	112782-22-01A	EA	LATCH - SINGLE ROTOR	FROM: 00-00-00 THRU: 05-30-04
7	112782-16-01A	EA	LATCH - INTERIOR PLATE	FROM: 05-31-04 THRU: 99-99-99
7	112782-21-01A	EA	LATCH - INTERIOR PLATE	FROM: 00-00-00 THRU: 05-30-04
8	112782-18-01A	EA	LATCH - EXTERIOR - W/O LOCK CYLINDER W/ICON-REVERSIBLE KEY	FROM: 05-31-04 THRU: 99-99-99
8	112782-20-01A	EA	LATCH - EXTERIOR - W/O LOCK CYLINDER W/ICON-REVERSIBLE KEY	FROM: 00-00-00 THRU: 05-30-04
9	132207-01-02B	EA	STIFFENER/DOOR - FORMED - E-COATED	FROM: 05-31-04 THRU: 99-99-99
10	137230-01-01A	EA	SPACER - NOTCHED, MILL	
11	147900-01-01A	EA	SPACER - STRIKE BOLT, MILL	
12	061420-14-000	EA	PLUG/PLASTIC - 7/8" DIAMETER - BLACK	

EXTERIOR SLIDEOUT GROUP

FRONT

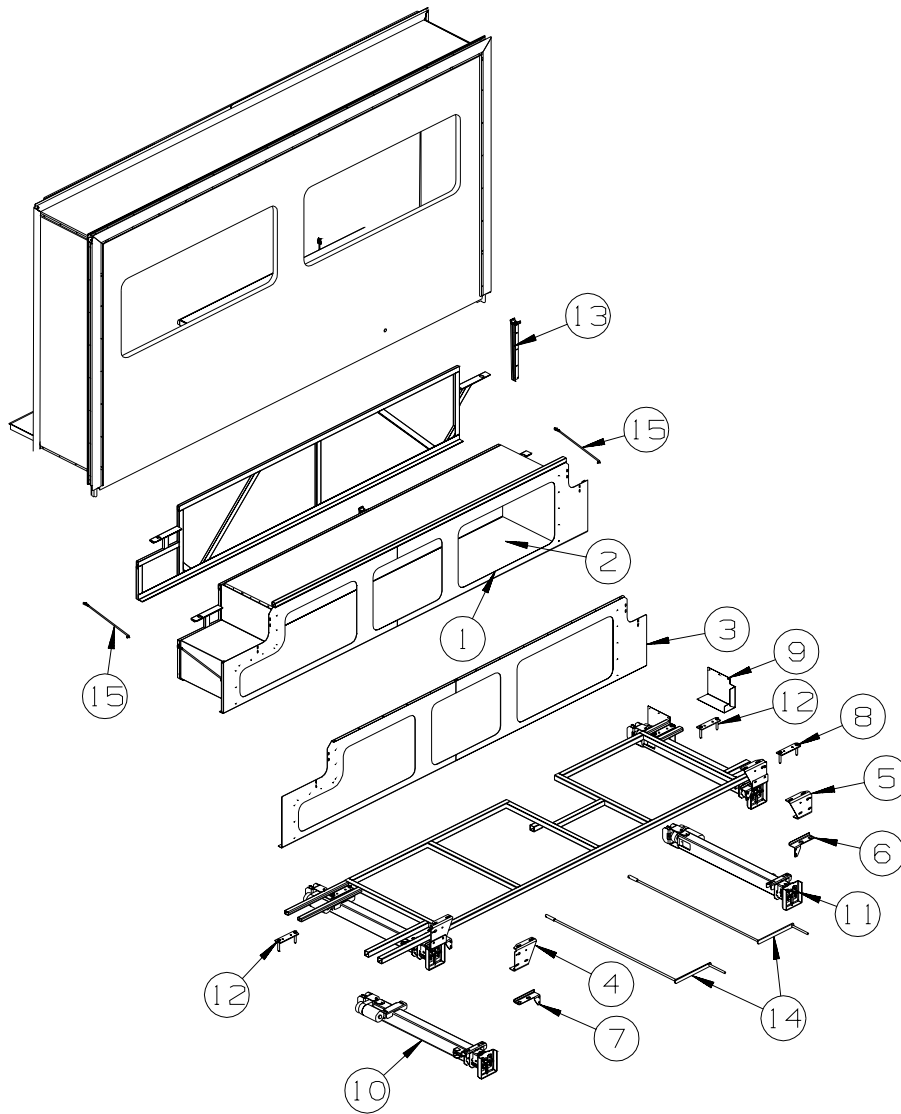

KEY	PART NUMBER	U/M	DESCRIPTION
1	126516-01-01A	FT	TRIM - VINYL/EXTRUDED - 8'
2	141162-08-S28	EA	COMPARTMENT - F/SLIDEOUT
3	137064-10-02B	EA	SEAL PLANE - F/SLIDEOUT - E-COATED
4	127030-07-02B	EA	BRACKET - INNER FRONT/MOUNT - E-COATED
5	127030-08-02B	EA	BRACKET - INNER REAR/MOUNT - E-COATED
6	125888-05-02B	EA	BRACKET/SLIDEOUT COMPARTMENT - RIGHT HAND - E-COATED
7	125888-06-02B	EA	BRACKET/SLIDEOUT COMPARTMENT - LEFT HAND - E-COATED
8	136995-05-02B	EA	PLATE W/BOLTS - 5.9" X 1" W/7/16" X 3" BOLTS
9	138777-01-02B	EA	COVER - MOTOR - F/SLIDEOUT - E-COATED
			FROM: 05-17-04 THRU: 99-99-99
10*	142599-01-000	EA	SLIDE ARM ASSEMBLY - FRONT - ELECTRIC
11*	142599-02-000	EA	SLIDE ARM ASSEMBLY - REAR - ELECTRIC
12	136995-03-02B	EA	PLATE W/BOLTS - 6.9" X 2" W/1/2" X 3" BOLTS
13	126591-01-02B	EA	CARRIER/EXTENSION - F/SLIDEOUT-F/WIRE/HOSES - E-COATED
14	138173-05-000	EA	WRENCH - RETRACT CRANK HANDLE - F/SLIDEOUT
15	107865-26-000	EA	ROD - SUPPORT - VALANCE PANEL - 18.9"

***COMPONENT PARTS LISTED LATER IN THIS GROUP**

EXTERIOR SLIDEOUT GROUP (CONTINUED) FRONT (CONTINUED)

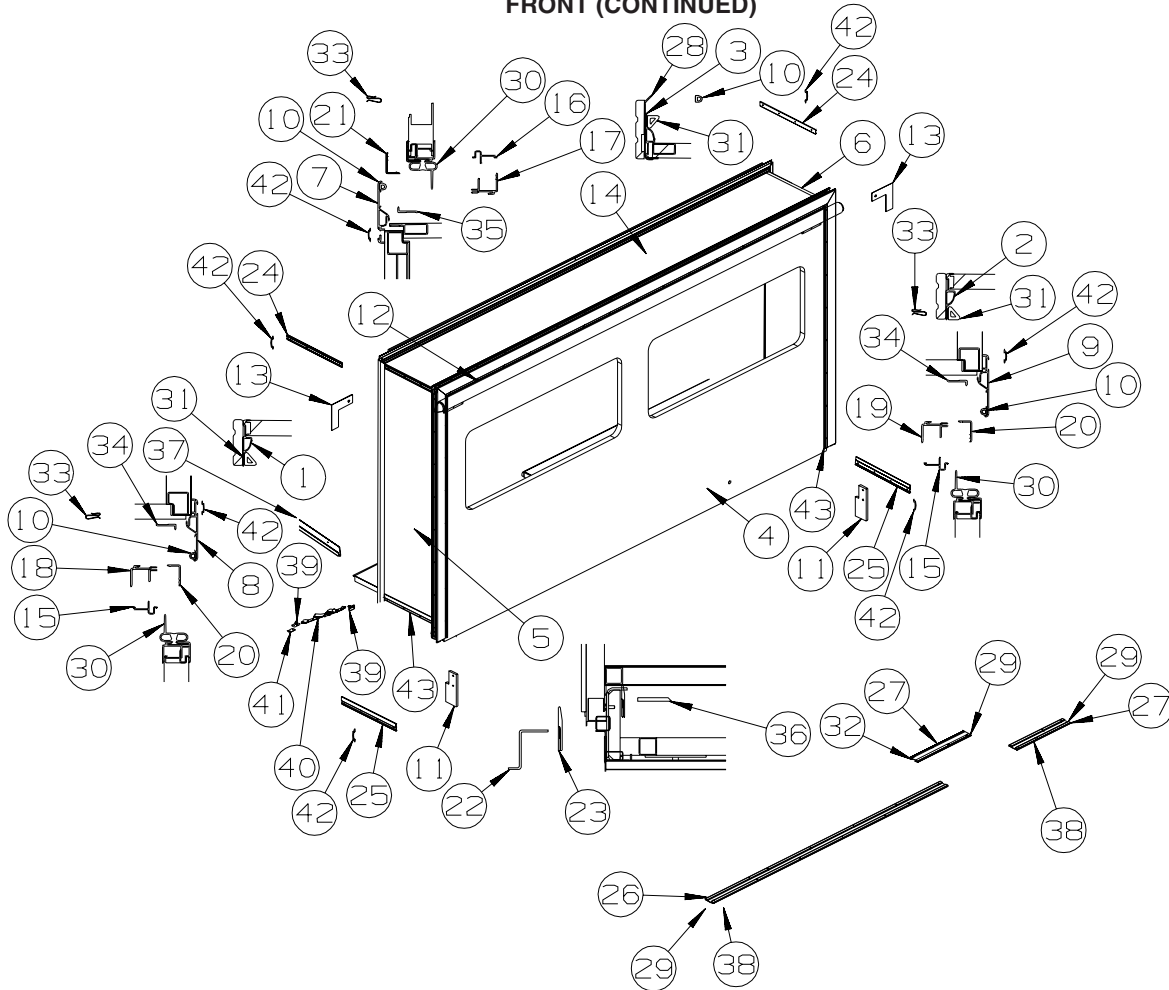

KEY	PART NUMBER	U/M	DESCRIPTION
1	139624-01-01A	EA	TRIM/SEAL - INNER/RIGHT HAND - 73.4" - BRIGHT WHITE
2	139624-02-01A	EA	TRIM/SEAL - INNER/LEFT HAND - 73.4" - BRIGHT WHITE
3	139624-06-01A	EA	TRIM/SEAL - INNER/TOP - 145.2" - BRIGHT WHITE
4	148267-11-S28	EA	SLUG - F/SLIDEOUT (S28, SJ0, SX2 THRU SX7, SY4 THRU SY9)
4	148267-11-S29	EA	SLUG - F/SLIDEOUT (S29, SJ1)
4	148267-11-S30	EA	SLUG - F/SLIDEOUT (S30, SJ2)
5	134728-01-S28	EA	PANEL END - F/SLIDEOUT (S28, SJ0, SX2, SX3, SX4, SX5, SX6, SX7, SY4, SY5, SY6, SY7, SY8, SY9)
5	134728-01-S29	EA	PANEL END - F/SLIDEOUT (S29, SJ1)
5	134728-01-R08	EA	PANEL END - F/SLIDEOUT (S30, SJ2)
6	134729-01-S28	EA	PANEL END - F/SLIDEOUT (S28, SJ0, SX2, SX3, SX4, SX5, SX6, SX7, SY4, SY5, SY6, SY7, SY8, SY9)
6	134729-01-S29	EA	PANEL END - F/SLIDEOUT (S29, SJ1)
6	134729-01-R08	EA	PANEL END - F/SLIDEOUT (S30, SJ2)
7	139625-06-01A	EA	TRIM/SEAL - TOP/W/MITERED ENDS - 147" - BRIGHT WHITE
8	139625-42-01A	EA	TRIM/SEAL - TOP W/RH MITERED END - 76.2" - BRIGHT WHITE
9	139625-43-01A	EA	TRIM/SEAL - TOP W/LH MITERED END - 76.2" - BRIGHT WHITE
10	099418-01-000	FT	SEAL - D-SECTION/ADHESIVE BACK - .44" X .44" - BLK RUBBER
11	126546-01-02A	EA	COVER - END/SIDEWALL SLIDEOUT - BRIGHT WHITE
12	122977-07-03A	EA	AWNING/SLIDEOUT W/COVER - 147" - WHITE - VINYL/VINYL WRAP
13	116444-04-12B	EA	TRIM/KEY CORNER - SLIDEOUT - 3.1"X3.1" - BRT WHT
14	139519-01-N21	EA	ROOF - SLIDEOUT
15	142718-01-01A	EA	RETAINER - SIDEWALL/SLIDEOUT - 72.8"
16	142718-02-01A	EA	RETAINER - SIDEWALL/SLIDEOUT - 144.9" - MILL
17	142719-01-01A	EA	TRIM/SIDEWALL - TOP/SLIDEOUT - 146.7" - BRIGHT WHITE
18	142720-08-01A	EA	TRIM - SIDEWALL/SLIDEOUT - 74.4" - BRIGHT WHITE
19	142720-06-01A	EA	TRIM - SIDEWALL/SLIDEOUT - 74.4" - BRIGHT WHITE
20	136824-45-01A	EA	TRIM - SIDEWALL/SLIDEOUT - 74.4"
21	136824-05-01A	EA	TRIM - SIDEWALL/SLIDEOUT - 146.4" - BRIGHT WHITE
22	128621-39-01A	EA	BRACKET/ZEE - SLIDEOUT - 140.4" - MILL
23	115075-03-000	FT	SEAL - WIPE - .25" X 2.9"
	089275-02-000	FT	STRIP - 3/4" X 84" BLACK POLYETHYLENE
24	138659-01-01A	EA	TRIM/FEATURE STRIP - 181.7" - BRIGHT WHITE

EXTERIOR SLIDEOUT GROUP (CONTINUED)
FRONT (CONTINUED)

KEY	PART NUMBER	U/M	DESCRIPTION
25	125051-01-01A	EA	TRIM- FEATURE STRIP/LOWER - 20.2" - BRIGHT WHITE
26	115325-12-01A	EA	RAIL - FLOOR/SLIDEOUT ROOM - 86.5" LONG - BLACK FROM: 00-00-00 THRU: 01-16-05
26	152641-01-000	EA	SKID/GLIDE - SLIDEOUT ROOM - 1/4"X2"X117.9"- POLYETHYLENE FROM: 01-17-05 THRU: 99-99-99
27	115325-06-02A	EA	RAIL - FLOOR/SLIDEOUT ROOM - 19.7" LONG - BLACK FROM: 00-00-00 THRU: 01-16-05
27	152641-01-000	EA	SKID/GLIDE - SLIDEOUT ROOM - 1/4"X2"X117.9"- POLYETHYLENE FROM: 01-17-05 THRU: 99-99-99
28	125466-02-02A	EA	SUPPORT - ROOF/INTERIOR - BRIGHT WHITE
29	115661-01-000	FT	SHOE/GLIDE - SLIDEOUT ROOM - 1/16" X 3" - POLYETHYLENE
30	136978-01-01A	FT	SEAL - SLIDEOUT - BLACK
31	146056-01-000	FT	SEAL - TRIANGLE - W/PSA
32	134756-05-N52	EA	RAMP - FABRIC COVERED - F/SLIDEOUT - 15.7" - VINYL FLOOR THROUGHOUT FROM: 00-00-00 THRU: 06-17-04
32	134756-03-M30	EA	RAMP - FABRIC COVERED - SLIDEOUT - 18.3" - VINYL FLOOR THROUGHOUT FROM: 06-18-04 THRU: 99-99-99
33	142549-01-000	EA	CLIP - "S" TYPE
34	133954-09-01A	EA	TRIM/SEAL - W/MITERED ENDS - 71.6" - BRIGHT WHITE
35	133954-07-01A	EA	TRIM/SEAL - W/MITERED ENDS - 141.8" - BRIGHT WHITE
36	134837-01-01A	EA	RAMP - SLIDEOUT - BLACK PVC - VINYL FLOOR THROUGHOUT
37	136839-05-01A	EA	TRIM-J - CARPET EDGE/SLIDEOUT - 67.8" - BLACK FROM: 00-00-00 THRU: 04-18-04
37	151282-05-01A	EA	TRIM - CARPET EDGE/F-ANGLE - 67.8" - BLACK FROM: 04-19-04 THRU: 99-99-99
38	134756-04-N74	EA	RAMP - FABRIC COVERED - F/SLIDEOUT - 66.6" - VINYL FLOOR THROUGHOUT FROM: 00-00-00 THRU: 06-17-04
38	134756-06-S28	EA	RAMP - FABRIC COVERED - F/SLIDEOUT - 82.7" - VINYL FLOOR THROUGHOUT FROM: 06-18-04 THRU: 99-99-99
39	135619-02-01A	EA	PLATE - TIEDOWN - SLIDEOUT ROOM
40	135619-01-01A	EA	STRAP - TIEDOWN - SLIDEOUT ROOM
41	135622-01-02B	EA	PLATE - TIEDOWN - SLIDEOUT ROOM
42	105312-01-07A	FT	INSERT - FEATURE STRIP - VINYL - BRIGHT WHITE
43	075673-05-000	FT	SEAL - PILE - ADHESIVE BACK - BLACK

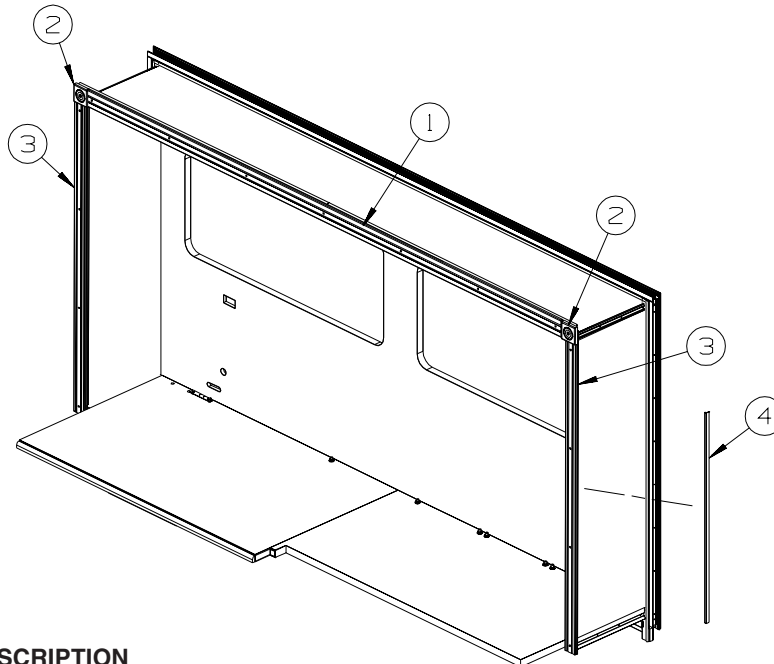

KEY	PART NUMBER	U/M	DESCRIPTION
1	132663-06-08A	EA	MOLDING-VINYL WRAP/PRE DRILLED - .6" X 3.8" X 137.4" - PORTSMOUTH OAK
1	132663-06-22A	EA	MOLDING-VINYL WRAP/PRE DRILLED - .6"X3.8"X137.4 - SIERRA MAPLE
2	132844-01-08A	EA	BLOCK - CORNER - 3.9" X 3.9" - PORTSMOUTH OAK
2	132844-01-22A	EA	BLOCK - CORNER - 3.9" X 3.9" - SIERRA MAPLE
3	132663-04-08A	EA	MOLDING-VINYL WRAP/PRE DRILLED-.6"X3"X70.2" - PORTSMOUTH OAK
3	132663-04-22A	EA	MOLDING-VINYL WRAP/PRE DRILLED-.6"X3"X70.2" - SIERRA MAPLE
4	130262-04-000	EA	PROTECTOR - CORNER - .4" X .7" X 48"

EXTERIOR SLIDEOUT GROUP (CONTINUED)
COMPONENT PARTS FOR FRONT

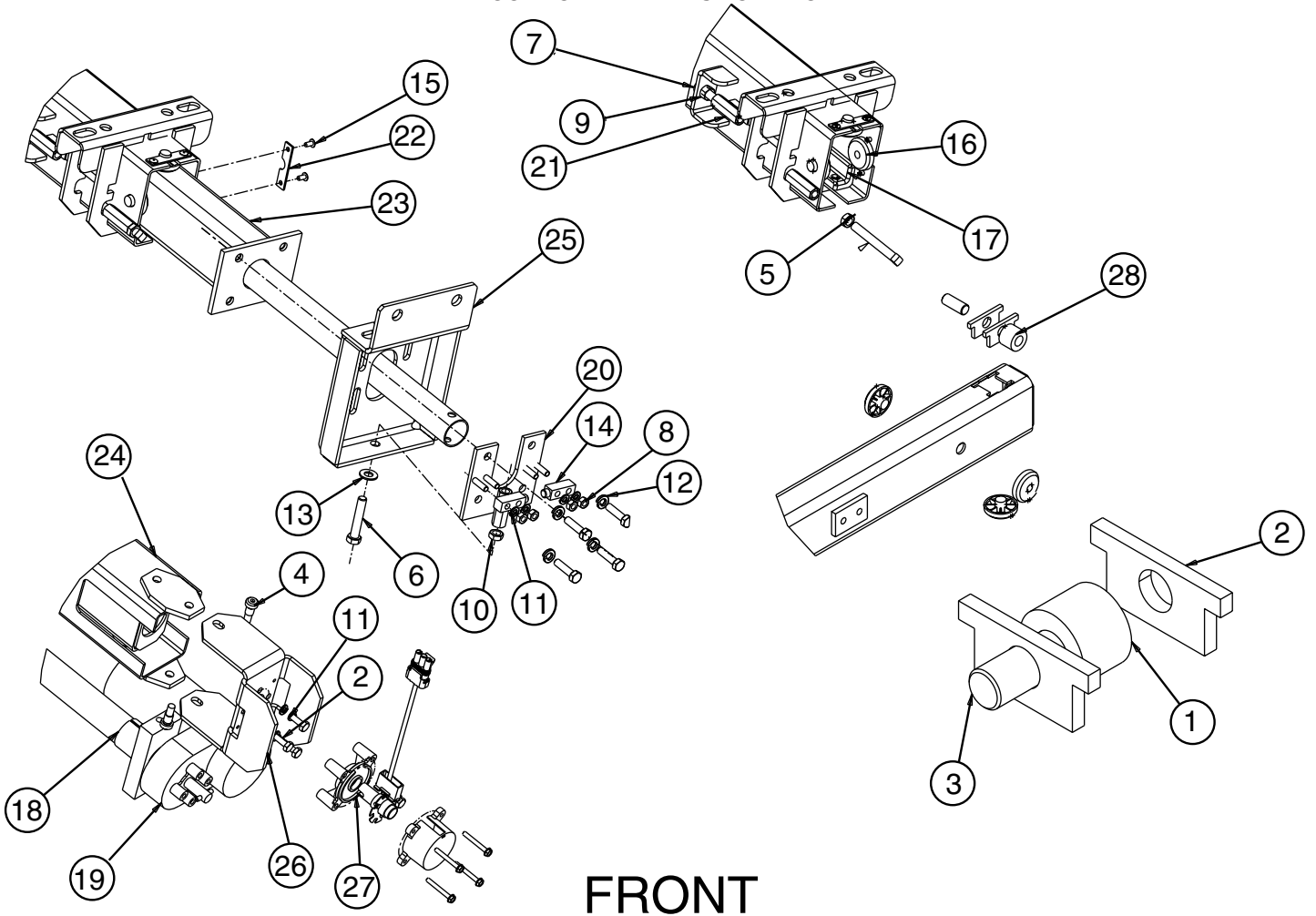

FRONT

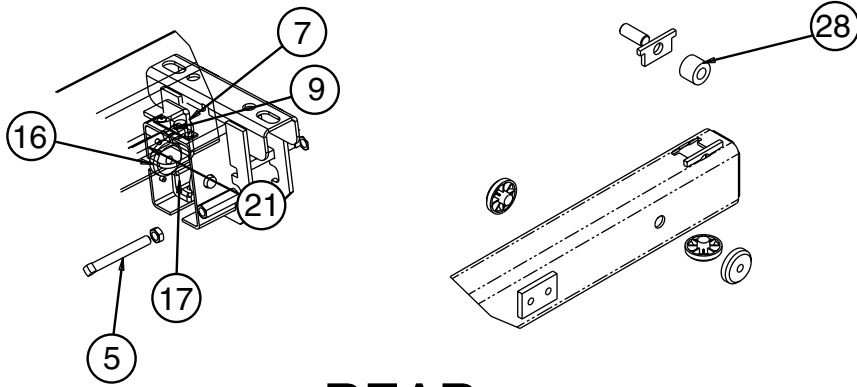

REAR

142599-01-000, 142599-02-000

KEY	PART NUMBER	U/M	DESCRIPTION	VENDOR NO.
1	140457-01-701	EA	BUSHING - 1" X 3/4" X 1/2"ID	1614006
3	140457-01-704	EA	SHAFT/AXLE - REAR ROLLER	7204523
14	138173-01-700	EA	PIN/CLEVIS - PLATED/Front	1213810
15	138173-01-701	EA	POP RIVET - SS 3/16"X1/4"	1214630
16	138173-01-707	EA	WEAR PUCK - PLASTIC F/DRIVE	1612523
17	138173-01-705	EA	WEAR PAD - PLASTIC	1612531
19	138173-01-706	EA	MOTOR - DRIVE W/WORM SHAFT	1820106
	138173-01-704	EA	HOUSING/ENCODER-MAIN ASSY	7200055
	142599-01-700	EA	SWITCH ASSEMBLY W/PIGTAIL	907202011

CONTACT WINNEBAGO PART SALES FOR UNLISTED COMPONENT

GENERATOR GROUP GAS

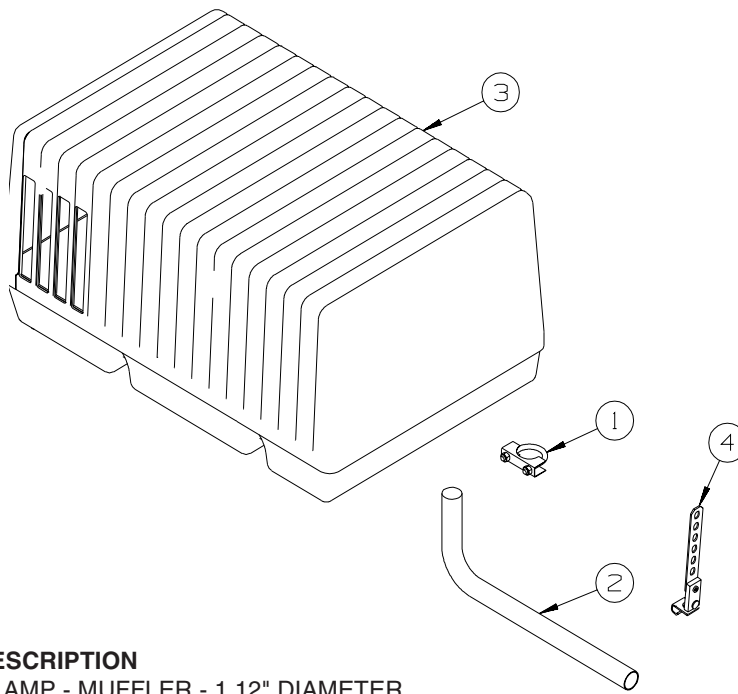

D27C, D29R, D30B

KEY	PART NUMBER	U/M	DESCRIPTION
1	007125-04-000	EA	CLAMP - MUFFLER - 1.12" DIAMETER
2	105958-23-000	EA	PIPE - EXHAUST - GENERATOR
3	109982-03-000	EA	GENERATOR - 4.0 MICROLITE
4	007131-01-000	EA	HANGER - TAILPIPE - 6 SLOTS - D29R

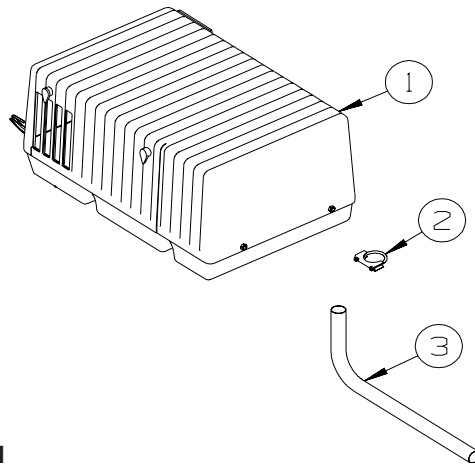

D33L, D34A, D35N

KEY	PART NUMBER	U/M	DESCRIPTION
1	135707-07-000	EA	GENERATOR - 5.5 - 30/20 - GAS - MARQUIS GOLD
2	007125-03-000	EA	CLAMP - MUFFLER - 1.5" DIAMETER
3	105958-07-000	EA	PIPE - EXHAUST - 1.4" INLET X 1.5" O.D. - 4.9" X 20.1"

HEATING & A/C GROUP AUTOMOTIVE

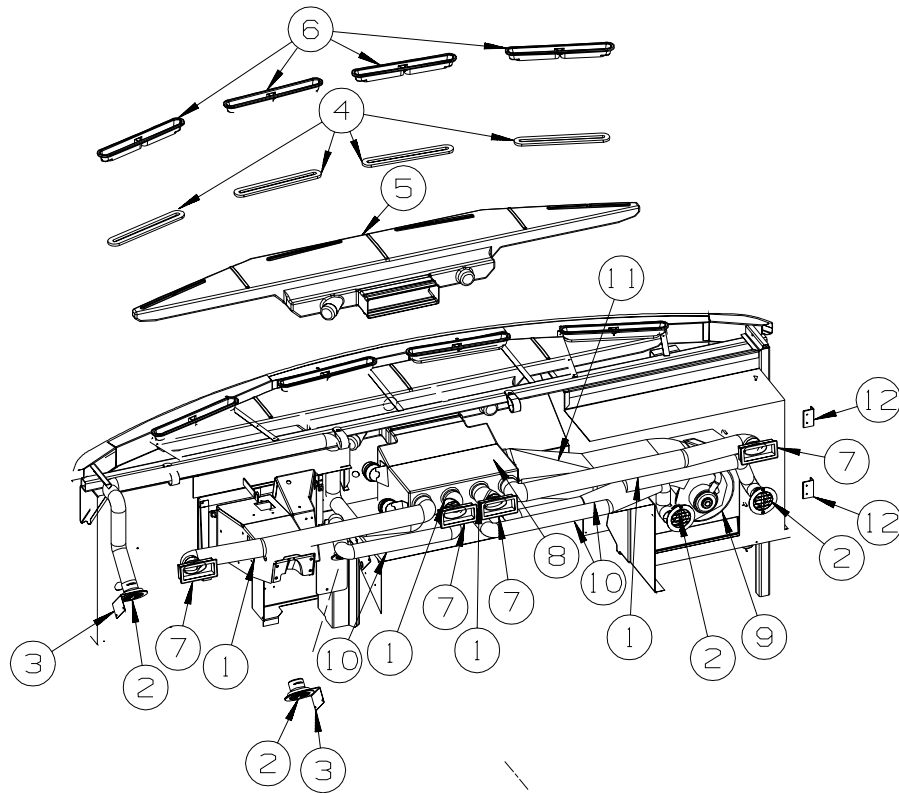

KEY	PART NUMBER	U/M	DESCRIPTION
1	007281-01-000	EA	HOSE - FLEXIBLE PVC - 2 1/2" ID X 50'
2	024990-05-000	EA	OUTLET - DEFROSTER - W/SWIVEL - 2" SLEEVE/4" OD - BLACK
3	136157-03-02B	EA	BRACKET - HEATER - E-COATED
4	077075-01-000	EA	GASKET - INSTRUMENT PANEL/DEFROSTER PLENUM - .6" X 10.2"
5	103017-03-000	EA	PLENUM - DEFROSTER
6	135265-01-04A	EA	VENT - DEFROSTER - PLASTIC - GLACIER
7	135803-01-01A	EA	LOUVER - A/C - 2.5" X 5.2" - BLACK
8*	103930-39-000	EA	CONTROL/PLENUM - ROTARY
9*	103930-55-000	EA	EVAPORATOR/HEATER - NONCHARGED - SINGLE OUTPUT
10	007076-01-000	EA	HOSE - FLEXIBLE PVC - 2" ID - INCREMENTS OF 50'
11	103016-03-000	EA	PLENUM - TRANSITION
12	083125-02-000	EA	BRACE
	113452-02-000	FT	SEAL/TRIM - FRONT - VINYL W/WIRE CARRIER - .027" - WHERE HOSES CROSS METAL
	103930-54-000	EA	MANUAL - OWNERS - HEATER/AC

*COMPONENT PARTS LISTED LATER IN THIS GROUP

HEATING & A/C GROUP (CONTINUED)

AUTOMOTIVE (CONTINUED)

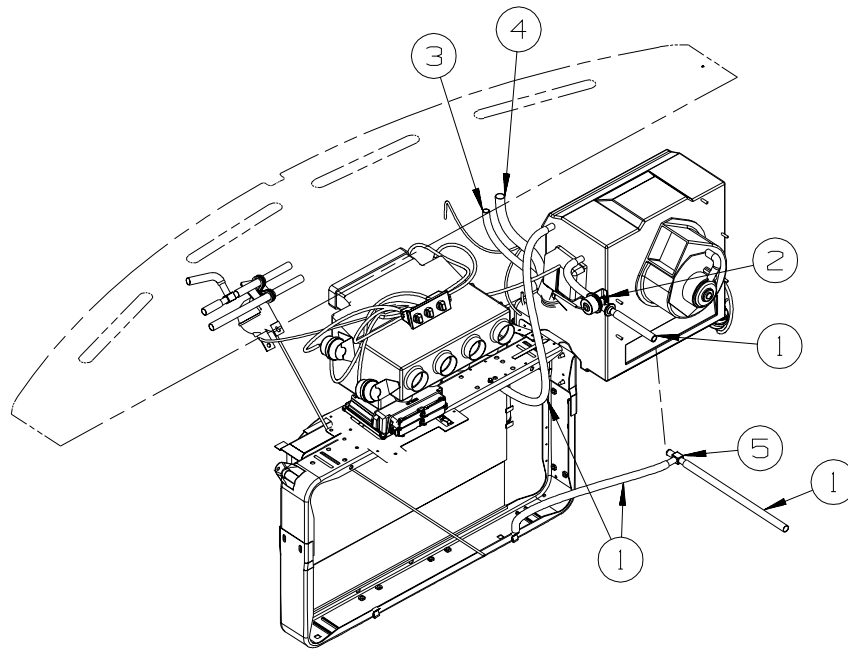

WORKHORSE

KEY	PART NUMBER	U/M	DESCRIPTION
1	007108-01-000	FT	HOSE - HEATER - 5/8" ID - HI-TEMP
2	103930-23-000	EA	VALVE/WATER - 2 PORT/VACUUM CONTROLLED - "NEW DESIGN"
3*	103930-46-000	EA	HOSE - EXPANSION BLOCK (EVAPORATOR) TO COMPRESSOR
4*	103930-47-000	EA	HOSE - EXPANSION VALVE (EVAPORATOR) TO DRIER
5	076776-01-000	EA	TEE - BEADED - 5/8" X 5/8" X 5/8"

***COMPONENT PARTS LISTED LATER IN THIS GROUP**

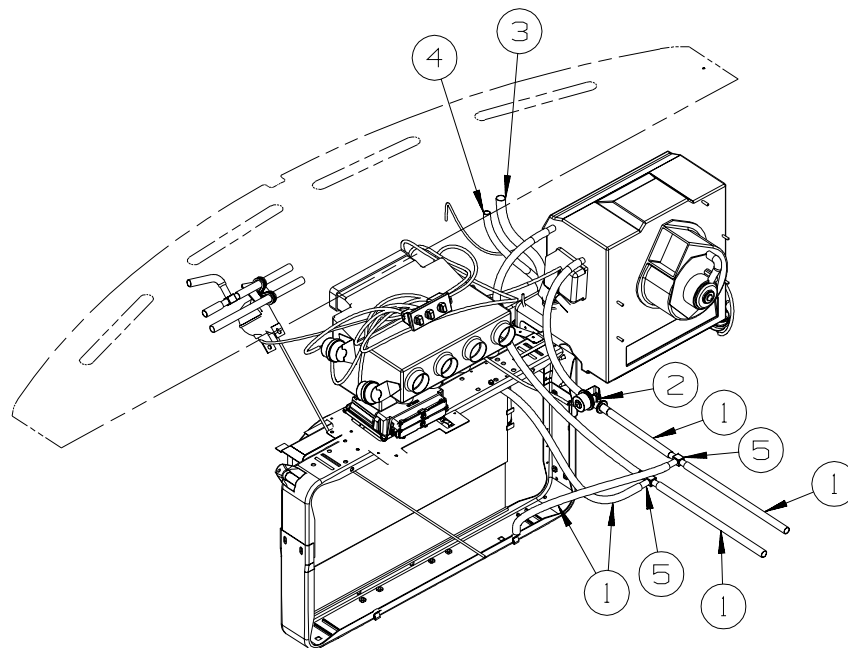

FORD

KEY	PART NUMBER	U/M	DESCRIPTION
1	007108-01-000	FT	HOSE - HEATER - 5/8" ID - HI-TEMP
2	103930-23-000	EA	VALVE/WATER - 2 PORT/VACUUM CONTROLLED - "NEW DESIGN"
3*	103930-44-000	EA	HOSE - EVAPORATOR/DRYER - #6
4*	103930-45-000	EA	HOSE - EVAPORATOR/COMPRESSOR - FORD
5	076776-01-000	EA	TEE - BEADED - 5/8" X 5/8" X 5/8"

***COMPONENT PARTS LISTED LATER IN THIS GROUP**

HEATING & A/C GROUP (CONTINUED)

COMPONENT PARTS FOR AUTOMOTIVE

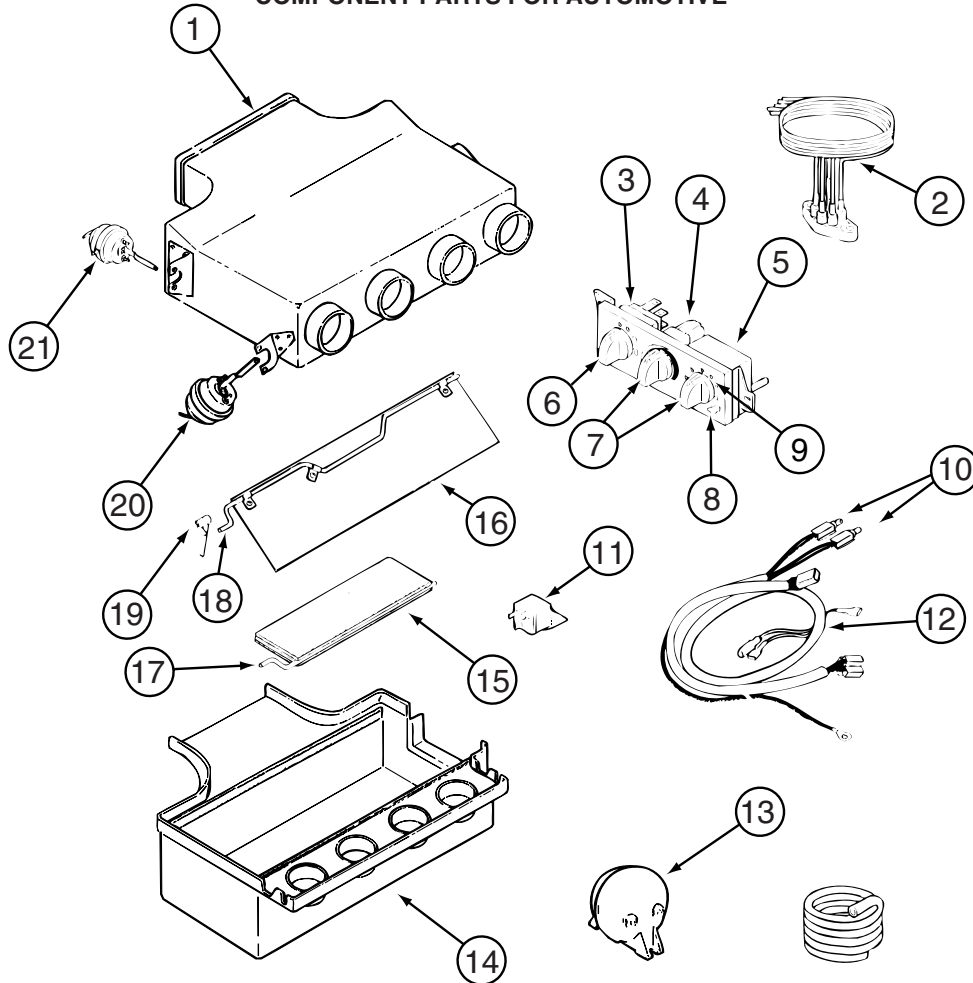

103930-39-000

KEY	PART NUMBER	U/M	DESCRIPTION	VENDOR NO.
1	103930-39-705	EA	PLENUM - TOP	060-0482
2	103930-33-703	EA	VACUUM HARNESS	036-0466
3	103930-33-707	EA	SWITCH - BLOWER	032-00066
4	103930-33-708	EA	SWITCH - POTENTIOMETER	032-0184
5	103930-33-709	EA	SWITCH - VACUUM	032-0183
6	103930-33-712	EA	KNOB - BLOWER	062-00539
7	103930-33-713	EA	KNOB - TEMPERATURE	062-0540
8	103930-33-702	EA	CONTROL PANEL	083-0169
9	103930-33-710	EA	DECAL F/CONTROL HEAD	058-0102
10	103930-33-705	EA	LIGHT BULBS	035-0030
11	103930-02-707	EA	RELAY-BOSCH W/RESISTER	031-0001
12	103930-33-711	EA	WIRE HARNESS-W/BULBS(CAVITY)	036-0496
13	103930-02-710	EA	CANISTER-VACUUM	054-0002
14	103930-39-707	EA	PLENUM - BOTTOM	060-0483
15	103930-39-706	EA	PLATE - DOOR - A/C	071-0623
16	103930-04-700	EA	DOOR - DEFROSTER-A/C	071-0149
17	103930-39-700	EA	ROD - DOOR - AC/HEAT	073-067
18	103930-39-701	EA	ROD - DOOR - AC/DEFROST	073-0069
19	103930-39-704	EA	SPRING	022-0119
20	103930-02-708	EA	MOTOR-VACUUM SERVO, A/C	030-0025
21	103930-33-701	EA	MOTOR - VACUUM, 3 STAGE	030-0105

HEATING & A/C GROUP (CONTINUED)
COMPONENT PARTS FOR AUTOMOTIVE (CONTINUED)

103930-44-000

KEY	PART NUMBER	U/M	DESCRIPTION	VENDOR NO
	103930-29-701	EA	O'RING F/LOW PRESSURE SWITCH	045-0483
	103930-44-700	EA	HOSE ASSEMBLY #6	085-0462
	113245-01-711	EA	O'RING #6	045-0129

103930-45-000

KEY	PART NUMBER	U/M	DESCRIPTION	VENDOR NO.
	103930-17-702	EA	O'RING #10	045-0127
	103930-45-700	EA	HOSE - #10 EVAP/COMP - 3'	085-0463

103930-46-000

KEY	PART NUMBER	U/M	DESCRIPTION	VENDOR NO
	103930-17-702	EA	O'RING #10	045-0127
	103930-29-701	EA	O'RING F/LOW PRESSURE SWITCH	045-0483
	103930-46-700	EA	HOSE - #10 EVAP/COMP - 4.3'	085-0486

103930-47-000

KEY	PART NUMBER	U/M	DESCRIPTION	VENDOR NO
	103930-47-700	EA	HOSE - #6-EVAP/DRIER - 2.2'	085-0485
	113245-01-710	EA	O'RING, #12	045-0128

HEATING & A/C GROUP (CONTINUED)
COMPONENT PARTS FOR AUTOMOTIVE (CONTINUED)

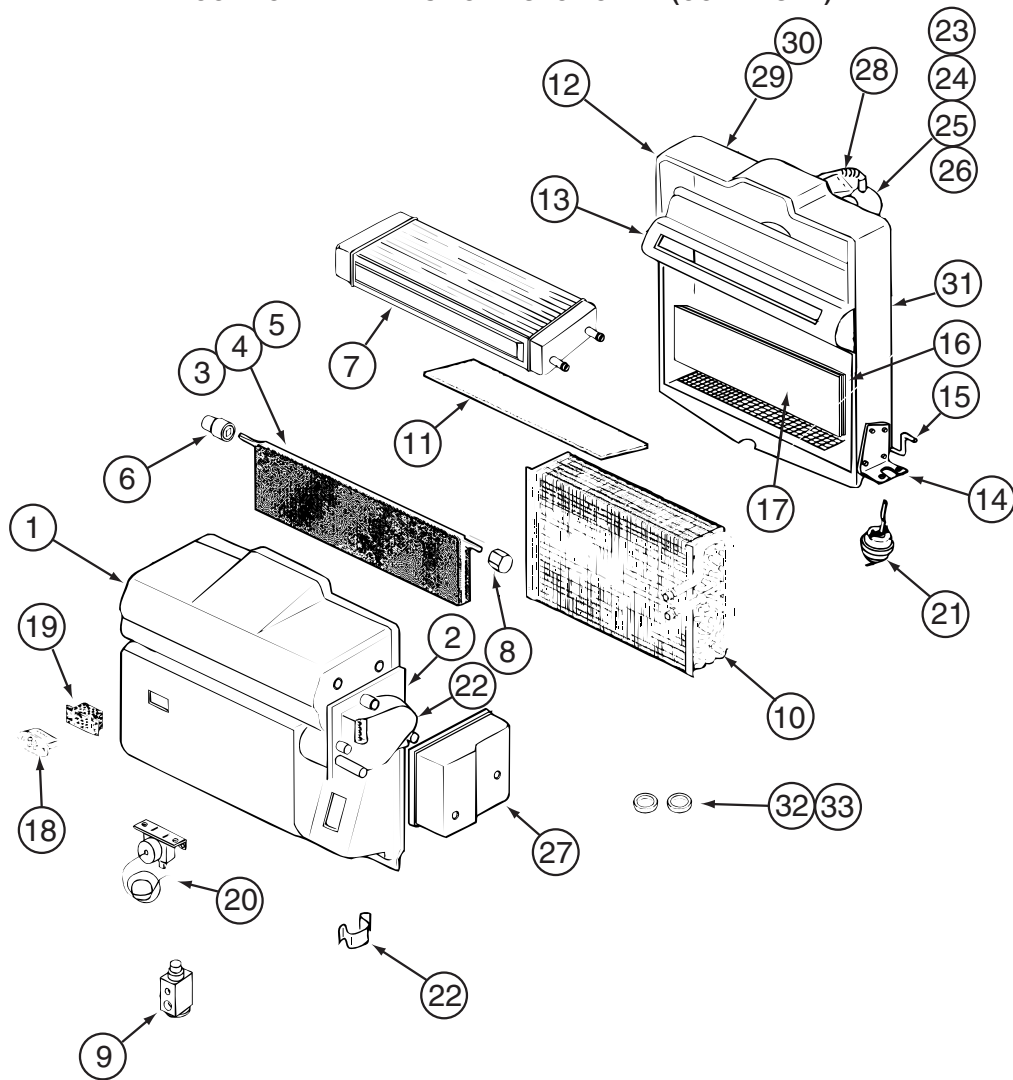

103930-55-000

KEY	PART NUMBER	U/M	DESCRIPTION	VENDOR NO.
1	103930-55-701	EA	CASE - FRONT	062-0658
2	103930-30-701	EA	PLATE - MOTOR MOUNT	062-0544
3	103930-55-705	EA	DOOR - BLEND AIR	071-0892
6	103930-30-702	EA	BUSHING/DRIVE (BLEND DOOR)	062-0168
7	103930-55-706	EA	CORE - HEATER - W/GASKET	084-0271
8	103930-30-709	EA	COUPLING - BLEND DOOR SHAFT	062-0634
9	103930-20-700	EA	VALVE-EXPANSION-BLOCK, 2 TON	034-0032
10	103930-55-700	EA	CORE-EVAPORATOR	041-00168
12	103930-55-702	EA	CASE-REAR	062-0657
14	103930-01-708	EA	BRACKET-VACUUM MOTOR	070-0113
15	103930-20-704	EA	ROD-DOOR-RECIRCULATING	073-0018
16	103930-55-707	EA	DOOR - RECIRCULATION	071-0891
18	103930-01-710	EA	RESISTOR-FUSED, A/C 4 TERM	035-0006
20	103930-01-711	EA	THERMOSTAT	033-0003
21	103930-02-708	EA	MOTOR-VACUUM SERVO, A/C	030-0025
22	103930-30-703	EA	MOTOR - SERVO	030-0104
23	103930-20-707	EA	HOUSING-BLOWER	062-0145
24	103930-55-703	EA	MOTOR-BLOWER W/O PIGTAIL	030-0137
25	103930-01-717	EA	WHEEL-BLOWER, CLOCKWISE	062-0010
26	103930-20-708	EA	CLIP-MOTOR SHAFT	022-0001
27	103930-30-704	EA	COVER - SERVO	062-0545
32	113245-01-707	EA	O'RING #8	045-0126
33	103930-17-702	EA	O'RING #10	045-0127
	103930-55-704	EA	CORE-HEATER	042-0059
	110279-01-703	EA	HOSE-VENT F/BLOWER MOTOR	051-0034

CONTACT WINNEBAGO PART SALES FOR UNLISTED COMPONENT(S)

HEATING & A/C GROUP (CONTINUED)

FURNACE

KEY	PART NUMBER	U/M	DESCRIPTION
*	139980-02-000	EA	FURNACE - 30000 BTU - SF QUIET - SUBURBAN SF-30 2321J - FURNACE-30,000BTU
*	143563-01-000	EA	FURNACE - 35000 BTU/HIGH QUIET - SUBURBAN SH-35 2322 - FURNACE-35,000 BTU
*	143563-02-000	EA	FURNACE - 40000 BTU HIGH QUIET - SUBURBAN SH-40 2322 - FURNACE-40,000 BTU
	098668-23-000	EA	DOOR - ACCESS - FURNACE - BRIGHT WHITE
	009200-01-000	EA	TAPE - FURNACE - 1 1/2"
	130837-02-01A	EA	REGISTER - HEAT - W/DAMPER - DURA BEIGE
	137965-01-01A	EA	REGISTER - 11.2" X 3.6"(9.7 X 2.1"R/O) W/O DAMPER- ANT BRS
	056464-10-000	EA	REGISTER W/O DAMPER - 4" DIAMETER - PLASTIC - BEIGE
	137965-01-01A	EA	REGISTER - 11.2" X 3.6"(9.7 X 2.1"R/O) W/O DAMPER- ANTIQUE BRASS
	137965-02-01A	EA	REGISTER - 11.2" X 3.6"(9.7 X 2.1"R/O) W/DAMPER - ANTIQUE BRASS
	093614-11-01A	EA	GRILLE - AIR RETURN - 13.9" X 7.9" - BEIGE
	093614-01-02A	EA	GRILLE - AIR RETURN - 15.9" X 7.9" - BEIGE
	143563-05-000	EA	GASKET - FIBERGLASS - SUBURBAN #071018
	098668-26-000	EA	BOTTOM DUCT KIT - 40,000 BTU
	143563-06-000	EA	DUCT KIT - BOTTOM
	009198-01-000	FT	DUCT - HEAT - FLEXIBLE - 4" ID X 25'
	009198-02-000	FT	DUCT - HEAT - FLEXIBLE - 2" ID X 25'
	069636-02-000	EA	CONNECTOR - DUCT - 4" ID
	092776-01-000	EA	ADAPTER - DUCT - 2"

*COMPONENT PARTS LISTED LATER IN THIS GROUP

HEATING & A/C GROUP (CONTINUED)

COMPONENT PARTS FOR FURNACE

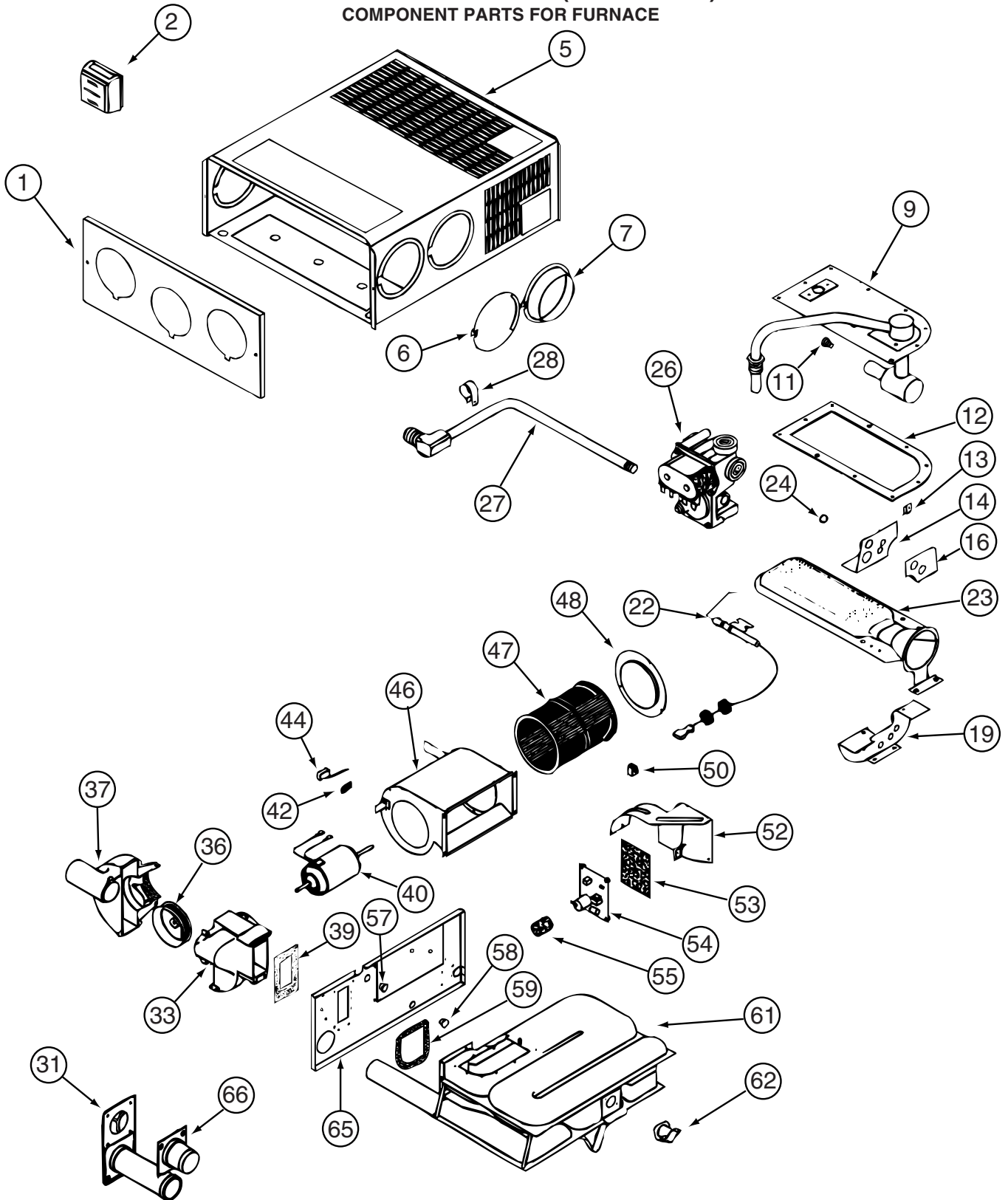

139980-02-000

HEATING & A/C GROUP (CONTINUED)
COMPONENT PARTS FOR FURNACE (CONTINUED)

139980-02-000 (CONTNUED)

KEY	PART NUMBER	U/M	DESCRIPTION	VENDOR NO.
9	139980-01-700	EA	MANIFOLD ASSEMBLY	171571
11	092300-02-701	EA	ORIFICE-MAIN BURNER (NT-30BW	180214
12	098668-22-703	EA	GASKET - BURNER ACCESS COVER	070811
22	139980-01-701	EA	ELECTRODE	232286
23	098668-02-700	EA	BURNER ASSEMBLY,SF-30 & SF35	010745
26	098668-01-718	EA	VALVE-GAS SF S.N.974903079	161122
27	139980-01-702	EA	PIPE ASSEMBLY/GAS INLET	171574
31	098668-01-707	EA	TUBE ASSEMBLY, EXHAUST W/CAP	260231
33	139980-01-703	EA	HOUSING/COMB. - FRONT/HALF	390852
36	098668-01-706	EA	WHEEL-COMBUSTION AIR	350184
37	139980-01-704	EA	HOUSING/COMB. - REAR/HALF	390848
39	139980-01-705	EA	GASKET/FIREWALL-COMB AIR	071084
40	139980-01-706	EA	MOTOR ASSEMBLY W/GASKET	232682
42	101990-01-714	EA	GASKET-MICROSWITCH	230877
44	098668-21-700	EA	SWITCH-MICRO-W/O FLAG 3 1/4"	232261
46	139980-01-708	EA	BLOWER ASSEMBLY - ROOM AIR	390739BK
47	098668-01-711	EA	WHEEL-BLOWER, ROOM AIR	350129
48	139980-01-709	EA	ORFICE RING	390696
50	139980-01-710	EA	SWITCH - ON/OFF	232351
52	139980-01-711	EA	PANEL ASSEMBLY-MODULE BD	101663
53	139980-01-712	EA	INSULATOR - MODULE BD	070807
54	098668-22-705	EA	MODULE BD W/RELAY TIME DELAY	520820
55	139980-01-713	EA	CAP/INSULATOR-MODULE BD	070973
57	139980-01-714	EA	BUSHING - UNIVERSAL	070362
58	139980-01-715	EA	BUSHING - STRAIN RELIEF	231809
59	098668-01-716	EA	GASKET-FIREWALL,CHAMBER SIDE	070808
61	139980-01-716	EA	CHAMBER ASSEMBLY - FINAL	021149BK
62	098668-21-701	EA	SWITCH - LIMIT	232504
66	098668-01-713	EA	TUBE ASSEMBLY, INTAKE	051248
			CONTACT WINNEBAGO PART SALES FOR UNLISTED COMPONENT(S)	

HEATING & A/C GROUP (CONTINUED)
COMPONENT PARTS FOR FURNACE (CONTINUED)

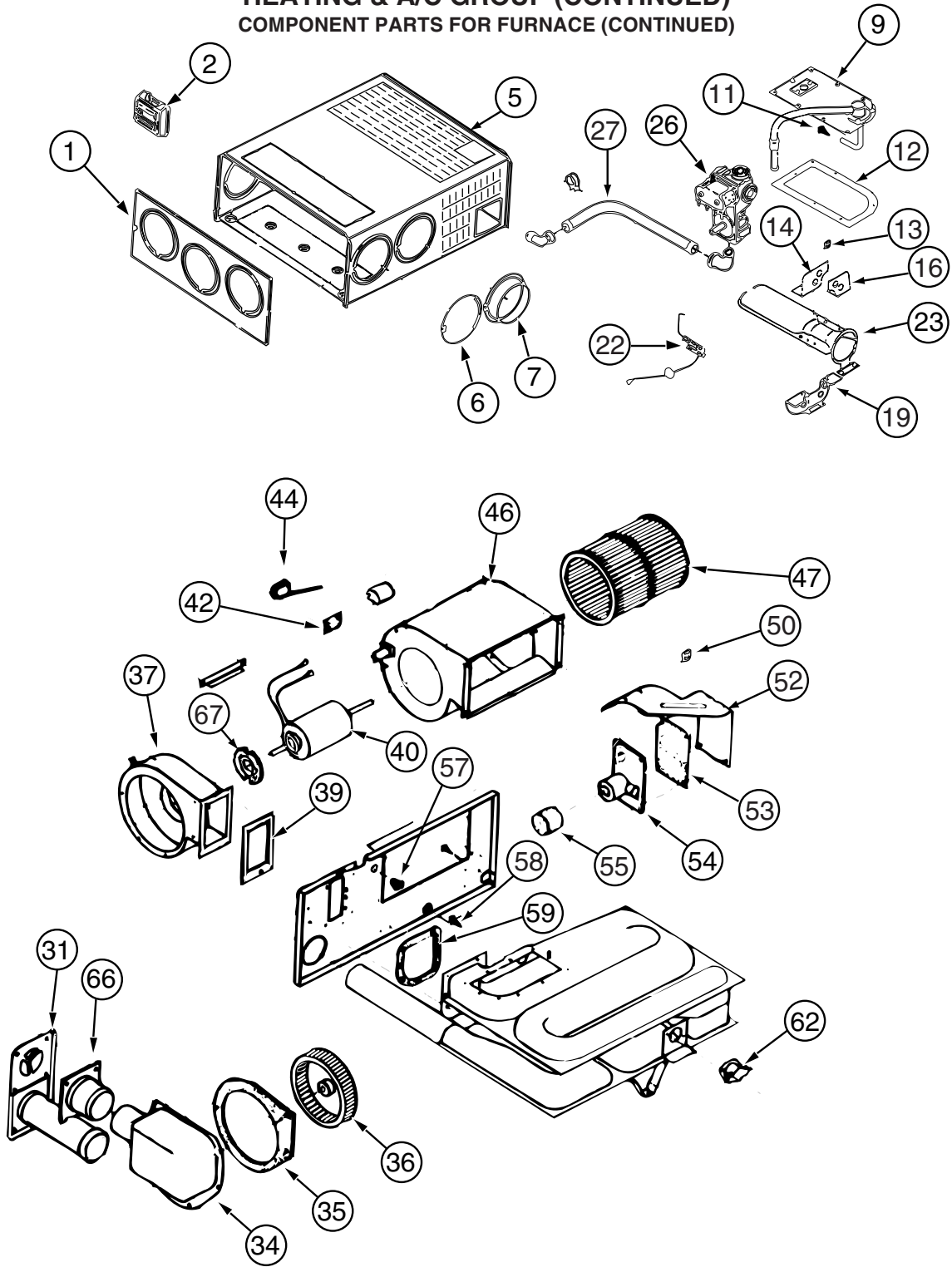

143563-01-000

HEATING & A/C GROUP (CONTINUED)
COMPONENT PARTS FOR FURNACE (CONTINUED)

143563-01-000 (CONTINUED)

KEY	PART NUMBER	U/M	DESCRIPTION	VENDOR NO.
1	143563-01-700	EA	CABINET - FRONT	101907
2			12 VOLT WIRING AREAS FOR CORRECT THERMOSTAT	
5	143563-01-701	EA	CABINET	101921
7	075696-02-703	EA	COLLAR - DUCT	050715
9	143563-01-702	EA	MANIFOLD ASSEMBLY	171599
11	143563-01-703	EA	ORFICE - MAIN BURNER	180308
12	098668-22-703	EA	GASKET - BURNER ACCESS COVER	070811
14	143563-01-704	EA	PLATE - SECONDARY AIR/TOP BACK	063199
16	143563-01-705	EA	PLATE - SECONDARY AIR/TOP FRT	062936
19	143563-01-706	EA	PLATE - SECONDARY AIR/BOTTOM	062938
22	139980-01-701	EA	ELECTRODE	232286
23	098668-02-700	EA	BURNER ASSEMBLY,SF-30 & SF35	010745
26	098668-01-718	EA	VALVE-GAS SF S.N.974903079	161122
27	143563-01-707	EA	PIPE ASSEMBLY (GAS INLET)	171603
31	098668-01-707	EA	TUBE ASSEMBLY, EXHAUST W/CAP	260231
34	143563-01-708	EA	BOX ASM (COMB. AIR INTAKE)	051430BK
35	143563-01-709	EA	GASKET (COMB. AIR HOUSING)	071108
36	143563-01-710	EA	WHEEL (COMBUSTION AIR)	350199
37	143563-01-711	EA	HOUSING (COMBUSTION AIR)	390862BK
39	143563-01-715	EA	GASKET-FIREWALL/COMB. AIR	071107
40	143563-01-712	EA	MOTOR ASSEMBLY	232727
42	101990-01-714	EA	GASKET-MICROSWITCH	230877
44	098668-21-700	EA	SWITCH-MICRO-W/O FLAG 3 1/4"	232261
46	143563-01-713	EA	BLOWER ASSEMBLY(ROOM AIR)	390867BK
47	143563-01-714	EA	WHEEL - ROOM AIR	350198
50	139980-01-710	EA	SWITCH - ON/OFF	232351
52	139980-01-711	EA	PANEL ASSEMBLY-MODULE BD	101663
53	139980-01-712	EA	INSULATOR - MODULE BD	070807
54	098668-22-705	EA	MODULE BD W/RELAY TIME DELAY	520820
55	139980-01-713	EA	CAP/INSULATOR-MODULE BD	070973
57	139980-01-714	EA	BUSHING - UNIVERSAL	070362
58	139980-01-715	EA	BUSHING - STRAIN RELIEF	231809
59	098668-01-716	EA	GASKET-FIREWALL,CHAMBER SIDE	070808
62	098668-21-701	EA	SWITCH - LIMIT	232504
66	098668-01-713	EA	TUBE ASSEMBLY, INTAKE	051248
67	075697-07-703	EA	GASKET - MOTOR	070448
	143563-01-716	EA	CHAMBER ASM. - FINAL	
			CONTACT WINNEBAGO PART SALES FOR UNLISTED COMPONENT(S)	

HEATING & A/C GROUP (CONTINUED)
COMPONENT PARTS FOR FURNACE (CONTINUED)

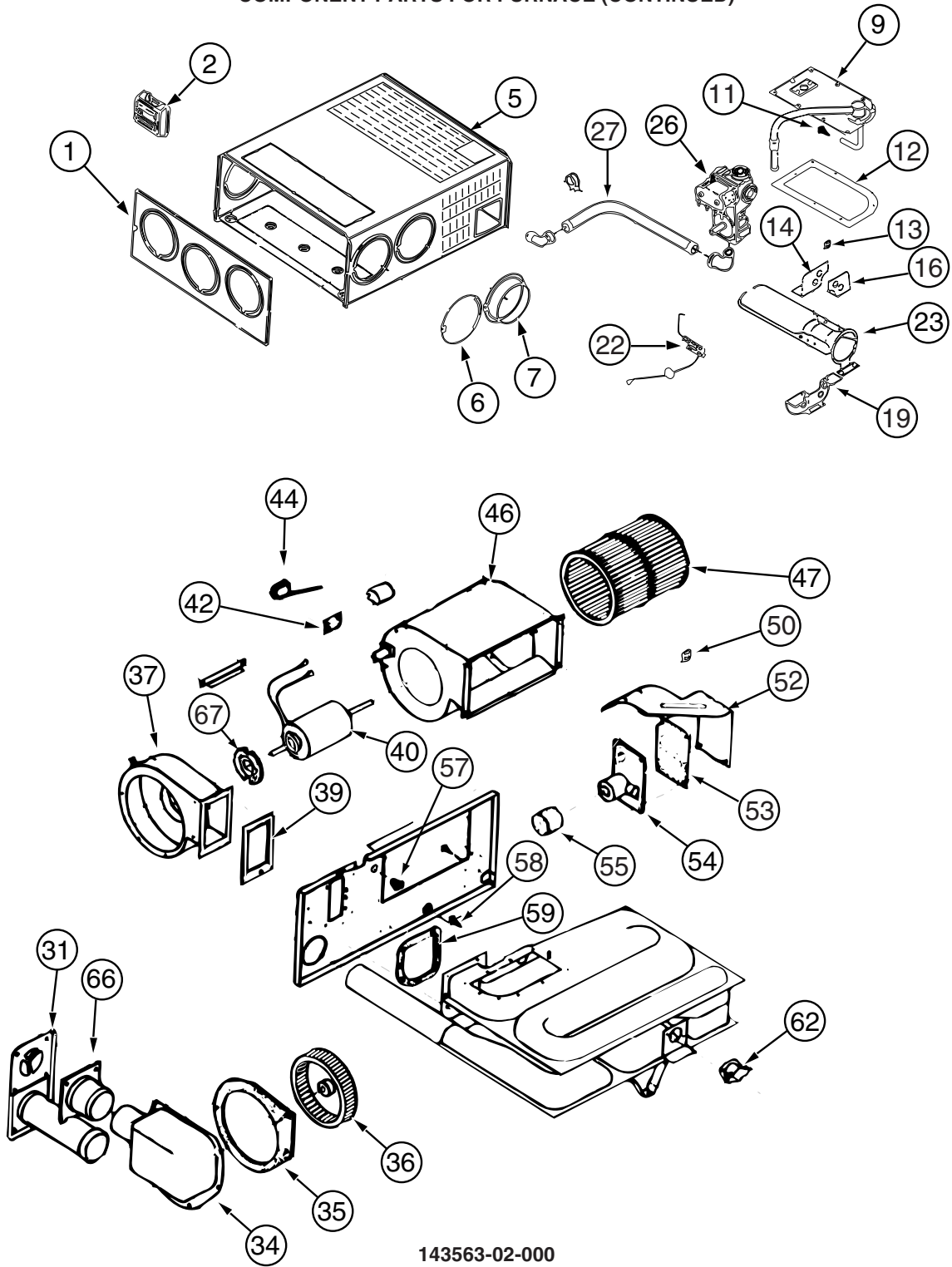

143563-02-000

HEATING & A/C GROUP (CONTINUED)
COMPONENT PARTS FOR FURNACE (CONTINUED)

143563-02-000 (CONTINUED)

KEY	PART NUMBER	U/M	DESCRIPTION	VENDOR NO.
1	143563-01-700	EA	CABINET - FRONT	101907
2			SEE 12 VOLT WIRING AREAS FOR CORRECT THERMOSTAT	
5	143563-02-700	EA	CABINET	101915
7	075696-02-703	EA	COLLAR - DUCT	050715
9	143563-01-702	EA	MANIFOLD ASSEMBLY	171599
11	143563-02-701	EA	ORFICE - MAIN BURNER	180309
12	098668-22-703	EA	GASKET - BURNER ACCESS COVER	070811
14	143563-02-702	EA	PLATE - SECONDARY AIR/TOP BACK	063198
16	143563-02-703	EA	PLATE - SECONDARY AIR/TOP FRT	062933
19	143563-02-704	EA	PLATE - SECONDARY AIR/BOTTOM	062935
22	139980-01-701	EA	ELECTRODE	232286
23	098668-11-701	EA	BURNER ASSEMBLY, SF-42F	010799
26	098668-01-718	EA	VALVE-GAS SF S.N.974903079	161122
27	143563-01-707	EA	PIPE ASSEMBLY (GAS INLET)	171603
31	098668-01-707	EA	TUBE ASSEMBLY, EXHAUST W/CAP	260231
34	143563-01-708	EA	BOX ASM (COMB. AIR INTAKE)	051430BK
35	143563-01-709	EA	GASKET (COMB. AIR HOUSING)	071108
36	143563-01-710	EA	WHEEL (COMBUSTION AIR)	350199
37	143563-01-711	EA	HOUSING (COMBUSTION AIR)	390862BK
39	143563-01-715	EA	GASKET-FIREWALL/COMB. AIR	071107
40	143563-02-705	EA	MOTOR ASSEMBLY	232726
42	101990-01-714	EA	GASKET-MICROSWITCH	230877
44	098668-21-700	EA	SWITCH-MICRO-W/O FLAG 3 1/4"	232261
46	143563-01-713	EA	BLOWER ASSEMBLY(ROOM AIR)	390867BK
47	143563-01-714	EA	WHEEL - ROOM AIR	350198
50	139980-01-710	EA	SWITCH - ON/OFF	232351
52	139980-01-711	EA	PANEL ASSEMBLY-MODULE BD	101663
53	139980-01-712	EA	INSULATOR - MODULE BD	070807
54	098668-22-705	EA	MODULE BD W/RELAY TIME DELAY	520820
55	139980-01-713	EA	CAP/INSULATOR-MODULE BD	070973
57	139980-01-714	EA	BUSHING - UNIVERSAL	070362
58	139980-01-715	EA	BUSHING - STRAIN RELIEF	231809
59	098668-01-716	EA	GASKET-FIREWALL,CHAMBER SIDE	070808
62	143563-02-706	EA	SWITCH - LIMIT	232735
66	098668-01-713	EA	TUBE ASSEMBLY, INTAKE	051248
67	075697-07-703	EA	GASKET - MOTOR	070448
	143563-02-707	EA	CHAMBER ASM. - FINAL	021172BK

CONTACT WINNEBAGO PART SALES FOR UNLISTED COMPONENT(S)

HEATING & A/C GROUP (CONTINUED)

REAR HEATER

KEY	PART NUMBER	U/M	DESCRIPTION
*	084405-01-000	EA	HEATER - REAR/DUCTED - W/MOTOR AID
	056464-10-000	EA	REGISTER W/O DAMPER - 4" DIAMETER - PLASTIC - BEIGE
	009198-01-000	FT	DUCT - HEAT - FLEXIBLE - 4" ID X 25'
	069636-02-000	EA	CONNECTOR - DUCT - 4" ID
	079059-13-000	EA	HOSE - 90 DEGREE - .61"ID X 4" X 48"
	079059-01-000	EA	HOSE - 90 DEGREE - 5/8"ID X 4" X 36"
	079059-02-000	EA	HOSE - 90 DEGREE - .61" ID X 4" X 6"
	007108-01-000	FT	HOSE - HEATER - 5/8" ID - HI-TEMP
	089353-01-000	EA	UNION - 5/8" - TUBE TO TUBE
	076776-01-000	EA	TEE - BEADED - 5/8" X 5/8" X 5/8"

*COMPONENT PARTS LISTED LATER IN THIS GROUP

COMPONENT PARTS FOR REAR HEATER

084405-01-000

KEY	PART NUMBER	U/M	DESCRIPTION	VENDOR NO.
	084405-01-700	EA	CORE-HEATER	FT200229
	084405-01-701	EA	FAN BLADES	HV029931
	084405-01-702	EA	MOTOR ASSEMBLY, 12 VOLT	RV010348

ROOF

KEY	PART NUMBER	U/M	DESCRIPTION
*	131186-02-01A	EA	A/C - ROOF - MACH 1 POWER SAVER - 9,600 BTU - WHITE - A/C ROOF-HI EFF (2) W/EMS
*	131188-03-01A	EA	A/C/ROOF - 14,800 BTU/MACH 15 - #8335B676 - WHT - A/C ROOF AIR (1) 14,800 BTU
*	131187-03-01A	EA	A/C - ROOF - MACH 3 POWER SAVER - WHITE - A/C ROOF-HI EFF (2) W/EMS
*	131184-01-01A	EA	CEILING ASSEMBLY - A/C DUCTED - WHITE
*	131188-04-01A	EA	A/C - ROOF - 14,800 BTU/HEAT PUMP - #8535B676- WHT - AC HEAT PUMP-1
*	131187-04-01A	EA	A/C - ROOF - MACH 3 POWER SAVER - WHITE - (1) HEAT PUMP
*	131184-05-01A	EA	CEILING ASSEMBLY - HEAT PUMP - WHITE
	131184-02-01A	EA	BOARD - DIVIDER - SILVER

*COMPONENT PARTS LISTED LATER IN THIS GROUP

HEATING & A/C GROUP (CONTINUED)
COMPONENT PARTS FOR ROOF

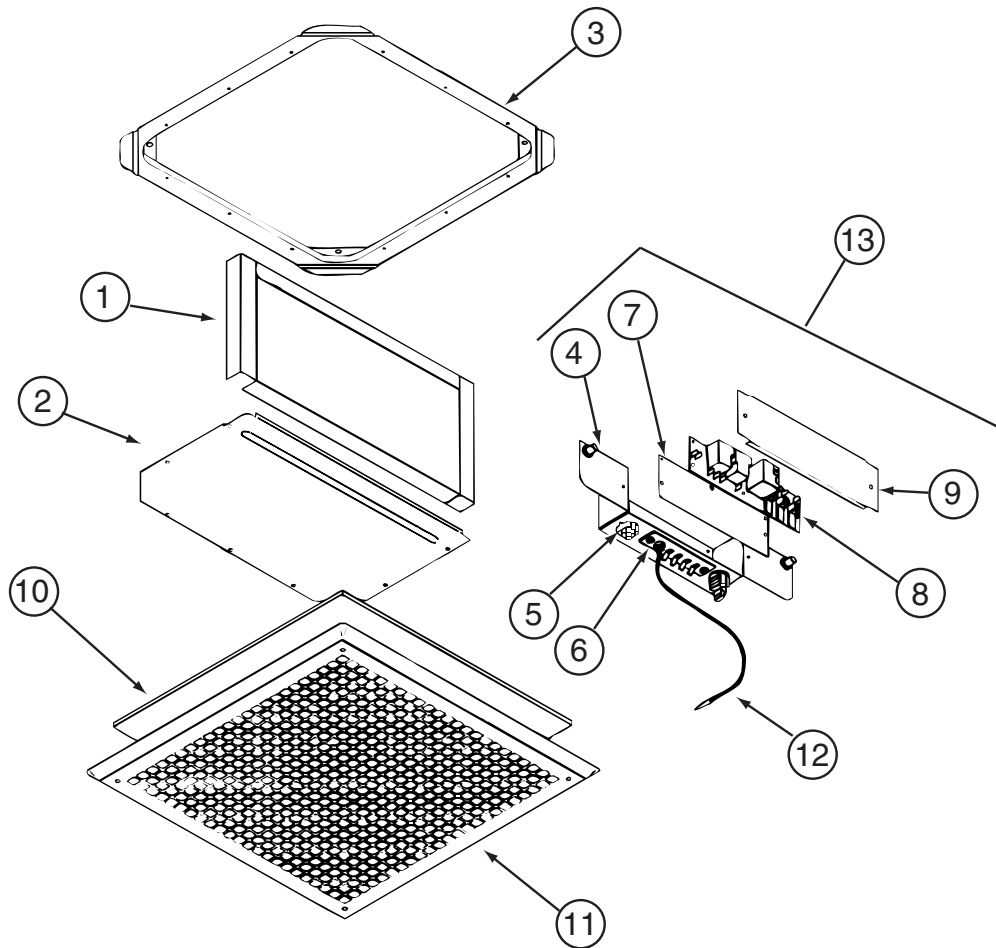

131184-01-01A

KEY	PART NUMBER	U/M	DESCRIPTION	VENDOR NO.
1	131184-01-707	EA	DUCT DIVIDER	8330-3501
5	131184-01-700	EA	PLUG ASSEMBLY	7330A389
6	131184-01-701	EA	TERMINAL BOARD	7330B3201
7	131184-01-702	EA	ISOLATOR - BLANK	7330C365
8	108892-01-702	EA	BOARD-P.C.	7330A3211
10	108892-01-703	EA	FILTER	6798A3761
11	108892-01-704	EA	GRILLE 16 3/8X16 3/8 RETURN	6798-3041
12	131184-01-704	EA	COIL SENSOR	7330-6111
13	131184-01-705	EA	JUNCTION BOX ASSEMBLY	7330B5551
	131184-01-703	EA	SMALL PARTS PKG	8330-5961

CONTACT WINNEBAGO PART SALES FOR UNLISTED COMPONENT(S)

HEATING & A/C GROUP (CONTINUED)
COMPONENT PARTS FOR ROOF (CONTINUED)

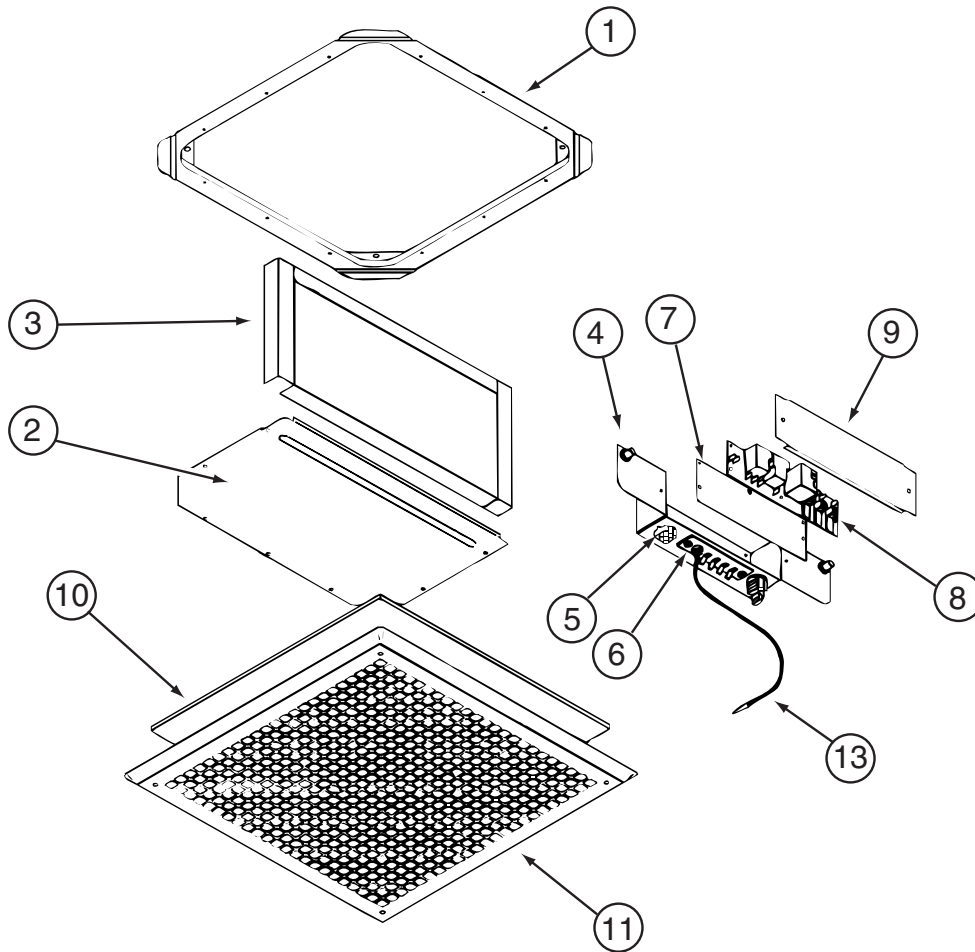

131184-05-01A

KEY	PART NUMBER	U/M	DESCRIPTION	VENDOR NO.
4	131184-05-700	EA	BOX - JUNCTION	8530-5091
5	131184-04-700	EA	PLUG ASSEMBLY	7530A340
6	131184-04-702	EA	BOARD - TERMINAL	7530B3201
7	131184-01-702	EA	ISOLATOR - BLANK	7330C365
8	131184-04-705	EA	BOARD - P.C.	7330B3311
10	108892-01-703	EA	FILTER	6798A3761
11	108892-01-704	EA	GRILLE 16 3/8X16 3/8 RETURN	6798-3041
13	105620-12-719	EA	COIL SENSOR	7330A3231
	131184-01-703	EA	SMALL PARTS PKG	8330-5961

CONTACT WINNEBAGO PART SALES FOR UNLISTED COMPONENT(S)

HEATING & A/C GROUP (CONTINUED)
COMPONENT PARTS FOR ROOF (CONTINUED)

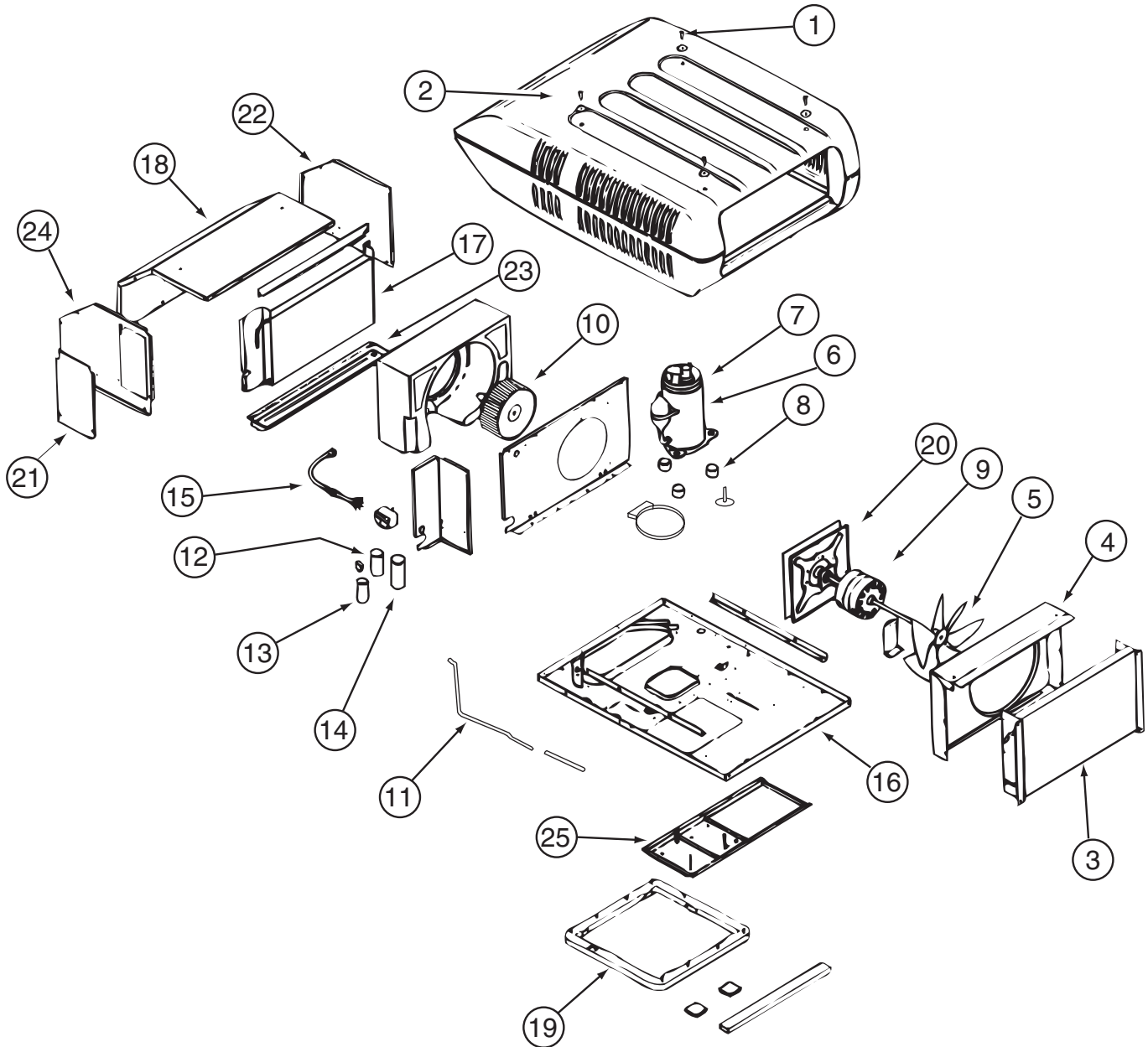

131186-02-01A

KEY	PART NUMBER	U/M	DESCRIPTION	VENDOR NO.
2	131185-03-700	EA	SHROUD - ROOF AIR	8333-4161
3	115219-01-700	EA	COIL-CONDENSER	1452A1321
5	093763-01-712	EA	BLADE-FAN-CONDENSER	6733-3221
6	126859-01-700	EA	COMPRESSOR RK124AT-001-A4Y	1450-2109
7	126859-01-701	EA	OVERLOAD PROTECTORMRA# 4761	1450-0061
8	105620-01-706	EA	MOUNTING PKG.,COMP., 3 PER	6759-3081
9	131186-01-700	EA	MOTOR - 115V, 60 HURTZ	1468-3109
10	131185-01-702	EA	BLOWER WHEEL PACKAGE	1472-1091
12	126859-01-703	EA	CAPACITOR - RUN	1499-5671
13	093763-01-704	EA	CAPACITOR-FAN	1499-5461
14	105620-10-704	EA	START COMPACITOR	1497-0861
15	105620-10-705	EA	PTCR (START DEVICE) - W/CAP.	8333A9021
18	131186-01-701	EA	EVAPORATOR COIL	1452-1521
21	131185-01-704	EA	MOTOR MOUNT & SEAL KIT	8333-5151
	093306-01-701	EA	DECAL PACKAGE, LEFT & RIGHT	6798B3591
	108889-01-710	EA	PAD-FILLER, CONDENSER SEAL	6759B3971
	126859-01-706	EA	LINE - SUCTION	7532A130

CONTACT WINNEBAGO PART SALES FOR UNLISTED COMPONENT

HEATING & A/C GROUP (CONTINUED)
COMPONENT PARTS FOR ROOF (CONTINUED)

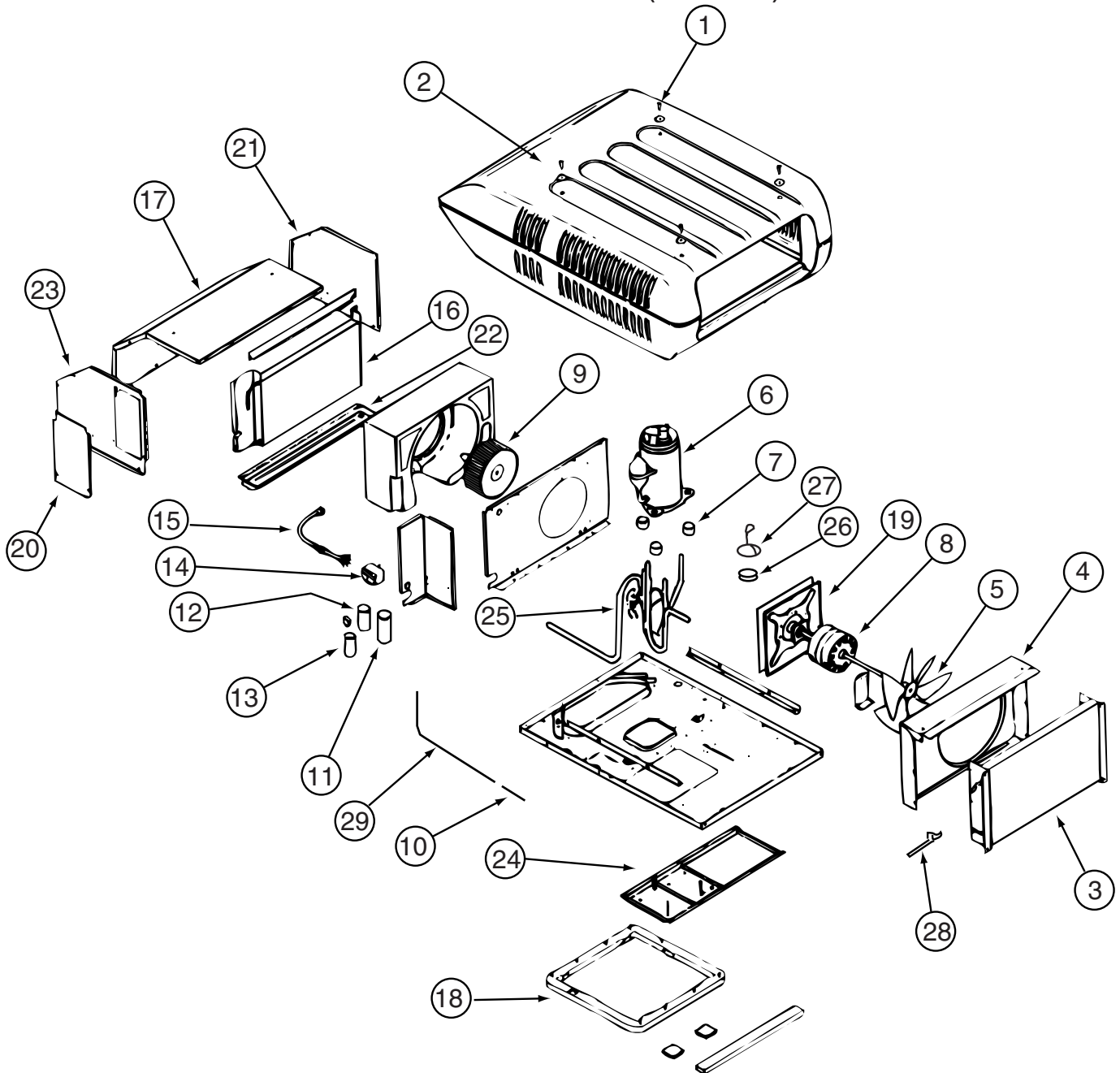

131187-03-01A

KEY	PART NUMBER	U/M	DESCRIPTION	VENDOR NO.
2	131185-03-700	EA	SHROUD - ROOF AIR	8333-4161
3	115219-01-700	EA	COIL-CONDENSER	1452A1321
5	093763-01-712	EA	BLADE-FAN-CONDENSER	6733-3221
6	126860-01-700	EA	COMPRESSOR RK136AT-002-A4Y	1450A2119
7	105620-01-706	EA	MOUNTING PKG.,COMP., 3 PER	6759-3081
8	131186-01-700	EA	MOTOR - 115V, 60 HURTZ	1468-3109
9	131185-01-702	EA	BLOWER WHEEL PACKAGE	1472-1091
11	126859-01-703	EA	CAPACITOR - RUN	1499-5671
12	105620-01-725	EA	CAPACITOR-BLOWER,I.D. 7.5MFD	1499-5461
13	105620-10-705	EA	PTCR (START DEVICE) - W/CAP.	8333A9021
16	131186-01-701	EA	EVAPORATOR COIL	1452-1521
19	131185-01-704	EA	MOTOR MOUNT & SEAL KIT	8333-5151
	093306-01-701	EA	DECAL PACKAGE, LEFT & RIGHT	6798B3591
	105620-10-704	EA	START COMPACITOR	1497-0861
	108889-01-710	EA	PAD-FILLER, CONDENSER SEAL	6759B3971
	126859-01-706	EA	LINE - SUCTION	7532A130
	126860-01-701	EA	OVERLOAD PROTECTOR MRA# 1460	1450-0071

CONTACT WINNEBAGO PART SALES FOR UNLISTED COMPONENT

HEATING & A/C GROUP (CONTINUED)
COMPONENT PARTS FOR ROOF (CONTINUED)

131187-04-01A

KEY	PART NUMBER	U/M	DESCRIPTION	VENDOR NO.
2	131185-03-700	EA	SHROUD - ROOF AIR	8333-4161
3	131188-02-700	EA	CONDENSER COIL	1452-1441
5	093763-01-712	EA	BLADE-FAN-CONDENSER	6733-3221
6	126860-01-700	EA	COMPRESSOR RK136AT-002-A4Y	1450A2119
7	105620-01-706	EA	MOUNTING PKG.,COMP., 3 PER	6759-3081
8	131186-01-700	EA	MOTOR - 115V, 60 HURTZ	1468-3109
9	131185-01-702	EA	BLOWER WHEEL PACKAGE	1472-1091
10	105620-12-711	EA	RESTRICTOR - BY FLOW	1454-2521
11	126859-01-703	EA	CAPACITOR - RUN	1499-5671
12	093763-01-704	EA	CAPACITOR-FAN	1499-5461
13	105620-10-705	EA	PTCR (START DEVICE) - W/CAP.	8333A9021
16	131186-01-701	EA	EVAPORATOR COIL	1452-1521
18	037648-01-714	EA	GASKET PACKAGE	8332-3301
19	131185-01-704	EA	MOTOR MOUNT & SEAL KIT	8333-5151
25	131188-02-704	EA	VALVE/REVERSE ASSEMBLY	7535A5301
26	105620-12-708	EA	COIL - SOLENOID	1460-1081
27	131188-02-705	EA	WIRE HARNESS F/SOLENOID	7535-109
28	131188-02-706	EA	SWITCH - FREEZE	1460-2041
29	131188-02-707	EA	LIQUID LINE	7535-135

CONTACT WINNEBAGO PART SALES FOR UNLISTED COMPONENT

HEATING & A/C GROUP (CONTINUED)
COMPONENT PARTS FOR ROOF (CONTINUED)

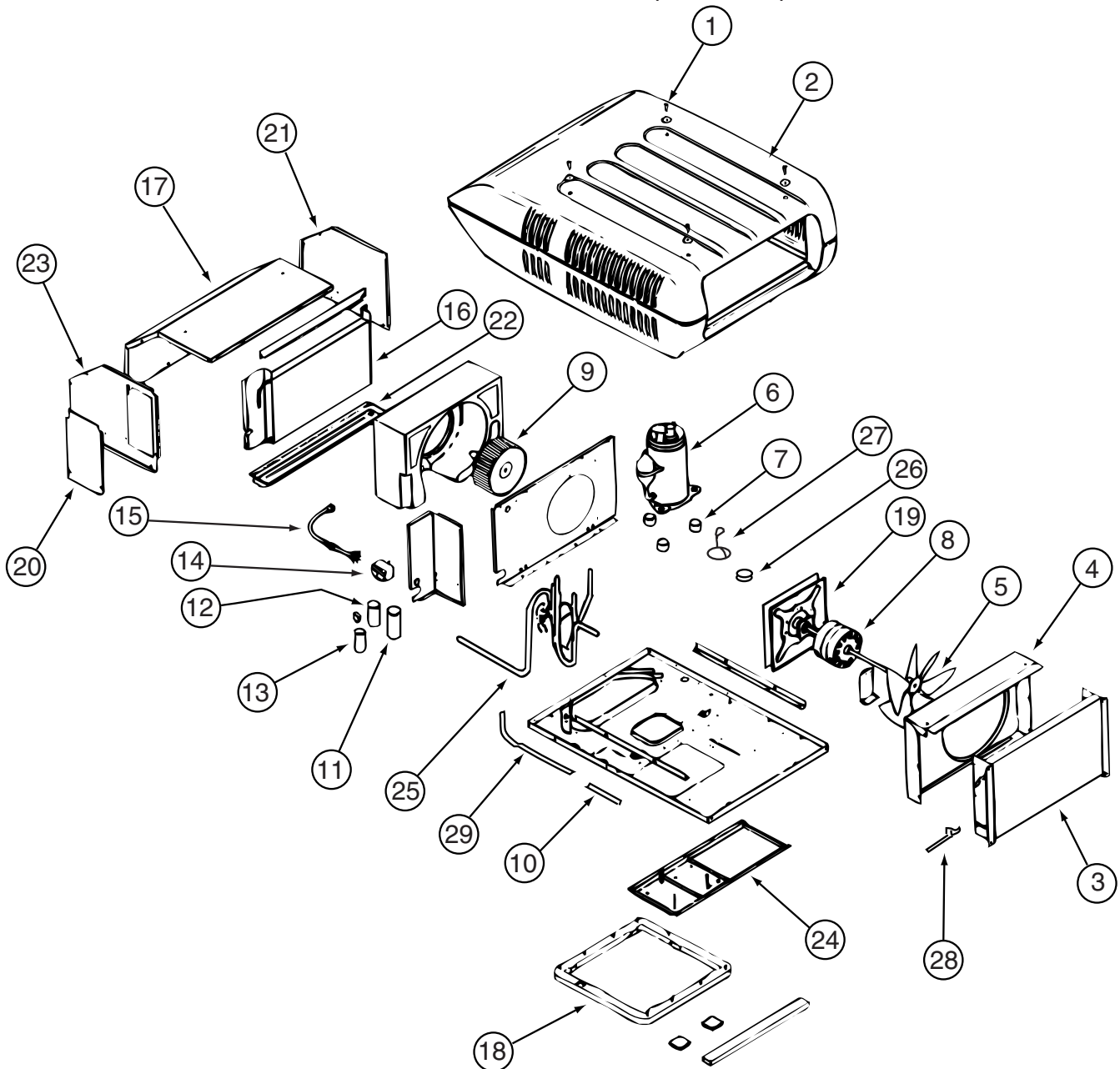

131188-03-01A

KEY	PART NUMBER	U/M	DESCRIPTION	VENDOR NO.
2	131185-03-700	EA	SHROUD-ROOF AIR W/HAIL GUARD	8333-4161
3	115219-01-700	EA	COIL-CONDENSER	1452A1321
5	093763-01-712	EA	BLADE-FAN-CONDENSER	6733-3221
6	131188-01-700	EA	COMPRESSOR - TECUMSEH	1450A2609
7	105620-01-706	EA	MOUNTING PKG.,COMP., 3 PER	6759-3081
8	131185-01-701	EA	MOTOR (115V, 60HZ)	1468-3069
9	131185-01-702	EA	BLOWER WHEEL PACKAGE	1472-1091
11	131188-01-701	EA	RUN CAP. (COMP-40MFD/370V)	1499-5721
12	108889-01-708	EA	CAPACITOR-FAN, 7.5MFD. 370U	1499-5461
13	126859-01-704	EA	CAPACITOR - START	1497-0871
14	091225-01-709	EA	RELAY-START	1497-4131
16	131186-01-701	EA	EVAPORATOR COIL	1452-1521
18	037648-01-714	EA	GASKET PACKAGE	8332-3301
19	131185-01-704	EA	MOTOR MOUNT & SEAL KIT	8333-5151
	093306-01-701	EA	DECAL PACKAGE, LEFT & RIGHT	6798B3591
	108889-01-710	EA	PAD-FILLER, CONDENSER SEAL	6759B3971
	131188-01-702	EA	LINE - SUCTION	7335A134
	131188-01-703	EA	LINE - DISCHARGE	7335A135

CONTACT WINNEBAGO PART SALES FOR UNLISTED COMPONENT(S)

HEATING & A/C GROUP (CONTINUED)
COMPONENT PARTS FOR ROOF (CONTINUED)

131188-04-01A

KEY	PART NUMBER	U/M	DESCRIPTION	VENDOR NO.
3	131188-02-700	EA	CONDENSER COIL	1452-1441
5	093763-01-712	EA	BLADE-FAN-CONDENSER	6733-3221
6	131188-02-701	EA	COMPRESSOR(TECUMSEH-RK225AT)	1450A2069
7	105620-01-706	EA	MOUNTING PKG.,COMP., 3 PER	6759-3081
8	131185-01-701	EA	MOTOR (115V, 60HZ)	1468-3069
9	131185-01-702	EA	BLOWER WHEEL PACKAGE	1472-1091
10	131188-02-702	EA	RESTRICTOR - BY FLOW	1454-2501
11	131188-01-701	EA	RUN CAP. (COMP-40MFD/370V)	1499-5721
12	093763-01-704	EA	CAPACITOR-FAN (INDOOR MOTOR)	1499-5461
13	131188-02-703	EA	CAPACITOR-START(21-25MFD)	1497-0211
14	091225-01-709	EA	RELAY-START	1497-4131
16	131186-01-701	EA	EVAPORATOR COIL	1452-1521
18	037648-01-714	EA	GASKET PACKAGE	8332-3301
19	131185-01-704	EA	MOTOR MOUNT & SEAL KIT	8333-5151
25	131188-02-704	EA	VALVE/REVERSE ASSEMBLY	7535A5301
26	105620-12-708	EA	COIL - SOLENOID	1460-1081
27	131188-02-705	EA	WIRE HARNESS F/SOLENOID	7535-109
28	131188-02-706	EA	SWITCH - FREEZE	1460-2041
29	131188-02-707	EA	LIQUID LINE	7535-135

CONTACT WINNEBAGO PART SALES FOR UNLISTED COMPONENT(S)

INTERIOR FINISH GROUP
MOLDINGS & TRIMS
PORTSMOUTH OAK, SIERRA MAPLE

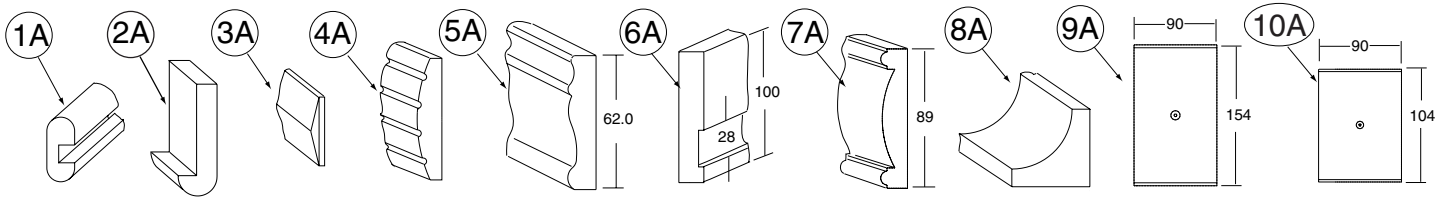

KEY	PART NUMBER	U/M	DESCRIPTION
1A	M09412-62-N42	EA	MOLDING/SHELF EDGE - .6" X 1.3" X 96" - PORTSMOUTH OAK
1A	M09412-62-M52	EA	MOLDING/SHELF EDGE - .6" X 1.3" X 96" - CHERRY - CONCERT CHERRY
1A	M09412-62-M62	EA	MOLDING/SHELF EDGE - .6" X 1.3" X 96" - WASHED MAPLE - WASHED MAPLE
1A	M09412-62-RC3	EA	MOLDING/SHELF EDGE - .6" X 1.3" X 96" - HONEY CHERRY - HONEY CHERRY
1A	M09412-62-SA3	EA	MOLDING/SHELF EDGE - .6" X 1.3" X 96" - MAPLE - SIERRA MAPLE
2A	M09438-25-N95	EA	MOLDING - HARDWOOD-W/NOTCH - 1.4"X 80.2" - OAK/PORTS OAK - PORTSMOUTH OAK
2A	M09438-25-N94	EA	MOLDING - HARDWOOD-W/NOTCH - 1.4"X 80.2" - CHERRY/CHERRY IV - CONCERT CHERRY
2A	M09438-25-NQ0	EA	MOLDING - HARDWOOD-W/NOTCH - 1.4"X 80.2" - MAPLE/WASHED MP - WASHED MAPLE
2A	M09438-25-RA3	EA	MOLDING - HARDWOOD-W/NOTCH - 1.4"X 80.2" - CHERRY/HONEY - HONEY CHERRY
2A	M09454-33-PC0	EA	MOLDING - HARDWOOD-W/NOTCH - 1"X 77.6" - OAK/PORTS OAK - PORTSMOUTH OAK
2A	M09454-33-PC1	EA	MOLDING - HARDWOOD-W/NOTCH - 1"X 77.6" - CHERRY/CHERRY IV - CONCERT CHERRY
2A	M09454-33-PC2	EA	MOLDING - HARDWOOD-W/NOTCH - 1"X 77.6" - MAPLE/WASHED MP - WASHED MAPLE
2A	M09454-33-RA3	EA	MOLDING - HARDWOOD-W/NOTCH - 1"X 77.6" - CHERRY/HONEY - HONEY CHERRY
3A	M09454-62-P54	EA	MOLDING - TRIM/VEE - .2" X 1" X 3.5" - OAK - PORTSMOUTH OAK
3A	M09454-62-P55	EA	MOLDING - TRIM/VEE - .2" X 1" X 3.5" - CHERRY - CONCERT CHERRY
3A	M09454-62-P56	EA	MOLDING - TRIM/VEE - .2" X 1" X 3.5" - MAPLE - WASHED MAPLE
3A	M09454-62-RE0	EA	MOLDING - TRIM/VEE - .2" X 1" X 3.5" - CHERRY - HONEY CHERRY
3A	M09462-50-R74	EA	MOLDING - TRIM/VEE - .2" X 1" X 93.5" - PORTSMOUTH OAK
3A	M09462-50-R75	EA	MOLDING - TRIM/VEE - .2" X 1" X 93.5" - CHERRY/CHERRY - CONCERT CHERRY
3A	M09462-50-R76	EA	MOLDING - TRIM/VEE - .2" X 1" X 93.5" - MAPLE/MAPLE - WASHED MAPLE
3A	M09462-50-SD3	EA	MOLDING - TRIM/VEE - .2" X 1" X 93.5" - HONEY/CHERRY - HONEY CHERRY
3A	M09462-50-S67	EA	MOLDING - TRIM/VEE - .2" X 1" X 93.5" - SIERRA/MAPLE - SIERRA MAPLE
4A	M09462-54-R89	EA	MOLDING - FLUTED, CURVED - .6" X 6" X 82.7" - PORTSMOUTH OAK
4A	M09462-54-R90	EA	MOLDING - FLUTED, CURVED - .6" X 6" X 82.7" - CONCERT CHERRY
4A	M09462-54-R91	EA	MOLDING - FLUTED, CURVED - .6" X 6" X 82.7" - WASHED MAPLE
4A	M09462-54-RE3	EA	MOLDING - FLUTED, CURVED - .6" X 6" X 82.7" - HONEY CHERRY
4A	M09471-09-R89	EA	MOLDING - STAINED - 4" X 8' - PORTSMOUTH OAK
4A	M09471-09-R90	EA	MOLDING - STAINED - 4" X 8' - CONCERT CHERRY
4A	M09471-09-R91	EA	MOLDING - STAINED - 4" X 8' - WASHED MAPLE
4A	M09471-09-RE3	EA	MOLDING - STAINED - 4" X 8' - HONEY CHERRY
4A	Y00202-42-438	EA	MOLDING - FLUTED - .75" X 3.5" X 96" - UNSTAINED - OAK
4A	Y00202-32-438	EA	MOLDING - FLUTED - .75" X 3.5" X 96" - UNSTAINED - CHERRY
4A	Y00202-22-438	EA	MOLDING - FLUTED - .75" X 3.5" X 96" - UNSTAINED - MAPLE
5A	M09462-66-R74	EA	TRIM - RAIL - .5" X 2.4" X 96" - PORTSMOUTH OAK
5A	M09462-66-R75	EA	TRIM - RAIL - .5" X 2.4" X 96" - CONCERT CHERRY
5A	M09462-66-R76	EA	TRIM - RAIL - .5" X 2.4" X 96" - WASHED MAPLE
5A	M09462-66-RE0	EA	TRIM - RAIL - .5" X 2.4" X 96" - HONEY CHERRY
5A	M09462-66-SA3	EA	TRIM - RAIL - .5" X 2.4" X 96" - SIERRA MAPLE
6A	M09471-20-R83	EA	MOLDING - STAINED - .75" X 4" X 74.6" - PORTSMOUTH OAK
6A	M09471-20-R84	EA	MOLDING - STAINED - .75" X 4" X 74.6" - CONCERT CHERRY
6A	M09471-20-R91	EA	MOLDING - STAINED - .75" X 4" X 74.6" - WASHED MAPLE
6A	M09471-20-RE0	EA	MOLDING - STAINED - .75" X 4" X 74.6" - HONEY CHERRY
7A	M09471-40-R83	EA	MOLDING - STAINED - .7" X 3.5" X 70.4" - PORTSMOUTH OAK
7A	M09471-40-R84	EA	MOLDING - STAINED - .7" X 3.5" X 70.4" - CONCERT CHERRY
7A	M09471-40-SD2	EA	MOLDING - STAINED - .7" X 3.5" X 70.4" - WASHED MAPLE
7A	M09471-40-RE0	EA	MOLDING - STAINED - .7" X 3.5" X 70.4" - HONEY CHERRY
8A	M09471-79-R38	EA	MOLDING - TRIM/COVE - .8" X .8" X 95.8" - OAK/PORTS OAK - PORTSMOUTH OAK
8A	M09471-79-R39	EA	MOLDING - TRIM/COVE - .8" X .8" X 95.8" - CHERRY/CHERRY - CONCERT CHERRY
8A	M09471-79-R46	EA	MOLDING - TRIM/COVE - .8" X .8" X 95.8" - MAPLE/MAPLE - WASHED MAPLE
8A	M09471-79-RE0	EA	MOLDING - TRIM/COVE - .8" X .8" X 95.8" - HONEY/CHERRY - HONEY CHERRY
8A	M09471-79-SA3	EA	MOLDING - TRIM/COVE - .8" X .8" X 95.8" - HONEY/MAPLE - SIERRA MAPLE
9A	P49186-01-SA0	EA	MOLDING/BLOCK - PORTSMOUTH OAK
9A	P49186-01-SA1	EA	MOLDING/BLOCK - CONCERT CHERRY
9A	P49186-01-SA2	EA	MOLDING/BLOCK - WASHED MAPLE
9A	P49186-01-SA3	EA	MOLDING/BLOCK - SIERRA MAPLE

INTERIOR FINISH GROUP (CONTINUED)

MOLDINGS & TRIMS (CONTINUED)

KEY	PART NUMBER	U/M	DESCRIPTION
10A	P49186-02-SA0	EA	MOLDING/BLOCK - PORTSMOUTH OAK
10A	P49186-02-SA1	EA	MOLDING/BLOCK - CONCERT CHERRY
10A	P49186-02-SA2	EA	MOLDING/BLOCK - WASHED MAPLE
10A	P49186-02-SA3	EA	MOLDING/BLOCK - SIERRA MAPLE

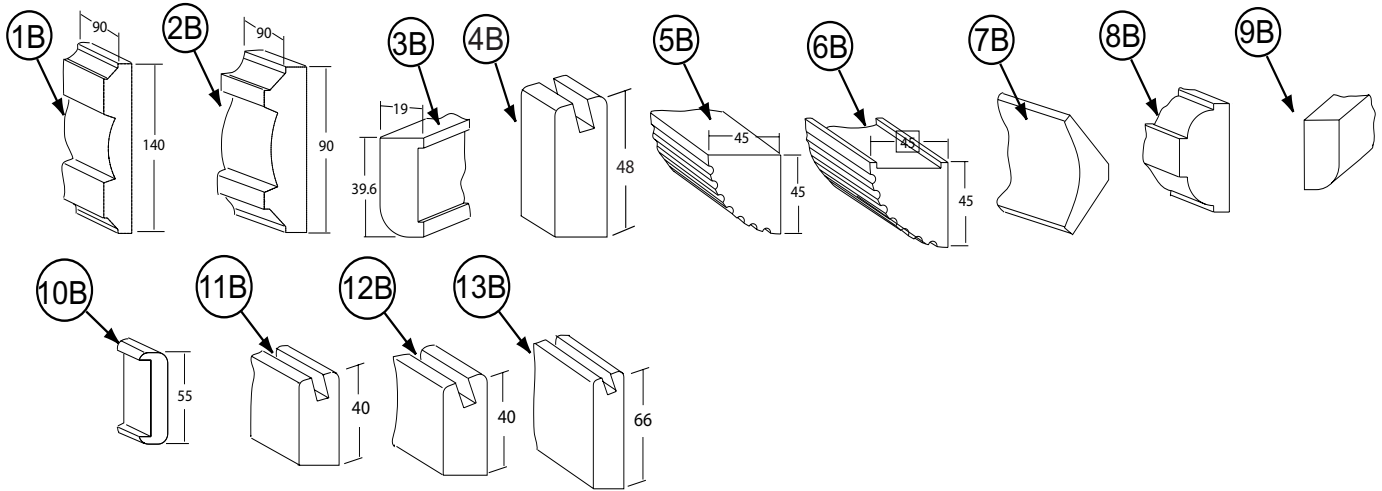

KEY	PART NUMBER	U/M	DESCRIPTION
1B	P49188-01-SA0	EA	MOLDING/BLOCK - PORTSMOUTH OAK
1B	P49188-01-SA1	EA	MOLDING/BLOCK - CONCERT CHERRY
1B	P49188-01-SA2	EA	MOLDING/BLOCK - WASHED MAPLE
1B	P49188-01-SA3	EA	MOLDING/BLOCK - SIERRA MAPLE
2B	P49188-02-SA0	EA	MOLDING/BLOCK - PORTSMOUTH OAK
2B	P49188-02-SA1	EA	MOLDING/BLOCK - CONCERT CHERRY
2B	P49188-02-SA2	EA	MOLDING/BLOCK - WASHED MAPLE
2B	P49188-02-SA3	EA	MOLDING/BLOCK - SIERRA MAPLE
3B	Y00007-42-438	EA	MOLDING - 12.7 RADIUS OAK - UNSTAINED
3B	Y00007-32-438	EA	MOLDING - 12.7 RADIUS CHERRY - UNSTAINED
3B	Y00007-22-438	EA	MOLDING - 12.7 RADIUS MAPLE - UNSTAINED
3B	Y00287-42-438	EA	MOLDING - 6.0 RADIUS OAK - UNSTAINED
3B	Y00287-32-438	EA	MOLDING - 6.0 RADIUS CHERRY - UNSTAINED
3B	Y00287-22-438	EA	MOLDING - 6.0 RADIUS MAPLE - UNSTAINED
4B	Y00054-72-438	EA	MOLDING - VINYL - W/SLOT - .7" X 1.9" X 96" - PORTSMOUTH OAK
4B	Y00054-62-438	EA	MOLDING - VINYL - W/SLOT - .7" X 1.9" X 96" - CONCERT CHERRY
4B	Y00054-A2-438	EA	MOLDING - VINYL - W/SLOT - .7" X 1.9" X 96" - WASHED MAPLE
4B	Y00054-92-438	EA	MOLDING - VINYL - W/SLOT - .7" X 1.9" X 96" - SIERRA MAPLE
5B	Y00070-42-438	EA	MOLDING/FLUTED - OAK - 96"
5B	Y00070-32-438	EA	MOLDING/FLUTED - CHERRY - 96"
5B	Y00070-22-438	EA	MOLDING/FLUTED - MAPLE - 96"
6B	Y00071-42-438	EA	MOLDING/FLUTED - W/NOTCH - OAK/UNSTAINED - 96"
6B	Y00071-32-438	EA	MOLDING/FLUTED - W/NOTCH - CHERRY/UNSTAINED - 96"
6B	Y00071-22-438	EA	MOLDING/FLUTED - W/NOTCH - MAPLE/UNSTAINED - 96"
7B	Y00074-72-438	EA	MOLDING/CROWN - VINYL WRAPPED - PORTSMOUTH OAK - 96" - PORTSMOUTH OAK
7B	Y00074-62-438	EA	MOLDING/CROWN - VINYL WRAPPED - CONCERT CHERRY - 96" - CONCERT CHERRY
7B	Y00074-A2-438	EA	MOLDING/CROWN - VINYL WRAPPED - MAPLE - 96" - WASHED MAPLE
7B	Y00074-92-438	EA	MOLDING/CROWN - VINYL WRAPPED - SIERRA MAPLE - 96" - SIERRA MAPLE
8B	Y00076-42-438	EA	MOLDING/TRIM - .5" X 1" X 96" - OAK (UNSTAINED)
8B	Y00076-32-438	EA	MOLDING/TRIM - .5" X 1" X 96" - CHERRY (UNSTAINED)
8B	Y00076-22-438	EA	MOLDING/TRIM - .5" X 1" X 96" - MAPLE (UNSTAINED)
9B	Y00086-72-438	EA	MOLDING - VINYL WRAP - .7" X 1.6" X 96" - PORTSMOUTH OAK - PORTSMOUTH OAK
9B	Y00086-62-438	EA	MOLDING - VINYL WRAP - .7" X 1.6" X 96" - CHERRY - CONCERT CHERRY
9B	Y00086-A2-438	EA	MOLDING - VINYL WRAP - .7" X 1.6" X 96" - WASHED MAPLE
9B	Y00086-82-438	EA	MOLDING - VINYL WRAP - .7" X 1.6" X 96" - HONEY CHERRY - HONEY CHERRY
9B	Y00086-92-438	EA	MOLDING - VINYL WRAP - .7" X 1.6" X 96" - SIERRA MAPLE - SIERRA MAPLE
9B	Y00087-A2-438	EA	MOLDING - VINYL WRAP - .7" X 2.9" X 96" - WASHED MAPLE
9B	Y00087-62-438	EA	MOLDING - VINYL WRAP - .7" X 2.9" X 96" - CONCERT CHERRY
9B	Y00087-72-438	EA	MOLDING - VINYL WRAP - .7" X 2.9" X 96" - PORTSMOUTH OAK
9B	Y00087-82-438	EA	MOLDING - VINYL WRAP - .7" X 2.9" X 96" - HONEY CHERRY
9B	Y00087-92-438	EA	MOLDING - VINYL WRAP - .7" X 2.9" X 96" - SIERRA MAPLE
9B	Y00267-72-438	EA	MOLDING - VINYL WRAP/MITERED - .6" X 96" - PORTSMOUTH OAK

INTERIOR FINISH GROUP (CONTINUED)
MOLDINGS & TRIMS (CONTINUED)

KEY	PART NUMBER	U/M	DESCRIPTION
9B	Y00267-62-438	EA	MOLDING - VINYL WRAP/MITERED - .6" X 96" - CONCERT CHERRY
9B	Y00267-A2-438	EA	MOLDING - VINYL WRAP/MITERED - .6" X 96" - WASHED MAPLE
9B	Y00267-A2-438	EA	MOLDING - VINYL WRAP/MITERED - .6" X 96" - SIERRA MAPLE
10B	Y00103-42-438	EA	MOLDING - STRAIGHT - .75" X 2.16" X 96" - UNSTAINED - OAK
10B	Y00103-32-438	EA	MOLDING - STRAIGHT - .75" X 2.16" X 96" - UNSTAINED - CHERRY
10B	Y00103-22-438	EA	MOLDING - STRAIGHT - .75" X 2.16" X 96" - UNSTAINED - MAPLE
11B	Y00203-72-438	EA	MOLDING - VINYL/BEVELED - 96" - PORTSMOUT OAK
11B	Y00203-62-438	EA	MOLDING - VINYL/BEVELED - 96" - CONCERT CHERRY
11B	Y00203-A2-438	EA	MOLDING - VINYL/BEVELED - 96" - WASHED MAPLE
11B	Y00203-82-438	EA	MOLDING - VINYL/BEVELED - 96" - HONEY CHERRY
12B	Y00204-72-438	EA	MOLDING - VINYL/BEVELED - 96" - PORTSMOUT OAK
12B	Y00204-62-438	EA	MOLDING - VINYL/BEVELED - 96" - CONCERT CHERRY
12B	Y00204-A2-438	EA	MOLDING - VINYL/BEVELED - 96" - WASHED MAPLE
12B	Y00204-82-438	EA	MOLDING - VINYL/BEVELED - 96" - HONEY CHERRY
13B	Y00205-72-438	EA	MOLDING - VINYL/BEVELED - 96" - PORTSMOUT OAK
13B	Y00205-62-438	EA	MOLDING - VINYL/BEVELED - 96" - CONCERT CHERRY
13B	Y00205-A2-438	EA	MOLDING - VINYL/BEVELED - 96" - WASHED MAPLE
13B	Y00205-82-438	EA	MOLDING - VINYL/BEVELED - 96" - HONEY CHERRY

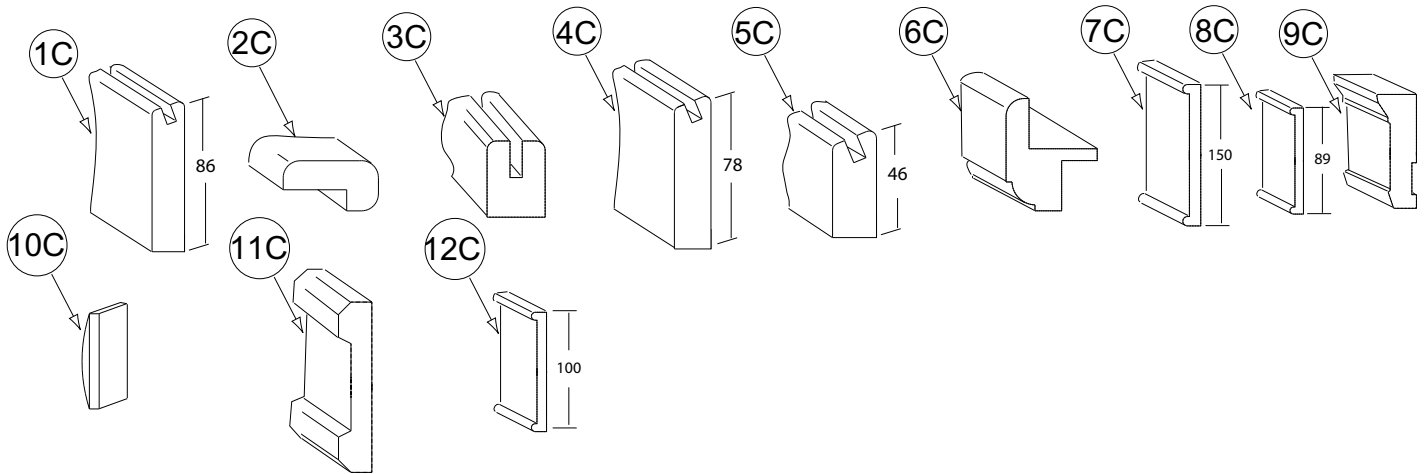

KEY	PART NUMBER	U/M	DESCRIPTION
1C	Y00206-72-438	EA	MOLDING - VINYL/BEVELED - 96" - PORTSMOUT OAK
1C	Y00206-62-438	EA	MOLDING - VINYL/BEVELED - 96" - CONCERT CHERRY
1C	Y00206-A2-438	EA	MOLDING - VINYL/BEVELED - 96" - WASHED MAPLE
1C	Y00206-82-438	EA	MOLDING - VINYL/BEVELED - 96" - HONEY CHERRY
2C	M09494-38-SD0	EA	MOLDING - TRIM - W/NOTCH - 1" X 79.6" - OAK/PORTSMOUTH OAK - PORTSMOUTH OAK
2C	M09494-38-SD1	EA	MOLDING - TRIM - W/NOTCH - 1" X 79.6" - CHERRY/CHERRY - CONCERT CHERRY
2C	M09494-38-SD2	EA	MOLDING - TRIM - W/NOTCH - 1" X 79.6" - MAPLE/WASHED MAPLE - WASHED MAPLE
2C	M09494-38-SD3	EA	MOLDING - TRIM - W/NOTCH - 1" X 79.6" - HONEY/CHERRY - HONEY CHERRY
2C	Y00207-42-438	EA	MOLDING - .75" X 1.4" X 96" - UNSTAINED OAK
2C	Y00207-32-438	EA	MOLDING - .75" X 1.4" X 96" - UNSTAINED CHERRY
2C	Y00207-22-438	EA	MOLDING - .75" X 1.4" X 96" - UNSTAINED MAPLE
3C	Y00223-42-438	EA	MOLDING - HARDWOOD/OAK - .7" X 1" X 96"
3C	Y00223-32-438	EA	MOLDING - HARDWOOD/CHERRY - .7" X 1" X 96"
3C	Y00223-22-438	EA	MOLDING - HARDWOOD/MAPLE - .7" X 1" X 96"
4C	Y00258-72-438	EA	MOLDING/VINYL WRAP-BEVELED-.73" X 3.1" X 96" - PORTSMOUTH OAK
4C	Y00258-62-438	EA	MOLDING/VINYL WRAP-BEVELED-.73" X 3.1" X 96" - CONCERT CHERRY
4C	Y00258-A2-438	EA	MOLDING/VINYL WRAP-BEVELED ENDS-.73"X3.1"X96" - WASHED MAPLE
4C	Y00258-92-438	EA	MOLDING/VINYL WRAP-BEVELED-.73" X 3.1" X 96" - SIERRA MAPLE
5C	Y00259-72-438	EA	MOLDING/VINYL WRAP-BEVELED-.73" X 1.8" X 96" - PORTSMOUTH OAK
5C	Y00259-62-438	EA	MOLDING/VINYL WRAP-BEVELED-.73" X 1.8" X 96" - CONCERT CHERRY
5C	Y00259-A2-438	EA	MOLDING/VINYL WRAP-BEVELED-.73"X1.8"X96" - WASHED MAPLE
5C	Y00259-92-438	EA	MOLDING/VINYL WRAP-BEVELED-.73"X1.8"X96" - SIERRA MAPLE
6C	Y00266-42-438	EA	MOLDING - .75" X 1.5" X 96" OAK - .7" X 1" X 96"
6C	Y00266-32-438	EA	MOLDING - .75" X 1.5" X 96" CHERRY - .7" X 1" X 96"
6C	Y00266-22-438	EA	MOLDING - .75" X 1.5" X 96" MAPLE - .7" X 1" X 96"
7C	Y00280-74-174	EA	MOLDING/TRIM - VINYL - F/SLIDEOUT - 164.1" - PORTSMOUTH OAK
7C	Y00280-64-174	EA	MOLDING/TRIM - VINYL - F/SLIDEOUT - 164.1" - CONCERT CHERRY

INTERIOR FINISH GROUP (CONTINUED)
MOLDINGS & TRIMS (CONTINUED)

KEY	PART NUMBER	U/M	DESCRIPTION
7C	Y00280-A4-174	EA	MOLDING/TRIM - VINYL - F/SLIDEOUT - 164.1" - WASHED MAPLE
7C	Y00280-94-174	EA	MOLDING/TRIM - VINYL - F/SLIDEOUT - 164.1" - SIERRA MAPLE
8C	Y00281-72-438	EA	MOLDING/TRIM - VINYL - F/SLIDEOUT - 96" - PORTSMTH OAK
8C	Y00281-62-438	EA	MOLDING/TRIM - VINYL - F/SLIDEOUT - 96" - CONCERT CHERRY
8C	Y00281-A2-438	EA	MOLDING/TRIM - VINYL - F/SLIDEOUT - 96" - WASHED MAPLE
8C	Y00281-92-438	EA	MOLDING/TRIM - VINYL - F/SLIDEOUT - 96" - SIERRA MAPLE
9C	Y00282-72-438	EA	MOLDING - SLIDEOUT/VINYL WRAP - 3.9" X 96"- PORTSMOUTH OAK
9C	Y00282-62-438	EA	MOLDING - SLIDEOUT/VINYL WRAP - 3.9" X 96"- CONCERT CHERRY
9C	Y00282-A2-438	EA	MOLDING - SLIDEOUT/VINYL WRAP - 3.9" X 96"- WASHED MAPLE
10C	Y00284-42-438	EA	MOLDING - STRAIGHT - .2" X1.5" X 96"- UNSTAINED OAK
10C	Y00284-32-438	EA	MOLDING - STRAIGHT - .2" X1.5" X 96"- UNSTAINED CHERRY
10C	Y00284-22-438	EA	MOLDING - STRAIGHT - .2" X1.5" X 96"- UNSTAINED MAPLE
11C	Y00285-42-438	EA	MOLDING - STRAIGHT - .63" X 3.2" X 96"- UNSTAINED OAK
11C	Y00285-32-438	EA	MOLDING - STRAIGHT - .63" X 3.2" X 96"- UNSTAINED CHERRY
11C	Y00285-22-438	EA	MOLDING - STRAIGHT - .63" X 3.2" X 96"- UNSTAINED MAPLE
12C	Y00291-72-438	EA	MOLDING - VINYL WRAPPED - 4" X 96" - PORTSMTH OAK
12C	Y00291-62-438	EA	MOLDING - VINYL WRAPPED - 4" X 96" - CONCERT CHERRY
12C	Y00291-A2-438	EA	MOLDING - VINYL WRAPPED - 4" X 96" - WASHED MAPLE
12C	Y00291-92-438	EA	MOLDING - VINYL WRAPPED - 4" X 96" - SIERRA MAPLE

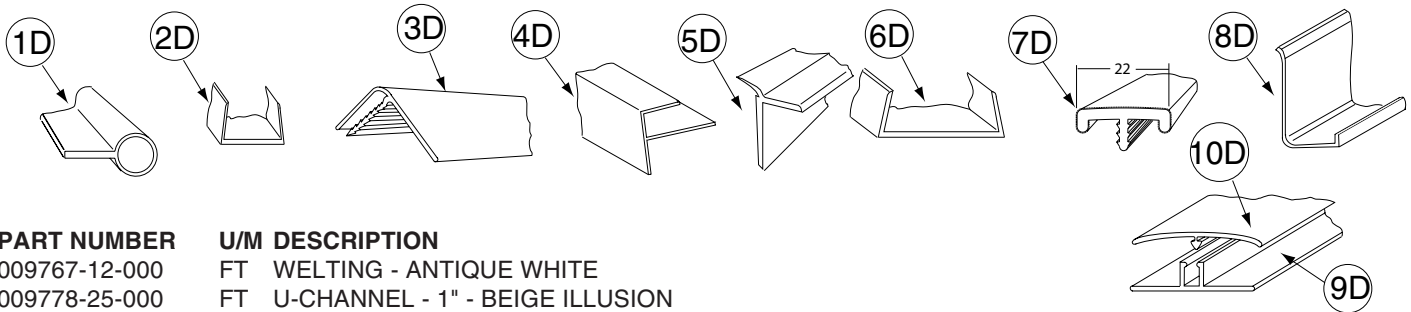

KEY	PART NUMBER	U/M	DESCRIPTION
1D	009767-12-000	FT	WELTING - ANTIQUE WHITE
2D	009778-25-000	FT	U-CHANNEL - 1" - BEIGE ILLUSION
2D	009778-32-000	FT	U-CHANNEL - 1" - PORTSMOUTH OAK
2D	009778-34-000	FT	U-CHANNEL - 1" - CONCERT CHERRY
2D	009778-35-000	FT	U-CHANNEL - 1" - HONEY CHERRY
2D	009778-36-000	FT	U-CHANNEL - 1" - SIERRA MAPLE
2D	009778-27-000	FT	U-CHANNEL - 1" - WASHED MAPLE
3D	009809-30-000	EA	MOLDING - CORNER - OUTSIDE - 1" X 84" - BEIGE ILLUSION
3D	009809-32-000	EA	MOLDING - CORNER - OUTSIDE - 1" X 84" - PORTSMOUTH OAK
3D	009809-33-000	EA	MOLDING - CORNER - OUTSIDE - 1" X 84" - CONCERT CHERRY
3D	009809-35-000	EA	MOLDING - CORNER - OUTSIDE - 1" X 84" - SIERRA MAPLE
3D	009809-34-000	EA	MOLDING - CORNER - OUTSIDE - 1" X 84" - HONEY CHERRY
3D	009809-31-000	EA	MOLDING - CORNER - OUTSIDE - 1" X 84" - WASHED MAPLE
4D	009812-31-000	EA	MOLDING - CORNER - 1/2" W/1/4"CHAN X 84" - BEIGE ILLUSION
4D	009812-34-000	EA	MOLDING - CORNER - 1/2" W/1/4"CHAN X 84" - VW LIGHT GRAY
4D	009812-35-000	EA	MOLDING - CORNER - 1/2" W/1/4"CHAN X 84" - PORTSMOUTH OAK
4D	009812-36-000	EA	MOLDING - CORNER - 1/2" W/1/4"CHAN X 84" - CONCERT CHERRY
4D	009812-37-000	EA	MOLDING - CORNER - 1/2" W/1/4"CHAN X 84" - HONEY CHERRY
4D	009812-38-000	EA	MOLDING - CORNER - 1/2" W/1/4"CHAN X 84" - SIERRA MAPLE
4D	009812-33-000	EA	MOLDING - CORNER - 1/2" W/1/4"CHAN X 84" - WASHED MAPLE
5D	022992-11-000	FT	MOLDING - REVERSE COVE - T-SHAPED - IVORY
5D	022992-14-000	FT	MOLDING - REVERSE COVE - T-SHAPED - BRIGHT WHITE
5D	022992-15-000	FT	MOLDING - REVERSE COVE - T-SHAPED - VW GRAY
6D	070504-42-000	FT	U-CHANNEL - PLASTIC - .13" X 84" - BEIGE ILLUSION
6D	070504-43-000	FT	U-CHANNEL - PLASTIC - .9" X 96" - BEIGE ILLUSION
6D	070504-57-000	FT	U-CHANNEL - PLASTIC - .13" X 84" - PORTSMOUTH OAK
6D	070504-58-000	FT	U-CHANNEL - PLASTIC - .9" X 84" - PORTSMOUTH OAK
6D	070504-60-000	FT	U-CHANNEL - PLASTIC - .13" X 84" - CONCERT CHERRY
6D	070504-61-000	FT	U-CHANNEL - PLASTIC - .9" X 84" - CONCERT CHERRY
6D	070504-62-000	FT	U-CHANNEL - PLASTIC - 1.65" X 84" - HONEY CHERRY
6D	070504-63-000	FT	U-CHANNEL - PLASTIC - .9" X 84" - HONEY CHERRY
6D	070504-65-000	FT	U-CHANNEL - PLASTIC - 1.65" X 84" - SIERRA MAPLE
6D	070504-66-000	FT	U-CHANNEL - PLASTIC - .9" X 84" - SIERRA MAPLE
6D	070504-50-000	FT	U-CHANNEL - PLASTIC - .13" X 96" - WASHED MAPLE
6D	070504-51-000	FT	U-CHANNEL - PLASTIC - .9" X 96" - WASHED MAPLE

INTERIOR FINISH GROUP (CONTINUED)
MOLDINGS & TRIMS (CONTINUED)

KEY	PART NUMBER	U/M	DESCRIPTION
7D	083620-15-000	FT	MOLDING-T - W/EDGE LIP - 7/8" FACE - BEIGE ILLUSION
7D	083620-20-000	FT	MOLDING-T - W/EDGE LIP - 7/8" FACE - PORTSMOUTH OAK
7D	083620-21-000	FT	MOLDING-T - W/EDGE LIP - 7/8" FACE - CONCERT CHERRY/HONEY CHERRY
7D	083620-22-000	FT	MOLDING-T - W/EDGE LIP - 7/8" FACE - SIERRA MAPLE
7D	083620-19-000	FT	MOLDING-T - W/EDGE LIP - 7/8" FACE - WASHED MAPLE
8D	085746-04-000	FT	TRIM-J - CARPET 1.2" X .5" ANGLE - 12' LONG - OFF WHITE
9D	086229-01-000	EA	RETAINER - BATTEN - .75" X 92.1" - ANY COLOR
10D	086229-20-000	EA	BATTEN - 1" X 96" - BEIGE

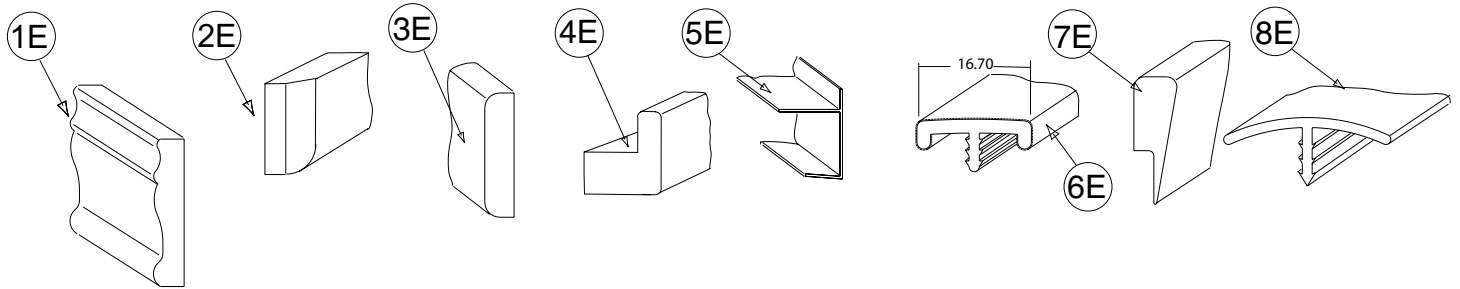

KEY	PART NUMBER	U/M	DESCRIPTION
1E	100182-10-N47	EA	TRIM/WOOD - CHAIR RAIL - 2.5" X 8' - PORTSMOUTH OAK
1E	100182-10-P85	EA	TRIM/WOOD - CHAIR RAIL - 2.5" X 8' - CONCERT CHERRY
1E	100182-10-J70	EA	TRIM/WOOD - CHAIR RAIL - 2.5" X 8' - WASHED MAPLE
1E	100182-10-RA3	EA	TRIM/WOOD - CHAIR RAIL - 2.5" X 8' - HONEY CHERRY
1E	100182-10-S67	EA	TRIM/WOOD - CHAIR RAIL - 2.5" X 8' - SIERRA MAPLE
2E	100659-30-N75	EA	MOLDING - TRIM - 8' - PORTSMOUTH OAK
2E	100659-30-N74	EA	MOLDING - TRIM - 8' - CONCERT CHERRY
2E	100659-30-M84	EA	MOLDING - TRIM - 8' - WASHED MAPLE
2E	100659-27-RA3	EA	MOLDING - TRIM - HONEY CHERRY
2E	100659-31-SA3	EA	MOLDING - TRIM - SIERRA MAPLE
3E	100818-01-12A	EA	MOLDING - VINYL WRAPPED - 1.6" X .4" X 84" - PORTSMOUTH OAK
3E	100818-01-13A	EA	MOLDING - VINYL WRAPPED - 1.6" X .4" X 84" - CONCERT CHERRY
3E	100818-01-14A	EA	MOLDING - VINYL WRAPPED - 1.6" X .4" X 84" - HONEY CHERRY
3E	100818-01-21A	EA	MOLDING - VINYL WRAPPED - 1.6" X .4" X 84" - WASHED MAPLE
3E	100818-01-22A	EA	MOLDING - VINYL WRAPPED - 1.6" X .4" X 84" - SIERRA MAPLE
4E	100819-01-12A	EA	MOLDING - VINYL WRAPPED-L-SHAPED-1.5"X1.5"X84" - PORTSMOUTH OAK
4E	100819-01-13A	EA	MOLDING - VINYL WRAPPED-L-SHAPED-1.5"X1.5"X84" - CONCERT CHERRY
4E	100819-01-14A	EA	MOLDING - VINYL WRAPPED-L-SHAPED-1.5"X1.5"X84" - HONEY CHERRY
4E	100819-01-21A	EA	MOLDING - VINYL WRAPPED-L-SHAPED-1.5"X1.5"X84" - WASHED MAPLE
4E	100819-01-22A	EA	MOLDING - VINYL WRAPPED-L-SHAPED-1.5"X1.5"X84" - SIERRA MAPLE
5E	103186-01-07A	FT	MOLDING/PLASTIC - 3/8" U-CHANNEL-3/4" FACE -BEIGE ILLUSION
5E	103186-01-09A	FT	MOLDING/PLASTIC - 3/8" U-CHAN'L-3/4" FACE - PORTSMOUTH OAK
5E	103186-01-10A	FT	MOLDING/PLASTIC - 3/8" U-CHAN'L-3/4" FACE - CONCERT CHERRY
5E	103186-01-11A	FT	MOLDING/PLASTIC - 3/8" U-CHAN'L-3/4" FACE - HONEY CHERRY
5E	103186-01-12A	FT	MOLDING/PLASTIC - 3/8" U-CHAN'L-3/4" FACE - SIERRA MAPLE
5E	103186-01-08A	FT	MOLDING/PLASTIC - 3/8" U-CHANNEL-3/4"FACE-WASHED MAPLE 8' - WASHED MAPLE
5E	103186-02-07A	FT	MOLDING/PLASTIC-1" U-CHAN'L-1 3/8" FACE - BEIGE ILLUSION
5E	103186-02-09A	FT	MOLDING/PLASTIC - 1" U-CHAN'L-1 3/8" FACE - PORTSMOUTH OAK
5E	103186-02-10A	FT	MOLDING/PLASTIC - 1" U-CHAN'L-1 3/8" FACE - CONCERT CHERRY
5E	103186-02-11A	FT	MOLDING/PLASTIC - 1" U-CHAN'L-1 3/8" FACE - HONEY CHERRY
5E	103186-02-12A	FT	MOLDING/PLASTIC - 1" U-CHAN'L-1 3/8" FACE - SIERRA MAPLE
5E	103186-02-08A	FT	MOLDING/PLASTIC - 1" U-CHANNEL-1 3/8"FACE - WASHED MAPLE
6E	104676-02-08A	FT	MOLDING-T - W/EDGE LIP - 11/16" FACE - PORTSMOUTH OAK
6E	104676-02-09A	FT	MOLDING-T - W/EDGE LIP - 11/16" FACE - CONCERT CHERRY
6E	104676-02-10A	FT	MOLDING-T - W/EDGE LIP - 11/16" FACE - HONEY CHERRY
6E	104676-02-06A	FT	MOLDING-T - W/EDGE LIP - 11/16" FACE - WASHED MAPLE
6E	104676-02-12A	FT	MOLDING-T - W/EDGE LIP - 11/16" FACE - SIERRA MAPLE
7E	105004-01-12A	EA	MOLDING - VINYL WRAPPED - 1" X 96" - PORTSMOUTH OAK
7E	105004-01-13A	EA	MOLDING - VINYL WRAPPED 1" X 8' - CONCERT CHERRY/HONEY CHERRY
7E	105004-01-21A	EA	MOLDING - VINYL WRAPPED - 1" X 8' - WASHED MAPLE
7E	105004-01-22A	EA	MOLDING - VINYL WRAPPED - 1" X 8' - SIERRA MAPLE
8E	105709-02-000	FT	MOLDING-T - W/EDGE LIP 3/4" FACE - BEIGE ILLUSION

INTERIOR FINISH GROUP (CONTINUED)
MOLDINGS & TRIMS (CONTINUED)

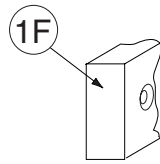

KEY	PART NUMBER	U/M	DESCRIPTION
1F	116951-11-N95	EA	MOLDING - TRIM - 3.5" X 75.9" - PORTSMOUTH
1F	116951-11-KQ1	EA	MOLDING - TRIM - 3.5" X 75.9" - CONCERT CHERRY
1F	116951-11-RE0	EA	MOLDING - TRIM - 3.5" X 75.8" - HONEY CHERRY
1F	116951-23-R83	EA	MOLDING - TRIM - 3.5" X 74.6" - PORTSMOUTH OAK
1F	116951-23-R84	EA	MOLDING - TRIM - 3.5" X 74.6" - CONCERT CHERRY
1F	116951-23-R91	EA	MOLDING - TRIM - 3.5" X 74.6" - WASHED MAPLE
1F	116951-23-RE0	EA	MOLDING - TRIM - 3.5" X 74.6" - HONEY CHERRY
1F	116951-24-R83	EA	MOLDING - TRIM - 3.5" X 74.6" - PORTSMOUTH OAK
1F	116951-24-R84	EA	MOLDING - TRIM - 3.5" X 74.6" - CONCERT CHERRY
1F	116951-24-R91	EA	MOLDING - TRIM - 3.5" X 74.6" - WASHED MAPLE
1F	116951-24-RE0	EA	MOLDING - TRIM - 3.5" X 74.6" - HONEY CHERRY
1F	116951-25-SD0	EA	MOLDING - TRIM - 5.5" X 69.8" - PORTSMOUTH OAK
1F	116951-25-SD1	EA	MOLDING - TRIM - 5.5" X 69.8" - CONCERT CHERRY
1F	116951-25-SD2	EA	MOLDING - TRIM - 5.5" X 69.8" - WASHED MAPLE
1F	116951-25-SD3	EA	MOLDING - TRIM - 5.5" X 69.8" - HONEY CHERRY
1F	116951-27-N75	EA	MOLDING - TRIM - 3.5" X 46.8" - PORTSMOUTH OAK
1F	116951-27-N85	EA	MOLDING - TRIM - 3.5" X 46.8" - CONCERT CHERRY
1F	116951-27-N84	EA	MOLDING - TRIM - 3.5" X 46.8" - WASHED MAPLE
1F	116951-28-N75	EA	MOLDING - TRIM - 3.5" X 79.4" - PORTSMOUTH OAK
1F	116951-28-N85	EA	MOLDING - TRIM - 3.5" X 79.4" - CONCERT CHERRY
1F	116951-28-N84	EA	MOLDING - TRIM - 3.5" X 79.4" - WASHED MAPLE
1F	116951-29-N70	EA	MOLDING - TRIM - 5.5" X 30.4" - PORTSMOUTH OAK
1F	116951-29-N85	EA	MOLDING - TRIM - 5.5" X 30.4" - CONCERT CHERRY
1F	116951-29-N84	EA	MOLDING - TRIM - 5.5" X 30.4" - WASHED MAPLE
1F	116951-29-RC3	EA	MOLDING - TRIM - 5.5" X 30.4" - HONEY CHERRY
1F	116951-29-SA3	EA	MOLDING - TRIM - 5.5" X 30.4" - SIERRA MAPLE
1F	116951-32-P75	EA	MOLDING - TRIM - 1.5" X 33.4" - PORTSMOUTH OAK
1F	116951-32-P25	EA	MOLDING - TRIM - 1.5" X 33.4" - CONCERT CHERRY
1F	116951-32-P28	EA	MOLDING - TRIM - 1.5" X 33.4" - WASHED MAPLE
1F	116951-32-RE0	EA	MOLDING - TRIM - 1.5" X 33.4" - HONEY CHERRY
1F	116951-34-P78	EA	MOLDING - TRIM - 3.5" X 44.3" - PORTSMOUTH OAK
1F	116951-34-P79	EA	MOLDING - TRIM - 3.5" X 44.3" - CONCERT CHERRY
1F	116951-34-P28	EA	MOLDING - TRIM - 3.5" X 44.3" - WASHED MAPLE
1F	116951-34-RE0	EA	MOLDING - TRIM - 3.5" X 44.3" - HONEY CHERRY
1F	116951-35-P78	EA	MOLDING - TRIM - 3.5" X 96" - PORTSMOUTH OAK
1F	116951-35-P79	EA	MOLDING - TRIM - 3.5" X 96" - CONCERT CHERRY
1F	116951-35-P28	EA	MOLDING - TRIM - 3.5" X 96" - WASHED MAPLE
1F	116951-35-RE0	EA	MOLDING - TRIM - 3.5" X 96" - HONEY CHERRY
1F	116951-36-R68	EA	MOLDING - TRIM - 3.5" X 48.8" - PORTSMOUTH OAK
1F	116951-36-R69	EA	MOLDING - TRIM - 3.5" X 48.8" - CONCERT CHERRY
1F	116951-36-R76	EA	MOLDING - TRIM - 3.5" X 48.8" - WASHED MAPLE
1F	116951-37-R68	EA	MOLDING - TRIM - 3.5" X 38.6" - PORTSMOUTH OAK
1F	116951-37-R69	EA	MOLDING - TRIM - 3.5" X 38.6" - CONCERT CHERRY
1F	116951-37-R76	EA	MOLDING - TRIM - 3.5" X 38.6" - WASHED MAPLE
1F	116951-38-R83	EA	MOLDING - TRIM - 3.5" X 82.6" - PORTSMOUTH OAK
1F	116951-38-R84	EA	MOLDING - TRIM - 3.5" X 82.6" - CONCERT CHERRY
1F	116951-38-R91	EA	MOLDING - TRIM - 3.5" X 82.6" - WASHED MAPLE
1F	116951-38-RE0	EA	MOLDING - TRIM - 3.5" X 82.6" - HONEY CHERRY
1F	116951-39-R83	EA	MOLDING - TRIM - 3.5" X 73.9" - PORTSMOUTH OAK
1F	116951-39-R84	EA	MOLDING - TRIM - 3.5" X 73.9" - CONCERT CHERRY
1F	116951-39-R91	EA	MOLDING - TRIM - 3.5" X 73.9" - WASHED MAPLE
1F	116951-39-RE0	EA	MOLDING - TRIM - 3.5" X 73.9" - HONEY CHERRY
1F	116951-40-R83	EA	MOLDING - TRIM - 4.5" X 81.9" - PORTSMOUTH OAK
1F	116951-40-R84	EA	MOLDING - TRIM - 4.5" X 81.9" - CONCERT CHERRY
1F	116951-40-R91	EA	MOLDING - TRIM - 4.5" X 81.9" - WASHED MAPLE
1F	116951-40-RE0	EA	MOLDING - TRIM - 4.5" X 81.9" - HONEY CHERRY
1F	116951-41-R83	EA	MOLDING - TRIM - 3.5" X 36.8" - PORTSMOUTH OAK
1F	116951-41-R84	EA	MOLDING - TRIM - 3.5" X 36.8" - CONCERT CHERRY
1F	116951-41-R91	EA	MOLDING - TRIM - 3.5" X 36.8" - WASHED MAPLE
1F	116951-41-RE0	EA	MOLDING - TRIM - 3.5" X 36.8" - HONEY CHERRY

INTERIOR FINISH GROUP (CONTINUED)
MOLDINGS & TRIMS (CONTINUED)

KEY	PART NUMBER	U/M	DESCRIPTION
1F	116951-42-R83	EA	MOLDING - TRIM - 3.5" X 46.8" - PORTSMOUTH OAK
1F	116951-42-R84	EA	MOLDING - TRIM - 3.5" X 46.8" - CONCERT CHERRY
1F	116951-42-R91	EA	MOLDING - TRIM - 3.5" X 46.8" - WASHED MAPLE
1F	116951-42-RE0	EA	MOLDING - TRIM - 3.5" X 46.8" - HONEY CHERRY
1F	116951-43-R83	EA	MOLDING - TRIM - 3.5" X 86.5" - PORTSMOUTH OAK
1F	116951-43-R84	EA	MOLDING - TRIM - 3.5" X 86.5" - CONCERT CHERRY
1F	116951-43-R91	EA	MOLDING - TRIM - 3.5" X 86.5" - WASHED MAPLE
1F	116951-43-RE0	EA	MOLDING - TRIM - 3.5" X 86.5" - HONEY CHERRY
1F	116951-44-R83	EA	MOLDING - TRIM - 3.5" X 76.1" - PORTSMOUTH OAK
1F	116951-44-R84	EA	MOLDING - TRIM - 3.5" X 76.1" - CONCERT CHERRY
1F	116951-44-R91	EA	MOLDING - TRIM - 3.5" X 76.1" - WASHED MAPLE
1F	116951-44-RE0	EA	MOLDING - TRIM - 3.5" X 76.1" - HONEY CHERRY
1F	116951-45-R68	EA	MOLDING - TRIM - 3" X 30.3" - PORTSMOUTH OAK
1F	116951-45-R69	EA	MOLDING - TRIM - 3" X 30.3" - CONCERT CHERRY
1F	116951-45-R76	EA	MOLDING - TRIM - 3" X 30.3" - WASHED MAPLE
1F	116951-46-R83	EA	MOLDING - TRIM - 4.5" X 72.3" - PORTSMOUTH OAK
1F	116951-46-R84	EA	MOLDING - TRIM - 4.5" X 72.3" - CONCERT CHERRY
1F	116951-46-R91	EA	MOLDING - TRIM - 4.5" X 72.3" - WASHED MAPLE
1F	116951-46-RE0	EA	MOLDING - TRIM - 4.5" X 72.3" - HONEY CHERRY
1F	116951-48-R83	EA	MOLDING - TRIM - 4.5" X 76.1" - PORTSMOUTH OAK
1F	116951-48-R84	EA	MOLDING - TRIM - 4.5" X 76.1" - CONCERT CHERRY
1F	116951-48-R91	EA	MOLDING - TRIM - 4.5" X 76.1" - WASHED MAPLE
1F	116951-48-RE0	EA	MOLDING - TRIM - 4.5" X 76.1" - HONEY CHERRY
1F	116951-49-R83	EA	MOLDING - TRIM - 4.5" X 69.8" - PORTSMOUTH OAK
1F	116951-49-R84	EA	MOLDING - TRIM - 4.5" X 69.8" - CONCERT CHERRY
1F	116951-49-R91	EA	MOLDING - TRIM - 4.5" X 69.8" - WASHED MAPLE
1F	116951-49-RE0	EA	MOLDING - TRIM - 4.5" X 69.8" - HONEY CHERRY
1F	116951-51-SA3	EA	MOLDING - TRIM - 3.5" X 47.3" - SIERRA MAPLE
1F	116951-51-SA2	EA	MOLDING - TRIM - 3.5" X 47.3" - WASHED MAPLE
1F	116951-51-SA0	EA	MOLDING - TRIM - 3.5" X 47.3" - PORTSMOUTH OAK
1F	116951-51-SA1	EA	MOLDING - TRIM - 3.5" X 47.3" - CONCERT CHERRY
1F	116951-52-SD0	EA	MOLDING - TRIM - 4.5" X 73.3" - PORTSMOUTH OAK
1F	116951-52-SD1	EA	MOLDING - TRIM - 4.5" X 73.3" - CONCERT CHERRY
1F	116951-52-SD2	EA	MOLDING - TRIM - 4.5" X 73.3" - WASHED MAPLE
1F	116951-52-SD3	EA	MOLDING - TRIM - 4.5" X 73.3" - HONEY CHERRY
1F	116951-53-SD0	EA	MOLDING - TRIM - 4.5" X 53.4" - PORTSMOUTH OAK
1F	116951-53-SD1	EA	MOLDING - TRIM - 4.5" X 53.4" - CONCERT CHERRY
1F	116951-53-SD2	EA	MOLDING - TRIM - 4.5" X 53.4" - WASHED MAPLE
1F	116951-53-SD3	EA	MOLDING - TRIM - 4.5" X 53.4" - HONEY CHERRY

INTERIOR FINISH GROUP (CONTINUED)
MOLDINGS & TRIMS (CONTINUED)

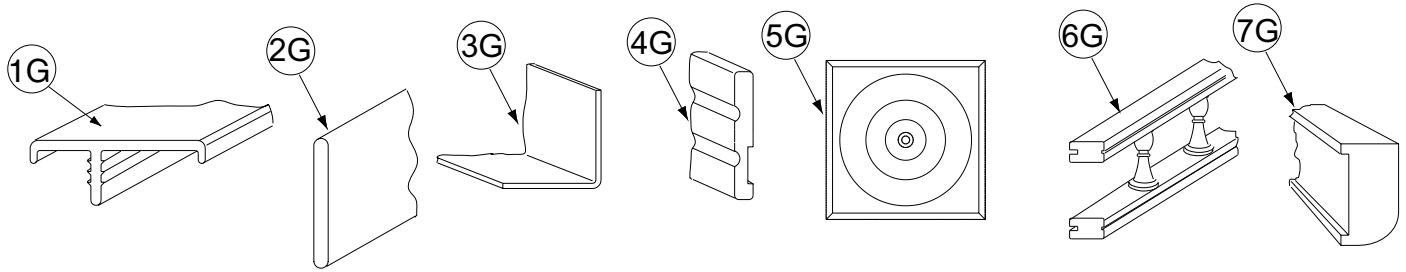

KEY	PART NUMBER	U/M	DESCRIPTION
1G	119520-01-01A	FT	MOLDING-T/OFFSET - W/EDGE LIP - 1"FACE - OFF WHITE
1G	119520-01-04A	FT	MOLDING-T - OFFSET W/EDGE LIP - 1"FACE - PORTSMOUTH OAK
1G	119520-01-02A	FT	MOLDING-T - OFFSET W/EDGE LIP - 1"FACE - CONCERT CHERRY/HONEY CHERRY
1G	119520-01-03A	FT	MOLDING-T - OFFSET W/EDGE LIP - 1"FACE - WASHED MAPLE
2G	127842-01-01A	FT	SEAL - SIGHT SHIELD - 2" BLACK
3G	130262-01-000	EA	PROTECTOR - CORNER SAVER - .7" X .7" X 48"
3G	130262-03-000	EA	PROTECTOR - CORNER - .75" X .75"
3G	130262-04-000	EA	PROTECTOR - CORNER SAVER - .4" X .7" X 48"
4G	132663-03-08A	EA	MOLDING-VINYL WRAP/PRE DRILLED-.6"X3.8"X150.6" - PORTSMOUTH OAK
4G	132663-11-07A	EA	MOLDING-VINYL WRAP/PRE DRILLED-.6"X3.8"X110.5" - CONCERT CHERRY/HONEY CHERRY
4G	132663-11-21A	EA	MOLDING-VINYL WRAP/PRE DRILLED-.6"X3.4"X57.9" - WASHED MAPLE
4G	132663-11-22A	EA	MOLDING-VINYL WRAP/PRE DRILLED-.6"X3.4"X57.9" - SIERRA MAPLE
4G	132663-09-08A	EA	MOLDING-VINYL WRAP/PRE DRILLED-.6"X3.4"X96.5" - PORTSMOUTH OAK
4G	132663-09-07A	EA	MOLDING-VINYL WRAP/PRE DRILLED-.6"X3.4"X96.5" - CONCERT CHERRY/ HONEY CHERRY
4G	132663-18-21A	EA	MOLDING-VINYL WRAP/PRE DRILLED-.6" X 3.4" X 73.1" - WASHED MAPLE
4G	132663-18-22A	EA	MOLDING-VINYL WRAP/PRE DRILLED-.6" X 3.4" X 73.1" - SIERRA MAPLE
4G	132663-15-08A	EA	MOLDING-VINYL WRAP/PRE DRILLED-.6"X3"X96" - PORTSMOUTH OAK
4G	132663-15-07A	EA	MOLDING-VINYL WRAP/PRE DRILLED-.6"X3"X96" - CONCERT CHERRY/HONEY CHERRY
4G	132663-04-21A	EA	MOLDING-VINYL WRAP/PRE DRILLED - .6" X 3" X 70.2" - WASHED MAPLE
4G	132663-04-22A	EA	MOLDING-VINYL WRAP/PRE DRILLED - .6" X 3" X 70.2" - SIERRA MAPLE
5G	132844-01-08A	EA	BLOCK - CORNER - 3.9" X 3.9" - PORTSMOUTH OAK
5G	132844-01-02A	EA	BLOCK - CORNER - 3.9" X 3.9" - CONCERT CHERRY/HONEY CHERRY
5G	132844-01-21A	EA	BLOCK - CORNER - 3.9" X 3.9" - WASHED MAPLE
5G	132844-01-22A	EA	BLOCK - CORNER - 3.9" X 3.9" - SIERRA MAPLE
5G	132844-02-08A	EA	BLOCK - CORNER - 3.5" X 3.5" - PORTSMOUTH OAK
5G	132844-02-02A	EA	BLOCK - CORNER - 3.5" X 3.5" - CONCERT CHERRY/HONEY CHERRY
5G	132844-02-21A	EA	BLOCK - CORNER - 3.5" X 3.5" - WASHED MAPLE
5G	132844-02-22A	EA	BLOCK - CORNER - 3.5" X 3.5" - SIERRA MAPLE
6G	137108-01-07A	EA	RAIL - DECORATIVE - 96" - PORTSMOUTH OAK
6G	137108-01-02A	EA	RAIL - DECORATIVE - 96" - CONCERT CHERRY
6G	137108-01-03A	EA	RAIL - DECORATIVE - 96" - WASHED MAPLE
6G	137108-01-08A	EA	RAIL - DECORATIVE - 96" - HONEY CHERRY
6G	137108-01-09A	EA	RAIL - DECORATIVE - 96" W/O REVERSE SIDE GROOVE - SIERRA MAPLE
6G	150167-01-07A	EA	RAIL - DECORATIVE - 96" W/O REVERSE SIDE GROOVE - PORTSMOUTH OAK
6G	150167-01-02A	EA	RAIL - DECORATIVE - 96" W/O REVERSE SIDE GROOVE - SALEM CHERRY - CONCERT CHERRY
6G	150167-01-03A	EA	RAIL - DECORATIVE - 96" W/O REVERSE SIDE GROOVE - WASHED MAPLE
6G	150167-01-09A	EA	RAIL - DECORATIVE - 96" W/O REVERSE SIDE GROOVE - SIERRA MAPLE
	137885-A2-438	EA	LUMBER - VINYL WRAPPED - .7" X .75" X 96" - CONCERT CHERRY
	137885-D2-438	EA	LUMBER - VINYL WRAPPED - .7" X 1.5" X 96" - CONCERT CHERRY
	137885-E2-438	EA	LUMBER - VINYL WRAPPED - .7" X 2" X 96" - CONCERT CHERRY
	137885-F2-438	EA	LUMBER - VINYL WRAPPED - .7" X 2.5" X 96" - CONCERT CHERRY
	137885-G2-438	EA	LUMBER - VINYL WRAPPED - .7" X 3" X 96" - CONCERT CHERRY
	137885-H2-438	EA	LUMBER - VINYL WRAPPED - .7" X 3.5" X 96" - CONCERT CHERRY
	137885-J2-438	EA	LUMBER - VINYL WRAPPED - .7" X 5.5" X 96" - CONCERT CHERRY
	137885-J2-743	EA	LUMBER - VINYL WRAPPED - .7" X 5.5" X 108" - CONCERT CHERRY
	137885-K2-438	EA	LUMBER - VINYL WRAPPED - .7" X 3.9" X 96" - CONCERT CHERRY
	137885-R2-438	EA	LUMBER - VINYL WRAPPED - .7" X 3" X 96" - CONCERT CHERRY
7G	137887-D2-134	EA	MOLDING - VINYL WRAPPED - .7" X 1.6" X 84" - CONCERT CHERRY
7G	137887-D2-743	EA	MOLDING - VINYL WRAPPED - .7" X 1.6" X 108" - CONCERT CHERRY
7G	137887-F2-134	EA	MOLDING - VINYL WRAPPED - .7" X 2.5" X 84" - CONCERT CHERRY
7G	137887-F2-743	EA	MOLDING - VINYL WRAPPED - .7" X 2.5" X 108" - CONCERT CHERRY
7G	137887-F2-438	EA	MOLDING - VINYL WRAPPED - .7" X 2.5" X 96" - CONCERT CHERRY

INTERIOR FINISH GROUP (CONTINUED)
MOLDINGS & TRIMS (CONTINUED)

KEY	PART NUMBER	U/M	DESCRIPTION
	137894-A2-438	EA	LUMBER - VINYL WRAPPED - .7" X .75" X 96" - PORTSMOUTH OAK
	137894-D2-438	EA	LUMBER - VINYL WRAPPED - .7" X 1.5" X 96" - PORTSMOUTH OAK
	137894-E2-438	EA	LUMBER - VINYL WRAPPED - .7" X 2" X 96" - PORTSMOUTH OAK
	137894-F2-438	EA	LUMBER - VINYL WRAPPED - .7" X 2.5" X 96" - PORTSMOUTH OAK
	137894-G2-438	EA	LUMBER - VINYL WRAPPED - .7" X 3" X 96" - PORTSMOUTH OAK
	137894-H2-438	EA	LUMBER - VINYL WRAPPED - .7" X 3.5" X 96" - PORTSMOUTH OAK
	137894-J2-438	EA	LUMBER - VINYL WRAPPED - .7" X 5.5" X 96" - PORTSMOUTH OAK
	137894-J2-743	EA	LUMBER - VINYL WRAPPED - .7" X 5.5" X 96" - PORTSMOUTH OAK
	137894-K2-438	EA	LUMBER - VINYL WRAPPED - .7" X 3.9" X 96" - PORTSMOUTH OAK
	137894-R2-438	EA	LUMBER - VINYL WRAPPED - .7" X 3" X 96" - PORTSMOUTH OAK
7G	137895-D2-134	EA	MOLDING - VINYL WRAPPED - .7" X 1.6" X 84"-PORTSMOUTH OAK
7G	137895-D2-743	EA	MOLDING - VINYL WRAPPED - .7" X 1.6" X 108"-PORTSMOUTH OAK
7G	137895-F2-743	EA	MOLDING - VINYL WRAPPED - .7" X 2.5" X 108" - PORTSMOUTH OAK
	146419-A2-438	EA	LUMBER - VINYL WRAPPED - .7" X .75" X 96" - HONEY CHERRY
	146419-D2-438	EA	LUMBER - VINYL WRAPPED - .7" X 1.5" X 96" - HONEY CHERRY
	146419-E2-438	EA	LUMBER - VINYL WRAPPED - .7" X 2" X 96" - HONEY CHERRY
	146419-F2-438	EA	LUMBER - VINYL WRAPPED - .7" X 2.5" X 96" - HONEY CHERRY
	146419-G2-438	EA	LUMBER - VINYL WRAPPED - .7" X 3" X 96" - HONEY CHERRY
	146419-H2-438	EA	LUMBER - VINYL WRAPPED - .7" X 3.5" X 96" - HONEY CHERRY
	146419-J2-438	EA	LUMBER - VINYL WRAPPED - .7" X 5.5" X 96" - HONEY CHERRY
	146419-J2-743	EA	LUMBER - VINYL WRAPPED - .7" X 5.5" X 108" - HONEY CHERRY
	146419-K2-438	EA	LUMBER - VINYL WRAPPED - .7" X 3.9" X 96" - HONEY CHERRY
	146419-R2-438	EA	LUMBER - VINYL WRAPPED - .7" X 3" X 96" - HONEY CHERRY
7G	146425-D2-134	EA	MOLDING - VINYL WRAPPED - .7" X 1.6" X 96" - HONEY CHERRY
7G	146425-F2-134	EA	MOLDING - VINYL WRAPPED - .7" X 2.5" X 84" - HONEY CHERRY
7G	146425-F2-134	EA	MOLDING - VINYL WRAPPED - .7" X 2.5" X 96" - HONEY CHERRY
7G	146425-F2-743	EA	MOLDING - VINYL WRAPPED - .7" X 2.5" X 108" - HONEY CHERRY
	149325-A2-438	EA	LUMBER - VINYL WRAPPED - .7" X .75" X 96" - WASHED MAPLE
	149325-D2-438	EA	LUMBER - VINYL WRAPPED - .7" X 1.5" X 96" - WASHED MAPLE
	149325-E2-438	EA	LUMBER - VINYL WRAPPED - .7" X 2" X 96" - WASHED MAPLE
	149325-F2-438	EA	LUMBER - VINYL WRAPPED - .7" X 2.5" X 96" - WASHED MAPLE
	149325-G2-438	EA	LUMBER - VINYL WRAPPED - .7" X 3" X 96" - WASHED MAPLE
	149325-H2-438	EA	LUMBER - VINYL WRAPPED - .7" X 3.5" X 96" - WASHED MAPLE
	149325-J2-438	EA	LUMBER - VINYL WRAPPED - .7" X 5.5" X 96" - WASHED MAPLE
	149325-J2-743	EA	LUMBER - VINYL WRAPPED - .7" X 5.5" X 108" - WASHED MAPLE
	149325-K2-438	EA	LUMBER - VINYL WRAPPED - .7" X 3.9" X 96" - WASHED MAPLE
	149325-R2-438	EA	LUMBER - VINYL WRAPPED - .7" X 3" X 96" - WASHED MAPLE
7G	149326-D2-134	EA	MOLDING - VINYL WRAPPED - .7" X 1.6" X 84" - WASHED MAPLE
7G	149326-F2-134	EA	MOLDING - VINYL WRAPPED - .7" X 2.5" X 84" - WASHED MAPLE
7G	149326-F2-438	EA	MOLDING - VINYL WRAPPED - .7" X 2.5" X 96" - WASHED MAPLE
7G	149326-F2-743	EA	MOLDING - VINYL WRAPPED - .7" X 2.5" X 108" - WASHED MAPLE
	149330-A2-438	EA	LUMBER - VINYL WRAPPED - .7" X .75" X 96" - SIERRA MAPLE
	149330-D2-438	EA	LUMBER - VINYL WRAPPED - .7" X 1.5" X 96" - SIERRA MAPLE
	149330-E2-438	EA	LUMBER - VINYL WRAPPED - .7" X 2" X 96" - SIERRA MAPLE
	149330-F2-438	EA	LUMBER - VINYL WRAPPED - .7" X 2.5" X 96" - SIERRA MAPLE
	149330-G2-438	EA	LUMBER - VINYL WRAPPED - .7" X 3" X 96" - SIERRA MAPLE
	149330-H2-438	EA	LUMBER - VINYL WRAPPED - .7" X 3.5" X 96" - SIERRA MAPLE
	149330-J2-438	EA	LUMBER - VINYL WRAPPED - .7" X 5.5" X 96" - SIERRA MAPLE
	149330-J2-743	EA	LUMBER - VINYL WRAPPED - .7" X 5.5" X 108" - SIERRA MAPLE
	149330-K2-438	EA	LUMBER - VINYL WRAPPED - .7" X 3.9" X 96" - SIERRA MAPLE
	149330-R2-438	EA	LUMBER - VINYL WRAPPED - .7" X 3" X 96" - SIERRA MAPLE
7G	149331-D2-134	EA	MOLDING - VINYL WRAPPED - .7" X 1.6" X 96" - SIERRA MAPLE
7G	149331-F2-134	EA	MOLDING - VINYL WRAPPED - .7" X 2.5" X 84" - SIERRA MAPLE
7G	149331-F2-439	EA	MOLDING - VINYL WRAPPED - .7" X 2.5" X 96" - SIERRA MAPLE
7G	149331-F2-743	EA	MOLDING - VINYL WRAPPED - .7" X 2.5" X 108" - SIERRA MAPLE

INTERIOR FINISH GROUP (CONTINUED)
MOLDINGS & TRIMS (CONTINUED)

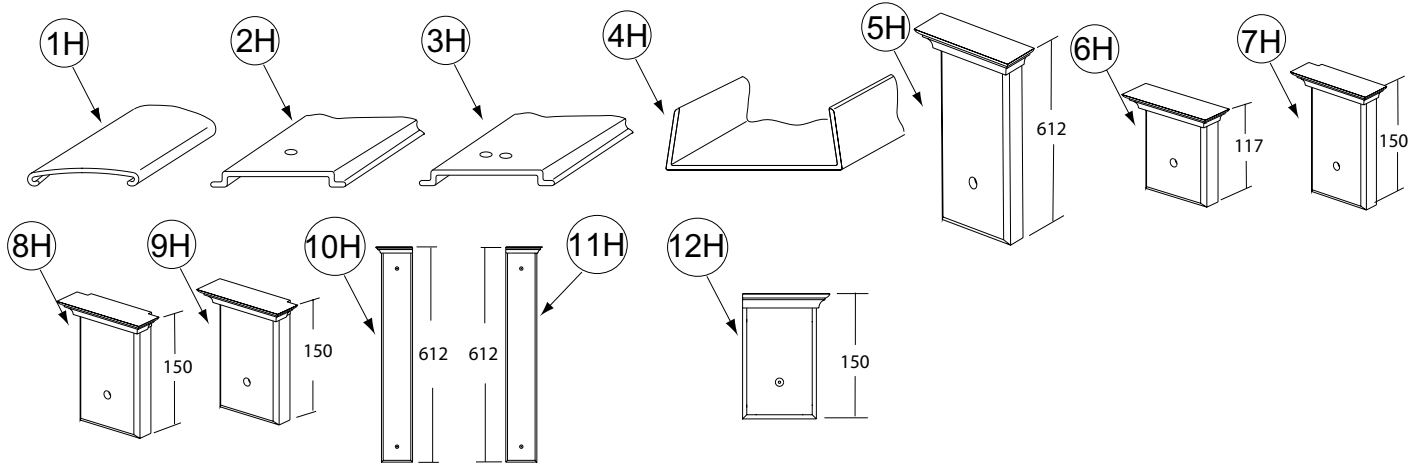

KEY	PART NUMBER	U/M	DESCRIPTION
1H	138359-01-01A	FT	COVER - ROOF BREAK - PEARL CREAM/PLASTIC - 96"
2H	138403-01-01A	EA	TRIM - ROOF - MILL
3H	138403-03-01A	EA	TRIM - ROOF - MILL
4H	141260-01-01A	FT	U-CHANNEL - 1" - VILLAGE OAK - PORTSMOUTH OAK/WASHED MAPLE/SIERRA MAPLE
4H	141260-01-02A	FT	U-CHANNEL - 1" - GRADY BROWN - CONCERT CHERRY/HONEY CHERRY
5H	141303-02-N53	EA	MOLDING - CROWN/BLOCK - PORTSMOUTH OAK
5H	141303-02-N52	EA	MOLDING - CROWN/BLOCK - CONCERT CHERRY
5H	141303-02-N62	EA	MOLDING - CROWN/BLOCK - WASHED MAPLE
5H	141303-02-RA3	EA	MOLDING - CROWN/BLOCK - HONEY CHERRY
6H	141303-03-N53	EA	MOLDING - CROWN/BLOCK - PORTSMOUTH OAK
6H	141303-03-N52	EA	MOLDING - CROWN/BLOCK - CONCERT CHERRY
6H	141303-03-N62	EA	MOLDING - CROWN/BLOCK - WASHED MAPLE
6H	141303-03-RA3	EA	MOLDING - CROWN/BLOCK - HONEY CHERRY
7H	141303-05-R89	EA	MOLDING - CROWN/BLOCK - PORTSMOUTH OAK
7H	141303-05-R91	EA	MOLDING - CROWN/BLOCK - WASHED MAPLE
7H	141303-05-R90	EA	MOLDING - CROWN/BLOCK - CONCERT CHERRY
7H	141303-05-RE3	EA	MOLDING - CROWN/BLOCK - HONEY CHERRY
8H	141303-06-R89	EA	MOLDING - CROWN/BLOCK - PORTSMOUTH OAK
8H	141303-06-R90	EA	MOLDING - CROWN/BLOCK - CONCERT CHERRY
8H	141303-06-R91	EA	MOLDING - CROWN/BLOCK - WASHED MAPLE
8H	141303-06-RE3	EA	MOLDING - CROWN/BLOCK - HONEY CHERRY
9H	141303-07-R89	EA	MOLDING - CROWN/BLOCK - PORTSMOUTH OAK
9H	141303-07-R90	EA	MOLDING - CROWN/BLOCK - CONCERT CHERRY
9H	141303-07-R91	EA	MOLDING - CROWN/BLOCK - WASHED MAPLE
9H	141303-07-RE3	EA	MOLDING - CROWN/BLOCK - HONEY CHERRY
10H	141303-08-R83	EA	MOLDING - CROWN/BLOCK - PORTSMOUTH OAK
10H	141303-08-R84	EA	MOLDING - CROWN/BLOCK - CONCERT CHERRY
10H	141303-08-R91	EA	MOLDING - CROWN/BLOCK - WASHED MAPLE
10H	141303-08-RE0	EA	MOLDING - CROWN/BLOCK - HONEY CHERRY
11H	141303-09-R83	EA	MOLDING - CROWN/BLOCK - PORTSMOUTH OAK
11H	141303-09-R84	EA	MOLDING - CROWN/BLOCK - CONCERT CHERRY
11H	141303-09-R91	EA	MOLDING - CROWN/BLOCK - WASHED MAPLE
11H	141303-09-RE0	EA	MOLDING - CROWN/BLOCK - HONEY CHERRY
12H	141303-10-R89	EA	MOLDING - CROWN/BLOCK - PORTSMOUTH OAK
12H	141303-10-R90	EA	MOLDING - CROWN/BLOCK - CONCERT CHERRY
12H	141303-10-R91	EA	MOLDING - CROWN/BLOCK - WASHED MAPLE
12H	141303-10-RE3	EA	MOLDING - CROWN/BLOCK - HONEY CHERRY

INTERIOR FINISH GROUP (CONTINUED)
MOLDINGS & TRIMS (CONTINUED)

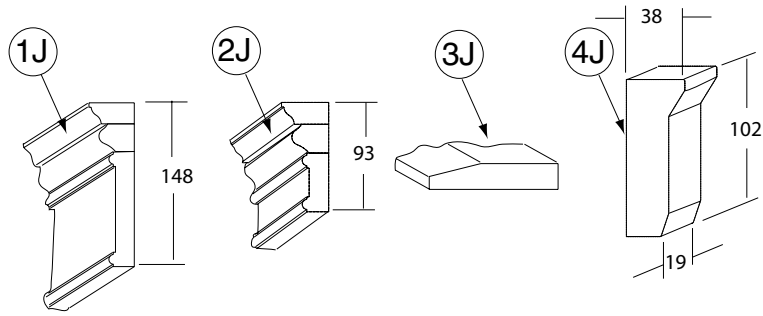

KEY	PART NUMBER	U/M	DESCRIPTION
1J	144885-14-R83	EA	MOLDING - F/SLIDEOUT - 86.5" - PORTSMOUTH OAK
1J	144885-14-R84	EA	MOLDING - F/SLIDEOUT - 86.5" - CHERRY
1J	144885-14-RE0	EA	MOLDING - F/SLIDEOUT - 86.5" - HONEY CHERRY
1J	144885-07-SD2	EA	MOLDING - F/SLIDEOUT - 82.5" - WASHED MAPLE
2J	145379-01-R83	EA	MOLDING/TRIM - 47.48" - PORTSMOUTH OAK
2J	145379-01-R84	EA	MOLDING/TRIM - 47.48" - CONCERT CHERRY
2J	145379-01-RE0	EA	MOLDING/TRIM - 47.48" - HONEY CHERRY
2J	145379-01-SD2	EA	MOLDING/TRIM - 47.48" - WASHED MAPLE
2J	145379-02-R83	E A	MOLDING/TRIM - 7.87" W/RIGHT SIDE ANGLE CUT - PORTSMOUTH OAK
2J	145379-02-R84	EA	MOLDING/TRIM - 7.87" W/RIGHT SIDE ANGLE CUT - CONCERT CHERRY
2J	145379-02-RE0	EA	MOLDING/TRIM - 7.87" W/RIGHT SIDE ANGLE CUT - HONEY CHERRY
2J	145379-02-SD2	EA	MOLDING/TRIM - 7.87" W/RIGHT SIDE ANGLE CUT - WASHED MAPLE
2J	145379-03-R83	EA	MOLDING/TRIM - 7.87" W/LEFT SIDE ANGLE CUT - PORTSMOUTH OAK
2J	145379-03-R84	EA	MOLDING/TRIM - 7.87" W/LEFT SIDE ANGLE CUT - CONCERT CHERRY
2J	145379-03-RE0	EA	MOLDING/TRIM - 7.87" W/LEFT SIDE ANGLE CUT - HONEY CHERRY
2J	145379-03-SD2	EA	MOLDING/TRIM - 7.87" W/LEFT SIDE ANGLE CUT - WASHED MAPLE
2J	145379-05-R83	EA	MOLDING/TRIM - 102.75" - PORTSMOUTH OAK
2J	145379-05-R84	EA	MOLDING/TRIM - 102.75" - CONCERT CHERRY
2J	145379-05-SD2	EA	MOLDING/TRIM - 102.75" - WASHED MAPLE
2J	145379-05-RE0	EA	MOLDING/TRIM - 102.75" - HONEY CHERRY
3J	146306-01-01A	FT	TRANSITION - CARPET/TILE
4J	149151-01-S46	EA	MOLDING - BLOCK - PORTSMOUTH OAK
4J	149151-01-S47	EA	MOLDING - BLOCK - CONCERT CHERRY
4J	149151-01-S48	EA	MOLDING - BLOCK - WASHED MAPLE

INTERIOR FINISH GROUP (CONTINUED)
PANELING & LAMINATES

KEY	PART NUMBER	U/M	DESCRIPTION
	088272-K6-000	SF	PANELING - CYPRESS - 4' X 7' (S28, SJ0, SX2, SX3, SX4, SX5, SX6, SX7, SY4, SY5, SY6, SY7, SY8, SY9)
	088272-K7-000	SF	PANELING - STONE - 4' X 7' (S29, SJ1)
	088272-K5-000	SF	PANELING - SILVERADO - 4' X 7' (S30, SJ2)
	074497-42-000	SF	PANELING - PORTSMOUTH OAK - 1/8" X 4' X 8'
	074497-48-000	SF	PANELING - SIERRA MAPLE - 1/8" X 4' X 8'
	076773-15-000	SF	PANELING - 2 SIDED/PORTSMOUTH OAK - 1/8" X 4' X 8'
	076773-19-000	SF	PANELING - 2 SIDED/SIERRA MAPLE - 1/8" X 4' X 8'
	088272-H9-000	SF	PANELING - PEBBLE EMBOSSED - WHITE - 4' X 7'
	085284-H9-000	FT	BATT TAPE - CYPRESS (S28, SJ0, SX2, SX3, SX4, SX5, SX6, SX7, SY4, SY5, SY6, SY7, SY8, SY9)
	085284-H0-000	FT	BATT TAPE - ADHESIVE BACKED - DECORATIVE - STONE (S29, SJ1)
	085284-H8-000	FT	BATT TAPE - ADHESIVE BACKED - DECORATIVE - SILVERADO (S30, SJ2)
	085284-G8-000	FT	BATT TAPE - ADHESIVE BACKED - PORTSMOUTH OAK
	085284-J4-000	FT	BATT TAPE - ADHESIVE BACKED - SIERRA MAPLE
	085284-F9-000	FT	BATT TAPE - ADHESIVE BACKED - PEBBLE EMBOSSED
	088263-H5-000	FT	BATT STRIP - CYPRESS (S28, SJ0, SX2, SX3, SX4, SX5, SX6, SX7, SY4, SY5, SY6, SY7, SY8, SY9)
	088263-H6-000	FT	BATT STRIP - DECORATIVE - STONE (S29, SJ1)
	088263-H4-000	FT	BATT STRIP - DECORATIVE - SILVERADO (S30, SJ2)
	069733-87-000	EA	BATT STRIP - WOODGRAINED/PORTSMOUTH OAK - 8'
	088263-J1-000	EA	BATT STRIP - WOODGRAINED/SIERRA MAPLE - 8'
	000885-A5-000	SF	PARTICLE BOARD - 3/8" X 4' X 8' - WHITE PEB EMB - 1 SIDED
	000885-92-000	SF	PARTICLE BOARD - 3/8" X 4' X 8' - PORTSMOUTH OAK - 1 SIDED
	000885-B1-000	SF	PARTICLE BOARD - 3/8" X 4' X 8' - SIERRA MAPLE - 1 SIDED
	000885-93-000	SF	PARTICLE BOARD - 3/8" X 4' X 8' - PORTSMOUTH OAK - 2 SIDED
	000885-B0-000	SF	PARTICLE BOARD - 3/8" X 4' X 8' - SIERRA MAPLE - 2 SIDED
	000885-94-000	SF	PARTICLE BOARD - 1/2" X 4' X 8' - PORTSMOUTH OAK - 2 SIDED
	000885-B3-000	SF	PARTICLE BOARD - 1/2" X 4' X 8' - SIERRA MAPLE - 2 SIDED
	000885-95-000	SF	PARTICLE BOARD - 3/4" X 4' X 8' - PORTSMOUTH OAK - 2 SIDED
	000885-B2-000	SF	PARTICLE BOARD - 3/4" X 4' X 8' - SIERRA MAPLE - 2 SIDED
	126339-01-000	SF	BOARD - WHEAT - 60" X 72"
	057882-04-000	SF	TAMBOUR - 48" X 96" SHEET - UNFINISHED
	074498-A1-000	SF	LAMNTE - LINO FRZE - 5' X 8' (S28, SJ0, SX2, SX3, SX4, SX5, SX6, SX7, (SY4, SY5, SY6, SY7, SY8, SY9)
	074498-99-000	SF	LAMINATE - PLASTIC - EGGSHELL - 5' X 8' (S29, SJ1)
	074498-97-000	SF	LAMINATE - PLASTIC - GRAY TRANQUILITY - 4' X 8' (S30, SJ2)
	074498-40-000	SF	LAMINATE - PLASTIC - OFF WHITE - 4' X 8'
	076325-39-000	FT	MOLDING - EDGE BAND - 1 5/16" X .030" - ALMOND
	076325-40-000	FT	MOLDING - EDGE BAND - .93" X .024" - ALMOND
	076325-78-000	FT	MOLDING - EDGE BAND - .93" X .024" - PORTSMOUTH OAK
	076325-83-000	FT	MOLDING - EDGE BAND - .93" X .024" - SIERRA MAPLE
	130247-01-04A	FT	MOLDING/PLASTIC - T/OFFSET - W/1.3" FACE - PORTSMOUTH OAK
	130247-01-06A	FT	MOLDING/PLASTIC - T/OFFSET - W/1.3" FACE - SIERRA MAPLE

INTERIOR FINISH GROUP (CONTINUED)

INTERIOR TRIM LAYOUT

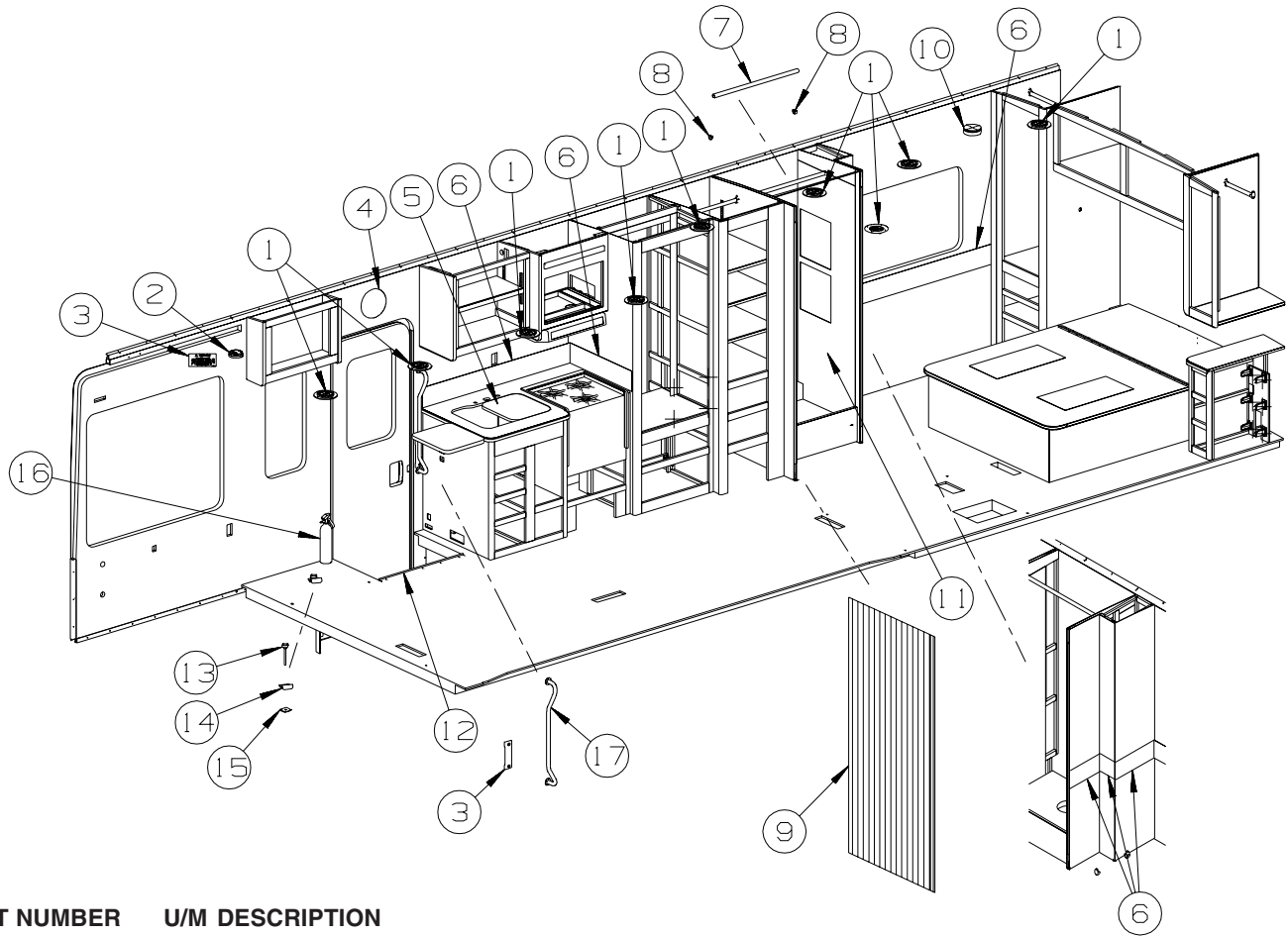

KEY	PART NUMBER	U/M	DESCRIPTION
1	120134-01-02A	EA	REGISTER - W/DAMPER - 4" PIPE/6.4" O.D. FACE - WHITE
2	072852-01-000	EA	DETECTOR - SMOKE - W/9 VOLT BATTERY - US
2	072852-02-000	EA	DETECTOR - SMOKE - W/9 VOLT BATTERY - CANADIAN
3	148362-01-01A	EA	COVER - BRACKET/STRIKE - BRIGHT WHITE
	140151-02-02A	EA	COVER - SCREW - BRIGHT WHITE
4	142368-01-01A	EA	CLOCK - 8" ROUND - BRASS
5	103610-04-R09	EA	COVER - SINK - LINO FRIEZE (S28, SJ0, SX2, SX3, SX4, SX5, SX6, SX7, SY4, SY5, SY6, SY7, SY8, SY9)
5	103610-04-P17	EA	COVER - SINK - 15.7" X 13.8" - EGGSHELL MOSAIC (S29, SJ1)
5	103610-04-N30	EA	COVER - SINK - 15.7" X 13.8" - GRAY TRANQUILITY (S30, SJ2)
6	132610-05-23A	FT	WALLPAPER - BORDER - 7" - SELF-ADHESIVE (S28, SJ0)
6	132610-05-24A	FT	WALLPAPER - BORDER - 7" - SELF-ADHESIVE (S29, SJ1)
6	132610-05-27A	FT	WALLPAPER - BORDER - 7" - SELF-ADHESIVE (S30, SJ2)
6	132610-06-15A	FT	WALLPAPER - BORDER - 5 1/4" - SELF-ADHESIVE (SX2, SX3, SY3, SY4, SY5, SY6, SY7, SY8, SY9)
6	132610-05-26A	FT	WALLPAPER - BORDER - 7" - SELF-ADHESIVE (SX4, SX5)
6	132610-05-28A	FT	WALLPAPER - BORDER - 7" - SELF-ADHESIVE (SX6, SX7)
7	102075-09-02A	EA	ROD - SHOWER CURTAIN - 3/4"OD X 29.5" - SOFT WHITE
8	113236-01-01A	EA	BRACKET - CLOTHES - ROD
9*	131595-01-01A	EA	DOOR/FOLDING-36.9"X 74.9"-4 CEILING BRKTS & STRAIGHT TRACK
10	125136-02-000	EA	DETECTOR/CO - GAS MODEL - 9 VOLT
11*	089318-01-000	EA	DOOR - SHOWER - HINGED W/GOLD FRAME - 29.8" X 65"
12	139955-06-02A	EA	TRIM - STEP/ENTRY - 29.3" - TITANIUM
	134128-02-02B	EA	PLATE - W/HOLES - W/WELDNUT - E-COATED
14	134057-01-11B	EA	BRACKET - RECLINER - FLAT BLACK
15	137598-01-01A	EA	KNOB - HOLD DOWN - RECLINER
16	094499-03-000	EA	EXTINGUISHER/FIRE - DRY - 10BC - W/GAUGE/BRACKET
16*	094499-02-000	EA	EXTINGUISHER/FIRE - DRY - 10BC - W/GAUGE - CANADIAN
16	094499-04-000	EA	STRAP - FIRE EXTINGUISHER MOUNTING - METAL
17	137605-01-01A	EA	RAIL - HAND - INTERIOR ENTRY DOOR - BLACK

*COMPONENT PARTS LISTED LATER IN THIS GROUP

INTERIOR FINISH GROUP (CONTINUED)
INTERIOR TRIM LAYOUT (CONTINUED)

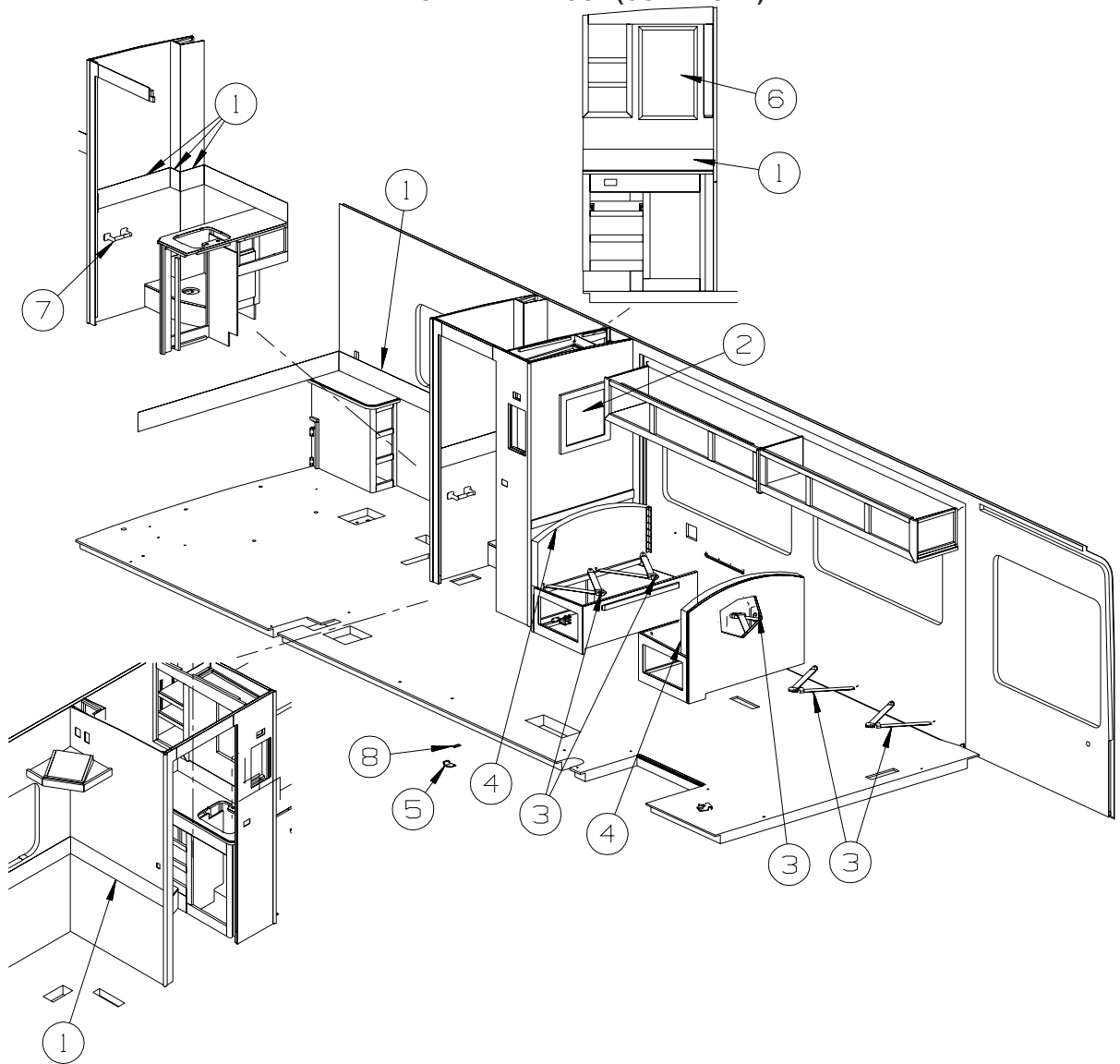

KEY	PART NUMBER	U/M	DESCRIPTION	
1	132610-05-23A	FT	WALLPAPER - BORDER - 7" - SELF-ADHESIVE (S28, SJ0)	
1	132610-05-24A	FT	WALLPAPER - BORDER - 7" - SELF-ADHESIVE (S29, SJ1)	
1	132610-05-27A	FT	WALLPAPER - BORDER - 7" - SELF-ADHESIVE (S30, SJ2)	
1	132610-06-15A	FT	WALLPAPER - BORDER - 5 1/4" - SELF-ADHESIVE (SX2, SX3, SY3, SY4, SY5, SY6, SY7, SY8, SY9)	
1	132610-05-26A	FT	WALLPAPER - BORDER - 7" - SELF-ADHESIVE (SX4, SX5)	
1	132610-05-28A	FT	WALLPAPER - BORDER - 7" - SELF-ADHESIVE (SX6, SX7)	
2	131493-02-18A	EA	PICTURE - DECORATIVE (S28, SJ0, SX2, SX3, SX4, SX5, SX6, SX7, SY4, SY5, SY6, SY7, SY8, SY9)	
2	131493-08-01A	EA	PICTURE - DECORATIVE - 14" X 14" - SCABISOSA (S29, SJ1)	
2	131493-08-02A	EA	PICTURE - DECORATIVE - 14" X 14" - POLYMONIUMS (S30, SJ2)	
3	007021-01-000	EA	SEAT BELT - 2" X 90" - BLACK	
4	104787-08-R28	EA	PAD - DINETTE - 58" (S28, SJ0, SY8, SY9)	
4	104787-08-R29	EA	PAD - DINETTE - 58" (S29, SJ1)	
4	104787-08-S30	EA	PAD - DINETTE - 58" (S30, SJ2)	
4	104787-08-SX2	EA	PAD - DINETTE - 58" (SX2, SX3)	
4	104787-08-SX4	EA	PAD - DINETTE - 58" (SX4, SX5)	
4	104787-08-S4X	EA	PAD - DINETTE - 58" (SX4, SX5)	FROM: 00-00-00 THRU: 11-16-04
4	104787-08-SX6	EA	PAD - DINETTE - 58" (SX6, SX7)	FROM: 11-17-04 THRU: 99-99-99
4	104787-08-S6X	EA	PAD - DINETTE - 58" (SX4, SX5)	FROM: 00-00-00 THRU: 11-10-04
				FROM: 11-11-04 THRU: 99-99-99

INTERIOR FINISH GROUP (CONTINUED)
INTERIOR TRIM LAYOUT (CONTINUED)

KEY	PART NUMBER	U/M	DESCRIPTION
4	104787-08-SY4	EA	PAD - DINETTE - 58" (SY4, SY5) FROM: 00-00-00 THRU: 11-11-04
4	104787-08-SY5	EA	PAD - DINETTE - 58" (SY4, SY5) FROM: 11-12-04 THRU: 99-99-99
4	104787-08-SY6	EA	PAD - DINETTE - 58" (SY6, SY7) FROM: 00-00-00 THRU: 12-08-04
4	104787-08-SY7	EA	PAD - DINETTE - 58" (SY6, SY7) FROM: 12-09-04 THRU: 99-99-99
5	150697-01-02B	EA	BRACKET - RESTRAINT/CHILD - E-COATED
6	113195-17-01A	EA	MIRROR - BEVELED SAFETY GLASS - CLEAR - 16.6" X 26.2"
7	145980-01-01A	EA	HOLDER - TOILET TISSUE - BRASS
8	150700-01-02B	EA	PLATE/MOUNTING - RESTRAINT/CHILD - E-COATED

INTERIOR FINISH GROUP (CONTINUED)
COMPONENT PARTS FOR INTERIOR TRIM LAYOUT

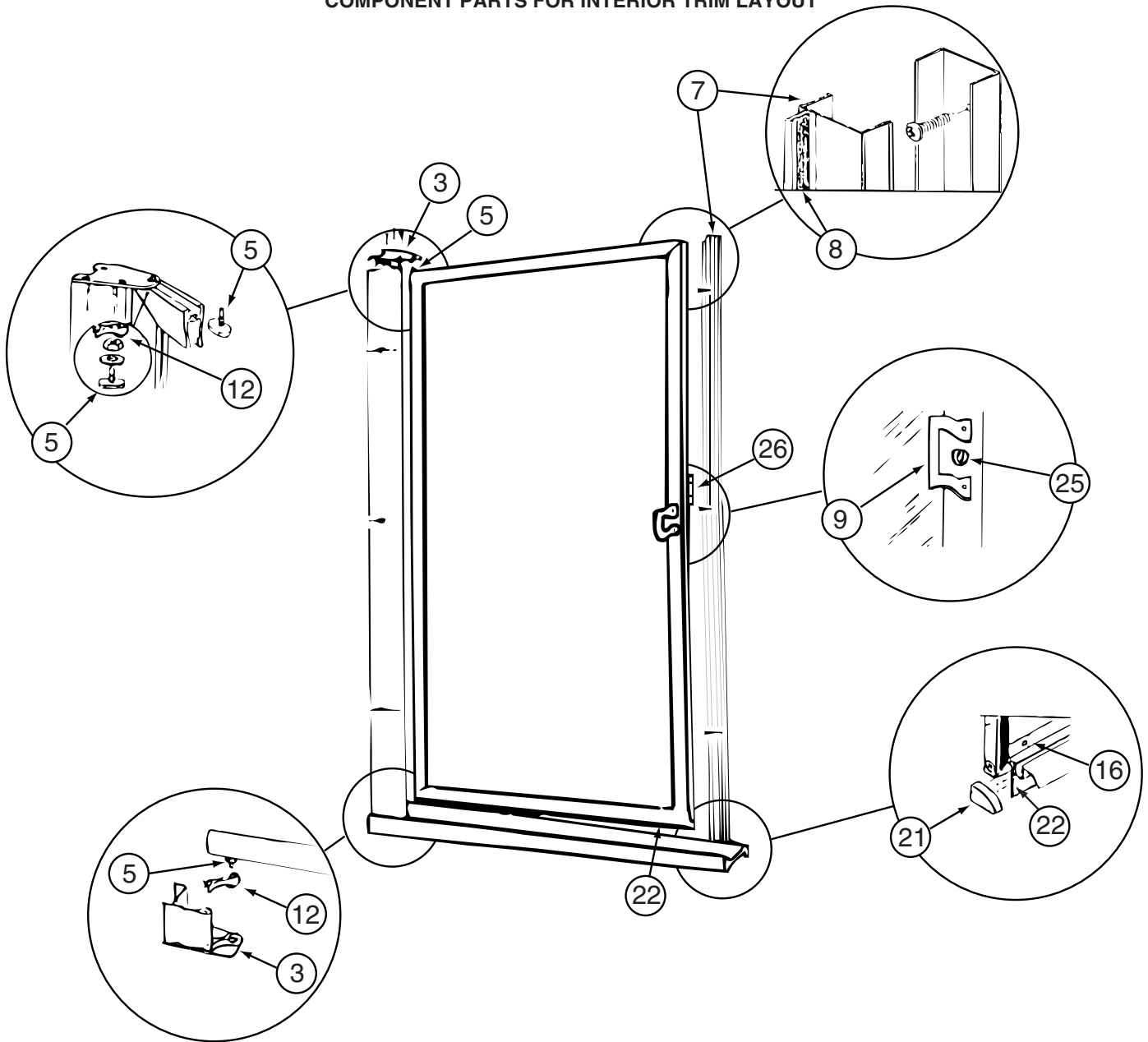

089318-01-000

KEY	PART NUMBER	U/M	DESCRIPTION	VENDOR NO.
3	089318-01-706	EA	PLATE - PIVOT (UPPER/LOWER)	796
5	089318-01-704	EA	BOLT-PIVOT, TOP OR BOTTOM	1428B
7	089318-01-703	EA	STRIKE-JAMB W/MAGNETIC STRIP	150G
8	092574-01-705	EA	STRIP-MAGNETIC, 66"	98-41G
9	092574-01-703	EA	BRACKET/DOOR PULL-W/O STUDS	8149G
12	089318-01-702	EA	BUSHING W/ARM, LOWER	18712A
12	092574-01-707	EA	BUSHING-PIVOT, TOP	18712B
16	092574-01-704	EA	SCREW-GOLD #6 3/8	638G
19	092574-01-708	EA	DRIP RAIL - (SWEEP)	927G-35"/OLD #34
21	107878-01-703	EA	CAP-DRIP, PLUG SET	CP933
22	089318-01-701	FT	SWEEP-VINYL	C171G 500FT RL
25	089318-01-707	EA	LATCH/CATCH - SAFETY - BLACK	9730N
25	092574-01-700	EA	KNOB/LATCH - SAFETY - BLACK	9728
26	092574-01-701	EA	BRACKET-DOOR PULL/TOWEL BAR	8141G
26	116814-01-700	EA	BAR-TOWEL 17 5/16"	68G
	092574-01-710	EA	SCREW-GOLD, FOR TOWEL BAR	83212G
	092574-01-711	EA	BRACKET/DOOR PULL - W/STUDS	8153G

CONTACT WINNEBAGO PART SALES FOR UNLISTED COMPONENT(S)

INTERIOR FINISH GROUP (CONTINUED)
COMPONENT PARTS FOR INTERIOR TRIM LAYOUT (CONTINUED)

094499-02-000

KEY	PART NUMBER	U/M	DESCRIPTION	VENDOR NO
	094499-01-700	EA	BRACKET MTG. W/PLAS. STRAP	294039

131595-01-01A, 131595-05-01A, 131595-10-01A

KEY	PART NUMBER	U/M	DESCRIPTION	VENDOR NO.
	117431-01-707	EA	CATCH/PIN - PLASTIC	
	131595-01-700	EA	END STOP ONLY	
	131595-01-701	EA	BRACKET/MOUNTING	908956
	131595-01-702	EA	TRACK/STRAIGHT - 37"	

FLOOR COVERINGS

KEY	PART NUMBER	U/M	DESCRIPTION
	096060-F0-000	SY	CARPET - PALE SAGE - INCREMENTS OF 4 SQ YARDS (S28, SJ0) FROM: 00-00-00 THRU: 11-14-04
	152251-05-01A	SY	CARPET - 4 SQUARE YARD INCREMENTS - SAGE (S28, SJ0) FROM: 11-15-04 THRU: 99-99-99
	096060-J7-000	SY	CARPET - SAHARA DESERT - INCREMENTS OF 4 SQ YDS (S29, SJ1) FROM: 00-00-00 THRU: 01-09-05
	152251-06-02A	SY	CARPET - 4 SQUARE YARD INCREMENTS - LAMBS WOOL (S29, SJ1) FROM: 01-10-05 THRU: 99-99-99
	096060-E6-000	SY	CARPET - OASIS - INCREMENTS OF 4 SQ YDS (S30, SJ2) FROM: 00-00-00 THRU: 11-07-04
	152251-05-05A	SY	CARPET - 4 SQUARE YARD INCREMENTS - SKY BLUE(S30, SJ2) FROM: 11-08-04 THRU: 99-99-99
	096060-G8-000	SY	CARPET - CAMEL - INCREMENTS OF 4 SQ YARDS (SX2, SX3, SX6, SX7)
	096060-G9-000	SY	CARPET - LAUREL - INCREMENTS OF 4 SQ YARDS (SX4, SX5, SY4, SY5, SY6, SY7, SY8, SY9)
	093486-01-000	SY	CARPET - COMPARTMENT - 72" WIDE - DARK GRAY
	075233-01-000	SY	PAD - CARPET - 3/8" X 6' ROLL
	042720-33-000	SY	VINYL - FLOOR COVERING - DIAMOND (S28, S29, S30, SJ0, SJ1, SJ2)
	042720-34-000	SY	VINYL - FLOOR COVER-SIERRA SAND (SX2, SX3, (SX4, SX5, SX6, SX7, SY4, SY5, SY6, SY7, SY8, SY9)
	089275-02-000	FT	STRIP - 3/4" X 84" BLACK POLYETHYLENE

INTERIOR FINISH GROUP (CONTINUED)

HARDWARE

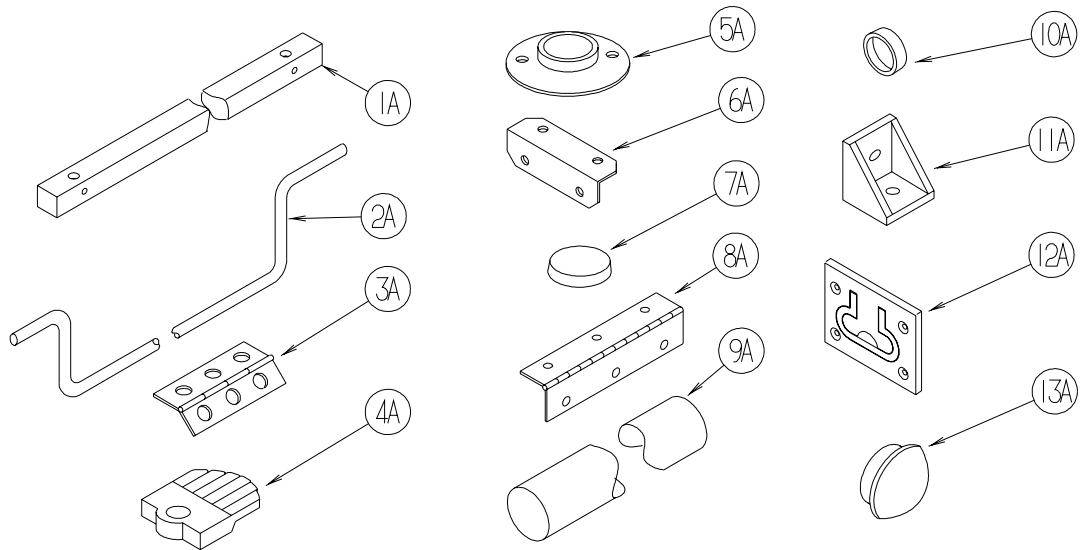

KEY	PART NUMBER	U/M	DESCRIPTION
1A	P34509-01-N01	EA	RAIL END - RH/LH - TOWEL RACK - PORTSMOUTH
1A	P34509-01-P14	EA	RAIL END - RH/LH - TOWEL RACK - CONCERT CHERRY
1A	P34509-01-J70	EA	RAIL END - RH/LH - TOWEL RACK - WASHED MAPLE
1A	P34509-01-RE0	EA	RAIL END - RH/LH - TOWEL RACK - HONEY CHERRY
1A	P34509-01-SA3	EA	RAIL END - RH/LH - TOWEL RACK - SIERRA MAPLE
2A	146801-01-01A	EA	ROD/TOWEL BAR (OFFSET) - BRASS
2A	146801-01-02A	EA	ROD/TOWEL BAR (OFFSET) - PEWTER
3A	009059-01-000	EA	HINGE - DOOR - 2" X 1.4" - BRASS
3A	009059-02-000	EA	HINGE - DOOR - 2" X 2.7" - BRASS
3A	009059-03-000	EA	HINGE - BRASS - 1.75"
3A	009059-04-000	EA	HINGE - 2" - ZINC
4A	009089-01-000	EA	CLIP - MIRROR
5A	009112-01-000	EA	FLANGE - PLASTIC - 1" CLOTHES ROD - OFF WHITE
5A	152301-01-01A	EA	FLANGE - PLASTIC - 1" CLOTHES ROD HOLDER - WHITE
6A	016604-05-000	EA	BRACE - ANGLE - 2 1/2" - OFF WHITE METAL
6A	016604-10-000	EA	BRACE - SEAT ANGLE - 2.5" - BLACK
7A	023320-01-000	EA	PAD - FELT 3/8" DIAMETER
8A	041389-25-000	EA	HINGE - PIANO - 1 1/2" X 55" - UNPAINTED
9A	042438-02-000	EA	DOWEL - WOOD - 2" DIAMETER X 2'
10A	057671-01-000	EA	COVER - SCREW - #8 - OFF WHITE
10A	057671-15-000	EA	COVER - SCREW - #8 - BRIGHT WHITE
10A	057671-16-000	EA	COVER - SCREW - #8 - SOFT WHITE
10A	057671-17-000	EA	COVER - SCREW - VW LT GRAY - #8
11A	065740-01-000	EA	BRACE - CABINET/CORNER - PLASTIC
12A	072871-01-000	EA	PULL - FLUSH - CHROME
13A	074045-08-000	EA	PLUG - OAK - 3/8" DOWEL-1/2" HEAD - CONCERT CHERRY
13A	074045-12-000	EA	PLUG - OAK - 3/8" DOWEL-1/2" HEAD - WASHED MAPLE
13A	074045-13-000	EA	PLUG - OAK - 3/8" DOWEL-1/2" HEAD - PORTSMOUTH OAK
13A	074045-14-000	EA	PLUG - OAK - 3/8" DOWEL-1/2" HEAD - HONEY CHERRY
13A	074045-15-000	EA	PLUG - OAK - 3/8" DOWEL-1/2" HEAD - SIERRA MAPLE

INTERIOR FINISH GROUP (CONTINUED)
HARDWARE (CONTINUED)

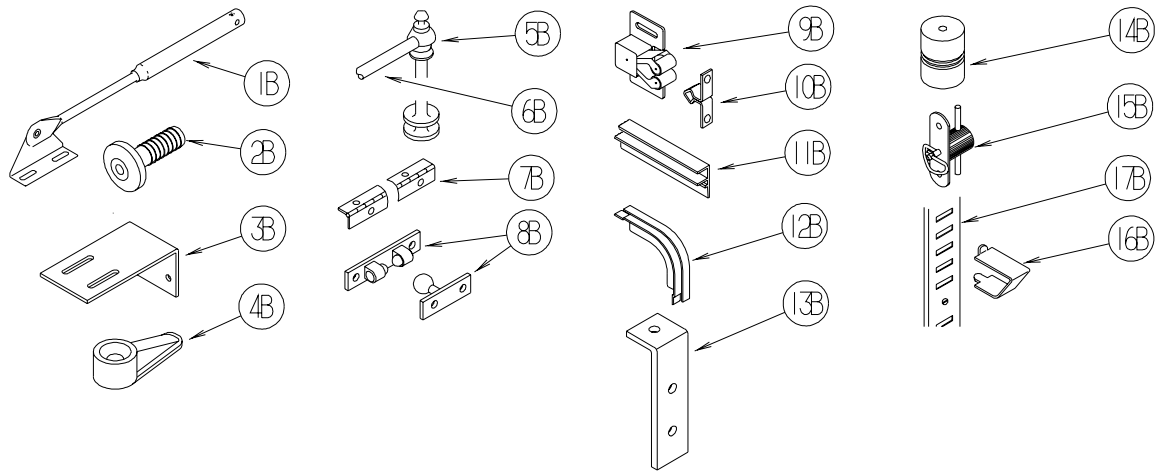

KEY	PART NUMBER	U/M	DESCRIPTION
1B	074493-02-000	EA	SUPPORT - PISTON SPRING - CABINET DOOR - 26 LBS
1B	074493-03-000	EA	SUPPORT - PISTON SPRING - CABINET DOOR - 12 LBS
2B	079921-01-000	EA	ROLLER - NYLON - W/STEEL SHAFT - BARBED
3B	083125-07-000	EA	BRACE - ANGLE/COUCH - 2.5" - OFF WHITE
4B	083204-03-000	EA	BUTTON - RETAINING MIRROR 5/16" TIP
5B	084070-03-000	EA	POST - END - 2.4" - SHINY BRASS
6B	084071-20-000	EA	ROD - BRASS - 9.8"
6B	146840-03-01A	EA	ROD - .25" DIAMETER - BRASS
6B	146840-03-02A	EA	ROD - .25" DIAMETER - PEWTER
6B	146840-04-01A	EA	ROD - .25" DIAMETER - BRASS
6B	146840-04-02A	EA	ROD - .25" DIAMETER - PEWTER
6B	146840-05-01A	EA	ROD - .25" DIAMETER - BRASS
6B	146840-05-02A	EA	ROD - .25" DIAMETER - PEWTER
7B	084413-01-000	EA	HINGE - 1" X 72" - ALUMINUM - W/HOLES
8B	084451-01-000	EA	CATCH & LATCH - 1.7" - BRASS
9B	093586-03-000	EA	CATCH - SPRING ROLLER - .377"
9B	093586-06-000	EA	CATCH - SPRING ROLLER - .236"
10B	093586-04-000	EA	STRIKE - SPRING STEEL - 1.14"
10B	093586-05-000	EA	STRIKE - SPRING STEEL - .943"
11B	093622-01-000	EA	TRACK - DOOR - TAMBOUR - PLASTIC - 8' LENGTHS
12B	093623-01-000	EA	CORNER - TRACK - TAMBOUR DOOR
13B	096826-01-01A	EA	BRACE-CABINET E-COATED
14B	097872-04-000	EA	DOWEL - WOOD - 1" DIAMETER X 1.38" LONG - UNFINISHED
15B	098196-01-000	EA	LATCH - 1/4 TURN - T-BAR
16B	098979-01-000	EA	CLIP - ADJUSTABLE SHELF
17B	098980-01-000	EA	PILASTER - ADJUSTABLE SHELF - 18"
17B	098980-02-000	EA	PILASTER - ADJUSTABLE SHELF - 12"
17B	098980-03-000	EA	PILASTER - ADJUSTABLE SHELF - 9"
17B	098980-04-000	EA	PILASTER - ADJUSTABLE SHELF - 48"
17B	098980-05-000	EA	PILASTER - ADJUSTABLE SHELF - 15"
17B	098980-06-000	EA	PILASTER - ADJUSTABLE SHELF - 24"

INTERIOR FINISH GROUP (CONTINUED)
HARDWARE (CONTINUED)

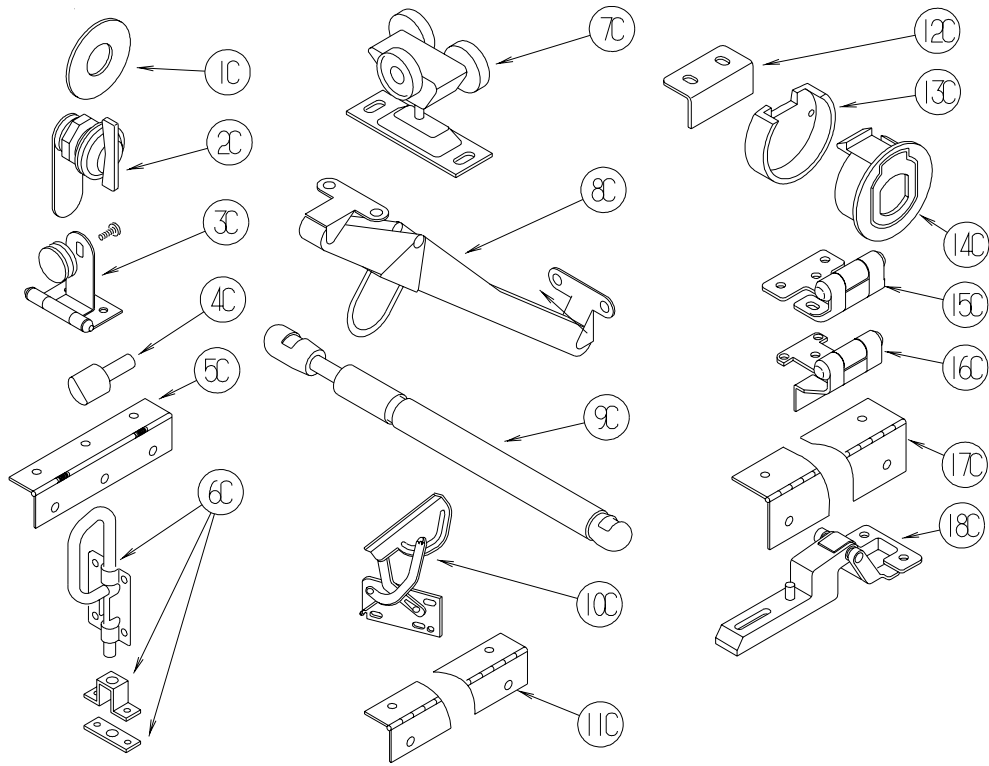

KEY	PART NUMBER	U/M	DESCRIPTION
1C	100707-01-000	EA	SPACER - GLASS DOOR - .8" DIA - .3" HOLE - PLASTIC
2C	100710-01-01A	EA	LOCK - GLASS DOOR/TWIST TYPE - BRASS
3C	100711-01-01A	EA	HINGE - GLASS DOOR
4C	101766-01-000	EA	PIN - SUPPORT/GLASS DOOR
5C	102920-01-01A	EA	HINGE - SPRING LOADED - BRASS
6C	103256-01-000	EA	LATCH COMPLETE (SLIDE)
7C	103874-01-000	EA	HANGER - SLIDING DOOR
8C	104181-01-01A	EA	SUPPORT - LEAF 5.3" EXTENDS TO 7.5" - SAFETY RING - METAL
9C	142569-15-000	EA	SPRING/GAS - 12" COMPRESSED/20" EXTENDED - 120 LB.
9C	142569-16-000	EA	SPRING/GAS - 12" COMPRESSED/20" EXTENDED - 90 LB
10C	108126-01-000	EA	TRAY HINGE SET (QTY. 2 PER SET)
11C	110496-01-01A	EA	HINGE - BRASS
12C	113375-02-01A	EA	STRIKE - DOOR - CHROME
13C	113375-05-01A	EA	LATCH - SLAM - BACK - .8" THICK
14C	113375-06-01A	EA	LATCH - SLAM - FACE - .7" THICK
15C	113676-01-01A	EA	HINGE - OVERLAY - VARIABLE - BURNISHED BRASS
16C	113677-01-01A	EA	HINGE - SELF CLOSING
17C	114278-02-000	EA	HINGE - CONTINUOUS - 3" WIDE
18C	114443-01-01A	EA	HINGE - CABINET DOOR

INTERIOR FINISH GROUP (CONTINUED)
HARDWARE (CONTINUED)

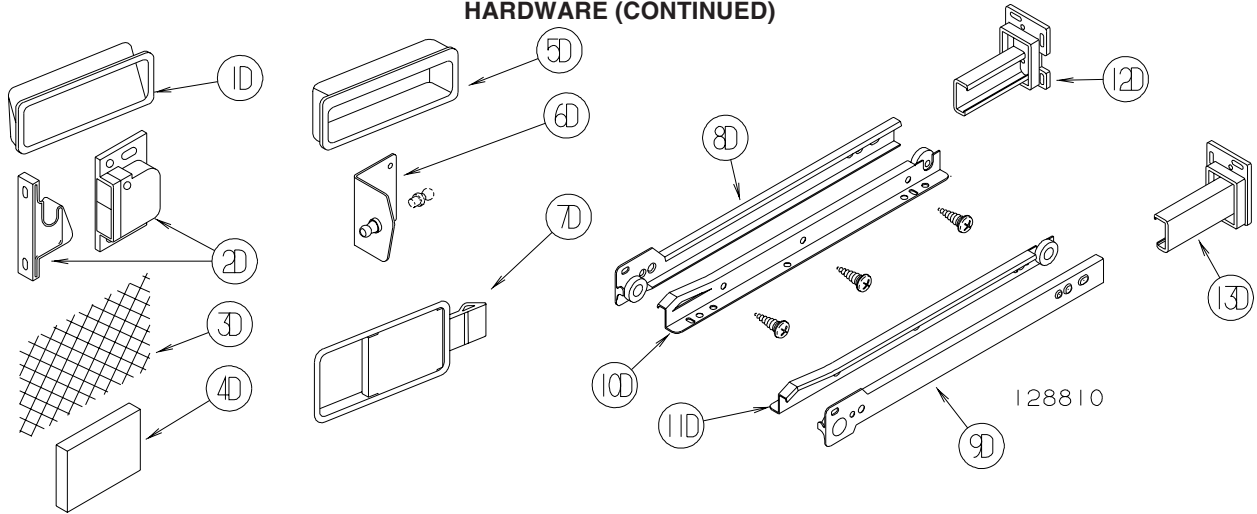

KEY	PART NUMBER	U/M	DESCRIPTION
1D	115994-01-01A	EA	HANDLE - POCKET
2D	117095-01-01A	EA	LATCH - DOOR - GRABBER W/KEEPER - PLASTIC - BLK-5 LB PULL
2D	117095-02-01A	EA	LATCH - DOOR - GRABBER W/KEEPER - PLASTIC - BLK-10 LB PULL
3D	118200-01-01A	SF	MESH - PLASTIC 1/2" - 48" X LENGTH = SF - BLACK
4D	122717-06-01A	FT	PAD - NON-SKID - PSA - 5"W
5D	124311-01-01A	EA	HANDLE - RECESSED - BRASS
6D	126263-06-02B	EA	BRACKET - GAS SPRING W/INSIDE BALL STUD - E-COATED
	057460-02-000	EA	BALL STUD - F/GAS SPRING .39" - 5/16" - 18
6D	126263-08-02B	EA	BRACKET - GAS SPRING W/CENTERED BALL STUD - E-COATED
7D	127349-01-01A	EA	LATCH - PADDLE

FROM: 00-00-00 THRU: 01-03-05

8D	128810-01-01A	EA	SLIDE - DRAWER - 12" - LEFT CABINET
8D	128810-05-01A	EA	SLIDE - DRAWER - 14" - LEFT CABINET
8D	128810-09-01A	EA	SLIDE - DRAWER - 16" - LEFT CABINET
8D	128810-13-01A	EA	SLIDE - DRAWER - 18" - LEFT CABINET
8D	128810-17-01A	EA	SLIDE - DRAWER - 20" - LEFT CABINET
8D	128810-21-01A	EA	SLIDE - DRAWER - 22" - LEFT CABINET
8D	128810-25-01A	EA	SLIDE - DRAWER - 24" - LEFT CABINET
9D	128810-02-01A	EA	SLIDE - DRAWER - 12" - RIGHT CABINET
9D	128810-06-01A	EA	SLIDE - DRAWER - 14" - RIGHT CABINET
9D	128810-10-01A	EA	SLIDE - DRAWER - 16" - RIGHT CABINET
9D	128810-14-01A	EA	SLIDE - DRAWER - 18" - RIGHT CABINET
9D	128810-18-01A	EA	SLIDE - DRAWER - 20" - RIGHT CABINET
9D	128810-22-01A	EA	SLIDE - DRAWER - 22" - RIGHT CABINET
9D	128810-26-01A	EA	SLIDE - DRAWER - 24" - RIGHT CABINET
10D	128810-03-01A	EA	SLIDE - DRAWER - 12" - LEFT DRAWER
10D	128810-07-01A	EA	SLIDE - DRAWER - 14" - LEFT DRAWER
10D	128810-11-01A	EA	SLIDE - DRAWER - 16" - LEFT DRAWER
10D	128810-15-01A	EA	SLIDE - DRAWER - 18" - LEFT DRAWER
10D	128810-19-01A	EA	SLIDE - DRAWER - 20" - LEFT DRAWER
10D	128810-23-01A	EA	SLIDE - DRAWER - 22" - LEFT DRAWER
10D	128810-27-01A	EA	SLIDE - DRAWER - 24" - LEFT DRAWER
11D	128810-04-01A	EA	SLIDE - DRAWER - 12" - RIGHT DRAWER
11D	128810-08-01A	EA	SLIDE - DRAWER - 14" - RIGHT DRAWER
11D	128810-12-01A	EA	SLIDE - DRAWER - 16" - RIGHT DRAWER
11D	128810-16-01A	EA	SLIDE - DRAWER - 18" - RIGHT DRAWER
11D	128810-20-01A	EA	SLIDE - DRAWER - 20" - RIGHT DRAWER
11D	128810-24-01A	EA	SLIDE - DRAWER - 22" - RIGHT DRAWER
11D	128810-28-01A	EA	SLIDE - DRAWER - 24" - RIGHT DRAWER
12D	128811-01-02A	EA	BACKSOCKET - ADJUSTABLE - LEFT
13D	128811-02-02A	EA	BACKSOCKET - ADJUSTABLE - RIGHT

FROM: 01-04-05 THRU: 99-99-99

153000-01-01A	EA	SLIDE - CABINET MOUNT - 11.8"
153000-02-01A	EA	SLIDE - DRAWER MOUNT - 11.8"
153000-03-01A	EA	SLIDE - CABINET MOUNT - 13.8"
153000-04-01A	EA	SLIDE - DRAWER MOUNT - 13.8"
153000-05-01A	EA	SLIDE - CABINET MOUNT - 15.7"
153000-06-01A	EA	SLIDE - DRAWER MOUNT - 15.7"

INTERIOR FINISH GROUP (CONTINUED)
HARDWARE (CONTINUED)

KEY	PART NUMBER	U/M	DESCRIPTION
	153000-07-01A	EA	SLIDE - CABINET MOUNT - 17.7"
	153000-08-01A	EA	SLIDE - DRAWER MOUNT - 17.7"
	153000-09-01A	EA	SLIDE - CABINET MOUNT - 19.7"
	153000-10-01A	EA	SLIDE - DRAWER MOUNT - 19.7"
	153000-11-01A	EA	SLIDE - CABINET MOUNT - 21.6"
	153000-12-01A	EA	SLIDE - DRAWER MOUNT - 21.6"
	153000-14-01A	EA	SLIDE - CABINET MOUNT - 23.6"
	153000-15-01A	EA	SLIDE - DRAWER MOUNT - 23.4"
	153000-16-01A	EA	SLIDE - CABINET MOUNT - 7.9"
	153000-17-01A	EA	SLIDE - DRAWER MOUNT - 7.7"
	153000-18-01A	EA	SLIDE - CABINET MOUNT - 9.8"
	153000-19-01A	EA	SLIDE - DRAWER MOUNT - 9.6"
	153000-13-01A	EA	BACKSOCKET - DRAWER SLIDE

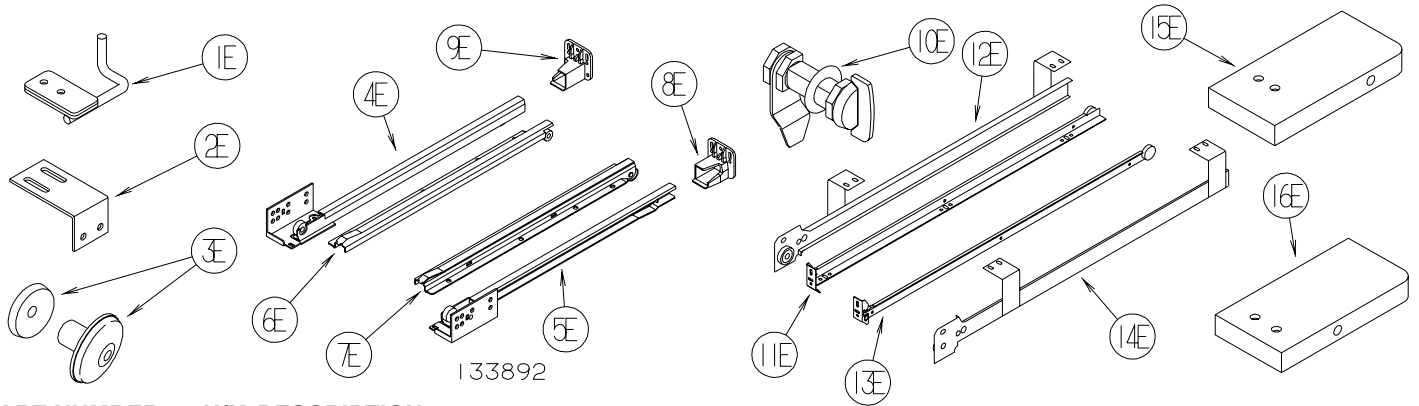

KEY	PART NUMBER	U/M	DESCRIPTION
1E	130798-01-02B	EA	GUIDE - POCKET DOOR - E-COATED
2E	132871-02-02B	EA	BRACKET/L-ANGLE W/HOLES - 1.9" X 2.8" - E-COATED
3E	133313-01-02A	EA	PULL - DOOR/DRAWER - BRIGHT BRASS - MINNIE, MINNIE WINNIE, BRAVE & SPIRIT
3E	133313-01-03A	EA	PULL - DOOR/DWR - CHROME/BRASS - SUNDANCER AND SUNRISE
4E	133892-01-01A	EA	SLIDE - DRAWER - 16" - LEFT CABINET
4E	133892-06-01A	EA	SLIDE - DRAWER - 22" - LEFT CABINET
4E	133892-10-01A	EA	SLIDE - DRAWER - 12" - LEFT CABINET
4E	133892-14-01A	EA	SLIDE - DRAWER - 18" - LEFT CABINET
5E	133892-02-01A	EA	SLIDE - DRAWER - 16" - RIGHT CABINET
5E	133892-07-01A	EA	SLIDE - DRAWER - 22" - RIGHT CABINET
5E	133892-11-01A	EA	SLIDE - DRAWER - 12" - RIGHT CABINET
5E	133892-15-01A	EA	SLIDE - DRAWER - 18" - RIGHT CABINET
6E	133892-03-01A	EA	SLIDE - DRAWER - 16" - LEFT DRAWER
6E	133892-08-01A	EA	SLIDE - DRAWER - 22" - LEFT DRAWER
6E	133892-12-01A	EA	SLIDE - DRAWER - 12" - LEFT DRAWER
6E	133892-16-01A	EA	SLIDE - DRAWER - 18" - LEFT DRAWER
7E	133892-04-01A	EA	SLIDE - DRAWER - 16" - RIGHT DRAWER
7E	133892-09-01A	EA	SLIDE - DRAWER - 22" - RIGHT DRAWER
7E	133892-13-01A	EA	SLIDE - DRAWER - 12" - RIGHT DRAWER
7E	133892-17-01A	EA	SLIDE - DRAWER - 18" - RIGHT DRAWER
8E	133907-01-01A	EA	BACKSOCKET - RIGHT HAND
9E	133907-02-01A	EA	BACKSOCKET - LEFT HAND
10E	135231-01-01A	EA	LATCH - COMPRESSION - BLACK
11E	136944-01-01A	EA	SLIDE - DRAWER/RIGHT HAND - 13.8"
12E	136944-02-01A	EA	SLIDE - CABINET/RIGHT HAND - 13.8"
13E	136944-03-01A	EA	SLIDE - DRAWER/LEFT HAND - 13.8"
14E	136944-04-01A	EA	SLIDE - CABINET/LEFT HAND - 13.8"
15E	137445-01-N42	EA	STOP - F/SLIDING DOOR - PORTSMOUTH OAK
15E	137445-01-P46	EA	STOP - F/SLIDING DOOR - CONCERT CHERRY
15E	137445-01-P56	EA	STOP - F/SLIDING DOOR - WASHED MAPLE
15E	137445-01-S67	EA	STOP - F/SLIDING DOOR - HONEY CHERRY
16E	137445-02-P45	EA	STOP - F/SLIDING DOOR - PORTSMOUTH OAK
16E	137445-02-P46	EA	STOP - F/SLIDING DOOR - CONCERT CHERRY
16E	137445-02-P56	EA	STOP - F/SLIDING DOOR - WASHED MAPLE
16E	137445-02-S67	EA	STOP - F/SLIDING DOOR - HONEY CHERRY

INTERIOR FINISH GROUP (CONTINUED) HARDWARE (CONTINUED)

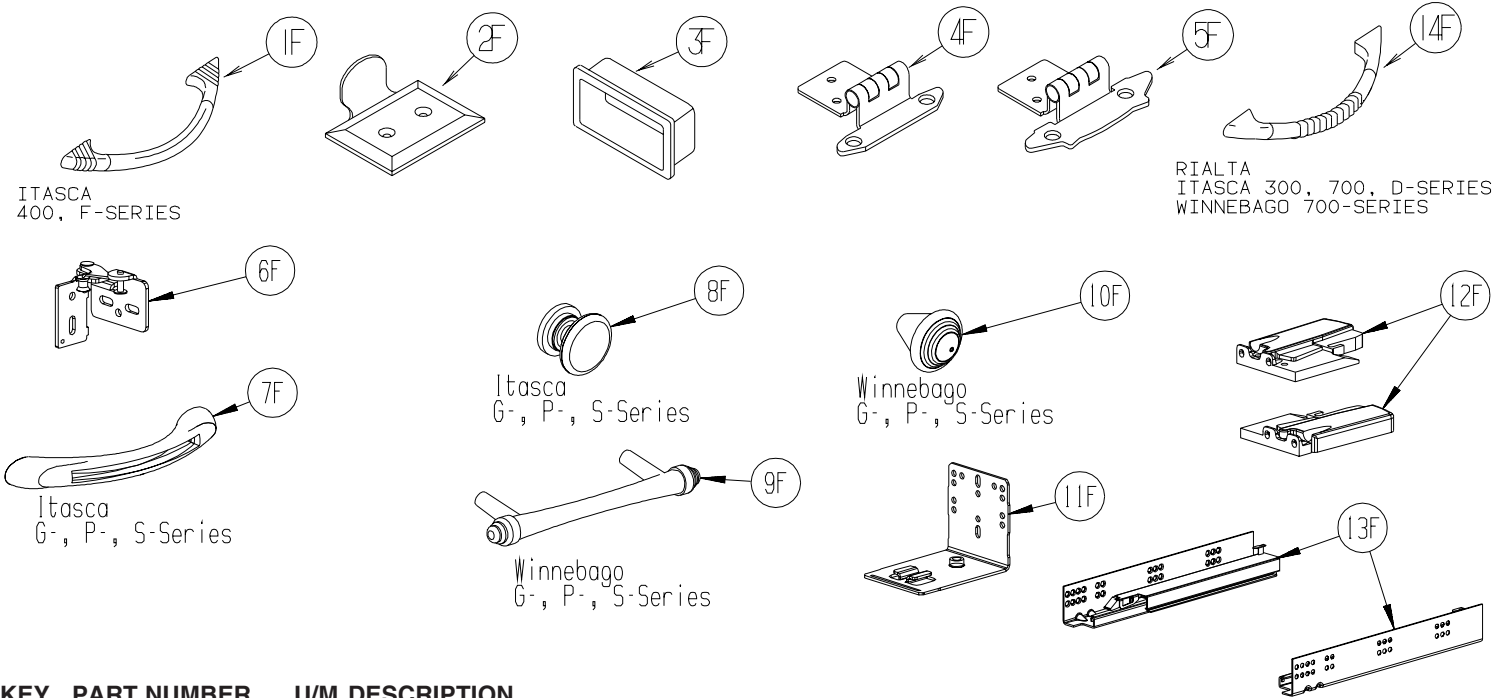

KEY	PART NUMBER	U/M	DESCRIPTION
1F	137446-01-01A	EA	PULL - CABINET - CHROME/BRASS - SUNDANCER, SUNRISE
2F	137463-01-01A	EA	LIFT - HOOK - SATIN BRASS
2F	137463-01-02A	EA	LIFT - HOOK - PEWTER
3F	139136-01-01A	EA	HANDLE - RECESSED .7" - BRASS
3F	139136-02-01A	EA	HANDLE - RECESSED .35" - BRASS
3F	139136-02-02A	EA	HANDLE - RECESSED .35" - PEWTER
4F	143468-01-02A	EA	HINGE - SELF CLOSING - POLISHED BRASS
5F	143468-02-03A	EA	HINGE - SELF CLOSING - SATIN NICKEL
6F	144488-01-02A	EA	HINGE - CABINET - NICKEL - HORIZON
7F	144917-01-01A	EA	PULL - DRAWER - SATIN NICKEL - SUNCRUISER, MERIDIAN, HORIZON
8F	144918-01-01A	EA	PULL - DRAWER/KNOB - SATIN NICKEL - SUNCRUISER, MERIDIAN, HORIZON
9F	145172-01-01A	EA	PULL - CABINET DOOR - BRASS - ADVENTURER, JOURNEY, VECTRA
9F	145172-01-02A	EA	PULL - CABINET DOOR - CHROME - ADVENTURER, JOURNEY, VECTRA
10F	145172-02-01A	EA	KNOB - CABINET DOOR - BRASS - ADVENTURER, JOURNEY, VECTRA
10F	145172-02-02A	EA	KNOB - CABINET DOOR - CHROME - ADVENTURER, JOURNEY, VECTRA
11F	145739-01-000	EA	BRACKET - REAR MOUNT
12F	145739-02-000	EA	LOCKING MECHANISM - LEFT
12F	145739-03-000	EA	LOCKING MECHANISM - RIGHT
13F	145739-04-000	EA	SLIDE - DRAWER - 12"
14F	148816-01-01A	EA	PULL - CABINET DOOR - BRASS - RIALTA, SUNDANCER, SUNOVA
14F	148816-01-02A	EA	PULL - CABINET DOOR - NICKEL - ASPECT, CAMBRIA

INTERIOR FINISH GROUP (CONTINUED)
HARDWARE (CONTINUED)

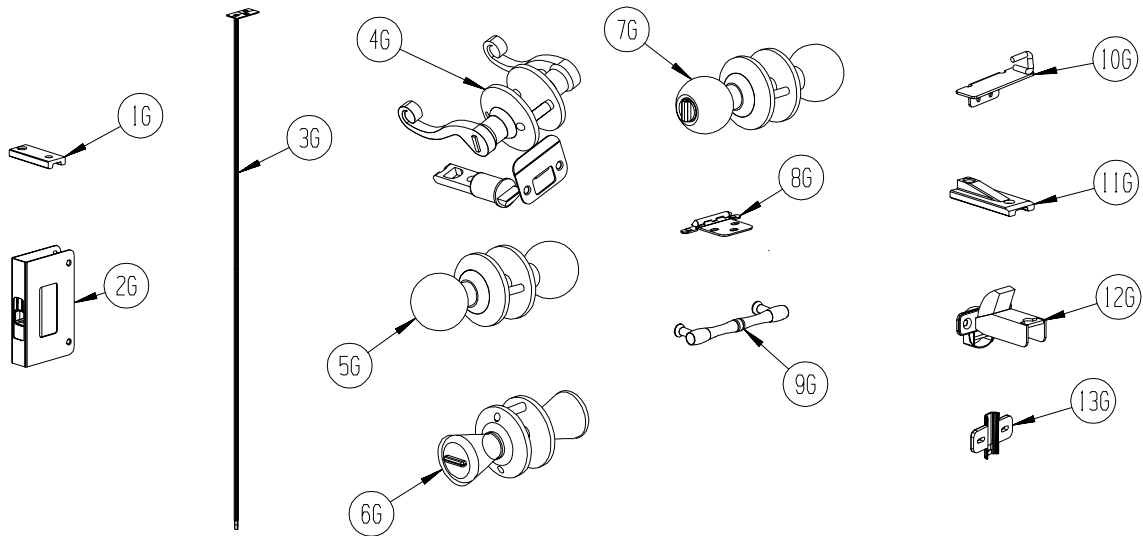

KEY	PART NUMBER	U/M	DESCRIPTION
1G	145815-01-000	EA	BLOCK - DOOR TRACK - 3" X 1.2" - BLACK
2G	145939-01-01A	EA	LATCH - SLIDE - AISLE DOOR(1" THICK DOOR) - BRASS
2G	145939-01-02A	EA	LATCH - SLIDE - AISLE DOOR(1" THICK DOOR) - NICKEL
3G	145939-03-01A	EA	ROD/LATCH - AISLE DOOR - BRASS
3G	145939-03-02A	EA	ROD/LATCH - AISLE DOOR - NICKEL
4G	146064-01-01A	EA	LOCK/PRIVACY (LOCKING) LEVER STYLE - POLISHED BRASS
4G	146064-01-02A	EA	LOCK/PRIVACY (LOCKING) LEVER STYLE - SATIN PEWTER
5G	146064-04-01A	EA	LOCK/PASSAGE (NON LOCKING) KNOB STYLE - POLISHED BRASS
6G	146064-05-01A	EA	LOCK/PRIVACY (LOCKING) KNOB STYLE - SATIN NICKEL
7G	146064-06-01A	EA	LOCK/PASSAGE (NON LOCKING) KNOB STYLE - SATIN NICKEL
8G	146553-01-01A	EA	HINGE - CABINET DOOR - BURNISHED BRASS
8G	146553-01-02A	EA	HINGE - CABINET DOOR - BRIGHT BRASS
8G	146553-01-03A	EA	HINGE - CABINET DOOR - SATIN NICKEL
9G	149090-01-01A	EA	PULL - CABINET DOOR - BRASS - MINNIE, MINNIE WINNIE, BRAVE, SIGHTSEER
10G	149607-01-02B	EA	GUIDE - F/POCKET DOOR - 1.6" BENT ROD - E-COATED
10G	149607-03-02B	EA	GUIDE - F/POCKET DOOR - 2.9" BENT ROD - E-COATED
11G	150983-01-01A	EA	BLOCK - DOOR TRACK - 3" X 1.2" - BLACK
12G	151305-01-01A	EA	HINGE - CONCEALED/Self CLOSING - BRASS
13G	151305-02-01A	EA	PLATE/MOUNTING - F/HINGE - WHITE

LABELS GROUP

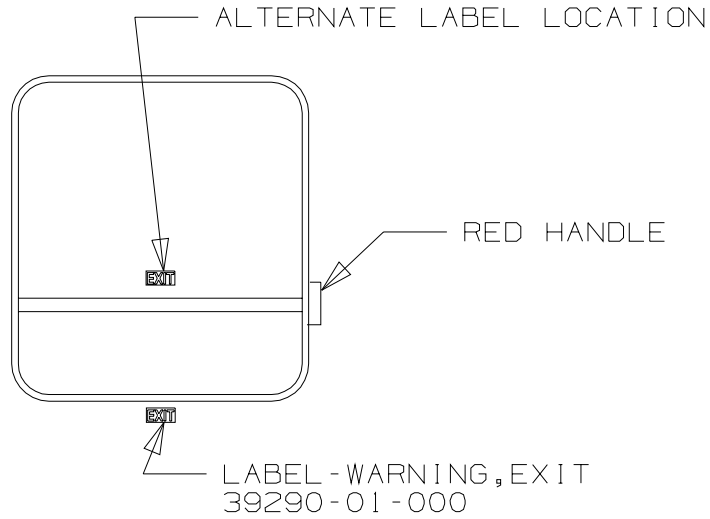

EXIT WINDOW (HINGE STYLE)

KEY	PART NUMBER	U/M DESCRIPTION
1	039290-01-000	EA LABEL - WARNING - EXIT

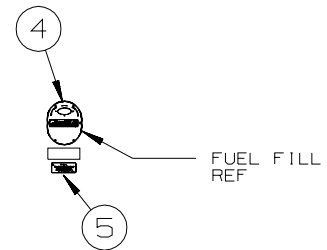
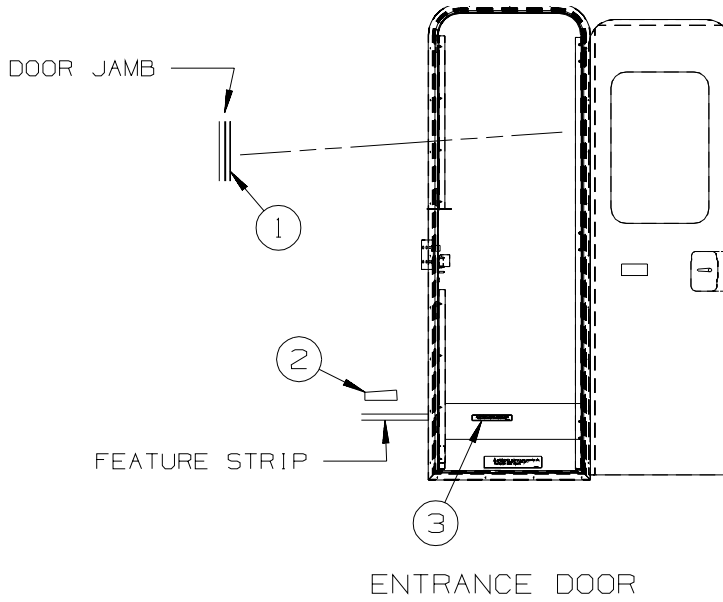

KEY	PART NUMBER	U/M DESCRIPTION
1	135869-01-01A	EA LABEL - MERCURY CONTENT - BLACK ON CLEAR
2	099509-01-000	EA LABEL - AWNING INSTALLATION
3	065748-01-000	EA LABEL - WARNING - BATTERY CHARGING - UL
3	065748-02-000	EA LABEL - WARNING - BATTERY CHARGING - CSA
4	087207-05-000	EA LABEL - FUEL CAP REMOVAL
5	124519-01-01A	EA LABEL - WARNING/REFUELING - BLACK ON CLEAR
5	124519-02-01A	EA LABEL - WARNING/REFUELING - BLACK ON CLEAR - CSA

LABELS GROUP (CONTINUED)

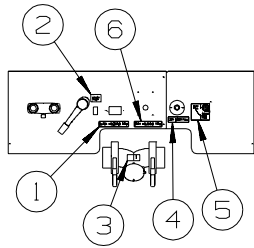

D27C/D30B/D33L SERVICE PANEL

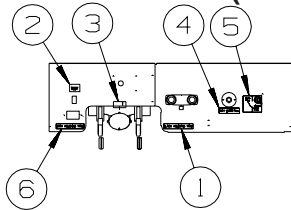

D35N SERVICE PANEL

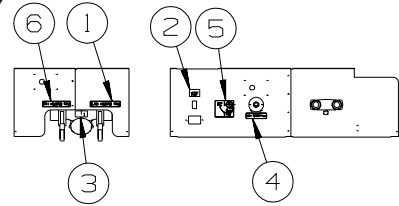

D29R SERVICE PANEL

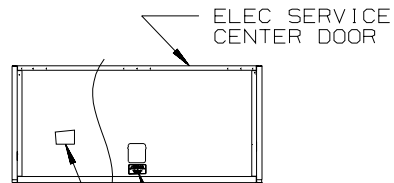
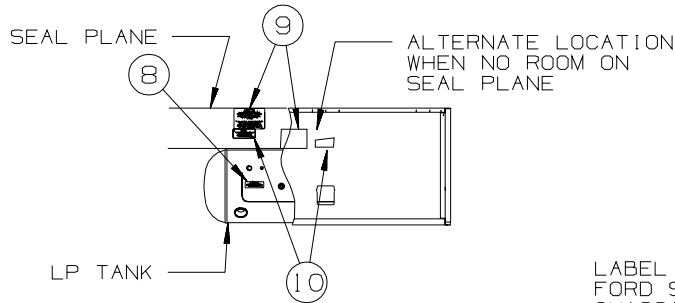

LABEL TIRE PRESSURE
FORD SUPPLIED-MATCH
CHASSIS VIN NO. LAST 6
CHARACTERS ON LABEL

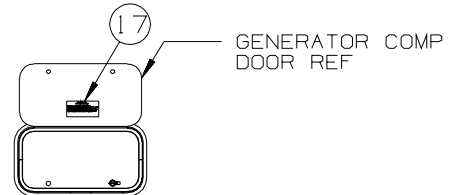
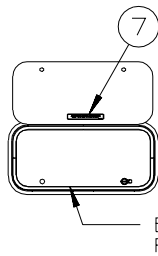
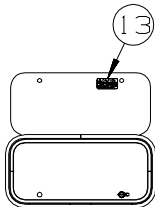
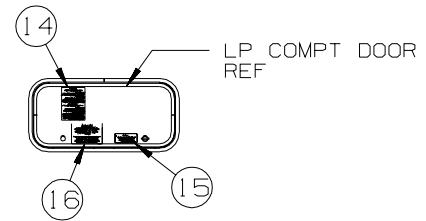
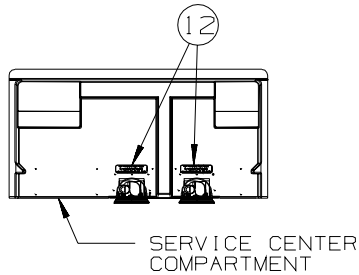

LOCATE ON INSIDE OF DOOR WHEN DOOR
COVERS WATER HEATER EXHAUST VENT

KEY	PART NUMBER	U/M	DESCRIPTION
1	126247-06-000	EA	LABEL - BLACK HOLDING TANK-BLACK LETTERS/CLEAR BACKGROUND
2	130170-03-000	EA	LABEL - SWITCH PANEL
3	144649-01-01A	EA	LABEL - ADJUSTABLE VALVE - WHITE ON CLEAR
4	126249-03-000	EA	LABEL - CITY WATER FILL-BLK LETTERS/CLEAR BACKGROUND .31"
5	117629-03-000	EA	LABEL - WATER PUMP/FILL-BLK LETTERS/CLEAR BACKGROUND-.31"
6	126247-05-000	EA	LABEL - GRAY HOLDING TANK-BLACK LETTERS/CLEAR BACKGROUND
7	065748-01-000	EA	LABEL - WARNING - BATTERY CHARGING - UL
8	079965-01-000	EA	LABEL - LPG - 80% CAPACITY
9	023769-01-000	EA	LABEL - WARNING - LPG - CANADIAN
10	124519-01-01A	EA	LABEL - WARNING/REFUELING - BLACK ON CLEAR
10	124519-02-01A	EA	LABEL - WARNING/REFUELING - BLACK ON CLEAR - CSA
11	125306-01-01A	EA	LABEL - ELECTRICAL ENTRANCE - 110V 30 AMP - BLACK ON CLEAR
11	125306-04-01A	EA	LABEL - ELECTRICAL ENTRANCE-120/20V 50 AMP-BLACK ON CLEAR
12	123562-01-000	EA	LABEL - SERVICE/UTILITY ACCESS
13	113402-01-000	EA	LABEL - CAUTION - WATER HEATER EXHAUST
14	023769-01-000	EA	LABEL - WARNING - LPG - CANADIAN
15	124519-01-01A	EA	LABEL - WARNING/REFUELING - BLACK ON CLEAR
15	124519-02-01A	EA	LABEL - WARNING/REFUELING - BLACK ON CLEAR - CSA
16	124520-01-01A	EA	LABEL - LP GAS ONLY - BLACK ON CLEAR
17	077510-01-000	EA	LABEL - GENERATOR PREP

LABELS GROUP (CONTINUED)

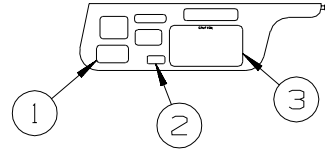
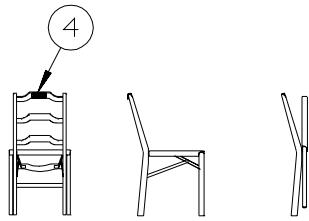

LABELS SHALL BE LOCATED ON OPPOSITE SIDE OF VISOR THAT THE AIR BAG LABEL IS INSTALLED ON.

TYPICAL SEAT AND BELT CONFIGURATIONS

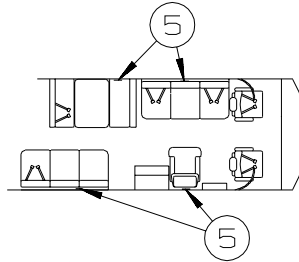

ATTACH LABEL ON OR NEXT TO:
 • ANY SINGLE CHAIR WITHOUT BELTS.
 • ANY DINETTE SEAT WITHOUT BELTS.
 • ANY COUCH WITHOUT BELTS OR ANY SEATING POSITION ON THAT COUCH.
 DO NOT ATTACH LABEL IF:
 • DINETTE SEAT HAS AT LEAST ONE SET OF BELTS INSTALLED.

KEY	PART NUMBER	U/M	DESCRIPTION
1	111802-01-000	EA	LABEL - CFC WARNING
2	099689-01-000	EA	LABEL - WARNING - CANCER/TOXICITY
3	056259-01-000	EA	LABEL - SAFETY CHECK LIST
4	134537-01-01A	EA	LABEL - OCCUPANCY - CHAIR - US
4	134537-02-01A	EA	LABEL - OCCUPANCY - CHAIR - CSA
5	134538-01-01A	EA	LABEL - OCCUPANCY - NO SEAT BELT - BLACK ON CLEAR - US
5	134538-02-01A	EA	LABEL - OCCUPANCY - NO SEAT BELT - BLACK ON CLEAR - CSA

LABELS GROUP (CONTINUED)

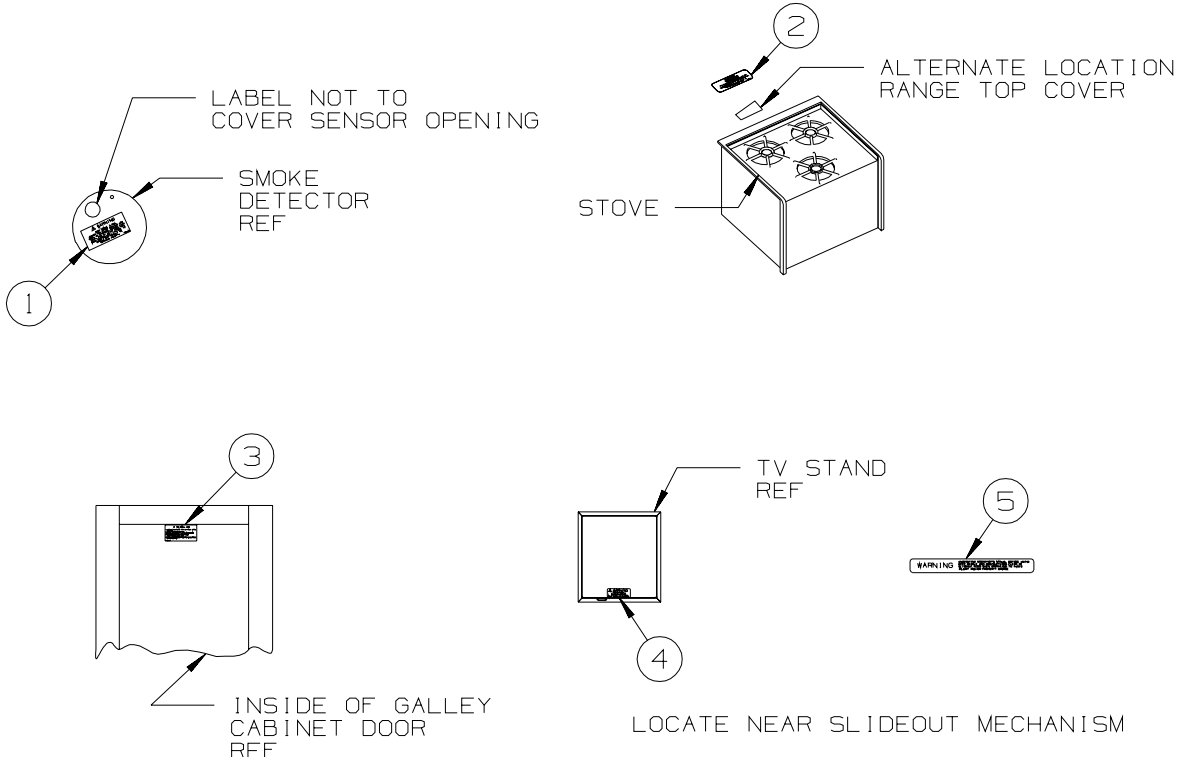

KEY	PART NUMBER	U/M DESCRIPTION
1	077956-01-000	EA LABEL - WARNING/SMOKE DETECTOR
2	134539-01-01A	EA LABEL - WARNING - STOVE/HEATING - US - BLACK ON CLEAR
2	134540-01-01A	EA LABEL - WARNING - STOVE/HEATING - CSA - BLACK ON CLEAR
3	073998-01-000	EA LABEL - LPG/ODOR WARNING
4	079966-01-000	EA LABEL - WARNING - STOWED - MOTION
5	116549-01-000	EA LABEL - WARNING - SLIDEOUT

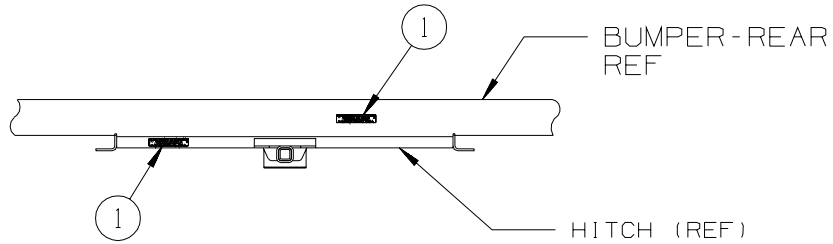

KEY	PART NUMBER	U/M DESCRIPTION
1	129669-01-01A	EA LABEL - HITCH/VEHICLE RATE - 350 - WHITE ON CLEAR

LP GROUP
LP SYSTEM

KEY	PART NUMBER	U/M	DESCRIPTION
	045703-03-000	EA	HOSE - LP - 3/8"ID X 18" - 3/8"MPT X 1/2"F SWIVEL - US
	045703-12-000	EA	HOSE - LP - 3/8"ID X 18" - 3/8"MPT X 1/2"F SWIVEL - CSA
	045703-13-000	EA	HOSE - LP - 3/8"ID X 120" - 3/8"F SWIVEL X 1/2"F SWIVEL US
	045703-15-000	EA	HOSE - LP - 3/8"ID X 142" - 1/2"F SWIVEL X 3/8"F SWIVEL
	045703-17-000	EA	HOSE - LP - 3/8"ID X 24" - 1/2"F SWIVEL X 3/8"F SWIVEL US
	106150-05-000	EA	REGULATOR - TWO STAGE
	144485-01-000	EA	COMPARTMENT - LP REGULATOR
	040440-02-000	EA	TRANSMITTER - DIAL/BOLT-ON - 0-90 OHM 2 TERM(POWER/GROUND)
*	144116-04-000	EA	TANK - LP - 60 LB - 14"D X 29.75"L
	150138-01-02A	EA	DETECTOR - LP GAS - BROWN
	010589-01-000	EA	NIPPLE - PIPE - 1/2" X 1 1/2" - BLACK
	010589-03-000	EA	NIPPLE - PIPE - 1/2" X 2 1/2" - BLACK
	141090-01-02B	EA	SHIELD - HEAT - E-COATED
	010265-01-000	EA	ELBOW - BRASS - 90 DEGREE - 3/8"F X 1/2"FPT
	010323-01-000	EA	ADAPTER - 3/8"F X 1/2"MPT - BRASS
	010326-01-000	EA	ADAPTER - FLARE - W/CONE GASKET - 3/8"F X 1/2"F
	010329-01-000	EA	ADAPTER - 1/2"F X 1/2"MPT - BRASS
	024250-01-000	EA	ADAPTER - BRASS - 3/8"F X 1/2"FPT
	010377-02-000	EA	NUT - 3/8" FLARE - FORGED - BRASS
	010380-02-000	EA	NUT - 1/2" FLARE - FORGED - BRASS
	139061-02-02B	EA	COVER - LP LINES - FRONT - E-COATED - D33L
	139062-02-02B	EA	COVER - LP LINES - FRONT/TOP - E-COATED - D33L

*COMPONENT PARTS LISTED LATER IN THIS GROUP

COMPONENT PARTS FOR LP SYSTEM

144116-04-000

KEY	PART NUMBER	U/M	DESCRIPTION	VENDOR NO.
	040421-01-712	EA	VALVE-SERV. W/O VAPOR RELIEF	V20373
	040421-01-713	EA	VALVE-RELIEF 1" W/SPRING 7"	V20479
	144116-01-700	EA	VALVE-OUTAGE(NO STEM REMOVE)	V20058
	144116-01-701	EA	VALVE/FILL 80 % W/YELLOW CAP	V13414
	144116-04-700	EA	FLOAT/SENDING UNIT W/O DIAL	G11530
	144116-04-701	EA	DIAL - TRANSMITER	G12845

SEALANTS & FASTENERS GROUP
SEALANTS & ADHESIVES

KEY	PART NUMBER	U/M	DESCRIPTION
	004001-02-000	EA	GUN - PLEXUS ADHESIVE - W/O NOZZLE
	004001-05-000	EA	ADHESIVE - SCOTCH-WELD - 3M DP100 - CLEAR - 50ML
	004001-06-000	EA	FASTWELD PIN TIPS
	004011-01-000	EA	ADHESIVE-3M-4475 TUBE
	010405-02-000	EA	TAPE - THREAD SEALING - 3/8"
	034552-06-000	EA	SILICONE - TUBE - W/O NOZZLE - OFF WHITE
	034552-15-000	EA	SILICONE - TUBE - W/O NOZZLE - BRIGHT WHITE
	063642-01-000	FT	TAPE - ADHESIVE - .4" X 1.5" X 180'
	064075-07-000	FT	SEAL - BULB - W/WIRED U CHANNEL - .3" X .5" CHANNEL-BLACK
	067788-01-000	EA	ADHESIVE - SPRAY - 3M - 19.5 OZ AEROSOL CAN
	069640-01-000	FT	SEALER - TAPE - .25" DIAMETER X 30' - BLACK OR GRAY
	069640-02-000	FT	SEALER - TAPE - .13" THICK X .5" WIDE X 60' - GRAY
	069640-03-000	FT	SEALER - TAPE - .13" THICK X .75" WIDE X 60' - BLACK
	069640-07-000	FT	SEALER - TAPE - .09" THICK X 2" WIDE X 45' - GRAY
	069640-09-000	FT	SEALER - TAPE - .03" THICK X 2.50" WIDE X 80' - GRAY
	069640-10-000	FT	SEALER - TAPE - .03" THICK X 1.50" WIDE X 90' - GRAY
	069640-11-000	FT	SEALER - TAPE - .19" THICK X .38" WIDE X 40' - BLACK
	069640-13-000	FT	SEALER - TAPE - .03" THICK X 2" WIDE X 45' - BLACK
	069640-14-000	FT	SEALER - TAPE - .06" THICK X 1" WIDE X 100' - GRAY
	069640-15-000	FT	SEALER - TAPE - .06" THICK X .38" WIDE X 100' - GRAY
	069640-17-000	FT	SEALER - TAPE - .03" THICK X 1" WIDE X 90' - GRAY
	069640-18-000	FT	SEALER - TAPE - .50" THICK X .13" WIDE X 60' - BRT WHITE
	069640-19-000	FT	SEALER - TAPE - .75" THICK X .13" WIDE X 60' - BRT WHITE
	069640-20-000	FT	SEALER - TAPE - .50" THICK X .5" WIDE X 60' - BLACK
	069640-21-000	FT	SEALER - TAPE - .50" THICK X .06" WIDE X 100' - BRT WHITE
	069640-22-000	FT	SEALER - TAPE - 1/32"THICK X 1/4"WIDE X 200 FT - BRT WHT
	069640-23-000	FT	SEALER - TAPE - 1/16"THICK X 3/4"WIDE X 100 FT - BRT WHT
	069640-27-000	FT	SEALER - TAPE - .06" THICK X 2.25" WIDE - BRIGHT WHITE
	069640-28-000	FT	SEALER - TAPE - .25" THICK X 1.86" WIDE X 90' - GRAY
	069640-30-000	FT	SEALER - TAPE - .03" THICK X .625" WIDE X 50' - GRAY
	069640-31-000	FT	SEALER - TAPE - .25"THICK X .75" WIDE X 15' - BLACK
	069640-32-000	FT	SEALER - RIBBON - 1/16" X 3/8" X 100' - BLACK
	069640-33-000	FT	SEALER - RIBBON - 3/8"DIAMETER X 20' - BLACK
	072889-01-000	EA	SEALANT - URETHANE - BLACK - TUBE W/NOZZLE TIP
	072889-10-000	EA	SEALANT - URETHANE - BRIGHT WHITE - TUBE W/NOZZLE TIP
	072889-27-000	EA	SEALANT - URETHANE - SILVER - 10 OZ TUBE W/NOZZLE TIP
	076322-01-000	FT	TAPE-DOUBLE COATED/ADHESIVE BK-.03"THK X .8"W X 216'- WHT
	076322-02-000	FT	TAPE-DOUBLE COATED/ADHESIVE BK-.05"THK X 1"W X 108' - WHT
	076322-03-000	FT	TAPE-DOUBLE COATED/ADHESIVE BK-.05"THK X .5"W X 108' - WHT
	076322-04-000	FT	TAPE-DOUBLE COATED/ADHESIVE BK-.05"THK X .8"W X 108' - WHT
	076322-05-000	FT	TAPE-DOUBLE COATED/ADHESIVE BK-.05"THK X .8"W X 108' - WHT
	076322-07-000	FT	TAPE-DOUBLE COATED/ADHESIVE BK-.05"THK X .5"W X 200' - BLK
	076322-11-000	FT	TAPE-DOUBLE COATED/ADHESIVE BK-.02"THK X 1"W X 216' - CLR
	076322-21-000	FT	TAPE - FOAM/DOUBLE COATED - .5"
	076322-22-000	FT	TAPE - FOAM/DOUBLE COATED - .045" X .75"
	076322-23-000	FT	TAPE - FOAM/DOUBLE COATED - .045" X 1"
	076322-24-000	FT	TAPE - FOAM/DOUBLE COATED - .025" X 1"
	076322-25-000	FT	TAPE - FOAM/DOUBLE COATED - .025" X .5"
	076813-02-000	FT	SEAL-D BULB, .5" X .7" - MEDIUM SPONGE RUBBER - BLACK
	086276-01-000	EA	TAPE - DOUBLE SIDED - 1/2" WIDE X 108' LONG (SOLD BY ROLL)
	088479-01-000	EA	TAPE - ALUMINUM - 3"
	090340-01-000	FT	SEAL - FOAM - CLOSED CELL - 1/4" X 1/2" X 50'
	091255-02-000	FT	SEAL - ADHESIVE BACKED/FOAM - 3/64" THICK X 3/16"W X 1000'
	091255-03-000	FT	SEAL - ADHESIVE BACKED/FOAM - 1/4" THICK X 1/4"W X 1000'
	094401-01-000	EA	SEALER - BODY SEAM - FLEXICLEAR
	094401-03-000	EA	SEALER - BODY SEAM - BLACK
	094401-04-000	EA	SEALER - BODY SEAM - CLEAR
	094401-05-000	EA	SEALER - BODY SEAM - 20OZ BLACK
	094401-06-000	EA	SEALER - BODY SEAM - 12OZ BLACK
	098408-01-000	FT	SEAL - SPONGE RUBBER - CLOSED CELL
	099069-01-000	FT	SEAL - RUBBER - CLOSED SPONGE - .5" WIDE X .12" THICK -BLK
	099418-01-000	FT	SEAL - D-SECTION/ADHESIVE BACK - .44" X .44"- BLK RUBBER
	099418-02-000	FT	SEAL - D-SECTION/ADHESIVE BACK - .44" X .44"- WHITE RUBBER
	100128-02-000	FT	SEAL - FOAM/ADHESIVE BACK - .37" WIDE X .37" THICK

SEALANTS & FASTENERS GROUP (CONTINUED)

SEALANTS & ADHESIVES (CONTINUED)

KEY	PART NUMBER	U/M	DESCRIPTION
	104692-01-000	FT	SEAL - ADHESIVE BACKED FOAM - 3/4" THICK X 3/4" WIDE X 25'
	104692-03-000	FT	SEAL - ADHESIVE BACKED FOAM - 1" THICK X 1 3/16"WIDE X 15'
	107828-01-000	EA	SEALANT - SB - 190 EVERSEAL
	109506-01-000	EA	FILM - URETHANE - PROTECTANT - 4.25" X 26.75"
	109506-12-000	EA	FILM/ABRASION-RESISTANT - TRANSPARENT - 1" DIA.
	109506-13-000	EA	FILM/ABRASION-RESISTANT - TRANSPARENT - 1" DIA.
	110274-01-000	FT	TAPE - DOUBLE SIDED/FOAM - .45" X 1" X 216' - BLACK
	112481-02-000	EA	ADHESIVE - PLEXUS ETHACRYLATE - CARTRIDGE
	112864-01-000	FT	SEAL - FOAM/BUTYL COVERED - 3/8" X 35'
	112864-02-000	FT	FOAM - BUTYL COVERED - 5/16" X 44'
	112864-04-000	FT	FOAM - BUTYL COVERED - 3/8" X 1/8"
	112901-02-000	EA	ADHESIVE - PLEXUS - MA330 - 50ML - GRAY
	112901-03-000	EA	ADHESIVE - PLEXUS - MA300 - 50ML - WHITE
	112902-01-000	EA	NOZZLE - ELEMENT - 3/8 X 24
	112902-03-000	EA	MIXER NOZZLE - F/GUN #00400102000 - SCOTCH-WELD & PLEXUS
	112902-04-000	EA	NOZZLE - ELEMENT - 1/4" X 3.5"
	113366-01-000	EA	ADHESIVE - INSTANT - 1 OZ
	113452-02-000	FT	SEAL/TRIM - FRONT - VINYL W/WIRE CARRIER - .027"
	115933-01-000	FT	TAPE - 1/64" X 3/8" X 100'
	120074-02-03A	EA	SILICONE - TUBE - W/O NOZZLE - LOW ODOR - SMOKEY WHITE
	120074-02-02A	EA	SILICONE - TUBE - W/O NOZZLE - LOW ODOR - SOFT WHITE
	120534-01-01A	EA	TAPE - SCOTCH - 3M - 1/2" FINE LINE
	123244-01-000	FT	TAPE - DOUBLE SIDED/FOAM - 5/64" THICK X 3/4" WIDE X 108'
	123816-01-000	FT	TAPE - DOUBLE SIDED - 1" X 3/4" X 200'
	123816-02-000	FT	TAPE - DOUBLE SIDED - 1/2" X 1 1/3" X 200'
	123816-03-000	FT	TAPE - DOUBLE SIDED - 1/2" X 3/4" X 200'
	123816-04-000	FT	TAPE - DOUBLE SIDED - 6" X 750'
	126427-01-000	EA	ADHESIVE - ALL PURPOSE - ABS/PVC
	126427-02-000	EA	PRIMER - CLEANER - FLEX PIPING
	131264-01-02A	EA	SILICONE - TUBE - W/O NOZZLE - CLEAR
	131264-01-01A	EA	SILICONE - TUBE - W/O NOZZLE - BLACK
	131264-02-01A	EA	SILICONE - TUBE - W/O NOZZLE - VW GRAY - BATH ONLY
	131264-03-01A	EA	SILICONE - TUBE - W/O NOZZLE- SELF LEVELING - BRIGHT WHITE
	131264-04-01A	EA	SILICONE/SEALANT/ADHESIVE - FAST CURE F/GLASS/VINYL - B/W
	131264-05-01A	EA	SILICONE/SEALANT - ODORLESS - TUBE - W/NOZZLE - BLACK
	131264-05-02A	EA	SILICONE/SEALANT - ODORLESS - TUBE - W/NOZZLE - CLEAR
	131384-01-000	EA	ADHESIVE - JET WELD
	134651-01-000	FT	SEAL - 1/2" X 3/4" PSA 1 SIDE
	900390-01-000	EA	NOZZLE - SILICONE TUBE - 2.5" LONG - W/EXTERNAL THREADS
	900390-03-000	EA	NOZZLE - SILICONE TUBE - 4.3" LONG W/INTERNAL THREADS
	900563-17-000	EA	TAPE - 2 SIDED, 2" X 36 YDS

BOLTS, NUTS AND WASHERS

KEY	PART NUMBER	U/M	DESCRIPTION
	OMC05K-08-055	EA	BOLT - HEX - M08 X 1.25 X 2.2
	OMD16K-10-000	EA	NUT - HEX PREV TORQUE M10 X 1 1/2 CLASS 8
	OMD39K-12-000	EA	NUT - HEX W/NYLON LOCK - M12 X 1 3/4
	OMD40K-14-000	EA	NUT - HEX W/NYLON LOCK - M14 X 2
	OMD54F-06-000	EA	NUT-HEX SER FLG M6X1,0 SS - DIN6923A2M6
	OME06K-14-280	EA	WASHER - FLAT - 14 ID X 28 OD
	000C12-04-08B	EA	BOLT - HEX - 1/4-20 X 1/2 - GRADE #5 - ZINC
	000C12-04-12A	EA	BOLT - HEX - 1/4-20 X 3/4 - PLAIN 5
	000C12-04-40B	EA	BOLT - HEX - 1/4-20 X 2 1/2 - GRADE #5 ZINC
	000C12-05-16B	EA	BOLT - HEX - 5/16 - 18X1 - GRADE #5 - ZINC
	000C12-05-40B	EA	BOLT - HEX - 5/16"-18 X 2.5" - GRADE #5 - ZINC
	000C12-06-44B	EA	BOLT - HEX - 3/8-16 X 2 3/4 - GRADE 5 - ZINC
	000C12-06-16B	EA	BOLT - HEX - 3/8 - 16X1 - GRADE #5 - ZINC
	000C12-08-28B	EA	BOLT - HEX - 1/2-13 X 1 3/4 - GRADE #5 - ZINC
	000C12-08-24B	EA	BOLT - HEX - 1/2 - 13X1 1/2 - GRADE #5 - ZINC
	000C12-08-16B	EA	BOLT - HEX - 1/2-13 X 1 - GRADE #5 - ZINC
	000C12-10-24B	EA	BOLT - HEX - 5/8 - 11X1 1/2 - GRADE #5 - ZINC
	000C13-07-48B	EA	BOLT - HEX - 7/16-20 X 3 - GRADE #5 - ZINC
	000C13-07-40B	EA	BOLT - HEX - 7/16-20 X 2 1/2 - GRADE #5 - ZINC
	000C14-07-28B	EA	BOLT - HEX - 7/16-14 X 1 3/4 - GRADE #8 - ZINC

SEALANTS & FASTENERS GROUP (CONTINUED)
BOLTS, NUTS AND WASHERS (CONTINUED)

KEY	PART NUMBER	U/M	DESCRIPTION
	000C14-10-32K	EA	BOLT - HEX - 5/8-11 X 2 - GRADE #8 - ZINC
	000C16-07-16B	EA	BOLT - CARRIAGE - ASSIST HANDLE - 7/16-14 X 1
	000C18-05-40A	EA	BOLT - ELEVATOR - 5/16-18 X 2 1/2 - PL
	000C26-04-10B	EA	BOLT - HEX - SERRATED FLANGE - 1/4-20 X 5/8 - ZINC
	000C26-04-18B	EA	BOLT - HEX - SERRATED FLANGE - 1/4-20 X 1 1/8 - ZINC
	000C26-04-14B	EA	BOLT - HEX - SERRATED FLANGE - 1/4-20 X 7/8 - ZINC
	000C26-05-20B	EA	BOLT - HEX - SERRATED FLANGE - 5/16-18 X 1 1/4 - ZINC
	000C26-05-12B	EA	BOLT - HEX - SERRATED FLANGE - 5/16-18 X 3/4 - ZINC
	000C26-06-40B	EA	BOLT - HEX - SERRATED FLANGE - 3/8-16 X 2 1/2 - ZINC
	000C26-06-28B	EA	BOLT - HEX - SERRATED FLANGE - 3/8-16 X 1 3/4 - ZINC
	000C26-06-20B	EA	BOLT - HEX - SERRATED FLANGE - 3/8-16 X 1 1/4 - ZINC
	000C26-06-12B	EA	BOLT - HEX - SERRATED FLANGE - 3/8-16 X 3/4 - ZINC
	000C26-08-24B	EA	BOLT - HEX - SERRATED FLANGE - 1/2-13 X 1 1/2 - ZINC
	000C27-04-40B	EA	BOLT - CARRIAGE - 1/4-20 X 2 1/2 - ZINC
	000C27-07-40B	EA	BOLT - CARRIAGE - 7/16-14 X 2 1/2 - GRADE #5
	000C27-08-48B	EA	BOLT - CARRIAGE - 1/2-13 X 3 - GRADE #5
	000D16-07-00B	EA	NUT - HEX - 7/16-14 - ZINC
	000D20-07-00B	EA	NUT - ACORN - ASSIST HANDLE - 7/16 - 14
	000D23-04-00B	EA	NUT - HEX SF/LK #4-40
	000D24-10-00B	EA	NUT - HEX - SELF LOCKING - 10-32 - ZINC
	000D25-06-00B	EA	NUT-3/8" W/BURR - FASTENER HOUSE
	000D28-10-00B	EA	NUT - HEX - W/NYLON LOCK - 10-32 ZINC
	000D29-04-00B	EA	NUT - HEX - SELF LOCKING - 1/4 X 20 - ZINC
	000D29-06-00B	EA	NUT - HEX - W/NYLON LOCK - 3/8-16 - ZINC
	000D29-09-00B	EA	NUT - HEX - SELF LOCKING - 9/16-12 - ZINC
	000D30-07-00B	EA	NUT - HEX LOCK - NYLON 7/16 X 20
	000D34-04-00B	EA	NUT - HEX - LOCKING - 1/4-20 - ZINC
	000D34-06-00B	EA	NUT - HEX - LOCKING - 3/8-16 GRADE C - ZINC
	000D39-04-00B	EA	NUT - HEX - LOCKING W/SERRATED FLANGE - 1/4-20 - ZINC
	000D39-05-00B	EA	NUT - HEX - LOCKING W/SERRATED FLANGE - 5/16-18 - ZINC
	000D39-06-00B	EA	NUT - HEX - LOCKING W/SERRATED FLANGE - 3/8-18 - ZINC
	000D39-07-00B	EA	NUT - HEX - LOCKING W/SERRATED FLANGE - 7/16-14 - ZINC
	000D39-08-00B	EA	NUT - HEX - LOCKING W/SERRATED FLANGE - 1/2-13 - ZINC
	000D44-04-00B	EA	NUT - HEX - LOCKING W/SERRATED FLANGE - 1/4-28 - ZINC
	000D44-07-00B	EA	NUT - HEX - LOCKING W/SERRATED FLANGE - 7/16-20 - ZINC
	000D44-08-00B	EA	NUT - HEX - LOCKING W/SERRATED FLANGE - 1/2-20 - ZINC
	000D46-04-00A	EA	NUT - HEX - WELD - 1/4-20 - PLAIN
	000D58-06-00A	EA	NUT - HEX - WELD 3/8-16 - PLAIN
	000D65-08-00B	EA	NUT - HEX - LOCKING W/SERRATED FLANGE - 8-32 - ZINC
	000D67-10-00B	EA	NUT - HEX - LOCK - 5/8-11 - ZINC
	000D73-08-00C	EA	NUT - HEX FLANGE - 1/2-13
	000D75-09-00B	EA	NUT - HEX LOCKING - 9/16-12 - ZINC
	000D76-06-00B	EA	NUT - HEX FLANGE - 3/8-16
	000E11-04-00F	EA	WASHER - LOCKING - 1/4 MED SPLIT - STAINLESS STEEL
	000E11-07-00B	EA	WASHER - LOCKING - 7/16 MED SPLIT - ZINC
	000E11-08-00B	EA	WASHER - LOCKING - 1/2 MED SPLIT - ZINC
	000E13-17-00B	EA	WASHER - FLAT - 3/8 AR - ZINC
	000E13-18-00B	EA	WASHER - FLAT - 3/8 WIDE - ZINC
	000E13-20-00B	EA	WASHER - FLAT - 7/16 WIDE - ZINC
	000E13-22-00B	EA	WASHER - FLAT - 1/2 WIDE - ZINC
	000E13-26-00B	EA	WASHER - FLAT - 5/8 WIDE - ZINC
	000E14-10-00B	EA	WASHER - LOCKING - #10 EXTERNAL TOOTH - ZINC
	000E16-10-00B	EA	WASHER - HARDENED - 5/8 - FLAT - ZINC
	000G45-05-16B	EA	BOLT - LAG - 5/16-9 X 1 - ZINC
	002329-01-000	EA	WASHER-FLAT, 9/32" ID X 5/8" OD - NYLON
	005081-01-000	EA	NUT - SPEED - C-TYPE - #8 SCREW
	040921-01-000	EA	NUT - SPEED - U TYPE - #10-24 - BLACK
	040921-03-000	EA	NUT - SPEED - U TYPE - #10
	040921-04-000	EA	NUT - SPEED - U TYPE - #8-.59" LENGTH X .44" WIDTH
	040921-05-000	EA	NUT - SPEED - U-TYPE - 8-.67" X .44" WIDE
	041322-01-000	EA	WASHER - FLANGE - 15/32 ID X 2 3/8 OD - F/SEAT BELT MTG
	044364-02-000	EA	NUT - SPEED - FLAT - ROUND
	044533-01-000	EA	WASHER - 1 3/8"OD - FOR BUTTONS - PLASTIC
	051387-06-000	EA	BOLT - CARRIAGE W/O HOLE - 5/16-18 X 9 1/2 - ZINC

SEALANTS & FASTENERS GROUP (CONTINUED)
BOLTS, NUTS AND WASHERS (CONTINUED)

KEY	PART NUMBER	U/M	DESCRIPTION
	058716-02-000	EA	WASHER - FLAT NYLON
	064081-03-000	EA	NUT - WING 3/8-16 - W/WELD NUT
	077071-01-000	EA	WASHER - FENDER - 3/16"ID X 1"OD
	084406-01-000	EA	NUT - CAPPED - CROSS RECESSED - BLACK - 1/4-20 THD
	087234-01-000	EA	NUT - JACK - 1/4 X 20 THD - MOLLY
	087718-01-000	EA	MONOBOLT - STEEL - 3/16 DIAMETER
	088787-12-000	EA	STUD - WELD - 1/4 - 20 X 1.0 LG - MN
	102333-01-06A	EA	BOLT - CARRIAGE - 7/16-14 STAINLESS STEEL CAP
	103020-02-000	EA	BOLT-U - #8-32 - GRADE 5 ZINC
	106956-03-000	EA	BOLT - HEX TAP - 1/2-12NC X 3 - GRADE 5 - FULL THREAD/ZINC
	107397-01-000	EA	WASHER - FENDER - 3/4"ID X 1"OD
	108067-03-000	EA	STUD - WELD - 1/4 - 20 X 1/2 CD
	109917-01-000	EA	WASHER - 1.5" X 1.25"
	109917-03-000	EA	WASHER - 1" X .50"
	109917-04-000	EA	WASHER - 1" X .75"
	110794-01-000	EA	WASHER - FLAT - 1"ID X 1 3/4"OD
	113985-02-000	EA	BOLT - FLANGE - M10-1 1/2 X 30CL 10.9
	114259-05-000	EA	BOLT - 7/16-20 X 1 1/4 W/WASHER
	128444-01-000	EA	WASHER - SPRING - CONICAL
	131377-01-000	EA	NUT-HEX HEAD W/WASHER-1/4-20 X 2" STEEL W/3/4" OD WASHER
	135092-02-01A	EA	BOLT - HEX - SERRATED FLANGE - 1/2-20 X 2 1/2-GRADE 5 ZINC
	143399-01-01A	EA	NUT/RETAINING - 3/8" - 24 NFT
	144904-01-01A	EA	BOLT - ADJUSTMENT - HEADLAMP
	147284-01-000	EA	NUT/SELF RETAINING - 3/8"-16
	147284-02-000	EA	NUT/SELF RETAINING - 5/16"-18
	148817-01-000	EA	WASHER/SPUR - LOCKING

SCREWS

KEY	PART NUMBER	U/M	DESCRIPTION
	0G1106-06-160	EA	SCREW - 6-20 X 3/8 PPH
	0G1106-08-240	EA	SCREW - 6-20 X 1/2 PPH - VW LIGHT GRAY
	0G1208-12-170	EA	SCREW - 8-18 X 3/4 POH - BRIGHT WHITE
	0G3804-22-180	EA	SCREW - MACHINE - 1/4-20 X 1 3/8 PFH - BLACK
	0G3908-08-170	EA	SCREW - SF/DR - 8-18 X 1/2 PPH - BRIGHT WHITE
	0G3908-08-160	EA	SCREW - SF/DR - 8-18 X 1/2 PPH - VW WHITE
	0G3908-12-250	EA	SCREW - SF/DR - 8-18 X 3/4 PPH - DARK GRAY
	0G3908-16-170	EA	SCREW - SF/DR - 8-18 X 1 PPH - BRIGHT WHITE
	0G3908-24-170	EA	SCREW - SF/DR - 8-18 X 1 1/2 PPH - BRIGHT WHITE
	0G3910-10-330	EA	SCREW - SF/DR - 20-16 X 5/8 PPH - PUTTY
	0G3910-10-320	EA	SCREW - SF/DR - 10-16 X 5/8 PPH - GLACIER
	0G3910-12-240	EA	SCREW - SF/DR - 10-16 X .75 PPH - VW LIGHT GRAY
	0G3910-12-170	EA	SCREW - SF/DR - 10-16 X 3/4 PPH - BRIGHT WHITE
	0G3910-12-320	EA	SCREW - SF/DR - 10-16 X 3/4 PPH - GLACIER
	0G5508-08-380	EA	SCREW - SF/DR - 8-18 X .5 PWH - CASHMERE
	0G5508-08-370	EA	SCREW - SF/DR - 8-18 X .5 PWH - RIVERSTONE
	0G5508-12-240	EA	SCREW - SF/DR - 8-18 X 3/4 PWH - VW LIGHT GRAY
	0G5508-12-170	EA	SCREW - SF/DR - 8-18 X 3/4 PWH - BRIGHT WHITE
	0G5508-12-330	EA	SCREW - SF/DR - 8-18 X 3/4 PWH - PUTTY
	0G5508-12-320	EA	SCREW - SF/DR - 8-18 X 3/4 PWH - GLACIER
	0G5508-12-270	EA	SCREW - SF/DR - 8-18 X 3/4 PWH - TITANIUM
	0G5508-16-250	EA	SCREW - SF/DR - 8-18 X 1 PWH - VW DARK GRAY
	0G5508-16-320	EA	SCREW - SF/DR - 8-18 X 1 PWH - GLACIER
	0G6008-16-170	EA	SCREW - SF/DR - 8-18 X 1 POH - BRIGHT WHITE
	0G6710-08-130	EA	SCREW - 10-12 X 1/2 PPH - TAUPE
	0G6710-08-170	EA	SCREW - 10-12 X 1/2 PPH - BRIGHT WHITE
	0G6710-08-240	EA	SCREW - 10-12 X 1/2 PPH - VW LIGHT GRAY
	0G6710-12-170	EA	SCREW - 10-12 X 3/4 PPH - BRIGHT WHITE
	0G6806-16-170	EA	SCREW - 6-18 X 1 POH - BRIGHT WHITE
	0G6810-24-280	EA	SCREW - 10-12 X 1 1/2 POH - SOFT WHITE
	000C20-05-28F	EA	SCREW - 5/16-18 X 1 3/4 FLAT SOC - STAINLESS STEEL
	000C20-06-24T	EA	SCREW - 3/8-16 X 1 1/2 - FLAT SOCKET
	000G11-06-10J	EA	SCREW - 6-20 X 5/8 PPH - BRASS

SEALANTS & FASTENERS GROUP (CONTINUED)
SCREWS (CONTINUED)

KEY	PART NUMBER	U/M	DESCRIPTION
	000G11-06-08B	EA	SCREW - 6-20 X 1/2 PPH - ZINC
	000G11-06-10B	EA	SCREW - 6-20 X 5/8 PPH - ZINC
	000G11-07-08B	EA	SCREW - 7-19 X 1/2 PPH - ZINC
	000G11-08-20G	EA	SCREW - 8-18 X 1 1/4 - ANTIQUE BRASS
	000G11-08-20B	EA	SCREW - 8-18 X 1 1/4 PPH - ZINC
	000G11-08-12T	EA	SCREW - 8-18 X 3/4 PPH - BLACK MAGNESIUM
	000G11-08-12P	EA	SCREW - 8-18 X 3/4 PPH - DARK BROWN
	000G11-08-12S	EA	SCREW - 8-18 X 3/4 PPH - OFF WHITE
	000G11-08-12B	EA	SCREW - 8-18 X 3/4 PPH - ZINC
	000G11-08-08T	EA	SCREW - 8-18 X 1/2 PPH - FLUOROCARBON COATING
	000G11-08-06B	EA	SCREW - 8-18 X 3/8 PPH - ZINC
	000G11-10-12D	EA	SCREW - 10-16 X 3/4 PPH - BLACK
	000G12-06-12J	EA	SCREW - 6-20 X .75 POH - BRASS
	000G12-06-08T	EA	SCREW - 6-20 X 1/2 POH - BLACK
	000G13-05-10B	EA	SCREW - 5-12 X 5/8 PFH - ZINC
	000G13-06-08G	EA	SCREW - 6-20 X 1/2 PFH - ANTIQUE BRASS
	000G13-06-08B	EA	SCREW - 6-20 X 1/2 PFH - ZINC
	000G13-06-06I	EA	SCREW - 6-20 X 3/8 PFH - BLACK ZINC
	000G13-06-24J	EA	SCREW - 6-20 X 1 1/2 PFH - BRASS
	000G13-06-16J	EA	SCREW - 6-20 X 1 PFH - BRASS
	000G13-06-10J	EA	SCREW - 6-20 X 5/8 PFH - BRASS
	000G13-06-10G	EA	SCREW - 6-20 X 5/8 PFH - ANTIQUE BRASS
	000G13-07-10H	EA	SCREW - 7-19 X 5/8 PFH - BLACK
	000G13-07-12B	EA	SCREW - 7-19 X 3/4 PFH - ZINC
	000G13-08-16B	EA	SCREW - 8-18 X 1 PFH - ZINC
	000G13-08-109	EA	SCREW - 8-18 X 5/8 PFH
	000G13-08-10B	EA	SCREW - 8-18 X 5/8 PFH - ZINC
	000G13-08-24B	EA	SCREW - 8-18 X 1 1/2 PFH - ZINC
	000G16-04-24B	EA	SCREW - MACHINE - 1/4-20 X 1 1/2 PPH
	000G18-04-12B	EA	SCREW - MACHINE - 4-40 X 3/4 PPH - ZINC
	000G18-08-12B	EA	SCREW - MACHINE - 8-32 X 3/4 PPH - ZINC
	000G18-08-16B	EA	SCREW - MACHINE - 8-32 X 1 PPH - ZINC
	000G18-08-24B	EA	SCREW - MACHINE - 8-32 X 1 1/2 PPH - ZINC
	000G18-08-22B	EA	SCREW - MACHINE - 8-32 X 1 3/8 PPH - ZINC
	000G19-10-10B	EA	SCREW - MACHINE - 10-32 X 5/8 - PPH - ZINC
	000G19-10-08B	EA	SCREW - MACHINE - 10-32 X 1/2 PPH - ZINC
	000G19-10-20B	EA	SCREW - MACHINE - 10-32 X 1 1/2 PPH - ZINC
	000G19-10-40B	EA	SCREW-MACH,10-32X2.50 PPH ZN
	000G19-10-12F	EA	SCREW - MACHINE - 10-32 X 3/4 PPH - STAINLESS STEEL
	000G32-10-06B	EA	SCREW - 10-32 X 3/8 PPH - ZINC
	000G36-10-12T	EA	SCREW - 10-24X 3/4 PFH TYPE 23 - BLACK
	000G39-06-06J	EA	SCREW - 6-20 X 3/8 PPH - BRASS
	000G39-06-10T	EA	SCREW - SF/DR - 6-20 X 5/8 PPH - BLACK
	000G39-06-16T	EA	SCREW - SF/DR - 6-20 X 1 PPH - BLACK
	000G39-08-08S	EA	SCREW - SF/DR - 8-18 X 1/2 PPH - OFF WHITE
	000G39-08-08B	EA	SCREW - SF/DR - 8-18 X 1/2 PPH - ZINC
	000G39-08-08T	EA	SCREW - SF/DR - 8-18 X 1/2 PPH - BLACK
	000G39-08-06B	EA	SCREW - SF/DR - 8-18 X 3/8 PPH - ZINC
	000G39-08-32B	EA	SCREW - SF/DR - 8-18 X 2 PPH - ZINC
	000G39-08-24T	EA	SCREW - SF/DR - 8-18 X 1 1/2 PPH - BLACK
	000G39-08-24S	EA	SCREW - SF/DR - 8-18 X 1 1/2 - OFF WHITE
	000G39-08-24B	EA	SCREW - SF/DR - 8-18 X 1 1/2 PPH - ZINC
	000G39-08-16T	EA	SCREW - SF/DR - 6-20 X 1 PPH - BLACK
	000G39-08-16B	EA	SCREW - SF/DR - 8-18 X 1 PPH - ZINC
	000G39-08-12B	EA	SCREW - SF/DR - 8-18 X 3/4 PPH - ZINC
	000G39-08-12T	EA	SCREW - SF/DR - 8-18 X 3/4 PPH - BLACK
	000G39-10-48T	EA	SCREW - SF/DR - 10-16 X 3 PPH - BLACK
	000G39-10-48B	EA	SCREW - SF/DR - 10-16 X 3 - PPH - ZINC
	000G39-10-40D	EA	SCREW - SF/DR - 10-16 X 2 1/2 PPH - BLACK
	000G39-10-32B	EA	SCREW - SF/DR - 10-16 X 2 - PPH - ZINC
	000G39-10-20T	EA	SCREW - SF/DR - 10-16 X 1 1/4 PPH - BLACK
	000G39-10-20B	EA	SCREW - SF/DR - 10-16 X 1 1/4 PPH - ZINC
	000G39-10-169	EA	SCREW - SF/DR - 10-16 X 1 PPH - FLUOROCARBON SILVER
	000G39-10-129	EA	SCREW - SF/DR - 10-16 X 3/4 PPH - FLUOROCARBON SILVER

SEALANTS & FASTENERS GROUP (CONTINUED)
SCREWS (CONTINUED)

KEY	PART NUMBER	U/M	DESCRIPTION
	000G39-10-12T	EA	SCREW - SF/DR - 10-16 X 3/4 - BLACK
	000G39-10-10T	EA	SCREW - SF/DR - 10-16 X 5/8 - BLACK
	000G39-10-10B	EA	SCREW - SF/DR - 10-16 X 5/8 PPH - ZINC
	000G39-10-08B	EA	SCREW - SF/DR - 10-16 X 1/2 PPH - ZINC
	000G39-12-12E	EA	SCREW - SF/DR - 12 - 14 X 3/4 PPH - CHROME
	000G42-04-24B	EA	SCREW - SF/DR - 1/4-14 X 1 1/2 - ZINC
	000G42-04-16B	EA	SCREW - SF/DR - 1/4-14 X 1 HWH - ZINC
	000G42-04-24B	EA	SCREW - SF/DR - 1/4-14 X 1 1/2 - ZINC
	000G46-08-24T	EA	SCREW - MACHINE - 8-32 X 1 1/2 PFH - BLACK
	000G50-04-08B	EA	SCREW - MACHINE - 1/4-20 X 1/2 PTH - ZINC
	000G52-06-05B	EA	SCREW - MACHINE - 6-32 X 5/16 PTH ZINC
	000G52-06-06B	EA	SCREW - MACHINE - 6-32 X 3/8 PIN - ZINC
	000G54-04-14B	EA	SCREW - 1/4-20 X 7/8 PTH - TYPE 23 - ZINC PLATED
	000G55-08-124	EA	SCREW - SF/DR - 8-18 X 3/4 PWH - ASH GRAY
	000G55-08-16T	EA	SCREW - SF/DR - 8-18 X 1 PWH - BLACK
	000G56-12-48B	EA	SCREW - WOOD - 12-11 X 3 POH - SPECIAL HARDENED
	000G57-14-64B	EA	SCREW - 14-10 X 4 PFH ZINC
	000G60-08-20F	EA	SCREW - SF/DR - 8-19X1.25 POH
	000G60-08-16E	EA	SCREW - SF/DR - 8-1 X 1 POH - CHROME
	000G60-08-22B	EA	SCREW - SF/DR - 8-18 X 1.38 POH - ZINC
	000G60-10-209	EA	SCREW - SF/DR - 10-16 X 1 1/4 POH - SILVER STALGAARD
	000G60-10-20B	EA	SCREW - SF/DR - 10-16 X 1 1/4 POH - ZINC
	000G60-10-16J	EA	SCREW - SF/DR - 10-16 X 1 POH - BRIGHT BRASS
	000G60-10-28T	EA	SCREW - SF/DR - 10-16 X 1 3/4 - BLACK
	000G62-08-24B	EA	SCREW - SF/DR - 8-18 X 1 1/2 PFH
	000G67-08-32B	EA	SCREW - 8-15 X 2 PPH - ZINC
	000G67-10-08B	EA	SCREW - 10-12 X 1/2 PPH - ZINC
	000G67-10-32J	EA	SCREW-10-12X2 PPH - BRIGHT BRASS
	000G67-10-24S	EA	SCREW - 10-12 X 1 1/2 PPH - OFF WHITE
	000G67-10-24B	EA	SCREW - 10-12 X 1 1/2 PPH - ZINC
	000G67-10-20D	EA	SCREW - 10-12 X 1 1/4 PPH - BLACK
	000G67-10-12P	EA	SCREW - 10-12 X 3/4 PPH - DARK BROWN
	000G67-10-12B	EA	SCREW - 10-12 X 3/4 PPH - ZINC
	000G67-10-10T	EA	SCREW - 10-12 X 5/8 PPH - BLACK
	000G67-10-10S	EA	SCREW - 10-12 X 5/8 PPH - OFF WHITE
	000G67-10-10P	EA	SCREW - 10-12 X 5/8 PPH - DARK BROWN
	000G67-10-10B	EA	SCREW - 10-12 X 5/8 PPH - ZINC - TYPE A
	000G67-10-08S	EA	SCREW - 10-12 X 1/2 PPH - OFF WHITE
	000G68-06-12B	EA	SCREW - 6-18 X 3/4 POH - ZINC & CLEAR
	000G68-06-10J	EA	SCREW - 6-18 X 5/8 POH - BRASS
	000G68-06-10G	EA	SCREW - 6-18 X 5/8 POH - ANTIQUE BRASS
	000G68-06-12J	EA	SCREW - 6-18 X 3/4 POH - BRASS
	029130-01-000	EA	SCREW - SNAP STUD - #8-16 X 5/8" LONG
	029130-03-000	EA	SCREW - SNAP STUD - #8-16 X 1" LONG
	049465-01-000	EA	SCREW - 10-16 PTH W/WASHER - DARK BROWN
	049465-03-000	EA	SCREW - 10-16 X 1 POH W/WASHER - OFF WHITE
	049465-04-000	EA	SCREW - 10-16 X 1 PTH W/WASHER - BEIGE
	049465-13-000	EA	SCREW-10+16X1 PTH W/WASHER - *ASH GRAY
	049465-17-000	EA	SCREW - 10-16 X 1 POH W/WASHER - BRIGHT WHITE
	054434-03-000	EA	SCREW - SF/DR - 10-16 X 2 - PWH - ZINC
	075908-01-000	EA	SCREW - MACHINE - 10-32 X .56 PTH - EXTERNAL TOOTH - ZINC
	076790-01-000	EA	SCREW - 6-20 X 1 1/4 PPH - BLACK
	076790-05-000	EA	SCREW - 6-20 X 1/2 PPH - BLACK - THREAD CUTTING/WOOD
	083554-01-000	EA	SCREW - DRYWALL - 8 X 1 1/4
	083554-04-000	EA	SCREW - DRYWALL - 8 X 2 1/2
	087721-01-000	EA	SCREW - FLAT HEAD - TAPPING - 1/4 X 1 1/4 LONG - ZINC
	087721-02-000	EA	SCREW - FLAT HEAD - TAPPING - 1/4" X 2 1/4" LONG - ZINC
	090033-02-000	EA	SCREW - 1/4-20 X 5/8 - ROUND WASHER HEAD - OFF/WHITE
	097974-01-000	EA	SCREW - PARTICLE BOARD - 7-9 X 3/4 PPH
	101618-01-000	EA	SCREW - 1/4-20 X 3/4 HEX - TAPPING - STALGARD TYPE F
	109235-01-05A	FT	COVER - SCREW - BRIGHT WHITE
	109235-01-01A	FT	COVER - SCREW - MAT BLACK
	113563-01-01A	EA	SCREW - 8 X 5/8 LONG SHOULDER/WASHER HEAD
	116111-02-01A	EA	SCREW - TAPTITE - 1/4-20 X 3/8 PPH - ZINC

SEALANTS & FASTENERS GROUP (CONTINUED)
SCREWS (CONTINUED)

KEY	PART NUMBER	U/M	DESCRIPTION
	117478-01-04A	EA	SCREW - 8-18 X 3/4 PPH W/WASHER - VW LIGHT GRAY
	118383-01-09A	EA	RETAINER/RECESSED - F/.22" SCREW - GLACIER
	118383-01-06A	EA	RETAINER/RECESSED - F/.22" SCREW - ALLANTE ANTELOPE
	118383-01-04A	EA	RETAINER/RECESSED - F/.22" SCREW - BRIGHT WHITE
	118383-02-09A	EA	RETAINER/RECESSED - F/.27" SCREW - GLACIER
	118383-02-05A	EA	RETAINER/RECESSED - F/.27" SCREW - VW LIGHT GRAY
	118383-02-10A	EA	RETAINER/RECESSED - F/.27" SCREW - RIVERSTONE
	118383-02-11A	EA	RETAINER/RECESSED - F/.27" SCREW - CASHMERE
	118383-03-09A	EA	RETAINER/RECESSED - F/.32" SCREW - GLACIER
	118383-04-04A	EA	CAP - F/RECESSED RETAINER - BRIGHT WHITE
	118383-04-08A	EA	CAP - F/RECESSED RETAINER - CADDY CREAM
	118383-04-05A	EA	CAP - F/RECESSED RETAINER - VW LIGHT GRAY
	118383-04-11A	EA	CAP - F/RECESSED RETAINER - CASHMERE
	118383-04-10A	EA	CAP - F/RECESSED RETAINER - RIVERSTONE
	118383-04-09A	EA	CAP - F/RECESSED RETAINER - GLACIER
	134126-01-01A	EA	SCREW/NAIL - HEX HEAD - 3/4"
	140040-01-000	EA	SCREW - 1/4-20 X 1 - BUTTON HEAD/SOCKET - W/LOCTITE
	144078-01-01A	EA	SCREW - HEX/FLANGE HEAD CAP-1" W/.75" THREAD LENGTH-ZINC
	149753-01-02A	EA	RETAINER/RECESSED - F/.22" SCREW - BRIGHT WHITE
	149753-01-01A	EA	RETAINER/RECESSED - F/.22" SCREW - BLACK
	149753-02-02A	EA	CAP - F/RECESSED RETAINER - BRIGHT WHITE
	149753-02-01A	EA	CAP - F/RECESSED RETAINER - BLACK

CLAMPS, CLIPS, GROMMETS, RIVETS & PLUGS

KEY	PART NUMBER	U/M	DESCRIPTION
	000F10-06-32B	EA	PIN - COTTER - 3/16" X 2" - ZINC
	000H14-06-06R	EA	RIVET-MANDREL BLIND,3/16 AL - CHERRY BSP-66
	000H16-04-06R	EA	RIVET - POP ALUMINUM - 1/8 X .313 - .375
	000H16-06-10R	EA	RIVET - POP ALUMINUM - 3/16 X .501 - .625
	007161-01-000	EA	CLAMP - HOSE - SPRING TYPE - 1/2"
	008386-01-000	EA	GROMMET - SNAP - 3/8" DIAMETER - NYLON
	010495-01-000	EA	CLAMP - CABLE - 9/16"ID - BLACK
	010495-02-000	EA	CLAMP - CABLE - 3/8"ID - BLACK
	010495-04-000	EA	CLAMP - CABLE - 11/16"ID - WHITE
	010497-01-000	EA	CLAMP - CLOSED - 5/8"ID
	010497-02-000	EA	CLAMP - CLOSED - 1.5"ID
	010497-03-000	EA	CLAMP - CLOSED - 1"ID - CUSHIONED
	010497-04-000	EA	CLAMP - CLOSED - 1 5/8"ID
	010497-05-000	EA	CLAMP - CLOSED - 1/2"ID
	010497-07-000	EA	CLAMP - CLOSED - 3/8"ID
	010497-09-000	EA	CLAMP - CLOSED - 5/16"ID
	010497-10-000	EA	CLAMP - CLOSED - 7/8"ID
	010499-01-000	EA	CLAMP - CLOSED - 3/8"ID
	016188-03-000	EA	GROMMET - LP LINE - 3/8"HOLE X 2 1/2"LONG - RUBBER
	016188-04-000	EA	GROMMET - LP LINE - 1/2"HOLE X 2 1/2"LONG - RUBBER
	016188-05-000	EA	GROMMET - LP LINE - 3/8"HOLE X 1 1/4"LONG - RUBBER
	016188-06-000	EA	GROMMET - L/P LINE - 3/8"HOLE X 3 1/4"LONG - RUBBER
	016188-08-000	EA	GROMMET - LP LINE - 1/2"HOLE X 1 1/4"LONG - RUBBER
	016188-09-000	EA	GROMMET - LP LINE - .68"HOLE X 1 1/4"LONG - RUBBER
	016188-10-000	EA	GROMMET - LP LINE - .68"HOLE X 2.5"LONG - RUBBER
	023942-01-000	EA	GROMMET - RUBBER - 2" OD
	034141-02-000	EA	PLUG/NYLON - .38" - BLACK
	061420-01-000	EA	PLUG/PLASTIC - 1 3/4" DIAMETER - BROWN
	061420-04-000	EA	PLUG/PLASTIC - 1 1/4" DIAMETER
	061420-05-000	EA	PLUG/PLASTIC - 1 1/2" DIAMETER
	061420-08-000	EA	PLUG/PLASTIC - 2 1/2" DIAMETER
	061420-09-000	EA	PLUG/PLASTIC - 1.00" - DIAMETER
	061420-10-000	EA	PLUG/PLASTIC - 1 1/2" DIAMETER - BLACK
	061420-14-000	EA	PLUG/PLASTIC - 7/8" DIAMETER - BLACK
	061420-15-000	EA	PLUG/PLASTIC - 2" DIAMETER - BLACK
	062401-01-000	EA	CLAMP - HOSE - WORMGEAR - .25" - 1"
	062401-02-000	EA	CLAMP - HOSE - WORMGEAR - 1.56" - 2.5"
	062401-03-000	EA	CLAMP - HOSE - WORMGEAR - .22" - 1"
	062401-04-000	EA	CLAMP - HOSE - WORMGEAR - .69" - 1.25"

SEALANTS & FASTENERS GROUP (CONTINUED)
CLAMPS, CLIPS, GROMMETS, RIVETS & PLUGS (CONTINUED)

KEY	PART NUMBER	U/M	DESCRIPTION
	062401-05-000	EA	CLAMP - HOSE - WORMGEAR - 2" - 3" ID
	062401-06-000	EA	CLAMP - HOSE - WORMGEAR - .22" - .62" ID
	062401-09-000	EA	CLAMP - HOSE - WORMGEAR - 2.8" - 3.75"
	062401-11-000	EA	CLAMP - HOSE - WORMGEAR - 3.50" - 4.50"
	062401-12-000	EA	CLAMP - HOSE - WORMGEAR - .79" X 1.26"
	062401-13-000	EA	CLAMP - HOSE - WORMGEAR
	071015-01-000	EA	GROMMET - RUBBER - .5"ID X 1"OD-W/.38" GROOVE - BLACK
	071015-11-000	EA	GROMMET - RUBBER - 1 ID - FITS .12 MATERIAL - BLACK
	071015-13-000	EA	GROMMET - RUBBER - .62 ID - FITS .09 GROOVE - BLACK
	071015-19-000	EA	GROMMET - RUBBER - .38 ID - FITS .06 MATERIAL - BLACK
	071015-26-000	EA	GROMMET - RUBBER - 1.5" ID X 2.1" OD W/.06" GROOVE-BLACK
	071015-29-000	EA	GROMMET - RUBBER - .3"ID X 1.3"OD W/.12" GROOVE - BLACK
	071015-30-000	EA	GROMMET - RUBBER - .3"ID X .81"OD W/.12" GROOVE - BLACK
	071015-32-000	EA	GROMMET - RUBBER - .75"ID X 1.375"OD W/.187" GROOVE-BLK
	071015-37-000	EA	GROMMET - .81 ID FITS .56 MTL
	071015-39-000	EA	GROMMET - .75 ID FITS .06 MTL
	071015-40-000	EA	GROMMET - .38 ID FITS .09 MTL
	071015-41-000	EA	GROMMET - .125 ID FITS .188 MTL
	071015-42-000	EA	GROMMET - RUBBER - .25 ID - FITS .06 MATERIAL - BLACK
	075148-02-000	EA	CLAMP - GROUNDING - BRONZE SCREWS
	077955-01-000	EA	CLIP/J - 3/8" - VINYL COATED
	080211-03-000	EA	CLIP - XMAS TREE W/PANEL RETAINING HEAD - 3/4" SHANK
	080734-02-000	EA	CLIP - WIRE NYLON
	081211-01-000	EA	PLUG - PLASTIC - .31"DIA - BLACK
	081211-03-000	EA	PLUG/PLASTIC - .50" DIAMETER - TRUSS HEAD - BLACK
	081211-04-000	EA	PLUG/PLASTIC - .46 DIAMETER - TRUSS HEAD - BLACK
	083609-01-000	EA	CLAMP - WIRE - DUAL - EQUAL DIAMETERS - 5/8"
	083610-01-000	EA	CLAMP - WIRE - DUAL - UNEQUAL DIAMETERS - 3/4" & 1 1/4"
	083610-02-000	EA	CLAMP - WIRE - DUAL - UNEQUAL DIAMETERS - 3/4" & 2"
	083610-03-000	EA	CLAMP - WIRE - DUAL - EQUAL DIAMETERS - 2"
	088756-01-000	EA	GROMMET - WEB - 1 1/8 " I.D.
	089329-02-000	EA	CLIP - SPRING
	091952-01-000	EA	CLIP - GRIPPER - 1"
	091952-02-000	EA	CLIP - GRIPPER - 3/4"
	091952-03-000	EA	CLIP - GRIPPER - 1/2" - BLACK VINYL COATED
	094362-02-000	EA	CLIP - XMAS TREE - BINDER HEAD - .9" LONG
	094362-05-000	EA	CLIP - XMAS TREE - ROUND HEAD - 1.4" LONG
	113133-02-01A	EA	RIVET - POP - ALUMINUM - 3/16 X .252 - .504 - BLACK
	114208-01-000	EA	GROMMET - EDGE LINER - FITS 1 3/4"
	114208-05-000	EA	GROMMET - EDGE LINER - FITS 2"
	115361-01-01A	EA	PLUG/PLASTIC - 1/2" DIAMETER
	118626-01-02A	EA	RIVET - POP - ALUMINUM - 3/16 X .08 - .375
	118626-01-01A	EA	RIVET - POP - ALUMINUM - 3/16 X .08 - .375
	137014-01-02A	EA	GROMMET - CABLE - BROWN
	137014-01-01A	EA	GROMMET - CABLE - ALMOND
	137014-01-03A	EA	GROMMET - CABLE - BLACK
	139118-02-01A	EA	GROMMET - SCREW - PLASTIC
	140171-01-000	EA	CLAMP - HOSE - STEPLESS EAR - .312

MISCELLANEOUS FASTENERS

KEY	PART NUMBER	U/M	DESCRIPTION
	008343-01-000	EA	TIE - WIRE - 6"
	008343-02-000	EA	TIE - WIRE - 14"
	008343-03-000	EA	TIE - WIRE - 7 1/2" - BLACK
	029094-04-000	YD	VELCRO TAPE - LOOP - 1" WIDE - BLACK
	029096-03-000	YD	VELCRO TAPE - HOOK - 1" WIDE - BLACK
	029096-04-000	YD	VELCRO TAPE/HOOK - 1" WIDE - BLACK - W/ADHESIVE BACK (PSA)
	048394-02-000	YD	VELCRO TAPE - HOOK - ADHESIVE BACK - 3/4" WIDE - BEIGE
	085774-01-000	FT	FASTENER - DUAL LOCK - 1" WIDE - ADHESIVE BACK - BLACK
	085774-02-000	FT	FASTENER - DUAL HOOK - 1" WIDE - ADHESIVE BACK - BLACK
	085774-03-000	FT	FASTENER - DUAL LOCK - 1/2" WIDE - ADHESIVE BACK - BLACK
	085774-04-000	FT	FASTENER - DUAL HOOK - 1/2" WIDE - ADHESIVE BACK - BLACK
	088792-02-000	YD	VELCRO TAPE - LOOP - 3/4" - ADHESIVE BACK - BEIGE
	088792-04-000	YD	VELCRO TAPE - HOOK - 5/8" - NON-ADHESIVE BACK - WHITE

SEALANTS & FASTENERS GROUP (CONTINUED)
CLAMPS, CLIPS, GROMMETS, RIVETS & PLUGS (CONTINUED)

KEY	PART NUMBER	U/M	DESCRIPTION
	088792-05-000	YD	VELCRO TAPE - LOOP - 5/8" - NON-ADHESIVE BACK - WHITE
	108046-01-000	EA	CABLE TIE - SCREW MOUNT 8"
	108046-02-000	EA	CABLE TIE - SCREW MOUNT 15"
	110943-01-000	FT	FELT STRIP - 3/8" - ADHESIVE BACK - BLACK - 75' PER ROLL
	110943-02-000	FT	FELT STRIP - 3/8" - ADHESIVE BACK - WHITE
	127960-01-01A	EA	RETAINER - 3/8" - STAINLESS STEEL

WATER & SEWAGE GROUP DRAINAGE SYSTEM

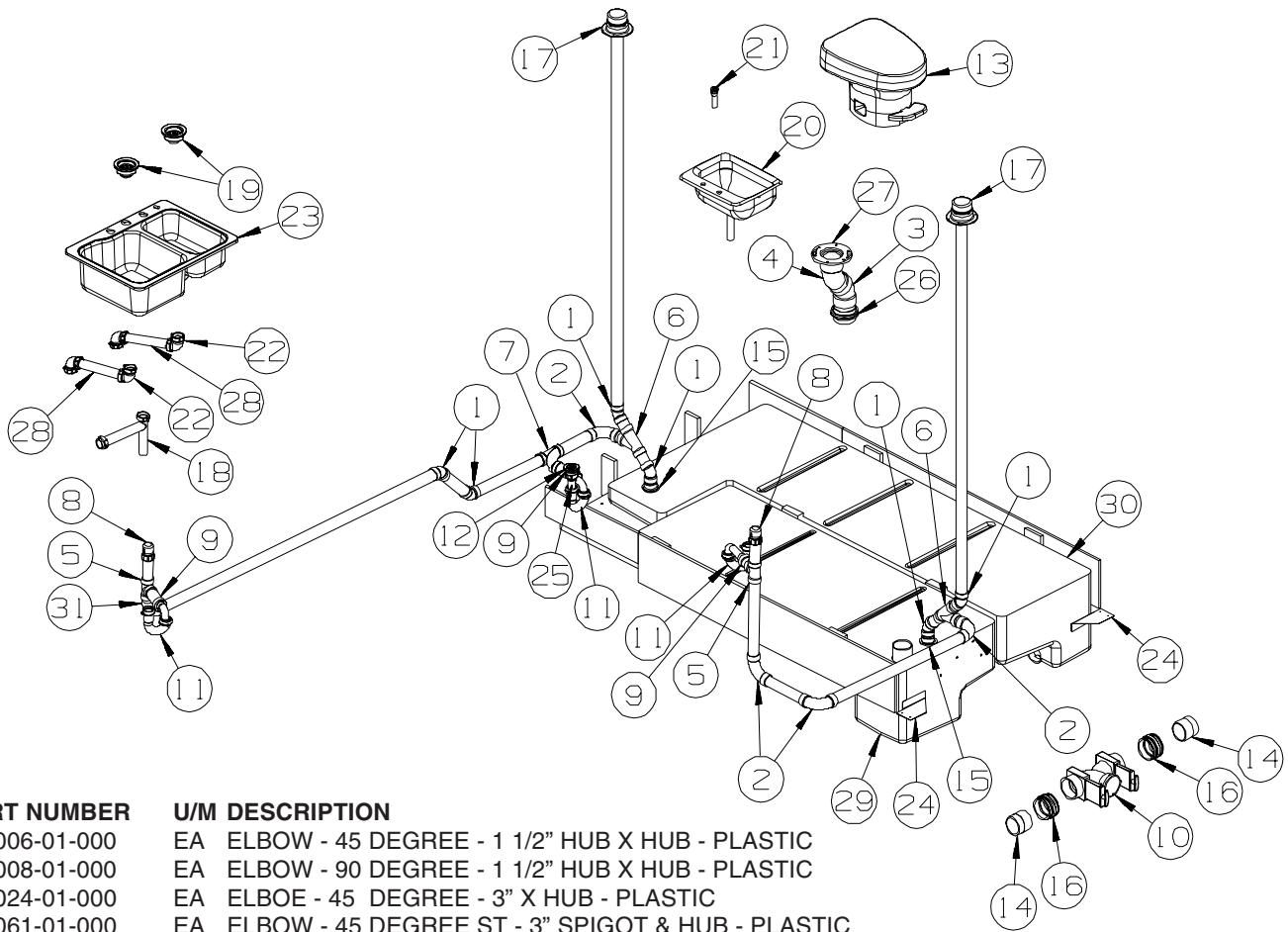

KEY	PART NUMBER	U/M	DESCRIPTION
1	010006-01-000	EA	ELBOW - 45 DEGREE - 1 1/2" HUB X HUB - PLASTIC
2	010008-01-000	EA	ELBOW - 90 DEGREE - 1 1/2" HUB X HUB - PLASTIC
3	010024-01-000	EA	ELBOE - 45 DEGREE - 3" X HUB - PLASTIC
4	010061-01-000	EA	ELBOW - 45 DEGREE ST - 3" SPIGOT & HUB - PLASTIC
5	010071-01-000	EA	TEE - SANITARY - 1 1/2" HUB X HUB X HUB - PLASTIC
6	010073-01-000	EA	WYE - 45 DEGREE - 1 1/2" HUB X HUB X HUB - PLASTIC
7	031365-02-000	EA	TEE - PLASTIC - 1 /12" EXTRA LONG TURN
8	079968-01-000	EA	VENT - MECHANICAL/TRAP ARM - ANTI SIPHON-2" X 7.3" PLASTIC
9	109571-01-000	EA	ADAPTER - P-TRAP - 1 1/2"P X 1 1/4"MPT
			FROM: 00-00-00 THRU: 10-12-04
9	152146-01-000	EA	CONNECTOR - 1 1/2"P X 1 1/2"MPT
			FROM: 10-13-04 THRU: 99-99-99
10	136143-01-000	EA	VALVE - DUAL - 3" X 3"
	139513-01-000	EA	HOSE - SEWER - 3" X 10' - W/ADAPTER
	062416-01-000	EA	ADAPTER - SEWER HOSE TO 3" PIPE
11	107538-01-000	EA	P-TRAP - PLASTIC - 1 1/4" W/EXTENSION ARM - USA
			FROM: 00-00-00 THRU: 10-12-04
11	107538-02-000	EA	P - TRAP - PLASTIC - 1 1/2" W/EXTENSION ARM - USA
			FROM: 10-13-04 THRU: 99-99-99
11	011071-01-000	EA	P-TRAP - 1 1/2" - CSA - PLASTIC - CANADIAN
12	066440-01-000	EA	STRAINER - SHOWER DRAIN - W/RUBBER WASHER
	127440-02-01A	EA	WASHER - RUBBER - 1.8" X .1"
13*	147421-02-01A	EA	TIOLET - AQUA MAGIC 5 - LOW/FOOTFLUSH/W/SPRAYER- WHITE
14	010129-03-000	EA	NIPPLE - PLASTIC - 3" X 3" TOE
15	061607-01-000	EA	GROMMET - HOLDING TANK - 1 1/2" NPS
16	078406-01-000	EA	COUPLER - RUBBER - W/CLAMPS - 3" X 3"
17	083558-03-000	EA	VENT W/COVER F/PLUMBING STACK - OFF WHITE
18	011091-02-000	EA	WASTE - CONTINUOUS - DOUBLE SINK
19	092303-01-000	EA	STRAINER - W/BASKET - GALLEY SINK - 4" OD
	127440-02-01A	EA	WASHER - RUBBER - 1.8" X .1"
20*	096927-01-02A	EA	SINK - LAVATORY - RECTANGULAR - PLASTIC - SOFT WHITE
21	106116-01-02A	EA	STRAINER/PLASTIC - STOPPER/TAILPIECE/GASKET & NUT-LAVATORY
	130403-01-000	EA	NUT - SLIP - W/WINGS 1 1/2"
22	125569-01-000	EA	ELBOW - 1 1/2" X 90 DEGREE - DOUBLE SLIP
23	148870-02-01A	EA	SINK/DOUBLE - LRG/SML BASIN - 25" X 19" X 7"
	148870-01-01A	EA	SINK/DOUBLE - LRG/SML BASIN - 25" X 19" X 7"
24	139004-01-02B	EA	BRACKET/TIEDOWN - WATER TANK - E-COATED

WATER & SEWAGE GROUP (CONTINUED)
DRAINAGE SYSTEM (CONTINUED)

KEY	PART NUMBER	U/M	DESCRIPTION
25	011069-02-000	EA	TAILPIECE - TUB/SHOWER - 1 1/2" X 1 1/4" X 4" - BRASS
	130403-01-000	EA	NUT - SLIP - W/WINGS 1 1/2"
26	061607-02-000	EA	GROMMET - HOLDING TANK - 3" NPS
27	063641-01-000	EA	FLANGE - CLOSET - 4" X 3"
28	126588-01-000	EA	ARM - WASTE - 1 1/2" X 9 1/2" - FEMALE
29	133436-01-700	EA	TANK - HOLDING - 41 GALLON - W/3" NIPPLE - W/O FITTINGS
30	142301-01-700	EA	TANK - HOLDING - 40 GALLON - W/3" NIPPLE OUTLET
	049032-01-000	EA	PATCH - SPINWELD - 3/8" - PLASTIC
31	033761-01-000	EA	ELBOW - 90 DEGREE - TURN - 1 1/2" HUB X 1 1/2" SPIGOT

***COMPONENT PARTS LISTED LATER IN THIS GROUP**

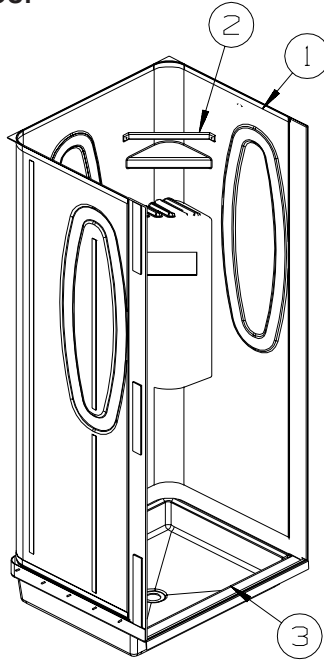

KEY	PART NUMBER	U/M	DESCRIPTION
1	147070-01-18A	EA	SURROUND - SHOWER - SOFT WHITE
2	113714-02-02A	EA	RETAINER - SHELF/SHOWER - 10.6" - SOFT WHITE
3	M02673-14-R28	EA	SHOWER PAN - W/STRAINER

COMPONENT PARTS FOR DRAINAGE SYSTEM

096927-01-02A

KEY	PART NUMBER	U/M	DESCRIPTION	VENDOR NO.
	096927-01-700	EA	SINK STOPPER	M9801
	096927-01-701	EA	TAILPIECE-DRAIN-LAVATORY	M9802

WATER & SEWAGE GROUP (CONTINUED)
DRAINAGE SYSTEM (CONTINUED)

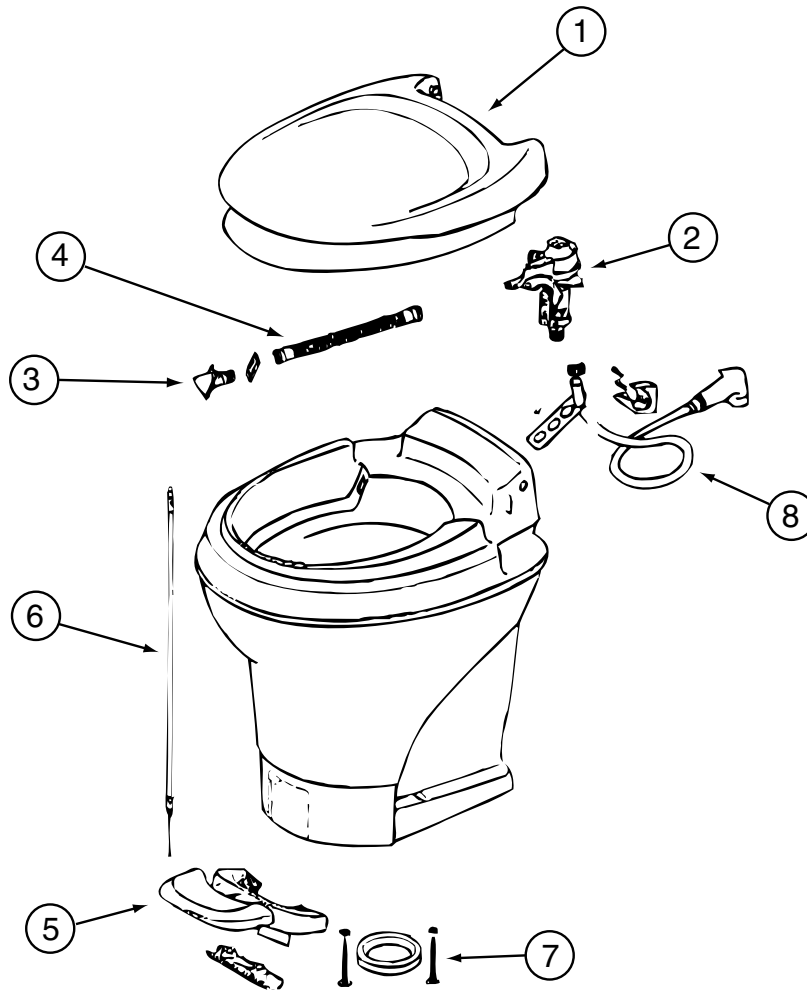

COMPONENT PARTS FOR DRAINAGE SYSTEM (CONTINUED)

147421-01-01A, 147421-02-01A

KEY	PART NUMBER	U/M	DESCRIPTION	VENDOR NO.
1	147421-01-700	EA	SEAT & COVER ASSEMBLY(WHT)	31703
2	147421-01-701	EA	WATER MODULE ASSEMBLY	31705
3	147421-01-702	EA	NOZZLE ASSEMBLY	31706
4	147421-01-703	EA	LINK - WATER MODULE	31621
5	147421-01-704	EA	PEDAL - WHITE	31709
6	147421-01-705	EA	FOOT CABLE	31711
7	063740-01-706	EA	BOLT PACKAGE-FLOOR FLANGE	12524 THETFORD
8	132389-01-708	EA	HAND SPRAY KIT	19289
	147421-01-706	EA	SEAL - BLADE	31708
	147421-01-707	EA	CAP (UNIVERSAL BOLT) - WHITE	31713

WATER & SEWAGE GROUP (CONTINUED)

WATER SYSTEM

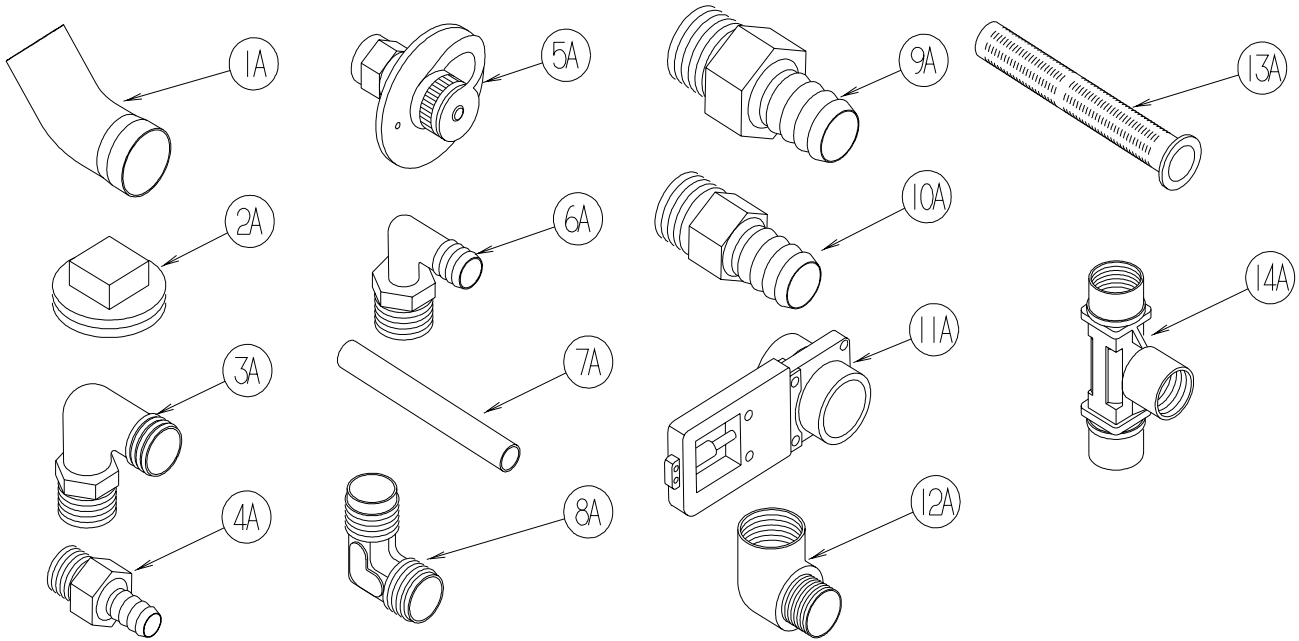

KEY	PART NUMBER	U/M	DESCRIPTION
1A	010009-01-000	EA	ELBOW - 90 DEGREE - 1/4 BEND - 1 1/2" PLASTIC
2A	010166-01-000	EA	PLUG/THREADED - 1 1/4"MPT - PLASTIC - BLACK - UL
3A	010219-01-000	EA	ELBOW - 1 1/4 MPT X 1 1/4 BARB - WATER FILL - PLASTIC
4A	010224-01-000	EA	ADAPTER - HOSE TO PIPE - 3/8 MPT X 3/8 BARB - PLASTIC
5A	010230-06-000	EA	FILL - CITY WATER - W/CHECK VALVE - MPT - BRUSHED ALUM
6A	035539-01-000	EA	ELBOW - 3/8 MPT X 3/8 BARB - PLASTIC
7A	039800-04-000	FT	TUBING - POLYBUTYL - 1/4"OD
7A	074462-02-000	FT	TUBING - VINYL - 3/8 ID X 20' - CLEAR
7A	112176-01-000	FT	TUBING - VINYL - REINFORCED - 1/2" ID
7A	124188-01-000	FT	TUBING - PEX - 1/2" ID X 20' - BLUE(COLD)
7A	124188-02-000	FT	TUBING - PEX - 1/2" ID X 20' - RED(HOT)
8A	039808-03-000	EA	ELBOW - 1/2" MPT X 1/2" MPT - PLASTIC
9A	044927-01-000	EA	ADAPTER - HOSE TO PIPE-1 1/4 MPTX1 1/4 BARB-BLACK PLASTIC
10A	044927-02-000	EA	ADAPTER - REDUCING - 1" MPT X 1.3" BARB - PLASTIC
11A	062421-03-000	EA	VALVE/DUMP W/O HANDLE - 1 1/2" X 1 1/2" HUB
	062421-05-000	EA	CABLE/ROD - F/DUMP VALVE - W/HANDLE - 48"
	062421-07-000	EA	CABLE/ROD - F/DUMP VALVE - W/HANDLE - 144"
	062421-08-000	EA	CABLE/ROD - F/DUMP VALVE - W/HANDLE - 108"
12A	065318-02-000	EA	ELBOW - 90 DEGREE - 3/8" MPT TO 3/8" FPT
13A	077954-02-000	EA	FILTER - WATER TANK - W/SCREEN IN TANK
14A	039798-01-000	EA	TEE - 1/2"MPT X 1/2"MPT X 1/2"MPT - PLASTIC

WATER & SEWAGE GROUP (CONTINUED)
WATER SYSTEM (CONTINUED)

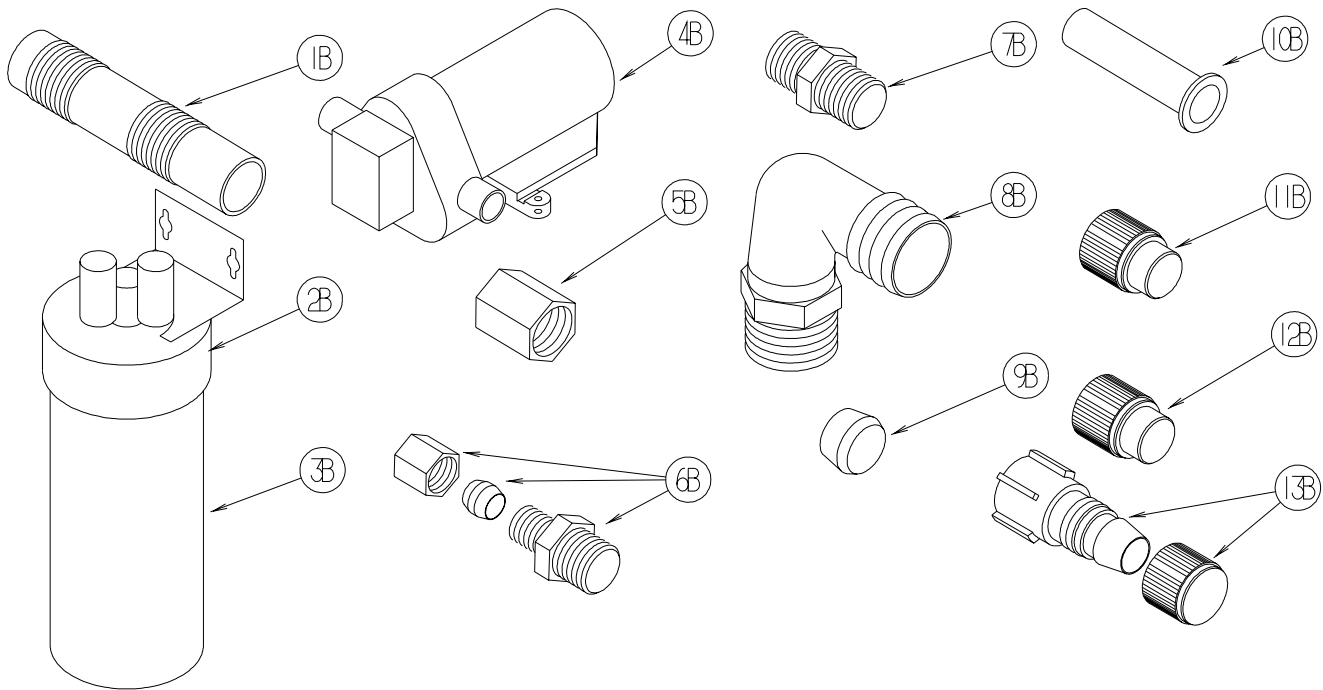

KEY	PART NUMBER	U/M	DESCRIPTION
1B	079381-01-000	FT	TUBING - RIBBED FLEXIBLE - WATER FILL - 1.4" ID
2B	087200-01-000	EA	FILTER-WATER PURIFCATION, EVERPURE QC2-AC
3B	087200-02-000	EA	CARTRIDGE-WATER FILTER,AC - EVERPURE 9601-11
4B*	098607-01-000	EA	PUMP - WATER - W/.5" MPT FITTING - FLOW 2.8 GPM
5B	101814-01-000	EA	COUPLING - FEMALE - 1/2" X 1/2" FPT - GRAY
6B	103798-01-000	EA	CONNECTOR - 1/4 OD X 3/8 MPT
7B	110438-02-000	EA	VALVE - CHECK - BRASS - 1/2 MPT X 1/2 MPT
8B	111223-02-000	EA	ELBOW - 1/2" MPT X 3/8" BARB - PLASTIC
8B	111223-03-000	EA	ELBOW - 3/4" MPT X 1/2" BARB - PLASTIC
8B	111223-04-000	EA	ELBOW - 1/2" MPT X 1/2" BARB - PLASTIC
9B	111888-01-000	EA	FERRULE - PLASTIC - .250 ID X .375 OD
10B	111888-02-000	EA	INSERT - BRASS - 1/4 COMP
11B	113697-01-000	EA	CAP - 3/8"P
12B	114427-01-000	EA	CAP - 1/2"P
13B	114427-02-000	EA	PLUG - W/COMP NUT - 1/2" PLASTIC PIPE/1/2" FLAIR-IT

WATER & SEWAGE GROUP (CONTINUED)
WATER SYSTEM (CONTINUED)

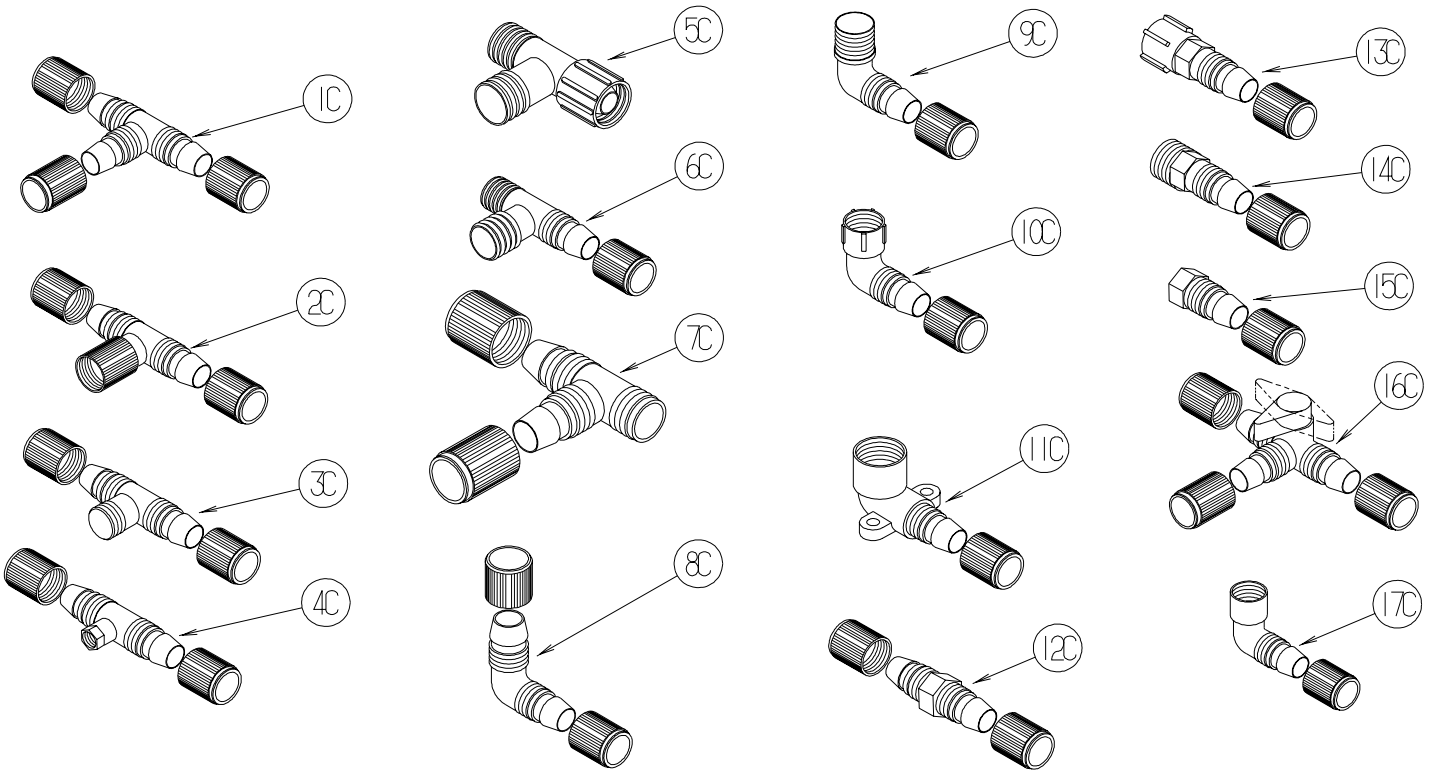

KEY	PART NUMBER	U/M	DESCRIPTION
1C	114428-01-000	EA	TEE - 1/2"P X 1/2"P X 1/2"P
2C	114428-02-000	EA	TEE - SWIVEL - 1/2"P X 1/2"P X 1/2"FPT
3C	114428-03-000	EA	TEE - 1/2"P X 1/2"P X 1/2"MPT
4C	114428-04-000	EA	TEE - 1/2"P X 1/2"P X 1/8"FPT
5C	114428-05-000	EA	TEE - 1/2" SWIVEL X 1/2" MPT X 1/2" MPT
6C	114428-06-000	EA	TEE - 1/2" P X 1/2" MPT X 1/2" MPT
7C	114428-07-000	EA	TEE - 1/2" P X 1/2" MPT X 1/2" P
8C	114429-01-000	EA	ELBOW - 1/2"P X 1/2"P
9C	114429-02-000	EA	ELBOW - 1/2"P X 1/2"MPT
9C	114429-04-000	EA	ELBOW - 1/2"P X 3/8"MPT
9C	114429-05-000	EA	ELBOW - 1/2"P X 3/4"MPT
9C	114429-10-000	EA	ELBOW - SWIVEL - 1/2"MPT X 1/2"FPT
10C	114429-06-000	EA	ELBOW - SWIVEL - 1/2"P X 3/4"FPT
10C	114429-08-000	EA	ELBOW - SWIVEL - 1/2"P X 1/2"FPT
11C	114429-09-000	EA	ELBOW - 1/2"P X 1/2"FPT DROP EAR
12C	114430-01-000	EA	ADAPTER - 1/2"P X 1/2"P
13C	114430-02-000	EA	ADAPTER - SWIVEL - 1/2"P X 1/2"FPT
13C	114430-04-000	EA	ADAPTER - SWIVEL - 1/2"P X 3/8"MPT
14C	114430-03-000	EA	ADAPTER - 1/2"P X 1/2"MPT
15C	114430-06-000	EA	ADAPTER - 1/2"P X 3/8"FPT
15C	114430-09-000	EA	ADAPTER - 1/2"P X 1/2"FPT
16C	114431-01-000	EA	VALVE - 180 DEGREE/CENTER DRAIN - 1/2"P - THREE WAY
17C	114429-11-000	EA	ELBOW - 1/2"P X 1/2"FPT

WATER & SEWAGE GROUP (CONTINUED)
WATER SYSTEM (CONTINUED)

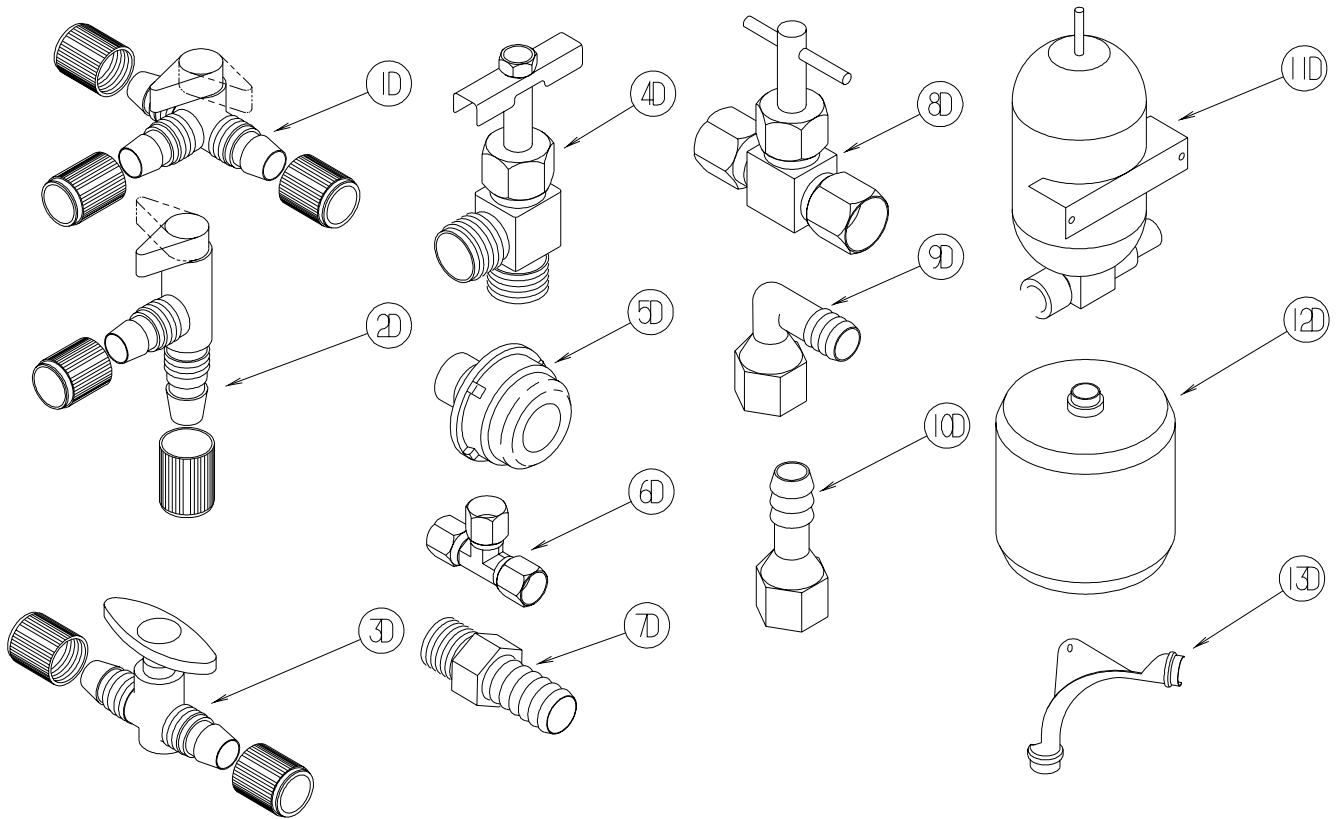

KEY	PART NUMBER	U/M	DESCRIPTION
1D	114431-02-000	EA	VALVE - WATER BYPASS - 1/2"P - THREE WAY (WATER HEATER)
2D	114431-03-000	EA	VALVE - 90 DEGREE DRAIN - 1/2"P
3D	114431-04-000	EA	VALVE - "INLINE SHUT-OFF" - 1/2"P
4D	114431-05-000	EA	VALVE - NEEDLE - 1/8" MPT X 1/4" COMPRESSION (ICE MAKER)
5D	114966-01-000	EA	FILTER - IN LINE - TWIST ON - 1/2"
			FROM: 00-00-00 THRU: 09-26-04
5D	152925-01-01A	EA	FILTER - IN LINE - TWIST ON - 1/2" - BLACK
			FROM: 09-27-04 THRU: 99-99-99
6D	118423-01-000	EA	FITTING - BRASS-TEE - 1/4C X 1/4C X 1/4C
7D	118809-01-000	EA	ADAPTER - 1/2" MPT X 3/8" BARB - PLASTIC
7D	118809-02-000	EA	ADAPTER - 1/2" MPT X 1/2" BARB - PLASTIC
8D	120868-01-000	EA	VALVE - NEEDLE - 1/4" COMPRESSION X 1/4" COMPRESSION
9D	123150-01-000	EA	ELBOW - 1/2 FPT X 1/2 BARB - SWIVEL
10D	123152-01-000	EA	ADAPTER - 1/2 FPT X 1/2 BARB - SWIVEL
11D	123243-01-000	EA	TANK - ACCUMULATOR - 24 OZ
12D	123317-01-000	EA	TANK - ACCUMULATOR - 2 GALLON
13D	124184-01-000	EA	SUPPORT - WATER LINE - BEND

WATER & SEWAGE GROUP (CONTINUED)
WATER SYSTEM (CONTINUED)

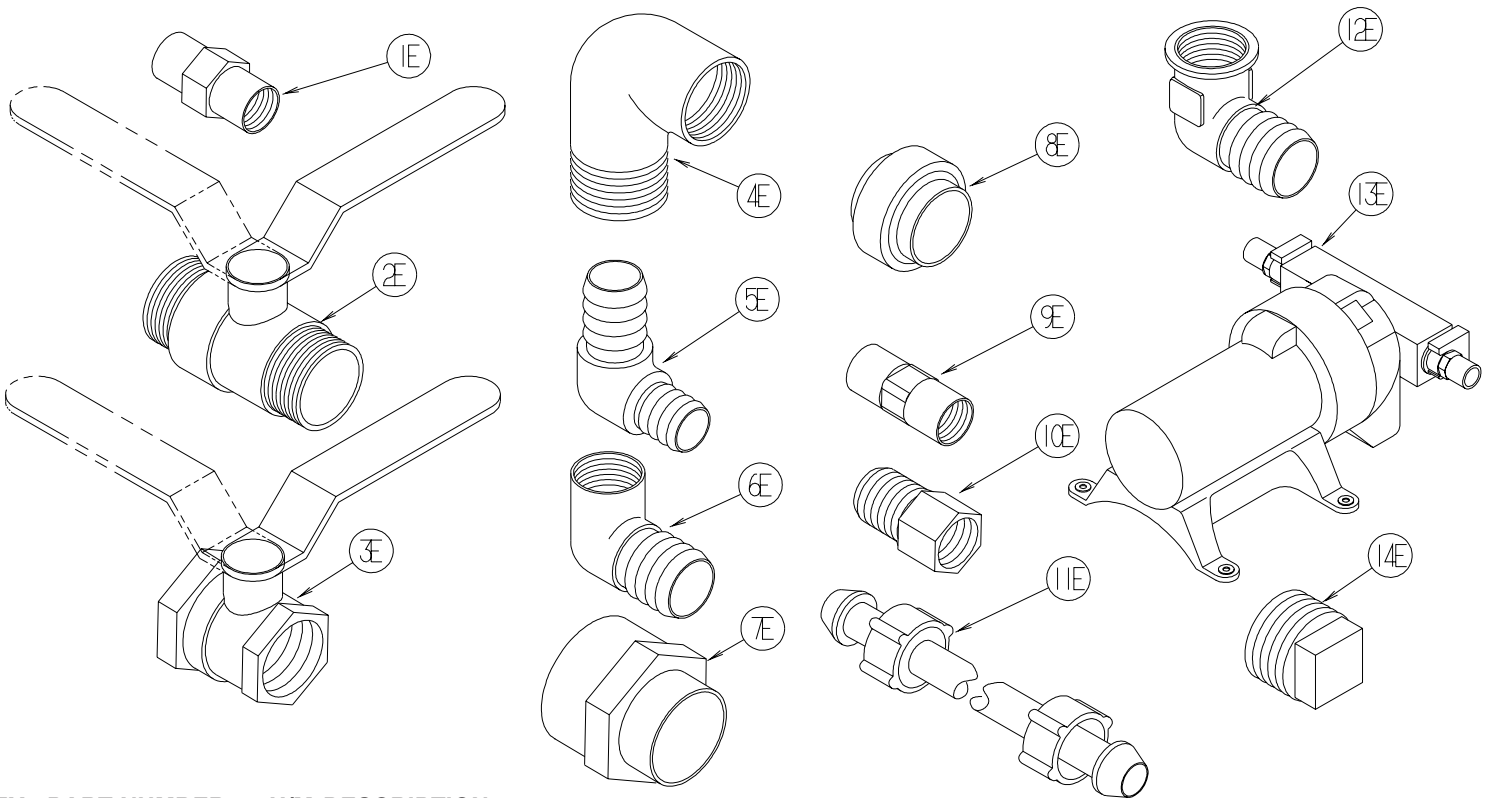

KEY	PART NUMBER	U/M	DESCRIPTION
1E	132148-01-000	EA	CONNECTOR - 1/2" X 1/2"MPT - BRASS
2E	132483-01-000	EA	VALVE/BALL - 1" - THREADED ENDS
3E	132483-02-000	EA	VALVE/BALL - 1/2" - BRASS - FPT
4E	132484-01-000	EA	ELBOW - 90 DEGREE - 1MPT X 1FPT - PLASTIC
5E	132781-01-000	EA	ELBOW - 1.3" BARB X 1.3" BARB - 90 DEGREE - PLASTIC
6E	132782-01-000	EA	ELBOW - 1"FPT X 1.3" BARB - 90 DEGREE - PLASTIC
7E	133835-01-000	EA	ADAPTER - REDUCING - 1 1/2" X 1 1/4"
8E	133889-01-000	EA	UNION - 1 1/2 DOUBLE SLIP - PVC
9E	135386-01-000	EA	NIPPLE - 1/2"
10E	136333-01-000	EA	ADAPTER - BRASS - 1/2"MPT X 1/2"FPT
11E	140821-01-000	EA	TUBE - WATER SUPPLY - 3/8" X 24"
11E	140821-02-000	EA	TUBE - WATER SUPPLY - 3/8" X 30"
11E	140821-03-000	EA	TUBE - WATER SUPPLY - 3/8" X 36"
11E	140821-04-000	EA	TUBE - WATER SUPPLY - 3/8" X 48"
11E	140821-05-000	EA	TUBE - WATER SUPPLY - 3/8" X 54"
11E	140821-06-000	EA	TUBE - WATER SUPPLY - 3/8" X 60"
11E	140821-07-000	EA	TUBE - WATER SUPPLY - 3/8" X 72"
12E	142812-01-000	EA	ELBOW - BRASS - 1/2"MPT X 1/2"FPT
13E*	144215-01-000	EA	PUMP - WATER - 5.7 GPM - W/1/2" MPT
*	144215-02-000	EA	STRAINER - WATER PUMP
14E	145609-01-000	EA	PLUG - BRASS - 1/2" MPT/HEX HEAD

***COMPONENT PARTS LISTED LATER IN THIS GROUP**

WATER & SEWAGE GROUP (CONTINUED)
WATER SYSTEM (CONTINUED)

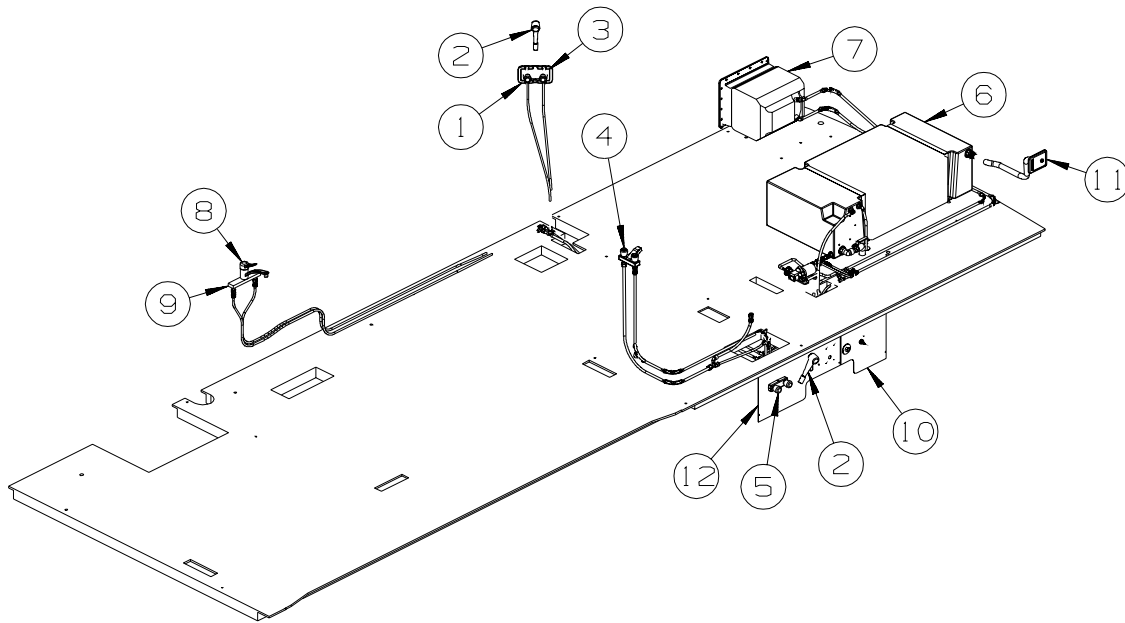

KEY	PART NUMBER	U/M	DESCRIPTION
1*	075241-04-000	EA	FAUCET - SHOWER/BRASS
2	131383-01-02A	EA	SHOWER HEAD - W/60" HOSE & BRACKET - WHITE
3	075606-03-000	EA	PANEL - FAUCET SHOWER - SOFT WHITE
4*	075240-05-000	EA	FAUCET - LAVATORY/BRASS - W/CLEAR KNOBS
5*	075241-06-000	EA	FAUCET - SHOWER/BRIGHT WHITE - .5" MPT W/1.9" INLET PIPES
6	148137-02-01A	EA	TANK - WATER - 70 GALLON - W/FITTINGS
	042989-03-000	EA	FITTING - SPINWELD - 1 1/4"NPT - PLASTIC
	042989-05-000	EA	FITTING - SPINWELD - 1/2"FPT - PLASTIC
	042989-08-000	EA	FITTING - SPINWELD - 1"FPT - PLASTIC
	049032-01-000	EA	PATCH - SPINWELD - 3/8" - PLASTIC
	148137-01-01A	EA	TANK - WATER - 70 GALLON - W/O FITTINGS
7*	051393-01-000	EA	WATER HEATER - GH6-8E - ELECTRONIC IGNITION W/MOTOR AID
7*	051391-03-000	EA	WATER HEATER G6A-8E ELECTRONIC IGNITION
7	052009-06-000	EA	DOOR - WATER HEATER - BRIGHT WHITE - 18" X 14.6"
8*	104114-05-01A	EA	FAUCET - GALLEY - SINGLE CONTROL/LOOP HANDLE - CHROME
			FROM: 00-00-00 THRU: 11-15-04
8	149164-01-01A	EA	FAUCET - GALLEY - SINGLE CONTROL - CHROME
			FROM: 11-16-04 THRU: 99-99-99
9	091253-01-000	EA	GASKET - FAUCET - LAVATORY/GALLEY
10	139549-02-12B	EA	PANEL - SERVICE CENTER - BRIGHT WHITE
11	137169-01-01A	EA	WATER FILL/GRAVITY - W/DOOR - W/O LOCK - BRIGHT WHITE
	138290-03-000	EA	CASE - W/CAM - W/O CYLINDER/KEY
12	148582-01-12B	EA	PANEL - SERVICE CENTER - BRIGHT WHITE

***COMPONENT PARTS LISTED LATER IN THIS GROUP**

WATER & SEWAGE GROUP (CONTINUED)
COMPONENT PARTS FOR WATER SYSTEM

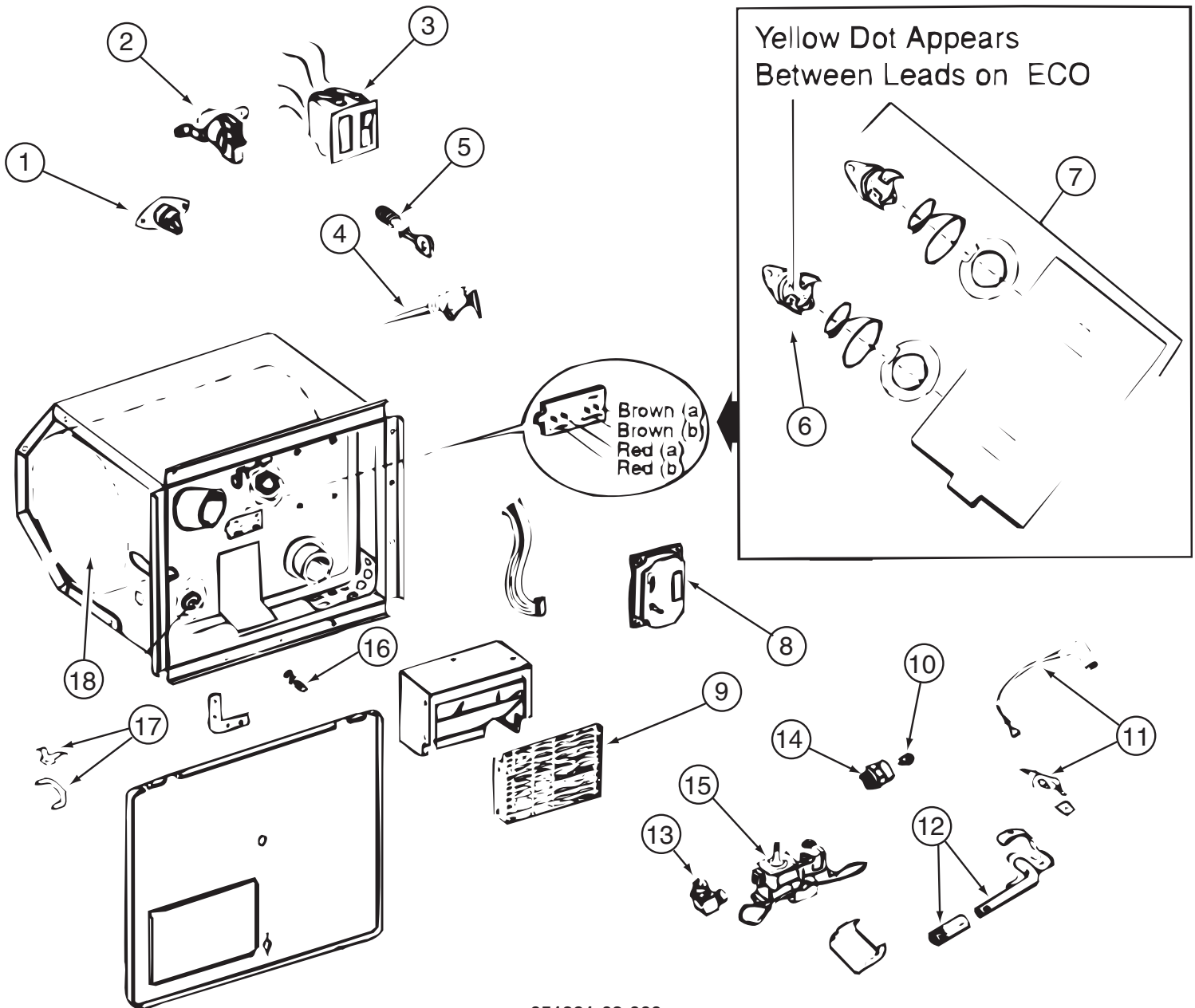

051391-03-000

KEY	PART NUMBER	U/M	DESCRIPTION	VENDOR NO.
3	051393-01-701	EA	SWITCH - REMOTE - W/LIGHT	91959
4	051391-01-704	EA	VALVE-RELIEF, 1/2" FITTING	91604
5	051391-01-705	EA	FASTENER-CAMLOCK	92609
6	051391-04-701	EA	THERMOSTAT 12V DC-120 PRESET	91470
7	051393-01-721	EA	THERMOSTAT W/ECO, 140 FRT MT	91447
9	051391-04-707	EA	KIT-EXHAUST, (FLUE & GASKET)	90960
10	051391-01-710	EA	ORIFICE-MAIN BURNER	92742
12	051391-04-703	EA	BURNER-MAIN/ELECTRONIC IG	91638
13	051391-01-714	EA	FITTING-ELBOW 45,3/8F X 3/8	MPT 1044
14	051391-03-700	EA	HOLDER-ORIFICE	91563
16	051391-01-715	EA	PLUG-DRAIN, 1 EA = 2 PER PKG	91857
17	051391-01-700	EA	HINGE KIT, (PIN & CLIP)	92568&92559
18	051391-04-706	EA	TANK-G6A-4E/6E/7E/8E-FRT.MT	91641
	051391-01-717	EA	GRILLE-WATER HEATER DOOR	92640
	051393-01-723	EA	SWITCH - THERMAL CUTOUT 2/PK	93853 NOW 93866
	051393-01-724	EA	BOARD-CIRCUIT, SPADE TERMINAL	93865
	051393-01-725	EA	ELECTRODE-SGL SPADE CONNECT.	93868
	051393-01-726	EA	VALVE/SOLENOID - W/O BRACKET	93870
	111129-01-711	EA	BRACKET-CORNER, SET OF FOUR	91928

CONTACT WINNEBAGO PARTS SALES FOR UNLISTED COMPONENT(S)

WATER & SEWAGE GROUP (CONTINUED)
COMPONENT PARTS FOR WATER SYSTEM (CONTINUED)

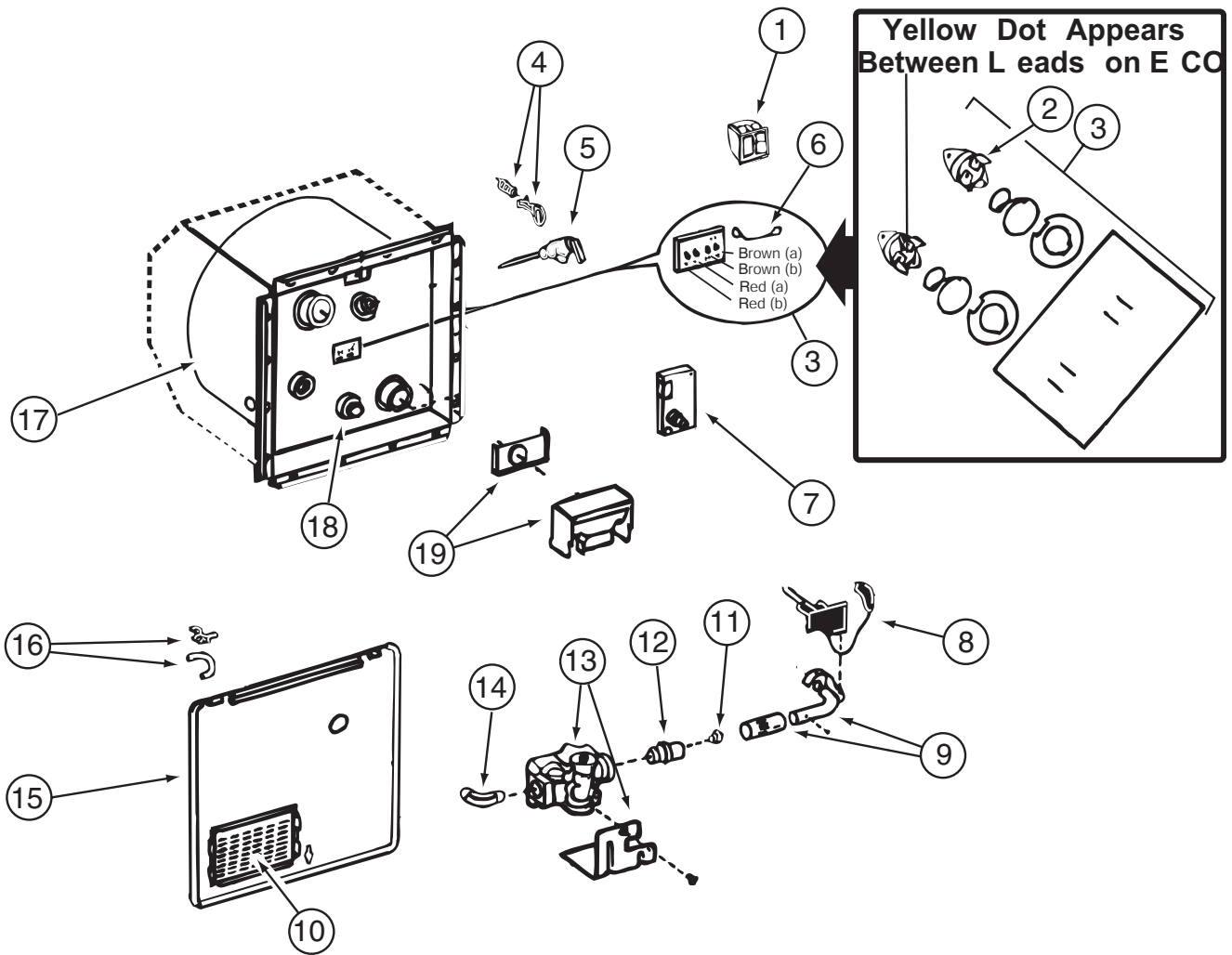

051393-01-000

KEY	PART NUMBER	U/M	DESCRIPTION	VENDOR NO.
1	051393-01-701	EA	SWITCH PACKAGE	91959
2	051391-04-701	EA	THERMOSTAT 12V DC-120 PRESET	91470
3	051393-01-721	EA	ECO & THERMOSTAT ASM - FRT MT - 140°	91447
4	051391-01-705	EA	FASTENER - CAMLOC	92609
5	051391-01-704	EA	VALVE - RELIEF - 1/2" FITTING	91604
6	051393-01-723	EA	SWITCH - ENERGY CUT-OFF	93866
7	051393-01-724	EA	CIRCUIT BOARD - W/ SPADE TERMINAL	93867
8	051393-01-725	EA	ELECTRODE - SINGLE SPADE CNT	93868
9	051391-04-703	EA	BURNER - MAIN	91638
10	051391-01-717	EA	GRILLE	92640
11	051391-01-710	EA	ORIFICE - MAIN BURNER	92742
12	051391-03-700	EA	ORIFICE HOLDER	91563
13	051393-01-726	EA	SOLENOID VALVE & BRACKET	93870
14	051391-01-714	EA	ELBOW - 45 DEGREE - 3/8" F X 3/8" MPT	91044
15		EA	DOOR-WATER HEATER - SEE EXTERIOR DOOR & COMPARTMENT GROUP BY MODEL	
16	051391-01-700	EA	HINGE KIT - W/CLIP	92568 & 92559
17	051391-04-704	EA	TANK - INNER	91642
18	051391-01-715	EA	DRAIN PLUG	91857
19	051391-04-707	EA	FLUE & GASKET	90960
	111129-01-711	EA	BRACKET-CORNER, SET OF FOUR	91928

WATER & SEWAGE GROUP (CONTINUED)
COMPONENT PARTS FOR WATER SYSTEM (CONTINUED)

075240-05-000

KEY	PART NUMBER	U/M DESCRIPTION	VENDOR NO.
	075240-05-700	EA CARTRIDGE - WASHERLESS	9-P42

075241-04-000, 075241-05-000, 075241-06-000

KEY	PART NUMBER	U/M DESCRIPTION	VENDOR NO.
	075240-05-700	EA CARTRIDGE - WASHERLESS	9-P42

098607-01-000

KEY	PART NUMBER	U/M DESCRIPTION	VENDOR NO.
	098607-01-702	EA DIAPHRAGM/DRIVE ASSEMBLY KIT	94-238-04
	098607-01-703	EA VALVE KIT	94-232-00
	098607-01-705	EA VALVE-CHECK, KIT	94-237-00
	098607-01-706	EA HOUSING, W/SWITCH ONLY	94-231-20
	098607-01-707	EA MOTOR W/BASEPLATE	11-148-04

104114-05-01A

KEY	PART NUMBER	U/M DESCRIPTION	VENDOR NO.
	104114-05-700	EA CARTRIDGE- REPAIR KIT	6-N1201-5-0WB

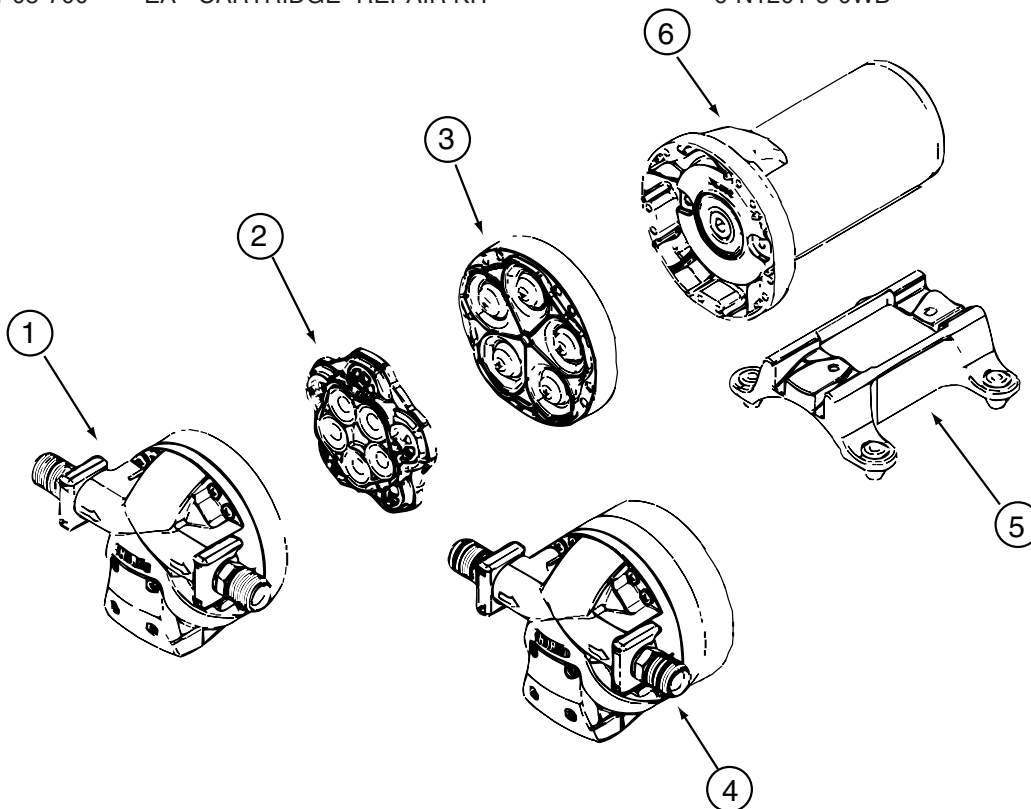

144215-01-000

KEY	PART NUMBER	U/M DESCRIPTION	VENDOR NO.
2	144215-01-700	EA VALVE ASSEMBLY	94-030-01
3	144215-01-701	EA DRIVE ASSEMBLY	94-030-02
	144215-01-702	EA FITTING KIT - W/ORINGS	94-615-06

CONTACT WINNEBAGO PARTS SALES FOR UNLISTED COMPONENT(S)

144215-02-000

KEY	PART NUMBER	U/M DESCRIPTION	VENDOR NO.
	144215-02-700	EA FITTING KIT- COUPLER W/ORING	94-637-00

WINDOW & VENTS GROUP

WINDOW & VENT LAYOUT

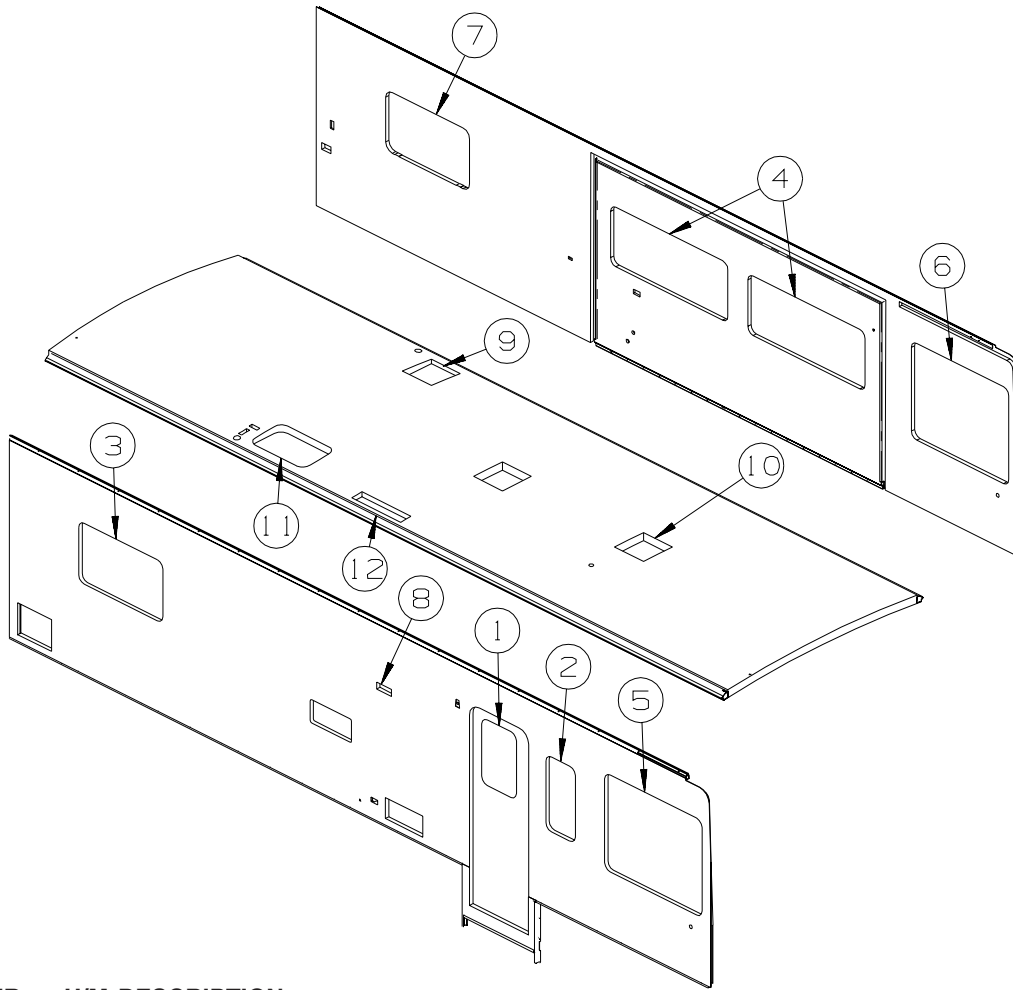

KEY	PART NUMBER	U/M	DESCRIPTION
1	117053-02-F36	EA	WINDOW - PICTURE - W/O TRIM - 60% TINTING - 26.4" X 17"
	002181-25-000	EA	GLASS - PICTURE WINDOW - 25.8"W X 16.4"H
	087561-01-000	FT	SEAL - GLASS - EXTERIOR - .5" WIDE - VINYL BLACK
1	117054-02-02A	EA	TRIM/RETAINER - INSIDE - 16.9" X 26.2" - BRIGHT WHITE
1*	113733-01-02A	EA	WINDOW - STATIONARY W/TRIM - THERMO - 17" X 26.4" - DUAL PANE FROM: 00-00-00 THRU: 05-02-04
1*	150651-01-01A	EA	WINDOW - STATIONARY/FLUSH/THERMO - 26.3" X 17" - DUAL PANE FROM: 05-03-04 THRU: 99-99-99
2*	098644-07-02A	EA	WINDOW - VERTICAL SLIDER W/TRIM - TINTED - 14" X 30"
2*	112898-04-02A	EA	WINDOW - VERTICAL SLIDER/THERMO W/TRIM - 14.5" X 30.2" - DUAL PANE FROM: 00-00-00 THRU: 05-02-04
2*	150649-01-01A	EA	WINDOW - VERT SLIDER/FLUSH/THERMO - 30.9" X 14.2" - DUAL PANE FROM: 05-03-04 THRU: 99-99-99
3*	098647-41-02A	EA	WINDOW - PASS HORIZ SLIDER W/TRIM - TINTED - 24.2" X 41"
3*	112795-21-02A	EA	WINDOW - PASS HORIZ SLIDER/THERMO W/TRIM - 24.3" X 41" - DUAL PANE FROM: 00-00-00 THRU: 05-02-04
3*	150648-11-01A	EA	WINDOW-HORIZ SLIDER/FLUSH/THERMO/RH - 24.5" X 41.2" - DUAL PANE FROM: 05-03-04 THRU: 99-99-99
4*	098647-47-02A	EA	WINDOW - DRVR HORIZ SLIDER W/TRIM - TINTED - 57.4" X 23.6"
4*	112795-54-02A	EA	WINDOW - DRVR HORIZ SLIDER/THERMO W/TRIM - 23.9" X 57.8" - DUAL PANE FROM: 00-00-00 THRU: 05-02-04
4*	150648-07-01A	EA	WINDOW-HORIZ SLIDER/FLUSH/THERMO/LH - 23.8" X 57.7" - DUAL PANE FROM: 05-03-04 THRU: 99-99-99
5*	145573-01-01A	EA	WINDOW - CAB/PASSENGER/RADIUS/3 GLASS - 39" X 47.9" - BLK
5*	145573-03-01A	EA	WINDOW - CAB/PASSENGER/RADIUS/3 GLASS/THERMO - 39" X 47.9" - DUAL PANE FROM: 00-00-00 THRU: 05-02-04
5*	151069-02-01A	EA	WINDOW - CAB/RIGHT HAND/FLUSH/THERMO - 39" X 47.9" - DUAL PANE FROM: 05-03-04 THRU: 99-99-99
6*	145573-02-01A	EA	WINDOW - CAB/DRIVER/RADIUS/3 GLASS - 39" X 47.9" - BLACK
6*	145573-04-01A	EA	WINDOW - CAB/DRIVER/RADIUS/3 GLASS/THERMO - 39" X 47.9" - DUAL PANE FROM: 00-00-00 THRU: 05-02-04

WINDOW & VENTS GROUP (CONTINUED)
WINDOW & VENT LAYOUT (CONTINUED)

KEY	PART NUMBER	U/M	DESCRIPTION
6*	151069-01-01A	EA	WINDOW - CAB/LEFT HAND/FLUSH/THERMO - 39" X 47.9" - DUAL PANE FROM: 05-03-04 THRU: 99-99-99
7*	098647-63-01A	EA	WINDOW - DRVR HORIZ SLIDER/EGRESS W/TRIM - 41" X 24.2"
7*	112795-90-01A	EA	WINDOW-DRVR HORIZ SLIDER/THERMO/ESC W/TRIM - 25.5" X 41.1" - DUAL PANE FROM: 00-00-00 THRU: 05-02-04
7*	150648-12-01A	EA	WINDOW-HORIZ SLIDER/ESCAPE/FLUSH/THERMO/LH - 24.5" X 41.2" - DUAL PANE FROM: 05-03-04 THRU: 99-99-99
8	084616-07-000	EA	SHROUD - EXHAUST VENT/RANGE HOOD - BRIGHT WHITE FROM: 00-00-00 THRU: 08-01-04
8	147821-02-01A	EA	SHROUD - VENT - RANGE - COVER - BRIGHT WHITE FROM: 08-02-04 THRU: 99-99-99
8	084878-09-000	EA	VENT - EXHAUST/RANGE HOOD - OFF WHITE FROM: 00-00-00 THRU: 08-01-04
8	147821-01-01A	EA	VENT - RANGE - OUTER - BRIGHT WHITE FROM: 08-02-04 THRU: 99-99-99
9*	122882-02-01A	EA	VENT - ROOF - W/FAN - W/O INSIDE GARNISH - UL - U.S. - POWER VENT
9*	122882-03-01A	EA	VENT - ROOF - W/FAN - W/O INSIDE GARNISH - CSA - CANADIAN - POWER VENT
	009440-01-000	EA	GEAR/ARM - LIFT - ROOF VENT COVER
	048648-01-000	EA	MOTOR/ROOF VENT - W/RESISTER - 1/8"SHAFT - 12VOLT
	048649-01-000	EA	FAN BLADE - ROOF VENT - 6 BLADED - 6"RADIUS
9	122882-07-01A	EA	GARNISH - ROOF VENT - 2.5" TO 4.1"
10*	122882-01-01A	EA	VENT - ROOF - NONPOWERED - W/O INSIDE GARNISH - NON-POWERED VENT
	009440-01-000	EA	GEAR/ARM - LIFT - ROOF VENT COVER
10	122882-07-01A	EA	GARNISH - ROOF VENT - 2.5" TO 4.1"
10*	123780-03-01A	EA	FANTASTIC VENT-3"4"ROOF-W/FAN-W/O THERM/PWR LIFT/WHT CVR - POWER VENTILATOR VENT
	009440-01-000	EA	GEAR/ARM - LIFT - ROOF VENT COVER
11	122193-01-02A	EA	PANEL - SKYLITE - INNER - W/LIGHT INDENTATION
11	138372-01-02B	EA	TRIM - CORNER - SKYLIGHT - E-COATED
11	138379-02-01A	EA	PANEL/SKYLIGHT OTR - RECT/4"H CTR DOME-18.4" X 29.5 - WHT
12	149508-01-02A	EA	CAP - ROOF/REFRIGERATOR VENT - WHITE
12	149508-02-02A	EA	BASE - ROOF/REFRIGERATOR VENT - BRIGHT WHITE

***COMPONENT PARTS LISTED LATER IN THIS GROUP**

WINDOW & VENTS GROUP (CONTINUED)
COMPONENT PARTS FOR WINDOWS & VENT LAYOUT

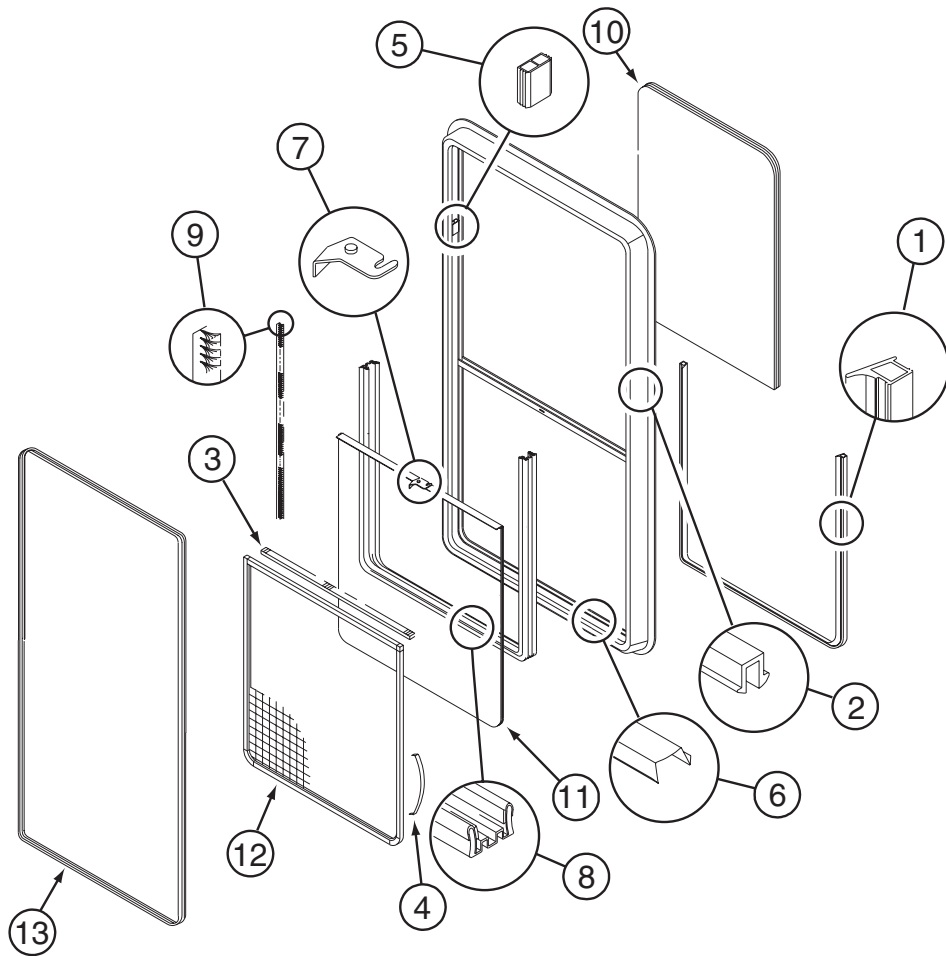

098644-07-02A

KEY	PART NUMBER	U/M	DESCRIPTION	VENDOR NO.
1	098644-01-716	FT	PLUG - FILLER	132-014470
2	098644-01-705	FT	GLAZING - STRIP	132-010231
3	098644-01-706	FT	WEATHERSTRIP - GLASS	171-010668
4	098644-01-713	EA	CLIP - SCREEN - METAL	226-016966
4	125582-01-701	EA	CLIP - SCREEN - PLASTIC	130-005153
5	098644-01-719	EA	STOP - SLIDER GLASS	132-014203
6	098644-01-710	FT	TRACK - SCREEN SPACER 12'	132-017135
7	098644-01-700	EA	LATCH - REPAIR KIT (BLACK)	B801-CK
7	098647-54-701	EA	LATCH - REPAIR KIT (RED)	B081-CK
8	098644-01-708	FT	CHANNEL - RUN PIERCED	122-016543
9	098644-01-711	FT	WEATHERSTRIP - SCREEN BLACK	171-016965
10	098644-07-702	EA	GLASS - STATIONARY	106-015777
11	098644-07-703	EA	GLASS-SLIDING W/SASH & LATCH	H170-G9
12	098644-07-704	EA	SCREEN ASM - W/SEALS & CLIPS	410-018863
13	098644-07-705	EA	RETAINER - TRIM	CH02-66
	098644-01-717	FT	SPLINE - SCREEN	132-004716

WINDOW & VENTS GROUP (CONTINUED)
COMPONENT PARTS FOR WINDOWS & VENT LAYOUT (CONTINUED)

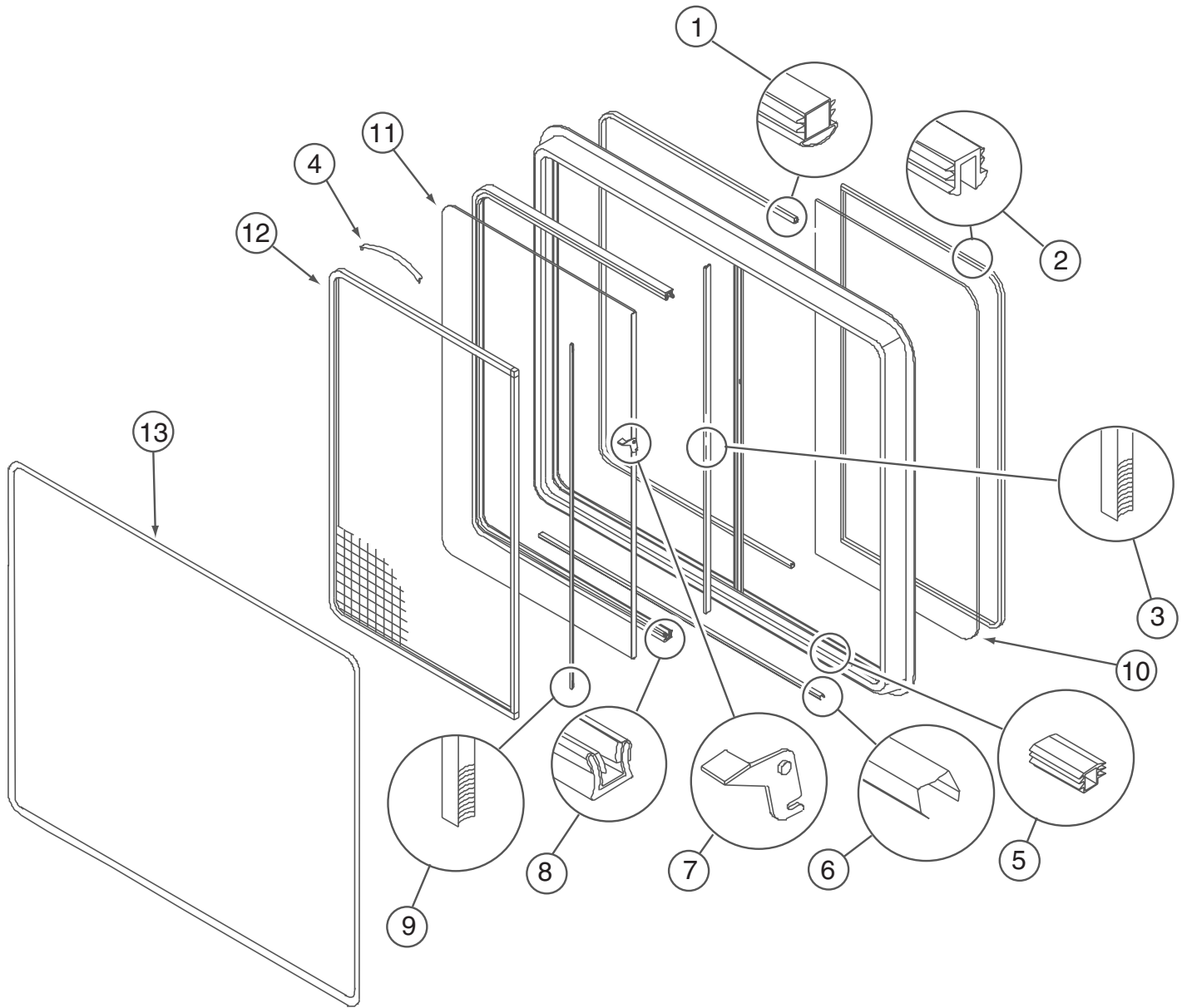

098647-41-02A

KEY	PART NUMBER	U/M	DESCRIPTION	VENDOR NO.
1	098644-01-716	FT	PLUG - FILLER	132-014470
2	098644-01-705	FT	GLAZING - STRIP	132-010231
3	098644-01-706	FT	WEATHERSTRIP - GLASS	171-010668
4	098644-01-713	EA	CLIP - SCREEN - METAL	226-016966
4	125582-01-701	EA	CLIP - SCREEN - PLASTIC	130-005153
5	098644-01-719	EA	STOP - SLIDER GLASS	132-014203
6	098644-01-710	FT	TRACK - SCREEN SPACER 12'	132-017135
7	098647-54-701	EA	LATCH - REPAIR KIT (RED)	B081-CK
8	098644-01-708	FT	CHANNEL - RUN PIERCED	122-016543
9	098644-01-711	FT	WEATHERSTRIP - SCREEN BLACK	171-016965
10	098647-41-701	EA	GLASS - STATIONARY	106-015474
11	098647-41-700	EA	GLASS-SLIDING W/SASH & LATCH	H172-G9
12	098647-29-704	EA	SCREEN ASM - W/SEALS & CLIPS	410-018864
13	098647-29-705	EA	RETAINER - TRIM	CH04-66
	098644-01-717	FT	SPLINE - SCREEN	132-004716

WINDOW & VENTS GROUP (CONTINUED)
COMPONENT PARTS FOR WINDOWS & VENT LAYOUT (CONTINUED)

098647-47-02A

KEY	PART NUMBER	U/M	DESCRIPTION	VENDOR NO.
1	098644-01-716	FT	PLUG - FILLER	132-014470
2	098644-01-705	FT	GLAZING - STRIP	132-010231
3	098644-01-706	FT	WEATHERSTRIP - GLASS	171-010668
4	098644-01-713	EA	CLIP - SCREEN - METAL	226-016966
4	125582-01-701	EA	CLIP - SCREEN - PLASTIC	130-005153
5	098644-01-719	EA	STOP - SLIDER GLASS	132-014203
6	098644-01-710	FT	TRACK - SCREEN SPACER 12'	132-017135
7	098644-01-700	EA	LATCH - REPAIR KIT (BLACK)	B801-CK
7	098647-54-701	EA	LATCH - REPAIR KIT (RED)	B081-CK
8	098644-01-708	FT	CHANNEL - RUN PIERCED	122-016543
9	098644-01-711	FT	WEATHERSTRIP - SCREEN BLACK	171-016965
10	098647-47-700	EA	GLASS - STATIONARY	106-025224
11	098647-47-701	EA	GLASS-SLIDING W/SASH & LATCH	H493-G9
12	098647-47-702	EA	SCREEN ASM - W/SEALS & CLIPS	410-025226
13	098647-47-704	EA	RETAINER - TRIM	H493-66
	098644-01-717	FT	SPLINE - SCREEN	132-004716

098647-63-01A

KEY	PART NUMBER	U/M	DESCRIPTION	VENDOR NO.
1	098644-01-716	FT	PLUG - FILLER	132-014470
2	098644-01-705	FT	GLAZING - STRIP	132-010231
3	098644-01-706	FT	WEATHERSTRIP - GLASS	171-010668
4	098644-01-713	EA	CLIP - SCREEN - METAL	226-016966
4	125582-01-701	EA	CLIP - SCREEN - PLASTIC	130-0
5	098644-01-719	EA	STOP - SLIDER GLASS	132-014203
6	098644-01-710	FT	TRACK - SCREEN SPACER 12'	132-017135
7	098647-54-701	EA	LATCH - REPAIR KIT (RED)	B081-CK
8	098644-01-708	FT	CHANNEL - RUN PIERCED	122-016543
9	098644-01-711	FT	WEATHERSTRIP - SCREEN BLACK	171-016965
10	098647-56-700	EA	GLASS - STATIONARY	106-019401
11	098647-63-700	EA	GLASS-SLIDING W/SASH & LATCH	H422-G9
12	112795-62-702	EA	SCREEN ASSY - W/SEAL & CLIPS	410-018866
13	112795-62-704	EA	RETAINER - TRIM	H422-64
	098644-01-717	FT	SPLINE - SCREEN	132-004716

WINDOW & VENTS GROUP (CONTINUED)
COMPONENT PARTS FOR WINDOWS & VENT LAYOUT (CONTINUED)

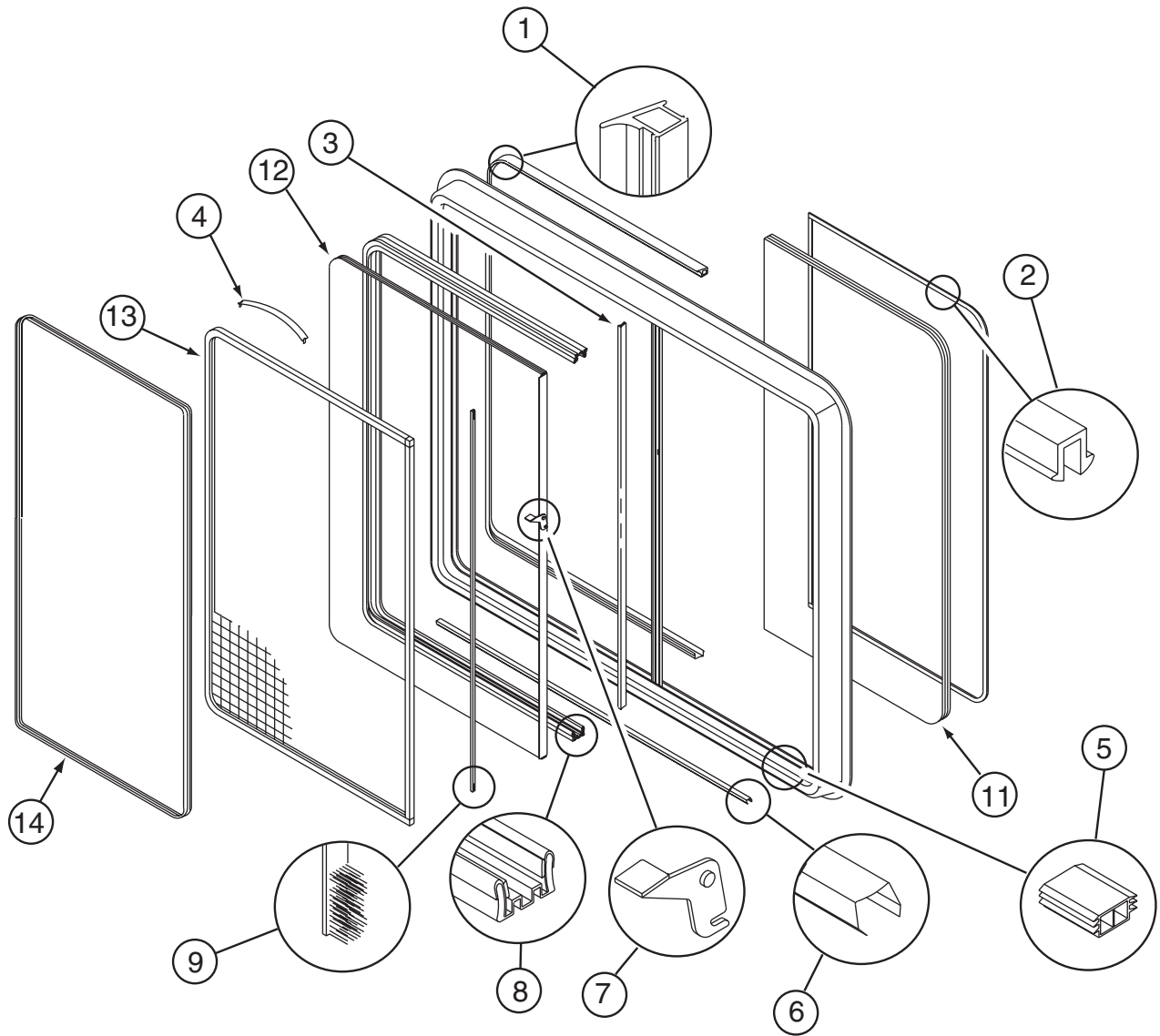

112795-21-02A

KEY	PART NUMBER	U/M	DESCRIPTION	VENDOR NO.
1	112795-01-704	FT	PLUG FILLER (DOUBLE GLAZED)	122-018737
2	112795-01-705	FT	VINYL - GLAZING	132-025736
3	098644-01-706	FT	WEATHERSTRIP - GLASS	171-010668
4	098644-01-713	EA	CLIP - SCREEN - METAL	226-016966
4	125582-01-701	EA	CLIP - SCREEN - PLASTIC	130-005153
5	112795-01-701	EA	SLIDE-STOP	132-019092
6	098644-01-710	FT	TRACK - SCREEN SPACER 12'	132-017135
7	112795-01-700	EA	LATCH ASM., BLK.,(BOLT ON)	DH287-CK
8	112795-01-703	IN	CHANNEL-RUN (INCHES)	122-018736
9	098644-01-711	FT	WEATHERSTRIP - SCREEN BLACK	171-016965
11	112795-21-701	EA	GLASS - STATIONARY	390-019133
12	112795-21-702	EA	GLASS-SLIDING W/SASH & LATCH	DC04-G9
13	098647-29-704	EA	SCREEN ASM - W/SEALS & CLIPS	410-018864
14	098647-29-705	EA	RETAINER - TRIM	CH04-66
	098644-01-717	FT	SPLINE - SCREEN	132-004716

WINDOW & VENTS GROUP (CONTINUED)
COMPONENT PARTS FOR WINDOWS & VENT LAYOUT (CONTINUED)

112795-54-02A

KEY	PART NUMBER	U/M	DESCRIPTION	VENDOR NO.
1	112795-01-704	FT	PLUG FILLER (DOUBLE GLAZED)	122-018737
2	112795-01-705	FT	VINYL - GLAZING	132-025736
3	098644-01-706	FT	WEATHERSTRIP - GLASS	171-010668
4	098644-01-713	EA	CLIP - SCREEN - METAL	226-016966
4	125582-01-701	EA	CLIP - SCREEN - PLASTIC	130-005153
5	112795-01-701	EA	SLIDE-STOP	132-019092
6	098644-01-710	FT	TRACK - SCREEN SPACER 12'	132-017135
7	112795-01-700	EA	LATCH ASM., BLK.,(BOLT ON)	DH287-CK
8	112795-01-703	IN	CHANNEL-RUN (INCHES)	122-018736
9	098644-01-711	FT	WEATHERSTRIP - SCREEN BLACK	171-016965
11	112795-54-701	EA	GLASS - STATIONARY	390-025248
12	112795-54-700	EA	GLASS-SLIDING W/SASH & LATCH	DH493-G9
13	098647-47-702	EA	SCREEN ASM - W/SEALS & CLIPS	410-025226
14	098647-47-704	EA	RETAINER - TRIM	H493-66
	098644-01-717	FT	SPLINE - SCREEN	132-004716

112795-90-01A

KEY	PART NUMBER	U/M	DESCRIPTION	VENDOR NO.
1	112795-01-704	FT	PLUG FILLER (DOUBLE GLAZED)	122-018737
2	112795-01-705	FT	VINYL - GLAZING	132-027331
3	098644-01-706	FT	WEATHERSTRIP - GLASS	171-010668
4	125582-01-701	EA	CLIP - SCREEN - PLASTIC	130-005153
4	098644-01-713	EA	CLIP - SCREEN - METAL	226-016966
5	112795-01-701	EA	SLIDE-STOP	132-019092
6	098644-01-710	FT	TRACK - SCREEN SPACER 12'	132-017135
7	112795-01-700	EA	LATCH ASM., BLK.,(BOLT ON)	DH287-CK
8	112795-01-703	IN	CHANNEL-RUN (INCHES)	122-027566
9	098644-01-711	FT	WEATHERSTRIP - SCREEN BLACK	171-016965
11	112795-90-700	EA	GLASS - STATIONARY	390-028347
12	112795-90-701	EA	GLASS-SLIDING/SASH/RED LATCH	DHR22G9
13	112795-62-702	EA	SCREEN ASM - W/SEALS & CLIPS	410-018866
14	112795-90-702	EA	RETAINER - TRIM	H422-66
	098644-01-717	FT	SPLINE - SCREEN	132-004716
	113502-01-700	EA	LATCH KIT(RED)SLIDING GLASS	DH407-CK

WINDOW & VENTS GROUP (CONTINUED)
COMPONENT PARTS FOR WINDOWS & VENT LAYOUT (CONTINUED)

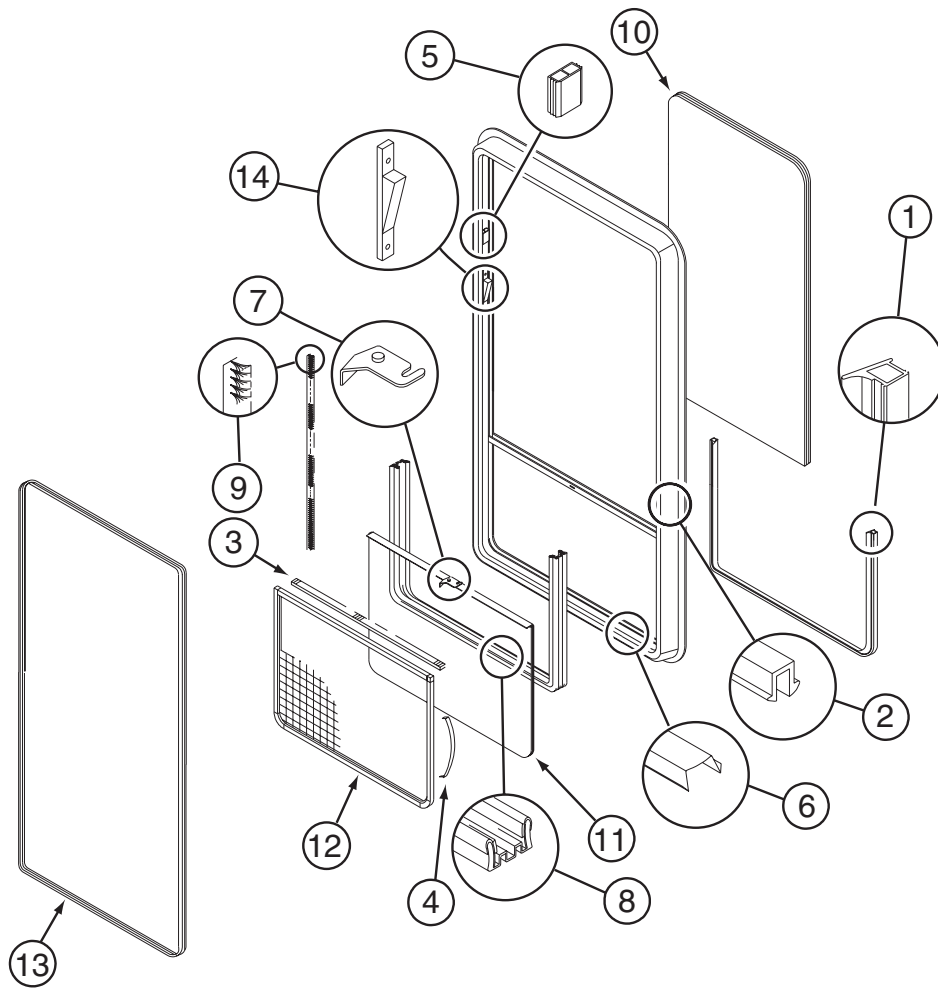

112898-04-02A

KEY	PART NUMBER	U/M	DESCRIPTION	VENDOR NO.
1	112795-01-704	FT	PLUG FILLER (DOUBLE GLAZED)	122-018737
2	112795-01-705	FT	VINYL - GLAZING	132-025736
3	098644-01-706	FT	WEATHERSTRIP - GLASS	171-010668
4	098644-01-713	EA	CLIP - SCREEN - METAL	226-016966
4	125582-01-701	EA	CLIP - SCREEN - PLASTIC	130-005153
5	112795-01-701	EA	SLIDE-STOP	132-019092
6	098644-01-710	FT	TRACK - SCREEN SPACER 12'	132-017135
7	112795-01-700	EA	LATCH ASM., BLK.,(BOLT ON)	DH287-CK
8	112795-01-703	IN	CHANNEL-RUN (INCHES)	122-018736
9	098644-01-711	FT	WEATHERSTRIP - SCREEN BLACK	171-016965
10	112898-04-701	EA	GLASS - STATIONARY	390-019130
11	112898-04-702	EA	GLASS-SLIDING W/SASH & LATCH	DC02-G9
12	098644-07-704	EA	SCREEN ASM - W/SEALS & CLIPS	410-018863
13	098644-07-705	EA	RETAINER - TRIM	CH02-66
14	112898-04-703	EA	VERTICAL LATCH (SASH KIT)	DH343-CK
	098644-01-717	FT	SPLINE - SCREEN	132-004716
	112795-24-706	FT	SEAL - SPLINE/GRAY - ESCAPE	132-010481

WINDOW & VENTS GROUP (CONTINUED)
COMPONENT PARTS FOR WINDOWS & VENT LAYOUT (CONTINUED)

113733-01-02A

KEY	PART NUMBER	U/M	DESCRIPTION	VENDOR NO.
	112795-01-705	FT	VINYL - GLAZING	132-025736
	113733-01-702	EA	GLASS-STATIONARY	390-019187
	113733-10-701	EA	RETAINER-TRIM	H416-66

122882-01-01A

KEY	PART NUMBER	U/M	DESCRIPTION	VENDOR NO.
	009440-01-000	EA	GEAR-ARM-ROOF VENT	705221K38
	064470-01-700	EA	COVER - VENT	J7291
	064470-01-701	EA	SLIDE BAR - VENT LID	JRP1291B
	122882-01-700	EA	HANDLE - CRANK - BLACK	90128
	122882-01-701	EA	SCREEN	JRP-1124-B
	122882-01-702	EA	HANDLE - CRANK - WHITE	JRP1031B

122882-02-01A, 122882-03-01A

KEY	PART NUMBER	U/M	DESCRIPTION	VENDOR NO.
	064470-01-700	EA	COVER - VENT	J7291
	064470-01-701	EA	SLIDE BAR - VENT LID	JRP1291B
	110051-03-700	EA	SWITCH-BLACK/PUSH BUTTON	27-0164
	122882-01-700	EA	HANDLE - CRANK - BLACK	90128
	122882-01-701	EA	SCREEN	JRP-1124-B
	122882-01-702	EA	HANDLE - CRANK - WHITE	JRP1031B

WINDOW & VENTS GROUP (CONTINUED)
COMPONENT PARTS FOR WINDOWS & VENT LAYOUT (CONTINUED)

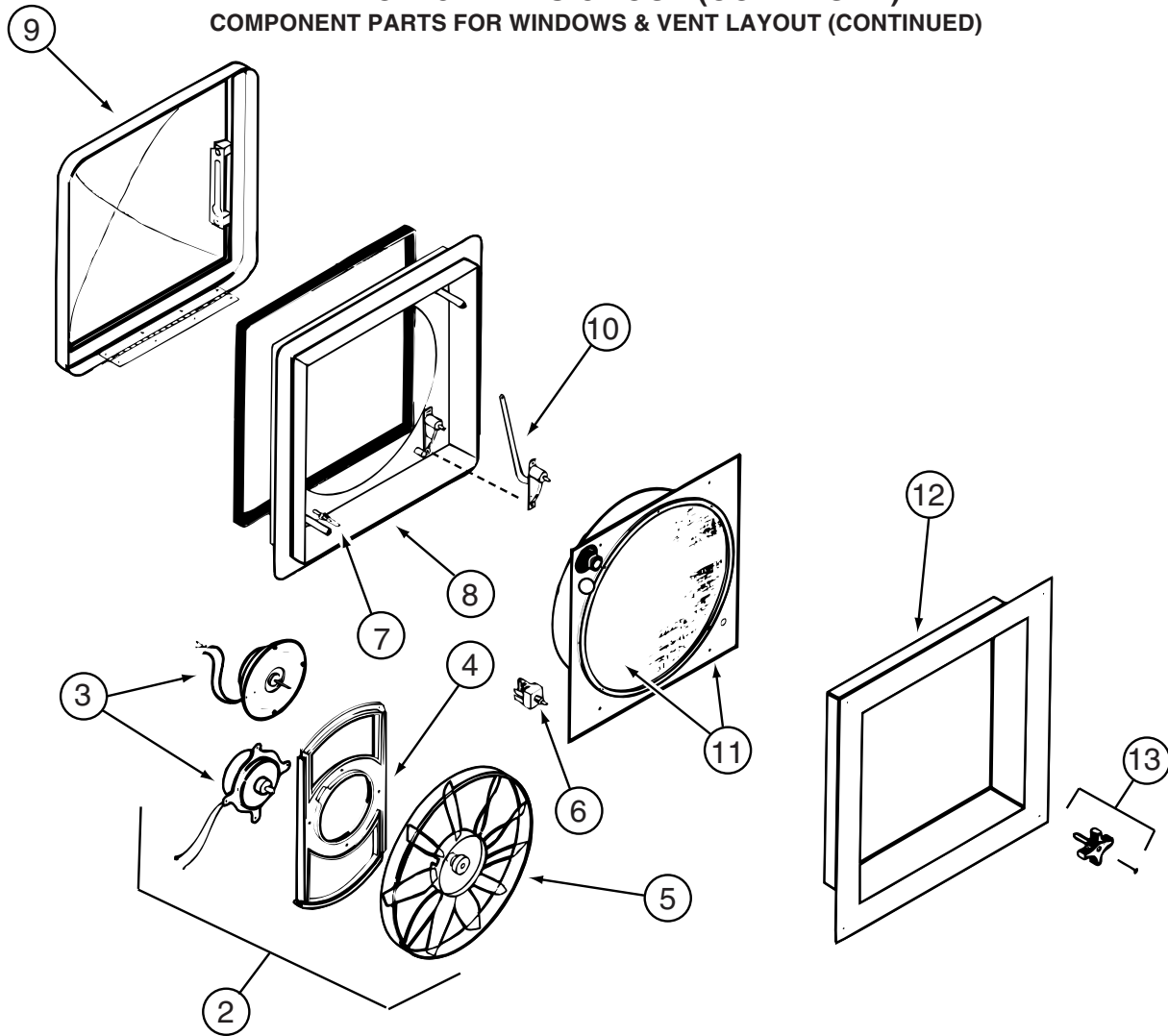

123780-03-01A

KEY	PART NUMBER	U/M	DESCRIPTION	VENDOR NO.
2	084079-11-700	EA	MOTOR & FAN BLADE W/BRACKET	K4017-09
3	084079-01-705	EA	MOTOR/EXT BRKT/FAN BLADE KIT	1080-00
4	084079-01-711	EA	MOTOR MOUNT (BOWTIE)	1015-00
5	084079-01-704	EA	BLADE-FAN	1138-00
6	084079-01-709	EA	SWITCH - MAIN - 3 SPEED	1031-05
7	084079-01-707	EA	SWITCH - SAFETY	1122-05
8	123780-05-700	EA	BASE/MAIN-BRT WHT W/GASKET	1010-81
9	123780-01-700	EA	COVER - VENT W/HINGE & SLIDE	1020K-81
11	123780-03-701	EA	SCREEN ASM 78-100MM W/SWITCH	1030BT-81
12	123780-03-700	EA	GARNISH - INT. 3"-4" BRT/WHT	2040-81
13	084079-01-703	EA	KNOB-LIFT	1140K-00
	084079-01-706	EA	PLUG, 12 VOLT	1090
	123780-01-702	EA	SCREEN INSERT (SCREEN RING)	K1035-81

CONTACT WINNEBAGO PART SALES FOR UNLISTED COMPONENT(S)

WINDOW & VENTS GROUP (CONTINUED)
COMPONENT PARTS FOR WINDOWS & VENT LAYOUT (CONTINUED)

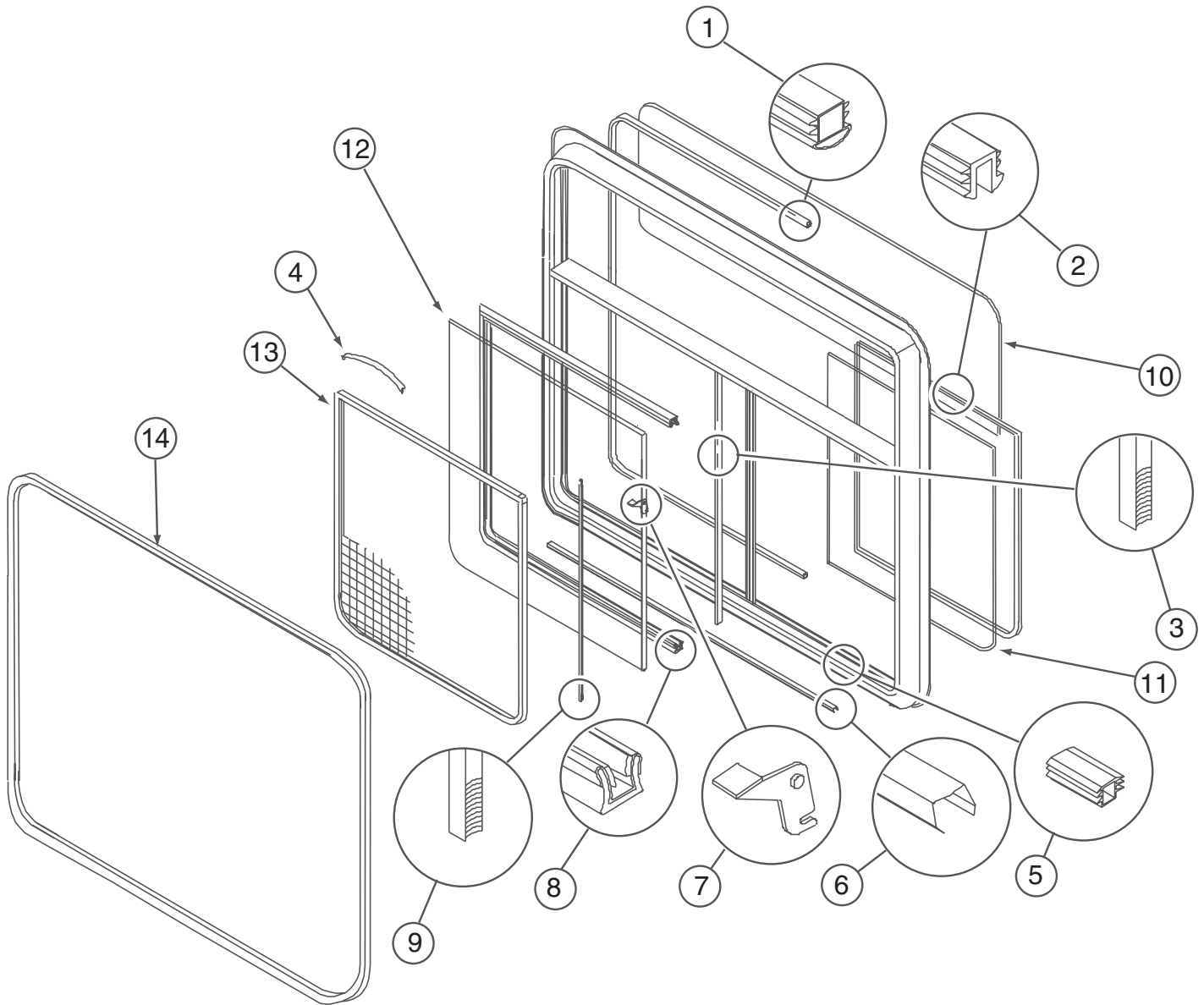

145573-01-01A

KEY	PART NUMBER	U/M	DESCRIPTION	VENDOR NO
1	098644-01-716	FT	PLUG - FILLER	132-014470
4	098644-01-713	EA	CLIP - SCREEN - METAL	226-016966
4	125582-01-701	EA	CLIP - SCREEN - PLASTIC	130-005153
5	098644-01-719	EA	STOP - SLIDER GLASS	132-014203
6	098644-01-710	FT	TRACK - SCREEN SPACER 12'	132-017135
7	098644-01-700	EA	LATCH - REPAIR KIT (BLACK)	B801-CK
8	098644-01-708	FT	CHANNEL - RUN PIERCED	122-016543
9	098644-01-711	FT	WEATHERSTRIP - SCREEN BLACK	171-016965
10	145573-01-701	EA	GLASS - STATIONARY (TOP)	106-030654
11	145573-01-702	EA	GLASS - STATIONARY (LOWER)	106-030926
12	145573-01-703	EA	GLASS-SLIDING W/SASH & LATCH	H841-A9
13	145573-01-700	EA	SCREEN ASM - W/SEALS & CLIP	410-030660
14	112795-66-703	EA	RETAINER - TRIM	H611-66
	098644-01-717	FT	SPLINE - SCREEN	132-004716

WINDOW & VENTS GROUP (CONTINUED)
COMPONENT PARTS FOR WINDOWS & VENT LAYOUT (CONTINUED)

145573-02-01A

KEY	PART NUMBER	U/M	DESCRIPTION	VENDOR NO
1	098644-01-716	FT	PLUG - FILLER	132-014470
3	098644-01-706	FT	WEATHERSTRIP - GLASS	171-010668
4	098644-01-713	EA	CLIP - SCREEN - METAL	226-016966
4	125582-01-701	EA	CLIP - SCREEN - PLASTIC	130-005153
6	098644-01-710	FT	TRACK - SCREEN SPACER 12'	132-017135
7	098644-01-700	EA	LATCH - REPAIR KIT (BLACK)	B801-CK
8	098644-01-708	FT	CHANNEL - RUN PIERCED	122-016543
9	098644-01-711	FT	WEATHERSTRIP - SCREEN BLACK	171-016965
10	145573-01-701	EA	GLASS - STATIONARY (TOP)	106-030654
11	145573-01-702	EA	GLASS - STATIONARY (LOWER)	106-030926
12	145573-02-701	EA	GLASS-SLIDING W/SASH & LATCH	H841-A9L
13	145573-02-700	EA	SCREEN W/SEALS AND CLIPS	410-030659
14	112795-66-703	EA	RETAINER - TRIM	H611-66
	098644-01-717	FT	SPLINE - SCREEN	132-004716

145573-03-01A

KEY	PART NUMBER	U/M	DESCRIPTION	VENDOR NO
1	112795-01-704	FT	PLUG FILLER (DOUBLE GLAZED)	120-018737
2	112795-01-705	FT	VINYL - GLAZING	132-027331
3	098644-01-706	FT	WEATHERSTRIP - GLASS	171-010668
4	125582-01-701	EA	CLIP - SCREEN - PLASTIC	130-005153
5	112795-01-701	EA	SLIDE-STOP	132-019092
6	098644-01-710	FT	TRACK - SCREEN SPACER 12'	132-017135
7	112795-01-700	EA	LATCH ASM., BLK., (BOLT ON)	DH287-CK
8	112795-01-703	IN	CHANNEL-RUN (INCHES)	122-027566
9	098644-01-711	FT	WEATHERSTRIP - SCREEN BLACK	171-016965
10	145573-03-700	EA	GLASS - STATIONARY (TOP)	390-035009
11	145573-03-701	EA	GLASS - STATIONARY (LOWER)	390-035011
12	145573-03-702	EA	GLASS-SLIDING W/SASH & LATCH	DH841-A9R
13	145573-01-700	EA	SCREEN ASM - W/SEALS & CLIP	410-030660
14	145573-03-704	EA	RETAINER - TRIM	H841-66
	098644-01-717	FT	SPLINE - SCREEN	132-004716

145573-04-01A

KEY	PART NUMBER	U/M	DESCRIPTION	VENDOR NO
1	112795-01-704	FT	PLUG FILLER (DOUBLE GLAZED)	120-018737
2	112795-01-705	FT	VINYL - GLAZING	132-027331
3	098644-01-706	FT	WEATHERSTRIP - GLASS	171-010668
4	125582-01-701	EA	CLIP - SCREEN - PLASTIC	130-005153
5	112795-01-701	EA	SLIDE-STOP	132-019092
6	098644-01-710	FT	TRACK - SCREEN SPACER 12'	132-017135
7	112795-01-700	EA	LATCH ASM., BLK., (BOLT ON)	DH287-CK
8	112795-01-703	IN	CHANNEL-RUN (INCHES)	122-027566
9	098644-01-711	FT	WEATHERSTRIP - SCREEN BLACK	171-016965
10	145573-03-700	EA	GLASS - STATIONARY (TOP)	390-035009
11	145573-04-700	EA	GLASS - STATIONARY (LOWER)	390-035010
12	145573-04-701	EA	GLASS-SLIDING W/SASH & LATCH	DH481-A9L
13	145573-02-700	EA	SCREEN ASM - W/SEALS & CLIP	410-030659
14	145573-03-704	EA	RETAINER - TRIM	H841-66
	098644-01-717	FT	SPLINE - SCREEN	132-004716

WINDOW & VENTS GROUP (CONTINUED)
COMPONENT PARTS FOR WINDOWS & VENT LAYOUT (CONTINUED)

150648-07-01A

KEY	PART NUMBER	U/M DESCRIPTION	VENDOR NO
	112795-01-705	FT VINYL - GLAZING	132-027331
	150648-01-700	EA LATCH-HORIZONTAL SLIDE-BLK	FH3000-CK
	150648-01-702	EA SCREEN ASM	410-031156
	150648-07-700	EA GLASS-SLIDING W/SASH & LATCH	FH3000G8
	151069-01-700	FT CHANNEL-RUN, SLIDING	122-030627

150648-11-01A

KEY	PART NUMBER	U/M DESCRIPTION	VENDOR NO
	151069-01-700	EA CHANNEL-RUN, SLIDING	122-030627

150648-12-01A

KEY	PART NUMBER	U/M DESCRIPTION	VENDOR NO
	151069-01-700	EA CHANNEL-RUN, SLIDING	122-030627

150649-01-01A

KEY	PART NUMBER	U/M DESCRIPTION	VENDOR NO
	150649-01-700	EA LATCH-VERTICLE SLIDE-BLK	FH3016-CK
	150649-01-702	EA SCREEN ASM	410-035464

150651-01-01A

KEY	PART NUMBER	U/M DESCRIPTION	VENDOR NO
	112795-01-705	FT VINYL - GLAZING	132-027331

151069-01-01A

KEY	PART NUMBER	U/M DESCRIPTION	VENDOR NO
	150648-01-700	EA LATCH-HORIZONTAL SLIDE-BLK	FH3000-CK
	151069-01-700	EA CHANNEL-RUN, SLIDING	122-030627
	151069-01-701	EA SCREEN ASM	410-035641
	151069-01-702	EA GLASS-SLIDING W/SASH & LATCH	FH3059A9L
	151069-01-703	EA COVER - DRAIN SLOT - LH	130-030398 LEFT

151069-02-01A

KEY	PART NUMBER	U/M DESCRIPTION	VENDOR NO
	150648-01-700	EA LATCH-HORIZONTAL SLIDE-BLK	FH3000-CK
	151069-01-700	EA CHANNEL-RUN, SLIDING	122-030627
	151069-02-703	EA COVER - DRAIN SLOT - RH HAND	130-030397 RIGHT

WINDSHIELD & WIPER GROUP

WINDSHIELD

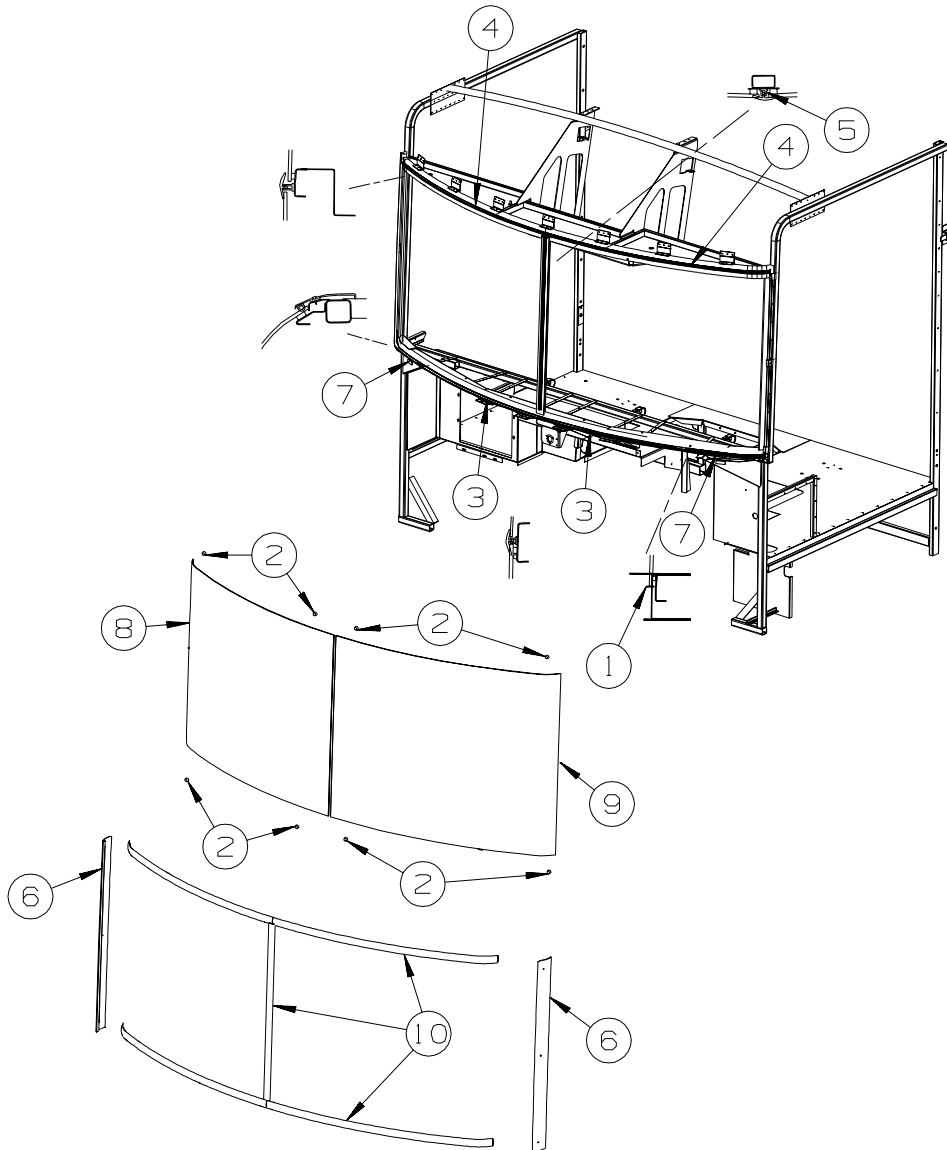

KEY	PART NUMBER	U/M	DESCRIPTION
1	002328-02-000	EA	BLOCK - WINDSHIELD - .062" X .5" X .98"
2	081914-02-000	EA	BUMPER - RUBBER - ROUND - 5/16" DIA. X 13/64" THICK
3	132375-04-000	EA	CARRIER/REVEAL - WINDSHIELD - 29.8"
4	127862-01-000	EA	CARRIER/REVEAL - WINDSHIELD - 47.2"
5	127862-09-000	EA	CARRIER/REVEAL - WINDSHIELD - 38.6"
6	129497-07-03A	EA	TRIM - WINDSHIELD/"A"-PILLAR - PASSENGER - BRIGHT WHITE
7	132375-01-000	EA	CARRIER/REVEAL - WINDSHIELD - 5.5"
8	137583-01-000	EA	WINDSHIELD - PASSENGER (CURVED) 52.4" X 40.5"
9	137583-02-000	EA	WINDSHIELD - DRIVER (CURVED) 52.4" X 40.5"
10	120533-01-000	FT	MOLDING - REVEAL - WINDSHIELD

WINDSHIELD & WIPER GROUP (CONTINUED)

WIPER

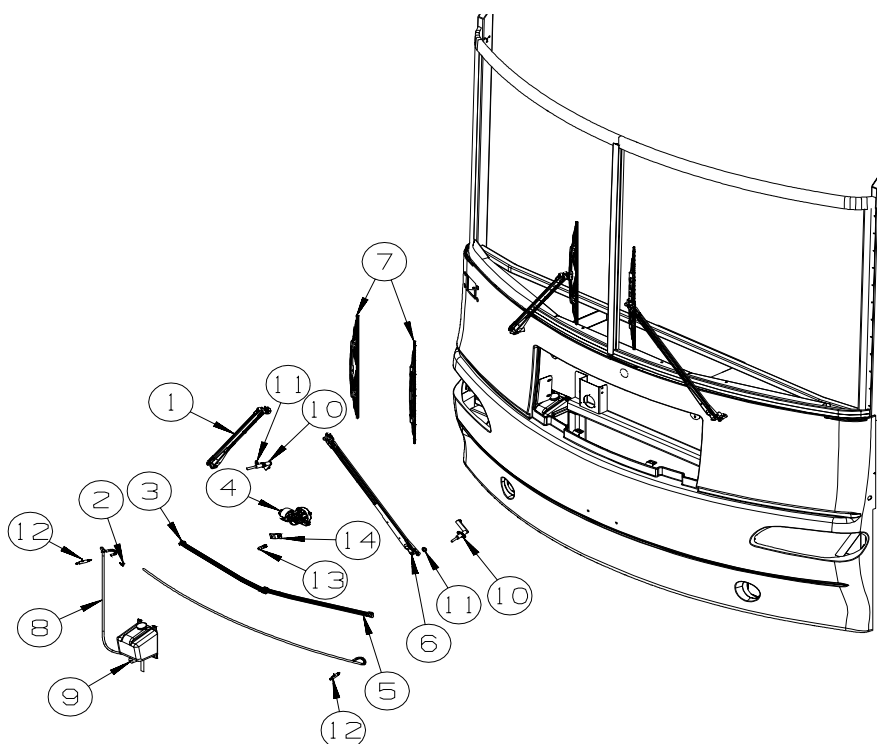

KEY	PART NUMBER	U/M	DESCRIPTION
1*	149402-01-000	EA	ARM - WINDSHIELD WIPER/PANTOGRAPH - RIGHT HAND - 28" FROM: 00-00-00 THRU: 03-18-05
1*	149402-03-000	EA	ARM - WINDSHIELD WIPER/PANTOGRAPH - RIGHT HAND - 28" FROM: 03-19-05 THRU: 99-99-99
2	146486-01-000	EA	TEE - PLASTIC - 5/32" X 5/32" X 5/32" - ON LEFT SIDE OF WORKHORSE CHASSIS
3	149403-01-000	EA	LINK/CONNECTING-WINDSHIELD WIPER - CLOSED/CLOSED - 24"
4	149409-01-000	EA	MOTOR - WIPER - DYNAMIC PARK
4	149409-02-000	EA	MOTOR - WIPER - COAST TO PARK - WORKHORSE P32 (15,000/18,000) CHASSIS
5	149403-02-000	EA	LINK/CONNECTING-WINDSHIELD WIPER - OPEN/CLOSED GROMMET-24"
6*	149402-02-000	EA	ARM - WINDSHIELD WIPER/PANTOGRAPH - LEFT HAND - 28" FROM: 00-00-00 THRU: 03-18-05
6*	149402-04-000	EA	ARM - WINDSHIELD WIPER/PANTOGRAPH - LEFT HAND - 28" FROM: 03-19-05 THRU: 99-99-99
7	149399-01-000	EA	BLADE - WINDSHIELD WIPER - 24"
8	045794-01-000	FT	HOSE - WINDSHIELD WASHER - 5/32"ID - BLACK - ON LEFT SIDE OF WORKHORSE CHASSIS
9	117766-02-000	EA	RESERVOIR/PUMP - WINDSHIELD WASHER - ON LEFT SIDE OF WORKHORSE CHASSIS
10*	149401-01-000	EA	SHAFT & PIVOT ASM. - WINDSHIELD WIPER FROM: 00-00-00 THRU: 04-15-05
10	149401-02-000	EA	SHAFT & PIVOT ASM. - WINDSHIELD WIPER FROM: 04-16-05 THRU: 99-99-99
11	110742-03-000	EA	GASKET - WIPER
12	145698-01-01A	EA	SHAFT/IDLER - PANTOGRAPH - W/WASHER DIVERTER - STAINLESS
13	149395-01-000	EA	STUD/DOUBLE BALL CRANK - WIPER MOTOR
14	149408-01-000	EA	ARM - DRIVE/WIPER MOTOR

*COMPONENT PARTS LISTED LATER IN THIS GROUP

COMPONENT PARTS FOR WIPER

149401-01-000

KEY	PART NUMBER	U/M	DESCRIPTION	VENDOR NO.
	096505-02-703	EA	NUT/ACORN - HD W/.687 BRL	51065-40-NT27WC
	149401-01-700	EA	HARDWARE PKG - F/SHAFT&PIVOT	PSHWKIT

149402-01-000, 149402-02-000, 149402-03-000, 149402-04-000

KEY	PART NUMBER	U/M	DESCRIPTION	VENDOR NO.
	096931-01-705	EA	CAP-PLASTIC	52699-40-CP27WC
	149402-01-700	EA	WASHER NOZZLE KIT - W/HDWR	5219140