

**2005  
SPIRIT  
IF327L**

**300-SERIES**

**PORTSMOUTH OAK**

**S04 PINEHURST - GREEN**

**S05 BLUE TOPAZ - BLUE**

**S06 TUMBLEWEED - NEUTRAL**

**SX1 MAPLE SUGAR - NEUTRAL**

**S97 MAPLE SUGAR - NEUTRAL**

**S98 PINE CREEK - GREEN**

**SIERRA MAPLE**

**S91 PINEHURST - GREEN**

**S92 BLUE TOPAZ - BLUE**

**S93 TUMBLEWEED - NEUTRAL**

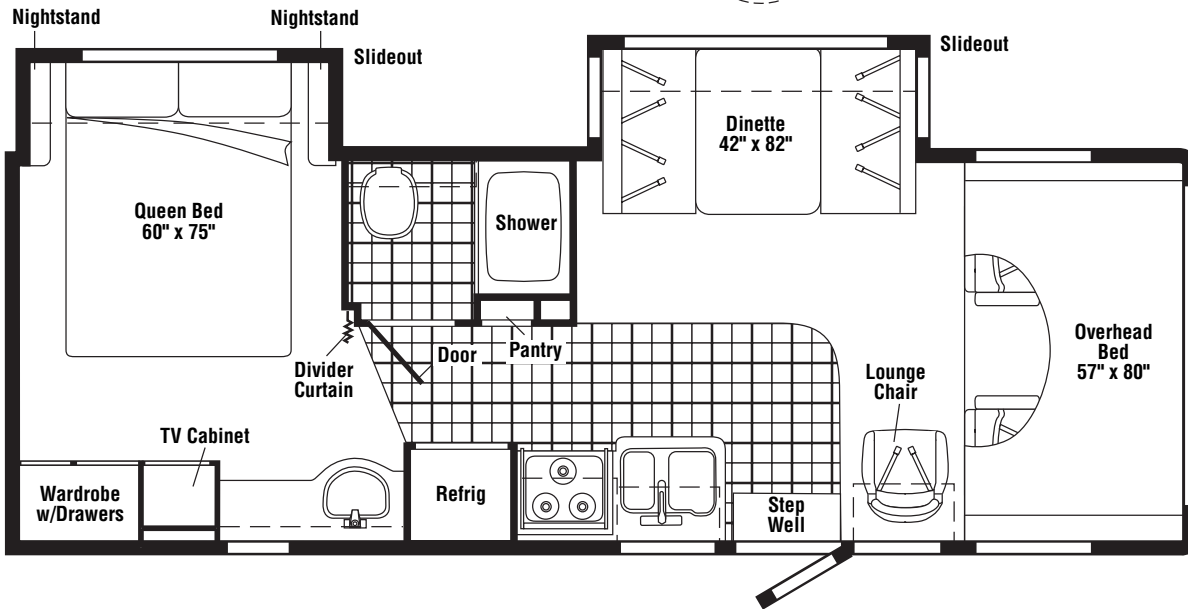
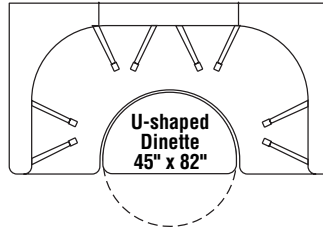

**FLOORPLAN**

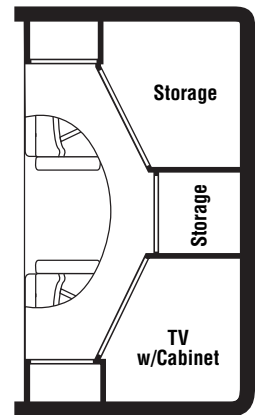

**Optional Front  
Overhead Area**

# CONTENTS

<b>FLOORPLAN</b> .....	<b>1</b>
<b>ACCESSORIES GROUP</b> .....	<b>6</b>
OPERATORS MANUAL .....	6
<b>AUDIO VIDEO GROUP</b> .....	<b>7</b>
RADIO SYSTEM .....	7
REAR MONITOR .....	7
<b>CABINET &amp; APPLIANCE GROUP</b> .....	<b>8</b>
CABINET & APPLIANCE LAYOUT .....	8
COMPONENT PARTS FOR CABINET & APPLIANCE LAYOUT .....	17
121568-06-01A, 121568-07-01A, 121568-08-01A .....	17
128527-09-000, 128527-10-000, 128527-13-000 .....	21
136354-01-02A .....	22
136354-02-02A .....	23
151277-01-01A, 151277-02-01A .....	24
<b>CHASSIS GROUP</b> .....	<b>28</b>
FRAME .....	28
DRIVETRAIN .....	28
EXHAUST .....	29
HITCH .....	29
REAR BUMPER .....	30
FUEL .....	31
SPARE TIRE .....	33
SUSPENSION .....	35
WHEEL, TIRE, COVERS &/OR LINERS .....	35
COMPONENT PARTS FOR WHEEL, TIRE, COVERS &/OR LINERS .....	35
109443-05-000 .....	35
110435-13-000 .....	35
BRAKELINE .....	35
<b>CURTAIN &amp; CUSHION GROUP</b> .....	<b>36</b>
NOTICE .....	36
CUSHION LAYOUT .....	37
BUCKET SEATS .....	40
LOUNGE CHAIR .....	42
WINDOW TREATMENT .....	43
HARDWARE .....	46
ACCESSORIES .....	47
FABRICS .....	48
<b>DRIVERS COMPARTMENT GROUP</b> .....	<b>49</b>
FRONT INTERIOR .....	49
COMPONENT PARTS FOR FRONT INTERIOR .....	50
106025-02-01A .....	50
CABINETS .....	51

# CONTENTS (CONTINUED)

<b>ELECTRICAL GROUP</b> .....	<b>53</b>
110V BODY WIRING .....	53
12V BODY WIRING .....	54
EXTERIOR LAMPS .....	59
FRONT END .....	60
FRONT TV/VCR .....	61
SIDE TV/VCR .....	62
COMPONENT PARTS FOR WIRING .....	63
076319-23-000 .....	63
076319-25-000 .....	63
081638-01-000 .....	64
086231-10-000 .....	64
087694-01-000 .....	64
097917-01-06A .....	64
108354-01-01A .....	64
113589-01-000 .....	64
113589-02-000 .....	64
120269-07-01A .....	64
121935-01-01A .....	64
123775-01-01A .....	64
124075-07-000 .....	64
134940-01-01A .....	65
134940-02-01A .....	66
134940-06-01A .....	67
134940-07-01A .....	67
137135-02-000 .....	68
137417-01-01A, 137417-03-01A .....	69
137417-02-01A .....	69
137417-05-01A .....	69
137417-06-01A .....	69
145641-02-000, 145641-04-000 .....	69
145641-03-000 .....	69
148230-01-000, 148230-02-000 .....	69
148230-03-000 .....	69
148231-01-000 .....	69
149040-02-000 .....	69
149925-01-000 .....	69
150089-01-000 .....	69
152441-01-000 .....	69
155619-01-000 .....	69
CIRCUIT BREAKERS, FUSES & RELAYS .....	70
CONVERTER, INVERTER, LOAD CENTERS .....	70
BOXES & CORDS .....	71
WIRE ASSEMBLIES .....	71
CONNECTORS & CONDUIT .....	72
CHASSIS .....	74
<b>EXTERIOR BODY GROUP</b> .....	<b>75</b>
GRAPHICS & PAINT .....	75
PANELS & TRIMS .....	77
COMPONENT PARTS FOR PANELS & TRIMS .....	80
072884-27-000 .....	80
133908-01 THRU 133908-08, 133908-10 THRU 133908-13, 133908-16, 133908-17, -01A/-02A/-03A .....	80
STRUCTURAL COMPONENTS .....	81
AWNINGS .....	81
COMPONENT PARTS FOR AWNINGS .....	82
113874-01-02A .....	82

## CONTENTS (CONTINUED)

<b>EXTERIOR DOORS &amp; COMPARTMENTS GROUP</b> .....	<b>83</b>
DOOR & COMPARTMENT LAYOUT .....	83
COMPONENT PARTS FOR DOOR & COMPARTMENT LAYOUT .....	86
084103-08-000 .....	86
094707-03-01A .....	86
094708-03-01A .....	87
COMPARTMENT DOOR PIECE PARTS .....	88
COMPONENT PARTS FOR COMPARTMENT DOOR PIECE PARTS .....	91
110506-A1-000, 110506-A2-000, 110506-26-000, 110506-27-000 .....	91
ENTRY .....	92
SCREEN .....	93
LATCH - ENTRY .....	94
<b>EXTERIOR SLIDEOUT GROUP</b> .....	<b>95</b>
FRONT LEFT .....	95
COMPONENT PARTS FOR FRONT LEFT .....	99
150661-01-000 .....	99
LEFT REAR .....	100
COMPONENT PARTS FOR LEFT REAR .....	102
140464-01-000 .....	102
<b>GENERATOR GROUP</b> .....	<b>103</b>
<b>HEATING &amp; A/C GROUP</b> .....	<b>104</b>
FURNACE .....	104
COMPONENT PARTS FOR FURNACE .....	105
139980-01-000 .....	105
139980-02-000 .....	105
ROOF .....	107
COMPONENT PARTS FOR ROOF .....	107
131184-01-01A .....	107
131184-05-01A .....	108
131185-03-01A .....	109
131188-03-01A .....	110
131188-04-01A .....	111
<b>INTERIOR FINISH GROUP</b> .....	<b>112</b>
MOLDINGS & TRIMS .....	112
PANELING & LAMINATES .....	123
INTERIOR TRIM LAYOUT .....	124
COMPONENT PARTS FOR INTERIOR TRIM LAYOUT .....	126
094499-02-000 .....	126
131595-01-01A, 131595-05-01A, 131595-10-01A .....	126
135615-01-01A, 135615-02-01A, 135615-05-01A .....	127
FLOOR COVERINGS .....	128
HARDWARE .....	129
<b>LABELS GROUP</b> .....	<b>136</b>
<b>LP GROUP</b> .....	<b>142</b>
LP SYSTEM .....	142
COMPONENT PARTS FOR LP SYSTEM .....	142
144116-04-000 .....	142
<b>SEALANTS &amp; FASTENERS GROUP</b> .....	<b>143</b>
SEALANTS & ADHESIVES .....	143
BOLTS, NUTS AND WASHERS .....	144
SCREWS .....	146
CLAMPS, CLIPS, GROMMETS, RIVETS & PLUGS .....	149
MISCELLANEOUS FASTENERS .....	150

## CONTENTS (CONTINUED)

<b>WATER &amp; SEWAGE GROUP .....</b>	<b>152</b>
DRAINAGE SYSTEM .....	152
COMPONENT PARTS FOR DRAINAGE SYSTEM .....	154
062415-01-000 .....	154
096927-01-02A .....	154
147421-01-01A, 147421-02-01A .....	154
147421-03-01A .....	154
WATER SYSTEM .....	155
COMPONENT PARTS FOR WATER SYSTEM .....	162
051391-03-000 .....	162
075240-05-000 .....	163
075241-04-000, 075241-05-000, 075241-06-000 .....	163
098607-01-000 .....	163
104114-05-01A .....	163
144215-01-000 .....	163
144215-02-000 .....	163
<b>WINDOW &amp; VENTS GROUP .....</b>	<b>164</b>
WINDOW & VENT LAYOUT .....	164
COMPONENT PARTS FOR WINDOW & VENT LAYOUT .....	166
098644-01-01A .....	166
098644-13-01A .....	166
098647-30-02A .....	167
098647-31-02A .....	168
098647-32-02A .....	168
098647-47-02A .....	168
098647-49-02A .....	169
113502-10-01A .....	170
116976-02-02A .....	171
122882-01-01A .....	171
122882-02-01A, 122882-03-01A .....	171
122882-02-01A, 122882-03-01A .....	172
123780-03-01A .....	172
150648-04-01A .....	173
150648-05-01A .....	173
150648-07-01A .....	173
150648-08-01A .....	173
150649-01-01A .....	173
150649-07-01A .....	173
150649-14-01A .....	173
150649-15-01A .....	173
150651-01-01A .....	173
150652-01-01A .....	173
151075-02-01A .....	173

**ACCESSORIES GROUP**  
**OPERATORS MANUAL**

<b>KEY</b>	<b>PART NUMBER</b>	<b>U/M</b>	<b>DESCRIPTION</b>
	129079-01-01A	EA	CASE - VINYL/BLACK-EXPANDABLE ACCORDION SIDES-7"WX9"HX14"L
	132000-12-005	EA	MANUAL/OWNER - SPIRIT - 2005
	148923-01-000	DW	TOP LEVEL - 300, 2005

**AUDIO VIDEO GROUP  
RADIO SYSTEM**

<b>KEY</b>	<b>PART NUMBER</b>	<b>U/M</b>	<b>DESCRIPTION</b>
	135420-09-000	EA	RADIO-AM/FM/CASS/CD COMBO-AUX/CD CHANGER INPUT-REMOTE FROM: 00-00-00 THRU: 05-09-04
	135420-13-000	EA	RADIO-AM/FM/CASS/CD COMBO-AUX/CD CHGR INPUT-IR REMOTE FROM: 05-10-04 THRU: 99-99-99
	135420-11-000	EA	REMOTE CONTROL/RADIO (STEERING WHEEL MOUNT) FROM: 05-12-04 THRU: 99-99-99
	135420-05-000	EA	MOUNTING KIT - RADIO - FORD
	135420-14-000	EA	RECEIVER - INFRARED FROM: 05-10-04 THRU: 99-99-99
	135420-10-000	EA	REMOTE CONTROL/RADIO (CREDIT CARD SIZE)
	108137-01-000	EA	PLUG - ANTENNA

**REAR MONITOR**

<b>KEY</b>	<b>PART NUMBER</b>	<b>U/M</b>	<b>DESCRIPTION</b>
	144677-04-000	EA	CAMERA - REAR VIEW W/BRACKET - BLACK & WHITE - VBGS150
	150079-01-000	EA	MONITOR/LCD - 5" - NO AUDIO - SUNVISOR MOUNT (FORD) FROM: 00-00-00 THRU: 05-10-04
	150079-02-000	EA	MONITOR/LCD - 5.6" - NO AUDIO - SUNVISOR MOUNT (FORD) FROM: 05-11-04 THRU: 99-99-99
	136514-02-000	EA	CABLE - MONITOR/CAMERA

**SEE 12V BODY WIRING IN THE ELECTRICAL GROUP FOR LOCATION OF OTHER  
AUDIO VIDEO COMPONENTS**

## CABINET & APPLIANCE GROUP

### CABINET & APPLIANCE LAYOUT

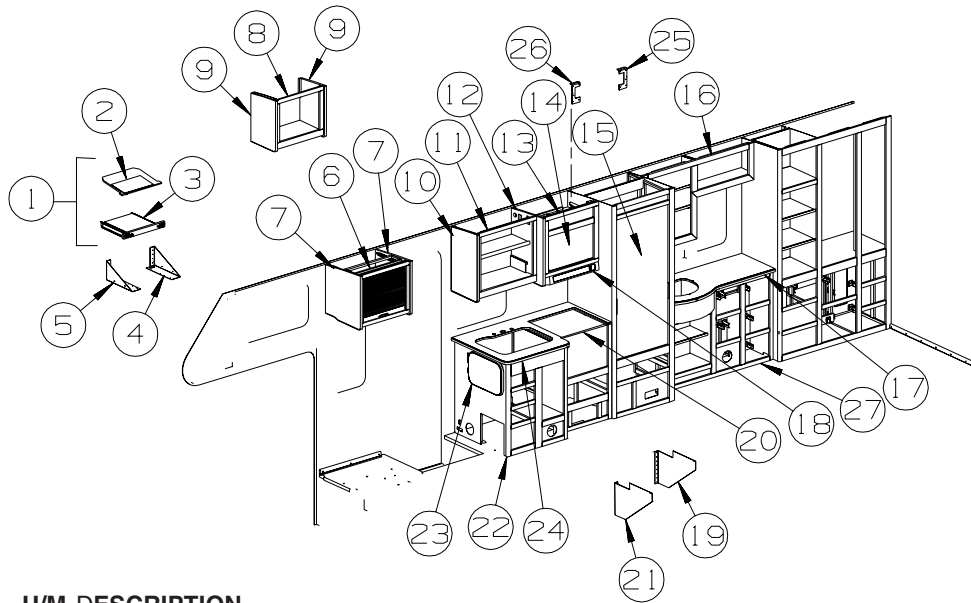

KEY	PART NUMBER	U/M	DESCRIPTION
1	149638-18-S01	EA	SHELF - W/SLIDE AND SWIVEL - PORTSMOUTH OAK - TV - 13" W/DVD - 12V
1	149638-18-S88	EA	SHELF - W/SLIDE AND SWIVEL - SIERRA MAPLE - TV - 13" W/DVD - 12V
2	091261-01-000	FT	SLIPNOT - ANTISLIP - 1' WIDE X 12" - BLACK - TV-13" W/DVD
3	116773-02-000	EA	SWIVEL/SLIDES - F/TV SHELF - B.9"D X 1.6"H X 15.3"W - TV-13" W/DVD
4	122298-03-02B	EA	BRACKET - TV/VCR W/ANGLE - RIGHT HAND - E-COATED - TV-13" W/DVD
5	122298-02-02B	EA	BRACKET - TV/VCR W/ANGLE - LEFT HAND - E-COATED - TV-13" W/DVD
6	149638-02-S01	EA	CABINET - OVHD/STORAGE - W/O TV SLIDE - W/TAMBOUR DOOR - PORTSMOUTH OAK
6	149638-02-S88	EA	CABINET - OVHD/STORAGE - W/O TV SLIDE - W/TAMBOUR DOOR - SIERRA MAPLE
6	149638-01-S01	EA	CABINET - OVHD/TV - W/TAMBOUR DOOR - PORTSMOUTH OAK - TV-13" W/DVD
6	149638-01-S88	EA	CABINET - OVHD/TV - W/TAMBOUR DOOR - SIERRA MAPLE - TV-13" W/DVD
7	140307-11-P07	EA	END CAP - OVHD CABINET - PORTSMOUTH OAK
7	140307-11-S88	EA	END CAP - OVHD CABINET - SIERRA MAPLE
8	142912-01-P13	EA	CABINET-OVHD/FRT/RH-W/O HDW - PORTSMOUTH OAK - TV-24" COLOR,STEREO W/REMOTE
8	142912-01-S88	EA	CABINET-OVHD/FRT/RH-W/O HDW - SIERRA MAPLE - TV-24" COLOR,STEREO W/REMOTE
9	140307-17-P07	EA	END CAP - OVHD CABINET - PORTSMOUTH OAK - TV-24" COLOR,STEREO W/REMOTE
9	140307-17-S88	EA	END CAP - OVHD CABINET - SIERRA MAPLE - TV-24" COLOR,STEREO W/REMOTE
10	140307-06-P10	EA	END CAP - OVHD CABINET - PORTSMOUTH OAK
10	140307-06-S88	EA	END CAP - OVHD CABINET - SIERRA MAPLE
11	150907-01-S01	EA	CABINET - OVHD/GALLEY - W/O DOORS/HDW - PORTSMOUTH OAK
11	150907-01-S88	EA	CABINET - OVHD/GALLEY - W/O DOORS/HDW - SIERRA MAPLE
11	150907-02-S01	EA	CABINET-OVHD/GALLEY-W/O DOORS/HDW- PORTSMOUTH OAK - TV-24" COLOR,STEREO W/REMOTE
11	150907-02-S88	EA	CABINET-OVHD/GALLEY-W/O DOORS/HDW- SIERRA MAPLE - TV-24" COLOR,STEREO W/REMOTE
12	140307-07-P10	EA	END CAP - OVHD CABINET - PORTSMOUTH OAK
12	140307-07-S88	EA	END CAP - OVHD CABINET - SIERRA MAPLE
13	148318-01-S04	EA	CABINET - OVERHEAD/MICROWAVE - W/O DOORS/HARDWARE
13	148318-01-S05	EA	CABINET - OVERHEAD/MICROWAVE - W/O DOORS/HARDWARE
13	148318-01-S06	EA	CABINET - OVERHEAD/MICROWAVE - W/O DOORS/HARDWARE
13	148318-01-S91	EA	CABINET - OVERHEAD/MICROWAVE - W/O DOORS/HARDWARE
13	148318-01-S92	EA	CABINET - OVERHEAD/MICROWAVE - W/O DOORS/HARDWARE
13	148318-01-S93	EA	CABINET - OVERHEAD/MICROWAVE - W/O DOORS/HARDWARE
13	148318-02-S04	EA	CABINET - OVHD/MICROWAVE - W/O DOORS/HARDWARE - TV-24" COLOR,STEREO W/REMOTE
13	148318-02-S05	EA	CABINET - OVHD/MICROWAVE - W/O DOORS/HARDWARE - TV-24" COLOR,STEREO W/REMOTE
13	148318-02-S06	EA	CABINET - OVHD/MICROWAVE - W/O DOORS/HARDWARE - TV-24" COLOR,STEREO W/REMOTE
13	148318-02-S91	EA	CABINET - OVHD/MICROWAVE - W/O DOORS/HARDWARE - TV-24" COLOR,STEREO W/REMOTE
13	148318-02-S92	EA	CABINET - OVHD/MICROWAVE - W/O DOORS/HARDWARE - TV-24" COLOR,STEREO W/REMOTE
13	148318-02-S93	EA	CABINET - OVHD/MICROWAVE - W/O DOORS/HARDWARE - TV-24" COLOR,STEREO W/REMOTE
14*	128527-09-000	EA	OVEN/MICROWAVE W/TRIM KIT - 1.1 CUBIC FT - NON CONVECTION FROM: 00-00-00 THRU: 10-05-04
14*	128527-13-000	EA	OVEN/MICROWAVE W/TRIM KIT - 1.0 CUBIC FT - NON CONVECTION FROM: 10-06-04 THRU: 99-99-99
14*	128527-10-000	EA	OVEN/MICROWAVE W/TRIM KIT - 1.1 CUBIC FT - NON CONV - CANADIAN FROM: 00-00-00 THRU: 11-07-04
14	128527-14-000	EA	OVEN/MICROWAVE W/TRIM KIT - 1.0 CUBIC FT - NON CONV - CANADIAN FROM: 11-08-04 THRU: 99-99-99



**CABINET & APPLIANCE GROUP (CONTINUED)**  
**CABINET & APPLIANCE LAYOUT (CONTINUED)**

KEY	PART NUMBER	U/M	DESCRIPTION
15*	121568-06-01A	EA	REFRIGERATOR - SMALL DBL DOOR-RH/2 WAY - 52.8"HX23.5"WX24"D
16	150935-01-S01	EA	CABINET - OVHD/VANITY - W/O DOORS/HARDWARE - PORTSMOUTH OAK
16	150935-01-S88	EA	CABINET - OVHD/VANITY - W/O DOORS/HARDWARE - SIERRA MAPLE
17	133654-42-S01	EA	COUNTERTOP - LAMINATED - MEADOW GREEN/PORTSMOUTH OAK (S04)
17	133654-42-S02	EA	COUNTERTOP - LAMINATED - GRAY TRANQUILITY/PORTSMOUTH OAK (S05)
17	133654-42-S03	EA	COUNTERTOP - LAMINATED - EGGSHELL/PORTSMOUTH OAK (S06)
17	133654-42-S88	EA	COUNTERTOP - LAMINATED - LINO FRIEZE/SIERRA MAPLE (S91)
17	133654-42-S89	EA	COUNTERTOP - LAMINATED - GRAY TRANQUILITY/SIERRA MAPLE (S92)
17	133654-42-S90	EA	COUNTERTOP - LAMINATED - EGGSHELL/SIERRA MAPLE (S93)
18*	136354-01-02A	EA	HOOD - RANGE - W/LITE/FAN - BLACK TEXTURED - US
18*	136354-02-02A	EA	HOOD - RANGE - W/LITE/FAN - BLACK TEXTURED - <b>CANADIAN</b>
19	140176-07-01B	EA	BRACKET/TIEDOWN - STOVE
20*	151277-01-01A	EA	RANGE-16"-3 BURNER - MERCURY FREE - BLACK DOOR/TEXTURED
21	140176-08-01B	EA	BRACKET/TIEDOWN - STOVE
22	P49951-01-S01	EA	CABINET - W/O CTRTP/DOORS/DRAWERS/HDW - PORTSMOUTH OAK
22	P49951-01-S88	EA	CABINET - W/O CTRTP/DOORS/DRAWERS/HDW - SIERRA MAPLE
22	P49951-02-S01	EA	CABINET - W/O CTRTP/DOORS/DRAWERS/HDW - PORTSMOUTH OAK - <b>ELECTRIC STEP</b>
22	P49951-02-S88	EA	CABINET - W/O CTRTP/DOORS/DRAWERS/HDW - SIERRA MAPLE - <b>ELECTRIC STEP</b>
22	P49951-03-S01	EA	CABINET - W/O CTRTP/DOORS/DRAWERS/HDW - PORTSMOUTH OAK - <b>2-WAY RADIO</b>
22	P49951-03-S88	EA	CABINET - W/O CTRTP/DOORS/DRAWERS/HDW - SIERRA MAPLE - <b>2-WAY RADIO</b>
22	P49951-04-S01	EA	CABINET - W/O CTRTP/DOORS/DRAWERS/HDW - PORTSMOUTH OAK - <b>ELECTRIC STEP/2-WAY RADIO</b>
22	P49951-04-S88	EA	CABINET - W/O CTRTP/DOORS/DRAWERS/HDW - SIERRA MAPLE - <b>ELECTRIC STEP/2-WAY RADIO</b>
23	144585-02-R09	EA	EXTENSION - GALLEY - LINO FRIEZE/PORTSMOUTH OAK (S04)
23	144585-02-R08	EA	EXTENSION - GALLEY - GRAY TRANQUILITY/PORTSMOUTH OAK (S05)
23	144585-02-R07	EA	EXTENSION - GALLEY - EGGSHELL/PORTSMOUTH OAK (S06)
23	144585-02-S88	EA	EXTENSION - GALLEY - LINO FRIEZE/SIERRA MAPLE (S91)
23	144585-02-S89	EA	EXTENSION - GALLEY - GRAY TRANQUILITY/SIERRA MAPLE (S92)
23	144585-02-S90	EA	EXTENSION - GALLEY - EGGSHELL/SIERRA MAPLE (S93)
24	133653-43-S01	EA	COUNTERTOP - LAMINATED - MEADOW GREEN/PORTSMOUTH OAK (S04)
24	133653-43-S02	EA	COUNTERTOP - LAMINATED - GRAY TRANQUILITY/PORTSMOUTH OAK (S05)
24	133653-43-S03	EA	COUNTERTOP - LAMINATED - EGGSHELL/PORTSMOUTH OAK (S06)
24	133653-43-S88	EA	COUNTERTOP - LAMINATED - LINO FRIEZE/SIERRA MAPLE (S91)
24	133653-43-S89	EA	COUNTERTOP - LAMINATED - GRAY TRANQUILITY/SIERRA MAPLE (S92)
24	133653-43-S90	EA	COUNTERTOP - LAMINATED - EGGSHELL/SIERRA MAPLE (S93)
25	098916-34-02B	EA	BRACE - MICROWAVE CABINET - RIGHT HAND - E-COATED
26	098916-33-02B	EA	BRACE - MICROWAVE CABINET - LEFT HAND - E-COATED
27	P50928-01-S01	EA	CABINET - VANITY - W/O COUNTERTOP/DOORS/DRAWERS/HDW (S04)
27	P50928-01-S02	EA	CABINET - VANITY - W/O COUNTERTOP/DOORS/DRAWERS/HDW (S05)
27	P50928-01-S03	EA	CABINET - VANITY - W/O COUNTERTOP/DOORS/DRAWERS/HDW (S06)
27	P50928-01-S88	EA	CABINET - VANITY - W/O COUNTERTOP/DOORS/DRAWERS/HDW (S91)
27	P50928-01-S89	EA	CABINET - VANITY - W/O COUNTERTOP/DOORS/DRAWERS/HDW (S92)
27	P50928-01-S90	EA	CABINET - VANITY - W/O COUNTERTOP/DOORS/DRAWERS/HDW (S93)

**\*COMPONENT PARTS LISTED LATER IN THIS GROUP**

**CABINET & APPLIANCE GROUP (CONTINUED)**  
**CABINET & APPLIANCE LAYOUT (CONTINUED)**

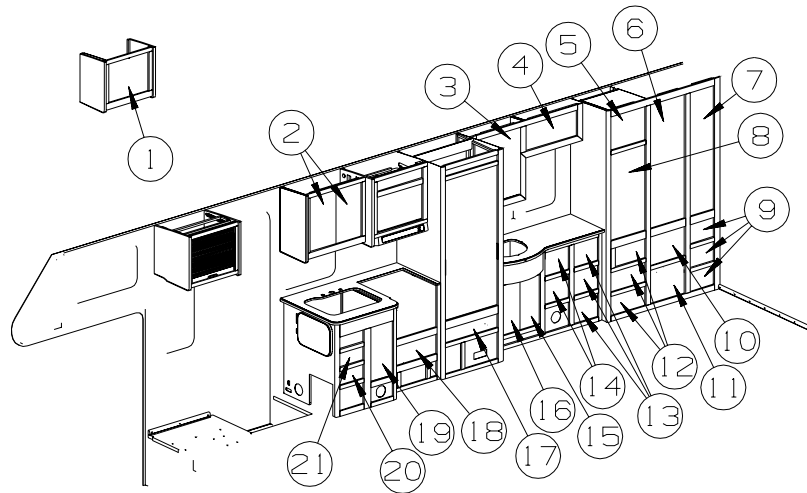

KEY	PART NUMBER	U/M	DESCRIPTION
1	136955-D0-S04	EA	DOOR - RAISED PANEL/PENCIL EDGE - 15.7" X 20.5" - W/O HDW - PORTSMOUTH OAK
1	136955-D0-S91	EA	DOOR - RAISED PANEL/PENCIL EDGE - 15.7" X 20.5" - W/O HDW - SIERRA MAPLE
2	136955-67-S31	EA	DOOR - RAISED PANEL/PENCIL EDGE - 12" X 21.9" - W/O HDW - PORTSMOUTH OAK
2	136955-67-SJ3	EA	DOOR - RAISED PANEL/PENCIL EDGE - 12" X 21.9" - W/O HDW - SIERRA MAPLE
3	145576-A5-S01	EA	DOOR - MIRRORED - 20.8" X 25.9" - W/O HARDWARE - PORTSMOUTH OAK
3	145576-A5-S88	EA	DOOR - MIRRORED - 20.8" X 25.9" - W/O HARDWARE - SIERRA MAPLE
	093606-47-000	EA	MIRROR - BEVELED EDGE - 20.8" X 25.9"
4	136955-43-S31	EA	DOOR - RAISED PANEL/PENCIL EDGE - 10.8" X 23.8" - W/O HDW - PORTSMOUTH OAK
4	136955-43-SJ3	EA	DOOR - RAISED PANEL/PENCIL EDGE - 10.8" X 23.8" - W/O HDW - SIERRA MAPLE
5	145268-40-S04	EA	DOOR - RAISED PANEL/PENCIL EDGE - 16.7" X 13.8" - W/O HDW - PORTSMOUTH OAK
5	145268-40-S91	EA	DOOR - RAISED PANEL/PENCIL EDGE - 16.7" X 13.8" - W/O HDW - SIERRA MAPLE
6	134786-02-N04	EA	DOOR - MIRROR/MITERED CORNERS - 16.7" X 47.9"-W/O HARDWARE - PORTSMOUTH OAK
			FROM: 00-00-00 THRU: 09-05-04
6	141507-03-S31	EA	DOOR - MIRRORED/PENCIL EDGE - 16.7" X 48" - W/O HDW - PORTSMOUTH OAK
			FROM: 09-06-04 THRU: 99-99-99
6	141507-03-S91	EA	DOOR - MIRRORED/PENCIL EDGE - 16.7" X 48" - W/O HDW - SIERRA MAPLE
7	136955-76-S04	EA	DOOR - RAISED PANEL/PENCIL EDGE - 12" X 48" - W/O HDW - PORTSMOUTH OAK
7	136955-76-S91	EA	DOOR - RAISED PANEL/PENCIL EDGE - 12" X 48" - W/O HDW - SIERRA MAPLE
8	145268-41-S04	EA	DOOR - RAISED PANEL/PENCIL EDGE - 16.7" X 33.4" - W/O HDW - PORTSMOUTH OAK
8	145268-41-S91	EA	DOOR - RAISED PANEL/PENCIL EDGE - 16.7" X 33.4" - W/O HDW - SIERRA MAPLE
9	145492-P4-R38	EA	DRAWER - PENCIL EDGE - 9.8"W X 11.8"D - W/O SLIDES/HDW - PORTSMOUTH OAK
9	145492-P4-S91	EA	DRAWER - PENCIL EDGE - 9.8"W X 11.8"D - W/O SLIDES/HDW - SIERRA MAPLE
10	145492-A0-R19	EA	DRAWER - PENCIL EDGE - 14.7"W X 17.7"D - W/O SLIDES/HDW - PORTSMOUTH OAK
10	145492-A0-SJ3	EA	DRAWER - PENCIL EDGE - 14.7"W X 17.7"D - W/O SLIDES/HDW - SIERRA MAPLE
11	145492-Z6-S04	EA	DRAWER - PENCIL EDGE - 12.7"W X 13.8"D - W/O SLIDES/HDW - PORTSMOUTH OAK
11	145492-Z6-S91	EA	DRAWER - PENCIL EDGE - 12.7"W X 13.8"D - W/O SLIDES/HDW - SIERRA MAPLE
12	145386-35-R44	EA	DRAWER - PENCIL EDGE - 15.1"W X 11.8"D - W/O SLIDES/HDW - PORTSMOUTH OAK
12	145386-35-SJ3	EA	DRAWER - PENCIL EDGE - 15.1"W X 11.8"D - W/O SLIDES/HDW - SIERRA MAPLE
13	145492-Z9-S04	EA	DRAWER - PENCIL EDGE - 9.9"W X 11.8"D - W/O SLIDES/HDW - PORTSMOUTH OAK
13	145492-Z9-S91	EA	DRAWER - PENCIL EDGE - 9.9"W X 11.8"D - W/O SLIDES/HDW - SIERRA MAPLE
14	145492-AA-S04	EA	DRAWER - PENCIL EDGE - 9.9"W X 13.8"D - W/O SLIDES/HDW - PORTSMOUTH OAK
14	145492-AA-S91	EA	DRAWER - PENCIL EDGE - 9.9"W X 13.8"D - W/O SLIDES/HDW - SIERRA MAPLE
15	136919-45-S04	EA	DOOR - FLAT/PENCIL EDGE - 10.8" X 23.8" - W/O HARDWARE - PORTSMOUTH OAK
15	136919-45-SJ3	EA	DOOR - FLAT/PENCIL EDGE - 10.8" X 23.8" - W/O HARDWARE - SIERRA MAPLE
16	136919-44-S04	EA	DOOR - FLAT/PENCIL EDGE - 10.8" X 23.8" - W/O HARDWARE - PORTSMOUTH OAK
16	136919-44-SJ3	EA	DOOR - FLAT/PENCIL EDGE - 10.8" X 23.8" - W/O HARDWARE - SIERRA MAPLE
17	145492-Z4-S04	EA	DRAWER - PENCIL EDGE - 22.5"W X 13.8"D - W/O SLIDES/HDW - PORTSMOUTH OAK
17	145492-Z4-S91	EA	DRAWER - PENCIL EDGE - 22.5"W X 13.8"D - W/O SLIDES/HDW - SIERRA MAPLE
18	145492-97-S04	EA	DRAWER - PENCIL EDGE - 19.8"W X 17.7"D - W/O SLIDES/HDW - PORTSMOUTH OAK
18	145492-97-S91	EA	DRAWER - PENCIL EDGE - 19.8"W X 17.7"D - W/O SLIDES/HDW - SIERRA MAPLE
19	136919-60-S04	EA	DOOR - FLAT/PENCIL EDGE - 11.4" X 21.8" - W/O HARDWARE - PORTSMOUTH OAK
19	136919-60-S91	EA	DOOR - FLAT/PENCIL EDGE - 11.4" X 21.8" - W/O HARDWARE - SIERRA MAPLE
20	145492-Z2-S04	EA	DRAWER - PENCIL EDGE - 9.9"W X 13.8"D - W/O SLIDES/HDW - PORTSMOUTH OAK
20	145492-Z2-S91	EA	DRAWER - PENCIL EDGE - 9.9"W X 13.8"D - W/O SLIDES/HDW - SIERRA MAPLE
21	145492-65-R30	EA	DRAWER - PENCIL EDGE - 9.9"W X 19.7"D - W/O SLIDES/HDW - PORTSMOUTH OAK
21	145492-65-SJ3	EA	DRAWER - PENCIL EDGE - 9.9"W X 19.7"D - W/O SLIDES/HDW - SIERRA MAPLE

**CABINET & APPLIANCE GROUP (CONTINUED)**  
**CABINET & APPLIANCE LAYOUT (CONTINUED)**

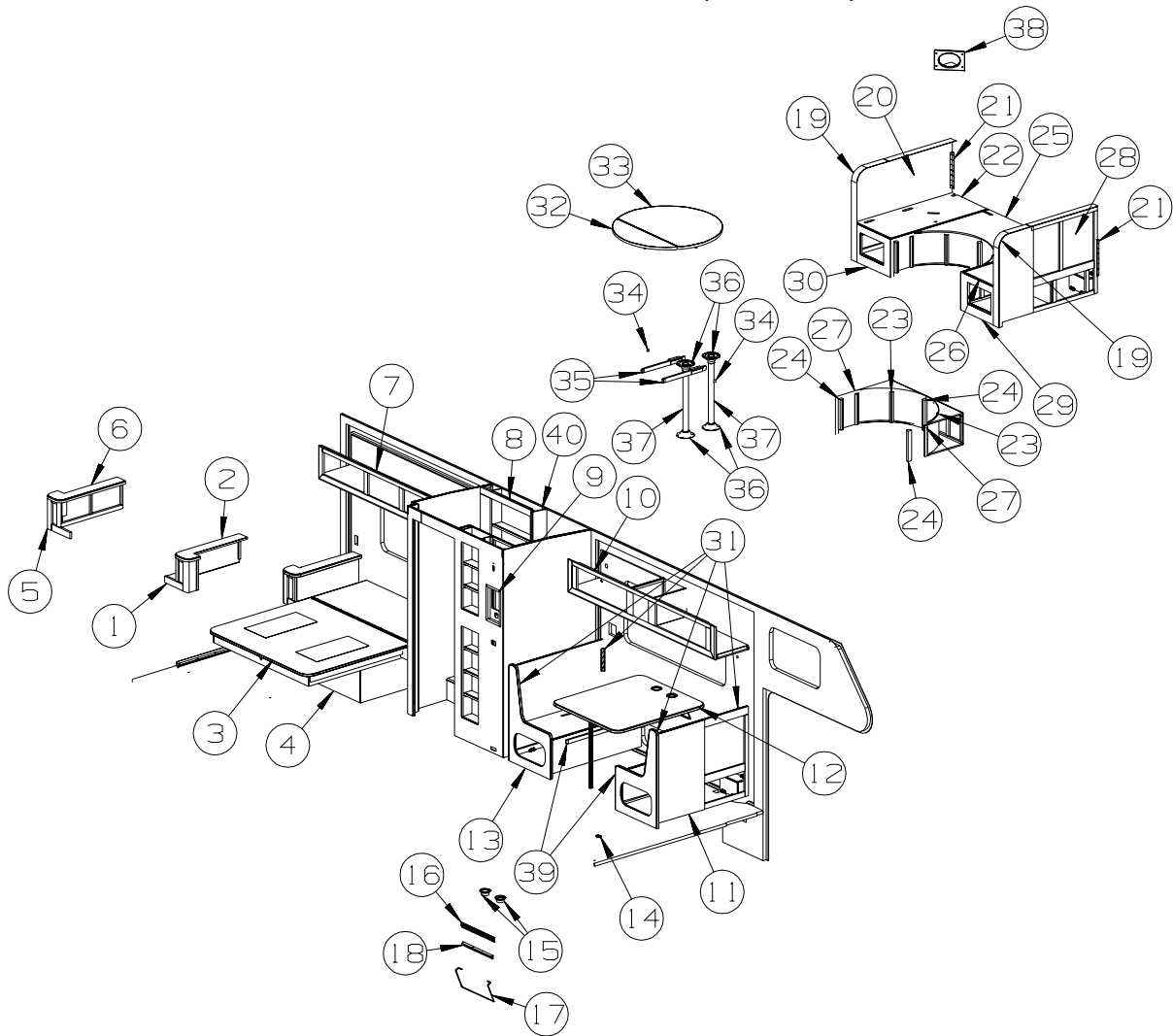

KEY	PART NUMBER	U/M	DESCRIPTION
1	136885-B4-S01	EA	CABINET - NIGHTSTAND/LH - W/O CTRTP/DOOR/DWR/HDW - PORTSMOUTH OAK
1	136885-B4-S88	EA	CABINET - NIGHTSTAND/LH - W/O CTRTP/DOOR/DWR/HDW - SIERRA MAPLE
2	140888-09-R15	EA	COUNTERTOP - LAMINATED - LINO FRIEZE/PORTSMOUTH OAK (S04)
2	140888-09-P13	EA	COUNTERTOP - LAMINATED - GRAY TRANQUILITY/PORTSMOUTH OAK (S05)
2	140888-09-P15	EA	COUNTERTOP - LAMINATED - EGGSHELL/PORTSMOUTH OAK (S06)
2	140888-09-SJ0	EA	COUNTERTOP - LAMINATED - LINO FRIEZE/SIERRA MAPLE (S91)
2	140888-09-SJ2	EA	COUNTERTOP - LAMINATED - GRAY TRANQUILITY/SIERRA MAPLE (S92)
2	140888-09-SJ1	EA	COUNTERTOP - LAMINATED - EGGSHELL/SIERRA MAPLE (S93)
3	137406-07-S01	EA	BEDBOARD - W/HINGE/T-MOLDING/SLIPNOT - FLIP-UP
	091261-01-000	FT	SLIPNOT - ANTISLIP - 1' WIDE X 12' - BLACK
4	150968-01-S01	EA	CABINET - BASE/QUEEN BED - W/O DOORS/DRAWERS/HDW - PORTSMOUTH OAK
4	150968-01-S88	EA	CABINET - BASE/QUEEN BED - W/O DOORS/DRAWERS/HDW - SIERRA MAPLE
5	136885-B3-S01	EA	CABINET - NIGHTSTAND/LH - W/O CTRTP/DOOR/DWR/HDW - PORTSMOUTH OAK
5	136885-B3-S88	EA	CABINET - NIGHTSTAND/LH - W/O CTRTP/DOOR/DWR/HDW - SIERRA MAPLE
6	140888-08-R09	EA	COUNTERTOP - LAMINATED - LINO FRIEZE/PORTSMOUTH OAK (S04)
6	140888-08-P13	EA	COUNTERTOP - LAMINATED - GRAY TRANQUILITY/PORTSMOUTH OAK (S05)
6	140888-08-P15	EA	COUNTERTOP - LAMINATED - EGGSHELL/PORTSMOUTH OAK (S06)
6	140888-08-SJ0	EA	COUNTERTOP - LAMINATED - LINO FRIEZE/SIERRA MAPLE (S91)
6	140888-08-SJ2	EA	COUNTERTOP - LAMINATED - GRAY TRANQUILITY/SIERRA MAPLE (S92)
6	140888-08-SJ1	EA	COUNTERTOP - LAMINATED - EGGSHELL/SIERRA MAPLE (S93)
7	136936-01-P13	EA	CABINET - OVERHEAD/REAR - W/O DOORS/HDW - PORTSMOUTH OAK
7	136936-01-SW0	EA	CABINET - OVERHEAD/REAR - W/O DOORS/HDW - SIERRA MAPLE
8	151032-01-S01	EA	CABINET - OVERHEAD/LINEN - W/O DOORS/HDW - PORTSMOUTH OAK
8	151032-01-S88	EA	CABINET - OVERHEAD/LINEN - W/O DOORS/HDW - SIERRA MAPLE
9	137602-E6-S28	EA	POCKET - MONITOR PANEL - PORTSMOUTH OAK
9	137602-E6-SJ0	EA	POCKET - MONITOR PANEL - SIERRA MAPLE

**CABINET & APPLIANCE GROUP (CONTINUED)**  
**CABINET & APPLIANCE LAYOUT (CONTINUED)**

KEY	PART NUMBER	U/M	DESCRIPTION
10	151051-01-S04	EA	CABINET - OVERHEAD/DINETTE - W/O DOORS/HARDWARE
10	151051-01-S05	EA	CABINET - OVERHEAD/DINETTE - W/O DOORS/HARDWARE
10	151051-01-S06	EA	CABINET - OVERHEAD/DINETTE - W/O DOORS/HARDWARE
10	151051-01-S91	EA	CABINET - OVERHEAD/DINETTE - W/O DOORS/HARDWARE
10	151051-01-S92	EA	CABINET - OVERHEAD/DINETTE - W/O DOORS/HARDWARE
10	151051-01-S93	EA	CABINET - OVERHEAD/DINETTE - W/O DOORS/HARDWARE
11	145004-12-S01	EA	CABINET/DINETTE-RH-W/END CAP/BACK/FACE-W/O DOOR/SEAT BOARD - PORTSMOUTH OAK
11	145004-12-S88	EA	CABINET/DINETTE-RH-W/END CAP/BACK/FACE-W/O DOOR/SEAT BOARD - SIERRA MAPLE
12	144605-08-S01	EA	TABLE - DINETTE - 41.6" X 37.6" - W/O HARDWARE (S04)
12	144605-08-S02	EA	TABLE - DINETTE - 41.6" X 37.6" - W/O HARDWARE (S05)
12	144605-08-S06	EA	TABLE - DINETTE - 41.6" X 37.6" - W/O HARDWARE (S06)
12	144605-08-S88	EA	TABLE - DINETTE - 41.6" X 37.6" - W/O HARDWARE (S91)
12	144605-08-S89	EA	TABLE - DINETTE - 41.6" X 37.6" - W/O HARDWARE (S92)
12	144605-08-S90	EA	TABLE - DINETTE - 41.6" X 37.6" - W/O HARDWARE (S93)
13	145004-13-S01	EA	CABINET/DINETTE-LH-W/END CAP/BACK/FACE-W/O DOOR/SEAT BOARD - PORTSMOUTH OAK
13	145004-13-S88	EA	CABINET/DINETTE-LH-W/END CAP/BACK/FACE-W/O DOOR/SEAT BOARD - SIERRA MAPLE
14	143798-01-01A	EA	CATCH - FLOOR TO TABLE LEG - BRIGHT WHITE
14	143798-03-01A	EA	WASHER/CATCH - TABLE LEG
15	064781-06-000	EA	HOLDER/CUP - TWO STEP - OFF WHITE
16	140921-02-01A	EA	BRACKET/TABLE SUPPORT - 18.5" - OFF WHITE
17	024275-13-000	EA	ROD - TABLE LIFT - OFF/WHITE
18	024281-15-000	EA	BRACKET/TABLE - LIFT ROD/LOWER WALL MOUNTED - 17.1"
19	149636-20-S04	EA	PAD - TOP - F/DINETTE BACK - FABRIC COVERED (S04, S91) - DINETTE - U-SHAPED
19	149636-20-S05	EA	PAD - TOP - F/DINETTE BACK - FABRIC COVERED (S05, S92) - DINETTE - U-SHAPED
19	149636-20-S06	EA	PAD - TOP - F/DINETTE BACK - FABRIC COVERED (S06, S93) - DINETTE - U-SHAPED
20	149636-22-S04	EA	SEAT BACK - DINETTE - LEFT - DINETTE - U-SHAPED
20	149636-22-S05	EA	SEAT BACK - DINETTE - LEFT - DINETTE - U-SHAPED
20	149636-22-S06	EA	SEAT BACK - DINETTE - LEFT - DINETTE - U-SHAPED
20	149636-22-S91	EA	SEAT BACK - DINETTE - LEFT - DINETTE - U-SHAPED
20	149636-22-S92	EA	SEAT BACK - DINETTE - LEFT - DINETTE - U-SHAPED
20	149636-22-S93	EA	SEAT BACK - DINETTE - LEFT - DINETTE - U-SHAPED
21	122021-02-02A	EA	ANGLE - W/HOLES - 13.7" LONG - OFF WHITE - DINETTE - U-SHAPED
22	P49636-AB-S01	EA	CABINET - SEATBASE/LEFT HAND ONLY - W/O HDW - PORTSMOUTH OAK - DINETTE - U-SHAPED
22	P49636-AB-S35	EA	CABINET - SEATBASE/LEFT HAND ONLY - W/O HDW - SIERRA MAPLE - DINETTE - U-SHAPED
23	149636-44-S01	EA	LUMBER - STAINED - BEVELED - .75" X 1.5" X 11.4" - PORTSMOUTH OAK - DINETTE - U-SHAPED
23	149636-44-S35	EA	LUMBER - STAINED - BEVELED - .75" X 1.5" X 11.4" - SIERRA MAPLE - DINETTE - U-SHAPED
	120760-01-000	EA	RUBBER BUMPER - CLEAR - .1" THICK X .8" DIAMETER - DINETTE - U-SHAPED
24	149636-37-S01	EA	LUMBER - STAINED - BEVELED - 1.5" X 1.5" X 11.4" - PORTSMOUTH OAK - DINETTE - U-SHAPED
24	149636-37-S35	EA	LUMBER - STAINED - BEVELED - 1.5" X 1.5" X 11.4" - SIERRA MAPLE - DINETTE - U-SHAPED
	120760-01-000	EA	RUBBER BUMPER - CLEAR - .1" THICK X .8" DIAMETER - DINETTE - U-SHAPED
25	P49636-AA-S01	EA	CABINET - SEATBASE/CENTER "CURVED" - W/O HDW - PORTSMOUTH OAK - DINETTE - U-SHAPED
25	P49636-AA-S35	EA	CABINET - SEATBASE/CENTER "CURVED" - W/O HDW - SIERRA MAPLE - DINETTE - U-SHAPED
26	P49636-AC-S01	EA	CABINET - SEATBASE/RIGHT HAND ONLY - W/O HDW - PORTSMOUTH OAK - DINETTE - U-SHAPED
26	P49636-AC-S35	EA	CABINET - SEATBASE/RIGHT HAND ONLY - W/O HDW - SIERRA MAPLE - DINETTE - U-SHAPED
27	149636-42-S01	EA	LUMBER - STAINED - BEVELED - .75" X 1.3" X 11.4" - PORTSMOUTH OAK - DINETTE - U-SHAPED
27	149636-42-S88	EA	LUMBER - STAINED - BEVELED - .75" X 1.3" X 11.4" - SIERRA MAPLE - DINETTE - U-SHAPED
	120760-01-000	EA	RUBBER BUMPER - CLEAR - .1" THICK X .8" DIAMETER - DINETTE - U-SHAPED
28	149636-11-S04	EA	SEAT BACK - DINETTE - RIGHT - DINETTE - U-SHAPED
28	149636-11-S05	EA	SEAT BACK - DINETTE - RIGHT - DINETTE - U-SHAPED
28	149636-11-S06	EA	SEAT BACK - DINETTE - RIGHT - DINETTE - U-SHAPED
28	149636-11-S91	EA	SEAT BACK - DINETTE - RIGHT - DINETTE - U-SHAPED
28	149636-11-S92	EA	SEAT BACK - DINETTE - RIGHT - DINETTE - U-SHAPED
28	149636-11-S93	EA	SEAT BACK - DINETTE - RIGHT - DINETTE - U-SHAPED
29	149636-14-S01	EA	END CAP - DINETTE - SEAT BASE/RIGHT - PORTSMOUTH OAK - DINETTE - U-SHAPED
29	149636-14-S35	EA	END CAP - DINETTE - SEAT BASE/RIGHT - SIERRA MAPLE - DINETTE - U-SHAPED
30	149636-25-S01	EA	END CAP - DINETTE - SEAT BASE/LEFT - PORTSMOUTH OAK - DINETTE - U-SHAPED
30	149636-25-S35	EA	END CAP - DINETTE - SEAT BASE/LEFT - SIERRA MAPLE - DINETTE - U-SHAPED
31	122021-01-02A	EA	ANGLE - W/HOLES - 8.6" LONG - OFF WHITE
32	150183-02-S01	EA	TABLE/DINETTE - DROP LEAF - W/O HDW (S04) - DINETTE - U-SHAPED
32	150183-02-S02	EA	TABLE/DINETTE - DROP LEAF - W/O HDW (S05) - DINETTE - U-SHAPED
32	150183-02-S03	EA	TABLE/DINETTE - DROP LEAF - W/O HDW (S06) - DINETTE - U-SHAPED
32	150183-02-S88	EA	TABLE/DINETTE - DROP LEAF - W/O HDW (S91) - DINETTE - U-SHAPED
32	150183-02-S89	EA	TABLE/DINETTE - DROP LEAF - W/O HDW (S92) - DINETTE - U-SHAPED
32	150183-02-S90	EA	TABLE/DINETTE - DROP LEAF - W/O HDW (S93) - DINETTE - U-SHAPED



**CABINET & APPLIANCE GROUP (CONTINUED)**  
**CABINET & APPLIANCE LAYOUT (CONTINUED)**

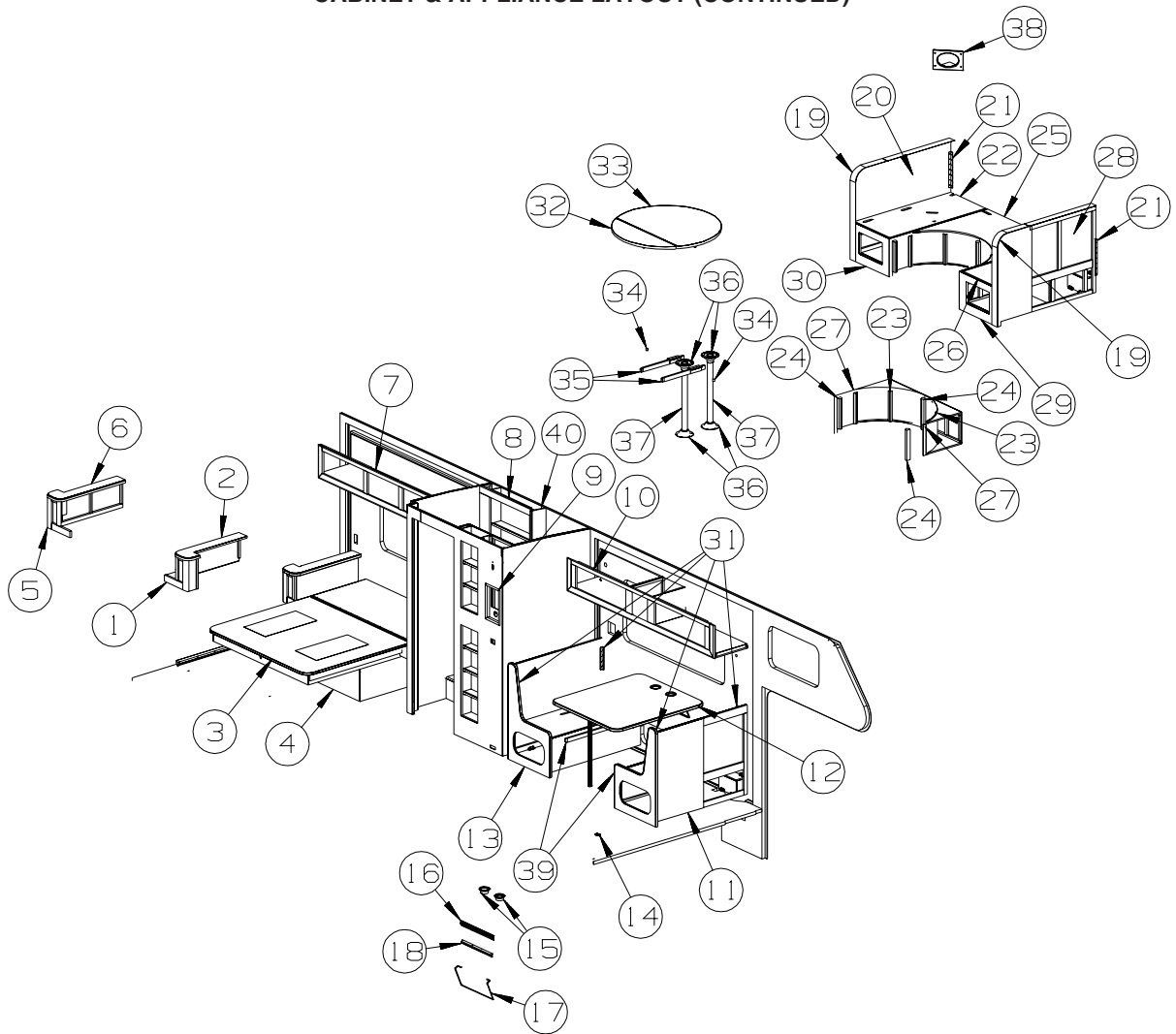

KEY	PART NUMBER	U/M	DESCRIPTION
33	150183-01-S01	EA	TABLE/DINETTE - ROUND - W/O DROP LEAF/LEG/HDW (S04) - <b>DINETTE - U-SHAPED</b>
33	150183-01-S02	EA	TABLE/DINETTE - ROUND - W/O DROP LEAF/LEG/HDW (S05) - <b>DINETTE - U-SHAPED</b>
33	150183-01-S03	EA	TABLE/DINETTE - ROUND - W/O DROP LEAF/LEG/HDW (S06) - <b>DINETTE - U-SHAPED</b>
33	150183-01-S88	EA	TABLE/DINETTE - ROUND - W/O DROP LEAF/LEG/HDW (S91) - <b>DINETTE - U-SHAPED</b>
33	150183-01-S89	EA	TABLE/DINETTE - ROUND - W/O DROP LEAF/LEG/HDW (S92) - <b>DINETTE - U-SHAPED</b>
33	150183-01-S90	EA	TABLE/DINETTE - ROUND - W/O DROP LEAF/LEG/HDW (S93) - <b>DINETTE - U-SHAPED</b>
34	117047-02-000	EA	BUMPER - RUBBER/WASHER INSERT - <b>DINETTE - U-SHAPED</b> FROM: 09-16-04 THRU: 99-99-99
35	120973-01-000	EA	SUPPORT - TABLE/DROP LEAF - PAIR - <b>DINETTE - U-SHAPED</b>
36	009040-03-000	EA	BASE - TABLE MOUNT - <b>DINETTE - U-SHAPED</b> FROM: 00-00-00 THRU: 04-17-05
36	155001-02-01A	EA	BASE - LEG MOUNT/FLOOR/TABLE - RAISED - SILVER - <b>DINETTE - U-SHAPED</b> FROM: 04-18-05 THRU: 99-99-99
37	009040-02-000	EA	PEDESTAL TABLE LEG - 27.5" X 2.25" DIAMETER - <b>DINETTE - U-SHAPED</b>
	062046-01-000	EA	CLIP - LEG - PEDESTAL - 1.7" X 2.2" - DIA FROM 2" - 2.5" - <b>DINETTE - U-SHAPED</b>
38	151005-01-S04	EA	CABINET - SPEAKER - W/O HARDWARE - <b>DINETTE - U-SHAPED</b>
38	151005-01-S05	EA	CABINET - SPEAKER - W/O HARDWARE - <b>DINETTE - U-SHAPED</b>
38	151005-01-S06	EA	CABINET - SPEAKER - W/O HARDWARE - <b>DINETTE - U-SHAPED</b>
38	151005-01-S91	EA	CABINET - SPEAKER - W/O HARDWARE - <b>DINETTE - U-SHAPED</b>
38	151005-01-S92	EA	CABINET - SPEAKER - W/O HARDWARE - <b>DINETTE - U-SHAPED</b>
38	151005-01-S93	EA	CABINET - SPEAKER - W/O HARDWARE - <b>DINETTE - U-SHAPED</b>
39	081295-01-N70	EA	SUPPORT - BED/DINETTE - 28" LONG - PORTSMOUTH OAK
39	081295-01-RE0	EA	SUPPORT - BED/DINETTE - 28" LONG - SIERRA MAPLE
40	140307-03-P07	EA	END CAP - OVHD CABINET - PORTSMOUTH OAK
40	140307-03-S88	EA	END CAP - OVHD CABINET - SIERRA MAPLE

**CABINET & APPLIANCE GROUP (CONTINUED)**  
**CABINET & APPLIANCE LAYOUT (CONTINUED)**

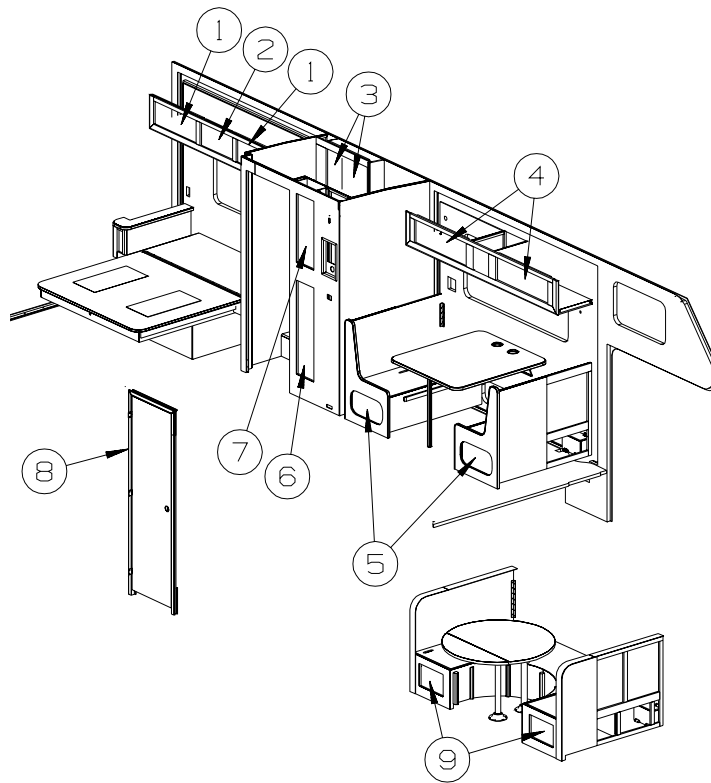

KEY	PART NUMBER	U/M	DESCRIPTION
1	136955-25-S31	EA	DOOR - RAISED PANEL/PENCIL EDGE - 10" X 25.2" - W/O HDW - PORTSMOUTH OAK
1	136955-25-S91	EA	DOOR - RAISED PANEL/PENCIL EDGE - 10" X 25.2" - W/O HDW - SIERRA MAPLE
2	136955-22-S31	EA	DOOR - RAISED PANEL/PENCIL EDGE - 10" X 19.1" - W/O HDW - PORTSMOUTH OAK
2	136955-22-S91	EA	DOOR - RAISED PANEL/PENCIL EDGE - 10" X 19.1" - W/O HDW - SIERRA MAPLE
3	136955-67-S31	EA	DOOR - RAISED PANEL/PENCIL EDGE - 12" X 21.9" - W/O HDW - PORTSMOUTH OAK
3	136955-67-SJ3	EA	DOOR - RAISED PANEL/PENCIL EDGE - 12" X 21.9" - W/O HDW - SIERRA MAPLE
4	136955-28-S31	EA	DOOR - RAISED PANEL/PENCIL EDGE - 10" X 29.5" - W/O HDW - PORTSMOUTH OAK
4	136955-28-S91	EA	DOOR - RAISED PANEL/PENCIL EDGE - 10" X 29.5" - W/O HDW - SIERRA MAPLE
5	147084-08-S04	EA	DOOR - FLAT PANEL/PENCIL EDGE - 10" X 19.1" - W/O HDW - PORTSMOUTH OAK
5	147084-08-S91	EA	DOOR - FLAT PANEL/PENCIL EDGE - 10" X 19.1" - W/O HDW - SIERRA MAPLE
6	136955-49-S31	EA	DOOR - RAISED PANEL/PENCIL EDGE - 10.8" X 36.4" - W/O HDW - PORTSMOUTH OAK
6	136955-49-S91	EA	DOOR - RAISED PANEL/PENCIL EDGE - 10.8" X 36.4" - W/O HDW - SIERRA MAPLE
7	136955-46-S04	EA	DOOR - RAISED PANEL/PENCIL EDGE - 10.8" X 28" - W/O HDW - PORTSMOUTH OAK
7	136955-46-S91	EA	DOOR - RAISED PANEL/PENCIL EDGE - 10.8" X 28" - W/O HDW - SIERRA MAPLE
8	144645-01-R07	EA	DOOR - BATH - W/O TOWEL RACK/HARDWARE - PORTSMOUTH OAK
			FROM: 00-00-00 THRU: 09-12-04
8	144645-02-R32	EA	DOOR - BATH - W/O FRAME (PICTURE)/TOWEL RACK/HDW - PORTSMOUTH OAK
			FROM: 09-13-04 THRU: 99-99-99
8	144645-01-S88	EA	DOOR - BATH - W/O TOWEL RACK/HARDWARE - SIERRA MAPLE
			FROM: 00-00-00 THRU: 09-12-04
8	144645-02-S88	EA	DOOR - BATH - W/O FRAME (PICTURE)/TOWEL RACK/HDW - SIERRA MAPLE
			FROM: 09-13-04 THRU: 99-99-99
9	147084-06-S04	EA	DOOR - FLAT PANEL/PENCIL EDGE - 10" X 15.7" - W/O HDW - PORTSMOUTH OAK
9	147084-06-S91	EA	DOOR - FLAT PANEL/PENCIL EDGE - 10" X 15.7" - W/O HDW - SIERRA MAPLE

**CABINET & APPLIANCE GROUP (CONTINUED)**  
**CABINET & APPLIANCE LAYOUT (CONTINUED)**

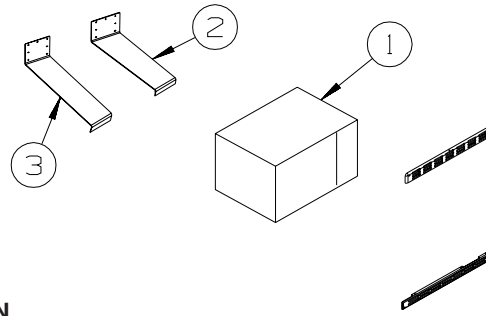

KEY	PART NUMBER	U/M	DESCRIPTION
1*	128527-09-000	EA	OVEN/MICROWAVE W/TRIM KIT - 1.1 CUBIC FT - NON CONVECTION FROM: 00-00-00 THRU: 09-30-04
1*	128527-13-000	EA	OVEN/MICROWAVE W/TRIM KIT - 1.0 CUBIC FT - NON CONVECTION FROM: 10-01-04 THRU: 99-99-99
1*	128527-10-000	EA	OVEN/MICROWAVE W/TRIM KIT - 1.1 CUBIC FT - NON CONVECTION - CANADIAN FROM: 00-00-00 THRU: 11-07-04
1	128527-14-000	EA	OVEN/MICROWAVE W/TRIM KIT - 1.0 CUBIC FT - NON CONV - CANADIAN FROM: 11-08-04 THRU: 99-99-99
2	143759-06-02B	EA	BRACKET - MICROWAVE - E-COATED
3	143759-06-02B	EA	BRACKET - MICROWAVE - E-COATED

**\*COMPONENT PARTS LISTED LATER IN THIS GROUP**

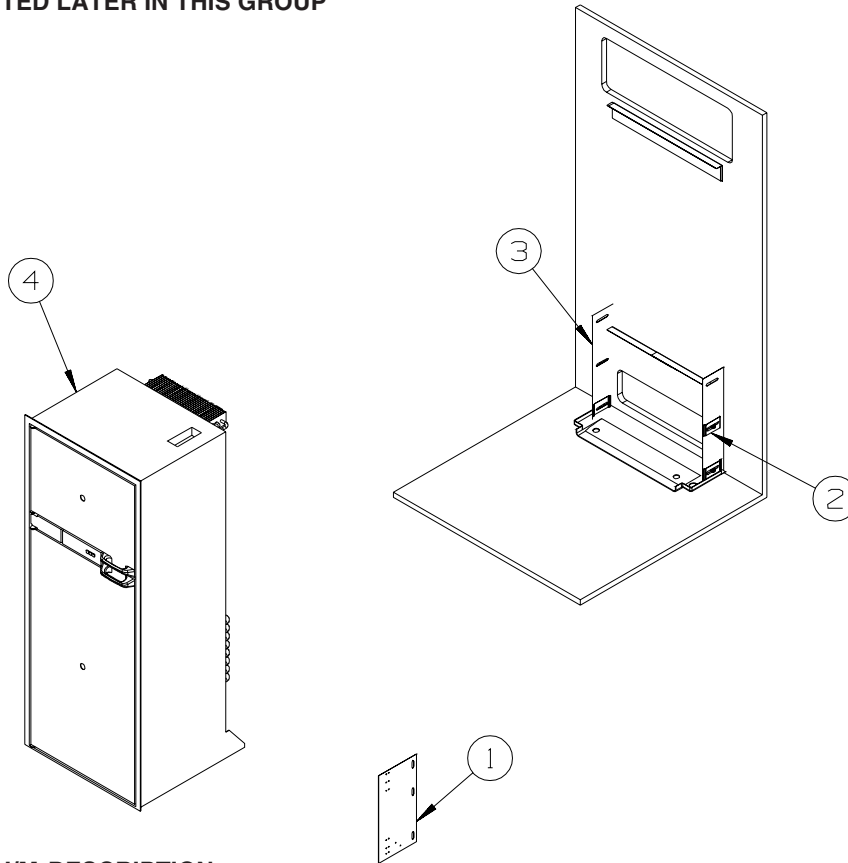

**FROM: 00-00-00**  
**THRU: 08-17-04**

KEY	PART NUMBER	U/M	DESCRIPTION
1	141975-04-02B	EA	PLATE/TIEDOWN - REFRIGERATOR - E-COATED
2	141550-01-02B	EA	BRACKET/TIEDOWN - REFRIGERATOR - E-COATED
3	141550-02-02B	EA	BRACKET/TIEDOWN - REFRIGERATOR - E-COATED
4*	121568-07-01A	EA	REFRIGERATOR - DBL DR-LH/2 WAY- 52.8"HX23.5"WX24"D - 322E, 322R, 324F, 324V, 326A
4*	121568-06-01A	EA	REFRIG - DBL DR-RH/2 WAY- 52.8"HX23.5"WX24"D - 327L, 329B, 329SB, 329K, 331T, 331SST, 332G
	112176-01-000	FT	TUBING - VINYL - REINFORCED - 1/2" ID
	090329-01-000	FT	SEAL/T - REFRIGERATOR CABINET
	116751-01-01A	EA	TRAY - REFRIGERATOR - 322E, 322R, 324V
	116751-02-01A	EA	TRAY - REFRIGERATOR - BLACK - 327L, 331T, 331ST, 332G
	116751-04-01A	EA	TRAY - REFRIGERATOR - BLACK - 324F, 326A
	116751-05-01A	EA	TRAY - REFRIGERATOR - BLACK - 329B, 329SB, 329K
	054450-01-000	EA	LEVEL - REFRIGERATOR

**\*COMPONENT PARTS LISTED LATER IN THIS GROUP**

**CABINET & APPLIANCE GROUP (CONTINUED)**  
**CABINET & APPLIANCE LAYOUT (CONTINUED)**

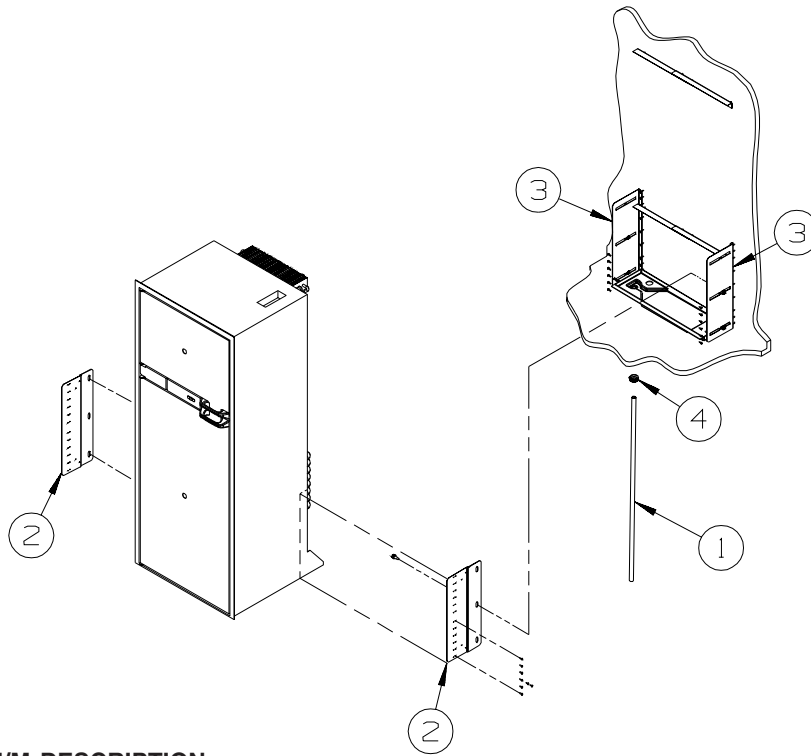

**FROM: 08-18-04**  
**THRU: 99-99-99**

KEY	PART NUMBER	U/M	DESCRIPTION
1	112176-01-000	FT	TUBING - VINYL - REINFORCED - 1/2" ID
2	150740-01-02B	EA	BRACKET - REFRIGERATOR - E-COATED
3	150740-02-02B	EA	BRACKET - REFRIGERATOR - E-COATED
4	152417-01-01A	EA	CLAMP/RATCHET - F/REFRIDGERATOR DRIP TRAY HOSE - BLACK
4*	121568-07-01A	EA	REFRIGERATOR - DBL DR-LH/2 WAY- 52.8"HX23.5"WX24"D - 322E, 322R, 324F, 324V, 326A
4*	121568-06-01A	EA	REFRIG - DBL DR-RH/2 WAY- 52.8"HX23.5"WX24"D - 327L, 329B, 329SB, 329K, 331T, 331SST, 332G
	090329-01-000	FT	SEAL/T - REFRIGERATOR CABINET
	116751-01-01A	EA	TRAY - REFRIGERATOR - 322E, 322R, 324V
	116751-02-01A	EA	TRAY - REFRIGERATOR - BLACK - 327L, 331T, 331ST, 332G
	116751-04-01A	EA	TRAY - REFRIGERATOR - BLACK - 324F, 326A
	116751-05-01A	EA	TRAY - REFRIGERATOR - BLACK - 329B, 329SB, 329K
	054450-01-000	EA	LEVEL - REFRIGERATOR

**\*COMPONENT PARTS LISTED LATER IN THIS GROUP**



**CABINET & APPLIANCE GROUP (CONTINUED)**  
**COMPONENT PARTS FOR CABINET & APPLIANCE LAYOUT**

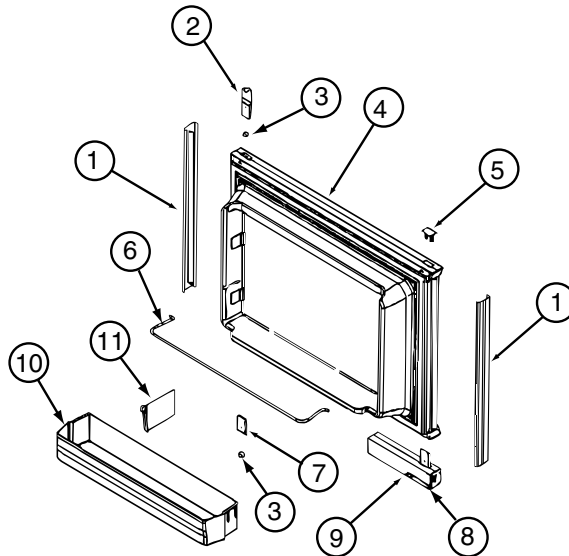

**121568-06-01A, 121568-07-01A, 121568-08-01A**

<b>KEY</b>	<b>PART NUMBER</b>	<b>U/M</b>	<b>DESCRIPTION</b>	<b>VENDOR NO.</b>
1	121568-03-700	EA	RETAINER - DOOR PANEL/BLACK	619559
2	120075-01-701	EA	HINGE-TOP RH/BOTTOM LH(DOOR)	618511
3	121568-03-701	EA	BUSHING - HINGE PIN/GRAY	619671
4	121568-03-702	EA	DOOR LINER - W/BLACK TRIM	619627
5	120075-01-702	EA	CAP, (HINGE PLUG)	618160
6	121568-01-700	EA	RAIL - DOOR UPPER	618618
7	120075-01-705	EA	HINGE-TOP LH/BOTTOM RH(DOOR)	618510
8	121568-03-705	EA	STORAGE LATCH - GRAY	619648
9	121568-03-721	EA	HANDLE/DOOR TOP LH/LWR RH	621465
9	121568-03-722	EA	HANDLE/DOOR LWR RH/TOP LH	621469
10	121568-01-701	EA	BIN - DOOR WHITE	618619

CONTACT WINNEBAGO PART SALES FOR UNLISTED COMPONENT(S)

**CABINET & APPLIANCE GROUP (CONTINUED)**  
**COMPONENT PARTS FOR CABINET & APPLIANCE LAYOUT (CONTINUED)**

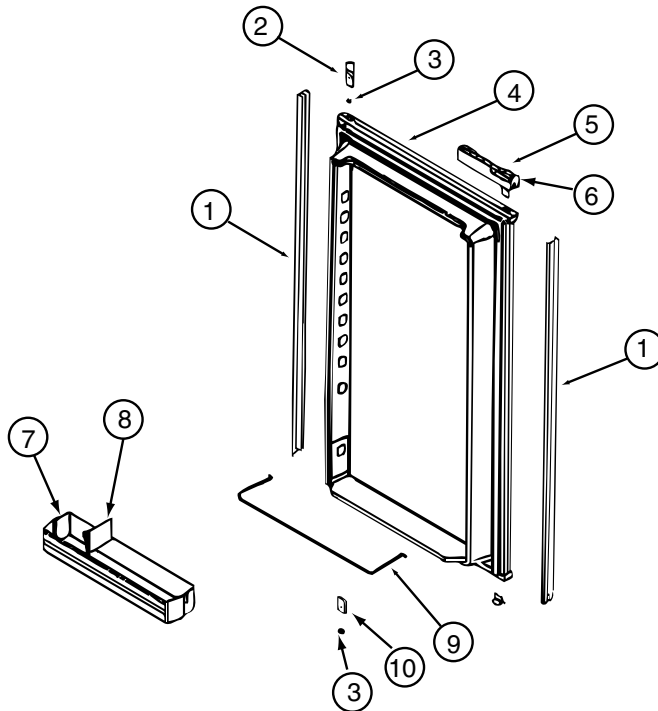

121568-06-01A, 121568-07-01A, 121568-08-01A (CONTINUED)

KEY	PART NUMBER	U/M	DESCRIPTION	VENDOR NO.
1	121568-03-706	EA	RETAINER - DOOR PANEL/BLACK	619559
2	120075-01-701	EA	HINGE-TOP RH/BOTTOM LH(DOOR)	618511
3	121568-03-701	EA	BUSHING - HINGE PIN/GRAY	619671
4	121568-03-707	EA	DOOR LINER - W/BLACK TRIM	619629
5	121568-03-721	EA	HANDLE/DOOR TOP LH/LWR RH	621465
5	121568-03-722	EA	HANDLE/DOOR LWR RH/TOP LH	621469
6	121568-03-705	EA	STORAGE LATCH - GRAY	619648
7	121568-01-701	EA	BIN - DOOR WHITE	618619
9	121568-01-704	EA	RAIL - DOOR LOWER	618578
10	120075-01-705	EA	HINGE-TOP LH/BOTTOM RH(DOOR)	618510

CONTACT WINNEBAGO PART SALES FOR UNLISTED COMPONENT(S)

**CABINET & APPLIANCE GROUP (CONTINUED)**  
**COMPONENT PARTS FOR CABINET & APPLIANCE LAYOUT (CONTINUED)**

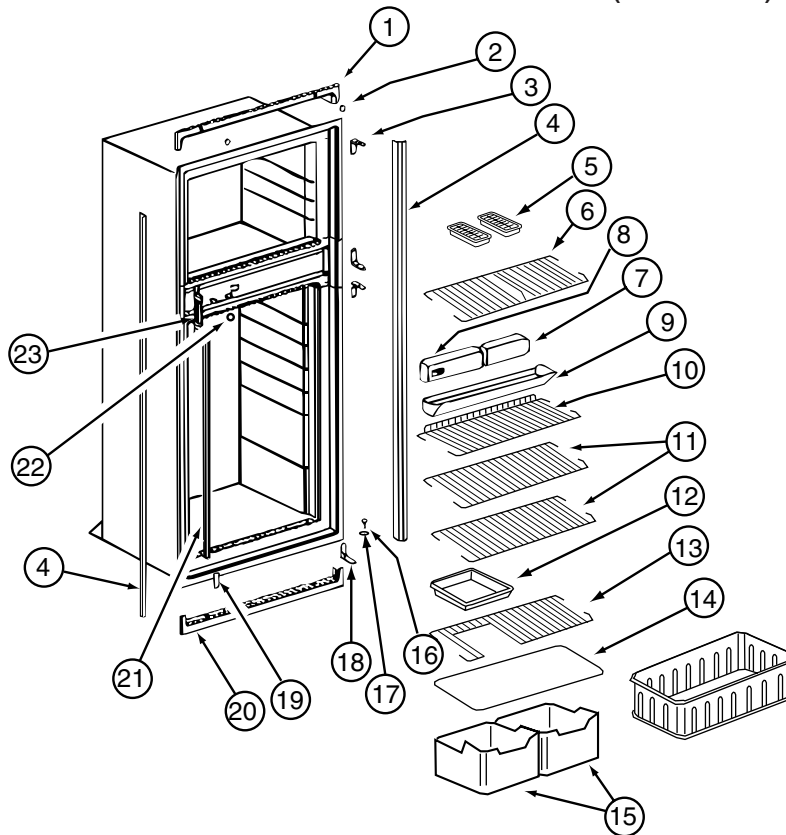

**121568-06-01A, 121568-07-01A, 121568-08-01A (CONTINUED)**

KEY	PART NUMBER	U/M	DESCRIPTION	VENDOR NO.
1	120075-01-713	EA	TRIM-TOP PIECE	619687
2	120075-01-714	EA	PLUG-HOLE (BLACK)	618170
3	121568-03-710	EA	HINGE/CABINET-TOP/RH-LWR/LH	619335
4	121568-03-711	EA	TRIM - SIDE/BLACK	622295
6	121568-01-705	EA	SHELF - WIRE FREEZER	620250
7	121568-06-700	EA	FRONT BOX-N611	622002
8	121568-06-701	EA	CONTROL ASSEMBLY-OPTICAL/N611	621988
9	120075-01-720	EA	TRAY-DRIP	618137
9	120075-01-721	EA	LOUVER-DRIP TRAY	618176
11	121568-01-708	EA	SHELF - WIRE	620273
13	121568-01-707	EA	SHELF - WIRE - SHORT	620272
14	120075-01-725	EA	COVER-CRISPER	618158
15	121568-01-709	EA	CRISPER	618571
16	120075-01-727	EA	PIN-HINGE	618145
17	121568-03-701	EA	BUSHING - HINGE PIN/GRAY	619671
18	121568-03-715	EA	HINGE/CABINET-TOP/LH-LWR/RH	619336
19	121568-03-716	EA	COVER - HINGE HOLES	619301
20	120075-01-729	EA	TRIM-BOTTOM PIECE	620958
21	121568-06-702	EA	CLIP - SHELF	61536522
22	121568-06-703	EA	HOLE PLUG - WHITE	620282
23	120075-01-732	EA	PLATE-STRIKE	618167

CONTACT WINNEBAGO PART SALES FOR UNLISTED COMPONENT(S)

**CABINET & APPLIANCE GROUP (CONTINUED)**  
**COMPONENT PARTS FOR CABINET & APPLIANCE LAYOUT (CONTINUED)**

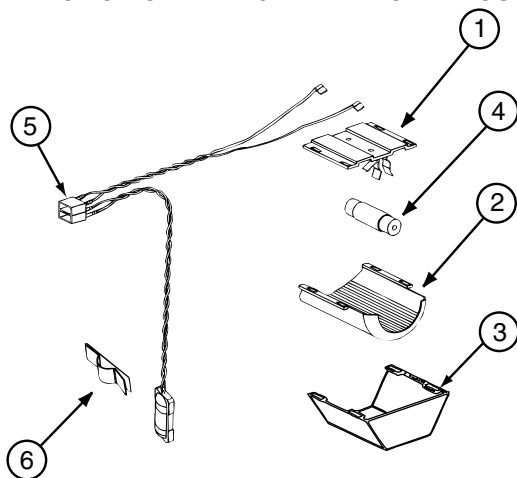

121568-06-01A, 121568-07-01A, 121568-08-01A (CONTINUED)

KEY	PART NUMBER	U/M	DESCRIPTION	VENDOR NO.
1	084880-01-760	EA	CLIP (THERMISTER)	61689122
2	120075-01-735	EA	THERMISTER W/LAMP & WIRE/ASM	618548
3	084880-03-705	EA	BRACKET-LIGHT-INTERIOR	61629722
4	084880-03-706	EA	BULB-LAMP	61628922
6	084880-03-707	EA	COVER-LAMP, LENS	61627922

CONTACT WINNEBAGO PART SALES FOR UNLISTED COMPONENT(S)

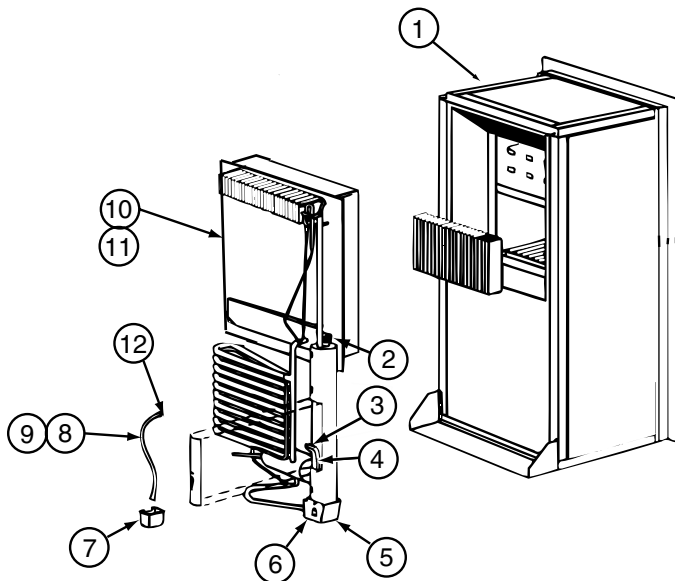

121568-06-01A, 121568-07-01A, 121568-08-01A (CONTINUED)

KEY	PART NUMBER	U/M	DESCRIPTION	VENDOR NO.
4	121568-06-704	EA	HEATER-AC/300W/120VAC	621702
10	120076-01-704	EA	COOLING UNIT, SERVICE PACK	618543

CONTACT WINNEBAGO PART SALES FOR UNLISTED COMPONENT(S)

**CABINET & APPLIANCE GROUP (CONTINUED)**  
**COMPONENT PARTS FOR CABINET & APPLIANCE LAYOUT (CONTINUED)**

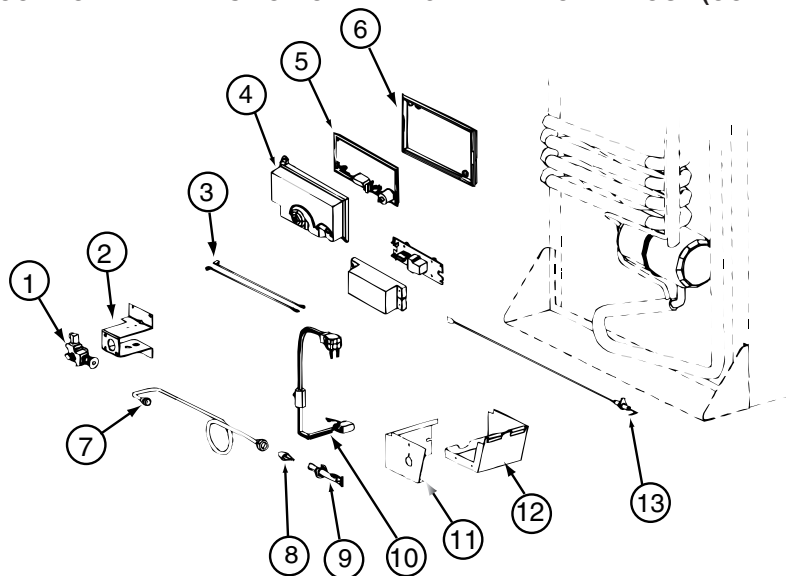

**121568-06-01A, 121568-07-01A, 121568-08-01A (CONTINUED)**

KEY	PART NUMBER	U/M	DESCRIPTION	VENDOR NO.
1	121568-06-705	EA	GAS VALVE/BRKT ASSY-COMBO	621439
1	121568-06-706	EA	GAS VALVE-COMBO/WRENCH FLAT	621329
4	120075-01-738	EA	COVER-POWER BOARD	618185
5	121568-06-707	EA	BOARD/POWER-N611	621991
6	120075-01-740	EA	COVER-BASE, POWER BOARD	618186
8	121568-06-708	EA	BURNER/ORFICE-ADAPTER KIT	621957
13	104137-06-715	EA	ELECTRODE-SPARK/SENSOR, SGL	61692222
			CONTACT WINNEBAGO PART SALES FOR UNLISTED COMPONENT(S)	

**121568-05-01A, 121568-07-01A, 121568-08-01A (CONTINUED)**

KEY	PART NUMBER	U/M	DESCRIPTION	VENDOR NO.
	121568-05-700	EA	FAN 12V KIT DBLE SIDEWALL	619020

**128527-09-000, 128527-10-000, 128527-13-000**

KEY	PART NUMBER	U/M	DESCRIPTION	VENDOR NO.
	128527-08-700	EA	TRIM RING-F/1.0 NON CONV	MR10BB

**CABINET & APPLIANCE GROUP (CONTINUED)**  
**COMPONENT PARTS FOR CABINET & APPLIANCE LAYOUT (CONTINUED)**

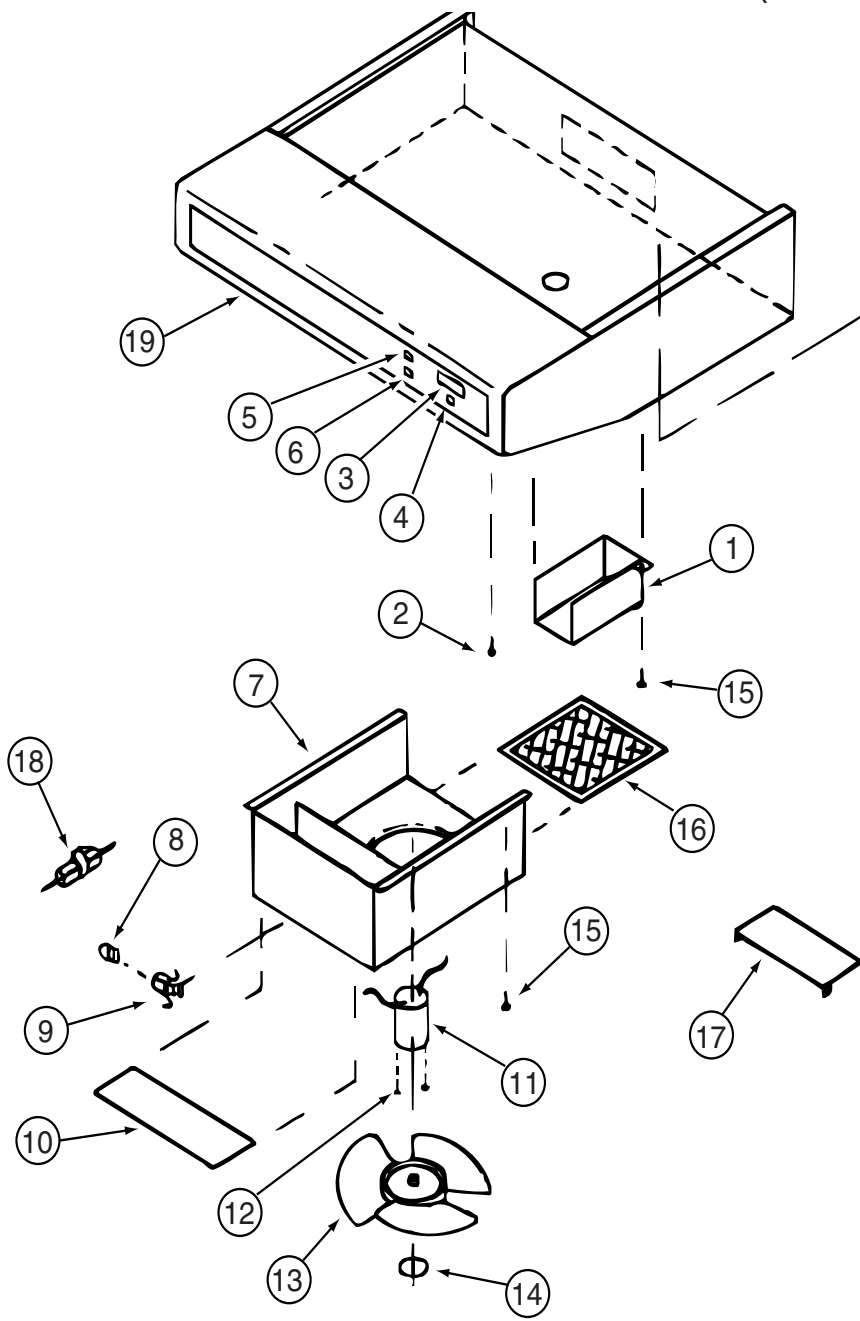

136354-01-02A

KEY	PART NUMBER	U/M	DESCRIPTION	VENDOR NO.
3	100258-10-700	EA	GAUGE-HOUR METER, SCREW ON	L0150-00 WAS 150
4	096983-01-702	EA	SWITCH - MOM/OFF/MOM/3 TERM	L0112-00
5	096983-01-700	EA	SWITCH/1 SPEED -ON/OFF- BLK	L0108-00
9	092696-01-710	EA	HOLDER-LAMP	CB267-02
10	096983-01-708	EA	LENS-LAMP	CC0179
11	136354-05-700	EA	MOTOR-12 VOLT	VC0536-02
13	136354-05-701	EA	BLADE-FAN 7" DIA	VD0216-00
16	096983-01-707	EA	FILTER-MESH	CC0246-00
17	100258-01-701	EA	DAMPER ASSEMBLY (METAL FLAP)	CA0565-00
19	100258-01-700	EA	LABEL-HOOD NOSE	CC0428-00

CONTACT WINNEBAGO PART SALES FOR UNLISTED COMPONENT(S)

**CABINET & APPLIANCE GROUP (CONTINUED)**  
**COMPONENT PARTS FOR CABINET & APPLIANCE LAYOUT (CONTINUED)**

136354-02-02A

<b>KEY</b>	<b>PART NUMBER</b>	<b>U/M</b>	<b>DESCRIPTION</b>	<b>VENDOR NO.</b>
5	096983-01-700	EA	SWITCH/1 SPEED -ON/OFF- BLK	L0108-00
9	092696-01-710	EA	HOLDER-LAMP	CB267-02
10	096983-01-708	EA	LENS-LAMP	CC0179
11	136354-06-700	EA	MOTOR - FAN (CSA)	VC0535-02
13	136354-05-701	EA	BLADE-FAN 7" DIA	VD0216-00
16	096983-01-707	EA	FILTER-MESH	CC0246-00
17	100258-01-701	EA	DAMPER ASSEMBLY (METAL FLAP)	CA0565-00
19	100258-01-700	EA	LABEL-HOOD NOSE	CC0428-00
			CONTACT WINNEBAGO PART SALES FOR UNLISTED COMPONENT(S)	

**CABINET & APPLIANCE GROUP (CONTINUED)**  
**COMPONENT PARTS FOR CABINET & APPLIANCE LAYOUT (CONTINUED)**

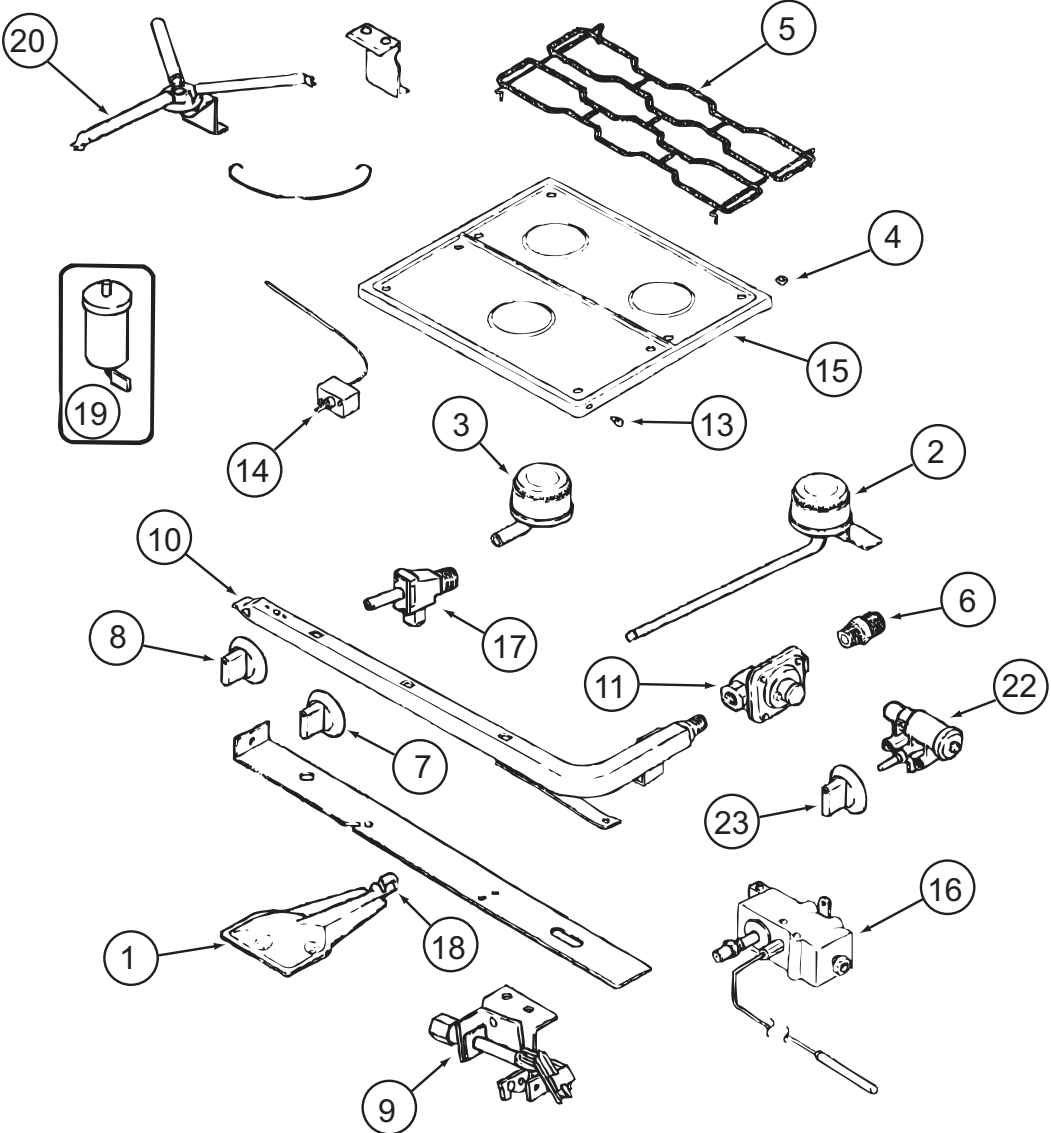

151277-01-01A, 151277-02-01A



**CABINET & APPLIANCE GROUP (CONTINUED)**  
**COMPONENT PARTS FOR CABINET & APPLIANCE LAYOUT (CONTINUED)**

151277-01-01A, 151277-02-01A (CONTINUED)

KEY	PART NUMBER	U/M	DESCRIPTION	VENDOR NO.
1	151279-02-700	EA	BURNER - OVEN - W/SHUTTER	74009853
2	112881-04-700	EA	BURNER - TOP/LEFT REAR	74004584
2	126023-01-700	EA	BURNER-TOP (RT-REAR) 5100BTU	74004583
3	112881-04-701	EA	BURNER - TOP/FRONT	74004582
4	102020-01-709	EA	BUMPER-GRATE	8007P020-60
5	112881-04-702	EA	GRATE - BLACK	74007277
6	135065-03-700	EA	FITTING - HALF UNION	74004234
7	128728-01-701	EA	KNOB - BURNER - REAR	74003941 (1 PER)
7	128728-01-702	EA	KNOB - BURNER - FRONT	74003942 (2 PER)
8	151279-02-701	EA	KNOB - THERMOSTAT - BLACK	74009858
9	151279-01-700	EA	PILOT - BURNER - 16" SERIES	74009852
10	151279-02-702	EA	PIPE - MANIFOLD	74009856
11	112881-03-701	EA	REGULATOR KIT W/FITTINGS	12001285
13	102020-01-724	EA	BUMPER-MAIN TOP	8003P008-60
14	151279-02-703	EA	THERMOSTAT	74009855
15	151277-01-700	EA	TOP - MAIN (BLACK)	74007287
16	151279-02-704	EA	ELBOW BLOCK ASM (VALVE-OVEN)	74009864
17	151277-01-701	EA	VALVE/REAR - W/SET SCREW	12002254
17	151277-01-702	EA	VALVE/FRONT - W/SET SCREW	12002246
19	112881-04-705	EA	PUSH RING (ELECTRODE MTG)	7104P002-60
19	126023-01-711	EA	ELECTRODE - IGNITER (ONLY)	7432P077-60
20	126023-01-736	EA	FLASH TUBE EXTENSION (REAR)	74003326
20	126023-01-737	EA	FLASH TUBE EXTENSION (FRONT)	74003327
21	112881-04-708	EA	CLIP-FLASH TUBE	7112P068-60
22	126023-01-735	EA	KIT - IGNITOR TOP BRNER & KNOB	12001296=74002413&4
23	128728-01-707	EA	KNOB - IGNITOR	74003944
26	112881-04-709	EA	SHIELD-SPARK	3604F211-45
			CONTACT WINNEBAGO PART SALES FOR UNLISTED COMPONENT(S)	

**CABINET & APPLIANCE GROUP (CONTINUED)**  
**COMPONENT PARTS FOR CABINET & APPLIANCE LAYOUT (CONTINUED)**

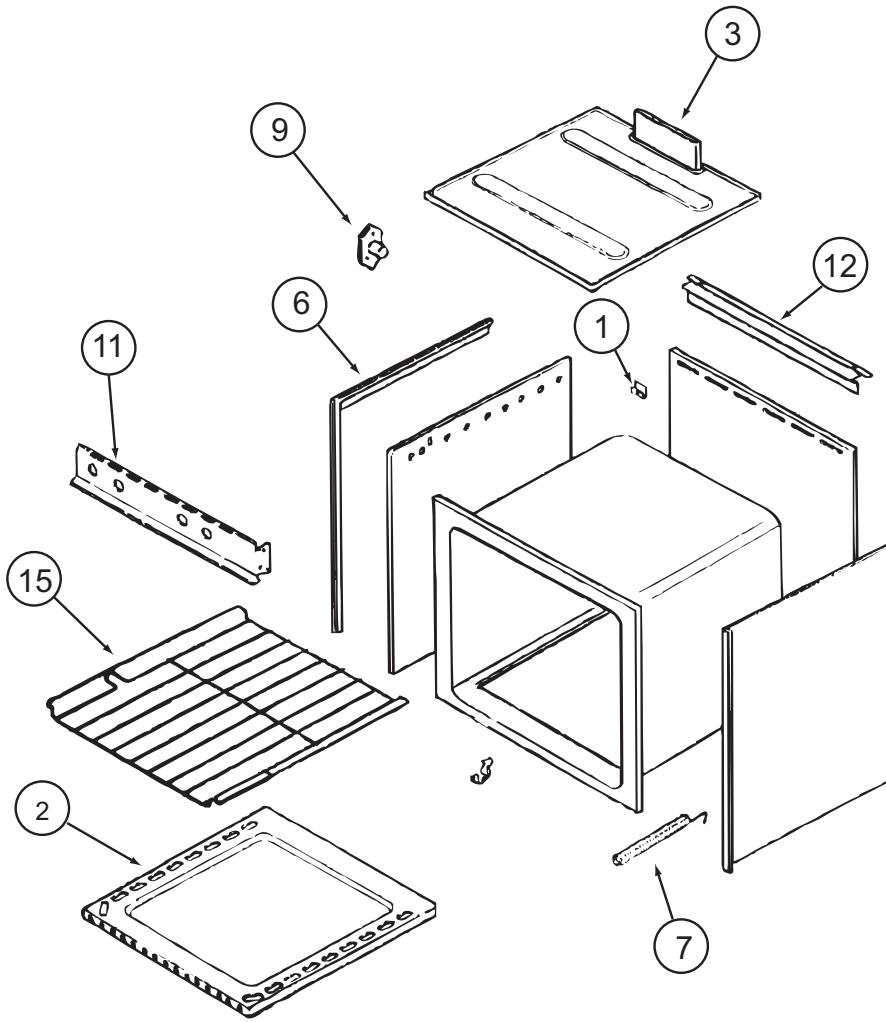

**151277-01-01A (CONTINUED)**

KEY	PART NUMBER	U/M	DESCRIPTION	VENDOR NO.
1	112881-03-702	EA	CLIP - MAIN TOP	74003998
2	126023-01-731	EA	BOTTOM - OVEN	2205F016-19
3	126023-01-718	EA	FLUE BOX ASSEMBLY	4006W075-80
6	126023-01-713	EA	TRIM - SIDE (RIGHT) BLACK	74002827
6	126023-01-714	EA	TRIM - SIDE (LEFT) BLACK	74002828
7	135066-03-700	EA	SPRING - OVEN DOOR	74001835
9	128728-01-703	EA	PIN/T-NUT F/HINGE	7103P109-60
11	112881-04-707	EA	MANIFOLD - BLACK	74007296
12	112881-01-721	EA	DEFLECTOR/FLUE-BLK-SEALED BR	74002829
15	126023-01-716	EA	RACK - OVEN	74003106

CONTACT WINNEBAGO PART SALES FOR UNLISTED COMPONENT(S)

**CABINET & APPLIANCE GROUP (CONTINUED)**  
**COMPONENT PARTS FOR CABINET & APPLIANCE LAYOUT (CONTINUED)**

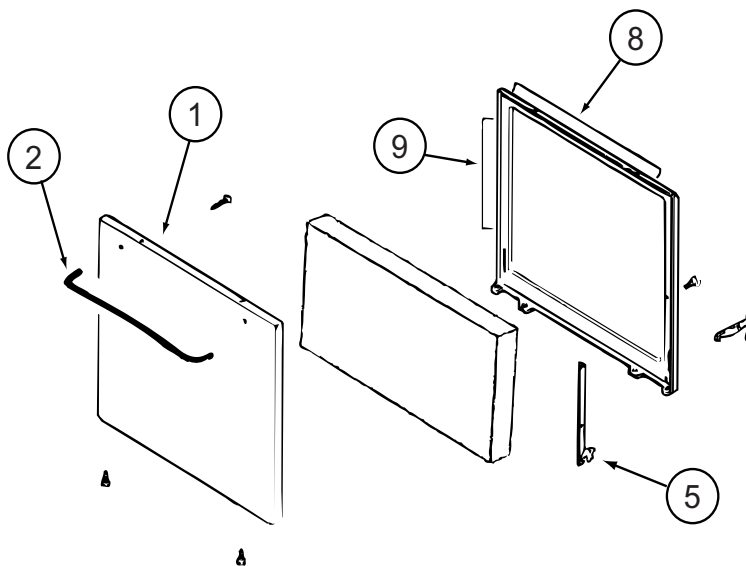

151277-01-01A (CONTINUED)

KEY	PART NUMBER	U/M	DESCRIPTION	VENDOR NO.
1	102022-01-704	EA	GLASS-OUTER	7902P261-60
1	112881-01-713	EA	DOOR/OVEN-TEXT/BLK NO WINDOW	2401F126-70
2	128727-01-701	EA	HANDLE - OVEN DOOR	74003929
5	151277-01-704	EA	HINGE KIT-OVEN DR/LT	12400028
5	151277-01-705	EA	HINGE KIT-OVEN DR/RT	12400029
8	126023-01-732	EA	SEAL/OVEN DR TOP	7212P014-60
9	135066-03-714	EA	SEAL - OVEN DOOR SIDES	7212P039-60

CONTACT WINNEBAGO PART SALES FOR UNLISTED COMPONENT(S)

## CHASSIS GROUP FRAME

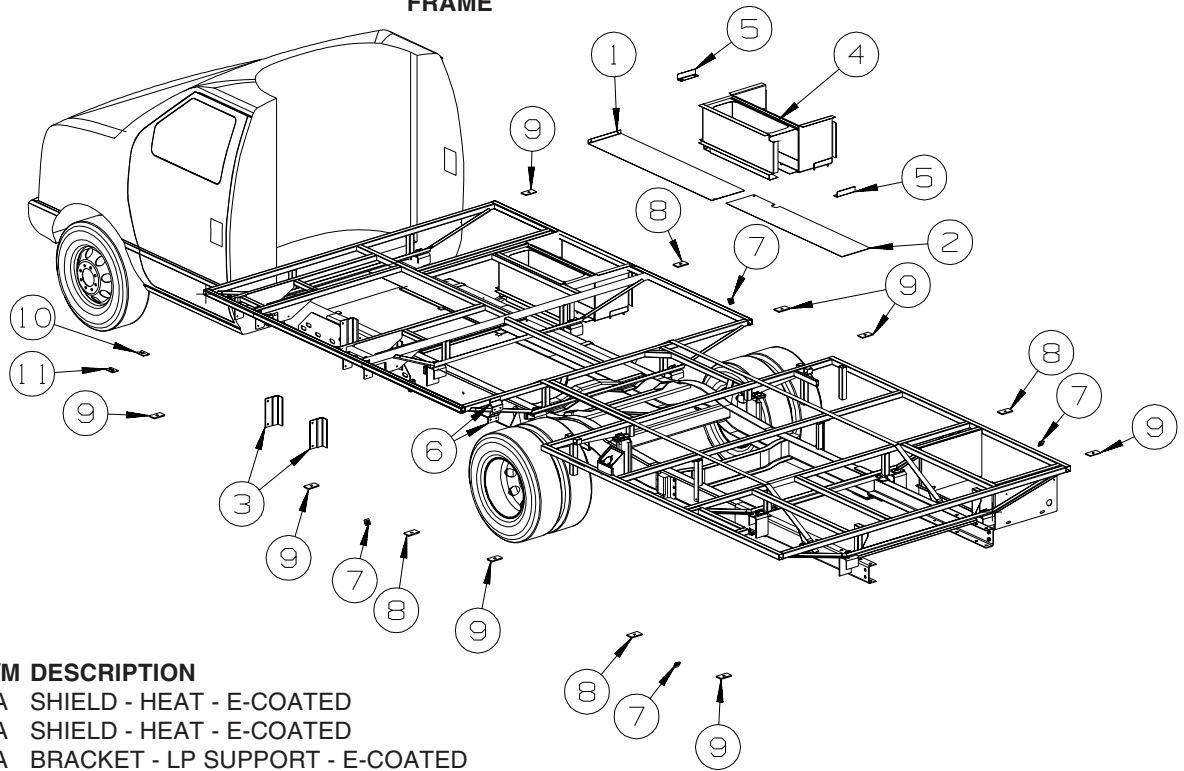

KEY	PART NUMBER	U/M	DESCRIPTION
1	135676-08-02B	EA	SHIELD - HEAT - E-COATED
2	145027-03-02B	EA	SHIELD - HEAT - E-COATED
3	136042-01-02B	EA	BRACKET - LP SUPPORT - E-COATED
4	135458-04-02B	EA	BOX - ENTRY STEP - E-COATED
5	139997-01-02B	EA	ANGLE - STEEL - W/2 SLOTS - E-COATED
6	141003-01-02B	EA	PLATE - VALVE - AIR SPRING - E-COATED
			FROM: 09-01-04 THRU: 99-99-99
7	141901-02-02B	EA	PLATE - TIE DOWN - E-COATED
8	135712-03-02B	EA	PLATE - BODY MOUNT - E-COATED
			FROM: 00-00-00 THRU: 10-24-04
8	135712-01-02B	EA	PLATE - BODY MOUNT - E-COATED
			FROM: 10-25-04 THRU: 99-99-99
9	135712-01-02B	EA	PLATE - BODY MOUNT - E-COATED
10	128310-01-02B	EA	SHIM-BODY,MOUNT,11GA,E-CT
11	128310-02-02B	EA	SHIM-BODY,MOUNT,14GA,E-CT

### DRIVETRAIN FROM 00-00-00 TO 08-24-04

KEY	PART NUMBER	U/M	DESCRIPTION
	103653-23-000	EA	BOLT - U-JOINT - 5/16-24 X .75
	103653-24-000	EA	STRAP - U-JOINT
	131695-06-000	EA	DRIVESHAFT - 3 BALANCED - 220" WHEELBASE - <b>331T, 331ST</b>
	131695-09-000	EA	DRIVESHAFT - 3 BALANCED - 215" WHEELBASE - <b>332G</b>
	131694-09-000	EA	DRIVESHAFT ASSEMBLY - BALANCED PAIR - 190" WHEELBASE - <b>329B, 329SB, 329K</b>
	131694-10-000	EA	DRIVESHAFT ASSEMBLY - BALANCED PAIR - 182" WHEELBASE - <b>327L</b>

### FROM 08-25-04 TO 99-99-99

KEY	PART NUMBER	U/M	DESCRIPTION
	103653-23-000	EA	BOLT - U-JOINT - 5/16-24 X .75
	103653-24-000	EA	STRAP - U-JOINT
	152619-04-000	EA	DRIVESHAFT - BALANCED - 3 SECTION - 5 SPD/E450 - 220" WB - <b>331T, 331ST</b>
	152619-02-000	EA	DRIVESHAFT - BALANCED - 3 SECTION - 5 SPD/E450 - 215" WB - <b>332G</b>
	152618-04-000	EA	DRIVESHAFT - BALANCED - 2 SECTION - 5 SPD/E450 - 190" WB - <b>329B, 329SB, 329K</b>
	152618-03-000	EA	DRIVESHAFT - BALANCED - 2 SECTION - 5 SPD/E450 - 182" WB - <b>327L</b>

**CHASSIS GROUP (CONTINUED)**  
**EXHAUST**

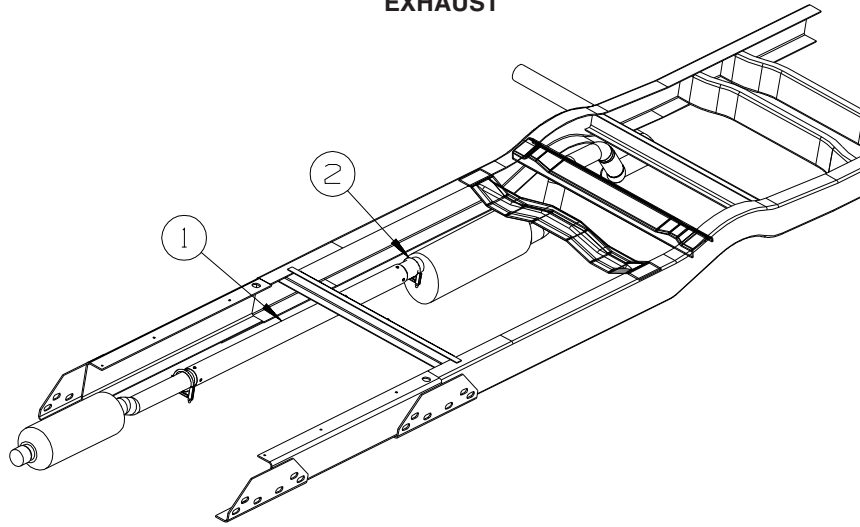

<b>KEY</b>	<b>PART NUMBER</b>	<b>U/M</b>	<b>DESCRIPTION</b>
1	111478-07-000	EA	EXHAUST PIPE - DOUBLE WALL STAINLESS STEEL - 25.9"
2	094918-06-000	EA	CLAMP - EXHAUST - 3" - HEAVY DUTY

**HITCH**

<b>KEY</b>	<b>PART NUMBER</b>	<b>U/M</b>	<b>DESCRIPTION</b>
	130339-11-000	EA	HITCH RECEIVER - BOLT ON CLASS III

## CHASSIS GROUP (CONTINUED)

### REAR BUMPER

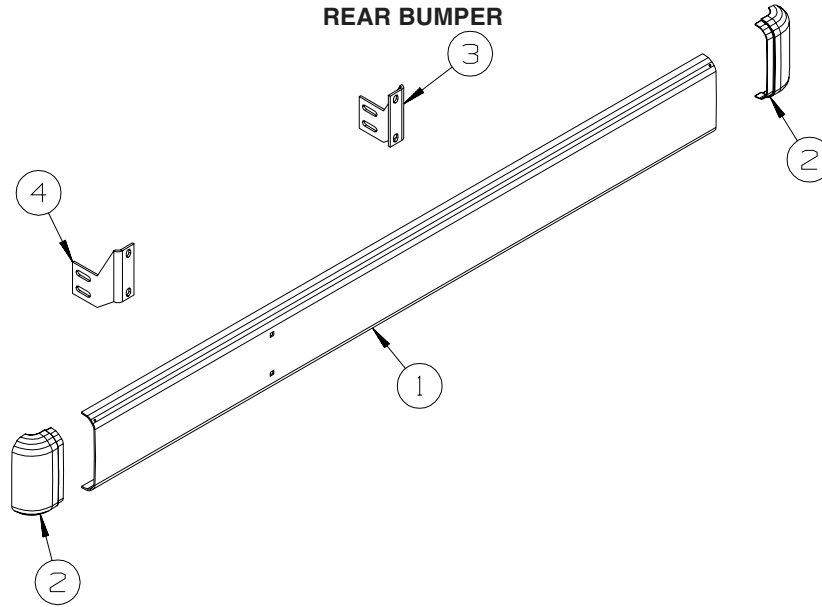

KEY	PART NUMBER	U/M	DESCRIPTION
1	103099-05-02A	EA	BUMPER - REAR - 91.7" - BRIGHT WHITE
2	106147-02-03A	EA	END CAP - BUMPER - BRIGHT WHITE
3	136945-03-02B	EA	BRACKET - BUMPER - REAR - E-COATED
4	136945-04-02B	EA	BRACKET - BUMPER - REAR - E-COATED
	038327-01-000	EA	TAPE - ANTI-SLIP - 2" X 60'

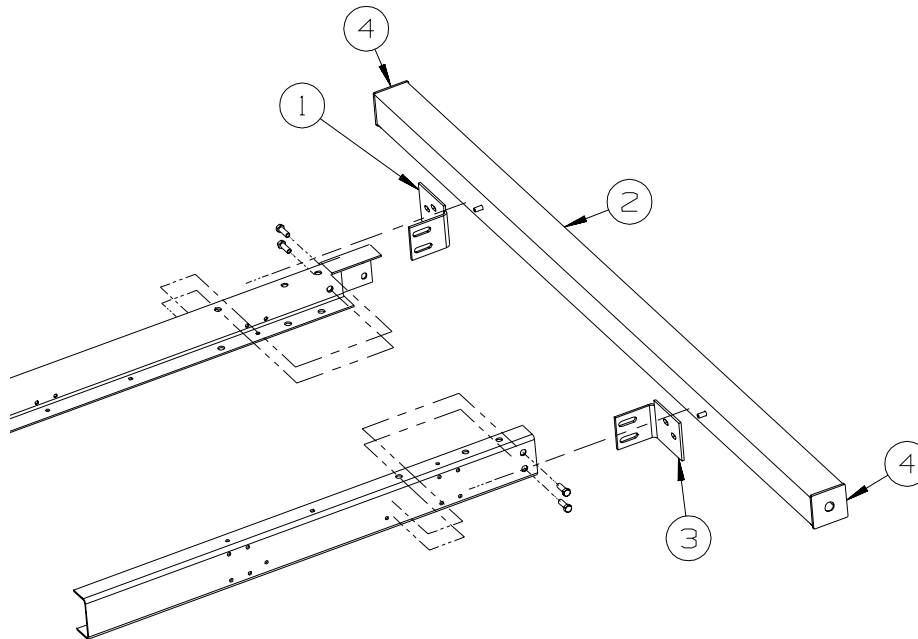

**329SB & 331ST**

KEY	PART NUMBER	U/M	DESCRIPTION
1	104420-01-000	EA	SUPPORT/ANGLE - REAR BUMPER - RIGHT HAND
2	103422-05-02A	EA	BUMPER - REAR - SQUARE ALUMINUM - 97.3" - BRIGHT WHITE
3	104420-02-000	EA	SUPPORT/ANGLE - REAR BUMPER - LEFT HAND
4	039779-01-000	EA	CAP - BUMPER - RUBBER - 4" X 4" - BLACK
	038327-01-000	EA	TAPE - ANTI-SLIP - 2" X 60'

## CHASSIS GROUP (CONTINUED)

### FUEL

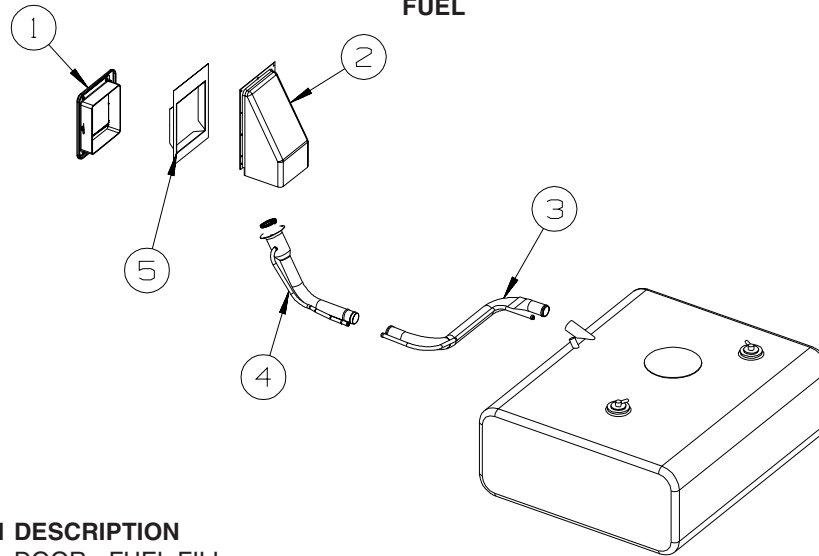

KEY	PART NUMBER	U/M	DESCRIPTION
1	147587-01-01A	EA	DOOR - FUEL FILL
	137169-02-01A	EA	ADAPTER/LOCK - (WASHER) F/GRAVITY WATERFILL
138637-03-000		EA	LOCK ASM. - KEYED - .9" CASE (CYLINDER/CAM/HDWR PKG)
			FROM: 00-00-00 THRU: 02-24-05
138637-52-000		EA	CASE/CYLINDER - LOCKING - W/O CAM/KEY - .9"
			FROM: 00-00-00 THRU: 02-24-05
138637-52-001		EA	CASE/CYLINDER - LOCKING - W/O CAM/KEY - .9"
			FROM: 00-00-00 THRU: 02-24-05
138637-52-002		EA	CASE/CYLINDER - LOCKING - W/O CAM/KEY - .9"
			FROM: 00-00-00 THRU: 02-24-05
138637-52-003		EA	CASE/CYLINDER - LOCKING - W/O CAM/KEY - .9"
			FROM: 00-00-00 THRU: 02-24-05
138637-52-004		EA	CASE/CYLINDER - LOCKING - W/O CAM/KEY - .9"
			FROM: 00-00-00 THRU: 02-24-05
138637-52-005		EA	CASE/CYLINDER - LOCKING - W/O CAM/KEY - .9"
			FROM: 00-00-00 THRU: 02-24-05
138637-52-006		EA	CASE/CYLINDER - LOCKING - W/O CAM/KEY - .9"
			FROM: 00-00-00 THRU: 02-24-05
138637-52-007		EA	CASE/CYLINDER - LOCKING - W/O CAM/KEY - .9"
			FROM: 00-00-00 THRU: 02-24-05
138637-52-008		EA	CASE/CYLINDER - LOCKING - W/O CAM/KEY - .9"
			FROM: 00-00-00 THRU: 02-24-05
138637-52-009		EA	CASE/CYLINDER - LOCKING - W/O CAM/KEY - .9"
			FROM: 00-00-00 THRU: 02-24-05
138637-62-000		EA	CAM - LATCHING - DOG LEG - 1" LONG
			FROM: 00-00-00 THRU: 02-24-05
144474-01-000		EA	ADAPTER - LOCK - 180 DEGREE
			FROM: 00-00-00 THRU: 02-24-05
138290-03-000		EA	CASE - W/CAM - W/O CYLINDER/KEY
			FROM: 02-25-05 THRU: 99-99-99
2	135557-02-01A	EA	SHROUD - FUEL FILL - UPPER - 13.5" X 8.2"
3	151095-01-000	EA	NECK - FILLER/MAIN/EXTENSION
4	148789-01-000	EA	NECK - FUEL FILL

**CHASSIS GROUP (CONTINUED)**  
**FUEL (CONTINUED)**

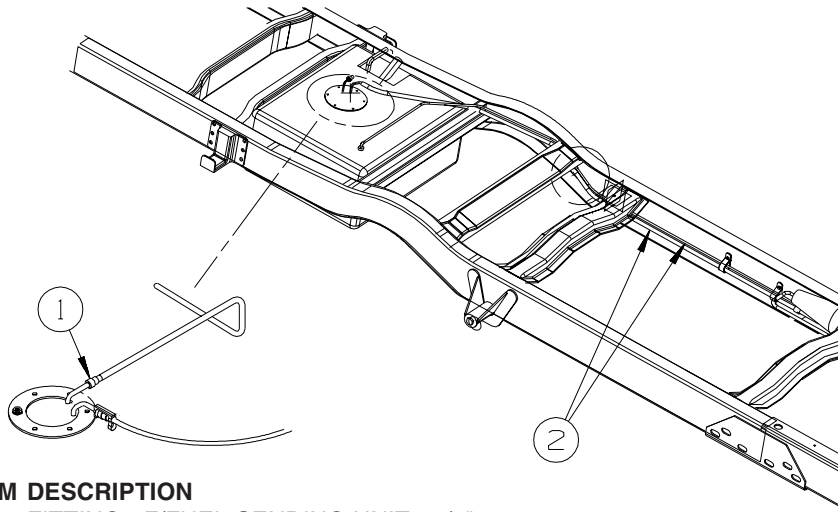

KEY	PART NUMBER	U/M	DESCRIPTION
1	149468-01-000	EA	FITTING - F/FUEL-SENDING UNIT - 1/4"
2	106388-13-000	EA	FUEL LINE - FORD - 5/16 HP - FORD E450



## CHASSIS GROUP (CONTINUED)

### SPARE TIRE

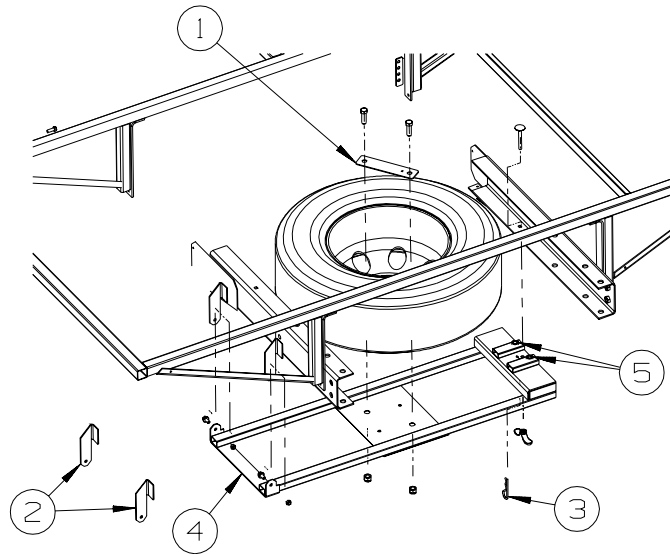

**324F, 324V, 327L,  
329B, 329SB & 329K**

KEY	PART NUMBER	U/M	DESCRIPTION
1	116338-02-02B	EA	BRACKET/CLAMP - SPARE TIRE - E-COATED
2	116349-04-02B	EA	BRACKET - HINGE - SPARE TIRE - E-COATED
3	034513-01-000	EA	PIN - HITCH - 3/16" WIRE
4	135796-02-02B	EA	CRADLE - SPARE TIRE - E-COATED
5	069726-02-000	EA	BUMPER - .88" OD X .40" THICK - BLACK

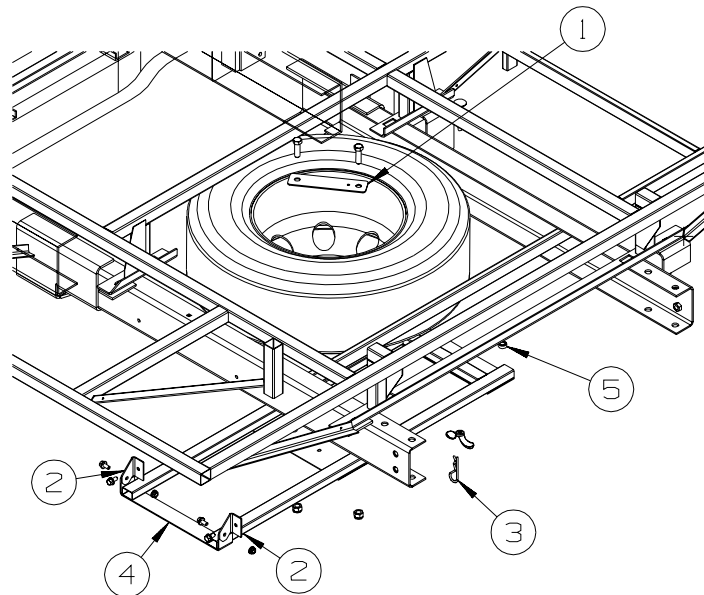

**331T & 331ST**

KEY	PART NUMBER	U/M	DESCRIPTION
1	116338-02-02B	EA	BRACKET/CLAMP - SPARE TIRE - E-COATED
2	116349-01-02B	EA	BRACKET - HINGE - SPARE TIRE - E-COATED
3	034513-01-000	EA	PIN - HITCH - 3/16" WIRE
4	135796-04-02B	EA	CRADLE - SPARE TIRE - E-COATED
5	069726-02-000	EA	BUMPER - .88" OD X .40" THICK - BLACK

**CHASSIS GROUP (CONTINUED)**  
**SPARE TIRE (CONTINUED)**

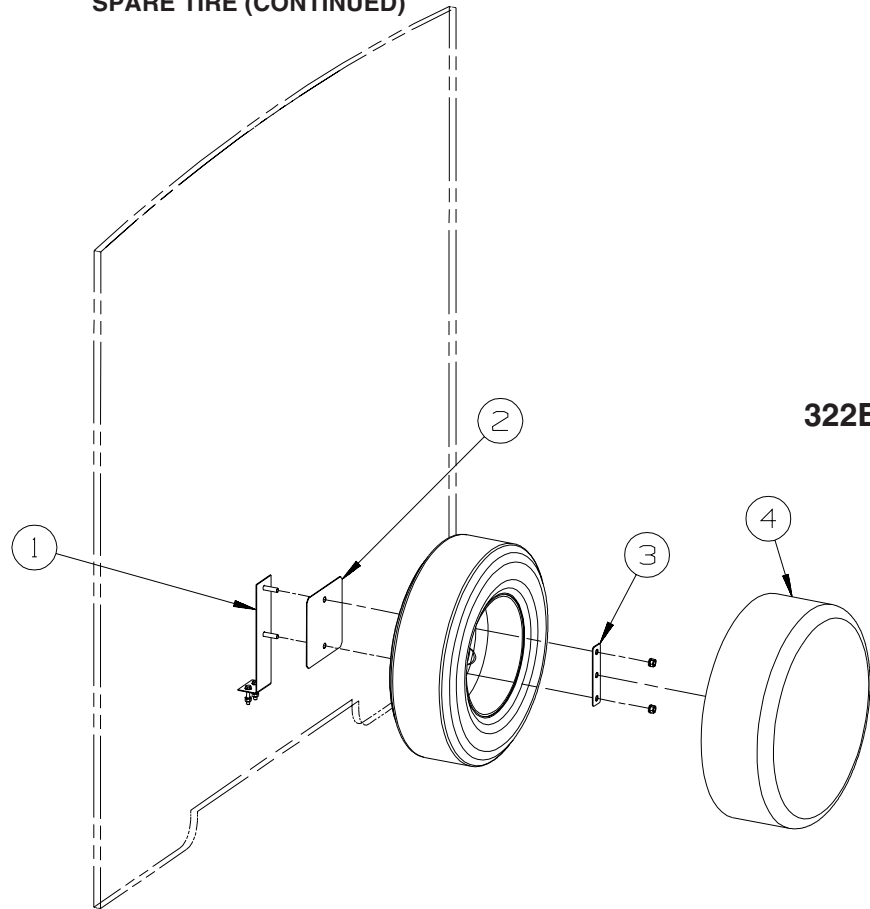

**322E & 322R**

KEY	PART NUMBER	U/M	DESCRIPTION
1	105209-05-C52	EA	BRACKET ASSEMBLY - SPARE TIRE
2	105208-01-000	EA	PLATE - SPARE TIRE
3	143547-01-02B	EA	RETAINER - SPARE TIRE - E-COATED
4	073322-09-S01	EA	COVER - TIRE - 30"
	073322-50-000	EA	COVER - UNIVERSAL LINER

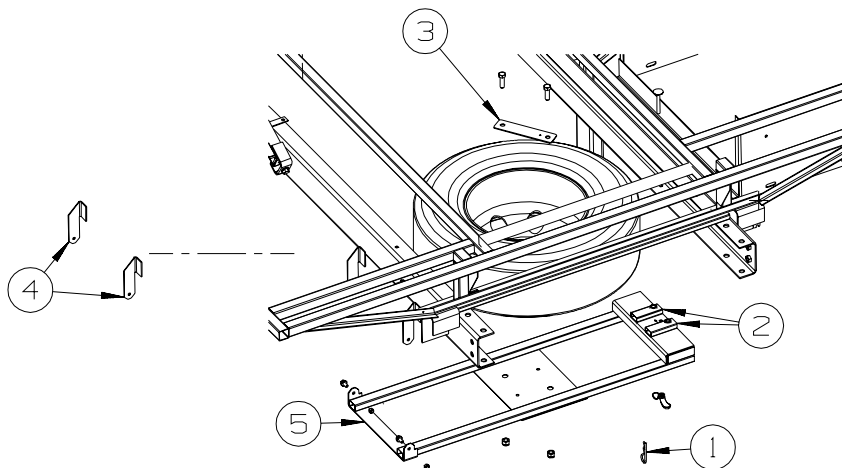

**326A & 332G**

KEY	PART NUMBER	U/M	DESCRIPTION
1	034513-01-000	EA	PIN - HITCH - 3/16" WIRE
2	069726-02-000	EA	BUMPER - .88" OD X .40" THICK - BLACK
3	116338-02-02B	EA	BRACKET/CLAMP - SPARE TIRE - E-COATED
4	116349-04-02B	EA	BRACKET - HINGE - SPARE TIRE - E-COATED
5	135796-02-02B	EA	CRADLE - SPARE TIRE - E-COATED

**CHASSIS GROUP (CONTINUED)**  
**SUSPENSION**

<b>KEY</b>	<b>PART NUMBER</b>	<b>U/M</b>	<b>DESCRIPTION</b>
	144887-02-000	EA	AIRSPRING - 4" DIAMETER/TWIN BAG SYSTEM - FIRESTONE - AIR SPRINGS REAR

**WHEEL, TIRE, COVERS &/OR LINERS**

<b>KEY</b>	<b>PART NUMBER</b>	<b>U/M</b>	<b>DESCRIPTION</b>
	112358-01-000	EA	WRENCH - LUG - 7/8" - L-SHAPE
*	109443-05-000	EA	WHEEL COVER SET - GM 16" STAINLESS/8 LUG (1 SET=4 COVERS)
	083425-14-000	EA	TIRE - LT225/75R16 LRE - MICHELIN LTX M/S
	083617-04-000	EA	WHEEL - STEEL - 6" X 16" - FORD
*	110435-13-000	EA	LINER - WHEEL - SET OF 4 - 16" (8 HOLE)
	077030-01-000	EA	EXTENSION - VALVE STEM - 1.25" - METAL
	095012-05-000	EA	EXTENSION/VALVE STEM - LIVE - 5"
	095012-06-000	EA	STABILIZER/VALVE EXTENSION - LIVE - 2"
	051377-04-000	EA	VALVE STEM - .5" X 2"

**\*COMPONENT PARTS LISTED LATER IN THIS GROUP**

**COMPONENT PARTS FOR WHEEL, TIRE, COVERS &/OR LINERS**

<b>KEY</b>	<b>PART NUMBER</b>	<b>U/M</b>	<b>DESCRIPTION</b>	<b>VENDOR NO.</b>
	098532-01-700	EA	COVER-LUG NUT (CHROME)	SHAU-LNC
	109443-05-700	EA	COVER-WHEEL, 16" SS EA=1	SHFM16-CVR

**109443-05-000**

<b>KEY</b>	<b>PART NUMBER</b>	<b>U/M</b>	<b>DESCRIPTION</b>	<b>VENDOR NO.</b>
	110435-01-711	EA	DECAL-CENTER CAP, 2"	2" DECAL
	110435-10-705	EA	TOOL/JAMB NUT INSTALLATION	V195P7-TOL
	110435-13-700	EA	LINER - WHEEL - FRONT	V160F7-FWC
	110435-13-701	EA	LINER - WHEEL - REAR	V160F7-RWC
	110435-13-702	EA	JAMB NUT W/COVER - 9/16"	V160F7-EJN

**110435-13-000**

**BRAKELINE**

<b>KEY</b>	<b>PART NUMBER</b>	<b>U/M</b>	<b>DESCRIPTION</b>
	088498-01-000	EA	UNION - INVERTED FLARE - BRASS - 3/16

## CURTAIN & CUSHION GROUP

### NOTICE

IN ORDER TO ASSIST OUR PARTS SALES DEPT. IN PROVIDING INTERIOR SOFTWARE ITEMS, PLEASE INCLUDE THE SERIAL NUMBER AND THE COLOR CODE NUMBER FROM THE VEHICLE CERTIFICATION LABEL WHEN ORDERING. THIS LABEL IS LOCATED ON THE LEFT SIDEWALL AT THE END OF THE DASH (A-BODY), OR ON THE DRIVER'S DOOR LATCH PLATE (C-BODY).

AN EXAMPLE OF A COLOR CODE NUMBER IS B07, WHICH DESIGNATES AN OVERALL COLOR SCHEME OF A PARTICULAR UNIT. THE COLOR LISTED AFTER THE ITEM DESCRIPTION ON THE MICROFICHE, INDICATES THE OVERALL UNIT COLOR. ORDER THE ITEM YOU DESIRE ACCORDING TO UNIT COLOR CODE. IF ALL COLORS USE THE SAME ITEM NO COLOR CODE WILL BE NOTED.

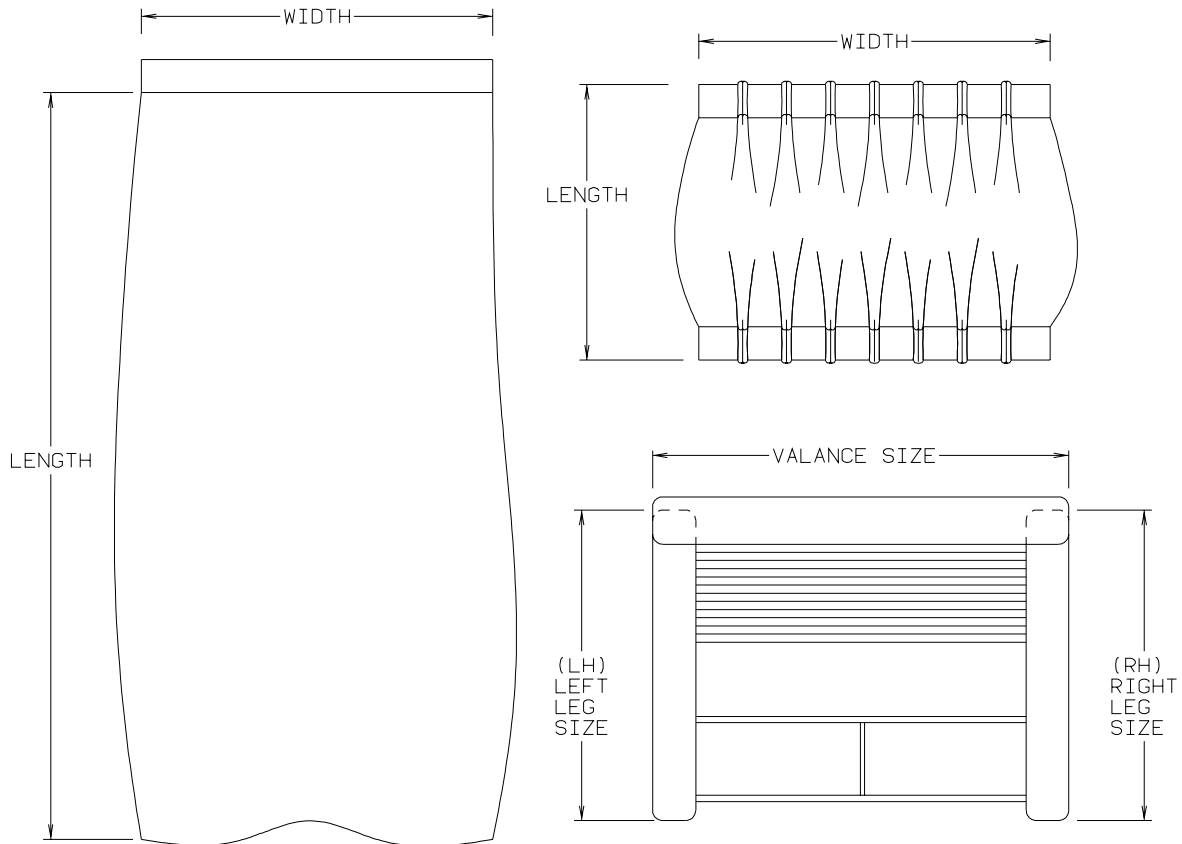

NOTE: USE THIS ILLUSTRATION WHEN DETERMINING LENGTH AND WIDTH MEASUREMENTS FOR CURTAINS. YOU WILL NOTE THE WIDTH MEASUREMENT IS TAKEN ON THE TOP OF THE CURTAIN WITH THE CURTAIN FULLY EXTENDED. THE LENGTH MEASUREMENT IS TAKEN FROM TOP TO BOTTOM. LEFT AND RIGHT WINDOW LEGS ARE DETERMINED WHEN FACING THE WINDOW.

## CURTAIN & CUSHION GROUP (CONTINUED)

### CUSHION LAYOUT

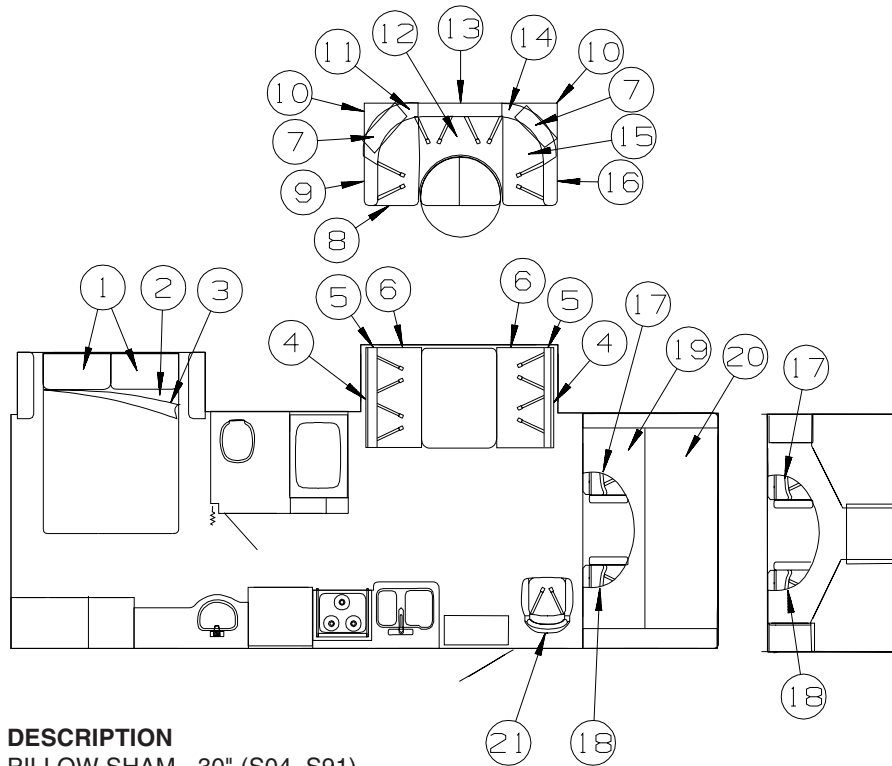

KEY	PART NUMBER	U/M	DESCRIPTION
1	104176-04-S04	EA	PILLOW SHAM - 30" (S04, S91)
1	104176-04-S05	EA	PILLOW SHAM - 30" (S05, S92)
1	104176-04-S06	EA	PILLOW SHAM - 30" (S06, S93)
2	123015-06-000	EA	MATTRESS - INNERSPRING - 60" X 74.5"
			FROM: 00-00-00 THRU: 01-02-05
2	154430-01-000	EA	MATTRESS - INNERSPRING - 60" X 74.5"
			FROM: 01-03-05 THRU: 99-99-99
3	132336-01-S04	EA	BEDSPREAD/CAP - 60" X 75" (S04, S91)
3	132336-01-S05	EA	BEDSPREAD/CAP - 60" X 75" (S05, S92)
3	132336-01-S06	EA	BEDSPREAD/CAP - 60" X 75" (S06, S93)
4	111338-11-S04	EA	PAD - DINETTE SEATBACK (S04, S91)
4	111338-11-S05	EA	PAD - DINETTE SEATBACK (S05, S92)
4	111338-11-S06	EA	PAD - DINETTE SEATBACK (S06, S93)
5	111897-29-S04	EA	CUSHION - BACK - 17.5" X 42" X 5" (S04, S91)
5	111897-29-S05	EA	CUSHION - BACK - 17.5" X 42" X 5" (S05, S92)
5	111897-29-S06	EA	CUSHION - BACK - 17.5" X 42" X 5" (S06, S93)
	P11897-29-S04	EA	COVER - BACK - 17.5" X 42" X 5" (S04, S91)
	P11897-29-S05	EA	COVER - BACK - 17.5" X 42" X 5" (S05, S92)
	P11897-29-S06	EA	COVER - BACK - 17.5" X 42" X 5" (S06, S93)
6	105603-15-S04	EA	CUSHION - SEAT - 23" X 42" X 5" (S04, S91)
6	105603-15-S05	EA	CUSHION - SEAT - 23" X 42" X 5" (S05, S92)
6	105603-15-S06	EA	CUSHION - SEAT - 23" X 42" X 5" (S06, S93)
	P05603-15-S04	EA	COVER - SEAT - 23" X 42" X 5" (S04, S91)
	P05603-15-S05	EA	COVER - SEAT - 23" X 42" X 5" (S05, S92)
	P05603-15-S06	EA	COVER - SEAT - 23" X 42" X 5" (S06, S93)
7	150855-12-S04	EA	CUSHION - FILLER - DINETTE (S04, S91)
7	150855-12-S05	EA	CUSHION - FILLER - DINETTE (S05, S92)
7	150855-12-S06	EA	CUSHION - FILLER - DINETTE (S06, S93)
	P50855-12-S04	EA	COVER/CUSHION - FILLER - DINETTE (S04, S91)
	P50855-12-S05	EA	COVER/CUSHION - FILLER - DINETTE (S05, S92)
	P50855-12-S06	EA	COVER/CUSHION - FILLER - DINETTE (S06, S93)
8	150855-09-S04	EA	CUSHION - SEAT/LEFT - DINETTE (S04, S91)
8	150855-09-S05	EA	CUSHION - SEAT/LEFT - DINETTE (S05, S92)
8	150855-09-S06	EA	CUSHION - SEAT/LEFT - DINETTE (S06, S93)
	P50855-09-S04	EA	COVER/CUSHION - SEAT/LEFT - DINETTE (S04, S91)
	P50855-09-S05	EA	COVER/CUSHION - SEAT/LEFT - DINETTE (S05, S92)
	P50855-09-S06	EA	COVER/CUSHION - SEAT/LEFT - DINETTE (S06, S93)

**CURTAIN & CUSHION GROUP (CONTINUED)**  
**CUSHION LAYOUT (CONTINUED)**

KEY	PART NUMBER	U/M	DESCRIPTION
9	150855-01-S04	EA	CUSHION - BACK/TOP - LEFT - DINETTE (S04, S91)
9	150855-01-S05	EA	CUSHION - BACK/TOP - LEFT - DINETTE (S05, S92)
9	150855-01-S06	EA	CUSHION - BACK/TOP - LEFT - DINETTE (S06, S93)
	P50855-01-S04	EA	COVER/CUSHION - BACK/TOP - LEFT - DINETTE (S04, S91)
	P50855-01-S05	EA	COVER/CUSHION - BACK/TOP - LEFT - DINETTE (S05, S92)
	P50855-01-S06	EA	COVER/CUSHION - BACK/TOP - LEFT - DINETTE (S06, S93)
10	150855-11-S04	EA	CUSHION - CORNER BLOCK - LEFT/RIGHT - DINETTE (S04, S91)
10	150855-11-S05	EA	CUSHION - CORNER BLOCK - LEFT/RIGHT - DINETTE (S05, S92)
10	150855-11-S06	EA	CUSHION - CORNER BLOCK - LEFT/RIGHT - DINETTE (S06, S93)
	P50855-11-S04	EA	COVER/CUSHION - CORNER BLOCK - LEFT/RIGHT - DINETTE (S04, S91)
	P50855-11-S05	EA	COVER/CUSHION - CORNER BLOCK - LEFT/RIGHT - DINETTE (S05, S92)
	P50855-11-S06	EA	COVER/CUSHION - CORNER BLOCK - LEFT/RIGHT - DINETTE (S06, S93)
11	150855-03-S04	EA	CUSHION - BACK/CORNER TOP - LEFT - DINETTE (S04, S91)
11	150855-03-S05	EA	CUSHION - BACK/CORNER TOP - LEFT - DINETTE (S05, S92)
11	150855-03-S06	EA	CUSHION - BACK/CORNER TOP - LEFT - DINETTE (S06, S93)
	P50855-03-S04	EA	COVER/CUSHION - BACK/CORNER TOP - LEFT - DINETTE (S04, S91)
	P50855-03-S05	EA	COVER/CUSHION - BACK/CORNER TOP - LEFT - DINETTE (S05, S92)
	P50855-03-S06	EA	COVER/CUSHION - BACK/CORNER TOP - LEFT - DINETTE (S06, S93)
12	150855-10-S04	EA	CUSHION - SEAT/CENTER - DINETTE (S04, S91)
12	150855-10-S05	EA	CUSHION - SEAT/CENTER - DINETTE (S05, S92)
12	150855-10-S06	EA	CUSHION - SEAT/CENTER - DINETTE (S06, S93)
	P50855-10-S04	EA	COVER/CUSHION - SEAT/CENTER - DINETTE (S04, S91)
	P50855-10-S05	EA	COVER/CUSHION - SEAT/CENTER - DINETTE (S05, S92)
	P50855-10-S06	EA	COVER/CUSHION - SEAT/CENTER - DINETTE (S06, S93)
13	150855-05-S04	EA	CUSHION - BACK/CENTER TOP - DINETTE (S04, S91)
13	150855-05-S05	EA	CUSHION - BACK/CENTER TOP - DINETTE (S05, S92)
13	150855-05-S06	EA	CUSHION - BACK/CENTER TOP - DINETTE (S06, S93)
	P50855-05-S04	EA	COVER/CUSHION - BACK/CENTER TOP - DINETTE (S04, S91)
	P50855-05-S05	EA	COVER/CUSHION - BACK/CENTER TOP - DINETTE (S05, S92)
	P50855-05-S06	EA	COVER/CUSHION - BACK/CENTER TOP - DINETTE (S06, S93)
14	150855-07-S04	EA	CUSHION - BACK/CORNER TOP - RIGHT - DINETTE (S04, S91)
14	150855-07-S05	EA	CUSHION - BACK/CORNER TOP - RIGHT - DINETTE (S05, S92)
14	150855-07-S06	EA	CUSHION - BACK/CORNER TOP - RIGHT - DINETTE (S06, S93)
	P50855-07-S04	EA	COVER/CUSHION - BACK/CORNER TOP - RIGHT - DINETTE (S04, S91)
	P50855-07-S05	EA	COVER/CUSHION - BACK/CORNER TOP - RIGHT - DINETTE (S05, S92)
	P50855-07-S06	EA	COVER/CUSHION - BACK/CORNER TOP - RIGHT - DINETTE (S06, S93)
15	150855-13-S04	EA	CUSHION - SEAT/RIGHT - DINETTE (S04, S91)
15	150855-13-S05	EA	CUSHION - SEAT/RIGHT - DINETTE (S05, S92)
15	150855-13-S06	EA	CUSHION - SEAT/RIGHT - DINETTE (S06, S93)
	P50855-13-S04	EA	COVER/CUSHION - SEAT/RIGHT - DINETTE (S04, S91)
	P50855-13-S05	EA	COVER/CUSHION - SEAT/RIGHT - DINETTE (S05, S92)
	P50855-13-S06	EA	COVER/CUSHION - SEAT/RIGHT - DINETTE (S06, S93)
16	150855-08-S04	EA	CUSHION - BACK/TOP - RIGHT - DINETTE (S04, S91)
16	150855-08-S05	EA	CUSHION - BACK/TOP - RIGHT - DINETTE (S05, S92)
16	150855-08-S06	EA	CUSHION - BACK/TOP - RIGHT - DINETTE (S06, S93)
	P50855-08-S04	EA	COVER/CUSHION - BACK/TOP - RIGHT - DINETTE (S04, S91)
	P50855-08-S05	EA	COVER/CUSHION - BACK/TOP - RIGHT - DINETTE (S05, S92)
	P50855-08-S06	EA	COVER/CUSHION - BACK/TOP - RIGHT - DINETTE (S06, S93)
17	149587-01-S04	EA	SEAT - BUCKET/DRIVER (S04, S91)
17	149587-01-S05	EA	SEAT - BUCKET/DRIVER (S05, S92)
17	149587-01-S06	EA	SEAT - BUCKET/DRIVER (S06, S93)
17	149587-05-S04	EA	SEAT - BUCKET/DRIVER - LEATHER - CAB SEATS-ULTRA LEATHER
18	149587-02-S04	EA	SEAT - BUCKET/PASSENGER (S04, S91)
18	149587-02-S05	EA	SEAT - BUCKET/PASSENGER (S05, S92)
18	149587-02-S06	EA	SEAT - BUCKET/PASSENGER (S06, S93)
18	149587-06-S04	EA	SEAT - BUCKET/PASSENGER - LEATHER - CAB SEATS-ULTRA LEATHER

**CURTAIN & CUSHION GROUP (CONTINUED)**  
**CUSHION LAYOUT (CONTINUED)**

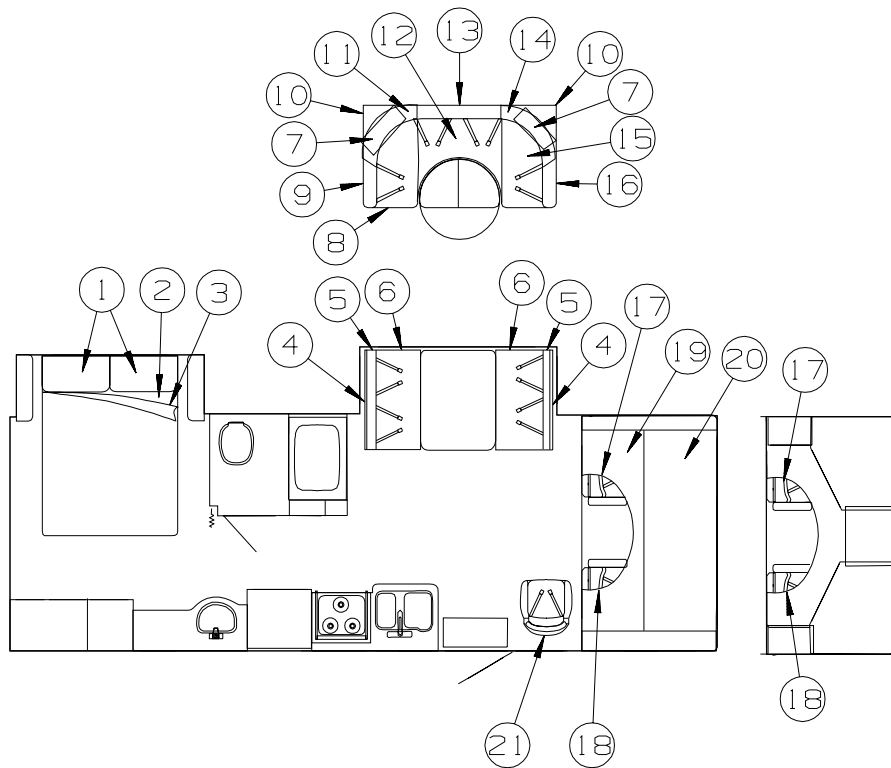

KEY	PART NUMBER	U/M	DESCRIPTION
19	105573-21-S04	EA	CUSHION - OVERHEAD BUNK/REAR - 27" X 23" X 80" X 5" (S04, S91)
19	105573-21-S05	EA	CUSHION - OVERHEAD BUNK/REAR - 27" X 23" X 80" X 5" (S05, S92)
19	105573-21-S06	EA	CUSHION - OVERHEAD BUNK/REAR - 27" X 23" X 80" X 5" (S06, S93)
	P05573-21-S04	EA	COVER - CUSHION/OVERHEAD BUNK/REAR - 27" X 23" X 80" X 5" (S04, S91)
	P05573-21-S05	EA	COVER - CUSHION/OVERHEAD BUNK/REAR - 27" X 23" X 80" X 5" (S05, S92)
	P05573-21-S06	EA	COVER - CUSHION/OVERHEAD BUNK/REAR - 27" X 23" X 80" X 5" (S06, S93)
20	105573-18-S04	EA	CUSHION - OVERHEAD BUNK/FRONT - 32.5" X 80" X 5" (S04, S91)
20	105573-18-S05	EA	CUSHION - OVERHEAD BUNK/FRONT - 32.5" X 80" X 5" (S05, S92)
20	105573-18-S06	EA	CUSHION - OVERHEAD BUNK/FRONT - 32.5" X 80" X 5" (S06, S93)
	P05573-18-S04	EA	COVER - CUSHION/OVERHEAD/FRT BUNK -32.5"X80"X5"-DBL ANGLED (S04, S91)
	P05573-18-S05	EA	COVER - CUSHION/OVERHEAD/FRT BUNK -32.5"X80"X5"-DBL ANGLED (S05, S92)
	P05573-18-S06	EA	COVER - CUSHION/OVERHEAD/FRT BUNK -32.5"X80"X5"-DBL ANGLED (S06, S93)
21	138523-02-S04	EA	CHAIR - W/SPRUNG SEAT (S04, S91)
21	138523-02-S05	EA	CHAIR - W/SPRUNG SEAT (S05, S92)
21	138523-02-S06	EA	CHAIR - W/SPRUNG SEAT (S06, S93)



## CURTAIN & CUSHION GROUP (CONTINUED)

### BUCKET SEATS

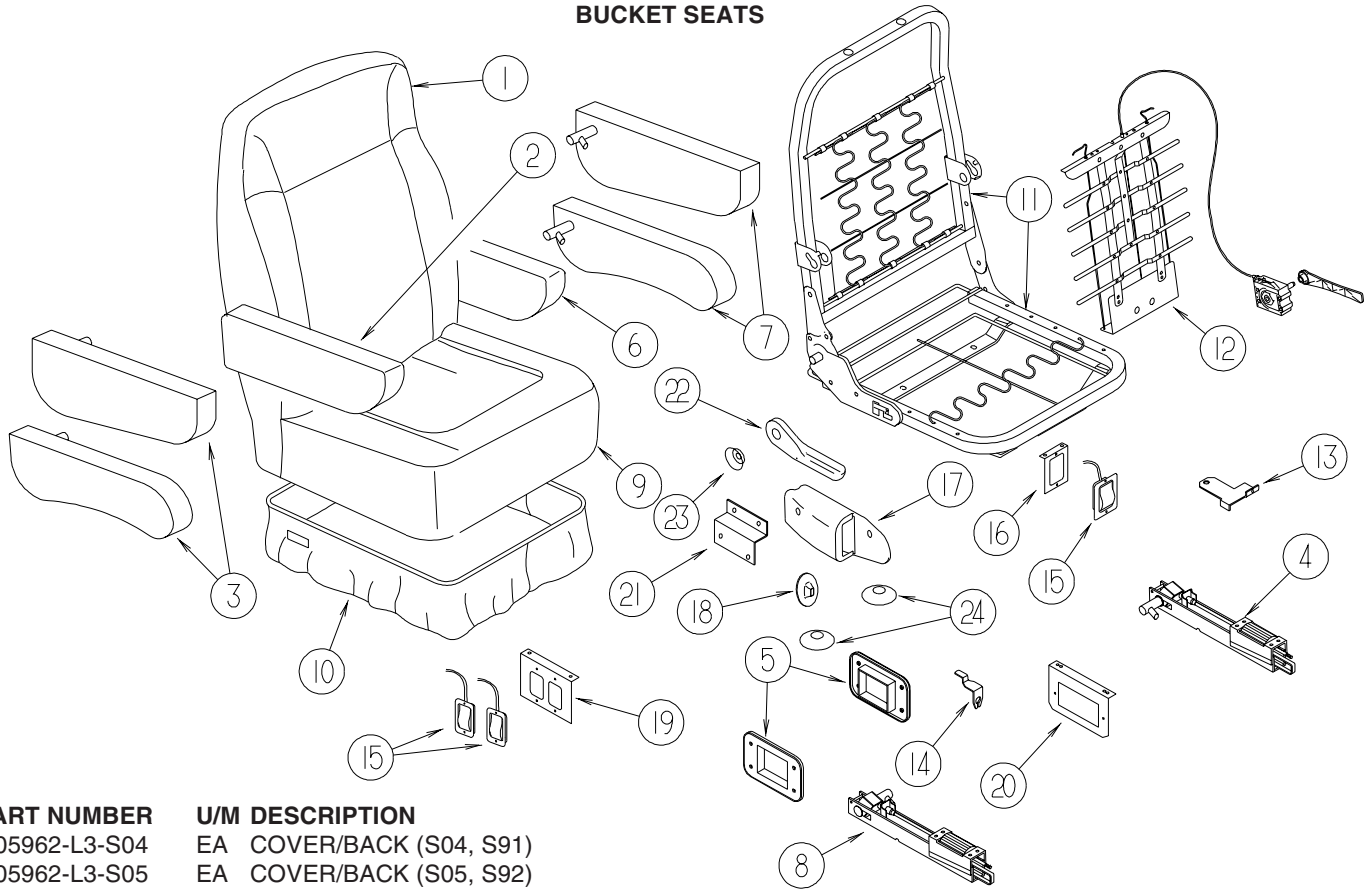

KEY	PART NUMBER	U/M	DESCRIPTION
1	M05962-L3-S04	EA	COVER/BACK (S04, S91)
1	M05962-L3-S05	EA	COVER/BACK (S05, S92)
1	M05962-L3-S06	EA	COVER/BACK (S06, S93)
1	M05962-L3-S97	EA	COVER/BACK (S97, SX1)
1	M05962-L3-S98	EA	COVER/BACK (S98)
1	M05962-M3-S04	EA	COVER/BACK - LEATHER - CAB SEATS-ULTRALEATHER
2	129666-07-S04	EA	ARMREST - RIGHT HAND (S04, S91)
2	129666-07-S05	EA	ARMREST - RIGHT HAND (S05, S92)
2	129666-07-S06	EA	ARMREST - RIGHT HAND (S06, S93)
2	129666-07-S97	EA	ARMREST - RIGHT HAND (S97, SX1)
2	129666-07-S98	EA	ARMREST - RIGHT HAND (S98)
2	129666-09-M04	EA	ARMREST - RIGHT HAND - CAB SEATS-ULTRALEATHER
	P29666-07-S04	EA	COVER/ARMREST - RIGHT HAND (S04, S91)
	P29666-07-S05	EA	COVER/ARMREST - RIGHT HAND (S05, S92)
	P29666-07-S06	EA	COVER/ARMREST - RIGHT HAND (S06, S93)
	P29666-07-S97	EA	COVER/ARMREST - RIGHT HAND (S97, SX1)
	P29666-07-S98	EA	COVER/ARMREST - RIGHT HAND (S98)
	P29666-09-M04	EA	COVER/ARMREST - RIGHT HAND - CAB SEATS-ULTRALEATHER
3	130698-01-000	EA	ARMREST/MOLDED - RIGHT - W/O COVER
4	NOT USED		
5	NOT USED		
6	129666-08-S04	EA	ARMREST - LEFT HAND (S04, S91)
6	129666-08-S05	EA	ARMREST - LEFT HAND (S05, S92)
6	129666-08-S06	EA	ARMREST - LEFT HAND (S06, S93)
6	129666-08-S97	EA	ARMREST - LEFT HAND (S97, SX1)
6	129666-08-S98	EA	ARMREST - LEFT HAND (S98)
6	129666-10-M04	EA	ARMREST - LEFT HAND - CAB SEATS-ULTRALEATHER
	P29666-08-S04	EA	COVER/ARMREST - LEFT HAND (S04, S91)
	P29666-08-S05	EA	COVER/ARMREST - LEFT HAND (S05, S92)
	P29666-08-S06	EA	COVER/ARMREST - LEFT HAND (S06, S93)
	P29666-08-S97	EA	COVER/ARMREST - LEFT HAND (S97, SX1)
	P29666-08-S98	EA	COVER/ARMREST - LEFT HAND (S98)
	P29666-10-M04	EA	COVER/ARMREST - LEFT HAND - CAB SEATS-ULTRALEATHER
7	130698-02-000	EA	ARMREST/MOLDED - LEFT - W/O COVER



**CURTAIN & CUSHION GROUP (CONTINUED)**  
**BUCKET SEATS (CONTINUED)**

<b>KEY</b>	<b>PART NUMBER</b>	<b>U/M</b>	<b>DESCRIPTION</b>
8	NOT USED		
9	M05962-N9-S04	EA	COVER/SEAT - PASSENGER (S04, S91)
9	M05962-N9-S05	EA	COVER/SEAT - PASSENGER (S05, S92)
9	M05962-N9-S06	EA	COVER/SEAT - PASSENGER (S06, S93)
9	M05962-N9-S97	EA	COVER/SEAT - PASSENGER (S97, SX1)
9	M05962-N9-S98	EA	COVER/SEAT - PASSENGER (S98)
9	M05962-P3-S04	EA	COVER/SEAT - PASSENGER - CAB SEATS-ULTRALEATHER
9	M05962-P0-S04	EA	COVER/SEAT - DRIVER (S04, S91)
9	M05962-P0-S05	EA	COVER/SEAT - DRIVER (S05, S92)
9	M05962-P0-S06	EA	COVER/SEAT - DRIVER (S06, S93)
9	M05962-P0-S97	EA	COVER/SEAT - DRIVER (S97, SX1)
9	M05962-P0-S98	EA	COVER/SEAT - DRIVER (S98)
9	M05962-P4-S04	EA	COVER/SEAT - DRIVER - CAB SEATS-ULTRALEATHER
10	NOT USED		
11	132875-03-000	EA	FRAME - RIGHT HAND CHAIR/TAPERED BACK
11	132875-04-000	EA	FRAME - LEFT HAND CHAIR/TAPERED BACK
12	NOT USED		
13	NOT USED		
14	NOT USED		
15	NOT USED		
16	NOT USED		
17	NOT USED		
18	NOT USED		
19	NOT USED		
20	NOT USED		
21	147457-01-02B	EA	BRACKET - ZEE W/HOLES - 2.8" - E-COATED
22	130802-02-000	EA	LEVER - RIGHT HAND
	130802-01-000	EA	LEVER - LEFT HAND
23	130802-03-000	EA	SCREW F/LEVER
24	007221-01-000	EA	SPACER - SEAT/ADJUSTER
	029134-01-000	EA	CLIP - FINISH - UPHOLSTERY

## CURTAIN & CUSHION GROUP (CONTINUED)

### LOUNGE CHAIR

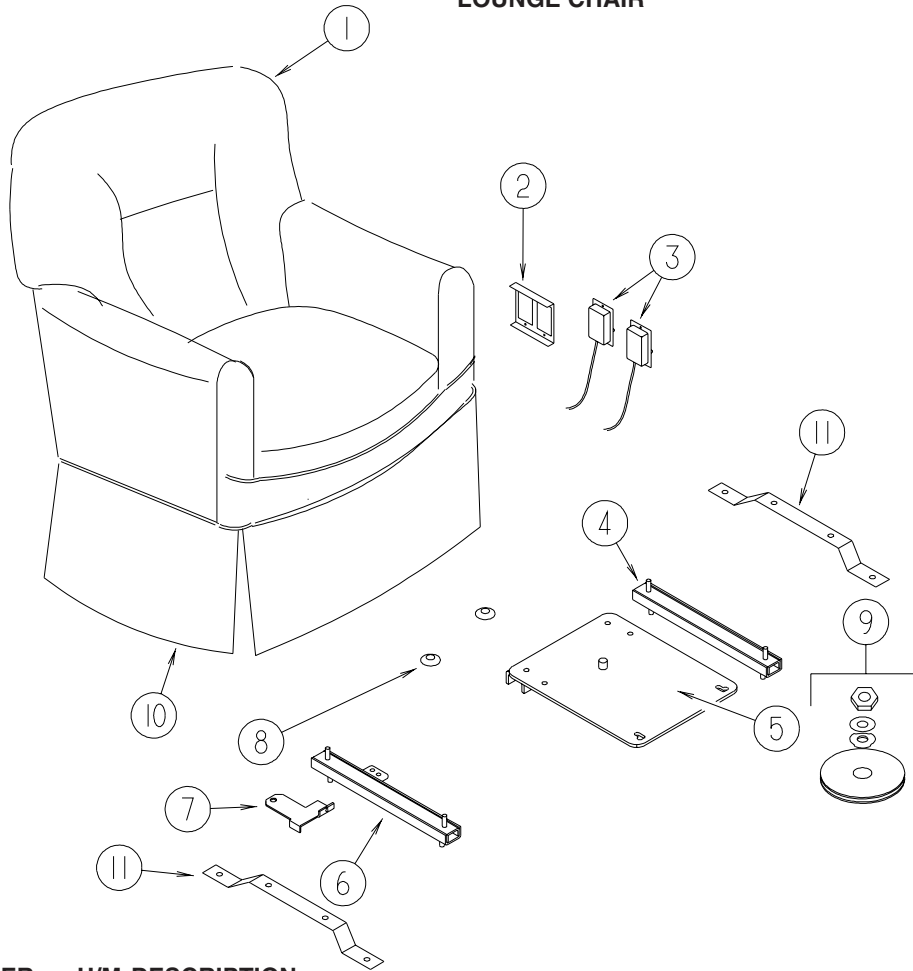

KEY	PART NUMBER	U/M	DESCRIPTION
1	P38523-01-S04	EA	COVER/CHAIR - W/SPRUNG SEAT (S04, S91)
1	P38523-01-S05	EA	COVER/CHAIR - W/SPRUNG SEAT (S05, S92)
1	P38523-01-S06	EA	COVER/CHAIR - W/SPRUNG SEAT (S06, S93)
1	P38523-01-SX1	EA	COVER/CHAIR - W/SPRUNG SEAT (SX1)
2	127159-02-02B	EA	BRACKET - SEAT RELEASE - DUAL REMOTE - E-COATED
3	108049-02-000	EA	CLIP - CABLE/PEDESTAL
	108049-04-000	EA	CABLE - W/MINI LEVER ACTION SWITCH - 28" SHEATH/30" CABLE
4	131566-04-000	EA	SLIDE/SEAT - HEAVY DUTY LOCKING - 5"
5	133408-07-000	EA	TOP PLATE - W/O BAR
6	131566-04-000	EA	SLIDE/SEAT - HEAVY DUTY LOCKING - 5"
	119952-07-000	EA	WIRE - LATCH RELEASE/ROTARY
7	117125-01-02B	EA	BRACKET - CABLE MOUNT - ADJUSTER W/LOCK
8	007221-01-000	EA	SPACER - SEAT/ADJUSTER
9	107921-06-000	EA	BEARING KIT - PEDESTAL
10	NOT USED		
11	139208-02-000	EA	SUPPORT BAR - SHORT - W/PEDESTAL

**CURTAIN & CUSHION GROUP (CONTINUED)**  
**WINDOW TREATMENT**

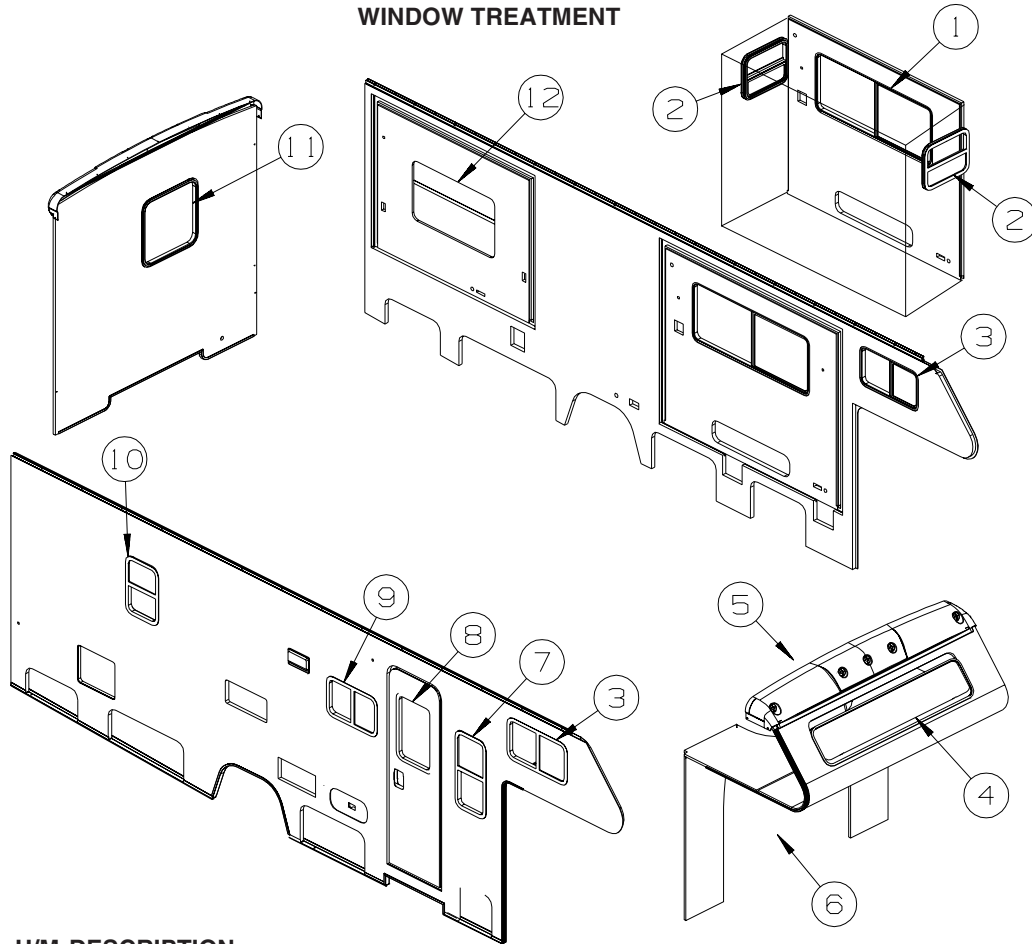

KEY	PART NUMBER	U/M	DESCRIPTION
1	149263-02-S04	EA	VALANCE - CLARION - 63" (S04, S91)
1	149263-02-S05	EA	VALANCE - CLARION - 63" (S05, S92)
1	149263-02-S06	EA	VALANCE - CLARION - 63" (S06, S93)
1	152664-07-S04	EA	LEG - RIGHT - 24" (S04, S91)
1	152664-07-S05	EA	LEG - RIGHT - 24" (S05, S92)
1	152664-07-S06	EA	LEG - RIGHT - 24" (S06, S93)
1	152664-03-S04	EA	LEG - RIGHT - 26" (S04, S91) - U-SHAPED DINETTE
1	152664-03-S05	EA	LEG - RIGHT - 26" (S05, S92) - U-SHAPED DINETTE
1	152664-03-S06	EA	LEG - RIGHT - 26" (S06, S93) - U-SHAPED DINETTE
1	152664-08-S04	EA	LEG - LEFT - 24" (S04, S91)
1	152664-08-S05	EA	LEG - LEFT - 24" (S05, S92)
1	152664-08-S06	EA	LEG - LEFT - 24" (S06, S93)
1	152664-04-S04	EA	LEG - LEFT - 26" (S04, S91) - U-SHAPED DINETTE
1	152664-04-S05	EA	LEG - LEFT - 26" (S05, S92) - U-SHAPED DINETTE
1	152664-04-S06	EA	LEG - LEFT - 26" (S06, S93) - U-SHAPED DINETTE
1	140789-08-N02	EA	BLIND - DAY/NIGHTER - 59" X 26.5"
2	149263-03-S04	EA	VALANCE - CLARION - 26" (S04, S91)
2	149263-03-S05	EA	VALANCE - CLARION - 26" (S05, S92)
2	149263-03-S06	EA	VALANCE - CLARION - 26" (S06, S93)
2	152664-05-S04	EA	LEG - RIGHT - 18" (S04, S91)
2	152664-05-S05	EA	LEG - RIGHT - 18" (S05, S92)
2	152664-05-S06	EA	LEG - RIGHT - 18" (S06, S93)
2	152664-01-S04	EA	LEG - RIGHT - 21.5" (S04, S91) - U-SHAPED DINETTE
2	152664-01-S05	EA	LEG - RIGHT - 21.5" (S05, S92) - U-SHAPED DINETTE
2	152664-01-S06	EA	LEG - RIGHT - 21.5" (S06, S93) - U-SHAPED DINETTE
2	152664-06-S04	EA	LEG - LEFT - 18" (S04, S91)
2	152664-06-S05	EA	LEG - LEFT - 18" (S05, S92)
2	152664-06-S06	EA	LEG - LEFT - 18" (S06, S93)
2	152664-02-S04	EA	LEG - LEFT - 21.5" (S04, S91) - U-SHAPED DINETTE
2	152664-02-S05	EA	LEG - LEFT - 21.5" (S05, S92) - U-SHAPED DINETTE
2	152664-02-S06	EA	LEG - LEFT - 21.5" (S06, S93) - U-SHAPED DINETTE
2	140789-62-S01	EA	BLIND - DAY/NIGHTER - 22.5" X 19"
2	140789-07-N02	EA	BLIND - DAY/NIGHTER - 22.5" X 23" - U-SHAPED DINETTE

**CURTAIN & CUSHION GROUP (CONTINUED)**  
**WINDOW TREATMENT (CONTINUED)**

KEY	PART NUMBER	U/M	DESCRIPTION
3	101034-63-S04	EA	CURTAIN - PRIVACY/RIGHT HAND - 19.5" X 31" (S04, S91)
3	101034-63-P08	EA	CURTAIN - PRIVACY/RIGHT HAND - 19.5" X 31" (S05, S92)
3	101034-63-S06	EA	CURTAIN - PRIVACY/RIGHT HAND - 19.5" X 31" (S06, S93)
3	101034-64-S04	EA	CURTAIN - PRIVACY/LEFT HAND - 19.5" X 31" (S04, S91)
3	101034-64-P08	EA	CURTAIN - PRIVACY/LEFT HAND - 19.5" X 31" (S05, S92)
3	101034-64-S06	EA	CURTAIN - PRIVACY/LEFT HAND - 19.5" X 31" (S06, S93)
4	101034-66-S04	EA	CURTAIN - PRIVACY/RIGHT HAND - 19" X 56" (S04, S91)
4	101034-66-P08	EA	CURTAIN - PRIVACY/RIGHT HAND - 19" X 56" (S05, S92)
4	101034-66-S06	EA	CURTAIN - PRIVACY/RIGHT HAND - 19" X 56" (S06, S93)
4	101034-67-S04	EA	CURTAIN - PRIVACY/LEFT HAND - 19" X 56" (S04, S91)
4	101034-67-P08	EA	CURTAIN - PRIVACY/LEFT HAND - 19" X 56" (S05, S92)
4	101034-67-S06	EA	CURTAIN - PRIVACY/LEFT HAND - 19" X 56" (S06, S93)
5	101668-39-S04	EA	CURTAIN - PRIVACY/RIGHT HAND - 35" X 50" (S04, S91)
5	101668-39-P08	EA	CURTAIN - PRIVACY/RIGHT HAND - 35" X 50" (S05, S92)
5	101668-39-S06	EA	CURTAIN - PRIVACY/RIGHT HAND - 35" X 50" (S06, S93)
5	101668-40-S04	EA	CURTAIN - PRIVACY/LEFT HAND - 35" X 50" (S04, S91)
5	101668-40-P08	EA	CURTAIN - PRIVACY/LEFT HAND - 35" X 50" (S05, S92)
5	101668-40-S06	EA	CURTAIN - PRIVACY/LEFT HAND - 35" X 50" (S06, S93)
5	073260-23-S04	EA	TIEBACK - 3" X 18" (S04, S91)
5	073260-23-P08	EA	TIEBACK - 3" X 18" (S05, S92)
5	073260-23-S06	EA	TIEBACK - 3" X 18" (S06, S93)
6	076892-30-S04	EA	CURTAIN - CAB PRIVACY - 47.5" X 74" (S04, S91)
6	076892-30-P08	EA	CURTAIN - CAB PRIVACY - 47.5" X 74" (S05, S92)
6	076892-30-S06	EA	CURTAIN - CAB PRIVACY - 47.5" X 74" (S06, S93)
6	076892-29-S04	EA	CURTAIN - CAB PRIVACY - 47.5" X 74" (S04, S91) - TV-24" COLOR,STEREO W/REMOTE
6	076892-29-P08	EA	CURTAIN - CAB PRIVACY - 47.5" X 74" (S05, S92) - TV-24" COLOR,STEREO W/REMOTE
6	076892-29-S06	EA	CURTAIN - CAB PRIVACY - 47.5" X 74" (S06, S93) - TV-24" COLOR,STEREO W/REMOTE
7	149263-11-S04	EA	VALANCE - CLARION - 19" (S04, S91)
7	149263-11-S05	EA	VALANCE - CLARION - 19" (S05, S92)
7	149263-11-S06	EA	VALANCE - CLARION - 19" (S06, S93)
7	152664-09-S04	EA	LEG - RIGHT - 32" (S04, S91)
7	152664-09-S05	EA	LEG - RIGHT - 32" (S05, S92)
7	152664-09-S06	EA	LEG - RIGHT - 32" (S06, S93)
7	152664-10-S04	EA	LEG - LEFT - 32" (S04, S91)
7	152664-10-S05	EA	LEG - LEFT - 32" (S05, S92)
7	152664-10-S06	EA	LEG - LEFT - 32" (S06, S93)
7	140789-23-N02	EA	BLIND - DAY/NIGHTER - 15.5" X 33"
8	121410-C8-S04	EA	VALANCE - MODERATE - 32" (S04, S91)
8	121410-C8-S05	EA	VALANCE - MODERATE - 32" (S05, S92)
8	121410-C8-S06	EA	VALANCE - MODERATE - 32" (S06, S93)
8	084755-57-P37	EA	SHADE - PULL - 27.25"
9	109041-57-03A	EA	BLIND - MINI - 26" X 17"
10	149263-06-S04	EA	VALANCE - CLARION - 19" (S04, S91)
10	149263-06-S05	EA	VALANCE - CLARION - 19" (S05, S92)
10	149263-06-S06	EA	VALANCE - CLARION - 19" (S06, S93)
10	152664-25-S04	EA	LEG - RIGHT - 24" (S04, S91)
10	152664-25-S05	EA	LEG - RIGHT - 24" (S05, S92)
10	152664-25-S06	EA	LEG - RIGHT - 24" (S06, S93)
10	152664-26-S04	EA	LEG - LEFT - 24" (S04, S91)
10	152664-26-S05	EA	LEG - LEFT - 24" (S05, S92)
10	152664-26-S06	EA	LEG - LEFT - 24" (S06, S93)
10	140789-63-S01	EA	BLIND - DAY/NIGHTER - 16.5" X 26"
11	149263-05-S04	EA	VALANCE - CLARION - 31" (S04, S91)
11	149263-05-S05	EA	VALANCE - CLARION - 31" (S05, S92)
11	149263-05-S06	EA	VALANCE - CLARION - 31" (S06, S93)
11	152664-21-S04	EA	LEG - RIGHT - 29" (S04, S91)
11	152664-21-S05	EA	LEG - RIGHT - 29" (S05, S92)
11	152664-21-S06	EA	LEG - RIGHT - 29" (S06, S93)
11	152664-22-S04	EA	LEG - LEFT - 29" (S04, S91)
11	152664-22-S05	EA	LEG - LEFT - 29" (S05, S92)
11	152664-22-S06	EA	LEG - LEFT - 29" (S06, S93)
11	140789-06-N30	EA	BLIND - DAY/NIGHTER - 28" X 28"

**CURTAIN & CUSHION GROUP (CONTINUED)**  
**WINDOW TREATMENT (CONTINUED)**

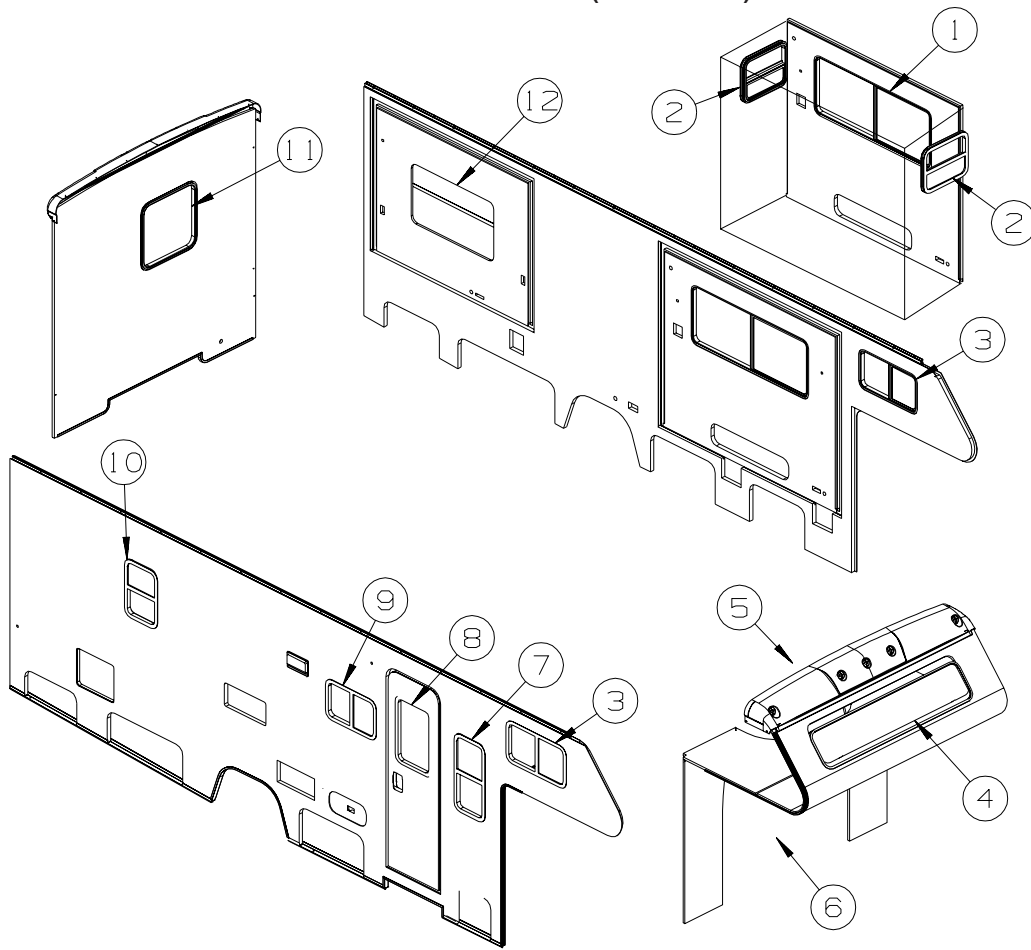

KEY	PART NUMBER	U/M	DESCRIPTION
12	149263-04-S04	EA	VALANCE - CLARION - 46" (S04, S91)
12	149263-04-S05	EA	VALANCE - CLARION - 46" (S05, S92)
12	149263-04-S06	EA	VALANCE - CLARION - 46" (S06, S93)
12	152664-23-S04	EA	LEG - RIGHT - 26" (S04, S91)
12	152664-23-S05	EA	LEG - RIGHT - 26" (S05, S92)
12	152664-23-S06	EA	LEG - RIGHT - 26" (S06, S93)
12	152664-24-S04	EA	LEG - LEFT - 26" (S04, S91)
12	152664-24-S05	EA	LEG - LEFT - 26" (S05, S92)
12	152664-24-S06	EA	LEG - LEFT - 26" (S06, S93)
12	140789-02-N02	EA	BLIND - DAY/NIGHTER - 43" X 28"

## CURTAIN & CUSHION GROUP (CONTINUED)

### HARDWARE

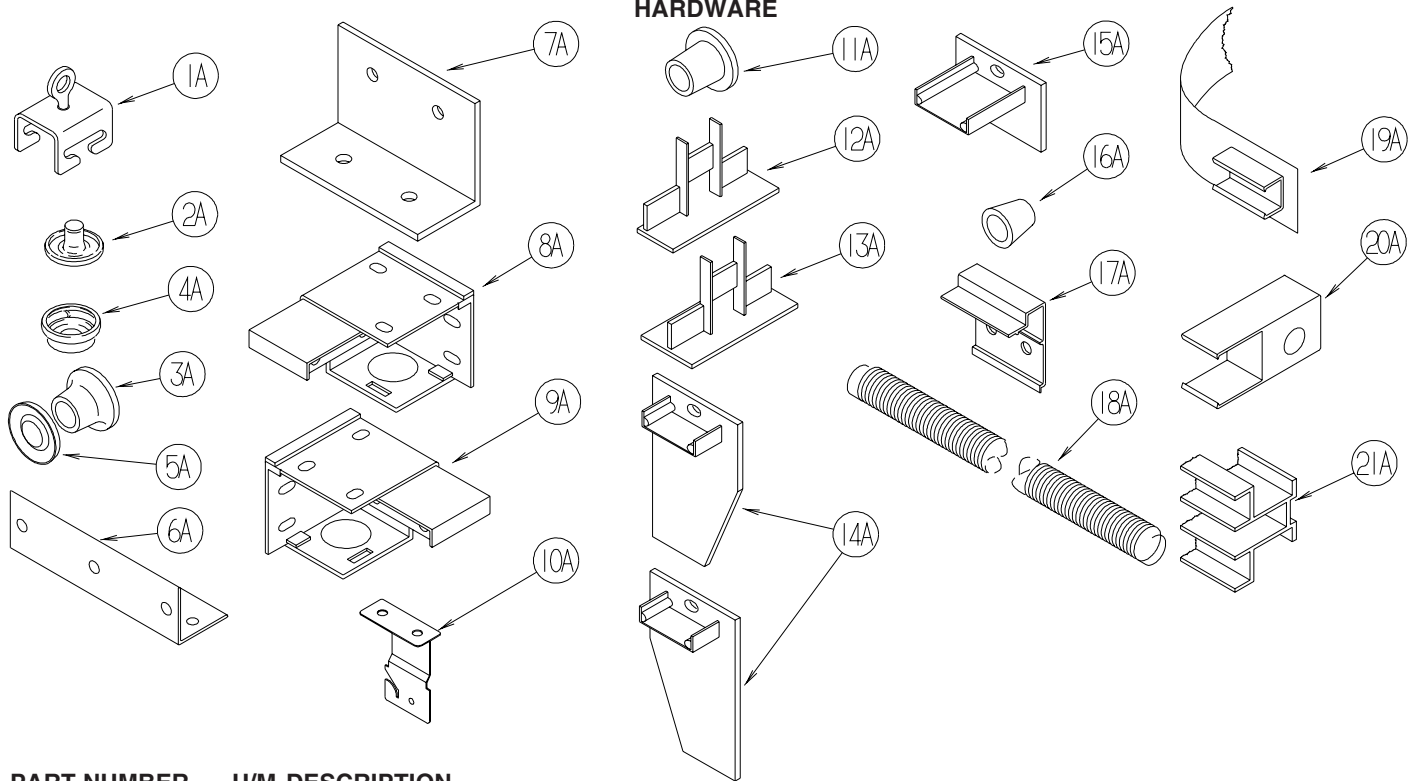

KEY	PART NUMBER	U/M	DESCRIPTION
1A	009702-01-000	EA	END STOP - CURTAIN CARRIER - L ROD
2A	029155-01-000	EA	CAP - SNAP - 5/32" OUTSIDE DIAMETER OF PIN
3A	029156-01-000	EA	SOCKET - SNAP - 9/16" O.D.
4A	046867-02-000	EA	WASHER - HANDY BUTTON #3
5A	046867-03-000	EA	GROMMET - HANDY BUTTON #3
6A	075943-10-000	EA	BRACE - VALANCE - 20" - OFF WHITE
7A	083125-08-000	EA	BRACE - WINDOW MOUNT - .75" - OFF WHITE
8A	083170-01-000	EA	BRACKET/BLIND - LEFT SIDE WHEN FACING WINDOW - CLEAR
9A	083170-02-000	EA	BRACKET/BLIND - RIGHT SIDE WHEN FACING WINDOW - CLEAR
10A	084434-01-000	EA	BRACKET - MOUNTING - ROLLER SHADE - 1 3/8"
11A	094896-02-000	EA	GROMMET - CORD/PLEATED BLIND - NYLON - GRAY
12A	094907-02-000	EA	END CAP - PLEATED BLIND/TOP - RH/LH - GRAY PLASTIC
13A	094907-04-000	EA	END CAP - PLEATED BLIND/BOTTOM - RH/LH
14A	094907-05-000	EA	END CAP - PLEATED BLIND/BOTTOM - PULL TYPE - PLASTIC
15A	094907-06-000	EA	END CAP/BLIND - TOP RH/LH
	094907-09-000	EA	END CAP/BLIND - CENTER RAIL - RH/LH
16A	097564-03-000	EA	HANDLE - KNOB - E-Z LIFT SHADE - TAN
16A	097564-06-000	EA	HANDLE - KNOB - E-Z LIFT SHADE - ALABASTER
	097593-02-000	FT	CORD - BLIND - PLEATED - GRAY
	097593-06-000	FT	CORD - BLIND - PLEATED - PEWTER
	097593-10-000	FT	CORD - BLIND - PLEATED - VANILLA
	109353-09-01A	EA	BLIND - SLAT - 21' - ALABASTER PEARL
17A	097565-01-000	EA	BRACKET - MOUNTING - PLEATED BLIND
18A	097591-01-000	EA	SPRING - EXTENSION - PLEATED BLIND
19A	101031-01-000	YD	TAPE/GLIDE - 4.25" SPACING
20A	101033-02-000	EA	END CAP - LOW PROFILE TRACK - CLEAR
21A	101033-08-000	EA	TRACK/WALL - 75" - <b>FRT BUNK WINDOW MINNIE/SPIRIT 300-SERIES</b>
21A	101033-09-000	EA	TRACK/WALL - 32" - <b>SIDE BUNK WINDOW MINNIE/SPIRIT 300-SERIES</b>

## CURTAIN & CUSHION GROUP (CONTINUED)

### HARDWARE (CONTINUED)

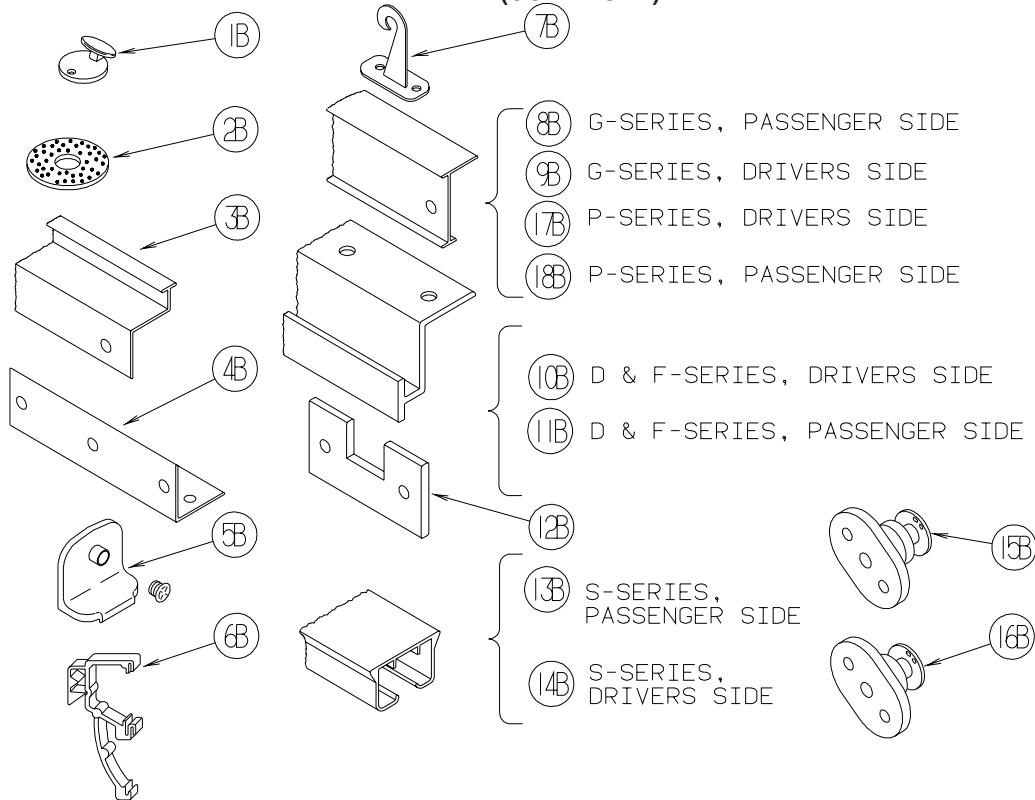

KEY	PART NUMBER	U/M DESCRIPTION
1B	102555-03-000	EA BRACKET - (CLEAT TYPE) - F/BLIND HOLDOWN - MILKY WHITE
2B	103242-01-000	EA VELCRO HOOK - BEIGE 7/8" ROUND W/CENTER HOLE
2B	103242-02-000	EA VELCRO HOOK - BLACK 7/8" ROUND W/CENTER HOLE
3B	105450-14-01A	EA TRACK - CURTAIN - 90" - OFF WHITE - <b>FRONT BUNK PRIVACY MINNIE/SPIRIT 300-SERIES</b>
4B	105648-01-02A	EA BRACE - VALANCE - OFF/WHITE - 14"
5B	106544-01-000	EA PULL - SHADE/BRASS
5B	106544-01-001	EA SCREW - SHADE/BRASS
5B	106544-02-000	EA PULL-SHADE - NICKEL
6B	109353-04-000	EA CLIP - VALANCE SLAT MOUNTING - CLEAR PLASTIC
7B	109441-03-000	EA BRACKET/HOOK - BLIND HOLD DOWN - NEW DESIGN/CLEAR
8B	126456-03-04A	EA TRACK/WRAPAROUND - PASSENGER - GLACIER - <b>ADVENTURER/SUNCRUISER G-SERIES</b>
9B	126456-04-04A	EA TRACK/WRAPAROUND - DRIVER - GLACIER - <b>ADVENTURER/SUNCRUISER G-SERIES</b>
10B	127254-04-05A	EA TRACK/WRAPAROUND-DRVR-GLACIER - <b>SIGHTSEER/SUNOVA D-SERIES, BRAVE/SUNRISE F-SERIES</b>
11B	127254-14-03A	EA TRACK/WRAPAROUND-PASS-GLACIER - <b>SIGHTSEER/SUNOVA D-SERIES, BRAVE/SUNRISE F-SERIES</b>
12B	130549-01-01A	EA STOP - CURTAIN TRACK
13B	138460-07-02A	EA TRACK/CURTAIN - PASSENGER - W/BRACKET/CARRIER/PULLEY - WHT - <b>VECTRA/HORIZON S-SERIES</b>
14B	138460-08-02A	EA TRACK/CURTAIN - DRIVER - W/BRACKET/CARRIER/PULLEY - WHT - <b>VECTRA/HORIZON S-SERIES</b>
15B	141634-01-000	EA BRACKET-(BOBBIN TYPE) 7/8"H HOLDUPBASE(OVAL)-2 HOLE-CLEAR
16B	143805-01-000	EA BRACKET-(BOBBIN TYPE) 1/2"H HOLDUPBASE(OVAL)-2 HOLES CLEAR
17B	146591-01-01A	EA TRACK - CURTAIN - LEFT HAND - GLACIER - <b>JOURNEY/MERIDIAN P-SERIES</b>
18B	146591-02-01A	EA TRACK - CURTAIN - RIGHT HAND - GLACIER - <b>JOURNEY/MERIDIAN P-SERIES</b>

### ACCESSORIES

KEY	PART NUMBER	U/M DESCRIPTION
	057534-01-000	EA TIEBACK - CLEAR PLASTIC - 6"
	057534-03-000	EA TIEBACK - CLEAR PLASTIC - 7.5"



**CURTAIN & CUSHION GROUP (CONTINUED)**  
**FABRICS**

**SX1 IS NOT AVAILABLE**

	<b>S04/S91 PINEHURST</b>	<b>S05/S92 BLUE TOPAZ</b>	<b>S06/S93 TUMBLEWEED</b>	<b>S97 MAPLE SUGAR</b>	<b>S98 PINE CREEK</b>
<b>2005 FAMILY BUCKET</b>	562H BUCKET	562H BUCKET	562H BUCKET	562H BUCKET	562H BUCKET
	126883-Y8-000	148797-01-000	148797-14-000	148797-54-000	148797-56-000
	*OPT. ULTRA/STEEL GRAY	*OPT. ULTRA/STEEL GRAY	*OPT. ULTRA/STEEL GRAY		
	079680-39-000	079680-39-000	079680-39-000		
<b>DINETTE</b>	SQUARE CLUB	SQUARE CLUB	SQUARE CLUB	SQUARE CLUB	SQUARE CLUB
	126883-Y7-000	126883-Y9-000	148797-13-000	148797-53-000	148797-55-000
<b>DINETTE PADS</b>	126883-Y8-000	148797-01-000	148797-14-000	137813-A3-000	138713-E4-000
<b>SOFA</b>	695 BACK W/685 SEAT	695 BACK W/685 SEAT	695 BACK W/685 SEAT	695 SOFA	695 SOFA
	#325 STYLE JACK KNIFE	#325 STYLE JACK KNIFE	#325 STYLE JACK KNIFE	#325 STYLE JACK KNIFE	#325 STYLE JACK KNIFE
	126883-Y7-000	126883-Y9-000	148797-13-000	148797-53-000	148797-55-000
<b>LOUNGE CHAIR</b>	465 CHAIR	465 CHAIR	465 CHAIR	NOT NEEDED	NOT NEEDED
	126883-Y8-000	148797-01-000	148797-14-000		
<b>LOUNGE WINDOWS</b>	CLARION VALANCE	CLARION VALANCE	CLARION VALANCE	JACOB VALANCE	JACOB VALANCE
	WRAP - 126883-Y7-000	WRAP - 126883-Y9-000	WRAP - 148797-13-000	OVERLAY - 148797-53-000	OVERLAY - 148797-55-000
	½ WELT (TOP) - 126883-Y8-000	½ WELT (TOP) - 148797-01-000	½ WELT (TOP) - 148797-14-000	UNDERLAY - 148797-54-000	UNDERLAY - 148797-54-000
	¼ WELT (BTM) - 126883-Y8-000	¼ WELT (BTM) - 148797-01-000	¼ WELT (BTM) - 148797-14-000	½ WELT (TOP) - 148797-54-000	½ WELT (TOP) - 148797-56-000
	LEGS - 126883-Y7-000	LEGS - 126883-Y9-000	LEGS - 148797-13-000	1/2" WELT (SIDE) - 148797-54-000	1/2" WELT (SIDE) - 148797-56-000
<b>ENTRANCE DOOR</b>	MODERATE VALANCE W/WELT	MODERATE VALANCE W/WELT	MODERATE VALANCE W/WELT		
	WRAP - 126883-Y7-000	WRAP - 126883-Y9-000	WRAP - 148797-13-000	FROSTED GLASS	FROSTED GLASS
	WELT - 126883-Y8-000	WELT - 148797-01-000	WELT - 148797-14-000	NO PULL SHADE	NO PULL SHADE
<b>LOUNGE PILLOW</b>	NOT NEEDED	NOT NEEDED	NOT NEEDED	NOT NEEDED	NOT NEEDED
	137813-B6-000	137813-27-000	137813-C1-000	137813-A3-000	137813-E4-000
<b>FWA, PRIVACY &amp; OVHD. CURTAINS</b>					
<b>OVERHEAD BUNK</b>	126883-Y8-000	148797-01-000	148797-14-000	137813-A3-000	137813-E4-000
<b>DIVIDER CURTAIN</b>	137813-B6/137813-B5	137813-27/137813-B7	137813-C1/137813-C0	137813-A3/137813-F6	137813-E4/137813-F7
<b>DAY/NIGHTER</b>	094911-53/094911-50	094911-53/094911-50	094911-53/094911-50	094911-53/094911-50	094911-53/094911-50
	COTTON/WT. DECO	COTTON/WT. DECO	COTTON/WT. DECO	COTTON/WT. DECO	COTTON/WT. DECO
<b>GALLEY BLINDS</b>	386 SNOCAP	386 SNOCAP	386 SNOCAP	386 SNOCAP	386 SNOCAP
<b>BEDROOM WDO TREATMENT</b>	CLARION VALANCE	CLARION VALANCE	CLARION VALANCE	JACOB VALANCE	JACOB VALANCE
	WRAP - 137813-B5-000	WRAP - 137813-B7-000	WRAP - 137813-C0-000	OVERLAY - 137813-F6-000	OVERLAY - 137813-F7-000
	½ WELT (TOP) - 137813-B6-000	½ WELT (TOP) - 137813-27-000	½ WELT (TOP) - 137813-C1-000	UNDERLAY - 137813-A3-000	UNDERLAY - 137813-A4-000
	¼ WELT (BTM) - 137813-B6-000	¼ WELT (BTM) - 137813-27-000	¼ WELT (BTM) - 137813-C1-000	½ WELT (TOP) - 137813-A3-000	½ WELT (TOP) - 137813-A4-000
	LEGS - 137813-B5-000	LEGS - 137813-B7-000	LEGS - 137813-C0-000	1/2" WELT (SIDE) - 137813-A3-000	1/2" WELT (SIDE) - 137813-A4-000
<b>BEDCOVER</b>	BEDCAP	BEDCAP	BEDCAP	FITTED QUILTED	FITTED QUILTED
	137813-B5-000	137813-B7-000	137813-C0-000	137813-F6-000	137813-F7-000
<b>QUILT PATTERN</b>	DIAMOND	DIAMOND	DIAMOND	DIAMOND	DIAMOND
<b>BED PILLOW</b>	NOT NEEDED	NOT NEEDED	NOT NEEDED	NOT NEEDED	NOT NEEDED
<b>SHAMS</b>	1/2" NON-GATH. WELT	1/2" NON-GATH. WELT	1/2" NON-GATH. WELT	NOT NEEDED	NOT NEEDED
	137813-B5/137813-B6	137813-B7/137813-27	137813-C0/137813-C1		
<b>VANITY CHAIR</b>	REM FOLDING CHAIR	REM FOLDING CHAIR	REM FOLDING CHAIR	NOT NEEDED	NOT NEEDED
	126883-Y8-000	148797-01-000	148797-14-000		
<b>CARPET</b>	139056-21-000	139056-26-000	096060-H1-000	139056-22-000	139056-21-000
	PALE SAGE	SKY BLUE	TAPIOCA	BURLWOOD	PALE SAGE
<b>CEILING</b>	113979-07-01A SOFT GEO	113979-07-01A SOFT GEO	113979-07-01A SOFT GEO	113979-07-01A SOFT GEO	113979-07-01A SOFT GEO



## DRIVERS COMPARTMENT GROUP FRONT INTERIOR

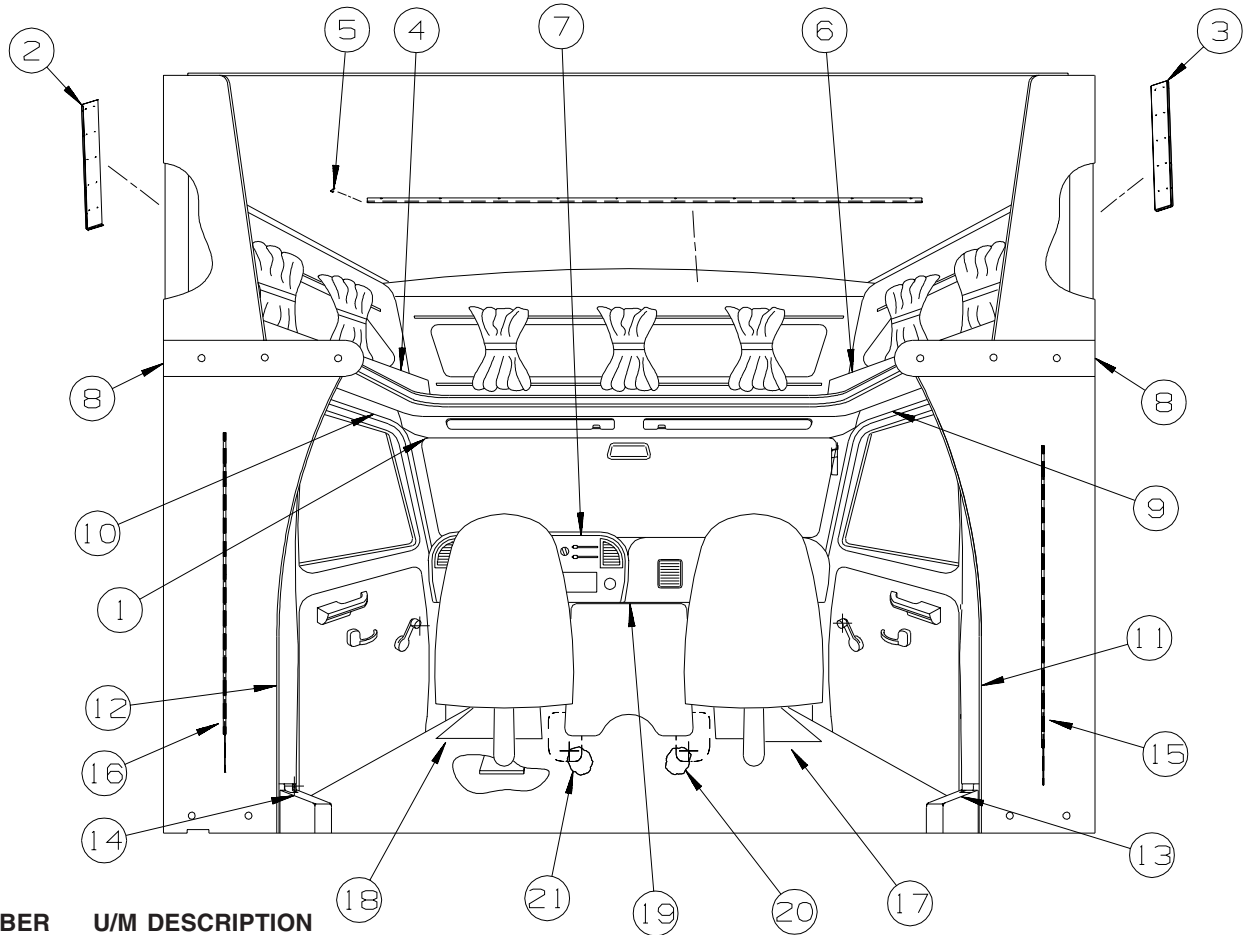

KEY	PART NUMBER	U/M	DESCRIPTION
1	106448-06-P13	EA	HEADLINER - W/VINYL
2	109709-01-01A	EA	BRACKET - WINGWALL - OFF WHITE
3	109709-02-01A	EA	BRACKET - WINGWALL - OFF WHITE
4	141795-01-S01	EA	CABINET/HAMPER - FRONT - W/DOOR - W/O HARDWARE (S04, S91, S98, SX1)
4	141795-01-R08	EA	CABINET/HAMPER - FRONT - W/DOOR - W/O HARDWARE (S05, S92)
4	141795-01-S03	EA	CABINET/HAMPER - FRONT - W/DOOR - W/O HARDWARE (S06, S93, S97)
5	141829-01-01A	EA	TRIM - J MOLDING - OFF WHITE - 96"
6	141795-02-S01	EA	CABINET/HAMPER - FRONT - W/DOOR - W/O HARDWARE (S04, S91, S98, SX1)
6	141795-02-R08	EA	CABINET/HAMPER - FRONT - W/DOOR - W/O HARDWARE (S05, S92)
6	141795-02-S03	EA	CABINET/HAMPER - FRONT - W/DOOR - W/O HARDWARE (S06, S93, S97)
7	136524-04-04A	EA	APPLIQUE - BEZEL - DASH - WOOD GRAINED/BRUSHED PEWTER - <b>INSTRUMENT PANEL APPLIQUE</b> FROM: 00-00-00 THRU: 07-27-04
7	150974-01-03A	EA	APPLIQUE - BEZEL - INSTRUMENT PANEL - BRUSHED PEWTER - <b>INSTRUMENT PANEL APPLIQUE</b> FROM: 07-28-04 THRU: 99-99-99
8	141793-01-S01	EA	CAP - SLEEPERBOARD (S04, S98, SX1)
8	141793-01-R08	EA	CAP - SLEEPERBOARD (S05)
8	141793-01-S03	EA	CAP - SLEEPERBOARD (S06, S97)
8	141793-01-S88	EA	CAP - SLEEPERBOARD (S91)
8	141793-01-S89	EA	CAP - SLEEPERBOARD (S92)
8	141793-01-S90	EA	CAP - SLEEPERBOARD (S93)
9	106447-09-R13	EA	TRIM - CAB DOOR - UPPER/RIGHT HAND
10	106447-10-P13	EA	TRIM - CAB DOOR - UPPER/LEFT HAND
11	125031-01-H04	EA	TRIM - CAB - B-PILLAR - PASSENGER SIDE
12	125031-02-H04	EA	TRIM - CAB - B-PILLAR - DRIVER SIDE
13	106431-01-02A	EA	COVER - SEATBELT RECOIL - PASSENGER SIDE - VW GREY
14	106431-02-02A	EA	COVER - SEATBELT RECOIL - DRIVER SIDE - VW GRAY
15	106445-06-H07	EA	TRIM - WINGWALL - VINYL WRAPPED - DRIVER SIDE
16	106445-08-H04	EA	TRIM - WINGWALL - VINYL WRAPPED - PASSENGER SIDE
17	125780-03-000	EA	MAT - FLOOR - FRONT PASSENGER - "I" - FORD (GRAY)
18	125780-04-000	EA	MAT - FLOOR - FRONT DRIVER - "I" - FORD (GRAY)
19	147623-01-01A	EA	TRAY - BEVERAGE - MOTOR COVER
	151391-01-01A	EA	PAD/TRAY - BEVERAGE TRAY
	151391-02-01A	EA	PAD/CUP - BEVERAGE TRAY

**DRIVERS COMPARTMENT GROUP (CONTINUED)**  
**FRONT INTERIOR (CONTINUED)**

<b>KEY</b>	<b>PART NUMBER</b>	<b>U/M</b>	<b>DESCRIPTION</b>
20	135426-02-000	EA	CAB FLOOR INSULATION - RIGHT HAND
21	135426-01-000	EA	CAB FLOOR INSULATION - LEFT HAND
*	106025-02-01A	EA	LADDER - BUNK - 52"
	094658-02-N01	EA	HANDLE - BUNK - 1.1" X 2" X 14.2" - PORTSMOUTH OAK
	094658-02-S88	EA	HANDLE - BUNK - 1.1" X 2" X 14.2" - SIERRA MAPLE

**\*COMPONENT PARTS LISTED LATER IN THIS GROUP**

**COMPONENT PARTS FOR FRONT INTERIOR**

<b>KEY</b>	<b>PART NUMBER</b>	<b>U/M</b>	<b>DESCRIPTION</b>	<b>106025-02-01A</b>	<b>VENDOR NO.</b>
	106025-01-700	EA	BRACKET SET-F/BUNK LADDER		08-0030-00
	106025-01-701	EA	END CAP-F/STEP LADDER RUNGS		

## DRIVERS COMPARTMENT GROUP (CONTINUED)

### CABINETS

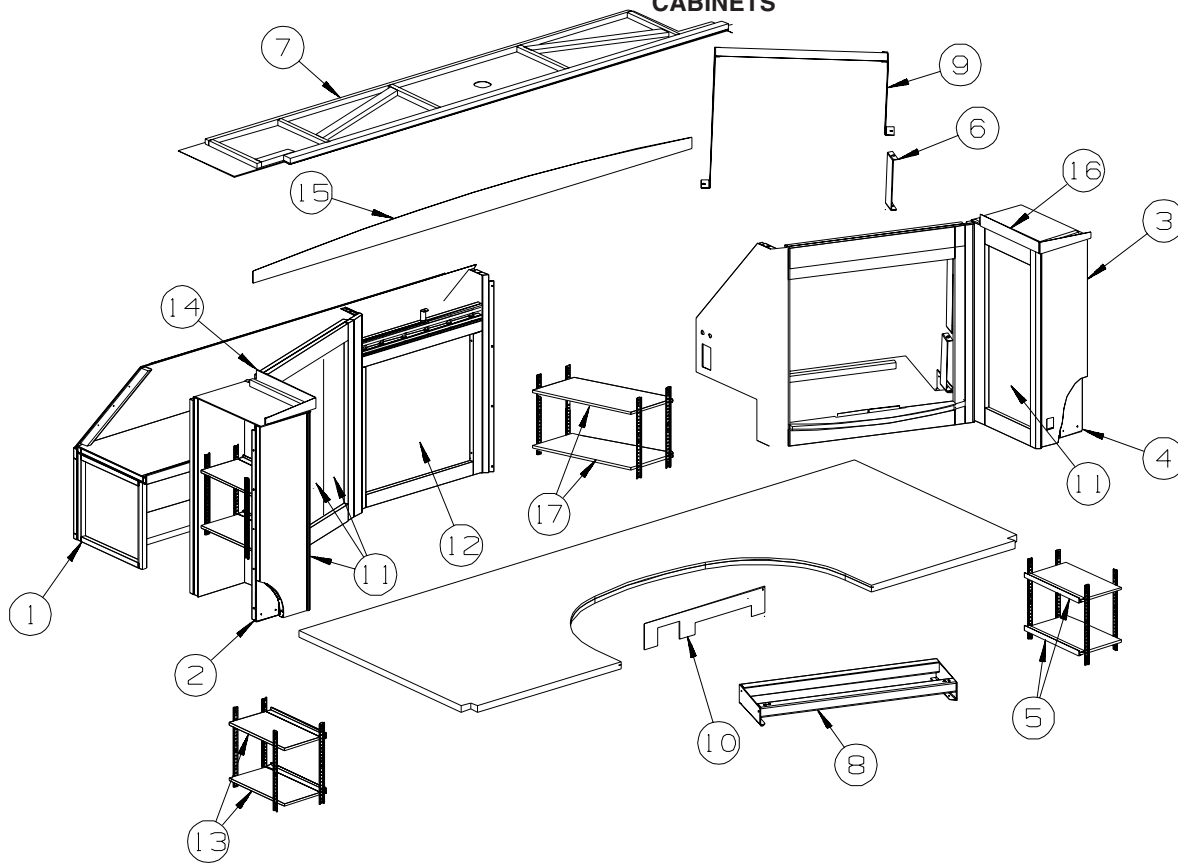

**FROM 00-00-00  
THRU 01-02-05**

KEY	PART NUMBER	U/M	DESCRIPTION
1	148347-05-S01	EA	CABINET - ENTERTAINMENT CENTER - LEFT HAND - W/O DOORS/HDW - PORTSMOUTH OAK
1	148347-05-S88	EA	CABINET - ENTERTAINMENT CENTER - LEFT HAND - W/O DOORS/HDW - SIERRA MAPLE
1	148347-06-S01	EA	CABT CTR/LH-W/O DRS/HDW - PORTSMOUTH OAK - HOME THEATER SYSTEM OR DVD/VCR STEREO
1	148347-06-S88	EA	CABT CTR/LH-W/O DRS/HDW - SIERRA MAPLE - HOME THEATER SYSTEM OR DVD/VCR STEREO
2	136268-04-03B	EA	BRACKET - WINGWALL - OFF WHITE
3	148339-01-R07	EA	CABINET - ENTERTAINMENT CENTER/TV - W/O DOORS/HDW - PORTSMOUTH OAK
3	148339-01-S88	EA	CABINET - ENTERTAINMENT CENTER/TV - W/O DOORS/HDW - SIERRA MAPLE
	096764-02-000	EA	SLIPNOT - ANTISLIP - 1'WIDE (180' ROLLS) - WHITE
4	136268-03-03B	EA	BRACKET - WINGWALL - OFF WHITE
5	148339-22-R07	EA	SHELF - W/PLASTIC EDGE MOLDING - PORTSMOUTH OAK
5	148339-22-S88	EA	SHELF - W/PLASTIC EDGE MOLDING - SIERRA MAPLE
6	136269-08-02B	EA	BRACKET/TV TIEDOWN - E-COATED
7	148349-01-R07	EA	CABINET - ENTERTAINMENT CENTER/TOP - W/O DOORS/HARDWARE
8	148344-01-02B	EA	BRACKET - ENTERTAINMENT CENTER - E-COATED
9	148247-03-02B	EA	BRACKET/TV TIEDOWN - E-COATED
10	142200-01-P07	EA	PANEL - VINYL COVERED
10	142200-03-P07	EA	PANEL - VINYL COVERED - INVERTER
11	136955-70-S04	EA	DOOR - RAISED PANEL/PENCIL EDGE - 12" X 26" - W/O HDW - PORTSMOUTH OAK
11	136955-70-S91	EA	DOOR - RAISED PANEL/PENCIL EDGE - 12" X 26" - W/O HDW - SIERRA MAPLE
	076767-04-000	EA	CABLE - STAINLESS STEEL - 5.9"
12	100708-30-000	EA	DOOR/GLASS - TV CABINET - 18.8" X 18.8" - W/O HARDWARE
13	148347-34-R07	EA	SHELF - W/PLASTIC EDGE MOLDING - PORTSMOUTH OAK
13	148347-34-S88	EA	SHELF - W/PLASTIC EDGE MOLDING - SIERRA MAPLE
14	148348-01-R07	EA	TRIM - ENTERTAINMENT CENTER
15	148348-02-R07	EA	TRIM - ENTERTAINMENT CENTER
16	148348-03-R07	EA	TRIM - ENTERTAINMENT CENTER
17	148347-46-R07	EA	SHELF - W/PLASTIC EDGE MOLDING - PORTSMOUTH OAK
17	148347-46-S88	EA	SHELF - W/PLASTIC EDGE MOLDING - SIERRA MAPLE

**DRIVERS COMPARTMENT GROUP (CONTINUED)**  
**CABINETS (CONTINUED)**

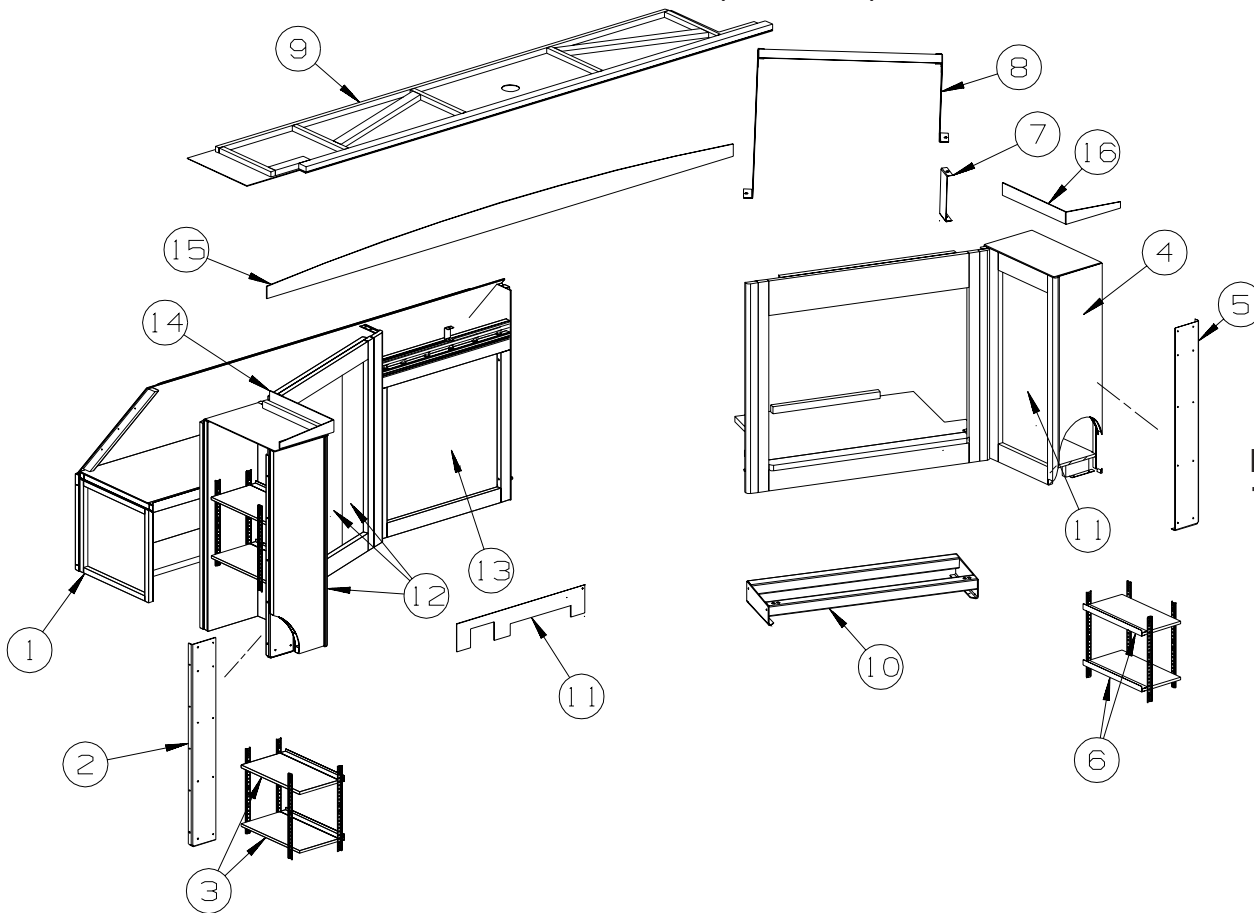

**FROM 01-03-05  
THRU 99-99-99**

KEY	PART NUMBER	U/M	DESCRIPTION
1	149244-05-S01	EA	CABINET - ENTERTAINMENT CENTER - LEFT HAND - W/O DOORS/HDW - PORTSMOUTH OAK
1	149244-05-S88	EA	CABINET - ENTERTAINMENT CENTER - LEFT HAND - W/O DOORS/HDW - SIERRA MAPLE
1	149244-06-S01	EA	CABT CTR/LH-W/O DRS/HDW - PORTSMOUTH OAK - <b>HOME THEATER SYSTEM OR DVD/VCR STEREO</b>
1	149244-06-S88	EA	CABT CTR/LH-W/O DRS/HDW - SIERRA MAPLE - <b>HOME THEATER SYSTEM OR DVD/VCR STEREO</b>
2	136268-04-03B	EA	BRACKET - WINGWALL - OFF WHITE
3	149244-34-S07	EA	SHELF - W/PLASTIC EDGE MOLDING - PORTSMOUTH OAK
3	149244-34-SW0	EA	SHELF - W/PLASTIC EDGE MOLDING - SIERRA MAPLE
4	153382-01-S01	EA	CABINET - ENTERTAINMENT CENTER/TV - W/O DOORS/HDW - PORTSMOUTH OAK
4	153382-01-S88	EA	CABINET - ENTERTAINMENT CENTER/TV - W/O DOORS/HDW - SIERRA MAPLE
	096764-02-000	EA	SLIPNOT - ANTISLIP - 1'WIDE (180' ROLLS) - WHITE
5	136268-03-03B	EA	BRACKET - WINGWALL - OFF WHITE
6	153382-22-S01	EA	SHELF - W/PLASTIC EDGE MOLDING - PORTSMOUTH OAK
6	153382-22-S88	EA	SHELF - W/PLASTIC EDGE MOLDING - SIERRA MAPLE
7	136269-08-02B	EA	BRACKET/TV TIEDOWN - E-COATED
8	148247-08-02B	EA	STRAP/TIEDOWN - TV - E-COATED
9	148349-01-S01	EA	CABINET - ENTERTAINMENT CENTER/TOP - W/O DOORS/HARDWARE
10	148344-01-02B	EA	BRACKET - ENTERTAINMENT CENTER - E-COATED
11	142200-01-P07	EA	PANEL - VINYL COVERED
			FROM: 00-00-00 THRU: 02-10-05
11	142200-05-S01	EA	PANEL - VINYL COVERED
			FROM: 02-11-05 THRU: 99-99-99
11	142200-03-P07	EA	PANEL - VINYL COVERED - <b>INVERTER</b>
			FROM: 00-00-00 THRU: 02-10-05
11	142200-04-S01	EA	PANEL - VINYL COVERED - <b>INVERTER</b>
			FROM: 02-11-05 THRU: 99-99-99
12	136955-70-S04	EA	DOOR - RAISED PANEL/PENCIL EDGE - 12" X 26" - W/O HDW - PORTSMOUTH OAK
12	136955-70-S91	EA	DOOR - RAISED PANEL/PENCIL EDGE - 12" X 26" - W/O HDW - SIERRA MAPLE
	076767-04-000	EA	CABLE - STAINLESS STEEL - 5.9"
13	100708-30-000	EA	DOOR/GLASS - TV CABINET - 18.8" X 18.8" - W/O HARDWARE
14	148348-01-R07	EA	TRIM - ENTERTAINMENT CENTER
15	148348-02-R07	EA	TRIM - ENTERTAINMENT CENTER
16	148348-03-R07	EA	TRIM - ENTERTAINMENT CENTER

# ELECTRICAL GROUP

## 110V BODY WIRING

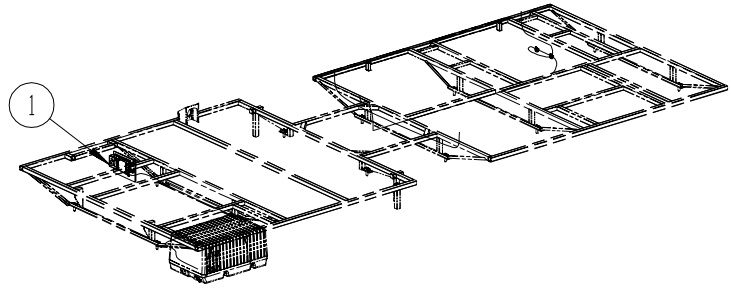

KEY	PART NUMBER	U/M	DESCRIPTION
1	024924-02-000	EA	RECEPTACLE - POWER CORD - W/PARTIAL PLATE

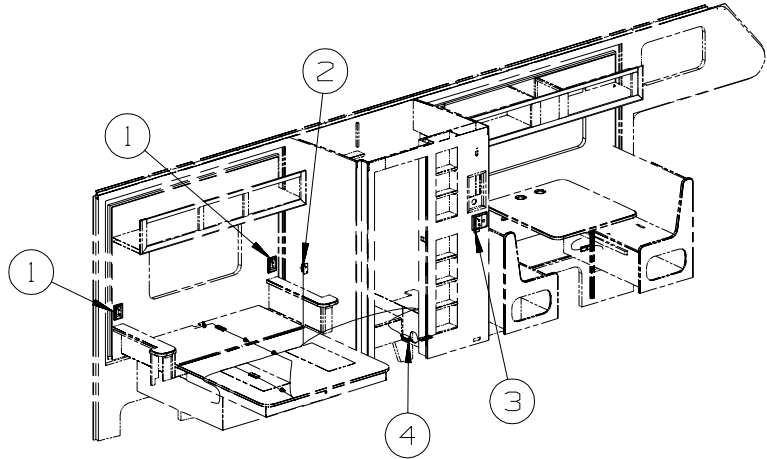

KEY	PART NUMBER	U/M	DESCRIPTION
1	133713-01-20A	EA	SPACER/RECEPTACLE - WHITE VINYL
1	058708-06-000	EA	RECEPTACLE - DUPLEX - WHITE
2	058708-05-000	EA	RECEPTACLE - ELECTRIC - SINGLE - BROWN
3	133713-04-20A	EA	SPACER/RECEPTACLE - WHITE VINYL
3	058708-06-000	EA	RECEPTACLE - DUPLEX - WHITE
4	058707-02-000	EA	RECEPTACLE - BLANK - JUNCTION BOX

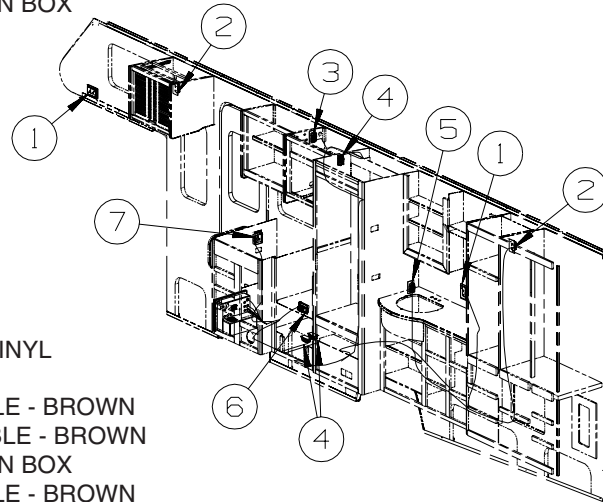

KEY	PART NUMBER	U/M	DESCRIPTION
1	133713-01-20A	EA	SPACER/RECEPTACLE - WHITE VINYL
1	058708-06-000	EA	RECEPTACLE - DUPLEX - WHITE
2	058708-05-000	EA	RECEPTACLE - ELECTRIC - SINGLE - BROWN
3	058708-01-000	EA	RECEPTACLE - ELECTRIC - DOUBLE - BROWN
4	058707-02-000	EA	RECEPTACLE - BLANK - JUNCTION BOX
5	058707-01-000	EA	RECEPTACLE - ELECTRIC - SINGLE - BROWN
6	131826-01-01A	EA	RECEPTACLE - EXTERIOR - W/COVER/GASKET - WHITE
7	147446-01-02A	EA	RECEPTACLE - GFCI - 15A 125V - BROWN

## ELECTRICAL GROUP (CONTINUED)

### 12V BODY WIRING

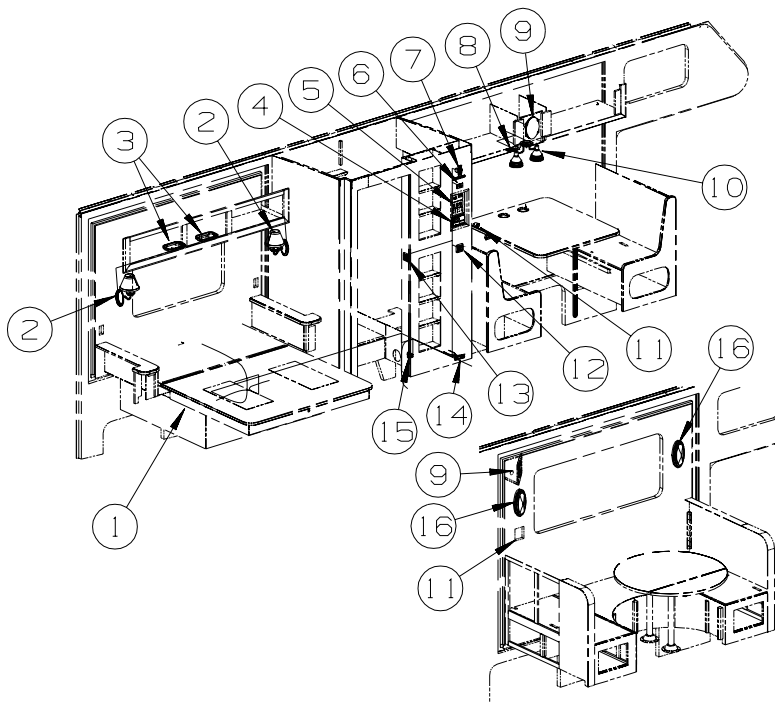

KEY	PART NUMBER	U/M	DESCRIPTION
1	139335-01-02B	EA	PLATE - ELECTRICAL - E-COATED
1	082134-01-000	EA	ADAPTER - TV - CABLE TO CABLE
1	082136-01-000	EA	NUT - HEX JAM - 3/8-32
1	087236-01-000	EA	LABEL - CABLE - INPUT
2	119258-31-01A	EA	LAMP - WALL - BRASS - UL/CSA
2	119257-08-01A	EA	SHADE - LAMP - SHORT - CRYSTAL/SMALL DIAMOND
2	067479-01-000	EA	BULB - 12V - #1076 - 1.80 AMP
3*	137417-02-01A	EA	LIGHT - DOME - SINGLE - W/SWITCH/OPTIC LENS - WHITE
4	135618-03-01A	EA	THERMOSTAT - ROOF A/C & FURNACE - WHITE
4	135618-01-01A	EA	THERMOSTAT - HEAT PUMP/FURNACE - WHITE
5*	134940-01-01A	EA	PANEL - MONITOR - 2 TANK - W/GENERATOR SWITCH/HOUR METER - <b>GENERATOR</b> FROM: 00-00-00 THRU: 05-02-04
5*	134940-06-01A	EA	PANEL - MONITOR - 2 TANK - W/GENERATOR SWITCH - <b>GENERATOR</b> FROM: 05-03-04 THRU: 99-99-99
5*	134940-02-01A	EA	PANEL - MONITOR - 2 TANK - W/O GENERATOR SWITCH/HOUR METER FROM: 00-00-00 THRU: 05-02-04
5*	134940-07-01A	EA	PANEL - MONITOR - 2 TANK FROM: 05-03-04 THRU: 99-99-99
6	079364-08-000	EA	SWITCH - ON/OFF LIGHTED - GREEN
6	098351-01-01A	EA	PLATE/SWITCH - 1 GANG - POLISHED BRASS - W/O LABEL
6	134563-01-01A	EA	LABEL - SWITCH - HEATER
7	144363-09-02B	EA	PLATE - SWITCH - E-COATED
7	108357-06-000	EA	SWITCH - ROCKER - DPDT - MOM/OFF/MOM - 6 TERM - W/O COVER
7	108356-02-01A	EA	COVER/ACTUATOR SWITCH - 2 ROWS DIMPLES - BLACK
7	108355-01-000	EA	HOUSING - SWITCH
7	116220-01-000	EA	APPLIQUE - SWITCH/SLIDEOUT
7	116549-01-000	EA	LABEL - WARNING - SLIDEOUT
8	135740-01-01A	EA	SWITCH - ROCKER - SPST - ON/OFF - BROWN
8	135741-01-01A	EA	SWITCH - BASE - SINGLE - BROWN
8	135742-01-01A	EA	BEZEL - SWITCH - SINGLE - BROWN
9	110465-01-000	EA	SPEAKER KIT, 4 5X7 SPEAKERS
10	093575-12-01A	EA	LIGHT - CEILING/DOUBLE - BRASS - UL/CSA
10	117805-01-000	EA	BULB - 12V - #921F - 1.4 AMPS
11	132958-01-000	EA	RECEPTACLE - 12 VOLT - MOUNTING FLANGE - BLACK

**ELECTRICAL GROUP (CONTINUED)**  
**12V BODY WIRING (CONTINUED)**

<b>KEY</b>	<b>PART NUMBER</b>	<b>U/M</b>	<b>DESCRIPTION</b>
12	135740-01-02A	EA	SWITCH - ROCKER - SPST - ON/OFF - WHITE - CEILING
12	135740-02-02A	EA	SWITCH - ROCKER - SPDT - ON/ON - WHITE - AISLE
12	135741-02-02A	EA	SWITCH - BASE - DOUBLE - WHITE
12	135742-13-01A	EA	BEZEL - SWITCH - CEILING/AISLE - WHITE
13	135740-01-02A	EA	SWITCH - ROCKER - SPST - ON/OFF - WHITE
13	135741-02-02A	EA	SWITCH - BASE - DOUBLE - WHITE
13	135742-15-01A	EA	BEZEL - SWITCH - CEILING/SHOWER - WHITE
14	061424-01-000	EA	LIGHT - AISLE - 12 VOLT - RECTANGULAR
15	108357-15-000	EA	SWITCH - ROCKER - DPDT - ON/NONE/ON - W/LIGHT W/O COVER
15	108356-01-01A	EA	COVER/ACTUATOR SWITCH - 3 GROOVES - BLACK
15	108355-01-000	EA	HOUSING - SWITCH
15	144363-02-04B	EA	PLATE - SWITCH - BLACK
16	093575-26-02A	EA	LIGHT - CEILING/OVAL - BRASS
16	117805-01-000	EA	BULB - 12V - #921F - 1.4 AMPS

**\*COMPONENT PARTS LISTED LATER IN THIS GROUP**



## ELECTRICAL GROUP (CONTINUED)

### 12V BODY WIRING (CONTINUED)

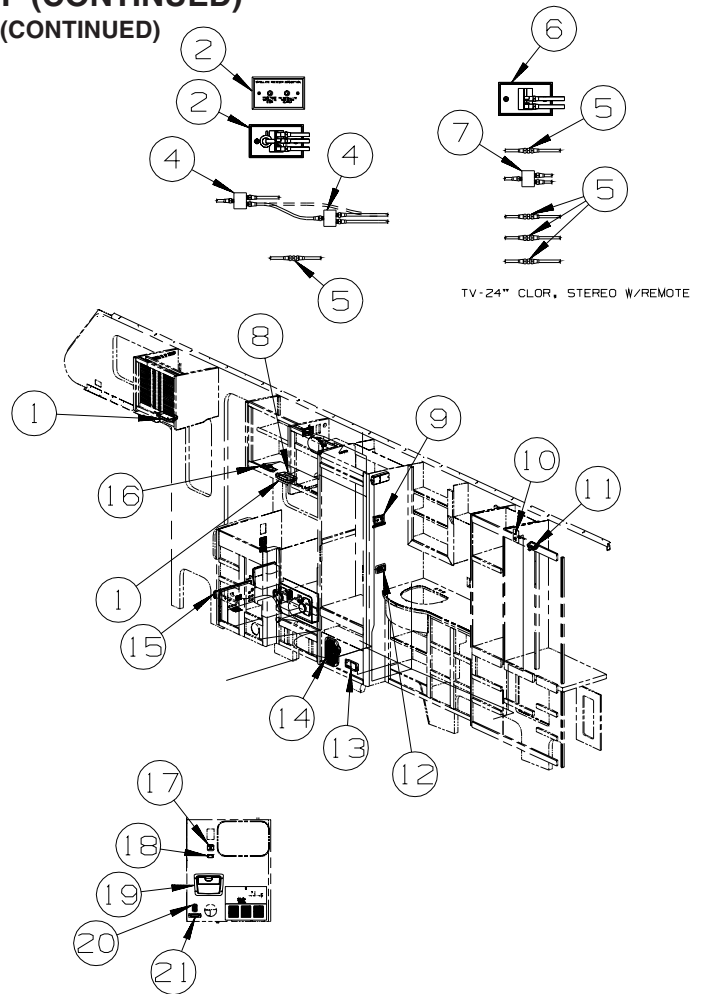

KEY	PART NUMBER	U/M	DESCRIPTION
1*	137417-02-01A	EA	LIGHT - DOME - SINGLE - W/SWITCH/OPTIC LENS - WHITE
2	149557-05-01A	EA	PLATE/WALL - DUAL COAXIAL/HORIZONTAL - WHITE
3	086777-02-000	EA	WALLPLATE/TV CABLE W/ANTENNA SWITCH/BOOSTER - 2 TV - BLACK
4	086756-01-000	EA	SPLITTER - TV/2 WAY
5	082134-01-000	EA	ADAPTER - TV - CABLE TO CABLE
6	086777-06-000	EA	WALLPLATE/TV CABLE - W/ANT. BOOSTER/1 OUTPUT-BLACK
7	086756-01-000	EA	SPLITTER - TV/2 WAY - ENTERTAINMENT CENTR/EXT W/CD
7	082134-01-000	EA	ADAPTER - TV - CABLE TO CABLE
8	110465-01-000	EA	SPEAKER KIT,4 5X7 SPEAKERS
9	140464-02-000	EA	CONTROL PANEL/SLIDEOUT - 2 CIRCUIT BOARDS/1 LED
9	116549-01-000	EA	LABEL - WARNING - SLIDEOUT
10	076319-09-000	EA	WALLPLATE - TV CABLE RECEPTACLE - SINGLE - BROWN
11*	087694-01-000	EA	LIGHT - WARDROBE/CLOSET - W/SWITCH
12	135740-01-02A	EA	SWITCH - ROCKER - SPST - ON/OFF - WHITE - BATH/CEILING
12	135740-02-02A	EA	SWITCH - ROCKER - SPDT - ON/ON - WHITE - AISLE
12	135741-03-02A	EA	SWITCH - BASE - TRIPLE - WHITE
12	135742-24-01A	EA	BEZEL - SWITCH - CEILING/AISLE/BATH - WHITE
13	150138-01-02A	EA	DETECTOR - LP GAS - BROWN
14	150090-01-000	EA	SPEAKER - 6" X 9" - SUB-WOOFER - MAGNADYNE LS69W - HOME THEATHER SYSTEM
14	124885-01-000	EA	GRILLE - SPEAKER - 6" X 9" - SUB WOOFER - HOME THEATHER SYSTEM
			FROM: 00-00-00 THRU: 05-09-04
14	151569-01-01A	EA	GRILLE - SPEAKER - 6" X 9" - SUB WOOFER - BLACK - HOME THEATHER SYSTEM
			FROM: 05-10-04 THRU: 99-99-99
15	116995-02-000	EA	SWITCH/MAGNET - ELECTRIC STEP - BLACK/WHITE- NORMALLY OPEN
16	132180-01-01A	EA	SWITCH - PADDLE - SPST - ON/OFF - BLACK - TV-13" W/DVD-12V
16	098351-14-01A	EA	PLATE/SWITCH - 1 GANG - POLISHED BRASS - TV - TV-13" W/DVD-12V
17	135740-01-01A	EA	SWITCH - ROCKER - SPST - ON/OFF - BROWN
17	135741-02-01A	EA	SWITCH - BASE - DOUBLE - BROWN
17	135742-19-02A	EA	BEZEL - SWITCH - CEILING/PORCH - BROWN
18	135740-01-01A	EA	SWITCH - ROCKER - SPST - ON/OFF - BROWN
18	135741-01-01A	EA	SWITCH - BASE - SINGLE - BROWN
18	135742-11-02A	EA	BEZEL - SWITCH - STEP - BROWN



## ELECTRICAL GROUP (CONTINUED)

### 12V BODY WIRING (CONTINUED)

KEY	PART NUMBER	U/M	DESCRIPTION
19	141679-03-000	EA	CHARGER/DOCK STATION ONLY - FOR #GMRS100 TWO-WAY RADIO
19	141679-04-000	EA	RADIO/TWO-WAY W/BATTERY (EACH = 1) - 5 MILE - ASA GMRS100
20	108357-06-000	EA	SWITCH - ROCKER - DPDT - MOM/OFF/MOM - 6 TERM - W/O COVER
20	108356-11-01A	EA	COVER/ACTUATOR SWITCH - 3 GROOVES - AUX BATT - BLACK
20	108355-01-000	EA	HOUSING - SWITCH
20	098351-07-01A	EA	PLATE/SWITCH - 1 GANG - POLISHED BRASS - GENERATOR
21	061424-01-000	EA	LIGHT - AISLE - 12 VOLT - RECTANGULAR
	036196-01-000	EA	BULB - 12V - #194 - .27 AMP - BAYONETTE

**\*COMPONENT PARTS LISTED LATER IN THIS GROUP**

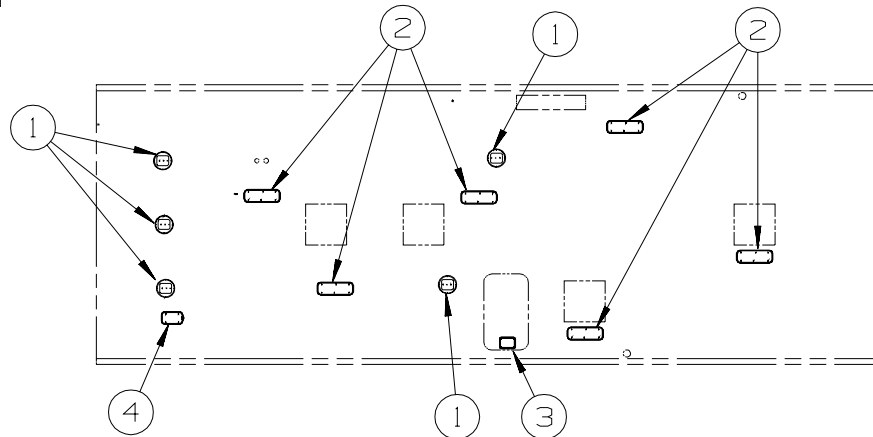

KEY	PART NUMBER	U/M	DESCRIPTION
1	150091-01-01A	EA	SPEAKER - CUBE - W/ADJ BRACKET - SILVER -MAGNADYNE LS3S - <b>HOME THEATER SYSTEM</b> FROM: 00-00-00 THRU: 05-09-04
1	151314-01-01A	EA	SPEAKER - CUBE/CEILING - WHITE - MAGNADYNE - LS3CM-WN - <b>HOME THEATER SYSTEM</b> FROM: 05-10-04 THRU: 99-99-99
2*	137417-06-01A	EA	LIGHT - DOME - DOUBLE - W/O SWITCH - W/FROSTED LENS-WHITE
3*	121935-01-01A	EA	LIGHT - DOME - SHOWER
4*	137417-03-01A	EA	LIGHT - DOME - SINGLE - W/O SWITCH - W/FROSTED LENS-WHITE FROM: 00-00-00 THRU: 03-07-05
4*	137417-01-01A	EA	LIGHT - DOME - SINGLE - W/SWITCH/FROSTED LENS - WHITE FROM: 03-08-05 THRU: 99-99-99

**\*COMPONENT PARTS LISTED LATER IN THIS GROUP**

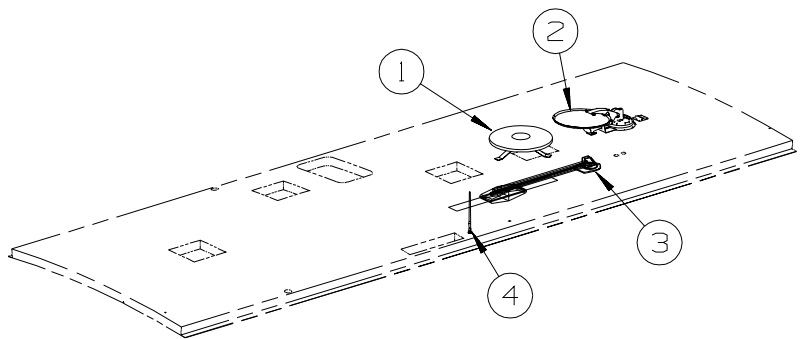

KEY	PART NUMBER	U/M	DESCRIPTION
1	132935-01-000	EA	ANTENNA - TV ROOF MOUNT - ROUND - W/O POWER SUPPLY
1	146488-01-000	EA	PLATE - ROOF - CABLE ENTRY
2*	137135-02-000	EA	ANTENNA - SATELLITE DSS - W/SENSOR
3*	076319-23-000	EA	ANTENNA - TV ROOF MOUNT - 44.5" MAST
3*	076319-25-000	EA	KIT - HARDWARE INTERIOR
4	090944-01-000	EA	ANTENNA - RADIO - 16" RUBBER - W/72" LEAD WIRE
4	109889-04-000	EA	EXTENDER - ANTENNA SHAFT - 3.7"
4	147741-01-09B	EA	BRACKET - ANTENNA GROUND - GALVANIZED
4	077069-02-000	EA	CABLE/EXTENSION - RADIO ANTENNA - 96"

**\*COMPONENT PARTS LISTED LATER IN THIS GROUP**

**ELECTRICAL GROUP (CONTINUED)**  
**12V BODY WIRING (CONTINUED)**

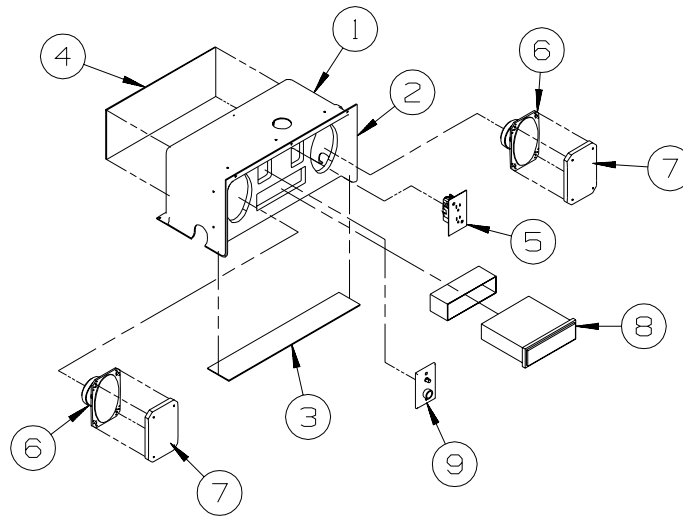

**322R, 322E, 331T,  
331ST**

KEY	PART NUMBER	U/M	DESCRIPTION
1	124696-01-01A	EA	BOX-ENTERTAINMENT CTR/EXT-19.4"W X 10"H X 10.2"D W/CUTOUTS
2	127409-02-L15	EA	PLATE - RADIO MOUNTING
3	104898-01-02A	EA	PLATE - PLASTIC BOTTOM - BRIGHT WHITE
4	104898-02-02A	EA	PLATE - PLASTIC BACK - BRIGHT WHITE
5	058708-01-000	EA	RECEPTACLE - ELECTRIC - DOUBLE - BROWN
6	110469-01-000	EA	SPEAKER - 4" X 6" OVAL - COAXIAL
7	110470-01-01A	EA	GRILLE - 4" X 6" - OVAL SPEAKER - BLACK
8*	148231-01-000	EA	RADIO - AM/FM CD W/REMOTE - MAGNADYNE M3100CD
			FROM: 00-00-00 THRU: 04-11-05
8*	155619-01-000	EA	RADIO - AM/FM CD - W/REMOTE - MAGNADYNE M3200CD
			FROM: 04-12-05 THRU: 99-99-99
9	076319-09-000	EA	WALLPLATE - TV CABLE RECEPTACLE - SINGLE - BROWN

**\*COMPONENT PARTS LISTED LATER IN THIS GROUP**

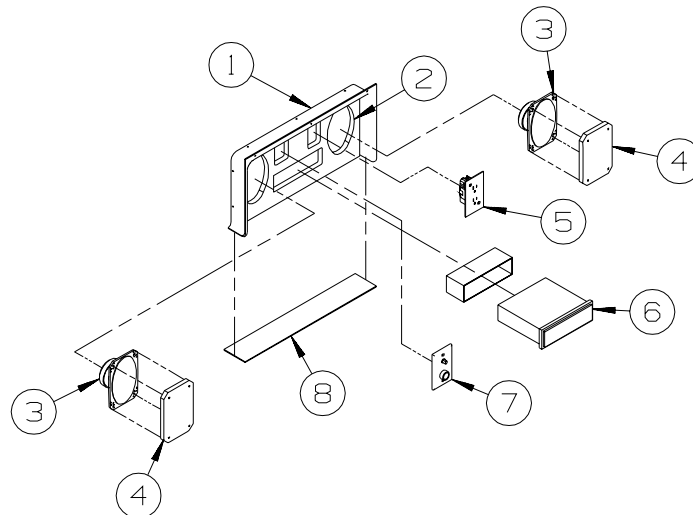

**324F, 324V, 326A, 327L,  
329B, 329SB, 329K, 332G**

KEY	PART NUMBER	U/M	DESCRIPTION
1	124696-02-01A	EA	BOX-19.4"W X 10"H X 2.5"D - BRT WHT
	124696-01-01A	EA	BOX-19.4"W X 10"H X 10.2"D W/CUTOUTS
2	127409-02-L15	EA	PLATE - RADIO MOUNTING
3	110469-01-000	EA	SPEAKER - 4" X 6" OVAL - COAXIAL
4	110470-01-01A	EA	GRILLE - 4" X 6" - OVAL SPEAKER - BLACK
5	058708-01-000	EA	RECEPTACLE - ELECTRIC - DOUBLE - BROWN
6*	148231-01-000	EA	RADIO - AM/FM CD W/REMOTE - MAGNADYNE M3100CD
			FROM: 00-00-00 THRU: 04-11-05
6*	155619-01-000	EA	RADIO - AM/FM CD - W/REMOTE - MAGNADYNE M3200CD
			FROM: 04-12-05 THRU: 99-99-99
7	076319-09-000	EA	WALLPLATE - TV CABLE RECEPTACLE - SINGLE - BROWN
8	104898-01-02A	EA	PLATE - PLASTIC BOTTOM - BRIGHT WHITE

**\*COMPONENT PARTS LISTED LATER IN THIS GROUP**

## ELECTRICAL GROUP (CONTINUED)

### EXTERIOR LAMPS

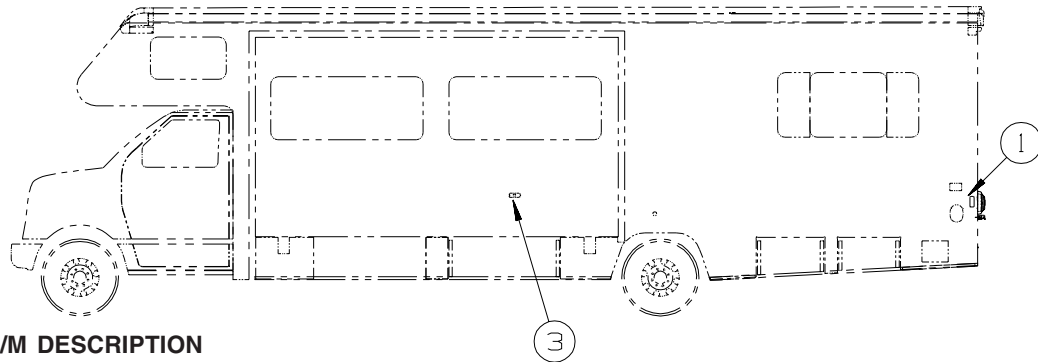
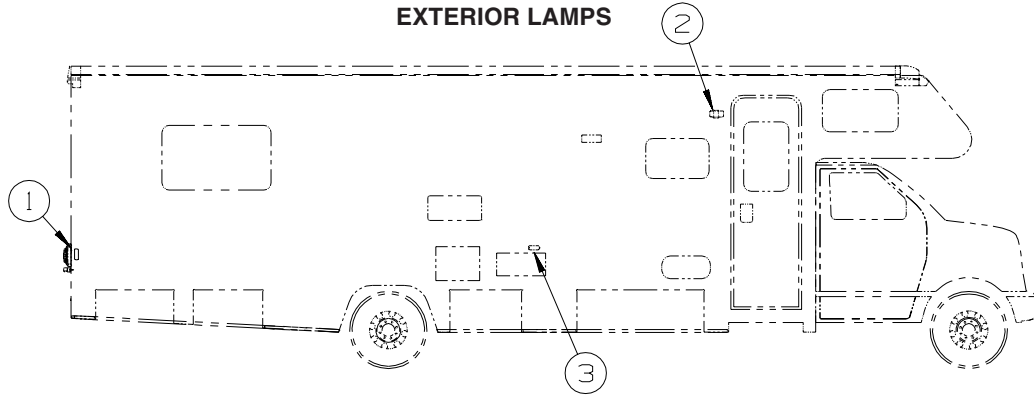

KEY	PART NUMBER	U/M	DESCRIPTION
1	111102-01-000	EA	BASE - MARKER LAMP
	036196-01-000	EA	BULB - 12V - #194 - .27 AMP - BAYONETTE
1	111102-03-000	EA	LENS - RED - MARKER LAMP
2*	097917-01-06A	EA	LIGHT - PORCH - BRIGHT WHITE
	008215-01-000	EA	BULB - 12 VOLT - #1003 - .94 AMP
3	111102-01-000	EA	BASE - MARKER LAMP
	036196-01-000	EA	BULB - 12V - #194 - .27 AMP - BAYONETTE
3	111102-02-000	EA	LENS - AMBER - MARKER LAMP

\*COMPONENT PARTS LISTED LATER IN THIS GROUP

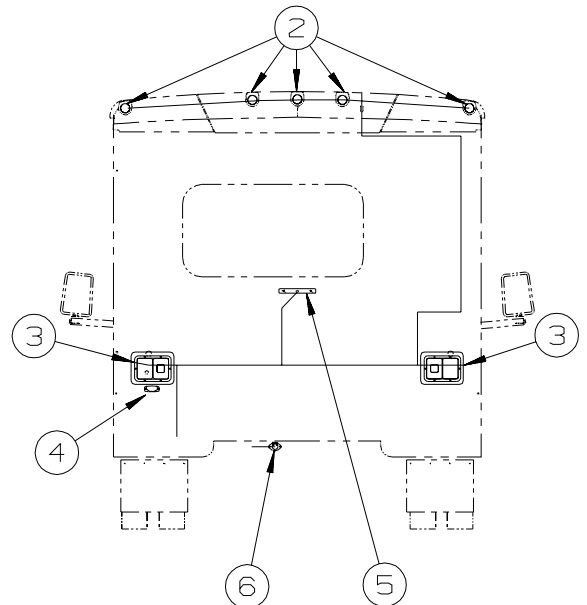
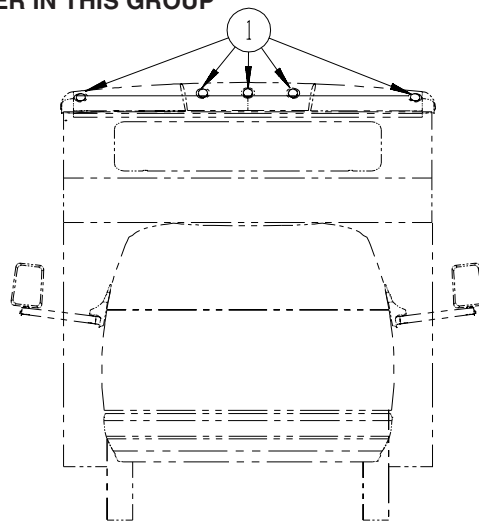

KEY	PART NUMBER	U/M	DESCRIPTION
1	138996-01-000	EA	LAMP - CLEARANCE - AMBER
1	138996-03-000	EA	BRACKET - CLEARANCE LIGHT
2	138996-02-000	EA	LAMP - CLEARANCE - RED
2	138996-03-000	EA	BRACKET - CLEARANCE LIGHT
3*	081638-01-000	EA	TAILLIGHT/DOUBLE W/BLACK TRIM - DRIVER/PASSENGER SIDE
3	103355-02-01A	EA	POD - TAIL LIGHT - BRIGHT WHITE
4	066432-02-000	EA	LIGHT - LICENSE - BLACK
4	066432-03-000	EA	BRACKET - LICENSE PLATE
5	136916-01-000	EA	LIGHT - CENTER BRAKE - L.E.D.
6*	113589-01-000	EA	CONNECTOR - PLUG - TRAILER
6*	113589-02-000	EA	CONNECTOR - SOCKET - TRAILER

\*COMPONENT PARTS LISTED LATER IN THIS GROUP

**ELECTRICAL GROUP (CONTINUED)**  
**FRONT END**

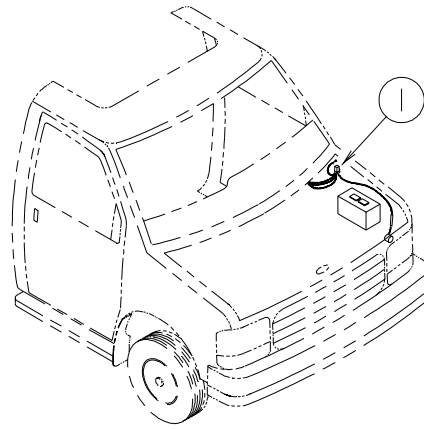

KEY	PART NUMBER	U/M DESCRIPTION
1	100138-01-000	EA MODULE - DAYTIME/RUNNING LIGHT - HAMSAR DRL #H8005B



**DRIVERS DOOR**

KEY	PART NUMBER	U/M DESCRIPTION
*	120269-07-01A	EA PANEL - W/ELECTRIC MIRROR/HEAT SWITCH - F/#L28X OPTION - MIRRORS-EXTERIOR W/DEFROST

**\*COMPONENT PARTS LISTED LATER IN THIS GROUP**

## ELECTRICAL GROUP (CONTINUED)

### FRONT TV/VCR

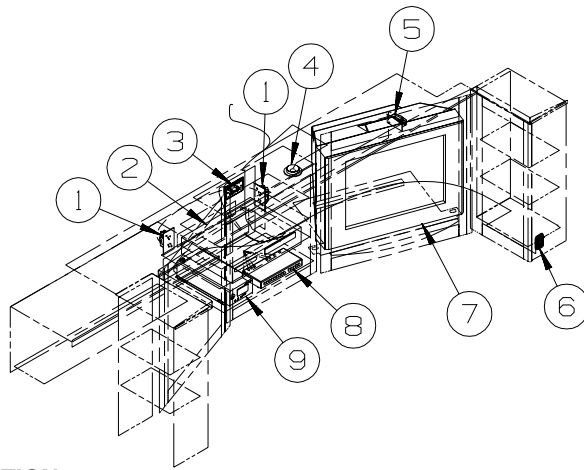

KEY	PART NUMBER	U/M	DESCRIPTION
1	058708-01-000	EA	RECEPTACLE - ELECTRIC - DOUBLE - BROWN
2*	150089-01-000	EA	DVD/VCR - HOME THEATER SYSTEM - RCA RTD300/SP - <b>HOME THEATER SYSTEM</b>
2*	145641-03-000	EA	DVD/VCR PLAYER - RCA DRC6200N - <b>DVD/VCR STEREO</b> FROM: 00-00-00 08-22-04
2*	145641-02-000	EA	DVD/VCR PLAYER - RCA DRC6100N - <b>DVD/VCR STEREO</b> FROM: 08-23-04 THRU: 10-17-04
2*	145641-04-000	EA	DVD/VCR PLAYER - RCA DRC6300N - <b>DVD/VCR STEREO</b> FROM: 10-18-04 THRU: 99-99-99
3	149557-05-01A	EA	PLATE/WALL - DUAL COAXIAL/HORIZONTAL - WHITE
4*	123775-01-01A	EA	LIGHT - HALOGEN - ROUND
5	058707-02-000	EA	RECEPTACLE - BLANK - JUNCTION BOX
6	135740-01-01A	EA	SWITCH - ROCKER - SPST - ON/OFF - BROWN
6	135741-01-01A	EA	SWITCH - BASE - SINGLE - BROWN
6	135742-07-02A	EA	BEZEL - SWITCH - CEILING - BROWN
7*	148230-01-000	EA	TV - 24" - STEREO/3 JACKS - RCA 24V510T FROM: 00-00-00 THRU: 01-02-05
7*	152441-01-000	EA	TV - 24" - STEREO/3 JACKS - RCA 24V511T FROM: 01-03-05 THRU: 99-99-99
7*	148230-03-000	EA	TV - 24" - STEREO/5 JACKS - RCA 24V510TAO - <b>HOME THEATER SYSTEM</b> FROM: 00-00-00 THRU: 11-14-04
7*	148230-01-000	EA	TV - 24" - STEREO/3 JACKS - RCA 24V510T - <b>HOME THEATER SYSTEM</b> FROM: 11-15-04 THRU: 01-02-05
7*	152441-01-000	EA	TV - 24" - STEREO/3 JACKS - RCA 24V511T - <b>HOME THEATER SYSTEM</b> FROM: 01-03-05 THRU: 99-99-99
8	086757-04-000	EA	CONTROL CENTER - SWITCH - VCR/TV - 5 INPUTS
9	099048-04-000	EA	INVERTER - 300 WATT

\*COMPONENT PARTS LISTED LATER IN THIS GROUP

## ELECTRICAL GROUP (CONTINUED)

SIDE TV/VCR

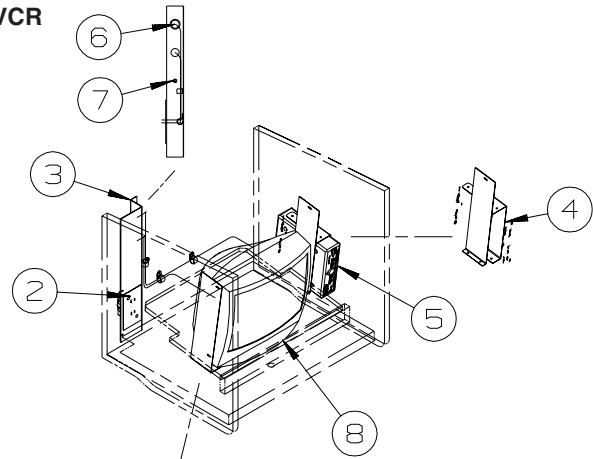

KEY	PART NUMBER	U/M	DESCRIPTION
1	143650-01-02B	EA	BRACKET - TV - E-COATED
2	058708-01-000	EA	RECEPTACLE - ELECTRIC - DOUBLE - BROWN
3	122469-01-02B	EA	BRACKET - ZEE - 13" TV W/DVD-12V
3	122469-02-02B	EA	BRACKET - ZEE - W/CUTOUT - E-COATED
4	143676-03-02B	EA	BRACKET - DVD - E-COATED - 13" TV W/DVD-12V
5*	149925-01-000	EA	DVD PLAYER - AUDIOVOX AVD300
6	111414-01-000	EA	RECEPTACLE/SOCKET - 12 VOLT
7	082134-01-000	EA	ADAPTER - TV - CABLE TO CABLE
8*	086231-10-000	EA	TV - 13" COLOR - AUDIOVOX - FLEX VISION/AVT-1498/DC

\*COMPONENT PARTS LISTED LATER IN THIS GROUP

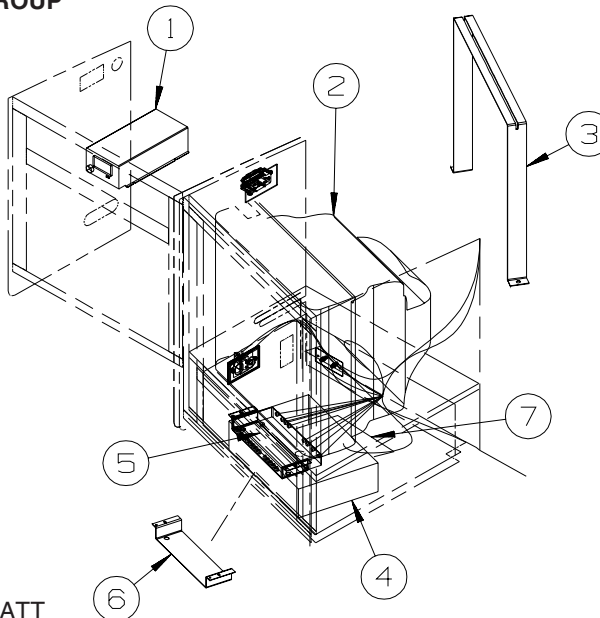

**331T, 331ST**

KEY	PART NUMBER	U/M	DESCRIPTION
1	099048-04-000	EA	INVERTER - 300 WATT
2*	124075-07-000	EA	TV - 19" - 1/8 JACK - W/RCA INPUT - RCA F19431 FROM: 00-00-00 THRU: 04-04-04
2*	149040-02-000	EA	TV - 20" FLAT SCREEN/STEREO - RCA 20F410T FROM: 04-05-04 THRU: 99-99-99
3	146843-02-02B	EA	BRACKET/TIEDOWN - TV - E-COATED FROM: 00-00-00 THRU: 04-04-04
3	148247-05-02B	EA	STRAP/TIEDOWN - TV - E-COATED FROM: 04-05-04 THRU: 99-99-99
4*	145641-03-000	EA	DVD/VCR PLAYER - RCA DRC6200N - DVD/VCR STEREO FROM: 00-00-00 08-22-04
4*	145641-02-000	EA	DVD/VCR PLAYER - RCA DRC6100N - DVD/VCR STEREO FROM: 08-23-04 THRU: 10-17-04
4*	145641-04-000	EA	DVD/VCR PLAYER - RCA DRC6300N - DVD/VCR STEREO FROM: 10-18-04 THRU: 99-99-99
5	086757-04-000	EA	CONTROL CENTER - SWITCH - VCR/TV - 5 INPUTS
6	118847-02-02B	EA	MOUNT - SWITCH BOX - E-COATED
7	136860-01-000	EA	CABLE - RCA - #3 MALE TO #12F MALE CONNECTOR - DVD/VCR STEREO

\*COMPONENT PARTS LISTED LATER IN THIS GROUP

**ELECTRICAL GROUP (CONTINUED)**  
**COMPONENT PARTS FOR WIRING**

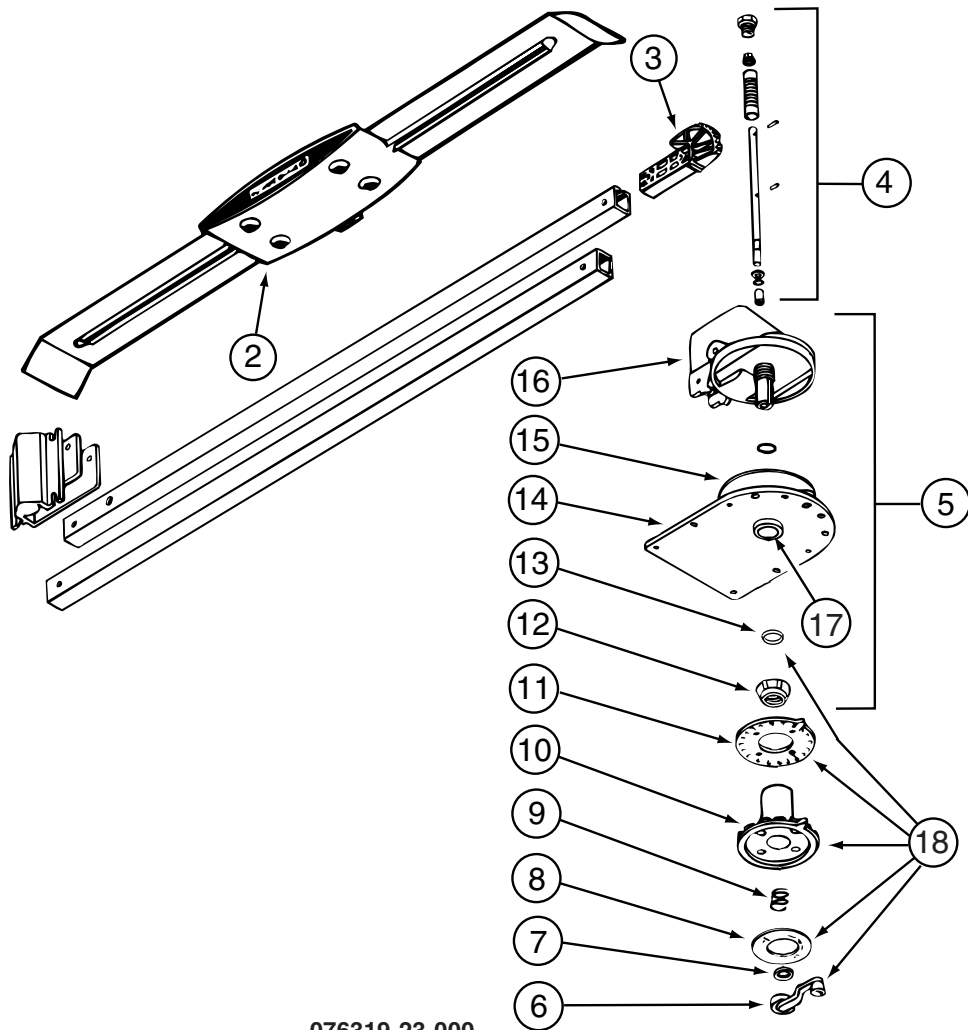

**076319-23-000**

KEY	PART NUMBER	U/M	DESCRIPTION	VENDOR NO.
2	076319-01-700	EA	HEAD-ANTENNA, AMPLIFIED	RVSA U/V
3	076319-01-701	EA	GEAR-ELEVATING, PLASTIC	2200046
4	076319-01-702	EA	SHAFT ASM-ELEVATING	RP-4000
5	076319-01-711	EA	BASE & LIFT ASM	2762802
7	076319-01-705	EA	GROMMET-NYLON, 7/8"ID	3200658
8	076319-01-708	EA	DECAL-CRANK	5413002
9	076319-01-707	EA	SPRING-HANDLE	2160822
11	076319-01-712	EA	PLATE - CEILING	3200608
12	076319-01-715	EA	NUT (GEAR HOUSING)	2200047
14	076319-01-713	EA	PLATE-BASE, STEEL	3100523
15	076319-01-703	EA	BEARING-NYLON, 5"OD	3200656
16	076319-01-714	EA	HOUSING, ROTATING GEAR	2200049
17	076319-01-704	EA	BEARING-NYLON, 1.25"OD	3200657
18	076319-01-709	EA	HANDLE-HEAD DIRECTIONAL	200644
	076319-01-716	EA	TUBING, ELEVATING	RP-2900

CONTACT WINNEBAGO PART SALES FOR UNLISTED COMPONENT(S)

**076319-25-000**

KEY	PART NUMBER	U/M	DESCRIPTION	VENDOR NO.
6	076319-01-706	EA	CRANK-W/SET SCREW UNIV/BEIGE	2750897
6	120233-01-710	EA	HANDLE-CRANK W/SCREW - WHITE	RP-6795
8	076319-01-708	EA	DECAL-CRANK	5413002
10	076319-25-700	EA	DIRECTIONAL HANDLE(WHITE)	3200612
11	076319-25-701	EA	PLATE - CEILING(WHITE)	3200609
13	120233-01-709	EA	WASHER-NYLON	RP-2658

CONTACT WINNEBAGO PART SALES FOR UNLISTED COMPONENT(S)

**ELECTRICAL GROUP (CONTINUED)**  
**COMPONENT PARTS FOR WIRING (CONTINUED)**

**081638-01-000**

<b>KEY</b>	<b>PART NUMBER</b>	<b>U/M</b>	<b>DESCRIPTION</b>	<b>VENDOR NO.</b>
	081638 01 700	EA	LENS-TAILLIGHT, RED	30-84-010
	081638 01 701	EA	LENS-TAILLIGHT, W/BACKUP	30-84-700

**086231-10-000**

<b>KEY</b>	<b>PART NUMBER</b>	<b>U/M</b>	<b>DESCRIPTION</b>	<b>VENDOR NO.</b>
	086231-08-700	EA	REMOTE-UNIVERSAL	0892325
	086231-10-700	EA	ADAPTER WIRE - (CIGARETTE)	0894000
	086231-10-701	EA	CONVERTER/POWER SUP 110/12 V	0891412

**087694-01-000**

<b>KEY</b>	<b>PART NUMBER</b>	<b>U/M</b>	<b>DESCRIPTION</b>	<b>VENDOR NO.</b>
	087694-01-700	EA	BULB	GE561

**097917-01-06A**

<b>KEY</b>	<b>PART NUMBER</b>	<b>U/M</b>	<b>DESCRIPTION</b>	<b>VENDOR NO.</b>
	097917-01-700	EA	LENS-LIGHT, CLEAR	30-78-021

**108354-01-01A**

<b>KEY</b>	<b>PART NUMBER</b>	<b>U/M</b>	<b>DESCRIPTION</b>	<b>VENDOR NO.</b>
	108354-01-700	EA	BULB-COURTESY LIGHT	395-B

**113589-01-000**

<b>KEY</b>	<b>PART NUMBER</b>	<b>U/M</b>	<b>DESCRIPTION</b>	<b>VENDOR NO.</b>
	113589-01-700	EA	ADAPTER, 4-WAY/6-WAY	5291

**113589-02-000**

<b>KEY</b>	<b>PART NUMBER</b>	<b>U/M</b>	<b>DESCRIPTION</b>	<b>VENDOR NO.</b>
	113589-03-700	EA	ADAPTER 7 RND SPADE/4 FLAT	5290

**120269-07-01A**

<b>KEY</b>	<b>PART NUMBER</b>	<b>U/M</b>	<b>DESCRIPTION</b>	<b>VENDOR NO.</b>
	120269-07-700	EA	SWITCH - REMOTE	7475720
	133908-09-700	EA	SWITCH - MIRROR HEATER	7475150

**121935-01-01A**

<b>KEY</b>	<b>PART NUMBER</b>	<b>U/M</b>	<b>DESCRIPTION</b>	<b>VENDOR NO.</b>
	121935-01-700	EA	LENS ONLY	809511

**123775-01-01A**

<b>KEY</b>	<b>PART NUMBER</b>	<b>U/M</b>	<b>DESCRIPTION</b>	<b>VENDOR NO.</b>
	123775-01-700	EA	BULB - 10 WATT - HALOGEN	71-JC10
	123775-01-701	EA	BEZEL/LENS - RECESSED LIGHT	99 BEZEL/LENS-BRASS

**124075-07-000**

<b>KEY</b>	<b>PART NUMBER</b>	<b>U/M</b>	<b>DESCRIPTION</b>	<b>VENDOR NO.</b>
	124075-04-700	EA	REMOTE	240959



**ELECTRICAL GROUP (CONTINUED)**  
**COMPONENT PARTS FOR WIRING (CONTINUED)**

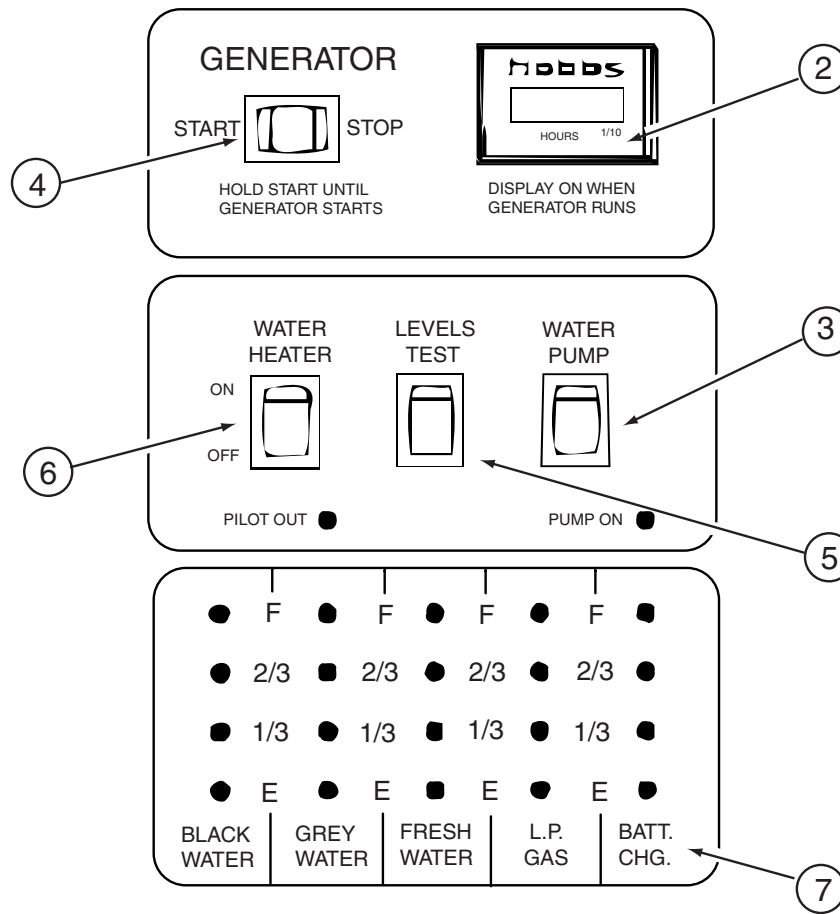

134940-01-01A

KEY	PART NUMBER	U/M	DESCRIPTION	VENDOR NO.
2	100258-10-701	EA	GAUGE-HR METER ONLY (LCD)	L0775-00
3	096983-01-703	EA	SWITCH - ON/ON	L0115-00
4	096983-01-702	EA	SWITCH - MOM/OFF/MOM/3 TERM	L0112-00
5	096983-01-701	EA	SWITCH - SPST/MOM 2 TERMINAL	L0111-00
6	134940-01-701	EA	SWITCH-SPST/ON-OFF/BLK W/LGT	L0109
7	134940-01-702	EA	CHASSIS - SILKSCREENED	CC0558-00
	100258-10-702	EA	HOUR METER(SNAP-IN)SW & WIRE	L4441-00
	134940-01-700	EA	BOARD - PC	L5118-01

**ELECTRICAL GROUP (CONTINUED)**  
**COMPONENT PARTS FOR WIRING (CONTINUED)**

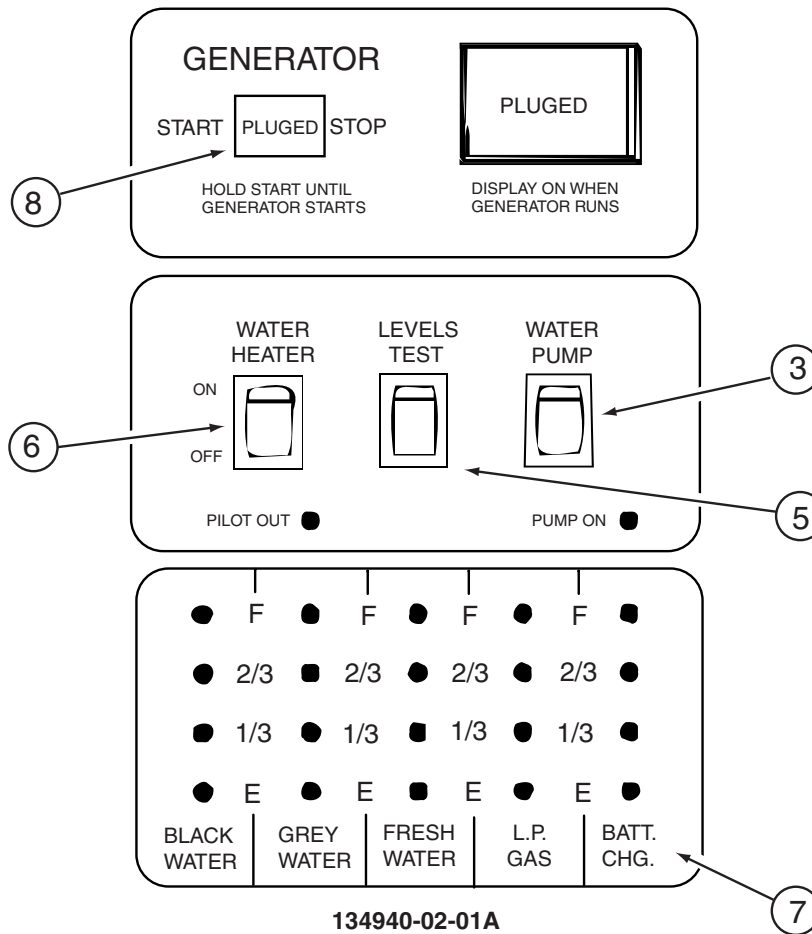

KEY	PART NUMBER	U/M	DESCRIPTION	VENDOR NO.
	134940-01-700	EA	BOARD - PC	L5118-01
3	096983-01-703	EA	SWITCH - ON/ON	L0115-00
5	096983-01-701	EA	SWITCH - SPST/MOM 2 TERMINAL	L0111-00
6	134940-01-701	EA	SWITCH-SPST/ON-OFF/BLK W/LGT	L0109
7	134940-01-702	EA	CHASSIS - SILKSCREENED	CC0558-00
8	134940-02-700	EA	SWITCH - DUMMY	L0118

**ELECTRICAL GROUP (CONTINUED)**  
**COMPONENT PARTS FOR WIRING (CONTINUED)**

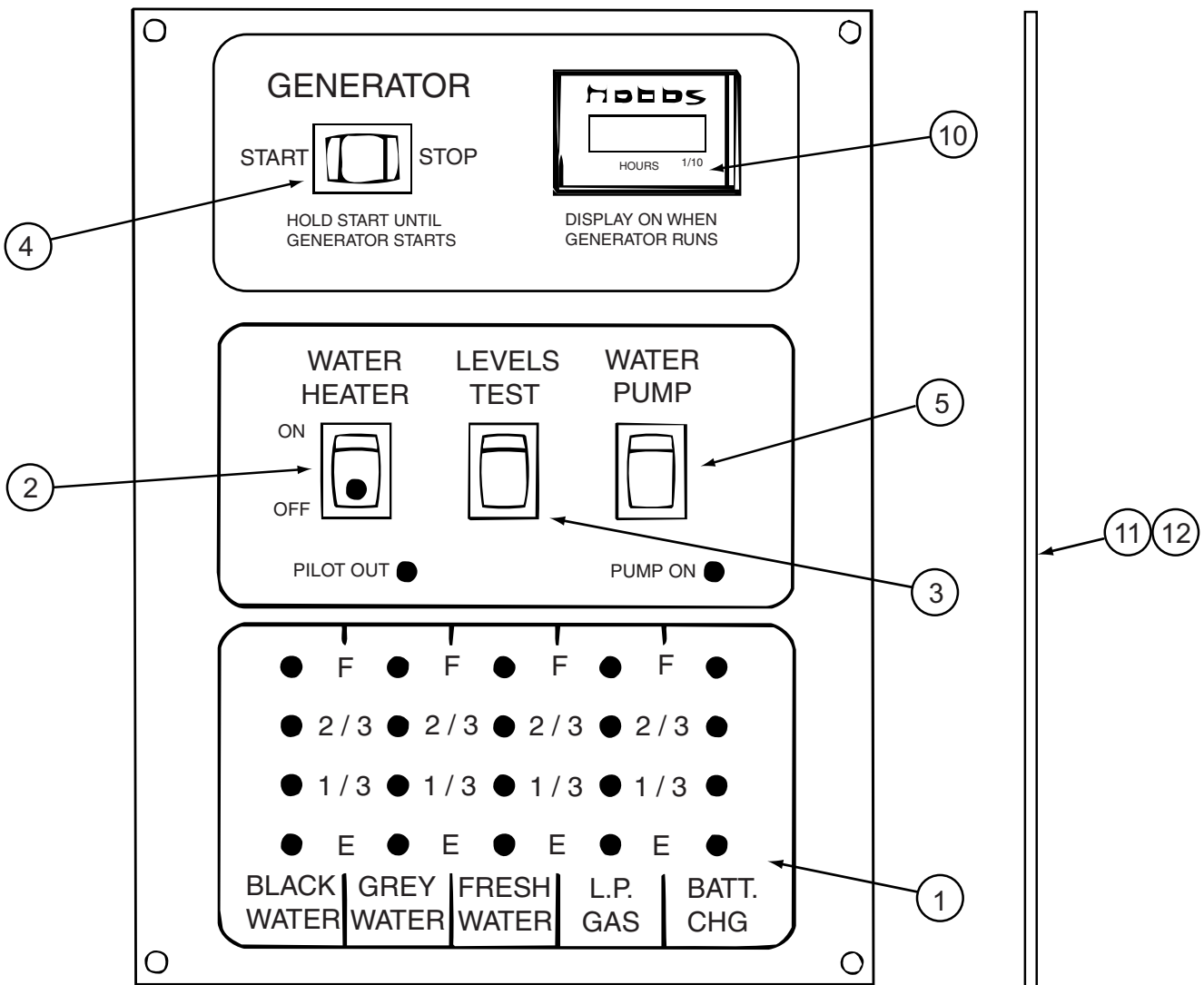

**134940-06-01A**

KEY	PART NUMBER	U/M	DESCRIPTION	VENDOR NO.
1	134940-01-702	EA	CHASSIS - SILKSCREENED	CC0558-00
2	134940-01-701	EA	SWITCH-SPST/ON-OFF/BLK W/LGT	L0109
3	096983-01-701	EA	SWITCH - SPST/MOM 2 TERMINAL	L0111-00
4	096983-01-702	EA	SWITCH - MOM/OFF/MOM/3 TERM	L0112-00
5	096983-01-703	EA	SWITCH - ON/ON	L0115-00
10	100258-10-701	EA	GAUGE-HR METER ONLY (LCD)	L0775-00
11	134940-06-700	EA	PC BOARD - SENSOR SYSTEM/RED	L5131-02

CONTACT WINNEBAGO PART SALES FOR UNLISTED COMPONENT(S)

**134940-07-01A**

KEY	PART NUMBER	U/M	DESCRIPTION	VENDOR NO.
1	134940-01-702	EA	CHASSIS - SILKSCREENED	CC0558-00
2	134940-01-701	EA	SWITCH-SPST/ON-OFF/BLK W/LGT	L0109
3	096983-01-701	EA	SWITCH - SPST/MOM 2 TERMINAL	L0111-00
4	096983-01-703	EA	SWITCH - ON/ON	L0115-00
5	134940-02-700	EA	SWITCH - DUMMY	L0118
11	134940-06-700	EA	PC BOARD - SENSOR SYSTEM/RED	L5131-02

CONTACT WINNEBAGO PART SALES FOR UNLISTED COMPONENT(S)

**ELECTRICAL GROUP (CONTINUED)**  
**COMPONENT PARTS FOR WIRING (CONTINUED)**

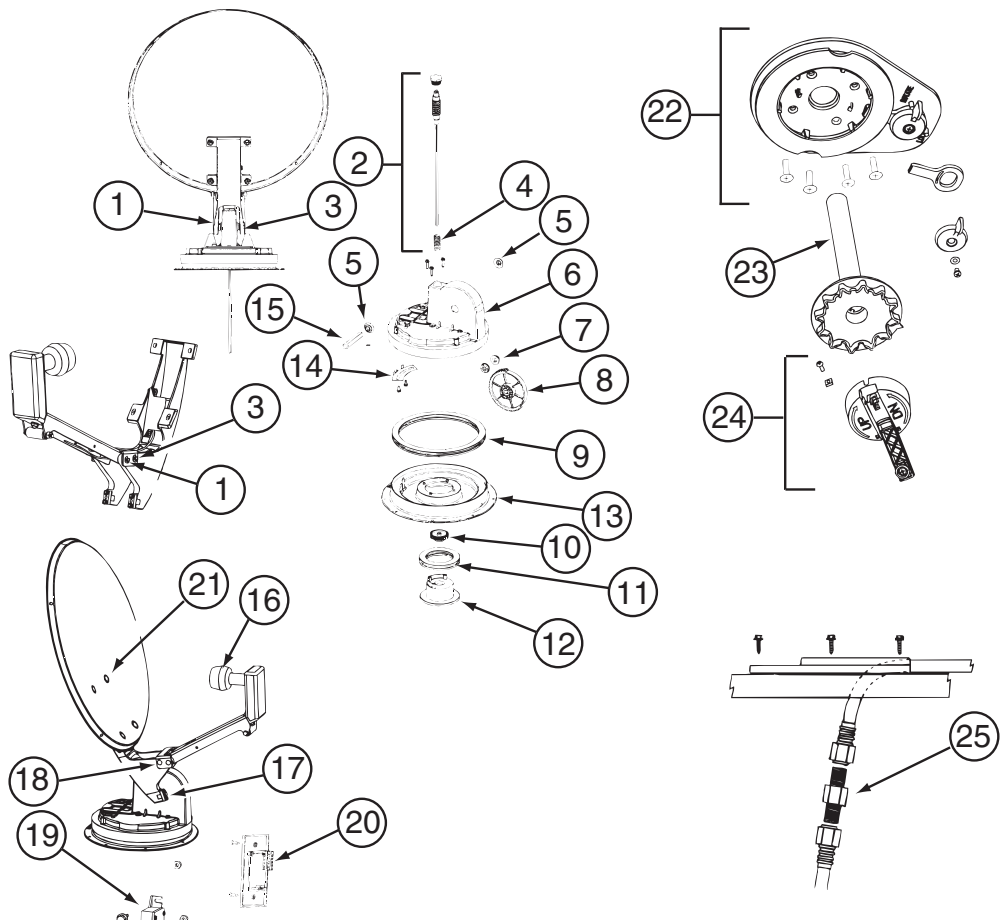

137135-02-000

KEY	PART NUMBER	U/M	DESCRIPTION	VENDOR NO.
1	120233-01-714	EA	CLIP-E	5160818
2	137135-01-703	EA	KIT ELEV - SHAFT/GEAR/SPRING	RP-4400
3	137135-01-704	EA	PIN - 1/4" X 3.25"	2160813
4	137135-01-705	EA	SPRING	2160818
5	137135-01-707	EA	SEAL - PIVOT SHAFT	2200852
6	137135-01-708	EA	TURRET	3100728
7	137135-01-709	EA	PIVOT BEARING	2200470
8	137135-01-711	EA	GEAR - ELEVATING	2200464
9	137135-01-712	EA	BEARING - OUTER	2590347
10	137135-01-714	EA	GEAR - ELEVATING SHAFT	2200465
11	137135-01-715	EA	BEARING - INNER	2590348
12	137135-01-716	EA	HUB	3100731
13	137135-01-713	EA	TURRET BASE	3100730
14	137135-01-710	EA	PLATE - ROTATE LIMIT	3720052
16	137135-02-703	EA	LOW NOISE BLOCK FILTER	LB-6000 - DUAL
17	137135-01-722	EA	CLAMP	2590343
18	137135-01-719	EA	BRACKET - PIVOT	2744945
19	137135-01-720	EA	DE-SENSOR UNIT W/43" CABLE	DM4000
20	137135-02-701	EA	BOX - SURFACE MOUNT	SM-100
21	137135-01-717	EA	BOLT - FLAT HEAD	2160362
22	120233-01-737	EA	PLATE/INT-W/DIRECTIONAL HDLE	RK-CEIL
23	120233-01-704	EA	DIAL/DIRECTIONAL 4"W/SPRING	3200364
24	120233-01-738	EA	HDW PKG-HANDLE/SPRING/WASHER	RK-HAND
25	137135-01-701	EA	CONNECTOR - F - MALE TO MALE	FS-8100
	120233-04-700	EA	KIT-WALL PLATE/CABLE - GRAY	DM4000
	137135-01-700	EA	ROOF WEDGE W/GASKET	RW-5000
	137135-01-706	EA	KIT-TURRET/SEAL/BEARING/GEAR	RP-RM30
	137135-01-718	EA	REFLECTOR/WHITE-46CM W/HDW	RP-35RM
	137135-02-700	EA	DE-SENSOR	2780096
	137135-02-704	EA	KIT-UPDATE DIRECTIONAL HDL	RP-RMDH
	137135-02-705	EA	KIT-TURRET & SHAFT COMPLETE	RP-RM46

CONTACT WINNEBAGO PART SALES FOR UNLISTED COMPONENT(S)

**ELECTRICAL GROUP (CONTINUED)**  
**COMPONENT PARTS FOR WIRING (CONTINUED)**

**137417-01-01A, 137417-03-01A**

<b>KEY</b>	<b>PART NUMBER</b>	<b>U/M</b>	<b>DESCRIPTION</b>	<b>VENDOR NO.</b>
	137417-01-700	EA	LENS - SINGLE (FROSTED)	810868

**137417-02-01A**

<b>KEY</b>	<b>PART NUMBER</b>	<b>U/M</b>	<b>DESCRIPTION</b>	<b>VENDOR NO.</b>
	137417-02-700	EA	LENS - SINGLE OPTIC	810844

**137417-05-01A**

<b>KEY</b>	<b>PART NUMBER</b>	<b>U/M</b>	<b>DESCRIPTION</b>	<b>VENDOR NO.</b>
	137417-05-700	EA	LENS - DOUBLE OPTIC	810845

**137417-06-01A**

<b>KEY</b>	<b>PART NUMBER</b>	<b>U/M</b>	<b>DESCRIPTION</b>	<b>VENDOR NO.</b>
	137417-06-700	EA	LENS - DOUBLE WHITE	810867

**145641-02-000, 145641-04-000**

<b>KEY</b>	<b>PART NUMBER</b>	<b>U/M</b>	<b>DESCRIPTION</b>	<b>VENDOR NO.</b>
	145641-02-700	EA	REMOTE	260607

**145641-03-000**

<b>KEY</b>	<b>PART NUMBER</b>	<b>U/M</b>	<b>DESCRIPTION</b>	<b>VENDOR NO.</b>
	145641-03-700	EA	REMOTE	RCR311DA1

**148230-01-000, 148230-02-000**

<b>KEY</b>	<b>PART NUMBER</b>	<b>U/M</b>	<b>DESCRIPTION</b>	<b>VENDOR NO.</b>
	148230-01-700	EA	REMOTE (TV)	260605

**148230-03-000**

<b>KEY</b>	<b>PART NUMBER</b>	<b>U/M</b>	<b>DESCRIPTION</b>	<b>VENDOR NO.</b>
	149040-02-700	EA	REMOTE (TV)	RCR311TBM1-RCA

**148231-01-000**

<b>KEY</b>	<b>PART NUMBER</b>	<b>U/M</b>	<b>DESCRIPTION</b>	<b>VENDOR NO.</b>
	148231-01-700	EA	REMOTE	RC3100

**149040-02-000**

<b>KEY</b>	<b>PART NUMBER</b>	<b>U/M</b>	<b>DESCRIPTION</b>	<b>VENDOR NO.</b>
	149040-02-700	EA	REMOTE - TV	RCR311TBM1-RCA

**149925-01-000**

<b>KEY</b>	<b>PART NUMBER</b>	<b>U/M</b>	<b>DESCRIPTION</b>	<b>VENDOR NO.</b>
	149925-01-700	EA	REMOTE - F/DVD	P42MA0101

**150089-01-000**

<b>KEY</b>	<b>PART NUMBER</b>	<b>U/M</b>	<b>DESCRIPTION</b>	<b>VENDOR NO.</b>
	150089-01-700	EA	REMOTE	265683

**152441-01-000**

<b>KEY</b>	<b>PART NUMBER</b>	<b>U/M</b>	<b>DESCRIPTION</b>	<b>VENDOR NO.</b>
	152441-01-700	EA	REMOTE - TV	265714

**155619-01-000**

<b>KEY</b>	<b>PART NUMBER</b>	<b>U/M</b>	<b>DESCRIPTION</b>	<b>VENDOR NO.</b>
	155619-01-700	EA	REMOTE	RC3200

## ELECTRICAL GROUP (CONTINUED)

### CIRCUIT BREAKERS, FUSES & RELAYS

KEY	PART NUMBER	U/M	DESCRIPTION
	008235-01-000	EA	FUSE - 15 AMP/12VOLT - AUTOMOTIVE
	033573-01-000	EA	CIRCUIT BREAKER W/MOUNT-20A, 12V - FASCO 1711-2026
	062901-02-000	EA	FUSE - 5 AMP - AUTOMOTIVE
	062901-04-000	EA	FUSE - 10 AMP - AUTOMOTIVE
	062901-05-000	EA	FUSE - 15 AMP - AUTOMOTIVE
	062901-06-000	EA	FUSE - 20 AMP - AUTOMOTIVE
	062901-07-000	EA	FUSE - 25 AMP - AUTOMOTIVE
	062901-08-000	EA	FUSE - 30 AMP - AUTOMOTIVE
	063910-01-000	EA	HOUSING - RELAY
	063912-02-000	EA	RELAY - CANISTER - SPDT
	083209-01-000	EA	CIRCUIT BREAKER - 15 AMP - 120 VOLT - CANADIAN
	083209-02-000	EA	CIRCUIT BREAKER - 15/15 AMP - 120 VOLT
	083209-03-000	EA	CIRCUIT BREAKER - 15/20 AMP - 120 VOLT
	083209-04-000	EA	CIRCUIT BREAKER - 30 AMP - 120 VOLT
	083209-05-000	EA	CIRCUIT BREAKER - 20 AMP - 120 VOLT
	083209-06-000	EA	CIRCUIT BREAKER - 30/15 AMP - 120 VOLT
	083209-07-000	EA	CIRCUIT BREAKER - 20/20 AMP - 120 VOLT
	083209-10-000	EA	CIRCUIT BREAKER - 20/30 AMP - 120 VOLT
	083209-11-000	EA	CIRCUIT BREAKER - 20/15 AMP - 120 VOLT
	092786-03-000	EA	BUSS BAR - 6.9" LONG
	092786-06-000	EA	BUSS BAR
	093654-01-000	EA	CIRCUIT BREAKER - 6 AMP - 12 VOLT - PUSH BUTTON - WHITE
	093654-02-000	EA	CIRCUIT BREAKER - 15 AMP - 12 VOLT - PUSH BUTTON - WHITE
	093654-03-000	EA	CIRCUIT BREAKER - 20 AMP - 12 VOLT - PUSH BUTTON - WHITE
	093654-11-000	EA	COVER - RESET BUTTON
	093655-01-000	EA	CIRCUIT BREAKER - 25 AMP - 12 VOLT - PUSH BUTTON - WHITE
	093655-02-000	EA	CIRCUIT BREAKER - 30 AMP - 12 VOLT - PUSH BUTTON - WHITE
	093655-03-000	EA	CIRCUIT BREAKER - 40 AMP - 12 VOLT - PUSH BUTTON - WHITE
	097611-01-000	EA	CIRCUIT BREAKER - 10 AMP
	097611-02-000	EA	CIRCUIT BREAKER - 30 AMP
	097611-03-000	EA	CIRCUIT BREAKER - 20 AMP
	097611-04-000	EA	CIRCUIT BREAKER - 25 AMP
	100341-01-000	EA	FUSE HOLDER - IN LINE TYPE
	106656-01-000	EA	FUSE BLOCK - 4 CAVITY - AUTOFUSE
	108567-01-000	EA	CIRCUIT BREAKER - 40 AMP - 12 VOLT - TYPE II
	111683-01-000	EA	FUSE - HOLDER - GLASS - 1/4" X 1 1/4"
	113482-01-000	EA	CIRCUIT BREAKER - 55 AMP - MANUAL
	115187-01-000	EA	FUSE - 300 AMP - NON-DELAY
	115187-02-000	EA	FUSE HOLDER - BUSS ANN/ANL BLOCK
	119930-01-000	EA	CAPACITOR - ELECTROLYTIC
	122811-01-000	EA	CIRCUIT BREAKER - 20/50/50/20 AMP - 250V
	125986-02-000	EA	FUSE - 5 AMP - AUTO - MINI BLADE
	125986-04-000	EA	FUSE - 10 AMP - AUTO - MINI BLADE
	125986-05-000	EA	FUSE - 15 AMP - AUTO - MINI BLADE
	125986-06-000	EA	FUSE - 20 AMP - AUTO - MINI BLADE
	125986-07-000	EA	FUSE - 25 AMP - AUTO - MINI BLADE
	134127-01-000	EA	CIRCUIT BREAKER - 10 AMP - MINI
	141789-01-000	EA	SPACER - CIRCUIT BREAKER

### CONVERTER, INVERTER, LOAD CENTERS

KEY	PART NUMBER	U/M	DESCRIPTION
	083208-06-000	EA	CONTROL CENTER - 45 AMP/120V/12V - W/O BREAKERS/ELECTRONIC
	099048-04-000	EA	INVERTER - 300 WATT

## ELECTRICAL GROUP (CONTINUED)

### BOXES & CORDS

KEY	PART NUMBER	U/M	DESCRIPTION
	008054-01-000	EA	CORD - POWER - 10/3 WIRE - 30 AMP - 25'
	008289-01-000	EA	BOX - ELECTRIC/STEEL - 4" X 4" - 1/2" & 3/4" KNOCKOUTS
	008294-01-000	EA	COVER - ELECTRIC BOX - BLANK/STEEL - 4" X 4" - GRAY
	069238-01-000	EA	COVER - ELECTRICAL BOX - W/HOLE - 4" X 4" - GRAY
	084993-01-000	EA	STRAP - BATTERY - 43.2" LONG
	084993-02-000	EA	STRAP - BATTERY - 55" LONG
	091910-01-000	EA	BOX - ELECTRIC - 3.8" X 3.5" X 1.8" - PLASTIC
	091910-02-000	EA	BOX - ELECTRIC - 2.2" X 3.5" X 1.8" - PLASTIC
	131679-01-000	EA	BOX/ELECTRIC-WATERPROOF-4" X 4" - W/4 3/4"OUTLETS-UL/CSA
	131680-01-000	EA	COVER - F/ELECTRIC BOX W/GASKET 4" X 4" - UL/CSA
	141272-01-02B	EA	BOX - ELECTRICAL - E-COATED
	141273-01-02B	EA	COVER - ELECTRICAL BOX - E-COATED
	084077-03-000	EA	COVER/BLANK - WIRE ACCESS - 5.2" X 3.5" - IVORY
	107165-01-01A	EA	BOX - CIRCUIT BREAKER - 14.6" X 4" - PLASTIC
	115832-01-000	FT	CORD - HEAVY DUTY - 14-2 W/GROUND
	131679-01-000	EA	BOX/ELECTRIC-WATERPROOF-4" X 4" - W/4 3/4"OUTLETS-UL/CSA
	131680-01-000	EA	COVER - F/ELECTRIC BOX W/GASKET 4" X 4" - UL/CSA
	133070-01-000	EA	BOX - ELECTRIC/PLASTIC - 3" X 2" X 2.8" - UL
	133070-02-000	EA	BOX - ELECTRIC/PLASTIC - 3" X 2" X 2.8" - CSA

### WIRE ASSEMBLIES

KEY	PART NUMBER	U/M	DESCRIPTION
	096449-01-000	EA	WIRE ASSEMBLY - WATER TANK TO MONITOR PANEL
	097618-02-000	EA	WIRE ASSEMBLY/MONITOR PANEL - 3 WIRES & RESISTOR - 102.4"
	096450-01-000	EA	WIRE F/SENSORS - BLACK WATER - 39.3" FROM: 00-00-00 THRU: 05-02-04
	096450-02-000	EA	WIRE F/SENSORS - BLACK WATER - 59" FROM: 00-00-00 THRU: 05-02-04
	096450-05-000	EA	WIRE F/SENSORS - BLACK WATER - 23.6" FROM: 00-00-00 THRU: 05-02-04
	151317-01-000	EA	WIRE ASM-W/NO CONTACT SENSORS - FRESH WATER/BLK TANK - MALE PLUG - 3.9" FROM: 05-03-04 THRU: 99-99-99
	151317-02-000	EA	WIRE ASM-W/NO CONTACT SENSORS - FRESH WATER/BLK TANK - MALE PLUG - 23.6" FROM: 05-03-04 THRU: 99-99-99
	151317-03-000	EA	WIRE ASM-W/NO CONTACT SENSORS - FRESH WATER/BLK TANK - MALE PLUG - 43.2" FROM: 05-03-04 THRU: 99-99-99
	151317-04-000	EA	WIRE ASM-W/NO CONTACT SENSORS - FRESH WATER/BLK TANK - MALE PLUG - 62.9" FROM: WIRE THRU: 99-99-99
	096451-03-000	EA	WIRE F/SENSORS - GREY WATER - 78.6" FROM: 00-00-00 THRU: 05-02-04
	096451-05-000	EA	WIRE F/SENSORS - GREY WATER - 43.2" FROM: 00-00-00 THRU: 05-02-04
	096451-06-000	EA	WIRE F/SENSORS - GREY WATER - 23.6" FROM: 00-00-00 THRU: 05-02-04
	151316-02-000	EA	WIRE ASM - W/NO CONTACT SENSORS - GREY WATER - FEMALE PLUG - 23.6" FROM: 05-03-04 THRU: 99-99-99
	151316-03-000	EA	WIRE ASM - W/NO CONTACT SENSORS - GREY WATER - FEMALE PLUG - 43.2" FROM: 05-03-04 THRU: 99-99-99
	151316-06-000	EA	WIRE ASM - W/NO CONTACT SENSORS - GREY WATER - FEMALE PLUG - 78.6" FROM: 05-03-04 THRU: 99-99-99
	106851-01-000	EA	WIRE ASSEMBLY - RUNNING LIGHTS - FUSE
	116894-01-000	EA	WIRE ASSEMBLY - SPEED SENSOR EXTENDED
	120269-08-000	EA	HARNESS/WIRE - F/ELECTRIC MIRRORS
	125853-04-000	EA	WIRE LOOM - ENTERTAINMENT CENTER
	126501-01-000	EA	WIRE ASSEMBLY - REMOTE MIRRORS - FORD
	134550-01-000	EA	WIRE ASSEMBLY - HEATER/RELAY
	134551-06-000	EA	WIRE ASSEMBLY - HEATER/TANKS - 3 PAD - 331T, 331ST
	134551-08-000	EA	WIRE ASSEMBLY - HEATER/TANKS - 2 PAD - 322E, 322R, 324F, 326A, 327L, 332G
	134551-09-000	EA	WIRE ASSEMBLY - HEATER/TANKS - 2 PAD - 324V
	134551-10-000	EA	WIRE ASSEMBLY - HEATER/TANKS - 2 PAD - 329B, 329SB, 329K
	135420-08-000	EA	WIRE - RADIO - FORD C - 4 PIN
	136514-02-000	EA	CABLE - MONITOR/CAMERA
	137135-03-000	EA	WIRE LOOM - DIGITAL ELEVATION SENSOR
	137135-04-000	EA	WIRE HARNESS - POWER - DIGITAL ELEVATION SENSOR



**ELECTRICAL GROUP (CONTINUED)**  
**CONNECTORS & CONDUIT**

KEY	PART NUMBER	U/M	DESCRIPTION
	007940-01-000	EA	RECEPTACLE/SLIDE 16 TO 12 AWG - FEMALE END
	007940-02-000	EA	RECEPTACLE-SLIDE 10 AWG - AMP 180351-2
	007954-01-000	EA	RECEPTACLE - HOUSING - 6 POSITION
	007956-05-000	EA	INSULATOR - SHRINK - 1/4"ID X 1 1/2"
	008058-01-000	EA	ADAPTER - POWER CORD - 30 AMP TO 15 AMP
	008311-01-000	EA	CONNECTOR - WIRE NUT - INSULATED - RED
	008312-01-000	EA	CONNECTOR - WIRE NUT - INSULATED - BLUE
	008313-01-000	EA	CONNECTOR - WIRE NUT - INSULATED - YELLOW
	008314-01-000	EA	CONNECTOR - WIRE NUT - INSULATED - GRAY
	008326-01-000	EA	TERMINAL - RING - 16/14 WIRE - 3/8" STUD
	008328-01-000	EA	TERMINAL - RING - 12/10 WIRE - #10 STUD FIT
	008331-01-000	EA	TERMINAL - RING - TONGUE - #4 WIRE - 3/8" STUD - COPPER
	008348-01-000	EA	TERMINAL - RING - 3/8" STUD 2 GA. WIRE
	008355-01-000	EA	CONNECTOR - CABLE CLAMPING - 3/4"
	008356-01-000	EA	CONNECTOR - PLASTIC - 3/8"
	008356-02-000	EA	CONNECTOR - PLASTIC - 21/32"
	008394-01-000	FT	CONDUIT - FLEXIBLE - 1/2"
	008398-01-000	EA	CONNECTOR - 1/2" X 90 DEGREE - FLEX CONDUIT - UL & CSA
	035416-04-000	EA	TERMINAL - RING - #10 STUD FIT - INSULATED BARREL #16/14
	041953-01-000	FT	CONDUIT - CONVOLUTE SLIT - .5" ID - POLYETHYLENE
	041953-03-000	FT	CONDUIT - CONVOLUTE SLIT - 1" ID (CLOTHES ROD COVER)
	041953-06-000	FT	CONDUIT - CONVOLUTE SLIT - .4" ID - POLYETHYLENE
	041953-07-000	FT	CONDUIT - CONVOLUTE SLIT - .25" ID - POLYETHYLENE
	041953-08-000	FT	CONDUIT - CONVOLUTE SLIT - 1.5" ID - POLYETHYLENE
	041953-09-000	FT	CONDUIT - CONVOLUTE SLIT - .5" ID - NYLON
	041953-10-000	FT	CONDUIT - CONVOLUTE SLIT - .75" ID - NYLON
	041953-11-000	FT	CONDUIT - CONVOLUTE SLIT - 1.06" ID - NYLON
	041953-12-000	FT	CONDUIT - CONVOLUTE SOLID - 1.1" ID - NYLON
	041953-13-000	FT	CONDUIT - CONVOLUTE SLIT - 1.25" ID
	041953-14-000	FT	CONDUIT - CONVOLUTE SLIT - 1.5" ID
	041953-15-000	FT	CONDUIT - CONVOLUTE SLIT - 2"
	041953-16-000	FT	CONDUIT - CONVOLUTE SLIT - 2"
	047443-01-000	EA	TERMINAL - .250 RECEPTACLE FIT - INSULATED - 16/14 AWG
	047443-02-000	EA	TERMINAL - .250 RECEPTACLE FIT - INSULATED - 12/10 AWG
	058028-01-000	EA	CONNECTOR - ELECTRICAL PIGTAIL - NYLON - CLEAR
	062036-01-000	EA	TERMINAL - PACK - CON - 12/10 AWG
	077479-01-000	EA	BOOT - BATTERY TERMINAL - DOUBLE CABLE
	077479-02-000	EA	BOOT - BATTERY TERMINAL - SINGLE CABLE
	080015-02-000	EA	RECEPTACLE - FLAG - .185 - 16/14 GAUGE
	080015-03-000	EA	RECEPTACLE - FLAG - .250 - 14/16 GAUGE
	082109-01-000	EA	HOUSING - CONNECTOR - PACKARD
	082741-01-000	EA	CONNECTOR BODY - 2 CONNECTOR MALE
	087225-01-000	FT	SLEEVING - 1/2" - TYPE H
	087949-01-000	EA	BUSS BAR - 2 POSITION - .6" X 1.5"
	087949-03-000	EA	BUSS BAR - 4 POSITION
	088473-01-000	EA	HOUSING - PIN - 12 CAVITY (3 ROWS OF 4)
	088473-02-000	EA	HOUSING - PIN - 15 CAVITY (3 ROWS OF 5)
	088473-03-000	EA	HOUSING - PIN - 9 CAVITY (3 ROWS OF 3)
	088473-04-000	EA	HOUSING - PIN - 8 CAVITY IN-LINE
	088473-06-000	EA	HOUSING - PIN - 6 CAVITY (2 ROWS OF 3)
	088473-07-000	EA	HOUSING - PIN - 5 CAVITY - IN-LINE
	088473-08-000	EA	HOUSING - PIN - 4 CAVITY - IN-LINE
	088473-09-000	EA	HOUSING - PIN - 3 CAVITY - IN-LINE
	088473-10-000	EA	HOUSING - PIN - 2 CAVITY - IN LINE
	088474-01-000	EA	HOUSING - SOCKET - 12 CAVITY
	088474-02-000	EA	HOUSING - SOCKET - 15 CAVITY
	088474-03-000	EA	HOUSING - SOCKET - 9 CAVITY
	088474-06-000	EA	HOUSING - SOCKET - 6 CAVITY
	088474-07-000	EA	HOUSING - SOCKET - 5 CAVITY
	088474-08-000	EA	HOUSING - SOCKET - 4 CAVITY
	088474-09-000	EA	HOUSING - SOCKET - 3 CAVITY
	088474-10-000	EA	HOUSING - SOCKET - 2 CAVITY



**ELECTRICAL GROUP (CONTINUED)**  
**CONNECTORS & CONDUIT (CONTINUED)**

KEY	PART NUMBER	U/M	DESCRIPTION
	088475-01-000	EA	PIN - CONNECTOR - 14-20 AWG
	088475-02-000	EA	PIN - CONNECTOR - 10-12 AWG
	088476-01-000	EA	TERMINAL - ELECTRICAL
	088476-02-000	EA	SOCKET - CONNECTOR - 12-10 GA - PRE-TIN
	098261-01-000	EA	SOCKET - CONNECTOR - WEATHERPACK - 12 AWG
	098261-02-000	EA	SOCKET - CONNECTOR - WEATHERPACK - 14-18 AWG
	098262-01-000	EA	SEAL - CONNECTOR - WEATHERPACK
	098264-01-000	EA	HOUSING - 2 PIN - WEATHER PACK - MALE W/FEMALE PINS
	098264-02-000	EA	HOUSING - 2 PIN - WEATHER PACK - FEMALE W/MALE PINS
	098265-02-000	EA	PIN - CONNECTOR - WEATHER PACK
	102777-02-000	EA	TERMINAL - RING - #6 STUD - 10 AWG
	103608-01-000	EA	SOCKET - WEDGE BASE W/LEADS
	104100-01-000	EA	HOUSING - 1 POSITION - 75 AMPS
	104100-03-000	EA	TERMINAL - 75 AMP
	110178-01-000	EA	HOUSING - WIPER MOTOR
	112823-01-000	EA	SPLICE - REDUCER - 16-14 TO 18-22
	113135-01-000	EA	TERMINAL - FEMALE - M/P - 14-16 - F/SEALED TERMINAL
	113308-01-000	EA	TERMINAL - FEMALE - M/P - 14-16 - 280
	113468-01-000	EA	HOUSING - 2 POSITION-FEMALE-USED ON WIPER/WASHER WIRE ASM
	115931-02-000	EA	COVER - CONNECTOR - 50 AMP W/LOCKING RING
	115932-01-000	EA	CONNECTOR - FEMALE - 30 AMP/120 VOLT
	116811-01-000	EA	TERMINAL - .110 RECEPTACLE - 16-14 AWG
	118571-01-000	EA	CONNECTOR - 3-WAY - MALE/SEALED
	118571-02-000	EA	CONNECTOR - 3-WAY - FEMALE/SEALED
	118571-05-000	EA	LOCK - SECONDARY - FEMALE/SEALED
	118571-06-000	EA	LOCK - SECONDARY - MALE
	118599-02-000	EA	TERMINAL - MALE - M/P - 280/14-12
	118820-01-000	EA	INSULATOR - TERMINAL
	129233-01-000	EA	HOUSING - 2-POSITION/FEMALE - 280-SERIES
	129233-02-000	EA	HOUSING - 2-POSITION/FEMALE - 280-SERIES
	131681-01-000	EA	CONNECTOR - 3/4" SO CORD - UL/CS
	137207-01-000	EA	HOUSING - PIN - 2 CAVITY/HIGH AMP
	137208-01-000	EA	HOUSING - SOCKET - 2 CAVITY/HIGH AMP
	137209-01-000	EA	PIN - CONNECTOR - 10AWG/HIGH AMP
	137210-01-000	EA	SOCKET - CONNECTOR - 10 AWG/HIGH AMP
	138419-03-000	EA	SOCKET - TURN SIGNAL LAMP - 3 WIRE
	142520-01-000	EA	TERMINAL - FEMALE - MINI-FIT 16
	142522-01-000	EA	HOUSING - 4 PIN/MALE - MINI FIT
	142524-01-000	EA	HOUSING - 4 PIN/FEMALE - WEATHER PACK
	142524-02-000	EA	HOUSING - 4 PIN/FEMALE - WEATHER PACK
	144283-01-000	EA	CONNECTOR - 110V - F/USE WITH SOW WIRE - BLUE
	144283-02-000	EA	CONNECTOR - 110V - F/USE WITH NM ROMEX WIRE - CLEAR
	145171-01-000	EA	CONNECTOR - COAXIAL
	149687-01-000	EA	HOUSING - 2 POSITION/MALE - PACKARD
	149687-02-000	EA	LOCK - F/2 POSITION HOUSING - PACKARD
	149688-01-000	EA	TERMINAL - MALE - 16 GAUGE WIRE

## ELECTRICAL GROUP (CONTINUED)

### CHASSIS

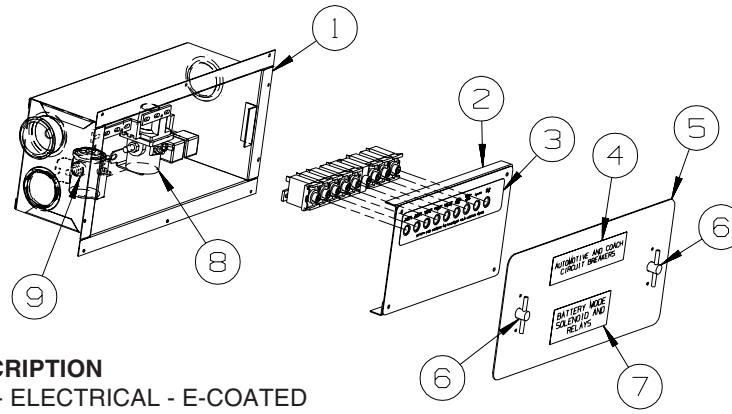

KEY	PART NUMBER	U/M	DESCRIPTION
1	141272-01-02B	EA	BOX - ELECTRICAL - E-COATED
2	139067-04-02B	EA	PLATE - CIRCUIT BREAKER/HOUSE - E-COATED
3	093236-38-000	EA	LABEL - CIRCUIT BREAKER
4	098379-01-000	EA	LABEL - CIRCUIT BREAKER - FRONT BOX
5	141273-01-02B	EA	COVER - ELECTRICAL BOX - E-COATED
5	092492-16-000	EA	SEAL - ELECTRICAL BOX
6	098196-01-000	EA	LATCH - 1/4 TURN - T-BAR
7	098379-04-000	EA	LABEL - ELECTRICAL BOX - SIDE
8	086273-01-000	EA	RELAY - BATTERY DISCONNECT
9	008188-01-000	EA	SOLENOID - 3 POST - BATTERY CHANGE OVER

KEY	PART NUMBER	U/M	DESCRIPTION
	065450-05-000	EA	TIEDOWN - BATTERY - 8.4" TUBE
	065451-05-000	EA	BRACKET/TIEDOWN - BATTERY - 7.7" FROM BRKT TO BRKT

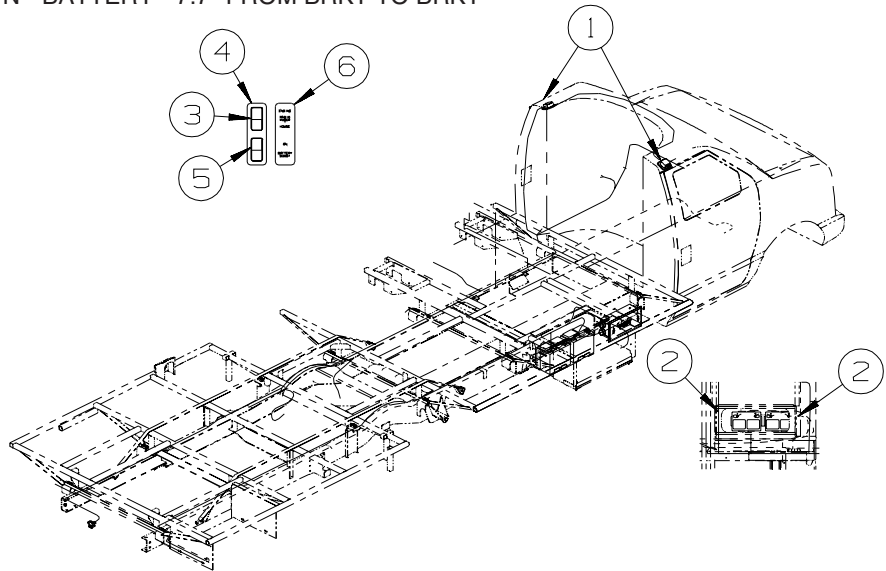

KEY	PART NUMBER	U/M	DESCRIPTION
1	112643-01-000	EA	LIGHT - SINGLE - SWIVEL
1	112642-01-06A	EA	TRIM RING - SINGLE LIGHT - BLACK
2	065451-05-000	EA	BRACKET/TIEDOWN - BATTERY - 7.7" FROM BRKT TO BRKT
	065450-05-000	EA	TIEDOWN - BATTERY - 8.4" TUBE
3	108357-08-000	EA	SWITCH - ROCKER - DPDT - 0N/NONE/ON - 6 TERM - W/O COVER
3	108356-02-01A	EA	COVER/ACTUATOR SWITCH - 2 ROWS DIMPLES - BLACK
3	108355-01-000	EA	HOUSING - SWITCH
4	144363-12-04B	EA	PLATE - SWITCH - BLACK
5	108357-09-000	EA	SWITCH - ROCKER - SPDT - ON/NONE/MOM - 3 TERM - W/O COVER
5	108356-02-01A	EA	COVER/ACTUATOR SWITCH - 2 ROWS DIMPLES - BLACK
5	108355-01-000	EA	HOUSING - SWITCH
6	145731-01-01A	EA	LABEL - SWITCH - RADIO/BATTERY - BLACK

## EXTERIOR BODY GROUP GRAPHICS & PAINT

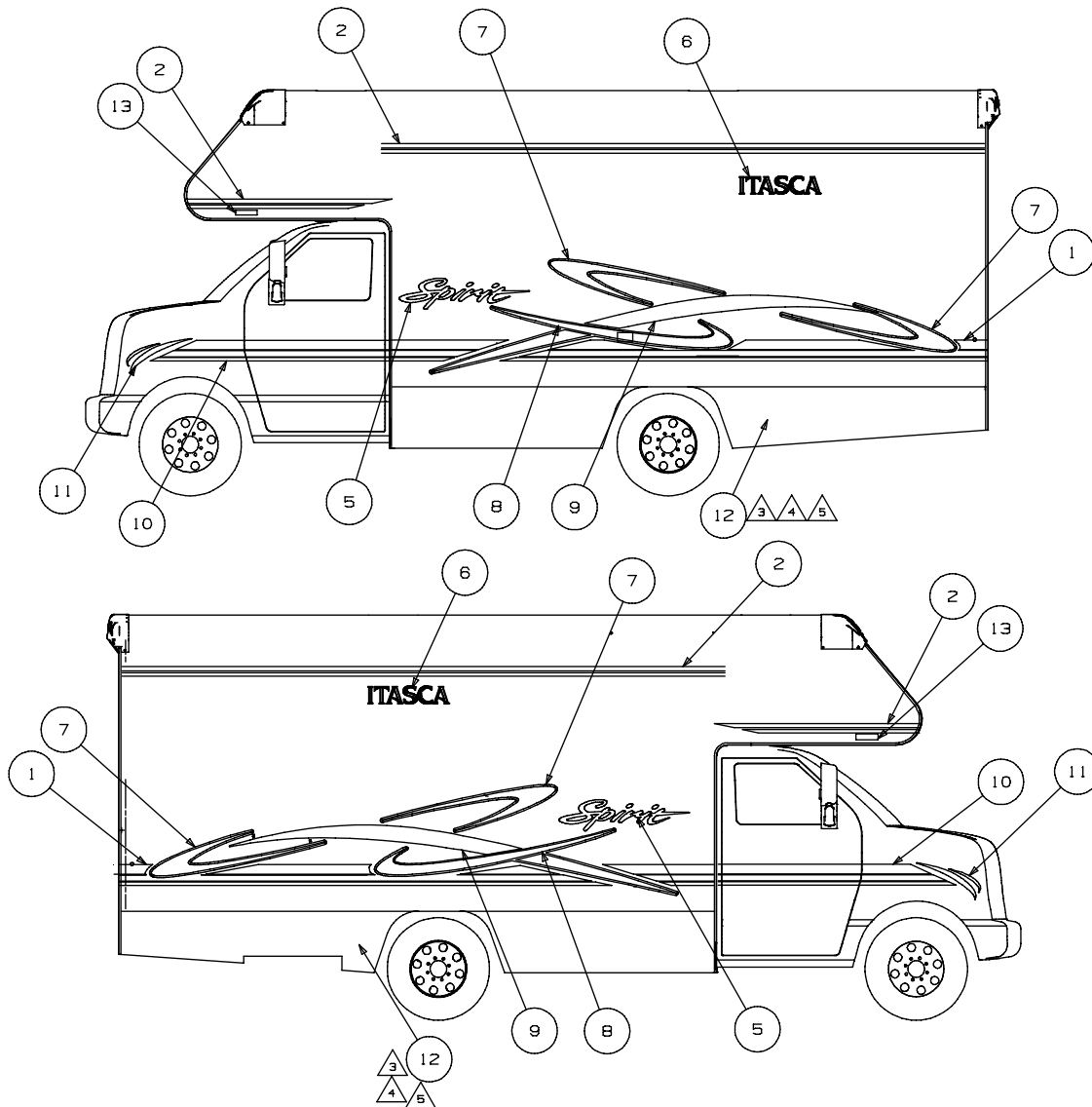

5. CLEAR COAT TO BE APPLIED ON PAINTED AREAS TO PROPECT PAINT.

4. PAINTED AREA IS TO BE BELOW FEATURE STRIPE, FOR OPTIONAL PAINTED MODELS & CONTINUES ON CAB DOORS TO WHEEL WELL.

3. OPTIONAL PAINT PACKAGE.

2. CENTERED ON UNIT.

1. APPLY PROTECTOR 116424-01-000 TO WATER HEATER DOOR LATCH.

KEY	PART NUMBER	U/M	DESCRIPTION
1	094443-79-CHT(O2A)	FT	MULTISTRIPE-152.4MM - VIOLET BLUE/LAGO BLUE/CRYSTAL GREEN
2	105781-82-CHT(O4A)	FT	MULTISTRIPE-69.9MM - LAGO BLUE/CRYSTAL GREEN
3	124806-01-CHT(28A)	EA	DECAL-ITASCA W/ICON - LAGO BLUE BRT WHITE
4	137507-01-CHT(O4A)	EA	DECAL-SPIRIT,SML W/SLASH - CRYSTAL GREEN/LAGO BLUE/BRT WHITE/VIOLET BLUE
5	137508-01-CHT(O4A)	EA	DECAL-SPIRIT - CRYSTAL GREEN/LAGO BLUE/BRT WHITE
6	144587-02-CHT(O3A)	EA	DECAL-ITASCA - LAGO BLUE/BRT WHITE
7	144638-01-CHT(O2A)	EA	DECAL-SWEEP,RH - BRT WHITE/ARCTIC BLUE
7	144638-02-CHT(O2A)	EA	DECAL-SWEEP,LH - BRT WHITE/ARCTIC BLUE
8	144639-01-CHT(O2A)	EA	DECAL-SWISH,RH - BRT WHITE/CRYSTAL GREEN/LAGO BLUE
8	144639-02-CHT(O2A)	EA	DECAL-SWISH,LH - BRT WHITE/CRYSTAL GREEN/LAGO BLUE
9	144640-01-CHT(O2A)	EA	DECAL-SLASH,RH - LAGO BLUE
9	144640-02-CHT(O2A)	EA	DECAL-SLASH,LH - LAGO BLUE
10	144641-01-CHT(O2A)	EA	DECAL-CAB STRIPE,RH - VIOLET BLUE/LAGO BLUE/CRYSTAL GREEN
10	144641-02-CHT(O2A)	EA	DECAL-CAB STRIPE,LH - VIOLET BLUE/LAGO BLUE/CRYSTAL GREEN
11	144642-01-CHT(O2A)	EA	DECAL-SWEEPS,CAB,RH - VIOLET BLUE/CRYSTAL GREEN
11	144642-02-CHT(O2A)	EA	DECAL-SWEEPS,CAB,LH - VIOLET BLUE/CRYSTAL GREEN
12	-----	GL	PAINT - GLACIERGREEN MET - SPIES-HECKER #61322
13	132664-01-CHT(O1A)	EA	DECAL-WINNEBAGO,DOMED - GOLD CHROME/BLACK

**IF329SB AND IF331ST DO NOT USE KEYS 1 AND 2 MULTISTRIPE  
KEY 5 SPECIAL EDITION DECAL 147534-01-01A**

**EXTERIOR BODY GROUP (CONTINUED)**  
**GRAPHICS & PAINT (CONTINUED)**

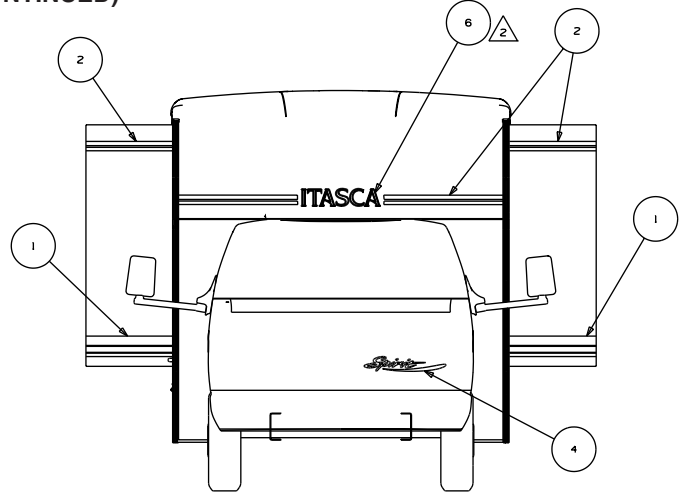
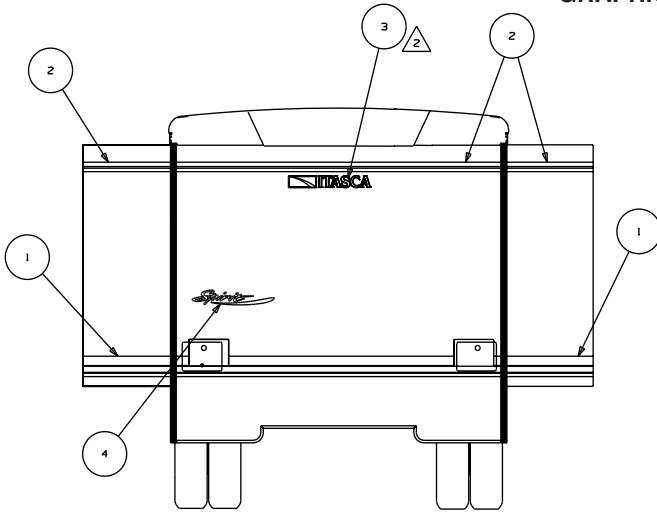

KEY	PART NUMBER	U/M	DESCRIPTION
1	094443-79-CHT(02A)	FT	MULTISTRIPE-152.4MM - VIOLET BLUE/LAGO BLUE/CRYSTAL GREEN
2	105761-82-CHT(04A)	FT	MULTISTRIPE-69.9MM - LAGO BLUE/CRYSTAL GREEN
3	124806-01-CHT(28A)	EA	DECAL-ITASCA W/ICON - LAGO BLUE BRT WHITE
4	137507-01-CHT(04A)	EA	DECAL-SPIRIT,SML W/SLASH - CRYSTAL GREEN/LAGO BLUE/BRT WHITE/VIOLET BLUE
5	137508-01-CHT(04A)	EA	DECAL-SPIRIT - CRYSTAL GREEN/LAGO BLUE/BRT WHITE
6	144587-02-CHT(03A)	EA	DECAL-ITASCA - LAGO BLUE/BRT WHITE
7	144638-01-CHT(02A)	EA	DECAL-SWEEP,RH - BRT WHITE/ARCTIC BLUE
8	144638-02-CHT(02A)	EA	DECAL-SWEEP,LH - BRT WHITE/ARCTIC BLUE
9	144639-01-CHT(02A)	EA	DECAL-SWISH,RH - BRT WHITE/CRYSTAL GREEN/LAGO BLUE
10	144639-02-CHT(02A)	EA	DECAL-SWISH,LH - BRT WHITE/CRYSTAL GREEN/LAGO BLUE
11	144640-01-CHT(02A)	EA	DECAL-SLASH,RH - LAGO BLUE
12	144640-02-CHT(02A)	EA	DECAL-SLASH,LH - LAGO BLUE
13	144641-01-CHT(02A)	EA	DECAL-CAB STRIPE,RH - VIOLET BLUE/LAGO BLUE/CRYSTAL GREEN
10	144641-02-CHT(02A)	EA	DECAL-CAB STRIPE,LH - VIOLET BLUE/LAGO BLUE/CRYSTAL GREEN
11	144642-01-CHT(02A)	EA	DECAL-SWEEPS,CAB,RH - VIOLET BLUE/CRYSTAL GREEN
11	144642-02-CHT(02A)	EA	DECAL-SWEEPS,CAB,LH - VIOLET BLUE/CRYSTAL GREEN
12	-----	GL	PAINT - GLACIERGREEN MET - SPIES-HECKER #61322
13	132664-01-CHT(01A)	EA	DECAL-WINNEBAGO,DOMED - GOLD CHROME/BLACK

KEY	PART NUMBER	U/M	DESCRIPTION
	041561-03-000	EA	PAINT/SPRAY - 12 OZ. NET - OFF WHITE
	116424-01-000	EA	PROTECTOR - LATCH - WATER HEATER

**IF329SB AND IF331ST DO NOT USE KEYS 1 AND 2 MULTISTRIPE  
 KEY 5 SPECIAL EDITION DECAL 147534-01-01A**

**DUPONT COLOR CODES ARE NOW FOUND IN THE PAINT CODE MANUAL.  
 YOU CAN FIND THIS MANUAL ON YOUR DEALER INDEX WEBPAGE UNDER SERVICE.**

## EXTERIOR BODY GROUP (CONTINUED)

### PANELS & TRIMS

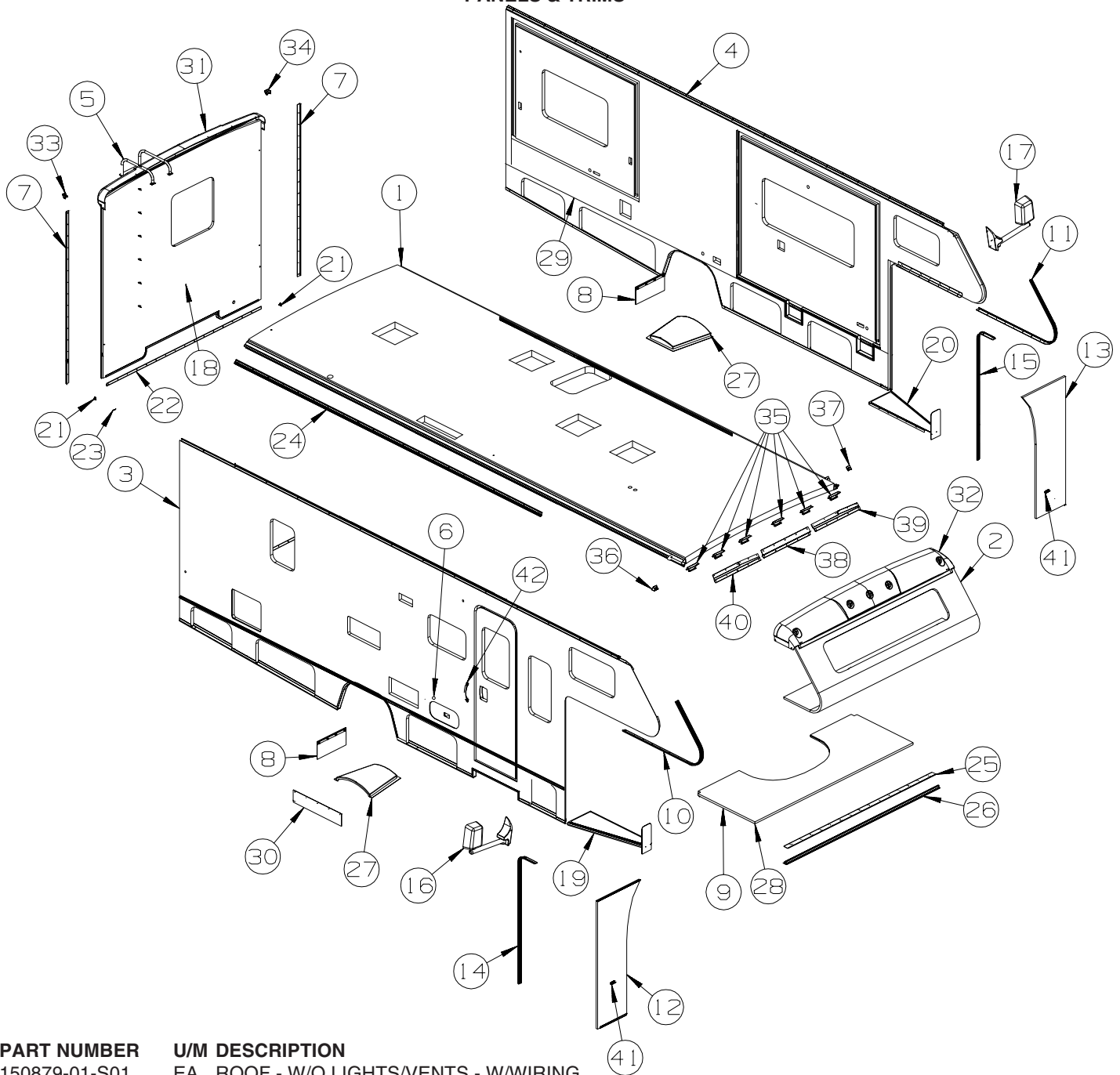

KEY	PART NUMBER	U/M	DESCRIPTION
1	150879-01-S01	EA	ROOF - W/O LIGHTS/VENTS - W/WIRING
2	141126-01-S01	EA	ROOF - FRONT SECTION - W/O LIGHTS/VENTS - W/WIRING
2	141126-02-S01	EA	ROOF - FRONT SECTION - FRONT BUNK WINDOW DELETE/BUNK FRONT OVHD DOUBLE
2	141126-03-S01	EA	ROOF - FRONT SECTION - W/O LIGHTS/VENTS - W/WIRING - TV-24" COLOR, STEREO W/REMOTE
3	P50877-01-S01	EA	SIDEWALL - PASSENGER - W/O WINDOWS/TRIMS (S04, S91)
3	P50877-01-S02	EA	SIDEWALL - PASSENGER - W/O WINDOWS/TRIMS (S05, S92)
3	P50877-01-S03	EA	SIDEWALL - PASSENGER - W/O WINDOWS/TRIMS (S06, S93)
4	P50878-01-S01	EA	SIDEWALL - DRIVER - W/O WINDOWS/TRIMS (S04, S91)
4	P50878-01-S02	EA	SIDEWALL - DRIVER - W/O WINDOWS/TRIMS (S05, S92)
4	P50878-01-S03	EA	SIDEWALL - DRIVER - W/O WINDOWS/TRIMS (S06, S93)
5	129639-04-01A	EA	LADDER - 85.1" - 6 STEP - BRUSHED ALUMINUM
6	117046-02-000	EA	BUMPER - RUBBER/ROUND END - 1.5"
7	096854-14-01A	EA	TRIM - CONTOUR - 88.2" - BRIGHT WHITE
8	017516-05-000	EA	MUD FLAP - 9"H X 18"W - RUBBER - BLACK
8	140922-01-02B	EA	RETAINER - MUD FLAP - 1" X 17.7" - E-COATED/BLACK
9	P25129-01-P07	EA	SLEEPERBOARD
10	136826-13-01A	EA	TRIM - CONTOUR - 80.2" - BRIGHT WHITE
11	136826-14-01A	EA	TRIM - CONTOUR - 80.2" - BRIGHT WHITE
12	125088-08-N01	EA	WINGWALL - RIGHT HAND

**EXTERIOR BODY GROUP (CONTINUED)**  
**PANELS & TRIMS (CONTINUED)**

KEY	PART NUMBER	U/M	DESCRIPTION
13	125088-09-N01	EA	WINGWALL - LEFT HAND
14	104479-09-02A	EA	TRIM - WINGWALL - PASSENGER SIDE - VERTICAL - BRIGHT WHITE
15	104479-10-02A	EA	TRIM - WINGWALL - DRIVER SIDE - VERTICAL - BRIGHT WHITE
16*	133908-10-01A	EA	MIRROR/PASS - 102" C BODY/FORD 4-BOLT MT - BRIGHT WHITE
16*	133908-12-01A	EA	MIRROR/PASS-102" C BODY/FORD 4 BOLT MT-HEATED/RMT-B/W - MIRRORS EXTERIOR W/DEFROST
17*	133908-11-01A	EA	MIRROR/DRVR - 102" C BODY/FORD 4-BOLT MT - BRIGHT WHITE
17*	133908-13-01A	EA	MIRROR/DRVR-102" C BODY/FORD 4-BOLT MT-HEATED/RMT-B/W - MIRRORS EXTERIOR W/DEFROST
18	148293-01-S01	EA	BACKWALL - W/O WINDOW/TRIMS (S04, S91)
18	148293-01-S02	EA	BACKWALL - W/O WINDOW/TRIMS (S05, S92)
18	148293-01-S03	EA	BACKWALL - W/O WINDOW/TRIMS (S06, S93)
18	148293-02-S01	EA	BACKWALL - W/O WINDOW/TRIMS (S04, S91) - DUAL PANE WINDOW
18	148293-02-S02	EA	BACKWALL - W/O WINDOW/TRIMS (S05, S92) - DUAL PANE WINDOW
18	148293-02-S03	EA	BACKWALL - W/O WINDOW/TRIMS (S06, S93) - DUAL PANE WINDOW
19*	072884-27-000	EA	RUNNING BOARD SET - 39" - FORD - ALUMINUM
19	149604-01-01A	EA	RUNNING BOARD/WEDGE - PASSENGER - FORD 300/400 - PRIMED - LOWER EXTERIOR PAINT
19	149604-05-01A	EA	MUD FLAP - FIBERGLASS - PASSENGER - LOWER EXTERIOR PAINT
19	149604-09-000	EA	HARDWARE KIT (RUNNING BOARD INSTALL) - LOWER EXTERIOR PAINT
19	146515-03-01A	EA	MAT - ANTI SLIP - RIGHT HAND - BLACK - LOWER EXTERIOR PAINT
20*	072884-27-000	EA	RUNNING BOARD SET - 39" - FORD - ALUMINUM
20	149604-02-01A	EA	RUNNING BOARD/WEDGE - DRIVER - FORD 300/400 - PRIMED - LOWER EXTERIOR PAINT
20	149604-06-01A	EA	MUD FLAP - FIBERGLASS - DRIVER - LOWER EXTERIOR PAINT
20	149604-09-000	EA	HARDWARE KIT (RUNNING BOARD INSTALL) - LOWER EXTERIOR PAINT
20	146515-04-01A	EA	MAT - ANTI SLIP - LEFT HAND - BLACK - LOWER EXTERIOR PAINT
21	108651-01-01A	EA	END CAP - FEATURE STRIP
22	108688-06-03A	EA	STRIP - FEATURE - W/O INSERT/END CAPS - 96.9" - BRIGHT WHT
23	105312-01-07A	FT	INSERT - FEATURE STRIP - VINYL - BRIGHT WHITE
24	131483-01-01A	EA	RAIL - AWNING - 192" - BRIGHT WHITE
25	100085-05-01A	EA	TRIM/STRAP - SLEEPERBOARD - OFF/WHITE - 92.9"
26	100086-04-01A	EA	TRIM - SLEEPERBOARD/ROOF/LOWER - BRIGHT WHITE - 96.5" FROM: 00-00-00 THRU: 06-13-04
26	100086-03-02A	EA	TRIM - SLEEPER BOARD BRIGHT WHITE - 2" X 96.5" FROM: 06-14-04 THRU: 99-99-99
27	112435-03-000	EA	WHEELWELL
28	099069-01-000	FT	SEAL - RUBBER - CLOSED SPONGE - .5" WIDE X .12" THICK-BLK
29	104692-01-000	FT	SEAL - ADHESIVE BACKED FOAM - 3/4" THICK X 3/4" WIDE X 25'
30	121948-02-000	EA	SHIELD - SIGHT
31	140443-02-P07	EA	CAP - ROOF/FRONT - W/O LIGHTS/VENTS - W/WIRING
32	140596-02-P07	EA	CAP - ROOF/REAR - W/O LIGHTS/VENTS/WIRING-W/STEEL SUPPORT
33	140620-01-01A	EA	CAP - TRIM - REAR/RIGHT - BRIGHT WHITE
34	140620-02-01A	EA	CAP - TRIM - REAR/LEFT - BRIGHT WHITE
35	134774-01-02B	EA	BRACKET - CAB ATTACHMENT - E-COATED
36	140476-01-01A	EA	CAP - TRIM - CORNER/PASSENGER
37	140476-02-01A	EA	CAP - TRIM - CORNER/DRIVER
38	140805-01-02B	EA	BRACKET - ROOF CAP/FRONT - E-COATED
39	141718-01-02B	EA	BRACKET - ROOF CAP - END/RIGHT HAND - E-COATED
40	141718-02-02B	EA	BRACKET - ROOF CAP - END/LEFT HAND - E-COATED
41	016604-01-000	EA	BRACE - ANGLE - 2 1/2" - UNPAINTED METAL
42	009126-03-000	EA	HANDLE - ASSIST - BLACK TEXTURED

\*COMPONENT PARTS LISTED LATER IN THIS GROUP

**EXTERIOR BODY GROUP (CONTINUED)**  
**PANELS & TRIMS (CONTINUED)**

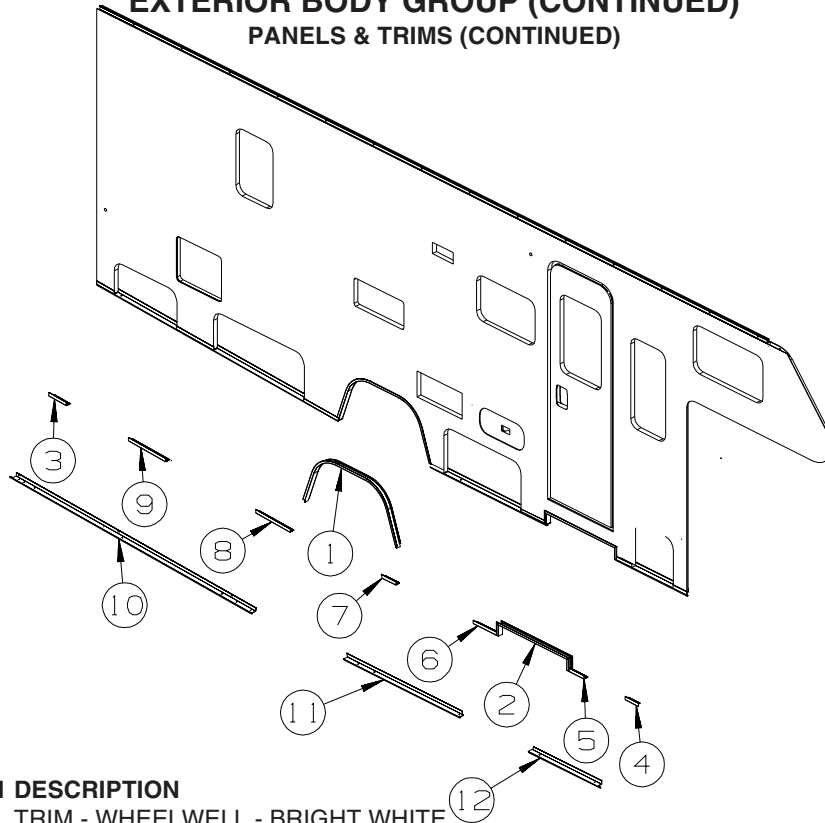

KEY	PART NUMBER	U/M	DESCRIPTION
1	127848-01-01A	EA	TRIM - WHEELWELL - BRIGHT WHITE
2	128732-15-S01	EA	TRIM - PASSENGER SIDEWALL W/ENTRY DOOR NOTCH - 105.4"
3	148759-80-01A	EA	TRIM - SIDEWALL/LOWER - MITERED ENDS - 7.2"
4	148759-91-01A	EA	TRIM - SIDEWALL/LOWER - MITERED ENDS - 5.5" - B/W
5	148759-92-01A	EA	TRIM - SIDEWALL/LOWER - MITERED ENDS - 6.3" - B/W
6	148759-93-01A	EA	TRIM - SIDEWALL/LOWER - MITERED ENDS - 9.6" - B/W
7	148759-94-01A	EA	TRIM - SIDEWALL/LOWER - MITERED ENDS - 6.5" - B/W
8	148759-95-01A	EA	TRIM - SIDEWALL/LOWER - MITERED ENDS - 14.5" - B/W
9	148759-96-01A	EA	TRIM - SIDEWALL/LOWER - MITERED ENDS - 15.3" - B/W
10	148760-40-01A	EA	TRIM - ROCKER - NOTCHED - 99.6" - BRIGHT WHITE

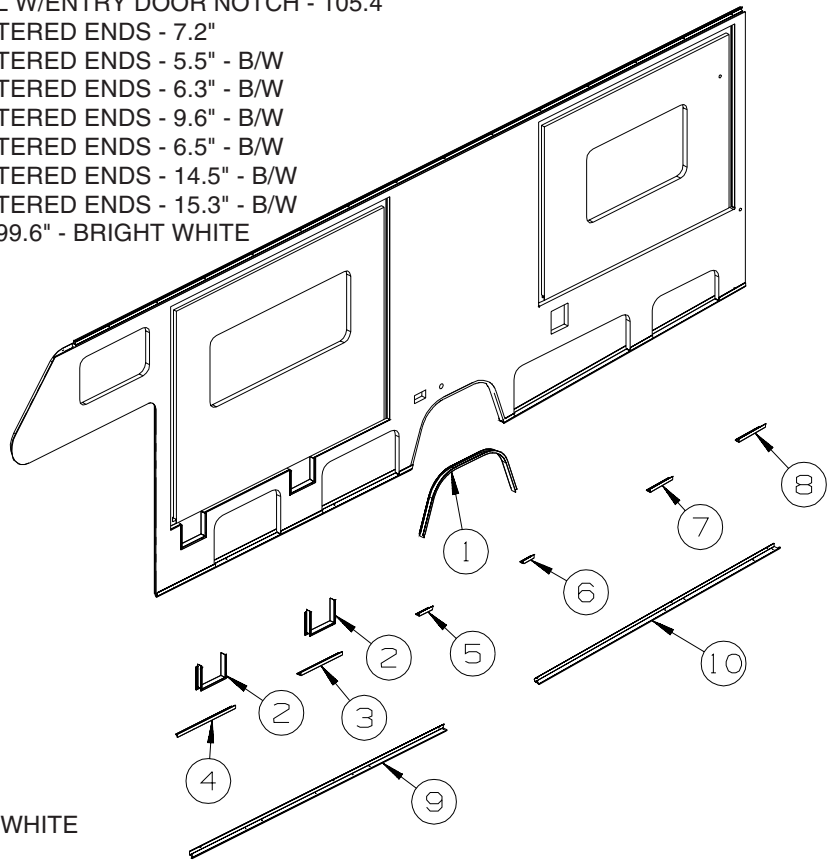

KEY	PART NUMBER	U/M	DESCRIPTION
1	127848-01-01A	EA	TRIM - WHEELWELL - BRIGHT WHITE
2	148736-01-S34	EA	TRIM - SIDEWALL
3	148759-85-01A	EA	TRIM - SIDEWALL/LOWER - MITERED ENDS - 16.9" - B/W
4	148759-86-01A	EA	TRIM - SIDEWALL/LOWER - MITERED ENDS - 23.5" - B/W
5	148759-87-01A	EA	TRIM - SIDEWALL/LOWER - MITERED ENDS - 5.5" - B/W
6	148759-88-01A	EA	TRIM - SIDEWALL/LOWER - MITERED ENDS - 4.6" - B/W
7	148759-89-01A	EA	TRIM - SIDEWALL/LOWER - MITERED ENDS - 9.2" - B/W
8	148759-90-01A	EA	TRIM - SIDEWALL/LOWER - MITERED ENDS - 10.9" - B/W
9	148760-36-01A	EA	TRIM - ROCKER - NOTCHED - 105" - BRIGHT WHITE
10	148760-37-01A	EA	TRIM - ROCKER - NOTCHED - 99.6" - BRIGHT WHITE



**EXTERIOR BODY GROUP (CONTINUED)**  
**PANELS & TRIMS (CONTINUED)**

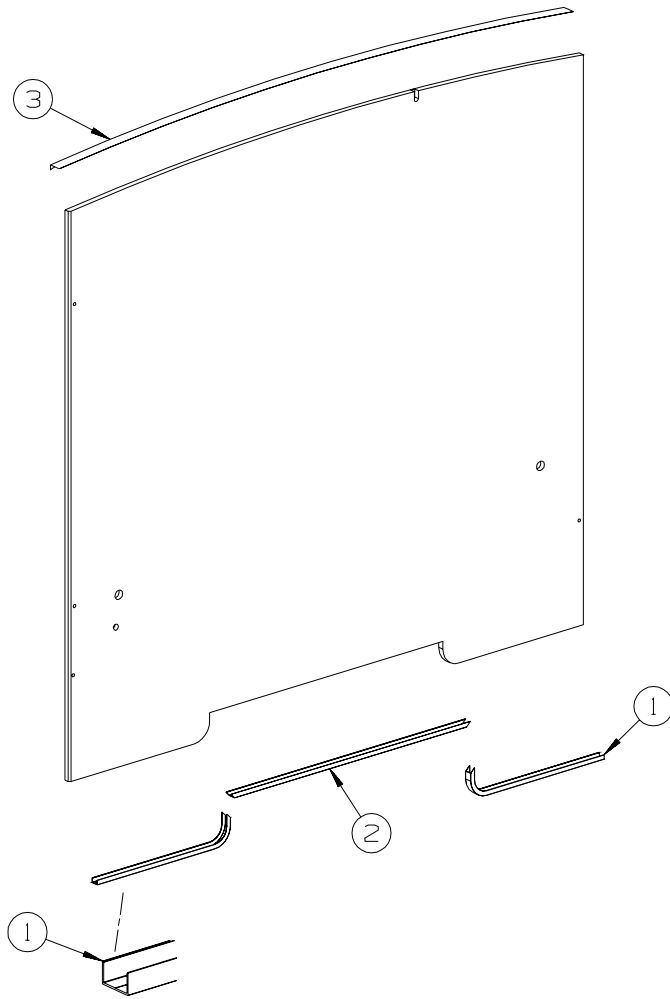

**BACKWALL**

KEY	PART NUMBER	U/M	DESCRIPTION
1	103334-03-02A	EA	TRIM - BACKWALL - LOWER/DRIVER/PASSENGER - 25.6" - BRT WHT
2	103335-02-02A	EA	TRIM - BACKWALL - LOWER/CENTER - 46.3" - BRIGHT WHITE
3	114248-02-01A	EA	ANGLE - PLASTIC - 96.6"

**COMPONENT PARTS FOR PANELS & TRIMS**

**072884-27-000**

KEY	PART NUMBER	U/M	DESCRIPTION	VENDOR NO.
	072884-27-700	EA	BRACKET SET 12" 92	RB2BRK/M
	072884-27-701	EA	RUNNING BOARD-FORD 39",RT&LT	
	072884-27-702	FT	TREAD TAPE	RB9202
	072884-27-703	EA	MUD FLAP W/HOLES, 1EA=PAIR	99171
	072884-27-704	EA	CAP-ENDS, 1EA=PAIR	99148

**133908-01 THRU 133908-08, 133908-10 THRU 133908-13, 133908-16, 133908-17, -01A/-02A/-03A**

KEY	PART NUMBER	U/M	DESCRIPTION	VENDOR NO.
	117051-01-700	EA	MIRROR-CONVEX	723068-4
	120269-05-701	EA	GLASS-HTD/REM RH/LH W/CONVEX	709411
	133908-03-700	EA	CAP - RECT/BLACK-W/O LIGHT	709557
	133908-04-700	EA	CAP-MIRROR/ROUND - W/O LIGHT	7095470



**EXTERIOR BODY GROUP (CONTINUED)**  
**STRUCTURAL COMPONENTS**

KEY	PART NUMBER	U/M	DESCRIPTION
	002365-03-006	EA	U-CHANNEL - EXTRUDED - 1" X 192" - BRIGHT WHITE
	002726-01-001	EA	GARNISH - U-CHANNEL - 1.38" X 19' - SERRATED
	002766-01-001	EA	ANGLE - EXTRUDED - 1" X 1 1/2" X 17'
	068716-01-001	EA	BRACE - 90 DEGREE - L- ANGLE - 16'
	076054-AC-000	EA	FIBERGLASS SHEET - 20" X 99.8" - OFF WHITE
	076054-Z3-000	EA	FIBERGLASS SHEET - 102" X 93.9" - ROOF/SIDEWALL - BRT WHT
	089297-01-000	SF	PLYWOOD - LUAN - OVERLAY GRADE - 4' X 8'
	089297-02-000	SF	PLYWOOD - LUAN - OVERLAY GRADE - 4' X 9'
	089297-03-000	SF	PLYWOOD - LUAN - OVERLAY GRADE - 4' X 8.3'
	100619-01-000	BF	FOAM - EXPANDED POLYSTYRENE - 1.34" X 48" X 96"
	100619-02-000	BF	FOAM - EXPANDED POLYSTYRENE - 1.5" X 48" X 96"
	100619-04-000	BF	FOAM - EXPANDED POLYSTYRENE - .5" X 48" X 96"
	100619-05-000	BF	FOAM - EXPANDED POLYSTYRENE - .75" X 48" X 96"-1.5"DENSITY
	100619-16-000	BF	FOAM - EXPANDED POLYSTYRENE - .75" X 48" X 96"-2" DENSITY
	100619-27-000	BF	FOAM - EXPANDED POLYSTYRENE - 3" X 48" X 92.8"
	105077-10-000	EA	FOAM - PLUG - ROOF CAP
	108535-05-03A	SF	FIBERGLASS SHEET - 108" X 500' ROLL - BRIGHT WHITE
	116942-03-01A	LB	ALUMINUM - .7" X 40" X 158"
	120107-01-000	EA	FOAM - ROOF COVE - 2.8" X 48" LONG
	120107-02-000	EA	FOAM - PLUG - ROOF TUBE - 2.2" X 2.9" X 1.8" LONG
	120107-03-000	EA	FOAM - PLUG - SIDEWALL TUBE - 1.2" X 2.1" X 1.8" LONG
	148884-02-01A	EA	FIBERGLASS SHEET - 96.7" X 355.7" -HIGH GLOSS-BRIGHT WHITE
	148884-04-01A	EA	FIBERGLASS SHEET - 99.5" X 100.2" -HIGH GLOSS-BRIGHT WHITE
	148884-07-01A	EA	FIBERGLASS SHEET - 56.4" X 99.8" - HIGH GLOSS-BRIGHT WHITE
	148884-10-01A	EA	FIBERGLASS SHEET - 22.1" X 68.2" - HIGH GLOSS-BRIGHT WHITE
	148884-12-01A	EA	FIBERGLASS SHEET - 31.1" X 68.2" - HIGH GLOSS-BRIGHT WHITE
	148884-20-01A	EA	FIBERGLASS SHEET - 4" X 93.8" - HIGH GLOSS - BRIGHT WHITE
	148884-22-01A	EA	FIBERGLASS SHEET - 47.9" X 95.8" - HIGH GLOSS-BRIGHT WHITE
	148884-23-01A	EA	FIBERGLASS SHEET - 47.9" X 95.8" - HIGH GLOSS-BRIGHT WHITE
	151523-01-01A	EA	CEILING PANEL - 48" X 97.1" - LAMINATED VINYL/FOAM/LUAN

**AWNINGS**

**PATIO AWNINGS**

SERIES	MODEL	COLOR	AWNING	AWNING	WEATHER	AWNING PART #
		DESIGNATION	FABRIC	LENGTH	WRAP(MANUAL)	MANUAL
SPIRIT	322E	ALPINE GREEN (DY)	VINYL	11.5'	VYL/BRT WHT	113874-03-45A
SPIRIT	322R	ALPINE GREEN (DY)	VINYL	11.5'	VYL/BRT WHT	113874-03-45A
SPIRIT	324F	ALPINE GREEN (DY)	VINYL	11.5'	VYL/BRT WHT	113874-03-45A
SPIRIT	324V	ALPINE GREEN (DY)	VINYL	11.5'	VYL/BRT WHT	113874-03-45A
SPIRIT	326A	ALPINE GREEN (DY)	VINYL	18'	VYL/BRT WHT	113874-07-45A
SPIRIT	327L	ALPINE GREEN (DY)	VINYL	18'	VYL/BRT WHT	113874-07-45A
SPIRIT	329B	ALPINE GREEN (DY)	VINYL	14'	VYL/BRT WHT	113874-05-45A
SPIRIT SE	329SB	ALPINE GREEN (DY)	VINYL	14'	VYL/BRT WHT	113874-05-45A
SPIRIT	329K	ALPINE GREEN (DY)	VINYL	14'	VYL/BRT WHT	113874-05-45A
SPIRIT	331T	ALPINE GREEN (DY)	VINYL	16'	VYL/BRT WHT	113874-06-45A
SPIRIT SE	331ST	ALPINE GREEN (DY)	VINYL	16'	VYL/BRT WHT	113874-06-45A
SPIRIT	332G	ALPINE GREEN (DY)	VINYL	16'	VYL/BRT WHT	113874-06-45A

KEY	PART NUMBER	U/M	DESCRIPTION
*	113874-01-02A	EA	HARDWARE KIT - AWNING - W/O STANDOFF BRACKET-BRIGHT WHITE
	113874-11-01A	EA	SCREW/LAG - AWNING - 1/4" X 1" STAINLESS STEEL
	113874-12-01A	EA	SCREW/LAG - AWNING - 1/4" X 2 3/4" STAINLESS STEEL
	127647-02-01A	EA	ROD/AWNING GUARD - ENTRY DOOR - 12.7" LONG
	137054-01-02A	EA	BRACKET - AWNING - BRIGHT WHITE

**\*COMPONENT PARTS LISTED LATER IN THIS GROUP**

**EXTERIOR BODY GROUP (CONTINUED)**  
**COMPONENT PARTS FOR AWNINGS**

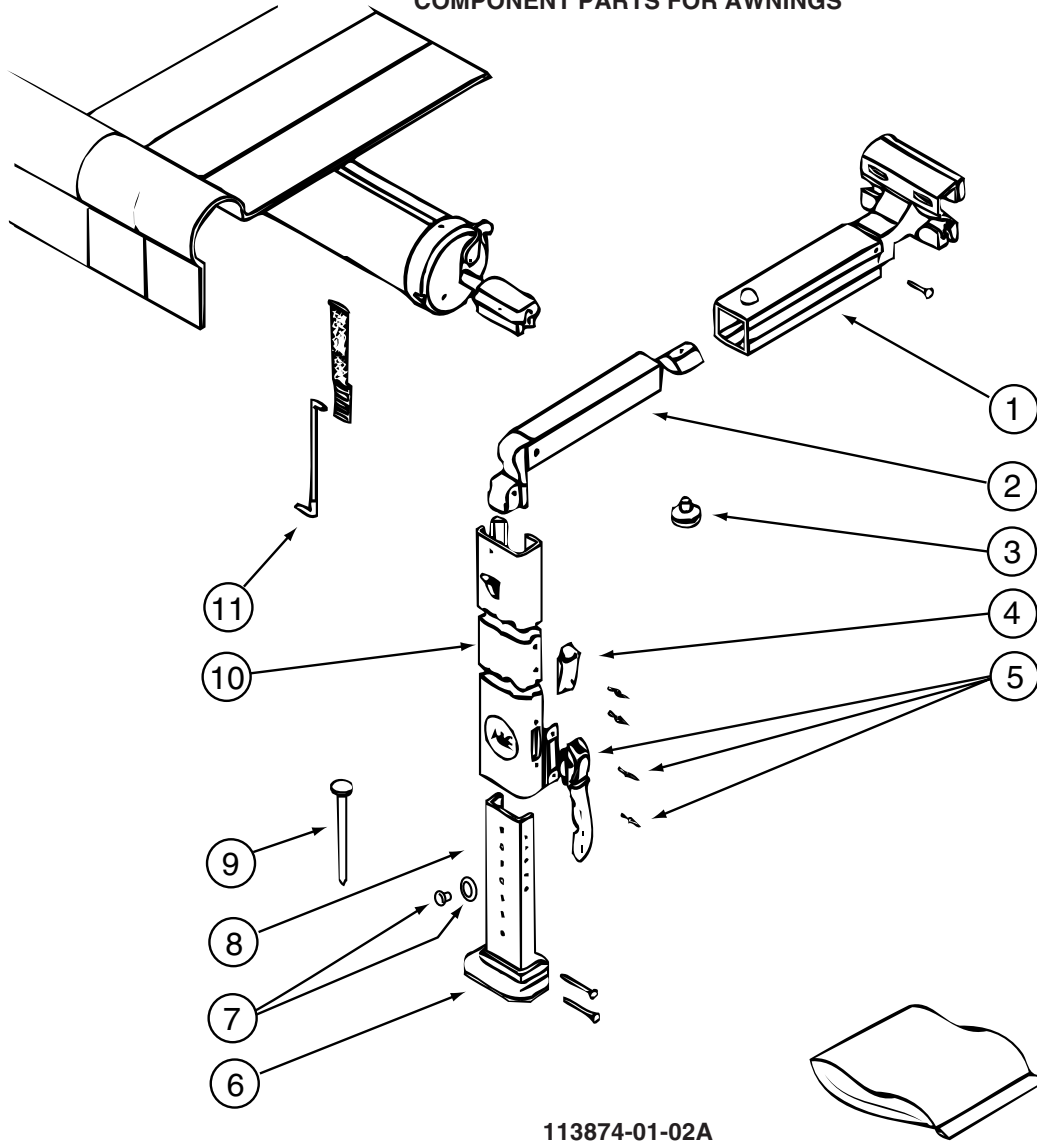

113874-01-02A

KEY	PART NUMBER	U/M	DESCRIPTION	VENDOR NO.
1	113874-01-714	EA	RAFTER - MAIN RH/LH BRT/WHT	830295.536F
2	113874-01-715	EA	RAFTER - SECONDARY BRT/WHT	830463.511F
3	113874-01-702	EA	KNOB - ADJUSTING	3105421.014
4	113874-01-706	EA	LOCK - TRAVEL	830587.001
5	113874-01-707	EA	HANDLE - LIFT W/RIVETS	830644
6	113874-01-712	EA	FOOT - PATIO	730366-001
7	113874-01-710	EA	PLUG-STOP KIT	830456
8	113874-01-717	EA	ARM - ADJUSTABLE BRT/WHT	830467.517/F
9	113874-01-709	EA	NAIL-SPIKE, 8"	113006
10	113874-01-716	EA	ARM - MAIN SUPPORT BRT/WHT	3104502.293/F
11	113874-01-703	EA	ROD-CENTER PULL W/ACCESSORY	830152.102

# EXTERIOR DOORS & COMPARTMENTS GROUP

## DOOR & COMPARTMENT LAYOUT

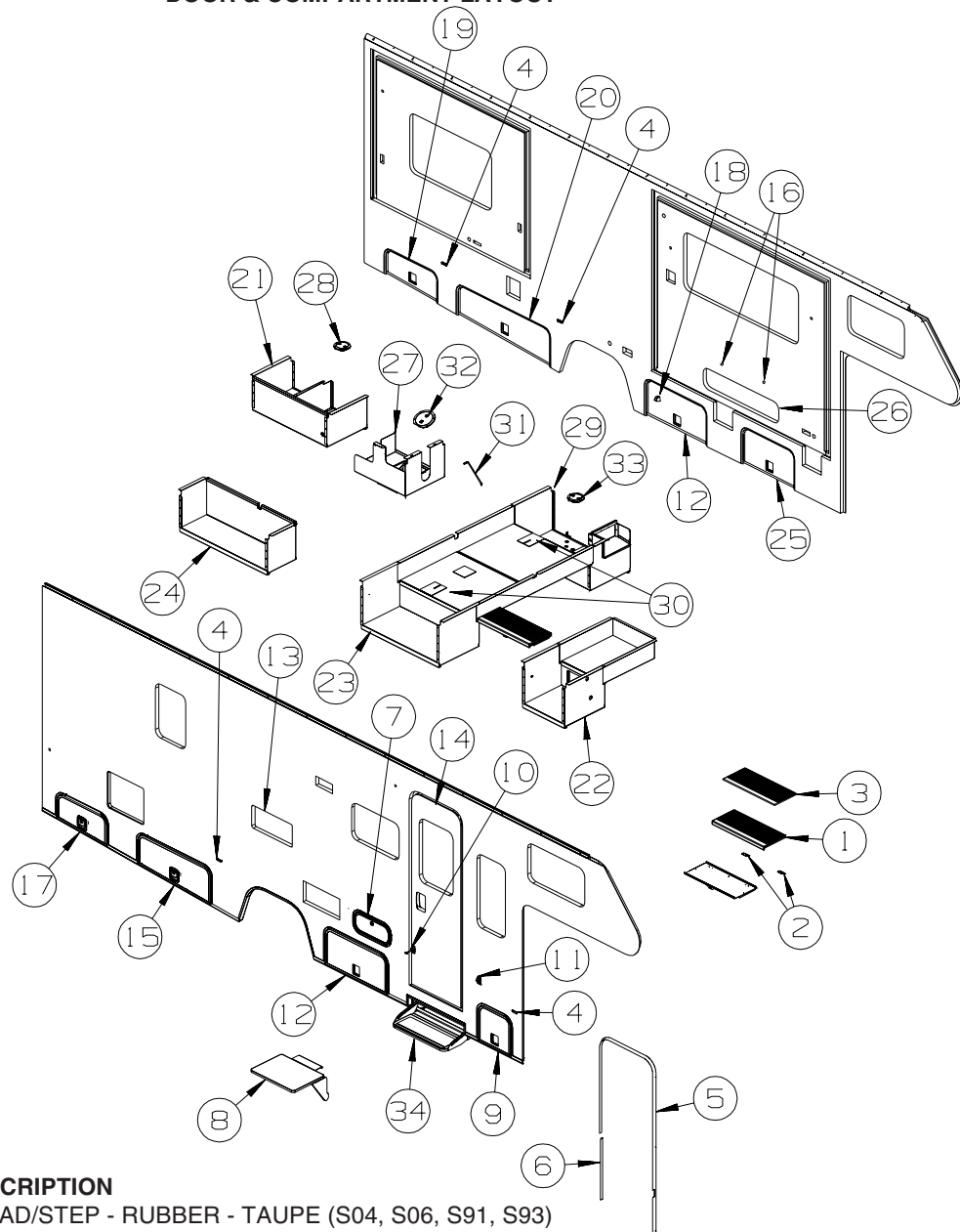

KEY	PART NUMBER	U/M	DESCRIPTION
1	147781-01-01A	EA	TREAD/STEP - RUBBER - TAUPE (S04, S06, S91, S93)
1	147781-01-03A	EA	TREAD/STEP - RUBBER - GRAY (S05, S92)
	116975-01-01A	EA	LATCH - W/O STRIKE - BLACK - NEW STYLE
2	146747-01-02B	EA	BRACKET/CATCH - E-COATED
3	133114-03-01A	EA	TREAD - STEP/RUBBER - 27.1" X 10.1" - TAUPE (S04, S06, S91, S93)
3	133114-03-03A	EA	TREAD - STEP/RUBBER - 27.1" X 10.1" - GRAY (S05, S92)
4	102768-01-000	EA	HOLDER - COMPARTMENT/ENTRY DOOR - METAL - MILL FINISH
5	139100-02-01A	EA	GARNISH/RADIUS - ENTRY DOOR - BRIGHT WHITE
6	139101-02-01A	EA	GARNISH/STRAIGHT - 35.31" - W/O NOTCHES - BRIGHT WHITE
7	126945-09-P07	EA	DOOR/STORAGE - W/O HDW/PADDLE LATCH - 18.3" X 9.9"
8	142034-01-01A	EA	SHelf - F/EXTERIOR TV - BRIGHT WHITE
9	148660-02-S01	EA	DOOR/STORAGE - W/O HDW/PADDLE LATCH - 16.7" X 16"
9	148660-02-AA1	EA	DOOR/STORAGE - W/O HDW/PADDLE LATCH - 16.7" X 16" - LOWER EXTERIOR PAINT
	056795-01-000	FT	TAPE-SEAL, 1/8" X 3/8" WIDE - PRESS ON
	107721-08-000	FT	SEAL - ACCESS DOOR - .9"WIDE X .9"HIGH
10	104099-01-04A	EA	CATCH - DOOR HOLDER - STRIKE - 3.9" - BRIGHT WHITE
11	104099-02-04A	EA	CATCH/RETAINER - DOOR HOLDER - BRIGHT WHITE
12	148660-12-S01	EA	DOOR/STORAGE - W/O HDW/PADDLE LATCH - 31.3" X 15.8"
12	148660-12-AA1	EA	DOOR/STORAGE - W/O HDW/PADDLE LATCH - 31.3" X 15.8" - LOWER EXTERIOR PAINT
	056795-01-000	FT	TAPE-SEAL, 1/8" X 3/8" WIDE - PRESS ON
	107721-08-000	FT	SEAL - ACCESS DOOR - .9"WIDE X .9"HIGH
13*	084103-08-000	EA	DOOR - VENT - REFRIGERATOR - W/O JAMB - BRIGHT WHITE
13	084104-08-000	EA	JAMB - VENT DOOR/REFRIGERATOR - BRIGHT WHITE

**EXTERIOR DOORS & COMPARTMENTS GROUP (CONTINUED)**  
**DOOR & COMPARTMENT LAYOUT (CONTINUED)**

KEY	PART NUMBER	U/M	DESCRIPTION
14	P32206-09-S01	EA	DOOR - ENTRY W/SCREEN DOOR - W/O WINDOW/LATCH (S04, S91)
14	P32206-09-S02	EA	DOOR - ENTRY W/SCREEN DOOR - W/O WINDOW/LATCH (S05, S92)
14	P32206-09-S03	EA	DOOR - ENTRY W/SCREEN DOOR - W/O WINDOW/LATCH (S06, S93)
15	148661-23-S01	EA	DOOR/STORAGE - PASS W/O HDW/LATCH - 15" X 36.8" X 13.1"
15	148661-23-AA1	EA	DOOR/STORAGE - PASS W/O HDW/LATCH - 15" X 36.8" X 13.1" - LOWER EXTERIOR PAINT
	056795-01-000	FT	TAPE-SEAL, 1/8" X 3/8" WIDE - PRESS ON
	107721-08-000	FT	SEAL - ACCESS DOOR - .9"WIDE X .9"HIGH
16	120863-05-000	EA	BUMPER - RUBBER/RADIUS TOP - 3/4" X 3/8"
17	148661-24-S01	EA	DOOR/STORAGE - PASS W/O HDW/LATCH - 12.3" X 25.3" X 10.9"
17	148661-24-AA1	EA	DOOR/STORAGE - PASS W/O HDW/LATCH - 12.3" X 25.3" X 10.9" - LOWER EXTERIOR PAINT
	056795-01-000	FT	TAPE-SEAL, 1/8" X 3/8" WIDE - PRESS ON
	107721-08-000	FT	SEAL - ACCESS DOOR - .9"WIDE X .9"HIGH
18	131383-03-02A	EA	BRACKET - SHOWER HEAD - WHITE
19	148661-22-S01	EA	DOOR/STORAGE - DRVR W/O HDW/LATCH - 12.5" X 26.9" X 11.1"
19	148661-22-AA1	EA	DOOR/STORAGE - DRVR W/O HDW/LATCH - 12.5" X 26.9" X 11.1" - LOWER EXTERIOR PAINT
	056795-01-000	FT	TAPE-SEAL, 1/8" X 3/8" WIDE - PRESS ON
	107721-08-000	FT	SEAL - ACCESS DOOR - .9"WIDE X .9"HIGH
20	148661-21-S01	EA	DOOR/STORAGE - DRVR W/O HDW/LATCH - 15.5" X 47.3" X 13"
20	148661-21-AA1	EA	DOOR/STORAGE - DRVR W/O HDW/LATCH - 15.5" X 47.3" X 13" - LOWER EXTERIOR PAINT
	056795-01-000	FT	TAPE-SEAL, 1/8" X 3/8" WIDE - PRESS ON
	107721-08-000	FT	SEAL - ACCESS DOOR - .9"WIDE X .9"HIGH
21	137554-35-S01	EA	COMPARTMENT - LUGGAGE
22	137554-19-P07	EA	COMPARTMENT - LUGGAGE
23	137554-33-S01	EA	COMPARTMENT - LUGGAGE
24	137554-34-S01	EA	COMPARTMENT - LUGGAGE
25	148660-15-S01	EA	DOOR/STORAGE - W/O HDW/PADDLE LATCH - 26.9" X 15.8"
25	148660-15-AA1	EA	DOOR/STORAGE - W/O HDW/PADDLE LATCH - 26.9" X 15.8" - LOWER EXTERIOR PAINT
	056795-01-000	FT	TAPE-SEAL, 1/8" X 3/8" WIDE - PRESS ON
	107721-08-000	FT	SEAL - ACCESS DOOR - .9"WIDE X .9"HIGH
26	126946-43-S34	EA	DOOR STORAGE - W/O HARDWARE - 37.8" X 8.3" - DINETTE, U-SHAPED
	056795-01-000	FT	TAPE-SEAL, 1/8" X 3/8" WIDE - PRESS ON
27	151472-01-02B	EA	COMPARTMENT - SEWER - E-COATED
28	092887-03-000	EA	HATCH/PLATE - 6.1" FLANGE/4.5" R.O. - BLACK
29	137554-36-S07	EA	COMPARTMENT - LUGGAGE
30	153157-01-14B	EA	PLATE/SEAL - GALVANIZED
31	107865-02-000	EA	ROD - SUPPORT - VALANCE PANEL - 13.2"
32	092887-02-000	EA	HATCH/PLATE - 7.4" FLANGE/6.5" R.O. - BLACK
33	092887-01-000	EA	HATCH/PLATE - 8.2" FLANGE/6.5" R.O. - BLACK
34	139748-03-04B	EA	STEP/PULLOUT - W/BRACKETS - BLACK
	102569-04-000	EA	MAT - ANTI SLIP
34*	094708-03-01A	EA	STEP - ELECTRIC - SINGLE - BLACK CONTROL BOX - KWIKEE - ELECTRIC ENTRANCE STEP
	104692-01-000	FT	SEAL - ADHESIVE BACKED FOAM - 3/4" THICK X 3/4" WIDE X 25'

**EARLY LOCK ASM**

FROM: 00-00-00 THRU: 02-24-05

138637-51-000	EA	KEYS - SET OF TWO
138637-51-001	EA	KEYS - SET OF TWO
138637-51-002	EA	KEYS - SET OF TWO
138637-51-003	EA	KEYS - SET OF TWO
138637-51-004	EA	KEYS - SET OF TWO
138637-51-005	EA	KEYS - SET OF TWO
138637-51-006	EA	KEYS - SET OF TWO
138637-51-007	EA	KEYS - SET OF TWO
138637-51-008	EA	KEYS - SET OF TWO
138637-51-009	EA	KEYS - SET OF TWO
138637-53-000	EA	CASE/CYLINDER - LOCKING - W/O CAM/KEY - 1.5"
138637-53-001	EA	CASE/CYLINDER - LOCKING - W/O CAM/KEY - 1.5"
138637-53-002	EA	CASE/CYLINDER - LOCKING - W/O CAM/KEY - 1.5"
138637-53-003	EA	CASE/CYLINDER - LOCKING - W/O CAM/KEY - 1.5"
138637-53-004	EA	CASE/CYLINDER - LOCKING - W/O CAM/KEY - 1.5"
138637-53-005	EA	CASE/CYLINDER - LOCKING - W/O CAM/KEY - 1.5"
138637-53-006	EA	CASE/CYLINDER - LOCKING - W/O CAM/KEY - 1.5"
138637-53-007	EA	CASE/CYLINDER - LOCKING - W/O CAM/KEY - 1.5"
138637-53-008	EA	CASE/CYLINDER - LOCKING - W/O CAM/KEY - 1.5"
138637-53-009	EA	CASE/CYLINDER - LOCKING - W/O CAM/KEY - 1.5"

**EXTERIOR DOORS & COMPARTMENTS GROUP (CONTINUED)**  
**DOOR & COMPARTMENT LAYOUT (CONTINUED)**

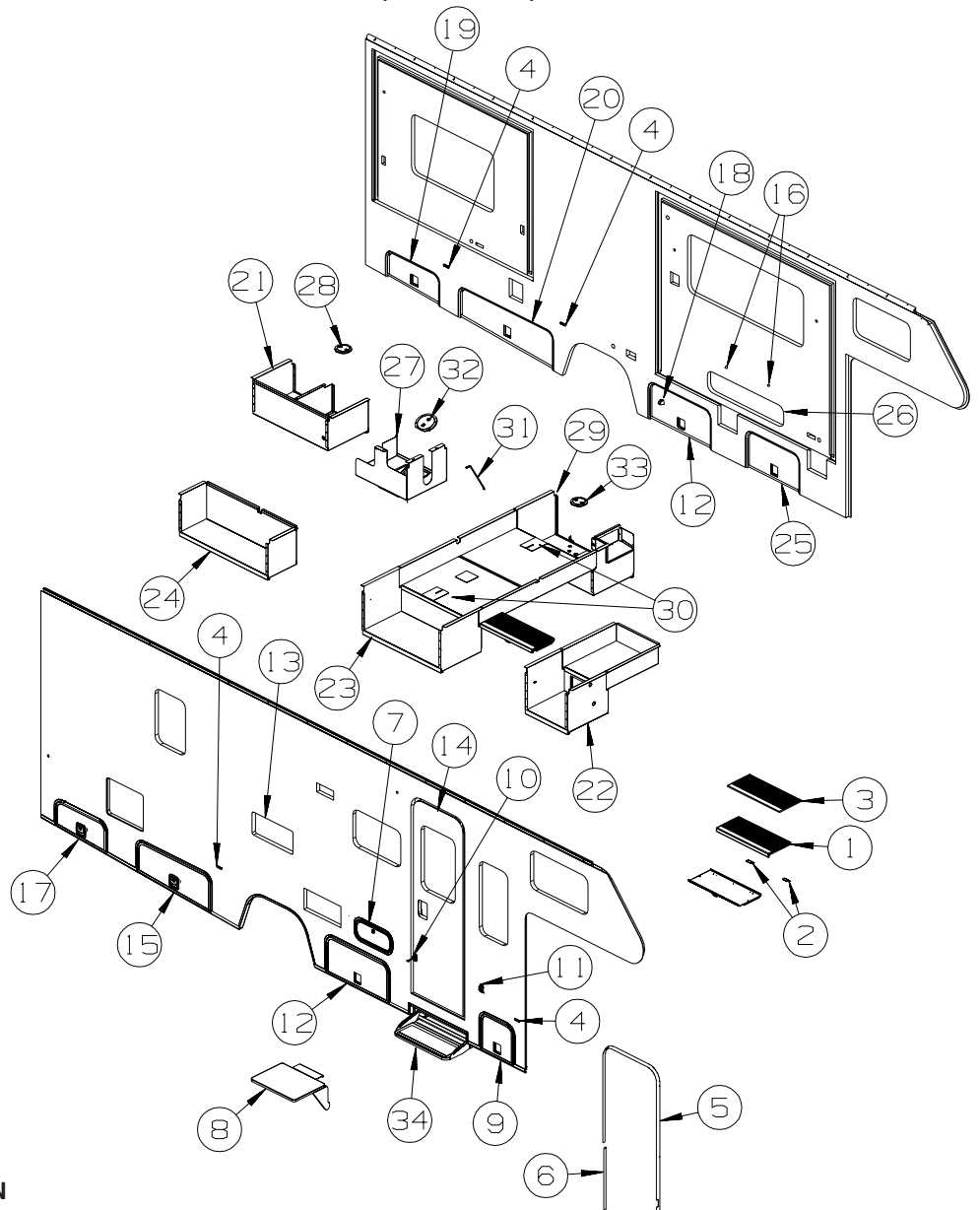

FROM: 02-25-05 THRU: 99-99-99

**KEY PART NUMBER  
LATER LOCK ASM**

**U/M DESCRIPTION**

138288-01-000	EA KEY - REVERSIBLE - #1151 - T/M 16169-02-1151
138288-02-000	EA KEY - REVERSIBLE - #1151 - T/M 16169-02-1152
138288-03-000	EA KEY - REVERSIBLE - #1151 - T/M 16169-02-1153
138288-04-000	EA KEY - REVERSIBLE - #1151 - T/M 16169-02-1154
138288-05-000	EA KEY - REVERSIBLE - #1151 - T/M 16169-02-1155
138288-06-000	EA KEY - REVERSIBLE - #1151 - T/M 16169-02-1156
138288-07-000	EA KEY - REVERSIBLE - #1151 - T/M 16169-02-1157
138288-08-000	EA KEY - REVERSIBLE - #1151 - T/M 16169-02-1158
138288-09-000	EA KEY - REVERSIBLE - #1151 - T/M 16169-02-1159
138288-10-000	EA KEY - REVERSIBLE - #1151 - T/M 16169-02-1150
138289-01-000	EA CYLINDER/LOCK - ACCESS DOOR
138289-02-000	EA CYLINDER/LOCK - ACCESS DOOR
138289-03-000	EA CYLINDER/LOCK - ACCESS DOOR
138289-04-000	EA CYLINDER/LOCK - ACCESS DOOR
138289-05-000	EA CYLINDER/LOCK - ACCESS DOOR
138289-06-000	EA CYLINDER/LOCK - ACCESS DOOR
138289-07-000	EA CYLINDER/LOCK - ACCESS DOOR
138289-08-000	EA CYLINDER/LOCK - ACCESS DOOR
138289-09-000	EA CYLINDER/LOCK - ACCESS DOOR
138289-10-000	EA CYLINDER/LOCK - ACCESS DOOR

**\*COMPONENT PARTS LISTED LATER IN THIS GROUP**

# EXTERIOR DOORS & COMPARTMENTS GROUP (CONTINUED)

## COMPONENT PARTS FOR DOOR & COMPARTMENT LAYOUT

084103-08-000

KEY	PART NUMBER	U/M	DESCRIPTION	VENDOR NO.
	084104-01-700	EA	LOCK-MALE, FASTENER	201-721-010
	084104-01-701	EA	LOCK-FEMALE, FASTENER	201-802-010

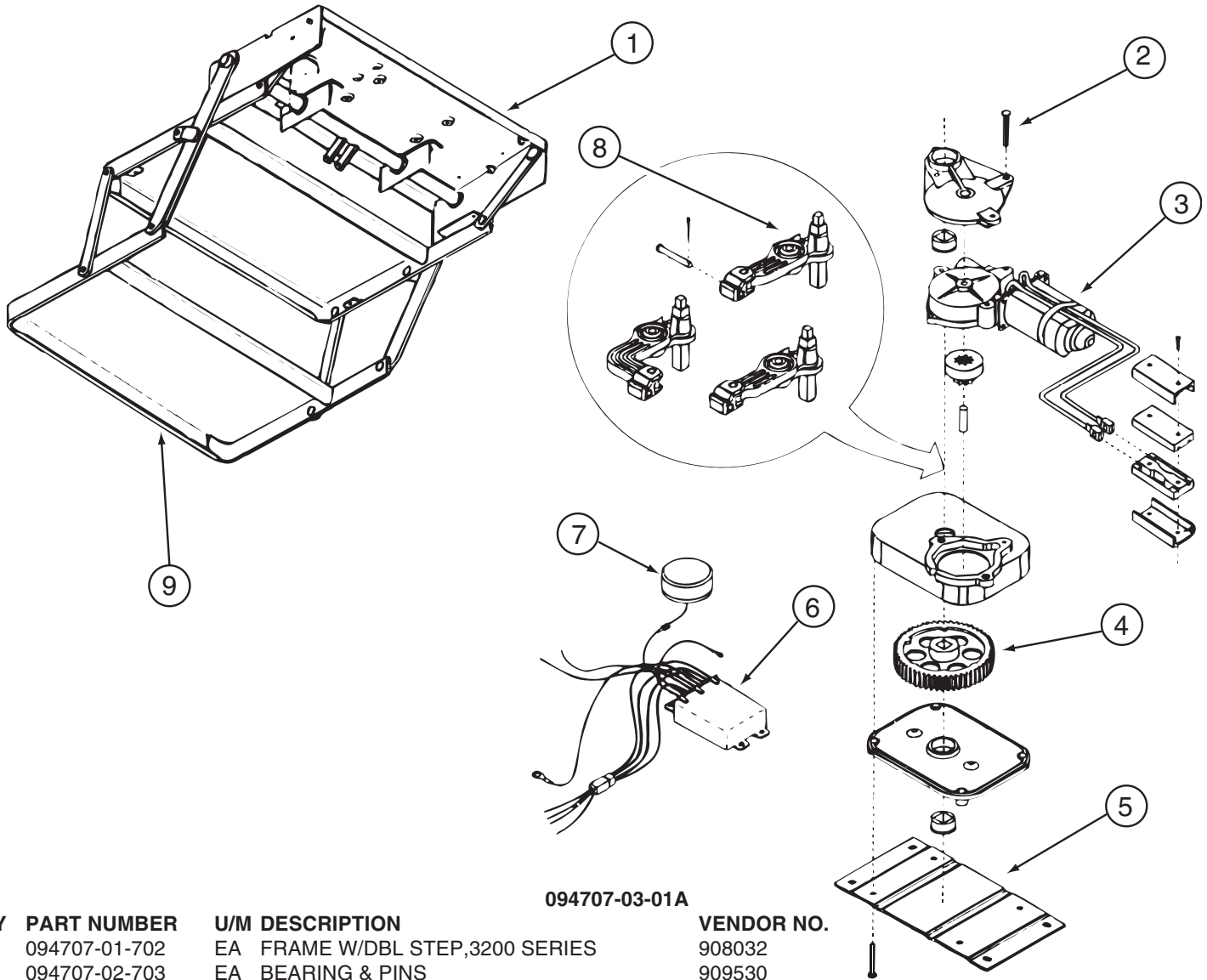

094707-03-01A

KEY	PART NUMBER	U/M	DESCRIPTION	VENDOR NO.
1	094707-01-702	EA	FRAME W/DBL STEP,3200 SERIES	908032
2	094707-02-703	EA	BEARING & PINS	909530
3	094707-02-700	EA	MOTOR - "UT" ASM W/BRGS/PIN	909520
4	094707-02-702	EA	GEAR KIT(GEAR-BEARING-PINS)	909525
5	094707-02-704	EA	CONNECTOR-MOTOR ASM.W/PLATES	909537
6	094707-03-700	EA	KIT CONTROL/SWITCH-RETROFIT	909506005
7	088746-01-705	EA	LIGHT-UNDER STEP	9004
7	088733-01-700	EA	BULB	9004
8	094707-02-701	EA	LINKAGE ASM. W/BEARINGS-PINS	909534
9	094707-02-707	EA	TREAD - NON-SKID - BLACK	909333
	094707-02-706	EA	GEAR BOX ASM. W/O MOTOR	9524
	094707-02-708	EA	TREAD - NON-SKID - YELLOW	909331
	094707-03-701	EA	PLUG - 4-WAY - PACKARD	909306



**EXTERIOR DOORS & COMPARTMENTS GROUP (CONTINUED)**  
**COMPONENT PARTS FOR DOOR & COMPARTMENT LAYOUT (CONTINUED)**

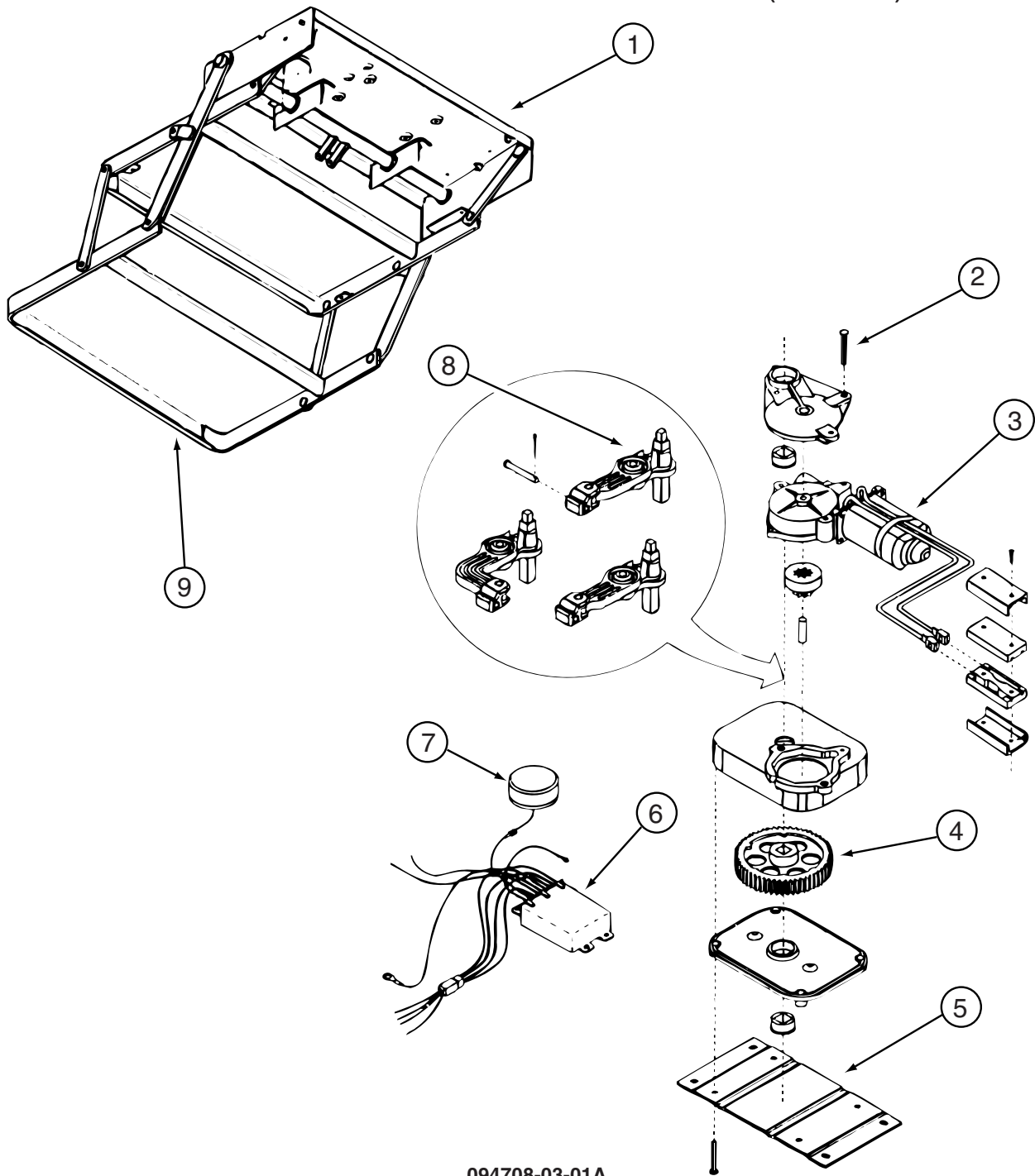

094708-03-01A

KEY	PART NUMBER	U/M	DESCRIPTION	VENDOR NO.
1	088746-01-709	EA	FRAME W/SSL STEP,2800 SERIES	908028
2	094707-02-703	EA	BEARING & PINS	909530
3	094707-02-700	EA	MOTOR ASM.,W/BEARINGS & PINS	909520
4	094707-02-702	EA	GEAR KIT(GEAR-BEARING-PINS)	909525
5	094707-02-704	EA	CONNECTOR-MOTOR ASM.W/PLATES	909537
6	094707-03-700	EA	KIT CONTROL/SWITCH-RETROFIT	909506005
7	088733-01-700	EA	BULB	9004
7	088746-01-705	EA	LIGHT-UNDER STEP	9004
8	094708-03-700	EA	LINKAGE ASSEMBLY-SERIES 28	909533
9	094707-02-707	EA	TREAD - NON-SKID - BLACK	909333
	094707-03-701	EA	PLUG - 4-WAY - PACKARD	909306

**EXTERIOR DOORS & COMPARTMENTS GROUP (CONTINUED)**  
**COMPARTMENT DOOR PIECE PARTS**

**ENTERTAINMENT CENTER**

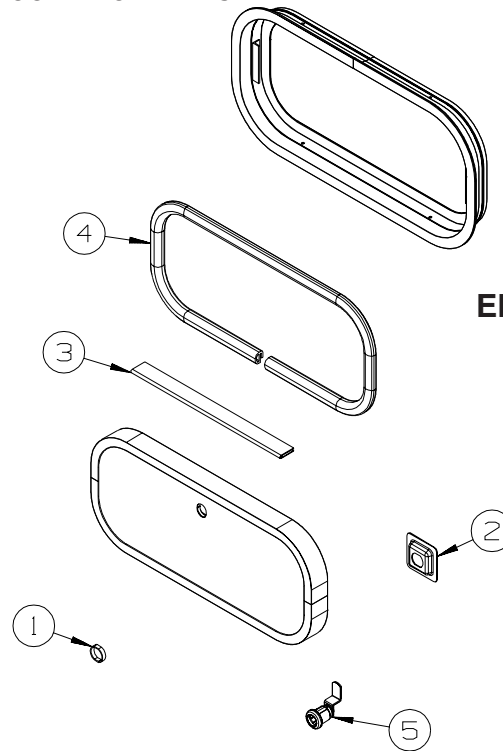

KEY	PART NUMBER	U/M	DESCRIPTION
1	139325-01-000	EA	SPACER - LOCK - 6MM
	139337-01-000	EA	GASKET - LOCK
2	097111-02-05A	EA	POCKET - LOCK - REAR DOOR - BRIGHT WHITE
2	097111-02-04A	EA	POCKET - LOCK - REAR DOOR - BLACK - <b>FULL BODY OR LOWER EXT PAINT</b>
3	081801-V3-000	EA	HINGE - DOOR - PIANO - 2" X 96" - BRIGHT WHITE
3	081801-FN-000	EA	HINGE - DOOR - PIANO - 2" X 96" - BLACK - <b>FULL BODY OR LOWER EXT PAINT</b>
4	106850-02-000	FT	SEAL-E - SPONGE RUBBER - .43" X .75"
5	138290-02-000	EA	CASE - W/CAM - W/O CYLINDER/KEY

**322E & 331ST**

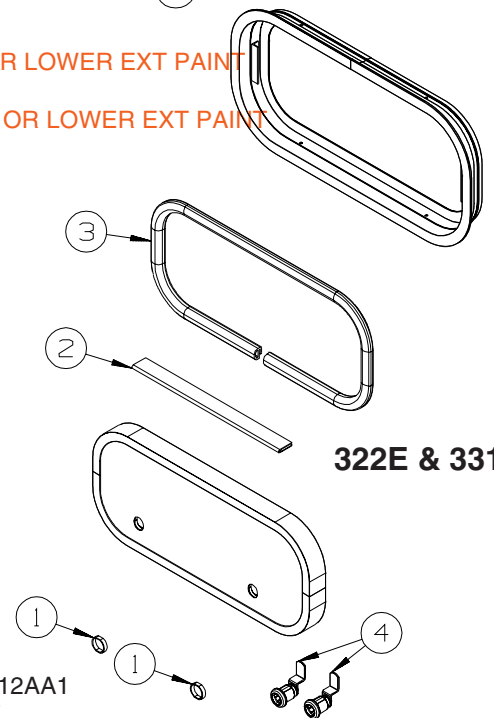

KEY	PART NUMBER	U/M	DESCRIPTION
1	144734-01-000	EA	SPACER - COMPARTMENT DOOR LOCK - 9/16" DEEP
2	081801-V3-000	EA	HINGE - DOOR - PIANO - 2" X 96" - BRIGHT WHITE
3	106850-02-000	FT	SEAL-E - SPONGE RUBBER - .43" X .75"
4*	110506-27-000	EA	LOCK - TWIST - 1.6"
	110506-55-000	EA	CASE/CYLINDER - TWIST LOCK - W/O CAM - 1.25" - 597312AA1
	110506-66-000	EA	CAM - LATCHING - DOG LEG - 1.5" LONG - <b>TWIST LOCK</b>
4	138637-04-000	EA	LOCK ASM. - KEYED - 1.5" CASE (CYLINDER/CAM/HDWR PKG) - <b>KEYED LOCK</b>
	144474-01-000	EA	ADAPTER - LOCK - 180 DEGREE - <b>KEYED LOCK</b>
	138637-63-000	EA	CAM - LATCHING - DOG LEG - 1 1/2" LONG - <b>KEYED LOCK</b>
	138637-53-000	EA	CASE/CYLINDER - LOCKING - W/O CAM/KEY - 1.5"
	138637-53-001	EA	CASE/CYLINDER - LOCKING - W/O CAM/KEY - 1.5"
	138637-53-002	EA	CASE/CYLINDER - LOCKING - W/O CAM/KEY - 1.5"
	138637-53-003	EA	CASE/CYLINDER - LOCKING - W/O CAM/KEY - 1.5"
	138637-53-004	EA	CASE/CYLINDER - LOCKING - W/O CAM/KEY - 1.5"
	138637-53-005	EA	CASE/CYLINDER - LOCKING - W/O CAM/KEY - 1.5"
	138637-53-006	EA	CASE/CYLINDER - LOCKING - W/O CAM/KEY - 1.5"
	138637-53-007	EA	CASE/CYLINDER - LOCKING - W/O CAM/KEY - 1.5"
	138637-53-008	EA	CASE/CYLINDER - LOCKING - W/O CAM/KEY - 1.5"
	138637-53-009	EA	CASE/CYLINDER - LOCKING - W/O CAM/KEY - 1.5"

\*COMPONENT PARTS LISTED LATER IN THIS GROUP



**EXTERIOR DOORS & COMPARTMENTS GROUP (CONTINUED)**  
**COMPARTMENT DOOR PIECE PARTS (CONTINUED)**

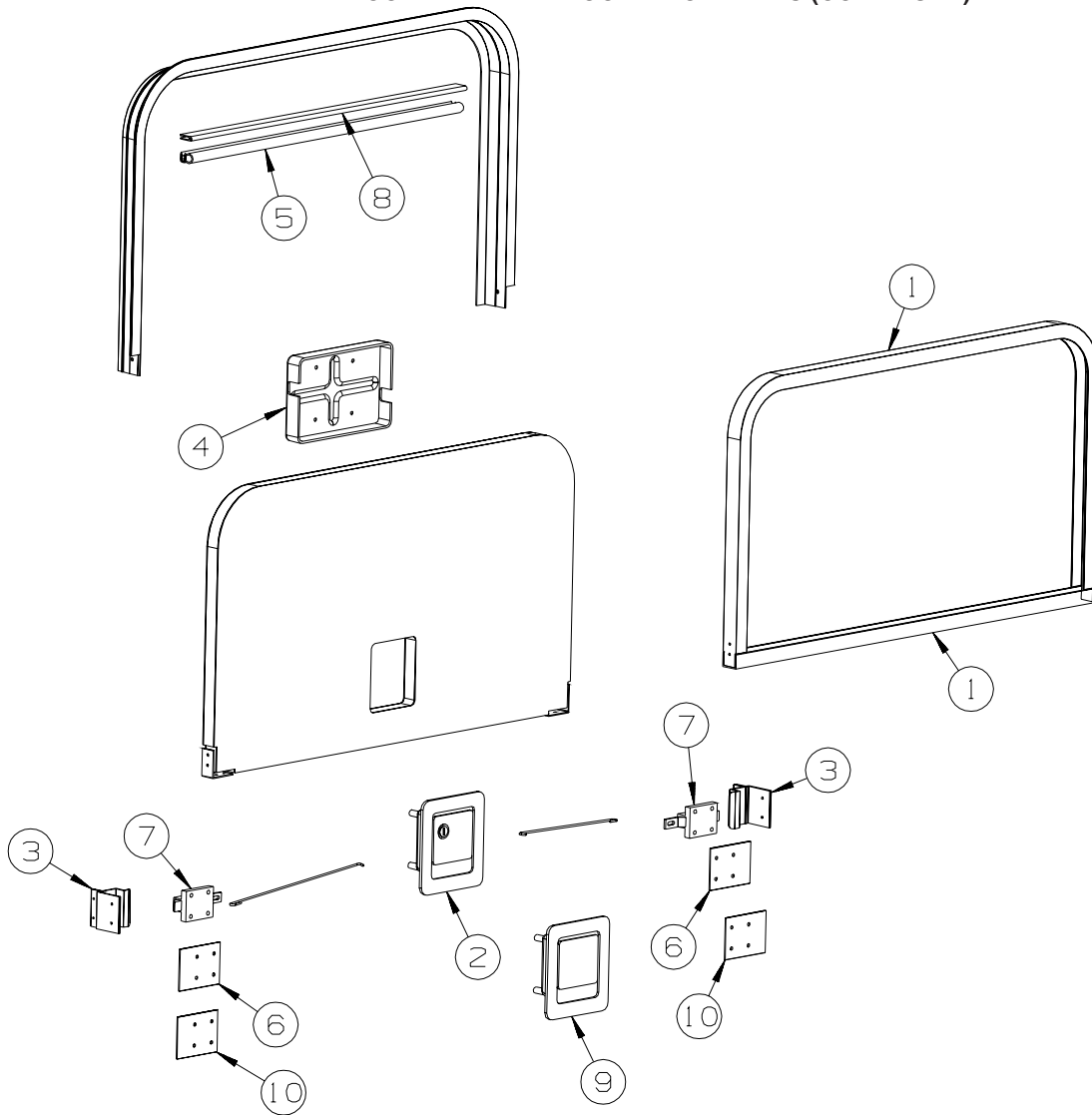

**PADDLE  
LATCH DOORS**

KEY	PART NUMBER	U/M DESCRIPTION
1	096217-55-006	EA U-CHANNEL - 210" - BRIGHT WHITE
1	096217-55-009	EA U-CHANNEL - 210" - BLACK
2	138277-01-01A	EA LATCH/PADDLE - COMPARTMENT DOOR - BLACK - KEY ONE
2	138277-01-02A	EA LATCH/PADDLE - COMPARTMENT DOOR - WHITE - KEY ONE
3	150789-01-S01	EA STRIKER - STORAGE DOOR
4	122277-06-02A	EA COVER - LATCH - WHITE
5	151104-01-01A	FT SEAL - BULB - W/WIRED U CHANNEL - .3" X .5" CHANNEL-BLACK
6	121577-07-01A	EA STRAP/PLATE - W/HOLE - 2.25" X 3" - BRIGHT WHITE
	035648-51-001	EA STRAP - EXTRUSION - 2.25" X 80.6"
7	149741-01-01A	EA BOLT - SLIDE/LATCH
8	151229-06-01A	EA HINGE - CONTINUOUS - 1.5" X 72.4" - BRIGHT WHITE
8	151229-06-02A	EA HINGE - CONTINUOUS - 1.5" X 72.4" - BLACK
8	151229-12-01A	EA HINGE - CONTINUOUS - 1.5" X 40.6" - BRIGHT WHITE
8	151229-12-02A	EA HINGE - CONTINUOUS - 1.5" X 40.6" - BLACK
9	112949-02-04A	EA LATCH/PADDLE - NON-LOCKING - BRIGHT WHITE
9	112949-02-05A	EA LATCH/PADDLE - NON-LOCKING - BLACK
10	149738-01-01A	EA SPACER - SLIDE BOLT

FROM: 00-00-00 THRU: 05-02-04

**EXTERIOR DOORS & COMPARTMENTS GROUP (CONTINUED)**  
**COMPARTMENT DOOR PIECE PARTS (CONTINUED)**

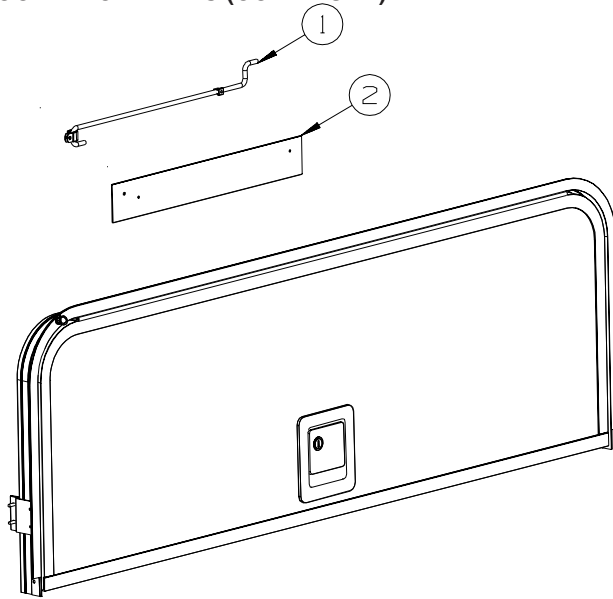

**WITH PROP  
RODS**

KEY	PART NUMBER	U/M	DESCRIPTION
1	155346-03-04B	EA	PROP ROD - 10.6" - BLACK
1	155346-04-04B	EA	PROP ROD - 15.3" - BLACK
1	155346-06-04B	EA	PROP ROD - 21" - BLACK
1	155346-07-04B	EA	PROP ROD - 17.3" - BLACK
2	121577-01-01A	EA	STRAP/PLATE - W/HOLE - 2.25" X 26" - BRIGHT WHITE
2	121577-02-01A	EA	STRAP/PLATE - W/HOLE - 2.25" X 11.8" - BRIGHT WHITE
2	121577-06-01A	EA	STRAP/PLATE - W/HOLE - 2.25" X 15.8" - BRIGHT WHITE
2	121577-08-01A	EA	STRAP/PLATE - W/HOLE - 2.25" X 10" - BRIGHT WHITE
	035648-51-001	EA	EXTR - STRAP .062 X 2.25 X 2050 MM, 6063T5

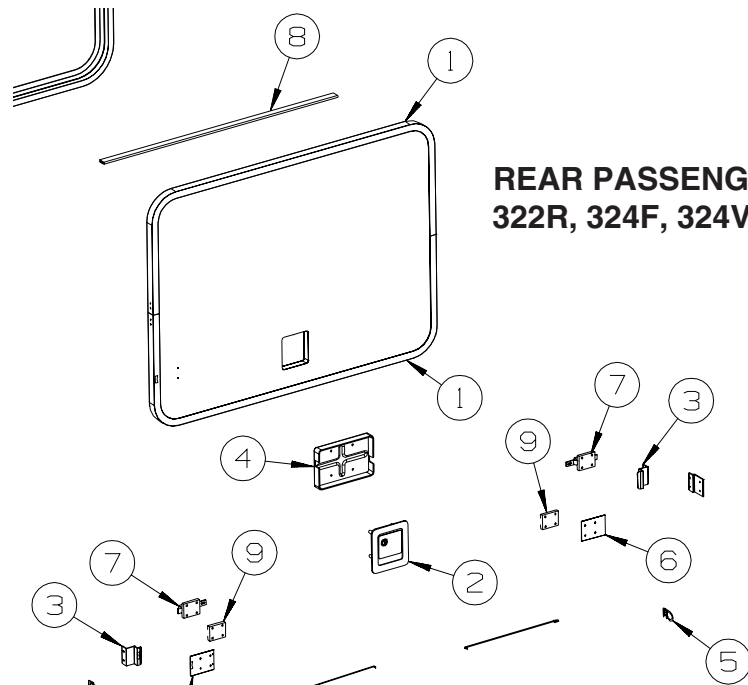

**REAR PASSENGER SIDE  
322R, 324F, 324V, & 326A**

KEY	PART NUMBER	U/M	DESCRIPTION
1	096217-55-006	EA	U-CHANNEL - 210" - BRIGHT WHITE
2	138277-01-02A	EA	LATCH/PADDLE - WHITE - KEY ONE
3	149737-01-01A	EA	STRIKER - STORAGE DOOR - BRIGHT WHITE
4	122277-06-02A	EA	COVER - LATCH - WHITE
5	151104-01-01A	FT	SEAL - BULB - W/WIRED U CHANNEL - .3" X .5" CHANNEL-BLACK
6	121577-07-01A	EA	PLATE - W/HOLE - BRIGHT WHITE
	035648-51-001	EA	EXTR - STRAP .062 X 2.25 X 2050 MM, 6063T5
7	149741-01-01A	EA	BOLT - SLIDE/LATCH
8	151229-06-01A	EA	HINGE - CONTINUOUS - 1.5" X 72.4" - BRIGHT WHITE
9	149738-01-01A	EA	SPACER - SLIDE BOLT

FROM: 00-00-00 THRU: 05-06-04

# EXTERIOR DOORS & COMPARTMENTS GROUP (CONTINUED)

## COMPONENT PARTS FOR COMPARTMENT DOOR PIECE PARTS

110506-A1-000, 110506-A2-000, 110506-26-000, 110506-27-000

KEY	PART NUMBER	U/M	DESCRIPTION	VENDOR NO .
	110506-40-700	EA	HARDWARE PACKAGE-CYLINDER/CASE	596950AAL

# EXTERIOR DOORS & COMPARTMENTS GROUP (CONTINUED)

## ENTRY

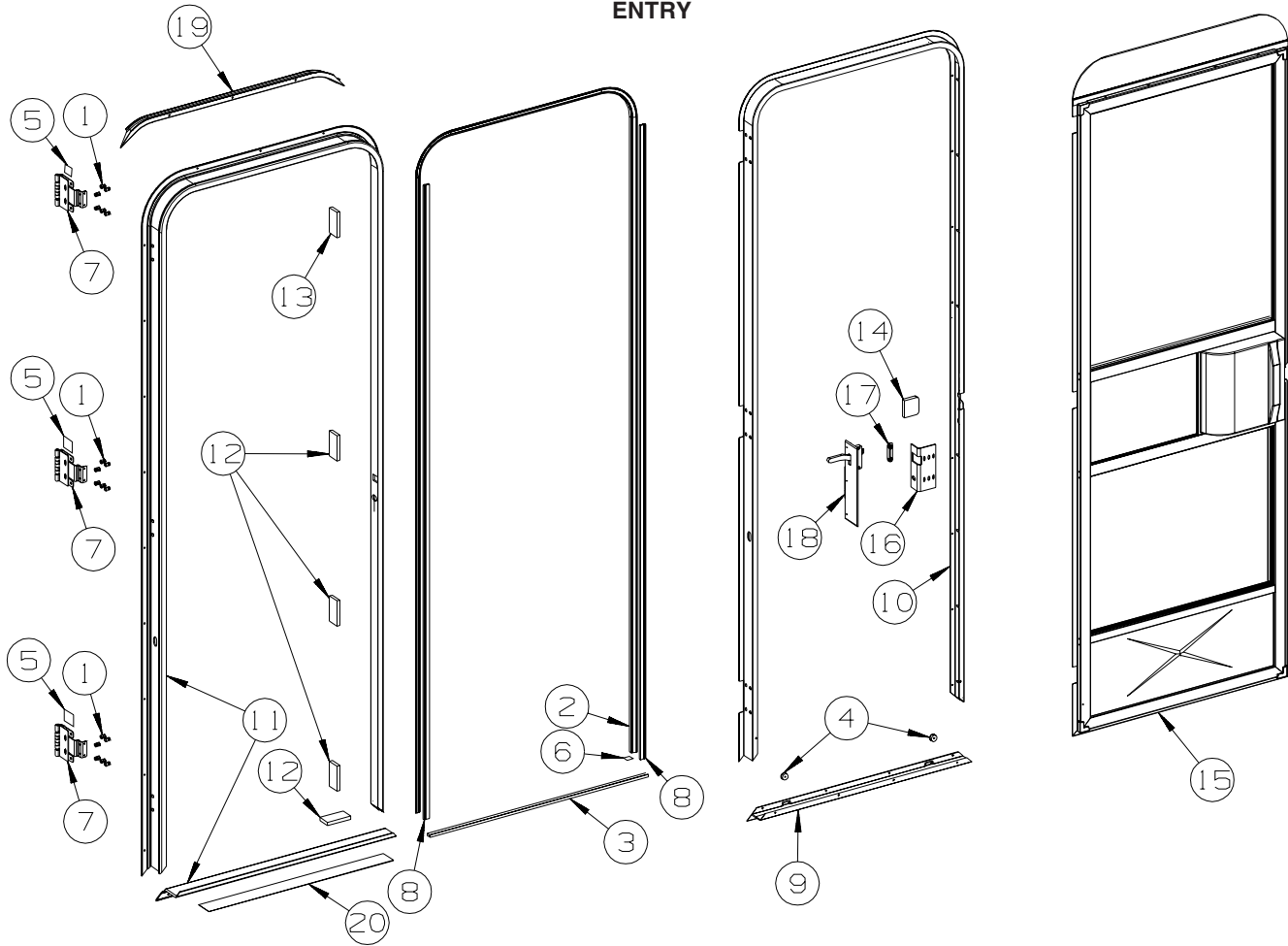

KEY	PART NUMBER	U/M	DESCRIPTION	
1	039715-01-000	EA	NUT-SERT - 1/4" DIAMETER - 20 THREADS	
2	075671-04-000	FT	SEAL - SPONGE - LAZY T - W/ADHESIVE STRIP - .5" WIDE	
3	075673-05-000	FT	SEAL/PILE - .5" HIGH W/ADHESIVE BACK - BLACK	
4	081914-02-000	EA	BUMPER - RUBBER - ROUND - 5/16" DIA. X 13/64" THICK	
5	100128-02-000	FT	SEAL - FOAM/ADHESIVE BACK - .37" WIDE X .37" THICK	
6	104692-01-000	FT	SEAL - ADHESIVE BACKED FOAM - 3/4" THICK X 3/4" WIDE X 25'	
7	106719-01-05A	EA	HINGE - ENTRY DOOR - BRIGHT WHITE	
8	118929-01-01A	FT	SEAL - PILE - PUSH ON	
9	121893-01-01A	EA	FRAME - ENTRY DOOR/BOTTOM - BRIGHT WHITE	
10	121894-28-01A	EA	FRAME - ENTRY DOOR - BRIGHT WHITE	ROTOR
11	121898-16-01A	EA	JAMB - DOOR/ENTRANCE - BRIGHT WHITE	
12	125724-01-000	EA	SHIM - DOOR, ENTRANCE	
13	125724-02-000	EA	SHIM - DOOR - ENTRANCE	
14	130096-05-000	EA	FOAM - SCREEN DOOR, RETAINER	
15	132208-04-L07	EA	DOOR - SCREEN - W/O HARDWARE	
16	137401-01-03B	EA	BRACKET - DOOR ANGLE - OFF WHITE	
17	148364-01-12B	EA	STRIKE - SCREEN DOOR - BRIGHT WHITE	
	138287-01-000	EA	CYLINDER/LOCK - ENTRY DOOR (MASTER)	
	138287-02-000	EA	CYLINDER/LOCK - ENTRY DOOR (MASTER)	
	138287-03-000	EA	CYLINDER/LOCK - ENTRY DOOR (MASTER)	
	138287-04-000	EA	CYLINDER/LOCK - ENTRY DOOR (MASTER)	
	138287-05-000	EA	CYLINDER/LOCK - ENTRY DOOR (MASTER)	
	138287-06-000	EA	CYLINDER/LOCK - ENTRY DOOR (MASTER)	
	138287-07-000	EA	CYLINDER/LOCK - ENTRY DOOR (MASTER)	
	138287-08-000	EA	CYLINDER/LOCK - ENTRY DOOR (MASTER)	
	138287-09-000	EA	CYLINDER/LOCK - ENTRY DOOR (MASTER)	
	138287-10-000	EA	CYLINDER/LOCK - ENTRY DOOR (MASTER)	

**EXTERIOR DOORS & COMPARTMENTS GROUP (CONTINUED)**  
**ENTRY (CONTINUED)**

KEY	PART NUMBER	U/M	DESCRIPTION
	138288-01-000	EA	KEY - REVERSIBLE - #1151 - T/M 16169-02-1151
	138288-02-000	EA	KEY - REVERSIBLE - #1152 - T/M 16169-02-1152
	138288-03-000	EA	KEY - REVERSIBLE - #1153 - T/M 16169-02-1153
	138288-04-000	EA	KEY - REVERSIBLE - #1154 - T/M 16169-02-1154
	138288-05-000	EA	KEY - REVERSIBLE - #1155 - T/M 16169-02-1155
	138288-06-000	EA	KEY - REVERSIBLE - #1156 - T/M 16169-02-1156
	138288-07-000	EA	KEY - REVERSIBLE - #1157 - T/M 16169-02-1157
	138288-08-000	EA	KEY - REVERSIBLE - #1158 - T/M 16169-02-1158
	138288-09-000	EA	KEY - REVERSIBLE - #1159 - T/M 16169-02-1159
	138288-10-000	EA	KEY - REVERSIBLE - #1150 - T/M 16169-02-1150
18	132915-01-01A	EA	LATCH - SCREEN DOOR - BLACK
	138292-01-000	EA	SEAL - LOCK CYLINDER
19	139054-01-01A	EA	CAP - DRIP - JAMB MOUNTED - BRIGHT WHITE
20	038327-01-000	EA	TAPE - ANTI-SLIP - 2" X 60'

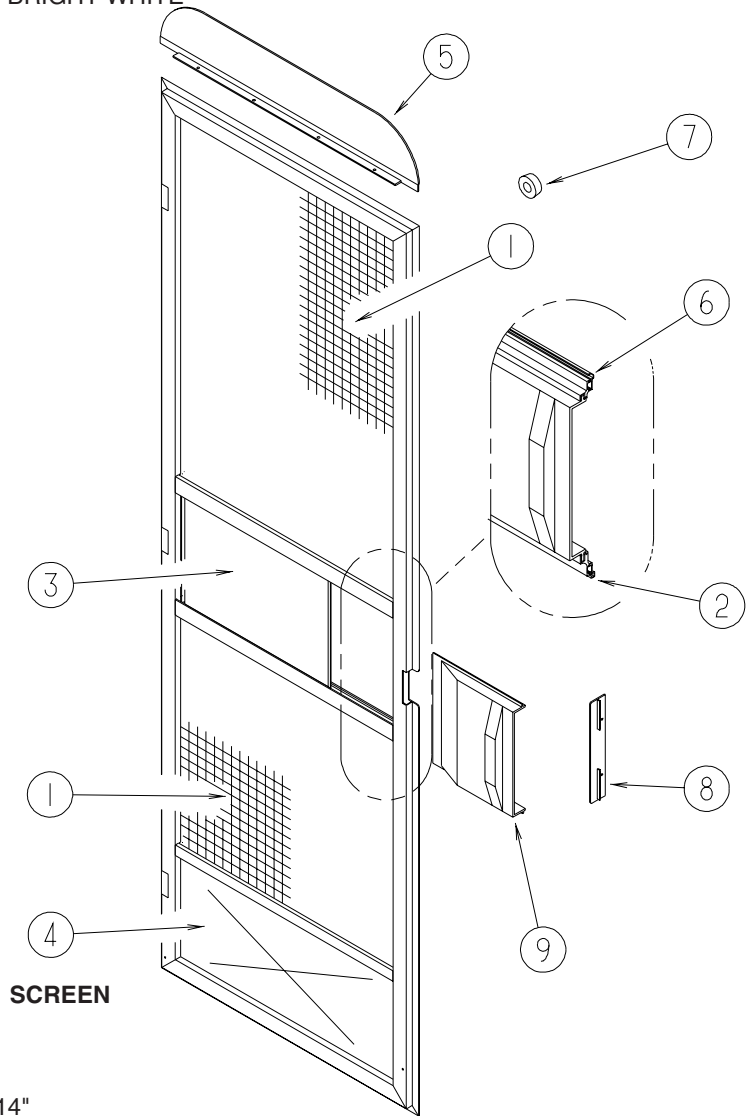

**SCREEN**

KEY	PART NUMBER	U/M	DESCRIPTION
1	002293-02-000	SF	SCREEN - 26" - CHARCOAL
2	002294-01-000	FT	SPLINE - SCREENING - .13" X .14"
3	016454-21-000	EA	INSERT/CENTER - SCREEN DOOR
4	078552-03-000	EA	KICK PANEL - SCREEN DOOR - LOWER INSERT - UNPAINTED
5	078595-01-000	EA	TOP PLATE - SCREEN DOOR - CURVED TOP - 4.7" X 25.35"
6	078777-08-000	FT	CHANNEL - SLIDER - 4 FOOT INCREMENTS
7	120863-06-000	EA	BUMPER - RUBBER/RADIUS TOP - 3/4" X 3/8" - LT GRAY
			FROM: 00-00-00 THRU: 06-26-05
7	120863-09-000	EA	BUMPER - RUBBER/RADIUS TOP - 3/4" X 3/8" - LT GRAY
			FROM: 06-27-05 THRU: 99-99-99
8	132081-01-01A	EA	STRIKE - SLIDER - SCREEN DOOR - BRIGHT WHITE
9	132082-01-01A	EA	SLIDER - SCREEN DOOR - BRIGHT WHITE

# EXTERIOR DOORS & COMPARTMENTS GROUP (CONTINUED)

## LATCH - ENTRY

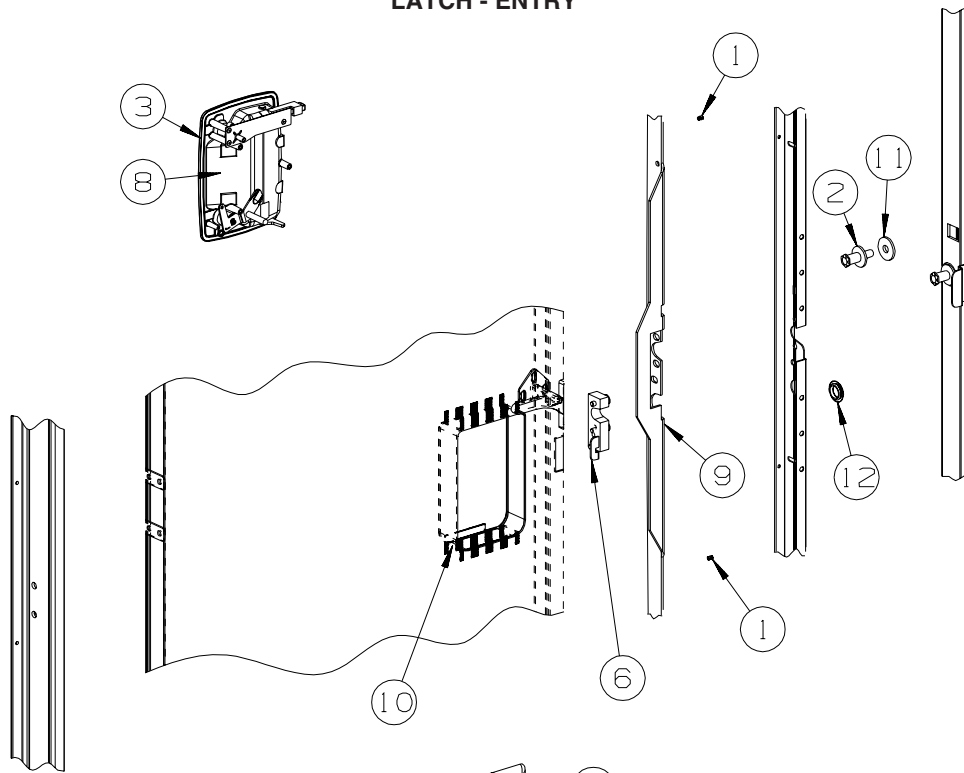

KEY	PART NUMBER	U/M	DESCRIPTION
1	072893-04-000	EA	NUTSERT - 10-32
2	092927-15-000	EA	STRIKER - BOLT
3	112782-04-01A	EA	GASKET
4	112782-05-01A	EA	CAP - VINYL - RED
5	112782-08-01A	EA	SCREW - MOUNTING/PLATE - ZINC
6	112782-15-01A	EA	LATCH - SINGLE ROTOR
6	112782-22-01A	EA	LATCH - SINGLE ROTOR
7	112782-16-01A	EA	LATCH - INTERIOR PLATE
7	112782-21-01A	EA	LATCH - INTERIOR PLATE
8	112782-18-01A	EA	LATCH - EXTERIOR - W/O LOCK CYLINDER W/ICON-REVERSIBLE KEY
8	112782-20-01A	EA	LATCH - EXTERIOR - W/O LOCK CYLINDER W/ICON-REVERSIBLE KEY
9	132207-01-02B	EA	STIFFENER/DOOR - FORMED - E-COATED
10	137230-01-01A	EA	SPACER - NOTCHED, MILL
11	147900-01-01A	EA	SPACER - STRIKE BOLT, MILL
12	061420-14-000	EA	PLUG/PLASTIC - 7/8" DIAMETER - BLACK

FROM: 00-00-00 THRU: 05-30-04

FROM: 05-31-04 THRU: 99-99-99

FROM: 00-00-00 THRU: 05-30-04

FROM: 05-31-04 THRU: 99-99-99

FROM: 00-00-00 THRU: 05-30-04

FROM: 05-31-04 THRU: 99-99-99

# EXTERIOR SLIDEOUT GROUP

## FRONT LEFT

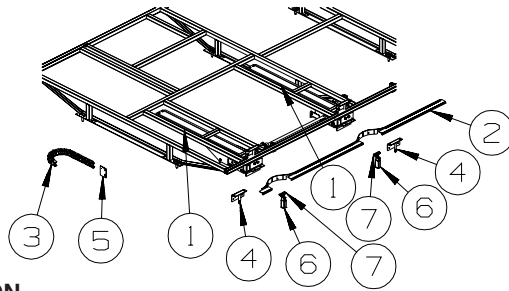
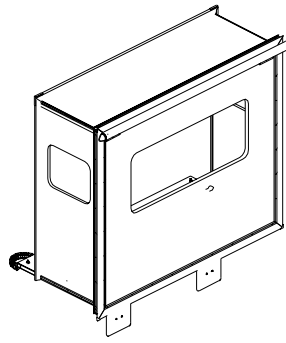

KEY	PART NUMBER	U/M	DESCRIPTION
1*	150661-01-000	EA	SLIDEOUT - ELECTRIC/SLIM
2	140282-03-S01	EA	TRIM - SIDEWALL - 89.9" - BRIGHT WHITE
3	143541-03-01A	EA	CARRIER/WIRING - F/SLIDEOUT ROOM - 13 LINKS
4	150569-01-02B	EA	BRACKET - MOUNTING - SLIDEOUT - W/HEX NUT/TUBE - E-COATED
	136995-05-02B	EA	PLATE W/BOLTS - 5.9" X 1" W/7/16" X 3" BOLTS FROM: 00-00-00 THRU: 11-18-04
5	151124-01-02B	EA	COVER - SLIDEOUT WIRES - E-COATED
6	126313-09-02B	EA	SUPPORT - ROLLER - SLIDE-OUT ROOM - E-COATED
			FROM: 10-27-04 THRU: 99-99-99
7	134855-01-000	EA	BEARING PAD - NARROW
			FROM: 10-27-04 THRU: 99-99-99

**\*COMPONENT PARTS LISTED LATER IN THIS GROUP**

**EXTERIOR SLIDEOUT GROUP (CONTINUED)**  
**FRONT LEFT (CONTINUED)**

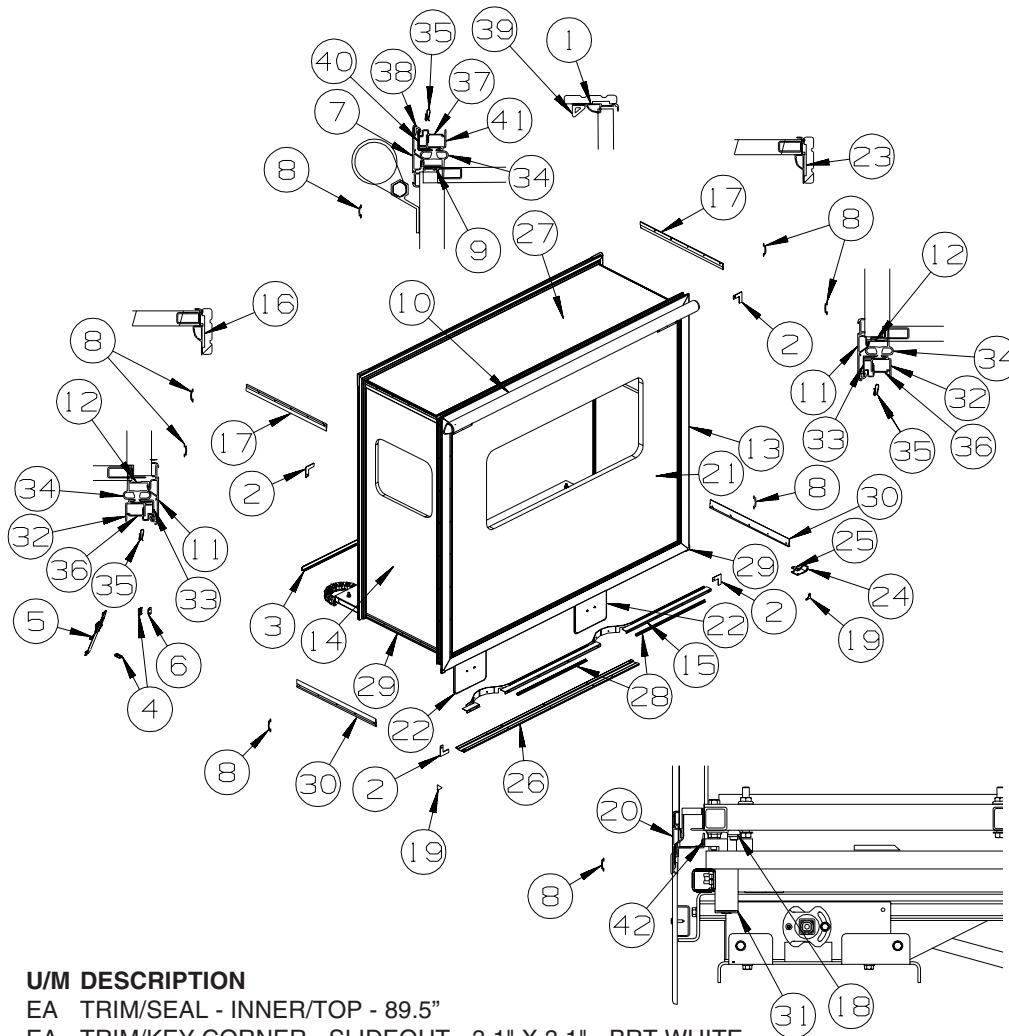

KEY	PART NUMBER	U/M	DESCRIPTION
1	139624-32-01A	EA	TRIM/SEAL - INNER/TOP - 89.5"
2	116444-04-12B	EA	TRIM/KEY CORNER - SLIDEOUT - 3.1" X 3.1" - BRT WHITE
3	151282-11-01A	EA	TRIM - CARPET EDGE/F-ANGLE - 83.7" - BLACK
3	151282-09-01A	EA	TRIM - CARPET EDGE/F-ANGLE - 75.4" - BLACK
FROM: 04-19-04 THRU: 99-99-99			
4	135619-02-01A	EA	PLATE - TIEDOWN - SLIDEOUT ROOM
5	135619-01-01A	EA	STRAP - TIEDOWN - SLIDEOUT ROOM
6	135622-01-02B	EA	PLATE - TIEDOWN - SLIDEOUT ROOM
7	139625-46-01A	EA	TRIM/SEAL - W/MITERED ENDS - 91.2" - BRIGHT WHITE
8	105312-01-07A	FT	INSERT - FEATURE STRIP - VINYL - BRIGHT WHITE
9	133954-51-01A	EA	TRIM/SEAL - 86" - BRIGHT WHITE
10	122977-05-03A	EA	AWNING/SLIDEOUT W/COVER - 90" - WHITE - VINYL/VINYL WRAP
11	139625-05-01A	EA	TRIM/SEAL - W/MITERED ENDS - 76.9" - BRIGHT WHITE
12	133954-48-01A	EA	TRIM/SEAL - 71.7" - BRIGHT WHITE
13	151431-01-S01	EA	PANEL END - F/SLIDEOUT (S04, S91)
13	151431-01-S02	EA	PANEL END - F/SLIDEOUT (S05, S92)
13	151431-01-S03	EA	PANEL END - F/SLIDEOUT (S06, S93)
14	151432-01-S01	EA	PANEL END - F/SLIDEOUT (S04, S91)
14	151432-01-S02	EA	PANEL END - F/SLIDEOUT (S05, S92)
14	151432-01-S03	EA	PANEL END - F/SLIDEOUT (S06, S93)
15	140282-03-01A	EA	TRIM - SIDEWALL - 89.9" - BRIGHT WHITE
16	139624-25-01A	EA	TRIM/SEAL - INNER/RIGHT HAND W/NOTCH - 73.3" -BRIGHT WHITE
17	138659-01-01A	EA	TRIM/FEATURE STRIP - 181.7" - BRIGHT WHIT
18	134855-01-000	EA	BEARING PAD - NARROW
19	135275-01-01A	EA	PROTECTOR - CORNER - SLIDEOUT - WHITE
20	142233-15-01A	EA	TRIM/SEAL - W/MITERED ENDS - 91.2 - BRIGHT WHITE
21	150878-11-S01	EA	SLUG - F/SLIDEOUT (S04, S91)
21	150878-11-S02	EA	SLUG - F/SLIDEOUT (S05, S92)
21	150878-11-S03	EA	SLUG - F/SLIDEOUT (S06, S93)
22	138077-07-01A	EA	COVER/RAM - 11" X 8.8" - W/O TUBE - BRIGHT WHITE
23	139624-26-01A	EA	TRIM/SEAL - INNER/LEFT HAND W/NOTCH - 73.3" - BRIGHT WHITE



**EXTERIOR SLIDEOUT GROUP (CONTINUED)**  
**FRONT LEFT (CONTINUED)**

KEY	PART NUMBER	U/M	DESCRIPTION
24	150697-03-02B	EA	PBRACKET - RESTRAINT/CHILD - E-COATED
25	150700-01-02B	EA	PLATE/MOUNTING - RESTRAINT/CHILD - 1" X 2.3" - E-COATED
26	115325-03-02A	EA	RAIL - FLOOR/SLIDEOUT ROOM - 64.5" LONG - BLACK
26	134756-03-M30	EA	RAMP - FABRIC COVERED - SLIDEOUT - 18.3" - VINYL FLOOR - THRU OUT
	115661-01-000	EA	SHOE/GLIDE - SLIDEOUT ROOM - 1/16" X 3" - POLYETHYLENE
27	149731-02-S01	EA	ROOF - F/SLIDEOUT
28	149821-16-01A	EA	TRIM/ANGLE - SIDEWALL - BLACK - 1/2" X 1/2" X 27"
29	075673-05-000	FT	SEAL - PILE - ADHESIVE BACK - BLACK
30	125051-03-01A	EA	TRIM - FEATURE STRIP/LOWER - 29.3" - BRIGHT WHITE
31	126313-09-01A	EA	SUPPORT - ROLLER - SLIDE-OUT ROOM - E-COATED
32	142720-09-01A	EA	TRIM - SIDEWALL/SLIDEOUT - 73.6" - BRIGHT WHITE
33	136824-31-01A	EA	TRIM - SIDEWALL/SLIDEOUT - 73.6" - BRIGHT WHITE
34	136978-01-01A	FT	SEAL - SLIDEOUT - BLACK
35	142549-01-000	EA	CLIP - "S" TYPE
36	142718-01-01A	EA	RETAINER - SIDEWALL/SLIDEOUT - 72.8"
37	142718-33-01A	EA	RETAINER - SIDEWALL/SLIDEOUT - 89.4"
38	099418-01-000	FT	SEAL - D-SECTION/ADHESIVE BACK - .44" X .44" - BLK RUBBER
39	146056-01-000	FT	SEAL - TRIANGLE - W/PSA
40	136824-46-01A	EA	TRIM - SIDEWALL/SLIDEOUT - 90.7" - BRIGHT WHITE
41	142719-25-01A	EA	TRIM/SIDEWALL - TOP/SLIDEOUT - 90.7" - BRIGHT WHITE
42	123012-03-000	EA	SEAL - SLIDEOUT - .09"/.13" THICK X 1.8" - W/ADHESIVE

## EXTERIOR SLIDEOUT GROUP (CONTINUED)

### FRONT LEFT (CONTINUED)

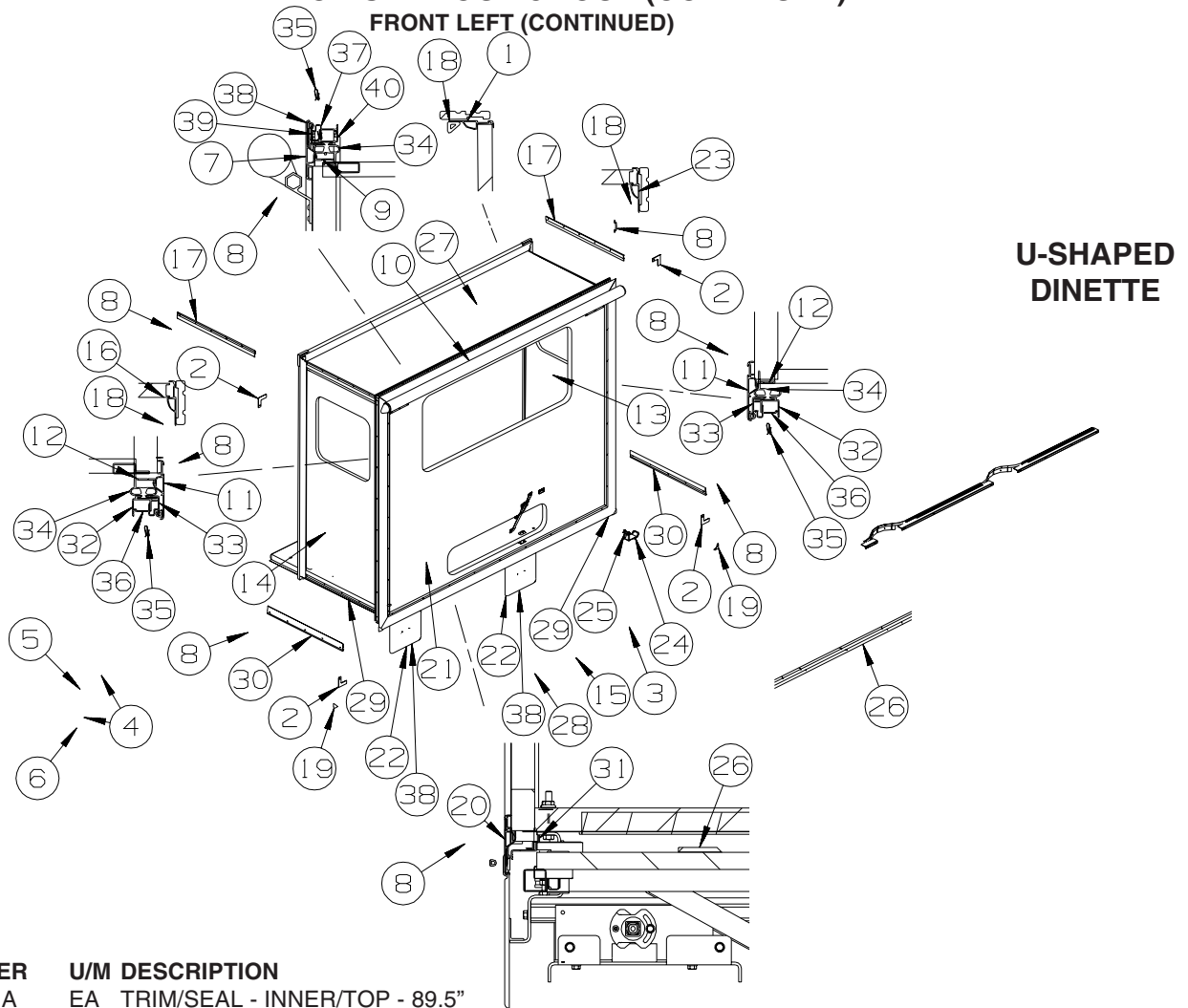

KEY	PART NUMBER	U/M	DESCRIPTION
1	139624-32-01A	EA	TRIM/SEAL - INNER/TOP - 89.5"
2	116444-04-12B	EA	TRIM/KEY CORNER - SLIDEOUT - 3.1" X 3.1" - BRT WHITE
3	149821-17-01A	EA	TRIM/ANGLE - SIDEWALL - BLACK - 1/2" X 1/2" X 28.9" - <b>DINETTE - U-SHAPED</b>
4	135619-02-01A	EA	PLATE - TIEDOWN - SLIDEOUT ROOM
5	135619-01-01A	EA	STRAP - TIEDOWN - SLIDEOUT ROOM
6	135622-01-02B	EA	PLATE - TIEDOWN - SLIDEOUT ROOM
7	139625-46-01A	EA	TRIM/SEAL - W/MITERED ENDS - 91.2" - BRIGHT WHITE
8	105312-01-07A	FT	INSERT - FEATURE STRIP - VINYL - BRIGHT WHITE
9	133954-51-01A	EA	TRIM/SEAL - 86" - BRIGHT WHITE
10	122977-05-03A	EA	AWNING/SLIDEOUT W/COVER - 90" - WHITE - VINYL/VINYL WRAP
11	139625-05-01A	EA	TRIM/SEAL - W/MITERED ENDS - 76.9" - BRIGHT WHITE
12	133954-48-01A	EA	TRIM/SEAL - 71.7" - BRIGHT WHITE
13	151431-02-S01	EA	PANEL END - F/SLIDEOUT (S04, S91) - <b>DINETTE - U-SHAPED</b>
13	151431-02-S02	EA	PANEL END - F/SLIDEOUT (S05, S92) - <b>DINETTE - U-SHAPED</b>
13	151431-02-S03	EA	PANEL END - F/SLIDEOUT (S06, S93) - <b>DINETTE - U-SHAPED</b>
14	151432-02-S01	EA	PANEL END - F/SLIDEOUT (S04, S91) - <b>DINETTE - U-SHAPED</b>
14	151432-02-S02	EA	PANEL END - F/SLIDEOUT (S05, S92) - <b>DINETTE - U-SHAPED</b>
14	151432-02-S03	EA	PANEL END - F/SLIDEOUT (S06, S93) - <b>DINETTE - U-SHAPED</b>
15	140282-03-01A	EA	TRIM - SIDEWALL - 89.9" - BRIGHT WHITE
16	139624-25-01A	EA	TRIM/SEAL - INNER/RIGHT HAND W/NOTCH - 73.3" - BRIGHT WHITE
17	138659-01-01A	EA	TRIM/FEATURE STRIP - 181.7" - BRIGHT WHIT
18	146056-01-000	EA	SEAL - TRIANGLE - W/PSA
19	135275-01-01A	EA	PROTECTOR - CORNER - SLIDEOUT - WHITE
20	142233-15-01A	EA	TRIM/SEAL - W/MITERED ENDS - 91.2" - BRIGHT WHITE
21	150878-13-S01	EA	SLUG - F/SLIDEOUT (S04, S91) - <b>DINETTE - U-SHAPED</b>
21	150878-13-S02	EA	SLUG - F/SLIDEOUT (S05, S92) - <b>DINETTE - U-SHAPED</b>
21	150878-13-S03	EA	SLUG - F/SLIDEOUT (S06, S93) - <b>DINETTE - U-SHAPED</b>
22	138077-07-01A	EA	COVER/RAM - 11" X 8.8" - W/O TUBE - BRIGHT WHITE
23	139624-26-01A	EA	TRIM/SEAL - INNER/LEFT HAND W/NOTCH - 73.3" - BRIGHT WHITE
24	150697-03-02B	EA	PBRACKET - RESTRAINT/CHILD - E-COATED
25	150700-01-02B	EA	PLATE/MOUNTING - RESTRAINT/CHILD - 1" X 2.3" - E-COATED

**EXTERIOR SLIDEOUT GROUP (CONTINUED)**  
**FRONT LEFT (CONTINUED)**

KEY	PART NUMBER	U/M	DESCRIPTION
26	115325-03-02A	EA	RAIL - FLOOR/SLIDEOUT ROOM - 64.5" LONG - BLACK
26	134756-02-L76	EA	RAMP - FABRIC COVERED - SLIDEOUT - 51.2" - VINYL FLOOR -THRU OUT - DINETTE U-SHAPED
	115661-01-000	EA	SHOE/GLIDE - SLIDEOUT ROOM - 1/16" X 3" - POLYETHYLENE
	134837-01-01A	EA	RAMP - SLIDEOUT - BLACK PVC
27	149731-01-S34	EA	ROOF - F/SLIDEOUT - DINETTE - U-SHAPED
28	149821-16-01A	EA	TRIM/ANGLE - SIDEWALL - BLACK - 1/2" X 1/2" X 27"
29	075673-05-000	FT	SEAL - PILE - ADHESIVE BACK - BLACK
30	125051-03-01A	EA	TRIM - FEATURE STRIP/LOWER - 29.3" - BRIGHT WHITE
31	123012-03-000	EA	SEAL - SLIDEOUT - .09"/.13" THICK X 1.8" - W/ADHESIVE
32	142720-09-01A	EA	TRIM - SIDEWALL/SLIDEOUT - 73.6" - BRIGHT WHITE
33	136824-31-01A	EA	TRIM - SIDEWALL/SLIDEOUT - 73.6" - BRIGHT WHITE
34	136978-01-01A	FT	SEAL - SLIDEOUT - BLACK
35	142549-01-000	EA	CLIP - "S" TYPE
36	142718-01-01A	EA	RETAINER - SIDEWALL/SLIDEOUT - 72.8"
37	142718-33-01A	EA	RETAINER - SIDEWALL/SLIDEOUT - 89.4"
38	099418-01-000	FT	SEAL - D-SECTION/ADHESIVE BACK - .44" X .44" - BLK RUBBER
39	146056-01-000	FT	SEAL - TRIANGLE - W/PSA
40	136824-46-01A	EA	TRIM - SIDEWALL/SLIDEOUT - 90.7" - BRIGHT WHITE
41	142719-25-01A	EA	TRIM/SIDEWALL - TOP/SLIDEOUT - 90.7" - BRIGHT WHITE

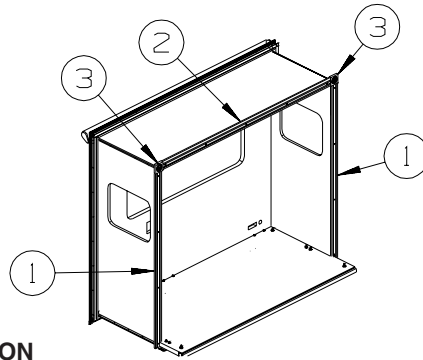

KEY	PART NUMBER	U/M	DESCRIPTION
1	132663-04-08A	EA	MOLDING-VINYL WRAP/PRE DRILLED-.6"X3"X70.2" - PORTS OAK
1	132663-04-22A	EA	MOLDING-VINYL WRAP/PRE DRILLED-.6"X3"X70.2" - SIERRA MAPLE
2	132663-28-08A	EA	MOLDING-VINYL WRAP/PRE DRILLED-.6" X 3.4" X 82.6"-PORT OAK
2	132663-28-22A	EA	MOLDING-VINYL WRAP/PRE DRILLED-.6" X 3.4" X 82.6"-S/MAP
3	132844-02-08A	EA	BLOCK - CORNER - 3.5" X 3.5" - PORTSMOUTH OAK
3	132844-02-22A	EA	BLOCK - CORNER - 3.5" X 3.5" - SIERRA MAPLE

**COMPONENT PARTS FOR FRONT LEFT**

150661-01-000

KEY	PART NUMBER	U/M	DESCRIPTION	VENDOR NO.
	150661-01-700	EA	SHAFT - SLAVE	29042
	150661-01-701	EA	SHAFT - ROUND DRIVE - 30"	29038
	150661-01-702	EA	POWER HEAD W/WORM DRIVE	29020
	150661-01-703	EA	CRANK TUBE	29022
	150661-01-704	EA	CAM FOLLOWER & NUT	28701
	150661-01-705	EA	FLANGE BEARING - .63" X .5"L	645-0028
	150661-01-706	EA	SPROCKET	28706
	150661-01-707	EA	SET SCREW - 1/4"-20	608-6005
	150661-01-708	EA	CLEVIS PIN	643-0030
	150661-01-709	EA	COTTOR PIN	625-0017
	150661-01-710	EA	CLEVIS PIN	643-0003
	150661-01-711	EA	COTTER PIN	625-0016
	150661-01-712	EA	SHAFT - ROUND DRIVE - 7.4"	29040
	150661-01-713	EA	ADAPTER - ADJUSTABLE SHAFT	28395
	150661-01-714	EA	RETAINING RING	634-0007

## EXTERIOR SLIDEOUT GROUP (CONTINUED)

LEFT REAR

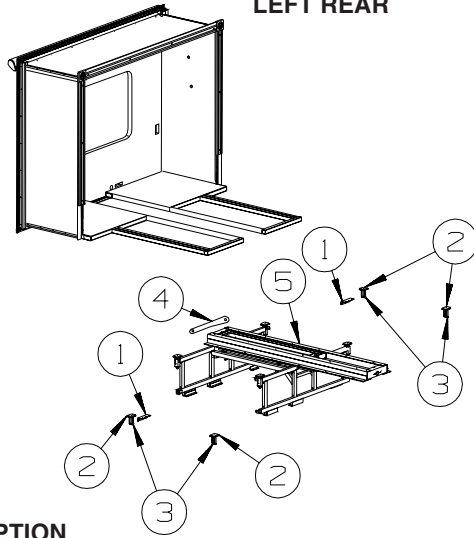

KEY	PART NUMBER	U/M	DESCRIPTION
1	113904-16-02B	EA	ANGLE - ATTACHMENT/WHEEL LIP - 5.1" - E-COAT
2	128599-03-000	EA	PAD - F/SLIDEOUT - 2" X 2.6"
3	126313-11-02B	EA	SUPPORT - ROLLER - SLIDE-OUT ROOM - E-COATED
4	140464-03-000	EA	WRENCH - SLIDE ROOM RETRACT - RATCHET W/2 EXTENSIONS
5*	140464-01-000	EA	SLIDEOUT CYLINDER ASM - REAR/SINGLE - ELECTRIC - KWIKEE

**\*COMPONENT PARTS LISTED LATER IN THIS GROUP**

**EXTERIOR SLIDEOUT GROUP (CONTINUED)**  
**LEFT REAR (CONTINUED)**

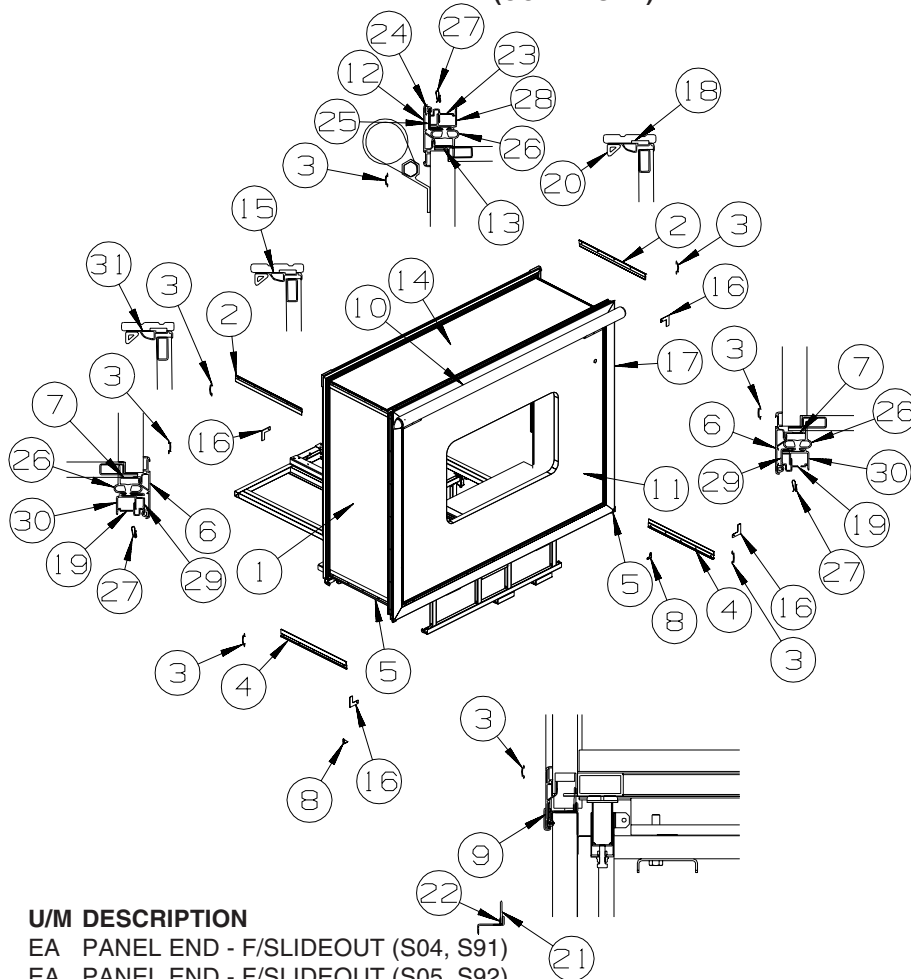

KEY	PART NUMBER	U/M	DESCRIPTION
1	151280-01-S01	EA	PANEL END - F/SLIDEOUT (S04, S91)
1	151280-01-S02	EA	PANEL END - F/SLIDEOUT (S05, S92)
1	151280-01-S03	EA	PANEL END - F/SLIDEOUT (S06, S93)
2	138659-01-01A	EA	TRIM/FEATURE STRIP - 181.7" - BRIGHT WHITE
3	105312-01-01A	FT	INSERT - FEATURE STRIP - VINYL - OFF WHITE
4	125051-02-01A	EA	TRIM - FEATURE STRIP/LOWER - 24.3" - BRIGHT WHITE
5	075673-01-000	FT	SEAL/PILE - .5" HIGH - ADHESIVE BACK - GRAY
6	139625-26-01A	EA	TRIM/SEAL - W/MITERED ENDS - 63.3" - BRIGHT WHITE
7	133954-54-01A	EA	TRIM/SEAL - 56.7" - BRIGHT WHITE
8	135275-01-01A	EA	PROTECTOR - CORNER - SLIDEOUT - WHITE
9	142233-04-01A	EA	TRIM/SEAL - W/MITERED ENDS - 82" - BRIGHT WHITE
10	122977-12-01A	EA	AWNING/SLIDEOUT W/COVER - 81.8" - BRIGHT WHITE
11	150878-12-S01	EA	SLUG - F/SLIDEOUT (S04, S91)
11	150878-12-S02	EA	SLUG - F/SLIDEOUT (S05, S92)
11	150878-12-S03	EA	SLUG - F/SLIDEOUT (S06, S93)
12	139625-03-01A	EA	TRIM/SEAL - W/MITERED ENDS - 82" - BRIGHT WHITE
13	133954-12-01A	EA	TRIM/SEAL - 77.8" - BRIGHT WHITE
14	136557-01-S01	EA	ROOF - F/SLIDEOUT
15	139624-04-01A	EA	TRIM/SEAL - INNER/TOP - 80.2" - BRIGHT WHITE
16	116444-04-12B	EA	TRIM/KEY CORNER - SLIDEOUT - 3.1" X 3.1" - BRIGHT WHITE
17	151246-01-S01	EA	PANEL END - F/SLIDEOUT (S04, S91)
17	151246-01-S02	EA	PANEL END - F/SLIDEOUT (S05, S92)
17	151246-01-S02	EA	PANEL END - F/SLIDEOUT (S06, S93)
18	139624-21-01A	EA	TRIM/SEAL - INNER/LEFT HAND W/NOTCH - 60.6" - BRIGHT WHITE
19	142718-26-01A	EA	RETAINER - SIDEWALL/SLIDEOUT - 60.2"
20	146056-01-000	FT	SEAL - TRIANGLE - W/PSA
21	145054-01-P07	EA	TRIM/ZEE - W/SEAL - SLIDEOUT/LOWER - 80.8" - BRIGHT WHITE
	141174-01-02A	EA	TRIM/ZEE - SIDEWALL - 81.4" - BRIGHT WHITE
	123012-04-000	EA	SEAL - SLIDEOUT - .09"/.13" THICK X 1.5" - W/ADHESIVE
22	149821-01-02A	EA	TRIM/ANGLE - SIDEWALL - BRIGHT WHITE - 1/2" X 1/2" X 77.9"
			FROM: 00-00-00 THRU: 10-24-04
22	149821-01-01A	EA	TRIM/ANGLE - SIDEWALL - BLACK - 1/2" X 1/2" X 77.9"
			FROM: 10-25-04 THRU: 99-99-99

**EXTERIOR SLIDEOUT GROUP (CONTINUED)**  
**LEFT REAR (CONTINUED)**

KEY	PART NUMBER	U/M	DESCRIPTION
23	142718-23-01A	EA	RETAINER - SIDEWALL/SLIDEOUT - 79.9"
24	099418-01-000	EA	SEAL - D-SECTION/ADHESIVE BACK - .44" X .44" - BLK RUBBER
25	136824-02-01A	EA	TRIM - SIDEWALL/SLIDEOUT - 81.2" - BRIGHT WHITE
26	136978-01-01A	FT	SEAL - SLIDEOUT - BLACK
27	142549-01-000	EA	CLIP - "S" TYPE
28	142715-05-01A	EA	RETAINER - SIDEWALL/SLIDEOUT - 74.6" - MILL
29	136824-19-01A	EA	TRIM - SIDEWALL/SLIDEOUT - 60.6" - BRIGHT WHITE
30	142720-13-01A	EA	TRIM - SIDEWALL/SLIDEOUT - 60.5" - BRIGHT WHITE

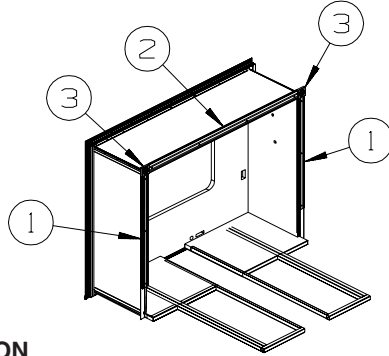

KEY	PART NUMBER	U/M	DESCRIPTION
1	132663-17-08A	EA	MOLDING-VINYL WRAP/PRE DRILLED-.6"X3"X45.5" - OAK
1	132663-17-22A	EA	MOLDING-VINYL WRAP/PRE DRILLED - .6" X 3" X 45.5"-S/MAPLE
2	132663-18-08A	EA	MOLDING-VINYL WRAP/PRE DRILLED - .6" X 3.4" X 73.2" - OAK
2	132663-18-22A	EA	MOLDING-VINYL WRAP/PRE DRILLED-.6" X 3.4" X 73.1"-S/MAPLE
3	132844-02-08A	EA	BLOCK - CORNER - 3.5" X 3.5" - PORTSMOUTH OAK
3	132844-02-22A	EA	BLOCK - CORNER - 3.5" X 3.5" - SIERRA MAPLE

**COMPONENT PARTS FOR LEFT REAR**

**140464-01-000**

KEY	PART NUMBER	U/M	DESCRIPTION	VENDOR NO.
	138173-01-700	EA	PIN/CLEVIS - PLATED/FRONT	1213810
	138173-01-706	EA	MOTOR - DRIVE W/WORM SHAFT	1820106

## GENERATOR GROUP

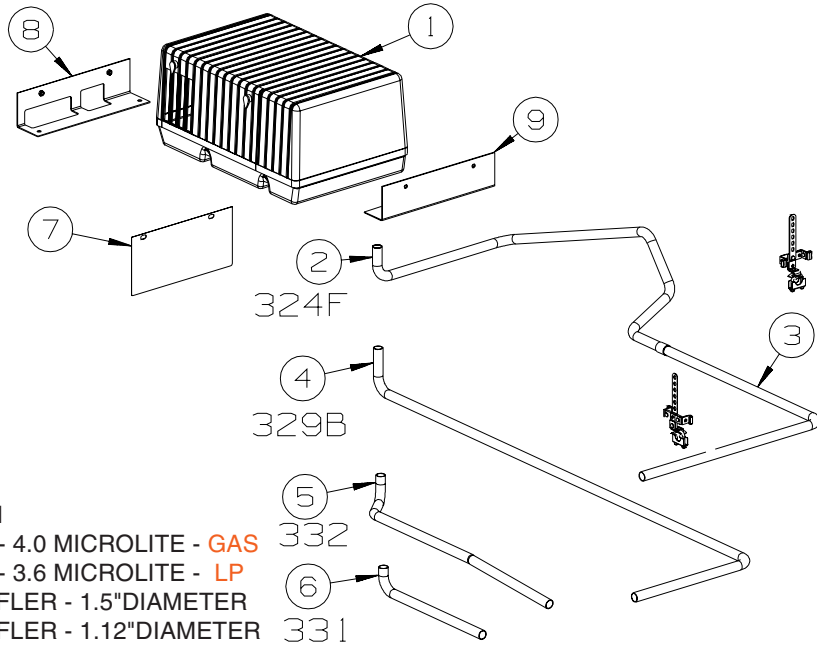

KEY	PART NUMBER	U/M	DESCRIPTION
1	109982-03-000	EA	GENERATOR - 4.0 MICROLITE - GAS
1	109982-04-000	EA	GENERATOR - 3.6 MICROLITE - LP
	007125-03-000	EA	CLAMP - MUFFLER - 1.5"DIAMETER
	007125-04-000	EA	CLAMP - MUFFLER - 1.12"DIAMETER
	007131-01-000	EA	HANGER - TAILPIPE - 6 SLOTS
2	138232-01-000	EA	PIPE - EXHAUST - GENERATOR
3	139763-01-000	EA	PIPE - EXHAUST - GENERATOR
4	141158-01-000	EA	PIPE/EXHAUST - GENERATOR
5	127920-01-000	EA	PIPE - EXHAUST - GENERATOR
6	105958-08-000	EA	PIPE - EXHAUST/GENERATOR - 1.5" OD X 3.1" X 19.7"
7	111848-07-02B	EA	SHIELD - HEAT - EXHAUST - E-COATED - 332G
8	114070-02-02B	EA	SUPPORT - GENERATOR - LEFT
9	114071-02-02B	EA	SUPPORT - GENERATOR - RIGHT
	128139-03-000	FT	HOSE - FUEL - LOW PERMEABILITY - 1/4 : DIAMETER
	084884-01-000	EA	PLUG - BRASS - 3/8"

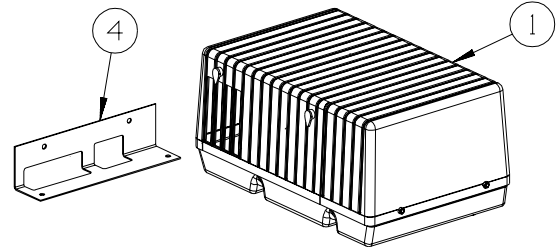

## 322E & 322R

KEY	PART NUMBER	U/M	DESCRIPTION
1	109982-03-000	EA	GENERATOR - 4.0 MICROLITE
2	007125-04-000	EA	CLAMP - MUFFLER - 1.12"DIAMETER
3	105958-08-000	EA	PIPE - EXHAUST/GENERATOR - 1.5" OD X 3.1" X 19.7"
4	114070-02-02B	EA	SUPPORT - GENERATOR - LEFT
5	114071-02-02B	EA	SUPPORT - GENERATOR - RIGHT
	088258-02-000	EA	CLIP - RETAINING - FUEL LINE SINGLE
	128139-03-000	FT	HOSE - FUEL - LOW PERMEABILITY - 1/4 : DIAMETER
	084884-01-000	EA	PLUG - BRASS - 3/8"

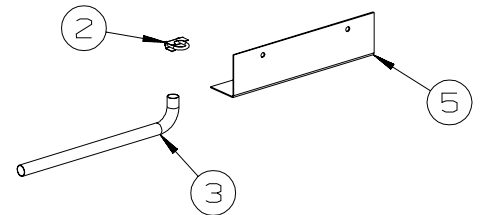

## 324V, 326A, 327L

KEY	PART NUMBER	U/M	DESCRIPTION
1	109982-03-000	EA	GENERATOR - 4.0 MICROLITE
2	007125-04-000	EA	CLAMP - MUFFLER - 1.12"DIAMETER
3	105958-08-000	EA	PIPE - EXHAUST/GENERATOR - 1.5" OD X 3.1" X 19.7"
4	114070-02-02B	EA	SUPPORT - GENERATOR - LEFT
5	114071-02-02B	EA	SUPPORT - GENERATOR - RIGHT
	088258-02-000	EA	CLIP - RETAINING - FUEL LINE SINGLE - 324V & 327L
	128139-03-000	FT	HOSE - FUEL - LOW PERMEABILITY - 1/4 : DIAMETER
	084884-01-000	EA	PLUG - BRASS - 3/8"

## HEATING & A/C GROUP

### FURNACE

KEY	PART NUMBER	U/M	DESCRIPTION
*	139980-01-000	EA	FURNACE - 25000 BTU - SF QUIET - SUBURBAN SF-25 2320J - 322R, 324F, 324V
*	139980-02-000	EA	FURNACE - 30000 BTU - SF QT - SBRN SF-30 2321J - 322E, 326A, 327L, 329B/SB, 329K, 331T/ST, 332G
	139980-07-000	EA	ADAPTOR - VENT BOTTOM SF-30/35 - 332G
	139980-08-000	EA	GASKET - BOTTOM VENT SF-30/35 - 332G
	098668-23-000	EA	DOOR - ACCESS - FURNACE - BRIGHT WHITE
	009198-01-000	FT	DUCT - HEAT - FLEXIBLE - 4" ID X 25'
	009198-02-000	FT	DUCT - HEAT - FLEXIBLE - 2" ID X 25'
	056464-09-000	EA	REGISTER W/DAMPER - 4" DIAMETER - PLASTIC - BEIGE
	056464-10-000	EA	REGISTER W/O DAMPER - 4" DIAMETER - PLASTIC - BEIGE
	056464-11-000	EA	REGISTER W/O DAMPER - 4" DIAMETER - PLASTIC - OFF WHITE
	137965-01-01A	EA	REGISTER - 11.2" X 3.6"(9.7 X 2.1"R/O) W/O DAMPER- ANTIQUE BRASS
	069636-02-000	EA	CONNECTOR - DUCT - 4" ID
	009200-01-000	EA	TAPE - FURNACE - 1 1/2"
	089367-01-000	EA	TEE - 4" OD - 7" LONG - METAL
	089367-02-000	EA	TEE - 4" X 2" X 4"
	024990-11-000	EA	OUTLET - DEFROSTER - W/SWIVEL - 2" SLEEVE/4" OD - CAD CRM
	093614-01-02A	EA	GRILL - AIR RETURN - 15.9" X 7.9" - BIEGE
	093614-11-01A	EA	GRILLE - AIR RETURN - 13.9" X 7.9" - BEIGE

**\*COMPONENT PARTS LISTED LATER IN THIS GROUP**



**HEATING & A/C GROUP (CONTINUED)**  
**COMPONENT PARTS FOR FURNACE**

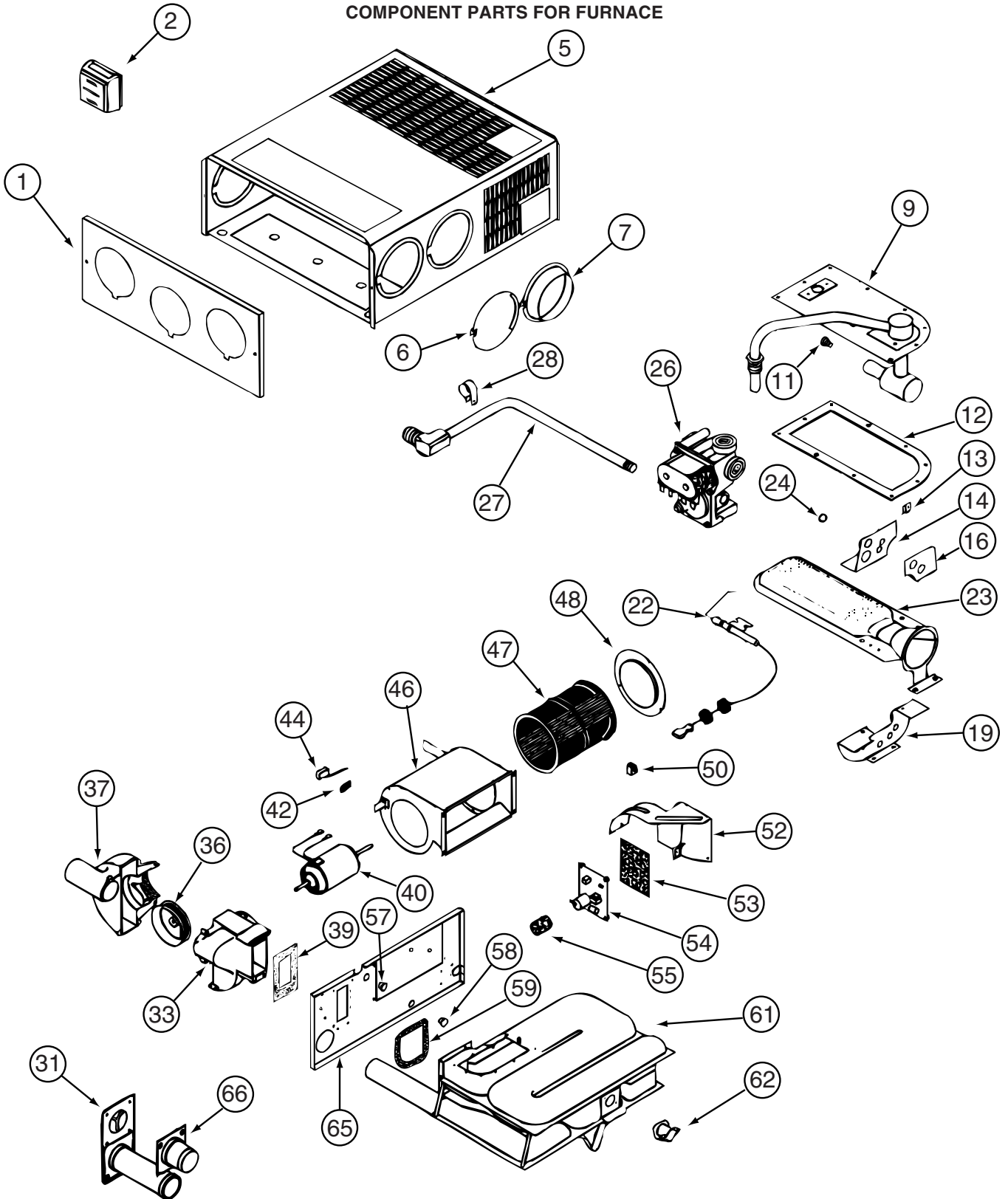

139980-01-000

139980-02-000

**HEATING & A/C GROUP (CONTINUED)  
COMPONENT PARTS FOR FURNACE (CONTINUED)**

**139980-01-000 (CONTINUED)**

<b>KEY</b>	<b>PART NUMBER</b>	<b>U/M</b>	<b>DESCRIPTION</b>	<b>VENDOR NO.</b>
9	139980-01-700	EA	MANIFOLD ASSEMBLY	171571
11	090039-01-703	EA	ORIFICE-MAIN BURNER	180193
12	098668-22-703	EA	GASKET - BURNER ACCESS COVER	070811
22	139980-01-701	EA	ELECTRODE	232286
23	098668-01-703	EA	BURNER ASSEMBLY	010762
26	098668-01-718	EA	VALVE-GAS SF S.N.974903079	161122
27	139980-01-702	EA	PIPE ASSEMBLY/GAS INLET	171574
31	098668-01-707	EA	TUBE ASSEMBLY, EXHAUST W/CAP	260231
33	139980-01-703	EA	HOUSING/COMB. - FRONT/HALF	390852
36	098668-01-706	EA	WHEEL-COMBUSTION AIR	350184
37	139980-01-704	EA	HOUSING/COMB. - REAR/HALF	390848
39	139980-01-705	EA	GASKET/FIREWALL-COMB AIR	071084
40	139980-01-706	EA	MOTOR ASSEMBLY W/GASKET	232682
42	101990-01-714	EA	GASKET-MICROSWITCH	230877
44	098668-21-700	EA	SWITCH-MICRO-W/O FLAG 3 1/4"	232261
46	139980-01-708	EA	BLOWER ASSEMBLY - ROOM AIR	390739BK
47	098668-01-711	EA	WHEEL-BLOWER, ROOM AIR	350129
48	139980-01-709	EA	ORFICE RING	390696
50	139980-01-710	EA	SWITCH - ON/OFF	232351
52	139980-01-711	EA	PANEL ASSEMBLY-MODULE BD	101663
53	139980-01-712	EA	INSULATOR - MODULE BD	070807
54	098668-22-705	EA	MODULE BD W/RELAY TIME DELAY	520820
55	139980-01-713	EA	CAP/INSULATOR-MODULE BD	070973
57	139980-01-714	EA	BUSHING - UNIVERSAL	070362
58	139980-01-715	EA	BUSHING - STRAIN RELIEF	231809
59	098668-01-716	EA	GASKET-FIREWALL,CHAMBER SIDE	070808
61	139980-01-716	EA	CHAMBER ASSEMBLY - FINAL	021149BK
62	098668-21-701	EA	SWITCH - LIMIT	232504
66	098668-01-713	EA	TUBE ASSEMBLY, INTAKE	051248
	098668-19-700	EA	DOOR/CABINET ACCESS	101888
			CONTACT WINNEBAGO PART SALES FOR UNLISTED COMPONENT(S)	

**139980-02-000 (CONTNUED)**

<b>KEY</b>	<b>PART NUMBER</b>	<b>U/M</b>	<b>DESCRIPTION</b>	<b>VENDOR NO.</b>
9	139980-01-700	EA	MANIFOLD ASSEMBLY	171571
11	092300-02-701	EA	ORIFICE-MAIN BURNER (NT-30BW	180214
12	098668-22-703	EA	GASKET - BURNER ACCESS COVER	070811
22	139980-01-701	EA	ELECTRODE	232286
23	098668-02-700	EA	BURNER ASSEMBLY,SF-30 & SF35	010745
26	098668-01-718	EA	VALVE-GAS SF S.N.974903079	161122
27	139980-01-702	EA	PIPE ASSEMBLY/GAS INLET	171574
31	098668-01-707	EA	TUBE ASSEMBLY, EXHAUST W/CAP	260231
33	139980-01-703	EA	HOUSING/COMB. - FRONT/HALF	390852
36	098668-01-706	EA	WHEEL-COMBUSTION AIR	350184
37	139980-01-704	EA	HOUSING/COMB. - REAR/HALF	390848
39	139980-01-705	EA	GASKET/FIREWALL-COMB AIR	071084
40	139980-01-706	EA	MOTOR ASSEMBLY W/GASKET	232682
42	101990-01-714	EA	GASKET-MICROSWITCH	230877
44	098668-21-700	EA	SWITCH-MICRO-W/O FLAG 3 1/4"	232261
46	139980-01-708	EA	BLOWER ASSEMBLY - ROOM AIR	390739BK
47	098668-01-711	EA	WHEEL-BLOWER, ROOM AIR	350129
48	139980-01-709	EA	ORFICE RING	390696
50	139980-01-710	EA	SWITCH - ON/OFF	232351
52	139980-01-711	EA	PANEL ASSEMBLY-MODULE BD	101663
53	139980-01-712	EA	INSULATOR - MODULE BD	070807
54	098668-22-705	EA	MODULE BD W/RELAY TIME DELAY	520820
55	139980-01-713	EA	CAP/INSULATOR-MODULE BD	070973
57	139980-01-714	EA	BUSHING - UNIVERSAL	070362
58	139980-01-715	EA	BUSHING - STRAIN RELIEF	231809
59	098668-01-716	EA	GASKET-FIREWALL,CHAMBER SIDE	070808
61	139980-01-716	EA	CHAMBER ASSEMBLY - FINAL	021149BK
62	098668-21-701	EA	SWITCH - LIMIT	232504
66	098668-01-713	EA	TUBE ASSEMBLY, INTAKE	051248
			CONTACT WINNEBAGO PART SALES FOR UNLISTED COMPONENT(S)	

## HEATING & A/C GROUP (CONTINUED)

### ROOF

KEY	PART NUMBER	U/M	DESCRIPTION
*	131185-03-01A	EA	A/C - ROOF - 13,500 BTU - MACH 3 WHITE
*	131188-03-01A	EA	A/C/ROOF - 14,800 BTU/MACH 15 - NEW MODEL #8335B676 - WHT
*	131188-04-01A	EA	A/C/ROOF - 14,800 BTU/HEAT PUMP - NEW MODEL #8535B676- WHT - <b>A/C HEAT PUMP</b>
*	131184-01-01A	EA	CEILING ASSEMBLY - A/C DUCTED - WHITE
*	131184-05-01A	EA	CEILING - HEAT PUMP - WHITE - <b>A/C HEAT PUMP</b>
	131184-02-01A	EA	BOARD - DIVIDER - SILVER

**\*COMPONENT PARTS LISTED LATER IN THIS GROUP**

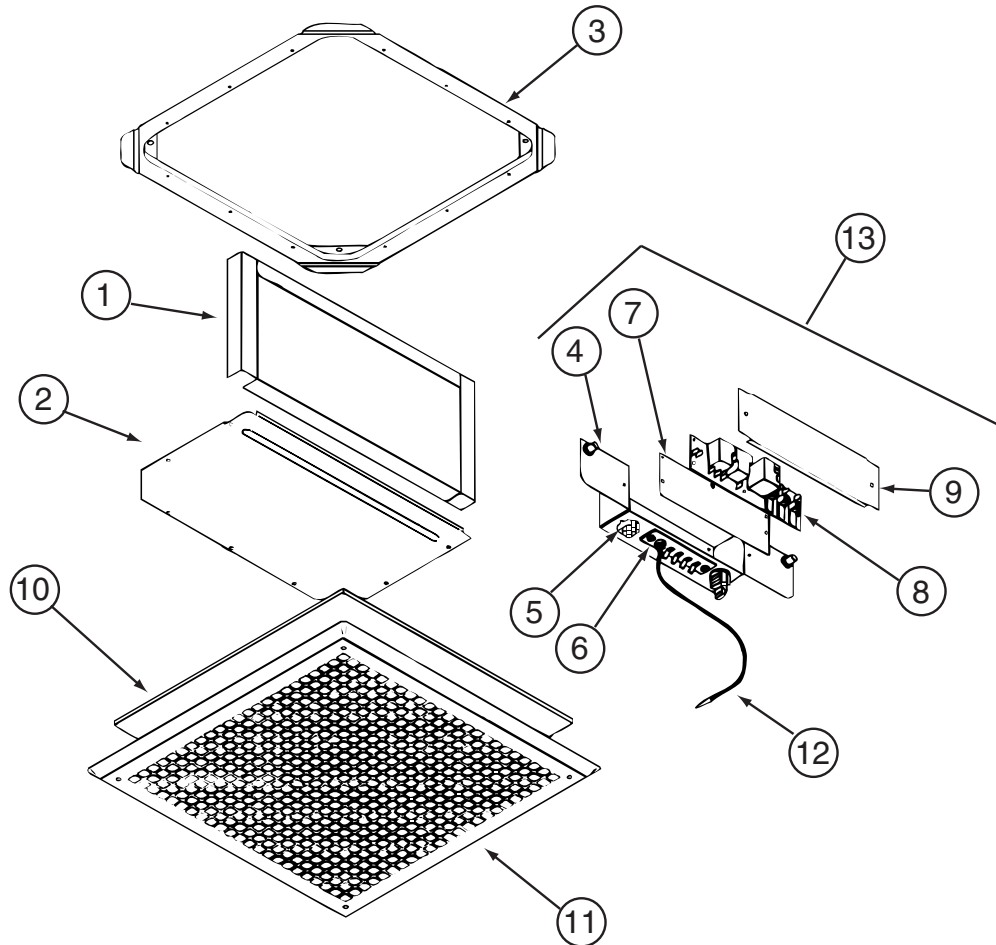

**COMPONENT PARTS FOR ROOF**

#### 131184-01-01A

KEY	PART NUMBER	U/M	DESCRIPTION	VENDOR NO.
1	131184-01-707	EA	DUCT DIVIDER	8330-3501
5	131184-01-700	EA	PLUG ASSEMBLY	7330A389
6	131184-01-701	EA	TERMINAL BOARD	7330B3201
7	131184-01-702	EA	ISOLATOR - BLANK	7330C365
8	108892-01-702	EA	BOARD-P.C.	7330A3211
10	108892-01-703	EA	FILTER	6798A3761
11	108892-01-704	EA	GRILLE 16 3/8X16 3/8 RETURN	6798-3041
12	131184-01-704	EA	COIL SENSOR	7330-6111
13	131184-01-705	EA	JUNCTION BOX ASSEMBLY	7330B5551
	131184-01-703	EA	SMALL PARTS PKG	8330-5961

CONTACT WINNEBAGO PART SALES FOR UNLISTED COMPONENT(S)

**HEATING & A/C GROUP (CONTINUED)**  
**COMPONENT PARTS FOR ROOF (CONTINUED)**

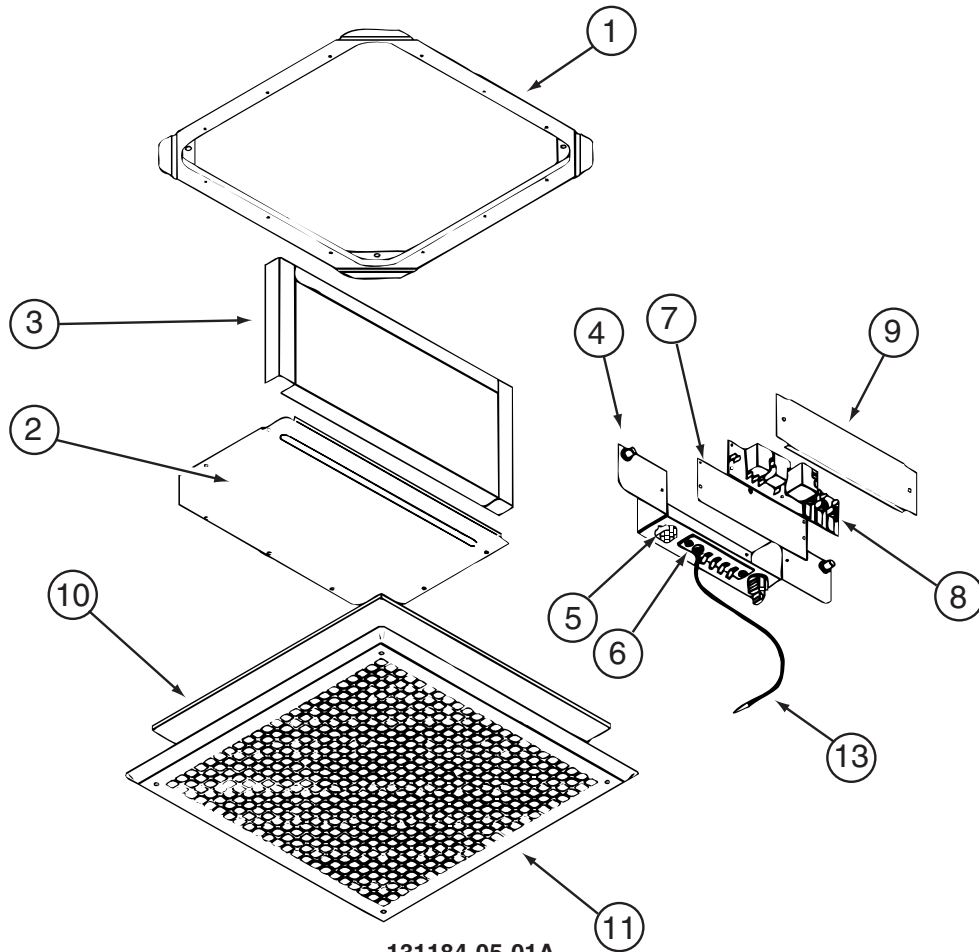

131184-05-01A

KEY	PART NUMBER	U/M	DESCRIPTION	VENDOR NO.
4	131184-05-700	EA	BOX - JUNCTION	8530-5091
5	131184-04-700	EA	PLUG ASSEMBLY	7530A340
6	131184-04-702	EA	BOARD - TERMINAL	7530B3201
7	131184-01-702	EA	ISOLATOR - BLANK	7330C365
8	131184-04-705	EA	BOARD - P.C.	7330B3311
10	108892-01-703	EA	FILTER	6798A3761
11	108892-01-704	EA	GRILLE 16 3/8X16 3/8 RETURN	6798-3041
13	105620-12-719	EA	COIL SENSOR	7330A3231
	131184-01-703	EA	SMALL PARTS PKG	8330-5961

CONTACT WINNEBAGO PART SALES FOR UNLISTED COMPONENT(S)

**HEATING & A/C GROUP (CONTINUED)**  
**COMPONENT PARTS FOR ROOF (CONTINUED)**

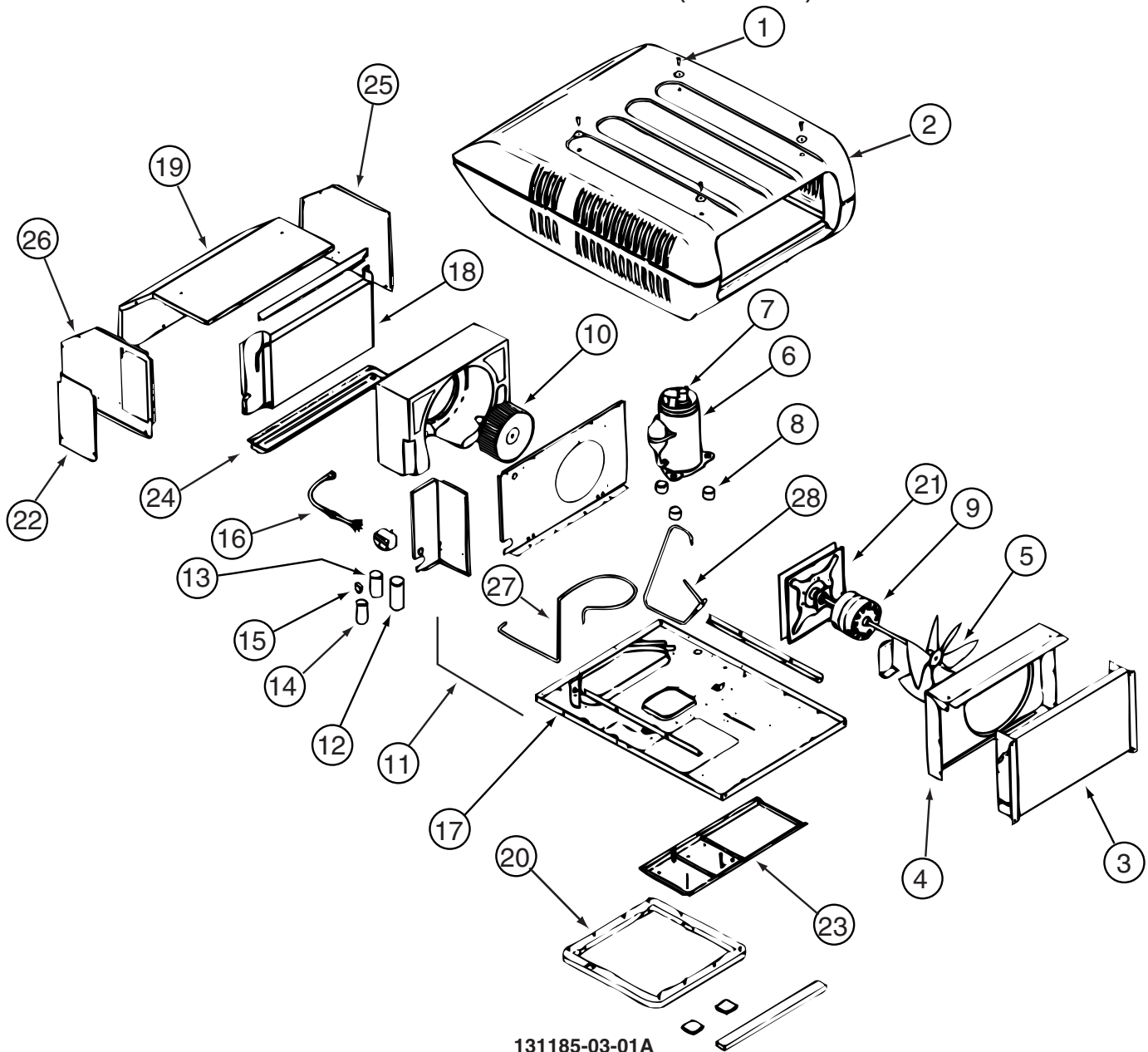

131185-03-01A

KEY	PART NUMBER	U/M	DESCRIPTION	VENDOR NO.
2	131185-03-700	EA	SHROUD - ROOF AIR	8333-4161
3	131185-01-700	EA	CONDENSER COIL	1452A1451
5	093763-01-712	EA	BLADE-FAN-CONDENSER	6733-3221
6	131185-03-701	EA	COMPRESSOR - (PANASONC)	1450A2059
6	105620-01-706	EA	MOUNTING PKG.,COMP., 3 PER	6759-3081
7	131185-03-702	EA	OVERLOAD	1450-0141
9	131185-01-701	EA	MOTOR (115V, 60HZ)	1468-3069
10	131185-01-702	EA	BLOWER WHEEL PACKAGE	1472-1091
12	105620-12-725	EA	COMPRESSOR RUN CAPACITO	1499-5731
13	108889-01-708	EA	CAPACITOR-FAN, 7.5MFD. 370U	1499-5461
15	105620-10-704	EA	START COMPACITOR	1497-0861
15	105620-10-705	EA	PTCR (START DEVICE) - W/CAP.	8333A9021
18	131185-01-703	EA	EVAPORATOR COIL	1452A1491
20	037648-01-714	EA	GASKET PACKAGE	8332-3301
21	131185-01-704	EA	MOTOR MOUNT & SEAL KIT	8333-5151
27	131185-03-704	EA	LINE - SUCTION	8333B530
28	131185-03-705	EA	LINE - DISCHARGE	8333-131
	131185-03-703	EA	PAD/FILLER (COND AIR SEAL)	8332-3301
	093306-01-701	EA	DECAL PACKAGE, LEFT & RIGHT	6798B3591

CONTACT WINNEBAGO PART SALES FOR UNLISTED COMPONENTS

**HEATING & A/C GROUP (CONTINUED)**  
**COMPONENT PARTS FOR ROOF (CONTINUED)**

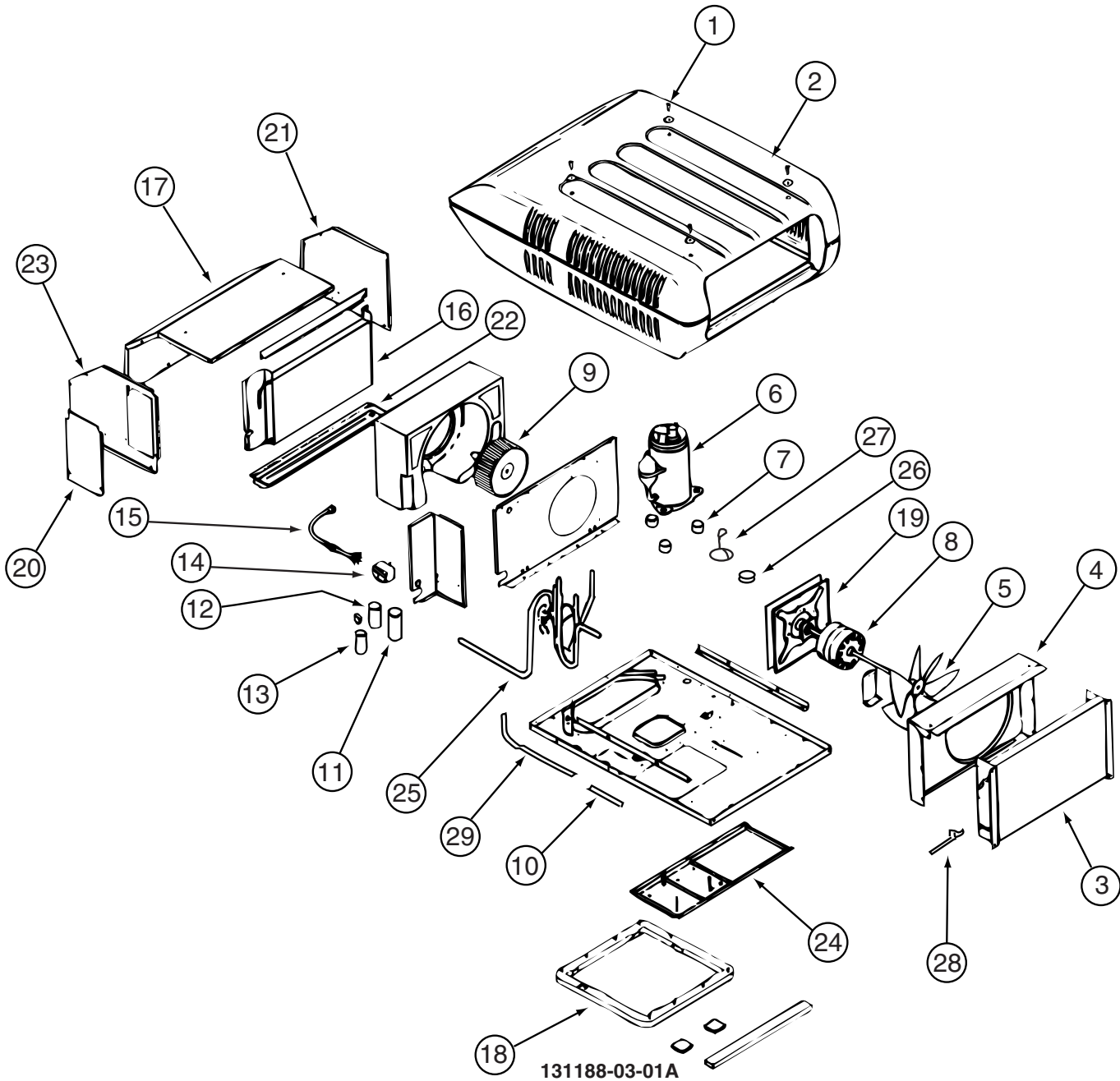

131188-03-01A

KEY	PART NUMBER	U/M	DESCRIPTION	VENDOR NO.
2	131185-03-700	EA	SHROUD-ROOF AIR W/HAIL GUARD	8333-4161
3	115219-01-700	EA	COIL-CONDENSER	1452A1321
5	093763-01-712	EA	BLADE-FAN-CONDENSER	6733-3221
6	131188-01-700	EA	COMPRESSOR - TECUMSEH	1450A2609
7	105620-01-706	EA	MOUNTING PKG.,COMP., 3 PER	6759-3081
8	131185-01-701	EA	MOTOR (115V, 60HZ)	1468-3069
9	131185-01-702	EA	BLOWER WHEEL PACKAGE	1472-1091
11	131188-01-701	EA	RUN CAP. (COMP-40MFD/370V)	1499-5721
12	108889-01-708	EA	CAPACITOR-FAN, 7.5MFD. 370U	1499-5461
13	126859-01-704	EA	CAPACITOR - START	1497-0871
14	091225-01-709	EA	RELAY-START	1497-4131
16	131186-01-701	EA	EVAPORATOR COIL	1452-1521
18	037648-01-714	EA	GASKET PACKAGE	8332-3301
19	131185-01-704	EA	MOTOR MOUNT & SEAL KIT	8333-5151
	093306-01-701	EA	DECAL PACKAGE, LEFT & RIGHT	6798B3591
	108889-01-710	EA	PAD-FILLER, CONDENSER SEAL	6759B3971
	131188-01-702	EA	LINE - SUCTION	7335A134
	131188-01-703	EA	LINE - DISCHARGE	7335A135

CONTACT WINNEBAGO PART SALES FOR UNLISTED COMPONENT(S)

**HEATING & A/C GROUP (CONTINUED)**  
**COMPONENT PARTS FOR ROOF (CONTINUED)**

131188-04-01A

KEY	PART NUMBER	U/M	DESCRIPTION	VENDOR NO.
3	131188-02-700	EA	CONDENSER COIL	1452-1441
5	093763-01-712	EA	BLADE-FAN-CONDENSER	6733-3221
6	131188-02-701	EA	COMPRESSOR(TECUMSEH-RK225AT)	1450A2069
7	105620-01-706	EA	MOUNTING PKG.,COMP., 3 PER	6759-3081
8	131185-01-701	EA	MOTOR (115V, 60HZ)	1468-3069
9	131185-01-702	EA	BLOWER WHEEL PACKAGE	1472-1091
10	131188-02-702	EA	RESTRICTOR - BY FLOW	1454-2501
11	131188-01-701	EA	RUN CAP. (COMP-40MFD/370V)	1499-5721
12	093763-01-704	EA	CAPACITOR-FAN (INDOOR MOTOR)	1499-5461
13	131188-02-703	EA	CAPACITOR-START(21-25MFD)	1497-0211
14	091225-01-709	EA	RELAY-START	1497-4131
16	131186-01-701	EA	EVAPORATOR COIL	1452-1521
18	037648-01-714	EA	GASKET PACKAGE	8332-3301
19	131185-01-704	EA	MOTOR MOUNT & SEAL KIT	8333-5151
25	131188-02-704	EA	VALVE/REVERSE ASSEMBLY	7535A5301
26	105620-12-708	EA	COIL - SOLENOID	1460-1081
27	131188-02-705	EA	WIRE HARNESS F/SOLENOID	7535-109
28	131188-02-706	EA	SWITCH - FREEZE	1460-2041
29	131188-02-707	EA	LIQUID LINE	7535-135
			CONTACT WINNEBAGO PART SALES FOR UNLISTED COMPONENT(S)	



**INTERIOR FINISH GROUP**  
**MOLDINGS & TRIMS**  
**PORTSMOUTH OAK AND SIERRA MAPLE**

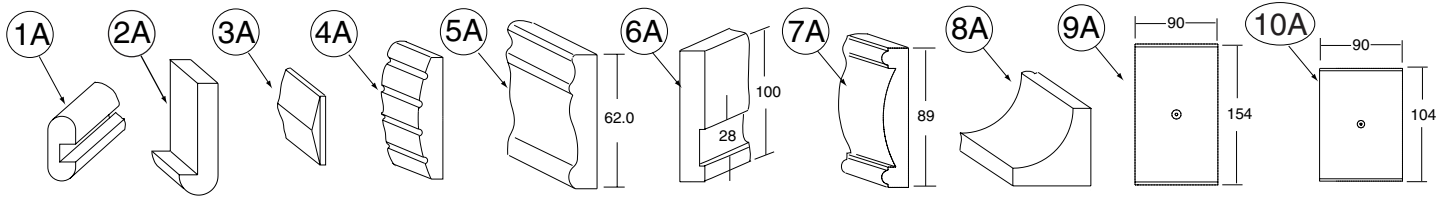

KEY	PART NUMBER	U/M	DESCRIPTION
1A	M09412-62-N42	EA	MOLDING/SHELF EDGE - .6" X 1.3" X 96" - PORTSMOUTH OAK
1A	M09412-62-M52	EA	MOLDING/SHELF EDGE - .6" X 1.3" X 96" - CHERRY - CONCERT CHERRY
1A	M09412-62-M62	EA	MOLDING/SHELF EDGE - .6" X 1.3" X 96" - WASHED MAPLE - WASHED MAPLE
1A	M09412-62-RC3	EA	MOLDING/SHELF EDGE - .6" X 1.3" X 96" - HONEY CHERRY - HONEY CHERRY
1A	M09412-62-SA3	EA	MOLDING/SHELF EDGE - .6" X 1.3" X 96" - MAPLE - SIERRA MAPLE
2A	M09438-25-N95	EA	MOLDING - HARDWOOD-W/NOTCH - 1.4"X 80.2" - OAK/PORTS OAK - PORTSMOUTH OAK
2A	M09438-25-N94	EA	MOLDING - HARDWOOD-W/NOTCH - 1.4"X 80.2" - CHERRY/CHERRY IV - CONCERT CHERRY
2A	M09438-25-NQ0	EA	MOLDING - HARDWOOD-W/NOTCH - 1.4"X 80.2" - MAPLE/WASHED MP - WASHED MAPLE
2A	M09438-25-RA3	EA	MOLDING - HARDWOOD-W/NOTCH - 1.4"X 80.2" - CHERRY/HONEY - HONEY CHERRY
2A	M09454-33-PC0	EA	MOLDING - HARDWOOD-W/NOTCH - 1"X 77.6" - OAK/PORTS OAK - PORTSMOUTH OAK
2A	M09454-33-PC1	EA	MOLDING - HARDWOOD-W/NOTCH - 1"X 77.6" - CHERRY/CHERRY IV - CONCERT CHERRY
2A	M09454-33-PC2	EA	MOLDING - HARDWOOD-W/NOTCH - 1"X 77.6" - MAPLE/WASHED MP - WASHED MAPLE
2A	M09454-33-RA3	EA	MOLDING - HARDWOOD-W/NOTCH - 1"X 77.6" - CHERRY/HONEY - HONEY CHERRY
3A	M09454-62-P54	EA	MOLDING - TRIM/VEE - .2" X 1" X 3.5" - OAK - PORTSMOUTH OAK
3A	M09454-62-P55	EA	MOLDING - TRIM/VEE - .2" X 1" X 3.5" - CHERRY - CONCERT CHERRY
3A	M09454-62-P56	EA	MOLDING - TRIM/VEE - .2" X 1" X 3.5" - MAPLE - WASHED MAPLE
3A	M09454-62-RE0	EA	MOLDING - TRIM/VEE - .2" X 1" X 3.5" - CHERRY - HONEY CHERRY
3A	M09462-50-R74	EA	MOLDING - TRIM/VEE - .2" X 1" X 93.5" - PORTSMOUTH OAK
3A	M09462-50-R75	EA	MOLDING - TRIM/VEE - .2" X 1" X 93.5" - CHERRY/CHERRY - CONCERT CHERRY
3A	M09462-50-R76	EA	MOLDING - TRIM/VEE - .2" X 1" X 93.5" - MAPLE/MAPLE - WASHED MAPLE
3A	M09462-50-SD3	EA	MOLDING - TRIM/VEE - .2" X 1" X 93.5" - HONEY/CHERRY - HONEY CHERRY
3A	M09462-50-S67	EA	MOLDING - TRIM/VEE - .2" X 1" X 93.5" - SIERRA/MAPLE - SIERRA MAPLE
4A	M09462-54-R89	EA	MOLDING - FLUTED, CURVED - .6" X 6" X 82.7" - PORTSMOUTH OAK
4A	M09462-54-R90	EA	MOLDING - FLUTED, CURVED - .6" X 6" X 82.7" - CONCERT CHERRY
4A	M09462-54-R91	EA	MOLDING - FLUTED, CURVED - .6" X 6" X 82.7" - WASHED MAPLE
4A	M09462-54-RE3	EA	MOLDING - FLUTED, CURVED - .6" X 6" X 82.7" - HONEY CHERRY
4A	M09471-09-R89	EA	MOLDING - STAINED - 4" X 8' - PORTSMOUTH OAK
4A	M09471-09-R90	EA	MOLDING - STAINED - 4" X 8' - CONCERT CHERRY
4A	M09471-09-R91	EA	MOLDING - STAINED - 4" X 8' - WASHED MAPLE
4A	M09471-09-RE3	EA	MOLDING - STAINED - 4" X 8' - HONEY CHERRY
4A	Y00202-42-438	EA	MOLDING - FLUTED - .75" X 3.5" X 96" - UNSTAINED - OAK
4A	Y00202-32-438	EA	MOLDING - FLUTED - .75" X 3.5" X 96" - UNSTAINED - CHERRY
4A	Y00202-22-438	EA	MOLDING - FLUTED - .75" X 3.5" X 96" - UNSTAINED - MAPLE
5A	M09462-66-R74	EA	TRIM - RAIL - .5" X 2.4" X 96" - PORTSMOUTH OAK
5A	M09462-66-R75	EA	TRIM - RAIL - .5" X 2.4" X 96" - CONCERT CHERRY
5A	M09462-66-R76	EA	TRIM - RAIL - .5" X 2.4" X 96" - WASHED MAPLE
5A	M09462-66-RE0	EA	TRIM - RAIL - .5" X 2.4" X 96" - HONEY CHERRY
5A	M09462-66-SA3	EA	TRIM - RAIL - .5" X 2.4" X 96" - SIERRA MAPLE
6A	M09471-20-R83	EA	MOLDING - STAINED - .75" X 4" X 74.6" - PORTSMOUTH OAK
6A	M09471-20-R84	EA	MOLDING - STAINED - .75" X 4" X 74.6" - CONCERT CHERRY
6A	M09471-20-R91	EA	MOLDING - STAINED - .75" X 4" X 74.6" - WASHED MAPLE
6A	M09471-20-RE0	EA	MOLDING - STAINED - .75" X 4" X 74.6" - HONEY CHERRY
7A	M09471-40-R83	EA	MOLDING - STAINED - .7" X 3.5" X 70.4" - PORTSMOUTH OAK
7A	M09471-40-R84	EA	MOLDING - STAINED - .7" X 3.5" X 70.4" - CONCERT CHERRY
7A	M09471-40-SD2	EA	MOLDING - STAINED - .7" X 3.5" X 70.4" - WASHED MAPLE
7A	M09471-40-RE0	EA	MOLDING - STAINED - .7" X 3.5" X 70.4" - HONEY CHERRY
8A	M09471-79-R38	EA	MOLDING - TRIM/COVE - .8" X .8" X 95.8" - OAK/PORTS OAK - PORTSMOUTH OAK
8A	M09471-79-R39	EA	MOLDING - TRIM/COVE - .8" X .8" X 95.8" - CHERRY/CHERRY - CONCERT CHERRY
8A	M09471-79-R46	EA	MOLDING - TRIM/COVE - .8" X .8" X 95.8" - MAPLE/MAPLE - WASHED MAPLE
8A	M09471-79-RE0	EA	MOLDING - TRIM/COVE - .8" X .8" X 95.8" - HONEY/CHERRY - HONEY CHERRY
8A	M09471-79-SA3	EA	MOLDING - TRIM/COVE - .8" X .8" X 95.8" - HONEY/MAPLE - SIERRA MAPLE
9A	P49186-01-SA0	EA	MOLDING/BLOCK - PORTSMOUTH OAK
9A	P49186-01-SA1	EA	MOLDING/BLOCK - CONCERT CHERRY
9A	P49186-01-SA2	EA	MOLDING/BLOCK - WASHED MAPLE
9A	P49186-01-SA3	EA	MOLDING/BLOCK - SIERRA MAPLE



**INTERIOR FINISH GROUP (CONTINUED)**  
**MOLDINGS & TRIMS (CONTINUED)**

KEY	PART NUMBER	U/M DESCRIPTION
10A	P49186-02-SA0	EA MOLDING/BLOCK - PORTSMOUTH OAK
10A	P49186-02-SA1	EA MOLDING/BLOCK - CONCERT CHERRY
10A	P49186-02-SA2	EA MOLDING/BLOCK - WASHED MAPLE
10A	P49186-02-SA3	EA MOLDING/BLOCK - SIERRA MAPLE

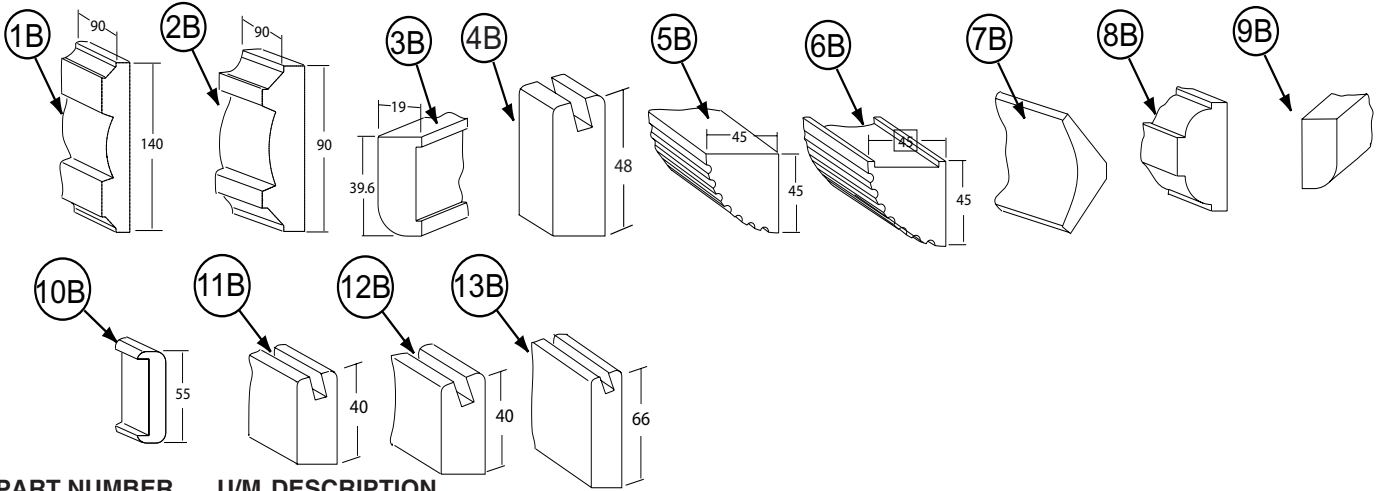

KEY	PART NUMBER	U/M DESCRIPTION
1B	P49188-01-SA0	EA MOLDING/BLOCK - PORTSMOUTH OAK
1B	P49188-01-SA1	EA MOLDING/BLOCK - CONCERT CHERRY
1B	P49188-01-SA2	EA MOLDING/BLOCK - WASHED MAPLE
1B	P49188-01-SA3	EA MOLDING/BLOCK - SIERRA MAPLE
2B	P49188-02-SA0	EA MOLDING/BLOCK - PORTSMOUTH OAK
2B	P49188-02-SA1	EA MOLDING/BLOCK - CONCERT CHERRY
2B	P49188-02-SA2	EA MOLDING/BLOCK - WASHED MAPLE
2B	P49188-02-SA3	EA MOLDING/BLOCK - SIERRA MAPLE
3B	Y00007-42-438	EA MOLDING - 12.7 RADIUS OAK - UNSTAINED
3B	Y00007-32-438	EA MOLDING - 12.7 RADIUS CHERRY - UNSTAINED
3B	Y00007-22-438	EA MOLDING - 12.7 RADIUS MAPLE - UNSTAINED
3B	Y00287-42-438	EA MOLDING - 6.0 RADIUS OAK - UNSTAINED
3B	Y00287-32-438	EA MOLDING - 6.0 RADIUS CHERRY - UNSTAINED
3B	Y00287-22-438	EA MOLDING - 6.0 RADIUS MAPLE - UNSTAINED
4B	Y00054-72-438	EA MOLDING - VINYL - W/SLOT - .7"X 1.9"X 96" - PORTSMOUTH OAK
4B	Y00054-62-438	EA MOLDING - VINYL - W/SLOT - .7"X 1.9"X 96" - CONCERT CHERRY
4B	Y00054-A2-438	EA MOLDING - VINYL - W/SLOT - .7"X 1.9"X 96" - WASHED MAPLE
4B	Y00054-92-438	EA MOLDING - VINYL - W/SLOT - .7"X 1.9"X 96" - SIERRA MAPLE
5B	Y00070-42-438	EA MOLDING/FLUTED - OAK - 96"
5B	Y00070-32-438	EA MOLDING/FLUTED - CHERRY - 96"
5B	Y00070-22-438	EA MOLDING/FLUTED - MAPLE - 96"
6B	Y00071-42-438	EA MOLDING/FLUTED - W/NOTCH - OAK/UNSTAINED - 96"
6B	Y00071-32-438	EA MOLDING/FLUTED - W/NOTCH - CHERRY/UNSTAINED - 96"
6B	Y00071-22-438	EA MOLDING/FLUTED - W/NOTCH - MAPLE/UNSTAINED - 96"
7B	Y00074-72-438	EA MOLDING/CROWN - VINYL WRAPPED - PORTSMOUTH OAK - 96" - PORTSMOUTH OAK
7B	Y00074-62-438	EA MOLDING/CROWN - VINYL WRAPPED - CONCERT CHERRY - 96" - CONCERT CHERRY
7B	Y00074-A2-438	EA MOLDING/CROWN - VINYL WRAPPED - MAPLE - 96" - WASHED MAPLE
7B	Y00074-92-438	EA MOLDING/CROWN - VINYL WRAPPED - SIERRA MAPLE - 96" - SIERRA MAPLE
8B	Y00076-42-438	EA MOLDING/TRIM - .5" X 1" X 96" - OAK (UNSTAINED)
8B	Y00076-32-438	EA MOLDING/TRIM - .5" X 1" X 96" - CHERRY (UNSTAINED)
8B	Y00076-22-438	EA MOLDING/TRIM - .5" X 1" X 96" - MAPLE (UNSTAINED)
9B	Y00086-72-438	EA MOLDING - VINYL WRAP - .7" X 1.6" X 96" - PORTSMOUTH OAK - PORTSMOUTH OAK
9B	Y00086-62-438	EA MOLDING - VINYL WRAP - .7" X 1.6" X 96" - CHERRY - CONCERT CHERRY
9B	Y00086-A2-438	EA MOLDING - VINYL WRAP - .7" X 1.6" X 96" - WASHED MAPLE
9B	Y00086-82-438	EA MOLDING - VINYL WRAP - .7" X 1.6" X 96" - HONEY CHERRY - HONEY CHERRY
9B	Y00086-92-438	EA MOLDING - VINYL WRAP - .7" X 1.6" X 96" - SIERRA MAPLE - SIERRA MAPLE
9B	Y00087-A2-438	EA MOLDING - VINYL WRAP - .7" X 2.9" X 96" - WASHED MAPLE
9B	Y00087-62-438	EA MOLDING - VINYL WRAP - .7" X 2.9" X 96" - CONCERT CHERRY
9B	Y00087-72-438	EA MOLDING - VINYL WRAP - .7" X 2.9" X 96" - PORTSMOUTH OAK
9B	Y00087-82-438	EA MOLDING - VINYL WRAP - .7" X 2.9" X 96" - HONEY CHERRY
9B	Y00087-92-438	EA MOLDING - VINYL WRAP - .7" X 2.9" X 96" - SIERRA MAPLE
9B	Y00267-72-438	EA MOLDING - VINYL WRAP/MITERED - .6" X 96" - PORTSMOUTH OAK

**INTERIOR FINISH GROUP (CONTINUED)**  
**MOLDINGS & TRIMS (CONTINUED)**

KEY	PART NUMBER	U/M	DESCRIPTION
9B	Y00267-62-438	EA	MOLDING - VINYL WRAP/MITERED - .6" X 96" - CONCERT CHERRY
9B	Y00267-A2-438	EA	MOLDING - VINYL WRAP/MITERED - .6" X 96" - WASHED MAPLE
9B	Y00267-A2-438	EA	MOLDING - VINYL WRAP/MITERED - .6" X 96" - SIERRA MAPLE
10B	Y00103-42-438	EA	MOLDING - STRAIGHT - .75" X 2.16" X 96" - UNSTAINED - OAK
10B	Y00103-32-438	EA	MOLDING - STRAIGHT - .75" X 2.16" X 96" - UNSTAINED - CHERRY
10B	Y00103-22-438	EA	MOLDING - STRAIGHT - .75" X 2.16" X 96" - UNSTAINED - MAPLE
11B	Y00203-72-438	EA	MOLDING - VINYL/BEVELED - 96" - PORTSMOUT OAK
11B	Y00203-62-438	EA	MOLDING - VINYL/BEVELED - 96" - CONCERT CHERRY
11B	Y00203-A2-438	EA	MOLDING - VINYL/BEVELED - 96" - WASHED MAPLE
11B	Y00203-82-438	EA	MOLDING - VINYL/BEVELED - 96" - HONEY CHERRY
12B	Y00204-72-438	EA	MOLDING - VINYL/BEVELED - 96" - PORTSMOUT OAK
12B	Y00204-62-438	EA	MOLDING - VINYL/BEVELED - 96" - CONCERT CHERRY
12B	Y00204-A2-438	EA	MOLDING - VINYL/BEVELED - 96" - WASHED MAPLE
12B	Y00204-82-438	EA	MOLDING - VINYL/BEVELED - 96" - HONEY CHERRY
13B	Y00205-72-438	EA	MOLDING - VINYL/BEVELED - 96" - PORTSMOUT OAK
13B	Y00205-62-438	EA	MOLDING - VINYL/BEVELED - 96" - CONCERT CHERRY
13B	Y00205-A2-438	EA	MOLDING - VINYL/BEVELED - WASHED MAPLE
13B	Y00205-82-438	EA	MOLDING - VINYL/BEVELED - 96" - HONEY CHERRY

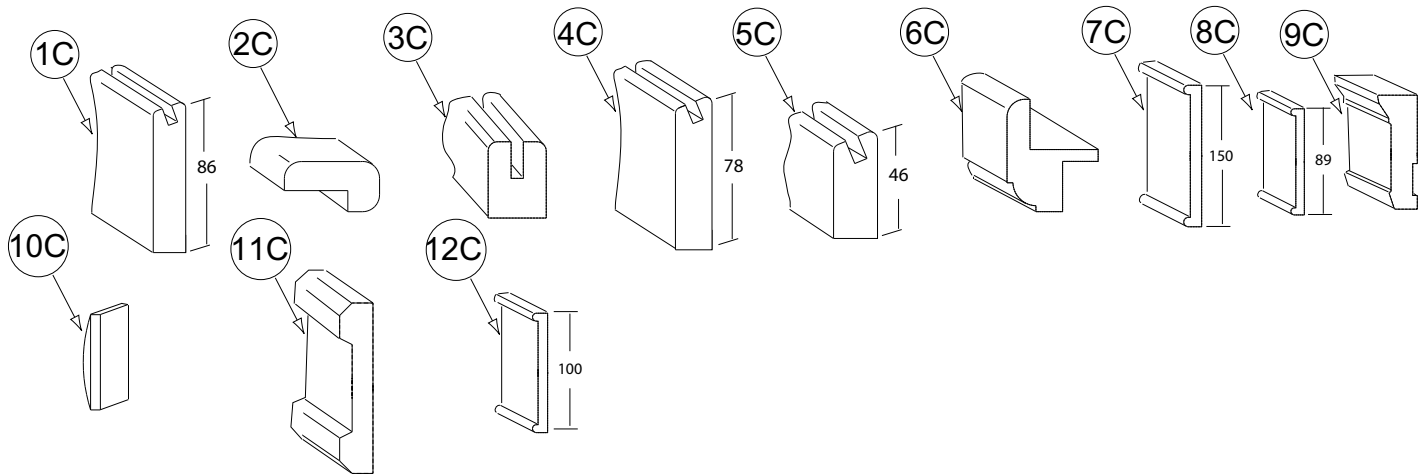

KEY	PART NUMBER	U/M	DESCRIPTION
1C	Y00206-72-438	EA	MOLDING - VINYL/BEVELED - 96" - PORTSMOUT OAK
1C	Y00206-62-438	EA	MOLDING - VINYL/BEVELED - 96" - CONCERT CHERRY
1C	Y00206-A2-438	EA	MOLDING - VINYL/BEVELED - 96" - WASHED MAPLE
1C	Y00206-82-438	EA	MOLDING - VINYL/BEVELED - 96" - HONEY CHERRY
2C	M09494-38-SD0	EA	MOLDING - TRIM - W/NOTCH - 1" X 79.6" - OAK/PORTSMOUTH OAK - PORTSMOUTH OAK
2C	M09494-38-SD1	EA	MOLDING - TRIM - W/NOTCH - 1" X 79.6" - CHERRY/CHERRY - CONCERT CHERRY
2C	M09494-38-SD2	EA	MOLDING - TRIM - W/NOTCH - 1" X 79.6" - MAPLE/WASHED MAPLE - WASHED MAPLE
2C	M09494-38-SD3	EA	MOLDING - TRIM - W/NOTCH - 1" X 79.6" - HONEY/CHERRY - HONEY CHERRY
2C	Y00207-42-438	EA	MOLDING - .75" X 1.4" X 96" - UNSTAINED OAK
2C	Y00207-32-438	EA	MOLDING - .75" X 1.4" X 96" - UNSTAINED CHERRY
2C	Y00207-22-438	EA	MOLDING - .75" X 1.4" X 96" - UNSTAINED MAPLE
3C	Y00223-42-438	EA	MOLDING - HARDWOOD/OAK - .7" X 1" X 96"
3C	Y00223-32-438	EA	MOLDING - HARDWOOD/CHERRY - .7" X 1" X 96"
3C	Y00223-22-438	EA	MOLDING - HARDWOOD/MAPLE - .7" X 1" X 96"
4C	Y00258-72-438	EA	MOLDING/VINYL WRAP-BEVELED-.73" X 3.1" X 96" - PORTSMOUTH OAK
4C	Y00258-62-438	EA	MOLDING/VINYL WRAP-BEVELED-.73" X 3.1" X 96" - CONCERT CHERRY
4C	Y00258-A2-438	EA	MOLDING/VINYL WRAP-BEVELED ENDS-.73"X3.1"X96" - WASHED MAPLE
4C	Y00258-92-438	EA	MOLDING/VINYL WRAP-BEVELED-.73" X 3.1" X 96" - SIERRA MAPLE
5C	Y00259-72-438	EA	MOLDING/VINYL WRAP-BEVELED-.73" X 1.8" X 96" - PORTSMOUTH OAK
5C	Y00259-62-438	EA	MOLDING/VINYL WRAP-BEVELED-.73" X 1.8" X 96" - CONCERT CHERRY
5C	Y00259-A2-438	EA	MOLDING/VINYL WRAP-BEVELED-.73"X1.8"X96" - WASHED MAPLE
5C	Y00259-92-438	EA	MOLDING/VINYL WRAP-BEVELED-.73"X1.8"X96" - SIERRA MAPLE
6C	Y00266-42-438	EA	MOLDING - .75" X 1.5" X 96" OAK - .7" X 1" X 96"
6C	Y00266-32-438	EA	MOLDING - .75" X 1.5" X 96" CHERRY - .7" X 1" X 96"
6C	Y00266-22-438	EA	MOLDING - .75" X 1.5" X 96" MAPLE - .7" X 1" X 96"
7C	Y00280-74-174	EA	MOLDING/TRIM - VINYL - F/SLIDEOUT - 164.1" - PORTSMOUTH OAK
7C	Y00280-64-174	EA	MOLDING/TRIM - VINYL - F/SLIDEOUT - 164.1" - CONCERT CHERRY

## INTERIOR FINISH GROUP (CONTINUED)

### MOLDINGS & TRIMS (CONTINUED)

KEY	PART NUMBER	U/M	DESCRIPTION
7C	Y00280-A4-174	EA	MOLDING/TRIM - VINYL - F/SLIDEOUT - 164.1" - WASHED MAPLE
7C	Y00280-94-174	EA	MOLDING/TRIM - VINYL - F/SLIDEOUT - 164.1" - SIERRA MAPLE
8C	Y00281-72-438	EA	MOLDING/TRIM - VINYL - F/SLIDEOUT - 96" - PORTSMOUTH OAK
8C	Y00281-62-438	EA	MOLDING/TRIM - VINYL - F/SLIDEOUT - 96" - CONCERT CHERRY
8C	Y00281-A2-438	EA	MOLDING/TRIM - VINYL - F/SLIDEOUT - 96" - WASHED MAPLE
8C	Y00281-92-438	EA	MOLDING/TRIM - VINYL - F/SLIDEOUT - 96" - SIERRA MAPLE
9C	Y00282-72-438	EA	MOLDING - SLIDEOUT/VINYL WRAP - 3.9" X 96"- PORTSMOUTH OAK
9C	Y00282-62-438	EA	MOLDING - SLIDEOUT/VINYL WRAP - 3.9" X 96"- CONCERT CHERRY
9C	Y00282-A2-438	EA	MOLDING - SLIDEOUT/VINYL WRAP - 3.9" X 96"- WASHED MAPLE
10C	Y00284-42-438	EA	MOLDING - STRAIGHT - .2" X 1.5" X 96"- UNSTAINED OAK
10C	Y00284-32-438	EA	MOLDING - STRAIGHT - .2" X 1.5" X 96"- UNSTAINED CHERRY
10C	Y00284-22-438	EA	MOLDING - STRAIGHT - .2" X 1.5" X 96"- UNSTAINED MAPLE
11C	Y00285-42-438	EA	MOLDING - STRAIGHT - .63" X 3.2" X 96"- UNSTAINED OAK
11C	Y00285-32-438	EA	MOLDING - STRAIGHT - .63" X 3.2" X 96"- UNSTAINED CHERRY
11C	Y00285-22-438	EA	MOLDING - STRAIGHT - .63" X 3.2" X 96"- UNSTAINED MAPLE
12C	Y00291-72-438	EA	MOLDING - VINYL WRAPPED - 4" X 96" - PORTSMOUTH OAK
12C	Y00291-62-438	EA	MOLDING - VINYL WRAPPED - 4" X 96" - CONCERT CHERRY
12C	Y00291-A2-438	EA	MOLDING - VINYL WRAPPED - 4" X 96" - WASHED MAPLE
12C	Y00291-92-438	EA	MOLDING - VINYL WRAPPED - 4" X 96" - SIERRA MAPLE

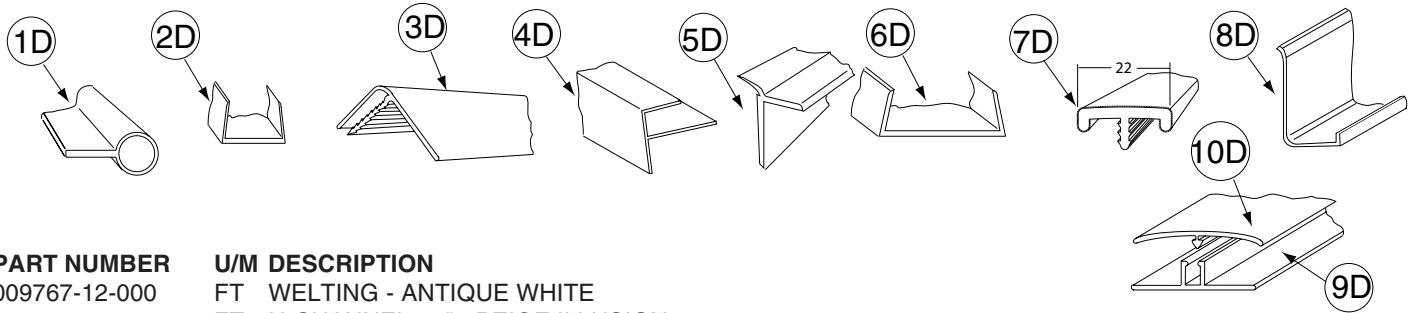

KEY	PART NUMBER	U/M	DESCRIPTION
1D	009767-12-000	FT	WELTING - ANTIQUE WHITE
2D	009778-25-000	FT	U-CHANNEL - 1" - BEIGE ILLUSION
2D	009778-32-000	FT	U-CHANNEL - 1" - PORTSMOUTH OAK
2D	009778-34-000	FT	U-CHANNEL - 1" - CONCERT CHERRY
2D	009778-35-000	FT	U-CHANNEL - 1" - HONEY CHERRY
2D	009778-36-000	FT	U-CHANNEL - 1" - SIERRA MAPLE
2D	009778-27-000	FT	U-CHANNEL - 1" - WASHED MAPLE
3D	009809-30-000	EA	MOLDING - CORNER - OUTSIDE - 1" X 84" - BEIGE ILLUSION
3D	009809-32-000	EA	MOLDING - CORNER - OUTSIDE - 1" X 84" - PORTSMOUTH OAK
3D	009809-33-000	EA	MOLDING - CORNER - OUTSIDE - 1" X 84" - CONCERT CHERRY
3D	009809-35-000	EA	MOLDING - CORNER - OUTSIDE - 1" X 84" - SIERRA MAPLE
3D	009809-34-000	EA	MOLDING - CORNER - OUTSIDE - 1" X 84" - HONEY CHERRY
3D	009809-31-000	EA	MOLDING - CORNER - OUTSIDE - 1" X 84" - WASHED MAPLE
4D	009812-31-000	EA	MOLDING - CORNER - 1/2" W/1/4"CHAN X 84" - BEIGE ILLUSION
4D	009812-34-000	EA	MOLDING - CORNER - 1/2" W/1/4"CHAN X 84" - VW LIGHT GRAY
4D	009812-35-000	EA	MOLDING - CORNER - 1/2" W/1/4"CHAN X 84" - PORTSMOUTH OAK
4D	009812-36-000	EA	MOLDING - CORNER - 1/2" W/1/4"CHAN X 84" - CONCERT CHERRY
4D	009812-37-000	EA	MOLDING - CORNER - 1/2" W/1/4"CHAN X 84" - HONEY CHERRY
4D	009812-38-000	EA	MOLDING - CORNER - 1/2" W/1/4"CHAN X 84" - SIERRA MAPLE
4D	009812-33-000	EA	MOLDING - CORNER - 1/2" W/1/4"CHAN X 84" - WASHED MAPLE
5D	022992-11-000	FT	MOLDING - REVERSE COVE - T-SHAPED - IVORY
5D	022992-14-000	FT	MOLDING - REVERSE COVE - T-SHAPED - BRIGHT WHITE
5D	022992-15-000	FT	MOLDING - REVERSE COVE - T-SHAPED - VW GRAY
6D	070504-42-000	FT	U-CHANNEL - PLASTIC - .13" X 84" - BEIGE ILLUSION
6D	070504-43-000	FT	U-CHANNEL - PLASTIC - .9" X 96" - BEIGE ILLUSION
6D	070504-57-000	FT	U-CHANNEL - PLASTIC - .13" X 84" - PORTSMOUTH OAK
6D	070504-58-000	FT	U-CHANNEL - PLASTIC - .9" X 84" - PORTSMOUTH OAK
6D	070504-60-000	FT	U-CHANNEL - PLASTIC - .13" X 84" - CONCERT CHERRY
6D	070504-61-000	FT	U-CHANNEL - PLASTIC - .9" X 84" - CONCERT CHERRY
6D	070504-62-000	FT	U-CHANNEL - PLASTIC - 1.65" X 84" - HONEY CHERRY
6D	070504-63-000	FT	U-CHANNEL - PLASTIC - .9" X 84" - HONEY CHERRY
6D	070504-65-000	FT	U-CHANNEL - PLASTIC - 1.65" X 84" - SIERRA MAPLE
6D	070504-66-000	FT	U-CHANNEL - PLASTIC - .9" X 84" - SIERRA MAPLE
6D	070504-50-000	FT	U-CHANNEL - PLASTIC - .13" X 96" - WASHED MAPLE
6D	070504-51-000	FT	U-CHANNEL - PLASTIC - .9" X 96" - WASHED MAPLE

## INTERIOR FINISH GROUP (CONTINUED)

### MOLDINGS & TRIMS (CONTINUED)

KEY	PART NUMBER	U/M	DESCRIPTION
7D	083620-15-000	FT	MOLDING-T - W/EDGE LIP - 7/8" FACE - BEIGE ILLUSION
7D	083620-20-000	FT	MOLDING-T - W/EDGE LIP - 7/8" FACE - PORTSMOUTH OAK
7D	083620-21-000	FT	MOLDING-T - W/EDGE LIP - 7/8" FACE - CONCERT CHERRY/HONEY CHERRY
7D	083620-22-000	FT	MOLDING-T - W/EDGE LIP - 7/8" FACE - SIERRA MAPLE
7D	083620-19-000	FT	MOLDING-T - W/EDGE LIP - 7/8" FACE - WASHED MAPLE
8D	085746-04-000	FT	TRIM-J - CARPET 1.2" X .5" ANGLE - 12' LONG - OFF WHITE
9D	086229-01-000	EA	RETAINER - BATTEN - .75" X 92.1" - ANY COLOR
10D	086229-20-000	EA	BATTEN - 1" X 96" - BEIGE

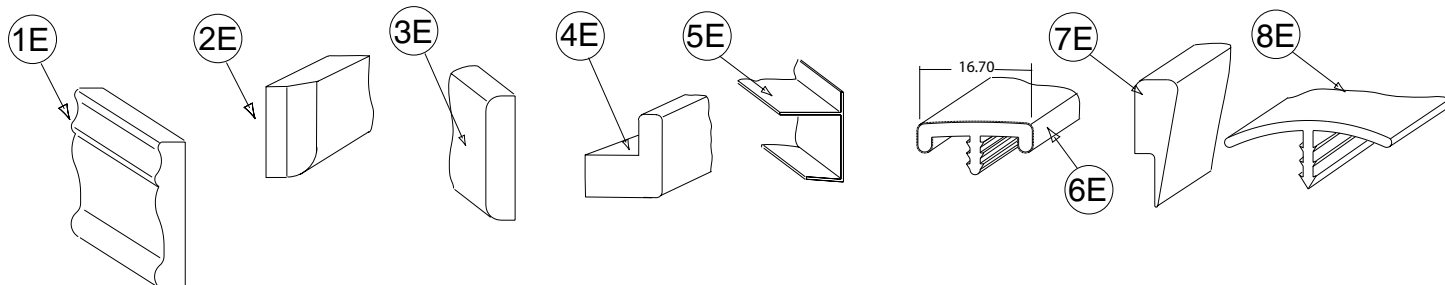

KEY	PART NUMBER	U/M	DESCRIPTION
1E	100182-10-N47	EA	TRIM/WOOD - CHAIR RAIL - 2.5" X 8' - PORTSMOUTH OAK
1E	100182-10-P85	EA	TRIM/WOOD - CHAIR RAIL - 2.5" X 8' - CONCERT CHERRY
1E	100182-10-J70	EA	TRIM/WOOD - CHAIR RAIL - 2.5" X 8' - WASHED MAPLE
1E	100182-10-RA3	EA	TRIM/WOOD - CHAIR RAIL - 2.5" X 8' - HONEY CHERRY
1E	100182-10-S67	EA	TRIM/WOOD - CHAIR RAIL - 2.5" X 8' - SIERRA MAPLE
2E	100659-30-N75	EA	MOLDING - TRIM - 8' - PORTSMOUTH OAK
2E	100659-30-N74	EA	MOLDING - TRIM - 8' - CONCERT CHERRY
2E	100659-30-M84	EA	MOLDING - TRIM - 8' - WASHED MAPLE
2E	100659-27-RA3	EA	MOLDING - TRIM - HONEY CHERRY
2E	100659-31-SA3	EA	MOLDING - TRIM - SIERRA MAPLE
3E	100818-01-12A	EA	MOLDING - VINYL WRAPPED - 1.6" X .4" X 84" - PORTSMOUTH OAK
3E	100818-01-13A	EA	MOLDING - VINYL WRAPPED - 1.6" X .4" X 84" - CONCERT CHERRY
3E	100818-01-14A	EA	MOLDING - VINYL WRAPPED - 1.6" X .4" X 84" - HONEY CHERRY
3E	100818-01-21A	EA	MOLDING - VINYL WRAPPED - 1.6" X .4" X 84" - WASHED MAPLE
3E	100818-01-22A	EA	MOLDING - VINYL WRAPPED - 1.6" X .4" X 84" - SIERRA MAPLE
4E	100819-01-12A	EA	MOLDING - VINYL WRAPPED-L-SHAPED-1.5"X1.5"X84" - PORTSMOUTH OAK
4E	100819-01-13A	EA	MOLDING - VINYL WRAPPED-L-SHAPED-1.5"X1.5"X84" - CONCERT CHERRY
4E	100819-01-14A	EA	MOLDING - VINYL WRAPPED-L-SHAPED-1.5"X1.5"X84" - HONEY CHERRY
4E	100819-01-21A	EA	MOLDING - VINYL WRAPPED-L-SHAPED-1.5"X1.5"X84" - WASHED MAPLE
4E	100819-01-22A	EA	MOLDING - VINYL WRAPPED-L-SHAPED-1.5"X1.5"X84" - SIERRA MAPLE
5E	103186-01-07A	FT	MOLDING/PLASTIC - 3/8" U-CHANNEL-3/4" FACE -BEIGE ILLUSION
5E	103186-01-09A	FT	MOLDING/PLASTIC - 3/8" U-CHAN'L-3/4" FACE - PORTSMOUTH OAK
5E	103186-01-10A	FT	MOLDING/PLASTIC - 3/8" U-CHAN'L-3/4" FACE - CONCERT CHERRY
5E	103186-01-11A	FT	MOLDING/PLASTIC - 3/8" U-CHAN'L-3/4" FACE - HONEY CHERRY
5E	103186-01-12A	FT	MOLDING/PLASTIC - 3/8" U-CHAN'L-3/4" FACE - SIERRA MAPLE
5E	103186-01-08A	FT	MOLDING/PLASTIC - 3/8" U-CHANNEL-3/4"FACE-WASHED MAPLE 8' - WASHED MAPLE
5E	103186-02-07A	FT	MOLDING/PLASTIC-1" U-CHAN'L-1 3/8" FACE - BEIGE ILLUSION
5E	103186-02-09A	FT	MOLDING/PLASTIC - 1" U-CHAN'L-1 3/8" FACE - PORTSMOUTH OAK
5E	103186-02-10A	FT	MOLDING/PLASTIC - 1" U-CHAN'L-1 3/8" FACE - CONCERT CHERRY
5E	103186-02-11A	FT	MOLDING/PLASTIC - 1" U-CHAN'L-1 3/8" FACE - HONEY CHERRY
5E	103186-02-12A	FT	MOLDING/PLASTIC - 1" U-CHAN'L-1 3/8" FACE - SIERRA MAPLE
5E	103186-02-08A	FT	MOLDING/PLASTIC - 1" U-CHANNEL-1 3/8"FACE - WASHED MAPLE
6E	104676-02-08A	FT	MOLDING-T - W/EDGE LIP - 11/16" FACE - PORTSMOUTH OAK
6E	104676-02-09A	FT	MOLDING-T - W/EDGE LIP - 11/16" FACE - CONCERT CHERRY
6E	104676-02-10A	FT	MOLDING-T - W/EDGE LIP - 11/16" FACE - HONEY CHERRY
6E	104676-02-06A	FT	MOLDING-T - W/EDGE LIP - 11/16" FACE - WASHED MAPLE
6E	104676-02-12A	FT	MOLDING-T - W/EDGE LIP - 11/16" FACE - SIERRA MAPLE
7E	105004-01-12A	EA	MOLDING - VINYL WRAPPED - 1" X 96" - PORTSMOUTH OAK
7E	105004-01-13A	EA	MOLDING - VINYL WRAPPED 1" X 8' - CONCERT CHERRY/HONEY CHERRY
7E	105004-01-21A	EA	MOLDING - VINYL WRAPPED - 1" X 8' - WASHED MAPLE
7E	105004-01-22A	EA	MOLDING - VINYL WRAPPED - 1" X 8' - SIERRA MAPLE
8E	105709-02-000	FT	MOLDING-T - W/EDGE LIP 3/4" FACE - BEIGE ILLUSION



# INTERIOR FINISH GROUP (CONTINUED)

## MOLDINGS & TRIMS (CONTINUED)

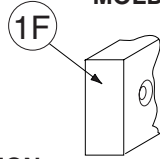

KEY	PART NUMBER	U/M	DESCRIPTION
1F	116951-11-N95	EA	MOLDING - TRIM - 3.5" X 75.9" - PORTSMOUTH
1F	116951-11-KQ1	EA	MOLDING - TRIM - 3.5" X 75.9" - CONCERT CHERRY
1F	116951-11-RE0	EA	MOLDING - TRIM - 3.5" X 75.8" - HONEY CHERRY
1F	116951-23-R83	EA	MOLDING - TRIM - 3.5" X 74.6" - PORTSMOUTH OAK
1F	116951-23-R84	EA	MOLDING - TRIM - 3.5" X 74.6" - CONCERT CHERRY
1F	116951-23-R91	EA	MOLDING - TRIM - 3.5" X 74.6" - WASHED MAPLE
1F	116951-23-RE0	EA	MOLDING - TRIM - 3.5" X 74.6" - HONEY CHERRY
1F	116951-24-R83	EA	MOLDING - TRIM - 3.5" X 74.6" - PORTSMOUTH OAK
1F	116951-24-R84	EA	MOLDING - TRIM - 3.5" X 74.6" - CONCERT CHERRY
1F	116951-24-R91	EA	MOLDING - TRIM - 3.5" X 74.6" - WASHED MAPLE
1F	116951-24-RE0	EA	MOLDING - TRIM - 3.5" X 74.6" - HONEY CHERRY
1F	116951-25-SD0	EA	MOLDING - TRIM - 5.5" X 69.8" - PORTSMOUTH OAK
1F	116951-25-SD1	EA	MOLDING - TRIM - 5.5" X 69.8" - CONCERT CHERRY
1F	116951-25-SD2	EA	MOLDING - TRIM - 5.5" X 69.8" - WASHED MAPLE
1F	116951-25-SD3	EA	MOLDING - TRIM - 5.5" X 69.8" - HONEY CHERRY
1F	116951-27-N75	EA	MOLDING - TRIM - 3.5" X 46.8" - PORTSMOUTH OAK
1F	116951-27-N85	EA	MOLDING - TRIM - 3.5" X 46.8" - CONCERT CHERRY
1F	116951-27-N84	EA	MOLDING - TRIM - 3.5" X 46.8" - WASHED MAPLE
1F	116951-28-N75	EA	MOLDING - TRIM - 3.5" X 79.4" - PORTSMOUTH OAK
1F	116951-28-N85	EA	MOLDING - TRIM - 3.5" X 79.4" - CONCERT CHERRY
1F	116951-28-N84	EA	MOLDING - TRIM - 3.5" X 79.4" - WASHED MAPLE
1F	116951-29-N70	EA	MOLDING - TRIM - 5.5" X 30.4" - PORTSMOUTH OAK
1F	116951-29-N85	EA	MOLDING - TRIM - 5.5" X 30.4" - CONCERT CHERRY
1F	116951-29-N84	EA	MOLDING - TRIM - 5.5" X 30.4" - WASHED MAPLE
1F	116951-29-RC3	EA	MOLDING - TRIM - 5.5" X 30.4" - HONEY CHERRY
1F	116951-29-SA3	EA	MOLDING - TRIM - 5.5" X 30.4" - SIERRA MAPLE
1F	116951-32-P75	EA	MOLDING - TRIM - 1.5" X 33.4" - PORTSMOUTH OAK
1F	116951-32-P25	EA	MOLDING - TRIM - 1.5" X 33.4" - CONCERT CHERRY
1F	116951-32-P28	EA	MOLDING - TRIM - 1.5" X 33.4" - WASHED MAPLE
1F	116951-32-RE0	EA	MOLDING - TRIM - 1.5" X 33.4" - HONEY CHERRY
1F	116951-34-P78	EA	MOLDING - TRIM - 3.5" X 44.3" - PORTSMOUTH OAK
1F	116951-34-P79	EA	MOLDING - TRIM - 3.5" X 44.3" - CONCERT CHERRY
1F	116951-34-P28	EA	MOLDING - TRIM - 3.5" X 44.3" - WASHED MAPLE
1F	116951-34-RE0	EA	MOLDING - TRIM - 3.5" X 44.3" - HONEY CHERRY
1F	116951-35-P78	EA	MOLDING - TRIM - 3.5" X 96" - PORTSMOUTH OAK
1F	116951-35-P79	EA	MOLDING - TRIM - 3.5" X 96" - CONCERT CHERRY
1F	116951-35-P28	EA	MOLDING - TRIM - 3.5" X 96" - WASHED MAPLE
1F	116951-35-RE0	EA	MOLDING - TRIM - 3.5" X 96" - HONEY CHERRY
1F	116951-36-R68	EA	MOLDING - TRIM - 3.5" X 48.8" - PORTSMOUTH OAK
1F	116951-36-R69	EA	MOLDING - TRIM - 3.5" X 48.8" - CONCERT CHERRY
1F	116951-36-R76	EA	MOLDING - TRIM - 3.5" X 48.8" - WASHED MAPLE
1F	116951-37-R68	EA	MOLDING - TRIM - 3.5" X 38.6" - PORTSMOUTH OAK
1F	116951-37-R69	EA	MOLDING - TRIM - 3.5" X 38.6" - CONCERT CHERRY
1F	116951-37-R76	EA	MOLDING - TRIM - 3.5" X 38.6" - WASHED MAPLE
1F	116951-38-R83	EA	MOLDING - TRIM - 3.5" X 82.6" - PORTSMOUTH OAK
1F	116951-38-R84	EA	MOLDING - TRIM - 3.5" X 82.6" - CONCERT CHERRY
1F	116951-38-R91	EA	MOLDING - TRIM - 3.5" X 82.6" - WASHED MAPLE
1F	116951-38-RE0	EA	MOLDING - TRIM - 3.5" X 82.6" - HONEY CHERRY
1F	116951-39-R83	EA	MOLDING - TRIM - 3.5" X 73.9" - PORTSMOUTH OAK
1F	116951-39-R84	EA	MOLDING - TRIM - 3.5" X 73.9" - CONCERT CHERRY
1F	116951-39-R91	EA	MOLDING - TRIM - 3.5" X 73.9" - WASHED MAPLE
1F	116951-39-RE0	EA	MOLDING - TRIM - 3.5" X 73.9" - HONEY CHERRY
1F	116951-40-R83	EA	MOLDING - TRIM - 4.5" X 81.9" - PORTSMOUTH OAK
1F	116951-40-R84	EA	MOLDING - TRIM - 4.5" X 81.9" - CONCERT CHERRY
1F	116951-40-R91	EA	MOLDING - TRIM - 4.5" X 81.9" - WASHED MAPLE
1F	116951-40-RE0	EA	MOLDING - TRIM - 4.5" X 81.9" - HONEY CHERRY
1F	116951-41-R83	EA	MOLDING - TRIM - 3.5" X 36.8" - PORTSMOUTH OAK
1F	116951-41-R84	EA	MOLDING - TRIM - 3.5" X 36.8" - CONCERT CHERRY
1F	116951-41-R91	EA	MOLDING - TRIM - 3.5" X 36.8" - WASHED MAPLE
1F	116951-41-RE0	EA	MOLDING - TRIM - 3.5" X 36.8" - HONEY CHERRY

**INTERIOR FINISH GROUP (CONTINUED)**  
**MOLDINGS & TRIMS (CONTINUED)**

KEY	PART NUMBER	U/M	DESCRIPTION
1F	116951-42-R83	EA	MOLDING - TRIM - 3.5" X 46.8" - PORTSMOUTH OAK
1F	116951-42-R84	EA	MOLDING - TRIM - 3.5" X 46.8" - CONCERT CHERRY
1F	116951-42-R91	EA	MOLDING - TRIM - 3.5" X 46.8" - WASHED MAPLE
1F	116951-42-RE0	EA	MOLDING - TRIM - 3.5" X 46.8" - HONEY CHERRY
1F	116951-43-R83	EA	MOLDING - TRIM - 3.5" X 86.5" - PORTSMOUTH OAK
1F	116951-43-R84	EA	MOLDING - TRIM - 3.5" X 86.5" - CONCERT CHERRY
1F	116951-43-R91	EA	MOLDING - TRIM - 3.5" X 86.5" - WASHED MAPLE
1F	116951-43-RE0	EA	MOLDING - TRIM - 3.5" X 86.5" - HONEY CHERRY
1F	116951-44-R83	EA	MOLDING - TRIM - 3.5" X 76.1" - PORTSMOUTH OAK
1F	116951-44-R84	EA	MOLDING - TRIM - 3.5" X 76.1" - CONCERT CHERRY
1F	116951-44-R91	EA	MOLDING - TRIM - 3.5" X 76.1" - WASHED MAPLE
1F	116951-44-RE0	EA	MOLDING - TRIM - 3.5" X 76.1" - HONEY CHERRY
1F	116951-45-R68	EA	MOLDING - TRIM - 3" X 30.3" - PORTSMOUTH OAK
1F	116951-45-R69	EA	MOLDING - TRIM - 3" X 30.3" - CONCERT CHERRY
1F	116951-45-R76	EA	MOLDING - TRIM - 3" X 30.3" - WASHED MAPLE
1F	116951-46-R83	EA	MOLDING - TRIM - 4.5" X 72.3" - PORTSMOUTH OAK
1F	116951-46-R84	EA	MOLDING - TRIM - 4.5" X 72.3" - CONCERT CHERRY
1F	116951-46-R91	EA	MOLDING - TRIM - 4.5" X 72.3" - WASHED MAPLE
1F	116951-46-RE0	EA	MOLDING - TRIM - 4.5" X 72.3" - HONEY CHERRY
1F	116951-48-R83	EA	MOLDING - TRIM - 4.5" X 76.1" - PORTSMOUTH OAK
1F	116951-48-R84	EA	MOLDING - TRIM - 4.5" X 76.1" - CONCERT CHERRY
1F	116951-48-R91	EA	MOLDING - TRIM - 4.5" X 76.1" - WASHED MAPLE
1F	116951-48-RE0	EA	MOLDING - TRIM - 4.5" X 76.1" - HONEY CHERRY
1F	116951-49-R83	EA	MOLDING - TRIM - 4.5" X 69.8" - PORTSMOUTH OAK
1F	116951-49-R84	EA	MOLDING - TRIM - 4.5" X 69.8" - CONCERT CHERRY
1F	116951-49-R91	EA	MOLDING - TRIM - 4.5" X 69.8" - WASHED MAPLE
1F	116951-49-RE0	EA	MOLDING - TRIM - 4.5" X 69.8" - HONEY CHERRY
1F	116951-51-SA3	EA	MOLDING - TRIM - 3.5" X 47.3" - SIERRA MAPLE
1F	116951-51-SA2	EA	MOLDING - TRIM - 3.5" X 47.3" - WASHED MAPLE
1F	116951-51-SA0	EA	MOLDING - TRIM - 3.5" X 47.3" - PORTSMOUTH OAK
1F	116951-51-SA1	EA	MOLDING - TRIM - 3.5" X 47.3" - CONCERT CHERRY
1F	116951-52-SD0	EA	MOLDING - TRIM - 4.5" X 73.3" - PORTSMOUTH OAK
1F	116951-52-SD1	EA	MOLDING - TRIM - 4.5" X 73.3" - CONCERT CHERRY
1F	116951-52-SD2	EA	MOLDING - TRIM - 4.5" X 73.3" - WASHED MAPLE
1F	116951-52-SD3	EA	MOLDING - TRIM - 4.5" X 73.3" - HONEY CHERRY
1F	116951-53-SD0	EA	MOLDING - TRIM - 4.5" X 53.4" - PORTSMOUTH OAK
1F	116951-53-SD1	EA	MOLDING - TRIM - 4.5" X 53.4" - CONCERT CHERRY
1F	116951-53-SD2	EA	MOLDING - TRIM - 4.5" X 53.4" - WASHED MAPLE
1F	116951-53-SD3	EA	MOLDING - TRIM - 4.5" X 53.4" - HONEY CHERRY

**INTERIOR FINISH GROUP (CONTINUED)**  
**MOLDINGS & TRIMS (CONTINUED)**

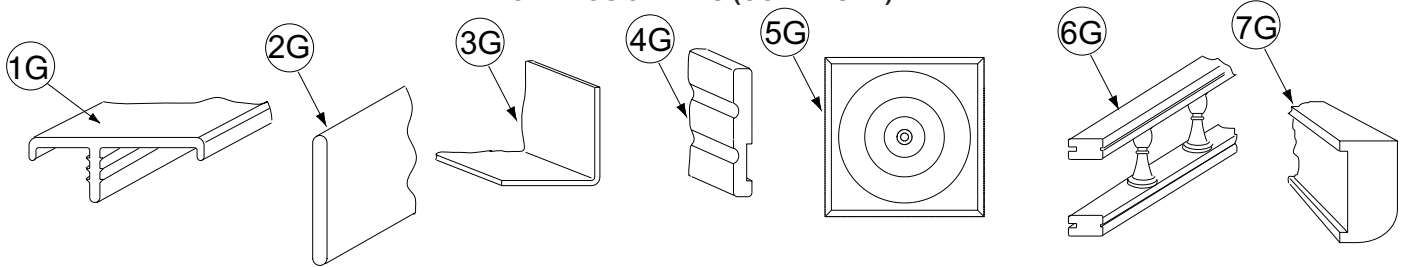

KEY	PART NUMBER	U/M	DESCRIPTION
1G	119520-01-01A	FT	MOLDING-T/OFFSET - W/EDGE LIP - 1"FACE - OFF WHITE
1G	119520-01-04A	FT	MOLDING-T - OFFSET W/EDGE LIP - 1"FACE - PORTSMOUTH OAK
1G	119520-01-02A	FT	MOLDING-T - OFFSET W/EDGE LIP - 1"FACE - CONCERT CHERRY/HONEY CHERRY
1G	119520-01-03A	FT	MOLDING-T - OFFSET W/EDGE LIP - 1"FACE - WASHED MAPLE
2G	127842-01-01A	FT	SEAL - SIGHT SHIELD - 2" BLACK
3G	130262-01-000	EA	PROTECTOR - CORNER SAVER - .7" X .7" X 48"
3G	130262-03-000	EA	PROTECTOR - CORNER - .75" X .75"
3G	130262-04-000	EA	PROTECTOR - CORNER SAVER - .4" X .7" X 48"
4G	132663-03-08A	EA	MOLDING-VINYL WRAP/PRE DRILLED-.6"X3.8"X150.6" - PORTSMOUTH OAK
4G	132663-11-07A	EA	MOLDING-VINYL WRAP/PRE DRILLED-.6"X3.8"X110.5" - CONCERT CHERRY/HONEY CHERRY
4G	132663-11-21A	EA	MOLDING-VINYL WRAP/PRE DRILLED-.6"X3.4"X57.9" - WASHED MAPLE
4G	132663-11-22A	EA	MOLDING-VINYL WRAP/PRE DRILLED-.6"X3.4"X57.9" - SIERRA MAPLE
4G	132663-09-08A	EA	MOLDING-VINYL WRAP/PRE DRILLED-.6"X3.4"X96.5" - PORTSMOUTH OAK
4G	132663-09-07A	EA	MOLDING-VINYL WRAP/PRE DRILLED-.6"X3.4"X96.5" - CONCERT CHERRY/ HONEY CHERRY
4G	132663-18-21A	EA	MOLDING-VINYL WRAP/PRE DRILLED-.6" X 3.4" X 73.1" - WASHED MAPLE
4G	132663-18-22A	EA	MOLDING-VINYL WRAP/PRE DRILLED-.6" X 3.4" X 73.1" - SIERRA MAPLE
4G	132663-15-08A	EA	MOLDING-VINYL WRAP/PRE DRILLED-.6"X3"X96" - PORTSMOUTH OAK
4G	132663-15-07A	EA	MOLDING-VINYL WRAP/PRE DRILLED-.6"X3"X96" - CONCERT CHERRY/HONEY CHERRY
4G	132663-04-21A	EA	MOLDING-VINYL WRAP/PRE DRILLED - .6" X 3" X 70.2" - WASHED MAPLE
4G	132663-04-22A	EA	MOLDING-VINYL WRAP/PRE DRILLED - .6" X 3" X 70.2" - SIERRA MAPLE
5G	132844-01-08A	EA	BLOCK - CORNER - 3.9" X 3.9" - PORTSMOUTH OAK
5G	132844-01-02A	EA	BLOCK - CORNER - 3.9" X 3.9" - CONCERT CHERRY/HONEY CHERRY
5G	132844-01-21A	EA	BLOCK - CORNER - 3.9" X 3.9" - WASHED MAPLE
5G	132844-01-22A	EA	BLOCK - CORNER - 3.9" X 3.9" - SIERRA MAPLE
5G	132844-02-08A	EA	BLOCK - CORNER - 3.5" X 3.5" - PORTSMOUTH OAK
5G	132844-02-02A	EA	BLOCK - CORNER - 3.5" X 3.5" - CONCERT CHERRY/HONEY CHERRY
5G	132844-02-21A	EA	BLOCK - CORNER - 3.5" X 3.5" - WASHED MAPLE
5G	132844-02-22A	EA	BLOCK - CORNER - 3.5" X 3.5" - SIERRA MAPLE
6G	137108-01-07A	EA	RAIL - DECORATIVE - 96" - PORTSMOUTH OAK
6G	137108-01-02A	EA	RAIL - DECORATIVE - 96" - CONCERT CHERRY
6G	137108-01-03A	EA	RAIL - DECORATIVE - 96" - WASHED MAPLE
6G	137108-01-08A	EA	RAIL - DECORATIVE - 96" - HONEY CHERRY
6G	137108-01-09A	EA	RAIL - DECORATIVE - 96" W/O REVERSE SIDE GROOVE - SIERRA MAPLE
6G	150167-01-07A	EA	RAIL - DECORATIVE - 96" W/O REVERSE SIDE GROOVE - PORTSMOUTH OAK
6G	150167-01-02A	EA	RAIL - DECORATIVE - 96" W/O REVERSE SIDE GROOVE - SALEM CHERRY - CONCERT CHERRY
6G	150167-01-03A	EA	RAIL - DECORATIVE - 96" W/O REVERSE SIDE GROOVE - WASHED MAPLE
6G	150167-01-09A	EA	RAIL - DECORATIVE - 96" W/O REVERSE SIDE GROOVE - SIERRA MAPLE
	137885-A2-438	EA	LUMBER - VINYL WRAPPED - .7" X .75" X 96" - CONCERT CHERRY
	137885-D2-438	EA	LUMBER - VINYL WRAPPED - .7" X 1.5" X 96" - CONCERT CHERRY
	137885-E2-438	EA	LUMBER - VINYL WRAPPED - .7" X 2" X 96" - CONCERT CHERRY
	137885-F2-438	EA	LUMBER - VINYL WRAPPED - .7" X 2.5" X 96" - CONCERT CHERRY
	137885-G2-438	EA	LUMBER - VINYL WRAPPED - .7" X 3" X 96" - CONCERT CHERRY
	137885-H2-438	EA	LUMBER - VINYL WRAPPED - .7" X 3.5" X 96" - CONCERT CHERRY
	137885-J2-438	EA	LUMBER - VINYL WRAPPED - .7" X 5.5" X 96" - CONCERT CHERRY
	137885-J2-743	EA	LUMBER - VINYL WRAPPED - .7" X 5.5" X 108" - CONCERT CHERRY
	137885-K2-438	EA	LUMBER - VINYL WRAPPED - .7" X 3.9" X 96" - CONCERT CHERRY
	137885-R2-438	EA	LUMBER - VINYL WRAPPED - .7" X 3" X 96" - CONCERT CHERRY
7G	137887-D2-134	EA	MOLDING - VINYL WRAPPED - .7" X 1.6" X 84" - CONCERT CHERRY
7G	137887-D2-743	EA	MOLDING - VINYL WRAPPED - .7" X 1.6" X 108" - CONCERT CHERRY
7G	137887-F2-134	EA	MOLDING - VINYL WRAPPED - .7" X 2.5" X 84" - CONCERT CHERRY
7G	137887-F2-743	EA	MOLDING - VINYL WRAPPED - .7" X 2.5" X 108" - CONCERT CHERRY
7G	137887-F2-438	EA	MOLDING - VINYL WRAPPED - .7" X 2.5" X 96" - CONCERT CHERRY

**INTERIOR FINISH GROUP (CONTINUED)**  
**MOLDINGS & TRIMS (CONTINUED)**

KEY	PART NUMBER	U/M	DESCRIPTION
	137894-A2-438	EA	LUMBER - VINYL WRAPPED - .7" X .75" X 96" - PORTSMOUTH OAK
	137894-D2-438	EA	LUMBER - VINYL WRAPPED - .7" X 1.5" X 96" - PORTSMOUTH OAK
	137894-E2-438	EA	LUMBER - VINYL WRAPPED - .7" X 2" X 96" - PORTSMOUTH OAK
	137894-F2-438	EA	LUMBER - VINYL WRAPPED - .7" X 2.5" X 96" - PORTSMOUTH OAK
	137894-G2-438	EA	LUMBER - VINYL WRAPPED - .7" X 3" X 96" - PORTSMOUTH OAK
	137894-H2-438	EA	LUMBER - VINYL WRAPPED - .7" X 3.5" X 96" - PORTSMOUTH OAK
	137894-J2-438	EA	LUMBER - VINYL WRAPPED - .7" X 5.5" X 96" - PORTSMOUTH OAK
	137894-J2-743	EA	LUMBER - VINYL WRAPPED - .7" X 5.5" X 96" - PORTSMOUTH OAK
	137894-K2-438	EA	LUMBER - VINYL WRAPPED - .7" X 3.9" X 96" - PORTSMOUTH OAK
	137894-R2-438	EA	LUMBER - VINYL WRAPPED - .7" X 3" X 96" - PORTSMOUTH OAK
7G	137895-D2-134	EA	MOLDING - VINYL WRAPPED - .7" X 1.6" X 84"-PORTSMOUTH OAK
7G	137895-D2-743	EA	MOLDING - VINYL WRAPPED - .7" X 1.6" X 108"-PORTSMOUTH OAK
7G	137895-F2-743	EA	MOLDING - VINYL WRAPPED - .7" X 2.5" X 108" - PORTSMOUTH OAK
	146419-A2-438	EA	LUMBER - VINYL WRAPPED - .7" X .75" X 96" - HONEY CHERRY
	146419-D2-438	EA	LUMBER - VINYL WRAPPED - .7" X 1.5" X 96" - HONEY CHERRY
	146419-E2-438	EA	LUMBER - VINYL WRAPPED - .7" X 2" X 96" - HONEY CHERRY
	146419-F2-438	EA	LUMBER - VINYL WRAPPED - .7" X 2.5" X 96" - HONEY CHERRY
	146419-G2-438	EA	LUMBER - VINYL WRAPPED - .7" X 3" X 96" - HONEY CHERRY
	146419-H2-438	EA	LUMBER - VINYL WRAPPED - .7" X 3.5" X 96" - HONEY CHERRY
	146419-J2-438	EA	LUMBER - VINYL WRAPPED - .7" X 5.5" X 96" - HONEY CHERRY
	146419-J2-743	EA	LUMBER - VINYL WRAPPED - .7" X 5.5" X 108" - HONEY CHERRY
	146419-K2-438	EA	LUMBER - VINYL WRAPPED - .7" X 3.9" X 96" - HONEY CHERRY
	146419-R2-438	EA	LUMBER - VINYL WRAPPED - .7" X 3" X 96" - HONEY CHERRY
7G	146425-D2-134	EA	MOLDING - VINYL WRAPPED - .7" X 1.6" X 96" - HONEY CHERRY
7G	146425-F2-134	EA	MOLDING - VINYL WRAPPED - .7" X 2.5" X 84" - HONEY CHERRY
7G	146425-F2-134	EA	MOLDING - VINYL WRAPPED - .7" X 2.5" X 96" - HONEY CHERRY
7G	146425-F2-743	EA	MOLDING - VINYL WRAPPED - .7" X 2.5" X 108" - HONEY CHERRY
	149325-A2-438	EA	LUMBER - VINYL WRAPPED - .7" X .75" X 96" - WASHED MAPLE
	149325-D2-438	EA	LUMBER - VINYL WRAPPED - .7" X 1.5" X 96" - WASHED MAPLE
	149325-E2-438	EA	LUMBER - VINYL WRAPPED - .7" X 2" X 96" - WASHED MAPLE
	149325-F2-438	EA	LUMBER - VINYL WRAPPED - .7" X 2.5" X 96" - WASHED MAPLE
	149325-G2-438	EA	LUMBER - VINYL WRAPPED - .7" X 3" X 96" - WASHED MAPLE
	149325-H2-438	EA	LUMBER - VINYL WRAPPED - .7" X 3.5" X 96" - WASHED MAPLE
	149325-J2-438	EA	LUMBER - VINYL WRAPPED - .7" X 5.5" X 96" - WASHED MAPLE
	149325-J2-743	EA	LUMBER - VINYL WRAPPED - .7" X 5.5" X 108" - WASHED MAPLE
	149325-K2-438	EA	LUMBER - VINYL WRAPPED - .7" X 3.9" X 96" - WASHED MAPLE
	149325-R2-438	EA	LUMBER - VINYL WRAPPED - .7" X 3" X 96" - WASHED MAPLE
7G	149326-D2-134	EA	MOLDING - VINYL WRAPPED - .7" X 1.6" X 84" - WASHED MAPLE
7G	149326-F2-134	EA	MOLDING - VINYL WRAPPED - .7" X 2.5" X 84" - WASHED MAPLE
7G	149326-F2-438	EA	MOLDING - VINYL WRAPPED - .7" X 2.5" X 96" - WASHED MAPLE
7G	149326-F2-743	EA	MOLDING - VINYL WRAPPED - .7" X 2.5" X 108" - WASHED MAPLE
	149330-A2-438	EA	LUMBER - VINYL WRAPPED - .7" X .75" X 96" - SIERRA MAPLE
	149330-D2-438	EA	LUMBER - VINYL WRAPPED - .7" X 1.5" X 96" - SIERRA MAPLE
	149330-E2-438	EA	LUMBER - VINYL WRAPPED - .7" X 2" X 96" - SIERRA MAPLE
	149330-F2-438	EA	LUMBER - VINYL WRAPPED - .7" X 2.5" X 96" - SIERRA MAPLE
	149330-G2-438	EA	LUMBER - VINYL WRAPPED - .7" X 3" X 96" - SIERRA MAPLE
	149330-H2-438	EA	LUMBER - VINYL WRAPPED - .7" X 3.5" X 96" - SIERRA MAPLE
	149330-J2-438	EA	LUMBER - VINYL WRAPPED - .7" X 5.5" X 96" - SIERRA MAPLE
	149330-J2-743	EA	LUMBER - VINYL WRAPPED - .7" X 5.5" X 108" - SIERRA MAPLE
	149330-K2-438	EA	LUMBER - VINYL WRAPPED - .7" X 3.9" X 96" - SIERRA MAPLE
	149330-R2-438	EA	LUMBER - VINYL WRAPPED - .7" X 3" X 96" - SIERRA MAPLE
7G	149331-D2-134	EA	MOLDING - VINYL WRAPPED - .7" X 1.6" X 96" - SIERRA MAPLE
7G	149331-F2-134	EA	MOLDING - VINYL WRAPPED - .7" X 2.5" X 84" - SIERRA MAPLE
7G	149331-F2-439	EA	MOLDING - VINYL WRAPPED - .7" X 2.5" X 96" - SIERRA MAPLE
7G	149331-F2-743	EA	MOLDING - VINYL WRAPPED - .7" X 2.5" X 108" - SIERRA MAPLE



**INTERIOR FINISH GROUP (CONTINUED)**  
**MOLDINGS & TRIMS (CONTINUED)**

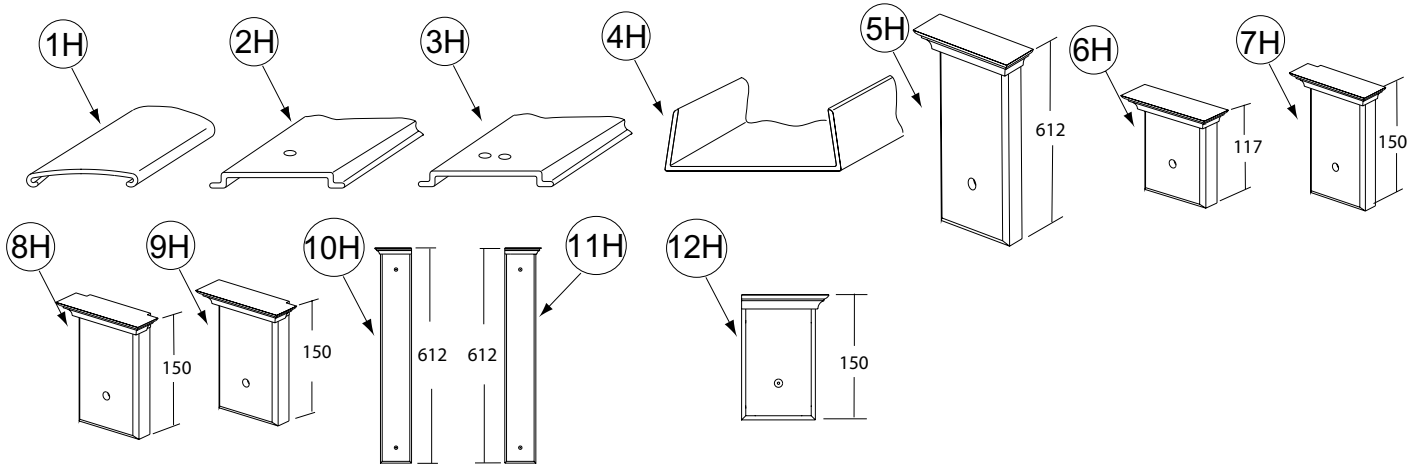

KEY	PART NUMBER	U/M	DESCRIPTION
1H	138359-01-01A	FT	COVER - ROOF BREAK - PEARL CREAM/PLASTIC - 96"
2H	138403-01-01A	EA	TRIM - ROOF - MILL
3H	138403-03-01A	EA	TRIM - ROOF - MILL
4H	141260-01-01A	FT	U-CHANNEL - 1" - VILLAGE OAK - PORTSMOUTH OAK/WASHED MAPLE/SIERRA MAPLE
4H	141260-01-02A	FT	U-CHANNEL - 1" - GRADY BROWN - CONCERT CHERRY/HONEY CHERRY
5H	141303-02-N53	EA	MOLDING - CROWN/BLOCK - PORTSMOUTH OAK
5H	141303-02-N52	EA	MOLDING - CROWN/BLOCK - CONCERT CHERRY
5H	141303-02-N62	EA	MOLDING - CROWN/BLOCK - WASHED MAPLE
5H	141303-02-RA3	EA	MOLDING - CROWN/BLOCK - HONEY CHERRY
6H	141303-03-N53	EA	MOLDING - CROWN/BLOCK - PORTSMOUTH OAK
6H	141303-03-N52	EA	MOLDING - CROWN/BLOCK - CONCERT CHERRY
6H	141303-03-N62	EA	MOLDING - CROWN/BLOCK - WASHED MAPLE
6H	141303-03-RA3	EA	MOLDING - CROWN/BLOCK - HONEY CHERRY
7H	141303-05-R89	EA	MOLDING - CROWN/BLOCK - PORTSMOUTH OAK
7H	141303-05-R91	EA	MOLDING - CROWN/BLOCK - WASHED MAPLE
7H	141303-05-R90	EA	MOLDING - CROWN/BLOCK - CONCERT CHERRY
7H	141303-05-RE3	EA	MOLDING - CROWN/BLOCK - HONEY CHERRY
8H	141303-06-R89	EA	MOLDING - CROWN/BLOCK - PORTSMOUTH OAK
8H	141303-06-R90	EA	MOLDING - CROWN/BLOCK - CONCERT CHERRY
8H	141303-06-R91	EA	MOLDING - CROWN/BLOCK - WASHED MAPLE
8H	141303-06-RE3	EA	MOLDING - CROWN/BLOCK - HONEY CHERRY
9H	141303-07-R89	EA	MOLDING - CROWN/BLOCK - PORTSMOUTH OAK
9H	141303-07-R90	EA	MOLDING - CROWN/BLOCK - CONCERT CHERRY
9H	141303-07-R91	EA	MOLDING - CROWN/BLOCK - WASHED MAPLE
9H	141303-07-RE3	EA	MOLDING - CROWN/BLOCK - HONEY CHERRY
10H	141303-08-R83	EA	MOLDING - CROWN/BLOCK - PORTSMOUTH OAK
10H	141303-08-R84	EA	MOLDING - CROWN/BLOCK - CONCERT CHERRY
10H	141303-08-R91	EA	MOLDING - CROWN/BLOCK - WASHED MAPLE
10H	141303-08-RE0	EA	MOLDING - CROWN/BLOCK - HONEY CHERRY
11H	141303-09-R83	EA	MOLDING - CROWN/BLOCK - PORTSMOUTH OAK
11H	141303-09-R84	EA	MOLDING - CROWN/BLOCK - CONCERT CHERRY
11H	141303-09-R91	EA	MOLDING - CROWN/BLOCK - WASHED MAPLE
11H	141303-09-RE0	EA	MOLDING - CROWN/BLOCK - HONEY CHERRY
12H	141303-10-R89	EA	MOLDING - CROWN/BLOCK - PORTSMOUTH OAK
12H	141303-10-R90	EA	MOLDING - CROWN/BLOCK - CONCERT CHERRY
12H	141303-10-R91	EA	MOLDING - CROWN/BLOCK - WASHED MAPLE
12H	141303-10-RE3	EA	MOLDING - CROWN/BLOCK - HONEY CHERRY

**INTERIOR FINISH GROUP (CONTINUED)**  
**MOLDINGS & TRIMS (CONTINUED)**

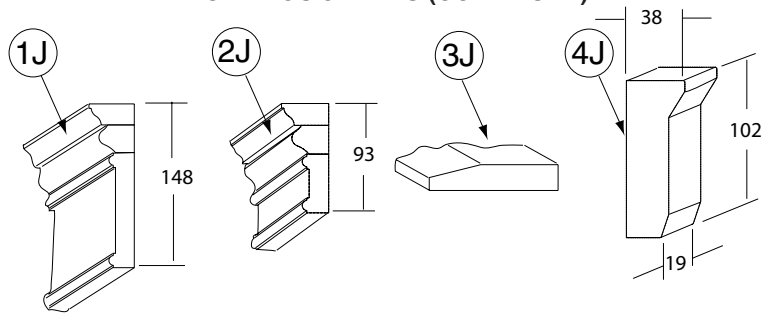

KEY	PART NUMBER	U/M	DESCRIPTION
1J	144885-14-R83	EA	MOLDING - F/SLIDEOUT - 86.5" - PORTSMOUTH OAK
1J	144885-14-R84	EA	MOLDING - F/SLIDEOUT - 86.5" - CHERRY
1J	144885-14-RE0	EA	MOLDING - F/SLIDEOUT - 86.5" - HONEY CHERRY
1J	144885-07-SD2	EA	MOLDING - F/SLIDEOUT - 82.5" - WASHED MAPLE
2J	145379-01-R83	EA	MOLDING/TRIM - 47.48" - PORTSMOUTH OAK
2J	145379-01-R84	EA	MOLDING/TRIM - 47.48" - CONCERT CHERRY
2J	145379-01-RE0	EA	MOLDING/TRIM - 47.48" - HONEY CHERRY
2J	145379-01-SD2	EA	MOLDING/TRIM - 47.48" - WASHED MAPLE
2J	145379-02-R83	E A	MOLDING/TRIM - 7.87" W/RIGHT SIDE ANGLE CUT - PORTSMOUTH OAK
2J	145379-02-R84	EA	MOLDING/TRIM - 7.87" W/RIGHT SIDE ANGLE CUT - CONCERT CHERRY
2J	145379-02-RE0	EA	MOLDING/TRIM - 7.87" W/RIGHT SIDE ANGLE CUT - HONEY CHERRY
2J	145379-02-SD2	EA	MOLDING/TRIM - 7.87" W/RIGHT SIDE ANGLE CUT - WASHED MAPLE
2J	145379-03-R83	EA	MOLDING/TRIM - 7.87" W/LEFT SIDE ANGLE CUT - PORTSMOUTH OAK
2J	145379-03-R84	EA	MOLDING/TRIM - 7.87" W/LEFT SIDE ANGLE CUT - CONCERT CHERRY
2J	145379-03-RE0	EA	MOLDING/TRIM - 7.87" W/LEFT SIDE ANGLE CUT - HONEY CHERRY
2J	145379-03-SD2	EA	MOLDING/TRIM - 7.87" W/LEFT SIDE ANGLE CUT - WASHED MAPLE
2J	145379-05-R83	EA	MOLDING/TRIM - 102.75" - PORTSMOUTH OAK
2J	145379-05-R84	EA	MOLDING/TRIM - 102.75" - CONCERT CHERRY
2J	145379-05-SD2	EA	MOLDING/TRIM - 102.75" - WASHED MAPLE
2J	145379-05-RE0	EA	MOLDING/TRIM - 102.75" - HONEY CHERRY
3J	146306-01-01A	FT	TRANSITION - CARPET/TILE
4J	149151-01-S46	EA	MOLDING - BLOCK - PORTSMOUTH OAK
4J	149151-01-S47	EA	MOLDING - BLOCK - CONCERT CHERRY
4J	149151-01-S48	EA	MOLDING - BLOCK - WASHED MAPLE

**INTERIOR FINISH GROUP (CONTINUED)**  
**PANELING & LAMINATES**

<b>KEY</b>	<b>PART NUMBER</b>	<b>U/M</b>	<b>DESCRIPTION</b>
	000885-A5-000	SF	PARTICLE BOARD - 3/8" X 4' X 8' - WHITE PEB EMB - 1 SIDED
	000885-92-000	SF	PARTICLE BOARD - 3/8" X 4' X 8' - PORTSMOUTH OAK - 1 SIDED - PORTSMOUTH OAK
	000885-93-000	SF	PARTICLE BOARD - 3/8" X 4' X 8' - PORTSMOUTH OAK - 2 SIDED - PORTSMOUTH OAK
	000885-94-000	SF	PARTICLE BOARD - 1/2" X 4' X 8' - PORTSMOUTH OAK - 2 SIDED - PORTSMOUTH OAK
	000885-95-000	SF	PARTICLE BOARD - 3/4" X 4' X 8' - PORTSMOUTH OAK - 2 SIDED - PORTSMOUTH OAK
	000885-B0-000	SF	PARTICLE BOARD - 3/8" X 4' X 8'- SIERRA MAPLE - 2 SIDED - SIERRA MAPLE
	000885-B1-000	SF	PARTICLE BOARD - 3/8" X 4' X 8'- SIERRA MAPLE - 1 SIDED - SIERRA MAPLE
	000885-B2-000	SF	PARTICLE BOARD - 3/4" X 4' X 8'- SIERRA MAPLE - 2 SIDED - SIERRA MAPLE
	000885-B3-000	SF	PARTICLE BOARD - 1/2" X 4' X 8'- SIERRA MAPLE - 2 SIDED - SIERRA MAPLE
	057882-04-000	SF	TAMBOUR - 48" X 96" SHEET - UNFINISHED
	126339-01-000	SF	BOARD - WHEAT - 60" X 72"
	074497-42-000	SF	PANELING - PORTSMOUTH OAK - 1/8" X 4' X 8' - PORTSMOUTH OAK
	076773-15-000	SF	PANELING - 2 SIDED/PORTSMOUTH OAK - 1/8" X 4' X 8' - PORTSMOUTH OAK
	074497-48-000	SF	PANELING - SIERRA MAPLE - 1/8" X 4' X 8' - SIERRA MAPLE
	076773-19-000	SF	PANELING - 2 SIDED/SIERRA MAPLE - 1/8" X 4' X 8' - SIERRA MAPLE
	074497-52-000	SF	PANELING/PAPER WRAPPED - SCULPTURES PA - 1/8" X 48" X 100"
	088272-H9-000	SF	PANELING - PEBBLE EMBOSSED - WHITE - 4' X 7'
	088272-K6-000	SF	PANELING - CYPRESS - 4' X 7' (S04, S91, S98, SX1)
	088272-K5-000	SF	PANELING - SILVERADO - 4' X 7' (S05, S92)
	088272-K7-000	SF	PANELING - STONE - 4' X 7' (S06, S93, S97)
	074498-40-000	SF	LAMINATE - PLASTIC - OFF WHITE - 4' X 8'
	074498-A1-000	SF	LAMINATE - PLASTIC - LINO FRIEZE - 5' X 8' (S04, S91, S98, SX1)
	074498-97-000	SF	LAMINATE - PLASTIC - GRAY TRANQUILITY - 4' X 8' (S05, S92)
	074498-99-000	SF	LAMINATE - PLASTIC - EGGSHELL - 5' X 8' (S06, S93, S97)
	076325-39-000	FT	MOLDING - EDGE BAND - 1 5/16" X .030" - ALMOND
	076325-40-000	FT	MOLDING - EDGE BAND - .93" X .024" - ALMOND
	085284-F9-000	FT	BATT TAPE - ADHESIVE BACKED - PEBBLE EMBOSSED
	085284-H9-000	FT	BATT TAPE - ADHESIVE BACKED - DECORATIVE - CYPRESS (S04, S91, S98, SX1)
	085284-H8-000	FT	BATT TAPE - ADHESIVE BACKED - DECORATIVE-ROCKET SILVERADO (S05, S92)
	085284-H0-000	FT	BATT TAPE - ADHESIVE BACKED - DECORATIVE - STONE (S06, S93, S97)
	085284-J8-000	FT	BATT TAPE - ADHESIVE BACK - SCULPTURES PARCHMENT
	085284-G8-000	FT	BATT TAPE - ADHESIVE BACKED/PAPER WRAP - PORTSMOUTH OAK
	085284-J4-000	FT	BATT TAPE - ADHESIVE BACKED - DECORATIVE-SIERRA MAPLE - SIERRA MAPLE
	069733-87-000	EA	BATT STRIP - WOODGRAINED/PORTSMOUTH OAK - 8' - PORTSMOUTH OAK
	069733-90-000	EA	BATT STRIP - WOODGRAINED/SIERRA MAPLE - 8' - SIERRA MAPLE
	088263-J1-000	EA	BATT STRIP - DECORATIVE - SIERRA MAPLE - SIERRA MAPLE
	088263-H5-000	EA	BATT STRIP - DECORATIVE - CYPRESS (S04, S91, S98, SX1)
	088263-H4-000	EA	BATT STRIP - DECORATIVE - ROCKET SILVERADO (S05, S92)
	088263-H6-000	EA	BATT STRIP - DECORATIVE - STONE (S06, S93, S97)
	088263-J4-000	EA	BATT STRIP - DECORATIVE - SCULPTURES PARCHMENT

## INTERIOR FINISH GROUP (CONTINUED)

### INTERIOR TRIM LAYOUT

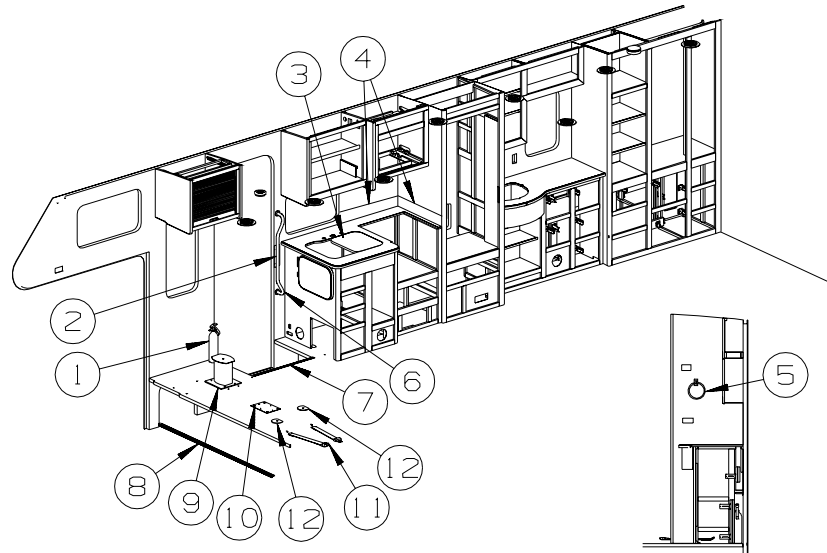

KEY	PART NUMBER	U/M	DESCRIPTION
1	094499-03-000	EA	EXTINGUISHER/FIRE - DRY - 10BC - W/GAUGE/BRACKET
1*	094499-02-000	EA	EXTINGUISHER/FIRE - DRY - 10BC - W/GAUGE - CANADIAN
1	094499-04-000	EA	STRAP - FIRE EXTINGUISHER MOUNTING - METAL
2	148362-01-01A	EA	COVER - BRACKET/STRIKE - BRIGHT WHITE
	140151-02-02A	EA	COVER - SCREW - BRIGHT WHITE
3	103610-04-R09	EA	COVER - SINK - 15.7" X 13.8" - LINO FRIEZE (S04, S91)
3	103610-04-N30	EA	COVER - SINK - 15.7" X 13.8" - GRAY TRANQUILITY (S05, S92)
3	103610-04-P17	EA	COVER - SINK - 15.7" X 13.8" - EGGSHELL MOSAIC (S06, S93)
4	132610-06-13A	FT	WALLPAPER - BORDER - 5 1/4" (S04, S91)
			FROM: 00-00-00 THRU: 10-03-04
4	132610-05-26A	FT	WALLPAPER - BORDER - 7" - SELF-ADHESIVE (S04, S91)
			FROM: 10-04-04 THRU: 99-99-99
4	132610-05-25A	FT	WALLPAPER - BORDER - 7" - SELF-ADHESIVE (S05, S92)
4	132610-06-15A	FT	WALLPAPER - BORDER - 5 1/4" - SELF-ADHESIVE (S06, S93)
5	145980-06-01A	EA	TOWEL RING - BRASS
6	137605-01-01A	EA	RAIL - HAND - INTERIOR ENTRY DOOR - BLACK
7	139955-14-04A	EA	TRIM - STEP/ENTRY - 26.7" - TITANIUM
7	139955-15-01A	EA	TRIM - STEP/ENTRY - 21.7" - MILL - VINYL FLOOR THRU OUT
7	139955-16-01A	EA	TRIM - STEP/ENTRY - 21.7" - MILL - VINYL FLOOR THRU OUT
7	139955-17-01A	EA	TRIM - STEP/ENTRY - 28" - MILL - VINYL FLOOR THRU OUT
8	139955-18-03A	EA	TRIM - STEP/ENTRY - 62.3" - TITANIUM - VINYL FLOOR THRU OUT
9	133408-01-000	EA	PEDESTAL - SEAT - DRIVER/PASSENGER - 9 3/4"
10	108445-02-000	EA	PLATE/FLOOR MOUNTED - PEDESTAL SEAT
11	007021-01-000	EA	SEAT BELT - 2" X 90" - BLACK
12	140221-01-02B	EA	WASHER - SEAT BELT - E-COAT

**\*COMPONENT PARTS LISTED LATER IN THIS GROUP**

**INTERIOR FINISH GROUP (CONTINUED)**  
**INTERIOR TRIM LAYOUT (CONTINUED)**

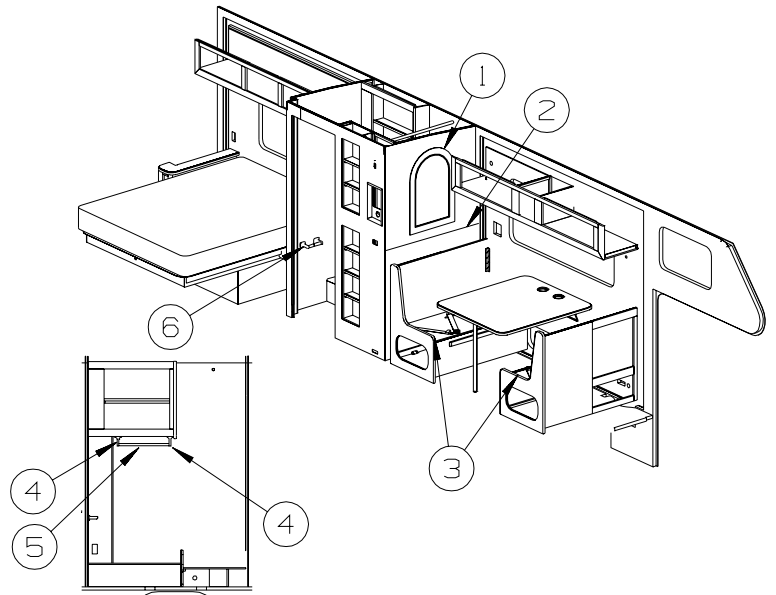

KEY	PART NUMBER	U/M	DESCRIPTION
1	131494-04-01A	EA	MIRROR - ARCHED TOP - 20" X 30" - W/DIAMOND
2	132610-06-13A	FT	WALLPAPER - BORDER - 5 1/4" (S04, S91) FROM: 00-00-00 THRU: 10-03-04
2	132610-05-26A	FT	WALLPAPER - BORDER - 7" - SELF-ADHESIVE (S04, S91) FROM: 10-04-04 THRU: 99-99-99
2	132610-05-25A	FT	WALLPAPER - BORDER - 7" - SELF-ADHESIVE (S05, S92)
2	132610-06-15A	FT	WALLPAPER - BORDER - 5 1/4" - SELF-ADHESIVE (S06, S93)
3	007021-01-000	EA	SEAT BELT - 2" X 90" - BLACK
4	145980-04-01A	EA	TOWEL BAR - POST - PAIR/BRASS
5	145980-05-01A	EA	TOWEL BAR - 18" - BRASS
6	145980-01-01A	EA	HOLDER - TOILET TISSUE - BRASS

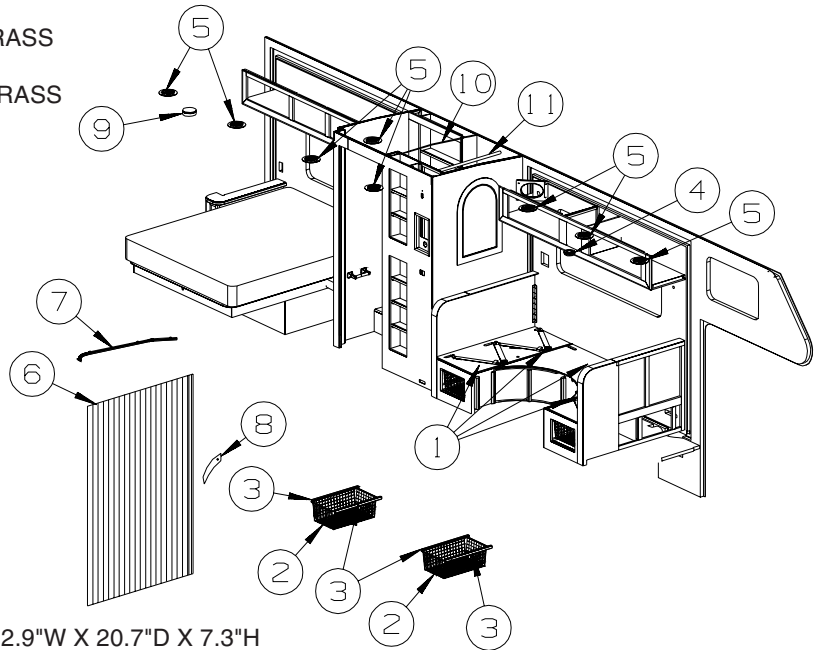

KEY	PART NUMBER	U/M	DESCRIPTION
1	007021-01-000	EA	SEAT BELT - 2" X 90" - BLACK
2	149728-01-01A	EA	BASKET/DRAWER - WHITE - 12.9"W X 20.7"D X 7.3"H
3	149728-02-01A	EA	RUNNER/RAIL - F/BASKET - 21" DEEP
4	072852-01-000	EA	DETECTOR - SMOKE - W/9 VOLT BATTERY - US
4	072852-02-000	EA	DETECTOR - SMOKE - W/9 VOLT BATTERY - <b>CANADIAN</b>
4	077956-01-000	EA	LABEL - WARNING/SMOKE DETECTOR
5	120134-01-02A	EA	REGISTER - W/DAMPER - 4" PIPE/6.4" O.D. FACE - WHITE
6*	131595-10-01A	EA	DOOR/FOLDING - 47.2" X 74.9"-4 CEILING BRKTS/STRAIGHT TRACK
7	131595-12-01A	EA	TRACK - DOOR - CURVED - 36.8"
8	057534-03-000	EA	TIEBACK - CLEAR PLASTIC - 7.5"
9	125136-02-000	EA	DETECTOR/CO - GAS MODEL - 9 VOLT
10*	135615-02-01A	EA	DOOR - SHOWER/FOLDING - 34.1" X 62.9" - WHITE
11	102075-16-02A	EA	ROD - SHOWER CURTAIN - 3/4"OD X 34.2" - SOFT WHITE
	081114-02-000	EA	CAP - INSERT/ROUND - 1" DIAMETER - WHITE PLASTIC

\*COMPONENT PARTS LISTED LATER IN THIS GROUP

**INTERIOR FINISH GROUP (CONTINUED)**  
**COMPONENT PARTS FOR INTERIOR TRIM LAYOUT**

094499-02-000

<b>KEY</b>	<b>PART NUMBER</b>	<b>U/M</b>	<b>DESCRIPTION</b>	<b>VENDOR NO</b>
	094499-01-700	EA	BRACKET MTG. W/PLAS. STRAP	294039

131595-01-01A, 131595-05-01A, 131595-10-01A

<b>KEY</b>	<b>PART NUMBER</b>	<b>U/M</b>	<b>DESCRIPTION</b>	<b>VENDOR NO.</b>
	117431-01-707	EA	CATCH/PIN - PLASTIC	
	131595-01-700	EA	END STOP ONLY	
	131595-01-701	EA	BRACKET/MOUNTING	908956
	131595-01-702	EA	TRACK/STRAIGHT - 37"	

**INTERIOR FINISH GROUP (CONTINUED)**  
**COMPONENT PARTS FOR INTERIOR TRIM LAYOUT (CONTINUED)**

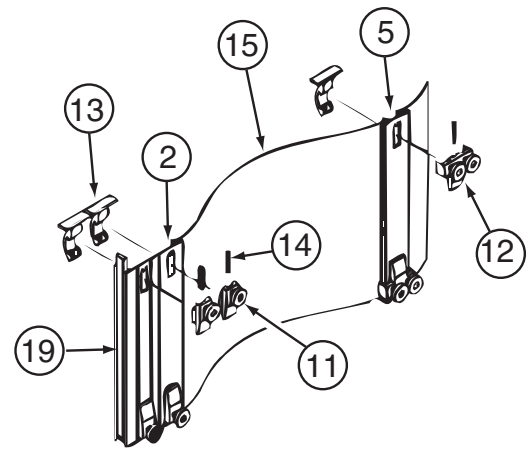
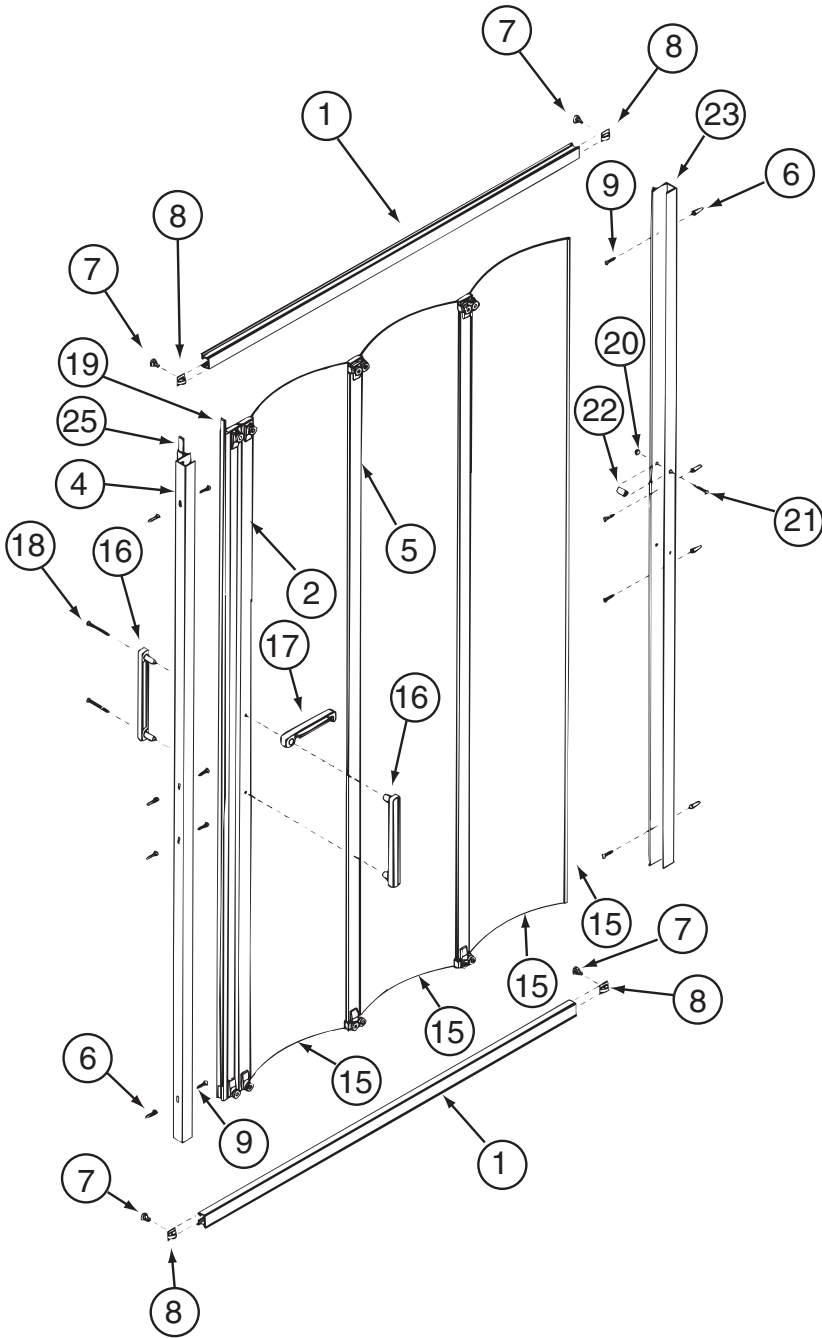

Roller Assembly Detail

135615-01-01A, 135615-02-01A, 135615-05-01A

KEY	PART NUMBER	U/M	DESCRIPTION	VENDOR NO.
1	135615-01-702	EA	TRACK - (TOP/BOTTOM) - 40"	117W
2	135615-01-701	EA	STRIKE ASSEMBLY - 66"	109W
4	135615-01-703	EA	JAMB/WALL - W/O MAG STRIKE 66"	112W
11	108351-01-703	EA	BRACKET & ROLLER ASM. SINGLE	GRB1
12	108351-01-704	EA	BRACKET & ROLLER ASM. DOUBLE	GRB2
13	108351-01-705	EA	CLIP ONLY F/SGL/DBL ROLLER	GRC1
14	108351-01-706	EA	SPRING-ROLLER BRACKET	GS1
16	108351-01-701	EA	HANDLES-DOOR, SET	SFH
17	108351-01-702	EA	LATCH-DOOR	SFL
23	135615-01-704	EA	JAMB/WALL PANEL RECEIVER 66"	110W
25	135615-01-700	EA	STRIP/MAGNETIC - 66"	98-41W

CONTACT WINNEBAGO PART SALES FOR UNLISTED COMPONENT(S)

**INTERIOR FINISH GROUP (CONTINUED)**  
**FLOOR COVERINGS**

<b>KEY</b>	<b>PART NUMBER</b>	<b>U/M</b>	<b>DESCRIPTION</b>
	042720-33-000	SY	VINYL-FLOOR COVER, DIAMOND (S04, S05, S06, S91, S92, S93, SX1)
	042720-34-000	SY	VINYL - FLOOR COVERING - CALAY/SIERRA SAND (S97)
	042720-35-000	SY	VINYL - FLOOR COVERING - CALAY/MESA GRAY (S98)
	075233-01-000	SY	PAD - CARPET - 3/8" X 6' ROLL
	089275-02-000	FT	STRIP - 3/4" X 84" BLACK POLYETHYLENE
	093486-01-000	SY	CARPET - COMPARTMENT - 72" WIDE - DARK GRAY
	096060-F0-000	SY	CARPET - PALE SAGE - INCREMENTS OF 4 SQ YARDS (S04, S91, S98, SX1) FROM: 00-00-00 THRU: 11-14-04
	152251-05-01A	SY	CARPET - 4 SQUARE YARD INCREMENTS - SAGE (S04, S91, S98, SX1) FROM: 11-15-04 THRU: 99-99-99
	096060-E6-000	SY	CARPET - OASIS - INCREMENTS OF 4 SQ YARDS (S05, S92) FROM: 00-00-00 THRU: 11-07-04
	152251-05-05A	SY	CARPET - 4 SQUARE YARD INCREMENTS - SKY BLUE (S05, S92) FROM: 11-08-04 THRU: 99-99-99
	096060-H1-000	SY	CARPET - TAPIOCA - INCREMENTS OF 4 SQ YARDS (S06, S93, S97) FROM: 00-00-00 THRU: 01-23-05
	152251-06-01A	SY	CARPET - 4 SQUARE YARD INCREMENTS - WHEAT (S06, S93, S97) FROM: 01-24-05 THRU: 99-99-99



## INTERIOR FINISH GROUP (CONTINUED)

### HARDWARE

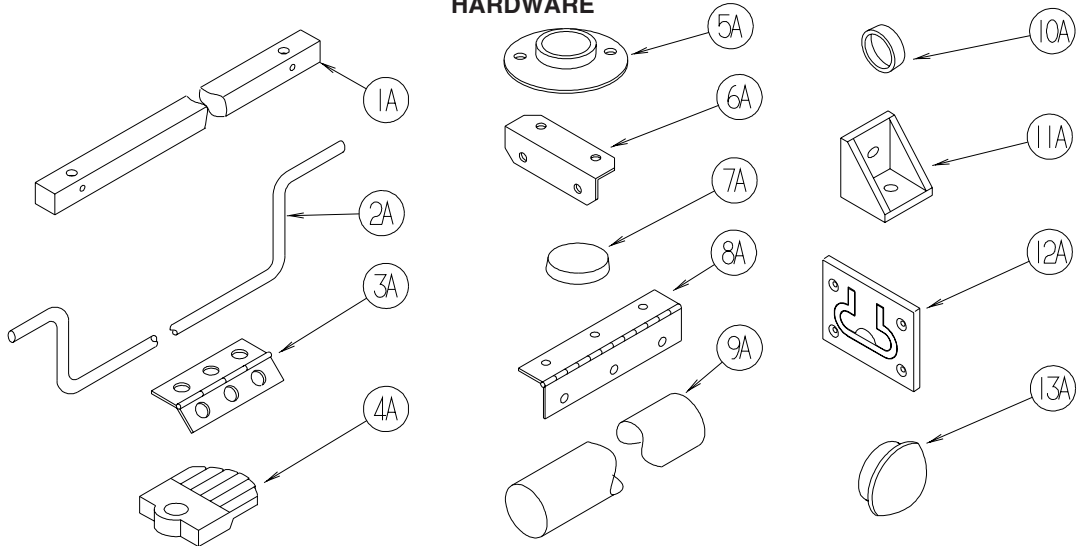

KEY	PART NUMBER	U/M	DESCRIPTION
1A	P34509-01-N01	EA	RAIL END - RH/LH - TOWEL RACK - PORTSMOUTH
1A	P34509-01-P14	EA	RAIL END - RH/LH - TOWEL RACK - CONCERT CHERRY
1A	P34509-01-J70	EA	RAIL END - RH/LH - TOWEL RACK - WASHED MAPLE
1A	P34509-01-RE0	EA	RAIL END - RH/LH - TOWEL RACK - HONEY CHERRY
1A	P34509-01-SA3	EA	RAIL END - RH/LH - TOWEL RACK - SIERRA MAPLE
2A	146801-01-01A	EA	ROD/TOWEL BAR (OFFSET) - BRASS
2A	146801-01-02A	EA	ROD/TOWEL BAR (OFFSET) - PEWTER
3A	009059-01-000	EA	HINGE - DOOR - 2" X 1.4" - BRASS
3A	009059-02-000	EA	HINGE - DOOR - 2" X 2.7" - BRASS
3A	009059-03-000	EA	HINGE - BRASS - 1.75"
3A	009059-04-000	EA	HINGE - 2" - ZINC
4A	009089-01-000	EA	CLIP - MIRROR
5A	009112-01-000	EA	FLANGE - PLASTIC - 1" CLOTHES ROD - OFF WHITE
5A	152301-01-01A	EA	FLANGE - PLASTIC - 1" CLOTHES ROD HOLDER - WHITE
6A	016604-05-000	EA	BRACE - ANGLE - 2 1/2" - OFF WHITE METAL
6A	016604-10-000	EA	BRACE - SEAT ANGLE - 2.5" - BLACK
7A	023320-01-000	EA	PAD - FELT 3/8" DIAMETER
8A	041389-25-000	EA	HINGE - PIANO - 1 1/2" X 55" - UNPAINTED
9A	042438-02-000	EA	DOWEL - WOOD - 2" DIAMETER X 2'
10A	057671-01-000	EA	COVER - SCREW - #8 - OFF WHITE
10A	057671-15-000	EA	COVER - SCREW - #8 - BRIGHT WHITE
10A	057671-16-000	EA	COVER - SCREW - #8 - SOFT WHITE
10A	057671-17-000	EA	COVER - SCREW - VW LT GRAY - #8
11A	065740-01-000	EA	BRACE - CABINET/CORNER - PLASTIC
12A	072871-01-000	EA	PULL - FLUSH - CHROME
13A	074045-08-000	EA	PLUG - OAK - 3/8" DOWEL-1/2" HEAD - CONCERT CHERRY
13A	074045-12-000	EA	PLUG - OAK - 3/8" DOWEL-1/2" HEAD - WASHED MAPLE
13A	074045-13-000	EA	PLUG - OAK - 3/8" DOWEL-1/2" HEAD - PORTSMOUTH OAK
13A	074045-14-000	EA	PLUG - OAK - 3/8" DOWEL-1/2" HEAD - HONEY CHERRY
13A	074045-15-000	EA	PLUG - OAK - 3/8" DOWEL-1/2" HEAD - SIERRA MAPLE

# INTERIOR FINISH GROUP (CONTINUED)

## HARDWARE (CONTINUED)

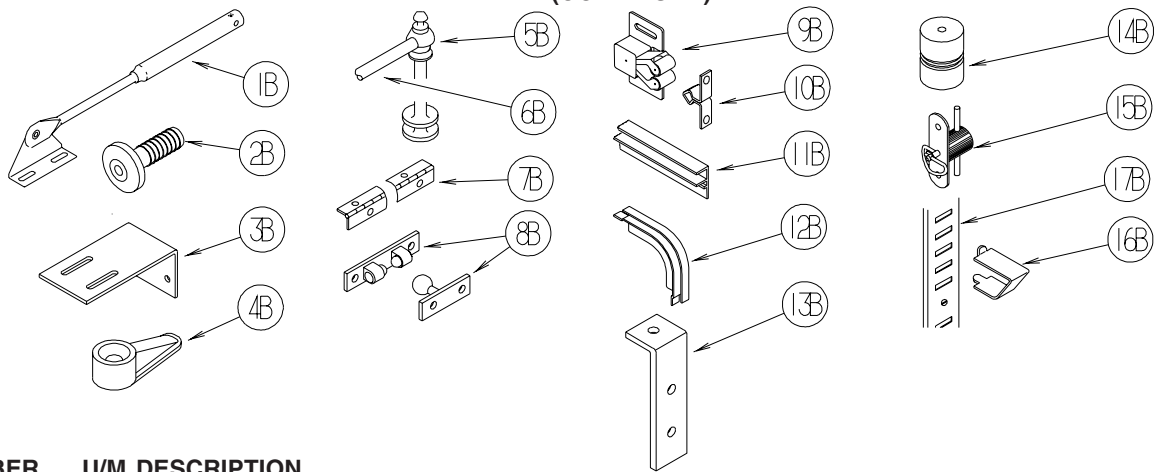

KEY	PART NUMBER	U/M	DESCRIPTION
1B	074493-02-000	EA	SUPPORT - PISTON SPRING - CABINET DOOR - 26 LBS
1B	074493-03-000	EA	SUPPORT - PISTON SPRING - CABINET DOOR - 12 LBS
2B	079921-01-000	EA	ROLLER - NYLON - W/STEEL SHAFT - BARBED
3B	083125-07-000	EA	BRACE - ANGLE/COUCH - 2.5" - OFF WHITE
4B	083204-03-000	EA	BUTTON - RETAINING MIRROR 5/16" TIP
5B	084070-03-000	EA	POST - END - 2.4" - SHINY BRASS
6B	084071-20-000	EA	ROD - BRASS - 9.8"
6B	146840-03-01A	EA	ROD - .25" DIAMETER - BRASS
6B	146840-03-02A	EA	ROD - .25" DIAMETER - PEWTER
6B	146840-04-01A	EA	ROD - .25" DIAMETER - BRASS
6B	146840-04-02A	EA	ROD - .25" DIAMETER - PEWTER
6B	146840-05-01A	EA	ROD - .25" DIAMETER - BRASS
6B	146840-05-02A	EA	ROD - .25" DIAMETER - PEWTER
7B	084413-01-000	EA	HINGE - 1" X 72" - ALUMINUM - W/HOLES
8B	084451-01-000	EA	CATCH & LATCH - 1.7" - BRASS
9B	093586-03-000	EA	CATCH - SPRING ROLLER - .377"
9B	093586-06-000	EA	CATCH - SPRING ROLLER - .236"
10B	093586-04-000	EA	STRIKE - SPRING STEEL - 1.14"
10B	093586-05-000	EA	STRIKE - SPRING STEEL - .943"
11B	093622-01-000	EA	TRACK - DOOR - TAMBOUR - PLASTIC - 8' LENGTHS
12B	093623-01-000	EA	CORNER - TRACK - TAMBOUR DOOR
13B	096826-01-01A	EA	BRACE-CABINET E-COATED
14B	097872-04-000	EA	DOWEL - WOOD - 1" DIAMETER X 1.38" LONG - UNFINISHED
15B	098196-01-000	EA	LATCH - 1/4 TURN - T-BAR
16B	098979-01-000	EA	CLIP - ADJUSTABLE SHELF
17B	098980-01-000	EA	PILASTER - ADJUSTABLE SHELF - 18"
17B	098980-02-000	EA	PILASTER - ADJUSTABLE SHELF - 12"
17B	098980-03-000	EA	PILASTER - ADJUSTABLE SHELF - 9"
17B	098980-04-000	EA	PILASTER - ADJUSTABLE SHELF - 48"
17B	098980-05-000	EA	PILASTER - ADJUSTABLE SHELF - 15"
17B	098980-06-000	EA	PILASTER - ADJUSTABLE SHELF - 24"

**INTERIOR FINISH GROUP (CONTINUED)**  
**HARDWARE (CONTINUED)**

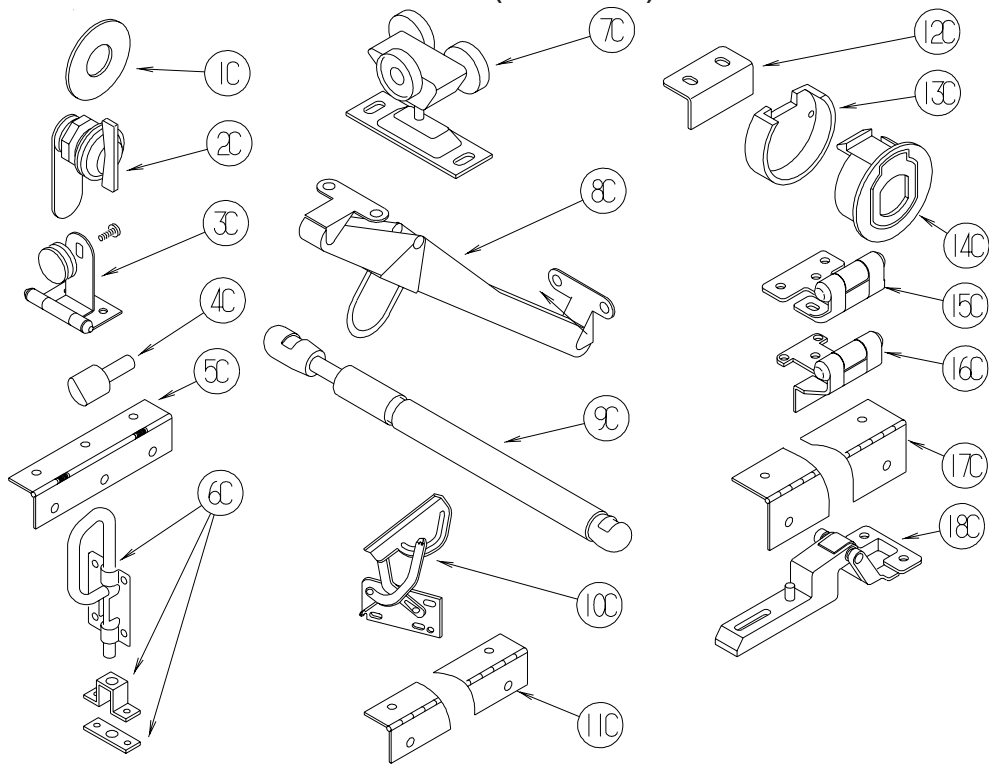

KEY	PART NUMBER	U/M	DESCRIPTION
1C	100707-01-000	EA	SPACER - GLASS DOOR - .8" DIA - .3" HOLE - PLASTIC
2C	100710-01-01A	EA	LOCK - GLASS DOOR/TWIST TYPE - BRASS
3C	100711-01-01A	EA	HINGE - GLASS DOOR
4C	101766-01-000	EA	PIN - SUPPORT/GLASS DOOR
5C	102920-01-01A	EA	HINGE - SPRING LOADED - BRASS
6C	103256-01-000	EA	LATCH COMPLETE (SLIDE)
7C	103874-01-000	EA	HANGER - SLIDING DOOR
8C	104181-01-01A	EA	SUPPORT - LEAF 5.3" EXTENDS TO 7.5" - SAFETY RING - METAL
9C	142569-15-000	EA	SPRING/GAS - 12" COMPRESSED/20" EXTENDED - 120 LB.
9C	142569-16-000	EA	SPRING/GAS - 12" COMPRESSED/20" EXTENDED - 90 LB
10C	108126-01-000	EA	TRAY HINGE SET (QTY. 2 PER SET)
11C	110496-01-01A	EA	HINGE - BRASS
12C	113375-02-01A	EA	STRIKE - DOOR - CHROME
13C	113375-05-01A	EA	LATCH - SLAM - BACK - .8" THICK
14C	113375-06-01A	EA	LATCH - SLAM - FACE - .7" THICK
15C	113676-01-01A	EA	HINGE - OVERLAY - VARIABLE - BURNISHED BRASS
16C	113677-01-01A	EA	HINGE - SELF CLOSING
17C	114278-02-000	EA	HINGE - CONTINUOUS - 3" WIDE
18C	114443-01-01A	EA	HINGE - CABINET DOOR

**INTERIOR FINISH GROUP (CONTINUED)**  
**HARDWARE (CONTINUED)**

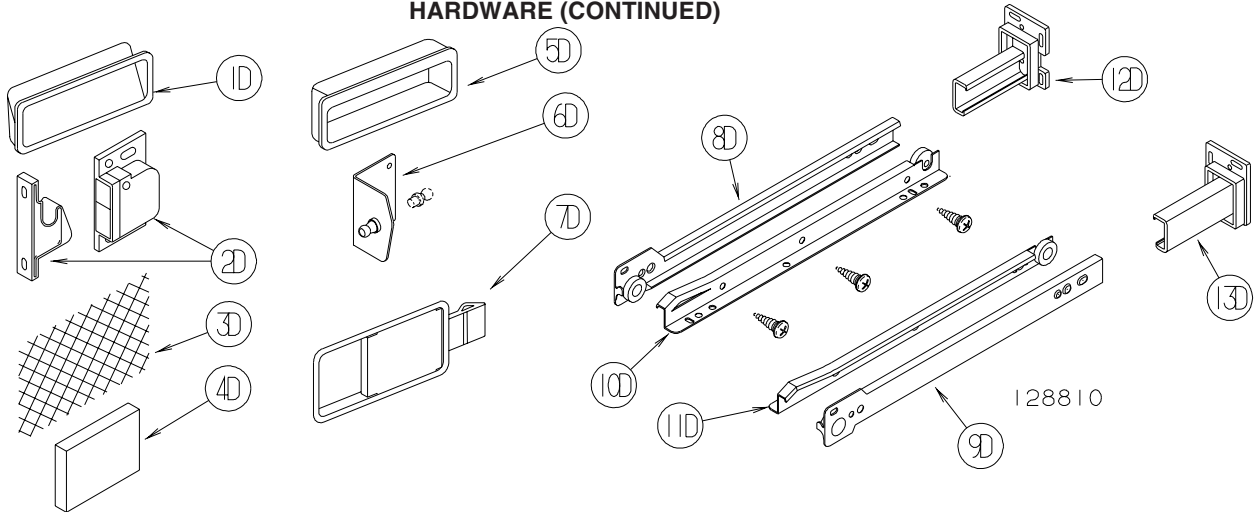

KEY	PART NUMBER	U/M	DESCRIPTION
1D	115994-01-01A	EA	HANDLE - POCKET
2D	117095-01-01A	EA	LATCH - DOOR - GRABBER W/KEEPER - PLASTIC - BLK-5 LB PULL
2D	117095-02-01A	EA	LATCH - DOOR - GRABBER W/KEEPER - PLASTIC - BLK-10 LB PULL
3D	118200-01-01A	SF	MESH - PLASTIC 1/2" - 48" X LENGTH = SF - BLACK
4D	122717-06-01A	FT	PAD - NON-SKID - PSA - 5"W
5D	124311-01-01A	EA	HANDLE - RECESSED - BRASS
6D	126263-06-02B	EA	BRACKET - GAS SPRING W/INSIDE BALL STUD - E-COATED
	057460-02-000	EA	BALL STUD - F/GAS SPRING .39" - 5/16" - 18
6D	126263-08-02B	EA	BRACKET - GAS SPRING W/CENTERED BALL STUD - E-COATED
7D	127349-01-01A	EA	LATCH - PADDLE

**FROM: 00-00-00 THRU: 01-03-05**

8D	128810-01-01A	EA	SLIDE - DRAWER - 12" - LEFT CABINET
8D	128810-05-01A	EA	SLIDE - DRAWER - 14" - LEFT CABINET
8D	128810-09-01A	EA	SLIDE - DRAWER - 16" - LEFT CABINET
8D	128810-13-01A	EA	SLIDE - DRAWER - 18" - LEFT CABINET
8D	128810-17-01A	EA	SLIDE - DRAWER - 20" - LEFT CABINET
8D	128810-21-01A	EA	SLIDE - DRAWER - 22" - LEFT CABINET
8D	128810-25-01A	EA	SLIDE - DRAWER - 24" - LEFT CABINET
9D	128810-02-01A	EA	SLIDE - DRAWER - 12" - RIGHT CABINET
9D	128810-06-01A	EA	SLIDE - DRAWER - 14" - RIGHT CABINET
9D	128810-10-01A	EA	SLIDE - DRAWER - 16" - RIGHT CABINET
9D	128810-14-01A	EA	SLIDE - DRAWER - 18" - RIGHT CABINET
9D	128810-18-01A	EA	SLIDE - DRAWER - 20" - RIGHT CABINET
9D	128810-22-01A	EA	SLIDE - DRAWER - 22" - RIGHT CABINET
9D	128810-26-01A	EA	SLIDE - DRAWER - 24" - RIGHT CABINET
10D	128810-03-01A	EA	SLIDE - DRAWER - 12" - LEFT DRAWER
10D	128810-07-01A	EA	SLIDE - DRAWER - 14" - LEFT DRAWER
10D	128810-11-01A	EA	SLIDE - DRAWER - 16" - LEFT DRAWER
10D	128810-15-01A	EA	SLIDE - DRAWER - 18" - LEFT DRAWER
10D	128810-19-01A	EA	SLIDE - DRAWER - 20" - LEFT DRAWER
10D	128810-23-01A	EA	SLIDE - DRAWER - 22" - LEFT DRAWER
10D	128810-27-01A	EA	SLIDE - DRAWER - 24" - LEFT DRAWER
11D	128810-04-01A	EA	SLIDE - DRAWER - 12" - RIGHT DRAWER
11D	128810-08-01A	EA	SLIDE - DRAWER - 14" - RIGHT DRAWER
11D	128810-12-01A	EA	SLIDE - DRAWER - 16" - RIGHT DRAWER
11D	128810-16-01A	EA	SLIDE - DRAWER - 18" - RIGHT DRAWER
11D	128810-20-01A	EA	SLIDE - DRAWER - 20" - RIGHT DRAWER
11D	128810-24-01A	EA	SLIDE - DRAWER - 22" - RIGHT DRAWER
11D	128810-28-01A	EA	SLIDE - DRAWER - 24" - RIGHT DRAWER
12D	128811-01-02A	EA	BACKSOCKET - ADJUSTABLE - LEFT
13D	128811-02-02A	EA	BACKSOCKET - ADJUSTABLE - RIGHT

**FROM: 01-04-05 THRU: 99-99-99**

153000-01-01A	EA	SLIDE - CABINET MOUNT - 11.8"
153000-02-01A	EA	SLIDE - DRAWER MOUNT - 11.8"
153000-03-01A	EA	SLIDE - CABINET MOUNT - 13.8"
153000-04-01A	EA	SLIDE - DRAWER MOUNT - 13.8"
153000-05-01A	EA	SLIDE - CABINET MOUNT - 15.7"
153000-06-01A	EA	SLIDE - DRAWER MOUNT - 15.7"

## INTERIOR FINISH GROUP (CONTINUED) HARDWARE (CONTINUED)

KEY	PART NUMBER	U/M	DESCRIPTION
	153000-07-01A	EA	SLIDE - CABINET MOUNT - 17.7"
	153000-08-01A	EA	SLIDE - DRAWER MOUNT - 17.7"
	153000-09-01A	EA	SLIDE - CABINET MOUNT - 19.7"
	153000-10-01A	EA	SLIDE - DRAWER MOUNT - 19.7"
	153000-11-01A	EA	SLIDE - CABINET MOUNT - 21.6"
	153000-12-01A	EA	SLIDE - DRAWER MOUNT - 21.6"
	153000-14-01A	EA	SLIDE - CABINET MOUNT - 23.6"
	153000-15-01A	EA	SLIDE - DRAWER MOUNT - 23.4"
	153000-16-01A	EA	SLIDE - CABINET MOUNT - 7.9"
	153000-17-01A	EA	SLIDE - DRAWER MOUNT - 7.7"
	153000-18-01A	EA	SLIDE - CABINET MOUNT - 9.8"
	153000-19-01A	EA	SLIDE - DRAWER MOUNT - 9.6"
	153000-13-01A	EA	BACKSOCKET - DRAWER SLIDE

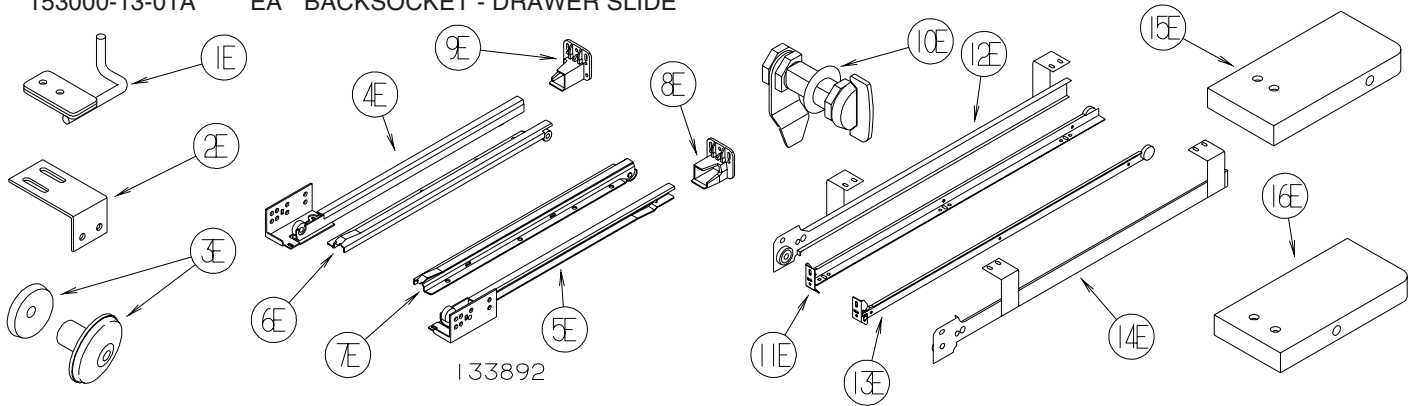

KEY	PART NUMBER	U/M	DESCRIPTION
1E	130798-01-02B	EA	GUIDE - POCKET DOOR - E-COATED
2E	132871-02-02B	EA	BRACKET/L-ANGLE W/HOLES - 1.9" X 2.8" - E-COATED
3E	133313-01-02A	EA	PULL - DOOR/DRAWER - BRIGHT BRASS - MINNIE, MINNIE WINNIE, BRAVE & SPIRIT
3E	133313-01-03A	EA	PULL - DOOR/DWR - CHROME/BRASS - SUNDANCER AND SUNRISE
4E	133892-01-01A	EA	SLIDE - DRAWER - 16" - LEFT CABINET
4E	133892-06-01A	EA	SLIDE - DRAWER - 22" - LEFT CABINET
4E	133892-10-01A	EA	SLIDE - DRAWER - 12" - LEFT CABINET
4E	133892-14-01A	EA	SLIDE - DRAWER - 18" - LEFT CABINET
5E	133892-02-01A	EA	SLIDE - DRAWER - 16" - RIGHT CABINET
5E	133892-07-01A	EA	SLIDE - DRAWER - 22" - RIGHT CABINET
5E	133892-11-01A	EA	SLIDE - DRAWER - 12" - RIGHT CABINET
5E	133892-15-01A	EA	SLIDE - DRAWER - 18" - RIGHT CABINET
6E	133892-03-01A	EA	SLIDE - DRAWER - 16" - LEFT DRAWER
6E	133892-08-01A	EA	SLIDE - DRAWER - 22" - LEFT DRAWER
6E	133892-12-01A	EA	SLIDE - DRAWER - 12" - LEFT DRAWER
6E	133892-16-01A	EA	SLIDE - DRAWER - 18" - LEFT DRAWER
7E	133892-04-01A	EA	SLIDE - DRAWER - 16" - RIGHT DRAWER
7E	133892-09-01A	EA	SLIDE - DRAWER - 22" - RIGHT DRAWER
7E	133892-13-01A	EA	SLIDE - DRAWER - 12" - RIGHT DRAWER
7E	133892-17-01A	EA	SLIDE - DRAWER - 18" - RIGHT DRAWER
8E	133907-01-01A	EA	BACKSOCKET - RIGHT HAND
9E	133907-02-01A	EA	BACKSOCKET - LEFT HAND
10E	135231-01-01A	EA	LATCH - COMPRESSION - BLACK
11E	136944-01-01A	EA	SLIDE - DRAWER/RIGHT HAND - 13.8"
12E	136944-02-01A	EA	SLIDE - CABINET/RIGHT HAND - 13.8"
13E	136944-03-01A	EA	SLIDE - DRAWER/LEFT HAND - 13.8"
14E	136944-04-01A	EA	SLIDE - CABINET/LEFT HAND - 13.8"
15E	137445-01-N42	EA	STOP - F/SLIDING DOOR - PORTSMOUTH OAK
15E	137445-01-P46	EA	STOP - F/SLIDING DOOR - CONCERT CHERRY
15E	137445-01-P56	EA	STOP - F/SLIDING DOOR - WASHED MAPLE
15E	137445-01-S67	EA	STOP - F/SLIDING DOOR - HONEY CHERRY
16E	137445-02-P45	EA	STOP - F/SLIDING DOOR - PORTSMOUTH OAK
16E	137445-02-P46	EA	STOP - F/SLIDING DOOR - CONCERT CHERRY
16E	137445-02-P56	EA	STOP - F/SLIDING DOOR - WASHED MAPLE
16E	137445-02-S67	EA	STOP - F/SLIDING DOOR - HONEY CHERRY

## INTERIOR FINISH GROUP (CONTINUED) HARDWARE (CONTINUED)

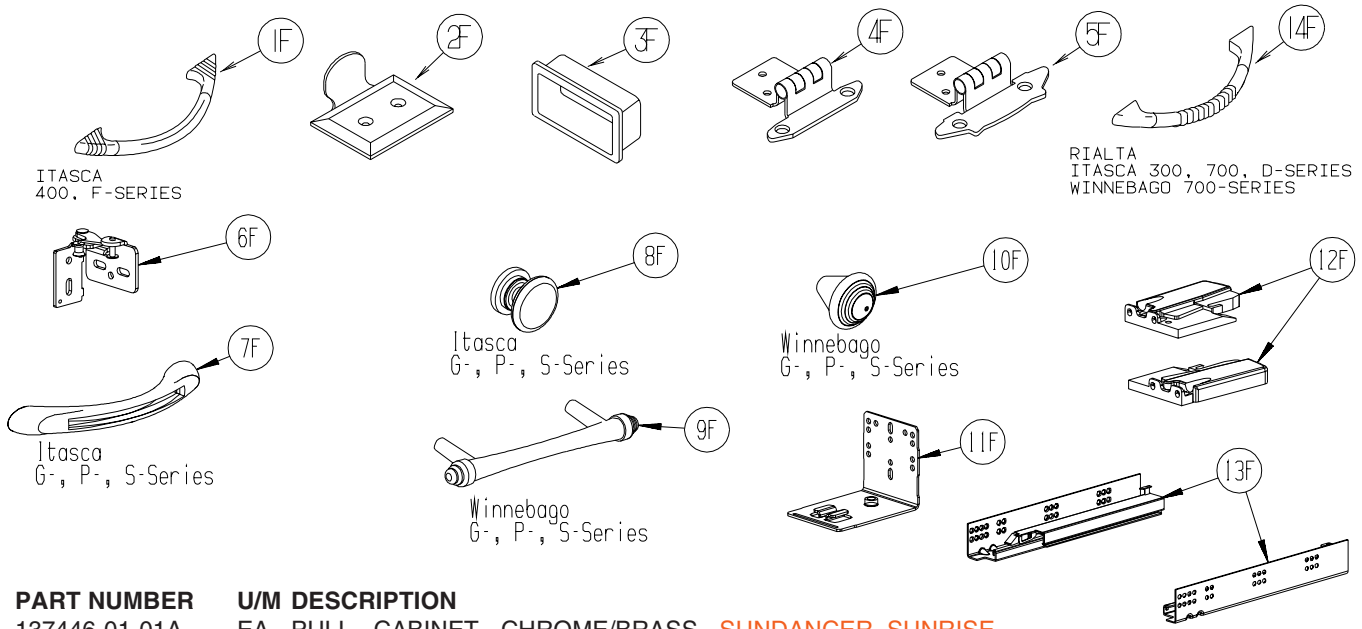

KEY	PART NUMBER	U/M	DESCRIPTION
1F	137446-01-01A	EA	PULL - CABINET - CHROME/BRASS - <b>SUNDANCER, SUNRISE</b>
2F	137463-01-01A	EA	LIFT - HOOK - SATIN BRASS
2F	137463-01-02A	EA	LIFT - HOOK - PEWTER
3F	139136-01-01A	EA	HANDLE - RECESSED .7" - BRASS
3F	139136-02-01A	EA	HANDLE - RECESSED .35" - BRASS
3F	139136-02-02A	EA	HANDLE - RECESSED .35" - PEWTER
4F	143468-01-02A	EA	HINGE - SELF CLOSING - POLISHED BRASS
5F	143468-02-03A	EA	HINGE - SELF CLOSING - SATIN NICKEL
6F	144488-01-02A	EA	HINGE - CABINET - NICKEL - <b>HORIZON</b>
7F	144917-01-01A	EA	PULL - DRAWER - SATIN NICKEL - <b>SUNCRUISER, MERIDIAN, HORIZON</b>
8F	144918-01-01A	EA	PULL - DRAWER/KNOB - SATIN NICKEL - <b>SUNCRUISER, MERIDIAN, HORIZON</b>
9F	145172-01-01A	EA	PULL - CABINET DOOR - BRASS - <b>ADVENTURER, JOURNEY, VECTRA</b>
9F	145172-01-02A	EA	PULL - CABINET DOOR - CHROME - <b>ADVENTURER, JOURNEY, VECTRA</b>
10F	145172-02-01A	EA	KNOB - CABINET DOOR - BRASS - <b>ADVENTURER, JOURNEY, VECTRA</b>
10F	145172-02-02A	EA	KNOB - CABINET DOOR - CHROME - <b>ADVENTURER, JOURNEY, VECTRA</b>
11F	145739-01-000	EA	BRACKET - REAR MOUNT
12F	145739-02-000	EA	LOCKING MECHANISM - LEFT
12F	145739-03-000	EA	LOCKING MECHANISM - RIGHT
13F	145739-04-000	EA	SLIDE - DRAWER - 12"
14F	148816-01-01A	EA	PULL - CABINET DOOR - BRASS - <b>RIALTA, SUNDANCER, SUNOVA</b>
14F	148816-01-02A	EA	PULL - CABINET DOOR - NICKEL - <b>ASPECT, CAMBRIA</b>

**INTERIOR FINISH GROUP (CONTINUED)**  
**HARDWARE (CONTINUED)**

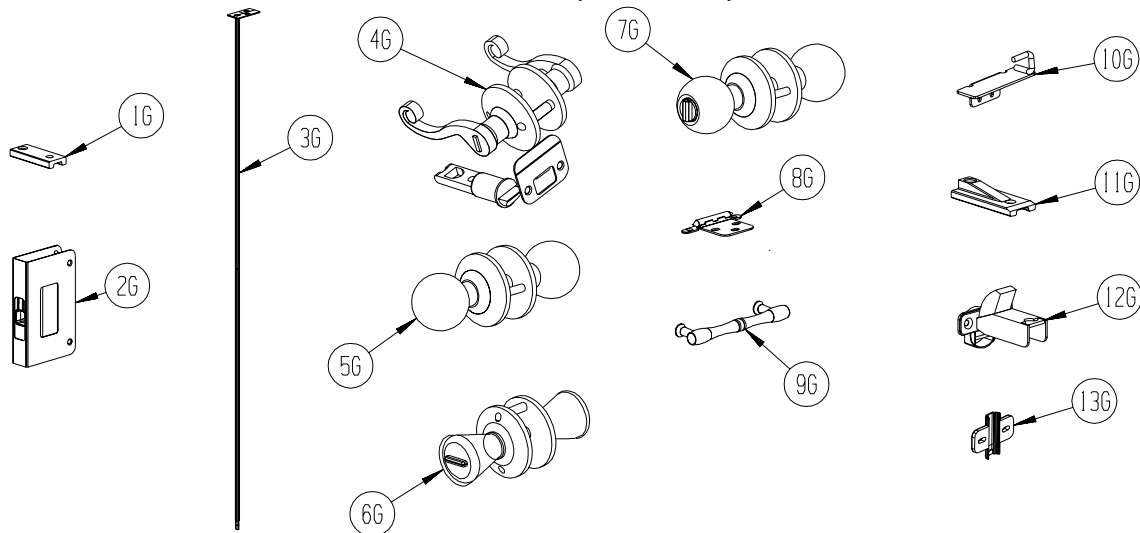

KEY	PART NUMBER	U/M	DESCRIPTION
1G	145815-01-000	EA	BLOCK - DOOR TRACK - 3" X 1.2" - BLACK
2G	145939-01-01A	EA	LATCH - SLIDE - AISLE DOOR(1" THICK DOOR) - BRASS
2G	145939-01-02A	EA	LATCH - SLIDE - AISLE DOOR(1" THICK DOOR) - NICKEL
3G	145939-03-01A	EA	ROD/LATCH - AISLE DOOR - BRASS
3G	145939-03-02A	EA	ROD/LATCH - AISLE DOOR - NICKEL
4G	146064-01-01A	EA	LOCK/PRIVACY (LOCKING) LEVER STYLE - POLISHED BRASS
4G	146064-01-02A	EA	LOCK/PRIVACY (LOCKING) LEVER STYLE - SATIN PEWTER
5G	146064-04-01A	EA	LOCK/PASSAGE (NON LOCKING) KNOB STYLE - POLISHED BRASS
6G	146064-05-01A	EA	LOCK/PRIVACY (LOCKING) KNOB STYLE - SATIN NICKEL
7G	146064-06-01A	EA	LOCK/PASSAGE (NON LOCKING) KNOB STYLE - SATIN NICKEL
8G	146553-01-01A	EA	HINGE - CABINET DOOR - BURNISHED BRASS
8G	146553-01-02A	EA	HINGE - CABINET DOOR - BRIGHT BRASS
8G	146553-01-03A	EA	HINGE - CABINET DOOR - SATIN NICKEL
9G	149090-01-01A	EA	PULL - CABINET DOOR - BRASS - MINNIE, MINNIE WINNIE, BRAVE, SIGHTSEER
10G	149607-01-02B	EA	GUIDE - F/POCKET DOOR - 1.6" BENT ROD - E-COATED
10G	149607-03-02B	EA	GUIDE - F/POCKET DOOR - 2.9" BENT ROD - E-COATED
11G	150983-01-01A	EA	BLOCK - DOOR TRACK - 3" X 1.2" - BLACK
12G	151305-01-01A	EA	HINGE - CONCEALED/SELF CLOSING - BRASS
13G	151305-02-01A	EA	PLATE/MOUNTING - F/HINGE - WHITE



# LABELS GROUP

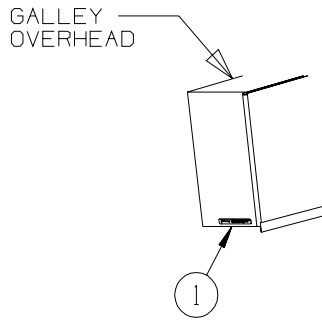

329B  
OVERHEAD DINETTE CABINET

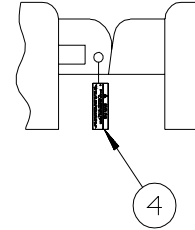
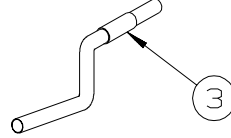
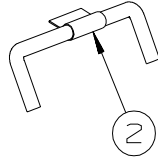
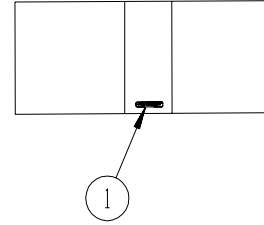

KEY	PART NUMBER	U/M DESCRIPTION
1	116549-01-000	EA LABEL - WARNING - SLIDEOUT
2	128658-01-000	EA LABEL - PROP ROD - ENTRY DOOR
3	126024-01-01A	EA LABEL - TIRE HANGER REMOVAL
4	126612-01-000	EA LABEL - HANG TAG - AIR BAG - DASH

ALTERNATE LABEL LOCATION

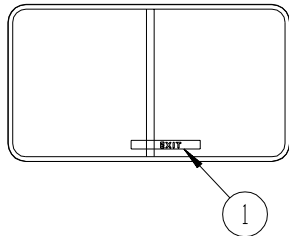

EXIT WINDOW POP-OUT STYLE

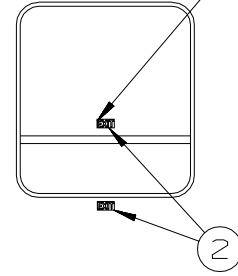

EXIT WINDOW HINGE STYLE

ALTERNATE LABEL LOCATION

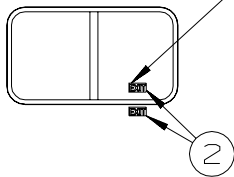

EXIT WINDOW SLIDER STYLE

KEY	PART NUMBER	U/M DESCRIPTION
1	107571-01-000	EA LABEL - EXIT/ESCAPE WINDOW
2	039290-01-000	EA LABEL - WARNING - EXIT

## LABELS GROUP (CONTINUED)

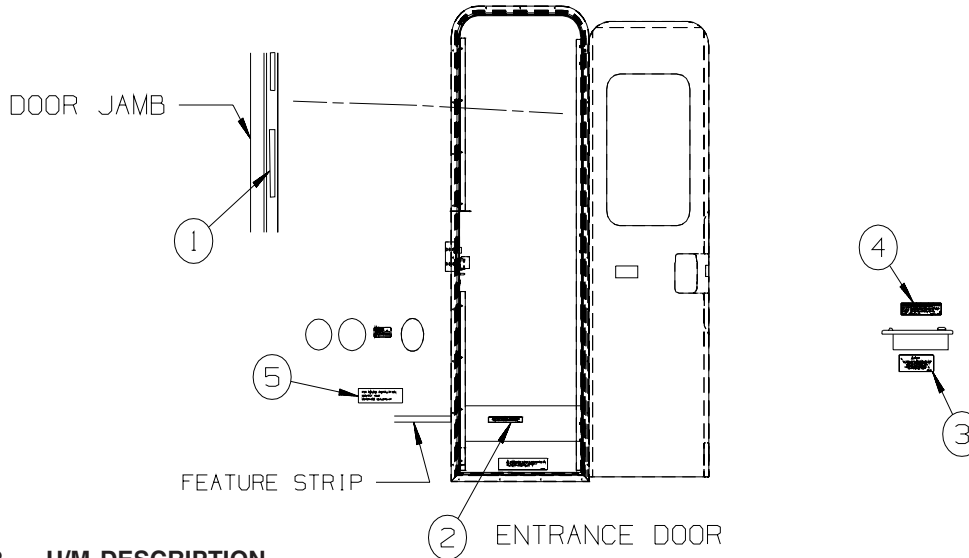

KEY	PART NUMBER	U/M	DESCRIPTION
1	135869-01-01A	EA	LABEL - MERCURY CONTENT - BLACK ON CLEAR
1	135869-01-02A	EA	LABEL - MERCURY CONTENT - WHITE ON CLEAR
2	065748-01-000	EA	LABEL - WARNING - BATTERY CHARGING - UL
2	065748-02-000	EA	LABEL - WARNING - BATTERY CHARGING - CSA - CANADIAN
3	124519-01-01A	EA	LABEL - WARNING/REFUELING - BLACK ON CLEAR
3	124519-01-02A	EA	LABEL - WARNING/REFUELING - WHITE ON CLEAR
3	124519-02-01A	EA	LABEL - WARNING/REFUELING - BLACK ON CLEAR - CSA - CANADIAN
3	124519-02-02A	EA	LABEL - WARNING/REFUELING - WHITE ON CLEAR - CSA - CANADIAN
4	068383-01-000	EA	LABEL - DIESEL FUELFORD - FORD DIESEL
5	099509-01-000	EA	LABEL - AWNING INSTALLATION

## LABELS GROUP (CONTINUED)

TYPICAL DRAINAGE AND UTILITY ACCESS

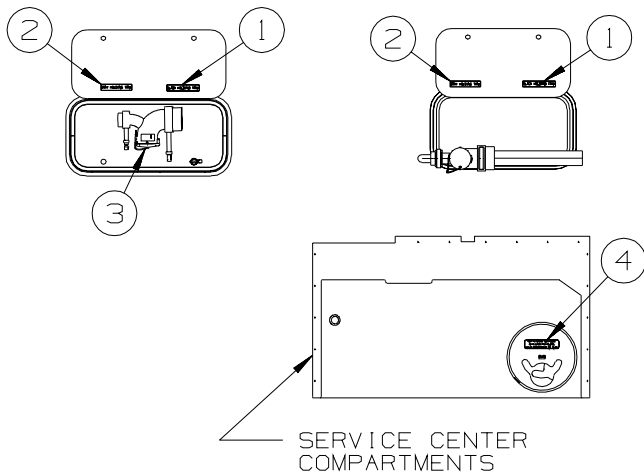

TYPICAL SERVICE PANEL

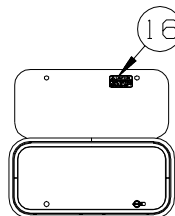
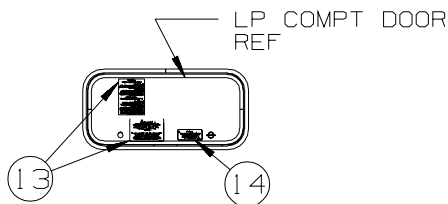
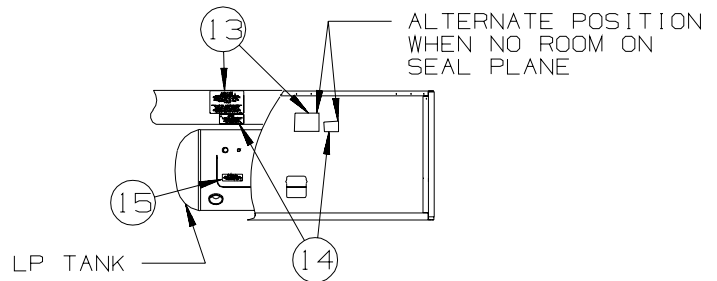
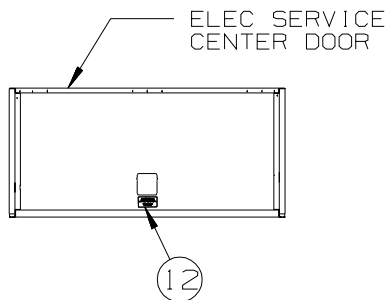
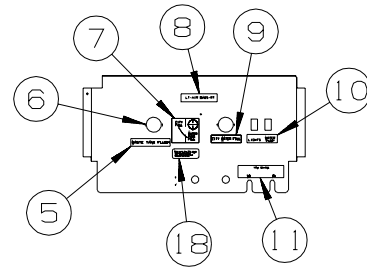

LOCATE ON INSIDE OF DOOR WHEN DOOR COVERS WATER HEATER EXHAUST VENT

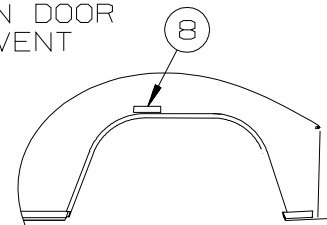
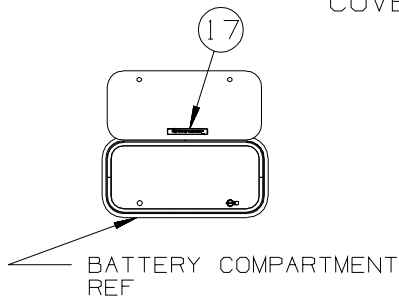

SIDEWALL LH

KEY	PART NUMBER	U/M	DESCRIPTION
1	126247-06-000	EA	LABEL - BLACK HOLDING TANK-BLACK LETTERS/CLEAR BACKGROUND
2	126247-05-000	EA	LABEL - GRAY HOLDING TANK-BLACK LETTERS/CLEAR BACKGROUND
3	144649-01-01A	EA	LABEL - ADJUSTABLE VALVE - WHITE ON CLEAR
4	123562-01-000	EA	LABEL - SERVICE/UTILITY ACCESS
5	130168-01-000	EA	LABEL - WASTE TANK FLUSH
6	125697-07-000	EA	LABEL - CAUTION - F/FLUSHING SYSTEM
7	117629-04-000	EA	LABEL - CITY WATER/TANK FILL
8	136360-01-01A	EA	LABEL - AIR BAGS
9	126249-03-000	EA	LABEL - CITY WATER FILL-BLK LETTERS/CLEAR BACKGROUND .31"
10	130170-02-000	EA	LABEL - SWITCH PANEL - BLK/CLEAR BACKGROUND- 1.4"H X 3.9"L
11	130166-02-000	EA	LABEL - DRAIN

## LABELS GROUP (CONTINUED)

KEY	PART NUMBER	U/M	DESCRIPTION
12	125306-01-01A	EA	LABEL - ELECTRICAL ENTRANCE - 110V 30 AMP - BLACK ON CLEAR
12	125306-01-02A	EA	LABEL - ELECTRICAL ENTRANCE - 110V 30 AMP - WHITE ON CLEAR
12	125306-04-01A	EA	LABEL - ELECTRICAL ENTRANCE-120/20V 50 AMP-BLACK ON CLEAR
12	125306-04-02A	EA	LABEL - ELECTRICAL ENTRANCE-120/240V 50 AMP-WHITE ON CLEAR
13	124520-01-01A	EA	LABEL - LP GAS ONLY - BLACK ON CLEAR
13	124520-01-02A	EA	LABEL - LP GAS ONLY - WHITE ON CLEAR
13	023769-01-000	EA	LABEL - WARNING - LPG - CANADIAN - <b>CANADIAN</b>
14	124519-01-01A	EA	LABEL - WARNING/REFUELING - BLACK ON CLEAR
14	124519-01-02A	EA	LABEL - WARNING/REFUELING - WHITE ON CLEAR
14	124519-02-01A	EA	LABEL - WARNING/REFUELING - BLACK ON CLEAR - CSA - <b>CANADIAN</b>
14	124519-02-02A	EA	LABEL - WARNING/REFUELING - WHITE ON CLEAR - CSA - <b>CANADIAN</b>
15	079965-01-000	EA	LABEL - LPG - 80% CAPACITY
16	113402-01-000	EA	LABEL - CAUTION - WATER HEATER EXHAUST
17	065748-01-000	EA	LABEL - WARNING - BATTERY CHARGING - UL
18	154292-01-01A	EA	LABEL - TANK FILL VALVE

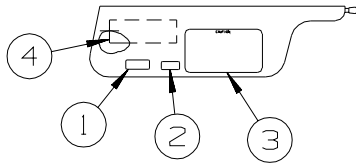

LABELS SHALL BE LOCATED ON OPPOSITE SIDE OF VISOR THAT THE AIR BAG LABEL IS INSTALLED ON.

### TYPICAL SEAT AND BELT CONFIGURATIONS

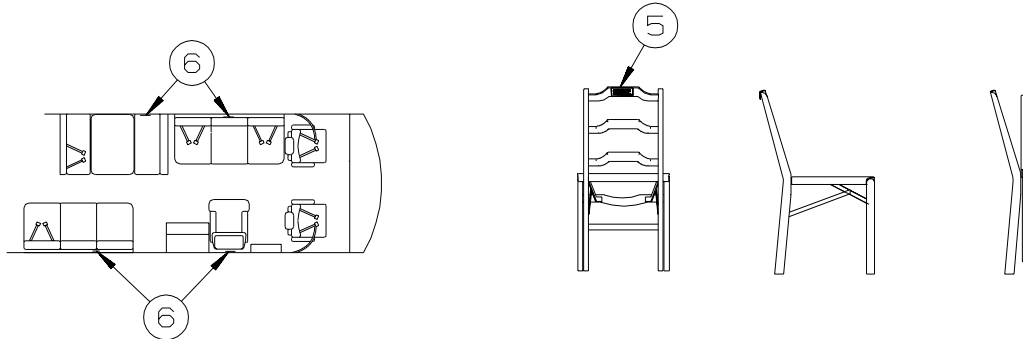

ATTACH LABEL ON OR NEXT TO:  
 +ANY SINGLE CHAIR WITHOUT BELTS.  
 +ANY DINETTE SEAT WITHOUT BELTS.  
 +ANY COUCH WITHOUT BELTS OR ANY SEATING POSITION ON THAT COUCH.  
 DO NOT ATTACH LABEL IF:  
 +DINETTE SEAT HAS AT LEAST ONE SET OF BELTS INSTALLED.

KEY	PART NUMBER	U/M	DESCRIPTION
1	111802-01-000	EA	LABEL - CFC WARNING
2	099689-01-000	EA	LABEL - WARNING - CANCER/TOXICITY
3	056259-01-000	EA	LABEL - SAFETY CHECK LIST
4	126611-01-000	EA	LABEL - AIR BAG - VISOR
5	134537-01-01A	EA	LABEL - OCCUPANCY - CHAIR - US
5	134537-02-01A	EA	LABEL - OCCUPANCY - CHAIR - CSA - <b>CANADIAN</b>
6	134538-01-01A	EA	LABEL - OCCUPANCY - NO SEAT BELT - BLACK ON CLEAR - US
6	134538-02-01A	EA	LABEL - OCCUPANCY - NO SEAT BELT - BLACK ON CLEAR - CSA - <b>CANADIAN</b>

## LABELS GROUP (CONTINUED)

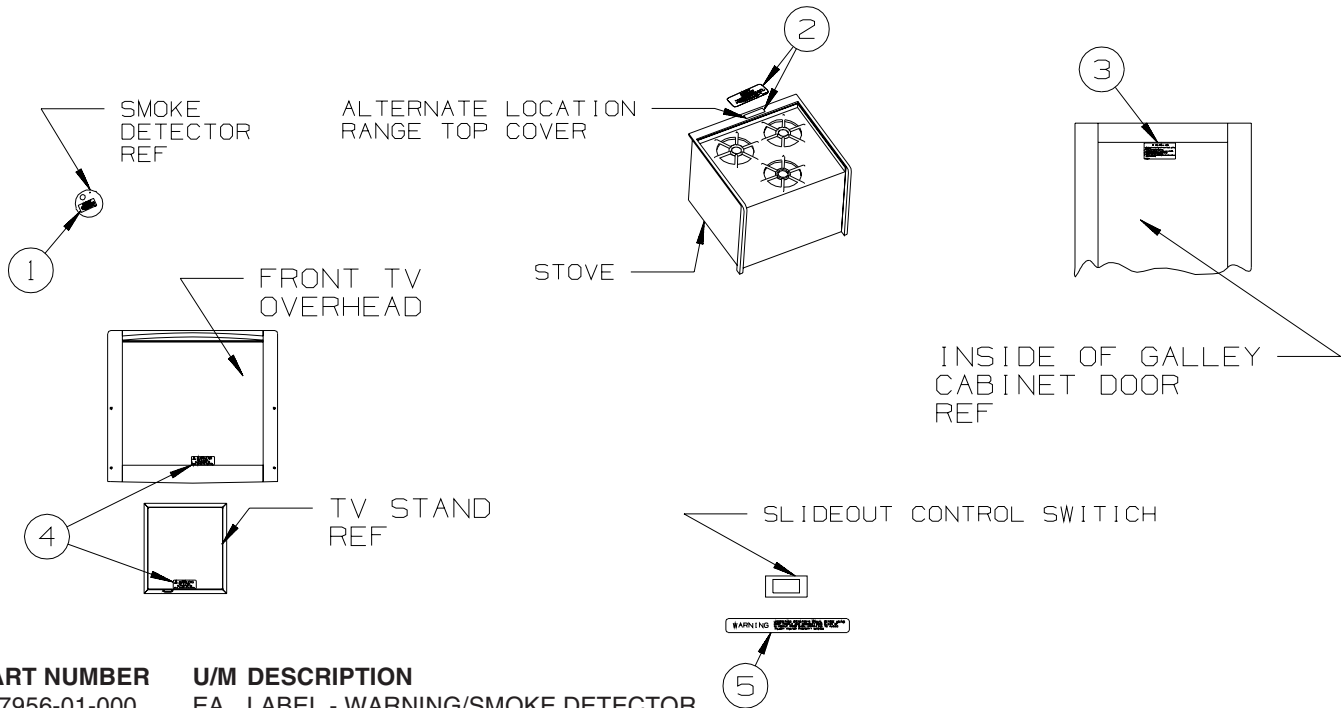

KEY	PART NUMBER	U/M	DESCRIPTION
1	077956-01-000	EA	LABEL - WARNING/SMOKE DETECTOR
2	134539-01-01A	EA	LABEL - WARNING - STOVE/HEATING - US - BLACK ON CLEAR
2	134540-01-01A	EA	LABEL - WARNING - STOVE/HEATING - CSA - BLACK ON CLEAR - <b>CANADIAN</b>
3	073998-01-000	EA	LABEL - LPG/ODOR WARNING
4	079966-01-000	EA	LABEL - WARNING - STOWED - MOTION
5	116549-01-000	EA	LABEL - WARNING - SLIDEOUT

## LABELS GROUP (CONTINUED)

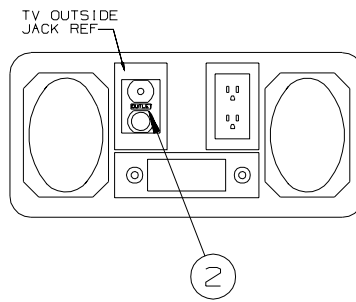
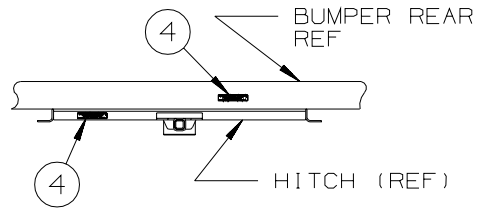
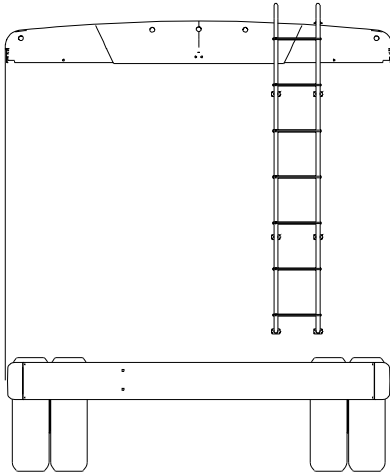
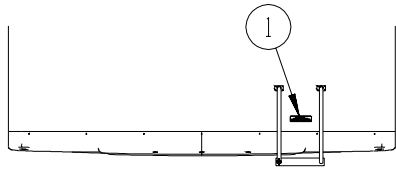

TYPICAL EXTERIOR  
ENTERTAINMENT CENTER

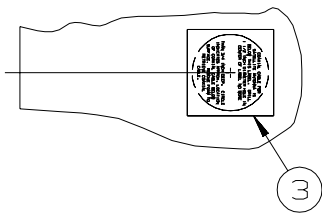

KEY	PART NUMBER	U/M	DESCRIPTION
1	128218-01-01A	EA	LABEL - WARNING - SLIPPERY ROOF
2	087236-02-000	EA	LABEL - TV OUTLET
3	120431-01-000	EA	LABEL - LOCATION - COAXIAL CABLE/SATELLITE ANTENNA
4	129669-01-01A	EA	LABEL - HITCH/VEHICLE RATE - 350 - WHITE ON CLEAR
4	129669-01-02A	EA	LABEL - HITCH/VEHICLE RATE - 350 - BLACK ON CLEAR

**LP GROUP  
LP SYSTEM**

KEY	PART NUMBER	U/M	DESCRIPTION
	010323-01-000	EA	ADAPTER - 3/8"F X 1/2"MPT - BRASS
	010326-01-000	EA	ADAPTER - FLARE - W/CONE GASKET - 3/8"F X 1/2"F
	010329-01-000	EA	ADAPTER - 1/2"F X 1/2"MPT - BRASS
	024250-01-000	EA	ADAPTER - BRASS - 3/8"F X 1/2"FPT
	057042-01-000	EA	ADAPTER - CROSS 1/2"PIPE
	010377-02-000	EA	NUT - 3/8" FLARE - FORGED - BRASS
	010380-02-000	EA	NUT - 1/2" FLARE - FORGED - BRASS
	010589-01-000	EA	NIPPLE - PIPE - 1/2" X 1 1/2" - BLACK
	040440-02-000	EA	TRANSMITTER - DIAL/BOLT-ON - 0-90 OHM 2 TERM(POWER/GROUND)
	045703-03-000	EA	HOSE - LP - 3/8"ID X 18" - 3/8"MPT X 1/2"F SWIVEL - US
	045703-12-000	EA	HOSE - LP - 3/8"ID X 18" - 3/8"MPT X 1/2"F SWIVEL - CANADIAN
	045703-05-000	EA	HOSE - LP - 3/8"ID X 28" - 3/8"MPT X 1/2"F SWIVEL - US
	045703-06-000	EA	HOSE - LP - 3/8"ID X 28" - 3/8"MPT X 1/2"F SWIVEL - CANADIAN
	045703-07-000	EA	HOSE - LP - 3/8"ID X 10" - 3/8"MPT X 1/2"F SWIVEL - US - FORD DIESEL
	045703-15-000	EA	HOSE - LP - 3/8"ID X 142" - 1/2"F SWIVEL X 3/8"F SWIVEL
	073050-04-000	EA	CLIP/MOUNTING - VALANCE PANEL
	106150-05-000	EA	REGULATOR - TWO STAGE
	106150-06-000	EA	REGULATOR - TWO STAGE - FORD DIESEL & 326A
	111848-06-02B	EA	SHIELD - HEAT - EXHAUST - E-COATED - 322R
	137828-01-02B	EA	PANEL - ROCKGUARD/LP - E-COATED - 324F, 324V, 326A
*	144116-04-000	EA	TANK - LP - 60 LB - 14"D X 29.75"L
	144485-01-000	EA	COMPARTMENT - LP REGULATOR
	145639-01-02B	EA	BRACKET - REGULATOR - E-COATED - FORD DIESEL

\*COMPONENT PARTS LISTED LATER IN THIS GROUP

**COMPONENT PARTS FOR LP SYSTEM**

**144116-04-000**

KEY	PART NUMBER	U/M	DESCRIPTION	VENDOR NO.
	040421-01-712	EA	VALVE-SERV. W/O VAPOR RELIEF	V20373
	040421-01-713	EA	VALVE-RELIEF 1" W/SPRING 7"	V20479
	144116-01-700	EA	VALVE-OUTAGE(NO STEM REMOVE)	V20058
	144116-01-701	EA	VALVE/FILL 80 % W/YELLOW CAP	V13414
	144116-04-700	EA	FLOAT/SENDING UNIT W/O DIAL	G11530
	144116-04-701	EA	DIAL - TRANSMITER	G12845



**SEALANTS & FASTENERS GROUP**  
**SEALANTS & ADHESIVES**

KEY	PART NUMBER	U/M	DESCRIPTION
	004001-02-000	EA	GUN - PLEXUS ADHESIVE - W/O NOZZLE
	004001-05-000	EA	ADHESIVE - SCOTCH-WELD - 3M DP100 - CLEAR - 50ML
	004001-06-000	EA	FASTWELD PIN TIPS
	004011-01-000	EA	ADHESIVE-3M-4475 TUBE
	010405-02-000	EA	TAPE - THREAD SEALING - 3/8"
	034552-06-000	EA	SILICONE - TUBE - W/O NOZZLE - OFF WHITE
	034552-15-000	EA	SILICONE - TUBE - W/O NOZZLE - BRIGHT WHITE
	063642-01-000	FT	TAPE - ADHESIVE - .4" X 1.5" X 180'
	064075-07-000	FT	SEAL - BULB - W/WIRED U CHANNEL - .3" X .5" CHANNEL-BLACK
	067788-01-000	EA	ADHESIVE - SPRAY - 3M - 19.5 OZ AEROSOL CAN
	069640-01-000	FT	SEALER - TAPE - .25" DIAMETER X 30' - BLACK OR GRAY
	069640-02-000	FT	SEALER - TAPE - .13" THICK X .5" WIDE X 60' - GRAY
	069640-03-000	FT	SEALER - TAPE - .13" THICK X .75" WIDE X 60' - BLACK
	069640-07-000	FT	SEALER - TAPE - .09" THICK X 2" WIDE X 45' - GRAY
	069640-09-000	FT	SEALER - TAPE - .03" THICK X 2.50" WIDE X 80' - GRAY
	069640-10-000	FT	SEALER - TAPE - .03" THICK X 1.50" WIDE X 90' - GRAY
	069640-11-000	FT	SEALER - TAPE - .19" THICK X .38" WIDE X 40' - BLACK
	069640-13-000	FT	SEALER - TAPE - .03" THICK X 2" WIDE X 45' - BLACK
	069640-14-000	FT	SEALER - TAPE - .06" THICK X 1" WIDE X 100' - GRAY
	069640-15-000	FT	SEALER - TAPE - .06" THICK X .38" WIDE X 100' - GRAY
	069640-17-000	FT	SEALER - TAPE - .03" THICK X 1" WIDE X 90' - GRAY
	069640-18-000	FT	SEALER - TAPE - .50" THICK X .13" WIDE X 60' - BRT WHITE
	069640-19-000	FT	SEALER - TAPE - .75" THICK X .13" WIDE X 60' - BRT WHITE
	069640-20-000	FT	SEALER - TAPE - .50" THICK X .5" WIDE X 60' - BLACK
	069640-21-000	FT	SEALER - TAPE - .50" THICK X .06" WIDE X 100' - BRT WHITE
	069640-22-000	FT	SEALER - TAPE - 1/32"THICK X 1/4"WIDE X 200 FT - BRT WHT
	069640-23-000	FT	SEALER - TAPE - 1/16"THICK X 3/4"WIDE X 100 FT - BRT WHT
	069640-27-000	FT	SEALER - TAPE - .06" THICK X 2.25" WIDE - BRIGHT WHITE
	069640-28-000	FT	SEALER - TAPE - .25" THICK X 1.86" WIDE X 90' - GRAY
	069640-30-000	FT	SEALER - TAPE - .03" THICK X .625" WIDE X 50' - GRAY
	069640-31-000	FT	SEALER - TAPE - .25"THICK X .75" WIDE X 15' - BLACK
	069640-32-000	FT	SEALER - RIBBON - 1/16" X 3/8" X 100' - BLACK
	069640-33-000	FT	SEALER - RIBBON - 3/8"DIAMETER X 20' - BLACK
	072889-01-000	EA	SEALANT - URETHANE - BLACK - TUBE W/NOZZLE TIP
	072889-10-000	EA	SEALANT - URETHANE - BRIGHT WHITE - TUBE W/NOZZLE TIP
	072889-27-000	EA	SEALANT - URETHANE - SILVER - 10 OZ TUBE W/NOZZLE TIP
	076322-01-000	FT	TAPE-DOUBLE COATED/ADHESIVE BK-.03"THK X .8"W X 216'- WHT
	076322-02-000	FT	TAPE-DOUBLE COATED/ADHESIVE BK-.05"THK X 1"W X 108' - WHT
	076322-03-000	FT	TAPE-DOUBLE COATED/ADHESIVE BK-.05"THK X .5"W X 108' - WHT
	076322-04-000	FT	TAPE-DOUBLE COATED/ADHESIVE BK-.05"THK X .8"W X 108' - WHT
	076322-05-000	FT	TAPE-DOUBLE COATED/ADHESIVE BK-.05"THK X .8"W X 108' - WHT
	076322-07-000	FT	TAPE-DOUBLE COATED/ADHESIVE BK-.05"THK X .5"W X 200' - BLK
	076322-11-000	FT	TAPE-DOUBLE COATED/ADHESIVE BK-.02"THK X 1"W X 216' - CLR
	076322-21-000	FT	TAPE - FOAM/DOUBLE COATED - .5"
	076322-22-000	FT	TAPE - FOAM/DOUBLE COATED - .045" X .75"
	076322-23-000	FT	TAPE - FOAM/DOUBLE COATED - .045" X 1"
	076322-24-000	FT	TAPE - FOAM/DOUBLE COATED - .025" X 1"
	076322-25-000	FT	TAPE - FOAM/DOUBLE COATED - .025" X .5"
	076813-02-000	FT	SEAL-D BULB, .5" X .7" - MEDIUM SPONGE RUBBER - BLACK
	086276-01-000	EA	TAPE - DOUBLE SIDED - 1/2" WIDE X 108' LONG (SOLD BY ROLL)
	088479-01-000	EA	TAPE - ALUMINUM - 3"
	090340-01-000	FT	SEAL - FOAM - CLOSED CELL - 1/4" X 1/2" X 50'
	091255-02-000	FT	SEAL - ADHESIVE BACKED/FOAM - 3/64" THICK X 3/16"W X 1000'
	091255-03-000	FT	SEAL - ADHESIVE BACKED/FOAM - 1/4" THICK X 1/4"W X 1000'
	094401-01-000	EA	SEALER - BODY SEAM - FLEXICLEAR
	094401-03-000	EA	SEALER - BODY SEAM - BLACK
	094401-04-000	EA	SEALER - BODY SEAM - CLEAR
	094401-05-000	EA	SEALER - BODY SEAM - 20OZ BLACK
	094401-06-000	EA	SEALER - BODY SEAM - 12OZ BLACK
	098408-01-000	FT	SEAL - SPONGE RUBBER - CLOSED CELL
	099069-01-000	FT	SEAL - RUBBER - CLOSED SPONGE - .5" WIDE X .12" THICK -BLK
	099418-01-000	FT	SEAL - D-SECTION/ADHESIVE BACK - .44" X .44"- BLK RUBBER
	099418-02-000	FT	SEAL - D-SECTION/ADHESIVE BACK - .44" X .44"- WHITE RUBBER
	100128-02-000	FT	SEAL - FOAM/ADHESIVE BACK - .37" WIDE X .37" THICK

## SEALANTS & FASTENERS GROUP (CONTINUED)

### SEALANTS & ADHESIVES (CONTINUED)

KEY	PART NUMBER	U/M	DESCRIPTION
	104692-01-000	FT	SEAL - ADHESIVE BACKED FOAM - 3/4" THICK X 3/4" WIDE X 25'
	104692-03-000	FT	SEAL - ADHESIVE BACKED FOAM - 1" THICK X 1 3/16"WIDE X 15'
	107828-01-000	EA	SEALANT - SB - 190 EVERSEAL
	109506-01-000	EA	FILM - URETHANE - PROTECTANT - 4.25" X 26.75"
	109506-12-000	EA	FILM/ABRASION-RESISTANT - TRANSPARENT - 1" DIA.
	109506-13-000	EA	FILM/ABRASION-RESISTANT - TRANSPARENT - 1" DIA.
	110274-01-000	FT	TAPE - DOUBLE SIDED/FOAM - .45" X 1" X 216' - BLACK
	112481-02-000	EA	ADHESIVE - PLEXUS ETHACRYLATE - CARTRIDGE
	112864-01-000	FT	SEAL - FOAM/BUTYL COVERED - 3/8" X 35'
	112864-02-000	FT	FOAM - BUTYL COVERED - 5/16" X 44'
	112864-04-000	FT	FOAM - BUTYL COVERED - 3/8" X 1/8"
	112901-02-000	EA	ADHESIVE - PLEXUS - MA330 - 50ML - GRAY
	112901-03-000	EA	ADHESIVE - PLEXUS - MA300 - 50ML - WHITE
	112902-01-000	EA	NOZZLE - ELEMENT - 3/8 X 24
	112902-03-000	EA	MIXER NOZZLE - F/GUN #00400102000 - SCOTCH-WELD & PLEXUS
	112902-04-000	EA	NOZZLE - ELEMENT - 1/4" X 3.5"
	113366-01-000	EA	ADHESIVE - INSTANT - 1 OZ
	113452-02-000	FT	SEAL/TRIM - FRONT - VINYL W/WIRE CARRIER - .027"
	115933-01-000	FT	TAPE - 1/64" X 3/8" X 100'
	120074-02-03A	EA	SILICONE - TUBE - W/O NOZZLE - LOW ODOR - SMOKEY WHITE
	120074-02-02A	EA	SILICONE - TUBE - W/O NOZZLE - LOW ODOR - SOFT WHITE
	120534-01-01A	EA	TAPE - SCOTCH - 3M - 1/2" FINE LINE
	123244-01-000	FT	TAPE - DOUBLE SIDED/FOAM - 5/64" THICK X 3/4" WIDE X 108'
	123816-01-000	FT	TAPE - DOUBLE SIDED - 1" X 3/4" X 200'
	123816-02-000	FT	TAPE - DOUBLE SIDED - 1/2" X 1 1/3" X 200'
	123816-03-000	FT	TAPE - DOUBLE SIDED - 1/2" X 3/4" X 200'
	123816-04-000	FT	TAPE - DOUBLE SIDED - 6" X 750'
	126427-01-000	EA	ADHESIVE - ALL PURPOSE - ABS/PVC
	126427-02-000	EA	PRIMER - CLEANER - FLEX PIPING
	131264-01-02A	EA	SILICONE - TUBE - W/O NOZZLE - CLEAR
	131264-01-01A	EA	SILICONE - TUBE - W/O NOZZLE - BLACK
	131264-02-01A	EA	SILICONE - TUBE - W/O NOZZLE - VW GRAY - BATH ONLY
	131264-03-01A	EA	SILICONE - TUBE - W/O NOZZLE- SELF LEVELING - BRIGHT WHITE
	131264-04-01A	EA	SILICONE/SEALANT/ADHESIVE - FAST CURE F/GLASS/VINYL - B/W
	131264-05-01A	EA	SILICONE/SEALANT - ODORLESS - TUBE - W/NOZZLE - BLACK
	131264-05-02A	EA	SILICONE/SEALANT - ODORLESS - TUBE - W/NOZZLE - CLEAR
	131384-01-000	EA	ADHESIVE - JET WELD
	134651-01-000	FT	SEAL - 1/2" X 3/4" PSA 1 SIDE
	900390-01-000	EA	NOZZLE - SILICONE TUBE - 2.5" LONG - W/EXTERNAL THREADS
	900390-03-000	EA	NOZZLE - SILICONE TUBE - 4.3" LONG W/INTERNAL THREADS
	900563-17-000	EA	TAPE - 2 SIDED, 2" X 36 YDS

### BOLTS, NUTS AND WASHERS

KEY	PART NUMBER	U/M	DESCRIPTION
	OMC05K-08-055	EA	BOLT - HEX - M08 X 1.25 X 2.2
	OMD16K-10-000	EA	NUT - HEX PREV TORQUE M10 X 1 1/2 CLASS 8
	OMD39K-12-000	EA	NUT - HEX W/NYLON LOCK - M12 X 1 3/4
	OMD40K-14-000	EA	NUT - HEX W/NYLON LOCK - M14 X 2
	OMD54F-06-000	EA	NUT-HEX SER FLG M6X1,0 SS - DIN6923A2M6
	OME06K-14-280	EA	WASHER - FLAT - 14 ID X 28 OD
	000C12-04-08B	EA	BOLT - HEX - 1/4-20 X 1/2 - GRADE #5 - ZINC
	000C12-04-12A	EA	BOLT - HEX - 1/4-20 X 3/4 - PLAIN 5
	000C12-04-40B	EA	BOLT - HEX - 1/4-20 X 2 1/2 - GRADE #5 ZINC
	000C12-05-16B	EA	BOLT - HEX - 5/16 - 18X1 - GRADE #5 - ZINC
	000C12-05-40B	EA	BOLT - HEX - 5/16"-18 X 2.5" - GRADE #5 - ZINC
	000C12-06-44B	EA	BOLT - HEX - 3/8-16 X 2 3/4 - GRADE 5 - ZINC
	000C12-06-16B	EA	BOLT - HEX - 3/8 - 16X1 - GRADE #5 - ZINC
	000C12-08-28B	EA	BOLT - HEX - 1/2-13 X 1 3/4 - GRADE #5 - ZINC
	000C12-08-24B	EA	BOLT - HEX - 1/2 - 13X1 1/2 - GRADE #5 - ZINC
	000C12-08-16B	EA	BOLT - HEX - 1/2-13 X 1 - GRADE #5 - ZINC
	000C12-10-24B	EA	BOLT - HEX - 5/8 - 11X1 1/2 - GRADE #5 - ZINC
	000C13-07-48B	EA	BOLT - HEX - 7/16-20 X 3 - GRADE #5 - ZINC
	000C13-07-40B	EA	BOLT - HEX - 7/16-20 X 2 1/2 - GRADE #5 - ZINC
	000C14-07-28B	EA	BOLT - HEX - 7/16-14 X 1 3/4 - GRADE #8 - ZINC

**SEALANTS & FASTENERS GROUP (CONTINUED)**  
**BOLTS, NUTS AND WASHERS (CONTINUED)**

<b>KEY</b>	<b>PART NUMBER</b>	<b>U/M</b>	<b>DESCRIPTION</b>
	000C14-10-32K	EA	BOLT - HEX - 5/8-11 X 2 - GRADE #8 - ZINC
	000C16-07-16B	EA	BOLT - CARRIAGE - ASSIST HANDLE - 7/16-14 X 1
	000C18-05-40A	EA	BOLT - ELEVATOR - 5/16-18 X 2 1/2 - PL
	000C26-04-10B	EA	BOLT - HEX - SERRATED FLANGE - 1/4-20 X 5/8 - ZINC
	000C26-04-18B	EA	BOLT - HEX - SERRATED FLANGE - 1/4-20 X 1 1/8 - ZINC
	000C26-04-14B	EA	BOLT - HEX - SERRATED FLANGE - 1/4-20 X 7/8 - ZINC
	000C26-05-20B	EA	BOLT - HEX - SERRATED FLANGE - 5/16-18 X 1 1/4 - ZINC
	000C26-05-12B	EA	BOLT - HEX - SERRATED FLANGE - 5/16-18 X 3/4 - ZINC
	000C26-06-40B	EA	BOLT - HEX - SERRATED FLANGE - 3/8-16 X 2 1/2 - ZINC
	000C26-06-28B	EA	BOLT - HEX - SERRATED FLANGE - 3/8-16 X 1 3/4 - ZINC
	000C26-06-20B	EA	BOLT - HEX - SERRATED FLANGE - 3/8-16 X 1 1/4 - ZINC
	000C26-06-12B	EA	BOLT - HEX - SERRATED FLANGE - 3/8-16 X 3/4 - ZINC
	000C26-08-24B	EA	BOLT - HEX - SERRATED FLANGE - 1/2-13 X 1 1/2 - ZINC
	000C27-04-40B	EA	BOLT - CARRIAGE - 1/4-20 X 2 1/2 - ZINC
	000C27-07-40B	EA	BOLT - CARRIAGE - 7/16-14 X 2 1/2 - GRADE #5
	000C27-08-48B	EA	BOLT - CARRIAGE - 1/2-13 X 3 - GRADE #5
	000D16-07-00B	EA	NUT - HEX - 7/16-14 - ZINC
	000D20-07-00B	EA	NUT - ACORN - ASSIST HANDLE - 7/16 - 14
	000D23-04-00B	EA	NUT - HEX SF/LK #4-40
	000D24-10-00B	EA	NUT - HEX - SELF LOCKING - 10-32 - ZINC
	000D25-06-00B	EA	NUT-3/8" W/BURR - FASTENER HOUSE
	000D28-10-00B	EA	NUT - HEX - W/NYLON LOCK - 10-32 ZINC
	000D29-04-00B	EA	NUT - HEX - SELF LOCKING - 1/4 X 20 - ZINC
	000D29-06-00B	EA	NUT - HEX - W/NYLON LOCK - 3/8-16 - ZINC
	000D29-09-00B	EA	NUT - HEX - SELF LOCKING - 9/16-12 - ZINC
	000D30-07-00B	EA	NUT - HEX LOCK - NYLON 7/16 X 20
	000D34-04-00B	EA	NUT - HEX - LOCKING - 1/4-20 - ZINC
	000D34-06-00B	EA	NUT - HEX - LOCKING - 3/8-16 GRADE C - ZINC
	000D39-04-00B	EA	NUT - HEX - LOCKING W/SERRATED FLANGE - 1/4-20 - ZINC
	000D39-05-00B	EA	NUT - HEX - LOCKING W/SERRATED FLANGE - 5/16-18 - ZINC
	000D39-06-00B	EA	NUT - HEX - LOCKING W/SERRATED FLANGE - 3/8-18 - ZINC
	000D39-07-00B	EA	NUT - HEX - LOCKING W/SERRATED FLANGE - 7/16-14 - ZINC
	000D39-08-00B	EA	NUT - HEX - LOCKING W/SERRATED FLANGE - 1/2-13 - ZINC
	000D44-04-00B	EA	NUT - HEX - LOCKING W/SERRATED FLANGE - 1/4-28 - ZINC
	000D44-07-00B	EA	NUT - HEX - LOCKING W/SERRATED FLANGE - 7/16-20 - ZINC
	000D44-08-00B	EA	NUT - HEX - LOCKING W/SERRATED FLANGE - 1/2-20 - ZINC
	000D46-04-00A	EA	NUT - HEX - WELD - 1/4-20 - PLAIN
	000D58-06-00A	EA	NUT - HEX - WELD 3/8-16 - PLAIN
	000D65-08-00B	EA	NUT - HEX - LOCKING W/SERRATED FLANGE - 8-32 - ZINC
	000D67-10-00B	EA	NUT - HEX - LOCK - 5/8-11 - ZINC
	000D73-08-00C	EA	NUT - HEX FLANGE - 1/2-13
	000D75-09-00B	EA	NUT - HEX LOCKING - 9/16-12 - ZINC
	000D76-06-00B	EA	NUT - HEX FLANGE - 3/8-16
	000E11-04-00F	EA	WASHER - LOCKING - 1/4 MED SPLIT - STAINLESS STEEL
	000E11-07-00B	EA	WASHER - LOCKING - 7/16 MED SPLIT - ZINC
	000E11-08-00B	EA	WASHER - LOCKING - 1/2 MED SPLIT - ZINC
	000E13-17-00B	EA	WASHER - FLAT - 3/8 AR - ZINC
	000E13-18-00B	EA	WASHER - FLAT - 3/8 WIDE - ZINC
	000E13-20-00B	EA	WASHER - FLAT - 7/16 WIDE - ZINC
	000E13-22-00B	EA	WASHER - FLAT - 1/2 WIDE - ZINC
	000E13-26-00B	EA	WASHER - FLAT - 5/8 WIDE - ZINC
	000E14-10-00B	EA	WASHER - LOCKING - #10 EXTERNAL TOOTH - ZINC
	000E16-10-00B	EA	WASHER - HARDENED - 5/8 - FLAT - ZINC
	000G45-05-16B	EA	BOLT - LAG - 5/16-9 X 1 - ZINC
	002329-01-000	EA	WASHER-FLAT, 9/32" ID X 5/8" OD - NYLON
	005081-01-000	EA	NUT - SPEED - C-TYPE - #8 SCREW
	040921-01-000	EA	NUT - SPEED - U TYPE - #10-24 - BLACK
	040921-03-000	EA	NUT - SPEED - U TYPE - #10
	040921-04-000	EA	NUT - SPEED - U TYPE - #8-.59" LENGTH X .44" WIDTH
	040921-05-000	EA	NUT - SPEED - U-TYPE - 8-.67" X .44" WIDE
	041322-01-000	EA	WASHER - FLANGE - 15/32 ID X 2 3/8 OD - F/SEAT BELT MTG
	044364-02-000	EA	NUT - SPEED - FLAT - ROUND
	044533-01-000	EA	WASHER - 1 3/8"OD - FOR BUTTONS - PLASTIC
	051387-06-000	EA	BOLT - CARRIAGE W/O HOLE - 5/16-18 X 9 1/2 - ZINC

**SEALANTS & FASTENERS GROUP (CONTINUED)**  
**BOLTS, NUTS AND WASHERS (CONTINUED)**

KEY	PART NUMBER	U/M	DESCRIPTION
	058716-02-000	EA	WASHER - FLAT NYLON
	064081-03-000	EA	NUT - WING 3/8-16 - W/WELD NUT
	077071-01-000	EA	WASHER - FENDER - 3/16"ID X 1"OD
	084406-01-000	EA	NUT - CAPPED - CROSS RECESSED - BLACK - 1/4-20 THD
	087234-01-000	EA	NUT - JACK - 1/4 X 20 THD - MOLLY
	087718-01-000	EA	MONOBOLT - STEEL - 3/16 DIAMETER
	088787-12-000	EA	STUD - WELD - 1/4 - 20 X 1.0 LG - MN
	102333-01-06A	EA	BOLT - CARRIAGE - 7/16-14 STAINLESS STEEL CAP
	103020-02-000	EA	BOLT-U - #8-32 - GRADE 5 ZINC
	106956-03-000	EA	BOLT - HEX TAP - 1/2-12NC X 3 - GRADE 5 - FULL THREAD/ZINC
	107397-01-000	EA	WASHER - FENDER - 3/4"ID X 1"OD
	108067-03-000	EA	STUD - WELD - 1/4 - 20 X 1/2 CD
	109917-01-000	EA	WASHER - 1.5" X 1.25"
	109917-03-000	EA	WASHER - 1" X .50"
	109917-04-000	EA	WASHER - 1" X .75"
	110794-01-000	EA	WASHER - FLAT - 1"ID X 1 3/4"OD
	113985-02-000	EA	BOLT - FLANGE - M10-1 1/2 X 30CL 10.9
	114259-05-000	EA	BOLT - 7/16-20 X 1 1/4 W/WASHER
	128444-01-000	EA	WASHER - SPRING - CONICAL
	131377-01-000	EA	NUT-HEX HEAD W/WASHER-1/4-20 X 2" STEEL W/3/4" OD WASHER
	135092-02-01A	EA	BOLT - HEX - SERRATED FLANGE - 1/2-20 X 2 1/2-GRADE 5 ZINC
	143399-01-01A	EA	NUT/RETAINING - 3/8"- 24 NFT
	144904-01-01A	EA	BOLT - ADJUSTMENT - HEADLAMP
	147284-01-000	EA	NUT/SELF RETAINING - 3/8"-16
	147284-02-000	EA	NUT/SELF RETAINING - 5/16"-18
	148817-01-000	EA	WASHER/SPUR - LOCKING

**SCREWS**

KEY	PART NUMBER	U/M	DESCRIPTION
	0G1106-06-160	EA	SCREW - 6-20 X 3/8 PPH
	0G1106-08-240	EA	SCREW - 6-20 X 1/2 PPH - VW LIGHT GRAY
	0G1208-12-170	EA	SCREW - 8-18 X 3/4 POH - BRIGHT WHITE
	0G3804-22-180	EA	SCREW - MACHINE - 1/4-20 X 1 3/8 PFH - BLACK
	0G3908-08-170	EA	SCREW - SF/DR - 8-18 X 1/2 PPH - BRIGHT WHITE
	0G3908-08-160	EA	SCREW - SF/DR - 8-18 X 1/2 PPH - VW WHITE
	0G3908-12-250	EA	SCREW - SF/DR - 8-18 X 3/4 PPH - DARK GRAY
	0G3908-16-170	EA	SCREW - SF/DR - 8-18 X 1 PPH - BRIGHT WHITE
	0G3908-24-170	EA	SCREW - SF/DR - 8-18 X 1 1/2 PPH - BRIGHT WHITE
	0G3910-10-330	EA	SCREW - SF/DR - 20-16 X 5/8 PPH - PUTTY
	0G3910-10-320	EA	SCREW - SF/DR - 10-16 X 5/8 PPH - GLACIER
	0G3910-12-240	EA	SCREW - SF/DR - 10-16 X .75 PPH - VW LIGHT GRAY
	0G3910-12-170	EA	SCREW - SF/DR - 10-16 X 3/4 PPH - BRIGHT WHITE
	0G3910-12-320	EA	SCREW - SF/DR - 10-16 X 3/4 PPH - GLACIER
	0G5508-08-380	EA	SCREW - SF/DR - 8-18 X .5 PWH - CASHMERE
	0G5508-08-370	EA	SCREW - SF/DR - 8-18 X .5 PWH - RIVERSTONE
	0G5508-12-240	EA	SCREW - SF/DR - 8-18 X 3/4 PWH - VW LIGHT GRAY
	0G5508-12-170	EA	SCREW - SF/DR - 8-18 X 3/4 PWH - BRIGHT WHITE
	0G5508-12-330	EA	SCREW - SF/DR - 8-18 X 3/4 PWH - PUTTY
	0G5508-12-320	EA	SCREW - SF/DR - 8-18 X 3/4 PWH - GLACIER
	0G5508-12-270	EA	SCREW - SF/DR - 8-18 X 3/4 PWH - TITANIUM
	0G5508-16-250	EA	SCREW - SF/DR - 8-18 X 1 PWH - VW DARK GRAY
	0G5508-16-320	EA	SCREW - SF/DR - 8-18 X 1 PWH - GLACIER
	0G6008-16-170	EA	SCREW - SF/DR - 8-18 X 1 POH - BRIGHT WHITE
	0G6710-08-130	EA	SCREW - 10-12 X 1/2 PPH - TAUPE
	0G6710-08-170	EA	SCREW - 10-12 X 1/2 PPH - BRIGHT WHITE
	0G6710-08-240	EA	SCREW - 10-12 X 1/2 PPH - VW LIGHT GRAY
	0G6710-12-170	EA	SCREW - 10-12 X 3/4 PPH - BRIGHT WHITE
	0G6806-16-170	EA	SCREW - 6-18 X 1 POH - BRIGHT WHITE
	0G6810-24-280	EA	SCREW - 10-12 X 1 1/2 POH - SOFT WHITE
	000C20-05-28F	EA	SCREW - 5/16-18 X 1 3/4 FLAT SOC - STAINLESS STEEL
	000C20-06-24T	EA	SCREW - 3/8-16 X 1 1/2 - FLAT SOCKET
	000G11-06-10J	EA	SCREW - 6-20 X 5/8 PPH - BRASS



**SEALANTS & FASTENERS GROUP (CONTINUED)**  
**SCREWS (CONTINUED)**

KEY	PART NUMBER	U/M	DESCRIPTION
	000G11-06-08B	EA	SCREW - 6-20 X 1/2 PPH - ZINC
	000G11-06-10B	EA	SCREW - 6-20 X 5/8 PPH - ZINC
	000G11-07-08B	EA	SCREW - 7-19 X 1/2 PPH - ZINC
	000G11-08-20G	EA	SCREW - 8-18 X 1 1/4 - ANTIQUE BRASS
	000G11-08-20B	EA	SCREW - 8-18 X 1 1/4 PPH - ZINC
	000G11-08-12T	EA	SCREW - 8-18 X 3/4 PPH - BLACK MAGNESIUM
	000G11-08-12P	EA	SCREW - 8-18 X 3/4 PPH - DARK BROWN
	000G11-08-12S	EA	SCREW - 8-18 X 3/4 PPH - OFF WHITE
	000G11-08-12B	EA	SCREW - 8-18 X 3/4 PPH - ZINC
	000G11-08-08T	EA	SCREW - 8-18 X 1/2 PPH - FLUOROCARBON COATING
	000G11-08-06B	EA	SCREW - 8-18 X 3/8 PPH - ZINC
	000G11-10-12D	EA	SCREW - 10-16 X 3/4 PPH - BLACK
	000G12-06-12J	EA	SCREW - 6-20 X .75 POH - BRASS
	000G12-06-08T	EA	SCREW - 6-20 X 1/2 POH - BLACK
	000G13-05-10B	EA	SCREW - 5-12 X 5/8 PFH - ZINC
	000G13-06-08G	EA	SCREW - 6-20 X 1/2 PFH - ANTIQUE BRASS
	000G13-06-08B	EA	SCREW - 6-20 X 1/2 PFH - ZINC
	000G13-06-06I	EA	SCREW - 6-20 X 3/8 PFH - BLACK ZINC
	000G13-06-24J	EA	SCREW - 6-20 X 1 1/2 PFH - BRASS
	000G13-06-16J	EA	SCREW - 6-20 X 1 PFH - BRASS
	000G13-06-10J	EA	SCREW - 6-20 X 5/8 PFH - BRASS
	000G13-06-10G	EA	SCREW - 6-20 X 5/8 PFH - ANTIQUE BRASS
	000G13-07-10H	EA	SCREW - 7-19 X 5/8 PFH - BLACK
	000G13-07-12B	EA	SCREW - 7-19 X 3/4 PFH - ZINC
	000G13-08-16B	EA	SCREW - 8-18 X 1 PFH - ZINC
	000G13-08-109	EA	SCREW - 8-18 X 5/8 PFH
	000G13-08-10B	EA	SCREW - 8-18 X 5/8 PFH - ZINC
	000G13-08-24B	EA	SCREW - 8-18 X 1 1/2 PFH - ZINC
	000G16-04-24B	EA	SCREW - MACHINE - 1/4-20 X 1 1/2 PPH
	000G18-04-12B	EA	SCREW - MACHINE - 4-40 X 3/4 PPH - ZINC
	000G18-08-12B	EA	SCREW - MACHINE - 8-32 X 3/4 PPH - ZINC
	000G18-08-16B	EA	SCREW - MACHINE - 8-32 X 1 PPH - ZINC
	000G18-08-24B	EA	SCREW - MACHINE - 8-32 X 1 1/2 PPH - ZINC
	000G18-08-22B	EA	SCREW - MACHINE - 8-32 X 1 3/8 PPH - ZINC
	000G19-10-10B	EA	SCREW - MACHINE - 10-32 X 5/8 - PPH - ZINC
	000G19-10-08B	EA	SCREW - MACHINE - 10-32 X 1/2 PPH - ZINC
	000G19-10-20B	EA	SCREW - MACHINE - 10-32 X 1 1/2 PPH - ZINC
	000G19-10-40B	EA	SCREW-MACH,10-32X2.50 PPH ZN
	000G19-10-12F	EA	SCREW - MACHINE - 10-32 X 3/4 PPH - STAINLESS STEEL
	000G32-10-06B	EA	SCREW - 10-32 X 3/8 PPH - ZINC
	000G36-10-12T	EA	SCREW - 10-24X 3/4 PFH TYPE 23 - BLACK
	000G39-06-06J	EA	SCREW - 6-20 X 3/8 PPH - BRASS
	000G39-06-10T	EA	SCREW - SF/DR - 6-20 X 5/8 PPH - BLACK
	000G39-06-16T	EA	SCREW - SF/DR - 6-20 X 1 PPH - BLACK
	000G39-08-08S	EA	SCREW - SF/DR - 8-18 X 1/2 PPH - OFF WHITE
	000G39-08-08B	EA	SCREW - SF/DR - 8-18 X 1/2 PPH - ZINC
	000G39-08-08T	EA	SCREW - SF/DR - 8-18 X 1/2 PPH - BLACK
	000G39-08-06B	EA	SCREW - SF/DR - 8-18 X 3/8 PPH - ZINC
	000G39-08-32B	EA	SCREW - SF/DR - 8-18 X 2 PPH - ZINC
	000G39-08-24T	EA	SCREW - SF/DR - 8-18 X 1 1/2 PPH - BLACK
	000G39-08-24S	EA	SCREW - SF/DR - 8-18 X 1 1/2 - OFF WHITE
	000G39-08-24B	EA	SCREW - SF/DR - 8-18 X 1 1/2 PPH - ZINC
	000G39-08-16T	EA	SCREW - SF/DR - 6-20 X 1 PPH - BLACK
	000G39-08-16B	EA	SCREW - SF/DR - 8-18 X 1 PPH - ZINC
	000G39-08-12B	EA	SCREW - SF/DR - 8-18 X 3/4 PPH - ZINC
	000G39-08-12T	EA	SCREW - SF/DR - 8-18 X 3/4 PPH - BLACK
	000G39-10-48T	EA	SCREW - SF/DR - 10-16 X 3 PPH - BLACK
	000G39-10-48B	EA	SCREW - SF/DR - 10-16 X 3 - PPH - ZINC
	000G39-10-40D	EA	SCREW - SF/DR - 10-16 X 2 1/2 PPH - BLACK
	000G39-10-32B	EA	SCREW - SF/DR - 10-16 X 2 - PPH - ZINC
	000G39-10-20T	EA	SCREW - SF/DR - 10-16 X 1 1/4 PPH - BLACK
	000G39-10-20B	EA	SCREW - SF/DR - 10-16 X 1 1/4 PPH - ZINC
	000G39-10-169	EA	SCREW - SF/DR - 10-16 X 1 PPH - FLUOROCARBON SILVER
	000G39-10-129	EA	SCREW - SF/DR - 10-16 X 3/4 PPH - FLUOROCARBON SILVER

**SEALANTS & FASTENERS GROUP (CONTINUED)**  
**SCREWS (CONTINUED)**

KEY	PART NUMBER	U/M	DESCRIPTION
	000G39-10-12T	EA	SCREW - SF/DR - 10-16 X 3/4 - BLACK
	000G39-10-10T	EA	SCREW - SF/DR - 10-16 X 5/8 - BLACK
	000G39-10-10B	EA	SCREW - SF/DR - 10-16 X 5/8 PPH - ZINC
	000G39-10-08B	EA	SCREW - SF/DR - 10-16 X 1/2 PPH - ZINC
	000G39-12-12E	EA	SCREW - SF/DR - 12 - 14 X 3/4 PPH - CHROME
	000G42-04-24B	EA	SCREW - SF/DR - 1/4-14 X 1 1/2 - ZINC
	000G42-04-16B	EA	SCREW - SF/DR - 1/4-14 X 1 HWH - ZINC
	000G42-04-24B	EA	SCREW - SF/DR - 1/4-14 X 1 1/2 - ZINC
	000G46-08-24T	EA	SCREW - MACHINE - 8-32 X 1 1/2 PFH - BLACK
	000G50-04-08B	EA	SCREW - MACHINE - 1/4-20 X 1/2 PTH - ZINC
	000G52-06-05B	EA	SCREW - MACHINE - 6-32 X 5/16 PTH ZINC
	000G52-06-06B	EA	SCREW - MACHINE - 6-32 X 3/8 PIN - ZINC
	000G54-04-14B	EA	SCREW - 1/4-20 X 7/8 PTH - TYPE 23 - ZINC PLATED
	000G55-08-124	EA	SCREW - SF/DR - 8-18 X 3/4 PWH - ASH GRAY
	000G55-08-16T	EA	SCREW - SF/DR - 8-18 X 1 PWH - BLACK
	000G56-12-48B	EA	SCREW - WOOD - 12-11 X 3 POH - SPECIAL HARDENED
	000G57-14-64B	EA	SCREW - 14-10 X 4 PFH ZINC
	000G60-08-20F	EA	SCREW - SF/DR - 8-19X1.25 POH
	000G60-08-16E	EA	SCREW - SF/DR - 8-1 X 1 POH - CHROME
	000G60-08-22B	EA	SCREW - SF/DR - 8-18 X 1.38 POH - ZINC
	000G60-10-209	EA	SCREW - SF/DR - 10-16 X 1 1/4 POH - SILVER STALGAARD
	000G60-10-20B	EA	SCREW - SF/DR - 10-16 X 1 1/4 POH - ZINC
	000G60-10-16J	EA	SCREW - SF/DR - 10-16 X 1 POH - BRIGHT BRASS
	000G60-10-28T	EA	SCREW - SF/DR - 10-16 X 1 3/4 - BLACK
	000G62-08-24B	EA	SCREW - SF/DR - 8-18 X 1 1/2 PFH
	000G67-08-32B	EA	SCREW - 8-15 X 2 PPH - ZINC
	000G67-10-08B	EA	SCREW - 10-12 X 1/2 PPH - ZINC
	000G67-10-32J	EA	SCREW-10-12X2 PPH - BRIGHT BRASS
	000G67-10-24S	EA	SCREW - 10-12 X 1 1/2 PPH - OFF WHITE
	000G67-10-24B	EA	SCREW - 10-12 X 1 1/2 PPH - ZINC
	000G67-10-20D	EA	SCREW - 10-12 X 1 1/4 PPH - BLACK
	000G67-10-12P	EA	SCREW - 10-12 X 3/4 PPH - DARK BROWN
	000G67-10-12B	EA	SCREW - 10-12 X 3/4 PPH - ZINC
	000G67-10-10T	EA	SCREW - 10-12 X 5/8 PPH - BLACK
	000G67-10-10S	EA	SCREW - 10-12 X 5/8 PPH - OFF WHITE
	000G67-10-10P	EA	SCREW - 10-12 X 5/8 PPH - DARK BROWN
	000G67-10-10B	EA	SCREW - 10-12 X 5/8 PPH - ZINC - TYPE A
	000G67-10-08S	EA	SCREW - 10-12 X 1/2 PPH - OFF WHITE
	000G68-06-12B	EA	SCREW - 6-18 X 3/4 POH - ZINC & CLEAR
	000G68-06-10J	EA	SCREW - 6-18 X 5/8 POH - BRASS
	000G68-06-10G	EA	SCREW - 6-18 X 5/8 POH - ANTIQUE BRASS
	000G68-06-12J	EA	SCREW - 6-18 X 3/4 POH - BRASS
	029130-01-000	EA	SCREW - SNAP STUD - #8-16 X 5/8" LONG
	029130-03-000	EA	SCREW - SNAP STUD - #8-16 X 1" LONG
	049465-01-000	EA	SCREW - 10-16 PTH W/WASHER - DARK BROWN
	049465-03-000	EA	SCREW - 10-16 X 1 POH W/WASHER - OFF WHITE
	049465-04-000	EA	SCREW - 10-16 X 1 PTH W/WASHER - BEIGE
	049465-13-000	EA	SCREW-10+16X1 PTH W/WASHER - *ASH GRAY
	049465-17-000	EA	SCREW - 10-16 X 1 POH W/WASHER - BRIGHT WHITE
	054434-03-000	EA	SCREW - SF/DR - 10-16 X 2 - PWH - ZINC
	075908-01-000	EA	SCREW - MACHINE - 10-32 X .56 PTH - EXTERNAL TOOTH - ZINC
	076790-01-000	EA	SCREW - 6-20 X 1 1/4 PPH - BLACK
	076790-05-000	EA	SCREW - 6-20 X 1/2 PPH - BLACK - THREAD CUTTING/WOOD
	083554-01-000	EA	SCREW - DRYWALL - 8 X 1 1/4
	083554-04-000	EA	SCREW - DRYWALL - 8 X 2 1/2
	087721-01-000	EA	SCREW - FLAT HEAD - TAPPING - 1/4 X 1 1/4 LONG - ZINC
	087721-02-000	EA	SCREW - FLAT HEAD - TAPPING - 1/4" X 2 1/4" LONG - ZINC
	090033-02-000	EA	SCREW - 1/4-20 X 5/8 - ROUND WASHER HEAD - OFF/WHITE
	097974-01-000	EA	SCREW - PARTICLE BOARD - 7-9 X 3/4 PPH
	101618-01-000	EA	SCREW - 1/4-20 X 3/4 HEX - TAPPING - STALGARD TYPE F
	109235-01-05A	FT	COVER - SCREW - BRIGHT WHITE
	109235-01-01A	FT	COVER - SCREW - MAT BLACK
	113563-01-01A	EA	SCREW - 8 X 5/8 LONG SHOULDER/WASHER HEAD
	116111-02-01A	EA	SCREW - TAPTITE - 1/4-20 X 3/8 PPH - ZINC

**SEALANTS & FASTENERS GROUP (CONTINUED)**  
**SCREWS (CONTINUED)**

KEY	PART NUMBER	U/M	DESCRIPTION
	117478-01-04A	EA	SCREW - 8-18 X 3/4 PPH W/WASHER - VW LIGHT GRAY
	118383-01-09A	EA	RETAINER/RECESSED - F/.22" SCREW - GLACIER
	118383-01-06A	EA	RETAINER/RECESSED - F/.22" SCREW - ALLANTE ANTELOPE
	118383-01-04A	EA	RETAINER/RECESSED - F/.22" SCREW - BRIGHT WHITE
	118383-02-09A	EA	RETAINER/RECESSED - F/.27" SCREW - GLACIER
	118383-02-05A	EA	RETAINER/RECESSED - F/.27" SCREW - VW LIGHT GRAY
	118383-02-10A	EA	RETAINER/RECESSED - F/.27" SCREW - RIVERSTONE
	118383-02-11A	EA	RETAINER/RECESSED - F/.27" SCREW - CASHMERE
	118383-03-09A	EA	RETAINER/RECESSED - F/.32" SCREW - GLACIER
	118383-04-04A	EA	CAP - F/RECESSED RETAINER - BRIGHT WHITE
	118383-04-08A	EA	CAP - F/RECESSED RETAINER - CADDY CREAM
	118383-04-05A	EA	CAP - F/RECESSED RETAINER - VW LIGHT GRAY
	118383-04-11A	EA	CAP - F/RECESSED RETAINER - CASHMERE
	118383-04-10A	EA	CAP - F/RECESSED RETAINER - RIVERSTONE
	118383-04-09A	EA	CAP - F/RECESSED RETAINER - GLACIER
	134126-01-01A	EA	SCREW/NAIL - HEX HEAD - 3/4"
	140040-01-000	EA	SCREW - 1/4-20 X 1 - BUTTON HEAD/SOCKET - W/LOCTITE
	144078-01-01A	EA	SCREW - HEX/FLANGE HEAD CAP-1" W/.75" THREAD LENGTH-ZINC
	149753-01-02A	EA	RETAINER/RECESSED - F/.22" SCREW - BRIGHT WHITE
	149753-01-01A	EA	RETAINER/RECESSED - F/.22" SCREW - BLACK
	149753-02-02A	EA	CAP - F/RECESSED RETAINER - BRIGHT WHITE
	149753-02-01A	EA	CAP - F/RECESSED RETAINER - BLACK

**CLAMPS, CLIPS, GROMMETS, RIVETS & PLUGS**

KEY	PART NUMBER	U/M	DESCRIPTION
	000F10-06-32B	EA	PIN - COTTER - 3/16" X 2" - ZINC
	000H14-06-06R	EA	RIVET-MANDREL BLIND,3/16 AL - CHERRY BSP-66
	000H16-04-06R	EA	RIVET - POP ALUMINUM - 1/8 X .313 - .375
	000H16-06-10R	EA	RIVET - POP ALUMINUM - 3/16 X .501 - .625
	007161-01-000	EA	CLAMP - HOSE - SPRING TYPE - 1/2"
	008386-01-000	EA	GROMMET - SNAP - 3/8" DIAMETER - NYLON
	010495-01-000	EA	CLAMP - CABLE - 9/16"ID - BLACK
	010495-02-000	EA	CLAMP - CABLE - 3/8"ID - BLACK
	010495-04-000	EA	CLAMP - CABLE - 11/16"ID - WHITE
	010497-01-000	EA	CLAMP - CLOSED - 5/8"ID
	010497-02-000	EA	CLAMP - CLOSED - 1.5"ID
	010497-03-000	EA	CLAMP - CLOSED - 1"ID - CUSHIONED
	010497-04-000	EA	CLAMP - CLOSED - 1 5/8"ID
	010497-05-000	EA	CLAMP - CLOSED - 1/2"ID
	010497-07-000	EA	CLAMP - CLOSED - 3/8"ID
	010497-09-000	EA	CLAMP - CLOSED - 5/16"ID
	010497-10-000	EA	CLAMP - CLOSED - 7/8"ID
	010499-01-000	EA	CLAMP - CLOSED - 3/8"ID
	016188-03-000	EA	GROMMET - LP LINE - 3/8"HOLE X 2 1/2"LONG - RUBBER
	016188-04-000	EA	GROMMET - LP LINE - 1/2"HOLE X 2 1/2"LONG - RUBBER
	016188-05-000	EA	GROMMET - LP LINE - 3/8"HOLE X 1 1/4"LONG - RUBBER
	016188-06-000	EA	GROMMET - L/P LINE - 3/8"HOLE X 3 1/4"LONG - RUBBER
	016188-08-000	EA	GROMMET - LP LINE - 1/2"HOLE X 1 1/4"LONG - RUBBER
	016188-09-000	EA	GROMMET - LP LINE - .68"HOLE X 1 1/4"LONG - RUBBER
	016188-10-000	EA	GROMMET - LP LINE - .68"HOLE X 2.5"LONG - RUBBER
	023942-01-000	EA	GROMMET - RUBBER - 2" OD
	034141-02-000	EA	PLUG/NYLON - .38" - BLACK
	061420-01-000	EA	PLUG/PLASTIC - 1 3/4" DIAMETER - BROWN
	061420-04-000	EA	PLUG/PLASTIC - 1 1/4" DIAMETER
	061420-05-000	EA	PLUG/PLASTIC - 1 1/2" DIAMETER
	061420-08-000	EA	PLUG/PLASTIC - 2 1/2" DIAMETER
	061420-09-000	EA	PLUG/PLASTIC - 1.00" - DIAMETER
	061420-10-000	EA	PLUG/PLASTIC - 1 1/2" DIAMETER - BLACK
	061420-14-000	EA	PLUG/PLASTIC - 7/8" DIAMETER - BLACK
	061420-15-000	EA	PLUG/PLASTIC - 2" DIAMETER - BLACK
	062401-01-000	EA	CLAMP - HOSE - WORMGEAR - .25" - 1"
	062401-02-000	EA	CLAMP - HOSE - WORMGEAR - 1.56" - 2.5"
	062401-03-000	EA	CLAMP - HOSE - WORMGEAR - .22" - 1"
	062401-04-000	EA	CLAMP - HOSE - WORMGEAR - .69" - 1.25"



**SEALANTS & FASTENERS GROUP (CONTINUED)**  
**CLAMPS, CLIPS, GROMMETS, RIVETS & PLUGS (CONTINUED)**

KEY	PART NUMBER	U/M	DESCRIPTION
	062401-05-000	EA	CLAMP - HOSE - WORMGEAR - 2" - 3" ID
	062401-06-000	EA	CLAMP - HOSE - WORMGEAR - .22" - .62" ID
	062401-09-000	EA	CLAMP - HOSE - WORMGEAR - 2.8" - 3.75"
	062401-11-000	EA	CLAMP - HOSE - WORMGEAR - 3.50" - 4.50"
	062401-12-000	EA	CLAMP - HOSE - WORMGEAR - .79" X 1.26"
	062401-13-000	EA	CLAMP - HOSE - WORMGEAR
	071015-01-000	EA	GROMMET - RUBBER - .5"ID X 1"OD-W/.38" GROOVE - BLACK
	071015-11-000	EA	GROMMET - RUBBER - 1 ID - FITS .12 MATERIAL - BLACK
	071015-13-000	EA	GROMMET - RUBBER - .62 ID - FITS .09 GROOVE - BLACK
	071015-19-000	EA	GROMMET - RUBBER - .38 ID - FITS .06 MATERIAL - BLACK
	071015-26-000	EA	GROMMET - RUBBER - 1.5" ID X 2.1" OD W/.06" GROOVE-BLACK
	071015-29-000	EA	GROMMET - RUBBER - .3"ID X 1.3"OD W/.12" GROOVE - BLACK
	071015-30-000	EA	GROMMET - RUBBER - .3"ID X .81"OD W/.12" GROOVE - BLACK
	071015-32-000	EA	GROMMET - RUBBER - .75"ID X 1.375"OD W/.187" GROOVE-BLK
	071015-37-000	EA	GROMMET - .81 ID FITS .56 MTL
	071015-39-000	EA	GROMMET - .75 ID FITS .06 MTL
	071015-40-000	EA	GROMMET - .38 ID FITS .09 MTL
	071015-41-000	EA	GROMMET - .125 ID FITS .188 MTL
	071015-42-000	EA	GROMMET - RUBBER - .25 ID - FITS .06 MATERIAL - BLACK
	075148-02-000	EA	CLAMP - GROUNDING - BRONZE SCREWS
	077955-01-000	EA	CLIP/J - 3/8" - VINYL COATED
	080211-03-000	EA	CLIP - XMAS TREE W/PANEL RETAINING HEAD - 3/4" SHANK
	080734-02-000	EA	CLIP - WIRE NYLON
	081211-01-000	EA	PLUG - PLASTIC - .31"DIA - BLACK
	081211-03-000	EA	PLUG/PLASTIC - .50" DIAMETER - TRUSS HEAD - BLACK
	081211-04-000	EA	PLUG/PLASTIC - .46 DIAMETER - TRUSS HEAD - BLACK
	083609-01-000	EA	CLAMP - WIRE - DUAL - EQUAL DIAMETERS - 5/8"
	083610-01-000	EA	CLAMP - WIRE - DUAL - UNEQUAL DIAMETERS - 3/4" & 1 1/4"
	083610-02-000	EA	CLAMP - WIRE - DUAL - UNEQUAL DIAMETERS - 3/4" & 2"
	083610-03-000	EA	CLAMP - WIRE - DUAL - EQUAL DIAMETERS - 2"
	088756-01-000	EA	GROMMET - WEB - 1 1/8 " I.D.
	089329-02-000	EA	CLIP - SPRING
	091952-01-000	EA	CLIP - GRIPPER - 1"
	091952-02-000	EA	CLIP - GRIPPER - 3/4"
	091952-03-000	EA	CLIP - GRIPPER - 1/2" - BLACK VINYL COATED
	094362-02-000	EA	CLIP - XMAS TREE - BINDER HEAD - .9" LONG
	094362-05-000	EA	CLIP - XMAS TREE - ROUND HEAD - 1.4" LONG
	113133-02-01A	EA	RIVET - POP - ALUMINUM - 3/16 X .252 - .504 - BLACK
	114208-01-000	EA	GROMMET - EDGE LINER - FITS 1 3/4"
	114208-05-000	EA	GROMMET - EDGE LINER - FITS 2"
	115361-01-01A	EA	PLUG/PLASTIC - 1/2" DIAMETER
	118626-01-02A	EA	RIVET - POP - ALUMINUM - 3/16 X .08 - .375
	118626-01-01A	EA	RIVET - POP - ALUMINUM - 3/16 X .08 - .375
	137014-01-02A	EA	GROMMET - CABLE - BROWN
	137014-01-01A	EA	GROMMET - CABLE - ALMOND
	137014-01-03A	EA	GROMMET - CABLE - BLACK
	139118-02-01A	EA	GROMMET - SCREW - PLASTIC
	140171-01-000	EA	CLAMP - HOSE - STEPLESS EAR - .312

**MISCELLANEOUS FASTENERS**

KEY	PART NUMBER	U/M	DESCRIPTION
	008343-01-000	EA	TIE - WIRE - 6"
	008343-02-000	EA	TIE - WIRE - 14"
	008343-03-000	EA	TIE - WIRE - 7 1/2" - BLACK
	029094-04-000	YD	VELCRO TAPE - LOOP - 1" WIDE - BLACK
	029096-03-000	YD	VELCRO TAPE - HOOK - 1" WIDE - BLACK
	029096-04-000	YD	VELCRO TAPE/HOOK - 1" WIDE - BLACK - W/ADHESIVE BACK (PSA)
	048394-02-000	YD	VELCRO TAPE - HOOK - ADHESIVE BACK - 3/4" WIDE - BEIGE
	085774-01-000	FT	FASTENER - DUAL LOCK - 1" WIDE - ADHESIVE BACK - BLACK
	085774-02-000	FT	FASTENER - DUAL HOOK - 1" WIDE - ADHESIVE BACK - BLACK
	085774-03-000	FT	FASTENER - DUAL LOCK - 1/2" WIDE - ADHESIVE BACK - BLACK
	085774-04-000	FT	FASTENER - DUAL HOOK - 1/2" WIDE - ADHESIVE BACK - BLACK
	088792-02-000	YD	VELCRO TAPE - LOOP - 3/4" - ADHESIVE BACK - BEIGE
	088792-04-000	YD	VELCRO TAPE - HOOK - 5/8" - NON-ADHESIVE BACK - WHITE

**SEALANTS & FASTENERS GROUP (CONTINUED)**  
**MISCELLANEOUS FASTENERS (CONTINUED)**

<b>KEY</b>	<b>PART NUMBER</b>	<b>U/M</b>	<b>DESCRIPTION</b>
	088792-05-000	YD	VELCRO TAPE - LOOP - 5/8" - NON-ADHESIVE BACK - WHITE
	108046-01-000	EA	CABLE TIE - SCREW MOUNT 8"
	108046-02-000	EA	CABLE TIE - SCREW MOUNT 15"
	110943-01-000	FT	FELT STRIP - 3/8" - ADHESIVE BACK - BLACK - 75' PER ROLL
	110943-02-000	FT	FELT STRIP - 3/8" - ADHESIVE BACK - WHITE
	127960-01-01A	EA	RETAINER - 3/8" - STAINLESS STEEL

# WATER & SEWAGE GROUP DRAINAGE SYSTEM

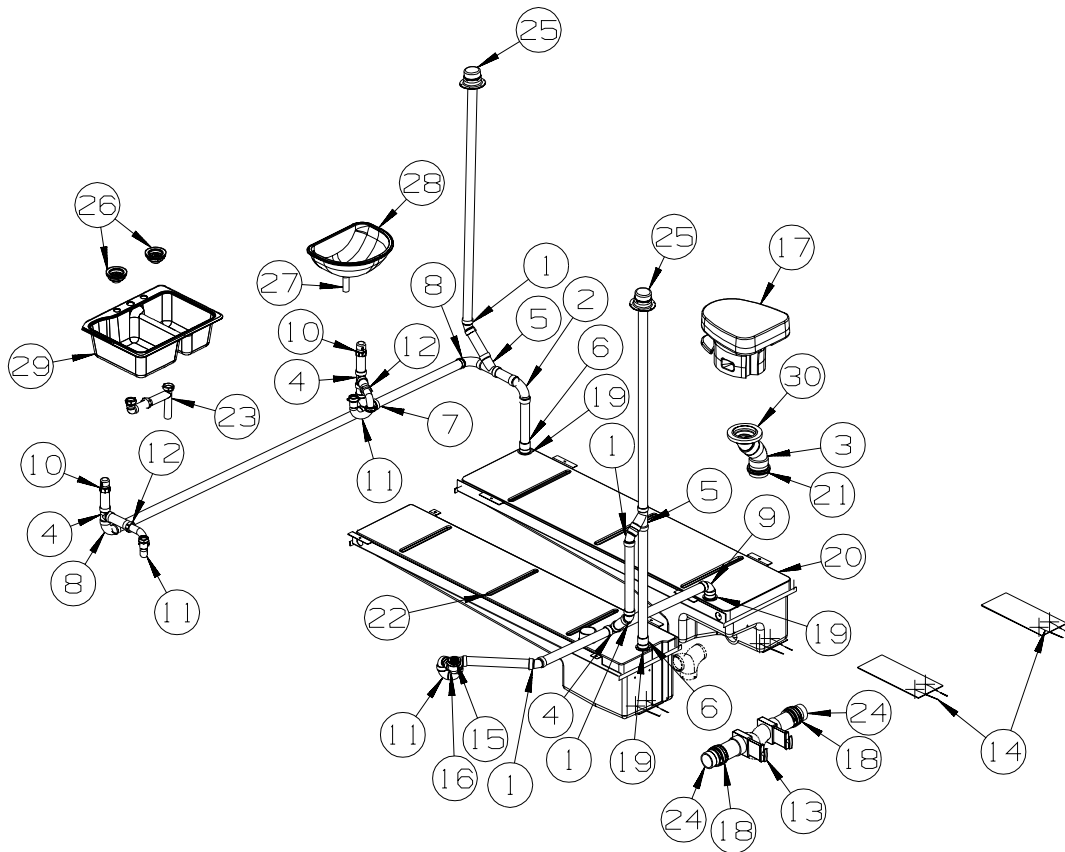

KEY	PART NUMBER	U/M	DESCRIPTION
1	010006-01-000	EA	ELBOW - 45 DEGREE - 1 1/2" HUB X HUB - PLASTIC
2	010008-01-000	EA	ELBOW - 90 DEGREE - 1 1/2" HUB X HUB - PLASTIC
3	010024-01-000	EA	ELBOW - 45 DEGREE - 3" HUB X HUB - PLASTIC
4	010071-01-000	EA	TEE - SANITARY - 1 1/2" HUB X HUB X HUB - PLASTIC
5	010073-01-000	EA	WYE - 45 DEGREE - 1 1/2" HUB X HUB X HUB - PLASTIC
6	010115-01-000	EA	COUPLING - 1 1/2" HUB X HUB - PLASTIC
7	031365-02-000	EA	TEE - 1 1/2" EXTRA LONG TURN - PLASTIC
8	033761-01-000	EA	ELBOW - 90 DEGREE - TURN - 1 1/2" HUB X 1 1/2" SPIGOT
9	034250-01-000	EA	ELBOW - 90 DEGREE - LONG TURN - 1 1/2" HUB X HUB - ABS
10	079968-01-000	EA	VENT - MECHANICAL/TRAP ARM - ANTI-SIPHON-2" X 7.3" PLASTIC
11	107538-01-000	EA	P-TRAP - PLASTIC - 1 1/4" W/EXTENSION ARM
			FROM: 00-00-00 THRU: 10-12-04
11	107538-02-000	EA	P-TRAP - PLASTIC - 1 1/2" W/EXTENSION ARM
			FROM: 10-13-04 THRU: 99-99-99
11	011071-01-000	EA	P-TRAP - 1 1/2" - CSA - PLASTIC - <b>CANADIAN</b>
12	109571-01-000	EA	ADAPTER - P-TRAP - 1 1/2" P X 1 1/4" MPT
			FROM: 00-00-00 THRU: 10-12-04
12	152146-01-000	EA	CONNECTOR - 1 1/2" P X 1 1/2" MPT
			FROM: 10-13-04 THRU: 99-99-99
13	136143-01-000	EA	VALVE - DUAL - 3" X 3"
	139513-01-000	EA	HOSE - SEWER - 3" X 10' - W/ADAPTER
	062416-01-000	EA	ADAPTER - SEWER HOSE TO 3" PIPE
14	133972-04-000	EA	PAD/HEATER - HOLDING TANK - F/34 GALLON
15	066440-01-000	EA	STRAINER - SHOWER DRAIN - W/RUBBER WASHER
16	131486-01-000	EA	ELBOW - DRAIN 1 1/2" - LOW PROFILE - TUB DRAIN
17*	147421-02-01A	EA	TOILET/AQUA MAGIC 5 (LOW) FOOTFLUSH - W/SPRAY - WHITE
18	010129-03-000	EA	NIPPLE - 3" X 3" TOE - PLASTIC
19	061607-01-000	EA	GROMMET - HOLDING TANK - 1 1/2" NPS

**WATER & SEWAGE GROUP (CONTINUED)**  
**DRAINAGE SYSTEM (CONTINUED)**

KEY	PART NUMBER	U/M	DESCRIPTION
20	139646-01-01A	EA	TANK - HOLDING - W/O FITTINGS
	049032-01-000	EA	PATCH - SPINWELD - 3/8" - PLASTIC
21	061607-02-000	EA	GROMMET - HOLDING TANK - 3" NPS
22	150881-01-01A	EA	TANK - HOLDING - 33 GALLON - W/O FITTINGS
	049032-01-000	EA	PATCH - SPINWELD - 3/8" - PLASTIC
23	011091-02-000	EA	WASTE - CONTINUOUS - DOUBLE SINK
24	078406-01-000	EA	COUPLER - 3" X 3" W/CLAMPS - RUBBER
24	010129-03-000	EA	NIPPLE - 3" X 3" TOE - PLASTIC
25	083558-03-000	EA	VENT W/COVER F/PLUMBING STACK - OFF WHITE
26	092303-01-000	EA	STRAINER - W/BASKET - GALLEY SINK - 4" OD
27	106116-01-02A	EA	STRAINER/PLASTIC - STOPPER/TAILPIECE/GASKET & NUT-LAVATORY
	106116-02-01A	EA	GASKET - STRAINER
28	142285-01-01A	EA	SINK - LAVATORY
29	148870-04-01A	EA	SINK/DOUBLE - LRG/SML BASIN - 25" X 19" X 7" W/LT/RR NOTCH
	148870-01-01A	EA	SINK/DOUBLE - LRG/SML BASIN - 25" X 19" X 7"
30	151541-01-000	EA	FLANGE - CLOSET - ELBOW/SWIVEL - 4" X 3"

**\*COMPONENT PARTS LISTED LATER IN THIS GROUP**

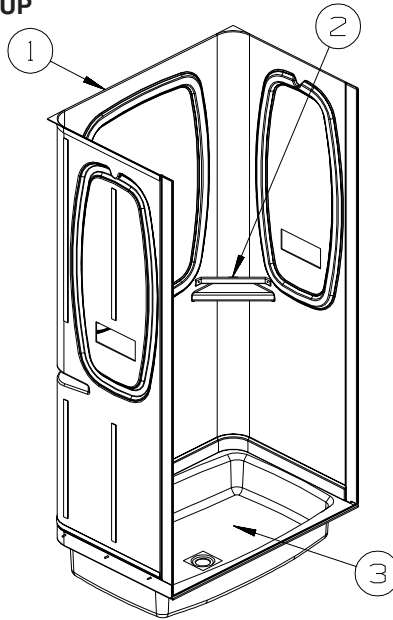

KEY	PART NUMBER	U/M	DESCRIPTION
1	147677-01-18A	EA	SURROUND - SHOWER/TUB
2	113714-04-02A	EA	RETAINER - SHELF/SHOWER - SOFT WHITE
3	M02630-87-S34	EA	SHOWER PAN - W/STRAINER

**WATER & SEWAGE GROUP (CONTINUED)**  
**COMPONENT PARTS FOR DRAINAGE SYSTEM**

062415-01-000

KEY	PART NUMBER	U/M	DESCRIPTION	VENDOR NO.
	062415-01-700	EA	STRING-SEWER CAP	V#SV7 STRAP

096927-01-02A

KEY	PART NUMBER	U/M	DESCRIPTION	VENDOR NO.
	096927-01-700	EA	SINK STOPPER	M9801
	096927-01-701	EA	TAILPIECE-DRAIN-LAVATORY	M9802

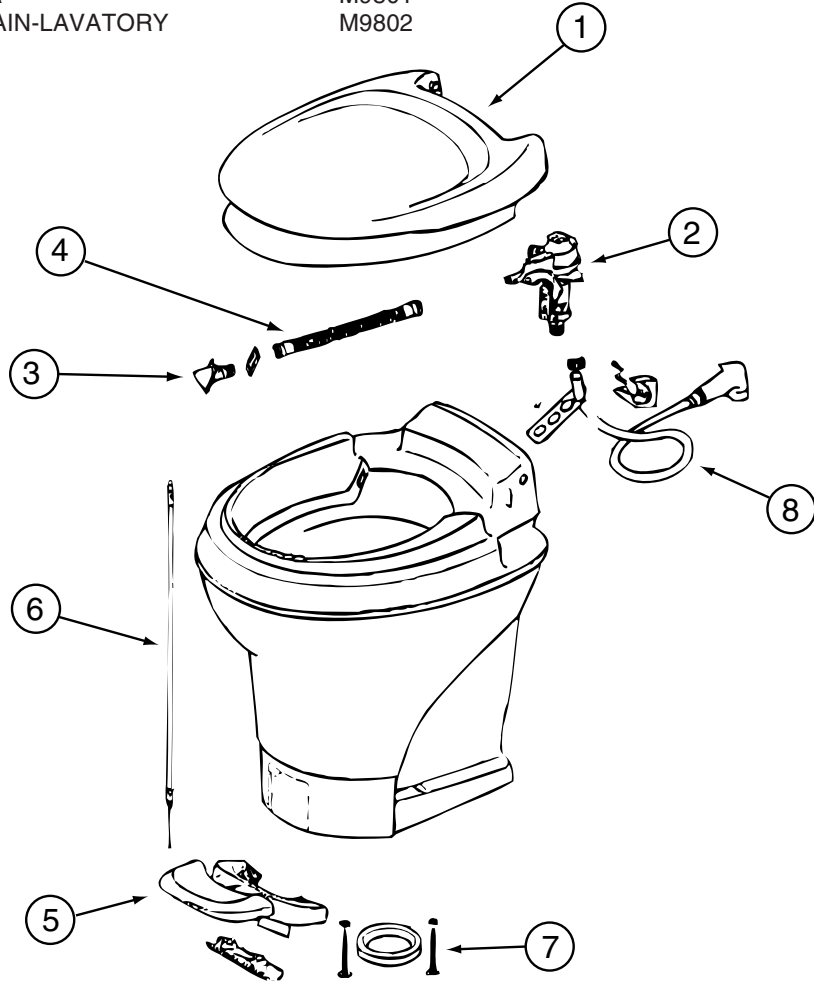

147421-01-01A, 147421-02-01A

KEY	PART NUMBER	U/M	DESCRIPTION	VENDOR NO.
1	147421-01-700	EA	SEAT & COVER ASSEMBLY(WHT)	31703
2	147421-01-701	EA	WATER MODULE ASSEMBLY	31705
3	147421-01-702	EA	NOZZLE ASSEMBLY	31706
4	147421-01-703	EA	LINK - WATER MODULE	31621
5	147421-01-704	EA	PEDAL - WHITE	31709
6	147421-01-705	EA	FOOT CABLE	31711
7	063740-01-706	EA	BOLT PACKAGE-FLOOR FLANGE	12524 THETFORD
8	132389-01-708	EA	HAND SPRAY KIT	19289
	147421-01-706	EA	SEAL - BLADE	31708
	147421-01-707	EA	CAP (UNIVERSAL BOLT) - WHITE	31713

147421-03-01A

KEY	PART NUMBER	U/M	DESCRIPTION	VENDOR NO.
1	147421-01-700	EA	SEAT & COVER ASSEMBLY(WHT)	31703
2	147421-01-701	EA	WATER MODULE ASSEMBLY	31705
3	147421-01-702	EA	NOZZLE ASSEMBLY	31706
4	147421-01-703	EA	LINK - WATER MODULE	31621
5	147421-01-704	EA	PEDAL - WHITE	31709
6	147421-01-705	EA	FOOT CABLE	31711
7	063740-01-706	EA	BOLT PACKAGE-FLOOR FLANGE	12524 THETFORD
	147421-01-706	EA	SEAL - BLADE	31708
	147421-01-707	EA	CAP (UNIVERSAL BOLT) - WHITE	31713

## WATER & SEWAGE GROUP (CONTINUED)

### WATER SYSTEM

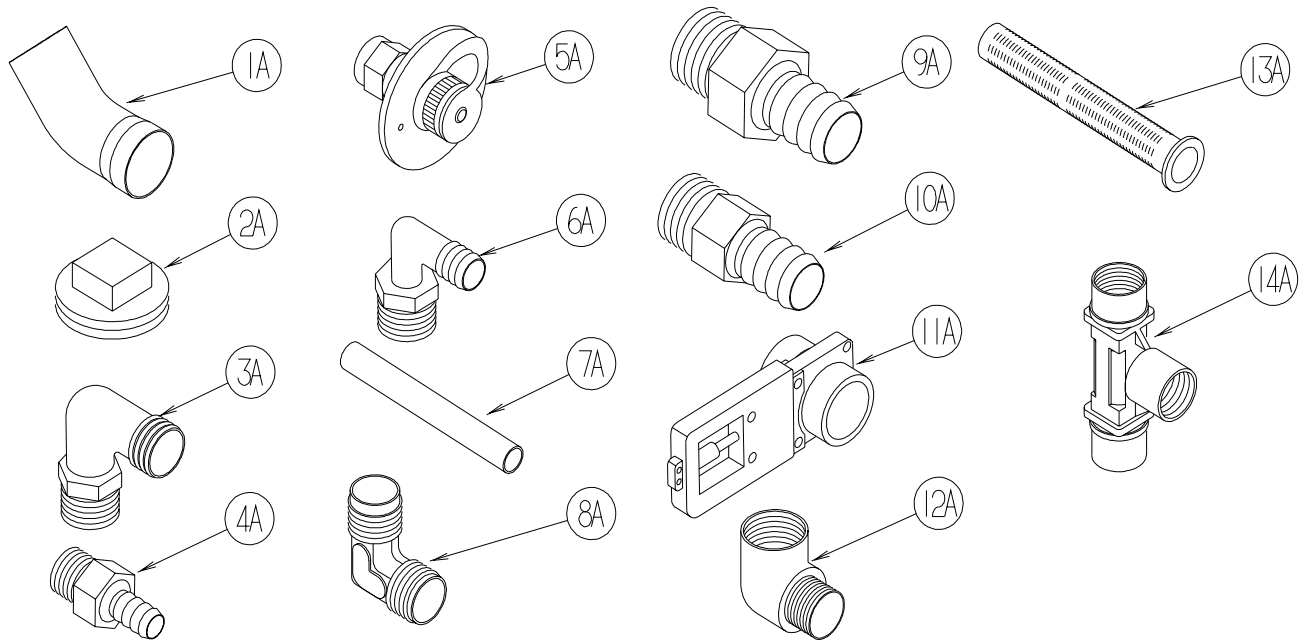

KEY	PART NUMBER	U/M	DESCRIPTION
1A	010009-01-000	EA	ELBOW - 90 DEGREE - 1/4 BEND - 1 1/2" PLASTIC
2A	010166-01-000	EA	PLUG/THREADED - 1 1/4"MPT - PLASTIC - BLACK - UL
3A	010219-01-000	EA	ELBOW - 1 1/4 MPT X 1 1/4 BARB - WATER FILL - PLASTIC
4A	010224-01-000	EA	ADAPTER - HOSE TO PIPE - 3/8 MPT X 3/8 BARB - PLASTIC
5A	010230-06-000	EA	FILL - CITY WATER - W/CHECK VALVE - MPT - BRUSHED ALUM
6A	035539-01-000	EA	ELBOW - 3/8 MPT X 3/8 BARB - PLASTIC
7A	039800-04-000	FT	TUBING - POLYBUTYL - 1/4"OD
7A	074462-02-000	FT	TUBING - VINYL - 3/8 ID X 20' - CLEAR
7A	112176-01-000	FT	TUBING - VINYL - REINFORCED - 1/2" ID
7A	124188-01-000	FT	TUBING - PEX - 1/2" ID X 20' - BLUE(COLD)
7A	124188-02-000	FT	TUBING - PEX - 1/2" ID X 20' - RED(HOT)
8A	039808-03-000	EA	ELBOW - 1/2" MPT X 1/2" MPT - PLASTIC
9A	044927-01-000	EA	ADAPTER - HOSE TO PIPE-1 1/4 MPTX1 1/4 BARB-BLACK PLASTIC
10A	044927-02-000	EA	ADAPTER - REDUCING - 1" MPT X 1.3" BARB - PLASTIC
11A	062421-03-000	EA	VALVE/DUMP W/O HANDLE - 1 1/2" X 1 1/2" HUB
	062421-05-000	EA	CABLE/ROD - F/DUMP VALVE - W/HANDLE - 48"
	062421-07-000	EA	CABLE/ROD - F/DUMP VALVE - W/HANDLE - 144"
	062421-08-000	EA	CABLE/ROD - F/DUMP VALVE - W/HANDLE - 108"
12A	065318-02-000	EA	ELBOW - 90 DEGREE - 3/8" MPT TO 3/8" FPT
13A	077954-02-000	EA	FILTER - WATER TANK - W/SCREEN IN TANK
14A	039798-01-000	EA	TEE - 1/2"MPT X 1/2"MPT X 1/2"MPT - PLASTIC

**WATER & SEWAGE GROUP (CONTINUED)**  
**WATER SYSTEM (CONTINUED)**

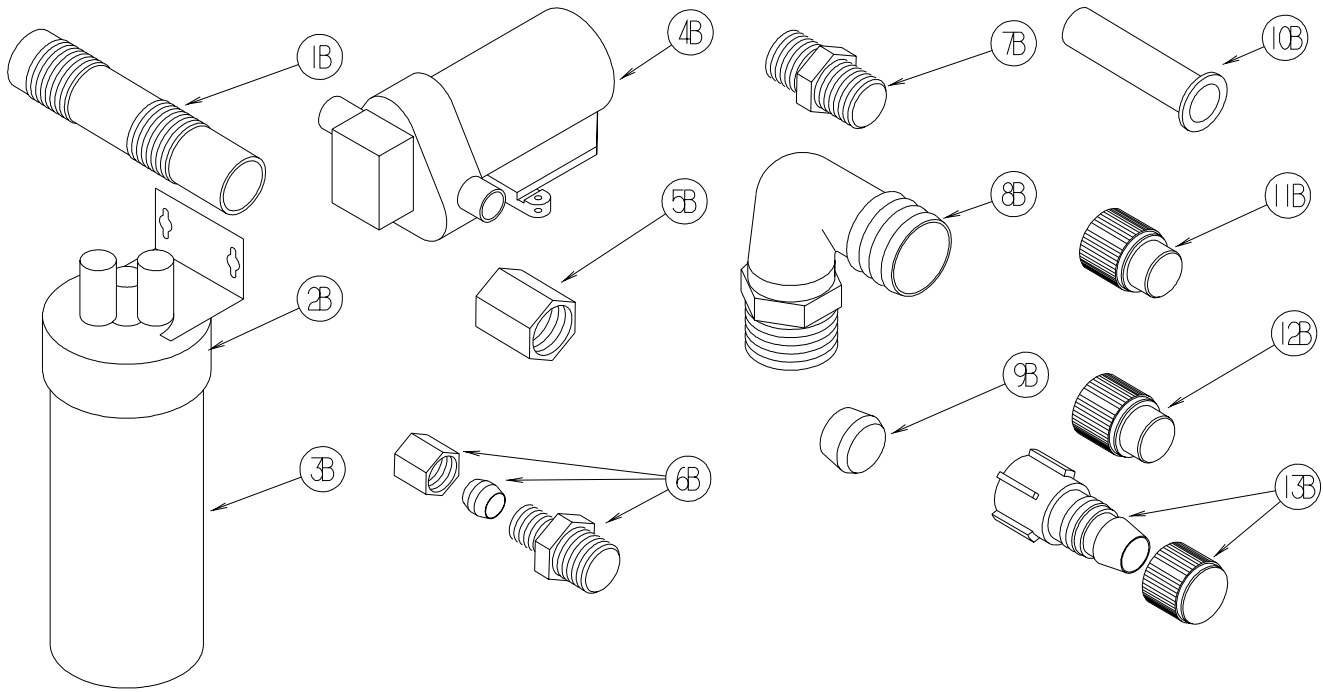

KEY	PART NUMBER	U/M	DESCRIPTION
1B	079381-01-000	FT	TUBING - RIBBED FLEXIBLE - WATER FILL - 1.4" ID
2B	087200-01-000	EA	FILTER-WATER PURIFCATION, EVERPURE QC2-AC
3B	087200-02-000	EA	CARTRIDGE-WATER FILTER,AC - EVERPURE 9601-11
4B*	098607-01-000	EA	PUMP - WATER - W/.5" MPT FITTING - FLOW 2.8 GPM
5B	101814-01-000	EA	COUPLING - FEMALE - 1/2" X 1/2" FPT - GRAY
6B	103798-01-000	EA	CONNECTOR - 1/4 OD X 3/8 MPT
7B	110438-02-000	EA	VALVE - CHECK - BRASS - 1/2 MPT X 1/2 MPT
8B	111223-02-000	EA	ELBOW - 1/2" MPT X 3/8" BARB - PLASTIC
8B	111223-03-000	EA	ELBOW - 3/4" MPT X 1/2" BARB - PLASTIC
8B	111223-04-000	EA	ELBOW - 1/2" MPT X 1/2" BARB - PLASTIC
9B	111888-01-000	EA	FERRULE - PLASTIC - .250 ID X .375 OD
10B	111888-02-000	EA	INSERT - BRASS - 1/4 COMP
11B	113697-01-000	EA	CAP - 3/8"P
12B	114427-01-000	EA	CAP - 1/2"P
13B	114427-02-000	EA	PLUG - W/COMP NUT - 1/2" PLASTIC PIPE/1/2" FLAIR-IT



**WATER & SEWAGE GROUP (CONTINUED)**  
**WATER SYSTEM (CONTINUED)**

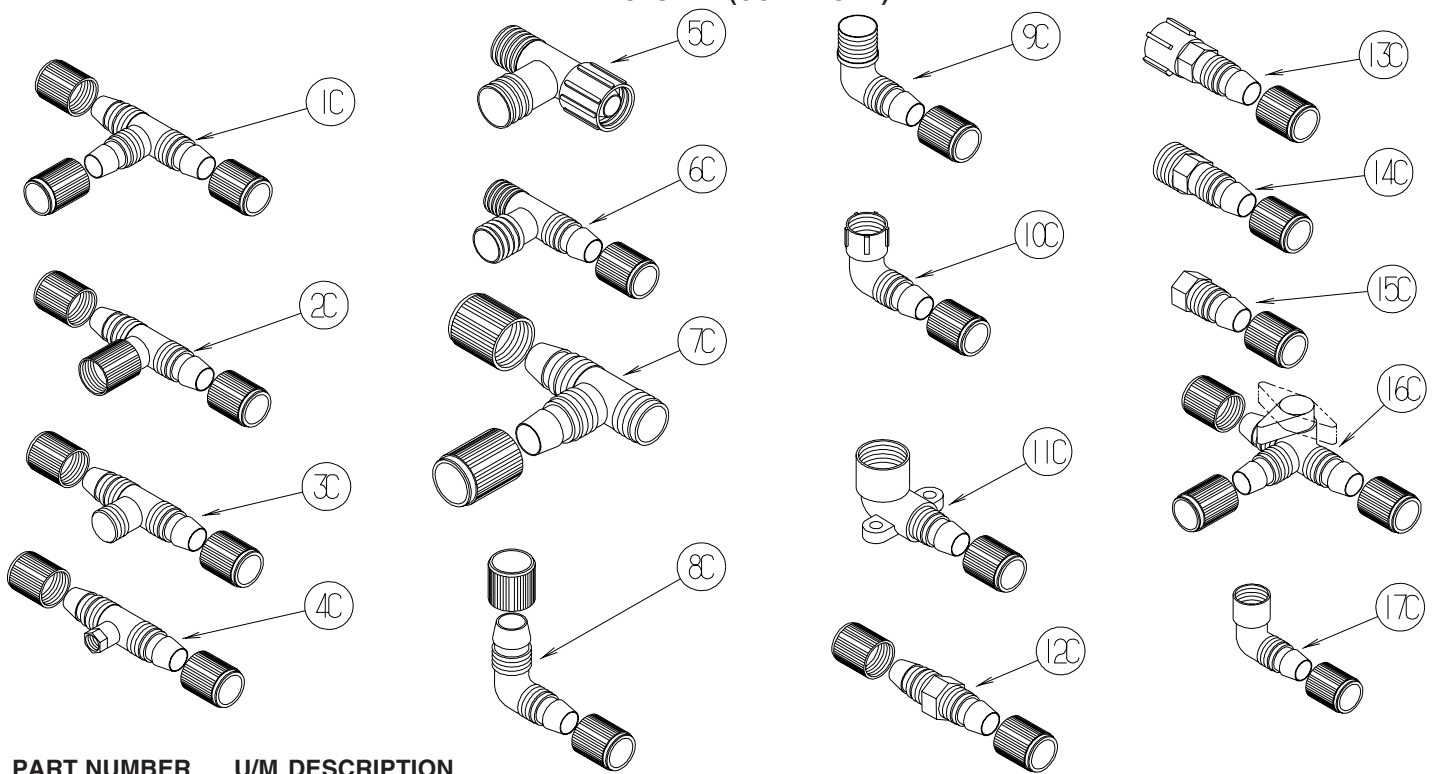

KEY	PART NUMBER	U/M	DESCRIPTION
1C	114428-01-000	EA	TEE - 1/2"P X 1/2"P X 1/2"P
2C	114428-02-000	EA	TEE - SWIVEL - 1/2"P X 1/2"P X 1/2"FPT
3C	114428-03-000	EA	TEE - 1/2"P X 1/2"P X 1/2"MPT
4C	114428-04-000	EA	TEE - 1/2"P X 1/2"P X 1/8"FPT
5C	114428-05-000	EA	TEE - 1/2" SWIVEL X 1/2" MPT X 1/2" MPT
6C	114428-06-000	EA	TEE - 1/2" P X 1/2" MPT X 1/2" MPT
7C	114428-07-000	EA	TEE - 1/2" P X 1/2" MPT X 1/2" P
8C	114429-01-000	EA	ELBOW - 1/2"P X 1/2"P
9C	114429-02-000	EA	ELBOW - 1/2"P X 1/2"MPT
9C	114429-04-000	EA	ELBOW - 1/2"P X 3/8"MPT
9C	114429-05-000	EA	ELBOW - 1/2"P X 3/4"MPT
9C	114429-10-000	EA	ELBOW - SWIVEL - 1/2"MPT X 1/2"FPT
10C	114429-06-000	EA	ELBOW - SWIVEL - 1/2"P X 3/4"FPT
10C	114429-08-000	EA	ELBOW - SWIVEL - 1/2"P X 1/2"FPT
11C	114429-09-000	EA	ELBOW - 1/2"P X 1/2"FPT DROP EAR
12C	114430-01-000	EA	ADAPTER - 1/2"P X 1/2"P
13C	114430-02-000	EA	ADAPTER - SWIVEL - 1/2"P X 1/2"FPT
13C	114430-04-000	EA	ADAPTER - SWIVEL - 1/2"P X 3/8"MPT
14C	114430-03-000	EA	ADAPTER - 1/2"P X 1/2"MPT
15C	114430-06-000	EA	ADAPTER - 1/2"P X 3/8"FPT
15C	114430-09-000	EA	ADAPTER - 1/2"P X 1/2"FPT
16C	114431-01-000	EA	VALVE - 180 DEGREE/CENTER DRAIN - 1/2"P - THREE WAY
17C	114429-11-000	EA	ELBOW - 1/2"P X 1/2"FPT

**WATER & SEWAGE GROUP (CONTINUED)**  
**WATER SYSTEM (CONTINUED)**

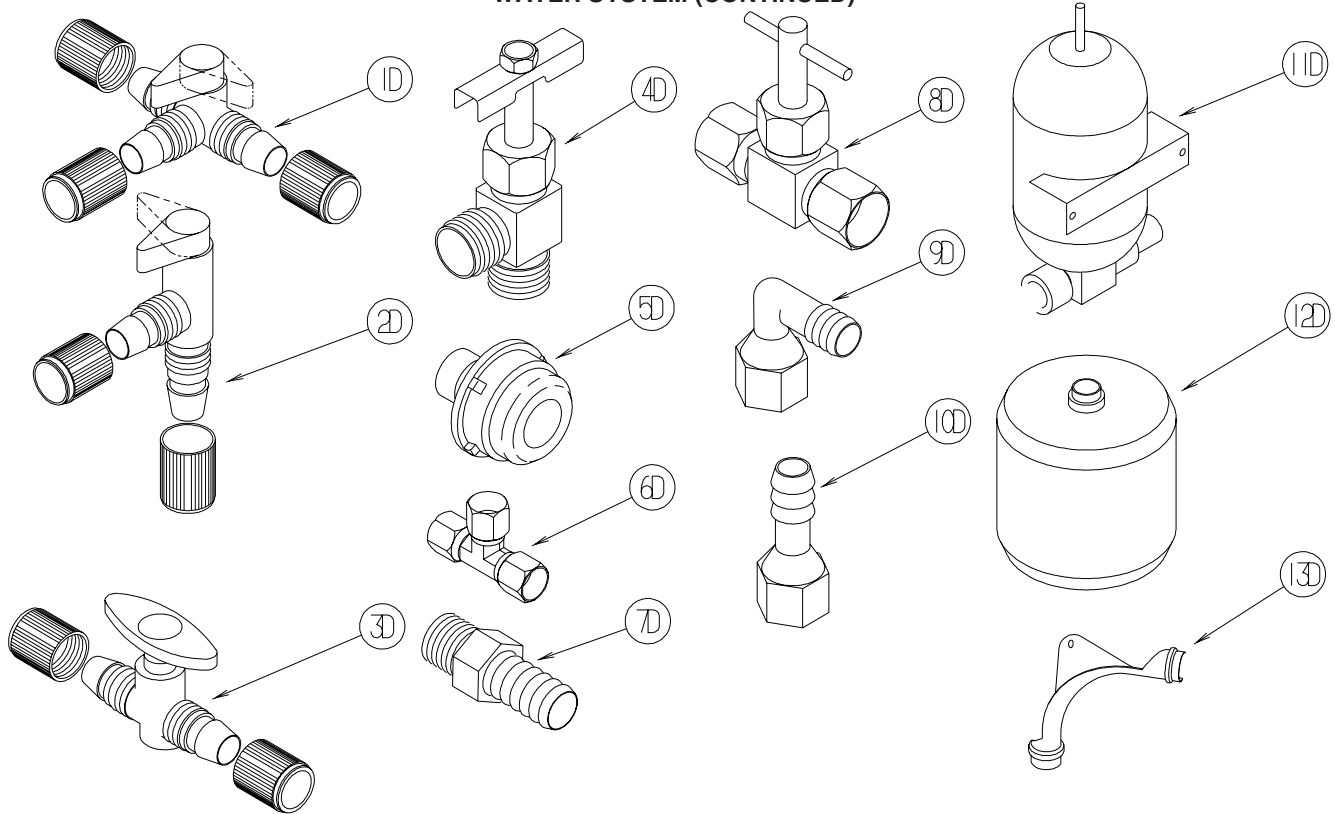

KEY	PART NUMBER	U/M	DESCRIPTION
1D	114431-02-000	EA	VALVE - WATER BYPASS - 1/2"P - THREE WAY (WATER HEATER)
2D	114431-03-000	EA	VALVE - 90 DEGREE DRAIN - 1/2"P
3D	114431-04-000	EA	VALVE - "INLINE SHUT-OFF" - 1/2"P
4D	114431-05-000	EA	VALVE - NEEDLE - 1/8" MPT X 1/4" COMPRESSION (ICE MAKER)
5D	114966-01-000	EA	FILTER - IN LINE - TWIST ON - 1/2"
			FROM: 00-00-00 THRU: 09-26-04
5D	152925-01-01A	EA	FILTER - IN LINE - TWIST ON - 1/2" - BLACK
			FROM: 09-27-04 THRU: 99-99-99
6D	118423-01-000	EA	FITTING - BRASS-TEE - 1/4C X 1/4C X 1/4C
7D	118809-01-000	EA	ADAPTER - 1/2" MPT X 3/8" BARB - PLASTIC
7D	118809-02-000	EA	ADAPTER - 1/2" MPT X 1/2" BARB - PLASTIC
8D	120868-01-000	EA	VALVE - NEEDLE - 1/4" COMPRESSION X 1/4" COMPRESSION
9D	123150-01-000	EA	ELBOW - 1/2 FPT X 1/2 BARB - SWIVEL
10D	123152-01-000	EA	ADAPTER - 1/2 FPT X 1/2 BARB - SWIVEL
11D	123243-01-000	EA	TANK - ACCUMULATOR - 24 OZ
12D	123317-01-000	EA	TANK - ACCUMULATOR - 2 GALLON
13D	124184-01-000	EA	SUPPORT - WATER LINE - BEND

**WATER & SEWAGE GROUP (CONTINUED)**  
**WATER SYSTEM (CONTINUED)**

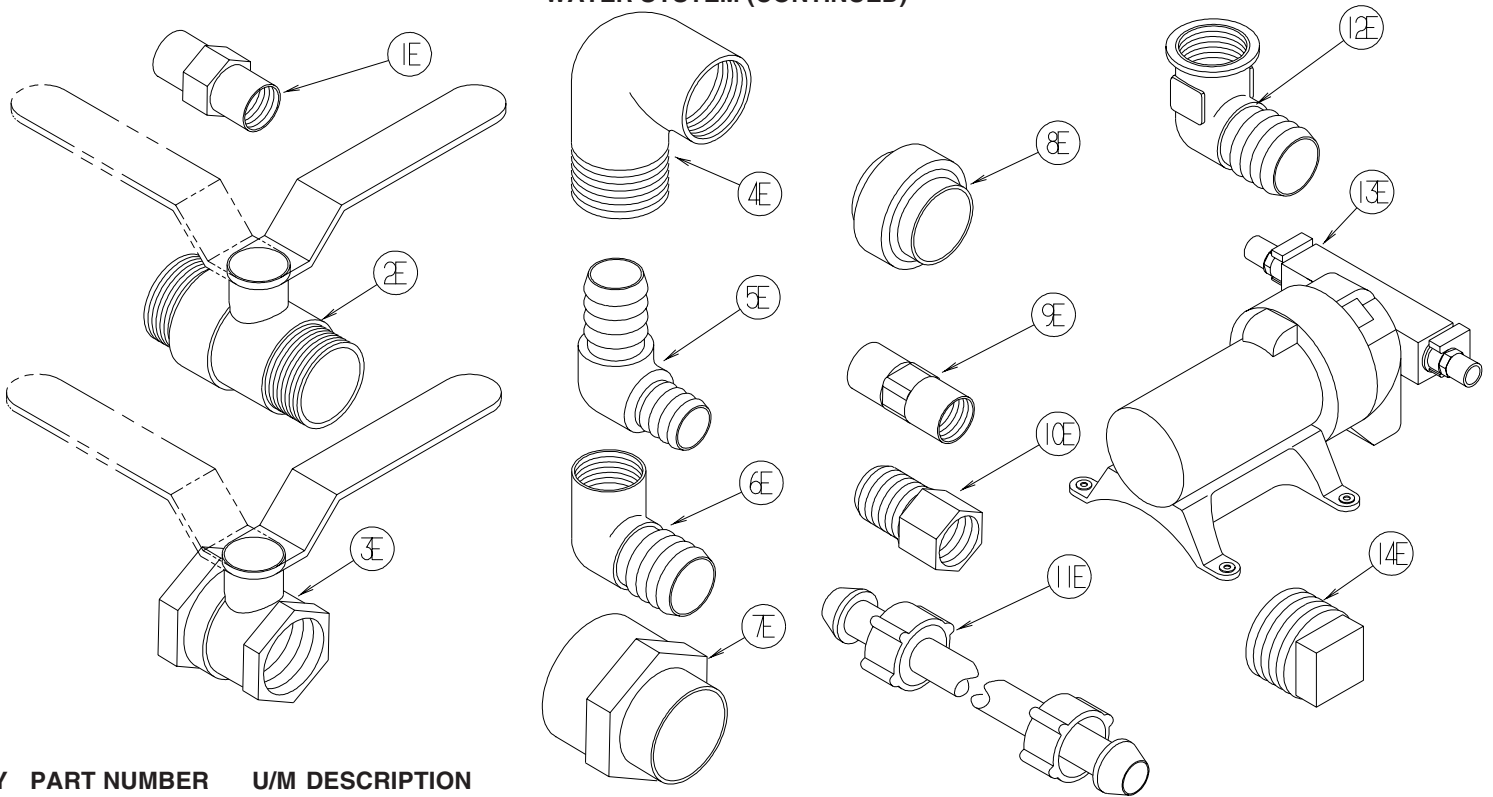

KEY	PART NUMBER	U/M	DESCRIPTION
1E	132148-01-000	EA	CONNECTOR - 1/2" X 1/2"MPT - BRASS
2E	132483-01-000	EA	VALVE/BALL - 1" - THREADED ENDS
3E	132483-02-000	EA	VALVE/BALL - 1/2" - BRASS - FPT
4E	132484-01-000	EA	ELBOW - 90 DEGREE - 1MPT X 1FPT - PLASTIC
5E	132781-01-000	EA	ELBOW - 1.3" BARB X 1.3" BARB - 90 DEGREE - PLASTIC
6E	132782-01-000	EA	ELBOW - 1"FPT X 1.3" BARB - 90 DEGREE - PLASTIC
7E	133835-01-000	EA	ADAPTER - REDUCING - 1 1/2" X 1 1/4"
8E	133889-01-000	EA	UNION - 1 1/2 DOUBLE SLIP - PVC
9E	135386-01-000	EA	NIPPLE - 1/2"
10E	136333-01-000	EA	ADAPTER - BRASS - 1/2"MPT X 1/2"FPT
11E	140821-01-000	EA	TUBE - WATER SUPPLY - 3/8" X 24"
11E	140821-02-000	EA	TUBE - WATER SUPPLY - 3/8" X 30"
11E	140821-03-000	EA	TUBE - WATER SUPPLY - 3/8" X 36"
11E	140821-04-000	EA	TUBE - WATER SUPPLY - 3/8" X 48"
11E	140821-05-000	EA	TUBE - WATER SUPPLY - 3/8" X 54"
11E	140821-06-000	EA	TUBE - WATER SUPPLY - 3/8" X 60"
11E	140821-07-000	EA	TUBE - WATER SUPPLY - 3/8" X 72"
12E	142812-01-000	EA	ELBOW - BRASS - 1/2"MPT X 1/2"FPT
13E*	144215-01-000	EA	PUMP - WATER - 5.7 GPM - W/1/2" MPT
*	144215-02-000	EA	STRAINER - WATER PUMP
14E	145609-01-000	EA	PLUG - BRASS - 1/2" MPT/HEX HEAD

**\*COMPONENT PARTS LISTED LATER IN THIS GROUP**

**WATER & SEWAGE GROUP (CONTINUED)**  
**WATER SYSTEM (CONTINUED)**

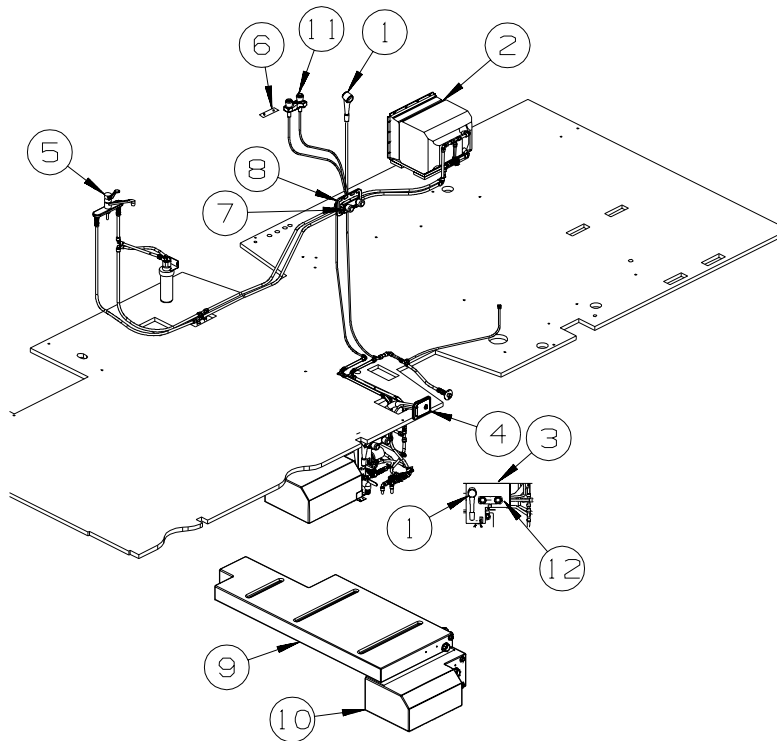

KEY	PART NUMBER	U/M	DESCRIPTION
1	131383-01-02A	EA	SHOWER HEAD - W/60" HOSE & BRACKET - WHITE
2*	051391-03-000	EA	WATER HEATER G6A-8E ELECTRONIC IGNITION
2	052009-06-000	EA	DOOR - WATER HEATER - BRIGHT WHITE - 18" X 14.6"
2	152239-01-01A	EA	FLANGE/MOUNTING/RECESSED - 19.3" X 15.8" - BRIGHT WHITE
3	114416-01-02B	EA	BRACKET/FAUCET SUPPORT - E-COATE
4	137169-01-01A	EA	WATER FILL/GRAVITY - W/DOOR - W/O LOCK - BRIGHT WHITE
<b>EARLY LOCK ASM</b>			
			FROM: 00-00-00 THRU: 02-24-05
	137169-02-01A	EA	ADAPTER/LOCK - (WASHER) F/GRAVITY WATERFILL
	138637-03-000	EA	LOCK ASM. - KEYED - .9" CASE (CYLINDER/CAM/HDWR PKG)
	138637-52-000	EA	CASE/CYLINDER - LOCKING - W/O CAM/KEY - .9"
	138637-52-001	EA	CASE/CYLINDER - LOCKING - W/O CAM/KEY - .9"
	138637-52-002	EA	CASE/CYLINDER - LOCKING - W/O CAM/KEY - .9"
	138637-52-003	EA	CASE/CYLINDER - LOCKING - W/O CAM/KEY - .9"
	138637-52-004	EA	CASE/CYLINDER - LOCKING - W/O CAM/KEY - .9"
	138637-52-005	EA	CASE/CYLINDER - LOCKING - W/O CAM/KEY - .9"
	138637-52-006	EA	CASE/CYLINDER - LOCKING - W/O CAM/KEY - .9"
	138637-52-007	EA	CASE/CYLINDER - LOCKING - W/O CAM/KEY - .9"
	138637-52-008	EA	CASE/CYLINDER - LOCKING - W/O CAM/KEY - .9"
	138637-52-009	EA	CASE/CYLINDER - LOCKING - W/O CAM/KEY - .9"
	138637-62-000	EA	CAM - LATCHING - DOG LEG - 1" LONG
	144474-01-000	EA	ADAPTER - LOCK - 180 DEGREE
<b>LATER LOCK CASE</b>			
			FROM: 02-25-05 THRU: 99-99-99
	138290-03-000	EA	CASE - W/CAM - W/O CYLINDER/KEY
5*	104114-05-01A	EA	FAUCET - GALLEY - SINGLE CONTROL/LOOP HANDLE - CHROME
			FROM: 00-00-00 THRU: 11-15-04
5	149164-01-01A	EA	FAUCET - GALLEY - SINGLE CONTROL - CHROME
			FROM: 11-16-04 THRU: 99-99-99
6	091253-01-000	EA	GASKET - FAUCET - LAVATORY/GALLEY
7*	075241-04-000	EA	FAUCET - SHOWER/BRASS
8	075606-03-000	EA	PANEL - FAUCET SHOWER - SOFT WHITE

**WATER & SEWAGE GROUP (CONTINUED)**  
**WATER SYSTEM (CONTINUED)**

KEY	PART NUMBER	U/M	DESCRIPTION
9	142398-03-01A	EA	TANK - WATER - 36 GALLON - W/FITTINGS
	042989-03-000	EA	FITTING - SPINWELD - 1 1/4"NPT - PLASTIC
	042989-04-000	EA	FITTING - SPINWELD - 3/8"FPT - PLASTIC
			FROM: 09-07-04 THRU: 99-99-99
	042989-05-000	EA	FITTING - SPINWELD - 1/2"FPT - PLASTIC
	049032-01-000	EA	PATCH - SPINWELD - 3/8" - PLASTIC
10	142399-03-01A	EA	TANK - WATER - 36 GALLON - W/FITTINGS
	042989-03-000	EA	FITTING - SPINWELD - 1 1/4"NPT - PLASTIC
	042989-05-000	EA	FITTING - SPINWELD - 1/2"FPT - PLASTIC
	042989-08-000	EA	FITTING - SPINWELD - 1"FPT - PLASTIC
	077954-02-000	EA	FILTER - WATER TANK - W/SCREEN IN TANK
	049032-01-000	EA	PATCH - SPINWELD - 3/8" - PLASTIC
11*	075240-05-000	EA	FAUCET - LAVATORY/BRASS - W/CLEAR KNOBS
12*	075241-06-000	EA	FAUCET/SHOWER -.5"MPT W/1.9" INLET PIPES- EXTERIOR/BRT WHT

**\*COMPONENT PARTS LISTED LATER IN THIS GROUP**

**WATER & SEWAGE GROUP (CONTINUED)**  
**COMPONENT PARTS FOR WATER SYSTEM**

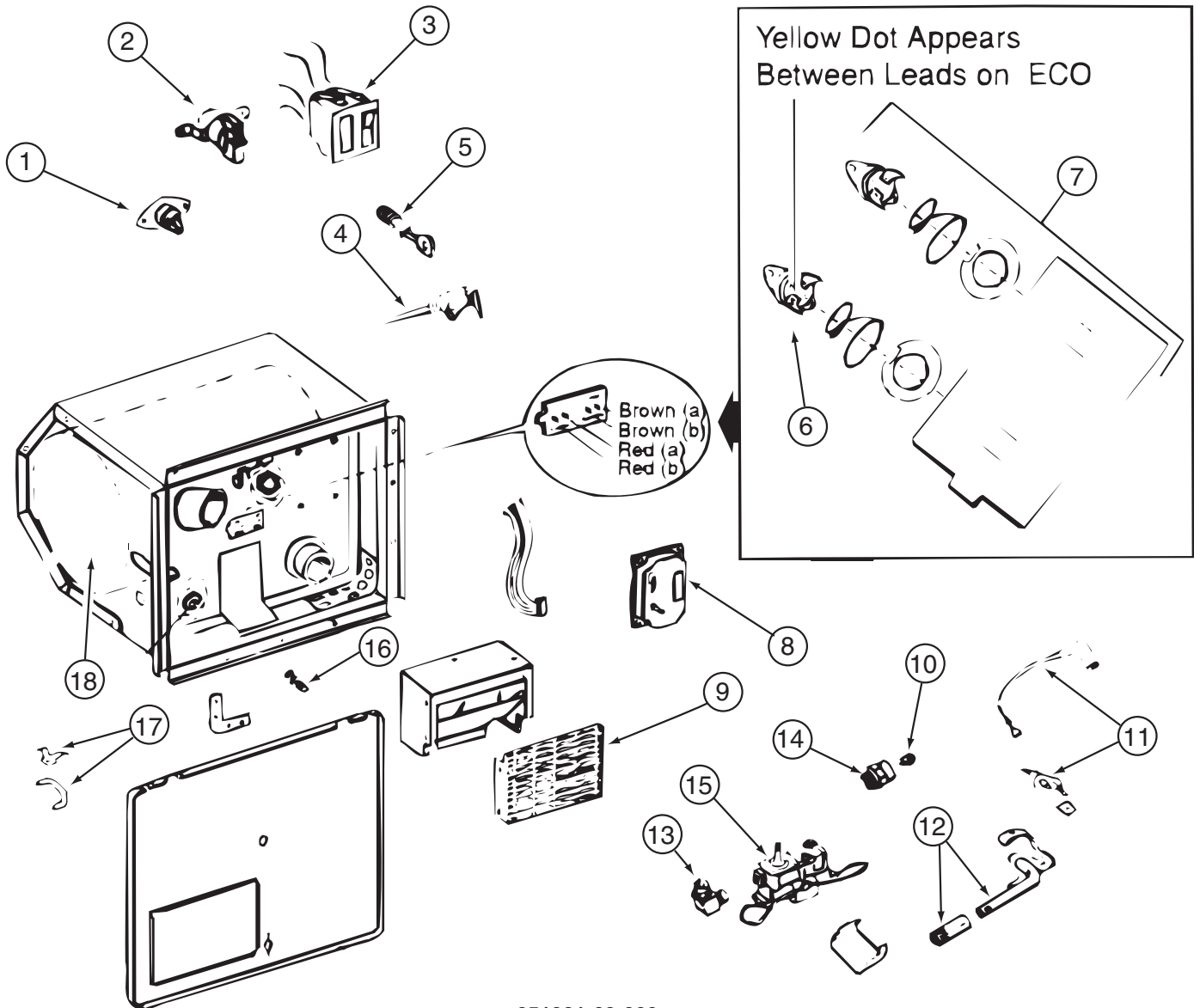

051391-03-000

KEY	PART NUMBER	U/M	DESCRIPTION	VENDOR NO.
3	051393-01-701	EA	SWITCH - REMOTE - W/LIGHT	91959
4	051391-01-704	EA	VALVE-RELIEF, 1/2" FITTING	91604
5	051391-01-705	EA	FASTENER-CAMLOCK	92609
6	051391-04-701	EA	THERMOSTAT 12V DC-120 PRESET	91470
7	051393-01-721	EA	THERMOSTAT W/ECO, 140 FRT MT	91447
9	051391-04-707	EA	KIT-EXHAUST, (FLUE & GASKET)	90960
10	051391-01-710	EA	ORIFICE-MAIN BURNER	92742
12	051391-04-703	EA	BURNER-MAIN/ELECTRONIC IG	91638
13	051391-01-714	EA	FITTING-ELBOW 45,3/8F X 3/8	MPT 1044
14	051391-03-700	EA	HOLDER-ORIFICE	91563
16	051391-01-715	EA	PLUG-DRAIN, 1 EA = 2 PER PKG	91857
17	051391-01-700	EA	HINGE KIT, (PIN & CLIP)	92568&92559
18	051391-04-706	EA	TANK-G6A-4E/6E/7E/8E-FRT.MT	91641
	051391-01-717	EA	GRILLE-WATER HEATER DOOR	92640
	051393-01-723	EA	SWITCH - THERMAL CUTOUT 2/PK	93853 NOW 93866
	051393-01-724	EA	BOARD-CIRCUIT, SPADE TERMINAL	93865
	051393-01-725	EA	ELECTRODE-SGL SPADE CONNECT.	93868
	051393-01-726	EA	VALVE/SOLENOID - W/O BRACKET	93870
	111129-01-711	EA	BRACKET-CORNER, SET OF FOUR	91928

CONTACT WINNEBAGO PARTS SALES FOR UNLISTED COMPONENT(S)

**WATER & SEWAGE GROUP (CONTINUED)**  
**COMPONENT PARTS FOR WATER SYSTEM (CONTINUED)**

**075240-05-000**

KEY	PART NUMBER	U/M DESCRIPTION	VENDOR NO.
	075240-05-700	EA CARTRIDGE - WASHERLESS	9-P42

**075241-04-000, 075241-05-000, 075241-06-000**

KEY	PART NUMBER	U/M DESCRIPTION	VENDOR NO.
	075240-05-700	EA CARTRIDGE - WASHERLESS	9-P42

**098607-01-000**

KEY	PART NUMBER	U/M DESCRIPTION	VENDOR NO.
	098607-01-702	EA DIAPHRAGM/DRIVE ASSEMBLY KIT	94-238-04
	098607-01-703	EA VALVE KIT	94-232-00
	098607-01-705	EA VALVE-CHECK, KIT	94-237-00
	098607-01-706	EA HOUSING, W/SWITCH ONLY	94-231-20
	098607-01-707	EA MOTOR W/BASEPLATE	11-148-04

**104114-05-01A**

KEY	PART NUMBER	U/M DESCRIPTION	VENDOR NO.
	104114-05-700	EA CARTRIDGE- REPAIR KIT	6-N1201-5-0WB

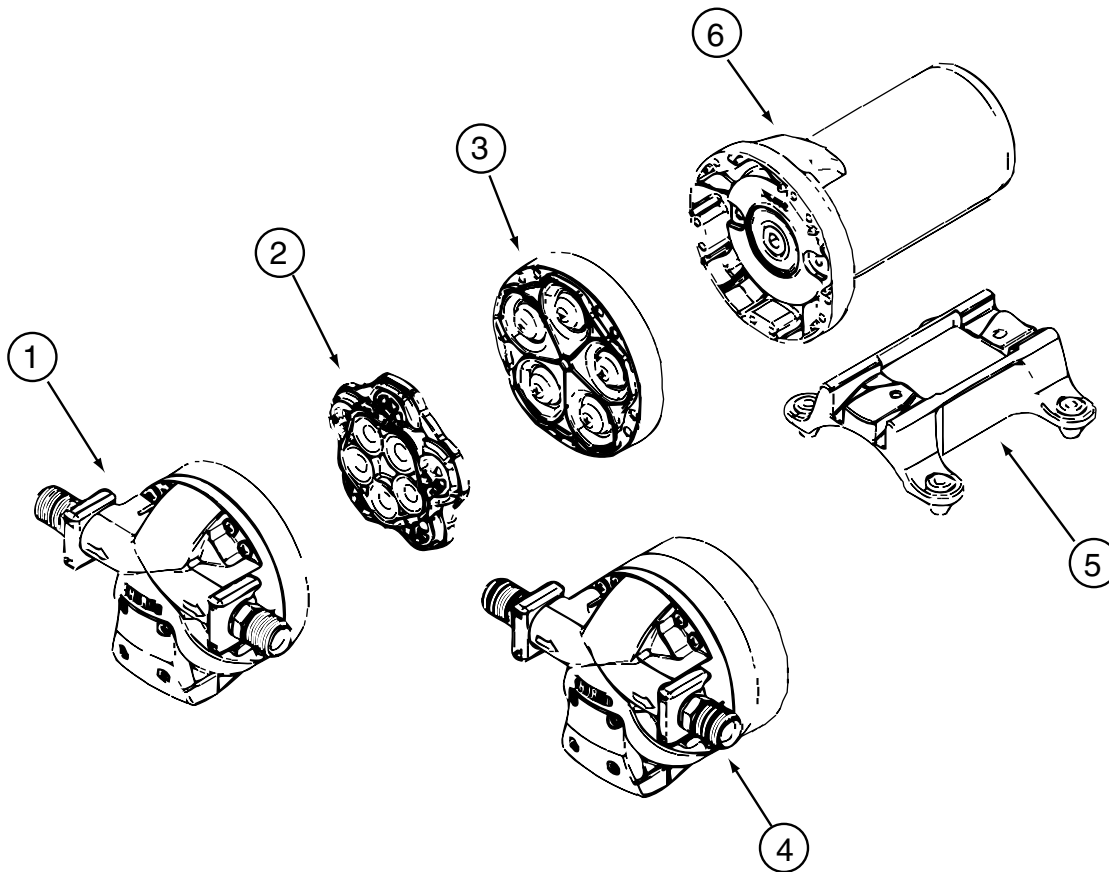

**144215-01-000**

KEY	PART NUMBER	U/M DESCRIPTION	VENDOR NO.
2	144215-01-700	EA VALVE ASSEMBLY	94-030-01
3	144215-01-701	EA DRIVE ASSEMBLY	94-030-02
	144215-01-702	EA FITTING KIT - W/ORINGS	94-615-06

CONTACT WINNEBAGO PARTS SALES FOR UNLISTED COMPONENT(S)

**144215-02-000**

KEY	PART NUMBER	U/M DESCRIPTION	VENDOR NO.
	144215-02-700	EA FITTING KIT- COUPLER W/ORING	94-637-00



## WINDOW & VENTS GROUP

### WINDOW & VENT LAYOUT

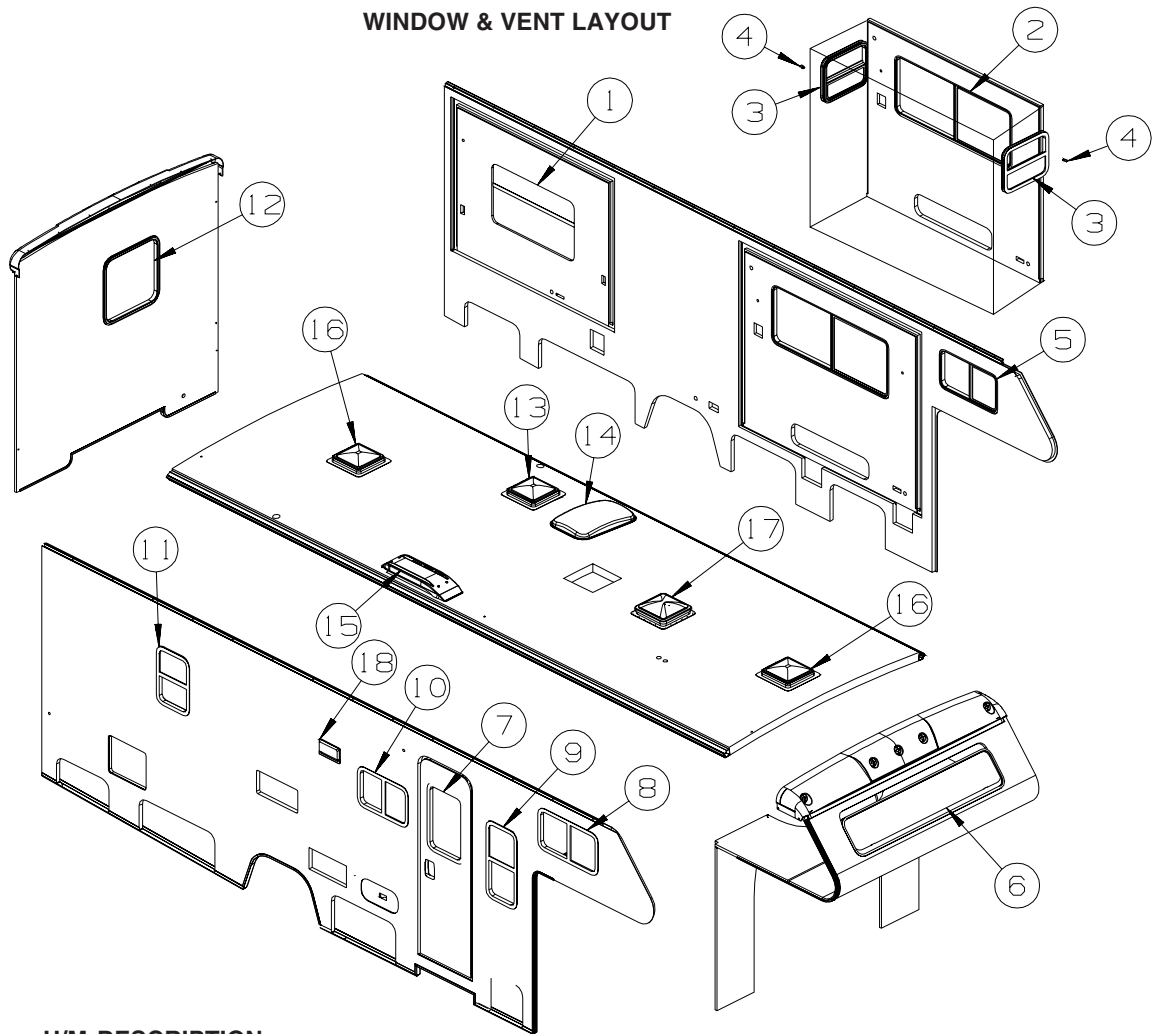

KEY	PART NUMBER	U/M	DESCRIPTION
1*	098647-30-02A	EA	WINDOW - DRVR HORIZ SLIDER W/TRIM - CLEAR - 24.2" X 41"
1	150656-03-01A	EA	WINDOW - TIPOUT/FLUSH/THERMO - 24.5" X 41.2" - <b>DUAL PANE</b>
2*	098647-47-02A	EA	WINDOW - DRVR HORIZ SLIDER W/TRIM - TINTED - 57.4" X 23.6"
			FROM: 00-00-00 THRU: 01-24-04
2	098647-74-01A	EA	WINDOW - DRIVER HORIZ SLIDER W/TRIM - 23.8" X 57.6"
			FROM: 01-25-04 THRU: 99-99-99
2*	150648-07-01A	EA	WINDOW-HORIZ SLIDER/FLUSH/THERMO/LH - 23.8" X 57.7" - <b>DUAL PANE</b>
3	098644-15-01A	EA	WINDOW - VERTICAL SLIDER W/TRIM - 16.9" X 20.8"
3*	150649-14-01A	EA	WINDOW - VERT SLIDER/FLUSH/THERMO - 16.9" X 20.8" - <b>DUAL PANE</b>
3*	098644-13-01A	EA	WINDOW - VERTICAL SLIDER W/TRIM - 19.8" X 20.9" - <b>DINETTE - U-SHAPED</b>
3*	150649-07-01A	EA	WINDOW - VERT SLIDER/FLUSH/THERMO - 19.8" X 20.8" - <b>DUAL PANE - DINETTE - U-SHAPED</b>
4	151905-01-01A	EA	CLIP/BRACKET - SCREEN RETAINER - BLACK
5*	098647-32-02A	EA	WINDOW - DRVR HORIZ SLIDER W/TRIM - CLEAR- 15.7" X 28.5"
5*	150648-05-01A	EA	WINDOW-HORIZ SLIDER/FLUSH/THERMO/LH - 16" X 28.7" - BLACK - <b>DUAL PANE</b>
6	103313-04-P07	EA	WINDOW - PICTURE - 14.3" X 71"
	002181-33-000	EA	GLASS - PICTURE WINDOW - 70.9"W X 14.2"H - TINTED
	099154-01-000	FT	CHANNEL - GLAZING - STATIONARY GLASS - .62" X .45" - BLK
6	117054-06-01A	EA	TRIM/RETAINER - INSIDE - 14.9" X 71.8" - BLACK
6*	150652-01-01A	EA	WINDOW - STATIONARY/FLUSH - BLACK - 15.2" X 71.9" - <b>DUAL PANE</b>
7	117053-04-FB1	EA	WINDOW - PICTURE/CLEAR - W/O TRIM - 17" X 26.4"
	002181-27-000	EA	GLASS - PICTURE WINDOW - 25.8"W X 16.4"H - CLEAR
	087561-01-000	FT	SEAL - GLASS - EXTERIOR - .5" WIDE - VINYL BLACK
7	117054-02-03A	EA	TRIM/RETAINER - INSIDE - 16.9" X 26.2" - BLACK
7*	150651-01-01A	EA	WINDOW - STATIONARY/FLUSH/THERMO - 26.3" X 17" - BLACK
8*	098647-31-02A	EA	WINDOW - PASS HORIZ SLIDER W/TRIM - CLEAR - 15.7" X 28.5"
8*	150648-04-01A	EA	WINDOW-HORIZ SLIDER/FLUSH/THERMO/RH - 16" X 28.7" - <b>DUAL PANE</b>
9	098644-16-01A	EA	WINDOW - VERTICAL SLIDER W/TRIM - 30.2" X 14.3"
9*	150649-01-01A	EA	WINDOW - VERT SLIDER/FLUSH/THERMO - 30.9" X 14.2" - <b>DUAL PANE</b>
10*	098647-49-02A	EA	WINDOW - PASS HORIZ SLIDER W/TRIM - TINTED - 15" X 23.7"
10*	150648-08-01A	EA	WINDOW-HORIZ SLIDER/FLUSH/THERMO/RH - 15.2" X 24" - <b>DUAL PANE</b>

**WINDOW & VENTS GROUP (CONTINUED)**  
**WINDOW & VENT LAYOUT (CONTINUED)**

KEY	PART NUMBER	U/M	DESCRIPTION
11*	098644-01-01A	EA	WINDOW - VERTICLE SLIDER W/TRIM - TINTED - 22.2" X 15.2"
11*	150649-15-01A	EA	WINDOW - VERT SLIDER/FLUSH/THERMO - 22.2" X 15.2" - DUAL PANE
12*	116976-02-02A	EA	WINDOW - PICTURE/TINTED/ESCAPE W/TRIM - 26.1" X 26" FROM: 00-00-00 THRU: 05-02-04
12*	151075-02-01A	EA	WINDOW - ESCAPE/PICTURE - 26.3" X 26.7" - 62% TINT FROM: 05-03-04 THRU: 99-99-99
12*	113502-10-01A	EA	WINDOW - REAR/ESCAPE - THERMO W/TRIM - 26.1" X 26" - DUAL PANE FROM: 00-00-00 THRU: 04-11-04
12	150651-04-01A	EA	WINDOW - STATIONARY/FLUSH/ESCAPE/THERMO - 26.3"X 26.2"-BLK - DUAL PANE FROM: 04-12-04 THRU: 99-99-99
13*	122882-02-01A	EA	VENT - ROOF - W/FAN - W/O INSIDE GARNISH - UL
13*	122882-03-01A	EA	VENT - ROOF - W/FAN - W/O INSIDE GARNISH - CSA - CANADIAN
	009440-01-000	EA	GEAR/ARM - LIFT - ROOF VENT COVER
	048648-01-000	EA	MOTOR/ROOF VENT - W/RESISTER - 1/8"SHAFT - 12VOLT
	048649-01-000	EA	FAN BLADE - ROOF VENT - 6 BLADED - 6"RADIUS
13	122882-07-01A	EA	GARNISH - ROOF VENT - 2.5" TO 4.1"
14	122193-01-02A	EA	PANEL - SKYLITE - INNER - W/LIGHT INDENTATION
14	138372-01-02B	EA	TRIM - CORNER - SKYLIGHT - E-COATED
14	138379-02-01A	EA	PANEL/SKYLIGHT OTR - RECT/4"H CTR DOME-18.4" X 29.5 - WHT
15	149508-01-02A	EA	CAP - ROOF/REFRIGERATOR VENT - WHITE
15	149508-02-02A	EA	BASE - ROOF/REFRIGERATOR VENT - BRIGHT WHITE
16*	122882-01-01A	EA	VENT - ROOF - NONPOWERED - W/O INSIDE GARNISH
	009440-01-000	EA	GEAR/ARM - LIFT - ROOF VENT COVER
16	122882-07-01A	EA	GARNISH - ROOF VENT - 2.5" TO 4.1"
17*	123780-03-01A	EA	FANTASTIC VENT-3"/4"ROOF-W/FAN-W/O THERM/PWR LIFT/WHT CVR - POWER VENT
	009440-01-000	EA	GEAR/ARM - LIFT - ROOF VENT COVER
18	147821-01-01A	EA	VENT - EXHAUST/RANGE HOOD - BRIGHT WHITE
18	147821-02-01A	EA	SHROUD - EXHAUST VENT/RANGE HOOD - BRIGHT WHITE

\*COMPONENT PARTS LISTED LATER IN THIS GROUP

**WINDOW & VENTS GROUP (CONTINUED)**  
**COMPONENT PARTS FOR WINDOW & VENT LAYOUT**

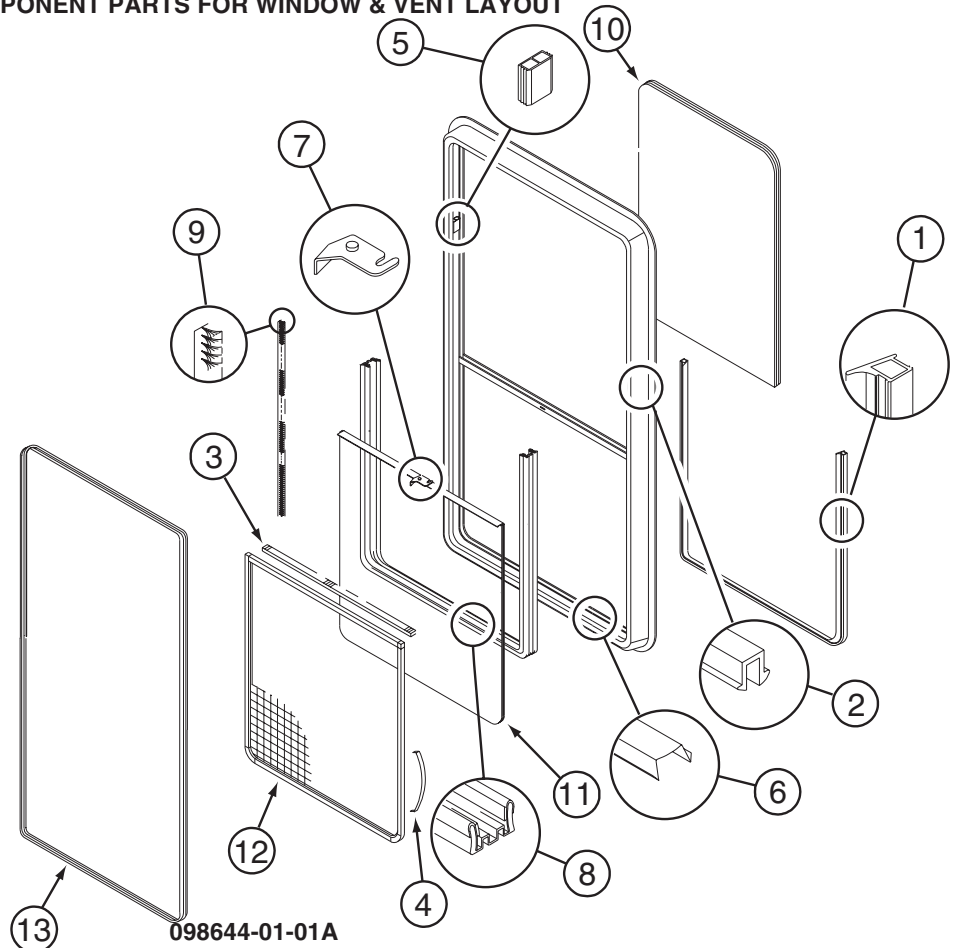

KEY	PART NUMBER	U/M	DESCRIPTION	VENDOR NO.
1	098644-01-716	FT	PLUG - FILLER	132-014470
2	098644-01-705	FT	GLAZING - STRIP	132-010231
3	098644-01-706	FT	WEATHERSTRIP - GLASS	171-010668
4	098644-01-713	EA	CLIP - SCREEN - METAL	226-016966
4	125582-01-701	EA	CLIP - SCREEN - PLASTIC	130-005153
5	098644-01-719	EA	STOP - SLIDER GLASS	132-014203
6	098644-01-710	FT	TRACK - SCREEN SPACER 12'	132-017135
7	098647-54-701	EA	LATCH - REPAIR KIT (RED)	B081-CK
8	098644-01-708	FT	CHANNEL - RUN PIERCED	122-016543
9	098644-01-711	FT	WEATHERSTRIP - SCREEN BLACK	171-016965
	098644-01-717	FT	SPLINE - SCREEN	132-004716
10	098644-01-704	EA	GLASS - STATIONARY 10"X13.7"	106-011866
11	098644-01-709	EA	GLASS - SLIDING W/SASH/LATCH	B963-G9
12	098644-01-712	EA	SCREEN ASM - W/SEALS & CLIPS	410-016476
13	098644-01-714	EA	RETAINER - TRIM	B963-67

**098644-13-01A**

KEY	PART NUMBER	U/M	DESCRIPTION	VENDOR NO.
1	098644-01-716	FT	PLUG - FILLER	132-014470
2	098644-01-705	FT	GLAZING - STRIP	132-010231
3	098644-01-706	FT	WEATHERSTRIP - GLASS	171-010668
4	098644-01-713	EA	CLIP - SCREEN - METAL	226-016966
4	125582-01-701	EA	CLIP - SCREEN - PLASTIC	130-005153
5	098644-01-719	EA	STOP - SLIDER GLASS	132-014203
6	098644-01-710	FT	TRACK - SCREEN SPACER 12'	132-017135
7	098647-54-701	EA	LATCH - REPAIR KIT (RED)	B081-CK
8	098644-01-708	FT	CHANNEL - RUN PIERCED	122-016543
9	098644-01-711	FT	WEATHERSTRIP - SCREEN BLACK	171-016965
10	098644-13-700	EA	GLASS - STATIONARY	106-028698
11	098644-13-701	EA	GLASS - SLIDING W/SASH/LATCH	H702-G9
12	098644-13-702	EA	SCREEN ASM - W/SEALS/CLIPS	410-028663
13	098644-13-703	EA	RETAINER - TRIM	H702-60
	098644-01-717	FT	SPLINE - SCREEN	132-004716

**WINDOW & VENTS GROUP (CONTINUED)**  
**COMPONENT PARTS FOR WINDOW & VENT LAYOUT (CONTINUED)**

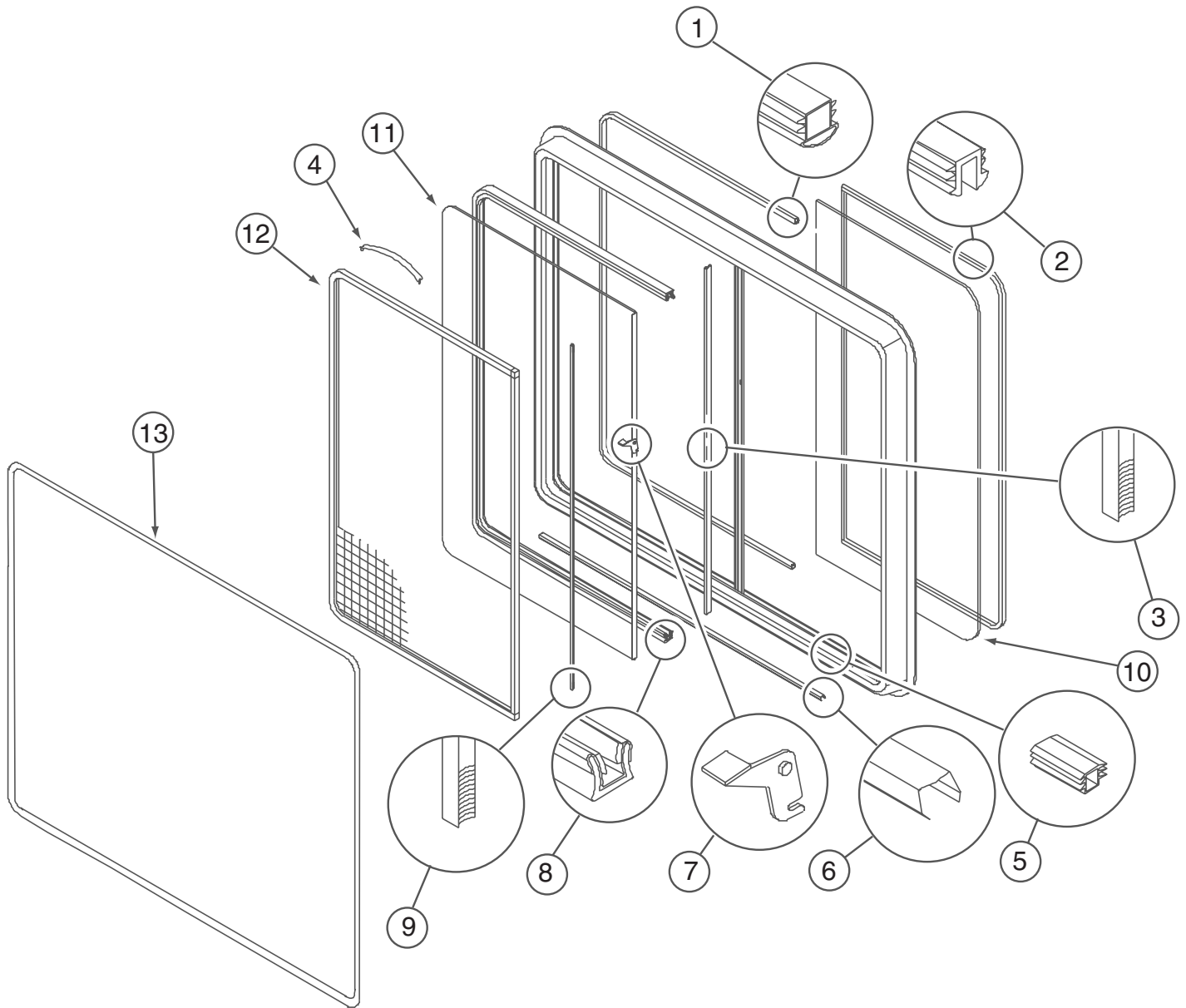

098647-30-02A

KEY	PART NUMBER	U/M	DESCRIPTION	VENDOR NO.
1	098644-01-716	FT	PLUG - FILLER	132-014470
2	098644-01-705	FT	GLAZING - STRIP	132-010231
3	098644-01-706	FT	WEATHERSTRIP - GLASS	171-010668
4	098644-01-713	EA	CLIP - SCREEN - METAL	226-016966
4	125582-01-701	EA	CLIP - SCREEN - PLASTIC	130-005153
5	098644-01-719	EA	STOP - SLIDER GLASS	132-014203
6	098644-01-710	FT	TRACK - SCREEN SPACER 12'	132-017135
7	098647-54-701	EA	LATCH - REPAIR KIT (RED)	B081-CK
8	098644-01-708	FT	CHANNEL - RUN PIERCED	122-016543
9	098644-01-711	FT	WEATHERSTRIP - SCREEN BLACK	171-016965
10	098647-29-702	EA	GLASS - STATIONARY	096-019295
11	098647-29-703	EA	GLASS-SLIDING W/SASH & LATCH	H172-C8
12	098647-29-704	EA	SCREEN ASM - W/SEALS & CLIPS	410-018864
13	098647-29-705	EA	RETAINER - TRIM	CH04-66
	098644-01-717	FT	SPLINE - SCREEN	132-004716

**WINDOW & VENTS GROUP (CONTINUED)**  
**COMPONENT PARTS FOR WINDOW & VENT LAYOUT (CONTINUED)**

**098647-31-02A**

<b>KEY</b>	<b>PART NUMBER</b>	<b>U/M</b>	<b>DESCRIPTION</b>	<b>VENDOR NO.</b>
1	098644-01-716	FT	PLUG - FILLER	132-014470
2	098644-01-705	FT	GLAZING - STRIP	132-010231
3	098644-01-706	FT	WEATHERSTRIP - GLASS	171-010668
4	098644-01-713	EA	CLIP - SCREEN - METAL	226-016966
4	125582-01-701	EA	CLIP - SCREEN - PLASTIC	130-005153
5	098644-01-719	EA	STOP - SLIDER GLASS	132-014203
6	098644-01-710	FT	TRACK - SCREEN SPACER 12'	132-017135
7	098647-54-701	EA	LATCH - REPAIR KIT (RED)	B081-CK
8	098644-01-708	FT	CHANNEL - RUN PIERCED	122-016543
9	098644-01-711	FT	WEATHERSTRIP - SCREEN BLACK	171-016965
10	098647-31-702	EA	GLASS - STATIONARY	096-019299
11	098647-31-703	EA	GLASS-SLIDING W/SASH & LATCH	H425-C8
12	098647-31-704	EA	SCREEN ASM - W/SEALS & CLIPS	410-019128
13	098647-31-705	EA	RETAINER - TRIM	CH29-66
	098644-01-717	FT	SPLINE - SCREEN	132-004716

**098647-32-02A**

<b>KEY</b>	<b>PART NUMBER</b>	<b>U/M</b>	<b>DESCRIPTION</b>	<b>VENDOR NO.</b>
1	098644-01-716	FT	PLUG - FILLER	132-014470
2	098644-01-705	FT	GLAZING - STRIP	132-010231
3	098644-01-706	FT	WEATHERSTRIP - GLASS	171-010668
4	098644-01-713	EA	CLIP - SCREEN - METAL	226-016966
4	125582-01-701	EA	CLIP - SCREEN - PLASTIC	130-0
5	098644-01-719	EA	STOP - SLIDER GLASS	132-014203
6	098644-01-710	FT	TRACK - SCREEN SPACER 12'	132-017135
7	098647-54-701	EA	LATCH - REPAIR KIT (RED)	B081-CK
8	098644-01-708	FT	CHANNEL - RUN PIERCED	122-016543
9	098644-01-711	FT	WEATHERSTRIP - SCREEN BLACK	171-016965
10	098647-31-702	EA	GLASS - STATIONARY	096-019299
11	098647-31-703	EA	GLASS-SLIDING W/SASH & LATCH	H425-C8
12	098647-31-704	EA	SCREEN ASM - W/SEALS & CLIPS	410-019128
13	098647-31-705	EA	RETAINER - TRIM	CH29-66
	098644-01-717	FT	SPLINE - SCREEN	132-004716

**098647-47-02A**

<b>KEY</b>	<b>PART NUMBER</b>	<b>U/M</b>	<b>DESCRIPTION</b>	<b>VENDOR NO.</b>
1	098644-01-716	FT	PLUG - FILLER	132-014470
2	098644-01-705	FT	GLAZING - STRIP	132-010231
3	098644-01-706	FT	WEATHERSTRIP - GLASS	171-010668
4	098644-01-713	EA	CLIP - SCREEN - METAL	226-016966
4	125582-01-701	EA	CLIP - SCREEN - PLASTIC	130-005153
5	098644-01-719	EA	STOP - SLIDER GLASS	132-014203
6	098644-01-710	FT	TRACK - SCREEN SPACER 12'	132-017135
7	098644-01-700	EA	LATCH - REPAIR KIT (BLACK)	B801-CK
7	098647-54-701	EA	LATCH - REPAIR KIT (RED)	B081-CK
8	098644-01-708	FT	CHANNEL - RUN PIERCED	122-016543
9	098644-01-711	FT	WEATHERSTRIP - SCREEN BLACK	171-016965
10	098647-47-700	EA	GLASS - STATIONARY	106-025224
11	098647-47-701	EA	GLASS-SLIDING W/SASH & LATCH	H493-G9
12	098647-47-702	EA	SCREEN ASM - W/SEALS & CLIPS	410-025226
13	098647-47-704	EA	RETAINER - TRIM	H493-66
	098644-01-717	FT	SPLINE - SCREEN	132-004716

**WINDOW & VENTS GROUP (CONTINUED)**  
**COMPONENT PARTS FOR WINDOW & VENT LAYOUT (CONTINUED)**

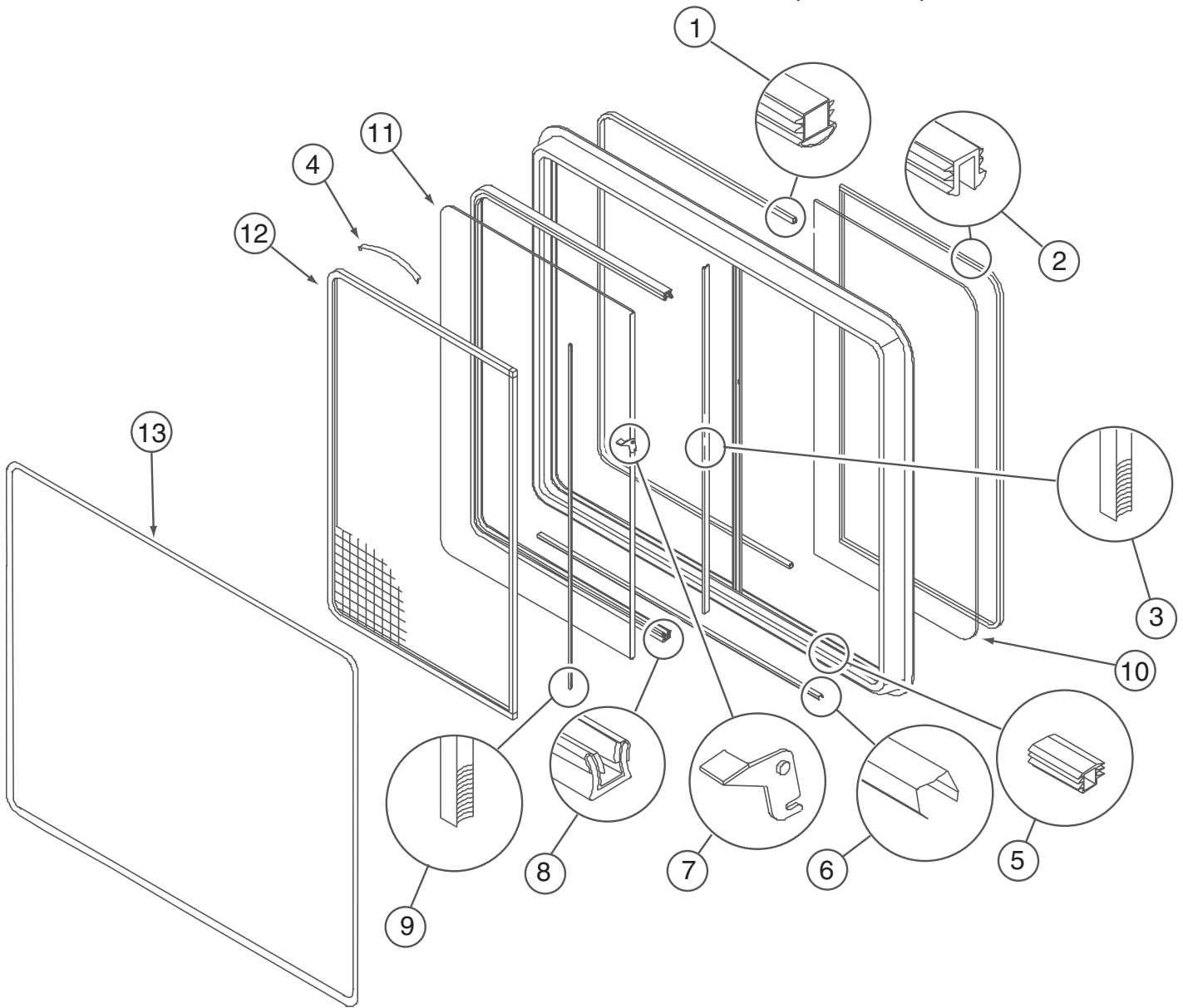

**098647-49-02A**

KEY	PART NUMBER	U/M	DESCRIPTION	VENDOR NO.
1	098644-01-716	FT	PLUG - FILLER	132-014470
2	098644-01-705	FT	GLAZING - STRIP	132-010231
3	098644-01-706	FT	WEATHERSTRIP - GLASS	171-010668
4	098644-01-713	EA	CLIP - SCREEN - METAL	226-016966
4	125582-01-701	EA	CLIP - SCREEN - PLASTIC	130-0
5	098644-01-719	EA	STOP - SLIDER GLASS	132-014203
6	098644-01-710	FT	TRACK - SCREEN SPACER 12'	132-017135
7	098647-54-701	EA	LATCH - REPAIR KIT (RED)	B081-CK
8	098644-01-708	FT	CHANNEL - RUN PIERCED	122-016543
9	098644-01-711	FT	WEATHERSTRIP - SCREEN BLACK	171-016965
10	098647-49-700	EA	GLASS - STATIONARY	096-012066
11	098647-49-701	EA	GLASS-SLIDING W/SASH & LATCH	B969-G8
12	112795-56-702	EA	SCREEN ASM - W/SEALS & CLIPS	410-019414
13	098647-49-702	EA	RETAINER - TRIM	H969-66
	098644-01-717	FT	SPLINE - SCREEN	132-004716

CONTACT WINNEBAGO PART SALES FOR UNLISTED COMPONENTS

**WINDOW & VENTS GROUP (CONTINUED)**  
**COMPONENT PARTS FOR WINDOW & VENT LAYOUT (CONTINUED)**

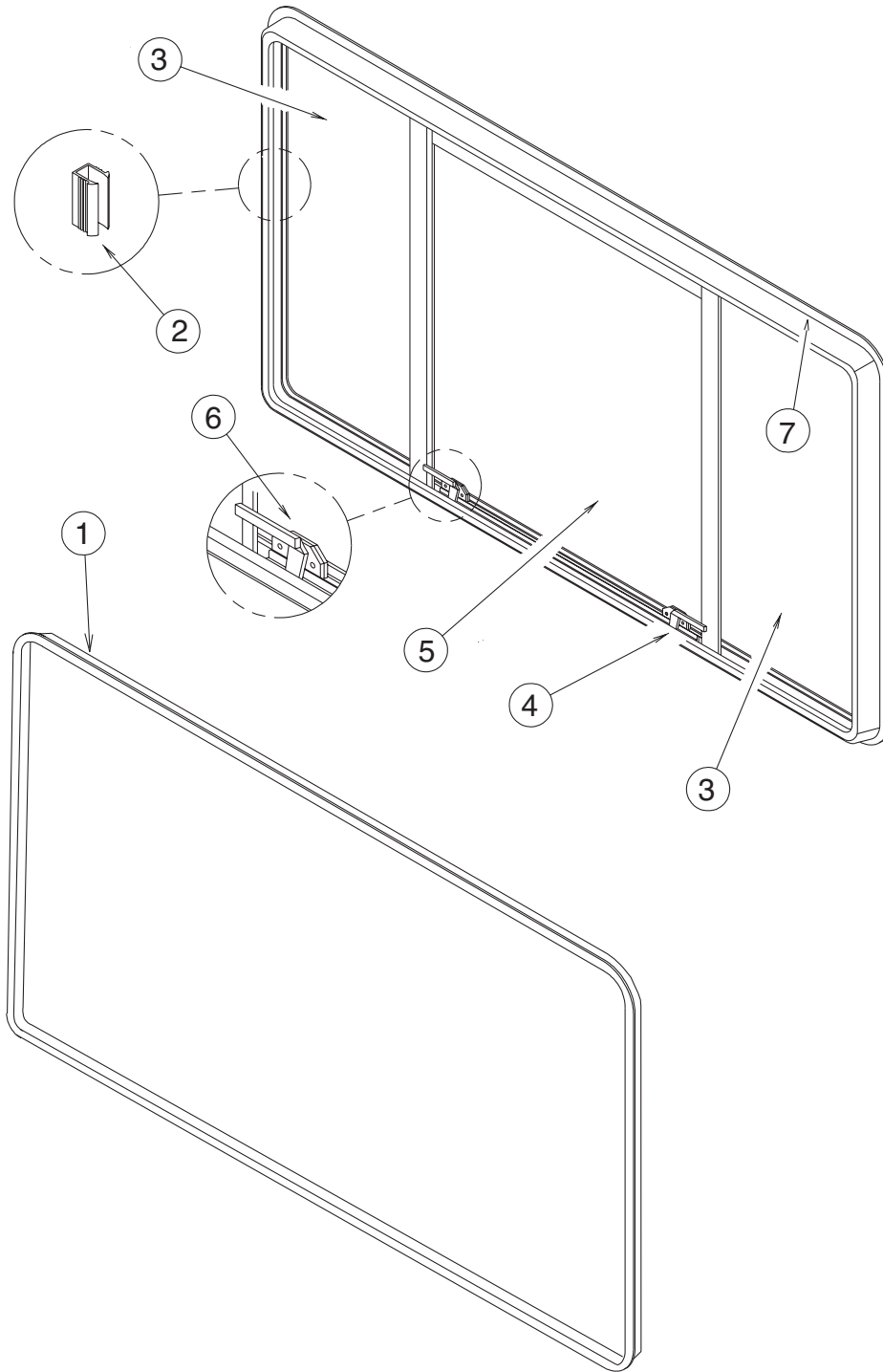

**113502-10-01A**

<b>KEY</b>	<b>PART NUMBER</b>	<b>U/M</b>	<b>DESCRIPTION</b>	<b>VENDOR NO.</b>
1	113502-04-703	EA	RETAINER - TRIM	H449-58
2	112795-24-706	FT	SEAL - SPLINE/GRAY - ESCAPE	132-010481
3	113502-10-700	EA	GLASS - STATIONARY	390-028328
4	112898-06-707	EA	HANDLE-LATCH/RED-RH (SLIDER)	182-025911
6	112898-06-708	EA	HANDLE-LATCH/RED-LH (SLIDER)	182-025912
7	098644-01-705	FT	GLAZING - STRIP	132-010231

CONTACT WINNEBAGO PART SALES FOR UNLISTED COMPONENTS



**WINDOW & VENTS GROUP (CONTINUED)**  
**COMPONENT PARTS FOR WINDOW & VENT LAYOUT (CONTINUED)**

**116976-02-02A**

<b>KEY</b>	<b>PART NUMBER</b>	<b>U/M</b>	<b>DESCRIPTION</b>	<b>VENDOR NO.</b>
	098644-01-705	FT	GLAZING - STRIP	132-010231
	100322-01-701	FT	SEAL-VENT	122-016071
	112898-06-707	EA	HANDLE-LATCH/RED-RH (SLIDER)	182-025911
	112898-06-708	EA	HANDLE-LATCH/RED-LH (SLIDER)	182-025912
	116976-01-702	FT	FILLER PLUG	132-016065
	116976-02-700	EA	GLASS - STATIONARY	106-018785
	116976-02-701	EA	RETAINER - TRIM	H386-53

**122882-01-01A**

<b>KEY</b>	<b>PART NUMBER</b>	<b>U/M</b>	<b>DESCRIPTION</b>	<b>VENDOR NO.</b>
	009440-01-000	EA	GEAR-ARM-ROOF VENT	705221K38
	064470-01-700	EA	COVER - VENT	J7291
	064470-01-701	EA	SLIDE BAR - VENT LID	JRP1291B
	122882-01-700	EA	HANDLE - CRANK - BLACK	90128
	122882-01-701	EA	SCREEN	JRP-1124-B
	122882-01-702	EA	HANDLE - CRANK - WHITE	JRP1031B

**122882-02-01A, 122882-03-01A**

<b>KEY</b>	<b>PART NUMBER</b>	<b>U/M</b>	<b>DESCRIPTION</b>	<b>VENDOR NO.</b>
	064470-01-700	EA	COVER - VENT	J7291
	064470-01-701	EA	SLIDE BAR - VENT LID	JRP1291B
	110051-03-700	EA	SWITCH-BLACK/PUSH BUTTON	27-0164
	122882-01-700	EA	HANDLE - CRANK - BLACK	90128
	122882-01-701	EA	SCREEN	JRP-1124-B
	122882-01-702	EA	HANDLE - CRANK - WHITE	JRP1031B

**WINDOW & VENTS GROUP (CONTINUED)**  
**COMPONENT PARTS FOR WINDOW & VENT LAYOUT (CONTINUED)**

122882-02-01A, 122882-03-01A

KEY	PART NUMBER	U/M	DESCRIPTION	VENDOR NO.
	064470-01-700	EA	COVER - VENT	J7291
	064470-01-701	EA	SLIDE BAR - VENT LID	JRP1291B
	110051-03-700	EA	SWITCH-BLACK/PUSH BUTTON	27-0164
	122882-01-700	EA	HANDLE - CRANK - BLACK	90128
	122882-01-701	EA	SCREEN	JRP-1124-B
	122882-01-702	EA	HANDLE - CRANK - WHITE	JRP1031B

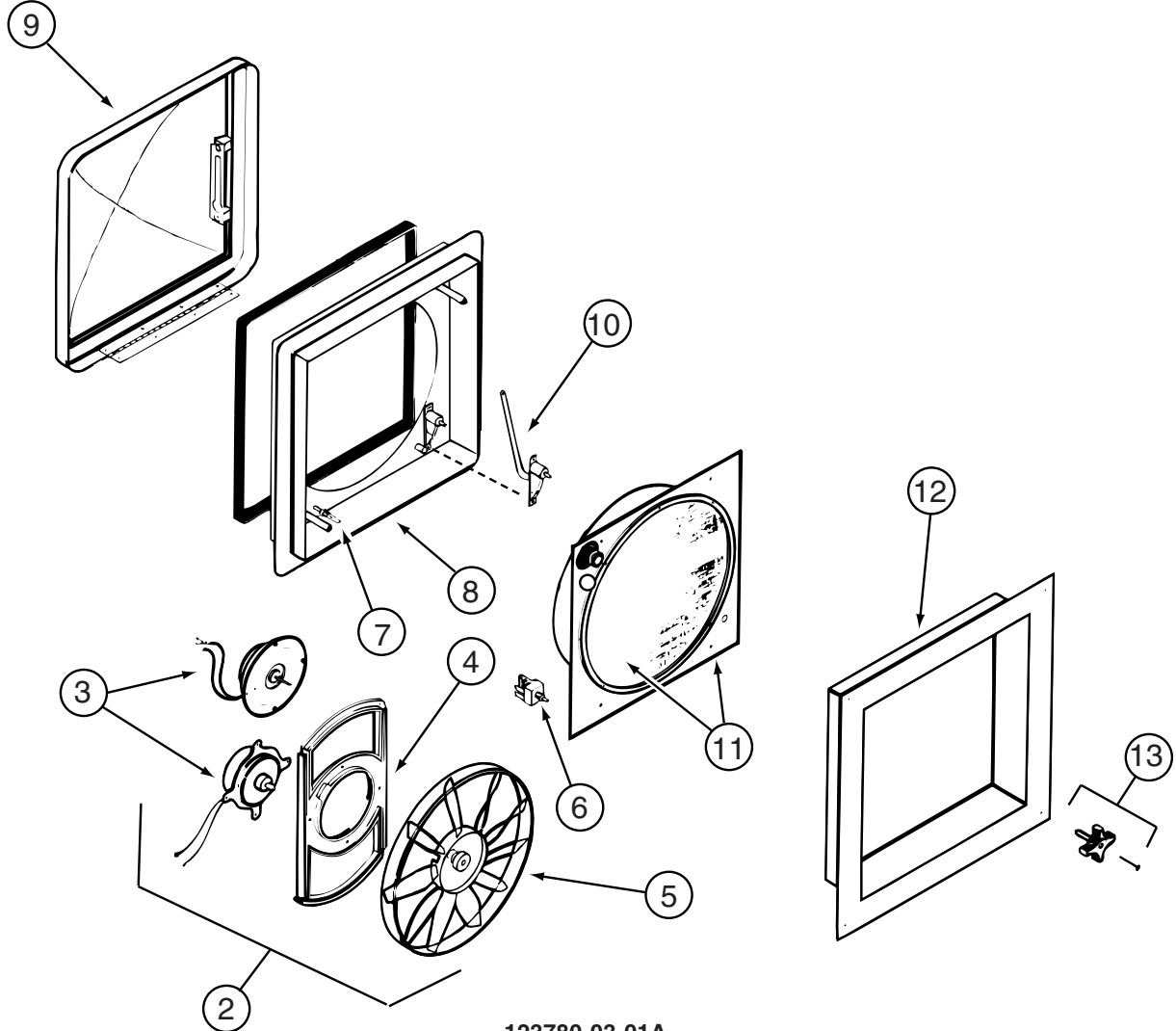

123780-03-01A

KEY	PART NUMBER	U/M	DESCRIPTION	VENDOR NO.
2	084079-11-700	EA	MOTOR & FAN BLADE W/BRACKET	K4017-09
3	084079-01-705	EA	MOTOR/EXT BRKT/FAN BLADE KIT	1080-00
4	084079-01-711	EA	MOTOR MOUNT (BOWTIE)	1015-00
5	084079-01-704	EA	BLADE-FAN	1138-00
6	084079-01-709	EA	SWITCH - MAIN - 3 SPEED	1031-05
7	084079-01-707	EA	SWITCH - SAFETY	1122-05
8	123780-05-700	EA	BASE/MAIN-BRT WHT W/GASKET	1010-81
9	123780-01-700	EA	COVER - VENT W/HINGE & SLIDE	1020K-81
11	123780-03-701	EA	SCREEN ASM 78-100MM W/SWITCH	1030BT-81
12	123780-03-700	EA	GARNISH - INT. 3"-4" BRT/WHT	2040-81
13	084079-01-703	EA	KNOB-LIFT	1140K-00
	084079-01-706	EA	PLUG, 12 VOLT	1090
	123780-01-702	EA	SCREEN INSERT (SCREEN RING)	K1035-81

CONTACT WINNEBAGO PART SALES FOR UNLISTED COMPONENT(S)

**WINDOW & VENTS GROUP (CONTINUED)**  
**COMPONENT PARTS FOR WINDOW & VENT LAYOUT (CONTINUED)**

<b>150648-04-01A</b>			
<b>KEY</b>	<b>PART NUMBER</b>	<b>U/M DESCRIPTION</b>	<b>VENDOR NO</b>
	151069-01-700	EA CHANNEL-RUN, SLIDING	122-030627
<b>150648-05-01A</b>			
<b>KEY</b>	<b>PART NUMBER</b>	<b>U/M DESCRIPTION</b>	<b>VENDOR NO</b>
	150648-05-7	EA SCREEN ASM	410-031158
	151069-01-700	EA CHANNEL-RUN, SLIDING	122-030627
<b>150648-07-01A</b>			
<b>KEY</b>	<b>PART NUMBER</b>	<b>U/M DESCRIPTION</b>	<b>VENDOR NO</b>
	112795-01-705	FT VINYL - GLAZING	132-027331
	150648-01-700	EA LATCH-HORIZONTAL SLIDE-BLK	FH3000-CK
	150648-01-702	EA SCREEN ASM	410-031156
	151069-01-700	FT CHANNEL-RUN, SLIDING	122-030627
<b>150648-08-01A</b>			
<b>KEY</b>	<b>PART NUMBER</b>	<b>U/M DESCRIPTION</b>	<b>VENDOR NO</b>
	151069-01-700	FT CHANNEL-RUN, SLIDING	122-030627
<b>150649-01-01A</b>			
<b>KEY</b>	<b>PART NUMBER</b>	<b>U/M DESCRIPTION</b>	<b>VENDOR NO</b>
	150649-01-700	EA LATCH-VERTICLE SLIDE-BLK	FH3016-CK
	150649-01-702	EA SCREEN ASM	410-035464
<b>150649-07-01A</b>			
<b>KEY</b>	<b>PART NUMBER</b>	<b>U/M DESCRIPTION</b>	<b>VENDOR NO</b>
	112898-04-703	EA VERTICAL LATCH/HOLD UP/OPEN	DH343-CK
	150649-01-700	EA LATCH-VERTICLE SLIDE-BLK	FH3016-CK
	150649-07-700	EA GLASS - STATIONARY	390-028662
	150649-07-701	EA SCREEN ASM	410-035475
<b>150649-14-01A</b>			
<b>KEY</b>	<b>PART NUMBER</b>	<b>U/M DESCRIPTION</b>	<b>VENDOR NO</b>
	15064901700	EA LATCH-VERTICLE SLIDE-BLK	FH3016-CK
<b>150649-15-01A</b>			
<b>KEY</b>	<b>PART NUMBER</b>	<b>U/M DESCRIPTION</b>	<b>VENDOR NO</b>
	150649-01-700	EA LATCH-VERTICLE SLIDE-BLK	FH3016-CK
	150649-15-700	EA SCREEN ASM	410-035769
<b>150651-01-01A</b>			
<b>KEY</b>	<b>PART NUMBER</b>	<b>U/M DESCRIPTION</b>	<b>VENDOR NO</b>
	112795-01-705	FT VINYL - GLAZING	132-027331
<b>150652-01-01A</b>			
<b>KEY</b>	<b>PART NUMBER</b>	<b>U/M DESCRIPTION</b>	<b>VENDOR NO</b>
	115630-01-705	EA TAPE - BUTYL	154-011956
	150652-01-700	EA VINYL GLAZING - 1 PER GLASS	DG438-12 MITER/WELD
<b>151075-02-01A</b>			
<b>KEY</b>	<b>PART NUMBER</b>	<b>U/M DESCRIPTION</b>	<b>VENDOR NO</b>
	137867-05-706	EA LOCK/CAM - RIGHT	182-011293
	137867-05-707	EA LOCK/CAM - LEFT	182-011294