

**2004
MERIDIAN
IKP39K
P-SERIES**

PORTSMOUTH OAK

R74 - PROVENCE BLUE - BLUE

R77 - GREENWICH - GREEN

R80 - STONEHENGE - TAUPE

CONCERT CHERRY

R75 - PROVENCE BLUE - BLUE

R78 - GREENWICH - GREEN

R81 - STONEHENGE - TAUPE

WASHED MAPLE

R76 - PROVENCE BLUE - BLUE

R79 - GREENWICH - GREEN

R82 - STONEHENGE - TAUPE

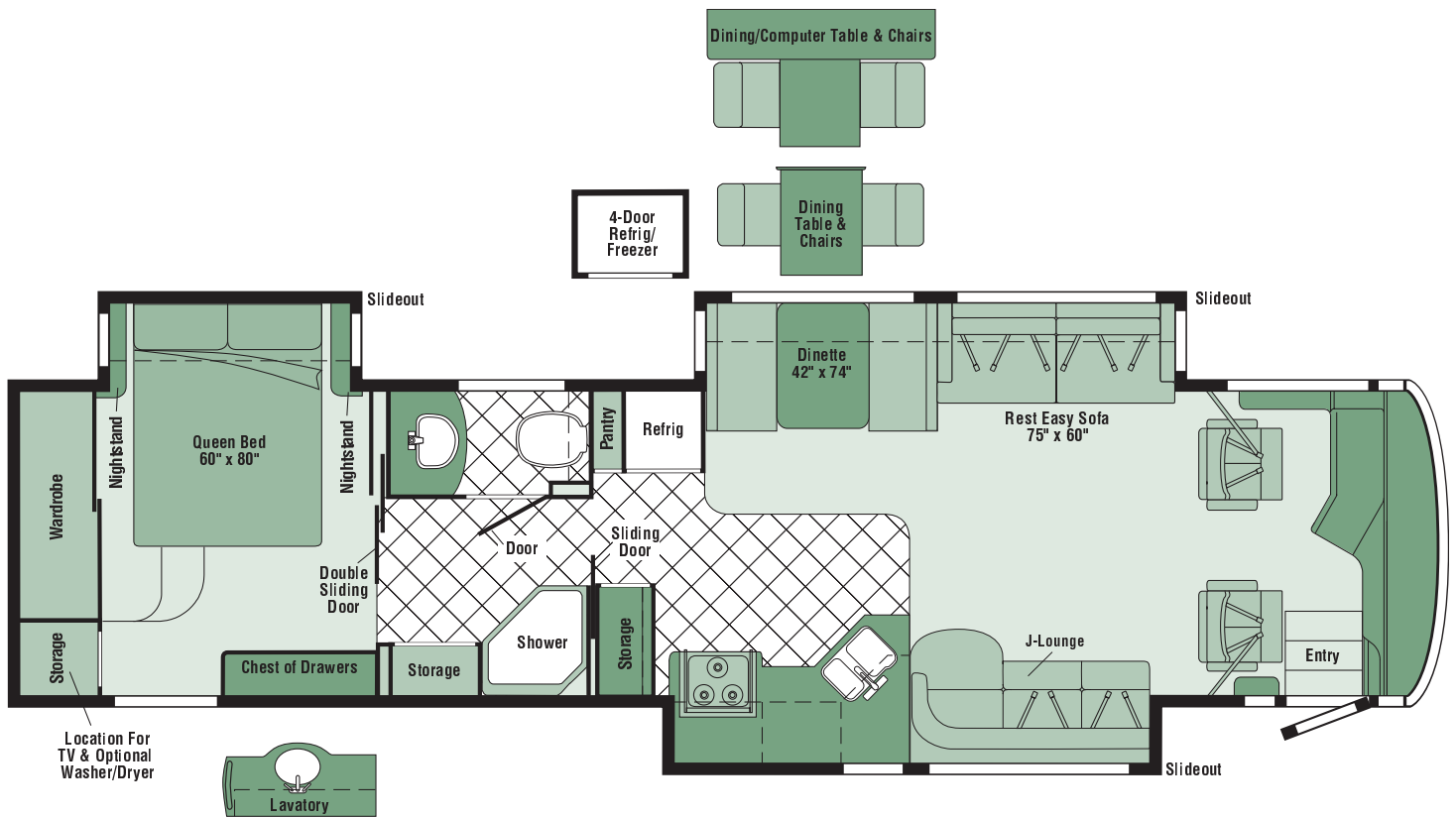

FLOORPLAN

CONTENTS

FLOORPLAN	1
ACCESSORIES GROUP	7
OPERATORS MANUAL	7
APPLIANCE GROUP	8
APPLIANCES	8
COMPONENT PARTS FOR APPLIANCE	16
115504-01-000	16
119267-10-01A	16
119267-12-01A	16
119267-13-01A	16
121569-05-01A, 121569-06-01A & 121569-07-01A	16
120075-12-01A, 120075-13-01A, 120075-14-01A, 120075-15-01A	22
125242-02-01A	29
126022-01-01A, 126022-02-01A, 126022-03-01A	39
133004-02-01A	39
135065-01-01A, 135065-01-02A, 135065-02-01A	40
135065-03-01A, 135065-03-03A, 135065-04-01A	42
135066-02-01A	44
135066-03-01A, 135066-03-04A, 150778-01-01A	48
AUDIO VIDEO GROUP	53
RADIO SYSTEM	53
COMPONENT PARTS FOR RADIO SYSTEM	55
102080-17-000	55
102080-18-000	55
102080-21-000	55
143509-01-000	55
148231-01-000	55
REAR VIEW MONITOR	56
TELEPHONE	57
TV & VCR	57
COMPONENT PARTS FOR TV & VCR	58
076319-23-000	58
076319-25-000	58
126696-07-000	59
137135-02-000	60
141454-01-01A	61
141454-03-01A	62
144377-01-000	63
146299-01-000	63
146396-01-000	63
146396-02-000 & 146396-03-000	63
EXTERIOR ENTERTAINMENT	64
BATH GROUP	65
CABINETS	65
SHOWER	68
COMPONENT PARTS FOR SHOWER DOOR	69
139047-01-01A/02A, 139047-02-01A/02A, 139049-03-01A/02A/03A, 139047-04-02A/03A, 139047-05-01A	69
BEDROOM GROUP	70
QUEEN CABINETS	70
QUEEN DOORS & DRAWERS	72

CONTENTS (CONTINUED)

CHASSIS GROUP	75
FRAME	75
FRONT END	77
AIR INTAKE	79
INSULATION	80
STEPWELL COVER	86
COMPONENT PARTS FOR STEPWELL COVER	87
141691-01-01A	87
EXHAUST	88
HITCH	88
REAR BUMPER	89
FUEL	92
HYDRAULIC LEVELING	93
COMPONENT PARTS FOR HYDRAULIC LEVELING	94
144226-12-000	94
144226-13-000	94
144226-25-000	94
WHEEL, TIRE, COVERS &/OR LINERS	95
COMPONENT PARTS FOR WHEEL, TIRE, COVERS &/OR LINERS	96
110435-22-000	96
145580-05-000	96
CURTAIN & CUSHION GROUP	97
NOTICE	97
CUSHION LAYOUT	98
BUCKET SEATS	100
COMPONENT PARTS FOR BUCKET SEATS	105
081373-03-000	105
122611-02-000	105
SOFA	106
COMPONENT PARTS FOR SOFA	110
136534-07-000, 136534-17-000	110
136534-13-000, 136534-15-000, 136534-28-000, 136534-29-000	110
148226-01-000, 148226-02-000, 148226-03-000	110
WINDOW TREATMENT	111
HARDWARE	113
ACCESSORIES	115
COMPONENT PARTS FOR ACCESSORIES	116
091990-08-01A	116
FABRICS	117
DINETTE GROUP	120
CABINETS	120
TABLE	122
DRIVERS COMPARTMENT GROUP	126
DASH	126
FRONT INTERIOR	127
CABINETS	132

CONTENTS (CONTINUED)

ELECTRICAL GROUP	134
12V BODY WIRING	134
FRONT END WIRING	141
COMPONENT PARTS FOR LIGHTS & SWITCHES	145
086280-01-000	145
091206-04-000	145
091937-08-000	145
093575-19-01A	145
102756-02-000	145
108354-01-01A	145
121935-01-01A	145
123775-01-01A	145
133054-03-000	145
133054-04-000	145
136119-01-000	145
137417-01-01A, 137417-03-01A	146
137417-06-01A	146
148158-01-000	146
CIRCUIT BREAKERS & FUSES	147
CONVERTER, INVERTER, LOAD CENTERS	148
110V WIRING	149
ENTERTAINMENT WIRING	152
BOXES & CORDS	153
WIRE ASSEMBLIES	153
CONNECTORS & CONDUIT	154
BOOTS, SOLENOIDS, RELAYS & MISCELLANEOUS	155
COMPONENT PARTS FOR BOOTS, SOLENOIDS, RELAYS & MISCELLANEOUS	156
113832-02-01A	156
113832-03-01A	156
EXTERIOR BODY GROUP	157
AIR HORN	157
COMPONENT PARTS FOR AIR HORN	158
077497-06-000	158
GRAPHICS & PAINT	159
PANELS & TRIMS	161
FRONT END	165
LADDER	168
MIRRORS	168
COMPONENT PARTS FOR MIRRORS	169
106015-20-01A, 106015-21-01A	169
131431-07-01A, 131431-08-01A	169
STRUCTURAL COMPONENTS	170
AWNINGS	170
EXTERIOR DOORS & COMPARTMENTS GROUP	172
DOOR & COMPARTMENT LAYOUT	172
DOOR & COMPARTMENT LAYOUT COMPONENTS	179
084103-08-000	179
094708-03-01A	179
142226-02-01A	179
COMPARTMENT DOOR PIECE PARTS	180
ENTRY	182
COMPONENT PARTS FOR ENTRY	183
128913-10-01A	183
128913-12-01A	186

CONTENTS (CONTINUED)

EXTERIOR SLIDEOUT GROUP	191
FRONT LEFT	191
COMPONENT PARTS FOR FRONT SLIDEOUT	197
100536-52-000	197
143625-01-000	197
143625-02-000	197
143625-03-000	197
RIGHT FRONT	198
COMPONENT PARTS FOR RIGHT FRONT	203
100536-42-000	203
143071-01-000	203
143071-02-000	203
LEFT REAR	204
COMPONENT PARTS FOR LEFT REAR SLIDEOUT	209
137390-01-000	209
GALLEY GROUP	210
CABINETS	210
DOORS & DRAWERS	214
GENERATOR GROUP	216
LP	216
DIESEL	217
HEATING & A/C GROUP	218
AUTOMOTIVE	218
COMPONENT PARTS FOR AUTOMOTIVE	220
072342-15-000	220
072342-16-000	220
072342-17-000	220
072342-18-000	221
103930-36-000	222
103930-41-000	223
103930-51-000	223
103930-55-000	223
FURNACE	224
COMPONENT PARTS FOR FURNACE	225
143563-02-000	225
CENTRAL	227
COMPONENT PARTS FOR CENTRAL	230
105620-12-000	230
105620-15-000	231
105620-16-000	232
INTERIOR FINISH GROUP	234
MOLDINGS & TRIMS	234
PANELING & LAMINATES	245
ACCESSORIES	247
COMPONENT PARTS FOR ACCESSORIES	249
094499-02-000	249
FLOOR COVERINGS	250
HARDWARE	251
LABELS GROUP	259
LP GROUP	288
LP SYSTEM	288
LP COMPONENTS	289
144116-02-000, 144116-06-000, 144116-07-000 & 144116-08-000	289
144116-03-000	289

CONTENTS (CONTINUED)

LOUNGE GROUP	290
CABINETS	290
SEALANTS & FASTENERS GROUP	291
SEALANTS & ADHESIVES	291
BOLTS, NUTS AND WASHERS	292
SCREWS	294
CLAMPS, CLIPS, GROMMETS, RIVETS & PLUGS	297
MISCELLANEOUS FASTENERS	299
WATER & SEWAGE GROUP	300
DRAINAGE SYSTEM	300
COMPONENTS PARTS FOR DRAINAGE	302
132389-01-01A	302
WATER SYSTEM	303
COMPONENT PARTS FOR WATER SYSTEM	313
075241-04-000, 075241-05-000, 075241-06-000	313
098607-01-000	313
123744-03-01A	313
125420-01-02A, 125420-01-03A, 125420-03-03A, 125420-04-03A	313
129390-03-01A	313
141490-01-01A, 141490-01-02A	313
144215-01-000	313
144596-01-01A	314
144596-02-01A, 144596-03-01A	314
145541-01-000	314
WINDOW & VENTS GROUP	315
WINDOW & VENT LAYOUT	315
COMPONENT PARTS FOR WINDOWS & VENT LAYOUT	316
106466-14-01A	316
112795-73-01A	317
112795-77-01A	318
112795-80-01A	318
112795-81-01A	318
112795-86-01A	319
112898-27-01A	320
123780-09-01A	321
123780-10-01A	322
129929-13-01A	323
134004-03-01A	324
WINDSHIELD & WIPER GROUP	325
WINDSHIELD	325
WIPER	326
COMPONENT PARTS FOR WIPER	327
095964-01-000	327
096505-09-000	327
117769-01-000	327

ACCESSORIES GROUP
OPERATORS MANUAL

KEY	PART NUMBER	U/M	DESCRIPTION
	129079-04-01A	EA	CASE - VINYL/BLK-EXPANDABLE ACCORDION SIDES-11"WX9"HX14"L
	132000-08-004	EA	MANUAL/OWNER - MERIDIAN - 2004
	143975-01-000	DW	TOP LEVEL-P,2004

APPLIANCE GROUP APPLIANCES

KEY	PART NUMBER	U/M	DESCRIPTION
*	135066-03-01A	EA	RANGE - 3 BURNER W/OVEN - 22" - W/BLACK GLASS DOOR - RANGE W/OVEN U.S.
*	135066-02-01A	EA	RANGE - 3 BURNER W/OVEN - SEALED BURNERS - 22" - CSA - RANGE W/OVEN CANADIAN FROM: 00-00-00 THRU: 02-22-04
	150778-01-01A	EA	RANGE - 3 BURNER (SEALED) - W/OVEN - BLACK - CSA - RANGE W/OVEN CANADIAN FROM: 02-23-04 THRU: 99-99-99
*	135065-03-01A	EA	RANGE - 3 SEALED BURNERS/NEW STYLE KNOBS-GRATES - BLACK - RANGE TOP U.S.
*	135065-02-01A	EA	RANGE - 3 BURNER W/O OVEN - SEALED BURNERS - CSA - RANGE TOP CANADIAN FROM: 00-00-00 THRU: 01-18-04
*	135065-04-01A	EA	RANGE - 3 BURNER (SEALED) - W/O OVEN - CSA - BLACK TOP - RANGE TOP CANADIAN FROM: 01-19-04 THRU: 99-99-99
	136382-01-04B	EA	BRACKET - TIEDOWN/OVEN - BLACK - FRONT - RANGE W/OVEN - P34H/P39W
	136382-02-04B	EA	BRACKET - TIEDOWN/OVEN - BLACK - BACK - RANGE W/OVEN - P34H/P39W
	136382-05-04B	EA	BRACKET - TIEDOWN/OVEN - BLACK - FRONT - RANGE W/OVEN - P36G
	136382-06-04B	EA	BRACKET - TIEDOWN/OVEN - BLACK - BACK - RANGE W/OVEN - P36G
	136382-08-04B	EA	BRACKET - TIEDOWN - OVEN - BLACK - RANGE W/OVEN - P32T
	136382-13-04B	EA	BRACKET - STOVE TIEDOWN - BLACK - RANGE W/OVEN - P39K
	136382-14-04B	EA	BRACKET - STOVE TIEDOWN - BLACK - RANGE W/OVEN - P39K
	118871-05-01A	EA	TRAY - REFRIGERATOR - SIDE/SIDE - BLACK - 35.5" LONG
	137915-01-04B	EA	BRACKET - TIEDOWN - BLACK - RANGE W/OVEN - P32T
	106936-21-04B	EA	BRACKET - STOVE TIEDOWN/FRONT - BLACK - RANGE TOP - P34H/P36W
	106936-22-04B	EA	BRACKET - STOVE TIEDOWN/REAR - BLACK - RANGE TOP - P34H/P36W
	106936-35-04B	EA	BRACKET - STOVE TIEDOWN/FRONT - BLACK - RANGE TOP - P36G
	106936-36-04B	EA	BRACKET - STOVE TIEDOWN/REAR - BLACK - RANGE TOP - P36G
	106936-43-04B	EA	BRACKET - STOVE TIEDOWN - BLACK - RANGE TOP - P39K
	106936-44-04B	EA	BRACKET - STOVE TIEDOWN - BLACK - RANGE TOP - P39K
	139031-01-04B	EA	BRACKET - TIEDOWN - STOVE - BLACK - RANGE TOP - P32T
	137915-02-04B	EA	BRACKET - TIEDOWN - BLACK - RANGE TOP - P32T
*	126022-01-01A	EA	COVER - RANGE/BI-FOLD - 16" & 22" - BLACK TEXTURED
	130816-01-04A	EA	COUNTERTOP/STOVE LID - 1/4" VENDURA - QUARRY
	130816-02-04A	EA	COUNTERTOP/STOVE LID - 1/4" VENDURA - QUARRY
	130816-03-04A	EA	COUNTERTOP/STOVE LID - 1/4" VENDURA - QUARRY - P32T
	138584-02-01A	EA	COFFEEMAKER/COUNTERTOP - AROME PLUS/BLACK - KRUPS 466-42
	145832-01-000	EA	STRAP - TIEDOWN
*	115504-01-000	EA	PANEL - SOLAR 10 WATT - 12.2"W X 26.9"L X 1.2"H
*	133004-02-01A	EA	PANEL - MONITOR - 2 TANK DIGITAL VOLT METER - SOLAR
	133068-01-000	EA	HAIR DRYER - 3 SPEED W/NIGHT LIGHT - WALL MOUNT
	144676-01-000	EA	VACUUM CLEANER - RECHARGEABLE - EUREKA 77A
	143981-01-000	EA	FLASHLIGHT - RECHARGEABLE
	130818-02-01A	EA	TRASH CONTAINER - 20 QUART ALMOND

*COMPONENT PARTS LISTED LATER IN THIS GROUP

APPLIANCE GROUP (CONTINUED)
APPLIANCES (CONTINUED)

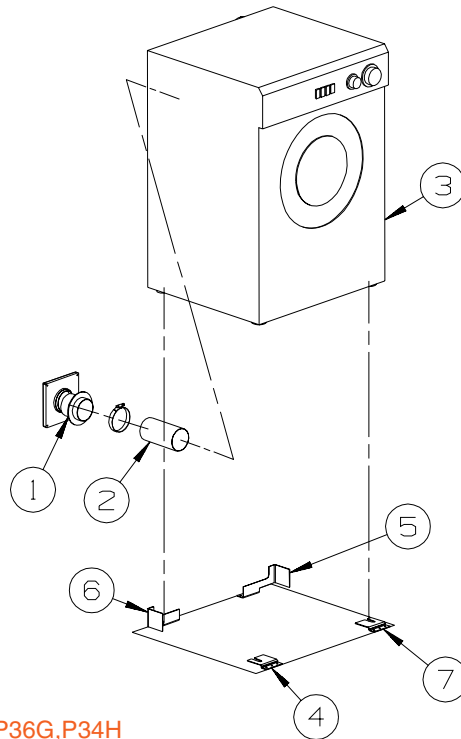

KEY	PART NUMBER	U/M	DESCRIPTION
1	111947-02-01A	EA	VENT - DRYER - 3" - P39W
1	111947-02-01A	EA	VENT - DRYER - 3" - P39K, P36G,P34H
			FROM: 00-00-00 THRU: 01-18-04
1	146292-01-01A	EA	COVER - DRYER VENT - BRIGHT WHITE - P39K, P36G,P34H
			FROM: 01-19-04 THRU: 99-99-99
1	146292-02-01A	EA	DRYER VENT - INNER - BRIGHT WHITE - P39K, P36G,P34H
			FROM: 01-19-04 THRU: 99-99-99
2	116653-02-000	FT	DUCT - FLEXIBLE - 3' COMPRESSED/8' EXTENDED
3	107753-04-01A	EA	WASHER - DRYER - VENTED - UL/CSA - WHITE
4	111913-02-04B	EA	BRACKET/WASHER - TIE DOWN - BLACK
5	113795-01-02B	EA	BRACKET - WASHER - E-COATED
6	113795-02-02B	EA	BRACKET - WASHER - E-COATED
7	111913-03-04B	EA	BRACKET/WASHER - TIE DOWN - BLACK

APPLIANCE GROUP (CONTINUED)
APPLIANCES (CONTINUED)

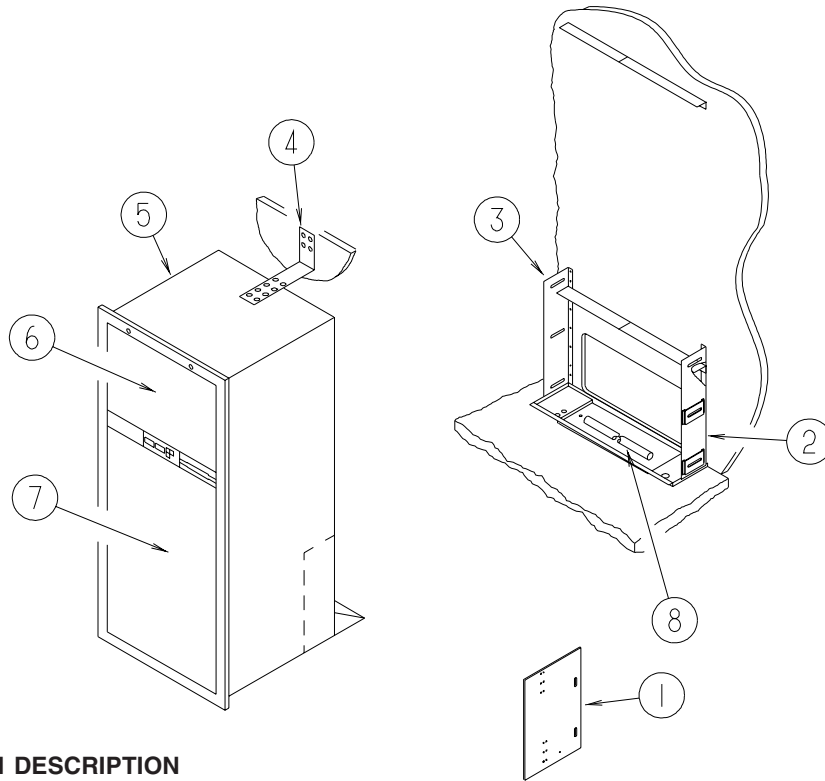

KEY	PART NUMBER	U/M	DESCRIPTION
1	141975-04-02B	EA	PLATE - TIEDOWN/REFRIGERATOR
2	141550-01-02B	EA	BRACKET - TIEDOWN/REFRIGERATOR - RIGHT HAND
3	141550-02-02B	EA	BRACKET - TIEDOWN/REFRIGERATOR - LEFT HAND
4	145445-02-02B	EA	STRAP - REFRIGERATOR
5*	121569-05-01A	EA	REFRIGERATOR - LARGE DOUBLE DOOR/RH - 2-WAY - BLACK
5*	120075-13-01A	EA	REFRIGERATOR-LARGE DOUBLE DOOR/RH - 2-WAY -ICE MAKER-BLACK - W/ICE MAKER
6	P34457-03-N47	EA	PANEL - INSERT RAISED MEMBRANE - 21.5" X 14.5" - PORTSMOUTH OAK
6	P34457-03-L85	EA	PANEL - INSERT RAISED MEMBRANE - 21.5" X 14.5" - CONCERT CHERRY
6	P34457-03-L94	EA	PANEL - INSERT RAISED MEMBRANE - 21.5" X 14.5" - WASHED MAPLE
7	P34457-04-N47	EA	PANEL - INSERT RAISED MEMBRANE - 21.5" X 38.5" - PORTSMOUTH OAK
7	P34457-04-L85	EA	PANEL - INSERT RAISED MEMBRANE - 21.5" X 38.5" - CONCERT CHERRY
7	P34457-04-L94	EA	PANEL - INSERT RAISED MEMBRANE - 21.5" X 38.5" - WASHED MAPLE
8	112176-01-000	FT	TUBING - VINYL - REINFORCED - 1/2" ID
	116751-02-01A	EA	TRAY - REFRIGERATOR - BLACK
	090329-01-000	FT	SEAL/T - REFRIGERATOR CABINET
	054450-01-000	EA	LEVEL - REFRIGERATOR

***COMPONENT PARTS LISTED LATER IN THIS GROUP**

APPLIANCE GROUP (CONTINUED)
APPLIANCES (CONTINUED)

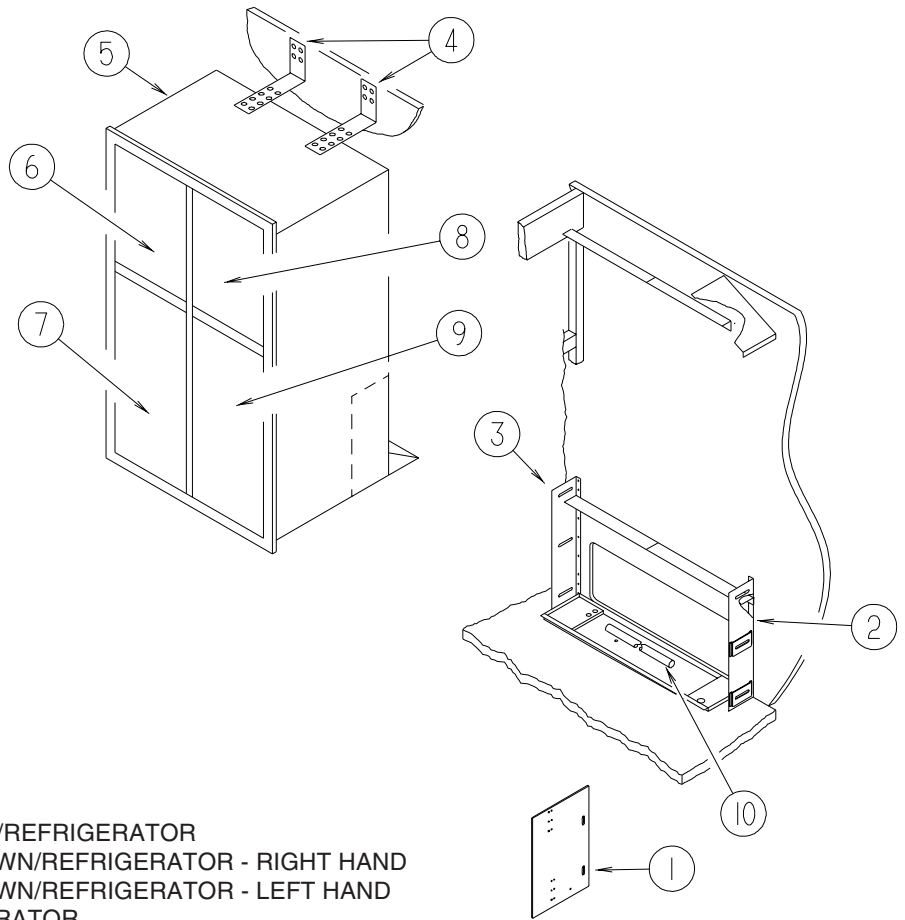

KEY	PART NUMBER	U/M	DESCRIPTION
1	141975-01-02B	EA	PLATE - TIEDOWN/REFRIGERATOR
2	141550-01-02B	EA	BRACKET - TIEDOWN/REFRIGERATOR - RIGHT HAND
3	141550-02-02B	EA	BRACKET - TIEDOWN/REFRIGERATOR - LEFT HAND
4	145445-02-02B	EA	STRAP - REFRIGERATOR
5*	125242-02-01A	EA	REFRIGERATOR-4 DR-W/ICE MKR-W/CONTOURED HANDLE-NORCOLD1201
6	P34457-01-N75	EA	PANEL - INSERT RAISED MEMBRANE - 16.1" X 18.3" - PORTSMOUTH OAK
6	P34457-01-LQ1	EA	PANEL - INSERT RAISED MEMBRANE - 16.1" X 18.3" - CONCERT CHERRY
6	P34457-01-L94	EA	PANEL - INSERT RAISED MEMBRANE - 16.1" X 18.3" - WASHED MAPLE
7	P34457-02-N75	EA	PANEL - INSERT RAISED MEMBRANE - 16.1" X 41.1" - PORTSMOUTH OAK
7	P34457-02-LQ1	EA	PANEL - INSERT RAISED MEMBRANE - 16.1" X 41.1" - CONCERT CHERRY
7	P34457-02-L94	EA	PANEL - INSERT RAISED MEMBRANE - 16.1" X 41.1" - WASHED MAPLE
8	P34457-01-N75	EA	PANEL - INSERT RAISED MEMBRANE - 16.1" X 18.3" - PORTSMOUTH OAK
8	P34457-01-LQ1	EA	PANEL - INSERT RAISED MEMBRANE - 16.1" X 18.3" - CONCERT CHERRY
8	P34457-01-L94	EA	PANEL - INSERT RAISED MEMBRANE - 16.1" X 18.3" - WASHED MAPLE
9	P34457-02-N75	EA	PANEL - INSERT RAISED MEMBRANE - 16.1" X 41.1" - PORTSMOUTH OAK
9	P34457-02-LQ1	EA	PANEL - INSERT RAISED MEMBRANE - 16.1" X 41.1" - CONCERT CHERRY
9	P34457-02-L94	EA	PANEL - INSERT RAISED MEMBRANE - 16.1" X 41.1" - WASHED MAPLE
10	112176-01-000	FT	TUBING - VINYL - REINFORCED - 1/2" ID
	090329-01-000	FT	SEAL/T - REFRIGERATOR CABINET
	054450-01-000	EA	LEVEL - REFRIGERATOR
	118871-05-01A	EA	TRAY - REFRIGERATOR - SIDE/SIDE - BLACK - 35.5" LONG
	118871-02-01A	EA	TRAY - REFRIGERATOR - SIDE/SIDE - BLACK - 34.4" LONG - P34H, P39W

*COMPONENT PARTS LISTED LATER IN THIS GROUP

APPLIANCE GROUP (CONTINUED)
APPLIANCES (CONTINUED)

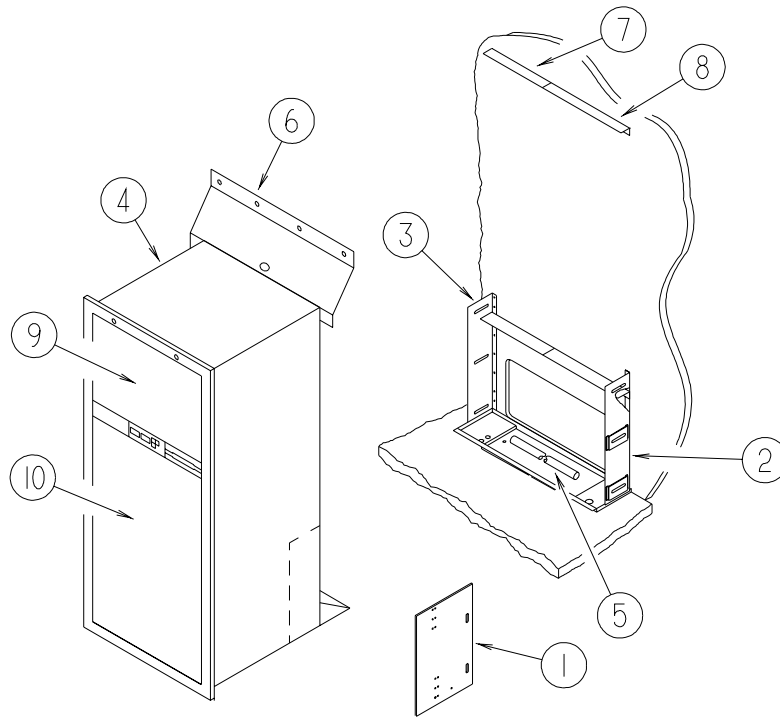

KEY	PART NUMBER	U/M	DESCRIPTION
1	141975-04-02B	EA	PLATE - TIEDOWN/REFRIGERATOR
2	141550-01-02B	EA	BRACKET - TIEDOWN/REFRIGERATOR - RIGHT HAND
3	141550-02-02B	EA	BRACKET - TIEDOWN/REFRIGERATOR - LEFT HAND
4*	120075-15-01A	EA	REFRIGERATOR - LARGE DOUBLE DOOR/LH/FLUSH HANDLE - BLACK
4*	120075-14-01A	EA	REFRIGERATOR-LGE DBL DR-2-WAY/LH/ICE MAKER/FLUSH HDL-BLACK
5	112176-01-000	FT	TUBING - VINYL - REINFORCED - 1/2" ID
6	136966-04-02B	EA	BAFFLE - REFRIGERATOR - E-COATED
7	143195-01-02B	EA	BAFFLE - REFRIGERATOR - E-COATED
8	143195-02-02B	EA	BAFFLE - REFRIGERATOR - E-COATED
9	P34457-03-N47	EA	PANEL - INSERT RAISED MEMBRANE - 21.5" X 14.5" - PORTSMOUTH OAK
9	P34457-03-L85	EA	PANEL - INSERT RAISED MEMBRANE - 21.5" X 14.5" - CONCERT CHERRY
9	P34457-03-L94	EA	PANEL - INSERT RAISED MEMBRANE - 21.5" X 14.5" - WASHED MAPLE
10	P34457-04-N47	EA	PANEL - INSERT RAISED MEMBRANE - 21.5" X 38.5" - PORTSMOUTH OAK
10	P34457-04-L85	EA	PANEL - INSERT RAISED MEMBRANE - 21.5" X 38.5" - CONCERT CHERRY
10	P34457-04-L94	EA	PANEL - INSERT RAISED MEMBRANE - 21.5" X 38.5" - WASHED MAPLE
	054450-01-000	EA	LEVEL - REFRIGERATOR
	090329-01-000	FT	SEAL/T - REFRIGERATOR CABINET
	136907-01-01A	EA	TRAY - REFRIGERATOR - BLACK

***COMPONENT PARTS LISTED LATER IN THIS GROUP**

APPLIANCE GROUP (CONTINUED)
APPLIANCES (CONTINUED)

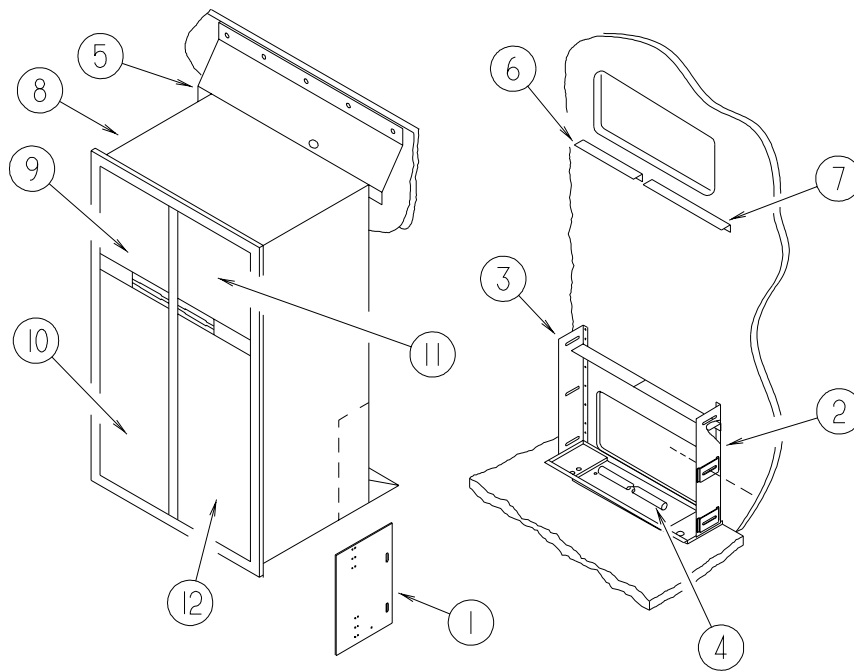

KEY	PART NUMBER	U/M	DESCRIPTION
1	141975-04-02B	EA	PLATE/TIEDOWN - REFRIGERATOR - E-COATED
2	141550-01-02B	EA	BRACKET - TIEDOWN/REFRIGERATOR - RIGHT HAND
3	141550-02-02B	EA	BRACKET - TIEDOWN/REFRIGERATOR - LEFT HAND
4	145445-02-02B	EA	STRAP - REFRIGERATOR
5	136966-03-02B	EA	BAFFLE - REFRIGERATOR - E-COATED
6	143195-01-02B	EA	BAFFLE - REFRIGERATOR - E-COATED
7	143195-02-02B	EA	BAFFLE - REFRIGERATOR - E-COATED
8*	125242-02-01A	EA	REFRIGERATOR-4 DR-W/ICE MKR-W/CONTOURED HANDLE-NORCOLD1201
9	P34457-01-N75	EA	PANEL - INSERT RAISED MEMBRANE - 16.1" X 18.3" - PORTSMOUTH OAK
9	P34457-01-LQ1	EA	PANEL - INSERT RAISED MEMBRANE - 16.1" X 18.3" - CONCERT CHERRY
9	P34457-01-L94	EA	PANEL - INSERT RAISED MEMBRANE - 16.1" X 18.3" - WASHED MAPLE
10	P34457-02-N75	EA	PANEL - INSERT RAISED MEMBRANE - 16.1" X 41.1" - PORTSMOUTH OAK
10	P34457-02-LQ1	EA	PANEL - INSERT RAISED MEMBRANE - 16.1" X 41.1" - CONCERT CHERRY
10	P34457-02-L94	EA	PANEL - INSERT RAISED MEMBRANE - 16.1" X 41.1" - WASHED MAPLE
11	P34457-01-N75	EA	PANEL - INSERT RAISED MEMBRANE - 16.1" X 18.3" - PORTSMOUTH OAK
11	P34457-01-LQ1	EA	PANEL - INSERT RAISED MEMBRANE - 16.1" X 18.3" - CONCERT CHERRY
11	P34457-01-L94	EA	PANEL - INSERT RAISED MEMBRANE - 16.1" X 18.3" - WASHED MAPLE
12	P34457-02-N75	EA	PANEL - INSERT RAISED MEMBRANE - 16.1" X 41.1" - PORTSMOUTH OAK
12	P34457-02-LQ1	EA	PANEL - INSERT RAISED MEMBRANE - 16.1" X 41.1" - CONCERT CHERRY
12	P34457-02-L94	EA	PANEL - INSERT RAISED MEMBRANE - 16.1" X 41.1" - WASHED MAPLE
	112176-01-000	FT	TUBING - VINYL - REINFORCED - 1/2" ID
	090329-01-000	FT	SEAL/T - REFRIGERATOR CABINET
	054450-01-000	EA	LEVEL - REFRIGERATOR
	137495-01-01A	EA	TRAY - REFRIGERATOR - BLACK

***COMPONENT PARTS LISTED LATER IN THIS GROUP**

APPLIANCE GROUP (CONTINUED)
APPLIANCES (CONTINUED)

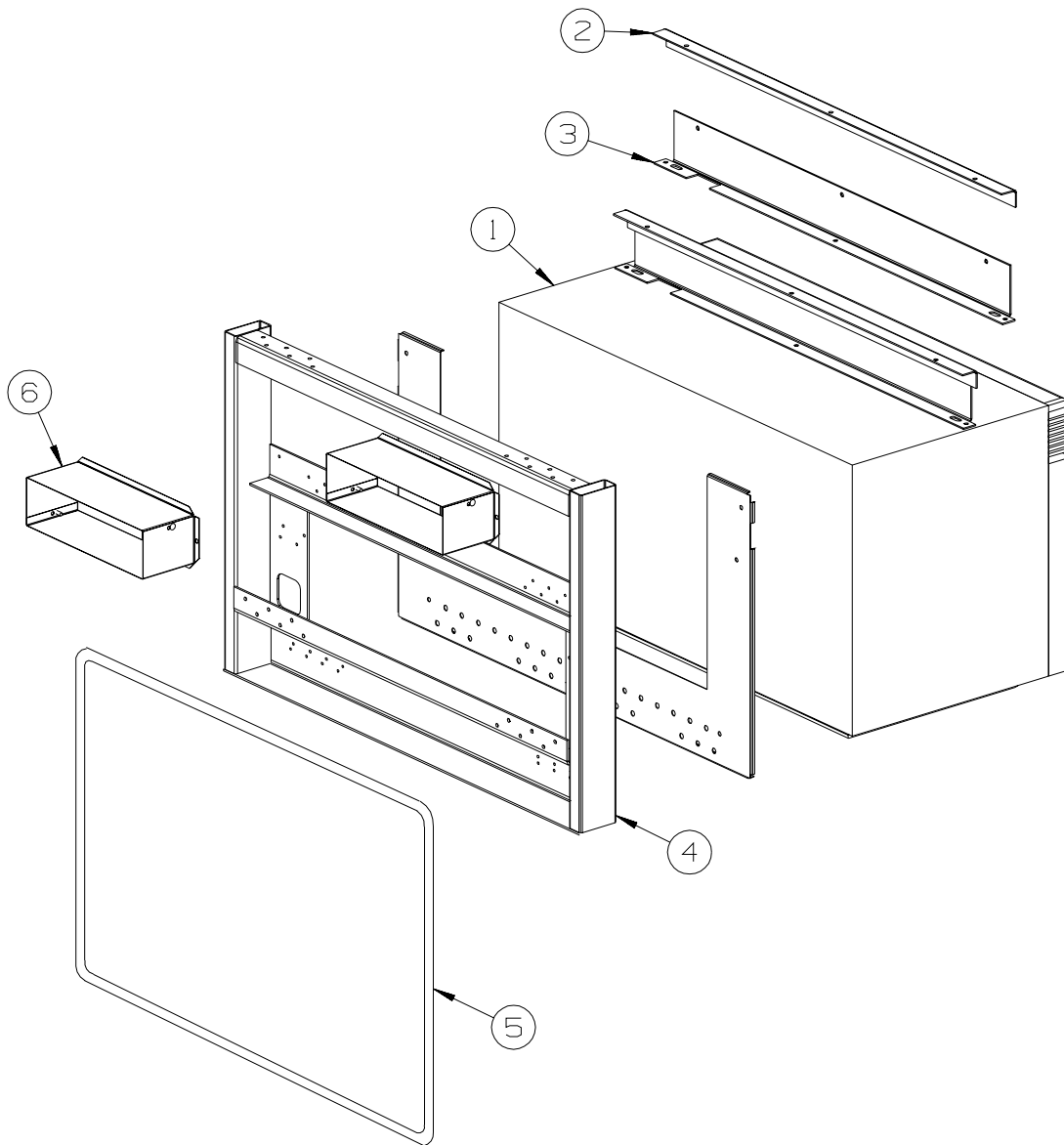

P39W

KEY	PART NUMBER	U/M	DESCRIPTION
1*	119267-12-01A	EA	OVEN - MICROWAVE/CONVECTION W/HOOD US - #R-1875 - CONVECTION U.S.
1*	119267-13-01A	EA	OVEN - MICROWAVE/CONVECTION W/HOOD CSA - #R-1875A - CONVECTION CANADIAN
1*	119267-10-01A	EA	OVEN - MICROWAVE/NON CONVECTION W/HOOD US - #R-1500 - OVEN W/FAN
	119267-14-000	EA	VENT - KIT - F/1510 - OVEN W/FAN
2	129836-02-02B	EA	ANGLE - W/HOLES - .7" X 1" X 28.3" - E-COATED - LH
3	129836-05-02B	EA	ANGLE - W/HOLES - E-COATED
4	137824-02-02B	EA	BRACKET - MICROWAVE - E-COATED
5	NOT USED		
6	140093-01-02B	EA	DUCT - E-COATED

***COMPONENT PARTS LISTED LATER IN THIS GROUP**

P36G & P32T

KEY	PART NUMBER	U/M	DESCRIPTION
1*	119267-12-01A	EA	OVEN - MICROWAVE/CONVECTION W/HOOD US - #R-1875 - CONVECTION U.S.
1*	119267-13-01A	EA	OVEN - MICROWAVE/CONVECTION W/HOOD CSA - #R-1875A - CONVECTION CANADIAN
1*	119267-10-01A	EA	OVEN - MICROWAVE/NON CONVECTION W/HOOD US - #R-1500 - OVEN W/FAN
	119267-14-000	EA	VENT - KIT - F/1510 - OVEN W/FAN

- 2 NOT USED
- 3 NOT USED
- 4 NOT USED
- 5 NOT USED
- 6 NOT USED

***COMPONENT PARTS LISTED LATER IN THIS GROUP**

APPLIANCE GROUP (CONTINUED)
APPLIANCES (CONTINUED)

P34H & P39K

KEY	PART NUMBER	U/M	DESCRIPTION
1*	119267-12-01A	EA	OVEN - MICROWAVE/CONVECTION W/HOOD US - #R-1875 - CONVECTION U.S.
1*	119267-13-01A	EA	OVEN - MICROWAVE/CONVECTION W/HOOD CSA - #R-1875A - CONVECTION CANADIAN
1*	119267-10-01A	EA	OVEN - MICROWAVE/NON CONVECTION W/HOOD US - #R-1500 - OVEN W/FAN
	119267-14-000	EA	VENT - KIT - F/1510 - OVEN W/FAN
2	129836-02-02B	EA	ANGLE - W/HOLES - .7" X 1" X 28.3" - E-COATED - LH
3	129836-01-02B	EA	ANGLE - W/HOLES - .7" X 1" X 28.3" - E-COATED
4	137824-03-02B	EA	BRACKET - MICROWAVE - E-COATED
5	NOT USED		
6	140093-03-02B	EA	DUCT - E-COATED

***COMPONENT PARTS LISTED LATER IN THIS GROUP**

APPLIANCE GROUP (CONTINUED)
COMPONENT PARTS FOR APPLIANCE

115504-01-000

KEY	PART NUMBER	U/M DESCRIPTION	VENDOR NO.
	115504-01-700	EA PLUG & CABLE, 10 WATT PANEL	600-016

119267-10-01A

KEY	PART NUMBER	U/M DESCRIPTION	VENDOR NO.
	119267-04-700	EA FILTER-GREASE	BOO2
	119267-10-700	EA BRACKET/MOUNTING	FANGTB005MRY0

119267-12-01A

KEY	PART NUMBER	U/M DESCRIPTION	VENDOR NO.
	119267-04-700	EA FILTER-GREASE	BOO2
	119267-04-704	EA LIGHT COVER-F/MOD R1480/1850	FANGKB009MRYO
	119267-12-700	EA LOUVER-EXHAUST	PDIF-BO32MRFO

119267-13-01A

KEY	PART NUMBER	U/M DESCRIPTION	VENDOR NO.
	119267-04-700	EA FILTER-GREASE	BOO2

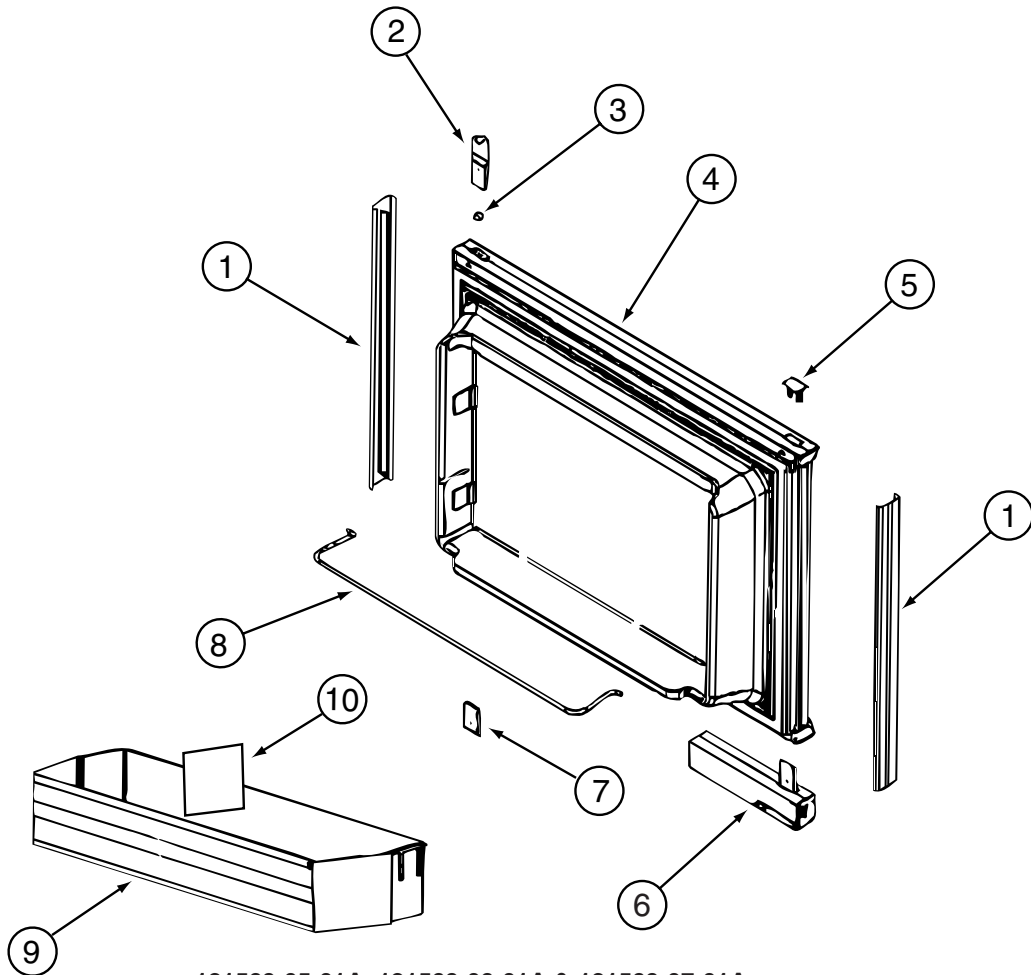

121569-05-01A, 121569-06-01A & 121569-07-01A

KEY	PART NUMBER	U/M DESCRIPTION	VENDOR NO.
1	121568-03-700	EA RETAINER - DOOR PANEL/BLACK	619558
2	120075-01-701	EA HINGE-TOP RH/BOTTOM LH(DOOR)	618511
3	121568-03-701	EA BUSHING - HINGE PIN/GRAY	619671
4	121568-03-702	EA DOOR LINER - W/TRIM/BLACK	619627 - SMALL DOOR
5	120075-01-702	EA CAP, (HINGE PLUG)	618160
6	120075-12-700	EA HANDLE(CONTOUR)TOP LH/BTM RH	621105
7	120075-01-705	EA HINGE-TOP LH/BOTTOM RH(DOOR)	618510
8	121568-01-700	EA RAIL - DOOR UPPER	618618
9	120075-07-700	EA DOOR BIN - CLEAR	619006
10	120075-07-701	EA DIVIDER/DOOR BIN CLEAR	619008
	121568-03-705	EA STORAGE LATCH - GRAY	619648

APPLIANCE GROUP (CONTINUED)
COMPONENTS PARTS FOR APPLIANCE (CONTINUED)

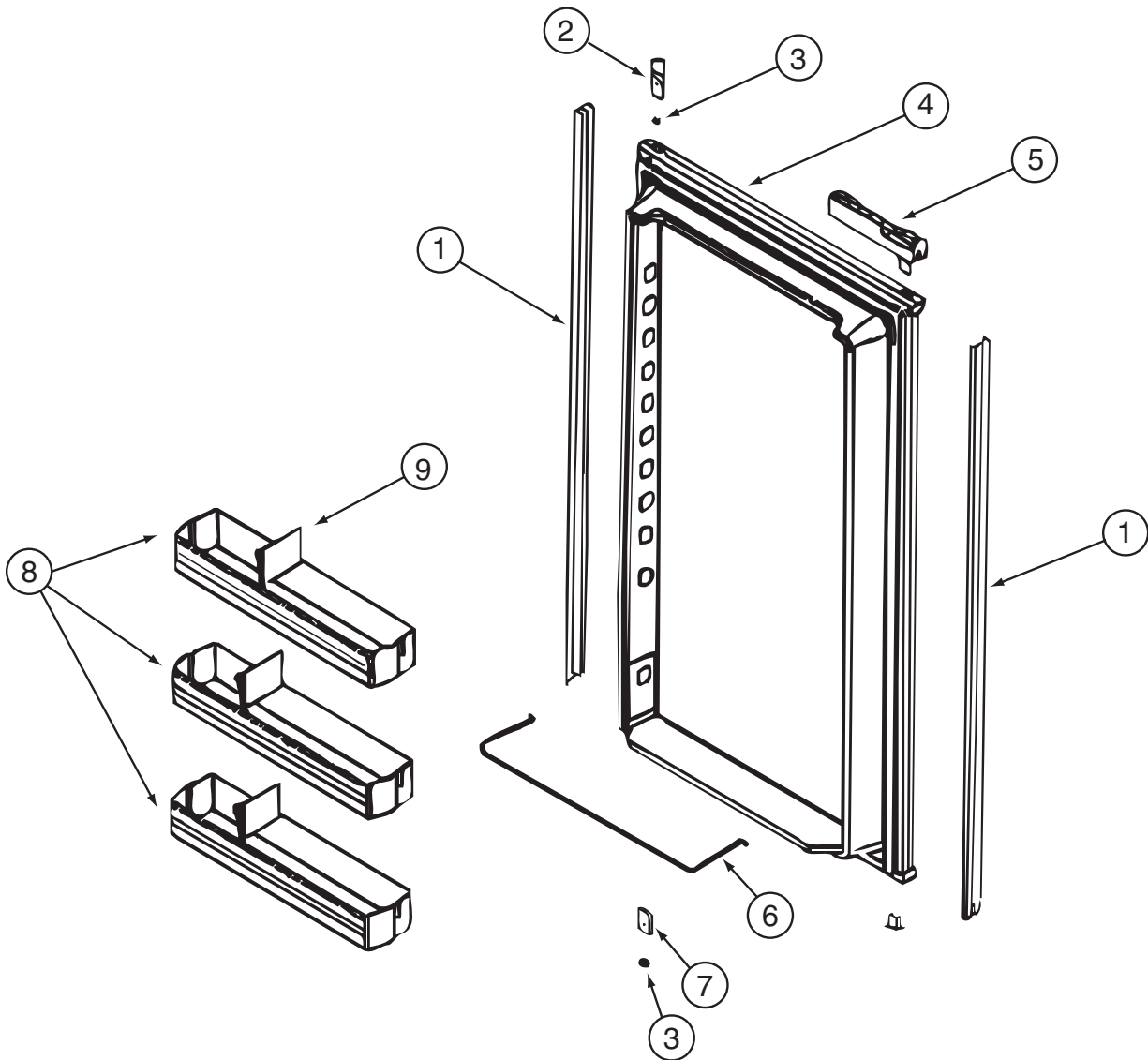

121569-05-01A, 121569-06-01A & 121569-07-01A (CONTINUED)

KEY	PART NUMBER	U/M	DESCRIPTION	VENDOR NO.
1	120075-07-702	EA	RETAINER - DOOR PANEL/BLACK	619560
2	120075-01-701	EA	HINGE-TOP RH/BOTTOM LH(DOOR)	618511
3	121568-03-701	EA	BUSHING - HINGE PIN/GRAY	619671
4	121568-03-707	EA	DOOR LINER - W/BLACK TRIM	619629
5	120075-12-701	EA	HANDLE(CONTOUR)TOP RH/BTM LH	621104
6	121568-01-704	EA	RAIL - DOOR LOWER	618578
7	120075-01-705	EA	HINGE-TOP LH/BOTTOM RH(DOOR)	618510
8	121568-01-701	EA	BIN - DOOR WHITE	618619
9	120075-07-701	EA	DIVIDER/DOOR BIN CLEAR	619008
	121568-03-705	EA	STORAGE LATCH - GRAY	619648

APPLIANCE GROUP (CONTINUED)
COMPONENTS PARTS FOR APPLIANCE (CONTINUED)

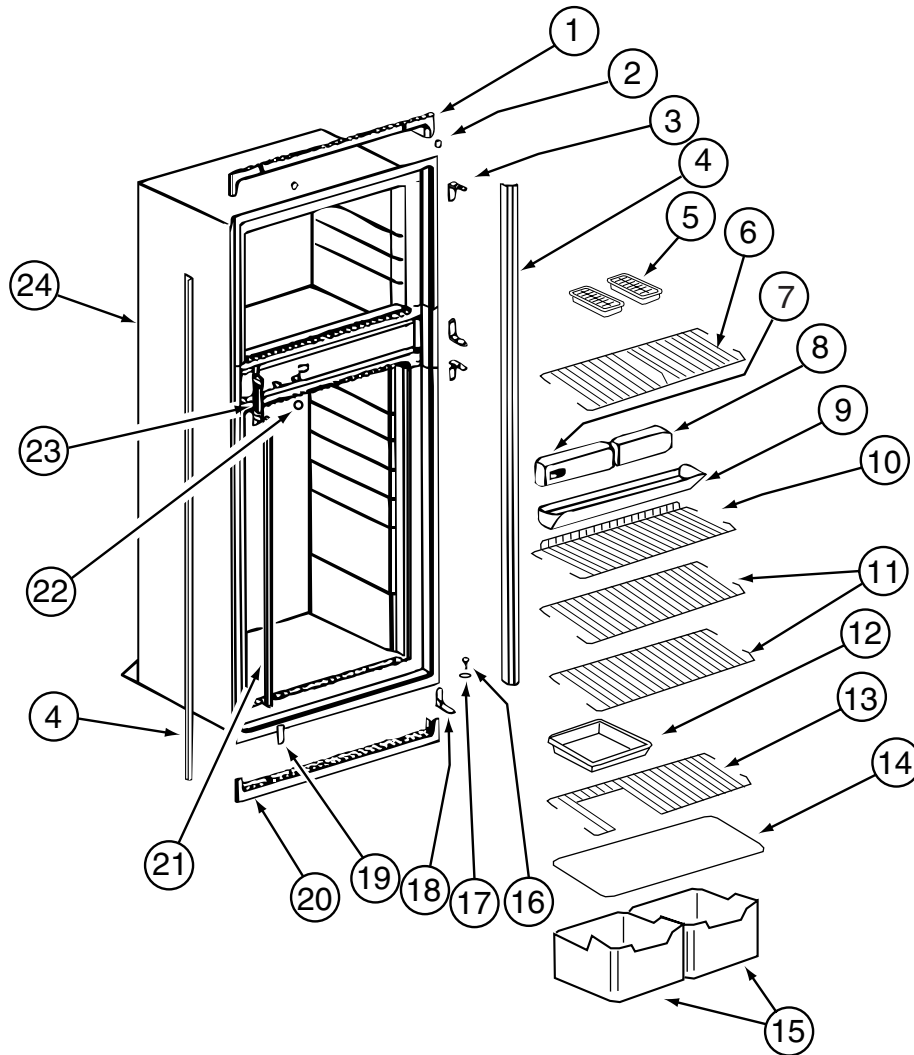

121569-05-01A, 121569-06-01A & 121569-07-01A (CONTINUED)

KEY	PART NUMBER	U/M	DESCRIPTION	VENDOR NO.
1	121568-03-709	EA	TRIM - TOP/BLACK	619687
2	120075-01-714	EA	PLUG-HOLE	618170
3	121568-03-710	EA	HINGE/CABINET-TOP/RH-LWR/LH	619335
4	120075-07-705	EA	TRIM - SIDE - BLACK	619802
6	121568-03-712	EA	SHELF - WIRE/FREEZER	620250
7	121568-03-714	EA	CONTROL ASM - 2 WAY BLACK	619350
8	121568-03-713	EA	FRONT BOX/DECORATIVE-BLACK	619282
9	120075-01-720	EA	TRAY-DRIP	618137
10	121568-01-707	EA	SHELF - WIRE - SHORT	618624
11	121568-01-708	EA	SHELF - WIRE	618589
14	120075-01-725	EA	COVER-CRISPER	618158
15	121568-01-709	EA	CRISPER	618571
16	120075-01-727	EA	PIN-HINGE	618145
18	121568-03-715	EA	HINGE/CABINET-TOP/LH-LWR/RH	619336
19	121568-03-716	EA	COVER - HINGE HOLES	619301
20	120075-01-729	EA	TRIM-BOTTOM PIECE	618136
21	120075-01-730	EA	RETAINER-SHELF	618181
22	121568-03-717	EA	HOLE PLUG - WHITE	619561
23	120075-01-732	EA	PLATE-STRIKE	618167
24	120075-07-709	EA	CABINET - FOAMED	619347
	120075-01-721	EA	LOUVER-DRIP TRAY	618176

CONTACT WINNEBAGO PART SALES FOR UNLISTED COMPONENTS

APPLIANCE GROUP (CONTINUED)
COMPONENTS PARTS FOR APPLIANCE (CONTINUED)

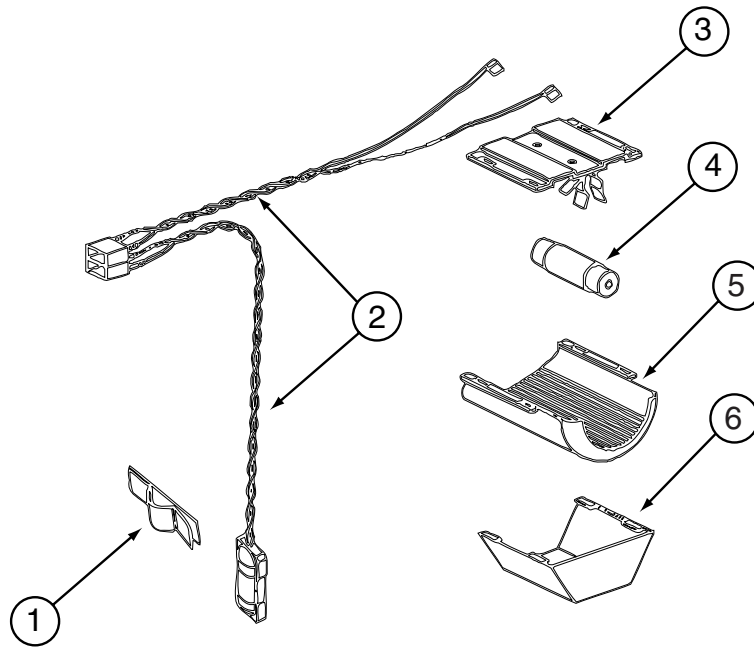

121569-05-01A, 121569-07-01A (CONTINUED)

KEY	PART NUMBER	U/M	DESCRIPTION	VENDOR NO.
1	084880-01-760	EA	CLIP (THERMISTER)	61689122
2	120075-01-735	EA	THERMISTER W/LAMP & WIRE/ASM	618548
3	084880-03-705	EA	BRACKET-LIGHT-INTERIOR	61629722
4	084880-03-706	EA	BULB-LAMP	61628922
6	084880-03-707	EA	COVER-LAMP, LENS	61627922

CONTACT WINNEBAGO PART SALES FOR UNLISTED COMPONENTS

APPLIANCE GROUP (CONTINUED)
COMPONENTS PARTS FOR APPLIANCE (CONTINUED)

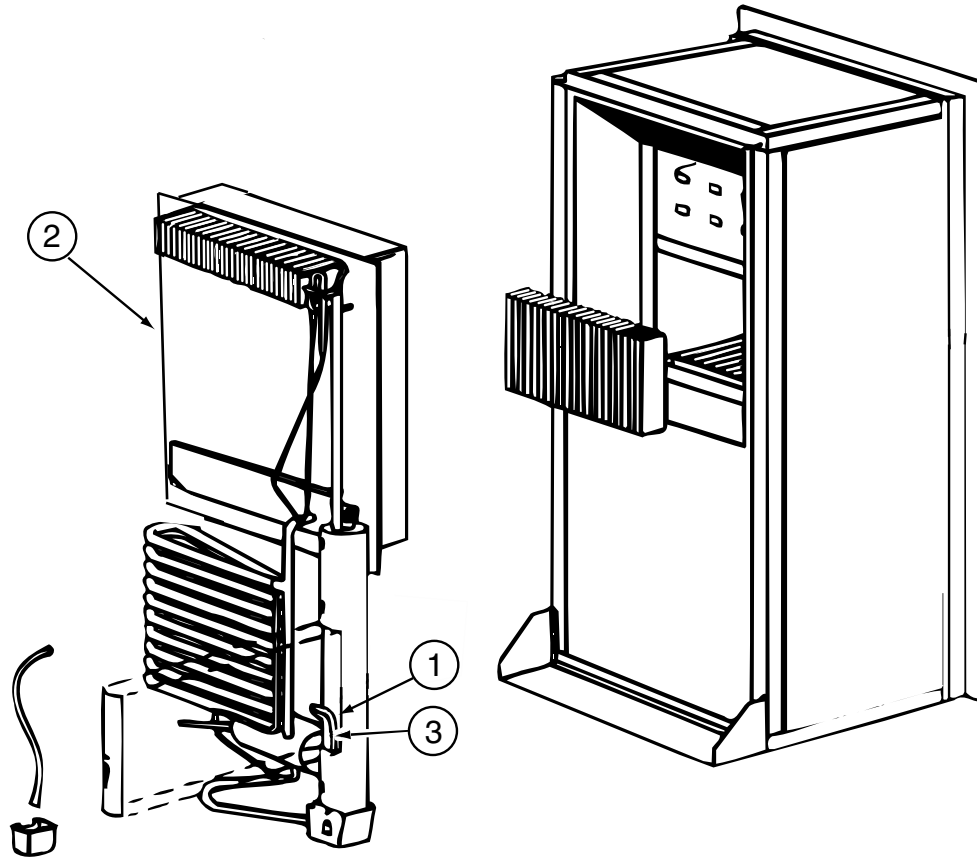

121569-05-01A, 121569-07-01A (CONTINUED)

KEY	PART NUMBER	U/M	DESCRIPTION	VENDOR NO.
2	120075-01-736	EA	COOLING UNIT, SERVICE PACK	618542
3	088248-01-709	EA	HEATER-AC (HORIZONTAL)	61562722
	120075-01-744	EA	KIT - GAS VALVE/BURNER TUBE	620609

CONTACT WINNEBAGO PART SALES FOR UNLISTED COMPONENTS

APPLIANCE GROUP (CONTINUED)
COMPONENTS PARTS FOR APPLIANCE (CONTINUED)

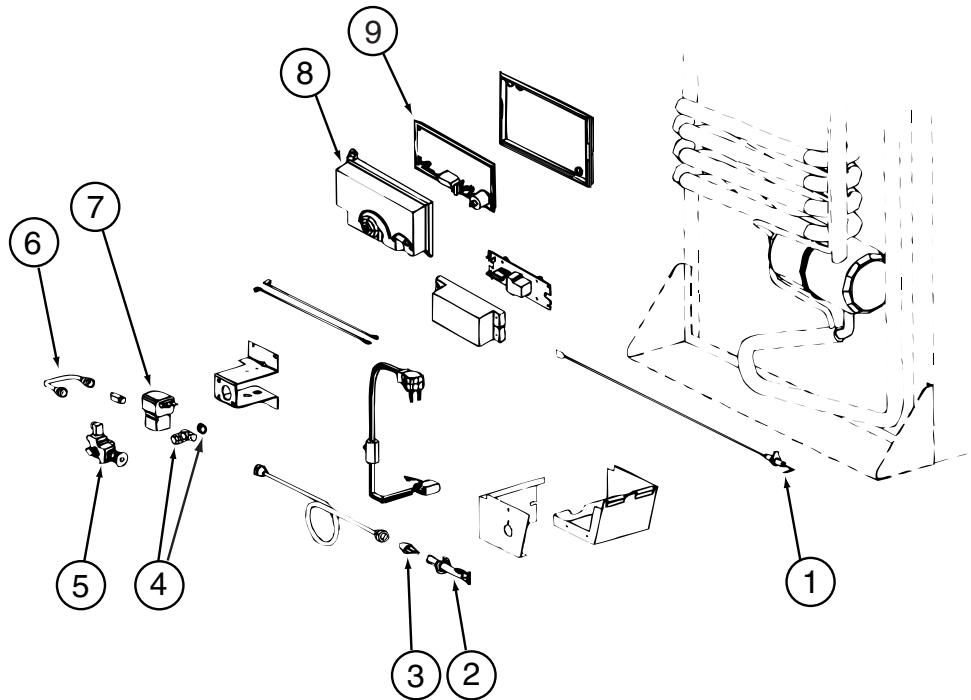

121569-05-01A, 121569-07-01A (CONTINUED)

KEY	PART NUMBER	U/M	DESCRIPTION	VENDOR NO.
1	104137-06-715	EA	ELECTRODE-SPARK/SENSOR, SGL	61692222
2	104137-06-714	EA	BURNER ASSEMBLY, 5-SLOT	61705222
3	120075-01-737	EA	ORIFICE - JEWEL - .0155	618284
4	113737-01-702	EA	PLUG 1/8" F/PRESSURE TAP	61445322
4	113737-01-716	EA	TAP-PRESSURE	61594422
6	113737-01-750	EA	TUBE-UNION	61694622
7	084880-01-718	EA	VALVE-GAS, (ASCO)	61551822
8	120075-01-738	EA	COVER-POWER BOARD	618185
9	121568-03-719	EA	POWER - BOARD - 2-WAY	619353
	121568-03-720	EA	VALVE/SHUT OF-MANUAL ELECT.	618696

CONTACT WINNEBAGO PART SALES FOR UNLISTED COMPONENTS

APPLIANCE GROUP (CONTINUED)
COMPONENTS PARTS FOR APPLIANCE (CONTINUED)

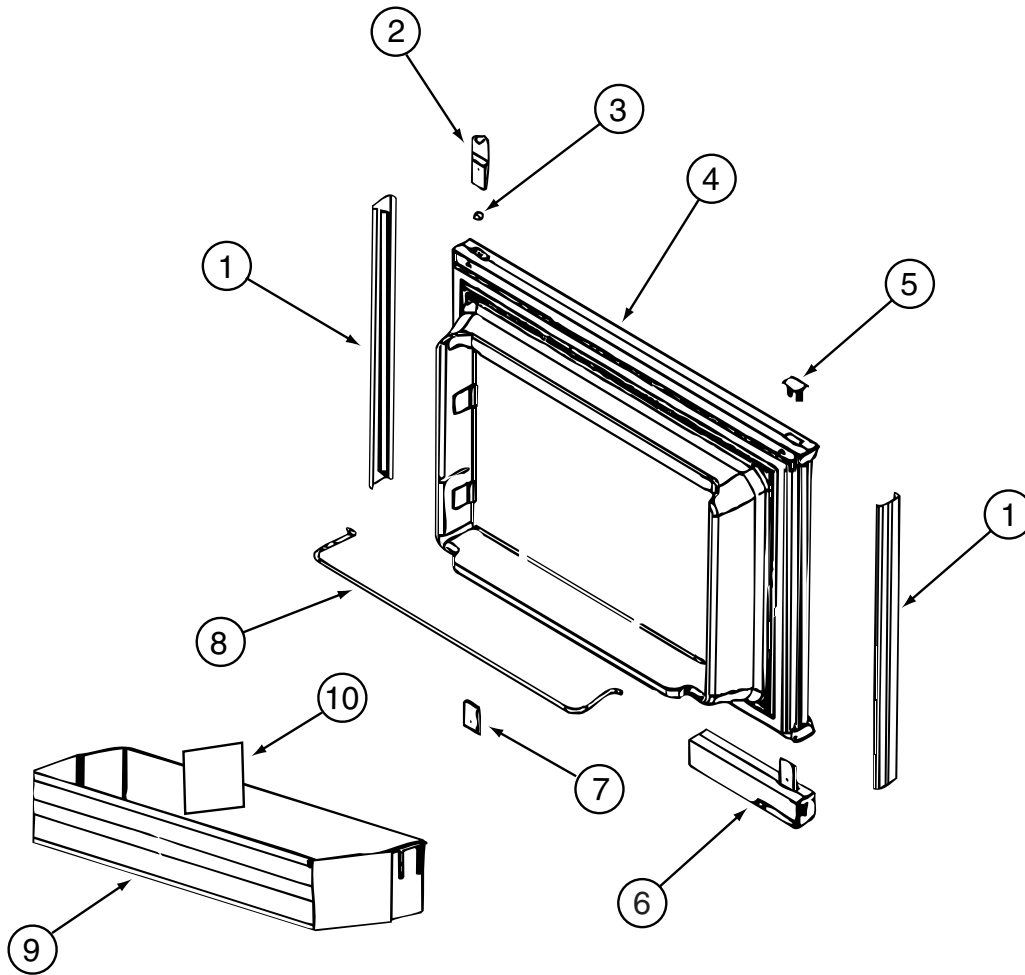

120075-12-01A, 120075-13-01A, 120075-14-01A, 120075-15-01A

KEY	PART NUMBER	U/M	DESCRIPTION	VENDOR NO.
1	121568-03-700	EA	RETAINER - DOOR PANEL/BLACK	619558
2	120075-01-701	EA	HINGE-TOP RH/BOTTOM LH(DOOR)	618511
3	121568-03-701	EA	BUSHING - HINGE PIN/GRAY	619671
4	121568-03-702	EA	DOOR LINER - W/TRIM/BLACK	619627 - SMALL DOOR
5	120075-01-702	EA	CAP, (HINGE PLUG)	618160
6	120075-12-700	EA	HANDLE(CONTOUR)TOP LH/BTM RH	621105
	120075-12-702	EA	HANDLE/HOUSING-TOP-LH/BTM RH	618159GEN
6	120075-12-701	EA	HANDLE(CONTOUR)TOP RH/BTM LH	621104
	120075-12-707	EA	LATCH	619648
	120075-12-709	EA	HANDLE/HOUSING-BTM LH/TOP RH	618122GEN
6	121568-03-703	EA	HANDLE/FLUSH-TOP/RH-LWR/LH	619865
6	121568-03-708	EA	HANDLE/FLUSH-TOP/LH-LWR/RH	619866
7	120075-01-705	EA	HINGE-TOP LH/BOTTOM RH(DOOR)	618510
8	121568-01-700	EA	RAIL - DOOR UPPER	618618
9	120075-07-700	EA	DOOR BIN - CLEAR	619006
10	120075-07-701	EA	DIVIDER/DOOR BIN CLEAR	619008
	121568-03-704	EA	TRAVEL LATCH - GRAY	619647
	121568-03-705	EA	STORAGE LATCH - GRAY	619648

APPLIANCE GROUP (CONTINUED)
COMPONENTS PARTS FOR APPLIANCE (CONTINUED)

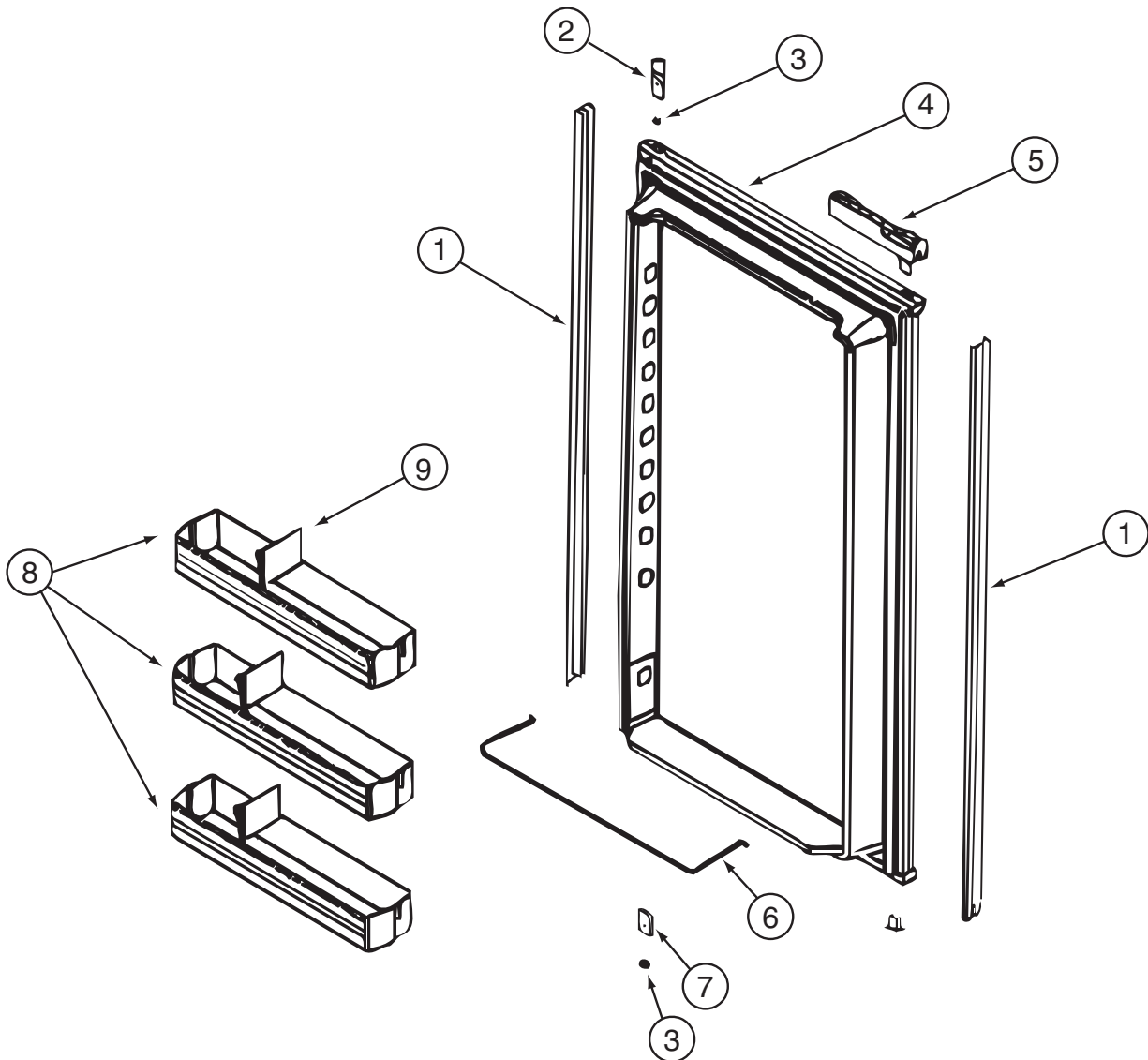

120075-12-01A, 120075-13-01A, 120075-14-01A, 120075-15-01A (CONTINUED)

KEY	PART NUMBER	U/M	DESCRIPTION	VENDOR NO.
1	120075-07-702	EA	RETAINER - DOOR PANEL/BLACK	619560
2	120075-01-701	EA	HINGE-TOP RH/BOTTOM LH(DOOR)	618511
3	121568-03-701	EA	BUSHING - HINGE PIN/GRAY	619671
4	120075-07-703	EA	DOOR LINER - BLACK	619631 - LARGE DOOR
5	120075-12-700	EA	HANDLE(CONTOUR)TOP LH/BTM RH	621105
	120075-12-702	EA	HANDLE/HOUSING-TOP-LH/BTM RH	618159GEN
5	120075-12-701	EA	HANDLE(CONTOUR)TOP RH/BTM LH	621104
	120075-12-707	EA	LATCH	619648
	120075-12-709	EA	HANDLE/HOUSING-BTM LH/TOP RH	618122GEN
5	121568-03-703	EA	HANDLE/FLUSH-TOP/RH-LWR/LH	619865
5	121568-03-708	EA	HANDLE/FLUSH-TOP/LH-LWR/RH	619866
6	121568-01-704	EA	RAIL - DOOR LOWER	618578
7	120075-01-705	EA	HINGE-TOP LH/BOTTOM RH(DOOR)	618510
8	120075-07-700	EA	DOOR BIN - CLEAR	619006
8	120075-07-704	EA	DOOR BIN - LARGE/CLEAR	619005
9	120075-07-701	EA	DIVIDER/DOOR BIN CLEAR	619008
	121568-03-704	EA	TRAVEL LATCH - GRAY	619647
	121568-03-705	EA	STORAGE LATCH - GRAY	619648

APPLIANCE GROUP (CONTINUED)
COMPONENTS PARTS FOR APPLIANCE (CONTINUED)

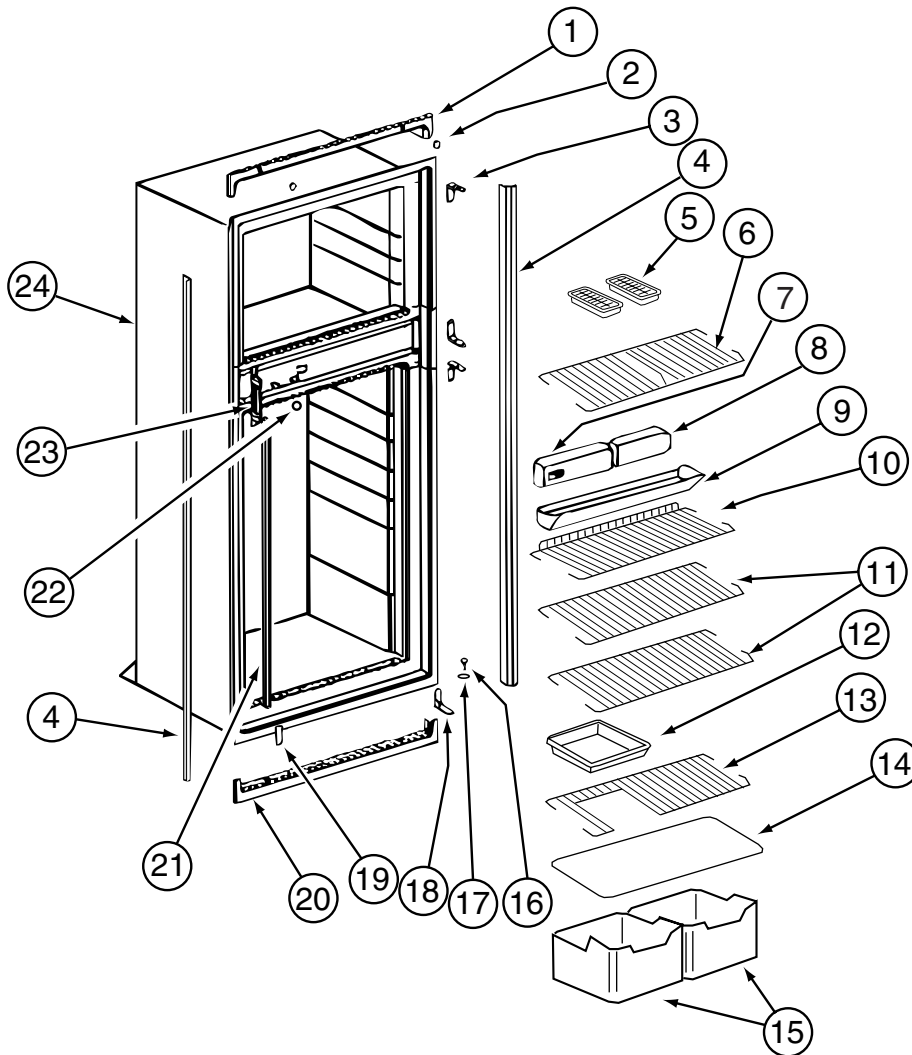

120075-12-01A, 120075-13-01A, 120075-14-01A, 120075-15-01A (CONTINUED)

KEY	PART NUMBER	U/M	DESCRIPTION	VENDOR NO.
1	121568-03-709	EA	TRIM - TOP/BLACK	619687
2	120075-01-714	EA	PLUG-HOLE (BLACK)	618170
3	121568-03-710	EA	HINGE/CABINET-TOP/RH-LWR/LH	619335
4	120075-07-705	EA	TRIM - SIDE - BLACK	622296
5	104137-06-724	EA	ICE TRAY	61630422
6	120075-07-706	EA	SHELF - WIRE/FREEZER	620249
7	120075-07-707	EA	CONTROL BOX - BLACK	619665
8	121568-03-713	EA	FRONT BOX/DECORATIVE-BLACK	619282
9	120075-01-720	EA	TRAY-DRIP	618137
10	120075-01-722	EA	SHELF-WIRE, SHORT	620269
11	120075-01-723	EA	SHELF-WIRE	620270
12	104137-06-718	EA	SHELF-TRAY, WHITE, W/CUTOUT	617756
13	120075-01-724	EA	SHELF-WIRE, W/CUTOUT	618177
14	120075-01-725	EA	COVER-CRISPER	618158
15	120075-07-708	EA	CRISPER/ICE BIN	619007
16	120075-01-727	EA	PIN-HINGE	618145
17	121568-03-701	EA	BUSHING - HINGE PIN/GRAY	619671
18	121568-03-715	EA	HINGE/CABINET-TOP/LH-LWR/RH	619336
19	121568-03-716	EA	COVER - HINGE HOLES	619301
20	120075-01-729	EA	TRIM-BOTTOM PIECE	620958
21	120075-01-730	EA	RETAINER-SHELF(SER#926684 DN	618181
22	121568-03-717	EA	HOLE PLUG - WHITE	619561
23	120075-01-732	EA	PLATE-STRIKE	618167
24	120075-09-700	EA	CABINET - FOAMED	619660
	120075-01-721	EA	LOUVER-DRIP TRAY	618176

APPLIANCE GROUP (CONTINUED)
COMPONENTS PARTS FOR APPLIANCE (CONTINUED)

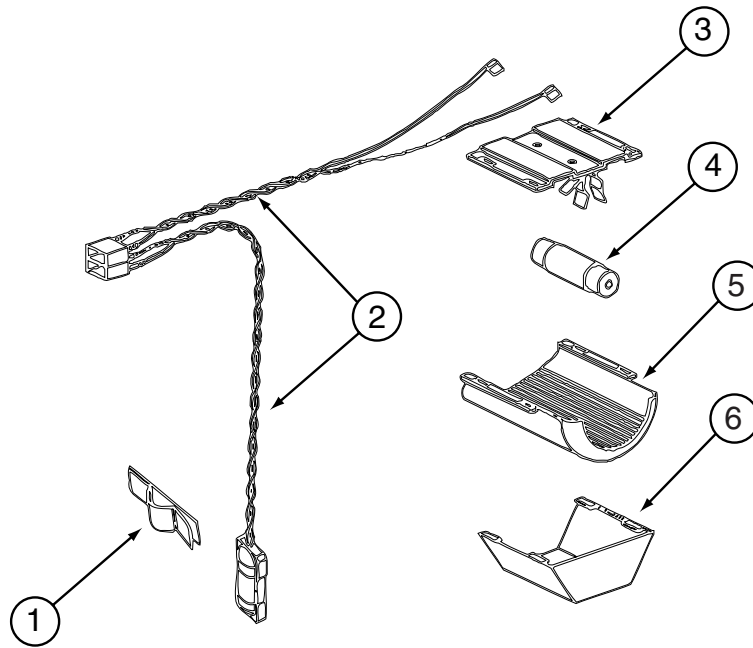

120075-12-01A, 120075-13-01A, 120075-14-01A, 120075-15-01A (CONTINUED)

KEY	PART NUMBER	U/M	DESCRIPTION	VENDOR NO.
1	084880-01-760	EA	CLIP (THERMISTER)	61689122
2	120075-01-735	EA	THERMISTER W/LAMP & WIRE/ASM	618548
3	084880-03-705	EA	BRACKET-LIGHT-INTERIOR	61629722
4	084880-03-706	EA	BULB-LAMP	61628922
5	120075-01-734	EA	COVER-LENS	618190
6	084880-03-707	EA	COVER-LAMP, LENS	61627922

APPLIANCE GROUP (CONTINUED)
COMPONENTS PARTS FOR APPLIANCE (CONTINUED)

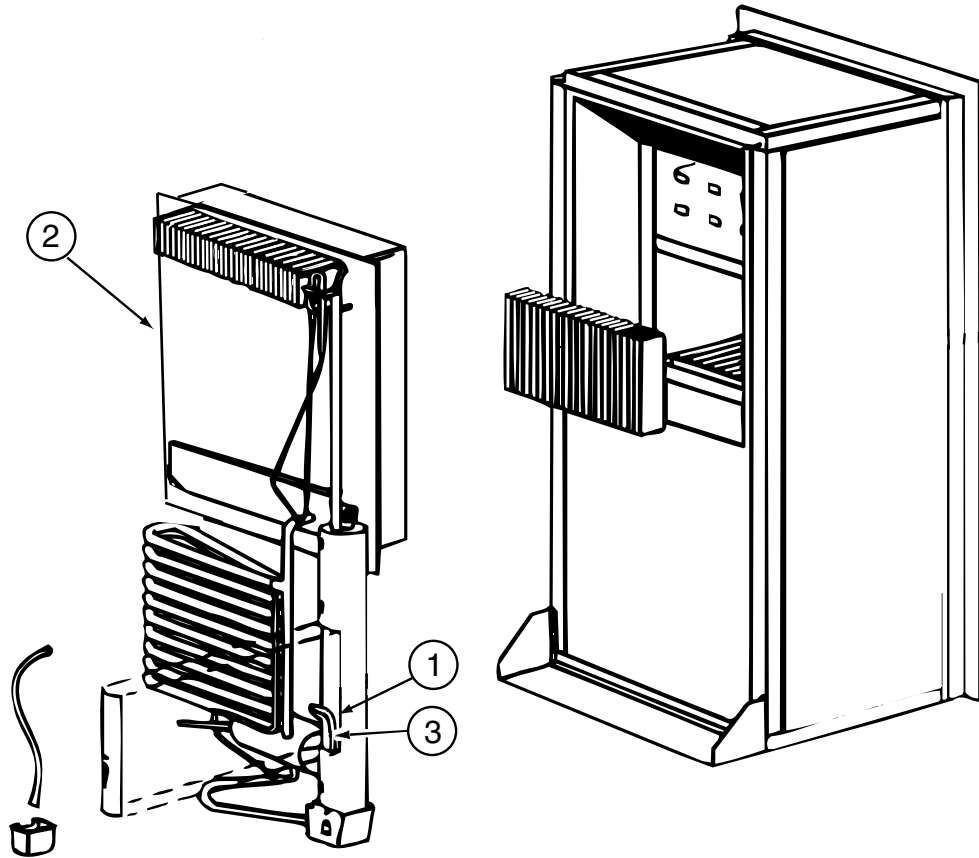

120075-12-01A, 120075-13-01A, 120075-14-01A, 120075-15-01A (CONTINUED)

KEY	PART NUMBER	U/M	DESCRIPTION	VENDOR NO.
1	088248-01-710	EA	HEATER DC (HORIZONTAL)	61562822
2	120075-01-736	EA	COOLING UNIT, SERVICE PACK	618542
3	088248-01-709	EA	HEATER-AC (HORIZONTAL)	61562722

APPLIANCE GROUP (CONTINUED)
COMPONENTS PARTS FOR APPLIANCE (CONTINUED)

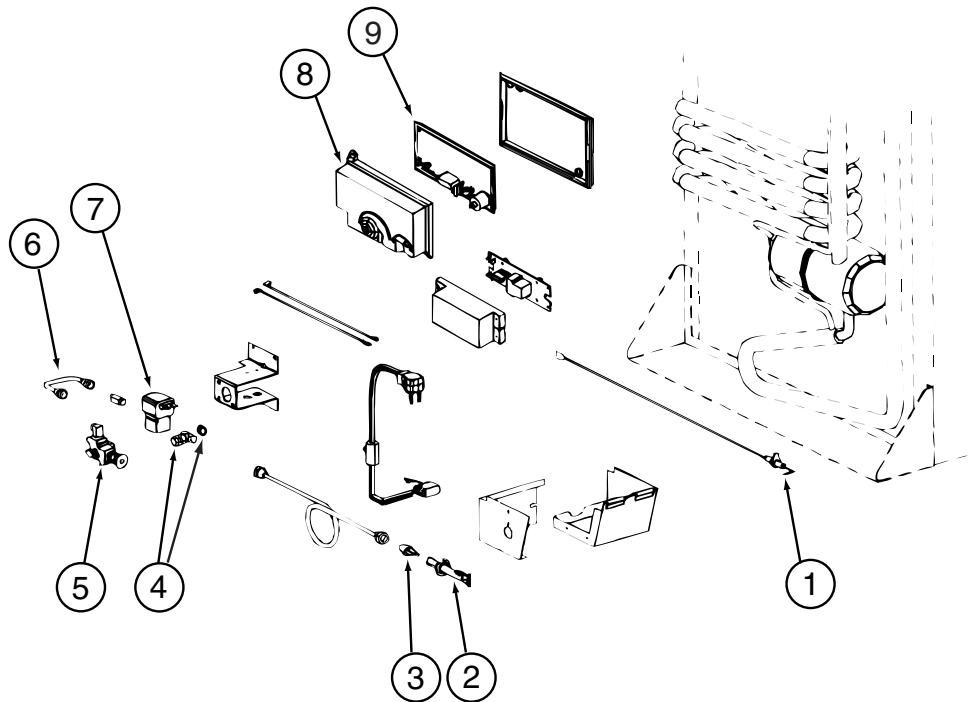

120075-12-01A, 120075-13-01A, 120075-14-01A, 120075-15-01A (CONTINUED)

KEY	PART NUMBER	U/M	DESCRIPTION	VENDOR NO.
1	104137-06-715	EA	ELECTRODE-SPARK/SENSOR, SGL	61692222
2	104137-06-714	EA	BURNER ASSEMBLY, 5-SLOT	61705222
3	120075-01-737	EA	ORIFICE - JEWEL - .0155	618284
4	113737-01-702	EA	PLUG 1/8" F/PRESSURE TAP	61445322
4	113737-01-716	EA	TAP-PRESSURE	61594422
5	104137-06-734	EA	VALVE-SHUT OFF/MAN-NEW STYLE	618696
6	113737-01-750	EA	TUBE-UNION	61694622
7	084880-01-718	EA	VALVE-GAS, (ASCO)	621447
8	120075-01-738	EA	COVER-POWER BOARD	618185
9	120075-07-710	EA	POWER - BOARD - 2-WAY	619360 = 621269
	120075-01-744	EA	KIT - GAS VALVE/BURNER TUBE	620609

APPLIANCE GROUP (CONTINUED)
COMPONENTS PARTS FOR APPLIANCE (CONTINUED)

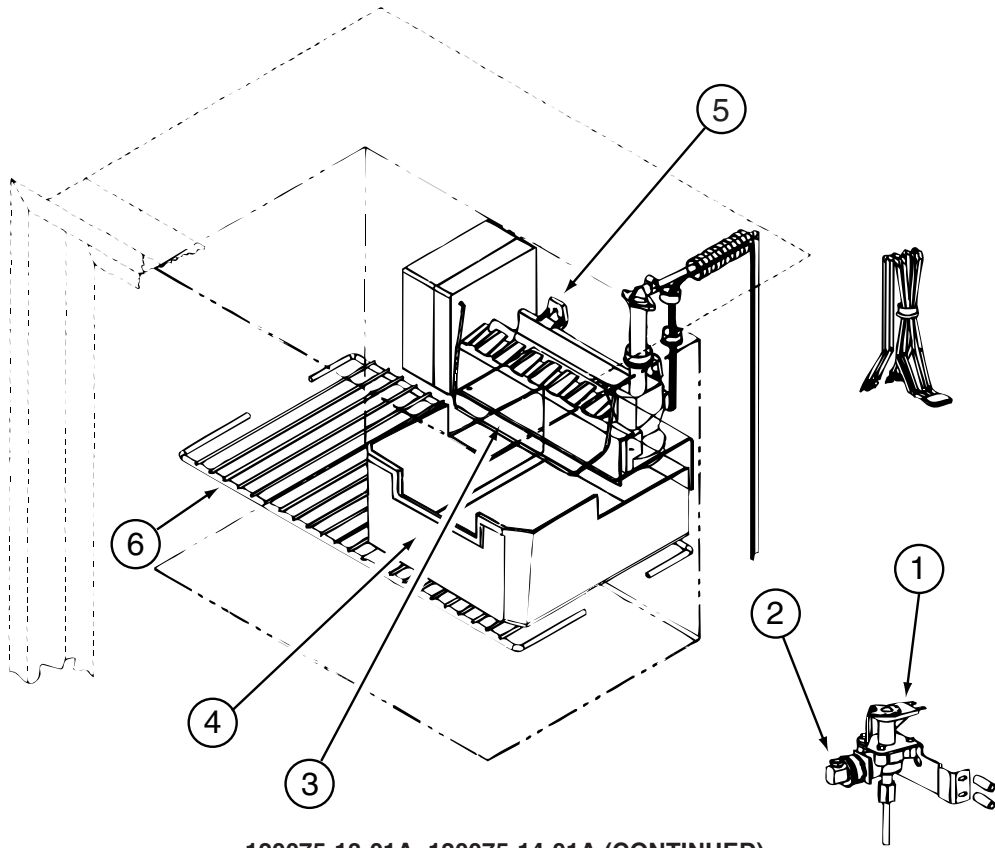

120075-13-01A, 120075-14-01A (CONTINUED)

KEY	PART NUMBER	U/M	DESCRIPTION	VENDOR NO.
1	120075-09-701	EA	WATER VALVE W/BRACKET	618253
2	120075-03-702	EA	NUT/COMPRESSION - FITTING	61678722
3	120075-03-703	EA	ARM-SHUT OFF	61656922
4	120075-03-704	EA	BIN-ICE CUBE	618154
5	094039-07-706	EA	ICE MAKER W/O PLATES	61656522
6	120075-01-717	EA	SHELF-FREEZER, WIRE	618172

APPLIANCE GROUP (CONTINUED)
COMPONENTS PARTS FOR APPLIANCE (CONTINUED)

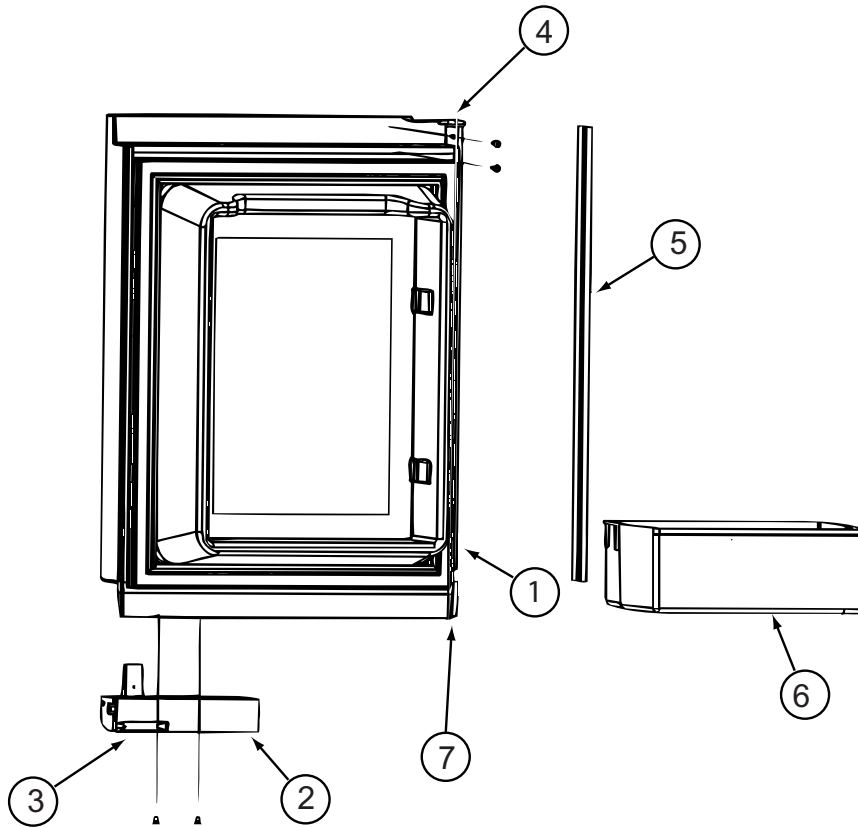

125242-02-01A

KEY	PART NUMBER	U/M	DESCRIPTION	VENDOR NO.
1	125242-01-762	EA	LINER/FOAMED-UPPER/LH-WHITE	619839
1	125242-02-734	EA	LINER/FOAMED-UPPER/LH-BLACK	625212 AFT #1291390
2	125242-02-700	EA	HANDLE(CONTOUR)TOP LH BTM RH	621107
3	125242-02-722	EA	LATCH-STORAGE DR/BLK POINTED	619374
4	125242-02-724	EA	HINGE - DOOR	618792
5	125242-02-723	EA	RETAINER/PANEL-UPPER DOOR	623166
6	125242-03-704	EA	DOOR BIN	622831
7	125242-01-704	EA	BUSHING-HINGE MIDDLE	618746
	125242-02-725	EA	DOOR ASM/UPR LH/WHITE GASKET	621148
	125242-02-735	EA	DOOR ASM/UPR LH/BLACK GASKET	625220 AFT #1291390
	125242-01-719	EA	RETAINER-UPPER PANEL	618825 = 623166

APPLIANCE GROUP (CONTINUED)
COMPONENTS PARTS FOR APPLIANCE (CONTINUED)

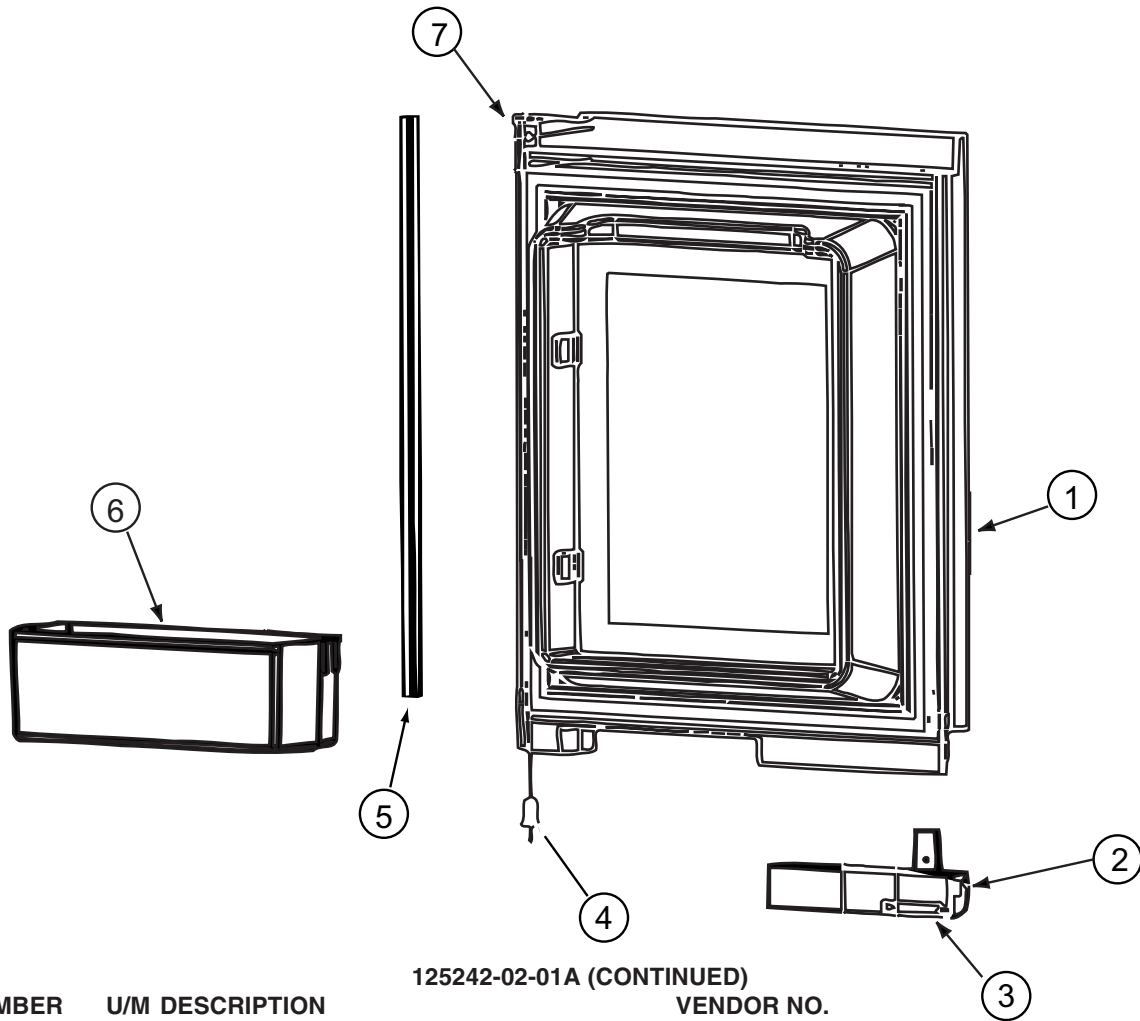

125242-02-01A (CONTINUED)

KEY	PART NUMBER	U/M	DESCRIPTION	VENDOR NO.
1	125242-01-763	EA	LINER/FOAMED-UPPER/RH-WHITE	619840
1	125242-02-733	EA	LINER/FOAMED-UPPER/RH-BLACK	625213 1291391 & UP
2	125242-02-701	EA	HANDLE(CONTOUR)TOP RH LWR LH	621106
3	125242-02-722	EA	LATCH-STORAGE DR/BLK POINTED	619374
4	125242-01-704	EA	BUSHING-HINGE MIDDLE	618746
5	125242-02-723	EA	RETAINER/PANEL-UPPER DOOR	623166
6	125242-03-704	EA	BIN - DOOR SHELF	622831
7	125242-02-724	EA	HINGE - DOOR	618792
	125242-02-721	EA	DOOR ASM-UPR/RH/WHITE GASKET	621149
	125242-02-732	EA	DOOR ASM-UPR/RH/BLACK GASKET	625221 1291391 & UP
	125242-01-719	EA	RETAINER-UPPER PANEL	618825 = 623166

APPLIANCE GROUP (CONTINUED)
COMPONENTS PARTS FOR APPLIANCE (CONTINUED)

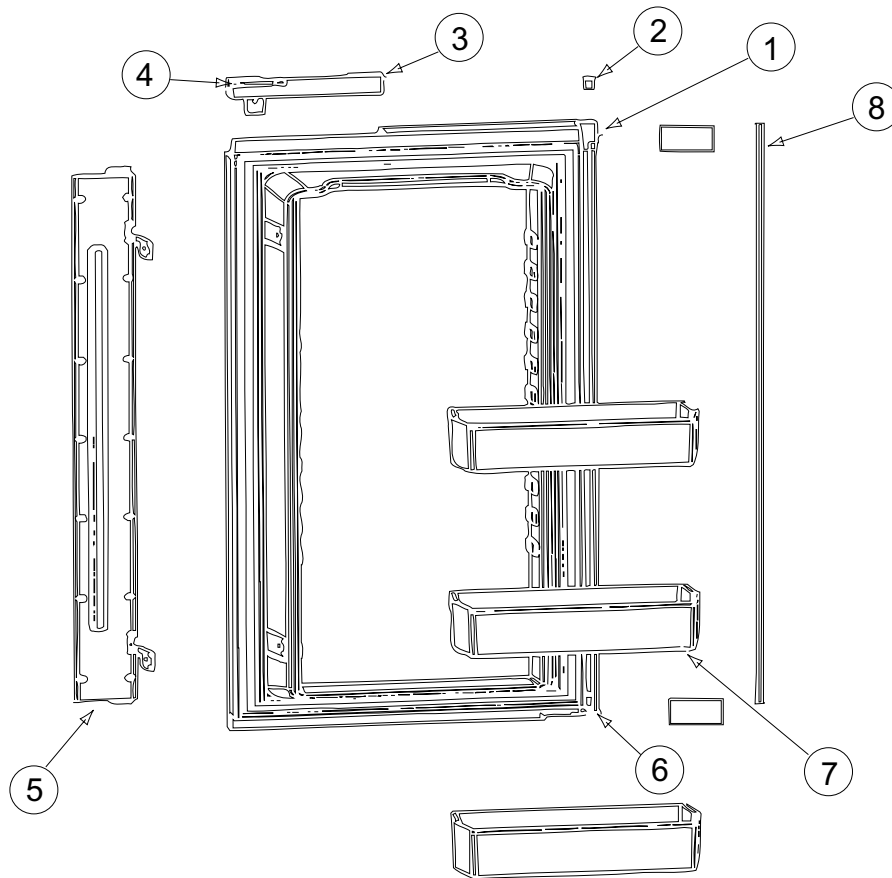

125242-02-01A (CONTINUED)

KEY	PART NUMBER	U/M	DESCRIPTION	VENDOR NO.
1	125242-01-765	EA	LINER/FOAMED-LOWER-LH-WHITE	619837
1	125242-02-739	EA	LINER/FOAMED-LOWER-LH-BLACK	625214 1291390 & UP
2	125242-01-704	EA	BUSHING-HINGE MIDDLE	618746
3	125242-02-701	EA	HANDLE(CONTOUR)TOP RH LWR LH	621106
4	125242-02-722	EA	LATCH-STORAGE DR/BLK POINTED	619374
5	125242-02-727	EA	FLAPPER/DBL POLE (SER#540295) UP	619845
5	125242-02-740	EA	FLAPPER/DBL POLE SER#1291391	623887 1291391 & UP
6	125242-02-724	EA	HINGE - DOOR	618792
7	125242-03-704	EA	BIN - DOOR SHELF	622831
8	125242-02-728	EA	RETAINER/PANEL - LOWER	623167
	125242-01-736	EA	CONTACT-PROBE PIN	618886
	125242-02-726	EA	DOOR ASM-LWR LH/WHITE GASKET	621150
	125242-02-738	EA	DOOR ASM-LWR LH/BLACK GASKET	625222 1291390 & UP
	125242-02-716	EA	GUIDE ASM LWR(SER#540294 DN)	620042
	125242-02-717	EA	GUIDE ASM LWR(SER#540295 UP)	620043

APPLIANCE GROUP (CONTINUED)
COMPONENTS PARTS FOR APPLIANCE (CONTINUED)

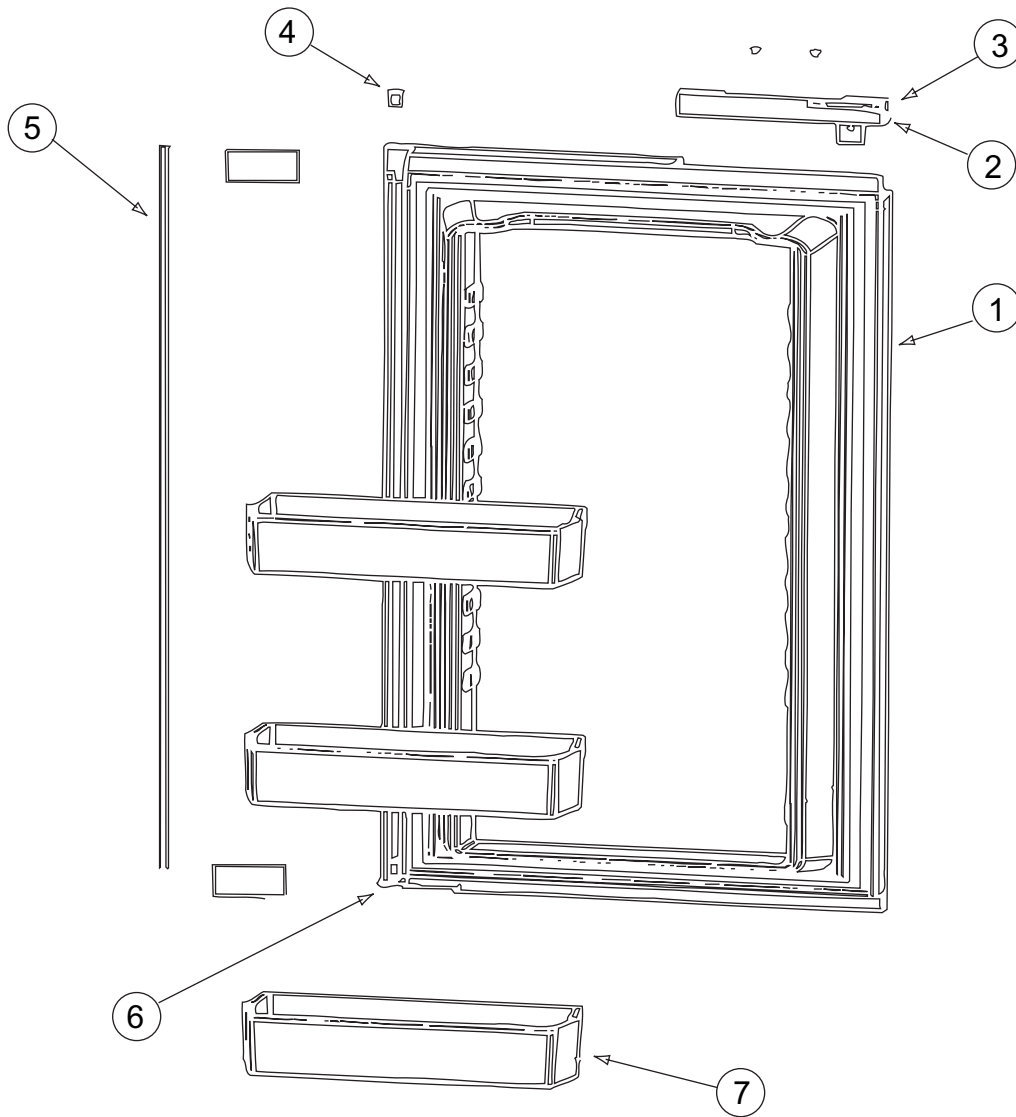

125242-02-01A (CONTINUED)

KEY	PART NUMBER	U/M	DESCRIPTION	VENDOR NO.
1	125242-01-764	EA	LINER/FOAMED-LOWER/RH-WHITE	619838
1	125242-02-737	EA	LINER/FOAMED-LOWER/RH-BLACK	625215 F/1291391&UP
2	125242-02-700	EA	HANDLE(CONTOUR)TOP LH BTM RH	621107
3	125242-02-722	EA	LATCH-STORAGE DR/BLK POINTED	619374
4	125242-01-704	EA	BUSHING-HINGE MIDDLE	618746
5	125242-02-728	EA	RETAINER/PANEL - LOWER	623167
6	125242-02-724	EA	HINGE - DOOR	618792
7	125242-03-704	EA	BIN - DOOR SHELF	622831
	125242-02-729	EA	DOOR ASM-LWR RH/WHITE GASKET	621151
	125242-02-736	EA	DOOR ASM-LWR RH/BLACK GASKET	625223 F/1291391&UP
	125242-02-716	EA	GUIDE ASM LWR(SER#540294 DN)	620042
	125242-02-717	EA	GUIDE ASM LWR(SER#540295 UP)	620043

APPLIANCE GROUP (CONTINUED)
COMPONENTS PARTS FOR APPLIANCE (CONTINUED)

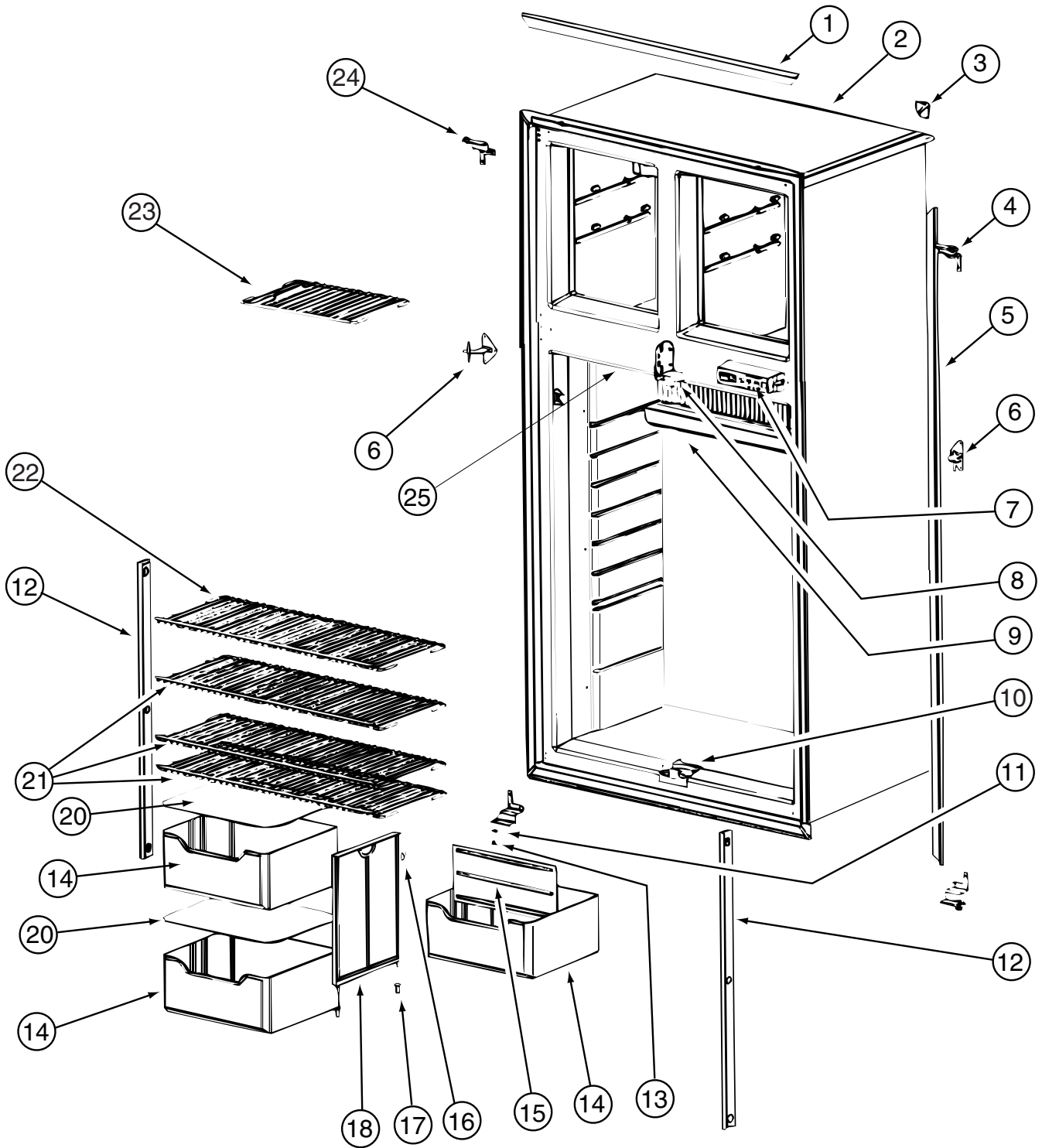

125242-02-01A (CONTINUED)

APPLIANCE GROUP (CONTINUED)
COMPONENTS PARTS FOR APPLIANCE (CONTINUED)

125242-02-01A (CONTINUED)

KEY	PART NUMBER	U/M	DESCRIPTION	VENDOR NO.
1	125242-01-723	EA	TRIM-HORIZONTAL-FRT SNAP ON	618845
1	125242-02-730	EA	TRIM - TOP/BOTTOM - SCREW ON	623255
2	125242-01-748	EA	CABINET/FOAMED ASSEMBLY	618748
3	125242-01-722	EA	TRIM-CORNER	618844
3	125242-01-767	EA	KIT INSTALL(U TRIM PCS)HDW	623528
4	125242-01-715	EA	HINGE - TOP RH/BOTTOM LH	618798
5	125242-01-724	EA	TRIM-LT/RT-FRT VERT SNAPON	618846
5	125242-01-766	EA	TRIM-LT/RT HAND-SCREW ON	623254
6	125242-01-713	EA	HINGE-MIDDLE (PAINTED)	618794
7	125242-02-704	EA	DISPLAY ASM (SER#832172) UP	621188
8	125242-01-751	EA	BLOCK - GUIDE - UPPER	618789
9	125242-01-712	EA	DRIP TRAY	618774
10	125242-01-752	EA	BLOCK - GUIDE - LOWER	618788
11	120075-01-708	EA	BUSHING-DOOR HINGE	618144
12	120075-01-730	EA	RETAINER-SHELF(SER#926684 DN	618181
12	125242-02-720	EA	RETAINER/SHELF(SER#926685 UP	622033
13	120075-01-727	EA	PIN-HINGE	618145
14	125242-01-734	EA	CRISPER/BOTTLE BIN	618878
15	125242-01-733	EA	DIVIDER-BOTTLE CRISPER	618877
16	125242-01-750	EA	CLIP	61409622
17	113737-01-701	EA	BUSHING-HINGE	61742022
18	125242-01-749	EA	SUPPORT - WALL	618840
20	125242-01-706	EA	COVER-CRISPER	618757
21	125242-01-726	EA	SHELF-WIRE (LONG)	618848
22	125242-01-727	EA	SHELF-WIRE (SHORT)	618849
23	125242-01-725	EA	SHELF-FREEZER (WIRE)	618847
24	125242-01-714	EA	HINGE - TOP LH/BOTTOM RH	618796
25	125242-01-735	EA	SWITCH - DOOR LIGHT	618884
25	125242-01-768	EA	SWITCH - DOOR LIGHT	623918
	120075-01-714	EA	PLUG-HOLE (BLACK)	618170
	125242-01-728	EA	CAP-SCREW WHITE	618853

APPLIANCE GROUP (CONTINUED)
COMPONENTS PARTS FOR APPLIANCE (CONTINUED)

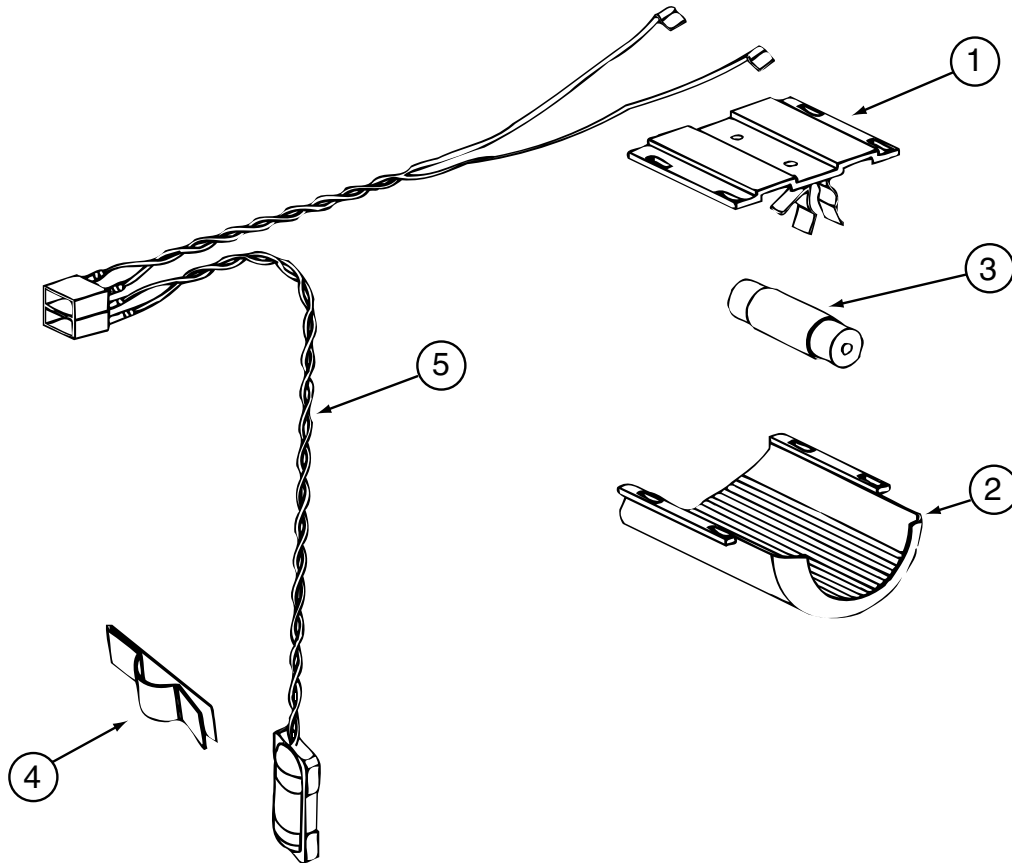

125242-02-01A (CONTINUED)

KEY	PART NUMBER	U/M	DESCRIPTION	VENDOR NO.
1	084880-03-705	EA	BRACKET-LIGHT-INTERIOR	61629722
2	120075-01-734	EA	COVER-LENS	618190
3	084880-03-706	EA	BULB-LAMP	61628922
4	084880-01-760	EA	CLIP (THERMISTER)	61689122
5	120075-01-735	EA	THERMISTER W/LAMP & WIRE/ASM	618548
	125242-02-706	EA	LAMP/WIRE ASM/SER#849677 UP	620871
	125242-02-707	EA	LAMP/WIRE ASM SER#849677 DWN	621742

APPLIANCE GROUP (CONTINUED)
COMPONENTS PARTS FOR APPLIANCE (CONTINUED)

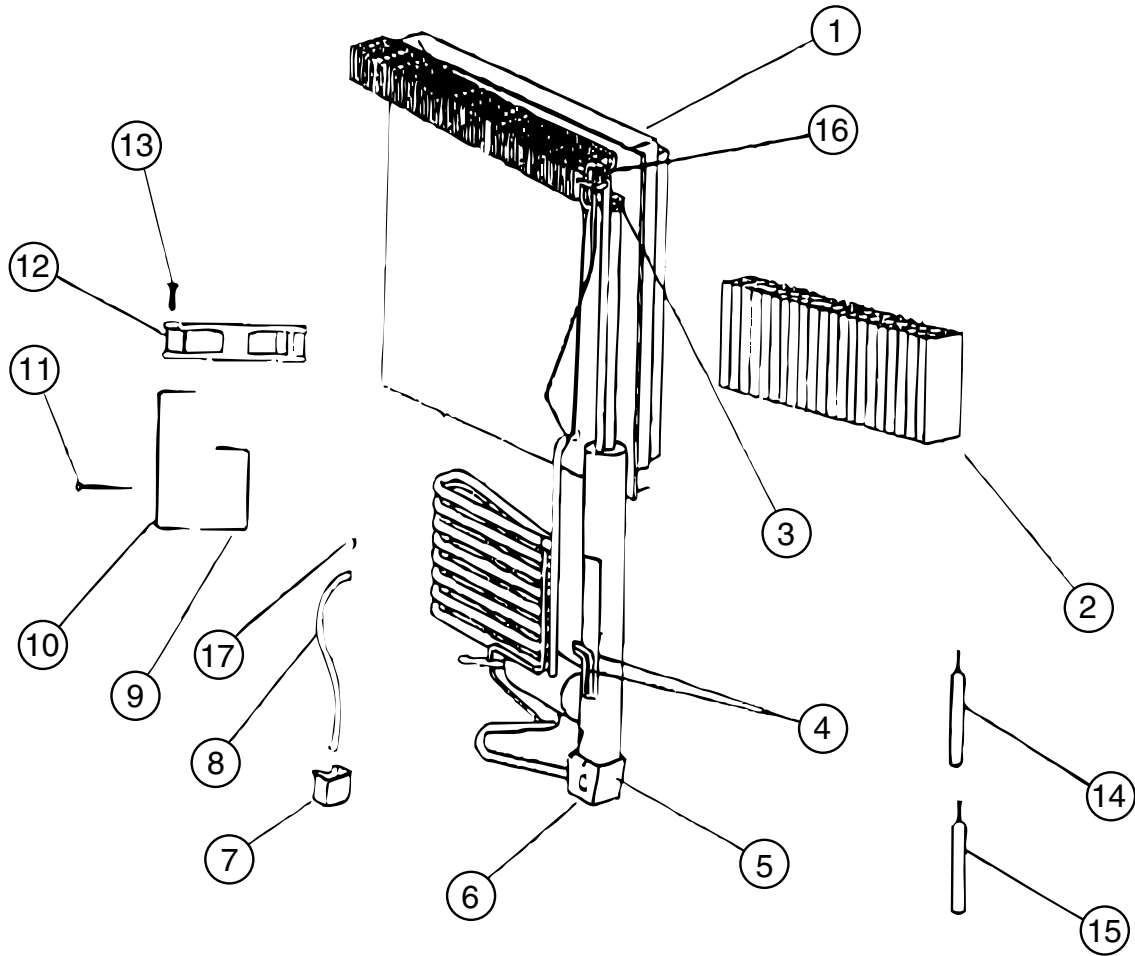

125242-02-01A (CONTINUED)

KEY	PART NUMBER	U/M	DESCRIPTION	VENDOR NO.
1	125242-01-746	EA	COOLING UNIT - 1200	618964
4	125242-01-732	EA	HEATER AC - 225W/110VAC	618872
5	125242-01-739	EA	BASE-BURNER BOX	618902
6	125242-01-740	EA	COVER-BURNER BOX	618910
9	125242-01-730	EA	BRACKET-DC FAN	618857
10	125242-01-741	EA	SUPPORT-DC FAN	618912
12	125242-01-729	EA	FAN-EXTERNAL DC	618856
16	113737-01-754	EA	THERMOSTAT (FAN 12V DC)	618093

CONTACT WINNEBAGO PART SALES FOR UNLISTED COMPONENTS

APPLIANCE GROUP (CONTINUED)
COMPONENTS PARTS FOR APPLIANCE (CONTINUED)

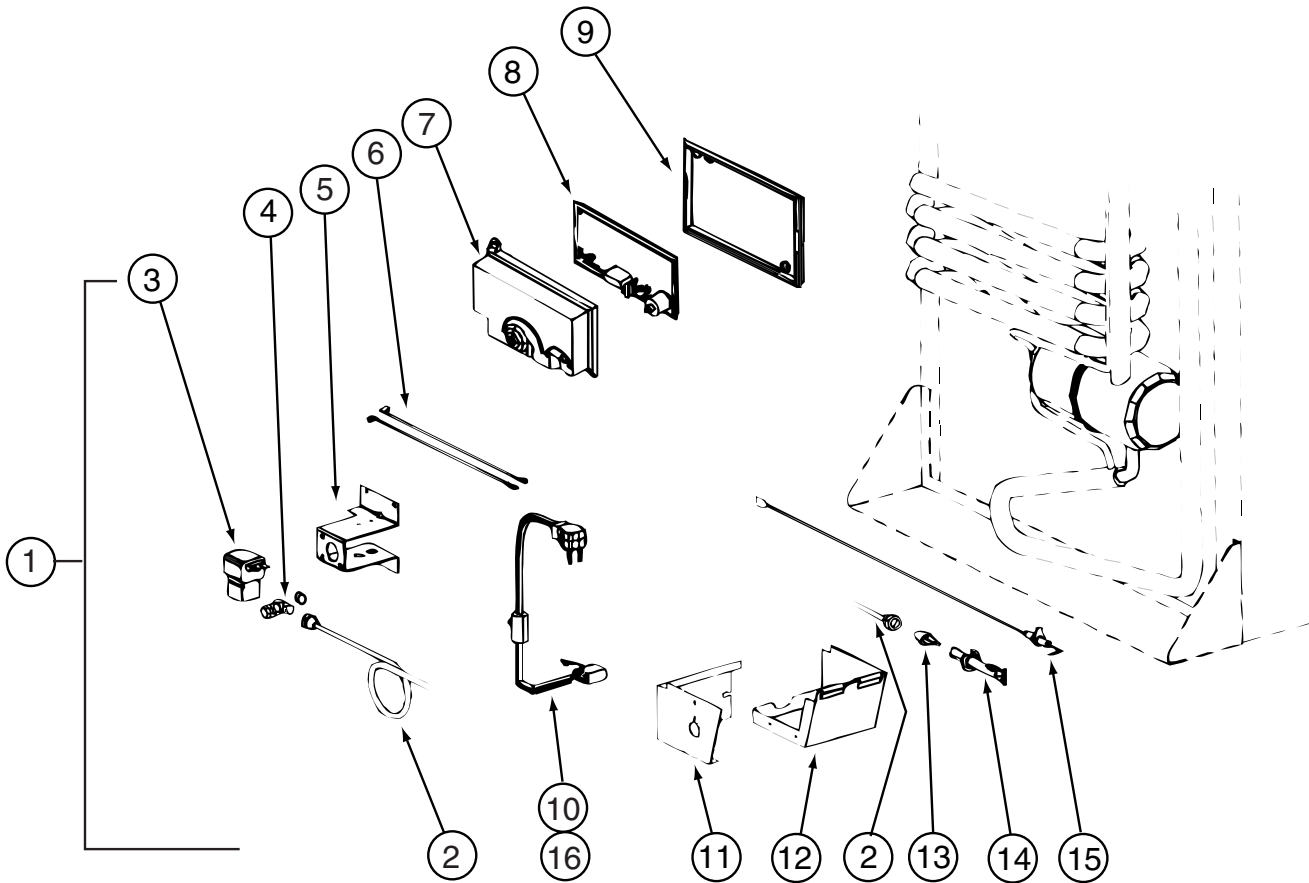

125242-02-01A (CONTINUED)

KEY	PART NUMBER	U/M	DESCRIPTION	VENDOR NO.
1	125242-01-753	EA	KIT-GAS VALVE/SOLENOID/TUBE	621445
2	125242-01-744	EA	BURNER TUBE	618937
4	113737-01-716	EA	TAP-PRESSURE	61594422
7	120075-01-738	EA	COVER-POWER BOARD	618185
8	125242-02-703	EA	POWER BOARD (SER #832171 UP)	621271
9	120075-01-740	EA	COVER-BASE, POWER BOARD	618186
11	125242-01-740	EA	COVER-BURNER BOX	618910
12	125242-01-739	EA	BASE-BURNER BOX	618902
13	125242-01-717	EA	ORIFICE-JEWELLED	618814
14	125242-01-743	EA	BURNER - 8 SLOT	618932
15	104137-06-715	EA	ELECTRODE-SPARK/SENSOR, SGL	61692222
			CONTACT WINNEBAGO PART SALES FOR UNLISTED COMPONENT(S)	

APPLIANCE GROUP (CONTINUED)
COMPONENTS PARTS FOR APPLIANCE (CONTINUED)

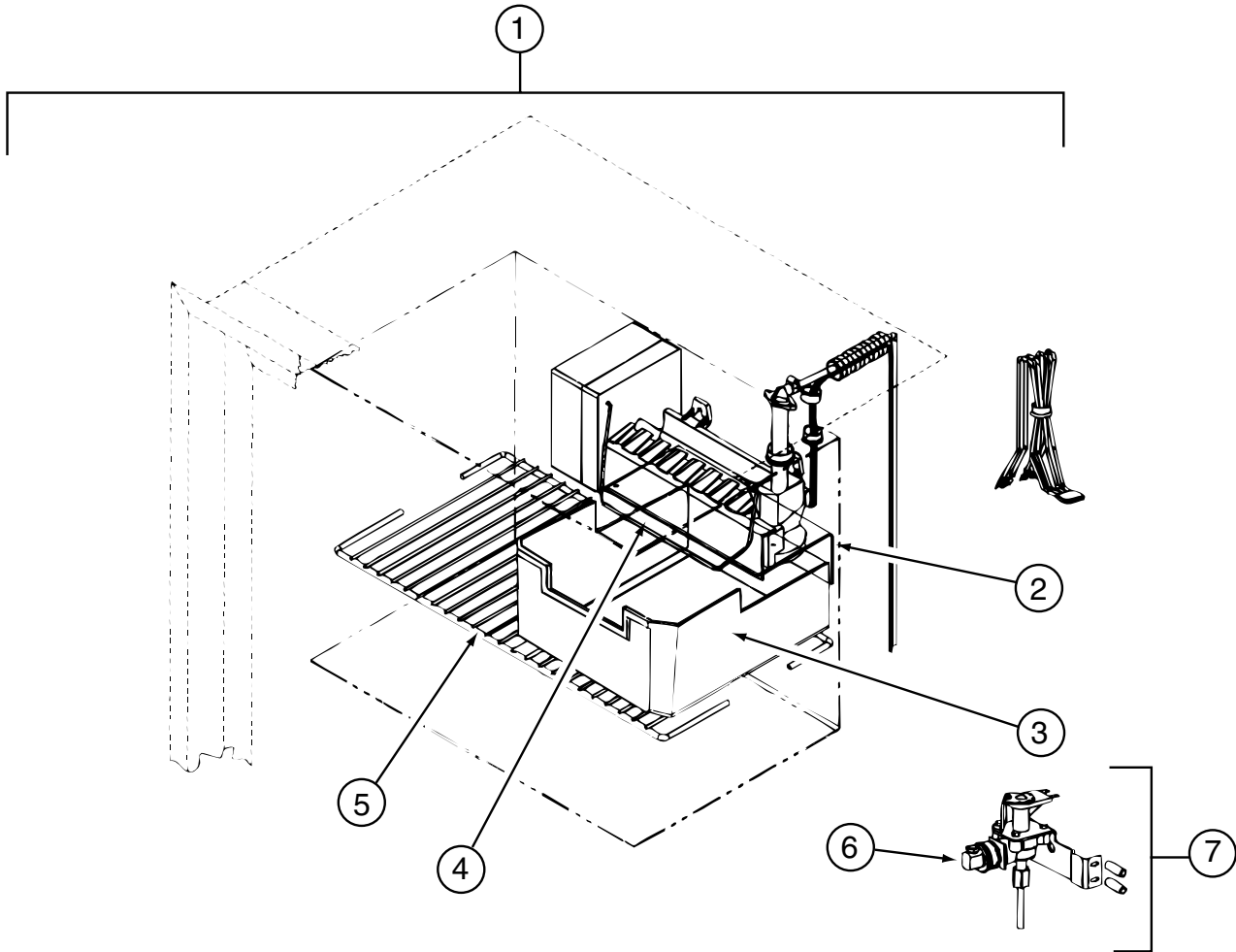

125242-02-01A (CONTINUED)

KEY	PART NUMBER	U/M	DESCRIPTION	VENDOR NO.
1	094039-07-706	EA	ICE MAKER W/O PLATES	61656522
2	125242-01-737	EA	BRACKET-MOUNTING (ICE MAKER)	618894/620890
3	125242-01-716	EA	ICE BIN	618803
4	120075-03-703	EA	ARM-SHUT OFF	61656922
5	125242-01-725	EA	SHELF-FREEZER (WIRE)	618847
6	120075-03-702	EA	NUT/COMPRESSION - FITTING	61678722
7	120075-03-701	EA	VALVE ASM., WATER, W/BRACKET	618253

APPLIANCE GROUP (CONTINUED)
COMPONENTS PARTS FOR APPLIANCE (CONTINUED)

126022-01-01A, 126022-02-01A, 126022-03-01A

KEY	PART NUMBER	U/M	DESCRIPTION	VENDOR NO.
	114030-01-707	EA	PLUG BUTTON BLACK	74002628
	126022-01-700	EA	BUMPER - RANGE BIFOLD COVER	MAGIC 8003P007-60
	126022-01-701	EA	HINGE-RANGE BIFOLD COVER-22"	MAGIC 3418F067-34

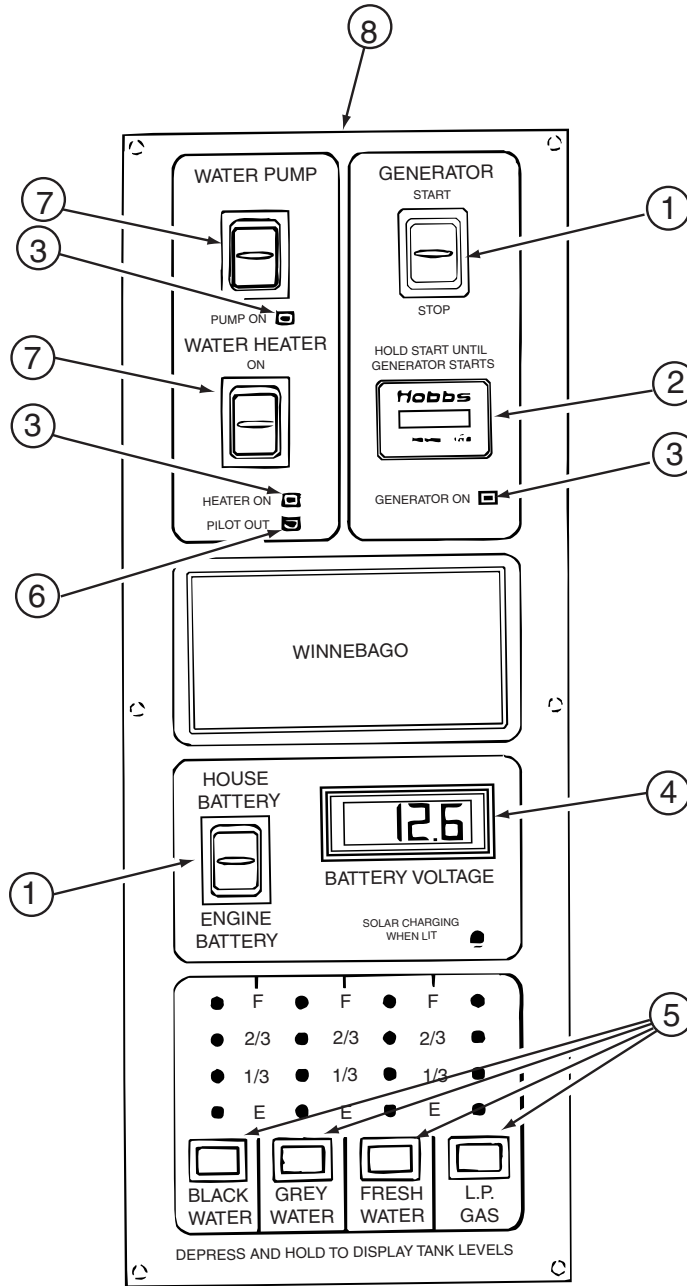

133004-02-01A

KEY	PART NUMBER	U/M	DESCRIPTION	VENDOR NO.
1	133004-01-702	EA	SWITCH/DPDT MOM=ON-OFF-ON	L1011-00
2	100258-10-701	EA	GAUGE-HR METER ONLY (LCD)	L0775-00
3	133004-01-706	EA	L.E.D. GREEN-PANEL MOUNT	L0785
4	133004-01-704	EA	METER/VOLT-DIGITAL - LCD	L1008-00
5	133004-01-705	EA	SWITCH/MOM ON - PUSH BUTTON	L0950-00
6	133004-01-703	EA	L.E.D. RED-PANEL MOUNT	L1009-00
7	133004-01-701	EA	SWITCH/DPDT ON-ON/MAINTAINED	L1025-00
8	133004-02-701	EA	SCREENED - CHASSIS	CC0547-00
	133004-02-700	EA	BOARD - PC	L5113-03

APPLIANCE GROUP (CONTINUED)
COMPONENTS PARTS FOR APPLIANCE (CONTINUED)

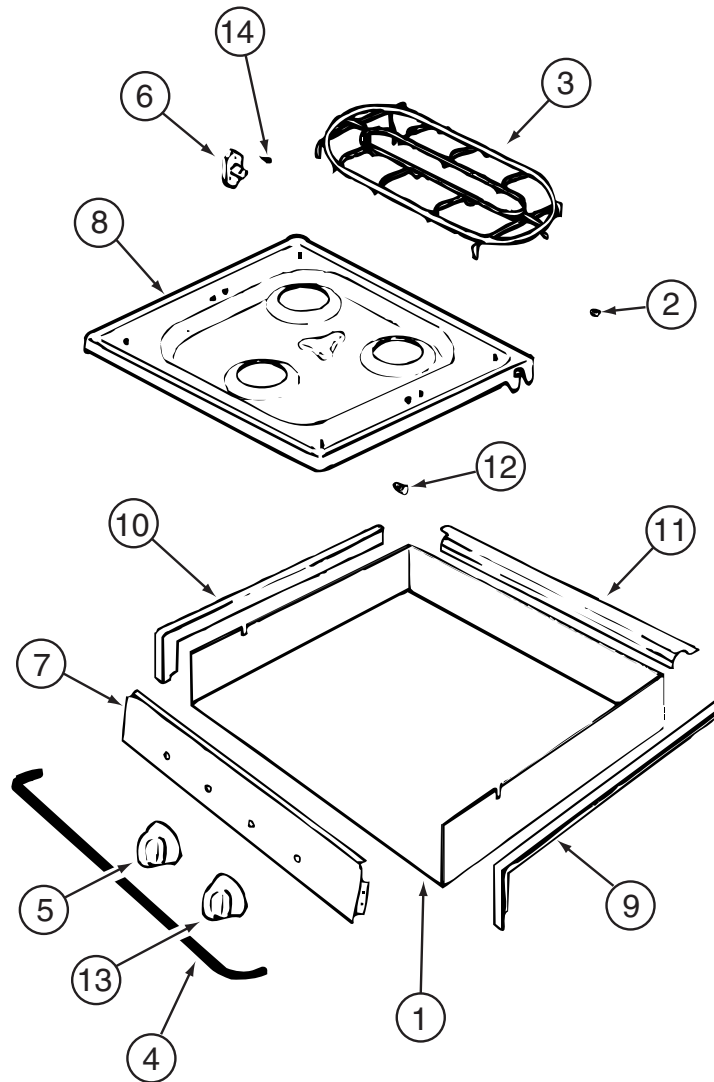

135065-01-01A, 135065-01-02A, 135065-02-01A

KEY	PART NUMBER	U/M	DESCRIPTION	VENDOR NO.
2	102020-01-709	EA	BUMPER-GRATE	8007-P020-60
3	128728-01-700	EA	GRATE - BURNER	74003948
4	114030-02-700	EA	GUARD/FABRIC - TOWEL BAR	3609F006-70
5	112881-01-705	EA	KNOB-TOP BURNER	7733P072-60
5	112881-01-718	EA	KNOB - TOP BURNER HI-OUTPUT	74001794
6	128728-01-703	EA	PIN/T-NUT F/HINGE	7103P109-60
7	135065-01-700	EA	PANEL/MANIFOLD	74003354
8	128728-01-705	EA	TOP - MAIN - BLACK	74003928
8	135066-01-700	EA	TOP - MAIN - BISQUE	74005332
9	114030-01-704	EA	TRIM - RIGHT/BLACK TEXTURED	74002839
10	114030-01-705	EA	TRIM - LEFT/BLACK TEXTURED	74002840
11	114030-01-706	EA	TRIM - REAR/BLACK TEXTURED	74002841
12	102020-01-724	EA	BUMPER-MAIN TOP	8003P008-60
13	126023-01-720	EA	KNOB - IGNITER	74002414

CONTACT WINNEBAGO PART SALES FOR UNLISTED COMPONENTS

APPLIANCE GROUP (CONTINUED)
COMPONENTS PARTS FOR APPLIANCE (CONTINUED)

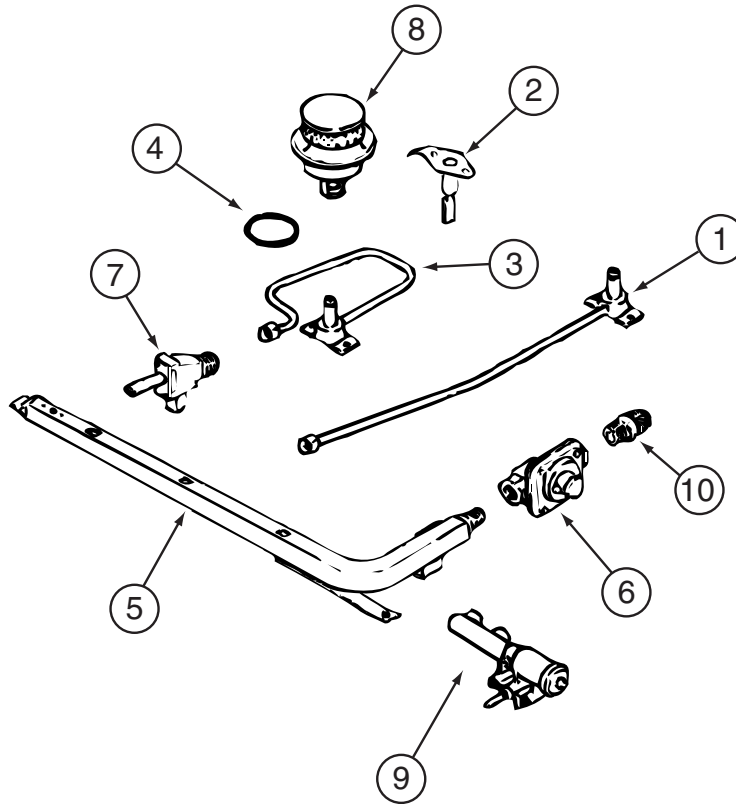

135065-01-01A, 135065-01-02A, 135065-02-01A (CONTINUED)

KEY	PART NUMBER	U/M	DESCRIPTION	VENDOR NO.
1	128728-01-708	EA	FITTING W/ORFICE/TUBE - REAR	74003931
2	135065-01-701	EA	IGNITOR/PORCELAIN-TOP BURNER	74004053
3	128728-01-710	EA	FITTING W/ORFICE/TUBE - FRT	74003930
4	128728-01-711	EA	GASKET - BURNER	74002745
5	135065-01-702	EA	PIPE/MANIFOLD	74004642
6	126023-02-703	EA	REGULATOR - PRESSURE	74004235
7	135065-01-703	EA	VALVE/BURNER - REAR	74004643
7	135065-01-704	EA	VALVE/BURNER-FRT-HI	74004644
8	135065-01-705	EA	BURNER/SEALED ASSEMBLY	12001497
9	128728-01-716	EA	BURNER - IGNITOR	74003946
9	128728-01-717	EA	WIRES - IGNITOR	74003947

APPLIANCE GROUP (CONTINUED)
COMPONENTS PARTS FOR APPLIANCE (CONTINUED)

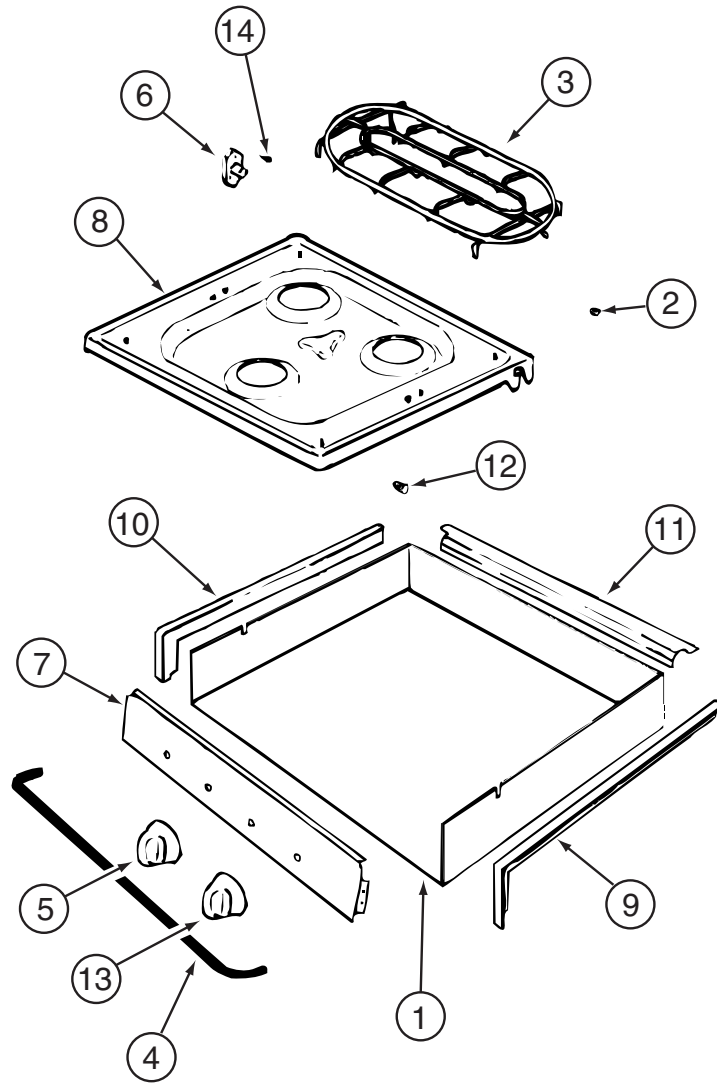

135065-03-01A, 135065-03-03A, 135065-04-01A

KEY	PART NUMBER	U/M	DESCRIPTION	VENDOR NO.
2	102020-01-709	EA	BUMPER-GRATE	8007-P020-60
3	135065-03-703	EA	GRATE - BLACK(SEALED BURNER)	74007304
4	114030-02-700	EA	GUARD/FABRIC - TOWEL BAR	3609F006-70
5	128728-01-701	EA	KNOB - BURNER - REAR	74003941
5	128728-01-702	EA	KNOB - BURNER - FRONT	74003942
6	128728-01-703	EA	PIN/T-NUT F/HINGE	7103P109-60
7	135065-03-704	EA	PANEL - MANIFOLD (BLACK)	74007330
8	128728-01-705	EA	TOP - MAIN - BLACK	74003928
8	135065-03-715	EA	TOP - MAIN - STAINLESS STEEL	74007299
9	114030-01-704	EA	TRIM - RIGHT/BLACK TEXTURED	74002839
10	114030-01-705	EA	TRIM - LEFT/BLACK TEXTURED	74002840
11	114030-01-706	EA	TRIM - REAR/BLACK TEXTURED	74002841
12	102020-01-724	EA	BUMPER-MAIN TOP	8003P008-60
13	128728-01-707	EA	KNOB - IGNITOR	74003944

CONTACT WINNEBAGO PART SALES FOR UNLISTED COMPONENTS

APPLIANCE GROUP (CONTINUED)
COMPONENTS PARTS FOR APPLIANCE (CONTINUED)

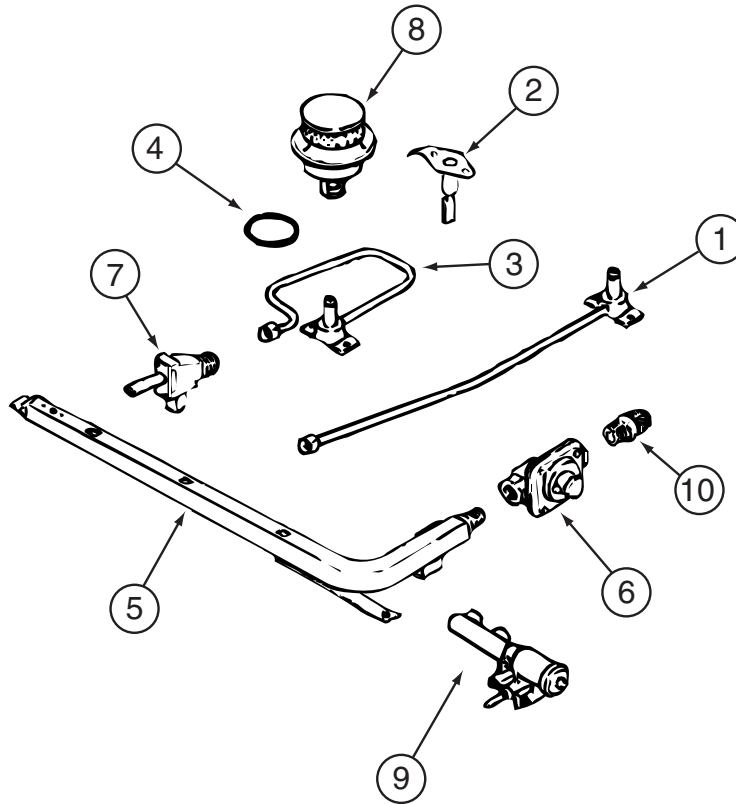

135065-03-01A, 135065-03-03A, 135065-04-01A (CONTINUED)

KEY	PART NUMBER	U/M	DESCRIPTION	VENDOR NO.
1	128728-01-708	EA	FITTING W/ORFICE/TUBE - REAR	74003931
2	135065-01-701	EA	IGNITOR/PORCELAIN-TOP BURNER	74004053
3	128728-01-710	EA	FITTING W/ORFICE/TUBE - FRT	74003930
4	135065-03-700	EA	FITTING - HALF UNION	74004234
5	135065-01-702	EA	PIPE/MANIFOLD	74004642
6	126023-02-703	EA	REGULATOR - PRESSURE	74004235
7	135065-01-703	EA	VALVE/BURNER - REAR	74004643
7	135065-01-704	EA	VALVE/BURNER-FRT-HI	74004644
7	135065-03-701	EA	SCREW - VALVE	71003231
8	135065-03-702	EA	SEALED BURNER ASM.(BLACK) RV	74003967
9	128728-01-716	EA	BURNER - IGNITOR	74003946
9	128728-01-717	EA	WIRES - IGNITOR	74003947

APPLIANCE GROUP (CONTINUED)
COMPONENTS PARTS FOR APPLIANCE (CONTINUED)

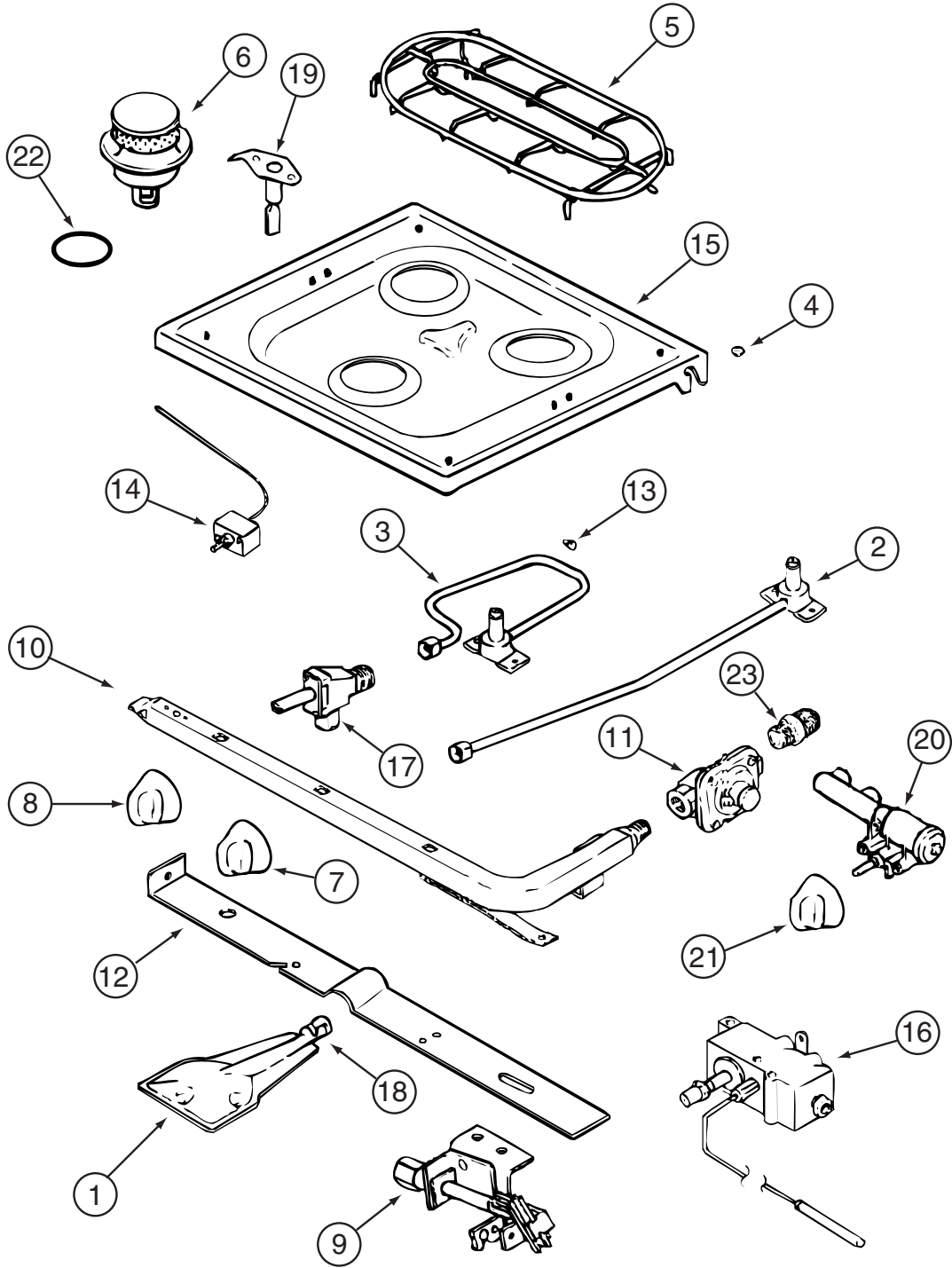

135066-02-01A

APPLIANCE GROUP (CONTINUED)
COMPONENTS PARTS FOR APPLIANCE (CONTINUED)

135066-02-01A (CONTINUED)

KEY	PART NUMBER	U/M	DESCRIPTION	VENDOR NO.
1	126023-01-717	EA	BURNER - OVEN	74003343
2	128728-01-708	EA	FITTING W/ORFICE/TUBE - REAR	74003931
3	128728-01-710	EA	FITTING W/ORFICE/TUBE - FRT	74003930
4	102020-01-709	EA	BUMPER-GRATE	8007-P020-60
5	128728-01-700	EA	GRATE - BURNER	74003948
6	135065-01-705	EA	BURNER/SEALED ASSEMBLY	12001497
7	112881-01-705	EA	KNOB-TOP BURNER	7733P072-60
7	112881-01-718	EA	KNOB - TOP BURNER HI-OUTPUT	74001794
8	135656-01-700	EA	KNOB/THERMOSTAT	74002529
9	126023-02-701	EA	PILOT - OVEN	74004586
10	126023-02-702	EA	PIPE - MANIFOLD	74004360
11	135066-02-700	EA	REGULATOR - PRESSURE	74004236
13	102020-01-724	EA	BUMPER-MAIN TOP	8003P008-60
14	126023-01-734	EA	THERMOSTAT/OVEN SERIES #11	74006332
15	128728-01-705	EA	TOP - MAIN - BLACK	74003928
16	126023-02-704	EA	VALVE/OVEN - MERCURY	74004585
17	135065-01-703	EA	VALVE/BURNER - REAR	74004643
17	135065-01-704	EA	VALVE/BURNER-FRT-HI	74004644
18	135656-01-701	EA	MIXER/AIR	3411F003-34
19	135065-01-701	EA	IGNITOR/PORCELAIN-TOP BURNER	74004053
20	128728-01-716	EA	BURNER - IGNITOR	74003946
20	128728-01-717	EA	WIRES - IGNITOR	74003947
21	126023-01-720	EA	KNOB - IGNITER	74002414

CONTACT WINNEBAGO PART SALES FOR UNLISTED COMPONENTS

APPLIANCE GROUP (CONTINUED)
COMPONENTS PARTS FOR APPLIANCE (CONTINUED)

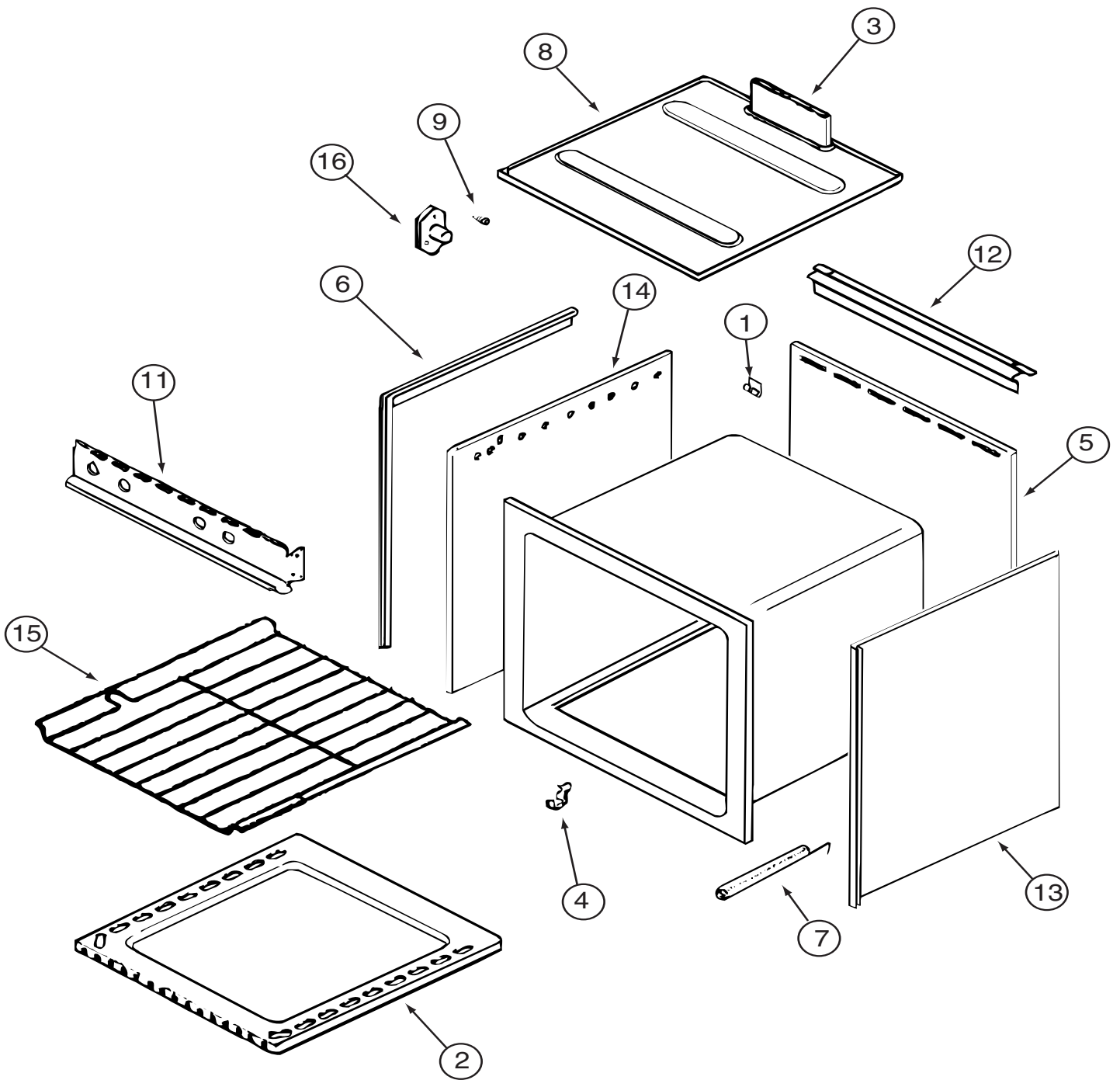

135066-01-01A, 135066-01-02A, 135066-02-01A (CONTINUED)

KEY	PART NUMBER	U/M	DESCRIPTION	VENDOR NO.
1	112881-03-702	EA	CLIP - MAIN TOP	74003998
2	126023-01-731	EA	BOTTOM - OVEN	2205F016-19
3	126023-01-718	EA	FLUE BOX ASSEMBLY	4006W075-80
6	126023-01-713	EA	TRIM - SIDE (RIGHT)	74002827
6	126023-01-714	EA	TRIM - SIDE (LEFT)	74002828
11	126023-01-729	EA	PANEL - MANIFOLD	74003351
15	126023-01-716	EA	RACK - OVEN	74003106
	126023-01-738	EA	CLIP - GLASS OVEN/BLACK	7112P093-60

CONTACT WINNEBAGO PART SALES FOR UNLISTED COMPONENTS

APPLIANCE GROUP (CONTINUED)
COMPONENTS PARTS FOR APPLIANCE (CONTINUED)

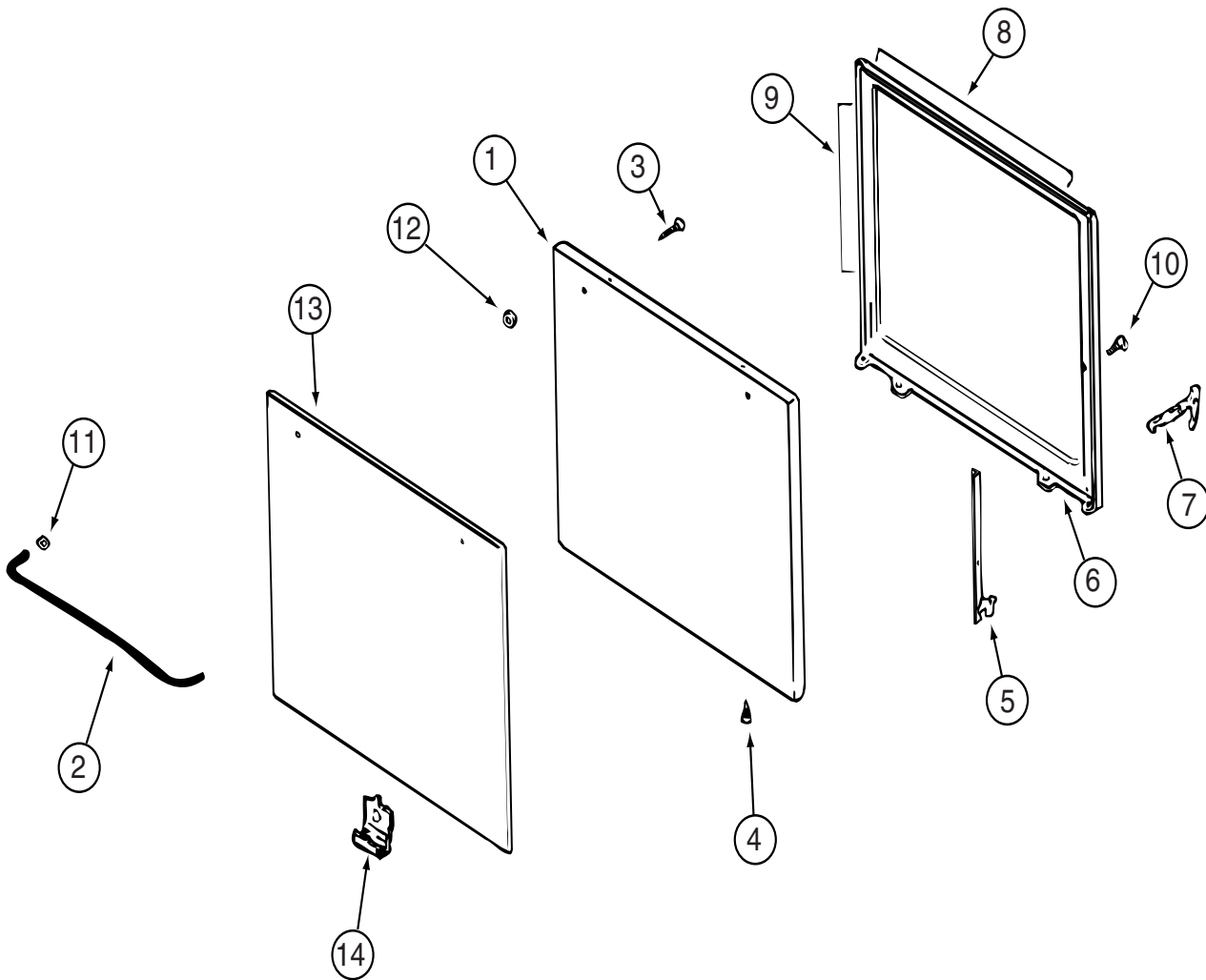

135066-01-01A, 135066-01-02A, 135066-02-01A (CONTINUED)

KEY	PART NUMBER	U/M	DESCRIPTION	VENDOR NO.
1	126023-01-712	EA	PANEL - DOOR (BLACK)	74001190
2	102020-01-701	EA	HANDLE,DOOR	7701P092-60
8	126023-01-732	EA	SEAL/OVEN DR TOP	7212P014-60
9	126023-01-733	EA	SEAL/OVEN DR SIDES(2PCS)	7212P038-60
13	102020-01-725	EA	GLASS OUTER	7902P266-60

CONTACT WINNEBAGO PART SALES FOR UNLISTED COMPONENTS

APPLIANCE GROUP (CONTINUED)
COMPONENTS PARTS FOR APPLIANCE (CONTINUED)

135066-03-01A, 135066-03-04A, 150778-01-01A (CONTINUED)

KEY	PART NUMBER	U/M	DESCRIPTION	VENDOR NO.
1	126023-01-717	EA	BURNER - OVEN	74003343
2	128728-01-708	EA	FITTING W/ORFICE/TUBE - REAR	74003931
3	128728-01-710	EA	FITTING W/ORFICE/TUBE - FRT	74003930
4	102020-01-709	EA	BUMPER-GRATE	8007-P020-60
5	135065-03-703	EA	GRATE - BLACK(SEALED BURNER)	74007304
6	135065-03-702	EA	SEALED BURNER ASM.(BLACK) RV	74003967
7	128728-01-701	EA	KNOB - BURNER - REAR	74003941
7	128728-01-702	EA	KNOB - BURNER - FRONT	74003942
8	112881-04-703	EA	KNOB - THERMOSTAT - BLACK	74004645
9	112881-04-706	EA	PILOT - OVEN	74006334
10	126023-02-702	EA	PIPE - MANIFOLD	74004360
11	126023-02-703	EA	REGULATOR - PRESSURE	74004235
13	102020-01-724	EA	BUMPER-MAIN TOP	8003P008-60
14	126023-01-734	EA	THERMOSTAT/OVEN SERIES #11	74006332
15	128728-01-705	EA	TOP - MAIN - BLACK	74003928
15	135065-03-705	EA	TOP - MAIN - BLACK F/1512790201A ONLY	74007300
15	135065-03-715	EA	TOP - MAIN - STAINLESS STEEL	74007299
16	112881-04-704	EA	VALVE - OVEN	74006333
17	135065-01-703	EA	VALVE/BURNER - REAR	74004643
17	135065-01-704	EA	VALVE/BURNER-FRT-HI	74004644
17	135065-03-701	EA	SCREW - VALVE	71003231
18	135656-01-701	EA	MIXER/AIR	3411F003-34
19	135065-01-701	EA	IGNITOR/PORCELAIN-TOP BURNER	74004053
20	128728-01-716	EA	BURNER - IGNITOR	74003946
20	128728-01-717	EA	WIRES - IGNITOR	74003947
21	128728-01-707	EA	KNOB - IGNITOR	74003944
22	135065-03-700	EA	FITTING - HALF UNION	74004234

CONTACT WINNEBAGO PART SALES FOR UNLISTED COMPONENTS

APPLIANCE GROUP (CONTINUED)
COMPONENTS PARTS FOR APPLIANCE (CONTINUED)

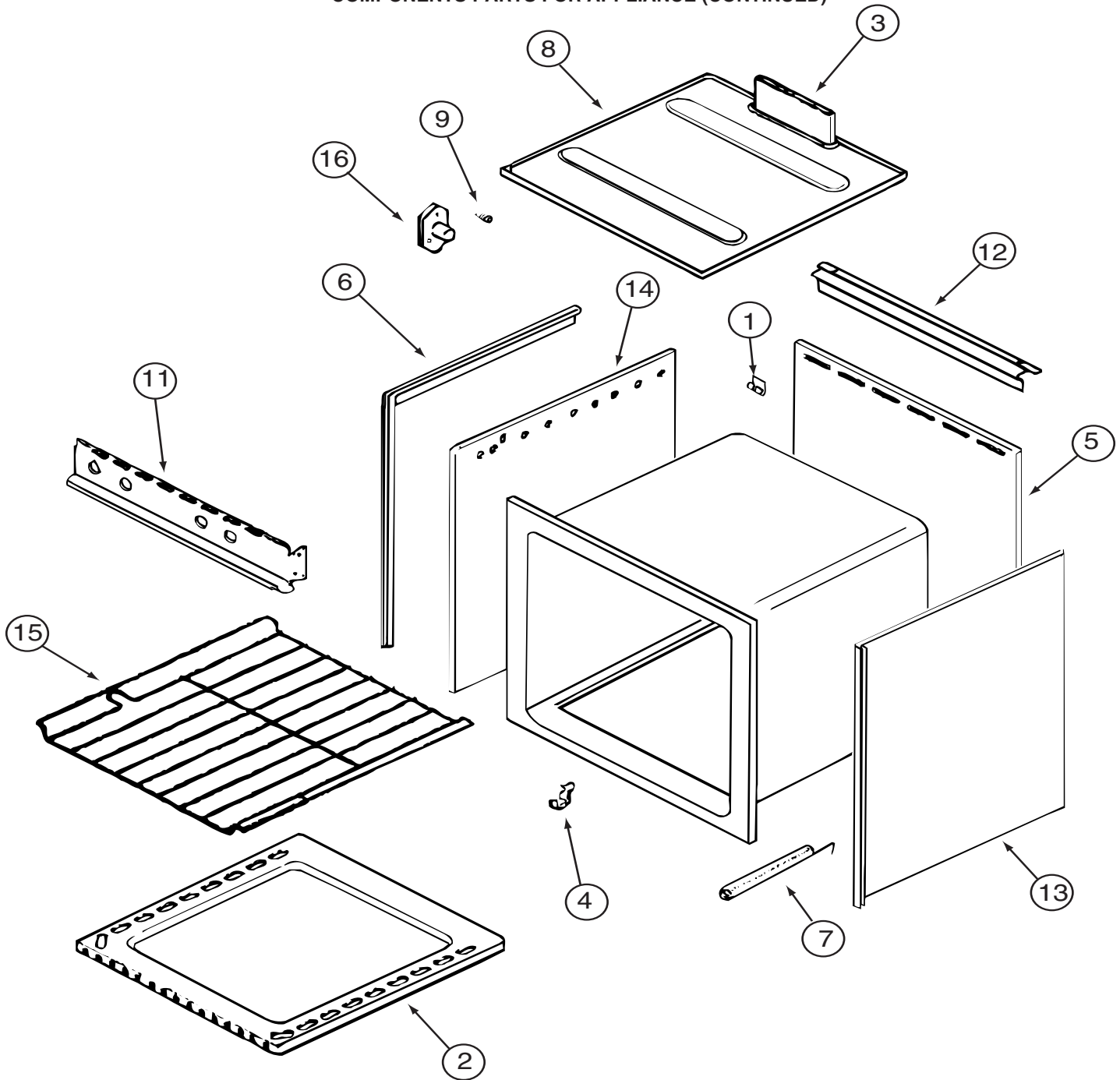

135066-03-01A/04A, 150778-01-01A, 151277-03-01A, 151279-02-01A/02A, 151279-03-01A (CONTINUED)

KEY	PART NUMBER	U/M	DESCRIPTION	VENDOR NO.
1	112881-03-702	EA	CLIP - MAIN TOP	74003998
2	126023-01-731	EA	BOTTOM - OVEN	2205F016-19
3	126023-01-718	EA	FLUE BOX ASSEMBLY	4006W075-80
6	126023-01-713	EA	TRIM - SIDE (RIGHT)	74002827
6	126023-01-714	EA	TRIM - SIDE (LEFT)	74002828
7	135066-03-708	EA	SPRING - OVEN DOOR	7803P053-60
9	128728-01-703	EA	PIN/T-NUT F/HINGE	7103P109-60
11	135066-03-701	EA	PANEL - MANIFOLD - BLACK	74007306
12	112881-01-721	EA	DEFLECTOR/FLUE-BLK-SEALED BR	74002829
15	126023-01-716	EA	RACK - OVEN	74003106

CONTACT WINNEBAGO PART SALES FOR UNLISTED COMPONENT(S)

APPLIANCE GROUP (CONTINUED)
COMPONENTS PARTS FOR APPLIANCE (CONTINUED)

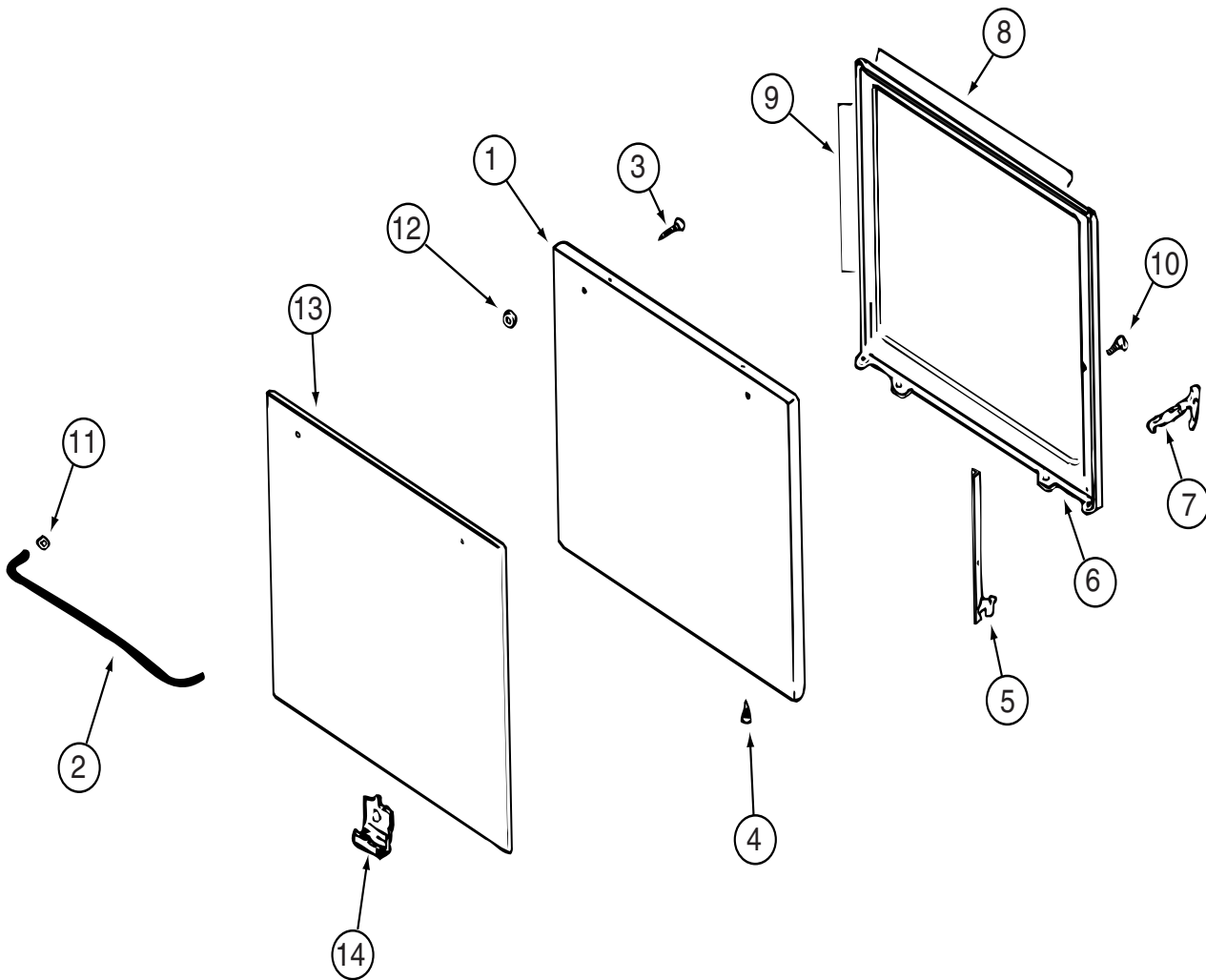

135066-03-01A, 135066-03-04A (CONTINUED)

KEY	PART NUMBER	U/M	DESCRIPTION	VENDOR NO.
1	126023-01-712	EA	PANEL - DOOR (BLACK)	74001190
1	135066-03-702	EA	PANEL - DOOR - STAINLESS STEEL	74007313
2	102020-01-701	EA	HANDLE,DOOR	7701P092-60
8	126023-01-732	EA	SEAL/OVEN DR TOP	7212P014-60
9	126023-01-733	EA	SEAL/OVEN DR SIDES(2PCS)	7212P038-60
13	102020-01-725	EA	GLASS OUTER	7902P266-60
			CONTACT WINNEBAGO PART SALES FOR UNLISTED COMPONENT(S)	

APPLIANCE GROUP (CONTINUED)
COMPONENTS PARTS FOR APPLIANCE (CONTINUED)

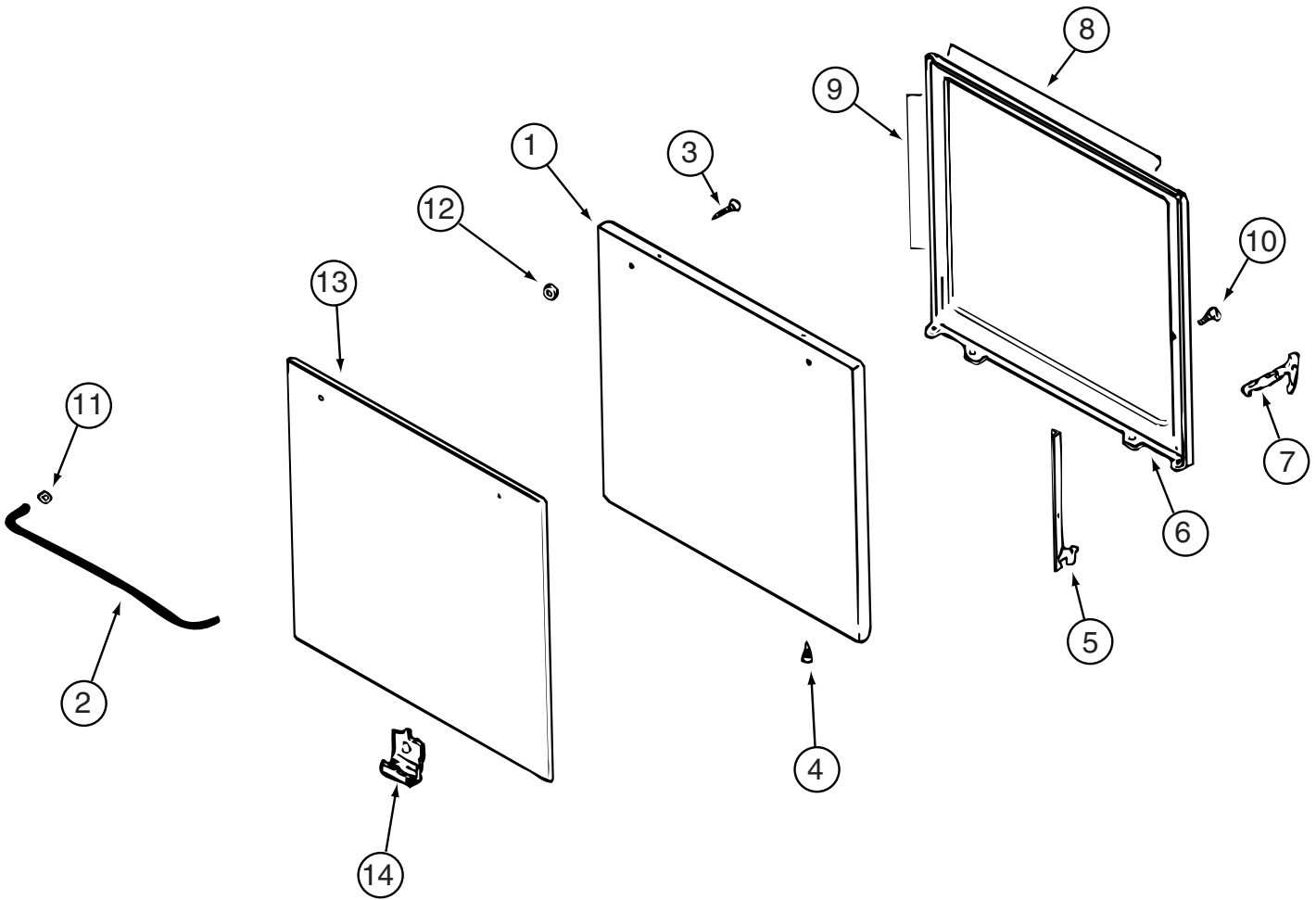

150778-01-01A, 151277-03-01A, 151279-02-01A, 151279-03-01A (CONTINUED)

KEY	PART NUMBER	U/M	DESCRIPTION	VENDOR NO.
1	126023-01-712	EA	PANEL - DOOR (BLACK)	74001190
2	128727-01-701	EA	HANDLE - OVEN DOOR	74003929
8	126023-01-732	EA	SEAL/OVEN DR TOP	7212P014-60
9	135066-03-714	EA	SEAL - OVEN DOOR SIDES	7212P039-60
13	102020-01-725	EA	GLASS OUTER	7902P266-60
14	126023-01-738	EA	CLIP - GLASS OVEN/BLACK	7112P093-60

CONTACT WINNEBAGO PART SALES FOR UNLISTED COMPONENT(S)

AUDIO VIDEO GROUP
RADIO SYSTEM

KEY	PART NUMBER	U/M	DESCRIPTION
*	143509-01-000	EA	RADIO - AM/FM CD - W/REMOTE - JENSEN CD3010X-W - EXT. ENTERTAINMENT FROM: 00-00-00 THRU: 11-09-03
*	148231-01-000	EA	RADIO - AM/FM CD W/REMOTE - MAGNADYNE M3100CD - EXT. ENTERTAINMENT FROM: 11-10-03 THRU: 99-99-99
	135420-01-000	EA	RADIO - AM/FM CASSETTE/CD COMBO - M9900 - 7.2" X 3.3" R.O. - DASH FROM: 00-00-00 THRU: 08-17-03
	135420-09-000	EA	RADIO-AM/FM/CASS/CD COMBO-AUX/CD CHANGER IMPUT-REMOTE COMP - DASH FROM: 08-18-03 THRU: 99-99-99
	135420-10-000	EA	REMOTE CONTROL/RADIO (CREDIT CARD SIZE) - DASH FROM: 08-18-03 THRU: 99-99-99
	135420-07-000	EA	RADIO - MOUNTING KIT - A-BODY - DASH
	148113-01-000	EA	RADIO - SATELLITE - SIRIUS - SATELLITE RADIO
	148113-02-000	EA	CRADLE - RADIO - KENWOOD - SATELLITE RADIO
	148114-01-000	EA	CABLE - AUDIO - 1/8" TO RCA STEREO - SATELLITE RADIO
	141679-02-000	EA	RADIO/BATTERY KIT - TWO WAY (4 RADIOS/8 BATTERIES) - TWO WAY RADIO FROM: 00-00-00 THRU: 10-05-03
	141679-04-000	EA	RADIO - TWO WAY - 5 MILE/BATTERY - ASA GMRS100 - TWO WAY RADIO FROM: 10-06-03 THRU: 99-99-99
	141679-01-000	EA	CHARGING STATION ONLY - F/TWO WAY RADIO SYSTEM - TWO WAY RADIO FROM: 00-00-00 THRU: 10-05-03
	141679-03-000	EA	RADIOS - TWO WAY/DOCK STATION - ASA GMRS4WMWIN - TWO WAY RADIO FROM: 10-06-03 THRU: 99-99-99
	124881-02-000	EA	AMPLIFIER - AUDIO - MTS Q SURROUND - ORANGE LABEL (LATEST) - SURROUND SOUND
	133089-01-000	EA	CONTROL - VOLUME - SPEAKER - W/O DELUXE SOUND
	110469-01-000	EA	SPEAKER - 4" X 6" OVAL - COAXIAL - EXT. ENTERTAINMENT
	124883-02-000	EA	SPEAKER/CUBE - W/BACKET - SURROUND SOUND FROM: 00-00-00 THRU: 07-13-03
	148026-01-01A	EA	SPEAKER - CUBE - W/FIXED BRACKET - SILVER - SURROUND SOUND FROM: 07-14-03 THRU: 99-99-99
	124883-03-000	EA	SPEAKER/CUBE - W/O CASE - SURROUND SOUND FROM: 00-00-00 THRU: 07-13-03
	148026-03-01A	EA	SPEAKER - CUBE - W/O CASE - SURROUND SOUND FROM: 07-14-03 THRU: 99-99-99
	124884-01-000	EA	SPEAKER - 6" X 9" - SUB-WOOFER - SURROUND SOUND
	094097-01-000	EA	SPEAKER - RADIO/TV - W/O GRILLE - 5.25" DIAMETER
	110470-01-01A	EA	GRILLE - 4" X 6" OVAL SPEAKER - BLACK - EXT. ENTERTAINMENT
	124883-04-000	EA	GRILLE/SPEAKER - F/CUBE SPEAKER - SURROUND SOUND FROM: 00-00-00 THRU: 07-13-03
	148026-02-01A	EA	SPEAKER GRILLE - CUBE - SILVER - SURROUND SOUND FROM: 07-14-03 THRU: 99-99-99
	124885-01-000	EA	GRILLE - SPEAKER - 6" X 9" - SUB-WOOFER - SURROUND SOUND
	089340-02-000	EA	GRILLE - SPEAKER - 6.5" SQUARE
	123256-01-000	EA	ANTENNA - CB - W/O CABLE - CB RADIO
	090944-02-000	EA	ANTENNA - RADIO - 16" RUBBER - W/O LEAD WIRE
	090944-01-000	EA	ANTENNA - RADIO - 16" RUBBER - W/72" LEAD WIRE
	147190-01-000	EA	ANTENNA/SATELLITE-RADIO/SIRIUS-W/GRD PLANE PLATE/6" LEAD - SATELLITE RADIO
	147190-03-000	EA	CABLE-ANTENNA SAT SIR W/O CO , RIVERPK SATSIR-CG - SATELLITE RADIO
	123256-02-000	EA	CABLE - CB - COAX - CB RADIO
	090944-03-000	EA	CABLE - ANTENNA
	147741-01-09B	EA	BRACKET - ANTENNA GROUND
	109889-04-000	EA	EXTENDER - ANTENNA SHAFT - 3.7"
	077069-03-000	EA	CABLE/EXTENSION - RADIO ANTENNA - 260"

AUDIO VIDEO GROUP (CONTINUED)
RADIO SYSTEM (CONTINUED)

KEY	PART NUMBER	U/M	DESCRIPTION
*	102080-17-000	EA	CHANGER - COMPACT DISC - SONY CDX-555RF FROM: 00-00-00 THRU: 07-09-03
	102080-20-000	EA	COMPACT DISC CHANGER - SONY CDX-565RF FROM: 07-10-03 THRU: 08-17-03
	148134-01-000	EA	CHANGER - COMPACT DISC - SANYO EAX-510 FROM: 08-18-03 THRU: 99-99-99
*	102080-18-000	EA	CHANGER - CONTROL/FM MODULE & REMOTE - SONY CDX-555RF KIT FROM: 00-00-00 THRU: 06-02-03
*	102080-21-000	EA	CHANGER - CONTROL/FM MODULE & REMOTE - SONY CDX-565RF FROM: 06-06-03 THRU: 99-99-99

***COMPONENT PARTS LISTED LATER IN THIS GROUP**

AUDIO VIDEO GROUP (CONTINUED)
COMPONENT PARTS FOR RADIO SYSTEM

KEY	PART NUMBER	U/M	DESCRIPTION	102080-17-000	VENDOR NO.
	102080-17-700	EA	REMOTE (WIRED)		1-476-488-V
	102080-17-701	EA	REMOTE (WIRELESS)		A1-3220-786-11
				102080-18-000	VENDOR NO.
KEY	PART NUMBER	U/M	DESCRIPTION		
	102080-15-700	EA	REMOTE - WIRELES		1-476-488-11
				102080-21-000	VENDOR NO.
KEY	PART NUMBER	U/M	DESCRIPTION		
	102080-21-700	EA	REMOTE		RM-X84RF
				143509-01-000	VENDOR NO.
KEY	PART NUMBER	U/M	DESCRIPTION		
	143509-01-700	EA	REMOTE - RADIO		VG70A0
				148231-01-000	VENDOR NO.
KEY	PART NUMBER	U/M	DESCRIPTION		
	148231-01-700	EA	REMOTE		RC3100

AUDIO VIDEO GROUP (CONTINUED)
REAR VIEW MONITOR

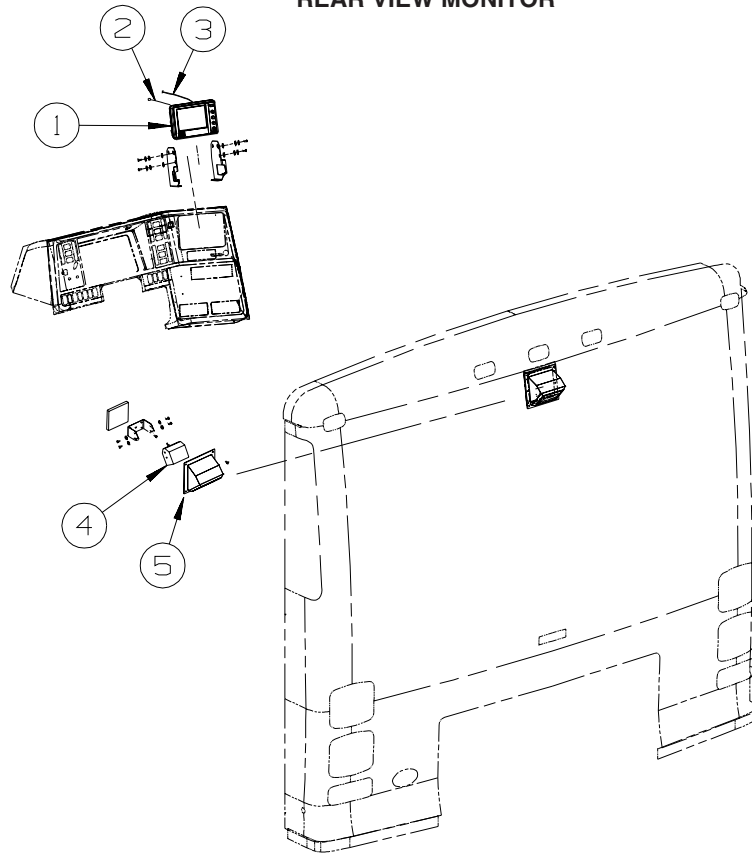

KEY	PART NUMBER	U/M	DESCRIPTION
1	143363-01-000	EA	MONITOR/REAR - COLOR - W/BRACKET - SONY VCB-MH1
2	143545-01-000	EA	WIRE ASSEMBLY - REAR MONITOR
3	143363-03-000	EA	CABLE - MONITOR/CAMERA - COLOR - SONY VCB-MHC20
4	143363-02-000	EA	CAMERA/REAR - COLOR - W/BRACKET - SONY VCB-MHD1
			FROM: 00-00-00 THRU: 09-07-03
4	143363-05-000	EA	CAMERA - REAR - COLOR W/BRACKET - SONY VCB-MH3
			FROM: 09-08-03 THRU: 99-99-99
5	123281-01-01A	EA	SHROUD - CAMERA/OUTER - BRIGHT WHITE
			FROM: 00-00-00 THRU: 09-07-03
5	148773-01-01A	EA	SHROUD/CAMERA - OUTER - BRIGHT WHITE
			FROM: 09-08-03 THRU: 03-11-04
5	137919-02-01A	EA	SHROUD - CAMERA/OUTER - BRIGHT WHITE
			FROM: 03-12-04 THRU: 99-99-99

AUDIO VIDEO GROUP (CONTINUED)

TELEPHONE

KEY	PART NUMBER	U/M	DESCRIPTION
	093253-01-02A	EA	PLATE - WALL - TELEPHONE - BROWN
	093253-01-03A	EA	PLATE - WALL - TELEPHONE - WHITE
	130686-01-01A	EA	PLATE - WALL - TELEPHONE/COAX - WHITE

TV & VCR

KEY	PART NUMBER	U/M	DESCRIPTION
*	146396-01-000	EA	DVD/VCR - COMBINATION PLAYER FROM: 00-00-00 THRU: 06-01-03
*	146396-02-000	EA	DVD/VCR COMBINATION PLAYER - SONY SLV-D300P FROM: 06-02-03 THRU: 99-99-99
	117420-01-000	EA	CABLE - W/MALE RCA ENDS - SHIELDED - 12"
	136860-01-000	EA	CABLE - RCA - #3 MALE TO #12F MALE CONNECTOR - SURROUND SOUND
	123324-01-000	EA	FILTER - GROUND LOOP - SURROUND SOUND
	147139-01-000	EA	AMPLIFIER - STEREO 2 CHANNEL
	086756-01-000	EA	SPLITTER - TV/2 WAY
	142258-01-000	EA	SWITCH - VIDEO/ANTENNA POWER SUPPLY - VIDEO SELECTION SYSTEM
*	126696-07-000	EA	TV - 19" COLOR - W/O 1/8" JACK - UL/CSA - GE 19GT243
*	146299-01-000	EA	TV - 24" STEREO W/5 JACKS - SONY 24FS100
	082134-01-000	EA	ADAPTER - TV - CABLE TO CABLE
	082136-01-000	EA	NUT - HEX JAM - 3/8-32
	134006-01-03B	EA	PLATE - COAXIAL CABLE/OFF WHITE
	076319-09-000	EA	WALLPLATE - CABLE RECEPTACLE - TV - SINGLE - BROWN
	145171-01-000	EA	CONNECTOR - COAXIAL
*	076319-23-000	EA	ANTENNA - TV ROOF MOUNT - 44.5" MAST
*	076319-25-000	EA	KIT - HARDWARE INTERIOR
*	137135-02-000	EA	ANTENNA - SATELLITE DSS - W/SENSOR
*	141454-01-01A	EA	ANTENNA - SATELLITE - AUTOMATIC - AUTOMATIC SATELLITE DISH FROM: 00-00-00 THRU: 07-06-03
*	141454-03-01A	EA	ANTENNA/SATELLITE - AUTOMATIC - WINEGARD AS-2053 - AUTOMATIC SATELLITE DISH FROM: 07-07-03 THRU: 99-99-99
*	144377-01-000	EA	ANTENNA - SATELLITE - IN MOTION - IN-MOTION SATELLITE SYSTEM

*COMPONENT PARTS LISTED LATER IN THIS GROUP

AUDIO VIDEO GROUP (CONTINUED)
COMPONENT PARTS FOR TV & VCR

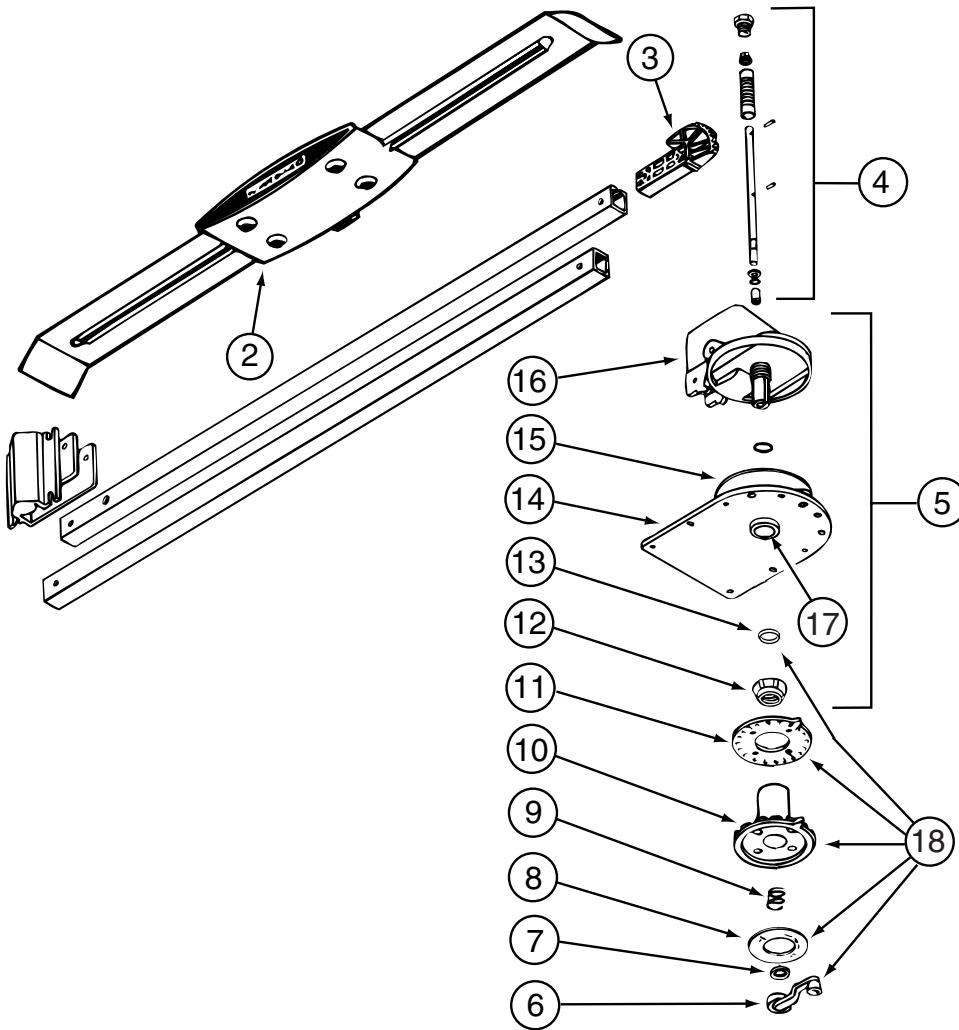

076319-23-000

KEY	PART NUMBER	U/M	DESCRIPTION	VENDOR NO.
2	076319-01-700	EA	HEAD-ANTENNA, AMPLIFIED	RVSA U/V
3	076319-01-701	EA	GEAR-ELEVATING, PLASTIC	2200046
4	076319-01-702	EA	SHAFT ASM-ELEVATING	RP-4000
5	076319-01-711	EA	BASE & LIFT ASM	2762802
7	076319-01-705	EA	GROMMET-NYLON, 7/8"ID	3200658
8	076319-01-708	EA	DECAL-CRANK	5413002
9	076319-01-707	EA	SPRING-HANDLE	2160822
11	076319-01-712	EA	PLATE - CEILING	3200608
12	076319-01-715	EA	NUT (GEAR HOUSING)	2200047
14	076319-01-713	EA	BASE-PLATE, STEEL	3100523
15	076319-01-703	EA	BEARING-NYLON, 5"OD	3200656
16	076319-01-714	EA	HOUSING, ROTATING GEAR	2200049
	076319-01-716	EA	TUBING, ELEVATING	RP-2900
17	076319-01-704	EA	BEARING-NYLON, 1.25"OD	3200657
18	076319-01-709	EA	HANDLE-HEAD DIRECTIONAL	200644

CONTACT WINNEBAGO PART SALES FOR UNLISTED COMPONENT

076319-25-000

KEY	PART NUMBER	U/M	DESCRIPTION	VENDOR NO.
6	076319-01-706	EA	CRANK-W/SET SCREW UNIV/BEIGE	2750897
6	120233-01-710	EA	HANDLE-CRANK W/SCREW - WHITE	RP-6795
8	076319-01-708	EA	DECAL-CRANK	5413002
10	076319-25-700	EA	DIRECTIONAL HANDLE(WHITE)	3200612
11	076319-25-701	EA	PLATE - CEILING(WHITE)	3200609
13	120233-01-709	EA	WASHER-NYLON	RP-2658

CONTACT WINNEBAGO PART SALES FOR UNLISTED COMPONENTS

AUDIO VIDEO GROUP (CONTINUED)
COMPONENT PARTS FOR TV & VCR (CONTINUED)

126696-07-000

KEY	PART NUMBER	U/M	DESCRIPTION	VENDOR NO.
	133377-01-700	EA	REMOTE	240961

AUDIO VIDEO GROUP (CONTINUED)
COMPONENT PARTS FOR TV & VCR (CONTINUED)

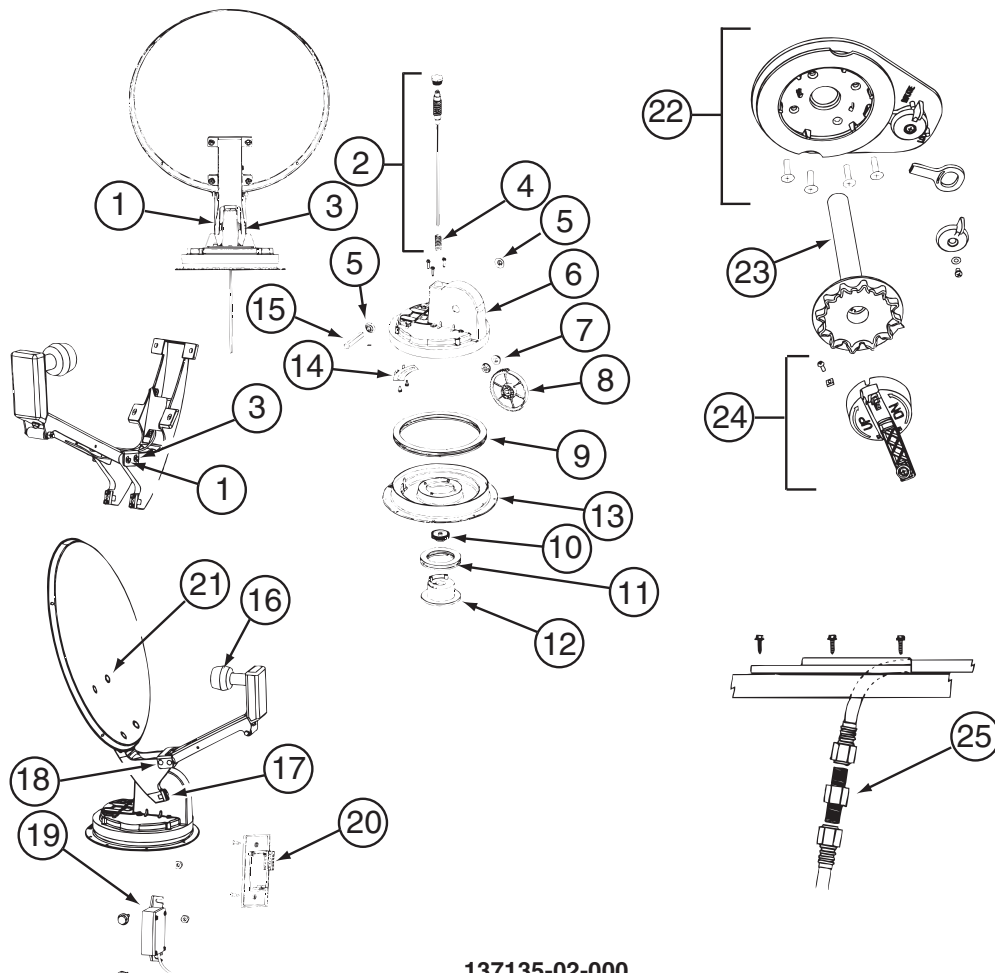

137135-02-000

KEY	PART NUMBER	U/M	DESCRIPTION	VENDOR NO.
1	120233-01-714	EA	CLIP-E	5160818
2	137135-01-703	EA	KIT ELEV - SHAFT/GEAR/SPRING	RP-4400
3	137135-01-704	EA	PIN - 1/4" X 3.25"	2160813
4	137135-01-705	EA	SPRING	2160818
5	137135-01-707	EA	SEAL - PIVOT SHAFT	2200852
6	137135-01-708	EA	TURRET	3100728
7	137135-01-709	EA	PIVOT BEARING	2200470
8	137135-01-711	EA	GEAR - ELEVATING	2200464
9	137135-01-712	EA	BEARING - OUTER	2590347
10	137135-01-714	EA	GEAR - ELEVATING SHAFT	2200465
11	137135-01-715	EA	BEARING - INNER	2590348
12	137135-01-716	EA	HUB	3100731
13	137135-01-713	EA	TURRET BASE	3100730
14	137135-01-710	EA	PLATE - ROTATE LIMIT	3720052
16	137135-02-703	EA	LOW NOISE BLOCK FILTER	LB-6000 - DUAL
17	137135-01-722	EA	CLAMP	2590343
18	137135-01-719	EA	BRACKET - PIVOT	2744945
19	137135-01-720	EA	DE-SENSOR UNIT W/43" CABLE	DM4000
20	137135-02-701	EA	BOX - SURFACE MOUNT	SM-100
21	137135-01-717	EA	BOLT - FLAT HEAD	2160362
22	120233-01-737	EA	PLATE/INT-W/DIRECTIONAL HDLE	RK-CEIL
23	120233-01-704	EA	DIAL/DIRECTIONAL 4"W/SPRING	3200364
24	120233-01-738	EA	HDW PKG-HANDLE/SPRING/WASHER	RK-HAND
25	137135-01-701	EA	CONNECTOR - F - MALE TO MALE	FS-8100
	120233-04-700	EA	KIT-WALL PLATE/CABLE - GRAY	DM4000
	137135-01-700	EA	ROOF WEDGE W/GASKET	RW-5000
	137135-01-706	EA	KIT-TURRET/SEAL/BEARING/GEAR	RP-RM30
	137135-01-718	EA	REFLECTOR/WHITE-46CM W/HDW	RP-35RM
	137135-02-700	EA	DE-SENSOR	2780096
	137135-02-704	EA	KIT-UPDATE DIRECTIONAL HDL	RP-RMDH

CONTACT WINNEBAGO PART SALES FOR UNLISTED COMPONENT(S)

AUDIO VIDEO GROUP (CONTINUED)
COMPONENT PARTS FOR TV & VCR (CONTINUED)

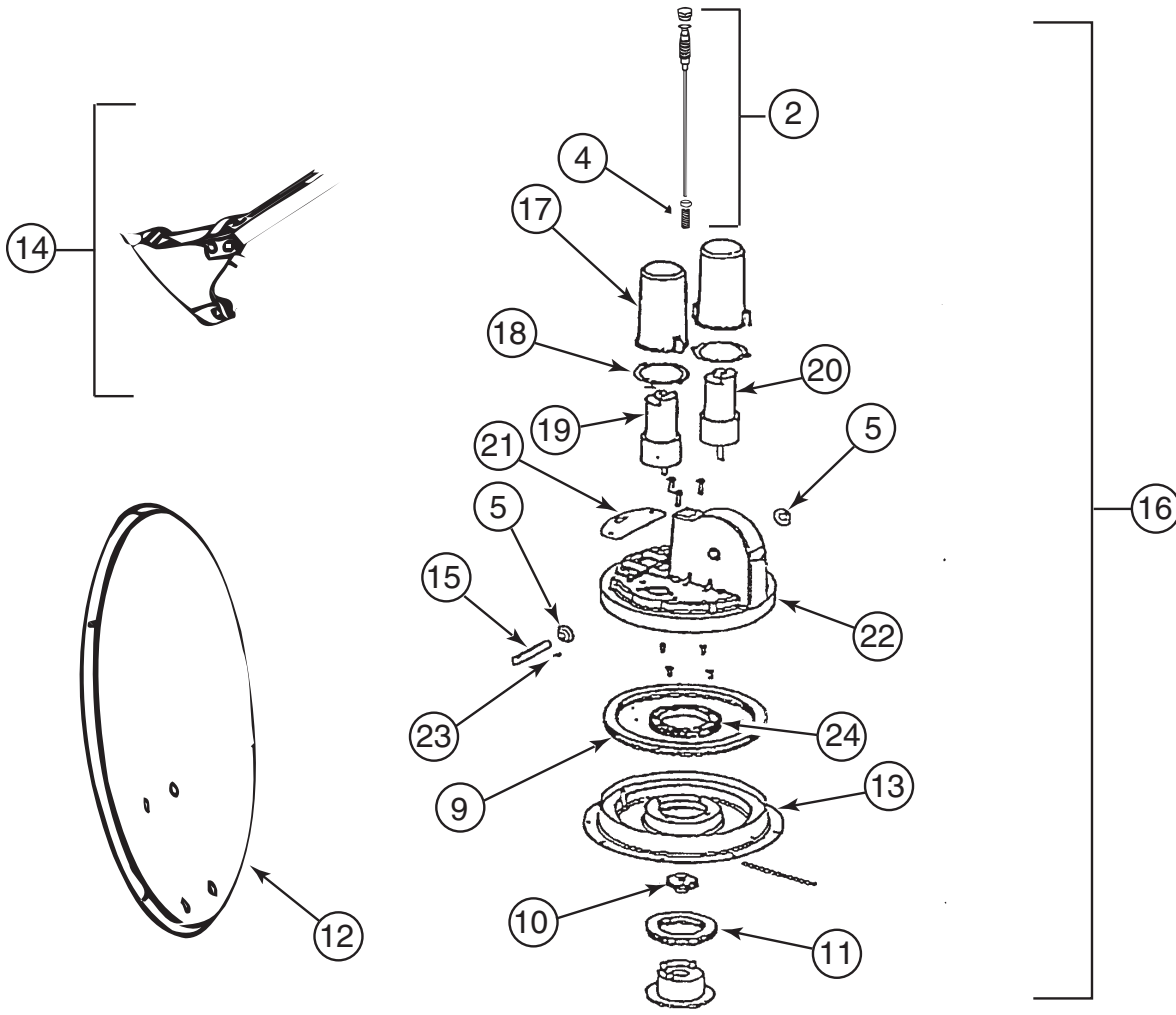

141454-01-01A

KEY	PART NUMBER	U/M	DESCRIPTION	VENDOR NO.
2	141454-01-700	EA	KIT ELEV-SHAFT/GEARS/SPRING	RP-RM20
4	137135-01-705	EA	SPRING	2160818
5	137135-01-707	EA	SEAL - PIVOT SHAFT	2200852
9	137135-01-712	EA	BEARING - OUTER	2590347
10	137135-01-714	EA	GEAR - ELEVATING SHAFT	2200465
11	137135-01-715	EA	BEARING - INNER	2590348
12	137135-01-718	EA	REFLECTOR/WHITE-46CM W/HDWE	RP-35RM
13	137135-01-713	EA	TURRET BASE	3100730
14	137135-01-723	EA	SUPPORT/FRAME-BACKUP-W/HDWE	RP-RM00
16	141454-01-704	EA	KIT LIFT ASSEMBLY COMPLETE	RP-RM05
17	141454-01-705	EA	HOUSING - MOTOR	3200260
18	141454-01-706	EA	GASKET - MOTOR HOUSING	2240054
19	141454-01-707	EA	MOTOR - AZIMUTH	2665039
20	141454-01-708	EA	MOTOR - ELEVATION	2665038
21	141454-01-709	EA	GASKET	2240056
22	141454-01-710	EA	TURRET	3100729
23	141454-01-711	EA	ROLL PIN	2160842
24	141454-01-712	EA	GEAR - ROTATE	2200469
	120233-01-714	EA	CLIP-E	5160818
	137135-01-704	EA	PIN - 1/4" X 3.25"	2160813
	137135-01-719	EA	BRACKET - PIVOT	2744945
	141454-01-701	EA	KIT - GEAR/MOTOR-GEAR/ROTATE	RP-RM25
	141454-01-702	EA	HOUSING/ELECTRONICS - UPPER	RP-RM10
	141454-01-703	EA	HOUSING/ELECTRONICS - LOWER	RP-RM15
	141454-01-713	EA	PANEL/FRT-W/DIGITAL READOUT	2764586
	141454-01-714	EA	KIT - TURRET ANTI-RATTLE	RP-RM45

CONTACT WINNEBAGO PART SALES FOR UNLISTED COMPONENT(S)

AUDIO VIDEO GROUP (CONTINUED)
COMPONENT PARTS FOR TV & VCR (CONTINUED)

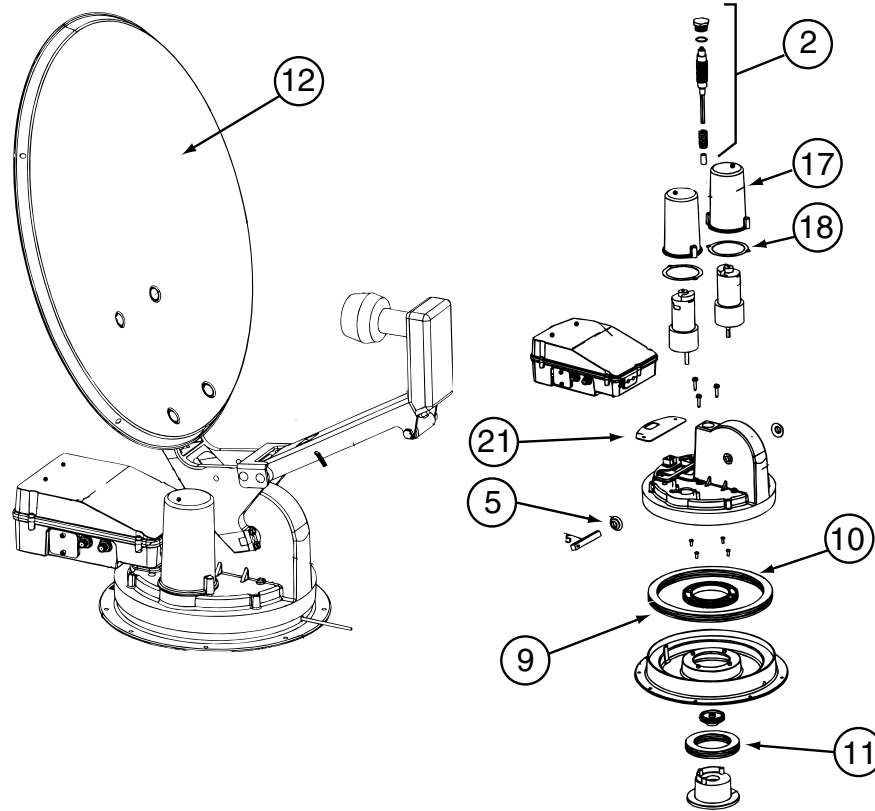

141454-03-01A

KEY	PART NUMBER	U/M	DESCRIPTION	VENDOR NO.
2	141454-01-700	EA	KIT ELEV-SHAFT/GEARS/SPRING	RP-RM20
4	137135-01-705	EA	SPRING	2160818
5	137135-01-707	EA	SEAL - PIVOT SHAFT	2200852
9	137135-01-712	EA	BEARING - OUTER	2590347
10	137135-01-714	EA	GEAR - ELEVATING SHAFT	2200465
10	141454-01-712	EA	GEAR - ROTATE	2200469
11	137135-01-715	EA	BEARING - INNER	2590348
12	137135-01-718	EA	REFLECTOR/WHITE-46CM W/HDWE	RP-35RM
13	137135-01-713	EA	TURRET BASE	3100730
17	141454-01-705	EA	HOUSING - MOTOR	3200260
18	141454-01-706	EA	GASKET - MOTOR HOUSING	2240054
21	141454-01-709	EA	GASKET	2240056
	120233-01-714	EA	CLIP-E	5160818
	137135-01-704	EA	PIN - 1/4" X 3.25"	2160813
	137135-01-719	EA	BRACKET - PIVOT	2744945
	137135-01-722	EA	CLAMP	2590343
	137135-01-723	EA	SUPPORT/FRAME-BACKUP-W/HDWE	RP-RM00
	137135-02-703	EA	LOW NOISE BLOCK FILTER	LB-6000 - DUAL
	141454-01-701	EA	KIT - GEAR/MOTOR-GEAR/ROTATE	RP-RM25
	141454-01-702	EA	HOUSING/ELECTRONICS - UPPER	RP-RM10
	141454-01-703	EA	HOUSING/ELECTRONICS - LOWER	RP-RM15
	141454-01-704	EA	KIT LIFT ASSEMBLY COMPLETE	RP-RM05
	141454-03-700	EA	MOTOR (AZIMUTH)	2665042
	141454-03-701	EA	MOTOR (ELEVATION)	2665041
	141454-03-702	EA	CIRCUIT BOARD(CONTROL BOARD)	RP-RM80
	141454-03-703	EA	CONTRL PANEL W/BOX (AS2003)	RP-AS85

CONTACT WINNEBAGO PART SALES FOR UNLISTED COMPONENT(S)

AUDIO VIDEO GROUP (CONTINUED)
COMPONENT PARTS FOR TV & VCR (CONTINUED)

144377-01-000

KEY	PART NUMBER	U/M	DESCRIPTION	VENDOR NO.
	144377-01-700	EA	SWITCH	2400101
	144377-01-701	EA	PLATE F/SWITCH	3202239
	144377-01-702	EA	DOME W/NOTCHES	2780402

146299-01-000

KEY	PART NUMBER	U/M	DESCRIPTION	VENDOR NO.
	146299-01-700	EA	REMOTE - TV	1-476-680-11

146396-01-000

KEY	PART NUMBER	U/M	DESCRIPTION	VENDOR NO.
	146396-01-700	EA	REMOTE - DVD/VCR	1-477-582-11

146396-02-000 & 146396-03-000

KEY	PART NUMBER	U/M	DESCRIPTION	VENDOR NO.
	146396-02-700	EA	REMOTE	9-885-035-23

AUDIO VIDEO GROUP (CONTINUED)
EXTERIOR ENTERTAINMENT

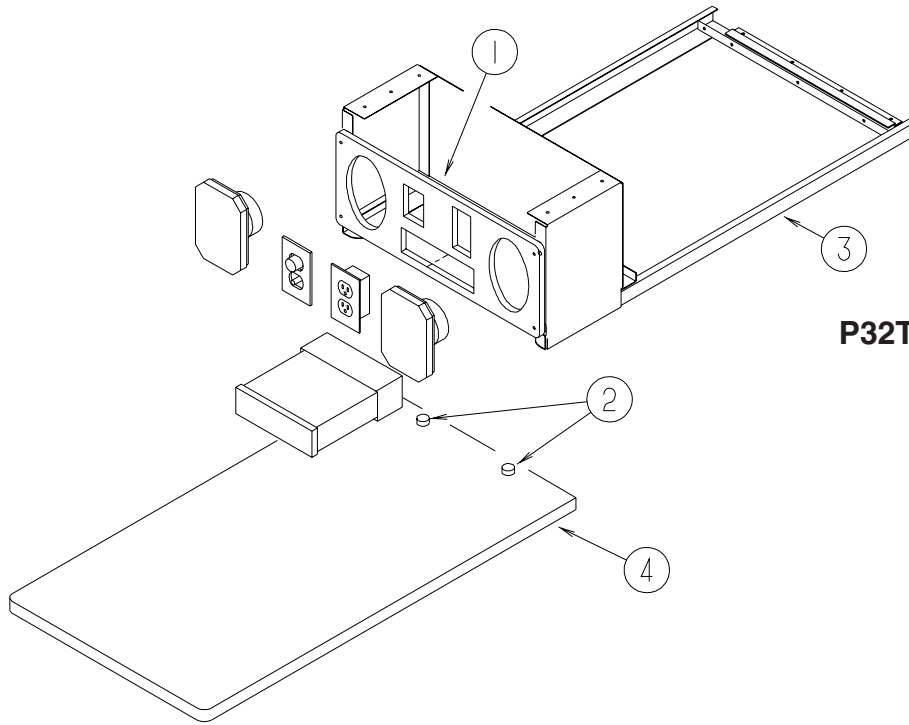

P32T, P34H, P36G, P39W

KEY	PART NUMBER	U/M	DESCRIPTION
1	126123-01-K30	EA	PLATE - RADIO MOUNTING - WHITE LAMINATE
2	069726-02-000	EA	BUMPER - .88" OD X .40" THICK - BLACK
3	126119-03-02B	EA	FRAME/ENTERTAINMENT CENTER - 24.6" X 10.3" - E-COATED
4	126125-01-K30	EA	TABLE - ENTERTAINMENT CENTER

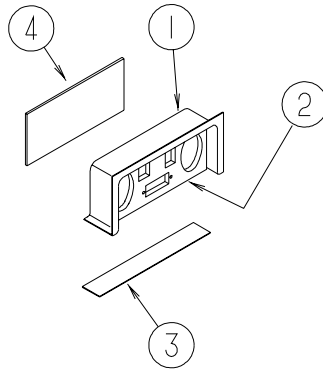

P39K

KEY	PART NUMBER	U/M	DESCRIPTION
1	124696-01-01A	EA	BOX - ENTERTAINMENT CENTER/EXTERIOR - BRIGHT WHITE
2	127409-02-L15	EA	PLATE - RADIO MOUNTING
3	104898-01-02A	EA	PLATE - PLASTIC BOTTOM - BRIGHT WHITE
4	104898-02-02A	EA	PLATE - PLASTIC BACK - BRIGHT WHITE

BATH GROUP CABINETS

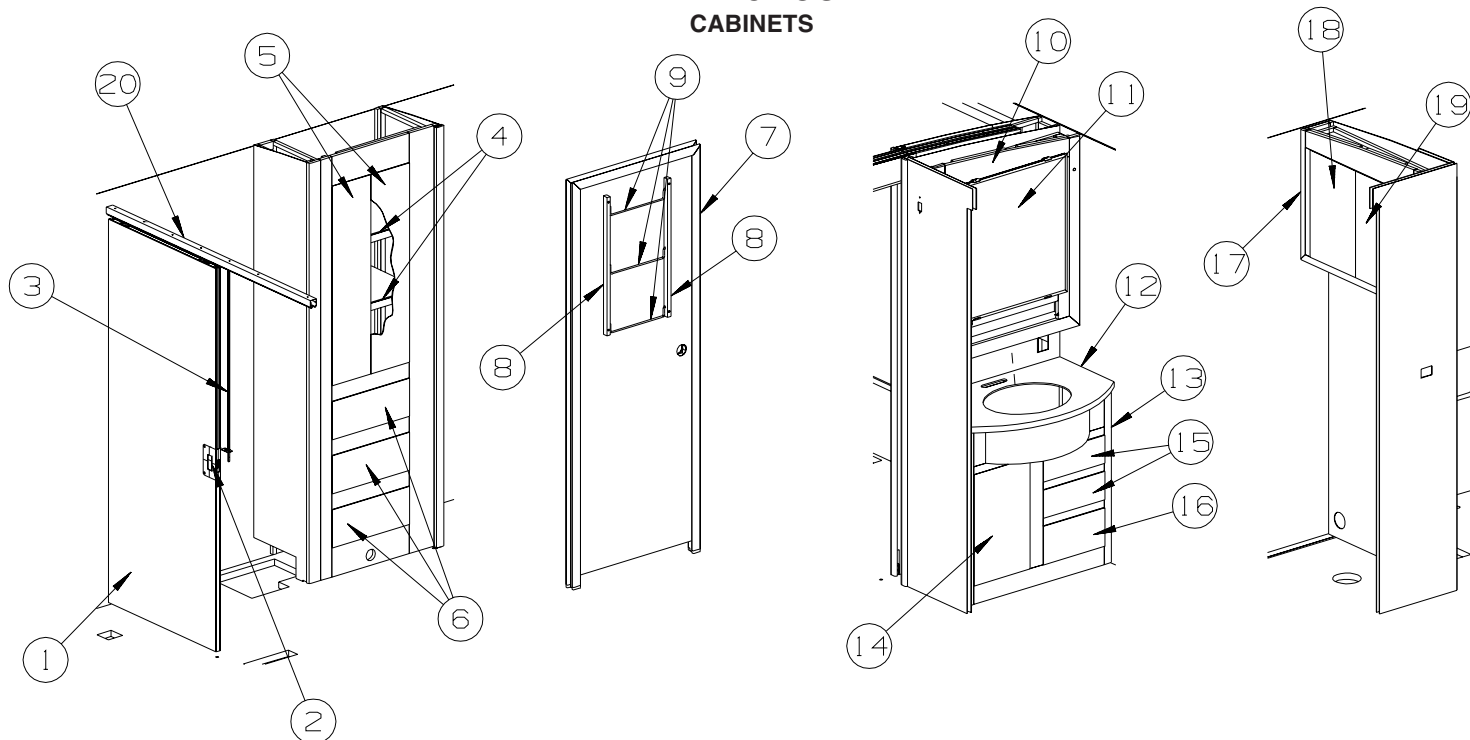

KEY	PART NUMBER	U/M	DESCRIPTION
1	146047-04-R68	EA	DOOR - SLIDING - W/O HARDWARE - PORTSMOUTH OAK
1	146047-04-R69	EA	DOOR - SLIDING - W/O HARDWARE - CONCERT CHERRY
1	146047-04-R76	EA	DOOR - SLIDING - W/O HARDWARE - WASHED MAPLE
1	146047-04-RW7	EA	DOOR - SLIDING - W/O HARDWARE - WASHED MAPLE FROM: 00-00-00 THRU: 01-04-04 FROM: 01-05-04 THRU: 99-99-99
2	145939-01-01A	EA	LATCH - SLIDE - AISLE DOOR(1" THICK DOOR) - BRASS
3	145939-03-01A	EA	ROD/LATCH - AISLE DOOR - BRASS
4	147178-24-R68	EA	SHELF - W/PLASTIC EDGE MOLDING - PORTSMOUTH OAK
4	147178-24-R69	EA	SHELF - W/PLASTIC EDGE MOLDING - CONCERT CHERRY
4	147178-24-R76	EA	SHELF - W/PLASTIC EDGE MOLDING - WASHED MAPLE
4	147178-24-RW7	EA	SHELF - W/PLASTIC EDGE MOLDING - WASHED MAPLE FROM: 00-00-00 THRU: 01-04-04 FROM: 01-05-04 THRU: 99-99-99
5	145268-21-R74	EA	DOOR - RAISED PANEL/PENCIL EDGE - 9.8" X 39.9" - W/O HDW - PORTSMOUTH OAK
5	145268-21-R75	EA	DOOR - RAISED PANEL/PENCIL EDGE - 9.8" X 39.9" - W/O HDW - CONCERT CHERRY
5	145268-21-R76	EA	DOOR - RAISED PANEL/PENCIL EDGE - 9.8" X 39.9" - W/O HDW - WASHED MAPLE
6	145492-T6-R74	EA	DRAWER - PENCIL EDGE - 16.2"W X 11.8"D - W/O SLIDES/HDW - PORTSMOUTH OAK
6	145492-T6-R75	EA	DRAWER - PENCIL EDGE - 16.2"W X 11.8"D - W/O SLIDES/HDW - CONCERT CHERRY
6	145492-T6-R76	EA	DRAWER - PENCIL EDGE - 16.2"W X 11.8"D - W/O SLIDES/HDW - WASHED MAPLE
7	144645-04-R13	EA	DOOR - BATH - W/O TOWEL RACK/HARDWARE - PORTSMOUTH OAK
7	144645-04-R14	EA	DOOR - BATH - W/O TOWEL RACK/HARDWARE - CONCERT CHERRY
7	144645-04-R21	EA	DOOR - BATH - W/O TOWEL RACK/HARDWARE - WASHED MAPLE
7	144645-04-RW1	EA	DOOR - BATH - W/O TOWEL RACK/HARDWARE - WASHED MAPLE FROM: 00-00-00 THRU: 01-04-04 FROM: 01-05-04 THRU: 99-99-99
	146064-01-01A	EA	LOCK/PRIVACY (LOCKING) LEVER STYLE - POLISHED BRASS
8	P34509-01-N01	EA	RAIL END - RH/LH - TOWEL RACK - PORTSMOUTH OAK - PORTSMOUTH OAK
8	P34509-01-P14	EA	RAIL END - RH/LH - TOWEL RACK - CHERRY - CONCERT CHERRY
8	P34509-01-J70	EA	RAIL END - RH/LH - TOWEL RACK - WASHED MAPLE - WASHED MAPLE
9	146801-01-01A	EA	ROD/TOWEL BAR (OFFSET) - BRASS
10	146927-01-R68	EA	CABINET - OVERHEAD/MEDICINE - W/O DOORS/HARDWARE - PORTSMOUTH OAK
10	146927-01-R69	EA	CABINET - OVERHEAD/MEDICINE - W/O DOORS/HARDWARE - CONCERT CHERRY
10	146927-01-R76	EA	CABINET - OVERHEAD/MEDICINE - W/O DOORS/HARDWARE - WASHED MAPLE
10	146927-01-RW7	EA	CABINET - OVERHEAD/MEDICINE - W/O DOORS/HARDWARE - WASHED MAPLE FROM: 00-00-00 THRU: 01-04-04 FROM: 01-05-04 THRU: 99-99-99

BATH GROUP (CONTINUED)
CABINETS (CONTINUED)

KEY	PART NUMBER	U/M	DESCRIPTION
11	145576-09-R83	EA	DOOR - W/MIRROR - 24.5" X 25.9" - W/O HARDWARE - PORTSMOUTH OAK
11	145576-09-R84	EA	DOOR - W/MIRROR - 24.5" X 25.9" - W/O HARDWARE - CONCERT CHERRY
11	145576-09-R76	EA	DOOR - W/MIRROR - 24.5" X 25.9" - W/O HARDWARE - WASHED MAPLE
	093606-46-000	EA	MIRROR - BEVELED EDGE - 24.5" X 25.9"
	137463-01-01A	EA	LIFT - HOOK - SATIN BRASS
12	137162-20-03A	EA	COUNTERTOP - 1/4" VENDURA - ROCKY MOUNTAIN HIGH
13	146926-01-R68	EA	CABINET - LAVATORY - W/O COUNTERTOP/DOORS/DRAWERS/HARDWARE - PORTSMOUTH OAK
13	146926-01-R69	EA	CABINET - LAVATORY - W/O COUNTERTOP/DOORS/DRAWERS/HARDWARE - CONCERT CHERRY
13	146926-01-R76	EA	CABINET - LAVATORY - W/O COUNTERTOP/DOORS/DRAWERS/HARDWARE - WASHED MAPLE FROM: 00-00-00 THRU: 01-04-04
13	146926-01-RW7	EA	CABINET - LAVATORY - W/O COUNTERTOP/DOORS/DRAWERS/HARDWARE - WASHED MAPLE FROM: 01-05-04 THRU: 99-99-99
14	136955-90-R74	EA	DOOR - RAISED PANEL/PENCIL EDGE - 13.4" X 21.9" - W/O HDW - PORTSMOUTH OAK FROM: 00-00-00 THRU: 09-21-03
14	136955-89-R74	EA	DOOR - RAISED PANEL/PENCIL EDGE - 13.4" X 21.9" - W/O HDW - PORTSMOUTH OAK FROM: 09-22-03 THRU: 99-99-99
14	136955-90-R75	EA	DOOR - RAISED PANEL/PENCIL EDGE - 13.4" X 21.9" - W/O HDW - CONCERT CHERRY FROM: 00-00-00 THRU: 09-21-03
14	136955-89-R75	EA	DOOR - RAISED PANEL/PENCIL EDGE - 13.4" X 21.9" - W/O HDW - CONCERT CHERRY FROM: 09-22-03 THRU: 99-99-99
14	136955-90-R76	EA	DOOR - RAISED PANEL/PENCIL EDGE - 13.4" X 21.9" - W/O HDW - WASHED MAPLE FROM: 00-00-00 THRU: 09-21-03
14	136955-89-R76	EA	DOOR - RAISED PANEL/PENCIL EDGE - 13.4" X 21.9" - W/O HDW - WASHED MAPLE FROM: 09-22-03 THRU: 99-99-99
15	145492-T2-R74	EA	DRAWER - PENCIL EDGE - 12.7"W X 11.8"D - W/O SLIDES/HDW - PORTSMOUTH OAK
15	145492-T2-R75	EA	DRAWER - PENCIL EDGE - 12.7"W X 11.8"D - W/O SLIDES/HDW - CONCERT CHERRY
15	145492-T2-R76	EA	DRAWER - PENCIL EDGE - 12.7"W X 11.8"D - W/O SLIDES/HDW - WASHED MAPLE
16	145492-T4-R74	EA	DRAWER - PENCIL EDGE - 12.7"W X 11.8"D - W/O SLIDES/HDW - PORTSMOUTH OAK
16	145492-T4-R75	EA	DRAWER - PENCIL EDGE - 12.7"W X 11.8"D - W/O SLIDES/HDW - CONCERT CHERRY
16	145492-T4-R76	EA	DRAWER - PENCIL EDGE - 12.7"W X 11.8"D - W/O SLIDES/HDW - WASHED MAPLE
17	146928-01-R68	EA	CABINET - OVERHEAD/LINEN - W/O DOORS/HARDWARE - PORTSMOUTH OAK
17	146928-01-R69	EA	CABINET - OVERHEAD/LINEN - W/O DOORS/HARDWARE - CONCERT CHERRY
17	146928-01-R76	EA	CABINET - OVERHEAD/LINEN - W/O DOORS/HARDWARE - WASHED MAPLE FROM: 00-00-00 THRU: 01-04-04
17	146928-01-RW7	EA	CABINET - OVERHEAD/LINEN - W/O DOORS/HARDWARE - WASHED MAPLE FROM: 01-05-04 THRU: 99-99-99
18	141518-A6-R74	EA	DOOR - ARCHED/PENCIL EDGE - 14.3" X 21.8" - W/O HARDWARE - PORTSMOUTH OAK FROM: 00-00-00 THRU: 09-21-03
18	141518-85-P54	EA	DOOR - ARCHED/PENCIL EDGE/LEFT HAND-12.8" X 21.8" -W/O HDW - PORTSMOUTH OAK FROM: 09-22-03 THRU: 99-99-99
18	141518-A6-R75	EA	DOOR - ARCHED/PENCIL EDGE - 14.3" X 21.8" - W/O HARDWARE - CONCERT CHERRY FROM: 00-00-00 THRU: 09-21-03
18	141518-85-P55	EA	DOOR - ARCHED/PENCIL EDGE/LEFT HAND-12.8" X 21.8" -W/O HDW - CONCERT CHERRY FROM: 09-22-03 THRU: 99-99-99
18	141518-A6-R76	EA	DOOR - ARCHED/PENCIL EDGE - 14.3" X 21.8" - W/O HARDWARE - WASHED MAPLE FROM: 00-00-00 THRU: 09-21-03
18	141518-85-P56	EA	DOOR - ARCHED/PENCIL EDGE/LEFT HAND-12.8" X 21.8" -W/O HDW - WASHED MAPLE FROM: 09-22-03 THRU: 99-99-99
19	141520-A6-R74	EA	DOOR - ARCHED/PENCIL EDGE/RIGHT HAND-14.3" X 21.8"-W/O HDW - PORTSMOUTH OAK FROM: 00-00-00 THRU: 09-21-03
19	141520-85-P54	EA	DOOR - ARCHED/PENCIL EDGE/RIGHT HAND -12.8"X21.8"-W/O HDW - PORTSMOUTH OAK FROM: 09-22-03 THRU: 99-99-99
19	141520-A6-R75	EA	DOOR - ARCHED/PENCIL EDGE/RIGHT HAND-14.3" X 21.8"-W/O HDW - CONCERT CHERRY FROM: 00-00-00 THRU: 09-21-03
19	141520-85-P55	EA	DOOR - ARCHED/PENCIL EDGE/RIGHT HAND -12.8"X21.8"-W/O HDW - CONCERT CHERRY FROM: 09-22-03 THRU: 99-99-99
19	141520-A6-R76	EA	DOOR - ARCHED/PENCIL EDGE/RIGHT HAND-14.3" X 21.8"-W/O HDW - WASHED MAPLE FROM: 00-00-00 THRU: 09-21-03
19	141520-85-P56	EA	DOOR - ARCHED/PENCIL EDGE/RIGHT HAND -12.8"X21.8"-W/O HDW - WASHED MAPLE FROM: 09-22-03 THRU: 99-99-99
20	145608-02-01A	EA	TRACK - DOOR - 56.1" - OFF WHITE

BATH GROUP (CONTINUED)
CABINETS (CONTINUED)

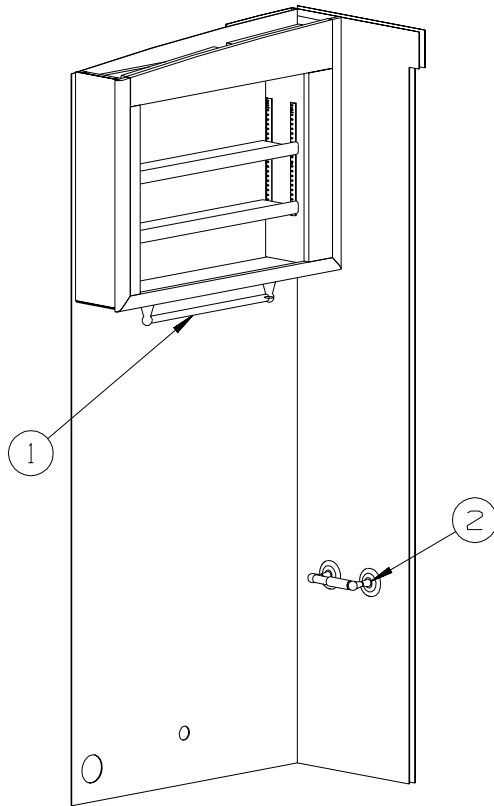

KEY	PART NUMBER	U/M	DESCRIPTION
1	140849-02-01A	EA	BAR - TOWEL - 18" - CHROME/BRASS
2	140973-02-01A	EA	TISSUE HOLDER - CHROME/BRASS

BATH GROUP (CONTINUED) SHOWER

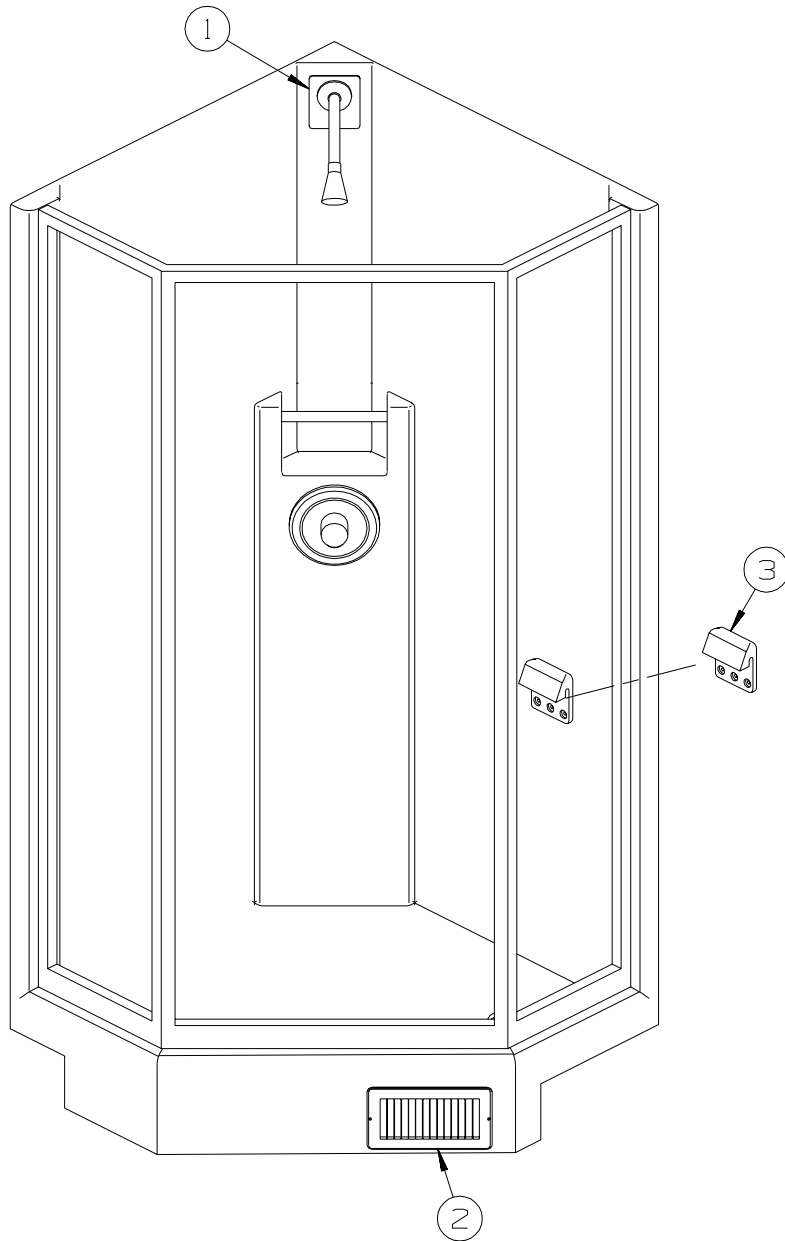

KEY	PART NUMBER	U/M	DESCRIPTION
1	143218-01-02A	EA	PLATE/COVER - SHOWER HEAD - SOFT WHITE
2	089326-02-000	EA	GRILLE - FLOOR - HEATING - 9.3" X 5.3" - SOFT WHITE
3	135607-03-01A	EA	SEAT - SHOWER/FOLDING(FOR REPLACEMENT OR OPTION INST ONLY)

SHOWER DOOR

KEY	PART NUMBER	U/M	DESCRIPTION
*	139047-05-01A	EA	DOOR - SHOWER - NEO ANGLE - 66.4" TALL - GOLD/AQUA

***COMPONENT PARTS LISTED LATER IN THIS GROUP**

BATH GROUP (CONTINUED)
COMPONENT PARTS FOR SHOWER DOOR

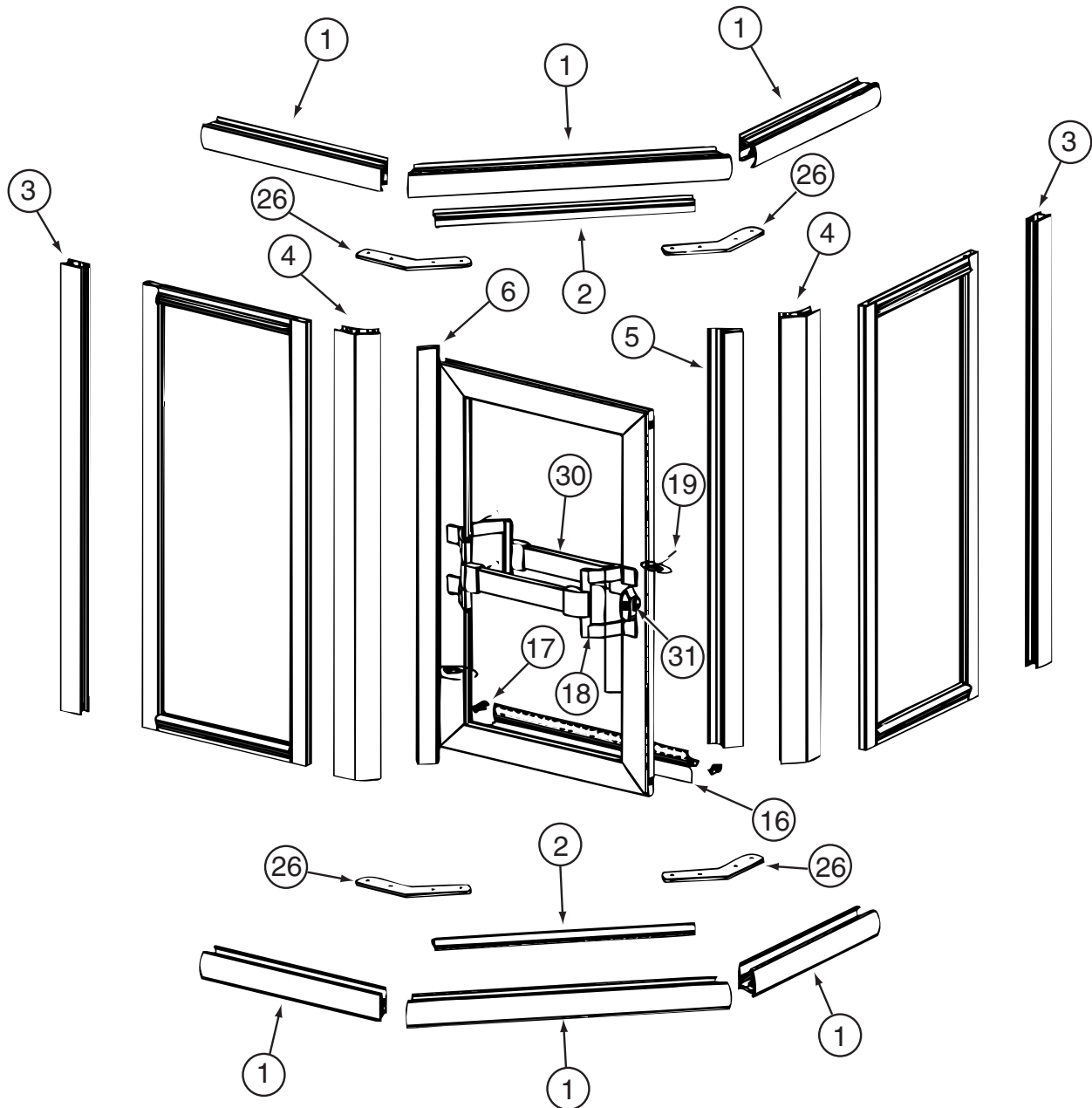

139047-01-01A/02A, 139047-02-01A/02A, 139049-03-01A/02A/03A, 139047-04-02A/03A, 139047-05-01A

KEY	PART NUMBER	U/M	DESCRIPTION	VENDOR NO.
1	139047-01-700	EA	HEADER/SILL - 30" (PAIR)	900
2	139047-01-701	EA	DAM STRIP-TOP/BOTTOM-35.4"	901
3	139047-01-702	EA	JAMB - WALL - 65.9"	903
4	139047-01-703	EA	CORNER POST-45 DEGREE- 65.9"	909
5	139047-01-704	EA	STRIKE - JAMB - 64.6"	926
6	139047-01-705	EA	HINGE/POST - DOOR - 64.5"	920
16	139047-01-710	EA	VINYL SWEEP	C176G
17	139047-01-711	EA	PLUG - DRIP CAP (SET)	CP933
18	092574-01-701	EA	BRACKET-DOOR PULL/TOWEL BAR	8141G
19	092574-01-710	EA	SCREW-GOLD, FOR TOWEL BAR	83212G
26	139047-01-712	EA	HEADER - CORNER BRACKET	313.45C
30	116814-01-700	EA	BAR-TOWEL 17 5/16"	68G
31	089318-01-707	EA	LATCH/CATCH - SAFETY - BLACK	9730N
	139047-01-706	EA	HINGE PINS	CP932
	139047-01-707	EA	WASHERS - HINGE	CP148TW
	139047-01-708	EA	HINGE - SLEEVE - 61.5"	C921B
	139047-01-709	EA	STRIP - MAGNETIC- 55"	98-42
	139047-01-713	EA	RAIL DRIP - 31.6"	927G

CONTACT WINNEBAGO PART SALES FOR UNLISTED COMPONENT(S)

BEDROOM GROUP QUEEN CABINETS

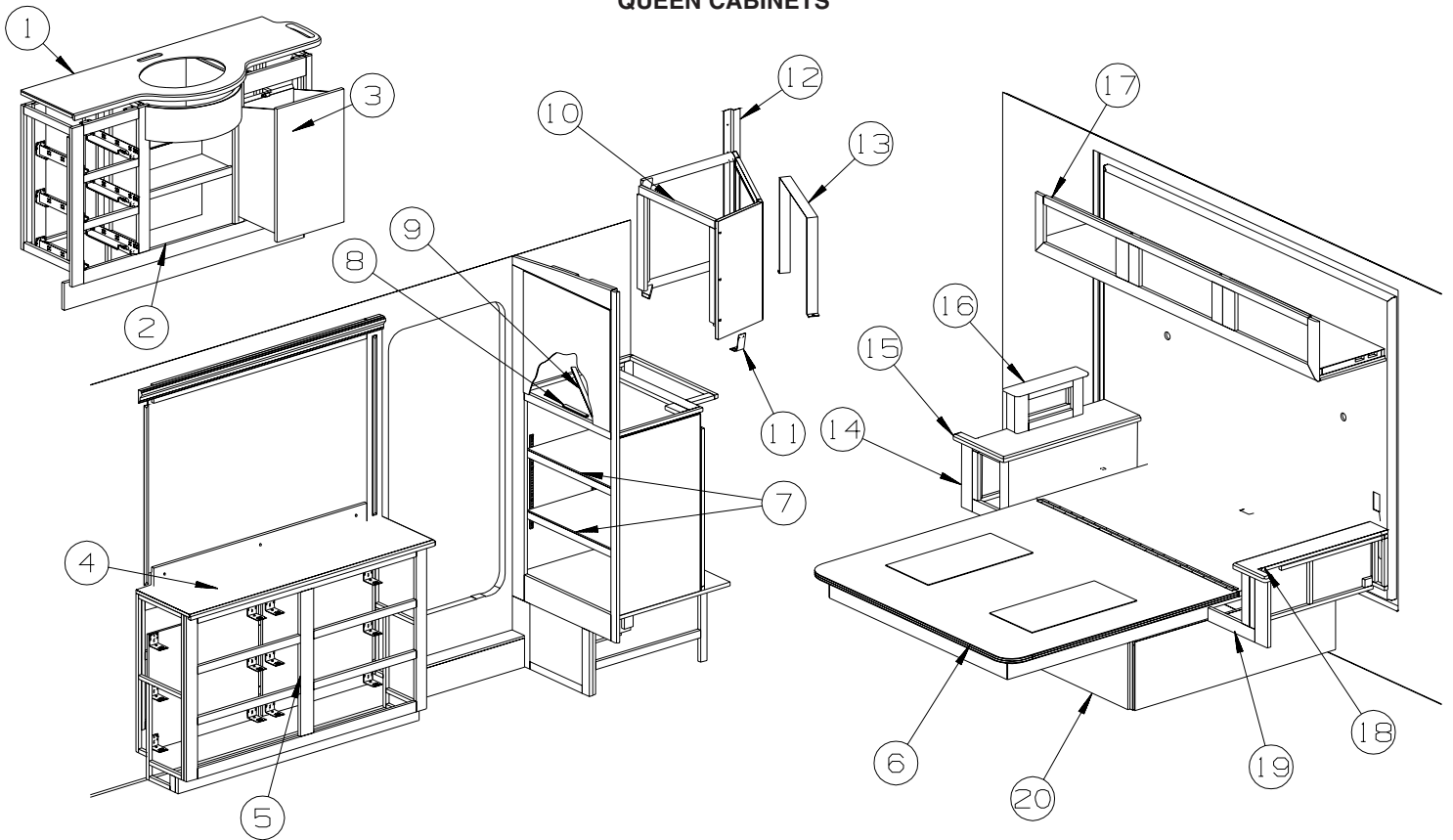

KEY	PART NUMBER	U/M	DESCRIPTION
1	137162-19-03A	EA	COUNTERTOP - 1/4" VENDURA - ROCKY MOUNTAIN HIGH
2	P47397-01-R68	EA	CABINET - VANITY - W/O DOORS/HARDWARE - PORTSMOUTH OAK
2	P47397-01-R69	EA	CABINET - VANITY - W/O DOORS/HARDWARE - CONCERT CHERRY
2	P47397-01-R76	EA	CABINET - VANITY - W/O DOORS/HARDWARE - WASHED MAPLE
			FROM: 00-00-00 THRU: 01-04-04
2	P47397-01-RW7	EA	CABINET - VANITY - W/O DOORS/HARDWARE - WASHED MAPLE
			FROM: 01-05-04 THRU: 99-99-99
3	147423-02-R74	EA	CABINET - HAMPER - W/O DOORS/HARDWARE - PORTSMOUTH OAK
3	147423-02-R75	EA	CABINET - HAMPER - W/O DOORS/HARDWARE - CONCERT CHERRY
3	147423-02-R76	EA	CABINET - HAMPER - W/O DOORS/HARDWARE - WASHED MAPLE
			FROM: 00-00-00 THRU: 01-04-04
3	147423-02-RW7	EA	CABINET - HAMPER - W/O DOORS/HARDWARE - WASHED MAPLE
			FROM: 01-05-04 THRU: 99-99-99
4	133655-91-R68	EA	COUNTERTOP - LAMINATED - PORTSMOUTH OAK - PORTSMOUTH OAK
4	133655-91-R69	EA	COUNTERTOP - LAMINATED - CHERRY - CONCERT CHERRY
4	133655-91-R76	EA	COUNTERTOP - LAMINATED - WASHED MAPLE - WASHED MAPLE
			FROM: 00-00-00 THRU: 01-04-04
4	133655-91-RW7	EA	COUNTERTOP - LAMINATED - HARDROCK MAPLE - WASHED MAPLE
			FROM: 01-05-04 THRU: 99-99-99
5	P45377-02-R68	EA	CABINET - DRESSER - W/O DRAWERS/HARDWARE - PORTSMOUTH OAK
5	P45377-02-R69	EA	CABINET - DRESSER - W/O DRAWERS/HARDWARE - CONCERT CHERRY
5	P45377-02-R76	EA	CABINET - DRESSER - W/O DRAWERS/HARDWARE - WASHED MAPLE
			FROM: 00-00-00 THRU: 01-04-04
5	P45377-02-RW7	EA	CABINET - DRESSER - W/O DRAWERS/HARDWARE - WASHED MAPLE
			FROM: 01-05-04 THRU: 99-99-99
6	137406-04-N52	EA	BEDBOARD - W/HINGE/T-MOLDING/SLIPNOT - FLIP-UP
7	146835-33-R68	EA	SHELF - W/PLASTIC EDGE MOLDING - PORTSMOUTH OAK
7	146835-33-R69	EA	SHELF - W/PLASTIC EDGE MOLDING - CONCERT CHERRY
7	146835-33-R76	EA	SHELF - W/PLASTIC EDGE MOLDING - WASHED MAPLE
			FROM: 00-00-00 THRU: 01-04-04
7	146835-33-RW7	EA	SHELF - W/PLASTIC EDGE MOLDING - WASHED MAPLE
			FROM: 01-05-04 THRU: 99-99-99
8	113797-02-01A	EA	STRIP - BLACK PLASTIC W/SELF ADHESIVE-.25" X .75" X 6.45"
9	113797-07-01A	EA	STRIP - RECTANGULAR - .2" X 23.4"

BEDROOM GROUP (CONTINUED)
QUEEN CABINETS (CONTINUED)

KEY	PART NUMBER	U/M	DESCRIPTION
10	141628-03-P84	EA	CABINET/TV - SWINGOUT - W/O DOORS/HARDWARE - PORTSMOUTH OAK
10	141628-03-P85	EA	CABINET/TV - SWINGOUT - W/O DOORS/HARDWARE - CONCERT CHERRY
10	141628-03-P28	EA	CABINET/TV - SWINGOUT - W/O DOORS/HARDWARE - WASHED MAPLE FROM: 00-00-00 THRU: 01-04-04
10	141628-03-RW7	EA	CABINET/TV - SWINGOUT - W/O DOORS/HARDWARE - WASHED MAPLE FROM: 01-05-04 THRU: 99-99-99
11	144050-01-02B	EA	ANGLE/SUPPORT - TV - E-COATED
12	116104-08-02B	EA	BRACKET - ZEE W/HOLES - 20.6" - E-COATED
13	115466-26-02B	EA	STRAP/TIEDOWN - TV - E-COATED
14	140557-01-N75	EA	CABINET - NIGHTSTAND - W/O COUNTERTOP/DOOR/DRAWERS/HDW - PORTSMOUTH OAK
14	140557-01-N85	EA	CABINET - NIGHTSTAND - W/O COUNTERTOP/DOOR/DRAWERS/HDW - CONCERT CHERRY
14	140557-01-N84	EA	CABINET - NIGHTSTAND - W/O COUNTERTOP/DOOR/DRAWERS/HDW - WASHED MAPLE FROM: 00-00-00 THRU: 01-04-04
14	140557-01-RW7	EA	CABINET - NIGHTSTAND - W/O COUNTERTOP/DOOR/DRAWERS/HDW - WASHED MAPLE FROM: 01-05-04 THRU: 99-99-99
15	133655-74-P82	EA	COUNTERTOP - LAMINATED - GRAY TRANQUILITY/PORTSMOUTH OAK (R74)
15	133655-74-P83	EA	COUNTERTOP - LAMINATED - GRAY TRANQUILITY/CHERRY IV (R75)
15	133655-74-R76	EA	COUNTERTOP - LAMINATED - GRAY TRANQUILITY/WASHED MAPLE (R76)
15	133655-74-R70	EA	COUNTERTOP - LAMINATED - LINO FRIEZE/PORTSMOUTH OAK (R77)
15	133655-74-R71	EA	COUNTERTOP - LAMINATED - LINO FRIEZE/CHERRY (R78)
15	133655-74-R79	EA	COUNTERTOP - LAMINATED - LINO FRIEZE/WASHED MAPLE (R79)
15	133655-74-R72	EA	COUNTERTOP - LAMINATED - ROCKY MT HIGH/PORTSMOUTH OAK (R80)
15	133655-74-R73	EA	COUNTERTOP - LAMINATED - ROCKY MT HIGH/CHERRY (R81)
15	133655-74-R82	EA	COUNTERTOP - LAMINATED - ROCKY MT HIGH/WASHED MAPLE (R82)
16	147702-01-R74	EA	CABINET - F/CLOCK - W/O CLOCK/HARDWARE - PORTSMOUTH OAK
16	147702-01-R75	EA	CABINET - F/CLOCK - W/O CLOCK/HARDWARE - CONCERT CHERRY
16	147702-01-R76	EA	CABINET - F/CLOCK - W/O CLOCK/HARDWARE - WASHED MAPLE FROM: 00-00-00 THRU: 01-04-04
16	147702-01-RW7	EA	CABINET - F/CLOCK - W/O CLOCK/HARDWARE - WASHED MAPLE FROM: 01-05-04 THRU: 99-99-99
17	148873-01-R68	EA	CABINET - OVERHEAD/REAR - W/O DOORS/HARDWARE - PORTSMOUTH OAK
17	148873-01-R69	EA	CABINET - OVERHEAD/REAR - W/O DOORS/HARDWARE - CONCERT CHERRY
17	148873-01-R76	EA	CABINET - OVERHEAD/REAR - W/O DOORS/HARDWARE - WASHED MAPLE FROM: 00-00-00 THRU: 01-04-04
17	148873-01-RW7	EA	CABINET - OVERHEAD/REAR - W/O DOORS/HARDWARE - WASHED MAPLE FROM: 01-05-04 THRU: 99-99-99
18	133655-70-P82	EA	COUNTERTOP - LAMINATED - GRAY TRANQUILITY/PORTSMOUTH OAK (R74)
18	133655-70-P83	EA	COUNTERTOP - LAMINATED - GRAY TRANQUILITY/CHERRY (R75)
18	133655-70-R76	EA	COUNTERTOP - LAMINATED - GRAY TRANQUILITY/WASHED MAPLE (R76)
18	133655-70-R70	EA	COUNTERTOP - LAMINATED - LINO FRIEZE/PORTSMOUTH OAK (R77)
18	133655-70-R71	EA	COUNTERTOP - LAMINATED - LINO FRIEZE/CHERRY (R78)
18	133655-70-R79	EA	COUNTERTOP - LAMINATED - LINO FRIEZE/WASHED MAPLE (R79)
18	133655-70-R72	EA	COUNTERTOP - LAMINATED - ROCKY MT HIGH/PORTSMOUTH OAK (R80)
18	133655-70-R73	EA	COUNTERTOP - LAMINATED - ROCKY MT HIGH/CHERRY (R81)
18	133655-70-R82	EA	COUNTERTOP - LAMINATED - ROCKY MT HIGH/WASHED MAPLE (R82)
19	140558-01-N75	EA	CABINET - NIGHTSTAND - W/O COUNTERTOP/DOORS/DRAWERS/HDW - PORTSMOUTH OAK
19	140558-01-N85	EA	CABINET - NIGHTSTAND - W/O COUNTERTOP/DOORS/DRAWERS/HDW - CONCERT CHERRY
19	140558-01-N84	EA	CABINET - NIGHTSTAND - W/O COUNTERTOP/DOORS/DRAWERS/HDW - WASHED MAPLE FROM: 00-00-00 THRU: 01-04-04
19	140558-01-RW7	EA	CABINET - NIGHTSTAND - W/O COUNTERTOP/DOORS/DRAWERS/HDW - WASHED MAPLE FROM: 01-05-04 THRU: 99-99-99
20	140361-01-N75	EA	CABINET/BASE - F/QUEEN BED - W/O DOORS/HARDWARE - PORTSMOUTH OAK
20	140361-01-N85	EA	CABINET/BASE - F/QUEEN BED - W/O DOORS/HARDWARE - CONCERT CHERRY
20	140361-01-N84	EA	CABINET/BASE - F/QUEEN BED - W/O DOORS/HARDWARE - WASHED MAPLE FROM: 00-00-00 THRU: 01-04-04
20	140361-01-RW7	EA	CABINET/BASE - F/QUEEN BED - W/O DOORS/HARDWARE - WASHED MAPLE FROM: 01-05-04 THRU: 99-99-99
20	140361-02-N75	EA	CABINET/BASE - F/QUEEN BED - W/O DRS/HARDWARE - PORTSMOUTH OAK - INVERTER/CHARGER
20	140361-02-N85	EA	CABINET/BASE - F/QUEEN BED - W/O DRS/HARDWARE - CONCERT CHERRY - INVERTER/CHARGER
20	140361-02-N84	EA	CABINET/BASE - F/QUEEN BED - W/O DRS/HARDWARE - WASHED MAPLE - INVERTER/CHARGER FROM: 00-00-00 THRU: 01-04-04
20	140361-02-RW7	EA	CABINET/BASE - F/QUEEN BED - W/O DRS/HARDWARE - WASHED MAPLE - INVERTER/CHARGER FROM: 01-05-04 THRU: 99-99-99

BEDROOM GROUP (CONTINUED)

QUEEN DOORS & DRAWERS

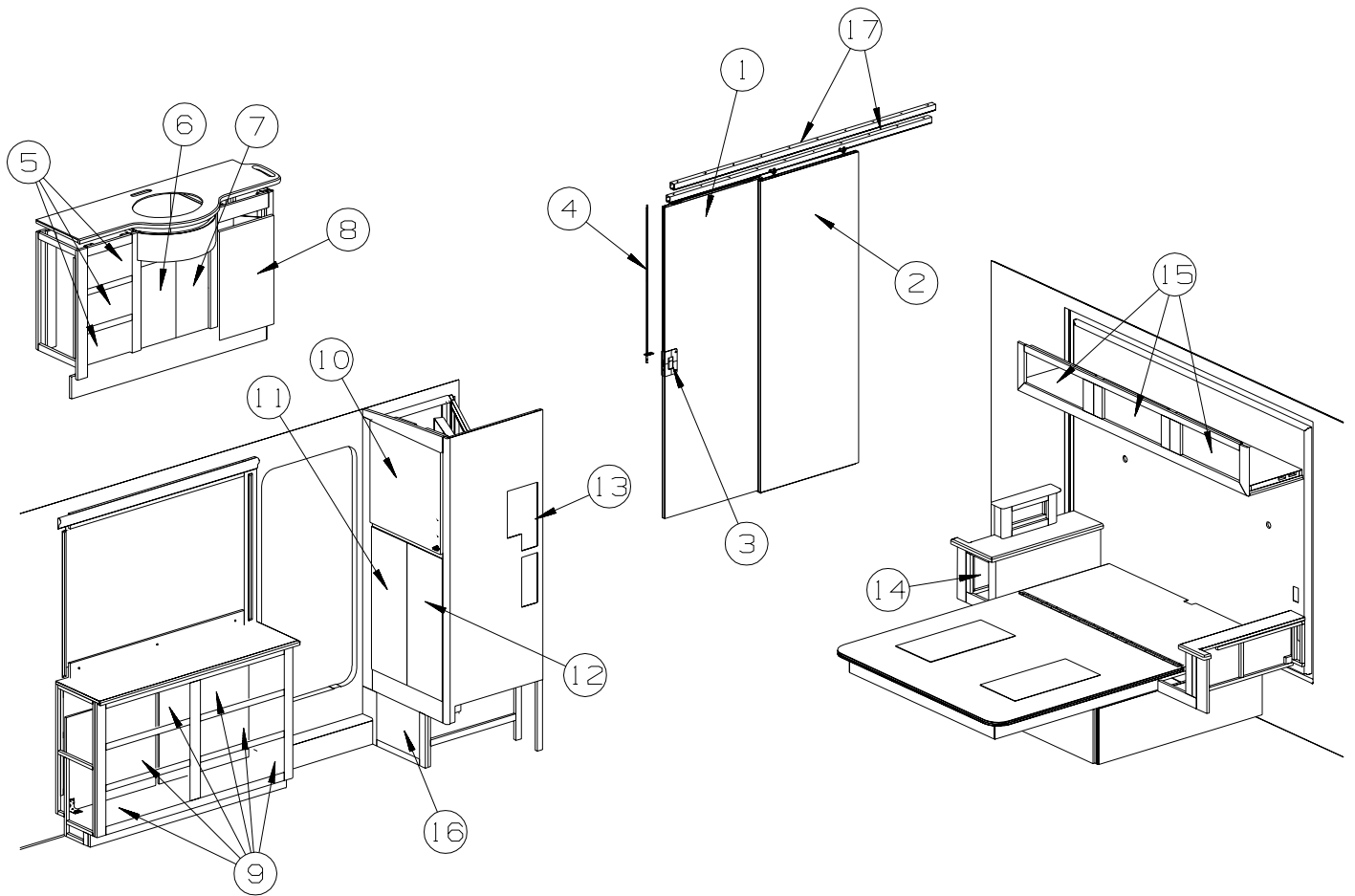

KEY	PART NUMBER	U/M	DESCRIPTION
1	146972-11-R68	EA	PANEL - SLIDING DOOR - W/O POCKET/HARDWARE - PORTSMOUTH OAK
1	146972-11-R69	EA	PANEL - SLIDING DOOR - W/O POCKET/HARDWARE - CONCERT CHERRY
1	146972-11-R76	EA	PANEL - SLIDING DOOR - W/O POCKET/HARDWARE - WASHED MAPLE
			FROM: 00-00-00 THRU: 01-04-04
1	146972-11-RW7	EA	PANEL - SLIDING DOOR - W/O POCKET/HARDWARE - WASHED MAPLE
			FROM: 01-05-04 THRU: 99-99-99
2	146972-14-R68	EA	PANEL - SLIDING DOOR - W/O POCKET/HARDWARE - PORTSMOUTH OAK
2	146972-14-R69	EA	PANEL - SLIDING DOOR - W/O POCKET/HARDWARE - CONCERT CHERRY
2	146972-14-R76	EA	PANEL - SLIDING DOOR - W/O POCKET/HARDWARE - WASHED MAPLE
			FROM: 00-00-00 THRU: 01-04-04
2	146972-14-RW7	EA	PANEL - SLIDING DOOR - W/O POCKET/HARDWARE - WASHED MAPLE
			FROM: 01-05-04 THRU: 99-99-99
3	145939-01-01A	EA	LATCH - SLIDE - AISLE DOOR(1" THICK DOOR) - BRASS
4	145939-03-01A	EA	ROD/LATCH - AISLE DOOR - BRASS
5	146084-11-R74	EA	DRAWER - PENCIL EDGE - 12"W X 12"D - W/O SLIDES/HARDWARE - PORTSMOUTH OAK
5	146084-11-R75	EA	DRAWER - PENCIL EDGE - 12"W X 12"D - W/O SLIDES/HARDWARE - CONCERT CHERRY
5	146084-11-R76	EA	DRAWER - PENCIL EDGE - 12"W X 12"D - W/O SLIDES/HARDWARE - WASHED MAPLE
6	136955-32-R74	EA	DOOR - RAISED PANEL/PENCIL EDGE - 10.2" X 21.5" - W/O HDW - PORTSMOUTH OAK
6	136955-32-R75	EA	DOOR - RAISED PANEL/PENCIL EDGE - 10.2" X 21.5" - W/O HDW - CONCERT CHERRY
6	136955-32-R76	EA	DOOR - RAISED PANEL/PENCIL EDGE - 10.2" X 21.5" - W/O HDW - WASHED MAPLE
7	136955-33-R74	EA	DOOR - RAISED PANEL/PENCIL EDGE - 10.2" X 21.5" - W/O HDW - PORTSMOUTH OAK
7	136955-33-R75	EA	DOOR - RAISED PANEL/PENCIL EDGE - 10.2" X 21.5" - W/O HDW - CONCERT CHERRY
7	136955-33-R76	EA	DOOR - RAISED PANEL/PENCIL EDGE - 10.2" X 21.5" - W/O HDW - WASHED MAPLE

BEDROOM GROUP (CONTINUED)
QUEEN DOORS & DRAWERS (CONTINUED)

KEY	PART NUMBER	U/M	DESCRIPTION
8	136955-C1-R74	EA	DOOR - RAISED PANEL/PENCIL EDGE - 15.4" X 25.6" - W/O HDW - PORTSMOUTH OAK FROM: 00-00-00 THRU: 10-09-03
8	145268-23-R74	EA	DOOR - RAISED PANEL/PENCIL EDGE - 25.6" X 15.3" - W/O HDW - PORTSMOUTH OAK FROM: 10-10-03 THRU: 99-99-99
8	136955-C1-R75	EA	DOOR - RAISED PANEL/PENCIL EDGE - 15.4" X 25.6" - W/O HDW - CONCERT CHERRY FROM: 00-00-00 THRU: 10-09-03
8	145268-23-R75	EA	DOOR - RAISED PANEL/PENCIL EDGE - 25.6" X 15.3" - W/O HDW - CONCERT CHERRY FROM: 10-10-03 THRU: 99-99-99
8	136955-C1-R76	EA	DOOR - RAISED PANEL/PENCIL EDGE - 15.4" X 25.6" - W/O HDW - WASHED MAPLE FROM: 00-00-00 THRU: 10-09-03
8	145268-23-R76	EA	DOOR - RAISED PANEL/PENCIL EDGE - 25.6" X 15.3" - W/O HDW - WASHED MAPLE FROM: 10-10-03 THRU: 99-99-99
9	146084-02-R74	EA	DRAWER - PENCIL EDGE - 23"W X 12"D - W/O HARDWARE - PORTSMOUTH OAK
9	146084-02-R75	EA	DRAWER - PENCIL EDGE - 23"W X 12"D - W/O HARDWARE - CONCERT CHERRY
9	146084-02-R76	EA	DRAWER - PENCIL EDGE - 23"W X 12"D - W/O HARDWARE - WASHED MAPLE
10	141628-23-P84	EA	DOOR - COMBINATION - 24.3" X 24" - W/O HARDWARE - PORTSMOUTH OAK
10	141628-23-P28	EA	DOOR - COMBINATION - 24.3" X 24" - W/O HARDWARE - CONCERT CHERRY
10	141628-23-P85	EA	DOOR - COMBINATION - 24.3" X 24" - W/O HARDWARE - WASHED MAPLE
11	144857-02-R74	EA	DOOR - LOUVERED/PENCIL EDGE/LEFT HAND - 12.4" X 36" - PORTSMOUTH OAK
11	144857-02-R75	EA	DOOR - LOUVERED/PENCIL EDGE/LEFT HAND - 12.4" X 36" - CONCERT CHERRY
11	144857-02-R76	EA	DOOR - LOUVERED/PENCIL EDGE/LEFT HAND - 12.4" X 36" - WASHED MAPLE
12	144856-02-R74	EA	DOOR - LOUVERED/PENCIL EDGE/RIGHT HAND - 12.4" X 36" - PORTSMOUTH OAK
12	144856-02-R75	EA	DOOR - LOUVERED/PENCIL EDGE/RIGHT HAND - 12.4" X 36" - CONCERT CHERRY
12	144856-02-R76	EA	DOOR - LOUVERED/PENCIL EDGE/RIGHT HAND - 12.4" X 36" - WASHED MAPLE
13	136955-28-R74	EA	DOOR - RAISED PANEL/PENCIL EDGE - 10" X 29.5" - W/O HDW - PORTSMOUTH OAK
13	136955-28-R75	EA	DOOR - RAISED PANEL/PENCIL EDGE - 10" X 29.5" - W/O HDW - CONCERT CHERRY
13	136955-28-R76	EA	DOOR - RAISED PANEL/PENCIL EDGE - 10" X 29.5" - W/O HDW - WASHED MAPLE
14	145492-77-R74	EA	DRAWER - PENCIL EDGE - 5.2"W X 13.8"D - W/O SLIDES/HDW - PORTSMOUTH OAK
14	145492-77-R75	EA	DRAWER - PENCIL EDGE - 5.2"W X 13.8"D - W/O SLIDES/HDW - CONCERT CHERRY
14	145492-77-R76	EA	DRAWER - PENCIL EDGE - 5.2"W X 13.8"D - W/O SLIDES/HDW - WASHED MAPLE
15	141522-07-R74	EA	DOOR - ARCHED/PENCIL EDGE/HORIZ - 9.2" X 21.8" - W/O HDW - PORTSMOUTH OAK
15	141522-07-R75	EA	DOOR - ARCHED/PENCIL EDGE/HORIZ - 9.2" X 21.8" - W/O HDW - CONCERT CHERRY
15	141522-07-R76	EA	DOOR - ARCHED/PENCIL EDGE/HORIZ - 9.2" X 21.8" - W/O HDW - WASHED MAPLE
16	P40283-09-R83	EA	DOOR - W/GRILL - OGEE EDGE - 13.4" X 15.7" - W/O HARDWARE - PORTSMOUTH OAK
16	P40283-09-R84	EA	DOOR - W/GRILL - OGEE EDGE - 13.4" X 15.7" - W/O HARDWARE - CONCERT CHERRY
16	P40283-09-R91	EA	DOOR - W/GRILL - OGEE EDGE - 13.4" X 15.7" - W/O HARDWARE - WASHED MAPLE FROM: 00-00-00 THRU: 01-04-04
16	P40283-09-RE0	EA	DOOR - W/GRILL - OGEE EDGE - 13.4" X 15.7" - W/O HARDWARE - WASHED MAPLE FROM: 01-05-04 THRU: 99-99-99
16	140594-06-01A	EA	GRILLE - RETURN AIR - 12.3" X 14.9" - BLACK
17	145608-09-01A	EA	TRACK - DOOR - 73.6" - OFF WHITE

BEDROOM GROUP (CONTINUED)
QUEEN DOORS & DRAWERS (CONTINUED)

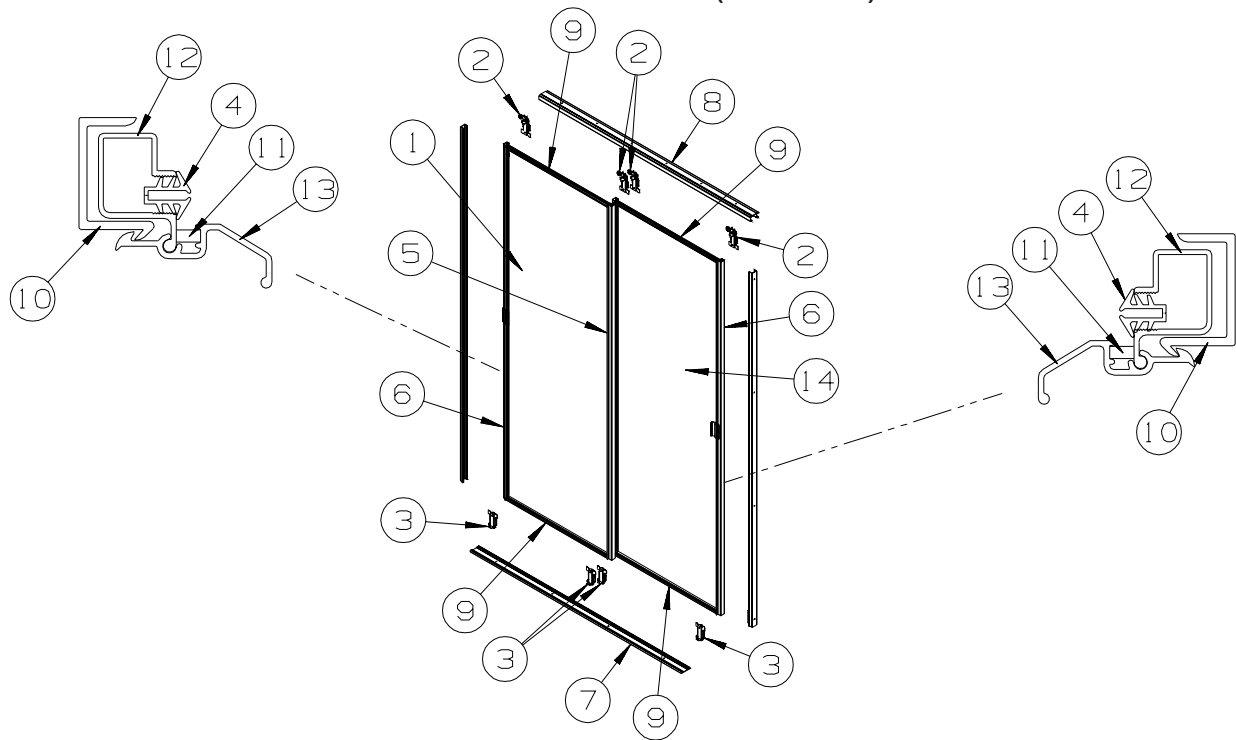

KEY	PART NUMBER	U/M	DESCRIPTION
1	136681-21-N84	EA	DOOR - MIRRORED/WARDROBE - LH - W/HANGERS/GUIDES/LATCH
2	107390-02-000	EA	CORNER HANGER (DOUBLE ROLLER W/BACKET) (SOLD AS 1 EACH)
3	107391-01-000	EA	GUIDE - BOTTOM - BY-PASS (4 USED PER DOOR)
4	111575-01-01A	FT	CHANNEL - GLAZING - SWING DOOR
5	114104-21-01A	EA	STILE - DOOR - SLIDING - 57.9" - TERRATONE
6	114104-22-01A	EA	STILE - DOOR - SLIDING - 57.9" - TERRATONE
7	114105-18-01A	EA	TRACK - SLIDING DOOR - LOWER - 67.2" - TERRATONE
8	114106-18-01A	EA	TRACK - SLIDING DOOR - UPPER - 67.2" - TERRATONE
9	114107-03-01A	EA	RAIL - DOOR/SLIDING - UPPER/LOWER - 34.1" - TERRATONE
10	115538-12-01A	EA	JAMB - DOOR - WARDROBE/MIRRORED - BLACK
11	115541-01-000	EA	SPRING - DOOR - SLIDING
12	123655-01-000	FT	SEAL - CLOSED CELL/FOAM
13	132038-01-01A	EA	LATCH - DOOR/WARDROBE - TERRATONE
			FROM: 00-00-00 THRU: 11-16-03
13	149252-01-01A	EA	LATCH - WARDROBE DOOR - TERRA COTTA
			FROM: 11-17-03 THRU: 99-99-99
14	136680-21-N84	EA	DOOR - MIRRORED/WARDROBE - RH - W/HANGERS/GUIDES/LATCH

CHASSIS GROUP

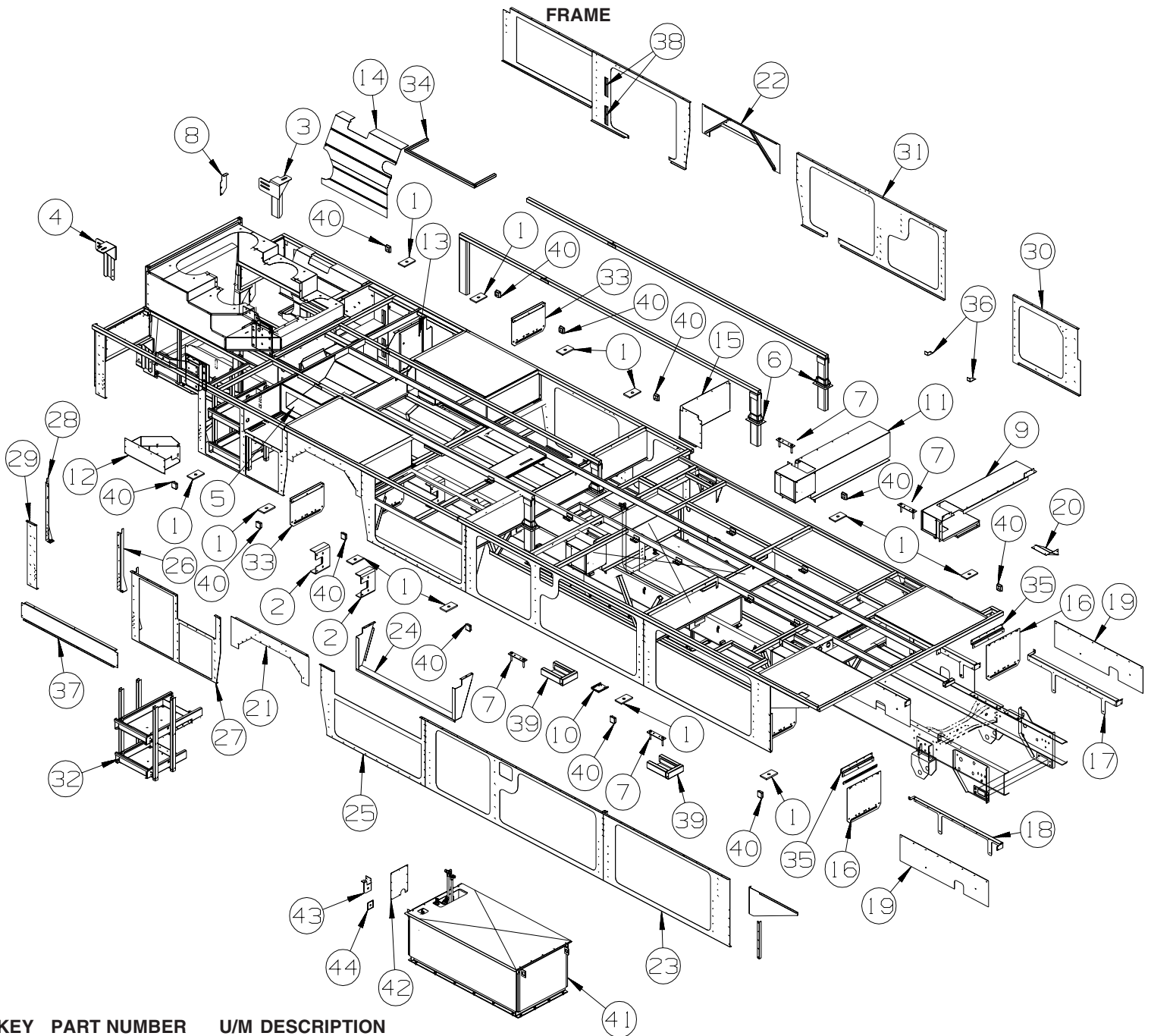

KEY	PART NUMBER	U/M	DESCRIPTION
1	135712-01-02B	EA	PLATE - BODY MOUNT - E-COATED
2	120867-01-02B	EA	MOUNT - LP TANK - E-COAT
3	131328-03-02B	EA	SUPPORT - REAR RISER - RIGHT HAND - E-COATED
4	131328-04-02B	EA	SUPPORT - REAR RISER - LEFT HAND - E-COATED
5	144842-03-02B	EA	COMPARTMENT - FURNACE - E-COATED
6	139724-01-01A	EA	BOOT - TOWER - BLACK
7	136995-02-02B	EA	PLATE - E-COATED
8	141728-01-02B	EA	HANGER - EXHAUST - E-COATED
9	135401-01-02B	EA	COMPARTMENT - E-COATED
10	144724-01-02B	EA	BRACKET - SENSOR/LEVELING - E-COATED
11	135401-03-02B	EA	COMPARTMENT - E-COATED
12	140290-01-02B	EA	PANEL - CONTROL/POWER - E-COATED
13	147542-01-02B	EA	COMPARTMENT - POWERCORD - E-COATED
			FROM: 00-00-00 THRU: 01-11-04
13	144391-01-02B	EA	COMPARTMENT - POWER CORD - E-COATED
			FROM: 01-12-04 THRU: 99-99-99
14	139420-01-02B	EA	SHIELD - A/C CONDENSOR - E-COATED
15	139885-01-02B	EA	PANEL - CLOSEOUT - E-COATED
16	136391-02-02B	EA	GUARD/ROCK - STEEL - W/ANGLE - 18"W X 15"H - E-COATED

CHASSIS GROUP (CONTINUED)
FRAME (CONTINUED)

KEY	PART NUMBER	U/M	DESCRIPTION
17	143916-02-02B	EA	BRACKET/SHIELD - SPLASH - E-COATED
18	143916-01-02B	EA	BRACKET/SHIELD - SPLASH - E-COATED
19	143917-01-01A	EA	SHIELD/SPLASH - WHEELWELL
20	143530-01-02B	EA	COVER/HOLE - SEAL ACCESS/SLIDEOUT - E-COATED
21	119750-04-02B	EA	SEAL PLANE/WHEEL WELL - RIGHT HAND - E-COATED
22	119750-05-02B	EA	SEAL PLANE/WHEEL WELL - LEFT HAND - E-COATED
23	138549-01-02B	EA	PLATE/SEAL - E-COATED
24	140166-01-02B	EA	SUPPORT - SEAL PLANE - E-COATED
25	135642-01-02B	EA	PLATE/SEAL - E-COATED
26	141649-02-02B	EA	BRACKET - A/C - E-COATED
			FROM: 00-00-00 THRU: 03-19-04
26	141649-03-02B	EA	BRACKET - A/C - E-COATED
			FROM: 03-20-04 THRU: 99-99-99
27	145055-01-02B	EA	PLATE/SEAL - FURNACE - E-COATED
			FROM: 00-00-00 THRU: 10-19-03
27	147896-01-02B	EA	PLATE/SEAL - FURNACE - E-COATED
			FROM: 10-20-03 THRU: 99-99-99
28	141649-01-02B	EA	BRACKET - A/C - E-COATED
29	141650-01-02B	EA	PLATE/SEAL - E-COATED
			FROM: 00-00-00 THRU: 10-19-03
29	141650-02-02B	EA	PLATE/SEAL - E-COATED
			FROM: 10-20-03 THRU: 99-99-99
30	136332-02-02B	EA	PANEL/SEAL - FRONT - E-COATED
			FROM: 00-00-00 THRU: 10-21-03
31	145142-01-02B	EA	PLATE - SEAL - E-COATED
32	138866-01-01A	EA	SLIDE - BATTERY TRAY
33	136391-01-02B	EA	GUARD/ROCK - STEEL - W/ANGLE - 18"W X 11"H - E-COATED
34	134225-01-02B	EA	SUPPORT - CONDENSOR SHIELD - E-COATED
35	140273-01-02B	EA	BRACE - ROCK GUARD - E-COATED
36	122922-02-02B	EA	BRACKET/CYLINDER SUPPORT - E-COATED
			FROM: 00-00-00 THRU: 08-18-03
37	145845-01-02B	EA	PANEL - CLOSEOUT - A/C - E-COATED
			FROM: 00-00-00 THRU: 10-21-03
38	130034-02-02B	EA	CLIP - TRIM - E-COATED
39	147997-01-02B	EA	BRACKET - F/SLIDEOUT - E-COATED
40	119845-01-01A	EA	PLUG/PLASTIC - 1 1/2" SQUARE - BLACK
41	P32937-07-000	EA	COMPARTMENT - WATER TANK
42	133352-01-02B	EA	PANEL - ACCESS - WATER TANK - E-COATED
43	143994-01-12B	EA	BRACKET/MOUNTING - VALVE - BRIGHT WHITE
44	127170-01-000	EA	LABEL - WATER TANK DRAIN
45	145039-01-02B	EA	SEAL PLANE - E-COATED
46	146245-01-000	EA	INSULATION - FIEBERGLASS/FOIL - 25"

CHASSIS GROUP (CONTINUED)

FRONT END

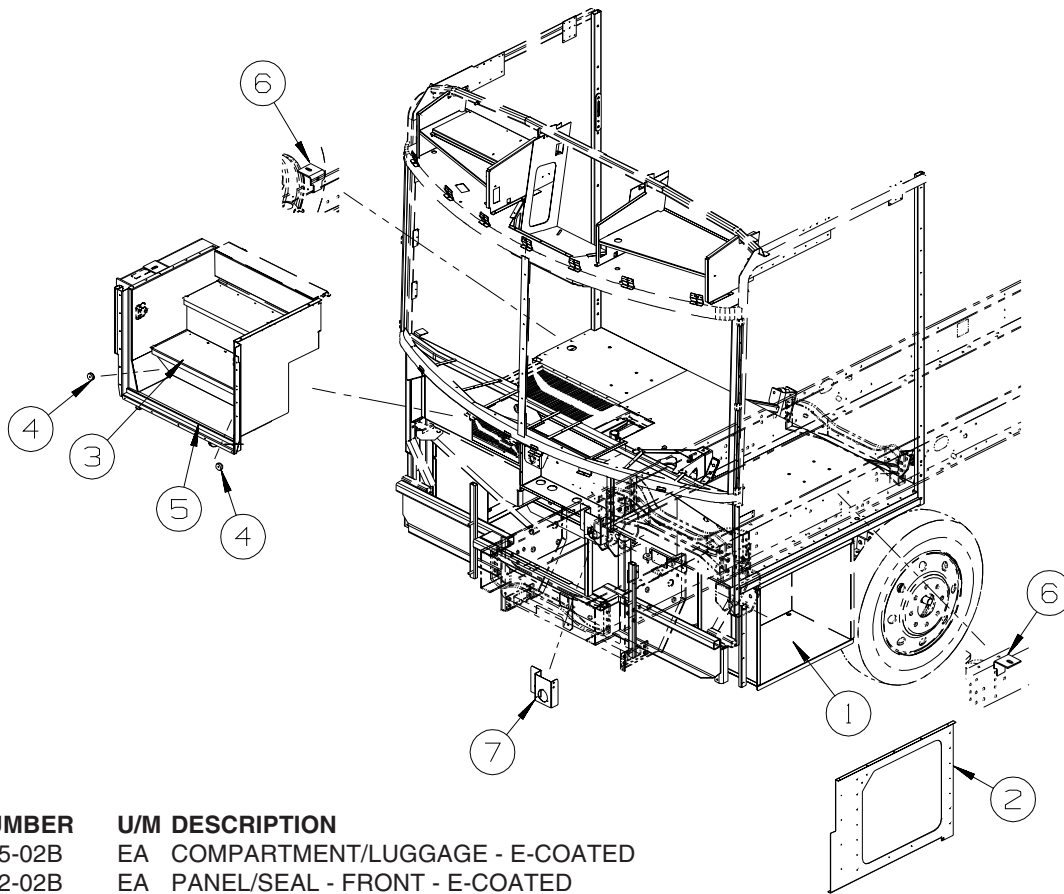

KEY	PART NUMBER	U/M	DESCRIPTION	
1	123764-05-02B	EA	COMPARTMENT/LUGGAGE - E-COATED	
2	136332-02-02B	EA	PANEL/SEAL - FRONT - E-COATED	
3	131519-03-PC0	EA	STEP - FOLD UP - ENTRY DOOR	
4	120863-08-000	EA	BUMPER - RUBBER - W/INSERT - .4" X .7"	FROM: 00-00-00 THRU: 03-28-03
5	132987-03-02B	EA	STEP - ENTRY DOOR - E-COATED	FROM: 00-00-00 THRU: 03-28-03
5	144034-02-02B	EA	STEP - ENTRY DOOR - E-COATED	FROM: 00-00-00 THRU: 03-28-03
5	144034-03-02B	EA	STEP - ENTRANCE DOOR - E-COATED	FROM: 03-29-03 THRU: 05-18-03
5	144034-03-02B	EA	STEP - ENTRANCE DOOR - E-COATED	FROM: 05-19-03 THRU: 99-99-99
6	117154-04-02B	EA	MOUNT - FRAME RAIL/FLOOR	
7	142478-01-01B	EA	BRACKET - GAUGE - AIR SOURCE - MILL	

CHASSIS GROUP (CONTINUED) FRONT END (CONTINUED)

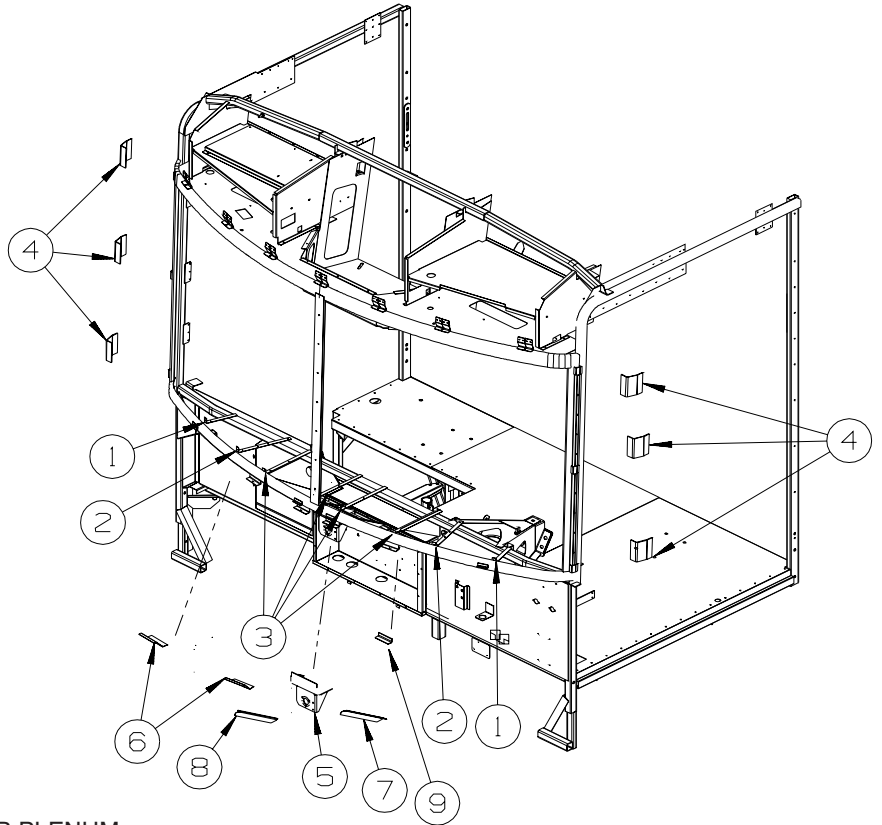

KEY	PART NUMBER	U/M	DESCRIPTION
1	137047-06-01B	EA	STRAP - DEFROSTER PLENUM
2	137047-05-01B	EA	STRAP - DEFROSTER PLENUM
3	137047-04-01B	EA	STRAP - DEFROSTER PLENUM
4	120363-01-01B	EA	BRACKET - WINDSHIELD
4	148935-01-01B	EA	BRACKET - WINDSHIELD
5	134506-01-01B	EA	BRACKET - WIPER MOTOR
6	134202-01-01B	EA	REINFORCEMENT - SUPPORT - LOWER WINDSHIELD/MIDDLE
7	134371-01-01B	EA	ANGLE/MOUNT - WIPER MOTOR
8	134371-02-01B	EA	ANGLE/MOUNT - WIPER MOTOR
9	126289-65-01B	EA	ANGLE - FORMED

FROM: 00-00-00 THRU: 04-04-04

FROM: 04-05-04 THRU: 99-99-99

CHASSIS GROUP (CONTINUED)

AIR INTAKE

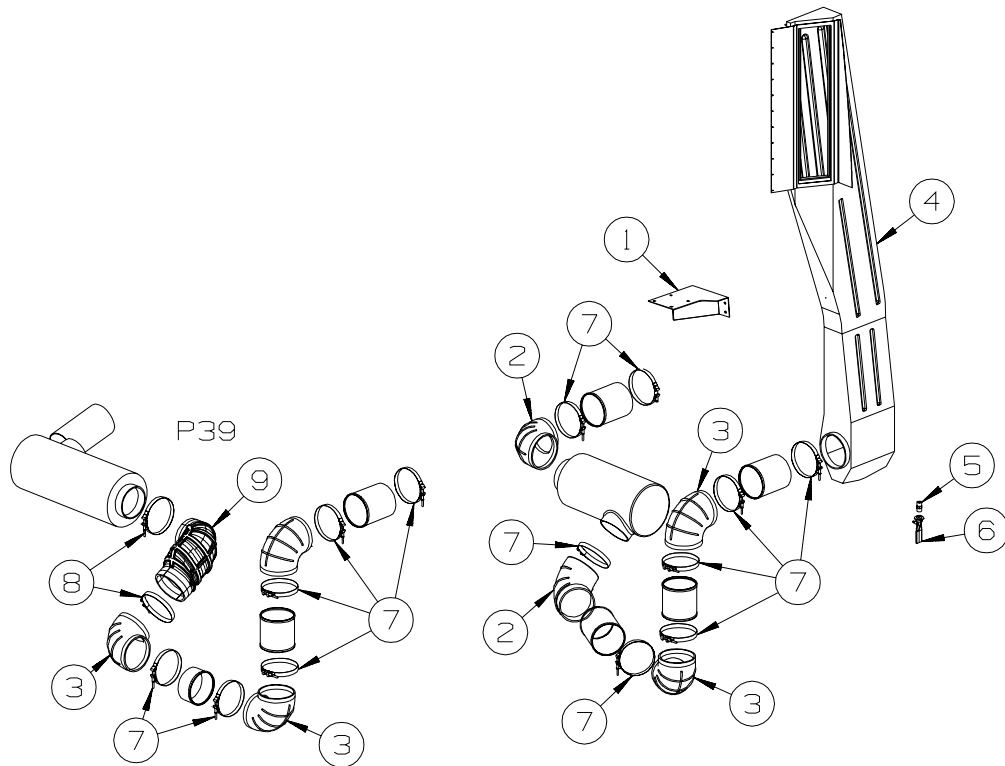

KEY	PART NUMBER	U/M	DESCRIPTION
1	136817-01-02B	EA	BRACKET/AIR FILTER - E-COATED - P32T
2	123362-03-000	EA	ELBOW - RUBBER - 68 DEGREE 6" ID
3	123362-02-000	EA	ELBOW - AIR INTAKE - RUBBER - 90 DEGREE 6" ID
4	129514-02-01A	EA	DUCT - INTAKE AIR - W/FITTING
	129514-01-01A	EA	DUCT - INTAKE AIR
5	135386-01-000	EA	NIPPLE - 1/2"
6	130377-01-000	EA	TUBE/DRAIN - KAZOO - 1 1/4" X 4"
7	125083-01-01A	EA	CLAMP - T BOLT - 6"
8	125083-03-01A	EA	CLAMP - T BOLT - 6.5"
9	150586-01-000	EA	ELBOW - RUBBER/COBRA HEAD - F/AIR INTAKE - 6" DIAMETER

CHASSIS GROUP (CONTINUED)

INSULATION

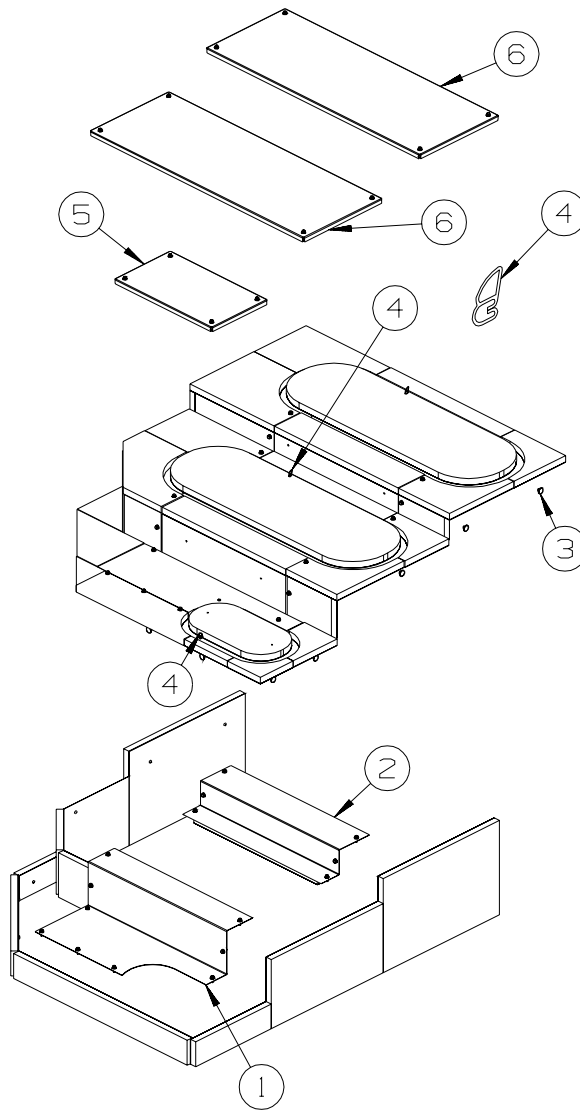

P39W & P39K

KEY	PART NUMBER	U/M	DESCRIPTION
1	140564-02-02B	EA	PANEL/ACCESS - ENGINE COMPARTMENT - E-COATED
2	140351-02-02B	EA	PANEL - ACCESS/COMPARTMENT - E-COATED
3	106648-01-000	EA	CAP - STUD - .120 TO .130 DIAMETER
4	039623-01-000	EA	SEAL - MOTOR COVER - RUBBER BULB TYPE
5	140420-01-02B	EA	COVER - ENGINE - E-COATED
6	140399-01-02B	EA	COVER - ENGINE - E-COATED
	072877-03-000	EA	INSULATION - SOUND BARRIER- 1" X 36" X 57" - ADHESIVE BACK

CHASSIS GROUP (CONTINUED)
INSULATION (CONTINUED)

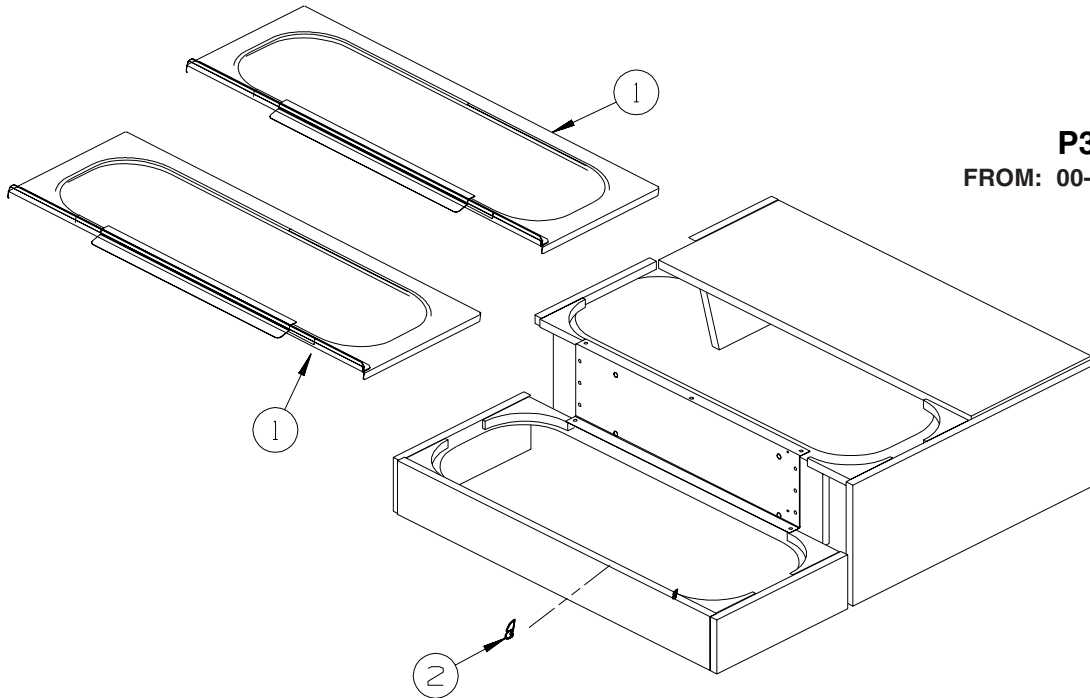

P34H & P36G
FROM: 00-00-00 THRU: 10-21-03

KEY	PART NUMBER	U/M	DESCRIPTION
1	134340-01-02B	EA	COVER - ENGINE - E-COATED
2	039623-01-000	FT	SEAL - MOTOR COVER - RUBBER BULB TYPE
	072877-03-000	EA	INSULATION - SOUND BARRIER- 1" X 36" X 57" - ADHESIVE BACK

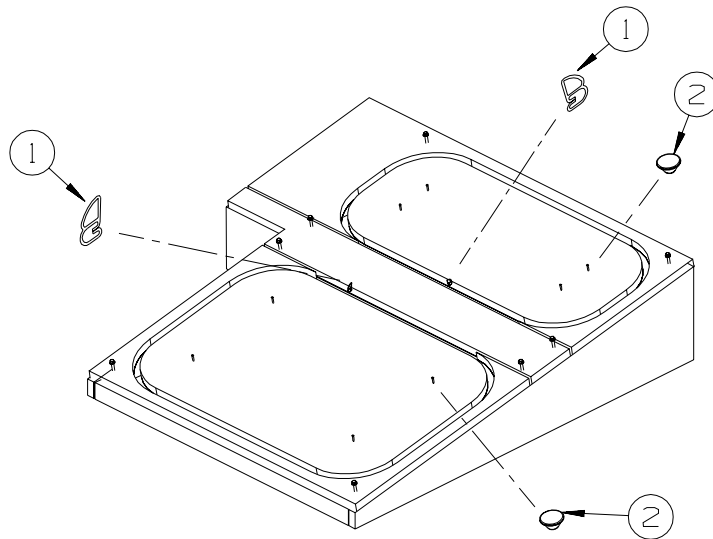

P34H & P36G
FROM: 10-22-03 THRU: 99-99-99

KEY	PART NUMBER	U/M	DESCRIPTION
1	039623-01-000	FT	SEAL - MOTOR COVER - RUBBER BULB TYPE
2	106648-01-000	EA	CAP - STUD - .120 TO .130 DIAMETER
	072877-03-000	EA	INSULATION - SOUND BARRIER- 1" X 36" X 57" - ADHESIVE BACK

CHASSIS GROUP (CONTINUED)
INSULATION (CONTINUED)

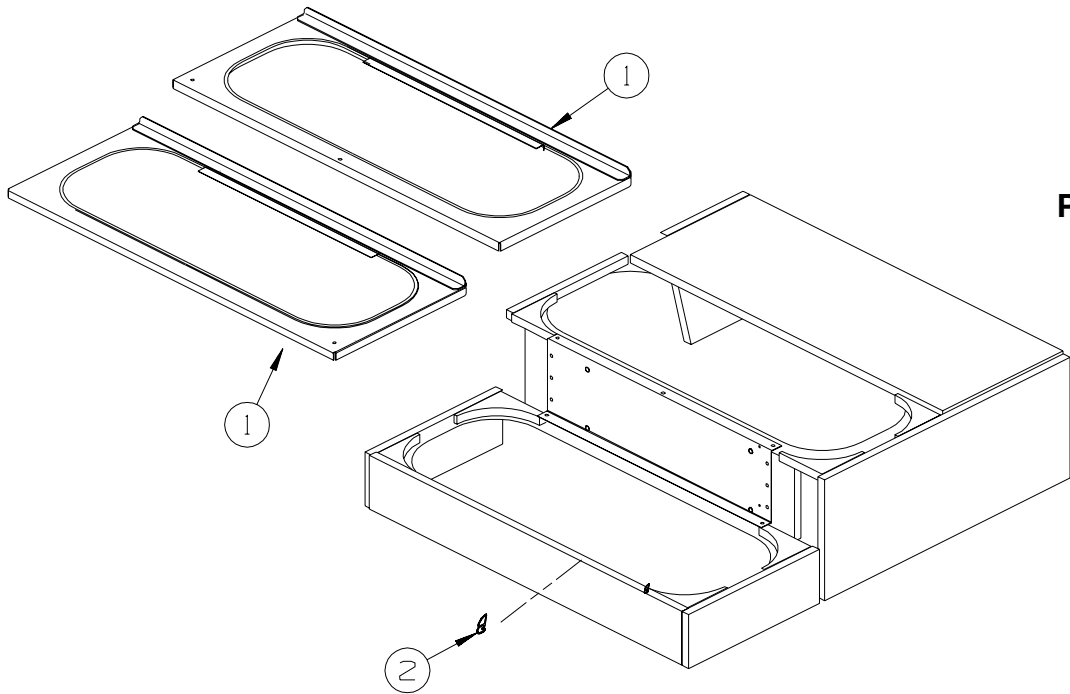

P32T

KEY	PART NUMBER	U/M	DESCRIPTION
1	134340-01-02B	EA	COVER - ENGINE - E-COATED
2	039623-01-000	FT	SEAL - MOTOR COVER - RUBBER BULB TYPE
	072877-03-000	EA	INSULATION - SOUND BARRIER- 1" X 36" X 57" - ADHESIVE BACK

CHASSIS GROUP (CONTINUED)
INSULATION (CONTINUED)

2003 CHASSIS

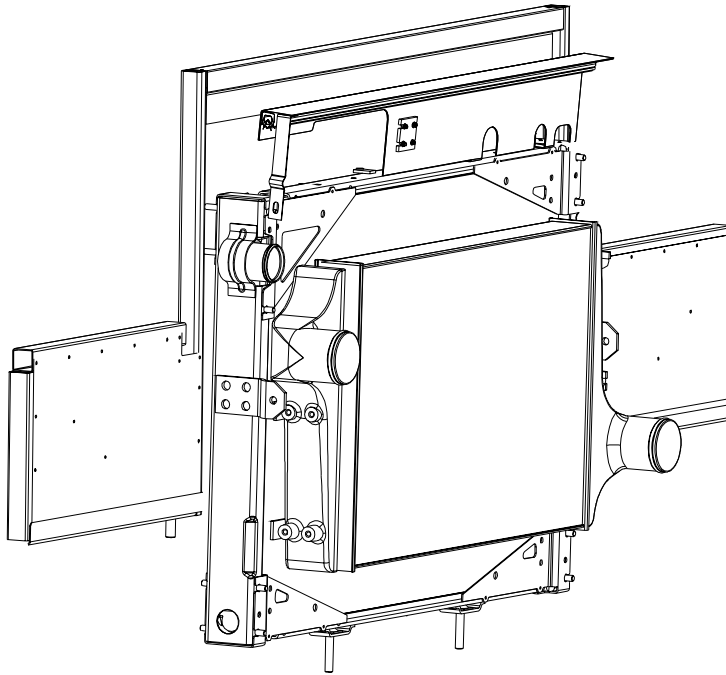
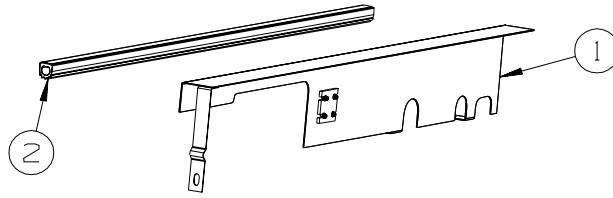

KEY	PART NUMBER	U/M	DESCRIPTION
1	134068-04-02B	EA	ANGLE - BAFFLE/TOP - E-COATED - FREIGHTLINER 5-SPEED
1	134068-02-02B	EA	ANGLE - BAFFLE/TOP - E-COATED - FREIGHTLINER 6-SPEED
2	107721-07-000	FT	SEAL - ACCESS DOOR - .9"WIDE X 1.1"HIGH

CHASSIS GROUP (CONTINUED)
INSULATION (CONTINUED)

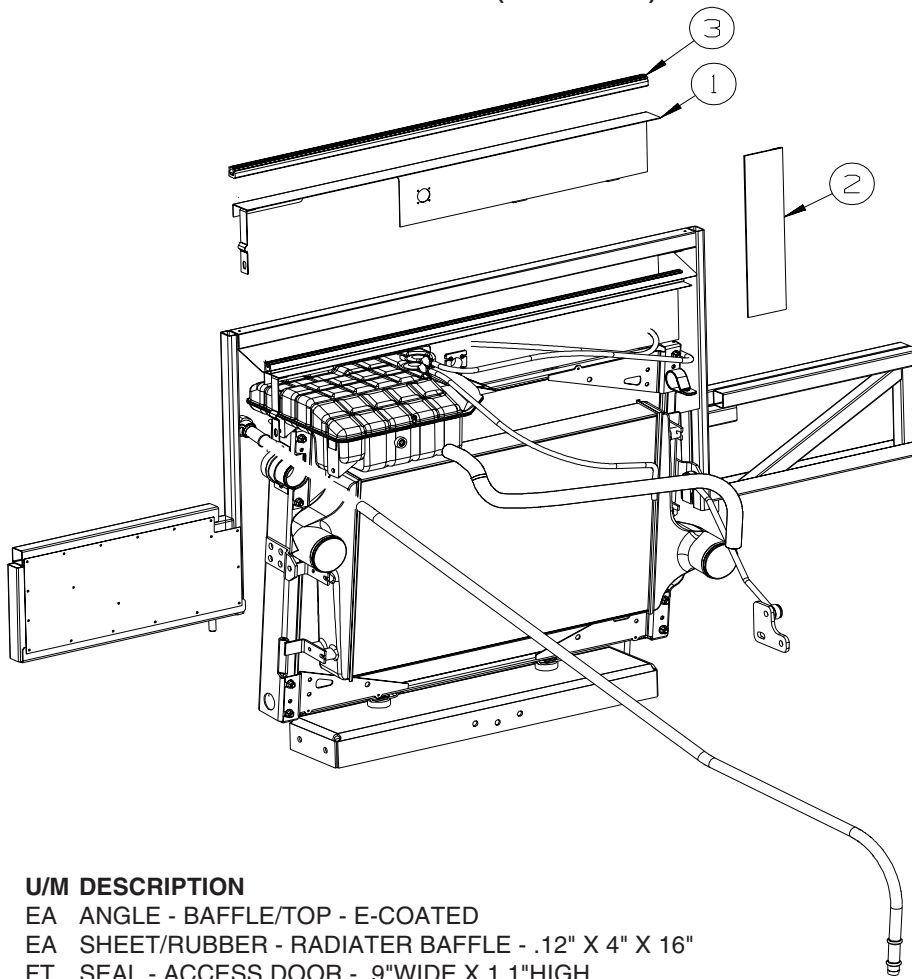

2004 CHASSIS

KEY	PART NUMBER	U/M	DESCRIPTION
1	134068-05-02B	EA	ANGLE - BAFFLE/TOP - E-COATED
2	076310-05-000	EA	SHEET/RUBBER - RADIATER BAFFLE - .12" X 4" X 16"
3	107721-07-000	FT	SEAL - ACCESS DOOR - .9"WIDE X 1.1"HIGH

CHASSIS GROUP (CONTINUED)
INSULATION (CONTINUED)

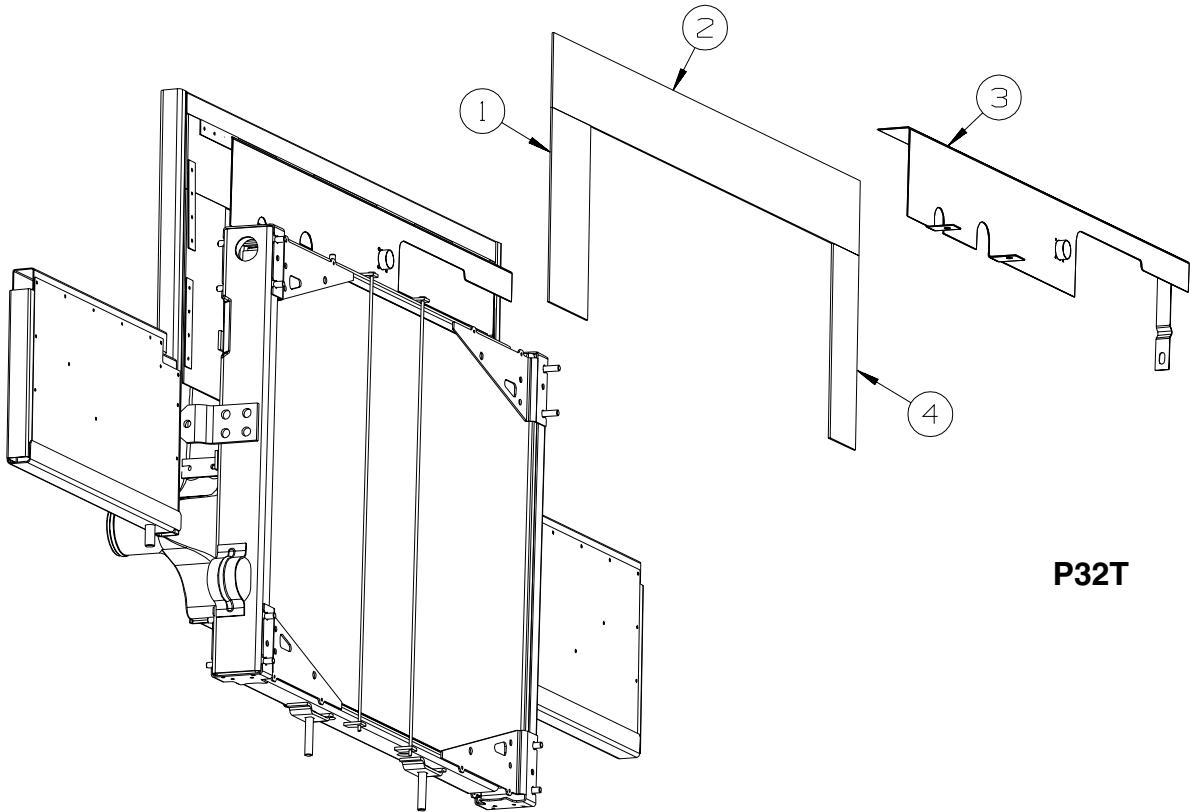

P32T

KEY	PART NUMBER	U/M	DESCRIPTION
1	076310-10-000	EA	SHEET/RUBBER - RADIATER BAFFLE - 6" X 13" X .1"
2	076310-08-000	EA	SHEET/RUBBER - RADIATER BAFFLE - 5" X 48" X .1"
3	134068-03-02B	EA	ANGLE - BAFFLE/TOP - E-COATED
4	076310-09-000	EA	SHEET/RUBBER - RADIATER BAFFLE - 4" X 13" X .1"

CHASSIS GROUP (CONTINUED)

STEPWELL COVER

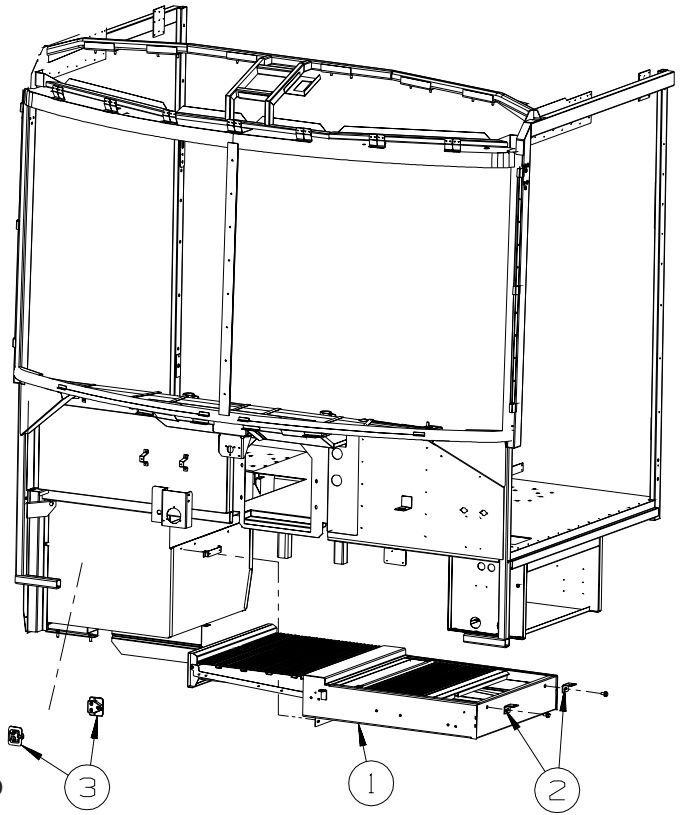

KEY	PART NUMBER	U/M	DESCRIPTION
1*	141691-01-01A	EA	STEP COVER - SLIDING
2	142274-01-02B	EA	BRACKET - STEP COVER - E-COATED
3	142499-01-01A	EA	BLOCK/SUPPORT (STEP COVER)

***COMPONENT PARTS LISTED LATER IN THIS GROUP**

CHASSIS GROUP (CONTINUED)
COMPONENT PARTS FOR STEPWELL COVER

141691-01-01A

KEY	PART NUMBER	U/M	DESCRIPTION	VENDOR NO.
	141691-01-700	EA	CABLE - 36"	1218751
	141691-01-701	EA	CABLE - 63"	1218752
	141691-01-702	EA	BEARING/ROLLER	1912040
	141691-01-703	EA	LATCH - CABLE RELEASE	1912125
	141691-01-704	EA	SPRING - CABLE PRELOAD	1217507
	141691-01-705	EA	DRUM - CABLE TO MOTOR	1612535
	141691-01-706	EA	BUSHING - .625" X .813"	1614003
	141691-01-707	EA	WIRE HARNESS - PACKARD END	1809938
	141691-01-708	EA	MOTOR W/9 TOOTH PINION	1820122
	141691-01-709	EA	BRACKET-SPRING DRAW BARCONN	3610586
	141691-01-710	EA	BRACKET-SPRING DRAW BAR CBL	3610599

CHASSIS GROUP (CONTINUED)

EXHAUST

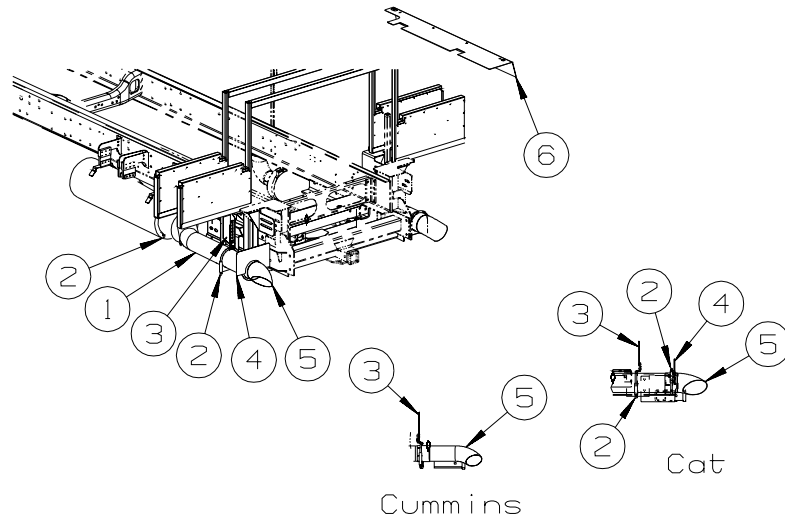

KEY	PART NUMBER	U/M	DESCRIPTION
1	114869-10-000	EA	PIPE - EXHAUST - CAT - P39W, P39K
1	114869-16-000	EA	PIPE - EXHAUST - CUMMINS - P39W, P39K
1	114869-06-000	EA	PIPE - EXHAUST - P34H, P36G
1	114869-09-000	EA	PIPE - EXHAUST - P32T
2	094918-08-000	EA	CLAMP - EXHAUST - 5" - P39W, P39K
2	094918-05-000	EA	CLAMP - EXHAUST - 4 7/16" - P34H, P36G, P32T
3	007131-01-000	EA	HANGER - TAILPIPE - 6 SLOTS
4	143766-02-02B	EA	SHIELD - EXHAUST/TAILPIPE - E-COATED - P39W, P39K
5	116425-02-000	EA	EXTENSION - EXHAUST - CHROMED - 5" - P39W, P39K
5	116425-03-000	EA	EXTENSION - EXHAUST - CHROMED - 4" - P34H, P36G, P32T
6	NOT USED		

HITCH

KEY	PART NUMBER	U/M	DESCRIPTION
	134016-03-01A	EA	DRAWBAR/HITCH - CLASS 4 - FREIGHTLINER, 6 SPEED CHASSIS
	134016-04-01A	EA	DRAWBAR/HITCH - CLASS 4 - WORKHORSE, 6 SPEED CHASSIS

CHASSIS GROUP (CONTINUED) REAR BUMPER

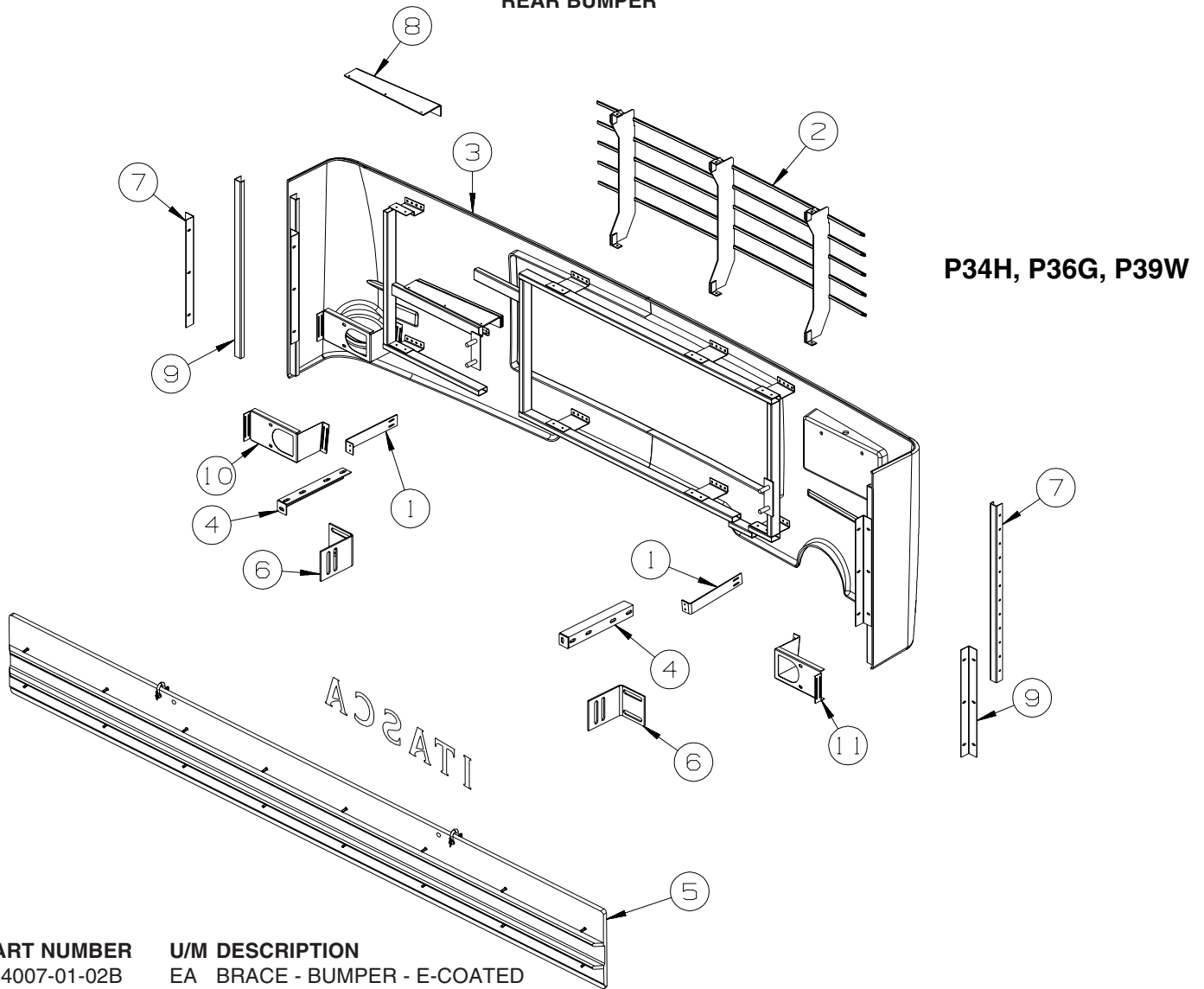

KEY	PART NUMBER	U/M	DESCRIPTION
1	134007-01-02B	EA	BRACE - BUMPER - E-COATED
2	132447-01-L76	EA	GRILL - REAR BUMPER
3	141262-02-P84	EA	PANEL - BUMPER/REAR
4	147866-01-02B	EA	BRACKET - MUDFLAP - E-COATED
5	143924-03-02A	EA	MUD FLAP - REAR - POLISHED/STAINLESS STEEL- BLANK(NO LOGO)
	142627-01-01A	EA	DECAL - LOGO - "ITASCA" - MUDFLAP - CHROME/BLACK
6	107524-03-000	EA	ANGLE - BUMPER - INNER/RIGHT & LEFT HAND
7	132071-01-02B	EA	BRACKET - BUMPER - FRONT/REAR - E-COATED
8	132857-02-R68	EA	SUPPORT - LOWER/LADDER
9	113041-03-02B	EA	ANGLE - BUMPER MOUNT - E-COATED
10	141264-02-02B	EA	BRACKET - DOCKING LAMP - E-COATED
11	141264-01-02B	EA	BRACKET - DOCKING LAMP - E-COATED

CHASSIS GROUP (CONTINUED)
REAR BUMPER (CONTINUED)

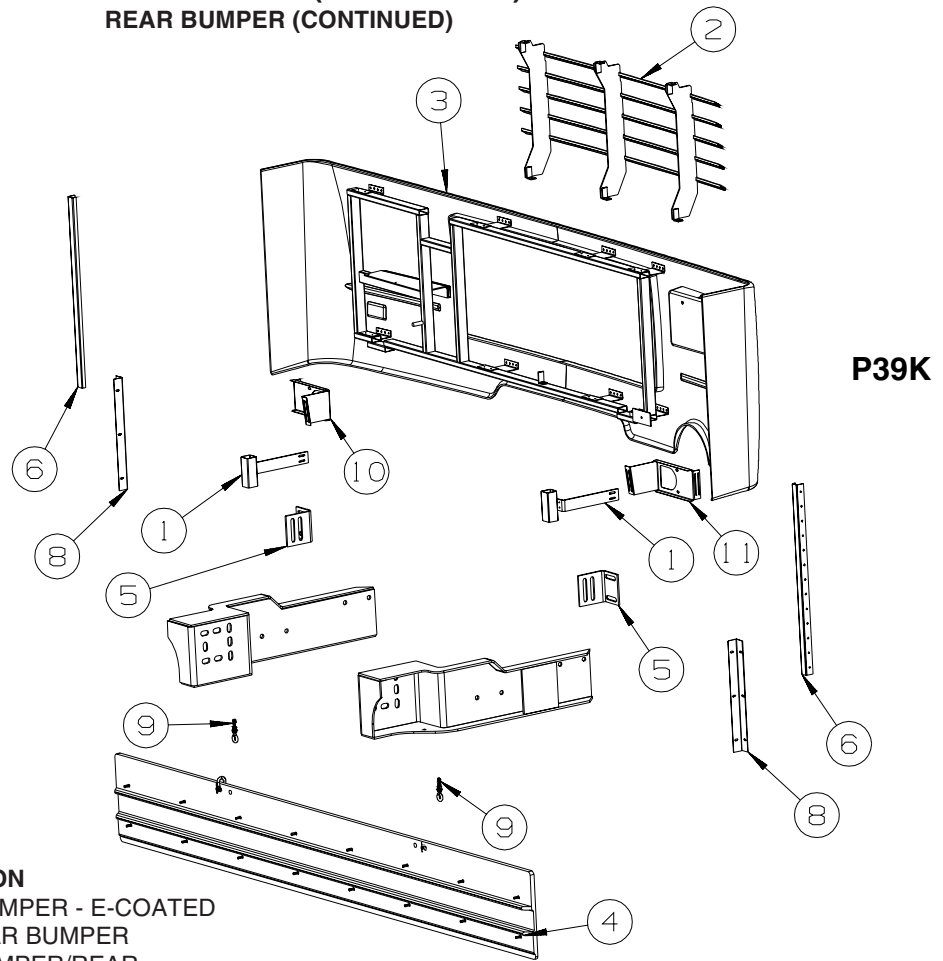

KEY	PART NUMBER	U/M	DESCRIPTION
1	134007-01-02B	EA	BRACE - BUMPER - E-COATED
2	132447-01-L76	EA	GRILL - REAR BUMPER
3	141262-02-P84	EA	PANEL - BUMPER/REAR
4	143924-03-02A	EA	MUD FLAP - REAR - POLISHED/STAINLESS STEEL- BLANK(NO LOGO)
	142627-01-01A	EA	DECAL - LOGO - "ITASCA" - MUDFLAP - CHROME/BLACK
5	107524-03-000	EA	ANGLE - BUMPER - INNER/RIGHT & LEFT HAND
6	132071-01-02B	EA	BRACKET - BUMPER - FRONT/REAR - E-COATED
7	132857-02-R68	EA	SUPPORT - LOWER/LADDER
8	113041-03-02B	EA	ANGLE - BUMPER MOUNT - E-COATED
9	139820-02-01A	EA	BOLT - HANGER/EYE - 5/16" STAINLESS STEEL
10	141264-02-02B	EA	BRACKET - DOCKING LAMP - E-COATED
11	141264-01-02B	EA	BRACKET - DOCKING LAMP - E-COATED

CHASSIS GROUP (CONTINUED)
REAR BUMPER (CONTINUED)

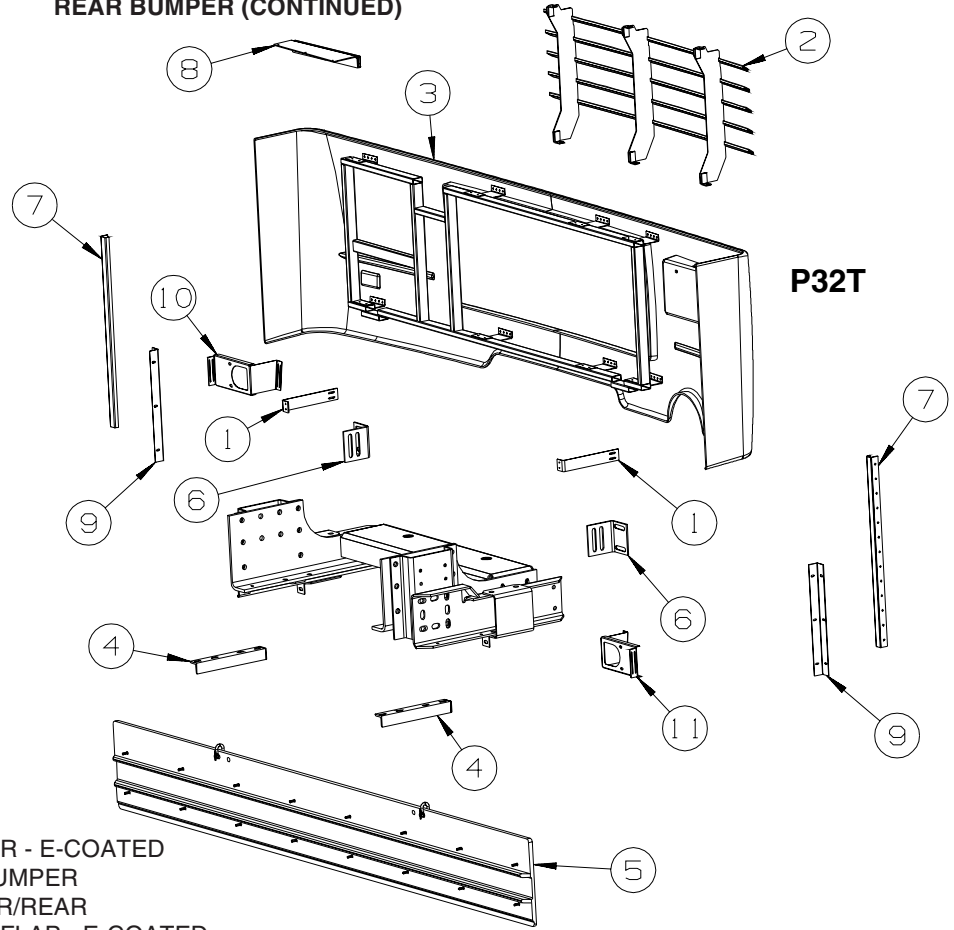

KEY	PART NUMBER	U/M	DESCRIPTION
1	134007-01-02B	EA	BRACE - BUMPER - E-COATED
2	132447-01-L76	EA	GRILL - REAR BUMPER
3	141262-02-P84	EA	PANEL - BUMPER/REAR
4	147866-01-02B	EA	BRACKET - MUDFLAP - E-COATED
5	143924-03-02A	EA	MUD FLAP - REAR - POLISHED/STAINLESS STEEL- BLANK(NO LOGO)
	142627-01-01A	EA	DECAL - LOGO - "ITASCA" - MUDFLAP - CHROME/BLACK
6	107524-03-000	EA	ANGLE - BUMPER - INNER/RIGHT & LEFT HAND
7	132071-01-02B	EA	BRACKET - BUMPER - FRONT/REAR - E-COATED
8	132857-02-R68	EA	SUPPORT - LOWER/LADDER
9	113041-03-02B	EA	ANGLE - BUMPER MOUNT - E-COATED
10	141264-02-02B	EA	BRACKET - DOCKING LAMP - E-COATED
11	141264-01-02B	EA	BRACKET - DOCKING LAMP - E-COATED

CHASSIS GROUP (CONTINUED) FUEL

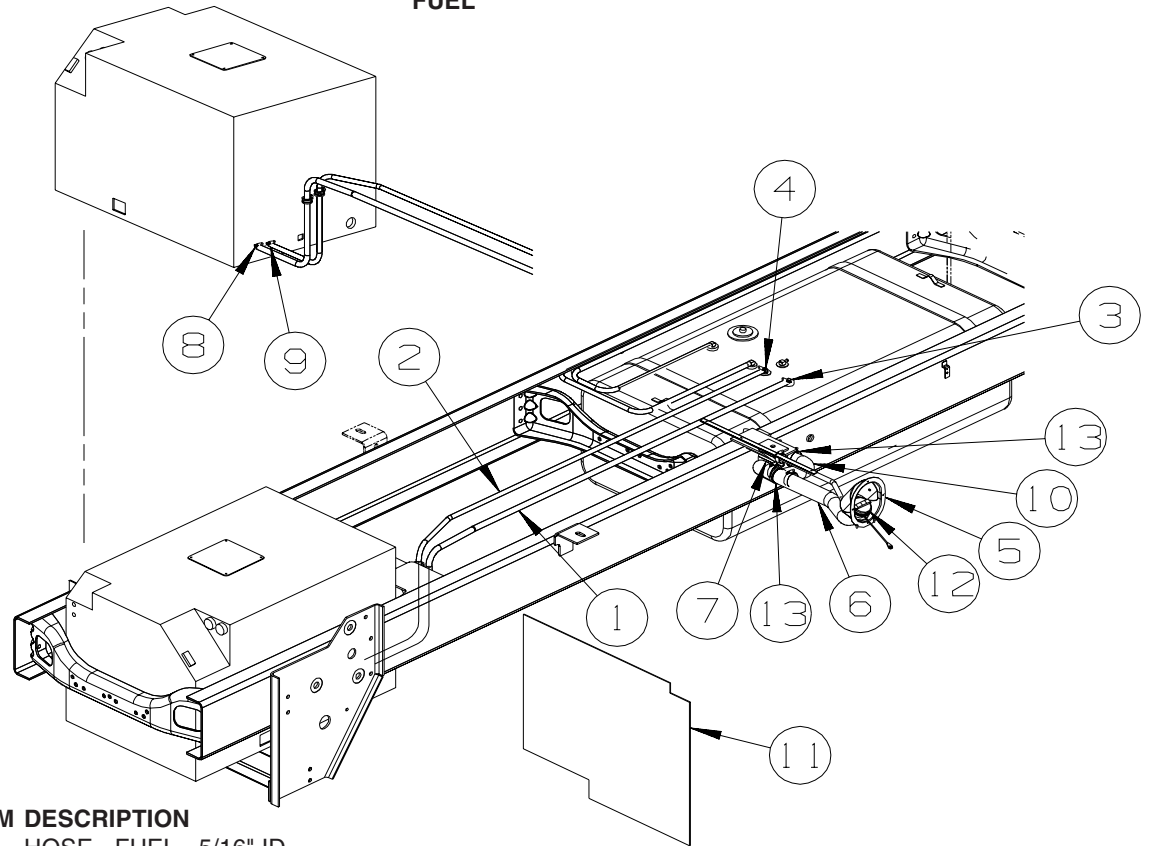

KEY	PART NUMBER	U/M	DESCRIPTION
1	024138-01-000	FT	HOSE - FUEL - 5/16" ID
2	128139-03-000	FT	HOSE - FUEL - LOW PERMEABILITY - 1/4" DIAMETER
3	114253-02-000	EA	ELBOW - 5/16 SINGLE BARB X 1/4 MPT
3	114254-02-000	EA	ADAPTER - 5/16 SINGLE BARB X 1/8 MPT - WORKHORSE
3	068382-02-000	EA	BUSHING - 3/8"MPT X 1/4"FPT - BRASS
3	068382-05-000	EA	BUSHING - 1/2"MPT X 1/8"FPT - BRASS - WORKHORSE
4	114253-01-000	EA	ELBOW - 1/4 SINGLE BARB X 1/8 MPT
4	114254-01-000	EA	ADAPTER - 1/4"BARB X 1/8"MPT - WORKHORSE
4	068382-06-000	EA	BUSHING - BRASS - 3/8"MPT X 1/8"FPT
4	068382-05-000	EA	BUSHING - 1/2"MPT X 1/8"FPT - BRASS - WORKHORSE
5	128299-01-01A	EA	SHROUD - FUEL FILL
6	132108-01-000	EA	NECK ASSEMBLY - FUEL FILL/DRIVER
7	066732-01-000	FT	HOSE - FUEL - .62"ID
8	114254-02-000	EA	ADAPTER - 5/16 SINGLE BARB X 1/8 MPT
9	114254-01-000	EA	ADAPTER - 1/4 BARB X 1/8 MPT
10	132405-01-000	EA	TUBE - FUEL INLET
11	118726-05-000	EA	BAFFLE - FUEL FILL
12	073220-04-000	EA	CAP - FUEL FILL - NON LOCKING DIESEL - WORKHORSE
13	007111-02-000	EA	HOSE - FUEL FILL - 2" ID - WORKHORSE

CHASSIS GROUP (CONTINUED)

HYDRAULIC LEVELING

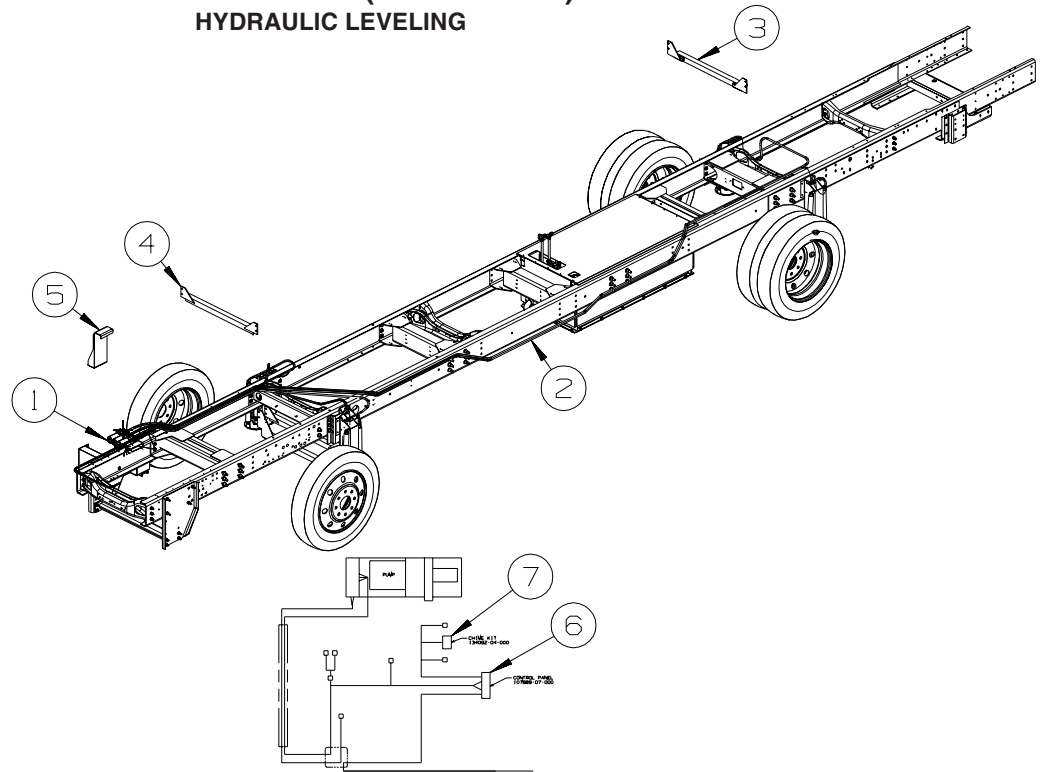

KEY	PART NUMBER	U/M	DESCRIPTION
1*	144226-12-000	EA	LEVELING SYSTEM - 325 SYSTEM W/2 SLIDEOUTS - FREIGHTLINER - P32T, P34H, P36G, P39W FROM: 00-00-00 THRU: 08-31-03
1*	144226-25-000	EA	LEVELING SYSTEM - 325 SYSTEM W/2 SLIDEOUTS - FREIGHTLINER - P32T, P34H, P36G, P39W FROM: 09-01-03 THRU: 99-99-99
1*	144226-13-000	EA	LEVELING SYSTEM - 325 SYSTEM W/3 SLIDEOUTS - FREIGHTLINER - P39K
1	144226-14-000	EA	LEVELING SYSTEM - 325 SYSTEM W/3 SLIDEOUTS - WORKHORSE - P39K
1	144226-28-000	EA	LEVELING SYSTEM - 325 SYSTEM W/2 SLIDEOUTS - WORKHORSE - P39W
2	100536-47-000	EA	HOSE KIT - LEVELING JACKS - P32T, P34H, P36G
2	100536-50-000	EA	HOSE KIT - LEVELING JACKS - P39W, P39K
3	114748-08-02B	EA	BRACKET - JACKS/REAR - E-COATED - FREIGHTLINER
3	148740-01-02B	EA	BRACKET - REAR JACKS - E-COATED - WORKHORSE
4	114748-02-02B	EA	CROSSMEMBER - REAR JACK MOUNTING - FREIGHTLINER
4	148740-02-02B	EA	BRACKET - FRONT JACKS - E-COATED - WORKHORSE
5	144224-02-01A	EA	BRACKET - PUMP/LEVELING - BLACK
6	107889-07-000	EA	PANEL - CONTROL - 325 AIR DUMP FROM: 00-00-00 THRU: 08-31-03
6	107889-09-000	EA	PANEL - CONTROL - 325 AIR DUMP FROM: 09-01-03 THRU: 99-99-99
7	134092-04-000	EA	CHIME KIT - LEVELING SYSTEM - 325 FROM: 00-00-00 THRU: 08-31-03
7	134092-03-000	EA	CHIME KIT - LEVELING SYSTEM - 625 FROM: 09-01-03 THRU: 09-14-03
7	134092-05-000	EA	CHIME KIT - LEVELING SYSTEM - 325/625 FROM: 09-15-03 THRU: 99-99-99

***COMPONENT PARTS LISTED LATER IN THIS GROUP**

CHASSIS GROUP (CONTINUED)
COMPONENT PARTS FOR HYDRAULIC LEVELING

144226-12-000

KEY	PART NUMBER	U/M	DESCRIPTION	VENDOR NO.
	144226-01-700	EA	SWITCH - WARNING/MAGNETIC	RAP90968/AP26641
	144226-01-701	EA	PUMP MOTOR/TANK ASM-MONRACH	RAP91169/AP30349

144226-13-000

KEY	PART NUMBER	U/M	DESCRIPTION	VENDOR NO.
	144226-01-700	EA	SWITCH - WARNING/MAGNETIC	RAP90968/AP26641
	144226-01-701	EA	PUMP MOTOR/TANK ASM-MONRACH	RAP91169/AP30349

144226-25-000

KEY	PART NUMBER	U/M	DESCRIPTION	VENDOR NO.
	144226-01-700	EA	SWITCH - WARNING/MAGNETIC	RAP90968/AP26641
	144226-01-701	EA	PUMP MOTOR/TANK ASM-MONRACH	RAP91169/AP30349

CHASSIS GROUP (CONTINUED)
WHEEL, TIRE, COVERS &/OR LINERS

KEY	PART NUMBER	U/M	DESCRIPTION
	080208-04-000	EA	LUG WRENCH - 1 3/16" - OSHKOSH/SPARTAN
	080208-05-000	EA	BAR - LEVERAGE - LUG WRENCH - .75"DIA. - OSHKOSH/SPARTAN ALUMINUM WHEELS ARE CHASSIS SUPPLIED
*	110435-22-000	EA	LINER - WHEEL - 22.5" X 19.5" - SET OF 4 FROM: 00-00-00 THRU: 08-10-03
*	145580-05-000	EA	LINER - WHEEL(SET OF 4) - 22.5"/10 BOLT FROM: 08-11-03 THRU: 99-99-99

***COMPONENT PARTS LISTED LATER IN THIS GROUP**

CHASSIS GROUP (CONTINUED)
COMPONENT PARTS FOR WHEEL, TIRE, COVERS &/OR LINERS

110435-22-000

KEY	PART NUMBER	U/M	DESCRIPTION	VENDOR NO.
	110435-04-705	EA	DECAL-CTR HUB 2 3/4" DIAMOND	
	110435-05-700	EA	CAP-CENTER 4.50"D W/O DECAL	V22510-POC
	110435-05-710	EA	NUT-JAMB - F/STUD EXTENDER	V22506-RJN
	110435-05-711	EA	COVER-JAMB NUT	V22506-LNC
	110435-17-700	EA	LINER - WHEEL - FRONT	V22515-FWC
	110435-17-701	EA	COVER/FRONT HUB - OLD STYLE W/1 3/8" JAMB NUT HOLE	V22510-FHC
	110435-17-702	EA	LINER - WHEEL - REAR	V22515-RWC
	110435-17-708	EA	STUD EXTENDER - TUBE STYLE	NH1422-TSX
	110435-22-700	EA	COVER-HUB(REAR)SMALL POPOUT	V22510-RHS
	110435-22-701	EA	COVER-HUB(REAR)LARGE POP OUT	V22510-RHL
	110435-22-702	EA	TOOL - INSTALLATION	N205-TOL

145580-05-000

KEY	PART NUMBER	U/M	DESCRIPTION	VENDOR NO.
	110435-04-705	EA	DECAL-CTR HUB 2 3/4"	
	110435-05-700	EA	CAP-CENTER 4.50"D W/O DECAL	V22510-POC
	145580-01-702	EA	COVER-LUG NUT/JAM NUT 22M	V19582-EJN
	145580-01-703	EA	TOOL-INSTALLATION	V22501-TOL
	145580-05-700	EA	LINER - WHEEL/FRONT - 1EA=1	V22587-FWC
	145580-05-701	EA	LINER - WHEEL/REAR - 1EA=1	V22587-RWC

CURTAIN & CUSHION GROUP

NOTICE

IN ORDER TO ASSIST OUR PARTS SALES DEPT. IN PROVIDING INTERIOR SOFTWARE ITEMS, PLEASE INCLUDE THE SERIAL NUMBER AND THE COLOR CODE NUMBER FROM THE VEHICLE CERTIFICATION LABEL WHEN ORDERING. THIS LABEL IS LOCATED ON THE LEFT SIDEWALL AT THE END OF THE DASH (A-BODY), OR ON THE DRIVER'S DOOR LATCH PLATE (C-BODY).

AN EXAMPLE OF A COLOR CODE NUMBER IS B07, WHICH DESIGNATES AN OVERALL COLOR SCHEME OF A PARTICULAR UNIT. THE COLOR LISTED AFTER THE ITEM DESCRIPTION ON THE MICROFICHE, INDICATES THE OVERALL UNIT COLOR. ORDER THE ITEM YOU DESIRE ACCORDING TO UNIT COLOR CODE. IF ALL COLORS USE THE SAME ITEM NO COLOR CODE WILL BE NOTED.

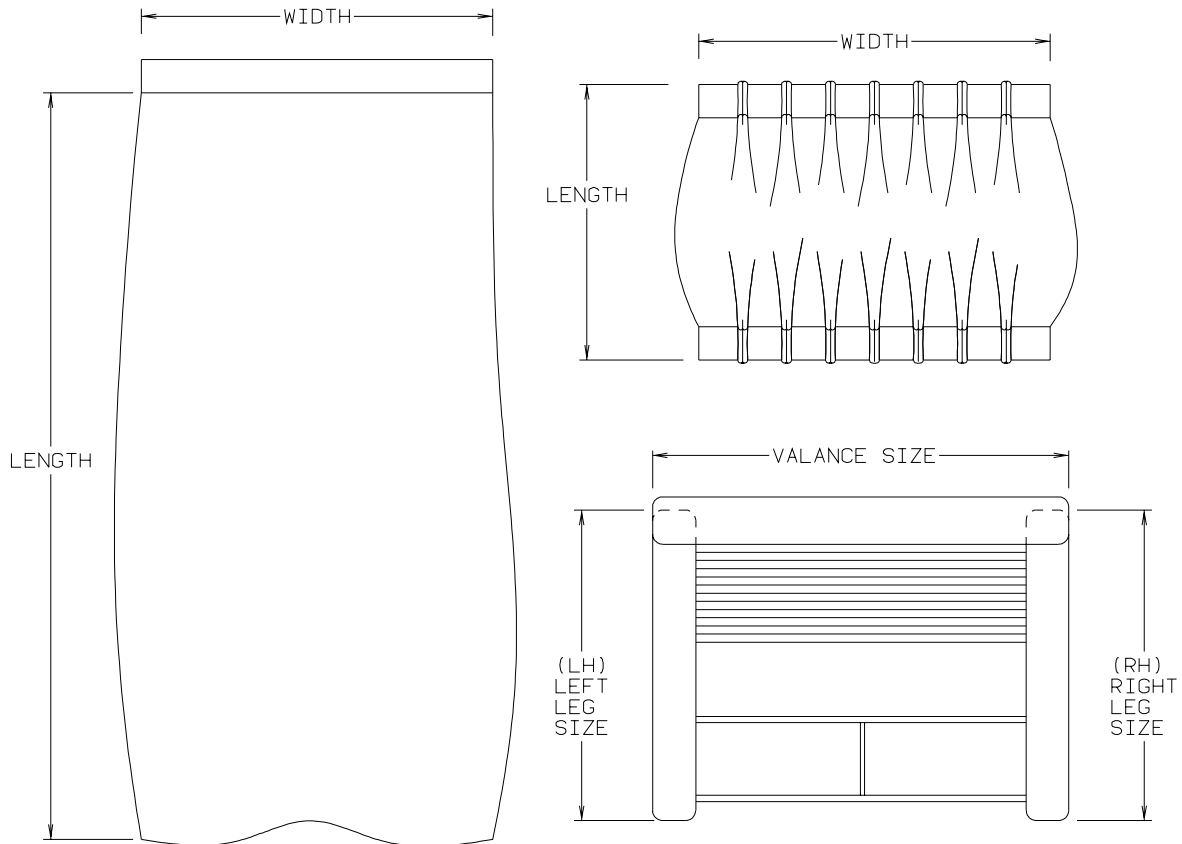

NOTE: USE THIS ILLUSTRATION WHEN DETERMINING LENGTH AND WIDTH MEASUREMENTS FOR CURTAINS. YOU WILL NOTE THE WIDTH MEASUREMENT IS TAKEN ON THE TOP OF THE CURTAIN WITH THE CURTAIN FULLY EXTENDED. THE LENGTH MEASUREMENT IS TAKEN FROM TOP TO BOTTOM. LEFT AND RIGHT WINDOW LEGS ARE DETERMINED WHEN FACING THE WINDOW.

CURTAIN & CUSHION GROUP (CONTINUED)

CUSHION LAYOUT

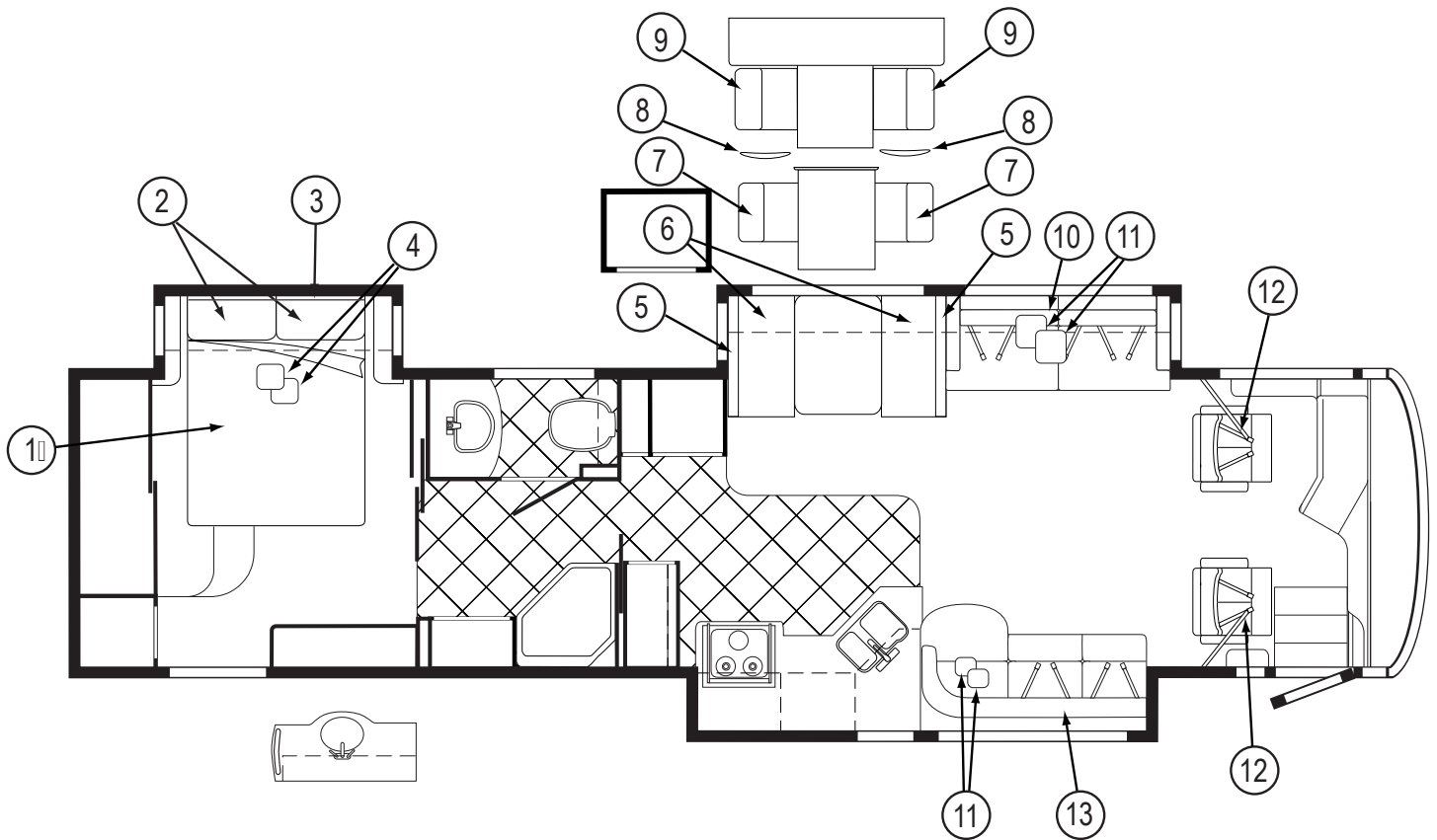

KEY	PART NUMBER	U/M	DESCRIPTION
1	123015-07-000	EA	MATTRESS - INNERSPRING - 60" X 79.5"
1	142411-02-000	EA	MATTRESS/AIR - 60" X 80" - SELECT COMFORT
1	142411-03-000	EA	AIR PUMP W/CONTROLS - F/SELECT COMFORT MATTRESS
1	132336-03-P84	EA	BEDSPREAD/CAP - 60" X 80" (R74,R75,R76)
1	132336-03-R77	EA	BEDSPREAD/CAP - 60" X 80" (R77,R78,R79)
1	132336-03-R80	EA	BEDSPREAD/CAP - 60" X 80" (R80,R81,R82)
2	126211-08-R74	EA	PILLOW SHAM (R74,R75,R76)
2	126211-08-R77	EA	PILLOW SHAM (R77,R78,R79)
2	126211-08-R44	EA	PILLOW SHAM (R80,R81,R82)
3	146059-02-R74	EA	HEADBOARD - MONTICELLO - 34" X 40" - FABRIC COVERED (R74,R75,R76)
3	146059-03-R77	EA	HEADBOARD - MONTICELLO - 34" X 40" - FABRIC COVERED (R77,R78,R79)
3	146059-02-R80	EA	HEADBOARD - MONTICELLO - 34" X 40" - FABRIC COVERED (R80,R81,R82)
4	132319-60-R74	EA	PILLOW - 17" - W/1" BUTTONS (R74,R75,R76)
4	132319-60-R77	EA	PILLOW - 17" - W/1" BUTTONS (R77,R78,R79)
4	132319-60-R80	EA	PILLOW - 17" - W/1" BUTTONS (R80,R81,R82)
5	142723-02-P84	EA	BACK - DINETTE - 13.5" X 40" (R74,R75,R76)
5	142723-02-R77	EA	BACK - DINETTE - 13.5" X 40" (R77,R78,R79)
5	142723-02-R44	EA	BACK - DINETTE - 13.5" X 40" (R80,R81,R82)
5	P42723-02-P84	EA	COVER/BACK - DINETTE - 13.5" X 40" (R74,R75,R76)
5	P42723-02-R77	EA	COVER/BACK - DINETTE - 13.5" X 40" (R77,R78,R79)
5	P42723-02-R80	EA	COVER/BACK - DINETTE - 13.5" X 40" (R80,R81,R82)
5	143730-01-000	EA	CAP - F/DINETTE BRACKET TUBE - PLASTIC
6	142292-05-P84	EA	SEAT - DINETTE CUSHION (SPRUNG) - 23.5" X 38.5" (R74,R75,R76)
6	142292-05-R77	EA	SEAT - DINETTE CUSHION (SPRUNG) - 23.5" X 38.5" (R77,R78,R79)
6	142292-05-R44	EA	SEAT - DINETTE CUSHION (SPRUNG) - 23.5" X 38.5" (R80,R81,R82)
6	P42292-05-P84	EA	COVER/SEAT - DINETTE CUSHION - 23.5" X 38.5" (R74,R75,R76)
6	P42292-05-R77	EA	COVER/SEAT - DINETTE CUSHION - 23.5" X 38.5" (R77,R78,R79)
6	P42292-05-R44	EA	COVER/SEAT - DINETTE CUSHION - 23.5" X 38.5" (R80,R81,R82)
6	142366-01-000	EA	FRAME - SPRUNG - DINETTE SEAT

CURTAIN & CUSHION GROUP (CONTINUED)
CUSHION LAYOUT (CONTINUED)

KEY	PART NUMBER	U/M	DESCRIPTION
7	132571-56-000	EA	CHAIR - DINETTE - SKY/PORTSMOUTH OAK (R74)
7	132571-57-000	EA	CHAIR - DINETTE - SKY/CHERRY (R75)
7	132571-58-000	EA	CHAIR - DINETTE - SKY/WASHED MAPLE (R76)
7	132571-59-000	EA	CHAIR - DINETTE - SAGE/PORTSMOUTH OAK (R77)
7	132571-60-000	EA	CHAIR - DINETTE - SAGE/CHERRY (R78)
7	132571-61-000	EA	CHAIR - DINETTE - SAGE/WASHED MAPLE (R79)
7	132571-62-000	EA	CHAIR - DINETTE - IVORY/PORTSMOUTH OAK (R80)
7	132571-63-000	EA	CHAIR - DINETTE - IVORY/CHERRY (R81)
7	132571-64-000	EA	CHAIR - DINETTE - IVORY/WASHED MAPLE (R82)
8	135600-B6-000	EA	CHAIR - FOLDING - FLANNEL/PORTSMOUTH OAK (R74)
8	135600-B7-000	EA	CHAIR - FOLDING - FLANNEL/CHERRY (R75)
8	135600-B8-000	EA	CHAIR - FOLDING - FLANNEL/WASHED MAPLE (R76)
8	135600-F8-000	EA	CHAIR - FOLDING - SAGE/PORTSMOUTH OAK (R77)
8	135600-F9-000	EA	CHAIR - FOLDING - SAGE/CHERRY (R78)
8	135600-G0-000	EA	CHAIR - FOLDING - SAGE/WASHED MAPLE (R79)
8	135600-G1-000	EA	CHAIR - FOLDING - IVORY/PORTSMOUTH OAK (R80)
8	135600-G2-000	EA	CHAIR - FOLDING - IVORY/CHERRY (R81)
8	135600-G3-000	EA	CHAIR - FOLDING - IVORY/WASHED MAPLE (R82)
9	141091-49-000	EA	CHAIR - COMPUTER - SKY/PORTSMOUTH OAK (R74)
9	141091-50-000	EA	CHAIR - COMPUTER - SKY/CHERRY (R75)
9	141091-51-000	EA	CHAIR - COMPUTER - SKY/MAPLE (R76)
9	141091-70-000	EA	CHAIR - COMPUTER - SAGE/PORTSMOUTH OAK (R77)
9	141091-71-000	EA	CHAIR - COMPUTER - SAGE/CHERRY (R78)
9	141091-89-000	EA	CHAIR - COMPUTER - WASHED MAPLE (R79)
9	141091-86-000	EA	CHAIR - COMPUTER - IVORY/PORTSMOUTH OAK (R80)
9	141091-87-000	EA	CHAIR - COMPUTER - IVORY/CHERRY (R81)
9	141091-88-000	EA	CHAIR - COMPUTER - IVORY/WASHED MAPLE (R82)
10	138095-17-P84	EA	SOFA/SLEEPER - REST EASY #805/805 ARMS - 30"F - W/TRAY (R74,R75,R76)
10	138095-17-R77	EA	SOFA/SLEEPER - REST EASY #805/805 ARMS - 30"F - W/TRAY (R77,R78,R79)
10	138095-17-R44	EA	SOFA/SLEEPER - REST EASY #805/805 ARMS - 30"F - W/TRAY (R80,R81,R82)
10	138095-18-N84	EA	SOFA/SLEEPER - REST EASY #805/805 ARMS-30"F-W/TRAY-LEATHER - ULTRA LEATHER
10	138647-24-R74	EA	SOFA/SLEEPER - REST EASY/DUAL CONTROLS-#815/805 ARMS-30"FF (R74,R75,R76)
10	138647-24-R77	EA	SOFA/SLEEPER - REST EASY/DUAL CONTROLS-#815/805 ARMS-30"FF (R77,R78,R79)
10	138647-24-R44	EA	SOFA/SLEEPER - REST EASY/DUAL CONTROLS-#815/805 ARMS-30"FF (R80,R81,R82)
10	139202-06-N84	EA	SOFA/DUAL SLEEPER/TRUNDLE - RECLINER/POWERED - LEATHER - ULTRA LEATHER
11	132319-47-R74	EA	PILLOW - 17" - W/RADIUS OVERLAY (R74,R75,R76)
11	132319-47-R77	EA	PILLOW - 17" - W/RADIUS OVERLAY (R77,R78,R79)
11	132319-47-R80	EA	PILLOW - 17" - W/RADIUS OVERLAY (R80,R81,R82)
12	145952-01-R74	EA	BUCKET SEAT - W/LUMBAR - DRIVER/PASSENGER (R74,R75,R76) FROM: 00-00-00 THRU: 09-07-03
12	145952-04-R74	EA	SEAT - BUCKET W/LUMBAR - DRIVER/PASSENGER (R74,R75,R76) FROM: 09-08-03 THRU: 99-99-99
12	145952-01-R77	EA	BUCKET SEAT - W/LUMBAR - DRIVER/PASSENGER (R77,R78,R79) FROM: 00-00-00 THRU: 09-07-03
12	145952-04-R77	EA	SEAT - BUCKET W/LUMBAR - DRIVER/PASSENGER (R77,R78,R79) FROM: 09-08-03 THRU: 99-99-99
12	145952-01-R80	EA	BUCKET SEAT - W/LUMBAR - DRIVER/PASSENGER (R80,R81,R82) FROM: 00-00-00 THRU: 09-07-03
12	145952-04-R80	EA	SEAT - BUCKET W/LUMBAR - DRIVER/PASSENGER (R80,R81,R82) FROM: 09-08-03 THRU: 99-99-99
12	145952-02-R74	EA	BUCKET SEAT - DRIVER - W/LUMBAR - LEATHER - ULTRA LEATHER FROM: 00-00-00 THRU: 09-07-03
12	145952-05-R74	EA	SEAT - BUCKET W/LUMBAR - DRIVER/PASSENGER - LEATHER - ULTRA LEATHER FROM: 09-08-03 THRU: 99-99-99
13	147707-17-000	EA	SOFA-J-LOUNGE(LOVE SEAT)70"-RAISED FLR-FABRIC COV/COPEN (R74,R75,R76)
13	147707-18-000	EA	SOFA-J-LOUNGE(LOVE SEAT)70"-RAISED FLR-FABRIC COV/OR CULP (R77,R78,R79)
13	147707-19-000	EA	SOFA-J-LOUNGE(LOVE SEAT)70"-RAISED FLR-FABRIC COV/ (R80,R81,R82)
13	147707-10-000	EA	SOFA-J-LOUNGE(LOVE SEAT)70"-RAISED FLOOR-ANT PEARL/LEATHER - ULTRA LEATHER

CURTAIN & CUSHION GROUP (CONTINUED)

BUCKET SEATS

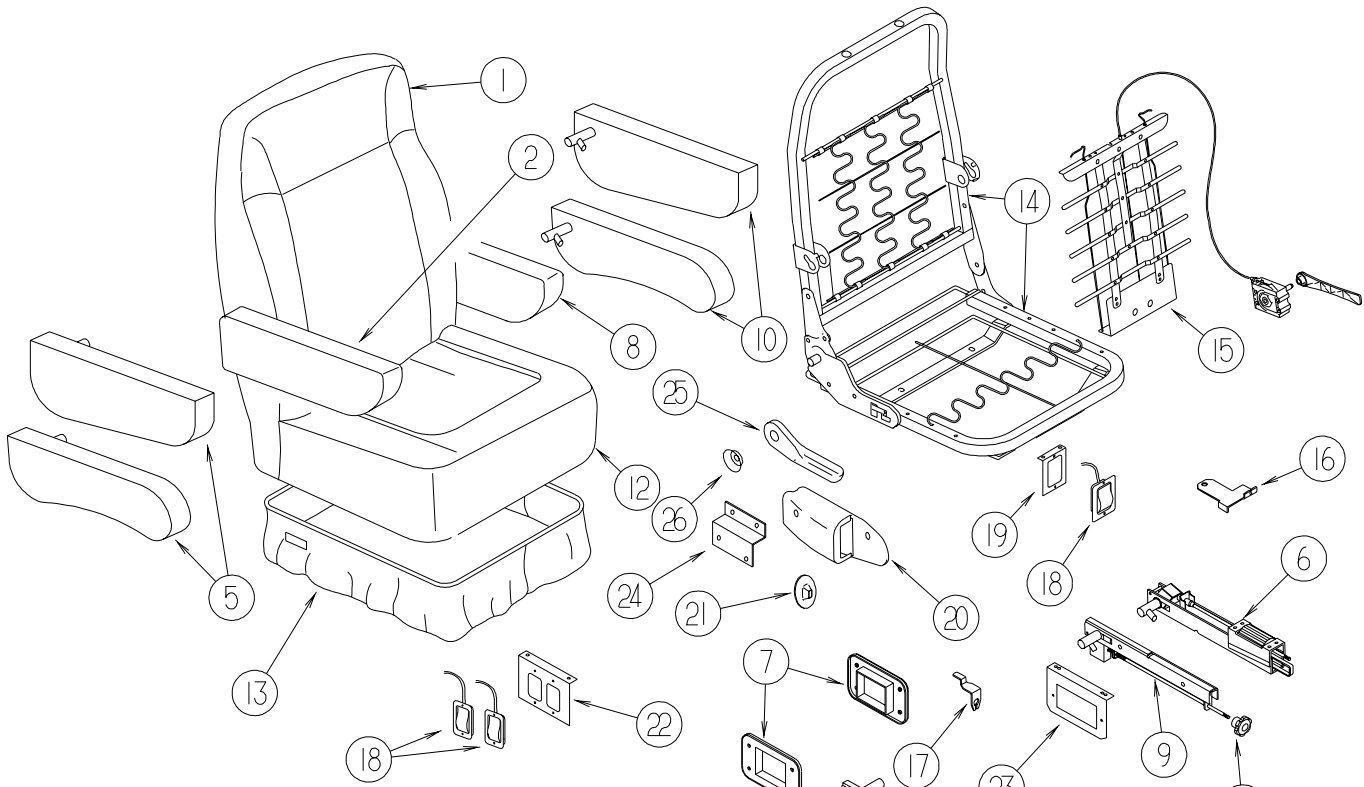

KEY	PART NUMBER	U/M	DESCRIPTION
1	M05962-H7-R74	EA	COVER/BACK (R74,R75,R76)
1	M05962-H7-R77	EA	COVER/BACK (R77,R78,R79)
1	M05962-H7-R80	EA	COVER/BACK (R80,R81,R82)
1	M05962-H9-R74	EA	COVER/BACK - ULTRA LEATHER
1	145958-01-000	EA	PILLOW - HEAD - W/MERIDIAN LOGO - ULTRA LEATHER
2	129666-05-R74	EA	ARMREST - RIGHT HAND (R74,R75,R76)
			FROM: 00-00-00 THRU: 09-07-03
2	148705-01-R74	EA	ARMREST - RIGHT HAND (R74,R75,R76)
			FROM: 09-08-03 THRU: 99-99-99
2	129666-05-R44	EA	ARMREST - RIGHT HAND (R77,R78,R79)
			FROM: 00-00-00 THRU: 09-07-03
2	148705-01-R44	EA	ARMREST - RIGHT HAND (R77,R78,R79)
			FROM: 09-08-03 THRU: 99-99-99
2	129666-05-R70	EA	ARMREST - RIGHT HAND (R80,R81,R82)
			FROM: 00-00-00 THRU: 09-07-03
2	148705-01-R70	EA	ARMREST - RIGHT HAND (R80,R81,R82)
			FROM: 09-08-03 THRU: 99-99-99
2	129666-17-P54	EA	ARMREST - RIGHT HAND - ULTRA LEATHER
			FROM: 00-00-00 THRU: 09-07-03
2	148705-03-R74	EA	ARMREST - RIGHT - ULTRA LEATHER
			FROM: 09-08-03 THRU: 99-99-99
	P29666-05-R74	EA	COVER/ARMREST - RIGHT HAND (R74,R75,R76)
			FROM: 00-00-00 THRU: 09-07-03
	P48705-01-R74	EA	COVER/ARMREST - RIGHT HAND (R74,R75,R76)
			FROM: 09-08-03 THRU: 99-99-99
	P29666-05-R44	EA	COVER/ARMREST - RIGHT HAND (R77,R78,R79)
			FROM: 00-00-00 THRU: 09-07-03
	P48705-01-R44	EA	COVER/ARMREST - RIGHT HAND (R77,R78,R79)
			FROM: 09-08-03 THRU: 99-99-99
	P29666-05-R70	EA	COVER/ARMREST - RIGHT HAND (R80,R81,R82)
			FROM: 00-00-00 THRU: 09-07-03
	P48705-01-R70	EA	COVER/ARMREST - RIGHT HAND (R80,R81,R82)
			FROM: 09-08-03 THRU: 99-99-99
	P29666-17-P54	EA	COVER/ARMREST - RIGHT HAND - ULTRA LEATHER
			FROM: 00-00-00 THRU: 09-07-03
	P48705-03-R74	EA	COVER/ARMREST - RIGHT - ULTRA LEATHER
			FROM: 09-08-03 THRU: 99-99-99

CURTAIN & CUSHION GROUP (CONTINUED)
BUCKET SEATS (CONTINUED)

KEY	PART NUMBER	U/M	DESCRIPTION	
3	122622-04-000	EA	BRACKET - ARMREST/RIGHT HAND	
				FROM: 00-00-00 THRU: 09-07-03
4	122622-06-000	EA	KNOB - W/3/8" THREAD INSERT	
				FROM: 00-00-00 THRU: 09-07-03
5	130699-01-000	EA	ARMREST/MOLDED - RIGHT - W/O COVER	
				FROM: 00-00-00 THRU: 09-07-03
6	148751-01-000	EA	BRACKET - ARMREST/RIGHT HAND	
				FROM: 09-08-03 THRU: 99-99-99
7	148751-03-000	EA	BRACKET - ROLLER TRIM PLATE	
				FROM: 09-08-03 THRU: 99-99-99
8	129666-06-R74	EA	ARMREST - LEFT HAND (R74,R75,R76)	
				FROM: 00-00-00 THRU: 09-07-03
8	148705-02-R74	EA	ARMREST - LEFT HAND (R74,R75,R76)	
				FROM: 09-08-03 THRU: 99-99-99
8	129666-06-R44	EA	ARMREST - LEFT HAND (R77,R78,R79)	
				FROM: 00-00-00 THRU: 09-07-03
8	148705-02-R44	EA	ARMREST - LEFT HAND (R77,R78,R79)	
				FROM: 09-08-03 THRU: 99-99-99
8	129666-06-R70	EA	ARMREST - LEFT HAND (R80,R81,R82)	
				FROM: 00-00-00 THRU: 09-07-03
8	148705-02-R70	EA	ARMREST - LEFT HAND (R80,R81,R82)	
				FROM: 09-08-03 THRU: 99-99-99
8	129666-18-P54	EA	ARMREST - LEFT HAND - ULTRA LEATHER	
				FROM: 00-00-00 THRU: 09-07-03
8	148705-04-R44	EA	ARMREST - LEFT - ULTRA LEATHER	
				FROM: 09-08-03 THRU: 99-99-99
	P29666-06-R74	EA	COVER/ARMREST - LEFT HAND (R74,R75,R76)	
				FROM: 00-00-00 THRU: 09-07-03
	P48705-02-R74	EA	COVER/ARMREST - LEFT HAND (R74,R75,R76)	
				FROM: 09-08-03 THRU: 99-99-99
	P29666-06-R44	EA	COVER/ARMREST - LEFT HAND (R77,R78,R79)	
				FROM: 00-00-00 THRU: 09-07-03
	P48705-02-R44	EA	COVER/ARMREST - LEFT HAND (R77,R78,R79)	
				FROM: 09-08-03 THRU: 99-99-99
	P29666-06-R70	EA	COVER/ARMREST - LEFT HAND (R80,R81,R82)	
				FROM: 00-00-00 THRU: 09-07-03
	P48705-02-R70	EA	COVER/ARMREST - LEFT HAND (R80,R81,R82)	
				FROM: 09-08-03 THRU: 99-99-99
	P29666-18-P54	EA	COVER/ARMREST - LEFT HAND - ULTRA LEATHER	
				FROM: 00-00-00 THRU: 09-07-03
	P48705-04-R74	EA	COVER/ARMREST - LEFT - ULTRA LEATHER	
				FROM: 09-08-03 THRU: 99-99-99
9	122622-05-000	EA	BRACKET - ARMREST/LEFT HAND	
				FROM: 00-00-00 THRU: 09-07-03
10	130699-02-000	EA	ARMREST/MOLDED - LEFT - W/O COVER	
				FROM: 00-00-00 THRU: 09-07-03
11	148751-02-000	EA	BRACKET - ARMREST/LEFT HAND	
				FROM: 09-08-03 THRU: 99-99-99
12	M05962-H8-R74	EA	COVER/SEAT (R74,R75,R76)	
12	M05962-H8-R77	EA	COVER/SEAT (R77,R78,R79)	
12	M05962-H8-R80	EA	COVER/SEAT (R80,R81,R82)	
12	M05962-J0-R74	EA	COVER/SEAT - ULTRA LEATHER	
13	148630-01-R74	EA	SKIRT - W/SEAT BELT SLOT (R74,R75,R76)	
13	148630-01-R70	EA	SKIRT - W/SEAT BELT SLOT (R77,R78,R79)	
13	148630-01-R80	EA	SKIRT - W/SEAT BELT SLOT (R80,R81,R82)	
13	148630-02-R35	EA	SKIRT - W/SEAT BELT SLOT - LEATHER - ULTRA LEATHER	
13	148630-05-R74	EA	SKIRT - W/SLOT & FOOTREST (R74,R75,R76)	
13	148630-05-R77	EA	SKIRT - W/SLOT & FOOTREST (R77,R78,R79)	
13	148630-05-R80	EA	SKIRT - W/SLOT & FOOTREST (R80,R81,R82)	
13	148630-06-R74	EA	SKIRT - W/SLOT & FOOTREST - LEATHER - ULTRA LEATHER	

CURTAIN & CUSHION GROUP (CONTINUED)

BUCKET SEATS (CONTINUED)

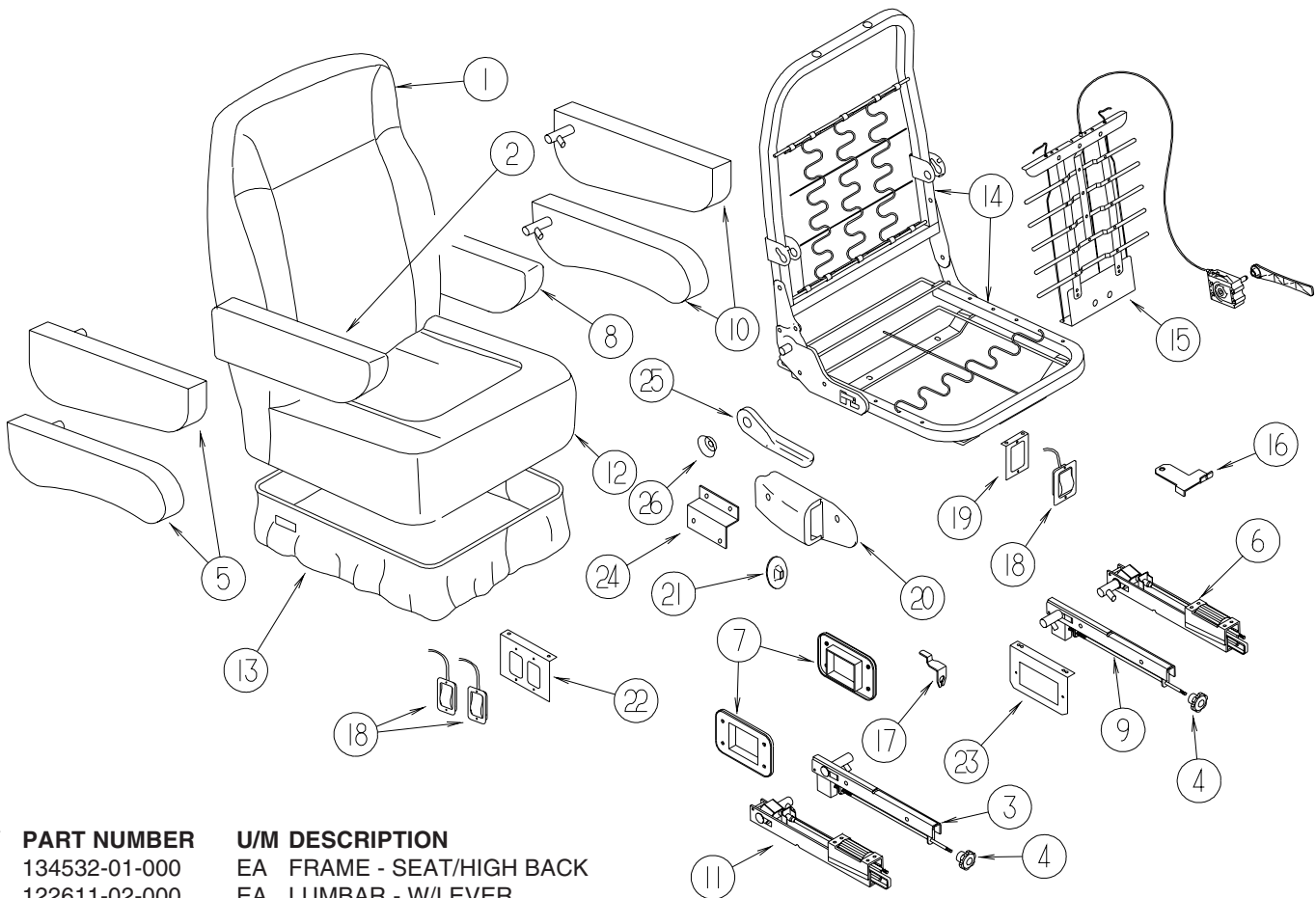

KEY	PART NUMBER	U/M	DESCRIPTION
	14	EA	FRAME - SEAT/HIGH BACK
	15*	EA	LUMBAR - W/LEVER
	16	EA	BRACKET - CABLE MOUNT - ADJUSTER W/LOCK
	17	EA	CLIP - CABLE/PEDESTAL
	18	EA	CABLE - W/MINI LEVER ACTION SWITCH - 28" SHEATH/30" CABLE
	19	EA	BRACKET - SEAT RELEASE - SINGLE REMOTE - E-COATED - POWER SEAT
	20	EA	SHIELD - RECLINER HANDLE
	21	EA	SHIELD - RUBBER BOOT
	22	EA	BRACKET - SEAT RELEASE - DUAL REMOTE - E-COATED
	23	EA	BRACKET - SEAT SWITCH - E-COATED - POWER SEAT
	24	EA	BRACKET - ZEE W/HOLES - 2.8" - E-COATED
	25	EA	LEVER - RIGHT HAND
	26	EA	SCREW F/LEVER

*COMPONENT PARTS LISTED LATER IN THIS GROUP

CURTAIN & CUSHION GROUP (CONTINUED)
BUCKET SEATS (CONTINUED)

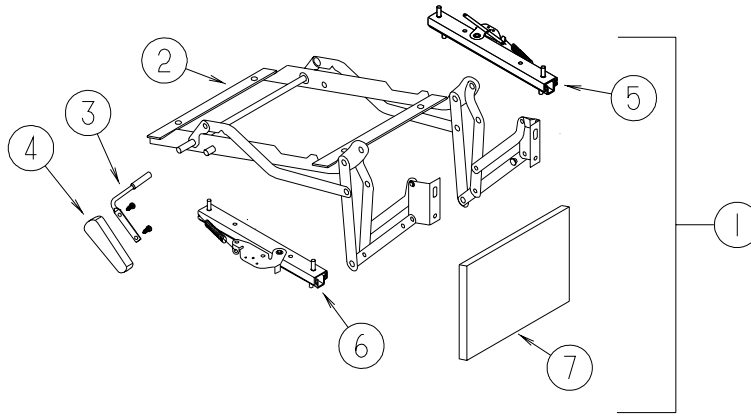

KEY	PART NUMBER	U/M	DESCRIPTION
1	131613-01-R74	EA	FOOTREST - BUCKET SEAT/PASSENGER (R74,R77,R80)
1	131613-01-R70	EA	FOOTREST - BUCKET SEAT/PASSENGER (R75,R78,R81)
1	131613-01-R80	EA	FOOTREST - BUCKET SEAT/PASSENGER (R76,R79,R82)
1	131613-04-R74	EA	FOOTREST - BUCKET SEAT/PASSENGER - ULTRA LEATHER
2	131566-01-000	EA	FOOTREST - MECHANICAL
3	131566-02-000	EA	ROD/LEVER - FOOT-REST EXTENSION
4	131566-03-000	EA	WOOD HANDLE
5	131566-04-000	EA	SLIDE/SEAT - HEAVY DUTY LOCKING - 5"
	131566-05-000	EA	WASHER - SLIDE SPACER
6	131566-07-000	EA	5" DOUBLE LOCKING SLIDE W/TAB
7	131613-99-000	EA	FOOTREST/WOOD - W/T-NUT

CURTAIN & CUSHION GROUP (CONTINUED)
BUCKET SEATS (CONTINUED)

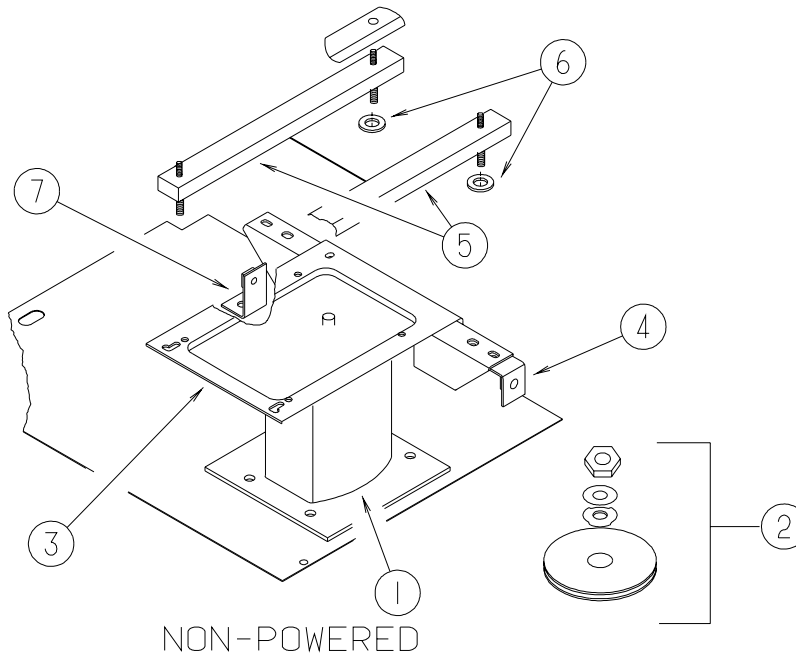

KEY	PART NUMBER	U/M	DESCRIPTION
1	133408-01-000	EA	PEDESTAL - SEAT - DRIVER/PASSENGER - 9 3/4"
2	107921-06-000	EA	BEARING KIT - PEDESTAL
3	133408-20-000	EA	TOP PLATE - PASSENGER - W/ANCHOR
4	133408-03-000	EA	BRACKET - ANCHOR/PEDESTAL
5	131566-04-000	EA	SLIDE/SEAT - HEAVY DUTY LOCKING - 5"
	119952-07-000	EA	WIRE - LATCH RELEASE/ROTARY
6	131566-05-000	EA	WASHER - SLIDE SPACER
7	133408-04-000	EA	BRACKET - ANCHOR/FLOOR

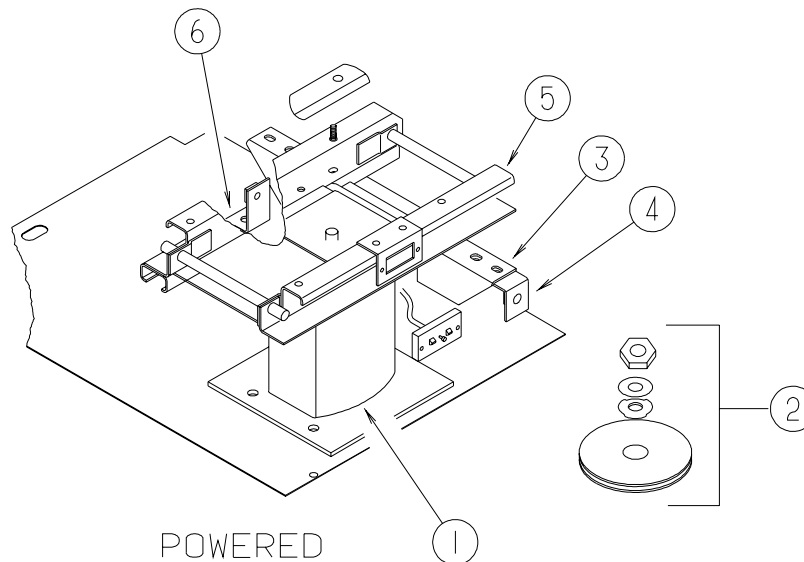

KEY	PART NUMBER	U/M	DESCRIPTION
1	133408-05-000	EA	PEDESTAL - SEAT - 5.75"
2	107921-06-000	EA	BEARING KIT - PEDESTAL
3	133408-20-000	EA	TOP PLATE - PASSENGER - W/ANCHOR
4	133408-03-000	EA	BRACKET - ANCHOR/PEDESTAL
5*	081373-03-000	EA	SEAT - POWER 6 WAY
5	147767-02-000	EA	SEAT - POWER - 6-WAY
6	133408-04-000	EA	BRACKET - ANCHOR/FLOOR

FROM: 00-00-00 THRU: 11-30-03

FROM: 12-01-03 THRU: 99-99-99

*COMPONENT PARTS LISTED LATER IN THIS GROUP

CURTAIN & CUSHION GROUP (CONTINUED)
COMPONENT PARTS FOR BUCKET SEATS

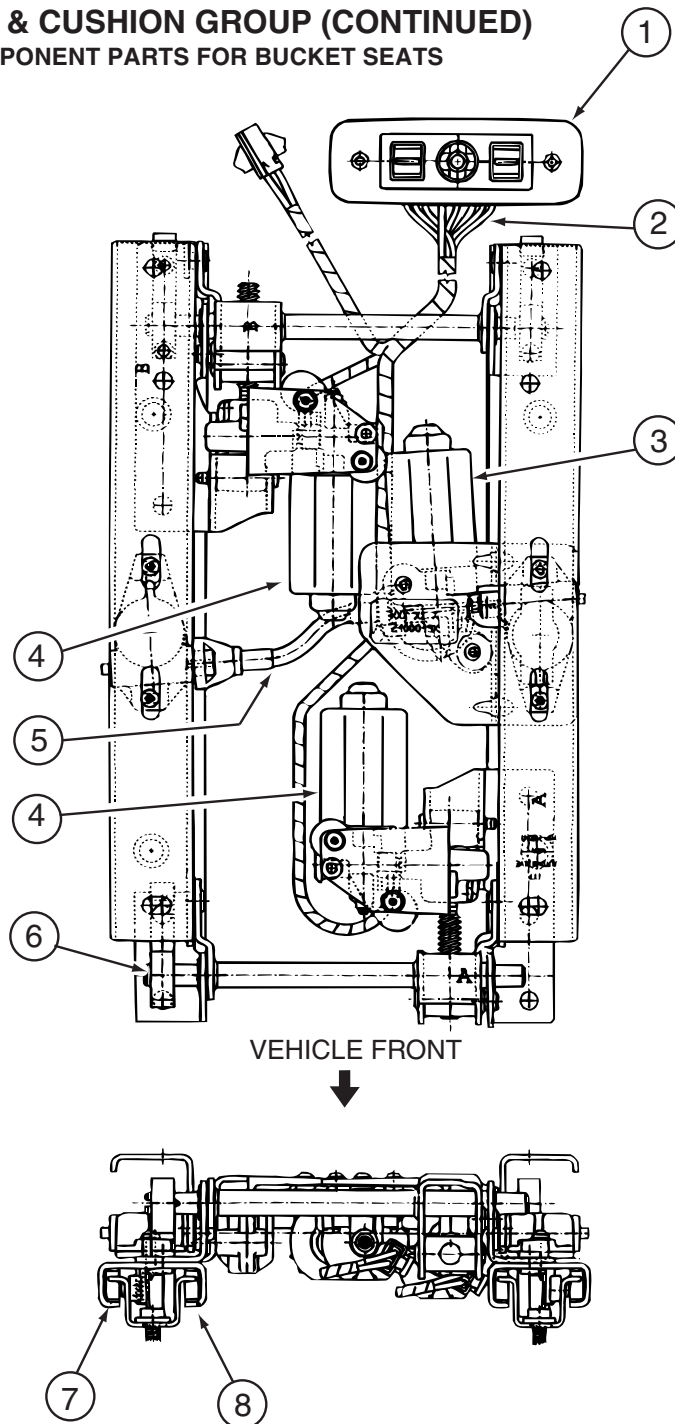

081373-03-000

KEY	PART NUMBER	U/M	DESCRIPTION	VENDOR NO.
1	081373-03-700	EA	SWITCH POWER	22543667 BLACK
2	081373-03-701	EA	WIRE HARNESS ASM., LT. SIDE	22138093
2	081373-03-702	EA	WIRE HARNESS ASM., RT. SIDE	22138094
3	081373-02-703	EA	MOTOR / HORIZONTAL	22128095
4	081373-02-704	EA	MOTOR PKG. ADJ. VERTICAL	22063238 & H-196
5	081373-03-704	EA	DRIVE CABLE	22143984
6	081373-03-705	EA	SPRING	22048978
7	081373-03-706	EA	SHOE GUIDE (WHITE)	22048993
8	081373-03-707	EA	SHOE GUIDE (BLACK)	22048994
	081373-03-700	EA	SWITCH POWER	22137945

122611-02-000

KEY	PART NUMBER	U/M	DESCRIPTION	VENDOR NO.
	122611-02-701	EA	LUMBAR - LEVER	412
	122611-02-702	EA	LUMBAR MECHANISM	24395-FLEXSTEEL

CURTAIN & CUSHION GROUP (CONTINUED)

SOFA

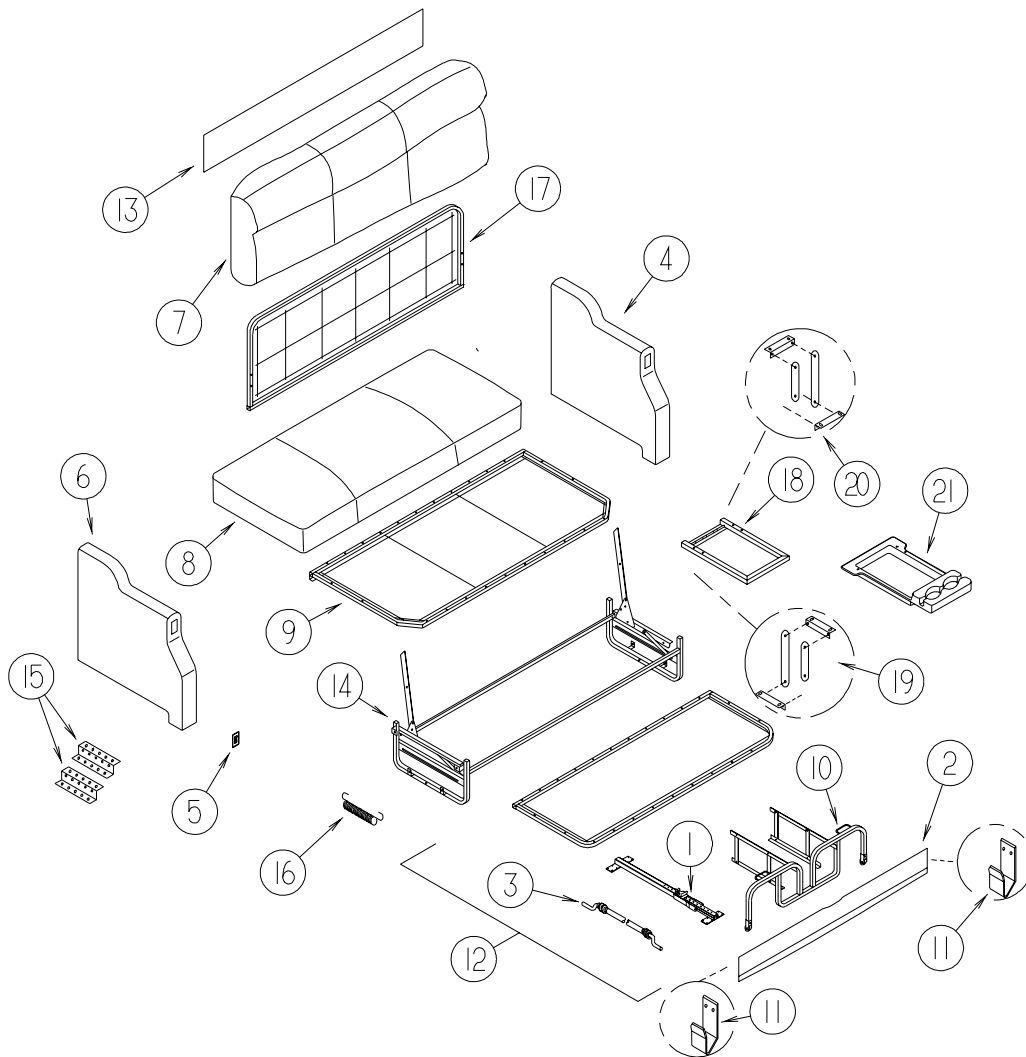

KEY	PART NUMBER	U/M DESCRIPTION
1*	148226-01-000	EA SLIDE RAIL - W/LATCH MECH/PLATES/STOP F/30" FLAT FLOOR
2	135824-07-P84	EA PANEL/FRONT KICK - SOFA/SLEEPER - 59.5" - FABRIC COVERED (R74, R75, R76)
2	135824-07-R77	EA PANEL/FRONT KICK - SOFA/SLEEPER - 59.5" - FABRIC COVERED (R77, R78, R79)
2	135824-07-R80	EA PANEL/FRONT KICK - SOFA/SLEEPER - 59.5" - FABRIC COVERED (R80, R81, R82)
2	135824-09-N84	EA PANEL/FRONT KICK - SOFA/SLEEPER - 59.5" - FABRIC COVERED - ULTRALEATHER
3	148225-01-000	EA CABLE ONLY - REMOTE - 31.9" W/Z-ENDS
4	139116-12-P84	EA ARMREST - LEFT HAND (R74, R75, R76)
4	139116-12-R77	EA ARMREST - LEFT HAND (R77, R78, R79)
4	139116-12-R44	EA ARMREST - LEFT HAND (R80, R81, R82)
4	139116-14-N84	EA ARMREST - LEFT HAND - ULTRALEATHER
	P39116-12-P84	EA COVER/ARMREST - LEFT HAND (R74, R75, R76)
	P39116-12-R77	EA COVER/ARMREST - LEFT HAND (R77, R78, R79)
	P39116-12-R44	EA COVER/ARMREST - LEFT HAND (R80, R81, R82)
	P39116-14-N84	EA COVER/ARMREST - LEFT HAND - ULTRALEATHER
5	136118-01-000	EA SWITCH - SOFA/RECLINER
6	139116-11-P84	EA ARMREST - RIGHT HAND (R74, R75, R76)
6	139116-11-R77	EA ARMREST - RIGHT HAND (R77, R78, R79)
6	139116-11-R44	EA ARMREST - RIGHT HAND (R80, R81, R82)
6	139116-13-N84	EA ARMREST - RIGHT HAND - ULTRALEATHER
	P39116-11-P84	EA COVER/ARMREST - LEFT HAND (R74, R75, R76)
	P39116-11-R77	EA COVER/ARMREST - LEFT HAND (R77, R78, R79)
	P39116-11-R44	EA COVER/ARMREST - LEFT HAND (R80, R81, R82)
	P39116-13-N84	EA COVER/ARMREST - LEFT HAND - ULTRALEATHER
7	138095-02-P84	EA BACK - SOFA/SLEEPER - RECLINER/POWERED (R74, R75, R76)
7	138095-02-R77	EA BACK - SOFA/SLEEPER - RECLINER/POWERED (R77, R78, R79)
7	138095-02-R44	EA BACK - SOFA/SLEEPER - RECLINER/POWERED (R80, R81, R82)
7	138095-06-M62	EA BACK - SOFA/SLEEPER - RECLINER/POWERED - ULTRALEATHER

CURTAIN & CUSHION GROUP (CONTINUED)
SOFA (CONTINUED)

KEY	PART NUMBER	U/M	DESCRIPTION
	P38095-02-P84	EA	COVER/BACK - SOFA/SLEEPER - RECLINER/POWERED (R74, R75, R76)
	P38095-02-R77	EA	COVER/BACK - SOFA/SLEEPER - RECLINER/POWERED (R77, R78, R79)
	P38095-02-R44	EA	COVER/BACK - SOFA/SLEEPER - RECLINER/POWERED (R80, R81, R82)
	P38095-06-M62	EA	COVER/BACK - SOFA/SLEEPER - RECLINER/POWERED - ULTRALEATHER
8	138095-03-P84	EA	SEAT - SOFA/SLEEPER - RECLINER/POWERED (R74, R75, R76)
8	138095-03-R77	EA	SEAT - SOFA/SLEEPER - RECLINER/POWERED (R77, R78, R79)
8	138095-03-R80	EA	SEAT - SOFA/SLEEPER - RECLINER/POWERED (R80, R81, R82)
8	138095-07-M62	EA	SEAT - SOFA/SLEEPER - RECLINER/POWERED - ULTRALEATHER
	P38095-03-P84	EA	COVER/SEAT - SOFA/SLEEPER - RECLINER/POWERED (R74, R75, R76)
	P38095-03-R77	EA	COVER/SEAT - SOFA/SLEEPER - RECLINER/POWERED (R77, R78, R79)
	P38095-03-R80	EA	COVER/SEAT - SOFA/SLEEPER - RECLINER/POWERED (R80, R81, R82)
	P38095-07-M62	EA	COVER/SEAT - SOFA/SLEEPER - RECLINER/POWERED - ULTRALEATHER
9	136534-04-000	EA	FRAME/SEAT - 26.5" X 60" W/FLEXOLATOR
10*	136534-17-000	EA	TRUNDLE FRAME - 17.5" X 55" - W/LINKAGE, LATCH & HANDLE
11	121906-01-02B	EA	BRACKET - KICKBOARD - E-COATED
12	138095-04-P84	EA	TRUNDLE - SOFA/SLEEPER (R74, R75, R76)
12	138095-04-R77	EA	TRUNDLE - SOFA/SLEEPER (R77, R78, R79)
12	138095-04-R80	EA	TRUNDLE - SOFA/SLEEPER (R80, R81, R82)
12	138095-08-M62	EA	TRUNDLE - SOFA/SLEEPER - ULTRALEATHER
	P38095-04-P84	EA	COVER/TRUNDLE - SOFA/SLEEPER (R74, R75, R76)
	P38095-04-R77	EA	COVER/TRUNDLE - SOFA/SLEEPER (R77, R78, R79)
	P38095-04-R80	EA	COVER/TRUNDLE - SOFA/SLEEPER (R80, R81, R82)
	P38095-08-M62	EA	COVER/TRUNDLE - SOFA/SLEEPER - ULTRALEATHER
13	139716-04-P84	EA	SIGHT SHIELD - 58" - FULL BACK - W/BEVERAGE TRAY (R74, R75, R76)
13	139716-04-R77	EA	SIGHT SHIELD - 58" - FULL BACK - W/BEVERAGE TRAY (R77, R78, R79)
13	139716-04-R80	EA	SIGHT SHIELD - 58" - FULL BACK - W/BEVERAGE TRAY (R80, R81, R82)
13	139716-05-N47	EA	SIGHT SHIELD - 58" - FULL BACK - W/BEVERAGE TRAY - ULTRALEATHER
14*	136534-15-000	EA	BASE - 27.5" X 60" - POWERED CL - W/10.5" OVERHANG
15	116104-04-02B	EA	BRACKET - ZEE W/HOLES - 3.2" - E-COATED
16	136534-33-000	EA	SPRING/ASSIST - 1/2" X 7" W/HOOK ENDS - REST EASY SOFAS
17	136534-20-000	EA	BACK - FRAME - BEVERAGE TRAY
18	136534-21-000	EA	FRAME - BEVERAGE TRAY
19	136534-22-000	EA	HINGE - RIGHT
20	136534-23-000	EA	HINGE - LEFT
21	139758-01-01A	EA	TRAY-BEVERAGE

***COMPONENT PARTS LISTED LATER IN THIS GROUP**

CURTAIN & CUSHION GROUP (CONTINUED)
SOFA (CONTINUED)

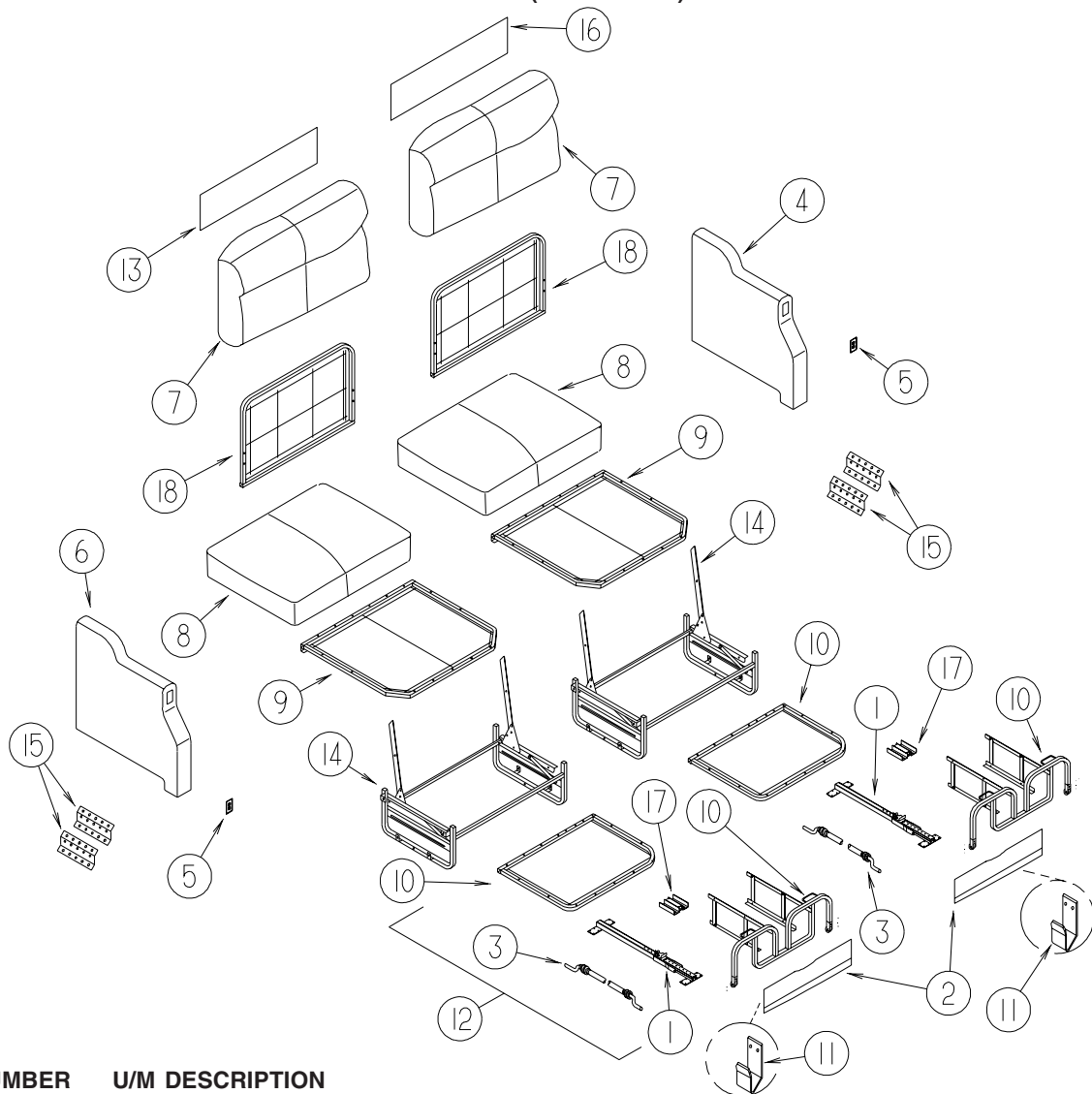

KEY	PART NUMBER	U/M	DESCRIPTION
1*	148226-03-000	EA	SLIDE RAIL - W/LATCH MECH/PLATES/STOP F/20" RAISED FLOOR
2	135824-12-R74	EA	PANEL/FRONT KICK - SOFA/SLEEPER (DUAL) - 30.2" (R74, R75, R76)
2	135824-12-R77	EA	PANEL/FRONT KICK - SOFA/SLEEPER (DUAL) - 30.2" (R77, R78, R79)
2	135824-12-R44	EA	PANEL/FRONT KICK - SOFA/SLEEPER (DUAL) - 30.2" (R80, R81, R82)
2	135824-11-N84	EA	PANEL/FRONT KICK - SOFA/SLEEPER (DUAL) - 30.2" - ULTRALEATHER
3	148225-01-000	EA	CABLE ONLY - REMOTE - 31.9" W/Z-ENDS
4	139116-17-R74	EA	ARMREST - LEFT HAND (R74, R75, R76)
4	139116-17-R77	EA	ARMREST - LEFT HAND (R77, R78, R79)
4	139116-17-R44	EA	ARMREST - LEFT HAND (R80, R81, R82)
4	139116-16-N84	EA	ARMREST - LEFT HAND - W/SWITCH - ULTRALEATHER
	P39116-12-P84	EA	COVER/ARMREST - LEFT HAND (R74, R75, R76)
	P39116-12-R77	EA	COVER/ARMREST - LEFT HAND (R77, R78, R79)
	P39116-12-R44	EA	COVER/ARMREST - LEFT HAND (R80, R81, R82)
	P39116-16-N84	EA	COVER/ARMREST - LEFT HAND - ULTRALEATHER
5	136118-01-000	EA	SWITCH - SOFA/RECLINER
6	139116-18-R74	EA	ARMREST - RIGHT HAND (R74, R75, R76)
6	139116-18-R77	EA	ARMREST - RIGHT HAND (R77, R78, R79)
6	139116-18-R44	EA	ARMREST - RIGHT HAND (R80, R81, R82)
6	139116-15-N84	EA	ARMREST - RIGHT HAND - W/SWITCH - ULTRALEATHER
	P39116-11-P84	EA	COVER/ARMREST - RIGHT HAND (R74, R75, R76)
	P39116-11-R77	EA	COVER/ARMREST - RIGHT HAND (R77, R78, R79)
	P39116-11-R44	EA	COVER/ARMREST - RIGHT HAND (R80, R81, R82)
	P39116-15-N84	EA	COVER/ARMREST - RIGHT HAND - ULTRALEATHER
7	138647-20-R74	EA	BACK - SOFA/SLEEPER - REST EASY/DUAL CONTROLLED (R74, R75, R76)
7	138647-20-R77	EA	BACK - SOFA/SLEEPER - REST EASY/DUAL CONTROLLED (R77, R78, R79)
7	138647-20-R44	EA	BACK - SOFA/SLEEPER - REST EASY/DUAL CONTROLLED (R80, R81, R82)
7	139202-02-N84	EA	BACK - SOFA/DUAL SLEEPER - RECLINER/POWERED - ULTRALEATHER

CURTAIN & CUSHION GROUP (CONTINUED)
SOFA (CONTINUED)

KEY	PART NUMBER	U/M	DESCRIPTION
	P38647-20-R74	EA	COVER/BACK - REST EASY/DUAL CONTROLLED - SOFA/SLEEPER (R74, R75, R76)
	P38647-20-R77	EA	COVER/BACK - REST EASY/DUAL CONTROLLED - SOFA/SLEEPER (R77, R78, R79)
	P38647-20-R44	EA	COVER/BACK - REST EASY/DUAL CONTROLLED - SOFA/SLEEPER (R80, R81, R82)
	P39202-02-N84	EA	COVER/BACK - SOFA/DUAL SLEEPER - RECLINER/POWERED - ULTRALEATHER
8	138647-21-R74	EA	SEAT - SOFA/SLEEPER - REST EASY/DUAL CONTROLLED (R74, R75, R76)
8	138647-21-R77	EA	SEAT - SOFA/SLEEPER - REST EASY/DUAL CONTROLLED (R77, R78, R79)
8	138647-21-R44	EA	SEAT - SOFA/SLEEPER - REST EASY/DUAL CONTROLLED (R80, R81, R82)
8	139202-03-N84	EA	SEAT - SOFA/DUAL SLEEPER - RECLINER/POWERED - ULTRALEATHER
	P38647-21-R74	EA	COVER/SEAT - REST EASY/DUAL CONTROLLED - SOFA/SLEEPER (R74, R75, R76)
	P38647-21-R77	EA	COVER/SEAT - REST EASY/DUAL CONTROLLED - SOFA/SLEEPER (R77, R78, R79)
	P38647-21-R44	EA	COVER/SEAT - REST EASY/DUAL CONTROLLED - SOFA/SLEEPER (R80, R81, R82)
	P39202-03-N84	EA	COVER/SEAT - SOFA/DUAL SLEEPER - RECLINER/POWERED - ULTRALEATHER
9	136534-26-000	EA	FRAME/SEAT - FOR DUAL REST EASY SOFA - ONE SIDE ONLY
10	136534-27-000	EA	TRUNDLE FRAME - 26" WIDE/DUAL - W/LINKAGE, LATCH & HANDLE
11	121906-01-02B	EA	BRACKET - KICKBOARD - E-COATED
12	138647-22-R74	EA	TRUNDLE - SOFA/SLEEPER - REST EASY/DUAL CONTROLLED (R74, R75, R76)
12	138647-22-R77	EA	TRUNDLE - SOFA/SLEEPER - REST EASY/DUAL CONTROLLED (R77, R78, R79)
12	138647-22-R44	EA	TRUNDLE - SOFA/SLEEPER - REST EASY/DUAL CONTROLLED (R80, R81, R82)
12	139202-04-N84	EA	TRUNDLE - SOFA/DUAL SLEEPER - ULTRALEATHER
	P38647-22-R74	EA	COVER/TRUNDLE - REST EASY/DUAL CONTROLLED - SOFA/SLEEPER (R74, R75, R76)
	P38647-22-R77	EA	COVER/TRUNDLE - REST EASY/DUAL CONTROLLED - SOFA/SLEEPER (R77, R78, R79)
	P38647-22-R44	EA	COVER/TRUNDLE - REST EASY/DUAL CONTROLLED - SOFA/SLEEPER (R80, R81, R82)
	P39202-04-N84	EA	COVER/TRUNDEL - SOFA/DUAL SLEEPER - ULTRALEATHER
13	139716-07-R74	EA	SIGHT SHIELD - 28" - DUAL BACK/RIGHT HAND (R74, R75, R76)
13	139716-07-R77	EA	SIGHT SHIELD - 28" - DUAL BACK/RIGHT HAND (R77, R78, R79)
13	139716-07-R44	EA	SIGHT SHIELD - 28" - DUAL BACK/RIGHT HAND (R80, R81, R82)
13	139716-03-N84	EA	SIGHT SHIELD - 28" - DUAL BACK - ULTRALEATHER
14*	136534-29-000	EA	BASE - 27.25" X 30" - POWERED/DUAL - FLAT
15	116104-04-02B	EA	BRACKET - ZEE W/HOLES - 3.2" - E-COATED
16	139716-08-R74	EA	SIGHT SHIELD - 28" - DUAL BACK/LEFT HAND (R74, R75, R76)
16	139716-08-R77	EA	SIGHT SHIELD - 28" - DUAL BACK/LEFT HAND (R77, R78, R79)
16	139716-08-R44	EA	SIGHT SHIELD - 28" - DUAL BACK/LEFT HAND (R80, R81, R82)
16	139716-06-N84	EA	SIGHT SHIELD - 28" - DUAL BACK - ULTRALEATHER
17	136534-32-000	EA	BRACKET - DUAL BASE
18	136534-25-000	EA	FRAME/BACK - FOR DUAL REST EASY SOFA - ONE SIDE ONLY

***COMPONENT PARTS LISTED LATER IN THIS GROUP**

CURTAIN & CUSHION GROUP (CONTINUED)

COMPONENT PARTS FOR SOFA

136534-07-000, 136534-17-000

KEY	PART NUMBER	U/M	DESCRIPTION	VENDOR NO.
	136534-07-701	EA	WHEEL - NYLON - 1 5/8", 9WHEEL-1.62	

136534-13-000, 136534-15-000, 136534-28-000, 136534-29-000

KEY	PART NUMBER	U/M	DESCRIPTION	VENDOR NO.
	136534-02-700	EA	MOTOR	9PL-MO-W/T-1
	136534-02-701	EA	CABLE/DRV MTR-REST EASY SOFA	9PL-FCA27.75

148226-01-000, 148226-02-000, 148226-03-000

KEY	PART NUMBER	U/M	DESCRIPTION	VENDOR NO.
	148226-01-700	EA	BUSHING/GUIDE - F/MECHANISM	9TN-SLD-GR-1
	148226-01-701	EA	SLIDE MECHANISM ASM W/LATCH	PTN-SLD-BUSH1

CURTAIN & CUSHION GROUP (CONTINUED)
WINDOW TREATMENT

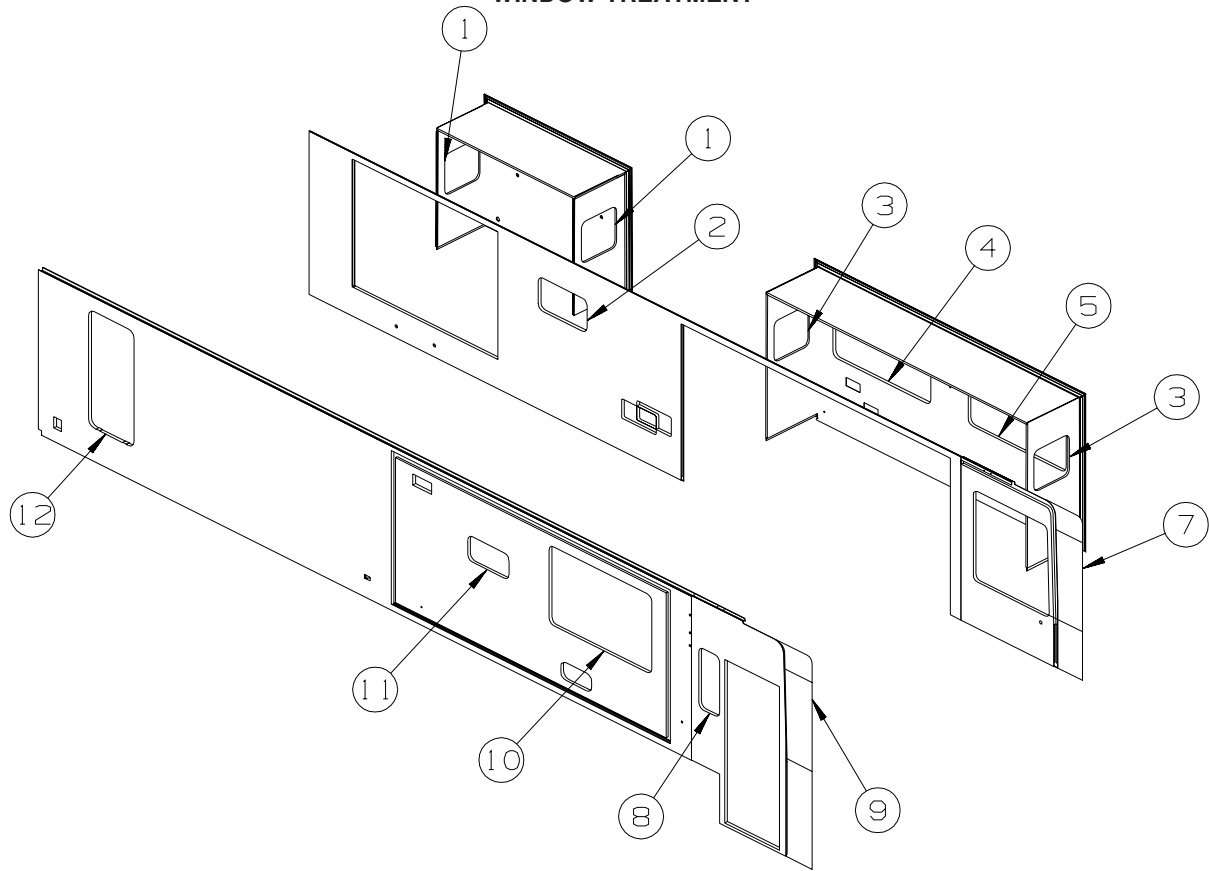

KEY	PART NUMBER	U/M	DESCRIPTION
1	146058-03-R74	EA	VALANCE - MONTICELLO - 26" (R74,R75,R76)
1	146058-03-R77	EA	VALANCE - MONTICELLO - 26" (R77,R78,R79)
1	146058-03-R44	EA	VALANCE - MONTICELLO - 26" (R80,R81,R82)
1	136988-59-P84	EA	LEG - RIGHT - 22" (R74,R75,R76)
1	136988-59-R77	EA	LEG - RIGHT - 22" (R77,R78,R79)
1	136988-59-R44	EA	LEG - RIGHT - 22" (R80,R81,R82)
1	136988-60-P84	EA	LEG - LEFT - 22" (R74,R75,R76)
1	136988-60-R77	EA	LEG - LEFT - 22" (R77,R78,R79)
1	136988-60-R44	EA	LEG - LEFT - 22" (R80,R81,R82)
1	140789-07-N44	EA	BLIND - DAY/NIGHTER - 22.5" X 23" (R74,R75,R76)
1	140789-07-N42	EA	BLIND - DAY/NIGHTER - 22.5" X 23" (R77,R78,R79,R80,R81,R82)
2	121410-A4-R74	EA	VALANCE - MODERATE - 32" (R74,R75,R76)
2	121410-A4-R77	EA	VALANCE - MODERATE - 32" (R77,R78,R79)
2	121410-A4-R80	EA	VALANCE - MODERATE - 32" (R80,R81,R82)
2	109041-44-04A	EA	BLIND - 30.5" X 18" (R74,R75,R76)
2	109041-44-02A	EA	BLIND - 30.5" X 18" (R77,R78,R79,R80,R81,R82)
3	142259-05-R74	EA	VALANCE - PALM COURT - 26" (R74,R75,R76)
3	142259-05-R77	EA	VALANCE - PALM COURT - 26" (R77,R78,R79)
3	142259-05-R80	EA	VALANCE - PALM COURT - 26" (R80,R81,R82)
3	136988-21-P84	EA	LEG - RIGHT - 22" (R74,R75,R76)
3	136988-21-R77	EA	LEG - RIGHT - 22" (R77,R78,R79)
3	136988-21-R44	EA	LEG - RIGHT - 22" (R80,R81,R82)
3	136988-22-P84	EA	LEG - LEFT - 22" (R74,R75,R76)
3	136988-22-R77	EA	LEG - LEFT - 22" (R77,R78,R79)
3	136988-22-R44	EA	LEG - LEFT - 22" (R80,R81,R82)
3	140789-07-N44	EA	BLIND - DAY/NIGHTER - 22.5" X 23" (R74,R75,R76)
3	140789-07-N42	EA	BLIND - DAY/NIGHTER - 22.5" X 23" (R77,R78,R79,R80,R81,R82)

CURTAIN & CUSHION GROUP (CONTINUED)
WINDOW TREATMENT (CONTINUED)

KEY	PART NUMBER	U/M	DESCRIPTION
4	142259-02-R74	EA	LAMBREQUIN - PALM COURT - 61" (R74,R75,R76)
4	142259-02-R77	EA	LAMBREQUIN - PALM COURT - 61" (R77,R78,R79)
4	142259-02-R80	EA	LAMBREQUIN - PALM COURT - 61" (R80,R81,R82)
4	140789-08-N44	EA	BLIND - DAY/NIGHTER - 59" X 26.5" (R74,R75,R76)
4	140789-08-N09	EA	BLIND - DAY/NIGHTER - 59" X 26.5" (R77,R78,R79,R80,R81,R82)
5	142259-01-R74	EA	LAMBREQUIN - PALM COURT - 61" (R74,R75,R76)
5	142259-01-R77	EA	LAMBREQUIN - PALM COURT - 61" (R77,R78,R79)
5	142259-01-R80	EA	LAMBREQUIN - PALM COURT - 61" (R80,R81,R82)
5	140789-08-N44	EA	BLIND - DAY/NIGHTER - 59" X 26.5" (R74,R75,R76)
5	140789-08-N09	EA	BLIND - DAY/NIGHTER - 59" X 26.5" (R77,R78,R79,R80,R81,R82)
6	126841-03-000	EA	SHADE - PULL - CHARCOAL MESH - 40.3" X 60"
7	147460-01-R68	EA	CURTAIN - DRVVR/WRAP/PRIVACY/PLEATED - 45" X 54"
8	126841-04-000	EA	SHADE - PULL - CHARCOAL MESH - 30.3" X 60"
9	147460-02-R68	EA	CURTAIN - PASS/FRONT WRAP/PRIVACY/PLEATED - 42.5" X 74.9"
9	147460-03-R68	EA	CURTAIN - PASS/REAR WRAP/PRIVACY/PLEATED - 42.5" X 74.9"
10	142259-08-R74	EA	LAMBREQUIN - PALM COURT - 63" (R74,R75,R76)
10	142259-08-R77	EA	LAMBREQUIN - PALM COURT - 63" (R77,R78,R79)
10	142259-08-R80	EA	LAMBREQUIN - PALM COURT - 63" (R80,R81,R82)
10	140789-13-N54	EA	BLIND - DAY/NIGHTER - 61" X 42" (R74,R75,R76)
10	140789-13-N52	EA	BLIND - DAY/NIGHTER - 61" X 42" (R77,R78,R79,R80,R81,R82)
11	121410-D4-R74	EA	VALANCE - MODERATE - 28" (R74,R75,R76)
11	121410-D4-R77	EA	VALANCE - MODERATE - 28" (R77,R78,R79)
11	121410-D4-R80	EA	VALANCE - MODERATE - 28" (R80,R81,R82)
11	109041-72-01A	EA	BLIND - MINI - 26" X 13.5" (R74,R75,R76)
11	109041-72-02A	EA	BLIND - MINI - 26" X 13.5" (R77,R78,R79,R80,R81,R82)
12	146058-11-R74	EA	VALANCE - MONTICELLO - 29" (R74,R75,R76)
12	146058-11-R77	EA	VALANCE - MONTICELLO - 29" (R77,R78,R79)
12	146058-11-R80	EA	VALANCE - MONTICELLO - 29" (R80,R81,R82)
12	140789-39-R68	EA	BLIND - DAY/NIGHTER - 28" X 57" (R74,R75,R76)
12	140789-39-R70	EA	BLIND - DAY/NIGHTER - 28" X 57" (R77,R78,R79,R80,R81,R82)

CURTAIN & CUSHION GROUP (CONTINUED)

HARDWARE

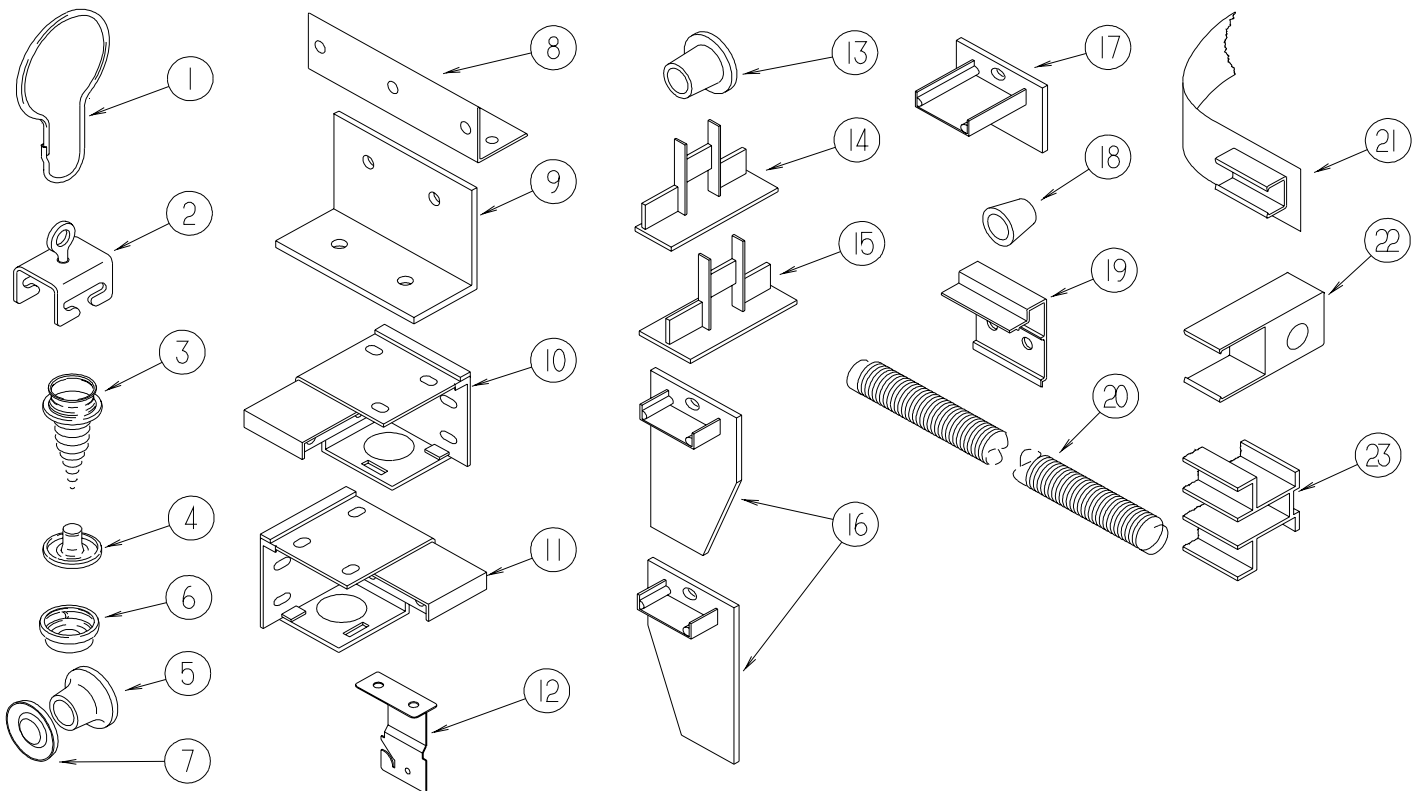

KEY	PART NUMBER	U/M	DESCRIPTION
1	009136-02-000	EA	HANGER - RING - PIN TYPE - CURTAIN - BRASS
2	009702-01-000	EA	END STOP - CURTAIN CARRIER - L - ROD
3	029130-01-000	EA	SCREW - SNAP STUD - #8-16 X 3/8" LONG
3	029130-03-000	EA	SCREW - SNAP STUD - #8-16 X 1" LONG
4	029155-01-000	EA	CAP - SNAP - 5/32" OUTSIDE DIAMETER OF PIN
5	029156-01-000	EA	SOCKET - SNAP - 9/16" O.D.
6	046867-02-000	EA	WASHER - HANDY BUTTON #3
7	046867-03-000	EA	GROMMET - HANDY BUTTON #3
8	075943-10-000	EA	BRACE - VALANCE - 20" - OFF WHITE
9	083125-07-000	EA	BRACE - ANGLE/COUCH - 2.5" - OFF WHITE
9	083125-08-000	EA	BRACE - WINDOW MOUNT - .75" - OFF WHITE
10	083170-01-000	EA	BRACKET/BLIND - LEFT SIDE WHEN FACING WINDOW - CLEAR
11	083170-02-000	EA	BRACKET/BLIND - RIGHT SIDE WHEN FACING WINDOW - CLEAR
12	084434-01-000	EA	BRACKET - MOUNTING - ROLLER SHADE - 1 3/8"
13	094896-02-000	EA	GROMMET - CORD/PLEATED BLIND - NYLON - GRAY
14	094907-02-000	EA	END CAP - PLEATED BLIND/TOP - RH/LH - GRAY PLASTIC
15	094907-04-000	EA	END CAP - PLEATED BLIND/BOTTOM - RH/LH
16	094907-05-000	EA	END CAP - PLEATED BLIND/BOTTOM - PULL TYPE - PLASTIC
17	094907-06-000	EA	END CAP - PLEATED BLIND/TOP
18	097564-03-000	EA	HANDLE - KNOB - E-Z LIFT SHADE - TAN
18	097564-05-000	EA	HANDLE - KNOB - E-Z LIFT SHADE - TEAL
18	097564-06-000	EA	HANDLE - KNOB - E-Z LIFT SHADE - ALABASTER
	097593-02-000	FT	CORD - BLIND - PLEATED - GRAY
	097593-06-000	FT	CORD - BLIND - PLEATED - PEWTER
	097593-10-000	FT	CORD - BLIND - PLEATED - VANILLA
19	097565-01-000	EA	BRACKET - MOUNTING - PLEATED BLIND
19	097565-02-000	EA	BRACKET - MOUNTING - PLEATED BLIND
20	097591-01-000	EA	SPRING - EXTENSION - PLEATED BLIND
21	101031-01-000	YD	TAPE/GLIDE - 4.25" SPACING
22	101033-02-000	EA	END CAP - LOW PROFILE TRACK - CLEAR
23	101033-08-000	EA	TRACK/WALL - 75" - FRT BUNK WINDOW 300 SERIES (MINNIE/SPIRIT)
23	101033-09-000	EA	TRACK/WALL - 32" - SIDE BUNK WINDOW 200 SERIES/300 SERIES (VISTA/SUNSTAR /MINNIE/SPIRIT)

CURTAIN & CUSHION GROUP (CONTINUED)
HARDWARE (CONTINUED)

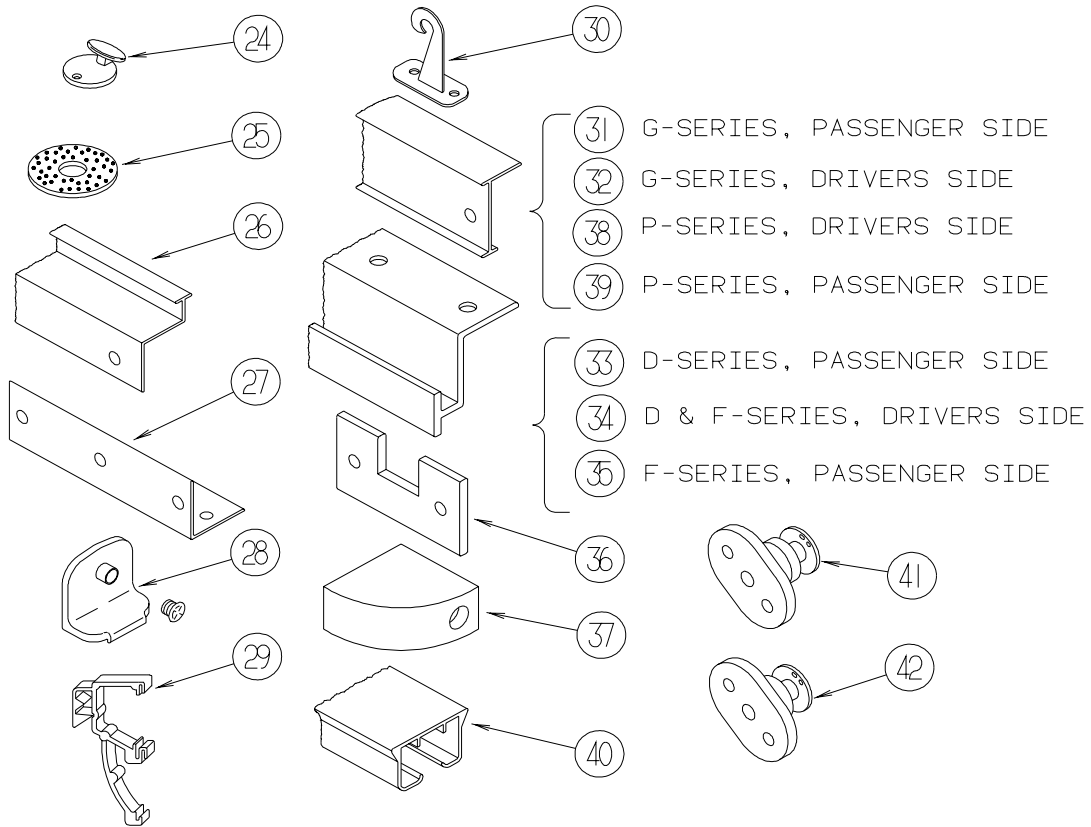

KEY	PART NUMBER	U/M	DESCRIPTION
24	102555-03-000	EA	CLEAT - BLIND CORD - MILKY WHITE - PLASTIC
25	103242-01-000	EA	VELCRO HOOK - BEIGE 7/8" ROUND W/CENTER HOLE
25	103242-02-000	EA	VELCRO HOOK - BLACK 7/8" ROUND W/CENTER HOLE
26	105450-14-01A	EA	TRACK - CURTAIN - 90" - OFF WHITE - FRONT BUNK PRIVACY 300 SERIES (MINNIE/SPIRIT)
26	105450-15-01A	EA	TRACK - CURTAIN - 82.3" - OFF WHITE - FRONT BUNK PRIVACY 200 SERIES (VISTA/SUNSTAR)
27	105648-01-02A	EA	BRACE - VALANCE - OFF/WHITE - 14"
28	106544-01-000	EA	PULL - SHADE/BRASS
	106544-01-001	EA	SCREW - SHADE/BRASS
29	109353-04-000	EA	CLIP - VALANCE SLAT MOUNTING - CLEAR PLASTIC
	109441-02-000	EA	SPACER/BRACKET - BLIND HOLD DOWN
30	109441-03-000	EA	BRACKET/HOOK - BLIND HOLD DOWN - NEW DESIGN/CLEAR
31	126456-03-04A	EA	TRACK/WRAPAROUND - PASSENGER - GLACIER - G SERIES (ADVENTURER/SUNCRUISER)
32	126456-04-04A	EA	TRACK/WRAPAROUND - DRIVER - GLACIER - G SERIES (ADVENTURER/SUNCRUISER)
33	127254-03-05A	EA	TRACK/WRAPAROUND - PASSENGER - GLACIER - D SERIES (SIGHTSEER/SUNOVA)
			FROM: 00-00-00 THRU: 09-07-03
33	127254-14-03A	EA	TRACK/WRAP - PASS - GLACIER - D SERIES (SIGHTSEER/SUNOVA)
			FROM: 09-08-03 THRU: 99-99-99
34	127254-04-05A	EA	TRACK/WRAP - DRIVER - GLACIER - D SERIES/F SERIES (SIGHTSEER/SUNOVA/BRAVE/SUNRISE)
35	127254-14-03A	EA	TRACK/WRAP - PASS - GLACIER - F SERIES (BRAVE/SUNRISE)
36	130549-01-01A	EA	STOP - CURTAIN TRACK
37	132504-01-N92	EA	BRACKET - SHADE
38	146591-01-01A	EA	TRACK - CURTAIN - LEFT HAND - GLACIER - P SERIES (JOURNEY/MERIDIAN)
39	146591-02-01A	EA	TRACK - CURTAIN - RIGHT HAND - GLACIER - P SERIES (JOURNEY/MERIDIAN)
40	138460-01-02A	EA	TRACK/CURTAIN - PASSENGER - WHITE - Q SERIES (ULTIMATE ADVANTAGE/ULTIMATE FREEDOM)
	138460-02-02A	EA	TRACK/CURTAIN - DRIVER - WHITE - Q SERIES (ULTIMATE ADVANTAGE/ULTIMATE FREEDOM)
40	138460-05-02A	EA	TRACK/CURTAIN - PASSENGER - WHITE - L SERIES (CHIEFTAIN/SUNFLYER)
	138460-06-02A	EA	TRACK/CURTAIN - DRIVER - WHITE - L SERIES (CHIEFTAIN/SUNFLYER)
40	138460-07-02A	EA	TRACK/CURTAIN - PASSENGER - WHITE - S SERIES (VECTRA/HORIZON)
	138460-08-02A	EA	TRACK/CURTAIN - DRIVER - WHITE - S SERIES (VECTRA/HORIZON)
41	141634-01-000	EA	BRACKET-(BOBBIN TYPE) 7/8"H HOLDUPBASE(OVAL)-2 HOLE-CLEAR
42	143805-01-000	EA	BRACKET-(BOBBIN TYPE) 1/2"H HOLDUPBASE(OVAL)-2 HOLES CLEAR

CURTAIN & CUSHION GROUP (CONTINUED)

ACCESSORIES

KEY	PART NUMBER	U/M	DESCRIPTION
	056271-01-000	EA	SEAT BELT - 2" X 102" - BLACK
	127598-01-01A	EA	ADJUSTER - SEATBELT - D-LOOP
	140221-01-02B	EA	WASHER - SEAT BELT - E-COAT
	070578-13-R74	EA	BUTTON - #30 - FABRIC COVERED (R74)
	070578-13-R75	EA	BUTTON - #30 - FABRIC COVERED (R75)
	070578-13-R76	EA	BUTTON - #30 - FABRIC COVERED (R76)
	070578-13-LA8	EA	BUTTON - #30 - FABRIC COVERED (R77,R78,R79)
	070578-13-R80	EA	BUTTON - #30 - FABRIC COVERED (R80)
	070578-13-R81	EA	BUTTON - #30 - FABRIC COVERED (R81)
	070578-13-R82	EA	BUTTON - #30 - FABRIC COVERED (R82)
	070578-12-R74	EA	BUTTON - #30 - FABRIC COVERED (R74,R75,R76)
	070578-12-R77	EA	BUTTON - #30 - FABRIC COVERED (R77,R78,R79)
	070578-12-R80	EA	BUTTON - #30 - FABRIC COVERED (R80,R81,R82)
	074494-05-000	EA	BUTTON - SINGLE PIVOT - #30
	057534-01-000	EA	TIEBACK - CLEAR PLASTIC - 6"
	057534-03-000	EA	TIEBACK - CLEAR PLASTIC - 7.5"
	057534-08-000	EA	TIEBACK - CLEAR PLASTIC - 16"
	105402-03-000	EA	STRAP - DINING CHAIR/TIEDOWN - 18"
	118337-08-R74	EA	BUTTON - #60 - FABRIC COVERED (R74,R75,R76)
	118337-08-R70	EA	BUTTON - #60 - FABRIC COVERED (R77,R78,R79)
	118337-08-R44	EA	BUTTON - #60 - FABRIC COVERED (R80,R81,R82)
	118337-19-R74	EA	BUTTON - #36 W/TACK (R74,R75,R76)
	118337-19-R77	EA	BUTTON - #36 W/TACK (R77,R78,R79)
	118337-19-R80	EA	BUTTON - #36 W/TACK (R80,R81,R82)
	118337-22-R74	EA	BUTTON - #36 - FABRIC COVERED (R74,R75,R76)
	118337-22-R77	EA	BUTTON - #36 - FABRIC COVERED (R77,R78,R79)
	118337-22-R44	EA	BUTTON - #36 - FABRIC COVERED (R80,R81,R82)

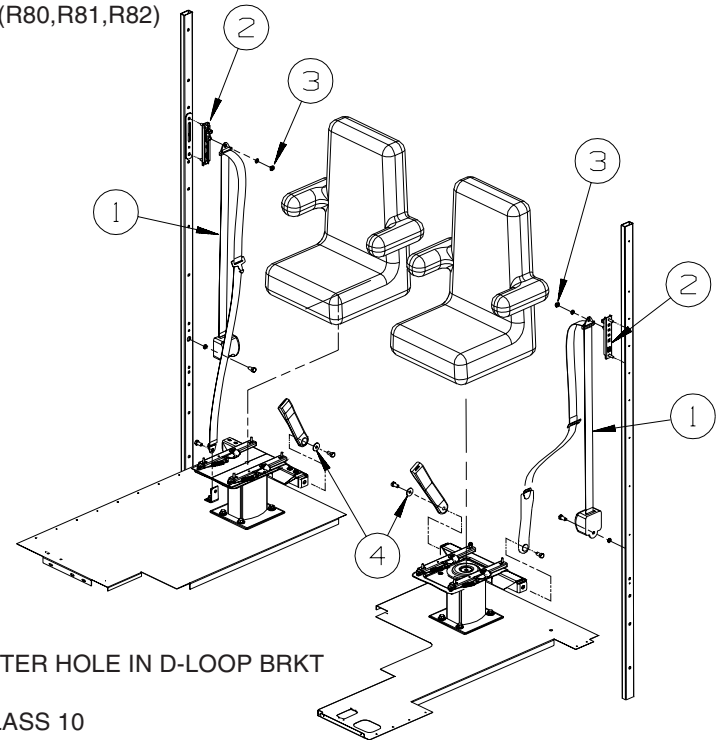

KEY	PART NUMBER	U/M	DESCRIPTION
1*	091990-08-01A	EA	SEAT BELT - 3 POINT - .766" DIAMETER HOLE IN D-LOOP BRKT
2	127598-01-01A	EA	ADJUSTER - SEATBELT - D-LOOP
3	127598-02-000	EA	NUT - HEX FLANGE - M10 X 1.5 - CLASS 10
4	NOT USED		

*COMPONENT PARTS LISTED LATER IN THIS GROUP

CURTAIN & CUSHION GROUP (CONTINUED)
COMPONENT PARTS FOR ACCESSORIES

091990-08-01A

KEY	PART NUMBER	U/M	DESCRIPTION	VENDOR NO.
	091990-01-701	EA	EXTENDER 9" FOR A8408 3 PT	I-1331-02
	091990-01-703	EA	RECEIVER/FEMALE END-SEATBELT	I-1159-02
	091990-05-700	EA	SLEEVE/BUCKLE COVER-PLASTIC	209S-2
	091990-05-701	EA	CAP/COVER - BOLT HOLE COVER	209SC-02
	091990-05-702	EA	SLEEVE/RETRACTABLE COVER	309C-02

CURTAIN & CUSHION GROUP (CONTINUED)

FABRICS

FAMILY ITASCA P'S	R74/R75/R76	R77/R78/R79	R80/R81/R82
MERIDIAN	PROVENCE BLUE	GREENWICH GREEN	STONEHENGE TAUPE
BUCKET	588PI W/ADJ. ARMS DR. & PASS. 126883-P3-000	588PI W/ADJ. ARMS DR. & PASS. 126883-S6-000	588PI W/ADJ. ARMS DR. & PASS. 126883-S8-000
	*OPT. ANTIQUE PEARL ULTRA W/LOGO 079680-36-000	*OPT. ANTIQUE PEARL ULTRA W/LOGO 079680-36-000	*OPT. ANTIQUE PEARL ULTRA W/LOGO 079680-36-000
DINETTE	730 TEAR DROP/728 SEAT 126883-P2-000	730 TEAR DROP/728 SEAT 126883-S4-000	730 TEAR DROP/728 SEAT 126883-S5-000
DINETTE WRAP	126883-P3-000	126883-S6-000	126883-S8-000
DINETTE CHAIRS & REM FOLDING	FLEX. C5703 DINETTE CHAIR REM FC200 FOLDING CHAIR 126883-P3-000	FLEX. C5703 DINETTE CHAIR REM FC200 FOLDING CHAIR 126883-S6-000	FLEX. C5703 DINETTE CHAIR REM FC200 FOLDING CHAIR 126883-S8-000
SOFA	805 W/805 OR 800 ARMS 126883-P2-000	805 W/805 OR 800 ARMS 126883-S4-000	805 W/805 OR 800 ARMS 126883-S5-000
	*OPT. ANTIQUE PEARL ULTRA 079680-36-000	*OPT. ANTIQUE PEARL ULTRA 079680-36-000	*OPT. ANTIQUE PEARL ULTRA 079680-36-000
NEW DUAL SOFA IKP32T/34H IKP36G/39K/39W	800 ARMS 126883-P2-000	800 ARMS 126883-S4-000	800 ARMS 126883-S5-000
	805 ARMS 126883-P2-000	126883-S4-000	126883-S5-000
BANQUETTE	676 W/810 ARMS 126883-P2-000	676 W/810 ARMS 126883-S4-000	676 W/810 ARMS 126883-S5-000
	*OPT. ANTIQUE PEARL ULTRA 079680-36-000	*OPT. ANTIQUE PEARL ULTRA 079680-36-000	*OPT. ANTIQUE PEARL ULTRA 079680-36-000
LOUNGE CHAIR	470 HOOP 126883-P3-000	470 HOOP 126883-S6-000	470 HOOP 126883-S8-000
	*OPT. ANTIQUE PEARL ULTRA 079680-36-000	*OPT. ANTIQUE PEARL ULTRA 079680-36-000	*OPT. ANTIQUE PEARL ULTRA 079680-36-000
LOUNGE WINDOWS	PALM COURT LAMBREQUIN UNDERLAY/OVERLAY 126883-P3-000/126883-P2-000	PALM COURT LAMBREQUIN UNDERLAY/OVERLAY 126883-S6-000/126883-S4-000	PALM COURT LAMBREQUIN UNDERLAY/OVERLAY 126883-S8-000/126883-S5-000
	CORD TRIM 139041-24-000	CORD TRIM 084415-F2-000	CORD TRIM 084415-F9-000
LOUNGE PILLOWS 2 PER SOFA/BANQ.	SQ. W/RADIUS FROWN OVLY BACK,BOTTOM,WELT 126883-P3-000	SQ. W/RADIUS FROWN OVLY BACK, BOTTOM,WELT 126883-S6-000	SQ. W/RADIUS FROWN OVLY BACK, BOTTOM, WELT 126883-S8-000
	RADIUS OVLY. 126883-P2 (PALM COURT)	RADIUS OVLY. 126883-S4 (PALM COURT)	RADIUS OVLY. 126883-S5 (PALM COURT)

CURTAIN & CUSHION GROUP (CONTINUED)
FABRICS (CONTINUED)

FAMILY ITASCA P'S	R74/R75/R76	R77/R78/R79	R80/R81/R82
MERIDIAN	PROVENCE BLUE	GREENWICH GREEN	STONEHENGE TAUPE
HALLWAY	PALM COURT LAMBREQUIN	PALM COURT LAMBREQUIN	PALM COURT LAMBREQUIN
	UNDERLAY/OVERLAY	UNDERLAY/OVERLAY	UNDERLAY/OVERLAY
	126883-P3-000/126883-P2-000	126883-S6-000/126883-S4-000	126883-S8-000/126883-S5-000
	CORD TRIM 139041-24-000	CORD TRIM 084415-F2-000	CORD TRIM 084415-F9-000
GALLEY VAL.	MODERATE VALANCE	MODERATE VALANCE	MODERATE VALANCE
	126883-P2-000	126883-S4-000	126883-S5-000
BEDSPREAD	DIAMOND QUILTING	CHANNEL QUILTING	DIAMOND QUILTING
	137813-52-000/139041-24-000	137813-67-000/084415-F2-000	137813-69-000/084415-F9-000
	BEDCAP W/CORD TRIM	BEDCAP W/CORD TRIM	BEDCAP W/CORD TRIM
SHAMS	LARGO W/2"FLANGE & (7) #36	LARGO W/2"FLANGE & (7) #36	LARGO W/2"FLANGE & (7) #36
	BUTTONS ON 1 SIDE	BUTTONS ON 1 SIDE	BUTTONS ON 1 SIDE
	137813-52-000/137813-53-000	137813-67-000/105745-R4-000	137813-69-000/137813-82-000
BEDROOM WINDOWS	MONTICELLO VALANCE	MONTICELLO VALANCE	MONTICELLO VALANCE
	TOP OVLY & BTM. UNDERLAY	TOP OVLY & BTM. UNDERLAY	TOP OVLY & BTM. UNDERLAY
	137813-52-000	137813-67-000	137813-69-000
	CENTER UNDERLAY	CENTER UNDERLAY	CENTER UNDERLAY
	137813-53-000	105745-R4-000	137813-82-000
	FLUSH LEGS 137813-52-000	FLUSH LEGS 137813-67-000	FLUSH LEGS 137813-69-000
ASHWELL	BODY 137813-52-000	BODY 137813-67-000	BODY 137813-69-000
*WHEN NEEDED	.25" WELTING 137813-53-000	.25" WELTING TBD	.25" WELTING TBD
BEDRM. PILLOW 2 PER	SQ. LARGO W/FLNG. & (5) #36	SQ. LARGO W/FLNG. & (5) #36	SQ. LARGO W/FLNG. & (5) #36
	BUTTONS ON 1 SIDE	BUTTONS ON 1 SIDE	BUTTONS ON 1 SIDE
	137813-53-000/137813-52-000	105745-R4-000/137813-67-000	137813-82-000/137813-69-000
HEADBOARD MONTICELLO	BODY & TOP ACCENT BAND	BODY & TOP ACCENT BAND	BODY & TOP ACCENT BAND
	137813-52-000	105745-R4-000	137813-69-000
	CTR. BAND 137813-53-000	CTR BAND 137813-67-000	CTR. BAND 137813-82-000
ROSEMONT R32,34,36	137813-53-000/139041-24-000	105745-R4-000/084415-F2-000	137813-82-000/084415-F9-000
BED BOARD	137813-53-000	105745-R4-000	137813-82-000
BATH VALANCE	MODERATE	MODERATE	MODERATE
	137813-52-000	137813-67-000	137813-69-000

CURTAIN & CUSHION GROUP (CONTINUED)
FABRICS (CONTINUED)

FAMILY ITASCA P'S	R74/R75/R76	R77/R78/R79	R80/R81/R82
MERIDIAN	PROVENCE BLUE	GREENWICH GREEN	STONEHENGE TAUPE
DAY-NITERS	EGGSHELL/WHITE DECO	PUTTY/WHITE DECO	PUTTY/WHITE DECO
LGE. & BEDROOM	094911-56-000/094911-50-000	094911-58-000/094911-50-000	094911-58-000/094911-50-000
GALLEY&BATH	386 SNO CAP	C011 BEIGE	C011 BEIGE
OVHD. INSERTS	LOUNGE 126883-P3-000	LOUNGE 126883-S6-000	LOUNGE 126833-S8-000
LOUNGE&BEDRM.	BEDROOM 137813-53-000	BEDROOM 105745-R4-000	BEDROOM 137813-69-000
SLIDE ROOM TRIM	126883-P3-000	126883-S6-000	126883-S8-000
FRONT WRAP	PURCHASED PLEATED	PURCHASED PLEATED	PURCHASED PLEATED
SUNVISORS	STD. 123298-04-05A GLACIER	STD. 123298-04-05A GLACIER	STD. 123298-04-05A GLACIER
	*OPT. 142380-03-01A POWER	*OPT. 142380-03-01A POWER	*OPT. 142380-03-01A POWER
FLOOR MAT	CARPET 096060-G8-000	CARPET 096060-F0-000	CARPET 096060-H1-000
DRIVER'S ONLY	TAPE 102695-12-000	TAPE 102695-20-000	TAPE 102695-12-000
CEILING	113979-12-01A	113979-12-01A	113979-12-01A
SLIDEOUT CEILING	113979-13-01A	113979-13-01A	113979-13-01A

DINETTE GROUP CABINETS

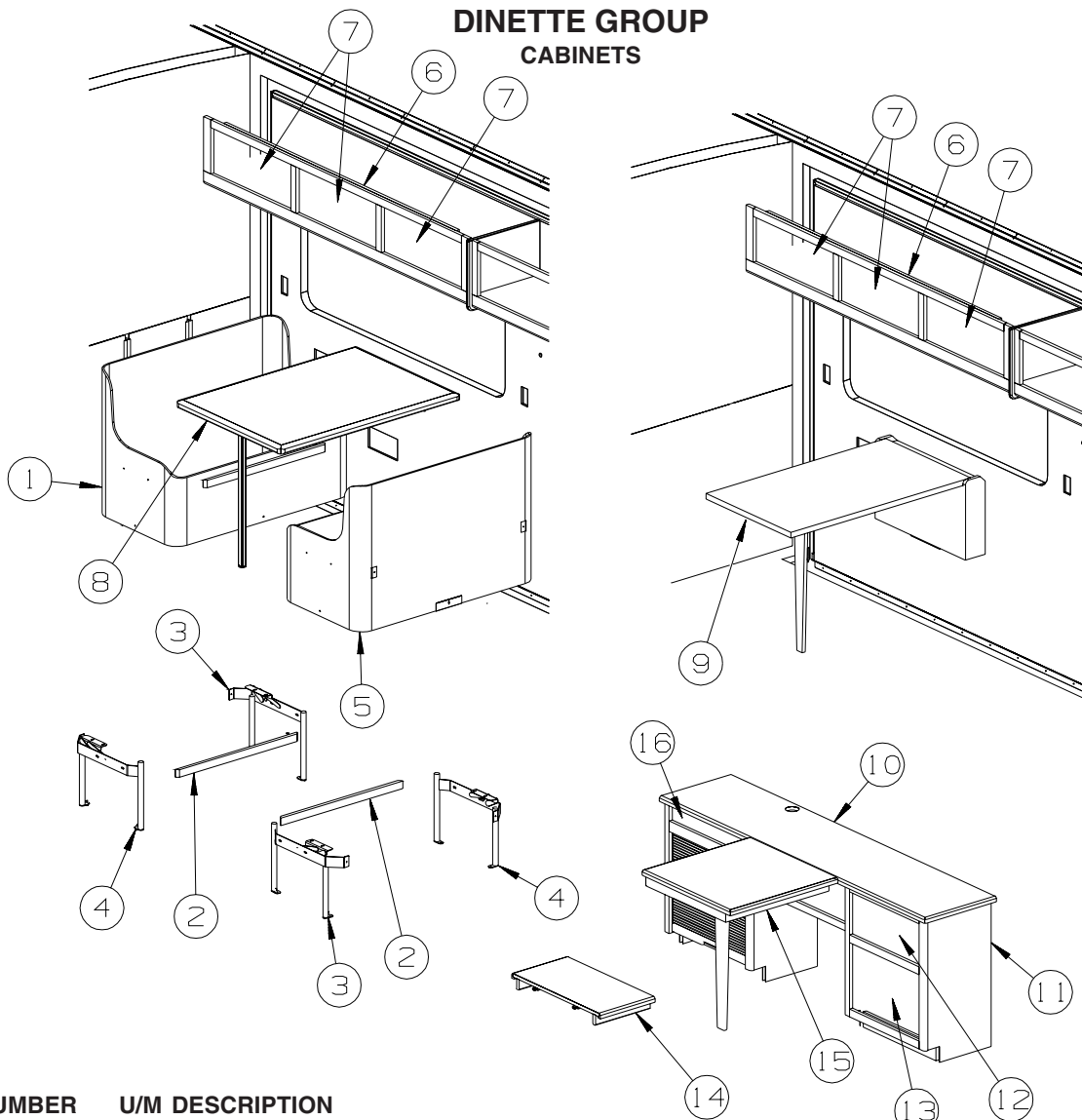

KEY	PART NUMBER	U/M	DESCRIPTION
1	141859-01-R74	EA	CABINET/BENCH - DINETTE - W/O DOORS/HARDWARE (R74)
1	141859-01-R75	EA	CABINET/BENCH - DINETTE - W/O DOORS/HARDWARE (R75)
1	141859-01-R76	EA	CABINET/BENCH - DINETTE - W/O DOORS/HARDWARE (R76)
1	141859-01-R70	EA	CABINET/BENCH - DINETTE - W/O DOORS/HARDWARE (R77)
1	141859-01-R71	EA	CABINET/BENCH - DINETTE - W/O DOORS/HARDWARE (R78)
1	141859-01-R79	EA	CABINET/BENCH - DINETTE - W/O DOORS/HARDWARE (R79)
1	141859-01-R44	EA	CABINET/BENCH - DINETTE - W/O DOORS/HARDWARE (R80)
1	141859-01-R45	EA	CABINET/BENCH - DINETTE - W/O DOORS/HARDWARE (R81)
1	141859-01-R46	EA	CABINET/BENCH - DINETTE - W/O DOORS/HARDWARE (R82)
2	081295-01-N70	EA	SUPPORT - BED/DINETTE - 28" LONG - PORTSMOUTH OAK
2	081295-01-M52	EA	SUPPORT - BED/DINETTE - 28" LONG - CONCERT CHERRY
2	081295-01-H37	EA	SUPPORT - BED/DINETTE - 28" LONG - WASHED MAPLE
3	142033-01-000	EA	BRACKET - DINETTE - RIGHT HAND
4	142033-02-000	EA	BRACKET - DINETTE - LEFT HAND
5	141859-02-R74	EA	CABINET/BENCH - DINETTE - W/O DOORS/HARDWARE (R74)
5	141859-02-R75	EA	CABINET/BENCH - DINETTE - W/O DOORS/HARDWARE (R75)
5	141859-02-R76	EA	CABINET/BENCH - DINETTE - W/O DOORS/HARDWARE (R76)
5	141859-02-R70	EA	CABINET/BENCH - DINETTE - W/O DOORS/HARDWARE (R77)
5	141859-02-R71	EA	CABINET/BENCH - DINETTE - W/O DOORS/HARDWARE (R78)
5	141859-02-R79	EA	CABINET/BENCH - DINETTE - W/O DOORS/HARDWARE (R79)
5	141859-02-R44	EA	CABINET/BENCH - DINETTE - W/O DOORS/HARDWARE (R80)
5	141859-02-R45	EA	CABINET/BENCH - DINETTE - W/O DOORS/HARDWARE (R81)
5	141859-02-R46	EA	CABINET/BENCH - DINETTE - W/O DOORS/HARDWARE (R82)
6	145273-02-R68	EA	CABINET - OVERHEAD/DINETTE - W/O DOORS/HARDWARE - PORTSMOUTH OAK
6	145273-02-R69	EA	CABINET - OVERHEAD/DINETTE - W/O DOORS/HARDWARE - CONCERT CHERRY
6	145273-02-R76	EA	CABINET - OVERHEAD/DINETTE - W/O DOORS/HARDWARE - WASHED MAPLE
6	145273-02-RW7	EA	CABINET - OVERHEAD/DINETTE - W/O DOORS/HARDWARE - WASHED MAPLE

FROM: 00-00-00 THRU: 01-04-04
FROM: 01-05-04 THRU: 99-99-99

DINETTE GROUP (CONTINUED)
CABINETS (CONTINUED)

KEY	PART NUMBER	U/M	DESCRIPTION
7	141522-43-P54	EA	DOOR - ARCHED/PENCIL EDGE/HORIZ - 10.8" X 23.8" - W/O HDW - PORTSMOUTH OAK
7	141522-43-P55	EA	DOOR - ARCHED/PENCIL EDGE/HORIZ - 10.8" X 23.8" - W/O HDW - CONCERT CHERRY
7	141522-43-P55	EA	DOOR - ARCHED/PENCIL EDGE/HORIZ - 10.8" X 23.8" - W/O HDW - WASHED MAPLE
8	143257-08-P49	EA	TABLE - 29.7" X 41.5" - GRAY TRANQUILITY/PORTSMOUTH OAK (R74)
8	143257-08-P50	EA	TABLE - 29.7" X 41.5" - GRAY TRANQUILITY/CHERRY (R75)
8	143257-08-P62	EA	TABLE - 29.7" X 41.5" - GRAY TRANQUILITY/WASHED MAPLE (R76)
8	143257-08-R40	EA	TABLE - 29.7" X 41.5" - LINO FRIEZE/PORTSMOUTH OAK (R77)
8	143257-08-R41	EA	TABLE - 29.7" X 41.5" - LINO FRIEZE/CHERRY (R78)
8	143257-08-R49	EA	TABLE - 29.7" X 41.5" - LINO FRIEZE/WASHED MAPLE (R79)
8	143257-08-R38	EA	TABLE - 29.7" X 41.5" - ROCKY MOUNTAIN HIGH/PORTSMOUTH OAK (R80)
8	143257-08-R39	EA	TABLE - 29.7" X 41.5" - ROCKY MOUNTAIN HIGH/CHERRY (R81)
8	143257-08-R46	EA	TABLE - 29.7" X 41.5" - ROCKY MOUNTAIN HIGH/WASHED MAPLE (R82)
9	133856-01-N42	EA	TABLE COMPLETE - LAMINATED - PORTSMOUTH OAK
9	133856-01-L52	EA	TABLE COMPLETE - LAMINATED - CONCERT CHERRY
9	133856-01-L58	EA	TABLE COMPLETE - LAMINATED - WASHED MAPLE
			FROM: 00-00-00 THRU: 01-04-04
9	133856-01-RW4	EA	TABLE COMPLETE - LAMINATED - WASHED MAPLE
			FROM: 01-05-04 THRU: 99-99-99
10	133655-82-P78	EA	COUNTERTOP - LAMINATED - PORTSMOUTH OAK
10	133655-82-P79	EA	COUNTERTOP - LAMINATED - CONCERT CHERRY
10	133655-82-P28	EA	COUNTERTOP - LAMINATED - WASHED MAPLE
			FROM: 00-00-00 THRU: 01-04-04
10	133655-82-RW4	EA	COUNTERTOP - LAMINATED - WASHED MAPLE
			FROM: 01-05-04 THRU: 99-99-99
11	P43782-01-P78	EA	CABINET - DINETTE/COMPUTER - W/O COUNTERTOPS/DRAWERS/HDW - PORTSMOUTH OAK
11	P43782-01-P79	EA	CABINET - DINETTE/COMPUTER - W/O COUNTERTOPS/DRAWERS/HDW - CONCERT CHERRY
11	P43782-01-P28	EA	CABINET - DINETTE/COMPUTER - W/O COUNTERTOPS/DRAWERS/HDW - WASHED MAPLE
			FROM: 00-00-00 THRU: 01-04-04
11	P43782-01-RW4	EA	CABINET - DINETTE/COMPUTER - W/O COUNTERTOPS/DRAWERS/HDW - WASHED MAPLE
			FROM: 01-05-04 THRU: 99-99-99
12	145386-31-R74	EA	DRAWER - PENCIL EDGE-19"W X 11.8"D - W/O SLIDES/HARDWARE - PORTSMOUTH OAK
12	145386-31-R75	EA	DRAWER - PENCIL EDGE-19"W X 11.8"D - W/O SLIDES/HARDWARE - CONCERT CHERRY
12	145386-31-R76	EA	DRAWER - PENCIL EDGE-19"W X 11.8"D - W/O SLIDES/HARDWARE - WASHED MAPLE
13	145386-30-R74	EA	DRAWER - PENCIL EDGE-19"W X 11.8"D - W/O SLIDES/HARDWARE - PORTSMOUTH OAK
13	145386-30-R75	EA	DRAWER - PENCIL EDGE-19"W X 11.8"D - W/O SLIDES/HARDWARE - CONCERT CHERRY
13	145386-30-R76	EA	DRAWER - PENCIL EDGE-19"W X 11.8"D - W/O SLIDES/HARDWARE - WASHED MAPLE
14	133655-83-P78	EA	COUNTERTOP - LAMINATED - PORTSMOUTH OAK
14	133655-83-P79	EA	COUNTERTOP - LAMINATED - CONCERT CHERRY
14	133655-83-P28	EA	COUNTERTOP - LAMINATED - WASHED MAPLE
			FROM: 00-00-00 THRU: 01-04-04
14	133655-83-RW4	EA	COUNTERTOP - LAMINATED - WASHED MAPLE
			FROM: 01-05-04 THRU: 99-99-99
15	133655-84-P78	EA	COUNTERTOP - LAMINATED - PORTSMOUTH OAK
15	133655-84-P79	EA	COUNTERTOP - LAMINATED - CONCERT CHERRY
15	133655-84-P28	EA	COUNTERTOP - LAMINATED - WASHED MAPLE
			FROM: 00-00-00 THRU: 01-04-04
15	133655-84-RW4	EA	COUNTERTOP - LAMINATED - WASHED MAPLE
			FROM: 01-05-04 THRU: 99-99-99
16	P36353-03-P54	EA	DRAWER - KEYBOARD - W/SLIDES - PORTSMOUTH OAK
16	P36353-03-N85	EA	DRAWER - KEYBOARD - W/SLIDES - CONCERT CHERRY
16	P36353-03-N84	EA	DRAWER - KEYBOARD - W/SLIDES - WASHED MAPLE

DINETTE GROUP (CONTINUED)

TABLE

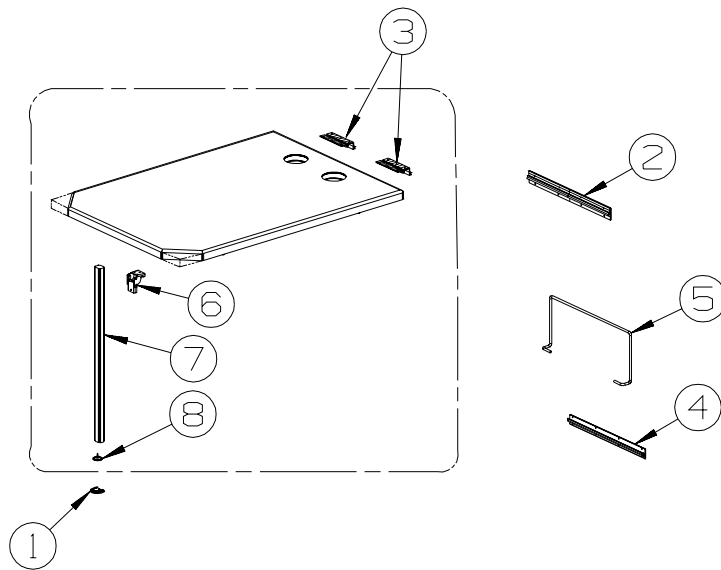

KEY	PART NUMBER	U/M	DESCRIPTION
1	143798-01-01A	EA	CATCH - FLOOR TO TABLE LEG - BRIGHT WHITE
2	140921-02-01A	EA	SUPPORT - TABLE - 18.5" - OFF WHITE
3	140921-03-01A	EA	HANGER - TABLE - W/VINYL - OFF WHITE
4	024281-15-000	EA	BRACKET/TABLE - LIFT ROD/LOWER WALL MOUNTED - 17.1"
5	024275-13-000	EA	ROD - TABLE LIFT - OFF/WHITE
6	093550-01-000	EA	BRACKET - HINGE - MOUNTS TO LEG & TABLE TOP - 1.7" X 2.6"
7	092707-10-03A	EA	LEG - TABLE - W/O HARDWARE - 26.8" - PORTSMOUTH OAK
7	092707-10-01A	EA	LEG - TABLE - W/O HARDWARE - 26.8" - CONCERT CHERRY
7	092707-10-02A	EA	LEG - TABLE - W/O HARDWARE - 26.8" - WASHED MAPLE
8	143798-02-01A	EA	CATCH - TABLE LEG TO FLOOR - ANY COLOR
	143798-03-01A	EA	WASHER - TABLE LEG - CATCH

DINETTE GROUP (CONTINUED)
TABLE (CONTINUED)

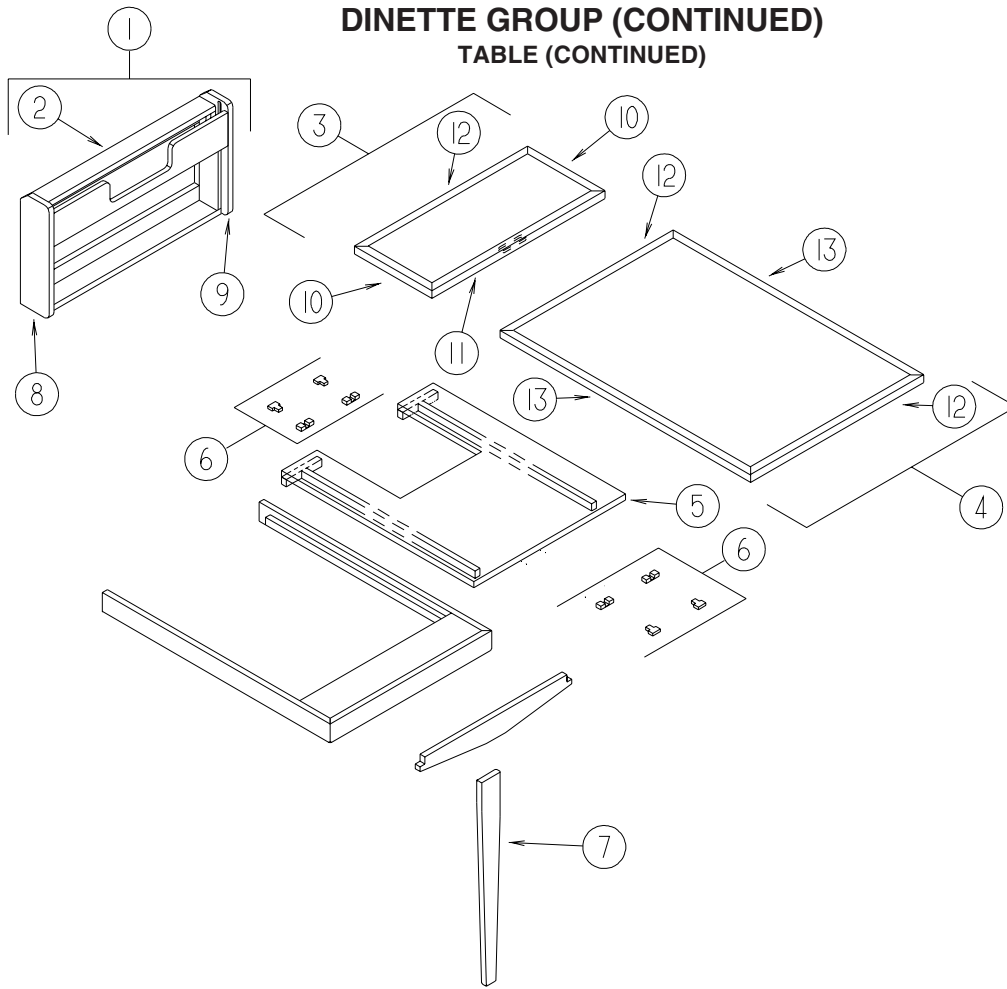

KEY	PART NUMBER	U/M	DESCRIPTION
1	133856-31-N42	EA	CABINET/WALL - W/O COUNTERTOP - F/PULLOUT TABLE - PORTSMOUTH OAK
1	133856-31-L52	EA	CABINET/WALL - W/O COUNTERTOP - F/PULLOUT TABLE - CONCERT CHERRY
1	133856-31-L58	EA	CABINET/WALL - W/O COUNTERTOP - F/PULLOUT TABLE - WASHED MAPLE
2	133856-23-N42	EA	COUNTERTOP - F/WALL CABINET - LAMINATED - PORTSMOUTH OAK
2	133856-23-L52	EA	COUNTERTOP - F/WALL CABINET - LAMINATED - CONCERT CHERRY
2	133856-23-L58	EA	COUNTERTOP - F/WALL CABINET - LAMINATED - WASHED MAPLE
			FROM: 00-00-00 THRU: 01-04-04
2	133856-23-RW4	EA	COUNTERTOP - F/WALL CABINET - WASHED MAPLE
			FROM: 01-05-04 THRU: 99-99-99
3	133856-12-N42	EA	TABLE TOP - SMALL HINGED SECTION - LAMINATED - PORTSMOUTH OAK
3	133856-12-L52	EA	TABLE TOP - SMALL HINGED SECTION - LAMINATED - CONCERT CHERRY
3	133856-12-L58	EA	TABLE TOP - SMALL HINGED SECTION - LAMINATED - WASHED MAPLE
			FROM: 00-00-00 THRU: 01-04-04
3	133856-12-RW4	EA	TABLE TOP - SMALL HINGED SECTION - WASHED MAPLE
			FROM: 01-05-04 THRU: 99-99-99
4	133856-11-N42	EA	TABLE TOP - LARGE SECTION - LAMINATED - PORTSMOUTH OAK
4	133856-11-L52	EA	TABLE TOP - LARGE SECTION - LAMINATED - CONCERT CHERRY
4	133856-11-L58	EA	TABLE TOP - LARGE SECTION - LAMINATED - WASHED MAPLE
			FROM: 00-00-00 THRU: 01-04-04
4	133856-11-RW4	EA	TABLE TOP - LARGE SECTION - LAMINATED - WASHED MAPLE
			FROM: 01-05-04 THRU: 99-99-99
5	133856-17-N42	EA	SLIDE - TABLE TOP - PORTSMOUTH OAK
5	133856-17-L52	EA	SLIDE - TABLE TOP - CONCERT CHERRY
5	133856-17-L58	EA	SLIDE - TABLE TOP - WASHED MAPLE
			FROM: 00-00-00 THRU: 01-04-04
5	133856-17-RW4	EA	SLIDE - TABLE TOP - WASHED MAPLE
			FROM: 01-05-04 THRU: 99-99-99
6	009050-02-000	EA	LEVELER - TABLE TOP - MALE END W/4 SCREWS - PLASTIC
6	009050-03-000	EA	LEVELER - TABLE TOP - FEMALE END W/2 SCREWS - PLASTIC

DINETTE GROUP (CONTINUED)
TABLE (CONTINUED)

KEY	PART NUMBER	U/M	DESCRIPTION
7	133856-28-N42	EA	LEG - F/TABLE - PORTSMOUTH OAK
7	133856-28-L52	EA	LEG - F/TABLE - CONCERT CHERRY
7	133856-28-L58	EA	LEG - F/TABLE - WASHED MAPLE
8	133856-27-N42	EA	END - LEFT HAND - F/TABLE CABINET - PORTSMOUTH OAK
8	133856-27-L52	EA	END - LEFT HAND - F/TABLE CABINET - CONCERT CHERRY
8	133856-27-L58	EA	END - LEFT HAND - F/TABLE CABINET - WASHED MAPLE
9	133856-26-N42	EA	END - RIGHT HAND - F/TABLE CABINET - PORTSMOUTH OAK
9	133856-26-L52	EA	END - RIGHT HAND - F/TABLE CABINET - CONCERT CHERRY
9	133856-26-L58	EA	END - RIGHT HAND - F/TABLE CABINET - WASHED MAPLE
10	133856-15-N42	EA	TRIM - TABLE MOLDING - 12" - PORTSMOUTH OAK
10	133856-15-L52	EA	TRIM - TABLE MOLDING - 12" - CONCERT CHERRY
10	133856-15-L58	EA	TRIM - TABLE MOLDING - 12" - WASHED MAPLE
11	133856-16-N42	EA	TRIM - TABLE MOLDING - 23.8" - PORTSMOUTH OAK
11	133856-16-L52	EA	TRIM - TABLE MOLDING - 23.8" - CONCERT CHERRY
11	133856-16-L58	EA	TRIM - TABLE MOLDING - 23.8" - WASHED MAPLE
12	133856-14-N42	EA	TRIM - TABLE MOLDING - 23.8" - PORTSMOUTH OAK
12	133856-14-L52	EA	TRIM - TABLE MOLDING - 23.8" - CONCERT CHERRY
12	133856-14-L58	EA	TRIM - TABLE MOLDING - 23.8" - WASHED MAPLE
13	133856-13-N42	EA	TRIM - TABLE MOLDING - 41.2" - PORTSMOUTH OAK
13	133856-13-L52	EA	TRIM - TABLE MOLDING - 41.2" - CONCERT CHERRY
13	133856-13-L58	EA	TRIM - TABLE MOLDING - 41.2" - WASHED MAPLE

DINETTE GROUP (CONTINUED) TABLE (CONTINUED)

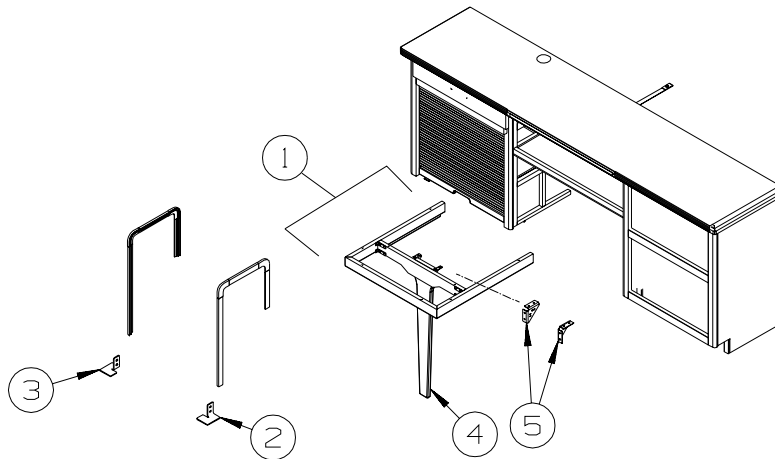

KEY	PART NUMBER	U/M	DESCRIPTION
1	143782-34-PA0	EA	SUPPORT/FRAME - W/LEG - W/O TOP - PORTSMOUTH OAK
1	143782-34-PA1	EA	SUPPORT/FRAME - W/LEG - W/O TOP - CONCERT CHERRY
1	143782-34-PA2	EA	SUPPORT/FRAME - W/LEG - W/O TOP - WASHED MAPLE
2	139264-01-02B	EA	STOP - DOOR - TAMBOUR - E-COATED
3	139264-02-02B	EA	STOP - DOOR - TAMBOUR - E-COATED
4	143782-39-PA0	EA	LEG - TABLE - PORTSMOUTH OAK
4	143782-39-PA1	EA	LEG - TABLE - CONCERT CHERRY
4	143782-39-PA2	EA	LEG - TABLE - WASHED MAPLE
5	102810-01-04A	EA	BRACE - TABLE LEG - BLACK

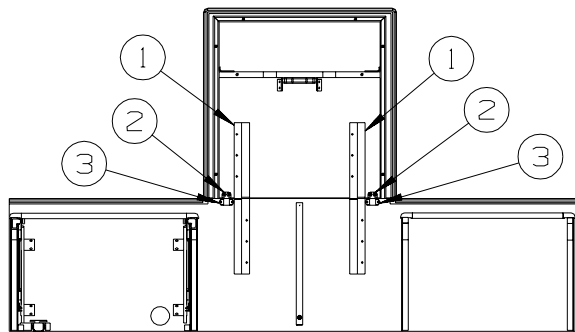

KEY	PART NUMBER	U/M	DESCRIPTION
1	110749-01-000	EA	SLIDE/EXTENSION - 19 3/4" TO 33 1/4"
2	009050-02-000	EA	LEVELER - TABLE TOP - MALE END W/4 SCREWS - PLASTIC
3	009050-03-000	EA	LEVELER - TABLE TOP - FEMALE END W/2 SCREWS - PLASTIC

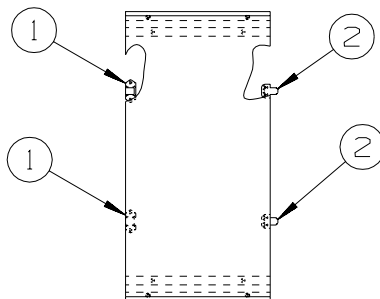

KEY	PART NUMBER	U/M	DESCRIPTION
1	009050-03-000	EA	LEVELER - TABLE TOP - FEMALE END W/2 SCREWS - PLASTIC
2	009050-02-000	EA	LEVELER - TABLE TOP - MALE END W/4 SCREWS - PLASTIC

DRIVERS COMPARTMENT GROUP

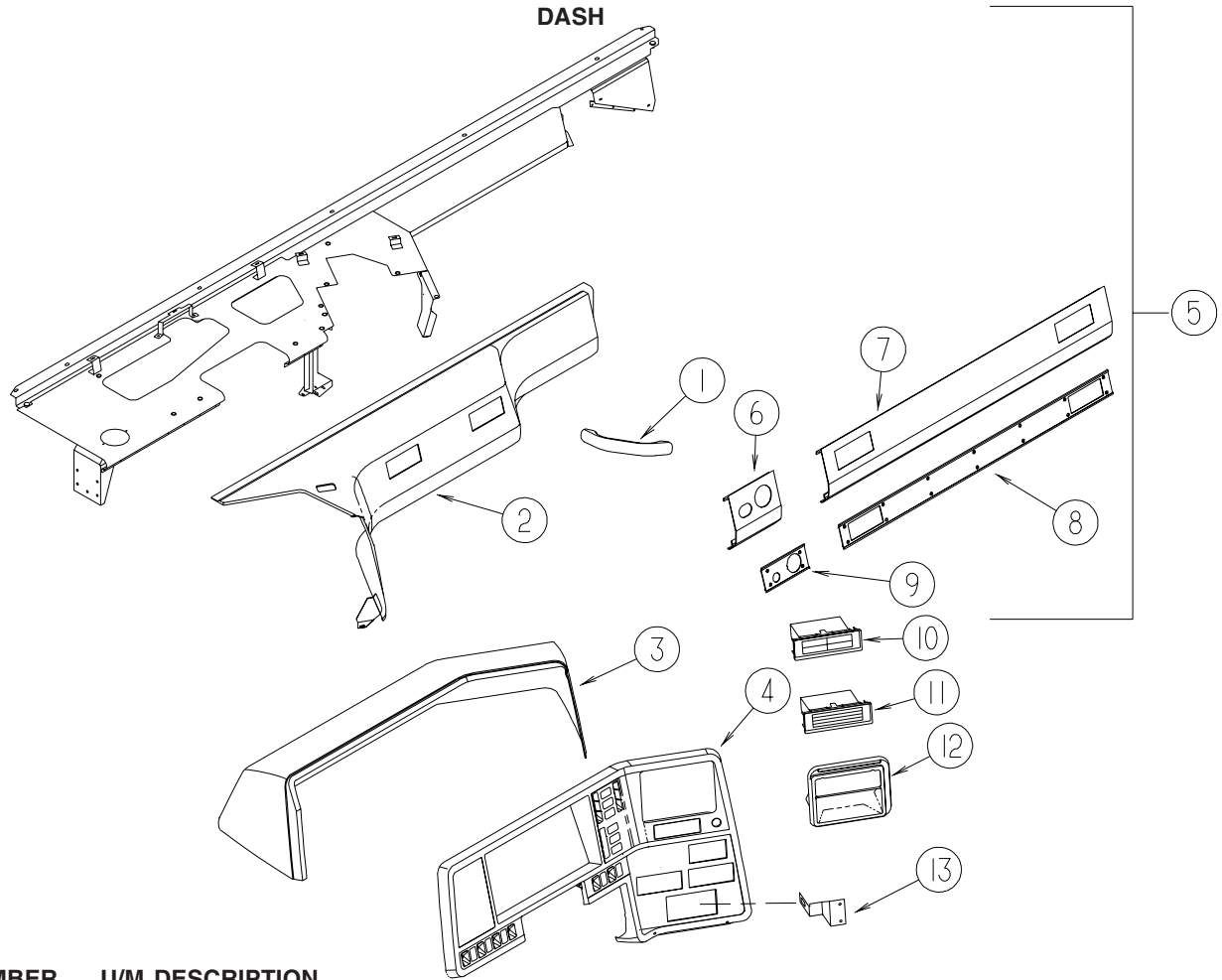

KEY	PART NUMBER	U/M	DESCRIPTION
1	123246-01-05A	EA	HANDLE - GRAB - GLACIER
2	122853-02-N74	EA	TRIM - DASH PANEL/RIGHT HAND - GLACIER
3	107263-03-N74	EA	POD - INSTRUMENT PANEL - GLACIER - REARVIEW MONITOR
3	107263-04-N70	EA	POD - INSTRUMENT PANEL - GLACIER
4	107031-15-01A	EA	BEZEL - INSTRUMENT PANEL - FREIGHTLINER 5-SPD CUMMINS/FREIGHTLINER 6-SPD CUMMINS
4	107031-15-01A	EA	BEZEL - INSTRUMENT PANEL - FREIGHTLINER 6-SPD CATERPILLAR
			FROM: 00-00-00 THRU: 10-17-03
4	107031-16-01A	EA	BEZEL - INSTRUMENT PANEL - BLACK VELVET - FREIGHTLINER 6-SPD CATERPILLAR
			FROM: 10-18-03 THRU: 99-99-99
4	107031-17-01A	EA	BEZEL - INSTRUMENT PANEL - BLACK VELVET - WORKHORSE 6-SPD CUMMINS
5	P23278-01-000	EA	DASH - W/O VINYL
5	P23278-01-000	EA	DASH - W/O VINYL - FREIGHTLINER 6-SPD CATERPILLAR
			FROM: 00-00-00 THRU: 10-17-03
5	P23278-02-000	EA	DASH - W/O VINYL - FREIGHTLINER 6-SPD CATERPILLAR
			FROM: 10-18-03 THRU: 99-99-99
	106569-09-06A	EA	VINYL - LAMINATE - ALLANTE DOESKIN - 1/4" X 25" X 100"
	106569-10-06A	EA	VINYL - LAMINATE - ALLANTE DOESKIN - 1/4" X 25" X 20"
6	117991-06-01A	EA	EXTENSION - DASH - DRIVER/LOWER/RIGHT HAND
7	117991-05-01A	EA	EXTENSION - DASH - DRIVER/LOWER/LEFT HAND
8	118024-05-06A	EA	TRIM - DASH - DRIVER/LOWER/LEFT HAND - GLACIER
9	118024-06-06A	EA	TRIM - DASH - DRIVER/LOWER/RIGHT HAND - GLACIER
9	118024-06-06A	EA	TRIM - DASH - DRIVER/LOWER/RIGHT HAND - GLACIER - FREIGHTLINER 6-SPD CATERPILLAR
			FROM: 00-00-00 THRU: 10-17-03
9	118024-07-06A	EA	TRIM - DASH - DRIVER/LOWER/RIGHT HAND - GLACIER - FREIGHTLINER 6-SPD CATERPILLAR
			FROM: 10-18-03 THRU: 99-99-99
10	096776-02-000	EA	STORAGE BOX - CASSETTE - 4 TAPE HOLDER - W/O REARVIEW MONITOR
11	096776-03-000	EA	STORAGE BOX - CD'S - 4 DISC HOLDER - W/O REARVIEW MONITOR
12	111350-01-01A	EA	POCKET - INSTRUMENT PANEL - UPPER - BLACK - W/O REARVIEW MONITOR
13	138721-01-02B	EA	BRACKET/SUPPORT - RADIO - E-COATED

DRIVERS COMPARTMENT GROUP (CONTINUED)

FRONT INTERIOR

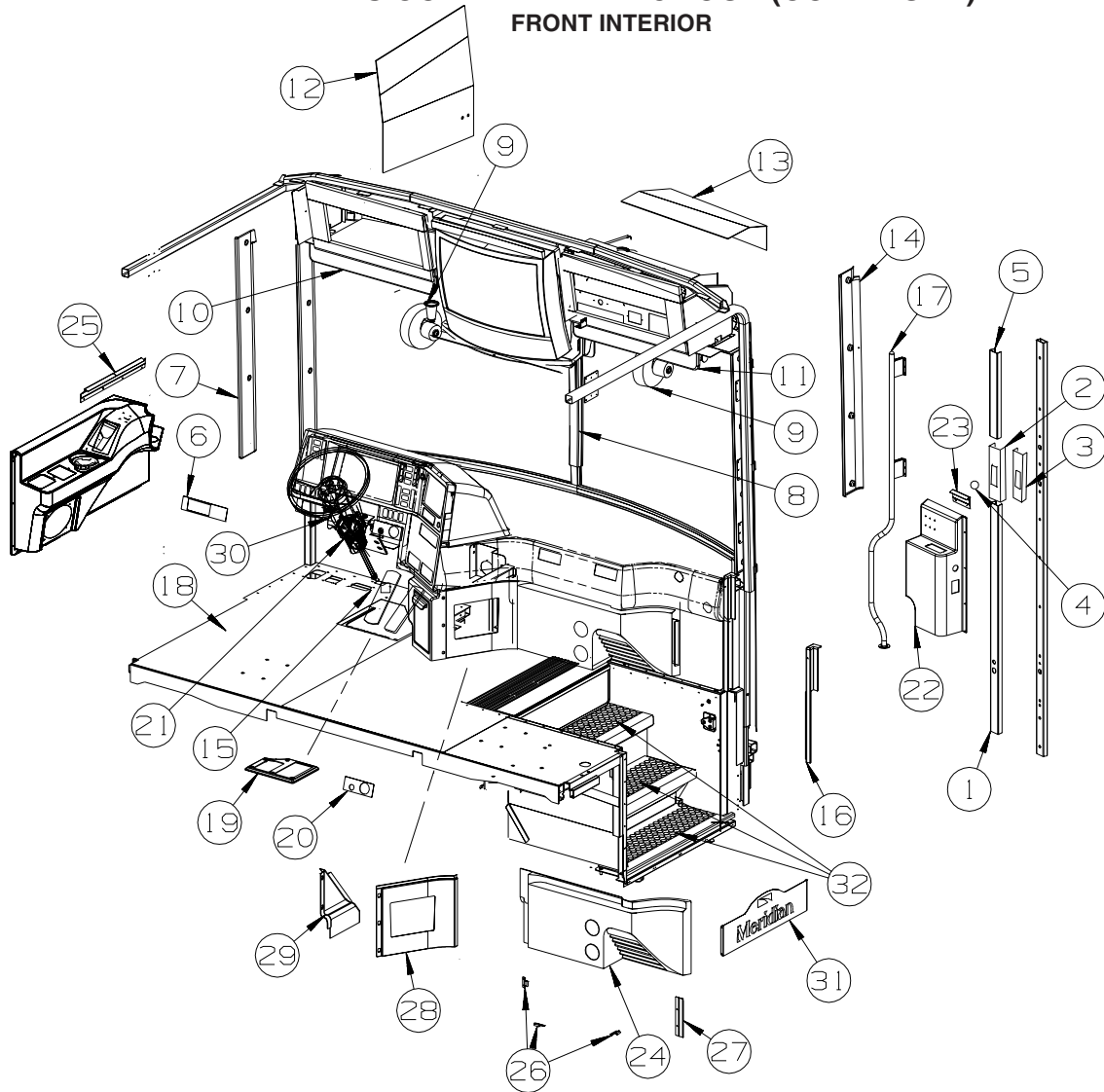

KEY	PART NUMBER	U/M	DESCRIPTION
1	024700-59-000	EA	COVER - ROLL BAR - SIDEWALL - 44.1" - OFF WHITE
2	140151-01-01A	EA	COVER - SEAT BELT - OFF WHITE
3	140151-03-01A	EA	COVER - SEAT BELT SLIDE - BLACK
4	140151-02-01A	EA	COVER - SCREW - OFF WHITE
5	024700-58-000	EA	COVER - ROLL BAR - SIDEWALL - 16.5" - OFF WHITE
6	118377-06-09A	EA	APPLIQUE - LOWER DASH - GM/OSH KOSH/SPARTAN - GLACIER
7	131792-01-04A	EA	TRIM - A-PILLAR - INTERIOR/DRIVER - GLACIER
8	118452-09-04A	EA	TRIM - WINDSHIELD/CENTER - GLACIER
9	122856-01-01A	EA	FAN-DEFROSTER-2 SPEED W/SWIVEL BASE/NON-OSCILLATING-CHROME
10	129004-02-05A	EA	TRIM - WINDSHIELD - INTERIOR/DRIVER TOP - GLACIER
11	129004-01-05A	EA	TRIM - WINDSHIELD - INTERIOR/PASSENGER TOP - GLACIER
12	132909-07-R68	EA	PANEL - VINYL COVERED
13	132909-04-R38	EA	PANEL - VINYL COVERED
14	146842-01-01A	EA	TRIM - A-PILLAR - INTERIOR/PASSENGER - GLACIER
15	103498-09-000	EA	BOOT - STEERING COLUMN - W/1/2 CIRCLE
16	129657-01-05A	EA	TRIM - A-PILLAR - INTERIOR/PASSENGER/LOWER - GLACIER
17	123577-01-01A	EA	HANDRAIL - ASSIST - ENTRY
18	105924-01-L32	EA	MAT/FLOOR - 18" X 27" (R74, R75, R76)
18	105924-01-P47	EA	MAT/FLOOR - 18" X 27" (R77, R78, R79)
18	105924-01-P41	EA	MAT/FLOOR - 18" X 27" (R80, R81, R82)
19	116993-01-01A	EA	COVER - PEDALS - BLACK
20	118377-05-09A	EA	APPLIQUE - LOWER DASH - FREIGHTLINER - GLACIER - SYSTEM 3 WIRING 2003 CHASSIS
20	149101-01-01A	EA	APPLIQUE - LOWER DASH - FREIGHTLINER - GLACIER - MMDC WIRING 2004 CHASSIS

DRIVERS COMPARTMENT GROUP (CONTINUED)
FRONT INTERIOR (CONTINUED)

KEY	PART NUMBER	U/M	DESCRIPTION
21	109832-03-03A	EA	COVER - STEERING COLUMN - BLACK
22	142206-03-P75	EA	PANEL/TRIM - INNER/PASSENGER
	130463-03-02B	EA	ANGLE - TRIM/BACKWALL - E-COATED
22	142206-04-P75	EA	PANEL/TRIM - INNER/PASSENGER - ELECTRIC AWNING
	130463-03-02B	EA	ANGLE - TRIM/BACKWALL - E-COATED
22	142206-08-P78	EA	PANEL/TRIM - INNER/RIGHT HAND - ELECTRIC AWNING/POWER DOOR LOCKS
	130463-03-02B	EA	ANGLE - TRIM/BACKWALL - E-COATED
23	130034-03-02B	EA	CLIP - TRIM - E-COATED
24	133037-02-N74	EA	PANEL - TRIM - HEATER/AC - RIGHT HAND - GLACIER
25	130034-04-02B	EA	CLIP - TRIM - E-COATED
26	073050-03-000	EA	MOUNTING CLIP - VALANCE PANEL
27	130034-02-02B	EA	CLIP - TRIM - E-COATED
28	133163-03-P75	EA	PANEL - BEVERAGE TRAY - RIGHT HAND
28	133163-04-P75	EA	PANEL - BEVERAGE TRAY/2 WAY RADIO - RIGHT HAND - TWO-WAY RADIOS
29	133164-02-P75	EA	PANEL - BEVERAGE TRAY - LEFT HAND
30	095933-07-000	EA	STOP/TILT - STEERING COLUMN
31	146411-04-01A	EA	PANEL/KICK - W/LOGO
32	120231-01-02A	EA	FLOORING - RUBBER - 66.4" X 19.8"

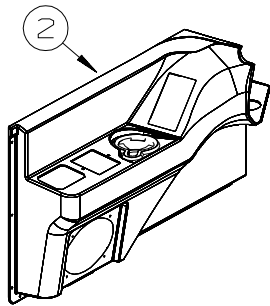

W/SURROUND SOUND

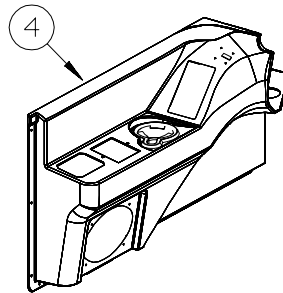

**W/SURROUND SOUND
& TRIP COMPUTER**

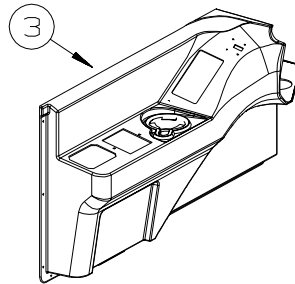
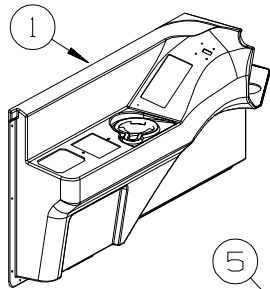

W/TRIP COMPUTER

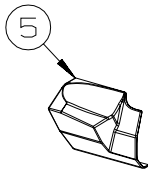

KEY	PART NUMBER	U/M	DESCRIPTION
1	140578-14-P78	EA	PANEL/TRIM - INNER/LEFT HAND
2	140578-16-P78	EA	PANEL/TRIM - INNER/LEFT HAND
3	140578-22-P78	EA	PANEL/TRIM - INNER/LEFT HAND
4	140578-24-P78	EA	PANEL/TRIM - INNER/LEFT HAND
5	140580-01-01A	EA	PANEL/TRIM - INSERT - LEFT HAND

DRIVERS COMPARTMENT GROUP (CONTINUED)
FRONT INTERIOR (CONTINUED)

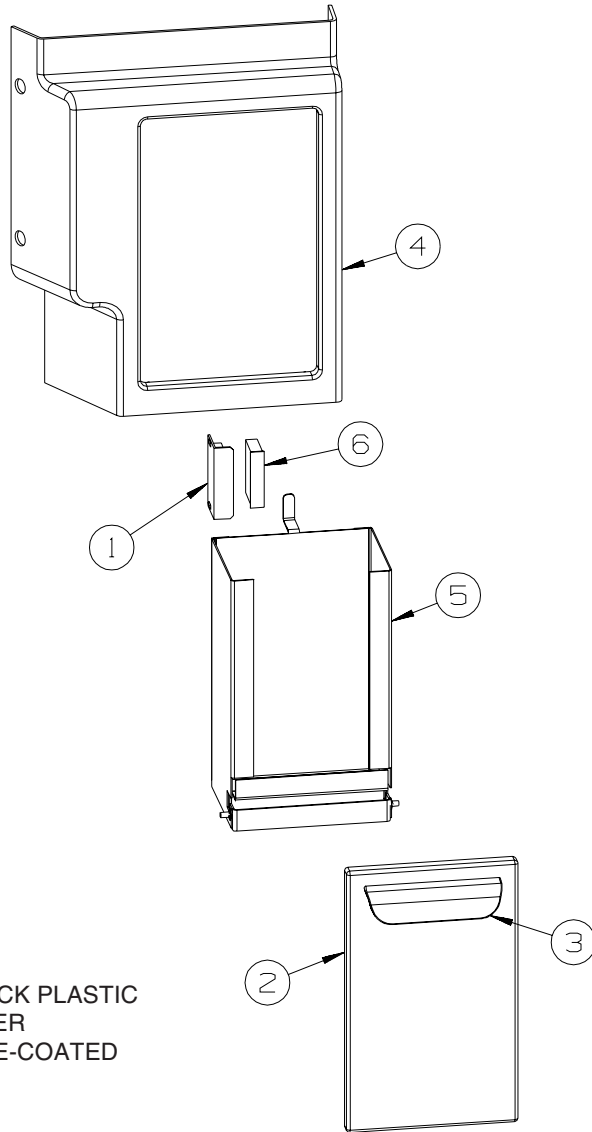

KEY	PART NUMBER	U/M DESCRIPTION
1	137018-03-01A	EA BRACKET - MOUNTING - 2"
2	142272-01-04A	EA PANEL/DOOR - GLACIER
3	074762-01-000	EA PULL - CABINET - 4.8" X .9" - BLACK PLASTIC
4	142273-01-04A	EA PANEL - DASH - LOWER - GLACIER
5	142283-01-02B	EA COMPARTMENT - GLOVE BOX - E-COATED
6	137018-01-01A	EA CATCH - MAGNETIC - 1.6"

DRIVERS COMPARTMENT GROUP (CONTINUED)
FRONT INTERIOR (CONTINUED)

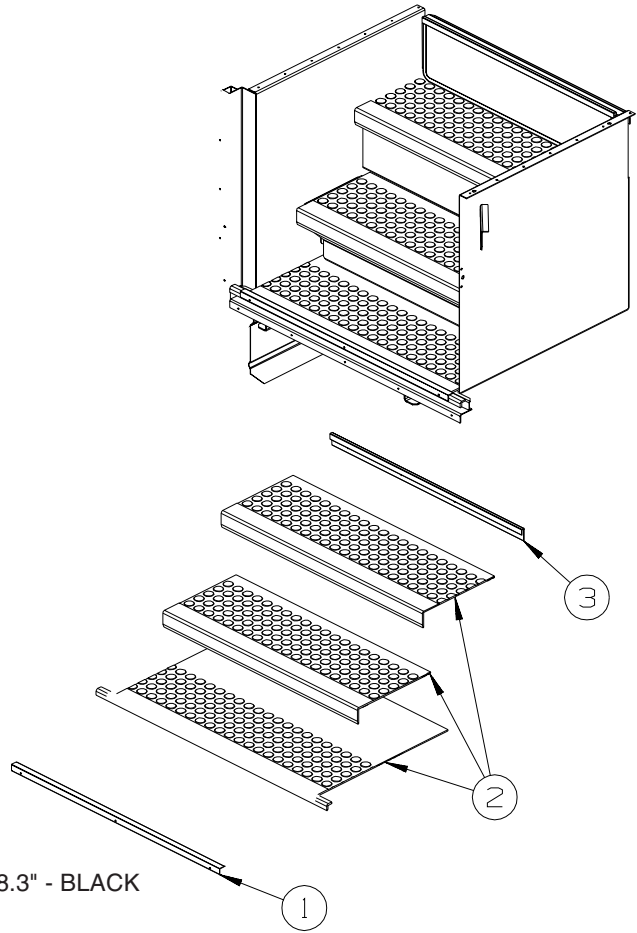

KEY	PART NUMBER	U/M	DESCRIPTION
1	136002-63-02A	EA	ANGLE - W/HOLES - BRIGHT WHITE
2	120231-01-02A	EA	FLOORING - RUBBER - 66.4" X 19.8"
3	136839-07-01A	EA	TRIM-J - CARPET EDGE/SLIDEOUT - 28.3" - BLACK

DRIVERS COMPARTMENT GROUP (CONTINUED)
FRONT INTERIOR (CONTINUED)

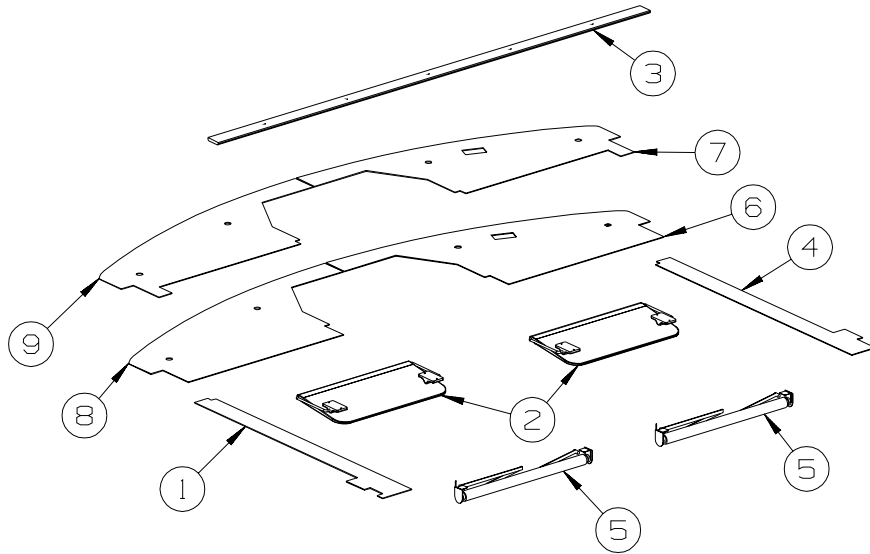

KEY	PART NUMBER	U/M	DESCRIPTION
1	146600-02-R68	EA	PANEL - OVERHEAD/LEFT HAND
2	123298-04-05A	EA	SUNVISOR - 10.5" X 21" - DRIVER/PASSENGER - GLACIER
3	133771-01-N75	EA	MOLDING - CAP - PORTSMOUTH OAK
			FROM: 00-00-00 THRU: 03-09-03
3	133771-04-R68	EA	MOLDING - CAP - PORTSMOUTH OAK
			FROM: 03-10-03 THRU: 99-99-99
3	133771-01-L85	EA	MOLDING - CAP - CONCERT CHERRY
			FROM: 00-00-00 THRU: 03-09-03
3	133771-04-R69	EA	MOLDING - CAP - CONCERT CHERRY
			FROM: 03-10-03 THRU: 99-99-99
3	133771-01-L84	EA	MOLDING - CAP - WASHED MAPLE
			FROM: 00-00-00 THRU: 03-09-03
3	133771-04-R76	EA	MOLDING - CAP - WASHED MAPLE
			FROM: 03-10-03 THRU: 99-99-99
4	146600-01-R68	EA	PANEL - OVERHEAD/RIGHT HAND
5	142380-01-01A	EA	SHADE - POWER - 25.7"
6	133017-03-R68	EA	PANEL - OVERHEAD/Front/BOTTOM/RIGHT HAND
7	133017-05-R68	EA	PANEL - OVERHEAD/Front/BOTTOM/RIGHT HAND - POWER SUNVISORS
8	133017-04-R68	EA	PANEL - OVERHEAD/Front/BOTTOM/LEFT HAND
9	133017-06-R68	EA	PANEL - OVERHEAD/Front/BOTTOM/LEFT HAND - POWER SUNVISORS

DRIVERS COMPARTMENT GROUP (CONTINUED)

CABINETS

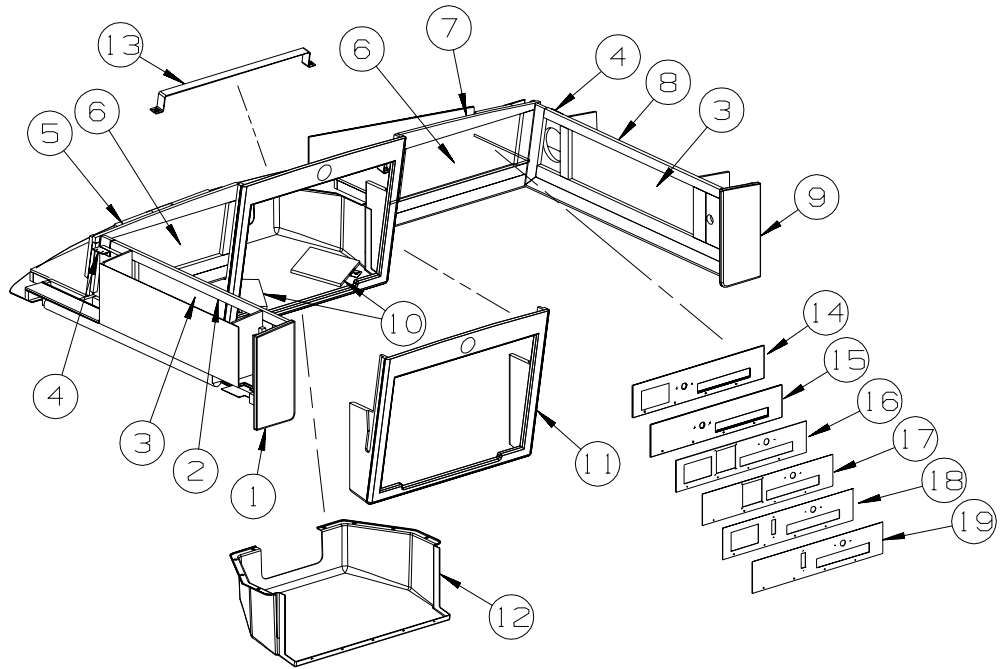

KEY	PART NUMBER	U/M	DESCRIPTION
1	146124-36-R68	EA	END CAP - OVERHEAD CABINET - PORTSMOUTH OAK
1	146124-36-R69	EA	END CAP - OVERHEAD CABINET - CONCERT CHERRY
1	146124-36-R76	EA	END CAP - OVERHEAD CABINET - WASHED MAPLE
2	146124-02-R74	EA	CABINET - FRONT/SIDE - W/O DOORS/HARDWARE (R74)
2	146124-02-R75	EA	CABINET - FRONT/SIDE - W/O DOORS/HARDWARE (R75)
2	146124-02-R76	EA	CABINET - FRONT/SIDE - W/O DOORS/HARDWARE (R76)
2	146124-02-RW7	EA	CABINET - FRONT/SIDE - W/O DOORS/HARDWARE (R76) FROM: 00-00-00 THRU: 01-04-04 FROM: 01-05-04 THRU: 99-99-99
2	146124-02-R70	EA	CABINET - FRONT/SIDE - W/O DOORS/HARDWARE (R77)
2	146124-02-R71	EA	CABINET - FRONT/SIDE - W/O DOORS/HARDWARE (R78)
2	146124-02-R79	EA	CABINET - FRONT/SIDE - W/O DOORS/HARDWARE (R79)
2	146124-02-RW8	EA	CABINET - FRONT/SIDE - W/O DOORS/HARDWARE (R79) FROM: 00-00-00 THRU: 01-04-04 FROM: 01-05-04 THRU: 99-99-99
2	146124-02-R72	EA	CABINET - FRONT/SIDE - W/O DOORS/HARDWARE (R80)
2	146124-02-R73	EA	CABINET - FRONT/SIDE - W/O DOORS/HARDWARE (R81)
2	146124-02-R82	EA	CABINET - FRONT/SIDE - W/O DOORS/HARDWARE (R82)
2	146124-02-RW4	EA	CABINET - FRONT/SIDE - W/O DOORS/HARDWARE (R82) FROM: 00-00-00 THRU: 01-04-04 FROM: 01-05-04 THRU: 99-99-99
3	145797-03-R74	EA	DOOR - ARCHED PANEL/PENCIL EDGE - 30.3" X 12" - W/O HDW - PORTSMOUTH OAK
3	145797-03-R75	EA	DOOR - ARCHED PANEL/PENCIL EDGE - 30.3" X 12" - W/O HDW - CONCERT CHERRY
3	145797-03-R76	EA	DOOR - ARCHED PANEL/PENCIL EDGE - 30.3" X 12" - W/O HDW - WASHED MAPLE
4	109216-03-000	EA	ANGLE - FURNACE DOOR
5	145656-02-R38	EA	CABINET - FRONT/OVERHEAD - W/O DOORS/HARDWARE (R74,R77,R80)
5	145656-02-R39	EA	CABINET - FRONT/OVERHEAD - W/O DOORS/HARDWARE (R75,R78,R81)
5	145656-02-R46	EA	CABINET - FRONT/OVERHEAD - W/O DOORS/HARDWARE (R76) FROM: 00-00-00 THRU: 01-04-04
5	145656-02-RW7	EA	CABINET - FRONT/OVERHEAD - W/O DOORS/HARDWARE (R76) FROM: 01-05-04 THRU: 99-99-99
5	145656-02-R46	EA	CABINET - FRONT/OVERHEAD - W/O DOORS/HARDWARE (R79,R82) FROM: 00-00-00 THRU: 01-04-04
5	145656-02-RW4	EA	CABINET - FRONT/OVERHEAD - W/O DOORS/HARDWARE (R79,R82) FROM: 01-05-04 THRU: 99-99-99
6	146028-03-R74	EA	DOOR - GLASS/PENCIL EDGE - 12" X 23.8" - W/O HARDWARE - PORTSMOUTH OAK
6	146028-03-R75	EA	DOOR - GLASS/PENCIL EDGE - 12" X 23.8" - W/O HARDWARE - CONCERT CHERRY
6	146028-03-R76	EA	DOOR - GLASS/PENCIL EDGE - 12" X 23.8" - W/O HARDWARE - WASHED MAPLE
6	146028-03-RW7	EA	DOOR - GLASS/PENCIL EDGE - 12" X 23.8" - W/O HARDWARE - WASHED MAPLE FROM: 00-00-00 THRU: 01-04-04 FROM: 01-05-04 THRU: 99-99-99

DRIVERS COMPARTMENT GROUP (CONTINUED)
CABINETS (CONTINUED)

KEY	PART NUMBER	U/M	DESCRIPTION
7	145656-01-R38	EA	CABINET - FRONT/OVERHEAD - W/O DOORS/HARDWARE (R74,R77,R80)
7	145656-01-R39	EA	CABINET - FRONT/OVERHEAD - W/O DOORS/HARDWARE (R75,R78,R81)
7	145656-01-R46	EA	CABINET - FRONT/OVERHEAD - W/O DOORS/HARDWARE (R76) FROM: 00-00-00 THRU: 01-04-04
7	145656-01-RW7	EA	CABINET - FRONT/OVERHEAD - W/O DOORS/HARDWARE (R76) FROM: 01-05-04 THRU: 99-99-99
7	145656-01-R46	EA	CABINET - FRONT/OVERHEAD - W/O DOORS/HARDWARE (R79,R82) FROM: 00-00-00 THRU: 01-04-04
7	145656-01-RW4	EA	CABINET - FRONT/OVERHEAD - W/O DOORS/HARDWARE (R79,R82) FROM: 01-05-04 THRU: 99-99-99
8	146124-01-R74	EA	CABINET - FRONT/SIDE - W/O DOORS/HARDWARE (R74)
8	146124-01-R75	EA	CABINET - FRONT/SIDE - W/O DOORS/HARDWARE (R75)
8	146124-01-R76	EA	CABINET - FRONT/SIDE - W/O DOORS/HARDWARE (R76) FROM: 00-00-00 THRU: 01-04-04
8	146124-01-RW7	EA	CABINET - FRONT/SIDE - W/O DOORS/HARDWARE (R76) FROM: 01-05-04 THRU: 99-99-99
8	146124-01-R70	EA	CABINET - FRONT/SIDE - W/O DOORS/HARDWARE (R77)
8	146124-01-R71	EA	CABINET - FRONT/SIDE - W/O DOORS/HARDWARE (R78)
8	146124-01-R79	EA	CABINET - FRONT/SIDE - W/O DOORS/HARDWARE (R79) FROM: 00-00-00 THRU: 01-04-04
8	146124-01-RW8	EA	CABINET - FRONT/SIDE - W/O DOORS/HARDWARE (R79) FROM: 01-05-04 THRU: 99-99-99
8	146124-01-R72	EA	CABINET - FRONT/SIDE - W/O DOORS/HARDWARE (R80)
8	146124-01-R73	EA	CABINET - FRONT/SIDE - W/O DOORS/HARDWARE (R81)
8	146124-01-R82	EA	CABINET - FRONT/SIDE - W/O DOORS/HARDWARE (R82) FROM: 00-00-00 THRU: 01-04-04
8	146124-01-RW4	EA	CABINET - FRONT/SIDE - W/O DOORS/HARDWARE (R82) FROM: 01-05-04 THRU: 99-99-99
9	146124-24-R68	EA	END CAP - OVERHEAD CABINET - PORTSMOUTH OAK
9	146124-24-R69	EA	END CAP - OVERHEAD CABINET - CONCERT CHERRY
9	146124-24-R76	EA	END CAP - OVERHEAD CABINET - WASHED MAPLE
10	140364-01-01A	EA	FOAM - PAD - .5" X 8" X 8"
11	145658-01-R38	EA	CABINET - FRONT/TV FACE - W/O DOORS/HARDWARE (R74,R77,R80)
11	145658-01-R39	EA	CABINET - FRONT/TV FACE - W/O DOORS/HARDWARE (R75,R78,R81)
11	145658-01-R46	EA	CABINET - FRONT/TV FACE - W/O DOORS/HARDWARE (R76) FROM: 00-00-00 THRU: 01-04-04
11	145658-01-RW7	EA	CABINET - FRONT/TV FACE - W/O DOORS/HARDWARE (R76) FROM: 01-05-04 THRU: 99-99-99
11	145658-01-R46	EA	CABINET - FRONT/TV FACE - W/O DOORS/HARDWARE (R79,R82) FROM: 00-00-00 THRU: 01-04-04
11	145658-01-RW4	EA	CABINET - FRONT/TV FACE - W/O DOORS/HARDWARE (R79,R82) FROM: 01-05-04 THRU: 99-99-99
11	145658-02-R38	EA	CABINET - FRONT/TV FACE -W/O DRS/HDW (R74,R77,R80) - SURROUND SOUND
11	145658-02-R39	EA	CABINET - FRONT/TV FACE -W/O DRS/HDW (R75,R78,R81) - SURROUND SOUND
11	145658-02-R46	EA	CABINET - FRONT/TV FACE -W/O DRS/HDW (R76) - SURROUND SOUND FROM: 00-00-00 THRU: 01-04-04
11	145658-02-RW7	EA	CABINET - FRONT/TV FACE -W/O DRS/HDW (R76) - SURROUND SOUND FROM: 01-05-04 THRU: 99-99-99
11	145658-02-R46	EA	CABINET - FRONT/TV FACE -W/O DRS/HDW (R79,R82) - SURROUND SOUND FROM: 00-00-00 THRU: 01-04-04
11	145658-02-RW4	EA	CABINET - FRONT/TV FACE -W/O DRS/HDW (R79,R82) - SURROUND SOUND FROM: 01-05-04 THRU: 99-99-99
12	145659-01-01A	EA	COVER - FRONT TV/OVERHEAD - GLACIER
13	133790-18-02B	EA	STRAP/TIEDOWN - TV - E-COATED
14	144652-01-R38	EA	PANEL - VINYL COVERED - DC/AC INVERTER
15	144652-02-R38	EA	PANEL - VINYL COVERED
16	144652-04-R68	EA	PANEL - VINYL COVERED - DC/AC INVERTER/ AUTOMATIC SATELLITE DISH
17	144652-05-R68	EA	PANEL - VINYL COVERED - AUTOMATIC SATELLITE DISH
18	144652-06-R68	EA	PANEL - VINYL COVERED - DC/AC INVERTER/ IN-MOTION SATELLITE SYSTEM
19	144652-07-R68	EA	PANEL - VINYL COVERED - IN-MOTION SATELLITE SYSTEM

ELECTRICAL GROUP
12V BODY WIRING

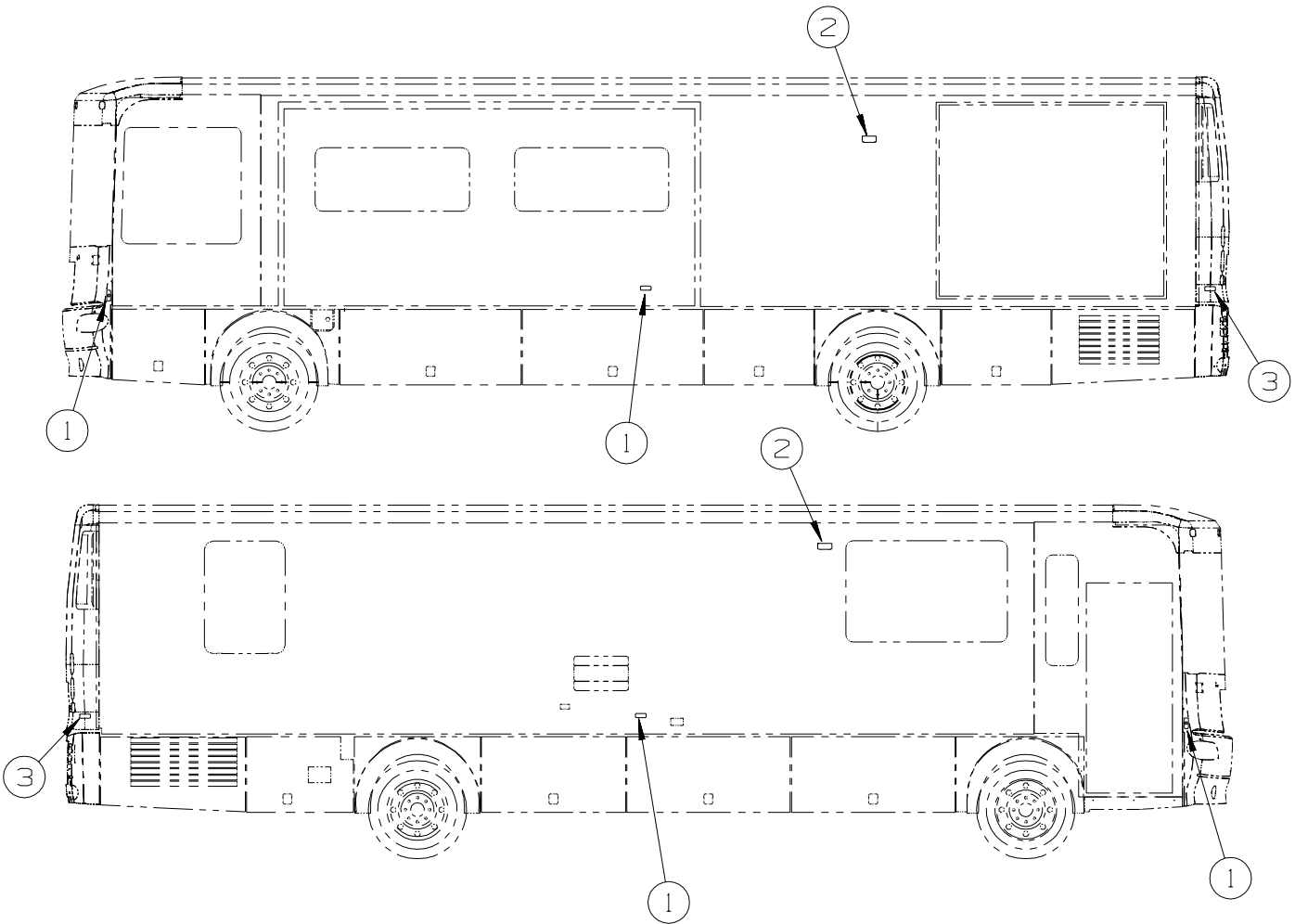

KEY	PART NUMBER	U/M	DESCRIPTION
1	111102-01-000	EA	BASE - MARKER LAMP
1	111102-02-000	EA	LENS - AMBER - MARKER LAMP
	036196-01-000	EA	BULB - 12V - #194 - .27 AMP - BAYONETTE
2	097917-01-08A	EA	LIGHT/PORCH - CHROME
	008215-01-000	EA	BULB - 12 VOLT - #1003 - .94 AMP
3	111102-01-000	EA	BASE - MARKER LAMP
3	111102-03-000	EA	LENS - RED - MARKER LAMP
	036196-01-000	EA	BULB - 12V - #194 - .27 AMP - BAYONETTE

ELECTRICAL GROUP (CONTINUED)

12V BODY WIRING (CONTINUED)

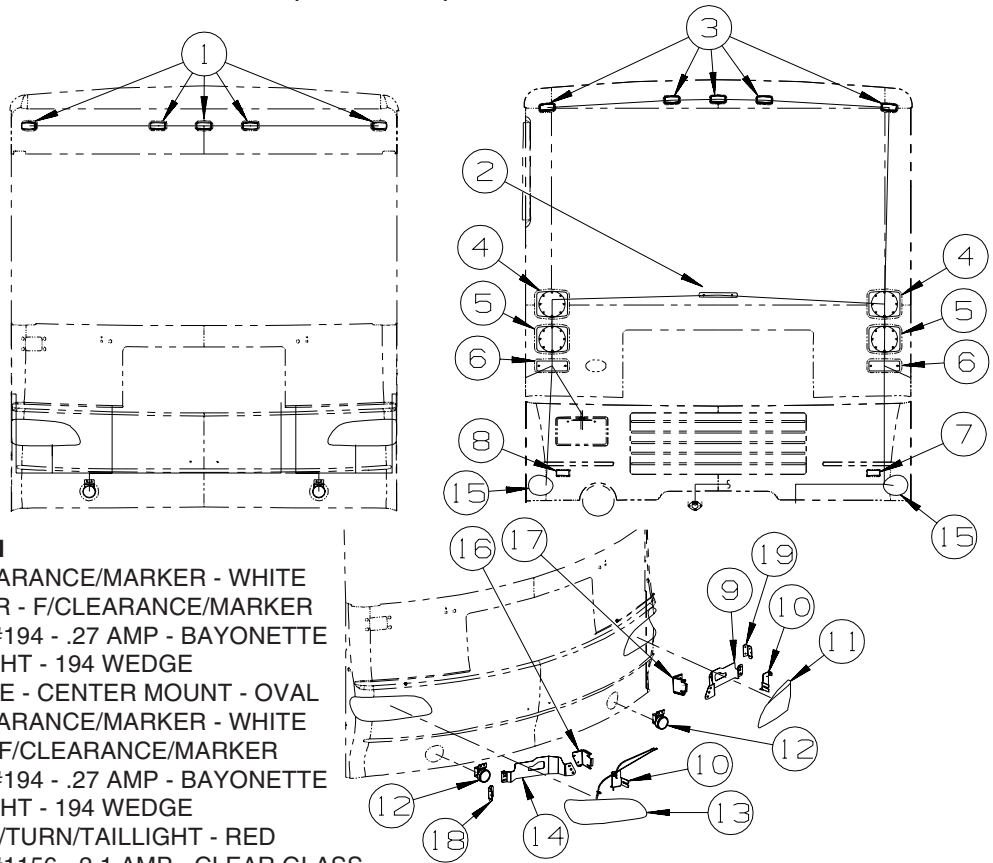

KEY	PART NUMBER	U/M	DESCRIPTION
1	133055-03-000	EA	BASE - F/CLEARANCE/MARKER - WHITE
1	133055-02-000	EA	LENS - AMBER - F/CLEARANCE/MARKER
	036196-01-000	EA	BULB - 12V - #194 - .27 AMP - BAYONETTE
	127536-02-000	EA	SOCKET - LIGHT - 194 WEDGE
2	136917-01-000	EA	LIGHT - BRAKE - CENTER MOUNT - OVAL
3	133055-03-000	EA	BASE - F/CLEARANCE/MARKER - WHITE
3	133055-01-000	EA	LENS - RED - F/CLEARANCE/MARKER
	036196-01-000	EA	BULB - 12V - #194 - .27 AMP - BAYONETTE
	127536-02-000	EA	SOCKET - LIGHT - 194 WEDGE
4*	133054-03-000	EA	LIGHT - STOP/TURN/TAILLIGHT - RED
4	037934-01-000	EA	BULB - 12V - #1156 - 2.1 AMP - CLEAR GLASS
5*	133054-04-000	EA	LIGHT - TURN - AMBER
5	037934-01-000	EA	BULB - 12V - #1156 - 2.1 AMP - CLEAR GLASS
5	145787-01-000	EA	SOCKET - PARK/TURN - GM# 12141302
6	106688-01-000	EA	LIGHT - BACK-UP W/WHITE LENS (LENS/BACK PAN)
6	037934-01-000	EA	BULB - 12V - #1156 - 2.1 AMP - CLEAR GLASS
6	106687-01-000	EA	SOCKET - LIGHT - 2-WIRE
7	106646-02-000	EA	REFLECTOR - STICK ON - RED
8	087201-01-000	EA	LIGHT - HALF ROUND - 1" X 1.7" - PLASTIC - BLACK OR WHITE
9	143903-02-01A	EA	BRACKET/HEADLAMP - DRIVER
10	145919-02-000	EA	CABLE - HEADLAMP - 21"
10	145919-01-000	EA	CABLE - HEADLAMP ADJUSTER - 16.9" LONG
10	145928-01-000	EA	CLAMP - CABLE - PLASTIC
10	145927-01-000	EA	CLAMP - CABLE - PLASTIC
10	147644-02-02B	EA	PLATE - HEADLAMP ADJUSTER - E-COATED - DRIVER
10	147644-01-02B	EA	PLATE - HEADLAMP ADJUSTER - E-COATED - PASSENGER
11	144834-02-000	EA	HEADLAMP - W/PARK&TURN - DRIVER
11	037936-01-000	EA	BULB - 12V NUMBER 1157A - 2.10 AMP - AMBER GLASS
11	124187-01-000	EA	SOCKET/HOUSING - LOW BEAM HEADLAMP
11	124187-02-000	EA	SOCKET/HOUSING - HIGH BEAM HEADLAMP
12	138910-01-000	EA	LAMP - FOG - CLEAR/ROUND - CHECK TO BE A HELLA 88085W BEFORE ORDERING
12	151421-01-000	EA	LAMP - FOG - CLEAR/ROUND - CHECK TO BE A HAMSAR 831458/S BEFORE ORDERING
12	139686-01-02B	EA	ANGLE - MOUNT - FOG/LAMP - E-COATED
13	144834-01-000	EA	HEADLAMP - W/PARK&TURN - PASSENGER
13	037936-01-000	EA	BULB - 12V NUMBER 1157A - 2.10 AMP - AMBER GLASS
13	124187-01-000	EA	SOCKET/HOUSING - LOW BEAM HEADLAMP
13	124187-02-000	EA	SOCKET/HOUSING - HIGH BEAM HEADLAMP
14	143903-01-01A	EA	BRACKET/HEADLAMP - PASSENGER
15	139001-01-000	EA	LIGHT ONLY (DOCKING)
15	139001-02-000	EA	SOCKET ONLY - F/DOCKING LAMP
15	117806-01-000	EA	BULB - 12V - #912 - 1.0 AMP

ELECTRICAL GROUP (CONTINUED)

12V BODY WIRING (CONTINUED)

KEY	PART NUMBER	U/M	DESCRIPTION	
16	144023-02-02B	EA	BRACKET ASM-HEADLAMP	FROM: 00-00-00 THRU: 05-10-04
16	151374-02-02B	EA	BRACKET - HEADLAMP MOUNT/INNER - E-COATED	FROM: 05-11-04 THRU: 99-99-99
17	144023-04-02B	EA	BRACKET ASM-HEADLAMP	FROM: 00-00-00 THRU: 05-10-04
17	151374-04-02B	EA	BRACKET - HEADLAMP MOUNT/INNER - E-COATED	FROM: 05-11-04 THRU: 99-99-99
18	144055-02-02B	EA	BRACKET ASM-HEADLAMP	FROM: 00-00-00 THRU: 05-10-04
18	151373-02-02B	EA	BRACKET - HEADLAMP MOUNT/OUTER - E-COATED	FROM: 05-11-04 THRU: 99-99-99
19	144055-04-02B	EA	BRACKET ASM-HEADLAMP	FROM: 00-00-00 THRU: 05-10-04
19	151373-04-02B	EA	BRACKET - HEADLAMP MOUNT/OUTER - E-COATED	FROM: 05-11-04 THRU: 99-99-99
	146246-01-000	EA	CONNECTOR/PLUG - TRAILER - 7 PIN	

***COMPONENT PARTS LISTED LATER IN THIS GROUP**

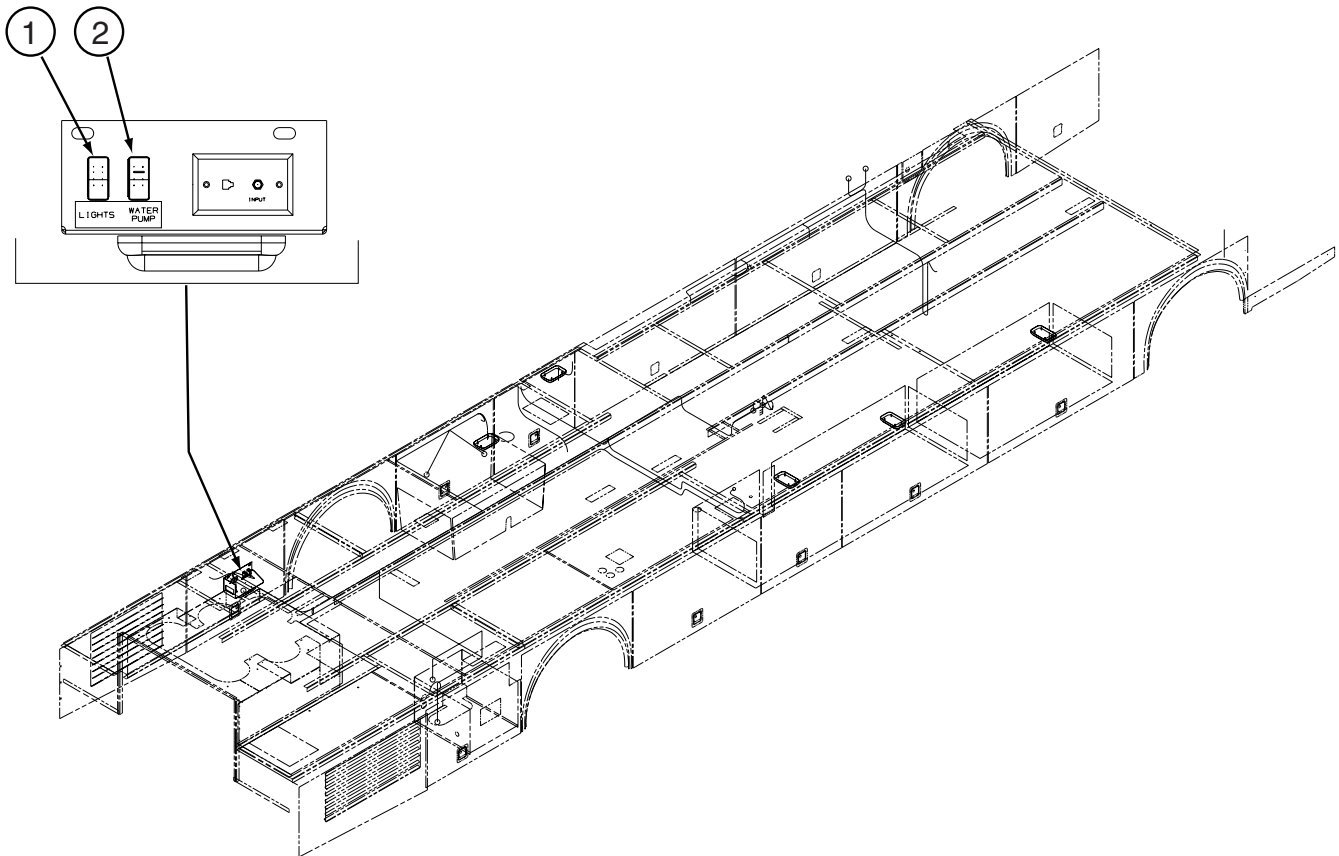

KEY	PART NUMBER	U/M	DESCRIPTION
1	108357-01-000	EA	SWITCH - ROCKER - SPST - ON/OFF - 2 TERMINAL - W/O COVER
1	108356-02-01A	EA	COVER/ACTUATOR SWITCH - 2 ROWS DIMPLES- CONTURA II - BLACK
1	108355-01-000	EA	HOUSING - SWITCH
2	108357-15-000	EA	SWITCH - ROCKER - DPDT - ON/NONE/ON - W/LIGHT W/O COVER
2	108356-04-01A	EA	COVER/ACTUATOR SWITCH - 2 ROWS DIMPLES W/LENS-CONTURA-BLK
2	108355-01-000	EA	HOUSING - SWITCH
2	145754-01-01A	EA	SWITCH - BLANK - BLACK

ELECTRICAL GROUP (CONTINUED)
12V BODY WIRING (CONTINUED)

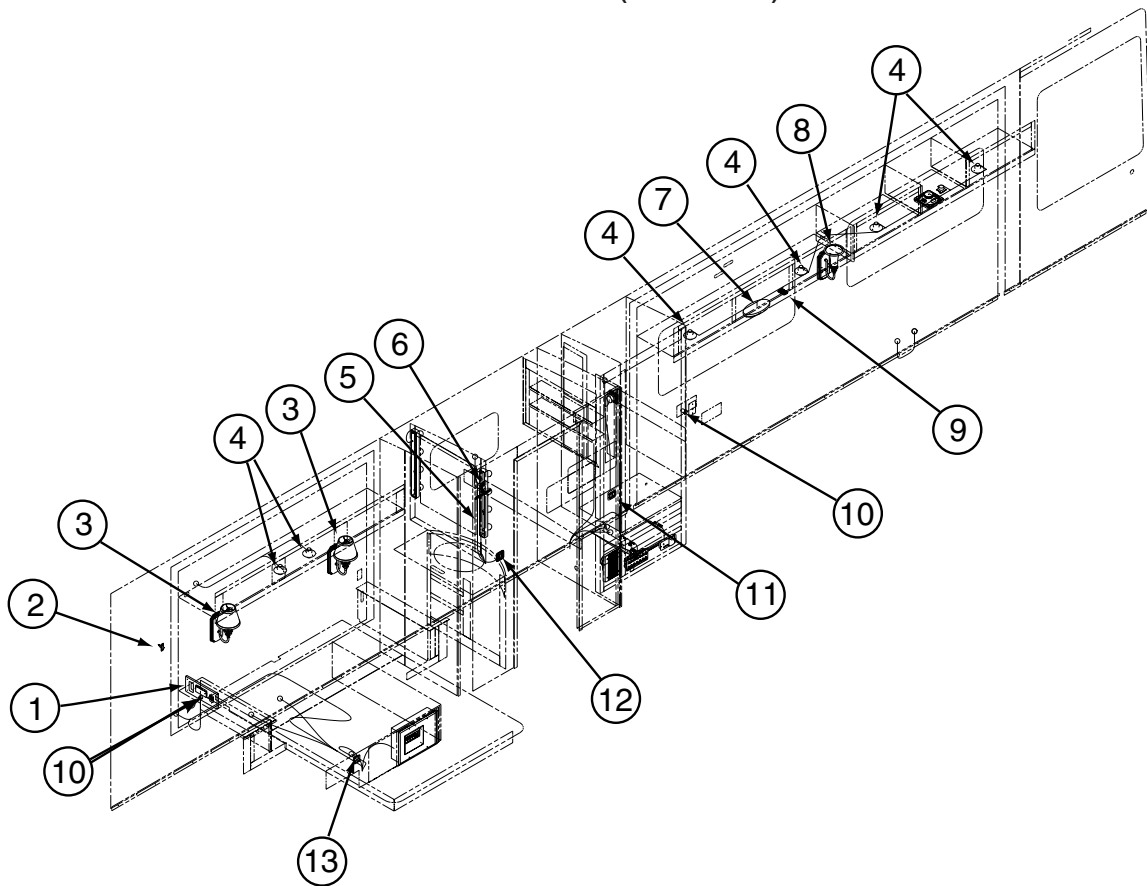

KEY	PART NUMBER	U/M	DESCRIPTION
1	133713-07-08A	EA	SPACER/RECEPTACLE - PHONE/CLOCK - VINYL/PORTSMOUTH OAK - PORTSMOUTH OAK
1	133713-07-03A	EA	SPACER/RECEPTACLE - PHONE/CLOCK - VINYL/SALEM CHERRY - CONCERT CHERRY
1	133713-07-02A	EA	SPACER/RECEPTACLE - PHONE/CLOCK - VINYL/WASHED MAPLE - WASHED MAPLE
1	133713-07-21A	EA	SPACER/RECEPTACLE - PHONE/CLOCK - NEAT/WASHED MAPLE - WASHED MAPLE FROM: 00-00-00 THRU: 01-04-04 FROM: 01-05-04 THRU: 99-99-99
2	041250-01-000	EA	SWITCH - PUSH BUTTON/DOOR JAMB - METAL - CHROME
3	119258-33-01A	EA	LAMP - WALL - UL/CSA
3	119257-16-01A	EA	SHADE - LAMP - WHISPER CHABLIS
3	067479-01-000	EA	BULB - 12V - #1076 - 1.80 AMP
4	132427-01-01A	EA	LIGHT - READING - SWIVEL/ROUND - BRASS
4	123917-01-000	EA	BULB - 12V - HALOGEN SPOT
5	138116-02-01A	EA	LIGHT/MAKE UP - 4 BULB - CURVED - W/O BULB - BRAS
	123918-01-000	EA	BULB - 12V - MAKEUP - WHITE
6	108357-06-000	EA	SWITCH - ROCKER - DPDT - MOM/OFF/MOM - 6 TERM - W/O COVER
6	108356-02-01A	EA	COVER/ACTUATOR SWITCH - 2 ROWS DIMPLES- CONTURA II - BLACK
6	108355-01-000	EA	HOUSING - SWITCH
7	093575-31-01A	EA	LIGHT - CEILING - DOUBLE - BRASS
7	117805-02-000	EA	BULB - 12V - #921 - 1.4 AMPS
8	119258-34-01A	EA	LAMP - WALL - UL/CSA
8	117805-02-000	EA	BULB - 12V - #921 - 1.4 AMPS
9	135740-01-02A	EA	SWITCH - ROCKER - SPST - ON/OFF - WHITE
9	135741-01-02A	EA	SWITCH - BASE - SINGLE - WHITE
9	135742-01-02A	EA	BEZEL - SWITCH - SINGLE - WHITE
10	132958-01-000	EA	RECEPTACLE - 12 VOLT - MOUNTING FLANGE - BLACK
11	135740-01-02A	EA	SWITCH - ROCKER - SPST - ON/OFF - WHITE - SHOWER
11	135740-02-02A	EA	SWITCH - ROCKER - SPDT - ON/ON - WHITE - CEILING
11	135741-02-02A	EA	SWITCH - BASE - DOUBLE - WHITE
11	135742-15-01A	EA	BEZEL - SWITCH - CEILING/SHOWER - WHITE
12	135740-01-02A	EA	SWITCH - ROCKER - SPST - ON/OFF - WHITE
12	135741-02-02A	EA	SWITCH - BASE - DOUBLE - WHITE
12	135742-38-01A	EA	BEZEL - SWITCH - MAKEUP/FAN - WHITE
13*	108354-01-01A	EA	LIGHT - COURTESY

*COMPONENT PARTS LISTED LATER IN THIS GROUP

ELECTRICAL GROUP (CONTINUED)

12V BODY WIRING (CONTINUED)

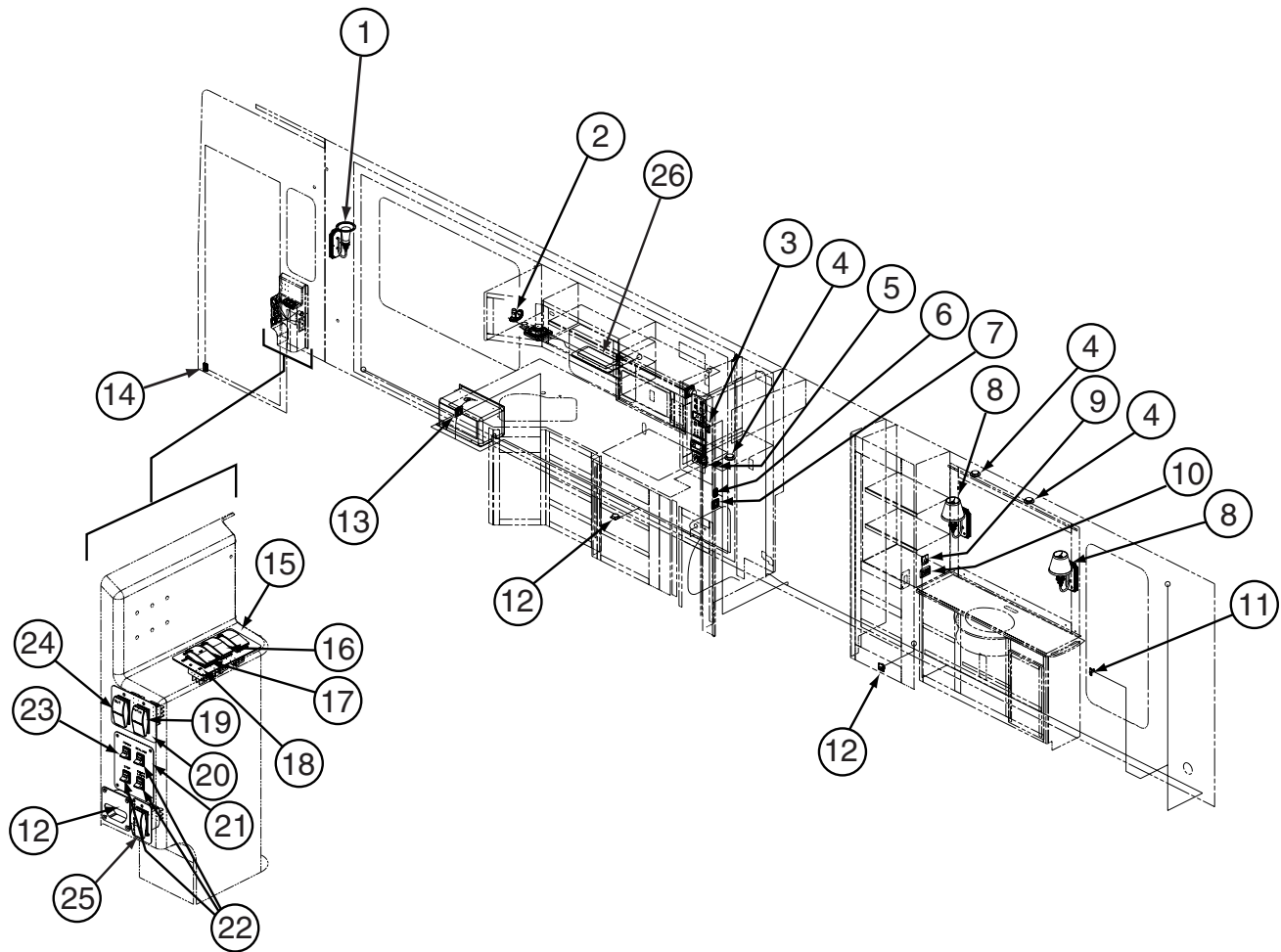

KEY	PART NUMBER	U/M	DESCRIPTION
1	119258-34-01A	EA	LAMP - WALL - UL/CSA
1	117805-02-000	EA	BULB - 12V - #921 - 1.4 AMPS
2	128786-02-01A	EA	LIGHT - READING/SWIVEL - W/O SWITCH - BRASS
	123917-01-000	EA	BULB - 12V - HALOGEN SPOT
3	135740-06-01A	EA	SWITCH - ROCKER - ON/OFF - LIGHTED - RED
3	135741-01-01A	EA	SWITCH - BASE - SINGLE - BROWN
3	135742-35-02A	EA	BEZEL - SWITCH - WATER HEATER/110 VOLT - BROWN
4*	123775-01-01A	EA	LIGHT - HALOGEN - ROUND
5	135740-01-02A	EA	SWITCH - ROCKER - SPST - ON/OFF - WHITE
5	135741-01-02A	EA	SWITCH - BASE - SINGLE - WHITE
5	135742-01-02A	EA	BEZEL - SWITCH - SINGLE - WHITE
6	135740-01-02A	EA	SWITCH - ROCKER - SPST - ON/OFF - WHITE
6	135741-01-02A	EA	SWITCH - BASE - SINGLE - WHITE
6	135742-30-01A	EA	BEZEL - SWITCH - MONITOR - WHITE
7	135740-01-01A	EA	SWITCH - ROCKER - SPST - ON/OFF - BROWN - GALLEY
7	135740-02-01A	EA	SWITCH - ROCKER - SPDT - ON/ON - BROWN - LOUNGE
7	135741-02-01A	EA	SWITCH - BASE - DOUBLE - BROWN
7	135742-18-02A	EA	BEZEL - SWITCH - LOUNGE/GALLEY - BROWN
8	119258-33-01A	EA	LAMP - WALL - UL/CSA
8	119257-16-01A	EA	SHADE - LAMP - WHISPER CHABLIS
8	067479-01-000	EA	BULB - 12V - #1076 - 1.80 AMP
9	137889-01-000	EA	SWITCH - LIGHT DIMMER

ELECTRICAL GROUP (CONTINUED)

12V BODY WIRING (CONTINUED)

KEY	PART NUMBER	U/M	DESCRIPTION
10	135740-01-02A	EA	SWITCH - ROCKER - SPST - ON/OFF - WHITE - VALANCE
10	135740-02-02A	EA	SWITCH - ROCKER - SPDT - ON/ON - WHITE - CEILING/AISLE
10	135741-03-02A	EA	SWITCH - BASE - TRIPLE - WHITE
10	135742-22-01A	EA	BEZEL - SWITCH - AISLE/VALANCE/CEILING - WHITE
11	041250-01-000	EA	SWITCH - PUSH BUTTON/DOOR JAMB - METAL - CHROME
12*	108354-01-01A	EA	LIGHT - COURTESY
13	135740-01-01A	EA	SWITCH - ROCKER - SPST - ON/OFF - BROWN - READING
13	135740-02-01A	EA	SWITCH - ROCKER - SPDT - ON/ON - BROWN - AISLE
13	135741-02-01A	EA	SWITCH - BASE - DOUBLE - BROWN
13	135742-21-02A	EA	BEZEL - SWITCH - AISLE/READING - BROWN
14	116995-02-000	EA	SWITCH/MAGNET - ELECTRIC STEP - BLACK/WHITE-CLOSED CIRCUIT
15	108357-01-000	EA	SWITCH - ROCKER - SPST - ON/OFF - 2 TERMINAL - W/O COVER
15	108356-01-01A	EA	COVER/ACTUATOR SWITCH - 3 GROOVES - CONTURA III - BLACK
15	108355-01-000	EA	HOUSING - SWITCH
16	096241-03-000	EA	SWITCH - BLANK - BLACK
16	108357-06-000	EA	SWITCH - ROCKER - DPDT - MOM/OFF/MOM - 6 TERM - W/O COVER - POWERED SUNVISORS
16	108356-01-01A	EA	COVER/ACTUATOR SWITCH - 3 GROOVES - CONTURA III - BLACK - POWERED SUNVISORS
16	108355-01-000	EA	HOUSING - SWITCH - POWERED SUNVISORS
17	108357-06-000	EA	SWITCH - ROCKER - DPDT - MOM/OFF/MOM - 6 TERM - W/O COVER
17	108356-01-01A	EA	COVER/ACTUATOR SWITCH - 3 GROOVES - CONTURA III - BLACK
17	108355-01-000	EA	HOUSING - SWITCH
18	142487-01-02B	EA	PLATE - SWITCH - E-COATED
18	142475-01-01A	EA	APPLIQUE - SWITCH - PASSENGER
19	108357-08-000	EA	SWITCH - ROCKER - DPDT - 0N/NONE/ON - 6 TERM - W/O COVER
19	108356-13-01A	EA	COVER/ACTUATOR SWITCH - 3 GROOVES
19	108355-01-000	EA	HOUSING - SWITCH
20	098351-22-01A	EA	PLATE/SWITCH - 2 GANG - POLISHED BRASS
21	098351-08-01A	EA	PLATE/SWITCH - 4 GANG/BRASS-PORCH/CEILING/STEP/COMPT LAMPS
22	132180-01-01A	EA	SWITCH - PADDLE - SPST - ON/OFF - BLACK - PORCH/STEP/COMPT LAMPS
23	132180-02-01A	EA	SWITCH - PADDLE - SPDT - ON/ON - BLACK - GALLEY
24	108357-06-000	EA	SWITCH - ROCKER - DPDT - MOM/OFF/MOM - 6 TERM - W/O COVER
24	108356-12-01A	EA	COVER/ACTUATOR SWITCH - 3 GROOVES
24	108355-01-000	EA	HOUSING - SWITCH
25	108357-07-000	EA	SWITCH - ROCKER - SPDT - MOM/OFF/MOM - 3 TERM - W/O COVER
25	108356-01-01A	EA	COVER/ACTUATOR SWITCH - 3 GROOVES - CONTURA III - BLACK
25	108355-01-000	EA	HOUSING - SWITCH
25	098351-24-01A	EA	PLATE/SWITCH - DOOR LOCK - POLISHED BRASS
26*	091937-09-000	EA	LIGHT-FLOURESCENT-12V/16 WATT RECESSED - W/SWITCH

*COMPONENT PARTS LISTED LATER IN THIS GROUP

ELECTRICAL GROUP (CONTINUED)
12V BODY WIRING (CONTINUED)

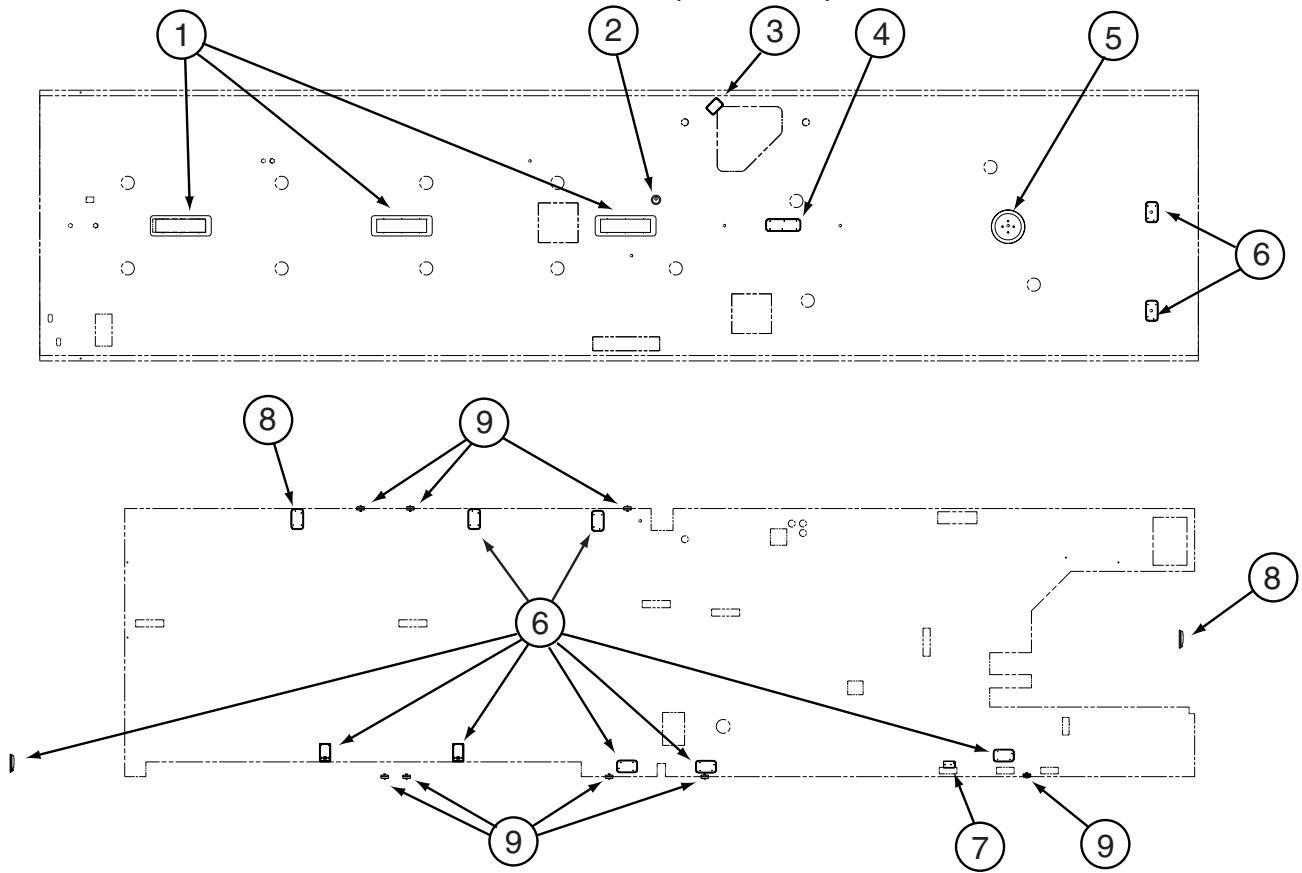

KEY	PART NUMBER	U/M	DESCRIPTION
1*	091937-08-000	EA	LIGHT - FLUORESCENT-12V/30WATT - RECESSED - W/O SWITCH
1	091937-03-000	EA	BULB - FLUORESCENT LIGHT - 12 VOLT
2	146048-01-01A	EA	LIGHT - HALOGEN/ADJUSTABLE - WHITE
3*	121935-01-01A	EA	LIGHT - DOME - SHOWER
4*	137417-06-01A	EA	LIGHT - DOME - DOUBLE - W/O SWITCH - W/FROSTED LENS-WHITE
5*	093575-19-01A	EA	LIGHT - CEILING/ROUND - BRASS
	117805-02-000	EA	BULB - 12V - #921 - 1.4 AMPS
6*	137417-03-01A	EA	LIGHT - DOME - SINGLE - W/FROSTED LENS - W/O SWITCH-WHITE
7*	086280-01-000	EA	LIGHT - SURFACE MOUNT - 12 VOLT
8*	137417-01-01A	EA	LIGHT - DOME - SINGLE - W/SWITCH/FROSTED LENS - WHITE
9	041250-01-000	EA	SWITCH - PUSH BUTTON/DOOR JAMB - METAL - CHROME
9	138494-01-02B	EA	BRACKET - SWITCH/LIGHT - E-COATED

***COMPONENT PARTS LISTED LATER IN THIS GROUP**

ELECTRICAL GROUP (CONTINUED)

FRONT END WIRING

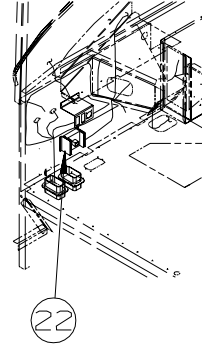
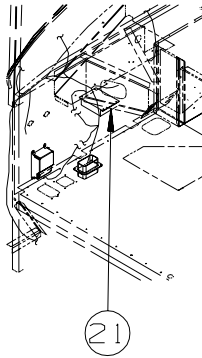
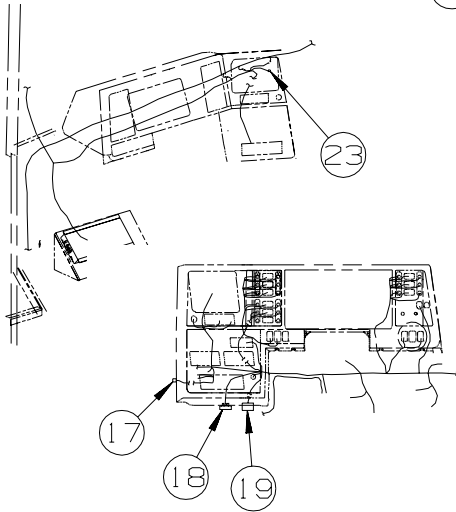
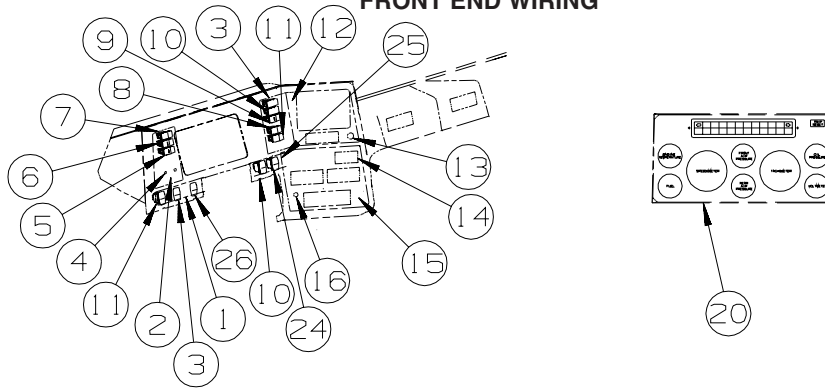

KEY	PART NUMBER	U/M	DESCRIPTION
1	104056-32-01A	EA	APPLIQUE - BEZEL - DRIVER/LOWER - BLACK VELVET - FRONT SLIDEOUT ROOM
1	104056-58-01A	EA	APPLIQUE - BEZEL - LOWER/LEFT HAND
1	104056-62-01A	EA	APPLIQUE - BEZEL/SWITCH - DRIVER - BLACK VELVET - WORKHORSE
2	104056-41-01A	EA	APPLIQUE - BEZEL - DRIVER SWEEP - 6 SPEED 2003 CHASSIS
2	104056-56-01A	EA	APPLIQUE - SWITCH BEZEL - DRIVER - BLACK VELVET - 6 SPEED 2004 CHASSIS
2	104056-59-01A	EA	APPLIQUE - BEZEL - SWITCH/LEFT HAND - BLACK VELVET - WORKHORSE
2	104056-61-01A	EA	APPLIQUE - BEZEL/SWITCH - DRIVER - BLACK VELVET - 5 SPEED 2004 CHASSIS
2	104056-63-01A	EA	APPLIQUE - BEZEL/SWITCH - DRIVER - BLACK VELVET - SMART WHEEL
FROM: 03-02-04 THRU: 99-99-99			
3	108357-08-000	EA	SWITCH - ROCKER DPDT - ON/NONE/ON - 6 TERMINAL - EXHAUST BRAKE - RADIO POWER
3	108356-01-01A	EA	COVER/ACTUATOR SWITCH - 3 GROOVES - CONTURA III - BLACK
3	108355-01-000	EA	HOUSING - SWITCH
4*	091206-04-000	EA	MODULE/WIPER CONTROL KIT - DYNAMIC PARK
5	108357-14-000	EA	SWITCH - ROCKER - SPST - W/LIGHT - ON/OFF - 4 TERMINAL - DOCKING LAMPS
5	108356-03-01A	EA	COVER/ACTUATOR SWITCH -3 GROOVES W/LIGHT-CONTRA III-BLACK
5	108355-01-000	EA	HOUSING - SWITCH
6	108357-14-000	EA	SWITCH - ROCKER - SPST - W/LIGHT - ON/OFF - 4 TERMINAL - FOG LAMPS
6	108356-03-01A	EA	COVER/ACTUATOR SWITCH -3 GROOVES W/LIGHT-CONTRA III-BLACK
6	108355-01-000	EA	HOUSING - SWITCH
6	096241-03-000	EA	SWITCH - BLANK - BLACK
7	108357-09-000	EA	SWITCH - ROCKER SPDT - ON/NONE/MOM - 3 TERMINAL - AUXILIARY START
7	108356-01-01A	EA	COVER/ACTUATOR SWITCH - 3 GROOVES - CONTURA III - BLACK
7	108355-01-000	EA	HOUSING - SWITCH
8	108357-03-000	EA	SWITCH - ROCKER SPDT - ON/OFF/ON - 3 TERMINAL - AUXILIARY FANS
8	108356-01-01A	EA	COVER/ACTUATOR SWITCH - 3 GROOVES - CONTURA III - BLACK
8	108355-01-000	EA	HOUSING - SWITCH
8	096241-03-000	EA	SWITCH - BLANK - BLACK
9	108357-10-000	EA	SWITCH - ROCKER SPDT - W/LIGHT - MOM/NONE/MOM - 5 TERMINAL - GENERATOR
9	108356-03-01A	EA	COVER/ACTUATOR SWITCH -3 GROOVES W/LIGHT-CONTRA III-BLACK
9	108355-01-000	EA	HOUSING - SWITCH
10	108357-06-000	EA	SWITCH - ROCKER DPDT - MOM/OFF/MOM - 6 TERMINAL
10	108356-01-01A	EA	COVER/ACTUATOR SWITCH - 3 GROOVES - CONTURA III - BLACK
10	108355-01-000	EA	HOUSING - SWITCH

ELECTRICAL GROUP (CONTINUED)

FRONT END WIRING (CONTINUED)

KEY	PART NUMBER	U/M	DESCRIPTION
11	108357-01-000	EA	SWITCH - ROCKER SPST - ON/OFF - 2 TERMINAL - AIR HORN
11	108356-01-01A	EA	COVER/ACTUATOR SWITCH - 3 GROOVES - CONTURA III - BLACK
11	108355-01-000	EA	HOUSING - SWITCH
11	096241-03-000	EA	SWITCH - BLANK - BLACK
12	104056-40-01A	EA	APPLIQUE - BEZEL - PASSENGER/UPPER - 6-SWITCH
13	089294-01-000	EA	LIGHTER - CIGARETTE - W/SOCKET & WIRE
14*	136119-01-000	EA	COMPASS/THERMOMETER - ELECTRONIC
15	104056-52-01A	EA	APPLIQUE - BEZEL - LOWER/RIGHT WING
16	133534-02-000	EA	LIGHT - AMBER INDICATOR WITH 1/4" TERMINALS
17	115539-01-000	EA	RELAY - RADIO/TV SPEAKER - SWITCH
18	133535-01-000	EA	MODULE - TIMER 20 SECOND
19	128074-02-000	EA	FILTER - NOISE - 12 VOLT DC W/PLUGS
20	133196-05-000	EA	SPEEDOMETER - FREIGHTLINER - KILOMETERS - CANADIAN/2003 CHASSIS
20	149032-01-01A	EA	SPEEDOMETER/KM - FACE/BEZEL - 5" - BLACK - CANADIAN/2004 CHASSIS
21*	102756-02-000	EA	KEYLESS ENTRY SYSTEM W/REMOTE
22	134090-02-000	EA	MODULE - DAY TIME RUNNING LIGHT
23	063912-02-000	EA	RELAY - CANISTER - SPDT
24	108357-06-000	EA	SWITCH - ROCKER DPDT - MOM/OFF/MOM - 6 TERMINAL - P39K
24	108356-01-01A	EA	COVER/ACTUATOR SWITCH - 3 GROOVES - CONTURA III - BLACK - P39K
24	108355-01-000	EA	HOUSING - SWITCH - P39K
25	104056-42-01A	EA	APPLIQUE - BEZEL - PASSENGER/LOWER - F/SLIDEOUT & JACKS
25	104056-57-01A	EA	APPLIQUE - BEZEL - LOWER RIGHT - F/SLIDEOUTS - BLACK VELVET - P39K
	077031-03-000	EA	FILM - WHITE - .75" X 1"
	103603-01-000	EA	BULB - 12 VOLT - #74 - .12A WEDGE - GE 22-25 USED IN DASH
	103608-01-000	EA	SOCKET - WEDGE BASE W/LEADS

*COMPONENT PARTS LISTED LATER IN THIS GROUP

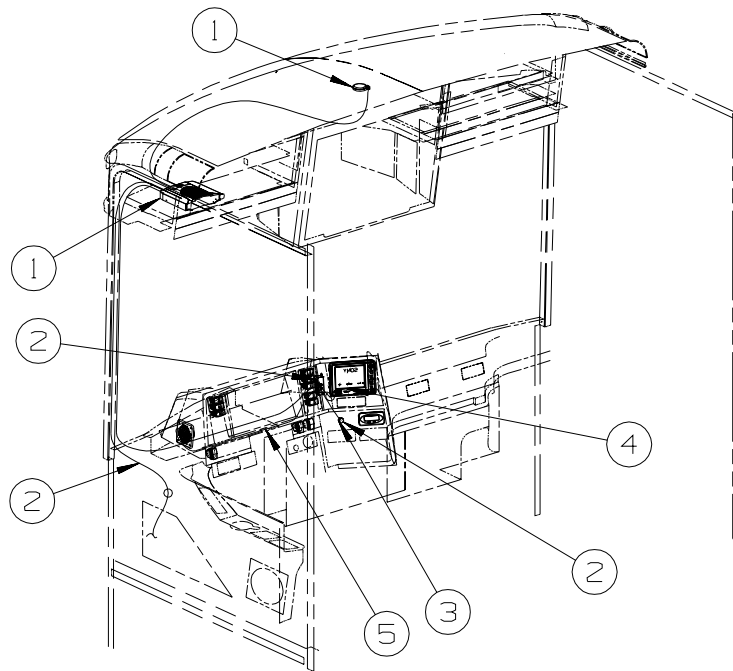

KEY	PART NUMBER	U/M	DESCRIPTION
1*	148158-01-000	EA	COMPUTER - GPS NAVIGATION SYSTEM - (MAGELLAN MAGNK-01W)
2	148158-02-000	EA	CABLES - F/GPS NAVIGATION SYSTEM - (MAGELLAN MAGNK-02W)
3	144734-03-000	EA	SPACER
4	148112-01-000	EA	CABLE - MONITOR - SONY AUX
5	148592-01-000	EA	CABLE - RCA MALE-1/4 FEMALE SPADES - RIVER PARK SCB-RCA120

*COMPONENT PARTS LISTED LATER IN THIS GROUP

ELECTRICAL GROUP (CONTINUED)

FRONT END WIRING (CONTINUED)

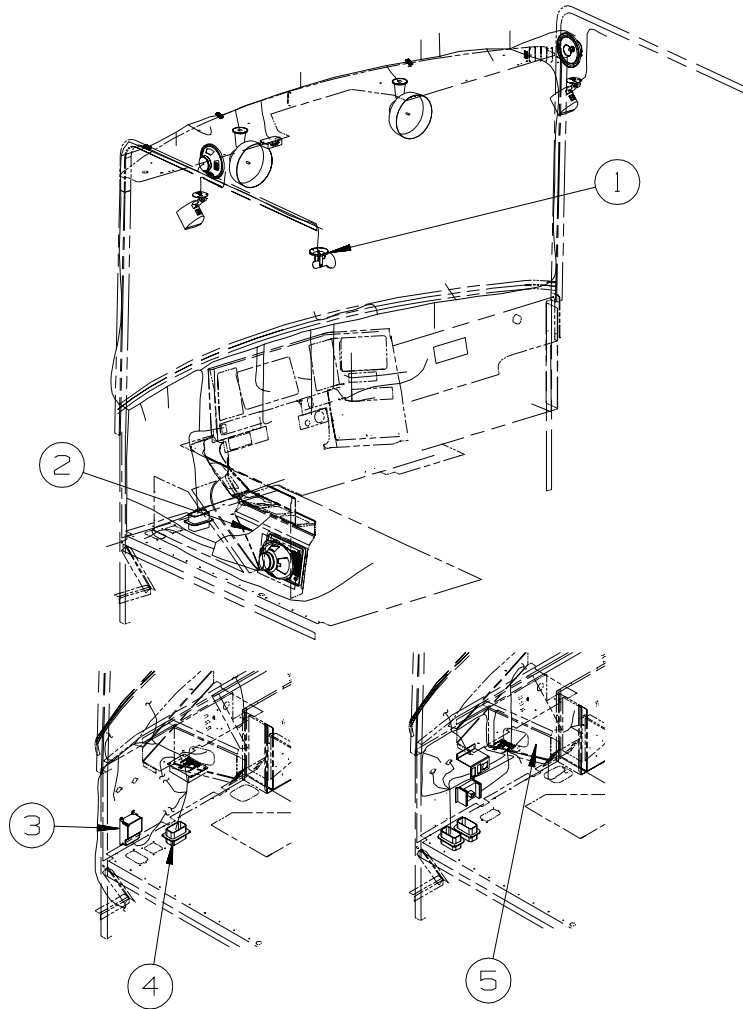

KEY	PART NUMBER	U/M	DESCRIPTION
1	128786-02-01A	EA	LIGHT - READING/SWIVEL - W/O SWITCH - BRASS
	123917-01-000	EA	BULB - 12V - HALOGEN SPOT
2	118662-14-02B	EA	PLATE - SWITCH - WINDOW - E-COATED - REMOTE POWER DOOR LOCKS
2	108357-07-000	EA	SWITCH - ROCKER - SPDT - MOM/OFF/MOM - 3 TERMINAL - REMOTE POWER DOOR LOCK
2	108356-01-01A	EA	COVER/ACTUATOR SWITCH - 3 GROOVES - CONTURA III - BLACK - REMOTE POWER DOOR LOCKS
2	108355-01-000	EA	HOUSING - SWITCH - REMOTE POWER DOOR LOCKS
2	096241-03-000	EA	SWITCH - BLANK - BLACK
2	143057-01-01A	EA	APPLIQUE/SWITCH - DRIVER - POWERED SUNVISORS
2	108357-06-000	EA	SWITCH - ROCKER - DPDT - MOM/OFF/MOM - 6 TERMINAL - POWERED SUNVISORS
2	108356-01-01A	EA	COVER/ACTUATOR SWITCH - 3 GROOVES - CONTURA III - BLACK - POWERED SUNVISORS
2	108355-01-000	EA	HOUSING - SWITCH - POWERED SUNVISORS
2	088246-01-000	EA	SWITCH/REMOTE MIRROR -W/2PIN & 6 PIN CONNECTORS/PIGTAIL-EXTERIOR MIRRORS W/DEFROST
2	108357-14-000	EA	SWITCH - ROCKER SPDT - W/LIGHT - ON/OFF - 4 TERMINAL - EXTERIOR MIRRORS W/DEFROST
2	108356-03-01A	EA	COVER/ACTUATOR SWITCH-3 GROOVES W/LIGHT-CONTRA III-BLACK-EXTE. MIRRORS W/DEFROST
2	108355-01-000	EA	HOUSING - SWITCH - MIRROR HEATER
3*	091206-04-000	EA	MODULE KIT - WIPER CONTROL - DYNAMIC PARK
4	118571-03-000	EA	BRACKET - MOUNTING
4	118571-04-000	EA	GASKET
5	113452-01-000	FT	SEAL/TRIM - FRONT - VINYL W/WIRE CARRIER - .020"

*COMPONENT PARTS LISTED LATER IN THIS GROUP

ELECTRICAL GROUP (CONTINUED)
FRONT END WIRING (CONTINUED)

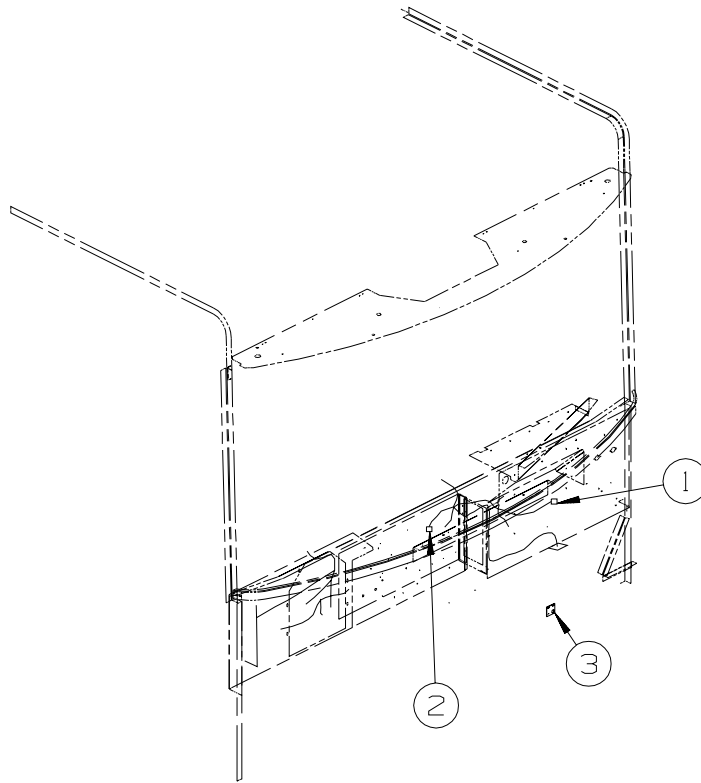

KEY	PART NUMBER	U/M	DESCRIPTION
1	114802-01-000	EA	PUMP - VACUUM - 12V
2*	137417-01-01A	EA	LIGHT - DOME - SINGLE - W/SWITCH/FROSTED LENS - WHITE
3	147428-02-02B	EA	BRACKET/ZEE - TEMPERATURE SENSOR - E-COATED

FROM: 03-03-04 THRU: 99-99-99

*COMPONENT PARTS LISTED LATER IN THIS GROUP

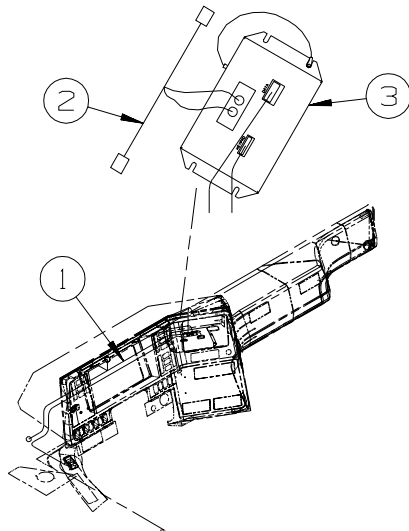

KEY	PART NUMBER	U/M	DESCRIPTION
1	143591-02-000	EA	WIRE LOOM - COMPUTER TRIP/ENGINE MONITOR-TRIP TEK 02-04007
2	143591-01-000	EA	COMPUTER - TRIP/ENGINE MONITOR - BLK/WHT - TRIP TEK 2500-2
3	143591-03-000	EA	CABLE - CAMERA INTERFACE - F/BLACK & WHITE MONITOR

ELECTRICAL GROUP (CONTINUED)
COMPONENT PARTS FOR LIGHTS & SWITCHES

086280-01-000

KEY	PART NUMBER	U/M	DESCRIPTION	VENDOR NO.
	086280-01-700	EA	BULB,12V	ARP1089

091206-04-000

KEY	PART NUMBER	U/M	DESCRIPTION	VENDOR NO.
	091206-02-700	EA	KNOB-INNER	66C-00019
	091206-02-701	EA	KNOB-OUTER	66C-00020
	091206-04-700	EA	SWITCH ASSEM. ONLY	250-6623
	102362-03-700	EA	MODULE-WIPER CONT., DYNAMIC	66D-00093

091937-08-000

KEY	PART NUMBER	U/M	DESCRIPTION	VENDOR NO.
	091937-08-700	EA	LENS - LIGHT - FLUORESCENT	D-766

093575-19-01A

KEY	PART NUMBER	U/M	DESCRIPTION	VENDOR NO.
	093575-19-700	EA	GLOBE F/55-556X2 LIGHT	9088

102756-02-000

KEY	PART NUMBER	U/M	DESCRIPTION	VENDOR NO.
	102756-01-704	EA	HARNESS-MAIN	203-6638
	102756-02-700	EA	REMOTE(TRANSMITTER) KEYLESS	412-1112
	102756-02-701	EA	BOARD-MODULE, NEW SYSTEM	202-3153
	102756-02-702	EA	BATTERY - 12 VOLT	402-1002
	102756-03-702	EA	RELAY- 30AMP - SPDT	463-1000

108354-01-01A

KEY	PART NUMBER	U/M	DESCRIPTION	VENDOR NO.
	108354-01-700	EA	BULB-COURTESY LIGHT	395-B

121935-01-01A

KEY	PART NUMBER	U/M	DESCRIPTION	VENDOR NO.
	121935-01-700	EA	LENS ONLY	809511

123775-01-01A

KEY	PART NUMBER	U/M	DESCRIPTION	VENDOR NO
	123775-01-700	EA	BULB - 10 WATT - HALOGEN	71-JC10
	123775-01-701	EA	BEZEL/LENS - RECESSED LIGHT	

133054-03-000

KEY	PART NUMBER	U/M	DESCRIPTION	VENDOR NO
	133054-03-700	EA	LENS	2011-0000-10
	133054-03-701	EA	GASKET - LIGHT MOUNTING	2004-0000-00
	133054-03-702	EA	GASKET - LENS	2003-0000-00

133054-04-000

KEY	PART NUMBER	U/M	DESCRIPTION	VENDOR NO
	133054-03-701	EA	GASKET - LIGHT MOUNTING	2004-0000-00
	133054-03-702	EA	GASKET - LENS	2003-0000-00
	133054-04-700	EA	LENS	2011-0000-20

136119-01-000

KEY	PART NUMBER	U/M	DESCRIPTION	VENDOR NO.
	136119-01-700	EA	COMPASS SENSOR (BLACK BOX)	AP-SUB-005
	136119-01-701	EA	PROBE/TEMPERATURE SENSOR(V1)	AP-SUB-004A
	136119-01-702	EA	DISPLAY MODULE-LED (V1)	AP-SUB-004B
	136119-01-703	EA	HARNESS - COMPASS POWER	AP-HRN-175
	136119-01-704	EA	HARNESS - COMPASS ENGINE	AP-HRN-176
	136119-01-705	EA	HRNSS-COMP.TEMP SENSOR V1	AP-HRN-177
	136119-01-706	EA	PROBE/TEMPERATURE SENSOR (V2)	AP-SUB-006
	136119-01-707	EA	DISPLAY MODULE - VISUAL (V2)	AP-SUB-007
	136119-01-708	EA	HARNESS/COMP. COMP/THERM(V2)	AP-HRN-239 W/PACKRD

ELECTRICAL GROUP (CONTINUED)
COMPONENT PARTS FOR LIGHTS & SWITCHES (CONTINUED)

137417-01-01A, 137417-03-01A

KEY	PART NUMBER	U/M	DESCRIPTION	VENDOR NO.
	137417-01-700	EA	LENS - SINGLE (FROSTED)	810868

137417-06-01A

KEY	PART NUMBER	U/M	DESCRIPTION	VENDOR NO.
	137417-06-700	EA	LENS - DOUBLE WHITE	810867

148158-01-000

KEY	PART NUMBER	U/M	DESCRIPTION	VENDOR NO.
	148158-01-700	EA	ANTENNA - F/GPS W/20' CABLE	DIS-CMP-ANTNGPS

ELECTRICAL GROUP (CONTINUED)
CIRCUIT BREAKERS & FUSES

KEY	PART NUMBER	U/M	DESCRIPTION
	008233-01-000	EA	FUSE - 12 VOLT - 6 AMP
	008235-01-000	EA	FUSE - 15 AMP/12VOLT - AUTOMOTIVE
	033573-01-000	EA	CIRCUIT BREAKER W/MOUNT-20A, 12V - FASCO 1711-2026
	062901-02-000	EA	FUSE - 5 AMP - AUTOMOTIVE
	062901-04-000	EA	FUSE - 10 AMP - AUTOMOTIVE
	062901-05-000	EA	FUSE - 15 AMP - AUTOMOTIVE
	062901-06-000	EA	FUSE - 20 AMP - AUTOMOTIVE
	062901-07-000	EA	FUSE - 25 AMP - AUTOMOTIVE
	062901-08-000	EA	FUSE - 30 AMP - AUTOMOTIVE
	083209-01-000	EA	CIRCUIT BREAKER - 15 AMP - 120 VOLT - CANADIAN
	083209-02-000	EA	CIRCUIT BREAKER - 15/15 AMP - 120 VOLT
	083209-03-000	EA	CIRCUIT BREAKER - 15/20 AMP - 120 VOLT
	083209-04-000	EA	CIRCUIT BREAKER - 30 AMP - 120 VOLT
	083209-05-000	EA	CIRCUIT BREAKER - 20 AMP - 120 VOLT
	083209-06-000	EA	CIRCUIT BREAKER - 30/15 AMP - 120 VOLT
	083209-07-000	EA	CIRCUIT BREAKER - 20/20 AMP - 120 VOLT
	083209-10-000	EA	CIRCUIT BREAKER - 20/30 AMP - 120 VOLT
	083209-11-000	EA	CIRCUIT BREAKER - 20/15 AMP - 120 VOLT
	092786-03-000	EA	BUSS BAR - 6.9" LONG
	092786-06-000	EA	BUSS BAR
	093654-01-000	EA	CIRCUIT BREAKER - 6 AMP - 12 VOLT - PUSH BUTTON - WHITE
	093654-02-000	EA	CIRCUIT BREAKER - 15 AMP - 12 VOLT - PUSH BUTTON - WHITE
	093654-03-000	EA	CIRCUIT BREAKER - 20 AMP - 12 VOLT - PUSH BUTTON - WHITE
	093654-11-000	EA	COVER - RESET BUTTON
	093655-01-000	EA	CIRCUIT BREAKER - 25 AMP - 12 VOLT - PUSH BUTTON - WHITE
	093655-02-000	EA	CIRCUIT BREAKER - 30 AMP - 12 VOLT - PUSH BUTTON - WHITE
	093655-03-000	EA	CIRCUIT BREAKER - 40 AMP - 12 VOLT - PUSH BUTTON - WHITE
	097611-01-000	EA	CIRCUIT BREAKER - 10 AMP
	097611-02-000	EA	CIRCUIT BREAKER - 30 AMP
	097611-03-000	EA	CIRCUIT BREAKER - 20 AMP
	097611-04-000	EA	CIRCUIT BREAKER - 25 AMP
	100341-01-000	EA	FUSE HOLDER - IN LINE TYPE
	106656-01-000	EA	FUSE BLOCK - 4 CAVITY - AUTOFUSE
	108567-01-000	EA	CIRCUIT BREAKER - 40 AMP - 12 VOLT - TYPE II
	111683-01-000	EA	FUSE - HOLDER - GLASS - 1/4" X 1 1/4"
	113482-01-000	EA	CIRCUIT BREAKER - 55 AMP - MANUAL
	115187-01-000	EA	FUSE - 300 AMP - NON-DELAY
	115187-02-000	EA	FUSE HOLDER - BUSS ANN/ANL BLOCK
	118531-05-02B	EA	PLATE - CIRCUIT BREAKER - E-COAT - CHIEFTAIN/SUNFLYER L-SERIES
	122811-01-000	EA	CIRCUIT BREAKER - 20/50/50/20 AMP - 250V
	134127-01-000	EA	CIRCUIT BREAKER - 10 AMP - MINI
	139067-01-02B	EA	PLATE - CIRCUIT BRKR-HOUSE - E-CTD - 10 PLACE
	139067-02-02B	EA	PLATE - CIRCUIT BRKR-HOUSE - E-CTD - 12 PLACE
	139067-03-02B	EA	PLATE-CIRCUIT BKR/HOUSE-E-CTD - 14 PLACE
	139067-04-02B	EA	PLATE - CIRCUIT BRKR-HOUSE - E-CTD - TOP 10 PLACE
	139067-05-02B	EA	PLATE - CIRCUIT BREAKER/HOUSE - E-COATED - 16 PLACE
	139067-06-02B	EA	PLATE - CIRCUIT BREAKER/HOUSE - E-COATED - 18 PLACE
	139067-07-02B	EA	PLATE - CIRCUIT BREAKER/HOUSE - E-COATED - 21 PLACE
	141789-01-000	EA	SPACER - CIRCUIT BREAKER

ELECTRICAL GROUP (CONTINUED)
CONVERTER, INVERTER, LOAD CENTERS

KEY	PART NUMBER	U/M	DESCRIPTION
	099048-04-000	EA	INVERTER - 300 WATT
	109677-01-000	EA	LOAD CENTER - 120 VOLT - 40 AMP
	113685-07-000	EA	INVERTER/CHARGER - 1500W AC
			FROM: 00-00-00 THRU: 04-20-03
	113685-08-000	EA	INVERTER/CHARGER - 2000W AC
			FROM: 04-21-03 THRU: 08-03-03
	148254-01-000	EA	INVERTER - CHARGER - 2000W AC
			FROM: 08-04-03 THRU: 99-99-99
	113685-01-000	EA	INVERTER - CHARGER - 2000W AC - P32T ONLY
			FROM: 00-00-00 THRU: 09-28-03
	148254-01-000	EA	INVERTER - CHARGER - 2000W AC - P32T ONLY
			FROM: 09-29-03 THRU: 99-99-99
	113685-05-000	EA	REMOTE PANEL - INVERTER/CHARGER
			FROM: 04-21-03 THRU: 08-03-03
	148254-02-000	EA	REMOTE PANEL - INVERTER/CHARGER
			FROM: 08-04-03 THRU: 99-99-99
	113685-05-000	EA	REMOTE PANEL - INVERTER/CHARGER - P32T ONLY
			FROM: 00-00-00 THRU: 09-28-03
	148254-02-000	EA	REMOTE PANEL - INVERTER/CHARGER - P32T ONLY
			FROM: 09-29-03 THRU: 99-99-99
	113685-06-000	EA	CABLE - MODULAR JACK - 50'
			FROM: 04-21-03 THRU: 08-03-03
	148254-03-000	EA	CABLE - MODULAR JACK - 50'
			FROM: 08-04-03 THRU: 99-99-99
	113685-06-000	EA	CABLE - MODULAR JACK - 50' - P32T ONLY
			FROM: 00-00-00 THRU: 09-28-03
	148254-03-000	EA	CABLE - MODULAR JACK - 50' - P32T ONLY
			FROM: 09-29-03 THRU: 99-99-99
	123058-01-000	EA	CONVERTER - 55 AMP - ELECTRONIC - 4 1/8"H X 7"W X 12 3/8"L
	127002-05-000	EA	PANEL/MONITOR - ENERGY MANAGEMENT SYSTEMS CTRL - W/PLUG
	127002-07-000	EA	SENSOR - CURRENT
	127002-08-000	EA	MODULE - EMS CENTER - W/REMOTE SENSOR
	141258-01-000	EA	LOAD CENTER - 120/240 - 50 AMP
	141258-02-000	EA	LOAD CENTER - COVER

ELECTRICAL GROUP (CONTINUED)

110V WIRING

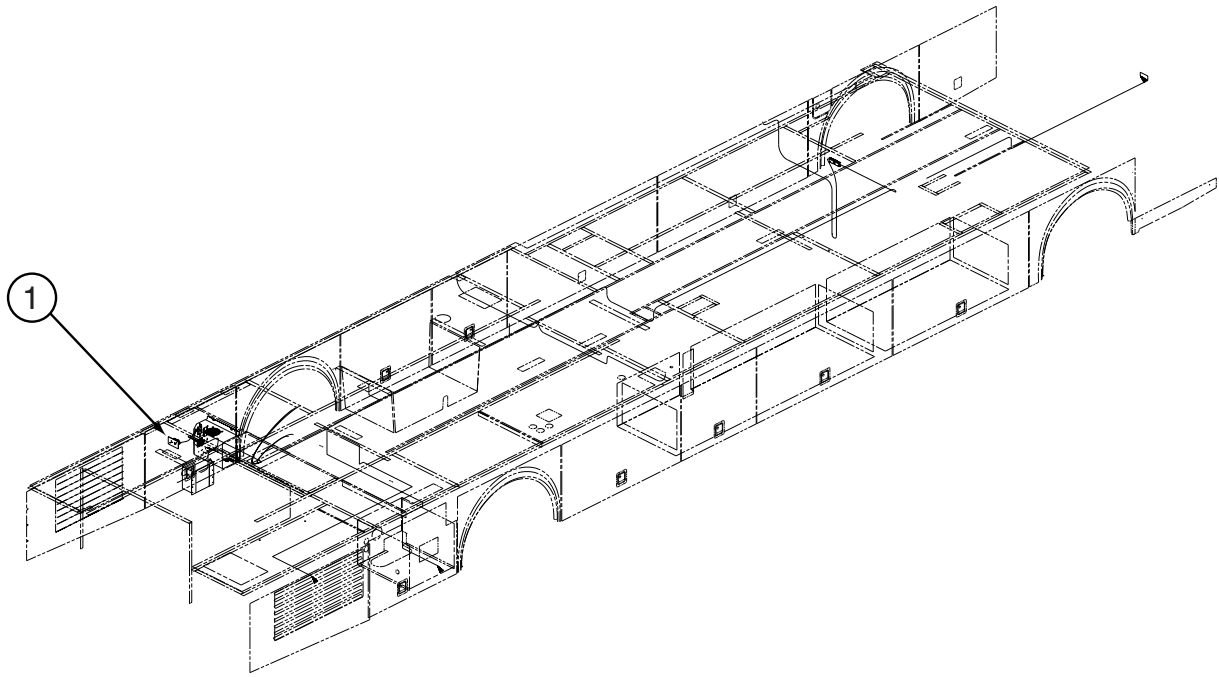

KEY	PART NUMBER	U/M	DESCRIPTION
1	058708-05-000	EA	RECEPTACLE - ELECTRIC - SINGLE - BROWN
1	058708-07-000	EA	RECEPTACLE - ELECTRICAL - SINGLE - WHITE

ELECTRICAL GROUP (CONTINUED)
110V WIRING (CONTINUED)

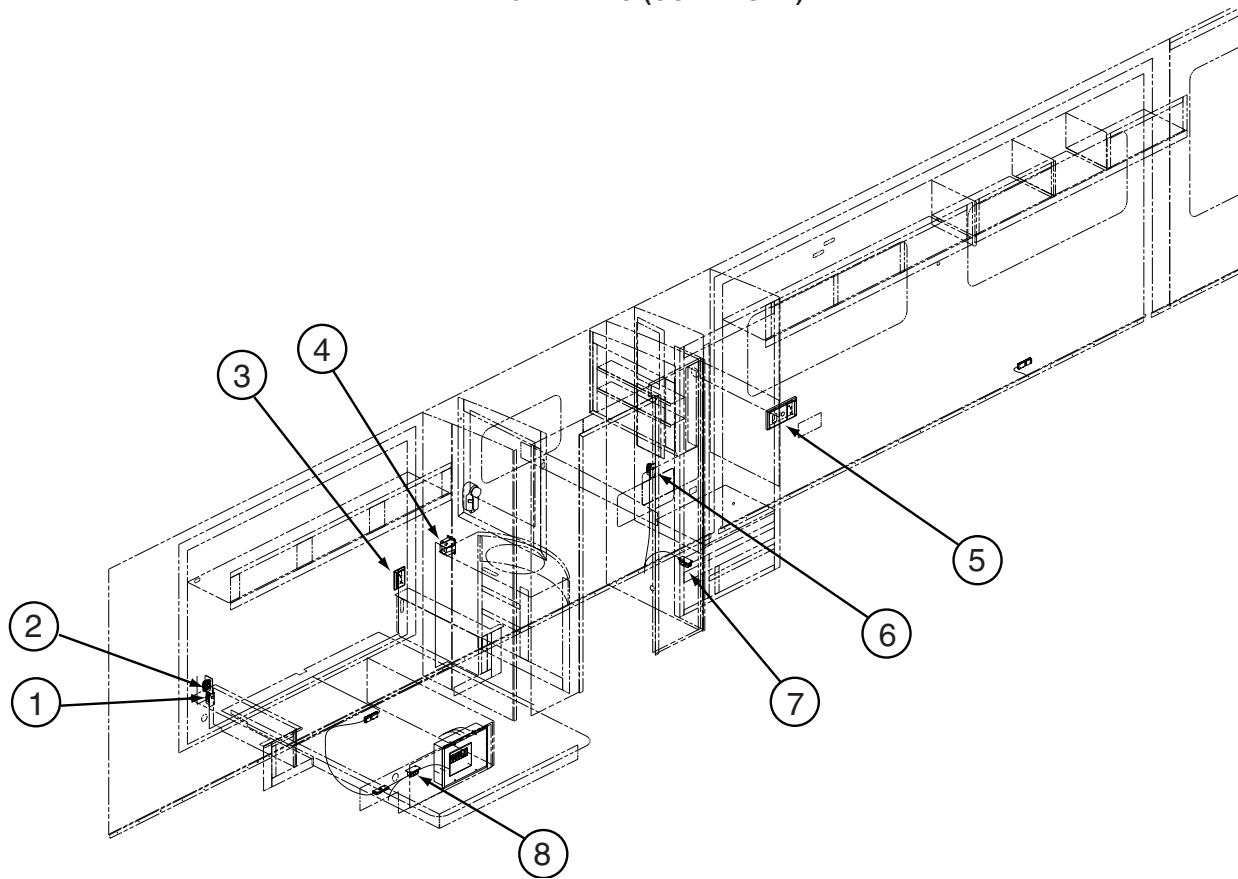

KEY	PART NUMBER	U/M	DESCRIPTION
1	058708-05-000	EA	RECEPTACLE - ELECTRIC - SINGLE - BROWN - W/SLEEP NUMBER BED
1	058708-07-000	EA	RECEPTACLE - ELECTRICAL - SINGLE - WHITE - W/SLEEP NUMBER BED
2	058708-01-000	EA	RECEPTACLE - ELECTRIC - DOUBLE - BROWN
3	058708-06-000	EA	RECEPTACLE - DUPLEX - WHITE
3	133713-01-20A	EA	SPACER/RECEPTACLE - WHITE VINYL
4	147446-01-01A	EA	RECEPTACLE - GFCI - 15A 125V - WHITE
4	147450-01-01A	EA	PLATE - ELECTRICAL OUTLET - WHITE
5	058708-06-000	EA	RECEPTACLE - DUPLEX - WHITE
5	133713-06-20A	EA	SPACER/RECEPTACLE - PHONE - WHITE VINYL
6	058707-01-000	EA	RECEPTACLE - ELECTRIC - SINGLE - BROWN
7	058708-05-000	EA	RECEPTACLE - ELECTRIC - SINGLE - BROWN
7	058708-07-000	EA	RECEPTACLE - ELECTRICAL - SINGLE - WHITE
8	058707-02-000	EA	RECEPTACLE - BLANK - JUNCTION BOX

ELECTRICAL GROUP (CONTINUED)
110V WIRING (CONTINUED)

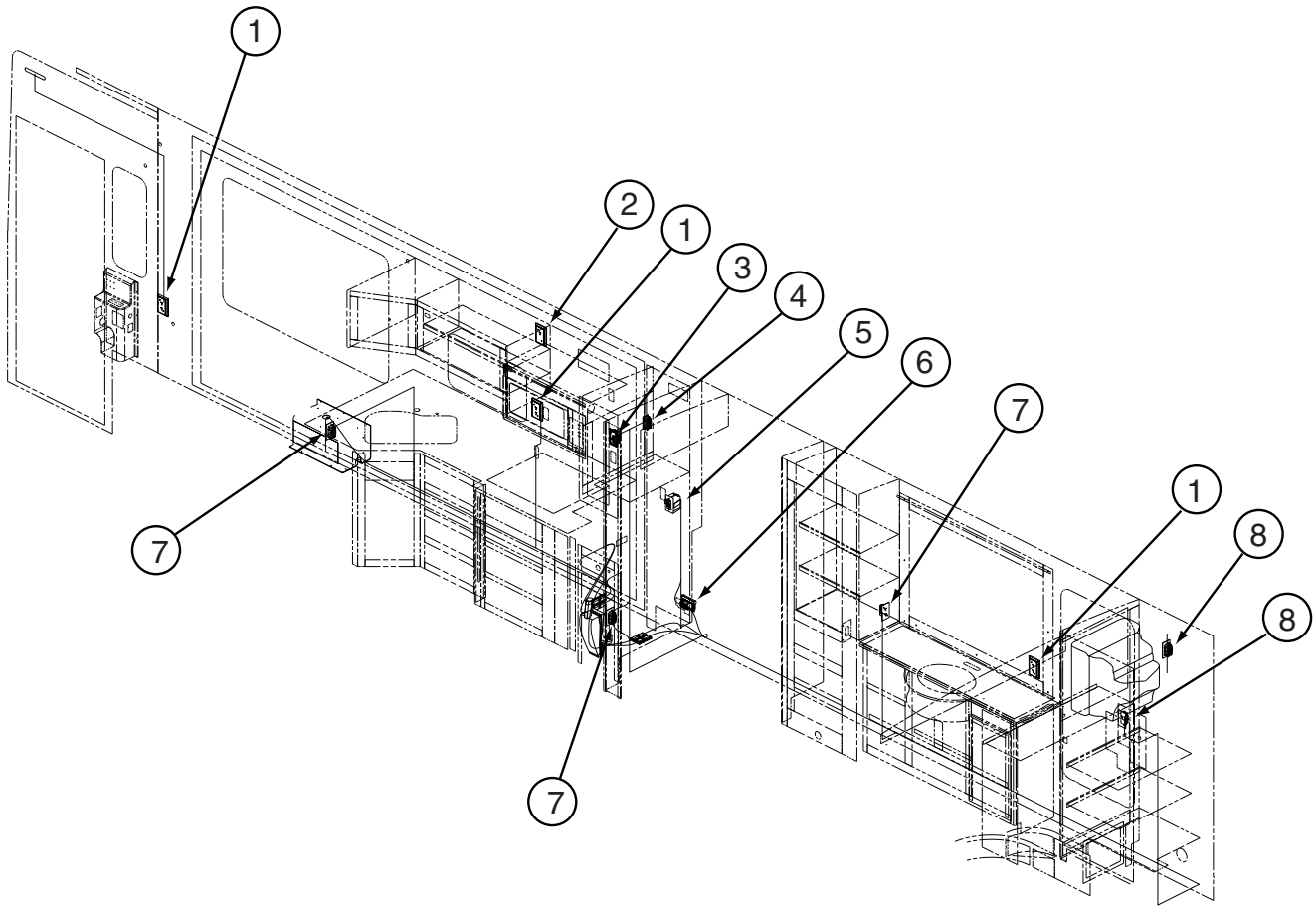

KEY	PART NUMBER	U/M	DESCRIPTION
1	058708-06-000	EA	RECEPTACLE - DUPLEX - WHITE
1	133713-01-20A	EA	SPACER/RECEPTACLE - WHITE VINYL
2	058708-05-000	EA	RECEPTACLE - ELECTRIC - SINGLE - BROWN
2	058708-07-000	EA	RECEPTACLE - ELECTRICAL - SINGLE - WHITE
2	133713-01-20A	EA	SPACER/RECEPTACLE - WHITE VINYL
3	084420-01-000	EA	SWITCH - TOGGLE - 15 AMP/120 VOLT - BROWN
4	058707-02-000	EA	RECEPTACLE - BLANK - JUNCTION BOX
5	147446-01-01A	EA	RECEPTACLE - GFCI - 15A 125V - WHITE
5	147450-01-01A	EA	PLATE - ELECTRICAL OUTLET - WHITE
6	131826-01-01A	EA	RECEPTACLE - EXTERIOR - W/COVER/GASKET - WHITE
7	058708-01-000	EA	RECEPTACLE - ELECTRIC - DOUBLE - BROWN
8	058708-05-000	EA	RECEPTACLE - ELECTRIC - SINGLE - BROWN
8	058708-07-000	EA	RECEPTACLE - ELECTRICAL - SINGLE - WHITE

ELECTRICAL GROUP (CONTINUED)
ENTERTAINMENT WIRING

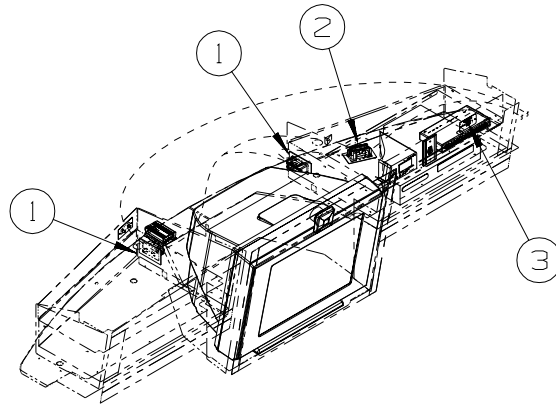

KEY	PART NUMBER	U/M	DESCRIPTION
1	058708-01-000	EA	RECEPTACLE - ELECTRIC - DOUBLE - BROWN
2	058708-06-000	EA	RECEPTACLE - DUPLEX - WHITE
3	079364-04-000	EA	SWITCH - ON/OFF ROCKER - 2 TERMINAL - BLACK
3	098351-09-01A	EA	PLATE/SWITCH - 1 GANG - POLISHED BRASS - SPEAKER SELECT/TV

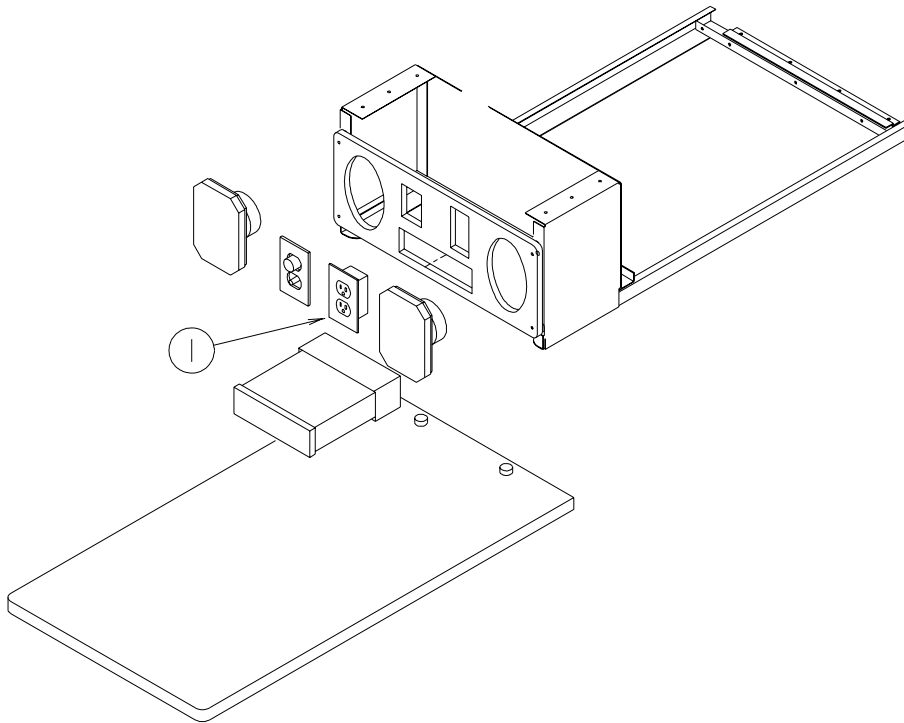

KEY	PART NUMBER	U/M	DESCRIPTION
1	058708-01-000	EA	RECEPTACLE - ELECTRIC - DOUBLE - BROWN

ELECTRICAL GROUP (CONTINUED)

BOXES & CORDS

KEY	PART NUMBER	U/M	DESCRIPTION
	091910-01-000	EA	BOX - ELECTRIC - 3.8" X 3.5" X 1.8" - PLASTIC
	091910-02-000	EA	BOX - ELECTRIC - 2.2" X 3.5" X 1.8" - PLASTIC
	092492-17-000	EA	SEAL - ELECTRICAL BOX
	106071-06-000	EA	SWITCH - AUTOMATIC TRANSFER
	108934-02-000	EA	CORD - POWER - 50 AMP - 4-WIRE - 36'
	113029-06-02B	EA	PANEL - ELECTRICAL BOX FRONT - E-COATED
	110080-05-000	EA	SEAL - ELECTRICAL BOX
	115832-01-000	FT	CORD - HEAVY DUTY - 14-2W GROUND
	131679-01-000	EA	BOX-ELEC-WATERPROOF SEALED 4" X 4" W/4 3/4"OUTLETS-UL/CSA
	131680-01-000	EA	COVER - W/GASKET FOR WATERPROOF 4" X 4" BOX - UL/CSA
	133070-01-000	EA	BOX - ELECTRIC/PLASTIC - 3" X 2" X 2.8" - UL
	133070-02-000	EA	BOX - ELECTRIC/PLASTIC - 3" X 2" X 2.8" - CSA
	142209-03-02B	EA	DOOR - ELECTRICAL BOX - E-COATED

WIRE ASSEMBLIES

KEY	PART NUMBER	U/M	DESCRIPTION
	096449-01-000	EA	WIRE ASSEMBLY - WATER TANK TO MONITOR PANEL
	096449-02-000	EA	WIRE ASSEMBLY - WATER TANK TO MONITOR PANEL
	096450-05-000	EA	WIRE F/SENSORS - BLACK WATER - 23.6"
	096451-07-000	EA	WIRE F/SENSORS - GREY WATER - 3.9"
	103991-01-000	EA	WIRE ASM-CRT BKR,POWER
	108029-05-000	EA	WIRE ASSEMBLY - POWER PASSENGER SEAT
	124843-07-000	EA	WIRE ASSEMBLY - SPEAKER ADAPTER
	124843-08-000	EA	WIRE ASSEMBLY - SPEAKER ADAPTER
	124882-08-000	EA	WIRE LOOM - AMPLIFIER - Q SURROUND
	125853-04-000	EA	WIRE LOOM - ENTERTAINMENT CENTER
	129888-01-000	EA	WIRE LOOM - INSTRUMENT PANEL - AIR HORN
	132267-01-000	EA	WIRE ASM-DOOR LOCK
	135131-01-000	EA	WIRE LOOM - THERMOSTAT
	135420-02-000	EA	WIRE LOOM - RADIO
	136028-01-000	EA	WIRE ASM-SOFA,REST EASY
	137135-03-000	EA	WIRE LOOM - DIGITAL ELEVATION SENSOR
	137135-04-000	EA	WIRE HARNESS - POWER - DIGITAL ELEVATION SENSOR
	139297-01-000	EA	RESISTOR - 10 OHM/10W CERAMIC
	139583-01-000	EA	WIRE LOOM - SOFA/DOUBLE REST EASY
	139583-02-000	EA	WIRE LOOM - SOFA/REAR SWITCH
	140167-01-000	EA	WIRE LOOM - GPS ADAPTER
	140195-01-000	EA	WIRE LOOM - RESISTOR/FAN
	141454-02-000	EA	WIRE LOOM - SATELLITE - AUTOMATIC
			FROM: 00-00-00 THRU: 07-06-03
	141454-04-000	EA	WIRE - SATELLITE - AUTOMATIC
			FROM: 07-07-03 THRU: 99-99-99
	142258-02-000	EA	WIRE LOOM - VIDEO SWITCH/POWER SUPPLY
	143545-01-000	EA	WIRE ASSEMBLY - REAR MONITOR
	143591-02-000	EA	WIRE LOOM - COMPUTER TRIP/ENGINE MONITOR-TRIP TEK 02-04007
	147139-02-000	EA	WIRE - STEREO KIT - ASA 100ZXIHAR
	147313-01-000	EA	WIRE - OUTSIDE TEMP SENSOR - W/O SENSOR
			FROM: 03-03-04 THRU: 99-99-99
	148115-01-000	EA	WIRE/POWER CABLE - SATELLITE RADIO
	149214-01-000	EA	WIRE - WINDSHIELD WIPER/WASHER - F/FL SYSTEM 3 ELECTRONICS
	149214-03-000	EA	WIRE - WINDSHIELD WIPER/WASHER - F/FL MMDC ELECTRICAL SYSTEM - W/O SMART WHEEL
	149214-02-000	EA	WIRE - WINDSHIELD WIPER/WASHER - F/FL MMDC ELECTRICAL SYSTEM - W/SMART WHEEL
			FROM: 00-00-00 THRU: 03-19-04
	149214-04-000	EA	WIRE - WINDSHIELD WIPER/WASHER - W/SMART WHEEL
			FROM: 03-20-04 THRU: 99-99-99
	151422-01-000	EA	PIGTAIL - F/FOG LIGHT
			FROM: 05-10-04 THRU: 99-99-99

ELECTRICAL GROUP (CONTINUED)
CONNECTORS & CONDUIT

KEY	PART NUMBER	U/M	DESCRIPTION
	007940-01-000	EA	RECEPTACLE/SLIDE 16 TO 12 AWG - FEMALE END
	007940-02-000	EA	RECEPTACLE-SLIDE 10 AWG - AMP 180351-2
	007954-01-000	EA	RECEPTACLE - HOUSING - 6 POSITION
	007956-05-000	EA	INSULATOR - SHRINK - 1/4" ID X 1 1/2"
	008058-01-700	EA	ADAP-ELEC.30AMP M X 50 AMP F 30M50F
	008058-01-000	EA	ADAPTER - POWER CORD - 30 AMP TO 15 AMP
	008311-01-000	EA	CONNECTOR - WIRE NUT - INSULATED - RED
	008312-01-000	EA	CONNECTOR - WIRE NUT - INSULATED - BLUE
	008313-01-000	EA	CONNECTOR - WIRE NUT - INSULATED - YELLOW
	008314-01-000	EA	CONNECTOR - WIRE NUT - INSULATED - GRAY
	008326-01-000	EA	TERMINAL - RING - 16/14 WIRE - 3/8" STUD
	008328-01-000	EA	TERMINAL - RING - 12/10 WIRE - #10 STUD FIT
	008331-01-000	EA	TERMINAL - RING - TONGUE - #4 WIRE - 3/8" STUD - COPPER
	008348-01-000	EA	TERMINAL - RING - 3/8" STUD 2 GA. WIRE
	008355-01-000	EA	CONNECTOR - CABLE CLAMPING - 3/4"
	008356-01-000	EA	CONNECTOR - PLASTIC - 3/8"
	008356-02-000	EA	CONNECTOR - PLASTIC - 21/32"
	008394-01-000	FT	CONDUIT - FLEXIBLE - 1/2"
	008398-01-000	EA	CONNECTOR - 1/2" X 90 DEGREE - FLEX CONDUIT - UL & CSA
	035416-04-000	EA	TERMINAL - RING - #10 STUD FIT - INSULATED BARREL #16/14
	041953-01-000	FT	CONDUIT - CONVOLUTE SLIT - .5" ID - POLYETHYLENE
	041953-02-000	FT	CONDUIT - CONVOLUTE SLIT - .6" ID - POLYETHYLENE
	041953-03-000	FT	CONDUIT - CONVOLUTE SLIT - 1" ID (CLOTHES ROD COVER)
	041953-06-000	FT	CONDUIT - CONVOLUTE SLIT - .4" ID - POLYETHYLENE
	041953-07-000	FT	CONDUIT - CONVOLUTE SLIT - .25" ID - POLYETHYLENE
	041953-08-000	FT	CONDUIT - CONVOLUTE SLIT - 1.5" ID - POLYETHYLENE
	041953-09-000	FT	CONDUIT - CONVOLUTE SLIT - .5" ID - NYLON
	041953-10-000	FT	CONDUIT - CONVOLUTE SLIT - .75" ID - NYLON
	041953-11-000	FT	CONDUIT - CONVOLUTE SLIT - 1.06" ID - NYLON
	041953-12-000	FT	CONDUIT - CONVOLUTE SOLID - 1.1" ID - NYLON
	041953-13-000	FT	CONDUIT - CONVOLUTE SLIT - 1.25" ID
	041953-14-000	FT	CONDUIT - CONVOLUTE SLIT - 1.5" ID
	041953-15-000	FT	CONDUIT - CONVOLUTE SLIT - 2"
	041953-16-000	FT	CONDUIT - CONVOLUTE SLIT - 2"
	047443-01-000	EA	TERMINAL - .250 RECEPTACLE FIT - INSULATED - 16/14 AWG
	047443-02-000	EA	TERMINAL - .250 RECEPTACLE FIT - INSULATED - 12/10 AWG
	058028-01-000	EA	CONNECTOR - ELECTRICAL PIGTAIL - NYLON - CLEAR
	062036-01-000	EA	TERMINAL - PACK - CON - 12/10 AWG
	074017-02-000	EA	HOUSING - 5 POSITION - RIGHT ANGLED
	077479-01-000	EA	BOOT - BATTERY TERMINAL - DOUBLE CABLE
	077479-02-000	EA	BOOT - BATTERY TERMINAL - SINGLE CABLE
	080015-02-000	EA	RECEPTACLE - FLAG - .185 - 16/14 GAUGE
	080015-03-000	EA	RECEPTACLE - FLAG - .250 - 14/16 GAUGE
	082109-01-000	EA	HOUSING - CONNECTOR - PACKARD
	082741-01-000	EA	CONNECTOR BODY - 2 CONNECTOR MALE
	087225-01-000	FT	SLEEVING - 1/2" - TYPE H
	087949-01-000	EA	BUSS BAR - 2 POSITION - .6" X 1.5"
	087949-03-000	EA	BUSS BAR - 4 POSITION
	087949-05-000	EA	BUSS BAR - 7 POSITION
	088473-01-000	EA	HOUSING - PIN - 12 CAVITY (3 ROWS OF 4)
	088473-02-000	EA	HOUSING - PIN - 15 CAVITY (3 ROWS OF 5)
	088473-03-000	EA	HOUSING - PIN - 9 CAVITY (3 ROWS OF 3)
	088473-04-000	EA	HOUSING - PIN - 8 CAVITY IN-LINE
	088473-06-000	EA	HOUSING - PIN - 6 CAVITY (2 ROWS OF 3)
	088473-07-000	EA	HOUSING - PIN - 5 CAVITY - IN LINE
	088473-08-000	EA	HOUSING - PIN - 4 CAVITY - IN-LINE
	088473-09-000	EA	HOUSING - PIN - 3 CAVITY - IN-LINE
	088473-10-000	EA	HOUSING - PIN - 2 CAVITY - IN LINE
	088474-01-000	EA	HOUSING - SOCKET - 12 CAVITY
	088474-02-000	EA	HOUSING - SOCKET - 15 CAVITY
	088474-03-000	EA	HOUSING - SOCKET - 9 CAVITY
	088474-06-000	EA	HOUSING - SOCKET - 6 CAVITY
	088474-07-000	EA	HOUSING - SOCKET - 5 CAVITY

ELECTRICAL GROUP (CONTINUED)
CONNECTORS & CONDUIT (CONTINUED)

KEY	PART NUMBER	U/M	DESCRIPTION
	088474-08-000	EA	HOUSING - SOCKET - 4 CAVITY
	088474-09-000	EA	HOUSING - SOCKET - 3 CAVITY
	088474-10-000	EA	HOUSING - SOCKET - 2 CAVITY
	088475-01-000	EA	PIN - CONNECTOR - 14-20 AWG
	088475-02-000	EA	PIN - CONNECTOR - 10-12 AWG
	088476-01-000	EA	TERMINAL - ELECTRICAL
	088476-02-000	EA	SOCKET - CONNECTOR - 12-10 GA - PRE-TIN
	098261-01-000	EA	SOCKET - CONNECTOR - WEATHERPACK - 12 AWG
	098261-02-000	EA	SOCKET - CONNECTOR - WEATHERPACK - 14-18 AWG
	098262-01-000	EA	SEAL - CONNECTOR - WEATHERPACK
	098264-01-000	EA	HOUSING - 2 PIN - WEATHER PACK - MALE W/FEMALE PINS
	098264-02-000	EA	HOUSING - 2 PIN - WEATHER PACK - FEMALE W/MALE PINS
	098265-02-000	EA	PIN - CONNECTOR - WEATHER PACK
	101751-02-000	EA	HOUSING - 1 PIN - WEATHERPACK
	102777-02-000	EA	TERMINAL - RING - #6 STUD - 10 AWG
	103608-01-000	EA	SOCKET - WEDGE BASE W/LEADS
	104100-01-000	EA	HOUSING - 1 POSITION - 75 AMPS
	104100-03-000	EA	TERMINAL - 75 AMP
	110178-01-000	EA	HOUSING - WIPER MOTOR
	112823-01-000	EA	SPLICE - REDUCER - 16-14 TO 18-22
	113135-01-000	EA	TERMINAL - FEMALE - M/P - 14-16 - F/SEALED TERMINAL
	113308-01-000	EA	TERMINAL - FEMALE - M/P - 14-16 - 280
	113468-01-000	EA	HOUSING - 2 POSITION-FEMALE-USED ON WIPER/WASHER WIRE ASM
	113638-02-000	EA	CONNECTOR - ACTUATOR
	115931-01-000	EA	COVER - CONNECTOR - 30 AMP W/LOCK RING
	115931-02-000	EA	COVER - CONNECTOR - 50 AMP W/LOCKING RING
	115932-01-000	EA	CONNECTOR - FEMALE - 30 AMP/120 VOLT
	115932-02-000	EA	CONNECTOR - FEMALE - 50 AMP/240 VOLT
	116811-01-000	EA	TERMINAL - .110 RECEPTACLE - 16-14 AWG
	118571-01-000	EA	CONNECTOR - 3-WAY - MALE/SEALED
	118571-02-000	EA	CONNECTOR - 3-WAY - FEMALE/SEALED
	118571-05-000	EA	LOCK - SECONDARY - FEMALE
	118571-06-000	EA	LOCK - SECONDARY - MALE
	118599-02-000	EA	TERMINAL - MALE - M/P - 280/14-12
	118820-01-000	EA	INSULATOR - TERMINAL
	129233-01-000	EA	HOUSING - 2-POSITION/FEMALE - 280-SERIES
	129233-02-000	EA	HOUSING - 2-POSITION/FEMALE - 280-SERIES
	131681-01-000	EA	CONNECTOR - 3/4" SO CORD - UL/CS
	137207-01-000	EA	HOUSING - PIN - 2 CAVITY/HIGH AMP
	137208-01-000	EA	HOUSING - SOCKET - 2 CAVITY/HIGH AMP
	137209-01-000	EA	PIN - CONNECTOR - 10AWG/HIGH AMP
	137210-01-000	EA	SOCKET - CONNECTOR - 10 AWG/HIGH AMP
	138419-03-000	EA	SOCKET - LAMP - 3 WIRE
	142520-01-000	EA	TERMINAL - FEMALE - MINI-FIT 16
	142522-01-000	EA	HOUSING - 4 PIN/MALE - MINI FIT
	142522-02-000	EA	HOUSING - 6 PIN/MALE - MINI FIT
	142522-03-000	EA	HOUSING - 8 PIN/MALE - MINI FIT
	142524-01-000	EA	HOUSING - 4 PIN/FEMALE - WEATHER PACK
	142524-02-000	EA	HOUSING - 4 PIN/WEATHER PACK/FEMALE
	144283-01-000	EA	CONNECTOR - WIRE, SOW, BLUE, MOLEX 19403-0011
	144283-02-000	EA	CONNECTOR - WIRE, NM, CLEAR, MOLEX 19045-1000

BOOTS, SOLENOIDS, RELAYS & MISCELLANEOUS

KEY	PART NUMBER	U/M	DESCRIPTION
	008188-02-000	EA	SOLENOID - VENTED - HEAVY DUTY
	063910-01-000	EA	HOUSING - RELAY
	063912-02-000	EA	RELAY - CANISTER - SPDT
	086233-01-000	EA	STUD - ISOLATED - 3/8" X 7/8" LONG
	086273-01-000	EA	RELAY - BATTERY DISCONNECT
*	113832-02-01A	EA	SLIDE - BATTERY TRAY - HEAVY DUTY - W/RETAINING STRAPS - P32T
*	113832-03-01A	EA	SLIDE-BATT. TRAY-W/BATT. RETAINING STRAPS-BATT. TWO - INVER./CHARGER 2,000 WATT. - P32T

*COMPONENT PARTS LISTED LATER IN THIS GROUP

ELECTRICAL GROUP (CONTINUED)
COMPONENT PARTS FOR BOOTS, SOLENOIDS, RELAYS & MISCELLANEOUS

113832-02-01A

KEY	PART NUMBER	U/M	DESCRIPTION	VENDOR NO.
	113832-01-700	EA	STRAP-FLAT W/J-HOOK & LATCH	8323

113832-03-01A

KEY	PART NUMBER	U/M	DESCRIPTION	VENDOR NO.
	113832-01-700	EA	STRAP-FLAT W/J-HOOK & LATCH	8323

EXTERIOR BODY GROUP AIR HORN

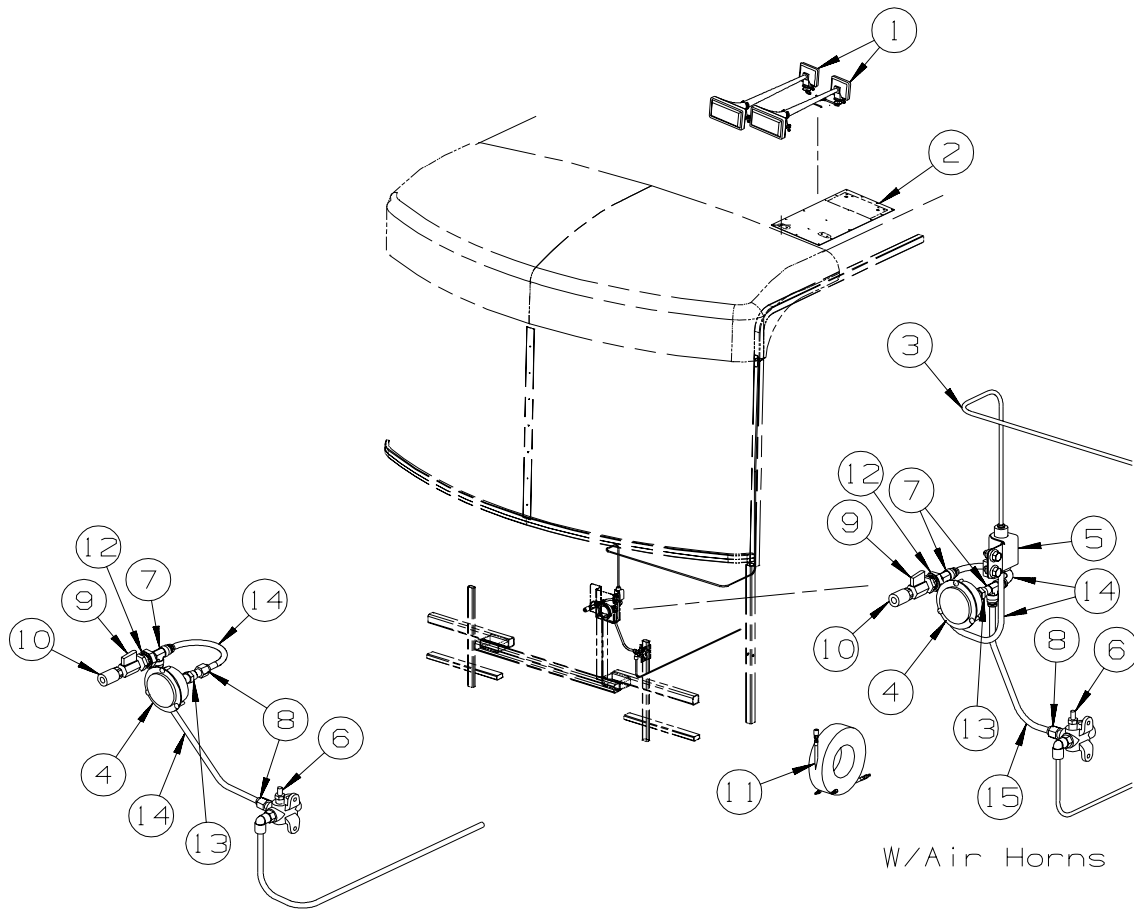

W/O Air Horns

W/Air Horns

KEY	PART NUMBER	U/M	DESCRIPTION
1*	077497-06-000	EA	HORN - AIR - CHROME - TWIN
2	125123-01-12B	EA	PLATE/MOUNT - AIR HORN - 25" X 13" - BRIGHT WHITE
3	071390-04-000	FT	TUBING - AIR BRAKE - 1/4" OD-BLK WEATHERHEAD(BRKS & HORN)
4	142609-01-000	EA	GAUGE/AIR - 2.5" MOUNTING FLANGE - 1/4" MPT
5	077497-11-000	EA	SOLENOID - HORN - REMOTE MOUNT
6	086241-01-000	EA	VALVE - AIR - 1/4 MPT X TIRE STEM
7	142570-01-000	EA	TEE - 3/8"T X 1/4"P
8	142571-01-000	EA	CONNECTOR - 3/8"T X 1/4"P
9	142597-01-000	EA	VALVE - BALL - AIR - 1/4"MFPT
10	142595-01-000	EA	COUPLER - QUICK CONNECT - AIR - 1/4"MPT
11	142607-03-000	EA	HOSE - AIR - 50'
12	071374-03-000	EA	FITTING - BULKHEAD - 1/4" X 1/4" MNPT
13	075155-03-000	EA	COUPLING-PIPE,1/4 BRASS
14	071390-07-000	FT	TUBING - AIR BRAKE - 3/8" - BLACK
15	071390-06-000	FT	TUBING - FUEL/DIESEL - 3/8" - BLUE (AIR HORNS) - S-SERIES

*COMPONENT PARTS LISTED LATER IN THIS GROUP

EXTERIOR BODY GROUP (CONTINUED)
COMPONENT PARTS FOR AIR HORN

077497-06-000

KEY	PART NUMBER	U/M	DESCRIPTION	VENDOR NO.
	077497-01-701	EA	SWITCH - COMPRESSOR	13940-S
	077497-01-702	EA	SWITCH - TOGGLE - W/WIRE	12949-S

EXTERIOR BODY GROUP (CONTINUED)

GRAPHICS & PAINT

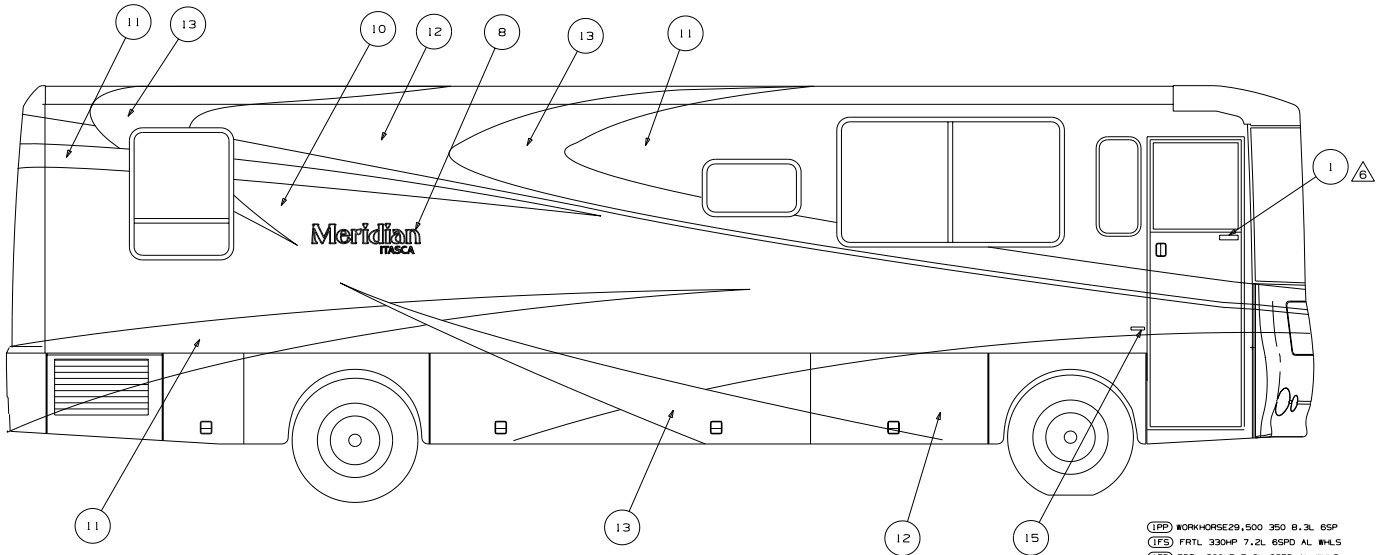

- (1PP) #ORKHORSE29,500 350 B,3L 6SP
- (IFS) FRTL 330HP 7,2L 6SPD AL WHLS
- (IFB) FRTL 300HP 5,9L 6SPD AL WHLS
- (24C) EXT FULL BODY PAINT PKG # 3
- (92A) EXT FULL BODY PAINT PKG # 2
- (27A) EXT FULL BODY PAINT PKG #1

- △ SATTELLITE DOME TO BE PAINTED.
- △ ALSO ON DRIVERS SIDE.
- △ DIE CUT ACRYLIC 3M FILM USED TO PROTECT FULL BODY PAINTED UNITS.
- 4. ON FULL BODY PAINT UNITS, USE 145487-01-000 (100 FT.) TO COVER UNSEALED ROOF SEAMS.
- △ CLEAR COAT TO BE APPLIED ON ENTIRE UNIT TO PROTECT PAINT.
- △ CENTER ON UNIT.
- 1. APPLY PROTECTOR 116424-01-000 TO WATER HEATER HATCH.

NOTES:

(27A) KEY	PART NUMBER	U/M	DESCRIPTION ARCTIC DUSK
1	132664-01-CHT(01A)	EA	DECAL-LOGO,DOMED,WINNEBAGO - GOLD CHROME/BLACK
(1PP) (IFS) → 3	135089-02-CHT(01A)	EA	DECAL-DOMED HORSEPOWER 330 - BRT WHITE/CHROME/BLACK
(IFB) → 4	135089-03-CHT(01A)	EA	DECAL-DOMED HORSEPOWER 300 - BRT WHITE/CHROME/BLACK
5	137618-03-CHT(01A)	EA	DECAL/BEZEL DOMED GRILLE LOGO - BLACK/GOLD
△ → 6	143366-68-000	GL	PAINT CLEAR - DUPONT/SPIES #8000
(24P) → 7	143369-01-000	EA	KIT - 3M PAINT PROTECTION
8	147293-01-CHT(01A)	EA	DECAL-LOGO,DOMED MERIDIAN,LG - CHROME/GOLD/BLACK/WHITE
9	147293-02-CHT(01A)	EA	DECAL-LOGO,DOMED MERIDIAN,SML - CHROME/GOLD/BLACK/WHITE
10	-----	GL	PAINT-SILVER - SHERWIN WILLIAMS #43638
11	-----	GL	PAINT-SLATE GREY PEARL - SHERWIN WILLIAMS #44995
12	-----	GL	PAINT-GUMMETAL - SHERWIN WILLIAMS #33936
13	-----	GL	PAINT-MED OPAL - SHERWIN WILLIAMS #45809
14	-----	EA	PLATE-FREIGHTLINER,LG - (CHASSIS SUPPLIED)
15	-----	EA	PLATE-FREIGHTLINER,SML - (CHASSIS SUPPLIED)
△ → 16	-----	GL	PAINT - CUSTOM BLEND NON-METALLIC PAINT TO MATCH SLATE GREY PEARL #44995

(92A) KEY	PART NUMBER	U/M	DESCRIPTION SILVER FROST
1	132664-01-CHT(01A)	EA	DECAL-LOGO,DOMED,WINNEBAGO - GOLD CHROME/BLACK
(1PP) (IFS) → 3	135089-02-CHT(01A)	EA	DECAL-DOMED HORSEPOWER 330 - BRT WHITE/CHROME/BLACK
(IFB) → 4	135089-03-CHT(01A)	EA	DECAL-DOMED HORSEPOWER 300 - BRT WHITE/CHROME/BLACK
5	137618-03-CHT(01A)	EA	DECAL/BEZEL DOMED GRILLE LOGO - BLACK/GOLD
△ → 6	143366-68-000	GL	PAINT CLEAR - DUPONT/SPIES #8000
(24P) → 7	143369-01-000	EA	KIT - 3M PAINT PROTECTION
8	147293-01-CHT(01A)	EA	DECAL-LOGO,DOMED MERIDIAN,LG - CHROME/GOLD/BLACK/WHITE
9	147293-02-CHT(01A)	EA	DECAL-LOGO,DOMED MERIDIAN,SML - CHROME/GOLD/BLACK/WHITE
10	-----	GL	PAINT-LT.GRAY - SHERWIN WILLIAMS #45729
11	-----	GL	PAINT-PURPLE PEARL - SHERWIN WILLIAMS #46838
12	-----	GL	PAINT-SILVER FROST - SHERWIN WILLIAMS #50312
13	-----	GL	PAINT-MED QUARTZ - SHERWIN WILLIAMS #41562
14	-----	EA	PLATE-FREIGHTLINER,LG - (CHASSIS SUPPLIED)
15	-----	EA	PLATE-FREIGHTLINER,SML - (CHASSIS SUPPLIED)
△ → 16	-----	GL	PAINT - CUSTOM BLEND NON-METALLIC PAINT TO MATCH PURPLE PEARL #46838

(24C) KEY	PART NUMBER	U/M	DESCRIPTION STONEHENGE
1	132664-01-CHT(01A)	EA	DECAL-LOGO,DOMED,WINNEBAGO - GOLD CHROME/BLACK
(1PP) (IFS) → 3	135089-02-CHT(01A)	EA	DECAL-DOMED HORSEPOWER 330 - BRT WHITE/CHROME/BLACK
(IFB) → 4	135089-03-CHT(01A)	EA	DECAL-DOMED HORSEPOWER 300 - BRT WHITE/CHROME/BLACK
5	137618-03-CHT(01A)	EA	DECAL/BEZEL DOMED GRILLE LOGO - BLACK/GOLD
△ → 6	143366-68-000	GL	PAINT CLEAR - DUPONT/SPIES #8000
(24P) → 7	143369-01-000	EA	KIT - 3M PAINT PROTECTION
8	147293-01-CHT(01A)	EA	DECAL-LOGO,DOMED MERIDIAN,LG - CHROME/GOLD/BLACK/WHITE
9	147293-02-CHT(01A)	EA	DECAL-LOGO,DOMED MERIDIAN,SML - CHROME/GOLD/BLACK/WHITE
10	-----	GL	PAINT-BRIGHT PLATINUM - SHERWIN WILLIAMS #48B23
11	-----	GL	PAINT-CINNAMON GLAZE - SHERWIN WILLIAMS #54469
12	-----	GL	PAINT-LT.PEARLSTONE - SHERWIN WILLIAMS #41824
13	-----	GL	PAINT-HARVEST GOLD - SHERWIN WILLIAMS #57343
14	-----	EA	PLATE-FREIGHTLINER,LG - (CHASSIS SUPPLIED)
15	-----	EA	PLATE-FREIGHTLINER,SML - (CHASSIS SUPPLIED)
△ → 16	-----	GL	PAINT - CUSTOM BLEND NON-METALLIC PAINT TO MATCH CINNAMON GLAZE #54469

EXTERIOR BODY GROUP (CONTINUED) GRAPHICS & PAINT (CONTINUED)

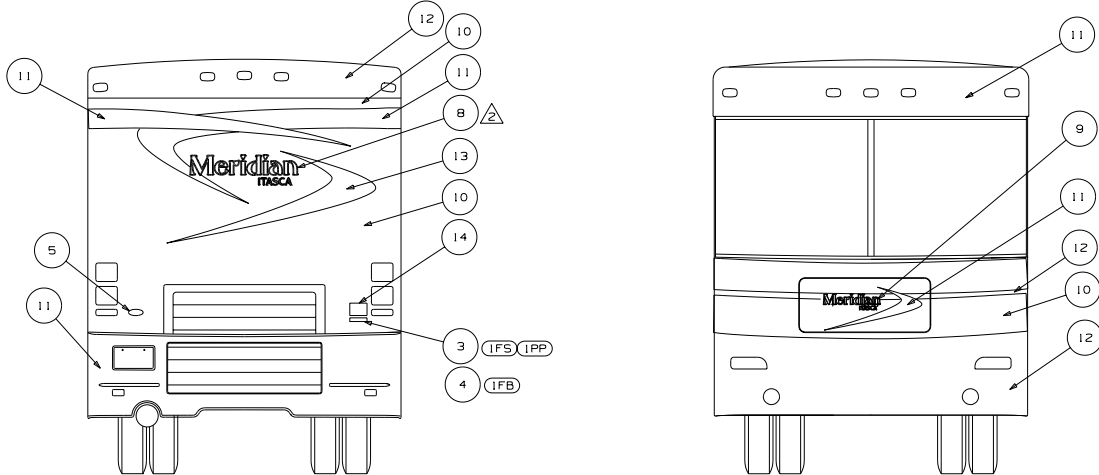

(27A) KEY

KEY	PART NUMBER	U/M	DESCRIPTION ARCTIC DUSK
1	132664-01-CHT(01A)	EA	DECAL-LOGO,DOMED,WINNEBAGO - GOLD CHROME/BLACK
3 (IFS, IPP)	135089-02-CHT(01A)	EA	DECAL-DOMED HORSEPOWER 330 - BRT WHITE/CHROME/BLACK
4 (IFB)	135089-03-CHT(01A)	EA	DECAL-DOMED HORSEPOWER 300 - BRT WHITE/CHROME/BLACK
5	137618-03-CHT(01A)	EA	DECAL/BEZEL DOMED GRILLE LOGO - BLACK/GOLD
6 (triangle)	143366-68-000	GL	PAINT CLEAR - DUPONT/SPIES #8000
7 (24P, triangle with 5)	143369-01-000	EA	KIT - 3M PAINT PROTECTION
8	147293-01-CHT(01A)	EA	DECAL-LOGO,DOMED MERIDIAN,LG - CHROME/GOLD/BLACK/WHITE
9	147293-02-CHT(01A)	EA	DECAL-LOGO,DOMED MERIDIAN,SML - CHROME/GOLD/BLACK/WHITE
10	-----	GL	PAINT-SILVER - SHERWIN WILLIAMS #43638
11	-----	GL	PAINT-SLATE GREY PEARL - SHERWIN WILLIAMS #44995
12	-----	GL	PAINT-GUMMETAL - SHERWIN WILLIAMS #33936
13	-----	GL	PAINT-MED OPAL - SHERWIN WILLIAMS #45809
14	-----	EA	PLATE-FREIGHTLINER,LG - (CHASSIS SUPPLIED)
15	-----	EA	PLATE-FREIGHTLINER,SML - (CHASSIS SUPPLIED)
16 (7, triangle)	-----	GL	PAINT - CUSTOM BLEND NON-METALLIC PAINT TO MATCH SLATE GREY PEARL #44995

(92A) KEY

KEY	PART NUMBER	U/M	DESCRIPTION SILVER FROST
1	132664-01-CHT(01A)	EA	DECAL-LOGO,DOMED,WINNEBAGO - GOLD CHROME/BLACK
3 (IFS, IPP)	135089-02-CHT(01A)	EA	DECAL-DOMED HORSEPOWER 330 - BRT WHITE/CHROME/BLACK
4 (IFB)	135089-03-CHT(01A)	EA	DECAL-DOMED HORSEPOWER 300 - BRT WHITE/CHROME/BLACK
5	137618-03-CHT(01A)	EA	DECAL/BEZEL-DOMED GRILLE LOGO - BLACK/GOLD
6 (triangle)	143366-68-000	GL	PAINT CLEAR - DUPONT/SPIES #8000
7 (24P, triangle with 5)	143369-01-000	EA	KIT - 3M PAINT PROTECTION
8	147293-01-CHT(01A)	EA	DECAL-LOGO,DOMED MERIDIAN,LG - CHROME/GOLD/BLACK/WHITE
9	147293-02-CHT(01A)	EA	DECAL-LOGO,DOMED MERIDIAN,SML - CHROME/GOLD/BLACK/WHITE
10	-----	GL	PAINT-LT.GRAY - SHERWIN WILLIAMS #45729
11	-----	GL	PAINT-PURPLE PEARL - SHERWIN WILLIAMS #46838
12	-----	GL	PAINT-SILVER FROST - SHERWIN WILLIAMS #50312
13	-----	GL	PAINT-MED QUARTZ - SHERWIN WILLIAMS #41562
14	-----	EA	PLATE-FREIGHTLINER,LG - (CHASSIS SUPPLIED)
15	-----	EA	PLATE-FREIGHTLINER,SML - (CHASSIS SUPPLIED)
16 (7, triangle)	-----	GL	PAINT - CUSTOM BLEND NON-METALLIC PAINT TO MATCH PURPLE PEARL #46838

(24C) KEY

KEY	PART NUMBER	U/M	DESCRIPTION STONEHENGE
1	132664-01-CHT(01A)	EA	DECAL-LOGO,DOMED,WINNEBAGO - GOLD CHROME/BLACK
3 (IFS, IPP)	135089-02-CHT(01A)	EA	DECAL-DOMED HORSEPOWER 330 - BRT WHITE/CHROME/BLACK
4 (IFB)	135089-03-CHT(01A)	EA	DECAL-DOMED HORSEPOWER 300 - BRT WHITE/CHROME/BLACK
5	137618-03-CHT(01A)	EA	DECAL/BEZEL-DOMED GRILLE LOGO - BLACK/GOLD
6 (triangle)	143366-68-000	GL	PAINT CLEAR - DUPONT/SPIES #8000
7 (24P, triangle with 5)	143369-01-000	EA	KIT - 3M PAINT PROTECTION
8	147293-01-CHT(01A)	EA	DECAL-LOGO,DOMED MERIDIAN,LG - CHROME/GOLD/BLACK/WHITE
9	147293-02-CHT(01A)	EA	DECAL-LOGO,DOMED MERIDIAN,SML - CHROME/GOLD/BLACK/WHITE
10	-----	GL	PAINT-BRIGHT PLATINUM - SHERWIN WILLIAMS #48B23
11	-----	GL	PAINT-CINNAMON GLAZE - SHERWIN WILLIAMS #54469
12	-----	GL	PAINT-LT.PEARLSTONE - SHERWIN WILLIAMS #41824
13	-----	GL	PAINT-HARVEST GOLD - SHERWIN WILLIAMS #57343
14	-----	EA	PLATE-FREIGHTLINER,LG - (CHASSIS SUPPLIED)
15	-----	EA	PLATE-FREIGHTLINER,SML - (CHASSIS SUPPLIED)
16 (7, triangle)	-----	GL	PAINT - CUSTOM BLEND NON-METALLIC PAINT TO MATCH CINNAMON GLAZE #54469

**DUPONT COLOR CODES ARE NOW FOUND IN THE PAINT CODE MANUAL.
YOU CAN FIND THIS MANUAL ON YOUR DEALER INDEX WEBPAGE UNDER SERVICE.**

EXTERIOR BODY GROUP (CONTINUED)

PANELS & TRIMS

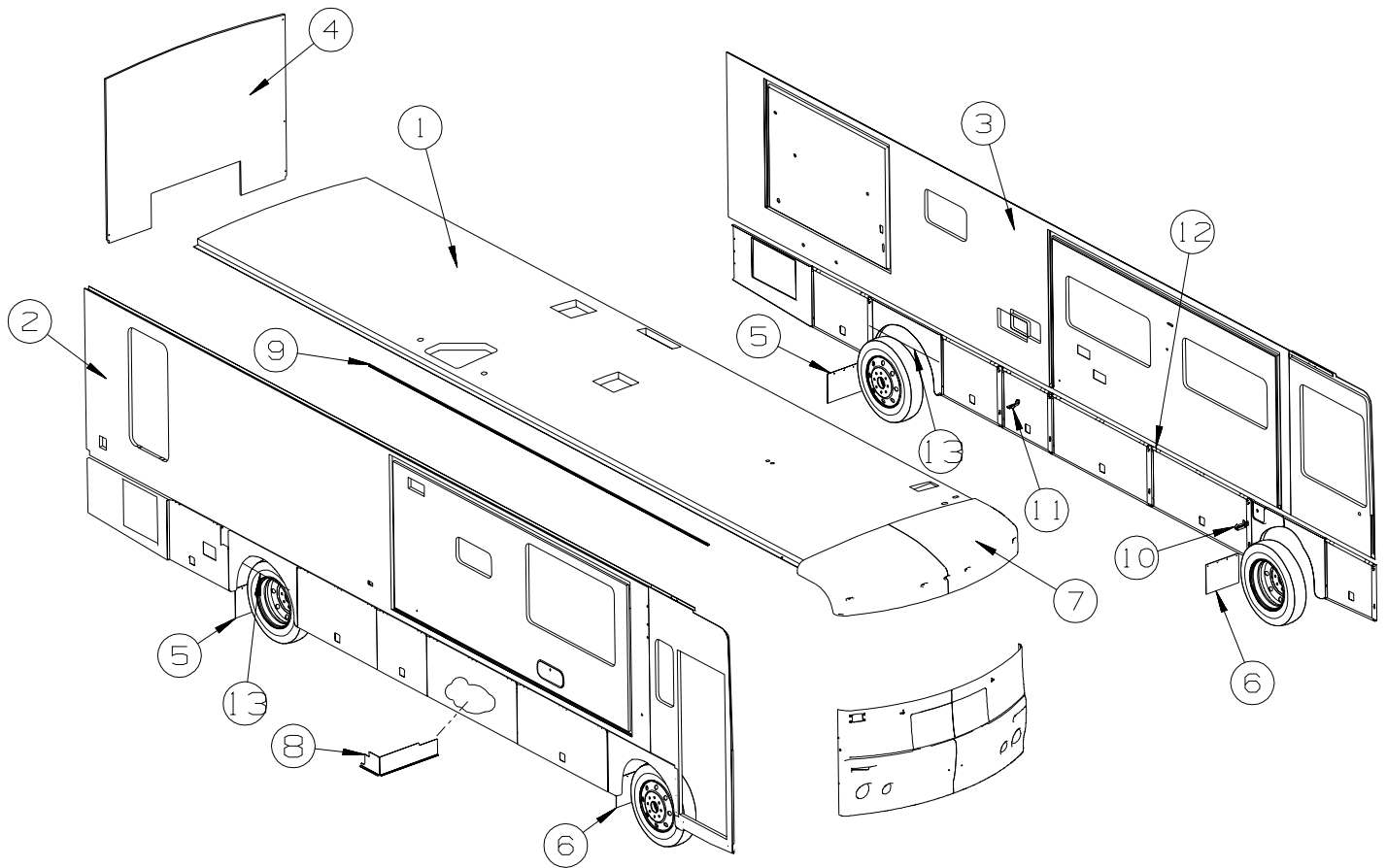

KEY	PART NUMBER	U/M	DESCRIPTION
1	147175-01-R68	EA	ROOF - W/O LIGHTS/VENTS - W/WIRING
2	147173-02-R74	EA	SIDEWALL - PASSENGER - W/O WINDOWS/TRIMS (R74)
2	147173-02-R75	EA	SIDEWALL - PASSENGER - W/O WINDOWS/TRIMS (R75)
2	147173-02-R76	EA	SIDEWALL - PASSENGER - W/O WINDOWS/TRIMS (R76)
			FROM: 00-00-00 THRU: 01-04-04
2	147173-02-RW7	EA	SIDEWALL - PASSENGER - W/O WINDOWS/TRIMS (R76)
			FROM: 01-05-04 THRU: 99-99-99
2	147173-02-R77	EA	SIDEWALL - PASSENGER - W/O WINDOWS/TRIMS (R77)
2	147173-02-R78	EA	SIDEWALL - PASSENGER - W/O WINDOWS/TRIMS (R78)
2	147173-02-R79	EA	SIDEWALL - PASSENGER - W/O WINDOWS/TRIMS (R79)
			FROM: 00-00-00 THRU: 01-04-04
2	147173-02-RW8	EA	SIDEWALL - PASSENGER - W/O WINDOWS/TRIMS (R79)
			FROM: 01-05-04 THRU: 99-99-99
2	147173-02-R80	EA	SIDEWALL - PASSENGER - W/O WINDOWS/TRIMS (R80)
2	147173-02-R81	EA	SIDEWALL - PASSENGER - W/O WINDOWS/TRIMS (R81)
2	147173-02-R82	EA	SIDEWALL - PASSENGER - W/O WINDOWS/TRIMS (R82)
			FROM: 00-00-00 THRU: 01-04-04
2	147173-02-RW4	EA	SIDEWALL - PASSENGER - W/O WINDOWS/TRIMS (R82)
			FROM: 01-05-04 THRU: 99-99-99
3	147174-01-R68	EA	SIDEWALL - DRIVER - W/O WINDOWS/TRIMS (R74, R75, R76)
3	147174-01-R70	EA	SIDEWALL - DRIVER - W/O WINDOWS/TRIMS (R77, R78, R79)
3	147174-01-R72	EA	SIDEWALL - DRIVER - W/O WINDOWS/TRIMS (R80, R81, R82)
4	140342-02-R74	EA	BACKWALL - W/O WINDOWS/TRIMS (R74, R75, R76) - FREIGHTLINER
4	140342-02-R77	EA	BACKWALL - W/O WINDOWS/TRIMS (R77, R78, R79) - FREIGHTLINER
4	140342-02-N88	EA	BACKWALL - W/O WINDOWS/TRIMS (R80, R81, R82) - FREIGHTLINER
4	147684-02-R74	EA	BACKWALL - W/O WINDOWS/TRIMS (R74, R75, R76) - WORKHORSE
4	147684-02-R77	EA	BACKWALL - W/O WINDOWS/TRIMS (R77, R78, R79) - WORKHORSE
4	147684-02-R80	EA	BACKWALL - W/O WINDOWS/TRIMS (R80, R81, R82) - WORKHORSE
5	017516-07-000	EA	MUD FLAP - 14"H X 23.5"W - BLACK
	140922-01-02B	EA	PLATE - MUD FLAP - E-COATED
6	017516-01-000	EA	MUD FLAP - 14"H X 18"W - W/O MOUNTING HOLES - BLACK
	140922-01-02B	EA	PLATE - MUD FLAP - E-COATED
7	131635-02-L76	EA	CAP - ROOF - W/O LIGHTS/WIRING

EXTERIOR BODY GROUP (CONTINUED)
PANELS AND TRIMS (CONTINUED)

KEY	PART NUMBER	U/M	DESCRIPTION
8	134811-01-02B	EA	PANEL - COVER - WATER SYSTEM - E-COATED
9	142123-02-02A	EA	RAIL/AWNING - 232" - BLACK
10	143219-01-01A	EA	SEAL - CORNER - F/REAR SLIDEOUT
11	143219-02-01A	EA	SEAL - CORNER - F/REAR SLIDEOUT
12	143905-01-000	FT	SEAL - LOWER - F/SLIDEOUT
13	105290-01-000	SF	INSULATION - AIR POCKET W/FOIL

EXTERIOR BODY GROUP (CONTINUED)
PANELS & TRIMS (CONTINUED)

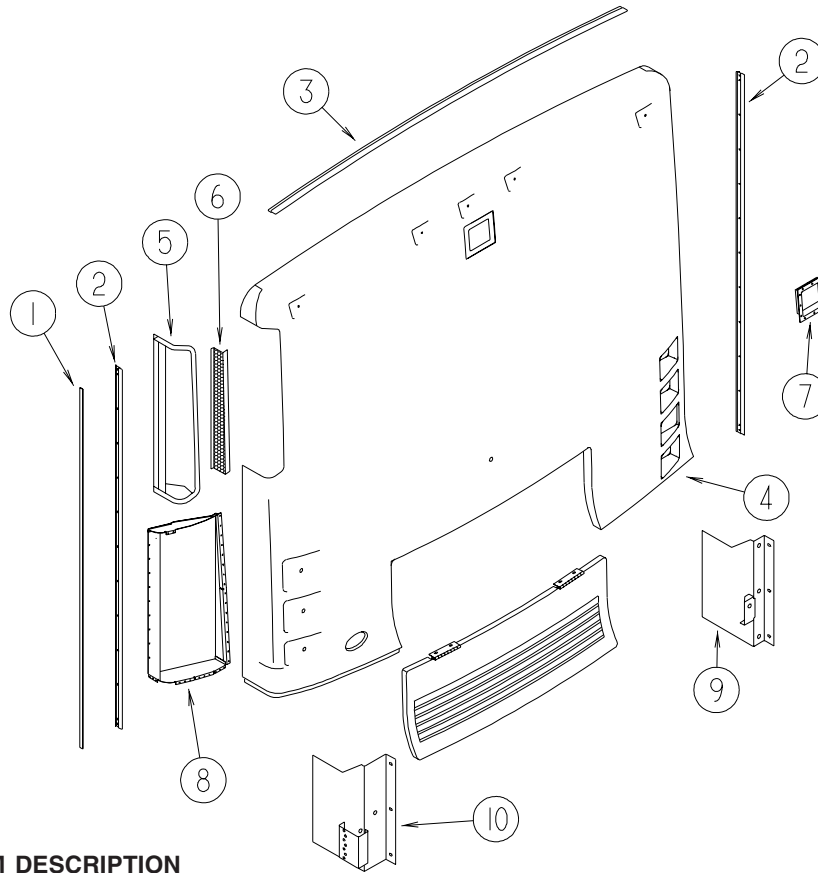

KEY	PART NUMBER	U/M	DESCRIPTION
1	091985-01-07A	FT	INSERT - TRIM - BRIGHT WHITE - 1"
2	092041-05-01A	EA	TRIM - REAR - CAP TO SIDEWALL - BRIGHT WHITE
2	092041-09-01A	EA	TRIM - FRONT/REAR CAP (SIDEWALL) - 77.3" - BRIGHT WHITE FROM: 00-00-00 THRU: 01-11-04 FROM: 01-12-04 THRU: 99-99-99
3	083805-23-000	EA	TRIM - ROOF CAP - 92.1" - BRIGHT WHITE
4	131897-06-R68	EA	PANEL/REAR CAP - W/O DOOR/LIGHTS - W/SHROUD BACKING PLATE - REAR VIEW MONITOR
4	131897-08-R68	EA	PANEL/REAR CAP - W/O DOOR/LIGHTS/SHROUD PLATE
5	131896-01-01A	EA	PANEL/AIR SCOOP - BRIGHT WHITE
6	129683-01-02A	EA	PANEL - AIR INTAKE - BLACK
7	P23280-01-01A	EA	SHROUD - CAMERA - INNER
8	132239-01-02B	EA	PANEL/AIR INTAKE - E-COATED
9	NA		CONTACT WINNEBAGO PART SALES
10	NA		CONTACT WINNEBAGO PART SALES

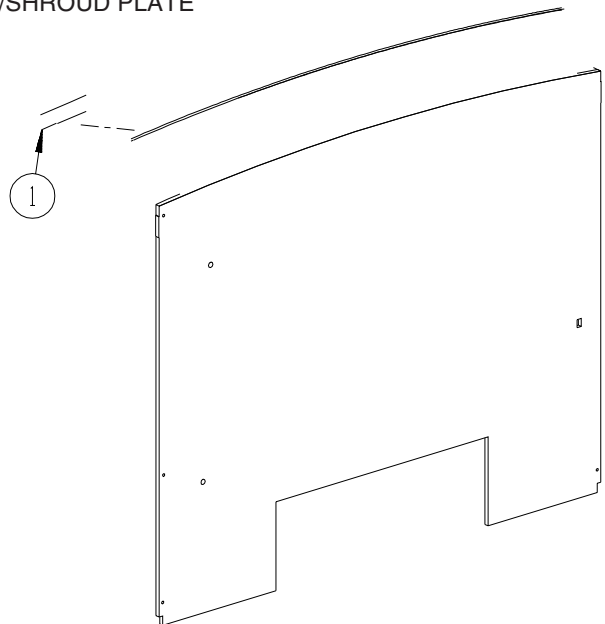

KEY	PART NUMBER	U/M	DESCRIPTION
1	114248-02-01A	EA	ANGLE - PLASTIC - 96.6"

EXTERIOR BODY GROUP (CONTINUED)
PANELS & TRIMS (CONTINUED)

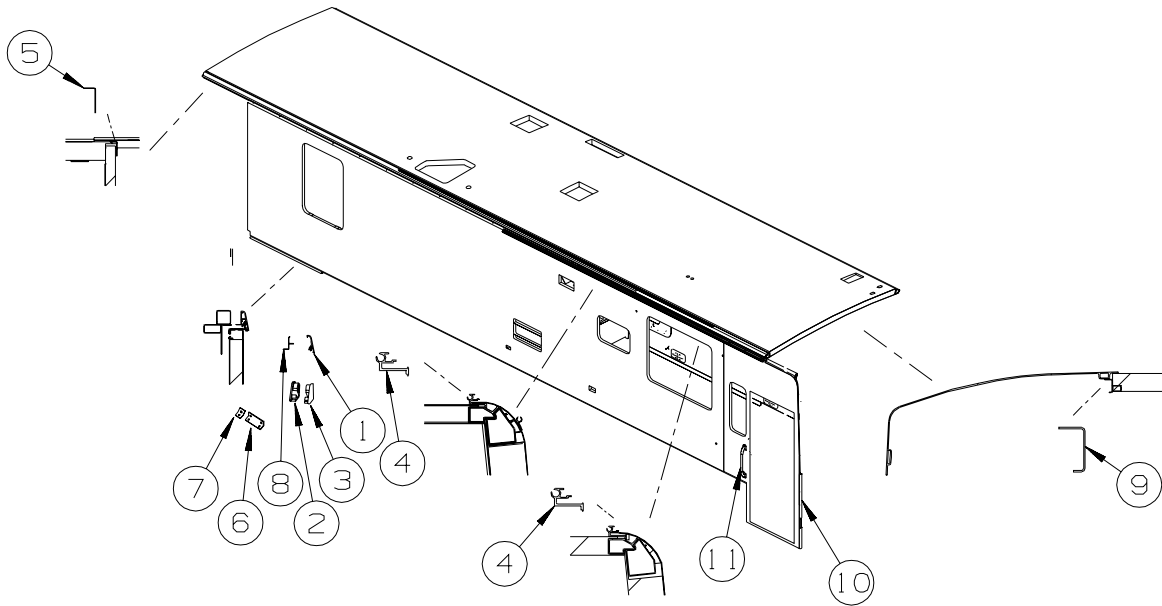

KEY	PART NUMBER	U/M	DESCRIPTION
1	123993-01-02A	EA	TRIM - COVER - 182" ALUMINUM - BLACK FROM: 00-00-00 THRU: 12-07-03
1	146550-01-02A	EA	TRIM COVER - SIDEWALL FROM: 12-08-03 THRU: 99-99-99
2	126775-01-02A	EA	END CAP - VALANCE TRIM - RIGHT HAND - BLACK FROM: 00-00-00 THRU: 12-07-03
2	146576-01-02A	EA	CAP - END/TRIM - RIGHT HAND FROM: 12-08-03 THRU: 99-99-99
3	126775-02-02A	EA	END CAP - VALANCE TRIM - LEFT HAND - BLACK FROM: 00-00-00 THRU: 12-07-03
3	146576-02-02A	EA	CAP - END/TRIM - LEFT HAND- BLACK FROM: 12-08-03 THRU: 99-99-99
4	131483-01-01A	EA	RAIL - AWNING - 192" - BRIGHT WHITE
5	132273-01-02B	EA	BRACKET - REAR TRIM - E-COATED
6	143143-02-01A	EA	ANGLE - SUPPORT/TRIM
7	143143-01-01A	EA	ANGLE - SUPPORT/TRIM
8	133376-01-01A	EA	TRIM - RETAINER - 144" - MILL FROM: 00-00-00 THRU: 12-07-03
8	146548-01-01A	EA	TRIM - RETAINER FROM: 12-08-03 THRU: 99-99-99
9	134774-01-02B	EA	BRACKET - CAB ATTACHMENT - E-COATED
10	093673-01-06A	FT	TRIM/MOLDING - 1.4" WIDE X 8' LONG - BRIGHT WHITE
11	132442-03-01A	EA	HANDLE - ASSIST/ITASCA LOGO W/CHROME ENDS

EXTERIOR BODY GROUP (CONTINUED)

FRONT END

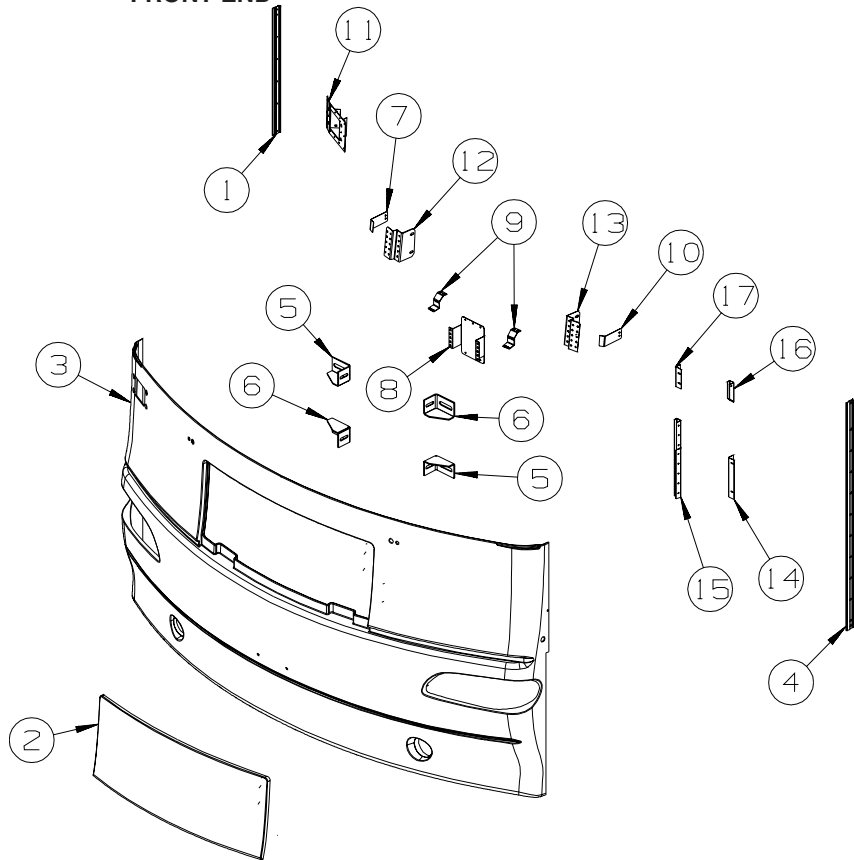

KEY	PART NUMBER	U/M	DESCRIPTION
1	092041-06-01A	EA	TRIM - REAR - CAP TO SIDEWALL - BRIGHT WHITE
1	091985-01-07A	FT	INSERT - TRIM - .65" WIDE - BRIGHT WHITE
2	137771-01-M76	EA	HOOD - FRONT
3	143830-02-R68	EA	PANEL - FRONT/LOWER
			FROM: 00-00-00 THRU: 03-10-03
3	143830-04-R68	EA	PANEL - FRONT/LOWER
			FROM: 03-11-03 THRU: 99-99-99
4	092041-07-01A	EA	TRIM - REAR - CAP TO SIDEWALL - BRIGHT WHITE
4	091985-01-07A	FT	INSERT - TRIM - .65" WIDE - BRIGHT WHITE
5	128455-03-02B	EA	BRACKET - BUMPER - RIGHT HAND UPPER/LEFT HAND LOWER
6	128455-04-02B	EA	BRACKET - BUMPER - LEFT HAND UPPER/RIGHT HAND LOWER
7	146103-02-02B	EA	PLATE - DRIVER HEADLAMP ADJUSTER - E-COATED
8	136446-02-02B	EA	BRACKET - WASHER TANK - E-COATED
9	134189-02-02B	EA	BRACKET - MOUNT/STRIKER - E-COATED
10	146103-01-02B	EA	PLATE - PASSENGER HEADLAMP ADJUSTER - E-COATED
11	120850-04-02B	EA	PLATE - SUPPORT/MIRROR - E-COATED
12	137703-01-02B	EA	SUPPORT - HINGE - RIGHT HAND - E-COATED
13	137703-02-02B	EA	SUPPORT - HINGE - LEFT HAND - E-COATED
14	113041-10-02B	EA	ANGLE - MOUNT - E-COATED
15	132071-03-02B	EA	BRACKET - BUMPER - REAR - E-COATED
			FROM: 00-00-00 THRU: 02-03-04
16	132071-04-02B	EA	BRACKET - REAR BUMPER - E-COATED
			FROM: 00-00-00 THRU: 02-03-04
16	144689-02-02B	EA	BRACKET - HEADLAMP MOUNT - E-COATED
			FROM: 00-00-00 THRU: 02-03-04
16	150634-01-02B	EA	BRACKET - HEADLAMP MOUNT - E-COATED
			FROM: 02-04-04 THRU: 05-10-04
16	151375-01-02B	EA	BRACKET - HEADLAMP MOUNT - E-COATED
			FROM: 05-11-04 THRU: 99-99-99
17	113041-17-02B	EA	ANGLE/MOUNT - BUMPER - E-COATED
	139685-18-02B	EA	SUPPORT - FOG LAMP - RIGHT HAND - E-COATED
	139685-20-02B	EA	SUPPORT - FOG LAMP - LEFT HAND - E-COATED

EXTERIOR BODY GROUP (CONTINUED)
FRONT END (CONTINUED)

KEY	PART NUMBER	U/M	DESCRIPTION
	144689-01-02B	EA	BRACKET - HEADLAMP MOUNT - E-COATED FROM: 00-00-00 THRU: 05-10-04
	151383-01-02B	EA	BRACKET - HEADLAMP MOUNT - E-COATED FROM: 05-11-04 THRU: 99-99-99
	144691-02-02B	EA	BRACKET - HEADLAMP MOUNT - E-COATED FROM: 00-00-00 THRU: 05-10-04
	151381-02-02B	EA	RACKET - HEADLAMP MOUNT/PASSENGER - E-COATED FROM: 05-11-04 THRU: 99-99-99
	144691-04-02B	EA	BRACKET - HEADLAMP MOUNT - E-COATED FROM: 00-00-00 THRU: 05-10-04
	151381-04-02B	EA	BRACKET - HEADLAMP MOUNT/DRIVER - E-COATED FROM: 05-11-04 THRU: 99-99-99
	146627-04-02B	EA	BRACKET - HEADLAMP MOUNT - E-COATED FROM: 00-00-00 THRU: 05-10-04
	151401-04-02B	EA	BRACKET - HEADLAMP MOUNT/DRIVER - E-COATED FROM: 05-11-04 THRU: 99-99-99
	146627-02-02B	EA	BRACKET - HEADLAMP MOUNT - E-COATED FROM: 00-00-00 THRU: 05-10-04
	151401-02-02B	EA	BRACKET - HEADLAMP MOUNT/PASSENGER - E-COATED FROM: 05-11-04 THRU: 99-99-99
	116617-02-02B	EA	SPACER - BUMPER
	148232-01-02B	EA	SUPPORT - FRONT END - E-COATED FROM: 08-11-03 THRU: 99-99-99
	151373-02-02B	EA	BRACKET - HEADLAMP MOUNT/OUTER - E-COATED FROM: 05-11-04 THRU: 99-99-99
	151373-04-02B	EA	BRACKET - HEADLAMP MOUNT/OUTER - E-COATED FROM: 05-11-04 THRU: 99-99-99
	151374-02-02B	EA	BRACKET - HEADLAMP MOUNT/INNER - E-COATED FROM: 05-11-04 THRU: 99-99-99
	151374-04-02B	EA	BRACKET - HEADLAMP MOUNT/INNER - E-COATED FROM: 05-11-04 THRU: 99-99-99

EXTERIOR BODY GROUP (CONTINUED)
FRONT END (CONTINUED)

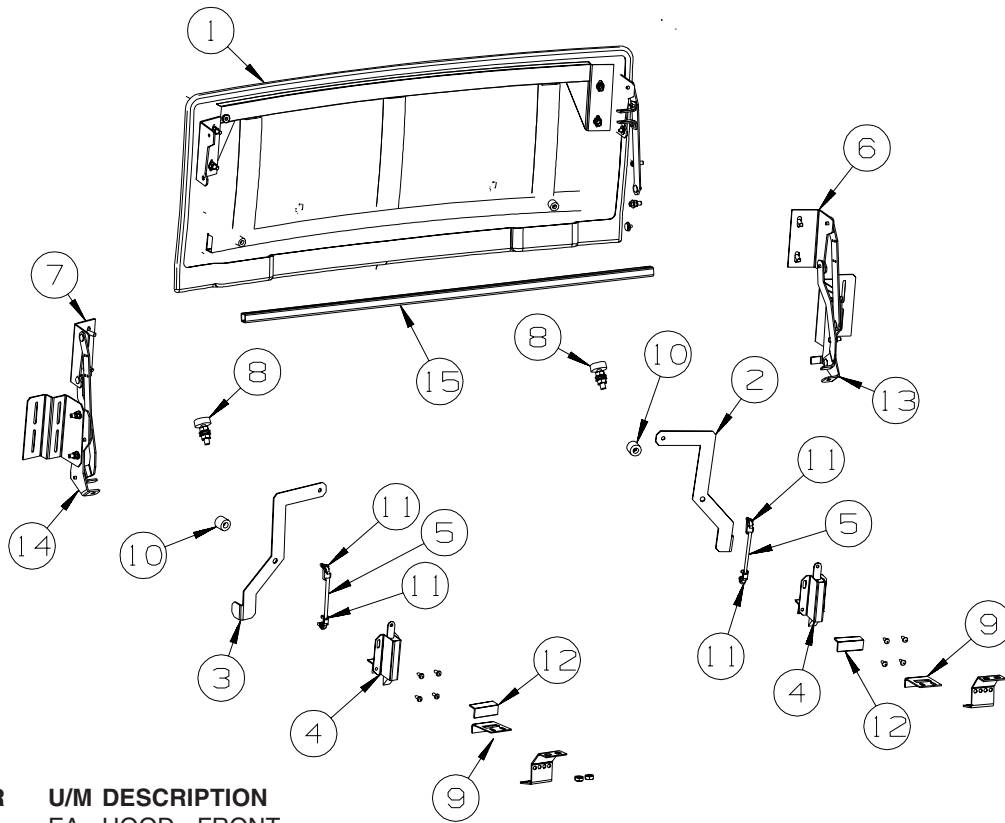

KEY	PART NUMBER	U/M	DESCRIPTION
1	137771-01-M76	EA	HOOD - FRONT
2	131545-01-02B	EA	LATCH-HANDLE,HOOD,RH,E-CT
3	131545-02-02B	EA	LATCH-HANDLE,HOOD,LH,E-CT
4	113908-01-000	EA	LATCH/PLUNGER - F/HOOD
5	131606-01-01A	EA	ROD - HOOD LATCH
6	137761-01-01A	EA	PLATE - HOOD - MOUNTING - RIGHT HAND
7	137761-02-01A	EA	PLATE - HOOD - MOUNTING - LEFT HAND
8	058786-01-000	EA	BOLT - HOOD ADJUSTMENT - 5/16"-18 X 1.5"-2"- W/BLACK PAD
9	134190-01-02B	EA	BRACKET - STRIKER/HOOD - E-COATED
10	120863-07-000	EA	BUMPER - RUBBER - .7" DIA X .7" THICK
11	102265-01-000	EA	CLIP - ROD END - 5/32" - BLACK PLASTIC
12	134189-02-02B	EA	BRACKET - MOUNT/STRIKER - E-COATED
13	137072-03-01A	EA	HINGE - HOOD - RIGHT HAND - BLACK
14	137072-04-01A	EA	HINGE - HOOD - LEFT HAND - BLACK
15	137300-02-02B	EA	TUBE/TIMING - HOOD - 38.5" - E-COATED

EXTERIOR BODY GROUP (CONTINUED)

LADDER

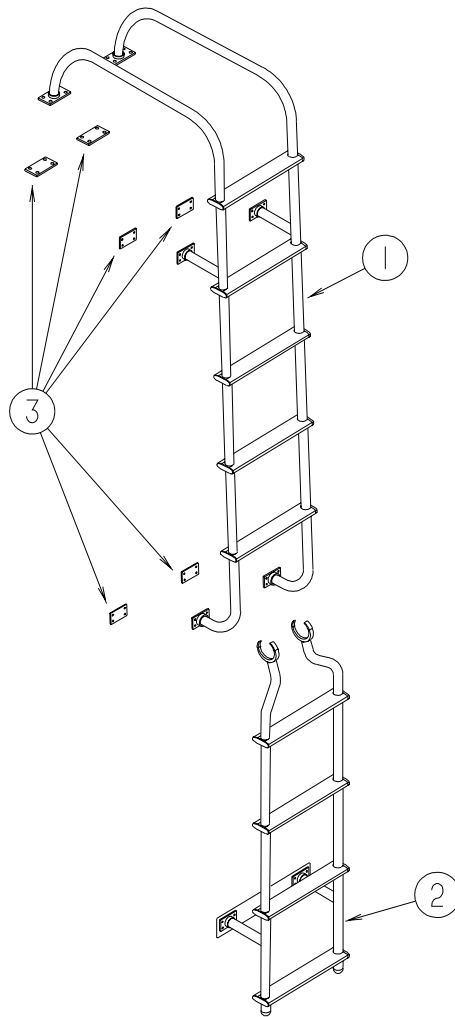

KEY	PART NUMBER	U/M DESCRIPTION
1	132804-01-01A	EA LADDER - UPPER - ANODIZED ALUMINUM
2	130163-04-01A	EA LADDER ASSEMBLY - LOWER - ALUMINUM ANODIZED
3	129375-02-000	EA SEAL - LADDER BRACKET

MIRRORS

KEY	PART NUMBER	U/M DESCRIPTION
*	106015-21-01A	EA MIRROR - EXTERIOR/REMOTE/HEAT - DRIVER - W/TURN SIGNAL FROM: 00-00-00 THRU: 04-20-03
*	142721-02-01A	EA MIRROR - EXTERIOR REMOTE/HEAT - DRIVER - BLACK FROM: 04-21-03 THRU: 99-99-99
*	131431-07-01A	EA MIRROR - EXTERIOR/REMOTE/HEAT - PASSENGER - W/TURN SIGNAL
	108825-03-000	EA GASKET - MIRROR
	133379-01-01A	EA SCREW - MACHINE - 5/16-18 X 2.00 - TORX

***COMPONENT PARTS LISTED LATER IN THIS GROUP**

EXTERIOR BODY GROUP (CONTINUED)

COMPONENT PARTS FOR MIRRORS

106015-20-01A, 106015-21-01A

KEY	PART NUMBER	U/M	DESCRIPTION	VENDOR NO.
	106015-12-702	EA	CAP/SCREW - (PKG OF 4) - BLK	748329 RND
	106015-16-700	EA	GLASS/FLAT-W/HEAT ELEMENT	709450
	106015-18-700	EA	GLASS/CONVEX	709650
	106015-18-703	EA	GLASS/CONVEX-ACT/HOUSING	709651
	106015-19-700	EA	GLASS/FLAT-W/BEZEL/HEAT/ANTI	709645
	131431-03-700	EA	LIGHT/TURN SIGNAL - AMBER	7475510

131431-07-01A, 131431-08-01A

KEY	PART NUMBER	U/M	DESCRIPTION	VENDOR NO.
	106015-16-700	EA	GLASS-FLAT W/HEAT ELEMENT	709450
	106015-18-700	EA	GLASS/CONVEX	709650
	106015-18-701	EA	ACTUATOR - CONVEX GLASS	7475410
	106015-18-702	EA	MOTOR - FLAT GLASS	7471180
	106015-18-703	EA	GLASS/CONVEX-ACT/HOUSING	709651
	131431-03-700	EA	LIGHT/TURN SIGNAL - AMBER	7475510
	131431-07-700	EA	KIT(SCREW CVR BLK)ROUND/OVAL	748344

EXTERIOR BODY GROUP (CONTINUED)
STRUCTURAL COMPONENTS

KEY	PART NUMBER	U/M	DESCRIPTION
	002754-01-001	EA	ANGLE - EXTRUDED - 3/4" X 3/4" X 16' - MILL ALUMINUM
	002766-01-001	EA	ANGLE - EXTRUDED - 1" X 1 1/2" X 17'
	068716-01-001	EA	BRACE - 90 DEGREE - L-ANGLE - 16'
	076054-Z3-000	EA	FIBERGLASS SHEET - 102" X 93.9" - ROOF/SIDEWALL - BRT WHT
	077517-62-000	EA	FIBERGLASS SHEET - 48" X 96" - BRIGHT WHITE
	089297-01-000	SF	PLYWOOD - LUAN - OVERLAY GRADE - 4' X 8'
	100619-01-000	BF	FOAM - EXPANDED POLYSTYRENE - 1.34" X 48" X 96"
	100619-02-000	BF	FOAM - EXPANDED POLYSTYRENE - 1.5" X 48" X 96"
	100619-04-000	BF	FOAM - EXPANDED POLYSTYRENE - .5" X 48" X 96"
	100619-05-000	BF	FOAM - EXPANDED POLYSTYRENE - .75" X 48" X 96"-1.5 DENSITY
	100619-13-000	BF	FOAM - EXPANDED POLYSTYRENE - .34" X 34.65" X 96"
	100619-16-000	BF	FOAM - EXPANDED POLYSTYRENE - .75" X 48" X 96"-2.0 DENSITY
	100619-27-000	BF	FOAM - EXPANDED POLYSTYRENE - 48" X 92.8" X 3"
	105077-08-000	EA	FOAM - PLUG - ROOF CAP
	120107-01-000	EA	FOAM - ROOF COVE - 2.8" X 96" LONG
	120107-02-000	EA	FOAM - PLUG - ROOF TUBE - 2.2" X 2.9" X 1.8" LONG
	120107-03-000	EA	FOAM - PLUG - SIDEWALL TUBE - 1.2" X 2.1" X 1.8" LONG
	120107-07-000	EA	FOAM - ROOF COVE
	120107-08-000	EA	FOAM - PLUG - ROOF TUBE
	076054-Z3-000	EA	FIBERGLASS SHEET - 102" X 93.9" - ROOF/SIDEWALL - BRT WHT
	108535-05-03A	SF	FIBERGLASS SHEET - 108" X 500' ROLL - BRIGHT WHITE
	128782-03-01A	EA	FIBERGLASS SHEET - 26.1" X 68.2" - HIGH GLOSS/SLIDEOUT-B/W
	128782-07-01A	EA	FIBERGLASS SHEET - 79" X 456" - HIGH GLOSS - BRIGHT WHITE
	128782-08-01A	EA	FIBERGLASS SHEET - 22" X 68.3" - HIGH GLOSS - BRIGHT WHITE
	128782-09-01A	EA	FIBERGLASS SHEET - 31" X 68.2" - HIGH GLOSS - BRIGHT WHITE
	128782-10-01A	EA	FIBERGLASS SHEET - 25" X 48" - HIGH GLOSS - BRIGHT WHITE
	148884-22-01A	EA	FIBERGLASS SHEET - 47.9" X 95.8" - HIGH GLOSS-BRIGHT WHITE

AWNINGS

MERIDIAN WINDOW & ENTRY DOOR AWNINGS

MODEL	COLOR CODE	AWNING COLOR	HARDWARE COLOR	ENTRY DOOR	WINDOW	WINDOW	WINDOW	WINDOW	WINDOW	WINDOW
					LT FRONT ROLLER	LT FRONT HARDWARE	LT MID ROLLER	LT MID HARDWARE	RT REAR ROLLER	RT REAR HARDWARE
IKP39W	27A & 92A	CHARCOAL GREY	SILVER	136767-02-33F	142199-07-33F	142199-01-03A	142199-03-33F	142199-01-03A	142199-05-33F	142199-02-03A
IKP39K	27A & 92A	CHARCOAL GREY	SILVER	136767-02-33F	142199-08-33F	142199-01-03A	142199-03-33F	142199-01-03A	142199-05-33F	142199-02-03A
IKP36G	27A & 92A	CHARCOAL GREY	SILVER	136767-02-33F	142199-08-33F	142199-01-03A	142199-03-33F	142199-01-03A	142199-05-33F	142199-02-03A
IKP34H	27A & 92A	CHARCOAL GREY	SILVER	136767-02-33F	142199-07-33F	142199-01-03A	NA-----	NA-----	142199-05-33F	142199-02-03A
IKP32T	27A & 92A	CHARCOAL GREY	SILVER	136767-02-33F	142199-06-33F	142199-01-03A	142199-04-33F	142199-01-03A	142199-05-33F	142199-02-03A
IKP39W	24C	TAUPE	CHAMPAGNE	136767-02-41E	142199-07-41E	142199-01-02A	142199-03-41E	142199-01-02A	142199-05-41E	142199-02-02A
IKP39K	24C	TAUPE	CHAMPAGNE	136767-02-41E	142199-08-41E	142199-01-02A	142199-03-41E	142199-01-02A	142199-05-41E	142199-02-02A
IKP36G	24C	TAUPE	CHAMPAGNE	136767-02-41E	142199-08-41E	142199-01-02A	142199-03-41E	142199-01-02A	142199-05-41E	142199-02-02A
IKP34H	24C	TAUPE	CHAMPAGNE	136767-02-41E	142199-07-41E	142199-01-02A	NA-----	NA-----	142199-05-41E	142199-02-02A
IKP32T	24C	TAUPE	CHAMPAGNE	136767-02-41E	142199-06-41E	142199-01-02A	142199-04-41E	142199-01-02A	142199-05-41E	142199-02-02A

EXTERIOR BODY GROUP (CONTINUED)
AWNINGS (CONTINUED)

MERIDIAN PATIO AWNINGS

SERIES	MODEL	COLOR DESIGNATION	AWNING FABRIC	AWNING LENGTH	WEATHER WRAP(ELEC)	PART # ELECTRIC	VENDOR
MERIDIAN (27A&92A)	P32T	CHARCOAL GRAY (4644)	ACRYLIC	18'	MTL/SILVER	143181-07-33F	A&E
	P34H	CHARCOAL GRAY (4644)	ACRYLIC	18'	MTL/SILVER	143181-07-33F	
	P36G	CHARCOAL GRAY (4644)	ACRYLIC	20'	MTL/SILVER	143181-09-33F	
	P39W	CHARCOAL GRAY (4644)	ACRYLIC	20'	MTL/SILVER	143181-09-33F	
	P39K	CHARCOAL GRAY (4644)	ACRYLIC	20'	MTL/SILVER	143181-12-33F	
MERIDIAN (24C)	P32T	TAUPE (4648)	ACRYLIC	18'	MTL/CHAMPAGNE	143181-07-41E	A&E
	P34H	TAUPE (4648)	ACRYLIC	18'	MTL/CHAMPAGNE	143181-07-41E	
	P36G	TAUPE (4648)	ACRYLIC	20'	MTL/CHAMPAGNE	143181-09-41E	
	P39W	TAUPE (4648)	ACRYLIC	20'	MTL/CHAMPAGNE	143181-09-41E	
	P39K	TAUPE (4648)	ACRYLIC	20'	MTL/CHAMPAGNE	143181-12-41E	

KEY	PART NUMBER	U/M DESCRIPTION
	143181-01-01A	EA HARDWARE/AWNING - WEATHERPROOF - BRIGHT WHITE - ELECTRIC PATIO
	143181-02-01A	EA HARDWARE/AWNING - ELECTRICAL KIT- ELECTRIC PATIO
	143181-01-03A	EA HARDWARE/AWNING - WEATHERPROOF - SATIN - 27A & 92A - MANUAL PATIO
	143181-10-03A	EA AWNING/WEATHERPROOF - HARDWARE KIT - SILVER - 27A & 92A - MANUAL PATIO
	143181-01-02A	EA HARDWARE/AWNING - WEATHERPROOF - CHAMPAGNE - 24C - MANUAL PATIO
	143181-10-02A	EA AWNING/WEATHERPROOF - HARDWARE KIT - CHAMPAGNE - 24C - MANUAL PATIO
	143181-11-03A	EA AWNING/WEATHERPROOF - SPACER KIT - SILVER - 27A & 92A - MANUAL PATIO
	143181-11-02A	EA AWNING/WEATHERPROOF - SPACER KIT - CHAMPAGNE - 24C - MANUAL PATIO
	113874-11-01A	EA SCREW/LAG - AWNING - 1/4" X 1" STAINLESS STEEL
	136770-03-01A	EA SPACER - AWNING - 2" - BRIGHT WHITE
	137029-01-01A	EA BRACKET - AWNING - BRIGHT WHITE

EXTERIOR DOORS & COMPARTMENTS GROUP

DOOR & COMPARTMENT LAYOUT

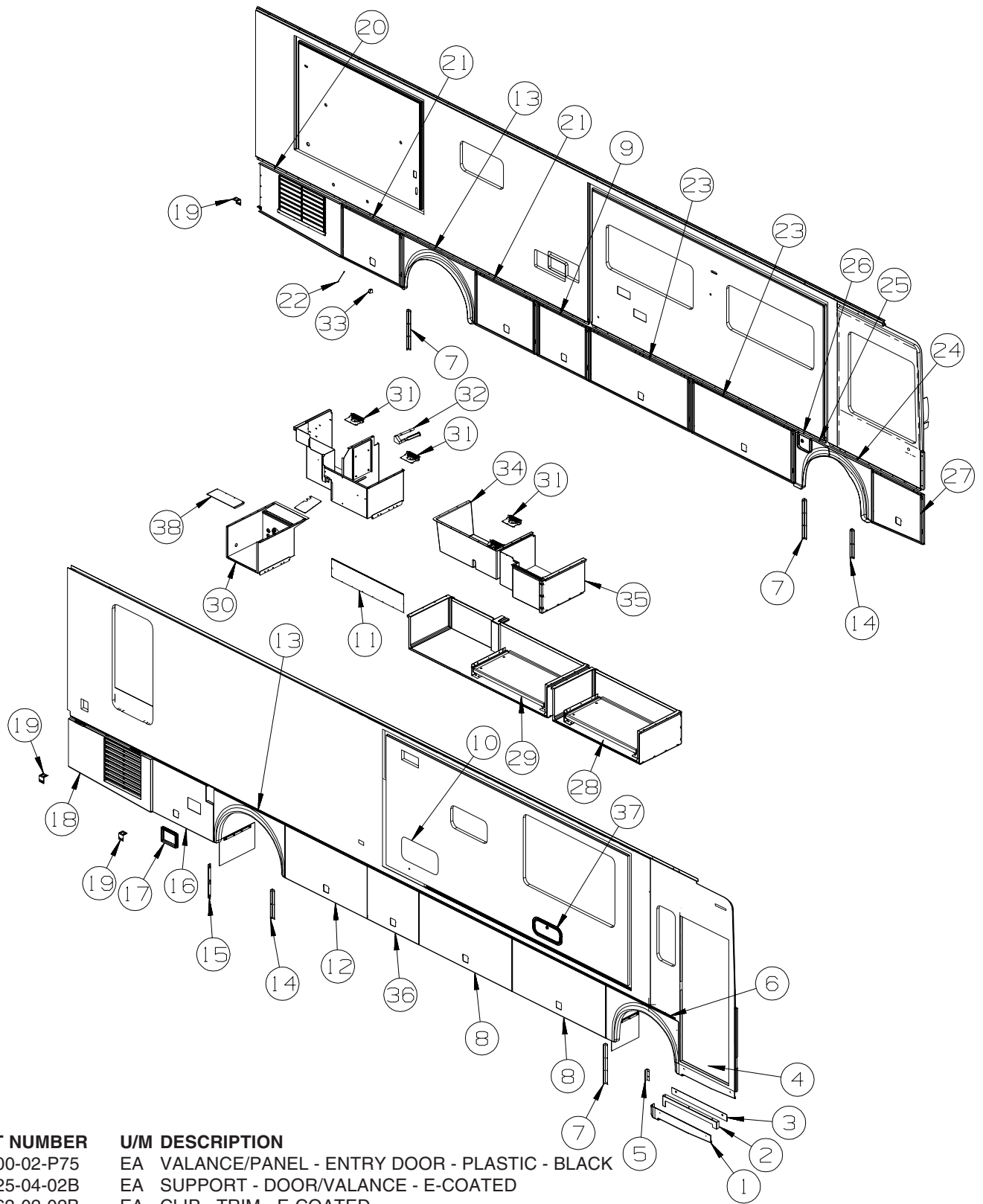

KEY	PART NUMBER	U/M	DESCRIPTION
1	131900-02-P75	EA	VALANCE/PANEL - ENTRY DOOR - PLASTIC - BLACK
2	134125-04-02B	EA	SUPPORT - DOOR/VALANCE - E-COATED
3	143362-02-02B	EA	CLIP - TRIM - E-COATED
4*	094708-03-01A	EA	STEP - ELECTRIC - SINGLE - BLACK CONTROL BOX - KWIKEE
5	113041-15-02B	EA	ANGLE - BUMPER MOUNT - E-COATED
6	131922-01-M70	EA	PANEL/WHEEL LIP - FRONT/PASSENGER - 48.1"
7	113904-11-02B	EA	ANGLE - ATTACHMENT/WHEEL LIP - 21.6" - E-COAT
8	140442-06-N70	EA	VALANCE/DOOR - W/O PADDLE LATCH/HDWR - 61" X 28"
			FROM: 00-00-00 THRU: 09-21-03
	132873-13-000	EA	ROD - LATCH - 32.4" W/3/4" DOG LEG
	132873-14-000	EA	ROD - LATCH - 26.4" W/3/4" DOG LEG
	142569-14-000	EA	SPRING/GAS - 100 LB. - 20" EXTENDED/12" COMPRESSED

EXTERIOR DOORS & COMPARTMENTS GROUP (CONTINUED)

DOOR & COMPARTMENT LAYOUT (CONTINUED)

KEY	PART NUMBER	U/M	DESCRIPTION
8	140442-28-R68	EA	VALANCE/DOOR - W/O PADDLE LATCH/HDWR FROM: 09-22-03 THRU: 99-99-99
	132873-13-000	EA	ROD - LATCH - 32.4" W/3/4" DOG LEG
	132873-14-000	EA	ROD - LATCH - 26.4" W/3/4" DOG LEG
	142569-02-000	EA	SPRING/GAS - 67 LB. - 21.1" EXTENDED/12"COMPRESSED
	147513-01-01A	EA	BALL STUD
	147513-02-01A	EA	BALL STUD
9	140442-01-N70	EA	VALANCE/DOOR - W/O PADDLE LATCH/HDWR - 34" X 28"
	132873-03-000	EA	ROD - LATCH - 10.9" W/DOG LEG
	132873-04-000	EA	ROD - LATCH - 12.7" W/3/4" DOG LEG
	142569-21-000	EA	SPRING/GAS - 60 LB. - 20" EXTENDED/12"COMPRESSED
10*	084103-08-000	EA	DOOR - VENT - REFRIGERATOR - W/O JAMB - BRIGHT WHITE
	084104-08-000	EA	JAMB - VENT DOOR/REFRIGERATOR - BRIGHT WHITE
11	133386-01-02B	EA	PANEL - CLOSEOUT - HOLDING TANK - E-COATED
12	140442-05-N70	EA	VALANCE/DOOR - W/O PADDLE LATCH/HDWR - 54" X 28"
	132873-11-000	EA	ROD - LATCH - 22.7" W/3/4" DOG LEG
	132873-12-000	EA	ROD - LATCH - 22.7" W/3/4" DOG LEG
	142569-14-000	EA	SPRING/GAS - 100 LB. - 20" EXTENDED/12"COMPRESSED
13	131922-06-N84	EA	PANEL/WHEEL LIP - REAR
14	113904-13-02B	EA	ANGLE - ATTACHMENT/WHEEL LIP - 15.7" - E-COAT
15	138789-01-02B	EA	ANGLE/MOUNT - WHEEL LIP/BACKWALL - E-COATED
16	140442-02-N70	EA	VALANCE/DOOR - W/O LATCH/HDWR - W/NOTCH/VENT - 40" X 28"
	132873-05-000	EA	ROD - LATCH - 18.7" W/3/4" DOG LEG
	132873-06-000	EA	ROD - LATCH - 14.4" W/3/4" DOG LEG
	142569-15-000	EA	SPRING/GAS - 120 LB. - 20" EXTENDED/12"COMPRESSED
	115620-01-12B	EA	PLATE - BACKING - BRIGHT WHITE
17	133049-01-L76	EA	TRIM - COVER - WATER HEATER
18	132198-03-N84	EA	VALANCE/DOOR - PASSENGER W/GRILLE - 27.8" X 52.6" X 52.2" - FREIGHTLINER FROM: 00-00-00 THRU: 10-21-03
18	147970-01-R68	EA	PANEL/VALANCE - DEPARTURE/RIGHT HAND - WORKHORSE FROM: 00-00-00 THRU: 10-21-03
18	147970-01-R68	EA	PANEL/VALANCE - DEPARTURE/RIGHT HAND FROM: 10-22-03 THRU: 99-99-99
	113333-06-L76	EA	GRILLE/DOOR - A/C - FREIGHTLINER FROM: 00-00-00 THRU: 10-21-03
	113333-12-R68	EA	GRILLE - A/C DOOR - WORKHORSE FROM: 00-00-00 THRU: 10-21-03
	113333-12-R68	EA	GRILLE - A/C DOOR FROM: 10-22-03 THRU: 99-99-99
19	140309-03-02B	EA	ANGLE - FURNACE DOOR - E-COATED
20	132197-01-N84	EA	VALANCE/DOOR - DRVR W/GRILL-W/O HDW - 26" X 53.4" X 28.7"
21	140442-03-N70	EA	VALANCE/DOOR - W/O PADDLE LATCH/HDWR - 41" X 28"
	132873-07-000	EA	ROD - LATCH - 16.2" W/3/4" DOG LEG
	132873-08-000	EA	ROD - LATCH - 16.2" W/3/4" DOG LEG
	142569-16-000	EA	SPRING/GAS - 90 LB. - 20" EXTENDED/12"COMPRESSED
22	076767-14-000	EA	CABLE - STAINLESS STEEL - 14.9"
23	140442-07-N52	EA	VALANCE/DOOR - W/O PADDLE LATCH/HDWR - 67" X 28"
	132873-15-000	EA	ROD - LATCH - 27.8" W/3/4" DOG LEG
	132873-16-000	EA	ROD - LATCH - 29.6" W/3/4" DOG LEG
	142569-15-000	EA	SPRING/GAS - 120 LB. - 20" EXTENDED/12"COMPRESSED
24	136040-01-M70	EA	PANEL/WHEEL LIP - DRIVER/FRONT WHEELWELL-FRONT SECTION
25	136041-02-N70	EA	PANEL/WHEEL LIP - DRIVER/FRONT WHEELWELL-REAR SECTION
26	131905-05-N70	EA	PANEL/DOOR - FUEL FILL - W/O LOCK - BLACK
	009065-01-000	EA	HINGE - ALUMINUM - 1 1/2" X 96" - UNPAINTED
	138290-01-000	EA	CASE - W/CAM - W/O CYLINDER/KEY
	113904-07-02B	EA	ANGLE - ATTACHMENT/WHEEL LIP - 8" - E-COAT FROM: 00-00-00 THRU: 12-17-03
	138789-01-02B	EA	ANGLE/MOUNT - WHEEL LIP/BACKWALL - E-COATED
27	140442-08-N70	EA	VALANCE/DOOR - DRVR FRT W/O LATCH/HDWR - 28" X 34" X 26"
	132873-17-000	EA	ROD - LATCH - 11.3" W/3/4" DOG LEG
	132873-18-000	EA	ROD - LATCH - 13.1" W/3/4" DOG LEG
	142569-22-000	EA	SPRING/GAS - 90 LB. - 17" EXTENDED/12"COMPRESSED

EXTERIOR DOORS & COMPARTMENTS GROUP (CONTINUED)
DOOR & COMPARTMENT LAYOUT (CONTINUED)

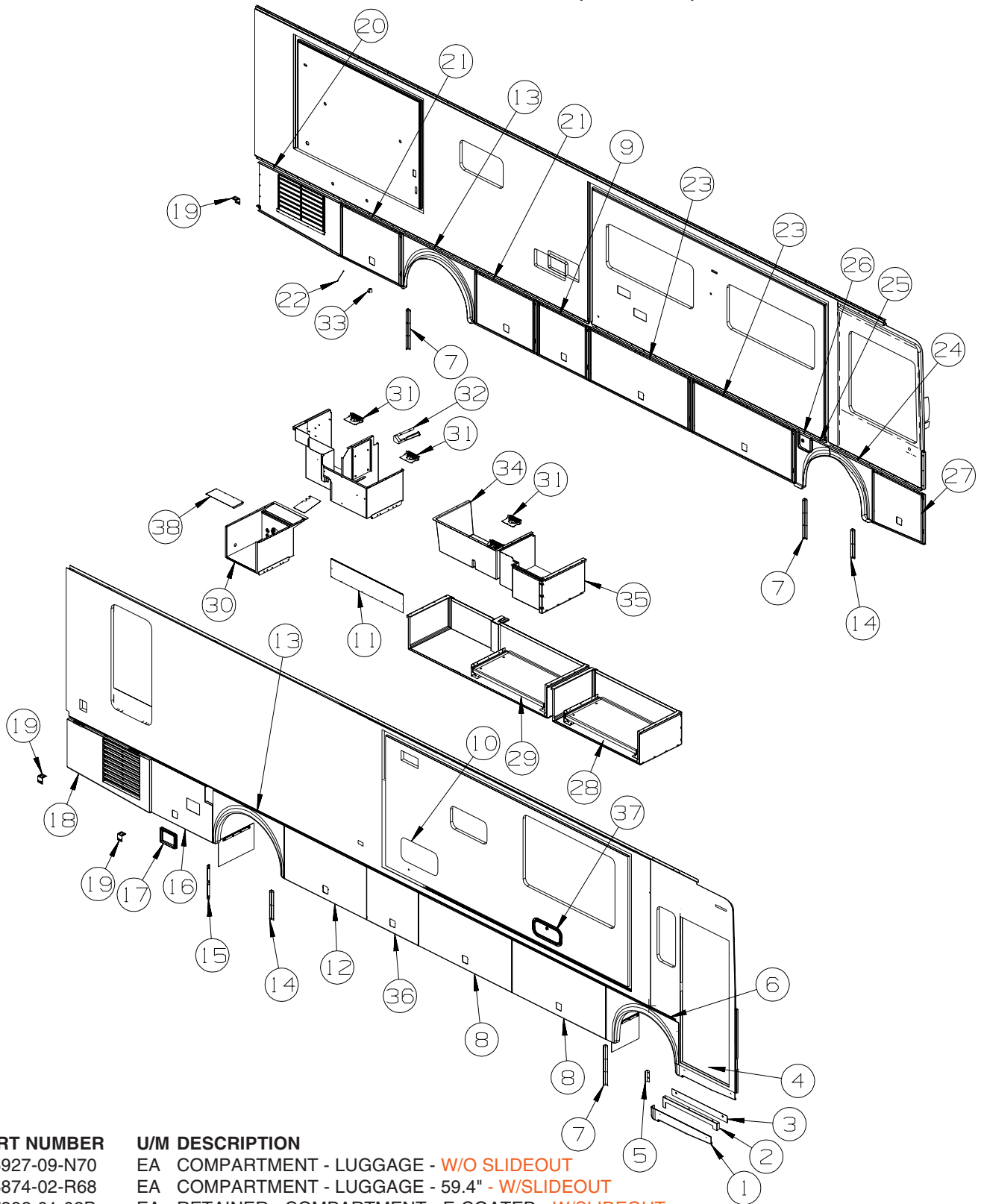

KEY	PART NUMBER	U/M	DESCRIPTION
28	135927-09-N70	EA	COMPARTMENT - LUGGAGE - W/O SLIDEOUT
28	145874-02-R68	EA	COMPARTMENT - LUGGAGE - 59.4" - W/SLIDEOUT
	147393-01-02B	EA	RETAINER - COMPARTMENT - E-COATED - W/SLIDEOUT
	145663-01-000	EA	SLIDE - TRAY/LUGGAGE - KWIKEE
29	140894-01-N84	EA	COMPARTMENT - LUGGAGE
29	145910-01-R68	EA	COMPARTMENT - LUGGAGE - 93.3" - W/SLIDEOUT
	147393-01-02B	EA	RETAINER - COMPARTMENT - E-COATED - W/SLIDEOUT
	145663-01-000	EA	SLIDE - TRAY/LUGGAGE - KWIKEE
30	132902-03-R68	EA	COMPARTMENT - LUGGAGE
	092887-03-000	EA	HATCH/PLATE - 6.1" FLANGE/4.5" R.O. - BLACK
	130034-08-02B	EA	CLIP - TRIM - E-COATED
31*	142226-02-01A	EA	HATCH - POWER

EXTERIOR DOORS & COMPARTMENTS GROUP (CONTINUED)
DOOR & COMPARTMENT LAYOUT (CONTINUED)

KEY	PART NUMBER	U/M	DESCRIPTION
32	129041-01-01A	EA	HOLDER - PAPER TOWEL
33	131383-03-02A	EA	BRACKET - SHOWER HEAD - WHITE
34	145137-01-01A	EA	COMPARTMENT - ELECTRICAL/DRAINAGE
	130377-07-000	EA	TUBE/DRAIN - KAZOO - 1 1/4" X 4"
35	141230-01-N74	EA	COMPARTMENT - LUGGAGE
36	140442-01-N70	EA	VALANCE/DOOR - W/O PADDLE LATCH/HDWR - 34" X 28"
			FROM: 00-00-00 THRU: 09-21-03
	132873-03-000	EA	ROD - LATCH - 10.9" W/DOG LEG
	132873-04-000	EA	ROD - LATCH - 12.7" W/3/4" DOG LEG
	142569-21-000	EA	SPRING/GAS - 60 LB. - 20" EXTENDED/12"COMPRESSED
36	140442-27-R68	EA	VALANCE/DOOR - W/O PADDLE LATCH/HDWR
			FROM: 09-22-03 THRU: 99-99-99
	132873-03-000	EA	ROD - LATCH - 10.9" W/DOG LEG
	132873-04-000	EA	ROD - LATCH - 12.7" W/3/4" DOG LEG
	142569-02-000	EA	SPRING/GAS - 67 LB. - 21.1" EXTENDED/12.6"COMPRESSED
	147513-01-01A	EA	BALL STUD
	147513-02-01A	EA	BALL STUD
37	126945-09-N42	EA	DOOR/STORAGE - W/O HARDWARE - 18.3" X 9.9"
	076767-07-000	EA	CABLE - STAINLESS STEEL - 7.1"
38	142436-02-02B	EA	PLATE - COVER - E-COATED
	138292-01-000	EA	SEAL - LOCK CYLINDER
	P38289-01-000	EA	LOCK ASM W/O MASTER,01-10
	138289-01-000	EA	CYLINDER - LOCKING
	138289-02-000	EA	CYLINDER - LOCKING
	138289-03-000	EA	CYLINDER - LOCKING
	138289-04-000	EA	CYLINDER - LOCKING
	138289-05-000	EA	CYLINDER - LOCKING
	138289-06-000	EA	CYLINDER - LOCKING
	138289-07-000	EA	CYLINDER - LOCKING
	138289-08-000	EA	CYLINDER - LOCKING
	138289-09-000	EA	CYLINDER - LOCKING
	138289-10-000	EA	CYLINDER - LOCKING
	138288-01-000	EA	KEY - REVERSIBLE - #1151 - T/M 16169-02-3091
	138288-02-000	EA	KEY - REVERSIBLE - #1151 - T/M 16169-02-3091
	138288-03-000	EA	KEY - REVERSIBLE - #1151 - T/M 16169-02-3091
	138288-04-000	EA	KEY - REVERSIBLE - #1151 - T/M 16169-02-3091
	138288-05-000	EA	KEY - REVERSIBLE - #1151 - T/M 16169-02-3091
	138288-06-000	EA	KEY - REVERSIBLE - #1151 - T/M 16169-02-3091
	138288-07-000	EA	KEY - REVERSIBLE - #1151 - T/M 16169-02-3091
	138288-08-000	EA	KEY - REVERSIBLE - #1151 - T/M 16169-02-3091
	138288-09-000	EA	KEY - REVERSIBLE - #1151 - T/M 16169-02-3091
	138288-10-000	EA	KEY - REVERSIBLE - #1151 - T/M 16169-02-3091

***COMPONENT PARTS LISTED LATER IN THIS GROUP**

EXTERIOR DOORS & COMPARTMENTS GROUP (CONTINUED)
DOOR & COMPARTMENT LAYOUT (CONTINUED)

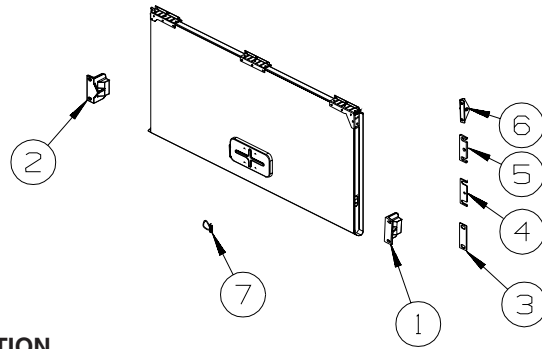

KEY	PART NUMBER	U/M	DESCRIPTION
1	130053-01-01A	EA	STRIKER - LUGGAGE DOOR - FLUSH - BLACK
2	130053-02-01A	EA	STRIKER - LUGGAGE DOOR - OFF SET - BLACK
3	143793-01-01A	EA	SHIM/STRIKER - LUGGAGE - 1.5" - BLACK
4	120494-03-02B	EA	SHIM - STRIKER - LUGGAGE DOOR - .20 - E-COATED
5	120494-04-02B	EA	SHIM - STRIKER - LUGGAGE DOOR - .27 - E-COATED
6	126263-02-02B	EA	BRACKET - GAS SPRING W/BALL STUD - E-COATED
7	132892-02-01A	FT	SEAL - BULB

FROM: 00-00-00 THRU: 11-05-03

7	132892-03-01A	FT	SEAL - BULB - W/LEG
---	---------------	----	---------------------

FROM: 11-06-03 THRU: 99-99-99

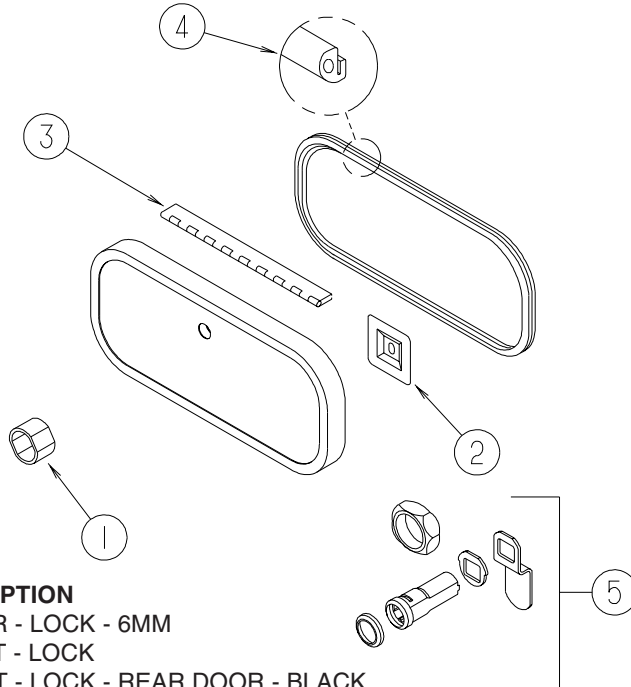

KEY	PART NUMBER	U/M	DESCRIPTION
1	139325-01-000	EA	SPACER - LOCK - 6MM
	139337-01-000	EA	GASKET - LOCK
2	097111-02-04A	EA	POCKET - LOCK - REAR DOOR - BLACK
2	097111-02-05A	EA	POCKET - LOCK - REAR DOOR - BRIGHT WHITE
3	081801-V3-000	EA	HINGE - ALUMINUM - 2" X 96" - BRIGHT WHITE
4	106850-02-000	FT	SEAL-E - SPONGE RUBBER - .43" X .75"
5	138290-02-000	EA	CASE - W/CAM - W/O CYLINDER/KEY

EXTERIOR DOORS & COMPARTMENTS GROUP (CONTINUED)
DOOR & COMPARTMENT LAYOUT (CONTINUED)

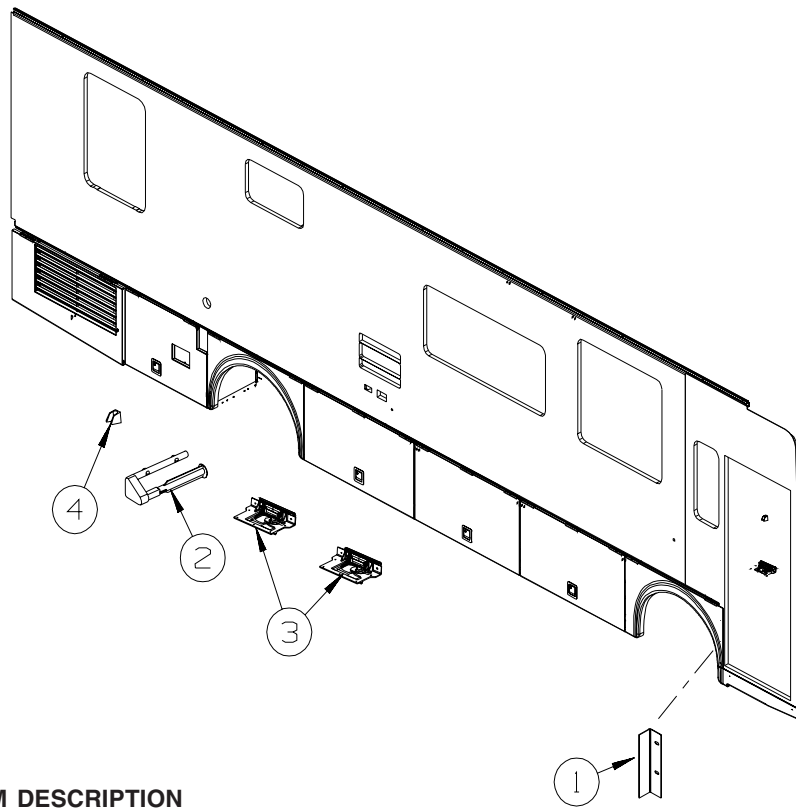

KEY	PART NUMBER	U/M	DESCRIPTION
1	113041-15-02B	EA	ANGLE - BUMPER MOUNT - E-COATED
2	129041-01-01A	EA	HOLDER - PAPER TOWEL
3*	142226-02-01A	EA	HATCH - POWER
4	131383-03-02A	EA	BRACKET - SHOWER HEAD - WHITE

***COMPONENT PARTS LISTED LATER IN THIS GROUP**

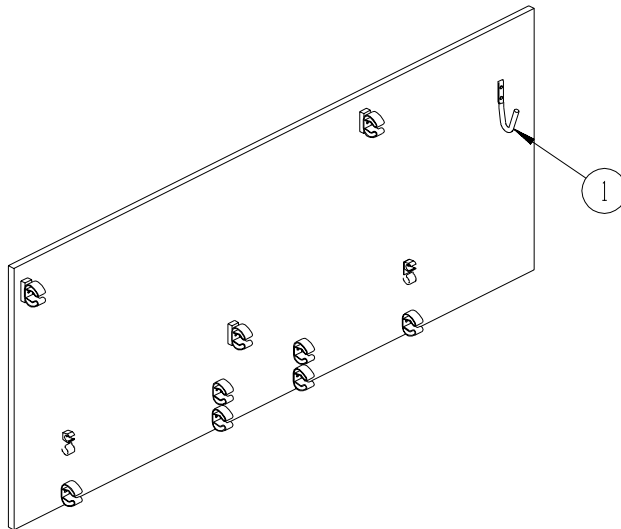

KEY	PART NUMBER	U/M	DESCRIPTION
1	143506-01-000	EA	HOOK - J

EXTERIOR DOORS & COMPARTMENTS GROUP (CONTINUED)
DOOR & COMPARTMENT LAYOUT (CONTINUED)

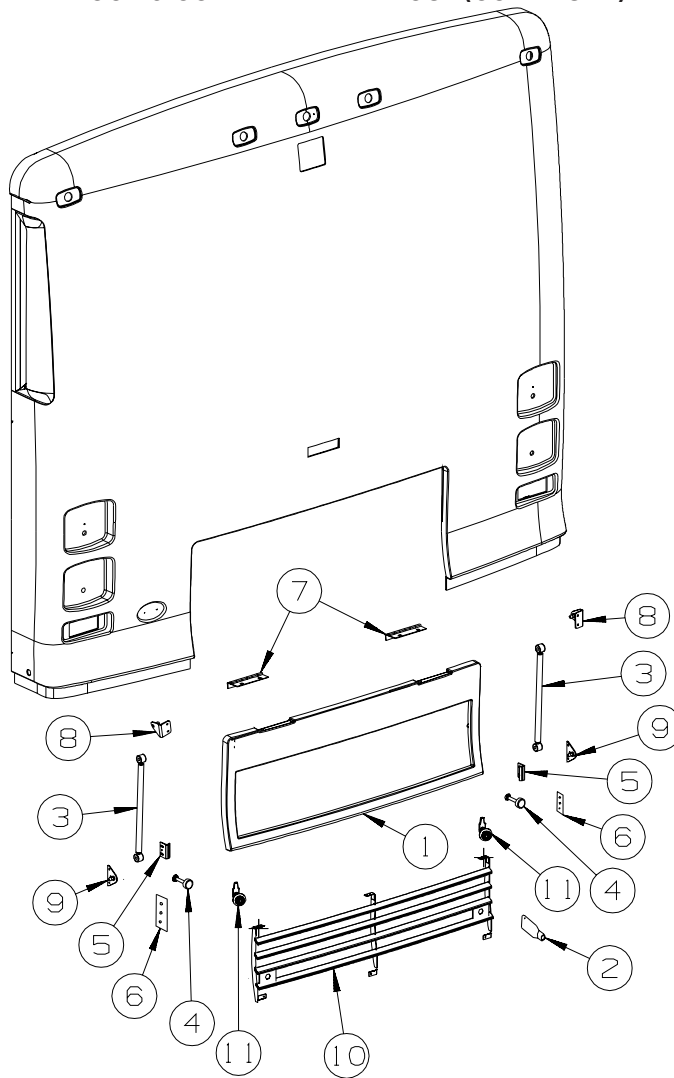

KEY	PART NUMBER	U/M	DESCRIPTION
1	132182-01-L76	EA	DOOR - REAR ENGINE - W/O HARDWARE
2	102328-01-000	EA	KEY - BARREL - NICKEL PLATED
3	107796-23-000	EA	SPRING/GAS - 11.3" COMPRESSED/18.5" EXTENDED - 45 LB.
4	058786-01-000	EA	BOLT - HOOD ADJUSTMENT - 5/16"-18 X 1.5"-2" - W/BLACK PAD
5	107719-01-01A	EA	STRIKE - VALANCE DOOR
6	118931-01-02B	EA	SHIM - STRIKER - DOOR
7	102325-02-07A	EA	HINGE/TRUNK DOOR - 6" W/.6" OFF SET - BRIGHT WHITE
8	126263-10-02B	EA	BRACKET - GAS SPRING W/BALL STUD - E-COATED
9	126263-08-02B	EA	BRACKET - GAS SPRING W/CENTERED BALL STUD - E-COATED
10	132412-01-L76	EA	GRILLE/DOOR - TRUNK
11	102330-02-000	EA	LATCH - VISE ACTION/KEY OPERATED

EXTERIOR DOORS & COMPARTMENTS GROUP (CONTINUED)

DOOR & COMPARTMENT LAYOUT COMPONENTS

084103-08-000

KEY	PART NUMBER	U/M	DESCRIPTION	VENDOR NO.
	084104-01-700	EA	LOCK-MALE, FASTENER	201-721-010
	084104-01-701	EA	LOCK-FEMALE, FASTENER	201-802-010

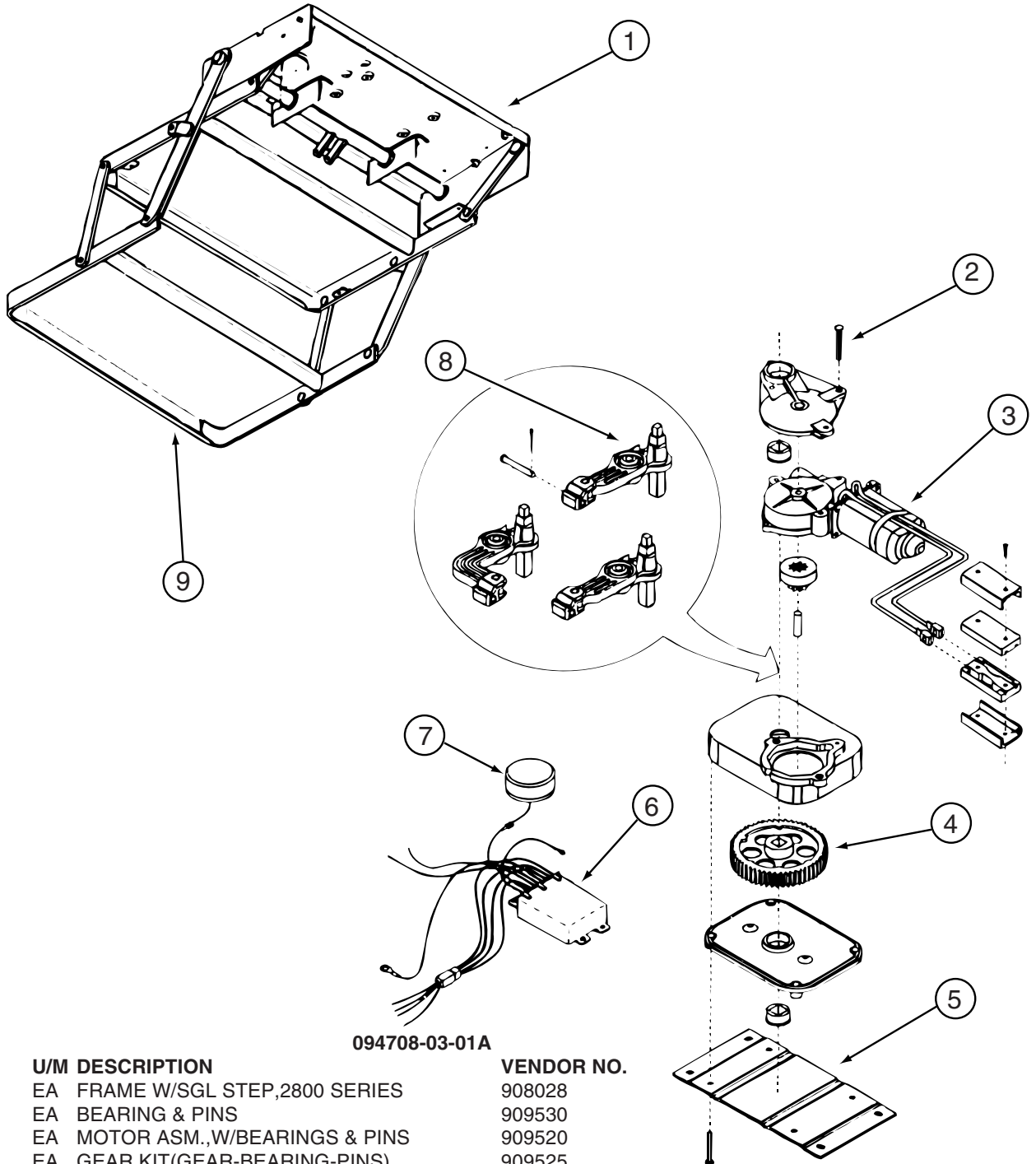

094708-03-01A

KEY	PART NUMBER	U/M	DESCRIPTION	VENDOR NO.
1	088746-01-709	EA	FRAME W/SGL STEP,2800 SERIES	908028
2	094707-02-703	EA	BEARING & PINS	909530
3	094707-02-700	EA	MOTOR ASM.,W/BEARINGS & PINS	909520
4	094707-02-702	EA	GEAR KIT(GEAR-BEARING-PINS)	909525
5	094707-02-704	EA	CONNECTOR-MOTOR ASM.W/PLATES	909537
6	094707-03-700	EA	KIT CONTROL/SWITCH-RETROFIT	909506005
7	088733-01-700	EA	BULB	9004
7	088746-01-705	EA	LIGHT-UNDER STEP	9004
8	094708-03-700	EA	LINKAGE ASSEMBLY-SERIES 28	909533
9	094707-02-707	EA	TREAD - NON-SKID - BLACK	909333
	094707-03-701	EA	PLUG - 4-WAY - PACKARD	909306

142226-02-01A

KEY	PART NUMBER	U/M	DESCRIPTION	VENDOR NO
	142226-02-700	EA	TAB/LOCKING - ESCAPE (RED)	9667709

EXTERIOR DOORS & COMPARTMENTS GROUP (CONTINUED)
COMPARTMENT DOOR PIECE PARTS

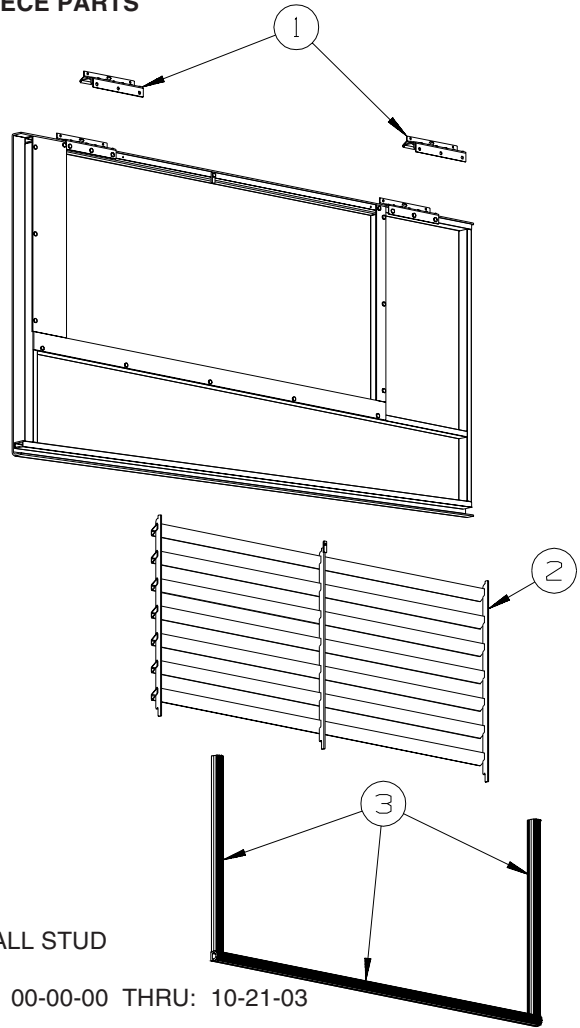

KEY	PART NUMBER	U/M	DESCRIPTION
1	139793-03-01A	EA	HINGE - CENTER/VALANCE DOOR - W/O BALL STUD
2	113333-06-L76	EA	GRILLE/DOOR - A/C
			FROM: 00-00-00 THRU: 10-21-03
2	113333-12-R68	EA	GRILLE/DOOR - A/C
			FROM: 10-22-03 THRU: 99-99-99
3	107721-08-000	FT	SEAL - ACCESS DOOR - .9"WIDE X .9"HIGH

EXTERIOR DOORS & COMPARTMENTS GROUP (CONTINUED)
COMPARTMENT DOOR PIECE PARTS (CONTINUED)

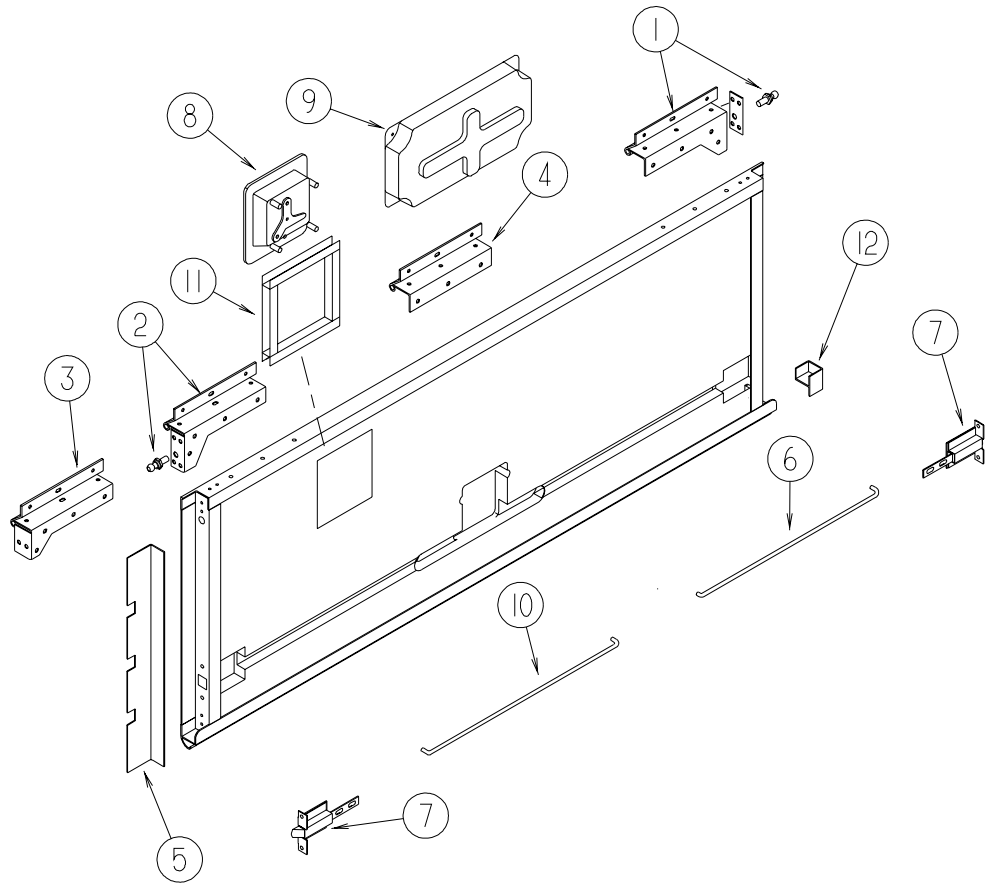

KEY	PART NUMBER	U/M	DESCRIPTION
1	139793-01-01A	EA	HINGE - RIGHT HAND/VALANCE DOOR - W/BALL STUD
2	139793-02-01A	EA	HINGE - LEFT HAND/VALANCE DOOR - W/BALL STUD
3	139793-05-01A	EA	HINGE - LEFT HAND/VALANCE DOOR - W/O BALL STUD
4	139793-03-01A	EA	HINGE - CENTER/VALANCE DOOR - W/O BALL STUD
5	139207-01-02B	EA	PANEL - SUPPORT - A/C DOOR - E-COATED
6	132873-01-000	EA	ROD - LATCH (BLANK) - RIGHT HAND
7	121947-01-01A	EA	BOLT - SLIDE W/PLASTIC PLUNGER
8	138277-01-01A	EA	LATCH/PADDLE - COMPARTMENT DOOR - BLACK - KEY ONE
8	112949-02-04A	EA	LATCH - PADDLE NON-LOCKING - BRIGHT WHITE
9	137359-01-01A	EA	COVER - LATCH - WHITE
10	132873-02-000	EA	ROD - LATCH (BLANK) - LEFT HAND
11	133049-01-L76	EA	TRIM - COVER - WATER HEATER
12	NOT USED		

EXTERIOR DOORS & COMPARTMENTS GROUP (CONTINUED)

ENTRY

KEY	PART NUMBER	U/M	DESCRIPTION
*	128913-10-01A	EA	DOOR - ENTRY/FRONT - POWER LOCK - BLACK FROM: 00-00-00 THRU: 04-06-03
*	128913-12-01A	EA	DOOR - ENTRY/FRONT - POWER LOCK - BLACK FROM: 04-07-03 THRU: 99-99-99
	112782-04-01A	EA	GASKET
	134450-02-01A	EA	TAPE - ANTI SLIP - 1.25" X 29.9" - BLACK
	138292-01-000	EA	SEAL - LOCK CYLINDER
	039715-01-000	EA	NUT-SERT - 1/4" DIAMETER - 20 THREADS
	138287-01-000	EA	CYLINDER/LOCK - ENTRY DOOR (MASTER)
	138287-02-000	EA	CYLINDER/LOCK - ENTRY DOOR (MASTER)
	138287-03-000	EA	CYLINDER/LOCK - ENTRY DOOR (MASTER)
	138287-04-000	EA	CYLINDER/LOCK - ENTRY DOOR (MASTER)
	138287-05-000	EA	CYLINDER/LOCK - ENTRY DOOR (MASTER)
	138287-06-000	EA	CYLINDER/LOCK - ENTRY DOOR (MASTER)
	138287-07-000	EA	CYLINDER/LOCK - ENTRY DOOR (MASTER)
	138287-08-000	EA	CYLINDER/LOCK - ENTRY DOOR (MASTER)
	138287-09-000	EA	CYLINDER/LOCK - ENTRY DOOR (MASTER)
	138287-10-000	EA	CYLINDER/LOCK - ENTRY DOOR (MASTER)
	138288-01-000	EA	KEY - REVERSIBLE - #1151 - T/M 16169-02-3091
	138288-02-000	EA	KEY - REVERSIBLE - #1152 - T/M 16169-02-3092
	138288-03-000	EA	KEY - REVERSIBLE - #1153 - T/M 16169-02-3093
	138288-04-000	EA	KEY - REVERSIBLE - #1154 - T/M 16169-02-3094
	138288-05-000	EA	KEY - REVERSIBLE - #1155 - T/M 16169-02-3095
	138288-06-000	EA	KEY - REVERSIBLE - #1156 - T/M 16169-02-3096
	138288-07-000	EA	KEY - REVERSIBLE - #1157 - T/M 16169-02-3097
	138288-08-000	EA	KEY - REVERSIBLE - #1158 - T/M 16169-02-3098
	138288-09-000	EA	KEY - REVERSIBLE - #1159 - T/M 16169-02-3099
	138288-10-000	EA	KEY - REVERSIBLE - #1150 - T/M 16169-02-3100

*COMPONENT PARTS LISTED LATER IN THIS GROUP

EXTERIOR DOORS & COMPARTMENTS GROUP (CONTINUED)
COMPONENT PARTS FOR ENTRY

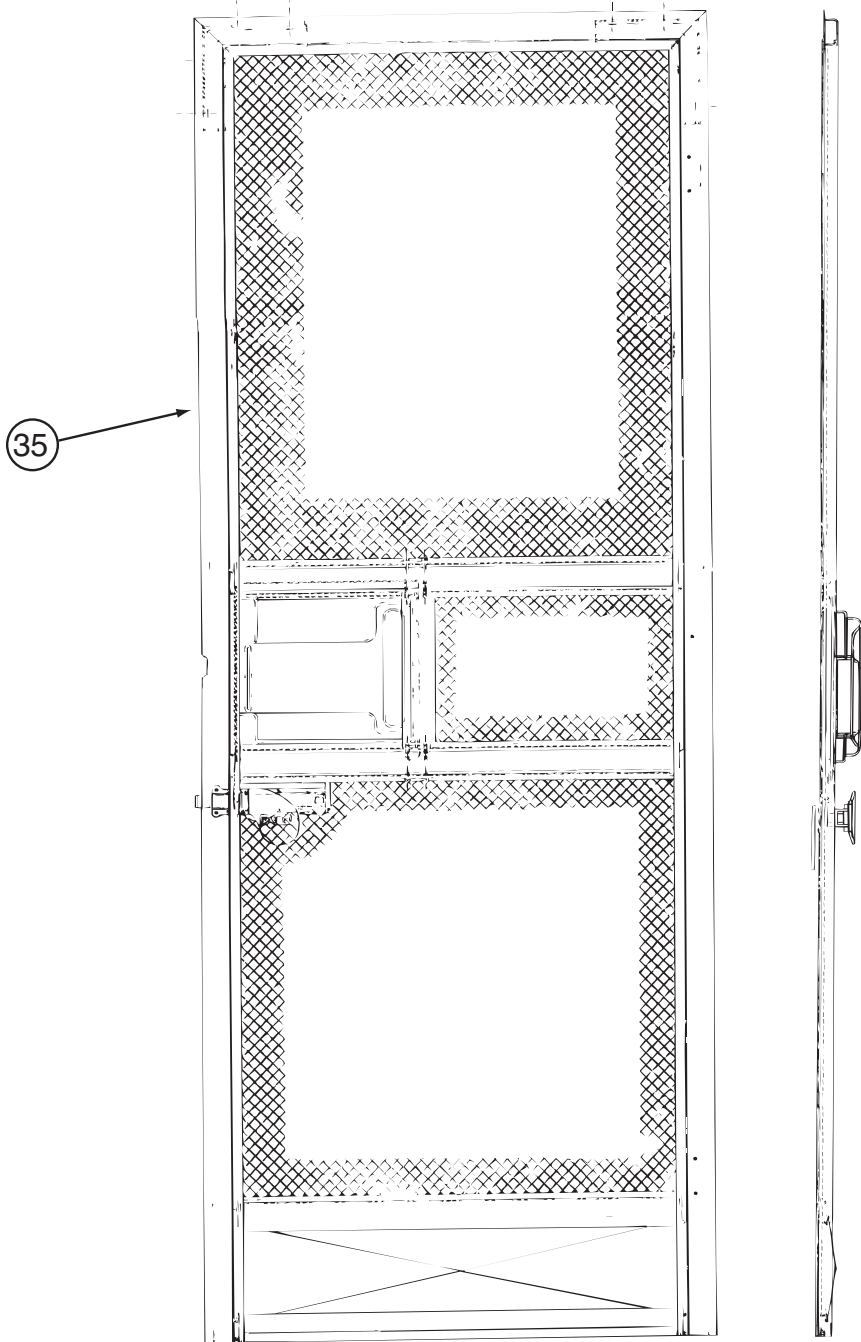

128913-10-01A

KEY	PART NUMBER	U/M DESCRIPTION	VENDOR NO.
35	128913-09-700	EA SCREEN DOOR ASSEMBLY	490056

EXTERIOR DOORS & COMPARTMENTS GROUP (CONTINUED)
COMPONENT PARTS FOR ENTRY (CONTINUED)

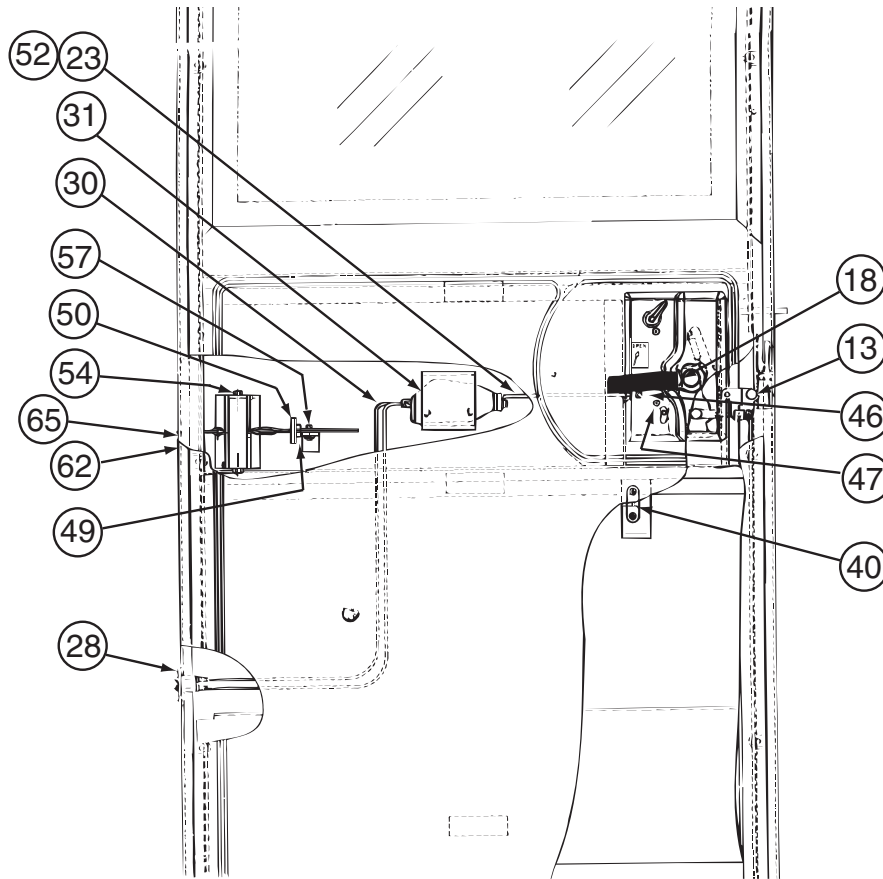

128913-10-01A (CONTINUED)

KEY	PART NUMBER	U/M	DESCRIPTION	VENDOR NO.
13	128913-04-706	FT	LATCH/ROTARY - W/LINKAGE RH	B248-041726/T/M1799
18	128913-08-700	EA	HANDLE - INSIDE - REV.	248-041725
23	128913-04-704	EA	ROD/LOCK - (POWER)	17705-01
28	128913-01-714	EA	CONTACT - MALE/2-POSITION	400-041934
30	128913-01-712	EA	WIRE HARNESS-POWER DOOR LOCK	400-041935
31	106469-05-701	EA	ACTUATOR, F/ELECTRICE LOCK	4110-041096
40	128913-01-710	EA	STRIKER - LATCH/SCREEN DOOR	130-041815
46	128913-02-711	EA	SLIDE BAR ASSEMBLY	V196-29
47	128913-01-746	EA	SCREW #8 X 3/4" OVAL HEAD	276-042030
49	128913-02-712	EA	PIN - COILED SPRING	248-042237
50	128913-02-713	EA	BUMPER STOP	V196-24
54	128913-01-733	EA	DOOR CHECK-SUB ASM ADJUST	V196-04
57	128913-01-705	EA	BOLT - SHOULDER - #10 X 1/4	268-042011
62	128913-02-714	EA	GUIDE BLOCK - DOOR CHECK	146-042045
65	128913-04-709	EA	PIN/CLEVIS-GROOVED W/E-RING	245-042260

CONTACT WINNEBAGO PARTS SALES FOR UNLISTED COMPONENTS

EXTERIOR DOORS & COMPARTMENTS GROUP (CONTINUED)
COMPONENT PARTS FOR ENTRY (CONTINUED)

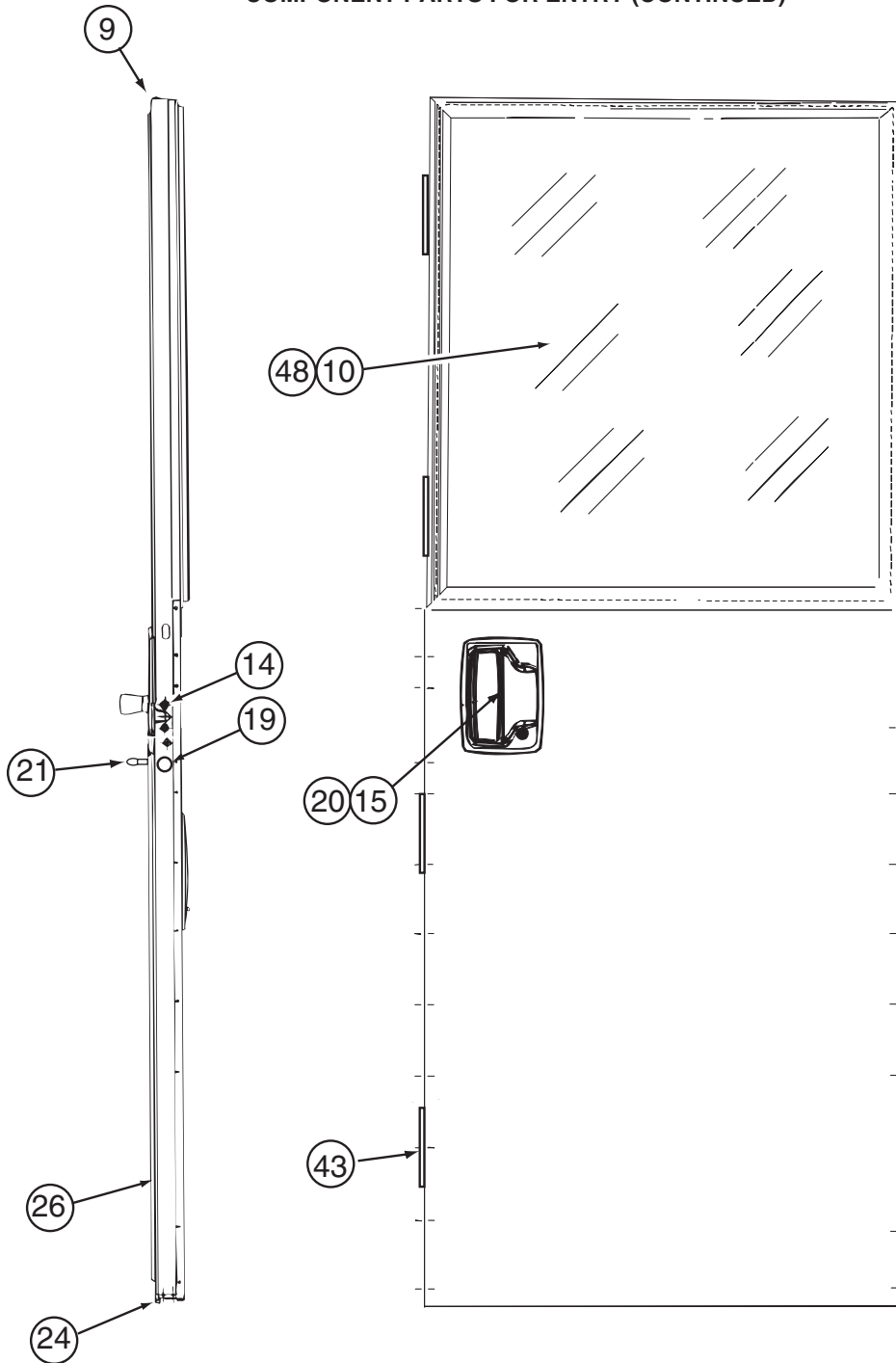

128913-10-01A (CONTINUED)

KEY	PART NUMBER	U/M	DESCRIPTION	VENDOR NO.
9	128913-04-708	EA	DOOR FRAME - SUB ASM - BLACK	V266-90
10	128913-04-707	EA	WINDOW-DUAL PANE	V231-85
14	128913-03-713	EA	BOLT-ROTARY LATCH - 1/4" -20	81066-01
15	128913-08-701	EA	PADDLE ASM - OUTSIDE	490060
20	128913-04-705	EA	GASKET - OUTSIDE HANDLE	81480
21	128913-04-717	EA	CAP - VINYL- RED	130-042257
24	128913-01-744	EA	SEAL/BULB-STICK ON/THRESHOLD	122-042230
26	128913-04-712	EA	PANEL - INNER PLASTIC	490057
48	128913-04-700	FT	TAPE/BUTYL - FOAM CORE	154-041549

CONTACT WINNEBAGO PARTS SALES FOR UNLISTED COMPONENTS

EXTERIOR DOORS & COMPARTMENTS GROUP (CONTINUED)

COMPONENT PARTS FOR ENTRY (CONTINUED)

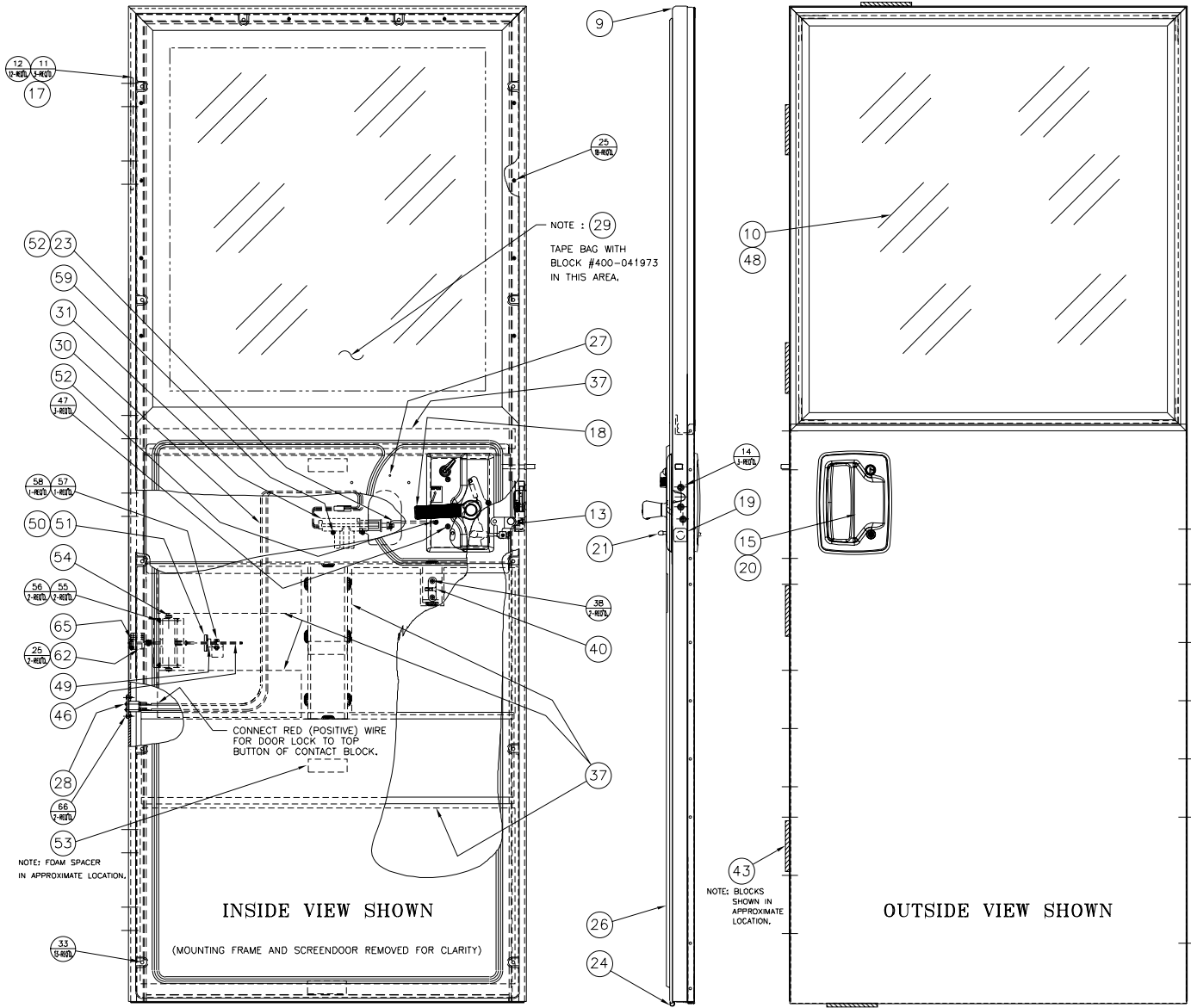

128913-12-01A

EXTERIOR DOORS & COMPARTMENTS GROUP (CONTINUED)

COMPONENT PARTS FOR ENTRY (CONTINUED)

128913-12-01A (CONTINUED)

KEY	PART NUMBER	U/M	DESCRIPTION	VENDOR NO.
9	128913-12-704	EA	FRAME/DOOR-SUB ASM BLACK	490488
10	128913-12-701	EA	WINDOW-DUAL PANE	490505
10	128913-12-700	FT	SEAL - GLAZING	132-030529
13	128913-04-706	EA	LATCH/ROTARY - W/LINKAGE RH	B248-041726/T/M179
15	128913-08-701	EA	PADDLE ASM - OUTSIDE	490060
18	128913-08-700	EA	HANDLE - INSIDE - REV.	248-041725
20	112782-04-01A	EA	GASKET	*T/M 81480
21	128913-04-717	EA	CAP - VINYL - RED	130-042257
23	128913-04-704	EA	ROD/LOCK - (POWER)	17705-01
24	128913-01-744	EA	SEAL/BULB-STICK ON/THRESHOLD	122-042230
26	128913-04-712	EA	PANEL - INNER PLASTIC	490057
28	128913-01-714	EA	CONTACT - MALE/2-POSITION	400-041934
29	128913-01-713	EA	CONTACT - FEMALE/2-POSITION	400-041973
30	128913-01-712	EA	WIRE HARNESS-POWER DOOR LOCK	400-041935
31	128913-01-702	EA	ACTUATOR	410-041096
40	128913-01-710	EA	STRIKER - LATCH/SCREEN DOOR	130-041815
46	128913-02-711	EA	SLIDE BAR ASSEMBLY	V196-29
47	128913-01-746	EA	SCREW #8 X 3/4" OVAL HEAD	276-042030
48	128913-04-700	FT	TAPE/BUTYL - FOAM CORE	154-041549
49	128913-02-712	EA	PIN - COILED SPRING	248-042237
50	128913-02-713	EA	BUMPER STOP	V196-24
52	106469-05-700	EA	ROD CLIP	231-041095
54	128913-01-733	EA	DOOR CHECK KIT - ADJ SUB ASM	V196-04
57	128913-01-705	EA	BOLT - SHOULDER - #10 X 1/4	268-042011
62	128913-02-714	EA	GUIDE BLOCK - DOOR CHECK	146-042045
65	128913-04-709	EA	PIN/CLEVIS-GROOVED W/E-RING	245-042260

CONTACT WINNEBAGO PARTS SALES FOR UNLISTED COMPONENT(S)

EXTERIOR DOORS & COMPARTMENTS GROUP (CONTINUED)
COMPONENT PARTS FOR ENTRY (CONTINUED)

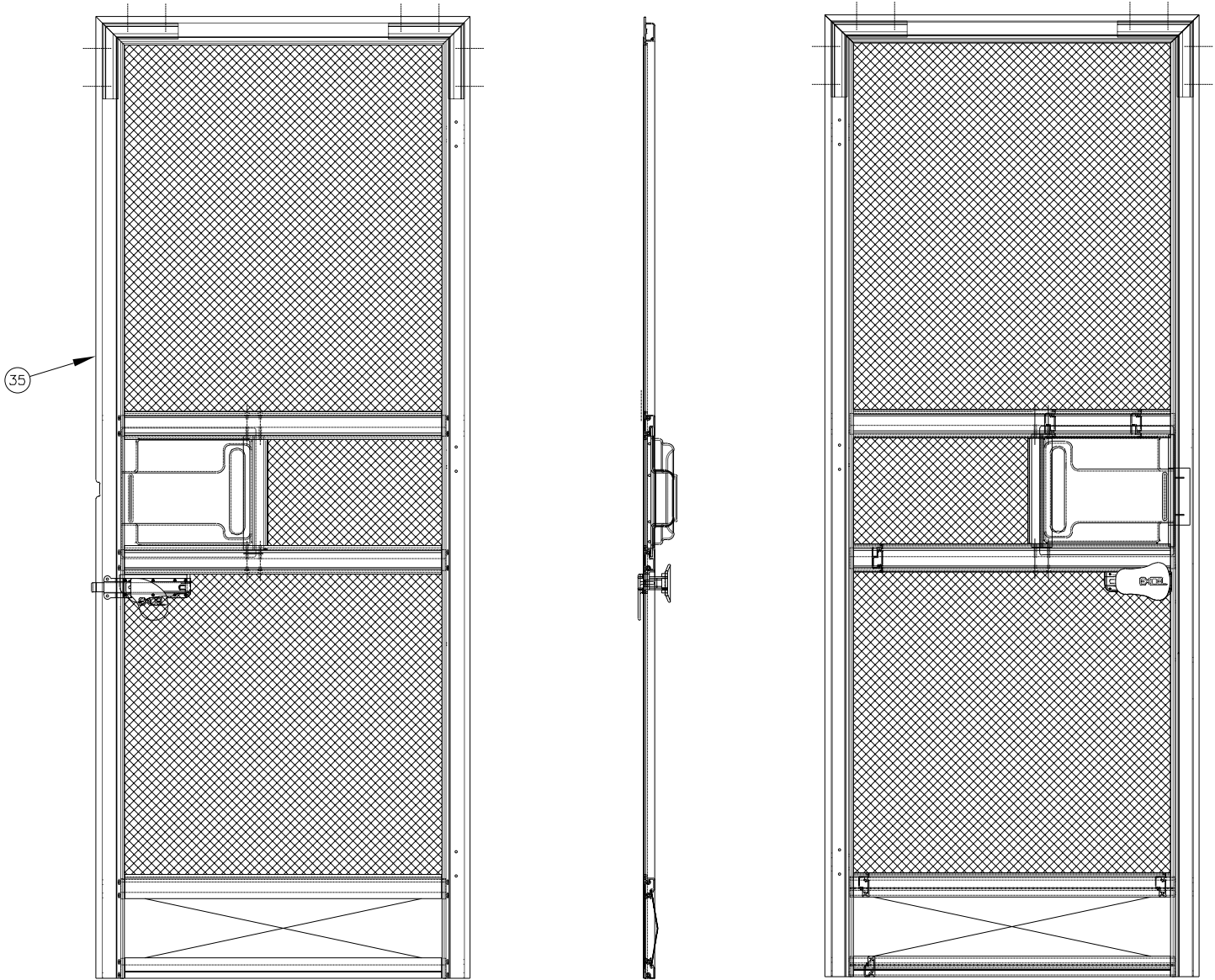

OUTSIDE VIEW SHOWN

INSIDE VIEW SHOWN

128913-12-01A (CONTINUED)

KEY	PART NUMBER	U/M	DESCRIPTION	VENDOR NO.
35	128913-09-700	EA	SCREEN DOOR ASSEMBLY	490056
			CONTACT WINNEBAGO PARTS SALES FOR UNLISTED COMPONENT(S)	

EXTERIOR DOORS & COMPARTMENTS GROUP (CONTINUED)

COMPONENT PARTS FOR ENTRY (CONTINUED)

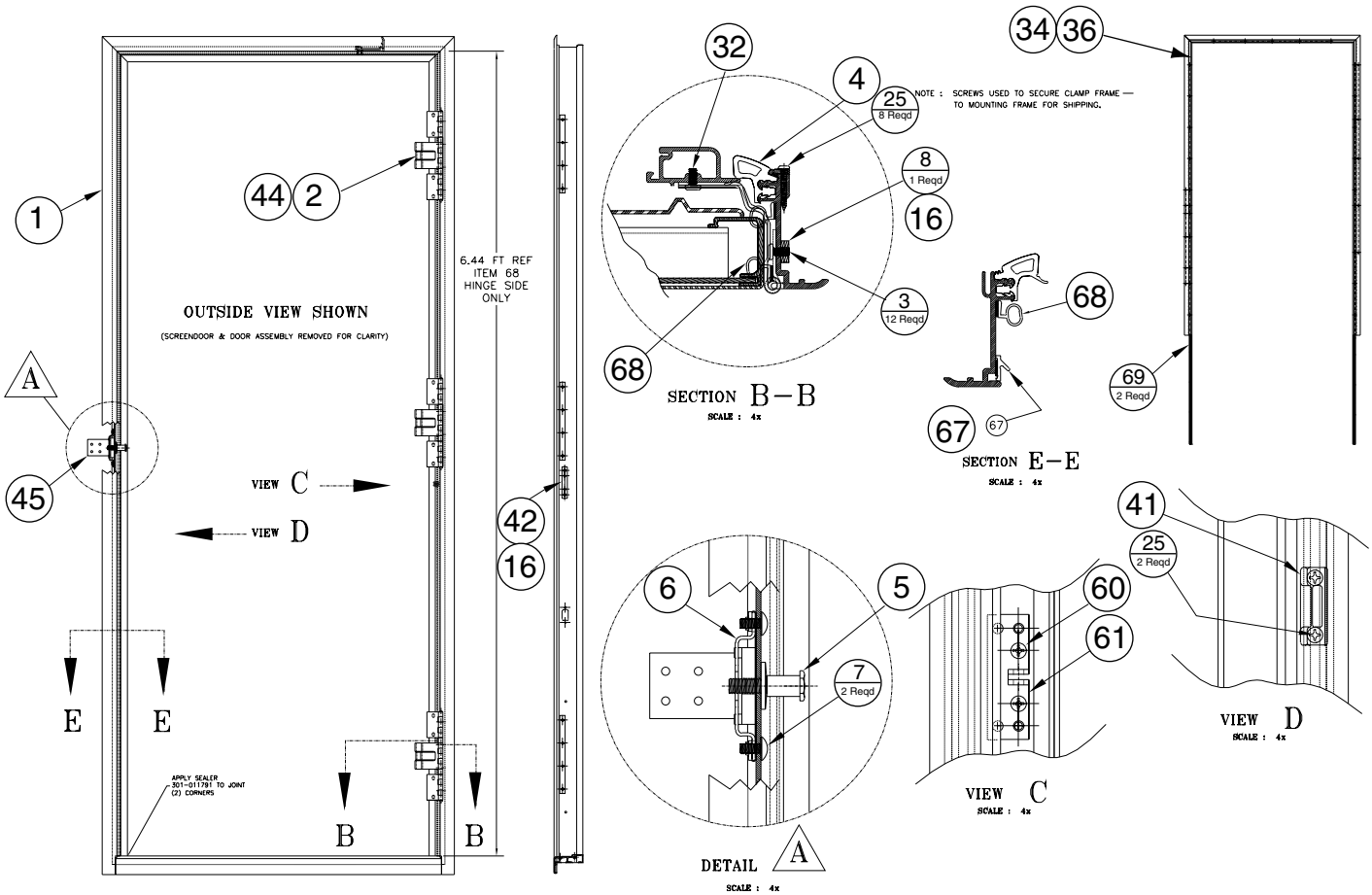

128913-12-01A (CONTINUED)

KEY	PART NUMBER	U/M	DESCRIPTION	VENDOR NO.
1	128913-12-702	EA	FRAME/MOUNTING-SUB ASM BLACK	490486
2	128913-12-703	EA	HINGE (TAKES 3)	490487
4	128913-01-728	EA	SEAL - DOOR/CORNER- MITERED	122-041917
5	128913-01-727	EA	STRIKER - BOLT - LONG	11628-16
6	128913-01-726	EA	NUT ASSEMBLY-CAGED (STRIKER)	11920-16
36	128913-10-700	EA	FRAME/CLAMP - WELD ASM BLACK	490195
41	128913-01-709	EA	STRIKER-SCREEN DR/FRAME MT	130-041824
44	128913-03-708	EA	SEAL/HINGE (3 PER DOOR)	124-042236
45	128913-02-700	EA	LATCH - BRACKET	210-042215
61	128913-01-704	EA	BRACKET - PIVOT/BRASS	370-042315
67	128913-01-732	FT	SEAL - LAZY T	122-041986
68	128913-01-748	FT	SEAL/BULB	132-042483

CONTACT WINNEBAGO PARTS SALES FOR UNLISTED COMPONENT(S)

EXTERIOR DOORS & COMPARTMENTS GROUP (CONTINUED)
COMPONENT PARTS FOR ENTRY (CONTINUED)

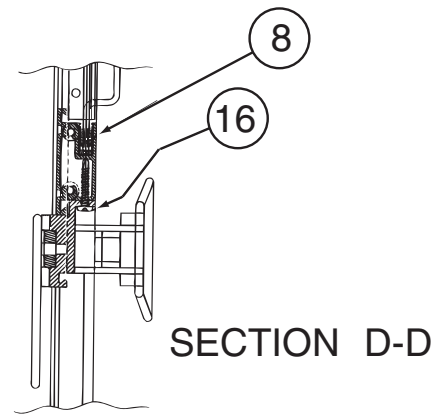
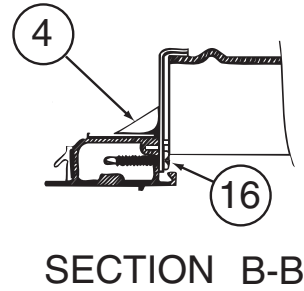
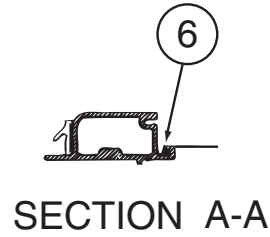
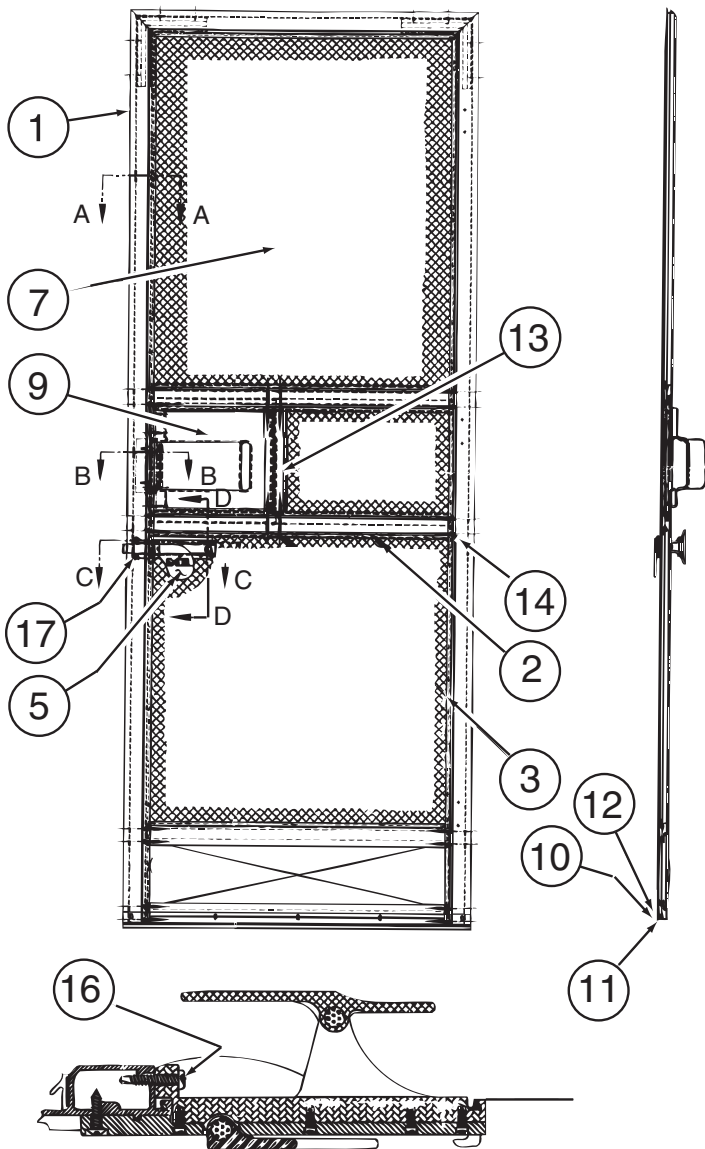

SECTION C-C

128913-10-01A/02A, 128913-11-01A, 128913-12-01A, 128913-13-01A/02A (CONTINUED)

KEY	PART NUMBER	U/M	DESCRIPTION	VENDOR NO.
2	128913-09-704	EA	RAIL/MID SCREEN-GLACIER BEIGE	490054
4	128913-09-703	EA	END CAP/SLIDER - GLACIER BEIGE	490061
5	128913-01-731	EA	LATCH - SCREEN DOOR	146-041950
6	128913-01-742	FT	SPLINE - SCREEN	132-041775
7	128913-01-741	EA	SCREEN ONLY - SCREENDOOR	110-041928
8	128913-01-740	FT	RUN CHANNEL-SCREEN DR SLIDER	170-041263
9	128913-09-702	EA	SLIDER/SCREENDOOR - GLACIER	490059
10	128913-09-701	EA	SWEEPER/SCREENDOOR- GLACIER	490052
11	128913-01-736	FT	WEATHERSTRIP-SCREEN DOOR	171-041284
13	128913-01-738	FT	WEATHERSTRIP - SLIDER	171-041285

CONTACT WINNEBAGO PARTS SALES FOR UNLISTED COMPONENT(S)

EXTERIOR SLIDEOUT GROUP

FRONT LEFT

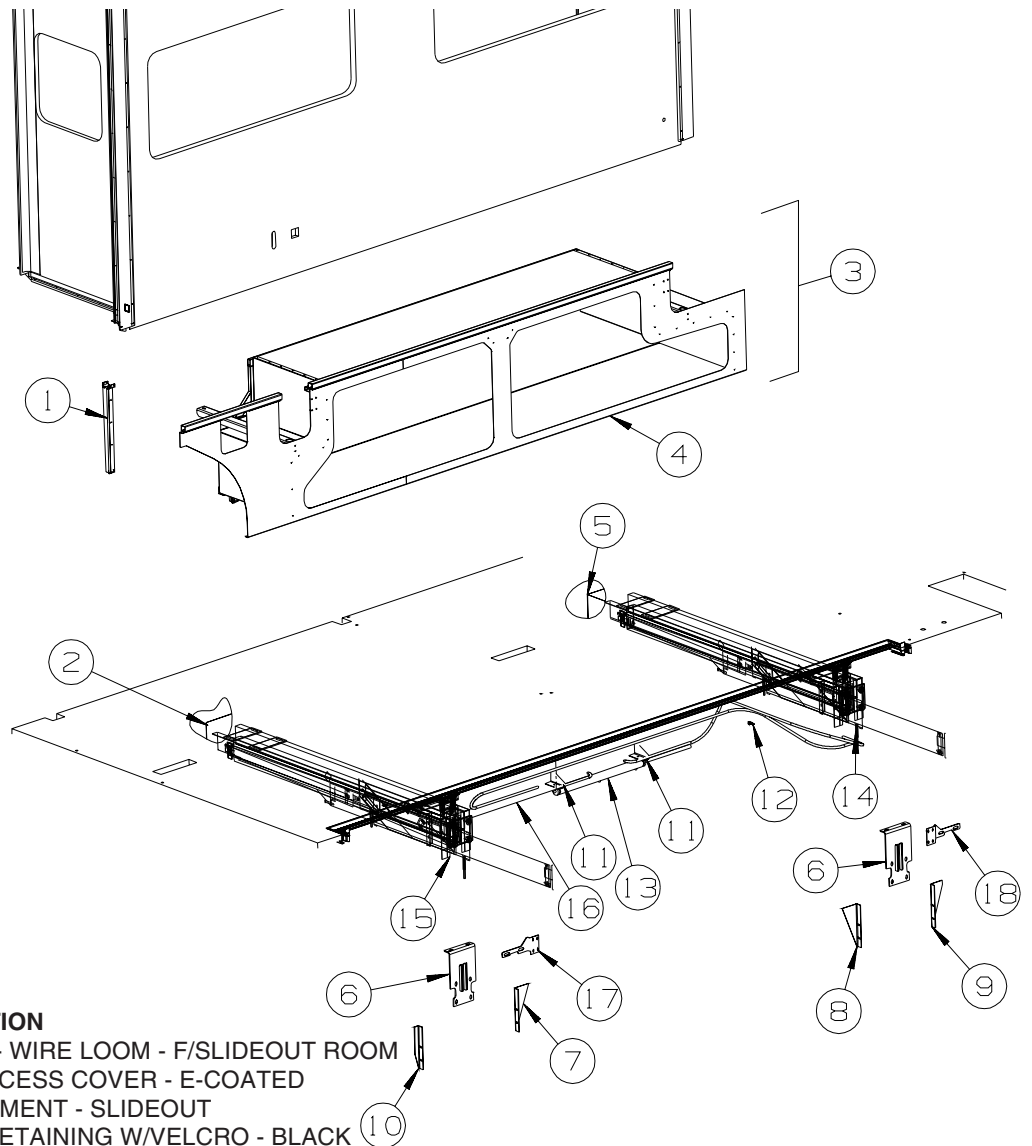

KEY	PART NUMBER	U/M	DESCRIPTION
1	126591-02-02B	EA	CARRIER - WIRE LOOM - F/SLIDEOUT ROOM
2	136749-01-02B	EA	PANEL/ACCESS COVER - E-COATED
3	141834-02-R68 143505-01-01A	EA	COMPARTMENT - SLIDEOUT
4	139573-02-02B	EA	STRAP - RETAINING W/VELCRO - BLACK
5	136749-11-02B	EA	SEAL PLANE - F/SLIDEOUT - E-COATED
5	136749-02-02B	EA	PANEL/ACCESS COVER - E-COATED
6	131529-01-02B	EA	BRACKET - MOUNTING - F/SLIDEOUT COMPARTMENT - E-COATED
7	131531-01-02B	EA	GUSSET - SLIDEOUT - E-COATED
8	131531-02-02B	EA	GUSSET - SLIDEOUT - E-COATED
9	131531-03-02B	EA	GUSSET - SLIDEOUT - E-COATED
10	131531-04-02B	EA	GUSSET - SLIDEOUT - E-COATED
11	147732-01-02B	EA	BRACKET/CYLINDER SUPPORT - E-COATED
12	123264-01-000	EA	TEE - UNION - 1/4" X 1/4" X 1/4"
13*	143625-03-000	EA	SLIDEOUT - HYDRAULIC - KIT
14*	143625-02-000	EA	SLIDEOUT - HYDRAULIC - FLAT - 29"
15*	151323-01-000	EA	BOLT - HANGER/STOREMORE - SHORT - 1/2" THREADS
15*	143625-01-000	EA	SLIDEOUT - HYDRAULIC - FLAT - 29"
	143738-01-000	EA	WRENCH - RATCHET - 13/16" X 7/8"
	151323-01-000	EA	BOLT - HANGER/STOREMORE - SHORT - 1/2" THREADS
16*	100536-52-000	EA	HOSE KIT - F/SLIDEOUT
17	143183-01-02B	EA	BRACKET - SLIDEOUT COMPARTMENT - E-COATED
18	143183-02-02B	EA	BRACKET - SLIDEOUT COMPARTMENT - E-COATED

*COMPONENT PARTS LISTED LATER IN THIS GROUP

EXTERIOR SLIDEOUT GROUP (CONTINUED)
FRONT LEFT (CONTINUED)

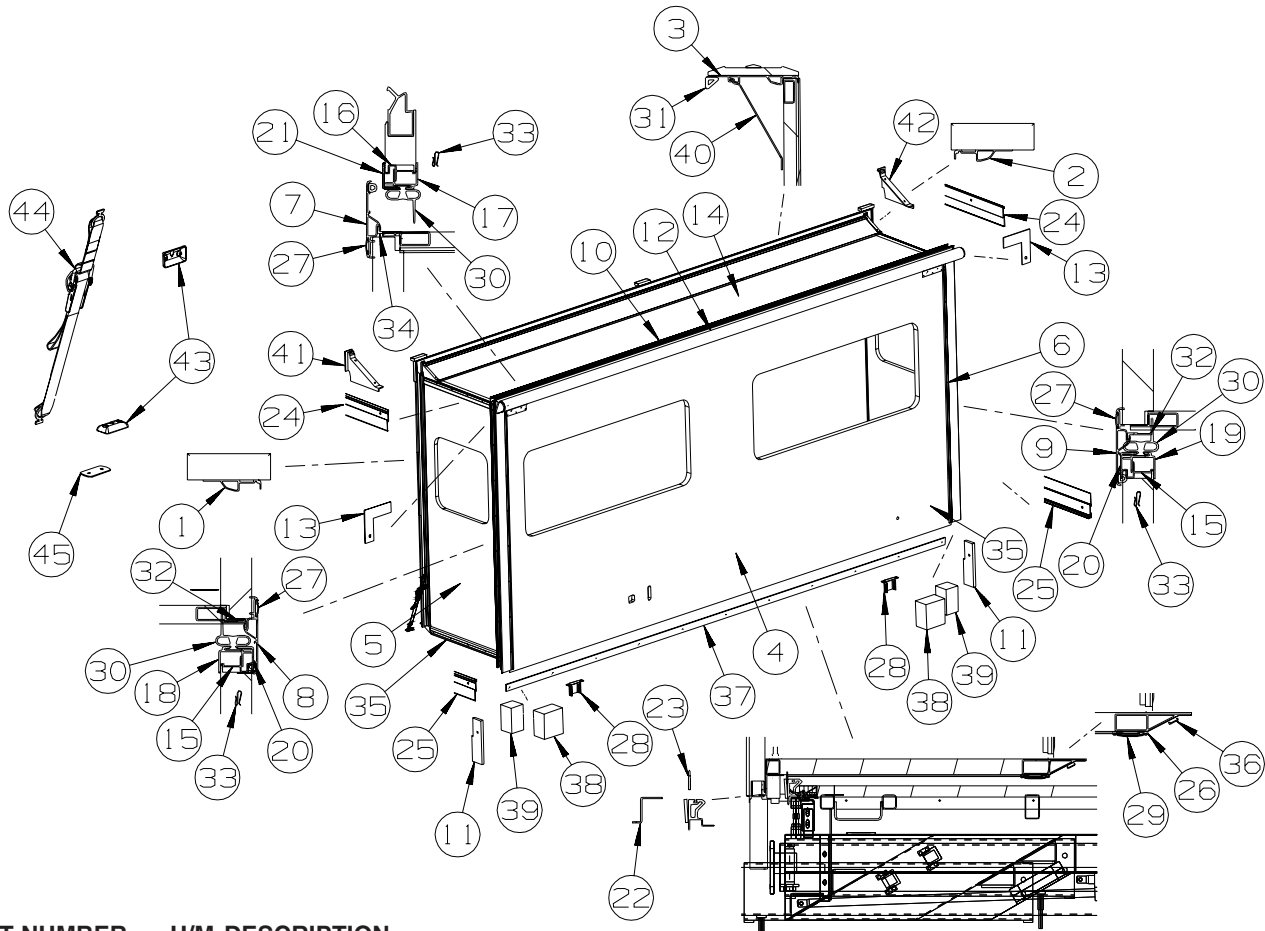

KEY	PART NUMBER	U/M	DESCRIPTION
1	139624-18-01A	EA	TRIM/SEAL - INNER/RIGHT HAND - 71.3" - BRIGHT WHITE
2	139624-19-01A	EA	TRIM/SEAL - INNER/LEFT HAND - 71.3" - BRIGHT WHITE
3	141893-01-01A	EA	TRIM/SEAL - 158.5" - F/SLIDEOUT - BRIGHT WHITE
			FROM: 00-00-00 THRU: 10-26-03
3	148916-01-01A	EA	TRIM/SEAL - W/MITERED CORNERS - F/SLIDEOUT - 158.5" - B/W
			FROM: 10-27-03 THRU: 99-99-99
4	147174-11-R68	EA	SLUG - F/SLIDEOUT (R74, R75, R76)
4	147174-11-R70	EA	SLUG - F/SLIDEOUT (R77, R78, R79)
4	147174-11-R72	EA	SLUG - F/SLIDEOUT (R80, R81, R82)
5	141972-01-R42	EA	PANEL/END - F/SLIDEOUT (R74, R75, R76)
5	141972-01-P47	EA	PANEL/END - F/SLIDEOUT (R77, R78, R79)
5	141972-01-N70	EA	PANEL/END - F/SLIDEOUT (R80, R81, R82)
6	141973-01-R42	EA	PANEL/END - F/SLIDEOUT (R74, R75, R76)
6	141973-01-R40	EA	PANEL/END - F/SLIDEOUT (R77, R78, R79)
6	141973-01-P67	EA	PANEL/END - F/SLIDEOUT (R80, R81, R82)
7	139625-10-02A	EA	TRIM/SEAL - W/MITERED ENDS - 160" - BLACK
8	139625-16-02A	EA	TRIM/SEAL - W/RH MITERED END - 76.1" - BLACK
			FROM: 00-00-00 THRU: 12-07-03
8	139625-44-02A	EA	TRIM/SEAL - W/RH MITERED END - 75.9" - BLACK
			FROM: 12-08-03 THRU: 99-99-99
9	139625-17-02A	EA	TRIM/SEAL - W/LH MITERED END - 76.1" - BLACK
			FROM: 00-00-00 THRU: 12-07-03
9	139625-45-02A	EA	TRIM/SEAL - W/LH MITERED END - 75.9" - BLACK
			FROM: 12-08-03 THRU: 99-99-99
10	117058-01-02A	FT	TAPE - LOOP - 3/4" WIDE - ADHESIVE BACKED
11	126546-01-02A	EA	COVER - END/SIDEWALL SLIDEOUT - BRIGHT WHITE

EXTERIOR SLIDEOUT GROUP (CONTINUED)

KEY PART NUMBER U/M DESCRIPTION FRONT LEFT (CONTINUED)
 12 SLIDEOUT AWNING - FULL BODY PAINT

SLIDEOUT AWNINGS UP TO 08-03-03

MODEL	COLOR CODE	HARDWARE COLOR	SLIDEROOM LT FRONT	SLIDEROOM LT REAR	SLIDEROOM RT FRONT
IKP39W	27A & 92A	SILVER	122977-06-05A	122977-19-05A	NA
IKP39K	27A & 92A	SILVER	122977-06-05A	122977-04-05A	122977-23-05A
IKP36G	27A & 92A	SILVER	122977-06-05A	122977-18-05A	NA
IKP34H	27A & 92A	SILVER	122977-07-05A	122977-18-05A	NA
IKP32T	27A & 92A	SILVER	122977-11-05A	122977-18-05A	NA
IKP39W	24C	CHAMPAGNE	122977-06-04A	122977-19-04A	NA
IKP39K	24C	CHAMPAGNE	122977-06-04A	122977-04-04A	122977-23-04A
IKP36G	24C	CHAMPAGNE	122977-06-04A	122977-18-04A	NA
IKP34H	24C	CHAMPAGNE	122977-07-04A	122977-18-04A	NA
IKP32T	24C	CHAMPAGNE	122977-11-04A	122977-18-04A	NA

SLIDEOUT AWNINGS AFTER 08-03-03

MODEL	COLOR CODE	HARDWARE COLOR	SLIDEROOM LT FRONT	SLIDEROOM LT REAR	SLIDEROOM RT FRONT
IKP39W	27A & 92A	SILVER	122977-06-07A	122977-19-07A	NA
IKP39K	27A & 92A	SILVER	122977-06-07A	122977-04-07A	122977-23-07A
IKP36G	27A & 92A	SILVER	122977-06-07A	122977-18-07A	NA
IKP34H	27A & 92A	SILVER	122977-07-07A	122977-18-07A	NA
IKP32T	27A & 92A	SILVER	122977-11-07A	122977-18-07A	NA
IKP39W	24C	CHAMPAGNE	122977-06-06A	122977-19-06A	NA
IKP39K	24C	CHAMPAGNE	122977-06-06A	122977-04-06A	122977-23-06A
IKP36G	24C	CHAMPAGNE	122977-06-06A	122977-18-06A	NA
IKP34H	24C	CHAMPAGNE	122977-07-06A	122977-18-06A	NA
IKP32T	24C	CHAMPAGNE	122977-11-06A	122977-18-06A	NA

KEY	PART NUMBER	U/M	DESCRIPTION
13	116444-04-02B	EA	TRIM/KEY CORNER - SLIDEOUT - 3.1"X3.1" - E-COATED
14	136039-01-M84	EA	ROOF - F/SLIDEOUT
15	142718-01-01A	EA	RETAINER - SIDEWALL/SLIDEOUT - 72.8"
16	142718-09-01A	EA	RETAINER - SIDEWALL/SLIDEOUT - 157.9"
17	142719-11-01A	EA	TRIM/SIDEWALL - TOP/SLIDEOUT - 159.5" - BRIGHT WHITE
18	142720-02-01A	EA	TRIM - SIDEWALL/SLIDEOUT - 74.8" - BRIGHT WHITE
19	142720-01-01A	EA	TRIM - SIDEWALL/SLIDEOUT - 74.8" - BRIGHT WHITE
20	136824-39-02A	EA	TRIM - SIDEWALL/SLIDEOUT - 74.8" - BLACK
			FROM: 00-00-00 THRU: 12-07-03
20	136824-38-02A	EA	TRIM - SIDEWALL/SLIDEOUT - 74.6" - BLACK
			FROM: 12-08-03 THRU: 99-99-99
21	136824-11-02A	EA	TRIM - SIDEWALL/SLIDEOUT - 159.8" - BLACK
22	131520-08-01A	EA	EXTRUSION/ZEE - F/SLIDEOUT - 150.4"
23	123012-01-000	FT	SEAL - SLIDEOUT - .09"/.13" THICK X 1.25" - W/ADHESIVE
24	138659-01-02A	EA	TRIM/FEATURE STRIP - 181.7" - BLACK
25	125051-03-02A	EA	TRIM - FEATURE STRIP/LOWER - 29.3" - BLACK
26	115325-01-02A	EA	RAIL - FLOOR/SLIDEOUT ROOM - 147.2" LONG - BLACK
27	105312-01-13A	FT	INSERT - FEATURE STRIP - VINYL - BLACK
28	133233-01-02B	EA	BRACKET - SLIDEOUT - E-COATED
29	115661-01-000	FT	SHOE/GLIDE - SLIDEOUT ROOM - 1/16" X 3" - POLYETHYLENE
30	136978-01-01A	FT	SEAL - SLIDEOUT - BLACK
31	146056-01-000	FT	SEAL - TRIANGLE - W/PSA
32	133954-16-02A	EA	TRIM/SEAL - 71.2" - BLACK
33	142549-01-000	EA	CLIP - "S" TYPE
34	133954-01-02A	EA	TRIM/SEAL - 154.3" - BLACK

EXTERIOR SLIDEOUT GROUP (CONTINUED)
FRONT LEFT (CONTINUED)

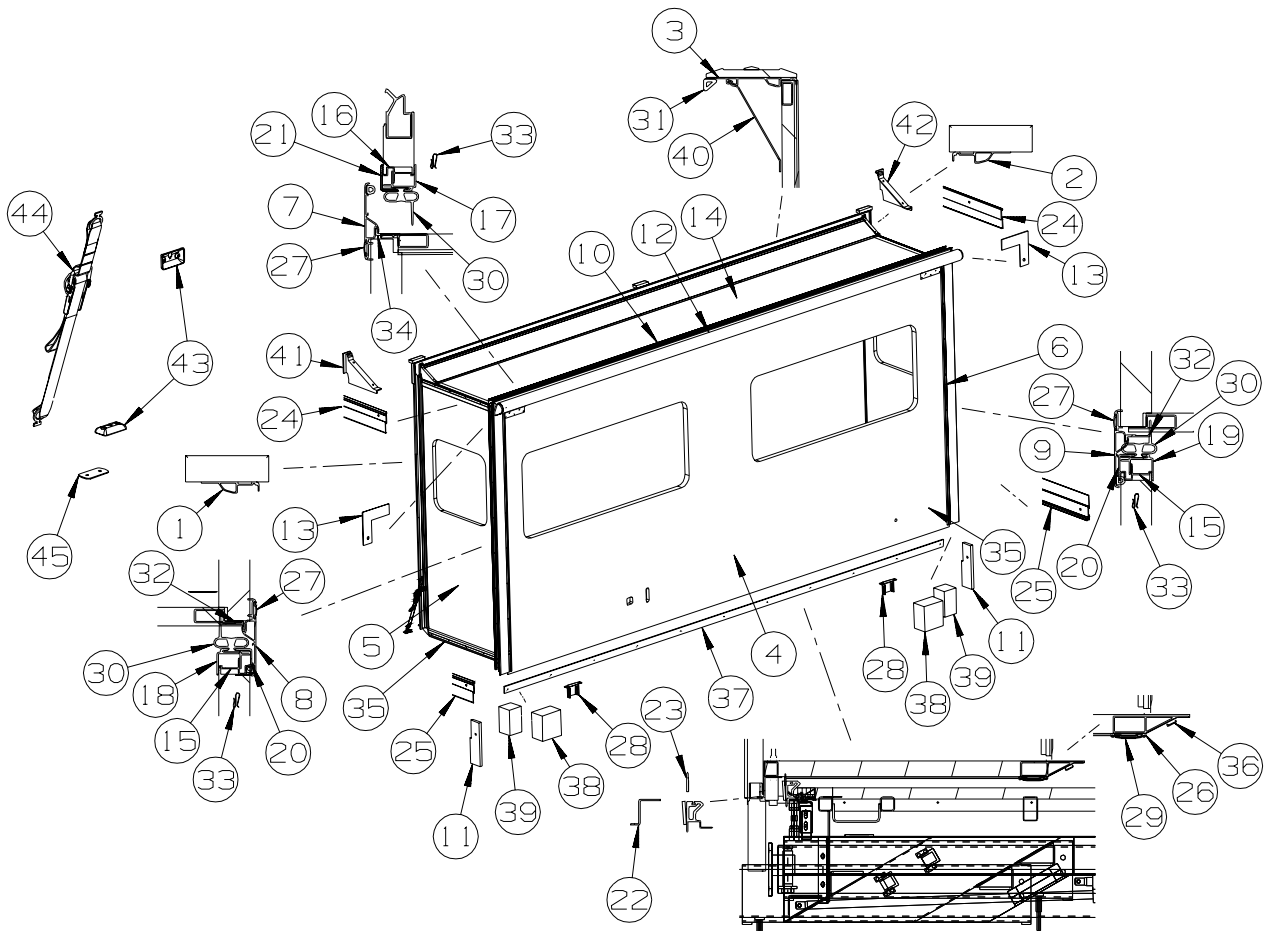

KEY	PART NUMBER	U/M	DESCRIPTION	
35	075673-05-000	FT	SEAL - PILE - ADHESIVE BACK - BLACK	
36	131358-01-01A	EA	RETAINER - U-CHANNEL - 153.4" - BLACK	
37	137343-01-02B	EA	PLATE - W/HOLES - E-COATED	
38	137408-01-000	EA	SEAL - BLOCK - F/SLIDEOUT - 2.2"	
				FROM: 00-00-00 THRU: 11-02-03
38	134588-06-000	EA	GASKET - TIMING BAR - 2" X 2" X 3/4"	FROM: 11-03-03 THRU: 99-99-99
38	134588-07-000	EA	GASKET - TIMING BAR - 2" X 3/4" X 3/4"	FROM: 11-03-03 THRU: 99-99-99
39	137408-02-000	EA	SEAL - BLOCK - F/SLIDEOUT - 1.4"	
40	131579-01-02A	EA	TRIM - RETAINER - BLACK	
				FROM: 00-00-00 THRU: 10-26-03
40	148915-01-02A	EA	RETAINER/TRIM - 154.3" - BLACK	FROM: 10-27-03 THRU: 99-99-99
41	131584-01-02A	EA	COVER - TRIM - SLIDEOUT - FRONT - BLACK	FROM: 00-00-00 THRU: 10-26-03
41	148913-01-01A	EA	COVER/TRIM - RH - F/SLIDEOUT - BLACK	FROM: 10-27-03 THRU: 99-99-99
42	131584-02-02A	EA	COVER - TRIM - SLIDEOUT - REAR - BLACK	FROM: 00-00-00 THRU: 10-26-03
42	148913-02-01A	EA	COVER/TRIM - LH - F/SLIDEOUT - BLACK	FROM: 10-27-03 THRU: 99-99-99
43	135619-02-01A	EA	PLATE - TIEDOWN - SLIDEOUT ROOM	
44	135619-01-01A	EA	STRAP - TIEDOWN - SLIDEOUT ROOM	
45	135622-01-02B	EA	PLATE - TIEDOWN - SLIDEOUT ROOM	

EXTERIOR SLIDEOUT GROUP (CONTINUED)
FRONT LEFT (CONTINUED)

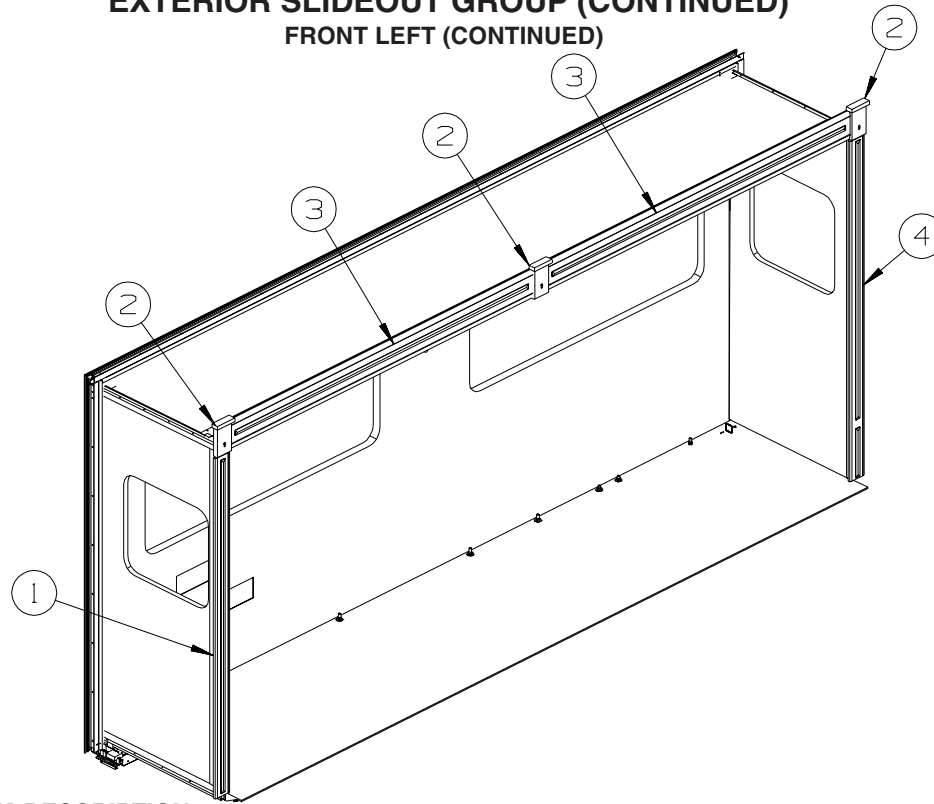

KEY	PART NUMBER	U/M	DESCRIPTION
1	Y00152-72-438	EA	MOLDING/TRIM - VINYL - .6" X 3.5" X 96" - PORTSMOUTH OAK
1	Y00152-62-438	EA	MOLDING/TRIM - VINYL - .6" X 3.5" X 96" - CHERRY - CONCERT CHERRY
1	Y00152-22-438	EA	MOLDING/TRIM - VINYL - .6" X 3.5" X 96" - WASHED MAPLE
1	Y00152-A2-438	EA	MOLDING/TRIM - VINYL - .6" X 3.5" X 96" - WASHED MAPLE FROM: 00-00-00 THRU: 01-04-04
1	120993-07-R74	EA	TRIM - DECORATIVE - 2.7" X 68.5" - FABRIC COVERED (R74, R75, R76) FROM: 01-05-04 THRU: 99-99-99
1	120993-29-R74	EA	TRIM - DECORATIVE - 2.7" X 70.1" - FABRIC COVERED (R74, R75, R76) FROM: 00-00-00 THRU: 01-04-04
1	120993-07-R70	EA	TRIM - DECORATIVE - 2.7" X 68.5" - FABRIC COVERED (R77, R78, R79) FROM: 01-05-04 THRU: 99-99-99
1	120993-29-R70	EA	TRIM - DECORATIVE - 2.7" X 70.1" - FABRIC COVERED (R77, R78, R79) FROM: 00-00-00 THRU: 01-04-04
1	120993-07-R44	EA	TRIM - DECORATIVE - 2.7" X 68.5" - FABRIC COVERED (R80, R81, R82) FROM: 01-05-04 THRU: 99-99-99
1	120993-29-R44	EA	TRIM - DECORATIVE - 2.7" X 70.1" - FABRIC COVERED (R80, R81, R82) FROM: 00-00-00 THRU: 01-04-04
1	M09462-17-R74	EA	MOLDING - TRIM/VEE - .2" X 1" X 66.8" - OAK/PORTSMOUTH OAK
1	M09462-17-R75	EA	MOLDING - TRIM/VEE - .2" X 1" X 66.8" - CHERRY/CHERRY - CONCERT CHERRY
1	M09462-17-R76	EA	MOLDING - TRIM/VEE - .2" X 1" X 66.8" - MAPLE/MAPLE - WASHED MAPLE
2	141930-02-04A	EA	MOLDING/BLOCK - OAK - PORTSMOUTH OAK
2	141930-02-02A	EA	MOLDING/BLOCK - CHERRY - CONCERT CHERRY
2	141930-02-03A	EA	MOLDING/BLOCK - MAPLE - WASHED MAPLE
2	141930-02-21A	EA	MOLDING/BLOCK - VINYL WRAPPED - WASHED MAPLE FROM: 00-00-00 THRU: 01-04-04
2			FROM: 01-05-04 THRU: 99-99-99
3	Y00154-72-438	EA	MOLDING/TRIM - VINYL - .6" X 5.9" X 96" - PORTSMOUTH OAK
3	Y00154-62-438	EA	MOLDING/TRIM - VINYL - .6" X 5.9" X 96" - CONCERT CHERRY
3	Y00154-22-438	EA	MOLDING/TRIM - VINYL - .6" X 5.9" X 96" - WASHED MAPLE
3	Y00154-A2-438	EA	MOLDING/TRIM - VINYL - .6" X 5.9" X 96" - WASHED MAPLE FROM: 00-00-00 THRU: 01-04-04
3			FROM: 01-05-04 THRU: 99-99-99
3	120993-10-R74	EA	TRIM - DECORATIVE - 3.7" X 74.4" - FABRIC COVERED (R74, R75, R76)
3	120993-10-R70	EA	TRIM - DECORATIVE - 3.7" X 74.4" - FABRIC COVERED (R77, R78, R79)
3	120993-10-R44	EA	TRIM - DECORATIVE - 3.7" X 74.4" - FABRIC COVERED (R80, R81, R82)
3	M09450-68-P45	EA	MOLDING - TRIM/VEE - .2" X 1" X 72" - OAK/PORTSMOUTH OAK
3	M09450-68-P46	EA	MOLDING - TRIM/VEE - .2" X 1" X 72" - CHERRY/CHERRY - CONCERT CHERRY
3	M09450-68-P56	EA	MOLDING - TRIM/VEE - .2" X 1" X 72" - MAPLE/MAPLE - WASHED MAPLE

EXTERIOR SLIDEOUT GROUP (CONTINUED)
FRONT LEFT (CONTINUED)

KEY	PART NUMBER	U/M	DESCRIPTION
4	Y00152-72-438	EA	MOLDING/TRIM - VINYL - .6" X 3.5" X 96" - PORTSMOUTH OAK
4	Y00152-62-438	EA	MOLDING/TRIM - VINYL - .6" X 3.5" X 96" - CHERRY - CONCERT CHERRY
4	Y00152-22-438	EA	MOLDING/TRIM - VINYL - .6" X 3.5" X 96" - WASHED MAPLE
			FROM: 00-00-00 THRU: 01-04-04
4	Y00152-A2-438	EA	MOLDING/TRIM - VINYL - .6" X 3.5" X 96" - WASHED MAPLE
			FROM: 01-05-04 THRU: 99-99-99
4	120993-07-R74	EA	TRIM - DECORATIVE - 2.7" X 68.5" - FABRIC COVERED (R74, R75, R76)
			FROM: 00-00-00 THRU: 01-04-04
4	120993-29-R74	EA	TRIM - DECORATIVE - 2.7" X 70.1" - FABRIC COVERED (R74, R75, R76)
			FROM: 01-05-04 THRU: 99-99-99
4	120993-07-R70	EA	TRIM - DECORATIVE - 2.7" X 68.5" - FABRIC COVERED (R77, R78, R79)
			FROM: 00-00-00 THRU: 01-04-04
4	120993-29-R70	EA	TRIM - DECORATIVE - 2.7" X 70.1" - FABRIC COVERED (R77, R78, R79)
			FROM: 01-05-04 THRU: 99-99-99
4	120993-07-R44	EA	TRIM - DECORATIVE - 2.7" X 68.5" - FABRIC COVERED (R80, R81, R82)
			FROM: 00-00-00 THRU: 01-04-04
4	120993-29-R44	EA	TRIM - DECORATIVE - 2.7" X 70.1" - FABRIC COVERED (R80, R81, R82)
			FROM: 01-05-04 THRU: 99-99-99
4	M09450-93-P45	EA	MOLDING - TRIM/VEE - .2" X 1" X 55.8" - OAK/PORTSMOUTH OAK
4	M09450-93-P46	EA	MOLDING - TRIM/VEE - .2" X 1" X 55.8" - CHERRY/CHERRY - CONCERT CHERRY
4	M09450-93-P56	EA	MOLDING - TRIM/VEE - .2" X 1" X 55.8" - MAPLE/MAPLE - WASHED MAPLE
4	M09450-92-P45	EA	MOLDING - TRIM/VEE - .2" X 1" X 9.8" - OAK/PORTSMOUTH OAK
4	M09450-92-P46	EA	MOLDING - TRIM/VEE - .2" X 1" X 9.8" - CHERRY/CHERRY - CONCERT CHERRY
4	M09450-92-P56	EA	MOLDING - TRIM/VEE - .2" X 1" X 9.8" - MAPLE/WASHED MAPLE

EXTERIOR SLIDEOUT GROUP (CONTINUED)
COMPONENT PARTS FOR FRONT SLIDEOUT

100536-52-000

KEY	PART NUMBER	U/M	DESCRIPTION	VENDOR NO.
	100536-52-700	EA	HOSE-HYDRAULIC - 1/4" X 207"	RAP90119/AP11212
	100536-52-701	EA	HOSE-HYDRAULIC 1/4" X 228"	AP5924

143625-01-000

KEY	PART NUMBER	U/M	DESCRIPTION	VENDOR NO.
	128599-06-703	EA	BEARING KIT - SLIDE-OUT TUBE	RAP90698
	131360-01-700	EA	CYLINDER - HYDRAULIC (RAM)	RAP90696/AP19256
	131360-01-703	EA	HOSE-HYDRAULIC-3/16" X 42"	AP20533
	131360-01-709	EA	PIN/UPPER MOUNT - FLAT FLOOR	P19685
	143625-01-700	EA	BRACKET/ROOM SUPPORT - OUTER	AP18668
	143625-01-701	EA	JAMB NUT	H115002

143625-02-000

KEY	PART NUMBER	U/M	DESCRIPTION	VENDOR NO.
	128599-06-703	EA	BEARING KIT - SLIDE-OUT TUBE	RAP90698
	131360-01-700	EA	CYLINDER - HYDRAULIC (RAM)	RAP90696/AP19256
	131360-01-704	EA	STUD/COMPT MOUNT-3 3/8" LONG	P19715
	131360-01-705	EA	STUD/COMPT MOUNT-4 5/8" LONG	P19716
	131360-01-706	EA	HOSE-HYDRAULIC - 1/8" X 42"	AP24631
	131360-01-709	EA	PIN/UPPER MOUNT - FLAT FLOOR	P19685
	131360-01-711	EA	STUD KIT - COMPT.MOUNT	RAP91341

143625-03-000

KEY	PART NUMBER	U/M	DESCRIPTION	VENDOR NO.
	100536-44-700	EA	HOSE-HYDRAULIC - 1/8" X 172"	AP24649
	131360-01-701	EA	HOSE-HYDRAULIC-1/4" X 125"	AP4906
	132540-01-701	EA	CYLINDER - SYNCRONIZING	RAP90690/AP17966

EXTERIOR SLIDEOUT GROUP (CONTINUED)

RIGHT FRONT

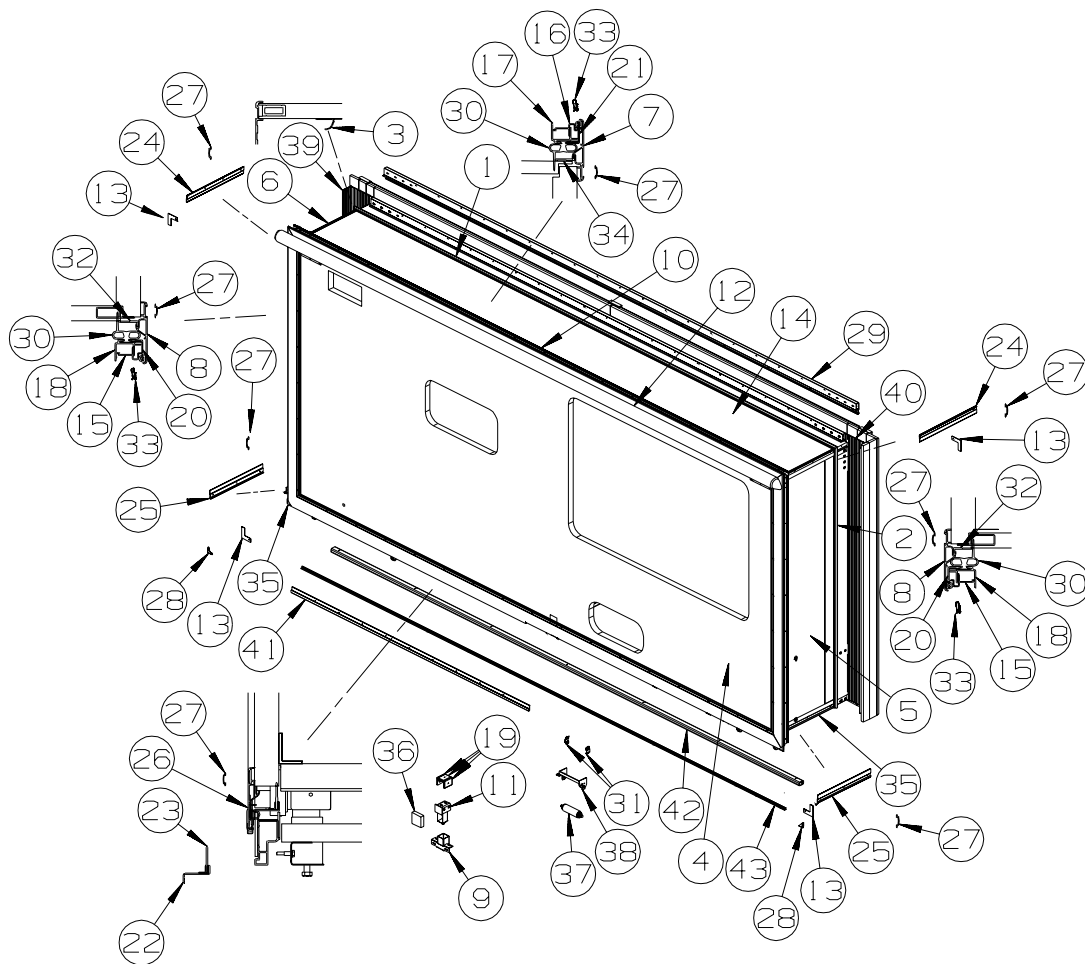

KEY	PART NUMBER	U/M	DESCRIPTION
1	141429-03-01A	EA	TRIM/SEAL - INNER - W/MITERED ENDS - 163.6"
2	141429-01-01A	EA	TRIM/SEAL - INNER - W/MITERED ENDS - 71.8"
3	141429-02-01A	EA	TRIM/SEAL - INNER - W/MITERED ENDS - 71.8"
4	147173-11-R68	EA	SLUG - F/SLIDEOUT (R74, R75, R76)
4	147173-11-R70	EA	SLUG - F/SLIDEOUT (R77, R78, R79)
4	147173-11-R72	EA	SLUG - F/SLIDEOUT (R80, R81, R82)
5	147565-01-R68	EA	PANEL END - F/SLIDEOUT (R74, R75, R76)
5	147565-01-R70	EA	PANEL END - F/SLIDEOUT (R77, R78, R79)
5	147565-01-R72	EA	PANEL END - F/SLIDEOUT (R80, R81, R82)
6	147566-01-R68	EA	PANEL END - F/SLIDEOUT (R74, R75, R76)
6	147566-01-R70	EA	PANEL END - F/SLIDEOUT (R77, R78, R79)
6	147566-01-R72	EA	PANEL END - F/SLIDEOUT (R80, R81, R82)
7	139625-24-02A	EA	TRIM/SEAL - W/MITERED ENDS - 167.8" - BLACK
8	139625-35-02A	EA	TRIM/SEAL - W/MITERED ENDS - 75.2" - BLACK
8	139625-11-02A	EA	TRIM/SEAL - W/MITERED ENDS - 75.9" - BLACK FROM: 00-00-00 THRU: 01-04-04 FROM: 01-05-04 THRU: 99-99-99
9	142488-01-02B	EA	ADJUSTER - SLIDE - E-COATED
10	117058-01-01A	FT	TAPE - LOOP - 3/4" WIDE - ADHESIVE BACKED
11	142529-01-02B	EA	GUIDE - F/SLIDEOUT ROOM - E-COATED
	142881-01-01B	EA	CHANNEL/GUIDE - SLIDEOUT

EXTERIOR SLIDEOUT GROUP (CONTINUED)

RIGHT FRONT (CONTINUED)

KEY PART NUMBER U/M DESCRIPTION
12 SLIDEOUT AWNING

SLIDEOUT AWNINGS UP TO 08-03-03

MODEL	COLOR CODE	HARDWARE COLOR	SLIDEROOM LT FRONT	SLIDEROOM LT REAR	SLIDEROOM RT FRONT
IKP39W	27A & 92A	SILVER	122977-06-05A	122977-19-05A	NA
IKP39K	27A & 92A	SILVER	122977-06-05A	122977-04-05A	122977-23-05A
IKP36G	27A & 92A	SILVER	122977-06-05A	122977-18-05A	NA
IKP34H	27A & 92A	SILVER	122977-07-05A	122977-18-05A	NA
IKP32T	27A & 92A	SILVER	122977-11-05A	122977-18-05A	NA
IKP39W	24C	CHAMPAGNE	122977-06-04A	122977-19-04A	NA
IKP39K	24C	CHAMPAGNE	122977-06-04A	122977-04-04A	122977-23-04A
IKP36G	24C	CHAMPAGNE	122977-06-04A	122977-18-04A	NA
IKP34H	24C	CHAMPAGNE	122977-07-04A	122977-18-04A	NA
IKP32T	24C	CHAMPAGNE	122977-11-04A	122977-18-04A	NA

SLIDEOUT AWNINGS AFTER 08-03-03

MODEL	COLOR CODE	HARDWARE COLOR	SLIDEROOM LT FRONT	SLIDEROOM LT REAR	SLIDEROOM RT FRONT
IKP39W	27A & 92A	SILVER	122977-06-07A	122977-19-07A	NA
IKP39K	27A & 92A	SILVER	122977-06-07A	122977-04-07A	122977-23-07A
IKP36G	27A & 92A	SILVER	122977-06-07A	122977-18-07A	NA
IKP34H	27A & 92A	SILVER	122977-07-07A	122977-18-07A	NA
IKP32T	27A & 92A	SILVER	122977-11-07A	122977-18-07A	NA
IKP39W	24C	CHAMPAGNE	122977-06-06A	122977-19-06A	NA
IKP39K	24C	CHAMPAGNE	122977-06-06A	122977-04-06A	122977-23-06A
IKP36G	24C	CHAMPAGNE	122977-06-06A	122977-18-06A	NA
IKP34H	24C	CHAMPAGNE	122977-07-06A	122977-18-06A	NA
IKP32T	24C	CHAMPAGNE	122977-11-06A	122977-18-06A	NA

KEY	PART NUMBER	U/M	DESCRIPTION
13	116444-04-02B	EA	TRIM/KEY CORNER - SLIDEOUT - 3.1"X3.1" - E-COATED
14	147562-01-R68	EA	ROOF - F/SLIDEOUT
15	142718-14-01A	EA	RETAINER - SIDEWALL/SLIDEOUT - 75"
16	142718-25-01A	EA	RETAINER - SIDEWALL/SLIDEOUT - 163.1"
17	142719-17-01A	EA	TRIM/SIDEWALL - TOP/SLIDEOUT - 167.3" - BRIGHT WHITE
18	142720-11-01A	EA	TRIM - SIDEWALL/SLIDEOUT - 72.9" - BRIGHT WHITE
19	128599-03-000	EA	PAD - F/SLIDEOUT - 2" X 2.6"
20	136824-16-02A	EA	TRIM - SIDEWALL/SLIDEOUT - 72.7" - BLACK
21	136824-28-02A	EA	TRIM - SIDEWALL/SLIDEOUT - 167.6" - BLACK
22	141174-06-03A	EA	TRIM/ZEE - SIDEWALL - 165.6" - BLACK
23	123012-03-000	FT	SEAL - F/SLIDEOUT
24	138659-01-02A	EA	TRIM/FEATURE STRIP - 181.7" - BLACK
25	125051-05-02A	EA	TRIM - FEATURE STRIP/LOWER - 17.7" - BLACK
26	142233-08-02A	EA	TRIM/SEAL - W/MITERED ENDS - 166.1" - BLACK
27	105312-01-13A	FT	INSERT - FEATURE STRIP - VINYL - BLACK
28	135275-01-01A	EA	PROTECTOR - CORNER - SLIDEOUT - WHITE
29	141927-01-01A	EA	TRIM - SLIDEOUT - INNER/TOP - BRIGHT WHITE
30	136978-01-01A	FT	SEAL - SLIDEOUT - BLACK
31	143017-01-02B	EA	ZEE - FORMED/RETAINER - ROLLER - E-COATED
32	133954-23-02A	EA	TRIM/SEAL - 68.3" - BLACK
33	142549-01-000	EA	CLIP - "S" TYPE
34	133954-38-02A	EA	TRIM/SEAL - 160.4" - BLACK
35	075673-05-000	FT	SEAL - PILE - ADHESIVE BACK - BLACK
36	143240-01-000	EA	SEAL - SPONGE RUBBER
37	127033-02-01A	EA	ROLLER - GUIDE

EXTERIOR SLIDEOUT GROUP (CONTINUED)
RIGHT FRONT (CONTINUED)

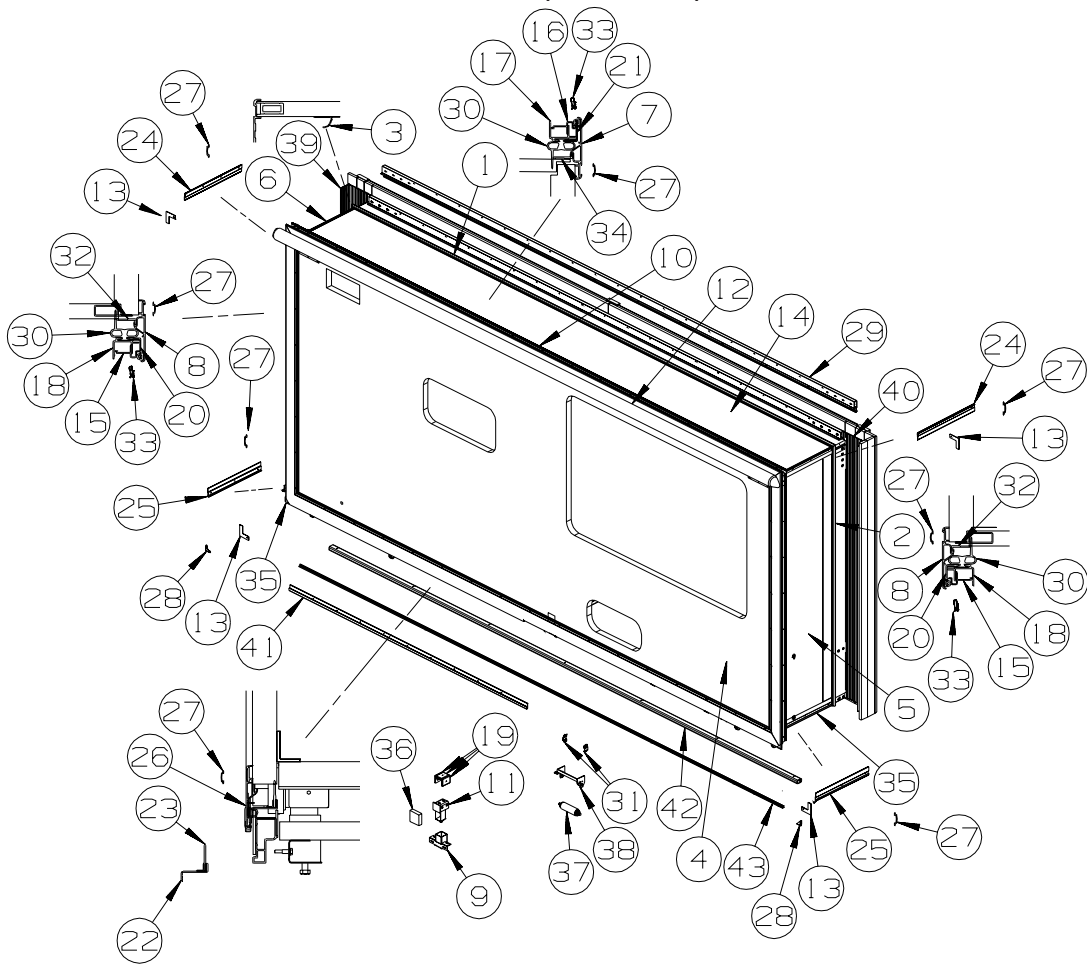

KEY	PART NUMBER	U/M	DESCRIPTION
38	140928-02-02B	EA	BRACKET - ROLLER - E-COATED
	139517-06-01B	EA	BRACKET - ROLLER - F/SLIDEOUT ROOM - E-COATED
39	142982-01-01A	EA	TRIM - SLIDEOUT/INNER - 72.5" - BRIGHT WHITE
40	142982-02-01A	EA	TRIM - SLIDEOUT/INNER - 72.5" - BRIGHT WHITE
41	136839-01-01A	EA	TRIM-J - CARPET EDGE/SLIDEOUT - 79.5" - BLACK
			FROM: 00-00-00 THRU: 01-04-04
41	136839-02-01A	EA	TRIM-J - CARPET EDGE/SLIDEOUT - 76.8" - BLACK
41	136839-02-01A	EA	TRIM-J - CARPET EDGE/SLIDEOUT - 76.8" - BLACK
			FROM: 01-05-04 THRU: 04-18-04
41	151282-02-01A	EA	TRIM - CARPET EDGE/F-ANGLE - 76.8" - BLACK
			FROM: 04-19-04 THRU: 99-99-99
42	142722-01-02B	EA	TUBE - W/HOLES - F/SLIDEOUT FLOOR - E-COATED
43	149821-06-01A	EA	TRIM/ANGLE - SIDEWALL - BLACK - 1/2" X 1/2" X 162"

EXTERIOR SLIDEOUT GROUP (CONTINUED)
RIGHT FRONT (CONTINUED)

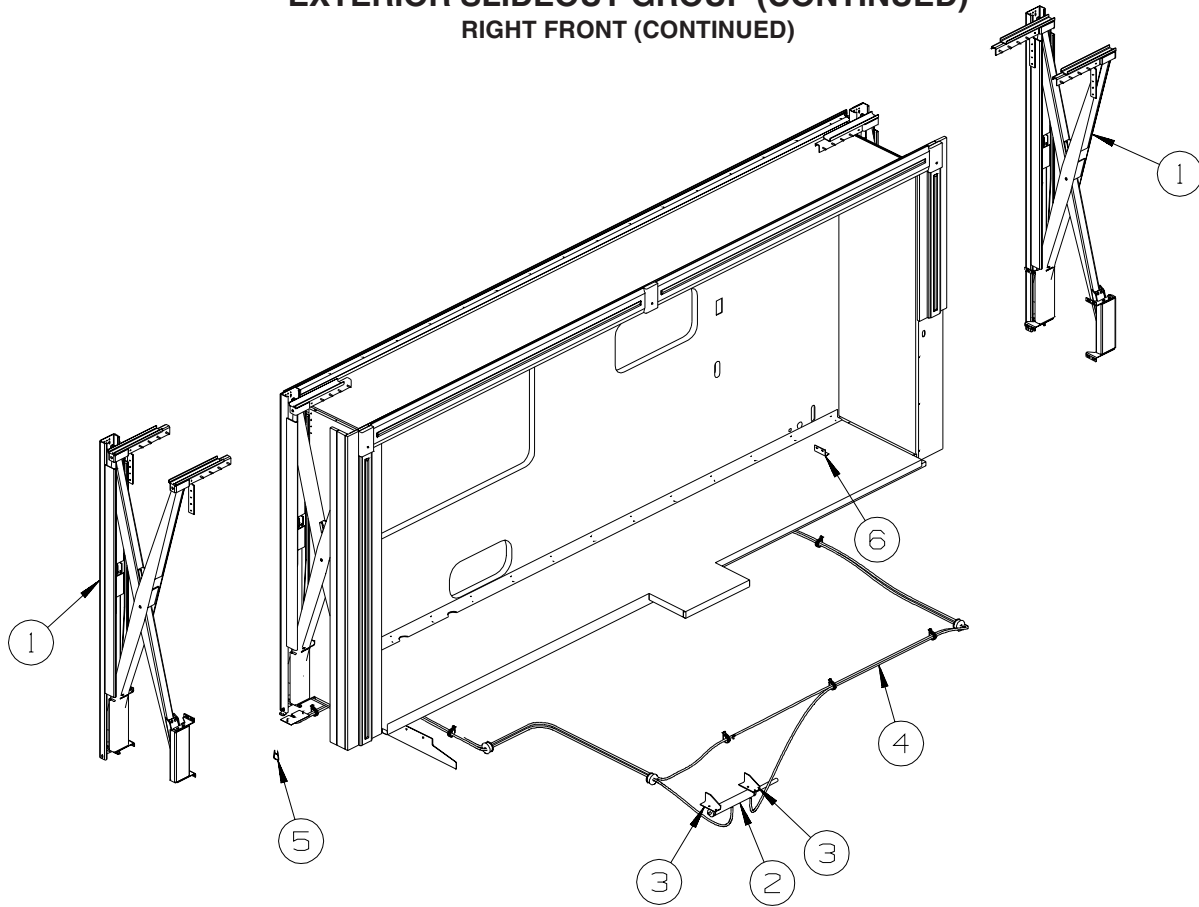

KEY	PART NUMBER	U/M	DESCRIPTION
1*	143071-01-000	EA	SLIDEOUT - "X" ARM 2 CYLINDER ROOM SYSTEM - 18"
2*	143071-02-000	EA	SLIDEOUT-X ARM, KIT
3	147732-01-02B	EA	BRACKET/CYLINDER SUPPORT - E-COATED
4*	100536-42-000	EA	HOSE KIT - PUMP TO SLIDE-OUT VALVE
5	113452-01-000	FT	SEAL/TRIM - FRONT - VINYL W/WIRE CARRIER - .020"
6	128252-01-02B	EA	BRACKET/ANGLE - SLIDEOUT - E-COAT

***COMPONENT PARTS LISTED LATER IN THIS GROUP**

EXTERIOR SLIDEOUT GROUP (CONTINUED)
RIGHT FRONT (CONTINUED)

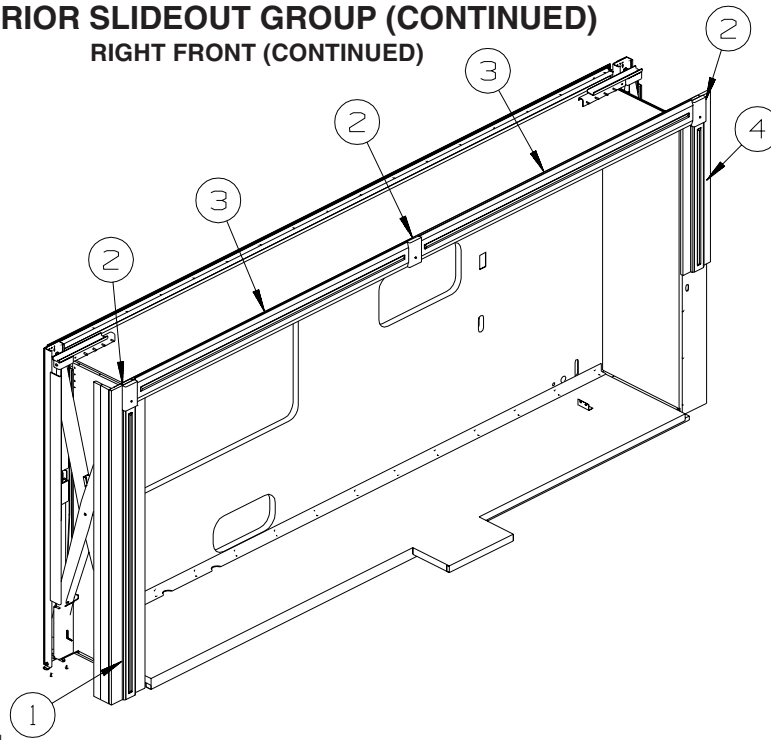

KEY	PART NUMBER	U/M	DESCRIPTION
1	Y00152-72-438	EA	MOLDING/TRIM - VINYL - .6" X 3.5" X 96" - PORTSMOUTH OAK
1	Y00152-62-438	EA	MOLDING/TRIM - VINYL - .6" X 3.5" X 96" - CHERRY - CONCERT CHERRY
1	Y00152-22-438	EA	MOLDING/TRIM - VINYL - .6" X 3.5" X 96" - WASHED MAPLE
1	Y00152-A2-438	EA	MOLDING/TRIM - VINYL - .6" X 3.5" X 96" - WASHED MAPLE FROM: 00-00-00 THRU: 01-04-04
1	120993-32-R74	EA	TRIM - DECORATIVE - 2.7" X 72.5" - FABRIC COVERED (R74, R75, R76)
1	120993-32-R70	EA	TRIM - DECORATIVE - 2.7" X 72.5" - FABRIC COVERED (R77, R78, R79)
1	120993-32-R80	EA	TRIM - DECORATIVE - 2.7" X 72.5" - FABRIC COVERED (R80, R81, R82)
1	M09477-41-R74	EA	MOLDING - TRIM/VEE - .2" X 1" X 67.5" - OAK/PORTSMOUTH OAK
1	M09477-41-R75	EA	MOLDING - TRIM/VEE - .2" X 1" X 67.5" - CHERRY/CHERRY - CONCERT CHERRY
1	M09477-41-R76	EA	MOLDING - TRIM/VEE - .2" X 1" X 67.5" - MAPLE/MAPLE - WASHED MAPLE
2	141930-02-04A	EA	MOLDING/BLOCK - OAK - PORTSMOUTH OAK
2	141930-02-02A	EA	MOLDING/BLOCK - CHERRY - CONCERT CHERRY
2	141930-02-03A	EA	MOLDING/BLOCK - MAPLE - WASHED MAPLE
2	141930-02-21A	EA	MOLDING/BLOCK - VINYL WRAPPED - WASHED MAPLE FROM: 00-00-00 THRU: 01-04-04 FROM: 01-05-04 THRU: 99-99-99
3	Y00154-72-438	EA	MOLDING/TRIM - VINYL - .6" X 5.9" X 96" - PORTSMOUTH OAK
3	Y00154-62-438	EA	MOLDING/TRIM - VINYL - .6" X 5.9" X 96" - CONCERT CHERRY
3	Y00154-22-438	EA	MOLDING/TRIM - VINYL - .6" X 5.9" X 96" - WASHED MAPLE
3	Y00154-A2-438	EA	MOLDING/TRIM - VINYL - .6" X 5.9" X 96" - WASHED MAPLE FROM: 00-00-00 THRU: 01-04-04 FROM: 01-05-04 THRU: 99-99-99
3	120993-34-R74	EA	TRIM - DECORATIVE - 3.7" X 80.3" - FABRIC COVERED (R74, R75, R76)
3	120993-34-R70	EA	TRIM - DECORATIVE - 3.7" X 80.3" - FABRIC COVERED (R77, R78, R79)
3	120993-34-R80	EA	TRIM - DECORATIVE - 3.7" X 80.3" - FABRIC COVERED (R80, R81, R82)
3	M09471-05-R44	EA	MOLDING - TRIM/VEE - .2" X 1" X 78" - OAK/PORTSMOUTH OAK
3	M09471-05-R45	EA	MOLDING - TRIM/VEE - .2" X 1" X 78" - CHERRY/CHERRY - CONCERT CHERRY
3	M09471-05-R46	EA	MOLDING - TRIM/VEE - .2" X 1" X 78" - MAPLE/MAPLE - WASHED MAPLE
4	Y00152-72-438	EA	MOLDING/TRIM - VINYL - .6" X 3.5" X 96" - PORTSMOUTH OAK
4	Y00152-62-438	EA	MOLDING/TRIM - VINYL - .6" X 3.5" X 96" - CHERRY - CONCERT CHERRY
4	Y00152-22-438	EA	MOLDING/TRIM - VINYL - .6" X 3.5" X 96" - WASHED MAPLE
4	Y00152-A2-438	EA	MOLDING/TRIM - VINYL - .6" X 3.5" X 96" - WASHED MAPLE FROM: 00-00-00 THRU: 01-04-04 FROM: 01-05-04 THRU: 99-99-99
4	120993-33-R74	EA	TRIM - DECORATIVE - 2.7" X 35.1" - FABRIC COVERED (R74, R75, R76)
4	120993-33-R70	EA	TRIM - DECORATIVE - 2.7" X 35.1" - FABRIC COVERED (R77, R78, R79)
4	120993-33-R80	EA	TRIM - DECORATIVE - 2.7" X 35.1" - FABRIC COVERED (R80, R81, R82)
4	M09471-58-R74	EA	MOLDING - TRIM/VEE - .2" X 1" X 35.1" - OAK/PORTSMOUTH OAK
4	M09471-58-R75	EA	MOLDING - TRIM/VEE - .2" X 1" X 35.1" - CHERRY/CHERRY - CONCERT CHERRY
4	M09471-58-R76	EA	MOLDING - TRIM/VEE - .2" X 1" X 35.1" - MAPLE/MAPLE - WASHED MAPLE

EXTERIOR SLIDEOUT GROUP (CONTINUED)

COMPONENT PARTS FOR RIGHT FRONT

100536-42-000

KEY	PART NUMBER	U/M	DESCRIPTION	VENDOR NO.
	100536-42-700	EA	HOSE/HYDRAULIC - 180" - PRESS	RAP90120/AP5965
	100536-42-701	EA	HOSE/HYDRAULIC - 175" - RETURN	RAP90350/AP7358

143071-01-000

KEY	PART NUMBER	U/M	DESCRIPTION	VENDOR NO.
	143071-01-700	EA	HOSE - HYDRAULIC 1/8" X 192"	RAP90821/AP24652
	143071-01-701	EA	CYLINDER - SYNCRONIZING	RAP91006/AP27302
	143071-01-702	EA	HOSE - HYDRAULIC 1/8" X 196"	AP26471
	143071-01-703	EA	HOSE - HYDRAULI 1/8" X 18.8"	AP25732
	143071-01-704	EA	HOSE - HYDRAULI 1/8" X 15.8"	AP25957
	143071-01-705	EA	CYLINDER/RAM - SLIDEOUT ROOM	RAP91007/AP27723
	143071-01-706	EA	ROLLER KIT - X-ARM SLIDE	RP91596

143071-02-000

KEY	PART NUMBER	U/M	DESCRIPTION	VENDOR NO.
	143071-01-701	EA	CYLINDER - SYNCRONIZING	RAP91006/AP27302

EXTERIOR SLIDEOUT GROUP (CONTINUED)

LEFT REAR

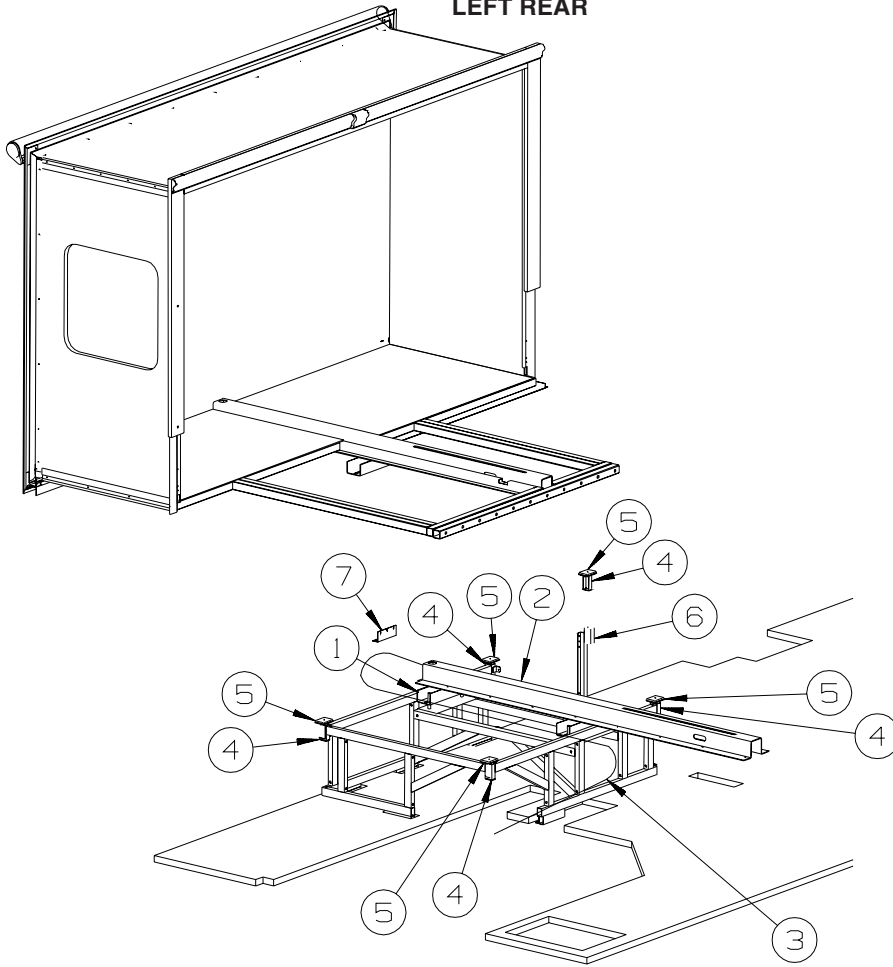

KEY	PART NUMBER	U/M	DESCRIPTION
1*	137390-01-000	EA	HYDRAULIC/BED - F/SLIDEOUT
2	137390-02-000	EA	CHANNEL - HYDRAULIC - F/SLIDEOUT
3	100536-51-000	EA	HOSE KIT - F/SLIDEOUT
4	126313-11-02B	EA	SUPPORT - ROLLER - SLIDE-OUT ROOM - E-COATED
4	142881-05-01B	EA	CHANNEL/GUIDE - F/SLIDEOUT - MILL
5	128599-03-000	EA	PAD - F/SLIDEOUT - 2" X 2.6"
6	NOT USED		
7	142889-01-02B	EA	ANGLE/SUPPORT - SIDEWALL - E-COATED

***COMPONENT PARTS LISTED LATER IN THIS GROUP**

EXTERIOR SLIDEOUT GROUP (CONTINUED)
LEFT REAR (CONTINUED)

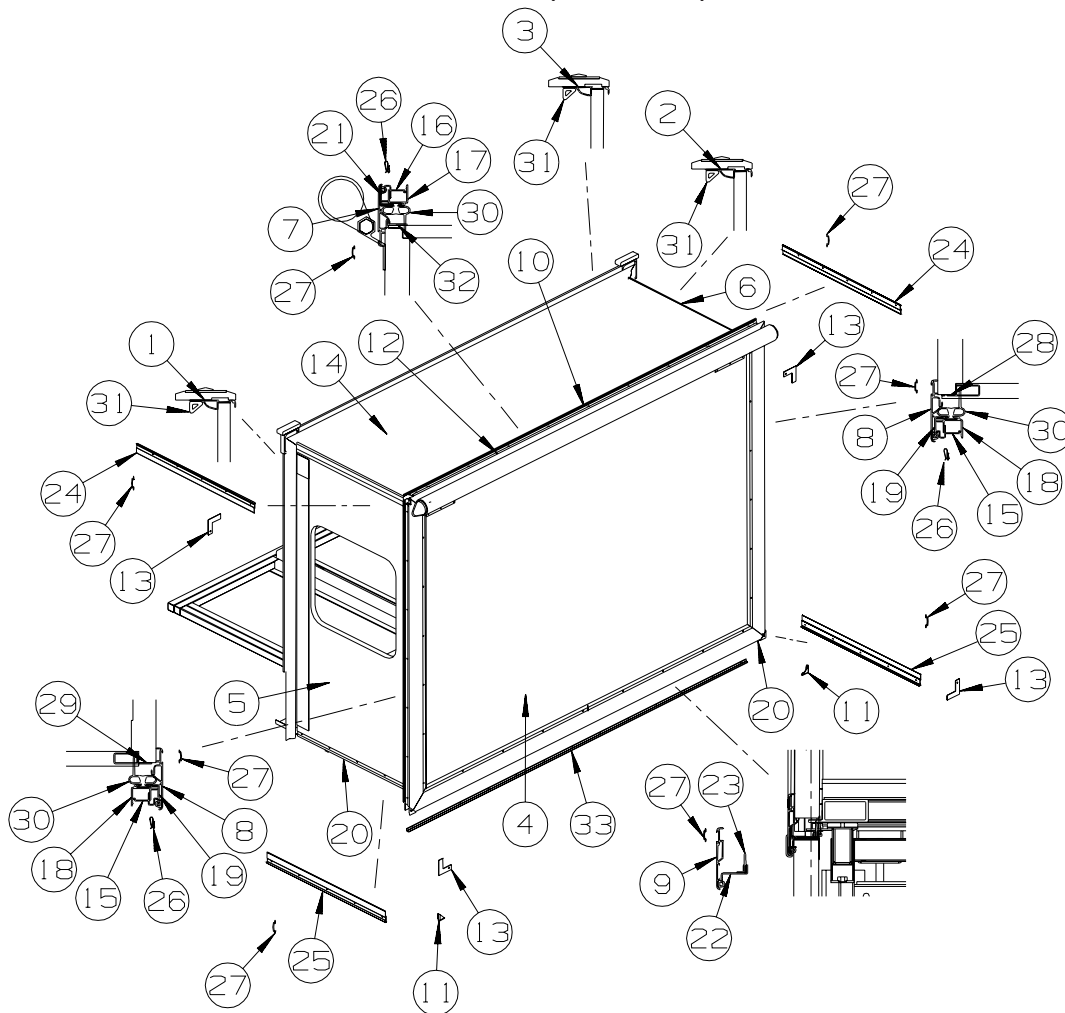

KEY	PART NUMBER	U/M	DESCRIPTION
1	139624-20-01A	EA	TRIM/SEAL - INNER/RIGHT HAND W/NOTCH - 60.6" - BRIGHT WHITE
2	139624-21-01A	EA	TRIM/SEAL - INNER/LEFT HAND W/NOTCH - 60.6" - BRIGHT WHITE
3	139624-29-01A	EA	TRIM/SEAL - INNER TOP - 85.5" - BRIGHT WHITE
4	147174-12-R68	EA	SLUG - F/SLIDEOUT (R74, R75, R76)
4	147174-12-R70	EA	SLUG - F/SLIDEOUT (R77, R78, R79)
4	147174-12-R72	EA	SLUG - F/SLIDEOUT (R80, R81, R82)
5	140731-01-R68	EA	PANEL END - F/SLIDEOUT (R74, R75, R76)
5	140731-01-R70	EA	PANEL END - F/SLIDEOUT (R77, R78, R79)
5	140731-01-N88	EA	PANEL END - F/SLIDEOUT (R80, R81, R82)
6	140732-01-R68	EA	PANEL END - F/SLIDEOUT (R74, R75, R76)
6	140732-01-R70	EA	PANEL END - F/SLIDEOUT (R77, R78, R79)
6	140732-01-N88	EA	PANEL END - F/SLIDEOUT (R80, R81, R82)
7	139625-36-02A	EA	TRIM/SEAL - W/MITERED ENDS - 87.1" - BLACK
8	139625-26-02A	EA	TRIM/SEAL - W/MITERED ENDS - 63.3" - BLACK
9	142233-03-02A	EA	TRIM/SEAL - W/MITERED ENDS - 87.3" - BLACK
10	117058-01-01A	FT	TAPE - LOOP - 3/4" WIDE - ADHESIVE BACKED
11	135275-01-01A	EA	PROTECTOR - CORNER - SLIDEOUT - WHITE

EXTERIOR SLIDEOUT GROUP (CONTINUED)

KEY PART NUMBER U/M DESCRIPTION LEFT REAR (CONTINUED)
 12 AWNING - SEE FOLLOWING AWNING CHART

SLIDEOUT AWNINGS UP TO 08-03-03

MODEL	COLOR CODE	HARDWARE COLOR	SLIDEROOM LT FRONT	SLIDEROOM LT REAR	SLIDEROOM RT FRONT
IKP39W	27A & 92A	SILVER	122977-06-05A	122977-19-05A	NA
IKP39K	27A & 92A	SILVER	122977-06-05A	122977-04-05A	122977-23-05A
IKP36G	27A & 92A	SILVER	122977-06-05A	122977-18-05A	NA
IKP34H	27A & 92A	SILVER	122977-07-05A	122977-18-05A	NA
IKP32T	27A & 92A	SILVER	122977-11-05A	122977-18-05A	NA
IKP39W	24C	CHAMPAGNE	122977-06-04A	122977-19-04A	NA
IKP39K	24C	CHAMPAGNE	122977-06-04A	122977-04-04A	122977-23-04A
IKP36G	24C	CHAMPAGNE	122977-06-04A	122977-18-04A	NA
IKP34H	24C	CHAMPAGNE	122977-07-04A	122977-18-04A	NA
IKP32T	24C	CHAMPAGNE	122977-11-04A	122977-18-04A	NA

SLIDEOUT AWNINGS AFTER 08-03-03

MODEL	COLOR CODE	HARDWARE COLOR	SLIDEROOM LT FRONT	SLIDEROOM LT REAR	SLIDEROOM RT FRONT
IKP39W	27A & 92A	SILVER	122977-06-07A	122977-19-07A	NA
IKP39K	27A & 92A	SILVER	122977-06-07A	122977-04-07A	122977-23-07A
IKP36G	27A & 92A	SILVER	122977-06-07A	122977-18-07A	NA
IKP34H	27A & 92A	SILVER	122977-07-07A	122977-18-07A	NA
IKP32T	27A & 92A	SILVER	122977-11-07A	122977-18-07A	NA
IKP39W	24C	CHAMPAGNE	122977-06-06A	122977-19-06A	NA
IKP39K	24C	CHAMPAGNE	122977-06-06A	122977-04-06A	122977-23-06A
IKP36G	24C	CHAMPAGNE	122977-06-06A	122977-18-06A	NA
IKP34H	24C	CHAMPAGNE	122977-07-06A	122977-18-06A	NA
IKP32T	24C	CHAMPAGNE	122977-11-06A	122977-18-06A	NA

KEY	PART NUMBER	U/M	DESCRIPTION
13	116444-04-02B	EA	TRIM/KEY CORNER - SLIDEOUT - 3.1"X3.1" - BLACK
14	140336-01-N84	EA	ROOF - F/SLIDEOUT
15	142718-26-01A	EA	RETAINER - SIDEWALL/SLIDEOUT - 60.2"
16	142718-11-01A	EA	RETAINER - SIDEWALL/SLIDEOUT - 84.4"
17	142719-13-01A	EA	TRIM/SIDEWALL - TOP/SLIDEOUT - 86.6" - BRIGHT WHITE
18	142720-13-01A	EA	TRIM - SIDEWALL/SLIDEOUT - 60.5" - BRIGHT WHITE
19	136824-19-02A	EA	TRIM - SIDEWALL/SLIDEOUT - 60.6" - BLACK
20	075673-05-000	FT	SEAL - PILE - ADHESIVE BACK - BLACK
21	136824-20-02A	EA	TRIM - SIDEWALL/SLIDEOUT - 86.6" - BLACK
22	141174-09-01A	EA	TRIM/ZEE - SIDEWALL - 86.8" - BLACK
23	123012-01-000	FT	SEAL - SLIDEOUT - .09"/.13" THICK X 1.25" - W/ADHESIVE
24	138659-01-02A	EA	TRIM/FEATURE STRIP - 181.7" - BLACK
25	125051-03-02A	EA	TRIM - FEATURE STRIP/LOWER - 29.3" - BLACK
26	142549-01-000	EA	CLIP - "S" TYPE
27	105312-01-13A	FT	INSERT - FEATURE STRIP - VINYL - BLACK
28	133954-31-02A	EA	TRIM/SEAL - W/NOTCHED ENDS - 56.7" - BLACK
			FROM: 00-00-00 THRU: 03-07-04
28	133954-54-02A	EA	TRIM/SEAL - 56.7" - BLACK
			FROM: 03-08-04 THRU: 99-99-99
29	133954-34-02A	EA	TRIM/SEAL - W/NOTCHED ENDS - 56.7" - BLACK
			FROM: 00-00-00 THRU: 03-07-04
28	133954-54-02A	EA	TRIM/SEAL - 56.7" - BLACK
			FROM: 03-08-04 THRU: 99-99-99
30	136978-01-01A	FT	SEAL - SLIDEOUT - BLACK
31	146056-01-000	FT	SEAL - TRIANGLE - W/PSA

EXTERIOR SLIDEOUT GROUP (CONTINUED)
LEFT REAR (CONTINUED)

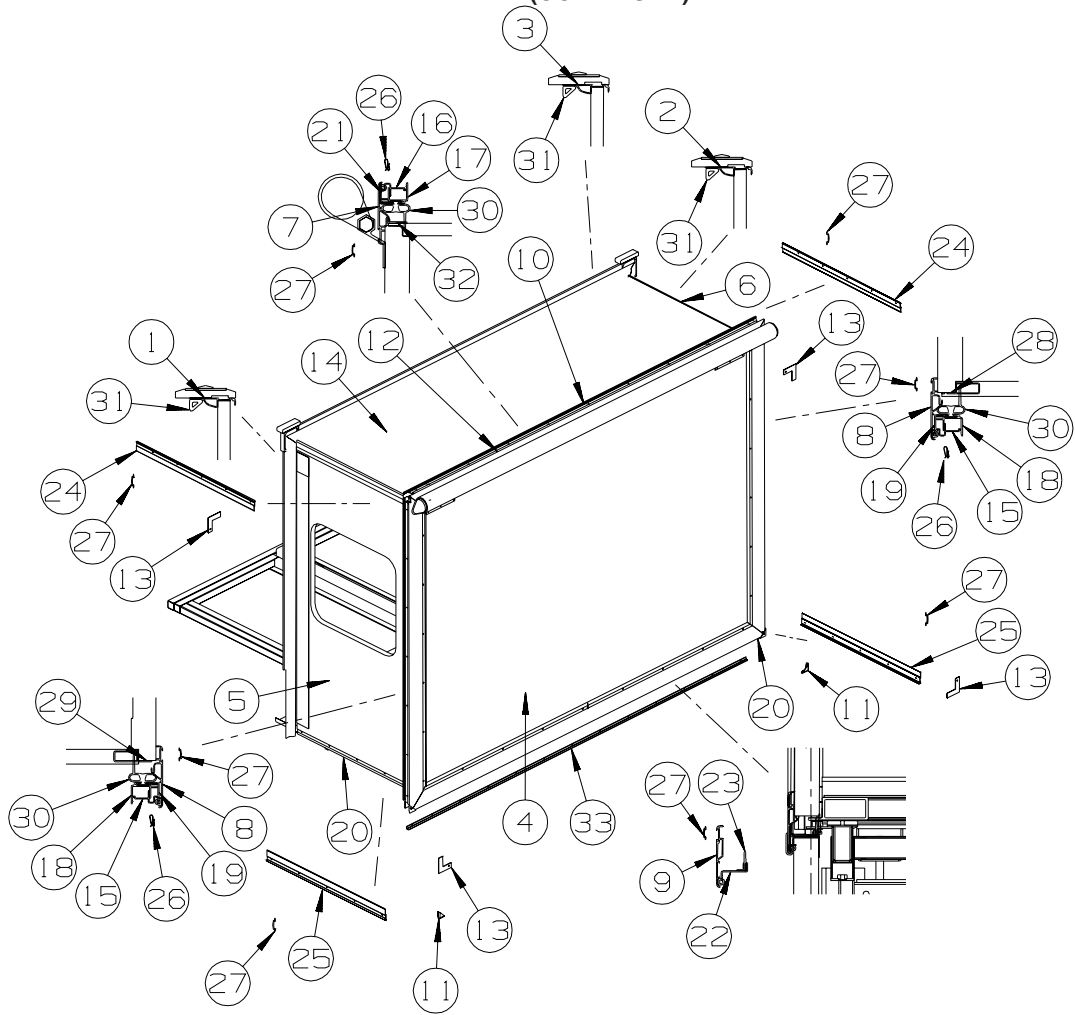

KEY	PART NUMBER	U/M DESCRIPTION
32	133954-33-02A	EA TRIM/SEAL - 81.8" - BLACK
33	149821-09-01A	EA TRIM/ANGLE - SIDEWALL - BLACK - 1/2" X 1/2" X 83.3"

FROM: 12-08-03 THRU: 99-99-99

EXTERIOR SLIDEOUT GROUP (CONTINUED)
LEFT REAR (CONTINUED)

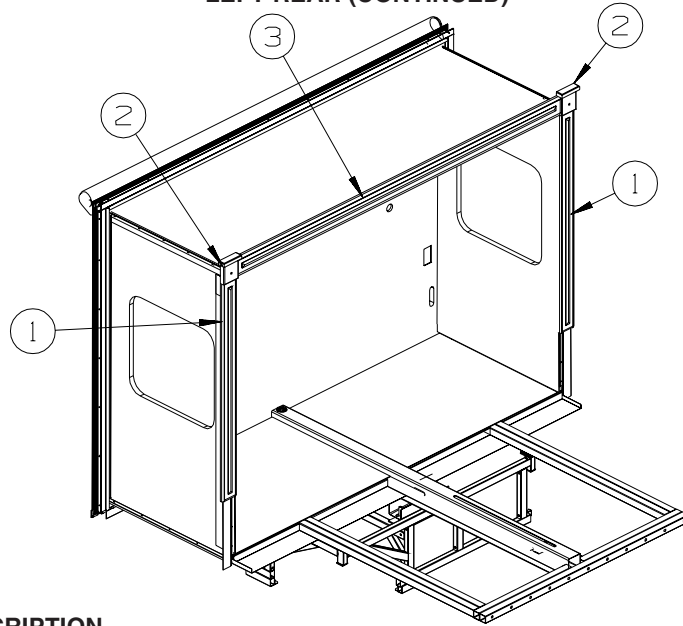

KEY	PART NUMBER	U/M	DESCRIPTION
1	Y00152-72-438	EA	MOLDING/TRIM - VINYL - .6" X 3.5" X 96" - PORTSMOUTH OAK
1	Y00152-62-438	EA	MOLDING/TRIM - VINYL - .6" X 3.5" X 96" - CHERRY - CONCERT CHERRY
1	Y00152-22-438	EA	MOLDING/TRIM - VINYL - .6" X 3.5" X 96" - WASHED MAPLE
1	Y00152-A2-438	EA	MOLDING/TRIM - VINYL - .6" X 3.5" X 96" - WASHED MAPLE FROM: 00-00-00 THRU: 01-04-04
1	120993-26-R74	EA	TRIM - DECORATIVE - 2.7" X 43.2" - FABRIC COVERED (R74, R75, R76)
1	120993-26-R70	EA	TRIM - DECORATIVE - 2.7" X 43.2" - FABRIC COVERED (R77, R78, R79)
1	120993-26-R80	EA	TRIM - DECORATIVE - 2.7" X 43.2" - FABRIC COVERED (R80, R81, R82)
1	M09471-48-R74	EA	MOLDING - TRIM/VEE - .2" X 1" X 41.4" - OAK/PORTSMOUTH OAK
1	M09471-48-R75	EA	MOLDING - TRIM/VEE - .2" X 1" X 41.4" - CHERRY/CHERRY - CONCERT CHERRY
1	M09471-48-R76	EA	MOLDING - TRIM/VEE - .2" X 1" X 41.4" - MAPLE/MAPLE - WASHED MAPLE
2	141930-01-04A	EA	MOLDING/BLOCK - OAK - PORTSMOUTH OAK
2	141930-01-02A	EA	MOLDING/BLOCK - CHERRY - CONCERT CHERRY
2	141930-01-03A	EA	MOLDING/BLOCK - MAPLE - WASHED MAPLE
2	141930-01-21A	EA	MOLDING/BLOCK - MAPLE - WASHED MAPLE FROM: 00-00-00 THRU: 01-04-04
2	141930-01-21A	EA	MOLDING/BLOCK - MAPLE - WASHED MAPLE FROM: 01-05-04 THRU: 99-99-99
3	Y00153-72-438	EA	MOLDING/TRIM - VINYL - .6" X 3.9" X 96" - PORTSMOUTH OAK
3	Y00153-62-438	EA	MOLDING/TRIM - VINYL - .6" X 3.9" X 96" - CHERRY - CONCERT CHERRY
3	Y00153-22-438	EA	MOLDING/TRIM - VINYL - .6" X 3.9" X 96" - WASHED MAPLE
3	Y00153-A2-438	EA	MOLDING/TRIM - VINYL - .6" X 3.9" X 96" - WASHED MAPLE FROM: 00-00-00 THRU: 01-04-04
3	Y00153-A2-438	EA	MOLDING/TRIM - VINYL - .6" X 3.9" X 96" - WASHED MAPLE FROM: 01-05-04 THRU: 99-99-99
3	120993-25-R74	EA	TRIM - DECORATIVE - 2.7" X 95.7" - FABRIC COVERED (R74, R75, R76) FROM: 00-00-00 THRU: 09-25-03
3	120993-25-R70	EA	TRIM - DECORATIVE - 2.7" X 95.7" - FABRIC COVERED (R77, R78, R79) FROM: 00-00-00 THRU: 09-25-03
3	120993-25-R80	EA	TRIM - DECORATIVE - 2.7" X 95.7" - FABRIC COVERED (R80, R81, R82) FROM: 00-00-00 THRU: 09-25-03
3	120993-31-R74	EA	TRIM - DECORATIVE - 2.7" X 72.5" - FABRIC COVERED (R74, R75, R76) FROM: 09-26-03 THRU: 99-99-99
3	120993-31-R70	EA	TRIM - DECORATIVE - 2.7" X 72.5" - FABRIC COVERED (R77, R78, R79) FROM: 09-26-03 THRU: 99-99-99
3	120993-31-R80	EA	TRIM - DECORATIVE - 2.7" X 72.5" - FABRIC COVERED (R80, R81, R82) FROM: 09-26-03 THRU: 99-99-99
3	M09471-49-R74	EA	MOLDING - TRIM/VEE - .2" X 1" X 77.1" - OAK/PORTSMOUTH OAK
3	M09471-49-R75	EA	MOLDING - TRIM/VEE - .2" X 1" X 77.1" - CHERRY/CHERRY - CONCERT CHERRY
3	M09471-49-R76	EA	MOLDING - TRIM/VEE - .2" X 1" X 77.1" - MAPLE/MAPLE - WASHED MAPLE

EXTERIOR SLIDEOUT GROUP (CONTINUED)

COMPONENT PARTS FOR LEFT REAR SLIDEOUT

137390-01-000

KEY	PART NUMBER	U/M	DESCRIPTION	VENDOR NO.
	128599-06-700	EA	HOSE/HYDRAULIC -1/8" X 72"	AP24635
	128599-06-701	EA	HOSE/HYDRAULIC - 1/8" X 84"	AP24636
	128599-06-703	EA	BEARING KIT - SLIDE-OUT TUBE	RAP90698
	128599-06-704	EA	BEARING PAD - SLIDE-OUT	P14811
	137390-01-700	EA	RAM/CYLINDER - SLIDEOUT ROOM	RAP90876/AP23425
	137390-01-701	EA	CYLINDER NUT KIT - SLIDEOUT	RAP90947
	137390-01-702	EA	SLOT COVER ASM. - RUBBER	AP26959

GALLEY GROUP CABINETS

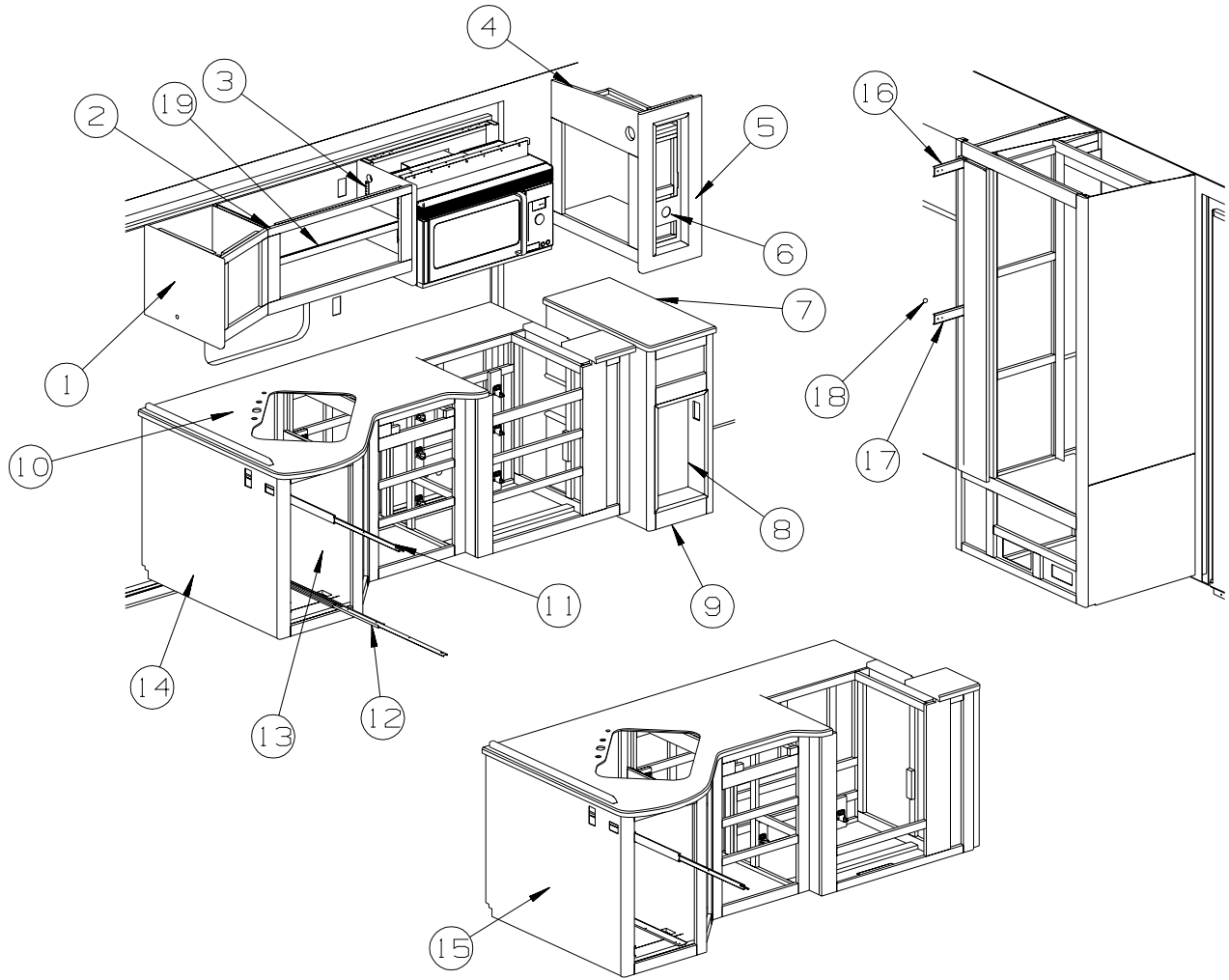

KEY	PART NUMBER	U/M	DESCRIPTION
1	147335-22-R68	EA	END CAP - OVERHEAD CABINET - PORTSMOUTH OAK
1	147335-22-R69	EA	END CAP - OVERHEAD CABINET - CONCERT CHERRY
1	147335-22-R76	EA	END CAP - OVERHEAD CABINET - WASHED MAPLE
1	147335-22-RW7	EA	END CAP - OVERHEAD CABINET - WASHED MAPLE FROM: 00-00-00 THRU: 01-04-04
2	147335-01-R68	EA	CABINET - OVERHEAD/GALLEY - W/O DOORS/HDW - PORTSMOUTH OAK - SURROUND SOUND
2	147335-01-R69	EA	CABINET - OVERHEAD/GALLEY - W/O DOORS/HDW - CONCERT CHERRY - SURROUND SOUND
2	147335-01-R76	EA	CABINET - OVERHEAD/GALLEY - W/O DOORS/HDW - WASHED MAPLE - SURROUND SOUND FROM: 00-00-00 THRU: 01-04-04
2	147335-01-RW7	EA	CABINET - OVERHEAD/GALLEY - W/O DOORS/HDW - WASHED MAPLE - SURROUND SOUND FROM: 01-05-04 THRU: 99-99-99
2	147335-02-R68	EA	CABINET - OVERHEAD/GALLEY - W/O DOORS/HARDWARE - PORTSMOUTH OAK
2	147335-02-R69	EA	CABINET - OVERHEAD/GALLEY - W/O DOORS/HARDWARE - CONCERT CHERRY
2	147335-02-R76	EA	CABINET - OVERHEAD/GALLEY - W/O DOORS/HARDWARE - WASHED MAPLE FROM: 00-00-00 THRU: 01-04-04
2	147335-02-RW7	EA	CABINET - OVERHEAD/GALLEY - W/O DOORS/HARDWARE - WASHED MAPLE FROM: 01-05-04 THRU: 99-99-99
3	147335-25-R68	EA	END CAP - OVERHEAD CABINET - PORTSMOUTH OAK
3	147335-25-R69	EA	END CAP - OVERHEAD CABINET - CONCERT CHERRY
3	147335-25-R76	EA	END CAP - OVERHEAD CABINET - WASHED MAPLE

GALLEY GROUP (CONTINUED)
CABINETS (CONTINUED)

KEY	PART NUMBER	U/M	DESCRIPTION
4	147061-01-R68	EA	CABINET - OVERHEAD/STORAGE - W/O DOORS/HDW - PORTSMOUTH OAK - SURROUND SOUND
4	147061-01-R69	EA	CABINET - OVERHEAD/STORAGE - W/O DOORS/HDW - CONCERT CHERRY - SURROUND SOUND
4	147061-01-R76	EA	CABINET - OVERHEAD/STORAGE - W/O DOORS/HDW - WASHED MAPLE - SURROUND SOUND FROM: 00-00-00 THRU: 01-04-04
4	147061-01-RW7	EA	CABINET - OVERHEAD/STORAGE - W/O DOORS/HDW - WASHED MAPLE - SURROUND SOUND FROM: 01-05-04 THRU: 99-99-99
4	147061-02-R68	EA	CABINET - OVERHEAD/STORAGE - W/O DOORS/HARDWARE - PORTSMOUTH OAK
4	147061-02-R69	EA	CABINET - OVERHEAD/STORAGE - W/O DOORS/HARDWARE - CONCERT CHERRY
4	147061-02-R76	EA	CABINET - OVERHEAD/STORAGE - W/O DOORS/HARDWARE - WASHED MAPLE FROM: 00-00-00 THRU: 01-04-04
4	147061-02-RW7	EA	CABINET - OVERHEAD/STORAGE - W/O DOORS/HARDWARE - WASHED MAPLE FROM: 01-05-04 THRU: 99-99-99
5	147061-20-R68	EA	END CAP - OVERHEAD CABINET - PORTSMOUTH OAK
5	147061-20-R69	EA	END CAP - OVERHEAD CABINET - CONCERT CHERRY
5	147061-20-R76	EA	END CAP - OVERHEAD CABINET - WASHED MAPLE
6	137602-62-P78	EA	POCKET - MONITOR PANEL - PORTSMOUTH OAK - PORTSMOUTH OAK - W/DC/AC
6	137602-62-P79	EA	POCKET - MONITOR PANEL - CHERRY - CONCERT CHERRY - W/DC/AC
6	137602-62-P28	EA	POCKET - MONITOR PANEL - WASHED MAPLE - WASHED MAPLE - W/DC/AC FROM: 00-00-00 THRU: 01-04-04
6	137602-62-RW7	EA	POCKET - MONITOR PANEL - WASHED MAPLE - WASHED MAPLE - W/DC/AC FROM: 01-05-04 THRU: 99-99-99
6	137602-65-P78	EA	POCKET - MONITOR PANEL - PORTSMOUTH OAK - PORTSMOUTH OAK
6	137602-65-P79	EA	POCKET - MONITOR PANEL - CHERRY - CONCERT CHERRY
6	137602-65-P28	EA	POCKET - MONITOR PANEL - WASHED MAPLE - WASHED MAPLE FROM: 00-00-00 THRU: 01-04-04
6	137602-65-RW7	EA	POCKET - MONITOR PANEL - WASHED MAPLE - WASHED MAPLE FROM: 01-05-04 THRU: 99-99-99
7	140623-13-02A	EA	COUNTERTOP - 1/4" VENDURA - ROCKY MOUNTAIN HIGH
8	140359-04-R68	EA	CABINET - STORAGE - W/O DOORS/HARDWARE - PORTSMOUTH OAK
8	140359-04-R69	EA	CABINET - STORAGE - W/O DOORS/HARDWARE - CONCERT CHERRY
8	140359-04-R76	EA	CABINET - STORAGE - W/O DOORS/HARDWARE - WASHED MAPLE FROM: 00-00-00 THRU: 01-04-04
8	140359-04-RW7	EA	CABINET - STORAGE - W/O DOORS/HARDWARE - WASHED MAPLE FROM: 01-05-04 THRU: 99-99-99
9	P47079-01-R68	EA	CABINET - STORAGE/PANTRY - W/O DOORS/HARDWARE - PORTSMOUTH OAK
9	P47079-01-R69	EA	CABINET - STORAGE/PANTRY - W/O DOORS/HARDWARE - CONCERT CHERRY
9	P47079-01-R76	EA	CABINET - STORAGE/PANTRY - W/O DOORS/HARDWARE - WASHED MAPLE FROM: 00-00-00 THRU: 01-04-04
9	P47079-01-RW7	EA	CABINET - STORAGE/PANTRY - W/O DOORS/HARDWARE - WASHED MAPLE FROM: 01-05-04 THRU: 99-99-99
9	147079-16-R68	EA	PANEL/ACCESS - FLIP UP - W/O HARDWARE - PORTSMOUTH OAK
9	147079-16-R69	EA	PANEL/ACCESS - FLIP UP - W/O HARDWARE - CONCERT CHERRY
9	147079-16-R76	EA	PANEL/ACCESS - FLIP UP - W/O HARDWARE - WASHED MAPLE
10	137475-23-03A	EA	COUNTERTOP - 1/4" VENDURA - ROCKY MOUNTAIN HIGH
11	122360-06-000	EA	SLIDE - PANTRY W/LOCK - RIGHT HAND FROM: 00-00-00 THRU: 12-17-03
11	122360-05-000	EA	SLIDE - PANTRY W/O LOCK FROM: 12-18-03 THRU: 99-99-99
12	122360-05-000	EA	SLIDE - PANTRY W/O LOCK
13	147514-01-R68	EA	CABINET - PANTRY/UNDER COUNTER - PORTSMOUTH OAK
13	147514-01-R69	EA	CABINET - PANTRY/UNDER COUNTER - CONCERT CHERRY
13	147514-01-R76	EA	CABINET - PANTRY/UNDER COUNTER - WASHED MAPLE FROM: 00-00-00 THRU: 01-04-04
13	147514-01-RW7	EA	CABINET - PANTRY/UNDER COUNTER - WASHED MAPLE FROM: 01-05-04 THRU: 99-99-99
14	P47483-01-R68	EA	CABINET - GALLEY - W/O COUNTERTOP/DOORS/DRAWERS/HARDWARE - PORTSMOUTH OAK
14	P47483-01-R69	EA	CABINET - GALLEY - W/O COUNTERTOP/DOORS/DRAWERS/HARDWARE - CONCERT CHERRY
14	P47483-01-R76	EA	CABINET - GALLEY - W/O COUNTERTOP/DOORS/DRAWERS/HARDWARE - WASHED MAPLE FROM: 00-00-00 THRU: 01-04-04
14	P47483-01-RW7	EA	CABINET - GALLEY - W/O COUNTERTOP/DOORS/DRAWERS/HARDWARE - WASHED MAPLE FROM: 01-05-04 THRU: 99-99-99

GALLEY GROUP (CONTINUED) CABINETS (CONTINUED)

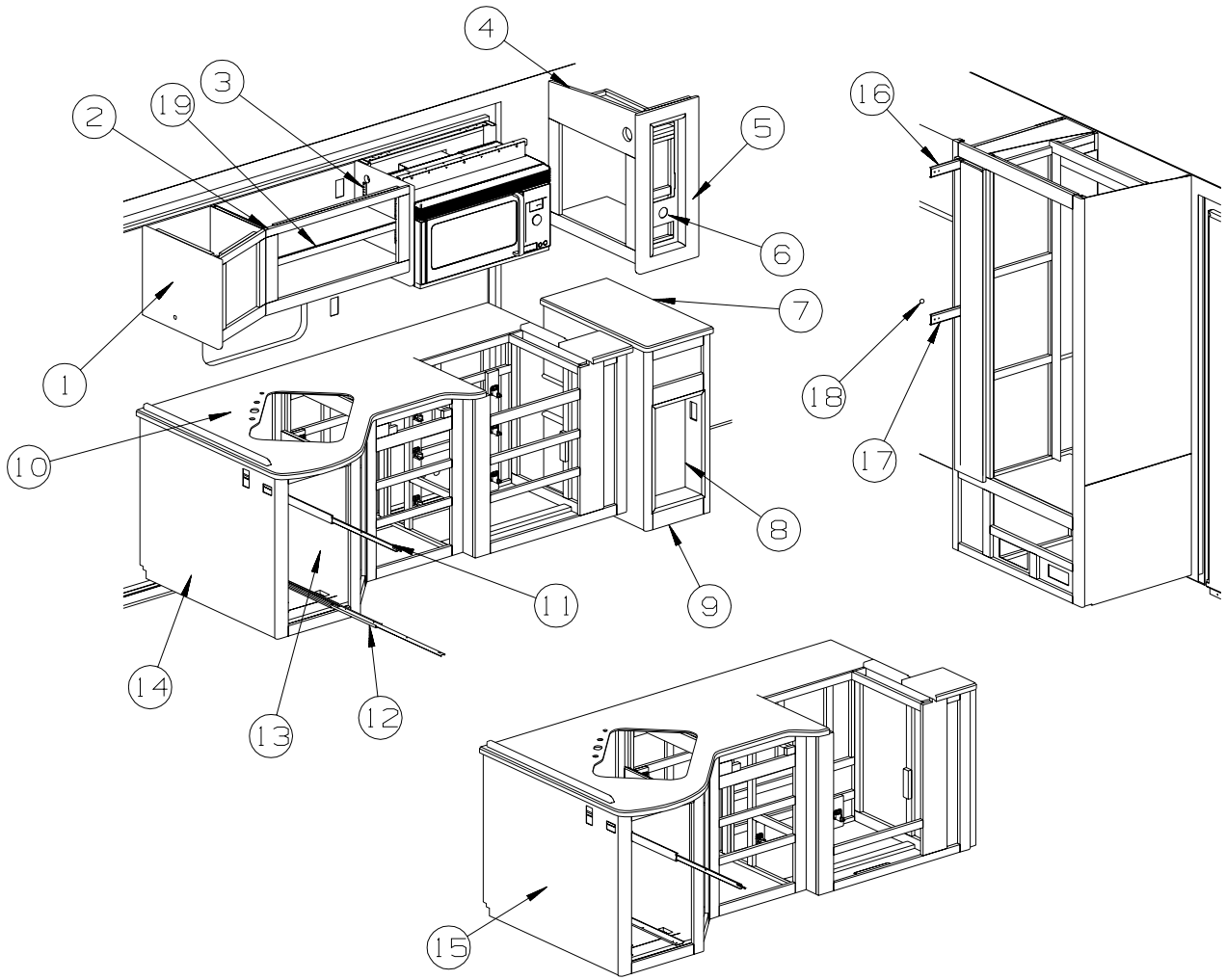

KEY	PART NUMBER	U/M	DESCRIPTION
15	P47483-02-R68	EA	CABINET - GALLEY - W/O COUNTERTOP/DOORS/DRAWERS/HARDWARE - PORTSMOUTH OAK
15	P47483-02-R69	EA	CABINET - GALLEY - W/O COUNTERTOP/DOORS/DRAWERS/HARDWARE - CONCERT CHERRY
15	P47483-02-R76	EA	CABINET - GALLEY - W/O COUNTERTOP/DOORS/DRAWERS/HARDWARE - WASHED MAPLE
15	P47483-02-RW7	EA	CABINET - GALLEY - W/O COUNTERTOP/DOORS/DRAWERS/HARDWARE - WASHED MAPLE FROM: 00-00-00 THRU: 01-04-04 FROM: 01-05-04 THRU: 99-99-99
16	122360-02-000	EA	SLIDE - PANTRY - W/O LOCK - RIGHT/LEFT HAND
17	122360-01-000	EA	SLIDE - PANTRY - W/LOCK - LEFT HAND (FACING PANEL)
18	123673-01-01A	EA	KNOB - PANTRY SLIDE
19	147335-16-R68	EA	SHELF - W/PLASTIC EDGE MOLDING - PORTSMOUTH OAK
19	147335-16-R69	EA	SHELF - W/PLASTIC EDGE MOLDING - CONCERT CHERRY
19	147335-16-R76	EA	SHELF - W/PLASTIC EDGE MOLDING - WASHED MAPLE
19	147335-16-RW7	EA	SHELF - W/PLASTIC EDGE MOLDING - WASHED MAPLE FROM: 00-00-00 THRU: 01-04-04 FROM: 01-05-04 THRU: 99-99-99

GALLEY GROUP (CONTINUED)
CABINETS (CONTINUED)

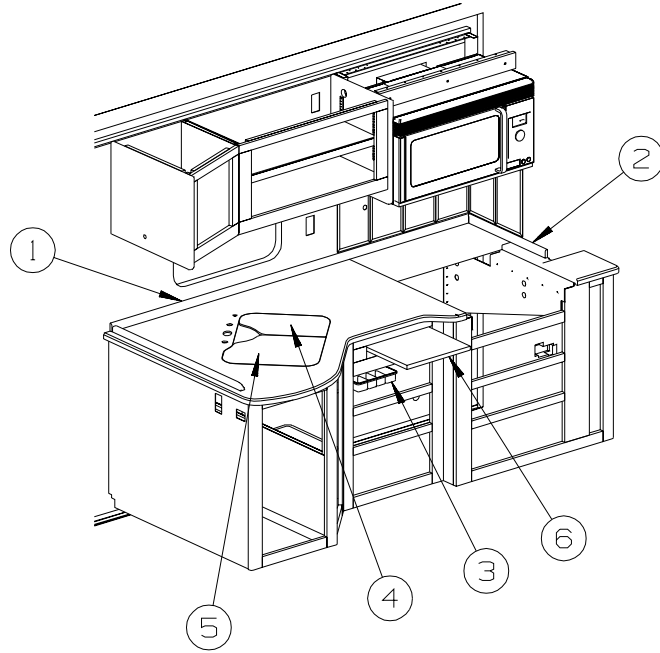

KEY	PART NUMBER	U/M	DESCRIPTION
1	130813-30-04A	EA	BACKSPLASH/COUNTERTOP - 1/2" VENDURA - QUARRY
2	130813-31-04A	EA	BACKSPLASH/COUNTERTOP - 1/2" VENDURA - QUARRY
3	100081-01-01A	EA	TRAY - SILVERWARE - 9" X 13.3" RUBBERMAID ALMOND PLASTIC
4	137489-02-03A	EA	COVER - SINK/SMALL - 9.6" X 15.7" - 1/4" VENDURA/QUARRY
5	137489-01-03A	EA	COVER - SINK/LARGE - 13.8" X 17" - 1/4" VENDURA/QUARRY
6	102778-12-000	EA	BOARD - CUTTING - .7" X 14.3" X 21.6" - WOOD

GALLEY GROUP (CONTINUED)

DOORS & DRAWERS

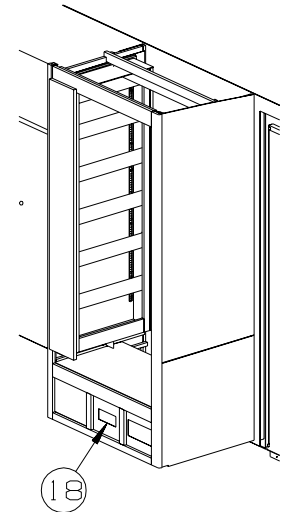
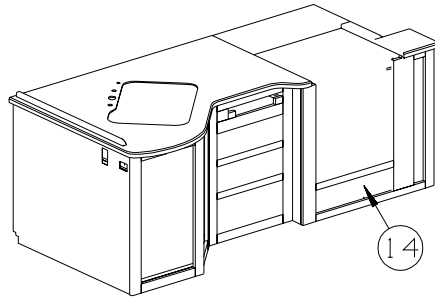
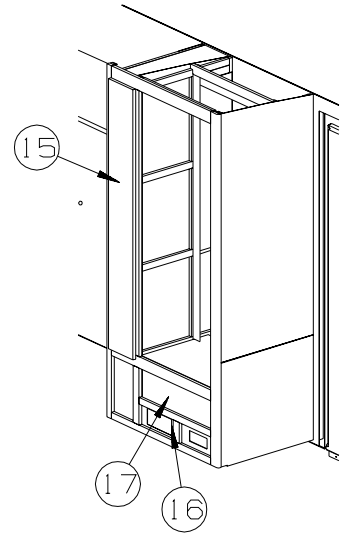
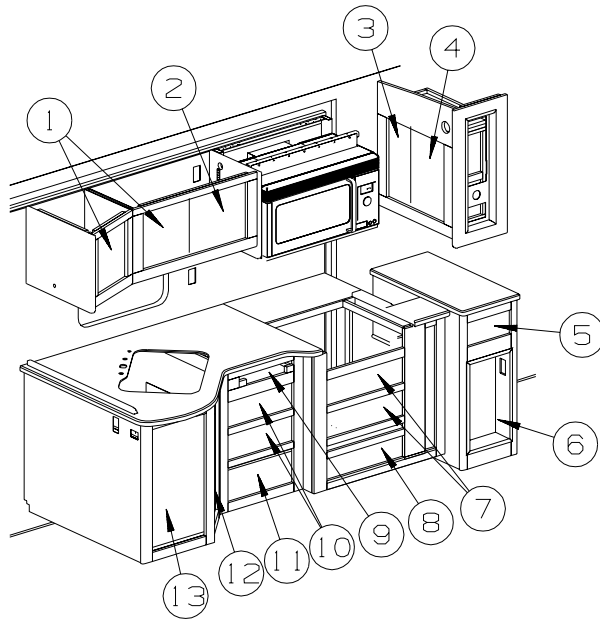

KEY	PART NUMBER	U/M	DESCRIPTION
1	141518-A1-R74	EA	DOOR - ARCHED/PENCIL EDGE - 14.3" X 14.3" - W/O HARDWARE - PORTSMOUTH OAK
1	141518-A1-R75	EA	DOOR - ARCHED/PENCIL EDGE - 14.3" X 14.3" - W/O HARDWARE - CONCERT CHERRY
1	141518-A1-R76	EA	DOOR - ARCHED/PENCIL EDGE - 14.3" X 14.3" - W/O HARDWARE - WASHED MAPLE
2	141520-A2-R74	EA	DOOR - ARCHED/PENCIL EDGE/RIGHT HAND-14.3" X 14.3"-W/O HDW - PORTSMOUTH OAK
2	141520-A2-R75	EA	DOOR - ARCHED/PENCIL EDGE/RIGHT HAND-14.3" X 14.3"-W/O HDW - CONCERT CHERRY
2	141520-A2-R76	EA	DOOR - ARCHED/PENCIL EDGE/RIGHT HAND-14.3" X 14.3"-W/O HDW - WASHED MAPLE
3	141518-22-P54	EA	DOOR - ARCHED/PENCIL EDGE/LEFT HAND-10" X 19.1" - W/O HDW - PORTSMOUTH OAK
3	141518-22-P55	EA	DOOR - ARCHED/PENCIL EDGE/LEFT HAND-10" X 19.1" - W/O HDW - CONCERT CHERRY
3	141518-22-P56	EA	DOOR - ARCHED/PENCIL EDGE/LEFT HAND-10" X 19.1" - W/O HDW - WASHED MAPLE
4	141520-22-P54	EA	DOOR - ARCHED/PENCIL EDGE/RIGHT HAND-10" X 19.1" - W/O HDW - PORTSMOUTH OAK
4	141520-22-P55	EA	DOOR - ARCHED/PENCIL EDGE/RIGHT HAND-10" X 19.1" - W/O HDW - CONCERT CHERRY
4	141520-22-P56	EA	DOOR - ARCHED/PENCIL EDGE/RIGHT HAND-10" X 19.1" - W/O HDW - WASHED MAPLE
5	145386-G5-R74	EA	DRAWER - PENCIL EDGE - 11.2"W X 21.6"D-W/O SLIDES/HARDWARE - PORTSMOUTH OAK
5	145386-G5-R75	EA	DRAWER - PENCIL EDGE - 11.2"W X 21.6"D-W/O SLIDES/HARDWARE - CONCERT CHERRY
5	145386-G5-R76	EA	DRAWER - PENCIL EDGE - 11.2"W X 21.6"D-W/O SLIDES/HARDWARE - WASHED MAPLE
6	136955-86-P54	EA	DOOR - RAISED PANEL/PENCIL EDGE - 12.8" X 21.9" - W/O HDW - PORTSMOUTH OAK
6	136955-86-P55	EA	DOOR - RAISED PANEL/PENCIL EDGE - 12.8" X 21.9" - W/O HDW - CONCERT CHERRY
6	136955-86-P56	EA	DOOR - RAISED PANEL/PENCIL EDGE - 12.8" X 21.9" - W/O HDW - WASHED MAPLE

GALLEY GROUP (CONTINUED)
DOORS & DRAWERS (CONTINUED)

KEY	PART NUMBER	U/M	DESCRIPTION
7	145386-12-R74	EA	DRAWER - PENCIL EDGE-20.2"W X 21.6"D - W/O SLIDES/HARDWARE - PORTSMOUTH OAK
7	145386-12-R75	EA	DRAWER - PENCIL EDGE-20.2"W X 21.6"D - W/O SLIDES/HARDWARE - CONCERT CHERRY
7	145386-12-R76	EA	DRAWER - PENCIL EDGE-20.2"W X 21.6"D - W/O SLIDES/HARDWARE - WASHED MAPLE
8	145386-F9-R74	EA	DRAWER - PENCIL EDGE-20.2"W X 21.6"D - W/O SLIDES/HARDWARE - PORTSMOUTH OAK
8	145386-F9-R75	EA	DRAWER - PENCIL EDGE-20.2"W X 21.6"D - W/O SLIDES/HARDWARE - CONCERT CHERRY
8	145386-F9-R76	EA	DRAWER - PENCIL EDGE-20.2"W X 21.6"D - W/O SLIDES/HARDWARE - WASHED MAPLE
9	144803-BW-R74	EA	FACE - DRAWER/CUTTING BOARD COVER - PORTSMOUTH OAK
9	144803-BW-R75	EA	FACE - DRAWER/CUTTING BOARD COVER - CONCERT CHERRY
9	144803-BW-R76	EA	FACE - DRAWER/CUTTING BOARD COVER - WASHED MAPLE
10	145386-G1-R74	EA	DRAWER - PENCIL EDGE - 17.1"W X 21.6"D-W/O SLIDES/HARDWARE - PORTSMOUTH OAK
10	145386-G1-R75	EA	DRAWER - PENCIL EDGE - 17.1"W X 21.6"D-W/O SLIDES/HARDWARE - CONCERT CHERRY
10	145386-G1-R76	EA	DRAWER - PENCIL EDGE - 17.1"W X 21.6"D-W/O SLIDES/HARDWARE - WASHED MAPLE
11	145386-G3-R74	EA	DRAWER - PENCIL EDGE - 17.1"W X 21.6"D-W/O SLIDES/HARDWARE - PORTSMOUTH OAK
11	145386-G3-R75	EA	DRAWER - PENCIL EDGE - 17.1"W X 21.6"D-W/O SLIDES/HARDWARE - CONCERT CHERRY
11	145386-G3-R76	EA	DRAWER - PENCIL EDGE - 17.1"W X 21.6"D-W/O SLIDES/HARDWARE - WASHED MAPLE
12	145268-27-R74	EA	DOOR - RAISED PANEL/PENCIL EDGE - 28.7" X 12" - W/O HDW - PORTSMOUTH OAK
12	145268-27-R75	EA	DOOR - RAISED PANEL/PENCIL EDGE - 28.7" X 12" - W/O HDW - CONCERT CHERRY
12	145268-27-R76	EA	DOOR - RAISED PANEL/PENCIL EDGE - 28.7" X 12" - W/O HDW - WASHED MAPLE
13	145268-29-R74	EA	DOOR - RAISED PANEL/PENCIL EDGE - 28.7" X 15.5" - W/O HDW - PORTSMOUTH OAK FROM: 00-00-00 THRU: 12-17-03
13	136955-C5-R74	EA	DOOR - RAISED PANEL/PENCIL EDGE - 15.6" X 29.5" - W/O HDW - PORTSMOUTH OAK FROM: 12-18-03 THRU: 99-99-99
13	145268-29-R75	EA	DOOR - RAISED PANEL/PENCIL EDGE - 28.7" X 15.5" - W/O HDW - CONCERT CHERRY FROM: 00-00-00 THRU: 12-17-03
13	136955-C5-R75	EA	DOOR - RAISED PANEL/PENCIL EDGE - 15.6" X 29.5" - W/O HDW - CONCERT CHERRY FROM: 12-18-03 THRU: 99-99-99
13	145268-29-R76	EA	DOOR - RAISED PANEL/PENCIL EDGE - 28.7" X 15.5" - W/O HDW - WASHED MAPLE FROM: 00-00-00 THRU: 12-17-03
13	136955-C5-R76	EA	DOOR - RAISED PANEL/PENCIL EDGE - 15.6" X 29.5" - W/O HDW - WASHED MAPLE FROM: 12-18-03 THRU: 99-99-99
14	145386-12-R74	EA	DRAWER - PENCIL EDGE-20.2"W X 21.6"D - W/O SLIDES/HARDWARE - PORTSMOUTH OAK
14	145386-12-R75	EA	DRAWER - PENCIL EDGE-20.2"W X 21.6"D - W/O SLIDES/HARDWARE - CONCERT CHERRY
14	145386-12-R76	EA	DRAWER - PENCIL EDGE-20.2"W X 21.6"D - W/O SLIDES/HARDWARE - WASHED MAPLE
15	134781-A7-N47	EA	DOOR - RAIL/VENEER - 8" X 60.7" - W/O HARDWARE - PORTSMOUTH OAK FROM: 00-00-00 THRU: 04-25-04
15	145268-43-SB4	EA	DOOR - RAISED PANEL/PENCIL EDGE - 8.1" X 60.7" - W/O HDW - PORTSMOUTH OAK FROM: 04-26-04 THRU: 99-99-99
15	134781-A7-P55	EA	DOOR - RAIL/VENEER - 8" X 60.7" - W/O HARDWARE - CONCERT CHERRY FROM: 00-00-00 THRU: 04-25-04
15	145268-43-SB5	EA	DOOR - RAISED PANEL/PENCIL EDGE - 8.1" X 60.7" - W/O HDW - CONCERT CHERRY FROM: 04-26-04 THRU: 99-99-99
15	134781-A7-P56	EA	DOOR - RAIL/VENEER - 8" X 60.7" - W/O HARDWARE - WASHED MAPLE FROM: 00-00-00 THRU: 04-25-04
15	145268-43-SB6	EA	DOOR - RAISED PANEL/PENCIL EDGE - 8.1" X 60.7" - W/O HDW - WASHED MAPLE FROM: 04-26-04 THRU: 99-99-99
16	145298-04-R74	EA	DOOR - SOLID PANEL/PENCIL EDGE - 12.6" X 6.1"-W/O HARDWARE - PORTSMOUTH OAK
16	145298-04-R75	EA	DOOR - SOLID PANEL/PENCIL EDGE - 12.6" X 6.1"-W/O HARDWARE - CONCERT CHERRY
16	145298-04-R76	EA	DOOR - SOLID PANEL/PENCIL EDGE - 12.6" X 6.1"-W/O HARDWARE - WASHED MAPLE
17	145492-42-R74	EA	DRAWER - PENCIL EDGE - 22.5"W X 17.7"D - W/O SLIDES/HDW - PORTSMOUTH OAK
17	145492-42-R75	EA	DRAWER - PENCIL EDGE - 22.5"W X 17.7"D - W/O SLIDES/HDW - CONCERT CHERRY
17	145492-42-R76	EA	DRAWER - PENCIL EDGE - 22.5"W X 17.7"D - W/O SLIDES/HDW - WASHED MAPLE
18	145298-06-R74	EA	DOOR - SOLID PANEL/PENCIL EDGE - 9.2" X 10.2"-W/O HARDWARE - PORTSMOUTH OAK
18	145298-06-R75	EA	DOOR - SOLID PANEL/PENCIL EDGE - 9.2" X 10.2"-W/O HARDWARE - CONCERT CHERRY
18	145298-06-R76	EA	DOOR - SOLID PANEL/PENCIL EDGE - 9.2" X 10.2"-W/O HARDWARE - WASHED MAPLE

GENERATOR GROUP LP

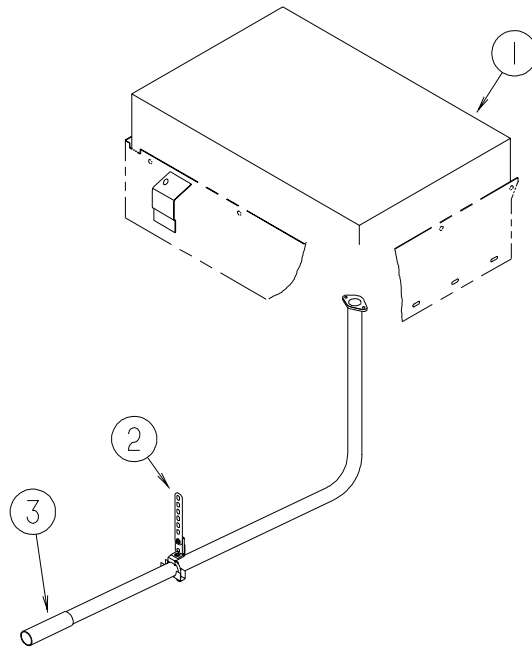

KEY	PART NUMBER	U/M	DESCRIPTION
1	135707-03-000	EA	GENERATOR - 6.5 - 30/30 - LIQUID LP - MARQUIS GOLD
1	135707-04-000	EA	GENERATOR - 6.5 - 30/20 - LIQUID LP - MARQUIS GOLD
2	007131-01-000	EA	HANGER - TAILPIPE - 6 SLOTS
	007125-03-000	EA	CLAMP - MUFFLER - 1.5" DIAMETER
3	138246-01-01A	EA	EXTENSION - TAILPIPE - 1.6" I.D.
4	137330-02-000	EA	PIPE - EXHAUST - GENERATOR/LP

GENERATOR GROUP (CONTINUED)

DIESEL

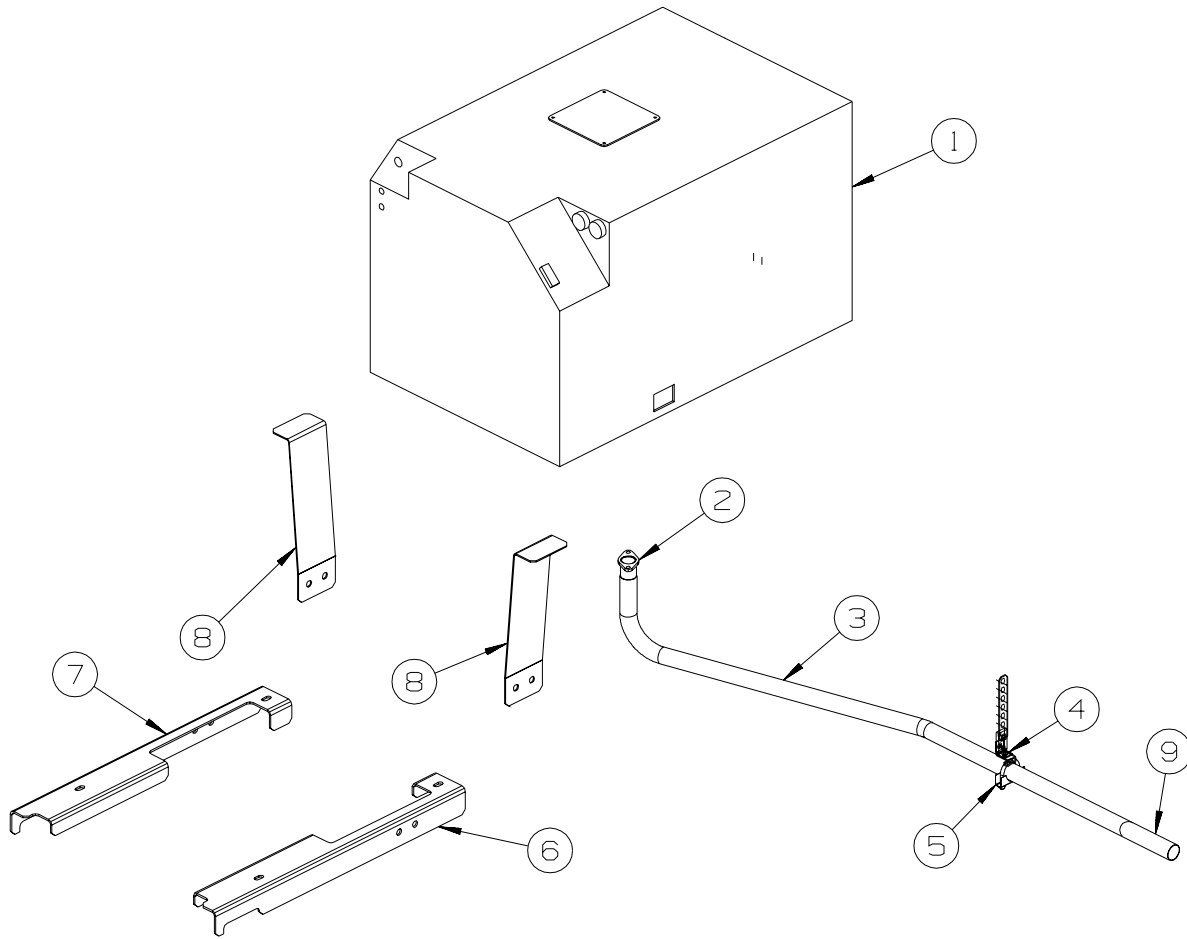

KEY	PART NUMBER	U/M	DESCRIPTION
1	122425-01-000	EA	GENERATOR - DIESEL - 7.5
2	106235-01-000	EA	ADAPTOR - GENERATOR EXHAUST
3	137330-03-000	EA	PIPE - EXHAUST - GENERATOR/DIESEL
4	007131-01-000	EA	HANGER - TAILPIPE - 6 SLOTS
5	007125-03-000	EA	CLAMP - MUFFLER - 1.5" DIAMETER
6	137328-02-02B	EA	SUPPORT - GENERATOR - LH - E-COATED
7	137328-01-02B	EA	SUPPORT - GENERATOR - RH - E-COATED
8	137329-02-02B	EA	BRACKET - HANGAR/GENERATOR - E-COATED
9	138246-01-01A	EA	EXTENSION - TAILPIPE - 1.6"ID X 7.7"

HEATING & A/C GROUP AUTOMOTIVE

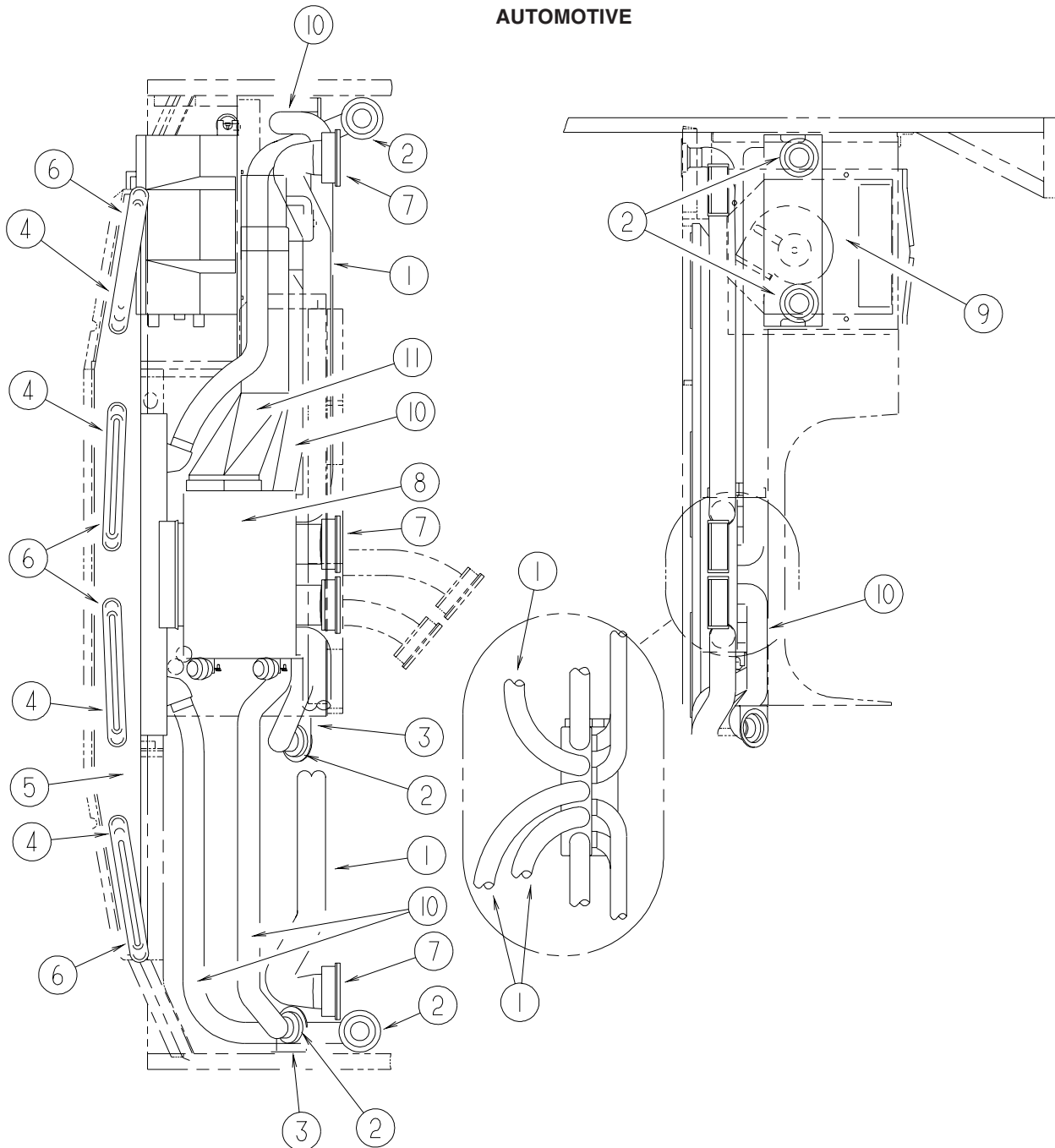

KEY	PART NUMBER	U/M DESCRIPTION
1	007281-01-000	EA HOSE - FLEXIBLE PVC - 2 1/2" ID X 50'
2	024990-05-000	EA OUTLET - DEFROSTER - W/SWIVEL - 2" SLEEVE/4" OD - BLACK - 1 USED
2	024990-12-000	EA OUTLET - DEFROSTER - W/SWIVEL - 2" SLEEVE/4" OD - GLACIER - 3 USED
3		NOT USED
4	077075-01-000	EA GASKET - INSTRUMENT PANEL/DEFROSTER PLENUM - .6" X 10.2"
5	103017-03-000	EA PLENUM - DEFROSTER
6	135265-01-04A	EA VENT - DEFROSTER - PLASTIC - GLACIER
7	135803-01-01A	EA LOUVER - A/C - 2.5" X 5.2" - BLACK - 3 USED
7	135803-02-01A	EA LOUVER - A/C - 2.5" - 5.7" - W/SCREW HOLES - BLACK - 2 USED
8*	103930-36-000	EA CONTROL/PLENUM - ROTARY CONTROL HEAD
9*	103930-55-000	EA EVAPORATOR/HEATER - NONCHARGED - SINGLE OUTPUT
10	007076-01-000	EA HOSE - FLEXIBLE PVC - 2" ID - INCREMENTS OF 50'
11	122822-01-01A	EA PLENUM - TRANSITION
	103930-54-000	EA MANUAL - OWNERS - HEATER/AC

*COMPONENT PARTS LISTED LATER IN THIS GROUP

HEATING & A/C GROUP (CONTINUED) AUTOMOTIVE (CONTINUED)

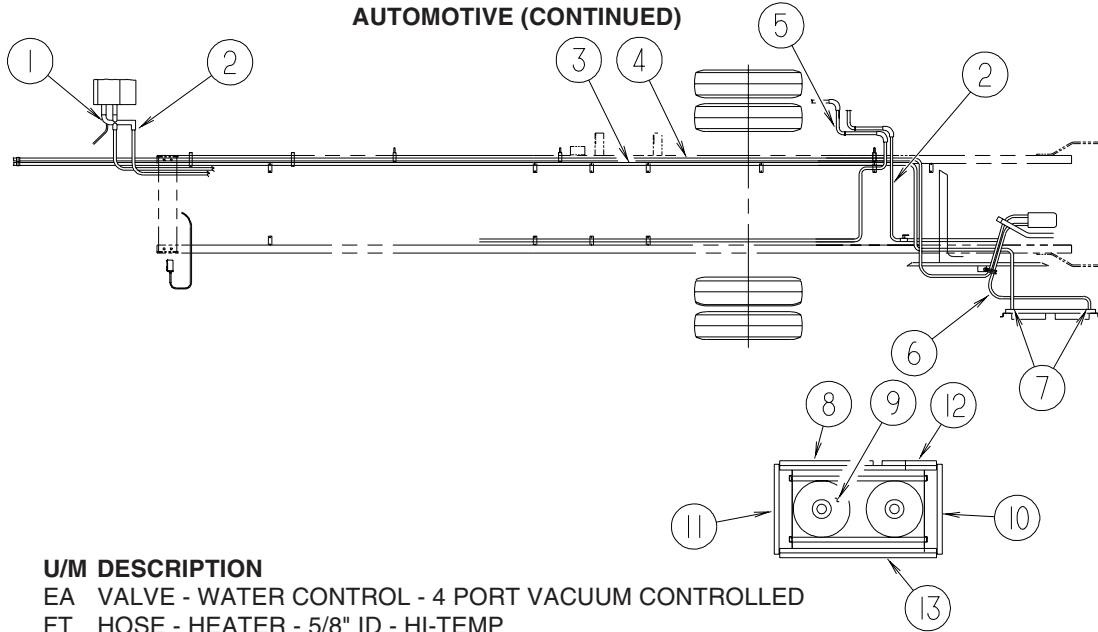

KEY	PART NUMBER	U/M	DESCRIPTION
1	103930-24-000	EA	VALVE - WATER CONTROL - 4 PORT VACUUM CONTROLLED
2	007108-01-000	FT	HOSE - HEATER - 5/8" ID - HI-TEMP
3*	072342-18-000	EA	HOSE - #6 - REC DRIER/EVAPORATOR - 42.8' LONG W/SWITCHES
4*	103930-51-000	EA	HOSE KIT - #12 496" 90 DEGREE BEND - COMPRESSOR/EVAPORATOR - CUMMINS
4*	103930-41-000	EA	HOSE KIT - EVAPORATOR/COMPRESSOR #12 - 41.3' - STRAIGHT END - CAT
5	079059-01-000	EA	HOSE - 90 DEGREE - 5/8"ID X 4" X 36"
6*	072342-17-000	EA	HOSE - #8 - STRAIGHT END - CONDENSER/COMPRESSOR - 62" - CUMMINS
6*	072342-16-000	EA	HOSE - #8 - CONDENSER/COMPRESSOR - 5.2' - W/STRAIGHT END - CAT
7	072368-02-000	EA	TRIM - VINYL - EDGE - BLACK
8	113572-02-02B	EA	BRACKET - CONDENSER - E-COAT
9*	072342-15-000	EA	CONDENSER - W/FAN SIDE - NO HOSE
10	113574-02-02B	EA	BRACKET - CONDENSER/SIDE - E-COAT
11	113574-01-02B	EA	BRACKET - CONDENSER/SIDE - E-COAT
12	113572-03-02B	EA	BRACKET - CONDENSER - E-COAT
13	113572-01-02B	EA	BRACKET - CONDENSER - E-COAT

*COMPONENT PARTS LISTED LATER IN THIS GROUP

HEATING & A/C GROUP (CONTINUED)

COMPONENT PARTS FOR AUTOMOTIVE

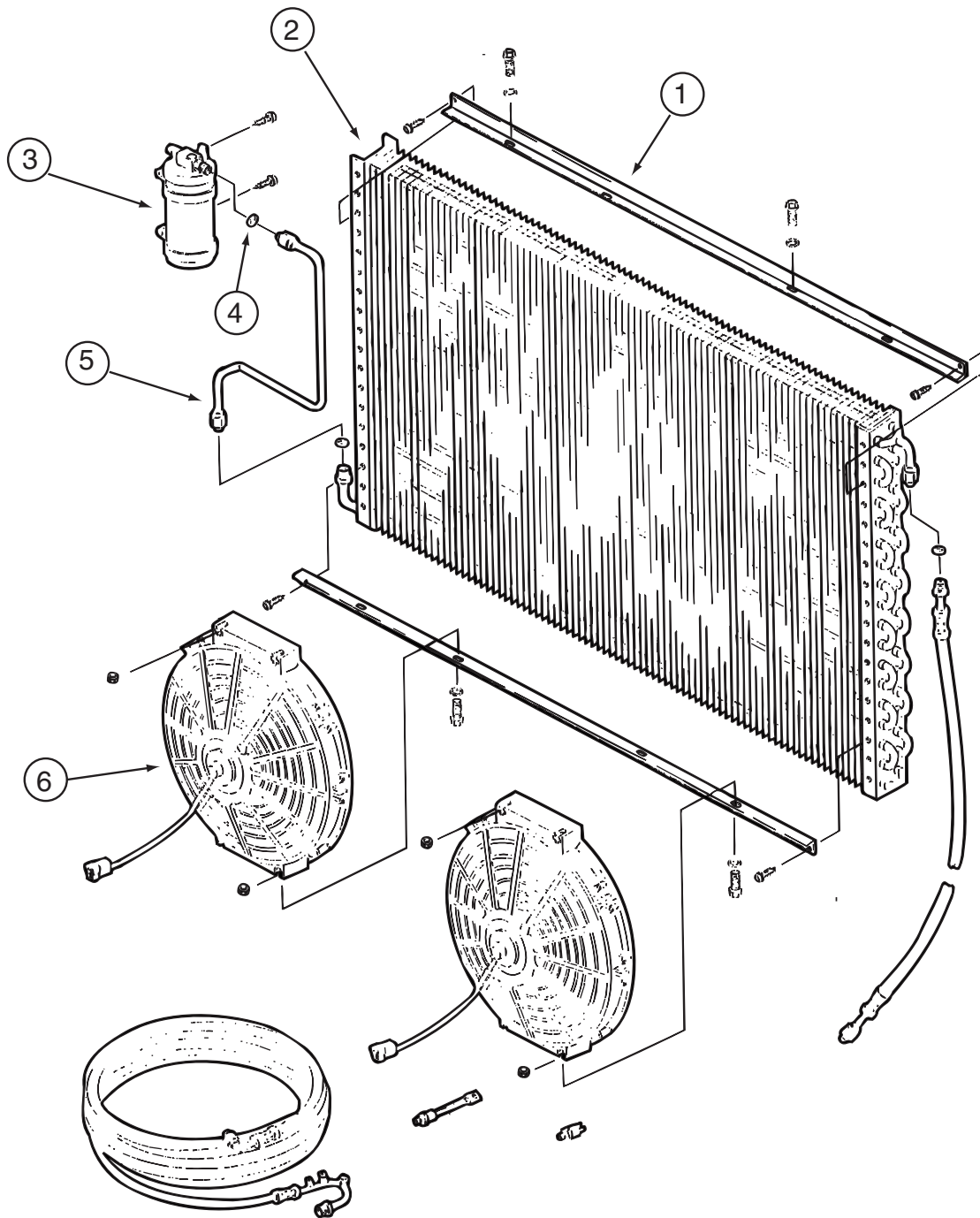

072342-15-000

KEY	PART NUMBER	U/M	DESCRIPTION	VENDOR NO.
	072342-13-700	EA	BRACKET - CONDENSER FAN	070-0148
	072342-12-700	EA	COIL-CONDENSER	040-0027
	072342-12-703	EA	RECEIVER DRIER	054-0001
	113245-01-711	EA	O'RING #6	045-0129
	072342-13-703	EA	TUBE ASM. #6	052-0040
	072342-08-703	EA	FAN BLADE/MOTOR & SHROUD 11"	062-0097

072342-16-000

KEY	PART NUMBER	U/M	DESCRIPTION	VENDOR NO.
	072342-13-701	EA	HOSE ASM. #8	085-0459
	113245-01-707	EA	O'RING #8	045-0126

072342-17-000

KEY	PART NUMBER	U/M	DESCRIPTION	VENDOR NO.
	072342-12-701	EA	HOSE ASM #8 CONDENSER/COMP	085-0142
	113245-01-707	EA	O'RING #8	045-0126

HEATING & A/C GROUP (CONTINUED)
COMPONENT PARTS FOR AUTOMOTIVE (CONTINUED)

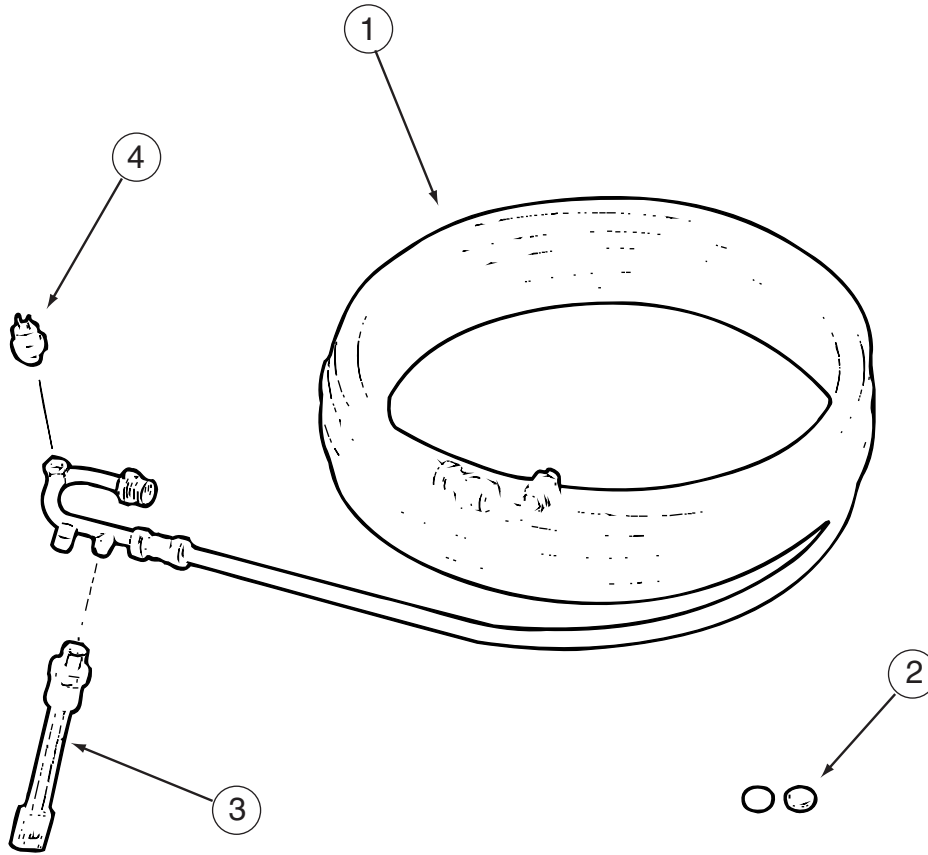

072342-18-000

KEY	PART NUMBER	U/M	DESCRIPTION	VENDOR NO.
1	072342-13-702	EA	HOSE ASM. #6	085-0460
2	113245-01-711	EA	O'RING #6	045-0129
3	103930-01-716	EA	SWITCH - PRESSURE - FAN	032-0036
4	103930-12-708	EA	SWITCH-BINARY-HI/LOW CUTOUT	032-0048

HEATING & A/C GROUP (CONTINUED)
COMPONENT PARTS FOR AUTOMOTIVE (CONTINUED)

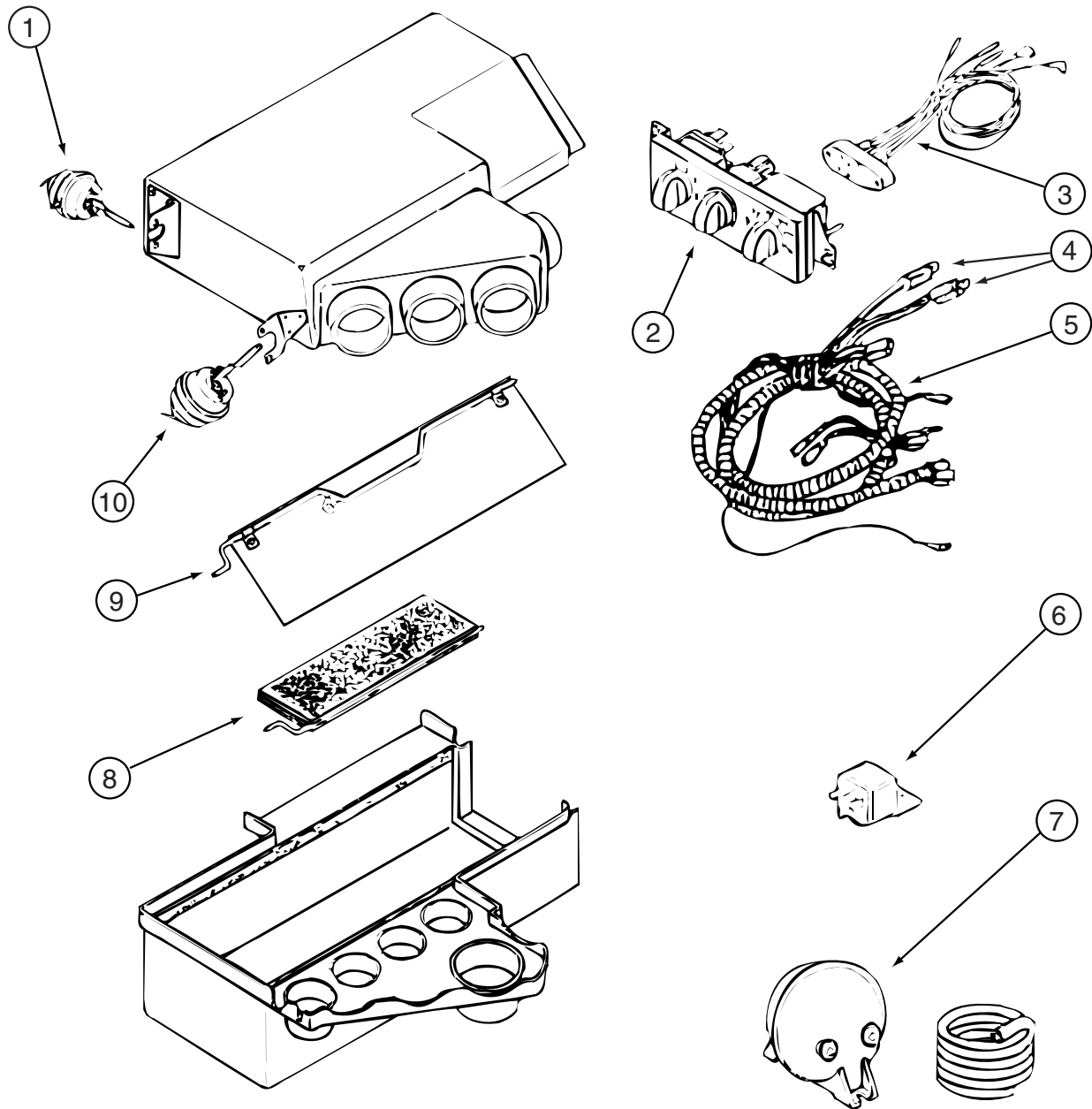

103930-36-000

KEY	PART NUMBER	U/M	DESCRIPTION	VENDOR NO.
	103930-36-000	EA	CONTROL/PLENUM - ROTARY CONTROL HEAD	
1	103930-33-701	EA	MOTOR - VACUUM, 3 STAGE	030-0105
2	103930-33-702	EA	CONTROL PANEL	083-0169
3	103930-33-703	EA	VACUUM HARNESS	036-0466
4	103930-33-705	EA	LIGHT BULBS	035-0030
5	103930-33-711	EA	WIRE HARNESS-W/BULBS(CAVITY)	036-0496
6	103930-02-707	EA	RELAY-BOSCH W/RESISTER	031-0001
7	103930-02-710	EA	CANISTER-VACUUM	054-0002
8	103930-36-701	EA	ROD - DOOR, AC	073-0062
9	103930-36-700	EA	ROD - DOOR, DEFROST	073-0061
10	103930-02-708	EA	MOTOR-VACUUM SERVO, A/C	030-0025
	103930-33-707	EA	SWITCH - BLOWER	032-00066
	103930-33-708	EA	SWITCH - POTENTIOMETER	032-0184
	103930-33-709	EA	SWITCH - VACUUM	032-0183
	103930-33-710	EA	DECAL F/CONTROL HEAD	058-0102
	103930-33-712	EA	KNOB - BLOWER	062-00539
	103930-33-713	EA	KNOB	062-0540
	103930-36-702	EA	PLENUM CASE - UPPER	060-0442
	103930-36-703	EA	PLENUM CASE - LOWER	060-0443
	103930-36-704	EA	SPRING	022-0119

HEATING & A/C GROUP (CONTINUED)
COMPONENT PARTS FOR AUTOMOTIVE (CONTINUED)

KEY PART NUMBER
 103930-17-702

U/M DESCRIPTION
 EA O'RING #10

103930-41-000

VENDOR NO.
 045-0127

KEY PART NUMBER
 103930-17-702

U/M DESCRIPTION
 EA O'RING #10

103930-51-000

VENDOR NO.
 045-0127

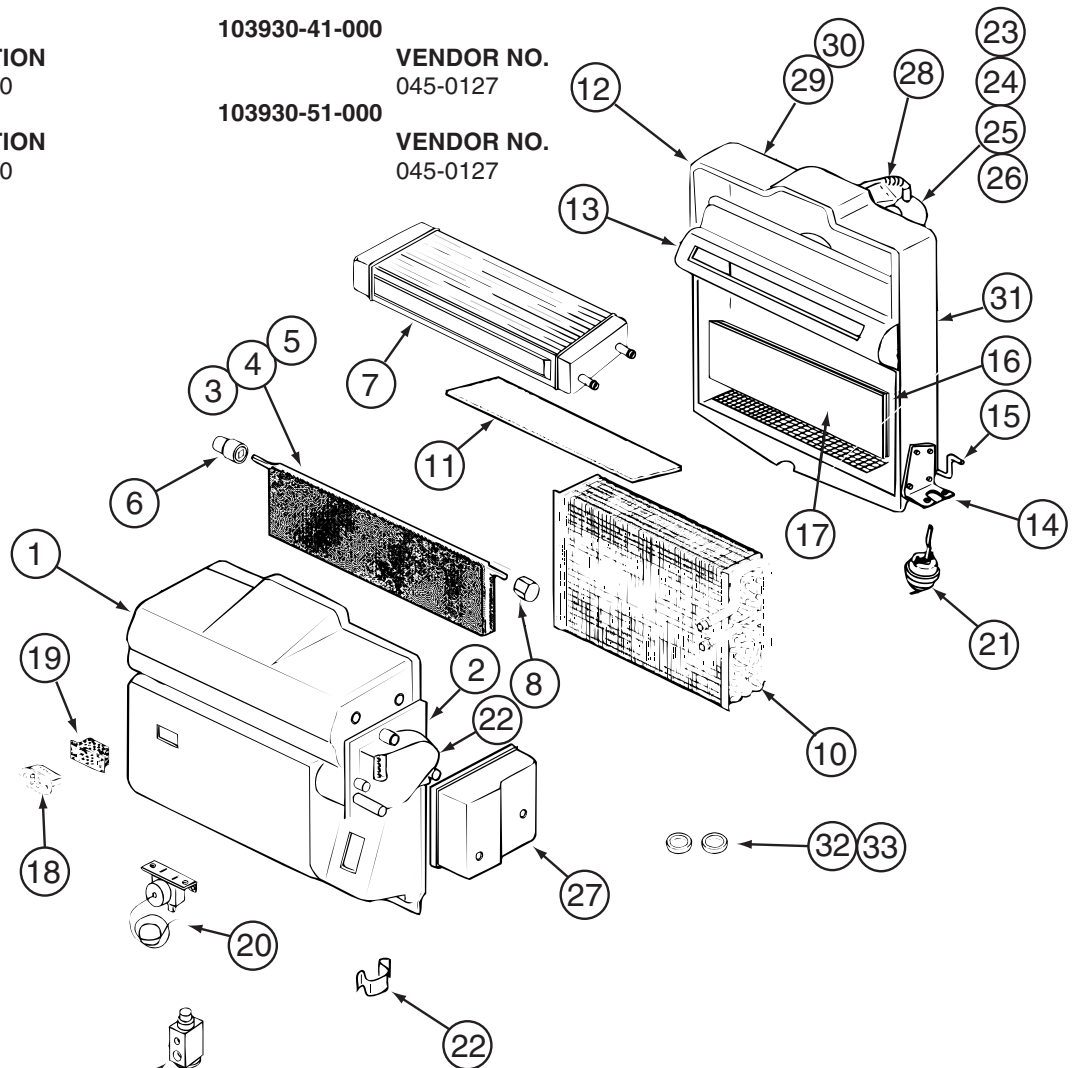

KEY PART NUMBER
 1 103930-55-701
 2 103930-30-701
 3 103930-55-705
 6 103930-30-702
 7 103930-55-706
 8 103930-30-709
 9 103930-20-700
 10 103930-55-700
 12 103930-55-702
 14 103930-01-708
 15 103930-20-704
 16 103930-55-707
 18 103930-01-710
 20 103930-01-711
 21 103930-02-708
 22 103930-30-703
 23 103930-20-707
 24 103930-55-703
 25 103930-01-717
 26 103930-20-708
 27 103930-30-704
 32 113245-01-707
 33 103930-17-702
 103930-55-704
 110279-01-703

U/M DESCRIPTION
 EA CASE - FRONT
 EA PLATE - MOTOR MOUNT
 EA DOOR - BLEND AIR
 EA BUSHING/DRIVE (BLEND DOOR)
 EA CORE - HEATER - W/GASKET
 EA COUPLING - BLEND DOOR SHAFT
 EA VALVE-EXPANSION-BLOCK, 2 TON
 EA CORE-EVAPORATOR
 EA CASE-REAR
 EA BRACKET-VACUUM MOTOR
 EA ROD-DOOR-RECIRCULATING
 EA DOOR - RECIRCULATION
 EA RESISTOR-FUSED, A/C 4 TERM
 EA THERMOSTAT
 EA MOTOR-VACUUM SERVO, A/C
 EA MOTOR - SERVO
 EA HOUSING-BLOWER
 EA MOTOR-BLOWER W/O PIGTAIL
 EA WHEEL-BLOWER, CLOCKWISE
 EA CLIP-MOTOR SHAFT
 EA COVER - SERVO
 EA O'RING #8
 EA O'RING #10
 EA CORE-HEATER
 EA HOSE-VENT F/BLOWER MOTOR

103930-55-000

VENDOR NO.
 062-0658
 062-0544
 071-0892
 062-0168
 084-0271
 062-0634
 034-0032
 041-00168
 062-0657
 070-0113
 073-0018
 071-0891
 035-0006
 033-0003
 030-0025
 030-0104
 062-0145
 030-0137
 062-0010
 022-0001
 062-0545
 045-0126
 045-0127
 042-0059
 051-0034

CONTACT WINNEBAGO PART SALES FOR UNLISTED COMPONENT(S)

HEATING & A/C GROUP (CONTINUED)
FURNACE

KEY	PART NUMBER	U/M	DESCRIPTION
*	143563-02-000	EA	FURNACE - 40000 BTU HIGH QUIET - SUBURBAN SH-40 2322
*	143563-01-000	EA	FURNACE - 35000 BTU/HIGH QUIET - SUBURBAN SH-35 2322 - P32T
	115764-01-01A	EA	THERMOSTAT - FURNACE
	093614-11-01A	EA	GRILLE - AIR RETURN - 13.9" X 7.9" - BEIGE
	092776-03-000	EA	ADAPTER - DUCT 2" X 4" X 3"
	093614-08-02A	EA	GRILLE - AIR RETURN - 9.8" X 13.9" - BEIGE
	093614-10-01A	EA	GRILLE -AIR RETURN-13.9" X 7.9"/11.6" X 5.6" OPENING-BEIGE
	098668-16-000	EA	VENT - INTAKE
	133322-01-02B	EA	PANEL - EXHAUST - FURNACE - E-COATED - P39K
	133323-01-01A	EA	SHROUD - FURNACE - BRIGHT WHITE
	137965-01-01A	EA	REGISTER - 2.25" X 10" - W/O DAMPER - ANTIQUE BRASS
	137965-02-01A	EA	REGISTER - 2.25" X 10" - W/DAMPER - ANTIQUE BRASS
	137965-06-01A	EA	REGISTER - 2.25" X 14" - W/O DAMPER - ANTIQUE BRASS
	143563-04-000	EA	PLATE END - COLLAR
	143563-05-000	EA	GASKET - FIBERGLASS - SUBURBAN #071018

***COMPONENT PARTS LISTED LATER IN THIS GROUP**

HEATING & A/C GROUP (CONTINUED)
COMPONENT PARTS FOR FURNACE

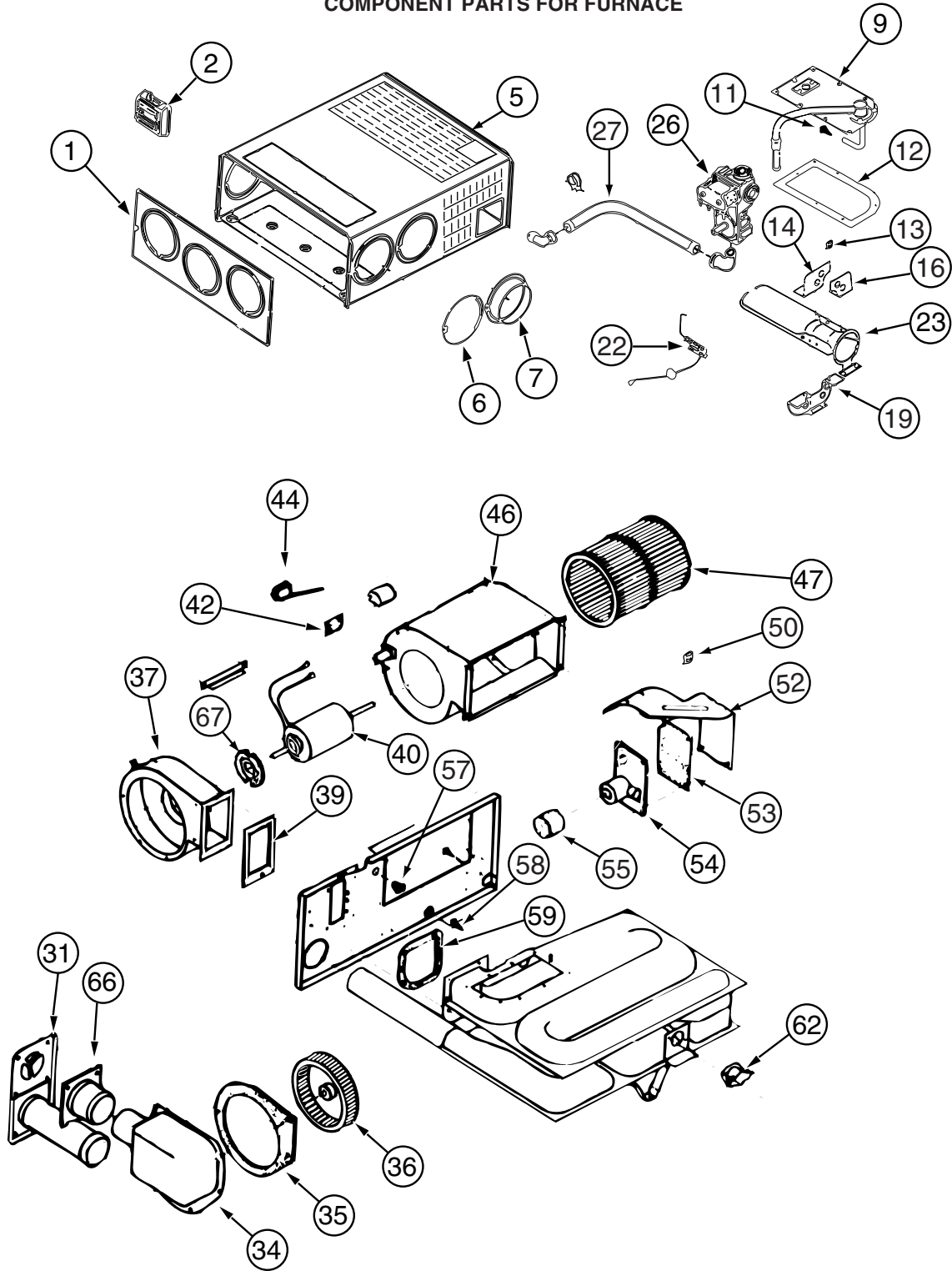

143563-02-000

HEATING & A/C GROUP (CONTINUED)
COMPONENT PARTS FOR FURNACE (CONTINUED)

143563-02-000 (CONTINUED)

KEY	PART NUMBER	U/M	DESCRIPTION	VENDOR NO.
1	143563-01-700	EA	CABINET - FRONT	101907
2			SEE EITHER FURNACE OR 12 VOLT WIRING AREAS FOR CORRECT THERMOSTAT	
5	143563-02-700	EA	CABINET	101915
7	075696-02-703	EA	COLLAR - DUCT	050715
9	143563-01-702	EA	MANIFOLD ASSEMBLY	171599
11	143563-02-701	EA	ORFICE - MAIN BURNER	180309
12	098668-22-703	EA	GASKET - BURNER ACCESS COVER	070811
14	143563-02-702	EA	PLATE - SECONDARY AIR/TOP BACK	063198
16	143563-02-703	EA	PLATE - SECONDARY AIR/TOP FRT	062933
19	143563-02-704	EA	PLATE - SECONDARY AIR/BOTTOM	062935
22	139980-01-701	EA	ELECTRODE	232286
23	098668-11-701	EA	BURNER ASSEMBLY,SF-30 & SF35	010799
26	098668-01-718	EA	VALVE-GAS SF S.N.974903079	161122
27	143563-01-707	EA	PIPE ASSEMBLY (GAS INLET)	171603
31	098668-01-707	EA	TUBE ASSEMBLY, EXHAUST W/CAP	260231
34	143563-01-708	EA	BOX ASM (COMB. AIR INTAKE)	051430BK
35	143563-01-709	EA	GASKET (COMB. AIR HOUSING)	071108
36	143563-01-710	EA	WHEEL (COMBUSTION AIR)	350199
37	143563-01-711	EA	HOUSING (COMBUSTION AIR)	390862BK
39	143563-01-715	EA	GASKET-FIREWALL/COMB. AIR	071107
40	143563-02-705	EA	MOTOR ASSEMBLY	232726
42	101990-01-714	EA	GASKET-MICROSWITCH	230877
44	098668-21-700	EA	SWITCH-MICRO-W/O FLAG 3 1/4"	232261
46	143563-01-713	EA	BLOWER ASSEMBLY(ROOM AIR)	390867BK
47	143563-01-714	EA	WHEEL - ROOM AIR	350198
50	139980-01-710	EA	SWITCH - ON/OFF	232351
52	139980-01-711	EA	PANEL ASSEMBLY-MODULE BD	101663
53	139980-01-712	EA	INSULATOR - MODULE BD	070807
54	098668-22-705	EA	MODULE BD W/RELAY TIME DELAY	520820
55	139980-01-713	EA	CAP/INSULATOR-MODULE BD	070973
57	139980-01-714	EA	BUSHING - UNIVERSAL	070362
58	139980-01-715	EA	BUSHING - STRAIN RELIEF	231809
59	098668-01-716	EA	GASKET-FIREWALL,CHAMBER SIDE	070808
62	143563-02-706	EA	SWITCH - LIMIT	232735
66	098668-01-713	EA	TUBE ASSEMBLY, INTAKE	051248
67	075697-07-703	EA	GASKET - MOTOR	070448
	143563-02-707	EA	CHAMBER ASM. - FINAL	021172BK

CONTACT WINNEBAGO PART SALES FOR UNLISTED COMPONENTS

HEATING & A/C GROUP (CONTINUED) CENTRAL

**P32T, P34H & P36G
W/FREIGHTLINER
CHASSIS PRIOR TO
CAT C7 CHASSIS**

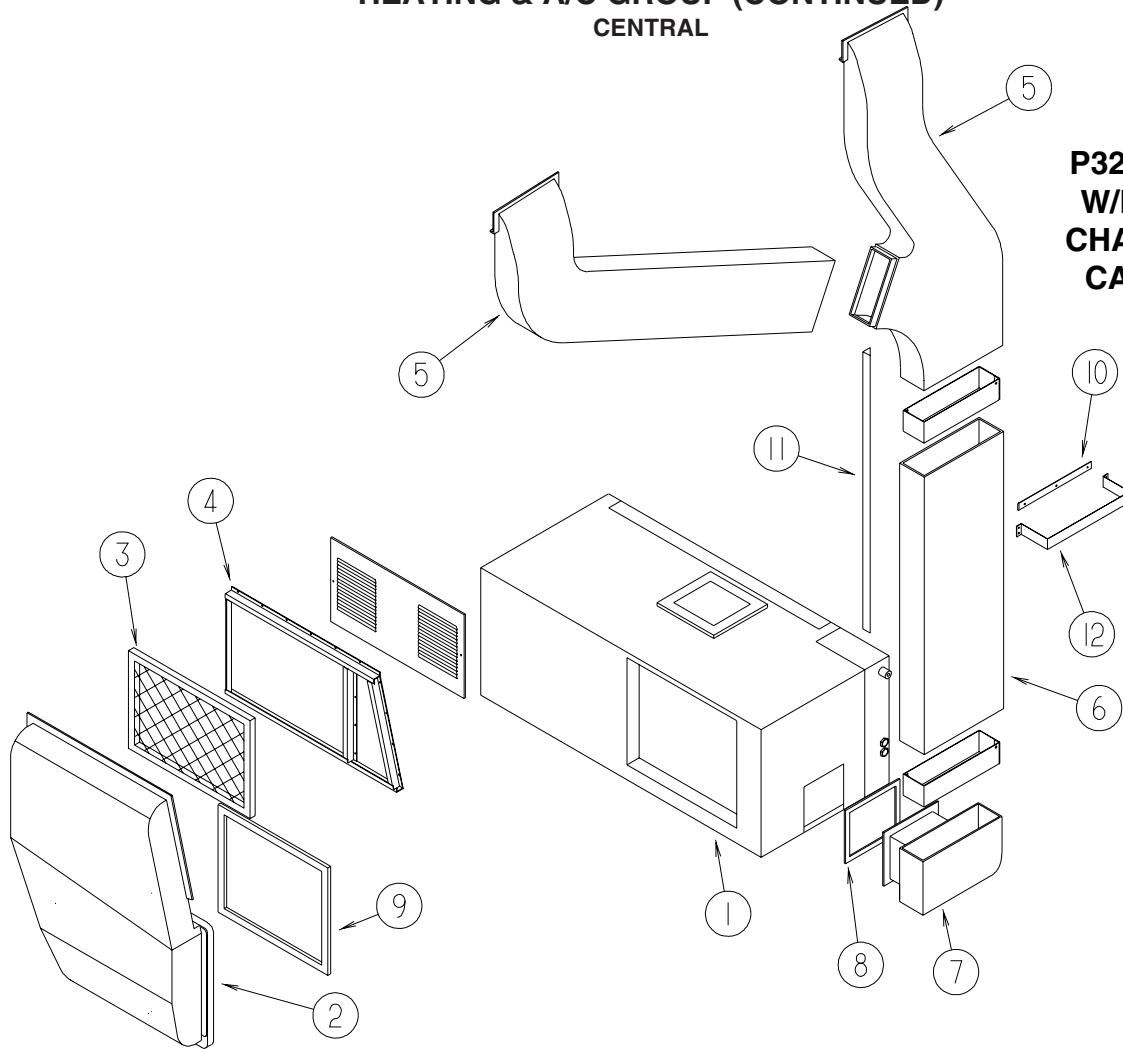

KEY	PART NUMBER	U/M	DESCRIPTION
1*	105620-12-000	EA	A/C - CONTROL PACK RIGHT HAND/HEAT PUMP - 12,000BTU COMP
2	135036-01-000	EA	DUCT - CENTRAL AIR - RETURN
3	109050-02-000	EA	FILTER - FIBERGLASS - 1" X 14" X 20"
4	129604-01-KQ0	EA	FRAME - A/C FILTER
5	M09204-01-000	EA	DUCT/AC - UPPER RIGHT HAND & LEFT HAND
	128862-01-000	EA	DUCT/AIR - UPPER LEFT HAND
	128868-01-000	EA	DUCT/AIR - UPPER RIGHT HAND
5	105290-01-000	EA	INSULATION - AIR POCKET W/FOIL
6	117870-03-01A	EA	PLENUM - A/C - 42.3"
7	P28855-01-000	EA	DUCT/CENTRAL AIR - LOWER
	105290-01-000	EA	INSULATION - AIR POCKET W/FOIL
8	134588-02-000	EA	GASKET - DUCT - 6.4" X 7.4" IS - 8.3" X 9.4" OS
9	134588-01-000	EA	GASKET - DUCT - 15.5" X 18.2" IS - 17.4" X 20.2" OS
10	115886-11-02A	EA	RETAINER - SIDEWALL - BRIGHT WHITE - 11.8"
11	130262-01-000	EA	PROTECTOR - CORNER SAVER - .7" X .7" X 48"
12	129047-01-02B	EA	STRAP/MOUNTING - AIR DUCT - E-COATED
	120134-01-02A	EA	REGISTER - W/DAMPER - 4" PIPE/7" O.D. FACE - WHITE
*	105620-15-000	EA	THERMOSTAT - FURNACE/HEAT PUMP-A/C

*COMPONENT PARTS LISTED LATER IN THIS GROUP

HEATING & A/C GROUP (CONTINUED)
CENTRAL (CONTINUED)

**P39W, P39K
W/FREIGHTLINER
CHASSIS PRIOR TO
CAT C7 CHASSIS**

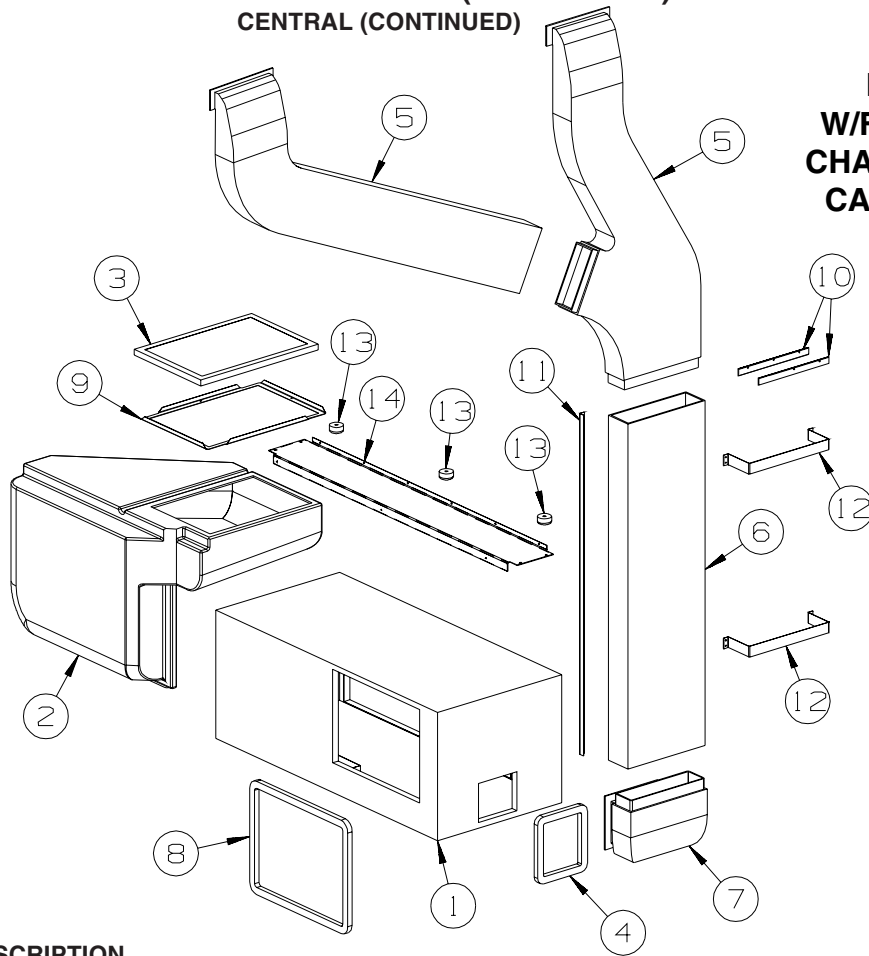

KEY	PART NUMBER	U/M	DESCRIPTION
1*	105620-12-000	EA	A/C - CONTROL PACK RIGHT HAND/HEAT PUMP - 12,000BTU COMP
2	140289-01-01A	EA	DUCT - CENTRAL AIR RETURN
	105290-01-000	EA	INSULATION - AIR POCKET W/FOIL
3	109050-02-000	EA	FILTER - FIBERGLASS - 1" X 14" X 20"
4	134588-02-000	EA	GASKET - DUCT - 6.4" X 7.4" IS - 8.3" X 9.4" OS
5	M09204-01-000	EA	DUCT/AC - UPPER RIGHT HAND & LEFT HAND
	128862-01-000	EA	DUCT/AIR - UPPER LEFT HAND
	128868-01-000	EA	DUCT/AIR - UPPER RIGHT HAND
	105290-01-000	EA	INSULATION - AIR POCKET W/FOIL
6	117870-10-01A	EA	PLENUM - A/C - 48.5"
7	P28855-01-000	EA	DUCT/CENTRAL AIR - LOWER
	105290-01-000	EA	INSULATION - AIR POCKET W/FOIL
8	134588-04-000	EA	GASKET - DUCT - 13.9" X 18.2" IS - 15.9" X 20.2" OS
9	139757-01-02B	EA	PANEL - TRAY - A/C FILTER - E-COATED
10	115886-11-02A	EA	RETAINER - SIDEWALL - BRIGHT WHITE - 11.8"
11	130262-01-000	EA	PROTECTOR - CORNER SAVER - .7" X .7" X 48"
12	129047-01-02B	EA	STRAP/MOUNTING - AIR DUCT - E-COATED
13	120863-06-000	EA	BUMPER - RUBBER/RADIUS TOP - 3/4" X 3/8"
14	NOT USED		
	120134-01-02A	EA	REGISTER - W/DAMPER - 4" PIPE/7" O.D. FACE - WHITE
	135036-01-000	EA	DUCT - CENTRAL AIR - RETURN
*	105620-15-000	EA	THERMOSTAT - FURNACE/HEAT PUMP-A/C

***COMPONENT PARTS LISTED LATER IN THIS GROUP**

HEATING & A/C GROUP (CONTINUED) CENTRAL (CONTINUED)

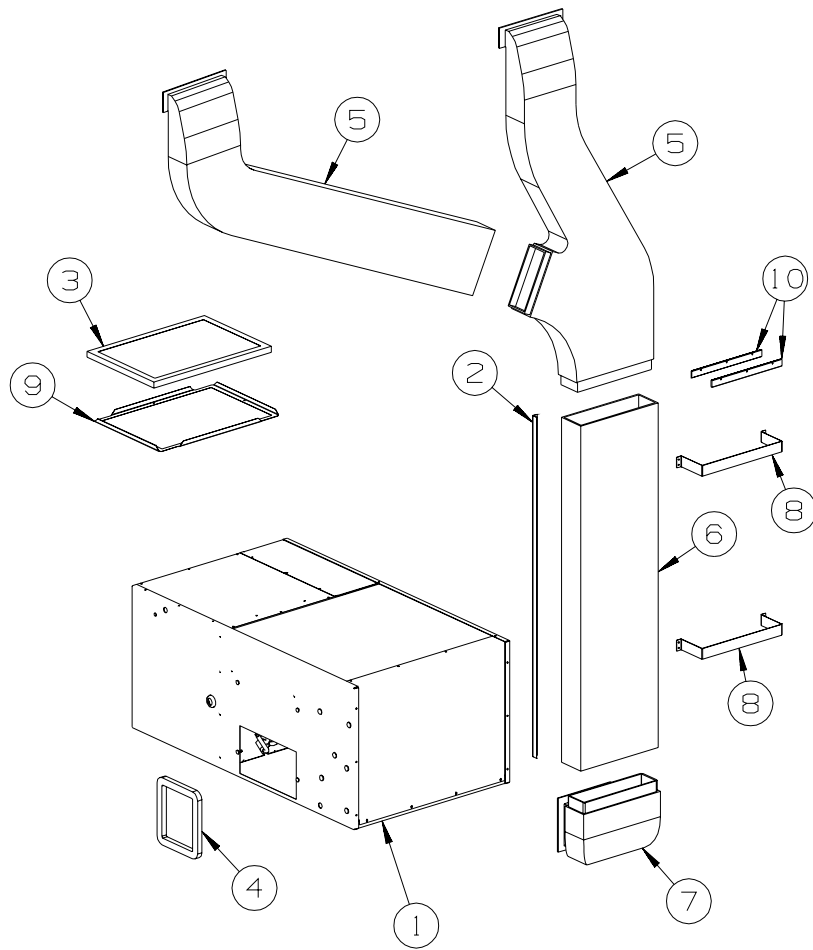

**WORKHORSE & CAT
C7 FREIGHTLINER
CHASSIS**

KEY	PART NUMBER	U/M	DESCRIPTION
1*	105620-16-000	EA	A/C - CENTRAL - RIGHT HAND/HEAT PUMP - TOP RETURN
2	130262-01-000	EA	PROTECTOR - CORNER SAVER - .7" X .7" X 48"
3	109050-02-000	EA	FILTER/FURNACE-AC - FIBERGLASS - 1" X 14" X 20"
4	134588-02-000	EA	GASKET - DUCT - 6.4" X 7.4" IS - 8.3" X 9.4" OS
5	M09204-02-000	EA	DUCT/AC - UPPER RIGHT HAND/LEFT HAND
	128862-01-000	EA	DUCT/AIR - UPPER LEFT HAND
	128868-01-000	EA	DUCT/AIR - UPPER RIGHT HAND
5	105290-01-000	SF	INSULATION - AIR POCKET W/FOIL
6	117870-10-01A	EA	PLENUM - A/C - 48.5"
7	147621-01-01A	EA	DUCT - CENTRAL AIR/FORCED - LOWER
7	105290-01-000	SF	INSULATION - AIR POCKET W/FOIL
8	129047-01-02B	EA	STRAP/MOUNTING - AIR DUCT - E-COATED
9	139757-01-02B	EA	PANEL - TRAY - A/C FILTER - E-COATED
10	115886-11-02A	EA	RETAINER - SIDEWALL - BRIGHT WHITE - 11.8"
*	105620-15-000	EA	THERMOSTAT - FURNACE/HEAT PUMP-A/C
	107721-07-000	FT	SEAL - ACCESS DOOR - .9"WIDE X 1.1"HIGH
	130481-01-01A	EA	BRACKET - ZEE W/HOLES - 7"
	147613-01-02B	EA	CRADLE - A/C - E-COATED
	120134-01-02A	EA	REGISTER - W/DAMPER - 4" PIPE/6.4" O.D. FACE - WHITE
	120134-02-01A	EA	REGISTER - TRIM RING - WHITE
	134588-04-000	EA	GASKET - DUCT - 13.9" X 18.2" IS - 15.9" X 20.2" OS

*COMPONENT PARTS LISTED LATER IN THIS GROUP

HEATING & A/C GROUP (CONTINUED)
COMPONENT PARTS FOR CENTRAL

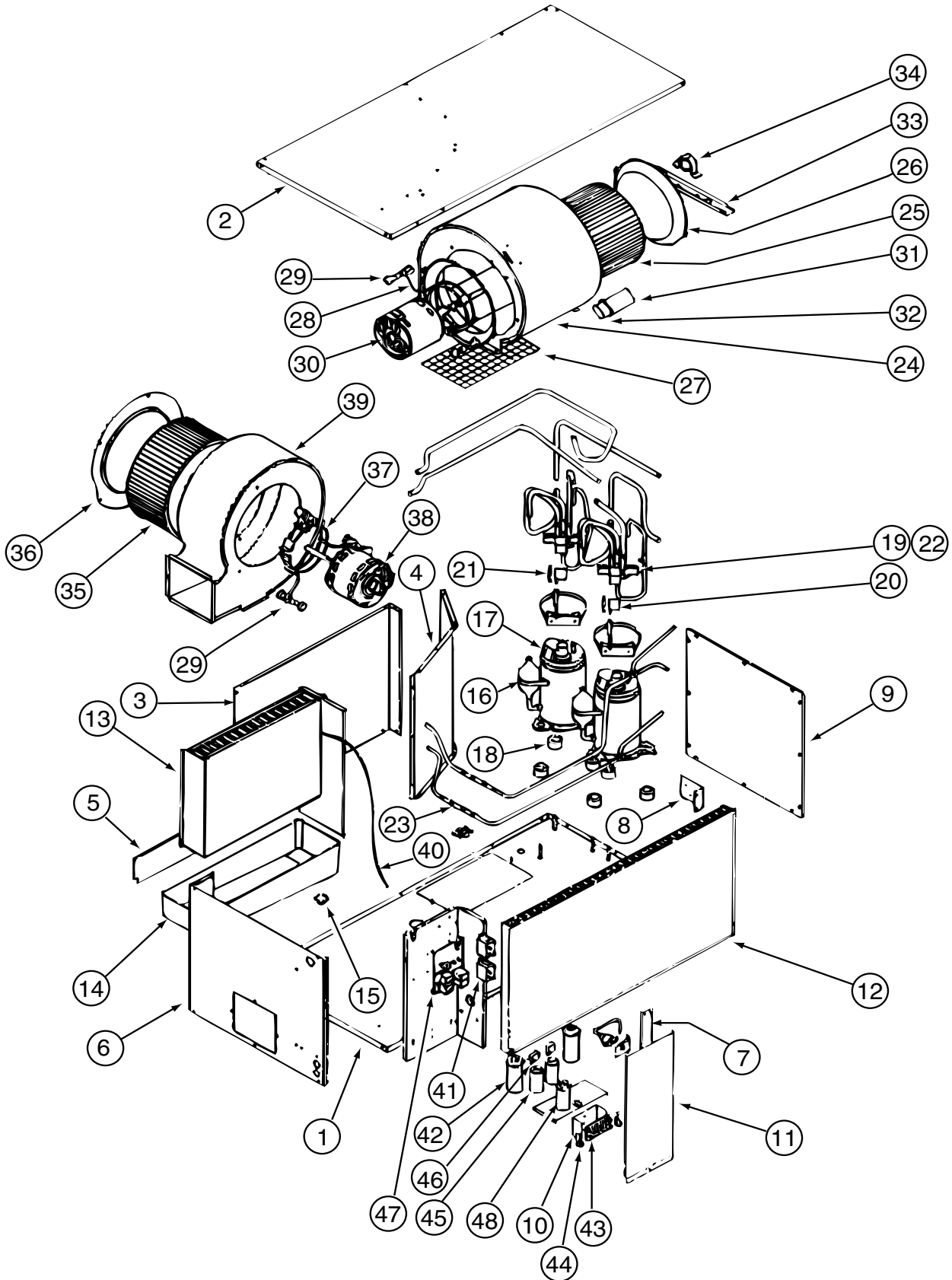

105620-12-000

HEATING & A/C GROUP (CONTINUED)
COMPONENT PARTS FOR CENTRAL (CONTINUED)

105620-12-000 (CONTINUED)

KEY	PART NUMBER	U/M	DESCRIPTION	VENDOR NO.
10	105620-01-733	EA	ISOLATOR-HIGH VOLTAGE	6795-117
11	105620-10-716	EA	DOOR - ELECTRIC BOX	6535B346
12	105620-12-701	EA	COIL - CONDENSER	1452A1621
13	105620-12-702	EA	COIL - EVAPORATOR	1452A1611
15	105620-12-703	EA	VALVE - DRAIN	6795-200
16	105620-12-704	EA	COMPRESSOR	1450-2149
				FROM: 00-00-00 THRU: 07-27-03
16	105620-12-723	EA	COMPRESSOR (PANASONIC)	1450-2229
				FROM: 07-28-03 THRU: 99-99-99
17	105620-12-705	EA	OVERLOAD	1450-0081
18	105620-01-706	EA	MOUNTING PKG.,COMP., 3 PER	6759-3081
19	105620-12-706	EA	REVERSING VALVE ASSEMBLY #1	6535A533
				FROM: 00-00-00 THRU: 07-27-03
	105620-12-707	EA	REVERSING VALVE ASSEMBLY #2	6535-5321
				FROM: 00-00-00 THRU: 07-27-03
19	105620-12-724	EA	REVERSING VALVE ASSEMBLY	6535-535
				FROM: 07-28-03 THRU: 99-99-99
20	105620-12-708	EA	COIL - SOLENOID	1460-1081
21	105620-12-709	EA	WIRE HARNESS-REVERSING VALVE	6536-111
22	105620-12-710	EA	VALVE - REVERSE ONLY	1454A350
23	105620-12-711	EA	RESTRICTOR - BY FLOW	1454-2521
24	105620-10-718	EA	BLOWER HOUSING/OUTSIDE AIR	6536-515
25	105620-01-713	EA	WHEEL-BLOWER/OUTSIDE AIR	1472-1011
26	105620-01-714	EA	VENTURI-BLOWER/OUTSIDE AIR	6795A150
28	105620-01-715	EA	MOUNT-BLOWER/OUTSIDE AIR	6795A3011
29	105620-01-716	EA	SLEEVE & GROMMET, 4 PER PKKG.	6795A3031
30	105620-10-721	EA	MOTOR/BLOWER-8 3/4" SHAFT	1468A3029
31	105620-01-718	EA	CAPACITOR-FAN (OUTDOOR MOTOR))	1499-5631
32	105620-10-715	EA	RUBBER CAPACITOR BOOT	1499-951
33	105620-10-700	EA	BEARING BRACKET/OUTSIDE AIR	6536-514
34	105620-10-701	EA	BEARING/PILLOW BLOCK-O/S AIR	6536-3011
35	105620-11-701	EA	BLOWER WHEEL/INSIDE AIR	1472-1151
36	105620-12-715	EA	BLOWER VENTURI/INSIDE AIR	6535A287
37	105620-01-723	EA	MOUNT-BLOWER MOTOR - I/S AIR	6795-302
38	105620-12-716	EA	BLOWER MTR/IN AIR/REVERSIBLE	1468-3219
39	105620-11-706	EA	MOTOR/BLOWER KIT	6535B5901
				FROM: 07-28-03 THRU: 99-99-99
40	105620-12-719	EA	COIL SENSOR	7330A3231
41	105620-01-729	EA	RELAY-COMPRESSOR -4 TERMINAL	1460-1131
42	126859-01-703	EA	CAPACITOR - RUN	1499-5671
				FROM: 00-00-00 THRU: 07-27-03
42	105620-12-725	EA	COMPRESSOR RUN CAPACITOR	1499-5731
				FROM: 07-28-03 THRU: 99-99-99
43	105620-01-738	EA	BOARD-TERMINAL, HIGH VOLTAGE	6795-315
46	105620-10-705	EA	PTCR (START DEVICE) - W/CAP.	8333A9021
47	105620-12-720	EA	KIT-CIRCUIT BD (6535-SERIES)	6535-3209
				FROM: 00-00-00 THRU: 07-27-03
47	105620-12-721	EA	CIRCUIT BD (6535 A SERIES)	6535A3201
48	093763-01-704	EA	CAPACITOR-FAN (INDOOR MOTOR)	1499-5461
	105620-10-720	EA	FUSE/BUSS(8AMP/250V) 2 PKG	6535-3081
			CONTACT WINNEBAGO PART SALES FOR UNLISTED COMPONENT(S)	

105620-15-000

KEY	PART NUMBER	U/M	DESCRIPTION	VENDOR NO.
	105620-15-700	EA	FUSE/BUSS (2AMP/250V) 3 PER PK	8330-3343

HEATING & A/C GROUP (CONTINUED)
COMPONENT PARTS FOR CENTRAL (CONTINUED)

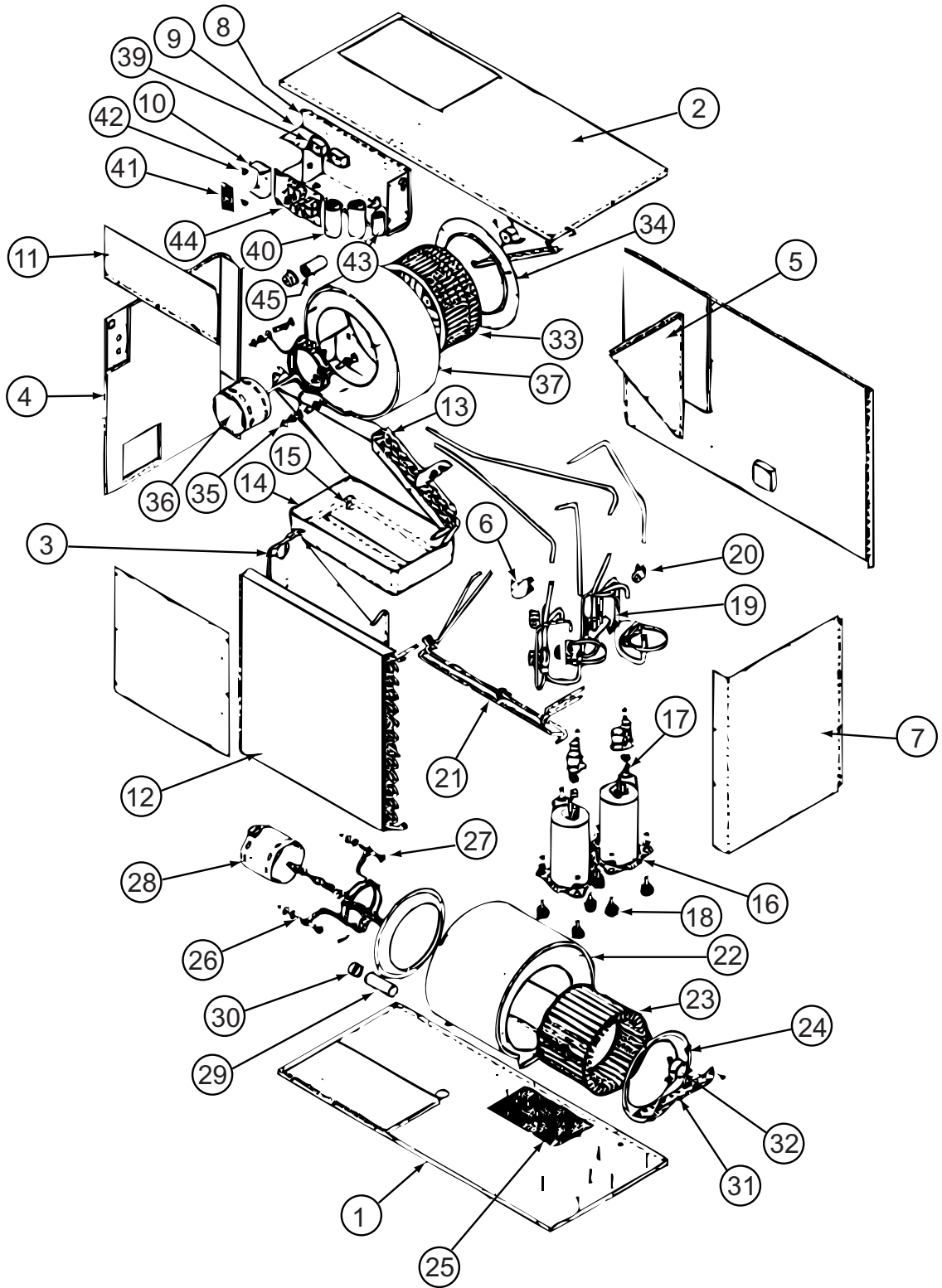

105620-16-000

HEATING & A/C GROUP (CONTINUED)
COMPONENT PARTS FOR CENTRAL (CONTINUED)

105620-16-000 (CONTINUED)

KEY	PART NUMBER	U/M	DESCRIPTION	VENDOR NO.
10	105620-01-733	EA	ISOLATOR-HIGH VOLTAGE	6795-117
12	105620-16-700	EA	CONDENSOR COIL	1452-1681
13	105620-16-701	EA	EVAPORATOR COIL	14521671
14	105620-16-702	EA	DRAIN PAN	6537-104
15	105620-12-703	EA	VALVE - DRAIN	6795-200
16	105620-12-723	EA	COMPRESSOR (PANASONIC)	1450-2229
17	105620-16-703	EA	OVERLOAD	1450-0161
18	105620-01-706	EA	MOUNTING PKG.,COMP., 3 PER	6759-3081
19	105620-16-704	EA	REVERSING VALVE	6537-5321
20	105620-12-708	EA	COIL - SOLENOID	1460-1081
21	105620-16-705	EA	BY-FLO RESTRICTOR	1454-2561
22	105620-10-718	EA	HOUSING/OUTSIDE AIR	6536-515
23	105620-01-713	EA	WHEEL-BLOWER/OUTSIDE AIR	1472-1011
24	105620-01-714	EA	VENTURI-BLOWER/OUTSIDE AIR	6795A150
26	105620-01-715	EA	MOUNT-BLOWER/OUTSIDE AIR	6795A3011
27	105620-01-716	EA	SLEEVE & GROMMET, 4 PER PKG	6795A3031
28	105620-10-721	EA	MOTOR/BLOWER-8 3/4" SHAFT	1468A3029
29	105620-01-718	EA	CAPACITOR-FAN(OUTDOOR MOTOR)	1499-5631
30	105620-10-715	EA	RUBBER CAPACITOR BOOT	1499-951
31	105620-10-700	EA	BEARING BRACKET/OUTSIDE AIR	6536-514
32	105620-10-701	EA	BEARING/PILLOW BLOCK-O/S AIR	6536-3011
33	105620-11-701	EA	BLOWER WHEEL/INSIDE AIR	1472-1151
34	105620-12-715	EA	BLOWER VENTURI/INSIDE AIR	6535A287
35	105620-01-723	EA	MOUNT-BLOWER MOTOR - I/S AIR	6795-302
36	105620-12-716	EA	BLOWER MTR/IN AIR/REVERSIBLE	1468-3219
37	105620-16-707	EA	BLOWER HOUSING/INSIDE AIR	6537-590
38	105620-12-719	EA	COIL SENSOR	7330A3231
39	105620-01-729	EA	RELAY-COMPRESSOR -4 TERMINAL	1460-1131
40	105620-12-725	EA	COMPRESSOR RUN CAPACITOR	1499-5731
41	105620-16-708	EA	BOARD/TERMINAL- HIGH VOLTAGE	6795-3151
43	105620-10-705	EA	PTCR (START DEVICE) - W/CAP.	8333A9021
45	093763-01-704	EA	CAPACITOR-FAN (INDOOR MOTOR)	1499-5461
	105620-16-709	EA	CIRCUIT BOARD	6636-3201

CONTACT WINNEBAGO PART SALES FOR UNLISTED COMPONENTS

INTERIOR FINISH GROUP

MOLDINGS & TRIMS

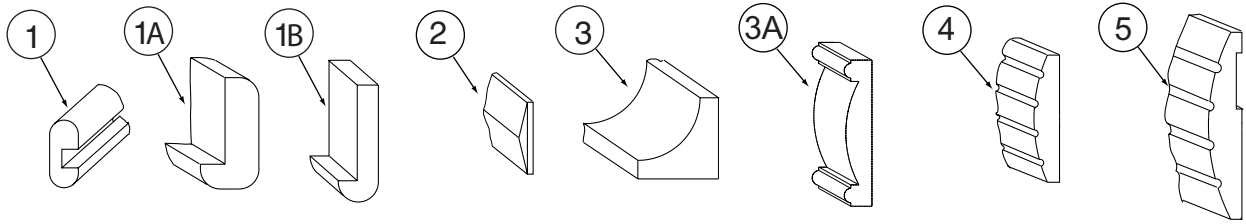

KEY	PART NUMBER	U/M	DESCRIPTION
1	M09412-62-N42	EA	MOLDING/SHELF EDGE - W/.4" NOTCH - PORTSMOUTH II - PORTSMOUTH OAK
1	M09412-62-M52	EA	MOLDING/SHELF EDGE - W/.4" NOTCH - CHERRY IV - CONCERT CHERRY
1	M09412-62-M62	EA	MOLDING/SHELF EDGE - W/.4" NOTCH - WASHED MAPLE
1	M09412-62-RC3	EA	MOLDING/SHELF EDGE - W/.4" NOTCH - .6" X 1.3" X 96" - HONEY CHERRY
1A	M09438-02-N70	EA	MOLDING - HARDWOOD-W/NOTCH - 1.4"X 80.5" - OAK/PORTS OAK - PORTSMOUTH OAK
1A	M09438-02-N85	EA	MOLDING - HARDWOOD-W/NOTCH - 1.4"X 80.5" - CHERRY/CHERRY IV - CONCERT CHERRY
1A	M09438-02-N84	EA	MOLDING - HARDWOOD-W/NOTCH - 1.4"X 80.5" - MAPLE/WASHED MP - WASHED MAPLE
1B	M09438-21-N95	EA	MOLDING/TRIM - .8" X 2.2" X 80.2" - OAK/PORTS OAK - PORTSMOUTH OAK
1B	M09438-21-N94	EA	MOLDING/TRIM - .8" X 2.2" X 80.2" - CHERRY/CHERRY IV - CONCERT CHERRY
1B	M09438-21-NQ0	EA	MOLDING/TRIM - .8" X 2.2" X 80.2" - MAPLE/WASHED MP - WASHED MAPLE
1B	M09438-23-N95	EA	MOLDING - HARDWOOD-W/NOTCH - 4" X 80.2" - OAK/PORTS OAK - PORTSMOUTH OAK
1B	M09438-23-N94	EA	MOLDING - HARDWOOD-W/NOTCH - 4" X 80.2" - CHERRY/CHERRY IV - CONCERT CHERRY
1B	M09438-23-NQ0	EA	MOLDING - HARDWOOD-W/NOTCH - 4" X 80.2" - MAPLE/WASHED MP - WASHED MAPLE
1B	M09438-25-N95	EA	MOLDING - HARDWOOD-W/NOTCH - 1.4"X 80.2" - OAK/PORTS OAK - PORTSMOUTH OAK
1B	M09438-25-N94	EA	MOLDING - HARDWOOD-W/NOTCH - 1.4"X 80.2" - CHERRY/CHERRY IV - CONCERT CHERRY
1B	M09438-25-NQ0	EA	MOLDING - HARDWOOD-W/NOTCH - 1.4"X 80.2" - MAPLE/WASHED MP - WASHED MAPLE
1B	M09438-25-RA3	EA	MOLDING - HARDWOOD-W/NOTCH - 1.4"X 80.2" - CHERRY/HONEY - HONEY CHERRY
1B	M09450-77-PC0	EA	MOLDING - TRIM/HDWD W/LIP -.4"X3.2"X79.6" - OAK/PORTS OAK - PORTSMOUTH OAK
1B	M09450-77-PC1	EA	MOLDING - TRIM/HDWD W/LIP -.4"X3.2"X79.6" - CHERRY/CHERRY IV - CONCERT CHERRY
1B	M09450-77-PC2	EA	MOLDING - TRIM/HDWD W/LIP -.4"X3.2"X79.6" - MAPLE/WASHED MP - WASHED MAPLE
1B	M09450-77-RC3	EA	MOLDING - TRIM/HDWD W/LIP -.4"X3.2"X79.6" - CHERRY/HONEY - HONEY CHERRY
1B	M09462-75-R38	EA	MOLDING/TRIM - .75" X 1.2" X 80.2" - PORTSMOUTH OAK
1B	M09462-75-R39	EA	MOLDING/TRIM - .75" X 1.2" X 80.2" - CONCERT CHERRY
1B	M09462-75-R46	EA	MOLDING/TRIM - .75" X 1.2" X 80.2" - WASHED MAPLE
2	M09454-62-P54	EA	MOLDING - TRIM/VEE - .2" X 1" X 3.5" - OAK - PORTSMOUTH OAK
2	M09454-62-P55	EA	MOLDING - TRIM/VEE - .2" X 1" X 3.5" - CHERRY - CONCERT CHERRY
2	M09454-62-P56	EA	MOLDING - TRIM/VEE - .2" X 1" X 3.5" - MAPLE - WASHED MAPLE
2	M09454-62-RE0	EA	MOLDING - TRIM/VEE - .2" X 1" X 3.5" - CHERRY - HONEY CHERRY
2	M09462-50-R74	EA	MOLDING - TRIM/VEE - .2" X 1" X 93.5" - PORTSMOUTH OAK
2	M09462-50-R75	EA	MOLDING - TRIM/VEE - .2" X 1" X 93.5" - CONCERT CHERRY
2	M09462-50-R76	EA	MOLDING - TRIM/VEE - .2" X 1" X 93.5" - WASHED MAPLE
2	M09477-18-R83	EA	MOLDING - TRIM/VEE - .2" X 1" X 32" - OAK - PORTSMOUTH OAK
2	M09477-18-R84	EA	MOLDING - TRIM/VEE - .2" X 1" X 32" - CHERRY - CONCERT CHERRY
2	M09477-18-R91	EA	MOLDING - TRIM/VEE - .2" X 1" X 32" - MAPLE - WASHED MAPLE
2	M09477-18-RE0	EA	MOLDING - TRIM/VEE - .2" X 1" X 32" - CHERRY - HONEY CHERRY
3	M09471-79-R38	EA	MOLDING-STAINED - PORTSMOUTH OAK
3	M09471-79-R39	EA	MOLDING-STAINED - CONCERT CHERRY
3	M09471-79-R46	EA	MOLDING-STAINED - WASHED MAPLE
3	M09471-79-RE0	EA	MOLDING-STAINED - HONEY CHERRY
3A	M09471-40-R83	EA	MOLDING-STAINED - PORTSMOUTH OAK
3A	M09471-40-R84	EA	MOLDING-STAINED - CONCERT CHERRY
3A	M09471-40-RE0	EA	MOLDING-STAINED - HONEY CHERRY
4	M09454-52-PA0	EA	MOLDING - FLUTED - .75" X 3.5" X 76.7" - OAK - PORTSMOUTH OAK
4	M09454-52-PA1	EA	MOLDING - FLUTED - .75" X 3.5" X 76.7" - CHERRY - CONCERT CHERRY
4	M09454-52-PA2	EA	MOLDING - FLUTED - .75" X 3.5" X 76.7" - MAPLE - WASHED MAPLE
4	P39129-01-N53	EA	MOLDING - FLUTED/CURVED - 3.5" X 44.5" - PORTSMOUTH OAK
4	P39129-01-N52	EA	MOLDING - FLUTED/CURVED - 3.5" X 44.5" - CONCERT CHERRY
4	P39129-01-N62	EA	MOLDING - FLUTED/CURVED - 3.5" X 44.5" - WASHED MAPLE
4	P39129-01-RA3	EA	MOLDING - FLUTED/CURVED - 3.5" X 44.5" - HONEY CHERRY

INTERIOR FINISH GROUP (CONTINUED)
MOLDINGS & TRIMS (CONTINUED)

KEY	PART NUMBER	U/M	DESCRIPTION
4	P39129-08-N53	EA	MOLDING - FLUTED/CURVED - 3.5" X 45.5" - PORTSMOUTH OAK
4	P39129-08-N52	EA	MOLDING - FLUTED/CURVED - 3.5" X 45.5" - CONCERT CHERRY
4	P39129-08-N62	EA	MOLDING - FLUTED/CURVED - 3.5" X 45.5" - WASHED MAPLE
4	P39129-08-RA3	EA	MOLDING - FLUTED/CURVED - 3.5" X 45.5" - HONEY CHERRY
4	P39129-14-PA0	EA	MOLDING - FLUTED/CURVED - 3.5" X 40.8" - PORTSMOUTH OAK
4	P39129-14-PA1	EA	MOLDING - FLUTED/CURVED - 3.5" X 40.8" - CONCERT CHERRY
4	P39129-14-PA2	EA	MOLDING - FLUTED/CURVED - 3.5" X 40.8" - WASHED MAPLE
4	P39129-14-RA3	EA	MOLDING - FLUTED/CURVED - 3.5" X 40.8" - HONEY CHERRY
4	P39129-20-PA0	EA	MOLDING - FLUTED/CURVED - 3.5" X 33.4" - PORTSMOUTH OAK
4	P39129-20-PA1	EA	MOLDING - FLUTED/CURVED - 3.5" X 33.4" - CONCERT CHERRY
4	P39129-20-PA2	EA	MOLDING - FLUTED/CURVED - 3.5" X 33.4" - WASHED MAPLE
4	P39129-20-RA3	EA	MOLDING - FLUTED/CURVED - 3.5" X 33.4" - HONEY CHERRY
4	P39129-25-PA0	EA	MOLDING - FLUTED/CURVED - 3.5" X 46.6" - PORTSMOUTH OAK
4	P39129-25-PA1	EA	MOLDING - FLUTED/CURVED - 3.5" X 46.6" - CONCERT CHERRY
4	P39129-25-PA2	EA	MOLDING - FLUTED/CURVED - 3.5" X 46.6" - WASHED MAPLE
4	P39129-25-RA3	EA	MOLDING - FLUTED/CURVED - 3.5" X 46.6" - HONEY CHERRY
4	P39129-31-PA0	EA	MOLDING - FLUTED/CURVED - 3.5" X 80.7" - PORTSMOUTH OAK
4	P39129-31-PA1	EA	MOLDING - FLUTED/CURVED - 3.5" X 80.7" - CONCERT CHERRY
4	P39129-31-PA2	EA	MOLDING - FLUTED/CURVED - 3.5" X 80.7" - WASHED MAPLE
4	P39129-31-RA3	EA	MOLDING - FLUTED/CURVED - 3.5" X 80.7" - HONEY CHERRY
4	P39129-32-RA0	EA	MOLDING - FLUTED/CURVED - 3.5" X 99.2" - PORTSMOUTH OAK
4	P39129-32-RA1	EA	MOLDING - FLUTED/CURVED - 3.5" X 99.2" - CONCERT CHERRY
4	P39129-32-RA2	EA	MOLDING - FLUTED/CURVED - 3.5" X 99.2" - WASHED MAPLE
4	P39129-32-RA3	EA	MOLDING - FLUTED/CURVED - 3.5" X 99.2" - HONEY CHERRY
4	P39129-33-RA0	EA	MOLDING - FLUTED/CURVED - 3.5" X 98.58" - PORTSMOUTH OAK
4	P39129-33-RA1	EA	MOLDING - FLUTED/CURVED - 3.5" X 98.58" - CONCERT CHERRY
4	P39129-33-RA2	EA	MOLDING - FLUTED/CURVED - 3.5" X 98.58" - WASHED MAPLE
4	P39129-33-RA3	EA	MOLDING - FLUTED/CURVED - 3.5" X 98.58" - HONEY CHERRY
5	P39129-19-PA0	EA	MOLDING - FLUTED/CURVED - 5.9" X 32.1" - PORTSMOUTH OAK
5	P39129-19-PA1	EA	MOLDING - FLUTED/CURVED - 5.9" X 32.1" - CONCERT CHERRY
5	P39129-19-PA2	EA	MOLDING - FLUTED/CURVED - 5.9" X 32.1" - WASHED MAPLE
5	P39129-19-RA3	EA	MOLDING - FLUTED/CURVED - 5.9" X 32.1" - HONEY CHERRY
5	P39129-28-PA0	EA	MOLDING - FLUTED/CURVED - 5.9" X 63.3" - PORTSMOUTH OAK
5	P39129-28-PA1	EA	MOLDING - FLUTED/CURVED - 5.9" X 63.3" - CONCERT CHERRY
5	P39129-28-PA2	EA	MOLDING - FLUTED/CURVED - 5.9" X 63.3" - WASHED MAPLE
5	P39129-28-RA3	EA	MOLDING - FLUTED/CURVED - 5.9" X 63.3" - HONEY CHERRY
5	P39129-29-PA0	EA	MOLDING - FLUTED/CURVED - 5.9" X 70.1" - PORTSMOUTH OAK
5	P39129-29-PA1	EA	MOLDING - FLUTED/CURVED - 5.9" X 70.1" - CONCERT CHERRY
5	P39129-29-PA2	EA	MOLDING - FLUTED/CURVED - 5.9" X 70.1" - WASHED MAPLE
5	P39129-29-RA3	EA	MOLDING - FLUTED/CURVED - 5.9" X 70.1" - HONEY CHERRY

INTERIOR FINISH GROUP (CONTINUED)
MOLDINGS & TRIMS (CONTINUED)

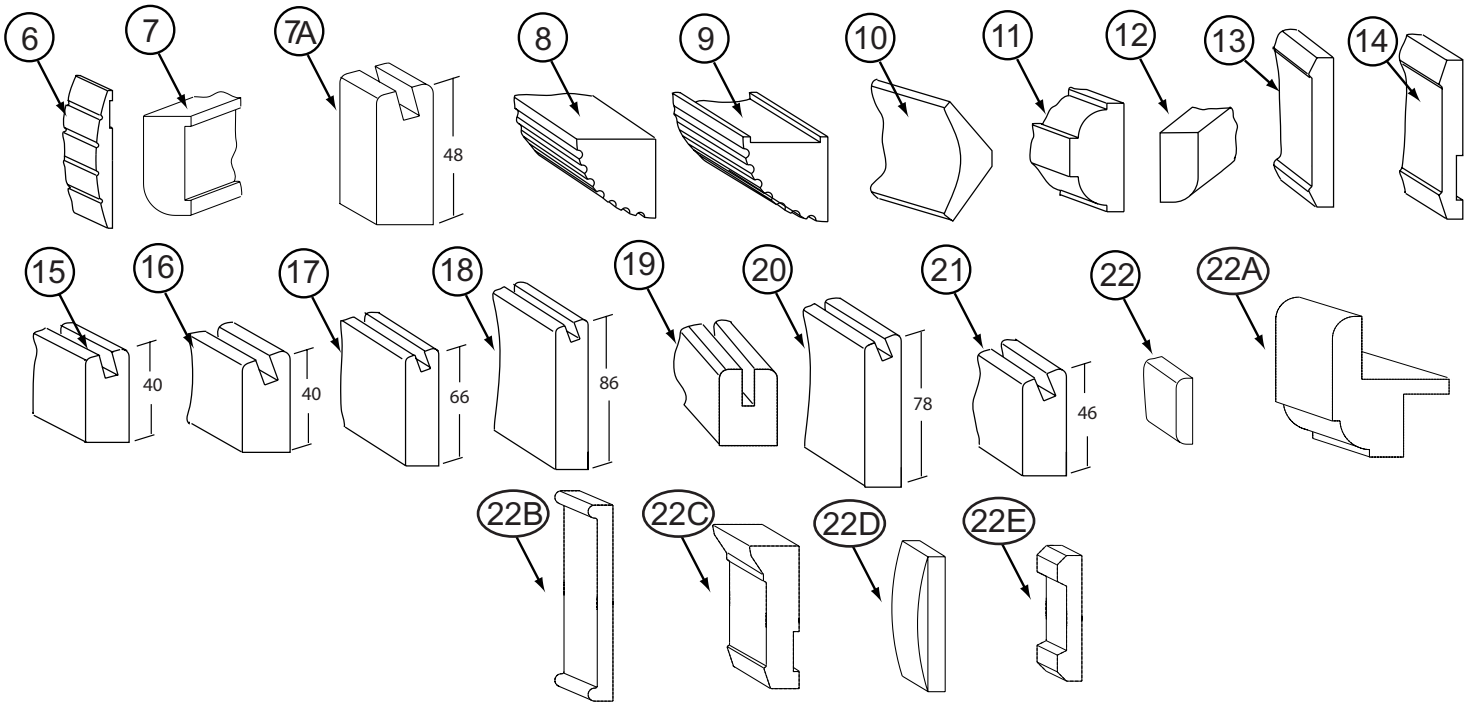

KEY	PART NUMBER	U/M	DESCRIPTION
6	P39129-21-PA0	EA	MOLDING - FLUTED/CURVED - 5.9" X 2.5" - PORTSMOUTH OAK
6	P39129-21-PA1	EA	MOLDING - FLUTED/CURVED - 5.9" X 2.5" - CONCERT CHERRY
6	P39129-21-PA2	EA	MOLDING - FLUTED/CURVED - 5.9" X 2.5" - WASHED MAPLE
6	P39129-21-RA3	EA	MOLDING - FLUTED/CURVED - 5.9" X 2.5" - HONEY CHERRY
6	P39129-22-PA0	EA	MOLDING - FLUTED/CURVED - 5.9" X 5.3" - PORTSMOUTH OAK
6	P39129-22-PA1	EA	MOLDING - FLUTED/CURVED - 5.9" X 5.3" - CONCERT CHERRY
6	P39129-22-PA2	EA	MOLDING - FLUTED/CURVED - 5.9" X 5.3" - WASHED MAPLE
6	P39129-22-RA3	EA	MOLDING - FLUTED/CURVED - 5.9" X 5.3" - HONEY CHERRY
7	Y00007-22-438	EA	MOLDING - MAPLE - UNSTAINED
7	Y00007-32-438	EA	MOLDING - CHERRY - UNSTAINED
7	Y00007-42-438	EA	MOLDING - OAK - UNSTAINED
7A	Y00054-72-438	EA	MOLDING - VINYL - W/SLOT - .7"X 1.9"X 96" - PORTSMOUTH OAK
7A	Y00054-62-438	EA	MOLDING - VINYL - W/SLOT - .7"X 1.9"X 96" - CONCERT CHERRY
7A	Y00054-A2-438	EA	MOLDING - VINYL - W/SLOT - .7"X 1.9"X 96" - WASHED MAPLE
8	Y00070-22-438	EA	MOLDING/FLUTED - MAPLE - 96" - WASHED MAPLE
8	Y00070-32-438	EA	MOLDING/FLUTED - CHERRY - 96" - CONCERT CHERRY
8	Y00070-42-438	EA	MOLDING/FLUTED - OAK - 96" - PORTSMOUTH OAK
9	Y00071-22-438	EA	MOLDING/FLUTED - W/NOTCH - MAPLE/UNSTAINED - 96"
9	Y00071-32-438	EA	MOLDING/FLUTED - W/NOTCH - CHERRY/UNSTAINED - 96"
9	Y00071-42-438	EA	MOLDING/FLUTED - W/NOTCH - OAK/UNSTAINED - 96"
10	Y00074-A2-438	EA	MOLDING/CROWN - VINYL WRAPPED - MAPLE - 96" - WASHED MAPLE
10	Y00074-62-438	EA	MOLDING/CROWN - VINYL WRAPPED - CONCERT CHERRY - 96" - CONCERT CHERRY
10	Y00074-72-438	EA	MOLDING/CROWN - VINYL WRAPPED - PORTSMOUTH OAK - 96" - PORTSMOUTH OAK
11	Y00076-22-438	EA	MOLDING/TRIM - .5" X 1" X 96" - MAPLE (UNSTAINED)
11	Y00076-32-438	EA	MOLDING/TRIM - .5" X 1" X 96" - CHERRY (UNSTAINED)
11	Y00076-42-438	EA	MOLDING/TRIM - .5" X 1" X 96" - OAK (UNSTAINED)
12	Y00086-A2-438	EA	MOLDING - VINYL WRAP - .7" X 1.6" X 96" - WASHED MAPLE
12	Y00086-62-438	EA	MOLDING - VINYL WRAP - .7" X 1.6" X 96" - CONCERT CHERRY
12	Y00086-72-438	EA	MOLDING - VINYL WRAP - .7" X 1.6" X 96" - PORTSMOUTH OAK
12	Y00086-82-438	EA	MOLDING - VINYL WRAP - .7" X 1.6" X 96" - HONEY CHERRY
12	Y00087-A2-438	EA	MOLDING - VINYL WRAP - .7" X 2.9" X 96" - WASHED MAPLE
12	Y00087-62-438	EA	MOLDING - VINYL WRAP - .7" X 2.9" X 96" - CONCERT CHERRY
12	Y00087-72-438	EA	MOLDING - VINYL WRAP - .7" X 2.9" X 96" - PORTSMOUTH OAK
12	Y00087-82-438	EA	MOLDING - VINYL WRAP - .7" X 2.9" X 96" - HONEY CHERRY
12	Y00267-72-438	EA	MOLDING - VINYL WRAP/MITERED - .6" X 96" - PORTSMOUTH OAK
12	Y00267-62-438	EA	MOLDING - VINYL WRAP/MITERED - .6" X 96" - CONCERT CHERRY
12	Y00267-A2-438	EA	MOLDING - VINYL WRAP/MITERED - .6" X 96" - WASHED MAPLE

INTERIOR FINISH GROUP (CONTINUED)
MOLDINGS & TRIMS (CONTINUED)

KEY	PART NUMBER	U/M	DESCRIPTION
13	Y00152-A2-438	EA	MOLDING/TRIM - VINYL - .6" X 3.5" X 96" - WASHED MAPLE
13	Y00152-62-438	EA	MOLDING/TRIM - VINYL - .6" X 3.5" X 96" - CONCERT CHERRY
13	Y00152-72-438	EA	MOLDING/TRIM - VINYL - .6" X 3.5" X 96" - PORTSMOUTH OAK
14	Y00153-A2-438	EA	MOLDING/TRIM - VINYL - .6" X 3.9" X 96" - WASHED MAPLE
14	Y00153-62-438	EA	MOLDING/TRIM - VINYL - .6" X 3.9" X 96" - CONCERT CHERRY
14	Y00153-72-438	EA	MOLDING/TRIM - VINYL - .6" X 3.9" X 96" - PORTSMOUTH OAK
14	Y00153-82-438	EA	MOLDING/TRIM - VINYL - .6" X 3.9" X 96" - HONEY CHERRY
15	Y00203-A2-438	EA	MOLDING - VINYL/BEVELED - 96" - WASHED MAPLE
15	Y00203-62-438	EA	MOLDING - VINYL/BEVELED - 96" - CONCERT CHERRY
15	Y00203-72-438	EA	MOLDING - VINYL/BEVELED - 96" - PORTSMOUT OAK
15	Y00203-82-438	EA	MOLDING - VINYL/BEVELED - 96" - HONEY CHERRY
16	Y00204-A2-438	EA	MOLDING - VINYL/BEVELED - 96" - WASHED MAPLE
16	Y00204-62-438	EA	MOLDING - VINYL/BEVELED - 96" - CONCERT CHERRY
16	Y00204-72-438	EA	MOLDING - VINYL/BEVELED - 96" - PORTSMOUT OAK
16	Y00204-82-438	EA	MOLDING - VINYL/BEVELED - 96" - HONEY CHERRY
17	Y00205-A2-438	EA	MOLDING - VINYL/BEVELED - 96" - WASHED MAPLE
17	Y00205-62-438	EA	MOLDING - VINYL/BEVELED - 96" - CONCERT CHERRY
17	Y00205-72-438	EA	MOLDING - VINYL/BEVELED - 96" - PORTSMOUT OAK
17	Y00205-82-438	EA	MOLDING - VINYL/BEVELED - 96" - HONEY CHERRY
18	Y00206-A2-438	EA	MOLDING - VINYL/BEVELED - 96" - WASHED MAPLE
18	Y00206-62-438	EA	MOLDING - VINYL/BEVELED - 96" - CONCERT CHERRY
18	Y00206-72-438	EA	MOLDING - VINYL/BEVELED - 96" - PORTSMOUT OAK
18	Y00206-82-438	EA	MOLDING - VINYL/BEVELED - 96" - HONEY CHERRY
19	Y00223-22-438	EA	MOLDING - HARDWOOD/MAPLE - .7" X 1" X 96"
19	Y00223-32-438	EA	MOLDING - HARDWOOD/CHERRY - .7" X 1" X 96"
19	Y00223-42-438	EA	MOLDING - HARDWOOD/OAK - .7" X 1" X 96"
20	Y00258-A2-438	EA	MOLDING - VINYL/BEVELED - 96" - WASHED MAPLE
20	Y00258-62-438	EA	MOLDING - VINYL/BEVELED - 96" - CONCERT CHERRY
20	Y00258-72-438	EA	MOLDING - VINYL/BEVELED - 96" - PORTSMOUT OAK
20	Y00258-82-438	EA	MOLDING - VINYL/BEVELED - 96" - HONEY CHERRY
21	Y00259-A2-438	EA	MOLDING - VINYL/BEVELED - 96" - WASHED MAPLE
21	Y00259-62-438	EA	MOLDING - VINYL/BEVELED - 96" - CONCERT CHERRY
21	Y00259-72-438	EA	MOLDING - VINYL/BEVELED - 96" - PORTSMOUT OAK
21	Y00259-82-438	EA	MOLDING - VINYL/BEVELED - 96" - HONEY CHERRY
22	Y00262-22-438	EA	MOLDING - 96" - MAPLE, UNSTAINED
22	Y00262-32-438	EA	MOLDING - 96" - CHERRY, UNSTAINED
22	Y00262-42-438	EA	MOLDING - 96" - OAK, UNSTAINED
22A	Y00266-42-438	EA	MOLDING - .75" X 1.5" X 96" OAK - .7" X 1" X 96"
22A	Y00266-32-438	EA	MOLDING - .75" X 1.5" X 96" CHERRY - .7" X 1" X 96"
22A	Y00266-22-438	EA	MOLDING - .75" X 1.5" X 96" MAPLE - .7" X 1" X 96"
22B	Y00280-74-174	EA	MOLDING/TRIM - VINYL - F/SLIDEOUT - 164.1" - PORTSMOUTH OAK
22B	Y00280-64-174	EA	MOLDING/TRIM - VINYL - F/SLIDEOUT - 164.1" - CONCERT CHERRY
22B	Y00280-A4-174	EA	MOLDING/TRIM - VINYL - F/SLIDEOUT - 164.1" - WASHED MAPLE
22B	Y00281-72-438	EA	MOLDING/TRIM - VINYL - F/SLIDEOUT - 96" - PORTSMTH OAK
22B	Y00281-62-438	EA	MOLDING/TRIM - VINYL - F/SLIDEOUT - 96" - CONCERT CHERRY
22B	Y00281-A2-438	EA	MOLDING/TRIM - VINYL - F/SLIDEOUT - 96" - WASHED MAPLE
22B	Y00291-72-438	EA	MOLDING - VINYL WRAPPED - 4" X 96" - PORTSMTH OAK
22B	Y00291-62-438	EA	MOLDING - VINYL WRAPPED - 4" X 96" - CONCERT CHERRY
22B	Y00291-A2-438	EA	MOLDING - VINYL WRAPPED - 4" X 96" - WASHED MAPLE
22C	Y00282-72-438	EA	MOLDING - SLIDEOUT/VINYL WRAP - 3.9" X 96"- PORTSMOUTH OAK
22C	Y00282-62-438	EA	MOLDING - SLIDEOUT/VINYL WRAP - 3.9" X 96"- CONCERT CHERRY
22C	Y00282-A2-438	EA	MOLDING - SLIDEOUT/VINYL WRAP - 3.9" X 96"- WASHED MAPLE
22D	Y00284-42-438	EA	MOLDING - STRAIGHT - .2" X 1.5" X 96"- UNSTAINED OAK
22D	Y00284-32-438	EA	MOLDING - STRAIGHT - .2" X 1.5" X 96"- UNSTAINED CHERRY
22D	Y00284-22-438	EA	MOLDING - STRAIGHT - .2" X 1.5" X 96"- UNSTAINED MAPLE
22E	Y00285-42-438	EA	MOLDING - STRAIGHT - .63" X 3.2" X 96"- UNSTAINED OAK
22E	Y00285-32-438	EA	MOLDING - STRAIGHT - .63" X 3.2" X 96"- UNSTAINED CHERRY
22E	Y00285-22-438	EA	MOLDING - STRAIGHT - .63" X 3.2" X 96"- UNSTAINED MAPLE

INTERIOR FINISH GROUP (CONTINUED)

MOLDINGS & TRIMS (CONTINUED)

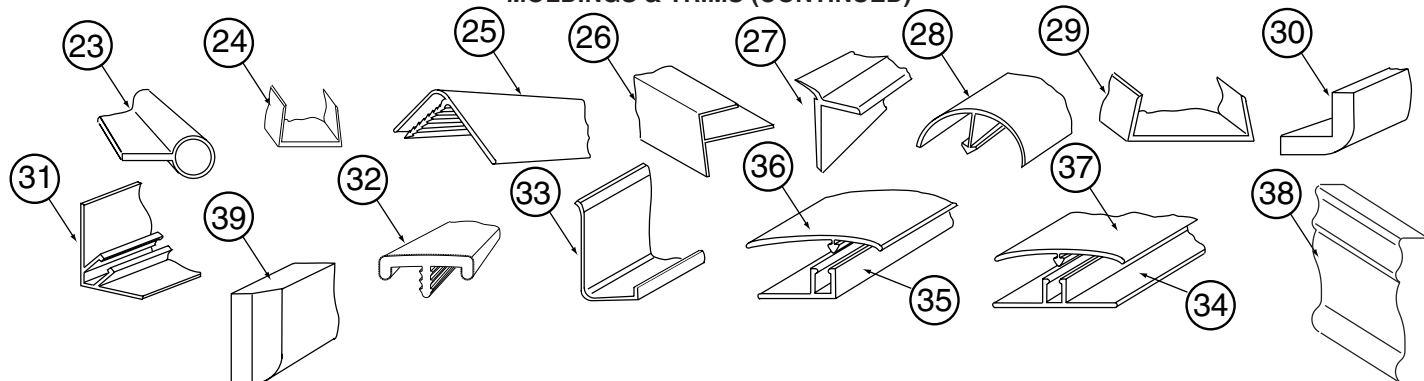

KEY	PART NUMBER	U/M	DESCRIPTION
23	009767-12-000	FT	WELTING - ANTIQUE WHITE
24	009778-25-000	FT	U-CHANNEL - 1" - BEIGE ILLUSION
24	009778-27-000	FT	U-CHANNEL - 1" - WASHED MAPLE
24	009778-32-000	FT	U-CHANNEL - 1" - PORTSMOUTH OAK
24	009778-34-000	FT	U-CHANNEL - 1" - CONCERT CHERRY
24	009778-35-000	FT	U-CHANNEL - 1" - HONEY CHERRY
25	009809-30-000	EA	MOLDING - CORNER - OUTSIDE - 1" X 84" - BEIGE ILLUSION
25	009809-32-000	EA	MOLDING - CORNER - OUTSIDE - 1" X 84" - PORTSMOUTH OAK
25	009809-31-000	EA	MOLDING - CORNER - OUTSIDE - 1" X 84" - WASHED MAPLE
25	009809-33-000	EA	MOLDING - CORNER - OUTSIDE - 1" X 84" - CONCERT CHERRY
25	009809-34-000	EA	MOLDING - CORNER - OUTSIDE - 1" X 84" - HONEY CHERRY
26	009812-31-000	EA	MOLDING - CORNER - 1/2" W/1/4"CHAN X 84" - BEIGE ILLUSION
26	009812-33-000	EA	MOLDING - CORNER - 1/2" W/1/4"CHAN X 84" - WASHED MAPLE
26	009812-34-000	EA	MOLDING - CORNER - 1/2" W/1/4"CHAN X 84" - VW LIGHT GRAY
26	009812-35-000	EA	MOLDING - CORNER - 1/2" W/1/4"CHAN X 84" - PORTSMOUTH OAK
26	009812-36-000	EA	MOLDING - CORNER - 1/2" W/1/4"CHAN X 84" - CONCERT CHERRY
26	009812-37-000	EA	MOLDING - CORNER - 1/2" W/1/4"CHAN X 84" - HONEY CHERRY
27	022992-11-000	FT	MOLDING - REVERSE COVE - T-SHAPED - IVORY
27	022992-14-000	FT	MOLDING - REVERSE COVE - T-SHAPED - BRIGHT WHITE
27	022992-15-000	FT	MOLDING - REVERSE COVE - T-SHAPED - VW GRAY
28	042357-25-000	EA	MOLDING - CORNER - RADIUS/PLASTIC - WASHED MAPLE
29	070504-42-000	FT	U-CHANNEL - PLASTIC - .13" X 84" - BEIGE ILLUSION
29	070504-50-000	FT	U-CHANNEL - PLASTIC - .13" X 96" - WASHED MAPLE
29	070504-51-000	FT	U-CHANNEL - PLASTIC - .9" X 96" - WASHED MAPLE
29	070504-54-000	FT	U-CHANNEL - PLASTIC - .9" X 96" - VILLAGE OAK
29	070504-57-000	FT	U-CHANNEL - PLASTIC - .13" X 84" - PORTSMOUTH OAK
29	070504-58-000	FT	U-CHANNEL - PLASTIC - .9" X 84" - PORTSMOUTH OAK
29	070504-60-000	FT	U-CHANNEL - PLASTIC - .13" X 84" - CONCERT CHERRY
29	070504-61-000	FT	U-CHANNEL - PLASTIC - .9" X 84" - CONCERT CHERRY
29	070504-62-000	FT	U-CHANNEL - PLASTIC - 1.65" X 84" - HONEY CHERRY
29	070504-63-000	FT	U-CHANNEL - PLASTIC - .9" X 84" - HONEY CHERRY
29	070504-64-000	FT	U-CHANNEL - PLASTIC - .7" X 84" - HONEY CHERRY
30	080176-08-000	EA	CAP - CORNER - RADIUS MOLDING - PLASTIC - WASHED MAPLE
31	081521-02-007	EA	MOUNT - METAL MOLDING - F/RADIUS CORNER MOLDING - 151.5"
32	083620-15-000	FT	MOLDING-T - W/EDGE LIP - 7/8" FACE - BEIGE ILLUSION
32	083620-19-000	FT	MOLDING-T - W/EDGE LIP - 7/8" FACE - WASHED MAPLE
32	083620-20-000	FT	MOLDING-T - W/EDGE LIP - 7/8" FACE - PORTSMOUTH OAK
32	083620-21-000	FT	MOLDING-T - W/EDGE LIP - 7/8" FACE - CONCERT CHERRY/HONEY CHERRY
33	085746-04-000	FT	TRIM-J - CARPET 1.2" X .5" ANGLE - 10' LONG - OFF WHITE
34	086229-01-000	EA	RETAINER - BATTEN - .75" X 92.1" - ANY COLOR
35	086229-11-000	EA	RETAINER - OFFSET - 97"
36	086229-21-000	EA	BATTEN - 1.5" X 83.9" OFFSET - WHITE
37	086229-20-000	EA	BATTEN - 1" X 96" - BEIGE
38	100182-10-J70	EA	TRIM/WOOD - CHAIR RAIL - 2.5" X 8' - WASHED MAPLE
38	100182-10-N47	EA	TRIM/WOOD - CHAIR RAIL - 2.5" X 8' - PORTSMOUTH OAK
38	100182-10-P85	EA	TRIM/WOOD - CHAIR RAIL - 2.5" X 8' - CHERRY - CONCERT CHERRY
38	100182-10-RA3	EA	TRIM/WOOD - CHAIR RAIL - 2.5" X 8' - HONEY CHERRY
39	100659-30-N75	EA	MOLDING - TRIM - 8' - PORTSMOUTH OAK
39	100659-30-N74	EA	MOLDING - TRIM - 8' - CHERRY - CONCERT CHERRY
39	100659-30-M84	EA	MOLDING - TRIM - 8' - WASHED MAPLE
39	100659-27-RA2	EA	MOLDING - TRIM - HONEY CHERRY

INTERIOR FINISH GROUP (CONTINUED)
MOLDINGS & TRIMS (CONTINUED)

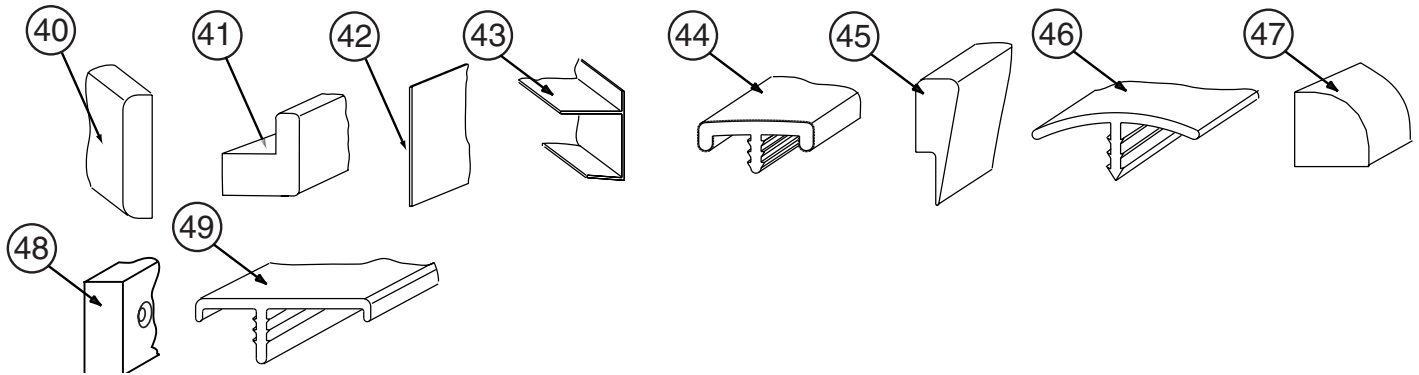

KEY	PART NUMBER	U/M	DESCRIPTION
40	100818-01-21A	EA	MOLDING - VINYL WRAPPED - 1.6" X .4" X 84" - WASHED MAPLE
40	100818-01-12A	EA	MOLDING - VINYL WRAPPED - 1.6" X .4" X 84" - PORTSMOUTH OAK
40	100818-01-13A	EA	MOLDING - VINYL WRAPPED - 1.6" X .4" X 84" - CHERRY - CONCERT CHERRY
40	100818-01-14A	EA	MOLDING - VINYL WRAPPED - 1.6" X .4" X 84" - HONEY CHERRY
41	100819-01-21A	EA	MOLDING - VINYL WRAPPED-L-SHAPED-1.5"X1.5"X84" - WASHED MAPLE
41	100819-01-12A	EA	MOLDING - VINYL WRAPPED-L-SHAPED - 1.5" X 1.5" X 84" - OAK - PORTSMOUTH OAK
41	100819-01-13A	EA	MOLDING - VINYL WRAPPED-L-SHAPED-1.5"X1.5"X84" - CONCERT CHERRY
41	100819-01-14A	EA	MOLDING - VINYL WRAPPED-L-SHAPED-1.5"X1.5"X84" - HONEY CHERRY
42	101957-01-06A	EA	EXTRUDED - PLASTIC - WASHED MAPLE
43	103186-01-07A	FT	MOLDING/PLASTIC - 3/8" U-CHANNEL-3/4"FACE - BEIGE ILLUS 8'
43	103186-01-08A	FT	MOLDING/PLASTIC - 3/8" U-CHANNEL-3/4"FACE-WASHED MAPLE 8' - WASHED MAPLE
43	103186-01-09A	FT	MOLDING/PLASTIC - 3/8" U-CHAN'L-3/4"FACE-PORTSMOUTH OAK 8' - PORTSMOUTH OAK
43	103186-01-10A	FT	MOLDING/PLASTIC-3/8" U-CHAN'L-3/4"FACE-CONCERT CHERRY 8' - CONCERT CHERRY
43	103186-01-11A	FT	MOLDING/PLASTIC-3/8" U-CHAN'L-3/4"FACE-CONCERT CHERRY 8' - HONEY CHERRY
43	103186-02-07A	FT	MOLDING/PLASTIC-1" U-CHAN'L-1 3/8"FACE-BEIGE ILLUSION - 8'
43	103186-02-08A	FT	MOLDING/PLASTIC - 1" U-CHANNEL-1 3/8"FACE-WASHED MAPLE 8' - WASHED MAPLE
43	103186-02-09A	FT	MOLDING/PLASTIC - 1" U-CHAN'L-1 3/8"FACE-PORTSMOUTH OAK 8' - PORTSMOUTH OAK
43	103186-02-10A	FT	MOLDING/PLASTIC - 1" U-CHAN'L-1 3/8"FACE-CONCERT CHERRY 8' - CONCERT CHERRY
43	103186-02-11A	FT	MOLDING/PLASTIC - 1" U-CHAN'L-1 3/8"FACE-CONCERT CHERRY 8' - HONEY CHERRY
44	104676-02-06A	FT	MOLDING-T - W/EDGE LIP - 11/16" FACE - WASHED MAPLE
44	104676-02-08A	FT	MOLDING-T - W/EDGE LIP - 11/16" FACE - PORTSMOUTH OAK
44	104676-02-09A	FT	MOLDING-T - W/EDGE LIP - 11/16" FACE - CONCERT CHERRY
44	104676-02-10A	FT	MOLDING-T - W/EDGE LIP - 11/16" FACE - HONEY CHERRY
45	105004-01-21A	EA	MOLDING - VINYL WRAPPED - 1" X 96" - WASHED MAPLE
45	105004-01-12A	EA	MOLDING - VINYL WRAPPED 1" X 96" - PORTSMOUTH OAK
45	105004-01-13A	EA	MOLDING - VINYL WRAPPED 1" X 96" - CONCERT CHERRY
45	105004-01-14A	EA	MOLDING - VINYL WRAPPED 1" X 96" - HONEY CHERRY
46	105709-02-000	FT	MOLDING-T - W/EDGE LIP - 3/4" FACE - BEIGE ILLUSION
47	109410-01-P25	EA	MOLDING - TRIM - 8' - BLACK CHERRY/CHERRY IV - CONCERT CHERRY
47	109410-01-N75	EA	MOLDING - TRIM - 8' - PORTSMOUTH OAK
47	109410-01-J70	EA	MOLDING - TRIM - 8' - WHITE MAPLE - WASHED MAPLE
48	116951-11-KQ0	EA	MOLDING - TRIM - 3.5" X 75.9" - WASHED MAPLE
48	116951-11-KQ1	EA	MOLDING - TRIM - 3.5" X 75.9" - CONCERT CHERRY
48	116951-11-N95	EA	MOLDING - TRIM - 3.5" X 75.9" - PORTSMOUTH OAK
48	116951-11-RE0	EA	MOLDING - TRIM - 3.5" X 75.9" - HONEY CHERRY
48	116951-16-K37	EA	MOLDING - TRIM - 3.5" X 74.3" - CONCERT CHERRY
48	116951-16-K90	EA	MOLDING - TRIM - 3.5" X 74.3" - WASHED MAPLE
48	116951-16-N75	EA	MOLDING - TRIM - 3.5" X 74.3" - PORTSMOUTH OAK
48	116951-16-RC3	EA	MOLDING - TRIM - 3.5" X 74.3" - HONEY CHERRY
48	116951-23-L52	EA	MOLDING - TRIM - 3.5" X 74.3" - CONCERT CHERRY
48	116951-23-L58	EA	MOLDING - TRIM - 3.5" X 74.3" - WASHED MAPLE
48	116951-23-RE0	EA	MOLDING - TRIM - 3.5" X 74.3" - HONEY CHERRY
48	116951-23-R83	EA	MOLDING - TRIM - 3.5" X 74.3" - PORTSMOUTH OAK
48	116951-24-L52	EA	MOLDING - TRIM - 3.5" X 74.6" - CONCERT CHERRY
48	116951-24-L58	EA	MOLDING - TRIM - 3.5" X 74.6" - WASHED MAPLE
48	116951-24-RE0	EA	MOLDING - TRIM - 3.5" X 74.6" - HONEY CHERRY
48	116951-24-R83	EA	MOLDING - TRIM - 3.5" X 74.6" - PORTSMOUTH OAK
48	116951-27-N75	EA	MOLDING - TRIM - 3.5" X 46.8" - PORTSMOUTH OAK
48	116951-27-N84	EA	MOLDING - TRIM - 3.5" X 46.8" - WASHED MAPLE
48	116951-27-N85	EA	MOLDING - TRIM - 3.5" X 46.8" - CONCERT CHERRY
48	116951-28-N75	EA	MOLDING - TRIM - 3.5" X 79.4" - PORTSMOUTH OAK

INTERIOR FINISH GROUP (CONTINUED)

MOLDINGS & TRIMS (CONTINUED)

KEY	PART NUMBER	U/M	DESCRIPTION
48	116951-28-N84	EA	MOLDING - TRIM - 3.5" X 79.4" - WASHED MAPLE
48	116951-28-N85	EA	MOLDING - TRIM - 3.5" X 79.4" - CONCERT CHERRY
48	116951-29-N70	EA	MOLDING - TRIM - 5.5" X 30.4" - PORTSMOUTH OAK
48	116951-29-N84	EA	MOLDING - TRIM - 5.5" X 30.4" - WASHED MAPLE
48	116951-29-N85	EA	MOLDING - TRIM - 5.5" X 30.4" - CONCERT CHERRY
48	116951-29-RC3	EA	MOLDING - TRIM - 5.5" X 30.4" - HONEY CHERRY
48	116951-32-P75	EA	MOLDING - TRIM - 3" X 33.4" - PORTSMOUTH OAK
48	116951-32-P25	EA	MOLDING - TRIM - 3" X 33.4" - CONCERT CHERRY
48	116951-32-P28	EA	MOLDING - TRIM - 3" X 33.4" - WASHED MAPLE
48	116951-32-RE0	EA	MOLDING - TRIM - 3" X 33.4" - HONEY CHERRY
48	116951-34-P28	EA	MOLDING - TRIM - 3" X 33.4" - WASHED MAPLE
48	116951-34-P78	EA	MOLDING - TRIM - 3" X 33.4" - PORTSMOUTH OAK
48	116951-34-P79	EA	MOLDING - TRIM - 3" X 33.4" - CONCERT CHERRY
48	116951-34-RE0	EA	MOLDING - TRIM - 3" X 33.4" - HONEY CHERRY
48	116951-35-P28	EA	MOLDING - TRIM - 3.5" X 96" - WASHED MAPLE
48	116951-35-P78	EA	MOLDING - TRIM - 3.5" X 96" - PORTSMOUTH OAK
48	116951-35-P79	EA	MOLDING - TRIM - 3.5" X 96" - CONCERT CHERRY
48	116951-35-RE0	EA	MOLDING - TRIM - 3.5" X 96" - HONEY CHERRY
48	116951-36-R68	EA	MOLDING - TRIM - 3.5" X 48.8" - WASHED MAPLE
48	116951-36-R69	EA	MOLDING - TRIM - 3.5" X 48.8" - PORTSMOUTH OAK
48	116951-36-R76	EA	MOLDING - TRIM - 3.5" X 48.8" - CONCERT CHERRY
48	116951-37-R68	EA	MOLDING - TRIM - 3.5" X 38.6" - WASHED MAPLE
48	116951-37-R69	EA	MOLDING - TRIM - 3.5" X 38.6" - PORTSMOUTH OAK
48	116951-37-R76	EA	MOLDING - TRIM - 3.5" X 38.6" - CONCERT CHERRY
48	116951-38-RE0	EA	MOLDING - TRIM - 3.5" X 82.6" - HONEY CHERRY
48	116951-38-R83	EA	MOLDING - TRIM - 3.5" X 82.6" - PORTSMOUTH OAK
48	116951-38-R84	EA	MOLDING - TRIM - 3.5" X 82.6" - CONCERT CHERRY
48	116951-38-R91	EA	MOLDING - TRIM - 3.5" X 82.6" - WASHED MAPLE
48	116951-39-RE0	EA	MOLDING - TRIM - 3.5" X 73.9" - HONEY CHERRY
48	116951-39-R83	EA	MOLDING - TRIM - 3.5" X 73.9" - PORTSMOUTH OAK
48	116951-39-R84	EA	MOLDING - TRIM - 3.5" X 73.9" - CONCERT CHERRY
48	116951-39-R91	EA	MOLDING - TRIM - 3.5" X 73.9" - WASHED MAPLE
48	116951-40-RE0	EA	MOLDING - TRIM - 4.5" X 81.9" - HONEY CHERRY
48	116951-40-R83	EA	MOLDING - TRIM - 4.5" X 81.9" - PORTSMOUTH OAK
48	116951-40-R84	EA	MOLDING - TRIM - 4.5" X 81.9" - CONCERT CHERRY
48	116951-40-R91	EA	MOLDING - TRIM - 4.5" X 81.9" - WASHED MAPLE
48	116951-41-RE0	EA	MOLDING - TRIM - 3.5" X 36.8" - HONEY CHERRY
48	116951-41-R83	EA	MOLDING - TRIM - 3.5" X 36.8" - PORTSMOUTH OAK
48	116951-41-R84	EA	MOLDING - TRIM - 3.5" X 36.8" - CONCERT CHERRY
48	116951-41-R91	EA	MOLDING - TRIM - 3.5" X 36.8" - WASHED MAPLE
48	116951-42-RE0	EA	MOLDING - TRIM - 3.5" X 46.8" - HONEY CHERRY
48	116951-42-R83	EA	MOLDING - TRIM - 3.5" X 46.8" - PORTSMOUTH OAK
48	116951-42-R84	EA	MOLDING - TRIM - 3.5" X 46.8" - CONCERT CHERRY
48	116951-42-R91	EA	MOLDING - TRIM - 3.5" X 46.8" - WASHED MAPLE
48	116951-43-RE0	EA	MOLDING - TRIM - 3.5" X 86.5" - HONEY CHERRY
48	116951-43-R83	EA	MOLDING - TRIM - 3.5" X 86.5" - PORTSMOUTH OAK
48	116951-43-R84	EA	MOLDING - TRIM - 3.5" X 86.5" - CONCERT CHERRY
48	116951-43-R91	EA	MOLDING - TRIM - 3.5" X 86.5" - WASHED MAPLE
48	116951-44-RE0	EA	MOLDING - TRIM - 3.5" X 76.1" - HONEY CHERRY
48	116951-44-R83	EA	MOLDING - TRIM - 3.5" X 76.1" - PORTSMOUTH OAK
48	116951-44-R84	EA	MOLDING - TRIM - 3.5" X 76.1" - CONCERT CHERRY
48	116951-44-R91	EA	MOLDING - TRIM - 3.5" X 76.1" - WASHED MAPLE
48	116951-45-R68	EA	MOLDING - TRIM - 3" X 30.3" - PORTSMOUTH OAK
48	116951-45-R69	EA	MOLDING - TRIM - 3" X 30.3" - CONCERT CHERRY
48	116951-45-R76	EA	MOLDING - TRIM - 3" X 30.3" - WASHED MAPLE
48	116951-46-RE0	EA	MOLDING - TRIM - 4.5" X 72.3" - HONEY CHERRY
48	116951-46-R83	EA	MOLDING - TRIM - 4.5" X 72.3" - PORTSMOUTH OAK
48	116951-46-R84	EA	MOLDING - TRIM - 4.5" X 72.3" - CONCERT CHERRY
48	116951-46-R91	EA	MOLDING - TRIM - 4.5" X 72.3" - WASHED MAPLE
48	116951-48-RE0	EA	MOLDING - TRIM - 4.5" X 76.1" - HONEY CHERRY
48	116951-48-R83	EA	MOLDING - TRIM - 4.5" X 76.1" - PORTSMOUTH OAK
48	116951-48-R84	EA	MOLDING - TRIM - 4.5" X 76.1" - CONCERT CHERRY
48	116951-48-R91	EA	MOLDING - TRIM - 4.5" X 76.1" - WASHED MAPLE
48	116951-49-RE0	EA	MOLDING - TRIM - 4.5" X 69.8" - HONEY CHERRY

INTERIOR FINISH GROUP (CONTINUED)
MOLDINGS & TRIMS (CONTINUED)

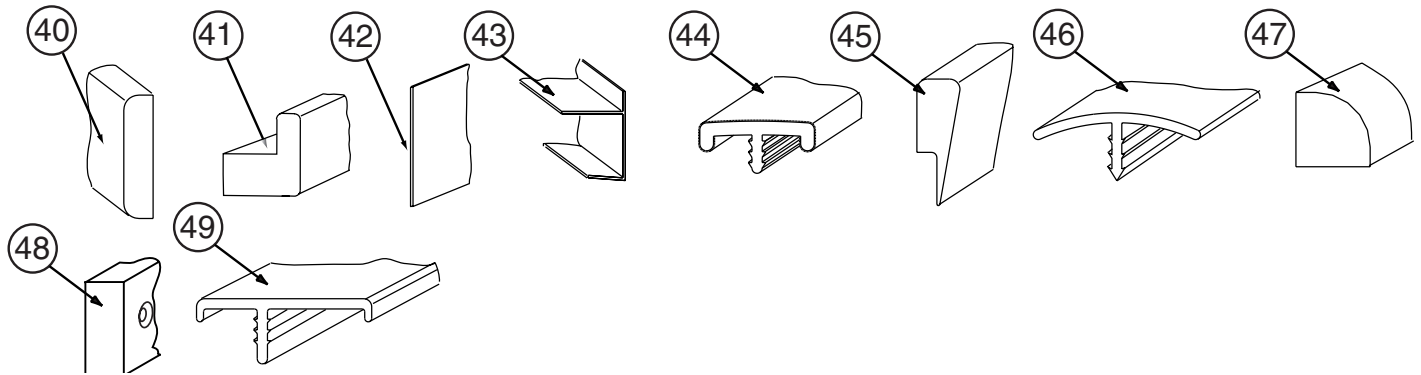

KEY	PART NUMBER	U/M	DESCRIPTION
48	116951-49-R83	EA	MOLDING - TRIM - 4.5" X 69.8" - PORTSMOUTH OAK
48	116951-49-R84	EA	MOLDING - TRIM - 4.5" X 69.8" - CONCERT CHERRY
48	116951-49-R91	EA	MOLDING - TRIM - 4.5" X 69.8" - WASHED MAPLE
48	116951-50-RE0	EA	MOLDING - TRIM - 4.5" X 70.3" - HONEY CHERRY
48	116951-50-R83	EA	MOLDING - TRIM - 4.5" X 70.3" - PORTSMOUTH OAK
48	116951-50-R84	EA	MOLDING - TRIM - 4.5" X 70.3" - CONCERT CHERRY
48	116951-50-R91	EA	MOLDING - TRIM - 4.5" X 70.3" - WASHED MAPLE
49	119520-01-01A	FT	MOLDING-T/OFFSET - W/EDGE LIP - 1.3" FACE - OFF WHITE
49	119520-01-04A	FT	MOLDING-T/OFFSET - W/EDGE LIP - 1.3" FACE - PORTSMOUTH OAK
49	119520-01-02A	FT	MOLDING-T/OFFSET - W/EDGE LIP - 1.3" FACE - CONCERT CHERRY
49	119520-01-03A	FT	MOLDING-T/OFFSET - W/EDGE LIP - 1.3" FACE - WASHED MAPLE
49	119520-02-01A	FT	MOLDING-T - OFFSET W/EDGE LIP - 1.3" FACE - OFF WHITE

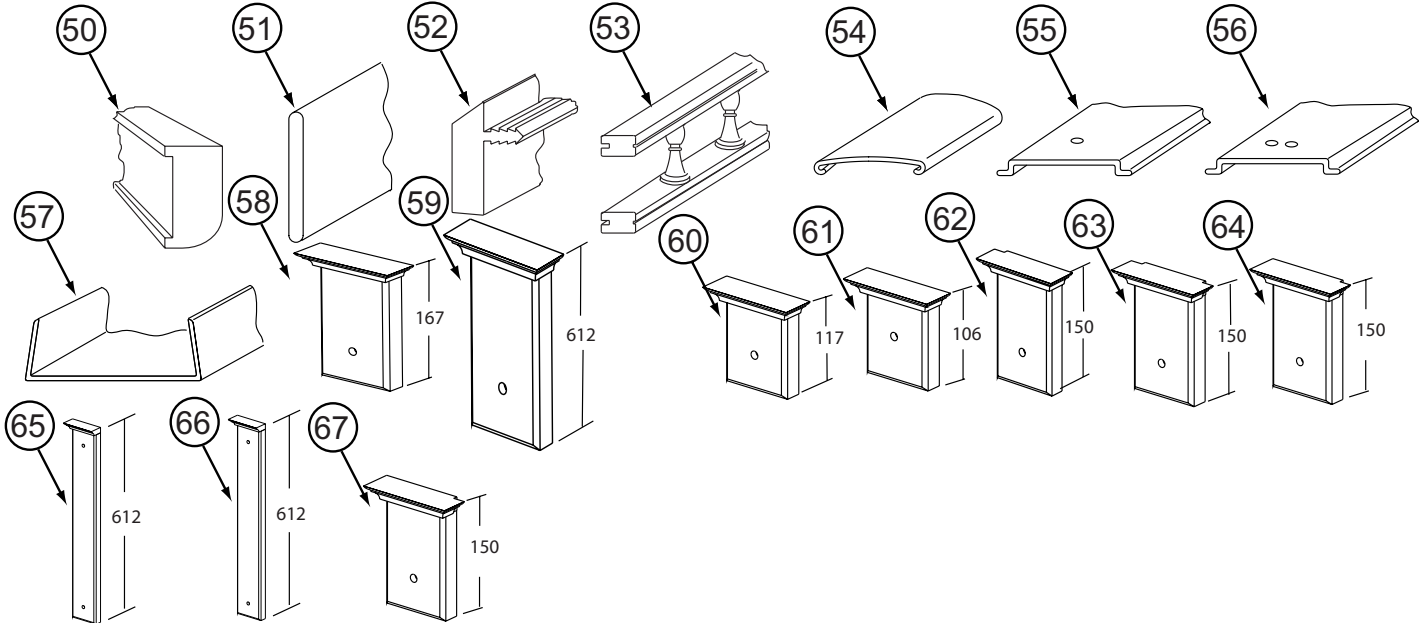

KEY	PART NUMBER	U/M	DESCRIPTION
50	149326-D2-134	EA	MOLDING - VINYL WRAPPED - .7" X 1.6" X 84" - WASHED MAPLE
50	149326-F2-134	EA	MOLDING - VINYL WRAPPED - .7" X 2.5" X 84" - WASHED MAPLE
50	137887-D2-134	EA	MOLDING - VINYL WRAPPED - .7" X 1.6" X 96" - CONCERT CHERRY
50	137887-D2-743	EA	MOLDING - VINYL WRAPPED - .7" X 1.6" X 108" - CONCERT CHERRY
50	137887-F2-134	EA	MOLDING - VINYL WRAPPED - .7" X 2.5" X 84" - CONCERT CHERRY
50	137887-F2-743	EA	MOLDING - VINYL WRAPPED - .7" X 2.5" X 108" - CONCERT CHERRY
50	137895-D2-134	EA	MOLDING - VINYL WRAPPED - .7" X 1.6" X 84" - PORTSMOUTH OAK
50	137895-D2-743	EA	MOLDING - VINYL WRAPPED - .7" X 1.5" X 108" - PORTSMOUTH OAK
50	137895-F2-743	EA	MOLDING - VINYL WRAPPED - .7" X 2.5" X 108" - PORTSMOUTH OAK
50	146425-D2-134	EA	MOLDING - VINYL WRAPPED - .7" X 1.6" X 96" - HONEY CHERRY
50	146425-F2-134	EA	MOLDING - VINYL WRAPPED - .7" X 2.5" X 84" - HONEY CHERRY
50	146425-F2-743	EA	MOLDING - VINYL WRAPPED - .7" X 2.5" X 108" - HONEY CHERRY
51	127842-01-01A	FT	SEAL - SIGHT SHIELD - 2" BLACK
52	130247-01-02A	FT	MOLDING-T/OFF SET - 1.3" FACE - WASHED MAPLE
52	130247-01-04A	FT	MOLDING-T/OFF SET - 1.3" FACE - PORTSMOUTH OAK
52	130247-01-05A	FT	MOLDING-T/OFF SET - 1.3" FACE - CONCERT CHERRY/HONEY CHERRY

INTERIOR FINISH GROUP (CONTINUED)
MOLDINGS & TRIMS (CONTINUED)

KEY	PART NUMBER	U/M	DESCRIPTION
53	137108-01-02A	EA	RAIL - DECORATIVE - SALEM CHERRY - CONCERT CHERRY
53	137108-01-03A	EA	RAIL - DECORATIVE - WASHED MAPLE
53	137108-01-07A	EA	RAIL - DECORATIVE - PORTSMOUTH OAK
53	137108-01-08A	EA	RAIL - DECORATIVE - HONEY CHERRY
54	138359-01-01A	FT	COVER - ROOF BREAK - PEARL CREAM/PLASTIC - 96"
55	138403-01-01A	EA	TRIM - ROOF - MILL
56	138403-02-01A	EA	TRIM - ROOF - MILL
56	138403-03-01A	EA	TRIM - ROOF - MILL
57	141260-01-01A	FT	U-CHANNEL - 1" - VILLAGE OAK
57	141260-01-02A	FT	U-CHANNEL - 1" - GRADY BROWN
58	141303-01-N52	EA	MOLDING - CROWN/BLOCK - CONCERT CHERRY
58	141303-01-N53	EA	MOLDING - CROWN/BLOCK - PORTSMOUTH OAK
58	141303-01-N62	EA	MOLDING - CROWN/BLOCK - WASHED MAPLE
58	141303-01-RA3	EA	MOLDING - CROWN/BLOCK - HONEY CHERRY
59	141303-02-N52	EA	MOLDING - CROWN/BLOCK - CONCERT CHERRY
59	141303-02-N53	EA	MOLDING - CROWN/BLOCK - PORTSMOUTH OAK
59	141303-02-N62	EA	MOLDING - CROWN/BLOCK - WASHED MAPLE
59	141303-02-RA3	EA	MOLDING - CROWN/BLOCK - HONEY CHERRY
60	141303-03-N52	EA	MOLDING - CROWN/BLOCK - CONCERT CHERRY
60	141303-03-N53	EA	MOLDING - CROWN/BLOCK - PORTSMOUTH OAK
60	141303-03-N62	EA	MOLDING - CROWN/BLOCK - WASHED MAPLE
60	141303-03-RA3	EA	MOLDING - CROWN/BLOCK - HONEY CHERRY
61	141303-04-PC0	EA	MOLDING - CROWN/BLOCK - PORTSMOUTH OAK
61	141303-04-PC1	EA	MOLDING - CROWN/BLOCK - CONCERT CHERRY
61	141303-04-PC2	EA	MOLDING - CROWN/BLOCK - WASHED MAPLE
61	141303-04-RA3	EA	MOLDING - CROWN/BLOCK - HONEY CHERRY
62	141303-05-RE3	EA	MOLDING - CROWN/BLOCK - HONEY CHERRY
62	141303-05-R89	EA	MOLDING - CROWN/BLOCK - PORTSMOUTH OAK
62	141303-05-R90	EA	MOLDING - CROWN/BLOCK - CONCERT CHERRY
62	141303-05-R91	EA	MOLDING - CROWN/BLOCK - WASHED MAPLE
63	141303-06-RE3	EA	MOLDING - CROWN/BLOCK - HONEY CHERRY
63	141303-06-R89	EA	MOLDING - CROWN/BLOCK - PORTSMOUTH OAK
63	141303-06-R90	EA	MOLDING - CROWN/BLOCK - CONCERT CHERRY
63	141303-06-R91	EA	MOLDING - CROWN/BLOCK - WASHED MAPLE
64	141303-07-RE3	EA	MOLDING - CROWN/BLOCK - HONEY CHERRY
64	141303-07-R89	EA	MOLDING - CROWN/BLOCK - PORTSMOUTH OAK
64	141303-07-R90	EA	MOLDING - CROWN/BLOCK - CONCERT CHERRY
64	141303-07-R91	EA	MOLDING - CROWN/BLOCK - WASHED MAPLE
65	141303-08-RE3	EA	MOLDING - CROWN/BLOCK - HONEY CHERRY
65	141303-08-R89	EA	MOLDING - CROWN/BLOCK - PORTSMOUTH OAK
65	141303-08-R90	EA	MOLDING - CROWN/BLOCK - CONCERT CHERRY
65	141303-08-R91	EA	MOLDING - CROWN/BLOCK - WASHED MAPLE
66	141303-09-RE3	EA	MOLDING - CROWN/BLOCK - HONEY CHERRY
66	141303-09-R89	EA	MOLDING - CROWN/BLOCK - PORTSMOUTH OAK
66	141303-09-R90	EA	MOLDING - CROWN/BLOCK - CONCERT CHERRY
66	141303-09-R91	EA	MOLDING - CROWN/BLOCK - WASHED MAPLE
67	141303-10-RE3	EA	MOLDING - CROWN/BLOCK - HONEY CHERRY
67	141303-10-R89	EA	MOLDING - CROWN/BLOCK - PORTSMOUTH OAK
67	141303-10-R90	EA	MOLDING - CROWN/BLOCK - CONCERT CHERRY
67	141303-10-R91	EA	MOLDING - CROWN/BLOCK - WASHED MAPLE

INTERIOR FINISH GROUP (CONTINUED)
MOLDINGS & TRIMS (CONTINUED)

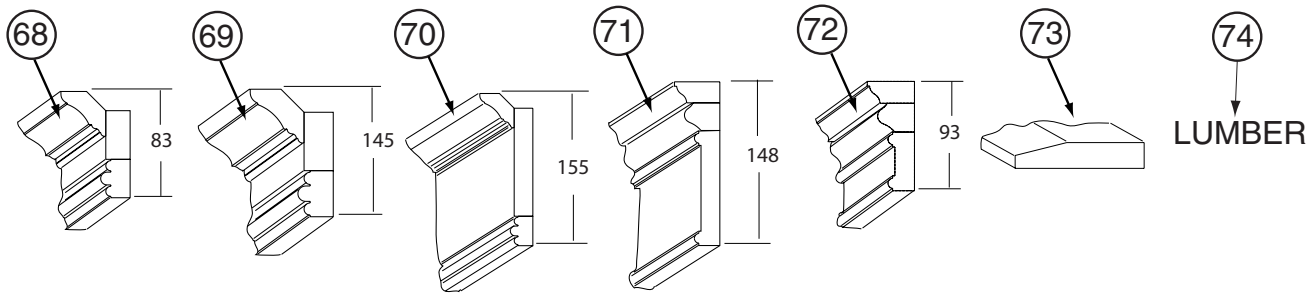

KEY	PART NUMBER	U/M	DESCRIPTION
68	141915-29-PC0	EA	MOLDING - F/SLIDEOUT - 81.8" - PORTSMOUTH OAK
68	141915-29-PC1	EA	MOLDING - F/SLIDEOUT - 81.8" - CONCERT CHERRY
68	141915-29-PC2	EA	MOLDING - F/SLIDEOUT - 81.8" - WASHED MAPLE
68	141915-29-RC3	EA	MOLDING - F/SLIDEOUT - 81.8" - HONEY CHERRY
69	141915-35-RC0	EA	MOLDING - F/SLIDEOUT - 8.89' - PORTSMOUTH OAK
69	141915-35-RC1	EA	MOLDING - F/SLIDEOUT - 8.89' - CONCERT CHERRY
69	141915-35-RC2	EA	MOLDING - F/SLIDEOUT - 8.89' - WASHED MAPLE
69	141915-35-RC3	EA	MOLDING - F/SLIDEOUT - 8.89' - HONEY CHERRY
70	141915-47-RC0	EA	MOLDING - F/SLIDEOUT - 6.82' - PORTSMOUTH OAK
70	141915-47-RC1	EA	MOLDING - F/SLIDEOUT - 6.82' - CONCERT CHERRY
70	141915-47-RC2	EA	MOLDING - F/SLIDEOUT - 6.82' - WASHED MAPLE
70	141915-47-RC3	EA	MOLDING - F/SLIDEOUT - 6.82' - HONEY CHERRY
71	144885-14-RE0	EA	MOLDING - F/SLIDEOUT - 86.5" - HONEY CHERRY
71	144885-14-R83	EA	MOLDING - F/SLIDEOUT - 86.5" - PORTSMOUTH OAK
71	144885-14-R84	EA	MOLDING - F/SLIDEOUT - 86.5" - CONCERT CHERRY
72	145379-01-RE0	EA	MOLDING/TRIM - 47.48" - HONEY CHERRY
72	145379-01-R83	EA	MOLDING/TRIM - 47.48" - PORTSMOUTH OAK
72	145379-01-R84	EA	MOLDING/TRIM - 47.48" - CONCERT CHERRY
72	145379-02-RE0	EA	MOLDING/TRIM - 7.87" W/RIGHT SIDE ANGLE CUT - HONEY CHERRY
72	145379-02-R83	EA	MOLDING/TRIM - 7.87" W/RIGHT SIDE ANGLE CUT - PORTSMOUTH OAK
72	145379-02-R84	EA	MOLDING/TRIM - 7.87" W/RIGHT SIDE ANGLE CUT - CONCERT CHERRY
72	145379-03-RE0	EA	MOLDING/TRIM - 7.87" W/LEFT SIDE ANGLE CUT - HONEY CHERRY
72	145379-03-R83	EA	MOLDING/TRIM - 7.87" W/LEFT SIDE ANGLE CUT - PORTSMOUTH OAK
72	145379-03-R84	EA	MOLDING/TRIM - 7.87" W/LEFT SIDE ANGLE CUT - CONCERT CHERRY
72	145379-04-RE0	EA	MOLDING/TRIM - 86.61" - HONEY CHERRY
72	145379-04-R83	EA	MOLDING/TRIM - 86.61" - PORTSMOUTH OAK
72	145379-04-R84	EA	MOLDING/TRIM - 86.61" - CONCERT CHERRY
72	145379-05-RE0	EA	MOLDING/TRIM - 102.75" - HONEY CHERRY
72	145379-05-R83	EA	MOLDING/TRIM - 102.75" - PORTSMOUTH OAK
72	145379-05-R84	EA	MOLDING/TRIM - 102.75" - CONCERT CHERRY
73	146306-01-01A	FT	TRANSITION - CARPET/TILE
74	149325-A2-438	EA	LUMBER - VINYL WRAPPED - .7" X .75" X 96" - WASHED MAPLE
74	149325-D2-438	EA	LUMBER - VINYL WRAPPED - .7" X 1.5" X 96" - WASHED MAPLE
74	149325-E2-438	EA	LUMBER - VINYL WRAPPED - .7" X 2" X 96" - WASHED MAPLE
74	149325-F2-438	EA	LUMBER - VINYL WRAPPED - .7" X 2.5" X 96" - WASHED MAPLE
74	149325-G2-438	EA	LUMBER - STAINED - .7" X 3" X 96" - WASHED MAPLE
74	149325-H2-438	EA	LUMBER - STAINED - .7" X 3.5" X 96" - WASHED MAPLE
74	149325-J2-438	EA	LUMBER - VINYL WRAPPED - .7" X 5.5" X 96" - WASHED MAPLE
74	149325-J2-743	EA	LUMBER - VINYL WRAPPED - .7" X 5.5" X 108" - WASHED MAPLE
74	149325-K2-438	EA	LUMBER - VINYL WRAPPED - .7" X 3.9" X 96" - WASHED MAPLE
74	149325-R2-438	EA	LUMBER - VINYL WRAPPED - .7" X 3" X 96" - WASHED MAPLE
74	137885-A2-438	EA	LUMBER - VINYL WRAPPED - .7" X .75" X 96" - CHERRY - CONCERT CHERRY
74	137885-D2-438	EA	LUMBER - VINYL WRAPPED - .7" X 1.5" X 96" - CHERRY - CONCERT CHERRY
74	137885-E2-438	EA	LUMBER - VINYL WRAPPED - .7" X 2" X 96" - CHERRY - CONCERT CHERRY
74	137885-F2-438	EA	LUMBER - VINYL WRAPPED - .7" X 2.5" X 96" - CHERRY - CONCERT CHERRY
74	137885-G2-438	EA	LUMBER - VINYL WRAPPED - .7" X 3" X 96" - CHERRY - CONCERT CHERRY
74	137885-H2-438	EA	LUMBER - VINYL WRAPPED - .7" X 3.5" X 96" - CHERRY - CONCERT CHERRY
74	137885-J2-438	EA	LUMBER - VINYL WRAPPED - .7" X 5.5" X 96" - CHERRY - CONCERT CHERRY
74	137885-J2-743	EA	LUMBER - VINYL WRAPPED - .7" X 5.5" X 108" - CHERRY - CONCERT CHERRY
74	137885-K2-438	EA	LUMBER - VINYL WRAPPED - .7" X 3.9" X 96" - CHERRY - CONCERT CHERRY
74	137885-R2-438	EA	LUMBER - VINYL WRAPPED - .7" X 3" X 96" - CHERRY - CONCERT CHERRY
74	137894-A2-438	EA	LUMBER - VINYL WRAPPED - .7" X .75" X 96" - PORTSMOUTH OAK
74	137894-D2-438	EA	LUMBER - VINYL WRAPPED - .7" X 1.5" X 96" - PORTSMOUTH OAK

INTERIOR FINISH GROUP (CONTINUED)
MOLDINGS & TRIMS (CONTINUED)

KEY	PART NUMBER	U/M	DESCRIPTION
74	137894-E2-438	EA	LUMBER - VINYL WRAPPED - .7" X 2" X 96" - PORTSMOUTH OAK
74	137894-F2-438	EA	LUMBER - VINYL WRAPPED - .7" X 2.5" X 96" - PORTSMOUTH OAK
74	137894-G2-438	EA	LUMBER - VINYL WRAPPED - .7" X 3" X 96" - PORTSMOUTH OAK
74	137894-H2-438	EA	LUMBER - VINYL WRAPPED - .7" X 3.5" X 96" - PORTSMOUTH OAK
74	137894-J2-438	EA	LUMBER - VINYL WRAPPED - .7" X 5.5" X 96" - PORTSMOUTH OAK
74	137894-J2-743	EA	LUMBER - VINYL WRAPPED - .7" X 5.5" X 96" - PORTSMOUTH OAK
74	137894-K2-438	EA	LUMBER - VINYL WRAPPED - .7" X 3.9" X 96" - PORTSMOUTH OAK
74	137894-R2-438	EA	LUMBER - VINYL WRAPPED - .7" X 3" X 96" - PORTSMOUTH OAK
74	146419-A2-438	EA	LUMBER - VINYL WRAPPED - .7" X .75" X 96" - HONEY CHERRY
74	146419-D2-438	EA	LUMBER - VINYL WRAPPED - .7" X 1.5" X 96" - HONEY CHERRY
74	146419-E2-438	EA	LUMBER - VINYL WRAPPED - .7" X 2" X 96" - HONEY CHERRY
74	146419-F2-438	EA	LUMBER - VINYL WRAPPED - .7" X 2.5" X 96" - HONEY CHERRY
74	146419-G2-438	EA	LUMBER - VINYL WRAPPED - .7" X 3" X 96" - HONEY CHERRY
74	146419-H2-438	EA	LUMBER - VINYL WRAPPED - .7" X 3.5" X 96" - HONEY CHERRY
74	146419-J2-438	EA	LUMBER - VINYL WRAPPED - .7" X 5.5" X 96" - HONEY CHERRY
74	146419-J2-743	EA	LUMBER - VINYL WRAPPED - .7" X 5.5" X 108" - HONEY CHERRY
74	146419-K2-438	EA	LUMBER - VINYL WRAPPED - .7" X 3.9" X 96" - HONEY CHERRY
74	146419-R2-438	EA	LUMBER - VINYL WRAPPED - .7" X 3" X 96" - HONEY CHERRY

INTERIOR FINISH GROUP (CONTINUED)
PANELING & LAMINATES

KEY	PART NUMBER	U/M	DESCRIPTION
	000885-A5-000	SF	PARTICLE BOARD - 3/8" X 4' X 8'- WHT PEB EMBOSSED-1 SIDED
	000885-96-000	SF	PARTICLE BOARD - 3/8" X 4' X 8' - SALEM CHERRY - 1 SIDED - CONCERT CHERRY FROM: 00-00-00 THRU: 10-19-03
	000885-B9-000	SF	PARTICLE BOARD - 3/8" X 4' X 8' - NEW CONCERT CHERRY - 1 SIDED - CONCERT CHERRY FROM: 10-20-03 THRU: 99-99-99
	000885-A3-000	SF	PARTICLE BOARD - 3/4" X 4' X 8' - SALEM CHERRY - 2 SIDED - CONCERT CHERRY FROM: 00-00-00 THRU: 10-19-03
	000885-C0-000	SF	PARTICLE BOARD - 3/4" X 4' X 8'- NEW CONC CHERRY - 2 SIDED - CONCERT CHERRY FROM: 10-20-03 THRU: 99-99-99
	000885-98-000	SF	PARTICLE BOARD - 3/8" X 4' X 8' - SALEM CHERRY - 2 SIDED - CONCERT CHERRY FROM: 00-00-00 THRU: 10-19-03
	000885-B8-000	SF	PARTICLE BOARD - 3/8" X 4' X 8'- NEW CONC CHERRY - 2 SIDED - CONCERT CHERRY FROM: 10-20-03 THRU: 99-99-99
	000885-A1-000	SF	PARTICLE BOARD - 1/2" X 4' X 8' - SALEM CHERRY - 2 SIDED - CONCERT CHERRY FROM: 00-00-00 THRU: 10-19-03
	000885-C1-000	SF	PARTICLE BOARD - 1/2" X 4' X 8'- NEW CONC CHERRY - 2 SIDED - CONCERT CHERRY FROM: 10-20-03 THRU: 99-99-99
	000885-92-000	SF	PARTICLE BOARD-3/8" X 4' X 8'-PORTSMOUTH OAK-VINYL 1 SIDED - PORTSMOUTH OAK
	000885-93-000	SF	PARTICLE BOARD - 3/8" X 4' X 8' - PORTSMOUTH OAK - 2-SIDED - PORTSMOUTH OAK
	000885-94-000	SF	PARTICLE BOARD - 1/2" X 4' X 8' - PORTSMOUTH OAK - 2 SIDED - PORTSMOUTH OAK
	000885-95-000	SF	PARTICLE BOARD - 3/4" X 4' X 8' - PORTSMOUTH OAK - 2-SIDED - PORTSMOUTH OAK
	000885-88-000	SF	PARTICLE BOARD - 3/8" X 4' X 8' - WASHED MAPLE - 1-SIDED - WASHED MAPLE FROM: 00-00-00 THRU: 01-04-04
	000885-B5-000	SF	PARTICLE BOARD - 3/8" X 4' X 8'- NEAT/WASHED MPL - 1 SIDED - WASHED MAPLE FROM: 01-05-04 THRU: 99-99-99
	000885-89-000	SF	PARTICLE BOARD - 3/8" X 4' X 8' - WASHED MAPLE - 2-SIDED - WASHED MAPLE FROM: 00-00-00 THRU: 01-04-04
	000885-B4-000	SF	PARTICLE BOARD - 3/8" X 4' X 8'- NEAT/WASHED MPL - 2 SIDED - WASHED MAPLE FROM: 01-05-04 THRU: 99-99-99
	000885-91-000	SF	PARTICLE BOARD - 3/4" X 4' X 8' - WASHED MAPLE - 2-SIDED - WASHED MAPLE FROM: 00-00-00 THRU: 01-04-04
	000885-B6-000	SF	PARTICLE BOARD - 3/4" X 4' X 8'- NEAT/WASHED MPL - 2 SIDED - WASHED MAPLE FROM: 01-05-04 THRU: 99-99-99
	000885-90-000	SF	PARTICLE BOARD - 1/2" X 4' X 8' - WASHED MAPLE - 2 SIDED - WASHED MAPLE FROM: 00-00-00 THRU: 01-04-04
	000885-B7-000	SF	PARTICLE BOARD - 1/2" X 4' X 8'- NEAT/WASHED MPL - 2 SIDED - WASHED MAPLE FROM: 01-05-04 THRU: 99-99-99
	057882-04-000	SF	TAMBOUR - 48" X 96" SHEET - UNFINISHED - PORTSMOUTH OAK
	057882-06-000	SF	TAMBOUR - 48" X 96" - SHEET - CONCERT CHERRY
	057882-05-000	SF	TAMBOUR - 48" X 96" - SHEET - UNFINISHED - WASHED MAPLE
	074497-43-000	SF	PANELING - SALEM CHERRY - 4' X 8' - CONCERT CHERRY FROM: 00-00-00 THRU: 10-19-03
	074497-50-000	SF	PANELING/PAPER WRAP - NEW CONCERT CHERRY - 1/8" X 4' X 8' - CONCERT CHERRY FROM: 10-20-03 THRU: 99-99-99
	074497-42-000	SF	PANELING - PORTSMOUTH OAK - 4' X 8' - PORTSMOUTH OAK
	074497-39-000	SF	PANELING - WASHED MAPLE - 4' X 8' - WASHED MAPLE FROM: 00-00-00 THRU: 01-04-04
	074497-49-000	SF	PANELING/PAPER WRAPPED - NEAT/WASHED MAPLE- 1/8" X 4' X 8' - WASHED MAPLE FROM: 01-05-04 THRU: 99-99-99
	079666-03-000	SF	PANELING - CLOSET - CEDAR - 4' X 7'
	074498-40-000	SF	LAMINATE - PLASTIC - OFF WHITE - 4' X 8'
	074498-97-000	SF	LAMINATE - PLASTIC - GRAY TRANQUILITY - 4' X 8' (R74,R75,R76)
	074498-A1-000	SF	LAMINATE - PLASTIC - LINO FRIEZE - 5' X 8' (R77,R78,R79)
	074498-A0-000	SF	LAMINATE - PLASTIC - ROCKY MOUNTAIN HIGH - 4' X 8' (R80,R81,R82)
	074498-96-000	SF	LAMINATE - PLASTIC - CHERRY - 4' X 8' - CONCERT CHERRY
	074498-95-000	SF	LAMINATE - PLASTIC - PORTSMOUTH OAK - 4' X 8' - PORTSMOUTH OAK
	074498-82-000	SF	LAMINATE - PLASTIC - WASHED MAPLE - 4' X 8' - WASHED MAPLE FROM: 00-00-00 THRU: 01-04-04
	074498-A6-000	SF	LAMINATE - PLASTIC - HARDROCK MAPLE - 5' X 8' - WASHED MAPLE FROM: 01-05-04 THRU: 99-99-99
	076325-73-000	FT	MOLDING - EDGE BAND - .93" X .024" - OFF WHITE

INTERIOR FINISH GROUP (CONTINUED)
PANELING & LAMINATES (CONTINUED)

KEY	PART NUMBER	U/M	DESCRIPTION
	088272-H9-000	SF	PANELING - PEBBLE EMBOSSED - WHITE - 4' X 7'
	088272-K5-000	SF	PANELING - SILVERADO - 4' X 7' (R74,R75,R76)
	088272-K4-000	SF	PANELING - MULTI - 4' X 7' (R77,R78,R79)
	088272-K1-000	SF	PANELING - GRAY - 4' X 7' (R80,R81,R82)
	076773-16-000	SF	PANELING - 2 SIDED/SALEM CHERRY - 1/8" X 4' X 8' - CONCERT CHERRY FROM: 00-00-00 THRU: 10-19-03
	076773-21-000	SF	PANELING/PAPER WRAP 2 SIDED/NEW CONC CHERRY-1/8" X 4' X 8' - CONCERT CHERRY FROM: 10-20-03 THRU: 99-99-99
	076773-15-000	SF	PANELING - 2 SIDED/PORTSMOUTH OAK - 1/8" X 4' X 8' - PORTSMOUTH OAK
	080215-14-000	SF	PANELING - 2 SIDED/PORTSMOUTH OAK - 3/16" X 4' X 8' - PORTSMOUTH OAK
	080215-15-000	SF	PANELING - 2 SIDED/SALEM CHERRY - 3/16" X 4' X 8' - CONCERT CHERRY FROM: 00-00-00 THRU: 10-19-03
	080215-17-000	SF	PANELING-PAPER WRAP - 2 SIDED/N CON CHERRY-3/16" X 4' X 8' - CONCERT CHERRY FROM: 10-20-03 THRU: 99-99-99
	076773-14-000	SF	PANELING - 2 SIDED/WASHED MAPLE - 1/8" X 4' X 8' - WASHED MAPLE FROM: 00-00-00 THRU: 01-04-04
	076773-20-000	SF	PANELING - 2 SIDED/NEAT/WASHED MAPLE - 1/8" X 4' X 8' - WASHED MAPLE FROM: 01-05-04 THRU: 99-99-99
	088263-H4-000	EA	BATT STRIP - DECORATIVE - SILVERADO - 8' (R74,R75,R76)
	088263-H2-000	EA	BATT STRIP - DECORATIVE - MULTI - 8' (R77,R78,R79)
	088263-H0-000	EA	BATT STRIP - DECORATIVE - VILLA/GRAY - 8' LONG (R80,R81,R82)
	085284-H8-000	FT	BATT TAPE - ADHESIVE BACKED - DECORATIVE - SILVERADO (R74,R75,R76)
	085284-H6-000	FT	BATT TAPE - ADHESIVE BACKED - DECORATIVE - MULTI (R77,R78,R79)
	085284-H1-000	FT	BATT TAPE - ADHESIVE BACKED - DECORATIVE - GRAY (R80,R81,R82)
	126339-01-000	SF	BOARD - WHEAT - 60" X 72"
	132610-05-08A	FT	WALLPAPER - BORDER - 7" - SELF-ADHESIVE (R74,R75,R76)
	132610-05-23A	FT	WALLPAPER - BORDER - 7" - SELF-ADHESIVE (R77,R78,R79)
	132610-05-07A	FT	WALLPAPER - BORDER - 7" - SELF-ADHESIVE (R80,R81,R82)

INTERIOR FINISH GROUP (CONTINUED)
ACCESSORIES

KEY	PART NUMBER	U/M	DESCRIPTION
	072852-01-000	EA	DETECTOR - SMOKE - W/9 VOLT BATTERY - US
	072852-02-000	EA	DETECTOR - SMOKE - W/9 VOLT BATTERY - CANADIAN
	125136-02-000	EA	DETECTOR/CO - GAS MODEL - 9 VOLT
	094499-03-000	EA	EXTINGUISHER/FIRE - DRY - 10BC - W/GAUGE/BRACKET
*	094499-02-000	EA	EXTINGUISHER/FIRE - DRY - 10BC - W/GAUGE - CANADIAN
	094499-04-000	EA	STRAP - FIRE EXTINGUISHER MOUNTING - METAL
	131493-02-11A	EA	PICTURE - DECORATIVE - 13" X 15" - RHODODENDRON (R74,R75,R76,R80)
	131493-02-14A	EA	PICTURE - DECORATIVE - 13" X 15" - WINTER WHITE (R77,R78,R79,R81,R82)
			P32T (R74,R75,R76)
	131493-02-17A	EA	PICTURE - DECORATIVE - 13" X 15" - ORCHIDS FROM: 00-00-00 THRU: 11-02-03
	131493-02-14A	EA	PICTURE - DECORATIVE - 13" X 15" - WINTER WHITE FROM: 11-03-03 THRU: 03-29-04
	131493-02-09A	EA	PICTURE - DECORATIVE - 13" X 15" - MEDITERRANEAN FROM: 03-30-04 THRU: 99-99-99
	131493-02-11A	EA	PICTURE - DECORATIVE - 13" X 15" - RHODODENDRON FROM: 00-00-00 THRU: 09-07-03
	131493-02-06A	EA	PICTURE - DECORATIVE - 13" X 15" - TOPAZ BOTANICAL FROM: 09-08-03 THRU: 11-16-03
	131493-02-29A	EA	PICTURE - DECORATIVE - 13" X 15" - GINGER JAR FROM: 11-17-03 THRU: 99-99-99
			P32T (R77,R78,R79,R80,R80,R81)
	131493-02-17A	EA	PICTURE - DECORATIVE - 13" X 15" - ORCHIDS FROM: 00-00-00 THRU: 11-02-03
	131493-02-14A	EA	PICTURE - DECORATIVE - 13" X 15" - WINTER WHITE FROM: 11-03-03 THRU: 99-99-99
	131493-02-09A	EA	PICTURE - DECORATIVE - 13" X 15" - MEDITERRANEAN FROM: 03-30-04 THRU: 99-99-99
			P34H (R74,R75,R76)
	131493-02-11A	EA	PICTURE - DECORATIVE - 13" X 15" - RHODODENDRON FROM: 00-00-00 THRU: 09-07-03
	131493-02-06A	EA	PICTURE - DECORATIVE - 13" X 15" - TOPAZ BOTANICAL FROM: 09-08-03 THRU: 11-16-03
	131493-02-29A	EA	PICTURE - DECORATIVE - 13" X 15" - GINGER JAR FROM: 11-17-03 THRU: 99-99-99
			P34H (R77,R78,R79,R80,R80,R81)
	131493-02-14A	EA	PICTURE - DECORATIVE - 13" X 15" - WINTER WHITE
			P39W (R74,R75,R76)
	131493-02-11A	EA	PICTURE - DECORATIVE - 13" X 15" - RHODODENDRON FROM: 00-00-00 THRU: 09-07-03
	131493-02-06A	EA	PICTURE - DECORATIVE - 13" X 15" - TOPAZ BOTANICAL FROM: 09-08-03 THRU: 11-16-03
	131493-02-29A	EA	PICTURE - DECORATIVE - 13" X 15" - GINGER JAR FROM: 11-17-03 THRU: 99-99-99
			P39W (R77,R78,R79,R80,R80,R81)
	131493-02-14A	EA	PICTURE - DECORATIVE - 13" X 15" - WINTER WHITE

INTERIOR FINISH GROUP (CONTINUED)
ACCESSORIES (CONTINUED)

KEY	PART NUMBER	U/M	DESCRIPTION
	133485-01-03A	EA	MIRROR - BEVELED GLASS - W/VERTICAL GROOVE - 20" X 20.9" FROM: 00-00-00 THRU: 04-27-03
	147282-01-01A	EA	MIRROR - BEVELED W/V-GROOVES - 10" X 21" FROM: 04-28-03 THRU: 99-99-99
	133485-02-03A	EA	MIRROR - BEVELED GLASS W/2 VERTICAL GROOVES - 44.9"X 20.9" FROM: 00-00-00 THRU: 04-27-03
	147282-02-01A	EA	MIRROR - BEVELED W/V-GROOVES - 44.4" X 21" FROM: 04-28-03 THRU: 99-99-99
	133485-03-03A	EA	MIRROR - BEVELED GLASS-W/2 VERTICAL GROOVES - 30" X 20.9" FROM: 00-00-00 THRU: 04-27-03
	147282-03-01A	EA	MIRROR - BEVELED W/V-GROOVES - 30" X 21" FROM: 04-28-03 THRU: 99-99-99
	133485-03-03A	EA	MIRROR - BEVELED GLASS-W/2 VERTICAL GROOVES - 30" X 20.9"
	093606-43-000	EA	MIRROR - BEVELED EDGE - 7.4" X 12.8"
	131494-03-01A	EA	MIRROR - BEVELED/GLASS - OCTAGON - 1" X 20" X 36"
	113195-25-01A	EA	MIRROR - BEVELED SAFETY GLASS - 15.7" X 31.4"
	140374-36-000	EA	MIRROR - SAFETY GLASS - 20.9" X 25.2" FROM: 00-00-00 THRU: 09-21-03
	140374-66-000	EA	MIRROR - SAFETY GLASS - 20.1" X 25.2" FROM: 09-22-03 THRU: 99-99-99
	140374-30-000	EA	MIRROR - SAFETY GLASS - 25.6" X 31.5"
	142631-01-03A	EA	FRAME - MIRROR - 29.5"H X 25.2"W - PORTSMOUTH OAK FROM: 00-00-00 THRU: 09-21-03
	142631-03-03A	EA	FRAME - MIRROR - 29.5"H X 24.4"W - PORTSMOUTH OAK FROM: 09-22-03 THRU: 99-99-99
	142631-01-01A	EA	FRAME - MIRROR - 29.5"H X 25.2"W - CONCERT CHERRY FROM: 00-00-00 THRU: 09-21-03
	142631-03-01A	EA	FRAME - MIRROR - 29.5"H X 24.4"W - CONCERT CHERRY FROM: 09-22-03 THRU: 99-99-99
	142631-01-02A	EA	FRAME - MIRROR - 29.5"H X 25.2"W - WASHED MAPLE FROM: 00-00-00 THRU: 09-21-03
	142631-03-02A	EA	FRAME - MIRROR - 29.5"H X 24.4"W - WASHED MAPLE FROM: 09-22-03 THRU: 99-99-99
	142631-02-03A	EA	FRAME - MIRROR - 35.8"H X 29.9"W - PORTSMOUTH OAK
	142631-02-01A	EA	FRAME - MIRROR - 35.8"H X 29.9"W - CONCERT CHERRY
	142631-02-02A	EA	FRAME - MIRROR - 35.8"H X 29.9"W - WASHED MAPLE
	096764-02-000	FT	SLIPNOT - ANTISLIP - 1'WIDE (180' ROLLS) - WHITE
	091261-01-000	FT	SLIPNOT - ANTISLIP - 1' WIDE X 12' - BLACK
	118718-01-01A	EA	HOLDER/DRINK - COLLAPSIBLE MUG - BLACK PLASTIC
	133831-01-01A	EA	HOLDER - CUP W/THREE CENTERLINE RUBBER FINGERS
	132738-01-01A	EA	CLOCK - DIGITAL W/ALARM - 12 VOLT - BLACK

***COMPONENT PARTS LISTED LATER IN THIS GROUP**

INTERIOR FINISH GROUP (CONTINUED)
COMPONENT PARTS FOR ACCESSORIES

094499-02-000

KEY	PART NUMBER	U/M	DESCRIPTION	VENDOR NO
	094499-01-700	EA	BRACKET MTG. W/PLAS. STRAP	294039

INTERIOR FINISH GROUP (CONTINUED)
FLOOR COVERINGS

KEY	PART NUMBER	U/M	DESCRIPTION
	075233-01-000	SY	PAD - CARPET - 3/8" X 6' ROLL
	093486-01-000	SY	CARPET - COMPARTMENT - 72" WIDE - DARK GRAY
	096060-G8-000	SY	CARPET - CAMEL - INCREMENTS OF 4 SQ YARDS (R74,R75,R76)
	096060-F0-000	SY	CARPET - PALE SAGE - INCREMENTS OF 4 SQ YARDS (R77,R78,R79)
	096060-H1-000	SY	CARPET - TAPIOCA - INCREMENTS OF 4 SQ YARDS (R80,R81,R82)
	096060-H5-000	SY	CARPET - CHARCOAL - INCREMENTS OF 4 SQ YARDS
	096060-K1-000	SY	CARPET - WICKER - INCREMENTS OF 4 SQ YARDS
	096060-J5-000	SY	CARPET - MUSLIN - INCREMENTS OF 4 SQ YDS
	131711-01-07A	EA	TILE/FLOOR - VINYL - 12" X 12"
	136839-01-01A	EA	TRIM-J - CARPET EDGE/SLIDEOUT - 79.5" - BLACK
	136839-03-01A	EA	TRIM-J - CARPET EDGE/SLIDEOUT - 69.6" - BLACK
			FROM: 00-00-00 THRU: 04-18-04
	151282-02-01A	EA	TRIM - CARPET EDGE/F-ANGLE - 69.6" - BLACK
			FROM: 04-19-04 THRU: 99-99-99
	136839-06-01A	EA	TRIM-J - CARPET EDGE/SLIDEOUT - 62.7" - BLACK
	136839-07-01A	EA	TRIM-J - CARPET EDGE/SLIDEOUT - 28.3" - BLACK

INTERIOR FINISH GROUP (CONTINUED)

HARDWARE

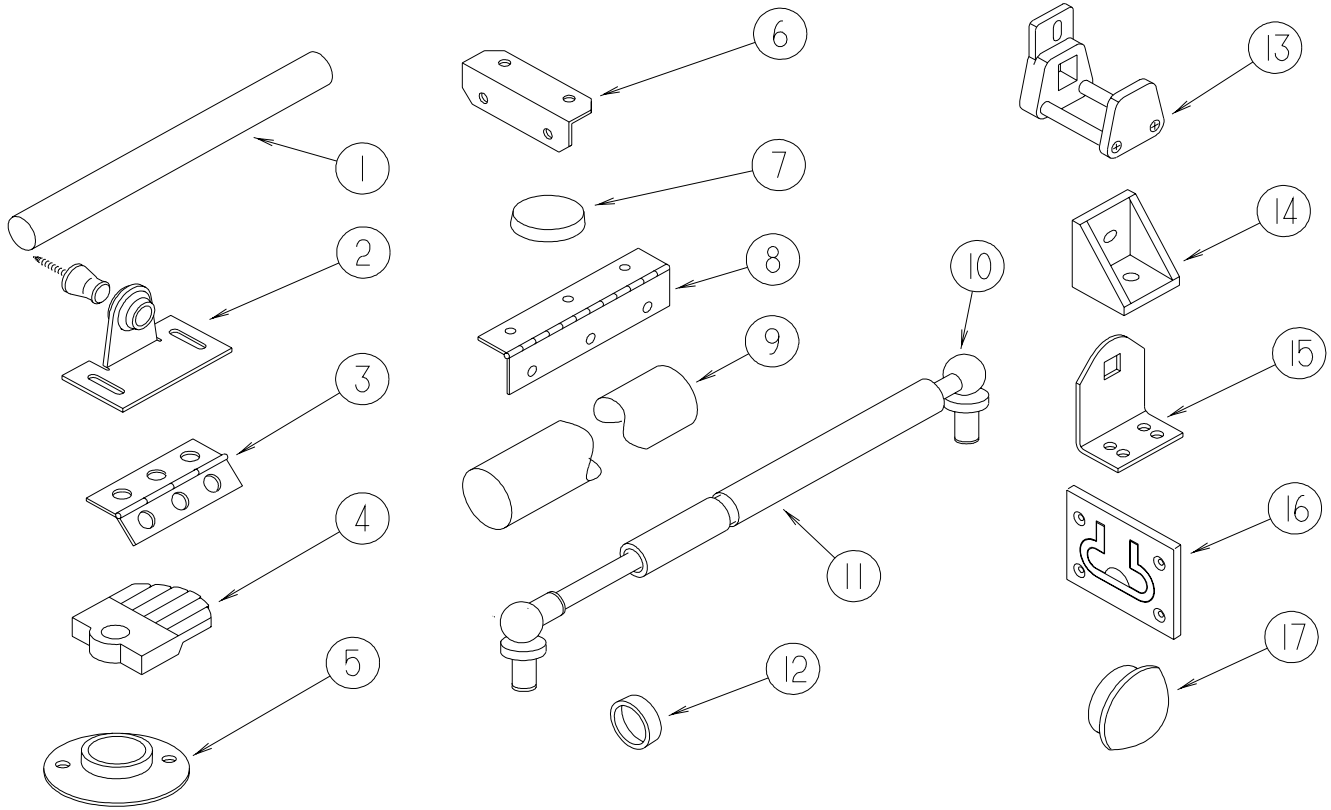

KEY	PART NUMBER	U/M	DESCRIPTION
1	Y00136-21-218	EA	DOWEL - WOOD - 1" X 4'
2	009013-01-000	EA	CATCH - BULLDOG - MALE/FEMALE
3	009059-01-000	EA	HINGE - DOOR - 2" X 1.4" - BRASS
3	009059-02-000	EA	HINGE - DOOR - 2" X 2.7" - BRASS
3	009059-03-000	EA	HINGE - BRASS - 1.75"
3	009059-04-000	EA	HINGE - 2" - ZINC
4	009089-01-000	EA	CLIP - MIRROR
5	009112-01-000	EA	FLANGE - PLASTIC - 1" CLOTHES ROD - OFF WHITE
6	016604-01-000	EA	BRACE - ANGLE - 2 1/2" - UNPAINTED METAL
6	016604-05-000	EA	BRACE - ANGLE - 2 1/2" - OFF WHITE METAL
6	016604-10-000	EA	BRACE - SEAT ANGLE - 2.5" - BLACK
7	023320-01-000	EA	PAD - FELT 3/8" DIAMETER
8	041389-25-000	EA	HINGE - PIANO - 1 1/2" X 55" - UNPAINTED
9	042438-02-000	EA	DOWEL - WOOD - 2" DIAMETER X 2'
10	057460-02-000	EA	BALL STUD - F/GAS SPRING .39" - 5/16"-18
11	057460-04-000	EA	SPRING/GAS - BALL STUD STYLE - 120 PI - "SPD6209"
12	057671-01-000	EA	COVER - SCREW - #8 - OFF WHITE
12	057671-15-000	EA	COVER - SCREW - #8 - BRIGHT WHITE
12	057671-16-000	EA	COVER - SCREW - #8 - SOFT WHITE
12	057671-17-000	EA	COVER - SCREW - VW LT GRAY - #8
13	064467-01-000	EA	GUIDE - POCKET - SLIDING DOOR - WALL MOUNTED
14	065740-01-000	EA	BRACE - CABINET/CORNER - PLASTIC
15	069178-03-000	EA	BRACKET/MOUNTING - ASSIST HANDLE - BRIGHT WHITE
16	072871-01-000	EA	PULL - FLUSH - CHROME
17	074045-08-000	EA	PLUG - OAK - 3/8" DOWEL-1/2" HEAD - SALEM CHERRY - CONCERT CHERRY
17	074045-12-000	EA	PLUG - OAK - 3/8" DOWEL-1/2" HEAD - WASHED MAPLE
17	074045-13-000	EA	PLUG - OAK - 3/8" DOWEL-1/2" HEAD - PORTSMOUTH OAK
17	074045-14-000	EA	PLUG - OAK - 3/8" DOWEL-1/2" HEAD - HONEY CHERRY

INTERIOR FINISH GROUP (CONTINUED)

HARDWARE (CONTINUED)

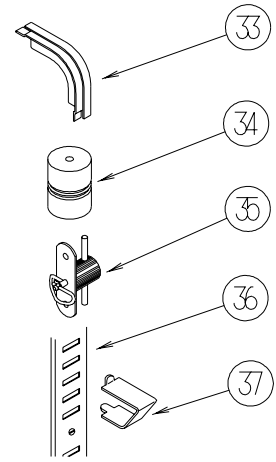
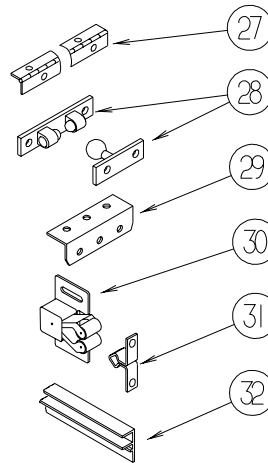
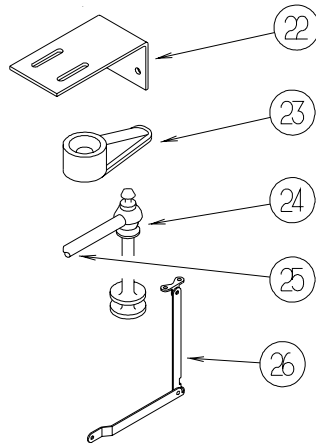
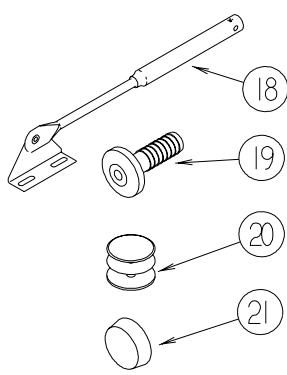

KEY	PART NUMBER	U/M	DESCRIPTION
18	074493-02-000	EA	SUPPORT - PISTON SPRING - CABINET DOOR - 26 LBS
18	074493-03-000	EA	SUPPORT - PISTON SPRING - CABINET DOOR - 12 LBS
19	079921-01-000	EA	ROLLER - NYLON - W/STEEL SHAFT - BARBED
20	081114-02-000	EA	CAP - INSERT - ROUND - 1" DIAMETER - WHITE PLASTIC
21	004354-01-000	EA	BUMPER - RUBBER - 1/2" DIA - BROWN
21	081914-01-000	EA	BUMPER - RUBBER - ROUND - 1/2" DIA. X 1/8" THICK
22	083125-07-000	EA	BRACE - ANGLE/COUCH - 2.5" - OFF WHITE
22	132871-02-02B	EA	BRACKET/L-SHAPED W/HOLES - 1.9" X 2.8" - E-COATED
23	083204-03-000	EA	BUTTON - RETAINING MIRROR 5/16" TIP
24	084070-03-000	EA	POST - END - 2.4" - SHINY BRASS
25	084071-05-000	EA	ROD - BRASS - 15"
25	084071-19-000	EA	ROD - BRASS - 7.1"
25	084071-20-000	EA	ROD - BRASS - 9.8"
25	084071-23-000	EA	ROD - BRASS - 13.1"
25	084071-24-000	EA	ROD - BRASS - 3.8"
25	084071-33-000	EA	ROD - BRASS - 20.4"
25	146840-01-01A	EA	ROD - .25" DIAMETER - BRASS
25	146840-01-02A	EA	ROD - .25" DIAMETER - PEWTER
25	146840-02-01A	EA	ROD - .25" DIAMETER - BRASS
25	146840-02-02A	EA	ROD - .25" DIAMETER - PEWTER
25	146840-03-01A	EA	ROD - .25" DIAMETER - BRASS
25	146840-03-02A	EA	ROD - .25" DIAMETER - PEWTER
25	146840-04-01A	EA	ROD - .25" DIAMETER - BRASS
25	146840-04-02A	EA	ROD - .25" DIAMETER - PEWTER
25	146840-05-01A	EA	ROD - .25" DIAMETER - BRASS
25	146840-05-02A	EA	ROD - .25" DIAMETER - PEWTER
26	084412-01-000	EA	SUPPORT/HINGE KIT (LEFT & RIGHT HINGES)
27	084413-01-000	EA	HINGE - 1" X 72" - ALUMINUM - W/HOLES
28	084451-01-000	EA	CATCH & LATCH - 1.7" - BRASS
29	089025-01-000	EA	SUPPORT - SPRING TO BED - ANGLE 1.5" X 11.8"
30	093586-03-000	EA	CATCH - SPRING ROLLER - .377"
30	093586-06-000	EA	CATCH - SPRING ROLLER - .236"
31	093586-04-000	EA	STRIKE - SPRING STEEL - 1.14"
31	093586-05-000	EA	STRIKE - SPRING STEEL - .943"
32	093622-01-000	EA	TRACK - DOOR - TAMBOUR - PLASTIC - 8' LENGTHS
33	093623-01-000	EA	CORNER - TRACK - TAMBOUR DOOR
34	097872-04-000	EA	DOWEL - WOOD - 1" DIAMETER X 1.38" LONG - UNFINISHED
35	098196-01-000	EA	LATCH - 1/4 TURN - T-BAR
36	098979-01-000	EA	CLIP - ADJUSTABLE SHELF
37	098980-01-000	EA	PILASTER - ADJUSTABLE SHELF - 18"
37	098980-02-000	EA	PILASTER - ADJUSTABLE SHELF - 12"
37	098980-03-000	EA	PILASTER - ADJUSTABLE SHELF - 9"
37	098980-04-000	EA	PILASTER - ADJUSTABLE SHELF - 48"
37	098980-05-000	EA	PILASTER - ADJUSTABLE SHELF - 15"
37	098980-06-000	EA	PILASTER - ADJUSTABLE SHELF - 24"

INTERIOR FINISH GROUP (CONTINUED)
HARDWARE (CONTINUED)

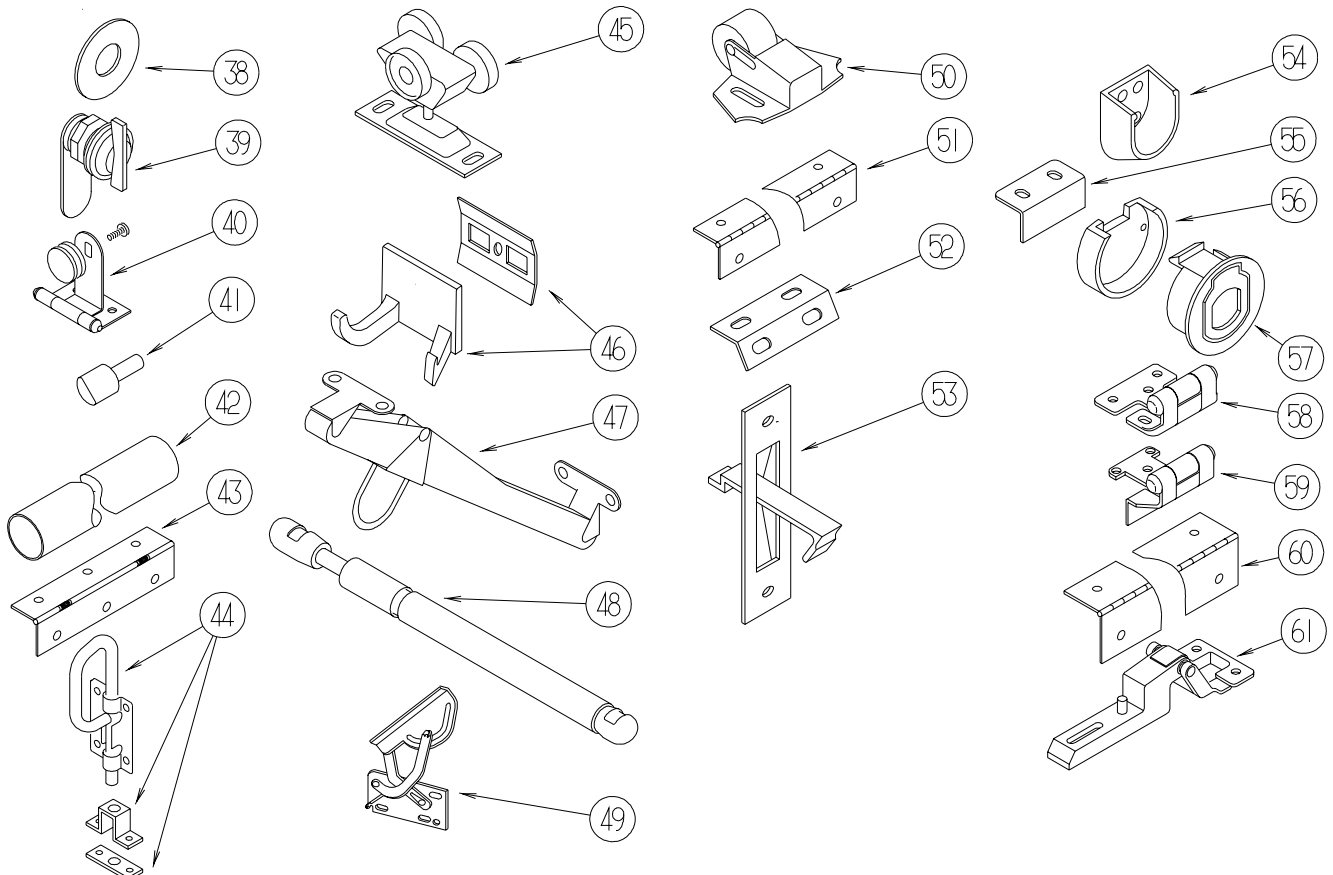

KEY	PART NUMBER	U/M	DESCRIPTION
38	100707-01-000	EA	SPACER - GLASS DOOR - .8" DIA - .3" HOLE - PLASTIC
39	100710-01-01A	EA	LOCK - GLASS DOOR/TWIST TYPE - BRASS
40	100711-01-01A	EA	HINGE - GLASS DOOR
41	101766-01-000	EA	PIN - SUPPORT/GLASS DOOR
42	102075-10-02A	EA	ROD - SHOWER CURTAIN - 1" OD X 46.3" - SOFT WHITE
43	102920-01-01A	EA	HINGE - SPRING LOADED - BRASS
44	103256-01-000	EA	LATCH COMPLETE (SLIDE)
45	103874-01-000	EA	HANGER - SLIDING DOOR
46	104174-01-000	EA	HOOK - ROBE - DOUBLE
47	104181-01-01A	EA	SUPPORT - LEAF 5.3" EXTENDS TO 7.5" - SAFETY RING - METAL
48	142569-15-000	EA	SPRING/GAS - 12" COMPRESSED/20" EXTENDED - 120 LB.
48	142569-16-000	EA	SPRING/GAS - 12" COMPRESSED/20" EXTENDED - 90 LB
48	142569-05-000	EA	SPRING - GAS - 15 LB. - 39.9"
48	142569-18-000	EA	SPRING/GAS - 6.5" COMPRESSED/9.6" EXTENDED - 65 LB.
49	108126-01-000	EA	TRAY HINGE SET (QTY. 2 PER SET)
50	109403-01-000	EA	CATCH - SINGLE ROLLER - SCREEN DOOR
51	110496-01-01A	EA	HINGE - BRASS
52	111866-01-02A	EA	BRACE - SEAT - ANGLE - OFF WHITE
53	113130-01-01A	EA	PULL - DOOR POCKET
54	113236-01-01A	EA	BRACKET - CLOTHES - ROD
55	113375-02-01A	EA	STRIKE - DOOR - CHROME
56	113375-05-01A	EA	LATCH - SLAM - BACK - .8" THICK
57	113375-06-01A	EA	LATCH - SLAM - FACE - .7" THICK
58	113676-01-01A	EA	HINGE - OVERLAY - VARIABLE - BURNISHED BRASS
59	113677-01-01A	EA	HINGE - SELF CLOSING
60	114278-02-000	EA	HINGE - CONTINUOUS - 3" WIDE
61	114443-01-01A	EA	HINGE - CABINET DOOR

INTERIOR FINISH GROUP (CONTINUED)
HARDWARE (CONTINUED)

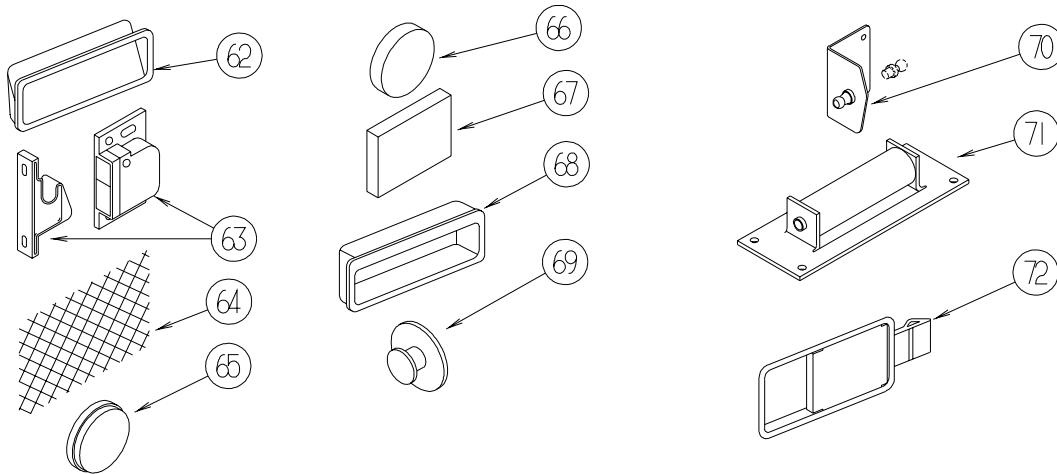

KEY	PART NUMBER	U/M	DESCRIPTION
62	115994-01-01A	EA	HANDLE - POCKET
63	117095-01-01A	EA	LATCH - DOOR - GRABBER W/KEEPER - PLASTIC - BLK-5 LB PULL
63	117095-02-01A	EA	LATCH - DOOR - GRABBER W/KEEPER - PLASTIC - BLK-10 LB PULL
64	118200-01-01A	SF	MESH - PLASTIC 1/2" - 48" X LENGTH = SF - BLACK
65	120760-01-000	EA	RUBBER BUMPER - CLEAR - .1" THICK X .8" DIAMETER
66	122717-01-01A	EA	PAD - NON SKID - 4" DIAMETER ROUND
67	122717-06-01A	FT	PAD - NON-SKID - PSA - 5"W
68	124311-01-01A	EA	HANDLE - RECESSED - BRASS
69	125221-01-01A	EA	PULL - MIRROR - W/ROUND HANDLE
70	126263-06-02B	EA	BRACKET - GAS SPRING W/INSIDE BALL STUD - E-COATED
70	126263-08-02B	EA	BRACKET - GAS SPRING W/CENTERED BALL STUD - E-COATED
71	126584-02-000	EA	ROLLER - FLAT
72	127349-01-01A	EA	LATCH - PADDLE

INTERIOR FINISH GROUP (CONTINUED)
HARDWARE (CONTINUED)

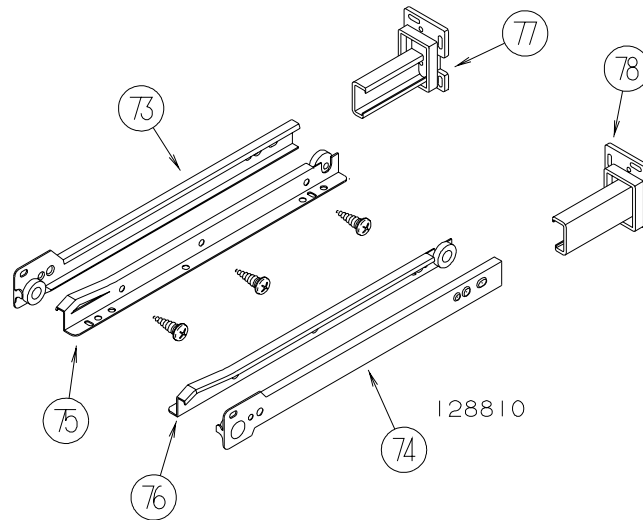

KEY	PART NUMBER	U/M	DESCRIPTION
73	128810-01-01A	EA	SLIDE - DRAWER - 12" - LEFT CABINET
73	128810-05-01A	EA	SLIDE - DRAWER - 14" - LEFT CABINET
73	128810-09-01A	EA	SLIDE - DRAWER - 16" - LEFT CABINET
73	128810-13-01A	EA	SLIDE - DRAWER - 18" - LEFT CABINET
73	128810-17-01A	EA	SLIDE - DRAWER - 20" - LEFT CABINET
73	128810-21-01A	EA	SLIDE - DRAWER - 22" - LEFT CABINET
73	128810-25-01A	EA	SLIDE - DRAWER - 24" - LEFT CABINET
73	128810-29-01A	EA	SLIDE - DRAWER - 9" - LEFT CABINET
74	128810-02-01A	EA	SLIDE - DRAWER - 12" - RIGHT CABINET
74	128810-06-01A	EA	SLIDE - DRAWER - 14" - RIGHT CABINET
74	128810-10-01A	EA	SLIDE - DRAWER - 16" - RIGHT CABINET
74	128810-14-01A	EA	SLIDE - DRAWER - 18" - RIGHT CABINET
74	128810-18-01A	EA	SLIDE - DRAWER - 20" - RIGHT CABINET
74	128810-22-01A	EA	SLIDE - DRAWER - 22" - RIGHT CABINET
74	128810-26-01A	EA	SLIDE - DRAWER - 24" - RIGHT CABINET
74	128810-30-01A	EA	SLIDE - DRAWER - 9" - RIGHT CABINET
75	128810-03-01A	EA	SLIDE - DRAWER - 12" - LEFT DRAWER
75	128810-07-01A	EA	SLIDE - DRAWER - 14" - LEFT DRAWER
75	128810-11-01A	EA	SLIDE - DRAWER - 16" - LEFT DRAWER
75	128810-15-01A	EA	SLIDE - DRAWER - 18" - LEFT DRAWER
75	128810-19-01A	EA	SLIDE - DRAWER - 20" - LEFT DRAWER
75	128810-23-01A	EA	SLIDE - DRAWER - 22" - LEFT DRAWER
75	128810-27-01A	EA	SLIDE - DRAWER - 24" - LEFT DRAWER
75	128810-27-01A	EA	SLIDE - DRAWER - 24" - LEFT DRAWER
75	128810-31-01A	EA	SLIDE - DRAWER - 9" - LEFT DRAWER
76	128810-04-01A	EA	SLIDE - DRAWER - 12" - RIGHT DRAWER
76	128810-08-01A	EA	SLIDE - DRAWER - 14" - RIGHT DRAWER
76	128810-12-01A	EA	SLIDE - DRAWER - 16" - RIGHT DRAWER
76	128810-16-01A	EA	SLIDE - DRAWER - 18" - RIGHT DRAWER
76	128810-20-01A	EA	SLIDE - DRAWER - 20" - RIGHT DRAWER
76	128810-24-01A	EA	SLIDE - DRAWER - 22" - RIGHT DRAWER
76	128810-28-01A	EA	SLIDE - DRAWER - 24" - RIGHT DRAWER
76	128810-32-01A	EA	SLIDE - DRAWER - 9" - RIGHT DRAWER
77	128811-01-02A	EA	BACKSOCKET - ADJUSTABLE - LEFT
78	128811-02-02A	EA	BACKSOCKET - ADJUSTABLE - RIGHT

INTERIOR FINISH GROUP (CONTINUED) HARDWARE (CONTINUED)

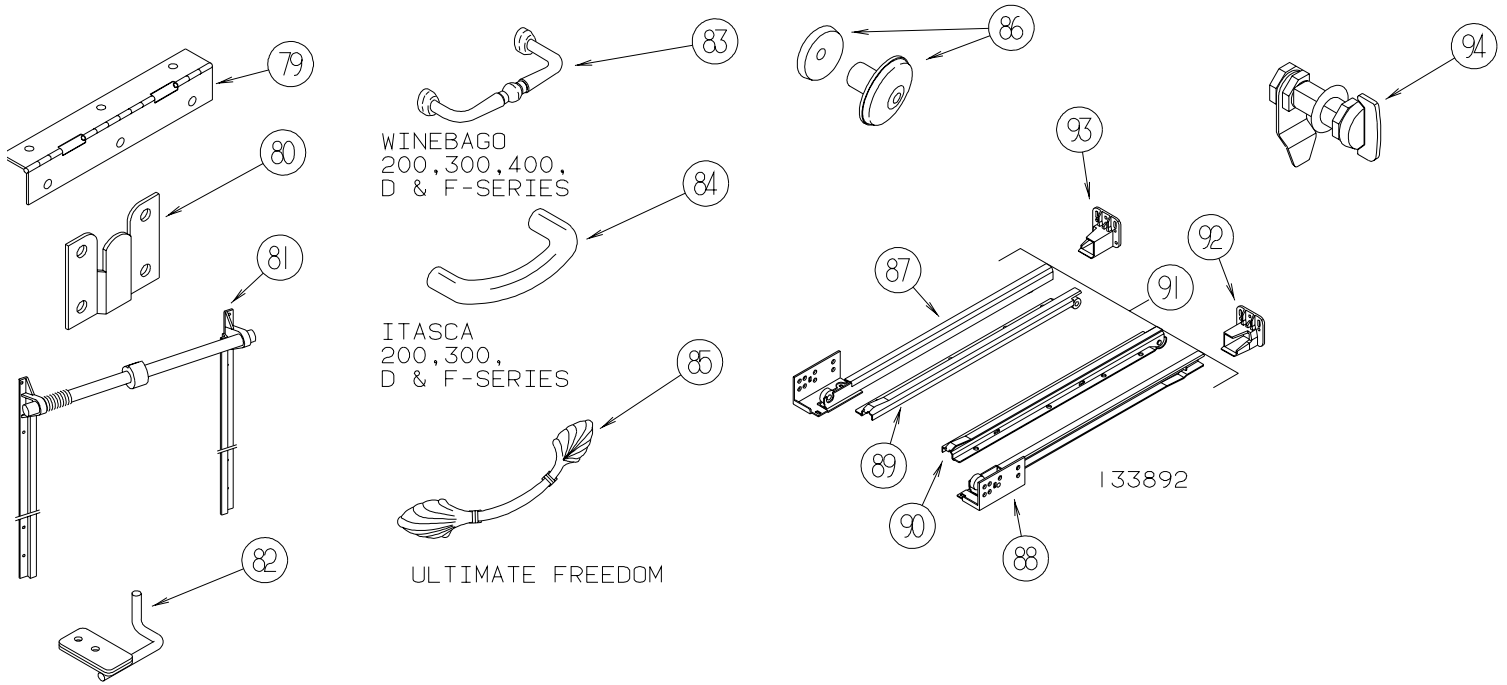

KEY	PART NUMBER	U/M	DESCRIPTION
79	129753-01-01A	EA	HINGE - SPRING LOADED - 19" X 19" - BLACK
80	130120-01-01A	EA	BRACKET - MIRROR
81	130787-02-000	EA	TRACK - TAMBOUR DOOR/SPRING - 24"
81	130787-04-000	EA	TRACK - TAMBOUR DOOR - SPRING
82	130798-01-02B	EA	GUIDE - POCKET DOOR - E-COATED
83	131963-01-01A	EA	PULL - POLISHED BRASS - WINNEBAGO VISTA/MINNIE/MINNIE WINNIE/SIGHTSEER & BRAVE
84	131964-01-01A	EA	PULL - POLISHED BRASS - ITASCA SUNSTAR/SPIRIT/SUNOVA & SUNRISE
85	131965-01-01A	EA	PULL - DOOR/DRAWER - 6.3" - BURNISHED BRASS - ULTIMATE FREEDOM
86	133313-01-02A	EA	PULL - DOOR/DRAWER - BRIGHT BRASS
86	133313-01-03A	EA	PULL - DOOR/DWR - CHROME/BRASS - ITASCA SUNDANCER/SUNCRUISER/SUNFLYER/MERIDIAN
87	133892-01-01A	EA	SLIDE - DRAWER - 16" - LEFT CABINET
87	133892-06-01A	EA	SLIDE - DRAWER - 22" - LEFT CABINET
87	133892-10-01A	EA	SLIDE - DRAWER - 12" - LEFT CABINET
87	133892-14-01A	EA	SLIDE - DRAWER - 18" - LEFT CABINET
88	133892-02-01A	EA	SLIDE - DRAWER - 16" - RIGHT CABINET
88	133892-07-01A	EA	SLIDE - DRAWER - 22" - RIGHT CABINET
88	133892-11-01A	EA	SLIDE - DRAWER - 12" - RIGHT CABINET
88	133892-15-01A	EA	SLIDE - DRAWER - 18" - RIGHT CABINET
89	133892-03-01A	EA	SLIDE - DRAWER - 16" - LEFT DRAWER
89	133892-08-01A	EA	SLIDE - DRAWER - 22" - LEFT DRAWER
89	133892-12-01A	EA	SLIDE - DRAWER - 12" - LEFT DRAWER
89	133892-16-01A	EA	SLIDE - DRAWER - 18" - LEFT DRAWER
90	133892-04-01A	EA	SLIDE - DRAWER - 16" - RIGHT DRAWER
90	133892-09-01A	EA	SLIDE - DRAWER - 22" - RIGHT DRAWER
90	133892-13-01A	EA	SLIDE - DRAWER - 12" - RIGHT DRAWER
90	133892-17-01A	EA	SLIDE - DRAWER - 18" - RIGHT DRAWER
91	133892-05-01A	EA	SLIDE - DRAWER - 9" - FULL SET
92	133907-01-01A	EA	BACKSOCKET - RIGHT HAND
93	133907-02-01A	EA	BACKSOCKET - LEFT HAND
94	135231-01-01A	EA	LATCH - COMPRESSION - BLACK

INTERIOR FINISH GROUP (CONTINUED) HARDWARE (CONTINUED)

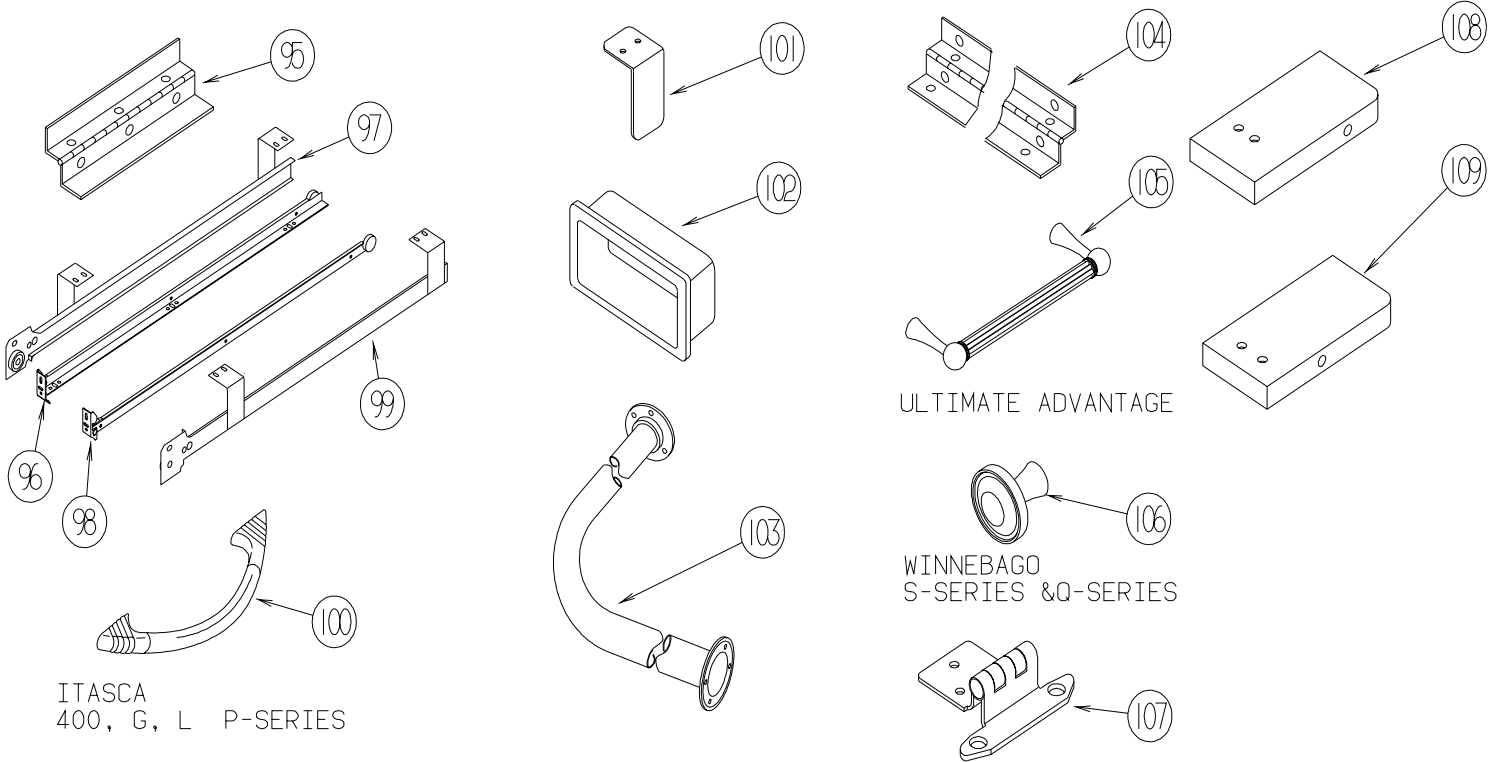

KEY	PART NUMBER	U/M	DESCRIPTION
95	135538-01-01A	EA	HINGE - PIANO - FULL WRAP - BRASS PLATED
95	135538-03-01A	EA	HINGE - PIANO - FULL WRAP - STOCKER BRASS
95	135538-06-01A	EA	HINGE - PIANO - FULL WRAP
96	136944-01-01A	EA	SLIDE - DRAWER/RIGHT HAND - 13.8"
97	136944-02-01A	EA	SLIDE - CABINET/RIGHT HAND - 13.8"
98	136944-03-01A	EA	SLIDE - DRAWER/LEFT HAND - 13.8"
99	136944-04-01A	EA	SLIDE - CABINET/LEFT HAND - 13.8"
100	137446-01-01A	EA	PULL - CABINET - CHROME/BRASS - ITASCA SUNDANCE/SUNCRUISER/SUNFLYER & MERIDIAN
101	138136-02-02B	EA	GUIDE - DOOR - E-COATED
102	139136-01-01A	EA	HANDLE - RECESSED - BRASS
102	139136-02-01A	EA	HANDLE - RECESSED - BRASS
102	139136-02-02A	EA	HANDLE - RECESSED - PEWTER
103	140494-01-01A	EA	ROD - SHOWER
103	140494-01-02A	EA	ROD - SHOWER - SOFT WHITE
104	142276-01-01A	EA	HINGE - PIANO - FULL WRAP - BRASS
105	142909-01-01A	EA	PULL - CABINET - BRASS - ULTIMATE ADVANTAGE
106	142910-01-01A	EA	KNOB - CABINET - BRASS - WINNEBAGO VECTRA & ULTIMATE ADVANTAGE
107	143468-01-01A	EA	HINGE - SELF CLOSING - BURNISHED BRASS - ULTIMATE FREEDOM
107	143468-01-02A	EA	HINGE - SELF CLOSING - POLISHED BRASS
107	143468-02-02A	EA	HINGE - SELF CLOSING - POLISHED BRASS
107	143468-02-03A	EA	HINGE - SELF CLOSING - SATIN NICKEL - ITASCA SUNFLYER, L-SERIES
107	146553-01-02A	EA	HINGE - CABINET DOOR - BRIGHT BRASS
107	146553-01-03A	EA	HINGE - CABINET DOOR - SATIN NICKEL
108	137445-01-N42	EA	STOP - F/SLIDING DOOR
108	137445-01-P46	EA	STOP - F/SLIDING DOOR
108	137445-01-P56	EA	STOP - F/SLIDING DOOR
109	137445-02-P45	EA	STOP - F/SLIDING DOOR
109	137445-02-P46	EA	STOP - F/SLIDING DOOR
109	137445-02-P56	EA	STOP - F/SLIDING DOOR

INTERIOR FINISH GROUP (CONTINUED)
HARDWARE (CONTINUED)

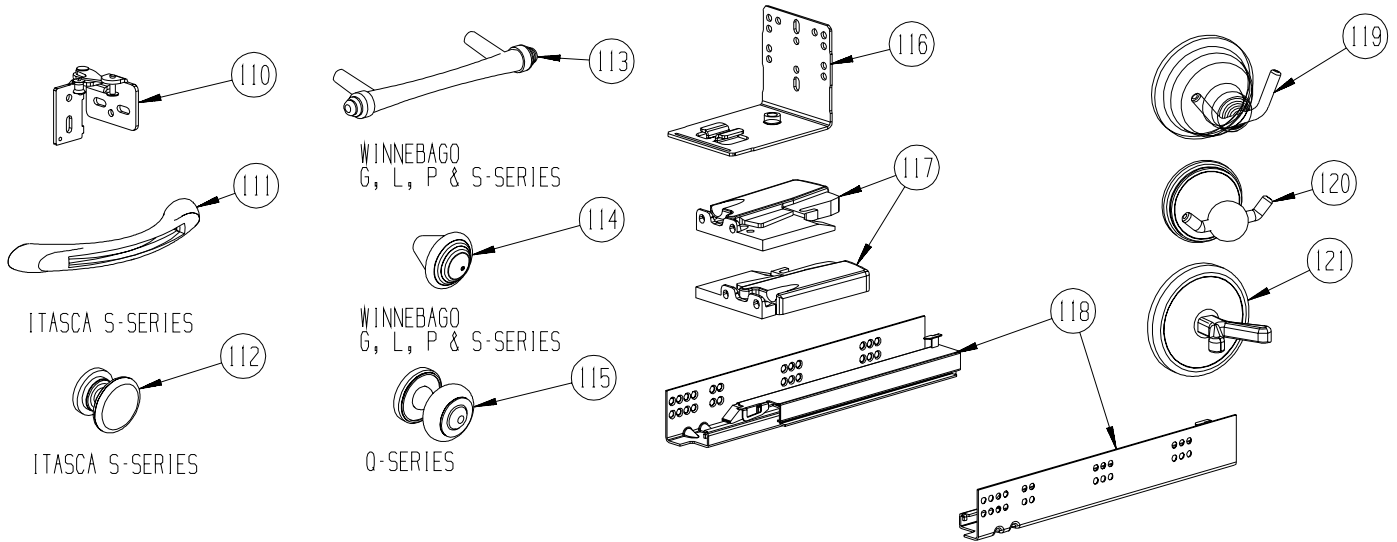

KEY	PART NUMBER	U/M	DESCRIPTION
110	144488-01-01A	EA	HINGE - CABINET - ANTIQUE BRASS
110	144488-01-02A	EA	HINGE - CABINET - NICKEL - ITASCA HORIZON
111	144917-01-01A	EA	PULL - DRAWER - SATIN NICKEL - ITASCA HORIZON
112	144918-01-01A	EA	PULL - DRAWER/KNOB - SATIN NICKEL - ITASCA HORIZON
113	145172-01-01A	EA	PULL - CABINET DOOR - WINNEBAGO ADVENTURER/CHEFTAIN/JOURNEY & VECTRA
114	145172-02-01A	EA	PULL - DRAWER/DNOB - WINNEBAGO ADVENTURER/CHEFTAIN & JOURNEY
115	145180-01-01A	EA	KNOB - CABINET DOOR - ULTIMATE FREEDOM
116	145739-01-000	EA	BRACKET - REAR MOUNT
117	145739-02-000	EA	LOCKING MECHANISM - LEFT
117	145739-03-000	EA	LOCKING MECHANISM - RIGHT
118	145739-04-000	EA	SLIDE - DRAWER - 12"
119	145849-01-01A	EA	ROBE HOOK - TWIN - BRASS
119	145849-02-01A	EA	ROBE HOOK - TWIN - CHROME
120	145849-03-01A	EA	ROBE HOOK - TWIN - BRASS
121	145849-04-01A	EA	ROBE HOOK - TWIN - CHROME/BRASS

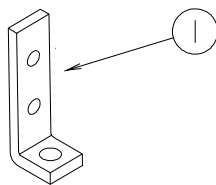

KEY	PART NUMBER	U/M	DESCRIPTION
1	096826-01-01A	EA	BRACE-CABINET E-COATED

LABELS GROUP

SEWAGE

KEY PART NUMBER U/M DESCRIPTION
006187-01-000 EA LABEL - SEWAGE

WASTE WATER

KEY PART NUMBER U/M DESCRIPTION
006188-01-000 EA LABEL - WASTE WATER

WARNING

THIS SYSTEM IS DESIGNED FOR USE WITH PROPANE ONLY
DO NOT CONNECT NATURAL GAS TO THIS SYSTEM

BEFORE TURNING ON PROPANE:

- (A) BE CERTAIN APPLIANCES ARE CERTIFIED FOR PROPANE AND ARE EQUIPPED WITH CORRECT BURNING ORIFICES.
- (B) MAKE CERTAIN ALL PROPANE CONNECTIONS ARE TIGHT BY TESTING WITH SOAPY WATER. ALL APPLIANCE VALVES ARE TURNED OFF, AND ANY UNCONNECTED OUTLETS ARE CAPPED.

AFTER TURNING ON PROPANE:

- (A) LIGHT ALL PILOT LIGHTS
- (B) (B) ALL CONNECTIONS, INCLUDING THOSE AT THE APPLIANCES, REGULATORS AND CYLINDERS SHOULD BE LEAK-TESTED PERIODICALLY WITH SOAPY WATER BY THE OCCUPANT. NEVER USE A LIGHTED MATCH OR OTHER FLAME WHEN CHECKING FOR LEAKS.
- (C) DO NOT LEAVE SYSTEM TURNED ON OF CONTAINERS CONNECTED UNTIL THE SYSTEM HAS BEEN PROVEN TO BE FREE OF LEAKS.
- (D) COOKING APPLIANCES SHOULD NOT BE USED FOR SPACE HEATING.
- (E) WHEN THE CONTAINERS ARE DISCONNECTED THE PROPANE SUPPLY LINE SHOULD BE CAPPED OR PLUGGED.

AVERTISSEMENT

CETTE INSTALLATION EST CONCUE POUR LE PROPANE SEULEMENT
NE PAS L'ALIMENTER EN GAZ NATUREL

AVANT LA MISE EN SERVICE:

- (A) S'ASSURER QUE LES APPAREILS SONT CERTIFIES POUR LE PROPANE ET MUNIS D'ORIFICES DE BRULEUR APPROPRIES.
- (B) VERIFIER L'ETANCHEITE DE TOUS LES RACCORDEMENTS AU PROPANE. LA PERMETURE DE TOUS LES ROBINETS D'APPAREILS ET L'OBTURATION DE TOUTES LES SORTIES NON RACCORDEES.

APRES LA MISE EN SERVICE:

- (A) ALLUMER TOUTES LES VEILLEUSES.
- (B) L'OCCUPANT DOIT EPROUVER PERIODIQUEMENT L'ETANCHEITE DE TOUS LES RACCORDEMENTS Y COMPRIS CEUX AUX APPAREILS, AUX DETENDEURS ET AUX BOUTEILLES, EN Y APPLIQUANT DE L'EAU SAVONNEUSE NE JAMA'S SE SERVIR D'UNE ALLUMETTE OU AUTRE POUR LA DETECTION DES FUITES.
- (C) NE PAS LAISSER L'ALIMENTATION OUVERTE NI LES RECIPIENTS RACCORDES AVANT D'AVOIR COMPLETE L'EPREUVE D'ETANCHEITE AU PROPANE DE L'INSTALLATION.
- (D) LES APPAREILS DE CUISSON NE DOIVENT PAS ETRE UTILISES POUR LE CHAUFFAGE DES LOCAUX.
- (E) LORSQUE LES RECIPIENTS SONT DECONNECTES, L'ALIMENTATION DE PROPANE DOIT ETRE OBTUREE OU SCELLEE.

KEY PART NUMBER U/M DESCRIPTION
023769-01-000 EA LABEL - WARNING - LPG - CANADIAN

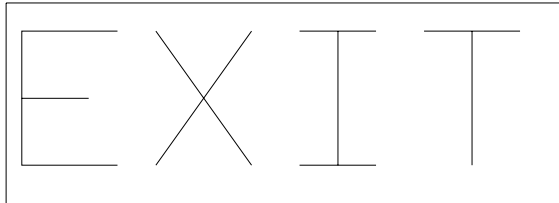

KEY PART NUMBER U/M DESCRIPTION
039290-01-000 EA LABEL - WARNING - EXIT

LABELS GROUP (CONTINUED)



KEY PART NUMBER U/M DESCRIPTION
040944-01-000 EA LABEL - ENTRANCE DOOR - "OPEN"

CAUTION

THIS MOTOR HOME HAS BEEN DESIGNED, MANUFACTURED AND TESTED WITH CONCERN FOR THE PROTECTION OF IT'S OCCUPANTS. WE RECOMMEND YOU PERFORM THE FOLLOWING INSPECTIONS FOR YOUR SAFETY AND THE SAFETY OF YOUR PASSENGERS BEFORE STARTING YOUR VEHICLE.

1. LP GAS SYSTEM- TURN OFF AT TANK FOR TRAVELING. TEST FOR LEAKS UPON ARRIVAL AT DESTINATION. BEFORE LIGHTING PILOTS.
2. WHEELS- INSPECT FOR DAMAGE AND CHECK LUG NUTS FOR TIGHTNESS.
3. TIRES- INSPECT FOR WEAR AND DAMAGE AND CHECK FOR RECOMMENDED AIR PRESSURE.
4. LIGHTING- TEST FOR PROPER OPERATION OF ALL INTERIOR AND EXTERIOR LIGHTS INCLUDING DASH LIGHTS, HEADLIGHTS, TAIL LIGHTS, BRAKE LIGHTS, CLEARANCE LIGHTS AND TURN SIGNALS.
5. EXITS- INSPECT RELEASE MECHANISM ON EMERGENCY EXIT WINDOW. TEST BOTH LOCKS ON MAIN ENTRANCE DOOR FOR EASE OF OPERATION AND INSTRUCT PASSENGERS HOW TO USE BOTH MEANS OF EXIT.
6. SEAT BELTS- DIRECT PASSENGERS TO DESIGNATED SEATS AND REQUIRE USE OF SEAT BELTS.
7. APPLIANCES- TURN OFF AND LATCH OR LOCK DOORS WHERE PROVIDED.
8. LOOSE PARCELS- STORE SECURELY.
9. UTILITY SUPPLY LINES- DISCONNECT ALL ELECTRIC, SEWER AND WATER LINES AND SECURE PROPERLY.
10. ENTRANCE DOOR STEP- PLACE IN RETRACTED POSITION FOR TRAVELING.

READ YOUR MOTOR HOME AND CHASSIS OWNER'S
MANUAL FOR FURTHER PRECAUTIONS

KEY PART NUMBER U/M DESCRIPTION
056259-01-000 EA LABEL - SAFETY CHECK LIST

UNLEADED FUEL ONLY

KEY PART NUMBER U/M DESCRIPTION
062043-01-000 EA LABEL - FUEL - UNLEADED

WARNING DISCONNECT BATTERIES BEFORE
CONNECTING EXTERNAL CHARGING EQUIPMENT.

KEY PART NUMBER U/M DESCRIPTION
065748-01-000 EA LABEL - WARNING - BATTERY CHARGING - UL

AVERTISSEMENT : DEBRANCHER LES BATTERIES AVANT
DE BRANCHER TOUT EQUIPEMENT DE CHARGE EXTERIEUR.

KEY PART NUMBER U/M DESCRIPTION
065748-02-000 EA LABEL - WARNING - BATTERY CHARGING - CSA - CANADIAN

DIESEL FUEL ONLY

KEY PART NUMBER U/M DESCRIPTION
068383-01-000 EA LABEL - DIESEL FUEL

VEHICLE EMISSION CONTROL INFORMATION
THIS VEHICLE CONFORMS TO U.S. EPA
REGULATIONS APPLICABLE TO XXXX MODEL
YEAR NEW VEHICLES.

072887-07-000-7 CATALYST

KEY PART NUMBER U/M DESCRIPTION
072887-14-000 EA LABEL - EPA - 2003 MODEL YEAR

LABELS GROUP (CONTINUED)

IF YOU SMELL GAS

1. EXTINGUISH ANY OPEN FLAME, PILOT LIGHTS AND ALL SMOKING MATERIALS.
2. DO NOT TOUCH ELECTRICAL SWITCHES.
3. SHUT OFF THE GAS SUPPLY AT THE TANK VALVE(S) OR GAS SUPPLY CONNECTION.
4. OPEN DOORS AND OTHER VENTILATING OPENINGS.
5. LEAVE THE AREA UNTIL ODOR CLEARS.
6. HAVE THE GAS SYSTEM CHECKED AND LEAKAGE SOURCE CORRECTED BEFORE USING AGAIN.

KEY PART NUMBER U/M DESCRIPTION
073998-01-000 EA LABEL - LPG ODOR WARNING

WARNING: TEST SMOKE DETECTOR
OPERATION AFTER VEHICLE HAS BEEN IN
STORAGE, BEFORE EACH TRIP AND AT
LEAST ONCE PER WEEK DURING USE.

KEY PART NUMBER U/M DESCRIPTION
077956-01-000 EA LABEL - WARNING - SMOKE DETECTOR

DO NOT FILL
LP-GAS CONTAINER(S)
TO MORE THAN 80%
OF CAPACITY.

KEY PART NUMBER U/M DESCRIPTION
079965-01-000 EA LABEL - LPG - 80% CAPACITY

WARNING
MUST BE STOWED
IN LATCHED POSITION
WHILE VEHICLE IS IN MOTION

KEY PART NUMBER U/M DESCRIPTION
079966-01-000 EA LABEL - WARNING - STOWED - MOTION

W
A
T
E
R
O
N
H
E
A
T
E
R
O
F
F

KEY PART NUMBER U/M DESCRIPTION
083588-01-000 EA LABEL - ON/OFF - WATER HEATER

E
N
G
I
N
E
O
N
H
E
A
T
E
R
O
F
F

KEY PART NUMBER U/M DESCRIPTION
083588-02-000 EA LABEL - ON/OFF - ENGINE HEATER
083588-04-000 EA LABEL - ON/OFF - ENGINE HEATER

LABELS GROUP (CONTINUED)

CAUTION	TO HELP AVOID PERSONAL INJURY DURING REMOVAL OF FUEL FILLER CAP, SLOWLY LOOSEN CAP 1/2 TURN TO ALLOW ANY FUEL PRESSURE TO BE RELIEVED BEFORE TURNING CAP FURTHER.
FUEL SPRAY MAY CAUSE PERSONAL INJURY	STOP ADDING FUEL AFTER FIRST SHUTOFF BY AUTOMATIC NOZZLE WHEN TANK IS NEARLY FULL. DO NOT OVERFILL FUEL TANK. SEE OWNERS MANUAL FOR ADDITIONAL INFORMATION. PRINTED IN U.S.A. WLC PT NO 15611763

KEY PART NUMBER U/M DESCRIPTION
087207-05-000 EA LABEL - FUEL CAP REMOVAL



KEY PART NUMBER U/M DESCRIPTION
087236-01-000 EA LABEL - CABLE - INPUT



KEY PART NUMBER U/M DESCRIPTION
087236-02-000 EA LABEL - TV OUTLET

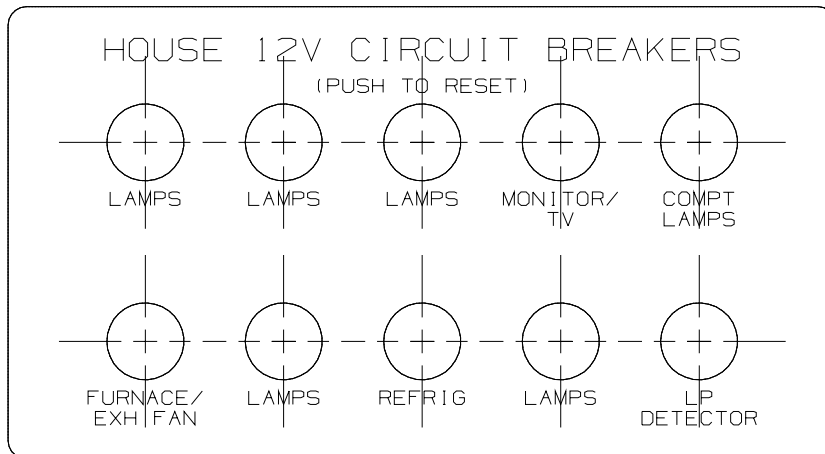

KEY PART NUMBER U/M DESCRIPTION
092547-06-000 EA LABEL - CIRCUIT BREAKER

LABELS GROUP (CONTINUED)

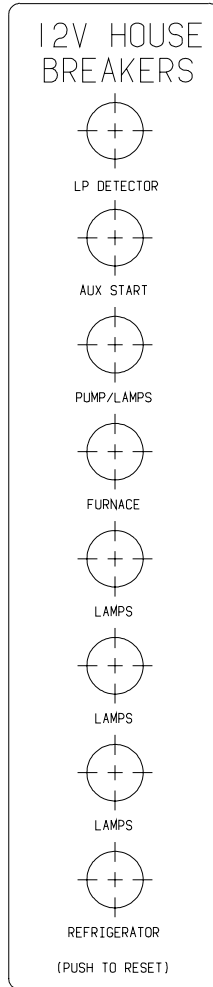

KEY	PART NUMBER	U/M	DESCRIPTION
	092547-08-000	EA	LABEL - CIRCUIT BREAKER

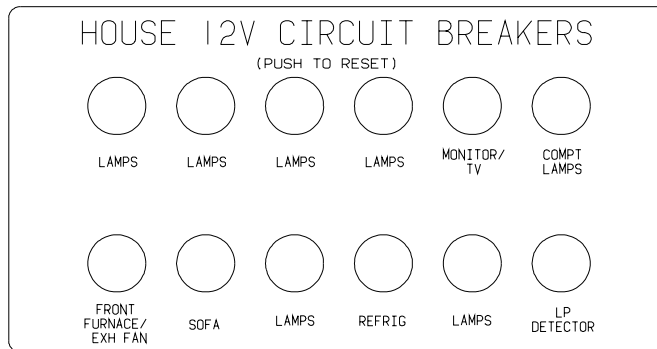

KEY	PART NUMBER	U/M	DESCRIPTION
	092547-10-000	EA	LABEL - CIRCUIT BREAKER

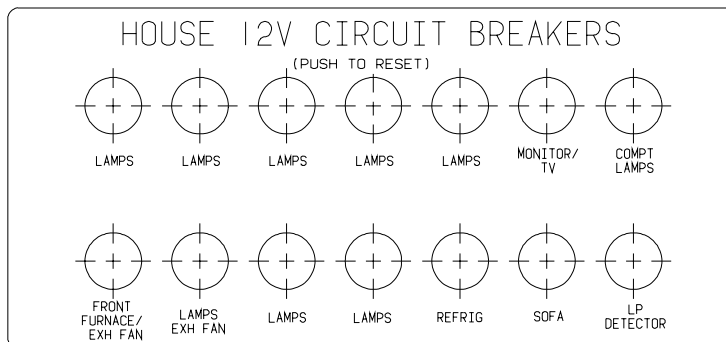

KEY	PART NUMBER	U/M	DESCRIPTION
	092547-12-000	EA	LABEL - CIRCUIT BREAKER

LABELS GROUP (CONTINUED)

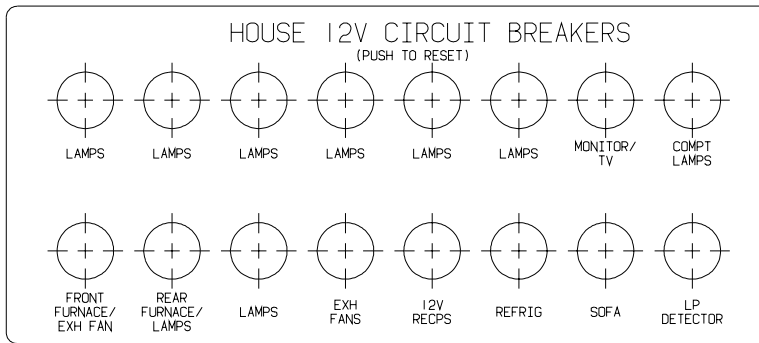

KEY PART NUMBER **U/M DESCRIPTION**
 092547-13-000 EA LABEL - CIRCUIT BREAKER

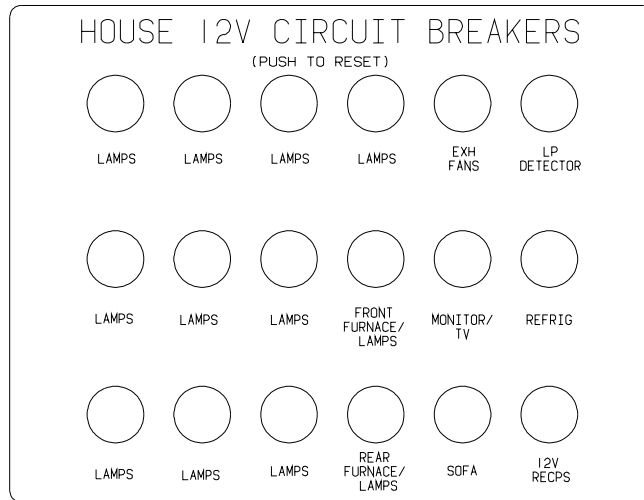

KEY PART NUMBER **U/M DESCRIPTION**
 092547-14-000 EA LABEL - CIRCUIT BREAKER

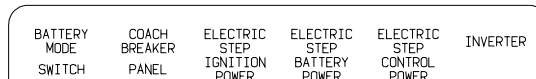

KEY PART NUMBER **U/M DESCRIPTION**
 093236-08-000 EA LABEL - CIRCUIT BREAKER

LABELS GROUP (CONTINUED)

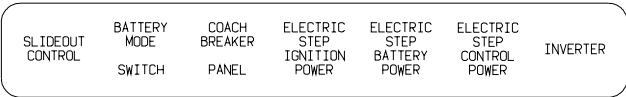

KEY PART NUMBER **U/M DESCRIPTION**
 093236-21-000 EA LABEL - CIRCUIT BREAKER

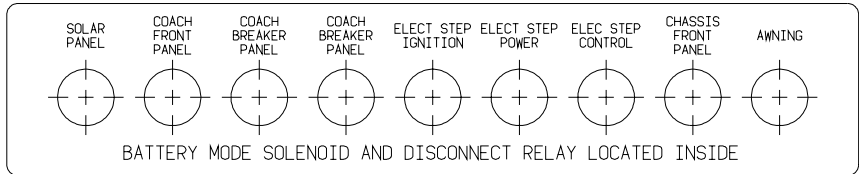

KEY PART NUMBER **U/M DESCRIPTION**
 093236-26-000 EA LABEL - CIRCUIT BREAKER

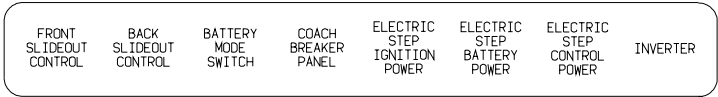

KEY PART NUMBER **U/M DESCRIPTION**
 093236-28-000 EA LABEL - CIRCUIT BREAKER

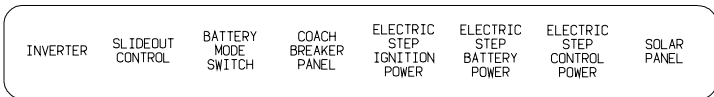

KEY PART NUMBER **U/M DESCRIPTION**
 093236-29-000 EA LABEL - CIRCUIT BREAKER

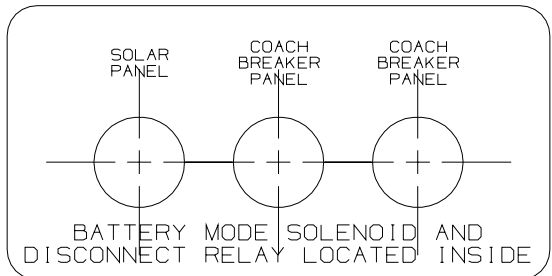

KEY PART NUMBER **U/M DESCRIPTION**
 093236-31-000 EA LABEL - CIRCUIT BREAKER

LABELS GROUP (CONTINUED)

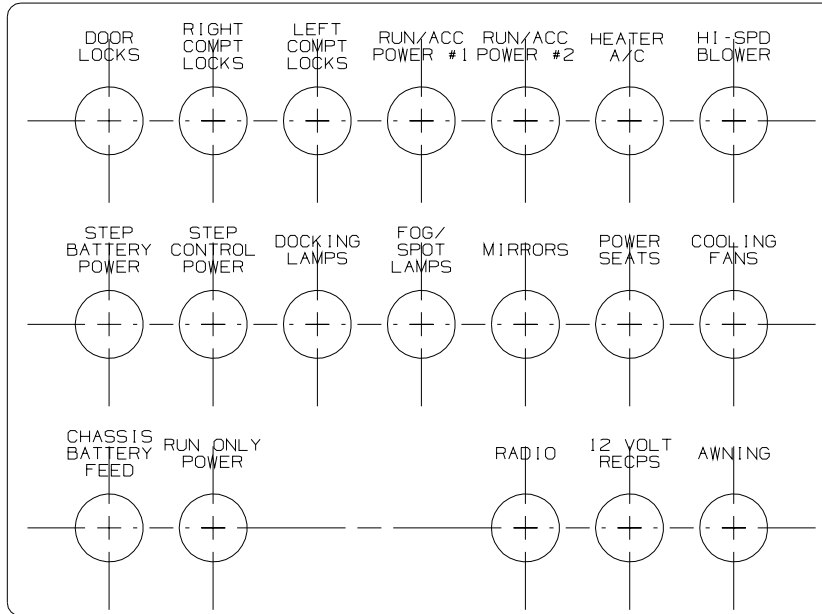

KEY PART NUMBER
093236-32-000

U/M DESCRIPTION
EA LABEL - CIRCUIT BREAKER

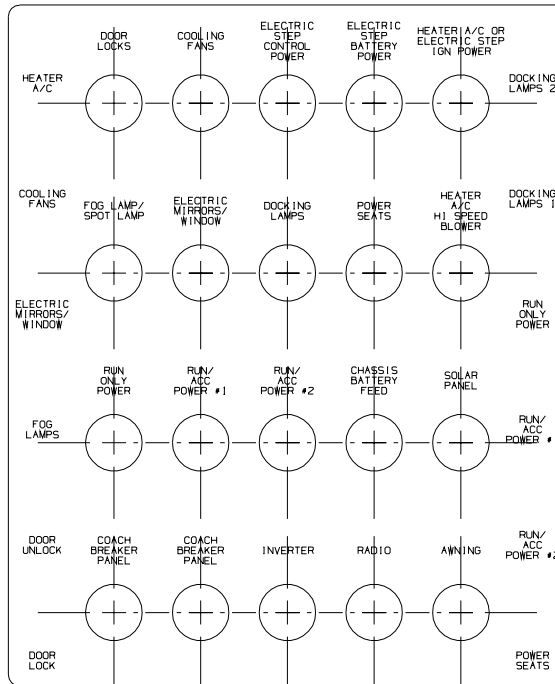

KEY PART NUMBER
093236-33-000

U/M DESCRIPTION
EA LABEL - CIRCUIT BREAKER

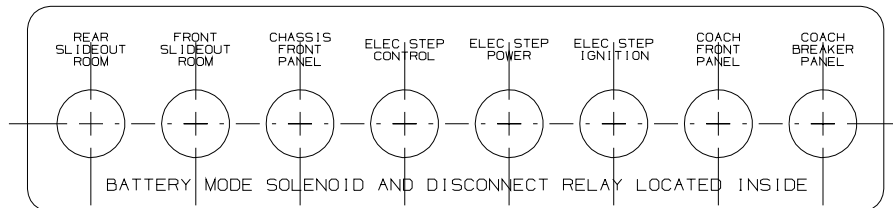

KEY PART NUMBER
093236-34-000

U/M DESCRIPTION
EA LABEL - CIRCUIT BREAKER

LABELS GROUP (CONTINUED)

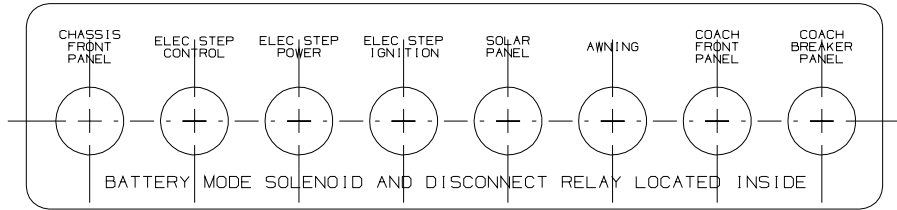

KEY	PART NUMBER	U/M	DESCRIPTION
	093236-35-000	EA	LABEL - CIRCUIT BREAKER

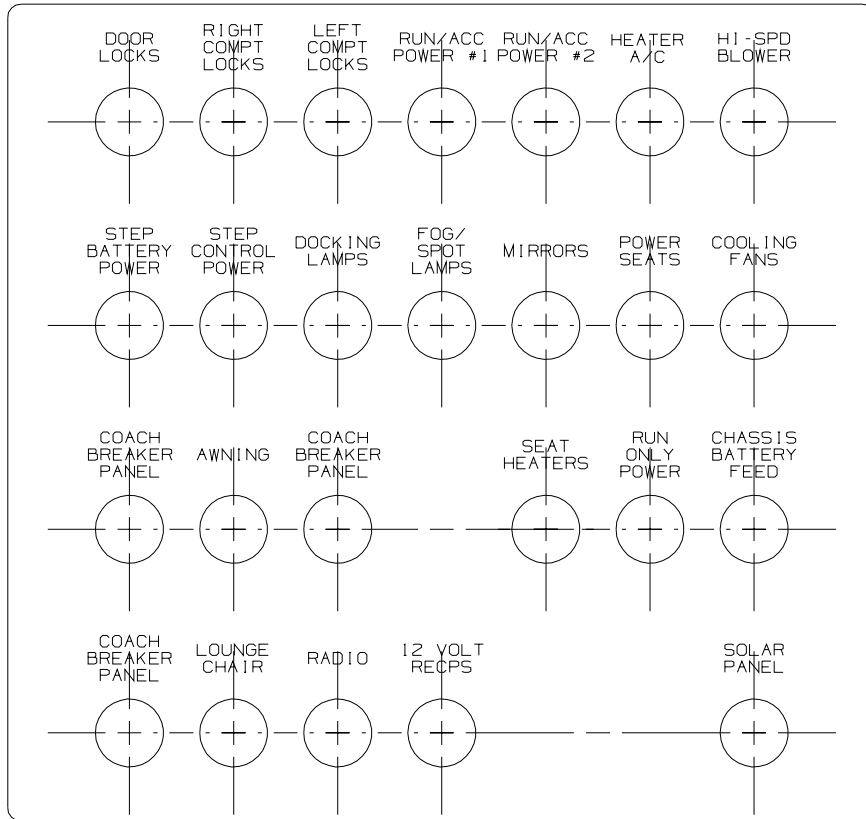

KEY	PART NUMBER	U/M	DESCRIPTION
	093236-37-000	EA	LABEL - CIRCUIT BREAKER

LABELS GROUP (CONTINUED)

SUB MAIN	DISHWASHER	RECP S 1	RECP S 2	RECP S 3	MICROWAVE
-------------	------------	----------------	----------------	----------------	-----------

KEY PART NUMBER U/M DESCRIPTION
 095721-20-000 EA LABEL - CONTROL CENTER W/INVERTER

A/C CIRCUIT 1	MAIN	A/C CIRCUIT 2	REFFRIG/CONV	MICROWAVE	RECP S 1	RECP S 2	RECP S 3		
---------------------	------	---------------------	--------------	-----------	----------------	----------------	----------------	--	--

KEY PART NUMBER U/M DESCRIPTION
 095721-27-000 EA LABEL - CONTROL CENTER - 30 AMP

A/C CIRCUIT 1	MAIN	A/C CIRCUIT 2	REFFRIG/CONV	MICROWAVE	RECP S 1	RECP S 2	RECP S 3	WASHER/DRYER	WATER HEATER	
---------------------	------	---------------------	--------------	-----------	----------------	----------------	----------------	--------------	-----------------	--

KEY PART NUMBER U/M DESCRIPTION
 095721-31-000 EA LABEL - CONTROL CENTER - 30 AMP - US

LABELS GROUP (CONTINUED)

A / C CIRCUIT 1	M A I N	M A I N	A / C CIRCUIT 2	R E F R I G / C O N V	M I C R O W A V E	R E C P S 1	R E C P S 2	R E C P S 3	W A S H E R / D R Y E R	W A T E R H E A T E R
-----------------------	------------------	------------------	-----------------------	---	---	--------------------------------	--------------------------------	--------------------------------	--	---

KEY PART NUMBER U/M DESCRIPTION
 095721-33-000 EA LABEL - CONTROL CENTER - 50 AMP - US

M A I N	M I C R O W A V E	G F I / R E C E P S	R E F E R / C O N V	W A T E R H T R	A / C
------------------	---	--	--	--------------------------------------	-------------

KEY PART NUMBER U/M DESCRIPTION
 095721-38-000 EA LABEL - CONTROL CENTER - 30 AMP - US

A / C CIRCUIT 1	M A I N	M A I N	A / C CIRCUIT 2	I N V E R T E R / C H A R G E R	W A S H E R / D R Y E R	W A T E R H E A T E R	W A T E R H E A T E R	D I S H W A S H E R	F I R E P L A C E / R E C P S 4	F I R E P L A C E / R E C P S 4
-----------------------	------------------	------------------	-----------------------	--	--	---	---	--	--	--

KEY PART NUMBER U/M DESCRIPTION
 095721-44-000 EA LABEL - CONTROL CENTER - 30 AMP - US

AUTOMOTIVE AND COACH CIRCUIT BREAKERS
--

KEY PART NUMBER U/M DESCRIPTION
 098379-01-000 EA LABEL - CIRCUIT BREAKER - FRONT BOX

CIRCUIT BREAKERS AND AUTOMOTIVE FUSE PANEL
--

KEY PART NUMBER U/M DESCRIPTION
 098379-03-000 EA LABEL - ELECTRICAL BOX - FRONT

LABELS GROUP (CONTINUED)

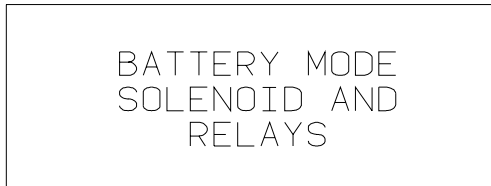

KEY PART NUMBER U/M DESCRIPTION
098379-04-000 EA LABEL - ELECTRICAL BOX - SIDE



KEY PART NUMBER U/M DESCRIPTION
098641-01-000 EA LABEL - FUEL - UNLEADED - DASH



KEY PART NUMBER U/M DESCRIPTION
099509-01-000 EA LABEL - AWNING INSTALLATION

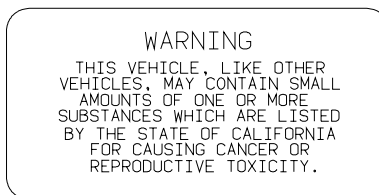

KEY PART NUMBER U/M DESCRIPTION
099689-01-000 EA LABEL - WARNING - CANCER/TOXICITY

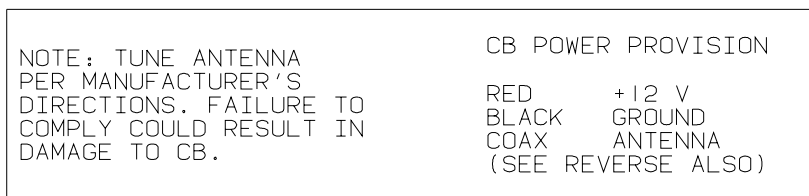

KEY PART NUMBER U/M DESCRIPTION
104678-01-000 EA LABEL - CB PREP



KEY PART NUMBER U/M DESCRIPTION
107571-01-000 EA LABEL - EXIT/ESCAPE WINDOW

LABELS GROUP (CONTINUED)

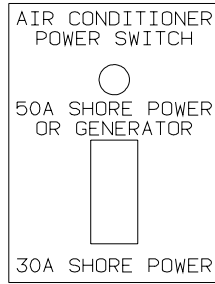

KEY PART NUMBER U/M DESCRIPTION
 109051-02-000 EA LABEL - SWITCH - 50 AMP POWER



KEY PART NUMBER U/M DESCRIPTION
 111104-01-000 EA LABEL - HITCH - READ MANUAL - WHITE

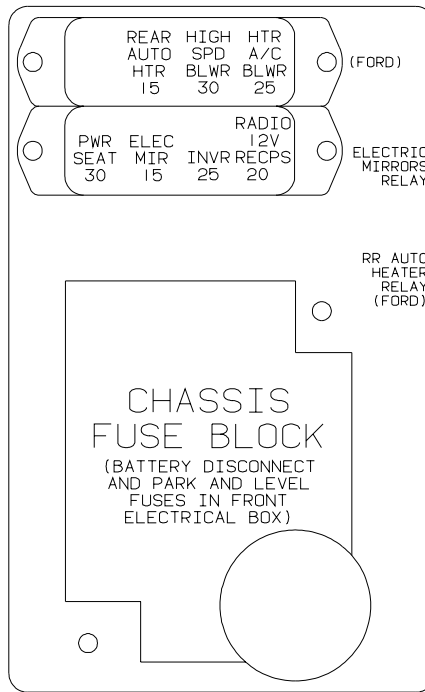

KEY PART NUMBER U/M DESCRIPTION
 111537-08-000 EA LABEL - FUSES

LABELS GROUP (CONTINUED)

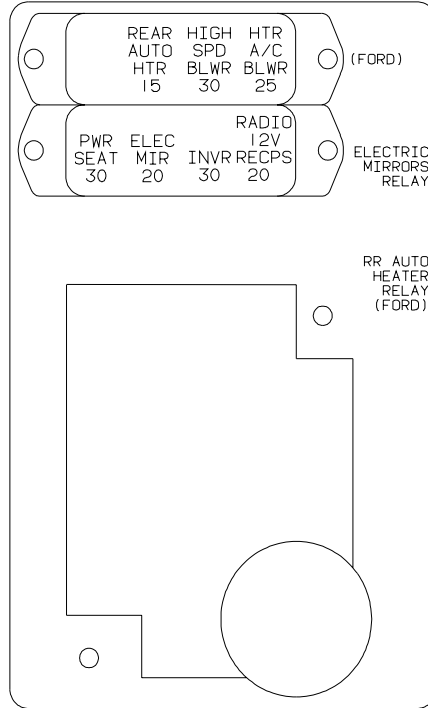

KEY PART NUMBER U/M DESCRIPTION
 111537-09-000 EA LABEL - FUSES

WARNING: CONTAINS "CFC" A SUBSTANCE WHICH HARMS
 PUBLIC HEALTH AND ENVIRONMENT BY DESTROYING
 OZONE IN THE UPPER ATMOSPHERE.

KEY PART NUMBER U/M DESCRIPTION
 111802-01-000 EA LABEL - CFC WARNING



KEY PART NUMBER U/M DESCRIPTION
 113402-01-000 EA LABEL - CAUTION - WATER HEATER EXHAUST

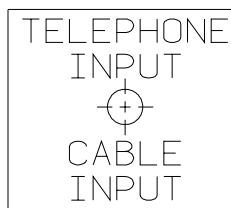

KEY PART NUMBER U/M DESCRIPTION
 114866-02-000 EA LABEL - PHONE & CABLE INPUT - WHITE/CLEAR BACKGROUND

LABELS GROUP (CONTINUED)

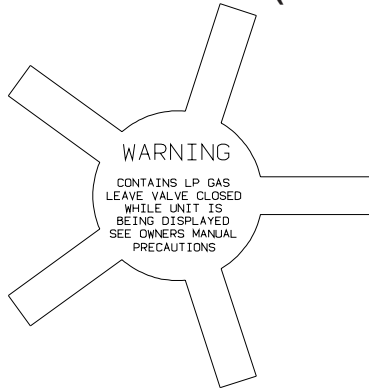

KEY	PART NUMBER	U/M DESCRIPTION
	115600-01-000	EA LABEL - WARNING LPG VALVE

WARNING: REPLACE TIRE ONLY WITH ONE OF EXACTLY SAME TYPE AND RATING. DO NOT REPLACE WITH PASSENGER CAR TIRE. SEE OPERATOR'S MANUAL FOR MORE INFORMATION CALL WINNEBAGO OWNER RELATIONS AT 1-800-537-1885.

KEY	PART NUMBER	U/M DESCRIPTION
	115869-01-000	EA LABEL - WARNING - TIRE

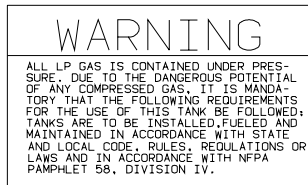

KEY	PART NUMBER	U/M DESCRIPTION
	116112-01-000	EA LABEL - CAUTION - LP

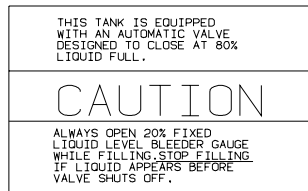

KEY	PART NUMBER	U/M DESCRIPTION
	116113-01-000	EA LABEL - CAUTION - LP

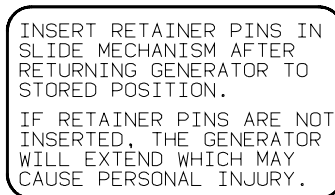

KEY	PART NUMBER	U/M DESCRIPTION
	116273-01-000	EA LABEL - WARNING - GENERATOR

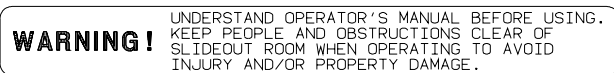

KEY	PART NUMBER	U/M DESCRIPTION
	116549-01-000	EA LABEL - WARNING - SLIDEOUT

LABELS GROUP (CONTINUED)

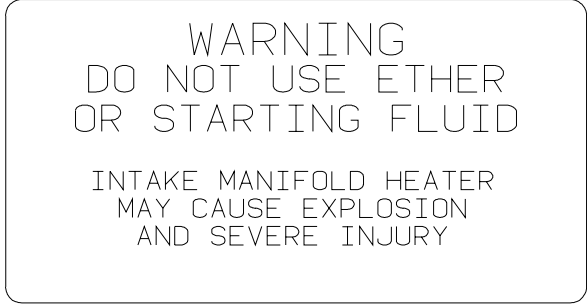

KEY	PART NUMBER	U/M DESCRIPTION
	116756-02-000	EA LABEL - WARNING - ETHER/STARTING - RED W/CLEAR BACKGROUND
	116756-03-000	EA LABEL - WARNING - ETHER/STARTING - RED W/WHITE BACKGROUND



KEY	PART NUMBER	U/M DESCRIPTION
	116775-01-000	EA LABEL/CAUTION - TRAVEL LATCH

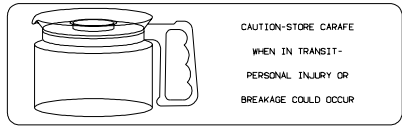

KEY	PART NUMBER	U/M DESCRIPTION
	116829-02-000	EA LABEL - COFFEEMAKER



KEY	PART NUMBER	U/M DESCRIPTION
	117628-02-000	EA LABEL - SWITCH - WATER PUMP/LIGHTS-WHITE/CLEAR BACKGROUND

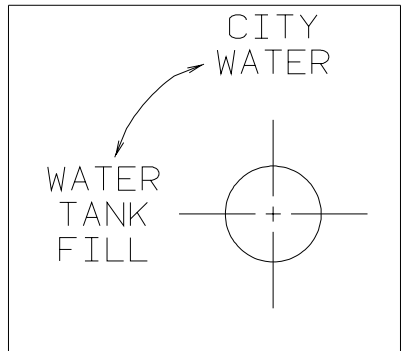

KEY	PART NUMBER	U/M DESCRIPTION
	117629-01-000	EA LABEL - WATER PUMP/FILL-BLK LETTER/CLEAR BACKGROUND-.24"
	117629-03-000	EA LABEL - WATER PUMP/FILL-BLK LETTERS/CLEAR BACKGROUND-.31"

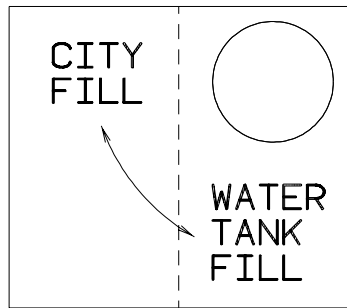

KEY	PART NUMBER	U/M DESCRIPTION
	117629-04-000	EA LABEL - CITY WATER/TANK FILL

LABELS GROUP (CONTINUED)

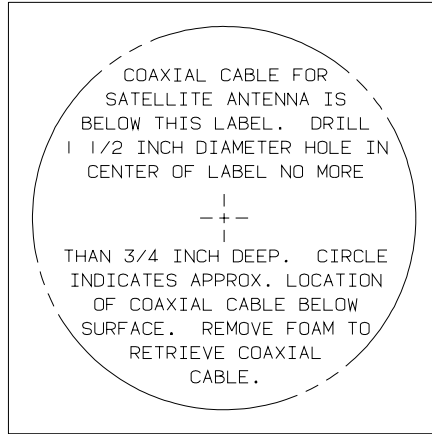

KEY PART NUMBER U/M DESCRIPTION
 120431-01-000 EA LABEL - LOCATION - COAXIAL CABLE/SATELLITE ANTENNA

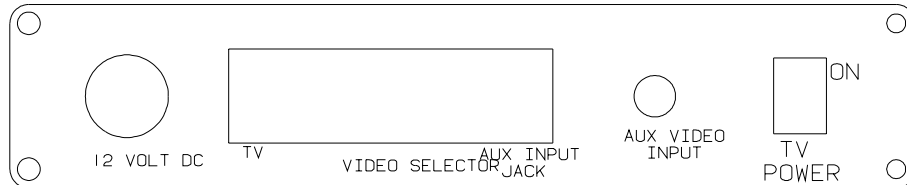

KEY PART NUMBER U/M DESCRIPTION
 120677-01-000 EA LABEL - TV

KEEP THE SERVICE INLET ACCESS
 IN THE CLOSED POSITION WHEN
 UTILITY CONNECTIONS ARE NOT IN USE

KEY PART NUMBER U/M DESCRIPTION
 123562-01-000 EA LABEL - SERVICE/UTILITY ACCESS

WARNING
 ALL PILOT LIGHTS, APPLIANCES AND THIER
 IGNITORS (SEE OPERATING INSTRUCTIONS) SHALL
 BE TURNED OFF DURING REFUELING OF MOTOR
 FUEL TANKS AND/OR LP GAS CONTAINERS

KEY PART NUMBER U/M DESCRIPTION
 124519-01-01A EA LABEL - WARNING/REFUELING - BLACK ON CLEAR
 124519-01-02A EA LABEL - WARNING/REFUELING - WHITE ON CLEAR

WARNING:
 ALL PILOT LIGHTS AND APPLIANCES SHALL BE TURNED
 OFF DURING REFUELING OF MOTOR FUEL TANKS AND/
 OR PROPANE CONTAINERS.
 AVERTISSEMENT:
 FERMER TOUTES LES VEILLEUSES AINSI QUE TOUS LES
 APPAREILS LORSQU'ON FAIT LE PLEIN DES RESERVOIRS
 A CARBURANT OU A PROPANE.
 124519-02

KEY PART NUMBER U/M DESCRIPTION
 124519-02-01A EA LABEL - WARNING/REFUELING - BLACK ON CLEAR - CSA
 124519-02-02A EA LABEL - WARNING/REFUELING - WHITE ON CLEAR - CSA

LABELS GROUP (CONTINUED)

LP-GAS SYSTEM
 THIS GAS PIPING SYSTEM IS
 DESIGNED FOR USE OF
 LIQUIFIED PETROLEUM GAS
 ONLY. DO NOT CONNECT
 NATURAL GAS TO THIS
 SYSTEM.
 SECURE CAP INLET(S) WHEN NOT
 CONNECTED FOR USE. AFTER TURNING
 ON GAS, EXCEPT AFTER NORMAL
 CONTAINER REPLACEMENT, TEST GAS
 PIPING AND CONNECTIONS TO
 APPLIANCES FOR LEAKAGE WITH SOAPY
 WATER OR BUBBLE SOLUTION. DO NOT
 USE PRODUCTS THAT CONTAIN AMMONIA
 OR CLORINE.

124520

KEY	PART NUMBER	U/M	DESCRIPTION
	124520-01-01A	EA	LABEL - LP GAS ONLY - BLACK ON CLEAR
	124520-01-02A	EA	LABEL - LP GAS ONLY - WHITE ON CLEAR

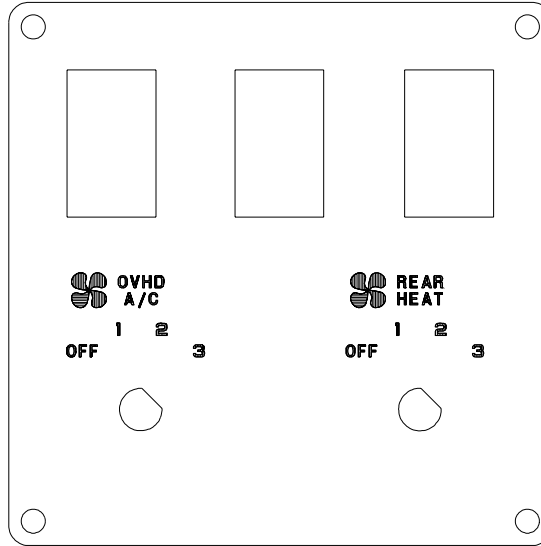

KEY	PART NUMBER	U/M	DESCRIPTION
	124572-01-000	EA	LABEL - SWITCHES

THIS CONNECTION IS FOR
 (B) VOLT AC, 60 HZ(CYCLES)
 (A) AMPERE SUPPLY

 DO NOT CONNECT TO
 HIGHER VOLTAGE

KEY	PART NUMBER	U/M	DESCRIPTION
	125306-01-01A	EA	LABEL - ELECTRICAL ENTRANCE - 110V 30 AMP - BLACK ON CLEAR

LABELS GROUP (CONTINUED)

THIS CONNECTION IS FOR
 (B) VOLT AC, 3-POLE, 4 WIRE
 60 HZ (CYCLES), (A) AMPERE SUPPLY

DO NOT CONNECT TO
 HIGHER VOLTAGE

KEY	PART NUMBER	U/M	DESCRIPTION
	125306-04-01A	EA	LABEL-ELECTRICAL ENTRANCE-120/240V 50 AMP-BLACK ON CLEAR
	125306-04-02A	EA	LABEL - ELECTRICAL ENTRANCE-120/240V 50 AMP-WHITE ON CLEAR

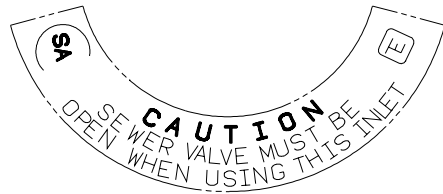

KEY	PART NUMBER	U/M	DESCRIPTION
	125697-07-000	EA	LABEL - CAUTION - FLUSHING SYSTEM

REMOVE PRIMARY TIRE HANGER BEFORE USING
 SPARE TIRE HOIST-SEE OWNERS MANUAL- PERSONAL
 INJURY MAY RESULT IF NOT FOLLOWED

KEY	PART NUMBER	U/M	DESCRIPTION
	126024-01-01A	EA	LABEL - TIRE HANGER REMOVAL

GRAY HOLDING TANK

KEY	PART NUMBER	U/M	DESCRIPTION
	126247-01-000	EA	LABEL - GRAY HOLDING TANK-WHITE LETTERS/CLEAR BACKGROUND
	126247-05-000	EA	LABEL - GRAY HOLDING TANK-BLACK LETTERS/CLEAR BACKGROUND

BLACK HOLDING TANK

KEY	PART NUMBER	U/M	DESCRIPTION
	126247-02-000	EA	LABEL - BLACK HOLDING TANK-WHITE LETTERS/BLACK BACKGROUND
	126247-06-000	EA	LABEL - BLACK HOLDING TANK-BLACK LETTERS/CLEAR BACKGROUND

EXTERIOR SHOWER

KEY	PART NUMBER	U/M	DESCRIPTION
	126248-03-000	EA	LABEL - EXTERIOR SHOWER

CITY WATER FILL

KEY	PART NUMBER	U/M	DESCRIPTION
	126249-03-000	EA	LABEL - CITY WATER FILL-BLK LETTERS/CLEAR BACKGROUND .31"

LABELS GROUP (CONTINUED)

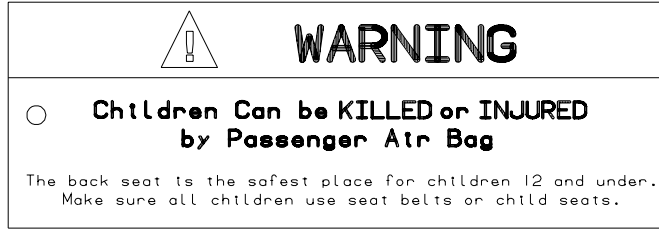

KEY PART NUMBER U/M DESCRIPTION
 126612-01-000 EA LABEL - HANG TAG - AIR BAG - DASH

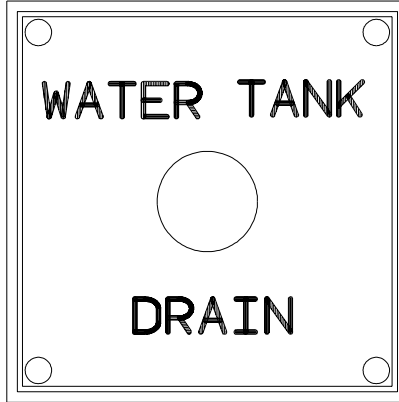

KEY PART NUMBER U/M DESCRIPTION
 127170-01-000 EA LABEL - WATER TANK DRAIN



KEY PART NUMBER U/M DESCRIPTION
 128218-01-01A EA LABEL - WARNING - SLIPPERY ROOF



KEY PART NUMBER U/M DESCRIPTION
 128658-01-000 EA LABEL - PROP ROD - ENTRY DOOR

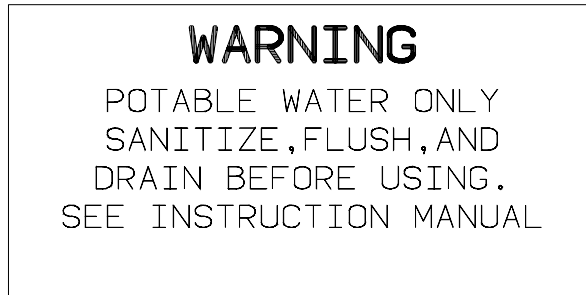

KEY PART NUMBER U/M DESCRIPTION
 128725-01-01A EA LABEL - POTABLE WATER ONLY - BLACK ON CLEAR

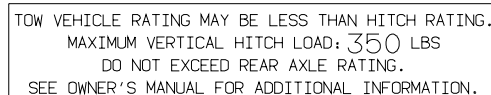

KEY PART NUMBER U/M DESCRIPTION
 129669-01-01A EA LABEL - HITCH/VEHICLE RATE - 350 - WHITE ON CLEAR
 129669-01-02A EA LABEL - HITCH/VEHICLE RATE - 350 - BLACK ON CLEAR
 129669-02-01A EA LABEL - HITCH/VEHICLE RATE - 500 - WHITE ON CLEAR
 129669-02-02A EA LABEL - HITCH/VEHICLE RATE - 500 - BLACK ON CLEAR

LABELS GROUP (CONTINUED)

TIRE ROTATION
 SEE RIALTA OWNERS MANUAL
 SECTION 9

KEY PART NUMBER U/M DESCRIPTION
 129684-01-000 EA LABEL - TIRE ROTATION

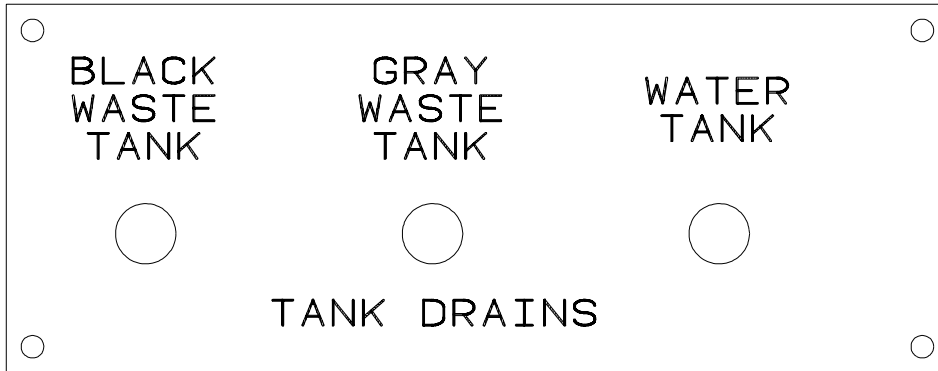

KEY PART NUMBER U/M DESCRIPTION
 130166-01-000 EA LABEL - DRAIN



KEY PART NUMBER U/M DESCRIPTION
 130166-02-000 EA LABEL - DRAIN

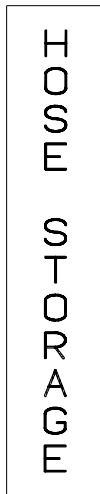

KEY PART NUMBER U/M DESCRIPTION
 130167-02-000 EA LABEL - HOSE STORAGE



KEY PART NUMBER U/M DESCRIPTION
 130168-01-000 EA LABEL - WASTE TANK FLUSH

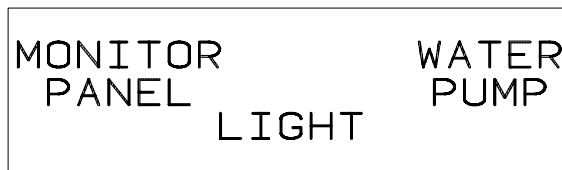

KEY PART NUMBER U/M DESCRIPTION
 130170-01-000 EA LABEL - SWITCH PANEL - BLK/CLEAR BACKGROUND-1.8"H X 5.9"L

LABEL GROUP (CONTINUED)



KEY PART NUMBER U/M DESCRIPTION
130170-02-000 EA LABEL - SWITCH PANEL-BLK/CLEAR BACKGROUND-1.4"H X 3.9"L

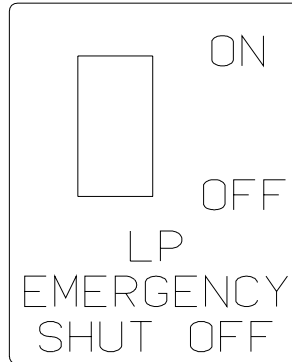

KEY PART NUMBER U/M DESCRIPTION
130170-04-000 EA LABEL - SWITCH PANEL



KEY PART NUMBER U/M DESCRIPTION
130170-05-000 EA LABEL - SWITCH PANEL

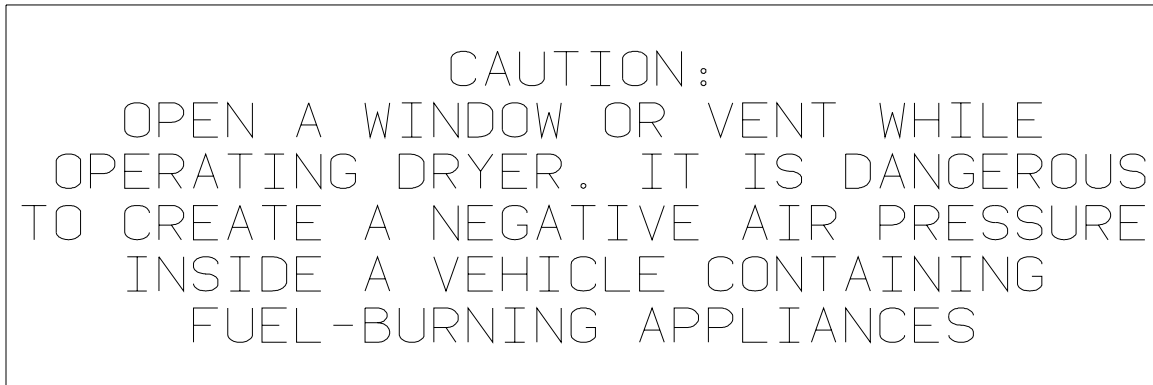

KEY PART NUMBER U/M DESCRIPTION
130670-01-01A EA LABEL - CAUTION DRYER VENTING - BLACK ON CLEAR



KEY PART NUMBER U/M DESCRIPTION
131779-01-01A EA LABEL - GENERATOR

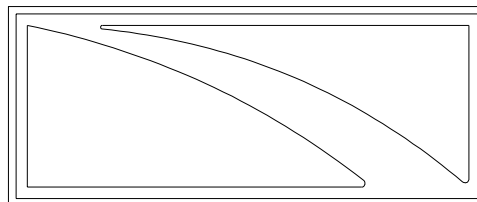

KEY PART NUMBER U/M DESCRIPTION
132651-01-01A EA DECAL - MIRROR/GALLEY

LABEL GROUP (CONTINUED)

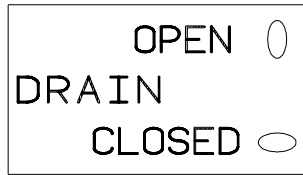

KEY PART NUMBER U/M DESCRIPTION
133423-01-01A EA LABEL - DRAIN



KEY PART NUMBER U/M DESCRIPTION
133424-01-01A EA LABEL - WATER HEATER BYPASS - BLACK/CLEAR



KEY PART NUMBER U/M DESCRIPTION
133424-02-01A EA LABEL - NORMAL OPERATION



KEY PART NUMBER U/M DESCRIPTION
133424-03-01A EA LABEL - WATER HEATER BYPASS - BLACK/CLEAR



KEY PART NUMBER U/M DESCRIPTION
133533-01-01A EA LABEL - JACKS DOWN - CLEAR W/WHITE LETTERING



KEY PART NUMBER U/M DESCRIPTION
133533-02-01A EA LABEL - CHECK ANTENNA - CLEAR W/WHITE LETTERING



KEY PART NUMBER U/M DESCRIPTION
133533-03-01A EA LABEL - LOCK/UNLOCK - BLACK/WHITE



KEY PART NUMBER U/M DESCRIPTION
133533-04-01A EA LABEL - WINDOW/MIRROR HEAT- BLACK/CLEAR



KEY PART NUMBER U/M DESCRIPTION
133533-05-01A EA LABEL - SUNVISOR - DRIVER/PASSENGER - BLACK/CLEAR

LABELS GROUP (CONTINUED)

SUNVISOR PASSENGER	MAP LIGHT
-----------------------	--------------

KEY PART NUMBER U/M DESCRIPTION
 133533-06-01A EA LABEL - MAP LIGHT/SUNVISOR - BLACK/CLEAR

TO SATELLITE RECEIVER			
○	○	○	○
DISH INPUT		OUTPUT	

KEY PART NUMBER U/M DESCRIPTION
 134250-01-01A EA LABEL - SATELLITE RECEIVER - BLACK/CLEAR

THIS CHAIR IS NOT INTENDED FOR OCCUPANCY WHEN VEHICLE IS IN MOTION AND MUST BE RETURNED TO STOWED POSITION
--

DTS ISICE SIEGE N/EST PAS DESTINE A ETRE OCCUPE LORSQUE LE VEHICULE EST IN MOVEMENT ET IL FAUT QUE LE RANGER	THIS CHAIR IS NOT INTENDED FOR OCCUPANCY WHEN VEHICLE IS IN MOTION AND MUST BE RETURNED TO STOWED POSITION
--	--

KEY PART NUMBER U/M DESCRIPTION
 134537-01-01A EA LABEL - OCCUPANCY - CHAIR - US

THIS SEAT IS NOT INTENDED FOR OCCUPANCY WHEN VEHICLE IS IN MOTION

KEY PART NUMBER U/M DESCRIPTION
 134538-01-01A EA LABEL - OCCUPANCY - NO SEAT BELT - BLACK ON CLEAR - US

DST ISICE SIEGE N/EST PAS DESTINE A ETRE OCCUPE LORSQUE LE VEHICULE EST IN MOVUEMENT	THIS SEAT IS NOT INTENDED FOR OCCUPANCY WHILE VEHICLE IS IN MOTION
--	--

KEY PART NUMBER U/M DESCRIPTION
 134538-02-01A EA LABEL - OCCUPANCY - NO SEAT BELT - BLACK ON CLEAR - CSA

<p style="font-size: 1.2em; margin: 0;">WARNING</p> <p style="margin: 5px 0;">IT IS NOT SAFE TO USE COOKING APPLICANCES FOR COMFORT HEATING</p> <p style="margin: 5px 0;">COOKING APPLICANCES NEED FRESH AIR FOR SAFE OPERATION BEFORE OPERATION.</p> <p style="margin: 5px 0;">1. OPEN OVERHEAD VENT OR TURN ON EXHAUST FAN AND; 2. OPEN WINDOW.</p>
--

KEY PART NUMBER U/M DESCRIPTION
 134539-01-01A EA LABEL - WARNING - STOVE/HEATING - US - BLACK ON CLEAR

LABELS GROUP (CONTINUED)

TO ENSURE A SUPPLY OF FRESH AIR TO OCCUPANTS, OPEN VENTILATORS WHEN FUEL-BURNING RANGE, FUEL BURNING CARRY-ON APPLIANCES AND/OR FUEL-BURNING LIGHTS ARE IN OPERATION.	DE MANIERE A ASSURER UNE ALIMENTATION EN AIR FRAIS AUX OCCUPANTS, OUVRIER LES VENTILATEURS LORSQUE LA CUISINIERE LES APPARELS DE CHAUFFAGE PORTABLES ET/OU LES LAMPES DE COMBUSTION D'HUILE SONT EN FONCTIONNEMENT.
COOKING APPLIANCES SHOULD NOT BE USED FOR SPACE HEATING PURPOSES.	LES APPARELS DE CUISSON NE DOIVENT PAS SERVIR AU CHAUFFAGE DES LOCAUX.

KEY PART NUMBER U/M DESCRIPTION
 134540-01-01A EA LABEL - WARNING - STOVE/HEATING - CSA - BLACK ON CLEAR

HOLDING TANK HEATER

TURN OFF WHEN NOT IN USE

SEE OPERATOR'S MANUAL

KEY PART NUMBER U/M DESCRIPTION
 134563-01-01A EA LABEL - SWITCH - HEATER

THIS VEHICLE MAY INCLUDE MERCURY-CONTAINING DEVICES INSTALLED BY THE MANUFACTURER:

FLUORESCENT TUBES, RANGES WITH OVEN, HWH LEVEL SENSING UNIT.

REMOVE DEVICES BEFORE VEHICLE DISPOSAL UPON REMOVAL OF DEVICES: PLEASE REUSE, RECYCLE, OR DISPOSE AS HAZARDOUS WASTE

135869-01A

KEY PART NUMBER U/M DESCRIPTION
 135869-01-01A EA LABEL - MERCURY CONTENT - BLACK ON CLEAR
 135869-01-02A EA LABEL - MERCURY CONTENT - WHITE ON CLEAR

LIQUID SOAP

KEY PART NUMBER U/M DESCRIPTION
 136047-01-01A EA LABEL - LIQUID SOAP

DOOR LOCK	DOOR UNLOCK	RIGHT COMPT DOOR LOCK	RIGHT COMPT DOOR UNLOCK	LEFT COMPT DOOR LOCK	LEFT COMPT DOOR UNLOCK	AUX START SOLENOID	AMP SOURCE
POWER MIRRORS	HEATER BLOWER	PASS HEATER BLOWER	FOG LAMPS	DOCKING LAMPS	DOCKING LAMPS SWITCH TRIGGER	COOLING FANS	

KEY PART NUMBER U/M DESCRIPTION
 136161-01-01A EA LABEL - RELAY - MATTE BLACK/WHITE LETTERS

DOOR LOCK	DOOR UNLOCK	RIGHT COMPT DOOR LOCK	RIGHT COMPT DOOR UNLOCK	LEFT COMPT DOOR LOCK	LEFT COMPT DOOR UNLOCK	AUX START SOLENOID	RUN/ACC POWER #1	POWER SEATS
POWER MIRRORS	HEATER BLOWER	RUN ONLY POWER	FOG LAMPS	DOCKING LAMPS	DOCKING LAMPS SWITCH TRIGGER	COOLING FANS	RUN/ACC POWER #2	

KEY PART NUMBER U/M DESCRIPTION
 136161-02-01A EA LABEL - RELAY - BLACK/WHITE

LT - AIR BAGS - RT

KEY PART NUMBER U/M DESCRIPTION
 136360-01-01A EA LABEL - AIR BAGS

LABELS GROUP (CONTINUED)

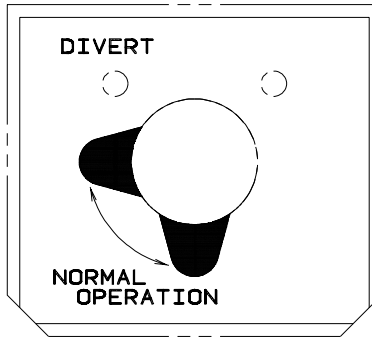

KEY PART NUMBER U/M DESCRIPTION
137997-01-01A EA LABEL - WINTERIZATION VALVE - BLACK/CLEAR



KEY PART NUMBER U/M DESCRIPTION
140190-01-01A EA DECAL/LOGO - V6 (DOMED) - CYAN/MAGENTA/YELLOW/BLACK

WASHER/DRYER
BRACKETS

KEY PART NUMBER U/M DESCRIPTION
141523-01-01A EA LABEL - WASHER/DRYER BRACKETS - BLACK/WHITE

 **WARNING:** COMPRESSED AIR CAN BE HAZARDOUS.

PROPER EYE PROTECTION MUST BE WORN WHEN CONNECTING, DISCONNECTING OR USING AIR HOSE.

CLOSE VALVE BEHIND CONNECTOR BEFORE CONNECTING OR DISCONNECTING AIR HOSE.

HOSE DISCONNECT WILL PRODUCE AIR DISCHARGE FROM HOSE. DIRECT AIR DISCHARGE AWAY FROM SELF AND OTHERS.

KEY PART NUMBER U/M DESCRIPTION
142771-01-01A EA LABEL - WARNING/COMPRESSED AIR - WHITE LETTERING ON CLEAR

LABELS GROUP (CONTINUED)

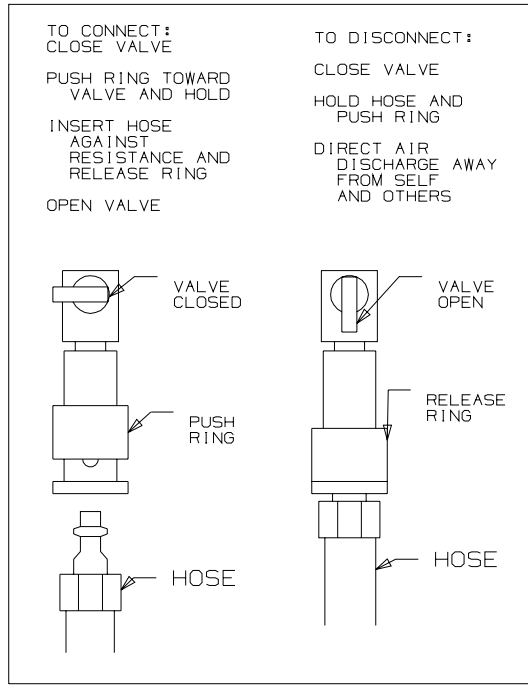

KEY	PART NUMBER	U/M DESCRIPTION
	142773-01-01A	EA LABEL - CONNECT/COMPRESS AIR - WHITE LETTERING ON CLEAR



KEY	PART NUMBER	U/M DESCRIPTION
	142908-01-000	EA LABEL - FREON CHARG



KEY	PART NUMBER	U/M DESCRIPTION
	144040-01-01A	EA COUNTERTOP - MEDALLION/GOLD - CORIAN



KEY	PART NUMBER	U/M DESCRIPTION
	144183-01-01A	EA LABEL - CAUTION RELEASE CATCH - WHITE/CLEAR



KEY	PART NUMBER	U/M DESCRIPTION
	144649-01-01A	EA LABEL - ADJUSTABLE VALVE - WHITE ON CLEAR

LABELS GROUP (CONTINUED)

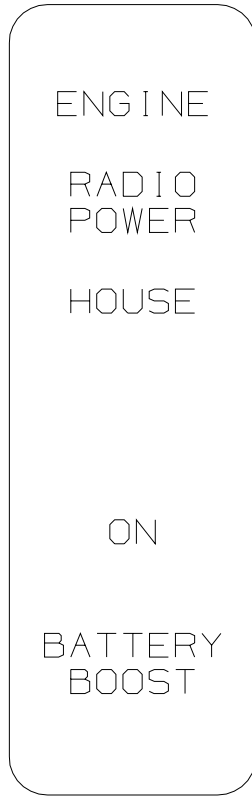

KEY PART NUMBER U/M DESCRIPTION
145731-01-01A EA LABEL - SWITCH - RADIO/BATTERY - BLACK

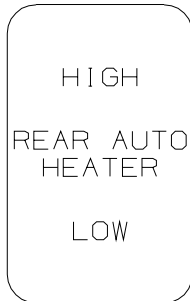

KEY PART NUMBER U/M DESCRIPTION
145731-03-01A EA LABEL - SWITCH - REAR AUTO HEATER - BLACK

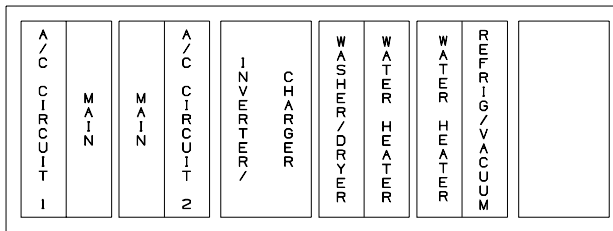

KEY PART NUMBER U/M DESCRIPTION
095721-45-000 EA LABEL - CONTROL CENTER - 50 AMP

LABELS GROUP (CONTINUED)

FOR FUTURE INSTALLATION OF WASHER/DRYER EXHAUST DUCT

- (A) A CLOTHES DRYER MOISTURE-LINT EXHAUST DUCT SHALL NOT BE CONNECTED TO ANY OTHER DUCT, VENT, OR CHIMNEY.
- (B) THE EXHAUST DUCT SHALL BE OF SUFFICIENT LENGTH SO AS NOT TO TERMINATE BENEATH THE RECREATION VEHICLE.
- (C) MOISTURE-LINT EXHAUST DUCTS SHALL NOT BE CONNECTED WITH SHEET METAL SCREWS OR OTHER FASTENING DEVICES THAT EXTEND INTO THE INTERIOR OF THE DUCT.
- (D) MOISTURE-LINT EXHAUST DUCT AND TERMINATION FITTINGS SHALL BE INSTALLED IN ACCORDANCE WITH THE APPLIANCE MANUFACTURER'S PRINTED INSTRUCTIONS.
- (E) SEE MARKED INTERIOR AREA ON SIDEWALL TO LOCATE CUTOUT FOR EXHAUST VENT.
- (F) AS PART OF WASHER/DRYER PREP 4 HOLD DOWN BRACKETS WERE SHIPPED WITH YOUR VEHICLE WHICH ARE INTENDED TO BE USED WITH THE WINNEBAGO OFFERED APPLIANCE.

147524-01

KEY PART NUMBER
147524-01-000

U/M DESCRIPTION
EA LABEL - DRYER VENTING

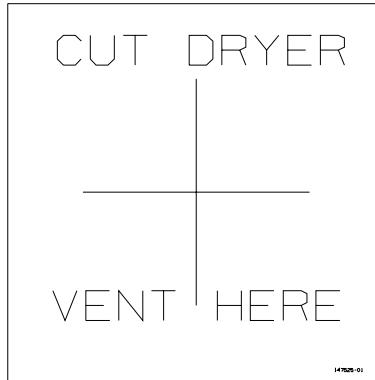

147525-01

KEY PART NUMBER
147525-01-000

U/M DESCRIPTION
EA LABEL - DRYER VENT CUTOUT

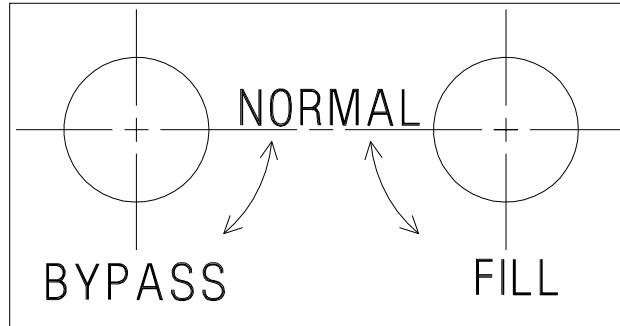

KEY PART NUMBER
147581-01-01A

U/M DESCRIPTION
EA LABEL - WATERFILL/BYPASS - BLACK/CLEAR

YOUR MOTORHOME IS EQUIPPED WITH A SEWER HOSE END ELBOW WHICH INCLUDES A CLOSEABLE DRIP VALVE. AFTER PLACING THE END OF THE HOSE ELBOW INTO THE PARK SEWER DISPOSAL OPENING, USE THUMB TO LIFT HANDLE LOCK AND MOVE HANDLE FORWARD TO OPEN VALVE

NEVER OPERATE TANK VALVES WITHOUT FIRST OPENING THE DRIP VALVE.

AFTER TANKS ARE EMPTY, CLOSE TANK VALVES, THEN PULL HANDLE ON ELBOW TO A VERTICAL CARRYING POSITION TO CLOSE DRIP VALVE. THIS WILL ELIMINATE ANY DRIPPING FROM THE HOSE INTO YOUR STORAGE AREA. SEE OPERATORS MANUAL FOR ADDITIONAL INFORMATION.

147845-01A

KEY PART NUMBER
147845-01-01A

U/M DESCRIPTION
EA LABEL - DRIP VALVE - BLACK/WHITE

LP GROUP
LP SYSTEM

KEY	PART NUMBER	U/M	DESCRIPTION
	045703-01-000	EA	HOSE - LP - 3/8"ID X 24" - 3/8"MPT X 1/2"F SWIVEL - U.S.
	045703-02-000	EA	HOSE - LP - 3/8"ID X 24" - 3/8"MPT X 1/2"F SWIVEL - CANADA
	045703-03-000	EA	HOSE - LP - 3/8"ID X 18" - 3/8"MPT X 1/2"F SWIVEL - U.S.
	045703-09-000	EA	HOSE - LP - 3/8"ID X 24" - 3/8"ID F SWIVEL X 3/8"ID F SWIV
	045703-12-000	EA	HOSE - LP - 3/8"ID X 18" - 3/8"MPT X 1/2"F SWIVEL - CANADA
	045703-13-000	EA	HOSE - LP - 3/8"ID X 120" - 3/8"F SWIVEL X 1/2"F SWIVEL US
	045703-15-000	EA	HOSE - LP - 3/8"ID X 142" - 1/2"F SWIVEL X 3/8"F SWIVEL
	045703-16-000	EA	HOSE - LP - 3/8ID X 109" - 1/2" F SWIV FLR X 3/8" M FLR
	106150-05-000	EA	REGULATOR - TWO STAGE
	106150-01-000	EA	REGULATOR - TWO STAGE-W/90 DEGREE ELBOW & 3/8" FPT OUTLET
	144485-01-000	EA	COMPARTMENT - LP REGULATOR
	105658-01-000	EA	COMPARTMENT - LP REGULATOR
	010251-02-000	EA	ELBOW - BRASS - 90 DEGREE - 3/8"F X 1/4"MPT
	010515-03-000	EA	ELBOW - BLACK - 1/2 X 90 DEGREE STEEL
	010265-01-000	EA	ELBOW - BRASS - 90 DEGREE - 3/8"F X 1/2"FPT
	033759-01-000	EA	ELBOW - 90 DEGREE - 3/8" F X 3/8" F
	010329-01-000	EA	ADAPTER - BRASS - 1/2"F X 1/2"MPT
	010323-01-000	EA	ADAPTER - BRASS - 3/8"F X 1/2"MPT
	010326-01-000	EA	ADAPTER - FLARE - W/CONE GASKET - 3/8"F X 1/2"F
	106871-01-000	EA	BUSHING - 1/2 X 1/4 - BLACK
	106846-01-000	EA	VALVE - RELIEF
	010377-02-000	EA	NUT - BRASS - 3/8" FLARE - FORGED
	010380-02-000	EA	NUT - BRASS - 1/2" FLARE - FORGED
	016188-09-000	EA	GROMMET - LP LINE - .68"HOLE X 1 1/4"LONG - RUBBER
*	144116-03-000	EA	TANK - LP - 100 LB - 16"D X 47.5"L
			FROM: 00-00-00 THRU: 09-17-03
*	144116-08-000	EA	TANK - LP - 130 LB - 16"D X 47.5"LG
			FROM: 09-18-03 THRU: 99-99-99
*	144116-02-000	EA	TANK - LP - 100 LB - 16"D X 47.5"L
			FROM: 00-00-00 THRU: 10-17-03
*	144116-07-000	EA	TANK - LP - 130 LB - 16"D X 47.5"LG
			FROM: 10-18-03 THRU: 99-99-99
	040440-03-000	EA	TRANSMITTER - DIAL/SNAP-ON - 0-90 OHM 2 TERM(POWER/GROUND)
	040440-02-000	EA	TRANSMITTER - DIAL/BOLT-ON - 0-90 OHM 2 TERM(POWER/GROUND)
	103613-03-000	EA	DETECTOR - LP GAS - W/O SHUT-OFF VALVE
			FROM: 00-00-00 THRU: 02-08-04
	150138-01-01A	EA	DETECTOR - LP GAS - WHITE
			FROM: 02-09-04 THRU: 99-99-99
	150138-01-02A	EA	DETECTOR - LP GAS - BROWN
			FROM: 02-09-04 THRU: 99-99-99

*COMPONENT PARTS LISTED LATER IN THIS GROUP

LP GROUP (CONTINUED)
LP COMPONENTS

144116-02-000, 144116-06-000, 144116-07-000 & 144116-08-000

KEY	PART NUMBER	U/M	DESCRIPTION	VENDOR NO.
	040421-01-712	EA	VALVE-SERV. W/O VAPOR RELIEF	29000853
	040421-01-713	EA	VALVE-RELIEF 1" W/SPRING 7"	V-20479
	088253-01-702	EA	FLOAT/SCREW IN-SNAP ON DIAL	SG16C0001442
	144116-01-700	EA	VALVE-OUTAGE(NO STEM REMOVE)	V20058
	144116-01-701	EA	VALVE/FILL 80 % W/YELLOW CAP	V13414

144116-03-000

KEY	PART NUMBER	U/M	DESCRIPTION	VENDOR NO.
	040421-01-712	EA	VALVE-SERV. W/O VAPOR RELIEF	29000853
	040421-01-713	EA	VALVE-RELIEF 1" W/SPRING 7"	V-20479
	088253-01-702	EA	FLOAT/SCREW IN-SNAP ON DIAL	SG16C0001442
	144116-01-700	EA	VALVE-OUTAGE(NO STEM REMOVE)	V20058
	144116-01-701	EA	VALVE/FILL 80 % W/YELLOW CAP	V13414
	144116-03-700	EA	VALVE - SERVICE/LIQUID	V12550

LOUNGE GROUP CABINETS

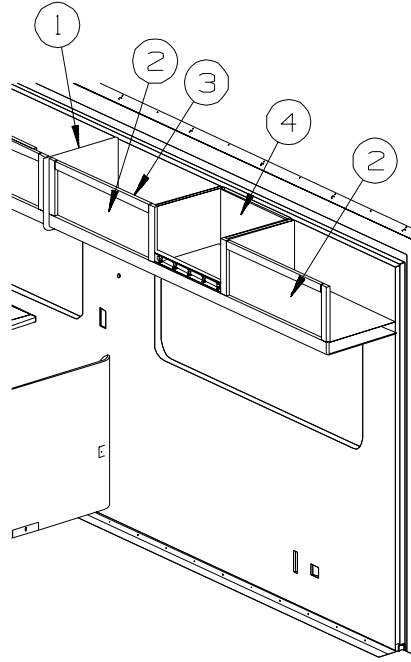
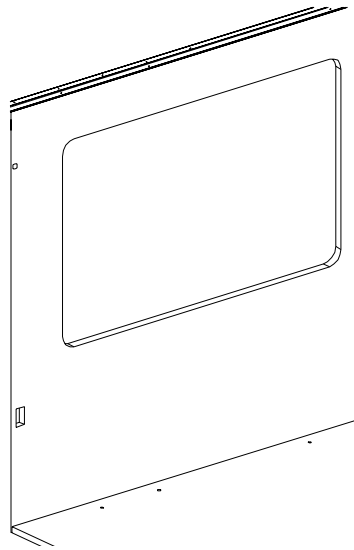

KEY	PART NUMBER	U/M	DESCRIPTION
1	145274-30-R38	EA	END CAP - OVERHEAD CABINET - PORTSMOUTH OAK
1	145274-30-R39	EA	END CAP - OVERHEAD CABINET - CONCERT CHERRY
1	145274-30-R46	EA	END CAP - OVERHEAD CABINET - WASHED MAPLE
2	141522-46-P54	EA	DOOR - ARCHED/PENCIL EDGE/HORIZ - 10.8" X 27.9" - W/O HDW - PORTSMOUTH OAK
2	141522-46-P55	EA	DOOR - ARCHED/PENCIL EDGE/HORIZ - 10.8" X 27.9" - W/O HDW - CONCERT CHERRY
2	141522-46-P56	EA	DOOR - ARCHED/PENCIL EDGE/HORIZ - 10.8" X 27.9" - W/O HDW - WASHED MAPLE
3	145274-01-R38	EA	CABINET - OVERHEAD/COUCH - W/O DOORS/HDW - PORTSMOUTH OAK
3	145274-01-R39	EA	CABINET - OVERHEAD/COUCH - W/O DOORS/HDW - CONCERT CHERRY
3	145274-01-R46	EA	CABINET - OVERHEAD/COUCH - W/O DOORS/HDW - WASHED MAPLE
3	145274-01-RW4	EA	CABINET - OVERHEAD/COUCH - W/O DOORS/HDW - WASHED MAPLE FROM: 00-00-00 THRU: 01-04-04 FROM: 01-05-04 THRU: 99-99-99
3	145274-02-R38	EA	CABINET - OVERHEAD/COUCH - W/O DOORS/HDW - PORTSMOUTH OAK - DELUXE SOUND SYSTEM
3	145274-02-R39	EA	CABINET - OVERHEAD/COUCH - W/O DOORS/HDW - CONCERT CHERRY - DELUXE SOUND SYSTEM
3	145274-02-R46	EA	CABINET - OVERHEAD/COUCH - W/O DOORS/HDW - WASHED MAPLE - DELUXE SOUND SYSTEM
3	145274-02-RW4	EA	CABINET - OVERHEAD/COUCH - W/O DOORS/HDW - WASHED MAPLE - DELUXE SOUND SYSTEM FROM: 00-00-00 THRU: 01-04-04 FROM: 01-05-04 THRU: 99-99-99
4	140374-37-000	EA	MIRROR - SAFETY GLASS - 10.3" X 18.2" FROM: 00-00-00 THRU: 09-28-03
4	140374-69-000	EA	MIRROR - SAFETY GLASS - 10.3" X 16.4" FROM: 09-29-03 THRU: 99-99-99

SEALANTS & FASTENERS GROUP

SEALANTS & ADHESIVES

KEY	PART NUMBER	U/M	DESCRIPTION
	004001-05-000	EA	ADHESIVE - SCOTCH-WELD - 3M DP100 - CLEAR - 50ML
	010405-02-000	EA	TAPE - THREAD SEALING - 3/8"
	034552-06-000	EA	SILICONE - TUBE - W/O NOZZLE - OFF WHITE
	034552-15-000	EA	SILICONE - TUBE - W/O NOZZLE - BRIGHT WHITE
	063642-01-000	FT	TAPE - ADHESIVE - .4" X 1.5" X 180'
	064075-07-000	FT	SEAL - BULB - W/WIRED U CHANNEL - .3" X .5" CHANNEL-BLACK
	067788-01-000	EA	ADHESIVE - SPRAY - 3M - 19.5 OZ AEROSOL CAN
	069640-01-000	FT	SEALER - TAPE - .25" DIAMETER X 30' - BLACK OR GRAY
	069640-02-000	FT	SEALER - TAPE - .13" THICK X .5" WIDE X 60' - GRAY
	069640-03-000	FT	SEALER - TAPE - .13" THICK X .75" WIDE X 60' - BLACK
	069640-07-000	FT	SEALER - TAPE - .09" THICK X 2" WIDE X 45' - GRAY
	069640-09-000	FT	SEALER - TAPE - .03" THICK X 2.50" WIDE X 80' - GRAY
	069640-10-000	FT	SEALER - TAPE - .03" THICK X 1.50" WIDE X 90' - GRAY
	069640-11-000	FT	SEALER - TAPE - .19" THICK X .38" WIDE X 40' - BLACK
	069640-13-000	FT	SEALER - TAPE - .03" THICK X 2" WIDE X 45' - BLACK
	069640-14-000	FT	SEALER - TAPE - .06" THICK X 1" WIDE X 100' - GRAY
	069640-15-000	FT	SEALER - TAPE - .06" THICK X .38" WIDE X 100' - GRAY
	069640-17-000	FT	SEALER - TAPE - .03" THICK X 1" WIDE X 90' - GRAY
	069640-18-000	FT	SEALER - TAPE - .50" THICK X .13" WIDE X 60' - BRT WHITE
	069640-19-000	FT	SEALER - TAPE - .75" THICK X .13" WIDE X 60' - BRT WHITE
	069640-20-000	FT	SEALER - TAPE - .50" THICK X .5" WIDE X 60' - BLACK
	069640-21-000	FT	SEALER - TAPE - .50" THICK X .06" WIDE X 100'- BRT WHITE
	069640-22-000	FT	SEALER - TAPE - 1/32" THICK X 1/4" WIDE X 200' - BRT WHITE
	069640-23-000	FT	SEALER - TAPE - 1/16" THICK X 3/4" WIDE X 100' - BRT WHITE
	069640-27-000	FT	SEALER - TAPE - .06" THICK X 2.25" WIDE - BRIGHT WHITE
	069640-28-000	FT	SEALER - TAPE - .25" THICK X 1.86" WIDE X 90' - GRAY
	069640-30-000	FT	SEALER - TAPE - .03" THICK X .625" WIDE X 50' - GRAY
	069640-31-000	FT	SEALER - TAPE - .25" THICK X .75" WIDE X 15' - BLACK
	069640-32-000	FT	SEALER - RIBBON - 1/16" X 3/8" X 100' - BLACK
	072889-01-000	EA	SEALANT - URETHANE - BLACK - TUBE W/NOZZLE TIP
	072889-27-000	EA	SEALANT - URETHANE - SILVER 10 OZ - TUBE W/NOZZLE TIP
	076322-01-000	FT	TAPE-DOUBLE COATED/ADHESIVE BK-.03"THK X .8"W X 216'- WHT
	076322-02-000	FT	TAPE-DOUBLE COATED/ADHESIVE BK-.05"THK X 1"W X 108' - WHT
	076322-03-000	FT	TAPE-DOUBLE COATED/ADHESIVE BK-.05"THK X .5"W X 108' - WHT
	076322-04-000	FT	TAPE-DOUBLE COATED/ADHESIVE BK-.05"THK X .8"W X 108' - WHT
	076322-05-000	FT	TAPE-DOUBLE COATED/ADHESIVE BK-.05"THK X .8"W X 108' - WHT
	076322-07-000	FT	TAPE-DOUBLE COATED/ADHESIVE BK-.05"THK X .5"W X 200' - WHT
	076322-11-000	FT	TAPE-DOUBLE COATED/ADHESIVE BK-.02"THK X 1"W X 216' - CLR
	076322-21-000	FT	TAPE - FOAM/DOUBLE COATED - .5"
	076322-22-000	FT	TAPE - FOAM/DOUBLE COATED - .045" X .75"
	076322-23-000	FT	TAPE - FOAM/DOUBLE COATED - .045" X 1"
	076322-24-000	FT	TAPE - FOAM/DOUBLE COATED - .025" X 1"
	076322-25-000	FT	TAPE - FOAM/DOUBLE COATED - .025" X .5"
	086276-01-000	EA	TAPE - DOUBLE SIDED - 1/2" WIDE X 108' LONG (SOLD BY ROLL)
	088479-01-000	EA	TAPE - ALUMINUM - 3"
	090340-01-000	FT	SEAL - FOAM - CLOSED CELL - 1/4" X 1/2" X 50'
	091255-02-000	FT	SEAL - ADHESIVE BACKED/FOAM - 3/64" THICK X 3/16"W X 1000'
	091255-03-000	FT	SEAL - ADHESIVE BACKED/FOAM - 1/4" THICK X 1/4"W X 1000'
	094401-01-000	EA	SEALER - BODY SEAM - FLEXICLEAR
	094401-03-000	EA	SEALER - BODY SEAM - BLACK
	094401-04-000	EA	SEALER - BODY SEAM - CLEAR
	098408-01-000	FT	SEAL - SPONGE RUBBER - CLOSED CELL
	099069-01-000	FT	SEAL - RUBBER - CLOSED SPONGE - .5" WIDE X .12" THICK -BLK
	099418-01-000	FT	SEAL - D-SECTION/ADHESIVE BACK - .44" X .44"- BLK RUBBER
	099418-02-000	FT	SEAL - D-SECTION/ADHESIVE BACK - .44" X .44"- WHITE RUBBER
	100128-02-000	FT	SEAL - FOAM/ADHESIVE BACK - .37" WIDE X .37" THICK
	104692-01-000	FT	SEAL - ADHESIVE BACKED FOAM - 3/4" THICK X 3/4" WIDE X 25'
	104692-03-000	FT	SEAL - ADHESIVE BACKED FOAM - 1" THICK X 1 3/16"WIDE X 15'
	107828-01-000	EA	SEALANT - SB - 190 EVERSEAL
	109506-12-000	EA	FILM/ABRASION-RESISTANT - TRANSPARENT - 1" DIA.
	110274-01-000	FT	TAPE - DOUBLE SIDED/FOAM - .45" X 1" X 216' - BLACK
	112481-02-000	EA	ADHESIVE - PLEXUS ETHACRYLATE - CARTRIDGE
	112864-01-000	FT	SEAL - FOAM/BUTYL COVERED - 3/8" X 35'

SEALANTS & FASTENERS GROUP (CONTINUED)

SEALANTS & ADHESIVES (CONTINUED)

KEY	PART NUMBER	U/M	DESCRIPTION
	112091-01-000	FT	SEAL/D - NEOPRENE - HEAT ACTIVE ADHESIVE - .9" X .7"
	112901-03-000	EA	ADHESIVE - PLEXUS - MA300 - 50ML - WHITE
	112902-01-000	EA	NOZZLE - ELEMENT - 3/8 X 24
	112902-03-000	EA	MIXER NOZZLE - F/GUN #00400102000 - SCOTCH-WELD & PLEXUS
	112902-04-000	EA	NOZZLE - ELEMENT - 1/4" X 3.5"
	113366-01-000	EA	ADHESIVE - INSTANT - 1 OZ
	113452-02-000	FT	SEAL/TRIM - FRONT - VINYL W/WIRE CARRIER - .027"
	120074-02-03A	EA	SILICONE - TUBE - W/O NOZZLE - LOW ODOR - SMOKEY WHITE
	120074-02-02A	EA	SILICONE - TUBE - W/O NOZZLE - LOW ODOR - SOFT WHITE
	120534-01-01A	EA	TAPE - SCOTCH - 3M - 1/2" FINE LINE
	123244-01-000	FT	TAPE - DOUBLE SIDED/FOAM - 5/64" THICK X 3/4" WIDE X 108'
	123816-01-000	FT	TAPE - DOUBLE SIDED - 1" X 3/4" X 200'
	123816-02-000	FT	TAPE - DOUBLE SIDED - 1/2" X 1 1/3" X 200'
	123816-03-000	FT	TAPE - DOUBLE SIDED - 1/2" X 3/4" X 200'
	123816-04-000	FT	TAPE - DOUBLE SIDED - 6" X 750'
	126427-01-000	EA	ADHESIVE - ALL PURPOSE - ABS/PVC
	126427-02-000	EA	PRIMER - CLEANER - FLEX PIPING
	131264-01-02A	EA	SILICONE - TUBE - W/O NOZZLE - CLEAR
	131264-01-01A	EA	SILICONE - TUBE - W/O NOZZLE - BLACK
	131264-02-01A	EA	SILICONE - TUBE - W/O NOZZLE - VW GRAY - BATH ONLY
	131264-03-01A	EA	SILICONE - TUBE - W/O NOZZLE - SELF LEVELING - BRIGHT WHITE
	131264-04-01A	EA	SILICONE/SEALANT/ADHESIVE - FAST CURE F/GLASS/VINYL - B/W
	131384-01-000	EA	ADHESIVE - JET WELD
	134651-01-000	FT	SEAL - 1/2" X 3/4" PSA 1 SIDE
	900390-01-000	EA	NOZZLE - SILICONE TUBE - 2.5" LONG - W/EXTERNAL THREADS
	900390-03-000	EA	NOZZLE - SILICONE TUBE - 4.3" LONG W/INTERNAL THREADS

BOLTS, NUTS AND WASHERS

KEY	PART NUMBER	U/M	DESCRIPTION
	OMC04K-06-016	EA	BOLT - HEX - M06 X 1 X 016
	OMC05K-08-055	EA	BOLT - HEX - M08 X 1.25 X 2.2
	OMC13K-14-110	EA	BOLT - HEX
	OMC13K-14-070	EA	BOLT - HEX - M14 X 2 X 2 3/4
	OMC31K-08-020	EA	BOLT - HEX - SERRATED FLANGE - M8 X 020
	OMC32K-10-030	EA	BOLT - HEX - SERRATED FLANGE - M10 X 1 1/2
	OMD16K-10-000	EA	NUT - HEX PREV TORQUE M10 X 1 1/2 CLASS 8
	OMD39K-12-000	EA	NUT - HEX W/NYLON LOCK - M12 X 1 3/4
	OMD40K-14-000	EA	NUT - HEX W/NYLON LOCK - M14 X 2
	OMD54F-06-000	EA	NUT-HEX SER FLG M6X1,0 SS - DIN6923A2M6
	OME06K-14-280	EA	WASHER - FLAT - 14 ID X 28 OD
	000C12-04-08B	EA	BOLT - HEX - 1/4-20 X 1/2 - GRADE #5 - ZINC
	000C12-04-12A	EA	BOLT - HEX - 1/4-20 X 3/4 - PLAIN 5
	000C12-04-40B	EA	BOLT - HEX - 1/4-20 X 2 1/2 - GRADE 5 ZINC
	000C12-05-16B	EA	BOLT - HEX - 5/16 - 18X1 - GRADE #5 - ZINC
	000C12-06-44B	EA	BOLT - HEX - 3/8-16 X 2 3/4 - GRADE 5 - ZINC
	000C12-06-16B	EA	BOLT - HEX - 3/8 - 16X1 - GRADE #5 - ZINC
	000C12-08-28B	EA	BOLT - HEX - 1/2-13 X 1 3/4 - GRADE #5 - ZINC
	000C12-08-24B	EA	BOLT - HEX - 1/2 - 13X1 1/2 - GRADE #5 - ZINC
	000C12-08-16B	EA	BOLT - HEX - 1/2-13 X 1 - GRADE #5 - ZINC
	000C12-10-24B	EA	BOLT - HEX - 5/8 - 11X1 1/2 - GRADE #5 - ZINC
	000C13-07-48B	EA	BOLT - HEX - 7/16-20 X 3 - GRADE #5 - ZINC
	000C13-07-40B	EA	BOLT - HEX - 7/16-20 X 2 1/2 - GRADE #5 - ZINC
	000C14-07-28B	EA	BOLT - HEX - 7/16-14 X 1 3/4 - GRADE #8 - ZINC
	000C14-10-32K	EA	BOLT - HEX - 5/8-11 X 2 - GRADE #8 - ZINC
	000C14-10-24K	EA	BOLT - HEX - 5/8-11 X 1 1/2 - GRADE #8 - ZINC
	000C16-07-16B	EA	BOLT - CARRIAGE - ASSIST HANDLE - 7/16TH - 14 X 1
	000C18-05-40A	EA	BOLT - ELEVATOR - 5/16-18 X 2 1/2 - PL
	000C26-04-10B	EA	BOLT - HEX - SERRATED FLANGE - 1/4-20 X 5/8 - ZINC
	000C26-04-18B	EA	BOLT - HEX - SERRATED FLANGE - 1/4-20 X 1 1/8 - ZINC
	000C26-04-14B	EA	BOLT - HEX - SERRATED FLANGE - 1/4-20 X 7/8 - ZINC
	000C26-05-20B	EA	BOLT - HEX - SERRATED FLANGE - 5/16-18 X 1 1/4 - ZINC

SEALANTS & FASTENERS GROUP (CONTINUED)
BOLTS, NUTS AND WASHERS (CONTINUED)

KEY	PART NUMBER	U/M	DESCRIPTION
	000C26-06-12B	EA	BOLT - HEX - SERRATED FLANGE - 3/8-16 X 3/4 - ZINC
	000C26-08-24B	EA	BOLT - HEX - SERRATED FLANGE - 1/2-13 X 1 1/2 - ZINC
	000C27-04-40B	EA	BOLT - CARRIAGE - 1/4-20 X 2 1/2 - ZINC
	000C27-07-40B	EA	BOLT - CARRIAGE - 7/16-14 X 2 1/2 - GRADE #5
	000C27-08-48B	EA	BOLT - CARRIAGE - 1/2-13 X 3 - GRADE #5
	000D16-07-00B	EA	NUT - HEX - 7/16-14 - ZINC
	000D20-07-00B	EA	NUT - ACORN - ASSIST HANDLE - 7/16 - 14
	000D24-10-00B	EA	NUT - HEX - SELF LOCKING - 10-32 - ZINC
	000D28-10-00B	EA	NUT - HEX - W/NYLON LOCK - 10-32 ZINC
	000D29-04-00B	EA	NUT - HEX - SELF LOCKING - 1/4 X 20 - ZINC
	000D29-06-00B	EA	NUT - HEX - W/NYLON LOCK - 3/8-16 - ZINC
	000D29-09-00B	EA	NUT - HEX - SELF LOCKING - 9/16-12 - ZINC
	000D30-07-00B	EA	NUT - HEX LOCK - NYLON 7/16 X 20
	000D34-04-00B	EA	NUT - HEX - LOCKING - 1/4-20 - ZINC
	000D34-06-00B	EA	NUT - HEX - LOCKING - 3/8-16 GRADE C - ZINC
	000D39-04-00B	EA	NUT - HEX - LOCKING W/SERRATED FLANGE - 1/4-20 - ZINC
	000D39-05-00B	EA	NUT - HEX - LOCKING W/SERRATED FLANGE - 5/16-18 - ZINC
	000D39-06-00B	EA	NUT - HEX - LOCKING W/SERRATED FLANGE - 3/8-18 - ZINC
	000D39-07-00B	EA	NUT - HEX - LOCKING W/SERRATED FLANGE - 7/16-14 - ZINC
	000D39-08-00B	EA	NUT - HEX - LOCKING W/SERRATED FLANGE - 1/2-13 - ZINC
	000D44-04-00B	EA	NUT - HEX - LOCKING W/SERRATED FLANGE - 1/4-28 - ZINC
	000D44-07-00B	EA	NUT - HEX - LOCKING W/SERRATED FLANGE - 7/16-20 - ZINC
	000D44-08-00B	EA	NUT - HEX - LOCKING W/SERRATED FLANGE - 1/2-20 - ZINC
	000D46-04-00A	EA	NUT - HEX - WELD - 1/4-20 - PLAIN
	000D58-06-00A	EA	NUT - HEX - WELD 3/8-16 - PLAIN
	000D65-08-00B	EA	NUT - HEX - LOCKING W/SERRATED FLANGE - 8-32 - ZINC
	000D67-10-00B	EA	NUT - HEX - LOCK - 5/8-11 - ZINC
	000D73-08-00C	EA	NUT - HEX FLANGE - 1/2-13
	000D75-09-00B	EA	NUT - HEX LOCKING - 9/16-12 - ZINC
	000D76-06-00B	EA	NUT - HEX FLANGE - 3/8-16
	000E11-04-00F	EA	WASHER - LOCKING - 1/4 MED SPLIT - STAINLESS STEEL
	000E11-07-00B	EA	WASHER - LOCKING - 7/16 MED SPLIT - ZINC
	000E11-08-00B	EA	WASHER - LOCKING - 1/2 MED SPLIT - ZINC
	000E13-17-00B	EA	WASHER - FLAT - 3/8 AR - ZINC
	000E13-18-00B	EA	WASHER - FLAT - 3/8 WIDE - ZINC
	000E13-20-00B	EA	WASHER - FLAT - 7/16 WIDE - ZINC
	000E13-22-00B	EA	WASHER - FLAT - 1/2 WIDE - ZINC
	000E13-26-00B	EA	WASHER - FLAT - 5/8 WIDE - ZINC
	000E14-10-00B	EA	WASHER - LOCKING - #10 EXTERNAL TOOTH - ZINC
	000E16-10-00B	EA	WASHER - HARDENED - 5/8 - FLAT - ZINC
	000G45-05-16B	EA	BOLT - LAG - 5/16-9 X 1 - ZINC
	000G62-08-24B	EA	SCREW - SF/DR - 8-18 X 1 1/2 PFH
	005081-01-000	EA	NUT - SPEED - C-TYPE - #8 SCREW
	040921-03-000	EA	NUT - SPEED - U TYPE - #10
	040921-04-000	EA	NUT - SPEED - U TYPE - #8-.59" LENGTH X .44" WIDTH
	040921-05-000	EA	NUT - SPEED - U-TYPE - 8-.67" X .44" WIDE
	041322-01-000	EA	WASHER - FLANGE - 15/32 ID X 2 3/8 OD - F/SEAT BELT MTG
	044364-02-000	EA	NUT - SPEED - FLAT - ROUND
	044533-01-000	EA	WASHER - 1 3/8"OD - FOR BUTTONS - PLASTIC
	051387-06-000	EA	BOLT - CARRIAGE W/O HOLE - 5/16-18 X 9 1/2 - ZINC
	058716-02-000	EA	WASHER - FLAT NYLON
	064081-03-000	EA	NUT - WING 3/8-16 - W/WELD NUT
	077071-01-000	EA	WASHER - FENDER - 3/16"ID X 1"OD
	084406-01-000	EA	NUT - CAPPED - CROSS RECESSED - BLACK - 1/4-20 THD
	087234-01-000	EA	NUT - JACK - 1/4 X 20 THD - MOLLY
	088787-12-000	EA	STUD - WELD - 1/4 - 20 X 1.0 LG - MN
	102333-01-06A	EA	BOLT - CARRIAGE - 7/16-14 STAINLESS STEEL CAP
	103020-02-000	EA	BOLT-U - #8-32 - GRADE 5 ZINC
	106166-01-000	EA	BOLT/COLLARED HANGER - 8-32 X 1
	106956-03-000	EA	BOLT - HEX TAP - 1/2-12NC X 3 - GRADE 5 - FULL THREAD/ZINC
	106956-08-000	EA	BOLT - HEX TAP - 1/2-13NC X 4 - GRADE 5 - FULL THREAD/ZINC
	107397-01-000	EA	WASHER - FENDER - 3/4"ID X 1"OD
	108067-03-000	EA	STUD - WELD - 1/4 - 20 X 1/2 CD

SEALANTS & FASTENERS GROUP (CONTINUED)
BOLTS, NUTS AND WASHERS (CONTINUED)

KEY	PART NUMBER	U/M	DESCRIPTION
	103020-02-000	EA	BOLT-U - #8-32 - GRADE 5 ZINC
	106166-01-000	EA	BOLT/COLLARED HANGER - 8-32 X 1
	106956-03-000	EA	BOLT - HEX TAP - 1/2-12NC X 3 - GRADE 5 - FULL THREAD/ZINC
	106956-08-000	EA	BOLT - HEX TAP - 1/2-13NC X 4 - GRADE 5 - FULL THREAD/ZINC
	107397-01-000	EA	WASHER - FENDER - 3/4"ID X 1"OD
	108067-03-000	EA	STUD - WELD - 1/4 - 20 X 1/2 CD
	109235-01-05A	FT	COVER - SCREW - BRIGHT WHITE
	109235-01-01A	FT	COVER - SCREW - MAT BLACK
	109917-03-000	EA	WASHER - 1" X .50"
	109917-04-000	EA	WASHER - 1" X .75"
	110794-01-000	EA	WASHER - FLAT - 1" ID X 1 3/4" OD
	121511-01-000	EA	WASHER - SPUR
	113985-02-000	EA	BOLT - FLANGE - M10-1 1/2 X 30CL 10.9
	114259-05-000	EA	BOLT - 7/16-20 X 1 1/4 W/WASHER
	128444-01-000	EA	WASHER - SPRING - CONICAL
	131377-01-000	EA	NUT-HEX HEAD W/WASHER-1/4-20 X 2" STEEL W/3/4" OD WASHER
	135092-01-01A	EA	BOLT - HEX - SERRATED FLANGE - 1/2-20 X 1 3/4-GRADE 5 ZINC
	135092-02-01A	EA	BOLT - HEX - SERRATED FLANGE - 1/2-20 X 2 1/2-GRADE 5 ZINC
	143399-01-01A	EA	NUT/RETAINING - 3/8"- 24 NFT
	144904-01-01A	EA	BOLT - ADJUSTMENT - HEADLAMP
	148817-01-000	EA	WASHER/SPUR - LOCKING

SCREWS

KEY	PART NUMBER	U/M	DESCRIPTION
	0G1106-06-160	EA	SCREW - 6-20 X 3/8 PPH
	0G1106-08-240	EA	SCREW - 6-20 X 1/2 PPH - VW LIGHT GRAY
	0G1108-12-240	EA	SCREW - 8-18 X 3/4 PPH - VW LIGHT GRAY
	0G1108-16-240	EA	SCREW - 8-18 X 1.00 PPS - VW LIGHT GRAY
	0G1208-12-170	EA	SCREW - 8-18 X 3/4 POH - BRIGHT WHITE
	0G1308-10-240	EA	SCREW - 8-18 X 5/8 PFH - VW LIGHT GRAY
	0G3804-22-180	EA	SCREW - MACHINE - 1/4-20 X 1 3/8 PFH - BLACK
	0G3908-08-170	EA	SCREW - SF/DR - 8-18 X 1/2 PPH - BRIGHT WHITE
	0G3908-08-160	EA	SCREW - SF/DR - 8-18 X 1/2 PPH - VW WHITE
	0G3908-08-240	EA	SCREW - SF/DR - 8-18 X 1/2 PPH - VW LIGHT GRAY
	0G3908-12-250	EA	SCREW - SF/DR - 8-18 X 3/4 PPH - DARK GRAY
	0G3908-12-240	EA	SCREW - SF/DR - 8-18 X .75 PPH - VW LIGHT GRAY
	0G3908-16-170	EA	SCREW - SF/DR - 8-18 X 1 PPH - BRIGHT WHITE
	0G3908-24-170	EA	SCREW - SF/DR - 8-18 X 1 1/2 PPH - BRIGHT WHITE
	0G3910-10-330	EA	SCREW - SF/DR - 20-16 X 5/8 PPH - PUTTY
	0G3910-10-320	EA	SCREW - SF/DR - 10-16 X 5/8 PPH - GLACIER
	0G3910-10-240	EA	SCREW - SF/DR - 10-16 X 5/8 PPH - VW LIGHT GRAY
	0G3910-12-240	EA	SCREW - SF/DR - 10-16 X .75 PPH - VW LIGHT GRAY
	0G3910-12-170	EA	SCREW - SF/DR - 10-16 X 3/4 PPH - BRIGHT WHITE
	0G3910-12-320	EA	SCREW - SF/DR - 10-16 X 3/4 PPH - GLACIER
	0G5508-12-240	EA	SCREW - SF/DR - 8-18 X 3/4 PWH - VW LIGHT GRAY
	0G5508-12-170	EA	SCREW - SF/DR - 8-18 X 3/4 PWH - BRIGHT WHITE
	0G5508-12-330	EA	SCREW - SF/DR - 8-18 X 3/4 PWH - PUTTY
	0G5508-12-320	EA	SCREW - SF/DR - 8-18 X 3/4 PWH - GLACIER
	0G5508-12-260	EA	SCREW - SF/DR - 8-18 X 3/4 PWH - ALLANTE ANTELOPE
	0G5508-12-270	EA	SCREW - SF/DR - 8-18 X 3/4 PWH - TITANIUM
	0G5508-16-250	EA	SCREW - SF/DR - 8-18 X 1 PWH - VW DARK GRAY
	0G5508-16-330	EA	SCREW - SF/DR - 8-18 X 1 PWH - PUTTY
	0G5508-16-320	EA	SCREW - SF/DR - 8-18 X 1 PWH - GLACIER
	0G6008-16-170	EA	SCREW - SF/DR - 8-18 X 1 POH - BRIGHT WHITE
	0G6710-08-130	EA	SCREW - 10-12 X 1/2 PPH - TAUPE
	0G6710-08-170	EA	SCREW - 10-12 X 1/2 PPH - BRIGHT WHITE
	0G6710-08-240	EA	SCREW - 10-12 X 1/2 PPH - VW LIGHT GRAY
	0G6710-12-170	EA	SCREW - 10-12 X 3/4 PPH - BRIGHT WHITE
	0G6806-16-170	EA	SCREW - 6-18 X 1 POH - BRIGHT WHITE
	0G6810-24-280	EA	SCREW - 10-12 X 1 1/2 POH - SOFT WHITE
	000C20-04-16A	EA	SCREW - 1/4-20X 1 - FLAT SOCKET HEAD
	000C20-05-28F	EA	SCREW - 5/16-18 X 1 3/4 FLAT SOC - STAINLESS STEEL
	000C20-06-24T	EA	SCREW - 3/8-16 X 1 1/2 - FLAT SOCKET

SEALANTS & FASTENERS GROUP (CONTINUED)
SCREWS (CONTINUED)

KEY	PART NUMBER	U/M	DESCRIPTION
	000G11-06-10J	EA	SCREW - 6-20 X 5/8 PPH - BRASS
	000G11-06-08P	EA	SCREW - 6-20 X 1/2 PPH - DARK BROWN
	000G11-06-08B	EA	SCREW - 6-20 X 1/2 PPH - ZINC
	000G11-07-08B	EA	SCREW - 7-19 X 1/2 PPH - ZINC
	000G11-08-20G	EA	SCREW - 8-18 X 1 1/4 - ANTIQUE BRASS
	000G11-08-20B	EA	SCREW - 8-18 X 1 1/4 PPH - ZINC
	000G11-08-16B	EA	SCREW - 8-18 X 1 PPH - ZINC
	000G11-08-12T	EA	SCREW - 8-18 X 3/4 PPH - BLACK MAGNESIUM
	000G11-08-12P	EA	SCREW - 8-18 X 3/4 PPH - DARK BROWN
	000G11-08-12B	EA	SCREW - 8-18 X 3/4 PPH - ZINC
	000G11-08-08T	EA	SCREW - 8-18 X 1/2 PPH - FLUOROCARBON COATING
	000G11-08-06B	EA	SCREW - 8-18 X 3/8 PPH - ZINC
	000G11-10-24P	EA	SCREW - 10-16 X 1 1/2 PPH - DARK BROWN
	000G11-10-12D	EA	SCREW - 10-16 X 3/4 PPH - BLACK
	000G12-06-12J	EA	SCREW - 6-20 X .75 POH - BRASS
	000G12-06-08T	EA	SCREW - 6-20 X 1/2 POH - BLACK
	000G13-05-10B	EA	SCREW - 5-12 X 5/8 PFH - ZINC
	000G13-06-08G	EA	SCREW - 6-20 X 1/2 PFH - ANTIQUE BRASS
	000G13-06-08B	EA	SCREW - 6-20 X 1/2 PFH - ZINC
	000G13-06-06I	EA	SCREW - 6-20 X 3/8 PFH - BLACK ZINC
	000G13-06-24J	EA	SCREW - 6-20 X 1 1/2 PFH - BRASS
	000G13-06-16J	EA	SCREW - 6-20 X 1 PFH - BRASS
	000G13-06-10J	EA	SCREW - 6-20 X 5/8 PFH - BRASS
	000G13-06-10G	EA	SCREW - 6-20 X 5/8 PFH - ANTIQUE BRASS
	000G13-07-10H	EA	SCREW - 7-19 X 5/8 PFH - BLACK
	000G13-08-16B	EA	SCREW - 8-18 X 1 PFH - ZINC
	000G13-08-109	EA	SCREW - 8-18 X 5/8 PFH
	000G13-08-10B	EA	SCREW - 8-18 X 5/8 PFH - ZINC
	000G13-08-24B	EA	SCREW - 8-18 X 1 1/2 PFH - ZINC
	000G13-10-16I	EA	SCREW - 10-16 X 1 PFH - BLACK
	000G16-04-24B	EA	SCREW - MACHINE - 1/4-20 X 1 1/2 PPH
	000G18-08-16B	EA	SCREW - MACHINE - 8-32 X 1 PPH - ZINC
	000G18-08-24B	EA	SCREW - MACHINE - 8-32 X 1 1/2 PPH - ZINC
	000G18-08-22B	EA	SCREW - MACHINE - 8-32 X 1 3/8 PPH - ZINC
	000G19-10-10B	EA	SCREW - MACHINE - 10-32 X 5/8 - PPH - ZINC
	000G19-10-08B	EA	SCREW - MACHINE - 10-32 X 1/2 PPH - ZINC
	000G19-10-20B	EA	SCREW - MACHINE - 10-32 X 1 1/2 PPH - ZINC
	000G19-10-12F	EA	SCREW - MACHINE - 10-32 X 3/4 PPH - STAINLESS STEEL
	000G36-10-12T	EA	SCREW - 10-24X 3/4 PFH TYPE 23 - BLACK
	000G39-06-10T	EA	SCREW - SF/DR - 6-20 X 5/8 PPH - BLACK
	000G39-06-16T	EA	SCREW - SF/DR - 6-20 X 1 PPH - BLACK
	000G39-08-08S	EA	SCREW - SF/DR - 8-18 X 1/2 PPH - OFF WHITE
	000G39-08-08B	EA	SCREW - SF/DR - 8-18 X 1/2 PPH - ZINC
	000G39-08-08T	EA	SCREW - SF/DR - 8-18 X 1/2 PPH - BLACK
	000G39-08-06B	EA	SCREW - SF/DR - 8-18 X 3/8 PPH - ZINC
	000G39-08-32B	EA	SCREW - SF/DR - 8-18 X 2 PPH - ZINC
	000G39-08-24T	EA	SCREW - SF/DR - 8-18 X 1 1/2 PPH - BLACK
	000G39-08-24S	EA	SCREW - SF/DR - 8-18 X 1 1/2 - OFF WHITE
	000G39-08-24B	EA	SCREW - SF/DR - 8-18 X 1 1/2 PPH - ZINC
	000G39-08-16T	EA	SCREW - SF/DR - 6-20 X 1 PPH - BLACK
	000G39-08-16B	EA	SCREW - SF/DR - 8-18 X 1 PPH - ZINC
	000G39-08-12B	EA	SCREW - SF/DR - 8-18 X 3/4 PPH - ZINC
	000G39-08-12T	EA	SCREW - SF/DR - 8-18 X 3/4 PPH - BLACK
	000G39-10-48T	EA	SCREW - SF/DR - 10-16 X 3 PPH - BLACK
	000G39-10-48B	EA	SCREW - SF/DR - 10-16 X 3 - PPH - ZINC
	000G39-10-40D	EA	SCREW - SF/DR - 10-16 X 2 1/2 PPH - BLACK
	000G39-10-32B	EA	SCREW - SF/DR - 10-16 X 2 - PPH - ZINC
	000G39-10-20T	EA	SCREW - SF/DR - 10-16 X 1 1/4 PPH - BLACK
	000G39-10-20B	EA	SCREW - SF/DR - 10-16 X 1 1/4 PPH - ZINC
	000G39-10-169	EA	SCREW - SF/DR - 10-16 X 1 PPH - FLUOROCARBON SILVER
	000G39-10-129	EA	SCREW - SF/DR - 10-16 X 3/4 PPH - FLUOROCARBON SILVER
	000G39-10-12T	EA	SCREW - SF/DR - 10-16 X 3/4 - BLACK
	000G39-10-10T	EA	SCREW - SF/DR - 10-16 X 5/8 - BLACK

SEALANTS & FASTENERS GROUP (CONTINUED)
SCREWS (CONTINUED)

KEY	PART NUMBER	U/M	DESCRIPTION
	000G39-10-10B	EA	SCREW - SF/DR - 10-16 X 5/8 PPH - ZINC
	000G39-10-08B	EA	SCREW - SF/DR - 10-16 X 1/2 PPH - ZINC
	000G39-10-088	EA	SCREW - SF/DR - 10-16 X 1/2 PPH - FLEX FLUOROCARBON
	000G39-12-12E	EA	SCREW - SF/DR - 12 - 14 X 3/4 PPH - CHROME
	000G42-04-24B	EA	SCREW - SF/DR - 1/4-14 X 1 1/2 - ZINC
	000G42-04-16B	EA	SCREW - SF/DR - 1/4-14 X 1 HWH - ZINC
	000G42-04-24B	EA	SCREW - SF/DR - 1/4-14 X 1 1/2 - ZINC
	000G46-08-24T	EA	SCREW - MACHINE - 8-32 X 1 1/2 PFH - BLACK
	000G50-04-48B	EA	SCREW - MACHINE - 1/4-14 X 3 - ZINC
	000G52-06-05B	EA	SCREW - MACHINE - 6-32 X 5/16 PTH ZINC
	000G52-06-06B	EA	SCREW - MACHINE - 6-32 X 3/8 PIN - ZINC
	000G54-04-14B	EA	SCREW - 1/4-20 X 7/8 PTH - TYPE 23 - ZINC PLATED
	000G55-08-124	EA	SCREW - SF/DR - 8-18 X 3/4 PWH - ASH GRAY
	000G55-08-12M	EA	SCREW - SF/DR - 8-19 X .75 PWH - GRAY
	000G55-08-165	EA	SCREW - SF/DR - 8-18 X 1 PWH - WILLOW
	000G55-08-16T	EA	SCREW - SF/DR - 8-18 X 1 PWH - BLACK
	000G55-08-16S	EA	SCREW - SF/DR - 8-18 X 1.00 - PWH - OFF WHITE
	000G56-12-48B	EA	SCREW - WOOD - 12-11 X 3 POH - SPECIAL HARDENED
	000G57-14-72B	EA	SCREW-14-10-X4 1/2 PFH ZN GENERAL MOTORHOMES
	000G57-14-64B	EA	SCREW - 14-10 X 4 PFH ZINC
	000G60-08-20F	EA	SCREW - SF/DR - 8-19X1.25 POH
	000G60-08-16E	EA	SCREW - SF/DR - 8-1 X 1 POH - CHROME
	000G60-08-22B	EA	SCREW - SF/DR - 8-18 X 1.38 POH - ZINC
	000G60-10-209	EA	SCREW - SF/DR - 10-16 X 1 1/4 POH - SILVER STALGAARD
	000G60-10-20B	EA	SCREW - SF/DR - 10-16 X 1 1/4 POH - ZINC
	000G60-10-16J	EA	SCREW - SF/DR - 10-16 X 1 POH - BRIGHT BRASS
	000G60-10-28T	EA	SCREW - SF/DR - 10-16 X 1 3/4 - BLACK
	000G67-08-32B	EA	SCREW - 8-15 X 2 PPH - ZINC
	000G67-10-08B	EA	SCREW - 10-12 X 1/2 PPH - ZINC
	000G67-10-24S	EA	SCREW - 10-12 X 1 1/2 PPH - OFF WHITE
	000G67-10-24B	EA	SCREW - 10-12 X 1 1/2 PPH - ZINC
	000G67-10-20D	EA	SCREW - 10-12 X 1 1/4 PPH - BLACK
	000G67-10-12P	EA	SCREW - 10-12 X 3/4 PPH - DARK BROWN
	000G67-10-12B	EA	SCREW - 10-12 X 3/4 PPH - ZINC
	000G67-10-10T	EA	SCREW - 10-12 X 5/8 PPH - BLACK
	000G67-10-10S	EA	SCREW - 10-12 X 5/8 PPH - OFF WHITE
	000G67-10-10P	EA	SCREW - 10-12 X 5/8 PPH - DARK BROWN
	000G67-10-10B	EA	SCREW - 10-12 X 5/8 PPH - ZINC - TYPE A
	000G67-10-08S	EA	SCREW - 10-12 X 1/2 PPH - OFF WHITE
	000G68-06-10J	EA	SCREW - 6-18 X 5/8 POH - BRASS
	000G68-06-10G	EA	SCREW - 6-18 X 5/8 POH - ANTIQUE BRASS
	000G68-06-12J	EA	SCREW - 6-18 X 3/4 POH - BRASS
	000G68-06-12B	EA	SCREW - 6-18 X 3/4 POH - ZINC & CLEAR
	029130-01-000	EA	SCREW - SNAP STUD - #8-16 X 5/8" LONG
	029130-03-000	EA	SCREW - SNAP STUD - #8-16 X 1" LONG
	049465-01-000	EA	SCREW - 10-16 PTH W/WASHER - DARK BROWN
	049465-03-000	EA	SCREW - 10-16 X 1 POH W/WASHER - OFF WHITE
	049465-04-000	EA	SCREW - 10-16 X 1 PTH W/WASHER - BEIGE
	049465-13-000	EA	SCREW-10+16X1 PTH W/WASHER - *ASH GRAY
	049465-17-000	EA	SCREW - 10-16 X 1 POH W/WASHER - BRIGHT WHITE
	049465-23-000	EA	SCREW - 10-16 X 1.5 POH W/WASHER - VW LIGHT GRAY
	054434-02-000	EA	SCREW - SF/DR - 10-16 X 2 - ZINC
	054434-03-000	EA	SCREW - SF/DR - 10-16 X 2 - PWH - ZINC
	075908-01-000	EA	SCREW - MACHINE - 10-32 X .56 PTH - EXTERNAL TOOTH - ZINC
	076790-01-000	EA	SCREW - 6-20 X 1 1/4 PPH - BLACK
	076790-05-000	EA	SCREW - 6-20 X 1/2 PPH - BLACK - THREAD CUTTING/WOOD
	083554-01-000	EA	SCREW - DRYWALL - 8 X 1 1/4
	083554-04-000	EA	SCREW - DRYWALL - 8 X 2 1/2
	087721-01-000	EA	SCREW - FLAT HEAD - TAPPING - 1/4 X 1 1/4 LONG - ZINC
	087721-02-000	EA	SCREW - FLAT HEAD - TAPPING - 1/4 X 2 1/4 LONG - ZINC
	090033-02-000	EA	SCREW - 1/4-20 X 5/8 - ROUND WASHER HEAD - OFF/WHITE
	097974-01-000	EA	SCREW - PARTICLE BOARD - 7-9 X 3/4 PPH
	101618-01-000	EA	SCREW - 1/4-20 X 3/4 HEX - TAPPING - STALGARD TYPE F

SEALANTS & FASTENERS GROUP (CONTINUED)
SCREWS (CONTINUED)

KEY	PART NUMBER	U/M	DESCRIPTION
	110460-05-02A	EA	SCREW - MACHINE - 10-24 X 2 1/2 PFH - WHITE
	113563-01-01A	EA	SCREW - 8 X 5/8 LONG SHOULDER/WASHER HEAD
	114469-01-02A	EA	COVER - SCREW - VW DARK GRAY
	117478-01-04A	EA	SCREW - 8-18 X 3/4 PPH W/WASHER - VW LIGHT GRAY
	118383-01-09A	EA	RETAINER/RECESSED - F/.22" SCREW - GLACIER
	118383-01-06A	EA	RETAINER/RECESSED - F/.22" SCREW - ALLANTE ANTELOPE
	118383-01-05A	EA	RETAINER/RECESSED - F/.22" SCREW - VW LIGHT GRAY
	118383-01-04A	EA	RETAINER/RECESSED - F/.22" SCREW - BRIGHT WHITE
	118383-02-09A	EA	RETAINER/RECESSED - F/.27" SCREW - GLACIER
	118383-02-05A	EA	RETAINER/RECESSED - F/.27" SCREW - VW LIGHT GRAY
	118383-02-04A	EA	RETAINER/RECESSED - F/.27" SCREW - BRIGHT WHITE
	118383-03-09A	EA	RETAINER/RECESSED - F/.32" SCREW - GLACIER
	118383-04-05A	EA	CAP - F/RECESSED RETAINER - VW LIGHT GRAY
	118383-04-04A	EA	CAP - F/RECESSED RETAINER - BRIGHT WHITE
	118383-04-09A	EA	CAP - F/RECESSED RETAINER - GLACIER
	118383-04-06A	EA	CAP - F/RECESSED RETAINER - ALLANTE ANTELOPE
	134126-01-01A	EA	SCREW/NAIL - HEX HEAD - 3/4"
	140040-01-000	EA	SCREW - 1/4-20 X 1 - BUTTON HEAD/SOCKET - W/LOCTITE
	144078-01-01A	EA	SCREW - HEX/FLANGE HEAD CAP - 1" W/.75" THREAD LENGTH - ZINC
	149753-01-01A	EA	RETAINER/RECESSED - F/.22" SCREW - BLACK
	149753-01-02A	EA	RETAINER/RECESSED - F/.22" SCREW - BRIGHT WHITE
	149753-02-01A	EA	CAP - F/RECESSED RETAINER - BLACK
	149753-02-02A	EA	CAP - F/RECESSED RETAINER - BRIGHT WHITE

CLAMPS, CLIPS, GROMMETS, RIVETS & PLUGS

KEY	PART NUMBER	U/M	DESCRIPTION
	000F10-06-32B	EA	PIN - COTTER - 3/16" X 2" - ZINC
	000H14-06-06R	EA	RIVET-MANDREL BLIND,3/16 AL - CHERRY BSP-66
	000H16-04-06R	EA	RIVET - POP ALUMINUM - 1/8 X .313 - .375
	000H16-06-10R	EA	RIVET - POP ALUMINUM - 3/16 X .501 - .625
	007161-01-000	EA	CLAMP - HOSE - SPRING TYPE - 1/2"
	008386-01-000	EA	GROMMET - SNAP - 3/8" DIAMETER - NYLON
	010495-01-000	EA	CLAMP - CABLE - 9/16"ID - BLACK
	010495-02-000	EA	CLAMP - CABLE - 3/8"ID - BLACK
	010495-04-000	EA	CLAMP - CABLE - 11/16"ID - WHITE
	010497-01-000	EA	CLAMP - CLOSED - 5/8"ID
	010497-02-000	EA	CLAMP - CLOSED - 1.5"ID
	010497-03-000	EA	CLAMP - CLOSED - 1"ID - CUSHIONED
	010497-04-000	EA	CLAMP - CLOSED - 1 5/8"ID
	010497-07-000	EA	CLAMP - CLOSED - 3/8"ID
	010497-09-000	EA	CLAMP - CLOSED - 5/16"ID
	010497-10-000	EA	CLAMP - CLOSED - 7/8"ID
	010499-01-000	EA	CLAMP - CLOSED - 3/8"ID
	016188-03-000	EA	GROMMET - LP LINE - 3/8"HOLE X 2 1/2"LONG - RUBBER
	016188-04-000	EA	GROMMET - LP LINE - 1/2"HOLE X 2 1/2"LONG - RUBBER
	016188-05-000	EA	GROMMET - LP LINE - 3/8"HOLE X 1 1/4"LONG - RUBBER
	016188-06-000	EA	GROMMET - L/P LINE - 3/8"HOLE X 3 1/4"LONG - RUBBER
	016188-08-000	EA	GROMMET - LP LINE - 1/2"HOLE X 1 1/4"LONG - RUBBER
	016188-09-000	EA	GROMMET - LP LINE - .68"HOLE X 1 1/4"LONG - RUBBER
	016188-10-000	EA	GROMMET - LP LINE - .68"HOLE X 2.5"LONG - RUBBER
	023942-01-000	EA	GROMMET - RUBBER - 2" OD
	034141-02-000	EA	PLUG/NYLON - .38" - BLACK
	061420-01-000	EA	PLUG/PLASTIC - 1 3/4" DIAMETER - BROWN
	061420-04-000	EA	PLUG/PLASTIC - 1 1/4" DIAMETER
	061420-05-000	EA	PLUG/PLASTIC - 1 1/2" DIAMETER
	061420-08-000	EA	PLUG/PLASTIC - 2 1/2" DIAMETER
	061420-09-000	EA	PLUG/PLASTIC - 1.00" - DIAMETER
	061420-10-000	EA	PLUG/PLASTIC - 1 1/2" DIAMETER - BLACK
	061420-13-000	EA	PLUG/PLASTIC - 3/8 - 3"
	061420-14-000	EA	PLUG/PLASTIC - 7/8" DIAMETER - BLACK
	061420-15-000	EA	PLUG/PLASTIC - 2" DIAMETER - BLACK
	061420-16-000	EA	PLUG/PLASTIC - 2 1/8" DIAMETER - BLACK

SEALANTS & FASTENERS GROUP (CONTINUED)
CLAMPS, CLIPS, GROMMETS, RIVETS & PLUGS (CONTINUED)

KEY	PART NUMBER	U/M	DESCRIPTION
	062401-01-000	EA	CLAMP - HOSE - WORMGEAR - .25" - 1"
	062401-02-000	EA	CLAMP - HOSE - WORMGEAR - 1.56" - 2.5"
	062401-03-000	EA	CLAMP - HOSE - WORMGEAR - .22" - 1"
	062401-04-000	EA	CLAMP - HOSE - WORMGEAR - .69" - 1.25"
	062401-05-000	EA	CLAMP - HOSE - WORMGEAR - 2" - 3" ID
	062401-06-000	EA	CLAMP - HOSE - WORMGEAR - .22" - .62" ID
	062401-09-000	EA	CLAMP - HOSE - WORMGEAR - 2.8" - 3.75"
	062401-11-000	EA	CLAMP - HOSE - WORMGEAR - 3.50" - 4.50"
	062401-12-000	EA	CLAMP - HOSE - WORMGEAR - .79" X 1.26"
	071015-11-000	EA	GROMMET - RUBBER - 1 ID - FITS .12 MATERIAL - BLACK
	071015-13-000	EA	GROMMET - RUBBER - .62 ID - FITS .09 GROOVE - BLACK
	071015-19-000	EA	GROMMET - RUBBER - .38 ID - FITS .06 MATERIAL - BLACK
	071015-22-000	EA	GROMMET - RUBBER - .62 ID - 1.12 OD - W/.19 GROOVE - BLACK
	071015-26-000	EA	GROMMET - RUBBER - 1.5" ID X 2.1" OD W/.06" GROOVE-BLACK
	071015-29-000	EA	GROMMET - RUBBER - .3" ID X 1.3"OD W/.12" GROOVE - BLACK
	071015-30-000	EA	GROMMET - RUBBER - .3" ID X .81"OD W/.12" GROOVE - BLACK
	071015-32-000	EA	GROMMET - RUBBER - .75 ID X 1.375 OD W/.187 GROOVE - BLACK
	071015-40-000	EA	GROMMET - RUBBER - .38 ID - FITS .09 MATERIAL - BLACK
	071015-41-000	EA	GROMMET - .125 ID FITS .188 MTL
	071015-42-000	EA	GROMMET - RUBBER - .25 ID - FITS .06 MATERIAL - BLACK
	075148-02-000	EA	CLAMP - GROUNDING - BRONZE SCREWS
	077955-01-000	EA	CLIP/J - 3/8" - VINYL COATED
	080734-02-000	EA	CLIP - WIRE NYLON
	081211-01-000	EA	PLUG/PLASTIC - .31" DIAMETER - BLACK
	081211-03-000	EA	PLUG/PLASTIC - .50" DIAMETER - TRUSS HEAD - BLACK
	081211-04-000	EA	PLUG/PLASTIC - .46 DIAMETER - TRUSS HEAD - BLACK
	083609-01-000	EA	CLAMP - WIRE - DUAL - EQUAL DIAMETERS - 5/8"
	083610-01-000	EA	CLAMP - WIRE - DUAL - UNEQUAL DIAMETERS - 3/4" & 1 1/4"
	083610-02-000	EA	CLAMP - WIRE - DUAL - UNEQUAL DIAMETERS - 3/4" & 2"
	083610-03-000	EA	CLAMP - WIRE - DUAL - EQUAL DIAMETERS - 2"
	088756-01-000	EA	GROMMET - WEB - 1 1/8 " I.D.
	089329-02-000	EA	CLIP - SPRING
	091952-01-000	EA	CLIP - GRIPPER - 1"
	091952-02-000	EA	CLIP - GRIPPER - 3/4"
	091952-03-000	EA	CLIP - GRIPPER - 1/2" - BLACK VINYL COATED
	094362-02-000	EA	CLIP - XMAS TREE - BINDER HEAD - .9" LONG
	094362-05-000	EA	CLIP - XMAS TREE - ROUND HEAD - 1.4" LONG
	114208-01-000	EA	GROMMET - EDGE LINER - FITS 1 3/4"
	114208-03-000	EA	GROMMET - EDGE LINER - FITS 2 1/2"
	114208-05-000	EA	GROMMET - EDGE LINER - FITS 2"
	118626-01-02A	EA	RIVET - POP - ALUMINUM - 3/16 X .08 - .375
	118626-01-01A	EA	RIVET - POP - ALUMINUM - 3/16 X .08 - .375
	118626-02-01A	EA	RIVET - POP - ALUMINUM - 3/16 X .500 - .750
	137014-01-01A	EA	GROMMET - CABLE - ALMOND
	137014-01-02A	EA	GROMMET - CABLE - BROWN
	137014-01-03A	EA	GROMMET - CABLE - BLACK
	139118-02-01A	EA	GROMMET - SCREW - PLASTIC
	140171-01-000	EA	CLAMP - HOSE - STEPLESS EAR - .312
	140171-02-000	EA	CLAMP - HOSE - STEPLESS EAR - .250

SEALANTS & FASTENERS GROUP (CONTINUED)

MISCELLANEOUS FASTENERS

KEY	PART NUMBER	U/M	DESCRIPTION
	008343-01-000	EA	TIE - WIRE - 6"
	008343-02-000	EA	TIE - WIRE - 14"
	008343-03-000	EA	TIE - WIRE - 7 1/2" - BLACK
	029094-04-000	YD	VELCRO TAPE - LOOP - 1" WIDE - BLACK
	029094-06-000	YD	VELCRO TAPE - LOOP - 2" WIDE - BLACK
	029096-03-000	YD	VELCRO TAPE - HOOK - 1" WIDE - BLACK
	029096-04-000	YD	VELCRO TAPE/HOOK - 1"WIDE - BLACK - W/ADHESIVE BACK (PSA)
	048394-02-000	YD	VELCRO TAPE - HOOK - ADHESIVE BACK - 3/4" WIDE - BEIGE
	085774-01-000	FT	FASTENER - DUAL LOCK - 1" WIDE - ADHESIVE BACK - BLACK
	085774-02-000	FT	FASTENER - DUAL HOOK - 1" WIDE - ADHESIVE BACK - BLACK
	085774-07-000	FT	FASTENER - DUAL HOOK - 1" WIDE
	088792-02-000	YD	VELCRO TAPE - LOOP - 3/4" - ADHESIVE BACK - BEIGE
	088792-04-000	YD	VELCRO TAPE - HOOK - 5/8" - NON-ADHESIVE BACK - WHITE
	088792-05-000	YD	VELCRO TAPE - LOOP - 5/8" - NON-ADHESIVE BACK - WHITE
	108046-01-000	EA	CABLE TIE - SCREW MOUNT 8"
	108046-02-000	EA	CABLE TIE - SCREW MOUNT 15"
	110943-01-000	FT	FELT STRIP - 3/8" - ADHESIVE BACK - BLACK
	110943-02-000	FT	FELT STRIP - 3/8" - ADHESIVE BACK - WHITE
	113133-02-01A	EA	RIVET - POP - ALUMINUM - 3/16 X .252 - .504 - BLACK
	115361-01-01A	EA	PLUG/PLASTIC - 1/2" DIAMETER
	127960-01-01A	EA	RETAINER - 3/8" - STAINLESS STEEL

WATER & SEWAGE GROUP DRAINAGE SYSTEM

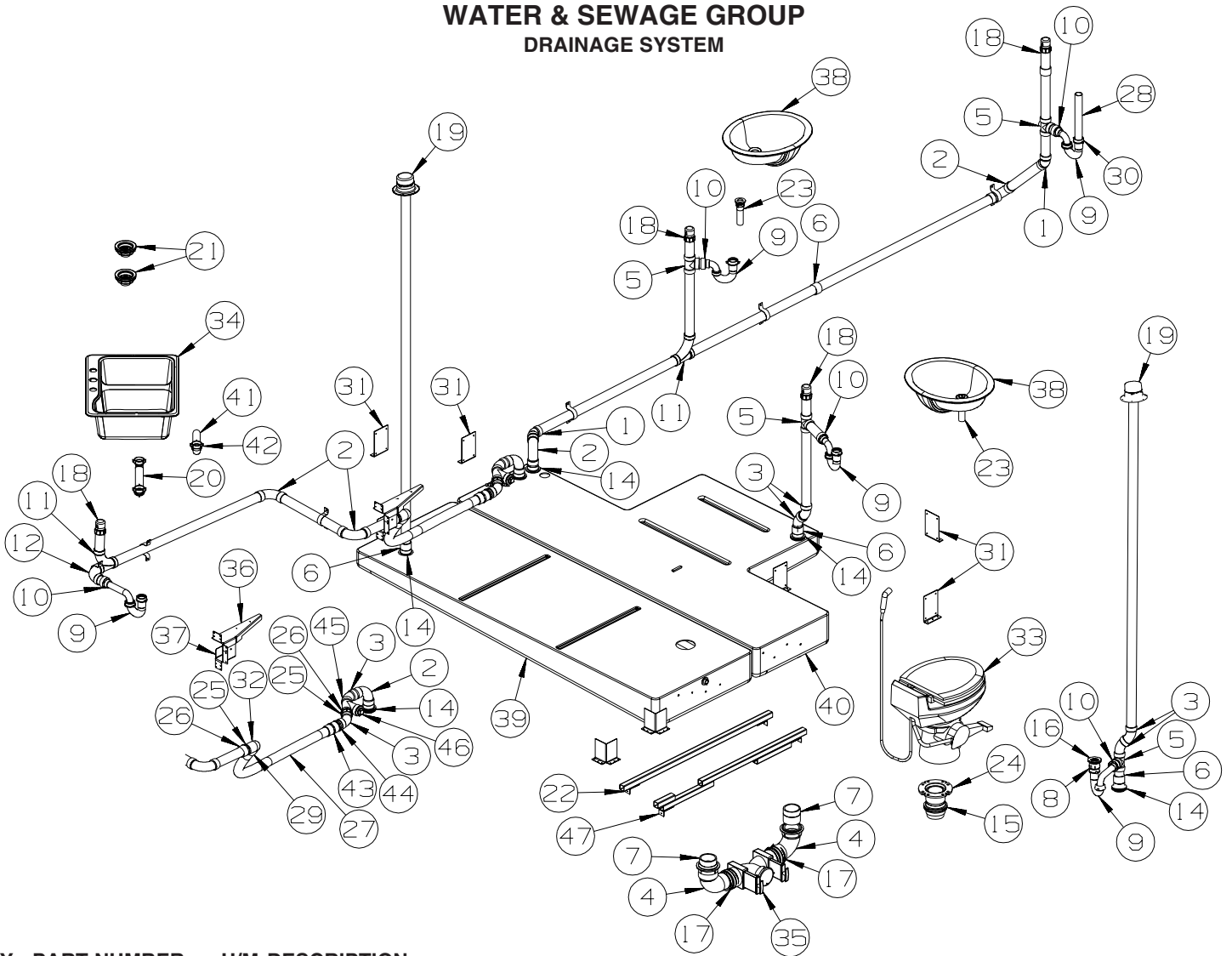

KEY	PART NUMBER	U/M	DESCRIPTION
1	010006-01-000	EA	ELBOW - 45 DEGREE - 1 1/2" HUB X HUB - PLASTIC
2	010008-01-000	EA	ELBOW - 90 DEGREE - 1 1/2" HUB X HUB - PLASTIC
3	010051-01-000	EA	ELBOW - 45 DEGREE - 1 1/2" SPIGOT X HUB - PLASTIC
4	010062-01-000	EA	ELBOW - 3 90 SPIGOT X HUB - PLASTIC
5	010071-01-000	EA	TEE - SANITARY - 1 1/2" HUB X HUB X HUB - PLASTIC
6	010115-01-000	EA	COUPLING - 1 1/2" HUB X HUB - PLASTIC
7	010129-03-000	EA	NIPPLE - 3" X 3" TOE - PLASTIC
8	011069-06-000	EA	TAILPIECE - 1 1/2" X 1 1/4" X 2 1/2"
	127440-02-01A	EA	WASHER - RUBBER - 1.8" X .1"
	130403-01-000	EA	NUT - SLIP - W/WINGS 1 1/2"
9	107538-01-000	EA	P-TRAP - PLASTIC - 1 1/4" W/EXTENSION ARM - USA
9	011071-01-000	EA	P-TRAP - 1 1/2" - CSA - PLASTIC - CANADIAN
10	109571-01-000	EA	ADAPTER - P-TRAP - 1 1/2" P X 1 1/4" MPT
11	031365-02-000	EA	TEE - 1 1/2" EXTRA LONG TURN - PLASTIC
12	033761-01-000	EA	ELBOW - 90 DEGREE - TURN - 1 1/2" HUB X 1 1/2" SPIGOT
13	034250-01-000	EA	ELBOW - 90 DEGREE - LONG TURN - 1 1/2" HUB X HUB - ABS
14	061607-01-000	EA	GROMMET - HOLDING TANK - 1 1/2" NPS
15	061607-02-000	EA	GROMMET - HOLDING TANK - 3" NPS
16	066440-01-000	EA	STRAINER - SHOWER DRAIN - W/RUBBER WASHER
	127440-02-01A	EA	WASHER - RUBBER - 1.8" X .1"
	130403-01-000	EA	NUT - SLIP - W/WINGS 1 1/2"
17	078406-01-000	EA	COUPLER - 3" X 3" W/CLAMPS - RUBBER
18	079968-01-000	EA	VENT - MECHANICAL/TRAP ARM - ANTI-SIPHON-2" X 7.3" PLASTIC
19	083558-03-000	EA	VENT W/COVER F/PLUMBING STACK - OFF WHITE
20	091980-01-000	EA	WASTE - CONTINUOUS
20	011091-02-000	EA	WASTE - CONTINUOUS

FROM: 00-00-00 THRU: 01-18-04

FROM: 01-19-04 THRU: 99-99-99

WATER & SEWAGE GROUP (CONTINUED)
DRAINAGE SYSTEM (CONTINUED)

KEY	PART NUMBER	U/M	DESCRIPTION
21	092303-01-000	EA	STRAINER - W/BASKET - GALLEY SINK - 4" OD
	127440-02-01A	EA	WASHER - RUBBER - 1.8" X .1"
22	094756-02-01A	EA	BRACKET - L - 6.1" LONG X 3.9" WIDE - STEEL
23	147930-01-000	EA	WASHER/SEAL - FOAM - 1.4"ID X 2.1"OD - F/POP-UP DRAIN
24	116644-01-000	EA	FLANGE/CLOSET - 3" FEMALE - 4 BOLT
25	126424-01-000	EA	ADAPTER - 1 1/2" MPT X 1 1/2" HUB
26	126425-02-000	EA	ADAPTER - SWIVEL - 1 1/2 FPT X SPIGOT
27	126426-01-000	FT	PIPE - 1 1/2" FLEXIBLE
28	126588-02-000	EA	ARM - WASTE - 1 1/2" X 20" - FEMALE
29	130685-02-000	EA	ADAPTER - 1 7/8 FEMALE SLIP X 1 1/2" MALE THREAD/O-RING
30	061420-10-000	EA	PLUG/PLASTIC - 1 1/2" DIAMETER - BLACK
31	132871-03-02B	EA	BRACKET/L ANGLE W/HOLES - 1.2" X 2.8" - E-COATED
32	136111-01-000	EA	ELBOW - 1/2"SOCKET X SLIP FIT
33*	132389-01-01A	EA	TOILET - CHINA - WHITE
34	136828-01-01A	EA	SINK/DBL - LGE/SM BASIN-25"X19"X7" W/O NOTCH/FAUCET HOLES FROM: 00-00-00 THRU: 01-18-04
34	148870-01-01A	EA	SINK/DOUBLE - LRG/SML BASIN - 25" X 19" X 7" FROM: 01-19-04 THRU: 99-99-99
35	136143-01-000	EA	VALVE - DUAL - 3" X 3"
	139513-01-000	EA	HOSE - SEWER - 3" X 10' - W/ADAPTER
	062416-01-000	EA	ADAPTER - SEWER HOSE TO 3" PIPE
	144728-01-000	EA	VALVE - SEWER HOSE - 3"
36	142526-01-02B	EA	BRACKET/COVER - PLUMBING - E-COATED
37	142527-01-02B	EA	BRACKET/CARRIER - PLUMBING - E-COATED
38	143310-01-01A	EA	SINK - LAVATORY - OVAL - 19" X 16" - WHITE
39	132407-01-700	EA	TANK - HOLDING
	010232-01-000	EA	FITTING - SPINWELD - PLASTIC 3FPT
40	132408-01-700	EA	TANK - HOLDING
	010232-01-000	EA	FITTING - SPINWELD - PLASTIC 3FPT
41	125569-01-000	EA	1 1/2" X 90 DEGREE - DOUBLE SLIP
42	126588-01-000	EA	ARM - WASTE - 1 1/2" X 9 1/2" - FEMALE
43	130685-01-000	EA	ADAPTER - 1 7/8" FEMALE SLIP X 1 1/2" FEMALE THREAD/O-RING
44	130685-03-000	EA	ADAPTER - 1 7/8" MALE SLIP X 1 1/2" MALE THREAD/O-RING
45	010073-01-000	EA	WYE - 45 DEGREE - 1 1/2" HUB X HUB X HUB - PLASTIC
46	010166-01-000	EA	PLUG/THREADED - 1 1/4"MPT - PLASTIC - BLACK - UL
	010122-01-000	EA	BUSHING/PLASTIC - REDUCER - 1 1/2"SMTH X 1 1/4"THD - BLACK
46	010166-02-000	EA	PLUG/THREADED - 1 1/4"MPT - PLASTIC - BLACK - CSA - CANADIAN
	010122-02-000	EA	BUSHING/PLASTIC - REDUCER - 1 1/4" X 1 1/4"THD - RED - CANADIAN
47	094756-02-01A	EA	BRACKET - L - 6.1" LONG X 3.9" WIDE - STEEL FROM: 00-00-00 THRU: 01-01-04
47	149999-01-02B	EA	SUPPORT - HOLDING TANK FROM: 01-02-04 THRU: 99-99-99

*COMPONENT PARTS LISTED LATER IN THIS GROUP

WATER & SEWAGE GROUP (CONTINUED)
COMPONENTS PARTS FOR DRAINAGE

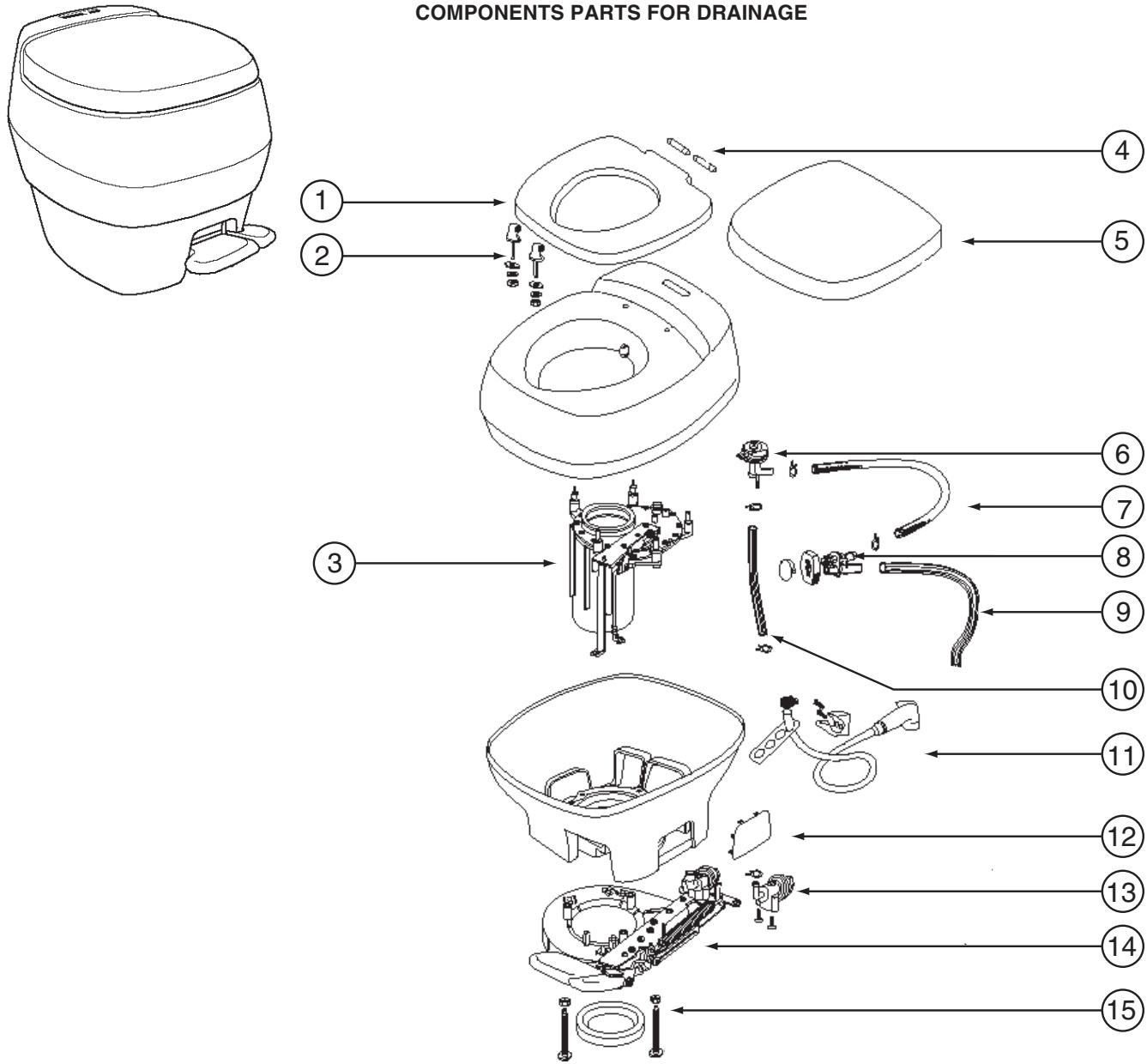

132389-01-01A

KEY	PART NUMBER	U/M	DESCRIPTION	VENDOR NO.
1	132389-01-700	EA	SEAT ONLY - WHITE	1927632
2	132389-01-701	EA	HINGE POST KIT	1927732
3	132389-01-702	EA	UPPER MECHANISM KIT - WHITE	1928432
4	132389-01-703	EA	HINGE PINS	19292
5	132389-01-704	EA	COVER - SEAT - WHITE	1929332
6	132389-01-705	EA	VACUUM BREAKER PACKAGE	19278
8	132389-01-706	EA	FLUSH NOZZLE - PACKAGE	1927932
10	132389-01-707	EA	TUBE - WATER SUPPLY	19282
11	132389-01-708	EA	HAND SPRAY KIT	19289
12	132389-01-709	EA	COVER - SIDE ACCESS- WHITE	1929832
13	132389-01-710	EA	WATER VALVE PACKAGE	19283
14	132389-01-711	EA	LOWER MECHANISM - WHITE	1928532
15	132389-01-712	EA	CLOSET FLANGE-SEAL/BOLT PKG	19309
	132389-01-713	EA	SEAL - BLADE	8308
	132389-01-714	EA	BOLT PACKAGE - F/RISER	24819
	132389-01-715	EA	SEAL - FLANGE	19325

CONTACT WINNEBAGO PART SALES FOR UNLISTED COMPONENTS

WATER & SEWAGE GROUP (CONTINUED)

WATER SYSTEM

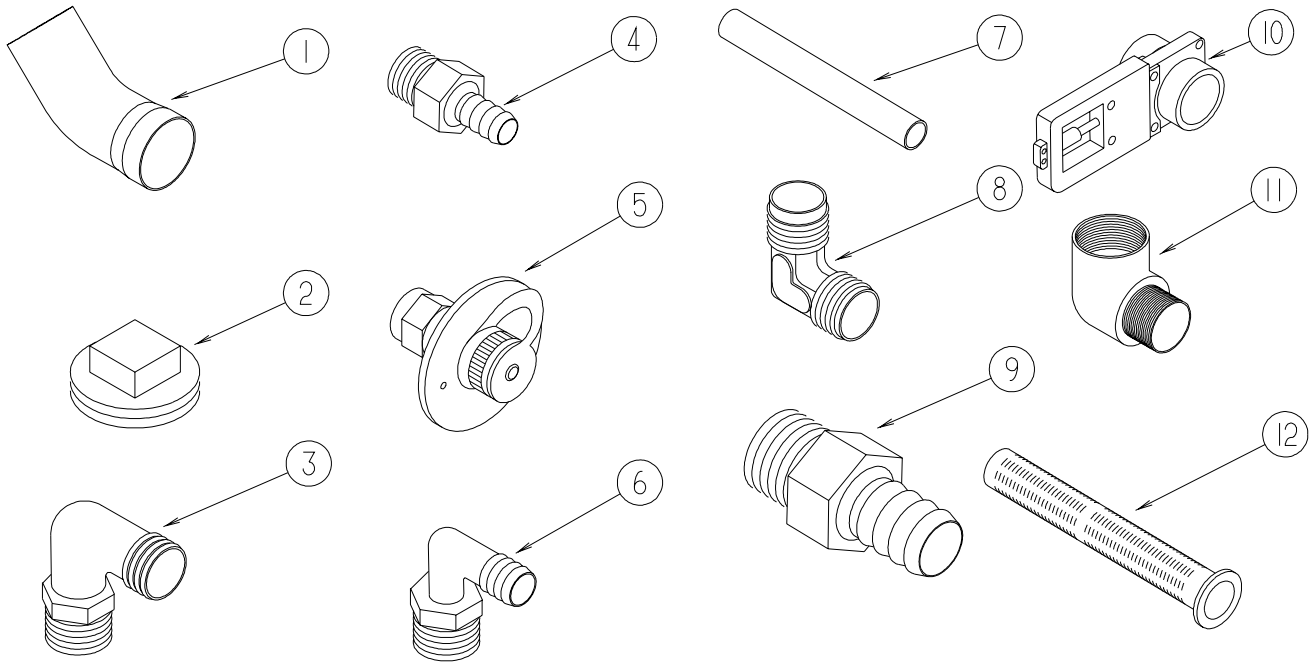

KEY	PART NUMBER	U/M	DESCRIPTION
1	010009-01-000	EA	ELBOW - 90 DEGREE - 1/4 BEND - 1 1/2" PLASTIC
2	010166-01-000	EA	PLUG/THREADED - 1 1/4"MPT - PLASTIC - BLACK - UL
3	010219-01-000	EA	ELBOW - 1 1/4 MPT X 1 1/4 BARB - WATER FILL - PLASTIC
4	010224-01-000	EA	ADAPTER - HOSE TO PIPE - 3/8 MPT X 3/8 BARB - PLASTIC
5	010230-06-000	EA	FILL - CITY WATER - W/CHECK VALVE - MPT - BRUSHED ALUM
6	035539-01-000	EA	ELBOW - 3/8 MPT X 3/8 BARB - PLASTIC
7	039800-04-000	FT	TUBING - POLYBUTYL - 1/4"OD
7	074462-02-000	FT	TUBING - VINYL - 3/8 ID X 20' - CLEAR
7	112176-01-000	FT	TUBING - VINYL - REINFORCED - 1/2" ID
7	124188-01-000	FT	TUBING - PEX - 1/2" ID X 20' - BLUE(COLD)
7	124188-02-000	FT	TUBING - PEX - 1/2" ID X 20' - RED(HOT)
8	039808-03-000	EA	ELBOW - 1/2" MPT X 1/2" MPT - PLASTIC
9	044927-01-000	EA	ADAPTER - HOSE TO PIPE-1 1/4 MPTX1 1/4 BARB-BLACK PLASTIC
10	062421-03-000	EA	VALVE/DUMP W/O HANDLE - 1 1/2" X 1 1/2" HUB
	062421-05-000	EA	CABLE/ROD - F/DUMP VALVE - W/HANDLE - 48"
11	065318-02-000	EA	ELBOW - 90 DEGREE - 3/8" MPT TO 3/8" FPT
12	077954-02-000	EA	FILTER - WATER TANK - W/SCREEN IN TANK

WATER & SEWAGE GROUP (CONTINUED)
WATER SYSTEM (CONTINUED)

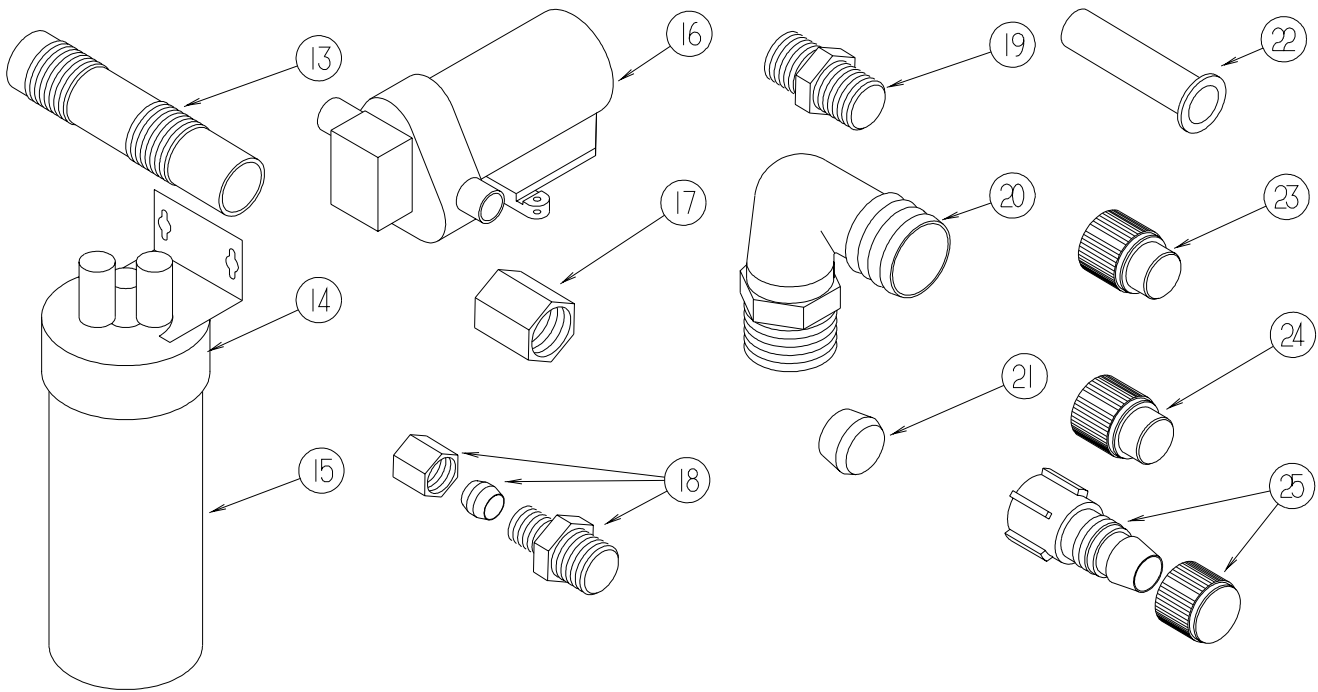

KEY	PART NUMBER	U/M	DESCRIPTION
13	079381-01-000	FT	TUBING - RIBBED FLEXIBLE - WATER FILL - 1.4" ID
14	087200-01-000	EA	FILTER-WATER PURIFICATION, EVERPURE QC2-AC
15	087200-02-000	EA	CARTRIDGE-WATER FILTER,AC - EVERPURE 9601-11
16*	098607-01-000	EA	PUMP - WATER - W/.5" MPT FITTING - FLOW 2.8 GPM
17	101814-01-000	EA	COUPLING - FEMALE - 1/2" X 1/2" FPT - GRAY
18	103798-01-000	EA	CONNECTOR - 1/4 OD X 3/8 MPT
19	110438-02-000	EA	VALVE - CHECK - BRASS - 1/2 MPT X 1/2 MPT
20	111223-02-000	EA	ELBOW - 1/2" MPT X 3/8" BARB - PLASTIC
20	111223-03-000	EA	ELBOW - 3/4" MPT X 1/2" BARB - PLASTIC
20	111223-04-000	EA	ELBOW - 1/2" MPT X 1/2" BARB - PLASTIC
21	111888-01-000	EA	FERRULE - PLASTIC - .250 ID X .375 OD
22	111888-02-000	EA	INSERT - BRASS - 1/4 COMP
23	113697-01-000	EA	CAP - 3/8"P
24	114427-01-000	EA	CAP - 1/2"P
25	114427-02-000	EA	PLUG - W/COMP NUT - 1/2" PLASTIC PIPE/1/2" FLAIR-IT

WATER & SEWAGE GROUP (CONTINUED)
WATER SYSTEM (CONTINUED)

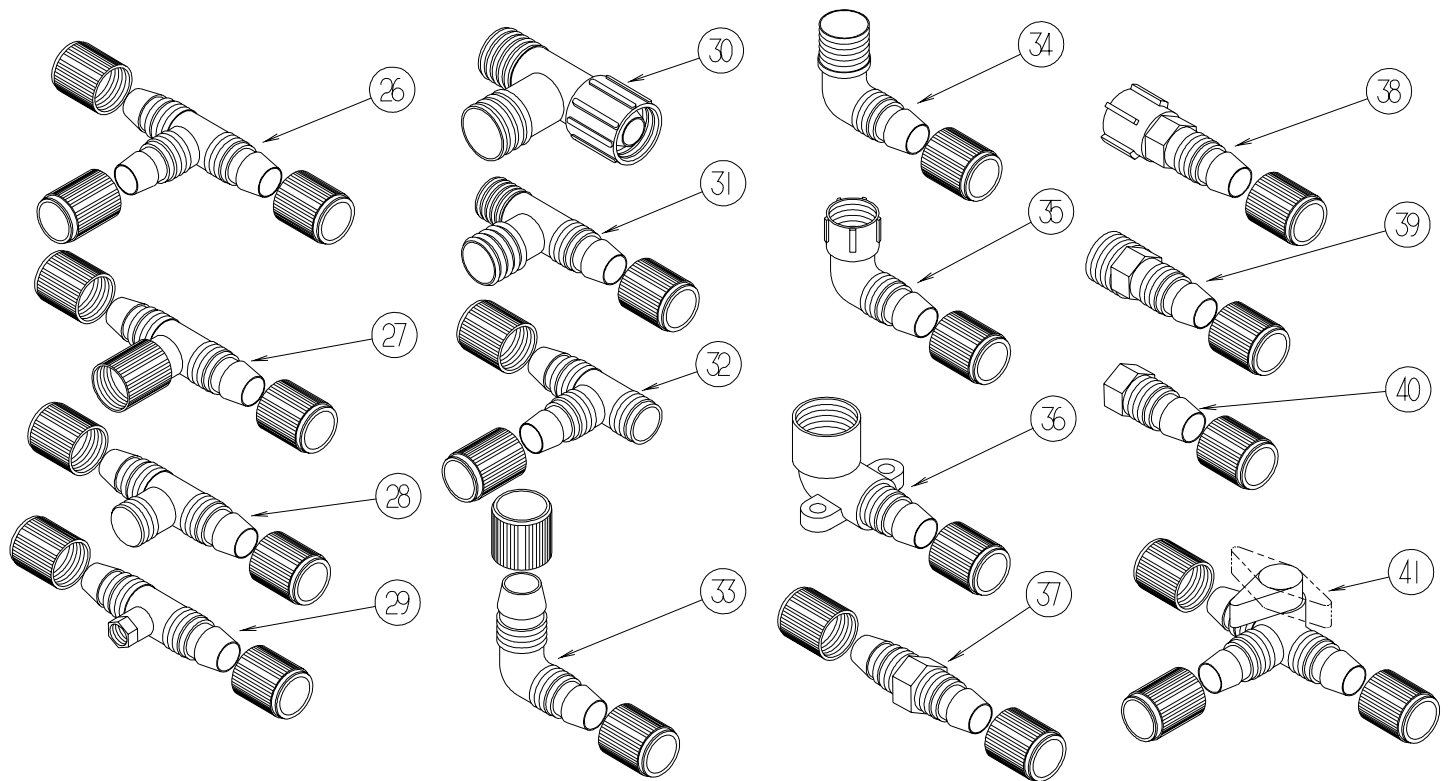

KEY	PART NUMBER	U/M	DESCRIPTION
	039798-01-000	EA	TEE - 1/2"MPT X 1/2"MPT X 1/2"MPT - PLASTIC
26	114428-01-000	EA	TEE - 1/2"P X 1/2"P X 1/2"P
27	114428-02-000	EA	TEE - SWIVEL - 1/2"P X 1/2"P X 1/2"FPT
28	114428-03-000	EA	TEE - 1/2"P X 1/2"P X 1/2"MPT
29	114428-04-000	EA	TEE - 1/2"P X 1/2"P X 1/8"FPT
30	114428-05-000	EA	TEE - 1/2" SWIVEL X 1/2" MPT X 1/2" MPT
31	114428-06-000	EA	TEE - 1/2" P X 1/2" MPT X 1/2" MPT
32	114428-07-000	EA	TEE - 1/2" P X 1/2" MPT X 1/2" P
33	114429-01-000	EA	ELBOW - 1/2"P X 1/2"P
34	114429-02-000	EA	ELBOW - 1/2"P X 1/2"MPT
34	114429-04-000	EA	ELBOW - 1/2"P X 3/8"MPT
34	114429-05-000	EA	ELBOW - 1/2"P X 3/4"MPT
34	114429-10-000	EA	ELBOW - SWIVEL - 1/2"MPT X 1/2"FPT
35	114429-03-000	EA	ELBOW - SWIVEL - 1/2"P X 1/2"FPT
35	114429-06-000	EA	ELBOW - SWIVEL - 1/2"P X 3/4"FPT
35	114429-08-000	EA	ELBOW - SWIVEL - 1/2"P X 1/2"FPT
35	114429-11-000	EA	ELBOW - 1/2"P X 1/2"FPT
36	114429-09-000	EA	ELBOW - 1/2"P X 1/2"FPT DROP EAR
37	114430-01-000	EA	ADAPTER - 1/2"P X 1/2"P
38	114430-02-000	EA	ADAPTER - SWIVEL - 1/2"P X 1/2"FPT
38	114430-04-000	EA	ADAPTER - SWIVEL - 1/2"P X 3/8"MPT
39	114430-03-000	EA	ADAPTER - 1/2"P X 1/2"MPT
40	114430-06-000	EA	ADAPTER - 1/2"P X 3/8"FPT
40	114430-09-000	EA	ADAPTER - 1/2"P X 1/2"FPT
41	114431-01-000	EA	VALVE - 180 DEGREE/CENTER DRAIN - 1/2"P - THREE WAY

WATER & SEWAGE GROUP (CONTINUED)
WATER SYSTEM (CONTINUED)

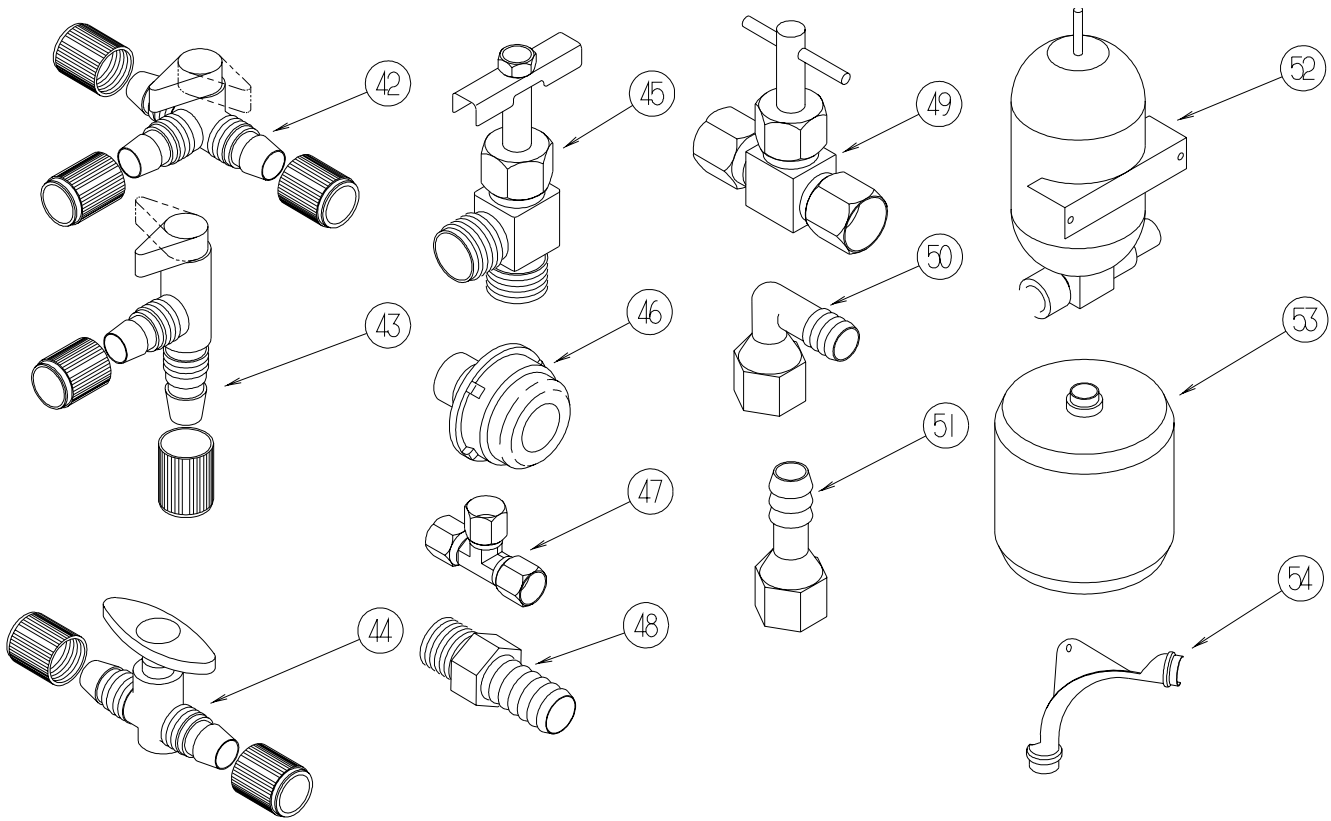

KEY	PART NUMBER	U/M	DESCRIPTION
42	114431-02-000	EA	VALVE - WATER BYPASS - 1/2" P - THREE WAY (WATER HEATER)
43	114431-03-000	EA	VALVE - 90 DEGREE DRAIN - 1/2" P
44	114431-04-000	EA	VALVE - "INLINE SHUT-OFF" - 1/2" P
45	114431-05-000	EA	VALVE - NEEDLE - 1/8" MPT X 1/4" COMPRESSION (ICE MAKER)
46	114966-01-000	EA	FILTER - IN LINE - TWIST ON - 1/2"
47	118423-01-000	EA	FITTING - BRASS-TEE - 1/4" X 1/4" X 1/4"
48	118809-01-000	EA	ADAPTER - 1/2" MPT X 3/8" BARB - PLASTIC
48	118809-02-000	EA	ADAPTER - 1/2" MPT X 1/2" BARB - PLASTIC
49	120868-01-000	EA	VALVE - NEEDLE - 1/4" COMPRESSION X 1/4" COMPRESSION
50	123150-01-000	EA	ELBOW - 1/2 FPT X 1/2 BARB - SWIVEL
51	123152-01-000	EA	ADAPTER - 1/2 FPT X 1/2 BARB - SWIVEL
52	123243-01-000	EA	TANK - ACCUMULATOR - 24 OZ
53	123317-01-000	EA	TANK - ACCUMULATOR - 2 GALLON
54	124184-01-000	EA	SUPPORT - WATER LINE - BEND

WATER & SEWAGE GROUP (CONTINUED)
WATER SYSTEM (CONTINUED)

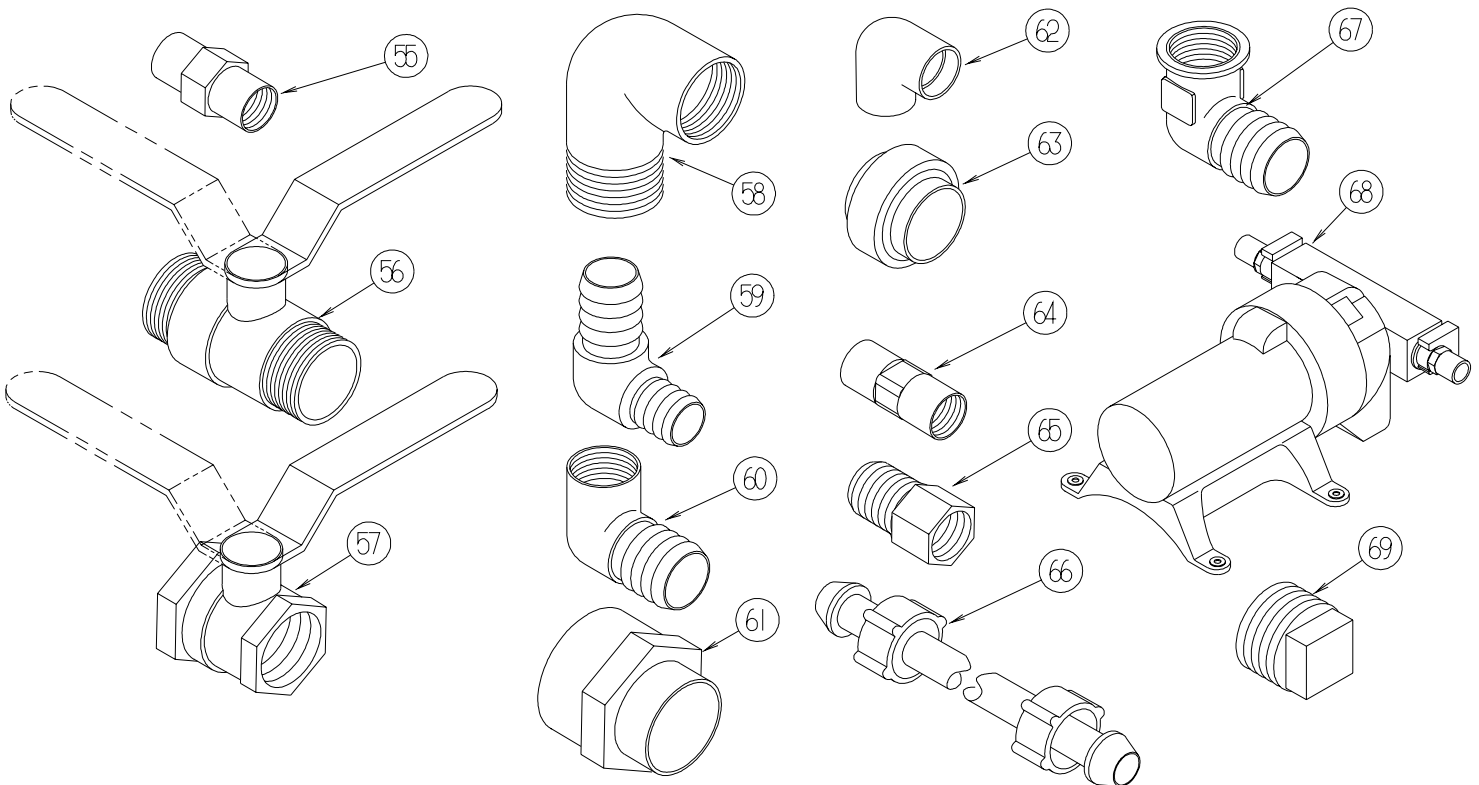

KEY	PART NUMBER	U/M	DESCRIPTION
55	132148-01-000	EA	CONNECTOR - 1/2" X 1/2" MPT - BRASS
56	132483-01-000	EA	VALVE/BALL - 1" - THREADED ENDS
57	132483-02-000	EA	VALVE/BALL - 1/2" - BRASS - FPT
58	132484-01-000	EA	ELBOW - 90 DEGREE - 1 MPT X 1 FPT - PLASTIC
59	132781-01-000	EA	ELBOW - 1.3" BARB X 1.3" BARB - 90 DEGREE - PLASTIC
60	132782-01-000	EA	ELBOW - 1" FPT X 1.3" BARB - 90 DEGREE - PLASTIC
61	133835-01-000	EA	ADAPTER - REDUCING - 1 1/2" X 1 1/4"
62	133837-01-000	EA	ELBOW - 1 1/2" X 90 DEGREE - DOUBLE SLIP
63	133889-01-000	EA	UNION - 1 1/2" DOUBLE SLIP - PVC
64	135386-01-000	EA	NIPPLE - 1/2"
65	136333-01-000	EA	ADAPTER - BRASS - 1/2" MPT X 1/2" FPT
66	140821-01-000	EA	TUBE - WATER SUPPLY - 3/8" X 24"
66	140821-02-000	EA	TUBE - WATER SUPPLY - 3/8" X 30"
66	140821-03-000	EA	TUBE - WATER SUPPLY - 3/8" X 36"
66	140821-04-000	EA	TUBE - WATER SUPPLY - 3/8" X 48"
66	140821-05-000	EA	TUBE - WATER SUPPLY - 3/8" X 54"
66	140821-06-000	EA	TUBE - WATER SUPPLY - 3/8" X 60"
66	140821-07-000	EA	TUBE - WATER SUPPLY - 3/8" X 72"
67	142812-01-000	EA	ELBOW - BRASS - 1/2" MPT X 1/2" FPT
68*	144215-01-000	EA	PUMP - WATER - 5.7 GPM - W/1/2" MPT
*	144215-02-000	EA	STRAINER - WATER PUMP
69	145609-01-000	EA	PLUG - BRASS - 1/2" MPT/HEX HEAD

***COMPONENT PARTS LISTED LATER IN THIS GROUP**

WATER & SEWAGE GROUP (CONTINUED)
WATER SYSTEM (CONTINUED)

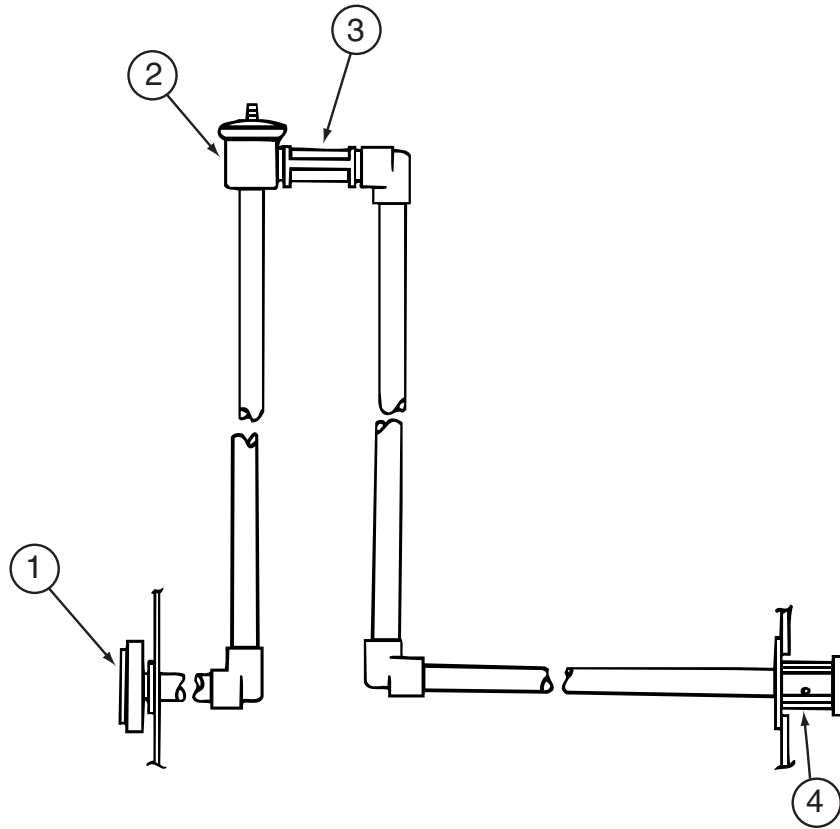

KEY	PART NUMBER	U/M	DESCRIPTION
1	125697-05-000	EA	INLET/WATER - F/FLUSHING SYSTEM
2	125697-04-000	EA	BREAKER/VACUUM - F/FLUSHING SYSTEM
3	125697-03-000	EA	CHECK VALVE - F/FLUSHING SYSTEM
4	125697-02-000	EA	NOZZLE - WELD-A-FLUSH
	125697-06-000	EA	INSTRUCTIONS - USER - F/FLUSHING SYSTEM

WATER & SEWAGE GROUP (CONTINUED)
WATER SYSTEM (CONTINUED)

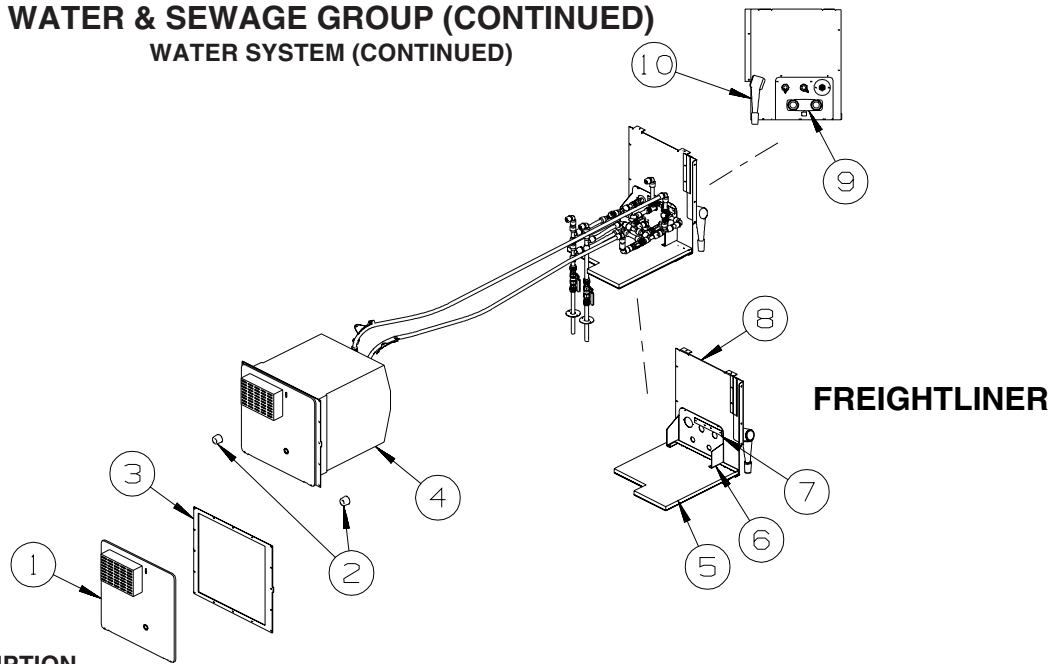

KEY	PART NUMBER	U/M	DESCRIPTION
1*	125420-01-03A	EA	DOOR - WATER HEATER - 10 GALLON - BLACK W/BLACK GRILLE
2	117047-02-000	EA	BUMPER - RUBBER/WASHER INSERT
3	144898-01-02B	EA	PANEL - SERVICE CENTER - BRIGHT WHITE
4*	145541-01-000	EA	WATER HEATER - 10 GALLONS-GAS/120 DEGREES-REMOTE IGNITION
5	144927-01-R68	EA	SHELF - WATER CENTER
6	146820-01-12B	EA	BRACKET - EXTERIOR SHOWER - BRIGHT WHITE
7	146821-01-12B	EA	STRAP - VALVE - BRIGHT WHITE
8	144989-01-12B	EA	PANEL - SERVICE CENTER - BRIGHT WHITE
9*	075241-06-000	EA	FAUCET - SHOWER/BRIGHT WHITE - .5" MPT W/1.9" INLET PIPES
10	131383-01-02A	EA	SHOWER HEAD - W/60" HOSE & BRACKET - WHITE

*COMPONENT PARTS LISTED LATER IN THIS GROUP

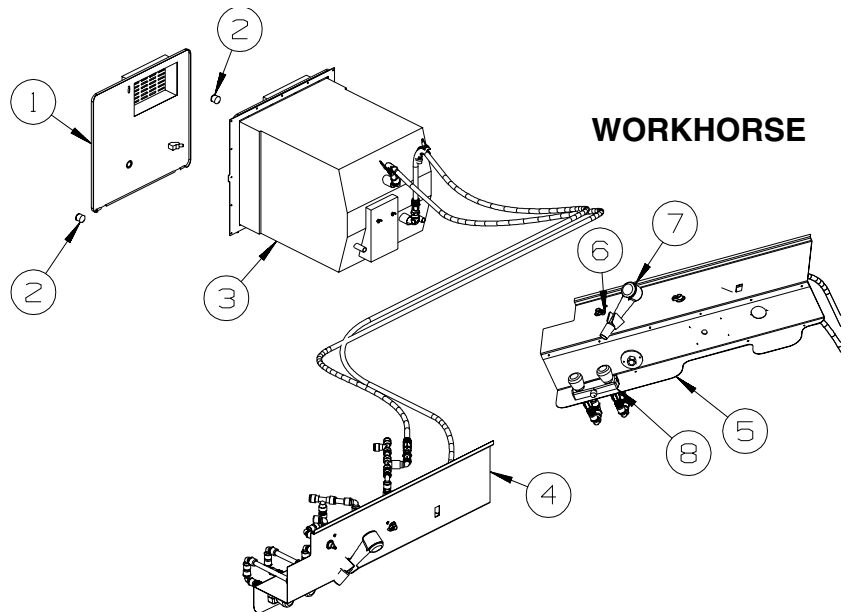

KEY	PART NUMBER	U/M	DESCRIPTION
1*	125420-01-03A	EA	DOOR - WATER HEATER - 10 GALLON - BLACK W/BLACK GRILLE
2	117047-02-000	EA	BUMPER - RUBBER/WASHER INSERT
3*	145541-01-000	EA	WATER HEATER - 10 GALLONS-GAS/120 DEGREES-REMOTE IGNITION
4	150012-01-12B	EA	PANEL/COVER - DRAIN - BRIGHT WHITE
5	150013-01-12B	EA	PANEL/COVER - DRAIN - BRIGHT WHITE
6	143021-02-12B	EA	BRACKET - SHOWER - EXTERIOR - BRIGHT WHITE
			FROM: 00-00-00 THRU: 02-23-03
6	146820-01-12B	EA	BRACKET - EXTERIOR SHOWER - BRIGHT WHITE
			FROM: 02-24-03 THRU: 99-99-99
7	131383-01-02A	EA	SHOWER HEAD - W/60" HOSE & BRACKET - WHITE
8*	075241-06-000	EA	FAUCET - SHOWER/BRIGHT WHITE - .5" MPT W/1.9" INLET PIPES

*COMPONENT PARTS LISTED LATER IN THIS GROUP

WATER & SEWAGE GROUP (CONTINUED)

WATER SYSTEM (CONTINUED)

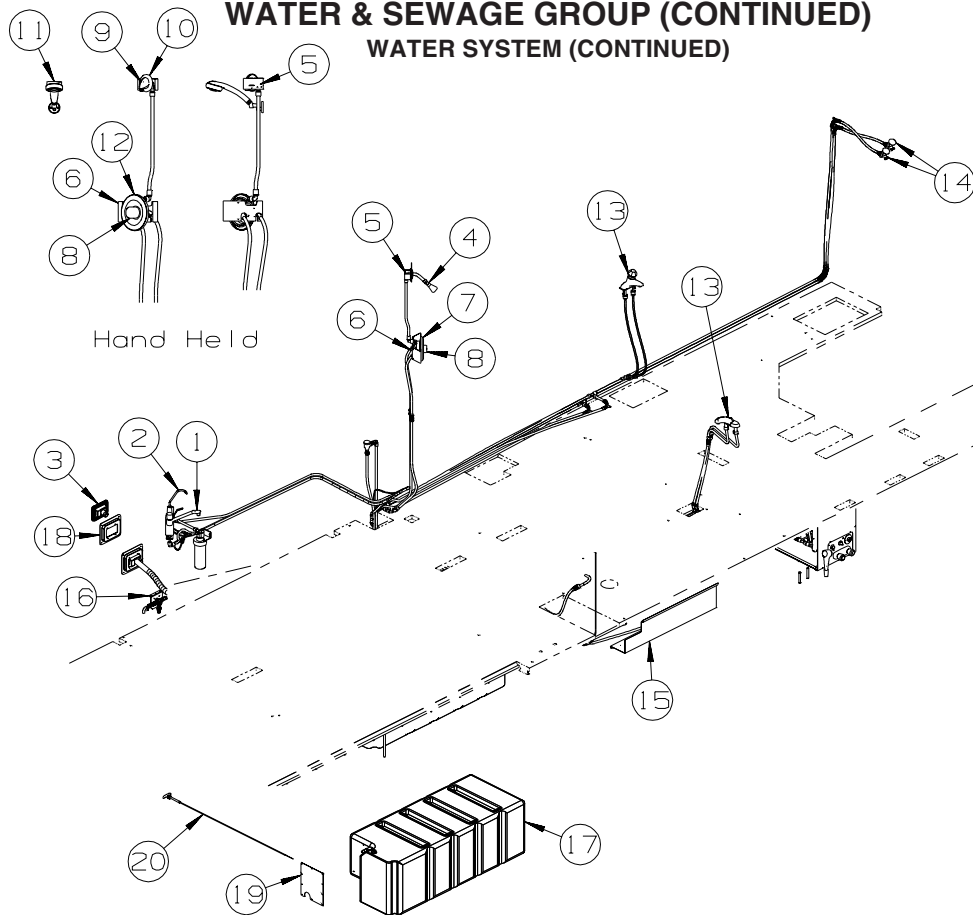

FREIGHTLINER

KEY	PART NUMBER	U/M	DESCRIPTION
1	123744-03-01A	EA	FAUCET - GALLEY/SINGLE CONTROL W/SPRAYER HEAD - CHROME
2	103635-01-000	EA	FAUCET - SINGLE CONTROL/DRINKING WATER
3	137169-01-01A	EA	WATER FILL/GRAVITY - W/DOOR - W/O LOCK - BRIGHT WHITE
	138290-03-000	EA	CASE - W/CAM - W/O CYLINDER/KEY
4	128974-01-02A	EA	VALVE - SHOWER HEAD/WATER SAVER (ON/OFF) - CHROME
5	143101-01-01A	EA	BRACKET - SHOWER HEAD
6	131554-01-02B	EA	BRACKET/SHOWER CONTROL - E-COATED
7*	144596-03-01A	EA	TRIM KIT - (KNOB-HANDLE/PLATE/SHOWER HEAD & ARM) - BRASS
8*	144596-01-01A	EA	FAUCET/VALVE ONLY - SHOWER - W/TEMP LIMIT STOP(MOEN 62300)
9	135028-01-01A	EA	DROP ELL - F/HAND HELD SHOWER HEAD - 1/2"IPS - BRASS
			FROM: 00-00-00 THRU: 05-09-04
9	135028-02-01A	EA	DROP ELL - F/HAND HELD SHOWER HEAD/OVAL - W/1/2"IPS-BRASS
			FROM: 05-10-04 THRU: 99-99-99
10	130041-01-02A	EA	SPACER/SHOWER HEAD - SOFT WHITE
			FROM: 00-00-00 THRU: 05-09-04
10	130041-03-18A	EA	SPACER/SHOWER HEAD
			FROM: 05-10-04 THRU: 99-99-99
11*	129390-03-01A	EA	SHOWER HEAD - W/HOSE & BRACKET - BRASS
12*	144596-02-01A	EA	TRIM KIT - (KNOB & PLATE) - CHATEAU - POLISHED BRASS
13*	141490-01-01A	EA	FAUCET - LAVATORY - W/STOP - CHROME/POLISHED BRASS
13	105218-01-01A	EA	SPACER - FAUCET/LAVATORY SINK - 2" X 5.9" - ABS PLASTIC
14	098419-01-000	EA	FAUCET - 90 DEGREE
15	142093-01-12B	EA	PANEL/COVER - DRAIN - BRIGHT WHITE
16	137410-01-12B	EA	BRACKET - VALVE - WINTERIZATION - BRIGHT WHITE
17	132678-02-000	EA	TANK - WATER - 85 GALLON - W/FITTINGS
	042989-05-000	EA	FITTING - SPINWELD - 1/2"FPT - PLASTIC
	042989-03-000	EA	FITTING - SPINWELD - 1 1/4"NPT - PLASTIC
	049032-01-000	EA	PATCH - SPINWELD - 3/8" - PLASTIC
	077954-02-000	EA	FILTER - WATER TANK - W/SCREEN IN TANK
	132678-01-000	EA	TANK - WATER - 85 GALLON - W/O FITTINGS
18	147154-01-R68	EA	POCKET - WATER FILL
18	147153-01-01A	EA	POCKET - WATER FILL
19	133352-01-02B	EA	PANEL - ACCESS - WATER TANK - E-COATED
20	062421-05-000	EA	CABLE/ROD - F/DUMP VALVE - W/HANDLE - 48"

*COMPONENT PARTS LISTED LATER IN THIS GROUP

WATER & SEWAGE GROUP (CONTINUED)
WATER SYSTEM (CONTINUED)

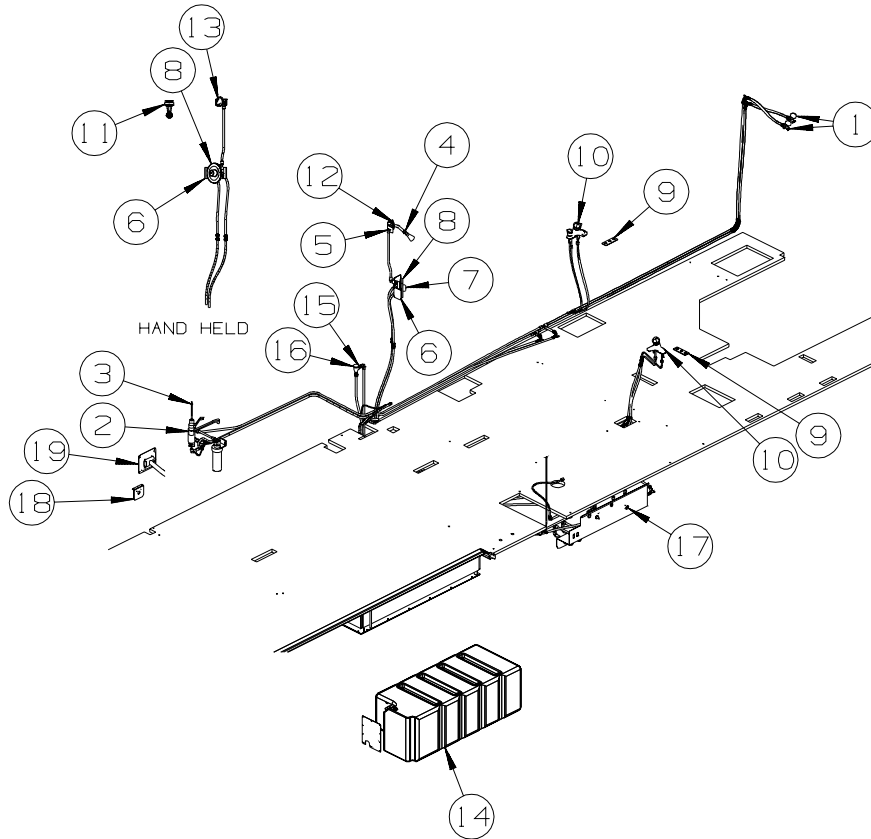

WORKHORSE

KEY	PART NUMBER	U/M	DESCRIPTION
1	098419-01-000	EA	FAUCET - 90 DEGREE
2	123744-03-01A	EA	FAUCET - GALLEY/SINGLE CONTROL W/SPRAYER HEAD - CHROME
3*	103635-01-000	EA	FAUCET - SINGLE CONTROL/DRINKING WATER
4	128974-01-01A	EA	VALVE - SHOWER HEAD/WATER SAVER (ON/OFF) - BRIGHT BRASS
5	143101-01-01A	EA	BRACKET - SHOWER HEAD
6	131554-01-02B	EA	BRACKET/SHOWER CONTROL - E-COATED
7*	144596-01-01A	EA	FAUCET/VALVE ONLY - SHOWER - W/TEMP LIMIT STOP(MOEN 62300)
8*	144596-03-01A	EA	TRIM KIT - (KNOB/HANDLE/PLATE/SHOWER HEAD & ARM) - BRASS
8*	144596-02-01A	EA	TRIM KIT - (KNOB & PLATE) - CHATEAU - POLISHED BRASS - HAND HELD SHOWER HEAD
9	105218-01-01A	EA	SPACER - FAUCET/LAVATORY SINK - 2" X 5.9" - ABS PLASTIC
10*	141490-01-01A	EA	FAUCET - LAVATORY - W/STOP - CHROME/POLISHED BRASS
11*	129390-03-01A	EA	SHOWER HEAD - W/HOSE & BRACKET - BRASS
12	130041-01-02A	EA	SPACER/SHOWER HEAD - SOFT WHITE
			FROM: 00-00-00 THRU: 05-09-04
12	130041-03-18A	EA	SPACER/SHOWER HEAD
			FROM: 05-10-04 THRU: 99-99-99
13	135028-01-01A	EA	DROP ELL - F/HAND HELD SHOWER HEAD - W/1/2"IPS - BRASS
			FROM: 00-00-00 THRU: 05-09-04
13	135028-02-01A	EA	DROP ELL - F/HAND HELD SHOWER HEAD/OVAL - W/1/2"IPS-BRASS
			FROM: 05-10-04 THRU: 99-99-99
14	132678-02-000	EA	TANK - WATER - 86 GALLON - W/FITTINGS
			FROM: 00-00-00 THRU: 05-02-04
14	132678-03-000	EA	TANK - WATER - 86 GALLON - W/FITTINGS
			FROM: 05-03-04 THRU: 99-99-99
	042989-03-000	EA	FITTING - SPINWELD - 1 1/4"NPT - PLASTIC
	042989-05-000	EA	FITTING - SPINWELD - 1/2"FPT - PLASTIC
	049032-01-000	EA	PATCH - SPINWELD - 3/8" - PLASTIC
	132678-01-000	EA	TANK - WATER - 86 GALLON - W/O FITTINGS

WATER & SEWAGE GROUP (CONTINUED)
WATER SYSTEM (CONTINUED)

KEY	PART NUMBER	U/M	DESCRIPTION
15	125697-03-000	EA	CHECK VALVE - F/FLUSHING SYSTEM
16	125697-04-000	EA	BREAKER/VACUUM - F/FLUSHING SYSTEM
17	125697-05-000	EA	INLET/WATER - F/FLUSHING SYSTEM
	125697-06-000	EA	INSTRUCTIONS - USER - F/FLUSHING SYSTEM
18	137410-01-12B	EA	BRACKET - VALVE - WINTERIZATION - BRIGHT WHITE
19	147154-01-R68	EA	POCKET - WATER FILL
	137169-01-01A	EA	WATER FILL/GRAVITY - W/DOOR - W/O LOCK - BRIGHT WHITE
	147153-01-01A	EA	POCKET - WATER FILL

WATER & SEWAGE GROUP (CONTINUED)

COMPONENT PARTS FOR WATER SYSTEM

075241-04-000, 075241-05-000, 075241-06-000

KEY	PART NUMBER	U/M	DESCRIPTION	VENDOR NO.
	075240-05-700	EA	CARTRIDGE - WASHERLESS	9-P42

098607-01-000

KEY	PART NUMBER	U/M	DESCRIPTION	VENDOR NO.
	098607-01-702	EA	DIAPHRAGM/DRIVE ASSEMBLY KIT	94-238-04
	098607-01-703	EA	VALVE KIT	94-232-00
	098607-01-705	EA	VALVE-CHECK, KIT	94-237-00
	098607-01-706	EA	HOUSING, W/SWITCH ONLY	94-231-20
	098607-01-707	EA	MOTOR W/BASEPLATE	11-148-04

123744-03-01A

KEY	PART NUMBER	U/M	DESCRIPTION	VENDOR NO.
	135027-01-700	EA	CLIP - RETAINER	883
	135027-01-705	EA	CARTRIDGE F/SGL LEVER FAUCET	1225

125420-01-02A, 125420-01-03A, 125420-03-03A, 125420-04-03A

KEY	PART NUMBER	U/M	DESCRIPTION	VENDOR NO.
	051391-01-705	EA	FASTENER - CAMLOCK	92609

129390-03-01A

KEY	PART NUMBER	U/M	DESCRIPTION	VENDOR NO.
	129390-03-700	EA	BRACKET-HANGAR/SHOWER HEAD	5001-210PK
	129390 03 701	EA	CONNECTOR-SWIVE	4002-210PK

141490-01-01A, 141490-01-02A

KEY	PART NUMBER	U/M	DESCRIPTION	VENDOR NO.
	132410-01-700	EA	CARTRIDGE F/DBL HDLE FAUCET	1224

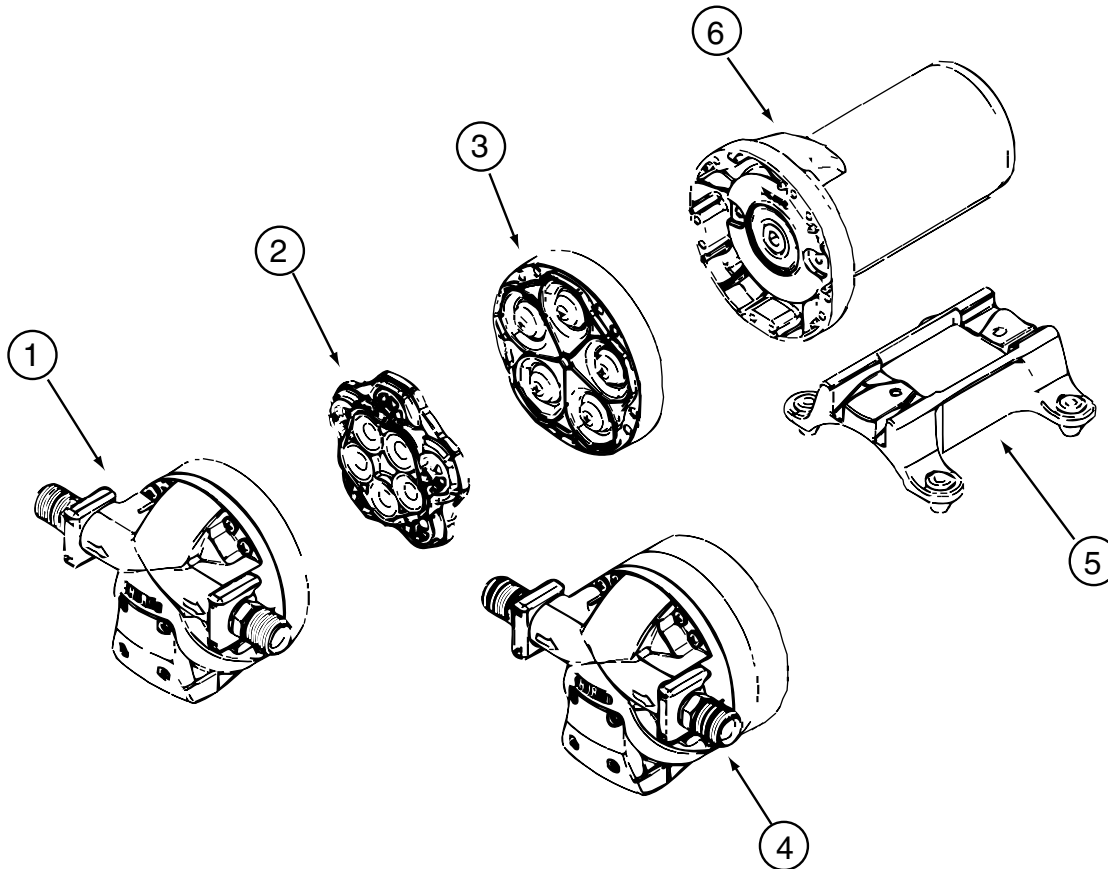

144215-01-000

KEY	PART NUMBER	U/M	DESCRIPTION	VENDOR NO.
2	144215-01-700	EA	VALVE ASSEMBLY	94-030-01
3	144215-01-701	EA	DRIVE ASSEMBLY	94-030-02
	144215-01-702	EA	FITTING KIT - W/ORINGS	94-615-06

CONTACT WINNEBAGO PARTS SALES FOR UNLISTED COMPONENT(S)

WATER & SEWAGE GROUP (CONTINUED)
COMPONENT PARTS FOR WATER SYSTEM (CONTINUED)

144596-01-01A

KEY	PART NUMBER	U/M DESCRIPTION	VENDOR NO.
	144596-01-700	EA CARTRIDGE (REPLACEMENT)	1222

144596-02-01A, 144596-03-01A

KEY	PART NUMBER	U/M DESCRIPTION	VENDOR NO.
	144596-03-700	EA KNOB (INSERT KIT) WHITE/GOLD	M0-91754

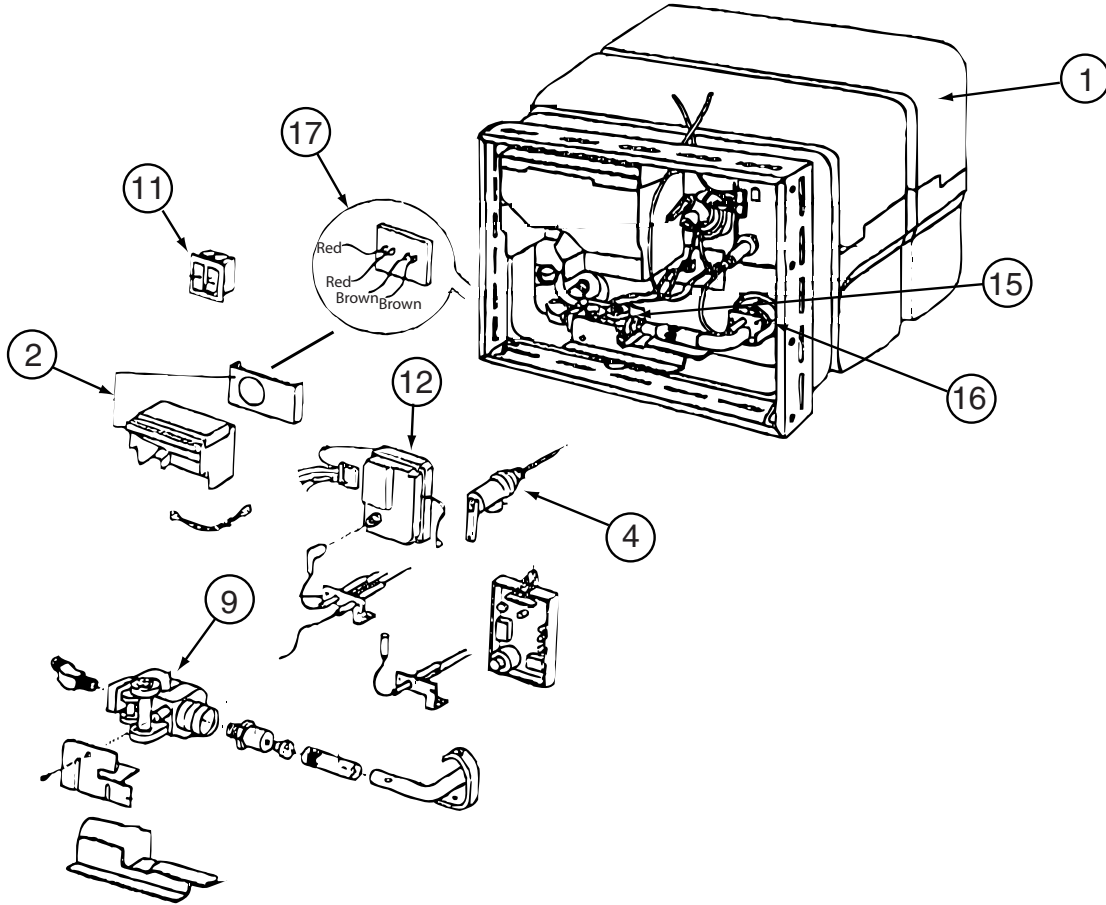

145541-01-000

KEY	PART NUMBER	U/M DESCRIPTION	VENDOR NO.
1	145541-01-700	EA TANK - W/INSULATION - 10 GAL	91028
2	051391-04-707	EA KIT-EXHAUST, (FLUE & GASKET)	90960
3	051391-01-715	EA PLUG-DRAIN, 1 EA = 2 PER PKG	91857
4	051391-01-704	EA VALVE-RELIEF, 1/2" FITTING	91604
9	051393-01-726	EA VALVE/SOLENOID - W/O BRACKET	93870
11	145541-01-701	EA SWITCH - ON/OFF - WHITE	91859
11	051393-01-701	EA SWITCH - REMOTE - W/LIGHT	91959
12	145541-01-702	EA CIRCUIT BOARD	91226
15	145541-01-703	EA SWITCH - THERMAL CUT OFF	93866
16	051393-01-725	EA ELECTRODE-SGL SPADE CONNECT.	93868
17	051393-01-721	EA THERMOSTAT W/ECO, 140 FRT MT	91447
	051391-05-706	EA ELEMENT-HEATING 1500 WATT	92249 W/GASKET
	145541-01-704	EA RELAY	90061
	145541-01-705	EA JUNCTION BOX(PLASTIC) 10 GAL	91224

CONTACT WINNEBAGO PARTS SALES FOR UNLISTED COMPONENT(S)

WINDOW & VENTS GROUP

WINDOW & VENT LAYOUT

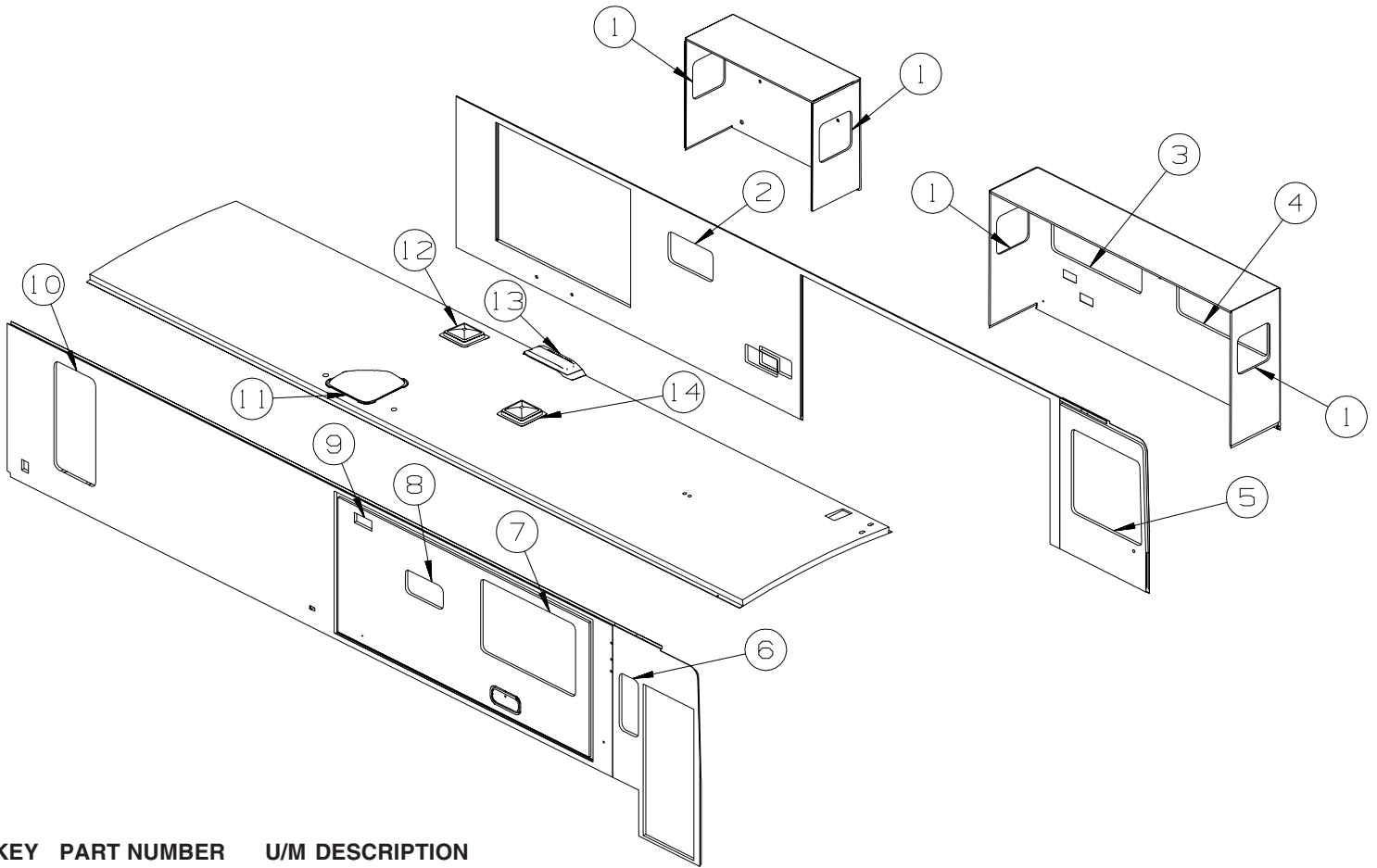

KEY	PART NUMBER	U/M	DESCRIPTION
1*	134004-03-01A	EA	WINDOW - VERT SLIDER/FLUSH O/S-THERMO W/TRIM - 21" X 19.8"
2*	112795-73-01A	EA	WINDOW - DRVR HORIZ SLIDER/THERMO W/TRIM - 28.7" X 15.7"
3*	112795-77-01A	EA	WINDOW - DRVR HORIZ SLIDER/THERMO W/TRIM - 57.4" X 23.6"
4*	112795-81-01A	EA	WINDOW-DRVR HORIZ SLIDER/THERMO/ESC W/TRIM - 23.8" X 57.7"
5*	106466-14-01A	EA	WINDOW - CAB/DRVR THERMO W/RETAINER-44.6"T X 44.7"H X 46"B
6*	112898-27-01A	EA	WINDOW - VERTICAL SLIDER/THERMO-W/TRIM - 12" X 29.4"
7*	112795-80-01A	EA	WINDOW - PASS HORIZ SLIDER/THERMO W/TRIM - 37.9" X 60.4"
8*	112795-86-01A	EA	WINDOW - PASS HORIZ SLIDER/THERMO W/TRIM - 12.3" X 24.2"
9	138983-01-01A	EA	VENT - MICROWAVE/OUTER - BRIGHT WHITE
9	138983-01-02A	EA	VENT - MICROWAVE/OUTER - BLACK
9	138983-03-01A	EA	COVER - VENT MICROWAVE/OUTER - BRIGHT WHITE
10*	129929-13-01A	EA	WINDOW - TIPOUT/THERMO/ESCAPE W/TRIM - 56.1" X 26.7"
11	122214-01-02A	EA	PANEL - SKYLITE - INNER - W/ANGLED CORNER - WHITE
11	138372-01-02B	EA	TRIM - CORNER - SKYLIGHT - E-COATED
11	139411-01-01A	EA	PANEL/SKYLITE - OUTER - NEO ANGLE - WHITE
12*	123780-10-01A	EA	FANTASTIC VENT-4"ROOF-W/FAN/PWR LIFT/DBL DOME-W/O THERM
	009440-01-000	EA	GEAR/ARM - LIFT - ROOF VENT COVER
13	084073-04-000	EA	BASE/VENT - ROOF/REFRIGERATOR - BLACK - NORCOLD FROM: 00-00-00 THRU: 11-09-03
13	149508-01-01A	EA	BASE - REFRIGERATOR ROOF VENT - GRAY FROM: 11-10-03 THRU: 99-99-99
13	149508-02-02A	EA	BASE - REFRIGERATOR ROOF VENT - BRIGHT WHITE FROM: 11-10-03 THRU: 01-11-04
13	149508-02-01A	EA	BASE - ROOF/REFRIGERATOR VENT - BLACK FROM: 01-12-04 THRU: 99-99-99
13	084073-07-000	EA	CAP - ROOF/REFRIGERATOR VENT - 10" X 32" - BRIGHT WHITE FROM: 00-00-00 THRU: 11-09-03
13	149508-01-02A	EA	CAP - ROOF/REFRIGERATOR VENT - WHITE FROM: 11-10-03 THRU: 99-99-99
14*	123780-09-01A	EA	FANTASTIC VENT-4"ROOF- W/FAN/DBL DOME-W/O THERM/PWR LIFT
	009440-01-000	EA	GEAR/ARM - LIFT - ROOF VENT COVER

*COMPONENT PARTS LISTED LATER IN THIS GROUP

WINDOW & VENTS GROUP (CONTINUED)
COMPONENT PARTS FOR WINDOWS & VENT LAYOUT

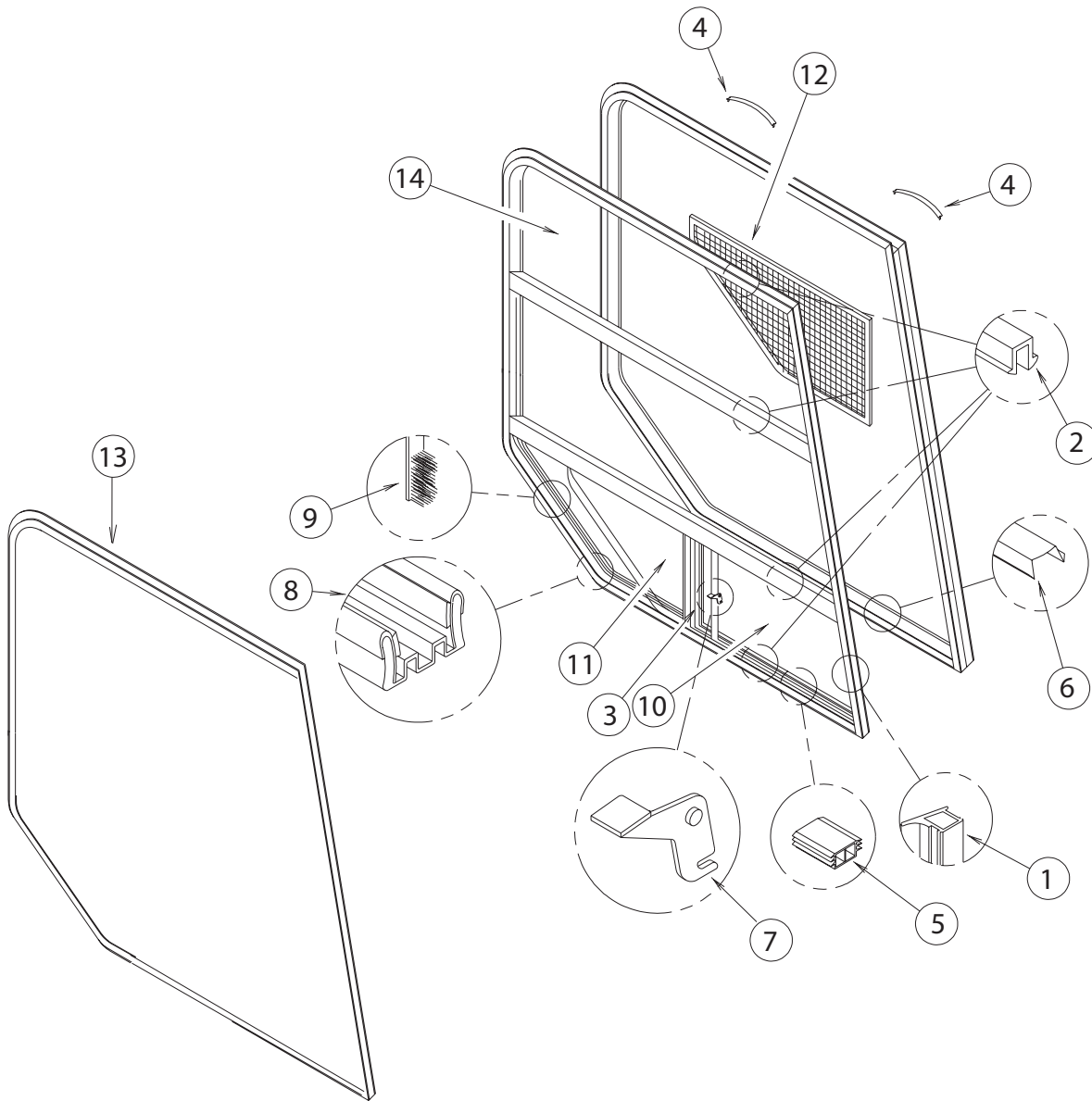

106466-14-01A

KEY	PART NUMBER	U/M	DESCRIPTION	VENDOR NO.
1	112795-01-704	FT	PLUG FILLER (DOUBLE GLAZED)	122-018737
2	112795-01-705	FT	VINYL - GLAZING	132-027331
3	098644-01-706	FT	WEATHERSTRIP - GLASS	171-010668
4	098644-01-713	EA	CLIP - SCREEN - METAL	226-016966
4	125582-01-701	EA	CLIP - SCREEN - PLASTIC	130-005153
5	112795-01-701	EA	SLIDE-STOP	132-019092
6	098644-01-710	FT	TRACK - SCREEN SPACER 12'	132-017135
7	112795-01-700	EA	LATCH ASM., BLK.,(BOLT ON)	DH287-CK
8	112795-01-703	IN	CHANNEL-RUN (INCHES)	122-027566
9	075673-05-000	FT	SEAL-PILE ADH BACK,BLK	AMESBURY
10	106466-14-701	EA	GLASS - STATIONERY - LOWER	390-027478
11	106466-14-702	EA	GLASS-SLIDING W/SASH & LATCH	DH567-A9L
12	125582-04-701	EA	SCREEN ASM - W/SEALS & CLIPS	410-026544
13	106466-13-703	EA	RETAINER - TRIM	H671-66L
14	106466-14-700	EA	GLASS - STATIONERY - UPPER	390-027477
	098644-01-717	FT	SPLINE - SCREEN	132-004716
	125582-01-708	EA	WEEPHOLE COVER - RIGHT HAND	130-026598
	125582-01-709	EA	WEEPHOLE COVER - LEFT HAND	130-026599

WINDOW & VENTS GROUP (CONTINUED)
COMPONENT PARTS FOR WINDOWS & VENT LAYOUT (CONTINUED)

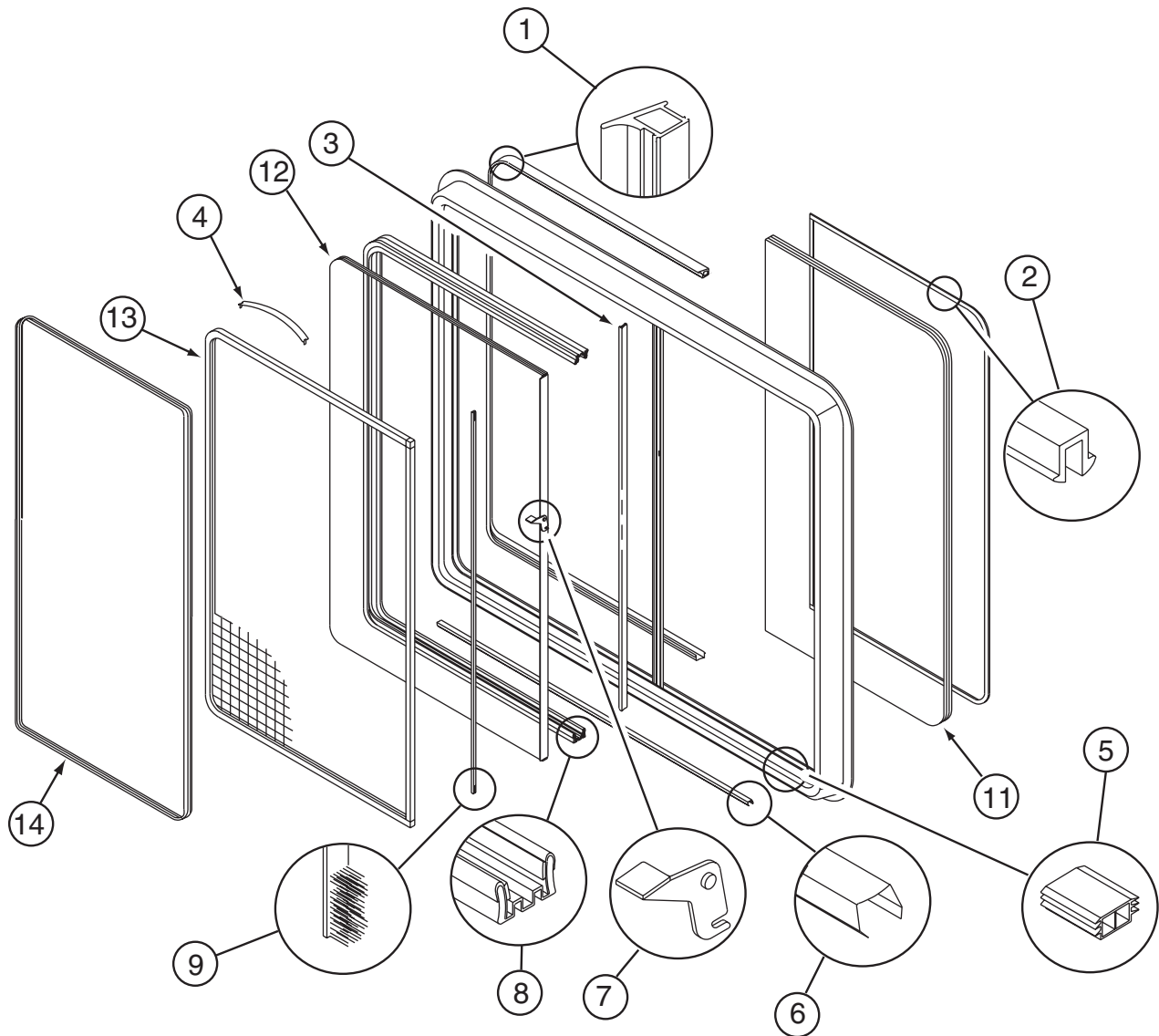

112795-73-01A

KEY	PART NUMBER	U/M	DESCRIPTION	VENDOR NO.
1	112795-01-704	FT	PLUG FILLER (DOUBLE GLAZED)	122-018737
2	112795-01-705	FT	VINYL - GLAZING	132-025736
3	098644-01-706	FT	WEATHERSTRIP - GLASS	171-010668
4	098644-01-713	EA	CLIP - SCREEN - METAL	226-016966
4	125582-01-701	EA	CLIP - SCREEN - PLASTIC	130-005153
	098644-01-717	FT	SPLINE - SCREEN	132-004716
5	112795-01-701	EA	SLIDE-STOP	132-019092
6	098644-01-710	FT	TRACK - SCREEN SPACER 12'	132-017135
7	112795-01-700	EA	LATCH ASM., BLK.,(BOLT ON)	DH287-CK
8	112795-01-703	IN	CHANNEL-RUN (INCHES)	122-018736
9	098644-01-711	FT	WEATHERSTRIP - SCREEN BLACK	171-016965
11	112795-72-700	EA	GLASS - STATIONARY	390-028307
12	112795-72-701	EA	GLASS - SLIDING W/SASH LATCH	DC29-G8
13	098647-31-704	EA	SCREEN ASSY - W/SEAL & CLIPS	410-019128
14	098647-31-705	EA	RETAINER - TRIM	CH29-66

WINDOW & VENTS GROUP (CONTINUED)
COMPONENT PARTS FOR WINDOWS & VENT LAYOUT (CONTINUED)

112795-77-01A

KEY	PART NUMBER	U/M	DESCRIPTION	VENDOR NO.
1	112795-01-704	FT	PLUG FILLER (DOUBLE GLAZED)	122-018737
2	112795-01-705	FT	VINYL - GLAZING	132-025736
3	098644-01-706	FT	WEATHERSTRIP - GLASS	171-010668
4	098644-01-713	EA	CLIP - SCREEN - METAL	226-016966
4	125582-01-701	EA	CLIP - SCREEN - PLASTIC	130-005153
5	112795-01-701	EA	SLIDE-STOP	132-019092
6	098644-01-710	FT	TRACK - SCREEN SPACER 12'	132-017135
7	112795-01-700	EA	LATCH ASM., BLK.,(BOLT ON)	DH287-CK
8	112795-01-703	IN	CHANNEL-RUN (INCHES)	122-018736
9	098644-01-711	FT	WEATHERSTRIP - SCREEN BLACK	171-016965
11	112795-77-700	EA	GLASS - STATIONARY	390-28313
12	112795-77-701	EA	GLASS - SLIDING W/SASH LATCH	DH493-G8
13	098647-47-702	EA	SCREEN ASSY - W/SEAL & CLIPS	410-025226
14	098647-47-704	EA	RETAINER - TRIM	H493-66
	098644-01-717	FT	SPLINE - SCREEN	132-004716

112795-80-01A

KEY	PART NUMBER	U/M	DESCRIPTION	VENDOR NO.
1	112795-01-704	FT	PLUG FILLER (DOUBLE GLAZED)	122-018737
2	112795-01-705	FT	VINYL - GLAZING	132-025736
3	098644-01-706	FT	WEATHERSTRIP - GLASS	171-010668
4	098644-01-713	EA	CLIP - SCREEN - METAL	226-016966
4	125582-01-701	EA	CLIP - SCREEN - PLASTIC	130-005153
	098644-01-717	FT	SPLINE - SCREEN	132-004716
5	112795-01-701	EA	SLIDE-STOP	132-019092
6	098644-01-710	FT	TRACK - SCREEN SPACER 12'	132-017135
7	112795-01-700	EA	LATCH ASM., BLK.,(BOLT ON)	DH287-CK
8	112795-01-703	IN	CHANNEL-RUN (INCHES)	122-018736
9	098644-01-711	FT	WEATHERSTRIP - SCREEN BLACK	171-016965
11	112795-80-700	EA	GLASS - STATIONARY	390-028379
12	112795-80-701	EA	GLASS - SLIDING W/SASH LATCH	DH442-G8
13	112795-80-702	EA	SCREEN ASSY - W/SEAL & CLIPS	410-019057
14	112795-64-700	EA	RETAINER - TRIM	H442-66

112795-81-01A

KEY	PART NUMBER	U/M	DESCRIPTION	VENDOR NO.
1	112795-01-704	FT	PLUG FILLER (DOUBLE GLAZED)	122-018737
2	112795-01-705	FT	VINYL - GLAZING	132-025736
3	098644-01-706	FT	WEATHERSTRIP - GLASS	171-010668
4	098644-01-713	EA	CLIP - SCREEN - METAL	226-016966
4	125582-01-701	EA	CLIP - SCREEN - PLASTIC	130-005153
	098644-01-717	FT	SPLINE - SCREEN	132-004716
5	112795-01-701	EA	SLIDE-STOP	132-019092
6	098644-01-710	FT	TRACK - SCREEN SPACER 12'	132-017135
7	112795-01-700	EA	LATCH ASM., BLK.,(BOLT ON)	DH287-CK
8	112795-01-703	IN	CHANNEL-RUN (INCHES)	122-018736
9	098644-01-711	FT	WEATHERSTRIP - SCREEN BLACK	171-016965
11	112795-77-700	EA	GLASS - STATIONARY	390-28313
12	112795-77-701	EA	GLASS - SLIDING W/SASH LATCH	DH493-G8
13	098647-47-702	EA	SCREEN ASSY - W/SEAL & CLIPS	410-025226
14	098647-47-704	EA	RETAINER - TRIM	H493-66

WINDOW & VENTS GROUP (CONTINUED)
COMPONENT PARTS FOR WINDOWS & VENT LAYOUT (CONTINUED)

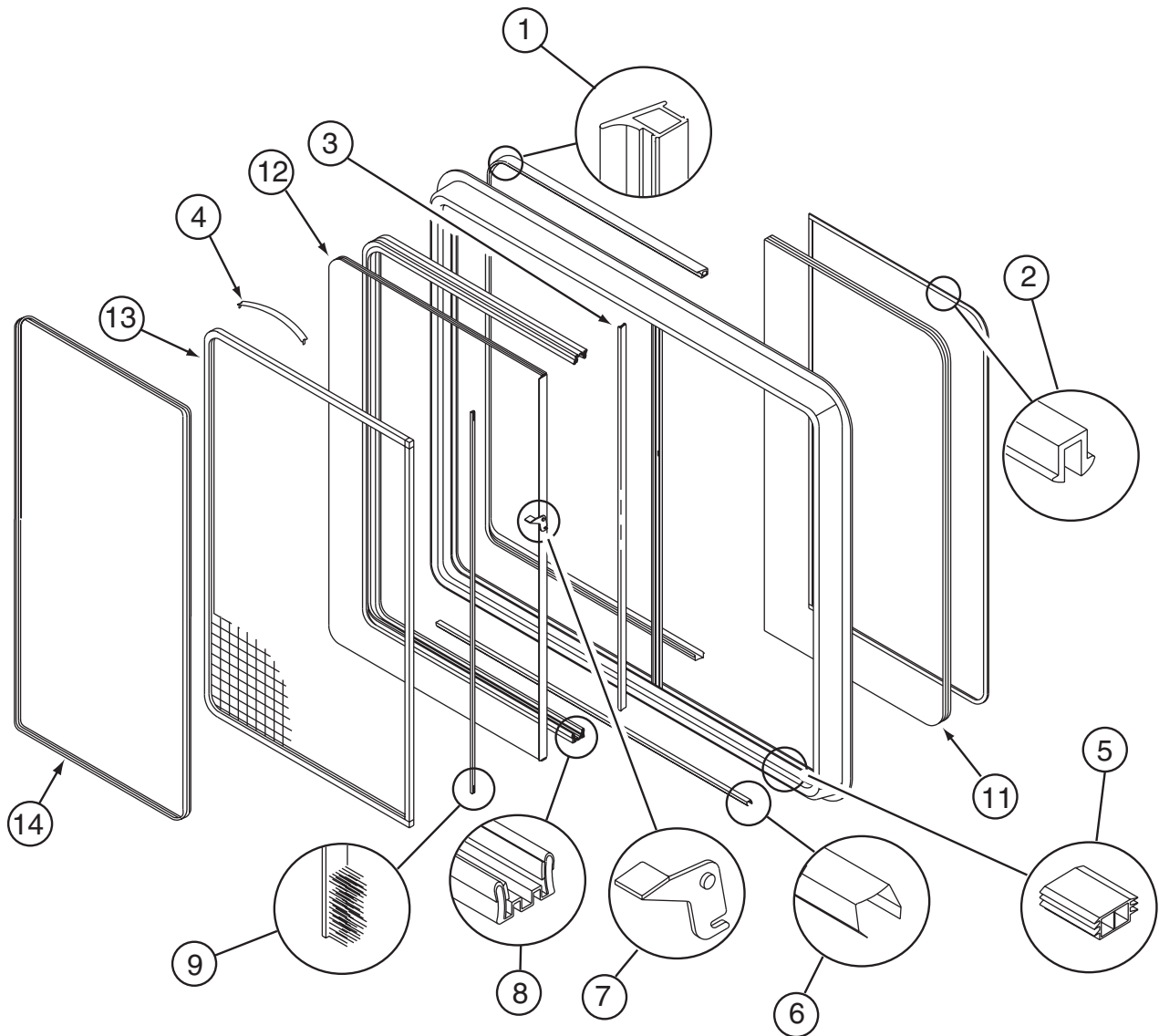

112795-86-01A

KEY	PART NUMBER	U/M	DESCRIPTION	VENDOR NO.
1	112795-01-704	FT	PLUG FILLER (DOUBLE GLAZED)	122-018737
2	112795-01-705	FT	VINYL - GLAZING	132-027331
3	098644-01-706	FT	WEATHERSTRIP - GLASS	171-010668
4	125582-01-701	EA	CLIP - SCREEN - PLASTIC	130-005153
4	098644-01-713	EA	CLIP - SCREEN - METAL	226-016966
5	112795-01-701	EA	SLIDE-STOP	132-019092
6	098644-01-710	FT	TRACK - SCREEN SPACER 12'	132-017135
7	112795-01-700	EA	LATCH ASM., BLK.,(BOLT ON)	DH287-CK
8	112795-01-703	IN	CHANNEL-RUN (INCHES)	122-027566
9	098644-01-711	FT	WEATHERSTRIP - SCREEN BLACK	171-016965
11	112795-86-700	EA	GLASS - STATIONARY	390-030058
12	112795-86-701	EA	GLASS-SLIDING W/SASH & LATCH	DB951-G8
13	112795-86-702	EA	SCREEN ASM W/SEALS & CLIPS	410-030059
14	112795-86-703	EA	RETAINER - TRIM	B951-66
	098644-01-717	FT	SPLINE - SCREEN	132-004716

WINDOW & VENTS GROUP (CONTINUED)
COMPONENT PARTS FOR WINDOWS & VENT LAYOUT (CONTINUED)

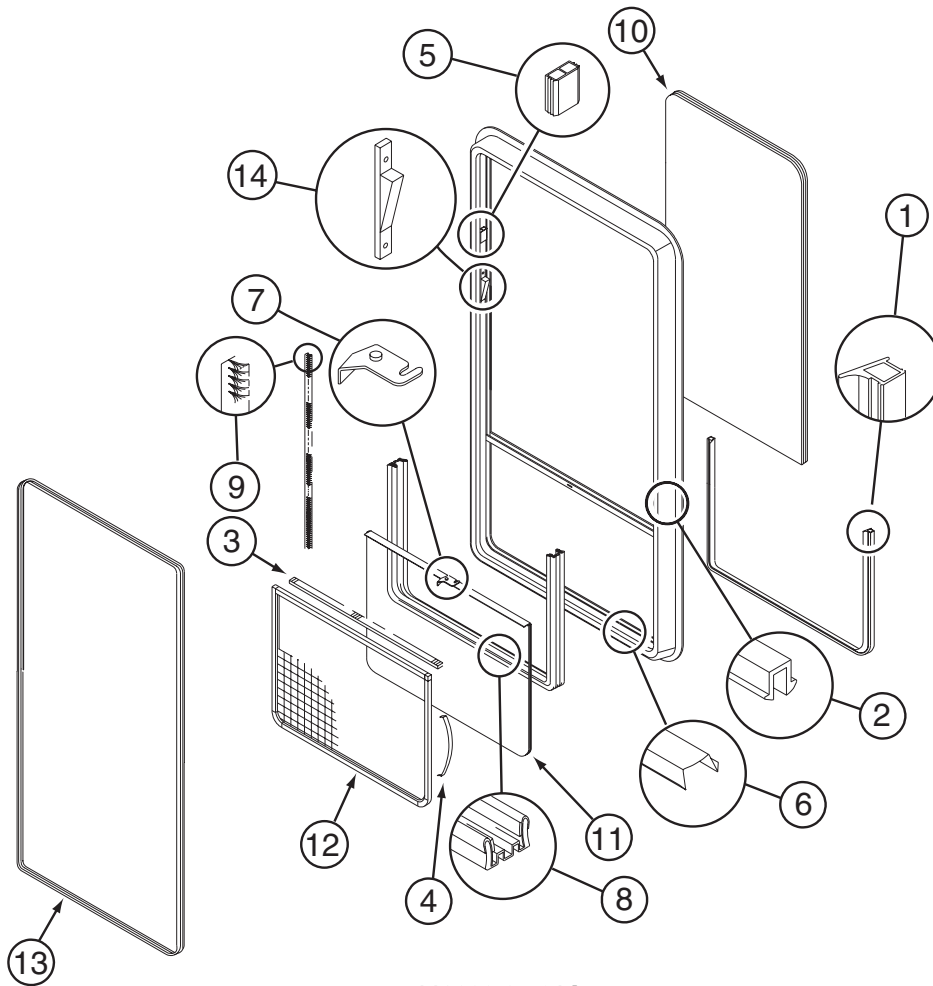

112898-27-01A

KEY	PART NUMBER	U/M	DESCRIPTION	VENDOR NO.
1	112795-01-704	FT	PLUG FILLER (DOUBLE GLAZED)	122-018737
2	112795-01-705	FT	VINYL - GLAZING	132-027331
3	098644-01-706	FT	WEATHERSTRIP - GLASS	171-010668
4	098644-01-713	EA	CLIP - SCREEN - METAL	226-016966
4	125582-01-701	EA	CLIP - SCREEN - PLASTIC	130-005153
5	112795-01-701	EA	SLIDE-STOP	132-019092
6	098644-01-710	FT	TRACK - SCREEN SPACER 12'	132-017135
7	112795-01-700	EA	LATCH ASM., BLK.,(BOLT ON)	DH287-CK
8	112795-01-703	IN	CHANNEL-RUN (INCHES)	122-027566
9	075673-05-000	FT	SEAL-PILE ADH BACK,BLK	AMESBURY
10	112898-27-700	EA	GLASS - STATIONARY	390-029191
11	112898-27-701	EA	GLASS-SLIDING W/SASH & LATCH	DH755-G8
12	112898-27-702	EA	SCREEN ASM W/SEALS & CLIPS	410-029193
13	113733-13-701	EA	RETAINER - TRIM	H754-66
14	112898-04-703	EA	VERTICAL LATCH (SASH KIT)	DH343-CK
	098644-01-717	FT	SPLINE - SCREEN	132-004716

WINDOW & VENTS GROUP (CONTINUED)
COMPONENT PARTS FOR WINDOWS & VENTS (CONTINUED)

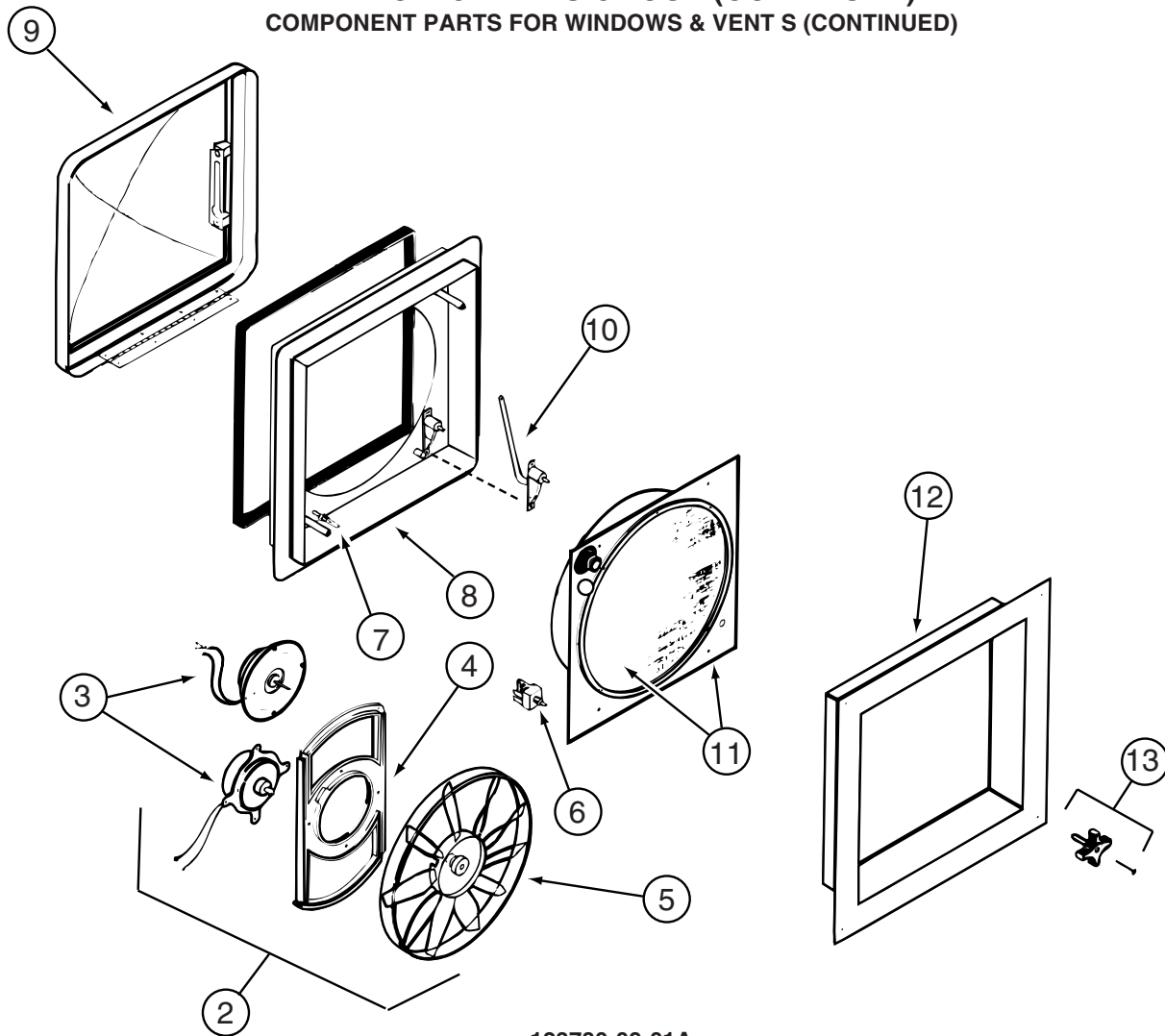

123780-09-01A

KEY	PART NUMBER	U/M	DESCRIPTION	VENDOR NO.
2	084079-11-700	EA	MOTOR & FAN BLADE W/BRACKET	K4017-09
3	084079-01-705	EA	MOTOR/EXT BRKT/FAN BLADE KIT	1080-00
5	084079-01-704	EA	BLADE-FAN	1138-00
6	084079-01-709	EA	SWITCH - MAIN - 3 SPEED	1031-05
7	084079-01-707	EA	SWITCH - SAFETY	1122-05
8	123780-05-700	EA	BASE/MAIN-BRT WHT W/GASKET	1010-81
9	123780-09-700	EA	DOME (DOUBLE)WHT TRANSPARENT	K2020-82
10	009440-01-000	EA	GEAR-ARM-ROOF VENT	705221K38
11	123780-03-701	EA	SCREEN ASM 78-100MM W/SWITCH	1030BT-81
12	123780-03-700	EA	GARNISH - INT. 3"-4" BRT/WHT	2040-81
13	084079-01-703	EA	KNOB-LIFT, W/EXT.	1140K-00
	123780-01-702	EA	SCREEN INSERT (SCREEN RING)	K1035-81

CONTACT WINNEBAGO PART SALES FOR UNLISTED COMPONENTS

WINDOW & VENTS GROUP (CONTINUED)
COMPONENT PARTS FOR WINDOWS & VENT S (CONTINUED)

123780-10-01A

KEY	PART NUMBER	U/M	DESCRIPTION	VENDOR NO.
2	084079-11-700	EA	MOTOR & FAN BLADE W/BRACKET	K4017-09
3	084079-01-705	EA	MOTOR/EXT BRKT/FAN BLADE KIT	1080-00
4	084079-01-711	EA	MOTOR MOUNT (BOWTIE)	1015-00
5	084079-01-704	EA	BLADE-FAN	1138-00
6	084079-01-709	EA	SWITCH - MAIN - 3 SPEED	1031-05
7	084079-01-707	EA	SWITCH - SAFETY	1122-05
8	123780-05-700	EA	BASE/MAIN-BRT WHT W/GASKET	1010-81
9	123780-09-700	EA	DOME (DOUBLE)WHT TRANSPARENT	K2020-82
10	009440-01-000	EA	GEAR-ARM-ROOF VENT	705221K38
11	123780-01-702	EA	SCREEN INSERT (SCREEN RING)	K1035-81
12	123780-03-700	EA	GARNISH - INT. 3"-4" BRT/WHT	2040-81
13	084079-01-710	EA	THERMOSTAT(WALL MT)ANY COLOR	9988-81
14	123780-05-701	EA	SCREEN INT W/ALL SWITCHES	KIT-81
15	084079-11-703	EA	MOTOR/AUTO LIFT OFF/WHT CAP	6050-80 OS
15	084079-11-705	EA	MOTOR - LIFT (BC MOTOR)	5050-40
15	084079-11-707	EA	MOTOR-AUTO LIFT-WHT CAP NS	6050-81 NS
			CONTACT WINNEBAGO PART SALES FOR UNLISTED COMPONENT(S)	

WINDOW & VENTS GROUP (CONTINUED)
COMPONENT PARTS FOR WINDOWS & VENTS (CONTINUED)

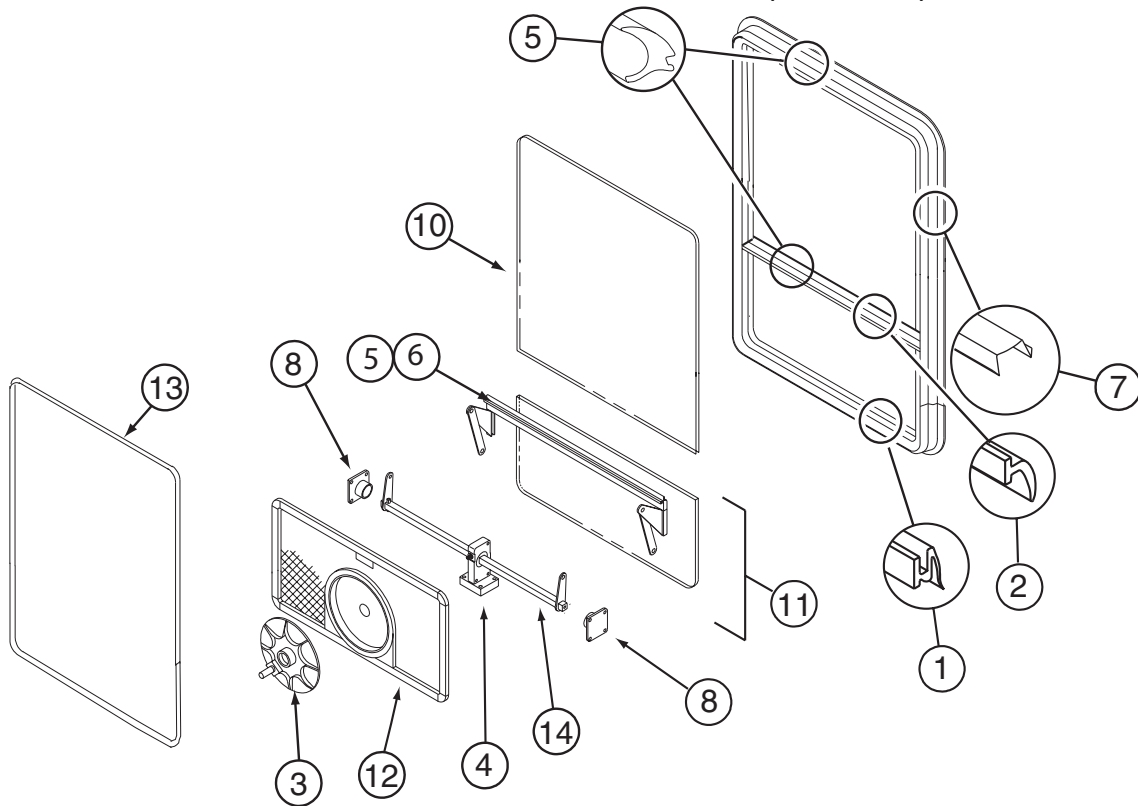

129929-13-01A

KEY	PART NUMBER	U/M	DESCRIPTION	VENDOR NO .
1	100322-01-701	FT	SEAL-VENT	122-016071
3	100322-01-718	EA	HANDLE-DIAL	410-016081
4	129929-01-710	EA	TORQUE-CTR SUPPORT (2 HOLE)	410-026806
5	129929-01-705	FT	GLAZING VINYL	132-026811
6	129929-01-707	FT	COVER/SCREW-FILLER STRIP	132-026808
8	129929-01-708	EA	SUPPORT - TORQUE BAR - RT/LT	130-026804
10	129929-13-700	EA	GLASS - STATIONARY	390-030042
11	129929-13-701	EA	VENT GLASS ASSEMBLY	DTH028-G8
12	129929-13-702	EA	SCREEN ASM - W/SEALS & CLIPS	410-030044
13	129929-13-703	EA	RETAINER - TRIM	DTH028-62
14	129929-13-704	EA	OPERATOR BAR	DTH028-18
	129929-13-705	EA	OPRTR BAR ASM - INCLUDES KEYS 4 & 14	DTH028-15
	100322-01-717	EA	E-RING	245-015975
	129929-01-706	FT	SEAL - TOP F/CENTER EGRESS	132-026811
	129929-02-706	FT	SEAL - FOAM	140-027022
	112898-06-704	EA	HANDLE/RH-(TIPOUT)ESCAPE-RED	182-11293
	112898-06-705	EA	HANDLE-LH-(TIPOUT)ESCAPE-RED	182-11294

CONTACT WINNEBAGO PART SALES FOR UNLISTED COMPONENTS

WINDOW & VENTS GROUP (CONTINUED)
COMPONENT PARTS FOR WINDOWS & VENTS (CONTINUED)

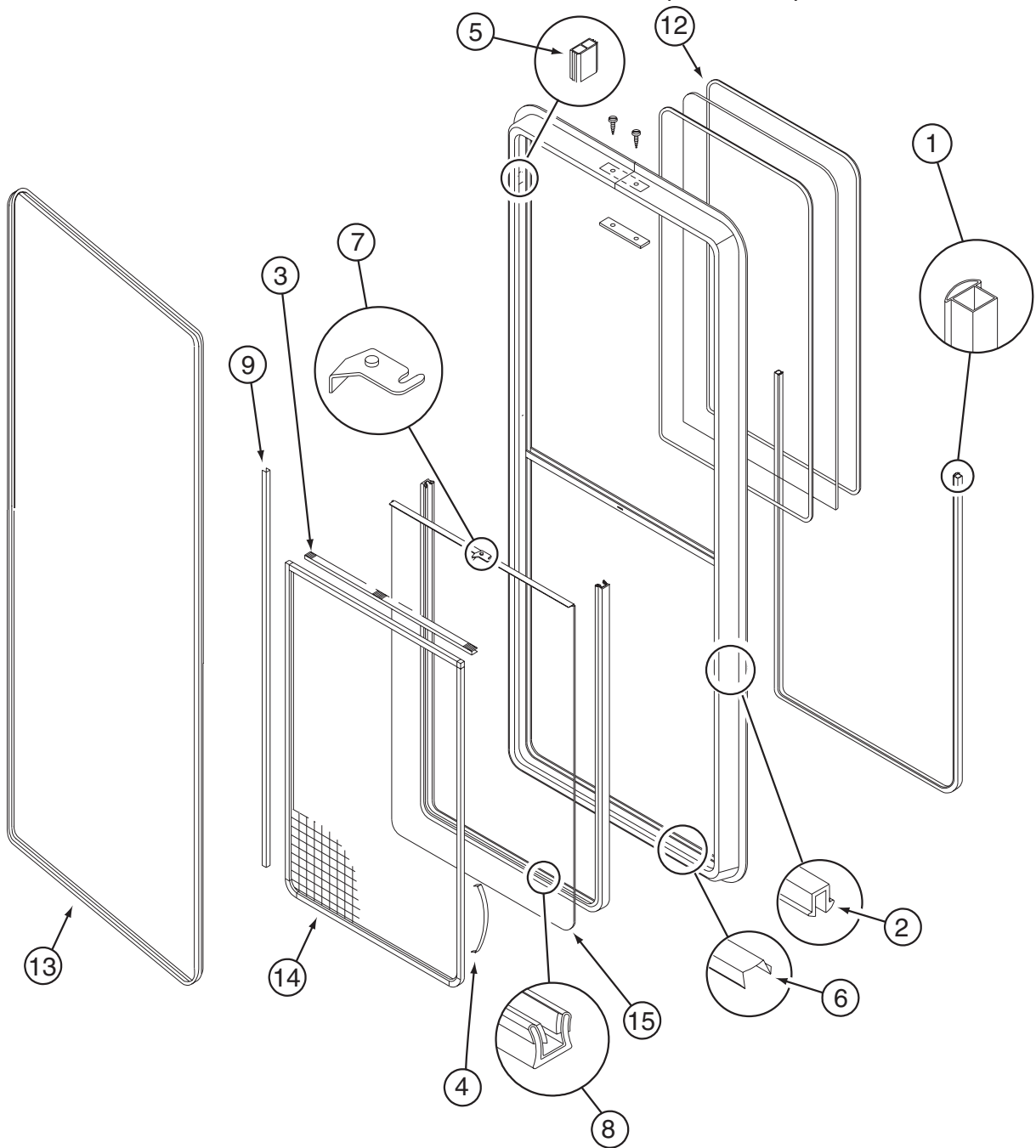

134004-03-01A

KEY	PART NUMBER	U/M	DESCRIPTION	VENDOR NO
1	112795-01-704	FT	PLUG FILLER (DOUBLE GLAZED)	122-018737
2	112795-01-705	FT	VINYL - GLAZING	132-027331
3	098644-01-706	FT	WEATHERSTRIP - GLASS	171-010668
4	098644-01-713	EA	CLIP - SCREEN - METAL	226-016966
4	125582-01-701	EA	CLIP - SCREEN - PLASTIC	130-005153
5	112795-01-701	EA	SLIDE-STOP	132-019092
6	098644-01-710	FT	TRACK - SCREEN SPACER 12'	132-017135
7	112795-01-700	EA	LATCH ASM., BLK.,(BOLT ON)	DH287-CK
8	112795-01-703	IN	CHANNEL-RUN (INCHES)	122-027566
9	075673-05-000	FT	SEAL-PILE ADH BACK,BLK	AMESBURY
12	134004-03-700	EA	GLASS - STATIONARY	390-028662
13	134004-03-702	EA	RETAINER - TRIM	H702-56
14	098644-13-702	EA	SCREEN ASM W/SEALS & CLIPS	410-028663
15	134004-03-701	EA	GLASS-SLIDING W/SASH & LATCH	DH702-G8
	098644-01-717	FT	SPLINE - SCREEN	132-004716
	112898-04-703	EA	VERTICAL LATCH (SASH KIT)	DH343-CK

CONTACT WINNEBAGO PART SALES FOR UNLISTED COMPONENTS

WINDSHIELD & WIPER GROUP

WINDSHIELD

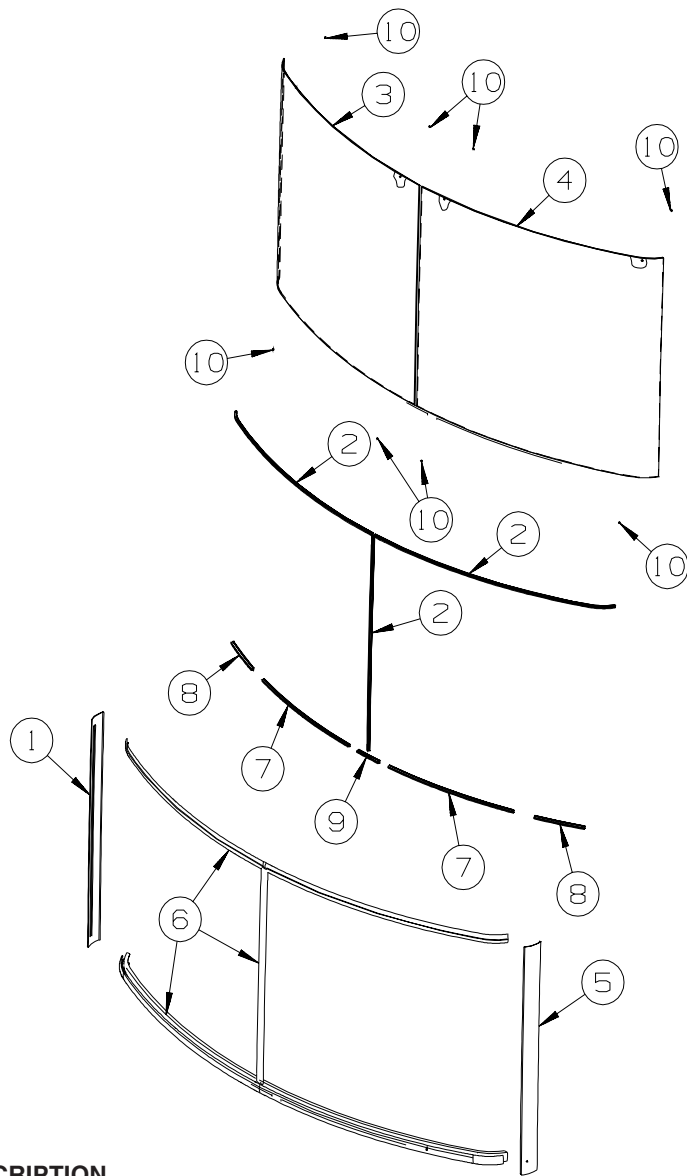

KEY	PART NUMBER	U/M	DESCRIPTION
1	129497-05-03A	EA	TRIM - WINDSHIELD - PASSENGER A-PILLAR - BRIGHT WHITE FROM: 00-00-00 THRU: 07-28-02
1	129497-05-02A	EA	TRIM - PASSENGER A-PILLAR - BLACK FROM: 07-29-02 THRU: 99-99-99
2	127862-01-000	EA	CARRIER - REVEAL - WINDSHIELD - 47.2"
3	131244-01-000	EA	WINDSHIELD - PASSENGER - 52.5" X 44.4" (CURVED)
4	131244-02-000	EA	WINDSHIELD - DRIVER - 52.5" X 44.4" (CURVED)
5	129497-06-03A	EA	TRIM - WINDSHIELD - DRIVER A-PILLAR - BRIGHT WHITE FROM: 00-00-00 THRU: 07-28-02
5	129497-06-02A	EA	TRIM - DRIVER A-PILLAR - BLACK FROM: 07-29-02 THRU: 99-99-99
6	120533-01-000	FT	MOLDING - REVEAL - WINDSHIELD
7	117335-06-000	EA	CARRIER/REVEAL - 29.8"
8	132375-02-000	EA	CARRIER - REVEAL/WINDSHIELD - 10 FROM: 00-00-00 THRU: 06-14-03
8	132375-01-000	EA	CARRIER/REVEAL - WINDSHIELD - 5.5" FROM: 06-15-03 THRU: 99-99-99
9	132375-01-000	EA	CARRIER/REVEAL - WINDSHIELD - 5.5"
10	081914-02-000	EA	BUMPER - RUBBER - ROUND - 5/16" DIA. X 13/64" THICK

WINDSHIELD & WIPER GROUP (CONTINUED)

WIPER

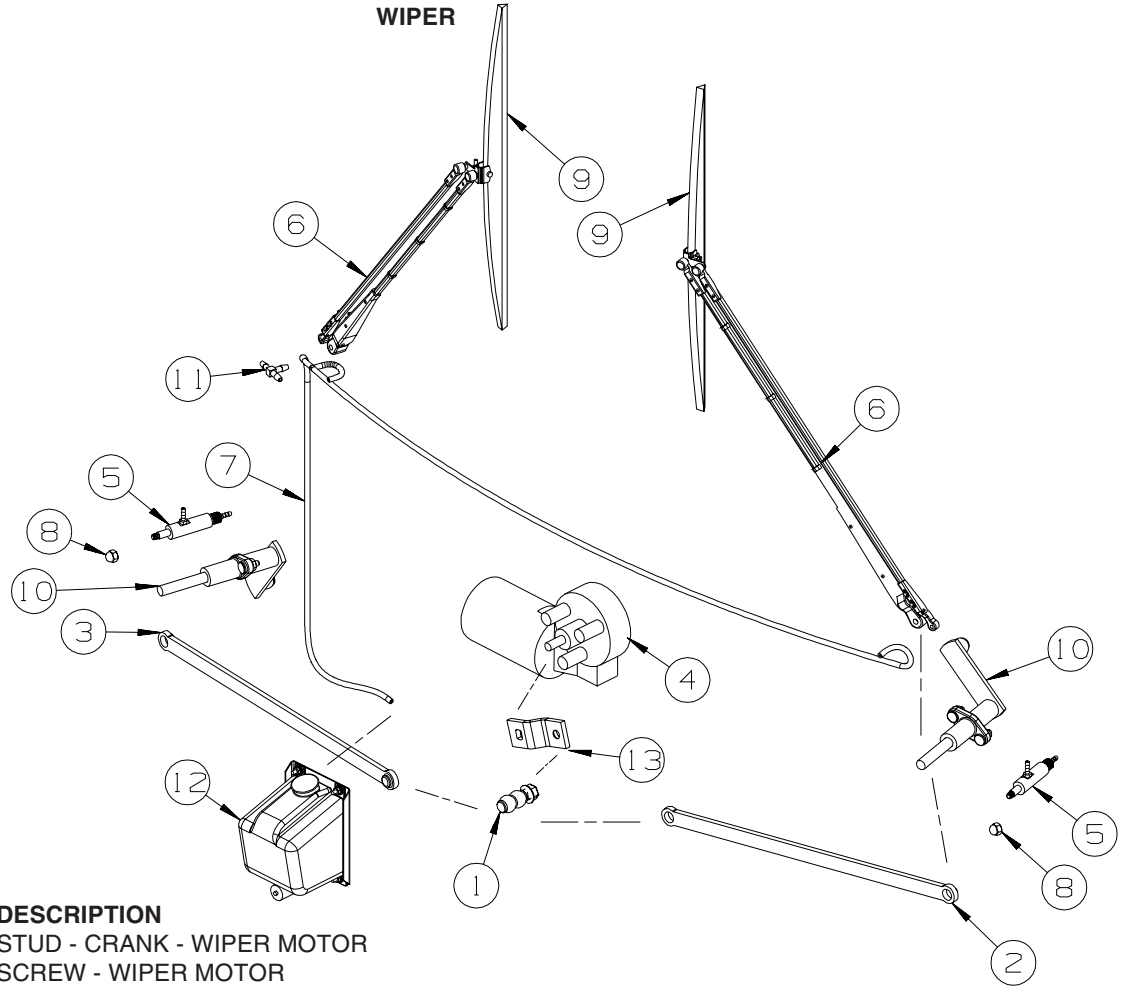

KEY	PART NUMBER	U/M	DESCRIPTION
1	067188-01-000	EA	STUD - CRANK - WIPER MOTOR
	145627-01-000	EA	SCREW - WIPER MOTOR
			FROM: 00-00-00 THRU: 05-08-03
	117322-01-000	EA	SCREW - 1/4-28 UNFINISHED - 2A - TORX
			FROM: 05-09-03 THRU: 99-99-99
2	117770-01-000	EA	LINK - CONNECTING - 24" - CLOSED GROMMET/OPEN GROMMET
3	117770-02-000	EA	LINK - CONNECTING - 24" - CLOSED GROMMET/CLOSED GROMMET
4	104346-05-000	EA	WIPER MOTOR - "DYNAMIC PARK" - W/INT BREAKER
5	117768-01-000	EA	SHAFT - ADAPTER - PANTOGRAPH ARM
			FROM: 00-00-00 THRU: 03-10-03
5	145698-01-01A	EA	SHAFT/ADAPTER - PANTOGRAPH - W/WASHER DIVERTER - STAINLESS
			FROM: 03-11-03 THRU: 99-99-99
6*	117769-01-000	EA	ARM - WIPER - PANTOGRAPH - 28"
7	045794-01-000	FT	HOSE - WASHER - WINDSHIELD - 5/32" ID - BLACK
8	077049-02-000	EA	NUT - ACORN - 10-32 BLACK/ANODIZED
9*	095964-01-000	EA	BLADE - WINDSHIELD WIPER - 24"
10*	096505-09-000	EA	SHAFT/PIVOT - WINDSHIELD WIPER
11	110605-01-000	EA	TEE - PLASTIC - BARBED - 1/8" X 1/8" X 3/16"
			FROM: 00-00-00 THRU: 03-10-03
11	146486-01-000	EA	TEE - PLASTIC - 5/32" X 5/32" X 5/32"
			FROM: 03-11-03 THRU: 99-99-99
12	117766-02-000	EA	RESERVOIR/PUMP - WINDSHIELD WASHER
13	104347-04-000	EA	ARM - DRIVE - WIPER MOTOR
	110742-02-000	EA	GASKET - NEOPRENE - WIPER ADAPTER SHAFT - .5" ID X .9" OD
			FROM: 00-00-00 THRU: 05-25-03
	110742-03-000	EA	GASKET - WIPER
			FROM: 05-26-03 THRU: 99-99-99

*COMPONENT PARTS LISTED LATER IN THIS GROUP

WINDSHIELD & WIPER GROUP (CONTINUED)
COMPONENT PARTS FOR WIPER

095964-01-000

KEY	PART NUMBER	U/M	DESCRIPTION	VENDOR NO.
	095964-01-700	EA	BLADE-REFILL 24" EA= 1 PAIR	12360

096505-09-000

KEY	PART NUMBER	U/M	DESCRIPTION	VENDOR NO.
	096505-02-700	EA	DRIVER-KNURLED,(HD) BRL .687	NT721017
	096505-02-701	EA	NUT-HEX (HD) W/.687 BARREL	NT721021
	096505-02-702	EA	CAP-RUBBER (HD) BARREL .687	CP721084
	096505-02-703	EA	NUT/ACORN - HD W/.687 BRL	51065-40-NT27WC

117769-01-000

KEY	PART NUMBER	U/M	DESCRIPTION	VENDOR NO.
	096931-01-700	FT	HOSE - WASHER - 1/8" ID	XTU-66-0001
	117769-01-700	EA	RETAINER CLIP - HOSE	