

2004
SUNDANCER
IF430V
400-SERIES
PORTSMOUTH OAK
R19 CRYSTAL LAKE - BLUE
R22 FERN GARDEN - GREEN
R25 ALABASTER - TAN
CONCERT CHERRY
R20 CRYSTAL LAKE - BLUE
R23 FERN GARDEN - GREEN
R26 ALABASTER - TAN
WASHED MAPLE
R21 CRYSTAL LAKE - BLUE
R24 FERN GARDEN - GREEN
R27 ALABASTER - TAN

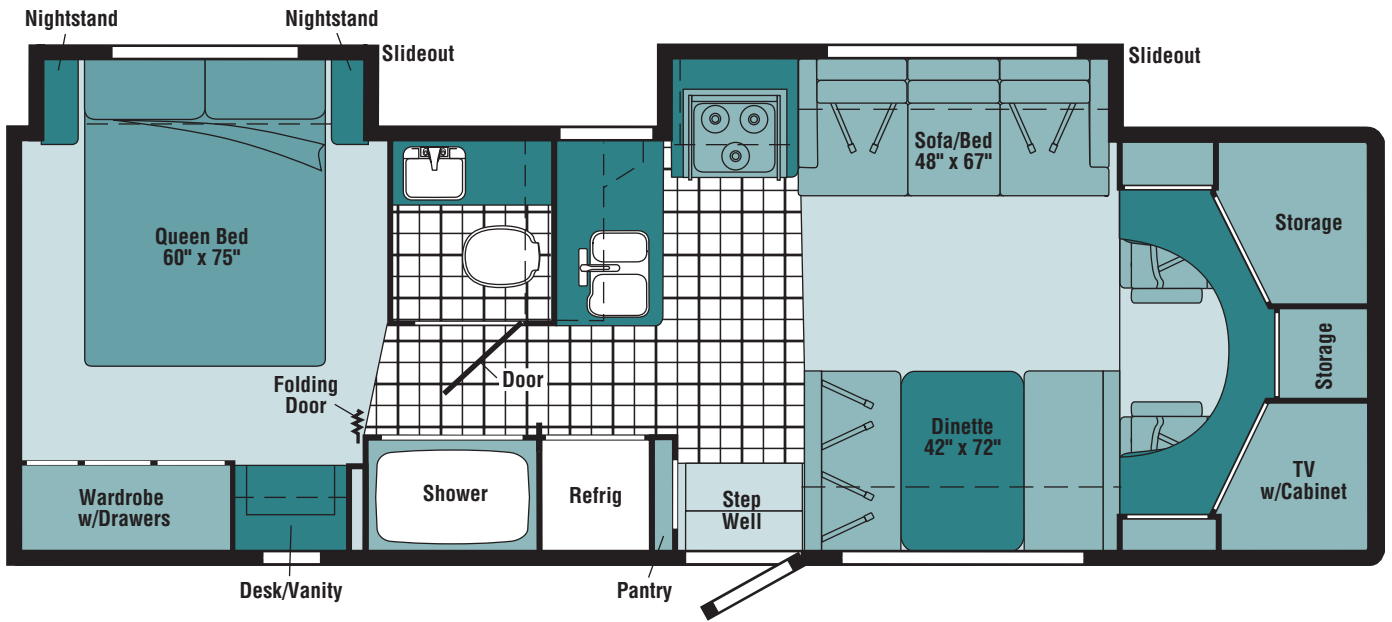

FLOOR PLAN

CONTENTS

FLOOR PLAN	1
ACCESSORIES GROUP	6
OPERATORS MANUAL	6
APPLIANCE GROUP	7
APPLIANCES	7
COMPONENT PARTS FOR APPLIANCE	10
115504-01-000	10
120075-12-01A, 120075-13-01A, 120075-14-01A, 120075-15-01A	10
121569-05-01A, 121569-07-01A	16
134940-01-01A	21
134940-02-01A	22
134940-04-01A	23
135656-03-01A	24
137354-01-000	26
AUDIO VIDEO GROUP	27
RADIO SYSTEM	27
COMPONENT PARTS FOR RADIO SYSTEM	28
143509-01-000	28
REAR VIEW MONITOR	29
TELEPHONE	29
TV & VCR	29
COMPONENT PARTS FOR TV & VCR	30
076319-23-000	30
076319-25-000	30
136162-03-000	30
137135-02-000	31
145641-01-000	31
EXTERIOR ENTERTAINMENT	32
BATH GROUP	33
CABINETS	33
SHOWER	36
COMPONENT PARTS FOR SHOWER DOOR	37
115011-03-01A	37
BEDROOM GROUP	38
CABINETS	38
COMPONENT PARTS FOR QUEEN CABINETS	42
131595-01-01A, 131595-05-01A, 131595-10-01A	42
CHASSIS GROUP	43
FRAME	43
DRIVETRAIN	44
EXHAUST	45
HITCH	46
FUEL	46
SPARE TIRE	48
SUSPENSION	48
COMPONENT PARTS FOR SUSPENSION	49
144887-01-000	49
WHEEL, TIRE, COVERS &/OR LINERS	50
COMPONENT PARTS FOR WHEEL, TIRE, COVERS &/OR LINERS	51
109443-05-000	51
110435-13-000	51
BRAKELINE	52

CONTENTS (CONTINUED)

CURTAIN & CUSHION GROUP	53
NOTICE	53
CUSHION LAYOUT	54
BUCKET SEATS	56
COMPONENT PARTS FOR BUCKET SEATS	57
122611-02-000	57
SOFA	58
WINDOW TREATMENT	59
HARDWARE	60
ACCESSORIES	62
FABRICS	63
DINETTE GROUP	65
CABINETS	65
TABLE	69
DRIVERS COMPARTMENT GROUP	70
FRONT INTERIOR	70
CABINETS	71
ELECTRICAL GROUP	73
12V BODY WIRING	73
FRONT END WIRING	77
COMPONENT PARTS FOR LIGHTS & SWITCHES	78
087694-01-000	78
097917-01-06A	78
113589-01-000	78
113589-02-000	78
121935-01-01A	78
137417-01-01A	78
137417-02-01A	78
137417-03-01A	78
137417-05-01A	78
137417-06-01A	78
CIRCUIT BREAKERS & FUSES	79
CONVERTER, INVERTER, LOAD CENTERS	79
110V WIRING	80
ENTERTAINMENT WIRING	81
COMPONENT PARTS FOR ENTERTAINMENT WIRING	82
123775-01-01A	82
BOXES & CORDS	83
WIRE ASSEMBLIES	83
CONNECTORS & CONDUIT	84
BOOTS, SOLENOIDS, RELAYS & MISCELLANEOUS	85
EXTERIOR BODY GROUP	86
GRAPHICS & PAINT	86
PANELS & TRIMS	88
LADDER	91
RUNNING BOARDS	91
MIRRORS	91
COMPONENT PARTS FOR MIRRORS	92
120269-07-01A	92
133908-01-01A, 133908-01-02A, 133908-02-01A, 133908-03-01A, 133908-03-02A, 133908-04-01A, 133908-05-01A, 133908-06-01A,	92
133908-07-01A, 133908-08-01A, 133908-10-01A, 133908-11-01A, 133908-12-01A, 133908-13-01A	92
STRUCTURAL COMPONENTS	93
AWNINGS	93
COMPONENT PARTS FOR AWNINGS	94
113874-01-02A	94

CONTENTS (CONTINUED)

EXTERIOR DOORS & COMPARTMENTS GROUP	95
DOOR & COMPARTMENT LAYOUT	95
COMPONENT PARTS FOR DOOR & COMPARTMENT LAYOUT	99
084103-08-000	99
094707-03-01A	99
COMPARTMENT DOOR PIECE PARTS	100
ENTRY	102
SCREEN	103
LATCH - ENTRY	104
EXTERIOR SLIDEOUT GROUP	105
FRONT LEFT	105
COMPONENT PARTS FOR FRONT LEFT SLIDEOUT	109
136747-01-000	109
143394-01-000	109
REAR LEFT	110
COMPONENT PARTS FOR REAR LEFT SLIDEOUT	113
100536-42-000	113
128599-02-000	113
128599-04-000	113
GALLEY GROUP	114
CABINETS	114
DOORS & DRAWERS	116
GENERATOR GROUP	118
GAS	118
HEATING & A/C GROUP	119
FURNACE	119
COMPONENT PARTS FOR FURNACE	120
139980-02-000	120
REAR HEATER	122
COMPONENT PARTS FOR REAR HEATER	123
084405-01-000	123
ROOF	124
COMPONENT PARTS FOR ROOF	125
131184-01-01A	125
131184-05-01A	126
131188-03-01A	127
131188-04-01A	128
INTERIOR FINISH GROUP	129
MOLDINGS & TRIMS	129
PANELING & LAMINATES	140
ACCESSORIES	141
COMPONENT PARTS FOR ACCESSORIES	142
094499-02-000	142
FLOOR COVERINGS	143
HARDWARE	144
LABELS GROUP	152
LP GROUP	181
LP SYSTEM	181
COMPONENT PARTS LP SYSTEM	182
144116-04-000	182
LOUNGE GROUP	183
CABINETS	183
SEALANTS & FASTENERS GROUP	185
SEALANTS & ADHESIVES	185
BOLTS, NUTS AND WASHERS	186
SCREWS	188
CLAMPS, CLIPS, GROMMETS, RIVETS & PLUGS	191
MISCELLANEOUS FASTENERS	192

CONTENTS (CONTINUED)

WATER & SEWAGE GROUP	193
DRAINAGE SYSTEM	193
COMPONENT PARTS FOR DRAINAGE SYSTEM	195
067487-04-000	195
096927-01-02A	195
147421-02-01A	196
WATER SYSTEM	197
COMPONENT PARTS FOR WATER SYSTEM	204
051391-03-000	204
075240-05-000	205
075241-04-000, 075241-05-000, 075241-06-000	205
098607-01-000	205
141432-01-01A	205
145541-02-000	205
WINDOW & VENTS GROUP	206
WINDOW & VENT LAYOUT	206
COMPONENT PARTS FOR WINDOW & VENT LAYOUT	208
098644-07-02A	208
098647-07-03A	209
098647-23-02A	210
098647-47-02A	210
112795-69-01A	211
112795-77-01A	212
112795-84-01A	212
112898-22-01A	213
113733-04-01A, 113733-10-01A, 113733-11-01A	214
113500-09-02A	215
122882-01-01A	216
122882-02-01A, 122882-03-01A	216
123780-03-01A	217
123780-09-01A	218
123780-11-01A	218
129929-12-01A	219

ACCESSORIES GROUP
OPERATORS MANUAL

KEY	PART NUMBER	U/M	DESCRIPTION
	132000-13-004	EA	MANUAL/OWNER - SUNDANCER - 2004
	129079-01-01A	EA	CASE - VINYL/BLACK-EXPANDABLE ACCORDION SIDES-7"WX9"HX14"L
	144432-01-000	EA	TOP LEVEL-C,2004

APPLIANCE GROUP APPLIANCES

KEY	PART NUMBER	U/M	DESCRIPTION
	138584-03-01A	EA	COFFEE MAKER/CARAFE - NO TIMER - KRUPS #536-42 - BLACK
*	135656-03-01A	EA	RANGE-16"/3 BURNER W/OVEN/NEW STYLE KNOBS/GRATES-BLK DR/GL
	112881-05-01A	EA	RANGE-16"-3 BRNR/NEW STYLE KNOBS/GRATE/HDL - BLACK TEXTURE - 430V CANADIAN ONLY
	140176-03-02B	EA	BRACKET/STOVE TIEDOWN - E-COATED
	140176-04-02B	EA	BRACKET/STOVE TIEDOWN - E-COATED
*	115504-01-000	EA	PANEL - SOLAR 10 WATT - 12.2"W X 26.9"L X 1.2"H
*	134940-01-01A	EA	PANEL - MONITOR - 2 TANK - W/GENERATOR SWITCH/HOUR METER - GENERATOR
*	134940-02-01A	EA	PANEL - MONITOR - 2 TANK - W/O GENERATOR SWITCH/HOUR METER
*	134940-04-01A	EA	PANEL - MONITOR - 2 TANK - W/GEN SWITCH/SOLAR CHARGER - GENERATOR/SOLAR PANEL
	130818-02-01A	EA	TRASH CONTAINER - 20 QUART ALMOND

*COMPONENT PARTS LISTED LATER IN THIS GROUP

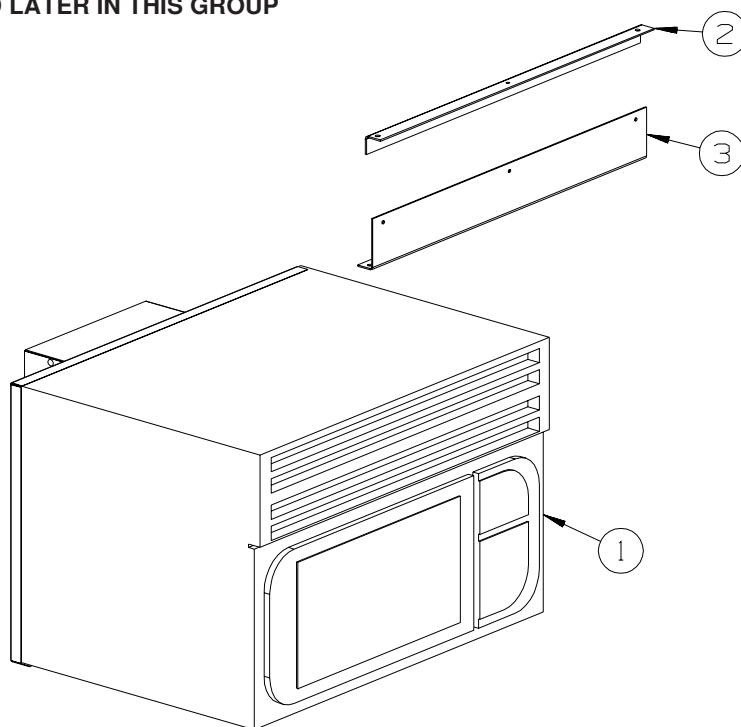

KEY	PART NUMBER	U/M	DESCRIPTION
1*	137354-01-000	EA	OVEN - MICROWAVE - 1.2 OTR - W/VENT
2	138230-02-02B	EA	ANGLE - W/HOLES - E - COATED - 430V
3	138230-01-02B	EA	ANGLE - W/HOLES - E - COATED - 430V

*COMPONENT PARTS LISTED LATER IN THIS GROUP

APPLIANCE GROUP (CONTINUED)
APPLIANCES (CONTINUED)

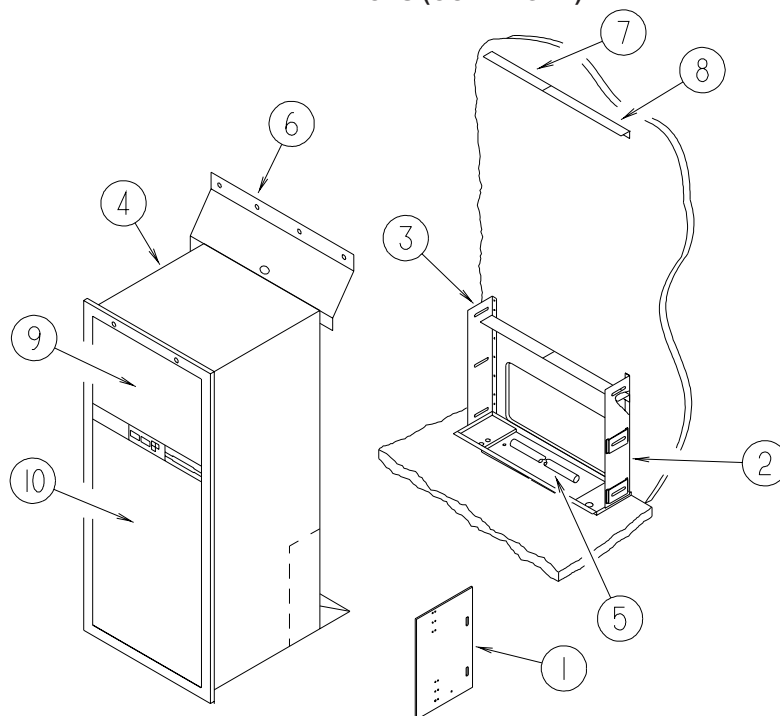

427P

KEY	PART NUMBER	U/M	DESCRIPTION
1	141975-04-02B	EA	PLATE/TIEDOWN - REFRIGERATOR - E-COATED
2	141550-01-02B	EA	BRACKET/TIEDOWN - REFRIGERATOR - E-COATED
3	141550-02-02B	EA	BRACKET/TIEDOWN - REFRIGERATOR - E-COATED
4*	121569-07-01A	EA	REFRIGERATOR - LARGE DBL DOOR/LEFT HAND -2 WAY- F/SLIDEOUT
4*	120075-14-01A	EA	REFRIGERATOR-LGE DBL DR-2-WAY/LH/ICE MAKER/FLUSH HDL-BLACK - W/ICE MAKER
5	112176-01-000	FT	TUBING - VINYL - REINFORCED - 1/2" ID
6	136966-04-02B	EA	BAFFLE - REFRIGERATOR - E-COATED
7	143195-01-02B	EA	BAFFLE - REFRIGERATOR - E-COATED
8	143195-02-02B	EA	BAFFLE - REFRIGERATOR - E-COATED
9	P34457-03-N47	EA	PANEL - INSERT RAISED MEMBRANE - 21.5" X 14.5" - PORTSMOUTH OAK
9	P34457-03-L85	EA	PANEL - INSERT RAISED MEMBRANE - 21.5" X 14.5" - CONCERT CHERRY
9	P34457-03-L94	EA	PANEL - INSERT RAISED MEMBRANE - 21.5" X 14.5" - WASHED MAPLE
10	P34457-04-N47	EA	PANEL - INSERT RAISED MEMBRANE - 21.5" X 38.5" - PORTSMOUTH OAK
10	P34457-04-L85	EA	PANEL - INSERT RAISED MEMBRANE - 21.5" X 38.5" - CONCERT CHERRY
10	P34457-04-L94	EA	PANEL - INSERT RAISED MEMBRANE - 21.5" X 38.5" - WASHED MAPLE
	054450-01-000	EA	LEVEL - REFRIGERATOR
	090329-01-000	FT	SEAL/T - REFRIGERATOR CABINET
	136907-01-01A	EA	TRAY - REFRIGERATOR - BLACK

***COMPONENT PARTS LISTED LATER IN THIS GROUP**

APPLIANCE GROUP (CONTINUED)
APPLIANCES (CONTINUED)

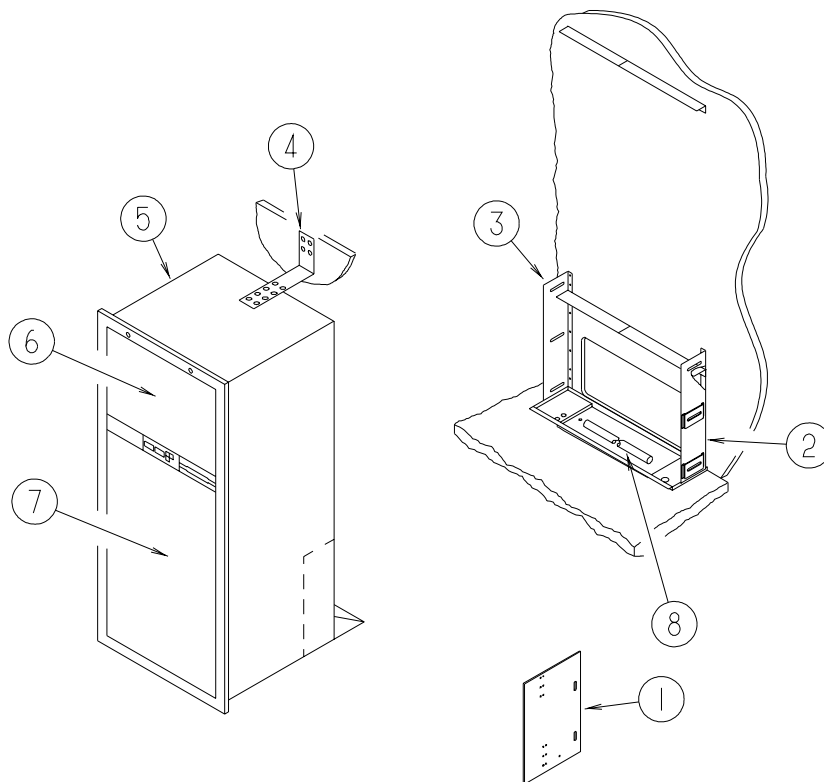

430V AND 431C

KEY	PART NUMBER	U/M	DESCRIPTION
1	141975-04-02B	EA	PLATE - TIEDOWN/REFRIGERATOR
2	141550-01-02B	EA	BRACKET - TIEDOWN/REFRIGERATOR - RIGHT HAND
3	141550-02-02B	EA	BRACKET - TIEDOWN/REFRIGERATOR - LEFT HAND
4	145445-02-02B	EA	STRAP - REFRIGERATOR
5*	121569-05-01A	EA	REFRIGERATOR - LARGE DOUBLE DOOR/RH - 2-WAY - BLACK
5*	120075-13-01A	EA	REFRIGERATOR-LARGE DOUBLE DOOR/RH - 2-WAY -ICE MAKER-BLACK - W/ICE MAKER
6	P34457-03-N47	EA	PANEL - INSERT RAISED MEMBRANE - 21.5" X 14.5" - PORTSMOUTH OAK
6	P34457-03-L85	EA	PANEL - INSERT RAISED MEMBRANE - 21.5" X 14.5" - CONCERT CHERRY
6	P34457-03-L94	EA	PANEL - INSERT RAISED MEMBRANE - 21.5" X 14.5" - WASHED MAPLE
7	P34457-04-N47	EA	PANEL - INSERT RAISED MEMBRANE - 21.5" X 38.5" - PORTSMOUTH OAK
7	P34457-04-L85	EA	PANEL - INSERT RAISED MEMBRANE - 21.5" X 38.5" - CONCERT CHERRY
7	P34457-04-L94	EA	PANEL - INSERT RAISED MEMBRANE - 21.5" X 38.5" - WASHED MAPLE
8	112176-01-000	FT	TUBING - VINYL - REINFORCED - 1/2" ID
	116751-02-01A	EA	TRAY - REFRIGERATOR - BLACK - 431C
	116751-05-01A	EA	TRAY - REFRIGERATOR - BLACK - 430V
	090329-01-000	FT	SEAL/T - REFRIGERATOR CABINET
	054450-01-000	EA	LEVEL - REFRIGERATOR

***COMPONENT PARTS LISTED LATER IN THIS GROUP**

APPLIANCE GROUP (CONTINUED)
COMPONENT PARTS FOR APPLIANCE

115504-01-000

KEY	PART NUMBER	U/M	DESCRIPTION	VENDOR NO.
	115504-01-700	EA	PLUG & CABLE, 10 WATT PANEL	600-016

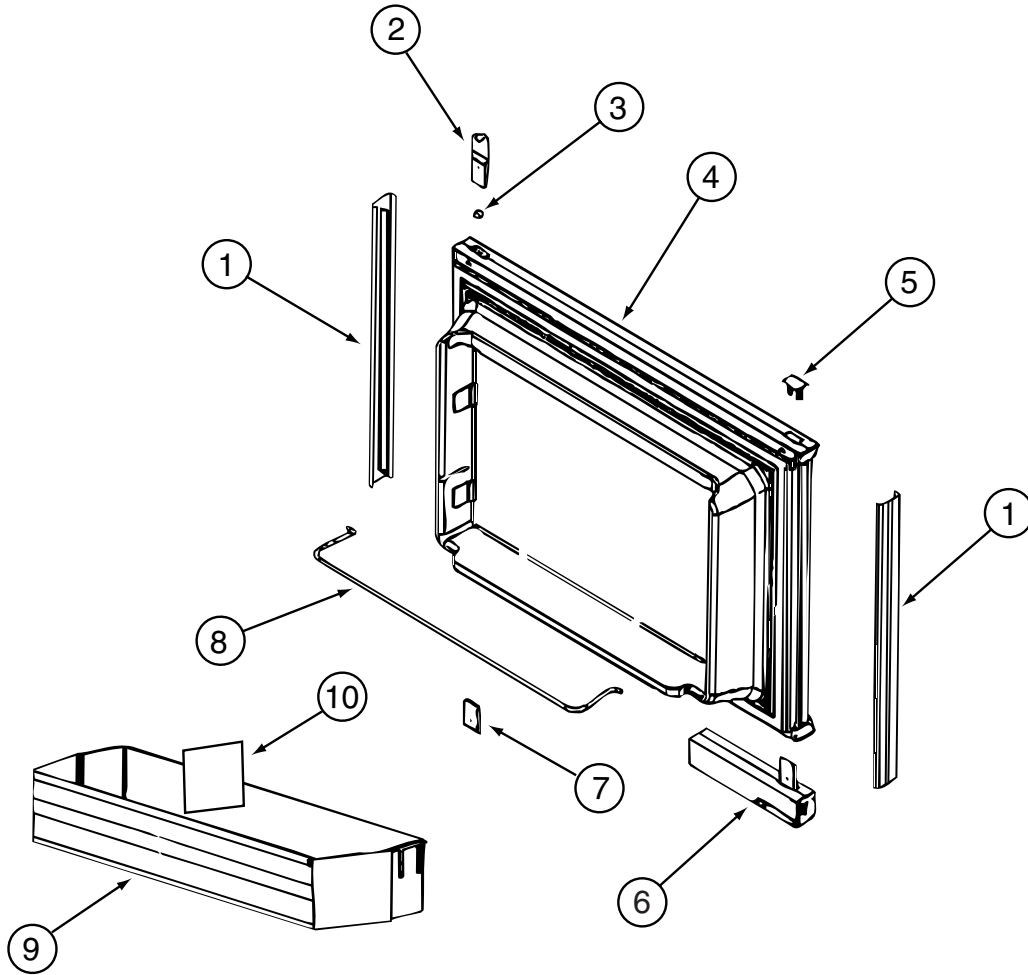

120075-12-01A, 120075-13-01A, 120075-14-01A, 120075-15-01A

KEY	PART NUMBER	U/M	DESCRIPTION	VENDOR NO.
1	121568-03-700	EA	RETAINER - DOOR PANEL/BLACK	619558
2	120075-01-701	EA	HINGE-TOP RH/BOTTOM LH(DOOR)	618511
3	121568-03-701	EA	BUSHING - HINGE PIN/GRAY	619671
4	121568-03-702	EA	DOOR LINER - W/TRIM/BLACK	619627 - SMALL DOOR
5	120075-01-702	EA	CAP, (HINGE PLUG)	618160
6	120075-12-700	EA	HANDLE(CONTOUR)TOP LH/BTM RH	621105
	120075-12-702	EA	HANDLE/HOUSING-TOP-LH/BTM RH	618159GEN
6	120075-12-701	EA	HANDLE(CONTOUR)TOP RH/BTM LH	621104
	120075-12-707	EA	LATCH	619648
	120075-12-709	EA	HANDLE/HOUSING-BTM LH/TOP RH	618122GEN
6	121568-03-703	EA	HANDLE/FLUSH-TOP/RH-LWR/LH	619865
6	121568-03-708	EA	HANDLE/FLUSH-TOP/LH-LWR/RH	619866
7	120075-01-705	EA	HINGE-TOP LH/BOTTOM RH(DOOR)	618510
8	121568-01-700	EA	RAIL - DOOR UPPER	618618
9	120075-07-700	EA	DOOR BIN - CLEAR	619006
10	120075-07-701	EA	DIVIDER/DOOR BIN CLEAR	619008
	121568-03-704	EA	TRAVEL LATCH - GRAY	619647
	121568-03-705	EA	STORAGE LATCH - GRAY	619648

APPLIANCE GROUP (CONTINUED)
COMPONENT PARTS FOR APPLIANCE (CONTINUED)

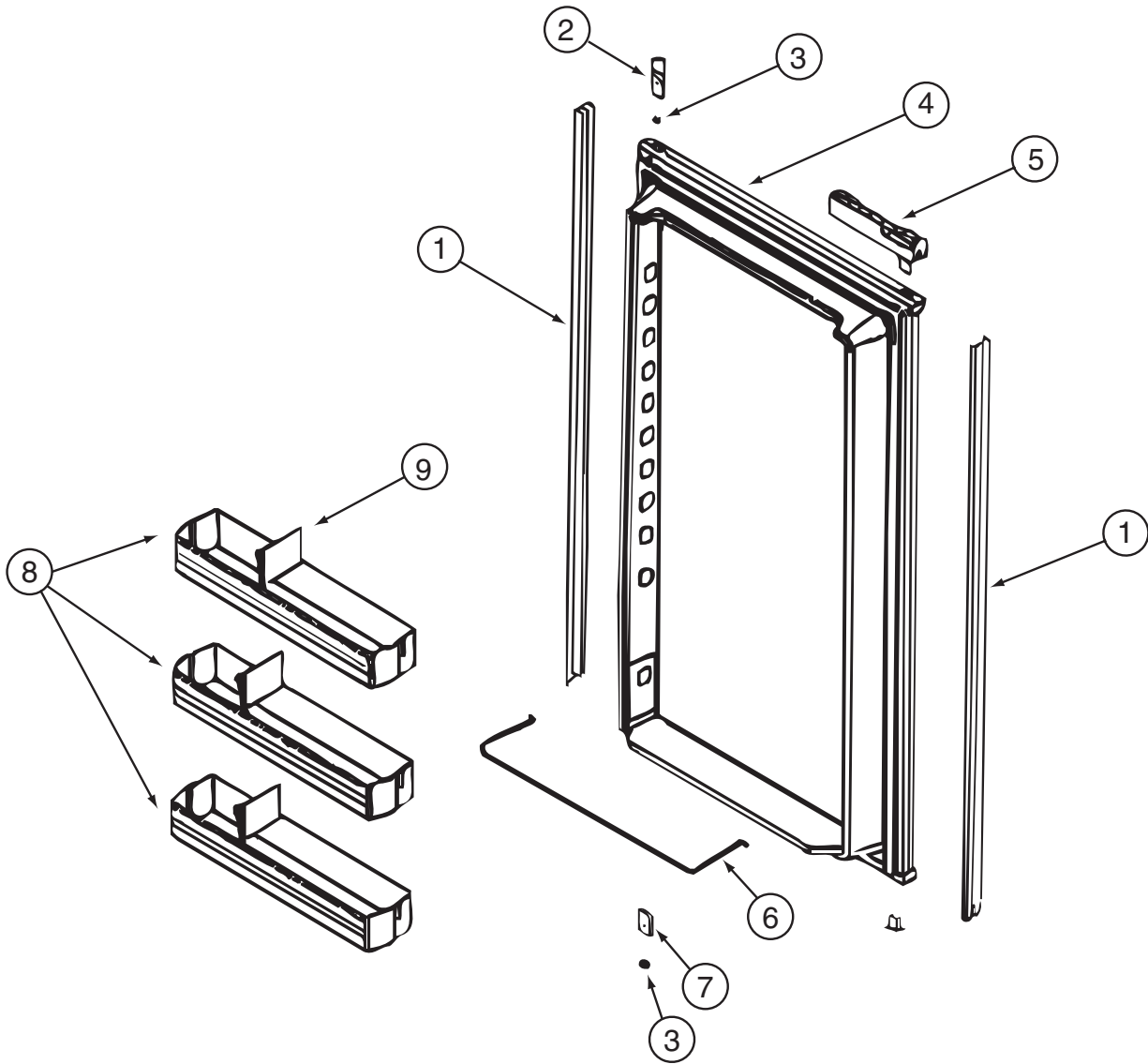

120075-12-01A, 120075-13-01A, 120075-14-01A, 120075-15-01A (CONTINUED)

KEY	PART NUMBER	U/M	DESCRIPTION	VENDOR NO.
1	120075-07-702	EA	RETAINER - DOOR PANEL/BLACK	619560
2	120075-01-701	EA	HINGE-TOP RH/BOTTOM LH(DOOR)	618511
3	121568-03-701	EA	BUSHING - HINGE PIN/GRAY	619671
4	120075-07-703	EA	DOOR LINER - BLACK	619631 - LARGE DOOR
5	120075-12-700	EA	HANDLE(CONTOUR)TOP LH/BTM RH	621105
	120075-12-702	EA	HANDLE/HOUSING-TOP-LH/BTM RH	618159GEN
5	120075-12-701	EA	HANDLE(CONTOUR)TOP RH/BTM LH	621104
	120075-12-707	EA	LATCH	619648
	120075-12-709	EA	HANDLE/HOUSING-BTM LH/TOP RH	618122GEN
5	121568-03-703	EA	HANDLE/FLUSH-TOP/RH-LWR/LH	619865
5	121568-03-708	EA	HANDLE/FLUSH-TOP/LH-LWR/RH	619866
6	121568-01-704	EA	RAIL - DOOR LOWER	618578
7	120075-01-705	EA	HINGE-TOP LH/BOTTOM RH(DOOR)	618510
8	120075-07-700	EA	DOOR BIN - CLEAR	619006
8	120075-07-704	EA	DOOR BIN - LARGE/CLEAR	619005
9	120075-07-701	EA	DIVIDER/DOOR BIN CLEAR	619008
	121568-03-704	EA	TRAVEL LATCH - GRAY	619647
	121568-03-705	EA	STORAGE LATCH - GRAY	619648

APPLIANCE GROUP (CONTINUED)
COMPONENT PARTS FOR APPLIANCE (CONTINUED)

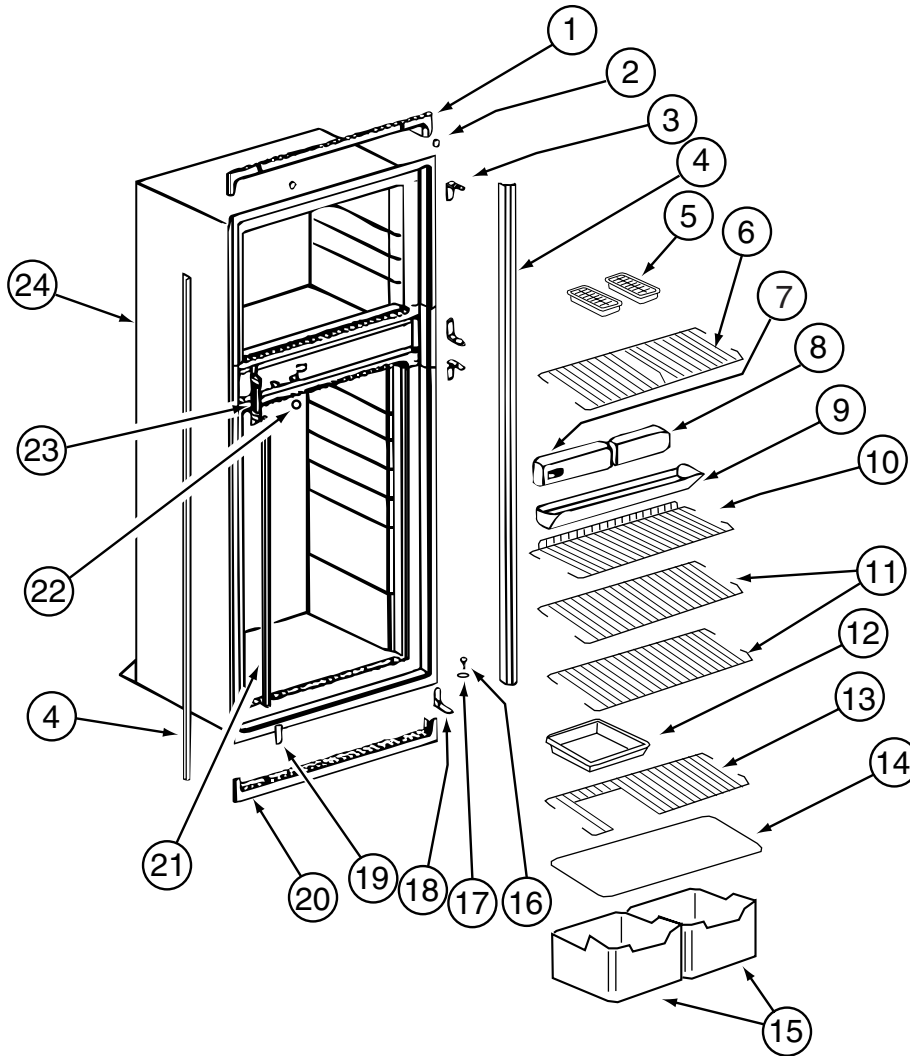

120075-12-01A, 120075-13-01A, 120075-14-01A, 120075-15-01A (CONTINUED)

KEY	PART NUMBER	U/M DESCRIPTION	VENDOR NO.
1	121568-03-709	EA TRIM - TOP/BLACK	619687
2	120075-01-714	EA PLUG-HOLE (BLACK)	618170
3	121568-03-710	EA HINGE/CABINET-TOP/RH-LWR/LH	619335
4	120075-07-705	EA TRIM - SIDE - BLACK	622296
5	104137-06-724	EA ICE TRAY	61630422
6	120075-07-706	EA SHELF - WIRE/FREEZER	620249
7	120075-07-707	EA CONTROL BOX - BLACK	619665
8	121568-03-713	EA FRONT BOX/DECORATIVE-BLACK	619282
9	120075-01-720	EA TRAY-DRIP	618137
10	120075-01-722	EA SHELF-WIRE, SHORT	620269
11	120075-01-723	EA SHELF-WIRE	620270
12	104137-06-718	EA SHELF-TRAY, WHITE, W/CUTOUT	617756
13	120075-01-724	EA SHELF-WIRE, W/CUTOUT	618177
14	120075-01-725	EA COVER-CRISPER	618158
15	120075-07-708	EA CRISPER/ICE BIN	619007
16	120075-01-727	EA PIN-HINGE	618145
17	121568-03-701	EA BUSHING - HINGE PIN/GRAY	619671
18	121568-03-715	EA HINGE/CABINET-TOP/LH-LWR/RH	619336
19	121568-03-716	EA COVER - HINGE HOLES	619301
20	120075-01-729	EA TRIM-BOTTOM PIECE	620958
21	120075-01-730	EA RETAINER-SHELF(SER#926684 DN	618181
22	121568-03-717	EA HOLE PLUG - WHITE	619561
23	120075-01-732	EA PLATE-STRIKE	618167
24	120075-09-700	EA CABINET - FOAMED	619660
	120075-01-721	EA LOUVER-DRIP TRAY	618176

APPLIANCE GROUP (CONTINUED)
COMPONENT PARTS FOR APPLIANCE (CONTINUED)

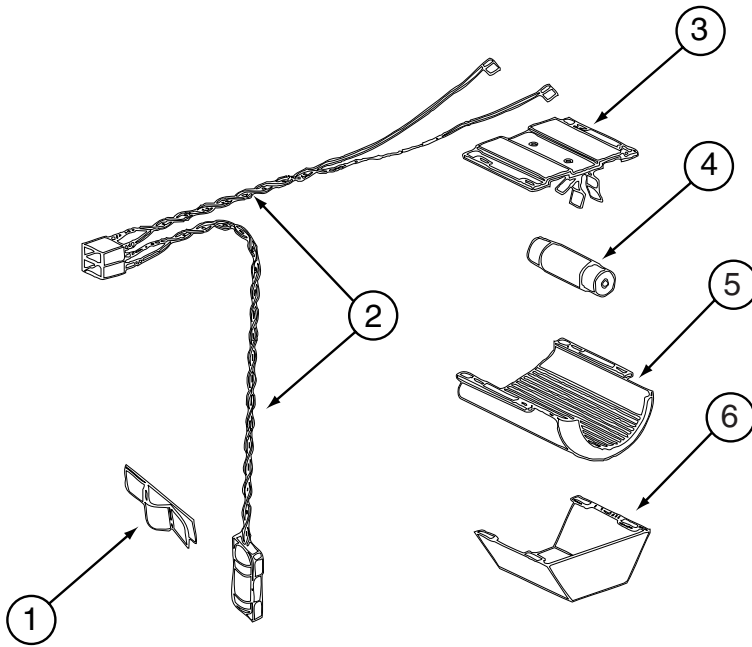

120075-12-01A, 120075-13-01A, 120075-14-01A, 120075-15-01A (CONTINUED)

KEY	PART NUMBER	U/M	DESCRIPTION	VENDOR NO.
1	084880-01-760	EA	CLIP (THERMISTER)	61689122
2	120075-01-735	EA	THERMISTER W/LAMP & WIRE/ASM	618548
3	084880-03-705	EA	BRACKET-LIGHT-INTERIOR	61629722
4	084880-03-706	EA	BULB-LAMP	61628922
5	120075-01-734	EA	COVER-LENS	618190
6	084880-03-707	EA	COVER-LAMP, LENS	61627922

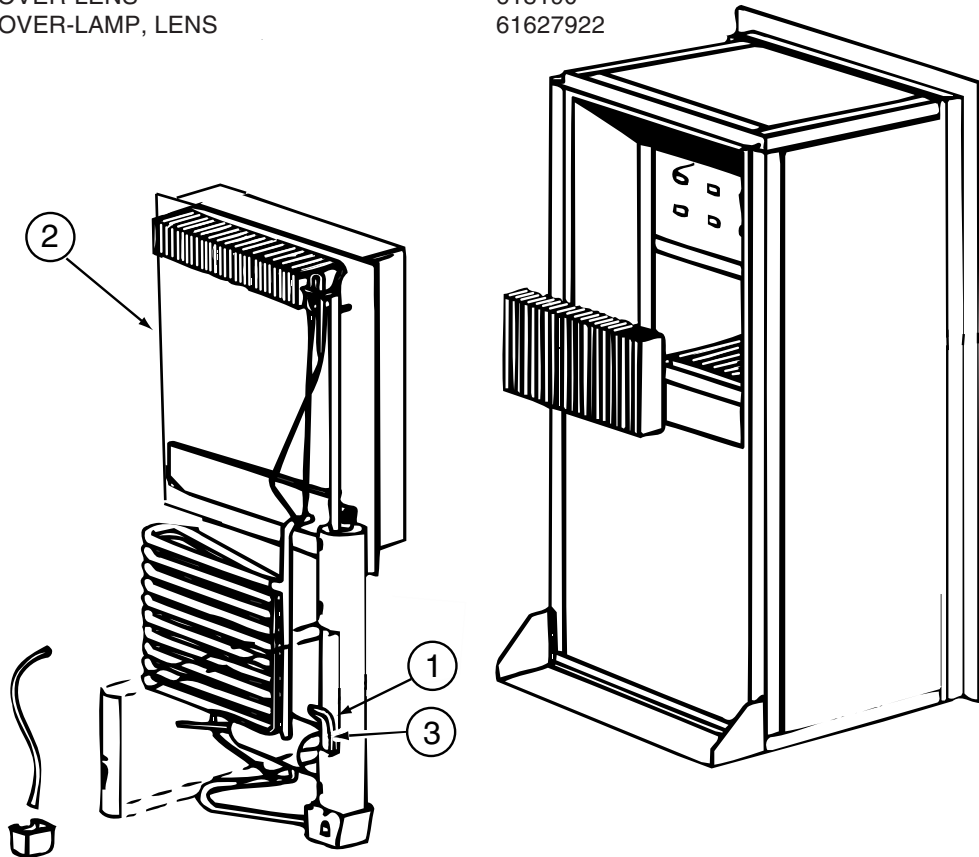

120075-12-01A, 120075-13-01A, 120075-14-01A, 120075-15-01A (CONTINUED)

KEY	PART NUMBER	U/M	DESCRIPTION	VENDOR NO.
1	088248-01-710	EA	HEATER DC (HORIZONTAL)	61562822
2	120075-01-736	EA	COOLING UNIT, SERVICE PACK	618542
3	088248-01-709	EA	HEATER-AC (HORIZONTAL)	61562722

APPLIANCE GROUP (CONTINUED)
COMPONENT PARTS FOR APPLIANCE (CONTINUED)

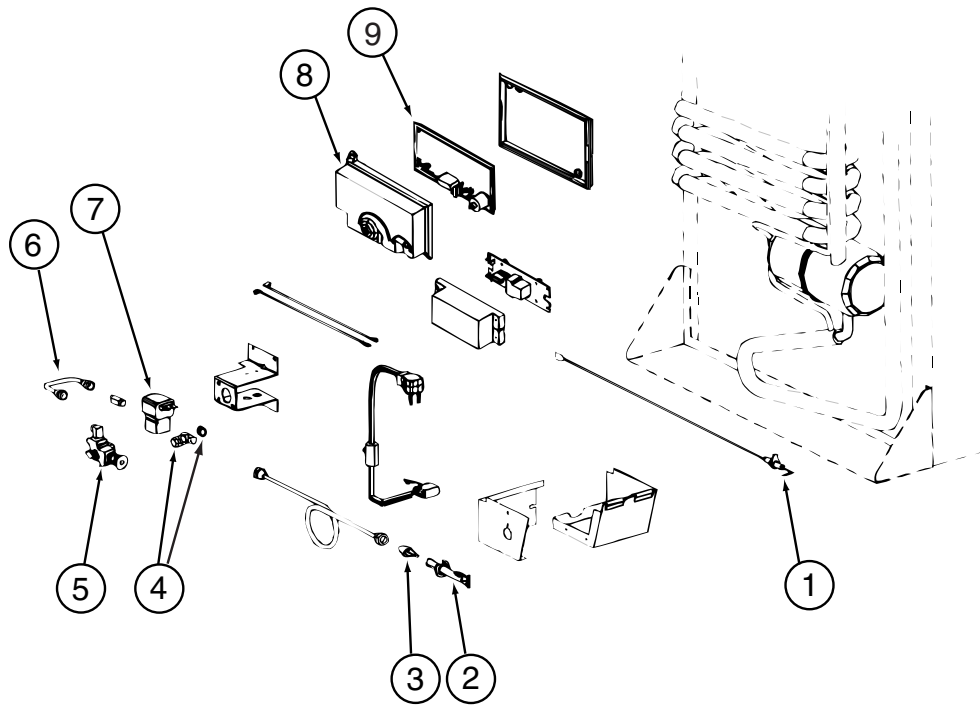

120075-12-01A, 120075-13-01A, 120075-14-01A, 120075-15-01A (CONTINUED)

KEY	PART NUMBER	U/M	DESCRIPTION	VENDOR NO.
1	104137-06-715	EA	ELECTRODE-SPARK/SENSOR, SGL	61692222
2	104137-06-714	EA	BURNER ASSEMBLY, 5-SLOT	61705222
3	120075-01-737	EA	ORIFICE - JEWEL - .0155	618284
4	113737-01-702	EA	PLUG 1/8" F/PRESSURE TAP	61445322
4	113737-01-716	EA	TAP-PRESSURE	61594422
5	104137-06-734	EA	VALVE-SHUT OFF/MAN-NEW STYLE	618696
6	113737-01-750	EA	TUBE-UNION	61694622
7	084880-01-718	EA	VALVE-GAS, (ASCO)	621447
8	120075-01-738	EA	COVER-POWER BOARD	618185
9	120075-07-710	EA	POWER - BOARD - 2-WAY	619360 = 621269
	120075-01-744	EA	KIT - GAS VALVE/BURNER TUBE	620609

APPLIANCE GROUP (CONTINUED)
COMPONENT PARTS FOR APPLIANCE (CONTINUED)

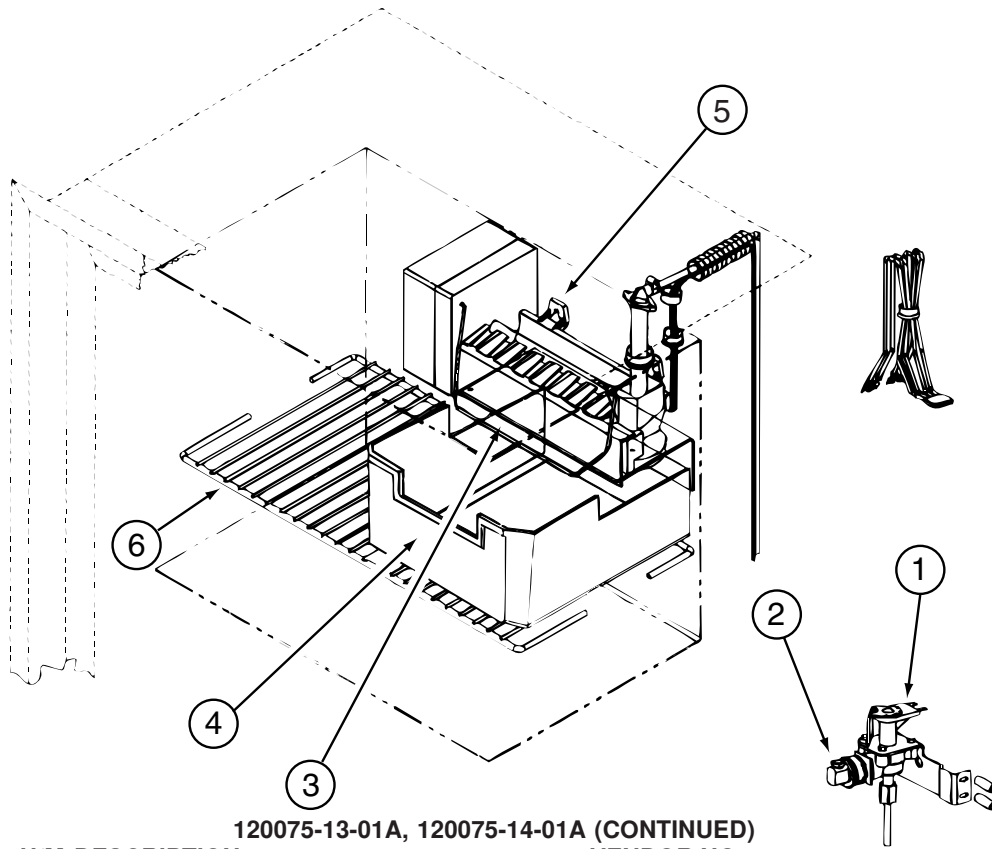

120075-13-01A, 120075-14-01A (CONTINUED)

KEY	PART NUMBER	U/M	DESCRIPTION	VENDOR NO.
1	120075-09-701	EA	WATER VALVE W/BRACKET	618253
2	120075-03-702	EA	NUT/COMPRESSION - FITTING	61678722
3	120075-03-703	EA	ARM-SHUT OFF	61656922
4	120075-03-704	EA	BIN-ICE CUBE	618154
5	094039-07-706	EA	ICE MAKER W/O PLATES	61656522
6	120075-01-717	EA	SHELF-FREEZER, WIRE	618172

APPLIANCE GROUP (CONTINUED)
COMPONENT PARTS FOR APPLIANCE (CONTINUED)

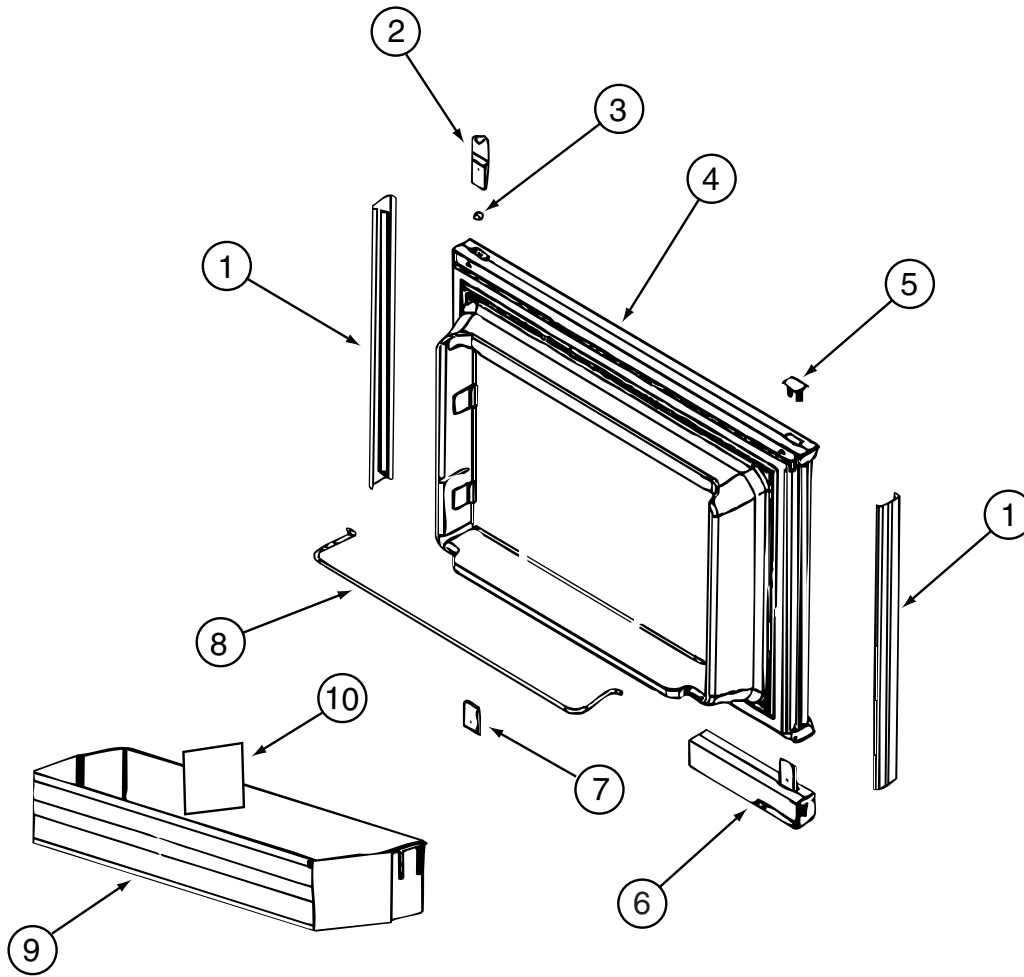

121569-05-01A, 121569-07-01A

KEY	PART NUMBER	U/M	DESCRIPTION	VENDOR NO.
1	121568-03-700	EA	RETAINER - DOOR PANEL/BLACK	619558
2	120075-01-701	EA	HINGE-TOP RH/BOTTOM LH(DOOR)	618511
3	121568-03-701	EA	BUSHING - HINGE PIN/GRAY	619671
4	121568-03-702	EA	DOOR LINER - W/TRIM/BLACK	619627 - SMALL DOOR
5	120075-01-702	EA	CAP, (HINGE PLUG)	618160
6	120075-12-700	EA	HANDLE(CONTOUR)TOP LH/BTM RH	621105
7	120075-01-705	EA	HINGE-TOP LH/BOTTOM RH(DOOR)	618510
8	121568-01-700	EA	RAIL - DOOR UPPER	618618
9	120075-07-700	EA	DOOR BIN - CLEAR	619006
10	120075-07-701	EA	DIVIDER/DOOR BIN CLEAR	619008
	121568-03-705	EA	STORAGE LATCH - GRAY	619648

APPLIANCE GROUP (CONTINUED)
COMPONENT PARTS FOR APPLIANCE (CONTINUED)

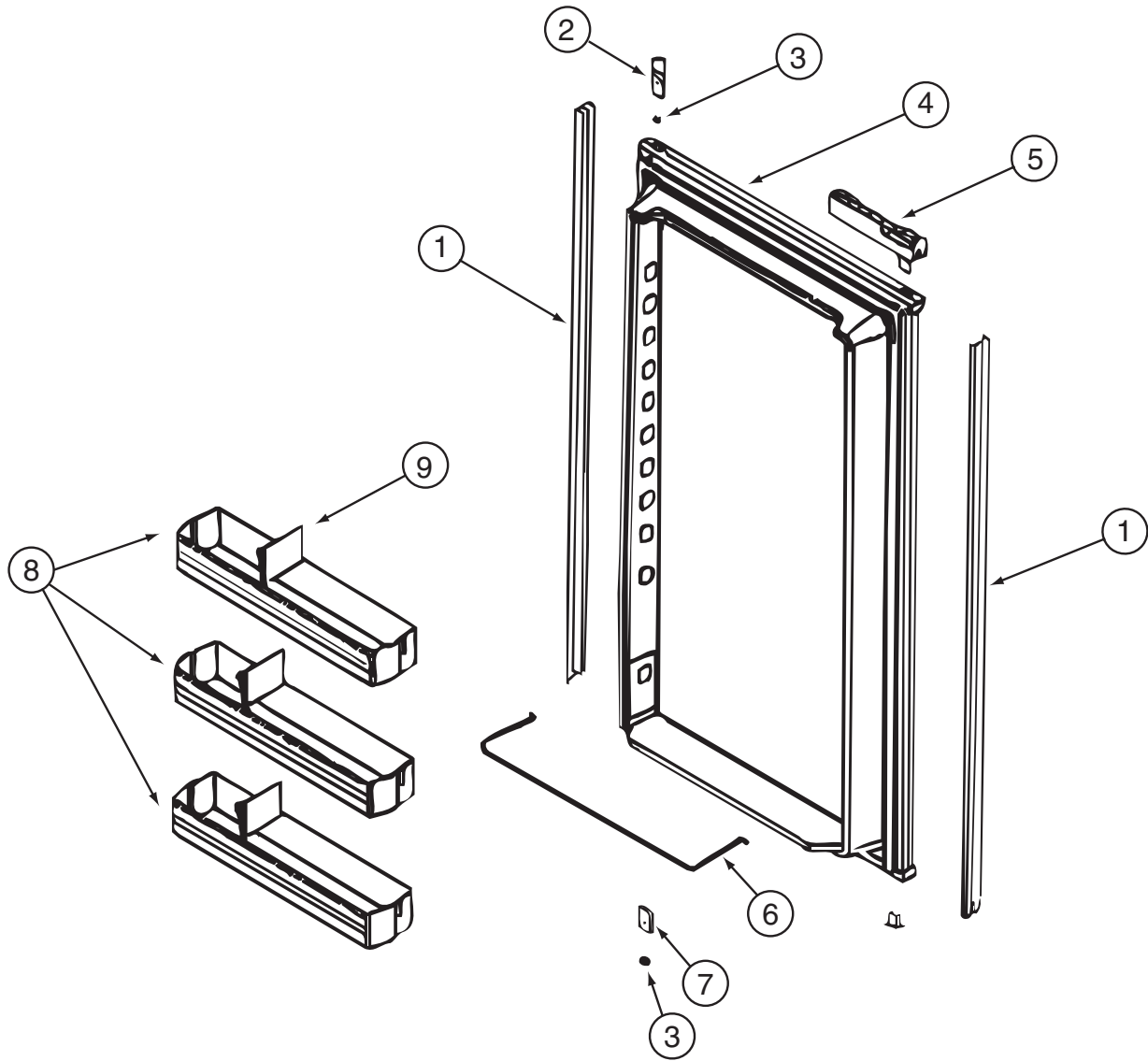

121569-05-01A, 121569-07-01A (CONTINUED)

KEY	PART NUMBER	U/M	DESCRIPTION	VENDOR NO.
1	120075-07-702	EA	RETAINER - DOOR PANEL/BLACK	619560
2	120075-01-701	EA	HINGE-TOP RH/BOTTOM LH(DOOR)	618511
3	121568-03-701	EA	BUSHING - HINGE PIN/GRAY	619671
4	121568-03-707	EA	DOOR LINER - W/BLACK TRIM	619629
5	120075-12-701	EA	HANDLE(CONTOUR)TOP RH/BTM LH	621104
6	121568-01-704	EA	RAIL - DOOR LOWER	618578
7	120075-01-705	EA	HINGE-TOP LH/BOTTOM RH(DOOR)	618510
8	121568-01-701	EA	BIN - DOOR WHITE	618619
9	120075-07-701	EA	DIVIDER/DOOR BIN CLEAR	619008
	121568-03-705	EA	STORAGE LATCH - GRAY	619648

APPLIANCE GROUP (CONTINUED)
COMPONENT PARTS FOR APPLIANCE (CONTINUED)

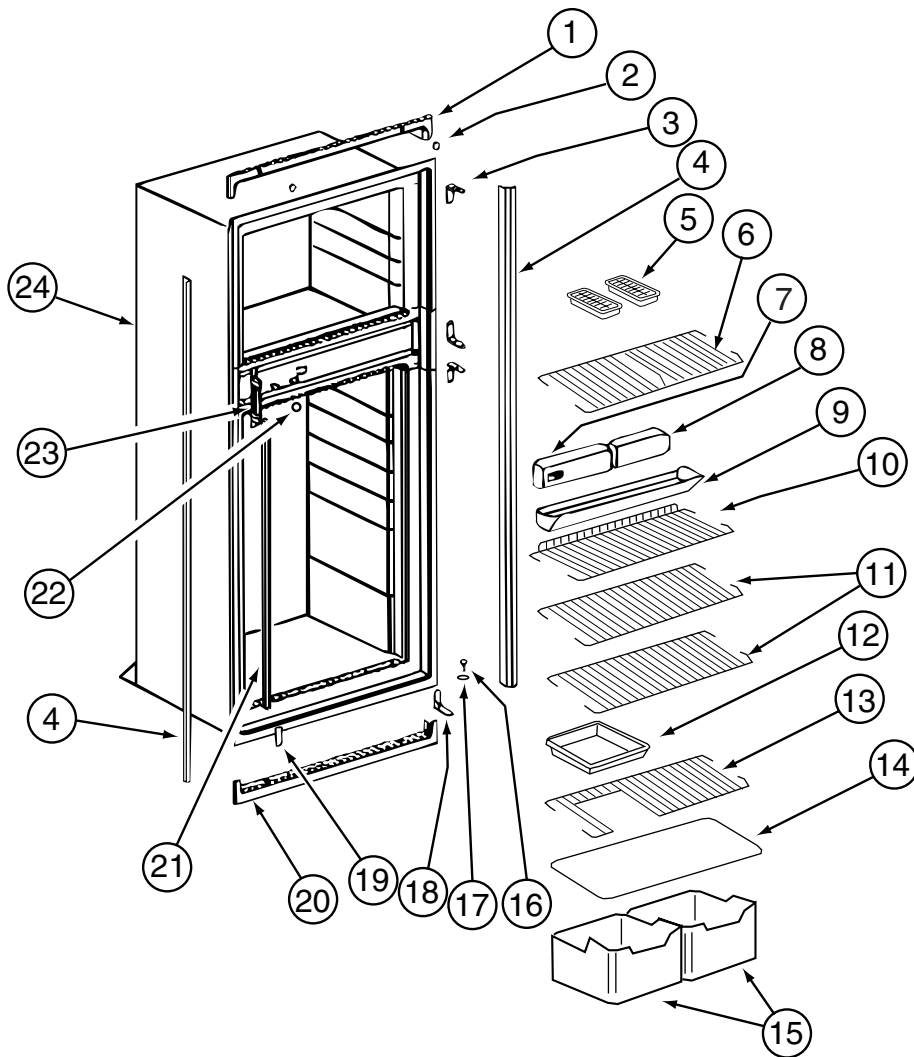

121569-05-01A, 121569-07-01A (CONTINUED)

KEY	PART NUMBER	U/M	DESCRIPTION	VENDOR NO.
1	121568-03-709	EA	TRIM - TOP/BLACK	619687
2	120075-01-714	EA	PLUG-HOLE	618170
3	121568-03-710	EA	HINGE/CABINET-TOP/RH-LWR/LH	619335
4	120075-07-705	EA	TRIM - SIDE - BLACK	619802
6	121568-03-712	EA	SHELF - WIRE/FREEZER	620250
7	121568-03-714	EA	CONTROL ASM - 2 WAY BLACK	619350
8	121568-03-713	EA	FRONT BOX/DECORATIVE-BLACK	619282
9	120075-01-720	EA	TRAY-DRIP	618137
10	121568-01-707	EA	SHELF - WIRE - SHORT	618624
11	121568-01-708	EA	SHELF - WIRE	618589
14	120075-01-725	EA	COVER-CRISPER	618158
15	121568-01-709	EA	CRISPER	618571
16	120075-01-727	EA	PIN-HINGE	618145
18	121568-03-715	EA	HINGE/CABINET-TOP/LH-LWR/RH	619336
19	121568-03-716	EA	COVER - HINGE HOLES	619301
20	120075-01-729	EA	TRIM-BOTTOM PIECE	618136
21	120075-01-730	EA	RETAINER-SHELF	618181
22	121568-03-717	EA	HOLE PLUG - WHITE	619561
23	120075-01-732	EA	PLATE-STRIKE	618167
24	120075-07-709	EA	CABINET - FOAMED	619347
	120075-01-721	EA	LOUVER-DRIP TRAY	618176

CONTACT WINNEBAGO PART SALES FOR UNLISTED COMPONENTS

APPLIANCE GROUP (CONTINUED)
COMPONENT PARTS FOR APPLIANCE (CONTINUED)

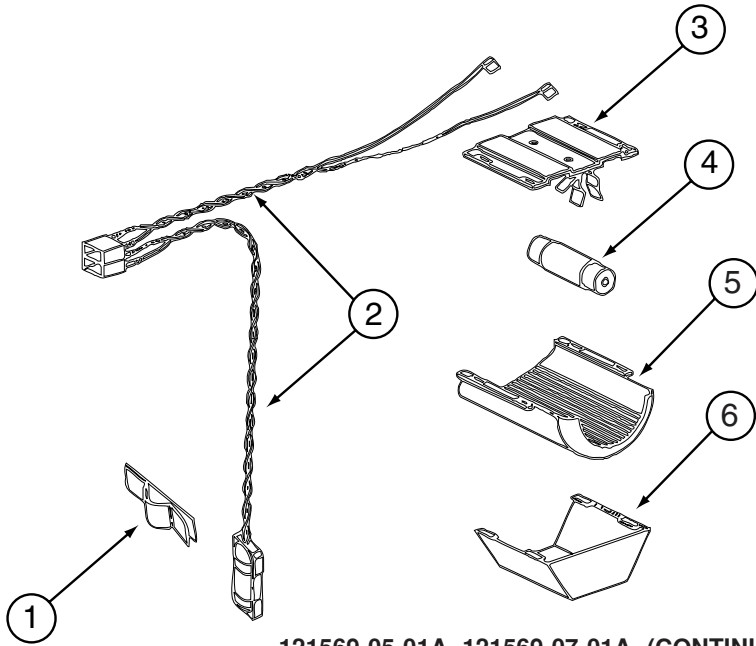

121569-05-01A, 121569-07-01A (CONTINUED)

KEY	PART NUMBER	U/M	DESCRIPTION	VENDOR NO.
1	084880-01-760	EA	CLIP (THERMISTER)	61689122
2	120075-01-735	EA	THERMISTER W/LAMP & WIRE/ASM	618548
3	084880-03-705	EA	BRACKET-LIGHT-INTERIOR	61629722
4	084880-03-706	EA	BULB-LAMP	61628922
6	084880-03-707	EA	COVER-LAMP, LENS	61627922

CONTACT WINNEBAGO PART SALES FOR UNLISTED COMPONENTS

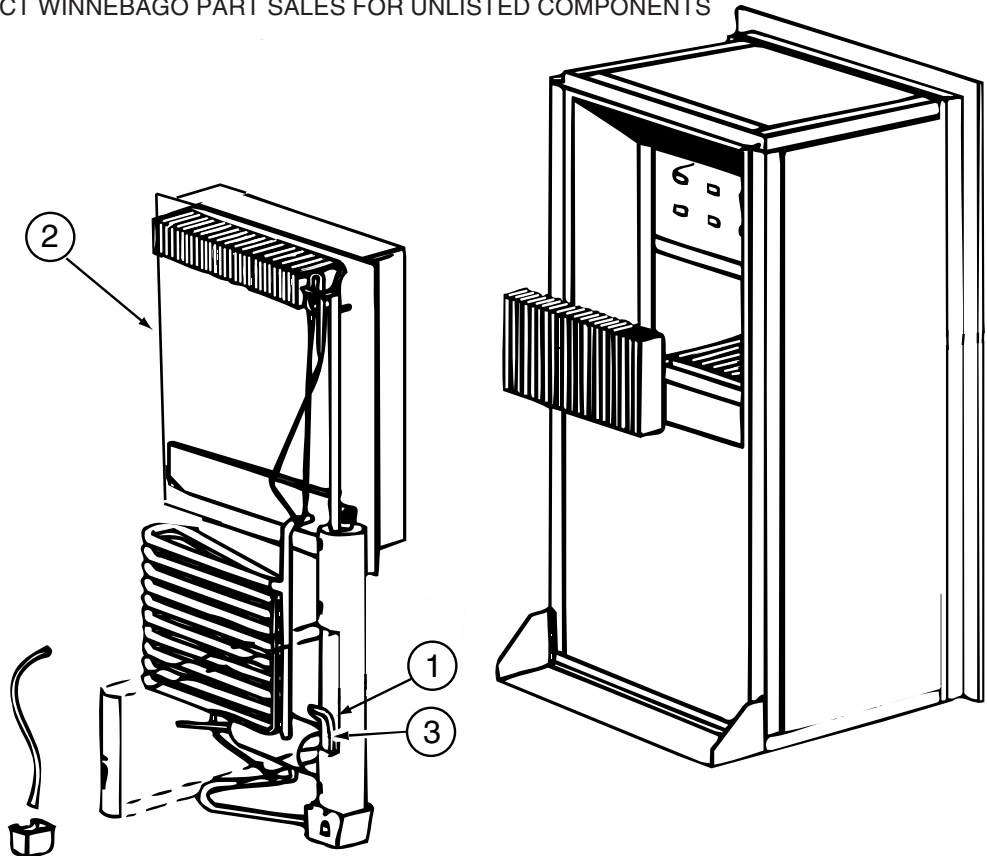

121569-05-01A, 121569-07-01A (CONTINUED)

KEY	PART NUMBER	U/M	DESCRIPTION	VENDOR NO.
2	120075-01-736	EA	COOLING UNIT, SERVICE PACK	618542
3	088248-01-709	EA	HEATER-AC (HORIZONTAL)	61562722
	120075-01-744	EA	KIT - GAS VALVE/BURNER TUBE	620609

CONTACT WINNEBAGO PART SALES FOR UNLISTED COMPONENTS

APPLIANCE GROUP (CONTINUED)
COMPONENT PARTS FOR APPLIANCE (CONTINUED)

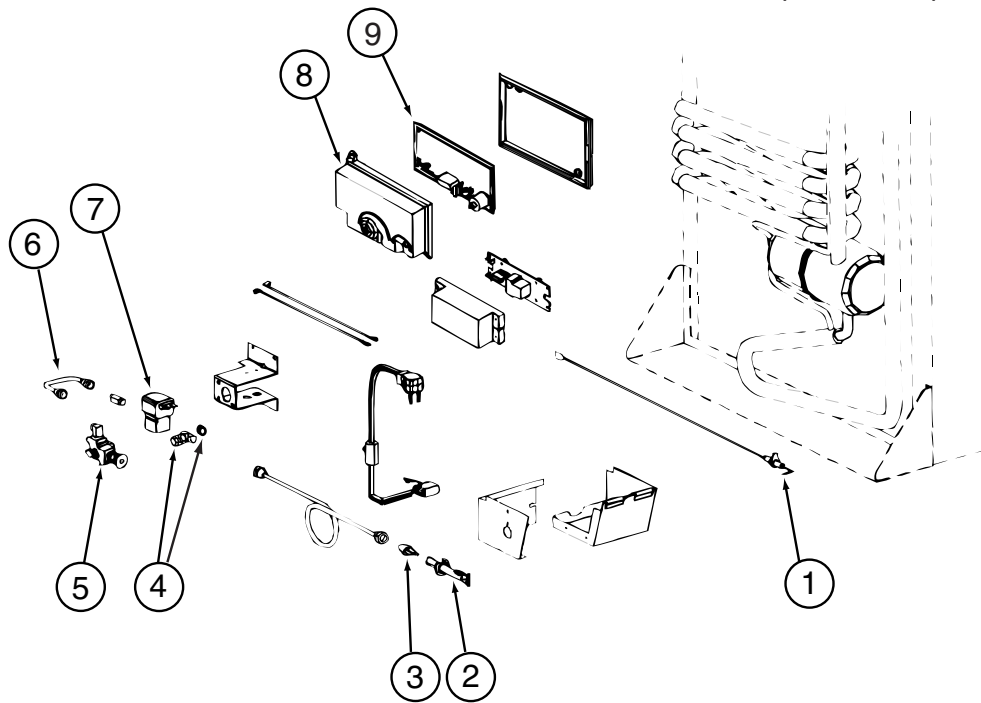

121569-05-01A, 121569-07-01A (CONTINUED)

KEY	PART NUMBER	U/M	DESCRIPTION	VENDOR NO.
1	104137-06-715	EA	ELECTRODE-SPARK/SENSOR, SGL	61692222
2	104137-06-714	EA	BURNER ASSEMBLY, 5-SLOT	61705222
3	120075-01-737	EA	ORIFICE - JEWEL - .0155	618284
4	113737-01-702	EA	PLUG 1/8" F/PRESSURE TAP	61445322
4	113737-01-716	EA	TAP-PRESSURE	61594422
6	113737-01-750	EA	TUBE-UNION	61694622
7	084880-01-718	EA	VALVE-GAS, (ASCO)	61551822
8	120075-01-738	EA	COVER-POWER BOARD	618185
9	121568-03-719	EA	POWER - BOARD - 2-WAY	619353
	121568-03-720	EA	VALVE/SHUT OF-MANUAL ELECT.	618696

CONTACT WINNEBAGO PART SALES FOR UNLISTED COMPONENTS

APPLIANCE GROUP (CONTINUED)
COMPONENT PARTS FOR APPLIANCE (CONTINUED)

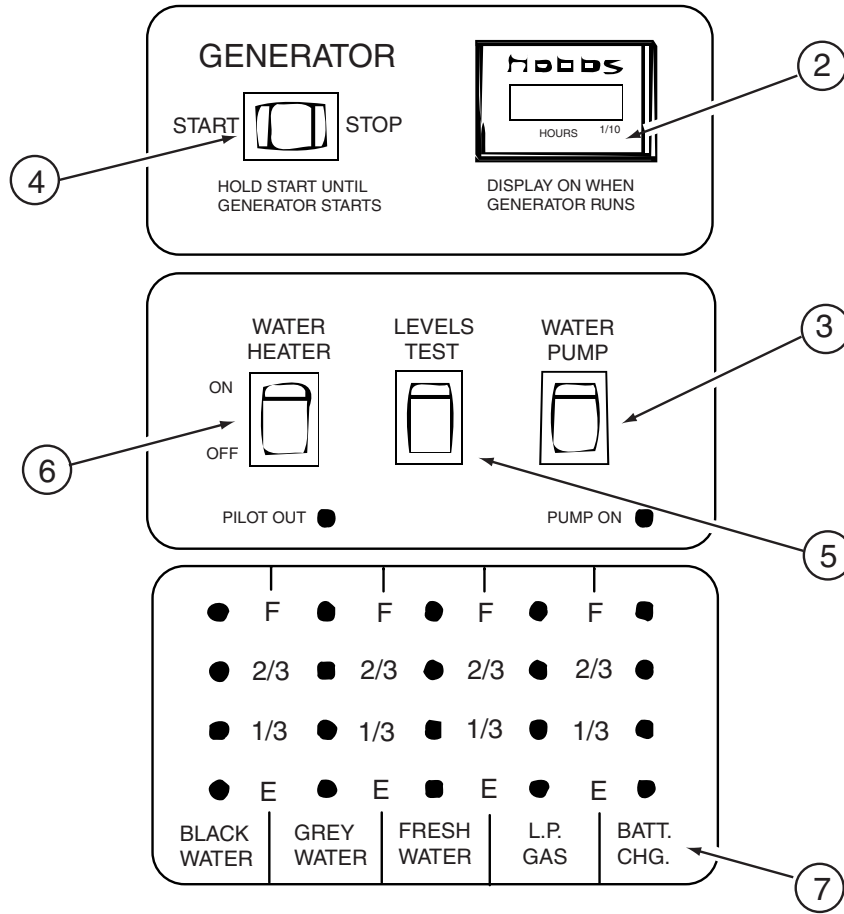

134940-01-01A

KEY	PART NUMBER	U/M	DESCRIPTION	VENDOR NO.
	134940-01-700	EA	BOARD - PC	L5118-01
2	100258-10-701	EA	GAUGE-HR METER ONLY (LCD)	L0775-00
3	096983-01-703	EA	SWITCH - ON/ON	L0115-00
4	096983-01-702	EA	SWITCH - MOM/OFF/MOM/3 TERM	L0112-00
5	096983-01-701	EA	SWITCH - SPST/MOM 2 TERMINAL	L0111-00
6	134940-01-701	EA	SWITCH-SPST/ON-OFF/BLK W/LGT	L0109
7	134940-01-702	EA	CHASSIS - SILKSCREENED	CC0558-00
	100258-10-702	EA	HOUR METER(CLIP ON)SW & WIRE	L4441-00

APPLIANCE GROUP (CONTINUED)
COMPONENT PARTS FOR APPLIANCE (CONTINUED)

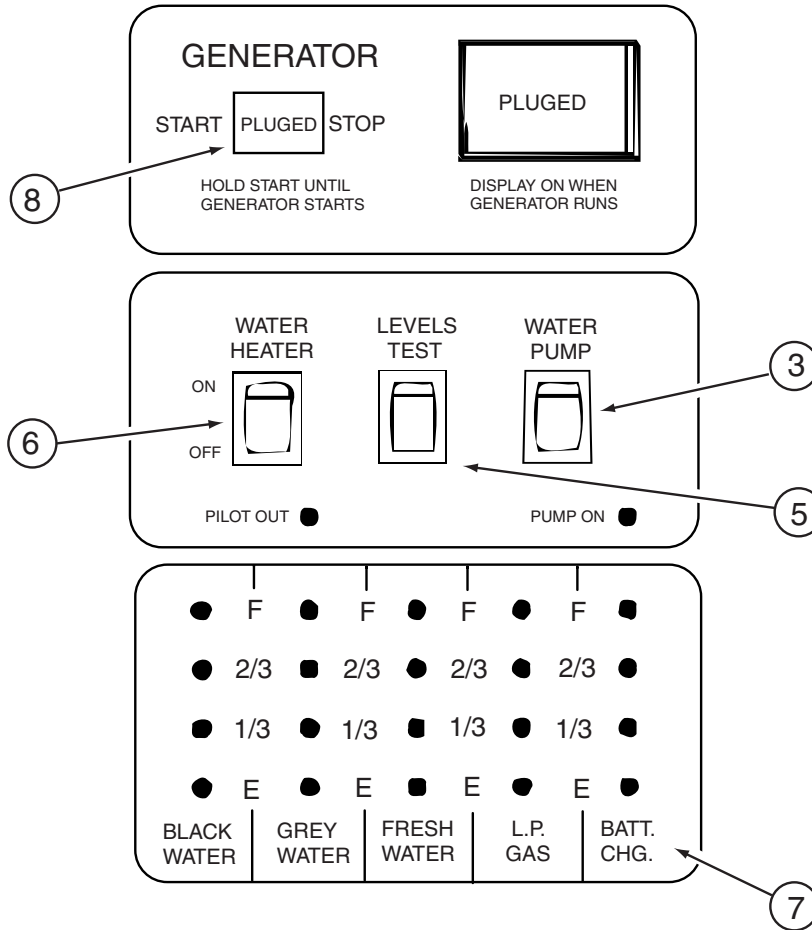

134940-02-01A

KEY	PART NUMBER	U/M	DESCRIPTION	VENDOR NO.
	134940-01-700	EA	BOARD - PC	L5118-01
3	096983-01-703	EA	SWITCH - ON/ON	L0115-00
5	096983-01-701	EA	SWITCH - SPST/MOM 2 TERMINAL	L0111-00
6	134940-01-701	EA	SWITCH-SPST/ON-OFF/BLK W/LGT	L0109
7	134940-01-702	EA	CHASSIS - SILKSCREENED	CC0558-00
8	134940-02-700	EA	SWITCH - DUMMY	L0118

APPLIANCE GROUP (CONTINUED)
COMPONENT PARTS FOR APPLIANCE (CONTINUED)

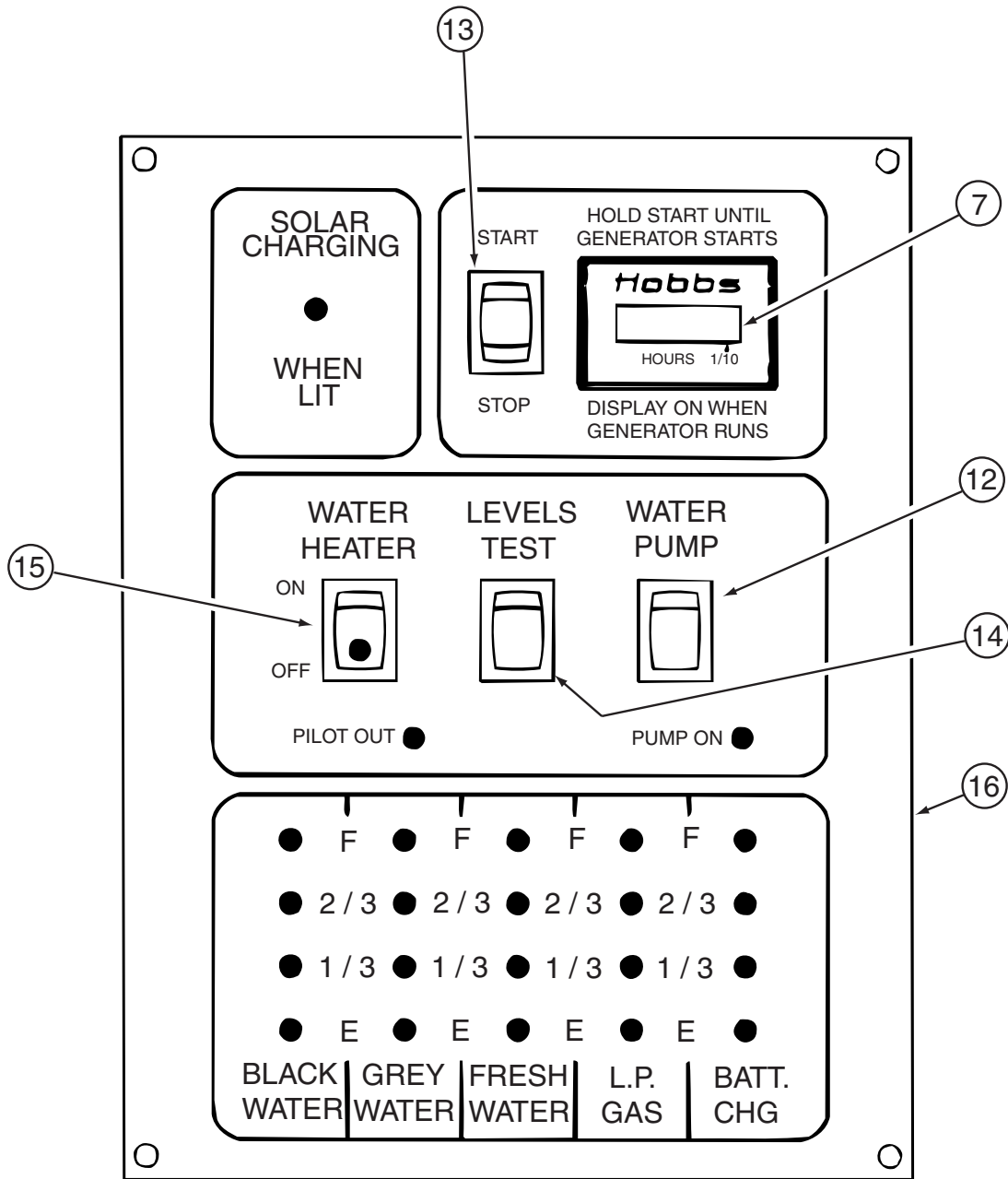

134940-04-01A

KEY	PART NUMBER	U/M	DESCRIPTION	VENDOR NO.
7	100258-10-701	EA	GAUGE/HOUR METER-CLIP ON LCD	L0775-00
12	096983-01-703	EA	SWITCH - ON/ON	L0115-00
13	096983-01-702	EA	SWITCH - MOM/OFF/MOM/3 TERM	L0112-00
14	096983-01-701	EA	SWITCH - SPST/MOM 2 TERMINAL	L0111-00
15	134940-01-701	EA	SWITCH-SPST/ON-OFF/BLK W/LGT	L0109
16	134940-04-700	EA	CHASSIS - SILKSCREENED	CE0136-00

APPLIANCE GROUP (CONTINUED)
COMPONENT PARTS FOR APPLIANCE (CONTINUED)

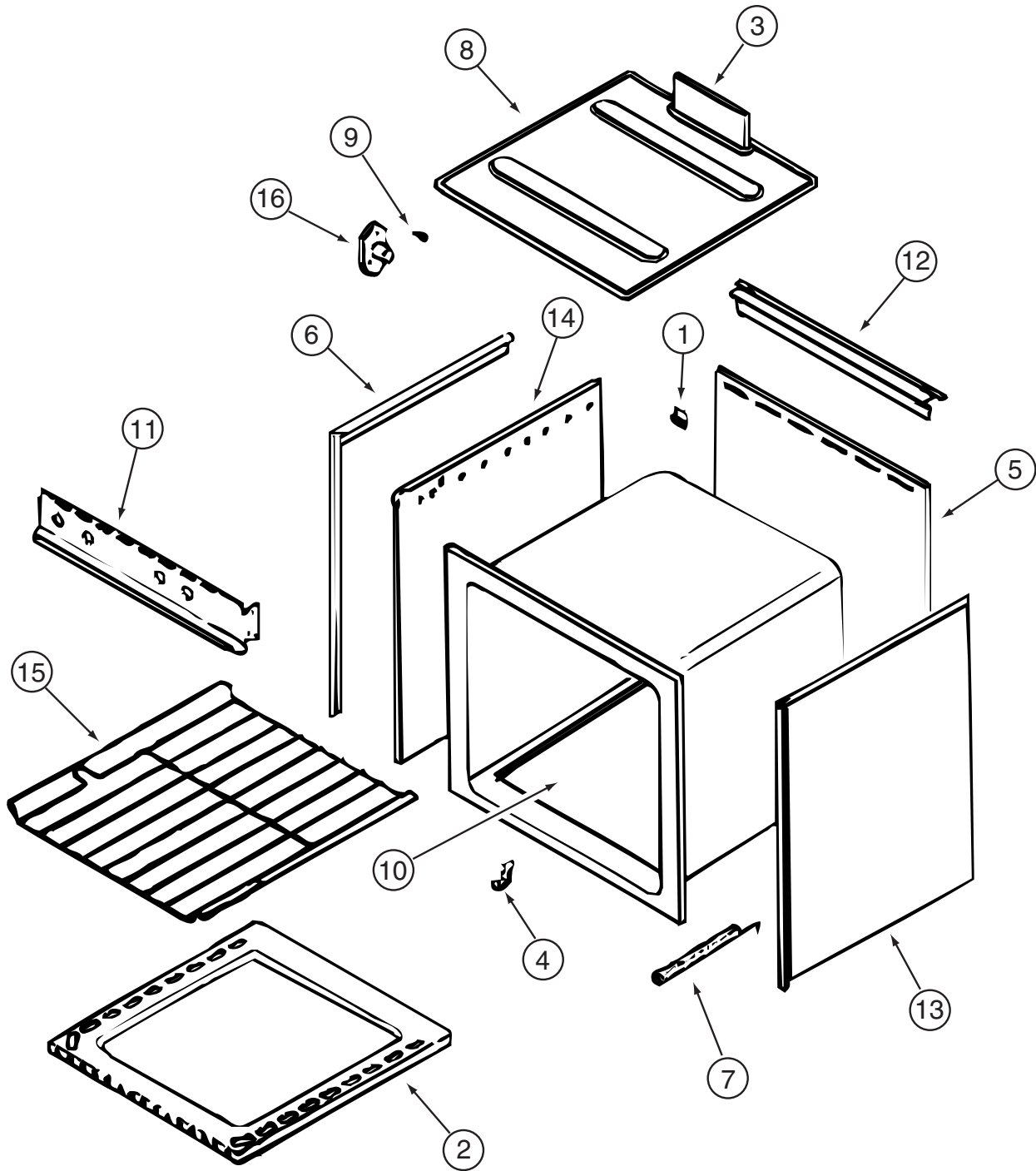

135656-03-01A

KEY	PART NUMBER	U/M	DESCRIPTION	VENDOR NO.
1	112881-03-702	EA	CLIP - MAIN TOP	74003998
2	126023-01-731	EA	BOTTOM - OVEN	2205F016-19
3	126023-01-718	EA	FLUE BOX ASSEMBLY	4006W075-80
6	112881-01-719	EA	TRIM-FLAT LH BLACK TEXTURED	74002813
6	112881-01-720	EA	TRIM-FLAT RH BLACK TEXTURED	74002812
7	135066-03-700	EA	SPRING - OVEN DOOR	74001835
9	128728-01-703	EA	PIN/T-NUT F/HINGE	7103P109-60
11	135066-03-701	EA	PANEL - MANIFOLD - BLACK	74007306
12	112881-01-723	EA	DEFLECTOR/FLUE-BLK-NON SEAL	74002809
15	126023-01-716	EA	RACK - OVEN	74003106

CONTACT WINNEBAGO PART SALES FOR UNLISTED COMPONENTS

APPLIANCE GROUP (CONTINUED)
COMPONENT PARTS FOR APPLIANCE (CONTINUED)

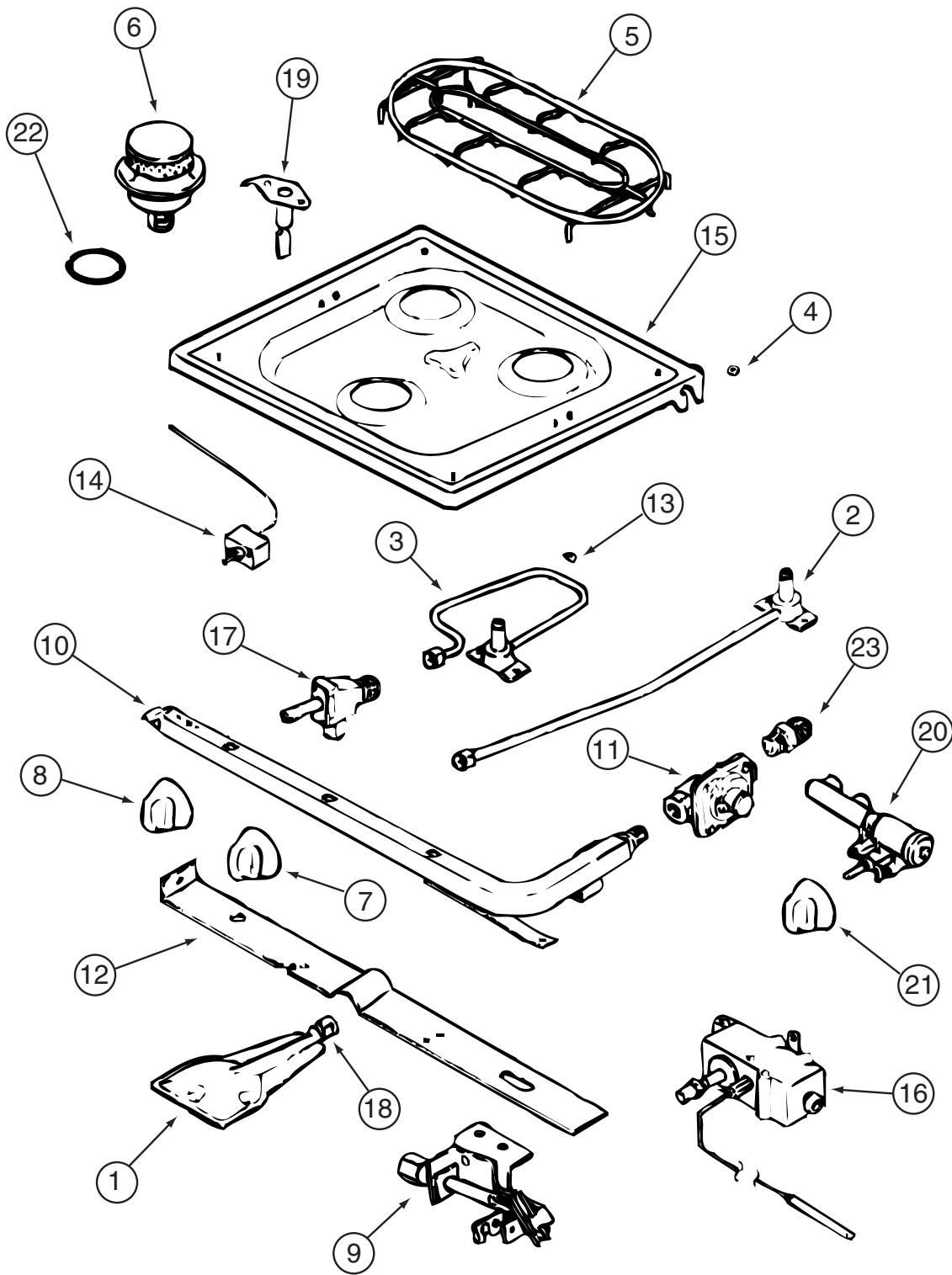

135656-01-01A (CONTINUED)

APPLIANCE GROUP (CONTINUED)
COMPONENT PARTS FOR APPLIANCE (CONTINUED)

135656-01-01A (CONTINUED)

KEY	PART NUMBER	U/M	DESCRIPTION	VENDOR NO.
1	126023-01-717	EA	BURNER - OVEN	74003343
2	128728-01-708	EA	FITTING - ORFICE TUBE - REAR	74003931
3	128728-01-710	EA	FITTING - ORFICE TUBE - FRT	74003930
4	102020-01-709	EA	BUMPER-GRATE	8007-P020-60
5	128728-01-700	EA	GRATE - BURNER	74003948
6	135065-01-705	EA	BURNER/SEALED ASSEMBLY	74003967
7	112881-01-705	EA	KNOB-TOP BURNER	7733P072-60
7	112881-01-718	EA	KNOB - TOP BURNER HI-OUTPUT	74001794
8	135656-01-700	EA	KNOB/THERMOSTAT	74002529
9	126023-02-701	EA	PILOT - OVEN	74004586
10	126023-02-702	EA	PIPE - MANIFOLD	74004360
11	126023-02-703	EA	REGULATOR - PRESSURE	74004235
13	102020-01-724	EA	BUMPER-MAIN TOP	8003P008-60
14	126023-01-734	EA	THERMOSTAT OVEN 11/CLY MODEL	74004361
15	128728-01-705	EA	TOP - MAIN - BLACK	74003928
16	126023-02-704	EA	VALVE - OVEN	74004585

CONTACT WINNEBAGO PART SALES FOR UNLISTED COMPONENTS

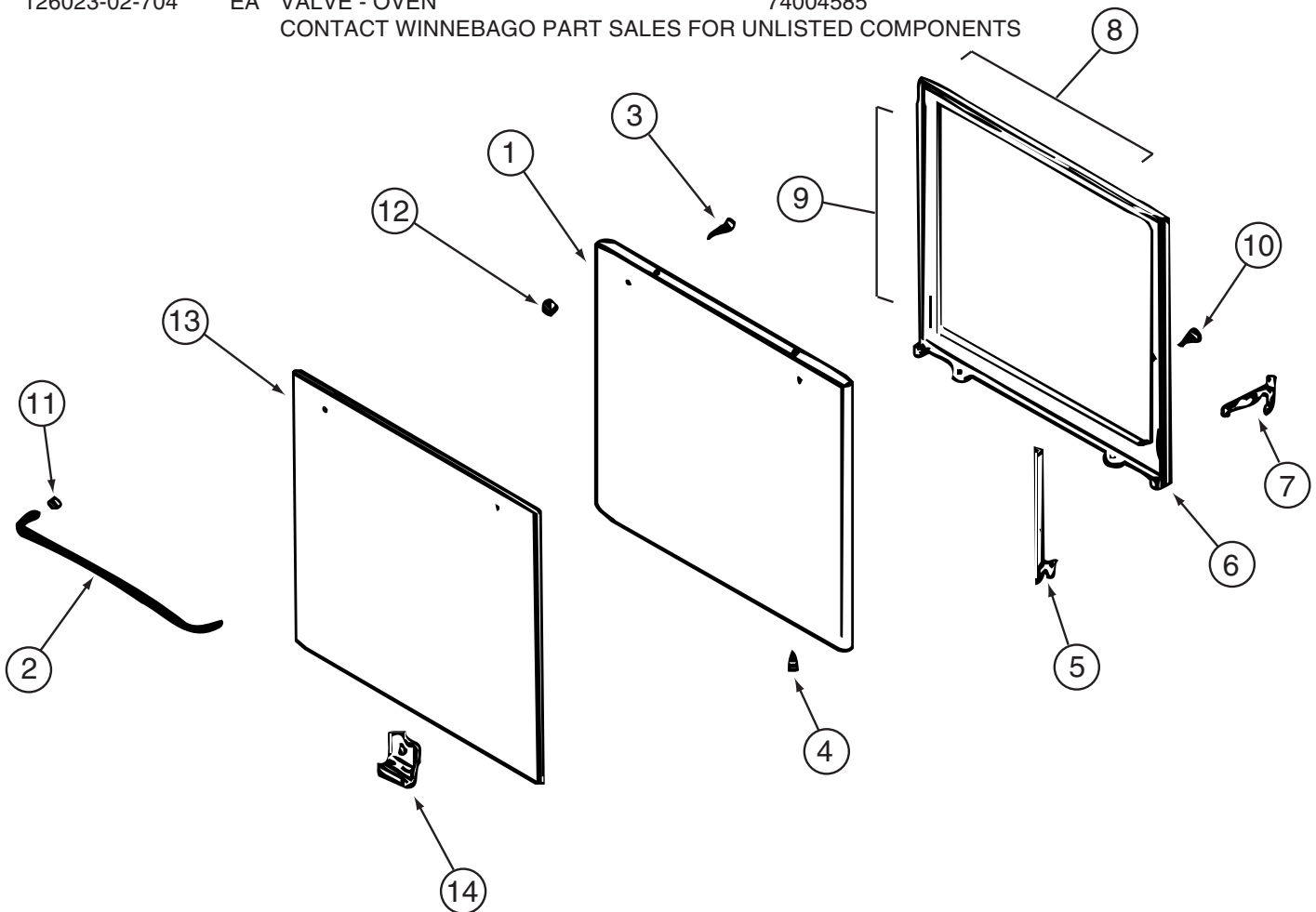

135656-03-01A (CONTINUED)

KEY	PART NUMBER	U/M	DESCRIPTION	VENDOR NO.
1	112881-02-705	EA	DOOR/OVEN-TEXT/BLK-F/WINDOW	74001273
2	128727-01-701	EA	HANDLE - OVEN DOOR	74003929
8	126023-01-732	EA	SEAL/OVEN DR TOP	7212P014-60
9	126023-01-733	EA	SEAL/OVEN DR SIDES(2PCS)	7212P038-60
13	102020-01-725	EA	GLASS OUTER	7902P266-60

CONTACT WINNEBAGO PART SALES FOR UNLISTED COMPONENTS

137354-01-000

KEY	PART NUMBER	U/M	DESCRIPTION	VENDOR NO.
	137354-01-700	EA	FILTER	UN38

**AUDIO VIDEO GROUP
RADIO SYSTEM**

KEY	PART NUMBER	U/M	DESCRIPTION
	077069-02-000	EA	CABLE/EXTENSION - RADIO ANTENNA - 96"
	090944-01-000	EA	ANTENNA - RADIO - 16" RUBBER - W/72" LEAD WIRE
	108847-01-000	EA	BRACKET - ANTENNA GROUND
			FROM: 00-00-00 THRU: 06-26-03
	147741-01-09B	EA	BRACKET - ANTENNA GROUND
			FROM: 06-27-03 THRU: 99-99-99
	109889-04-000	EA	EXTENDER - ANTENNA SHAFT - 3.7"
	110469-01-000	EA	SPEAKER - 4" X 6" OVAL - COAXIAL
	124883-02-000	EA	SPEAKER/CUBE - W/BRACKET - SURROUND SOUND
			FROM: 00-00-00 THRU: 07-13-03
	148026-01-01A	EA	SPEAKER - CUBE - W/FIXED BRACKET - SILVER - SURROUND SOUND
			FROM: 07-14-03 THRU: 99-99-99
	124883-03-000	EA	SPEAKER/CUBE - W/O CASE - SURROUND SOUND
			FROM: 00-00-00 THRU: 07-13-03
	148026-03-01A	EA	SPEAKER - CUBE - W/O CASE - SURROUND SOUND
			FROM: 07-14-03 THRU: 99-99-99
	124884-01-000	EA	SPEAKER - 6" X 9" - SUB-WOOFER - W/O GRILLE - SURROUND SOUND
	110470-01-01A	EA	GRILLE - 4" X 6" - OVAL SPEAKER - BLACK
	124883-04-000	EA	GRILLE/SPEAKER - F/CUBE SPEAKER - SURROUND SOUND
			FROM: 00-00-00 THRU: 07-13-03
	148026-02-01A	EA	SPEAKER GRILLE - CUBE - SILVER - SURROUND SOUND
			FROM: 07-14-03 THRU: 99-99-99
	124885-01-000	EA	GRILLE - SPEAKER - 6" X 9" - SUB WOOFER - SURROUND SOUND
	124881-02-000	EA	AMPLIFIER - AUDIO - MTS Q SURROUND - ORANGE LABEL (LATEST) - SURROUND SOUND
	135420-01-000	EA	RADIO - AM/FM CASSETTE/CD COMBO - M9900 - 7.2" X 3.3" R.O. - DASH
	135420-05-000	EA	RADIO - MOUNTING KIT - FORD - DASH
	135420-10-000	EA	REMOTE CONTROL/RADIO (CREDIT CARD SIZE) - DASH
			FROM: 08-18-03 THRU: 99-99-99
	135420-11-000	EA	REMOTE CONTROL/RADIO (STEERING WHEEL MOUNT) - DASH
			FROM: 08-18-03 THRU: 99-99-99
*	143509-01-000	EA	RADIO - AM/FM CD - W/REMOTE - JENSEN CD3010X - EXTERIOR ENTERTAINMENT
	141679-01-000	EA	CHARGING STATION ONLY - F/TWO WAY RADIO SYSTEM
	141679-02-000	EA	RADIO/BATTERY KIT - TWO WAY (4 RADIOS/8 BATTERIES)

***COMPONENT PARTS LISTED LATER IN THIS GROUP**

AUDIO VIDEO GROUP (CONTINUED)
COMPONENT PARTS FOR RADIO SYSTEM

143509-01-000

KEY	PART NUMBER	U/M	DESCRIPTION	VENDOR NO.
	143509-01-700	EA	REMOTE - RADIO	VG70A0

AUDIO VIDEO GROUP (CONTINUED)
REAR VIEW MONITOR

KEY	PART NUMBER	U/M	DESCRIPTION
	136514-02-000	EA	CABLE - MONITOR/CAMERA
	136514-04-000	EA	MONITOR ONLY/COLOR - 6.8" FLAT PANEL - REAR VIEW/VISOR MNT
	136514-05-000	EA	CAMERA ONLY - REAR VIEW W/BRACKET - "BLACK & WHITE" FROM: 00-00-00 THRU: 06-15-03
	144677-04-000	EA	CAMERA - REAR VIEW W/BRACKET FROM: 06-16-03 THRU: 99-99-99
	143999-01-01A	EA	SPACER - MONITOR - BLACK

TELEPHONE

KEY	PART NUMBER	U/M	DESCRIPTION
	093253-01-03A	EA	PLATE - WALL - TELEPHONE - WHITE
	130686-01-01A	EA	PLATE - WALL - TELEPHONE/COAX - WHITE

TV & VCR

KEY	PART NUMBER	U/M	DESCRIPTION
	076319-09-000	EA	WALLPLATE - TV CABLE RECEPTACLE - SINGLE - BROWN
*	076319-23-000	EA	ANTENNA - TV ROOF MOUNT - 44.5" MAST
*	076319-25-000	EA	KIT - HARDWARE INTERIOR
	076319-27-000	EA	WALLPLATE/RECEPTACLE - WHITE
	082134-01-000	EA	ADAPTER - TV - CABLE TO CABLE
	082136-01-000	EA	NUT - HEX JAM - 3/8-32
	086756-01-000	EA	SPLITTER - TV/2 WAY
	123324-01-000	EA	FILTER - GROUND LOOP
	134006-01-03B	EA	PLATE - COAXIAL CABLE/OFF WHITE
*	136162-03-000	EA	TV - 27" STEREO W/5 JACKS - RCA F27440M FROM: 00-00-00 THRU: 10-12-03
	136162-04-000	EA	TV - 27" STEREO - W/5 JACKS - RCA 27R411TA0 FROM: 10-13-03 THRU: 99-99-99
	136860-01-000	EA	CABLE - RCA - #3 MALE TO #12F MALE CONNECTOR
*	137135-02-000	EA	ANTENNA - SATELLITE DSS - W/SENSOR
	142258-01-000	EA	SWITCH - VIDEO/ANTENNA POWER SUPPLY
	145171-01-000	EA	CONNECTOR - COAXIAL
*	145641-01-000	EA	DVD/VCR PLAYER - COMBINATION - RCA DRC6000N FROM: 00-00-00 THRU: 08-10-03
*	145641-02-000	EA	DVD/VCR PLAYER - COMBINATION - RCA DRC6100N FROM: 08-11-03 THRU: 99-99-99

*COMPONENT PARTS LISTED LATER IN THIS GROUP

AUDIO VIDEO GROUP (CONTINUED)
COMPONENT PARTS FOR TV & VCR

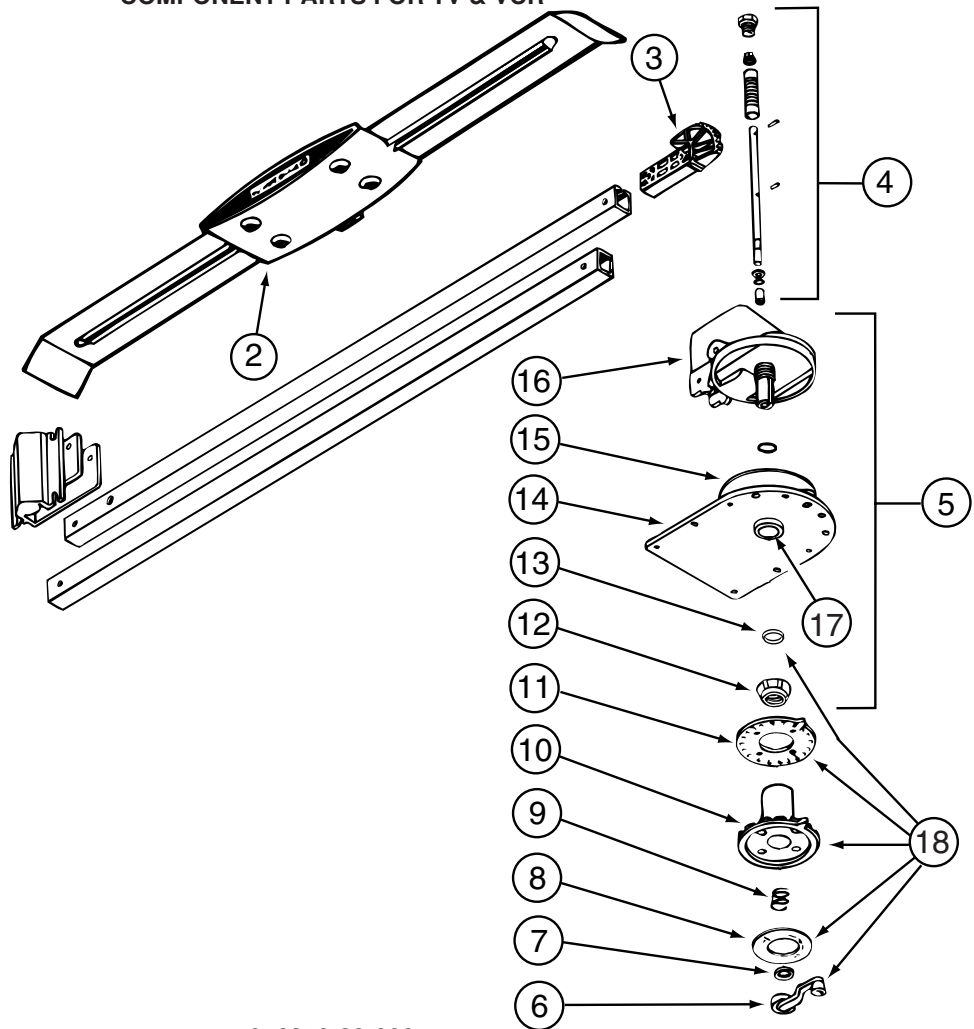

076319-23-000

KEY	PART NUMBER	U/M	DESCRIPTION	VENDOR NO.
2	076319-01-700	EA	HEAD-ANTENNA, AMPLIFIED	RVSA U/V
3	076319-01-701	EA	GEAR-ELEVATING, PLASTIC	2200046
4	076319-01-702	EA	SHAFT ASM-ELEVATING	RP-4000
5	076319-01-711	EA	BASE & LIFT ASM	2762802
7	076319-01-705	EA	GROMMET-NYLON, 7/8"ID	3200658
8	076319-01-708	EA	DECAL-CRANK	5413002
9	076319-01-707	EA	SPRING-HANDLE	2160822
11	076319-01-712	EA	PLATE - CEILING	3200608
12	076319-01-715	EA	NUT (GEAR HOUSING)	2200047
14	076319-01-713	EA	BASE-PLATE, STEEL	3100523
15	076319-01-703	EA	BEARING-NYLON, 5"OD	3200656
16	076319-01-714	EA	HOUSING, ROTATING GEAR	2200049
	076319-01-716	EA	TUBING, ELEVATING	RP-2900
17	076319-01-704	EA	BEARING-NYLON, 1.25"OD	3200657

CONTACT WINNEBAGO PART SALES FOR UNLISTED COMPONENT

076319-25-000

KEY	PART NUMBER	U/M	DESCRIPTION	VENDOR NO.
6	076319-01-706	EA	CRANK-W/SET SCREW UNIV/BEIGE	2750897
6	120233-01-710	EA	HANDLE-CRANK W/SCREW - WHITE	RP-6795
8	076319-01-708	EA	DECAL-CRANK	5413002
10	076319-25-700	EA	DIRECTIONAL HANDLE(WHITE)	3200612
11	076319-25-701	EA	PLATE - CEILING(WHITE)	3200609
13	120233-01-709	EA	WASHER-NYLON	RP-2658

CONTACT WINNEBAGO PART SALES FOR UNLISTED COMPONENTS

136162-03-000

KEY	PART NUMBER	U/M	DESCRIPTION	VENDOR NO.
	124075-05-700	EA	REMOTE - TV	242778

AUDIO VIDEO GROUP (CONTINUED)
COMPONENT PARTS FOR TV & VCR (CONTINUED)

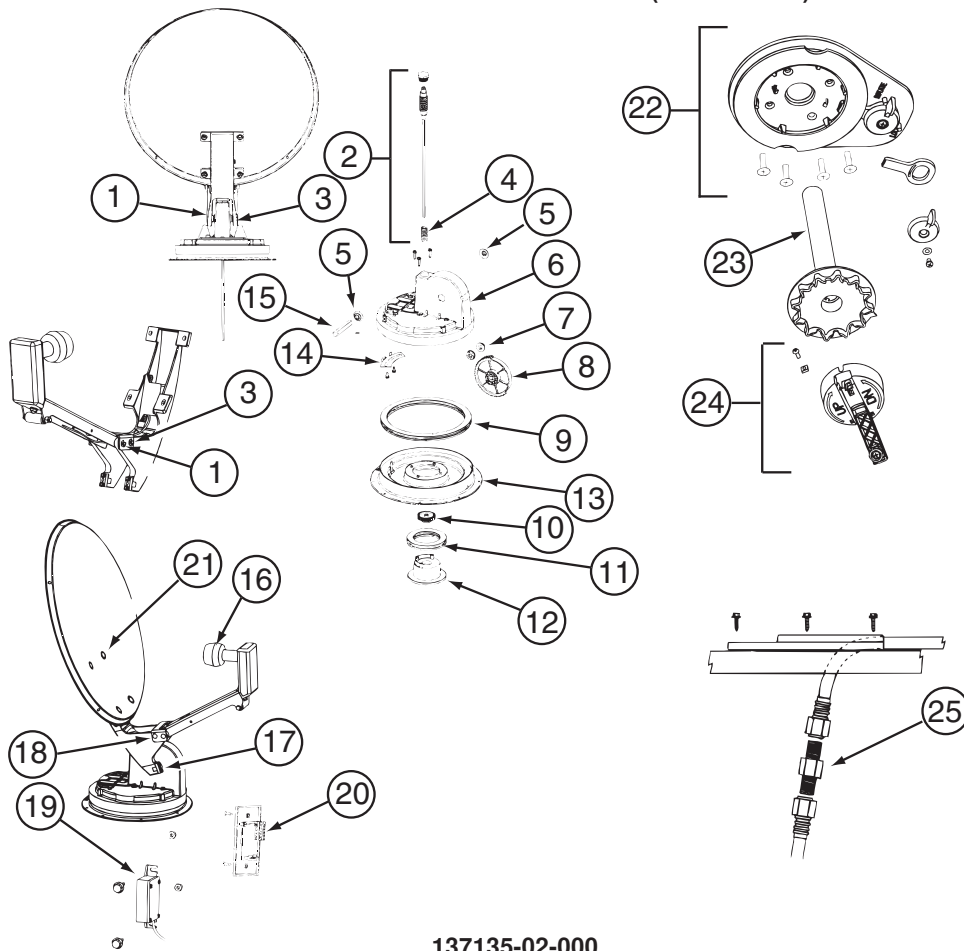

137135-02-000

KEY	PART NUMBER	U/M	DESCRIPTION	VENDOR NO.
1	120233-01-714	EA	CLIP-E	5160818
2	137135-01-703	EA	KIT ELEV - SHAFT/GEAR/SPRING	RP-4400
3	137135-01-704	EA	PIN - 1/4" X 3.25"	2160813
5	137135-01-707	EA	SEAL - PIVOT SHAFT	2200852
6	137135-01-708	EA	TURRET	3100728
7	137135-01-709	EA	PIVOT BEARING	2200470
8	137135-01-711	EA	GEAR - ELEVATING	2200464
9	137135-01-712	EA	BEARING - OUTER	2590347
10	137135-01-714	EA	GEAR - ELEVATING SHAFT	2200465
11	137135-01-715	EA	BEARING - INNER	2590348
12	137135-01-716	EA	HUB	3100731
13	137135-01-713	EA	TURRET BASE	3100730
14	137135-01-710	EA	PLATE - ROTATE LIMIT	3720052
16	137135-02-703	EA	LOW NOISE BLOCK FILTER	LB-6000 - DUAL
17	137135-01-722	EA	CLAMP	2590343
18	137135-01-719	EA	BRACKET - PIVOT	2744945
19	137135-01-720	EA	DE-SENSOR UNIT W/43" CABLE	DM4000
20	137135-02-701	EA	BOX - SURFACE MOUNT	SM-100
21	137135-01-717	EA	BOLT - FLAT HEAD	2160362
22	120233-01-737	EA	PLATE/INT-W/DIRECTIONAL HDLE	RK-CEIL
23	120233-01-704	EA	DIAL/DIRECTIONAL 4"W/SPRING	3200364
24	120233-01-738	EA	HDW PKG-HANDLE/SPRING/WASHER	RK-HAND
25	137135-01-701	EA	CONNECTOR - F - MALE TO MALE	FS-8100
	137135-01-700	EA	ROOF WEDGE W/GASKET	RW-5000
	137135-01-706	EA	KIT-TURRET/SEAL/BEARING/GEAR	RP-RM30
	137135-01-718	EA	REFLECTOR/WHITE-46CM W/HDWE	RP-35RM
	137135-02-700	EA	DE-SENSOR	2780090
	137135-02-704	EA	KIT-UPDATE DIRECTIONAL HDL	RP-RMDH

145641-01-000

KEY	PART NUMBER	U/M	DESCRIPTION	VENDOR NO.
	145641-01-700	EA	REMOTE	258154

AUDIO VIDEO GROUP (CONTINUED)
EXTERIOR ENTERTAINMENT

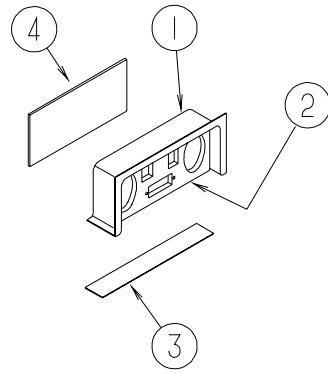

KEY	PART NUMBER	U/M	DESCRIPTION
1	124696-02-01A	EA	BOX - ENTERTAINMENT CENTER/EXTERIOR - BRIGHT WHITE
	124696-01-01A	EA	BOX - ENTERTAINMENT CENTER/EXTERIOR - BRIGHT WHITE
2	127409-02-L15	EA	PLATE - RADIO MOUNTING
3	104898-01-02A	EA	PLATE - PLASTIC BOTTOM - BRIGHT WHITE
4	NOT USED		

BATH GROUP CABINETS

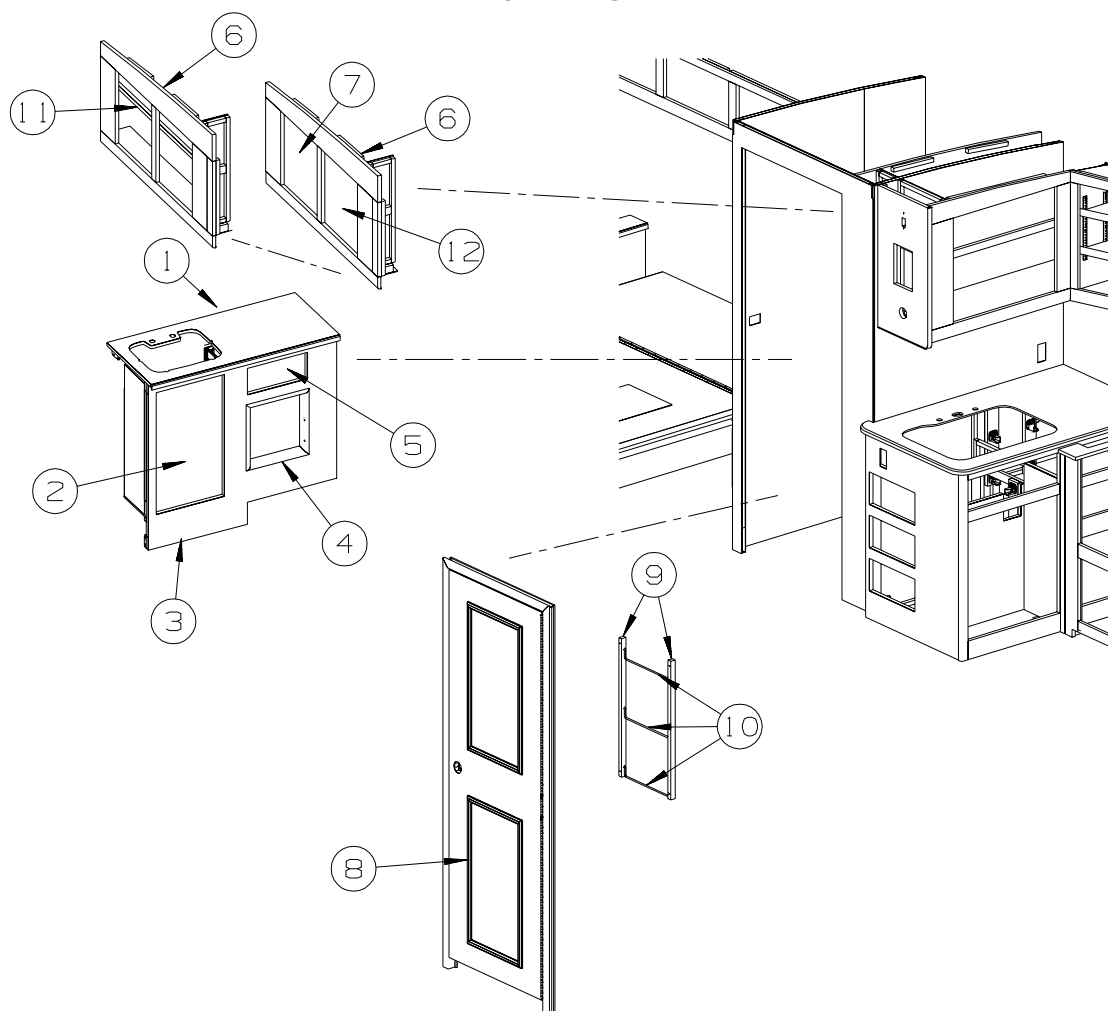

KEY	PART NUMBER	U/M	DESCRIPTION
1	133654-21-P13	EA	COUNTERTOP - LAMINATED - GRAY TRANQUILITY/PORTSMOUTH OAK (R19)
1	133654-21-P14	EA	COUNTERTOP - LAMINATED - GRAY TRANQUILITY/CONCERT CHERRY (R20)
1	133654-21-P33	EA	COUNTERTOP - LAMINATED - GRAY TRANQUILITY/WASHED MAPLE (R21) FROM: 00-00-00 THRU: 01-04-04
1	133654-21-RW1	EA	COUNTERTOP - LAVATORY (R21) FROM: 01-05-04 THRU: 99-99-99
1	133654-21-R15	EA	COUNTERTOP - LAMINATED - LINO FRIEZE/PORTSMOUTH OAK (R22)
1	133654-21-R16	EA	COUNTERTOP - LAMINATED - LINO FRIEZE/CHERRY (R23)
1	133654-21-R24	EA	COUNTERTOP - LAMINATED - LINO FRIEZE (R24) FROM: 00-00-00 THRU: 01-04-04
1	133654-21-RW2	EA	COUNTERTOP - LAMINATED (R24) FROM: 01-05-04 THRU: 99-99-99
1	133654-21-R17	EA	COUNTERTOP - LAMINATED - ROCKY MOUNTAIN HIGH/PORTS OAK (R25)
1	133654-21-R18	EA	COUNTERTOP - LAMINATED - ROCKY MOUNTAIN HIGH/CHERRY (R26)
1	133654-21-R27	EA	COUNTERTOP - LAMINATED - ROCKY MOUNTAIN HIGH/WASHED MAPLE (R27) FROM: 00-00-00 THRU: 01-04-04
1	133654-21-RW3	EA	COUNTERTOP - LAMINATED (R27) FROM: 01-05-04 THRU: 99-99-99
2	136919-B0-R19	EA	DOOR - FLAT/PENCIL EDGE - 14.3" X 26.7" - W/O HARDWARE - PORTSMOUTH OAK
2	136919-B0-R20	EA	DOOR - FLAT/PENCIL EDGE - 14.3" X 26.7" - W/O HARDWARE - CONCERT CHERRY
2	136919-B0-R21	EA	DOOR - FLAT/PENCIL EDGE - 14.3" X 26.7" - W/O HARDWARE - WASHED MAPLE
3	141605-01-P13	EA	CABINET - LAVATORY - W/O COUNTERTOP/DOORS/DRAWERS/HARDWARE - PORTSMOUTH OAK
3	141605-01-P14	EA	CABINET - LAVATORY - W/O COUNTERTOP/DOORS/DRAWERS/HARDWARE - CONCERT CHERRY
3	141605-01-P33	EA	CABINET - LAVATORY - W/O COUNTERTOP/DOORS/DRAWERS/HARDWARE - WASHED MAPLE FROM: 00-00-00 THRU: 01-04-04
3	141605-01-RW1	EA	CABINET - LAVATORY - W/O COUNTERTOP/DOORS/DRAWERS/HARDWARE - WASHED MAPLE FROM: 01-05-04 THRU: 99-99-99

BATH GROUP (CONTINUED)
CABINETS (CONTINUED)

KEY	PART NUMBER	U/M	DESCRIPTION
4	137602-07-N01	EA	POCKET - MAGAZINE - PORTSMOUTH OAK - PORTSMOUTH OAK
4	137602-07-P46	EA	POCKET - MAGAZINE - CHERRY - CONCERT CHERRY
4	137602-07-P33	EA	POCKET - MAGAZINE - WASHED MAPLE
			FROM: 00-00-00 THRU: 01-04-04
4	137602-07-RW1	EA	POCKET - MAGAZINE - WASHED MAPLE
			FROM: 01-05-04 THRU: 99-99-99
5	145492-36-R10	EA	DRAWER - PENCIL EDGE - 10.7"W X 13.8"D-W/O SLIDES/HARDWARE - PORTSMOUTH OAK
5	145492-36-R20	EA	DRAWER - PENCIL EDGE - 10.7"W X 13.8"D - W/O SLIDES/HDW - CONCERT CHERRY
5	145492-36-R21	EA	DRAWER - PENCIL EDGE - 10.7"W X 13.8"D-W/O SLIDES/HARDWARE - WASHED MAPLE
6	141607-01-P13	EA	CABINET - OVERHEAD/MEDICINE - W/O DOORS/HARDWARE - PORTSMOUTH OAK
6	141607-01-P14	EA	CABINET - OVERHEAD/MEDICINE - W/O DOORS/HARDWARE - CONCERT CHERRY
6	141607-01-P33	EA	CABINET - OVERHEAD/MEDICINE - W/O DOORS/HARDWARE - WASHED MAPLE
			FROM: 00-00-00 THRU: 01-04-04
6	141607-01-RW1	EA	CABINET - OVERHEAD/MEDICINE - W/O DOORS/HARDWARE - WASHED MAPLE
			FROM: 01-05-04 THRU: 99-99-99
7	141518-A3-R74	EA	DOOR - ARCHED/PENCIL EDGE - 14.3" X 17.9" - W/O HARDWARE - PORTSMOUTH OAK
7	141518-A3-R75	EA	DOOR - ARCHED/PENCIL EDGE - 14.3" X 17.9" - W/O HARDWARE - CONCERT CHERRY
7	141518-A3-R76	EA	DOOR - ARCHED/PENCIL EDGE - 14.3" X 17.9" - W/O HARDWARE - WASHED MAPLE
8	144645-04-R13	EA	DOOR - BATH - W/O TOWEL RACK/HARDWARE - PORTSMOUTH OAK
8	144645-04-R14	EA	DOOR - BATH - W/O TOWEL RACK/HARDWARE - CONCERT CHERRY
8	144645-04-R21	EA	DOOR - BATH - W/O TOWEL RACK/HARDWARE - WASHED MAPLE
	146064-01-01A	EA	LOCK/PRIVACY (LOCKING) LEVER STYLE - POLISHED BRASS
9	P34509-01-N01	EA	RAIL END - RH/LH - TOWEL RACK - PORTSMOUTH OAK - PORTSMOUTH OAK
9	P34509-01-P14	EA	RAIL END - RH/LH - TOWEL RACK - CHERRY - CONCERT CHERRY
9	P34509-01-J70	EA	RAIL END - RH/LH - TOWEL RACK - WASHED MAPLE - WASHED MAPLE
10	146801-01-01A	EA	ROD/TOWEL BAR (OFFSET) - BRASS
11	141607-24-R13	EA	SHELF - W/PLASTIC EDGE MOLDING - PORTSMOUTH OAK
			FROM: 08-18-03 THRU: 99-99-99
11	141607-24-R14	EA	SHELF - W/PLASTIC EDGE MOLDING - CONCERT CHERRY
			FROM: 08-18-03 THRU: 99-99-99
11	141607-24-R21	EA	SHELF - W/PLASTIC EDGE MOLDING - WASHED MAPLE
			FROM: 08-18-03 THRU: 01-04-04
11	141607-24-RW1	EA	SHELF - W/PLASTIC EDGE MOLDING - WASHED MAPLE
			FROM: 01-05-04 THRU: 99-99-99
12	141520-A3-R74	EA	DOOR - ARCHED/PENCIL EDGE/RIGHT HAND-14.3" X 17.9"-W/O HDW - PORTSMOUTH OAK
12	141520-A3-R75	EA	DOOR - ARCHED/PENCIL EDGE/RIGHT HAND-14.3" X 17.9"-W/O HDW - CONCERT CHERRY
12	141520-A3-R76	EA	DOOR - ARCHED/PENCIL EDGE/RIGHT HAND-14.3" X 17.9"-W/O HDW - WASHED MAPLE

BATH GROUP (CONTINUED)
CABINETS (CONTINUED)

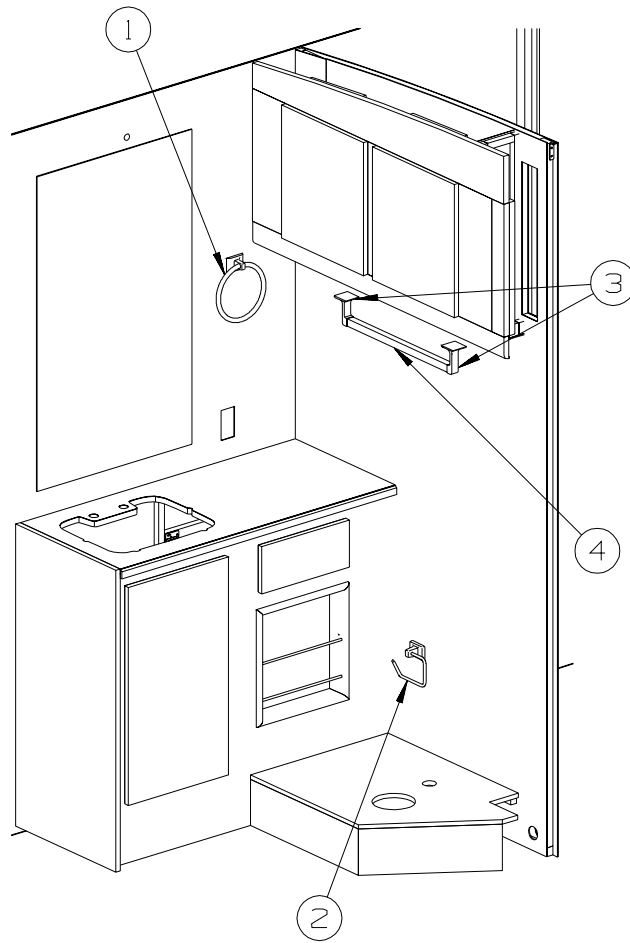

KEY	PART NUMBER	U/M	DESCRIPTION
1	145980-06-02A	EA	TOWEL RING - BRASS/CHROME
2	145980-03-02A	EA	PAPER HOLDER - EURO - BRASS/CHROME
3	145980-04-01A	EA	TOWEL BAR - POST - PAIR/BRASS
4	145980-05-02A	EA	TOWEL BAR - 18" - CHROME

BATH GROUP (CONTINUED) SHOWER

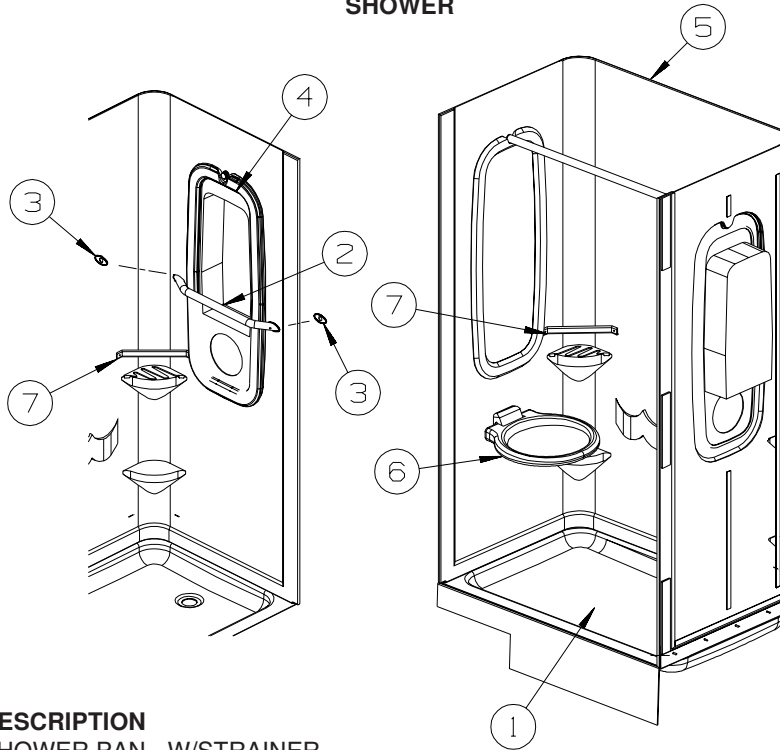

KEY	PART NUMBER	U/M	DESCRIPTION	
1	M02630-66-N09	EA	SHOWER PAN - W/STRAINER	FROM: 00-00-00 THRU: 08-24-03
1	M02630-80-R28	EA	SHOWER PAN - W/STRAINER - SOFT WHITE	FROM: 08-25-03 THRU: 99-99-99
2	NOT USED			
3	NOT USED			
4	NOT USED			
5	132216-02-01A	EA	SHOWER - SURROUND - SOFT WHITE	FROM: 00-00-00 THRU: 08-24-03
5	147188-03-01A	EA	SURROUND/SHOWER - SOFT WHITE	FROM: 08-25-03 THRU: 99-99-99
6	NOT USED			
7	113714-04-02A	EA	RETAINER - SHELF/SHOWER - SOFT WHITE	

SHOWER DOOR

KEY	PART NUMBER	U/M	DESCRIPTION
*	115011-03-01A	EA	DOOR - SHOWER/BYPASS - 39.3" X 65" - W/HARDWARE & LOCK

***COMPONENT PARTS LISTED LATER IN THIS GROUP**

BATH GROUP (CONTINUED)
COMPONENT PARTS FOR SHOWER DOOR

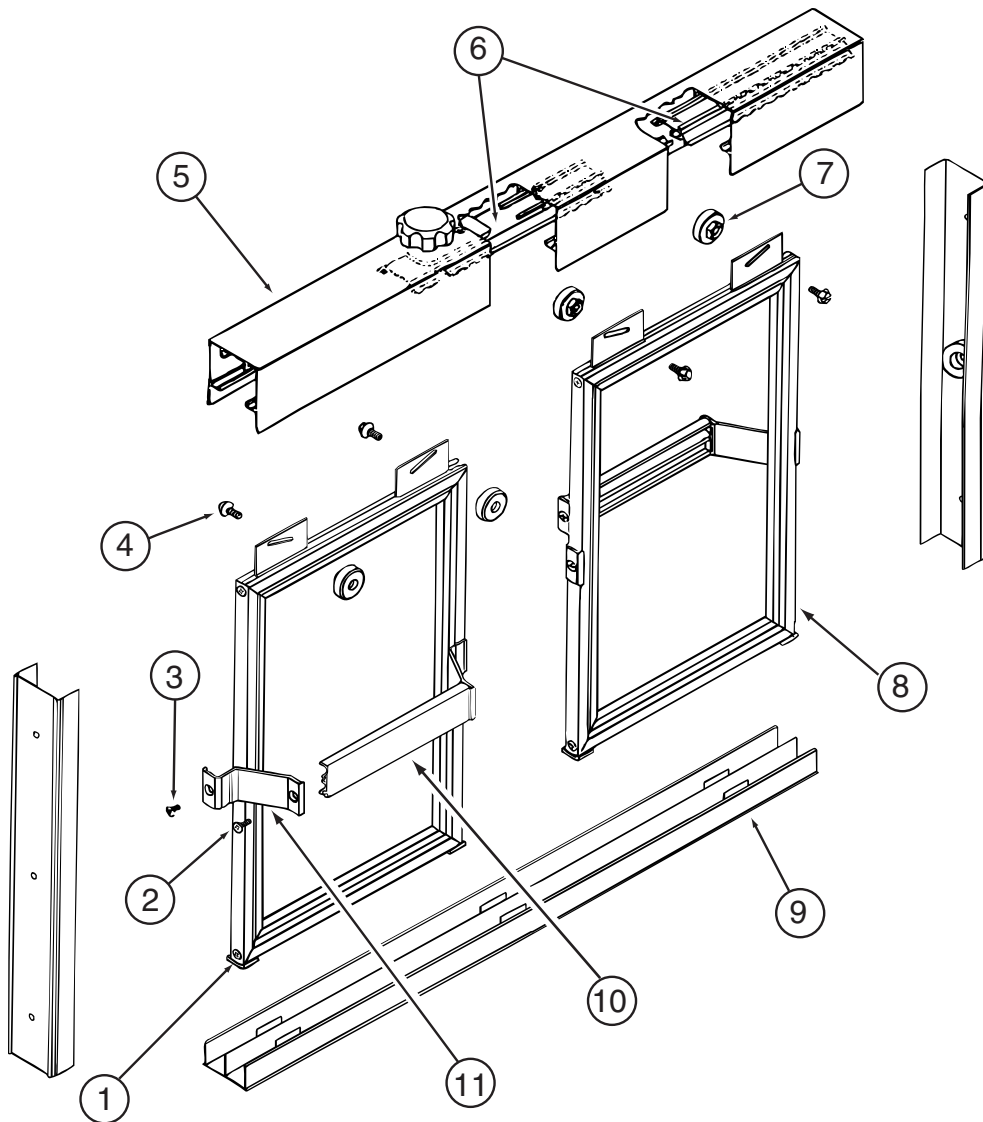

115011-03-01A

KEY	PART NUMBER	U/M	DESCRIPTION	VENDOR NO.
1	115011-01-701	EA	GUIDE-NYLON, (W-TRACK)	1104
2	115011-01-707	EA	SCREW F/TOWEL BAR	612F
3	115011-01-708	EA	SCREW F/TOWEL BAR BRKTS	638F
4	115011-01-705	EA	SCREW-ROLLER, (HEX HEAD)	832HEX
5	115011-01-700	EA	HEADER, W/O ANTI JUMP GUARD	120G
6	115011-01-710	EA	HEADER LOCK (ANTI JUMP) ADJ	130MIDDLE
6	115011-01-716	EA	GUARD-ANTI JUMP-W/O TENSION	130END
7	115011-01-704	EA	ROLLERS	PN193
8	115011-01-706	FT	GLAZING VINYL	C 169
9	115011-01-709	EA	TRACK-BOTTOM- 50"	90
10	115011-01-703	EA	BAR-TOWEL	136
11	115011-01-702	EA	BRACKET-TOWEL BAR	135
	115011-01-711	EA	KNOB-TENSION,(HEADER W/BOLT)	1420K-1420S
	115011-01-714	EA	BUMPER - RATTLE/SHOWER DOOR	5168S
	115011-01-715	EA	PAD - FOAM	116R

BEDROOM GROUP CABINETS

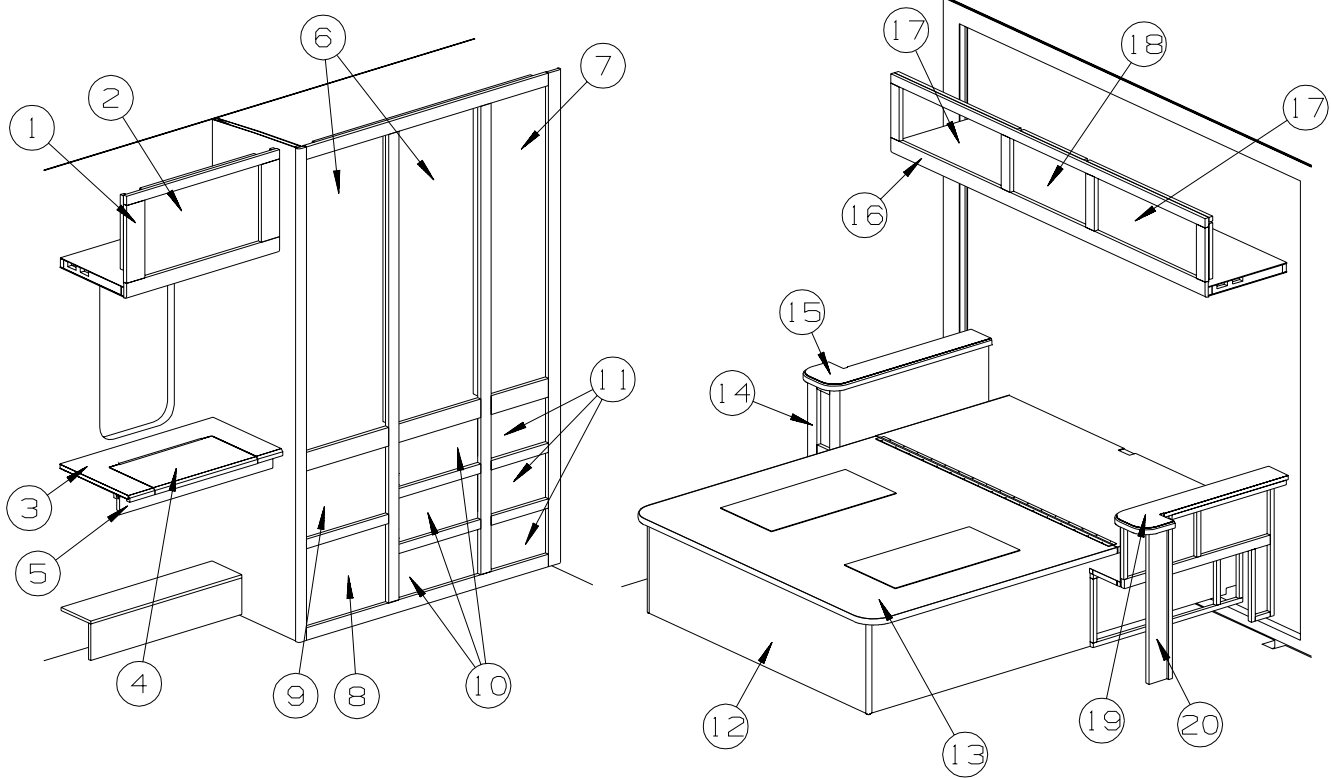

KEY	PART NUMBER	U/M	DESCRIPTION
1	141320-01-P13	EA	CABINET - OVERHEAD/VANITY - W/O DOORS/HARDWARE - PORTSMOUTH OAK
1	141320-01-P14	EA	CABINET - OVERHEAD/VANITY - W/O DOORS/HARDWARE - CONCERT CHERRY
1	141320-01-P33	EA	CABINET - OVERHEAD/VANITY - W/O DOORS/HARDWARE - WASHED MAPLE
1	141320-01-RW1	EA	CABINET - OVERHEAD/VANITY - W/O DOORS/HARDWARE - WASHED MAPLE FROM: 00-00-00 THRU: 01-04-04 FROM: 01-05-04 THRU: 99-99-99
2	141522-97-R19	EA	DOOR - ARCHED/PENCIL EDGE/HORIZ - 13.8" X 23.2" - W/O HDW - PORTSMOUTH OAK
2	141522-97-R20	EA	DOOR - ARCHED/PENCIL EDGE/HORIZ - 13.8" X 23.2" - W/O HDW - CONCERT CHERRY
2	141522-97-R21	EA	DOOR - ARCHED/PENCIL EDGE/HORIZ - 13.8" X 23.2" - W/O HDW - WASHED MAPLE
3	140889-03-P13	EA	COUNTERTOP - LAMINATED - GRAY TRANQUILITY/PORTSMOUTH OAK (R19)
3	140889-03-P14	EA	COUNTERTOP - LAMINATED - GRAY TRANQUILITY/CHERRY (R20)
3	140889-03-P33	EA	COUNTERTOP - LAMINATED (R21)
3	140889-03-R15	EA	COUNTERTOP - LAMINATED - LINO FRIEZE/PORTSMOUTH OAK (R22)
3	140889-03-R16	EA	COUNTERTOP - LAMINATED - LINO FRIEZE/CHERRY (R23)
3	140889-03-R24	EA	COUNTERTOP - LAMINATED - LINO FRIEZE/WASHED MAPLE (R24)
3	140889-03-R17	EA	COUNTERTOP - LAMINATED - ROCKY MOUNTAIN HIGH/PORTS OAK (R25)
3	140889-03-R18	EA	COUNTERTOP - LAMINATED - ROCKY MOUNTAIN HIGH/CHERRY (R26)
3	140889-03-R27	EA	COUNTERTOP - LAMINATED - ROCKY MOUNTAIN HIGH/WASHED MAPLE (R27)
4	140889-04-P13	EA	COUNTERTOP - LAMINATED - GRAY TRANQUILITY/PORTSMOUTH OAK (R19)
4	140889-04-P14	EA	COUNTERTOP - LAMINATED - GRAY TRANQUILITY/CHERRY (R20)
4	140889-04-P33	EA	COUNTERTOP - LAMINATED (R21)
4	140889-04-R15	EA	COUNTERTOP - LAMINATED - LINO FRIEZE/PORTSMOUTH OAK (R22)
4	140889-04-R16	EA	COUNTERTOP - LAMINATED - LINO FRIEZE/CHERRY (R23)
4	140889-04-R24	EA	COUNTERTOP - LAMINATED - LINO FRIEZE/WASHED MAPLE (R24)
4	140889-04-R17	EA	COUNTERTOP - LAMINATED - ROCKY MOUNTAIN HIGH/PORTS OAK (R25)
4	140889-04-R18	EA	COUNTERTOP - LAMINATED - ROCKY MOUNTAIN HIGH/CHERRY (R26)
4	140889-04-R27	EA	COUNTERTOP - LAMINATED - ROCKY MOUNTAIN HIGH/WASHED MAPLE (R27)
5	136937-01-M07	EA	DRAWER/VANITY - W/O COUNTERTOP/MIRROR - PORTSMOUTH OAK
5	136937-01-M08	EA	DRAWER/VANITY - W/O COUNTERTOP/MIRROR - CONCERT CHERRY
5	136937-01-M15	EA	DRAWER/VANITY - W/O COUNTERTOP/MIRROR - WASHED MAPLE
5	136937-01-RW1	EA	DRAWER/VANITY - W/O COUNTERTOP/MIRROR - WASHED MAPLE FROM: 00-00-00 THRU: 01-04-04 FROM: 01-05-04 THRU: 99-99-99
	140374-35-000	EA	MIRROR - SAFETY GLASS - 9" X 14.9"

BEDROOM GROUP (CONTINUED)
QUEEN CABINETS (CONTINUED)

KEY	PART NUMBER	U/M	DESCRIPTION
6	134786-02-N04	EA	DOOR - MIRROR/MITERED CORNERS - 16.7" X 47.9"-W/O HARDWARE - PORTSMOUTH OAK
6	134786-02-M16	EA	DOOR - MIRROR/MITERED CORNERS - 16.7" X 47.9"-W/O HARDWARE - CONCERT CHERRY
6	134786-02-M15	EA	DOOR - MIRROR/MITERED CORNERS - 16.7" X 47.9"-W/O HARDWARE - WASHED MAPLE FROM: 00-00-00 THRU: 01-04-04
6	134786-02-RW1	EA	DOOR - MIRROR/MITERED CORNERS - 16.7" X 47.9"-W/O HARDWARE - WASHED MAPLE FROM: 01-05-04 THRU: 99-99-99
6	076767-04-000	EA	CABLE - STAINLESS STEEL - 5.9"
7	141520-76-P54	EA	DOOR - ARCHED/PENCIL EDGE/RIGHT HAND -12"X48"- W/O HDW - PORTSMOUTH OAK
7	141520-76-P55	EA	DOOR - ARCHED/PENCIL EDGE/RIGHT HAND -12"X48"- W/O HDW - CONCERT CHERRY
7	141520-76-P56	EA	DOOR - ARCHED/PENCIL EDGE/RIGHT HAND -12"X48"- W/O HDW - WASHED MAPLE
8	145386-34-R19	EA	DRAWER - PENCIL EDGE-15.1"W X 13.8"D - W/O SLIDES HARDWARE - PORTSMOUTH OAK
8	145386-34-R20	EA	DRAWER - PENCIL EDGE-15.1"W X 13.8"D - W/O SLIDES HARDWARE - CONCERT CHERRY
8	145386-34-R21	EA	DRAWER - PENCIL EDGE - 15.1"W X 13.8"D-W/O SLIDES/HARDWARE - WASHED MAPLE
9	145492-A0-R19	EA	DRAWER - PENCIL EDGE - 14.7"W X 17.7"D - W/O SLIDES/HDW - PORTSMOUTH OAK
9	145492-A0-R20	EA	DRAWER - PENCIL EDGE - 14.7"W X 17.7"D - W/O SLIDES/HDW - CONCERT CHERRY
9	145492-A0-R21	EA	DRAWER - PENCIL EDGE - 14.7"W X 17.7"D-W/O SLIDES/HARDWARE - WASHED MAPLE
10	145492-50-R10	EA	DRAWER - PENCIL EDGE - 14.6"W X 17.7"D-W/O SLIDES/HARDWARE - PORTSMOUTH OAK
10	145492-50-R20	EA	DRAWER - PENCIL EDGE - 14.6"W X 17.7"D - W/O SLIDES/HDW - CONCERT CHERRY
10	145492-50-R21	EA	DRAWER - PENCIL EDGE - 14.6"W X 17.7"D-W/O SLIDES/HARDWARE - WASHED MAPLE
11	145492-P4-R38	EA	DRAWER - PENCIL EDGE - 9.8"W X 11.8"D - W/O SLIDES/HDW - PORTSMOUTH OAK
11	145492-P4-R39	EA	DRAWER - PENCIL EDGE - 9.8"W X 11.8"D - W/O SLIDES/HDW - CONCERT CHERRY
11	145492-P4-R21	EA	DRAWER - PENCIL EDGE - 9.8"W X 11.8"D-W/O SLIDES/HARDWARE - WASHED MAPLE
12	140655-03-R13	EA	CABINET/BASE - W/O DOORS/HARDWARE - QUEEN BED - PORTSMOUTH OAK
12	140655-03-R14	EA	CABINET/BASE - W/O DOORS/HARDWARE - QUEEN BED - CONCERT CHERRY
12	140655-03-R21	EA	CABINET/BASE - W/O DOORS/HARDWARE - QUEEN BED - WASHED MAPLE FROM: 00-00-00 THRU: 01-04-04
12	140655-03-RW1	EA	CABINET/BASE - W/O DOOR/HARDWARE - F/QUEEN BED - WASHED MAPLE FROM: 01-05-04 THRU: 99-99-99
13	137406-05-P13	EA	BEDBOARD - W/HINGE/T-MOLDING/SLIPNOT - FLIP-UP
14	136885-10-N09	EA	CABINET - NIGHTSTAND - W/O COUNTERTOP/DOOR/DRAWER/HARDWARE - PORTSMOUTH OAK
14	136885-10-N10	EA	CABINET - NIGHTSTAND - W/O COUNTERTOP/DOOR/DRAWER/HARDWARE - CONCERT CHERRY
14	136885-10-N15	EA	CABINET - NIGHTSTAND - W/O COUNTERTOP/DOOR/DRAWER/HARDWARE - WASHED MAPLE FROM: 00-00-00 THRU: 01-04-04
14	136885-10-RW1	EA	CABINET - NIGHTSTAND - W/O COUNTERTOP/DOOR/DRAWER/HARDWARE - WASHED MAPLE FROM: 01-05-04 THRU: 99-99-99
15	140888-08-P13	EA	COUNTERTOP - LAMINATED - GRAY TRANQUILITY/PORTSMOUTH OAK (R19)
15	140888-08-P14	EA	COUNTERTOP - LAMINATED - GRAY TRANQUILITY/CHERRY (R20)
15	140888-08-P33	EA	COUNTERTOP - LAMINATED - GRAY TRANQUILITY/WASHED MAPLE (R21) FROM: 00-00-00 THRU: 01-04-04
15	140888-08-RW1	EA	COUNTERTOP - LAMINATED (R21) FROM: 01-05-04 THRU: 99-99-99
15	140888-08-R09	EA	COUNTERTOP - LAMINATED - LINO FRIEZE/PORTSMOUTH OAK (R22)
15	140888-08-R16	EA	COUNTERTOP - LAMINATED - LINO FRIEZE/CHERRY (R23)
15	140888-08-R24	EA	COUNTERTOP - LAMINATED - LINO FRIEZE (R24) FROM: 00-00-00 THRU: 01-04-04
15	140888-08-RW2	EA	COUNTERTOP - LAMINATED (R24) FROM: 01-05-04 THRU: 99-99-99
15	140888-08-R17	EA	COUNTERTOP - LAMINATED - ROCKY MOUNTAIN HIGH/PORTS OAK (R25)
15	140888-08-R18	EA	COUNTERTOP - LAMINATED - ROCKY MOUNTAIN HIGH/CHERRY (R26)
15	140888-08-R27	EA	COUNTERTOP - LAMINATED - ROCKY MOUNTAIN HIGH/WASHED MAPLE (R27) FROM: 00-00-00 THRU: 01-04-04
15	140888-08-RW3	EA	COUNTERTOP - LAMINATED (R27) FROM: 01-05-04 THRU: 99-99-99
16	136936-01-P13	EA	CABINET - OVERHEAD/REAR - W/O DOORS/HARDWARE - PORTSMOUTH OAK
16	136936-01-P14	EA	CABINET - OVERHEAD/REAR - W/O DOORS/HARDWARE - CONCERT CHERRY
16	136936-01-P33	EA	CABINET - OVERHEAD/REAR - W/O DOORS/HARDWARE - WASHED MAPLE FROM: 00-00-00 THRU: 01-04-04
16	136936-01-RW1	EA	CABINET - OVERHEAD/REAR - W/O DOORS/HARDWARE - WASHED MAPLE FROM: 01-05-04 THRU: 99-99-99
17	141522-25-P54	EA	DOOR - ARCHED/PENCIL EDGE/HORIZ - 10" X 25.2" - W/O HDW - PORTSMOUTH OAK
17	141522-25-P55	EA	DOOR - ARCHED/PENCIL EDGE/HORIZ - 10" X 25.2" - W/O HDW - CONCERT CHERRY
17	141522-25-P56	EA	DOOR - ARCHED/PENCIL EDGE/HORIZ - 10" X 25.2" - W/O HDW - WASHED MAPLE

BEDROOM GROUP (CONTINUED)
QUEEN CABINETS (CONTINUED)

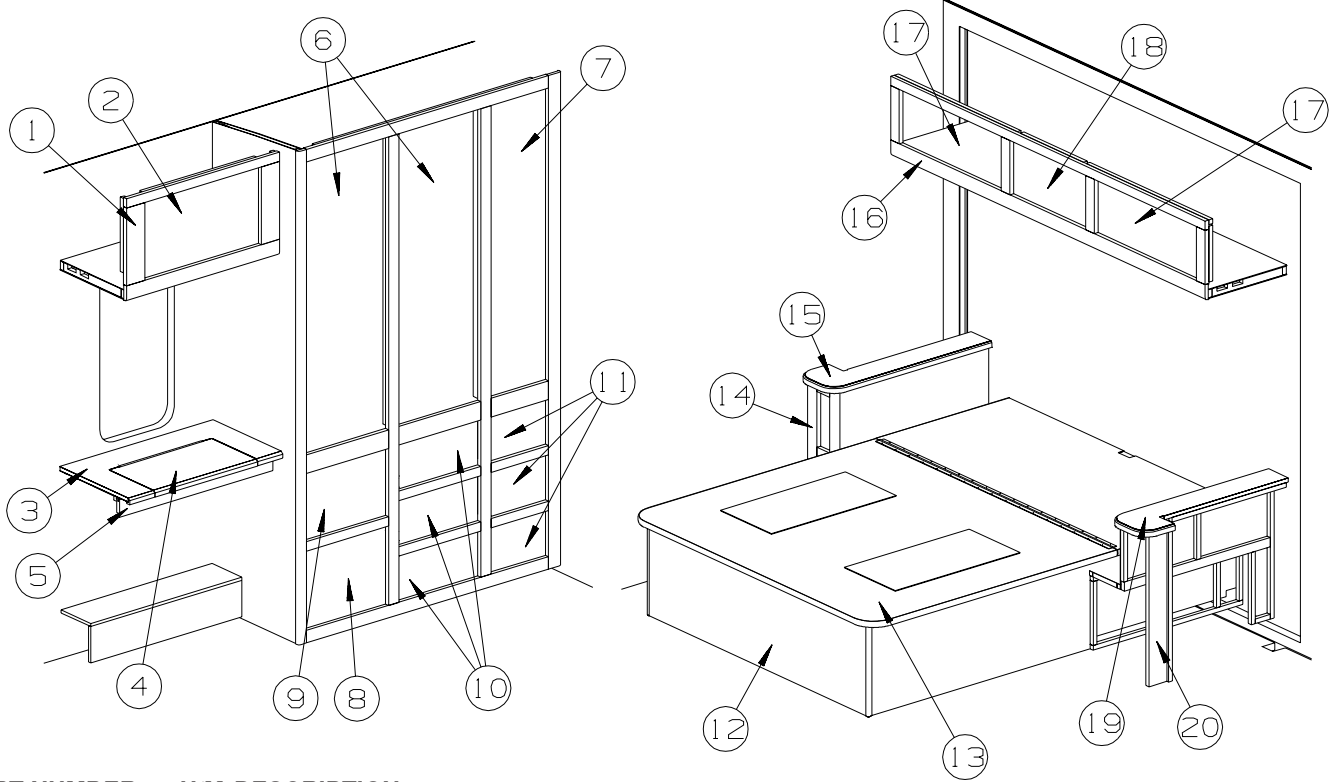

KEY	PART NUMBER	U/M	DESCRIPTION
18	141522-22-R74	EA	DOOR - ARCHED/PENCIL EDGE/HORIZ - 10" X 19.1" - W/O HDW - PORTSMOUTH OAK
18	141522-22-R75	EA	DOOR - ARCHED/PENCIL EDGE/HORIZ - 10" X 19.1" - W/O HDW - CONCERT CHERRY
18	141522-22-R76	EA	DOOR - ARCHED/PENCIL EDGE/HORIZ - 10" X 19.1" - W/O HDW - WASHED MAPLE
19	140888-09-P13	EA	COUNTERTOP - LAMINATED - GRAY TRANQUILITY/PORTSMOUTH OAK (R19)
19	140888-09-P14	EA	COUNTERTOP - LAMINATED - GRAY TRANQUILITY/CHERRY (R20)
19	140888-09-P33	EA	COUNTERTOP - LAMINATED - GRAY TRANQUILITY/WASHED MAPLE (R21) FROM: 00-00-00 THRU: 01-04-04
19	140888-09-RW1	EA	COUNTERTOP - LAMINATED (R21) FROM: 01-05-04 THRU: 99-99-99
19	140888-09-R15	EA	COUNTERTOP - LAMINATED - LINO FRIEZE/PORTSMOUTH OAK (R22)
19	140888-09-R16	EA	COUNTERTOP - LAMINATED - LINO FRIEZE/CHERRY (R23)
19	140888-09-R24	EA	COUNTERTOP - LAMINATED - LINO FRIEZE (R24) FROM: 00-00-00 THRU: 01-04-04
19	140888-09-RW2	EA	COUNTERTOP - LAMINATED (R24) FROM: 01-05-04 THRU: 99-99-99
19	140888-09-R17	EA	COUNTERTOP - LAMINATED - ROCKY MOUNTAIN HIGH/PORTS OAK (R25)
19	140888-09-R18	EA	COUNTERTOP - LAMINATED - ROCKY MOUNTAIN HIGH/CHERRY (R26)
19	140888-09-R27	EA	COUNTERTOP - LAMINATED - ROCKY MOUNTAIN HIGH/WASHED MAPLE (R27) FROM: 00-00-00 THRU: 01-04-04
19	140888-09-RW3	EA	COUNTERTOP - LAMINATED (R27) FROM: 01-05-04 THRU: 99-99-99
20	136885-A0-N09	EA	CABINET - NIGHTSTAND - W/O COUNTERTOP/DOOR/DRAWER/HARDWARE - PORTSMOUTH OAK
20	136885-A0-N10	EA	CABINET - NIGHTSTAND - W/O COUNTERTOP/DOOR/DRAWER/HARDWARE - CONCERT CHERRY
20	136885-A0-N15	EA	CABINET - NIGHTSTAND - W/O COUNTERTOP/DOOR/DRAWER/HARDWARE - WASHED MAPLE FROM: 00-00-00 THRU: 01-04-04
20	136885-A0-RW1	EA	CABINET - NIGHTSTAND - W/O COUNTERTOP/DOOR/DRAWER/HARDWARE - WASHED MAPLE FROM: 01-05-04 THRU: 99-99-99

BEDROOM GROUP (CONTINUED)
QUEEN CABINETS (CONTINUED)

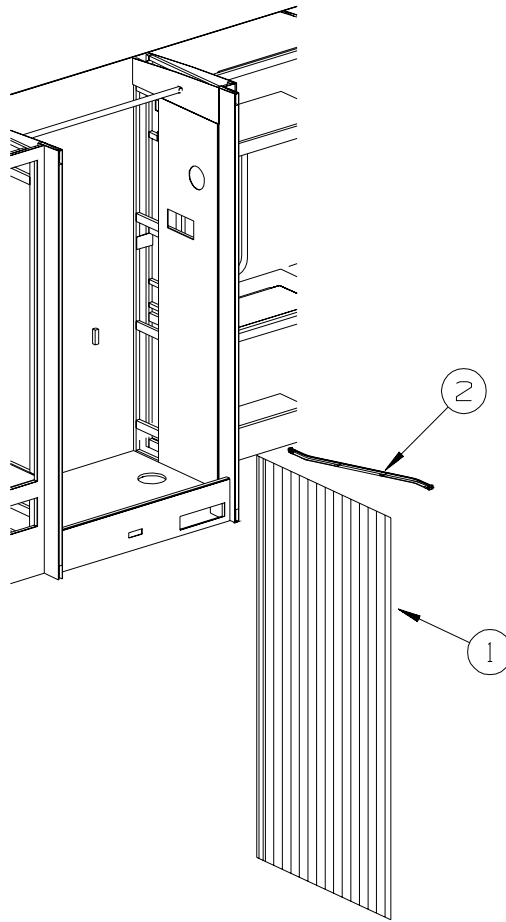

KEY	PART NUMBER	U/M	DESCRIPTION
1*	131595-01-01A	EA	DOOR/FOLDING- 37" X 74.9"-4 CEILING BRKTS & STRAIGHT TRACK
2	131595-07-01A	EA	TRACK - DOOR - CURVED/RIGHT - 28.5"

***COMPONENT PARTS LISTED LATER IN THIS GROUP**

BEDROOM GROUP (CONTINUED)
COMPONENT PARTS FOR QUEEN CABINETS

131595-01-01A, 131595-05-01A, 131595-10-01A

KEY	PART NUMBER	U/M	DESCRIPTION	VENDOR NO.
	117431-01-707	EA	CATCH/PIN - PLASTIC	
	131595-01-700	EA	END STOP ONLY	
	131595-01-701	EA	BRACKET/MOUNTING	908956
	131595-01-702	EA	TRACK/STRAIGHT - 37"	

CHASSIS GROUP FRAME

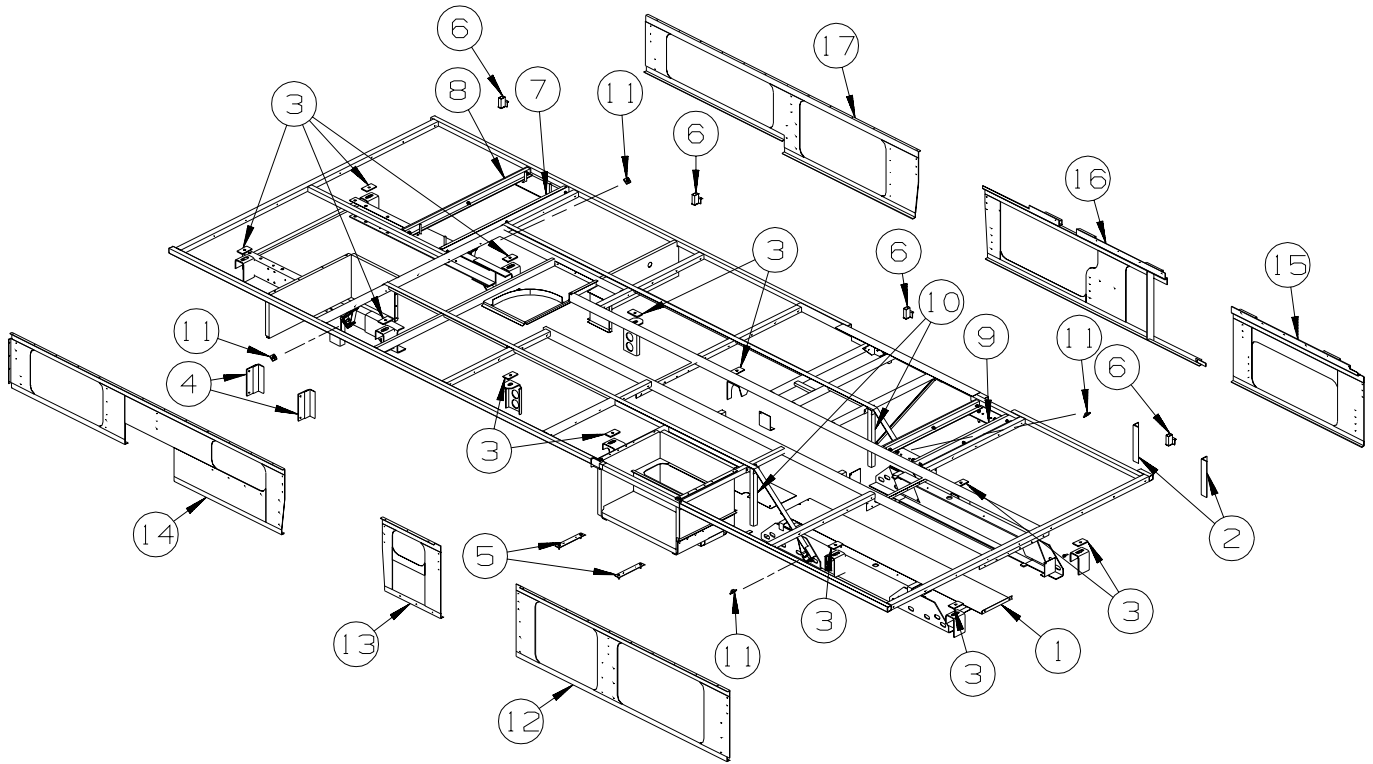

KEY	PART NUMBER	U/M	DESCRIPTION
1	135676-04-02B	EA	SHIELD - HEAT - E-COAT
2	143953-01-02B	EA	ANGLE - GENERATOR MOUNT - E-COATED
3	135712-01-02B	EA	PLATE - BODY MOUNT - E-COATED
4	136042-01-02B	EA	BRACKET - LP SUPPORT - E-COATED
5	143130-02-02B	EA	PLATE - BACKING - RIGHT/LEFT - E-COATED
6	136780-02-02B	EA	ADJUSTER - SLIDE - E-COATED
7	143020-02-02B	EA	FRAME - F/SLIDEOUT MECHANISM - E-COATED
8	143019-01-01B	EA	ZEE - BRACKET - SLIDEOUT
9	143020-01-02B	EA	FRAME - SLIDEOUT/MECHANISM - E-COATED
10	143275-01-02B	EA	TRUSS SUPPORT - E-COATED
11	141901-02-02B	EA	PLATE - TIE DOWN - E-COATED
12	146231-13-01A	EA	SEAL PLANE
13	146231-14-01A	EA	SEAL PLANE
14	146231-15-01A	EA	SEAL PLANE
15	146231-16-01A	EA	SEAL PLANE
16	146231-18-01A	EA	SEAL PLANE
17	146231-17-01A	EA	SEAL PLANE

CHASSIS GROUP (CONTINUED)
DRIVETRAIN

KEY	PART NUMBER	U/M	DESCRIPTION
	103653-23-000	EA	BOLT - U-JOINT - 5/16-24 X .75 - 430V, 431C
	103653-24-000	EA	STRAP - U-JOINT - 430V, 431C
	131694-09-000	EA	DRIVESHAFT ASSEMBLY - BALANCED PAIR - 190" WHEELBASE - 427P
	131695-05-000	EA	DRIVESHAFT - 3 BALANCED - 205" WHEELBASE - 430V
	131695-08-000	EA	DRIVESHAFT - 3 BALANCED - 216" WHEELBASE - 431C

CHASSIS GROUP (CONTINUED)

EXHAUST

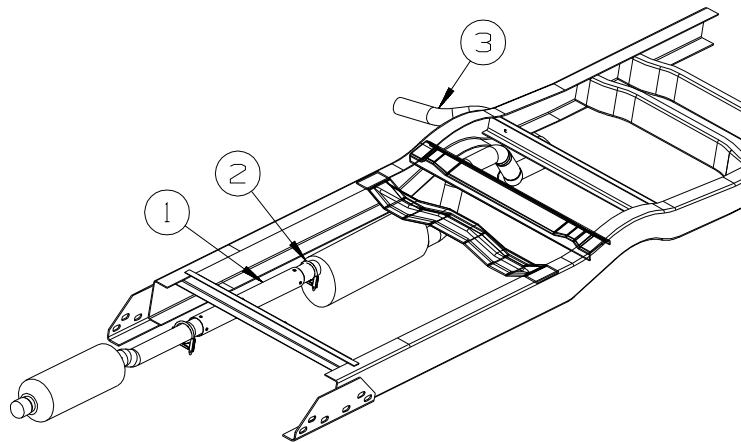

427P

KEY	PART NUMBER	U/M DESCRIPTION
1	111478-02-000	EA EXHAUST PIPE - DOUBLE WALL STAINLESS STEEL - 34" - GAS
2	094918-06-000	EA CLAMP - EXHAUST - 3" - HEAVY DUTY
3	129846-02-000	EA PIPE - EXHAUST - TAIL - 3"

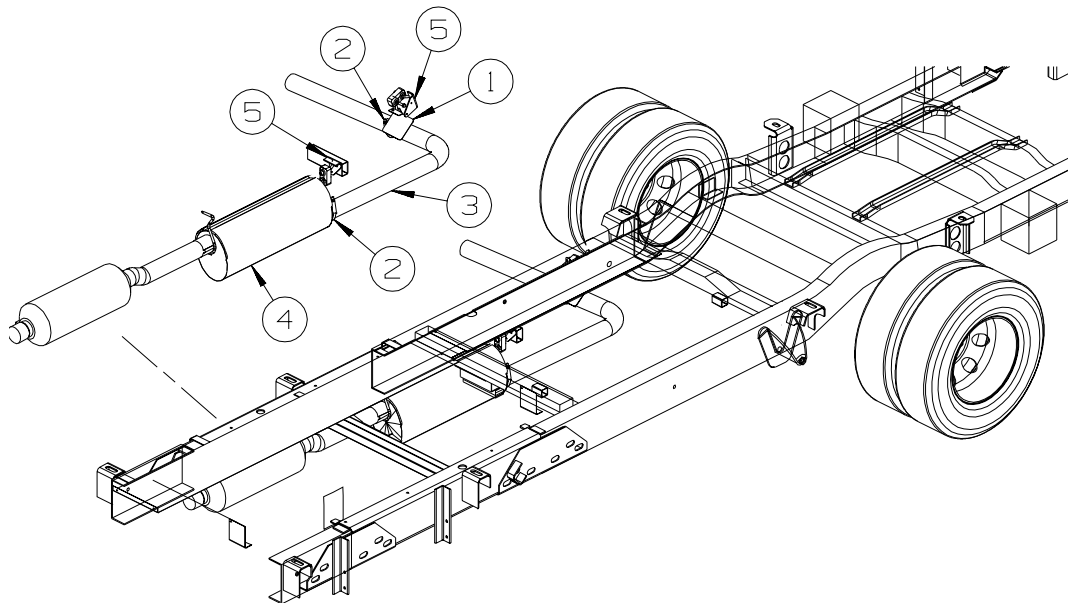

430V

KEY	PART NUMBER	U/M DESCRIPTION
1	143138-02-02B	EA SHIELD - EXHAUST - E-COATED
2	122392-02-02B	EA HANGER - TAILPIPE - E-COATED
3	143927-01-000	EA PIPE - EXHAUST - TAIL
4	143929-01-000	EA MUFFLER - EXHAUST
5	143811-02-000	EA HANGER - EXHAUST - FORD F53

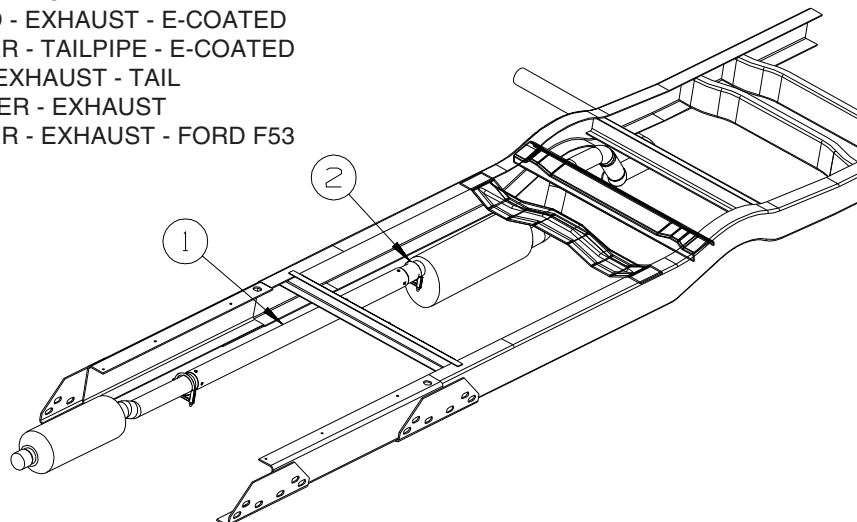

431C

KEY	PART NUMBER	U/M DESCRIPTION
1	111478-05-000	EA EXHAUST PIPE - DOUBLE WALL STAINLESS STEEL
2	094918-06-000	EA CLAMP - EXHAUST - 3" - HEAVY DUTY

CHASSIS GROUP (CONTINUED)

HITCH

KEY	PART NUMBER	U/M DESCRIPTION
	130339-11-000	EA HITCH RECEIVER - BOLT ON CLASS III

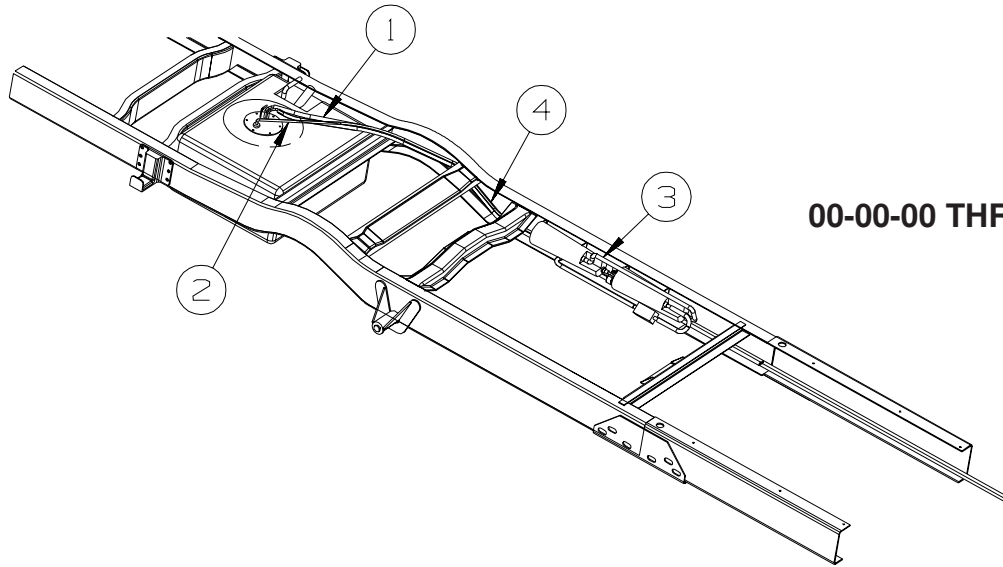

00-00-00 THRU 10-16-03

FUEL

KEY	PART NUMBER	U/M DESCRIPTION
1	106389-11-000	EA FUEL LINE - FORD - 3/8 HP - FORD
2	125187-01-000	FT HOSE - FUEL - LOW PERMEABILITY - .4" ID - FORD
3	125187-02-000	FT HOSE - FUEL - LOW PERMEABILITY - .5" ID - FORD
4	106388-11-000	EA FUEL LINE - FORD - 5/16 HP - FORD
	128139-03-000	FT HOSE - FUEL - LOW PERMEABILITY - 1/4" DIAMETER

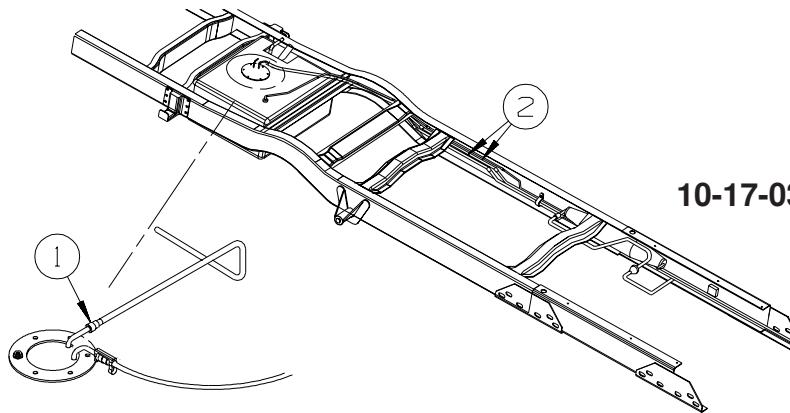

10-17-03 THRU 99-99-99

KEY	PART NUMBER	U/M DESCRIPTION
1	149468-01-000	EA FITTING - F/FUEL-SENDING UNIT - 1/4"
2	106388-11-000	EA FUEL LINE - FORD - 5/16 HP - FORD E350

**CHASSIS GROUP (CONTINUED)
FUEL (CONTINUED)**

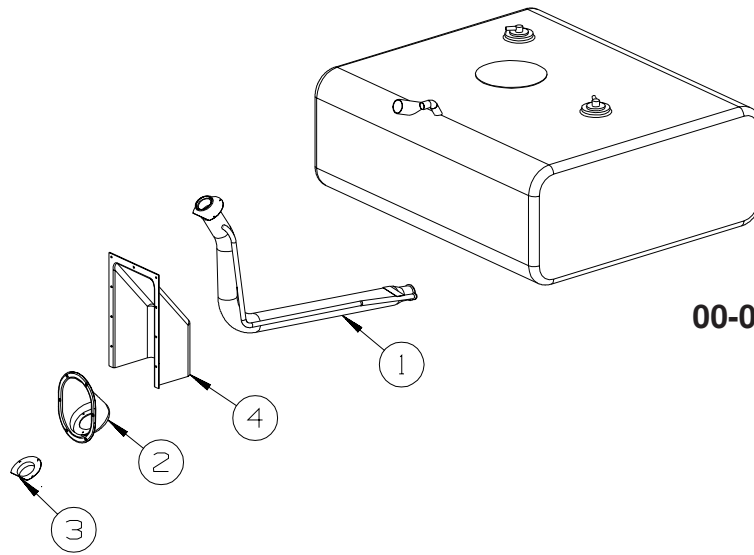

00-00-00 THRU 10-16-03

KEY	PART NUMBER	U/M	DESCRIPTION
1	144751-01-000	EA	NECK - FUEL FILL
2	127291-02-01A	EA	SHROUD - FUEL FILL - BRIGHT WHITE
3	078200-01-000	EA	GASKET - FUEL FILL - 3.5"OD X 2"ID
4	078040-09-000	EA	SHROUD - FUEL FILL - UPPER - RECTANGULAR

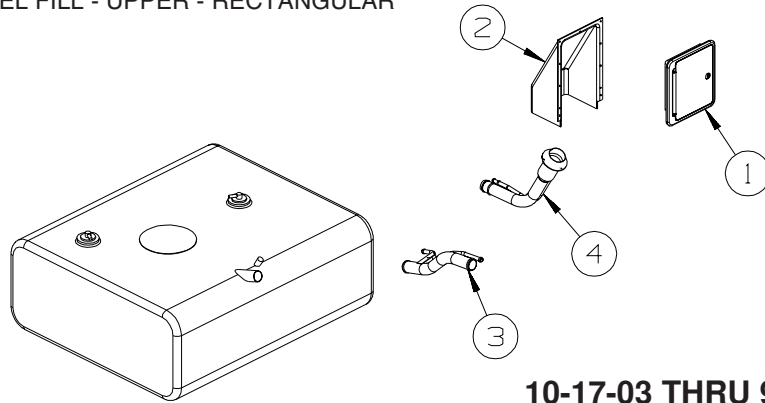

10-17-03 THRU 99-99-99

KEY	PART NUMBER	U/M	DESCRIPTION
1	147587-01-01A	EA	DOOR - FUEL FILL
2	135557-02-01A	EA	SHROUD - FUEL FILL - UPPER
3	148779-02-000	EA	NECK - FILLER/MAIN/EXTENSION
4	148789-01-000	EA	NECK - FUEL FILL

CHASSIS GROUP (CONTINUED) SPARE TIRE

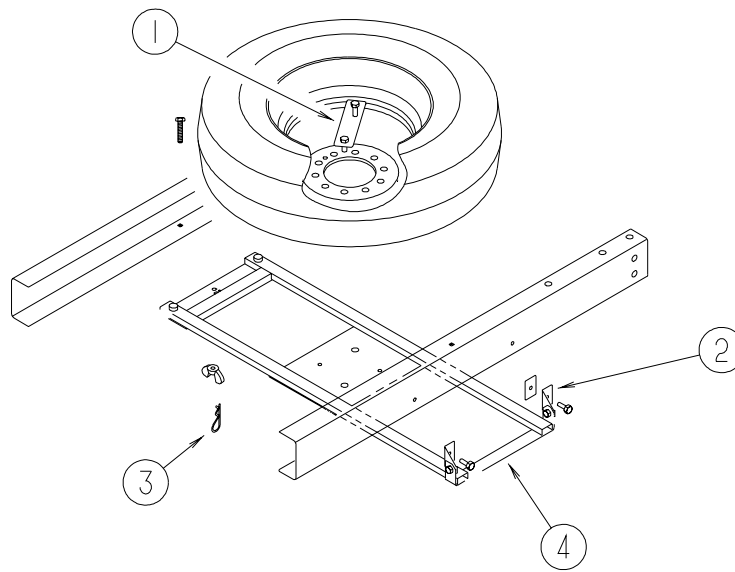

KEY	PART NUMBER	U/M	DESCRIPTION
1	116338-02-02B	EA	BRACKET/CLAMP - SPARE TIRE - E-COATED
2	116349-03-02B	EA	BRACKET/HINGE - SPARE TIRE - 2.4" - E-COATED - 427P, 431C
2	116349-04-02B	EA	BRACKET - HINGE - SPARE TIRE - E-COATED - 430V
3	034513-01-000	EA	PIN - HITCH - 3/16" WIRE
4	141986-01-02B	EA	CRADLE - SPARE TIRE - E-COATED
	069726-02-000	EA	BUMPER - .88" OD X .40" THICK - BLACK

SUSPENSION

KEY	PART NUMBER	U/M	DESCRIPTION
*	144887-01-000	EA	AIRSPRING - 4" DIAMETER TWIN

***COMPONENT PARTS LISTED LATER IN THIS GROUP**

CHASSIS GROUP (CONTINUED)
COMPONENT PARTS FOR SUSPENSION

144887-01-000

KEY	PART NUMBER	U/M	DESCRIPTION	VENDOR NO.
	144887-01-700	EA	BAG KIT - PASS - W/AIR LINE/FILL VALVE	T-9RKFH4WP
	144887-01-701	EA	BAG KIT - DR- W/AIR LINE/FILL VALVE	T-9RKFH4WD
	144887-01-702	EA	AIR LINE KIT - PASS - W/FILL VALVE	T-9FH4WALKP
	144887-01-703	EA	AIR LINE KIT - PR - W/FILL VALVE	T-9FH4WALKD

CHASSIS GROUP (CONTINUED)
WHEEL, TIRE, COVERS &/OR LINERS

KEY	PART NUMBER	U/M	DESCRIPTION
	112358-01-000	EA	WRENCH - LUG - 7/8" - L-SHAPE
*	109443-05-000	EA	WHEEL COVER - 4/SET - 16" STAINLESS STEEL - 8 LUG
	083425-14-000	EA	TIRE - LT225/75R16 LRE - MICHELIN LTX M/S
	083617-04-000	EA	WHEEL - STEEL - 6" X 16"
*	110435-13-000	EA	LINER - WHEEL - SET OF 4 - 16" (8 HOLE)
	077030-01-000	EA	EXTENSION - VALVE STEM - 1.25" - METAL
	095012-05-000	EA	EXTENSION/VALVE STEM - LIVE - 5"
	095012-06-000	EA	STABILIZER/VALVE EXTENSION - LIVE - 2"
	051377-04-000	EA	VALVE STEM - .5" X 2"

***COMPONENT PARTS LISTED LATER IN THIS GROUP**

CHASSIS GROUP (CONTINUED)
COMPONENT PARTS FOR WHEEL, TIRE, COVERS &/OR LINERS

109443-05-000

KEY	PART NUMBER	U/M	DESCRIPTION	VENDOR NO.
	098532-01-700	EA	COVER-LUG NUT (CHROME)	SHAU-LNC
	109443-05-700	EA	COVER-WHEEL, 16" SS EA=1	SHFM16-CVR

110435-13-000

KEY	PART NUMBER	U/M	DESCRIPTION	VENDOR NO.
	110435-01-711	EA	DECAL-CENTER CAP, 2"	2" DECAL
	110435-10-705	EA	TOOL - INSTALLATION	V195P7-TOL
	110435-13-700	EA	LINER - WHEEL - FRONT	V160F7-FWC
	110435-13-701	EA	LINER - WHEEL - REAR	V160F7-RWC
	110435-13-702	EA	COVER-LUG NUT W/JAMB NUT FT	V160F7-EJN

CHASSIS GROUP (CONTINUED)
BRAKELINE

KEY	PART NUMBER	U/M	DESCRIPTION
	088498-01-000	EA	UNION - INVERTED FLARE - BRASS - 3/16

CURTAIN & CUSHION GROUP

NOTICE

IN ORDER TO ASSIST OUR PARTS SALES DEPT. IN PROVIDING INTERIOR SOFTWARE ITEMS, PLEASE INCLUDE THE SERIAL NUMBER AND THE COLOR CODE NUMBER FROM THE VEHICLE CERTIFICATION LABEL WHEN ORDERING. THIS LABEL IS LOCATED ON THE LEFT SIDEWALL AT THE END OF THE DASH (A-BODY), OR ON THE DRIVER'S DOOR LATCH PLATE (C-BODY).

AN EXAMPLE OF A COLOR CODE NUMBER IS B07, WHICH DESIGNATES AN OVERALL COLOR SCHEME OF A PARTICULAR UNIT. THE COLOR LISTED AFTER THE ITEM DESCRIPTION ON THE MICROFICHE, INDICATES THE OVERALL UNIT COLOR. ORDER THE ITEM YOU DESIRE ACCORDING TO UNIT COLOR CODE. IF ALL COLORS USE THE SAME ITEM NO COLOR CODE WILL BE NOTED.

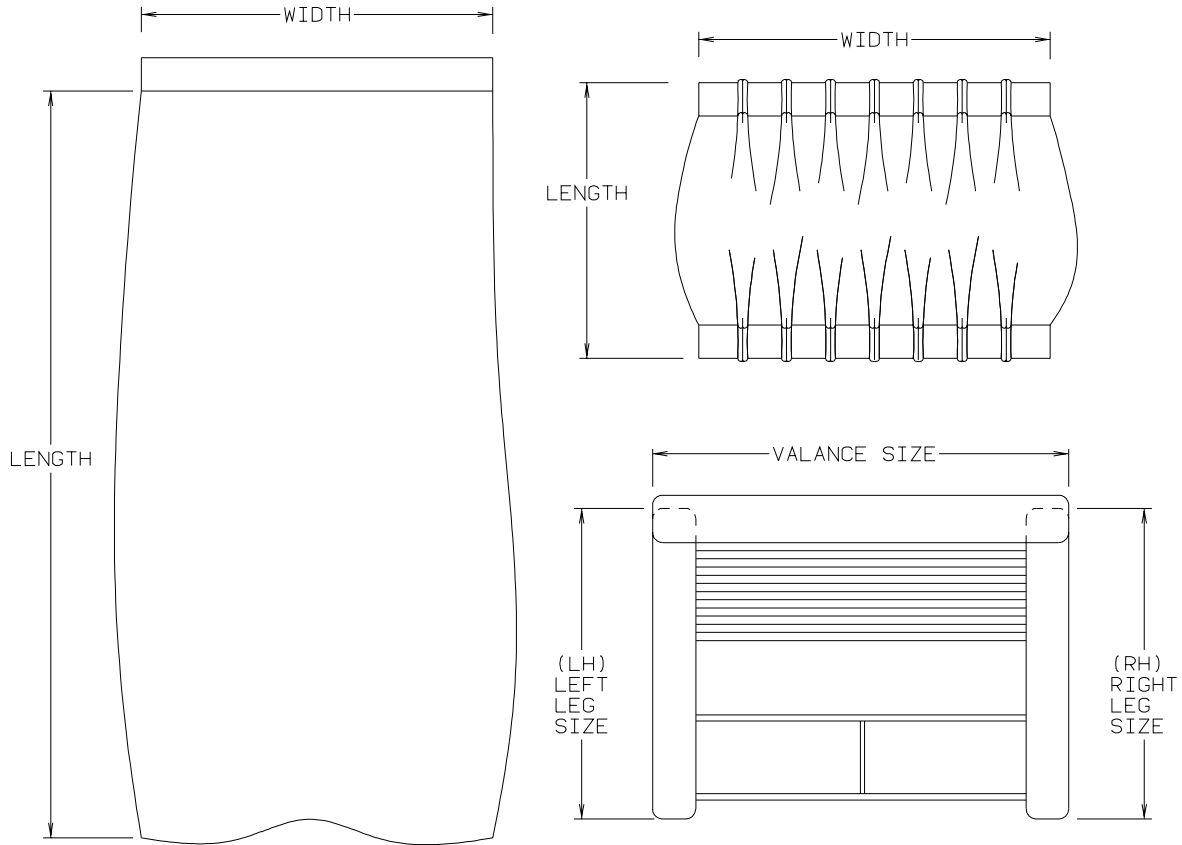

NOTE: USE THIS ILLUSTRATION WHEN DETERMINING LENGTH AND WIDTH MEASUREMENTS FOR CURTAINS. YOU WILL NOTE THE WIDTH MEASUREMENT IS TAKEN ON THE TOP OF THE CURTAIN WITH THE CURTAIN FULLY EXTENDED. THE LENGTH MEASUREMENT IS TAKEN FROM TOP TO BOTTOM. LEFT AND RIGHT WINDOW LEGS ARE DETERMINED WHEN FACING THE WINDOW.

CURTAIN & CUSHION GROUP (CONTINUED)

CUSHION LAYOUT

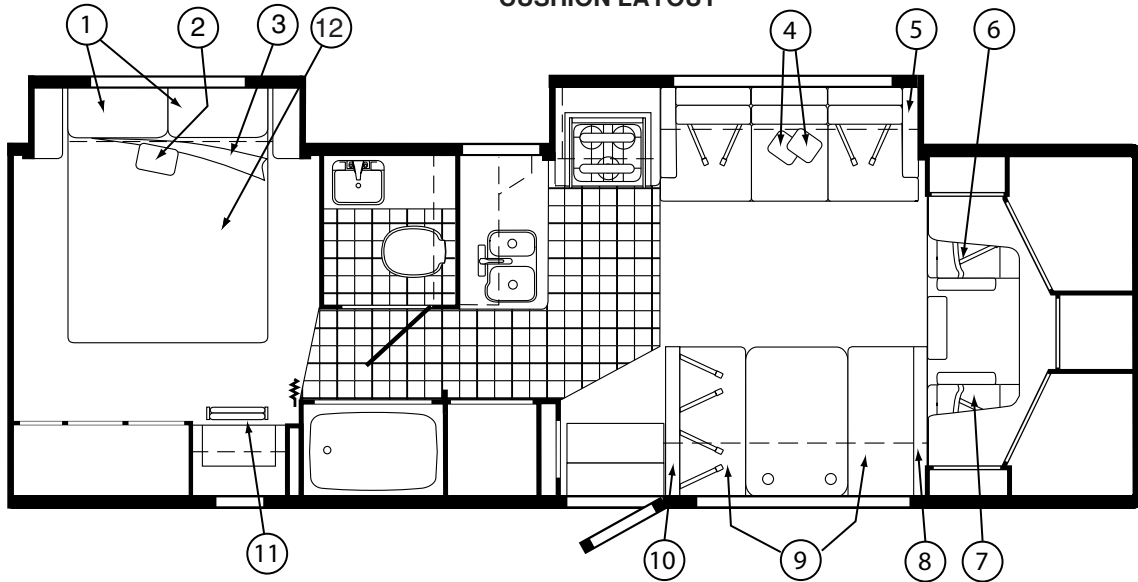

KEY	PART NUMBER	U/M	DESCRIPTION
1	142405-02-P60	EA	PILLOW SHAM (R19, R20, R21)
1	142405-02-P21	EA	PILLOW SHAM (R22, R23, R24)
1	142405-02-R25	EA	PILLOW SHAM (R25, R26, R27)
2	132338-28-P60	EA	PILLOW - 10" X 17" (R19, R20, R21)
2	132338-28-P21	EA	PILLOW - 10" X 17" (R22, R23, R24)
2	132338-28-R25	EA	PILLOW - 10" X 17" (R25, R26, R27)
3	132336-05-R50	EA	BEDSPREAD/CAP - 60" X 75" (R19, R20, R21)
3	132336-05-R47	EA	BEDSPREAD/CAP - 60" X 75" (R22, R23, R24)
3	132336-05-R25	EA	BEDSPREAD/CAP - 60" X 75" (R25, R26, R27)
4	132319-48-P60	EA	PILLOW - 17" - W/FROWN OVERLAY (R19, R20, R21)
4	132319-48-R22	EA	PILLOW - 17" - W/FROWN OVERLAY (R22, R23, R24)
4	132319-65-R25	EA	PILLOW - 17" - W/FROWN OVERLAY (R25, R26, R27)
5			SEE SOFA AREA
6	136590-15-R19	EA	BUCKET SEAT - DRIVER - W/LUMBAR (R19, R20, R21)
6	136590-15-P21	EA	BUCKET SEAT - DRIVER - W/LUMBAR (R22, R23, R24)
6	136590-15-R25	EA	BUCKET SEAT - DRIVER - W/LUMBAR (R25, R26, R27)
6	136590-17-P19	EA	BUCKET SEAT - DRIVER - W/LUMBAR - LEATHER - ULTRALEATHER
7	136590-16-R19	EA	BUCKET SEAT - PASSENGER (R19, R20, R21)
7	136590-16-P21	EA	BUCKET SEAT - PASSENGER (R22, R23, R24)
7	136590-16-R25	EA	BUCKET SEAT - PASSENGER (R25, R26, R27)
7	136590-18-P19	EA	BUCKET SEAT - PASSENGER - LEATHER - ULTRALEATHER
8	142291-04-R19	EA	BACK - DINETTE CUSHION - LEFT - 12.5" X 42" (R19, R20, R21)
8	142291-04-P21	EA	BACK - DINETTE CUSHION - LEFT - 12.5" X 42" (R22, R23, R24)
8	142291-10-R25	EA	BACK - DINETTE CUSHION - LEFT - 12.5" X 42" (R25, R26, R27)
	P42291-04-R19	EA	COVER/BACK - DINETTE CUSHION - LEFT - 12.5" X 42" (R19, R20, R21)
	P42291-04-P21	EA	COVER/BACK - DINETTE CUSHION - LEFT - 12.5" X 42" (R22, R23, R24)
	P42291-10-R25	EA	COVER/BACK - DINETTE CUSHION - LEFT - 12.5" X 42" (R25, R26, R27)
9	142292-06-R19	EA	SEAT - DINETTE CUSHION (SPRUNG) - 22" X 37" (R19, R20, R21)
9	142292-06-P21	EA	SEAT - DINETTE CUSHION (SPRUNG) - 22" X 37" (R22, R23, R24)
9	142292-08-R25	EA	SEAT - DINETTE CUSHION (SPRUNG) - 22" X 37" (R25, R26, R27)
	P42292-06-R19	EA	COVER/SEAT - DINETTE CUSHION (SPRUNG) - 22" X 37" (R19, R20, R21)
	P42292-06-P21	EA	COVER/SEAT - DINETTE CUSHION (SPRUNG) - 22" X 37" (R22, R23, R24)
	P42292-08-R25	EA	COVER/SEAT - DINETTE CUSHION (SPRUNG) - 22" X 37" (R25, R26, R27)
	142366-03-000	EA	FRAME - SPRUNG - DINETTE SEAT
10	142291-03-R19	EA	BACK - DINETTE CUSHION - RIGHT - 12.5" X 42" (R19, R20, R21)
10	142291-03-P21	EA	BACK - DINETTE CUSHION - RIGHT - 12.5" X 42" (R22, R23, R24)
10	142291-09-R25	EA	BACK - DINETTE CUSHION - RIGHT - 12.5" X 42" (R25, R26, R27)
	P42291-03-R19	EA	COVER/BACK - DINETTE CUSHION - RIGHT - 12.5" X 42" (R19, R20, R21)
	P42291-03-P21	EA	COVER/BACK - DINETTE CUSHION - RIGHT - 12.5" X 42" (R22, R23, R24)
	P42291-09-R25	EA	COVER/BACK - DINETTE CUSHION - RIGHT - 12.5" X 42" (R25, R26, R27)

CURTAIN & CUSHION GROUP (CONTINUED)
CUSHION LAYOUT (CONTINUED)

KEY	PART NUMBER	U/M	DESCRIPTION
11	135600-B3-000	EA	CHAIR - FOLDING - HIGH HEEL/PORTSMOUTH OAK (R19)
11	135600-B4-000	EA	CHAIR - FOLDING - HIGH HEEL/CHERRY (R20)
11	135600-B5-000	EA	CHAIR - FOLDING - HIGH HEEL/WASHED MAPLE (R21)
11	135600-95-000	EA	CHAIR - FOLDING - DESTIN/PORTSMOUTH OAK (R22)
11	135600-96-000	EA	CHAIR - FOLDING - DESTIN/CHERRY (R23)
11	135600-97-000	EA	CHAIR - FOLDING - DESTIN/WASHED MAPLE (R24)
11	135600-L1-000	EA	CHAIR - FOLDING - SAGE/PORTSMOUTH OAK (R25)
11	135600-L2-000	EA	CHAIR - FOLDING - SAGE/CONCERT CHERRY (R26)
11	135600-L3-000	EA	CHAIR - FOLDING - SAGE/WASHED MAPLE (R27)
12	142411-04-000	EA	MATTRESS/AIR - 60" X 75" - SELECT COMFORT
	142411-03-000	EA	AIR PUMP W/CONTROLS - F/SELECT COMFORT MATTRESS

CURTAIN & CUSHION GROUP (CONTINUED)

BUCKET SEATS

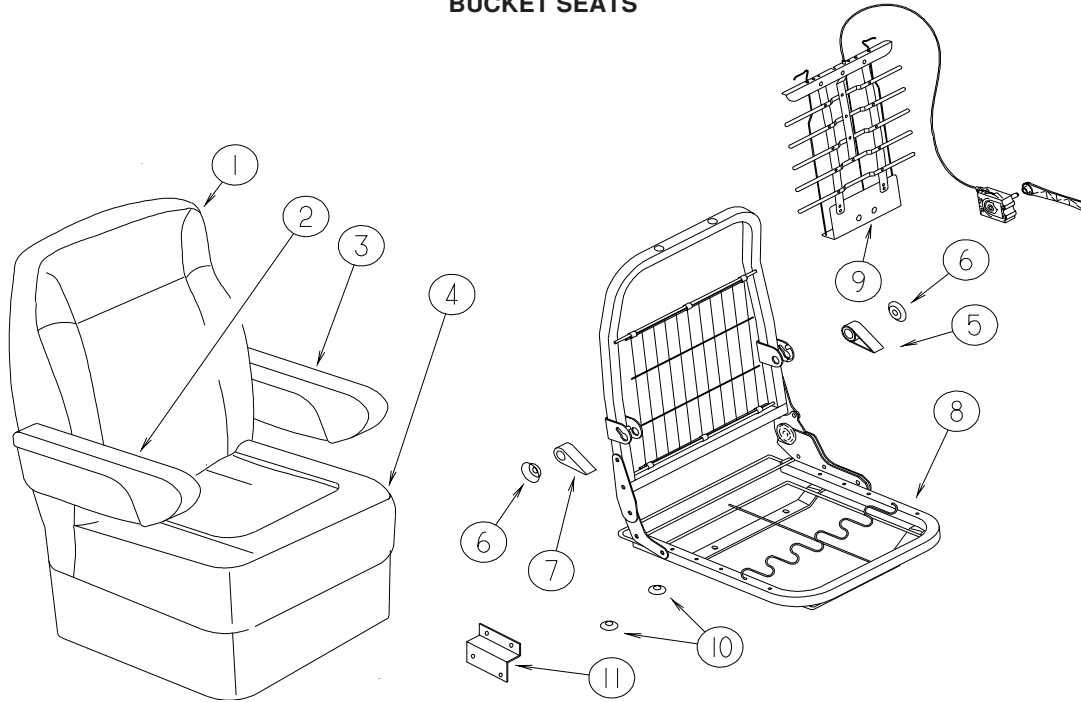

KEY	PART NUMBER	U/M	DESCRIPTION
1	M05962-F0-R19	EA	COVER - BACK (R19, R20, R21)
1	M05962-F0-P21	EA	COVER - BACK (R22, R23, R24)
1	M05962-F0-R25	EA	COVER - BACK (R25, R26, R27)
1	M05962-F2-M15	EA	COVER - BACK - ULTRALEATHER
2	129666-07-P13	EA	ARMREST - RIGHT HAND (R19, R20, R21)
2	129666-07-P21	EA	ARMREST - RIGHT HAND (R22, R23, R24)
2	129666-07-R25	EA	ARMREST - RIGHT HAND (R25, R26, R27)
2	129666-09-M04	EA	ARMREST - RIGHT HAND - ULTRALEATHER
	P29666-07-P13	EA	COVER/ARMREST - RIGHT HAND (R19, R20, R21)
	P29666-07-P21	EA	COVER/ARMREST - RIGHT HAND (R22, R23, R24)
	P29666-07-R25	EA	COVER/ARMREST - RIGHT HAND (R25, R26, R27)
	P29666-09-M04	EA	COVER/ARMREST - RIGHT HAND - ULTRALEATHER
	130698-01-000	EA	ARMREST/MOLDED - RIGHT - W/O COVER
3	129666-08-P13	EA	ARMREST - LEFT HAND (R19, R20, R21)
3	129666-08-P21	EA	ARMREST - LEFT HAND (R22, R23, R24)
3	129666-08-R25	EA	ARMREST - LEFT HAND (R25, R26, R27)
3	129666-10-N06	EA	ARMREST - LEFT HAND - ULTRALEATHER
	P29666-08-P13	EA	COVER/ARMREST - LEFT HAND (R19, R20, R21)
	P29666-08-P21	EA	COVER/ARMREST - LEFT HAND (R22, R23, R24)
	P29666-08-R25	EA	COVER/ARMREST - LEFT HAND (R25, R26, R27)
	P29666-10-N06	EA	COVER/ARMREST - LEFT HAND - ULTRALEATHER
	130698-02-000	EA	ARMREST/MOLDED - LEFT - W/O COVER
4	M05962-F1-R19	EA	COVER - SEAT (R19, R20, R21)
4	M05962-F1-P21	EA	COVER - SEAT (R22, R23, R24)
4	M05962-F1-R25	EA	COVER - SEAT (R25, R26, R27)
4	M05962-F3-M15	EA	COVER - SEAT - ULTRALEATHER
	029134-01-000	EA	CLIP - FINISH - UPHOLSTERY
5	130802-01-000	EA	LEVER - LEFT HAND
6	130802-03-000	EA	SCREW F/LEVER
7	130802-02-000	EA	LEVER - RIGHT HAND
8	132875-04-000	EA	FRAME - LEFT HAND CHAIR/TAPERED BACK
8	132875-03-000	EA	FRAME - RIGHT HAND CHAIR/TAPERED BACK
9*	122611-02-000	EA	LUMBAR - W/LEVER
10	007221-01-000	EA	SPACER - SEAT/ADJUSTER
11	147457-01-02B	EA	BRACKET - ZEE W/HOLES - 2.8" - E-COATED
	029134-01-000	EA	CLIP - FINISH - UPHOLSTERY

*COMPONENT PARTS LISTED LATER IN THIS GROUP

CURTAIN & CUSHION GROUP (CONTINUED)
COMPONENT PARTS FOR BUCKET SEATS

122611-02-000

KEY	PART NUMBER	U/M	DESCRIPTION	VENDOR NO.
	122611-02-701	EA	LUMBAR - LEVER	412
	122611-02-702	EA	LUMBAR MECHANISM	24395-FLEXSTEEL

CURTAIN & CUSHION GROUP (CONTINUED)

SOFA

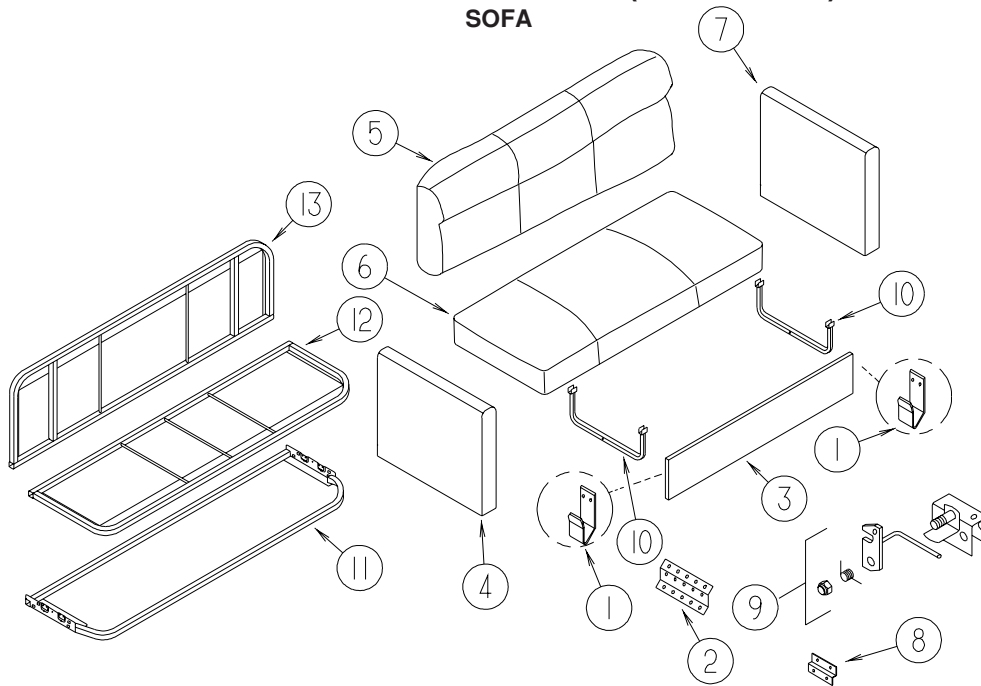

KEY	PART NUMBER	U/M	DESCRIPTION
1	121906-01-02B	EA	BRACKET - KICKBOARD - E-COATED
2	116104-04-02B	EA	BRACKET - ZEE W/HOLES - 3.2" - E-COATED - MOUNTS ARM TO FLOOR
3	120992-34-R19	EA	PANEL/FRONT KICK - SOFA/BED - 67.5" - FABRIC COVERED (R19, R20, R21)
3	120992-34-P21	EA	PANEL/FRONT KICK - SOFA/BED - 67.5" - FABRIC COVERED (R22, R23, R24)
3	120992-34-R25	EA	PANEL/FRONT KICK - SOFA/BED - 67.5" - FABRIC COVERED (R25, R26, R27)
4	123381-05-R19	EA	ARMREST - RIGHT HAND (R13, R14)
4	123381-05-P21	EA	ARMREST - RIGHT HAND (R22, R23, R24)
4	123381-05-R25	EA	ARMREST - RIGHT HAND (R25, R26, R27)
	P23381-05-R19	EA	COVER/ARMREST - RIGHT HAND (R13, R14)
	P23381-05-P21	EA	COVER/ARMREST - RIGHT HAND (R22, R23, R24)
	P23381-05-R25	EA	COVER/ARMREST - RIGHT HAND (R25, R26, R27)
4	123499-04-000	EA	SOFA/ARM - WOOD - RIGHT HAND
5	135138-04-R19	EA	BACK - SOFA/BED - 67.5" (R13, R14)
5	135138-04-R22	EA	BACK - SOFA/BED - 67.5" (R22, R23, R24)
5	135138-04-R25	EA	BACK - SOFA/BED - 67.5" (R25, R26, R27)
	P35138-04-R19	EA	COVER/BACK - SOFA/BED - 67.5" (R13, R14)
	P35138-04-R22	EA	COVER/BACK - SOFA/BED - 67.5" (R22, R23, R24)
	P35138-04-R25	EA	COVER/BACK - SOFA/BED - 67.5" (R25, R26, R27)
6	135138-03-R19	EA	SEAT - SOFA/BED - 67.5" (R13, R14)
6	135138-03-P21	EA	SEAT - SOFA/BED - 67.5" (R22, R23, R24)
6	135138-03-R25	EA	SEAT - SOFA/BED - 67.5" (R25, R26, R27)
	P35138-03-R19	EA	COVER/SEAT - SOFA/BED - 67.5" (R13, R14)
	P35138-03-P21	EA	COVER/SEAT - SOFA/BED - 67.5" (R22, R23, R24)
	P35138-03-R25	EA	COVER/SEAT - SOFA/BED - 67.5" (R25, R26, R27)
7	123381-06-R19	EA	ARMREST - LEFT HAND (R13, R14)
7	123381-06-P21	EA	ARMREST - LEFT HAND (R22, R23, R24)
7	123381-06-R25	EA	ARMREST - LEFT HAND (R25, R26, R27)
	P23381-06-R19	EA	COVER/ARMREST - LEFT HAND (R13, R14)
	P23381-06-P21	EA	COVER/ARMREST - LEFT HAND (R22, R23, R24)
	P23381-06-R25	EA	COVER/ARMREST - LEFT HAND (R25, R26, R27)
7	123499-05-000	EA	SOFA/ARM - WOOD - LEFT HAND
8	101926-01-02A	EA	BRACKET - ZEE - 2" - BLACK - MOUNTS SOFA TO FLOOR
9	127335-10-000	EA	BRACKET - CANADIAN LATCH - CANADIAN
10	127335-07-000	EA	LEG - SOFA/BED - 8"
11	127335-04-000	EA	FRAME/BASE - (SEAT) - 67.5"
12	127335-06-000	EA	FRAME/BASE - (SEAT) - 67.5"
13	127335-05-000	EA	FRAME/BASE - (BACK) - 67.5"

CURTAIN & CUSHION GROUP (CONTINUED)
WINDOW TREATMENT

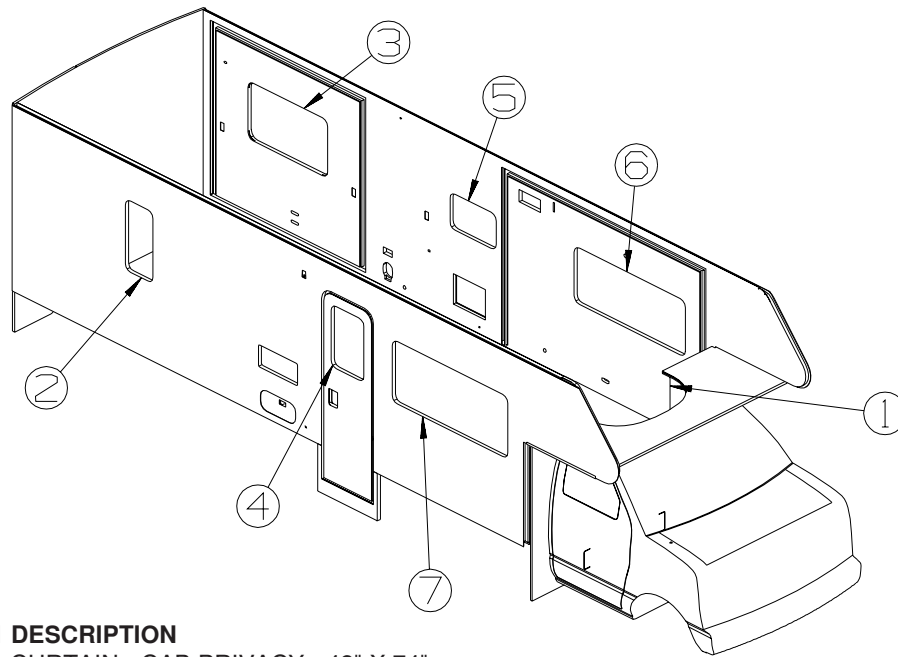

KEY	PART NUMBER	U/M	DESCRIPTION
1	076892-28-P13	EA	CURTAIN - CAB PRIVACY - 42" X 74"
2	142266-02-R19	EA	VALANCE - BEL AIR - 19" (R19, R20, R21)
2	142266-02-P21	EA	VALANCE - BEL AIR - 19" (R22, R23, R24)
2	142266-02-R25	EA	VALANCE - BEL AIR - 19" (R25, R26, R27)
2	136988-A8-R19	EA	LEG - RIGHT - 32" (R19, R20, R21)
2	136988-A8-P21	EA	LEG - RIGHT - 32" (R22, R23, R24)
2	136988-A8-R25	EA	LEG - RIGHT - 32" (R25, R26, R27)
2	136988-A9-R19	EA	LEG - LEFT - 32" (R19, R20, R21)
2	136988-A9-P21	EA	LEG - LEFT - 32" (R22, R23, R24)
2	136988-A9-R25	EA	LEG - LEFT - 32" (R25, R26, R27)
2	140789-23-P13	EA	BLIND - DAY/NIGHTER - 15.5" X 33" (R19, R20, R21, R22, R23, R24)
2	140789-23-N09	EA	BLIND - DAY/NIGHTER - 15.5" X 33" (R25, R26, R27)
3	142266-01-R19	EA	VALANCE - BEL AIR - 46" (R19, R20, R21)
3	142266-01-P21	EA	VALANCE - BEL AIR - 46" (R22, R23, R24)
3	142266-01-R25	EA	VALANCE - BEL AIR - 46" (R25, R26, R27)
3	136988-37-R19	EA	LEG - RIGHT - 26" (R19, R20, R21)
3	136988-37-R22	EA	LEG - RIGHT - 26" (R22, R23, R24)
3	136988-37-R25	EA	LEG - RIGHT - 26" (R25, R26, R27)
3	136988-38-R19	EA	LEG - LEFT - 26" (R19, R20, R21)
3	136988-38-R22	EA	LEG - LEFT - 26" (R22, R23, R24)
3	136988-38-R25	EA	LEG - LEFT - 26" (R25, R26, R27)
3	140789-02-N94	EA	BLIND - DAY/NIGHTER - 43" X 28" (R19, R20, R21, R22, R23, R24)
3	140789-02-R25	EA	BLIND - DAY/NIGHTER - 43" X 28" (R25, R26, R27)
4	121410-B4-R19	EA	VALANCE - MODERATE - 31.75" (R19, R20, R21)
4	121410-B4-P21	EA	VALANCE - MODERATE - 31.75" (R22, R23, R24)
4	121410-B4-R25	EA	VALANCE - MODERATE - 31.75" (R25, R26, R27)
4	084755-57-E07	EA	SHADE - PULL - 27.25"
5	109041-57-03A	EA	BLIND - MINI, - 26" X 17" (R19, R20, R21, R22, R23, R24)
5	109041-57-02A	EA	BLIND - MINI - 26" X 17" (R25, R26, R27)
6	142259-02-P60	EA	LAMBREQUIN - BARRYMORE - 61" (R19, R20, R21)
6	142259-02-P21	EA	LAMBREQUIN - BARRYMORE - 61" (R22, R23, R24)
6	142259-02-R25	EA	LAMBREQUIN - BARRYMORE - 61" (R25, R26, R27)
6	140789-08-N44	EA	BLIND - DAY/NIGHTER - 59" X 26.5" (R19, R20, R21, R22, R23, R24)
6	140789-08-N09	EA	BLIND - DAY/NIGHTER - 59" X 26.5" (R25, R26, R27)
7	142259-07-P60	EA	LAMBREQUIN - BARRYMORE - 63" (R19, R20, R21)
7	142259-07-P21	EA	LAMBREQUIN - BARRYMORE - 63" (R22, R23, R24)
7	142259-07-R25	EA	LAMBREQUIN - BARRYMORE - 63" (R25, R26, R27)
7	140789-14-N72	EA	BLIND - DAY/NIGHTER - 61" X 28.5" (R19, R20, R21, R22, R23, R24)
7	140789-14-N09	EA	BLIND - DAY/NIGHTER - 61" X 28.5" (R25, R26, R27)

CURTAIN & CUSHION GROUP (CONTINUED)

HARDWARE

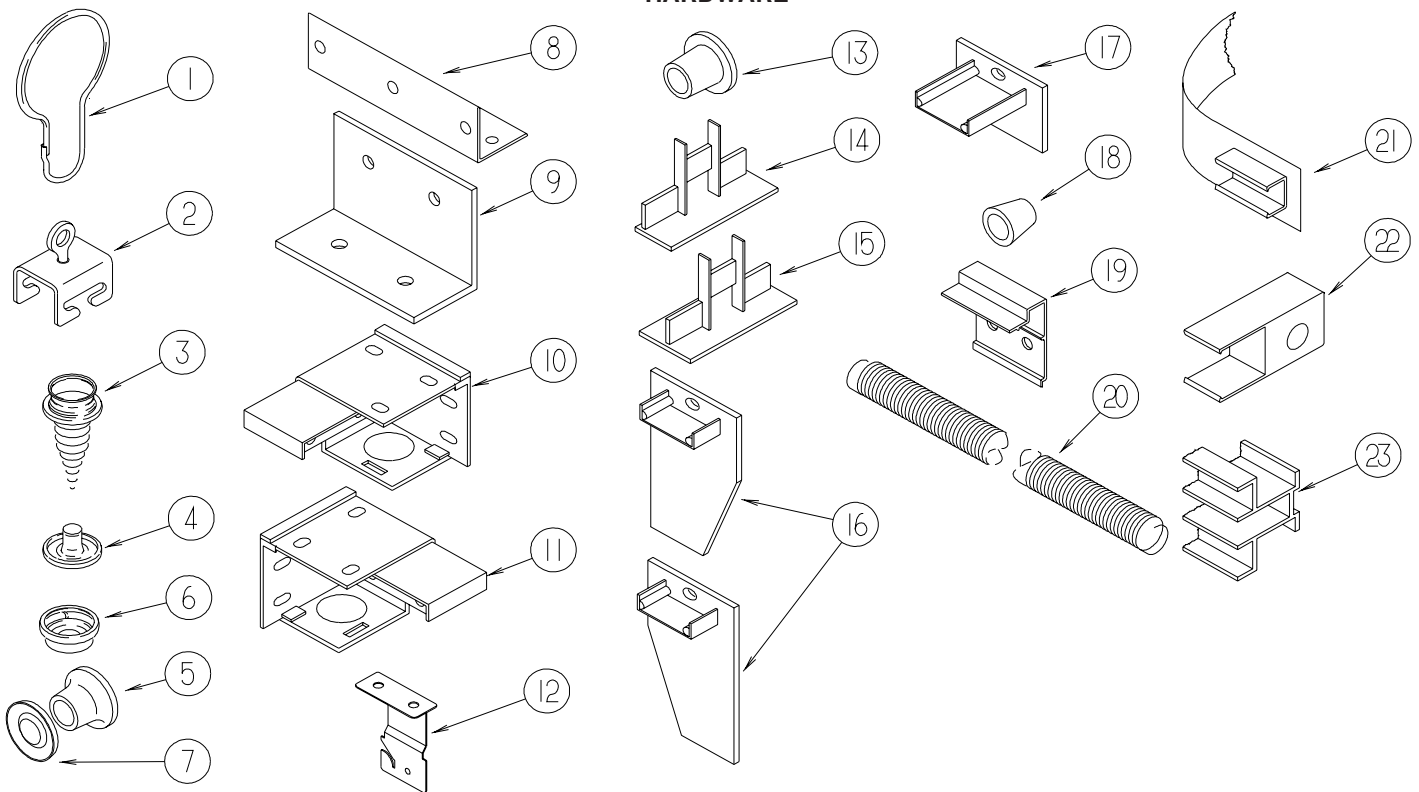

KEY	PART NUMBER	U/M	DESCRIPTION
1	009136-02-000	EA	HANGER - RING - PIN TYPE - CURTAIN - BRASS
2	009702-01-000	EA	END STOP - CURTAIN CARRIER - L - ROD
3	029130-01-000	EA	SCREW - SNAP STUD - #8-16 X 3/8" LONG
3	029130-03-000	EA	SCREW - SNAP STUD - #8-16 X 1" LONG
4	029155-01-000	EA	CAP - SNAP - 5/32" OUTSIDE DIAMETER OF PIN
5	029156-01-000	EA	SOCKET - SNAP - 9/16" O.D.
6	046867-02-000	EA	WASHER - HANDY BUTTON #3
7	046867-03-000	EA	GROMMET - HANDY BUTTON #3
8	075943-10-000	EA	BRACE - VALANCE - 20" - OFF WHITE
9	083125-07-000	EA	BRACE - ANGLE/COUCH - 2.5" - OFF WHITE
9	083125-08-000	EA	BRACE - WINDOW MOUNT - .75" - OFF WHITE
10	083170-01-000	EA	BRACKET/BLIND - LEFT SIDE WHEN FACING WINDOW - CLEAR
11	083170-02-000	EA	BRACKET/BLIND - RIGHT SIDE WHEN FACING WINDOW - CLEAR
12	084434-01-000	EA	BRACKET - MOUNTING - ROLLER SHADE - 1 3/8"
13	094896-02-000	EA	GROMMET - CORD/PLEATED BLIND - NYLON - GRAY
14	094907-02-000	EA	END CAP - PLEATED BLIND/TOP - RH/LH - GRAY PLASTIC
15	094907-04-000	EA	END CAP - PLEATED BLIND/BOTTOM - RH/LH
16	094907-05-000	EA	END CAP - PLEATED BLIND/BOTTOM - PULL TYPE - PLASTIC
17	094907-06-000	EA	END CAP - PLEATED BLIND/TOP
18	097564-03-000	EA	HANDLE - KNOB - E-Z LIFT SHADE - TAN
18	097564-05-000	EA	HANDLE - KNOB - E-Z LIFT SHADE - TEAL
18	097564-06-000	EA	HANDLE - KNOB - E-Z LIFT SHADE - ALABASTER
	097593-02-000	FT	CORD - BLIND - PLEATED - GRAY
	097593-06-000	FT	CORD - BLIND - PLEATED - PEWTER
	097593-10-000	FT	CORD - BLIND - PLEATED - VANILLA
19	097565-01-000	EA	BRACKET - MOUNTING - PLEATED BLIND
19	097565-02-000	EA	BRACKET - MOUNTING - PLEATED BLIND
20	097591-01-000	EA	SPRING - EXTENSION - PLEATED BLIND
21	101031-01-000	YD	TAPE/GLIDE - 4.25" SPACING
22	101033-02-000	EA	END CAP - LOW PROFILE TRACK - CLEAR
23	101033-08-000	EA	TRACK/WALL - 75" - FRT BUNK WINDOW 300 SERIES (MINNIE/SPIRIT)
23	101033-09-000	EA	TRACK/WALL - 32" - SIDE BUNK WINDOW 200 SERIES/300 SERIES (VISTA/SUNSTAR /MINNIE/SPIRIT)

CURTAIN & CUSHION GROUP (CONTINUED) HARDWARE (CONTINUED)

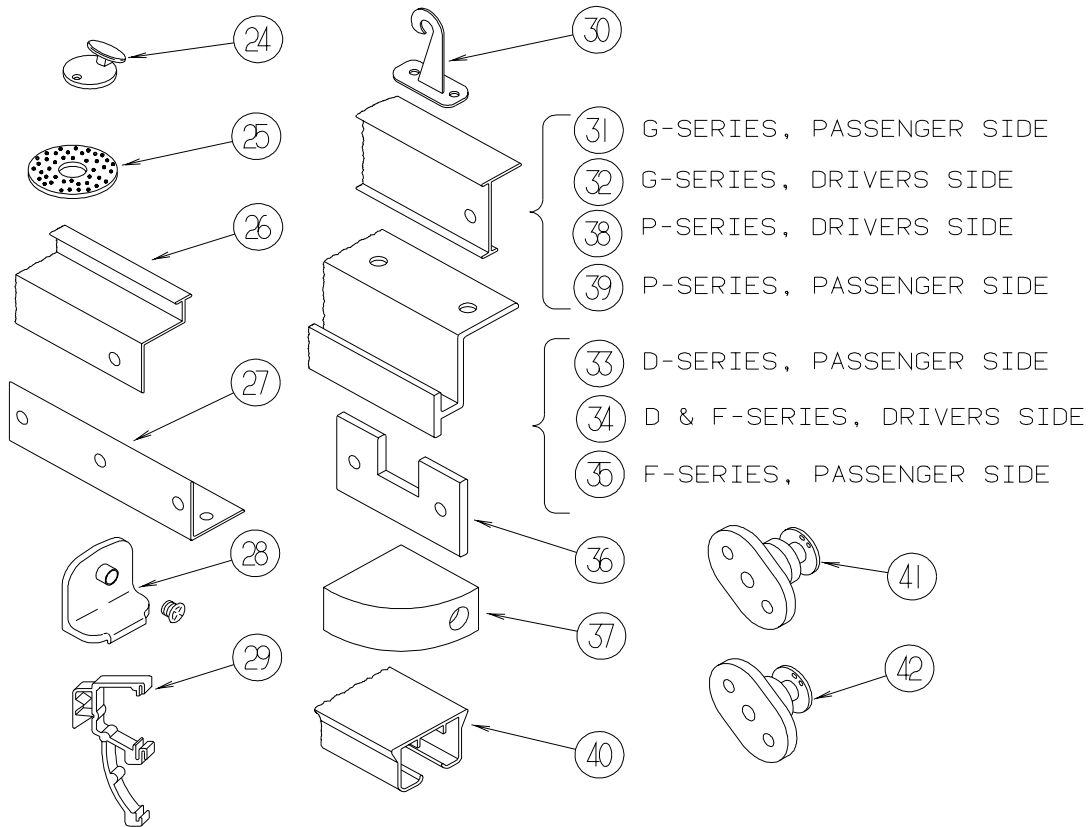

KEY	PART NUMBER	U/M	DESCRIPTION
24	102555-03-000	EA	CLEAT - BLIND CORD - MILKY WHITE - PLASTIC
25	103242-01-000	EA	VELCRO HOOK - BEIGE 7/8" ROUND W/CENTER HOLE
25	103242-02-000	EA	VELCRO HOOK - BLACK 7/8" ROUND W/CENTER HOLE
26	105450-14-01A	EA	TRACK - CURTAIN - 90" - OFF WHITE - FRONT BUNK PRIVACY 300 SERIES (MINNIE/SPIRIT)
26	105450-15-01A	EA	TRACK - CURTAIN - 82.3" - OFF WHITE - FRONT BUNK PRIVACY 200 SERIES (VISTA/SUNSTAR)
27	105648-01-02A	EA	BRACE - VALANCE - OFF/WHITE - 14"
28	106544-01-000	EA	PULL - SHADE/BRASS
	106544-01-001	EA	SCREW - SHADE/BRASS
29	109353-04-000	EA	CLIP - VALANCE SLAT MOUNTING - CLEAR PLASTIC
	109441-02-000	EA	SPACER/BRACKET - BLIND HOLD DOWN
30	109441-03-000	EA	BRACKET/HOOK - BLIND HOLD DOWN - NEW DESIGN/CLEAR
31	126456-03-04A	EA	TRACK/WRAPAROUND - PASSENGER - GLACIER - G SERIES (ADVENTURER/SUNCRUISER)
32	126456-04-04A	EA	TRACK/WRAPAROUND - DRIVER - GLACIER - G SERIES (ADVENTURER/SUNCRUISER)
33	127254-03-05A	EA	TRACK/WRAPAROUND - PASSENGER - GLACIER - D SERIES (SIGHTSEER/SUNOVA)
			FROM: 00-00-00 THRU: 09-07-03
33	127254-14-03A	EA	TRACK/WRAP - PASS - GLACIER - D SERIES (SIGHTSEER/SUNOVA)
			FROM: 09-08-03 THRU: 99-99-99
34	127254-04-05A	EA	TRACK/WRAP - DRIVER - GLACIER - D SERIES/F SERIES (SIGHTSEER/SUNOVA/BRAVE/SUNRISE)
35	127254-14-03A	EA	TRACK/WRAP - PASS - GLACIER - F SERIES (BRAVE/SUNRISE)
36	130549-01-01A	EA	STOP - CURTAIN TRACK
37	132504-01-N92	EA	BRACKET - SHADE
38	146591-01-01A	EA	TRACK - CURTAIN - LEFT HAND - GLACIER - P SERIES (JOURNEY/MERIDIAN)
39	146591-02-01A	EA	TRACK - CURTAIN - RIGHT HAND - GLACIER - P SERIES (JOURNEY/MERIDIAN)
40	138460-01-02A	EA	TRACK/CURTAIN - PASSENGER - WHITE - Q SERIES (ULTIMATE ADVANTAGE/ULTIMATE FREEDOM)
	138460-02-02A	EA	TRACK/CURTAIN - DRIVER - WHITE - Q SERIES (ULTIMATE ADVANTAGE/ULTIMATE FREEDOM)
40	138460-05-02A	EA	TRACK/CURTAIN - PASSENGER - WHITE - L SERIES (CHIEFTAIN/SUNFLYER)
	138460-06-02A	EA	TRACK/CURTAIN - DRIVER - WHITE - L SERIES (CHIEFTAIN/SUNFLYER)
40	138460-07-02A	EA	TRACK/CURTAIN - PASSENGER - WHITE - S SERIES (VECTRA/HORIZON)
	138460-08-02A	EA	TRACK/CURTAIN - DRIVER - WHITE - S SERIES (VECTRA/HORIZON)
41	141634-01-000	EA	BRACKET-(BOBBIN TYPE) 7/8"H HOLDUPBASE(OVAL)-2 HOLE-CLEAR
42	143805-01-000	EA	BRACKET-(BOBBIN TYPE) 1/2"H HOLDUPBASE(OVAL)-2 HOLES CLEAR

CURTAIN & CUSHION GROUP (CONTINUED)
ACCESSORIES

KEY	PART NUMBER	U/M	DESCRIPTION
	007021-01-000	EA	SEAT BELT - 2" X 90" - BLACK
	056271-01-000	EA	SEAT BELT - 2" X 102" - BLACK
	057534-03-000	EA	TIEBACK - CLEAR PLASTIC - 7.5"
	057759-01-000	EA	WASHER - FLAT F/SEAT BELT - 4" DIAMETER
	140221-01-02B	EA	WASHER - SEAT BELT - E-COAT

CURTAIN & CUSHION GROUP (CONTINUED)
FABRICS

2004 FAMILY	R19/R20/R21	R22/R23/R24	R25/R26/R27
	CRYSTAL LAKE	FERN GARDEN	ALABASTER
BUCKET	566H STYLE	566H STYLE	566H STYLE
	126883-L1-000	126883-K9-000	126883-U9-000
	*OPT. ULTRA/STEEL GRAY	*OPT. ULTRA/STEEL GRAY	*OPT. ULTRA/STEEL GRAY
	079680-39-000	079680-39-000	079680-39-000
DINETTE CUSHIONS	CLUB	CLUB	CLUB
	126883-L0-000	126883-K8-000	126883-V8-000
DINETTE WRAP	126883-L1-000	126883-K9-000	126883-U9-000
SOFA (2 CUSHION)	427P/430V: 695 COMFORT SOFA	427P/430V: 695 COMFORT SOFA	427P/430V: 695 COMFORT SOFA
	431C: 605 ARMLESS JACK KNIFE	431C: 605 ARMLESS JACK KNIFE	431C: 605 ARMLESS JACK KNIFE
	126883-L0-000	126883-K8-000	126883-U9-000
LOUNGE CHAIR	#465	#465	#465
	126883-L1-000	126883-K9-000	126883-U9-000
LOUNGE WINDOWS	PALM COURT LAMBREQUIN	PALM COURT LAMBREQUIN	PALM COURT LAMBREQUIN
	UNDERLAY - 126883-L1-000	UNDERLAY - 126883-K9-000	UNDERLAY - 126883-V9-000
	OVLY - 126883-L0-000	OVLY - 126883-K8-000	OVLY - 126883-U9-000
	BRAID - 139041-11-000	BRAID - 084415-F2-000	BRAID - 084415-F4-000
LOUNGE PILLOW	(2) 17" PALM COURT	(2) 17" PALM COURT	(2) 17" PALM COURT
	BACK & BODY - 126883-L1-000	BACK & BODY - 126883-K9-000	BACK & BODY - 126883-U9-000
	OVERLAY - 126883-L0-000	OVERLAY - 126883-K8-000	OVERLAY - 126883-V8-000
	WELT - 126883-L1-000	WELT - 126883-K9-000	WELT - 126883-U9-000
	BRAID - 139041-11-000	BRAID - 084415-F2-000	BRAID - 084415-F4-000
FWA, BLACKOUT & PRIVACY CURTAIN	0732333-85-000	0732333-85-000	0732333-85-000
	CLOUDS MUSHROOM	CLOUDS MUSHROOM	CLOUDS MUSHROOM
DAY/NIGHTER	094911-56/126883-50	094911-56/126883-50	094911-58/126883-50
	EGGSHELL/WT. DECO	EGGSHELL/WT. DECO	PUTTY/WT. DECO
GALLEY BLINDS	386 SNOCAP	386 SNOCAP	C011 BEIGE

CURTAIN & CUSHION GROUP (CONTINUED)
FABRICS (CONTINUED)

2004 FAMILY	R19/R20/R21	R22/R23/R24	R25/R26/R27
	CRYSTAL LAKE	FERN GARDEN	ALABASTER
BEDROOM WDO TREATMENT	BEL-AIR VALANCE	BEL-AIR VALANCE	BEL-AIR VALANCE
	BODY - 105745-Y1-000	BODY - 137813-20-000	BODY - 105745-V0-000
	GATH. OVLY - 137813-23-000	GATH. OVLY - 137813-21-000	GATH. OVLY - 137813-72-000
	LEGS - 105745-Y1-000	LEGS - 137813-20-000	LEGS - 105745-V0-000
	CORD - 139041-11-000	CORD - 084415-F2-000	CORD - 084415-F5-000
BEDCOVER	BEDCAP W/CORD	BEDCAP W/CORD	BEDCAP W/CORD
	137813-Y1/139041-11	137813-20/084415-F2	137813-22/084415-F4
QUILT PATTERN	LARGE DIAMOND	LARGE DIAMOND	LARGE DIAMOND
SHAMS	SHAM W/2" GATH. BAND	SHAM W/2" GATH. BAND	SHAM W/2" GATH. BAND
	BODY - 105745-Y1-000	BODY - 137813-20-000	BODY - 105745-V0-000
	BAND - 137813-23-000	BAND - 137813-23-000	BAND - 137813-72-000
	BRAID - 139041-11-000	BRAID - 084415-F2-000	BRAID - 084415-F4-000
BED PILLOW	(2) 10X17" W/1½" GATH. BAND	(2) 10X17" W/1½" GATH. BAND	(2) 10X17" W/1½" GATH. BAND
	BODY - 137813-23-000	BODY - 137813-21-000	BODY - 137813-72-000
	GATH. BAND - 105745-Y1-000	GATH. BAND - 137813-20-000	GATH. BAND - 105745-V0-000
	BRAID - 139041-11-000	BRAID - 084415-F2-000	BRAID - 084415-F4-000
HEADBOARD	CAMEO STYLE	CAMEO STYLE	CAMEO STYLE
	CTR - 105745-Y1-000	CTR - 137813-20-000	CTR - 105745-V0-000
	SIDES - 137813-23-000	SIDES - 137813-21-000	SIDES - 137813-72-000
	CORD - 139041-11-000	CORD - 084415-F2-000	CORD - 084415-F4-000
BEDROOM VANITY CHAIR	REM	REM	REM
	126883-L1-000	126883-K9-000	126883-V9-000
CARPET	139056-06-000	096060-F0-000	096060-H1-000
	CRYSTAL LAKE	PALE SAGE	TAPIOCA
LOUNGE CABINET FABRIC INSERT	126883-L1-000	126883-K9-000	126883-V9-000
BEDROOM CABINET INSERT	105745-Y1-000	137813-21-000	105745-V0-000

DINETTE GROUP CABINETS

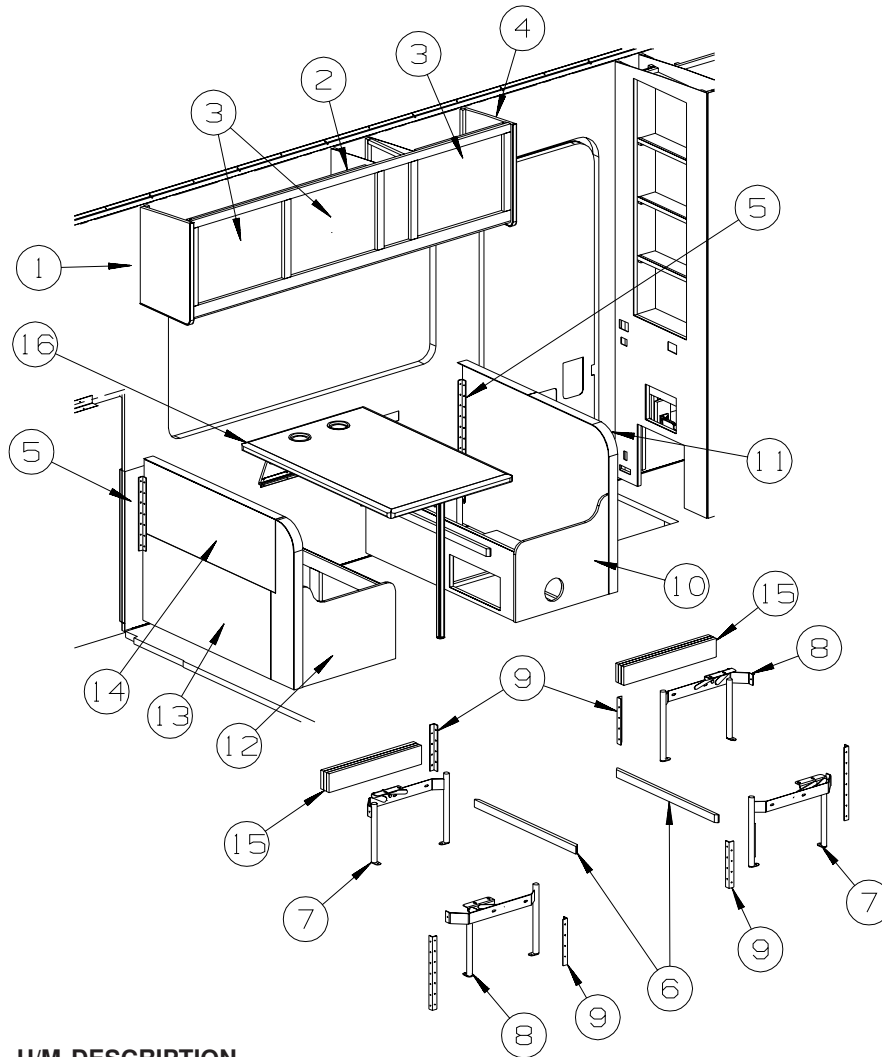

KEY	PART NUMBER	U/M	DESCRIPTION
1	141565-18-P13	EA	END CAP - OVERHEAD CABINET - PORTSMOUTH OAK
1	141565-18-P14	EA	END CAP - OVERHEAD CABINET - CONCERT CHERRY
1	141565-18-P33	EA	END CAP - OVERHEAD CABINET - WASHED MAPLE
1	141565-18-RW1	EA	END CAP - OVERHEAD CABINET - WASHED MAPLE FROM: 00-00-00 THRU: 01-04-04
2	141565-01-P13	EA	CABINET - OVERHEAD/FRONT - W/O DOORS/HARDWARE (R19)
2	141565-01-P14	EA	CABINET - OVERHEAD/FRONT - W/O DOORS/HARDWARE (R20)
2	141565-01-R21	EA	CABINET - OVERHEAD/FRONT - W/O DOORS/HARDWARE (R21) FROM: 00-00-00 THRU: 01-04-04
2	141565-01-RW1	EA	CABINET - OVERHEAD/FRONT - W/O DOORS/HARDWARE (R21) FROM: 01-05-04 THRU: 99-99-99
2	141565-01-P21	EA	CABINET - OVERHEAD/FRONT - W/O DOORS/HARDWARE (R22)
2	141565-01-P22	EA	CABINET - OVERHEAD/FRONT - W/O DOORS/HARDWARE (R23)
2	141565-01-P36	EA	CABINET - OVERHEAD/FRONT - W/O DOORS/HARDWARE (R24) FROM: 00-00-00 THRU: 01-04-04
2	141565-01-RW2	EA	CABINET - OVERHEAD/FRONT - W/O DOORS/HARDWARE (R24) FROM: 01-05-04 THRU: 99-99-99
2	141565-01-R25	EA	CABINET - OVERHEAD/FRONT - W/O DOORS/HARDWARE (R25)
2	141565-01-R26	EA	CABINET - OVERHEAD/FRONT - W/O DOORS/HARDWARE (R26)
2	141565-01-R27	EA	CABINET - OVERHEAD/FRONT - W/O DOORS/HARDWARE (R27) FROM: 00-00-00 THRU: 01-04-04
2	141565-01-RW3	EA	CABINET - OVERHEAD/FRONT - W/O DOORS/HARDWARE (R27) FROM: 01-05-04 THRU: 99-99-99
3	141522-D0-P54	EA	DOOR - ARCHED/PENCIL EDGE/HORIZ - 15.7" X 20.4" - W/O HDW - PORTSMOUTH OAK
3	141522-D0-P55	EA	DOOR - ARCHED/PENCIL EDGE/HORIZ - 15.7" X 20.4" - W/O HDW - CONCERT CHERRY
3	141522-D0-P56	EA	DOOR - ARCHED/PENCIL EDGE/HORIZ - 15.7" X 20.4" - W/O HDW - WASHED MAPLE

DINETTE GROUP (CONTINUED)
CABINETS (CONTINUED)

KEY	PART NUMBER	U/M	DESCRIPTION
4	141565-19-P13	EA	END CAP - OVERHEAD CABINET - PORTSMOUTH OAK
4	141565-19-P14	EA	END CAP - OVERHEAD CABINET - CONCERT CHERRY
4	141565-19-P33	EA	END CAP - OVERHEAD CABINET - WASHED MAPLE
			FROM: 00-00-00 THRU: 01-04-04
4	141565-19-RW1	EA	CAP - OVERHEAD CABINET - WASHED MAPLE
			FROM: 01-05-04 THRU: 99-99-99
5	122021-02-02A	EA	ANGLE - W/HOLES - 13.7" LONG - OFF WHITE
6	081295-01-N70	EA	SUPPORT - BED/DINETTE - 28" LONG - PORTSMOUTH OAK
6	081295-01-M52	EA	SUPPORT - BED/DINETTE - 28" LONG - CONCERT CHERRY
6	081295-01-H37	EA	SUPPORT - BED/DINETTE - 28" LONG - WASHED MAPLE
7	142033-01-000	EA	BRACKET - DINETTE - RIGHT HAND
8	142033-02-000	EA	BRACKET - DINETTE - LEFT HAND
9	122021-01-02A	EA	ANGLE - W/HOLES - 8.6" LONG - OFF WHITE
10	142046-01-R19	EA	CABINET/BASE - DINETTE W/O BACK-F/FLIP UP CUSHION - RH (R19)
10	142046-01-R20	EA	CABINET/BASE - DINETTE W/O BACK-F/FLIP UP CUSHION - RH (R20)
10	142046-01-R21	EA	CABINET/BASE - DINETTE W/O BACK-F/FLIP UP CUSHION - RH (R21)
			FROM: 00-00-00 THRU: 01-04-04
10	142046-01-RW1	EA	CABINET/BASE - DINETTE W/O BACK-F/FLIP UP CUSHION - RH (R21)
			FROM: 01-05-04 THRU: 99-99-99
10	142046-01-P21	EA	CABINET/BASE - DINETTE W/O BACK-F/FLIP UP CUSHION - RH (R22)
10	142046-01-R23	EA	CABINET/BASE - DINETTE W/O BACK-F/FLIP UP CUSHION - RH (R23)
10	142046-01-R24	EA	CABINET/BASE - DINETTE W/O BACK-F/FLIP UP CUSHION - RH (R24)
			FROM: 00-00-00 THRU: 01-04-04
10	142046-01-RW2	EA	CABINET/BASE - DINETTE W/O BACK-F/FLIP UP CUSHION - RH (R24)
			FROM: 01-05-04 THRU: 99-99-99
10	142046-01-R25	EA	CABINET/BASE - DINETTE W/O BACK-F/FLIP UP CUSHION - RH (R25)
10	142046-01-R26	EA	CABINET/BASE - DINETTE W/O BACK-F/FLIP UP CUSHION - RH (R26)
10	142046-01-R27	EA	CABINET/BASE - DINETTE W/O BACK-F/FLIP UP CUSHION - RH (R27)
			FROM: 00-00-00 THRU: 01-04-04
10	142046-01-RW3	EA	CABINET/BASE - DINETTE W/O BACK-F/FLIP UP CUSHION - RH (R27)
			FROM: 01-05-04 THRU: 99-99-99
10	142046-04-R19	EA	CABINET/BASE - DINETTE W/O BACK-F/FLIP UP CUSHION - RH (R19) - HOME COMFORT PLUS PKG
10	142046-04-R20	EA	CABINET/BASE - DINETTE W/O BACK-F/FLIP UP CUSHION - RH (R20) - HOME COMFORT PLUS PKG
10	142046-04-R21	EA	CABINET/BASE - DINETTE W/O BACK-F/FLIP UP CUSHION - RH (R21) - HOME COMFORT PLUS PKG
			FROM: 00-00-00 THRU: 01-04-04
10	142046-04-RW1	EA	CABINET/BASE - DINETTE W/O BACK-F/FLIP UP CUSHION - RH (R21) - HOME COMFORT PLUS PKG
			FROM: 01-05-04 THRU: 99-99-99
10	142046-04-P21	EA	CABINET/BASE - DINETTE W/O BACK-F/FLIP UP CUSHION - RH (R22) - HOME COMFORT PLUS PKG
10	142046-04-R23	EA	CABINET/BASE - DINETTE W/O BACK-F/FLIP UP CUSHION - RH (R23) - HOME COMFORT PLUS PKG
10	142046-04-R24	EA	CABINET/BASE - DINETTE W/O BACK-F/FLIP UP CUSHION - RH (R24) - HOME COMFORT PLUS PKG
			FROM: 00-00-00 THRU: 01-04-04
10	142046-04-RW2	EA	CABINET/BASE - DINETTE W/O BACK-F/FLIP UP CUSHION - RH (R24) - HOME COMFORT PLUS PKG
			FROM: 01-05-04 THRU: 99-99-99
10	142046-04-R25	EA	CABINET/BASE - DINETTE W/O BACK-F/FLIP UP CUSHION - RH (R25) - HOME COMFORT PLUS PKG
10	142046-04-R26	EA	CABINET/BASE - DINETTE W/O BACK-F/FLIP UP CUSHION - RH (R26) - HOME COMFORT PLUS PKG
10	142046-04-R27	EA	CABINET/BASE - DINETTE W/O BACK-F/FLIP UP CUSHION - RH (R27) - HOME COMFORT PLUS PKG
			FROM: 00-00-00 THRU: 01-04-04
10	142046-04-RW3	EA	CABINET/BASE - DINETTE W/O BACK-F/FLIP UP CUSHION - RH (R27) - HOME COMFORT PLUS PKG
			FROM: 01-05-04 THRU: 99-99-99
11	142046-16-P13	EA	PANEL/BACK - DINETTE SEAT - RIGHT HAND (R19)
11	142046-16-P14	EA	PANEL/BACK - DINETTE SEAT - RIGHT HAND (R20)
11	142046-16-R21	EA	PANEL/BACK - DINETTE SEAT - RIGHT HAND (R21)
			FROM: 00-00-00 THRU: 01-04-04
11	142046-16-RW1	EA	PANEL/BACK - DINETTE SEAT - RIGHT HAND (R21)
			FROM: 01-05-04 THRU: 99-99-99
11	142046-16-P21	EA	PANEL/BACK - DINETTE SEAT - RIGHT HAND (R22)
11	142046-16-P22	EA	PANEL/BACK - DINETTE SEAT - RIGHT HAND (R23)
11	142046-16-P36	EA	PANEL/BACK - DINETTE SEAT - RIGHT HAND (R24)
			FROM: 00-00-00 THRU: 01-04-04
11	142046-16-RW2	EA	PANEL/BACK - DINETTE SEAT - RIGHT HAND (R24)
			FROM: 01-05-04 THRU: 99-99-99
11	142046-16-R25	EA	PANEL/BACK - DINETTE SEAT - RIGHT HAND (R25)
11	142046-16-R26	EA	PANEL/BACK - DINETTE SEAT - RIGHT HAND (R26)

DINETTE GROUP (CONTINUED) CABINETS (CONTINUED)

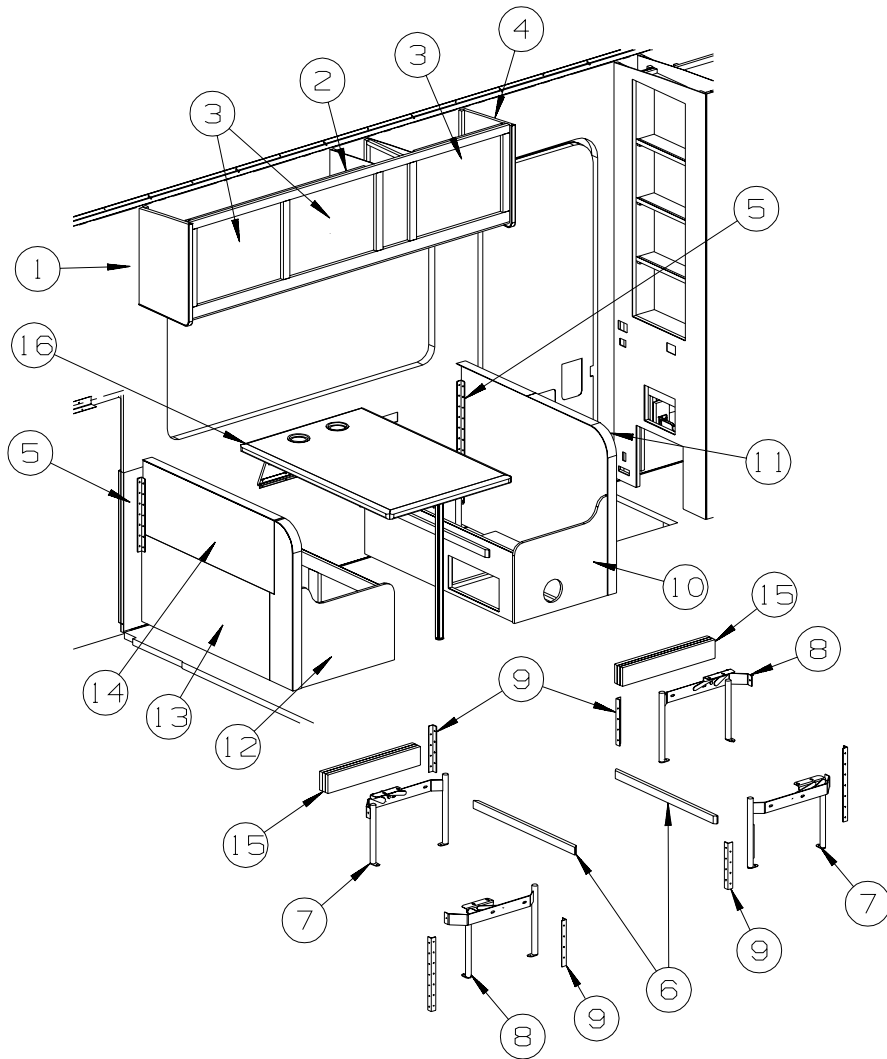

KEY	PART NUMBER	U/M	DESCRIPTION
11	142046-16-R27	EA	PANEL/BACK - DINETTE SEAT - RIGHT HAND (R27) FROM: 00-00-00 THRU: 01-04-04
11	142046-16-RW3	EA	PANEL/BACK - DINETTE SEAT - RIGHT HAND (R27) FROM: 01-05-04 THRU: 99-99-99
12	142046-09-P13	EA	CABINET/BASE - DINETTE W/O BACK-F/FLIP UP CUSHION - LH (R19)
12	142046-09-P14	EA	CABINET/BASE - DINETTE W/O BACK-F/FLIP UP CUSHION - LH (R20)
12	142046-09-R21	EA	CABINET/BASE - DINETTE W/O BACK-F/FLIP UP CUSHION - LH (R21) FROM: 00-00-00 THRU: 01-04-04
12	142046-09-RW1	EA	CABINET/BASE - DINETTE W/O BACK-F/FLIP UP CUSHION - LH (R21) FROM: 01-05-04 THRU: 99-99-99
12	142046-09-P21	EA	CABINET/BASE - DINETTE W/O BACK-F/FLIP UP CUSHION - LH (R22)
12	142046-09-P22	EA	CABINET/BASE - DINETTE W/O BACK-F/FLIP UP CUSHION - LH (R23)
12	142046-09-P36	EA	CABINET/BASE - DINETTE W/O BACK-F/FLIP UP CUSHION - LH (R24) FROM: 00-00-00 THRU: 01-04-04
12	142046-09-RW2	EA	CABINET/BASE - DINETTE W/O BACK-F/FLIP UP CUSHION - LH (R24) FROM: 01-05-04 THRU: 99-99-99
12	142046-09-R25	EA	CABINET/BASE - DINETTE W/O BACK-F/FLIP UP CUSHION - LH (R25)
12	142046-09-R26	EA	CABINET/BASE - DINETTE W/O BACK-F/FLIP UP CUSHION - LH (R26)
12	142046-09-R27	EA	CABINET/BASE - DINETTE W/O BACK-F/FLIP UP CUSHION - LH (R27) FROM: 00-00-00 THRU: 01-04-04
12	142046-09-RW3	EA	CABINET/BASE - DINETTE W/O BACK-F/FLIP UP CUSHION - LH (R27) FROM: 01-05-04 THRU: 99-99-99
13	142046-72-P13	EA	PANEL/BACK - DINETTE SEAT/W/O HINGED PORTION - LEFT HAND (R19)
13	142046-72-P14	EA	PANEL/BACK - DINETTE SEAT/W/O HINGED PORTION - LEFT HAND (R20)

DINETTE GROUP (CONTINUED)
CABINETS (CONTINUED)

KEY	PART NUMBER	U/M	DESCRIPTION
13	142046-72-R21	EA	PANEL/BACK - DINETTE SEAT/W/O HINGED PORTION - LEFT HAND (R21) FROM: 00-00-00 THRU: 01-04-04
13	142046-72-RW1	EA	PANEL/BACK - DINETTE SEAT/W/O HINGED PORTION - LEFT HAND (R21) FROM: 01-05-04 THRU: 99-99-99
13	142046-72-P21	EA	PANEL/BACK - DINETTE SEAT/W/O HINGED PORTION - LEFT HAND (R22)
13	142046-72-P22	EA	PANEL/BACK - DINETTE SEAT/W/O HINGED PORTION - LEFT HAND (R23)
13	142046-72-P36	EA	PANEL/BACK - DINETTE SEAT/W/O HINGED PORTION - LEFT HAND (R24) FROM: 00-00-00 THRU: 01-04-04
13	142046-72-RW2	EA	PANEL/BACK - DINETTE SEAT/W/O HINGED PORTION - LEFT HAND (R24) FROM: 01-05-04 THRU: 99-99-99
13	142046-72-R25	EA	PANEL/BACK - DINETTE SEAT/W/O HINGED PORTION - LEFT HAND (R25)
13	142046-72-R26	EA	PANEL/BACK - DINETTE SEAT/W/O HINGED PORTION - LEFT HAND (R26)
13	142046-72-R27	EA	PANEL/BACK - DINETTE SEAT/W/O HINGED PORTION - LEFT HAND (R27) FROM: 00-00-00 THRU: 01-04-04
13	142046-72-RW3	EA	PANEL/BACK - DINETTE SEAT/W/O HINGED PORTION - LEFT HAND (R27) FROM: 01-05-04 THRU: 99-99-99
14	142046-75-P13	EA	PANEL - BACK/HINGED - PORTSMOUTH OAK
14	142046-75-P14	EA	PANEL - BACK/HINGED - CONCERT CHERRY
14	142046-75-P33	EA	PANEL - BACK/HINGED - WASHED MAPLE FROM: 00-00-00 THRU: 01-04-04
14	142046-75-RW1	EA	PANEL - BACK/HINGED - WASHED MAPLE FROM: 01-05-04 THRU: 99-99-99
15	142046-62-P13	EA	SPACER/BASE - DINETTE SEAT (R19, R20, R21)
15	142046-62-P21	EA	SPACER/BASE - DINETTE SEAT (R22, R23, R24)
15	142046-62-R25	EA	SPACER/BASE - DINETTE SEAT (R25, R26, R27)
16	143257-10-R13	EA	TABLE - 27.8" X 41.6" - GRAY TRANQUILITY/PORTSMOUTH OAK (R19)
16	143257-10-R14	EA	TABLE - 27.8" X 41.6" - GRAY TRANQUILITY/CONCERT CHERRY (R20)
16	143257-10-R21	EA	TABLE - 27.8" X 41.6" - GRAY TRANQUILITY/WASHED MAPLE (R21)
16	143257-10-R15	EA	TABLE - 27.8" X 41.6" - LINO FRIEZE/PORTSMOUTH OAK (R22)
16	143257-10-R16	EA	TABLE - 27.8" X 41.6" - LINO FRIEZE/CONCERT CHERRY (R23)
16	143257-10-R24	EA	TABLE - 27.8" X 41.6" - LINO FRIEZE/WASHED MAPLE (R24)
16	143257-10-R17	EA	TABLE - 27.8" X 41.6" - ROCKY MOUNTAIN HIGH (R25)
16	143257-10-R18	EA	TABLE - 27.8" X 41.6" - ROCKY MOUNTAIN HIGH/CONCERT CHERRY (R26)
16	143257-10-R27	EA	TABLE - 27.8" X 41.6" - ROCKY MOUNTAIN HIGH/WASHED MAPLE (R27)

DINETTE GROUP (CONTINUED) TABLE

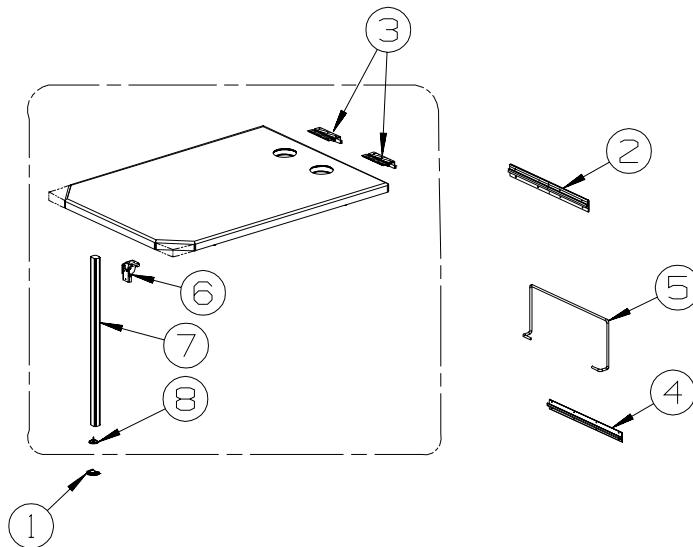

KEY	PART NUMBER	U/M	DESCRIPTION
1	143798-01-01A	EA	CATCH - FLOOR TO TABLE LEG - BRIGHT WHITE
2	140921-02-01A	EA	SUPPORT - TABLE - 18.5" - OFF WHITE
3	140921-03-01A	EA	HANGER - TABLE - W/VINYL - OFF WHITE
4	024281-15-000	EA	BRACKET/TABLE - LIFT ROD/LOWER WALL MOUNTED - 17.1"
5	024275-13-000	EA	ROD - TABLE LIFT - OFF/WHITE
6	093550-01-000	EA	BRACKET - HINGE - MOUNTS TO LEG & TABLE TOP - 1.7" X 2.6"
7	092707-04-10A	EA	LEG - TABLE - W/O HARDWARE - 27" - PORTSMOUTH OAK
7	092707-04-04A	EA	LEG - TABLE - W/O HARDWARE - 27" - CONCERT CHERRY
7	092707-04-08A	EA	LEG - TABLE - W/O HARDWARE - 27" - WASHED MAPLE
8	143798-02-01A	EA	CATCH - TABLE LEG - BRIGHT WHITE
	143798-03-01A	EA	WASHER - TABLE LEG - CATCH

DRIVERS COMPARTMENT GROUP FRONT INTERIOR

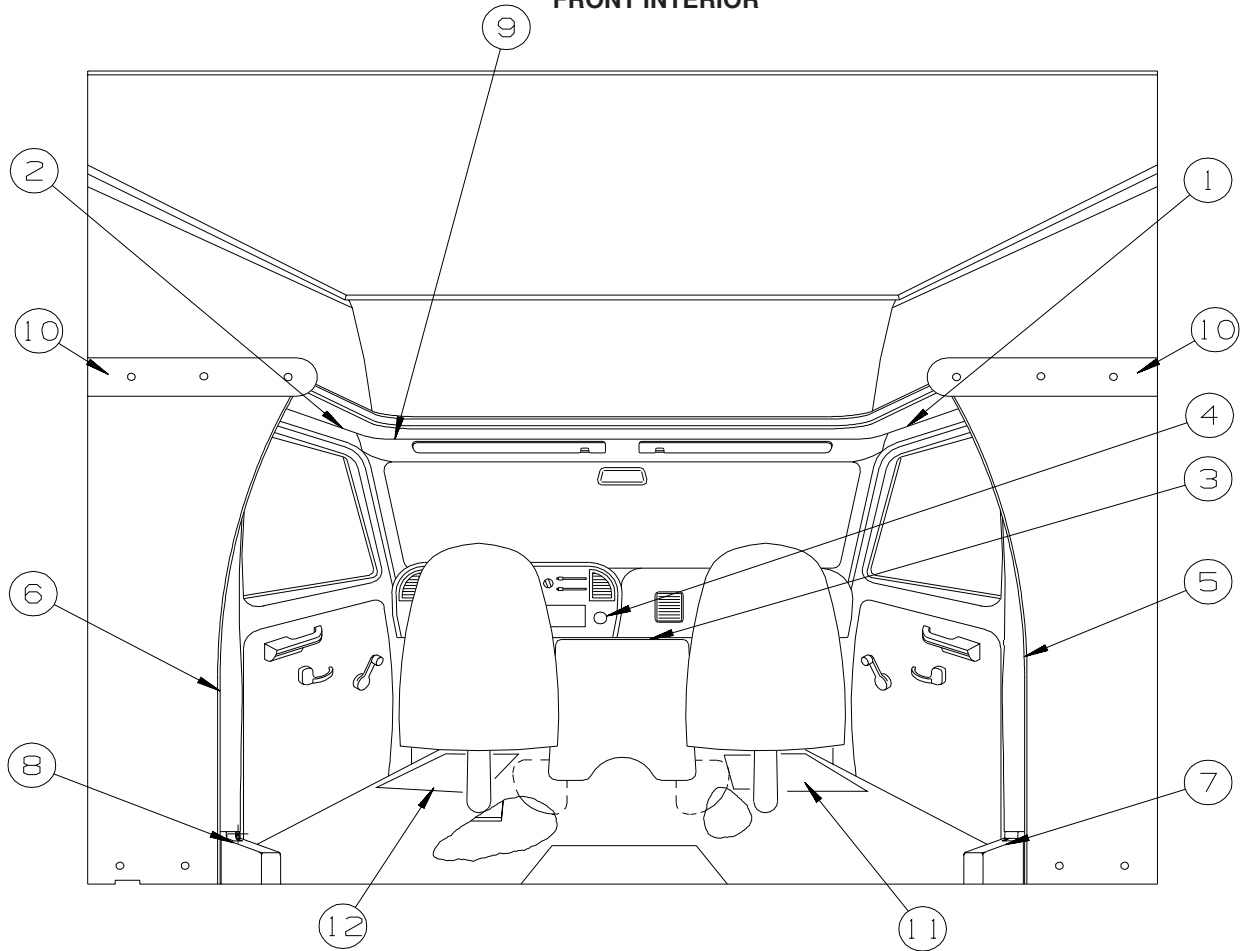

KEY	PART NUMBER	U/M	DESCRIPTION
1	106447-09-R13	EA	TRIM - CAB DOOR - UPPER/RIGHT HAND
2	106447-10-P13	EA	TRIM - CAB DOOR - UPPER/LEFT HAND
3	136524-03-03A	EA	APPLIQUE - BEZEL - DASH - WOOD GRAINED/GRAY BURL
4	136524-04-03A	EA	APPLIQUE - BEZEL - DASH - WOOD GRAINED/GRAY BURL
5	125031-01-H04	EA	TRIM - CAB - B-PILLAR - PASSENGER SIDE
6	125031-02-H04	EA	TRIM - CAB - B-PILLAR - DRIVER SIDE
7	106431-01-02A	EA	COVER - SEATBELT RECOIL - PASSENGER SIDE - VW GREY
8	106431-02-02A	EA	COVER - SEATBELT RECOIL - DRIVER SIDE - VW GREY
9	106448-06-P13	EA	HEADLINER - W/VINYL
10	142374-01-P13	EA	CAP - SLEEPERBOARD - PORTSMOUTH OAK
10	142374-01-P14	EA	CAP - SLEEPERBOARD - CONCERT CHERRY
10	142374-01-P33	EA	CAP - SLEEPERBOARD - WASHED MAPLE
11	125780-03-000	EA	MAT - FLOOR - FRONT PASSENGER - "1" - FORD (GRAY)
12	125780-04-000	EA	MAT - FLOOR - FRONT DRIVER - "1" - FORD (GRAY)

DRIVERS COMPARTMENT GROUP (CONTINUED)

CABINETS

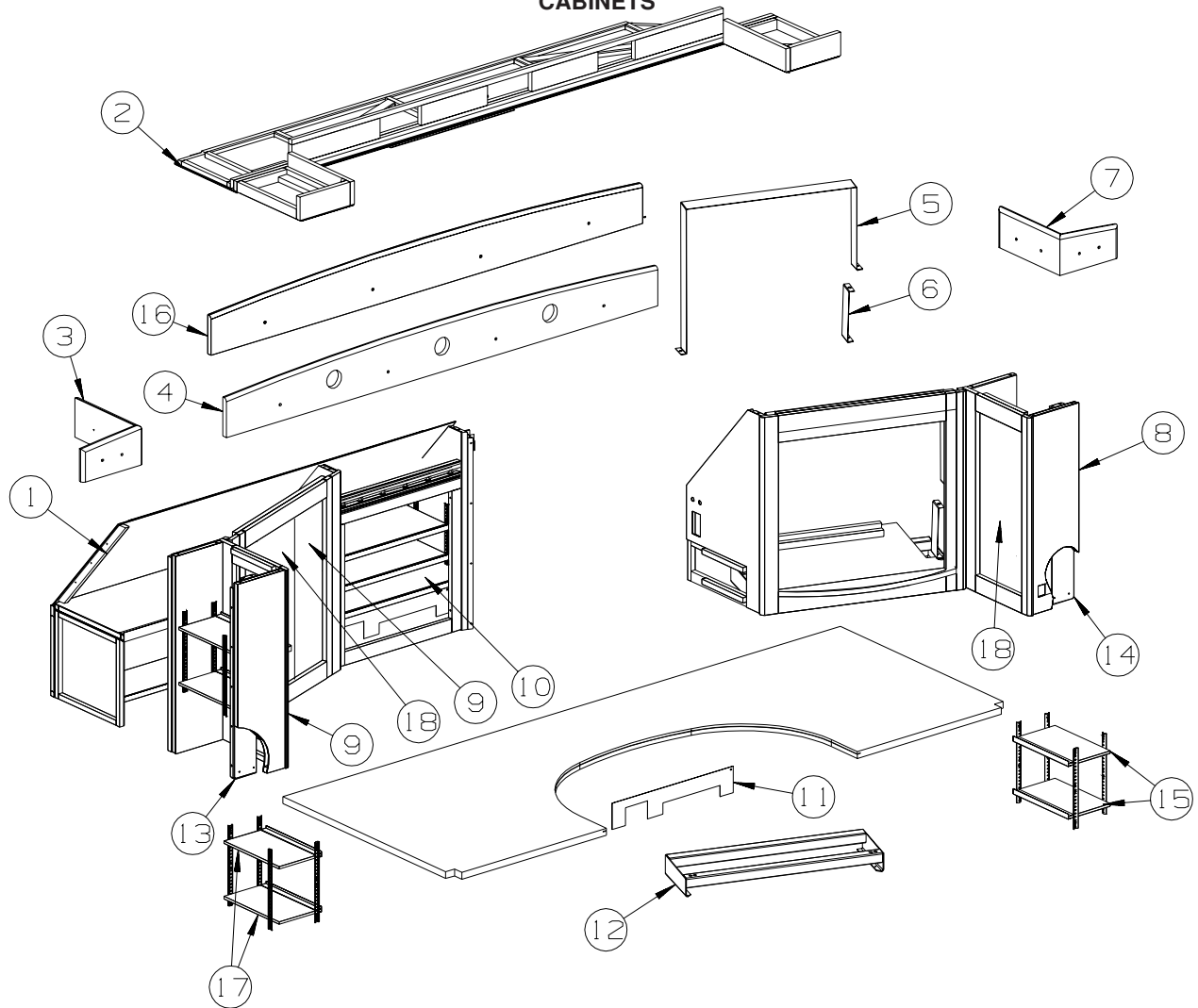

KEY	PART NUMBER	U/M	DESCRIPTION
1	142076-01-P07	EA	CABINET - ENT CTR - LH - W/O DOORS/HDW - PORTSMOUTH OAK
1	142076-01-P14	EA	CABINET - ENT CTR - LH - W/O DOORS/HDW - CONCERT CHERRY
1	142076-01-P33	EA	CABINET - ENT CTR - LH - W/O DOORS/HDW - WASHED MAPLE
1	142076-04-R13	EA	CABINET - ENT CTR - LH - W/O DOORS/HDW - PORTSMOUTH OAK - STEREO DVD/VCR W/REMOTE
1	142076-04-R14	EA	CABINET - ENT CTR - LH - W/O DOORS/HDW - CONCERT CHERRY - STEREO DVD/VCR W/REMOTE
1	142076-04-R21	EA	CABINET - ENT CTR - LH - W/O DOORS/HDW - WASHED MAPLE - STEREO DVD/VCR W/REMOTE
2	142079-01-P13	EA	CABINET - ENTERTAINMENT CENTER/TOP - W/O DOORS/HARDWARE
3	142078-07-P13	EA	TRIM/FACE - ENTERTAINMENT CENTER - PORTSMOUTH OAK
3	142078-07-P14	EA	TRIM/FACE - ENTERTAINMENT CENTER - CONCERT CHERRY
3	142078-07-P33	EA	TRIM/FACE - ENTERTAINMENT CENTER - WASHED MAPLE
4	142078-03-P13	EA	TRIM/FACE - ENTERTAINMENT CENTER - PORTSMOUTH OAK - SURROUND SOUND
4	142078-03-P14	EA	TRIM/FACE - ENTERTAINMENT CENTER - CONCERT CHERRY - SURROUND SOUND
4	142078-03-P33	EA	TRIM/FACE - ENTERTAINMENT CENTER - WASHED MAPLE - SURROUND SOUND
5	144148-03-02B	EA	BRACKET/TV TIEDOWN - E-COATED
6	136269-08-02B	EA	BRACKET/TV TIEDOWN - E-COATED
7	142078-08-P13	EA	TRIM/FACE - ENTERTAINMENT CENTER - PORTSMOUTH OAK
7	142078-08-P14	EA	TRIM/FACE - ENTERTAINMENT CENTER - CONCERT CHERRY
7	142078-08-P33	EA	TRIM/FACE - ENTERTAINMENT CENTER - WASHED MAPLE
8	142077-05-P13	EA	CABINET - ENTERTAINMENT CENTER/RIGHT HAND - W/O DOORS/HDW - PORTSMOUTH OAK
8	142077-05-P14	EA	CABINET - ENTERTAINMENT CENTER/RIGHT HAND - W/O DOORS/HDW - CONCERT CHERRY
8	142077-05-P33	EA	CABINET - ENTERTAINMENT CENTER/RIGHT HAND - W/O DOORS/HDW - WASHED MAPLE
9	141518-70-P19	EA	DOOR - ARCHED/PENCIL EDGE/LEFT HAND-12" X 25.9"-W/O HDW - PORTSMOUTH OAK
9	141518-70-P20	EA	DOOR - ARCHED/PENCIL EDGE/LEFT HAND-12" X 25.9"-W/O HDW - CONCERT CHERRY
9	141518-70-P33	EA	DOOR - ARCHED/PENCIL EDGE/LEFT HAND-12" X 25.9"-W/O HDW - WASHED MAPLE
10	100708-30-000	EA	DOOR/GLASS - TV CABINET - 18.8" X 18.8" - W/O HARDWARE
11	142200-01-R13	EA	PANEL - VINYL COVERED
11	142200-03-P07	EA	PANEL - VINYL COVERED - DC/AC INVERTER

DRIVERS COMPARTMENT GROUP (CONTINUED)
CABINETS (CONTINUED)

KEY	PART NUMBER	U/M	DESCRIPTION
12	142119-01-02B	EA	BRACKET - ENTERTAINMENT CENTER - E-COATED
13	136268-04-03B	EA	BRACKET - WINGWALL - OFF WHITE
14	136268-03-03B	EA	BRACKET - WINGWALL - OFF WHITE
15	142077-17-P07	EA	SHELF - W/PLASTIC EDGE MOLDING - PORTSMOUTH OAK
15	142077-17-P14	EA	SHELF - W/PLASTIC EDGE MOLDING - CONCERT CHERRY
15	142077-17-P33	EA	SHELF - W/PLASTIC EDGE MOLDING - WASHED MAPLE
16	142078-06-P13	EA	TRIM/FACE - ENTERTAINMENT CENTER - PORTSMOUTH OAK
16	142078-06-P14	EA	TRIM/FACE - ENTERTAINMENT CENTER - CONCERT CHERRY
16	142078-06-P33	EA	TRIM/FACE - ENTERTAINMENT CENTER - WASHED MAPLE
17	142076-34-P07	EA	SHELF - W/PLASTIC EDGE MOLDING - PORTSMOUTH OAK
17	142076-34-P14	EA	SHELF - W/PLASTIC EDGE MOLDING - CONCERT CHERRY
17	142076-34-P33	EA	SHELF - W/PLASTIC EDGE MOLDING - WASHED MAPLE
18	141520-70-P19	EA	DOOR - ARCHED/PENCIL EDGE/RIGHT HAND -12"X25.9"- W/O HDW - PORTSMOUTH OAK
18	141520-70-P20	EA	DOOR - ARCHED/PENCIL EDGE/RIGHT HAND -12"X25.9"- W/O HDW - CONCERT CHERRY
18	141520-70-P33	EA	DOOR - ARCHED/PENCIL EDGE/RIGHT HAND -12"X25.9"- W/O HDW - WASHED MAPLE
	076767-04-000	EA	CABLE - STAINLESS STEEL - 5.9"

ELECTRICAL GROUP 12V BODY WIRING

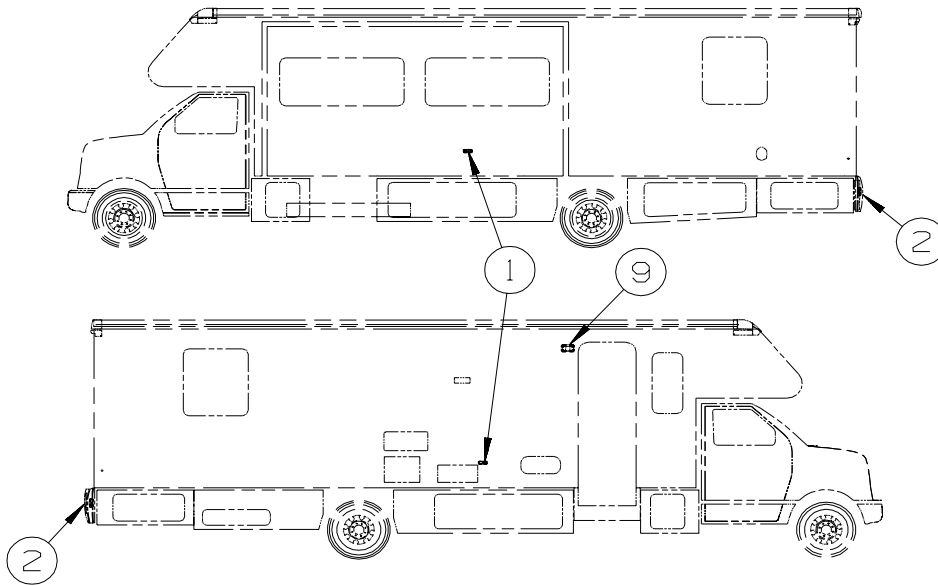
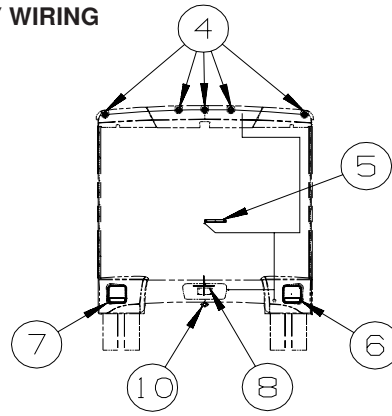
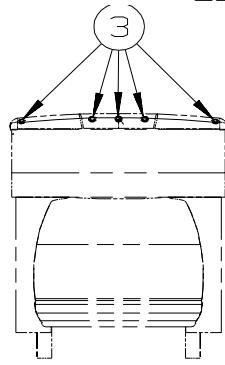

KEY	PART NUMBER	U/M	DESCRIPTION
1	111102-01-000	EA	BASE - MARKER LAMP - 430V, 431C
1	111102-02-000	EA	LENS - AMBER - MARKER LAMP - 430V, 431C
1	036196-01-000	EA	BULB - 12V - #194 - .27 AMP - BAYONETTE
2	111102-01-000	EA	BASE - MARKER LAMP
2	111102-03-000	EA	LENS - RED - MARKER LAMP
2	036196-01-000	EA	BULB - 12V - #194 - .27 AMP - BAYONETTE
3	138996-01-000	EA	LAMP - CLEARANCE - AMBER
3	138996-03-000	EA	BRACKET - CLEARANCE LIGHT
4	138996-02-000	EA	LAMP - CLEARANCE - RED
4	138996-03-000	EA	BRACKET - CLEARANCE LIGHT
5	136916-01-000	EA	LIGHT - CENTER BRAKE - L.E.D.
6	117831-01-000	EA	LAMP - STOP/TURN/TAILO/BACKUP
6	119157-01-000	EA	SOCKET - SINGLE CONTACT
6	119158-01-000	EA	SOCKET - DOUBLE CONTACT
6	037934-01-000	EA	BULB - 12V - #1156 - 2.1 AMP - CLEAR GLASS
6	037935-01-000	EA	BULB - 12V - #1157 OR #2057 - 2.1 AMP - CLEAR GLASS
7	117831-02-000	EA	LAMP - STOP/TURN/TAILO/BACKUP
7	119157-01-000	EA	SOCKET - SINGLE CONTACT
7	119158-01-000	EA	SOCKET - DOUBLE CONTACT
7	037934-01-000	EA	BULB - 12V - #1156 - 2.1 AMP - CLEAR GLASS
7	037935-01-000	EA	BULB - 12V - #1157 OR #2057 - 2.1 AMP - CLEAR GLASS
8	087201-01-000	EA	LIGHT - HALF ROUND - 1" X 1.7" - PLASTIC - BLACK OR WHITE
9*	097917-01-06A	EA	LIGHT - PORCH - ENTRY DOOR - BRIGHT WHITE
	008215-01-000	EA	BULB - 12 VOLT - #1003 - .94 AMP
10*	113589-01-000	EA	CONNECTOR - PLUG - TRAILER
10*	113589-02-000	EA	CONNECTOR - SOCKET - TRAILER

*COMPONENT PARTS LISTED LATER IN THIS GROUP

ELECTRICAL GROUP (CONTINUED)

12V BODY WIRING (CONTINUED)

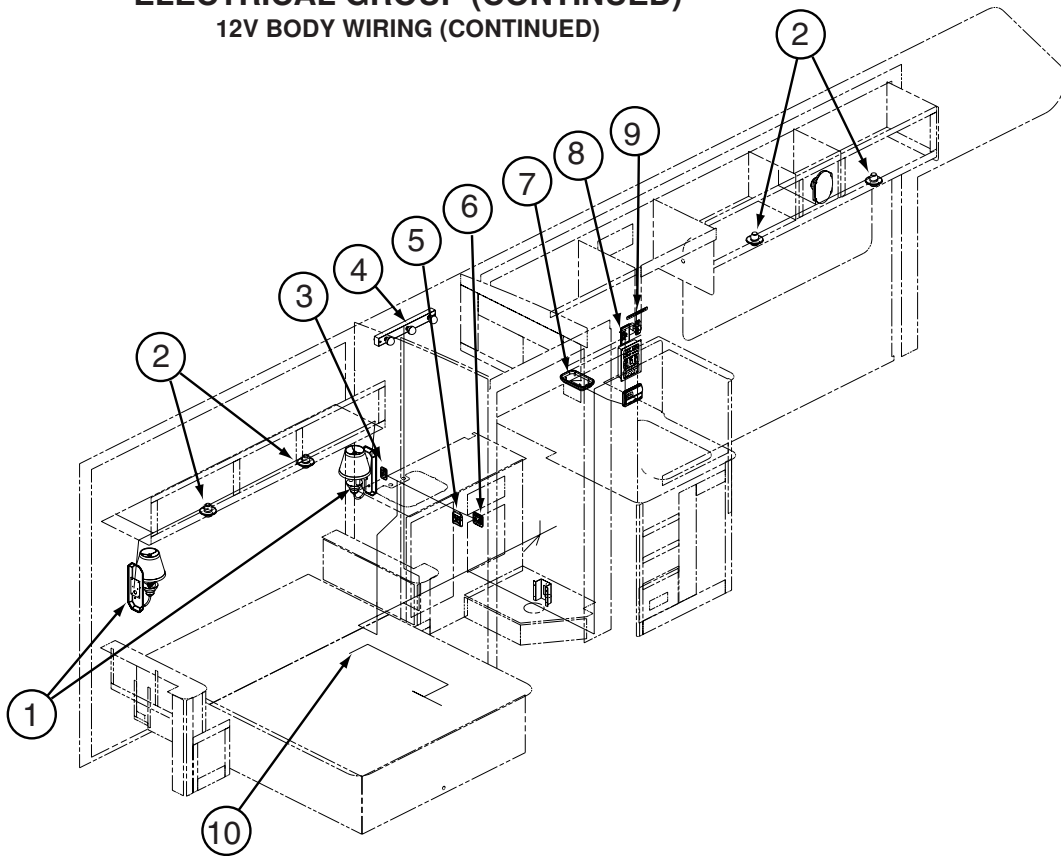

KEY	PART NUMBER	U/M	DESCRIPTION
1	119258-32-01A	EA	LAMP - WALL - BRASS - UL/CSA
1	119257-15-01A	EA	SHADE - LAMP - LINEN SILKARA FABRIC
1	067479-01-000	EA	BULB - 12V - #1076 - 1.80 AMP
2	132427-01-01A	EA	LIGHT - READING - SWIVEL/ROUND - BRASS
2	123917-01-000	EA	BULB - 12V - HALOGEN SPOT
3	135740-01-02A	EA	SWITCH - ROCKER - SPST - ON/OFF - WHITE
3	135741-01-02A	EA	SWITCH - BASE - SINGLE - WHITE
3	135742-08-01A	EA	BEZEL - SWITCH - MAKEUP - WHITE
4	138116-01-01A	EA	LIGHT/MAKE UP - 3 BULB - CURVED - W/O BULB - BRASS
	123918-01-000	EA	BULB - 12V - MAKEUP - WHITE
5	135740-01-01A	EA	SWITCH - ROCKER - SPST - ON/OFF - BROWN - CEILING
5	135740-02-01A	EA	SWITCH - ROCKER - SPDT - ON/ON - BROWN - AISLE
5	135741-02-01A	EA	SWITCH - BASE - DOUBLE - BROWN
5	135742-13-02A	EA	BEZEL - SWITCH - CEILING/AISLE - BROWN
6	135740-01-01A	EA	SWITCH - ROCKER - SPST - ON/OFF - BROWN
6	135741-02-01A	EA	SWITCH - BASE - DOUBLE - BROWN
6	135742-15-02A	EA	BEZEL - SWITCH - CEILING/SHOWER - BROWN
7*	137417-02-01A	EA	LIGHT - DOME - SINGLE - W/SWITCH/OPTIC LENS - WHITE
8	101894-03-01A	EA	SWITCH - TOGGLE - 15 AMP/120 VOLT - BROWN
			FROM: 00-00-00 THRU: 07-06-03
8	101911-01-01A	EA	WALL PLATE - SWITCH (1 GANG)
			FROM: 00-00-00 THRU: 07-06-03
8	135740-06-01A	EA	SWITCH - ROCKER - ON/OFF - LIGHTED - RED
			FROM: 07-07-03 THRU: 99-99-99
8	135741-01-01A	EA	SWITCH - BASE - SINGLE - BROWN
			FROM: 07-07-03 THRU: 99-99-99
8	135742-35-02A	EA	BEZEL - SWITCH - WATER HEATER/110 VOLT - BROWN
			FROM: 07-07-03 THRU: 99-99-99
9	081994-10-000	EA	PLATE/SWITCH - SLIDEOUT
9	108357-06-000	EA	SWITCH - ROCKER - DPDT - MOM/OFF/MOM - 6 TERM - W/O COVER
9	108356-02-01A	EA	COVER/ACTUATOR SWITCH - 2 ROWS DIMPLES- CONTURA II - BLACK
9	108355-01-000	EA	HOUSING - SWITCH
10	108357-15-000	EA	SWITCH - ROCKER - DPDT - ON/NONE/ON - W/LIGHT W/O COVER
10	108356-04-01A	EA	COVER/ACTUATOR SWITCH - 2 ROWS DIMPLES W/LENS-CONTURA-BLK
10	108355-01-000	EA	HOUSING - SWITCH

*COMPONENT PARTS LISTED LATER IN THIS GROUP

ELECTRICAL GROUP (CONTINUED)

12V BODY WIRING (CONTINUED)

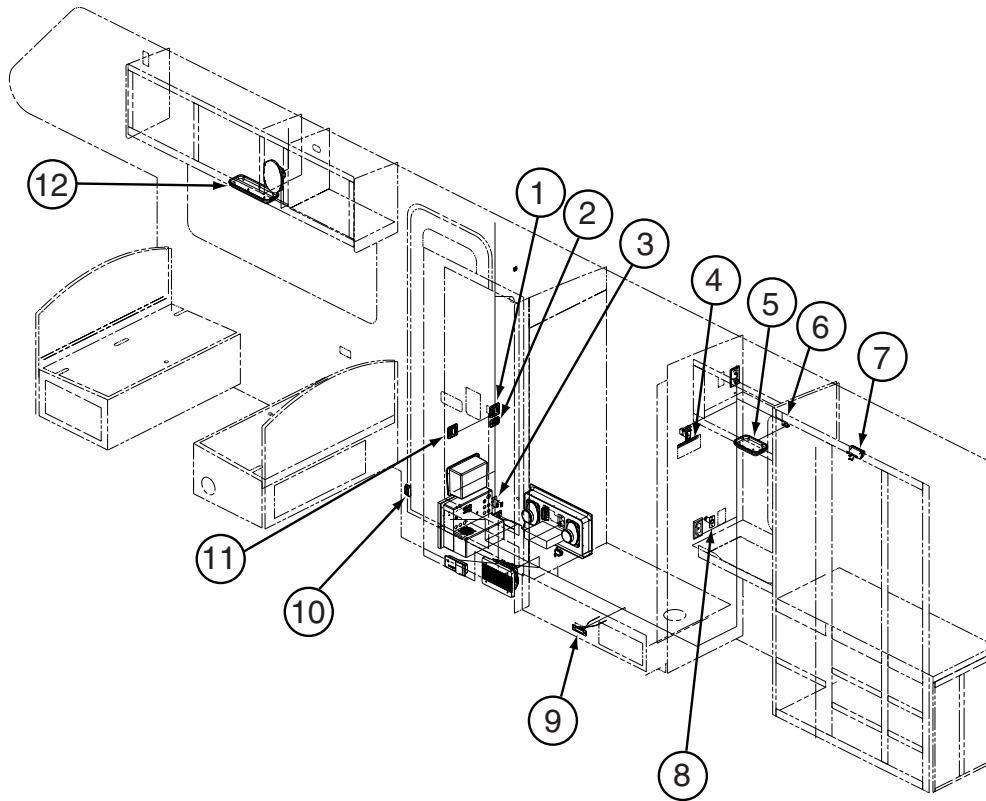

KEY	PART NUMBER	U/M	DESCRIPTION
1	135740-01-01A	EA	SWITCH - ROCKER - SPST - ON/OFF - BROWN
1	135741-02-01A	EA	SWITCH - BASE - DOUBLE - BROWN
1	135742-19-02A	EA	BEZEL - SWITCH - CEILING/PORCH - BROWN
2	135740-01-01A	EA	SWITCH - ROCKER - SPST - ON/OFF - BROWN
2	135741-01-01A	EA	SWITCH - BASE - SINGLE - BROWN
2	135742-11-02A	EA	BEZEL - SWITCH - STEP - BROWN
3	108357-06-000	EA	SWITCH - ROCKER - DPDT - MOM/OFF/MOM - 6 TERM - W/O COVER
3	108356-11-01A	EA	COVER/ACTUATOR SWITCH - 3 GROOVES - AUX BATT - BLACK
3	108355-01-000	EA	HOUSING - SWITCH
3	098351-07-01A	EA	PLATE/SWITCH - 1 GANG - POLISHED BRASS - GENERATOR
4	108357-06-000	EA	SWITCH - ROCKER - DPDT - MOM/OFF/MOM - 6 TERM - W/O COVER
4	108356-02-01A	EA	COVER/ACTUATOR SWITCH - 2 ROWS DIMPLES- CONTURA II - BLACK
4	108355-01-000	EA	HOUSING - SWITCH
4	081994-10-000	EA	PLATE/SWITCH - SLIDEOUT
5*	137417-02-01A	EA	LIGHT - DOME - SINGLE - W/SWITCH/OPTIC LENS - WHITE
6	056264-01-000	EA	SWITCH - LEAF ACTUATOR
7*	087694-01-000	EA	LIGHT - WARDROBE/CLOSET - W/SWITCH
8	111414-01-000	EA	RECEPTACLE/SOCKET - 12 VOLT
8	111386-01-04B	EA	PLATE - RECEPTACLE - 12 VOLT - BLACK
9	061424-01-000	EA	LIGHT - AISLE - 12 VOLT - RECTANGULAR
10	116995-02-000	EA	SWITCH/MAGNET - ELECTRIC STEP - BLACK/WHITE-CLOSED CIRCUIT
11	135740-01-01A	EA	SWITCH - ROCKER - SPST - ON/OFF - BROWN - CEILING
11	135740-02-01A	EA	SWITCH - ROCKER - SPDT - ON/ON - BROWN - AISLE
11	135741-02-01A	EA	SWITCH - BASE - DOUBLE - BROWN
11	135742-13-02A	EA	BEZEL - SWITCH - CEILING/AISLE - BROWN
12*	137417-05-01A	EA	LIGHT - DOME - DOUBLE - W/SWITCH/OPTIC LENS - WHITE

*COMPONENT PARTS LISTED LATER IN THIS GROUP

ELECTRICAL GROUP (CONTINUED)
12V BODY WIRING (CONTINUED)

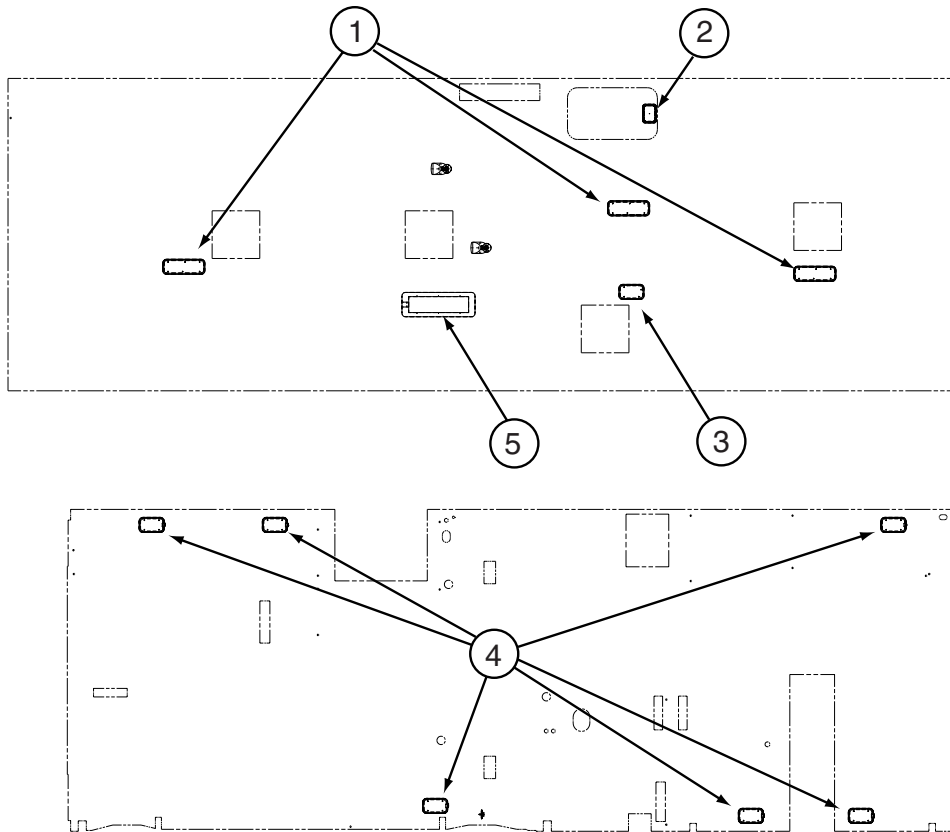

KEY	PART NUMBER	U/M	DESCRIPTION
1*	137417-06-01A	EA	LIGHT - DOME - DOUBLE - W/FROSTED LENS - W/O SWITCH-WHITE
2*	121935-01-01A	EA	LIGHT - DOME - SHOWER
3*	137417-03-01A	EA	LIGHT - DOME - SINGLE - W/O SWITCH - W/FROSTED LENS-WHITE
4*	137417-01-01A	EA	LIGHT - DOME - SINGLE - W/SWITCH/FROSTED LENS - WHITE
5	130338-01-01A	EA	LIGHT - FLUORESCENT 18" - THIN LITE
5	091937-03-000	EA	BULB - FLUORESCENT LIGHT - 12 VOLT

***COMPONENT PARTS LISTED LATER IN THIS GROUP**

ELECTRICAL GROUP (CONTINUED)

FRONT END WIRING

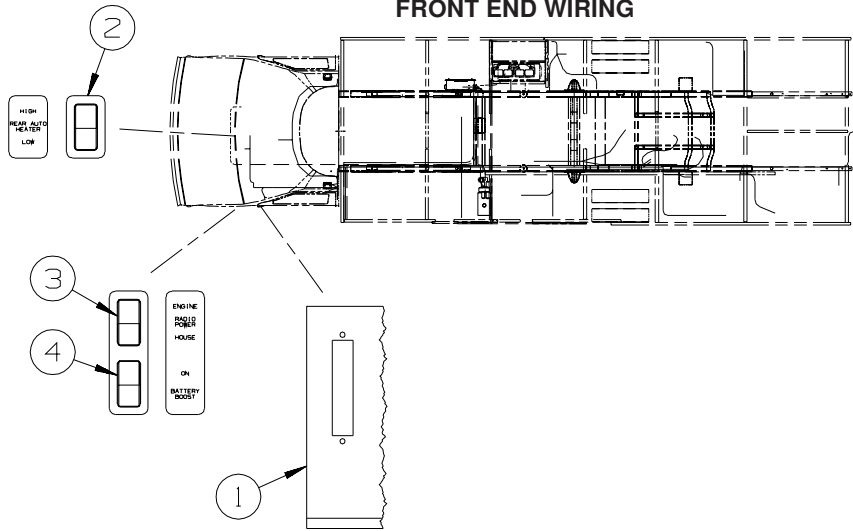

KEY	PART NUMBER	U/M	DESCRIPTION
1	112643-01-000	EA	LIGHT - SINGLE - SWIVEL
	112642-01-06A	EA	TRIM RING - SINGLE LIGHT - BLACK
	058028-01-000	EA	CONNECTOR - ELECTRICAL PIGTAIL - NYLON - CLEAR
2	108357-03-000	EA	SWITCH - ROCKER - SPDT - ON/OFF/ON - 3 TERM - W/O COVER
	108356-02-01A	EA	COVER/ACTUATOR SWITCH - 2 ROWS DIMPLES- CONTURA II - BLACK
3	108357-08-000	EA	SWITCH - ROCKER - DPDT - 0N/NONE/ON - 6 TERM - W/O COVER
	108356-02-01A	EA	COVER/ACTUATOR SWITCH - 2 ROWS DIMPLES- CONTURA II - BLACK
4	108357-09-000	EA	SWITCH - ROCKER - SPDT - ON/NONE/MOM - 3 TERM - W/O COVER
	108356-02-01A	EA	COVER/ACTUATOR SWITCH - 2 ROWS DIMPLES- CONTURA II - BLACK

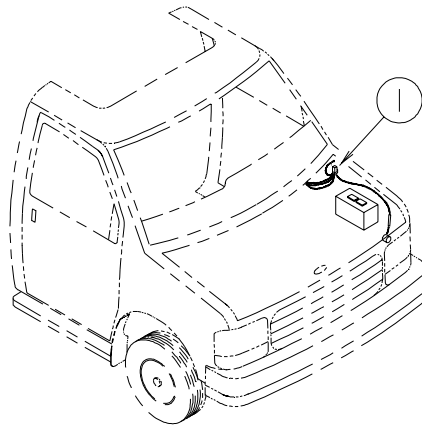

KEY	PART NUMBER	U/M	DESCRIPTION
1	100138-01-000	EA	MODULE - DAYTIME/RUNNING LIGHT - HAMSAR DRL #H8005B

ELECTRICAL GROUP (CONTINUED)
COMPONENT PARTS FOR LIGHTS & SWITCHES

			087694-01-000	
KEY	PART NUMBER	U/M DESCRIPTION		VENDOR NO.
	087694-01-700	EA BULB		GE561
			097917-01-06A	
KEY	PART NUMBER	U/M DESCRIPTION		VENDOR NO.
	097917-01-700	EA LENS-LIGHT, CLEAR		30-78-021
			113589-01-000	
KEY	PART NUMBER	U/M DESCRIPTION		VENDOR NO.
	113589-01-700	EA ADAPTER, 4-WAY/6-WAY		5291
			113589-02-000	
KEY	PART NUMBER	U/M DESCRIPTION		VENDOR NO.
	113589-03-700	EA ADAPTER 7 RND SPADE/4 FLAT		5290
			121935-01-01A	
KEY	PART NUMBER	U/M DESCRIPTION		VENDOR NO.
	121935-01-700	EA LENS ONLY		809511
			137417-01-01A	
KEY	PART NUMBER	U/M DESCRIPTION		VENDOR NO.
	137417-01-700	EA LENS - SINGLE (FROSTED)		810868
			137417-02-01A	
KEY	PART NUMBER	U/M DESCRIPTION		VENDOR NO.
	137417-02-700	EA LENS - SINGLE OPTIC		810844
			137417-03-01A	
KEY	PART NUMBER	U/M DESCRIPTION		VENDOR NO.
	137417-01-700	EA LENS - SINGLE (FROSTED)		810868
			137417-05-01A	
KEY	PART NUMBER	U/M DESCRIPTION		VENDOR NO.
	137417-05-700	EA LENS - DOUBLE OPTIC		810845
			137417-06-01A	
KEY	PART NUMBER	U/M DESCRIPTION		VENDOR NO.
	137417-06-700	EA LENS - DOUBLE WHITE		810867

ELECTRICAL GROUP (CONTINUED)

CIRCUIT BREAKERS & FUSES

KEY	PART NUMBER	U/M	DESCRIPTION
	008233-01-000	EA	FUSE - 12 VOLT - 6 AMP
	008235-01-000	EA	FUSE - 15 AMP/12VOLT - AUTOMOTIVE
	033573-01-000	EA	CIRCUIT BREAKER W/MOUNT-20A, 12V - FASCO 1711-2026
	062901-02-000	EA	FUSE - 5 AMP - AUTOMOTIVE
	062901-04-000	EA	FUSE - 10 AMP - AUTOMOTIVE
	062901-05-000	EA	FUSE - 15 AMP - AUTOMOTIVE
	062901-06-000	EA	FUSE - 20 AMP - AUTOMOTIVE
	062901-07-000	EA	FUSE - 25 AMP - AUTOMOTIVE
	062901-08-000	EA	FUSE - 30 AMP - AUTOMOTIVE
	083209-01-000	EA	CIRCUIT BREAKER - 15 AMP - 120 VOLT - CANADIAN
	083209-02-000	EA	CIRCUIT BREAKER - 15/15 AMP - 120 VOLT
	083209-03-000	EA	CIRCUIT BREAKER - 15/20 AMP - 120 VOLT
	083209-04-000	EA	CIRCUIT BREAKER - 30 AMP - 120 VOLT
	083209-05-000	EA	CIRCUIT BREAKER - 20 AMP - 120 VOLT
	083209-06-000	EA	CIRCUIT BREAKER - 30/15 AMP - 120 VOLT
	083209-07-000	EA	CIRCUIT BREAKER - 20/20 AMP - 120 VOLT
	083209-10-000	EA	CIRCUIT BREAKER - 20/30 AMP - 120 VOLT
	083209-11-000	EA	CIRCUIT BREAKER - 20/15 AMP - 120 VOLT
	092786-03-000	EA	BUSS BAR - 6.9" LONG
	092786-06-000	EA	BUSS BAR
	093654-01-000	EA	CIRCUIT BREAKER - 6 AMP - 12 VOLT - PUSH BUTTON - WHITE
	093654-02-000	EA	CIRCUIT BREAKER - 15 AMP - 12 VOLT - PUSH BUTTON - WHITE
	093654-03-000	EA	CIRCUIT BREAKER - 20 AMP - 12 VOLT - PUSH BUTTON - WHITE
	093654-11-000	EA	COVER - RESET BUTTON
	093655-01-000	EA	CIRCUIT BREAKER - 25 AMP - 12 VOLT - PUSH BUTTON - WHITE
	093655-02-000	EA	CIRCUIT BREAKER - 30 AMP - 12 VOLT - PUSH BUTTON - WHITE
	093655-03-000	EA	CIRCUIT BREAKER - 40 AMP - 12 VOLT - PUSH BUTTON - WHITE
	097611-01-000	EA	CIRCUIT BREAKER - 10 AMP
	097611-03-000	EA	CIRCUIT BREAKER - 20 AMP
	097611-04-000	EA	CIRCUIT BREAKER - 25 AMP
	106656-01-000	EA	FUSE BLOCK - 4 CAVITY - AUTOFUSE
	108567-01-000	EA	CIRCUIT BREAKER - 40 AMP - 12 VOLT - TYPE II
	111683-01-000	EA	FUSE - HOLDER - GLASS - 1/4" X 1 1/4"
	113482-01-000	EA	CIRCUIT BREAKER - 55 AMP - MANUAL
	115187-01-000	EA	FUSE - 300 AMP - NON-DELAY
	115187-02-000	EA	FUSE HOLDER - BUSS ANN/ANL BLOCK
	118531-05-02B	EA	PLATE - CIRCUIT BREAKER - E-COAT - CHIEFTAIN/SUNFLYER L-SERIES
	122811-01-000	EA	CIRCUIT BREAKER - 20/50/50/20 AMP - 250V
	134127-01-000	EA	CIRCUIT BREAKER - 10 AMP - MINI
	139067-01-02B	EA	PLATE - CIRCUIT BRKR-HOUSE - E-CTD - 10 PLACE
	139067-02-02B	EA	PLATE - CIRCUIT BRKR-HOUSE - E-CTD - 12 PLACE
	139067-03-02B	EA	PLATE-CIRCUIT BKR/HOUSE-E-CTD - 14 PLACE
	139067-04-02B	EA	PLATE - CIRCUIT BRKR-HOUSE - E-CTD - TOP 10 PLACE
	139067-05-02B	EA	PLATE - CIRCUIT BREAKER/HOUSE - E-COATED - 16 PLACE
	139067-06-02B	EA	PLATE - CIRCUIT BREAKER/HOUSE - E-COATED - 18 PLACE
	139067-07-02B	EA	PLATE - CIRCUIT BREAKER/HOUSE - E-COATED - 21 PLACE
	141789-01-000	EA	SPACER - CIRCUIT BREAKER

CONVERTER, INVERTER, LOAD CENTERS

KEY	PART NUMBER	U/M	DESCRIPTION
	083208-06-000	EA	CONTROL CENTER - 45 AMP/120V/12V - W/O BREAKERS/ELECTRONIC
	099048-04-000	EA	INVERTER - 300 WATT

ELECTRICAL GROUP (CONTINUED)

110V WIRING

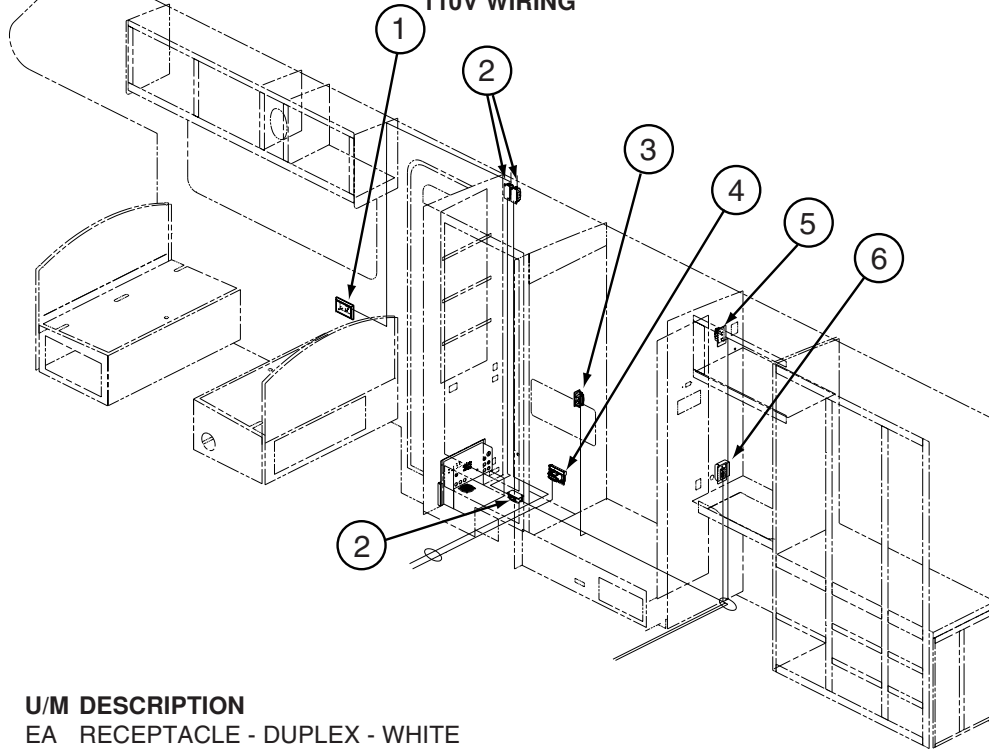

KEY	PART NUMBER	U/M	DESCRIPTION
1	058708-06-000	EA	RECEPTACLE - DUPLEX - WHITE
1	133713-01-20A	EA	SPACER/RECEPTACLE - WHITE VINYL
2	058707-02-000	EA	RECEPTACLE - BLANK - JUNCTION BOX
3	058707-01-000	EA	RECEPTACLE - ELECTRIC - SINGLE - BROWN
4	131826-01-01A	EA	RECEPTACLE - EXTERIOR - W/COVER/GASKET - WHITE
5	058708-01-000	EA	RECEPTACLE - ELECTRIC - DOUBLE - BROWN
6	147446-01-02A	EA	RECEPTACLE - GFCI - 15A 125V - BROWN
6	147450-01-02A	EA	PLATE - ELECTRICAL OUTLET - BROWN

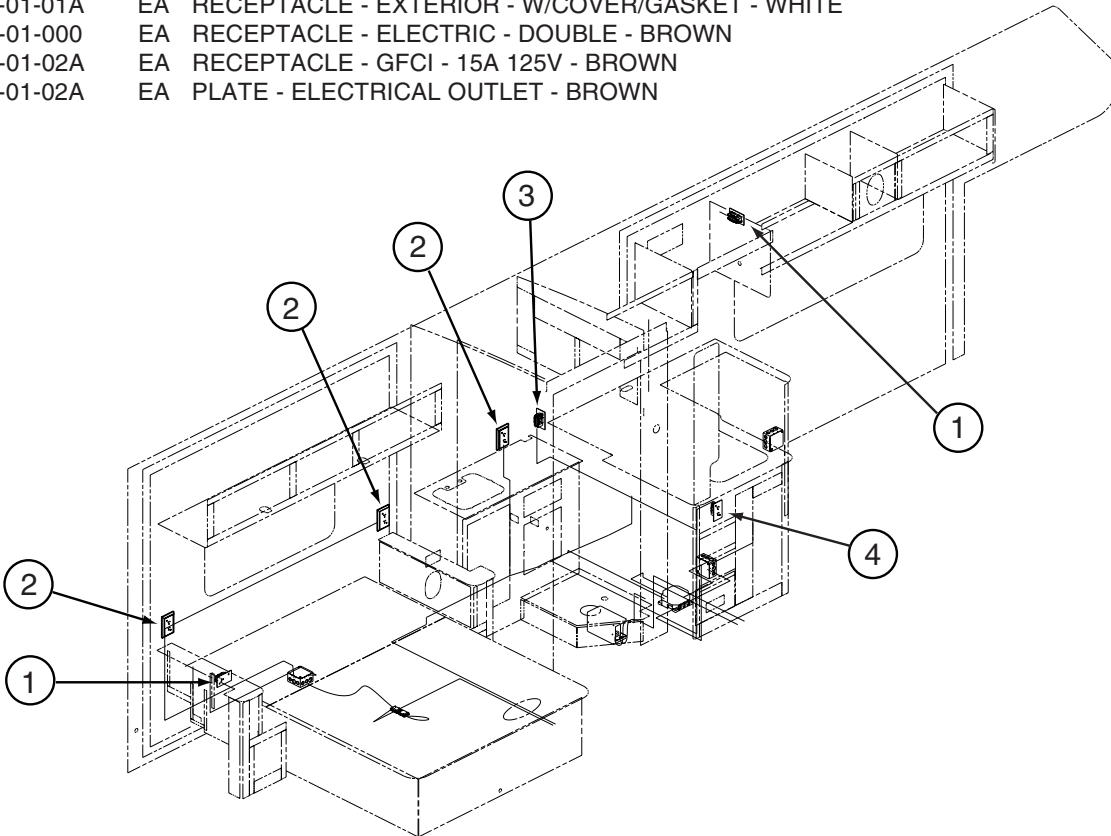

KEY	PART NUMBER	U/M	DESCRIPTION
1	058708-05-000	EA	RECEPTACLE - ELECTRIC - SINGLE - BROWN
2	058708-06-000	EA	RECEPTACLE - DUPLEX - WHITE
2	133713-01-20A	EA	SPACER/RECEPTACLE - WHITE VINYL
3	058708-06-000	EA	RECEPTACLE - DUPLEX - WHITE
3	133713-11-20A	EA	SPACER - RECEPTACLE - VINYL WHITE
4	058708-01-000	EA	RECEPTACLE - ELECTRIC - DOUBLE - BROWN

ELECTRICAL GROUP (CONTINUED)

ENTERTAINMENT WIRING

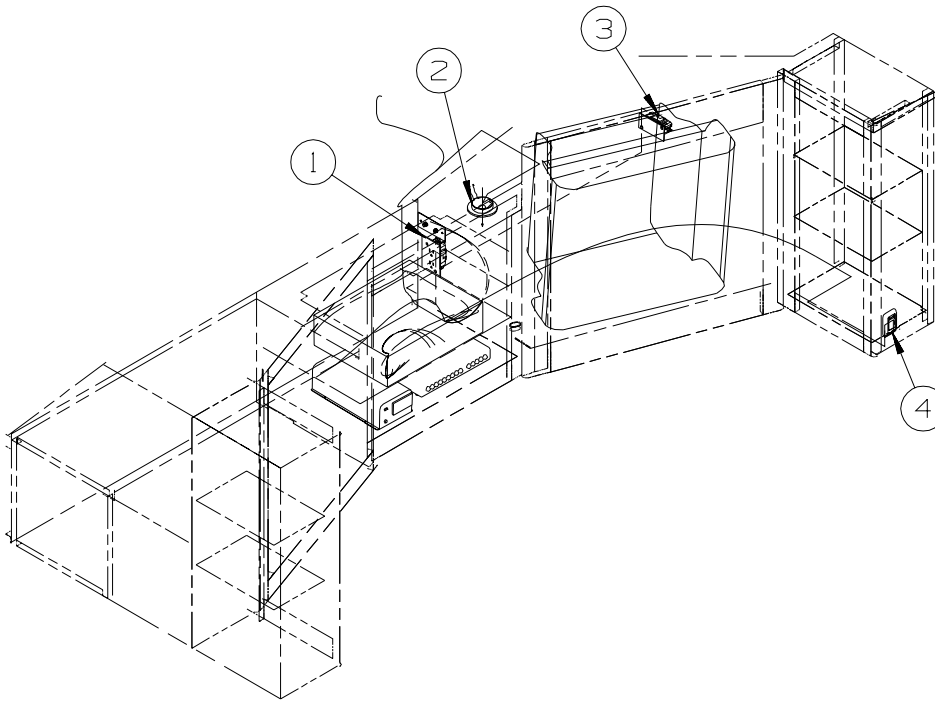

KEY	PART NUMBER	U/M	DESCRIPTION
1	058708-01-000	EA	RECEPTACLE - ELECTRIC - DOUBLE - BROWN
2*	123775-01-01A	EA	LIGHT - HALOGEN - ROUND
3	058707-02-000	EA	RECEPTACLE - BLANK - JUNCTION BOX
4	135740-01-01A	EA	SWITCH - ROCKER - SPST - ON/OFF - BROWN
4	135741-01-01A	EA	SWITCH - BASE - SINGLE - BROWN
4	135742-07-02A	EA	BEZEL - SWITCH - CEILING - BROWN

***COMPONENT PARTS LISTED LATER IN THIS GROUP**

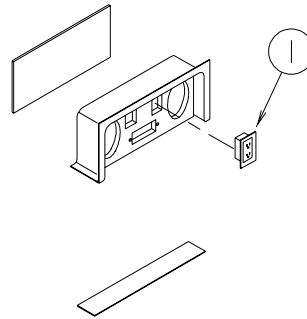

KEY	PART NUMBER	U/M	DESCRIPTION
1	058708-01-000	EA	RECEPTACLE - ELECTRIC - DOUBLE - BROWN

ELECTRICAL GROUP (CONTINUED)
COMPONENT PARTS FOR ENTERTAINMENT WIRING

123775-01-01A

KEY	PART NUMBER	U/M	DESCRIPTION	VENDOR NO
	123775-01-700	EA	BULB - 10 WATT - HALOGEN	71-JC10
	123775-01-701	EA	BEZEL/LENS - RECESSED LIGHT	

ELECTRICAL GROUP (CONTINUED)

BOXES & CORDS

KEY	PART NUMBER	U/M	DESCRIPTION
	008289-01-000	EA	BOX - ELECTRIC/STEEL - 4" X 4" - 1/2" & 3/4" KNOCKOUTS
	091910-01-000	EA	BOX - ELECTRIC - 3.8" X 3.5" X 1.8" - PLASTIC
	091910-02-000	EA	BOX - ELECTRIC - 2.2" X 3.5" X 1.8" - PLASTIC
	131679-01-000	EA	BOX/ELECTRIC-WATERPROOF-4" X 4" - W/4 3/4"OUTLETS-UL/CSA
	133070-01-000	EA	BOX - ELECTRIC/PLASTIC - 3" X 2" X 2.8" - UL
	133070-02-000	EA	BOX - ELECTRIC/PLASTIC - 3" X 2" X 2.8" - CSA
	141272-01-02B	EA	BOX - ELECTRICAL - E-COATED
	092492-16-000	EA	SEAL - ELECTRICAL BOX
	008054-01-000	EA	CORD - POWER - 10/3 WIRE - 30 AMP - 25'
	115832-01-000	FT	CORD - HEAVY DUTY - 14-2W GROUND
	008294-01-000	EA	COVER - ELECTRIC BOX - BLANK/STEEL - 4" X 4" - GRAY
	131680-01-000	EA	COVER - F/ELECTRIC BOX W/GASKET 4" X 4" - UL/CSA
	141273-01-02B	EA	COVER - ELECTRICAL BOX - E-COATED

WIRE ASSEMBLIES

KEY	PART NUMBER	U/M	DESCRIPTION
	096449-01-000	EA	WIRE ASSEMBLY - WATER TANK TO MONITOR PANEL
	106851-01-000	EA	WIRE ASSEMBLY - RUNNING LIGHTS - FUSE
	116894-01-000	EA	WIRE ASSEMBLY - SPEED SENSOR EXTENDED
	096451-06-000	EA	WIRE F/SENSORS - GREY WATER - 23.6"
	096450-01-000	EA	WIRE F/SENSORS - BLACK WATER - 39.3"
	096450-05-000	EA	WIRE F/SENSORS - BLACK WATER - 23.6"
	124882-10-000	EA	WIRE LOOM - AMPLIFIER - Q SURROUND
	125853-04-000	EA	WIRE LOOM - ENTERTAINMENT CENTER
	137135-03-000	EA	WIRE LOOM - DIGITAL ELEVATION SENSOR
	137135-04-000	EA	WIRE HARNESS - POWER - DIGITAL ELEVATION SENSOR
	142258-02-000	EA	WIRE LOOM - VIDEO SWITCH/POWER SUPPLY
	135420-08-000	EA	WIRE - RADIO - FORD C - 4 PIN

ELECTRICAL GROUP (CONTINUED)

CONNECTORS & CONDUIT

KEY	PART NUMBER	U/M	DESCRIPTION
	007940-01-000	EA	RECEPTACLE/SLIDE 16 TO 12 AWG - FEMALE END
	007954-01-000	EA	RECEPTACLE - HOUSING - 6 POSITION
	007956-05-000	EA	INSULATOR - SHRINK - 1/4" ID X 1 1/2"
	008058-01-700	EA	ADAP-ELEC.30AMP M X 50 AMP F 30M50F
	008058-01-000	EA	ADAPTER - POWER CORD - 30 AMP TO 15 AMP
	008311-01-000	EA	CONNECTOR - WIRE NUT - INSULATED - RED
	008312-01-000	EA	CONNECTOR - WIRE NUT - INSULATED - BLUE
	008313-01-000	EA	CONNECTOR - WIRE NUT - INSULATED - YELLOW
	008314-01-000	EA	CONNECTOR - WIRE NUT - INSULATED - GRAY
	008326-01-000	EA	TERMINAL - RING - 16/14 WIRE - 3/8" STUD
	008328-01-000	EA	TERMINAL - RING - 12/10 WIRE - #10 STUD FIT
	008331-01-000	EA	TERMINAL - RING - TONGUE - #4 WIRE - 3/8" STUD - COPPER
	008348-01-000	EA	TERMINAL - RING - 3/8" STUD 2 GA. WIRE
	008355-01-000	EA	CONNECTOR - CABLE CLAMPING - 3/4"
	008356-01-000	EA	CONNECTOR - PLASTIC - 3/8"
	008356-02-000	EA	CONNECTOR - PLASTIC - 21/32"
	008394-01-000	FT	CONDUIT - FLEXIBLE - 1/2"
	008398-01-000	EA	CONNECTOR - 1/2" X 90 DEGREE - FLEX CONDUIT - UL & CSA
	035416-04-000	EA	TERMINAL - RING - #10 STUD FIT - INSULATED BARREL #16/14
	041953-01-000	FT	CONDUIT - CONVOLUTE SLIT - .5" ID - POLYETHYLENE
	041953-02-000	FT	CONDUIT - CONVOLUTE SLIT - .6" ID - POLYETHYLENE
	041953-03-000	FT	CONDUIT - CONVOLUTE SLIT - 1" ID (CLOTHES ROD COVER)
	041953-06-000	FT	CONDUIT - CONVOLUTE SLIT - .4" ID - POLYETHYLENE
	041953-07-000	FT	CONDUIT - CONVOLUTE SLIT - .25" ID - POLYETHYLENE
	041953-08-000	FT	CONDUIT - CONVOLUTE SLIT - 1.5" ID - POLYETHYLENE
	041953-09-000	FT	CONDUIT - CONVOLUTE SLIT - .5" ID - NYLON
	041953-10-000	FT	CONDUIT - CONVOLUTE SLIT - .75" ID - NYLON
	041953-11-000	FT	CONDUIT - CONVOLUTE SLIT - 1.06" ID - NYLON
	041953-12-000	FT	CONDUIT - CONVOLUTE SOLID - 1.1" ID - NYLON
	041953-13-000	FT	CONDUIT - CONVOLUTE SLIT - 1.25" ID
	041953-14-000	FT	CONDUIT - CONVOLUTE SLIT - 1.5" ID
	041953-15-000	FT	CONDUIT - CONVOLUTE SLIT - 2"
	041953-16-000	FT	CONDUIT - CONVOLUTE SLIT - 2"
	047443-01-000	EA	TERMINAL - .250 RECEPTACLE FIT - INSULATED - 16/14 AWG
	047443-02-000	EA	TERMINAL - .250 RECEPTACLE FIT - INSULATED - 12/10 AWG
	058028-01-000	EA	CONNECTOR - ELECTRICAL PIGTAIL - NYLON - CLEAR
	062036-01-000	EA	TERMINAL - PACK - CON - 12/10 AWG
	074017-02-000	EA	HOUSING - 5 POSITION - RIGHT ANGLED
	077479-01-000	EA	BOOT - BATTERY TERMINAL - DOUBLE CABLE
	077479-02-000	EA	BOOT - BATTERY TERMINAL - SINGLE CABLE
	080015-02-000	EA	RECEPTACLE - FLAG - .185 - 16/14 GAUGE
	080015-03-000	EA	RECEPTACLE - FLAG - .250 - 14/16 GAUGE
	082109-01-000	EA	HOUSING - CONNECTOR - PACKARD
	082741-01-000	EA	CONNECTOR BODY - 2 CONNECTOR MALE
	087225-01-000	FT	SLEEVING - 1/2" - TYPE H
	087949-01-000	EA	BUSS BAR - 2 POSITION - .6" X 1.5"
	087949-03-000	EA	BUSS BAR - 4 POSITION
	087949-05-000	EA	BUSS BAR - 7 POSITION
	088473-01-000	EA	HOUSING - PIN - 12 CAVITY (3 ROWS OF 4)
	088473-02-000	EA	HOUSING - PIN - 15 CAVITY (3 ROWS OF 5)
	088473-03-000	EA	HOUSING - PIN - 9 CAVITY (3 ROWS OF 3)
	088473-04-000	EA	HOUSING - PIN - 8 CAVITY IN-LINE
	088473-06-000	EA	HOUSING - PIN - 6 CAVITY (2 ROWS OF 3)
	088473-08-000	EA	HOUSING - PIN - 4 CAVITY - IN-LINE
	088473-09-000	EA	HOUSING - PIN - 3 CAVITY - IN-LINE
	088473-10-000	EA	HOUSING - PIN - 2 CAVITY - IN LINE
	088474-01-000	EA	HOUSING - SOCKET - 12 CAVITY
	088474-02-000	EA	HOUSING - SOCKET - 15 CAVITY
	088474-03-000	EA	HOUSING - SOCKET - 9 CAVITY
	088474-06-000	EA	HOUSING - SOCKET - 6 CAVITY
	088474-08-000	EA	HOUSING - SOCKET - 4 CAVITY
	088474-09-000	EA	HOUSING - SOCKET - 3 CAVITY
	088474-10-000	EA	HOUSING - SOCKET - 2 CAVITY

ELECTRICAL GROUP (CONTINUED)
CONNECTORS & CONDUIT (CONTINUED)

KEY	PART NUMBER	U/M	DESCRIPTION
	088475-01-000	EA	PIN - CONNECTOR - 14-20 AWG
	088475-02-000	EA	PIN - CONNECTOR - 10-12 AWG
	088476-01-000	EA	TERMINAL - ELECTRICAL
	088476-02-000	EA	SOCKET - CONNECTOR - 12-10 GA - PRE-TIN
	098261-01-000	EA	SOCKET - CONNECTOR - WEATHERPACK - 12 AWG
	098261-02-000	EA	SOCKET - CONNECTOR - WEATHERPACK - 14-18 AWG
	098264-01-000	EA	HOUSING - 2 PIN - WEATHER PACK - MALE W/FEMALE PINS
	098264-02-000	EA	HOUSING - 2 PIN - WEATHER PACK - FEMALE W/MALE PINS
	098265-02-000	EA	PIN - CONNECTOR - WEATHER PACK
	101751-02-000	EA	HOUSING - 1 PIN - WEATHERPACK
	102777-02-000	EA	TERMINAL - RING - #6 STUD - 10 AWG
	104100-01-000	EA	HOUSING - 1 POSITION - 75 AMPS
	104100-03-000	EA	TERMINAL - 75 AMP
	110178-01-000	EA	HOUSING - WIPER MOTOR
	112823-01-000	EA	SPLICE - REDUCER - 16-14 TO 18-22
	113135-01-000	EA	TERMINAL - FEMALE - M/P - 14-16 - F/SEALED TERMINAL
	113308-01-000	EA	TERMINAL - FEMALE - M/P - 14-16 - 280
	113468-01-000	EA	HOUSING - 2 POSITION-FEMALE-USED ON WIPER/WASHER WIRE ASM
	113638-02-000	EA	CONNECTOR - ACTUATOR
	115931-01-000	EA	COVER - CONNECTOR - 30 AMP W/LOCK RING
	115931-02-000	EA	COVER - CONNECTOR - 50 AMP W/LOCKING RING
	115932-01-000	EA	CONNECTOR - FEMALE - 30 AMP/120 VOLT
	115932-02-000	EA	CONNECTOR - FEMALE - 50 AMP/240 VOLT
	116811-01-000	EA	TERMINAL - .110 RECEPTACLE - 16-14 AWG
	118820-01-000	EA	INSULATOR - TERMINAL
	129233-01-000	EA	HOUSING - 2-POSITION/FEMALE - 280-SERIES
	129233-02-000	EA	HOUSING - 2-POSITION/FEMALE - 280-SERIES
	131681-01-000	EA	CONNECTOR - 3/4" SO CORD - UL/CS
	137207-01-000	EA	HOUSING - PIN - 2 CAVITY/HIGH AMP
	137208-01-000	EA	HOUSING - SOCKET - 2 CAVITY/HIGH AMP
	137209-01-000	EA	PIN - CONNECTOR - 10AWG/HIGH AMP
	137210-01-000	EA	SOCKET - CONNECTOR - 10 AWG/HIGH AMP
	138419-03-000	EA	SOCKET - LAMP - 3 WIRE
	142520-01-000	EA	TERMINAL - FEMALE - MINI-FIT 16
	142522-01-000	EA	HOUSING - 4 PIN/MALE - MINI FIT
	142524-01-000	EA	HOUSING - 4 PIN/FEMALE - WEATHER PACK
	142524-02-000	EA	HOUSING - 4 PIN/WEATHER PACK/FEMALE

BOOTS, SOLENOIDS, RELAYS & MISCELLANEOUS

KEY	PART NUMBER	U/M	DESCRIPTION
	008188-01-000	EA	SOLENOID - 3 POST - BATTERY CHANGE OVER
	063910-01-000	EA	HOUSING - RELAY
	063912-02-000	EA	RELAY - CANISTER - SPDT
	065450-05-000	EA	TIEDOWN - BATTERY - 8.4" TUBE
	065451-05-000	EA	BRACKET/TIEDOWN - BATTERY - 7.7" FROM BRKT TO BRKT
	086273-01-000	EA	RELAY - BATTERY DISCONNECT
	136481-01-000	EA	MODULE - AUTO ENERGY SELECTOR

EXTERIOR BODY GROUP (CONTINUED)
GRAPHICS & PAINT (CONTINUED)

KEY	PART NUMBER	U/M	DESCRIPTION
	072882-01-000	GL	PAINT - LOW BAKE - OFF WHITE
	141599-02-000	GL	PAINT - JAGUAR BLUE METALLIC - DUPONT #P7414
	141599-04-000	GL	PAINT - SAND METALLIC - DUPONT #7415
	141599-27-000	GL	PAINT - IMRON CLEAR - DUPONT #3440S

**DUPONT COLOR CODES ARE NOW FOUND IN THE PAINT CODE MANUAL.
YOU CAN FIND THIS MANUAL ON YOUR DEALER INDEX WEBPAGE UNDER SERVICE.**

EXTERIOR BODY GROUP (CONTINUED)

PANELS & TRIMS

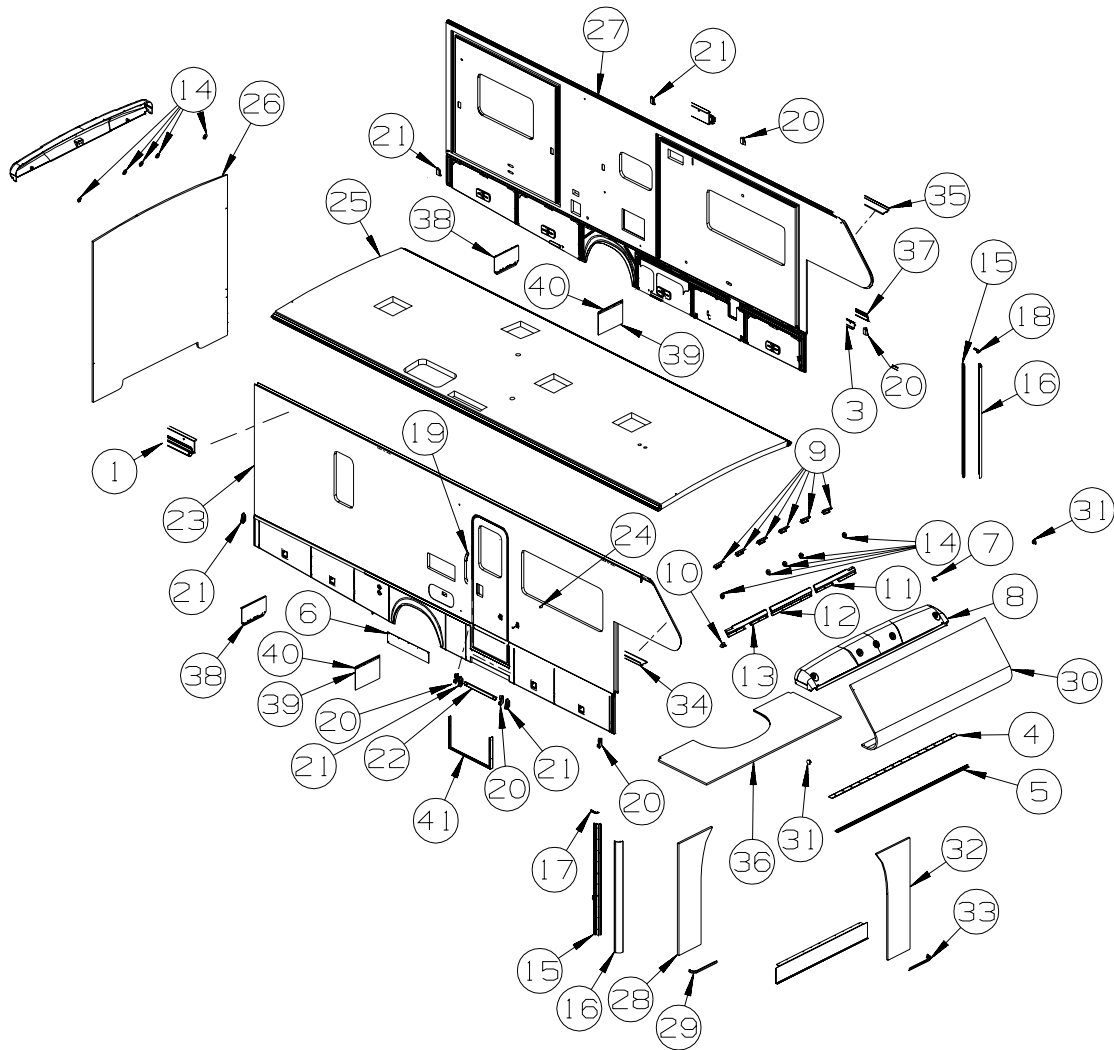

KEY	PART NUMBER	U/M	DESCRIPTION
1	131483-01-01A	EA	RAIL - AWNING - 192" - BRIGHT WHITE
2	143143-01-01A	EA	ANGLE - SUPPORT/TRIM
3	133376-01-01A	EA	TRIM - RETAINER - 144" - MILL
4	100085-05-01A	EA	TRIM/STRAP - SLEEPERBOARD - OFF/WHITE - 92.9"
5	100086-04-01A	EA	TRIM - SLEEPERBOARD/ROOF/LOWER - BRIGHT WHITE - 96.5"
6	121948-02-000	EA	SHIELD - SIGHT
7	140476-02-01A	EA	CAP - TRIM - CORNER/DRIVER
8	140443-02-P07	EA	CAP - ROOF/FRONT - W/O LIGHTS/VENTS - W/WIRING
9	134774-01-02B	EA	BRACKET - CAB ATTACHMENT - E-COATED
10	140476-01-01A	EA	CAP - TRIM - CORNER/PASSENGER
11	141718-02-02B	EA	BRACKET - ROOF CAP - END/LEFT HAND - E-COATED
12	140805-01-02B	EA	BRACKET - ROOF CAP/FRONT - E-COATED
13	141718-01-02B	EA	BRACKET - ROOF CAP - END/RIGHT HAND - E-COATED
14	138423-01-12B	EA	PLATE/BACKING - LITE - BRIGHT WHITE
15	105015-03-02A	EA	TRIM - WINGWALL/SIDEWALL CURVED - INNER SUPT BRKT - B/W
16	108037-03-02A	EA	COVER - WINGWALL OUTER/CURVED - BRIGHT WHITE
17	104444-01-02A	EA	COVER - WINGWALL TRIM - UPPER PASSENGER - BRIGHT WHITE
18	104444-02-02A	EA	COVER - WINGWALL TRIM - UPPER DRIVER - BRIGHT WHITE
19	132442-03-01A	EA	HANDLE - ASSIST/ITASCA LOGO W/CHROME ENDS
20	126775-01-01A	EA	END CAP - VALANCE TRIM - RIGHT HAND - WHITE

EXTERIOR BODY GROUP (CONTINUED)
PANELS & TRIMS (CONTINUED)

KEY	PART NUMBER	U/M	DESCRIPTION
21	126775-02-01A	EA	END CAP - VALANCE TRIM - LEFT HAND - WHITE
22	133045-02-01A	EA	TRIM - W/HOLES - 23.1" - BRIGHT WHITE
23	P46343-01-R13	EA	SIDEWALL - PASSENGER - W/O WINDOWS/TRIMS (R19,R20,R21)
23	P46343-01-R15	EA	SIDEWALL - PASSENGER - W/O WINDOWS/TRIMS (R22,R23,R24)
23	P46343-01-R17	EA	SIDEWALL - PASSENGER - W/O WINDOWS/TRIMS (R25,R26,R27)
24	117046-02-000	EA	BUMPER - RUBBER/ROUND END - 1.5"
25	146345-01-R13	EA	ROOF - W/O LIGHTS/VENTS - W/WIRING
26	146346-01-R13	EA	BACKWALL - W/O WINDOWS/TRIMS (R19,R20,R21)
26	146346-01-R15	EA	BACKWALL - W/O WINDOWS/TRIMS (R22,R23,R24)
26	146346-01-R17	EA	BACKWALL - W/O WINDOWS/TRIMS (R25,R26,R27)
27	P46344-01-R13	EA	SIDEWALL - DRIVER - W/O WINDOWS/TRIMS (R19,R20,R21)
27	P46344-01-R15	EA	SIDEWALL - DRIVER - W/O WINDOWS/TRIMS (R22,R23,R24)
27	P46344-01-R17	EA	SIDEWALL - DRIVER - W/O WINDOWS/TRIMS (R25,R26,R27)
28	141437-01-P13	EA	WINGWALL - PASSENGER
29	122910-01-G07	EA	COVER - WINGWALL - PASSENGER
30	141436-01-R13	EA	ROOF - FRONT SECTION - W/O LIGHTS/VENTS - W/WIRING
31	137050-01-01A	EA	PLUG - CAP - PUSH-IN
32	141437-02-P13	EA	WINGWALL - DRIVER
33	122910-02-G07	EA	COVER - WINGWALL - DRIVER
34	136826-15-01A	EA	TRIM - CONTOUR - 83.5"
35	136826-16-01A	EA	TRIM - CONTOUR - 83.5"
36	125129-03-P13	EA	SLEEPERBOARD - PORTSMOUTH OAK
36	125129-03-P14	EA	SLEEPERBOARD - CONCERT CHERRY
36	125129-03-P33	EA	SLEEPERBOARD - WASHED MAPLE
37	123993-01-03A	EA	TRIM - COVER - 182" ALUMINUM - BRIGHT WHITE
38	136389-01-02B	EA	GUARD/ROCK - STEEL - W/BEND - 18"W X 10.9"H - E-COATED
39	017516-01-000	EA	MUD FLAP - 14"H X 18"W - W/O MOUNTING HOLES - BLACK
40	140922-01-02B	EA	PLATE - MUD FLAP - E-COATED
41	144153-02-P13	EA	ANGLE ASM - "U" F/ENTRANCE DOOR - 31" X 18.9"

EXTERIOR BODY GROUP (CONTINUED)
PANELS & TRIMS (CONTINUED)

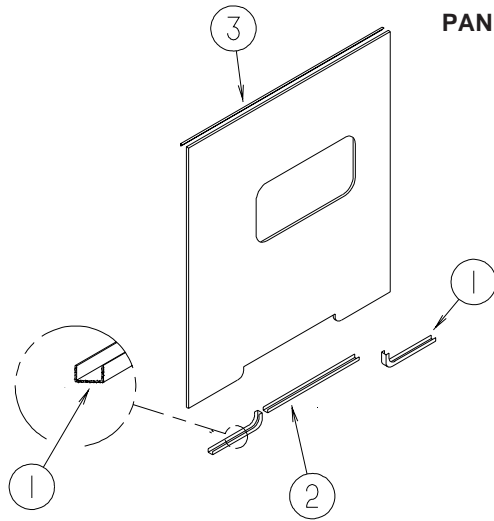

KEY	PART NUMBER	U/M	DESCRIPTION
1	103334-08-02A	EA	TRIM - BACKWALL/LOWER - 20.4" - BRIGHT WHITE
2	103335-09-02A	EA	TRIM - BACKWALL/LOWER - 56.9" - BRIGHT WHITE
3	114248-02-01A	EA	ANGLE - PLASTIC - 96.6"

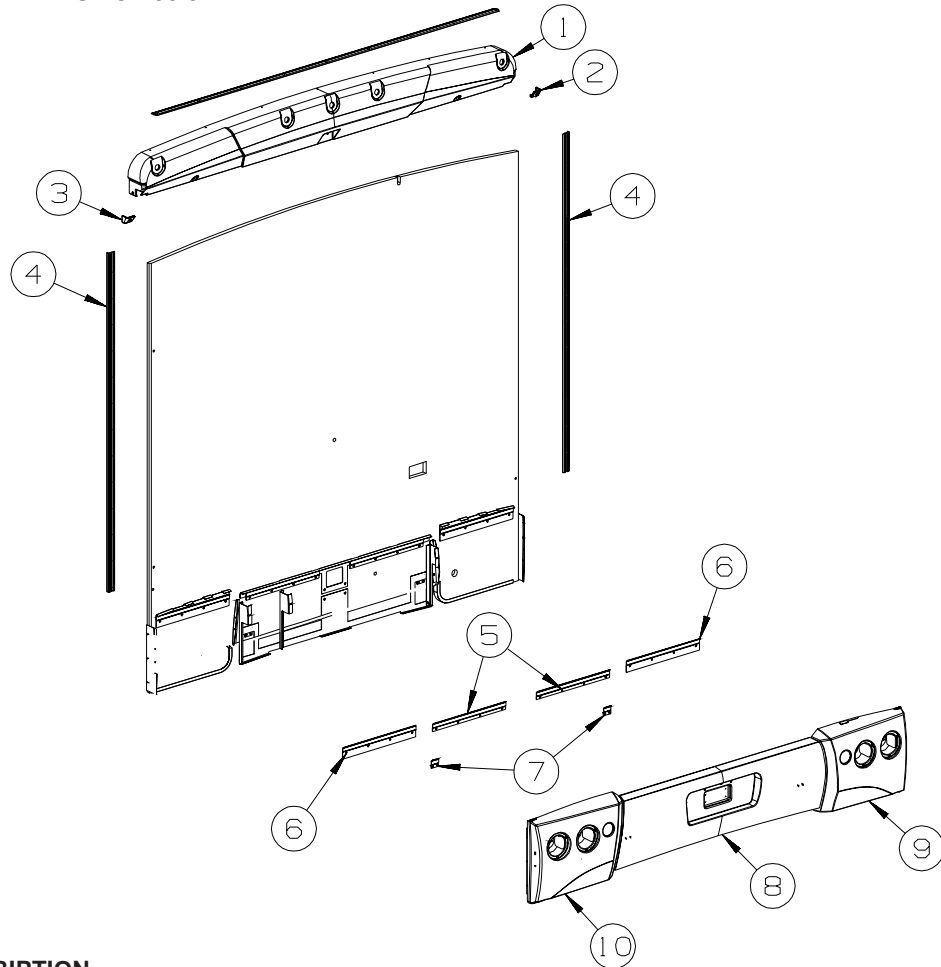

KEY	PART NUMBER	U/M	DESCRIPTION
1	140596-02-P07	EA	CAP - ROOF/REAR - W/O LIGHTS/VENTS/WIRING-W/STEEL SUPPORT
2	140620-01-01A	EA	CAP - TRIM - REAR/RIGHT - BRIGHT WHITE
3	140620-02-01A	EA	CAP - TRIM - REAR/LEFT - BRIGHT WHITE
4	096854-13-01A	EA	TRIM - CONTOUR - 76.3" - BRIGHT WHITE
5	130034-04-02B	EA	CLIP - TRIM - E-COATED
6	130034-05-02B	EA	CLIP - TRIM - E-COATED
7	130034-07-02B	EA	CLIP - TRIM - E-COATED
8	144427-02-R13	EA	BUMPER - REAR
9	140460-03-P19	EA	TRIM/BACKWALL - LOWER/PASSENGER - W/BACKWALL SUPT BRACKETS
10	140460-04-P19	EA	TRIM/BACKWALL - LOWER/DRIVER - W/BACKWALL SUPT BRACKETS

EXTERIOR BODY GROUP (CONTINUED)

LADDER

KEY	PART NUMBER	U/M	DESCRIPTION
	129639-07-01A	EA	LADDER - 81.7" - 6 STEP - BRUSHED ALUMINUM
	130163-10-01A	EA	LADDER EXTENSION/LOWER - 35.6" - 3 STEP - BRUSHED ALUMINUM

RUNNING BOARDS

KEY	PART NUMBER	U/M	DESCRIPTION
	106461-03-000	EA	HARDWARE KIT - RUNNING BOARD
	106461-08-01A	EA	RUNNING BOARD - PASSENGER/FORD - BRIGHT WHITE
	106461-09-01A	EA	RUNNING BOARD - DRIVER/FORD - BRIGHT WHITE

MIRRORS

KEY	PART NUMBER	U/M	DESCRIPTION
*	120269-07-01A	EA	PANEL - W/ELECTRIC MIRROR/HEAT SWITCH - F/#L28X OPTION
	120269-08-000	EA	HARNESS/WIRE - F/ELECTRIC MIRRORS
*	133908-12-01A	EA	MIRROR/PASS - 102" C BODY/FORD 4 BOLT MT-HEATED/REMOTE-B/W
*	133908-13-01A	EA	MIRROR/DRVR - 102" C BODY/FORD 4-BOLT MT-HEATED/REMOTE-B/W

*COMPONENT PARTS LISTED LATER IN THIS GROUP

EXTERIOR BODY GROUP (CONTINUED)
COMPONENT PARTS FOR MIRRORS

120269-07-01A

KEY	PART NUMBER	U/M	DESCRIPTION	VENDOR NO.
	120269-07-700	EA	SWITCH - REMOTE	7475720
	133908-09-700	EA	SWITCH-MIRROR HEATER	7475150

133908-01-01A, 133908-01-02A, 133908-02-01A, 133908-03-01A, 133908-03-02A, 133908-04-01A, 133908-05-01A, 133908-06-01A,
 133908-07-01A, 133908-08-01A, 133908-10-01A, 133908-11-01A, 133908-12-01A, 133908-13-01A

KEY	PART NUMBER	U/M	DESCRIPTION	VENDOR NO.
	117051-01-700	EA	MIRROR-CONVEX	723068-4
	120269-05-701	EA	GLASS ONLY REPLACEMENT RH/LH	709411
	133908-03-700	EA	CAP - RECT/BLACK-W/O LIGHT	7095570
	133908-04-700	EA	CAP-MIRROR/ROUND - W/O LIGHT	7095470

EXTERIOR BODY GROUP (CONTINUED)
STRUCTURAL COMPONENTS

KEY	PART NUMBER	U/M	DESCRIPTION
	002726-01-001	EA	GARNISH - U-CHANNEL - 1.38" X 19' - SERRATED
	076054-AC-000	EA	FIBERGLASS SHEET - 20" X 99.8" - OFF WHITE
	076054-P9-000	EA	FIBERGLASS SHEET - 37.4" X 99.3" - BRIGHT WHITE
	076054-X9-000	EA	FIBERGLASS SHEET - 22.1" X 70.6" - BRIGHT WHITE
	076054-Z3-000	EA	FIBERGLASS SHEET - 102" X 93.9" - ROOF/SIDEWALL - BRT WHT
	077517-62-000	EA	FIBERGLASS SHEET - 48" X 96" - BRIGHT WHITE
	089297-01-000	SF	PLYWOOD - LUAN - OVERLAY GRADE - 4' X 8'
	100619-01-000	BF	FOAM - EXPANDED POLYSTYRENE - 1.34" X 48" X 96"
	100619-02-000	BF	FOAM - EXPANDED POLYSTYRENE - 1.5" X 48" X 96"
	100619-04-000	BF	FOAM - EXPANDED POLYSTYRENE - .5" X 48" X 96"
	100619-05-000	BF	FOAM - EXPANDED POLYSTYRENE - .75" X 48" X 96"-1.5"DENSITY
	100619-05-001	EA	FOAM-EXPND 0190X1400 - 48"X96"X.77"
	100619-11-000	BF	FOAM - EXPANDED POLYSTYRENE - 2" X 48" X 96"
	100619-11-006	EA	FOAM - EXPANDED POLYSTYRENE - 2" X 48" X 96"
	100619-13-000	BF	FOAM - EXPANDED POLYSTYRENE-.34" X 34.7" X 96"-2" DENSITY
	100619-16-000	BF	FOAM - EXPANDED POLYSTYRENE - .75" X 48" X 96"-2" DENSITY
	100619-27-000	BF	FOAM - EXPANDED POLYSTYRENE - 3" X 48" X 92.8"
	100619-27-001	EA	FOAM-EXPND 0190X0600 - 48"X92.80"X3.0"
	105077-10-000	EA	FOAM - PLUG - ROOF CAP
	108535-05-03A	SF	FIBERGLASS SHEET - 108" X 500' ROLL - BRIGHT WHITE
	116942-03-01A	LB	ALUMINUM - .7" X 40" X 158"
	120107-01-000	EA	FOAM - ROOF COVE - 2.8" X 96" LONG
	120107-02-000	EA	FOAM - PLUG - ROOF TUBE - 2.2" X 2.9" X 1.8" LONG
	120107-03-000	EA	FOAM - PLUG - SIDEWALL TUBE - 1.2" X 2.1" X 1.8" LONG
	135926-02-01A	EA	FIBERGLASS - SHEET - 80.8" X 308.7" - BRIGHT WHITE
	135926-04-01A	EA	FIBERGLASS - SHEET - 26.1" X 68.2" - BRIGHT WHITE
	135926-06-01A	EA	FIBERGLASS - SHEET - 79" X 346" - BRIGHT WHITE
	135926-13-01A	EA	FIBERGLASS - SHEET - 27.4" X 67.2" - BRIGHT WHITE
	135926-17-01A	EA	FIBERGLASS - SHEET - 12.6" X 68" - BRIGHT WHITE
	135926-20-01A	EA	FIBERGLASS - SHEET - 99.5" X 100.2" - BRIGHT WHITE

AWNINGS

SUNDANCER PATIO AWNINGS

SERIES	MODEL	COLOR DESIGNATION	AWNING FABRIC	AWNING LENGTH	WEATHER WRAP(MANUAL)	PART # MANUAL	VENDOR
SUN-	427P	POLAR NAVY TAUPE	VINYL	11.5'	VYL/BRT WHT	113874-03-48A	A&E
DANCER	430V	POLAR NAVY TAUPE	VINYL	14'	VYL/BRT WHT	113874-05-48A	
	431C	POLAR NAVY TAUPE	VINYL	14'	VYL/BRT WHT	113874-05-48A	

KEY	PART NUMBER	U/M	DESCRIPTION
*	113874-01-02A	EA	HARDWARE KIT - AWNING - W/O STANDOFF BRACKET-BRIGHT WHITE
	113874-11-01A	EA	SCREW/LAG - AWNING - 1/4" X 1" STAINLESS STEEL
	113874-12-01A	EA	SCREW/LAG - AWNING - 1/4" X 2 3/4" STAINLESS STEEL
	127647-02-01A	EA	ROD/AWNING GUARD - ENTRANCE DOOR - 12.7" LONG - 431C
	137054-01-02A	EA	BRACKET - AWNING - BRIGHT WHITE

***COMPONENT PARTS LISTED LATER IN THIS GROUP**

EXTERIOR BODY GROUP (CONTINUED)
COMPONENT PARTS FOR AWNINGS

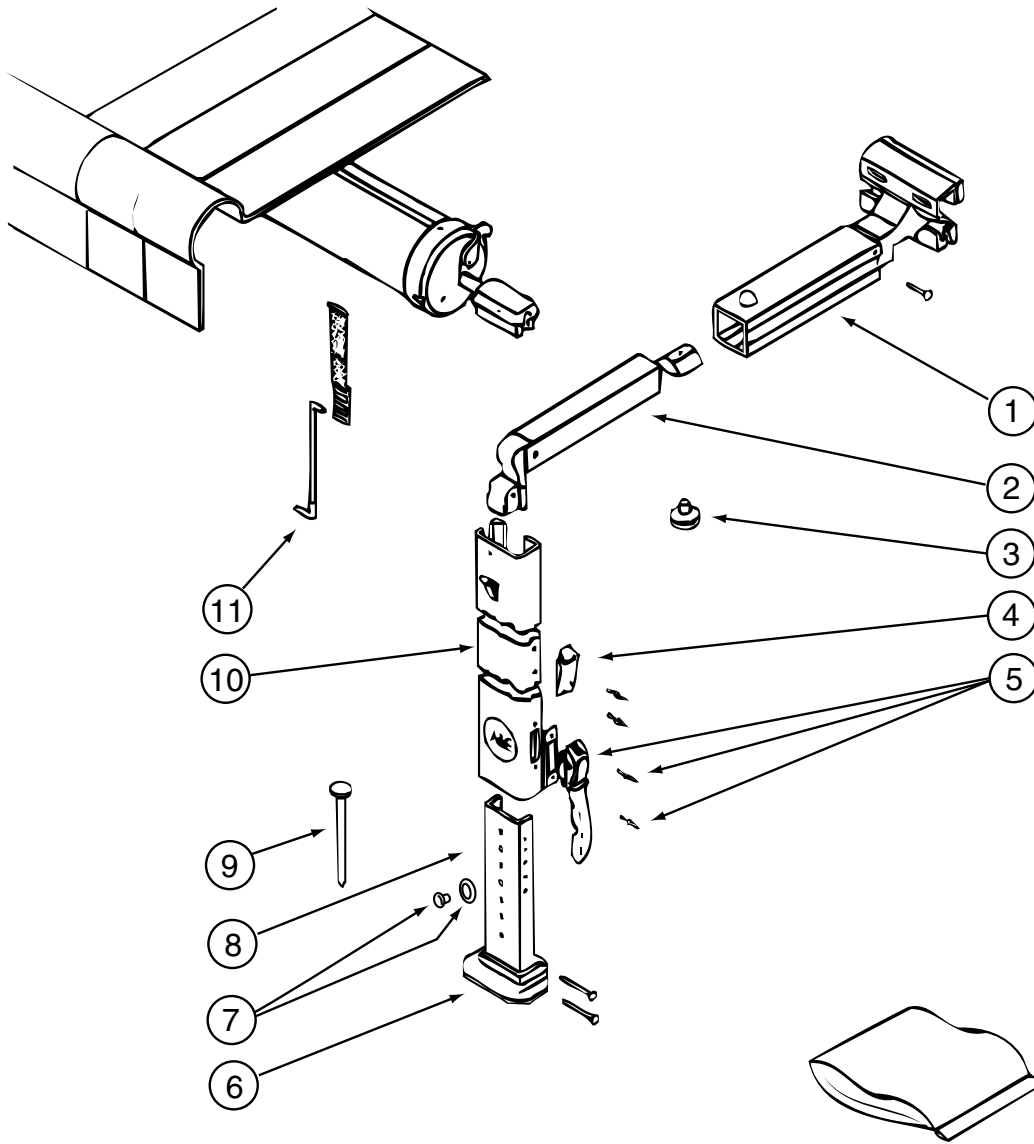

113874-01-02A

KEY	PART NUMBER	U/M	DESCRIPTION	VENDOR NO.
1	113874-01-714	EA	RAFTER - MAIN RH/LH BRT/WHT	830295.536F
2	113874-01-715	EA	RAFTER - SECONDARY BRT/WHT	830463.511F
3	113874-01-702	EA	KNOB - ADJUSTING	3105421.014
4	113874-01-706	EA	LOCK - TRAVEL	830587.001
5	113874-01-707	EA	HANDLE - LIFT W/RIVETS	830644
6	113874-01-712	EA	FOOT - PATIO	730366-001
7	113874-01-710	EA	PLUG-STOP KIT	830456
8	113874-01-717	EA	ARM - ADJUSTABLE BRT/WHT	830467.517/F
9	113874-01-709	EA	NAIL-SPIKE, 8"	113006
10	113874-01-716	EA	ARM - MAIN SUPPORT BRT/WHT	3104502.293/F
11	113874-01-703	EA	ROD-CENTER PULL W/ACCESSORY	830152.102

EXTERIOR DOORS & COMPARTMENTS GROUP

DOOR & COMPARTMENT LAYOUT

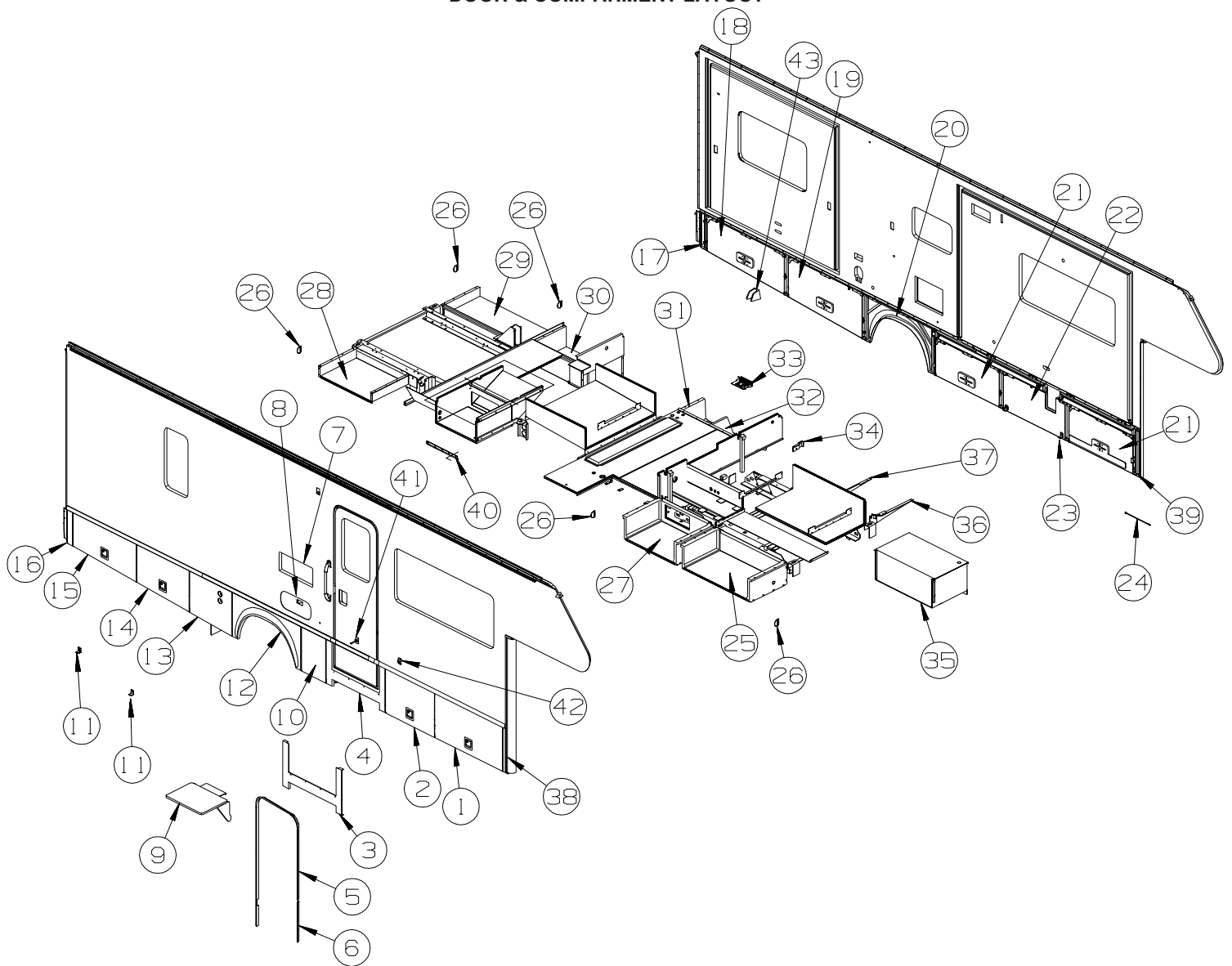

KEY	PART NUMBER	U/M	DESCRIPTION
1	140552-19-P14	EA	VALANCE/DOOR - W/O PADDLE LATCH - 40.6" X 22.4"
	132873-A8-000	EA	ROD - LATCH - 14.1" W/3/4" DOG LEG
	132873-A9-000	EA	ROD - LATCH - 16" W/3/4" DOG LEG
	142569-12-000	EA	SPRING/GAS - 90 LB. - 15" EXTENDED/9.5" COMPRESSED
	126263-02-02B	EA	BRACKET - GAS SPRING W/BALL STUD - E-COATED
2	140552-18-P14	EA	VALANCE/DOOR - W/O PADDLE LATCH - 29.4" X 22.4"
	132873-A7-000	EA	ROD - LATCH - 8.6" W/3/4" DOG LEG
	132873-24-000	EA	ROD - LATCH - 10.3" W/3/4" DOG LEG
	142569-12-000	EA	SPRING/GAS - 90 LB. - 15" EXTENDED/9.5" COMPRESSED
	126263-02-02B	EA	BRACKET - GAS SPRING W/BALL STUD - E-COATED
3	143065-01-P14	EA	VALANCE/PANEL - ENTRY DOOR - HORSESHOE - 35.4" - BRT WHT
4*	094707-03-01A	EA	STEP - ELECTRIC DOUBLE - W/BLACK CONTROL BOX - KWIKEE
5	139100-07-01A	EA	GARNISH/RADIUS - ENTRY DOOR
6	139101-06-01A	EA	GARNISH/STRAIGHT - ENTRY DOOR
7*	084103-08-000	EA	DOOR - VENT - REFRIGERATOR - W/O JAMB - BRIGHT WHITE
	084104-08-000	EA	JAMB - VENT DOOR/REFRIGERATOR - BRIGHT WHITE
8	126945-09-N42	EA	DOOR/STORAGE - W/O HARDWARE - 18" X 8.3"
9	142034-02-01A	EA	SHELF - F/EXTERIOR TV - BRIGHT WHITE
10	140552-20-P14	EA	VALANCE/DOOR - W/O PADDLE LATCH - 14.6" X 22.4"
11	119568-01-01A	EA	STANDOFF - VALANCE PANEL - BLACK
12	135983-01-M07	EA	PANEL - WHEEL LIP - REAR
	123512-06-02B	EA	BRACKET - DOOR/VALANCE - E-COATED

EXTERIOR DOORS & COMPARTMENTS GROUP (CONTINUED)
DOOR & COMPARTMENT LAYOUT (CONTINUED)

KEY	PART NUMBER	U/M	DESCRIPTION
13	140552-21-P13	EA	VALANCE/DOOR - PASS W/O PADDLE LATCH - 22.4" X 46.6" X 20"
	107865-01-000	EA	ROD - SUPPORT - VALANCE PANEL - 14.3"
	107721-07-000	FT	SEAL - ACCESS DOOR - .9"WIDE X 1.1"HIGH
14	140552-27-P13	EA	VALANCE/DOOR - PASS W/O PAD LATCH - 21.1" X 31.5" X 19.4"
	132873-A0-000	EA	ROD - LATCH - 11.3" W/3/4" DOG LEG
			FROM: 00-00-00 THRU: 09-15-03
	132873-D0-000	EA	ROD - LATCH
			FROM: 09-16-03 THRU: 99-99-99
	132873-B9-000	EA	ROD - LATCH - 9.6" W/3/4" DOG LEG
	142569-17-000	EA	SPRING/GAS - 90 LB. - 12" EXTENDED/8.5"COMPRESSED
	126263-02-02B	EA	BRACKET - GAS SPRING W/BALL STUD - E-COATED
15	140552-07-N09	EA	VALANCE/DOOR - PASS W/O PADDLE LATCH - 19.4" X 38" X 17.3"
	132873-56-000	EA	ROD - LATCH - 12.9" W/3/4" DOG LEG
	132873-57-000	EA	ROD - LATCH - 14.6" W/3/4" DOG LEG
	142569-17-000	EA	SPRING/GAS - 90 LB. - 12" EXTENDED/8.5"COMPRESSED
	126263-02-02B	EA	BRACKET - GAS SPRING W/BALL STUD - E-COATED
16	135764-03-M07	EA	PANEL/FILLER - VALANCE
17	135764-04-M07	EA	PANEL/FILLER - VALANCE
18	140552-23-P13	EA	VALANCE/DOOR - DRVR W/O PAD LATCH - 17.4" X 48.6" X 19.9"
	132873-B1-000	EA	ROD - LATCH - 18.1" W/3/4" DOG LEG
	132873-B2-000	EA	ROD - LATCH - 20.1" W/3/4" DOG LEG
	142569-17-000	EA	SPRING/GAS - 90 LB. - 12" EXTENDED/8.5"COMPRESSED
	126263-02-02B	EA	BRACKET - GAS SPRING W/BALL STUD - E-COATED
	076767-15-000	EA	CABLE - STAINLESS STEEL - 9.8"
19	140552-22-P13	EA	VALANCE/DOOR - DRVR W/O PADDLE LATCH - 22.4" X 46.6" X 20"
	132873-68-000	EA	ROD - LATCH - 17.2" W/3/4" DOG LEG
	132873-69-000	EA	ROD - LATCH - 19" W/3/4" DOG LEG
	142569-17-000	EA	SPRING/GAS - 90 LB. - 12" EXTENDED/8.5"COMPRESSED
	126263-02-02B	EA	BRACKET - GAS SPRING W/BALL STUD - E-COATED
	076767-15-000	EA	CABLE - STAINLESS STEEL - 9.8"
20	135983-02-P13	EA	PANEL - WHEEL LIP - REAR
	123512-06-02B	EA	BRACKET - DOOR/VALANCE - E-COATED
21	140552-26-P14	EA	VALANCE/DOOR - W/O PADDLE LATCH - 40.6" X 18.5"
	132873-A8-000	EA	ROD - LATCH - 14.1" W/3/4" DOG LEG
	132873-A9-000	EA	ROD - LATCH - 16" W/3/4" DOG LEG
	142569-25-000	EA	SPRING/GAS - 60 LB - 12" EXTENDED/8.5" COMPRESSED
	126263-02-02B	EA	BRACKET - GAS SPRING W/BALL STUD - E-COATED
	076767-15-000	EA	CABLE - STAINLESS STEEL - 9.8"
22	140552-25-P14	EA	VALANCE/DOOR
	133049-05-P13	EA	TRIM/COVER - WATER HEATER
23	119568-01-01A	EA	STANDOFF - VALANCE PANEL - BLACK
24	107865-06-000	EA	ROD - SUPPORT - VALANCE PANEL - 15"
25	135927-18-P13	EA	COMPARTMENT - LUGGAGE
26	143749-01-01A	EA	EXTRUDED - VINYL - TRIM
27	142456-01-P13	EA	COMPARTMENT - LUGGAGE
28	135929-08-P13	EA	COMPARTMENT - LUGGAGE
29	135929-04-P13	EA	COMPARTMENT - LUGGAGE
30	135929-09-R13	EA	COMPARTMENT - LUGGAGE
31	146323-01-R13	EA	COMPARTMENT - STORAGE
32	146322-01-01A	EA	COMPARTMENT - SEWER
33	142226-02-01A	EA	HATCH - POWER
34	143491-01-02B	EA	BRACKET/SUPPORT - E-COATED
35	147453-01-02B	EA	COMPARTMENT - STORAGE - E-COATED - (W/O GENERATOR)
36	143938-01-02B	EA	BRACKET - GENERATOR - E-COATED
37	143938-02-02B	EA	BRACKET - GENERATOR - E-COATED
38	135764-01-M07	EA	PANEL/FILLER - VALANCE
39	135764-05-P13	EA	PANEL/FILLER - VALANCE
40	143627-01-02B	EA	ANGLE - W/HOLES - E-COATED
41	104099-01-04A	EA	CATCH - DOOR HOLDER - STRIKE - 3.9" - BRIGHT WHITE
42	104099-02-04A	EA	CATCH/RETAINER - DOOR HOLDER - BRIGHT WHITE
43	131383-03-02A	EA	BRACKET - SHOWER HEAD - WHITE

EXTERIOR DOORS & COMPARTMENTS GROUP (CONTINUED)
DOOR & COMPARTMENT LAYOUT (CONTINUED)

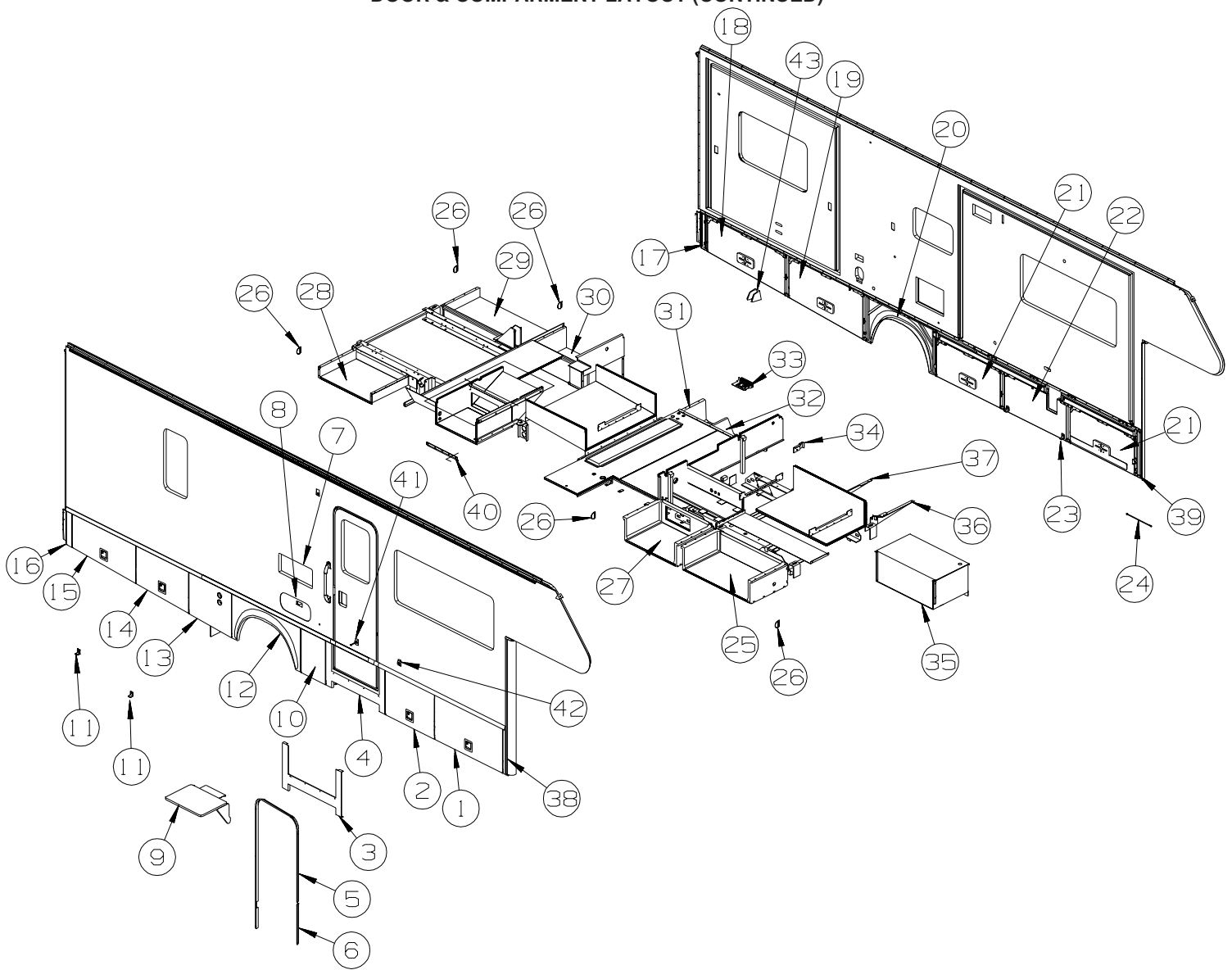

KEY	PART NUMBER	U/M	DESCRIPTION
	138292-01-000	EA	SEAL - LOCK CYLINDER
	P38289-01-000	EA	LOCK ASM W/O MASTER,01-10
	138289-01-000	EA	CYLINDER - LOCKING
	138289-02-000	EA	CYLINDER - LOCKING
	138289-03-000	EA	CYLINDER - LOCKING
	138289-04-000	EA	CYLINDER - LOCKING
	138289-05-000	EA	CYLINDER - LOCKING
	138289-06-000	EA	CYLINDER - LOCKING
	138289-07-000	EA	CYLINDER - LOCKING
	138289-08-000	EA	CYLINDER - LOCKING
	138289-09-000	EA	CYLINDER - LOCKING
	138289-10-000	EA	CYLINDER - LOCKING
	138288-01-000	EA	KEY - REVERSIBLE - #1151 - T/M 16169-02-3091
	138288-02-000	EA	KEY - REVERSIBLE - #1151 - T/M 16169-02-3091
	138288-03-000	EA	KEY - REVERSIBLE - #1151 - T/M 16169-02-3091
	138288-04-000	EA	KEY - REVERSIBLE - #1151 - T/M 16169-02-3091
	138288-05-000	EA	KEY - REVERSIBLE - #1151 - T/M 16169-02-3091
	138288-06-000	EA	KEY - REVERSIBLE - #1151 - T/M 16169-02-3091
	138288-07-000	EA	KEY - REVERSIBLE - #1151 - T/M 16169-02-3091
	138288-08-000	EA	KEY - REVERSIBLE - #1151 - T/M 16169-02-3091
	138288-09-000	EA	KEY - REVERSIBLE - #1151 - T/M 16169-02-3091
	138288-10-000	EA	KEY - REVERSIBLE - #1151 - T/M 16169-02-3091

*COMPONENT PARTS LISTED LATER IN THIS GROUP

EXTERIOR DOORS & COMPARTMENTS GROUP (CONTINUED)
DOOR & COMPARTMENT LAYOUT (CONTINUED)

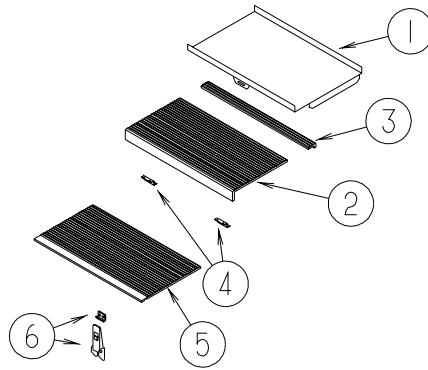

KEY	PART NUMBER	U/M	DESCRIPTION
1	123330-05-02B	EA	SUPPORT ASM-ENTRANCE STEP
2	133114-07-03A	EA	TREAD - STEP - RUBBER - 26.3" - GRAY (R19, R20, R21) FROM: 00-00-00 THRU: 10-12-03
2	133114-07-01A	EA	TREAD - STEP - RUBBER - 26.3" - TAUPE (R22, R23, R24, R25, R26, 27) FROM: 00-00-00 THRU: 10-12-03
2	147781-01-03A	EA	TREAD/STEP - RUBBER - GRAY (R19, R20, R21) FROM: 10-13-03 THRU: 99-99-99
2	147781-01-01A	EA	TREAD/STEP - RUBBER - TAUPE (R22, R23, R24, R25, R26, R27) FROM: 10-13-03 THRU: 99-99-99
3	133114-08-03A	EA	TREAD - STEP - RUBBER - 26.3" - GRAY (R19, R20, R21) FROM: 00-00-00 THRU: 10-12-03
3	133114-08-01A	EA	TREAD - STEP - RUBBER - 26.3" - TAUPE (R22, R23, R24, R25, R26, R27) FROM: 00-00-00 THRU: 10-12-03
3	147781-01-03A	EA	TREAD/STEP - RUBBER - GRAY (R19, R20, R21) FROM: 10-13-03 THRU: 99-99-99
3	147781-01-01A	EA	TREAD/STEP - RUBBER - TAUPE (R22, R23, R24, R25, R26, R27) FROM: 10-13-03 THRU: 99-99-99
4	146747-01-02B	EA	BRACKET/CATCH - E-COATED
5	133114-03-03A	EA	TREAD - STEP - RUBBER - 27.1" - GRAY (R19, R20, R21)
5	133114-03-01A	EA	TREAD - STEP - RUBBER - 27.1" - TAUPE (R22, R23, R24, R25, R26, R27)
6	116975-01-01A	EA	LATCH - W/O STRIKE - BLACK - NEW STYLE

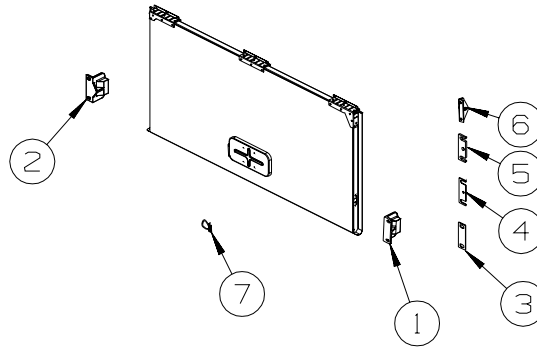

KEY	PART NUMBER	U/M	DESCRIPTION
1	130053-01-01A	EA	STRIKER - LUGGAGE DOOR - FLUSH - BLACK
2	130053-02-01A	EA	STRIKER - LUGGAGE DOOR - OFF SET - BLACK
3	143793-01-01A	EA	SHIM/STRIKER - LUGGAGE - 1.5" - BLACK
4	120494-03-02B	EA	SHIM - STRIKER - LUGGAGE DOOR - .20 - E-COATED
5	120494-04-02B	EA	SHIM - STRIKER - LUGGAGE DOOR - .27 - E-COATED
6	126263-02-02B	EA	BRACKET - GAS SPRING W/BALL STUD - E-COATED
7	132892-02-01A	FT	SEAL - BULB
	132892-03-01A	FT	SEAL - BULB - W/LEG - 431C ONLY

EXTERIOR DOORS & COMPARTMENTS GROUP (CONTINUED)
COMPONENT PARTS FOR DOOR & COMPARTMENT LAYOUT

084103-08-000

KEY	PART NUMBER	U/M DESCRIPTION	VENDOR NO.
	084104-01-700	EA LOCK-MALE, FASTENER	201-721-010
	084104-01-701	EA LOCK-FEMALE, FASTENER	201-802-010

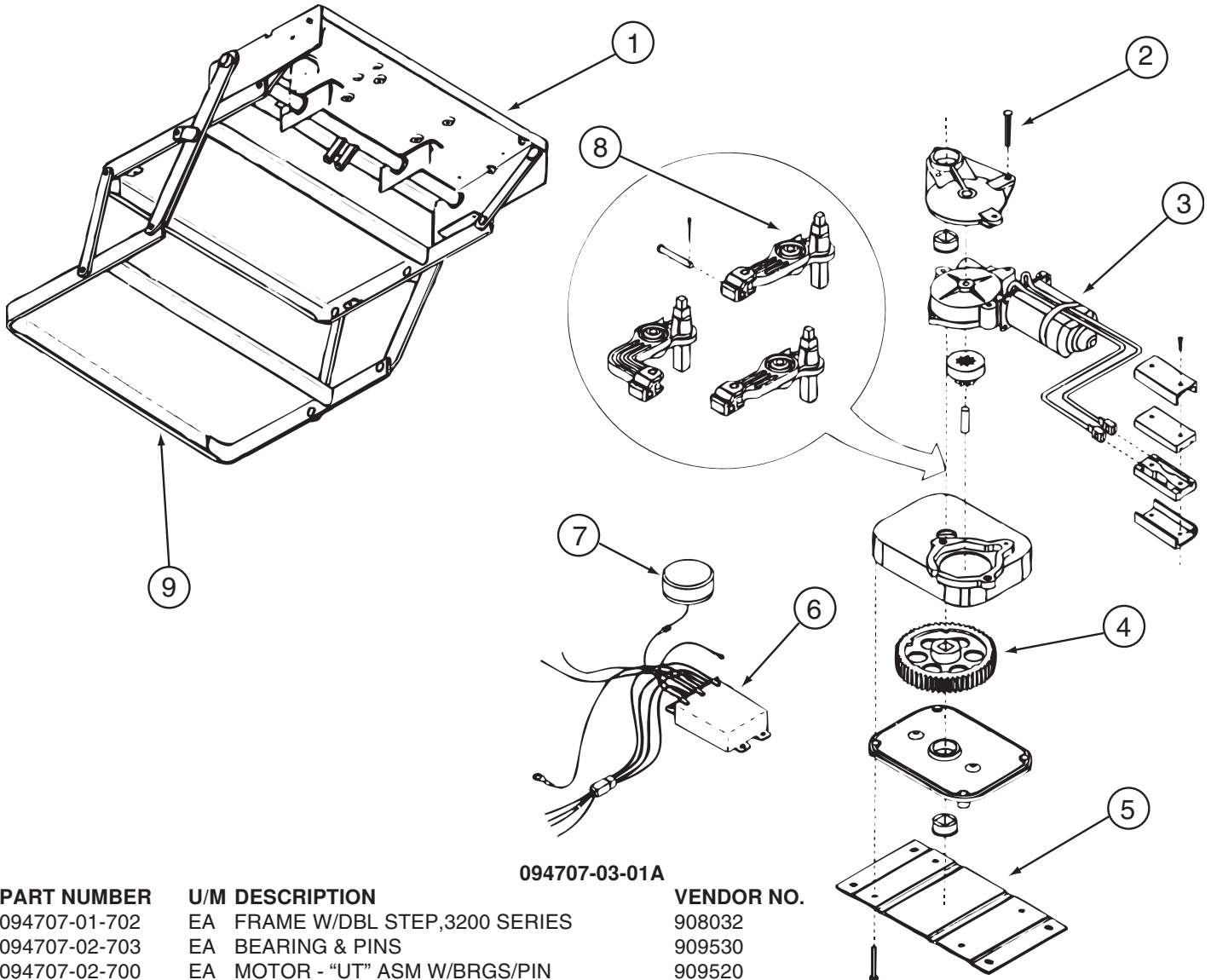

094707-03-01A

KEY	PART NUMBER	U/M DESCRIPTION	VENDOR NO.
1	094707-01-702	EA FRAME W/DBL STEP,3200 SERIES	908032
2	094707-02-703	EA BEARING & PINS	909530
3	094707-02-700	EA MOTOR - "UT" ASM W/BRGS/PIN	909520
4	094707-02-702	EA GEAR KIT(GEAR-BEARING-PINS)	909525
5	094707-02-704	EA CONNECTOR-MOTOR ASM.W/PLATES	909537
6	094707-03-700	EA KIT CONTROL/SWITCH-RETROFIT	909506005
7	088746-01-705	EA LIGHT-UNDER STEP	9004
8	094707-02-701	EA LINKAGE ASM. W/BEARINGS-PINS	909534
	094707-02-706	EA GEAR BOX ASM. W/O MOTOR	9524
	094707-02-708	EA TREAD - NON-SKID - YELLOW	909331
	094707-03-701	EA PLUG - 4-WAY - PACKARD	909306

CONTACT WINNEBAGO PART SALES FOR UNLISTED COMPONENTS

EXTERIOR DOORS & COMPARTMENTS GROUP (CONTINUED)
COMPARTMENT DOOR PIECE PARTS

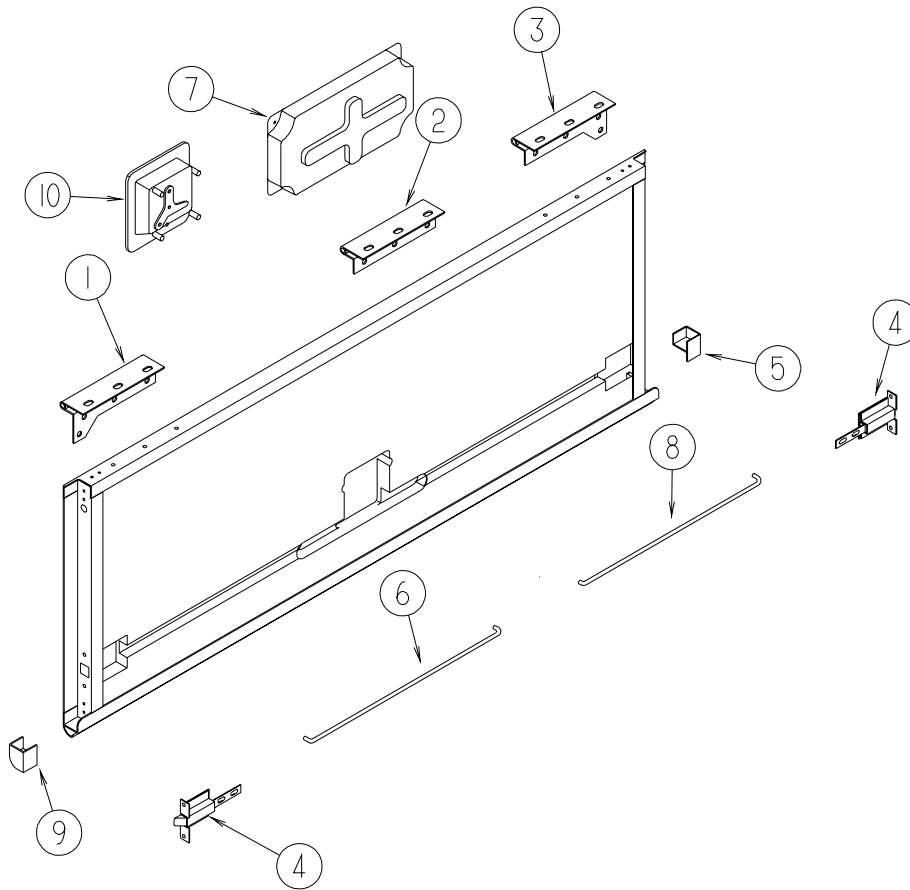

KEY	PART NUMBER	U/M	DESCRIPTION
1	139793-02-01A	EA	HINGE - LEFT HAND/VALANCE DOOR - W/BALLSTUD
1	139793-05-01A	EA	HINGE - LEFT HAND/VALANCE DOOR - W/O BALLSTUD
2	139793-03-01A	EA	HINGE - CENTER/VALANCE DOOR - W/O BALLSTUD
2	139793-09-01A	EA	HINGE - VALANCE DOOR - CENTER - W/O BALLSTUD - SHORT
3	139793-04-01A	EA	HINGE - RIGHT HAND/VALANCE DOOR - W/O BALLSTUD
4	121947-01-01A	EA	BOLT - SLIDE/LATCH - W/PLASTIC PLUNGER
5	135276-01-01A	EA	REINFORCEMENT - CORNER - RIGHT HAND
6	132873-02-000	EA	ROD - LATCH (BLANK) - LEFT HAND
6			SEE DOOR & COMPARTMENT LAYOUT FOR ROD-LATCH
7	137359-01-01A	EA	COVER - LATCH - WHITE
8	132873-01-000	EA	ROD - LATCH (BLANK) - RIGHT HAND
8			SEE DOOR & COMPARTMENT LAYOUT FOR ROD-LATCH
9	135276-02-01A	EA	REINFORCEMENT - CORNER - LEFT HAND
10	138277-01-01A	EA	LATCH/PADDLE - COMPARTMENT DOOR - BLACK - KEY ONE
10	138277-01-02A	EA	LATCH/PADDLE - COMPARTMENT DOOR - WHITE - KEY ONE
10	112949-02-05A	EA	LATCH/PADDLE - NON-LOCKING - BLACK

EXTERIOR DOORS & COMPARTMENTS GROUP (CONTINUED)
COMPARTMENT DOOR PIECE PARTS (CONTINUED)

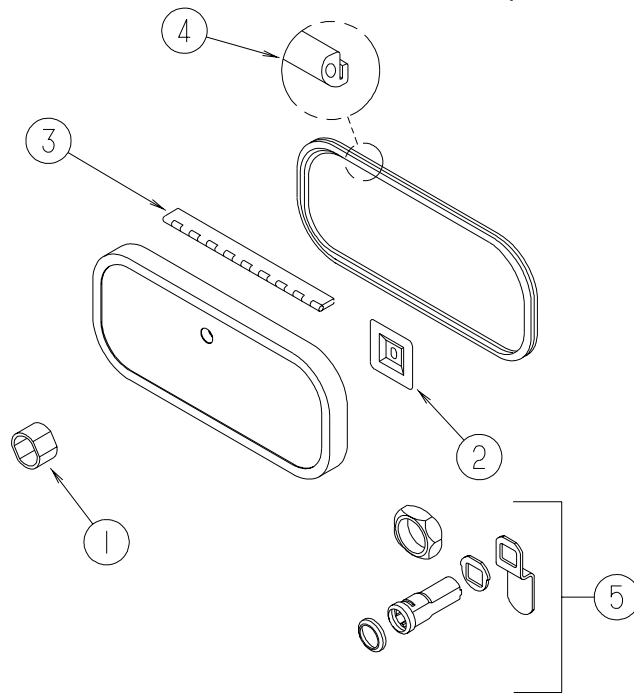

KEY	PART NUMBER	U/M	DESCRIPTION
1	139325-01-000	EA	SPACER - LOCK - 6MM
	139337-01-000	EA	GASKET - LOCK
2	097111-02-04A	EA	POCKET - LOCK - REAR DOOR - BLACK
2	097111-02-05A	EA	POCKET - LOCK - REAR DOOR - BRIGHT WHITE
3	081801-V3-000	EA	HINGE - ALUMINUM - 2" X 96" - BRIGHT WHITE
4	106850-02-000	FT	SEAL-E - SPONGE RUBBER - .43" X .75"
5	138290-02-000	EA	CASE - W/CAM - W/O CYLINDER/KEY

EXTERIOR DOORS & COMPARTMENTS GROUP (CONTINUED)

ENTRY

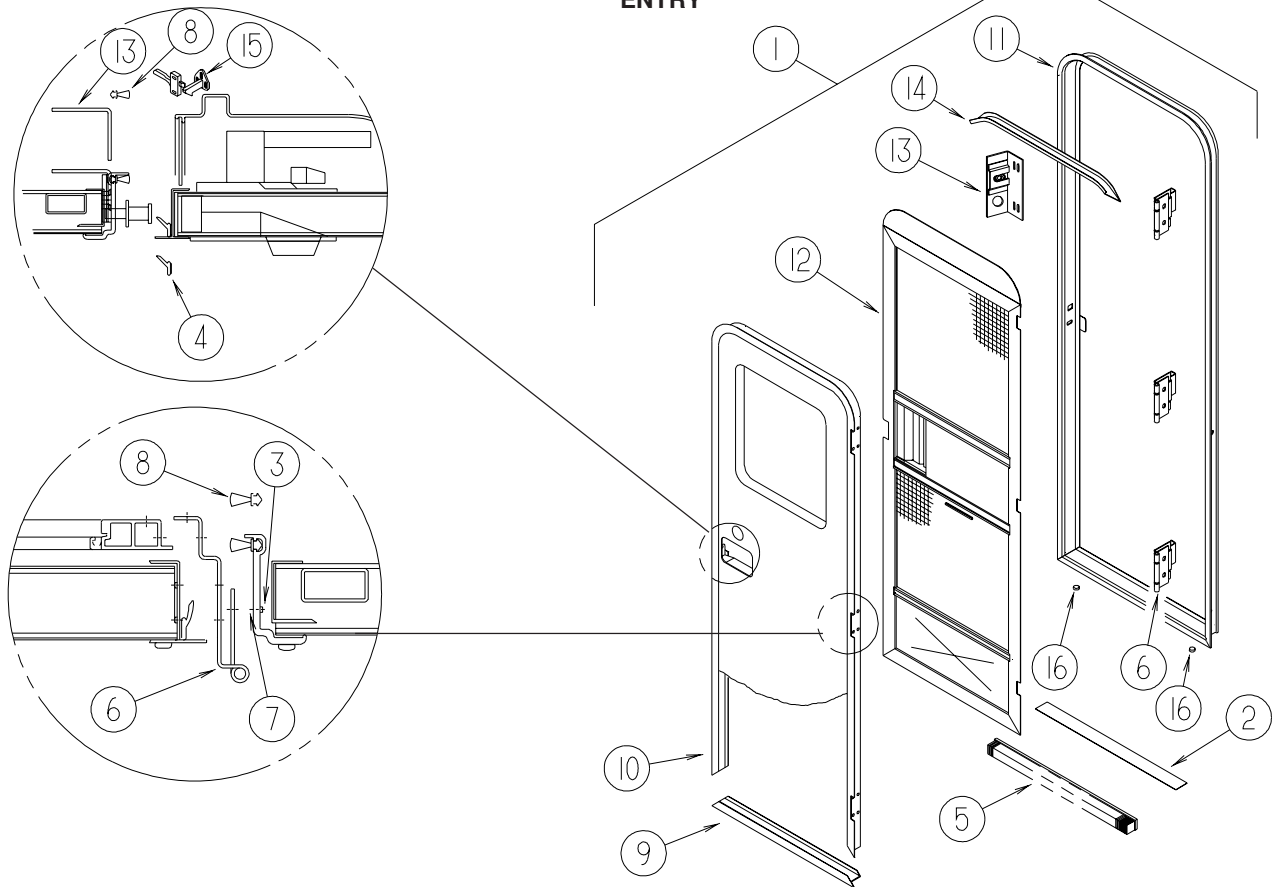

KEY	PART NUMBER	U/M	DESCRIPTION
1	P32206-10-R13	EA	DOOR - ENTRY W/SCREEN DOOR - W/O WINDOW/LATCH (R19, R20, R21)
1	P32206-10-P15	EA	DOOR - ENTRY W/SCREEN DOOR - W/O WINDOW/LATCH (R22, R23, R24)
1	P32206-10-R17	EA	DOOR - ENTRY W/SCREEN DOOR - W/O WINDOW/LATCH (R25, R26, R27)
2	038327-01-000	FT	TAPE - ANTI-SLIP - 2" X 60'
3	039715-01-000	EA	NUT-SERT - 1/4" DIAMETER - 20 THREADS
4	075671-04-000	FT	SEAL - SPONGE - LAZY T - W/ADHESIVE STRIP - .5" WIDE
5	075673-05-000	FT	SEAL - PILE - ADHESIVE BACK - BLACK
6	106719-01-05A	EA	HINGE - ENTRY DOOR - BRIGHT WHITE
7	116111-02-01A	EA	SCREW - TAPTITE - 1/4-20 X 3/8 PPH 0 ZINC
8	118929-01-01A	FT	SEAL - PILE - PUSH ON
9	121893-01-01A	EA	FRAME - ENTRY DOOR/BOTTOM - BRIGHT WHITE
10	121894-23-01A	EA	FRAME - ENTRY DOOR - BRIGHT WHITE
11	121898-18-01A	EA	JAMB - ENTRY DOOR - BRIGHT WHITE
12	132208-04-L07	EA	DOOR - SCREEN - W/O HARDWARE
13	137401-01-03B	EA	BRACKET - DOOR ANGLE - OFF WHITE
14	139054-01-01A	EA	CAP - DRIP - JAMB MOUNTED - BRIGHT WHITE
15	132915-01-01A	EA	LATCH - SCREEN DOOR - BLACK
	148364-01-02A	EA	STRIKE - SCREEN DOOR - BRIGHT WHITE
			FROM: 12-19-03 THRU: 99-99-99
16	081914-02-000	EA	BUMPER - RUBBER - ROUND - 5/16" DIA. X 13/64" THICK
	138287-01-000	EA	CYLINDER/LOCK - ENTRY DOOR (MASTER)
	138287-02-000	EA	CYLINDER/LOCK - ENTRY DOOR (MASTER)
	138287-03-000	EA	CYLINDER/LOCK - ENTRY DOOR (MASTER)
	138287-04-000	EA	CYLINDER/LOCK - ENTRY DOOR (MASTER)
	138287-05-000	EA	CYLINDER/LOCK - ENTRY DOOR (MASTER)
	138287-06-000	EA	CYLINDER/LOCK - ENTRY DOOR (MASTER)
	138287-07-000	EA	CYLINDER/LOCK - ENTRY DOOR (MASTER)
	138287-08-000	EA	CYLINDER/LOCK - ENTRY DOOR (MASTER)
	138287-09-000	EA	CYLINDER/LOCK - ENTRY DOOR (MASTER)
	138287-10-000	EA	CYLINDER/LOCK - ENTRY DOOR (MASTER)

EXTERIOR DOORS & COMPARTMENTS GROUP (CONTINUED)
ENTRY (CONTINUED)

KEY	PART NUMBER	U/M	DESCRIPTION
	138288-01-000	EA	KEY - REVERSIBLE - #1151 - T/M 16169-02-3091
	138288-02-000	EA	KEY - REVERSIBLE - #1152 - T/M 16169-02-3092
	138288-03-000	EA	KEY - REVERSIBLE - #1153 - T/M 16169-02-3093
	138288-04-000	EA	KEY - REVERSIBLE - #1154 - T/M 16169-02-3094
	138288-05-000	EA	KEY - REVERSIBLE - #1155 - T/M 16169-02-3095
	138288-06-000	EA	KEY - REVERSIBLE - #1156 - T/M 16169-02-3096
	138288-07-000	EA	KEY - REVERSIBLE - #1157 - T/M 16169-02-3097
	138288-08-000	EA	KEY - REVERSIBLE - #1158 - T/M 16169-02-3098
	138288-09-000	EA	KEY - REVERSIBLE - #1159 - T/M 16169-02-3099
	138288-10-000	EA	KEY - REVERSIBLE - #1150 - T/M 16169-02-3100

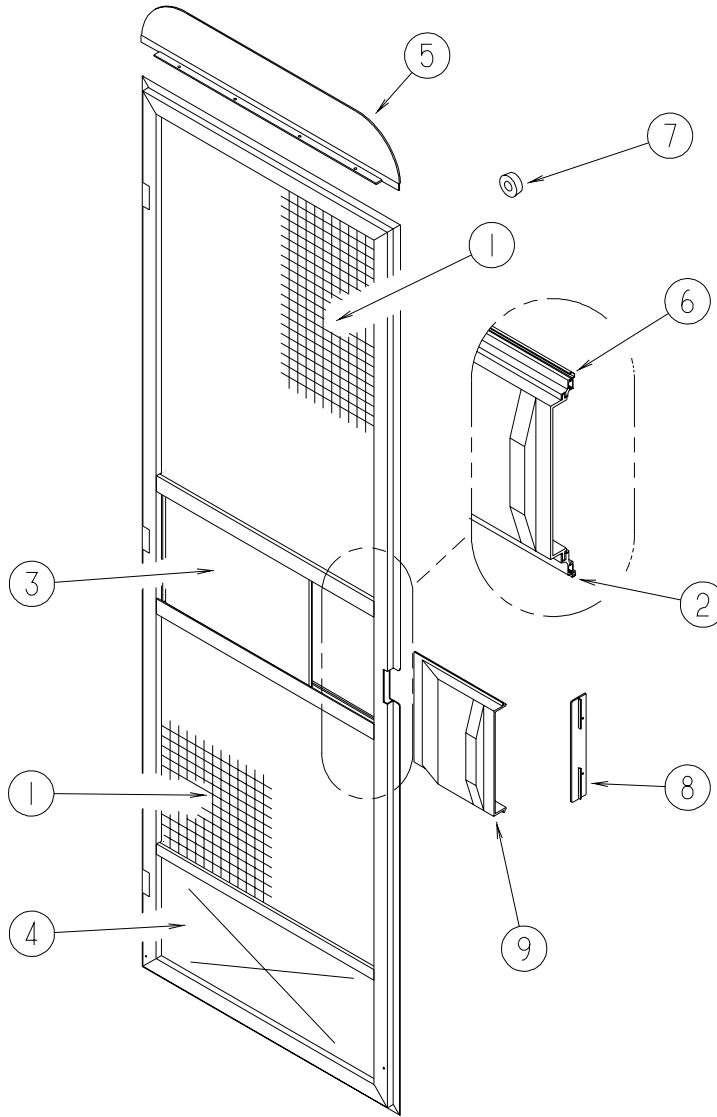

SCREEN

KEY	PART NUMBER	U/M	DESCRIPTION
1	002293-02-000	SF	SCREEN - 26" - CHARCOAL
2	002294-01-000	FT	SPLINE - SCREENING - .13" X .14"
3	016454-21-000	EA	INSERT - SCREEN DOOR - CENTER
4	078552-03-000	EA	KICK PANEL - SCREEN DOOR - LOWER INSERT - UNPAINTED
5	078595-01-000	EA	TOP PLATE - SCREEN DOOR - CURVED TOP - 4.7" X 25.35"
6	078777-08-000	FT	CHANNEL - SLIDER
7	120863-06-000	EA	BUMPER - RUBBER - 3/4" X 3/8"
8	132081-01-01A	EA	STRIKE - SLIDER - SCREEN DOOR - BRIGHT WHITE
9	132082-01-01A	EA	SLIDER - SCREEN DOOR - BRIGHT WHITE

EXTERIOR DOORS & COMPARTMENTS GROUP (CONTINUED)

LATCH - ENTRY

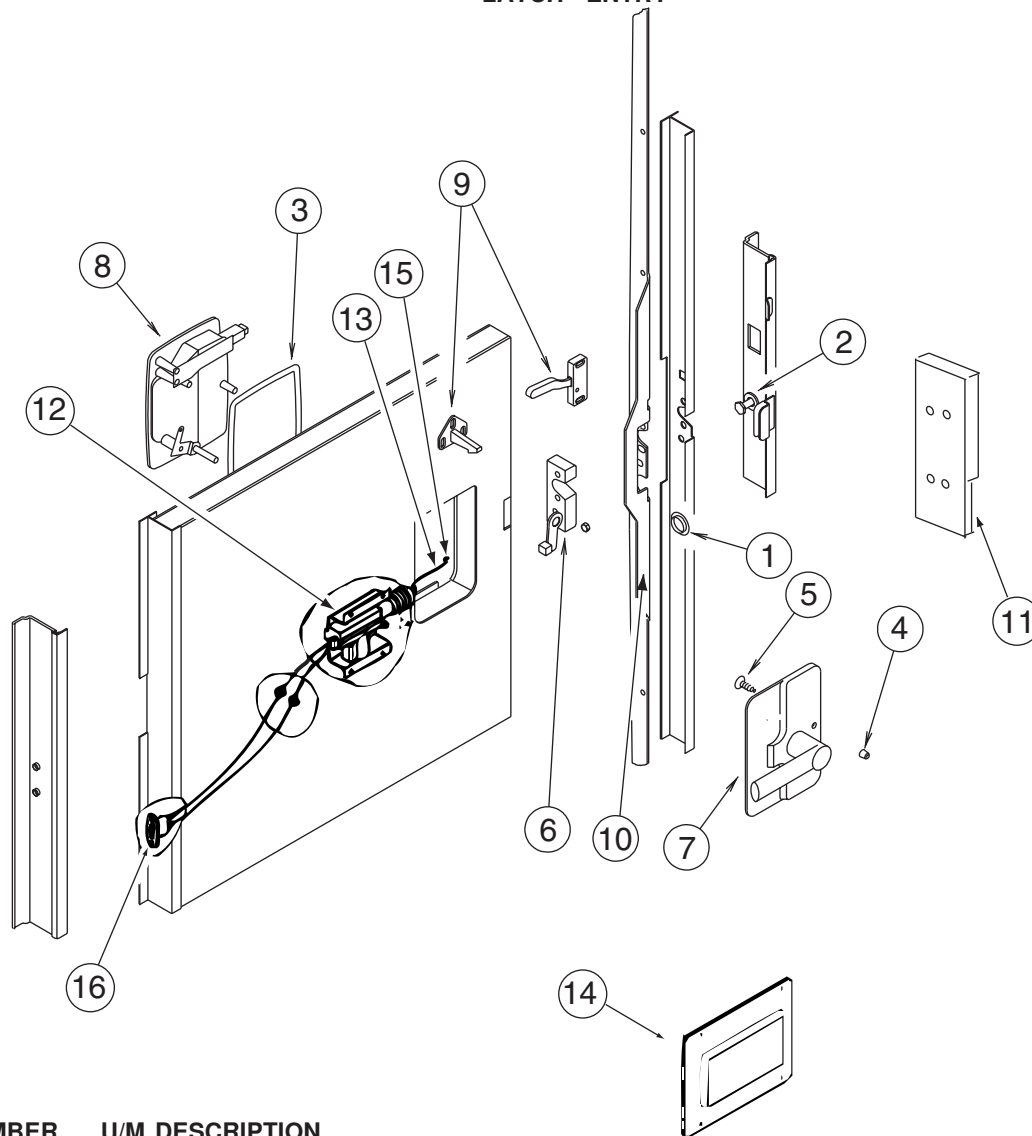

KEY	PART NUMBER	U/M	DESCRIPTION
1	061420-14-000	EA	PLUG/PLASTIC - 7/8" DIAMETER - BLACK
2	092927-14-000	EA	STRIKER - ROUND - JAMB MOUNTED
			FROM: 00-00-00 THRU: 11-02-03
2	092927-15-000	EA	STRIKER - BOLT
			FROM: 11-03-03 THRU: 99-99-99
3	112782-04-01A	EA	GASKET
4	112782-05-01A	EA	CAP - VINYL - RED
5	112782-08-01A	EA	SCREW - MOUNTING/PLATE - ZINC
6	112782-15-01A	EA	LATCH - SINGLE ROTOR
			FROM: 00-00-00 THRU: 04-25-04
6	112782-22-01A	EA	LATCH - SINGLE ROTOR
			FROM: 04-26-04 THRU: 99-99-99
7	112782-16-01A	EA	LATCH - INTERIOR PLATE
			FROM: 00-00-00 THRU: 04-25-04
7	112782-21-01A	EA	LATCH - INTERIOR PLATE
			FROM: 04-26-04 THRU: 99-99-99
8	112782-18-01A	EA	LATCH - EXTERIOR - W/O LOCK CYLINDER W/ICON-REVERSIBLE KEY
			FROM: 00-00-00 THRU: 04-25-04
8	112782-20-01A	EA	LATCH - EXTERIOR - W/O LOCK CYLINDER W/ICON-REVERSIBLE KEY
			FROM: 04-26-04 THRU: 99-99-99
9	132915-01-01A	EA	LATCH - SCREEN DOOR - BLACK
10	132207-01-02B	EA	STIFFENER/DOOR - FORMED - E-COATED
	072893-04-000	EA	NUTSERT - 10-32
11	139102-01-01A	EA	COVER - BRACKET - STRIKE - BRIGHT WHITE
12	113650-02-02B	EA	BRACKET - ACTUATOR - ELECTRIC - E-COATED
	138898-01-000	EA	ACTUATOR/LOCK - ELECTRIC
13	113651-01-01A	EA	ROD - CONTROL - MOTOR/LOCK
14	113960-01-01A	EA	COVER - ACTUATOR - POWER LOCK

EXTERIOR SLIDEOUT GROUP FRONT LEFT

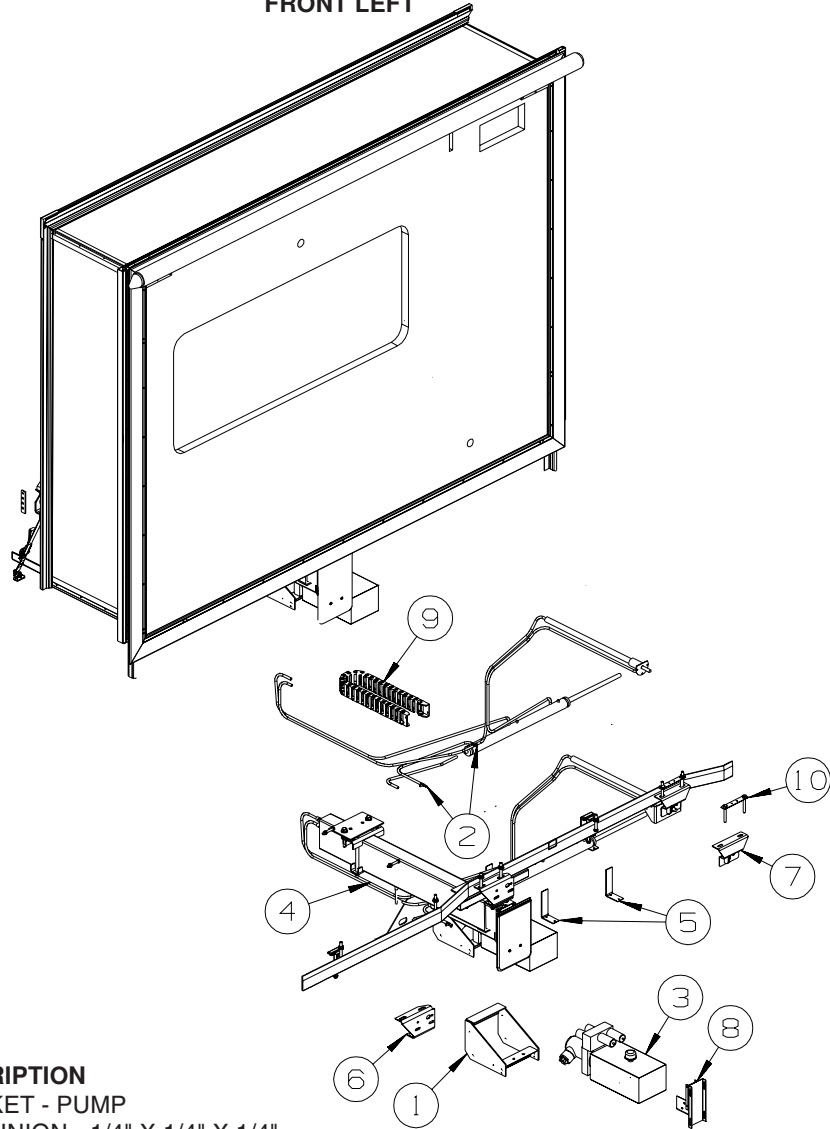

KEY	PART NUMBER	U/M	DESCRIPTION
1	107938-08-000	EA	BRACKET - PUMP
2	123264-01-000	EA	TEE - UNION - 1/4" X 1/4" X 1/4"
3*	136747-01-000	EA	PUMP - SLIDEOUT - 2 ROOM
4*	143394-01-000	EA	SLIDEOUT - HYDRAULIC KIT
5	122922-03-02B	EA	BRACKET/SUPPORT - CYLINDER - (QTY 2)
6	127030-02-02B	EA	BRACKET - INNER REAR/MOUNT - E-COATED
7	143198-01-02B	EA	BRACKET/MOUNT - F/SLIDEOUT - E-COATED
8	145262-01-02B	EA	BRACKET - RAM - E-COATED
9	143541-01-01A	EA	CARRIER/WIRING - F/SLIDE-OUT ROOM - 29 LINKS
10	136995-05-02B	EA	PLATE W/BOLTS - 5.9" X 1" W/7/16" X 3" BOLTS

FROM: 08-18-03 THRU: 99-99-99

*COMPONENT PARTS LISTED LATER IN THIS GROUP

EXTERIOR SLIDEOUT GROUP (CONTINUED)
FRONT LEFT (CONTINUED)

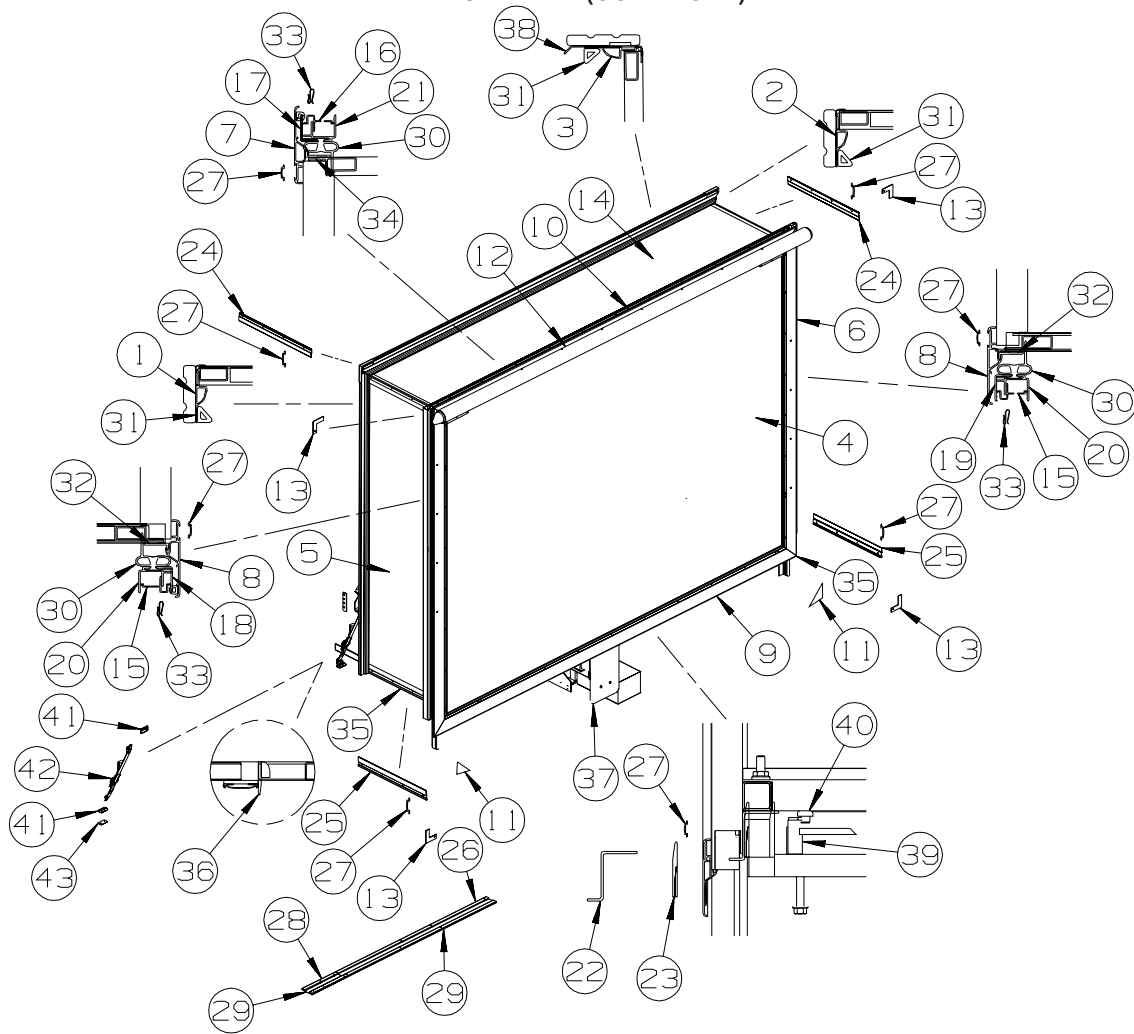

KEY	PART NUMBER	U/M	DESCRIPTION
1	139624-01-01A	EA	TRIM/SEAL - INNER/RIGHT HAND - 73.4" - BRIGHT WHITE
2	139624-02-01A	EA	TRIM/SEAL - INNER/LEFT HAND - 73.4" - BRIGHT WHITE
3	139624-23-01A	EA	TRIM/SEAL - INNER/TOP - 105.3" - BRIGHT WHITE
4	146344-11-R13	EA	SLUG - F/SIDEWALL (R19, R20, R21)
4	146344-11-R15	EA	SLUG - F/SLIDEOUT (R22, R23, R24)
4	146344-11-R17	EA	SLUG - F/SLIDEOUT (R25, R26, R27)
5	121401-07-R08	EA	PANEL/FRAMED WALL - FRONT - F/SLIDEOUT (R19, R20, R21)
5	121401-07-P38	EA	PANEL/FRAMED WALL - FRONT - F/SLIDEOUT (R22, R23, R24)
5	121401-07-M31	EA	PANEL/FRAMED WALL - FRONT - F/SLIDEOUT (R25, R26, R27)
6	121402-05-R08	EA	PANEL/FRAMED WALL - REAR - F/SLIDEOUT (R19, R20, R21)
6	121402-05-P15	EA	PANEL/FRAMED WALL - REAR - F/SLIDEOUT (R22, R23, R24)
6	121402-05-R17	EA	PANEL/FRAMED WALL - REAR - F/SLIDEOUT (R25, R26, R27)
7	139625-25-01A	EA	TRIM/SEAL - TOP/W/MITERED ENDS - 107" - BRIGHT WHITE
8	139625-13-01A	EA	TRIM/SEAL - TOP/W/MITERED ENDS - 79.4" - BRIGHT WHITE
9	142233-01-01A	EA	TRIM/SEAL - W/MITERED ENDS - 107" - BRIGHT WHITE
10	117058-01-01A	FT	TAPE - LOOP - 3/4" WIDE - ADHESIVE BACKED
11	137275-01-01A	EA	PROTECTOR - CORNER - SLIDEOUT - WHITE

EXTERIOR SLIDEOUT GROUP (CONTINUED)
FRONT LEFT (CONTINUED)

KEY	PART NUMBER	U/M	DESCRIPTION
12	122977-20-03A	EA	AWNING/SLIDEOUT W/COVER - 108" - WHITE - VINYL/VINYL WRAP
13	116444-04-12B	EA	TRIM/KEY CORNER - SLIDEOUT - 3.1"X3.1" - BRT WHITE
14	142949-01-P13	EA	ROOF - F/FRONT SLIDEOUT
15	142718-01-01A	EA	RETAINER - SIDEWALL/SLIDEOUT - 72.8"
16	142718-16-01A	EA	RETAINER - SIDEWALL/SLIDEOUT - 104.7"
17	142719-16-01A	EA	TRIM - SIDEWALL/TOP/SLIDEOUT - 106.3" - BRIGHT WHITE
18	142720-08-01A	EA	TRIM - SIDEWALL/SLIDEOUT - 74.4" - BRIGHT WHITE
19	142720-06-01A	EA	TRIM - SIDEWALL/SLIDEOUT - 74.4" - BRIGHT WHITE
20	136824-38-01A	EA	TRIM - SIDEWALL/SLIDEOUT - 74.6" - BRIGHT WHITE
21	136824-24-01A	EA	TRIM - SIDEWALL/SLIDEOUT - 106.4" - BRIGHT WHITE
22	128621-30-01A	EA	BRACKET/ZEE - SLIDEOUT - 100.6" - MILL
23	115075-03-000	FT	SEAL - WIPE - .25" X 2.9"
24	138659-01-01A	EA	TRIM/FEATURE STRIP - 181.7" - BRIGHT WHITE
25	125051-01-01A	EA	TRIM - FEATURE STRIP/LOWER - 20.2" - BRIGHT WHITE
26	115325-07-01A	EA	RAIL - FLOOR/SLIDEOUT ROOM - 44.2" LONG - BLACK
27	105312-01-07A	FT	INSERT - FEATURE STRIP - VINYL - BRIGHT WHITE
28	115325-16-01A	EA	RAIL - FLOOR/SLIDEOUT ROOM - 9.8" LONG - BLACK
29	115661-01-000	FT	SHOE/GLIDE - SLIDEOUT ROOM - 1/16" X 3" - POLYETHYLENE
30	136978-01-01A	FT	SEAL - SLIDEOUT - BLACK
31	146056-01-000	FT	SEAL - TRIANGLE - W/PSA
32	133954-09-01A	EA	TRIM/SEAL - 71.6" - BRIGHT WHITE
33	142549-01-000	EA	CLIP-S TYPE
34	133954-32-01A	EA	TRIM/SEAL - 101.7" - BRIGHT WHITE
35	075673-05-000	FT	SEAL - PILE - ADHESIVE BACK - BLACK
36	115075-02-000	FT	SEAL - WIPE - .25" X 2.9"
37	138077-04-P13	EA	COVER - RAM
	138077-03-01A	EA	COVER - RAM - BRIGHT WHITE
38	125466-09-02A	EA	SUPRT ASM-RF,INTR,B/W,2652MM
39	126313-09-02B	EA	SUPPORT - ROLLER - SLIDE-OUT ROOM - E-COATED
40	134855-01-000	EA	BEARING PAD - NARROW
41	135619-02-01A	EA	PLATE - TIEDOWN - SLIDEOUT ROOM
42	135619-01-01A	EA	STRAP - TIEDOWN - SLIDEOUT ROOM
43	135622-01-01B	EA	PLATE - TIEDOWN - SLIDEOUT ROOM
			FROM: 00-00-00 THRU: 07-17-03
43	135622-01-02B	EA	PLATE - TIEDOWN - SLIDEOUT ROOM
			FROM: 07-18-03 THRU: 99-99-99

EXTERIOR SLIDEOUT GROUP (CONTINUED)
FRONT LEFT (CONTINUED)

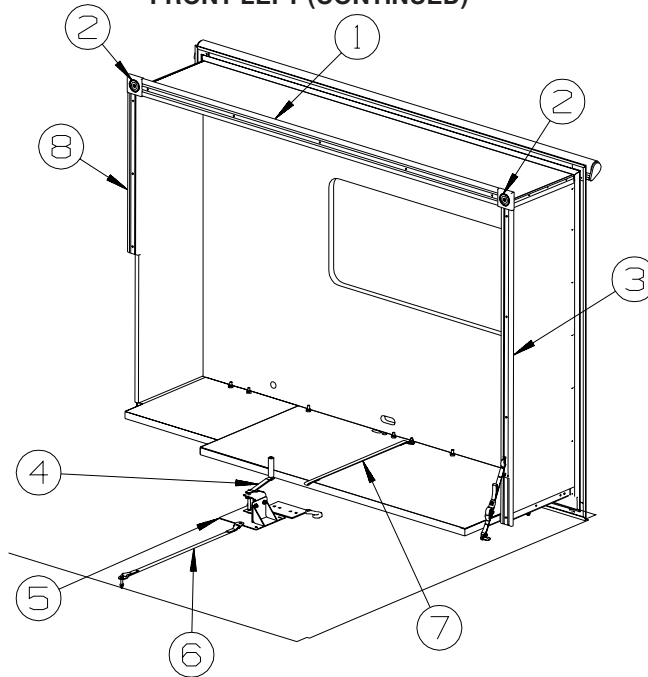

KEY	PART NUMBER	U/M	DESCRIPTION
1	132663-25-08A	EA	MOLDING-VINYL,014X97X2480 - PORTSMOUTH OAK
1	132663-25-07A	EA	MOLDING-VINYL,014X97X2480 - CONCERT CHERRY
1	132663-25-03A	EA	MOLDING-VINYL,014X97X2480 - WASHED MAPLE
1	132663-25-21A	EA	MOLDING-VINYL WRAP/PREDRILLED-.6" X 3.8" X 97.5"-W. MAPLE - WASHED MAPLE FROM: 00-00-00 THRU: 01-04-04 FROM: 01-05-04 THRU: 99-99-99
2	132844-01-08A	EA	BLOCK - CORNER - 3.9" X 3.9" - PORTSMOUTH OAK
2	132844-01-02A	EA	BLOCK - CORNER - 3.9" X 3.9" - SALEM CHERRY - CONCERT CHERRY
2	132844-01-03A	EA	BLOCK - CORNER - 3.9" X 3.9" - WASHED MAPLE
2	132844-01-21A	EA	BLOCK - CORNER - 3.9" X 3.9" - NEAT/WASHED MAPLE - WASHED MAPLE FROM: 00-00-00 THRU: 01-04-04 FROM: 01-05-04 THRU: 99-99-99
3	132663-04-08A	EA	MOLDING-VINYL WRAP/PRE DRILLED - .6" X 3" X 70.4" - OAK - PORTSMOUTH OAK
3	132663-04-07A	EA	MOLDING-VINYL WRAP/PRE DRILLED-.6"X3"X70.4" - CHERRY - CONCERT CHERRY
3	132663-04-03A	EA	MOLDING-VINYL WRAP/PRE DRILLED-.6"X3"X70.4" - WASHED MAPLE
3	132663-04-21A	EA	MOLDING-VINYL WRAP/PRE DRILLED - .6" X 3" X 70.4"-N/MAPLE - WASHED MAPLE FROM: 00-00-00 THRU: 01-04-04 FROM: 01-05-04 THRU: 99-99-99
4	115767-02-000	EA	WINCH - SLIDEOUT W/10' STRAP
5	116082-01-02B	EA	BRACKET - WINCH
	069726-02-000	EA	BUMPER - .88" OD X .40" THICK - BLACK
6	116101-03-H13	EA	STRAP - WINCH - 39.5" CENTER BRACKET/CENTER
	140221-01-02B	EA	WASHER - SEAT BELT - E-COAT
7	116101-02-F31	EA	STRAP - WINCH - 34" CENTER BRACKET/STRAP END
8	132663-13-08A	EA	MOLDING-VINYL WRAP/PRE DRILLED-.6"X3"X35.7" - OAK - PORTSMOUTH OAK
8	132663-13-07A	EA	MOLDING-VINYL WRAP/PRE DRILLED- .6" X 3" X 35.7" - CONCERT CHERRY
8	132663-13-03A	EA	MOLDING-VINYL WRAP/PRE DRILLED- .6" X 3" X 35.7" - WASHED MAPLE
8	132663-13-21A	EA	MOLDING-VINYL WRAP/PRE DRILLED-.6" X 3" X 35.7"-N/MAPLE - WASHED MAPLE FROM: 00-00-00 THRU: 01-04-04 FROM: 01-05-04 THRU: 99-99-99

EXTERIOR SLIDEOUT GROUP (CONTINUED)
COMPONENT PARTS FOR FRONT LEFT SLIDEOUT

136747-01-000

KEY	PART NUMBER	U/M	DESCRIPTION	VENDOR NO.
	100532-01-713	EA	PUMP/MOTOR/TANK - MONARCH	RAP90014/AP2260 & AP21255
	100532-03-715	EA	CAP-BREATHER W/DIPSTICK	RAP7876
	100532-03-723	EA	O-RING/SEAL KIT	RAP9171
	100532-09-710	EA	SOLENOID-INTERMITENT DUTY	RAP0533
	131306-12-702	EA	VALVE - PRESSURE SOLENOID - 3.3"X1.6"	RAP90729/AP24604

143394-01-000

KEY	PART NUMBER	U/M	DESCRIPTION	VENDOR NO.
	132540-01-706	EA	BOLT - SLIDE ROOM ADJUSTER	RAP90865/P19611

EXTERIOR SLIDEOUT GROUP (CONTINUED)

REAR LEFT

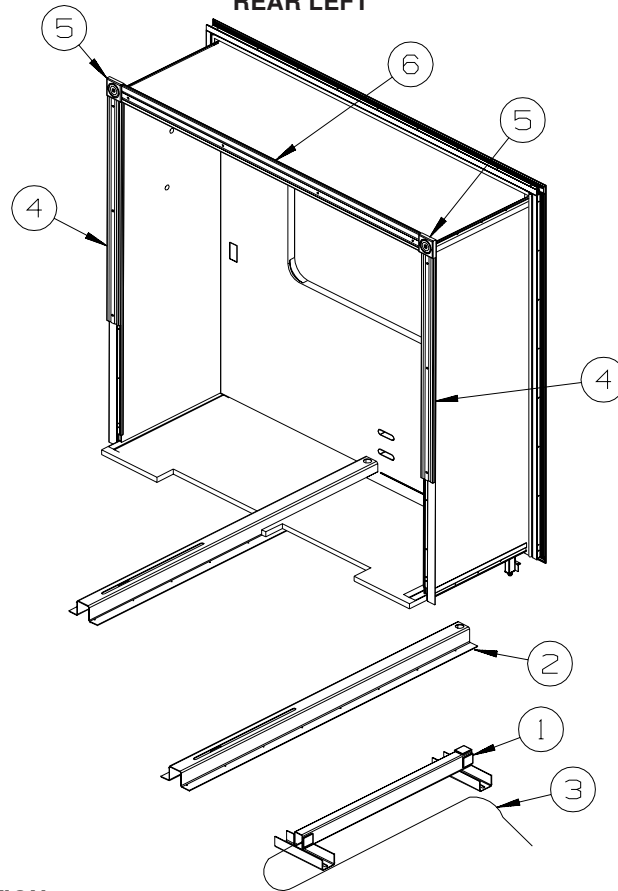

KEY	PART NUMBER	U/M	DESCRIPTION
1*	128599-04-000	EA	CYLINDER/HYDRAULIC - F/SLIDEOUT
2*	128599-02-000	EA	CHANNEL - F/SLIDEOUT
3*	100536-42-000	EA	HOSE KIT - PUMP TO SLIDE-OUT VALVE
4	132663-17-08A	EA	MOLDING-VINYL WRAP/PRE DRILLED-.6"X3"X45.5" - OAK - PORTSMOUTH OAK
4	132663-17-07A	EA	MOLDING-VINYL WRAP/PRE DRILLED-.6"X3"X45.5" - CHERRY - CONCERT CHERRY
4	132663-17-03A	EA	MOLDING-VINYL WRAP/PRE DRILLED-.6"X3"X45.5" - WASHED MAPLE
			FROM: 00-00-00 THRU: 01-04-04
4	132663-17-21A	EA	MOLDING-VINYL WRAP/PREDRILLED-.6" X 3" X 45.5"-N/MAPLE - WASHED MAPLE
			FROM: 01-05-04 THRU: 99-99-99
5	132844-02-08A	EA	BLOCK - CORNER - 3.5" X 3.5" - PORTSMOUTH OAK
5	132844-02-02A	EA	BLOCK - CORNER - 3.5" X 3.5" - SALEM CHERRY - CONCERT CHERRY
5	132844-02-03A	EA	BLOCK - CORNER - 3.5" X 3.5" - WASHED MAPLE
			FROM: 00-00-00 THRU: 01-04-04
5	132844-02-21A	EA	BLOCK - CORNER - 3.5" X 3.5" - NEAT/WASHED MAPLE - WASHED MAPLE
			FROM: 01-05-04 THRU: 99-99-99
6	132663-18-08A	EA	MOLDING-VINYL WRAP/PRE DRILLED - .6" X 3.4" X 73.2" - OAK - PORTSMOUTH OAK
6	132663-18-07A	EA	MOLDING-VINYL WRAP/PRE DRILLED - .6" X 3.4" X 73.2"-CHERRY - CONCERT CHERRY
6	132663-18-03A	EA	MOLDING-VINYL WRAP/PRE DRILLED - .6" X 3.4" X 73.2" -MAPLE - WASHED MAPLE
			FROM: 00-00-00 THRU: 01-04-04
6	132663-18-21A	EA	MOLDING-VINYL WRAP/PRE DRILLED-.6" X 3.4" X 73.1"-N/MAPLE - WASHED MAPLE
			FROM: 01-05-04 THRU: 99-99-99

*COMPONENT PARTS LISTED LATER IN THIS GROUP

EXTERIOR SLIDEOUT GROUP (CONTINUED)
REAR LEFT (CONTINUED)

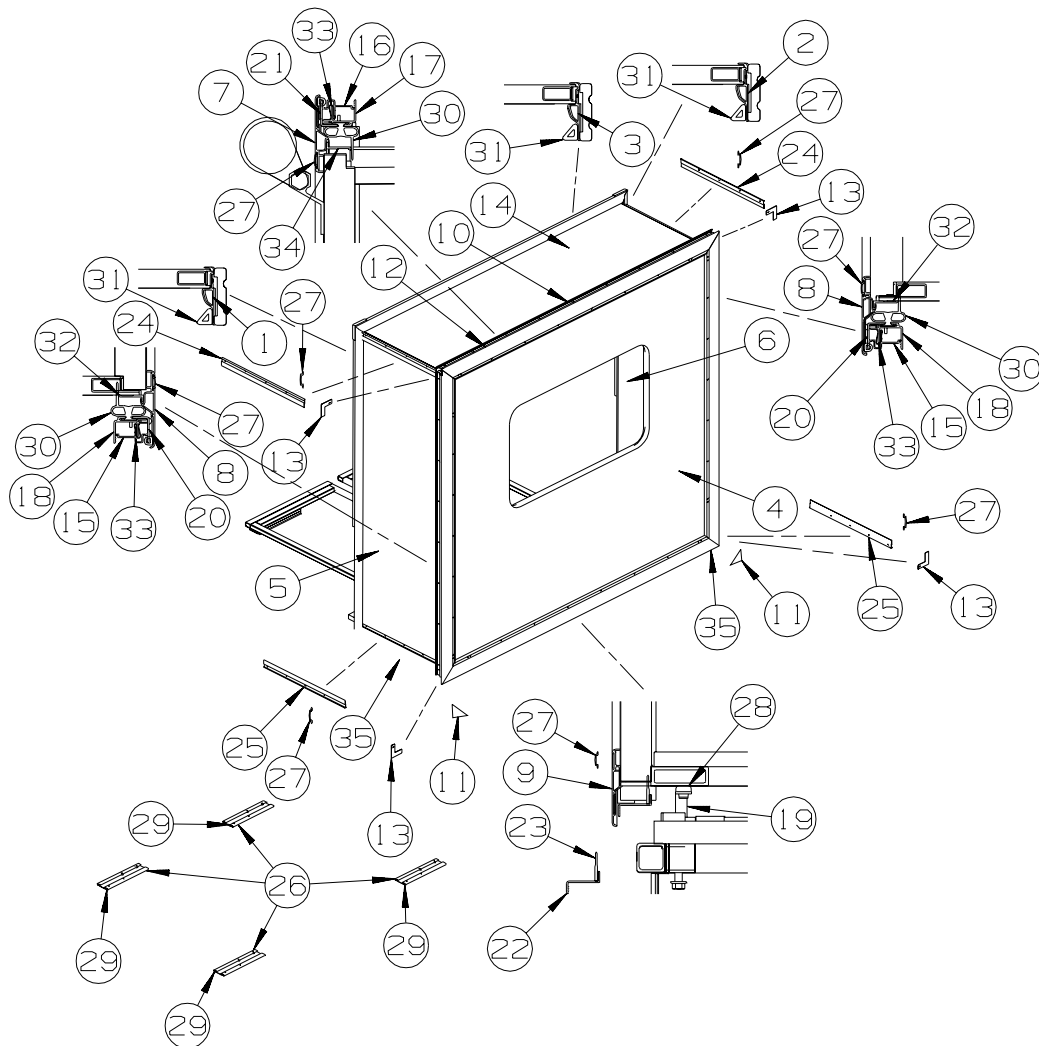

KEY	PART NUMBER	U/M	DESCRIPTION
1	139624-15-01A	EA	TRIM/SEAL - INNER/RIGHT HAND - 72.9" - BRIGHT WHITE
2	139624-16-01A	EA	TRIM/SEAL - INNER/LEFT HAND - 72.9" - BRIGHT WHITE
3	139624-04-01A	EA	TRIM/SEAL - INNER/TOP - 80.2" - BRIGHT WHITE
4	146344-12-R13	EA	SLUG - F/SIDEWALL (R19, R20, R21)
4	146344-12-R15	EA	SLUG - F/SIDEWALL (R22, R23, R24)
4	146344-12-R17	EA	SLUG - F/SIDEWALL (R25, R26, R27)
5	143039-01-R13	EA	PANEL/FRAMED WALL - REAR - F/SLIDEOUT (R19, R20, R21)
5	143039-01-P15	EA	PANEL/FRAMED WALL - REAR - F/SLIDEOUT (R22, R23, R24)
5	143039-01-R17	EA	PANEL/FRAMED WALL - REAR - F/SLIDEOUT (R25, R26, R27)
6	143041-01-R13	EA	PANEL/FRAMED WALL - FRONT - F/SLIDEOUT (R19, R20, R21)
6	143041-01-P15	EA	PANEL/FRAMED WALL - FRONT - F/SLIDEOUT (R22, R23, R24)
6	143041-01-R17	EA	PANEL/FRAMED WALL - FRONT - F/SLIDEOUT (R25, R26, R27)
7	139625-03-01A	EA	TRIM/SEAL - TOP/W/MITERED ENDS - 81.8" - BRIGHT WHITE
8	139625-11-01A	EA	TRIM/SEAL - TOP/W/MITERED ENDS - 75.6" - BRIGHT WHITE
9	142233-04-01A	EA	TRIM/SEAL - W/MITERED ENDS - 81.8" - BRIGHT WHITE
10	117058-01-01A	FT	TAPE - LOOP - 3/4" WIDE - ADHESIVE BACKED
11	135275-01-01A	EA	PROTECTOR - CORNER - SLIDEOUT - WHITE
12	122977-12-03A	EA	AWNING/SLIDEOUT W/COVER - 81.8" - WHITE - VINYL/VINYL WRAP
13	116444-04-12B	EA	TRIM/KEY CORNER - SLIDEOUT - 3.1" X 3.1" - BRT WHITE
14	136557-01-M07	EA	ROOF - F/SLIDEOUT
15	142718-01-01A	EA	RETAINER - SIDEWALL/SLIDEOUT - 72.8"
16	142718-23-01A	EA	RETAINER - SIDEWALL/SLIDEOUT - 79.9"
17	142719-05-01A	EA	TRIM - SIDEWALL/TOP SLIDEOUT - 81.3" - BRIGHT WHITE
18	142720-11-01A	EA	TRIM - SIDEWALL/SLIDEOUT - 72.9" - BRIGHT WHITE
19	126313-09-02B	EA	SUPPORT - ROLLER - SLIDEOUT ROOM - E-COATED
20	136824-16-01A	EA	TRIM - SIDEWALL/SLIDEOUT - 72.7" - BRIGHT WHITE
21	136824-02-01A	EA	TRIM - SIDEWALL/SLIDEOUT - 81.2" - BRIGHT WHITE
22	141174-01-02A	EA	TRIM/ZEE - SIDEWALL - 81.4" - BRIGHT WHITE

EXTERIOR SLIDEOUT GROUP (CONTINUED)
REAR LEFT (CONTINUED)

KEY	PART NUMBER	U/M	DESCRIPTION
23	123012-04-000	FT	SEAL - F/SLIDEOUT
24	138659-01-01A	EA	TRIM/FEATURE STRIP - 181.7" - BRIGHT WHITE
25	141435-04-01A	EA	TRIM - FEATURE - LOWER - 24" - BRIGHT WHITE
	141434-51-001	EA	TRIM - FLOOR/SIDEWALL - 16'
26	115325-08-01A	EA	RAIL - FLOOR/SLIDEOUT ROOM - 12" LONG - BLACK
27	105312-01-07A	FT	INSERT - FEATURE STRIP - VINYL - BRIGHT WHITE
28	134855-01-000	EA	BEARING PAD - NARROW
29	115661-01-000	FT	SHOE/GLIDE - SLIDEOUT ROOM - 1/16" X 3" - POLYETHYLENE
30	136978-01-01A	FT	SEAL - SLIDEOUT - BLACK
31	146056-01-000	FT	SEAL - TRIANGLE - W/PSA
32	133954-46-01A	EA	TRIM/SEAL - 68.8" - BRIGHT WHITE
33	142549-01-000	EA	CLIP-S TYPE
34	133954-18-01A	EA	TRIM/SEAL - 76.5" - BRIGHT WHITE
35	075673-05-000	FT	SEAL - PILE - ADHESIVE BACK - BLACK

EXTERIOR SLIDEOUT GROUP (CONTINUED)
COMPONENT PARTS FOR REAR LEFT SLIDEOUT

100536-42-000

KEY	PART NUMBER	U/M	DESCRIPTION	VENDOR NO.
	100536-42-700	EA	HOSE/HYDRAULIC - 180" - PRESS	RAP90120/AP5965
	100536-42-701	EA	HOSE/HYDRAULIC - 175" - RETURN	RAP90350/AP7358

128599-02-000

KEY	PART NUMBER	U/M	DESCRIPTION	VENDOR NO.
	128599-06-703	EA	BEARING KIT - SLIDE-OUT TUBE	RAP90698
	128599-06-704	EA	BEARING PAD - SLIDE-OUT	P14811

128599-04-000

KEY	PART NUMBER	U/M	DESCRIPTION	VENDOR NO.
	128599-05-700	EA	RAM/CYLINDER - SLIDEOUT	RAP90688
	137390-01-701	EA	CYLINDER NUT KIT - SLIDEOUT	RAP90947

GALLEY GROUP CABINETS

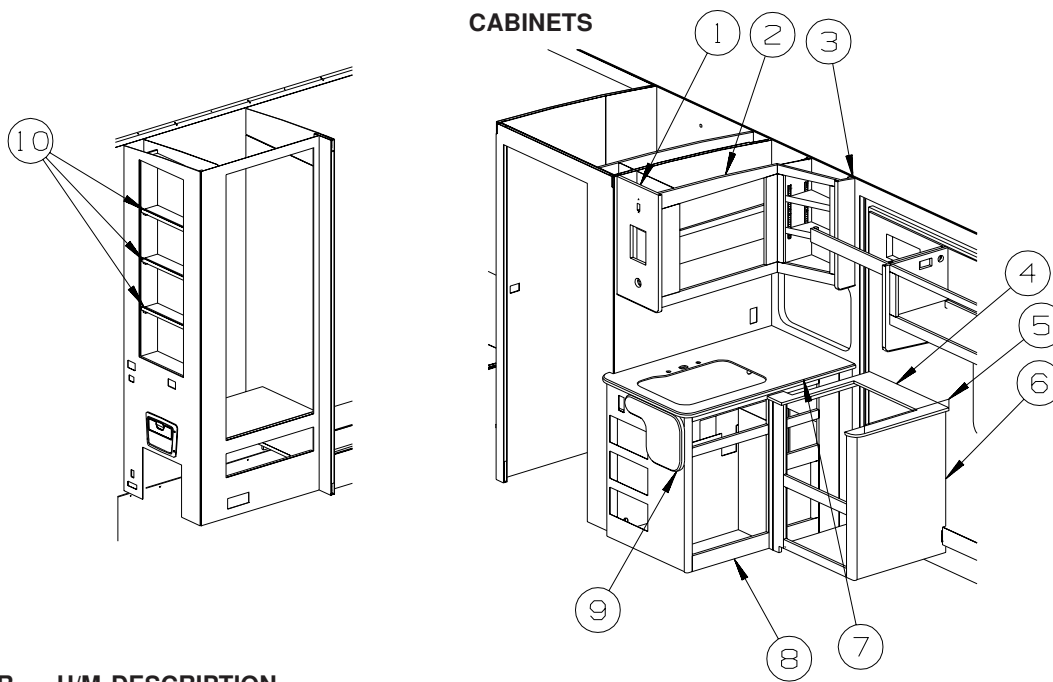

KEY	PART NUMBER	U/M	DESCRIPTION
1	143060-16-P13	EA	END CAP - OVERHEAD CABINET - PORTSMOUTH OAK - WATER HEATER - ELEC. IGNITION FROM: 00-00-00 THRU: 07-06-03
1	143060-31-P13	EA	END CAP - OVERHEAD CABINET - PORTSMOUTH OAK - WATER HEATER - ELEC. IGNITION FROM: 07-07-03 THRU: 99-99-99
1	143060-16-P14	EA	END CAP - OVERHEAD CABINET - CONCERT CHERRY - WATER HEATER - ELEC. IGNITION FROM: 00-00-00 THRU: 07-06-03
1	143060-31-P14	EA	END CAP - OVERHEAD CABINET - CONCERT CHERRY - WATER HEATER - ELEC. IGNITION FROM: 07-07-03 THRU: 99-99-99
1	143060-16-P33	EA	END CAP - OVERHEAD CABINET - WASHED MAPLE - WATER HEATER - ELEC. IGNITION FROM: 00-00-00 THRU: 07-06-03
1	143060-31-P33	EA	END CAP - OVERHEAD CABINET - WASHED MAPLE - WATER HEATER - ELEC. IGNITION FROM: 07-07-03 THRU: 01-04-04
1	143060-31-RW1	EA	END CAP - OVERHEAD CABINET - WASHED MAPLE - WATER HEATER - ELEC. IGNITION FROM: 01-05-04 THRU: 99-99-99
1	143060-30-P13	EA	END CAP - OVERHEAD CABINET - PORTSMOUTH OAK - WTR. HTR. - 6 GAL/ELEC/LP/MOTORAIID
1	143060-30-P14	EA	END CAP - OVERHEAD CABINET - CONCERT CHERRY - WTR. HTR. - 6 GAL/ELEC/LP/MOTORAIID
1	143060-30-P33	EA	END CAP - OVERHEAD CABINET - WASHED MAPLE - WTR. HTR. - 6 GAL/ELEC/LP/MOTORAIID
2	143060-01-P13	EA	CABINET - OVERHEAD/GALLEY - W/O DRS/HDW - PORTSMOUTH OAK - WTR HTR - ELEC. IGNITION
2	143060-01-P14	EA	CABINET - OVERHEAD/GALLEY - W/O DRS/HDW - CONCERT CHERRY - WTR HTR - ELEC. IGNITION
2	143060-01-P33	EA	CABINET - OVERHEAD/GALLEY - W/O DRS/HDW - WASHED MAPLE - WTR HTR - ELEC. IGNITION FROM: 00-00-00 THRU: 01-04-04
2	143060-01-RW1	EA	CABINET - OVERHEAD/GALLEY - W/O DRS/HDW - WASHED MAPLE - WTR HTR - ELEC. IGNITION FROM: 01-05-04 THRU: 99-99-99
2	143060-02-P13	EA	CABINET - OVERHEAD/GALLEY - W/O DRS/HDW - PORTSMOUTH OAK - 6 GAL/ELEC/LP/MOTORAIID FROM: 00-00-00 THRU: 07-06-03
2	143060-03-P13	EA	CABINET - OVERHEAD/GALLEY - W/O DRS/HDW - PORTSMOUTH OAK - 6 GAL/ELEC/LP/MOTORAIID FROM: 07-07-03 THRU: 99-99-99
2	143060-02-P14	EA	CABINET - OVERHEAD/GALLEY - W/O DRS/HDW - CONCERT CHERRY - 6 GAL/ELEC/LP/MOTORAIID FROM: 00-00-00 THRU: 07-06-03
2	143060-03-P14	EA	CABINET - OVERHEAD/GALLEY - W/O DRS/HDW - CONCERT CHERRY - 6 GAL/ELEC/LP/MOTORAIID FROM: 07-07-03 THRU: 99-99-99
2	143060-02-P33	EA	CABINET - OVERHEAD/GALLEY - W/O DRS/HDW - WASHED MAPLE - 6 GAL/ELEC/LP/MOTORAIID FROM: 00-00-00 THRU: 07-06-03
2	143060-03-P33	EA	CABINET - OVERHEAD/GALLEY - W/O DRS/HDW - WASHED MAPLE - 6 GAL/ELEC/LP/MOTORAIID FROM: 07-07-03 THRU: 01-04-04
2	143060-03-RW1	EA	CABINET - OVERHEAD/GALLEY - W/O DRS/HDW - WASHED MAPLE - 6 GAL/ELEC/LP/MOTORAIID FROM: 01-05-04 THRU: 99-99-99

GALLEY GROUP (CONTINUED)

CABINETS (CONTINUED)

KEY	PART NUMBER	U/M	DESCRIPTION
3	143060-15-P13	EA	END CAP - OVERHEAD CABINET - PORTSMOUTH OAK
3	143060-15-P14	EA	END CAP - OVERHEAD CABINET - CONCERT CHERRY
3	143060-15-P33	EA	END CAP - OVERHEAD CABINET - WASHED MAPLE
			FROM: 00-00-00 THRU: 01-04-04
3	143060-15-RW1	EA	END CAP - OVERHEAD CABINET - WASHED MAPLE
			FROM: 01-05-04 THRU: 99-99-99
4	137475-15-03A	EA	COUNTERTOP - 1/4" VENDURA - ROCKY MOUNTAIN HIGH
5	126875-02-N70	EA	FRAME ONLY - F/SPLASHGUARD - PORTSMOUTH OAK
5	126875-02-K13	EA	FRAME ONLY - F/SPLASHGUARD - CONCERT CHERRY
5	126875-02-M15	EA	FRAME ONLY - F/SPLASHGUARD - WASHED MAPLE
			FROM: 00-00-00 THRU: 01-04-04
5	126875-02-RW2	EA	FRAME ONLY - F/SPLASHGUARD - WASHED MAPLE
			FROM: 01-05-04 THRU: 99-99-99
5	127117-02-01A	EA	GLASS - STATIONARY - SPLASHGUARD
6	P43062-02-P13	EA	CABINET - GALLEY/SLIDEOUT - W/O DOORS/DRAWERS/HARDWARE - PORTSMOUTH OAK
6	P43062-02-P14	EA	CABINET - GALLEY/SLIDEOUT - W/O DOORS/DRAWERS/HARDWARE - CONCERT CHERRY
6	P43062-02-P33	EA	CABINET - GALLEY/SLIDEOUT - W/O DOORS/DRAWERS/HARDWARE - WASHED MAPLE
			FROM: 00-00-00 THRU: 01-04-04
6	P43062-02-RW1	EA	CABINET - GALLEY/SLIDEOUT - W/O DOORS/DRAWERS/HARDWARE - WASHED MAPLE
			FROM: 01-05-04 THRU: 99-99-99
7	137475-14-03A	EA	COUNTERTOP - 1/4" VENDURA - ROCKY MOUNTAIN HIGH
7	137475-19-03A	EA	COUNTERTOP - 1/4" VENDURA - W/WATER PURIFIER
8	143061-01-P13	EA	CABINET - GALLEY - W/O COUNTERTOP/DOORS/DRAWERS/HARDWARE - PORTSMOUTH OAK
8	143061-01-P14	EA	CABINET - GALLEY - W/O COUNTERTOP/DOORS/DRAWERS/HARDWARE - CONCERT CHERRY
8	143061-01-P33	EA	CABINET - GALLEY - W/O COUNTERTOP/DOORS/DRAWERS/HARDWARE - WASHED MAPLE
			FROM: 00-00-00 THRU: 01-04-04
8	143061-01-RW1	EA	CABINET - GALLEY - W/O COUNTERTOP/DOORS/DRAWERS/HARDWARE - WASHED MAPLE
			FROM: 01-05-04 THRU: 99-99-99
9	141784-03-03A	EA	COUNTERTOP - 1/4" VENDURA - ALMONDINE
10	146544-30-R13	EA	SHELF - W/PLASTIC EDGE MOLDING - PORTSMOUTH OAK
10	146544-30-R14	EA	SHELF - W/PLASTIC EDGE MOLDING - CONCERT CHERRY
10	146544-30-R21	EA	SHELF - W/PLASTIC EDGE MOLDING - WASHED MAPLE
			FROM: 00-00-00 THRU: 01-04-04
10	146544-30-RW1	EA	SHELF - W/PLASTIC EDGE MOLDING - WASHED MAPLE
			FROM: 01-05-04 THRU: 99-99-99

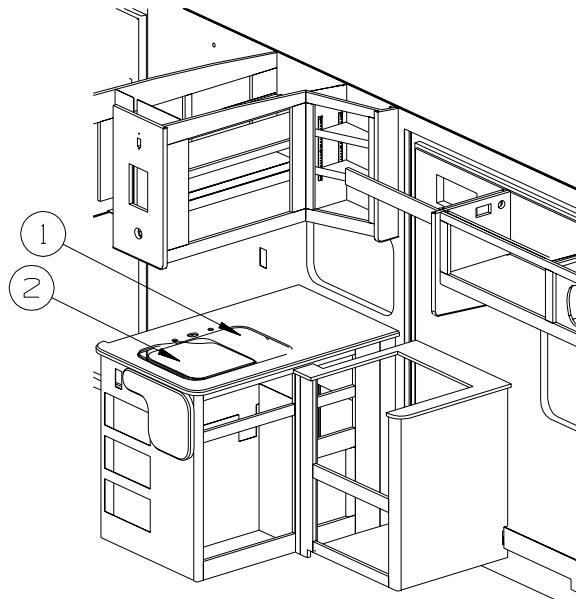

KEY	PART NUMBER	U/M	DESCRIPTION
1	137489-02-03A	EA	COVER - SINK/SMALL - 9.6" X 15.7" - 1/4" VENDURA/QUARRY
2	137489-01-03A	EA	COVER - SINK/LARGE - 13.8" X 17" - 1/4" VENDURA/QUARRY

GALLEY GROUP (CONTINUED)

DOORS & DRAWERS

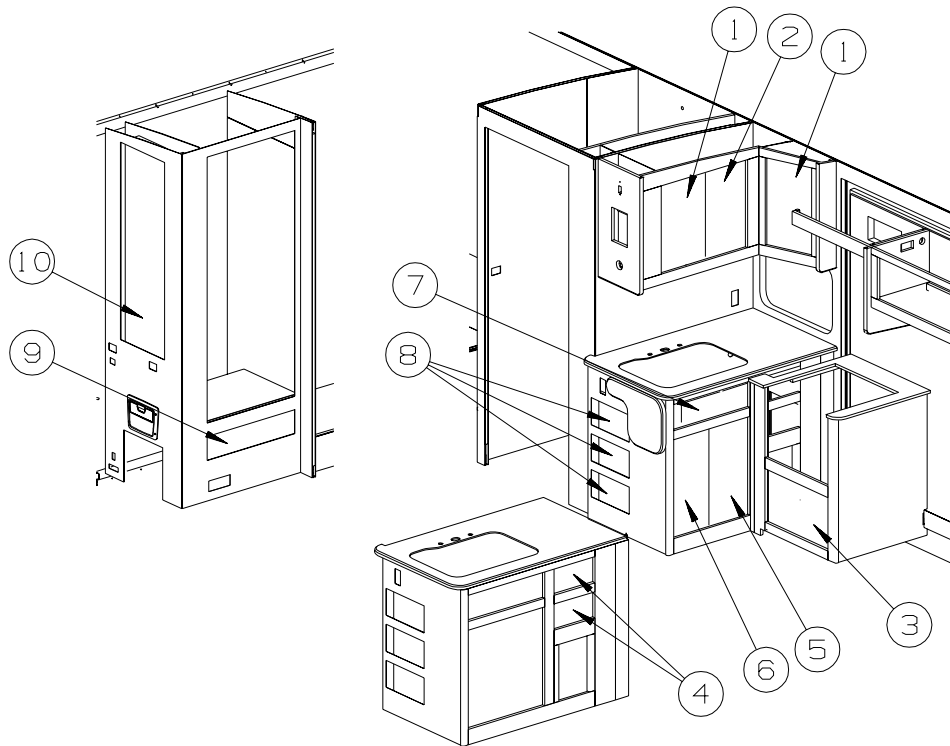

KEY	PART NUMBER	U/M	DESCRIPTION
1	141518-67-P54	EA	DOOR - ARCHED/PENCIL EDGE/LEFT HAND-12" X 21.8"-W/O HDW - PORTSMOUTH OAK
1	141518-67-P55	EA	DOOR - ARCHED/PENCIL EDGE/LEFT HAND-12" X 21.8"-W/O HDW - CONCERT CHERRY
1	141518-67-P56	EA	DOOR - ARCHED/PENCIL EDGE/LEFT HAND-12" X 21.8"-W/O HDW - WASHED MAPLE
1	076767-04-000	EA	CABLE - STAINLESS STEEL - 5.9"
2	141520-67-P54	EA	DOOR - ARCHED/PENCIL EDGE/RIGHT HAND -12"X21.8"- W/O HDW - PORTSMOUTH OAK
2	141520-67-P55	EA	DOOR - ARCHED/PENCIL EDGE/RIGHT HAND -12"X21.8"- W/O HDW - CONCERT CHERRY
2	141520-67-P56	EA	DOOR - ARCHED/PENCIL EDGE/RIGHT HAND -12"X21.8"- W/O HDW - WASHED MAPLE
2	076767-04-000	EA	CABLE - STAINLESS STEEL - 5.9"
3	145386-12-R74	EA	DRAWER - PENCIL EDGE-20.2"W X 21.6"D - W/O SLIDES/HARDWARE - PORTSMOUTH OAK FROM: 00-00-00 THRU: 06-01-03
3	145386-23-R19	EA	DRAWER - PENCIL EDGE-20.2"W X 21.6"D - W/O SLIDES/HARDWARE - PORTSMOUTH OAK FROM: 06-02-03 THRU: 99-99-99
3	145386-12-R75	EA	DRAWER - PENCIL EDGE-20.2"W X 21.6"D - W/O SLIDES/HARDWARE - CONCERT CHERRY FROM: 00-00-00 THRU: 06-01-03
3	145386-23-R20	EA	DRAWER - PENCIL EDGE-20.2"W X 21.6"D - W/O SLIDES/HARDWARE - CONCERT CHERRY FROM: 06-02-03 THRU: 99-99-99
3	145386-12-R76	EA	DRAWER - PENCIL EDGE-20.2"W X 21.6"D - W/O SLIDES/HARDWARE - WASHED MAPLE FROM: 00-00-00 THRU: 06-01-03
3	145386-23-R21	EA	DRAWER - PENCIL EDGE-20.2"W X 21.6"D - W/O SLIDES/HARDWARE - WASHED MAPLE FROM: 06-02-03 THRU: 99-99-99
4	145386-25-R19	EA	DRAWER - PENCIL EDGE-10.4"W X 15.7"D - W/O SLIDES/HARDWARE - PORTSMOUTH OAK
4	145386-25-R20	EA	DRAWER - PENCIL EDGE-10.4"W X 15.7"D - W/O SLIDES/HARDWARE - CONCERT CHERRY
4	145386-25-R21	EA	DRAWER - PENCIL EDGE-10.4"W X 15.7"D - W/O SLIDES/HARDWARE - WASHED MAPLE
5	136919-45-R19	EA	DOOR - FLAT/PENCIL EDGE - 10.8" X 23.8" - W/O HARDWARE - PORTSMOUTH OAK
5	136919-45-R20	EA	DOOR - FLAT/PENCIL EDGE - 10.8" X 23.8" - W/O HARDWARE - CONCERT CHERRY
5	136919-45-R21	EA	DOOR - FLAT/PENCIL EDGE - 10.8" X 23.8" - W/O HARDWARE - WASHED MAPLE
6	136919-44-R19	EA	DOOR - FLAT/PENCIL EDGE - 10.8" X 23.8" - W/O HARDWARE - PORTSMOUTH OAK
6	136919-44-R20	EA	DOOR - FLAT/PENCIL EDGE - 10.8" X 23.8" - W/O HARDWARE - CONCERT CHERRY
6	136919-44-R21	EA	DOOR - FLAT/PENCIL EDGE - 10.8" X 23.8" - W/O HARDWARE - WASHED MAPLE
7	134842-11-R19	EA	DRAWER - TIPOUT - W/HIDDEN TRAY - PORTSMOUTH OAK
7	134842-11-R20	EA	DRAWER - TIPOUT - W/HIDDEN TRAY - CONCERT CHERRY
7	134842-11-R21	EA	DRAWER - TIPOUT - W/HIDDEN TRAY - WASHED MAPLE
	108127-01-01A	EA	CAP - TRAY
	108128-01-01A	EA	TRAY - HIDDEN

GALLEY GROUP (CONTINUED)
DOORS & DRAWERS (CONTINUED)

KEY	PART NUMBER	U/M	DESCRIPTION
8	145386-99-R19	EA	DRAWER - PENCIL EDGE - 12"W X 17.7"D - W/O SLIDES/HDW - PORTSMOUTH OAK
8	145386-99-R20	EA	DRAWER - PENCIL EDGE - 12"W X 17.7"D - W/O SLIDES/HDW - CONCERT CHERRY
8	145386-99-R21	EA	DRAWER - PENCIL EDGE - 12"W X 17.7"D - W/O SLIDES/HDW - WASHED MAPLE
9	145492-06-R10	EA	DRAWER - PENCIL EDGE - 22.5"W X 13.8"D - W/O SLIDES/HDW - PORTSMOUTH OAK
9	145492-06-R20	EA	DRAWER - PENCIL EDGE - 22.5"W X 13.8"D - W/O SLIDES/HDW - CONCERT CHERRY
9	145492-06-R21	EA	DRAWER - PENCIL EDGE - 22.5"W X 13.8"D - W/O SLIDES/HDW - WASHED MAPLE
10	141518-C7-R19	EA	DOOR - ARCHED/PENCIL EDGE - 15.5" X 45.4" - W/O HARDWARE - PORTSMOUTH OAK
10	141518-C7-R20	EA	DOOR - ARCHED/PENCIL EDGE - 15.5" X 45.4" - W/O HARDWARE - CONCERT CHERRY
10	141518-C7-R21	EA	DOOR - ARCHED/PENCIL EDGE - 15.5" X 45.4" - W/O HARDWARE - WASHED MAPLE
10	076767-04-000	EA	CABLE - STAINLESS STEEL - 5.9"

GENERATOR GROUP

GAS

430V

KEY	PART NUMBER	U/M	DESCRIPTION
	109982-03-000	EA	GENERATOR - 4.0 MICROLITE
	007131-01-000	EA	HANGER - TAILPIPE - 6 SLOTS
	143954-01-000	EA	PIPE - EXHAUST - GENERATOR
	007125-04-000	EA	CLAMP - MUFFLER - 1.12" DIAMETER
	007125-03-000	EA	CLAMP - MUFFLER - 1.5" DIAMETER

FROM: 04-23-03 THRU: 99-99-99

427P & 431C

KEY	PART NUMBER	U/M	DESCRIPTION
	109982-03-000	EA	GENERATOR - 4.0 MICROLITE
	007131-01-000	EA	HANGER - TAILPIPE - 6 SLOTS
	105958-26-000	EA	PIPE - EXHAUST - GENERATOR
	007125-04-000	EA	CLAMP - MUFFLER - 1.12" DIAMETER

**HEATING & A/C GROUP
FURNACE**

427P

KEY	PART NUMBER	U/M	DESCRIPTION
*	139980-02-000	EA	FURNACE - 30000 BTU - SF QUIET - SUBURBAN SF-30 2321J
	137965-01-01A	EA	REGISTER - 2.25" X 10" - W/O DAMPER - ANTIQUE BRASS
	137965-02-01A	EA	REGISTER - 2.25" X 10" - W/DAMPER - ANTIQUE BRASS
	009200-01-000	EA	TAPE - FURNACE - 1 1/2"
	093741-01-000	EA	BOX - BOOT - FLOOR REGISTER
	098668-26-000	EA	BOTTOM DUCT KIT - 40,000 BTU

***COMPONENT PARTS LISTED LATER IN THIS GROUP**

430V

KEY	PART NUMBER	U/M	DESCRIPTION
*	139980-02-000	EA	FURNACE - 30000 BTU - SF QUIET - SUBURBAN SF-30 2321J
	137965-01-01A	EA	REGISTER - 2.25" X 10" - W/O DAMPER - ANTIQUE BRASS
	137965-02-01A	EA	REGISTER - 2.25" X 10" - W/DAMPER - ANTIQUE BRASS
	009200-01-000	EA	TAPE - FURNACE - 1 1/2"
	098668-15-000	EA	PLATE - FACE - SUBURBAN FURNACE

***COMPONENT PARTS LISTED LATER IN THIS GROUP**

431C

KEY	PART NUMBER	U/M	DESCRIPTION
*	139980-02-000	EA	FURNACE - 30000 BTU - SF QUIET - SUBURBAN SF-30 2321J
	137965-01-01A	EA	REGISTER - 2.25" X 10" - W/O DAMPER - ANTIQUE BRASS
	137965-02-01A	EA	REGISTER - 2.25" X 10" - W/DAMPER - ANTIQUE BRASS
	009200-01-000	EA	TAPE - FURNACE - 1 1/2"
	093741-01-000	EA	BOX - BOOT - FLOOR REGISTER
	098668-26-000	EA	BOTTOM DUCT KIT - 40,000 BTU

***COMPONENT PARTS LISTED LATER IN THIS GROUP**

HEATING & A/C GROUP (CONTINUED)
COMPONENT PARTS FOR FURNACE

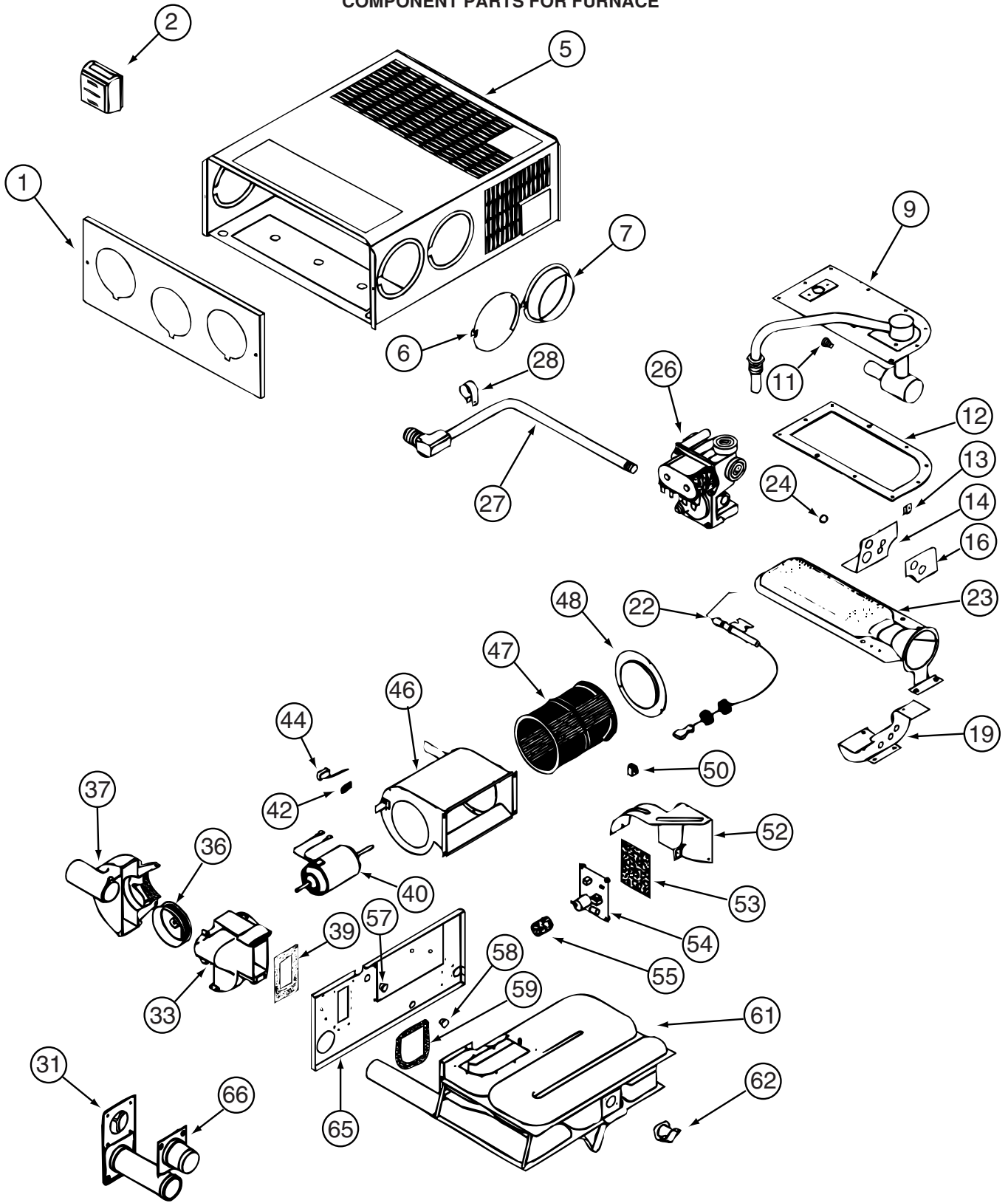

139980-02-000

**HEATING & A/C GROUP (CONTINUED)
COMPONENT PARTS FOR FURNACE (CONTINUED)**

139980-02-000 (CONTNUED)

KEY	PART NUMBER	U/M	DESCRIPTION	VENDOR NO.
9	139980-01-700	EA	MANIFOLD ASSEMBLY	171571
11	092300-02-701	EA	ORIFICE-MAIN BURNER (NT-30BW	180214
12	098668-22-703	EA	GASKET - BURNER ACCESS COVER	070811
22	139980-01-701	EA	ELECTRODE	232286
23	098668-02-700	EA	BURNER ASSEMBLY,SF-30 & SF35	010745
26	098668-01-718	EA	VALVE-GAS SF S.N.974903079	161122
27	139980-01-702	EA	PIPE ASSEMBLY/GAS INLET	171574
31	098668-01-707	EA	TUBE ASSEMBLY, EXHAUST W/CAP	260231
33	139980-01-703	EA	COMBUSTION AIR HOUS FRT/HALF	390852
36	098668-01-706	EA	WHEEL-COMBUSTION AIR	350184
37	139980-01-704	EA	COMBUSTION AIR HOUS RR HALF	390848
39	139980-01-705	EA	GASKET/FIREWALL-COMB AIR	071084
40	139980-01-706	EA	MOTOR ASSEMBLY W/GASKET	232682
42	101990-01-714	EA	GASKET-MICROSWITCH	230877
44	098668-21-700	EA	SWITCH-MICRO-W/O FLAG 3 1/4"	232261
46	139980-01-708	EA	BLOWER ASSEMBLY - ROOM AIR	390739BK
47	098668-01-711	EA	WHEEL-BLOWER, ROOM AIR	350129
48	139980-01-709	EA	ORFICE RING	390696
50	139980-01-710	EA	SWITCH - ON/OFF	232351
52	139980-01-711	EA	PANEL ASSEMBLY-MODULE BD	101663
53	139980-01-712	EA	INSULATOR - MODULE BD	070807
54	098668-22-705	EA	MODULE BD W/RELAY TIME DELAY	520820
55	139980-01-713	EA	CAP/INSULATOR-MODULE BD	070973
57	139980-01-714	EA	BUSHING - UNIVERSAL	070362
58	139980-01-715	EA	BUSHING - STRAIN RELIEF	231809
59	098668-01-716	EA	GASKET-FIREWALL,CHAMBER SIDE	070808
61	139980-01-716	EA	CHAMBER ASSEMBLY - FINAL	021149BK
62	098668-21-701	EA	SWITCH - LIMIT	232504
66	098668-01-713	EA	TUBE ASSEMBLY, INTAKE	051248

CONTACT WINNEBAGO PART SALES FOR UNLISTED COMPONENTS

HEATING & A/C GROUP (CONTINUED)

REAR HEATER

427P

KEY	PART NUMBER	U/M	DESCRIPTION
*	084405-01-000	EA	HEATER - REAR/DUCTED - W/MOTOR AID
	137965-01-01A	EA	REGISTER - 2.25" X 10" - W/O DAMPER - ANTIQUE BRASS
	009198-01-000	FT	DUCT - HEAT - FLEXIBLE - 4" ID X 25'
	069636-02-000	EA	CONNECTOR - DUCT - 4" ID
	007108-01-000	FT	HOSE - HEATER - 5/8" ID - HI-TEMP
	079059-01-000	EA	HOSE - 90 DEGREE - 5/8"ID X 4" X 36"
	079059-02-000	EA	HOSE - 90 DEGREE - .61" ID X 4" X 6"
	093741-01-000	EA	BOX - BOOT - FLOOR REGISTER
	076776-01-000	EA	TEE - BEADED - 5/8" X 5/8" X 5/8"

*COMPONENT PARTS LISTED LATER IN THIS GROUP

430V

KEY	PART NUMBER	U/M	DESCRIPTION
*	084405-01-000	EA	HEATER - REAR/DUCTED - W/MOTOR AID
	118761-01-000	EA	REDUCER - 4' - 2" - GALVANIZED
	009198-01-000	FT	DUCT - HEAT - FLEXIBLE - 4" ID X 25'
	009198-02-000	FT	DUCT - HEAT - FLEXIBLE - 2" ID X 25'
	069636-02-000	EA	CONNECTOR - DUCT - 4" ID
	007108-01-000	FT	HOSE - HEATER - 5/8" ID - HI-TEMP
	079059-01-000	EA	HOSE - 90 DEGREE - 5/8"ID X 4" X 36"
	093614-01-02A	EA	GRILLE - AIR RETURN - 15.9" X 7.9" - BEIGE
	076776-01-000	EA	TEE - BEADED - 5/8" X 5/8" X 5/8"

*COMPONENT PARTS LISTED LATER IN THIS GROUP

431C

KEY	PART NUMBER	U/M	DESCRIPTION
*	084405-01-000	EA	HEATER - REAR/DUCTED - W/MOTOR AID
	137965-01-01A	EA	REGISTER - 2.25" X 10" - W/O DAMPER - ANTIQUE BRASS
	009198-01-000	FT	DUCT - HEAT - FLEXIBLE - 4" ID X 25'
	069636-02-000	EA	CONNECTOR - DUCT - 4" ID
	007108-01-000	FT	HOSE - HEATER - 5/8" ID - HI-TEMP
	079059-01-000	EA	HOSE - 90 DEGREE - 5/8"ID X 4" X 36"
	079059-02-000	EA	HOSE - 90 DEGREE - .61" ID X 4" X 6"
	093741-01-000	EA	BOX - BOOT - FLOOR REGISTER
	076776-01-000	EA	TEE - BEADED - 5/8" X 5/8" X 5/8"

*COMPONENT PARTS LISTED LATER IN THIS GROUP

HEATING & A/C GROUP (CONTINUED)
COMPONENT PARTS FOR REAR HEATER

084405-01-000

KEY	PART NUMBER	U/M	DESCRIPTION	VENDOR NO.
	084405-01-700	EA	CORE-HEATER	FT200229
	084405-01-701	EA	FAN BLADES	HV029931
	084405-01-702	EA	MOTOR ASSEMBLY, 12 VOLT	RV010348

HEATING & A/C GROUP (CONTINUED)
ROOF

KEY	PART NUMBER	U/M	DESCRIPTION
*	131184-01-01A	EA	CEILING ASSEMBLY - A/C DUCTED - WHITE
*	131184-05-01A	EA	CEILING ASSEMBLY - HEAT PUMP - WHITE
*	131188-03-01A	EA	A/C/ROOF - 14,800 BTU/MACH 15 - NEW MODEL #8335B676 - WHT
*	131188-04-01A	EA	A/C/ROOF - 14,800 BTU/HEAT PUMP - NEW MODEL #8535B676- WHT
	131184-02-01A	EA	BOARD - DIVIDER - SILVER
	135618-01-01A	EA	THERMOSTAT - HEAT PUMP/FURNACE - WHITE
	135618-03-01A	EA	THERMOSTAT - A/C/FURNACE - WHITE
	120134-01-02A	EA	REGISTER - W/DAMPER - 4" PIPE/6.4" O.D. FACE - WHITE

***COMPONENT PARTS LISTED LATER IN THIS GROUP**

HEATING & A/C GROUP (CONTINUED)

COMPONENT PARTS FOR ROOF

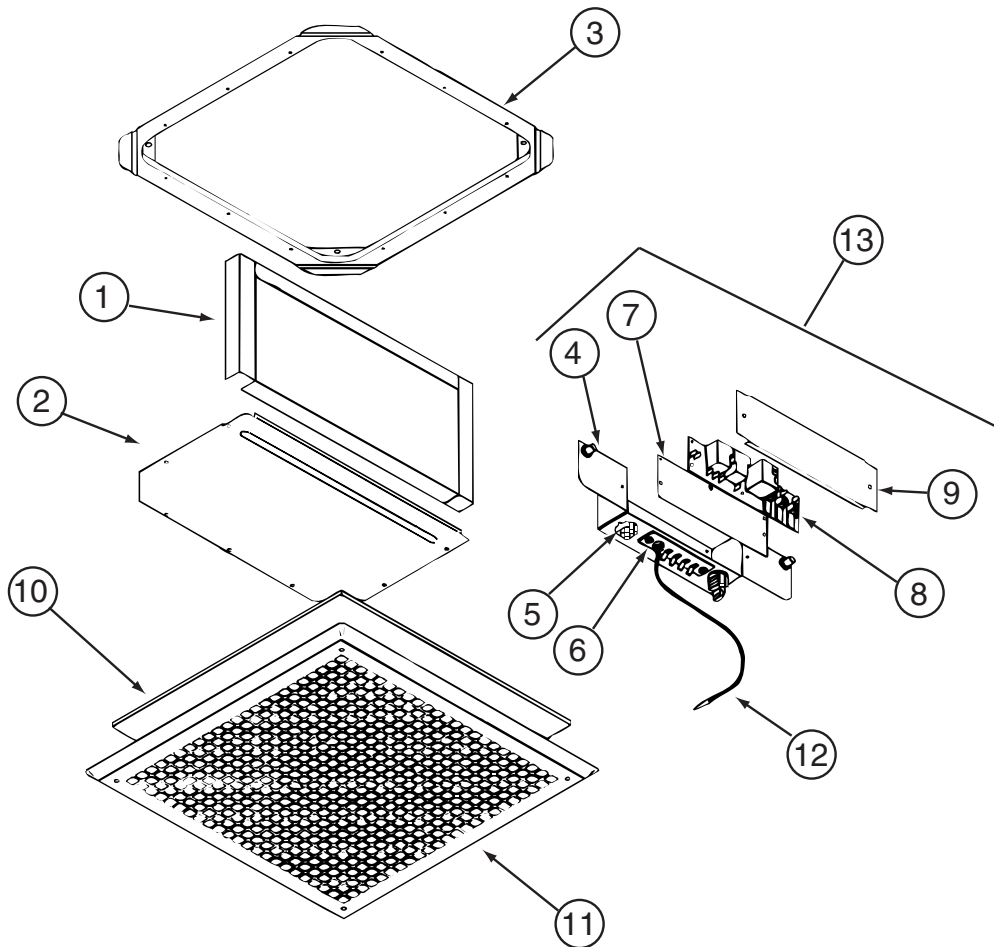

131184-01-01A

KEY	PART NUMBER	U/M	DESCRIPTION	VENDOR NO.
1	131184-01-707	EA	DUCT DIVIDER	8330-3501
5	131184-01-700	EA	PLUG ASSEMBLY	7330A389
6	131184-01-701	EA	TERMINAL BOARD	7330B3201
7	131184-01-702	EA	ISOLATOR - BLANK	7330C365
8	108892-01-702	EA	BOARD-P.C.	7330A3211
10	108892-01-703	EA	FILTER	6798A3761
11	108892-01-704	EA	GRILLE 16 3/8X16 3/8 RETURN	6798-3041
12	131184-01-704	EA	COIL SENSOR	7330-6111
13	131184-01-705	EA	JUNCTION BOX ASSEMBLY	7330B5551
	131184-01-703	EA	SMALL PARTS PKG	8330-5961

CONTACT WINNEBAGO PART SALES FOR UNLISTED COMPONENTS

HEATING & A/C GROUP (CONTINUED)
COMPONENT PARTS FOR ROOF (CONTINUED)

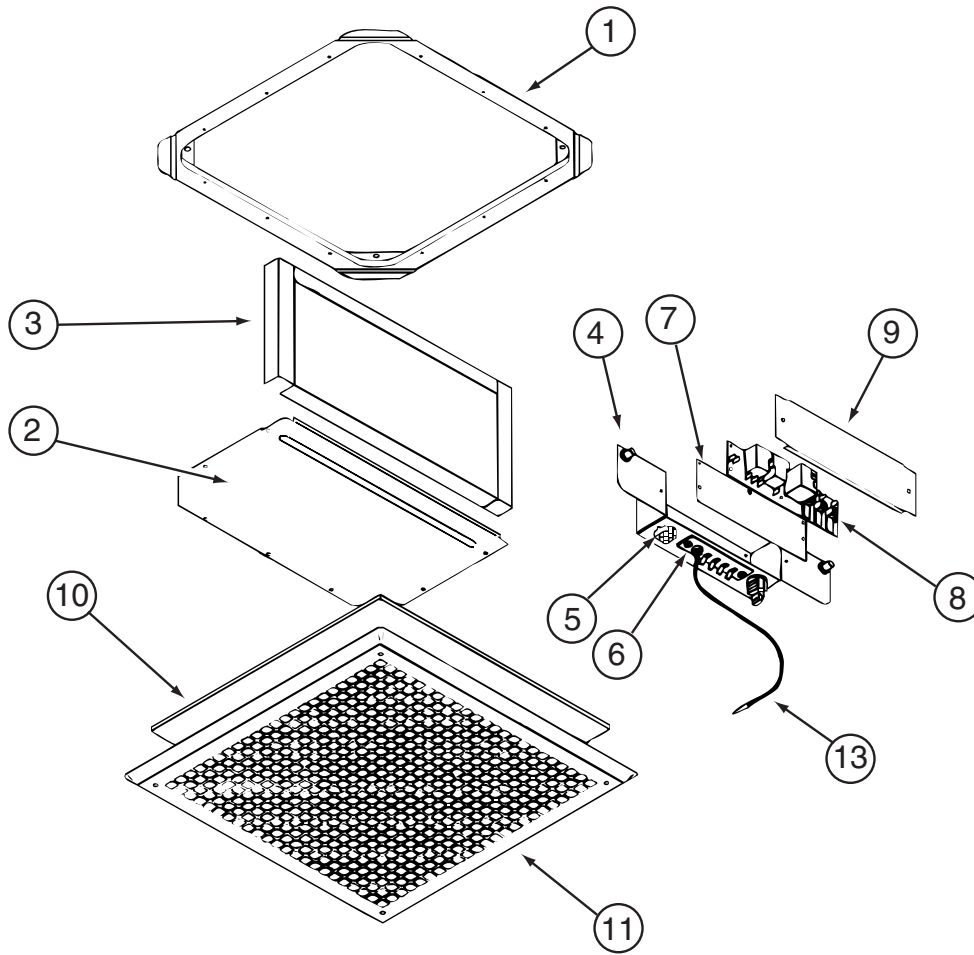

131184-05-01A

KEY	PART NUMBER	U/M	DESCRIPTION	VENDOR NO.
4	131184-04-703	EA	BOX - JUNCTION	7330-113
5	131184-04-700	EA	PLUG ASSEMBLY	7530A340
6	131184-04-702	EA	BOARD - TERMINAL	7530B3201
7	131184-01-702	EA	ISOLATOR - BLANK	7330C365
8	131184-04-705	EA	BOARD - P.C.	7330B3311
10	108892-01-703	EA	FILTER	6798A3761
11	108892-01-704	EA	GRILLE 16 3/8X16 3/8 RETURN	6798-3041
13	105620-12-719	EA	COIL SENSOR	7330A3231
	131184-01-703	EA	SMALL PARTS PKG	8330-5961

CONTACT WINNEBAGO PART SALES FOR UNLISTED COMPONENT

HEATING & A/C GROUP (CONTINUED)

COMPONENT PARTS FOR ROOF (CONTINUED)

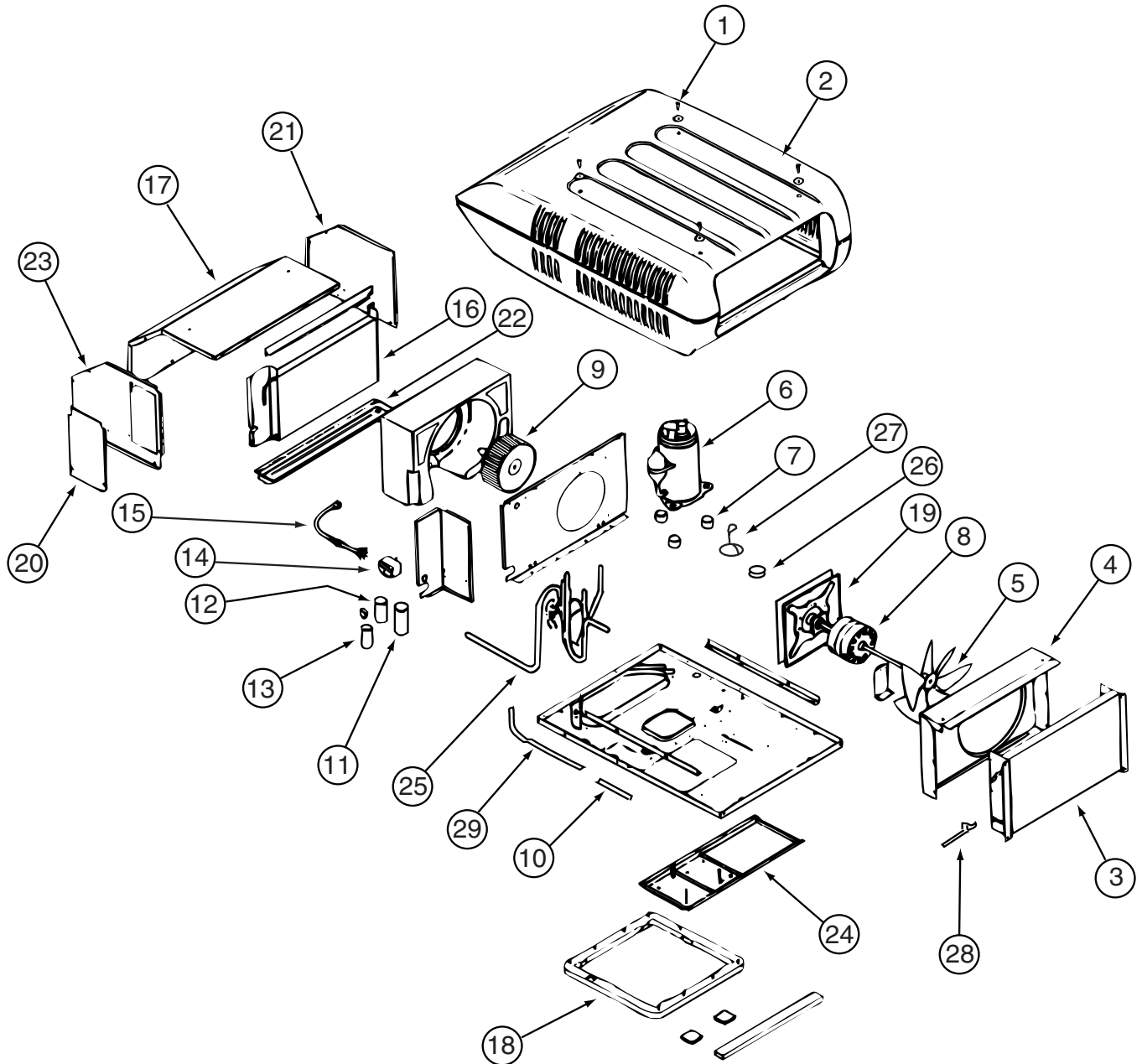

131188-03-01A

KEY	PART NUMBER	U/M	DESCRIPTION	VENDOR NO.
2	108889-05-700	EA	SHROUD-BRIGHT/WHT. W/O LOGO	7333-4601
3	115219-01-700	EA	COIL-CONDENSER	1452A1321
5	093763-01-712	EA	BLADE-FAN-CONDENSER	6733-3221
6	131188-01-700	EA	COMPRESSOR - TECUMSEH	1450A2609
7	105620-01-706	EA	MOUNTING PKG.,COMP., 3 PER	6759-3081
8	131185-01-701	EA	MOTOR (115V, 60HZ)	1468-3069
9	131185-01-702	EA	BLOWER WHEEL PACKAGE	1472-1091
11	131188-01-701	EA	RUN CAP. (COMP-40MFD/370V)	1499-5721
12	108889-01-708	EA	CAPACITOR-FAN, 7.5MFD. 370U	1499-5461
13	126859-01-704	EA	CAPACITOR - START	1497-0871
14	091225-01-709	EA	RELAY-START	1497-4131
16	131186-01-701	EA	EVAPORATOR COIL	1452-1521
18	037648-01-714	EA	GASKET PACKAGE	8332-3301
19	131185-01-704	EA	MOTOR MOUNT & SEAL KIT	8333-5151
	093306-01-701	EA	DECAL PACKAGE, LEFT & RIGHT	6798B3591
	108889-01-710	EA	PAD-FILLER, CONDENSER SEAL	6759B3971
	131188-01-702	EA	LINE - SUCTION	7335A134
	131188-01-703	EA	LINE - DISCHARGE	7335A135

CONTACT WINNEBAGO PART SALES FOR UNLISTED COMPONENT

HEATING & A/C GROUP (CONTINUED)
COMPONENT PARTS FOR ROOF (CONTINUED)

131188-04-01A

KEY	PART NUMBER	U/M	DESCRIPTION	VENDOR NO.
3	131188-02-700	EA	CONDENSER COIL	1452-1441
5	093763-01-712	EA	BLADE-FAN-CONDENSER	6733-3221
6	131188-02-701	EA	COMPRESSOR(TECUMSEH-RK225AT)	1450A2069
7	105620-01-706	EA	MOUNTING PKG.,COMP., 3 PER	6759-3081
8	131185-01-701	EA	MOTOR (115V, 60HZ)	1468-3069
9	131185-01-702	EA	BLOWER WHEEL PACKAGE	1472-1091
10	131188-02-702	EA	RESTRICTOR - BY FLOW	1454-2501
11	131188-01-701	EA	RUN CAP. (COMP-40MFD/370V)	1499-5721
12	093763-01-704	EA	CAPACITOR-FAN	1499-5461
13	131188-02-703	EA	CAPACITOR-START(21-25MFD)	1497-0211
14	091225-01-709	EA	RELAY-START	1497-4131
16	131186-01-701	EA	EVAPORATOR COIL	1452-1521
18	037648-01-714	EA	GASKET PACKAGE	8332-3301
19	131185-01-704	EA	MOTOR MOUNT & SEAL KIT	8333-5151
25	131188-02-704	EA	VALVE/REVERSE ASSEMBLY	7535A5301
26	105620-12-708	EA	COIL - SOLENOID	1460-1081
27	131188-02-705	EA	WIRE HARNESS F/SOLENOID	7535-109
28	131188-02-706	EA	SWITCH - FREEZE	1460-2041
29	131188-02-707	EA	LIQUID LINE	7535-135

CONTACT WINNEBAGO PART SALES FOR UNLISTED COMPONENT

INTERIOR FINISH GROUP

MOLDINGS & TRIMS

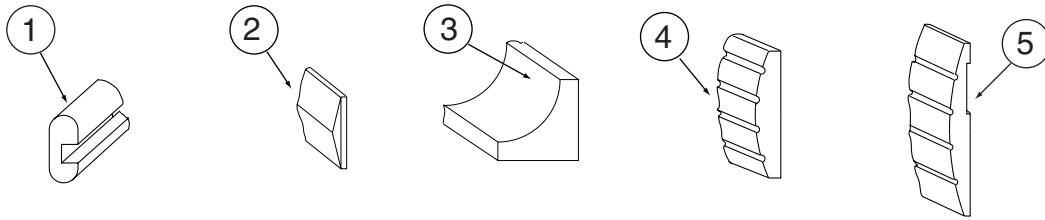

KEY	PART NUMBER	U/M	DESCRIPTION
1	M09412-62-N42	EA	MOLDING/SHELF EDGE - W/.4" NOTCH - PORTSMOUTH II - PORTSMOUTH OAK
1	M09412-62-M52	EA	MOLDING/SHELF EDGE - W/.4" NOTCH - CHERRY IV - CONCERT CHERRY
1	M09412-62-M62	EA	MOLDING/SHELF EDGE - W/.4" NOTCH - WASHED MAPLE
1	M09412-62-RC3	EA	MOLDING/SHELF EDGE - W/.4" NOTCH - .6" X 1.3" X 96" - HONEY CHERRY
2	M09454-62-P54	EA	MOLDING - TRIM/VEE - .2" X 1" X 3.5" - OAK/PORTSMOUTH OAK - PORTSMOUTH OAK
2	M09454-62-P55	EA	MOLDING - TRIM/VEE - .2" X 1" X 3.5" - CHERRY/CHERRY - CONCERT CHERRY
2	M09454-62-P56	EA	MOLDING - TRIM/VEE - .2" X 1" X 3.5" - MAPLE/MAPLE - WASHED MAPLE
2	M09454-62-RE0	EA	MOLDING - TRIM/VEE - .2" X 1" X 3.5" - CHERRY/HONEY CHERRY - HONEY CHERRY
2	M09462-50-R74	EA	MOLDING - TRIM/VEE - .2" X 1" X 93.5" - PORTSMOUTH OAK
2	M09462-50-R75	EA	MOLDING - TRIM/VEE - .2" X 1" X 93.5" - CONCERT CHERRY
2	M09462-50-R76	EA	MOLDING - TRIM/VEE - .2" X 1" X 93.5" - WASHED MAPLE
2	M09477-18-R83	EA	MOLDING - TRIM/VEE - .2" X 1" X 32" - OAK/PORTSMOUTH OAK - PORTSMOUTH OAK
2	M09477-18-R84	EA	MOLDING - TRIM/VEE - .2" X 1" X 32" - CHERRY/CHERRY - CONCERT CHERRY
2	M09477-18-R91	EA	MOLDING - TRIM/VEE - .2" X 1" X 32" - MAPLE/MAPLE - WASHED MAPLE
2	M09477-18-RE0	EA	MOLDING - TRIM/VEE - .2" X 1" X 32" - CHERRY/HONEY CHERRY - HONEY CHERRY
3	M09471-79-RE0	EA	MOLDING-STAINED - HONEY CHERRY
3	M09471-79-R38	EA	MOLDING-STAINED - PORTSMOUTH OAK
3	M09471-79-R39	EA	MOLDING-STAINED - CONCERT CHERRY
3	M09471-79-R46	EA	MOLDING-STAINED - WASHED MAPLE
4	P39129-01-N53	EA	MOLDING - FLUTED/CURVED - 3.5" X 44.5" - PORTSMOUTH OAK
4	P39129-01-N52	EA	MOLDING - FLUTED/CURVED - 3.5" X 44.5" - CONCERT CHERRY
4	P39129-01-N62	EA	MOLDING - FLUTED/CURVED - 3.5" X 44.5" - WASHED MAPLE
4	P39129-01-RA3	EA	MOLDING - FLUTED/CURVED - 3.5" X 44.5" - HONEY CHERRY
4	P39129-08-N53	EA	MOLDING - FLUTED/CURVED - 3.5" X 45.5" - PORTSMOUTH OAK
4	P39129-08-N52	EA	MOLDING - FLUTED/CURVED - 3.5" X 45.5" - CONCERT CHERRY
4	P39129-08-N62	EA	MOLDING - FLUTED/CURVED - 3.5" X 45.5" - WASHED MAPLE
4	P39129-08-RA3	EA	MOLDING - FLUTED/CURVED - 3.5" X 45.5" - HONEY CHERRY
4	P39129-14-PA0	EA	MOLDING - FLUTED/CURVED - 3.5" X 40.8" - PORTSMOUTH OAK
4	P39129-14-PA1	EA	MOLDING - FLUTED/CURVED - 3.5" X 40.8" - CONCERT CHERRY
4	P39129-14-PA2	EA	MOLDING - FLUTED/CURVED - 3.5" X 40.8" - WASHED MAPLE
4	P39129-14-RA3	EA	MOLDING - FLUTED/CURVED - 3.5" X 40.8" - HONEY CHERRY
4	P39129-20-PA0	EA	MOLDING - FLUTED/CURVED - 3.5" X 33.4" - PORTSMOUTH OAK
4	P39129-20-PA1	EA	MOLDING - FLUTED/CURVED - 3.5" X 33.4" - CONCERT CHERRY
4	P39129-20-PA2	EA	MOLDING - FLUTED/CURVED - 3.5" X 33.4" - WASHED MAPLE
4	P39129-20-RA3	EA	MOLDING - FLUTED/CURVED - 3.5" X 33.4" - HONEY CHERRY
4	P39129-25-PA0	EA	MOLDING - FLUTED/CURVED - 3.5" X 46.6" - PORTSMOUTH OAK
4	P39129-25-PA1	EA	MOLDING - FLUTED/CURVED - 3.5" X 46.6" - CONCERT CHERRY
4	P39129-25-PA2	EA	MOLDING - FLUTED/CURVED - 3.5" X 46.6" - WASHED MAPLE
4	P39129-25-RA3	EA	MOLDING - FLUTED/CURVED - 3.5" X 46.6" - HONEY CHERRY
4	P39129-31-PA0	EA	MOLDING - FLUTED/CURVED - 3.5" X 80.7" - PORTSMOUTH OAK
4	P39129-31-PA1	EA	MOLDING - FLUTED/CURVED - 3.5" X 80.7" - CONCERT CHERRY
4	P39129-31-PA2	EA	MOLDING - FLUTED/CURVED - 3.5" X 80.7" - WASHED MAPLE
4	P39129-31-RA3	EA	MOLDING - FLUTED/CURVED - 3.5" X 80.7" - HONEY CHERRY
4	P39129-32-RA0	EA	MOLDING - FLUTED/CURVED - 3.5" X 99.2" - PORTSMOUTH OAK
4	P39129-32-RA1	EA	MOLDING - FLUTED/CURVED - 3.5" X 99.2" - CONCERT CHERRY
4	P39129-32-RA2	EA	MOLDING - FLUTED/CURVED - 3.5" X 99.2" - WASHED MAPLE
4	P39129-32-RA3	EA	MOLDING - FLUTED/CURVED - 3.5" X 99.2" - HONEY CHERRY
4	P39129-33-RA0	EA	MOLDING - FLUTED/CURVED - 3.5" X 98.58" - PORTSMOUTH OAK
4	P39129-33-RA1	EA	MOLDING - FLUTED/CURVED - 3.5" X 98.58" - CONCERT CHERRY
4	P39129-33-RA2	EA	MOLDING - FLUTED/CURVED - 3.5" X 98.58" - WASHED MAPLE
4	P39129-33-RA3	EA	MOLDING - FLUTED/CURVED - 3.5" X 98.58" - HONEY CHERRY

INTERIOR FINISH GROUP (CONTINUED)

MOLDINGS & TRIMS (CONTINUED)

KEY	PART NUMBER	U/M	DESCRIPTION
5	P39129-19-PA0	EA	MOLDING - FLUTED/CURVED - 5.9" X 32.1" - PORTSMOUTH OAK
5	P39129-19-PA1	EA	MOLDING - FLUTED/CURVED - 5.9" X 32.1" - CONCERT CHERRY
5	P39129-19-PA2	EA	MOLDING - FLUTED/CURVED - 5.9" X 32.1" - WASHED MAPLE
5	P39129-19-RA3	EA	MOLDING - FLUTED/CURVED - 5.9" X 32.1" - HONEY CHERRY
5	P39129-28-PA0	EA	MOLDING - FLUTED/CURVED - 5.9" X 63.3" - PORTSMOUTH OAK
5	P39129-28-PA1	EA	MOLDING - FLUTED/CURVED - 5.9" X 63.3" - CONCERT CHERRY
5	P39129-28-PA2	EA	MOLDING - FLUTED/CURVED - 5.9" X 63.3" - WASHED MAPLE
5	P39129-28-RA3	EA	MOLDING - FLUTED/CURVED - 5.9" X 63.3" - HONEY CHERRY
5	P39129-29-PA0	EA	MOLDING - FLUTED/CURVED - 5.9" X 70.1" - PORTSMOUTH OAK
5	P39129-29-PA1	EA	MOLDING - FLUTED/CURVED - 5.9" X 70.1" - CONCERT CHERRY
5	P39129-29-PA2	EA	MOLDING - FLUTED/CURVED - 5.9" X 70.1" - WASHED MAPLE
5	P39129-29-RA3	EA	MOLDING - FLUTED/CURVED - 5.9" X 70.1" - HONEY CHERRY

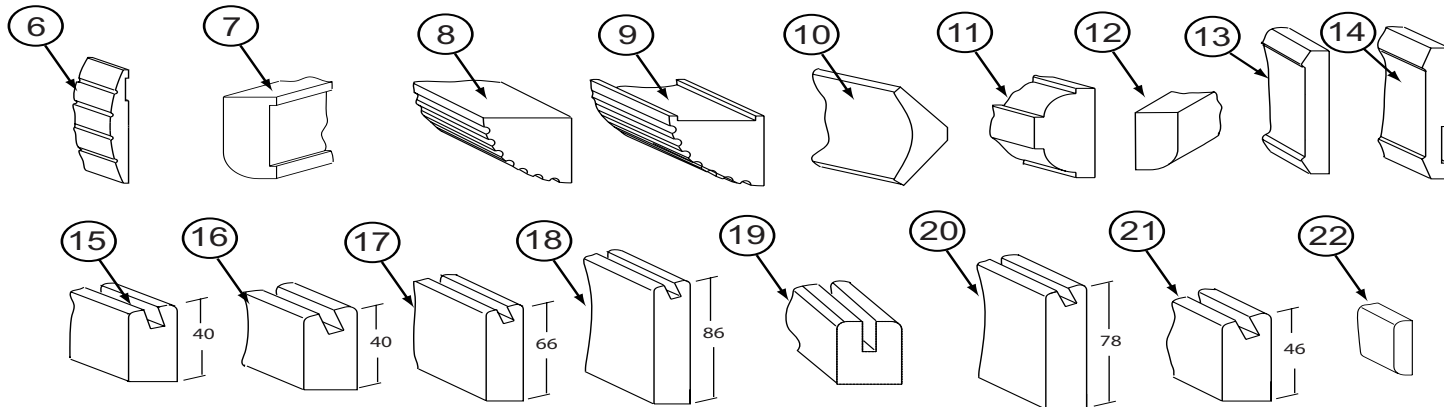

KEY	PART NUMBER	U/M	DESCRIPTION
6	P39129-21-PA0	EA	MOLDING - FLUTED/CURVED - 5.9" X 2.5" - PORTSMOUTH OAK
6	P39129-21-PA1	EA	MOLDING - FLUTED/CURVED - 5.9" X 2.5" - CONCERT CHERRY
6	P39129-21-PA2	EA	MOLDING - FLUTED/CURVED - 5.9" X 2.5" - WASHED MAPLE
6	P39129-21-RA3	EA	MOLDING - FLUTED/CURVED - 5.9" X 2.5" - HONEY CHERRY
6	P39129-22-PA0	EA	MOLDING - FLUTED/CURVED - 5.9" X 5.3" - PORTSMOUTH OAK
6	P39129-22-PA1	EA	MOLDING - FLUTED/CURVED - 5.9" X 5.3" - CONCERT CHERRY
6	P39129-22-PA2	EA	MOLDING - FLUTED/CURVED - 5.9" X 5.3" - WASHED MAPLE
6	P39129-22-RA3	EA	MOLDING - FLUTED/CURVED - 5.9" X 5.3" - HONEY CHERRY
7	Y00007-22-438	EA	MOLDING - MAPLE - UNSTAINED
7	Y00007-32-438	EA	MOLDING - CHERRY - UNSTAINED
7	Y00007-42-438	EA	MOLDING - OAK - UNSTAINED
8	Y00070-22-438	EA	MOLDING/FLUTED - MAPLE - 96" - WASHED MAPLE
8	Y00070-32-438	EA	MOLDING/FLUTED - CHERRY - 96" - CONCERT CHERRY
8	Y00070-42-438	EA	MOLDING/FLUTED - OAK - 96" - PORTSMOUTH OAK
9	Y00071-22-438	EA	MOLDING/FLUTED - W/NOTCH - MAPLE/UNSTAINED - 96"
9	Y00071-32-438	EA	MOLDING/FLUTED - W/NOTCH - CHERRY/UNSTAINED - 96"
9	Y00071-42-438	EA	MOLDING/FLUTED - W/NOTCH - OAK/UNSTAINED - 96"
10	Y00074-22-438	EA	MOLDING/CROWN - VINYL WRAPPED - MAPLE - 96" - WASHED MAPLE FROM: 00-00-00 THRU: 01-04-04
10	Y00074-A2-438	EA	MOLDING/CROWN - VINYL WRAPPED - MAPLE - 96" - WASHED MAPLE FROM: 01-05-04 THRU: 99-99-99
10	Y00074-62-438	EA	MOLDING/CROWN - VINYL WRAPPED - CONCERT CHERRY - 96" - CONCERT CHERRY
10	Y00074-72-438	EA	MOLDING/CROWN - VINYL WRAPPED - PORTSMOUTH OAK - 96" - PORTSMOUTH OAK
11	Y00076-22-438	EA	MOLDING/TRIM - .5" X 1" X 96" - MAPLE (UNSTAINED)
11	Y00076-32-438	EA	MOLDING/TRIM - .5" X 1" X 96" - CHERRY (UNSTAINED)
11	Y00076-42-438	EA	MOLDING/TRIM - .5" X 1" X 96" - OAK (UNSTAINED)
12	Y00086-22-438	EA	MOLDING - VINYL WRAP - 96" - WASHED MAPLE FROM: 00-00-00 THRU: 01-04-04
12	Y00086-A2-438	EA	MOLDING - VINYL WRAP - 96" - WASHED MAPLE FROM: 01-05-04 THRU: 99-99-99
12	Y00086-62-438	EA	MOLDING - VINYL WRAP - 96" - CONCERT CHERRY
12	Y00086-72-438	EA	MOLDING - VINYL WRAP - 96" - PORTSMOUTH OAK
12	Y00086-82-438	EA	MOLDING - VINYL WRAP - 96" - HONEY CHERRY

INTERIOR FINISH GROUP (CONTINUED)
MOLDINGS & TRIMS (CONTINUED)

KEY	PART NUMBER	U/M	DESCRIPTION
13	Y00152-22-438	EA	MOLDING/TRIM - VINYL - .6" X 3.5" X 96" - WASHED MAPLE FROM: 00-00-00 THRU: 01-04-04
13	Y00152-A2-438	EA	MOLDING/TRIM - VINYL - .6" X 3.5" X 96" - WASHED MAPLE FROM: 01-05-04 THRU: 99-99-99
13	Y00152-62-438	EA	MOLDING/TRIM - VINYL - .6" X 3.5" X 96" - CONCERT CHERRY
13	Y00152-72-438	EA	MOLDING/TRIM - VINYL - .6" X 3.5" X 96" - PORTSMOUTH OAK
14	Y00153-22-438	EA	MOLDING/TRIM - VINYL - .6" X 3.9" X 96" - WASHED MAPLE FROM: 00-00-00 THRU: 01-04-04
14	Y00153-A2-438	EA	MOLDING/TRIM - VINYL - .6" X 3.9" X 96" - WASHED MAPLE FROM: 01-05-04 THRU: 99-99-99
14	Y00153-62-438	EA	MOLDING/TRIM - VINYL - .6" X 3.9" X 96" - CONCERT CHERRY
14	Y00153-72-438	EA	MOLDING/TRIM - VINYL - .6" X 3.9" X 96" - PORTSMOUTH OAK
14	Y00153-82-438	EA	MOLDING/TRIM - VINYL - .6" X 3.9" X 96" - HONEY CHERRY
15	Y00203-22-438	EA	MOLDING - VINYL/BEVELED - 96" - WASHED MAPLE FROM: 00-00-00 THRU: 01-04-04
15	Y00203-A2-438	EA	MOLDING - VINYL/BEVELED - 96" - WASHED MAPLE FROM: 01-05-04 THRU: 99-99-99
15	Y00203-62-438	EA	MOLDING - VINYL/BEVELED - 96" - CONCERT CHERRY
15	Y00203-72-438	EA	MOLDING - VINYL/BEVELED - 96" - PORTSMOUT OAK
15	Y00203-82-438	EA	MOLDING - VINYL/BEVELED - 96" - HONEY CHERRY
16	Y00204-22-438	EA	MOLDING - VINYL/BEVELED - 96" - WASHED MAPLE FROM: 00-00-00 THRU: 01-04-04
16	Y00204-A2-438	EA	MOLDING - VINYL/BEVELED - 96" - WASHED MAPLE FROM: 01-05-04 THRU: 99-99-99
16	Y00204-62-438	EA	MOLDING - VINYL/BEVELED - 96" - CONCERT CHERRY
16	Y00204-72-438	EA	MOLDING - VINYL/BEVELED - 96" - PORTSMOUT OAK
16	Y00204-82-438	EA	MOLDING - VINYL/BEVELED - 96" - HONEY CHERRY
17	Y00205-22-438	EA	MOLDING - VINYL/BEVELED - 96" - WASHED MAPLE FROM: 00-00-00 THRU: 01-04-04
17	Y00205-A2-438	EA	MOLDING - VINYL/BEVELED - 96" - WASHED MAPLE FROM: 01-05-04 THRU: 99-99-99
17	Y00205-62-438	EA	MOLDING - VINYL/BEVELED - 96" - CONCERT CHERRY
17	Y00205-72-438	EA	MOLDING - VINYL/BEVELED - 96" - PORTSMOUT OAK
17	Y00205-82-438	EA	MOLDING - VINYL/BEVELED - 96" - HONEY CHERRY
18	Y00206-22-438	EA	MOLDING - VINYL/BEVELED - 96" - WASHED MAPLE FROM: 00-00-00 THRU: 01-04-04
18	Y00206-A2-438	EA	MOLDING - VINYL/BEVELED - 96" - WASHED MAPLE FROM: 01-05-04 THRU: 99-99-99
18	Y00206-62-438	EA	MOLDING - VINYL/BEVELED - 96" - CONCERT CHERRY
18	Y00206-72-438	EA	MOLDING - VINYL/BEVELED - 96" - PORTSMOUT OAK
18	Y00206-82-438	EA	MOLDING - VINYL/BEVELED - 96" - HONEY CHERRY
19	Y00223-22-438	EA	MOLDING - HARDWOOD/MAPLE - .7" X 1" X 96"
19	Y00223-32-438	EA	MOLDING - HARDWOOD/CHERRY - .7" X 1" X 96"
19	Y00223-42-438	EA	MOLDING - HARDWOOD/OAK - .7" X 1" X 96"
20	Y00258-22-438	EA	MOLDING - VINYL/BEVELED - 96" - WASHED MAPLE FROM: 00-00-00 THRU: 01-04-04
20	Y00258-A2-438	EA	MOLDING - VINYL/BEVELED - 96" - WASHED MAPLE FROM: 01-05-04 THRU: 99-99-99
20	Y00258-62-438	EA	MOLDING - VINYL/BEVELED - 96" - CONCERT CHERRY
20	Y00258-72-438	EA	MOLDING - VINYL/BEVELED - 96" - PORTSMOUT OAK
20	Y00258-82-438	EA	MOLDING - VINYL/BEVELED - 96" - HONEY CHERRY
21	Y00259-22-438	EA	MOLDING - VINYL/BEVELED - 96" - WASHED MAPLE FROM: 00-00-00 THRU: 01-04-04
21	Y00259-A2-438	EA	MOLDING - VINYL/BEVELED - 96" - WASHED MAPLE FROM: 01-05-04 THRU: 99-99-99
21	Y00259-62-438	EA	MOLDING - VINYL/BEVELED - 96" - CONCERT CHERRY
21	Y00259-72-438	EA	MOLDING - VINYL/BEVELED - 96" - PORTSMOUT OAK
21	Y00259-82-438	EA	MOLDING - VINYL/BEVELED - 96" - HONEY CHERRY
22	Y00262-22-438	EA	MOLDING - 96" - MAPLE, UNSTAINED
22	Y00262-32-438	EA	MOLDING - 96" - CHERRY, UNSTAINED
22	Y00262-42-438	EA	MOLDING - 96" - OAK, UNSTAINED

INTERIOR FINISH GROUP (CONTINUED)
MOLDINGS & TRIMS (CONTINUED)

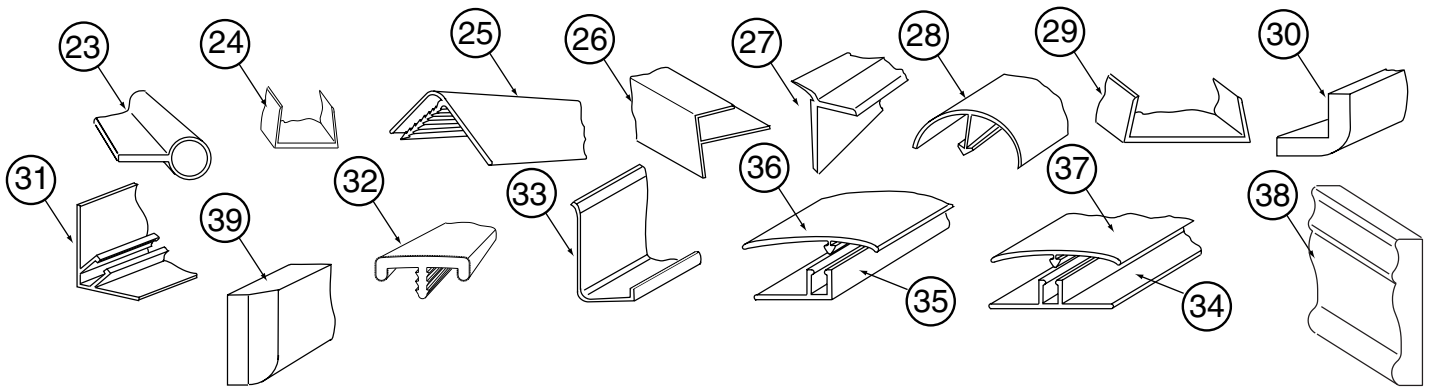

KEY	PART NUMBER	U/M	DESCRIPTION
23	009767-12-000	FT	WELTING - ANTIQUE WHITE
24	009778-25-000	FT	U-CHANNEL - 1" - BEIGE ILLUSION
24	009778-27-000	FT	U-CHANNEL - 1" - WASHED MAPLE
24	009778-37-000	FT	U-CHANNEL - 1" - NEAT/WASHED MAPLE
			FROM: 00-00-00 THRU: 01-04-04
			FROM: 01-05-04 THRU: 99-99-99
24	009778-30-000	FT	U-CHANNEL - 1" - VILLAGE OAK
24	009778-32-000	FT	U-CHANNEL - 1" - PORTSMOUTH OAK
24	009778-34-000	FT	U-CHANNEL - 1" - CONCERT CHERRY
24	009778-35-000	FT	U-CHANNEL - 1" - HONEY CHERRY
25	009809-30-000	EA	MOLDING - CORNER - OUTSIDE - 1" X 84" - BEIGE ILLUSION
25	009809-32-000	EA	MOLDING - CORNER - OUTSIDE - 1" X 84" - PORTSMOUTH OAK
25	009809-31-000	EA	MOLDING - CORNER - OUTSIDE - 1" X 84" - WASHED MAPLE
			FROM: 00-00-00 THRU: 01-04-04
25	009809-36-000	EA	MOLDING - CORNER - OUTSIDE - 1" X 84" - WASHED MAPLE
			FROM: 01-05-04 THRU: 99-99-99
25	009809-33-000	EA	MOLDING - CORNER - OUTSIDE - 1" X 84" - CONCERT CHERRY
25	009809-34-000	EA	MOLDING - CORNER - OUTSIDE - 1" X 84" - HONEY CHERRY
26	009812-24-000	EA	MOLDING - CORNER - 1/2" W/1/4"CHAN X 84" - IVORY PLASTIC
26	009812-31-000	EA	MOLDING - CORNER - 1/2" W/1/4"CHAN X 84" - BEIGE ILLUSION
26	009812-33-000	EA	MOLDING - CORNER - 1/2" W/1/4"CHAN X 84" - WASHED MAPLE
			FROM: 00-00-00 THRU: 01-04-04
26	009812-39-000	EA	MOLDING - CORNER - 1/2" W/1/4"CHAN X 84" - WASHED MAPLE
			FROM: 01-05-04 THRU: 99-99-99
26	009812-34-000	EA	MOLDING - CORNER - 1/2" W/1/4"CHAN X 84" - VW LIGHT GRAY
26	009812-35-000	EA	MOLDING - CORNER - 1/2" W/1/4"CHAN X 84" - PORTSMOUTH OAK
26	009812-36-000	EA	MOLDING - CORNER - 1/2" W/1/4"CHAN X 84" - CONCERT CHERRY
26	009812-37-000	EA	MOLDING - CORNER - 1/2" W/1/4"CHAN X 84" - HONEY CHERRY
27	022992-11-000	FT	MOLDING - REVERSE COVE - T-SHAPED - IVORY
27	022992-14-000	FT	MOLDING - REVERSE COVE - T-SHAPED - BRIGHT WHITE
27	022992-15-000	FT	MOLDING - REVERSE COVE - T-SHAPED - VW GRAY
28	042357-25-000	EA	MOLDING - CORNER - RADIUS/PLASTIC - WASHED MAPLE
29	070504-18-000	FT	U-CHANNEL - PLASTIC - .13" X 96" - IVORY
29	070504-35-000	FT	U-CHANNEL - PLASTIC - .13" X 72" - IVORY
29	070504-42-000	FT	U-CHANNEL - PLASTIC - .13" X 84" - BEIGE ILLUSION
29	070504-50-000	FT	U-CHANNEL - PLASTIC - .13" X 96" - WASHED MAPLE
			FROM: 00-00-00 THRU: 01-04-04
29	070504-67-000	FT	U-CHANNEL - PLASTIC - .13" X 96" - WASHED MAPLE
			FROM: 01-05-04 THRU: 99-99-99
29	070504-51-000	FT	U-CHANNEL - PLASTIC - .9" X 96" - WASHED MAPLE
			FROM: 00-00-00 THRU: 01-04-04
29	070504-68-000	FT	U-CHANNEL - PLASTIC - .9" X 96" - WASHED MAPLE
			FROM: 01-05-04 THRU: 99-99-99
29	070504-54-000	FT	U-CHANNEL - PLASTIC - .9" X 96" - VILLAGE OAK
29	070504-57-000	FT	U-CHANNEL - PLASTIC - .13" X 84" - PORTSMOUTH OAK
29	070504-58-000	FT	U-CHANNEL - PLASTIC - .9" X 84" - PORTSMOUTH OAK
29	070504-60-000	FT	U-CHANNEL - PLASTIC - .13" X 84" - CONCERT CHERRY
29	070504-62-000	FT	U-CHANNEL - PLASTIC - 1.65" X 84" - HONEY CHERRY
29	070504-63-000	FT	U-CHANNEL - PLASTIC - .9" X 84" - HONEY CHERRY
30	080176-08-000	EA	CAP - CORNER - RADIUS MOLDING - PLASTIC - WASHED MAPLE

INTERIOR FINISH GROUP (CONTINUED)
MOLDINGS & TRIMS (CONTINUED)

KEY	PART NUMBER	U/M	DESCRIPTION
31	081521-02-007	EA	MOUNT - METAL MOLDING - F/RADIUS CORNER MOLDING - 151.5"
32	083620-15-000	FT	MOLDING-T - W/EDGE LIP - 7/8" FACE - BEIGE ILLUSION
32	083620-19-000	FT	MOLDING-T - W/EDGE LIP - 7/8" FACE - WASHED MAPLE FROM: 00-00-00 THRU: 01-04-04
32	083620-23-000	FT	MOLDING-T - W/EDGE LIP - 7/8" FACE - WASHED MAPLE FROM: 01-05-04 THRU: 99-99-99
32	083620-20-000	FT	MOLDING-T - W/EDGE LIP - 7/8" FACE - PORTSMOUTH OAK
32	083620-21-000	FT	MOLDING-T - W/EDGE LIP - 7/8" FACE - CONCERT CHERRY/HONEY CHERRY
33	085746-04-000	FT	TRIM-J - CARPET 1.2" X .5" ANGLE - 10' LONG - OFF WHITE
34	086229-01-000	EA	RETAINER - BATTEN - .75" X 92.1" - ANY COLOR
35	086229-11-000	EA	RETAINER - OFFSET - 97"
36	086229-21-000	EA	BATTEN - 1.5" X 83.9" OFFSET - WHITE
37	086229-20-000	EA	BATTEN - 1" X 96" - BEIGE
38	100182-10-J70	EA	TRIM/WOOD - CHAIR RAIL - 2.5" X 8' - WASHED MAPLE
38	100182-10-N47	EA	TRIM/WOOD - CHAIR RAIL - 2.5" X 8' - PORTSMOUTH OAK
38	100182-10-P85	EA	TTRIM/WOOD - CHAIR RAIL - 2.5" X 8' - CHERRY - CONCERT CHERRY
38	100182-10-RA3	EA	TRIM/WOOD - CHAIR RAIL - 2.5" X 8' - HONEY CHERRY
39	100659-30-N75	EA	MOLDING - TRIM - 8' - PORTSMOUTH OAK
39	100659-30-N74	EA	MOLDING - TRIM - 8' - CHERRY - CONCERT CHERRY
39	100659-30-M84	EA	MOLDING - TRIM - 8' - WASHED MAPLE

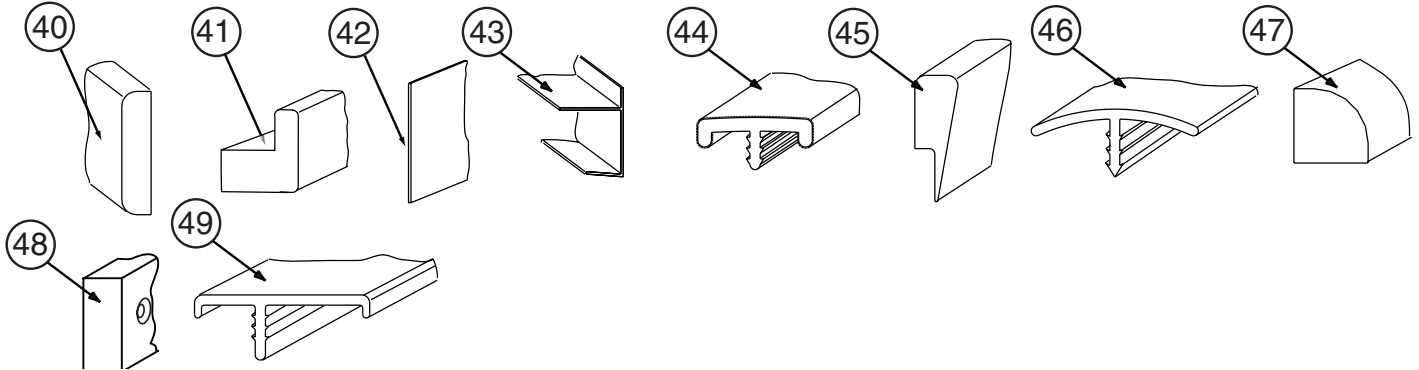

KEY	PART NUMBER	U/M	DESCRIPTION
40	100818-01-08A	EA	MOLDING - VINYL WRAPPED - 1.6" X .4" X 84" - WASHED MAPLE FROM: 00-00-00 THRU: 01-04-04
40	100818-01-21A	EA	MOLDING - VINYL WRAPPED - 1.6" X .4" X 84" - WASHED MAPLE FROM: 01-05-04 THRU: 99-99-99
40	100818-01-12A	EA	MOLDING - VINYL WRAPPED - 1.6" X .4" X 84" - PORTSMOUTH OAK
40	100818-01-13A	EA	MOLDING - VINYL WRAPPED - 1.6" X .4" X 84" - CHERRY - CONCERT CHERRY
40	100818-01-14A	EA	MOLDING - VINYL WRAPPED - 1.6" X .4" X 84" - HONEY CHERRY
41	100819-01-08A	EA	MOLDING - VINYL WRAPPED-L-SHAPED-1.5"X1.5"X84" - WASHED MAPLE FROM: 00-00-00 THRU: 01-04-04
41	100819-01-21A	EA	MOLDING - VINYL WRAPPED-L-SHAPED-1.5"X1.5"X84" - WASHED MAPLE FROM: 01-05-04 THRU: 99-99-99
41	100819-01-12A	EA	MOLDING - VINYL WRAPPED-L-SHAPED - 1.5" X 1.5" X 84" - OAK - PORTSMOUTH OAK
41	100819-01-13A	EA	MOLDING - VINYL WRAPPED-L-SHAPED-1.5"X1.5"X84" - CONCERT CHERRY
41	100819-01-14A	EA	MOLDING - VINYL WRAPPED-L-SHAPED-1.5"X1.5"X84" - HONEY CHERRY
42	101957-01-06A	EA	EXTRUDED - PLASTIC - WASHED MAPLE
43	103186-01-07A	FT	MOLDING/PLASTIC - 3/8" U-CHANNEL-3/4"FACE - BEIGE ILLUS 8'
43	103186-01-08A	FT	MOLDING/PLASTIC - 3/8" U-CHANNEL-3/4"FACE-WASHED MAPLE 8' - WASHED MAPLE FROM: 00-00-00 THRU: 01-04-04
43	103186-01-13A	FT	MOLDING/PLASTIC - 3/8" U-CHANNEL-3/4"FACE-WASHED MAPLE 8' - WASHED MAPLE FROM: 01-05-04 THRU: 99-99-99
43	103186-01-09A	FT	MOLDING/PLASTIC - 3/8" U-CHAN'L-3/4"FACE-PORTSMOUTH OAK 8' - PORTSMOUTH OAK
43	103186-01-10A	FT	MOLDING/PLASTIC-3/8" U-CHAN'L-3/4"FACE-CONCERT CHERRY 8' - CONCERT CHERRY
43	103186-01-11A	FT	MOLDING/PLASTIC-3/8" U-CHAN'L-3/4"FACE-CONCERT CHERRY 8' - HONEY CHERRY
43	103186-02-07A	FT	MOLDING/PLASTIC-1" U-CHAN'L-1 3/8"FACE-BEIGE ILLUSION - 8'
43	103186-02-08A	FT	MOLDING/PLASTIC - 1" U-CHANNEL-1 3/8"FACE-WASHED MAPLE 8' - WASHED MAPLE FROM: 00-00-00 THRU: 01-04-04
43	103186-02-13A	FT	MOLDING/PLASTIC - 1" U-CHANNEL-1 3/8"FACE-WASHED MAPLE 8' - WASHED MAPLE FROM: 01-05-04 THRU: 99-99-99
43	103186-02-09A	FT	MOLDING/PLASTIC - 1" U-CHAN'L-1 3/8"FACE-PORTSMOUTH OAK 8' - PORTSMOUTH OAK
43	103186-02-10A	FT	MOLDING/PLASTIC - 1" U-CHAN'L-1 3/8"FACE-CONCERT CHERRY 8' - CONCERT CHERRY

INTERIOR FINISH GROUP (CONTINUED)
MOLDINGS & TRIMS (CONTINUED)

KEY	PART NUMBER	U/M	DESCRIPTION
43	103186-02-11A	FT	MOLDING/PLASTIC - 1" U-CHAN'L-1 3/8"FACE-CONCERT CHERRY 8' - HONEY CHERRY
44	104676-02-06A	FT	MOLDING-T - W/EDGE LIP - 11/16" FACE - WASHED MAPLE FROM: 00-00-00 THRU: 01-04-04
44	104676-02-11A	FT	MOLDING-T - W/EDGE LIP - 11/16" FACE - WASHED MAPLE FROM: 01-05-04 THRU: 99-99-99
44	104676-02-08A	FT	MOLDING-T - W/EDGE LIP - 11/16" FACE - PORTSMOUTH OAK
44	104676-02-09A	FT	MOLDING-T - W/EDGE LIP - 11/16" FACE - CONCERT CHERRY
44	104676-02-10A	FT	MOLDING-T - W/EDGE LIP - 11/16" FACE - HONEY CHERRY
45	105004-01-08A	EA	MOLDING - VINYL WRAPPED - 1" X 96" - WASHED MAPLE FROM: 00-00-00 THRU: 01-04-04
45	105004-01-21A	EA	MOLDING - VINYL WRAPPED - 1" X 96" - WASHED MAPLE FROM: 01-05-04 THRU: 99-99-99
45	105004-01-12A	EA	MOLDING - VINYL WRAPPED 1" X 96" - PORTSMOUTH OAK
45	105004-01-13A	EA	MOLDING - VINYL WRAPPED 1" X 96" - CONCERT CHERRY
45	105004-01-14A	EA	MOLDING - VINYL WRAPPED 1" X 96" - HONEY CHERRY
46	105709-02-000	FT	MOLDING-T - W/EDGE LIP - 3/4" FACE - BEIGE ILLUSION
47	109410-01-P25	EA	MOLDING - TRIM - 8' - BLACK CHERRY/CHERRY IV - CONCERT CHERRY
47	109410-01-N75	EA	MOLDING - TRIM - 8' - PORTSMOUTH OAK
47	109410-01-J70	EA	MOLDING - TRIM - 8' - WHITE MAPLE - WASHED MAPLE
48	116951-11-KQ0	EA	MOLDING - TRIM - 3.5" X 75.9" - WASHED MAPLE
48	116951-11-KQ1	EA	MOLDING - TRIM - 3.5" X 75.9" - CONCERT CHERRY
48	116951-11-N95	EA	MOLDING - TRIM - 3.5" X 75.9" - PORTSMOUTH OAK
48	116951-11-RE0	EA	MOLDING - TRIM - 3.5" X 75.9" - HONEY CHERRY
48	116951-16-K37	EA	MOLDING - TRIM - 3.5" X 74.3" - CONCERT CHERRY
48	116951-16-K90	EA	MOLDING - TRIM - 3.5" X 74.3" - WASHED MAPLE
48	116951-16-N75	EA	MOLDING - TRIM - 3.5" X 74.3" - PORTSMOUTH OAK
48	116951-16-RC3	EA	MOLDING - TRIM - 3.5" X 74.3" - HONEY CHERRY
48	116951-23-L52	EA	MOLDING - TRIM - 3.5" X 74.3" - CONCERT CHERRY
48	116951-23-L58	EA	MOLDING - TRIM - 3.5" X 74.3" - WASHED MAPLE
48	116951-23-RE0	EA	MOLDING - TRIM - 3.5" X 74.3" - HONEY CHERRY
48	116951-23-R83	EA	MOLDING - TRIM - 3.5" X 74.3" - PORTSMOUTH OAK
48	116951-24-L52	EA	MOLDING - TRIM - 3.5" X 74.6" - CONCERT CHERRY
48	116951-24-L58	EA	MOLDING - TRIM - 3.5" X 74.6" - WASHED MAPLE
48	116951-24-RE0	EA	MOLDING - TRIM - 3.5" X 74.6" - HONEY CHERRY
48	116951-24-R83	EA	MOLDING - TRIM - 3.5" X 74.6" - PORTSMOUTH OAK
48	116951-27-N75	EA	MOLDING - TRIM - 3.5" X 46.8" - PORTSMOUTH OAK
48	116951-27-N84	EA	MOLDING - TRIM - 3.5" X 46.8" - WASHED MAPLE
48	116951-27-N85	EA	MOLDING - TRIM - 3.5" X 46.8" - CONCERT CHERRY
48	116951-28-N75	EA	MOLDING - TRIM - 3.5" X 79.4" - PORTSMOUTH OAK
48	116951-28-N84	EA	MOLDING - TRIM - 3.5" X 79.4" - WASHED MAPLE
48	116951-28-N85	EA	MOLDING - TRIM - 3.5" X 79.4" - CONCERT CHERRY
48	116951-29-N70	EA	MOLDING - TRIM - 5.5" X 30.4" - PORTSMOUTH OAK
48	116951-29-N84	EA	MOLDING - TRIM - 5.5" X 30.4" - WASHED MAPLE
48	116951-29-N85	EA	MOLDING - TRIM - 5.5" X 30.4" - CONCERT CHERRY
48	116951-29-RC3	EA	MOLDING - TRIM - 5.5" X 30.4" - HONEY CHERRY
48	116951-32-P75	EA	MOLDING - TRIM - 3" X 33.4" - PORTSMOUTH OAK
48	116951-32-P25	EA	MOLDING - TRIM - 3" X 33.4" - CONCERT CHERRY
48	116951-32-P28	EA	MOLDING - TRIM - 3" X 33.4" - WASHED MAPLE
48	116951-32-RE0	EA	MOLDING - TRIM - 3" X 33.4" - HONEY CHERRY
48	116951-34-P28	EA	MOLDING - TRIM - 3" X 33.4" - WASHED MAPLE
48	116951-34-P78	EA	MOLDING - TRIM - 3" X 33.4" - PORTSMOUTH OAK
48	116951-34-P79	EA	MOLDING - TRIM - 3" X 33.4" - CONCERT CHERRY
48	116951-34-RE0	EA	MOLDING - TRIM - 3" X 33.4" - HONEY CHERRY
48	116951-35-P28	EA	MOLDING - TRIM - 3.5" X 96" - WASHED MAPLE
48	116951-35-P78	EA	MOLDING - TRIM - 3.5" X 96" - PORTSMOUTH OAK
48	116951-35-P79	EA	MOLDING - TRIM - 3.5" X 96" - CONCERT CHERRY
48	116951-35-RE0	EA	MOLDING - TRIM - 3.5" X 96" - HONEY CHERRY
48	116951-36-R68	EA	MOLDING - TRIM - 3.5" X 48.8" - WASHED MAPLE
48	116951-36-R69	EA	MOLDING - TRIM - 3.5" X 48.8" - PORTSMOUTH OAK
48	116951-36-R76	EA	MOLDING - TRIM - 3.5" X 48.8" - CONCERT CHERRY
48	116951-37-R68	EA	MOLDING - TRIM - 3.5" X 38.6" - WASHED MAPLE
48	116951-37-R69	EA	MOLDING - TRIM - 3.5" X 38.6" - PORTSMOUTH OAK
48	116951-37-R76	EA	MOLDING - TRIM - 3.5" X 38.6" - CONCERT CHERRY
48	116951-38-RE0	EA	MOLDING - TRIM - 3.5" X 82.6" - HONEY CHERRY

INTERIOR FINISH GROUP (CONTINUED)
MOLDINGS & TRIMS (CONTINUED)

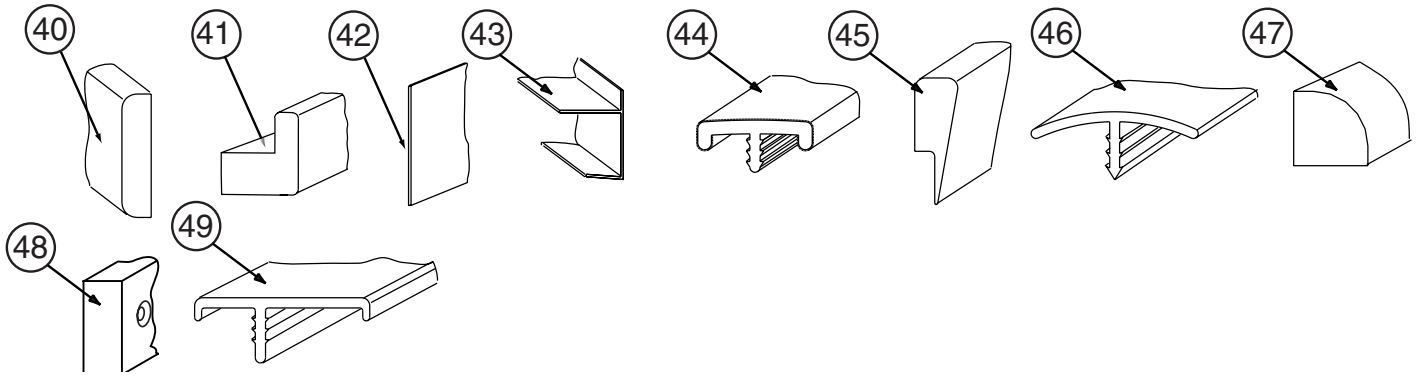

KEY	PART NUMBER	U/M	DESCRIPTION
48	116951-38-R83	EA	MOLDING - TRIM - 3.5" X 82.6" - PORTSMOUTH OAK
48	116951-38-R84	EA	MOLDING - TRIM - 3.5" X 82.6" - CONCERT CHERRY
48	116951-38-R91	EA	MOLDING - TRIM - 3.5" X 82.6" - WASHED MAPLE
48	116951-39-RE0	EA	MOLDING - TRIM - 3.5" X 73.9" - HONEY CHERRY
48	116951-39-R83	EA	MOLDING - TRIM - 3.5" X 73.9" - PORTSMOUTH OAK
48	116951-39-R84	EA	MOLDING - TRIM - 3.5" X 73.9" - CONCERT CHERRY
48	116951-39-R91	EA	MOLDING - TRIM - 3.5" X 73.9" - WASHED MAPLE
48	116951-40-RE0	EA	MOLDING - TRIM - 4.5" X 81.9" - HONEY CHERRY
48	116951-40-R83	EA	MOLDING - TRIM - 4.5" X 81.9" - PORTSMOUTH OAK
48	116951-40-R84	EA	MOLDING - TRIM - 4.5" X 81.9" - CONCERT CHERRY
48	116951-40-R91	EA	MOLDING - TRIM - 4.5" X 81.9" - WASHED MAPLE
48	116951-41-RE0	EA	MOLDING - TRIM - 3.5" X 36.8" - HONEY CHERRY
48	116951-41-R83	EA	MOLDING - TRIM - 3.5" X 36.8" - PORTSMOUTH OAK
48	116951-41-R84	EA	MOLDING - TRIM - 3.5" X 36.8" - CONCERT CHERRY
48	116951-41-R91	EA	MOLDING - TRIM - 3.5" X 36.8" - WASHED MAPLE
48	116951-42-RE0	EA	MOLDING - TRIM - 3.5" X 46.8" - HONEY CHERRY
48	116951-42-R83	EA	MOLDING - TRIM - 3.5" X 46.8" - PORTSMOUTH OAK
48	116951-42-R84	EA	MOLDING - TRIM - 3.5" X 46.8" - CONCERT CHERRY
48	116951-42-R91	EA	MOLDING - TRIM - 3.5" X 46.8" - WASHED MAPLE
48	116951-43-RE0	EA	MOLDING - TRIM - 3.5" X 86.5" - HONEY CHERRY
48	116951-43-R83	EA	MOLDING - TRIM - 3.5" X 86.5" - PORTSMOUTH OAK
48	116951-43-R84	EA	MOLDING - TRIM - 3.5" X 86.5" - CONCERT CHERRY
48	116951-43-R91	EA	MOLDING - TRIM - 3.5" X 86.5" - WASHED MAPLE
48	116951-44-RE0	EA	MOLDING - TRIM - 3.5" X 76.1" - HONEY CHERRY
48	116951-44-R83	EA	MOLDING - TRIM - 3.5" X 76.1" - PORTSMOUTH OAK
48	116951-44-R84	EA	MOLDING - TRIM - 3.5" X 76.1" - CONCERT CHERRY
48	116951-44-R91	EA	MOLDING - TRIM - 3.5" X 76.1" - WASHED MAPLE
48	116951-45-R68	EA	MOLDING - TRIM - 3" X 30.3" - PORTSMOUTH OAK
48	116951-45-R69	EA	MOLDING - TRIM - 3" X 30.3" - CONCERT CHERRY
48	116951-45-R76	EA	MOLDING - TRIM - 3" X 30.3" - WASHED MAPLE
48	116951-46-RE0	EA	MOLDING - TRIM - 4.5" X 72.3" - HONEY CHERRY
48	116951-46-R83	EA	MOLDING - TRIM - 4.5" X 72.3" - PORTSMOUTH OAK
48	116951-46-R84	EA	MOLDING - TRIM - 4.5" X 72.3" - CONCERT CHERRY
48	116951-46-R91	EA	MOLDING - TRIM - 4.5" X 72.3" - WASHED MAPLE
48	116951-48-RE0	EA	MOLDING - TRIM - 4.5" X 76.1" - HONEY CHERRY
48	116951-48-R83	EA	MOLDING - TRIM - 4.5" X 76.1" - PORTSMOUTH OAK
48	116951-48-R84	EA	MOLDING - TRIM - 4.5" X 76.1" - CONCERT CHERRY
48	116951-48-R91	EA	MOLDING - TRIM - 4.5" X 76.1" - WASHED MAPLE
48	116951-49-RE0	EA	MOLDING - TRIM - 4.5" X 69.8" - HONEY CHERRY
48	116951-49-R83	EA	MOLDING - TRIM - 4.5" X 69.8" - PORTSMOUTH OAK
48	116951-49-R84	EA	MOLDING - TRIM - 4.5" X 69.8" - CONCERT CHERRY
48	116951-49-R91	EA	MOLDING - TRIM - 4.5" X 69.8" - WASHED MAPLE
48	116951-50-RE0	EA	MOLDING - TRIM - 4.5" X 70.3" - HONEY CHERRY
48	116951-50-R83	EA	MOLDING - TRIM - 4.5" X 70.3" - PORTSMOUTH OAK
48	116951-50-R84	EA	MOLDING - TRIM - 4.5" X 70.3" - CONCERT CHERRY
48	116951-50-R91	EA	MOLDING - TRIM - 4.5" X 70.3" - WASHED MAPLE
49	119520-01-01A	FT	MOLDING-T/OFFSET - W/EDGE LIP - 1"FACE - OFF WHITE
49	119520-01-02A	FT	MOLDING-T/OFFSET - W/EDGE LIP - 1"FACE - CONCERT CHERRY
49	119520-01-03A	FT	MOLDING-T/OFFSET - W/EDGE LIP - 1"FACE - WASHED MAPLE
49	119520-01-04A	FT	MOLDING-T/OFFSET - W/EDGE LIP - 1"FACE - PORTSMOUTH OAK

INTERIOR FINISH GROUP (CONTINUED)

MOLDINGS & TRIMS (CONTINUED)

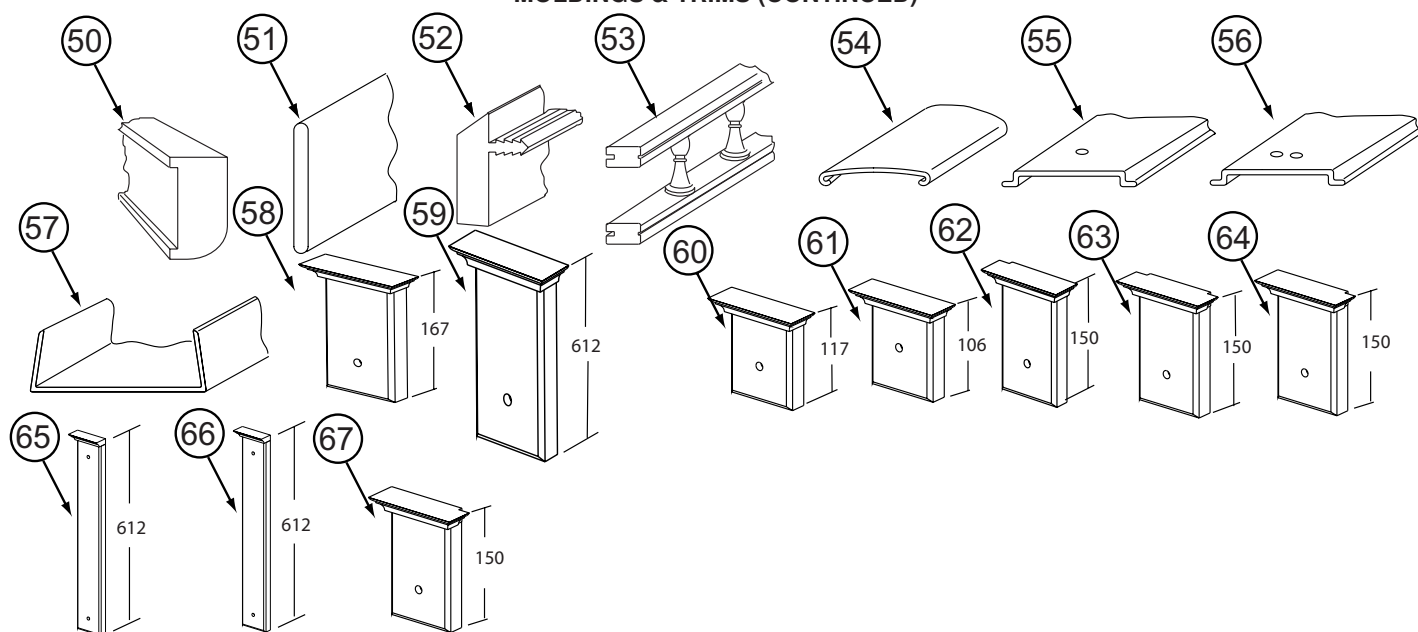

KEY	PART NUMBER	U/M	DESCRIPTION
50	126204-D2-134	EA	MOLDING - VINYL WRAPPED - .7" X 1.6" X 84" - WASHED MAPLE FROM: 00-00-00 THRU: 01-04-04
50	149326-D2-134	EA	MOLDING - VINYL WRAPPED - .7" X 1.6" X 84" - WASHED MAPLE FROM: 01-05-04 THRU: 99-99-99
50	126204-F2-134	EA	MOLDING - VINYL WRAPPED - .7" X 2.5" X 84" - WASHED MAPLE FROM: 00-00-00 THRU: 01-04-04
50	149326-F2-134	EA	MOLDING - VINYL WRAPPED - .7" X 2.5" X 84" - WASHED MAPLE FROM: 01-05-04 THRU: 99-99-99
50	137887-D2-134	EA	MOLDING - VINYL WRAPPED - .7" X 1.6" X 96" - CONCERT CHERRY
50	137887-D2-743	EA	MOLDING - VINYL WRAPPED - .7" X 1.6" X 108" - CONCERT CHERRY
50	137887-F2-134	EA	MOLDING - VINYL WRAPPED - .7" X 2.5" X 84" - CONCERT CHERRY
50	137887-F2-743	EA	MOLDING - VINYL WRAPPED - .7" X 2.5" X 108" - CONCERT CHERRY
50	137895-D2-134	EA	MOLDING - VINYL WRAPPED - .7" X 1.6" X 84" - PORTSMOUTH OAK
50	137895-D2-743	EA	MOLDING - VINYL WRAPPED - .7" X 1.5" X 108" - PORTSMOUTH OAK
50	137895-F2-743	EA	MOLDING - VINYL WRAPPED - .7" X 2.5" X 108" - PORTSMOUTH OAK
50	146425-D2-134	EA	MOLDING - VINYL WRAPPED - .7" X 1.6" X 96" - HONEY CHERRY
50	146425-F2-134	EA	MOLDING - VINYL WRAPPED - .7" X 2.5" X 84" - HONEY CHERRY
50	146425-F2-743	EA	MOLDING - VINYL WRAPPED - .7" X 2.5" X 108" - HONEY CHERRY
51	127842-01-01A	FT	SEAL - SIGHT SHIELD - 2" BLACK
52	130247-01-02A	FT	MOLDING-T/OFF SET - 1.3" FACE - WASHED MAPLE FROM: 00-00-00 THRU: 01-04-04
52	130247-01-07A	FT	MOLDING-T/OFF SET - 1.3" FACE - WASHED MAPLE FROM: 01-05-04 THRU: 99-99-99
52	130247-01-04A	FT	MOLDING-T/OFF SET - 1.3" FACE - PORTSMOUTH OAK
52	130247-01-05A	FT	MOLDING-T/OFF SET - 1.3" FACE - CONCERT CHERRY/HONEY CHERRY
53	137108-01-02A	EA	RAIL - DECORATIVE - SALEM CHERRY - CONCERT CHERRY
53	137108-01-03A	EA	RAIL - DECORATIVE - WASHED MAPLE
53	137108-01-07A	EA	RAIL - DECORATIVE - PORTSMOUTH OAK
53	137108-01-08A	EA	RAIL - DECORATIVE - HONEY CHERRY
54	138359-01-01A	FT	COVER - ROOF BREAK - PEARL CREAM/PLASTIC - 96"
55	138403-01-01A	EA	TRIM - ROOF - MILL
56	138403-02-01A	EA	TRIM - ROOF - MILL
56	138403-03-01A	EA	TRIM - ROOF - MILL
57	141260-01-01A	FT	U-CHANNEL - 1" - VILLAGE OAK
57	141260-01-02A	FT	U-CHANNEL - 1" - GRADY BROWN
58	141303-01-N52	EA	MOLDING - CROWN/BLOCK - CONCERT CHERRY
58	141303-01-N53	EA	MOLDING - CROWN/BLOCK - PORTSMOUTH OAK
58	141303-01-N62	EA	MOLDING - CROWN/BLOCK - WASHED MAPLE
58	141303-01-RA3	EA	MOLDING - CROWN/BLOCK - HONEY CHERRY
59	141303-02-N52	EA	MOLDING - CROWN/BLOCK - CONCERT CHERRY
59	141303-02-N53	EA	MOLDING - CROWN/BLOCK - PORTSMOUTH OAK
59	141303-02-N62	EA	MOLDING - CROWN/BLOCK - WASHED MAPLE
59	141303-02-RA3	EA	MOLDING - CROWN/BLOCK - HONEY CHERRY

INTERIOR FINISH GROUP (CONTINUED)
MOLDINGS & TRIMS (CONTINUED)

KEY	PART NUMBER	U/M	DESCRIPTION
60	141303-03-N52	EA	MOLDING - CROWN/BLOCK - CONCERT CHERRY
60	141303-03-N53	EA	MOLDING - CROWN/BLOCK - PORTSMOUTH OAK
60	141303-03-N62	EA	MOLDING - CROWN/BLOCK - WASHED MAPLE
60	141303-03-RA3	EA	MOLDING - CROWN/BLOCK - HONEY CHERRY
61	141303-04-PC0	EA	MOLDING - CROWN/BLOCK - PORTSMOUTH OAK
61	141303-04-PC1	EA	MOLDING - CROWN/BLOCK - CONCERT CHERRY
61	141303-04-PC2	EA	MOLDING - CROWN/BLOCK - WASHED MAPLE
61	141303-04-RA3	EA	MOLDING - CROWN/BLOCK - HONEY CHERRY
62	141303-05-RE3	EA	MOLDING - CROWN/BLOCK - HONEY CHERRY
62	141303-05-R89	EA	MOLDING - CROWN/BLOCK - PORTSMOUTH OAK
62	141303-05-R90	EA	MOLDING - CROWN/BLOCK - CONCERT CHERRY
62	141303-05-R91	EA	MOLDING - CROWN/BLOCK - WASHED MAPLE
63	141303-06-RE3	EA	MOLDING - CROWN/BLOCK - HONEY CHERRY
63	141303-06-R89	EA	MOLDING - CROWN/BLOCK - PORTSMOUTH OAK
63	141303-06-R90	EA	MOLDING - CROWN/BLOCK - CONCERT CHERRY
63	141303-06-R91	EA	MOLDING - CROWN/BLOCK - WASHED MAPLE
64	141303-07-RE3	EA	MOLDING - CROWN/BLOCK - HONEY CHERRY
64	141303-07-R89	EA	MOLDING - CROWN/BLOCK - PORTSMOUTH OAK
64	141303-07-R90	EA	MOLDING - CROWN/BLOCK - CONCERT CHERRY
64	141303-07-R91	EA	MOLDING - CROWN/BLOCK - WASHED MAPLE
65	141303-08-RE3	EA	MOLDING - CROWN/BLOCK - HONEY CHERRY
65	141303-08-R89	EA	MOLDING - CROWN/BLOCK - PORTSMOUTH OAK
65	141303-08-R90	EA	MOLDING - CROWN/BLOCK - CONCERT CHERRY
65	141303-08-R91	EA	MOLDING - CROWN/BLOCK - WASHED MAPLE
66	141303-09-RE3	EA	MOLDING - CROWN/BLOCK - HONEY CHERRY
66	141303-09-R89	EA	MOLDING - CROWN/BLOCK - PORTSMOUTH OAK
66	141303-09-R90	EA	MOLDING - CROWN/BLOCK - CONCERT CHERRY
66	141303-09-R91	EA	MOLDING - CROWN/BLOCK - WASHED MAPLE
67	141303-10-RE3	EA	MOLDING - CROWN/BLOCK - HONEY CHERRY
67	141303-10-R89	EA	MOLDING - CROWN/BLOCK - PORTSMOUTH OAK
67	141303-10-R90	EA	MOLDING - CROWN/BLOCK - CONCERT CHERRY
67	141303-10-R91	EA	MOLDING - CROWN/BLOCK - WASHED MAPLE

INTERIOR FINISH GROUP (CONTINUED)

MOLDINGS & TRIMS (CONTINUED)

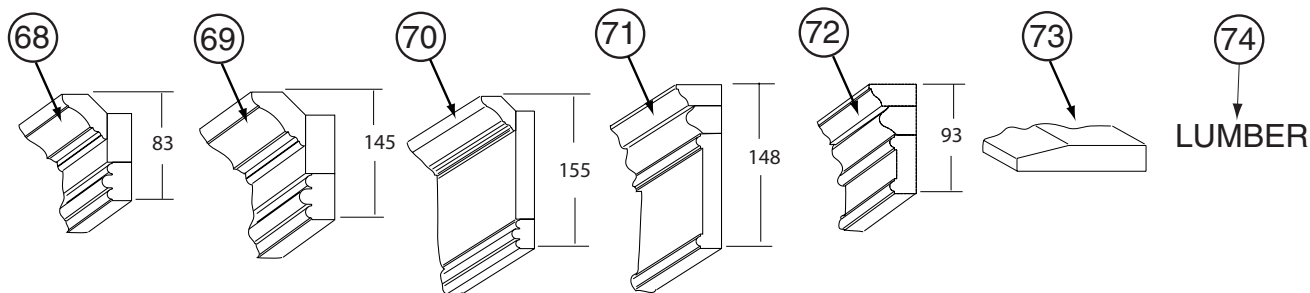

KEY	PART NUMBER	U/M	DESCRIPTION
68	141915-29-PC0	EA	MOLDING - F/SLIDEOUT - 81.8" - PORTSMOUTH OAK
68	141915-29-PC1	EA	MOLDING - F/SLIDEOUT - 81.8" - CONCERT CHERRY
68	141915-29-PC2	EA	MOLDING - F/SLIDEOUT - 81.8" - WASHED MAPLE
68	141915-29-RC3	EA	MOLDING - F/SLIDEOUT - 81.8" - HONEY CHERRY
69	141915-35-RC0	EA	MOLDING - F/SLIDEOUT - 8.89' - PORTSMOUTH OAK
69	141915-35-RC1	EA	MOLDING - F/SLIDEOUT - 8.89' - CONCERT CHERRY
69	141915-35-RC2	EA	MOLDING - F/SLIDEOUT - 8.89' - WASHED MAPLE
69	141915-35-RC3	EA	MOLDING - F/SLIDEOUT - 8.89' - HONEY CHERRY
70	141915-47-RC0	EA	MOLDING - F/SLIDEOUT - 6.82' - PORTSMOUTH OAK
70	141915-47-RC1	EA	MOLDING - F/SLIDEOUT - 6.82' - CONCERT CHERRY
70	141915-47-RC2	EA	MOLDING - F/SLIDEOUT - 6.82' - WASHED MAPLE
70	141915-47-RC3	EA	MOLDING - F/SLIDEOUT - 6.82' - HONEY CHERRY
71	144885-12-RE0	EA	MOLDING - F/SLIDEOUT - HONEY CHERRY
71	144885-12-R83	EA	MOLDING - F/SLIDEOUT - PORTSMOUTH OAK
71	144885-12-R84	EA	MOLDING - F/SLIDEOUT - CONCERT CHERRY
72	145379-01-RE0	EA	MOLDING/TRIM - 47.48" - HONEY CHERRY
72	145379-01-R83	EA	MOLDING/TRIM - 47.48" - PORTSMOUTH OAK
72	145379-01-R84	EA	MOLDING/TRIM - 47.48" - CONCERT CHERRY
72	145379-02-RE0	EA	MOLDING/TRIM - 7.87" W/RIGHT SIDE ANGLE CUT - HONEY CHERRY
72	145379-02-R83	EA	MOLDING/TRIM - 7.87" W/RIGHT SIDE ANGLE CUT - PORTSMOUTH OAK
72	145379-02-R84	EA	MOLDING/TRIM - 7.87" W/RIGHT SIDE ANGLE CUT - CONCERT CHERRY
72	145379-03-RE0	EA	MOLDING/TRIM - 7.87" W/LEFT SIDE ANGLE CUT - HONEY CHERRY
72	145379-03-R83	EA	MOLDING/TRIM - 7.87" W/LEFT SIDE ANGLE CUT - PORTSMOUTH OAK
72	145379-03-R84	EA	MOLDING/TRIM - 7.87" W/LEFT SIDE ANGLE CUT - CONCERT CHERRY
72	145379-04-RE0	EA	MOLDING/TRIM - 86.61" - HONEY CHERRY
72	145379-04-R83	EA	MOLDING/TRIM - 86.61" - PORTSMOUTH OAK
72	145379-04-R84	EA	MOLDING/TRIM - 86.61" - CONCERT CHERRY
72	145379-05-RE0	EA	MOLDING/TRIM - 102.75" - HONEY CHERRY
72	145379-05-R83	EA	MOLDING/TRIM - 102.75" - PORTSMOUTH OAK
72	145379-05-R84	EA	MOLDING/TRIM - 102.75" - CONCERT CHERRY
73	146306-01-01A	FT	TRANSITION - CARPET/TILE
74	126205-A2-438	EA	LUMBER - VINYL WRAPPED - .7" X .75" X 96" - WASHED MAPLE FROM: 00-00-00 THRU: 01-04-04
74	149325-A2-438	EA	LUMBER - VINYL WRAPPED - .7" X .75" X 96" - WASHED MAPLE FROM: 01-05-04 THRU: 99-99-99
74	126205-D2-438	EA	LUMBER - VINYL WRAPPED - .7" X 1.5" X 96" - WASHED MAPLE FROM: 00-00-00 THRU: 01-04-04
74	149325-D2-438	EA	LUMBER - VINYL WRAPPED - .7" X 1.5" X 96" - WASHED MAPLE FROM: 01-05-04 THRU: 99-99-99
74	126205-E2-438	EA	LUMBER - VINYL WRAPPED - .7" X 2" X 96" - WASHED MAPLE FROM: 00-00-00 THRU: 01-04-04
74	149325-E2-438	EA	LUMBER - VINYL WRAPPED - .7" X 2" X 96" - WASHED MAPLE FROM: 01-05-04 THRU: 99-99-99
74	126205-F2-438	EA	LUMBER - VINYL WRAPPED - .7" X 2.5" X 96" - WASHED MAPLE FROM: 00-00-00 THRU: 01-04-04
74	149325-F2-438	EA	LUMBER - VINYL WRAPPED - .7" X 2.5" X 96" - WASHED MAPLE FROM: 01-05-04 THRU: 99-99-99
74	126205-G2-438	EA	LUMBER - STAINED - .7" X 3" X 96" - WASHED MAPLE FROM: 00-00-00 THRU: 01-04-04
74	149325-G2-438	EA	LUMBER - STAINED - .7" X 3" X 96" - WASHED MAPLE FROM: 01-05-04 THRU: 99-99-99

INTERIOR FINISH GROUP (CONTINUED)
MOLDINGS & TRIMS (CONTINUED)

KEY	PART NUMBER	U/M	DESCRIPTION
74	126205-H2-438	EA	LUMBER - STAINED - .7" X 3.5" X 96" - WASHED MAPLE FROM: 00-00-00 THRU: 01-04-04
74	149325-H2-438	EA	LUMBER - STAINED - .7" X 3.5" X 96" - WASHED MAPLE FROM: 01-05-04 THRU: 99-99-99
74	126205-J2-438	EA	LUMBER - VINYL WRAPPED - .7" X 5.5" X 96" - WASHED MAPLE FROM: 00-00-00 THRU: 01-04-04
74	149325-J2-438	EA	LUMBER - VINYL WRAPPED - .7" X 5.5" X 96" - WASHED MAPLE FROM: 01-05-04 THRU: 99-99-99
74	126205-J2-743	EA	LUMBER - VINYL WRAPPED - .7" X 5.5" X 108" - WASHED MAPLE FROM: 00-00-00 THRU: 01-04-04
74	149325-J2-743	EA	LUMBER - VINYL WRAPPED - .7" X 5.5" X 108" - WASHED MAPLE FROM: 01-05-04 THRU: 99-99-99
74	126205-K2-438	EA	LUMBER - VINYL WRAPPED - .7" X 3.9" X 96" - WASHED MAPLE FROM: 00-00-00 THRU: 01-04-04
74	149325-K2-438	EA	LUMBER - VINYL WRAPPED - .7" X 3.9" X 96" - WASHED MAPLE FROM: 01-05-04 THRU: 99-99-99
74	126205-R2-438	EA	LUMBER - VINYL WRAPPED - .7" X 3" X 96" - WASHED MAPLE FROM: 00-00-00 THRU: 01-04-04
74	149325-R2-438	EA	LUMBER - VINYL WRAPPED - .7" X 3" X 96" - WASHED MAPLE FROM: 01-05-04 THRU: 99-99-99
74	137885-A2-438	EA	LUMBER - VINYL WRAPPED - .7" X .75" X 96" - CHERRY - CONCERT CHERRY
74	137885-D2-438	EA	LUMBER - VINYL WRAPPED - .7" X 1.5" X 96" - CHERRY - CONCERT CHERRY
74	137885-E2-438	EA	LUMBER - VINYL WRAPPED - .7" X 2" X 96" - CHERRY - CONCERT CHERRY
74	137885-F2-438	EA	LUMBER - VINYL WRAPPED - .7" X 2.5" X 96" - CHERRY - CONCERT CHERRY
74	137885-G2-438	EA	LUMBER - VINYL WRAPPED - .7" X 3" X 96" - CHERRY - CONCERT CHERRY
74	137885-H2-438	EA	LUMBER - VINYL WRAPPED - .7" X 3.5" X 96" - CHERRY - CONCERT CHERRY
74	137885-J2-438	EA	LUMBER - VINYL WRAPPED - .7" X 5.5" X 96" - CHERRY - CONCERT CHERRY
74	137885-J2-743	EA	LUMBER - VINYL WRAPPED - .7" X 5.5" X 108" - CHERRY - CONCERT CHERRY
74	137885-K2-438	EA	LUMBER - VINYL WRAPPED - .7" X 3.9" X 96" - CHERRY - CONCERT CHERRY
74	137885-R2-438	EA	LUMBER - VINYL WRAPPED - .7" X 3" X 96" - CHERRY - CONCERT CHERRY
74	137894-A2-438	EA	LUMBER - VINYL WRAPPED - .7" X .75" X 96" - PORTSMOUTH OAK
74	137894-D2-438	EA	LUMBER - VINYL WRAPPED - .7" X 1.5" X 96" - PORTSMOUTH OAK
74	137894-E2-438	EA	LUMBER - VINYL WRAPPED - .7" X 2" X 96" - PORTSMOUTH OAK
74	137894-F2-438	EA	LUMBER - VINYL WRAPPED - .7" X 2.5" X 96" - PORTSMOUTH OAK
74	137894-G2-438	EA	LUMBER - VINYL WRAPPED - .7" X 3" X 96" - PORTSMOUTH OAK
74	137894-H2-438	EA	LUMBER - VINYL WRAPPED - .7" X 3.5" X 96" - PORTSMOUTH OAK
74	137894-J2-438	EA	LUMBER - VINYL WRAPPED - .7" X 5.5" X 96" - PORTSMOUTH OAK
74	137894-J2-743	EA	LUMBER - VINYL WRAPPED - .7" X 5.5" X 96" - PORTSMOUTH OAK
74	137894-K2-438	EA	LUMBER - VINYL WRAPPED - .7" X 3.9" X 96" - PORTSMOUTH OAK
74	137894-R2-438	EA	LUMBER - VINYL WRAPPED - .7" X 3" X 96" - PORTSMOUTH OAK
74	146419-A2-438	EA	LUMBER - VINYL WRAPPED - .7" X .75" X 96" - HONEY CHERRY
74	146419-D2-438	EA	LUMBER - VINYL WRAPPED - .7" X 1.5" X 96" - HONEY CHERRY
74	146419-E2-438	EA	LUMBER - VINYL WRAPPED - .7" X 2" X 96" - HONEY CHERRY
74	146419-F2-438	EA	LUMBER - VINYL WRAPPED - .7" X 2.5" X 96" - HONEY CHERRY
74	146419-G2-438	EA	LUMBER - VINYL WRAPPED - .7" X 3" X 96" - HONEY CHERRY
74	146419-H2-438	EA	LUMBER - VINYL WRAPPED - .7" X 3.5" X 96" - HONEY CHERRY
74	146419-J2-438	EA	LUMBER - VINYL WRAPPED - .7" X 5.5" X 96" - HONEY CHERRY
74	146419-J2-743	EA	LUMBER - VINYL WRAPPED - .7" X 5.5" X 108" - HONEY CHERRY
74	146419-K2-438	EA	LUMBER - VINYL WRAPPED - .7" X 3.9" X 96" - HONEY CHERRY
74	146419-R2-438	EA	LUMBER - VINYL WRAPPED - .7" X 3" X 96" - HONEY CHERRY

INTERIOR FINISH GROUP (CONTINUED)
PANELING & LAMINATES

KEY	PART NUMBER	U/M	DESCRIPTION
	000885-A5-000	SF	PARTICLE BOARD - 3/8" X 4' X 8'- WHT PEB EMBOSSED-1 SIDED
	000885-92-000	SF	PARTICLE BOARD - 3/8" X 4' X 8' - PORTSMOUTH OAK - 1 SIDED
	000885-96-000	SF	PARTICLE BOARD - 3/8" X 4' X 8' - CONCERT CHERRY - 1-SIDED
	000885-88-000	SF	PARTICLE BOARD - 3/8" X 4' X 8' - WASHED MAPLE - 1-SIDED - WASHED MAPLE FROM: 00-00-00 THRU: 01-04-04
	000885-B5-000	SF	PARTICLE BOARD - 3/8" X 4' X 8' - NEAT WASHED MAPLE - 1-SIDED - WASHED MAPLE FROM: 01-05-04 THRU: 99-99-99
	000885-93-000	SF	PARTICLE BOARD - 3/8" X 4' X 8' - PORTSMOUTH OAK - 2-SIDED
	000885-98-000	SF	PARTICLE BOARD - 3/8" X 4' X 8' - SALEM CHERRY - 2 SIDED
	000885-89-000	SF	PARTICLE BOARD - 3/8" X 4' X 8' - WASHED MAPLE - 2-SIDED - WASHED MAPLE FROM: 00-00-00 THRU: 01-04-04
	000885-B4-000	SF	PARTICLE BOARD - 3/8" X 4' X 8' - NEAT WASHED MAPLE - 2-SIDED - WASHED MAPLE FROM: 01-05-04 THRU: 99-99-99
	000885-94-000	SF	PARTICLE BOARD - 1/2" X 4' X 8' - PORTSMOUTH OAK - 2-SIDED
	000885-A1-000	SF	PARTICLE BOARD - 1/2" X 4' X 8' - SALEM CHERRY - 2 SIDED
	000885-90-000	SF	PARTICLE BOARD - 1/2" X 4' X 8' - WASHED MAPLE - 2-SIDED FROM: 00-00-00 THRU: 01-04-04
	000885-B7-000	SF	PARTICLE BOARD - 1/2" X 4' X 8'- NEAT/WASHED MPL - 2 SIDED FROM: 01-05-04 THRU: 99-99-99
	000885-95-000	SF	PARTICLE BOARD - 3/4" X 4' X 8' - PORTSMOUTH OAK - 2-SIDED
	000885-A3-000	SF	PARTICLE BOARD - 3/4" X 4' X 8' - SALEM CHERRY - 2 SIDED
	000885-91-000	SF	PARTICLE BOARD - 3/4" X 4' X 8' - WASHED MAPLE - 2-SIDED FROM: 00-00-00 THRU: 01-04-04
	000885-B6-000	SF	PARTICLE BOARD - 3/4" X 4' X 8'- WASHED MAPLE - 2 SIDED FROM: 01-05-04 THRU: 99-99-99
	069733-87-000	EA	BATT STRIP - WOODGRAINED/PORTSMOUTH OAK - 8'
	069733-88-000	EA	BATT STRIP - WOODGRAINED/SALEM CHERRY - 8'
	069733-89-000	EA	BATT STRIP - WOODGRAINED/WASHED MAPLE - 8'
	074497-42-000	SF	PANELING - PORTSMOUTH OAK - 4' X 8'
	074497-43-000	SF	PANELING - SALEM CHERRY - 4' X 8'
	074497-39-000	SF	PANELING - WASHED MAPLE - 1/8" X 4' X 8' FROM: 00-00-00 THRU: 01-04-04
	074497-49-000	SF	PANELING/PAPER WRAPPED - WASHED MAPLE- 1/8" X 4' X 8' FROM: 01-05-04 THRU: 99-99-99
	074498-40-000	SF	LAMINATE - PLASTIC - OFF WHITE - 4' X 8'
	074498-97-000	SF	LAMINATE - PLASTIC - GRAY TRANQUILITY - 4' X 8' (R19, R20, R21)
	074498-A1-000	SF	LAMINATE - PLASTIC - LINO FRIEZE - 5' X 8' (R22, R23, R24)
	074498-A0-000	SF	LAMINATE - PLASTIC - ROCKY MOUNTAIN HIGH - 4' X 8' (R25, R26, R27)
	085284-G8-000	FT	BATT TAPE - ADHESIVE BACKED - PORTSMOUTH OAK
	085284-H2-000	FT	BATT TAPE - ADHESIVE BACKED - SALEM CHERRY
	085284-H3-000	FT	BATT TAPE - ADHESIVE BACKED - DECORATIVE - WASHED MAPLE
	085284-H8-000	FT	BATT TAPE - ADHESIVE BACKED - ROCKET SILVERADO (R19, R20, R21)
	085284-H6-000	FT	BATT TAPE - ADHESIVE BACKED - DECORATIVE - MULTI (R22, R23, R24)
	085284-H1-000	FT	BATT TAPE - ADHESIVE BACKED - DECORATIVE - GRAY (R25, R26, R27)
	088263-H4-000	EA	BATT STRIP - DECORATIVE - ROCKET SILVERADO (R19, R20, R21)
	088263-H2-000	EA	BATT STRIP - DECORATIVE - MULTI - 8' (R22, R23, R24)
	088263-H0-000	EA	BATT STRIP - DECORATIVE - VILLA/GRAY - 8' LONG (R25, R26, R27)
	076773-15-000	SF	PANELING - 2 SIDED/PORTSMOUTH OAK - 1/8" X 4' X 8'
	076773-16-000	SF	PANELING - 2 SIDED/SALEM CHERRY - 1/8" X 4' X 8'
	076773-14-000	SF	PANELING - 2 SIDED/WASHED MAPLE - 1/8" X 4' X 8' - WASHED MAPLE FROM: 00-00-00 THRU: 01-04-04
	076773-20-000	SF	PANELING - 2 SIDED/NEAT WASHED MAPLE - 1/8" X 4' X 8' - WASHED MAPLE FROM: 01-05-04 THRU: 99-99-99
	088272-H9-000	SF	PANELING - PEBBLE EMBOSSED - WHITE - 4' X 7'
	088272-K5-000	SF	PANELING - SILVERADO - 4' X 7' (R19, R20, R21)
	088272-K4-000	SF	PANELING - MULTI - 4' X 7' (R22, R23, R24)
	088272-K1-000	SF	PANELING - GRAY - 4' X 7' (R25, R26, R27)
	126339-01-000	SF	BOARD - WHEAT - 60" X 72"
	132610-05-11A	FT	WALLPAPER - BORDER - 7" - SELF ADHESIVE (R19, R20, R21)
	132610-05-01A	FT	WALLPAPER - BORDER - 7" - SELF-ADHESIVE (R22, R23, R24)
	132610-05-08A	FT	WALLPAPER - BORDER - 7" - SELF-ADHESIVE (R25, R26, R27)

INTERIOR FINISH GROUP (CONTINUED)
ACCESSORIES

KEY	PART NUMBER	U/M	DESCRIPTION
	072852-01-000	EA	DETECTOR - SMOKE - W/9 VOLT BATTERY - US
	072852-02-000	EA	DETECTOR - SMOKE - W/9 VOLT BATTERY - CANADIAN
	094499-03-000	EA	EXTINGUISHER/FIRE - DRY - 10BC - W/GAUGE/BRACKET
*	094499-02-000	EA	EXTINGUISHER/FIRE - DRY - 10BC - W/GAUGE - CANADIAN
	094499-04-000	EA	STRAP - FIRE EXTINGUISHER MOUNTING - METAL
	064781-06-000	EA	HOLDER/CUP - TWO STEP - OFF WHITE
	096764-02-000	FT	SLIPNOT - ANTISLIP - 1'WIDE (180' ROLLS) - WHITE
	118718-01-02A	EA	HOLDER/DRINK - COLLAPSIBLE MUG - WHITE PLASTIC
	118718-01-01A	EA	HOLDER/DRINK - COLLAPSIBLE MUG - BLACK PLASTIC
	142368-02-01A	EA	CLOCK - 8" SQUARE - BRASS
	125136-02-000	EA	DETECTOR/CO - GAS MODEL - 9 VOLT
	131493-02-12A	EA	PICTURE - DECORATIVE - 13" X 15" - AFRICAN LILY(R19, R20, R21)
	131493-02-11A	EA	PICTURE - DECORATIVE - 13" X 15" - RHODODENDRON(R22, R23, R24)
	131493-02-13A	EA	PICTURE - DECORATIVE - 13" X 15" - SANDCASTLE(R25, R26, R27)
	137605-01-01A	EA	RAIL - HAND - INTERIOR ENTRY DOOR
	140374-14-000	EA	MIRROR - SAFETY GLASS - 20.8" X 35.4" - 430V
	140374-36-000	EA	MIRROR - SAFETY GLASS - 20.9" X 25.2"- 427P, 431C
	131494-04-01A	EA	MIRROR - ARCHED TOP - 20" X 30" - W/DIAMOND - 431C
	140374-30-000	EA	MIRROR - SAFETY GLASS - 25.6" X 31.5" - 430V
	142631-02-03A	EA	FRAME - MIRROR - 35.8"H X 29.9"W - PORTSMOUTH OAK - 430V
	142631-02-01A	EA	FRAME - MIRROR - 35.8"H X 29.9"W - CONCERT CHERRY - 430V
	142631-02-02A	EA	FRAME - MIRROR - 35.8"H X 29.9"W - WASHED MAPLE - 430V

*COMPONENT PARTS LISTED LATER IN THIS GROUP

INTERIOR FINISH GROUP (CONTINUED)
COMPONENT PARTS FOR ACCESSORIES

094499-02-000

KEY	PART NUMBER	U/M	DESCRIPTION	VENDOR NO
	094499-01-700	EA	BRACKET MTG. W/PLAS. STRAP	294039

INTERIOR FINISH GROUP (CONTINUED)
FLOOR COVERINGS

KEY	PART NUMBER	U/M	DESCRIPTION
	042720-28-000	SY	VINYL - FLOOR COVERING - 14' WIDE - OPTIMATION
	139056-06-000	SY	CARPET - CRYSTAL LAKE - 4 SQUARE YARD INCREMENTS (R19, R20, R21)
	096060-F0-000	SY	CARPET - PALE SAGE - INCREMENTS OF 4 SQ YARDS (R22, R23, R24)
	096060-H1-000	SY	CARPET - TAPIOCA - INCREMENTS OF 4 SQ YARDS (R25, R26, R27)
	093486-01-000	SY	CARPET - COMPARTMENT - 72" WIDE - DARK GRAY
	075233-01-000	SY	PAD - CARPET - 3/8" X 6' ROLL

INTERIOR FINISH GROUP (CONTINUED)

HARDWARE

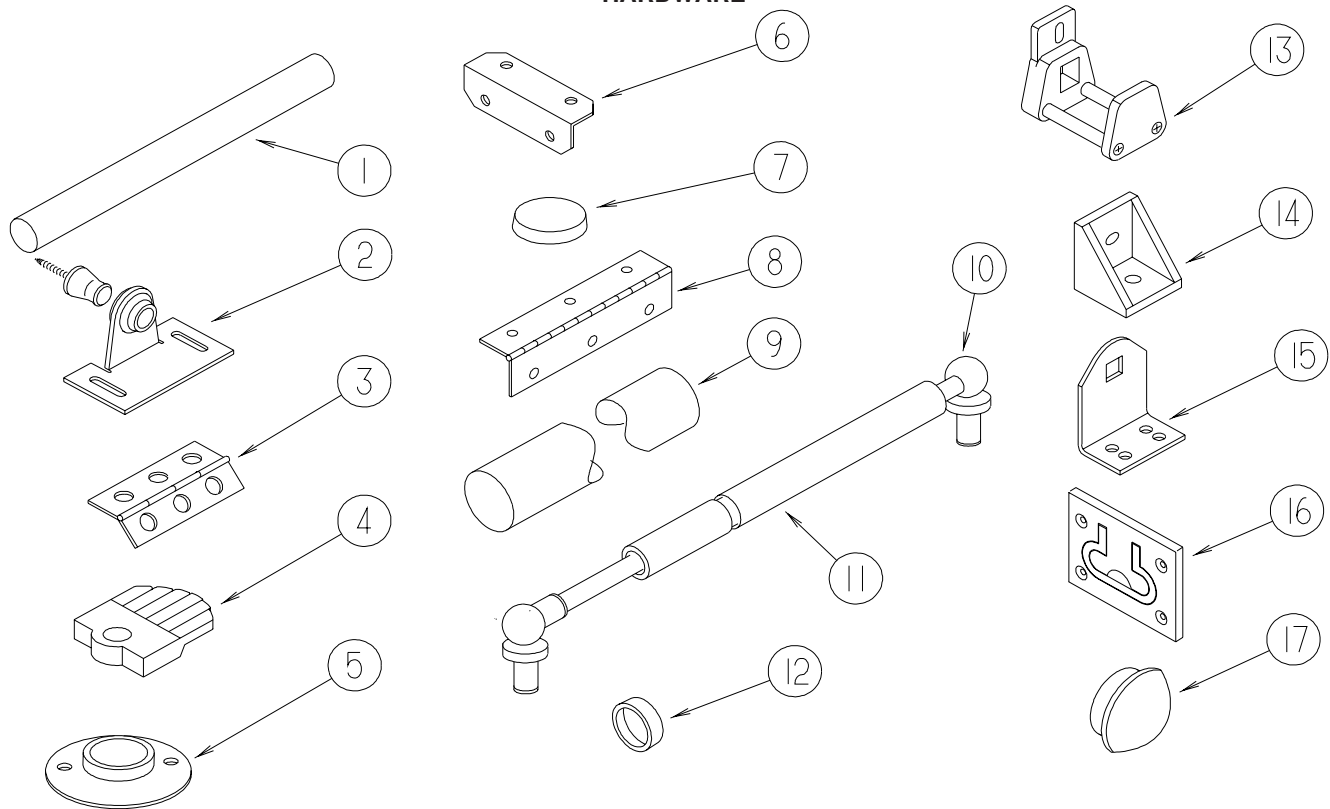

KEY	PART NUMBER	U/M	DESCRIPTION
1	Y00136-21-218	EA	DOWEL - WOOD - 1" X 4'
2	009013-01-000	EA	CATCH - BULLDOG - MALE/FEMALE
3	009059-01-000	EA	HINGE - DOOR - 2" X 1.4" - BRASS
3	009059-02-000	EA	HINGE - DOOR - 2" X 2.7" - BRASS
3	009059-03-000	EA	HINGE - BRASS - 1.75"
3	009059-04-000	EA	HINGE - 2" - ZINC
4	009089-01-000	EA	CLIP - MIRROR
5	009112-01-000	EA	FLANGE - PLASTIC - 1" CLOTHES ROD - OFF WHITE
6	016604-05-000	EA	BRACE - ANGLE - 2 1/2" - OFF WHITE METAL
6	016604-10-000	EA	BRACE - SEAT ANGLE - 2.5" - BLACK
7	023320-01-000	EA	PAD - FELT 3/8" DIAMETER
8	041389-25-000	EA	HINGE - PIANO - 1 1/2" X 55" - UNPAINTED
9	042438-02-000	EA	DOWEL - WOOD - 2" DIAMETER X 2'
10	057460-02-000	EA	BALL STUD - F/GAS SPRING .39" - 5/16"-18
11	057460-04-000	EA	SPRING/GAS - BALL STUD STYLE - 120 PI - "SPD6209"
12	057671-01-000	EA	COVER - SCREW - #8 - OFF WHITE
12	057671-15-000	EA	COVER - SCREW - #8 - BRIGHT WHITE
12	057671-16-000	EA	COVER - SCREW - #8 - SOFT WHITE
12	057671-17-000	EA	COVER - SCREW - VW LT GRAY - #8
13	064467-01-000	EA	GUIDE - POCKET - SLIDING DOOR - WALL MOUNTED
14	065740-01-000	EA	BRACE - CABINET/CORNER - PLASTIC
15	069178-03-000	EA	BRACKET/MOUNTING - ASSIST HANDLE - BRIGHT WHITE
16	072871-01-000	EA	PULL - FLUSH - CHROME
17	074045-08-000	EA	PLUG - OAK - 3/8" DOWEL-1/2" HEAD - SALEM CHERRY - CONCERT CHERRY
17	074045-12-000	EA	PLUG - OAK - 3/8" DOWEL-1/2" HEAD - WASHED MAPLE
17	074045-13-000	EA	PLUG - OAK - 3/8" DOWEL-1/2" HEAD - PORTSMOUTH OAK
17	074045-14-000	EA	PLUG - OAK - 3/8" DOWEL-1/2" HEAD - HONEY CHERRY

INTERIOR FINISH GROUP (CONTINUED)
HARDWARE (CONTINUED)

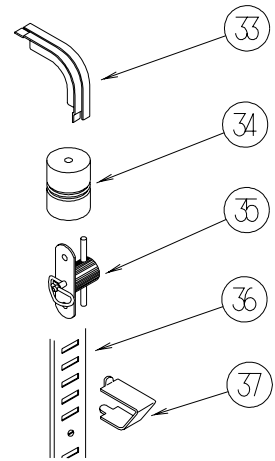
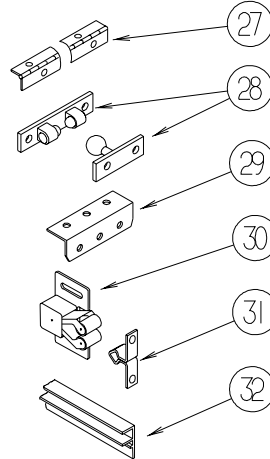
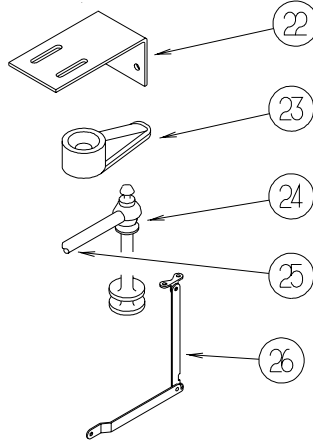
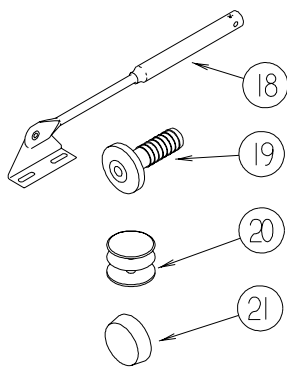

KEY	PART NUMBER	U/M	DESCRIPTION
18	074493-02-000	EA	SUPPORT - PISTON SPRING - CABINET DOOR - 26 LBS
18	074493-03-000	EA	SUPPORT - PISTON SPRING - CABINET DOOR - 12 LBS
19	079921-01-000	EA	ROLLER - NYLON - W/STEEL SHAFT - BARBED
20	081114-02-000	EA	CAP - INSERT - ROUND - 1" DIAMETER - WHITE PLASTIC
21	081914-01-000	EA	BUMPER - RUBBER - ROUND - 1/2" DIA. X 1/8" THICK
22	083125-07-000	EA	BRACE - ANGLE/COUCH - 2.5" - OFF WHITE
23	083204-03-000	EA	BUTTON - RETAINING MIRROR 5/16" TIP
24	084070-03-000	EA	POST - END - 2.4" - SHINY BRASS
25	084071-05-000	EA	ROD - BRASS - 15"
25	084071-19-000	EA	ROD - BRASS - 7.1"
25	084071-20-000	EA	ROD - BRASS - 9.8"
25	084071-23-000	EA	ROD - BRASS - 13.1"
25	084071-24-000	EA	ROD - BRASS - 3.8"
25	084071-33-000	EA	ROD - BRASS - 20.4"
25	146840-01-01A	EA	ROD - .25" DIAMETER - BRASS
25	146840-01-02A	EA	ROD - .25" DIAMETER - PEWTER
25	146840-02-01A	EA	ROD - .25" DIAMETER - BRASS
25	146840-02-02A	EA	ROD - .25" DIAMETER - PEWTER
25	146840-03-01A	EA	ROD - .25" DIAMETER - BRASS
25	146840-03-02A	EA	ROD - .25" DIAMETER - PEWTER
25	146840-04-01A	EA	ROD - .25" DIAMETER - BRASS
25	146840-04-02A	EA	ROD - .25" DIAMETER - PEWTER
25	146840-05-01A	EA	ROD - .25" DIAMETER - BRASS
25	146840-05-02A	EA	ROD - .25" DIAMETER - PEWTER
26	084412-01-000	EA	SUPPORT/HINGE KIT (LEFT & RIGHT HINGES)
27	084413-01-000	EA	HINGE - 1" X 72" - ALUMINUM - W/HOLES
28	084451-01-000	EA	CATCH & LATCH - 1.7" - BRASS
29	089025-01-000	EA	SUPPORT - SPRING TO BED - ANGLE 1.5" X 11.8"
30	093586-03-000	EA	CATCH - SPRING ROLLER - .377"
30	093586-06-000	EA	CATCH - SPRING ROLLER - .236"
31	093586-04-000	EA	STRIKE - SPRING STEEL - 1.14"
31	093586-05-000	EA	STRIKE - SPRING STEEL - .943"
32	093622-01-000	EA	TRACK - DOOR - TAMBOUR - PLASTIC - 8' LENGTHS
33	093623-01-000	EA	CORNER - TRACK - TAMBOUR DOOR
34	097872-04-000	EA	DOWEL - WOOD - 1" DIAMETER X 1.38" LONG - UNFINISHED
35	098196-01-000	EA	LATCH - 1/4 TURN - T-BAR
36	098979-01-000	EA	CLIP - ADJUSTABLE SHELF
37	098980-01-000	EA	PILASTER - ADJUSTABLE SHELF - 18"
37	098980-02-000	EA	PILASTER - ADJUSTABLE SHELF - 12"
37	098980-03-000	EA	PILASTER - ADJUSTABLE SHELF - 9"
37	098980-04-000	EA	PILASTER - ADJUSTABLE SHELF - 48"
37	098980-05-000	EA	PILASTER - ADJUSTABLE SHELF - 15"
37	098980-06-000	EA	PILASTER - ADJUSTABLE SHELF - 24"

INTERIOR FINISH GROUP (CONTINUED)
HARDWARE (CONTINUED)

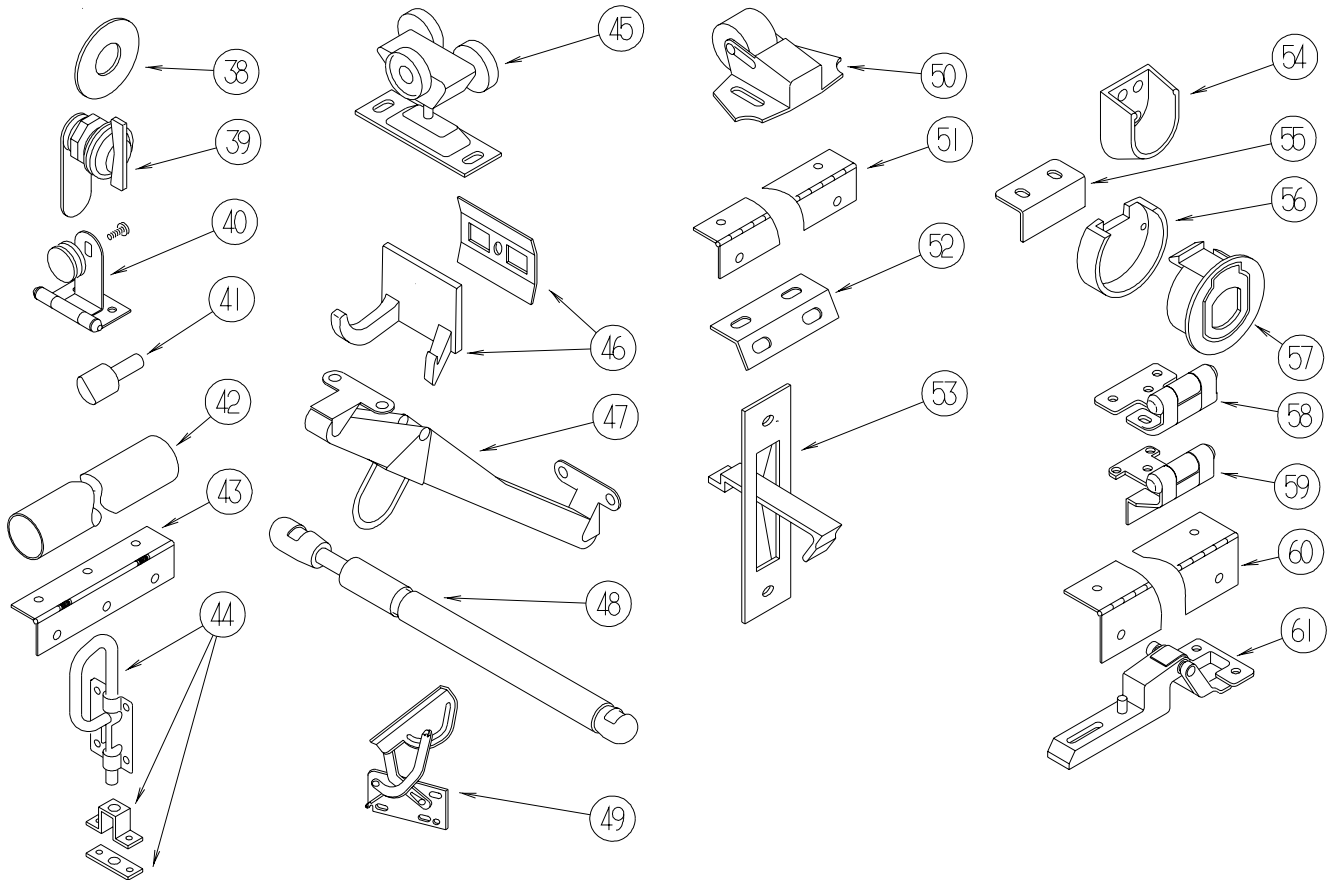

KEY	PART NUMBER	U/M	DESCRIPTION
38	100707-01-000	EA	SPACER - GLASS DOOR - .8" DIA - .3" HOLE - PLASTIC
39	100710-01-01A	EA	LOCK - GLASS DOOR/TWIST TYPE - BRASS
40	100711-01-01A	EA	HINGE - GLASS DOOR
41	101766-01-000	EA	PIN - SUPPORT/GLASS DOOR
42	102075-10-02A	EA	ROD - SHOWER CURTAIN - 1" OD X 46.3" - SOFT WHITE
43	102920-01-01A	EA	HINGE - SPRING LOADED - BRASS
44	103256-01-000	EA	LATCH COMPLETE (SLIDE)
45	103874-01-000	EA	HANGER - SLIDING DOOR
46	104174-01-000	EA	HOOK - ROBE - DOUBLE
47	104181-01-01A	EA	SUPPORT - LEAF 5.3" EXTENDS TO 7.5" - SAFETY RING - METAL
48	142569-15-000	EA	SPRING/GAS - 12" COMPRESSED/20" EXTENDED - 120 LB.
48	142569-16-000	EA	SPRING/GAS - 12" COMPRESSED/20" EXTENDED - 90 LB
48	142569-05-000	EA	SPRING - GAS - 15 LB. - 39.9"
48	142569-18-000	EA	SPRING/GAS - 6.5" COMPRESSED/9.6" EXTENDED - 65 LB.
49	108126-01-000	EA	TRAY HINGE SET (QTY. 2 PER SET)
50	109403-01-000	EA	CATCH - SINGLE ROLLER - SCREEN DOOR
51	110496-01-01A	EA	HINGE - BRASS
52	111866-01-02A	EA	BRACE - SEAT - ANGLE - OFF WHITE
53	113130-01-01A	EA	PULL - DOOR POCKET
54	113236-01-01A	EA	BRACKET - CLOTHES - ROD
55	113375-02-01A	EA	STRIKE - DOOR - CHROME
56	113375-05-01A	EA	LATCH - SLAM - BACK - .8" THICK
57	113375-06-01A	EA	LATCH - SLAM - FACE - .7" THICK
58	113676-01-01A	EA	HINGE - OVERLAY - VARIABLE - BURNISHED BRASS
59	113677-01-01A	EA	HINGE - SELF CLOSING
60	114278-02-000	EA	HINGE - CONTINUOUS - 3" WIDE
61	114443-01-01A	EA	HINGE - CABINET DOOR

INTERIOR FINISH GROUP (CONTINUED)
HARDWARE (CONTINUED)

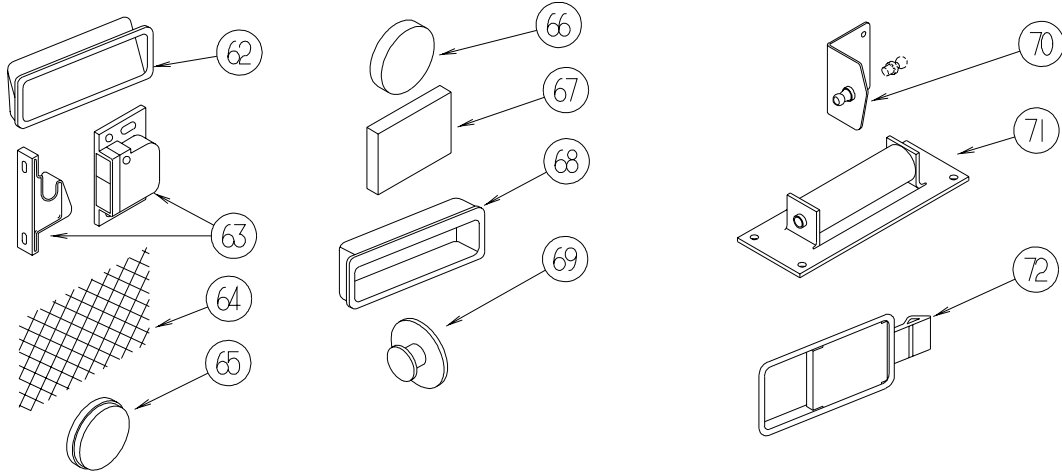

KEY	PART NUMBER	U/M	DESCRIPTION
62	115994-01-01A	EA	HANDLE - POCKET
63	117095-01-01A	EA	LATCH - DOOR - GRABBER W/KEEPER - PLASTIC - BLK-5 LB PULL
63	117095-02-01A	EA	LATCH - DOOR - GRABBER W/KEEPER - PLASTIC - BLK-10 LB PULL
64	118200-01-01A	SF	MESH - PLASTIC 1/2" - 48" X LENGTH = SF - BLACK
65	120760-01-000	EA	RUBBER BUMPER - CLEAR - .1" THICK X .8" DIAMETER
66	122717-01-01A	EA	PAD - NON SKID - 4" DIAMETER ROUND
67	122717-06-01A	FT	PAD - NON-SKID - PSA - 5"W
68	124311-01-01A	EA	HANDLE - RECESSED - BRASS
69	125221-01-01A	EA	PULL - MIRROR - W/ROUND HANDLE
70	126263-06-02B	EA	BRACKET - GAS SPRING W/INSIDE BALL STUD - E-COATED
70	126263-08-02B	EA	BRACKET - GAS SPRING W/CENTERED BALL STUD - E-COATED
71	126584-02-000	EA	ROLLER - FLAT
72	127349-01-01A	EA	LATCH - PADDLE

INTERIOR FINISH GROUP (CONTINUED)
HARDWARE (CONTINUED)

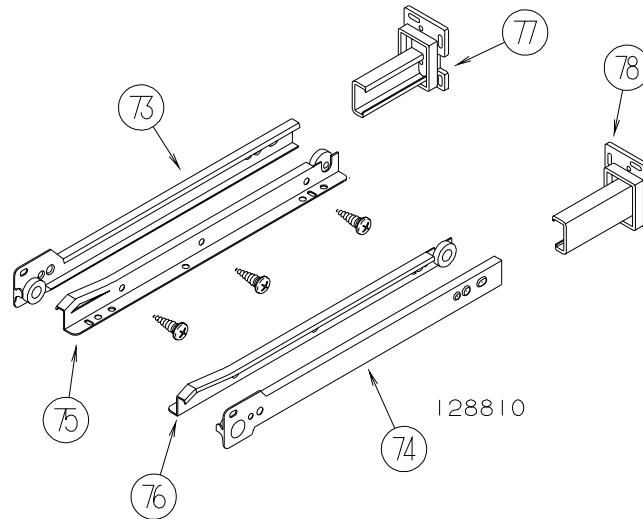

KEY	PART NUMBER	U/M	DESCRIPTION
73	128810-01-01A	EA	SLIDE - DRAWER - 12" - LEFT CABINET
73	128810-05-01A	EA	SLIDE - DRAWER - 14" - LEFT CABINET
73	128810-09-01A	EA	SLIDE - DRAWER - 16" - LEFT CABINET
73	128810-13-01A	EA	SLIDE - DRAWER - 18" - LEFT CABINET
73	128810-17-01A	EA	SLIDE - DRAWER - 20" - LEFT CABINET
73	128810-21-01A	EA	SLIDE - DRAWER - 22" - LEFT CABINET
73	128810-25-01A	EA	SLIDE - DRAWER - 24" - LEFT CABINET
73	128810-29-01A	EA	SLIDE - DRAWER - 9" - LEFT CABINET
74	128810-02-01A	EA	SLIDE - DRAWER - 12" - RIGHT CABINET
74	128810-06-01A	EA	SLIDE - DRAWER - 14" - RIGHT CABINET
74	128810-10-01A	EA	SLIDE - DRAWER - 16" - RIGHT CABINET
74	128810-14-01A	EA	SLIDE - DRAWER - 18" - RIGHT CABINET
74	128810-18-01A	EA	SLIDE - DRAWER - 20" - RIGHT CABINET
74	128810-22-01A	EA	SLIDE - DRAWER - 22" - RIGHT CABINET
74	128810-26-01A	EA	SLIDE - DRAWER - 24" - RIGHT CABINET
74	128810-30-01A	EA	SLIDE - DRAWER - 9" - RIGHT CABINET
75	128810-03-01A	EA	SLIDE - DRAWER - 12" - LEFT DRAWER
75	128810-07-01A	EA	SLIDE - DRAWER - 14" - LEFT DRAWER
75	128810-11-01A	EA	SLIDE - DRAWER - 16" - LEFT DRAWER
75	128810-15-01A	EA	SLIDE - DRAWER - 18" - LEFT DRAWER
75	128810-19-01A	EA	SLIDE - DRAWER - 20" - LEFT DRAWER
75	128810-23-01A	EA	SLIDE - DRAWER - 22" - LEFT DRAWER
75	128810-27-01A	EA	SLIDE - DRAWER - 24" - LEFT DRAWER
75	128810-27-01A	EA	SLIDE - DRAWER - 24" - LEFT DRAWER
75	128810-31-01A	EA	SLIDE - DRAWER - 9" - LEFT DRAWER
76	128810-04-01A	EA	SLIDE - DRAWER - 12" - RIGHT DRAWER
76	128810-08-01A	EA	SLIDE - DRAWER - 14" - RIGHT DRAWER
76	128810-12-01A	EA	SLIDE - DRAWER - 16" - RIGHT DRAWER
76	128810-16-01A	EA	SLIDE - DRAWER - 18" - RIGHT DRAWER
76	128810-20-01A	EA	SLIDE - DRAWER - 20" - RIGHT DRAWER
76	128810-24-01A	EA	SLIDE - DRAWER - 22" - RIGHT DRAWER
76	128810-28-01A	EA	SLIDE - DRAWER - 24" - RIGHT DRAWER
76	128810-32-01A	EA	SLIDE - DRAWER - 9" - RIGHT DRAWER
77	128811-01-02A	EA	BACKSOCKET - ADJUSTABLE - LEFT
78	128811-02-02A	EA	BACKSOCKET - ADJUSTABLE - RIGHT

INTERIOR FINISH GROUP (CONTINUED) HARDWARE (CONTINUED)

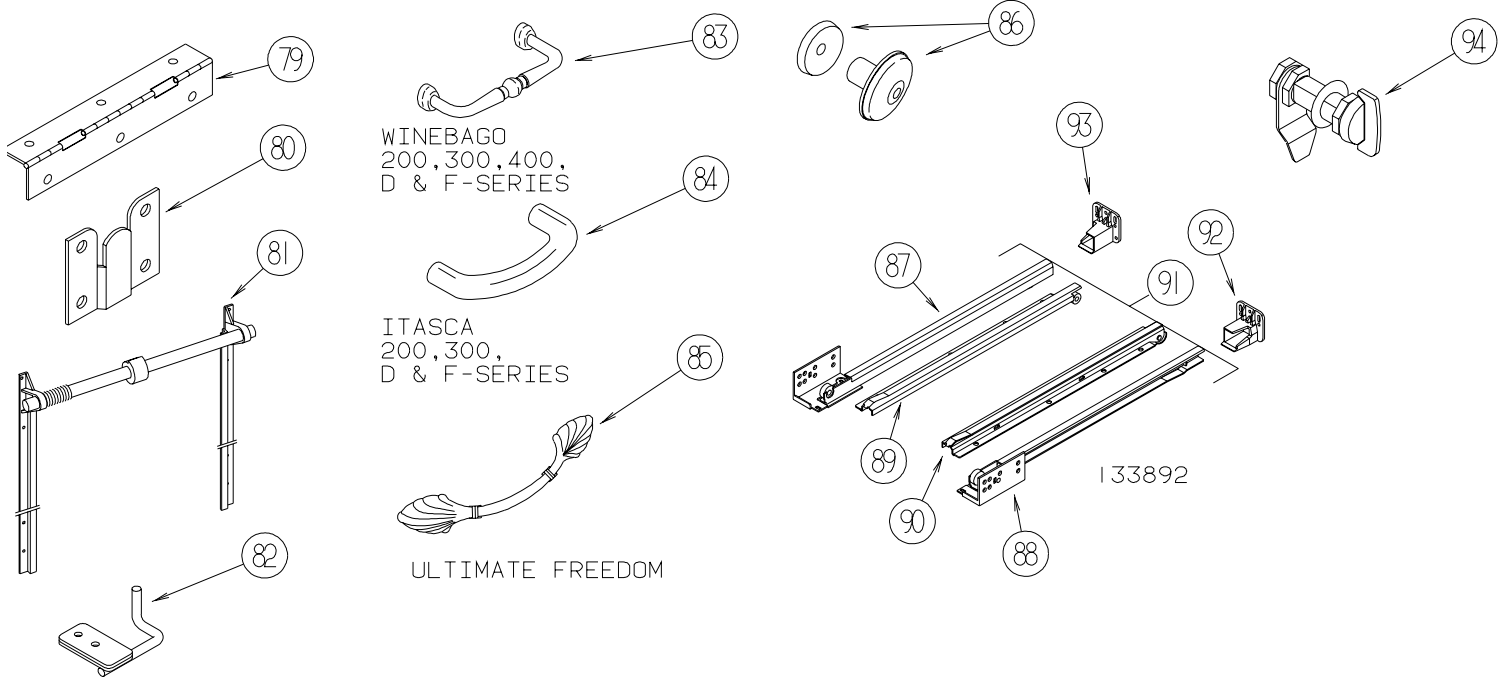

KEY	PART NUMBER	U/M	DESCRIPTION
79	129753-01-01A	EA	HINGE - SPRING LOADED - 19" X 19" - BLACK
80	130120-01-01A	EA	BRACKET - MIRROR
81	130787-02-000	EA	TRACK - TAMBOUR DOOR/SPRING - 24"
81	130787-04-000	EA	TRACK - TAMBOUR DOOR - SPRING
82	130798-01-02B	EA	GUIDE - POCKET DOOR - E-COATED
83	131963-01-01A	EA	PULL - POLISHED BRASS - WINNEBAGO VISTA/MINNIE/MINNIE WINNIE/SIGHTSEER & BRAVE
84	131964-01-01A	EA	PULL - POLISHED BRASS - ITASCA SUNSTAR/SPIRIT/SUNOVA & SUNRISE
85	131965-01-01A	EA	PULL - DOOR/DRAWER - 6.3" - BURNISHED BRASS - ULTIMATE FREEDOM
86	133313-01-02A	EA	PULL - DOOR/DRAWER - BRIGHT BRASS
86	133313-01-03A	EA	PULL - DOOR/DWR - CHROME/BRASS - ITASCA SUNDANCER/SUNCRUISER/SUNFLYER/MERIDIAN
87	133892-01-01A	EA	SLIDE - DRAWER - 16" - LEFT CABINET
87	133892-06-01A	EA	SLIDE - DRAWER - 22" - LEFT CABINET
87	133892-10-01A	EA	SLIDE - DRAWER - 12" - LEFT CABINET
87	133892-14-01A	EA	SLIDE - DRAWER - 18" - LEFT CABINET
88	133892-02-01A	EA	SLIDE - DRAWER - 16" - RIGHT CABINET
88	133892-07-01A	EA	SLIDE - DRAWER - 22" - RIGHT CABINET
88	133892-11-01A	EA	SLIDE - DRAWER - 12" - RIGHT CABINET
88	133892-15-01A	EA	SLIDE - DRAWER - 18" - RIGHT CABINET
89	133892-03-01A	EA	SLIDE - DRAWER - 16" - LEFT DRAWER
89	133892-08-01A	EA	SLIDE - DRAWER - 22" - LEFT DRAWER
89	133892-12-01A	EA	SLIDE - DRAWER - 12" - LEFT DRAWER
89	133892-16-01A	EA	SLIDE - DRAWER - 18" - LEFT DRAWER
90	133892-04-01A	EA	SLIDE - DRAWER - 16" - RIGHT DRAWER
90	133892-09-01A	EA	SLIDE - DRAWER - 22" - RIGHT DRAWER
90	133892-13-01A	EA	SLIDE - DRAWER - 12" - RIGHT DRAWER
90	133892-17-01A	EA	SLIDE - DRAWER - 18" - RIGHT DRAWER
91	133892-05-01A	EA	SLIDE - DRAWER - 9" - FULL SET
92	133907-01-01A	EA	BACKSOCKET - RIGHT HAND
93	133907-02-01A	EA	BACKSOCKET - LEFT HAND
94	135231-01-01A	EA	LATCH - COMPRESSION - BLACK

INTERIOR FINISH GROUP (CONTINUED)

HARDWARE (CONTINUED)

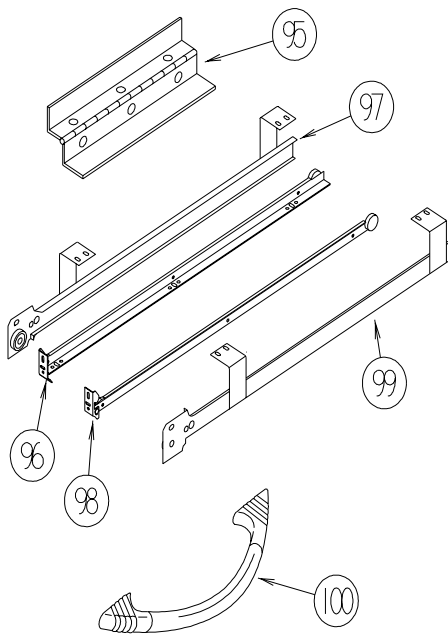

ITASCA
400, G, L P-SERIES

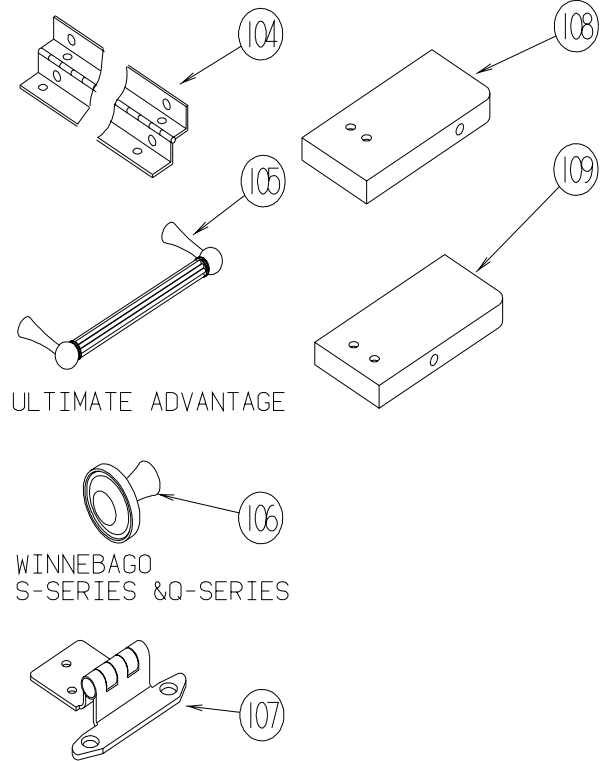
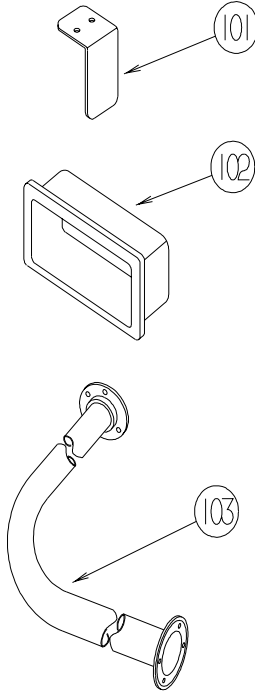

KEY	PART NUMBER	U/M	DESCRIPTION
95	135538-01-01A	EA	HINGE - PIANO - FULL WRAP - BRASS PLATED
95	135538-03-01A	EA	HINGE - PIANO - FULL WRAP - STOCKER BRASS
96	136944-01-01A	EA	SLIDE - DRAWER/RIGHT HAND - 13.8"
97	136944-02-01A	EA	SLIDE - CABINET/RIGHT HAND - 13.8"
98	136944-03-01A	EA	SLIDE - DRAWER/LEFT HAND - 13.8"
99	136944-04-01A	EA	SLIDE - CABINET/LEFT HAND - 13.8"
100	137446-01-01A	EA	PULL - CABINET - CHROME/BRASS - ITASCA SUNDANCE/SUNCRUISER/SUNFLYER & MERIDIAN
101	138136-02-02B	EA	GUIDE - DOOR - E-COATED
102	139136-01-01A	EA	HANDLE - RECESSED - BRASS
102	139136-02-01A	EA	HANDLE - RECESSED - BRASS
102	139136-02-02A	EA	HANDLE - RECESSED - PEWTER
103	140494-01-01A	EA	ROD - SHOWER
103	140494-01-02A	EA	ROD - SHOWER - SOFT WHITE
104	142276-01-01A	EA	HINGE - PIANO - FULL WRAP - BRASS
105	142909-01-01A	EA	PULL - CABINET - BRASS - ULTIMATE ADVANTAGE
106	142910-01-01A	EA	KNOB - CABINET - BRASS - WINNEBAGO VECTRA & ULTIMATE ADVANTAGE
107	143468-01-01A	EA	HINGE - SELF CLOSING - BURNISHED BRASS - ULTIMATE FREEDOM
107	143468-01-02A	EA	HINGE - SELF CLOSING - POLISHED BRASS
107	143468-02-03A	EA	HINGE - SELF CLOSING - SATIN NICKEL - ITASCA SUNFLYER, L-SERIES
107	146553-01-02A	EA	HINGE - CABINET DOOR - BRIGHT BRASS
107	146553-01-03A	EA	HINGE - CABINET DOOR - SATIN NICKEL
108	137445-01-N42	EA	STOP - F/SLIDING DOOR
108	137445-01-P46	EA	STOP - F/SLIDING DOOR
108	137445-01-P56	EA	STOP - F/SLIDING DOOR
109	137445-02-P45	EA	STOP - F/SLIDING DOOR
109	137445-02-P46	EA	STOP - F/SLIDING DOOR
109	137445-02-P56	EA	STOP - F/SLIDING DOOR

INTERIOR FINISH GROUP (CONTINUED)
HARDWARE (CONTINUED)

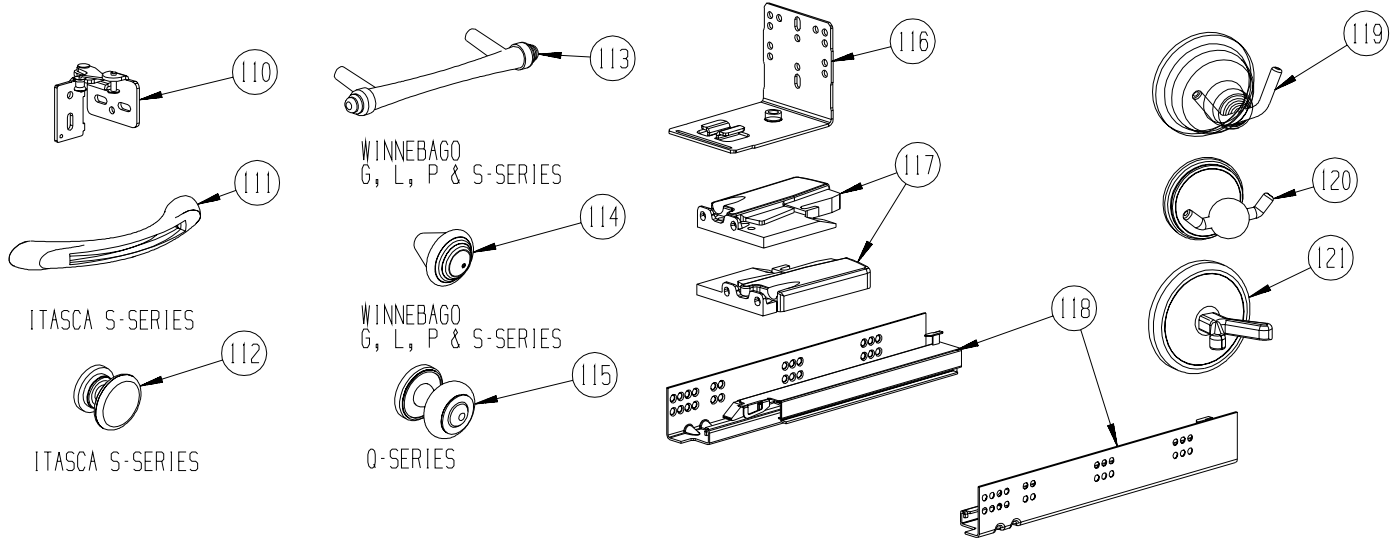

KEY	PART NUMBER	U/M	DESCRIPTION
110	144488-01-01A	EA	HINGE - CABINET - ANTIQUE BRASS
110	144488-01-02A	EA	HINGE - CABINET - NICKEL - ITASCA HORIZON
111	144917-01-01A	EA	PULL - DRAWER - SATIN NICKEL - ITASCA HORIZON
112	144918-01-01A	EA	PULL - DRAWER/KNOB - SATIN NICKEL - ITASCA HORIZON
113	145172-01-01A	EA	PULL - CABINET DOOR - WINNEBAGO ADVENTURER/CHIEFTAIN/JOURNEY & VECTRA
114	145172-02-01A	EA	PULL - DRAWER/DNOB - WINNEBAGO ADVENTURER/CHIEFTAIN & JOURNEY
115	145180-01-01A	EA	KNOB - CABINET DOOR - ULTIMATE FREEDOM
116	145739-01-000	EA	BRACKET - REAR MOUNT
117	145739-02-000	EA	LOCKING MECHANISM - LEFT
117	145739-03-000	EA	LOCKING MECHANISM - RIGHT
118	145739-04-000	EA	SLIDE - DRAWER - 12"
119	145849-01-01A	EA	ROBE HOOK - TWIN - BRASS
119	145849-02-01A	EA	ROBE HOOK - TWIN - CHROME
120	145849-03-01A	EA	ROBE HOOK - TWIN - BRASS
121	145849-04-01A	EA	ROBE HOOK - TWIN - CHROME/BRASS

LABELS GROUP

SEWAGE

KEY PART NUMBER U/M DESCRIPTION
006187-01-000 EA LABEL - SEWAGE

WASTE WATER

KEY PART NUMBER U/M DESCRIPTION
006188-01-000 EA LABEL - WASTE WATER

WARNING

THIS SYSTEM IS DESIGNED FOR USE WITH PROPANE ONLY
DO NOT CONNECT NATURAL GAS TO THIS SYSTEM

BEFORE TURNING ON PROPANE:

- (A) BE CERTAIN APPLIANCES ARE CERTIFIED FOR PROPANE AND ARE EQUIPPED WITH CORRECT BURNING ORIFICES.
- (B) MAKE CERTAIN ALL PROPANE CONNECTIONS ARE TIGHT BY TESTING WITH SOAPY WATER. ALL APPLIANCE VALVES ARE TURNED OFF, AND ANY UNCONNECTED OUTLETS ARE CAPPED.

AFTER TURNING ON PROPANE:

- (A) LIGHT ALL PILOT LIGHTS
- (B) (B) ALL CONNECTIONS, INCLUDING THOSE AT THE APPLIANCES, REGULATORS AND CYLINDERS SHOULD BE LEAK-TESTED PERIODICALLY WITH SOAPY WATER BY THE OCCUPANT. NEVER USE A LIGHTED MATCH OR OTHER FLAME WHEN CHECKING FOR LEAKS.
- (C) DO NOT LEAVE SYSTEM TURNED ON OF CONTAINERS CONNECTED UNTIL THE SYSTEM HAS BEEN PROVEN TO BE FREE OF LEAKS.
- (D) COOKING APPLIANCES SHOULD NOT BE USED FOR SPACE HEATING.
- (E) WHEN THE CONTAINERS ARE DISCONNECTED THE PROPANE SUPPLY LINE SHOULD BE CAPPED OR PLUGGED.

AVERTISSEMENT

CETTE INSTALLATION EST CONÇUE POUR LE PROPANE SEULEMENT
NE PAS L'ALIMENTER EN GAZ NATUREL

AVANT LA MISE EN SERVICE:

- (A) S'ASSURER QUE LES APPAREILS SONT CERTIFIÉS POUR LE PROPANE ET MUNIS D'ORIFICES DE BRULEUR APPROPRIÉS.
- (B) VÉRIFIER L'ÉTANCHEITÉ DE TOUS LES RACCORDEMENTS AU PROPANE. LA PERMÉABILITÉ DE TOUS LES ROBINETS D'APPAREILS ET L'OBTURATION DE TOUTES LES SORTIES NON RACCORDEES.

APRES LA MISE EN SERVICE:

- (A) ALLUMER TOUTES LES VEILLEUSES.
- (B) L'OCCUPANT DOIT ÉPROUVER PÉRIODIQUEMENT L'ÉTANCHEITÉ DE TOUS LES RACCORDEMENTS Y COMPRIS CEUX AUX APPAREILS, AUX DÉTENDEURS ET AUX BOUTEILLES, EN Y APPLIQUANT DE L'EAU SAVONNEUSE NE JAMAIS SE SERVIR D'UNE ALLUMETTE OU AUTRE POUR LA DÉTECTION DES FUITES.
- (C) NE PAS LAISSER L'ALIMENTATION OUVERTE NI LES RÉCIPIENTS RACCORDES AVANT D'AVOIR COMPLÉTÉ L'ÉPREUVE D'ÉTANCHEITÉ AU PROPANE DE L'INSTALLATION.
- (D) LES APPAREILS DE CUISSON NE DOIVENT PAS ÊTRE UTILISÉS POUR LE CHAUFFAGE DES LOCAUX.
- (E) LORSQUE LES RÉCIPIENTS SONT DÉCONNECTÉS, L'ALIMENTATION DE PROPANE DOIT ÊTRE OBTURÉE OU SCELLÉE.

KEY PART NUMBER U/M DESCRIPTION
023769-01-000 EA LABEL - WARNING - LPG - CANADIAN

EXIT

KEY PART NUMBER U/M DESCRIPTION
039290-01-000 EA LABEL - WARNING - EXIT

LABELS GROUP (CONTINUED)



KEY PART NUMBER 040944-01-000 **U/M DESCRIPTION**
EA LABEL - ENTRANCE DOOR - "OPEN"

CAUTION

THIS MOTOR HOME HAS BEEN DESIGNED, MANUFACTURED AND TESTED WITH CONCERN FOR THE PROTECTION OF IT'S OCCUPANTS. WE RECOMMEND YOU PERFORM THE FOLLOWING INSPECTIONS FOR YOUR SAFETY AND THE SAFETY OF YOUR PASSENGERS BEFORE STARTING YOUR VEHICLE.

1. LP GAS SYSTEM- TURN OFF AT TANK FOR TRAVELING. TEST FOR LEAKS UPON ARRIVAL AT DESTINATION. BEFORE LIGHTING PILOTS.
2. WHEELS- INSPECT FOR DAMAGE AND CHECK LUG NUTS FOR TIGHTNESS.
3. TIRES- INSPECT FOR WEAR AND DAMAGE AND CHECK FOR RECOMMENDED AIR PRESSURE.
4. LIGHTING- TEST FOR PROPER OPERATION OF ALL INTERIOR AND EXTERIOR LIGHTS INCLUDING DASH LIGHTS, HEADLIGHTS, TAIL LIGHTS, BRAKE LIGHTS, CLEARANCE LIGHTS AND TURN SIGNALS.
5. EXITS- INSPECT RELEASE MECHANISM ON EMERGENCY EXIT WINDOW. TEST BOTH LOCKS ON MAIN ENTRANCE DOOR FOR EASE OF OPERATION AND INSTRUCT PASSENGERS HOW TO USE BOTH MEANS OF EXIT.
6. SEAT BELTS- DIRECT PASSENGERS TO DESIGNATED SEATS AND REQUIRE USE OF SEAT BELTS.
7. APPLIANCES- TURN OFF AND LATCH OR LOCK DOORS WHERE PROVIDED.
8. LOOSE PARCELS- STORE SECURELY.
9. UTILITY SUPPLY LINES- DISCONNECT ALL ELECTRIC, SEWER AND WATER LINES AND SECURE PROPERLY.
10. ENTRANCE DOOR STEP- PLACE IN RETRACTED POSITION FOR TRAVELING.

READ YOUR MOTOR HOME AND CHASSIS OWNER'S
MANUAL FOR FURTHER PRECAUTIONS

KEY PART NUMBER 056259-01-000 **U/M DESCRIPTION**
EA LABEL - SAFETY CHECK LIST

UNLEADED FUEL ONLY

KEY PART NUMBER 062043-01-000 **U/M DESCRIPTION**
EA LABEL - FUEL - UNLEADED

WARNING DISCONNECT BATTERIES BEFORE
CONNECTING EXTERNAL CHARGING EQUIPMENT.

KEY PART NUMBER 065748-01-000 **U/M DESCRIPTION**
EA LABEL - WARNING - BATTERY CHARGING - UL

AVERTISSEMENT : DEBRANCHER LES BATTERIES AVANT
DE BRANCHER TOUT EQUIPEMENT DE CHARGE EXTERIEUR.

KEY PART NUMBER 065748-02-000 **U/M DESCRIPTION**
EA LABEL - WARNING - BATTERY CHARGING - CSA - **CANADIAN**

DIESEL FUEL ONLY

KEY PART NUMBER 068383-01-000 **U/M DESCRIPTION**
EA LABEL - DIESEL FUEL

VEHICLE EMISSION CONTROL INFORMATION
THIS VEHICLE CONFORMS TO U.S. EPA
REGULATIONS APPLICABLE TO XXXX MODEL
YEAR NEW VEHICLES.

072887-01-000-7 CATALYST

KEY PART NUMBER 072887-14-000 **U/M DESCRIPTION**
EA LABEL - EPA - 2003 MODEL YEAR

LABELS GROUP (CONTINUED)

IF YOU SMELL GAS

1. EXTINGUISH ANY OPEN FLAME, PILOT LIGHTS AND ALL SMOKING MATERIALS.
2. DO NOT TOUCH ELECTRICAL SWITCHES.
3. SHUT OFF THE GAS SUPPLY AT THE TANK VALVE(S) OR GAS SUPPLY CONNECTION.
4. OPEN DOORS AND OTHER VENTILATING OPENINGS.
5. LEAVE THE AREA UNTIL ODOR CLEARS.
6. HAVE THE GAS SYSTEM CHECKED AND LEAKAGE SOURCE CORRECTED BEFORE USING AGAIN.

KEY PART NUMBER U/M DESCRIPTION
073998-01-000 EA LABEL - LPG ODOR WARNING

WARNING: TEST SMOKE DETECTOR
OPERATION AFTER VEHICLE HAS BEEN IN
STORAGE, BEFORE EACH TRIP AND AT
LEAST ONCE PER WEEK DURING USE.

KEY PART NUMBER U/M DESCRIPTION
077956-01-000 EA LABEL - WARNING - SMOKE DETECTOR

DO NOT FILL
LP-GAS CONTAINER(S)
TO MORE THAN 80%
OF CAPACITY.

KEY PART NUMBER U/M DESCRIPTION
079965-01-000 EA LABEL - LPG - 80% CAPACITY

WARNING
MUST BE STOWED
IN LATCHED POSITION
WHILE VEHICLE IS IN MOTION

KEY PART NUMBER U/M DESCRIPTION
079966-01-000 EA LABEL - WARNING - STOWED - MOTION

W
A
T
E
R
H
E
A
T
E
R
O
N
O
F
F

KEY PART NUMBER U/M DESCRIPTION
083588-01-000 EA LABEL - ON/OFF - WATER HEATER

E
N
G
I
N
E
H
E
A
T
E
R
O
N
O
F
F

KEY PART NUMBER U/M DESCRIPTION
083588-02-000 EA LABEL - ON/OFF - ENGINE HEATER
083588-04-000 EA LABEL - ON/OFF - ENGINE HEATER

LABELS GROUP (CONTINUED)

<p>CAUTION</p>	<p>TO HELP AVOID PERSONAL INJURY DURING REMOVAL OF FUEL FILLER CAP, SLOWLY LOOSEN CAP 1/2 TURN TO ALLOW ANY FUEL PRESSURE TO BE RELIEVED BEFORE TURNING CAP FURTHER.</p>
<p>FUEL SPRAY MAY CAUSE PERSONAL INJURY</p>	<p>STOP ADDING FUEL AFTER FIRST SHUTOFF BY AUTOMATIC NOZZLE WHEN TANK IS NEARLY FULL. DO NOT OVERFILL FUEL TANK.</p> <p>SEE OWNERS MANUAL FOR ADDITIONAL INFORMATION.</p> <p style="font-size: small;">PRINTED IN U.S.A. WLC PT NO 15611763</p>

KEY PART NUMBER U/M DESCRIPTION
 087207-05-000 EA LABEL - FUEL CAP REMOVAL



KEY PART NUMBER U/M DESCRIPTION
 087236-01-000 EA LABEL - CABLE - INPUT



KEY PART NUMBER U/M DESCRIPTION
 087236-02-000 EA LABEL - TV OUTLET

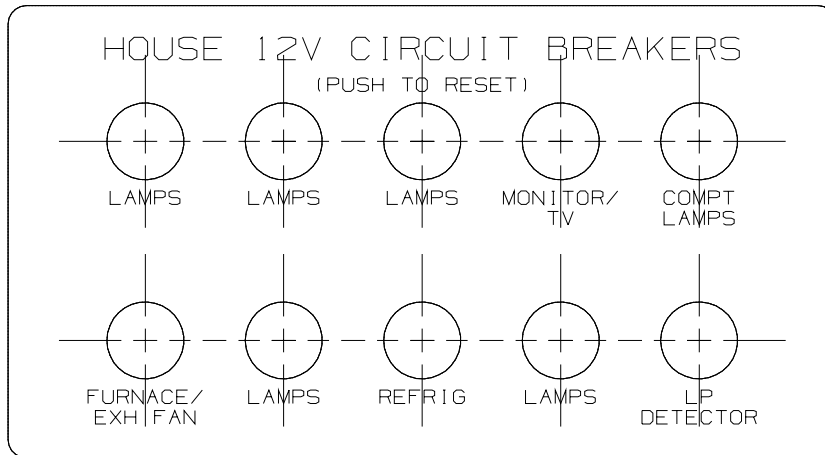

KEY PART NUMBER U/M DESCRIPTION
 092547-06-000 EA LABEL - CIRCUIT BREAKER

LABELS GROUP (CONTINUED)

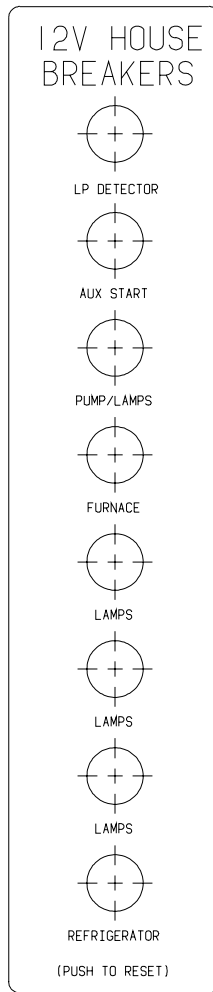

KEY	PART NUMBER 092547-08-000	U/M DESCRIPTION EA LABEL - CIRCUIT BREAKER
------------	-------------------------------------	--

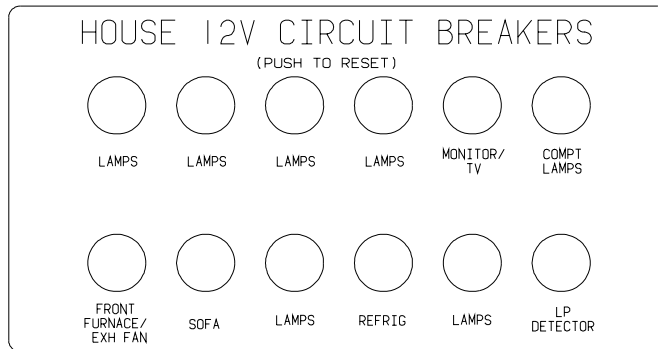

KEY	PART NUMBER 092547-10-000	U/M DESCRIPTION EA LABEL - CIRCUIT BREAKER
------------	-------------------------------------	--

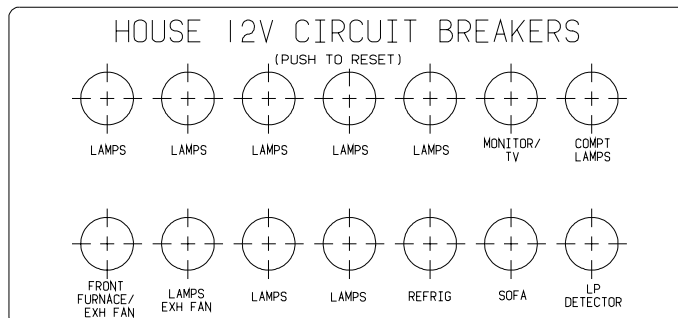

KEY	PART NUMBER 092547-12-000	U/M DESCRIPTION EA LABEL - CIRCUIT BREAKER
------------	-------------------------------------	--

LABELS GROUP (CONTINUED)

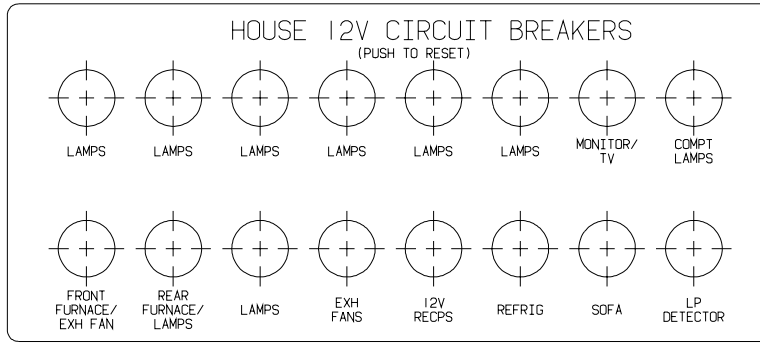

KEY PART NUMBER U/M DESCRIPTION
 092547-13-000 EA LABEL - CIRCUIT BREAKER

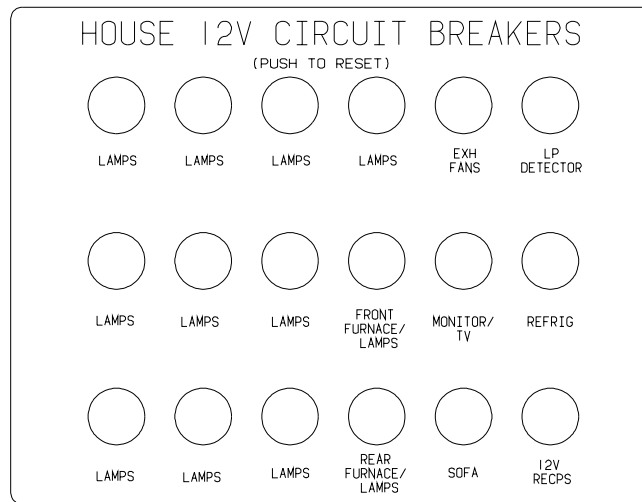

KEY PART NUMBER U/M DESCRIPTION
 092547-14-000 EA LABEL - CIRCUIT BREAKER

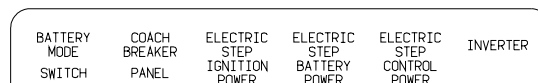

KEY PART NUMBER U/M DESCRIPTION
 093236-08-000 EA LABEL - CIRCUIT BREAKER

LABELS GROUP (CONTINUED)



KEY PART NUMBER 093236-21-000 **U/M DESCRIPTION**
EA LABEL - CIRCUIT BREAKER

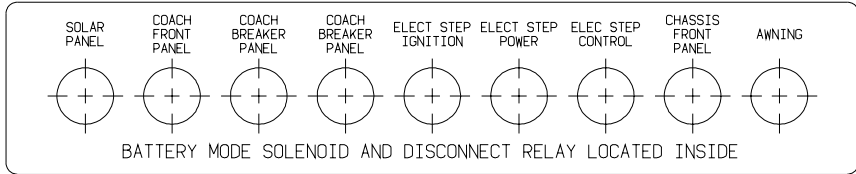

KEY PART NUMBER 093236-26-000 **U/M DESCRIPTION**
EA LABEL - CIRCUIT BREAKER

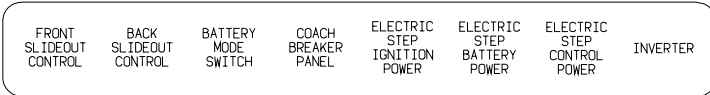

KEY PART NUMBER 093236-28-000 **U/M DESCRIPTION**
EA LABEL - CIRCUIT BREAKER

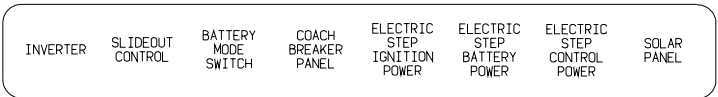

KEY PART NUMBER 093236-29-000 **U/M DESCRIPTION**
EA LABEL - CIRCUIT BREAKER

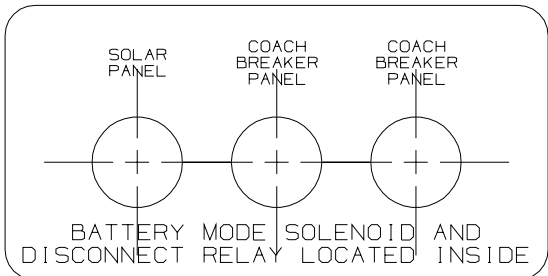

KEY PART NUMBER 093236-31-000 **U/M DESCRIPTION**
EA LABEL - CIRCUIT BREAKER

LABELS GROUP (CONTINUED)

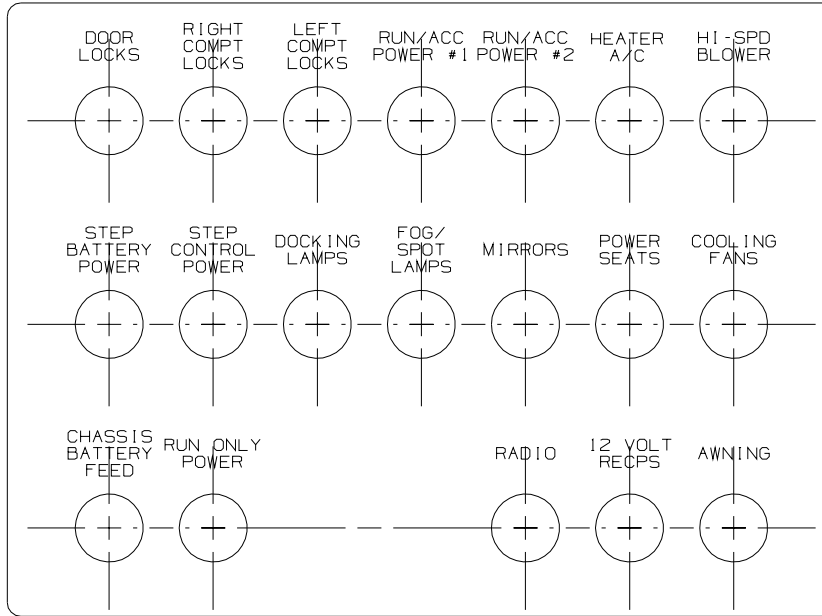

KEY PART NUMBER
093236-32-000

U/M DESCRIPTION
EA LABEL - CIRCUIT BREAKER

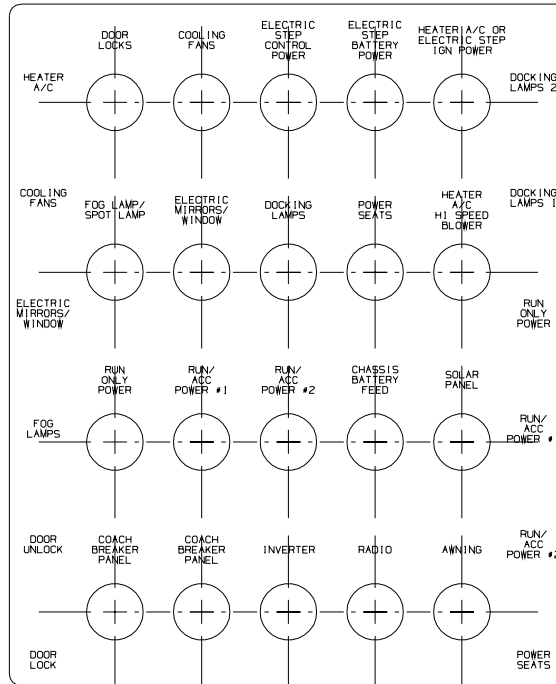

KEY PART NUMBER
093236-33-000

U/M DESCRIPTION
EA LABEL - CIRCUIT BREAKER

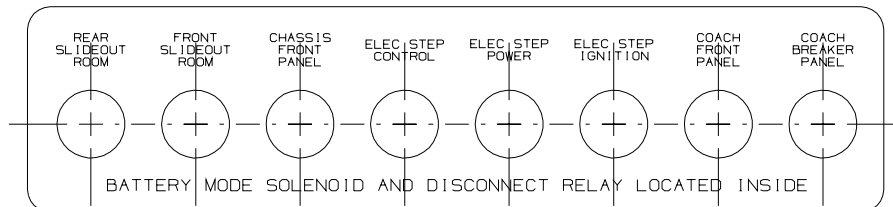

KEY PART NUMBER
093236-34-000

U/M DESCRIPTION
EA LABEL - CIRCUIT BREAKER

LABELS GROUP (CONTINUED)

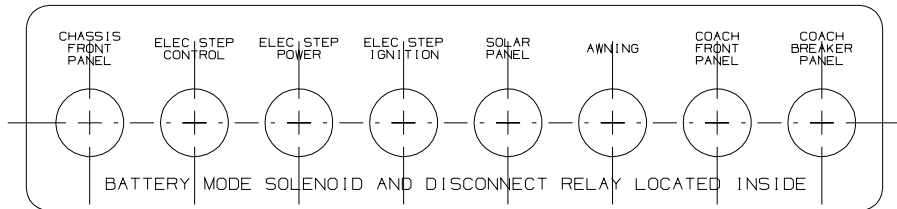

KEY	PART NUMBER	U/M DESCRIPTION
	093236-35-000	EA LABEL - CIRCUIT BREAKER

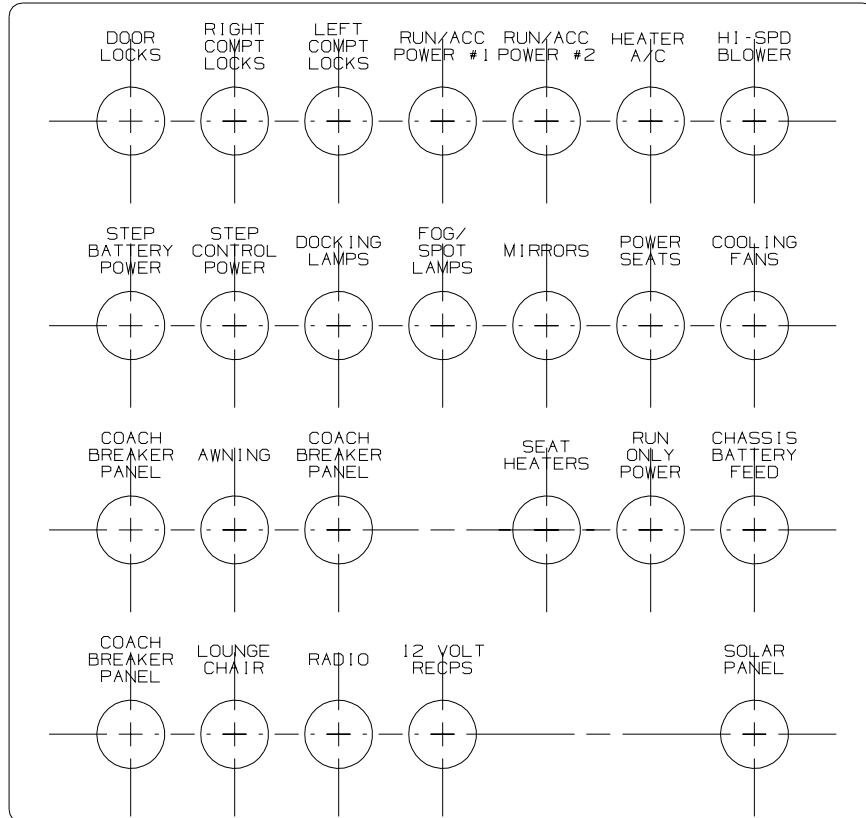

KEY	PART NUMBER	U/M DESCRIPTION
	093236-37-000	EA LABEL - CIRCUIT BREAKER

LABELS GROUP (CONTINUED)

S U B M A I N	D I S H W A S H E R	R E C P S 1	R E C P S 2	R E C P S 3	M I C R O W A V E
---------------------------------	--	--------------------------------	--------------------------------	--------------------------------	---

KEY PART NUMBER U/M DESCRIPTION
 095721-20-000 EA LABEL - CONTROL CENTER W/INVERTER

A / C C I R C U I T 1	M A I N	A / C C I R C U I T 2	R E F F R I G / C O N V	M I C R O W A V E	R E C P S 1	R E C P S 2	R E C P S 3		
---	------------------	---	--	---	--------------------------------	--------------------------------	--------------------------------	--	--

KEY PART NUMBER U/M DESCRIPTION
 095721-27-000 EA LABEL - CONTROL CENTER - 30 AMP

A / C C I R C U I T 1	M A I N	A / C C I R C U I T 2	R E F F R I G / C O N V	M I C R O W A V E	R E C P S 1	R E C P S 2	R E C P S 3	W A S H E R / D R Y E R	W A T E R H E A T E R	
---	------------------	---	--	---	--------------------------------	--------------------------------	--------------------------------	--	---	--

KEY PART NUMBER U/M DESCRIPTION
 095721-31-000 EA LABEL - CONTROL CENTER - 30 AMP - US

LABELS GROUP (CONTINUED)

A / C CIRCUIT 1	M A I N	M A I N	A / C CIRCUIT 2	R E F R I G / C O N V	M I C R O W A V E	R E C P S 1	R E C P S 2	R E C P S 3	W A S H E R / D R Y E R	W A T E R H E A T E R
-----------------------	------------------	------------------	-----------------------	---	---	----------------------------	----------------------------	----------------------------	--	---

KEY PART NUMBER U/M DESCRIPTION
 095721-33-000 EA LABEL - CONTROL CENTER - 50 AMP - US

M A I N	M I C R O W A V E	G F I / R E C E P S	R E F E R / C O N V	W A T E R H T R	A / C
------------------	---	--	--	--------------------------------------	-------------

KEY PART NUMBER U/M DESCRIPTION
 095721-38-000 EA LABEL - CONTROL CENTER - 30 AMP - US

A / C CIRCUIT 1	M A I N	M A I N	A / C CIRCUIT 2	I N V E R T E R / C H A R G E R	W A S H E R / D R Y E R	W A T E R H E A T E R	W A T E R H E A T E R	D I S H W A S H E R	F I R E P L A C E / R E C P S 4	F I R E P L A C E / R E C P S 4
-----------------------	------------------	------------------	-----------------------	--	--	---	---	--	--	--

KEY PART NUMBER U/M DESCRIPTION
 095721-44-000 EA LABEL - CONTROL CENTER - 30 AMP - US

AUTOMOTIVE AND COACH
CIRCUIT BREAKERS

KEY PART NUMBER U/M DESCRIPTION
 098379-01-000 EA LABEL - CIRCUIT BREAKER - FRONT BOX

CIRCUIT BREAKERS
AND AUTOMOTIVE
FUSE PANEL

KEY PART NUMBER U/M DESCRIPTION
 098379-03-000 EA LABEL - ELECTRICAL BOX - FRONT

LABELS GROUP (CONTINUED)

BATTERY MODE
SOLENOID AND
RELAYS

KEY PART NUMBER U/M DESCRIPTION
098379-04-000 EA LABEL - ELECTRICAL BOX - SIDE

UNLEADED
FUEL ONLY

KEY PART NUMBER U/M DESCRIPTION
098641-01-000 EA LABEL - FUEL - UNLEADED - DASH

FOR AWNING INSTALLATION
CONTACT YOUR MOTORHOME
DEALERSHIP

KEY PART NUMBER U/M DESCRIPTION
099509-01-000 EA LABEL - AWNING INSTALLATION

WARNING
THIS VEHICLE, LIKE OTHER
VEHICLES, MAY CONTAIN SMALL
AMOUNTS OF ONE OR MORE
SUBSTANCES WHICH ARE LISTED
BY THE STATE OF CALIFORNIA
FOR CAUSING CANCER OR
REPRODUCTIVE TOXICITY.

KEY PART NUMBER U/M DESCRIPTION
099689-01-000 EA LABEL - WARNING - CANCER/TOXICITY

NOTE: TUNE ANTENNA PER MANUFACTURER'S DIRECTIONS. FAILURE TO COMPLY COULD RESULT IN DAMAGE TO CB.	CB POWER PROVISION RED +12 V BLACK GROUND COAX ANTENNA (SEE REVERSE ALSO)
---	---

KEY PART NUMBER U/M DESCRIPTION
104678-01-000 EA LABEL - CB PREP

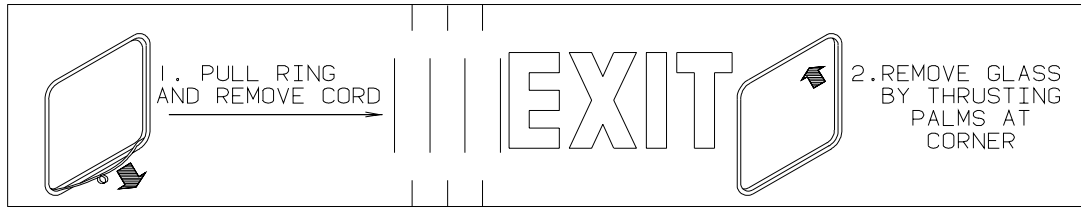

KEY PART NUMBER U/M DESCRIPTION
107571-01-000 EA LABEL - EXIT/ESCAPE WINDOW

LABELS GROUP (CONTINUED)

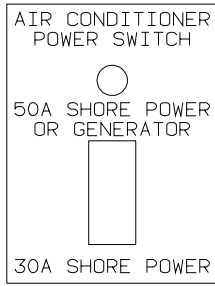

KEY	PART NUMBER	U/M DESCRIPTION
	109051-02-000	EA LABEL - SWITCH - 50 AMP POWER



KEY	PART NUMBER	U/M DESCRIPTION
	111104-01-000	EA LABEL - HITCH - READ MANUAL - WHITE

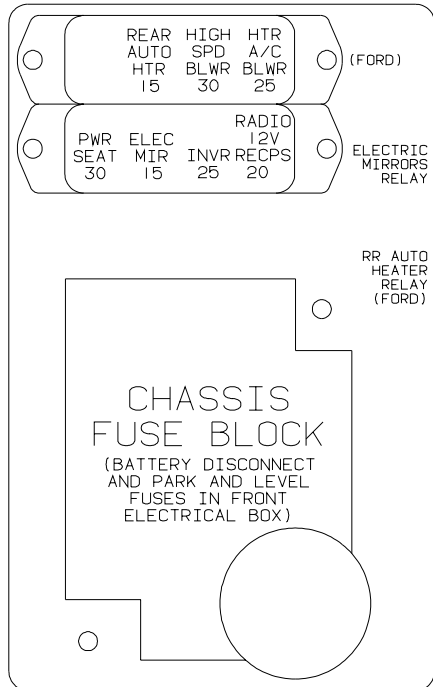

KEY	PART NUMBER	U/M DESCRIPTION
	111537-08-000	EA LABEL - FUSES

LABELS GROUP (CONTINUED)

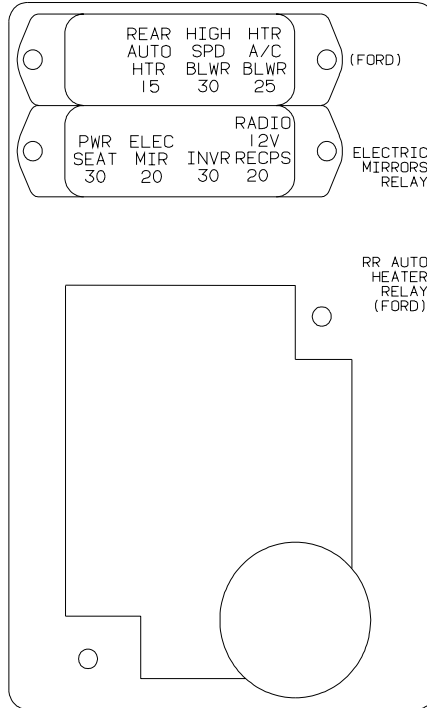

KEY PART NUMBER U/M DESCRIPTION
 111537-09-000 EA LABEL - FUSES

WARNING: CONTAINS "CFC" A SUBSTANCE WHICH HARMS PUBLIC HEALTH AND ENVIRONMENT BY DESTROYING OZONE IN THE UPPER ATMOSPHERE.

KEY PART NUMBER U/M DESCRIPTION
 111802-01-000 EA LABEL - CFC WARNING



KEY PART NUMBER U/M DESCRIPTION
 113402-01-000 EA LABEL - CAUTION - WATER HEATER EXHAUST

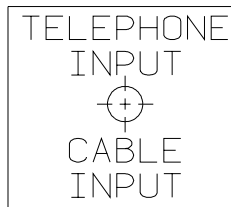

KEY PART NUMBER U/M DESCRIPTION
 114866-02-000 EA LABEL - PHONE & CABLE INPUT - WHITE/CLEAR BACKGROUND

LABELS GROUP (CONTINUED)

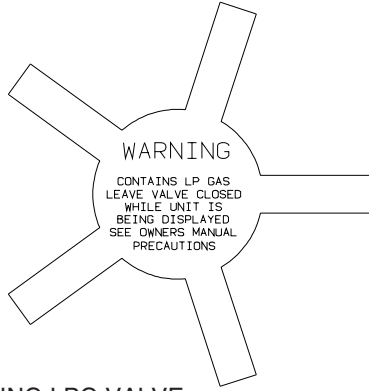

KEY PART NUMBER U/M DESCRIPTION
 115600-01-000 EA LABEL - WARNING LPG VALVE

WARNING: REPLACE TIRE ONLY WITH ONE OF EXACTLY SAME TYPE AND RATING. DO NOT REPLACE WITH PASSENGER CAR TIRE. SEE OPERATOR'S MANUAL FOR MORE INFORMATION CALL WINNEBAGO OWNER RELATIONS AT 1-800-537-1885.

KEY PART NUMBER U/M DESCRIPTION
 115869-01-000 EA LABEL - WARNING - TIRE

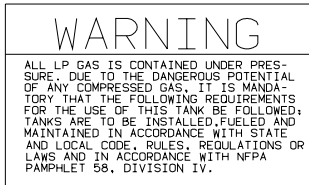

KEY PART NUMBER U/M DESCRIPTION
 116112-01-000 EA LABEL - CAUTION - LP

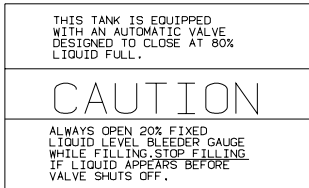

KEY PART NUMBER U/M DESCRIPTION
 116113-01-000 EA LABEL - CAUTION - LP

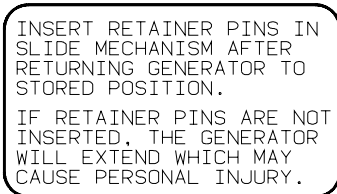

KEY PART NUMBER U/M DESCRIPTION
 116273-01-000 EA LABEL - WARNING - GENERATOR

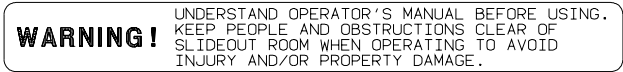

KEY PART NUMBER U/M DESCRIPTION
 116549-01-000 EA LABEL - WARNING - SLIDEOUT

LABELS GROUP (CONTINUED)

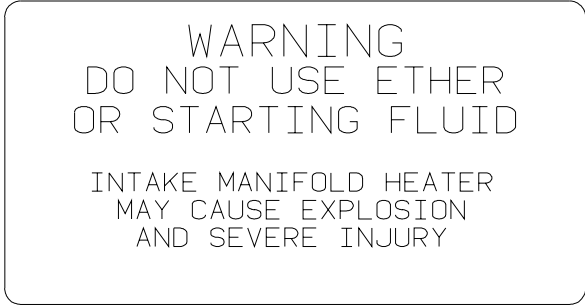

KEY	PART NUMBER	U/M DESCRIPTION
	116756-02-000	EA LABEL - WARNING - ETHER/STARTING - CLEAR BACKGROUND W/RED LETTERING
	116756-03-000	EA LABEL - WARNING - ETHER/STARTING - WHITE BACKGROUND W/RED LETTERING



KEY	PART NUMBER	U/M DESCRIPTION
	116775-01-000	EA LABEL/CAUTION - TRAVEL LATCH

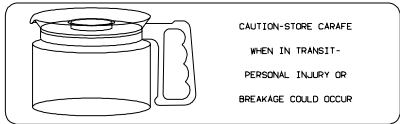

KEY	PART NUMBER	U/M DESCRIPTION
	116829-02-000	EA LABEL - COFFEEMAKER



KEY	PART NUMBER	U/M DESCRIPTION
	117628-02-000	EA LABEL - SWITCH - WATER PUMP/LIGHTS-WHITE/CLEAR BACKGROUND

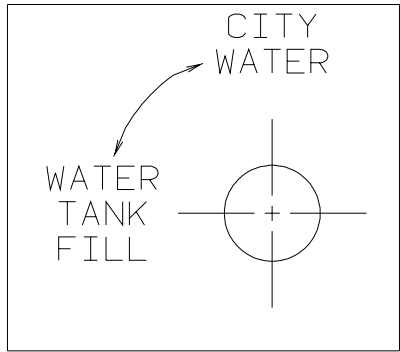

KEY	PART NUMBER	U/M DESCRIPTION
	117629-01-000	EA LABEL - WATER PUMP/FILL-BLK LETTER/CLEAR BACKGROUND-.24"
	117629-03-000	EA LABEL - WATER PUMP/FILL-BLK LETTERS/CLEAR BACKGROUND-.31"

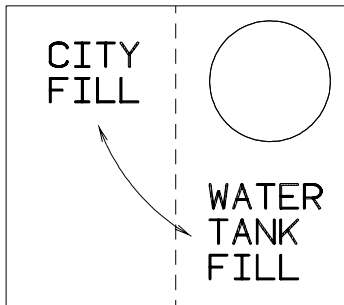

KEY	PART NUMBER	U/M DESCRIPTION
	117629-04-000	EA LABEL - CITY WATER/TANK FILL

LABELS GROUP (CONTINUED)

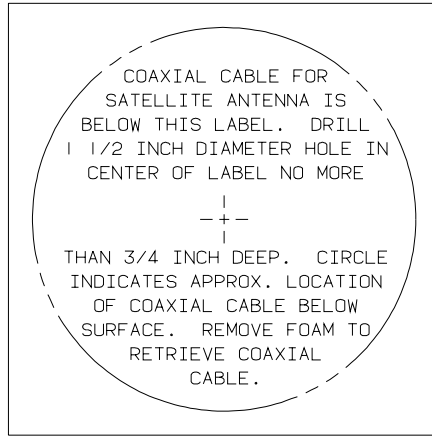

KEY PART NUMBER U/M DESCRIPTION
 120431-01-000 EA LABEL - LOCATION - COAXIAL CABLE/SATELLITE ANTENNA

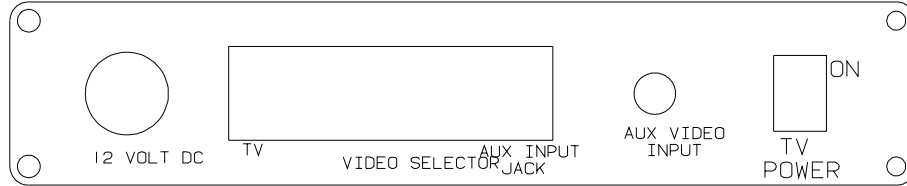

KEY PART NUMBER U/M DESCRIPTION
 120677-01-000 EA LABEL - TV

KEEP THE SERVICE INLET ACCESS
 IN THE CLOSED POSITION WHEN
 UTILITY CONNECTIONS ARE NOT IN USE

KEY PART NUMBER U/M DESCRIPTION
 123562-01-000 EA LABEL - SERVICE/UTILITY ACCESS

WARNING
 ALL PILOT LIGHTS, APPLIANCES AND THIER
 IGNITORS (SEE OPERATING INSTRUCTIONS) SHALL
 BE TURNED OFF DURING REFUELING OF MOTOR
 FUEL TANKS AND/OR LP GAS CONTAINERS

KEY PART NUMBER U/M DESCRIPTION
 124519-01-01A EA LABEL - WARNING/REFUELING - BLACK ON CLEAR
 124519-01-02A EA LABEL - WARNING/REFUELING - WHITE ON CLEAR

WARNING:
 ALL PILOT LIGHTS AND APPLIANCES SHALL BE TURNED
 OFF DURING REFUELING OF MOTOR FUEL TANKS AND/
 OR PROPANE CONTAINERS.
 AVERTISSEMENT:
 FERMER TOUTES LES VEILLEUSES AINSI QUE TOUS LES
 APPAREILS LORSQU'ON FAIT LE PLEIN DES RESERVOIRS
 A CARBURANT OU A PROPANE.
 124519-02

KEY PART NUMBER U/M DESCRIPTION
 124519-02-01A EA LABEL - WARNING/REFUELING - BLACK ON CLEAR - CSA
 124519-02-02A EA LABEL - WARNING/REFUELING - WHITE ON CLEAR - CSA

LABELS GROUP (CONTINUED)

LP-GAS SYSTEM
 THIS GAS PIPING SYSTEM IS
 DESIGNED FOR USE OF
 LIQUIFIED PETROLEUM GAS
 ONLY. DO NOT CONNECT
 NATURAL GAS TO THIS
 SYSTEM.
 SECURE CAP INLET(S) WHEN NOT
 CONNECTED FOR USE. AFTER TURNING
 ON GAS, EXCEPT AFTER NORMAL
 CONTAINER REPLACEMENT, TEST GAS
 PIPING AND CONNECTIONS TO
 APPLIANCES FOR LEAKAGE WITH SOAPY
 WATER OR BUBBLE SOLUTION. DO NOT
 USE PRODUCTS THAT CONTAIN AMMONIA
 OR CLORINE.

124520

KEY	PART NUMBER	U/M	DESCRIPTION
	124520-01-01A	EA	LABEL - LP GAS ONLY - BLACK ON CLEAR
	124520-01-02A	EA	LABEL - LP GAS ONLY - WHITE ON CLEAR

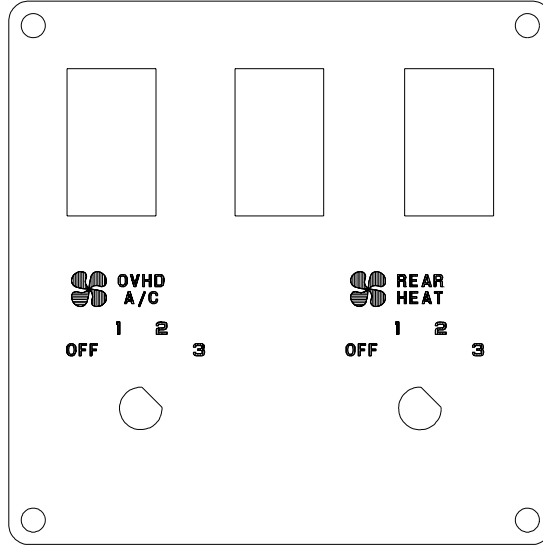

KEY	PART NUMBER	U/M	DESCRIPTION
	124572-01-000	EA	LABEL - SWITCHES

THIS CONNECTION IS FOR
 (B) VOLT AC, 60 HZ(CYCLES)
 (A) AMPERE SUPPLY

DO NOT CONNECT TO
 HIGHER VOLTAGE

KEY	PART NUMBER	U/M	DESCRIPTION
	125306-01-01A	EA	LABEL - ELECTRICAL ENTRANCE - 110V 30 AMP - BLACK ON CLEAR

LABELS GROUP (CONTINUED)

THIS CONNECTION IS FOR
 (B) VOLT AC, 3-POLE, 4 WIRE
 60 HZ (CYCLES), (A) AMPERE SUPPLY

DO NOT CONNECT TO
 HIGHER VOLTAGE

KEY	PART NUMBER	U/M	DESCRIPTION
	125306-04-01A	EA	LABEL-ELECTRICAL ENTRANCE-120/240V 50 AMP-BLACK ON CLEAR
	125306-04-02A	EA	LABEL - ELECTRICAL ENTRANCE-120/240V 50 AMP-WHITE ON CLEAR

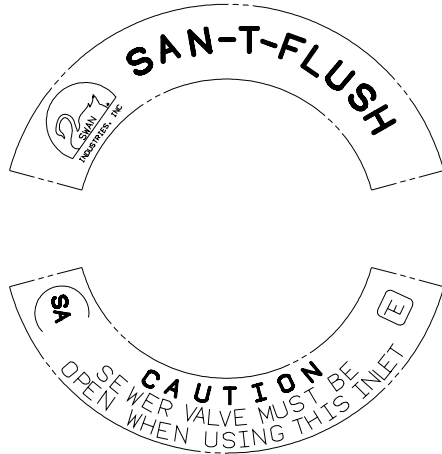

KEY	PART NUMBER	U/M	DESCRIPTION
	125697-07-000	EA	LABEL - CAUTION - FLUSHING SYSTEM

REMOVE PRIMARY TIRE HANGER BEFORE USING
 SPARE TIRE HOIST-SEE OWNERS MANUAL- PERSONAL
 INJURY MAY RESULT IF NOT FOLLOWED

KEY	PART NUMBER	U/M	DESCRIPTION
	126024-01-01A	EA	LABEL - TIRE HANGER REMOVAL

GRAY HOLDING TANK

KEY	PART NUMBER	U/M	DESCRIPTION
	126247-01-000	EA	LABEL - GRAY HOLDING TANK-WHITE LETTERS/CLEAR BACKGROUND
	126247-05-000	EA	LABEL - GRAY HOLDING TANK-BLACK LETTERS/CLEAR BACKGROUND

BLACK HOLDING TANK

KEY	PART NUMBER	U/M	DESCRIPTION
	126247-02-000	EA	LABEL - BLACK HOLDING TANK-WHITE LETTERS/BLACK BACKGROUND
	126247-06-000	EA	LABEL - BLACK HOLDING TANK-BLACK LETTERS/CLEAR BACKGROUND

EXTERIOR SHOWER

KEY	PART NUMBER	U/M	DESCRIPTION
	126248-03-000	EA	LABEL - EXTERIOR SHOWER

CITY WATER FILL

KEY	PART NUMBER	U/M	DESCRIPTION
	126249-03-000	EA	LABEL - CITY WATER FILL-BLK LETTERS/CLEAR BACKGROUND .31"

LABELS GROUP (CONTINUED)

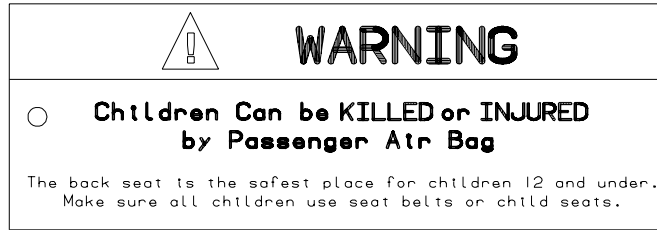

KEY PART NUMBER U/M DESCRIPTION
 126612-01-000 EA LABEL - HANG TAG - AIR BAG - DASH

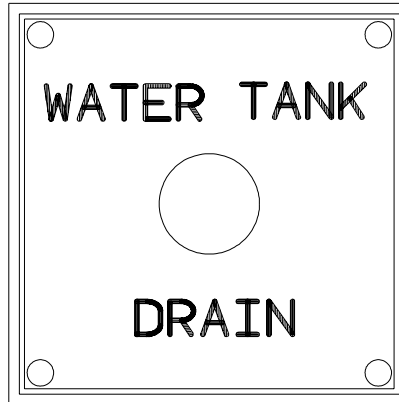

KEY PART NUMBER U/M DESCRIPTION
 127170-01-000 EA LABEL - WATER TANK DRAIN



KEY PART NUMBER U/M DESCRIPTION
 128218-01-01A EA LABEL - WARNING - SLIPPERY ROOF

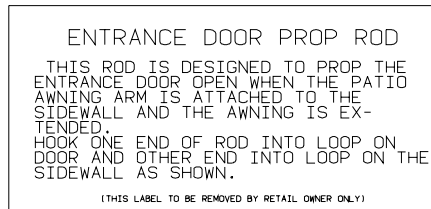

KEY PART NUMBER U/M DESCRIPTION
 128658-01-000 EA LABEL - PROP ROD - ENTRY DOOR

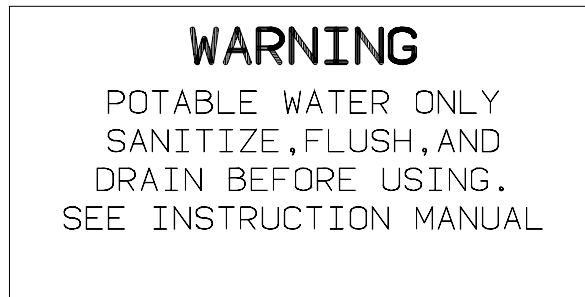

KEY PART NUMBER U/M DESCRIPTION
 128725-01-01A EA LABEL - POTABLE WATER ONLY - BLACK ON CLEAR

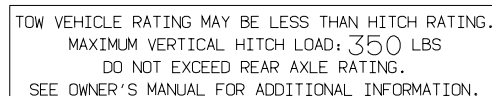

KEY PART NUMBER U/M DESCRIPTION
 129669-01-01A EA LABEL - HITCH/VEHICLE RATE - 350 - WHITE ON CLEAR
 129669-01-02A EA LABEL - HITCH/VEHICLE RATE - 350 - BLACK ON CLEAR
 129669-02-01A EA LABEL - HITCH/VEHICLE RATE - 500 - WHITE ON CLEAR
 129669-02-02A EA LABEL - HITCH/VEHICLE RATE - 500 - BLACK ON CLEAR

LABELS GROUP (CONTINUED)

TIRE ROTATION
 SEE RIALTA OWNERS MANUAL
 SECTION 9

KEY PART NUMBER U/M DESCRIPTION
 129684-01-000 EA LABEL - TIRE ROTATION

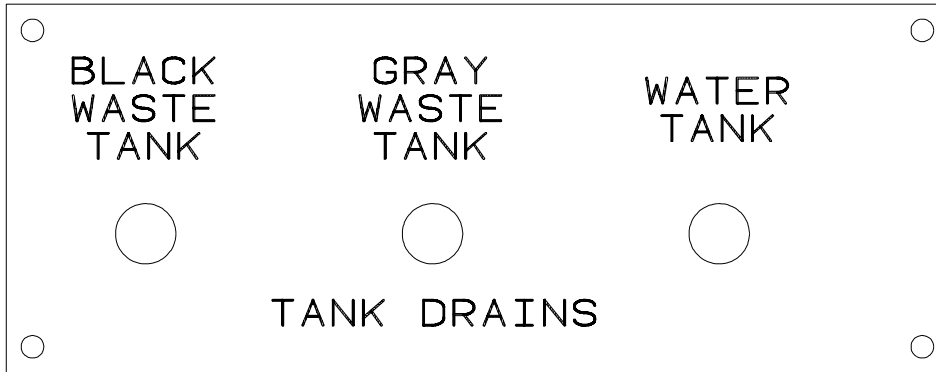

KEY PART NUMBER U/M DESCRIPTION
 130166-01-000 EA LABEL - DRAIN

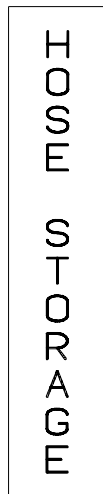

KEY PART NUMBER U/M DESCRIPTION
 130167-02-000 EA LABEL - HOSE STORAGE



KEY PART NUMBER U/M DESCRIPTION
 130168-01-000 EA LABEL - WASTE TANK FLUSH

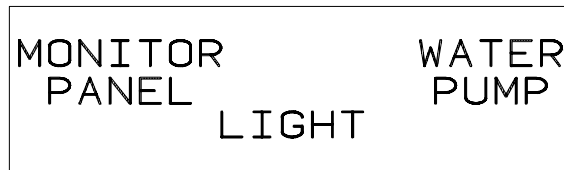

KEY PART NUMBER U/M DESCRIPTION
 130170-01-000 EA LABEL - SWITCH PANEL - BLK/CLEAR BACKGROUND-1.8"H X 5.9"L

LABEL GROUP (CONTINUED)



KEY PART NUMBER U/M DESCRIPTION
130170-02-000 EA LABEL - SWITCH PANEL-BLK/CLEAR BACKGROUND-1.4"H X 3.9"L

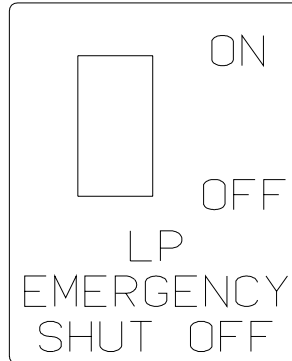

KEY PART NUMBER U/M DESCRIPTION
130170-04-000 EA LABEL - SWITCH PANEL



KEY PART NUMBER U/M DESCRIPTION
130170-05-000 EA LABEL - SWITCH PANEL

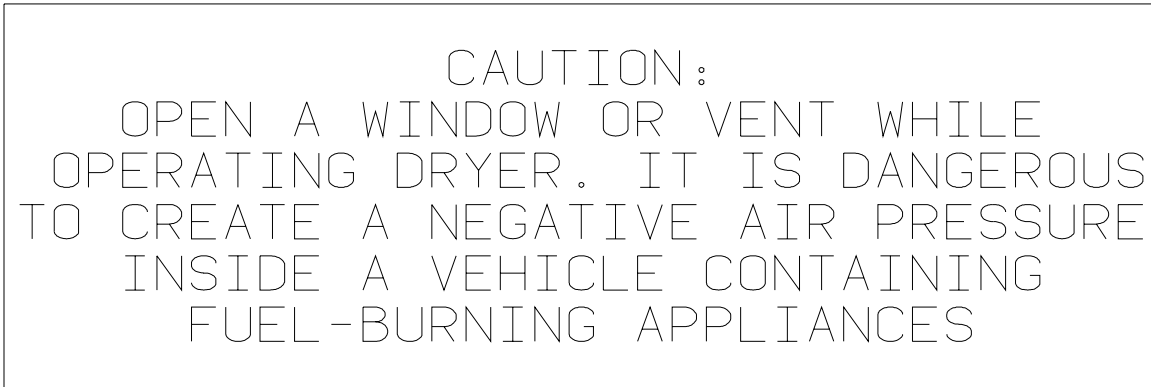

KEY PART NUMBER U/M DESCRIPTION
130670-01-01A EA LABEL - CAUTION DRYER VENTING - BLACK ON CLEAR



KEY PART NUMBER U/M DESCRIPTION
131779-01-01A EA LABEL - GENERATOR

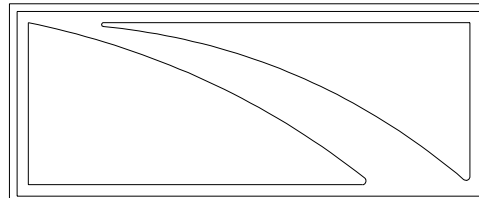

KEY PART NUMBER U/M DESCRIPTION
132651-01-01A EA DECAL - MIRROR/GALLEY

LABEL GROUP (CONTINUED)

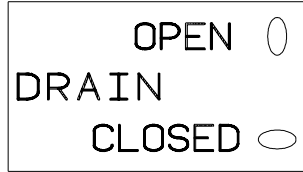

KEY PART NUMBER U/M DESCRIPTION
133423-01-01A EA LABEL - DRAIN



KEY PART NUMBER U/M DESCRIPTION
133424-01-01A EA LABEL - WATER HEATER BYPASS - BLACK/CLEAR



KEY PART NUMBER U/M DESCRIPTION
133424-02-01A EA LABEL - NORMAL OPERATION



KEY PART NUMBER U/M DESCRIPTION
133424-03-01A EA LABEL - WATER HEATER BYPASS - BLACK/CLEAR



KEY PART NUMBER U/M DESCRIPTION
133533-01-01A EA LABEL - JACKS DOWN - CLEAR W/WHITE LETTERING



KEY PART NUMBER U/M DESCRIPTION
133533-02-01A EA LABEL - CHECK ANTENNA - CLEAR W/WHITE LETTERING



KEY PART NUMBER U/M DESCRIPTION
133533-03-01A EA LABEL - LOCK/UNLOCK - BLACK/WHITE



KEY PART NUMBER U/M DESCRIPTION
133533-04-01A EA LABEL - WINDOW/MIRROR HEAT- BLACK/CLEAR



KEY PART NUMBER U/M DESCRIPTION
133533-05-01A EA LABEL - SUNVISOR - DRIVER/PASSENGER - BLACK/CLEAR

LABELS GROUP (CONTINUED)



KEY PART NUMBER U/M DESCRIPTION
 133533-06-01A EA LABEL - MAP LIGHT/SUNVISOR - BLACK/CLEAR

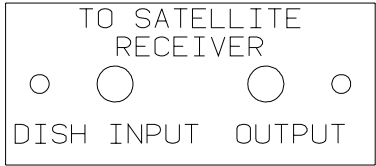

KEY PART NUMBER U/M DESCRIPTION
 134250-01-01A EA LABEL - SATELLITE RECEIVER - BLACK/CLEAR

THIS CHAIR IS NOT INTENDED FOR OCCUPANCY WHEN VEHICLE IS IN MOTION AND MUST BE RETURNED TO STOWED POSITION

DTS ISICE SIEGE N/EST PAS DESTINE A ETRE OCCUPE LORSQUE LE VEHICULE EST IN MOVEMENT ET IL FAUT QUE LE RANGER	THIS CHAIR IS NOT INTENDED FOR OCCUPANCY WHEN VEHICLE IS IN MOTION AND MUST BE RETURNED TO STOWED POSITION
---	---

KEY PART NUMBER U/M DESCRIPTION
 134537-01-01A EA LABEL - OCCUPANCY - CHAIR - US

THIS SEAT IS NOT INTENDED FOR OCCUPANCY WHEN VEHICLE IS IN MOTION

KEY PART NUMBER U/M DESCRIPTION
 134538-01-01A EA LABEL - OCCUPANCY - NO SEAT BELT - BLACK ON CLEAR - US

DST ISICE SIEGE N/EST PAS DESTINE A ETRE OCCUPE LORSQUE LE VEHICULE EST IN MOVVEMENT	THIS SEAT IS NOT INTENDED FOR OCCUPANCY WHILE VEHICLE IS IN MOTION
--	--

KEY PART NUMBER U/M DESCRIPTION
 134538-02-01A EA LABEL - OCCUPANCY - NO SEAT BELT - BLACK ON CLEAR - CSA

<p style="text-align: center;">WARNING</p> <p style="text-align: center;">IT IS NOT SAFE TO USE COOKING APPLICANCES FOR COMFORT HEATING</p> <p>COOKING APPLICANCES NEED FRESH AIR FOR SAFE OPERATION BEFORE OPERATION.</p> <p>1. OPEN OVERHEAD VENT OR TURN ON EXHAUST FAN AND; 2. OPEN WINDOW.</p>

KEY PART NUMBER U/M DESCRIPTION
 134539-01-01A EA LABEL - WARNING - STOVE/HEATING - US - BLACK ON CLEAR

LABELS GROUP (CONTINUED)

TO ENSURE A SUPPLY OF FRESH AIR TO OCCUPANTS, OPEN VENTILATORS WHEN FUEL-BURNING RANGE, FUEL BURNING CARRY-ON APPLIANCES AND/OR FUEL-BURNING LIGHTS ARE IN OPERATION.
 COOKING APPLIANCES SHOULD NOT BE USED FOR SPACE HEATING PURPOSES.

DE MANIERE A ASSURER UNE ALIMENTATION EN AIR FRAIS AUX OCCUPANTS, OUVRIER LES VENTILATEURS LORSQUE LA CUISINIÈRE LES APPAREILS DE CHAUFFAGE PORTABLES ET/OU LES LAMPES DE COMBUSTION D'HUILE SONT EN FONCTIONNEMENT.
 LES APPAREILS DE CUISSON NE DOIVENT PAS SERVIR AU CHAUFFAGE DES LOCAUX.

KEY PART NUMBER U/M DESCRIPTION
 134540-01-01A EA LABEL - WARNING - STOVE/HEATING - CSA - BLACK ON CLEAR

HOLDING TANK HEATER

TURN OFF WHEN NOT IN USE

SEE OPERATOR'S MANUAL

KEY PART NUMBER U/M DESCRIPTION
 134563-01-01A EA LABEL - SWITCH - HEATER

THIS VEHICLE MAY INCLUDE MERCURY-CONTAINING DEVICES INSTALLED BY THE MANUFACTURER:

FLUORESCENT TUBES, RANGES WITH OVEN, HWH LEVEL SENSING UNIT.

REMOVE DEVICES BEFORE VEHICLE DISPOSAL UPON REMOVAL OF DEVICES: PLEASE REUSE, RECYCLE, OR DISPOSE AS HAZARDOUS WASTE

135869-01A

KEY PART NUMBER U/M DESCRIPTION
 135869-01-01A EA LABEL - MERCURY CONTENT - BLACK ON CLEAR
 135869-01-02A EA LABEL - MERCURY CONTENT - WHITE ON CLEAR

LIQUID SOAP

KEY PART NUMBER U/M DESCRIPTION
 136047-01-01A EA LABEL - LIQUID SOAP

DOOR LOCK	DOOR UNLOCK	RIGHT COMPT DOOR LOCK	RIGHT COMPT DOOR UNLOCK	LEFT COMPT DOOR LOCK	LEFT COMPT DOOR UNLOCK	AUX START SOLENOID	AMP SOURCE
POWER MIRRORS	HEATER BLOWER	PASS HEATER BLOWER	FOG LAMPS	DOCKING LAMPS	DOCKING LAMPS SWITCH TRIGGER	COOLING FANS	

KEY PART NUMBER U/M DESCRIPTION
 136161-01-01A EA LABEL - RELAY - MATTE BLACK/WHITE LETTERS

DOOR LOCK	DOOR UNLOCK	RIGHT COMPT DOOR LOCK	RIGHT COMPT DOOR UNLOCK	LEFT COMPT DOOR LOCK	LEFT COMPT DOOR UNLOCK	AUX START SOLENOID	RUN/ACC POWER #1	POWER SEATS
POWER MIRRORS	HEATER BLOWER	RUN ONLY POWER	FOG LAMPS	DOCKING LAMPS	DOCKING LAMPS SWITCH TRIGGER	COOLING FANS	RUN/ACC POWER #2	

KEY PART NUMBER U/M DESCRIPTION
 136161-02-01A EA LABEL - RELAY - BLACK/WHITE

LT - AIR BAGS - RT

KEY PART NUMBER U/M DESCRIPTION
 136360-01-01A EA LABEL - AIR BAGS

LABELS GROUP (CONTINUED)

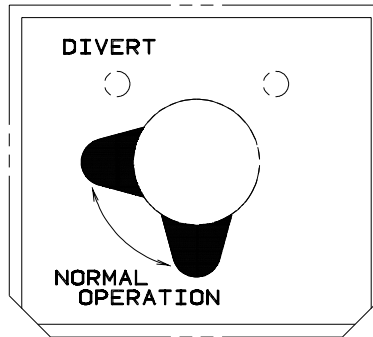

KEY PART NUMBER **U/M DESCRIPTION**
137997-01-01A EA LABEL - WINTERIZATION VALVE - BLACK/CLEAR



KEY PART NUMBER **U/M DESCRIPTION**
140190-01-01A EA DECAL/LOGO - V6 (DOMED) - CYAN/MAGENTA/YELLOW/BLACK

WASHER/DRYER
BRACKETS

KEY PART NUMBER **U/M DESCRIPTION**
141523-01-01A EA LABEL - WASHER/DRYER BRACKETS - BLACK/WHITE

 **WARNING:** COMPRESSED AIR CAN BE HAZARDOUS.

PROPER EYE PROTECTION MUST BE WORN WHEN
CONNECTING, DISCONNECTING OR USING AIR HOSE.

CLOSE VALVE BEHIND CONNECTOR BEFORE
CONNECTING OR DISCONNECTING AIR HOSE.

HOSE DISCONNECT WILL PRODUCE AIR DISCHARGE
FROM HOSE. DIRECT AIR DISCHARGE AWAY FROM
SELF AND OTHERS.

KEY PART NUMBER **U/M DESCRIPTION**
142771-01-01A EA LABEL - WARNING/COMPRESSED AIR - WHITE LETTERING ON CLEAR

LABELS GROUP (CONTINUED)

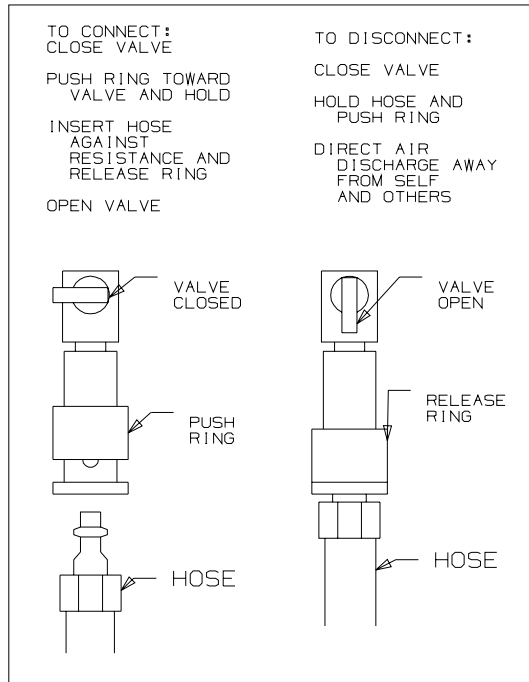

KEY	PART NUMBER	U/M DESCRIPTION
	142773-01-01A	EA LABEL - CONNECT/COMPRESS AIR - WHITE LETTERING ON CLEAR



KEY	PART NUMBER	U/M DESCRIPTION
	142908-01-000	EA LABEL - FREON CHARG



KEY	PART NUMBER	U/M DESCRIPTION
	144183-01-01A	EA LABEL - CAUTION RELEASE CATCH - WHITE/CLEAR



KEY	PART NUMBER	U/M DESCRIPTION
	144649-01-01A	EA LABEL - ADJUSTABLE VALVE - WHITE ON CLEAR

LABELS GROUP (CONTINUED)

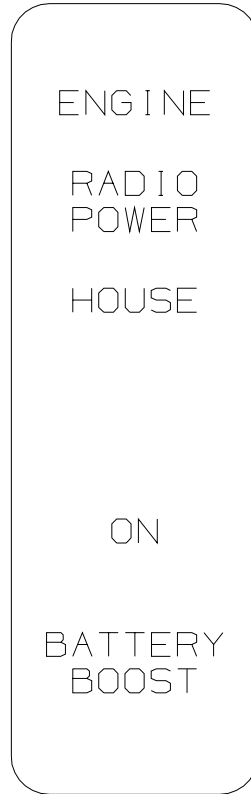

KEY	PART NUMBER	U/M	DESCRIPTION
	145731-01-01A	EA	LABEL - SWITCH - RADIO/BATTERY - BLACK

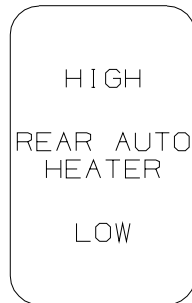

KEY	PART NUMBER	U/M	DESCRIPTION
	145731-03-01A	EA	LABEL - SWITCH - REAR AUTO HEATER - BLACK

LABELS GROUP (CONTINUED)



KEY PART NUMBER **U/M DESCRIPTION**
146057-01-01A EA LABEL - LP SHUT OFF - RED LETTER/WHITE BACK

FOR FUTURE INSTALLATION OF WASHER/DRYER EXHAUST DUCT

(A) A CLOTHES DRYER MOISTURE-LINT EXHAUST DUCT SHALL NOT BE CONNECTED TO ANY OTHER DUCT, VENT, OR CHIMNEY.

(B) THE EXHAUST DUCT SHALL BE OF SUFFICIENT LENGTH SO AS NOT TO TERMINATE BENEATH THE RECREATION VEHICLE.

(C) MOISTURE-LINT EXHAUST DUCTS SHALL NOT BE CONNECTED WITH SHEET METAL SCREWS OR OTHER FASTENING DEVICES THAT EXTEND INTO THE INTERIOR OF THE DUCT.

(D) MOISTURE-LINT EXHAUST DUCT AND TERMINATION FITTINGS SHALL BE INSTALLED IN ACCORDANCE WITH THE APPLIANCE MANUFACTURER'S PRINTED INSTRUCTIONS.

(E) SEE MARKED INTERIOR AREA ON SIDEWALL TO LOCATE CUTOUT FOR EXHAUST VENT.

(F) AS PART OF WASHER/DRYER PREP 4 HOLD DOWN BRACKETS WERE SHIPPED WITH YOUR VEHICLE WHICH ARE INTENDED TO BE USED WITH THE WINNEBAGO OFFERED APPLIANCE.

14724-01

KEY PART NUMBER **U/M DESCRIPTION**
147524-01-000 EA LABEL - DRYER VENTING

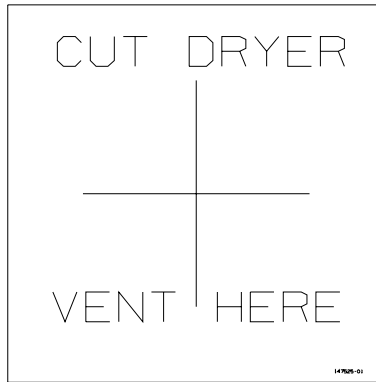

KEY PART NUMBER **U/M DESCRIPTION**
147525-01-000 EA LABEL - DRYER VENT CUTOUT

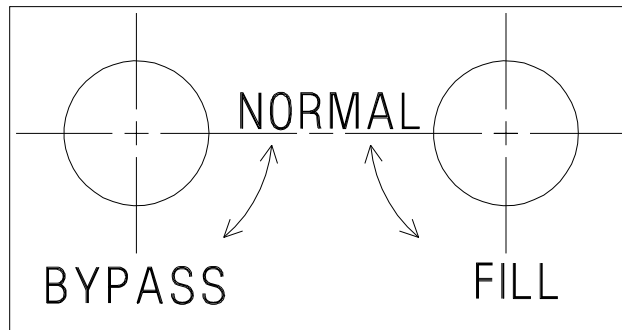

KEY PART NUMBER **U/M DESCRIPTION**
147581-01-01A EA LABEL - WATERFILL/BYPASS - BLACK/CLEAR

YOUR MOTORHOME IS EQUIPPED WITH A SEWER HOSE END ELBOW WHICH INCLUDES A CLOSEABLE DRIP VALVE. AFTER PLACING THE END OF THE HOSE ELBOW INTO THE PARK SEWER DISPOSAL OPENING, USE THUMB TO LIFT HANDLE LOCK AND MOVE HANDLE FORWARD TO OPEN VALVE.

NEVER OPERATE TANK VALVES WITHOUT FIRST OPENING THE DRIP VALVE.

AFTER TANKS ARE EMPTY, CLOSE TANK VALVES, THEN PULL HANDLE ON ELBOW TO A VERTICAL CARRYING POSITION TO CLOSE DRIP VALVE. THIS WILL ELIMINATE ANY DRIPPING FROM THE HOSE INTO YOUR STORAGE AREA. SEE OPERATORS MANUAL FOR ADDITIONAL INFORMATION.

147845-01A

KEY PART NUMBER **U/M DESCRIPTION**
147845-01-01A EA LABEL - DRIP VALVE - BLACK/WHITE

LP GROUP
LP SYSTEM

KEY	PART NUMBER	U/M	DESCRIPTION
	045703-03-000	EA	HOSE - LP - 3/8"ID X 18" - 3/8"MPT X 1/2"F SWIVEL - U.S.
	045703-12-000	EA	HOSE - LP - 3/8"ID X 18" - 3/8"MPT X 1/2"F SWIVEL - CANADA
	045703-15-000	EA	HOSE - LP - 3/8"ID X 142" - 1/2"F SWIVEL X 3/8"F SWIVEL - 430V
	045703-19-000	EA	HOSE - LP 3/8"ID X 102"-US/CGA - 1/2F SWIVEL X 3/8F SWIVEL - 427P
	106150-05-000	EA	REGULATOR - TWO STAGE
	144485-01-000	EA	COMPARTMENT - LP REGULATOR
	105658-01-000	EA	COMPARTMENT - LP REGULATOR - 430V
	024250-01-000	EA	ADAPTER - BRASS - 3/8"F X 1/2"FPT - 430V
	010323-01-000	EA	ADAPTER - 3/8"F X 1/2"MPT - BRASS - 427P, 431C
	010326-01-000	EA	ADAPTER - FLARE - W/CONE GASKET - 3/8"F X 1/2"F - 427P, 431C
	010329-01-000	EA	ADAPTER - 1/2"F X 1/2"MPT - BRASS
	040440-02-000	EA	TRANSMITTER - DIAL/BOLT-ON - 0-90 OHM 2 TERM(POWER/GROUND)
*	144116-04-000	EA	TANK - LP - 60 LB - 14"D X 29.75"L
	010377-02-000	EA	NUT - 3/8" FLARE - FORGED - BRASS - 430V, 431C
	010380-02-000	EA	NUT - 1/2" FLARE - FORGED - BRASS
	103613-03-000	EA	DETECTOR - LP GAS - W/O SHUT-OFF VALVE
	150138-01-01A	EA	DETECTOR - LP GAS - WHITE FROM: 00-00-00 THRU: 02-08-04
	150138-01-02A	EA	DETECTOR - LP GAS - BROWN FROM: 02-09-04 THRU: 99-99-99
	010265-01-000	EA	ELBOW - BRASS - 90 DEGREE - 3/8"F X 1/2"FPT - 430V
	010589-03-000	EA	NIPPLE - PIPE - 1/2" X 2 1/2" - BLACK - 427P, 430V

*COMPONENT PARTS LISTED LATER IN THIS GROUP

LP GROUP (CONTINUED)
COMPONENT PARTS LP SYSTEM

144116-04-000

KEY	PART NUMBER	U/M	DESCRIPTION	VENDOR NO.
	040421-01-712	EA	VALVE-SERV. W/O VAPOR RELIEF	29000853
	040421-01-713	EA	VALVE-RELIEF 1" W/SPRING 7"	V-20479
	144116-01-700	EA	VALVE-OUTAGE(NO STEM REMOVE)	V20058
	144116-01-701	EA	VALVE/FILL 80 % W/YELLOW CAP	V13414
	144116-04-700	EA	SENDING UNIT (SNAP ON GAUGE)	G11530

LOUNGE GROUP CABINETS

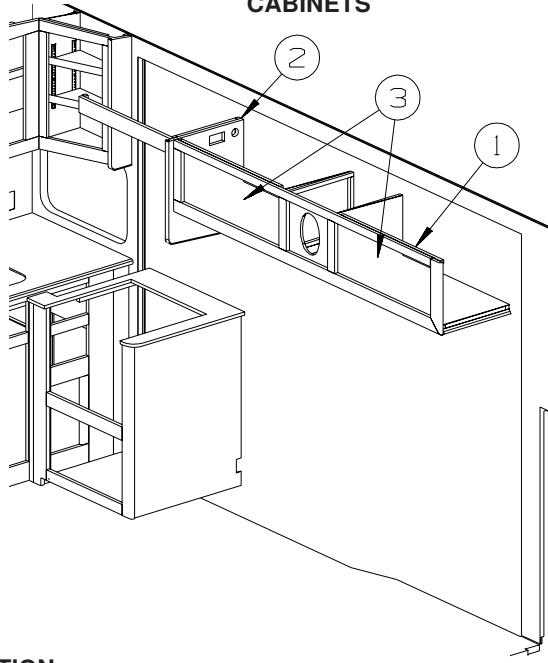

KEY	PART NUMBER	U/M	DESCRIPTION
1	142038-01-P13	EA	CABINET - OVERHEAD/FRONT/LEFT HAND - W/O DOORS/HARDWARE (R19)
1	142038-01-P14	EA	CABINET - OVERHEAD/FRONT/LEFT HAND - W/O DOORS/HARDWARE (R20)
1	142038-01-R21	EA	CABINET - OVERHEAD/FRONT/LEFT HAND - W/O DOORS/HARDWARE (R21) FROM: 00-00-00 THRU: 01-04-04
1	142038-01-RW1	EA	CABINET - OVERHEAD/FRONT/LEFT HAND - W/O DOORS/HARDWARE (R21) FROM: 01-05-04 THRU: 99-99-99
1	142038-01-P21	EA	CABINET - OVERHEAD/FRONT/LEFT HAND - W/O DOORS/HARDWARE (R22)
1	142038-01-P22	EA	CABINET - OVERHEAD/FRONT/LEFT HAND - W/O DOORS/HARDWARE (R23)
1	142038-01-P36	EA	CABINET - OVERHEAD/FRONT/LEFT HAND - W/O DOORS/HARDWARE (R24) FROM: 00-00-00 THRU: 01-04-04
1	142038-01-RW2	EA	CABINET - OVERHEAD/FRONT/LEFT HAND - W/O DOORS/HARDWARE (R24) FROM: 01-05-04 THRU: 99-99-99
1	142038-01-R25	EA	CABINET - OVERHEAD/FRONT/LEFT HAND - W/O DOORS/HARDWARE (R25)
1	142038-01-R26	EA	CABINET - OVERHEAD/FRONT/LEFT HAND - W/O DOORS/HARDWARE (R26)
1	142038-01-R27	EA	CABINET - OVERHEAD/FRONT/LEFT HAND - W/O DOORS/HARDWARE (R27) FROM: 00-00-00 THRU: 01-04-04
1	142038-01-RW3	EA	CABINET - OVERHEAD/FRONT/LEFT HAND - W/O DOORS/HARDWARE (R27) FROM: 01-05-04 THRU: 99-99-99
2	142038-21-P13	EA	END CAP - OVERHEAD CABINET - PORTSMOUTH OAK
2	142038-21-P14	EA	END CAP - OVERHEAD CABINET - CONCERT CHERRY
2	142038-21-P33	EA	END CAP - OVERHEAD CABINET - WASHED MAPLE FROM: 00-00-00 THRU: 01-04-04
2	142038-21-RW1	EA	END CAP - OVERHEAD CABINET - WASHED MAPLE FROM: 01-05-04 THRU: 99-99-99
3	141522-46-P54	EA	DOOR - ARCHED/PENCIL EDGE/HORIZ - 10.8" X 27.9" - W/O HDW - PORTSMOUTH OAK
3	141522-46-P55	EA	DOOR - ARCHED/PENCIL EDGE/HORIZ - 10.8" X 27.9" - W/O HDW - CONCERT CHERRY
3	141522-46-P56	EA	DOOR - ARCHED/PENCIL EDGE/HORIZ - 10.8" X 27.9" - W/O HDW - WASHED MAPLE

LOUNGE GROUP (CONTINUED)
CABINETS (CONTINUED)

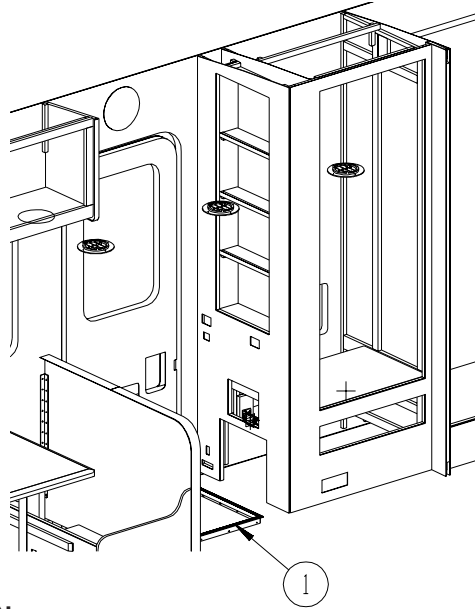

KEY	PART NUMBER	U/M	DESCRIPTION
1	139955-14-04A	EA	TRIM - ENTRY STEP - TITANIUM

SEALANTS & FASTENERS GROUP

SEALANTS & ADHESIVES

KEY	PART NUMBER	U/M	DESCRIPTION
	004001-05-000	EA	ADHESIVE - SCOTCH-WELD - 3M DP100 - CLEAR - 50ML
	010405-02-000	EA	TAPE - THREAD SEALING - 3/8"
	034552-06-000	EA	SILICONE - TUBE - W/O NOZZLE - OFF WHITE
	034552-15-000	EA	SILICONE - TUBE - W/O NOZZLE - BRIGHT WHITE
	063642-01-000	FT	TAPE - ADHESIVE - .4" X 1.5" X 180'
	064075-07-000	FT	SEAL - BULB - W/WIRED U CHANNEL - .3" X .5" CHANNEL-BLACK
	067788-01-000	EA	ADHESIVE - SPRAY - 3M - 19.5 OZ AEROSOL CAN
	069640-01-000	FT	SEALER - TAPE - .25" DIAMETER X 30' - BLACK OR GRAY
	069640-02-000	FT	SEALER - TAPE - .13" THICK X .5" WIDE X 60' - GRAY
	069640-03-000	FT	SEALER - TAPE - .13" THICK X .75" WIDE X 60' - BLACK
	069640-07-000	FT	SEALER - TAPE - .09" THICK X 2" WIDE X 45' - GRAY
	069640-09-000	FT	SEALER - TAPE - .03" THICK X 2.50" WIDE X 80' - GRAY
	069640-10-000	FT	SEALER - TAPE - .03" THICK X 1.50" WIDE X 90' - GRAY
	069640-11-000	FT	SEALER - TAPE - .19" THICK X .38" WIDE X 40' - BLACK
	069640-13-000	FT	SEALER - TAPE - .03" THICK X 2" WIDE X 45' - BLACK
	069640-14-000	FT	SEALER - TAPE - .06" THICK X 1" WIDE X 100' - GRAY
	069640-15-000	FT	SEALER - TAPE - .06" THICK X .38" WIDE X 100' - GRAY
	069640-17-000	FT	SEALER - TAPE - .03" THICK X 1" WIDE X 90' - GRAY
	069640-18-000	FT	SEALER - TAPE - .50" THICK X .13" WIDE X 60' - BRT WHITE
	069640-19-000	FT	SEALER - TAPE - .75" THICK X .13" WIDE X 60' - BRT WHITE
	069640-20-000	FT	SEALER - TAPE - .50" THICK X .5" WIDE X 60' - BLACK
	069640-21-000	FT	SEALER - TAPE - .50" THICK X .06" WIDE X 100'- BRT WHITE
	069640-27-000	FT	SEALER - TAPE - .06" THICK X 2.25" WIDE - BRIGHT WHITE
	069640-28-000	FT	SEALER - TAPE - .25" THICK X 1.86" WIDE X 90' - GRAY
	069640-30-000	FT	SEALER - TAPE - .03" THICK X .625" WIDE X 50' - GRAY
	069640-31-000	FT	SEALER - TAPE - .25" THICK X .75" WIDE X 15' - BLACK
	069640-32-000	FT	SEALER - RIBBON - 1/16" X 3/8" X 100' - BLACK
	072889-01-000	EA	SEALANT - URETHANE - BLACK - TUBE W/NOZZLE TIP
	076322-01-000	FT	TAPE-DOUBLE COATED/ADHESIVE BK-.03"THK X .8"W X 216'- WHT
	076322-02-000	FT	TAPE-DOUBLE COATED/ADHESIVE BK-.05"THK X 1"W X 108' - WHT
	076322-03-000	FT	TAPE-DOUBLE COATED/ADHESIVE BK-.05"THK X .5"W X 108' - WHT
	076322-04-000	FT	TAPE-DOUBLE COATED/ADHESIVE BK-.05"THK X .8"W X 108' - WHT
	076322-05-000	FT	TAPE-DOUBLE COATED/ADHESIVE BK-.05"THK X .8"W X 108' - WHT
	076322-07-000	FT	TAPE-DOUBLE COATED/ADHESIVE BK-.05"THK X .5"W X 200' - WHT
	076322-11-000	FT	TAPE-DOUBLE COATED/ADHESIVE BK-.02"THK X 1"W X 216' - CLR
	076322-21-000	FT	TAPE - FOAM/DOUBLE COATED - .5"
	086276-01-000	EA	TAPE - DOUBLE SIDED - 1/2" WIDE X 108' LONG (SOLD BY ROLL)
	088479-01-000	EA	TAPE - ALUMINUM - 3"
	090340-01-000	FT	SEAL - FOAM - CLOSED CELL - 1/4" X 1/2" X 50'
	091255-02-000	FT	SEAL - ADHESIVE BACKED/FOAM - 3/64" THICK X 3/16"W X 1000'
	091255-03-000	FT	SEAL - ADHESIVE BACKED/FOAM - 1/4" THICK X 1/4"W X 1000'
	094401-01-000	EA	SEALER - BODY SEAM - FLEXICLEAR
	094401-03-000	EA	SEALER - BODY SEAM - BLACK
	094401-04-000	EA	SEALER - BODY SEAM - CLEAR
	098408-01-000	FT	SEAL - SPONGE RUBBER - CLOSED CELL
	099069-01-000	FT	SEAL - RUBBER - CLOSED SPONGE - .5" WIDE X .12" THICK -BLK
	099418-01-000	FT	SEAL - D-SECTION/ADHESIVE BACK - .44" X .44"- BLK RUBBER
	099418-02-000	FT	SEAL - D-SECTION/ADHESIVE BACK - .44" X .44"- WHITE RUBBER
	100128-02-000	FT	SEAL - FOAM/ADHESIVE BACK - .37" WIDE X .37" THICK
	104692-01-000	FT	SEAL - ADHESIVE BACKED FOAM - 3/4" THICK X 3/4" WIDE X 25'
	104692-03-000	FT	SEAL - ADHESIVE BACKED FOAM - 1" THICK X 1 3/16"WIDE X 15'
	107828-01-000	EA	SEALANT - SB - 190 EVERSEAL
	109506-12-000	EA	FILM/ABRASION-RESISTANT - TRANSPARENT - 1" DIA.
	110274-01-000	FT	TAPE - DOUBLE SIDED/FOAM - .45" X 1" X 216' - BLACK
	112481-02-000	EA	ADHESIVE - PLEXUS ETHACRYLATE - CARTRIDGE
	112864-01-000	FT	SEAL - FOAM/BUTYL COVERED - 3/8" X 35'
	112864-02-000	FT	FOAM - BUTYL COVERED - 5/16" X 44'
	112864-04-000	FT	FOAM - BUTYL COVERED - 3/8" X 1/8"
	112901-02-000	EA	ADHESIVE - PLEXUS - MA330 - 50ML - GRAY
	112901-03-000	EA	ADHESIVE - PLEXUS - MA300 - 50ML - WHITE
	112902-01-000	EA	NOZZLE - ELEMENT - 3/8 X 24
	112902-03-000	EA	MIXER NOZZLE - F/GUN #00400102000 - SCOTCH-WELD & PLEXUS
	112902-04-000	EA	NOZZLE - ELEMENT - 1/4" X 3.5"

SEALANTS & FASTENERS GROUP (CONTINUED)

SEALANTS & ADHESIVES (CONTINUED)

KEY	PART NUMBER	U/M	DESCRIPTION
	113366-01-000	EA	ADHESIVE - INSTANT - 1 OZ
	113452-02-000	FT	SEAL/TRIM - FRONT - VINYL W/WIRE CARRIER - .027"
	120074-02-03A	EA	SILICONE - TUBE - W/O NOZZLE - LOW ODOR - SMOKEY WHITE
	120074-02-02A	EA	SILICONE - TUBE - W/O NOZZLE - LOW ODOR - SOFT WHITE
	120534-01-01A	EA	TAPE - SCOTCH - 3M - 1/2" FINE LINE
	123244-01-000	FT	TAPE - DOUBLE SIDED/FOAM - 5/64" THICK X 3/4" WIDE X 108'
	123816-01-000	FT	TAPE - DOUBLE SIDED - 1" X 3/4" X 200'
	123816-02-000	FT	TAPE - DOUBLE SIDED - 1/2" X 1 1/3" X 200'
	123816-03-000	FT	TAPE - DOUBLE SIDED - 1/2" X 3/4" X 200'
	123816-04-000	FT	TAPE - DOUBLE SIDED - 6" X 750'
	126427-01-000	EA	ADHESIVE - ALL PURPOSE - ABS/PVC
	126427-02-000	EA	PRIMER - CLEANER - FLEX PIPING
	131264-01-02A	EA	SILICONE - TUBE - W/O NOZZLE - CLEAR
	131264-01-01A	EA	SILICONE - TUBE - W/O NOZZLE - BLACK
	131264-02-01A	EA	SILICONE - TUBE - W/O NOZZLE - VW GRAY - BATH ONLY
	131264-03-01A	EA	SILICONE - TUBE - W/O NOZZLE - SELF LEVELING - BRIGHT WHITE
	131264-04-01A	EA	SILICONE/SEALANT/ADHESIVE - FAST CURE F/GLASS/VINYL - B/W
	131384-01-000	EA	ADHESIVE - JET WELD
	134651-01-000	FT	SEAL - 1/2" X 3/4" PSA 1 SIDE
	900390-01-000	EA	NOZZLE - SILICONE TUBE - 2.5" LONG - W/EXTERNAL THREADS
	900390-03-000	EA	NOZZLE - SILICONE TUBE - 4.3" LONG W/INTERNAL THREADS

BOLTS, NUTS AND WASHERS

KEY	PART NUMBER	U/M	DESCRIPTION
	OMC04K-06-016	EA	BOLT - HEX - M06 X 1 X 016
	OMC05K-08-055	EA	BOLT - HEX - M08 X 1.25 X 2.2
	OMC13K-14-110	EA	BOLT - HEX
	OMC13K-14-070	EA	BOLT - HEX - M14 X 2 X 2 3/4
	OMC31K-08-020	EA	BOLT - HEX - SERRATED FLANGE - M8 X 020
	OMC32K-10-030	EA	BOLT - HEX - SERRATED FLANGE - M10 X 1 1/2
	OMD16K-10-000	EA	NUT - HEX PREV TORQUE M10 X 1 1/2 CLASS 8
	OMD39K-12-000	EA	NUT - HEX W/NYLON LOCK - M12 X 1 3/4
	OMD40K-14-000	EA	NUT - HEX W/NYLON LOCK - M14 X 2
	OMD54F-06-000	EA	NUT-HEX SER FLG M6X1,0 SS - DIN6923A2M6
	OME06K-14-280	EA	WASHER - FLAT - 14 ID X 28 OD
	000C12-04-08B	EA	BOLT - HEX - 1/4-20 X 1/2 - GRADE #5 - ZINC
	000C12-04-12A	EA	BOLT - HEX - 1/4-20 X 3/4 - PLAIN 5
	000C12-04-40B	EA	BOLT - HEX - 1/4-20 X 2 1/2 - GRADE 5 ZINC
	000C12-05-16B	EA	BOLT - HEX - 5/16 - 18X1 - GRADE #5 - ZINC
	000C12-06-44B	EA	BOLT - HEX - 3/8-16 X 2 3/4 - GRADE 5 - ZINC
	000C12-06-16B	EA	BOLT - HEX - 3/8 - 16X1 - GRADE #5 - ZINC
	000C12-08-28B	EA	BOLT - HEX - 1/2-13 X 1 3/4 - GRADE #5 - ZINC
	000C12-08-24B	EA	BOLT - HEX - 1/2 - 13X1 1/2 - GRADE #5 - ZINC
	000C12-08-16B	EA	BOLT - HEX - 1/2-13 X 1 - GRADE #5 - ZINC
	000C12-10-24B	EA	BOLT - HEX - 5/8 - 11X1 1/2 - GRADE #5 - ZINC
	000C13-07-48B	EA	BOLT - HEX - 7/16-20 X 3 - GRADE #5 - ZINC
	000C13-07-40B	EA	BOLT - HEX - 7/16-20 X 2 1/2 - GRADE #5 - ZINC
	000C14-07-28B	EA	BOLT - HEX - 7/16-14 X 1 3/4 - GRADE #8 - ZINC
	000C14-10-32K	EA	BOLT - HEX - 5/8-11 X 2 - GRADE #8 - ZINC
	000C14-10-24K	EA	BOLT - HEX - 5/8-11 X 1 1/2 - GRADE #8 - ZINC
	000C18-05-40A	EA	BOLT - ELEVATOR - 5/16-18 X 2 1/2 - PL
	000C26-04-10B	EA	BOLT - HEX - SERRATED FLANGE - 1/4-20 X 5/8 - ZINC
	000C26-04-18B	EA	BOLT - HEX - SERRATED FLANGE - 1/4-20 X 1 1/8 - ZINC
	000C26-04-14B	EA	BOLT - HEX - SERRATED FLANGE - 1/4-20 X 7/8 - ZINC
	000C26-05-20B	EA	BOLT - HEX - SERRATED FLANGE - 5/16-18 X 1 1/4 - ZINC
	000C26-05-12B	EA	BOLT - HEX - SERRATED FLANGE - 5/16-18 X 3/4 - ZINC
	000C26-06-40B	EA	BOLT - HEX - SERRATED FLANGE - 3/8-16 X 2 1/2 - ZINC
	000C26-06-28B	EA	BOLT - HEX - SERRATED FLANGE - 3/8-16 X 1 3/4 - ZINC
	000C26-06-20B	EA	BOLT - HEX - SERRATED FLANGE - 3/8-16 X 1 1/4 - ZINC
	000C26-06-12B	EA	BOLT - HEX - SERRATED FLANGE - 3/8-16 X 3/4 - ZINC
	000C26-08-24B	EA	BOLT - HEX - SERRATED FLANGE - 1/2-13 X 1 1/2 - ZINC
	000C27-04-40B	EA	BOLT - CARRIAGE - 1/4-20 X 2 1/2 - ZINC
	000C27-07-40B	EA	BOLT - CARRIAGE - 7/16-14 X 2 1/2 - GRADE #5
	000C27-08-48B	EA	BOLT - CARRIAGE - 1/2-13 X 3 - GRADE #5

SEALANTS & FASTENERS GROUP (CONTINUED)
BOLTS, NUTS AND WASHERS (CONTINUED)

KEY	PART NUMBER	U/M	DESCRIPTION
	000D16-07-00B	EA	NUT - HEX - 7/16-14 - ZINC
	000D20-07-00B	EA	NUT - ACORN - ASSIST HANDLE - 7/16 - 14
	000D24-10-00B	EA	NUT - HEX - SELF LOCKING - 10-32 - ZINC
	000D28-10-00B	EA	NUT - HEX - W/NYLON LOCK - 10-32 ZINC
	000D29-04-00B	EA	NUT - HEX - SELF LOCKING - 1/4 X 20 - ZINC
	000D29-06-00B	EA	NUT - HEX - W/NYLON LOCK - 3/8-16 - ZINC
	000D29-09-00B	EA	NUT - HEX - SELF LOCKING - 9/16-12 - ZINC
	000D30-07-00B	EA	NUT - HEX LOCK - NYLON 7/16 X 20
	000D34-04-00B	EA	NUT - HEX - LOCKING - 1/4-20 - ZINC
	000D34-06-00B	EA	NUT - HEX - LOCKING - 3/8-16 GRADE C - ZINC
	000D39-04-00B	EA	NUT - HEX - LOCKING W/SERRATED FLANGE - 1/4-20 - ZINC
	000D39-05-00B	EA	NUT - HEX - LOCKING W/SERRATED FLANGE - 5/16-18 - ZINC
	000D39-06-00B	EA	NUT - HEX - LOCKING W/SERRATED FLANGE - 3/8-18 - ZINC
	000D39-07-00B	EA	NUT - HEX - LOCKING W/SERRATED FLANGE - 7/16-14 - ZINC
	000D39-08-00B	EA	NUT - HEX - LOCKING W/SERRATED FLANGE - 1/2-13 - ZINC
	000D44-04-00B	EA	NUT - HEX - LOCKING W/SERRATED FLANGE - 1/4-28 - ZINC
	000D44-07-00B	EA	NUT - HEX - LOCKING W/SERRATED FLANGE - 7/16-20 - ZINC
	000D44-08-00B	EA	NUT - HEX - LOCKING W/SERRATED FLANGE - 1/2-20 - ZINC
	000D46-04-00A	EA	NUT - HEX - WELD - 1/4-20 - PLAIN
	000D58-06-00A	EA	NUT - HEX - WELD 3/8-16 - PLAIN
	000D65-08-00B	EA	NUT - HEX - LOCKING W/SERRATED FLANGE - 8-32 - ZINC
	000D67-10-00B	EA	NUT - HEX - LOCK - 5/8-11 - ZINC
	000D73-08-00C	EA	NUT - HEX FLANGE - 1/2-13
	000D75-09-00B	EA	NUT - HEX LOCKING - 9/16-12 - ZINC
	000D76-06-00B	EA	NUT - HEX FLANGE - 3/8-16
	000E11-04-00F	EA	WASHER - LOCKING - 1/4 MED SPLIT - STAINLESS STEEL
	000E11-07-00B	EA	WASHER - LOCKING - 7/16 MED SPLIT - ZINC
	000E11-08-00B	EA	WASHER - LOCKING - 1/2 MED SPLIT - ZINC
	000E13-17-00B	EA	WASHER - FLAT - 3/8 AR - ZINC
	000E13-18-00B	EA	WASHER - FLAT - 3/8 WIDE - ZINC
	000E13-20-00B	EA	WASHER - FLAT - 7/16 WIDE - ZINC
	000E13-22-00B	EA	WASHER - FLAT - 1/2 WIDE - ZINC
	000E13-26-00B	EA	WASHER - FLAT - 5/8 WIDE - ZINC
	000E14-10-00B	EA	WASHER - LOCKING - #10 EXTERNAL TOOTH - ZINC
	000E16-10-00B	EA	WASHER - HARDENED - 5/8 - FLAT - ZINC
	000G45-05-16B	EA	BOLT - LAG - 5/16-9 X 1 - ZINC
	000G62-08-24B	EA	SCREW - SF/DR - 8-18 X 1 1/2 PFH
	005081-01-000	EA	NUT - SPEED - C-TYPE - #8 SCREW
	040921-03-000	EA	NUT - SPEED - U TYPE - #10
	040921-04-000	EA	NUT - SPEED - U TYPE - #8-.59" LENGTH X .44" WIDTH
	040921-05-000	EA	NUT - SPEED - U-TYPE - 8-.67" X .44" WIDE
	041322-01-000	EA	WASHER - FLANGE - 15/32 ID X 2 3/8 OD - F/SEAT BELT MTG
	044364-02-000	EA	NUT - SPEED - FLAT - ROUND
	044533-01-000	EA	WASHER - 1 3/8"OD - FOR BUTTONS - PLASTIC
	051387-06-000	EA	BOLT - CARRIAGE W/O HOLE - 5/16-18 X 9 1/2 - ZINC
	058716-02-000	EA	WASHER - FLAT NYLON
	064081-03-000	EA	NUT - WING 3/8-16 - W/WELD NUT
	077071-01-000	EA	WASHER - FENDER - 3/16"ID X 1"OD
	084406-01-000	EA	NUT - CAPPED - CROSS RECESSED - BLACK - 1/4-20 THD
	087234-01-000	EA	NUT - JACK - 1/4 X 20 THD - MOLLY
	088787-12-000	EA	STUD - WELD - 1/4 - 20 X 1.0 LG - MN
	102333-01-06A	EA	BOLT - CARRIAGE - 7/16-14 STAINLESS STEEL CAP
	103020-02-000	EA	BOLT-U - #8-32 - GRADE 5 ZINC
	106166-01-000	EA	BOLT/COLLARED HANGER - 8-32 X 1
	106956-03-000	EA	BOLT - HEX TAP - 1/2-12NC X 3 - GRADE 5 - FULL THREAD/ZINC
	106956-08-000	EA	BOLT - HEX TAP - 1/2-13NC X 4 - GRADE 5 - FULL THREAD/ZINC
	107397-01-000	EA	WASHER - FENDER - 3/4"ID X 1"OD
	108067-03-000	EA	STUD - WELD - 1/4 - 20 X 1/2 CD
	109235-01-05A	FT	COVER - SCREW - BRIGHT WHITE
	109235-01-01A	FT	COVER - SCREW - MAT BLACK
	109917-03-000	EA	WASHER - 1" X .50"
	109917-04-000	EA	WASHER - 1" X .75"
	121511-01-000	EA	WASHER - SPUR

SEALANTS & FASTENERS GROUP (CONTINUED)
BOLTS, NUTS AND WASHERS (CONTINUED)

KEY	PART NUMBER	U/M	DESCRIPTION
	113985-02-000	EA	BOLT - FLANGE - M10-1 1/2 X 30CL 10.9
	114259-05-000	EA	BOLT - 7/16-20 X 1 1/4 W/WASHER
	128444-01-000	EA	WASHER - SPRING - CONICAL
	131377-01-000	EA	NUT-HEX HEAD W/WASHER-1/4-20 X 2" STEEL W/3/4" OD WASHER
	135092-01-01A	EA	BOLT - HEX - SERRATED FLANGE - 1/2-20 X 1 3/4-GRADE 5 ZINC
	135092-02-01A	EA	BOLT - HEX - SERRATED FLANGE - 1/2-20 X 2 1/2-GRADE 5 ZINC
	143399-01-01A	EA	NUT/RETAINING - 3/8" - 24 NFT
	144904-01-01A	EA	BOLT - ADJUSTMENT - HEADLAMP

SCREWS

KEY	PART NUMBER	U/M	DESCRIPTION
	0G1106-06-160	EA	SCREW - 6-20 X 3/8 PPH
	0G1106-08-240	EA	SCREW - 6-20 X 1/2 PPH - VW LIGHT GRAY
	0G1108-12-240	EA	SCREW - 8-18 X 3/4 PPH - VW LIGHT GRAY
	0G1108-16-240	EA	SCREW - 8-18 X 1.00 PPS - VW LIGHT GRAY
	0G1208-12-170	EA	SCREW - 8-18 X 3/4 POH - BRIGHT WHITE
	0G1308-10-240	EA	SCREW - 8-18 X 5/8 PFH - VW LIGHT GRAY
	0G3804-22-180	EA	SCREW - MACHINE - 1/4-20 X 1 3/8 PFH - BLACK
	0G3908-08-170	EA	SCREW - SF/DR - 8-18 X 1/2 PPH - BRIGHT WHITE
	0G3908-08-160	EA	SCREW - SF/DR - 8-18 X 1/2 PPH - VW WHITE
	0G3908-08-240	EA	SCREW - SF/DR - 8-18 X 1/2 PPH - VW LIGHT GRAY
	0G3908-12-250	EA	SCREW - SF/DR - 8-18 X 3/4 PPH - DARK GRAY
	0G3908-12-240	EA	SCREW - SF/DR - 8-18 X .75 PPH - VW LIGHT GRAY
	0G3908-16-170	EA	SCREW - SF/DR - 8-18 X 1 PPH - BRIGHT WHITE
	0G3908-24-170	EA	SCREW - SF/DR - 8-18 X 1 1/2 PPH - BRIGHT WHITE
	0G3910-10-330	EA	SCREW - SF/DR - 20-16 X 5/8 PPH - PUTTY
	0G3910-10-320	EA	SCREW - SF/DR - 10-16 X 5/8 PPH - GLACIER
	0G3910-10-240	EA	SCREW - SF/DR - 10-16 X 5/8 PPH - VW LIGHT GRAY
	0G3910-12-240	EA	SCREW - SF/DR - 10-16 X .75 PPH - VW LIGHT GRAY
	0G3910-12-170	EA	SCREW - SF/DR - 10-16 X 3/4 PPH - BRIGHT WHITE
	0G3910-12-320	EA	SCREW - SF/DR - 10-16 X 3/4 PPH - GLACIER
	0G5508-12-240	EA	SCREW - SF/DR - 8-18 X 3/4 PWH - VW LIGHT GRAY
	0G5508-12-170	EA	SCREW - SF/DR - 8-18 X 3/4 PWH - BRIGHT WHITE
	0G5508-12-330	EA	SCREW - SF/DR - 8-18 X 3/4 PWH - PUTTY
	0G5508-12-320	EA	SCREW - SF/DR - 8-18 X 3/4 PWH - GLACIER
	0G5508-12-260	EA	SCREW - SF/DR - 8-18 X 3/4 PWH - ALLANTE ANTELOPE
	0G5508-12-270	EA	SCREW - SF/DR - 8-18 X 3/4 PWH - TITANIUM
	0G5508-16-250	EA	SCREW - SF/DR - 8-18 X 1 PWH - VW DARK GRAY
	0G5508-16-330	EA	SCREW - SF/DR - 8-18 X 1 PWH - PUTTY
	0G5508-16-320	EA	SCREW - SF/DR - 8-18 X 1 PWH - GLACIER
	0G6008-16-170	EA	SCREW - SF/DR - 8-18 X 1 POH - BRIGHT WHITE
	0G6710-08-130	EA	SCREW - 10-12 X 1/2 PPH - TAUPE
	0G6710-08-170	EA	SCREW - 10-12 X 1/2 PPH - BRIGHT WHITE
	0G6710-08-240	EA	SCREW - 10-12 X 1/2 PPH - VW LIGHT GRAY
	0G6710-12-170	EA	SCREW - 10-12 X 3/4 PPH - BRIGHT WHITE
	0G6806-16-170	EA	SCREW - 6-18 X 1 POH - BRIGHT WHITE
	0G6810-24-280	EA	SCREW - 10-12 X 1 1/2 POH - SOFT WHITE
	000C20-04-16A	EA	SCREW - 1/4-20X 1 - FLAT SOCKET HEAD
	000C20-05-28F	EA	SCREW - 5/16-18 X 1 3/4 FLAT SOC - STAINLESS STEEL
	000C20-06-24T	EA	SCREW - 3/8-16 X 1 1/2 - FLAT SOCKET
	000G11-06-10J	EA	SCREW - 6-20 X 5/8 PPH - BRASS
	000G11-06-08P	EA	SCREW - 6-20 X 1/2 PPH - DARK BROWN
	000G11-06-08B	EA	SCREW - 6-20 X 1/2 PPH - ZINC
	000G11-07-08B	EA	SCREW - 7-19 X 1/2 PPH - ZINC
	000G11-08-20G	EA	SCREW - 8-18 X 1 1/4 - ANTIQUE BRASS
	000G11-08-20B	EA	SCREW - 8-18 X 1 1/4 PPH - ZINC
	000G11-08-16B	EA	SCREW - 8-18 X 1 PPH - ZINC
	000G11-08-12T	EA	SCREW - 8-18 X 3/4 PPH - BLACK MAGNESIUM
	000G11-08-12P	EA	SCREW - 8-18 X 3/4 PPH - DARK BROWN
	000G11-08-12B	EA	SCREW - 8-18 X 3/4 PPH - ZINC
	000G11-08-08T	EA	SCREW - 8-18 X 1/2 PPH - FLUOROCARBON COATING
	000G11-08-06B	EA	SCREW - 8-18 X 3/8 PPH - ZINC
	000G11-10-24P	EA	SCREW - 10-16 X 1 1/2 PPH - DARK BROWN
	000G11-10-12D	EA	SCREW - 10-16 X 3/4 PPH - BLACK
	000G12-06-12J	EA	SCREW - 6-20 X .75 POH - BRASS

SEALANTS & FASTENERS GROUP (CONTINUED)
SCREWS (CONTINUED)

KEY	PART NUMBER	U/M	DESCRIPTION
	000G12-06-08T	EA	SCREW - 6-20 X 1/2 POH - BLACK
	000G13-05-10B	EA	SCREW - 5-12 X 5/8 PFH - ZINC
	000G13-06-08G	EA	SCREW - 6-20 X 1/2 PFH - ANTIQUE BRASS
	000G13-06-08B	EA	SCREW - 6-20 X 1/2 PFH - ZINC
	000G13-06-06I	EA	SCREW - 6-20 X 3/8 PFH - BLACK ZINC
	000G13-06-24J	EA	SCREW - 6-20 X 1 1/2 PFH - BRASS
	000G13-06-16J	EA	SCREW - 6-20 X 1 PFH - BRASS
	000G13-06-10J	EA	SCREW - 6-20 X 5/8 PFH - BRASS
	000G13-06-10G	EA	SCREW - 6-20 X 5/8 PFH - ANTIQUE BRASS
	000G13-07-10H	EA	SCREW - 7-19 X 5/8 PFH - BLACK
	000G13-08-16B	EA	SCREW - 8-18 X 1 PFH - ZINC
	000G13-08-109	EA	SCREW - 8-18 X 5/8 PFH
	000G13-08-10B	EA	SCREW - 8-18 X 5/8 PFH - ZINC
	000G13-08-24B	EA	SCREW - 8-18 X 1 1/2 PFH - ZINC
	000G13-10-16I	EA	SCREW - 10-16 X 1 PFH - BLACK
	000G16-04-24B	EA	SCREW - MACHINE - 1/4-20 X 1 1/2 PPH
	000G18-08-16B	EA	SCREW - MACHINE - 8-32 X 1 PPH - ZINC
	000G18-08-24B	EA	SCREW - MACHINE - 8-32 X 1 1/2 PPH - ZINC
	000G18-08-22B	EA	SCREW - MACHINE - 8-32 X 1 3/8 PPH - ZINC
	000G19-10-10B	EA	SCREW - MACHINE - 10-32 X 5/8 - PPH - ZINC
	000G19-10-08B	EA	SCREW - MACHINE - 10-32 X 1/2 PPH - ZINC
	000G19-10-20B	EA	SCREW - MACHINE - 10-32 X 1 1/2 PPH - ZINC
	000G19-10-12F	EA	SCREW - MACHINE - 10-32 X 3/4 PPH - STAINLESS STEEL
	000G36-10-12T	EA	SCREW - 10-24X 3/4 PFH TYPE 23 - BLACK
	000G39-06-10T	EA	SCREW - SF/DR - 6-20 X 5/8 PPH - BLACK
	000G39-06-16T	EA	SCREW - SF/DR - 6-20 X 1 PPH - BLACK
	000G39-08-08S	EA	SCREW - SF/DR - 8-18 X 1/2 PPH - OFF WHITE
	000G39-08-08B	EA	SCREW - SF/DR - 8-18 X 1/2 PPH - ZINC
	000G39-08-08T	EA	SCREW - SF/DR - 8-18 X 1/2 PPH - BLACK
	000G39-08-06B	EA	SCREW - SF/DR - 8-18 X 3/8 PPH - ZINC
	000G39-08-32B	EA	SCREW - SF/DR - 8-18 X 2 PPH - ZINC
	000G39-08-24T	EA	SCREW - SF/DR - 8-18 X 1 1/2 PPH - BLACK
	000G39-08-24S	EA	SCREW - SF/DR - 8-18 X 1 1/2 - OFF WHITE
	000G39-08-24B	EA	SCREW - SF/DR - 8-18 X 1 1/2 PPH - ZINC
	000G39-08-16T	EA	SCREW - SF/DR - 6-20 X 1 PPH - BLACK
	000G39-08-16B	EA	SCREW - SF/DR - 8-18 X 1 PPH - ZINC
	000G39-08-12B	EA	SCREW - SF/DR - 8-18 X 3/4 PPH - ZINC
	000G39-08-12T	EA	SCREW - SF/DR - 8-18 X 3/4 PPH - BLACK
	000G39-10-48T	EA	SCREW - SF/DR - 10-16 X 3 PPH - BLACK
	000G39-10-48B	EA	SCREW - SF/DR - 10-16 X 3 - PPH - ZINC
	000G39-10-40D	EA	SCREW - SF/DR - 10-16 X 2 1/2 PPH - BLACK
	000G39-10-32B	EA	SCREW - SF/DR - 10-16 X 2 - PPH - ZINC
	000G39-10-20T	EA	SCREW - SF/DR - 10-16 X 1 1/4 PPH - BLACK
	000G39-10-20B	EA	SCREW - SF/DR - 10-16 X 1 1/4 PPH - ZINC
	000G39-10-169	EA	SCREW - SF/DR - 10-16 X 1 PPH - FLUOROCARBON SILVER
	000G39-10-129	EA	SCREW - SF/DR - 10-16 X 3/4 PPH - FLUOROCARBON SILVER
	000G39-10-12T	EA	SCREW - SF/DR - 10-16 X 3/4 - BLACK
	000G39-10-10T	EA	SCREW - SF/DR - 10-16 X 5/8 - BLACK
	000G39-10-10B	EA	SCREW - SF/DR - 10-16 X 5/8 PPH - ZINC
	000G39-10-08B	EA	SCREW - SF/DR - 10-16 X 1/2 PPH - ZINC
	000G39-10-088	EA	SCREW - SF/DR - 10-16 X 1/2 PPH - FLEX FLUOROCARBON
	000G39-12-12E	EA	SCREW - SF/DR - 12 - 14 X 3/4 PPH - CHROME
	000G42-04-24B	EA	SCREW - SF/DR - 1/4-14 X 1 1/2 - ZINC
	000G42-04-16B	EA	SCREW - SF/DR - 1/4-14 X 1 HWH - ZINC
	000G42-04-24B	EA	SCREW - SF/DR - 1/4-14 X 1 1/2 - ZINC
	000G46-08-24T	EA	SCREW - MACHINE - 8-32 X 1 1/2 PFH - BLACK
	000G50-04-48B	EA	SCREW - MACHINE - 1/4-14 X 3 - ZINC
	000G52-06-05B	EA	SCREW - MACHINE - 6-32 X 5/16 PTH ZINC
	000G52-06-06B	EA	SCREW - MACHINE - 6-32 X 3/8 PIN - ZINC
	000G54-04-14B	EA	SCREW - 1/4-20 X 7/8 PTH - TYPE 23 - ZINC PLATED
	000G55-08-124	EA	SCREW - SF/DR - 8-18 X 3/4 PWH - ASH GRAY
	000G55-08-12M	EA	SCREW - SF/DR - 8-19 X .75 PWH - GRAY
	000G55-08-165	EA	SCREW - SF/DR - 8-18 X 1 PWH - WILLOW
	000G55-08-16T	EA	SCREW - SF/DR - 8-18 X 1 PWH - BLACK

SEALANTS & FASTENERS GROUP (CONTINUED)
SCREWS (CONTINUED)

KEY	PART NUMBER	U/M	DESCRIPTION
	000G55-08-16S	EA	SCREW - SF/DR - 8-18 X 1.00 - PWH - OFF WHITE
	000G56-12-48B	EA	SCREW - WOOD - 12-11 X 3 POH - SPECIAL HARDENED
	000G57-14-72B	EA	SCREW-14-10-X4 1/2 PFH ZN GENERAL MOTORHOMES
	000G57-14-64B	EA	SCREW - 14-10 X 4 PFH ZINC
	000G60-08-20F	EA	SCREW - SF/DR - 8-19X1.25 POH
	000G60-08-16E	EA	SCREW - SF/DR - 8-1 X 1 POH - CHROME
	000G60-08-22B	EA	SCREW - SF/DR - 8-18 X 1.38 POH - ZINC
	000G60-10-209	EA	SCREW - SF/DR - 10-16 X 1 1/4 POH - SILVER STALGAARD
	000G60-10-20B	EA	SCREW - SF/DR - 10-16 X 1 1/4 POH - ZINC
	000G60-10-16J	EA	SCREW - SF/DR - 10-16 X 1 POH - BRIGHT BRASS
	000G60-10-28T	EA	SCREW - SF/DR - 10-16 X 1 3/4 - BLACK
	000G67-08-32B	EA	SCREW - 8-15 X 2 PPH - ZINC
	000G67-10-08B	EA	SCREW - 10-12 X 1/2 PPH - ZINC
	000G67-10-24S	EA	SCREW - 10-12 X 1 1/2 PPH - OFF WHITE
	000G67-10-24B	EA	SCREW - 10-12 X 1 1/2 PPH - ZINC
	000G67-10-20D	EA	SCREW - 10-12 X 1 1/4 PPH - BLACK
	000G67-10-12P	EA	SCREW - 10-12 X 3/4 PPH - DARK BROWN
	000G67-10-12B	EA	SCREW - 10-12 X 3/4 PPH - ZINC
	000G67-10-10T	EA	SCREW - 10-12 X 5/8 PPH - BLACK
	000G67-10-10S	EA	SCREW - 10-12 X 5/8 PPH - OFF WHITE
	000G67-10-10P	EA	SCREW - 10-12 X 5/8 PPH - DARK BROWN
	000G67-10-10B	EA	SCREW - 10-12 X 5/8 PPH - ZINC - TYPE A
	000G67-10-08S	EA	SCREW - 10-12 X 1/2 PPH - OFF WHITE
	000G68-06-10J	EA	SCREW - 6-18 X 5/8 POH - BRASS
	000G68-06-10G	EA	SCREW - 6-18 X 5/8 POH - ANTIQUE BRASS
	000G68-06-12J	EA	SCREW - 6-18 X 3/4 POH - BRASS
	000G68-06-12B	EA	SCREW - 6-18 X 3/4 POH - ZINC & CLEAR
	029130-01-000	EA	SCREW - SNAP STUD - #8-16 X 5/8" LONG
	029130-03-000	EA	SCREW - SNAP STUD - #8-16 X 1" LONG
	049465-01-000	EA	SCREW - 10-16 PTH W/WASHER - DARK BROWN
	049465-03-000	EA	SCREW - 10-16 X 1 POH W/WASHER - OFF WHITE
	049465-04-000	EA	SCREW - 10-16 X 1 PTH W/WASHER - BEIGE
	049465-13-000	EA	SCREW-10+16X1 PTH W/WASHER - *ASH GRAY
	049465-17-000	EA	SCREW - 10-16 X 1 POH W/WASHER - BRIGHT WHITE
	049465-23-000	EA	SCREW - 10-16 X 1.5 POH W/WASHER - VW LIGHT GRAY
	054434-02-000	EA	SCREW - SF/DR - 10-16 X 2 - ZINC
	054434-03-000	EA	SCREW - SF/DR - 10-16 X 2 - PWH - ZINC
	075908-01-000	EA	SCREW - MACHINE - 10-32 X .56 PTH - EXTERNAL TOOTH - ZINC
	076790-01-000	EA	SCREW - 6-20 X 1 1/4 PPH - BLACK
	076790-05-000	EA	SCREW - 6-20 X 1/2 PPH - BLACK - THREAD CUTTING/WOOD
	083554-01-000	EA	SCREW - DRYWALL - 8 X 1 1/4
	083554-04-000	EA	SCREW - DRYWALL - 8 X 2 1/2
	087721-01-000	EA	SCREW - FLAT HEAD - TAPPING - 1/4 X 1 1/4 LONG - ZINC
	090033-02-000	EA	SCREW - 1/4-20 X 5/8 - ROUND WASHER HEAD - OFF/WHITE
	097974-01-000	EA	SCREW - PARTICLE BOARD - 7-9 X 3/4 PPH
	101618-01-000	EA	SCREW - 1/4-20 X 3/4 HEX - TAPPING - STALGARD TYPE F
	110460-05-02A	EA	SCREW - MACHINE - 10-24 X 2 1/2 PFH - WHITE
	113563-01-01A	EA	SCREW - 8 X 5/8 LONG SHOULDER/WASHER HEAD
	114469-01-02A	EA	COVER - SCREW - VW DARK GRAY
	117478-01-04A	EA	SCREW - 8-18 X 3/4 PPH W/WASHER - VW LIGHT GRAY
	118383-01-09A	EA	RETAINER/RECESSED - F/.22" SCREW - GLACIER
	118383-01-06A	EA	RETAINER/RECESSED - F/.22" SCREW - ALLANTE ANTELOPE
	118383-01-05A	EA	RETAINER/RECESSED - F/.22" SCREW - VW LIGHT GRAY
	118383-01-04A	EA	RETAINER/RECESSED - F/.22" SCREW - BRIGHT WHITE
	118383-02-09A	EA	RETAINER/RECESSED - F/.27" SCREW - GLACIER
	118383-02-05A	EA	RETAINER/RECESSED - F/.27" SCREW - VW LIGHT GRAY
	118383-02-04A	EA	RETAINER/RECESSED - F/.27" SCREW - BRIGHT WHITE
	118383-03-09A	EA	RETAINER/RECESSED - F/.32" SCREW - GLACIER
	118383-04-05A	EA	CAP - F/RECESSED RETAINER - VW LIGHT GRAY
	118383-04-04A	EA	CAP - F/RECESSED RETAINER - BRIGHT WHITE
	118383-04-09A	EA	CAP - F/RECESSED RETAINER - GLACIER
	118383-04-06A	EA	CAP - F/RECESSED RETAINER - ALLANTE ANTELOPE
	134126-01-01A	EA	SCREW/NAIL - HEX HEAD - 3/4"
	140040-01-000	EA	SCREW - 1/4-20 X 1 - BUTTON HEAD/SOCKET - W/LOCTITE

SEALANTS & FASTENERS GROUP (CONTINUED)
CLAMPS, CLIPS, GROMMETS, RIVETS & PLUGS

KEY	PART NUMBER	U/M	DESCRIPTION
	000F10-06-32B	EA	PIN - COTTER - 3/16" X 2" - ZINC
	000H14-06-06R	EA	RIVET-MANDREL BLIND,3/16 AL - CHERRY BSP-66
	000H16-04-06R	EA	RIVET - POP ALUMINUM - 1/8 X .313 - .375
	000H16-06-10R	EA	RIVET - POP ALUMINUM - 3/16 X .501 - .625
	007161-01-000	EA	CLAMP - HOSE - SPRING TYPE - 1/2"
	008386-01-000	EA	GROMMET - SNAP - 3/8" DIAMETER - NYLON
	010495-01-000	EA	CLAMP - CABLE - 9/16"ID - BLACK
	010495-02-000	EA	CLAMP - CABLE - 3/8"ID - BLACK
	010495-04-000	EA	CLAMP - CABLE - 11/16"ID - WHITE
	010497-01-000	EA	CLAMP - CLOSED - 5/8"ID
	010497-03-000	EA	CLAMP - CLOSED - 1"ID - CUSHIONED
	010497-04-000	EA	CLAMP - CLOSED - 1 5/8"ID
	010497-07-000	EA	CLAMP - CLOSED - 3/8"ID
	010497-09-000	EA	CLAMP - CLOSED - 5/16"ID
	010497-10-000	EA	CLAMP - CLOSED - 7/8"ID
	010499-01-000	EA	CLAMP - CLOSED - 3/8"ID
	016188-03-000	EA	GROMMET - LP LINE - 3/8"HOLE X 2 1/2"LONG - RUBBER
	016188-04-000	EA	GROMMET - LP LINE - 1/2"HOLE X 2 1/2"LONG - RUBBER
	016188-05-000	EA	GROMMET - LP LINE - 3/8"HOLE X 1 1/4"LONG - RUBBER
	016188-06-000	EA	GROMMET - L/P LINE - 3/8"HOLE X 3 1/4"LONG - RUBBER
	016188-08-000	EA	GROMMET - LP LINE - 1/2"HOLE X 1 1/4"LONG - RUBBER
	016188-09-000	EA	GROMMET - LP LINE - .68"HOLE X 1 1/4"LONG - RUBBER
	016188-10-000	EA	GROMMET - LP LINE - .68"HOLE X 2.5"LONG - RUBBER
	023942-01-000	EA	GROMMET - RUBBER - 2" OD
	034141-02-000	EA	PLUG/NYLON - .38" - BLACK
	061420-01-000	EA	PLUG/PLASTIC - 1 3/4" DIAMETER - BROWN
	061420-04-000	EA	PLUG/PLASTIC - 1 1/4" DIAMETER
	061420-05-000	EA	PLUG/PLASTIC - 1 1/2" DIAMETER
	061420-08-000	EA	PLUG/PLASTIC - 2 1/2" DIAMETER
	061420-09-000	EA	PLUG/PLASTIC - 1.00" - DIAMETER
	061420-10-000	EA	PLUG/PLASTIC - 1 1/2" DIAMETER - BLACK
	061420-13-000	EA	PLUG/PLASTIC - 3/8 - 3"
	061420-14-000	EA	PLUG/PLASTIC - 7/8" DIAMETER - BLACK
	061420-15-000	EA	PLUG/PLASTIC - 2" DIAMETER - BLACK
	061420-16-000	EA	PLUG/PLASTIC - 2 1/8" DIAMETER - BLACK
	062401-01-000	EA	CLAMP - HOSE - WORMGEAR - .25" - 1"
	062401-02-000	EA	CLAMP - HOSE - WORMGEAR - 1.56" - 2.5"
	062401-03-000	EA	CLAMP - HOSE - WORMGEAR - .22" - 1"
	062401-04-000	EA	CLAMP - HOSE - WORMGEAR - .69" - 1.25"
	062401-05-000	EA	CLAMP - HOSE - WORMGEAR - 2" - 3" ID
	062401-06-000	EA	CLAMP - HOSE - WORMGEAR - .22" - .62" ID
	062401-09-000	EA	CLAMP - HOSE - WORMGEAR - 2.8" - 3.75"
	062401-11-000	EA	CLAMP - HOSE - WORMGEAR - 3.50" - 4.50"
	062401-12-000	EA	CLAMP - HOSE - WORMGEAR - .79" X 1.26"
	071015-11-000	EA	GROMMET - RUBBER - 1 ID - FITS .12 MATERIAL - BLACK
	071015-13-000	EA	GROMMET - RUBBER - .62 ID - FITS .09 GROOVE - BLACK
	071015-19-000	EA	GROMMET - RUBBER - .38 ID - FITS .06 MATERIAL - BLACK
	071015-22-000	EA	GROMMET - RUBBER - .62 ID - 1.12 OD - W/.19 GROOVE - BLACK
	071015-26-000	EA	GROMMET - RUBBER - 1.5" ID X 2.1" OD W/.06" GROOVE-BLACK
	071015-29-000	EA	GROMMET - RUBBER - .3" ID X 1.3"OD W/.12" GROOVE - BLACK
	071015-30-000	EA	GROMMET - RUBBER - .3" ID X .81"OD W/.12" GROOVE - BLACK
	071015-32-000	EA	GROMMET - RUBBER - .75 ID X 1.375 OD W/.187 GROOVE - BLACK
	071015-40-000	EA	GROMMET - RUBBER - .38 ID - FITS .09 MATERIAL - BLACK
	071015-41-000	EA	GROMMET - .125 ID FITS .188 MTL
	071015-42-000	EA	GROMMET - RUBBER - .25 ID - FITS .06 MATERIAL - BLACK
	075148-02-000	EA	CLAMP - GROUNDING - BRONZE SCREWS
	077955-01-000	EA	CLIP/J - 3/8" - VINYL COATED
	080734-02-000	EA	CLIP - WIRE NYLON
	081211-03-000	EA	PLUG/PLASTIC - .50" DIAMETER - TRUSS HEAD - BLACK
	081211-04-000	EA	PLUG/PLASTIC - .46 DIAMETER - TRUSS HEAD - BLACK
	083609-01-000	EA	CLAMP - WIRE - DUAL - EQUAL DIAMETERS - 5/8"
	083610-01-000	EA	CLAMP - WIRE - DUAL - UNEQUAL DIAMETERS - 3/4" & 1 1/4"
	083610-02-000	EA	CLAMP - WIRE - DUAL - UNEQUAL DIAMETERS - 3/4" & 2"
	083610-03-000	EA	CLAMP - WIRE - DUAL - EQUAL DIAMETERS - 2"

SEALANTS & FASTENERS GROUP (CONTINUED)
CLAMPS, CLIPS, GROMMETS, RIVETS & PLUGS (CONTINUED)

KEY	PART NUMBER	U/M	DESCRIPTION
	088756-01-000	EA	GROMMET - WEB - 1 1/8 " I.D.
	089329-02-000	EA	CLIP - SPRING
	091952-01-000	EA	CLIP - GRIPPER - 1"
	091952-02-000	EA	CLIP - GRIPPER - 3/4"
	091952-03-000	EA	CLIP - GRIPPER - 1/2" - BLACK VINYL COATED
	094362-02-000	EA	CLIP - XMAS TREE - BINDER HEAD - .9" LONG
	094362-05-000	EA	CLIP - XMAS TREE - ROUND HEAD - 1.4" LONG
	114208-01-000	EA	GROMMET - EDGE LINER - FITS 1 3/4"
	114208-03-000	EA	GROMMET - EDGE LINER - FITS 2 1/2"
	114208-05-000	EA	GROMMET - EDGE LINER - FITS 2"
	118626-01-02A	EA	RIVET - POP - ALUMINUM - 3/16 X .08 - .375
	118626-01-01A	EA	RIVET - POP - ALUMINUM - 3/16 X .08 - .375
	118626-02-01A	EA	RIVET - POP - ALUMINUM - 3/16 X .500 - .750
	137014-01-02A	EA	GROMMET - CABLE - BROWN
	137014-01-01A	EA	GROMMET - CABLE - ALMOND
	139118-02-01A	EA	GROMMET - SCREW - PLASTIC
	140171-01-000	EA	CLAMP - HOSE - STEPLESS EAR - .312
	140171-02-000	EA	CLAMP - HOSE - STEPLESS EAR - .250

MISCELLANEOUS FASTENERS

KEY	PART NUMBER	U/M	DESCRIPTION
	008343-01-000	EA	TIE - WIRE - 6"
	008343-02-000	EA	TIE - WIRE - 14"
	008343-03-000	EA	TIE - WIRE - 7 1/2" - BLACK
	029094-04-000	YD	VELCRO TAPE - LOOP - 1" WIDE - BLACK
	029094-06-000	YD	VELCRO TAPE - LOOP - 2" WIDE - BLACK
	029096-03-000	YD	VELCRO TAPE - HOOK - 1" WIDE - BLACK
	048394-02-000	YD	VELCRO TAPE - HOOK - ADHESIVE BACK - 3/4" WIDE - BEIGE
	085774-01-000	FT	FASTENER - DUAL LOCK - 1" WIDE - ADHESIVE BACK - BLACK
	085774-02-000	FT	FASTENER - DUAL HOOK - 1" WIDE - ADHESIVE BACK - BLACK
	085774-07-000	FT	FASTENER - DUAL HOOK - 1" WIDE
	088792-02-000	YD	VELCRO TAPE - LOOP - 3/4" - ADHESIVE BACK - BEIGE
	088792-04-000	YD	VELCRO TAPE - HOOK - 5/8" - NON-ADHESIVE BACK - WHITE
	088792-05-000	YD	VELCRO TAPE - LOOP - 5/8" - NON-ADHESIVE BACK - WHITE
	108046-01-000	EA	CABLE TIE - SCREW MOUNT 8"
	108046-02-000	EA	CABLE TIE - SCREW MOUNT 15"
	110943-02-000	FT	FELT STRIP - 3/8" - ADHESIVE BACK - WHITE
	113133-02-01A	EA	RIVET - POP - ALUMINUM - 3/16 X .252 - .504 - BLACK
	115361-01-01A	EA	PLUG/PLASTIC - 1/2" DIAMETER
	127960-01-01A	EA	RETAINER - 3/8" - STAINLESS STEEL

WATER & SEWAGE GROUP DRAINAGE SYSTEM

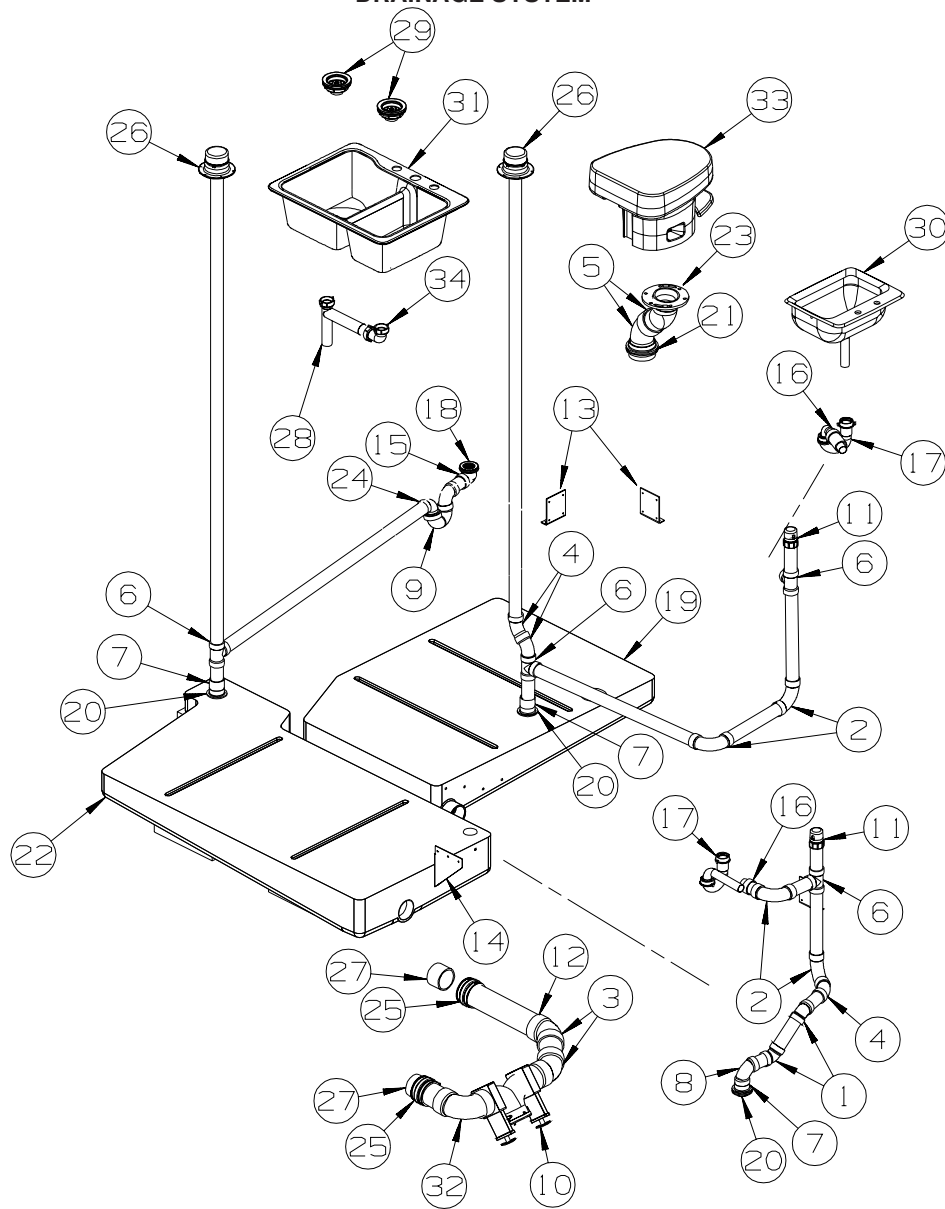

KEY	PART NUMBER	U/M	DESCRIPTION
1	010006-01-000	EA	ELBOW - 45 DEGREE - 1 1/2" HUB X HUB - PLASTIC
2	010008-01-000	EA	ELBOW - 90 DEGREE - 1 1/2" HUB X HUB - PLASTIC
3	010024-01-000	EA	ELBOW - 45 DEGREE - 3" HUB X HUB - PLASTIC
4	010051-01-000	EA	ELBOW - 45 DEGREE - 1 1/2" SPIGOT X HUB - PLASTIC
5	010061-01-000	EA	ELBOW - 45 DEGREE ST - 3" SPIGOT & HUB - PLASTIC
6	010071-01-000	EA	TEE - SANITARY - 1 1/2" HUB X HUB X HUB - PLASTIC
7	010115-01-000	EA	COUPLING - 1 1/2" HUB X HUB - PLASTIC
8	034250-01-000	EA	ELBOW - 90 DEGREE - LONG TURN - 1 1/2" HUB X HUB - ABS
9	037763-01-000	EA	P-TRAP - PLASTIC - 1 1/2 HXH W/UNION
10	136143-01-000	EA	VALVE - DUAL - 3" X 3"
	139513-01-000	EA	HOSE - SEWER - 3" X 10' - W/ADAPTER
	062416-01-000	EA	ADAPTER - SEWER HOSE TO 3" PIPE
11	079968-01-000	EA	VENT - MECHANICAL/TRAP ARM - ANTI-SIPHON-2" X 7.3" PLASTIC
12	141443-01-02B	EA	HOLDER - RING - E-COATED
13	094756-01-01A	EA	BRACKET/ANGLE - W/HOLES
14	112628-05-02B	EA	BRACKET/TIEDOWN - WATER TANK - E-COATED
15	131486-01-000	EA	ELBOW - DRAIN - 1 1/2 LOW PROFILE - TUB DRAIN
16	109571-01-000	EA	ADAPTER - P-TRAP - 1 1/2"P X 1 1/4"MPT
17	107538-01-000	EA	P-TRAP - PLASTIC - 1 1/4" W/EXTENSION ARM - USA
17	011071-01-000	EA	P-TRAP - PLASTIC - 1 1/2" - CSA - CANADIAN

WATER & SEWAGE GROUP (CONTINUED)
DRAINAGE SYSTEM (CONTINUED)

KEY	PART NUMBER	U/M	DESCRIPTION
18	066440-01-000	EA	STRAINER - SHOWER DRAIN - W/RUBBER WASHER
	011069-02-000	EA	TAILPIECE - TUB/SHOWER - 1 1/2" X 1 1/4" X 4" - BRASS
	127440-02-01A	EA	WASHER - RUBBER - 1.8" X .1"
	130403-01-000	EA	NUT - SLIP - W/WINGS 1 1/2"
19	129964-01-000	EA	TANK - HOLDING - 38 GALLON - W/O FITTINGS
20	061607-01-000	EA	GROMMET - HOLDING TANK - 1 1/2" NPS
21	061607-02-000	EA	GROMMET - HOLDING TANK - 3" NPS
22	146261-01-01A	EA	TANK - HOLDING - 40 GALLONS - W/O FITTINGS
23	063641-01-000	EA	FLANGE - CLOSET - 4" X 3"
24	010009-01-000	EA	ELBOW - 90 DEGREE - 1/4 BEND - 1 1/2" PLASTIC
25	078406-01-000	EA	COUPLER - 3" X 3" W/CLAMPS - RUBBER
26	083558-06-000	EA	VENT W/COVER F/PLUMBING STACK - VW WHITE
			FROM: 00-00-00 THRU: 07-06-03
26	083558-03-000	EA	VENT W/COVER F/PLUMBING STACK - OFF WHITE
			FROM: 07-07-03 THRU: 99-99-99
27	010129-03-000	EA	NIPPLE - 3" X 3" TOE - PLASTIC
28	091980-01-000	EA	WASTE - CONTINUOUS
			FROM: 00-00-00 THRU: 11-04-03
28	011091-02-000	EA	WASTE - CONTINUOUS
			FROM: 11-05-03 THRU: 99-99-99
29	092303-01-000	EA	STRAINER - W/BASKET - GALLEY SINK - 4" OD
	127440-02-01A	EA	WASHER - RUBBER - 1.8" X .1"
30*	096927-01-02A	EA	SINK - LAVATORY - RECTANGLE - SOFT WHITE
34	136828-01-01A	EA	SINK/DBL - LGE/SM BASIN-25"X19"X7" W/O NOTCH/FAUCET HOLES
			FROM: 00-00-00 THRU: 11-04-03
34	148870-01-01A	EA	SINK/DBL - LGE/SM BASIN-25"X19"X7" W/O NOTCH/FAUCET HOLES
			FROM: 11-05-03 THRU: 99-99-99
32	010062-01-000	EA	ELBOW - 3 90 SPIGOT X HUB - PLASTIC
33*	067487-04-000	EA	TOILET - LOW - FOOTFLUSH - WHITE
			FROM: 00-00-00 THRU: 07-27-03
33*	147421-02-01A	EA	TOILET - AQUA MAGIC 5 - LOW/FOOTFLUSH/W/SPRAYER- WHITE
			FROM: 07-28-03 THRU: 99-99-99
34	126588-01-000	EA	ARM - WASTE - 1 1/2" X 9 1/2" - FEMALE

*COMPONENT PARTS LISTED LATER IN THIS GROUP

WATER & SEWAGE GROUP (CONTINUED)
COMPONENT PARTS FOR DRAINAGE SYSTEM

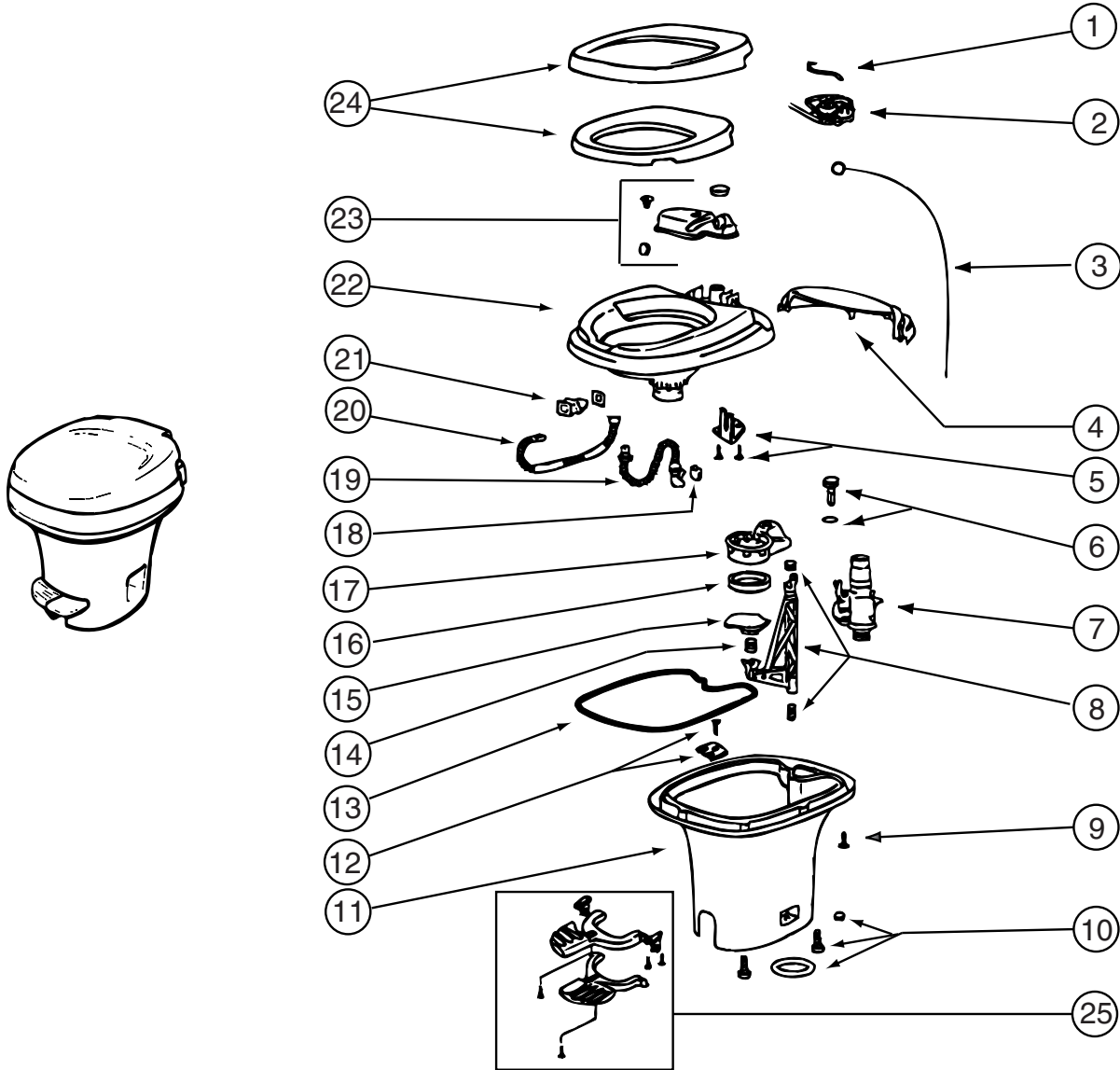

067487-04-000

KEY	PART NUMBER	U/M	DESCRIPTION	VENDOR NO.
2	063740-02-703	EA	KIT-LEVER/WIRE ASSM FOOT FL	24571
4	131932-02-701	EA	COVER -MECHANISM- WHITE	2086562
7	063740-01-714	EA	VALVE ASM (VALVE-BALL SEAL)	13168
10	063740-01-706	EA	BOLT PACKAGE-FLOOR FLANGE	12524THETFORD
15	063740-01-721	EA	BLADE ONLY	1248262
16	063740-01-722	EA	SEAL - BLADE	12481
20	063740-01-717	EA	TUBE-FLUSH	12509
23	063740-02-701	EA	RESERVOIR (TANK ASM.)	24630
24	131932-01-701	EA	SEAT/COVER ASSMBLY - WHITE	2464162
25	131932-02-702	EA	PEDAL PACKAGE(WHITE)	2082162

CONTACT WINNEBAGO PART SALES FOR UNLISTED COMPONENT

096927-01-02A

KEY	PART NUMBER	U/M	DESCRIPTION	VENDOR NO.
	096927-01-700	EA	SINK STOPPER	M9801
	096927-01-701	EA	TAILPIECE-DRAIN-LAVATORY	M9802

WATER & SEWAGE GROUP (CONTINUED)
COMPONENT PARTS FOR DRAINAGE SYSTEM (CONTINUED)

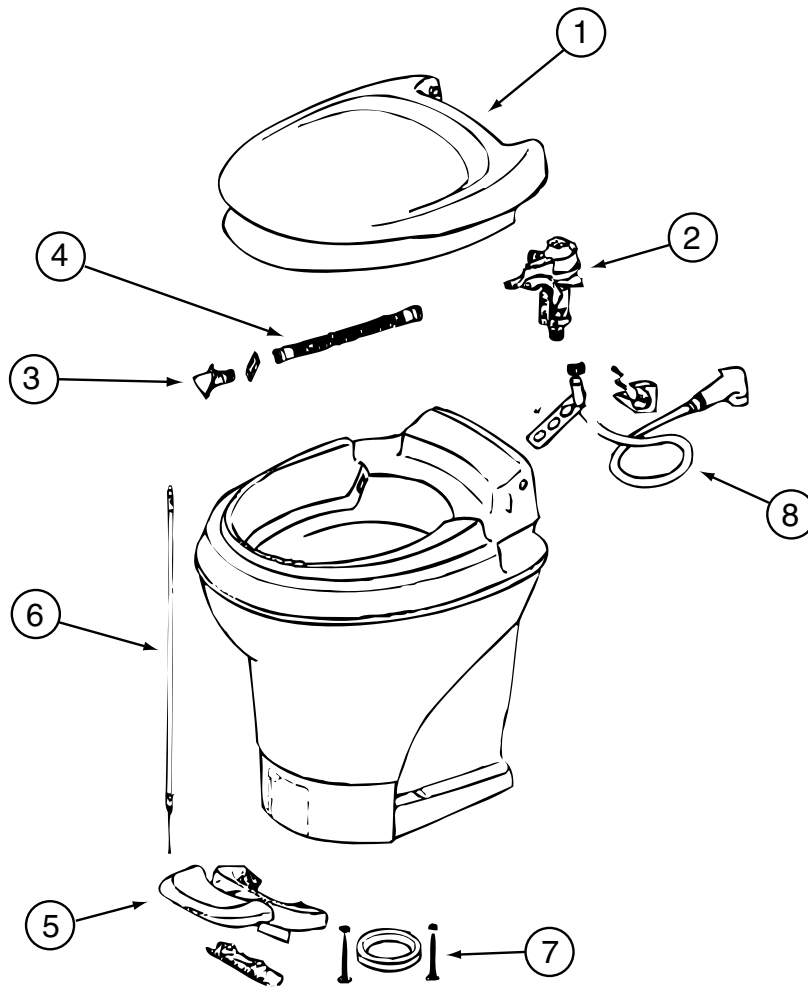

147421-02-01A

KEY	PART NUMBER	U/M	DESCRIPTION	VENDOR NO.
1	147421-01-700	EA	SEAT & COVER ASSEMBLY(WHT)	31703
2	147421-01-701	EA	WATER MODULE ASSEMBLY	31705
3	147421-01-702	EA	NOZZLE ASSEMBLY	31706
4	147421-01-703	EA	LINK - WATER MODULE	31621
5	147421-01-704	EA	PEDAL - WHITE	31709
6	147421-01-705	EA	FOOT CABLE	31711
7	063740-01-706	EA	BOLT PACKAGE-FLOOR FLANGE	12524 THETFORD
8	132389-01-708	EA	HAND SPRAY KIT	19289
	147421-01-706	EA	SEAL - BLADE	31708
	147421-01-707	EA	CAP (UNIVERSAL BOLT) - WHITE	31713

WATER & SEWAGE GROUP (CONTINUED)
WATER SYSTEM

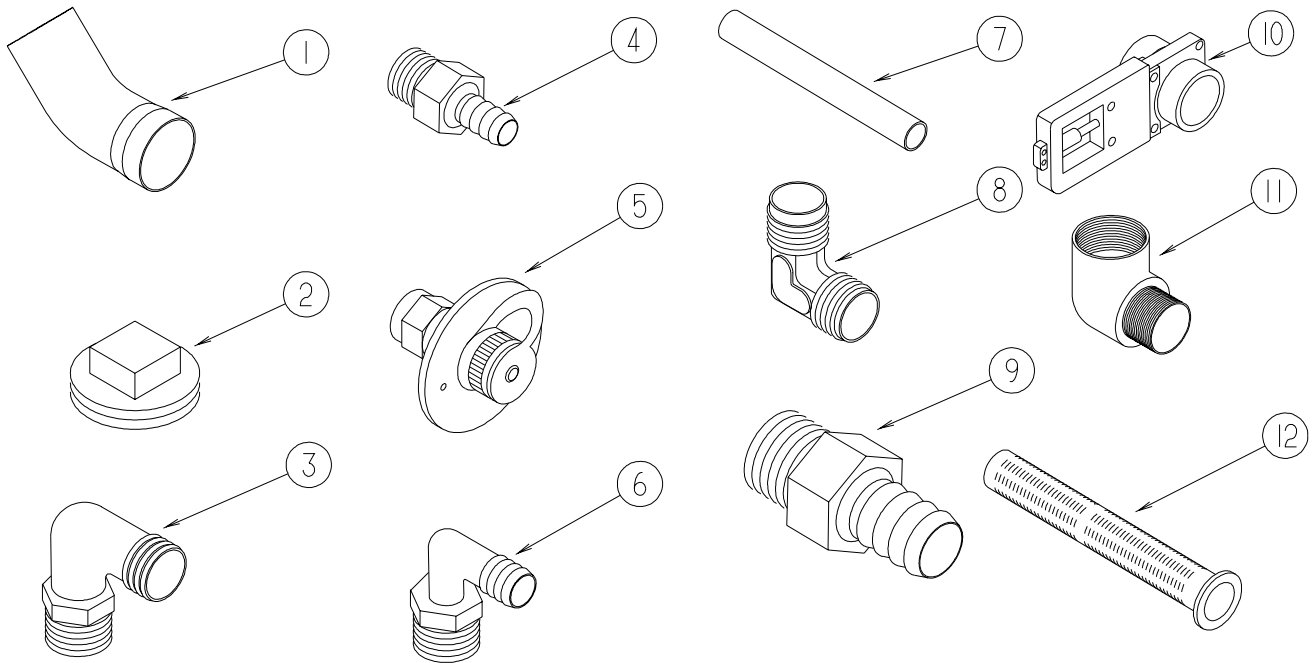

KEY	PART NUMBER	U/M	DESCRIPTION
1	010009-01-000	EA	ELBOW - 90 DEGREE - 1/4 BEND - 1 1/2" PLASTIC
2	010166-01-000	EA	PLUG/THREADED - 1 1/4"MPT - PLASTIC - BLACK - UL
3	010219-01-000	EA	ELBOW - 1 1/4 MPT X 1 1/4 BARB - WATER FILL - PLASTIC
4	010224-01-000	EA	ADAPTER - HOSE TO PIPE - 3/8 MPT X 3/8 BARB - PLASTIC
5	010230-06-000	EA	FILL - CITY WATER - W/CHECK VALVE - MPT - BRUSHED ALUM
6	035539-01-000	EA	ELBOW - 3/8 MPT X 3/8 BARB - PLASTIC
7	039800-04-000	FT	TUBING - POLYBUTYL - 1/4"OD
7	074462-02-000	FT	TUBING - VINYL - 3/8 ID X 20' - CLEAR
7	112176-01-000	FT	TUBING - VINYL - REINFORCED - 1/2" ID
7	124188-01-000	FT	TUBING - PEX - 1/2" ID X 20' - BLUE(COLD)
7	124188-02-000	FT	TUBING - PEX - 1/2" ID X 20' - RED(HOT)
8	039808-03-000	EA	ELBOW - 1/2" MPT X 1/2" MPT - PLASTIC
9	044927-01-000	EA	ADAPTER - HOSE TO PIPE-1 1/4 MPTX1 1/4 BARB-BLACK PLASTIC
10	062421-03-000	EA	VALVE/DUMP W/O HANDLE - 1 1/2" X 1 1/2" HUB
	062421-05-000	EA	CABLE/ROD - F/DUMP VALVE - W/HANDLE - 48"
11	065318-02-000	EA	ELBOW - 90 DEGREE - 3/8" MPT TO 3/8" FPT
12	077954-02-000	EA	FILTER - WATER TANK - W/SCREEN IN TANK

WATER & SEWAGE GROUP (CONTINUED)
WATER SYSTEM (CONTINUED)

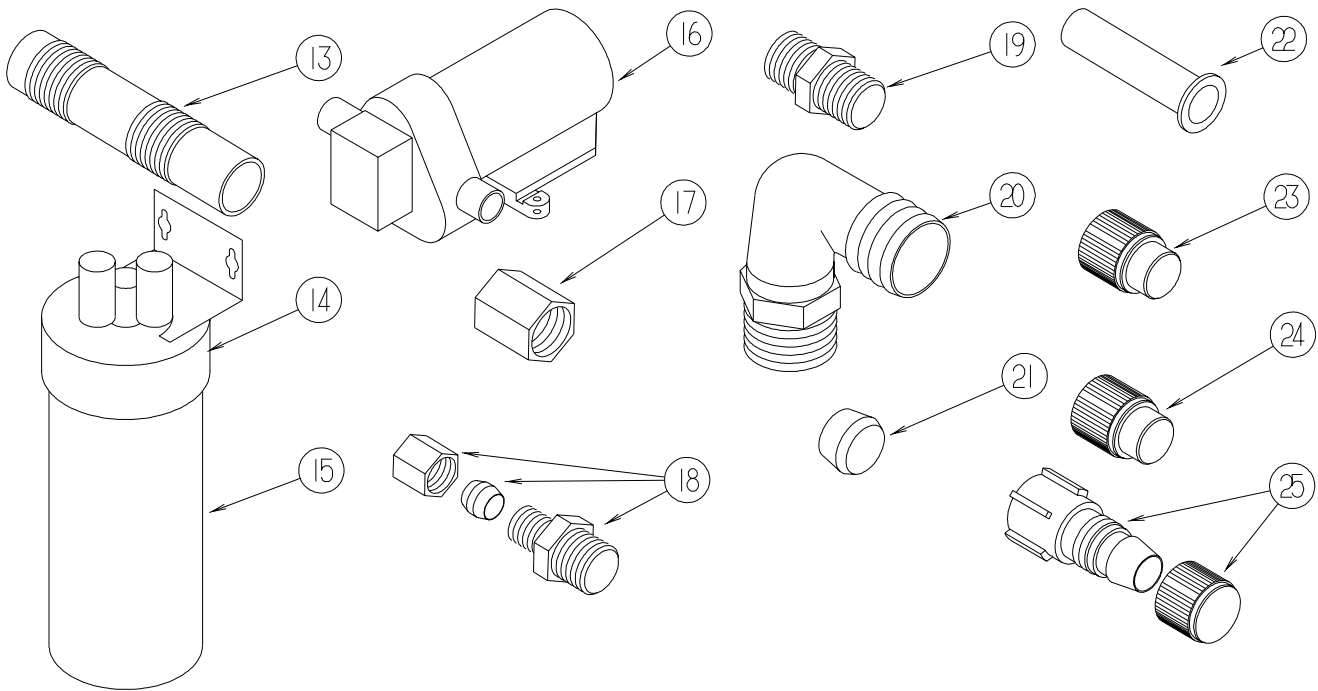

KEY	PART NUMBER	U/M	DESCRIPTION
13	079381-01-000	FT	TUBING - RIBBED FLEXIBLE - WATER FILL - 1.4" ID
14	087200-01-000	EA	FILTER-WATER PURIFICATION, EVERPURE QC2-AC
15	087200-02-000	EA	CARTRIDGE-WATER FILTER, AC - EVERPURE 9601-11
16*	098607-01-000	EA	PUMP - WATER - W/.5" MPT FITTING - FLOW 2.8 GPM
17	101814-01-000	EA	COUPLING - FEMALE - 1/2" X 1/2" FPT - GRAY
18	103798-01-000	EA	CONNECTOR - 1/4 OD X 3/8 MPT
19	110438-02-000	EA	VALVE - CHECK - BRASS - 1/2 MPT X 1/2 MPT
20	111223-02-000	EA	ELBOW - 1/2" MPT X 3/8" BARB - PLASTIC
20	111223-03-000	EA	ELBOW - 3/4" MPT X 1/2" BARB - PLASTIC
20	111223-04-000	EA	ELBOW - 1/2" MPT X 1/2" BARB - PLASTIC
21	111888-01-000	EA	FERRULE - PLASTIC - .250 ID X .375 OD
22	111888-02-000	EA	INSERT - BRASS - 1/4 COMP
23	113697-01-000	EA	CAP - 3/8"P
24	114427-01-000	EA	CAP - 1/2"P
25	114427-02-000	EA	PLUG - W/COMP NUT - 1/2" PLASTIC PIPE/1/2" FLAIR-IT

WATER & SEWAGE GROUP (CONTINUED)
WATER SYSTEM (CONTINUED)

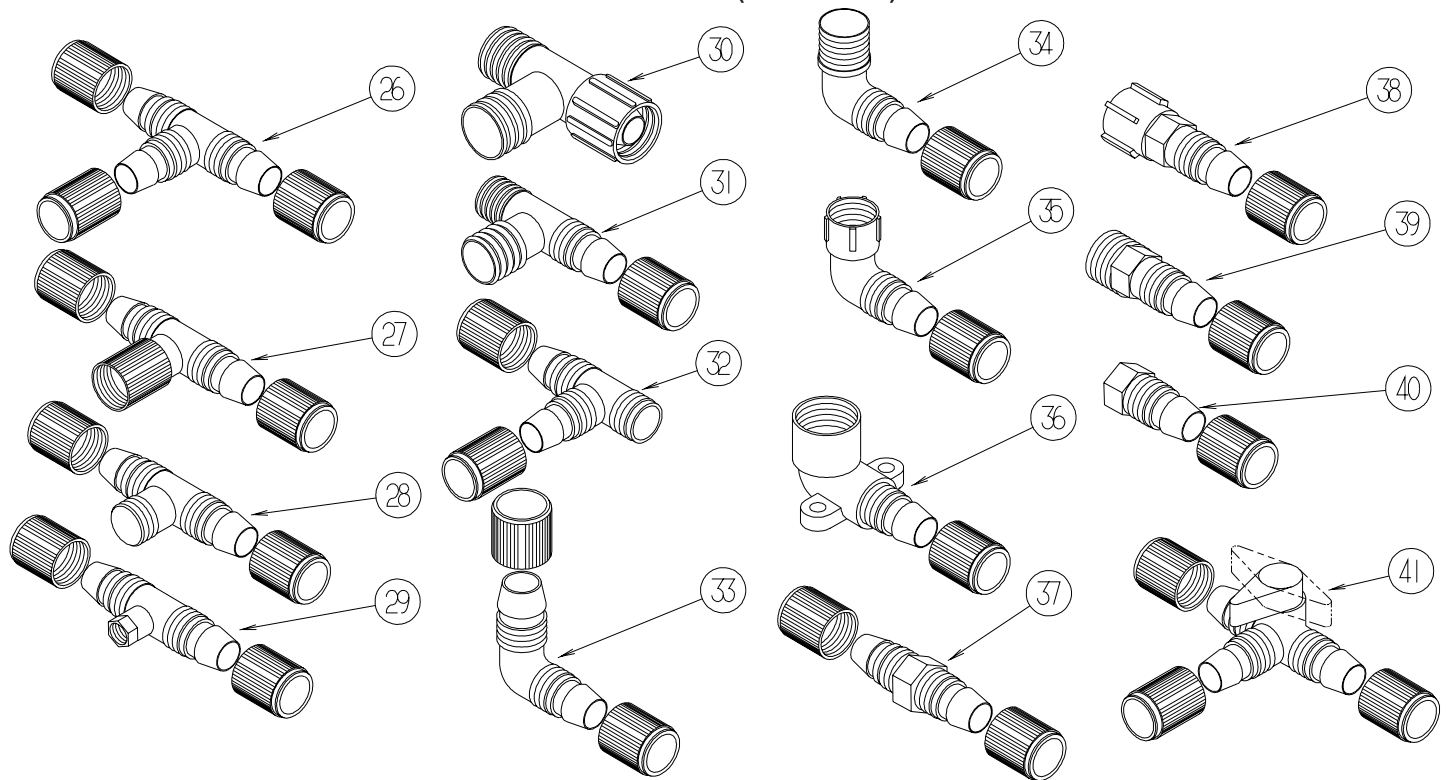

KEY	PART NUMBER	U/M	DESCRIPTION
26	114428-01-000	EA	TEE - 1/2"P X 1/2"P X 1/2"P
27	114428-02-000	EA	TEE - SWIVEL - 1/2"P X 1/2"P X 1/2"FPT
28	114428-03-000	EA	TEE - 1/2"P X 1/2"P X 1/2"MPT
29	114428-04-000	EA	TEE - 1/2"P X 1/2"P X 1/8"FPT
30	114428-05-000	EA	TEE - 1/2" SWIVEL X 1/2" MPT X 1/2" MPT
31	114428-06-000	EA	TEE - 1/2" P X 1/2" MPT X 1/2" MPT
32	114428-07-000	EA	TEE - 1/2" P X 1/2" MPT X 1/2" P
33	114429-01-000	EA	ELBOW - 1/2"P X 1/2"P
34	114429-02-000	EA	ELBOW - 1/2"P X 1/2"MPT
34	114429-04-000	EA	ELBOW - 1/2"P X 3/8"MPT
34	114429-05-000	EA	ELBOW - 1/2"P X 3/4"MPT
34	114429-10-000	EA	ELBOW - SWIVEL - 1/2"MPT X 1/2"FPT
35	114429-03-000	EA	ELBOW - SWIVEL - 1/2"P X 1/2"FPT
35	114429-06-000	EA	ELBOW - SWIVEL - 1/2"P X 3/4"FPT
35	114429-08-000	EA	ELBOW - SWIVEL - 1/2"P X 1/2"FPT
35	114429-11-000	EA	ELBOW - 1/2"P X 1/2"FPT
36	114429-09-000	EA	ELBOW - 1/2"P X 1/2"FPT DROP EAR
37	114430-01-000	EA	ADAPTER - 1/2"P X 1/2"P
38	114430-02-000	EA	ADAPTER - SWIVEL - 1/2"P X 1/2"FPT
38	114430-04-000	EA	ADAPTER - SWIVEL - 1/2"P X 3/8"MPT
39	114430-03-000	EA	ADAPTER - 1/2"P X 1/2"MPT
40	114430-06-000	EA	ADAPTER - 1/2"P X 3/8"FPT
40	114430-09-000	EA	ADAPTER - 1/2"P X 1/2"FPT
41	114431-01-000	EA	VALVE - 180 DEGREE/CENTER DRAIN - 1/2"P - THREE WAY

WATER & SEWAGE GROUP (CONTINUED)
WATER SYSTEM (CONTINUED)

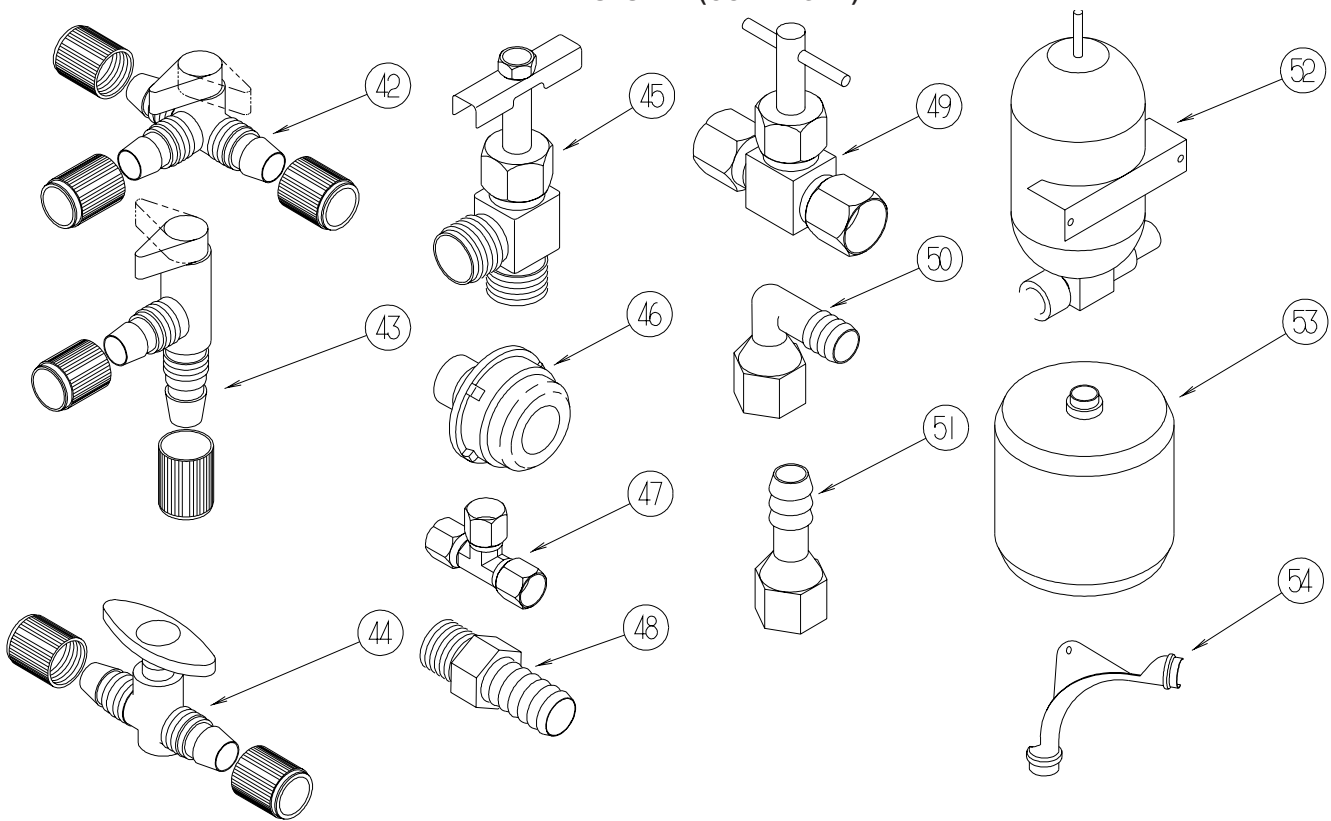

KEY	PART NUMBER	U/M	DESCRIPTION
42	114431-02-000	EA	VALVE - WATER BYPASS - 1/2"P - THREE WAY (WATER HEATER)
43	114431-03-000	EA	VALVE - 90 DEGREE DRAIN - 1/2"P
44	114431-04-000	EA	VALVE - "INLINE SHUT-OFF" - 1/2"P
45	114431-05-000	EA	VALVE - NEEDLE - 1/8" MPT X 1/4" COMPRESSION (ICE MAKER)
46	114966-01-000	EA	FILTER - IN LINE - TWIST ON - 1/2"
47	118423-01-000	EA	FITTING - BRASS-TEE - 1/4C X 1/4C X 1/4C
48	118809-01-000	EA	ADAPTER - 1/2" MPT X 3/8" BARB - PLASTIC
48	118809-02-000	EA	ADAPTER - 1/2" MPT X 1/2" BARB - PLASTIC
49	120868-01-000	EA	VALVE - NEEDLE - 1/4" COMPRESSION X 1/4" COMPRESSION
50	123150-01-000	EA	ELBOW - 1/2 FPT X 1/2 BARB - SWIVEL
51	123152-01-000	EA	ADAPTER - 1/2 FPT X 1/2 BARB - SWIVEL
52	123243-01-000	EA	TANK - ACCUMULATOR - 24 OZ
53	123317-01-000	EA	TANK - ACCUMULATOR - 2 GALLON
54	124184-01-000	EA	SUPPORT - WATER LINE - BEND

WATER & SEWAGE GROUP (CONTINUED)
WATER SYSTEM (CONTINUED)

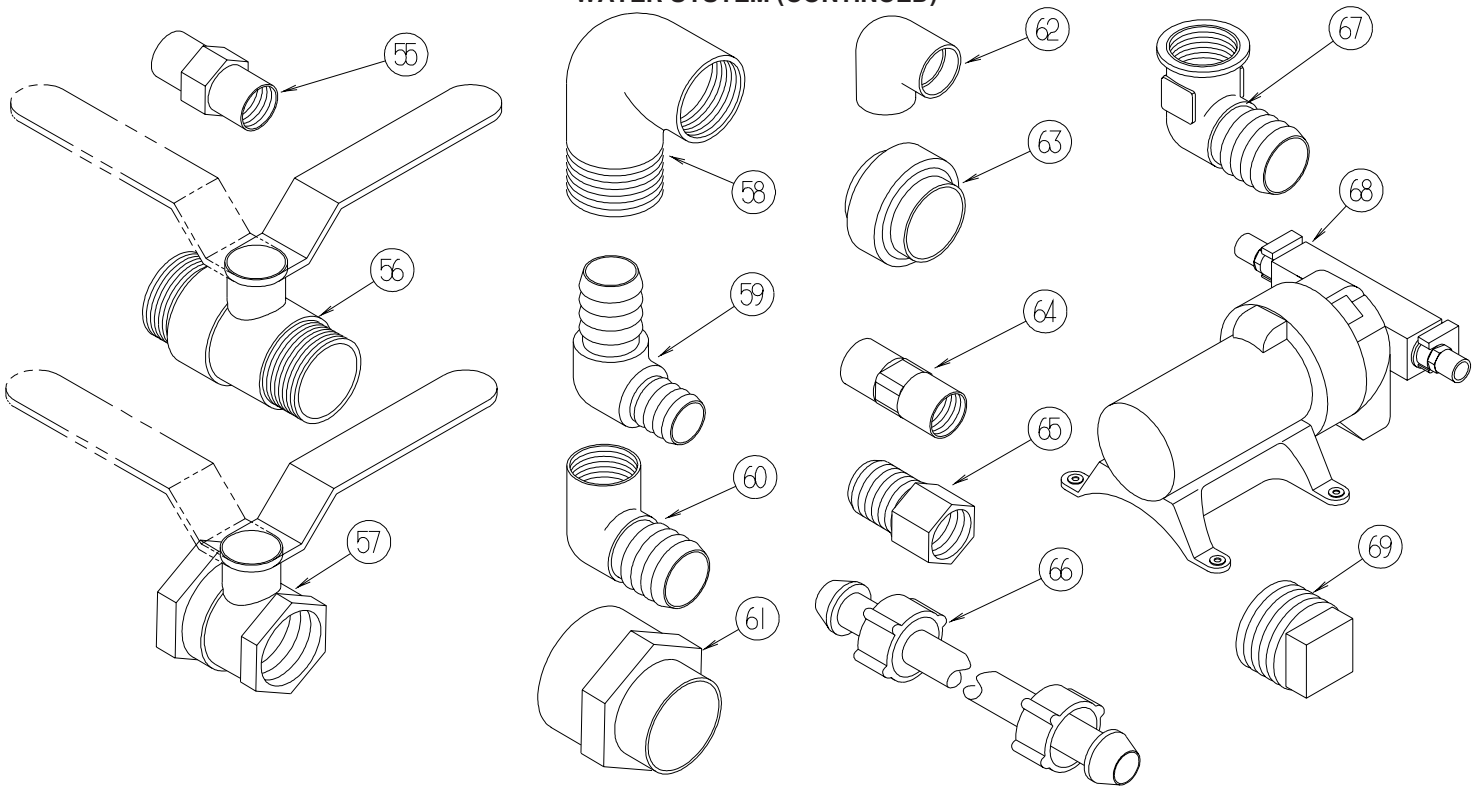

KEY	PART NUMBER	U/M	DESCRIPTION
55	132148-01-000	EA	CONNECTOR - 1/2" X 1/2"MPT - BRASS
56	132483-01-000	EA	VALVE/BALL - 1" - THREADED ENDS
57	132483-02-000	EA	VALVE/BALL - 1/2" - BRASS - FPT
58	132484-01-000	EA	ELBOW - 90 DEGREE - 1MPT X 1FPT - PLASTIC
59	132781-01-000	EA	ELBOW - 1.3" BARB X 1.3" BARB - 90 DEGREE - PLASTIC
60	132782-01-000	EA	ELBOW - 1"FPT X 1.3" BARB - 90 DEGREE - PLASTIC
61	133835-01-000	EA	ADAPTER - REDUCING - 1 1/2" X 1 1/4"
62	133837-01-000	EA	ELBOW - 1 1/2" X 90 DEGREE - DOUBLE SLIP
63	133889-01-000	EA	UNION - 1 1/2 DOUBLE SLIP - PVC
64	135386-01-000	EA	NIPPLE - 1/2"
65	136333-01-000	EA	ADAPTER - BRASS - 1/2"MPT X 1/2"FPT
66	140821-01-000	EA	TUBE - WATER SUPPLY - 3/8" X 24"
66	140821-02-000	EA	TUBE - WATER SUPPLY - 3/8" X 30"
66	140821-03-000	EA	TUBE - WATER SUPPLY - 3/8" X 36"
66	140821-04-000	EA	TUBE - WATER SUPPLY - 3/8" X 48"
66	140821-05-000	EA	TUBE - WATER SUPPLY - 3/8" X 54"
66	140821-06-000	EA	TUBE - WATER SUPPLY - 3/8" X 60"
66	140821-07-000	EA	TUBE - WATER SUPPLY - 3/8" X 72"
67	142812-01-000	EA	ELBOW - BRASS - 1/2"MPT X 1/2"FPT
68*	144215-01-000	EA	PUMP - WATER - 5.7 GPM - W/1/2" MPT
	144215-02-000	EA	STRAINER - WATER PUMP
69	145609-01-000	EA	PLUG - BRASS - 1/2" MPT/HEX HEAD

***COMPONENT PARTS LISTED LATER IN THIS GROUP**

WATER & SEWAGE GROUP (CONTINUED)
WATER SYSTEM (CONTINUED)

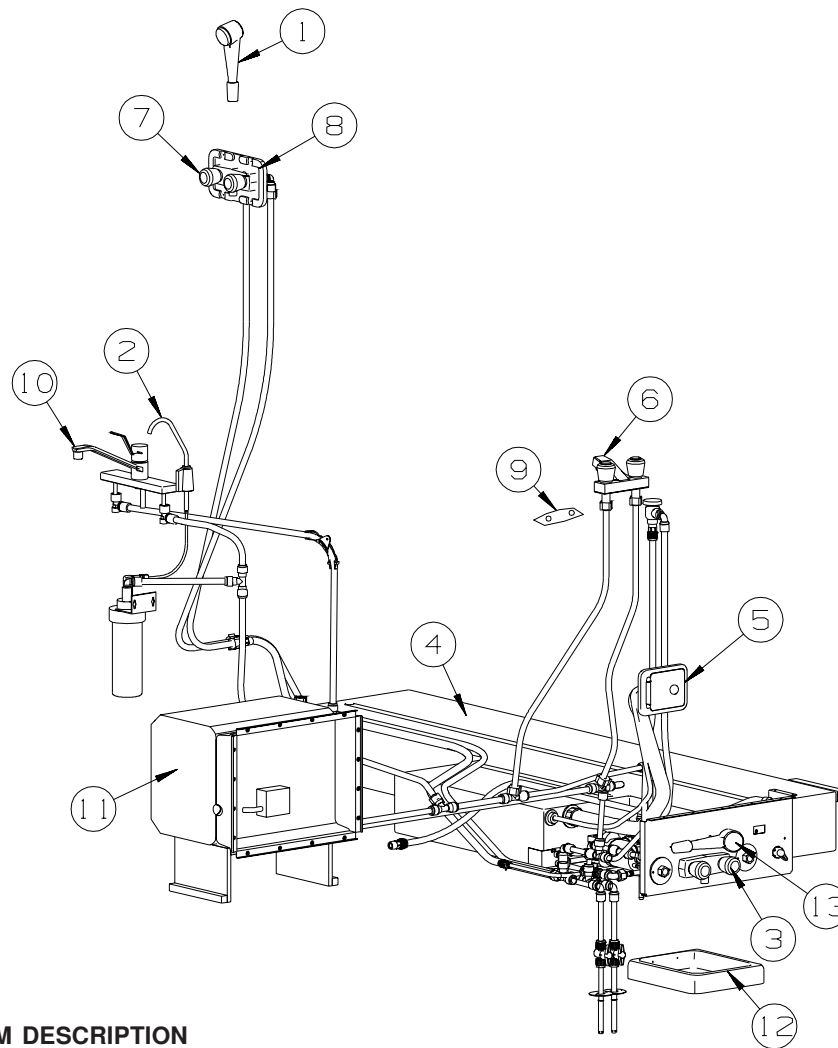

KEY	PART NUMBER	U/M	DESCRIPTION
1	129390-04-01A	EA	SHOWER HEAD - W/HOSE & BRACKET - WHITE
2	103635-01-000	EA	FAUCET - SINGLE CONTROL/DRINKING WATER
3*	075241-06-000	EA	FAUCET - SHOWER/BRIGHT WHITE - .5" MPT W/1.9" INLET PIPES
4	142250-01-01A	EA	TANK - WATER - W/O FITTINGS
4	142250-02-01A	EA	TANK - WATER - W/FITTINGS
	042989-03-000	EA	FITTING - SPINWELD - 1 1/4"NPT - PLASTIC
	042989-04-000	EA	FITTING - SPINWELD - 3/8"FPT - PLASTIC
	042989-05-000	EA	FITTING - SPINWELD - 1/2"FPT - PLASTIC
	042989-08-000	EA	FITTING - SPINWELD - 1"FPT - PLASTIC
	049032-01-000	EA	PATCH - SPINWELD - 3/8" - PLASTIC
5	137169-01-01A	EA	WATER FILL/GRAVITY - W/DOOR - W/O LOCK - BRIGHT WHITE
	138290-03-000	EA	CASE - W/CAM - W/O CYLINDER/KEY
	138637-03-000	EA	LOCK ASM. - KEYED - .9" CASE (CYLINDER/CAM/HDWR PKG)
	138637-52-000	EA	CASE/CYLINDER - LOCKING - W/O CAM/KEY - .9"
	138637-52-001	EA	CASE/CYLINDER - LOCKING - W/O CAM/KEY - .9"
	138637-52-002	EA	CASE/CYLINDER - LOCKING - W/O CAM/KEY - .9"
	138637-52-003	EA	CASE/CYLINDER - LOCKING - W/O CAM/KEY - .9"
	138637-52-004	EA	CASE/CYLINDER - LOCKING - W/O CAM/KEY - .9"
	138637-52-005	EA	CASE/CYLINDER - LOCKING - W/O CAM/KEY - .9"
	138637-52-006	EA	CASE/CYLINDER - LOCKING - W/O CAM/KEY - .9"
	138637-52-007	EA	CASE/CYLINDER - LOCKING - W/O CAM/KEY - .9"
	138637-52-008	EA	CASE/CYLINDER - LOCKING - W/O CAM/KEY - .9"
	138637-52-009	EA	CASE/CYLINDER - LOCKING - W/O CAM/KEY - .9"
	138637-62-000	EA	CAM - LATCHING - DOG LEG - 1" LONG
6*	075240-05-000	EA	FAUCET - LAVATORY/BRASS - W/CLEAR KNOBS
7*	075241-04-000	EA	FAUCET - SHOWER/BRASS

WATER & SEWAGE GROUP (CONTINUED)

WATER SYSTEM (CONTINUED)

KEY	PART NUMBER	U/M	DESCRIPTION
8	075606-03-000	EA	PANEL - FAUCET SHOWER - SOFT WHITE
9	091253-01-000	EA	GASKET - FAUCET - LAVATORY/GALLEY
10*	141432-01-01A	EA	FAUCET - GALLEY - SINGLE CONTROL
11*	145541-02-000	EA	WATER HEATER - 6 GALLONS-GAS/120 DEGREES-REMOTE IGNITION
11*	051391-03-000	EA	WATER HEATER G6A-8E ELECTRONIC IGNITION
11	052009-06-000	EA	DOOR - WATER HEATER - BRIGHT WHITE - 18" X 14.6"
12	114293-01-02A	EA	PAN/DRIP - EXTERIOR - BRIGHT WHITE
13	131383-01-02A	EA	SHOWER HEAD - W/60" HOSE & BRACKET - WHITE

*COMPONENT PARTS LISTED LATER IN THIS GROUP

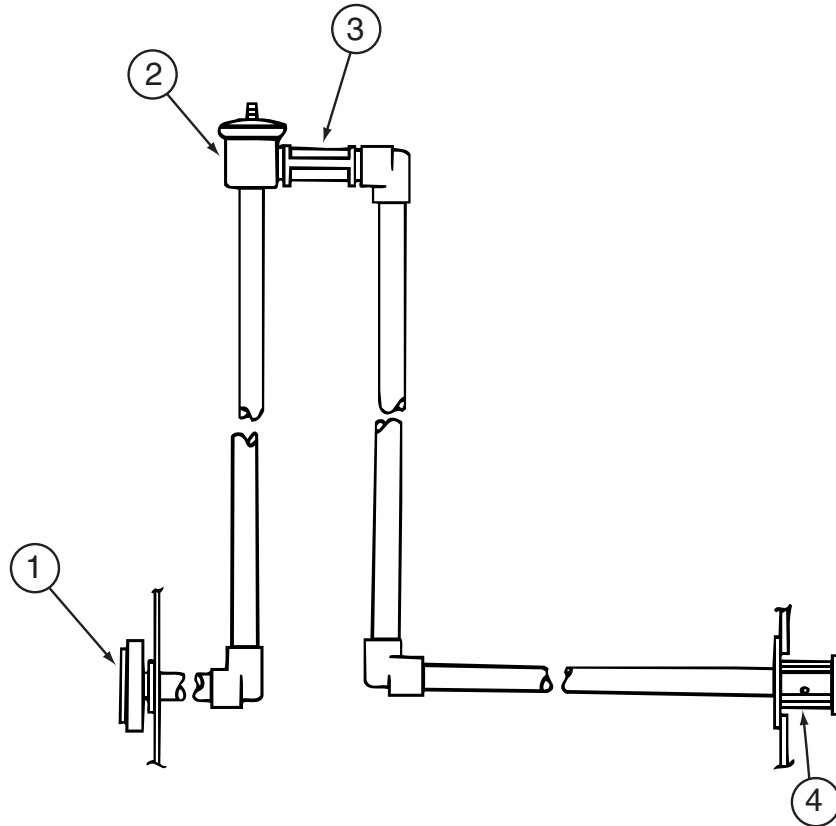

KEY	PART NUMBER	U/M	DESCRIPTION
1	125697-05-000	EA	INLET/WATER - F/FLUSHING SYSTEM
2	125697-04-000	EA	BREAKER/VACUUM - F/FLUSHING SYSTEM
3	125697-03-000	EA	CHECK VALVE - F/FLUSHING SYSTEM
4	125697-02-000	EA	NOZZLE - WELD-A-FLUSH
	125697-06-000	EA	INSTRUCTIONS - USER - F/FLUSHING SYSTEM

WATER & SEWAGE GROUP (CONTINUED)
COMPONENT PARTS FOR WATER SYSTEM

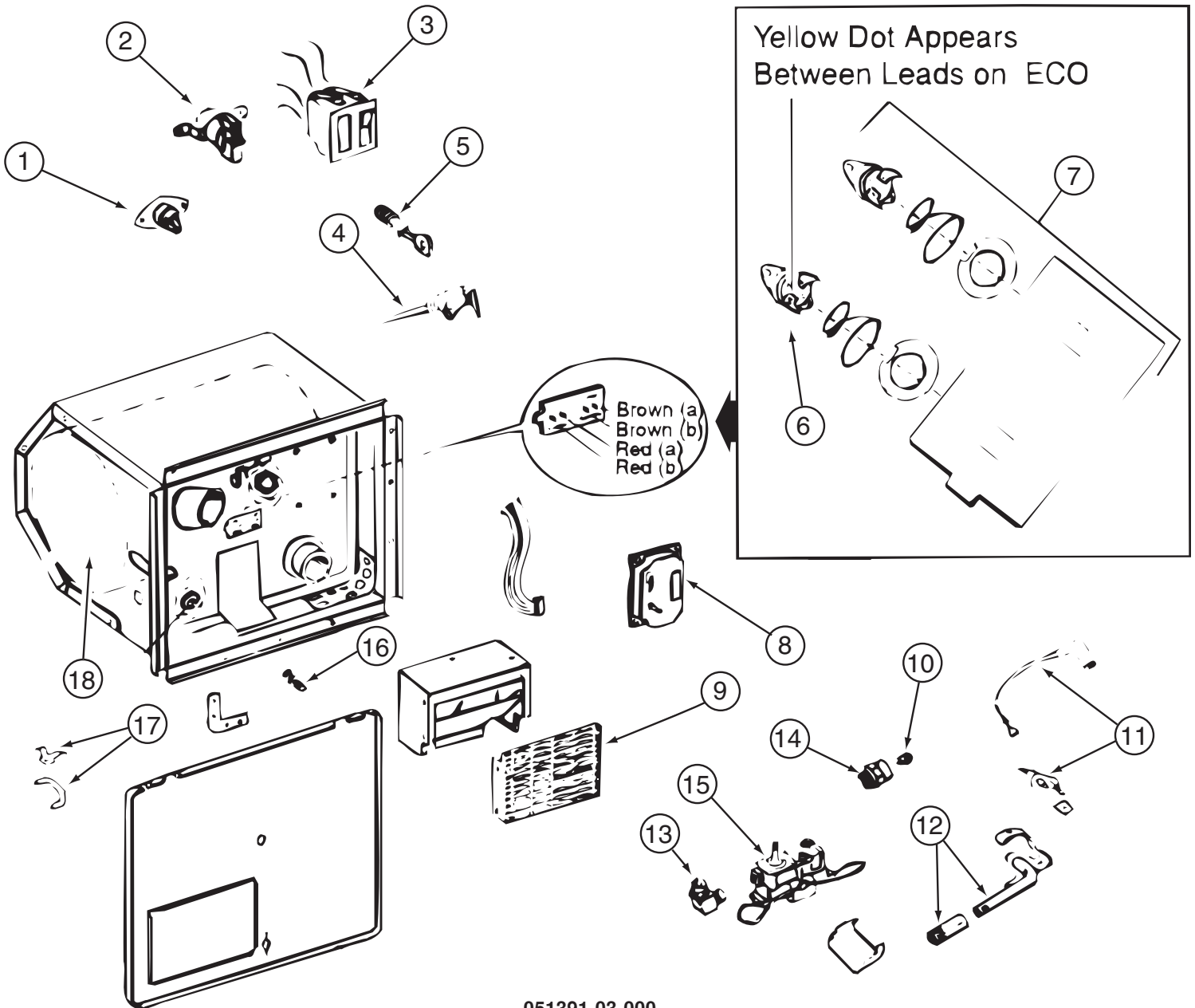

051391-03-000

KEY	PART NUMBER	U/M	DESCRIPTION	VENDOR NO.
3	051393-01-701	EA	SWITCH - REMOTE - W/LIGHT	91959
4	051391-01-704	EA	VALVE-RELIEF, 1/2" FITTING	91604
5	051391-01-705	EA	FASTENER-CAMLOCK	92609
6	051391-04-701	EA	THERMOSTAT 12V DC-120 PRESET	91470
7	051393-01-721	EA	THERMOSTAT W/ECO, 140 FRT MT	91447
9	051391-04-707	EA	KIT-EXHAUST, (FLUE & GASKET)	90960
10	051391-01-710	EA	ORIFICE-MAIN BURNER	92742
12	051391-04-703	EA	BURNER-MAIN/ELECTRONIC	91638
13	051391-01-714	EA	FITTING-ELBOW 45,3/8F X 3/8	MPT 1044
14	051391-03-700	EA	HOLDER-ORIFICE	91563
16	051391-01-715	EA	PLUG-DRAIN, 1 EA = 2 PER PKG	91857
17	051391-01-700	EA	HINGE KIT, (PIN & CLIP)	92568&92559
18	051391-04-706	EA	TANK-INNER,G6A-4E&6E FRT. MT	91641
	051391-01-717	EA	GRILLE-WATER HEATER DOOR	92640
	051393-01-723	EA	SWITCH - THERMAL CUTOUT 2/PK	93866
	051393-01-724	EA	BOARD-CIRCUIT,SPADE TERMINAL	93865
	051393-01-725	EA	ELECTRODE-SGL SPADE CONNECT.	93868
	051393-01-726	EA	VALVE-SOLENOID, W/O BRACKET	93870
	111129-01-711	EA	BRACKET-CORNER, SET OF FOUR	91928

CONTACT WINNEBAGO PARTS SALES FOR UNLISTED COMPONENTS

WATER & SEWAGE GROUP (CONTINUED)
COMPONENT PARTS FOR WATER SYSTEM (CONTINUED)

075240-05-000

KEY	PART NUMBER	U/M DESCRIPTION	VENDOR NO.
	075240-05-700	EA CARTRIDGE - WASHERLESS	9-P42

075241-04-000, 075241-05-000, 075241-06-000

KEY	PART NUMBER	U/M DESCRIPTION	VENDOR NO.
	075240-05-700	EA CARTRIDGE - WASHERLESS	9-P42

098607-01-000

KEY	PART NUMBER	U/M DESCRIPTION	VENDOR NO.
	098607-01-702	EA DIAPHRAGM/DRIVE ASSEMBLY KIT	94-238-04
	098607-01-703	EA VALVE KIT	94-232-00
	098607-01-705	EA VALVE-CHECK, KIT	94-237-00
	098607-01-706	EA HOUSING, W/SWITCH ONLY	94-231-20
	098607-01-707	EA MOTOR W/BASEPLATE	11-148-04

141432-01-01A

KEY	PART NUMBER	U/M DESCRIPTION	VENDOR NO.
	135027-01-705	EA CARTRIDGE F/SGL LEVER FAUCET,	1225

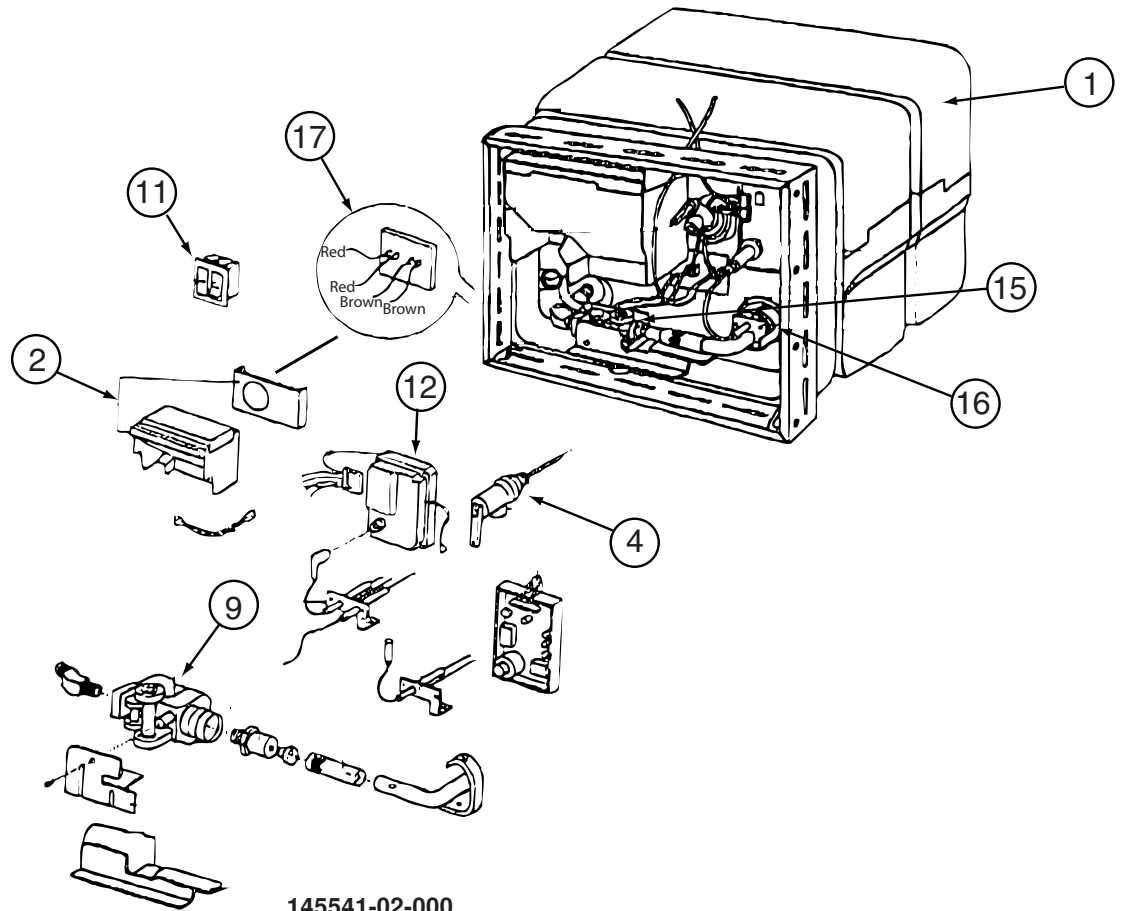

145541-02-000

KEY	PART NUMBER	U/M DESCRIPTION	VENDOR NO.
1	145541-02-700	EA TANK - W/INSULATION - 06 GAL	
2	051391-04-707	EA KIT-EXHAUST, (FLUE & GASKET)	90960
3	051391-01-715	EA PLUG-DRAIN, 1 EA = 2 PER PKG	91857
4	051391-01-704	EA VALVE-RELIEF, 1/2" FITTING	91604
9	051393-01-726	EA VALVE-SOLENOID, W/O BRACKET	93870
11	145541-01-701	EA SWITCH - ON/OFF - WHITE	91859
11	051393-01-701	EA SWITCH - REMOTE - W/LIGHT	91959
12	145541-01-702	EA CIRCUIT BOARD	91226
15	145541-01-703	EA SWITCH - THERMAL CUT OFF	93866
16	051393-01-725	EA ELECTRODE-SGL SPADE CONNECT.	93868
17	051393-01-721	EA THERMOSTAT W/ECO, 140 FRT MT	91447
	051391-05-706	EA ELEMENT-HEATING 1500 WATT	91160 W/GASKET
	145541-01-704	EA RELAY	90061

CONTACT WINNEBAGO PARTS SALES FOR UNLISTED COMPONENTS

WINDOW & VENTS GROUP

WINDOW & VENT LAYOUT

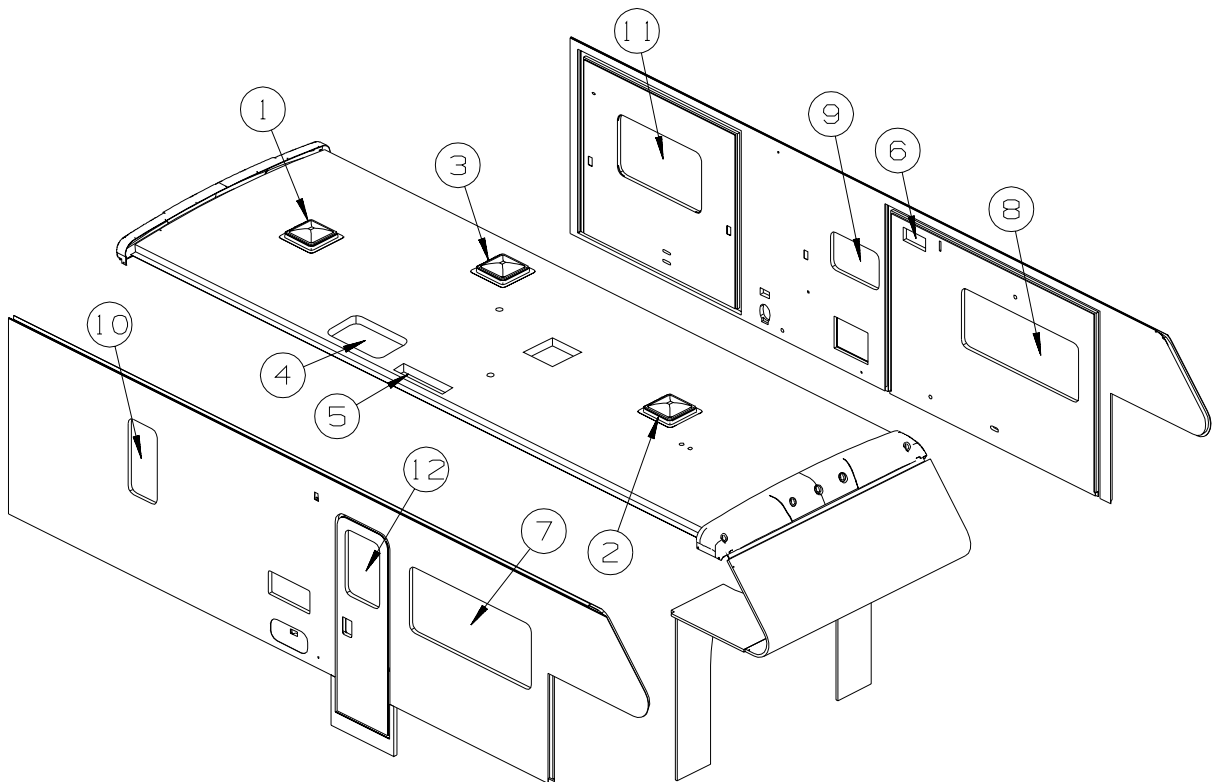

KEY	PART NUMBER	U/M	DESCRIPTION
1*	122882-01-01A	EA	VENT - ROOF - NONPOWERED - W/O INSIDE GARNISH - NON-POWERED VENT
	009440-01-000	EA	GEAR/ARM - LIFT - ROOF VENT COVER
1	122882-07-01A	EA	GARNISH - ROOF VENT - 2.5" TO 4.1"
1*	123780-11-01A	EA	VENT-4"ROOF-DBL DOME-W/O FAN/THERM/PWR LIFT - HOME COMFORT PLUS PACKAGE
	009440-01-000	EA	GEAR/ARM - LIFT - ROOF VENT COVER
2*	122882-01-01A	EA	VENT - ROOF - NONPOWERED - W/O INSIDE GARNISH - NON-POWERED VENT
	009440-01-000	EA	GEAR/ARM - LIFT - ROOF VENT COVER
2	122882-07-01A	EA	GARNISH - ROOF VENT - 2.5" TO 4.1"
2*	123780-03-01A	EA	VENT-3"/4"ROOF-W/FAN-W/O THERM/PWR LIFT/WHT CVR - POWERED VENTILATOR VENT
	009440-01-000	EA	GEAR/ARM - LIFT - ROOF VENT COVER
2*	123780-09-01A	EA	VENT-4"ROOF- W/FAN/DBL DOME-W/O THERM/PWR LIFT - HOME COMFORT PLUS PACKAGE
	009440-01-000	EA	GEAR/ARM - LIFT - ROOF VENT COVER
3*	122882-02-01A	EA	VENT - ROOF - W/FAN - W/O INSIDE GARNISH - UL - U.S. POWERED ROOF VENT
	009440-01-000	EA	GEAR/ARM - LIFT - ROOF VENT COVER
	048648-01-000	EA	MOTOR/ROOF VENT - W/RESISTER - 1/8"SHAFT - 12VOLT
	048649-01-000	EA	FAN BLADE - ROOF VENT - 6 BLADED - 6"RADIUS
3	122882-07-01A	EA	GARNISH - ROOF VENT - 2.5" TO 4.1"
3*	122882-03-01A	EA	VENT - ROOF - W/FAN - W/O INSIDE GARNISH - CSA - CANADIAN POWERED ROOF VENT
	009440-01-000	EA	GEAR/ARM - LIFT - ROOF VENT COVER
	048648-01-000	EA	MOTOR/ROOF VENT - W/RESISTER - 1/8"SHAFT - 12VOLT
	048649-01-000	EA	FAN BLADE - ROOF VENT - 6 BLADED - 6"RADIUS
3	122882-07-01A	EA	GARNISH - ROOF VENT - 2.5" TO 4.1"
3*	123780-09-01A	EA	VENT-4"ROOF- W/FAN/DBL DOME-W/O THERM/PWR LIFT - HOME COMFORT PLUS PACKAGE
	009440-01-000	EA	GEAR/ARM - LIFT - ROOF VENT COVER
4	122193-01-02A	EA	PANEL - SKYLITE - INNER
4	138372-01-02B	EA	TRIM - CORNER - SKYLIGHT - E-COATED
4	138379-02-01A	EA	PANEL/SKYLIGHT OTR - RECT/4"H CTR DOME-18.4" X 29.5 - WHT
5	084073-04-000	EA	BASE/VENT - ROOF/REFRIGERATOR - BLACK - NORCOLD
5	084073-07-000	EA	CAP - ROOF/REFRIGERATOR VENT - 10" X 32" - BRIGHT WHITE
6	138983-01-01A	EA	VENT - MICROWAVE/OUTER - BRIGHT WHITE
6	138983-03-01A	EA	COVER - VENT MICROWAVE/OUTER - BRIGHT WHITE
7*	098647-23-02A	EA	WINDOW - PASS HORIZ SLIDER TINTED W/RETAINER-26.1" X 59.7"
7*	112795-69-01A	EA	WINDOW - PASS HORIZ SLIDER/THERMO W/TRIM - 26.3" X 60" - DUAL PANE

WINDOW & VENTS GROUP (CONTINUED)

WINDOW & VENT LAYOUT (CONTINUED)

KEY	PART NUMBER	U/M	DESCRIPTION
8*	098647-47-02A	EA	WINDOW - DRVR HORIZ SLIDER W/TRIM - TINTED - 57.4" X 23.6"
8*	112795-77-01A	EA	WINDOW - DRVR HORIZ SLIDER/THERMO W/TRIM - 57.4" X 23.6" - DUAL PANE
9*	098644-07-02A	EA	WINDOW - VERTICAL SLIDER W/TRIM - TINTED - 14" X 30"
9*	112795-84-01A	EA	WINDOW - DRVR HORIZ SLIDER/THERMO W/TRIM - 27" X 24" - DUAL PANE
10*	098647-07-03A	EA	WINDOW - DRIVER HORIZ SLIDER W/TRIM - TINTED - 15" X 23.7"
10*	112898-22-01A	EA	WINDOW - VERTICAL SLIDER/THERMO W/TRIM - 30.9" X 14.2" - DUAL PANE
11*	113500-09-02A	EA	WINDOW - DBL TIPOUT/ESCAPE W/TRIM - TINTED - 24.2" X 41.2"
11*	129929-12-01A	EA	WINDOW - TIPOUT/THERMO/ESCAPE W/TRIM - 24.4" X 41.3" - DUAL PANE
12	117053-02-F36	EA	WINDOW - PICTURE - W/O TRIM - 60% TINTING - 26.4" X 17"
	002181-25-000	EA	GLASS - PICTURE WINDOW - 25.8"W X 16.4"H
	087561-01-000	FT	SEAL - GLASS - EXTERIOR - .5" WIDE - VINYL BLACK
12	117054-02-02A	EA	TRIM/RETAINER - INSIDE - 16.9" X 26.2" - BRIGHT WHITE
12*	113733-10-01A	EA	WINDOW - STATIONARY W/TRIM - THERMO/EURO - 26.3" X 17" - DUAL PANE

*COMPONENT PARTS LISTED LATER IN THIS GROUP

WINDOW & VENTS GROUP (CONTINUED)
COMPONENT PARTS FOR WINDOW & VENT LAYOUT

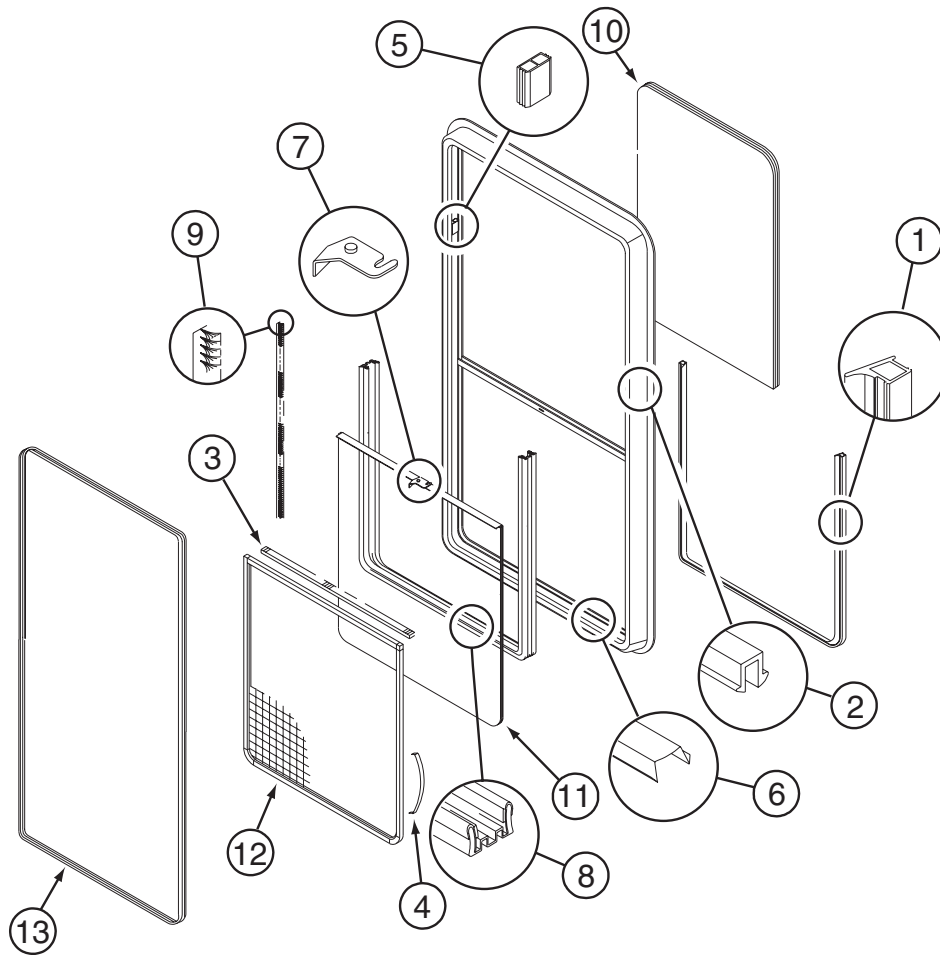

098644-07-02A

KEY	PART NUMBER	U/M	DESCRIPTION	VENDOR NO.
1	098644-01-716	FT	PLUG - FILLER	132-014470
2	098644-01-705	FT	GLAZING - STRIP	132-010231
3	098644-01-706	FT	WEATHERSTRIP - GLASS	171-010668
4	098644-01-713	EA	CLIP - SCREEN - METAL	226-016966
4	125582-01-701	EA	CLIP - SCREEN - PLASTIC	130-005153
5	098644-01-719	EA	STOP - SLIDER GLASS	132-014203
6	098644-01-710	FT	TRACK - SCREEN SPACER 12'	132-017135
7	098647-54-701	EA	LATCH - REPAIR KIT (RED)	B081-CK
8	098644-01-708	FT	CHANNEL - RUN PIERCED	122-016543
9	098644-01-711	FT	WEATHERSTRIP - SCREEN BLACK	171-016965
10	098644-07-702	EA	GLASS - STATIONARY	106-015777
11	098644-07-703	EA	GLASS-SLIDING W/SASH & LATCH	H170-G9
12	098644-07-704	EA	SCREEN ASM - W/SEALS & CLIPS	410-018863
13	098644-07-705	EA	RETAINER - TRIM	CH02-66
	098644-01-717	FT	SPLINE - SCREEN	132-004716

WINDOWS & VENTS GROUP (CONTINUED)
COMPONENT PARTS FOR WINDOW & VENT LAYOUT (CONTINUED)

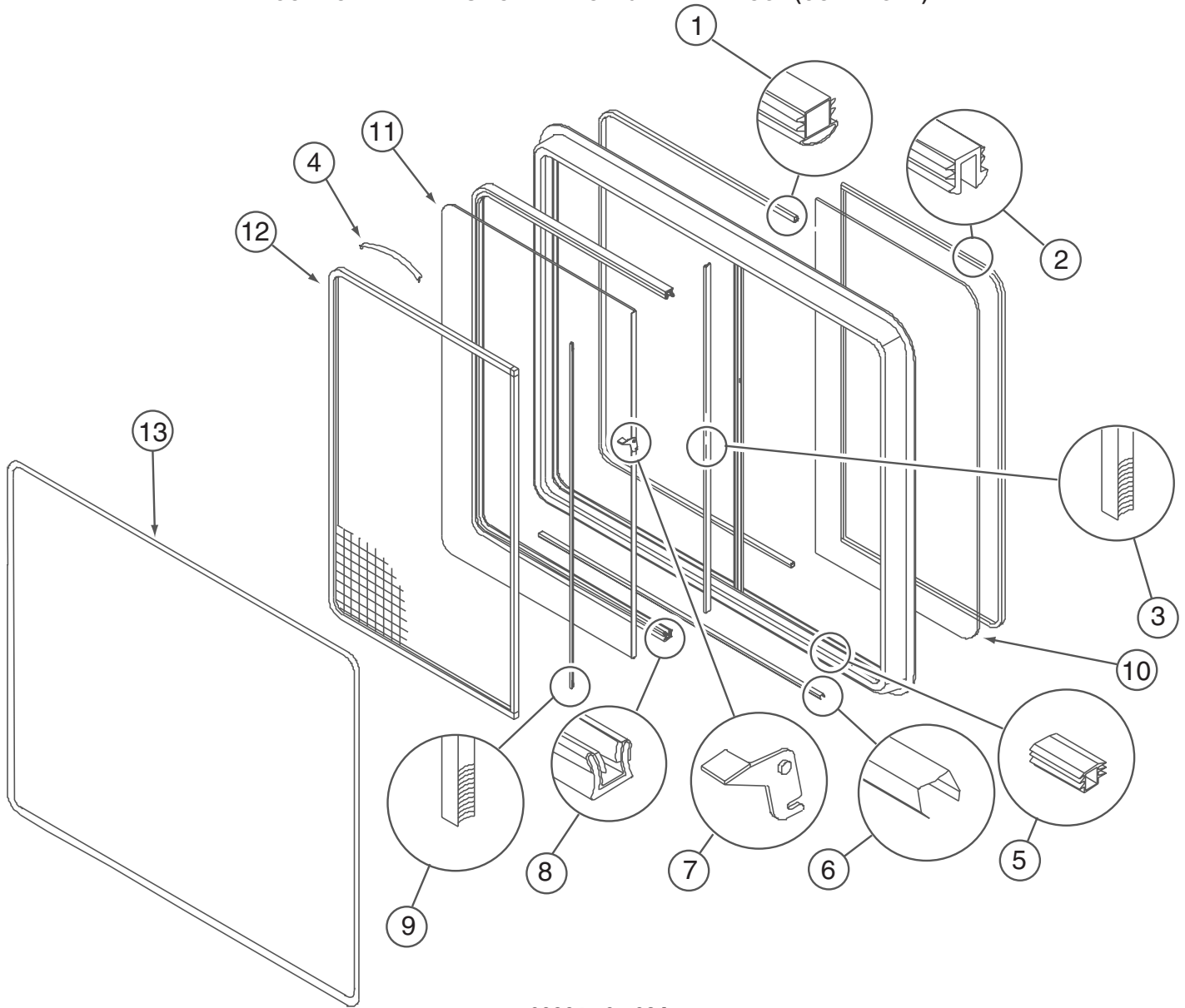

098647-07-03A

KEY	PART NUMBER	U/M	DESCRIPTION	VENDOR NO.
1	098644-01-716	FT	PLUG - FILLER	132-014470
2	098644-01-705	FT	GLAZING - STRIP	132-010231
3	098644-01-706	FT	WEATHERSTRIP - GLASS	171-010668
4	098644-01-713	EA	CLIP - SCREEN - METAL	226-016966
4	125582-01-701	EA	CLIP - SCREEN - PLASTIC	130-005153
5	098644-01-719	EA	STOP - SLIDER GLASS	132-014203
6	098644-01-710	FT	TRACK - SCREEN SPACER 12'	132-017135
7	098647-54-701	EA	LATCH - REPAIR KIT (RED)	B081-CK
8	098644-01-708	FT	CHANNEL - RUN PIERCED	122-016543
9	098644-01-711	FT	WEATHERSTRIP - SCREEN BLACK	171-016965
10	098647-06-700	EA	GLASS - STATIONARY 10.9X13.8	106-016921
11	098647-06-702	EA	GLASS-SLIDING W/SASH & LATCH	B969-G9
12	098647-06-703	EA	SCREEN ASM - W/SEALS & CLIPS	410-016477
13	098647-07-701	EA	RETAINER - TRIM	H969-67
	098644-01-717	FT	SPLINE - SCREEN	132-004716

WINDOWS & VENTS GROUP (CONTINUED)
COMPONENT PARTS FOR WINDOW & VENT LAYOUT (CONTINUED)

098647-23-02A

KEY	PART NUMBER	U/M	DESCRIPTION	VENDOR NO.
1	098644-01-716	FT	PLUG - FILLER	132-014470
2	098644-01-705	FT	GLAZING - STRIP	132-010231
3	098644-01-706	FT	WEATHERSTRIP - GLASS	171-010668
4	098644-01-713	EA	CLIP - SCREEN - METAL	226-016966
4	125582-01-701	EA	CLIP - SCREEN - PLASTIC	130-005153
5	098644-01-719	EA	STOP - SLIDER GLASS	132-014203
6	098644-01-710	FT	TRACK - SCREEN SPACER 12'	132-017135
7	098647-54-701	EA	LATCH - REPAIR KIT (RED)	B081-CK
8	098644-01-708	FT	CHANNEL - RUN PIERCED	122-016543
9	098644-01-711	FT	WEATHERSTRIP - SCREEN BLACK	171-016965
10	098647-23-703	EA	GLASS - STATIONARY	106-017622
11	098647-23-700	EA	GLASS SLIDING W/SASH & LATCH	H287-G9
12	098647-23-704	EA	SCREEN ASM - W/SEALS & CLIPS	410-019066
13	098647-22-701	EA	RETAINER - TRIM	H287-67
	098644-01-717	FT	SPLINE - SCREEN	132-004716

098647-47-02A

KEY	PART NUMBER	U/M	DESCRIPTION	VENDOR NO.
1	098644-01-716	FT	PLUG - FILLER	132-014470
2	098644-01-705	FT	GLAZING - STRIP	132-010231
3	098644-01-706	FT	WEATHERSTRIP - GLASS	171-010668
4	098644-01-713	EA	CLIP - SCREEN - METAL	226-016966
4	125582-01-701	EA	CLIP - SCREEN - PLASTIC	130-0
5	098644-01-719	EA	STOP - SLIDER GLASS	132-014203
6	098644-01-710	FT	TRACK - SCREEN SPACER 12'	132-017135
7	098647-54-701	EA	LATCH - REPAIR KIT (RED)	B081-CK
8	098644-01-708	FT	CHANNEL - RUN PIERCED	122-016543
9	098644-01-711	FT	WEATHERSTRIP - SCREEN BLACK	171-016965
10	098647-47-700	EA	GLASS - STATIONARY	106-025224
11	098647-47-701	EA	GLASS-SLIDING W/SASH & LATCH	H493-G9
12	098647-47-702	EA	SCREEN ASM - W/SEALS & CLIPS	410-025226
13	098647-47-704	EA	RETAINER - TRIM	H493-66
	098644-01-717	FT	SPLINE - SCREEN	132-004716

WINDOWS & VENTS GROUP (CONTINUED)
COMPONENT PARTS FOR WINDOW & VENT LAYOUT (CONTINUED)

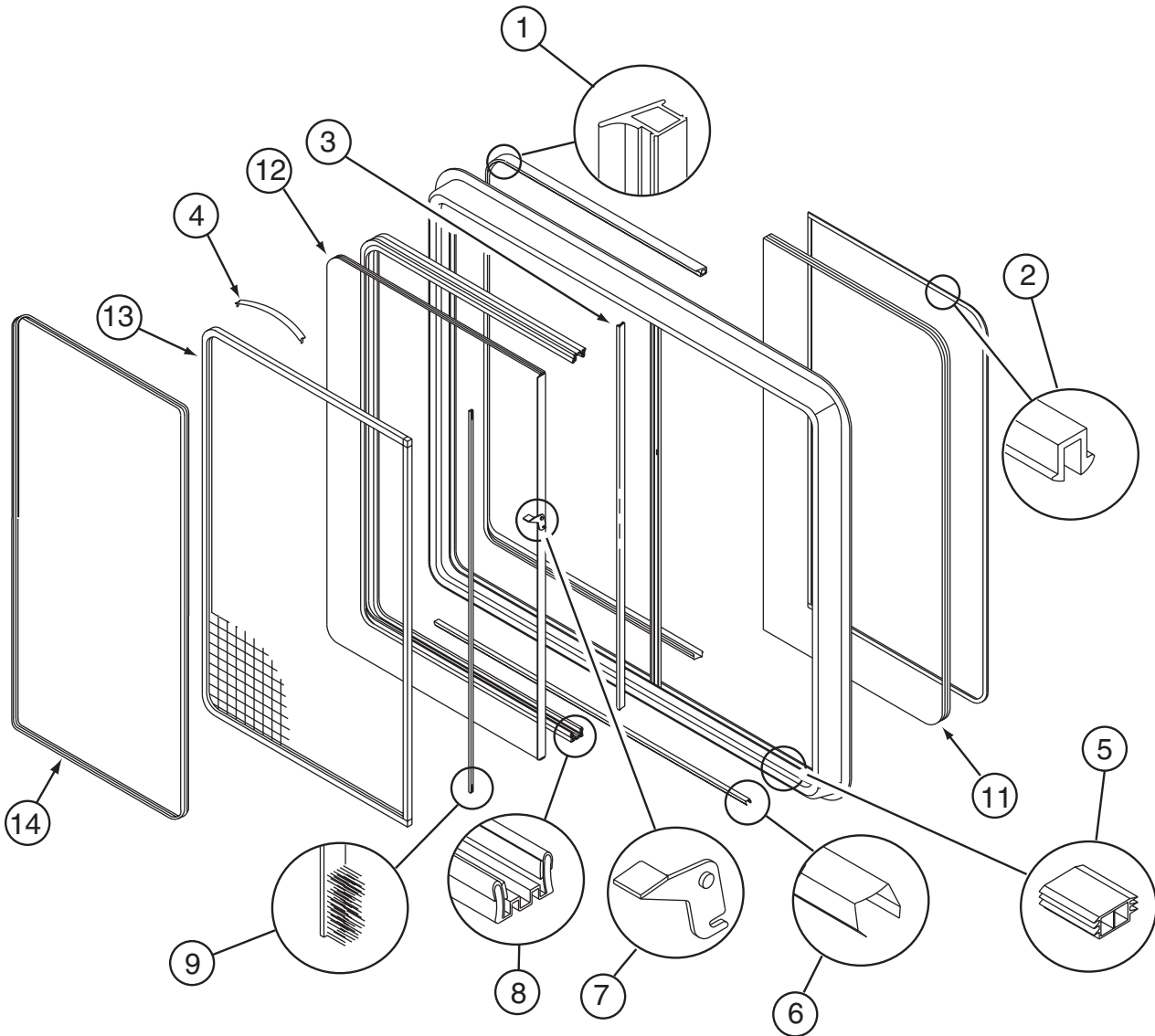

112795-69-01A

KEY	PART NUMBER	U/M	DESCRIPTION	VENDOR NO.
1	112795-01-704	FT	PLUG FILLER (DOUBLE GLAZED)	122-018737
2	112795-01-705	FT	VINYL - GLAZING	132-025736
3	098644-01-706	FT	WEATHERSTRIP - GLASS	171-010668
4	098644-01-713	EA	CLIP - SCREEN - METAL	226-016966
4	125582-01-701	EA	CLIP - SCREEN - PLASTIC	130-005153
	098644-01-717	FT	SPLINE - SCREEN	132-004716
5	112795-01-701	EA	SLIDE-STOP	132-019092
6	098644-01-710	FT	TRACK - SCREEN SPACER 12'	132-017135
7	112795-01-700	EA	LATCH ASM., BLK.,(BOLT ON)	DH287-CK
8	112795-01-703	IN	CHANNEL-RUN (INCHES)	122-018736
9	098644-01-711	FT	WEATHERSTRIP - SCREEN BLACK	171-016965
11	112795-68-700	EA	GLASS - STATIONARY	390-028353
12	112795-68-701	EA	GLASS - SLIDING W/SASH LATCH	390-028353
13	098647-23-704	EA	SCREEN ASSY - W/SEAL & CLIPS	410-019066
14	098647-27-704	EA	RETAINER - TRIM	H287-66

WINDOWS & VENTS GROUP (CONTINUED)
COMPONENT PARTS FOR WINDOW & VENT LAYOUT (CONTINUED)

112795-77-01A

KEY	PART NUMBER	U/M	DESCRIPTION	VENDOR NO.
1	112795-01-704	FT	PLUG FILLER (DOUBLE GLAZED)	122-018737
2	112795-01-705	FT	VINYL - GLAZING	132-025736
3	098644-01-706	FT	WEATHERSTRIP - GLASS	171-010668
4	098644-01-713	EA	CLIP - SCREEN - METAL	226-016966
4	125582-01-701	EA	CLIP - SCREEN - PLASTIC	130-005153
5	112795-01-701	EA	SLIDE-STOP	132-019092
6	098644-01-710	FT	TRACK - SCREEN SPACER 12'	132-017135
7	112795-01-700	EA	LATCH ASM., BLK.,(BOLT ON)	DH287-CK
8	112795-01-703	IN	CHANNEL-RUN (INCHES)	122-018736
9	098644-01-711	FT	WEATHERSTRIP - SCREEN BLACK	171-016965
11	112795-77-700	EA	GLASS - STATIONARY	390-28313
12	112795-77-701	EA	GLASS - SLIDING W/SASH LATCH	DH493-G8
13	098647-47-702	EA	SCREEN ASSY - W/SEAL & CLIPS	410-025226
14	098647-47-704	EA	RETAINER - TRIM	H493-66
	098644-01-717	FT	SPLINE - SCREEN	132-004716

112795-84-01A

KEY	PART NUMBER	U/M	DESCRIPTION	VENDOR NO.
1	112795-01-704	FT	PLUG FILLER (DOUBLE GLAZED)	122-018737
2	112795-01-705	FT	VINYL - GLAZING	132-025736
3	098644-01-706	FT	WEATHERSTRIP - GLASS	171-010668
4	098644-01-713	EA	CLIP - SCREEN - METAL	226-016966
4	125582-01-701	EA	CLIP - SCREEN - PLASTIC	130-005153
	098644-01-717	FT	SPLINE - SCREEN	132-004716
5	112795-01-701	EA	SLIDE-STOP	132-019092
6	098644-01-710	FT	TRACK - SCREEN SPACER 12'	132-017135
7	112795-01-700	EA	LATCH ASM., BLK.,(BOLT ON)	DH287-CK
8	112795-01-703	IN	CHANNEL-RUN (INCHES)	122-018736
9	098644-01-711	FT	WEATHERSTRIP - SCREEN BLACK	171-016965
11	112795-78-700	EA	GLASS - STATIONARY	390-028338
12	112795-78-701	EA	GLASS - SLIDING W/SASH LATCH	DB969-G8
13	112795-56-702	EA	SCREEN ASSY - W/SEAL & CLIPS	410-019414
14	112795-56-704	EA	RETAINER - TRIM	390-028338

WINDOW & VENTS GROUP (CONTINUED)
COMPONENT PARTS FOR WINDOW & VENT LAYOUT (CONTINUED)

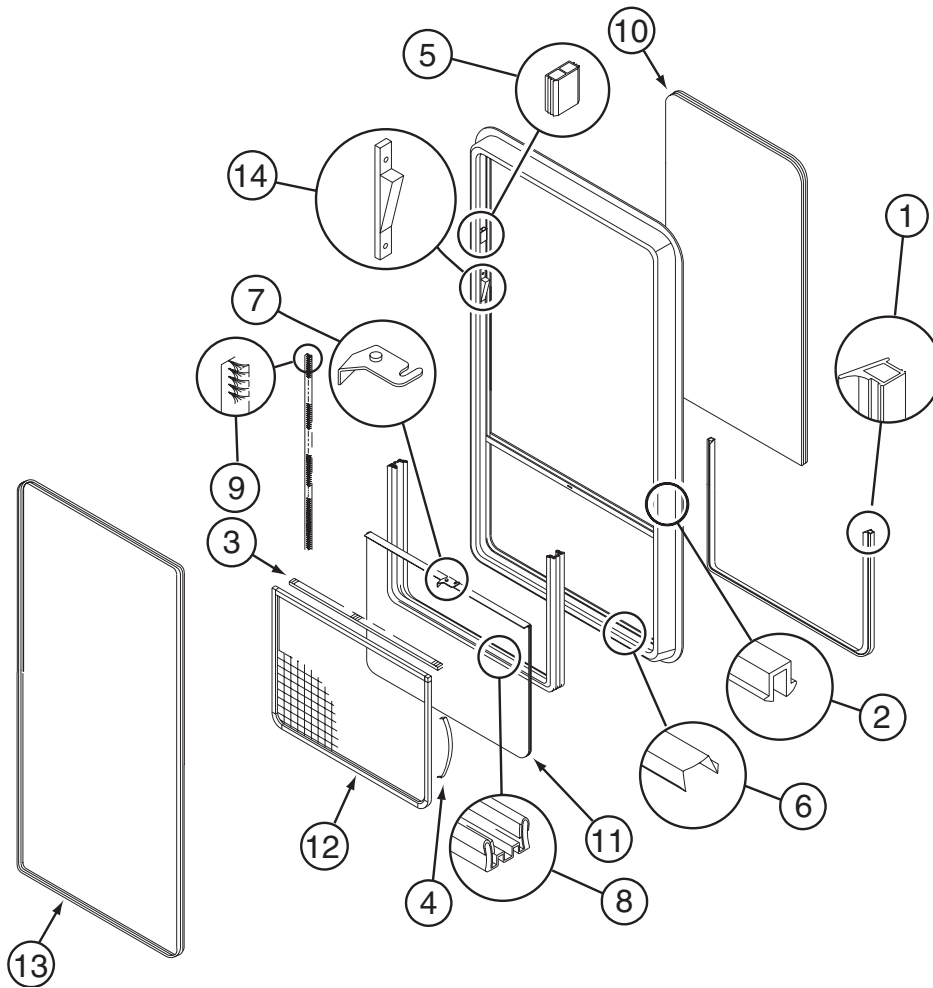

112898-22-01A

KEY	PART NUMBER	U/M	DESCRIPTION	VENDOR NO.
1	112795-01-704	FT	PLUG FILLER (DOUBLE GLAZED)	122-018737
2	112795-01-705	FT	VINYL - GLAZING	132-025736
3	098644-01-706	FT	WEATHERSTRIP - GLASS	171-010668
4	098644-01-713	EA	CLIP - SCREEN - METAL	226-016966
4	125582-01-701	EA	CLIP - SCREEN - PLASTIC	130-005153
5	112795-01-701	EA	SLIDE-STOP	132-019092
6	098644-01-710	FT	TRACK - SCREEN SPACER 12'	132-017135
7	112795-01-700	EA	LATCH ASM., BLK.,(BOLT ON)	DH287-CK
8	112795-01-703	IN	CHANNEL-RUN (INCHES)	122-018736
9	098644-01-711	FT	WEATHERSTRIP - SCREEN BLACK	171-016965
10	112898-22-700	EA	GLASS - STATIONARY	390-028345
11	112898-22-701	EA	GLASS-SLIDING-W/SASH & LATCH	DC02-G8
12	098644-07-704	EA	SCREEN ASM - W/SEALS & CLIPS	410-018863
13	098644-07-705	EA	RETAINER - TRIM	CH02-66
14	112898-04-703	EA	VERTICAL LATCH (SASH KIT)	DH343-CK
	098644-01-717	FT	SPLINE - SCREEN	132-004716

WINDOW & VENTS GROUP (CONTINUED)
COMPONENT PARTS FOR WINDOW & VENT LAYOUT (CONTINUED)

113733-04-01A, 113733-10-01A, 113733-11-01A

KEY	PART NUMBER	U/M	DESCRIPTION	VENDOR NO.
	112795-01-705	FT	VINYL - GLAZING	132-025736
	113733-10-700	EA	GLASS-STATIONARY	390-028306
	113733-10-701	EA	RETAINER-TRIM	H416-66

WINDOW & VENTS GROUP (CONTINUED)
COMPONENT PARTS FOR WINDOW & VENT LAYOUT (CONTINUED)

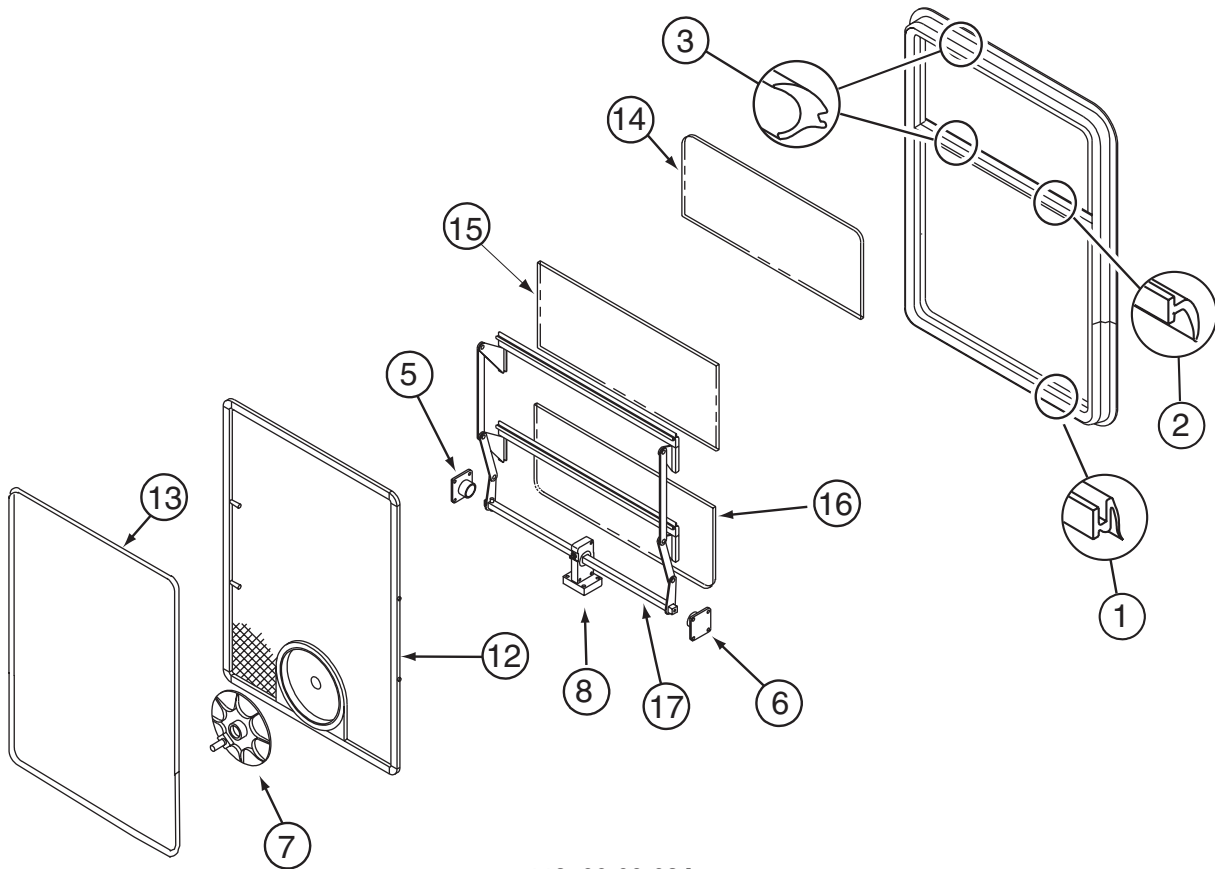

113500-09-02A

KEY	PART NUMBER	U/M	DESCRIPTION	VENDOR NO.
1	116976-01-702	FT	FILLER PLUG	132-016065
2	100322-01-701	FT	SEAL-VENT	122-016071
3	100322-01-702	EA	WEATHERSTRIP-HORIZ RAIL-148"	132-019631
	100322-01-703	FT	VINYL-GLAZING, BUTYL	132-010723
5	100322-01-714	EA	SUPPORT-TORQUE BAR, LH	130-015978
6	100322-01-715	EA	SUPPORT-TORQUE BAR, RH	130-015979
7	100322-01-718	EA	HANDLE-DIAL	410-016081
8	112519-01-702	EA	TORQUE-CTR SUPPORT (4 HOLE)	410-016123
12	113500-09-705	EA	SCREEN - W/SEAL & CLIPS	410-018794
14	113500-09-701	EA	GLASS - STATIONARY	106-018772
15	113500-09-702	EA	GLASS - UPPER VENT ASSEMBLY	CH73G7
16	113500-09-703	EA	GLASS - LOWER VENT ASSEMBLY	CH73G9L
17	113500-09-704	EA	OPERATOR BAR ASSEMBLY	CH73-15L
	112898-06-704	EA	HANDLE-LATCH/RED-RH (TIPOUT)	182-11293
	112898-06-705	EA	HANDLE-LATCH/RED-LH (TIPOUT)	182-11294
	100322-01-717	EA	E-RING	245-015975
	112463-02-706	FT	SEAL - FOAM RUBBER	140-014727

CONTACT WINNEBAGO PART SALES FOR UNLISTED COMPONENTS

WINDOW & VENTS GROUP (CONTINUED)
COMPONENT PARTS FOR WINDOW & VENT LAYOUT (CONTINUED)

122882-01-01A

KEY	PART NUMBER	U/M	DESCRIPTION	VENDOR NO.
	009440-01-000	EA	GEAR-ARM-ROOF VENT	705221K38
	064470-01-700	EA	COVER - VENT - W/O SLIDE BAR	J7291
	064470-01-701	EA	SLIDE BAR - VENT LID	JRP1291B
	122882-01-701	EA	SCREEN	JRP-1124-B
	122882-01-702	EA	HANDLE - CRANK - WHITE	JRP1031B

122882-02-01A, 122882-03-01A

KEY	PART NUMBER	U/M	DESCRIPTION	VENDOR NO.
	064470-01-700	EA	COVER - VENT - W/O SLIDE BAR	J7291
	009440-01-000	EA	GEAR-ARM-ROOF VENT	705221K38
	048648-01-000	EA	MOTOR-12V NONVENTED 1/8 SFT	
	048649-01-000	EA	FAN-PLAS-6 IN 6 BLADED	
	122882-01-701	EA	SCREEN	JRP-1124-B
	122882-01-702	EA	HANDLE - CRANK - WHITE	JRP1031B
	064470-01-701	EA	SLIDE BAR - VENT LID	JRP1291B
	110051-03-700	EA	SWITCH-BLACK/PUSH BUTTON	27-0164

WINDOW & VENTS GROUP (CONTINUED)
COMPONENT PARTS FOR WINDOW & VENT LAYOUT (CONTINUED)

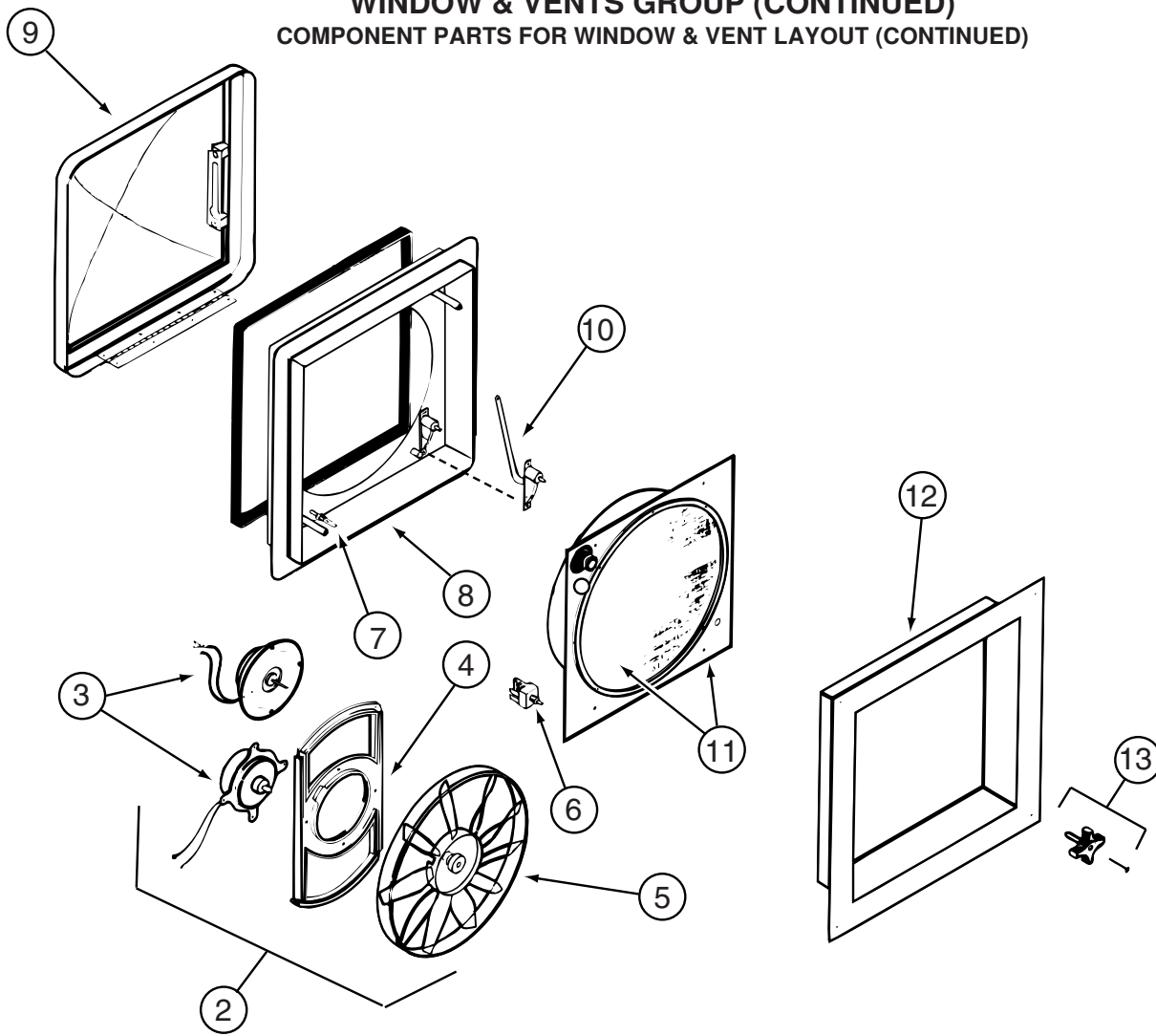

123780-03-01A

KEY	PART NUMBER	U/M	DESCRIPTION	VENDOR NO.
2	084079-11-700	EA	MOTOR & FAN BLADE W/BRACKET	K4017-09
3	084079-01-705	EA	MOTOR/EXT BRKT/FAN BLADE KIT	1080-00
5	084079-01-704	EA	BLADE-FAN	1138-00
6	084079-01-709	EA	SWITCH - MAIN - 3 SPEED	1031-05
7	084079-01-707	EA	SWITCH - SAFETY	1122-05
8	123780-05-700	EA	BASE/MAIN-BRT WHT W/GASKET	1010-81
9	123780-01-700	EA	COVER - VENT W/HINGE & SLIDE	1020K-81
10	009440-01-000	EA	GEAR-ARM-ROOF VENT	705221K38
11	123780-03-701	EA	SCREEN ASM 78-100MM W/SWITCH	1030BT-81
12	123780-03-700	EA	GARNISH - INT. 3"-4" BRT/WHT	2040-81
13	084079-01-703	EA	KNOB-LIFT, W/EXT.	1140K-00
	123780-01-702	EA	SCREEN INSERT (SCREEN RING)	K1035-81

CONTACT WINNEBAGO PART SALES FOR UNLISTED COMPONENTS

WINDOW & VENTS GROUP (CONTINUED)
COMPONENT PARTS FOR WINDOW & VENT LAYOUT (CONTINUED)

123780-09-01A

KEY	PART NUMBER	U/M	DESCRIPTION	VENDOR NO.
2	084079-11-700	EA	MOTOR & FAN BLADE W/BRACKET	K4017-09
3	084079-01-705	EA	MOTOR/EXT BRKT/FAN BLADE KIT	1080-00
5	084079-01-704	EA	BLADE-FAN	1138-00
6	084079-01-709	EA	SWITCH - MAIN - 3 SPEED	1031-05
7	084079-01-707	EA	SWITCH - SAFETY	1122-05
8	123780-05-700	EA	BASE/MAIN-BRT WHT W/GASKET	1010-81
9	123780-09-700	EA	DOME (DOUBLE)WHT TRANSPARENT	K2020-82
10	009440-01-000	EA	GEAR-ARM-ROOF VENT	705221K38
11	123780-03-701	EA	SCREEN ASM 78-100MM W/SWITCH	1030BT-81
12	123780-03-700	EA	GARNISH - INT. 3"-4" BRT/WHT	2040-81
13	084079-01-703	EA	KNOB-LIFT, W/EXT.	1140K-00
	123780-01-702	EA	SCREEN INSERT (SCREEN RING)	K1035-81

CONTACT WINNEBAGO PART SALES FOR UNLISTED COMPONENTS

123780-11-01A

KEY	PART NUMBER	U/M	DESCRIPTION	VENDOR NO.
8	123780-05-700	EA	BASE/MAIN-BRT WHT W/GASKET	1010-81
9	123780-09-700	EA	DOME (DOUBLE)WHT TRANSPARENT	K2020-82
10	009440-01-000	EA	GEAR-ARM-ROOF VENT	705221K38
12	123780-03-700	EA	GARNISH - INT. 3"-4" BRT/WHT	2040-81
13	084079-01-703	EA	KNOB-LIFT, W/EXT.	1140K-00
	123780-01-702	EA	SCREEN INSERT (SCREEN RING)	K1035-81

CONTACT WINNEBAGO PART SALES FOR UNLISTED COMPONENTS

WINDOW & VENTS GROUP (CONTINUED)
COMPONENT PARTS FOR WINDOW & VENT LAYOUT (CONTINUED)

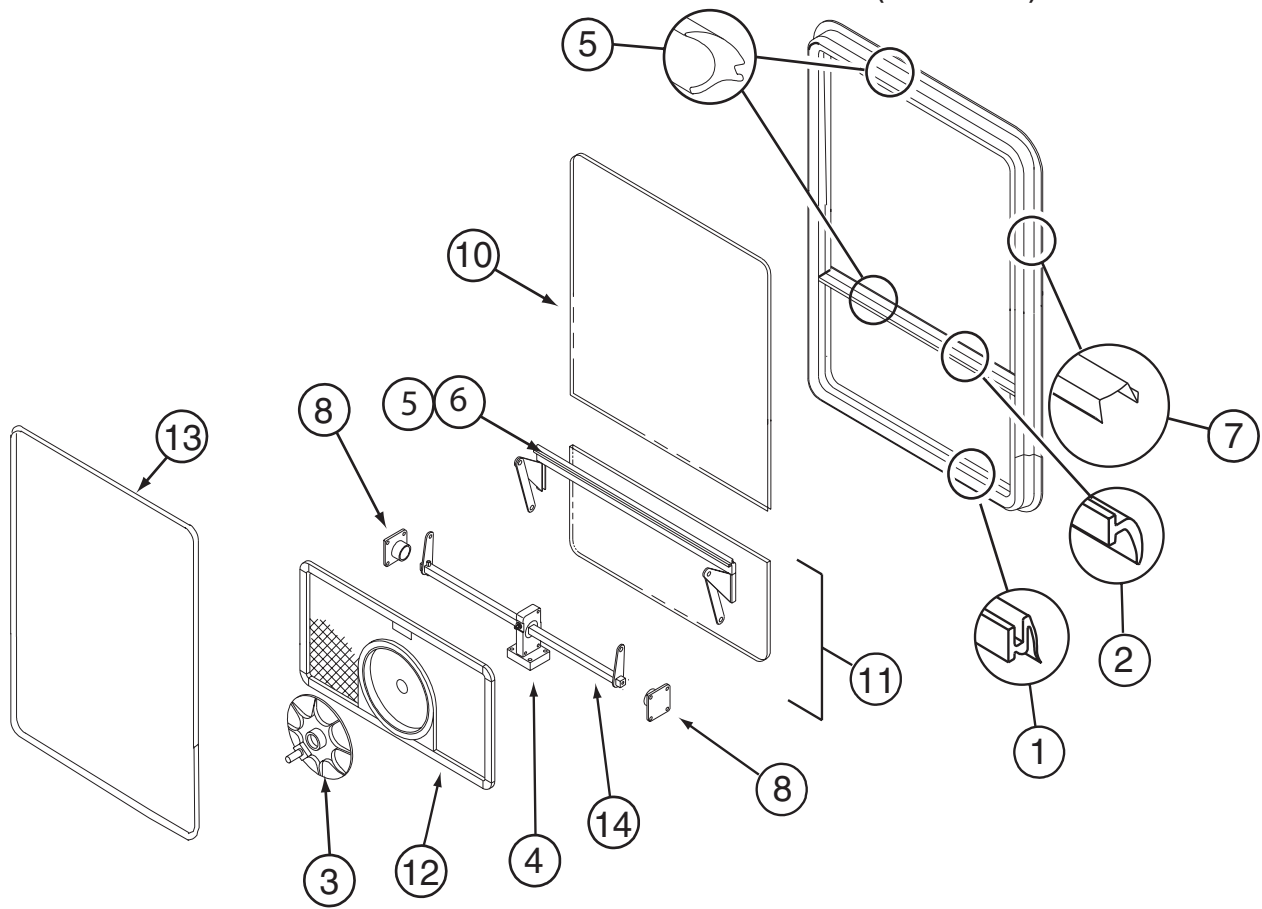

129929-12-01A

KEY	PART NUMBER	U/M	DESCRIPTION	VENDOR NO .
1	100322-01-701	FT	SEAL-VENT	122-016071
3	100322-01-718	EA	HANDLE-DIAL	410-016081
4	129929-01-710	EA	TORQUE-CTR SUPPORT (2 HOLE)	410-026806
5	129929-01-705	FT	GLAZING VINYL	132-026811
6	129929-01-707	FT	COVER/SCREW-FILLER STRIP	132-026808
8	129929-01-708	EA	SUPPORT - TORQUE BAR - RT/LT	130-026804
10	129929-12-700	EA	GLASS - STATIONARY	390-029808
11	129929-12-701	EA	VENT GLASS ASSEMBLY	DTH011-G8
12	129929-12-702	EA	SCREEN ASM - W/SEALS & CLIPS	410-028632
13	129929-12-703	EA	RETAINER - TRIM	DTH011-62
14	129929-12-704	EA	OPERATOR BAR ASSEMBLY	DTH011-18
	100322-01-717	EA	E-RING	245-015975
	129929-01-706	FT	SEAL - TOP F/CENTER EGRESS	132-026811
	129929-02-706	FT	SEAL - FOAM	140-027022

CONTACT WINNEBAGO PART SALES FOR UNLISTED COMPONENTS