

2003
HORIZON
IKP34HD
P-SERIES
PORTSMOUTH OAK
P84 PROVENCE BLUE - BLUE
P86 HARVEST TAPESTRY - GREEN
P88 CARRARA CREAM - NEUTRAL
CONCERT CHERRY
P85 PROVENCE BLUE - BLUE
P87 HARVEST TAPESTRY - GREEN
P89 CARRARA CREAM - NEUTRAL
WASHED MAPLE
P28 PROVENCE BLUE - BLUE
P29 HARVEST TAPESTRY - GREEN
P30 CARRARA CREAM - NEUTRAL

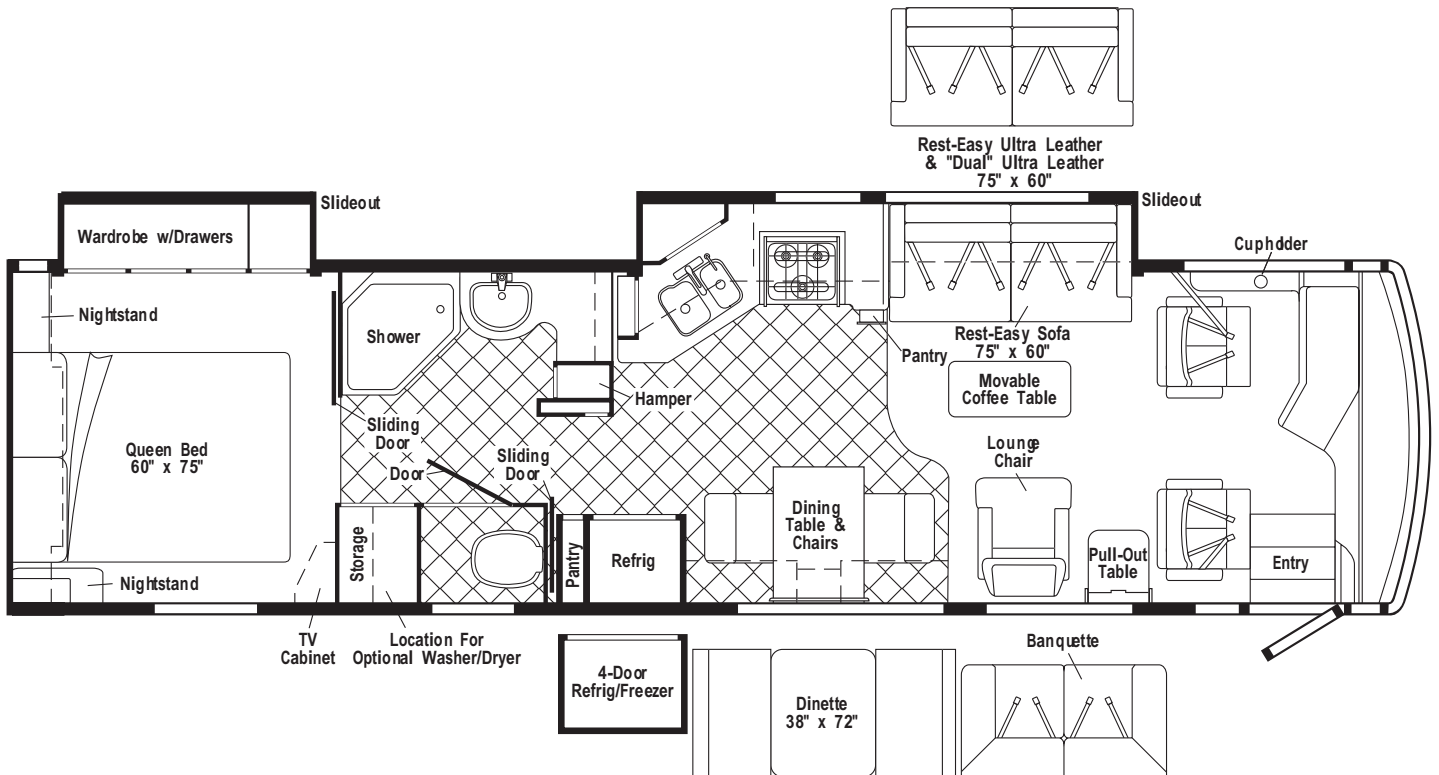

FLOORPLAN

CONTENTS

FLOORPLAN	1
ACCESSORIES GROUP	6
OPERATORS MANUAL	6
APPLIANCE GROUP	7
APPLIANCES	7
COMPONENT PARTS FOR APPLIANCE	13
115504-01-000	14
120075-13-01A, 120075-14-01A, 120075-15-01A	14
125242-02-01A	20
126019-01-01A	29
126022-01-01A, 126022-02-01A, 126022-03-01A	29
133004-02-01A	30
135065-01-01A, 135065-01-02A, 135065-02-01A	31
135066-02-01A	33
AUDIO VIDEO GROUP	37
RADIO SYSTEM	37
REAR VIEW MONITOR	38
TELEPHONE	38
TV & VCR	39
COMPONENT PARTS FOR TV & VCR	40
076319-23-000	40
076319-25-000	40
124073-11-000	41
124073-12-000	41
124073-13-000	41
126696-07-000	41
126697-07-000	41
130121-06-000	41
133377-01-000 & 133377-02-000	41
137135-01-000	42
EXTERIOR ENTERTAINMENT	43
BATH GROUP	44
CABINETS	44
SHOWER	47
COMPONENT PARTS FOR SHOWER DOOR	48
139047-05-01A	48
BEDROOM GROUP	49
QUEEN CABINETS	49
TV & RADIO CABINETS	51
CHASSIS GROUP	52
FRAME	52
FRONT END	54
AIR INTAKE	56
INSULATION	57
STEPWELL COVER	60
COMPONENT PARTS FOR STEPWELL COVER	61
141691-01-01A	61
EXHAUST	62
HITCH	62
REAR BUMPER	63
FUEL OR FUEL FILL OR EMISSIONS	64
HYDRAULIC LEVELING	65
COMPONENT PARTS FOR HYDRAULIC LEVELING	66
100536-45-000	66
131306-27-000	66
WHEEL, TIRE, COVERS &/OR LINERS	67
COMPONENT PARTS FOR WHEEL, TIRE, COVERS &/OR LINERS	68
110435-17-000	68

CONTENTS (CONTINUED)

CURTAIN & CUSHION GROUP	69
NOTICE	69
CUSHION LAYOUT	70
BUCKET SEATS	72
COMPONENT PARTS FOR BUCKET SEATS	73
081373-03-000	73
132575-01-000	73
LOUNGE CHAIR	74
SOFA	75
COMPONENT PARTS FOR SOFA	80
136534-13-000, 136534-28-000	80
136534-24-000	80
WINDOW TREATMENT	81
HARDWARE	83
ACCESSORIES	85
COMPONENT PARTS FOR ACCESSORIES	86
091990-08-01A	86
FABRICS	87
DINETTE GROUP	89
CABINETS	89
TABLE	91
DRIVERS COMPARTMENT GROUP	94
DASH	94
FRONT INTERIOR	95
CABINETS	100
ELECTRICAL GROUP	102
12V BODY WIRING	102
FRONT END WIRING	109
COMPONENT PARTS FOR LIGHTS & SWITCHES	112
008089-02-000	112
086280-01-000	112
087694-01-000	112
091206-04-000	112
091937-08-000	112
091937-09-000	112
093575-19-01A	112
108354-01-01A	112
121935-01-01A	112
123775-01-01A	112
133054-03-000	112
133054-04-000	112
137417-01-01A	112
137417-03-01A	112
137417-06-01A	112
139134-01-02A	112
CIRCUIT BREAKERS & FUSES	113
CONVERTER, INVERTER, LOAD CENTERS	114
110V WIRING	115
ENTERTAINMENT WIRING	118
BOXES & CORDS	119
WIRE ASSEMBLIES	119
CONNECTORS & CONDUIT	120
BOOTS, SOLENOIDS, RELAYS & MISCELLANEOUS	122

CONTENTS (CONTINUED)

EXTERIOR BODY GROUP	123
AIR HORN	123
COMPONENT PARTS FOR AIR HORN	124
077497-06-000	124
GRAPHICS & PAINT	125
PANELS & TRIMS	128
FRONT END	131
LADDER	133
MIRRORS	133
COMPONENT PARTS FOR MIRRORS	134
106015-18-01A, 106015-19-01A	134
131431-06-01A & 02A	134
STRUCTURAL COMPONENTS	135
AWNINGS	136
COMPONENT PARTS FOR AWNINGS	139
113874-01-02A	139
EXTERIOR DOORS & COMPARTMENTS GROUP	140
DOOR & COMPARTMENT LAYOUT	140
COMPARTMENT DOOR PIECE PARTS	144
ENTRY	145
COMPONENT PARTS FOR ENTRY	146
128913-10-02A	146
EXTERIOR SLIDEOUT GROUP	151
FRONT LEFT	151
COMPONENT PARTS FOR FRONT SLIDEOUT	156
100536-44-000	156
140121-01-000	156
LEFT REAR	157
COMPONENT PARTS FOR LEFT REAR SLIDEOUT	161
100536-52-000	161
139507-01-000	161
GALLEY GROUP	162
CABINETS	162
DOORS & DRAWERS	164
GENERATOR GROUP	166
LPG	166
DIESEL	167
HEATING & A/C GROUP	168
AUTOMOTIVE	168
COMPONENT PARTS FOR AUTOMOTIVE	170
072342-15-000	170
072342-16-000	170
072342-18-000	171
103930-36-000	172
103930-41-000	173
FURNACE	174
COMPONENT PARTS FOR FURNACE	175
139980-04-000	175
CENTRAL	177
COMPONENT PARTS FOR CENTRAL	179
105620-12-000	179
105620-15-000	180

CONTENTS (CONTINUED)

INTERIOR FINISH GROUP	181
MOLDINGS & TRIMS	181
PANELING & LAMINATES	185
COMPONENT PARTS FOR PANELING & LAMINATES	186
057882-04-000	186
057882-05-000	186
ACCESSORIES	187
COMPONENT PARTS FOR ACCESSORIES	188
094499-02-000	188
FLOOR COVERINGS	189
HARDWARE	190
LABELS GROUP	196
LP GROUP	220
LP SYSTEM	220
COMPONENT PARTS FOR LP SYSTEM	221
088253-05-000	221
088253-06-000	221
LOUNGE GROUP	222
CABINETS	222
TABLES	223
SEALANTS & FASTENERS GROUP	224
SEALANTS & ADHESIVES	224
BOLTS, NUTS AND WASHERS	225
SCREWS	227
CLAMPS, CLIPS, GROMMETS, RIVETS & PLUGS	230
MISCELLANEOUS FASTENERS	231
WATER & SEWAGE GROUP	232
DRAINAGE SYSTEM	232
COMPONENT PARTS FOR DRAINAGE SYSTEM	234
136729-01-01A	234
WATER SYSTEM	235
COMPONENT PARTS FOR WATER SYSTEM	243
051391-05-000	243
075241-04-000, 075241-05-000, 075241-06-000	243
118569-03-000	244
123744-03-01A	244
125420-01-02A, 125420-01-03A, 125420-04-03A	244
128997-01-01A	244
131340-01-01A	244
131340-02-01A	244
WINDOW & VENTS GROUP	245
WINDOW & VENT LAYOUT	245
COMPONENT PARTS FOR WINDOWS & VENT LAYOUT	246
106466-14-01A	246
112795-69-01A	247
112795-72-01A	248
112795-81-01A	248
112795-83-01A	248
112898-27-01A	249
123780-09-01A	250
123780-10-01A	251
129929-08-01A	252
137867-04-01A	253
WINDSHIELD & WIPER GROUP	254
WINDSHIELD	254
WIPER	255
COMPONENT PARTS FOR WIPER	256
095964-01-000	256
096505-09-000	256
117769-01-000	256

ACCESSORIES GROUP
OPERATORS MANUAL

KEY	PART NUMBER	U/M	DESCRIPTION
	129079-04-01A	EA	CASE - VINYL/BLK-EXPANDABLE ACCORDION SIDES-11"WX9"HX14"L
	132000-08-003	EA	MANUAL/OWNER - HORIZON - 2003
	141548-01-000	DW	TOP LEVEL-P,2003

APPLIANCE GROUP APPLIANCES

KEY	PART NUMBER	U/M	DESCRIPTION
	135066-03-01A	EA	RANGE - 3 BURNER W/OVEN - 22" - W/BLACK GLASS DOOR - RANGE W/OVEN U.S.
*	135066-02-01A	EA	RANGE - 3 BURNER W/OVEN - SEALED BURNERS - 22" - CSA - RANGE W/OVEN CANADIAN
	135065-03-01A	EA	RANGE - 3 SEALED BURNERS/NEW STYLE KNOBS-GRATES - BLACK - RANGE TOP U.S.
*	135065-02-01A	EA	RANGE - 3 BURNER W/O OVEN - SEALED BURNERS - CSA - RANGE TOP CANADIAN
	136382-08-04B	EA	BRACKET - TIEDOWN - OVEN - BLACK - RANGE W/OVEN - P32TD
	137915-01-04B	EA	BRACKET - TIEDOWN - BLACK - RANGE W/OVEN - P32TD
	136382-01-04B	EA	BRACKET - TIEDOWN/OVEN - BLACK - FRONT - RANGE W/OVEN - P34HD, P36LD, P39WD
	136382-02-04B	EA	BRACKET - TIEDOWN/OVEN - BLACK - BACK - RANGE W/OVEN - P34HD, P36LD, P39WD
	136382-05-04B	EA	BRACKET - TIEDOWN/OVEN - BLACK - FRONT - RANGE W/OVEN - P39QD
	136382-06-04B	EA	BRACKET - TIEDOWN/OVEN - BLACK - BACK - RANGE W/OVEN - P39QD
	139031-01-04B	EA	BRACKET - TIEDOWN - STOVE - BLACK - RANGE TOP - P32TD
	137915-02-04B	EA	BRACKET - TIEDOWN - BLACK - RANGE TOP - P32TD
	106936-21-04B	EA	BRACKET - STOVE TIEDOWN/FRONT - BLACK - RANGE TOP - P34HD, P36LD, P39WD
	106936-22-04B	EA	BRACKET - STOVE TIEDOWN/REAR - BLACK - RANGE TOP - P34HD, P36LD, P39WD
	106936-35-04B	EA	BRACKET - STOVE TIEDOWN/FRONT - BLACK - RANGE TOP - P39QD
	106936-36-04B	EA	BRACKET - STOVE TIEDOWN/REAR - BLACK - RANGE TOP - P39QD
*	126022-01-01A	EA	COVER - RANGE/BI-FOLD - 16" & 22" - BLACK TEXTURED
	130816-01-03A	EA	COUNTERTOP/STOVE LID - 1/4" VENDURA - ALMONDINE
	130816-02-03A	EA	COUNTERTOP/STOVE LID - 1/4" VENDURA - ALMONDINE
*	126019-01-01A	EA	COFFEEMAKER - OPTIMA - W/BRACKETS - BLACK & DECKER
*	115504-01-000	EA	PANEL - SOLAR 10 WATT - 12.2"W X 26.9"L X 1.2"H
*	133004-02-01A	EA	PANEL - MONITOR - 2 TANK DIGITAL VOLT METER - SOLAR
	133068-01-000	EA	HAIR DRYER - 3 SPEED W/NIGHT LIGHT - WALL MOUNT
	133139-01-000	EA	VACUUM CLEANER - RECHARGEABLE DUST-BUSTER - BLACK & DECKER
	143733-01-000	EA	VACUUM CLEANER - RECHARGEABLE - EUREKA 79A
			FROM: 00-00-00 THRU: 10-06-02
	144676-01-000	EA	VACUUM CLEANER - RECHARGEABLE - EUREKA 77A
			FROM: 10-07-02 THRU: 99-99-99
	133140-01-000	EA	FLASHLIGHT - RECHARGEABLE - BLACK & DECKER
			FROM: 00-00-00 THRU: 07-24-02
	143981-01-000	EA	FLASHLIGHT - RECHARGEABLE
			FROM: 07-25-02 THRU: 99-99-99
	130818-02-01A	EA	TRASH CONTAINER - 20 QUART ALMOND

*COMPONENT PARTS LISTED LATER IN THIS GROUP

APPLIANCE GROUP (CONTINUED)
APPLIANCES (CONTINUED)

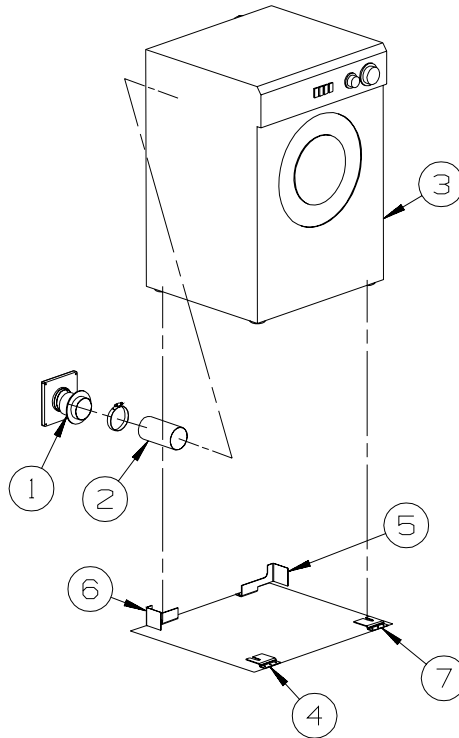

KEY	PART NUMBER	U/M	DESCRIPTION
1	111947-02-01A	EA	VENT - DRYER - 3"
2	116653-02-000	FT	DUCT - FLEXIBLE - 3' COMPRESSED/8' EXTENDED
3	107753-03-01A	EA	WASHER - DRYER - VENTED - UL/CSA - WHITE
			FROM: 00-00-00 THRU: 10-21-02
3	107753-04-01A	EA	WASHER - DRYER - VENTED - UL/CSA - WHITE
			FROM: 10-22-02 THRU: 99-99-99
4	111913-01-01A	EA	BRACKET - WASHER - TIE DOWN
			FROM: 00-00-00 THRU: 11-24-02
4	111913-02-04B	EA	BRACKET/WASHER - TIE DOWN - BLACK
			FROM: 11-25-02 THRU: 99-99-99
5	113795-01-02B	EA	BRACKET - WASHER - E-COATED
			FROM: 00-00-00 THRU: 02-09-03
5	113795-03-02B	EA	BRACKET - WASHER - E-COATED
			FROM: 02-10-03 THRU: 99-99-99
6	113795-02-02B	EA	BRACKET - WASHER - E-COATED
			FROM: 00-00-00 THRU: 02-09-03
6	113795-04-02B	EA	BRACKET - WASHER - E-COATED
			FROM: 02-10-03 THRU: 99-99-99
7	111913-01-01A	EA	BRACKET - WASHER - TIE DOWN
			FROM: 00-00-00 THRU: 11-24-02
7	111913-03-04B	EA	BRACKET/WASHER - TIE DOWN - BLACK
			FROM: 11-25-02 THRU: 99-99-99

APPLIANCE GROUP (CONTINUED)
APPLIANCES (CONTINUED)

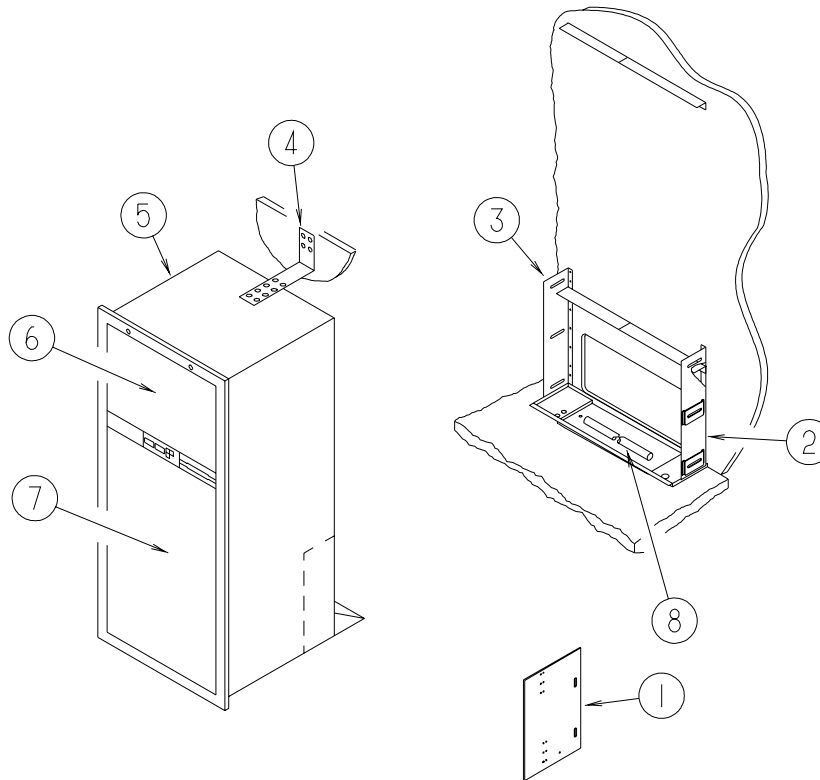

**P34HD, P36LD, P39QD,
P39WD**

KEY	PART NUMBER	U/M	DESCRIPTION
1	065225-04-000	EA	PLATE - TIEDOWN/REFRIGERATOR
2	093646-01-000	EA	BRACKET - TIEDOWN/REFRIGERATOR - RIGHT HAND
3	093646-02-000	EA	BRACKET - TIEDOWN/REFRIGERATOR - LEFT HAND
4	093369-02-000	EA	STRAP - REFRIGERATOR
5*	120075-13-01A	EA	REFRIGERATOR-LARGE DOUBLE DOOR/RH - 2-WAY -ICE MAKER-BLACK
6	P34457-03-N47	EA	PANEL - INSERT RAISED MEMBRANE - 21.5" X 14.5" - PORTSMOUTH OAK
6	P34457-03-L85	EA	PANEL - INSERT RAISED MEMBRANE - 21.5" X 14.5" - CONCERT CHERRY
6	P34457-03-L94	EA	PANEL - INSERT RAISED MEMBRANE - 21.5" X 14.5" - WASHED MAPLE
7	P34457-04-N47	EA	PANEL - INSERT RAISED MEMBRANE - 21.5" X 38.5" - PORTSMOUTH OAK
7	P34457-04-L85	EA	PANEL - INSERT RAISED MEMBRANE - 21.5" X 38.5" - CONCERT CHERRY
7	P34457-04-L94	EA	PANEL - INSERT RAISED MEMBRANE - 21.5" X 38.5" - WASHED MAPLE
8	112176-01-000	FT	TUBING - VINYL - REINFORCED - 1/2" ID
	090329-01-000	FT	SEAL/T - REFRIGERATOR CABINET
	116751-02-01A	EA	TRAY - REFRIGERATOR - BLACK
	054450-01-000	EA	LEVEL - REFRIGERATOR

***COMPONENT PARTS LISTED LATER IN THIS GROUP**

APPLIANCE GROUP (CONTINUED)
APPLIANCES (CONTINUED)

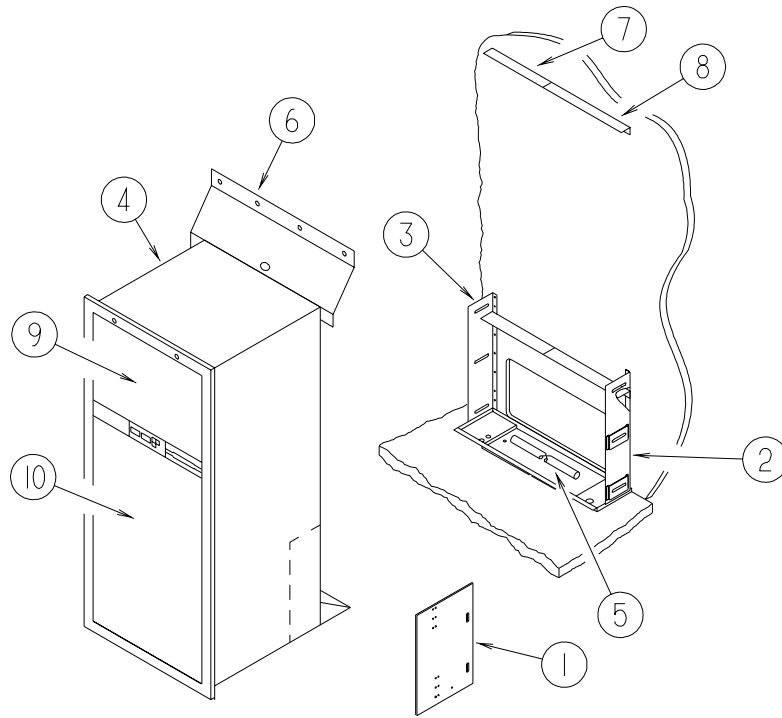

P32TD

KEY	PART NUMBER	U/M	DESCRIPTION
1	065225-04-000	EA	PLATE - TIEDOWN/REFRIGERATOR
2	093646-01-000	EA	BRACKET - TIEDOWN/REFRIGERATOR - RIGHT HAND
3	093646-02-000	EA	BRACKET - TIEDOWN/REFRIGERATOR - LEFT HAND
4*	120075-14-01A	EA	REFRIGERATOR - LARGE DOUBLE/DOOR/RH- 2-WAY-ICE MAKER-BLACK
5	112176-01-000	FT	TUBING - VINYL - REINFORCED - 1/2" ID
6	136966-01-02B	EA	BAFFLE - REFRIGERATOR - E-COATED
7	143195-02-02B	EA	BAFFLE - REFRIGERATOR - E-COATED
8	143195-01-02B	EA	BAFFLE - REFRIGERATOR - E-COATED
9	P34457-03-N47	EA	PANEL - INSERT RAISED MEMBRANE - 21.5" X 14.5" - PORTSMOUTH OAK
9	P34457-03-L85	EA	PANEL - INSERT RAISED MEMBRANE - 21.5" X 14.5" - CONCERT CHERRY
9	P34457-03-L94	EA	PANEL - INSERT RAISED MEMBRANE - 21.5" X 14.5" - WASHED MAPLE
10	P34457-04-N47	EA	PANEL - INSERT RAISED MEMBRANE - 21.5" X 38.5" - PORTSMOUTH OAK
10	P34457-04-L85	EA	PANEL - INSERT RAISED MEMBRANE - 21.5" X 38.5" - CONCERT CHERRY
10	P34457-04-L94	EA	PANEL - INSERT RAISED MEMBRANE - 21.5" X 38.5" - WASHED MAPLE
	090329-01-000	FT	SEAL/T - REFRIGERATOR CABINET
	054450-01-000	EA	LEVEL - REFRIGERATOR
	136907-01-01A	EA	TRAY - REFRIGERATOR - BLACK

***COMPONENT PARTS LISTED LATER IN THIS GROUP**

APPLIANCE GROUP (CONTINUED)
APPLIANCES (CONTINUED)

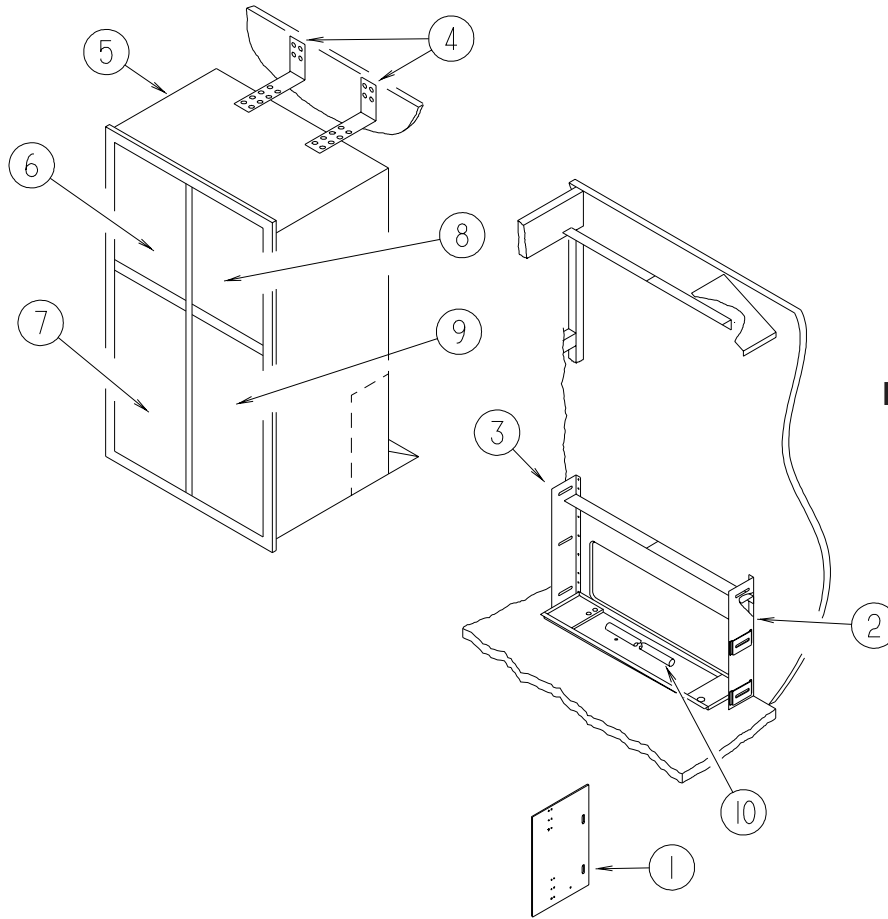

**P34HD, P36LD, P39QD,
P39WD**

KEY	PART NUMBER	U/M	DESCRIPTION
1	065225-01-000	EA	PLATE - TIEDOWN/REFRIGERATOR
2	093646-01-000	EA	BRACKET - TIEDOWN/REFRIGERATOR - RIGHT HAND
3	093646-02-000	EA	BRACKET - TIEDOWN/REFRIGERATOR - LEFT HAND
4	093369-02-000	EA	STRAP - REFRIGERATOR
5*	125242-02-01A	EA	REFRIGERATOR-4 DR-W/ICE MKR-W/CONTOURED HANDLE-NORCOLD1201
6	P34457-01-N75	EA	PANEL - INSERT RAISED MEMBRANE - 16.1" X 18.3" - PORTSMOUTH OAK
6	P34457-01-LQ1	EA	PANEL - INSERT RAISED MEMBRANE - 16.1" X 18.3" - CONCERT CHERRY
6	P34457-01-L94	EA	PANEL - INSERT RAISED MEMBRANE - 16.1" X 18.3" - WASHED MAPLE
7	P34457-02-N75	EA	PANEL - INSERT RAISED MEMBRANE - 16.1" X 41.1" - PORTSMOUTH OAK
7	P34457-02-LQ1	EA	PANEL - INSERT RAISED MEMBRANE - 16.1" X 41.1" - CONCERT CHERRY
7	P34457-02-L94	EA	PANEL - INSERT RAISED MEMBRANE - 16.1" X 41.1" - WASHED MAPLE
8	P34457-01-N75	EA	PANEL - INSERT RAISED MEMBRANE - 16.1" X 18.3" - PORTSMOUTH OAK
8	P34457-01-LQ1	EA	PANEL - INSERT RAISED MEMBRANE - 16.1" X 18.3" - CONCERT CHERRY
8	P34457-01-L94	EA	PANEL - INSERT RAISED MEMBRANE - 16.1" X 18.3" - WASHED MAPLE
9	P34457-02-N75	EA	PANEL - INSERT RAISED MEMBRANE - 16.1" X 41.1" - PORTSMOUTH OAK
9	P34457-02-LQ1	EA	PANEL - INSERT RAISED MEMBRANE - 16.1" X 41.1" - CONCERT CHERRY
9	P34457-02-L94	EA	PANEL - INSERT RAISED MEMBRANE - 16.1" X 41.1" - WASHED MAPLE
10	112176-01-000	FT	TUBING - VINYL - REINFORCED - 1/2" ID
	090329-01-000	FT	SEAL/T - REFRIGERATOR CABINET
	054450-01-000	EA	LEVEL - REFRIGERATOR
	118871-02-01A	EA	TRAY/PAN - F/SIDE BY SIDE REFRIGERATOR - BLACK

***COMPONENT PARTS LISTED LATER IN THIS GROUP**

APPLIANCE GROUP (CONTINUED)
APPLIANCES (CONTINUED)

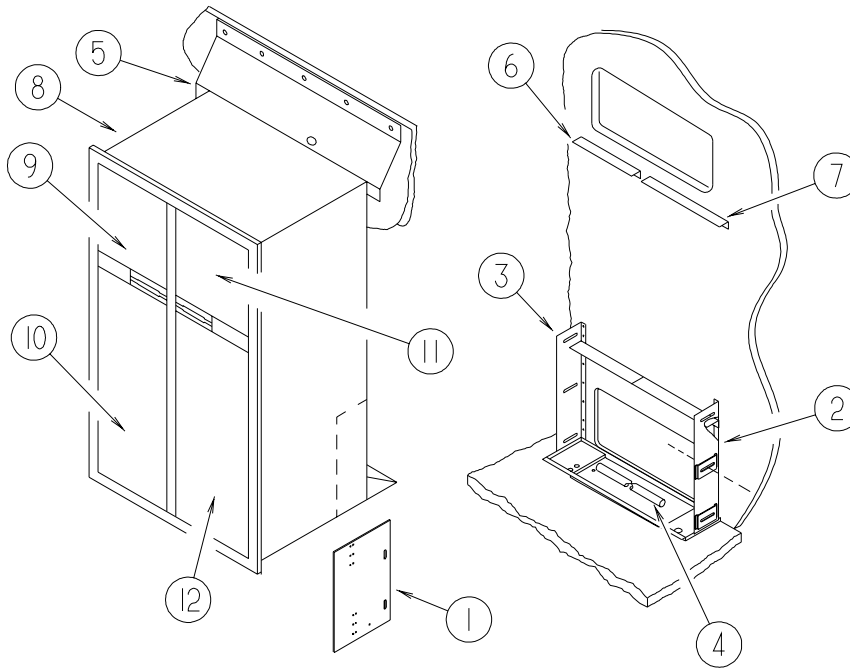

P32TD

KEY	PART NUMBER	U/M	DESCRIPTION
1	065225-01-000	EA	PLATE - TIEDOWN/REFRIGERATOR
2	093646-01-000	EA	BRACKET - TIEDOWN/REFRIGERATOR - RIGHT HAND
3	093646-02-000	EA	BRACKET - TIEDOWN/REFRIGERATOR - LEFT HAND
4	112176-01-000	FT	TUBING - VINYL - REINFORCED - 1/2" ID
5	136966-03-02B	EA	BAFFLE - REFRIGERATOR - E-COATED
6	143195-01-02B	EA	BAFFLE - REFRIGERATOR - E-COATED
7	143195-02-02B	EA	BAFFLE - REFRIGERATOR - E-COATED
8*	125242-02-01A	EA	REFRIGERATOR-4 DR-W/ICE MKR-W/CONTOURED HANDLE-NORCOLD1201
9	P34457-01-N75	EA	PANEL - INSERT RAISED MEMBRANE - 16.1" X 18.3" - PORTSMOUTH OAK
9	P34457-01-LQ1	EA	PANEL - INSERT RAISED MEMBRANE - 16.1" X 18.3" - CONCERT CHERRY
9	P34457-01-L94	EA	PANEL - INSERT RAISED MEMBRANE - 16.1" X 18.3" - WASHED MAPLE
10	P34457-02-N75	EA	PANEL - INSERT RAISED MEMBRANE - 16.1" X 41.1" - PORTSMOUTH OAK
10	P34457-02-LQ1	EA	PANEL - INSERT RAISED MEMBRANE - 16.1" X 41.1" - CONCERT CHERRY
10	P34457-02-L94	EA	PANEL - INSERT RAISED MEMBRANE - 16.1" X 41.1" - WASHED MAPLE
11	P34457-01-N75	EA	PANEL - INSERT RAISED MEMBRANE - 16.1" X 18.3" - PORTSMOUTH OAK
11	P34457-01-LQ1	EA	PANEL - INSERT RAISED MEMBRANE - 16.1" X 18.3" - CONCERT CHERRY
11	P34457-01-L94	EA	PANEL - INSERT RAISED MEMBRANE - 16.1" X 18.3" - WASHED MAPLE
12	P34457-02-N75	EA	PANEL - INSERT RAISED MEMBRANE - 16.1" X 41.1" - PORTSMOUTH OAK
12	P34457-02-LQ1	EA	PANEL - INSERT RAISED MEMBRANE - 16.1" X 41.1" - CONCERT CHERRY
12	P34457-02-L94	EA	PANEL - INSERT RAISED MEMBRANE - 16.1" X 41.1" - WASHED MAPLE
	090329-01-000	FT	SEAL/T - REFRIGERATOR CABINET
	054450-01-000	EA	LEVEL - REFRIGERATOR
	137495-01-01A	EA	TRAY - REFRIGERATOR - BLACK

***COMPONENT PARTS LISTED LATER IN THIS GROUP**

APPLIANCE GROUP (CONTINUED)
COMPONENT PARTS FOR APPLIANCE

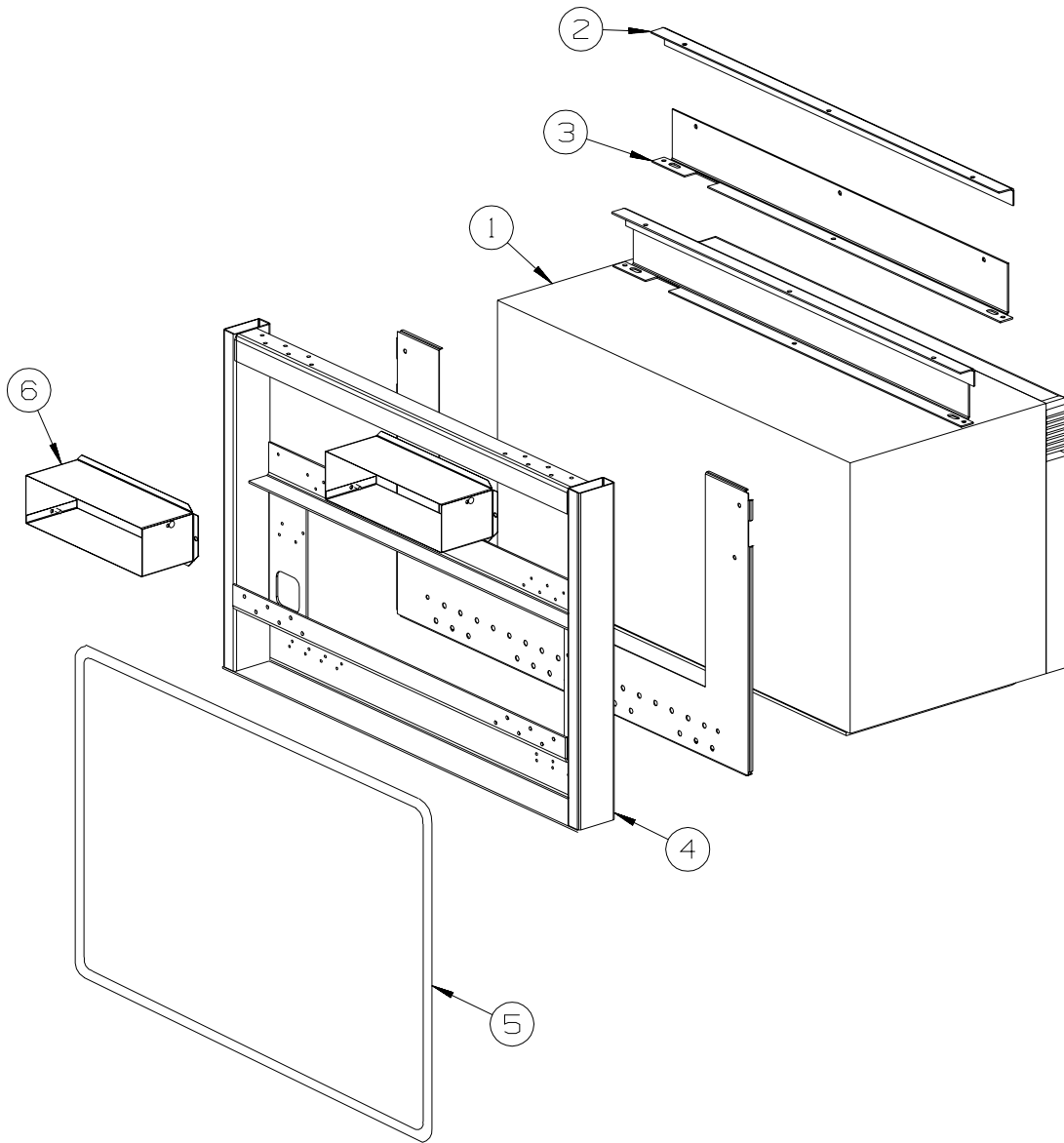

KEY	PART NUMBER	U/M	DESCRIPTION
1	119267-12-01A	EA	OVEN - MICROWAVE/CONVECTION W/HOOD US - #R-1875 - CONVECTION, U.S.
1	119267-13-01A	EA	OVEN - MICROWAVE/CONVECTION W/HOOD CSA - #R-1875A - CONVECTION, C.S.A.
1	140147-02-01A	EA	OVEN/MICROWAVE - 1.4 CUBIC FT - STAINLESS STEEL FACE - SPEEDCOOK
2	129836-02-02B	EA	ANGLE - W/HOLES - .7" X 1" X 28.3" - E-COATED - LH
3	129836-05-02B	EA	ANGLE - W/HOLES - E-COATED - P36LD,P39WD
3	129836-04-02B	EA	ANGLE - W/HOLES - .7" X 2.2" X 28.3" - E-COATED- CONVECTION P34HD
3	129836-01-02B	EA	ANGLE - W/HOLES - .7" X 1" X 28.3" - E-COATED - CONVECTION P34HD
			FROM: 00-00-00 THRU: 09-15-02
			FROM: 09-16-02 THRU: 99-99-99
3	129836-06-02B	EA	ANGLE - W/HOLES - E-COATED - SPEEDCOOK P34HD
4	137824-02-02B	EA	BRACKET - MICROWAVE - E-COATED - P36LD,P39WD
4	137824-03-02B	EA	BRACKET - MICROWAVE - E-COATED - P34HD
5	093305-01-01A	FT	TRIM - EDGE C-TYPE - WIRE CARRIER - .35" X .24" - VINYL - P34HD
6	140093-01-02B	EA	DUCT - E-COATED - CONVECTION P36LD,P39WD
6	140093-03-02B	EA	DUCT - E-COATED - CONVECTION P34HD
6	140093-04-02B	EA	DUCT - E-COATED - SPEEDCOOK P36LD,P39WD
6	140093-05-02B	EA	DUCT - E-COATED - SPEEDCOOK P34HD

*COMPONENT PARTS LISTED LATER IN THIS GROUP

APPLIANCE GROUP (CONTINUED)
COMPONENTS PARTS FOR APPLIANCE (CONTINUED)

115504-01-000

KEY	PART NUMBER	U/M DESCRIPTION	VENDOR NO.
	115504-01-700	EA PLUG & CABLE, 10 WATT PANEL	600-016

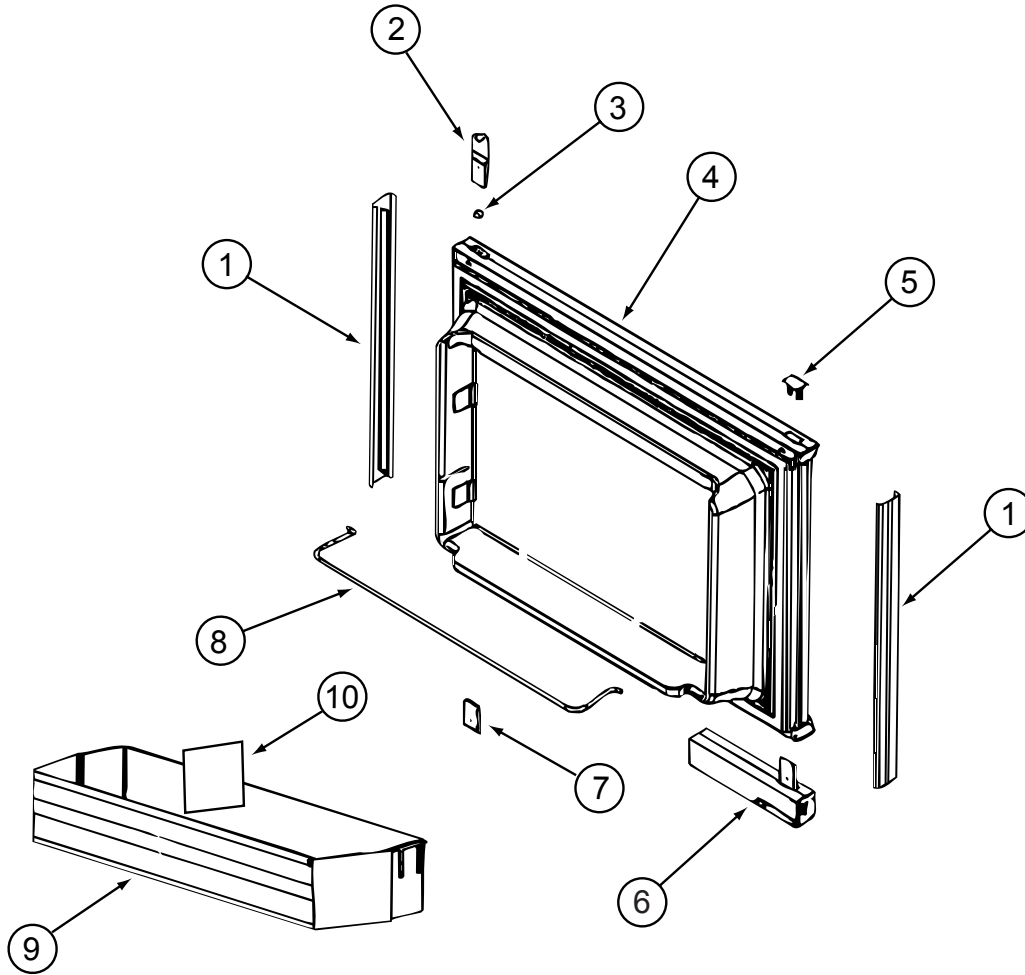

120075-13-01A, 120075-14-01A, 120075-15-01A

KEY	PART NUMBER	U/M DESCRIPTION	VENDOR NO.
1	121568-03-700	EA RETAINER - DOOR PANEL/BLACK	619558
2	120075-01-701	EA HINGE-TOP RH/BOTTOM LH(DOOR)	618511
3	121568-03-701	EA BUSHING - HINGE PIN/GRAY	619671
4	121568-03-702	EA DOOR LINER - W/TRIM/BLACK	619627 - SMALL DOOR
5	120075-01-702	EA CAP, (HINGE PLUG)	618160
6	120075-12-700	EA HANDLE(CONTOUR)TOP LH/BTM RH	621105
	120075-12-702	EA HANDLE/HOUSING-TOP-LH/BTM RH	618159GEN
6	120075-12-701	EA HANDLE(CONTOUR)TOP RH/BTM LH	621104
	120075-12-707	EA LATCH	619648
	120075-12-709	EA HANDLE/HOUSING-BTM LH/TOP RH	618122GEN
6	121568-03-703	EA HANDLE/FLUSH-TOP/RH-LWR/LH	619865
6	121568-03-708	EA HANDLE/FLUSH-TOP/LH-LWR/RH	619866
7	120075-01-705	EA HINGE-TOP LH/BOTTOM RH(DOOR)	618510
8	121568-01-700	EA RAIL - DOOR UPPER	618618
9	120075-07-700	EA DOOR BIN - CLEAR	619006
10	120075-07-701	EA DIVIDER/DOOR BIN CLEAR	619008
	121568-03-704	EA TRAVEL LATCH - GRAY	619647
	121568-03-705	EA STORAGE LATCH - GRAY	619648

APPLIANCE GROUP (CONTINUED)
COMPONENTS PARTS FOR APPLIANCE (CONTINUED)

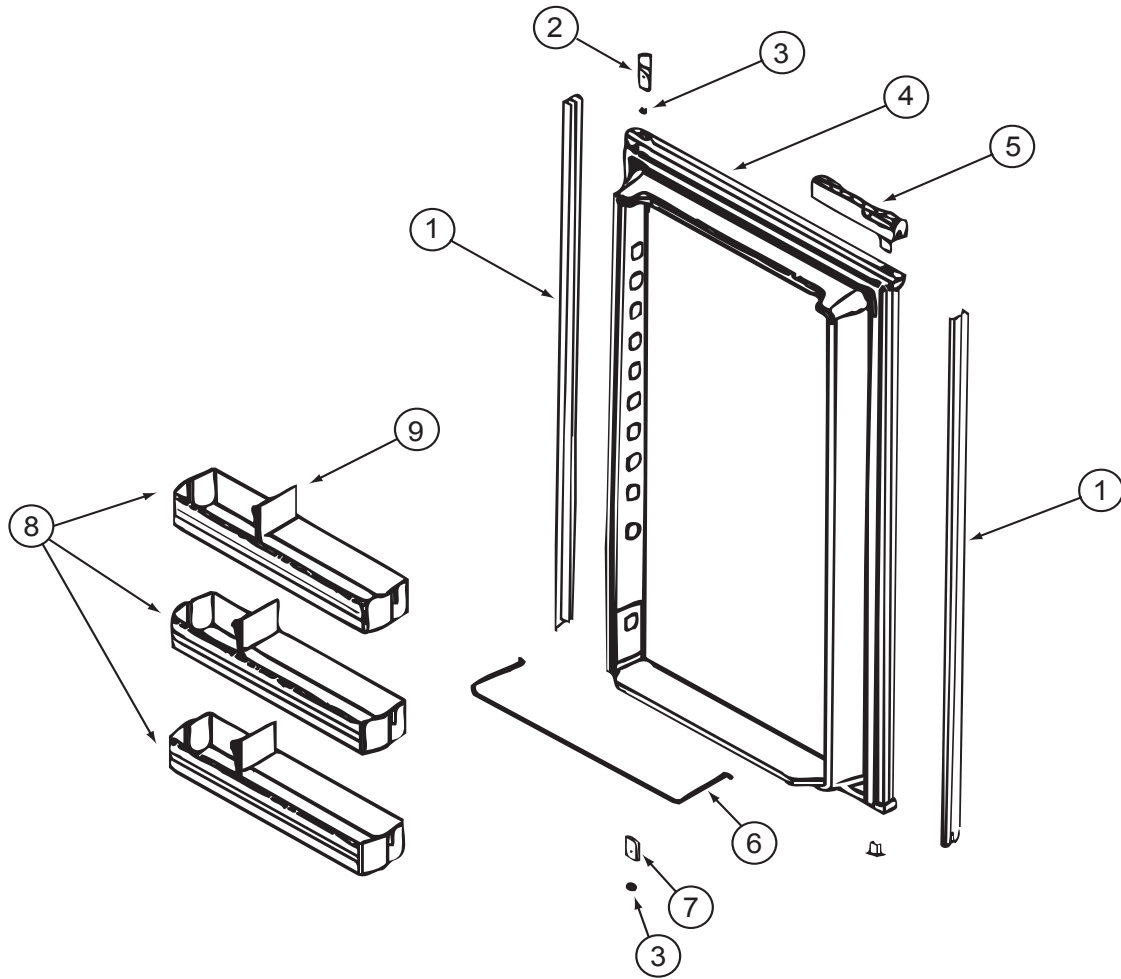

120075-13-01A, 120075-14-01A, 120075-15-01A (CONTINUED)

KEY	PART NUMBER	U/M	DESCRIPTION	VENDOR NO.
1	120075-07-702	EA	RETAINER - DOOR PANEL/BLACK	619560
2	120075-01-701	EA	HINGE-TOP RH/BOTTOM LH(DOOR)	618511
3	121568-03-701	EA	BUSHING - HINGE PIN/GRAY	619671
4	120075-07-703	EA	DOOR LINER - BLACK	619631 - LARGE DOOR
5	120075-12-700	EA	HANDLE(CONTOUR)TOP LH/BTM RH	621105
	120075-12-702	EA	HANDLE/HOUSING-TOP-LH/BTM RH	618159GEN
5	120075-12-701	EA	HANDLE(CONTOUR)TOP RH/BTM LH	621104
	120075-12-707	EA	LATCH	619648
	120075-12-709	EA	HANDLE/HOUSING-BTM LH/TOP RH	618122GEN
5	121568-03-703	EA	HANDLE/FLUSH-TOP/RH-LWR/LH	619865
5	121568-03-708	EA	HANDLE/FLUSH-TOP/LH-LWR/RH	619866
6	121568-01-704	EA	RAIL - DOOR LOWER	618578
7	120075-01-705	EA	HINGE-TOP LH/BOTTOM RH(DOOR)	618510
8	120075-07-700	EA	DOOR BIN - CLEAR	619006
8	120075-07-704	EA	DOOR BIN - LARGE/CLEAR	619005
9	120075-07-701	EA	DIVIDER/DOOR BIN CLEAR	619008
	121568-03-704	EA	TRAVEL LATCH - GRAY	619647
	121568-03-705	EA	STORAGE LATCH - GRAY	619648

APPLIANCE GROUP (CONTINUED)
COMPONENTS PARTS FOR APPLIANCE (CONTINUED)

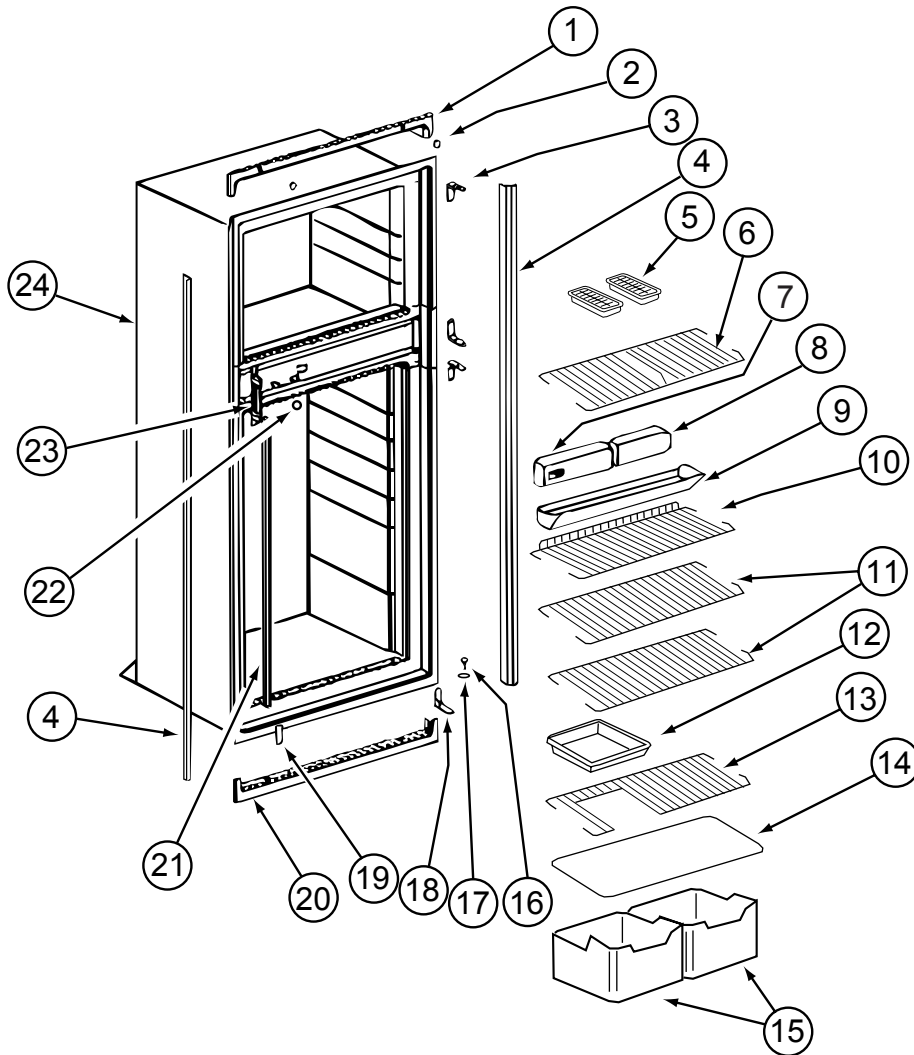

120075-13-01A, 120075-14-01A, 120075-15-01A (CONTINUED)

KEY	PART NUMBER	U/M	DESCRIPTION	VENDOR NO.
1	121568-03-709	EA	TRIM - TOP/BLACK	619687
2	120075-01-714	EA	PLUG-HOLE (BLACK)	618170
3	121568-03-710	EA	HINGE/CABINET-TOP/RH-LWR/LH	619335
4	120075-07-705	EA	TRIM - SIDE - BLACK	622296
5	104137-06-724	EA	ICE TRAY	61630422
6	120075-07-706	EA	SHELF - WIRE/FREEZER	620249
7	120075-07-707	EA	CONTROL BOX - BLACK	619665
8	121568-03-713	EA	FRONT BOX/DECORATIVE-BLACK	619282
9	120075-01-720	EA	TRAY-DRIP	618137
10	120075-01-722	EA	SHELF-WIRE, SHORT	620269
11	120075-01-723	EA	SHELF-WIRE	620270
12	104137-06-718	EA	SHELF-TRAY, WHITE, W/CUTOUT	617756
13	120075-01-724	EA	SHELF-WIRE, W/CUTOUT	618177
14	120075-01-725	EA	COVER-CRISPER	618158
15	120075-07-708	EA	CRISPER/ICE BIN	619007
16	120075-01-727	EA	PIN-HINGE	618145
17	121568-03-701	EA	BUSHING - HINGE PIN/GRAY	619671
18	121568-03-715	EA	HINGE/CABINET-TOP/LH-LWR/RH	619336
19	121568-03-716	EA	COVER - HINGE HOLES	619301
20	120075-01-729	EA	TRIM-BOTTOM PIECE	620958
21	120075-01-730	EA	RETAINER-SHELF(SER#926684 DN	618181
22	121568-03-717	EA	HOLE PLUG - WHITE	619561
23	120075-01-732	EA	PLATE-STRIKE	618167
24	120075-09-700	EA	CABINET - FOAMED	619660
	120075-01-721	EA	LOUVER-DRIP TRAY	618176

APPLIANCE GROUP (CONTINUED)
COMPONENTS PARTS FOR APPLIANCE (CONTINUED)

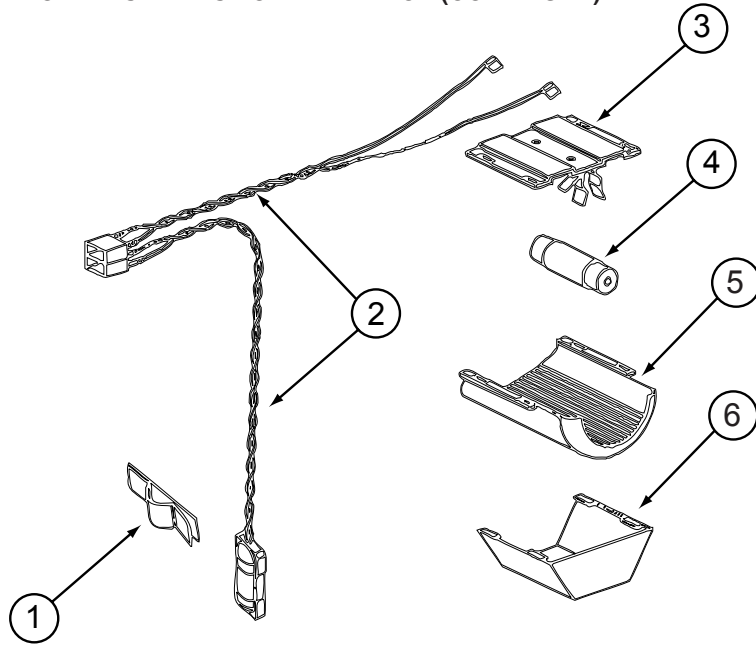

120075-13-01A, 120075-14-01A, 120075-15-01A (CONTINUED)

KEY	PART NUMBER	U/M	DESCRIPTION	VENDOR NO.
1	084880-01-760	EA	CLIP (THERMISTER)	61689122
2	120075-01-735	EA	THERMISTER W/LAMP & WIRE/ASM	618548
3	084880-03-705	EA	BRACKET-LIGHT-INTERIOR	61629722
4	084880-03-706	EA	BULB-LAMP	61628922
5	120075-01-734	EA	COVER-LENS	618190
6	084880-03-707	EA	COVER-LAMP, LENS	61627922

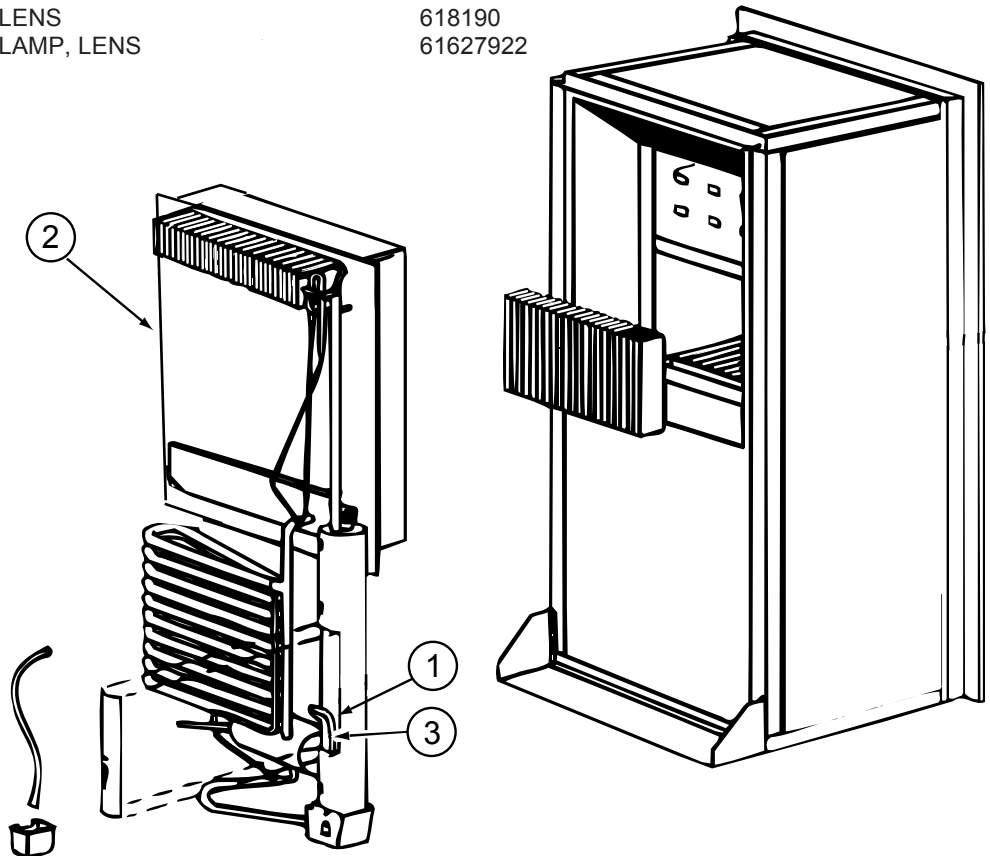

120075-13-01A, 120075-14-01A, 120075-15-01A (CONTINUED)

KEY	PART NUMBER	U/M	DESCRIPTION	VENDOR NO.
1	088248-01-710	EA	HEATER DC (HORIZONTAL)	61562822
2	120075-01-736	EA	COOLING UNIT, SERVICE PACK	618542
3	088248-01-709	EA	HEATER-AC (HORIZONTAL)	61562722

APPLIANCE GROUP (CONTINUED)
COMPONENTS PARTS FOR APPLIANCE (CONTINUED)

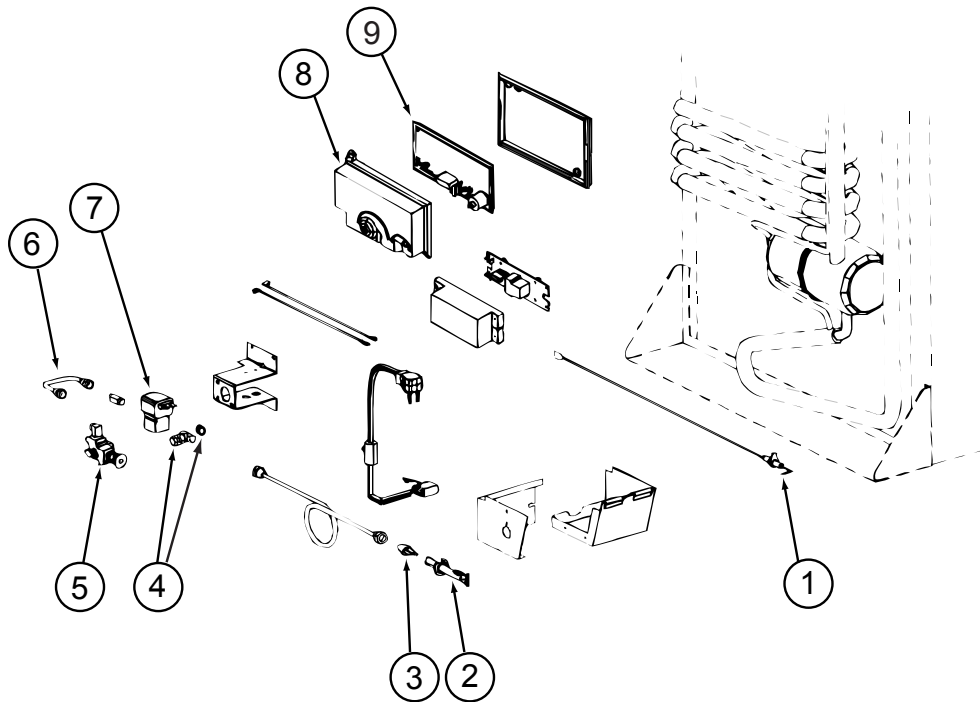

120075-13-01A, 120075-14-01A, 120075-15-01A (CONTINUED)

KEY	PART NUMBER	U/M	DESCRIPTION	VENDOR NO.
1	104137-06-715	EA	ELECTRODE-SPARK/SENSOR, SGL	61692222
2	104137-06-714	EA	BURNER ASSEMBLY, 5-SLOT	61705222
3	120075-01-737	EA	ORIFICE - JEWEL - .0155	618284
4	113737-01-702	EA	PLUG 1/8" F/PRESSURE TAP	61445322
4	113737-01-716	EA	TAP-PRESSURE	61594422
5	104137-06-734	EA	VALVE-SHUT OFF/MAN-OLD STYLE	61694922
6	113737-01-750	EA	TUBE-UNION	61694622
7	084880-01-718	EA	VALVE-GAS, (ASCO)	621447
8	120075-01-738	EA	COVER-POWER BOARD	618185
9	120075-07-710	EA	POWER - BOARD - 2-WAY	619360 = 621269
	104137-06-734	EA	VALVE-SHUT OFF/MAN-NEW STYLE	618696
	120075-01-744	EA	KIT - GAS VALVE/BURNER TUBE	620609

APPLIANCE GROUP (CONTINUED)
COMPONENTS PARTS FOR APPLIANCE (CONTINUED)

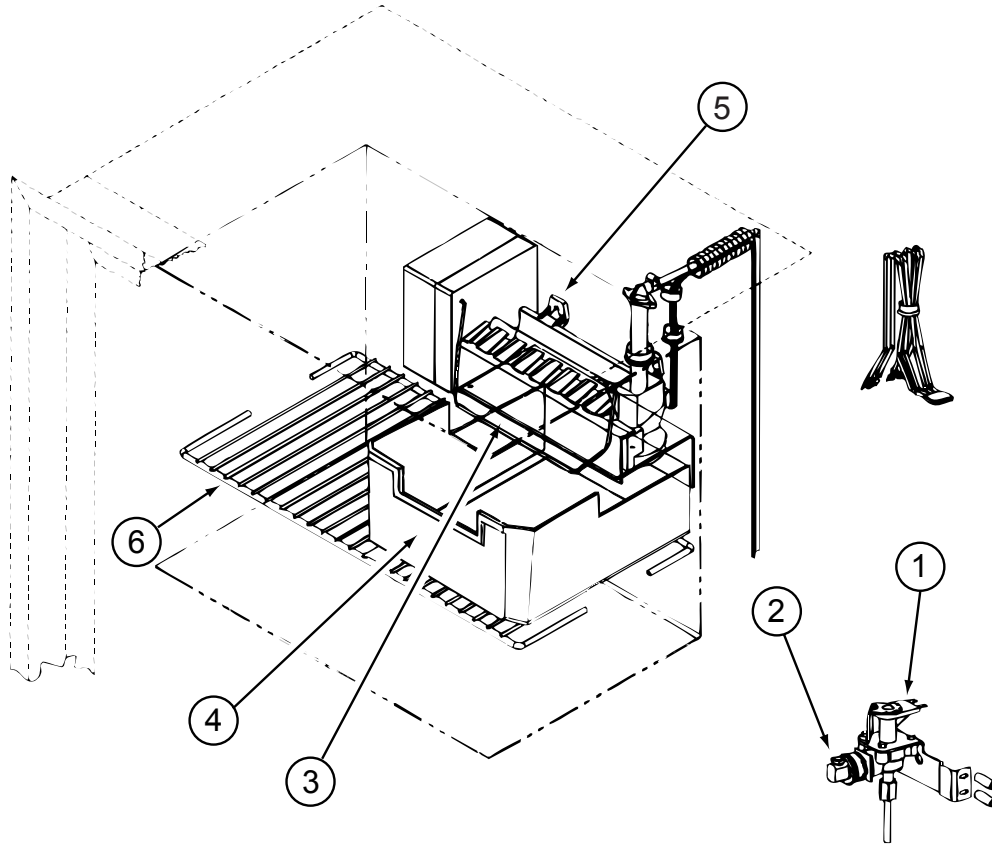

120075-13-01A, 120075-14-01A (CONTINUED)

KEY	PART NUMBER	U/M	DESCRIPTION	VENDOR NO.
1	120075-09-701	EA	WATER VALVE W/BRACKET	618253
2	120075-03-702	EA	NUT/COMPRESSION - FITTING	61678722
3	120075-03-703	EA	ARM-SHUT OFF	61656922
4	120075-03-704	EA	BIN-ICE CUBE	618154
5	094039-07-706	EA	ICE MAKER W/O PLATES	61656522
6	120075-01-717	EA	SHelf-FREEZER, WIRE	618172
	120075-09-702	EA	RELAY - 12 VOLT	620239

APPLIANCE GROUP (CONTINUED)
COMPONENTS PARTS FOR APPLIANCE (CONTINUED)

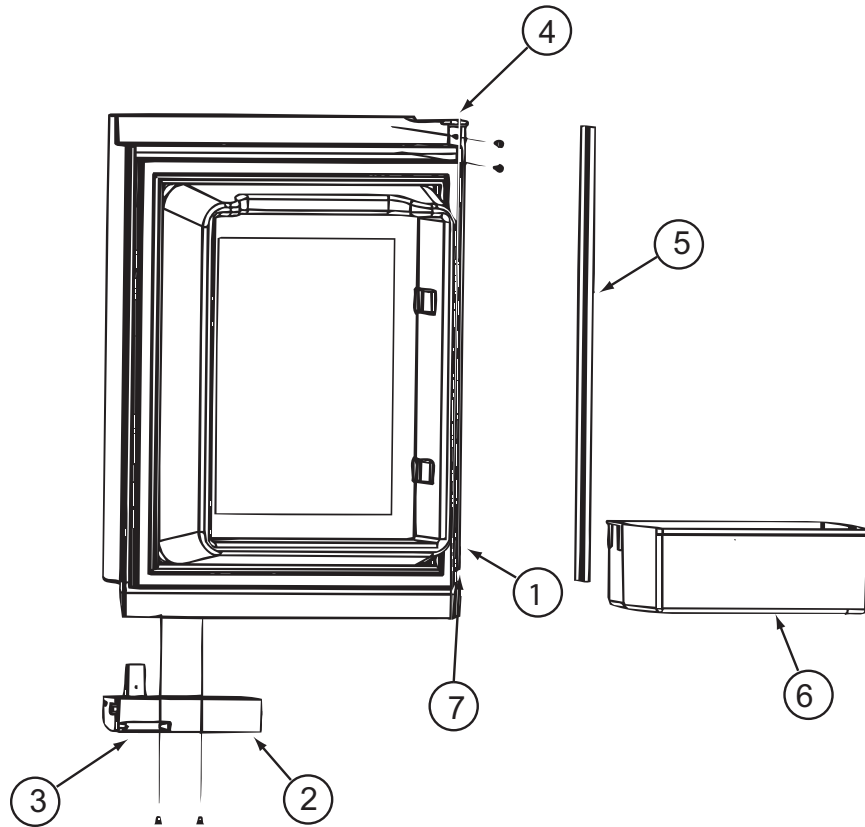

125242-02-01A

KEY	PART NUMBER	U/M	DESCRIPTION	VENDOR NO.
1	125242-01-762	EA	LINER/FOAMED-UPPER/LH-WHITE	619839
2	125242-02-700	EA	HANDLE(CONTOUR)TOP LH BTM RH	621107
3	125242-02-722	EA	LATCH-STORAGE DR/BLK POINTED	619374
4	125242-02-724	EA	HINGE - DOOR	618792
5	125242-02-723	EA	RETAINER/PANEL-UPPER DOOR	621974
6	125242-01-711	EA	DOOR BIN	618765
7	125242-01-704	EA	BUSHING-HINGE MIDDLE	618746
	125242-02-725	EA	DOOR ASM/UPR LH/WHITE GASKET	621148

APPLIANCE GROUP (CONTINUED)
COMPONENTS PARTS FOR APPLIANCE (CONTINUED)

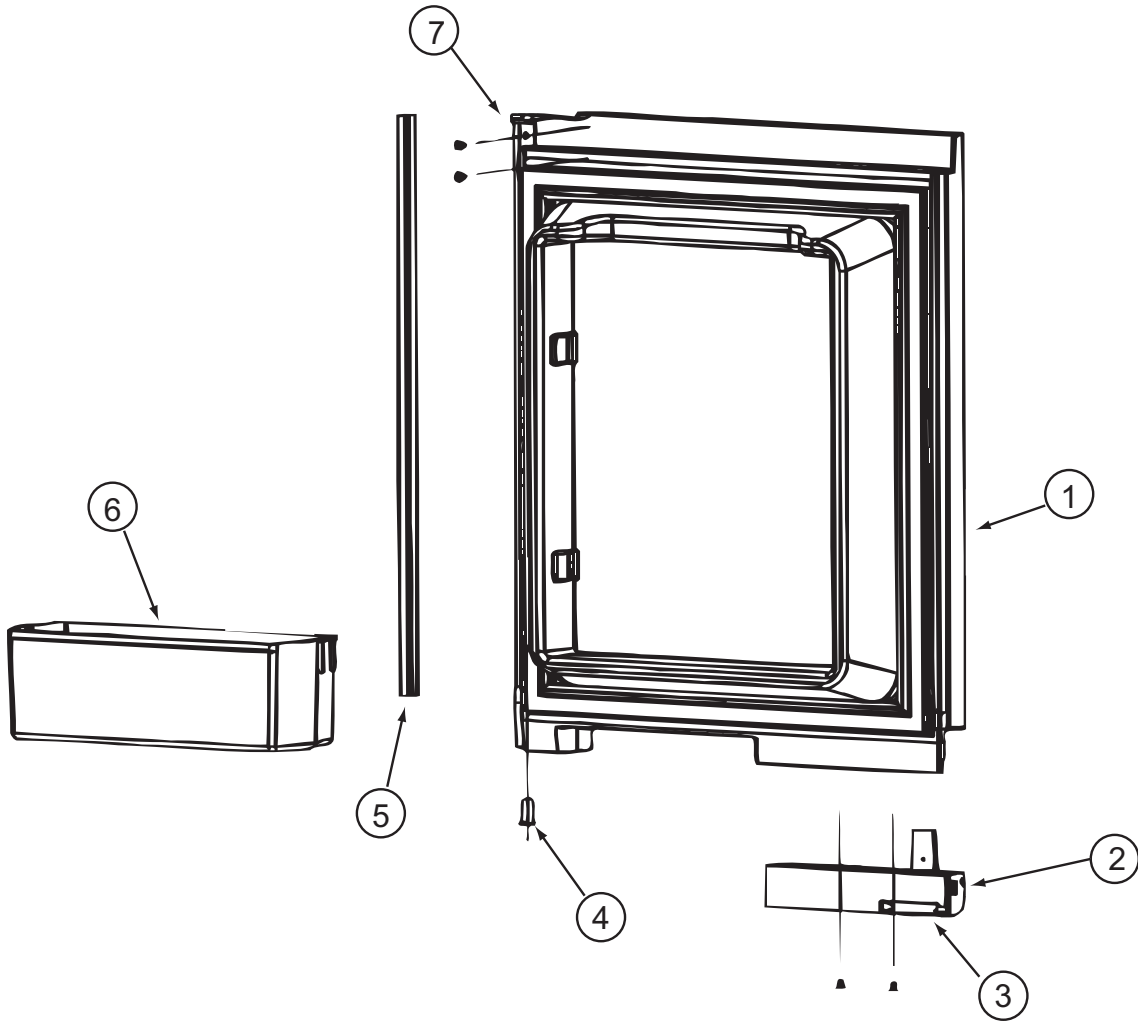

125242-02-01A (CONTINUED)

KEY	PART NUMBER	U/M	DESCRIPTION	VENDOR NO.
1	125242-01-763	EA	LINER/FOAMED-UPPER/RH-WHITE	619840
2	125242-02-701	EA	HANDLE(CONTOUR)TOP RH LWR LH	621106
3	125242-02-722	EA	LATCH-STORAGE DR/BLK POINTED	619374
4	125242-01-704	EA	BUSHING-HINGE MIDDLE	618746
5	125242-02-723	EA	RETAINER/PANEL-UPPER DOOR	621974
6	125242-01-711	EA	DOOR BIN	618765
7	125242-02-724	EA	HINGE - DOOR	618792
	125242-02-721	EA	DOOR ASM-UPR/RH/WHITE GASKET	621149

APPLIANCE GROUP (CONTINUED)
COMPONENTS PARTS FOR APPLIANCE (CONTINUED)

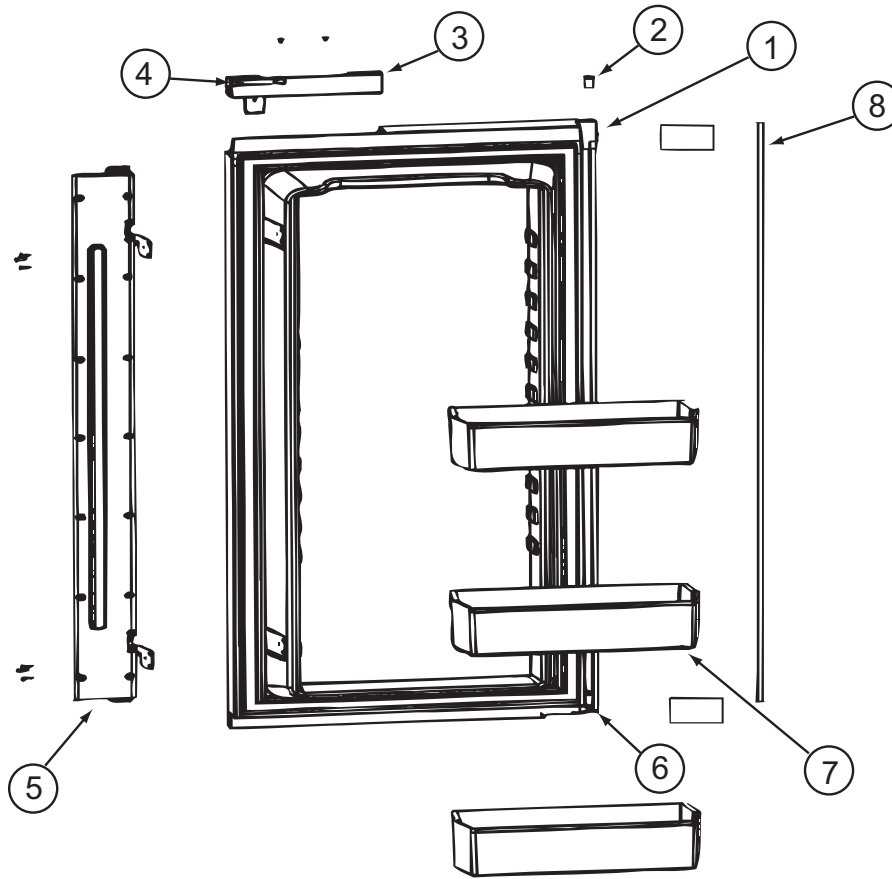

125242-02-01A (CONTINUED)

KEY	PART NUMBER	U/M	DESCRIPTION	VENDOR NO.
1	125242-01-765	EA	LINER/FOAMED-LOWER-LH-WHITE	619837
2	125242-01-704	EA	BUSHING-HINGE MIDDLE	618746
3	125242-02-701	EA	HANDLE(CONTOUR)TOP RH LWR LH	621106
4	125242-02-722	EA	LATCH-STORAGE DR/BLK POINTED	619374
5	125242-02-727	EA	FLAPPER ASM DOUBLE POLE	619845
6	125242-02-724	EA	HINGE - DOOR	618792
7	125242-01-711	EA	DOOR BIN	618765
8	125242-02-728	EA	RETAINER/PANEL - LOWER	621973
	125242-01-736	EA	CONTACT-PROBE PIN	618886
	125242-02-726	EA	DOOR ASM-LWR LH/WHITE GASKET	621150

APPLIANCE GROUP (CONTINUED)
COMPONENTS PARTS FOR APPLIANCE (CONTINUED)

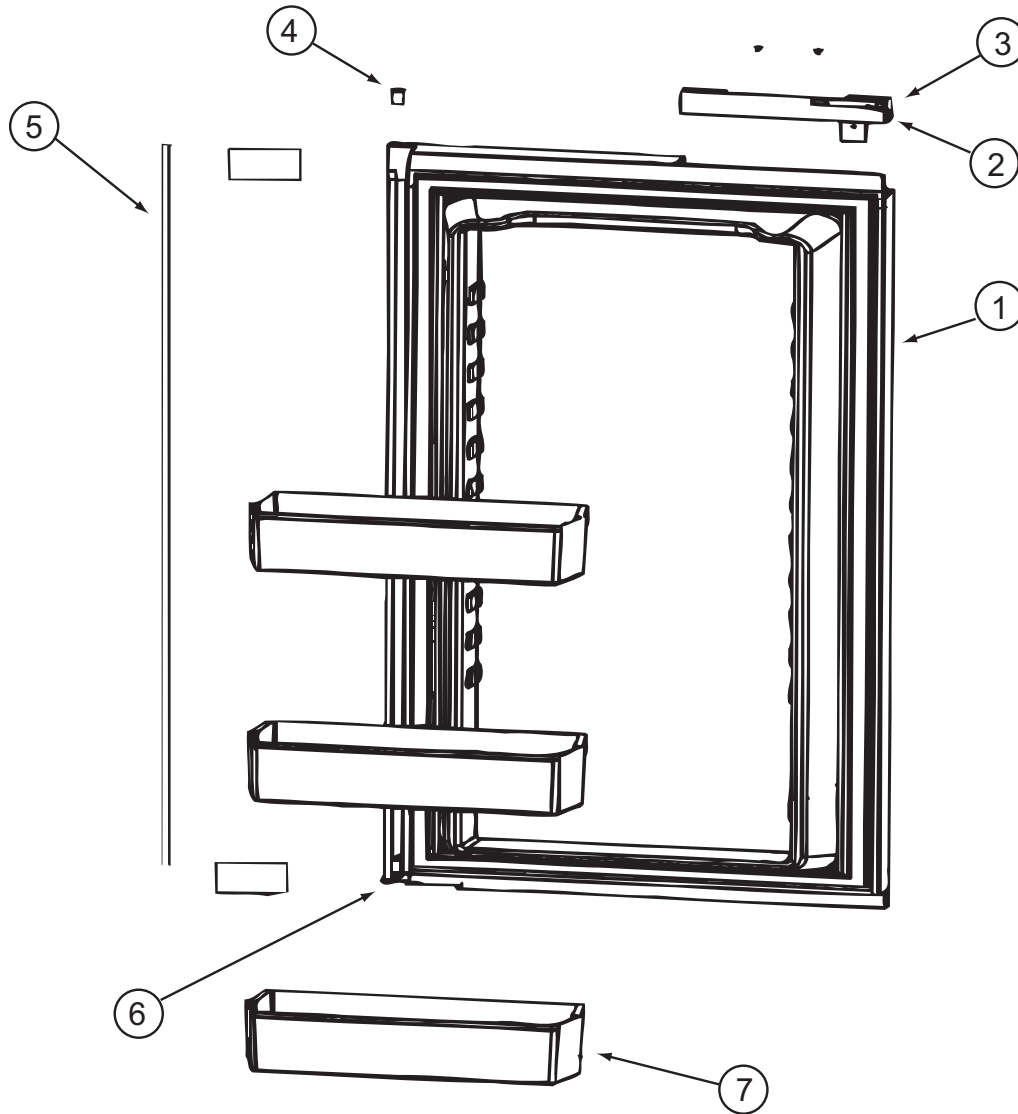

125242-02-01A (CONTINUED)

KEY	PART NUMBER	U/M	DESCRIPTION	VENDOR NO.
1	125242-01-764	EA	LINER/FOAMED-LOWER/RH-WHITE	619838
2	125242-02-700	EA	HANDLE(CONTOUR)TOP LH BTM RH	621107
3	125242-02-722	EA	LATCH-STORAGE DR/BLK POINTED	619374
4	125242-01-704	EA	BUSHING-HINGE MIDDLE	618746
5	125242-02-728	EA	RETAINER/PANEL - LOWER	621973
6	125242-02-724	EA	HINGE - DOOR	618792
7	125242-01-711	EA	DOOR BIN	618765
	125242-01-729	EA	FAN-EXTERNAL DC	618856
	125242-02-716	EA	GUIDE ASM LWR(SER#540294 DN)	620042
	125242-02-717	EA	GUIDE ASM LWR(SER#540295 UP)	620043

APPLIANCE GROUP (CONTINUED)
COMPONENTS PARTS FOR APPLIANCE (CONTINUED)

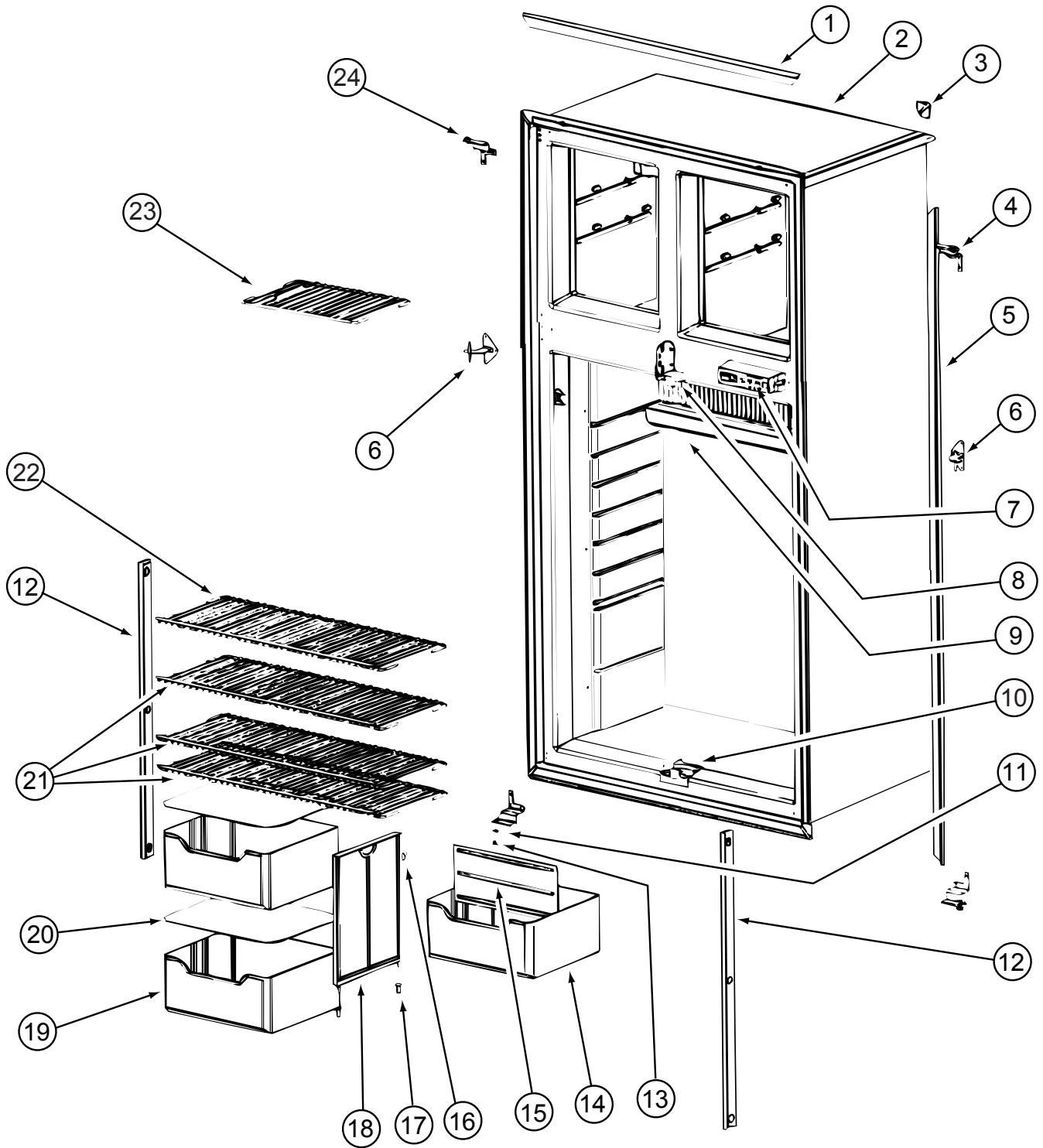

125242-02-01A (CONTINUED)

APPLIANCE GROUP (CONTINUED)
COMPONENTS PARTS FOR APPLIANCE (CONTINUED)

125242-02-01A (CONTINUED)

KEY	PART NUMBER	U/M	DESCRIPTION	VENDOR NO.
1	125242-01-723	EA	TRIM-HORIZONTAL-FRT SNAP ON	618845
2	125242-01-748	EA	CABINET/FOAMED ASSEMBLY	618748
3	125242-01-722	EA	TRIM - CORNER	618844
4	125242-01-715	EA	HINGE - TOP RH/BOTTOM LH	618798
5	125242-01-724	EA	RIM-LT/RT-FRT VERT SNAPON	618846
6	125242-01-713	EA	HINGE-MIDDLE (PAINTED)	618794
7	125242-02-704	EA	DISPLAY ASM (SER#832172) UP	621188
8	125242-01-751	EA	BLOCK - GUIDE - UPPER	618789
9	125242-01-712	EA	DRIP TRAY	618774
10	125242-01-752	EA	BLOCK - GUIDE - LOWER	618788
11	120075-01-708	EA	BUSHING - DOOR HINGE	618144
12	120075-01-730	EA	RETAINER - SHELF(SER#926684 DN	618181
13	120075-01-727	EA	PIN - HINGE	618145
14	125242-01-734	EA	CRISPER/BOTTLE BIN	618878
15	125242-01-733	EA	DIVIDER - BOTTLE CRISPER	618877
16	125242-01-750	EA	CLIP	61409622
17	113737-01-701	EA	BUSHING - HINGE	61742022
18	125242-01-749	EA	SUPPORT - WALL	618840
19	125242-01-734	EA	CRISPER/BOTTLE BIN	618878
20	125242-01-706	EA	COVER - CRISPER	618757
21	125242-01-726	EA	SHELF - WIRE (LONG)	618848
22	125242-01-727	EA	SHELF - WIRE (SHORT)	618849
23	125242-01-725	EA	SHELF - FREEZER (WIRE)	618847
24	125242-01-714	EA	HINGE - TOP LH/BOTTOM RH	618796
	125242-01-735	EA	SWITCH - DOOR LIGHT	618884

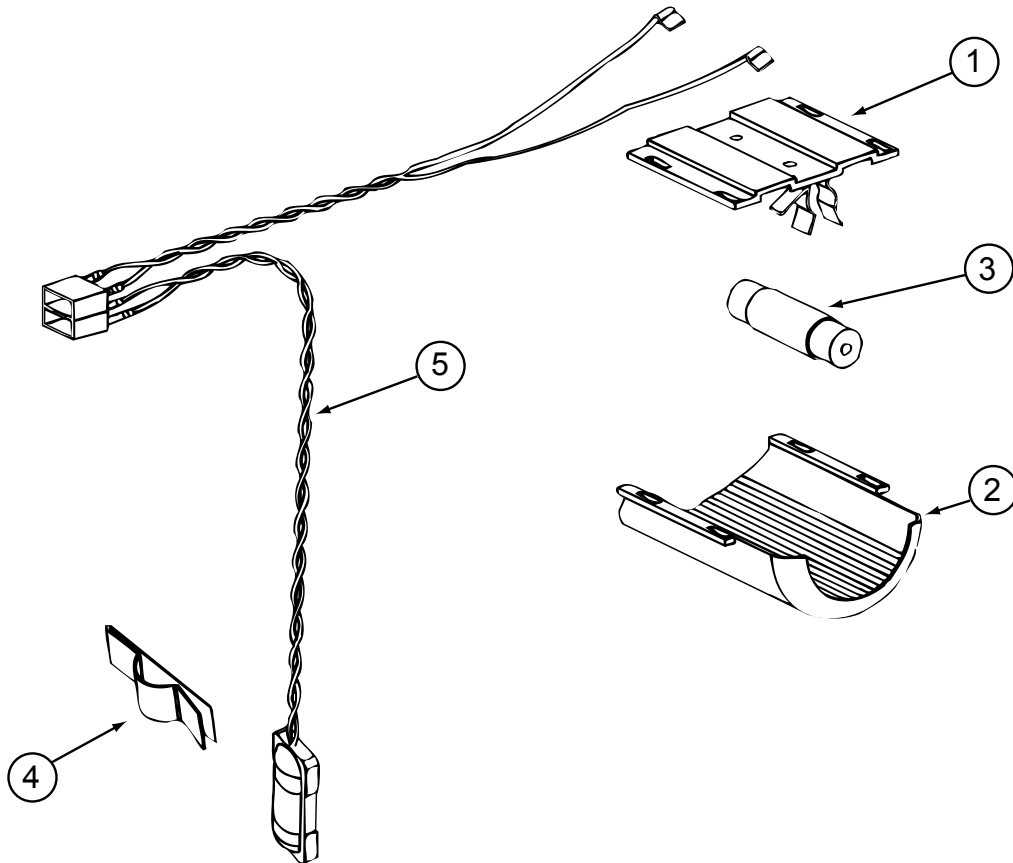

125242-02-01A (CONTINUED)

KEY	PART NUMBER	U/M	DESCRIPTION	VENDOR NO.
1	084880-03-705	EA	BRACKET - LIGHT - INTERIOR	61629722
2	120075-01-734	EA	COVER - LENS	618190
3	084880-03-706	EA	BULB - LAMP	61628922
4	084880-01-760	EA	CLIP (THERMISTER)	61689122
5	120075-01-735	EA	THERMISTER W/LAMP & WIRE/ASM	618548

APPLIANCE GROUP (CONTINUED)
COMPONENTS PARTS FOR APPLIANCE (CONTINUED)

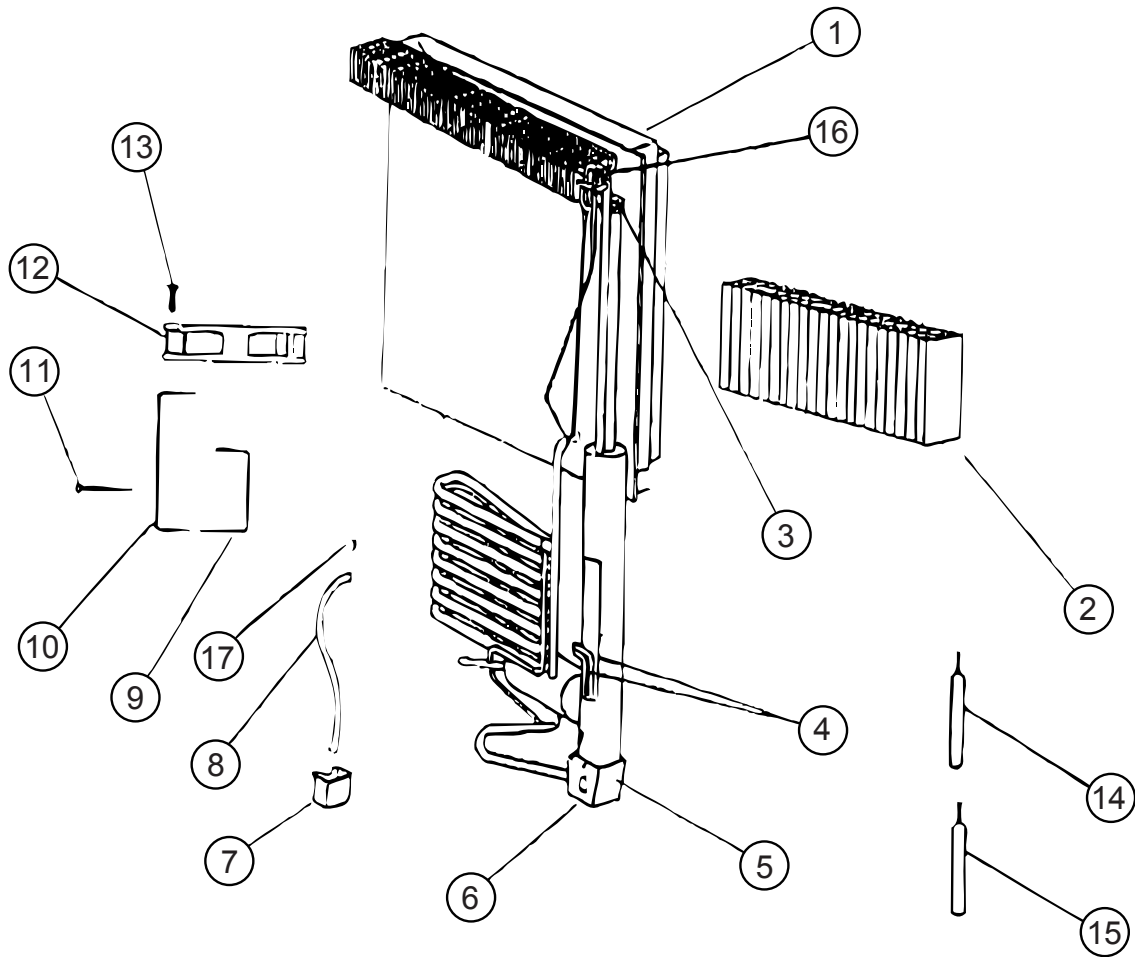

125242-02-01A (CONTINUED)

KEY	PART NUMBER	U/M	DESCRIPTION	VENDOR NO.
1	125242-01-746	EA	COOLING UNIT - 1200	618964
4	125242-01-732	EA	HEATER AC - 225W/110VAC	618872
5	125242-01-739	EA	BASE-BURNER BOX	618902
6	125242-01-740	EA	COVER-BURNER BOX	618910
9	125242-01-730	EA	BRACKET-DC FAN	618857
10	125242-01-741	EA	SUPPORT-DC FAN	618912
12	125242-01-729	EA	FAN-EXTERNAL DC	618856
16	113737-01-754	EA	THERMOSTAT (FAN 12V DC)	618093

CONTACT WINNEBAGO PART SALES FOR UNLISTED COMPONENTS

APPLIANCE GROUP (CONTINUED)
COMPONENTS PARTS FOR APPLIANCE (CONTINUED)

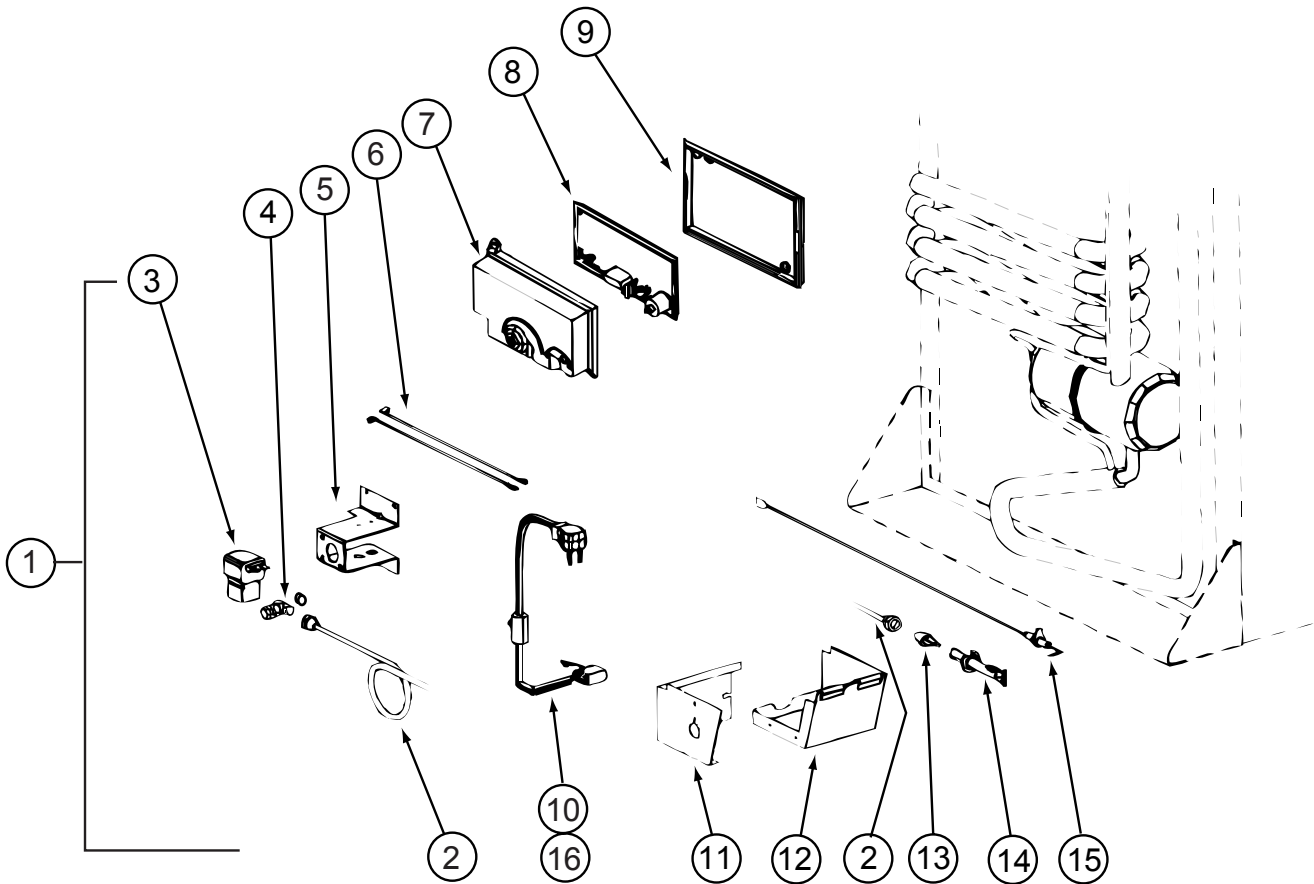

125242-02-01A (CONTINUED)

KEY	PART NUMBER	U/M	DESCRIPTION	VENDOR NO.
1	125242-01-753	EA	KIT - GAS VALVE/BURNER TUBE	620610
2	125242-01-744	EA	BURNER TUBE	618937
4	113737-01-716	EA	TAP-PRESSURE	61594422
7	120075-01-738	EA	COVER-POWER BOARD	618185
8	125242-02-703	EA	POWER BOARD	621271
9	120075-01-740	EA	COVER-BASE, POWER BOARD	618186
11	125242-01-739	EA	BASE-BURNER BOX	618902
12	125242-01-740	EA	COVER-BURNER BOX	618910
13	125242-01-717	EA	ORIFICE-JEWEL	618814
14	125242-01-743	EA	BURNER - 8 SLOT	618932
15	104137-06-715	EA	ELECTRODE-SPARK/SENSOR, SGL	61692222

CONTACT WINNEBAGO PART SALES FOR UNLISTED COMPONENTS

APPLIANCE GROUP (CONTINUED)
COMPONENTS PARTS FOR APPLIANCE (CONTINUED)

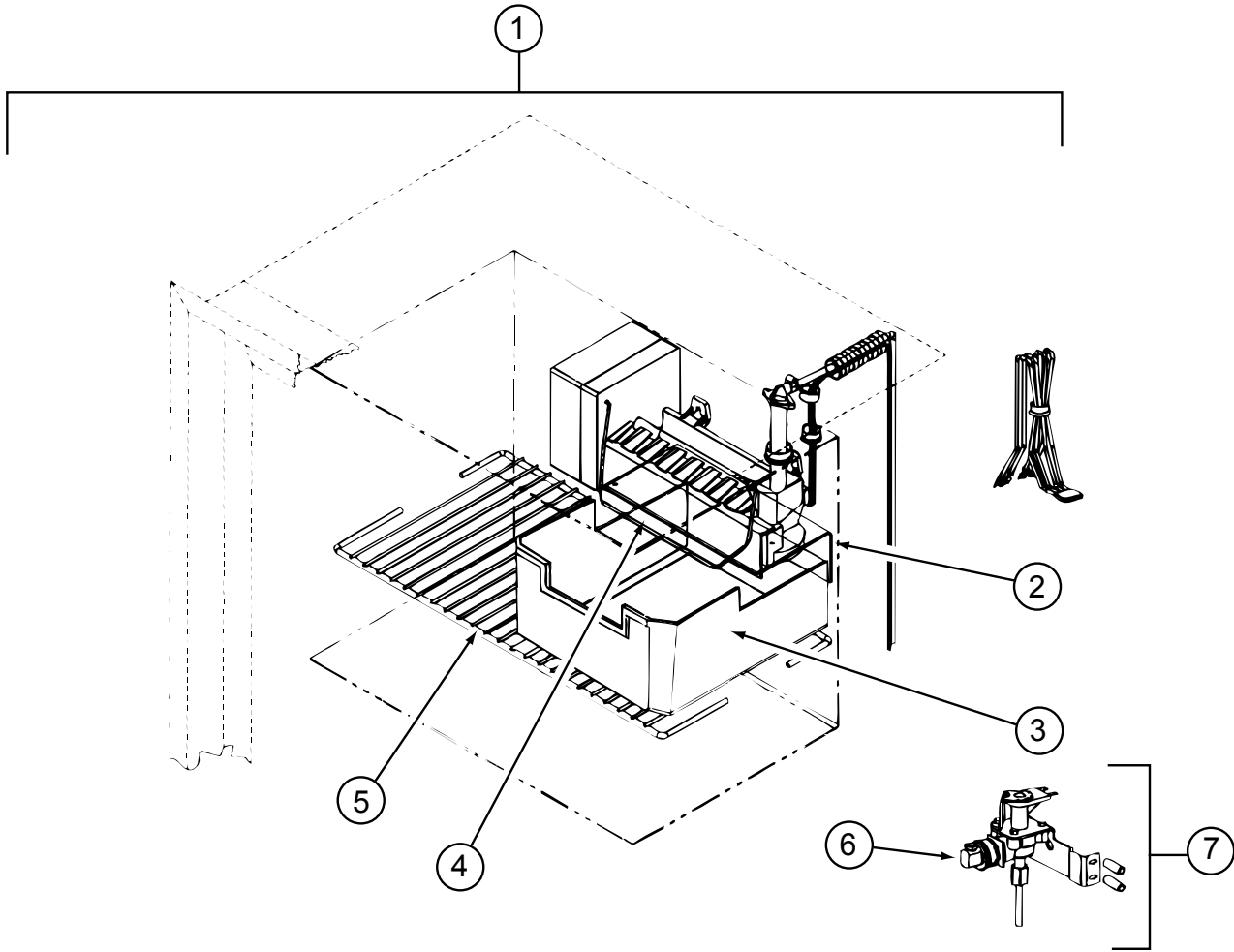

125242-02-01A (CONTINUED)

KEY	PART NUMBER	U/M	DESCRIPTION	VENDOR NO.
1	094039-07-706	EA	ICE MAKER W/O PLATES	61656522
2	125242-01-737	EA	BRACKET - MOUNTING (ICE MAKER)	618894
3	125242-01-716	EA	ICE BIN	618803
4	120075-03-703	EA	ARM - SHUT OFF	61656922
5	125242-01-725	EA	SHELF - FREEZER (WIRE)	618847
6	120075-03-702	EA	NUT/COMPRESSION - FITTING	61678722
7	120075-03-701	EA	VALVE - WATER - W/BRACKET	618523

APPLIANCE GROUP (CONTINUED)
COMPONENTS PARTS FOR APPLIANCE (CONTINUED)

126019-01-01A

KEY	PART NUMBER	U/M	DESCRIPTION	VENDOR NO.
	126019-01-700	EA	GLASS CARAFE	172547-00
	126019-01-701	EA	RESERVOIR- WATER	172554
	126019-01-702	EA	BASKET - FILTER	172553-00
	126019-01-703	EA	HARDWARE - MOUNTING	172174-00

126022-01-01A, 126022-02-01A, 126022-03-01A

KEY	PART NUMBER	U/M	DESCRIPTION	VENDOR NO.
	114030-01-707	EA	PLUG BUTTON BLACK	74002628
	126022-01-700	EA	BUMPER - RANGE BIFOLD COVER	MAGIC 8003P007-60
	126022-01-701	EA	HINGE-RANGE BIFOLD COVER-22"	MAGIC 3418F067-34

APPLIANCE GROUP (CONTINUED)
COMPONENTS PARTS FOR APPLIANCE (CONTINUED)

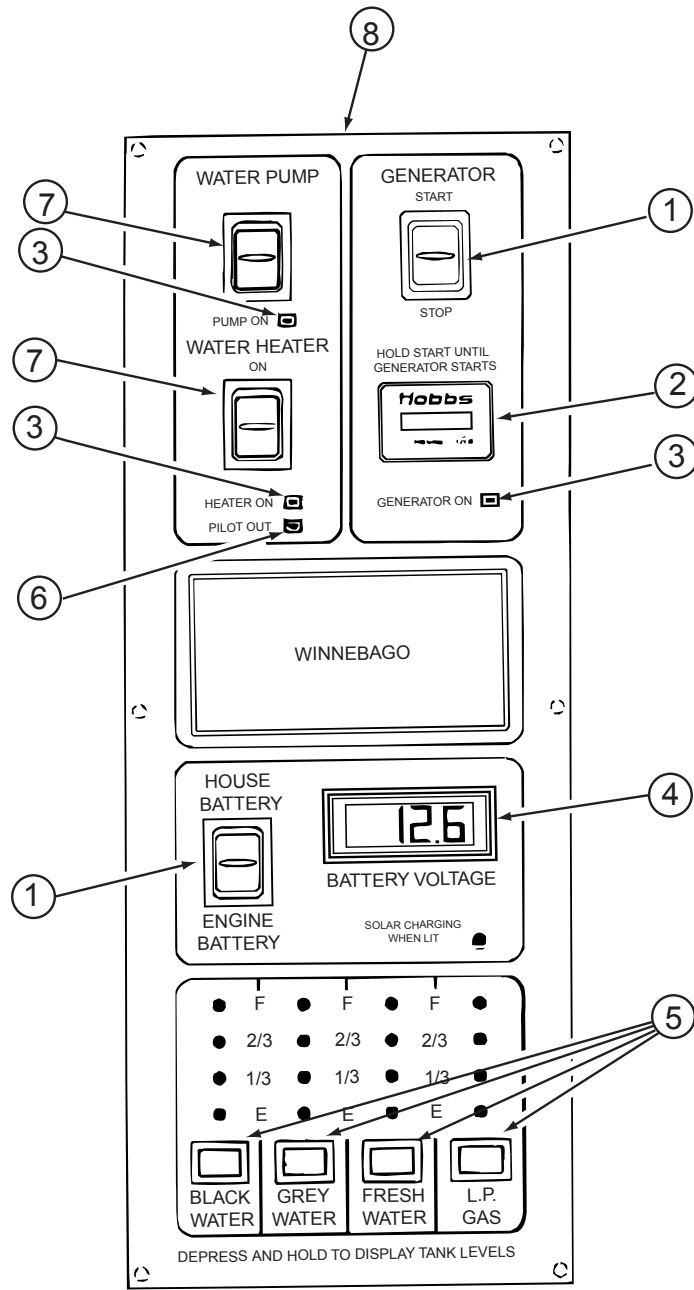

133004-02-01A

KEY	PART NUMBER	U/M	DESCRIPTION	VENDOR NO.
1	133004-01-702	EA	SWITCH/DPDT MOM=ON-OFF-ON	L1011-00
2	100258-10-701	EA	GAUGE-HR METER ONLY (LCD)	L0775-00
3	133004-01-706	EA	L.E.D. GREEN-PANEL MOUNT	L0785
4	133004-01-704	EA	METER/VOLT-DIGITAL - LCD	L1008-00
5	133004-01-705	EA	SWITCH/MOM ON - PUSH BUTTON	L0950-00
6	133004-01-703	EA	L.E.D. RED-PANEL MOUNT	L1009-00
7	133004-01-701	EA	SWITCH/DPDT ON-ON/MAINTAINED	L1025-00
8	133004-02-701	EA	SCREENED - CHASSIS	CC0547-00
	133004-02-700	EA	BOARD - PC	L5113-03

APPLIANCE GROUP (CONTINUED)
COMPONENTS PARTS FOR APPLIANCE (CONTINUED)

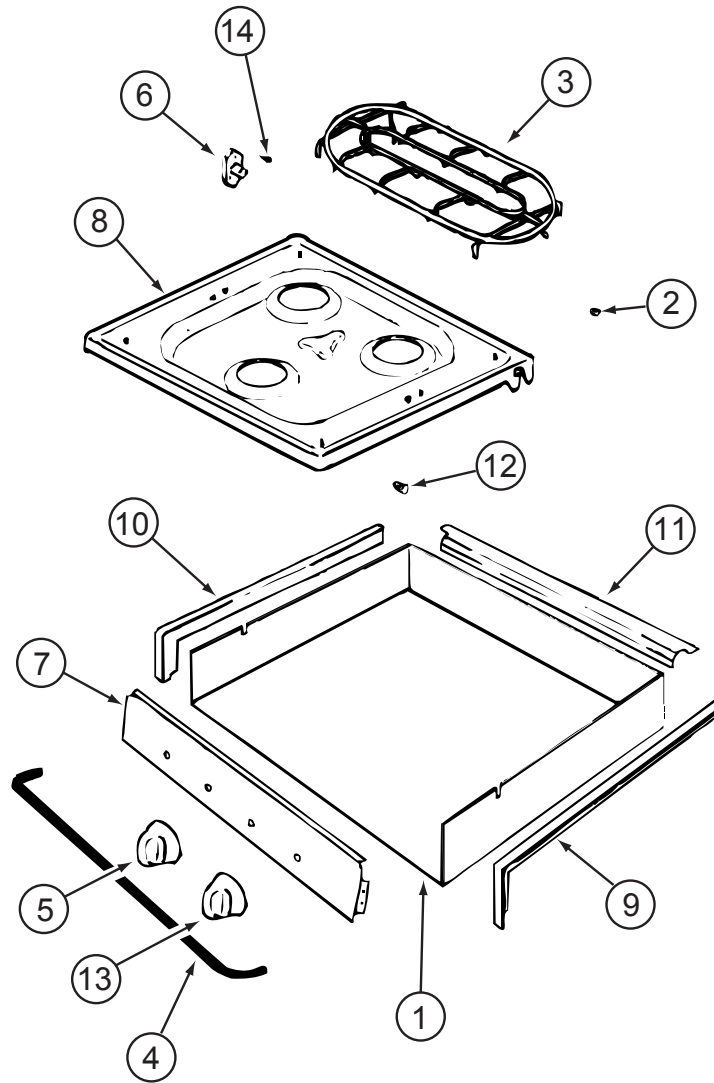

135065-01-01A, 135065-01-02A, 135065-02-01A

KEY	PART NUMBER	U/M	DESCRIPTION	VENDOR NO.
2	102020-01-709	EA	BUMPER-GRATE	8007-P020-60
3	128728-01-700	EA	GRATE - BURNER	74003948
4	114030-02-700	EA	GUARD/FABRIC - TOWEL BAR	3609F006-70
5	112881-01-705	EA	KNOB-TOP BURNER	7733P072-60
5	112881-01-718	EA	KNOB - TOP BURNER HI-OUTPUT	74001794
6	128728-01-703	EA	PIN/T-NUT F/HINGE	7103P109-60
7	135065-01-700	EA	PANEL/MANIFOLD	74003354
8	128728-01-705	EA	TOP - MAIN - BLACK	74003928
8	135066-01-700	EA	TOP - MAIN - BISQUE	74005332
9	114030-01-704	EA	TRIM - RIGHT/BLACK TEXTURED	74002839
10	114030-01-705	EA	TRIM - LEFT/BLACK TEXTURED	74002840
11	114030-01-706	EA	TRIM - REAR/BLACK TEXTURED	74002841
12	102020-01-724	EA	BUMPER-MAIN TOP	8003P008-60
13	126023-01-720	EA	KNOB - IGNITER	74002414

CONTACT WINNEBAGO PART SALES FOR UNLISTED COMPONENTS

APPLIANCE GROUP (CONTINUED)
COMPONENTS PARTS FOR APPLIANCE (CONTINUED)

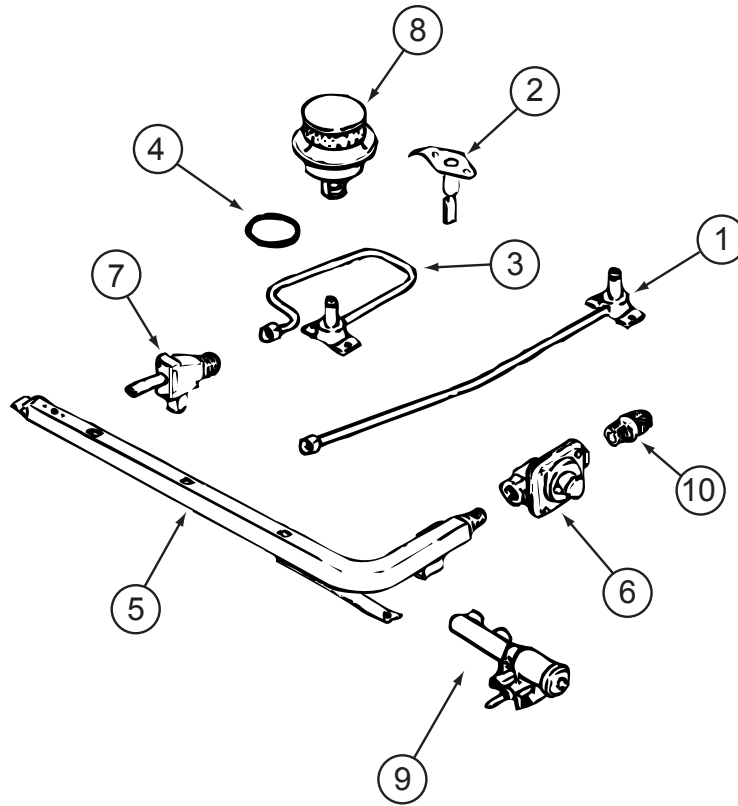

135065-01-01A, 135065-01-02A, 135065-02-01A (CONTINUED)

KEY	PART NUMBER	U/M	DESCRIPTION	VENDOR NO.
1	128728-01-708	EA	FITTING W/ORFICE/TUBE - REAR	74003931
2	135065-01-701	EA	IGNITOR/PORCELAIN-TOP BURNER	74004053
3	128728-01-710	EA	FITTING W/ORFICE/TUBE - FRT	74003930
4	128728-01-711	EA	GASKET - BURNER	74002745
5	135065-01-702	EA	PIPE/MANIFOLD	74004642
6	126023-02-703	EA	REGULATOR - PRESSURE	74004235
7	135065-01-703	EA	VALVE/BURNER - REAR	74004643
7	135065-01-704	EA	VALVE/BURNER-FRT-HI	74004644
8	135065-01-705	EA	BURNER/SEALED ASSEMBLY	12001497
9	128728-01-716	EA	BURNER - IGNITOR	74003946
9	128728-01-717	EA	WIRES - IGNITOR	74003947

APPLIANCE GROUP (CONTINUED)
COMPONENTS PARTS FOR APPLIANCE (CONTINUED)

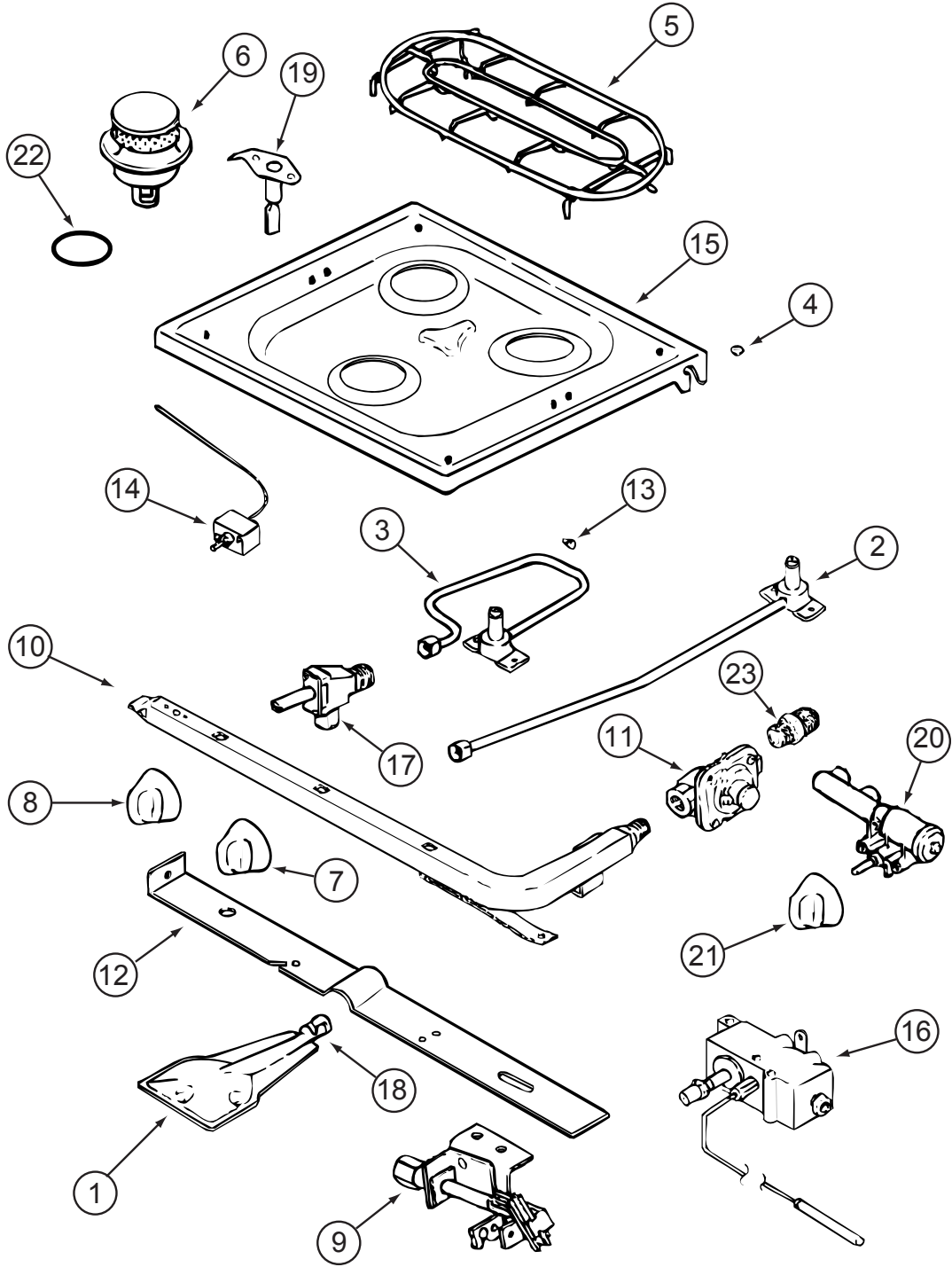

135066-02-01A

APPLIANCE GROUP (CONTINUED)
COMPONENTS PARTS FOR APPLIANCE (CONTINUED)

135066-02-01A (CONTINUED)

KEY	PART NUMBER	U/M	DESCRIPTION	VENDOR NO.
1	126023-01-717	EA	BURNER - OVEN	74003343
2	128728-01-708	EA	FITTING W/ORFICE/TUBE - REAR	74003931
3	128728-01-710	EA	FITTING W/ORFICE/TUBE - FRT	74003930
4	102020-01-709	EA	BUMPER-GRATE	8007-P020-60
5	128728-01-700	EA	GRATE - BURNER	74003948
6	135065-01-705	EA	BURNER/SEALED ASSEMBLY	12001497
7	112881-01-705	EA	KNOB-TOP BURNER	7733P072-60
7	112881-01-718	EA	KNOB - TOP BURNER HI-OUTPUT	74001794
8	135656-01-700	EA	KNOB/THERMOSTAT	74002529
9	126023-02-701	EA	PILOT - OVEN	74004586
10	126023-02-702	EA	PIPE - MANIFOLD	74004360
11	135066-02-700	EA	REGULATOR - PRESSURE	74004236
13	102020-01-724	EA	BUMPER-MAIN TOP	8003P008-60
14	126023-01-734	EA	THERMOSTAT/OVEN SERIES #11	74006332
15	128728-01-705	EA	TOP - MAIN - BLACK	74003928
16	126023-02-704	EA	VALVE/OVEN - MERCURY	74004585
17	135065-01-703	EA	VALVE/BURNER - REAR	74004643
17	135065-01-704	EA	VALVE/BURNER-FRT-HI	74004644
18	135656-01-701	EA	MIXER/AIR	3411F003-34
19	135065-01-701	EA	IGNITOR/PORCELAIN-TOP BURNER	74004053
20	128728-01-716	EA	BURNER - IGNITOR	74003946
20	128728-01-717	EA	WIRES - IGNITOR	74003947
21	126023-01-720	EA	KNOB - IGNITER	74002414

CONTACT WINNEBAGO PART SALES FOR UNLISTED COMPONENTS

APPLIANCE GROUP (CONTINUED)
COMPONENTS PARTS FOR APPLIANCE (CONTINUED)

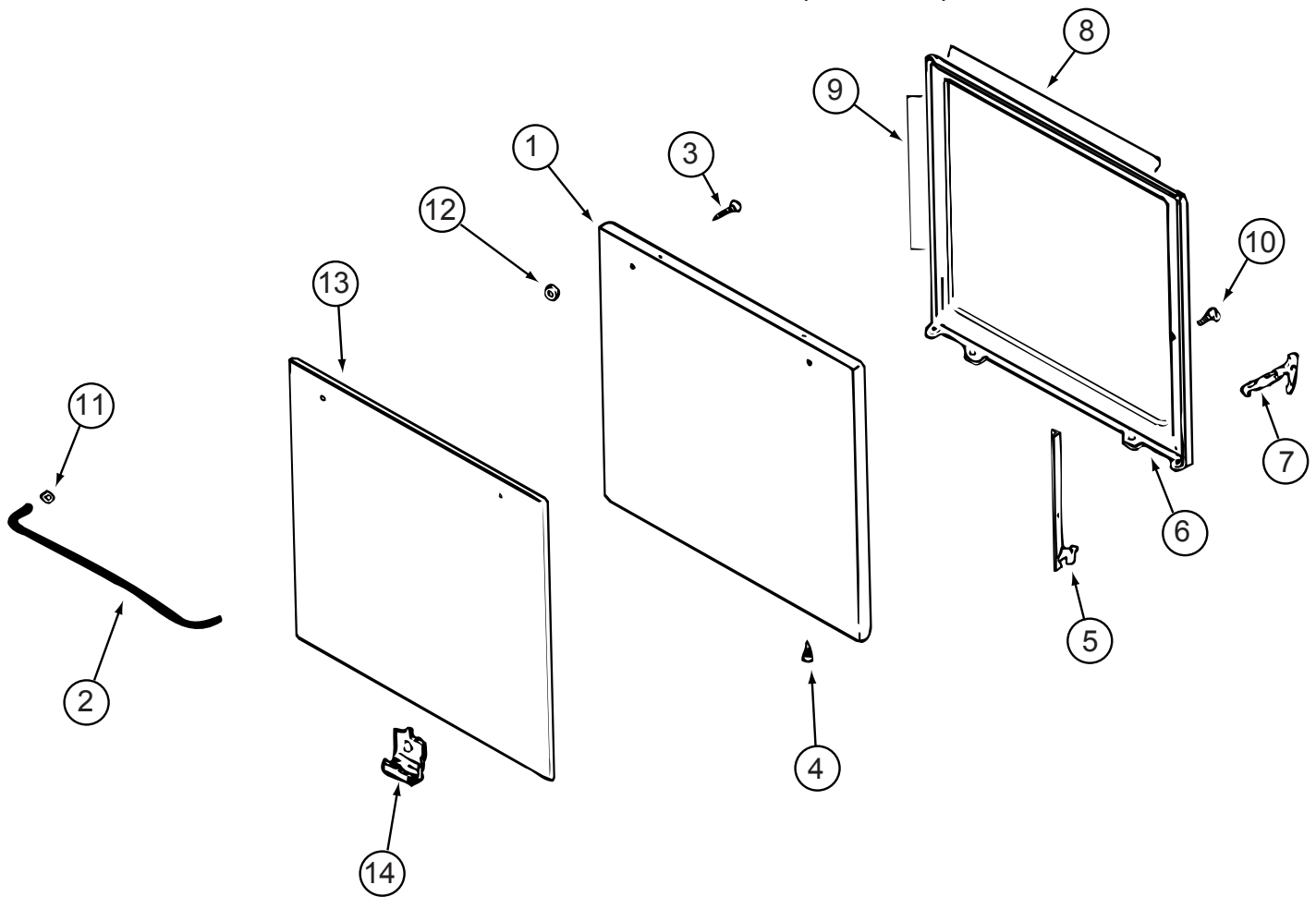

135066-01-01A, 135066-01-02A, 135066-02-01A (CONTINUED)

KEY	PART NUMBER	U/M	DESCRIPTION	VENDOR NO.
1	126023-01-712	EA	PANEL - DOOR (BLACK)	74001190
2	102020-01-701	EA	HANDLE,DOOR	7701P092-60
8	126023-01-732	EA	SEAL/OVEN DR TOP	7212P014-60
9	126023-01-733	EA	SEAL/OVEN DR SIDES(2PCS)	7212P038-60
13	102020-01-725	EA	GLASS OUTER	7902P266-60

CONTACT WINNEBAGO PART SALES FOR UNLISTED COMPONENTS

APPLIANCE GROUP (CONTINUED)
COMPONENTS PARTS FOR APPLIANCE (CONTINUED)

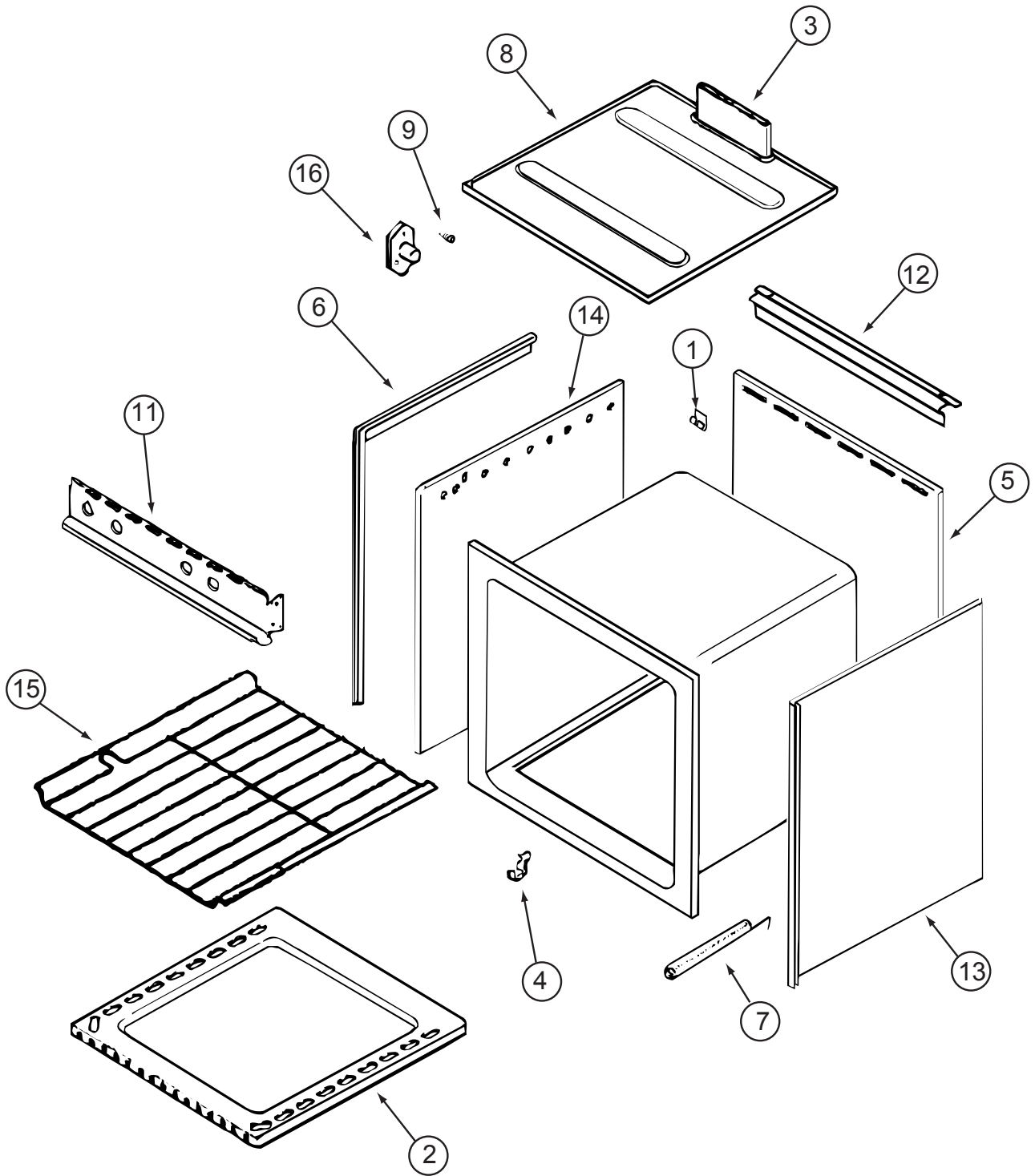

135066-01-01A, 135066-01-02A, 135066-02-01A (CONTINUED)

KEY	PART NUMBER	U/M	DESCRIPTION	VENDOR NO.
1	112881-03-702	EA	CLIP - MAIN TOP	74003998
2	126023-01-731	EA	BOTTOM - OVEN	2205F016-19
3	126023-01-718	EA	FLUE BOX ASSEMBLY	4006W075-80
6	126023-01-713	EA	TRIM - SIDE (RIGHT)	74002827
6	126023-01-714	EA	TRIM - SIDE (LEFT)	74002828
11	126023-01-729	EA	PANEL - MANIFOLD	74003351
15	126023-01-716	EA	RACK - OVEN	74003106

CONTACT WINNEBAGO PART SALES FOR UNLISTED COMPONENTS

AUDIO VIDEO GROUP
RADIO SYSTEM

KEY	PART NUMBER	U/M	DESCRIPTION
	133307-01-000	EA	RADIO - WALL MOUNT - CASSETTE W/ALARM - AUDIOVOX AWM-820 - REAR STEREO
	133307-02-000	EA	RADIO - WALL MOUNT - CD W/ALARM - AUDIOVOX AWN-930 - REAR STEREO W/CD
	125322-02-000	EA	RADIO-AM/FM STEREO/CASSETTE-AUDIOVOX-MS-306-EXT ENT W/CASS - EXT. ENTERTAINMENT
	127517-10-000	EA	RADIO - AM/FM STEREO/CD PLAYER - CDX-L250 - EXT. ENTERTAINMENT W/CD FROM: 00-00-00THRU: 02-10-02
	127517-11-000	EA	RADIO - AM/FM STEREO/CD PLAYER - SONY CDX-L300 - EXT. ENTERTAINMENT W/CD FROM: 02-11-02 THRU: 06-02-02
	143509-01-000	EA	RADIO - AM/FM CD - W/REMOTE - JENSEN CD3010X-W - EXT. ENTERTAINMENT W/CD FROM: 06-03-02 THRU: 99-99-99
	135420-01-000	EA	RADIO - AM/FM CASSETTE/CD COMBO - M9900 - 7.2" X 3.3" R.O. - DASH
	135420-07-000	EA	RADIO - MOUNTING KIT - A-BODY - DASH
	141679-02-000	EA	RADIO/BATTERY KIT - TWO WAY (4 RADIOS/8 BATTERIES) - TWO WAY RADIO
	141679-01-000	EA	CHARGING STATION ONLY - F/TWO WAY RADIO SYSTEM - TWO WAY RADIO
	124881-02-000	EA	AMPLIFIER - AUDIO - MTS Q SURROUND - ORANGE LABEL (LATEST) - DELUXE SOUND
	133089-01-000	EA	CONTROL - VOLUME - SPEAKER - W/O DELUXE SOUND
	110469-01-000	EA	SPEAKER - 4" X 6" OVAL - COAXIAL - EXT. ENTERTAINMENT
	124883-02-000	EA	SPEAKER - CUBE - W/BRACKET - DELUXE SOUND
	124884-01-000	EA	SPEAKER - 6" X 9" - SUB-WOOFER - DELUXE SOUND
	124883-03-000	EA	CUBE/SPEAKER - W/O CASE - DELUXE SOUND - P36GD ONLY
	124883-04-000	EA	GRILLE/SPEAKER - F/CUBE - DELUXE SOUND - P36GD ONLY
	094097-01-000	EA	SPEAKER - RADIO/TV - W/O GRILLE - 5.25" DIAMETER - W/O DELUXE SOUND
	110470-01-01A	EA	GRILLE - 4" X 6" OVAL SPEAKER - BLACK - EXT. ENTERTAINMENT
	124885-01-000	EA	GRILLE - SPEAKER - 6" X 9" - SUB-WOOFER - DELUXE SOUND
	089340-02-000	EA	GRILLE - SPEAKER - 6.5" SQUARE - W/O DELUXE SOUND
	123256-01-000	EA	ANTENNA - CB - W/O CABLE - CB RADIO
	123256-02-000	EA	CABLE - CB - COAX - CB RADIO
	090944-01-000	EA	ANTENNA - RADIO - 16" RUBBER - W/72" LEAD WIRE FROM: 00-00-00 THRU: 01-05-03
	090944-02-000	EA	ANTENNA - RADIO - 16" RUBBER - W/O LEAD WIRE FROM: 01-06-03 THRU: 99-99-99
	090944-03-000	EA	CABLE - ANTENNA FROM: 01-06-03 THRU: 99-99-99
	108847-01-000	EA	BRACKET - ANTENNA GROUND
	109889-04-000	EA	EXTENDER - ANTENNA SHAFT - 3.7"
	077069-02-000	EA	CABLE/EXTENSION - RADIO ANTENNA - 96" FROM: 00-00-00 THRU: 05-23-02
	077069-03-000	EA	CABLE/EXTENSION - RADIO ANTENNA - 260" FROM: 05-24-02 THRU: 99-99-99
	102080-17-000	EA	CHANGER - COMPACT DISC - SONY CDX-555RF - CD CHANGER
	102080-18-000	EA	CHANGER - CONTROL/FM MODULE & REMOTE - SONY CDX-555RF KIT - CD CHANGER

AUDIO VIDEO GROUP (CONTINUED)

REAR VIEW MONITOR

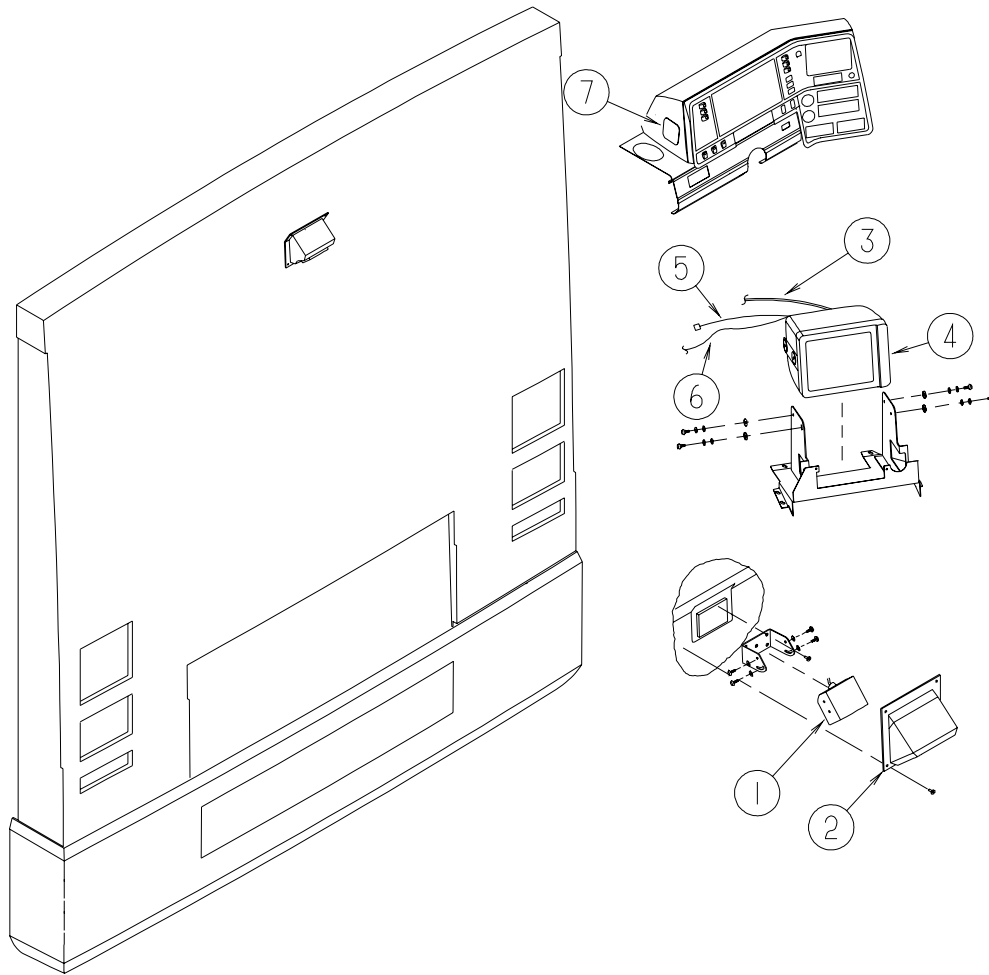

KEY	PART NUMBER	U/M	DESCRIPTION
1	143363-02-000	EA	CAMERA/REAR - COLOR - W/BRACKET - SONY VCB-MHD1
2	123281-01-01A	EA	SHROUD - CAMERA/OUTER - BRIGHT WHITE
3	143363-03-000	EA	CABLE - MONITOR/CAMERA - COLOR - SONY VCB-MHC20
4	143363-01-000	EA	MONITOR/REAR - COLOR - W/BRACKET - SONY VCB-MH1
5	143545-01-000	EA	WIRE ASSEMBLY - REAR MONITOR
6	114870-01-000	EA	PLUG - AUDIO W/LEADS - 48.5"
7	093214-01-03A	EA	GRILLE - SPEAKER - 4" - GLACIER
7	098819-01-000	EA	SPEAKER - 4" - 2 WATT - 8 OHM

TELEPHONE

KEY	PART NUMBER	U/M	DESCRIPTION
	093253-01-02A	EA	PLATE - WALL - TELEPHONE - BROWN
	093253-01-03A	EA	PLATE - WALL - TELEPHONE - WHITE
	130686-01-01A	EA	PLATE - WALL - TELEPHONE/COAX - WHITE

AUDIO VIDEO GROUP (CONTINUED)
TV & VCR

KEY	PART NUMBER	U/M	DESCRIPTION
	146396-01-000	EA	DVD/VCR - COMBINATION PLAYER
	136860-01-000	EA	CABLE - RCA - #3 MALE TO #12F MALE CONNECTOR - SURROUND SOUND
	123324-01-000	EA	FILTER - GROUND LOOP - SURROUND SOUND
	115540-01-000	EA	AMPLIFIER - TV SPEAKERS
	086756-01-000	EA	SPLITTER - TV/2 WAY
	142258-01-000	EA	SWITCH - VIDEO/ANTENNA POWER SUPPLY - VIDEO SELECTION SYSTEM
*	126696-07-000	EA	TV - 19" COLOR - W/O 1/8" JACK - UL/CSA - GE 19GT243
*	146299-01-000	EA	TV - 24" STEREO W/5 JACKS - SONY 24FS100
	082134-01-000	EA	ADAPTER - TV - CABLE TO CABLE
	082136-01-000	EA	NUT - HEX JAM - 3/8-32
	134006-01-03B	EA	PLATE - COAXIAL CABLE/OFF WHITE
	076319-09-000	EA	WALLPLATE - CABLE RECEPTACLE - TV - SINGLE - BROWN
	137135-03-000	EA	WIRE LOOM - DIGITAL ELEVATION SENSOR
	137135-04-000	EA	WIRE HARNESS - POWER - DIGITAL ELEVATION SENSOR
	145171-01-000	EA	CONNECTOR - COAXIAL
*	076319-23-000	EA	ANTENNA - TV ROOF MOUNT - 44.5" MAST
*	076319-25-000	EA	KIT - HARDWARE INTERIOR
*	137135-02-000	EA	ANTENNA - SATELLITE DSS - W/SENSOR
*	141454-01-01A	EA	ANTENNA - SATELLITE - AUTOMATIC
	144377-01-000	EA	ANTENNA - SATELLITE - IN MOTION
	120233-03-000	EA	CERTIFICATE - SATELLITE RECEIVER

*COMPONENT PARTS LISTED LATER IN THIS GROUP

AUDIO VIDEO GROUP (CONTINUED)
COMPONENT PARTS FOR TV & VCR

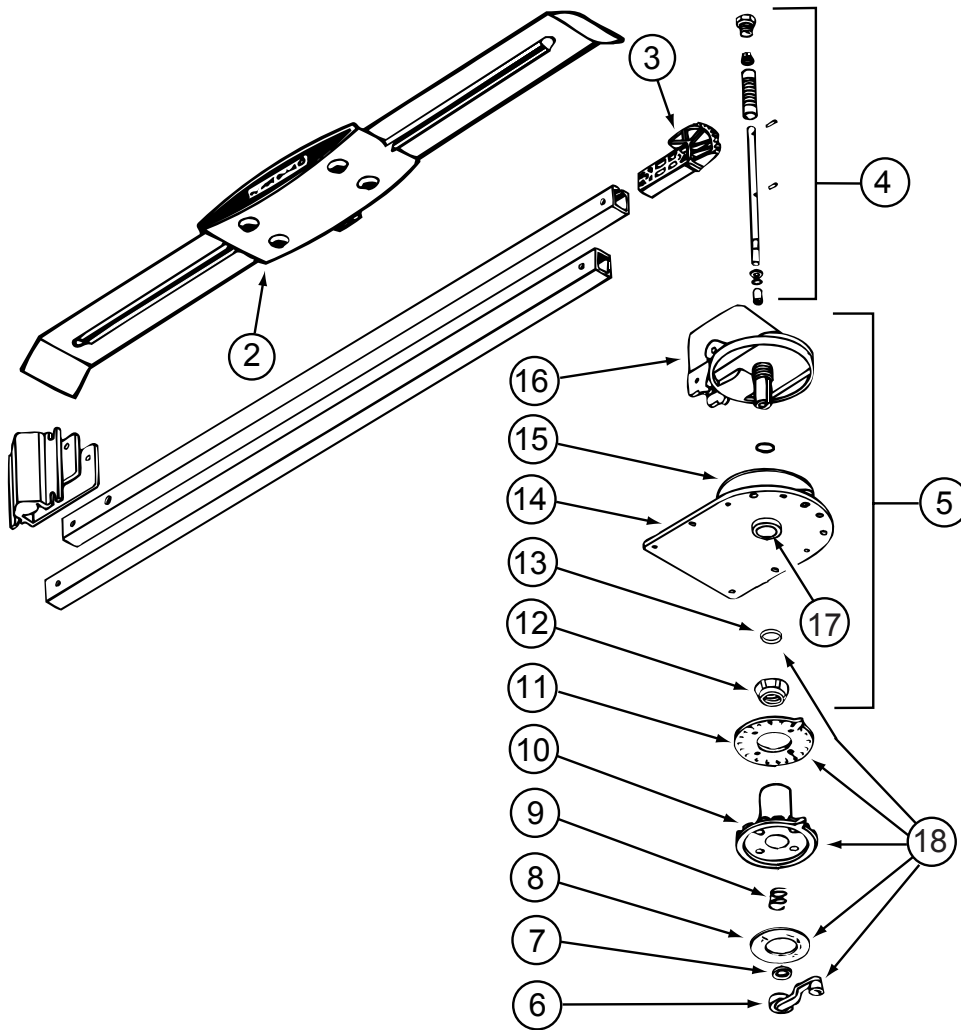

076319-23-000

KEY	PART NUMBER	U/M	DESCRIPTION	VENDOR NO.
2	076319-01-700	EA	HEAD-ANTENNA, AMPLIFIED	RVSA U/V
3	076319-01-701	EA	GEAR-ELEVATING, PLASTIC	2200046
4	076319-01-702	EA	SHAFT ASM-ELEVATING	RP-4000
5	076319-01-711	EA	BASE & LIFT ASM	2762802
7	076319-01-705	EA	GROMMET-NYLON, 7/8"ID	3200658
8	076319-01-708	EA	DECAL-CRANK	5413002
9	076319-01-707	EA	SPRING-HANDLE	2160822
11	076319-01-712	EA	PLATE - CEILING	3200608
12	076319-01-715	EA	NUT (GEAR HOUSING)	2200047
14	076319-01-713	EA	BASE-PLATE, STEEL	3100523
15	076319-01-703	EA	BEARING-NYLON, 5"OD	3200656
16	076319-01-714	EA	HOUSING, ROTATING GEAR	2200049
	076319-01-716	EA	TUBING, ELEVATING	RP-2900
17	076319-01-704	EA	BEARING-NYLON, 1.25"OD	3200657

CONTACT WINNEBAGO PART SALES FOR UNLISTED COMPONENT

076319-25-000

KEY	PART NUMBER	U/M	DESCRIPTION	VENDOR NO.
6	076319-01-706	EA	CRANK-W/SET SCREW UNIV/BEIGE	2750897
6	120233-01-710	EA	HANDLE-CRANK W/SCREW - WHITE	RP-6795
8	076319-01-708	EA	DECAL-CRANK	5413002
10	076319-25-700	EA	DIRECTIONAL HANDLE(WHITE)	3200612
11	076319-25-701	EA	PLATE - CEILING(WHITE)	3200609
13	120233-01-709	EA	WASHER-NYLON	RP-2658

CONTACT WINNEBAGO PART SALES FOR UNLISTED COMPONENTS

AUDIO VIDEO GROUP (CONTINUED)
COMPONENT PARTS FOR TV & VCR (CONTINUED)

			124073-11-000	
KEY	PART NUMBER	U/M DESCRIPTION		VENDOR NO.
	126697-04-700	EA REMOTE		239040
			124073-12-000	
KEY	PART NUMBER	U/M DESCRIPTION		VENDOR NO.
	126697-04-700	EA REMOTE		239040
			124073-13-000	
KEY	PART NUMBER	U/M DESCRIPTION		VENDOR NO.
	124073-13-700	EA REMOTE		257450
			126696-07-000	
KEY	PART NUMBER	U/M DESCRIPTION		VENDOR NO.
	133377-01-700	EA REMOTE		240961
			126697-07-000	
KEY	PART NUMBER	U/M DESCRIPTION		VENDOR NO.
	126697-07-700	EA REMOTE		248687
			130121-06-000	
KEY	PART NUMBER	U/M DESCRIPTION		VENDOR NO.
	130121-05-700	EA REMOTE		242524
			133377-01-000 & 133377-02-000	
KEY	PART NUMBER	U/M DESCRIPTION		VENDOR NO.
	133377-01-700	EA REMOTE		240961

AUDIO VIDEO GROUP (CONTINUED)
COMPONENT PARTS FOR TV & VCR (CONTINUED)

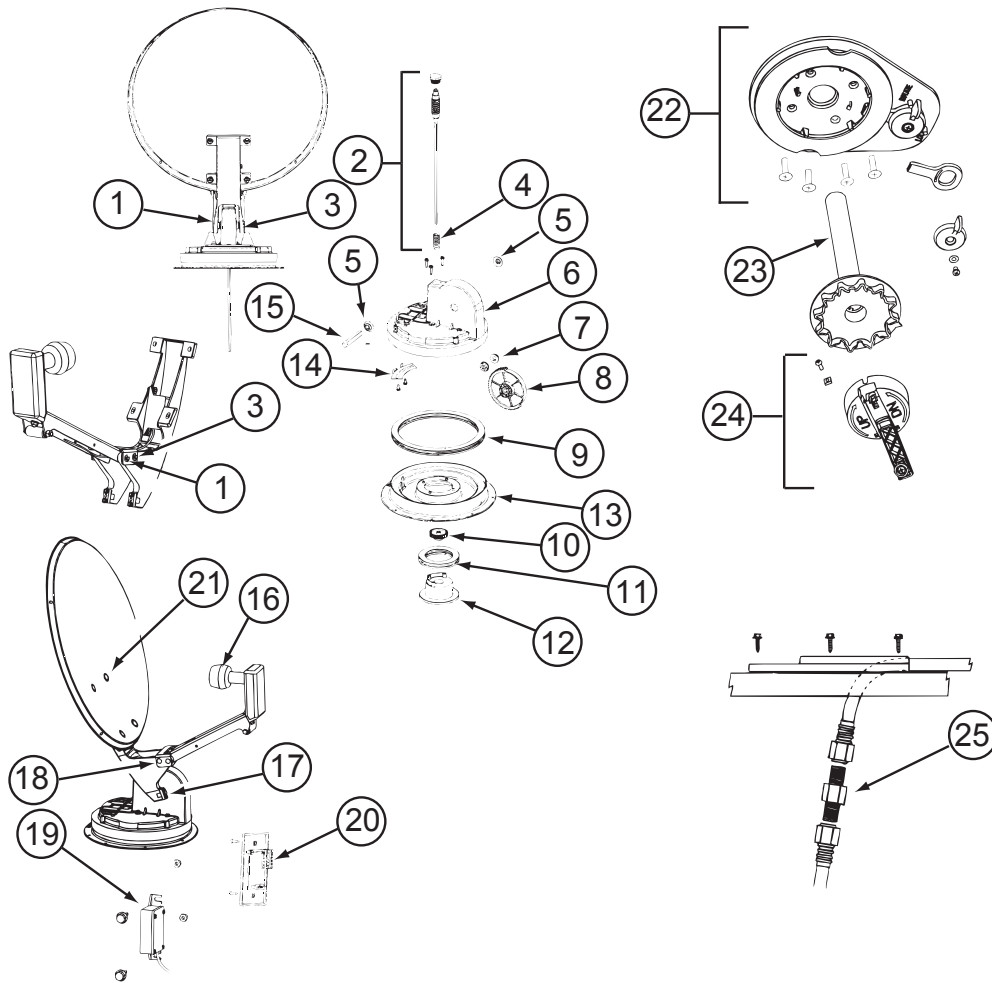

137135-01-000

KEY	PART NUMBER	U/M	DESCRIPTION	VENDOR NO.
1	120233-01-714	EA	CLIP-E	5160818
2	137135-01-703	EA	SHAFT-ELEVATING(SPRING/PLUG)	RP-4400
3	137135-01-704	EA	PIN - 1/4" X 3.25"	2160813
4	137135-01-705	EA	SPRING	2160818
5	137135-01-707	EA	SEAL - PIVOT SHAFT	2200852
6	137135-01-708	EA	TURRET	3100728
7	137135-01-709	EA	PIVOT BEARING	2200470
8	137135-01-711	EA	GEAR - ELEVATING	2200464
9	137135-01-712	EA	BEARING - OUTER	2590347
10	137135-01-714	EA	GEAR - ELEVATING SHAFT	2200465
11	137135-01-715	EA	BEARING - INNER	2590348
12	137135-01-716	EA	HUB	3100731
13	137135-01-713	EA	TURRET BASE	3100730
14	137135-01-710	EA	PLATE - ROTATE LIMIT	3720052
15	137135-01-706	EA	KIT-TURRET/SEAL/BEARING/GEAR	RP-RM30
16	120233-01-734	EA	LOW NOISE BLOCK FILTER (SGL)	LB10003
17	137135-01-722	EA	CLAMP	2590343
18	137135-01-719	EA	BRACKET - PIVOT	2744945
19	137135-01-720	EA	DE-SENSOR UNIT W/43" CABLE	276342
20	137135-01-721	EA	WALL PLATE	3200213
21	137135-01-717	EA	BOLT - FLAT HEAD	216032
22	120233-01-722	EA	PLATE ASSEMBLY (CEILING)	2762826
23	120233-01-704	EA	DIAL - DIRECTIONAL	3200364
24	120233-01-721	EA	CRANK HANDLE ASSEMBLY	2762825
25	137135-01-701	EA	CONNECTOR - F - MALE TO MALE	FS-8100
	137135-01-700	EA	ROOF WEDGE W/GASKET	RW-5000
	137135-01-718	EA	REFLECTOR/WHITE - 46CM	2745282

AUDIO VIDEO GROUP (CONTINUED)
EXTERIOR ENTERTAINMENT

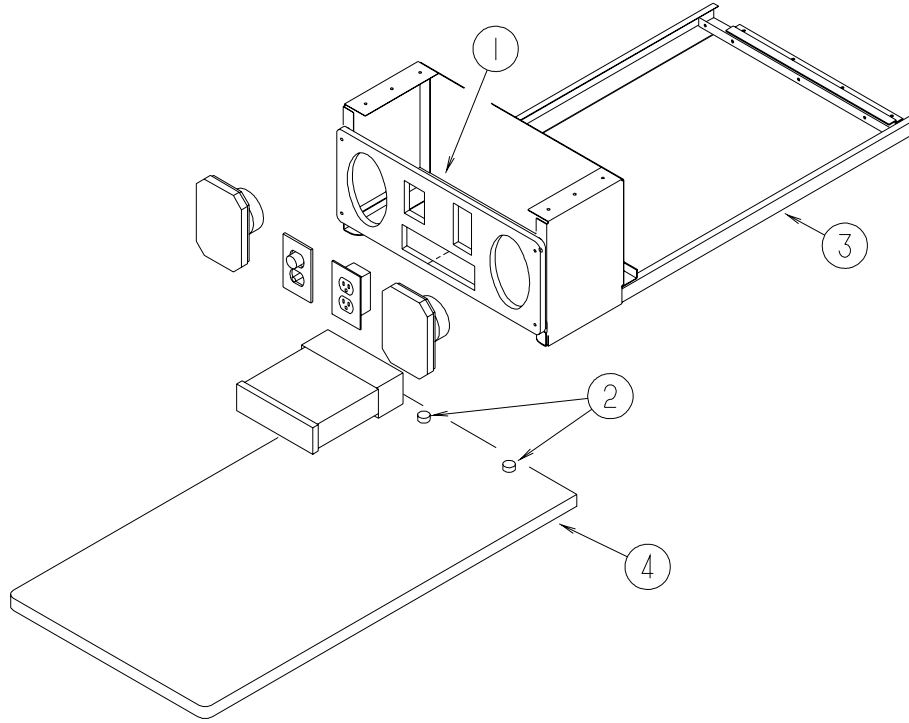

KEY	PART NUMBER	U/M	DESCRIPTION
1	126123-01-K30	EA	PLATE - RADIO MOUNTING - WHITE LAMINATE
2	069726-02-000	EA	BUMPER - .88" OD X .40" THICK - BLACK
3	126119-03-02B	EA	FRAME/ENTERTAINMENT CENTER - 24.6" X 10.3" - E-COATED
4	126125-01-K30	EA	TABLE - ENTERTAINMENT CENTER

BATH GROUP CABINETS

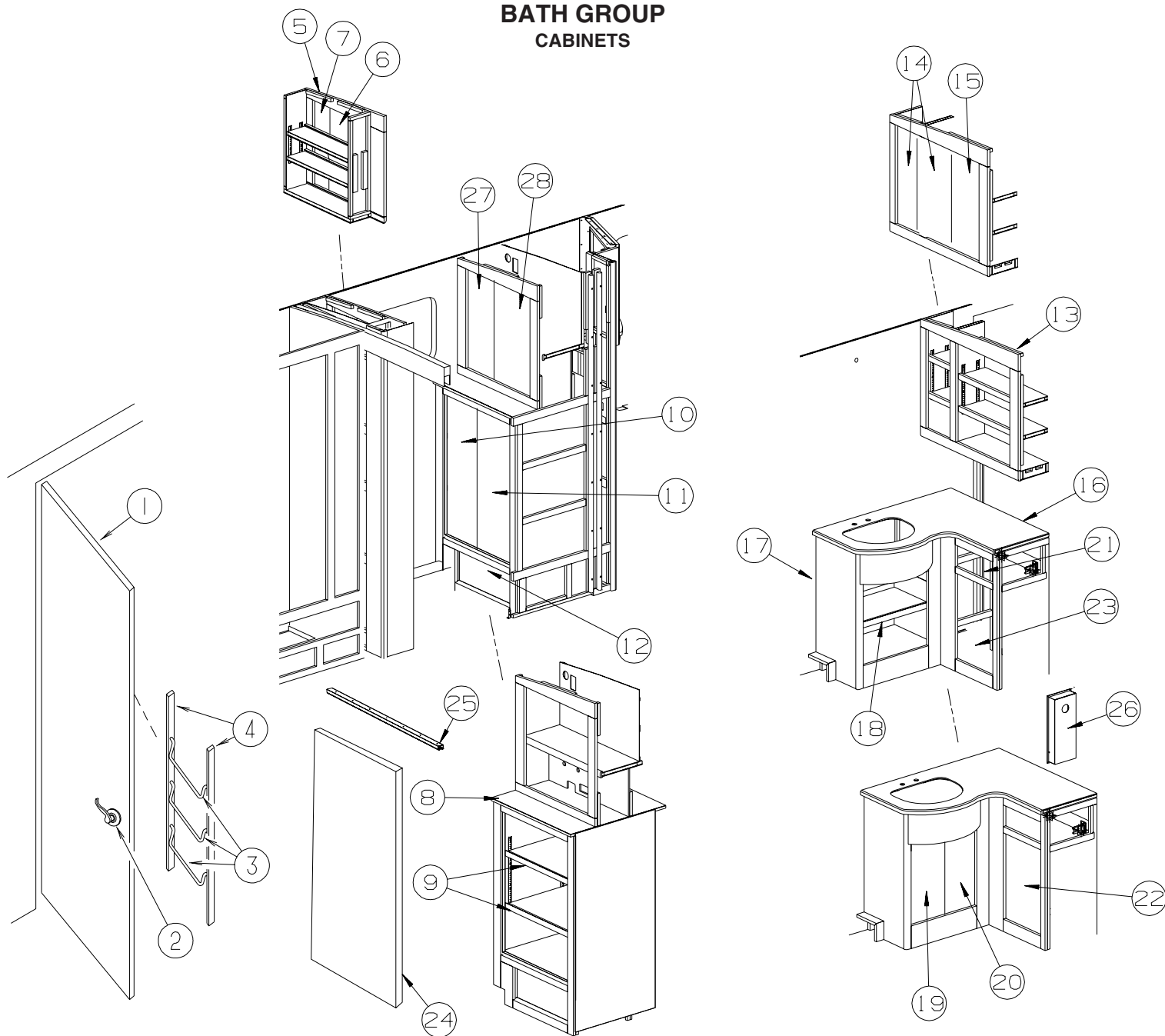

KEY	PART NUMBER	U/M	DESCRIPTION
1	131933-08-M42	EA	DOOR - BATH - W/O HARDWARE - PORTSMOUTH OAK
1	131933-08-M08	EA	DOOR - BATH - W/O HARDWARE - CONCERT CHERRY
1	131933-08-M15	EA	DOOR - BATH - W/O HARDWARE - WASHED MAPLE
2	111155-05-01A	EA	LOCK - PRIVACY/LOCKING - POLISHED BRASS - "S" SHAPE HANDLE FROM: 00-00-00 THRU: 01-26-03
2	146064-01-01A	EA	LOCK - PRIVACY HANDLE - POLISHED BRASS FROM: 01-27-03 THRU: 99-99-99
3	100357-01-000	EA	ROD - F/TOWEL BAR - BRASS
4	P34509-01-N01	EA	RAIL END - RH/LH - TOWEL RACK - PORTSMOUTH OAK - PORTSMOUTH OAK
4	P34509-01-P14	EA	RAIL END - RH/LH - TOWEL RACK - CHERRY - CONCERT CHERRY
4	P34509-01-J70	EA	RAIL END - RH/LH - TOWEL RACK - WASHED MAPLE - WASHED MAPLE
5	140191-01-N70	EA	CABINET - OVERHEAD/BATH - W/O DOORS/HARDWARE - PORTSMOUTH OAK
5	140191-01-N85	EA	CABINET - OVERHEAD/BATH - W/O DOORS/HARDWARE - CONCERT CHERRY
5	140191-01-N84	EA	CABINET - OVERHEAD/BATH - W/O DOORS/HARDWARE - WASHED MAPLE
6	141285-31-P84	EA	DOOR - ARCHED/PENCIL EDGE - 10.2" X 21.4" - W/O HARDWARE - PORTSMOUTH OAK
6	141285-31-P85	EA	DOOR - ARCHED/PENCIL EDGE - 10.2" X 21.4" - W/O HARDWARE - CONCERT CHERRY
6	141285-31-P28	EA	DOOR - ARCHED/PENCIL EDGE - 10.2" X 21.4" - W/O HARDWARE - WASHED MAPLE
7	141508-31-P84	EA	DOOR - ARCHED/PENCIL EDGE - 10.2" X 21.4" - W/O HARDWARE - PORTSMOUTH OAK
7	141508-31-P85	EA	DOOR - ARCHED/PENCIL EDGE - 10.2" X 21.4" - W/O HARDWARE - CONCERT CHERRY
7	141508-31-P28	EA	DOOR - ARCHED/PENCIL EDGE - 10.2" X 21.4" - W/O HARDWARE - WASHED MAPLE

BATH GROUP (CONTINUED)
CABINETS (CONTINUED)

KEY	PART NUMBER	U/M	DESCRIPTION
8	133655-48-N71	EA	COUNTERTOP - LAMINATED - BEIGE PAMPAS (P84, P86, P88)
8	133655-48-N85	EA	COUNTERTOP - LAMINATED - BEIGE PAMPAS/CHERRY IV (P85, P87, P89)
8	133655-48-N84	EA	COUNTERTOP - LAMINATED - BEIGE PAMPAS (P28, P29, P30)
9	140170-32-N70	EA	SHELF - W/PLASTIC EDGE MOLDING - PORTSMOUTH OAK - WASHER/DRYER PREP
9	140170-32-N85	EA	SHELF - W/PLASTIC EDGE MOLDING - CONCERT CHERRY - WASHER/DRYER PREP
9	140170-32-N84	EA	SHELF - W/PLASTIC EDGE MOLDING - WASHED MAPLE - WASHER/DRYER PREP
10	134847-06-P54	EA	DOOR - RH LOUVERED/ACCESS - 12" X 36" - W/O HARDWARE - PORTSMOUTH OAK
10	134847-06-N85	EA	DOOR - RH LOUVERED/ACCESS - 12" X 36" - W/O HARDWARE - CONCERT CHERRY
10	134847-06-N84	EA	DOOR - RH LOUVERED/ACCESS - 12" X 36" - W/O HARDWARE - WASHED MAPLE
11	134847-12-P54	EA	DOOR - LH LOUVERED ACCESS - 12.4" X 36" - W/O HARDWARE - PORTSMOUTH OAK
11	134847-12-N85	EA	DOOR - LH LOUVERED ACCESS - 12.4" X 36" - W/O HARDWARE - CONCERT CHERRY
11	134847-12-N84	EA	DOOR - LH LOUVERED ACCESS - 12.4" X 36" - W/O HARDWARE - WASHED MAPLE
12	P34767-A6-P84	EA	DRAWER - PENCIL EDGE - 18.6"W X 17.7"D-W/O SLIDES/HARDWARE - PORTSMOUTH OAK
12	P34767-A6-N85	EA	DRAWER - PENCIL EDGE - 18.6"W X 17.7"D-W/O SLIDES/HARDWARE - CONCERT CHERRY
12	P34767-A6-N84	EA	DRAWER - PENCIL EDGE - 18.6"W X 17.7"D-W/O SLIDES/HARDWARE - WASHED MAPLE
13	140310-01-N70	EA	CABINET - OVERHEAD/LAVATORY - W/O DOORS/HARDWARE - PORTSMOUTH OAK
13	140310-01-N85	EA	CABINET - OVERHEAD/LAVATORY - W/O DOORS/HARDWARE - CONCERT CHERRY
13	140310-01-N84	EA	CABINET - OVERHEAD/LAVATORY - W/O DOORS/HARDWARE - WASHED MAPLE
14	141285-25-P84	EA	DOOR - ARCHED/PENCIL EDGE - 10" X 25.2" - W/O HARDWARE - PORTSMOUTH OAK
14	141285-25-P85	EA	DOOR - ARCHED/PENCIL EDGE - 10" X 25.2" - W/O HARDWARE - CONCERT CHERRY
14	141285-25-P28	EA	DOOR - ARCHED/PENCIL EDGE - 10" X 25.2" - W/O HARDWARE - WASHED MAPLE
15	141508-25-P84	EA	DOOR - ARCHED/PENCIL EDGE - 10" X 25.2" - W/O HARDWARE - PORTSMOUTH OAK
15	141508-25-P85	EA	DOOR - ARCHED/PENCIL EDGE - 10" X 25.2" - W/O HARDWARE - CONCERT CHERRY
15	141508-25-P28	EA	DOOR - ARCHED/PENCIL EDGE - 10" X 25.2" - W/O HARDWARE - WASHED MAPLE
16	137162-07-03A	EA	COUNTERTOP - LAVATORY - 1/4" VENDURA - QUARRY
17	141968-01-P78	EA	CABINET - LAVATORY - W/O COUNTERTOP/DOORS/DRAWERS/HDW - PORTSMOUTH OAK
17	141968-01-P79	EA	CABINET - LAVATORY - W/O COUNTERTOP/DOORS/DRAWERS/HDW - CONCERT CHERRY
17	141968-01-P28	EA	CABINET - LAVATORY - W/O COUNTERTOP/DOORS/DRAWERS/HDW - WASHED MAPLE
18	141968-18-P78	EA	SHELF - W/PLASTIC EDGE TRIM
19	136710-23-P84	EA	DOOR - RAISED PANEL/PENCIL EDGE - 10" X 19.1" - W/O HDW - PORTSMOUTH OAK
19	136710-23-P85	EA	DOOR - RAISED PANEL/PENCIL EDGE - 10" X 19.1" - W/O HDW - CONCERT CHERRY
19	136710-23-P28	EA	DOOR - RAISED PANEL/PENCIL EDGE - 10" X 19.1" - W/O HDW - WASHED MAPLE
20	136710-24-P84	EA	DOOR - RAISED PANEL/PENCIL EDGE - 10" X 19.1" - W/O HDW - PORTSMOUTH OAK
20	136710-24-P85	EA	DOOR - RAISED PANEL/PENCIL EDGE - 10" X 19.1" - W/O HDW - CONCERT CHERRY
20	136710-24-P28	EA	DOOR - RAISED PANEL/PENCIL EDGE - 10" X 19.1" - W/O HDW - WASHED MAPLE
21	P34767-31-N47	EA	DRAWER - PENCIL EDGE - 12.3"W X 11.8"D-W/O SLIDES/HARDWARE - PORTSMOUTH OAK
21	P34767-31-N85	EA	DRAWER - PENCIL EDGE - 12.3"W X 11.8"D-W/O SLIDES/HARDWARE - CONCERT CHERRY
21	P34767-31-N84	EA	DRAWER - PENCIL EDGE - 12.3"W X 11.8"D-W/O SLIDES/HARDWARE - WASHED MAPLE
22	134783-T9-P84	EA	DOOR - RAIL/SOLID PANEL - 21.8" X 14.3" - W/O HARDWARE - PORTSMOUTH OAK
22	134783-T9-N85	EA	DOOR - RAIL/SOLID PANEL - 21.8" X 14.3" - W/O HARDWARE - CONCERT CHERRY
22	134783-T9-N84	EA	DOOR - RAIL/SOLID PANEL - 21.8" X 14.3" - W/O HARDWARE - WASHED MAPLE
23	140367-01-N70	EA	CABINET/HAMPER - W/O HARDWARE - PORTSMOUTH OAK
23	140367-01-N85	EA	CABINET/HAMPER - W/O HARDWARE - CONCERT CHERRY
23	140367-01-N84	EA	CABINET/HAMPER - W/O HARDWARE - WASHED MAPLE
24	104013-23-N70	EA	DOOR - SLIDING - W/O HARDWARE - PORTSMOUTH OAK
24	104013-23-M85	EA	DOOR - SLIDING - W/HARDWARE - CONCERT CHERRY
24	104013-23-M84	EA	DOOR - SLIDING - W/HARDWARE - WASHED MAPLE
25	137422-05-01A	EA	TRACK/DOOR - OFF WHITE
26	137602-51-N70	EA	POCKET - F/HAIR DRYER - PORTSMOUTH OAK
26	137602-51-N85	EA	POCKET - F/HAIR DRYER - CONCERT CHERRY
26	137602-51-N84	EA	POCKET - F/HAIR DRYER - WASHED MAPLE
27	141285-70-P84	EA	DOOR - ARCHED/PENCIL EDGE - 12" X 25.9" - W/O HARDWARE - PORTSMOUTH OAK
27	141285-70-P85	EA	DOOR - ARCHED/PENCIL EDGE - 12" X 25.9" - W/O HARDWARE - CONCERT CHERRY
27	141285-70-P28	EA	DOOR - ARCHED/PENCIL EDGE - 12" X 25.9" - W/O HARDWARE - WASHED MAPLE
28	141508-70-P84	EA	DOOR - ARCHED/PENCIL EDGE - 12" X 25.9" - W/O HARDWARE - PORTSMOUTH OAK
28	141508-70-P85	EA	DOOR - ARCHED/PENCIL EDGE - 12" X 25.9" - W/O HARDWARE - CONCERT CHERRY
28	141508-70-P28	EA	DOOR - ARCHED/PENCIL EDGE - 12" X 25.9" - W/O HARDWARE - WASHED MAPLE

BATH GROUP (CONTINUED)
CABINETS (CONTINUED)

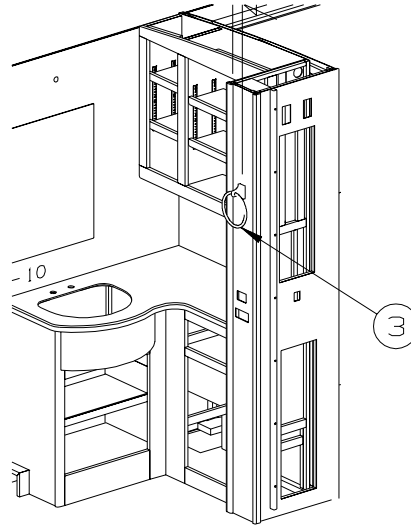
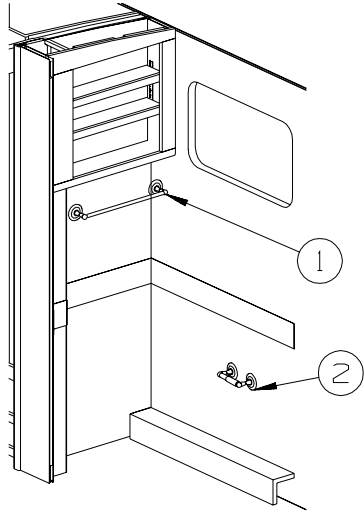

KEY	PART NUMBER	U/M	DESCRIPTION
1	140849-02-01A	EA	BAR - TOWEL - 18" - CHROME/BRASS
2	140973-02-01A	EA	TISSUE HOLDER - CHROME/BRASS
3	135009-01-01A	EA	RING - TOWEL - CHROME & BRASS

BATH GROUP (CONTINUED) SHOWER

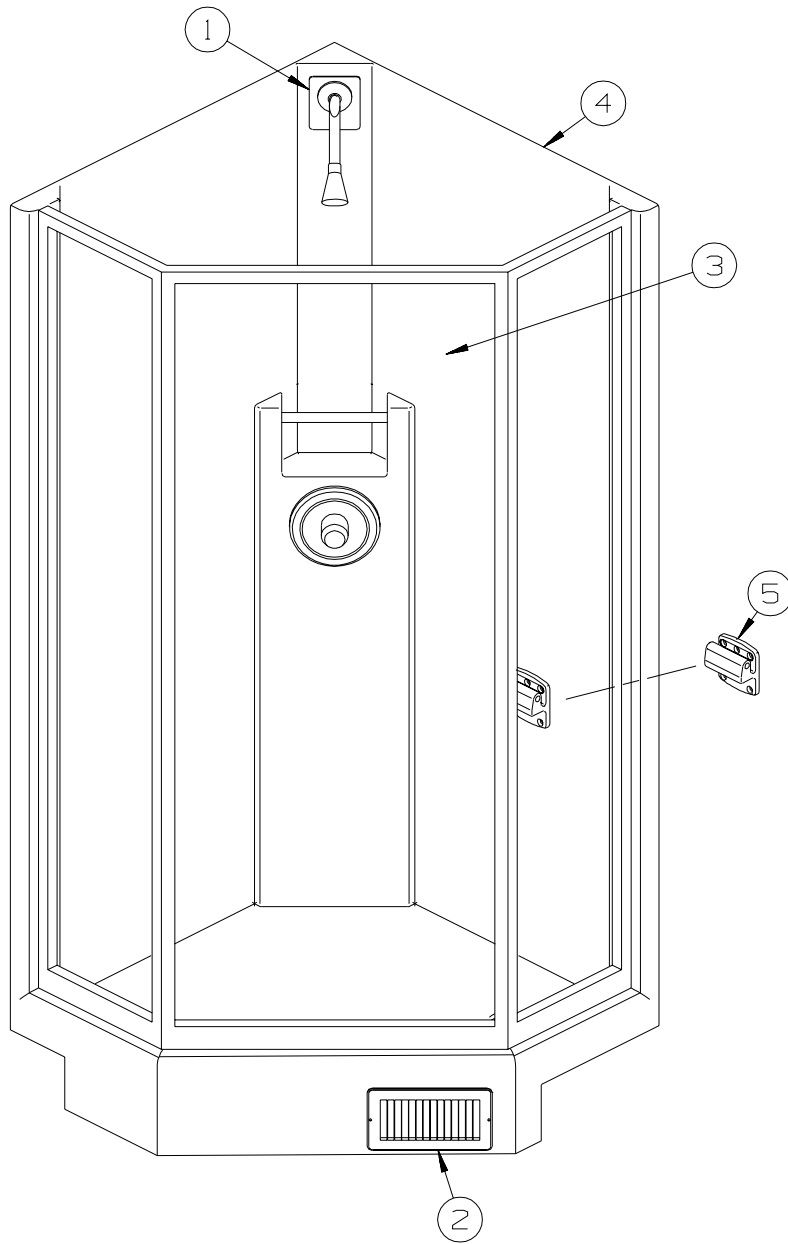

KEY	PART NUMBER	U/M	DESCRIPTION
1	143218-01-02A	EA	PLATE/COVER - SHOWER HEAD - SOFT WHITE
2	089326-02-000	EA	GRILLE - FLOOR - HEATING - 9.3" X 5.3" - SOFT WHITE
3*	139047-05-01A	EA	DOOR - SHOWER - NEO ANGLE - 66.4" TALL - GOLD/AQUA
4	142017-01-01A	EA	SHOWER - FIBERGLASS - SOFT WHITE
5	135607-03-01A	EA	SEAT - SHOWER/FOLDING(FOR REPLACMENT OR OPTION INST ONLY)

***COMPONENT PARTS LISTED LATER IN THIS GROUP**

BATH GROUP (CONTINUED)
COMPONENT PARTS FOR SHOWER DOOR

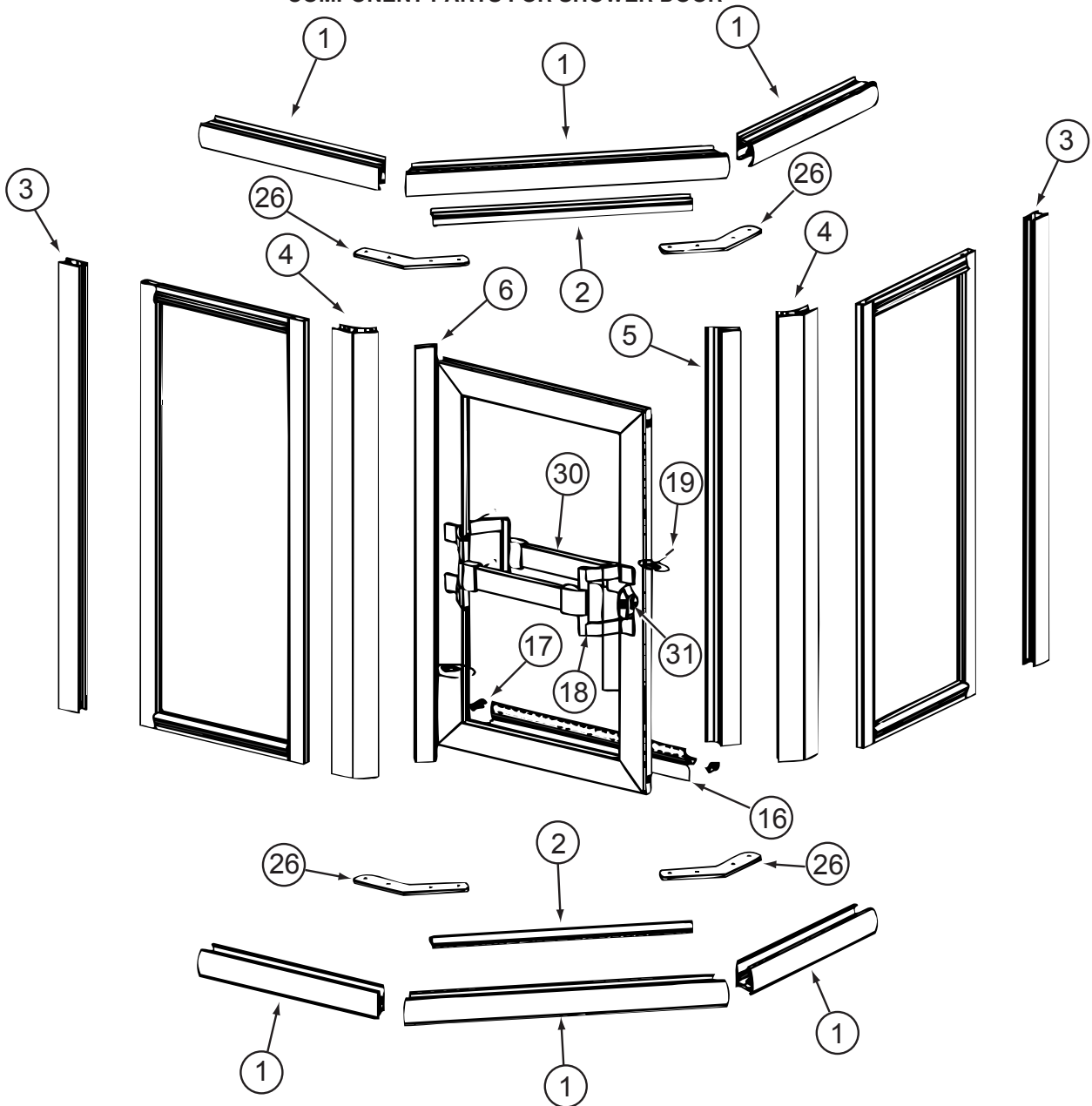

139047-05-01A

KEY	PART NUMBER	U/M	DESCRIPTION	VENDOR NO.
1	139047-01-700	EA	HEADER/SILL - 30" (PAIR)	900
2	139047-01-701	EA	DAM STRIP-TOP/BOTTOM-35.4"	901
3	139047-01-702	EA	JAMB - WALL - 65.9"	903
4	139047-01-703	EA	CORNER POST-45 DEGREE- 65.9"	909
5	139047-01-704	EA	STRIKE - JAMB - 64.6"	926
6	139047-01-705	EA	HINGE/POST - DOOR - 64.5"	920
16	139047-01-710	EA	VINYL SWEEP	C176G
17	139047-01-711	EA	PLUG - DRIP CAP (SET)	CP933
18	092574-01-701	EA	BRACKET/DOOR PULL/TOWEL BAR	8141G
19	092574-01-710	EA	SCREW-GOLD, FOR TOWEL BAR	83212G
26	139047-01-712	E	HEADER - CORNER BRACKET	313.45C
30	116814-01-700	EA	BAR-TOWEL 17 5/16"	68G
31	089318-01-707	EA	LATCH/CATCH - SAFETY - BLACK	9730N
	139047-01-706	EA	HINGE PINS	CP932
	139047-01-707	EA	WASHERS - HINGE	CP148TW
	139047-01-708	EA	HINGE - SLEEVE - 61.5"	C921B
	139047-01-709	EA	STRIP - MAGNETIC- 55"	98-42
	139047-01-713	EA	RAIL DRIP - 31.6"	927G

CONTACT WINNEBAGO PART SALES FOR UNLISTED COMPONENT

BEDROOM GROUP QUEEN CABINETS

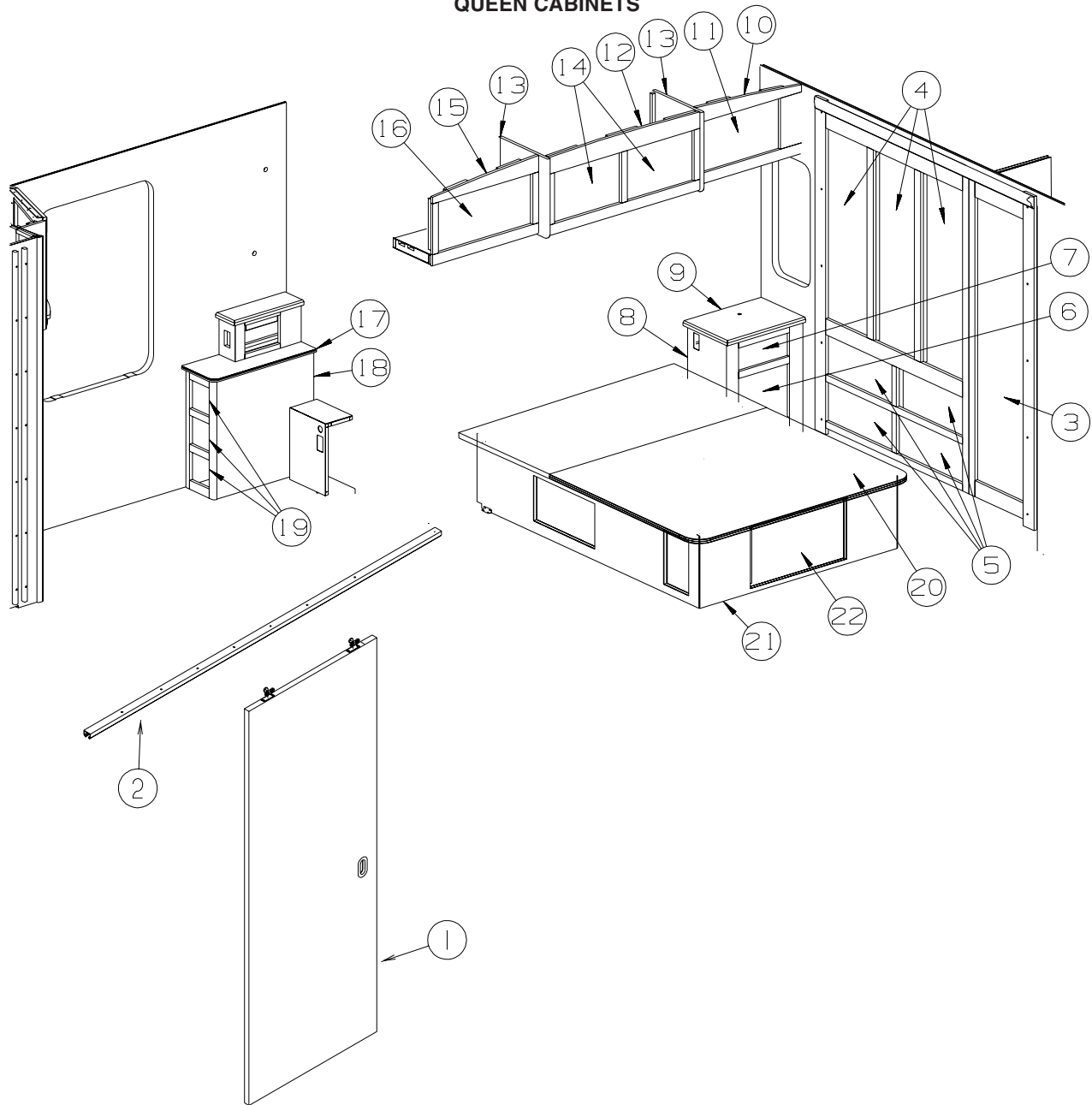

KEY	PART NUMBER	U/M	DESCRIPTION
1	104013-01-N70	EA	DOOR - SLIDING - W/O HARDWARE - PORTSMOUTH OAK
1	104013-01-M52	EA	DOOR - SLIDING - W/O HARDWARE - CONCERT CHERRY
1	104013-01-L58	EA	DOOR - SLIDING - W/O HARDWARE - WASHED MAPLE
2	137422-08-01A	EA	TRACK/DOOR - OFF WHITE
3	134786-01-N04	EA	DOOR - MIRROR/MITERED CORNERS - 16.1" X 65.2"-W/O HARDWARE - PORTSMOUTH OAK
3	134786-01-M16	EA	DOOR - MIRROR/MITERED CORNERS - 16.1" X 65.2"-W/O HARDWARE - CONCERT CHERRY
3	134786-01-M15	EA	DOOR - MIRROR/MITERED CORNERS - 16.1" X 65.2"-W/O HARDWARE - WASHED MAPLE
	140374-11-000	EA	MIRROR - SAFETY GLASS - 12.9" X 62"
4	141285-E2-P84	EA	DOOR - ARCHED/PENCIL EDGE - 14.3" X 45.4" - W/O HARDWARE - PORTSMOUTH OAK
4	141285-E2-P85	EA	DOOR - ARCHED/PENCIL EDGE - 14.3" X 45.4" - W/O HARDWARE - CONCERT CHERRY
4	141285-E2-P28	EA	DOOR - ARCHED/PENCIL EDGE - 14.3" X 45.4" - W/O HARDWARE - WASHED MAPLE
5	P34767-G5-P84	EA	DRAWER - PENCIL EDGE - 20.2"W X 17.7"D-W/O SLIDES/HARDWARE - PORTSMOUTH OAK
5	P34767-G5-P85	EA	DRAWER - PENCIL EDGE - 20.2"W X 17.7"D-W/O SLIDES/HARDWARE - CONCERT CHERRY
5	P34767-G5-P28	EA	DRAWER - PENCIL EDGE - 20.2"W X 17.7"D-W/O SLIDES/HARDWARE - WASHED MAPLE
6	136710-A0-P84	EA	DOOR - RAISED PANEL/PENCIL EDGE - 14.3" X 14.3" - W/O HDW - PORTSMOUTH OAK
6	136710-A0-P85	EA	DOOR - RAISED PANEL/PENCIL EDGE - 14.3" X 14.3" - W/O HDW - CONCERT CHERRY
6	136710-A0-P28	EA	DOOR - RAISED PANEL/PENCIL EDGE - 14.3" X 14.3" - W/O HDW - WASHED MAPLE
7	P34767-31-N47	EA	DRAWER - PENCIL EDGE - 12.3"W X 11.8"D-W/O SLIDES/HARDWARE - PORTSMOUTH OAK
7	P34767-31-N85	EA	DRAWER - PENCIL EDGE - 12.3"W X 11.8"D-W/O SLIDES/HARDWARE - CONCERT CHERRY
7	P34767-31-N84	EA	DRAWER - PENCIL EDGE - 12.3"W X 11.8"D-W/O SLIDES/HARDWARE - WASHED MAPLE

BEDROOM GROUP (CONTINUED)
QUEEN CABINETS (CONTINUED)

KEY	PART NUMBER	U/M	DESCRIPTION
8	141393-01-P75	EA	CABINET - NIGHTSTAND/LEFT - W/O COUNTERTOP/DOOR/DRW/HDW - PORTSMOUTH OAK
8	141393-01-P25	EA	CABINET - NIGHTSTAND/LEFT - W/O COUNTERTOP/DOOR/DRW/HDW - CONCERT CHERRY
8	141393-01-P28	EA	CABINET - NIGHTSTAND/LEFT - W/O COUNTERTOP/DOOR/DRW/HDW - WASHED MAPLE
9	133655-75-P84	EA	COUNTERTOP - LAMINATED - BEIGE PAMPAS (P84, P86, P88)
9	133655-75-P85	EA	COUNTERTOP - LAMINATED - BEIGE PAMPAS (P85, P87, P89)
9	133655-75-P28	EA	COUNTERTOP - LAMINATED - BEIGE PAMPAS (P28, P29, P30)
10	141280-01-P78	EA	CABINET - OVHD/REAR/LEFT HAND -W/O DOORS/HDW-PORTSMOUTH OAK - W/O REAR STEREO SYS
10	141280-01-P79	EA	CABINET - OVHD/REAR/LEFT HAND -W/O DOORS/HDW-CONCERT CHERRY - W/O REAR STEREO SYS
10	141280-01-P28	EA	CABINET - OVHD/REAR/LEFT HAND -W/O DOORS/HDW-WASHED MAPLE - W/O REAR STEREO SYS
10	141280-02-P78	EA	CABINET - OVHD/REAR/LEFT HAND - W/O DOORS/HDW - PORTSMOUTH OAK - REAR STEREO SYS
10	141280-02-P79	EA	CABINET - OVHD/REAR/LEFT HAND - W/O DOORS/HDW - CONCERT CHERRY - REAR STEREO SYS
10	141280-02-P28	EA	CABINET - OVHD/REAR/LEFT HAND - W/O DOORS/HDW - WASHED MAPLE - REAR STEREO SYS
11	141516-67-P84	EA	DOOR - ARCHED/PENCIL EDGE - 12" X 21.8" - W/O HARDWARE - PORTSMOUTH OAK
11	141516-67-P85	EA	DOOR - ARCHED/PENCIL EDGE - 12" X 21.8" - W/O HARDWARE - CONCERT CHERRY
11	141516-67-P28	EA	DOOR - ARCHED/PENCIL EDGE - 12" X 21.8" - W/O HARDWARE - WASHED MAPLE
12	141820-01-P78	EA	CABINET - OVERHEAD/REAR/CENTER - W/O DOORS/HARDWARE - PORTSMOUTH OAK
12	141820-01-P79	EA	CABINET - OVERHEAD/REAR/CENTER - W/O DOORS/HARDWARE - CONCERT CHERRY
12	141820-01-P28	EA	CABINET - OVERHEAD/REAR/CENTER - W/O DOORS/HARDWARE - WASHED MAPLE
13	P38119-01-N75	EA	END CAP - OVERHEAD CABINET - PORTSMOUTH OAK
13	P38119-01-N74	EA	END CAP - OVERHEAD CABINET - CONCERT CHERRY
13	P38119-01-N84	EA	END CAP - OVERHEAD CABINET - WASHED MAPLE
14	141516-64-P84	EA	DOOR - ARCHED/PENCIL EDGE - 12" X 18.7" - W/O HARDWARE - PORTSMOUTH OAK
14	141516-64-P85	EA	DOOR - ARCHED/PENCIL EDGE - 12" X 18.7" - W/O HARDWARE - CONCERT CHERRY
14	141516-64-P28	EA	DOOR - ARCHED/PENCIL EDGE - 12" X 18.7" - W/O HARDWARE - WASHED MAPLE
15	141357-01-P78	EA	CABINET -OVHD/REAR/RIGHT HAND-W/O DOORS/HDW-PORTSMOUTH OAK - W/O REAR STEREO SYS
15	141357-01-P79	EA	CABINET -OVHD/REAR/RIGHT HAND-W/O DOORS/HDW-CONCERT CHERRY - W/O REAR STEREO SYS
15	141357-01-P28	EA	CABINET -OVHD/REAR/RIGHT HAND-W/O DOORS/HDW-WASHED MAPLE - W/O REAR STEREO SYS
15	141357-02-P78	EA	CABINET - OVHD/REAR/RIGHT HAND - W/O DOORS/HDW - PORTSMOUTH OAK - REAR STEREO SYS
15	141357-02-P79	EA	CABINET - OVHD/REAR/RIGHT HAND - W/O DOORS/HDW - CONCERT CHERRY - REAR STEREO SYS
15	141357-02-P28	EA	CABINET - OVHD/REAR/RIGHT HAND - W/O DOORS/HDW - WASHED MAPLE - REAR STEREO SYS
16	141516-70-P84	EA	DOOR - ARCHED/PENCIL EDGE - 12" X 25.9" - W/O HARDWARE - PORTSMOUTH OAK
16	141516-70-P85	EA	DOOR - ARCHED/PENCIL EDGE - 12" X 25.9" - W/O HARDWARE - CONCERT CHERRY
16	141516-70-P28	EA	DOOR - ARCHED/PENCIL EDGE - 12" X 25.9" - W/O HARDWARE - WASHED MAPLE
17	133655-07-N71	EA	COUNTERTOP - LAMINATED - BEIGE PAMPAS (P84, P86, P88)
17	133655-07-M85	EA	COUNTERTOP - LAMINATED - BEIGE PAMPAS (P85, P87, P89)
17	133655-07-M84	EA	COUNTERTOP - LAMINATED - BEIGE PAMPAS (P28, P29, P30)
18	134910-01-M95	EA	CABINET - NIGHTSTAND/RH - W/O COUNTERTOP/DOOR/DRAWER/HDW - PORTSMOUTH OAK
18	134910-01-M94	EA	CABINET - NIGHTSTAND/RH - W/O COUNTERTOP/DOOR/DRAWER/HDW - CONCERT CHERRY
18	134910-01-M84	EA	CABINET - NIGHTSTAND/RH - W/O COUNTERTOP/DOOR/DRAWER/HDW - WASHED MAPLE
19	P34767-12-P84	EA	DRAWER - PENCIL EDGE - 5.2"W X 19.6"D-W/O SLIDES/HARDWARE - PORTSMOUTH OAK
19	P34767-12-P85	EA	DRAWER - PENCIL EDGE - 5.2"W X 19.6"D-W/O SLIDES/HARDWARE - CONCERT CHERRY
19	P34767-12-P28	EA	DRAWER - PENCIL EDGE - 5.2"W X 19.6"D-W/O SLIDES/HARDWARE - WASHED MAPLE
20	137406-05-P13	EA	BEDBOARD - W/HINGE/T-MOLDING/SLIPNOT - FLIP-UP
	097872-04-000	EA	DOWEL - WOOD - 1" DIAMETER X 1.38" LONG - UNFINISHED
	126263-08-02B	EA	BRACKET - GAS SPRING W/CENTERED BALL STUD - E-COATED
21	P34912-10-M71	EA	CABINET/BASE -QUEEN BED-W/O DOOR/DRAWER/HDW-PORTSMOUTH OAK-W/O DC/AC INVTR/CHGR
21	P34912-10-M70	EA	CABINET/BASE -QUEEN BED-W/O DOOR/DRAWER/HDW-CONCERT CHERRY-W/O DC/AC INVTR/CHGR
21	P34912-10-M84	EA	CABINET/BASE -QUEEN BED-W/O DOOR/DRAWER/HDW-WASHED MAPLE-W/O DC/AC INVTR/CHGR
21	P34912-51-M71	EA	CABINET/BASE - QUEEN BED - W/O DOOR/DRAWER/HDW - PORTSMOUTH OAK - 1.5 KW INVTR/CHGR
21	P34912-51-M70	EA	CABINET/BASE - QUEEN BED - W/O DOOR/DRAWER/HDW - CONCERT CHERRY - 1.5 KW INVTR/CHGR
21	P34912-51-M84	EA	CABINET/BASE - QUEEN BED - W/O DOOR/DRAWER/HDW - WASHED MAPLE - 1.5 KW INVTR/CHGR
22	136710-A9-P84	EA	DOOR - RAISED PANEL/PENCIL EDGE - 14.3" X 26.7" - W/O HDW - PORTSMOUTH OAK
22	136710-A9-P85	EA	DOOR - RAISED PANEL/PENCIL EDGE - 14.3" X 26.7" - W/O HDW - CONCERT CHERRY
22	136710-A9-P28	EA	DOOR - RAISED PANEL/PENCIL EDGE - 14.3" X 26.7" - W/O HDW - WASHED MAPLE

BEDROOM GROUP (CONTINUED)

TV & RADIO CABINETS

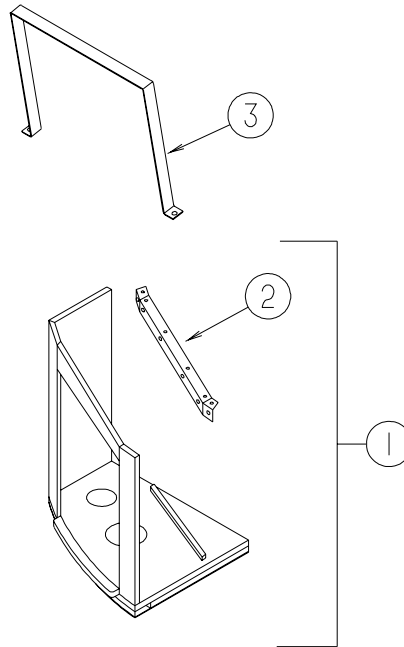

KEY	PART NUMBER	U/M	DESCRIPTION
1	135309-02-N70	EA	CABINET - OVERHEAD - F/19" TV - PORTSMOUTH OAK
1	135309-02-M70	EA	CABINET - OVERHEAD - F/19" TV - CONCERT CHERRY
1	135309-02-M84	EA	CABINET - OVERHEAD - F/19" TV - WASHED MAPLE
2	136518-01-02B	EA	BRACKET - TV FACE - E-COATED
3	115466-28-02B	EA	STRAP - TIEDOWN/TV - E-COATED

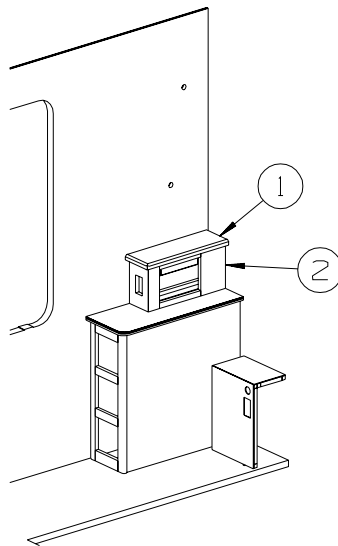

KEY	PART NUMBER	U/M	DESCRIPTION
1	133655-67-P84	EA	COUNTERTOP - LAMINATED - BEIGE PAMPAS (P84, P86, P88)
1	133655-67-N85	EA	COUNTERTOP - LAMINATED - BEIGE PAMPAS (P85, P87, P89)
1	133655-67-N84	EA	COUNTERTOP - LAMINATED - BEIGE PAMPAS (P28, P29, P30)
2	140452-03-P78	EA	CABINET - F/RADIO - W/O HARDWARE - PORTSMOUTH OAK
2	140452-03-P79	EA	CABINET - F/RADIO - W/O HARDWARE - CONCERT CHERRY
2	140452-03-P28	EA	CABINET - F/RADIO - W/O HARDWARE - WASHED MAPLE

CHASSIS GROUP FRAME

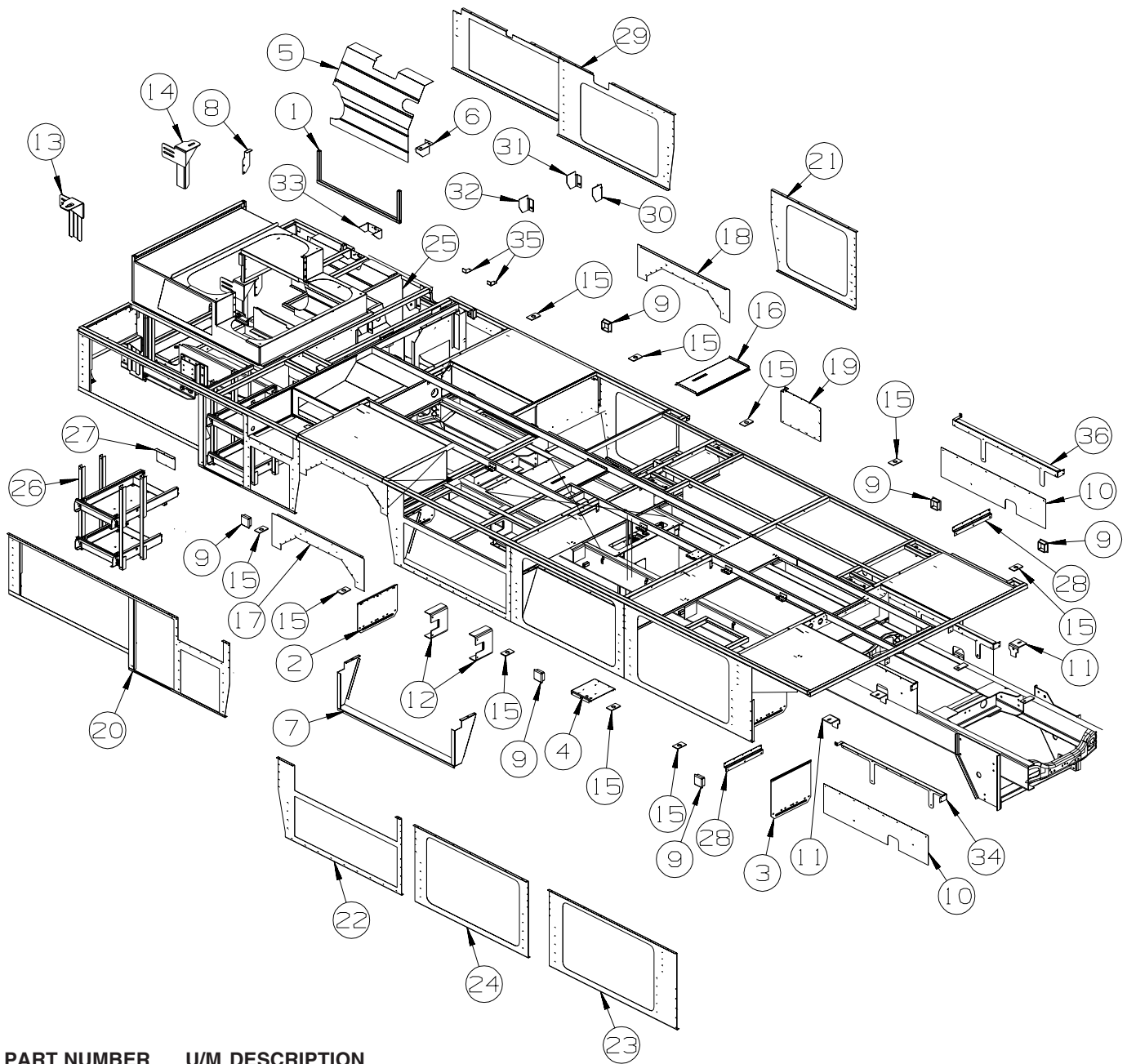

KEY	PART NUMBER	U/M	DESCRIPTION
1	134225-01-02B	EA	SUPPORT - CONDENSOR SHIELD - E-COATED
2	136391-01-02B	EA	GUARD/ROCK - STEEL - W/ANGLE - 18"W X 11"H - E-COATED
3	136391-02-02B	EA	GUARD/ROCK - STEEL - W/ANGLE - 18"W X 15"H - E-COATED
4	138799-01-02B	EA	SHIM - BODY - E-COATED
4	144724-01-02B	EA	BRACKET - SENSOR/LEVELING - E-COATED
			FROM: 00-00-00 THRU: 12-22-02
			FROM: 12-23-02 THRU: 99-99-99
5	139420-02-02B	EA	SHIELD - AC CONDENSOR - E-COATED
6	140045-02-02B	EA	BRACKET - CYLINDER - (RAM) - E-COATED
7	140166-01-02B	EA	SUPPORT - SEAL PLANE - E-COATED
8	141728-01-02B	EA	HANGER - EXHAUST - E-COATED
9	119845-01-01A	EA	PLUG/PLASTIC - 1 1/2" SQUARE - BLACK
10	143917-01-01A	EA	SHIELD/SPLASH - WHEELWELL
11	117154-04-02B	EA	MOUNT - FRAME RAIL/FLOOR
12	120867-01-02B	EA	MOUNT - LP TANK - E-COAT
13	131328-03-02B	EA	SUPPORT - REAR RISER - RIGHT HAND - E-COATED
14	131328-04-02B	EA	SUPPORT - REAR RISER - LEFT HAND - E-COATED
15	135712-01-02B	EA	PLATE - BODY MOUNT - E-COATED
16	117804-13-02B	EA	PANEL - CLOSEOUT - HEAT DUCT - E-COATED
17	119750-04-02B	EA	SEAL PLANE/WHEEL WELL - RIGHT HAND - E-COATED

CHASSIS GROUP (CONTINUED)
FRAME (CONTINUED)

KEY	PART NUMBER	U/M	DESCRIPTION
18	119750-05-02B	EA	SEAL PLANE/WHEEL WELL - LEFT HAND - E-COATED
19	132564-02-02B	EA	PANEL-CLOSEOUT, HLDNG TANK, EC
20	133147-01-02B	EA	SEAL PLANE - E-COATED
21	135634-02-02B	EA	PLATE/SEAL - E-COATED
22	135642-01-02B	EA	PLATE/SEAL - E-COATED
23	135643-02-02B	EA	PLATE - SEAL - E-COATED
24	136105-02-02B	EA	PLATE/SEAL - E-COATED
25	138117-01-02B	EA	COMPARTMENT - POWER CORD - E-COATED
26	138866-01-01A	EA	SLIDE - BATTERY TRAY
27	139982-01-02B	EA	PANEL/COVER - ACCESS - RAM - E-COATED
28	140273-01-02B	EA	BRACE - ROCK GUARD - E-COATED
FROM: 08-26-02 THRU: 99-99-99			
29	141223-01-02B	EA	SEAL PLANE - E-COATED
30	136910-01-02B	EA	BRACKET - CYLINDER/RAM - RIGHT HAND - E-COATED
31	136910-02-02B	EA	BRACKET - CYLINDER/RAM - LEFT HAND - E-COATED
32	136910-04-02B	EA	BRACKET - CYLINDER (RAM) - E-COATED
33	139409-02-02B	EA	BRACKET - MOUNTING - CYLINDER - E-COATED
34	143916-01-02B	EA	BRACKET/SHIELD - SPLASH - E-COATED
35	122922-02-02B	EA	BRACKET/CYLINDER SUPPORT - E-COATED
36	143916-02-02B	EA	BRACKET/SHIELD - SPLASH - E-COATED

CHASSIS GROUP (CONTINUED)

FRONT END

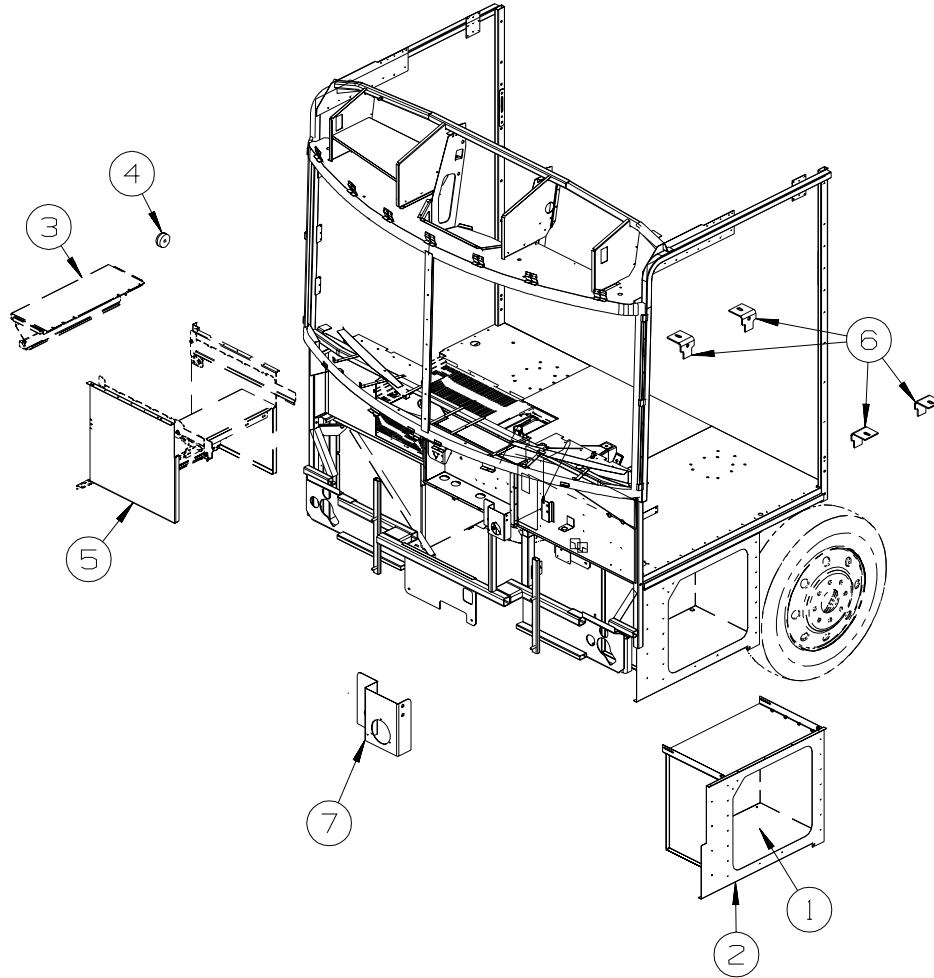

KEY	PART NUMBER	U/M	DESCRIPTION
1	123764-05-02B	EA	COMPARTMENT/LUGGAGE - E-COATED
2	136332-01-02B	EA	SEAL PLANE - FRONT - E-COAT
2	136332-02-02B	EA	PANEL/SEAL - FRONT - E-COATED
			FROM: 00-00-00 THRU: 12-08-02
			FROM: 12-09-02 THRU: 99-99-99
3	131519-03-PC0	EA	STEP - FOLD UP - ENTRY DOOR
4	120863-08-000	EA	BUMPER - RUBBER - W/INSERT - .4" X .7"
5	132987-03-02B	EA	STEP - ENTRY DOOR - E-COATED
6	117154-04-02B	EA	MOUNT - FRAME RAIL/FLOOR
7	142478-01-04B	EA	BRACKET - GAUGE - AIR SOURCE - BLACK

CHASSIS GROUP (CONTINUED) FRONT END (CONTINUED)

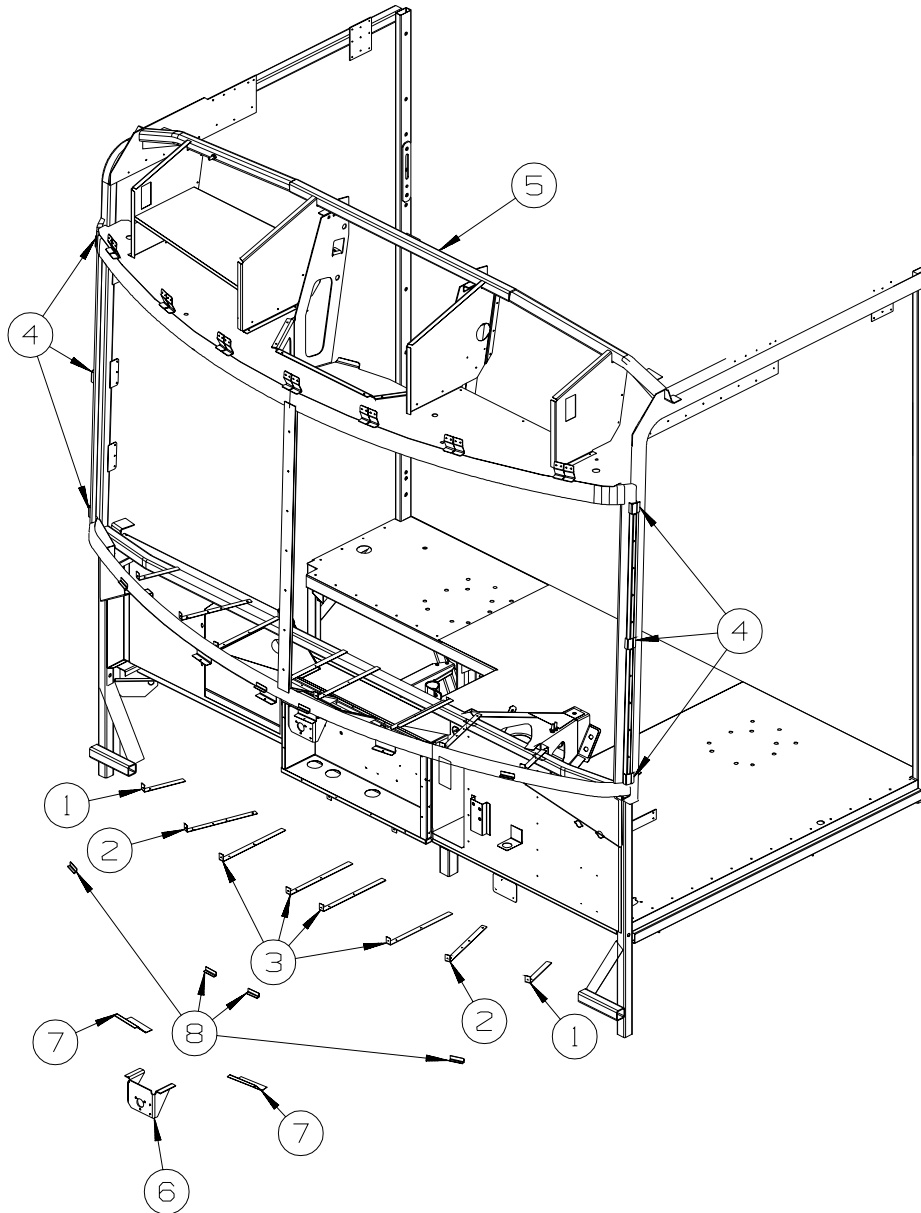

KEY	PART NUMBER	U/M	DESCRIPTION
1	137047-06-01B	EA	STRAP - DEFROSTER PLENUM
2	137047-05-01B	EA	STRAP - DEFROSTER PLENUM
3	137047-04-01B	EA	STRAP - DEFROSTER PLENUM
4	120363-01-01B	EA	BRACKET - WINDSHIELD
5	132796-01-01B	EA	SUPPORT - CABINET/TV - FRONT MIDDLE
6	134506-01-01B	EA	BRACKET - WIPER MOTOR
7	134202-01-01B	EA	REINFORCEMENT - SUPPORT - LOWER WINDSHIELD/MIDDLE
8	076364-57-000	EA	ANGLE - FORMED

CHASSIS GROUP (CONTINUED)

AIR INTAKE

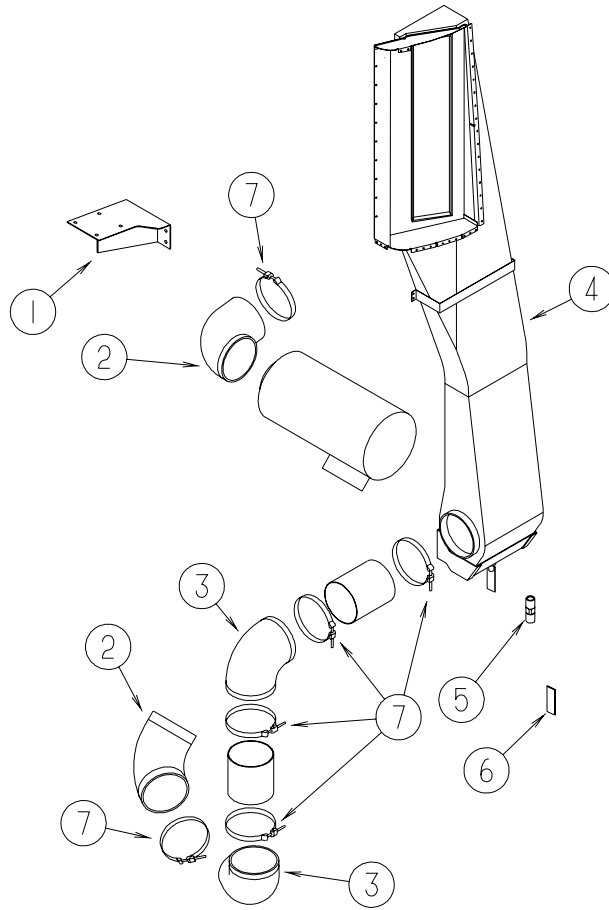

KEY	PART NUMBER	U/M	DESCRIPTION
1	136817-01-02B	EA	BRACKET/AIR FILTER - E-COATED - P32T, P32TD
2	123362-03-000	EA	ELBOW - RUBBER - 68 DEGREE 6" ID
3	123362-02-000	EA	ELBOW - AIR INTAKE - RUBBER - 90 DEGREE 6" ID
4	129514-02-01A	EA	DUCT - INTAKE AIR - W/FITTING
	129514-01-01A	EA	DUCT - INTAKE AIR
5	135386-01-000	EA	NIPPLE - 1/2"
6	130377-01-000	EA	TUBE/DRAIN - KAZOO - 1 1/4" X 4"
7	125083-01-01A	EA	CLAMP - T BOLT - 6"

CHASSIS GROUP (CONTINUED)

INSULATION

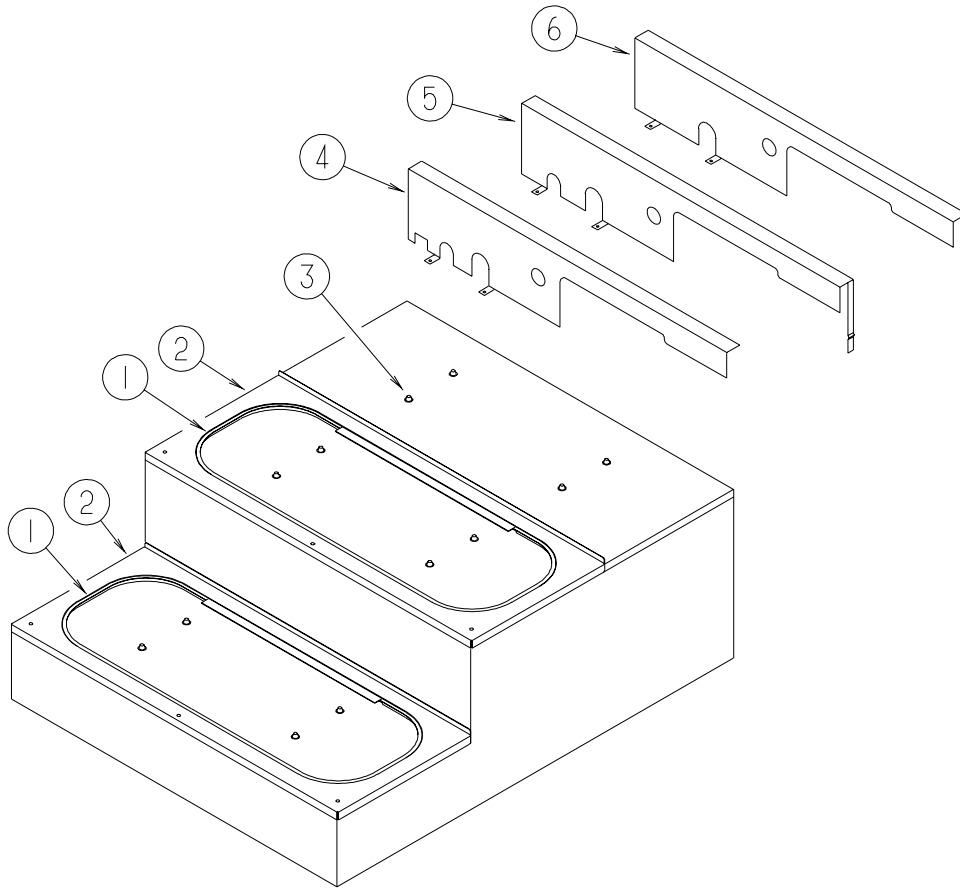

P32TD, P34HD. P36LD

KEY	PART NUMBER	U/M	DESCRIPTION
1	039623-01-000	FT	SEAL - MOTOR COVER - RUBBER BULB TYPE
2	134340-01-02B	EA	COVER - ENGINE - E-COATED
3	106648-01-000	EA	CAP - STUD - .120 TO .130 DIAMETER
4	NOT USED		
5	134068-03-02B	EA	ANGLE - BAFFLE/TOP - E-COATED - P32TD
6	134068-02-02B	EA	ANGLE - BAFFLE/TOP - E-COATED - P34HD, P36LD
	072877-03-000	EA	INSULATION - SOUND BARRIER- 1" X 36" X 57" - ADHESIVE BACK
	107721-07-000	FT	SEAL - ACCESS DOOR - .9" WIDE X 1.1" HIGH

CHASSIS GROUP (CONTINUED)
INSULATION (CONTINUED)

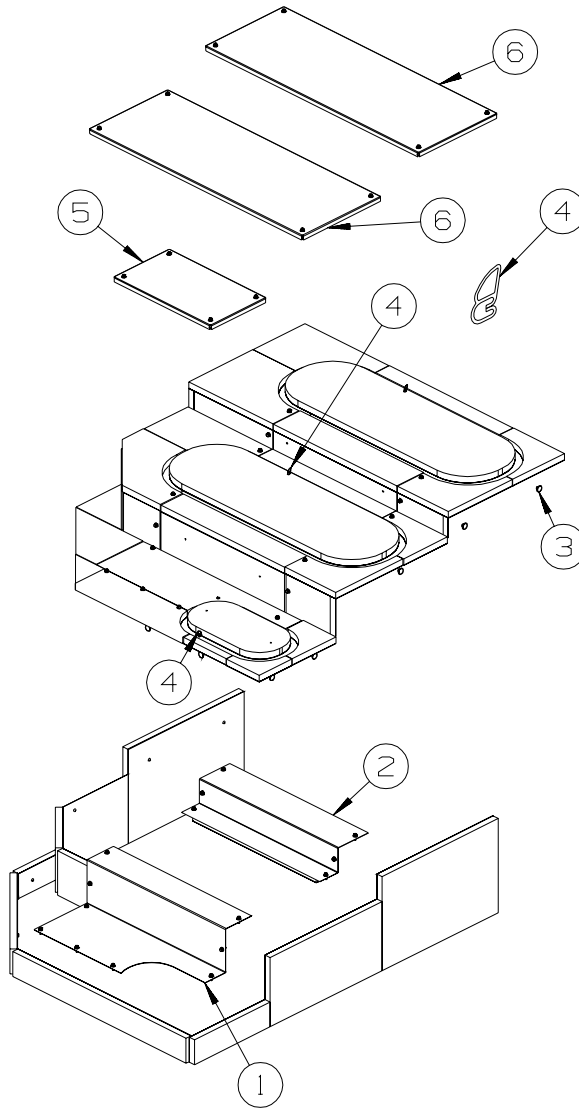

P39QD, P39WD

KEY	PART NUMBER	U/M	DESCRIPTION
1	140564-02-02B	EA	PANEL/ACCESS - ENGINE COMPARTMENT - E-COATED
2	140351-02-02B	EA	PANEL - ACCESS/COMPARTMENT - E-COATED
3	106648-01-000	EA	CAP - STUD - .120 TO .130 DIAMETER
4	039623-01-000	EA	SEAL - MOTOR COVER - RUBBER BULB TYPE
5	140420-01-02B	EA	COVER - ENGINE - E-COATED
6	140399-01-02B	EA	COVER - ENGINE - E-COATED
	072877-03-000	EA	INSULATION - SOUND BARRIER- 1" X 36" X 57" - ADHESIVE BACK

CHASSIS GROUP (CONTINUED)
INSULATION (CONTINUED)

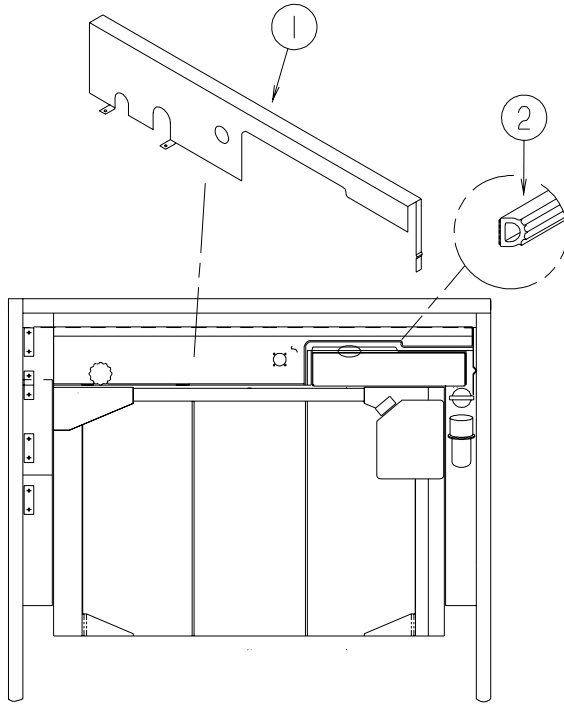

P39QD, P39WD

KEY	PART NUMBER	U/M	DESCRIPTION
1	134068-02-02B	EA	ANGLE - BAFFLE/TOP - E-COATED
2	107721-07-000	FT	SEAL - ACCESS DOOR - .9" WIDE X 1.1" HIGH

CHASSIS GROUP (CONTINUED)
STEPWELL COVER

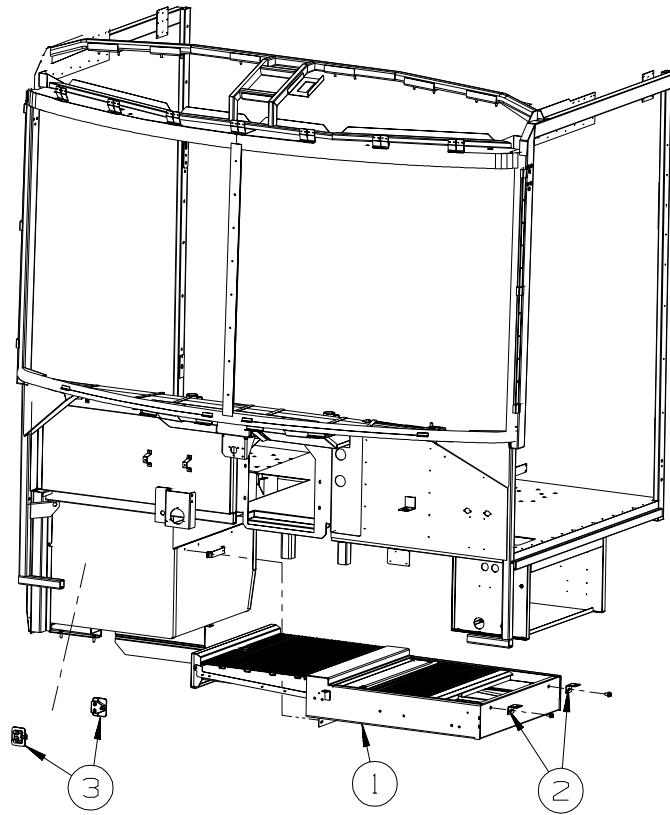

KEY	PART NUMBER	U/M	DESCRIPTION
1*	141691-01-01A	EA	STEP COVER - SLIDING
2	142274-01-02B	EA	BRACKET - STEP COVER - E-COATED
3	142499-01-01A	EA	BLOCK/SUPPORT (STEP COVER)

***COMPONENT PARTS LISTED LATER IN THIS GROUP**

CHASSIS GROUP (CONTINUED)
COMPONENT PARTS FOR STEPWELL COVER

141691-01-01A

KEY	PART NUMBER	U/M	DESCRIPTION	VENDOR NO.
	141691-01-700	EA	CABLE - 36"	1218751
	141691-01-701	EA	CABLE - 63"	1218752
	141691-01-702	EA	BEARING/ROLLER	1912040
	141691-01-703	EA	LATCH - CABLE RELEASE	1912125
	141691-01-704	EA	SPRING - CABLE PRELOAD	1217507
	141691-01-705	EA	DRUM - CABLE TO MOTOR	1612535
	141691-01-706	EA	BUSHING - .625" X .813"	1614003
	141691-01-707	EA	WIRE HARNESS - PACKARD END	1809938
	141691-01-708	EA	MOTOR W/9 TOOTH PINION	1820122

CHASSIS GROUP (CONTINUED)

EXHAUST

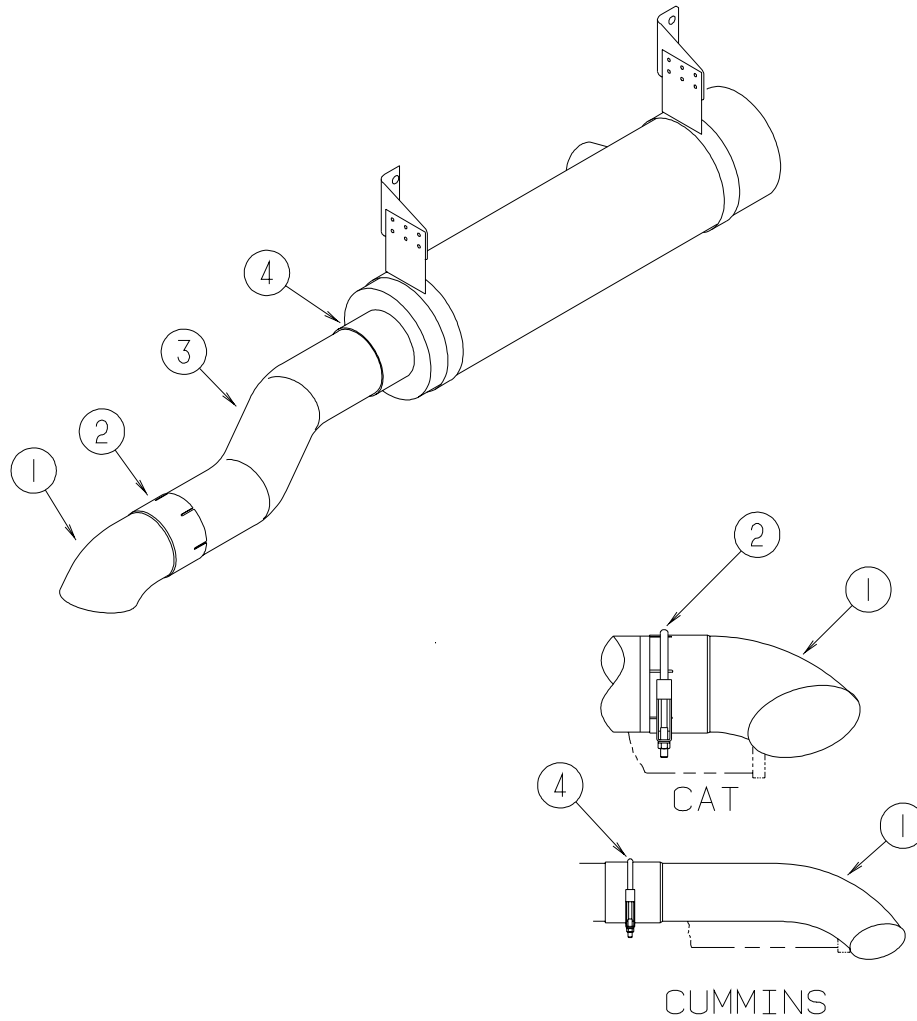

KEY	PART NUMBER	U/M	DESCRIPTION
1	116425-03-000	EA	EXTENSION - EXHAUST - CHROMED - 4"
2	NOT USED		
3	114869-09-000	EA	PIPE - EXHAUST - P32T
3	114869-06-000	EA	PIPE - EXHAUST
4	094918-05-000	EA	CLAMP - EXHAUST - 4 7/16" - GUILLOTINE STYLE

HITCH

KEY	PART NUMBER	U/M	DESCRIPTION
	134016-02-01A	EA	DRAWBAR - HITCH - CLASS 4
	134016-03-01A	EA	DRAWBAR/HITCH - CLASS 4 - TOW POWER CHASSIS

CHASSIS GROUP (CONTINUED)

REAR BUMPER

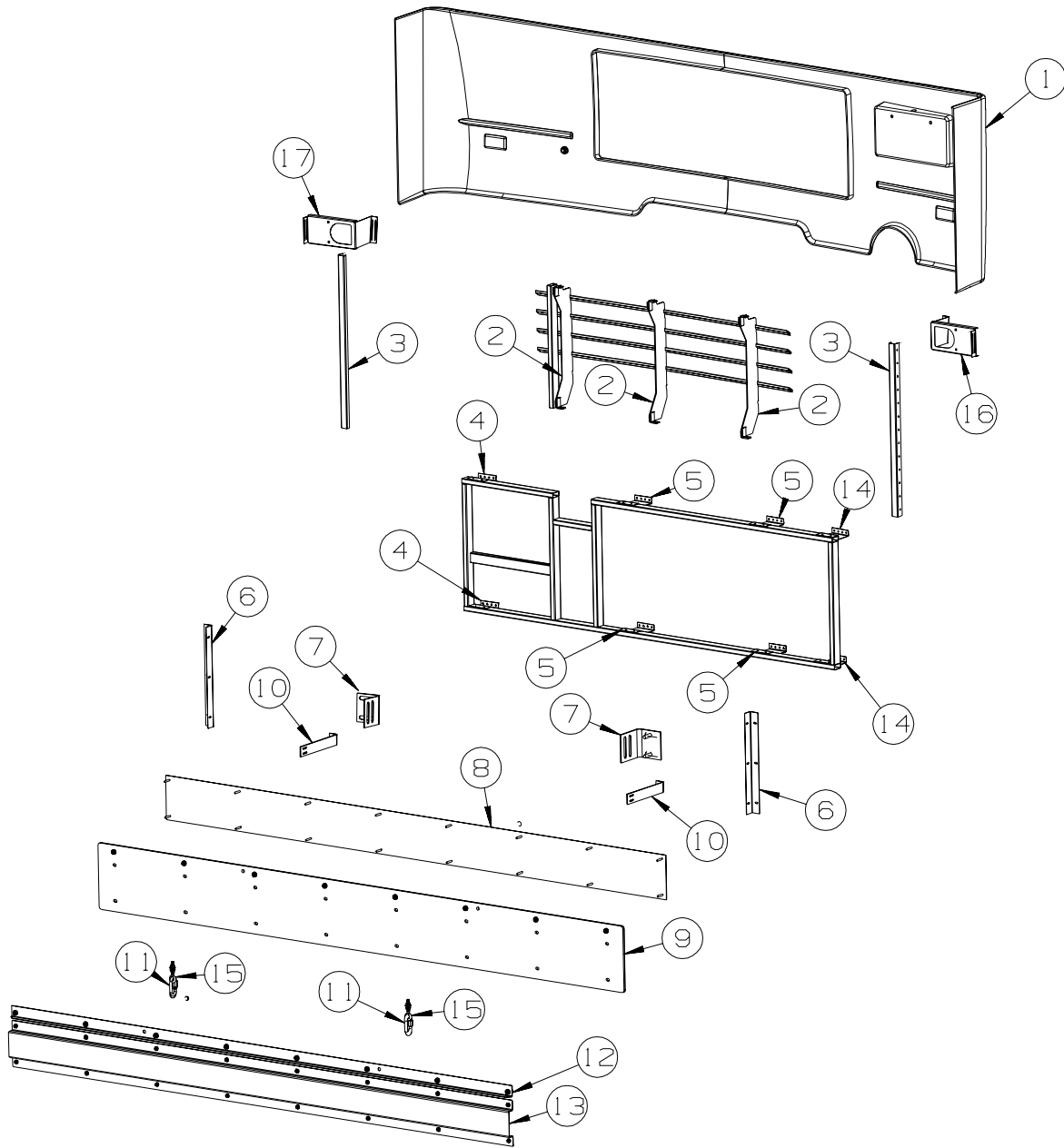

KEY	PART NUMBER	U/M	DESCRIPTION
1	141262-02-P84	EA	PANEL - BUMPER/REAR
2	132447-01-L76	EA	GRILL - REAR BUMPER
3	132071-01-02B	EA	BRACKET - BUMPER - FRONT/REAR - E-COATED
4	NOT AVAILABLE - CONTACT PART SALES		
5	NOT AVAILABLE - CONTACT PART SALES		
6	113041-03-02B	EA	ANGLE - BUMPER MOUNT - E-COATED
7	107524-03-000	EA	ANGLE - BUMPER - INNER/RIGHT & LEFT HAND
8	139238-03-01A	EA	PLATE - MUD FLAP - STAINLESS STEEL/BRUSHED
9	139635-01-01A	EA	MUD FLAP - FULL WIDTH
10	134007-01-02B	EA	BRACE - BUMPER - E-COATED
11	139818-01-01A	EA	LINK - QUICK - STAINLESS STEEL
12	139417-01-04B	EA	ANGLE - FORMED - MUDFLAP - BLACK
13	139416-01-02B	EA	STIFFENER - MUDFLAP - E-COATED
13	139416-01-04B	EA	STIFFNER-MUDFLAP BLACK
14	NOT AVAILABLE - CONTACT PART SALES		
15	139820-02-01A	EA	BOLT - HANGER/EYE - 5/16" STAINLESS STEEL
16	141264-01-02B	EA	BRACKET - DOCKING LAMP - E-COATED
17	141264-02-02B	EA	BRACKET - DOCKING LAMP - E-COATED

FROM: 00-00-00 THRU: 04-02-02

FROM: 04-03-02 THRU: 99-99-99

CHASSIS GROUP (CONTINUED)
FUEL OR FUEL FILL OR EMISSIONS

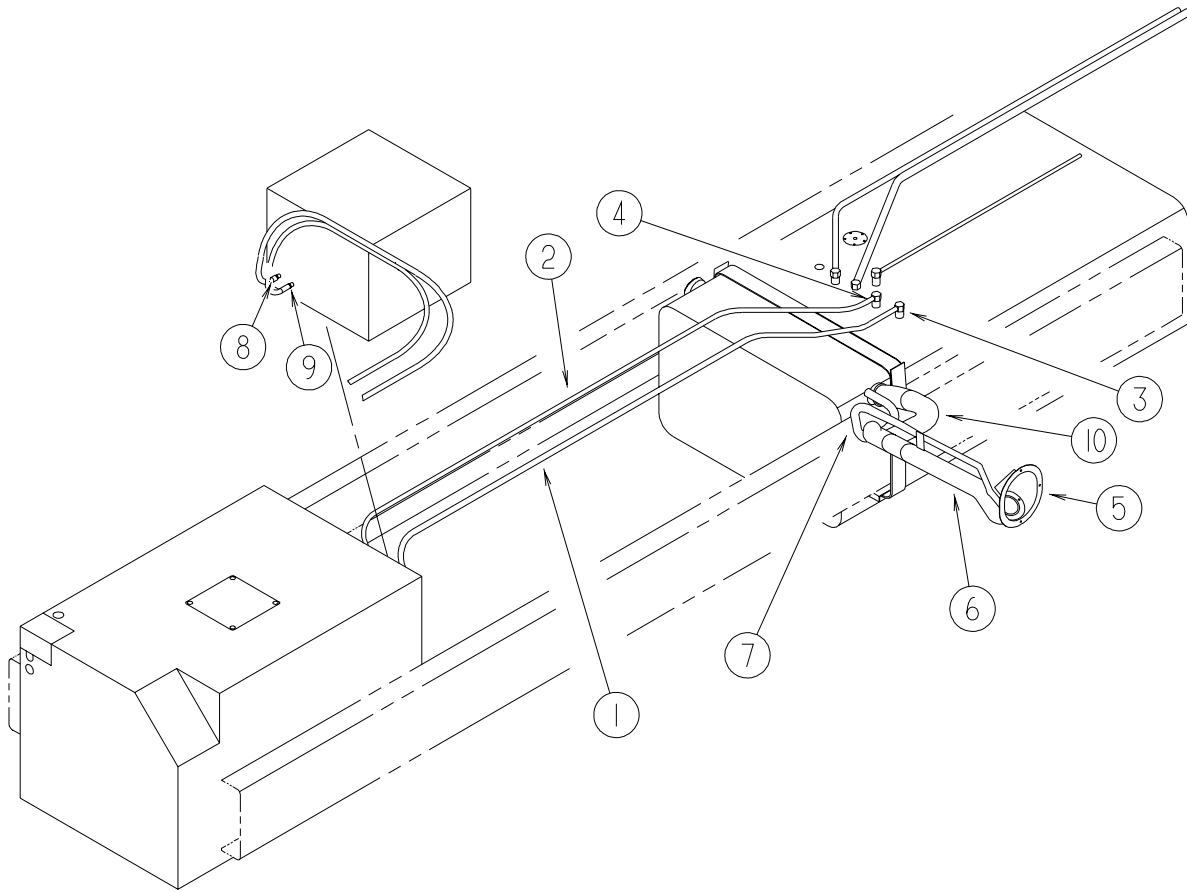

KEY	PART NUMBER	U/M	DESCRIPTION
1	024138-01-000	FT	HOSE - FUEL - 5/16" ID
2	128139-03-000	FT	HOSE - FUEL - LOW PERMEABILITY - 1/4" DIAMETER
3	114253-02-000	EA	ELBOW - 5/16 SINGLE BARB X 1/4 MPT
4	114253-01-000	EA	ELBOW - 1/4 SINGLE BARB X 1/8 MPT
4	068382-06-000	EA	BUSHING - BRASS - 3/8"MPT X 1/8"FPT
5	128299-01-01A	EA	SHROUD - FUEL FILL
6	132108-01-000	EA	NECK ASSEMBLY - FUEL FILL/DRIVER
7	066732-01-000	FT	HOSE - FUEL - .62"ID
8	114254-02-000	EA	ADAPTER - 5/16 SINGLE BARB X 1/8 MPT
9	114254-01-000	EA	ADAPTER - 1/4 BARB X 1/8 MPT
10	132405-01-000	EA	TUBE - FUEL INLET

CHASSIS GROUP (CONTINUED)

HYDRAULIC LEVELING

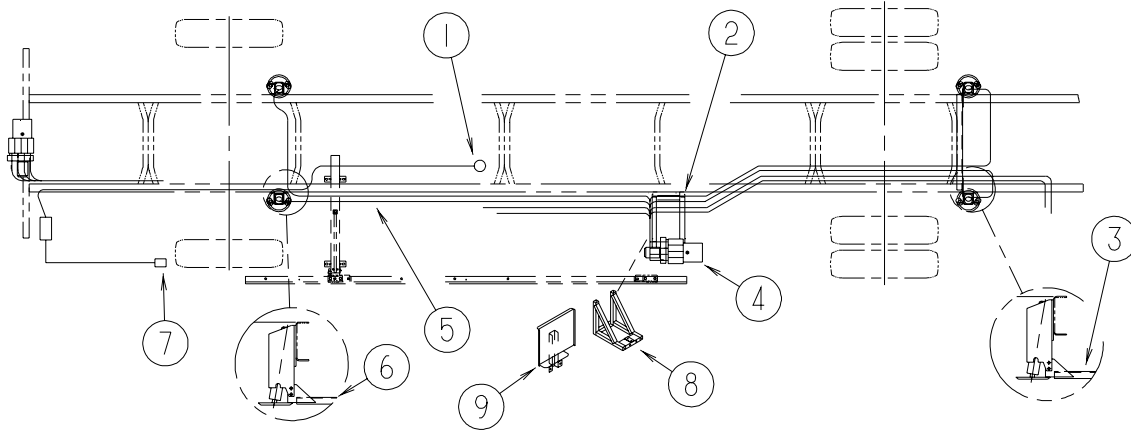

KEY	PART NUMBER	U/M	DESCRIPTION
1	117183-01-02B	EA	COVER - SENSOR - LEVELING
			FROM: 00-00-00 THRU: 12-22-02
1	144723-01-02B	EA	COVER - SENSOR - LEVELING
			FROM: 12-23-02 THRU: 99-99-99
2	133495-02-02B	EA	BRACKET - PUMP/LEVELING - E-COATED
3	114748-08-02B	EA	BRACKET - JACKS/REAR - E-COATED
4*	131306-27-000	EA	LEVELING SYSTEM - 2 S/O
5*	100536-45-000	EA	HOSE KIT - LEVELING JACKS
6	114748-02-02B	EA	CROSSMEMBER - REAR JACK MOUNTING
7	107889-04-000	EA	PANEL - CONTROL - 310 AIR DUMP
8			NO LONGER AVAILABLE - CONTACT PART SALES
9	140830-01-02B	EA	SHIELD - PUMP/LEVELING SYSTEM - E-COATED
	134092-02-000	EA	CHIME KIT - LEVELING SYSTEM - 310

***COMPONENT PARTS LISTED LATER IN THIS GROUP**

CHASSIS GROUP (CONTINUED)
COMPONENT PARTS FOR HYDRAULIC LEVELING

100536-45-000

KEY	PART NUMBER	U/M DESCRIPTION	VENDOR NO.
	100536-36-702	EA HOSE/HYDRAULIC - 1/4" X 408"	RAP4669/AP4669
	100536-42-701	EA HOSE - HYDRAULIC - 175"	RAP90350
	100536-45-700	EA HOSE/HYDRAULIC - 1/4" X 204"	AP4310
	100536-45-701	EA HOSE/HYDRAULIC - 1/4" X 198"	AP6601

131306-27-000

KEY	PART NUMBER	U/M DESCRIPTION	VENDOR NO.
	100532-01-713	EA PUMP/MOTOR/TANK - MONARCH	RAP90014/AP2260

CHASSIS GROUP (CONTINUED)
WHEEL, TIRE, COVERS &/OR LINERS

KEY	PART NUMBER	U/M	DESCRIPTION
	129058-10-000	EA	COVER - NUT - 1.9"H X 2"BASE X 1.4" NUT
	129058-11-000	EA	COVER - NUT - 2.24"H X 2" BASE X 1.4" NUT (REAR WHEELS) FROM: 00-00-00 THRU: 02-19-02
	129058-14-000	EA	COVER - FRONT AXLE - 10 BOLT FRONT - W/LOGO FROM: 02-20-02 THRU: 99-99-99
	129058-15-000	EA	COVER - REAR AXLE - 10 BOLT REAR - W/LOGO FROM: 02-20-02 THRU: 99-99-99
	129058-16-000	EA	CAP - REAR - THREADED - W/LOGO FROM: 02-20-02 THRU: 99-99-99
	129058-17-000	EA	BRACKET - REAR - THREADED FROM: 02-20-02 THRU: 99-99-99
	134439-01-000	EA	WHEEL - ALUMINUM - 7.5" X 22.5"/10 BOLT - FRONT
	134439-02-000	EA	WHEEL - ALUMINUM - 7.5" X 22.5"/10 BOLT - REAR
	077030-07-000	EA	EXTENSION - VALVE STEM - 5.9" LONG
*	110435-17-000	EA	LINER - WHEEL - SET/4 - 22.5" - 10 BOLT FROM: 00-00-00 THRU: 11-24-02
	145580-01-000	EA	LINER - WHEEL(SET OF 4) - 22.5"/10 BOLT FROM: 11-25-02 THRU: 99-99-99
	080208-04-000	EA	LUG WRENCH - 1 3/16" - OSHKOSH/SPARTAN
	080208-05-000	EA	BAR - LEVERAGE - LUG WRENCH - .75"DIA. - OSHKOSH/SPARTAN

***COMPONENT PARTS LISTED LATER IN THIS GROUP**

CHASSIS GROUP (CONTINUED)
COMPONENT PARTS FOR WHEEL, TIRE, COVERS &/OR LINERS

110435-17-000

KEY	PART NUMBER	U/M	DESCRIPTION	VENDOR NO.
	110435-04-705	EA	DECAL-CTR HUB 2 3/4" DIAMO	2 3/4 DECAL DIAMOND
	110435-05-700	EA	CAP-CENTER, POP-OUT 4 1/2"	V22510-POC
	110435-05-710	EA	NUT-JAMB-RIGHT HAND THREAD	V22506-RJN
	110435-05-711	EA	COVER-LUG NUT	V22506-LNC
	110435-05-712	EA	TOOL INSTALLATION	V22506-TOL
	110435-17-700	EA	LINER - WHEEL - FRONT	V22515-FWC
	110435-17-701	EA	COVER - HUB - FRONT	V22510-FHC
	110435-17-702	EA	LINER - WHEEL - REAR	V22515-RWC
	110435-17-703	EA	COVER - HUB - REAR	V22510-RHC
	110435-17-704	EA	STUD EXTENDER - 22MM	V22582-STX
	110435-17-705	EA	COVER - HUB FRT/NEW W/O DECAL	V22515-FHC
	110435-17-706	EA	COVER - HUB REAR/NEW W/O DECAL	V22515-RHC
	110435-17-707	EA	TOOL/JAMB NUT - STUD EXTENDER	PN205-T0L
	110435-17-708	EA	STUD EXTENDER - TUBE STYLE	NH1422-TSX
	110435-17-709	EA	NUT/JAMB - W/O STUD EXTENDER	V19582-JNT

CURTAIN & CUSHION GROUP

NOTICE

IN ORDER TO ASSIST OUR PARTS SALES DEPT. IN PROVIDING INTERIOR SOFTWARE ITEMS, PLEASE INCLUDE THE SERIAL NUMBER AND THE COLOR CODE NUMBER FROM THE VEHICLE CERTIFICATION LABEL WHEN ORDERING. THIS LABEL IS LOCATED ON THE LEFT SIDEWALL AT THE END OF THE DASH (A-BODY), OR ON THE DRIVER'S DOOR LATCH PLATE (C-BODY).

AN EXAMPLE OF A COLOR CODE NUMBER IS B07, WHICH DESIGNATES AN OVERALL COLOR SCHEME OF A PARTICULAR UNIT. THE COLOR LISTED AFTER THE ITEM DESCRIPTION ON THE MICROFICHE, INDICATES THE OVERALL UNIT COLOR. ORDER THE ITEM YOU DESIRE ACCORDING TO UNIT COLOR CODE. IF ALL COLORS USE THE SAME ITEM NO COLOR CODE WILL BE NOTED.

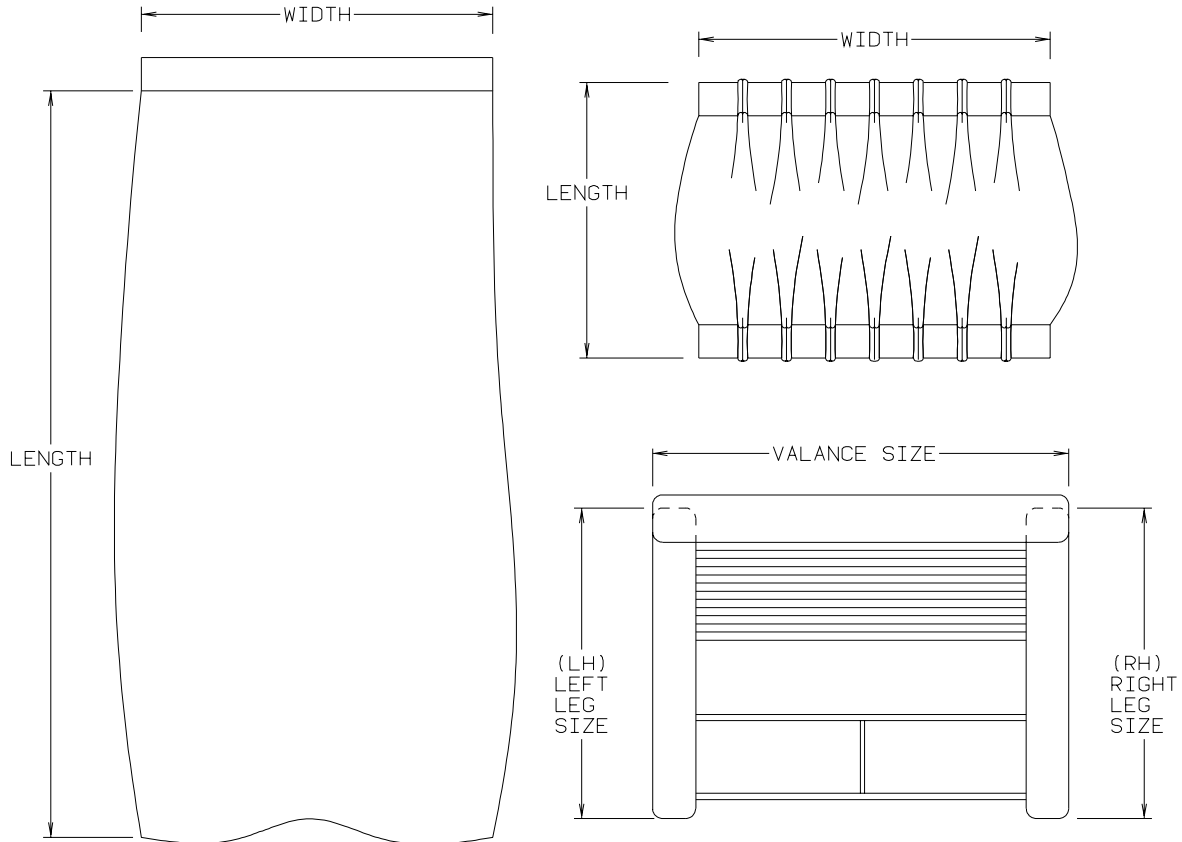

NOTE: USE THIS ILLUSTRATION WHEN DETERMINING LENGTH AND WIDTH MEASUREMENTS FOR CURTAINS. YOU WILL NOTE THE WIDTH MEASUREMENT IS TAKEN ON THE TOP OF THE CURTAIN WITH THE CURTAIN FULLY EXTENDED. THE LENGTH MEASUREMENT IS TAKEN FROM TOP TO BOTTOM. LEFT AND RIGHT WINDOW LEGS ARE DETERMINED WHEN FACING THE WINDOW.

CURTAIN & CUSHION GROUP (CONTINUED)

CUSHION LAYOUT

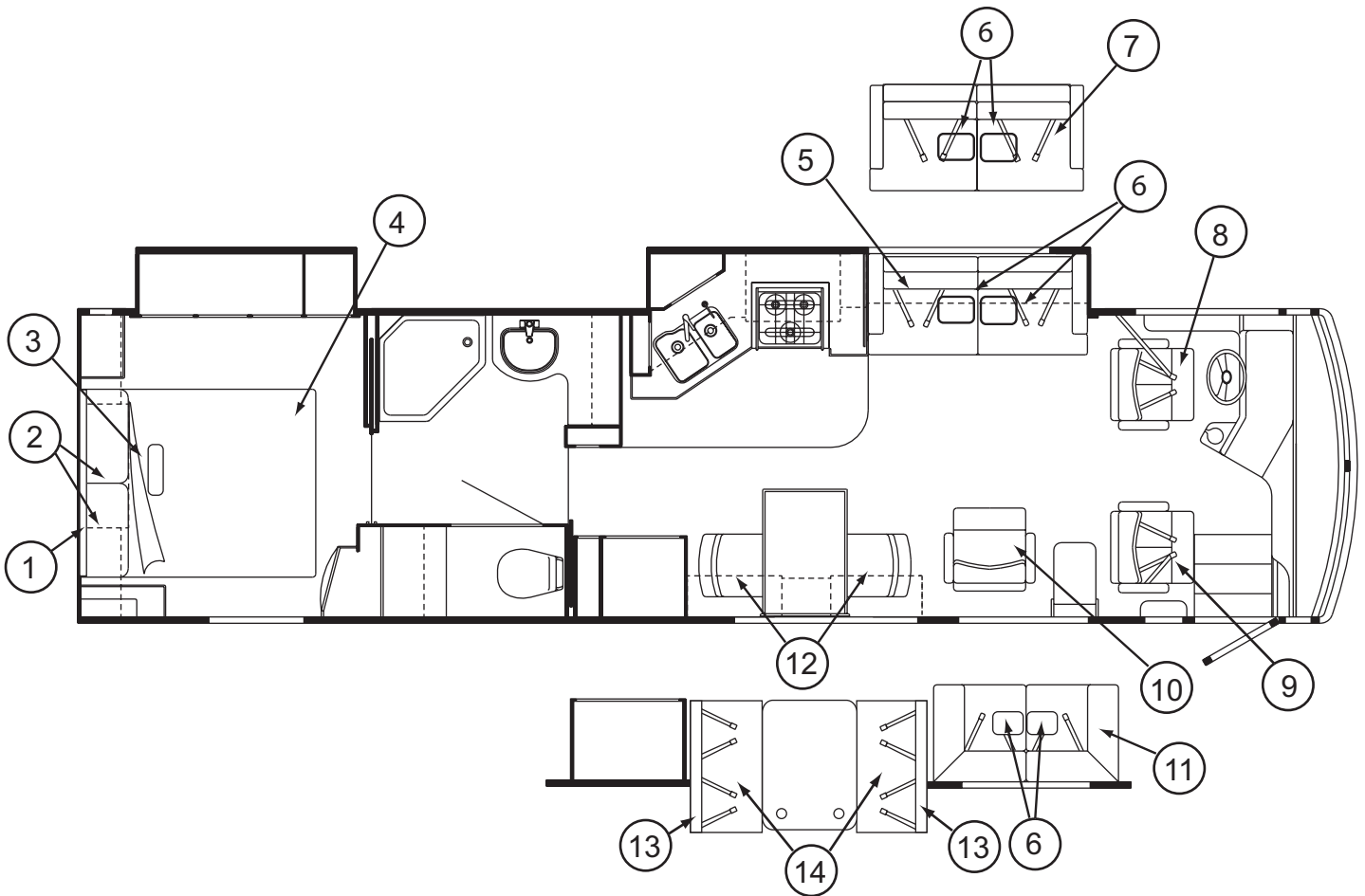

KEY	PART NUMBER	U/M	DESCRIPTION
1	136359-06-P84	EA	HEADBOARD - FABRIC COVERED - F/QUEEN BED (P84, P85, P28)
1	136359-06-P86	EA	HEADBOARD - FABRIC COVERED - F/QUEEN BED (P86, P87 ,P29)
1	136359-06-P88	EA	HEADBOARD - FABRIC COVERED - F/QUEEN BED (P88, P89, P30)
2	126211-05-P84	EA	PILLOW SHAM - 20" X 33" (P84, P85, P28)
2	126211-05-P86	EA	PILLOW SHAM - 20" X 33" (P86, P87 ,P29)
2	126211-05-P88	EA	PILLOW SHAM - 20" X 33" (P88, P89, P30)
3	139680-01-P84	EA	PILLOW - 13" X 20" - W/BOXING & OVERLAY (P84, P85, P28)
3	139680-01-P86	EA	PILLOW - 13" X 20" - W/BOXING & OVERLAY (P86, P87 ,P29)
3	139680-01-P88	EA	PILLOW - 13" X 20" - W/BOXING & OVERLAY (P88, P89, P30)
4	132336-05-P84	EA	BEDSPREAD/CAP - 60" X 75" (P84, P85, P28)
4	132336-05-P86	EA	BEDSPREAD/CAP - 60" X 75" (P86, P87 ,P29)
4	132336-05-P88	EA	BEDSPREAD/CAP - 60" X 75" (P88, P89, P30)
4	142411-01-000	EA	MATTRESS/AIR - 60" X 75" - SELECT COMFORT
4	142411-03-000	EA	AIR PUMP W/CONTROLS - F/SELECT COMFORT MATTRESS
5	138095-15-P84	EA	SOFA/SLEEPER - RECLINER/POWERED - W/TRUNDLE BED (P84, P85, P28)
5	138095-15-P86	EA	SOFA/SLEEPER - RECLINER/POWERED - W/TRUNDLE BED (P86, P87 ,P29)
5	138095-15-P88	EA	SOFA/SLEEPER - RECLINER/POWERED - W/TRUNDLE BED (P88, P89, P30)
5	138095-16-P84	EA	SOFA/SLEEPER - RECLINER/POWERED - W/TRUNDLE BED - ULTRALEATHER RESTEASY
6	132319-51-P84	EA	PILLOW - 18" - W/OVERLAY (P84, P85, P28)
6	132319-51-P86	EA	PILLOW - 18" - W/OVERLAY (P86, P87 ,P29)
6	132319-51-P88	EA	PILLOW - 18" - W/OVERLAY (P88, P89, P30)
7	139202-05-N84	EA	SOFA/DUAL SLEEPER/TRUNDLE - ULTRALEATHER RESTEASY DUAL CONTROL
8	143460-01-000	EA	BUCKET SEAT - W/LUMBAR/SKIRT/ARMRESTS (P84, P85, P28)
8	143460-02-000	EA	BUCKET SEAT - W/LUMBAR/SKIRT/ARMRESTS (P86, P87, P29)
8	143460-03-000	EA	BUCKET SEAT - W/LUMBAR/SKIRT/ARMRESTS (P88, P89, P30)
8	143461-04-000	EA	BUCKET SEAT- W/FOOTREST/LUMBAR/ARMREST-ANTIQUE PEARL VINYL- ULTRALEATHER CAB SEAT
8*	143460-04-000	EA	BUCKET SEAT - W/LUMBAR/SKIRT/ARMRESTS-ANTIQUE PEARL L THER - ULTRALEATHER CAB SEAT

CURTAIN & CUSHION GROUP (CONTINUED)
CUSHION LAYOUT (CONTINUED)

KEY	PART NUMBER	U/M	DESCRIPTION
9	143461-01-000	EA	BUCKET SEAT - W/FOOTREST/LUMBAR/ARMREST (P84, P85, P28) PASSENGER
9	143461-02-000	EA	BUCKET SEAT - W/FOOTREST/LUMBAR/ARMREST (P86, P87, P29) PASSENGER
9	143461-03-000	EA	BUCKET SEAT - W/FOOTREST/LUMBAR/ARMREST (P88, P89, P30) PASSENGER
9*	143460-04-000	EA	BUCKET SEAT - W/LUMBAR/SKIRT/ARMRESTS-ANTIQUE PEARL L THER - ULTRALEATHER CAB SEAT
9	143461-04-000	EA	BUCKET SEAT- W/FOOTREST/LUMBAR/ARMREST-ANTIQUE PEARL VINYL- ULTRALEATHER CAB SEAT
10	142958-01-P84	EA	CHAIR - RECLINER/GLIDER - W/SWIVEL BASE/FOOTREST (P84, P85, P28) - HOOP BASE LNG CHAIR
10	142958-01-P88	EA	CHAIR - RECLINER/GLIDER - W/SWIVEL BASE/FOOTREST (P88, P89, P30) - HOOP BASE LNG CHAIR
10	142958-05-P86	EA	CHAIR - RECLINER/GLIDER - W/SWIVEL BASE/FOOTREST (P86, P87, P29) - HOOP BASE LNG CHAIR
10	142958-02-P84	EA	CHAIR - RECLINER/GLIDER - W/SWIVEL BASE/FOOTREST - ULTRALEATHER RECLINER
11	145563-17-P84	EA	LOVE SEAT - 40" (P84, P85, P28)
11	145563-17-P86	EA	LOVE SEAT - 40" (P86, P87, P29)
11	145563-17-P88	EA	LOVE SEAT - 40" (P88, P89, P30)
11	145563-10-N84	EA	LOVE SEAT - 40" - BANQUETTE - ULTRALEATHER
12	132573-38-000	EA	CHAIR - DINETTE - SKY/WASHED MAPLE (P28)
12	132573-41-000	EA	CHAIR - DINETTE - FIESTA CE/WASHED MAPLE (P29)
12	132573-44-000	EA	CHAIR - DINETTE - WASHED MAPLE (P30)
12	132573-36-000	EA	CHAIR - DINETTE - SKY/PORTSMOUTH OAK (P84)
12	132573-37-000	EA	CHAIR - DINETTE - SKY/CHERRY (P85)
12	132573-39-000	EA	CHAIR - DINETTE - FIESTA CD/PORTSMOUTH OAK (P86)
12	132573-40-000	EA	CHAIR - DINETTE - FIESTA CD/CHERRY (P87)
12	132573-42-000	EA	CHAIR - DINETTE - PORTSMOUTH OAK (P88)
12	132573-43-000	EA	CHAIR - DINETTE - BELL BOTTOMS/CHERRY (P89)
12	135600-B8-000	EA	CHAIR - FOLDING - SKY/WASHED MAPLE (P28)
12	135600-E9-000	EA	CHAIR - FOLDING - FIESTA CD/MAPLE (P29)
12	135600-C1-000	EA	CHAIR - FOLDING - WASHED MAPLE (P30)
12	135600-B6-000	EA	CHAIR - FOLDING - FLANNEL/PORTSMOUTH OAK (P84)
12	135600-B7-000	EA	CHAIR - FOLDING - FLANNEL/CHERRY (P85)
12	135600-E7-000	EA	CHAIR - FOLDING - FIESTA CD/PORTSMOUTH OAK (P86)
12	135600-E8-000	EA	CHAIR - FOLDING - FIESTA CD/CHERRY (P87)
12	135600-B9-000	EA	CHAIR - FOLDING - BELL BOTTOMS/PORTSMOUTH OAK (P88)
12	135600-C0-000	EA	CHAIR - FOLDING - BELL BOTTOMS/CHERRY (P89)
	105402-03-000	EA	STRAP - DINING CHAIR/TIEDOWN - 18"
13	142723-01-P84	EA	BACK - DINETTE (P84, P85, P28)
13	142723-01-P86	EA	BACK - DINETTE (P86, P87, P29)
13	142723-01-P88	EA	BACK - DINETTE (P88, P89, P30)
	P42723-01-P84	EA	COVER/BACK - DINETTE - 13.5" X 36" (P84, P85, P28)
	P42723-01-P86	EA	COVER/BACK - DINETTE - 13.5" X 36" (P86, P87, P29)
	P42723-01-P88	EA	COVER/BACK - DINETTE - 13.5" X 36" (P88, P89, P30)
14	142292-11-P84	EA	SEAT - DINETTE CUSHION (SPRUNG) - 22" X 33.5" (P84, P85, P28)
14	142292-11-P86	EA	SEAT - DINETTE CUSHION (SPRUNG) - 22" X 33.5" (P86, P87, P29)
14	142292-11-P88	EA	SEAT - DINETTE CUSHION (SPRUNG) - 22" X 33.5" (P88, P89, P30)
	P42292-11-P84	EA	COVER/SEAT - DINETTE CUSHION - 22" X 33.5" (P84, P85, P28)
	P42292-11-P86	EA	COVER/SEAT - DINETTE CUSHION - 22" X 33.5" (P86, P87, P29)
	P42292-11-P88	EA	COVER/SEAT - DINETTE CUSHION - 22" X 33.5" (P88, P89, P30)
14	142366-04-000	EA	FRAME - SPRUNG - DINETTE SEAT
	143730-01-000	EA	DINETTE PIPE CAP W/STRAP

***COMPONENT PARTS LISTED LATER IN THIS GROUP**

CURTAIN & CUSHION GROUP (CONTINUED)

BUCKET SEATS

KEY	PART NUMBER	U/M	DESCRIPTION
	143460-01-000	EA	BUCKET SEAT - W/LUMBAR/SKIRT/ARMRESTS (P84,P85,P28)
	143460-02-000	EA	BUCKET SEAT - W/LUMBAR/SKIRT/ARMRESTS (P86,P87,P29)
	143460-03-000	EA	BUCKET SEAT - W/LUMBAR/SKIRT/ARMRESTS (P88,P89,P30)
	143461-01-000	EA	BUCKET SEAT - W/FOOTREST/LUMBAR/ARMREST (P84,P85,P28) PASSENGER
	143461-02-000	EA	BUCKET SEAT - W/FOOTREST/LUMBAR/ARMREST (P86,P87,P29) PASSENGER
	143461-03-000	EA	BUCKET SEAT - W/FOOTREST/LUMBAR/ARMREST (P88,P89,P30) PASSENGER
*	143460-04-000	EA	BUCKET SEAT - W/LUMBAR/SKIRT/ARMRESTS-ANTIQUE PEARL LTHER - ULTRALEATHER CAB SEAT
	143461-04-000	EA	BUCKET SEAT- W/FOOTREST/LUMBAR/ARMREST-ANTIQUE PEARL VINYL- ULTRALEATHER CAB SEAT

***COMPONENT PARTS LISTED LATER IN THIS GROUP**

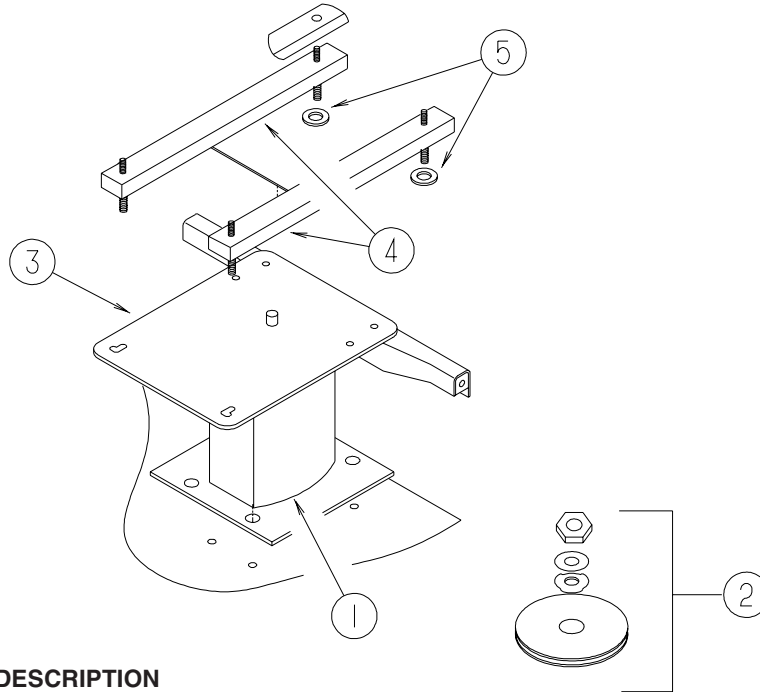

KEY	PART NUMBER	U/M	DESCRIPTION
1	133408-01-000	EA	PEDESTAL - SEAT/DRIVER - 9 3/4"
2	107921-06-000	EA	BEARING KIT - PEDESTAL
3	133408-08-000	EA	TOP PLATE - W/BAR
			FROM: 00-00-00 THRU: 02-09-03
3	133408-19-000	EA	TOP PLATE - DRIVERS - W/ANCHOR
			FROM: 02-10-03 THRU: 99-99-99
4	131566-04-000	EA	SLIDE/SEAT - HEAVY DUTY LOCKING - 5"
	119952-07-000	EA	WIRE - LATCH RELEASE/ROTARY
5	NOT USED		

KEY	PART NUMBER	U/M	DESCRIPTION
1	133408-05-000	EA	PEDESTAL - SEAT - 5.75"
2	107921-06-000	EA	BEARING KIT - PEDESTAL
3	133408-08-000	EA	TOP PLATE - W/BAR
			FROM: 00-00-00 THRU: 02-09-03
3	133408-19-000	EA	TOP PLATE - DRIVERS - W/ANCHOR
			FROM: 02-10-03 THRU: 99-99-99
4*	081373-03-000	EA	SEAT - POWER 6 WAY

***COMPONENT PARTS LISTED LATER IN THIS GROUP**

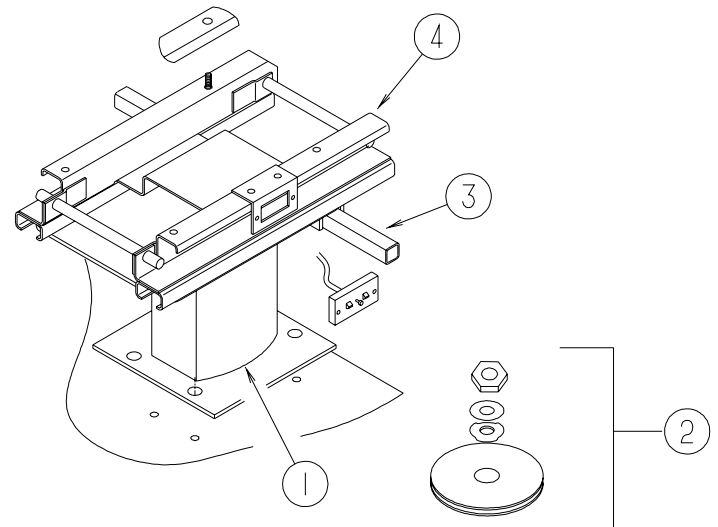

CURTAIN & CUSHION GROUP (CONTINUED)
COMPONENT PARTS FOR BUCKET SEATS

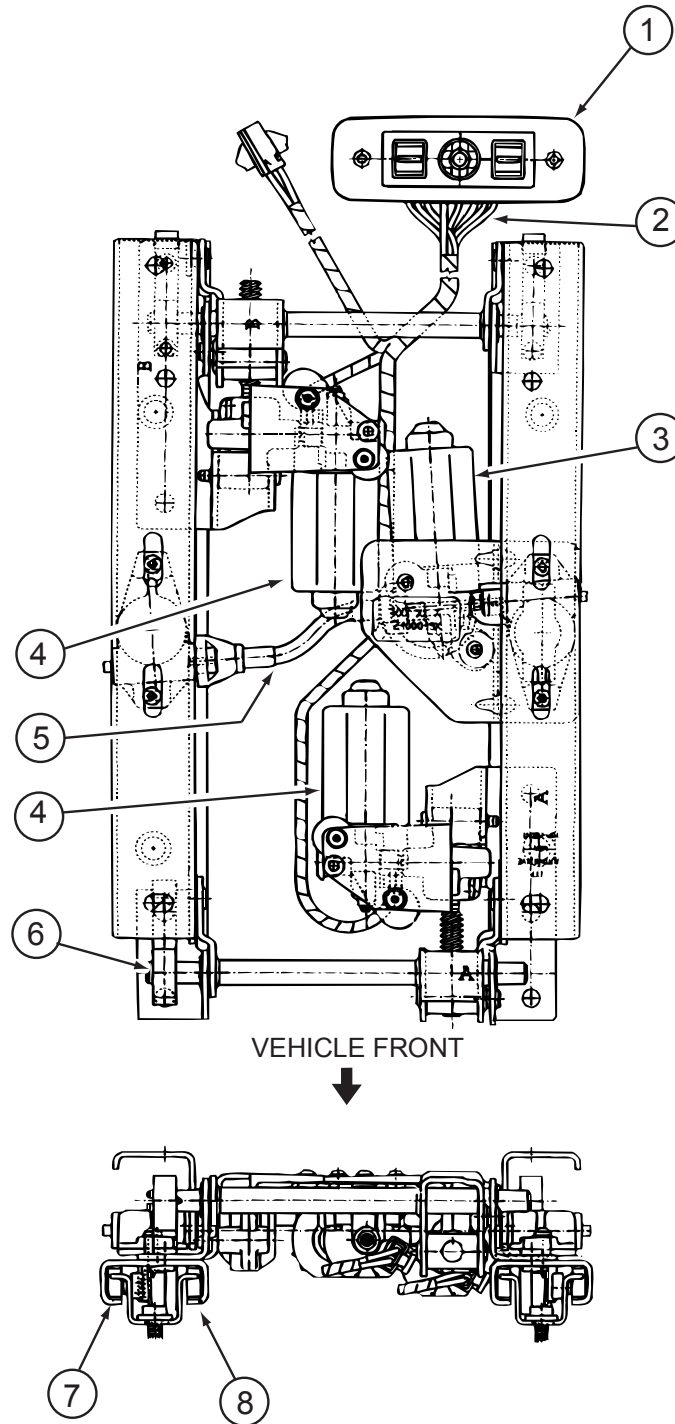

081373-03-000

KEY	PART NUMBER	U/M	DESCRIPTION	VENDOR NO.
1	081373-03-700	EA	SWITCH POWER	22543667 BLACK
2	081373-03-701	EA	WIRE HARNESS ASM., LT. SIDE	22138093
2	081373-03-702	EA	WIRE HARNESS ASM., RT. SIDE	22138094
3	081373-02-703	EA	MOTOR / HORIZONTAL	22128095
4	081373-02-704	EA	MOTOR PKG. ADJ. VERTICAL	22063238 & H-196
5	081373-03-704	EA	DRIVE CABLE	22143984
6	081373-03-705	EA	SPRING	22048978
7	081373-03-706	EA	SHOE GUIDE (WHITE)	22048993
8	081373-03-707	EA	SHOE GUIDE (BLACK)	22048994
	081373-03-700	EA	SWITCH POWER	22137945

132575-01-000

KEY	PART NUMBER	U/M	DESCRIPTION	VENDOR NO.
	132575-01-704	EA	CABLE SEAT SLIDE/SWIVEL	24022

CURTAIN & CUSHION GROUP (CONTINUED)
LOUNGE CHAIR

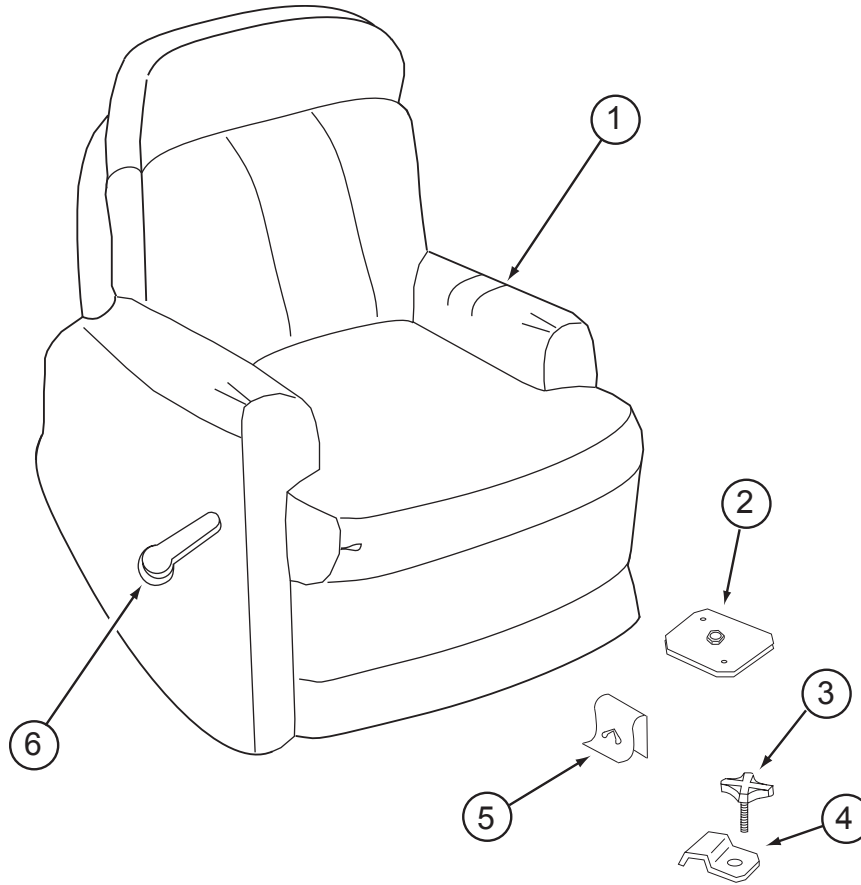

KEY	PART NUMBER	U/M	DESCRIPTION
1	142958-01-P84	EA	CHAIR - RECLINER/GLIDER - W/SWIVEL BASE/FOOTREST (P84,P85,P28) - HOOP BASE LNG CHAIR
1	142958-01-P88	EA	CHAIR - RECLINER/GLIDER - W/SWIVEL BASE/FOOTREST (P88,P89,P30) - HOOP BASE LNG CHAIR
1	142958-05-P86	EA	CHAIR - RECLINER/GLIDER - W/SWIVEL BASE/FOOTREST (P86,P87,P29) - HOOP BASE LNG CHAIR
1	142958-02-P84	EA	CHAIR - RECLINER/GLIDER - W/SWIVEL BASE/FOOTREST - ULTRALEATHER RECLINER
	P42958-01-P84	EA	COVER/CHAIR - RECLINER - W/FOOTREST (P84,P85,P28) - HOOP BASE LNG CHAIR
	P42958-01-P88	EA	COVER/CHAIR - RECLINER - W/FOOTREST (P88,P89,P30) - HOOP BASE LNG CHAIR
	P42958-05-P86	EA	COVER/CHAIR - RECLINER - W/FOOTREST (P86,P87,P29) - HOOP BASE LNG CHAIR
	P42958-02-P84	EA	COVER/CHAIR - RECLINER - W/FOOTREST - ULTRALEATHER RECLINER
2	134128-02-02B	EA	PLATE ASM-W/HOLES,E-COAT
3	134194-01-01A	EA	KNOB - HOLD DOWN - RECLINER - BLACK
4	134057-01-11B	EA	BRACKET - RECLINER - FLAT BLACK
5	029134-01-000	EA	CLIP-FINISH-K2915-UPHOLSTERY
6	133126-11-000	EA	RECLINER - (PLASTIC HANDLE)

CURTAIN & CUSHION GROUP (CONTINUED)

SOFA

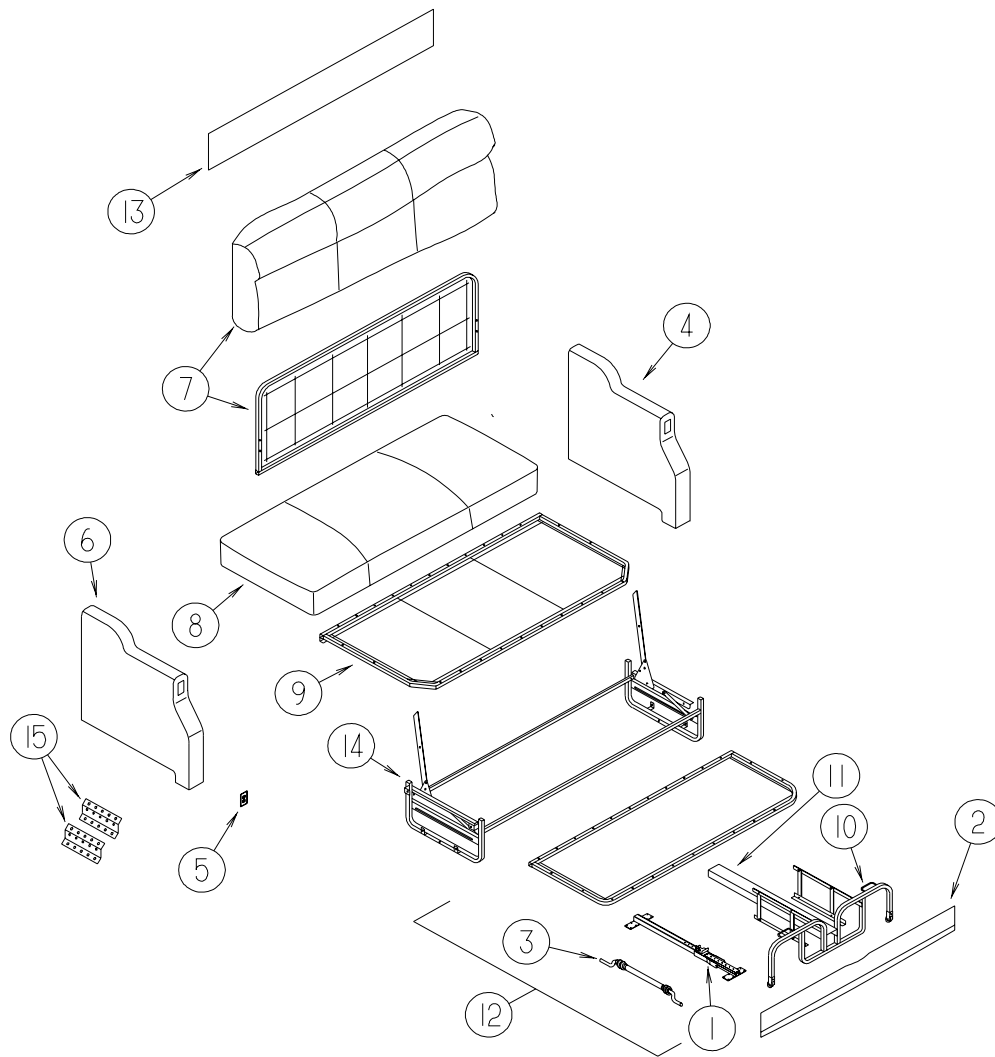

KEY	PART NUMBER	U/M DESCRIPTION
	138095-15-P84	EA SOFA/SLEEPER - RECLINER/POWERED - W/TRUNDLE BED (P84, P85, P28)
	138095-15-P86	EA SOFA/SLEEPER - RECLINER/POWERED - W/TRUNDLE BED (P86, P87 ,P29)
	138095-15-P88	EA SOFA/SLEEPER - RECLINER/POWERED - W/TRUNDLE BED (P88, P89, P30)
	138095-16-P84	EA SOFA/SLEEPER - RECLINER/POWERED - W/TRUNDLE BED - ULTRALEATHER RESTEASY
1*	136534-24-000	EA SLIDE RAIL - W/LATCH MECHANISM/PLATES/STOP F/20" RAISED
2	135824-07-P84	EA PANEL/FRONT KICK - SOFA/SLEEPER - 59.5" - FABRIC COVERED (P84, P85, P28)
2	135824-07-P86	EA PANEL/FRONT KICK - SOFA/SLEEPER - 59.5" - FABRIC COVERED (P86, P87 ,P29)
2	135824-07-P88	EA PANEL/FRONT KICK - SOFA/SLEEPER - 59.5" - FABRIC COVERED (P88, P89, P30)
2	135824-09-N84	EA PANEL/FRONT KICK - SOFA/SLEEPER - 59.5" - FABRIC COVERED - ULTRALEATHER RESTEASY
	121906-01-02B	EA BRACKET - KICKBOARD - E-COATED
3	136534-19-000	EA CABLE ONLY - REMOTE - 34" W/Z-ENDS (F/LEVER HANDLE -30-)
4	135823-08-P84	EA ARMREST - LEFT HAND (P84, P85, P28)
4	135823-08-P86	EA ARMREST - LEFT HAND (P86, P87 ,P29)
4	135823-08-P88	EA ARMREST - LEFT HAND (P88, P89, P30)
4	135823-18-N84	EA ARMREST - LEFT HAND - ULTRALEATHER RESTEASY
	P35823-08-P84	EA COVER/ARMREST - LEFT HAND (P84, P85, P28)
	P35823-08-P86	EA COVER/ARMREST - LEFT HAND (P86, P87 ,P29)
	P35823-08-P88	EA COVER/ARMREST - LEFT HAND (P88, P89, P30)
	P35823-18-N84	EA COVER/ARMREST - LEFT HAND - ULTRALEATHER RESTEASY
5	136118-01-000	EA SWITCH - SOFA/RECLINER

CURTAIN & CUSHION GROUP (CONTINUED)
SOFA (CONTINUED)

KEY	PART NUMBER	U/M	DESCRIPTION
6	135823-07-P84	EA	ARMREST - RIGHT HAND (P84, P85, P28)
6	135823-07-P86	EA	ARMREST - RIGHT HAND (P86, P87 ,P29)
6	135823-07-P88	EA	ARMREST - RIGHT HAND (P88, P89, P30)
6	135823-17-N84	EA	ARMREST - RIGHT HAND - ULTRALEATHER RESTEASY
	P35823-07-P84	EA	COVER/ARMREST - RIGHT HAND (P84, P85, P28)
	P35823-07-P86	EA	COVER/ARMREST - RIGHT HAND (P86, P87 ,P29)
	P35823-07-P88	EA	COVER/ARMREST - RIGHT HAND (P88, P89, P30)
	P35823-17-N84	EA	COVER/ARMREST - RIGHT HAND - ULTRALEATHER RESTEASY
7	138095-02-P84	EA	BACK - SOFA/SLEEPER - RECLINER/POWERED (P84, P85, P28)
7	138095-02-P86	EA	BACK - SOFA/SLEEPER - RECLINER/POWERED (P86, P87 ,P29)
7	138095-02-P88	EA	BACK - SOFA/SLEEPER - RECLINER/POWERED (P88, P89, P30)
7	138095-06-P84	EA	BACK - SOFA/SLEEPER - RECLINER/POWERED - ULTRALEATHER RESTEASY
	P38095-02-P84	EA	COVER/BACK - SOFA/SLEEPER - RECLINER/POWERED (P84, P85, P28)
	P38095-02-P86	EA	COVER/BACK - SOFA/SLEEPER - RECLINER/POWERED (P86, P87 ,P29)
	P38095-02-P88	EA	COVER/BACK - SOFA/SLEEPER - RECLINER/POWERED (P88, P89, P30)
	P38095-06-M62	EA	COVER/BACK - SOFA/SLEEPER - RECLINER/POWERED - ULTRALEATHER RESTEASY
7	136534-20-000	EA	BACK - FRAME - BEVERAGE TRAY
	136534-21-000	EA	FRAME - BEVERAGE TRAY
	136534-22-000	EA	HINGE - RIGHT
	136534-23-000	EA	HINGE - LEFT
	139758-01-01A	EA	TRAY-BEVERAGE
8	138095-03-P84	EA	SEAT - SOFA/SLEEPER - RECLINER/POWERED (P84, P85, P28)
8	138095-03-P86	EA	SEAT - SOFA/SLEEPER - RECLINER/POWERED (P86, P87 ,P29)
8	138095-03-P88	EA	SEAT - SOFA/SLEEPER - RECLINER/POWERED (P88, P89, P30)
8	138095-07-M62	EA	SEAT - SOFA/SLEEPER - RECLINER/POWERED - ULTRALEATHER RESTEASY
	P38095-03-P84	EA	COVER/SEAT - SOFA/SLEEPER - RECLINER/POWERED (P84, P85, P28)
	P38095-03-P86	EA	COVER/SEAT - SOFA/SLEEPER - RECLINER/POWERED (P86, P87 ,P29)
	P38095-03-P88	EA	COVER/SEAT - SOFA/SLEEPER - RECLINER/POWERED (P88, P89, P30)
	P38095-07-M62	EA	COVER/SEAT - SOFA/SLEEPER - RECLINER/POWERED - ULTRALEATHER RESTEASY
9	136534-04-000	EA	SEAT - 26.5" X 60" CL W/FLEXOLATOR
10	136534-17-000	EA	TRUNDLE FRAME - 17.5" X 55" - W/LINKAGE, LATCH & HANDLE
11	136534-31-000	EA	CAP - CABLE COVER
12	138095-04-P84	EA	TRUNDLE - SOFA/SLEEPER (P84, P85, P28)
12	138095-04-P86	EA	TRUNDLE - SOFA/SLEEPER (P86, P87 ,P29)
12	138095-04-P88	EA	TRUNDLE - SOFA/SLEEPER (P88, P89, P30)
12	138095-08-M62	EA	TRUNDLE - SOFA/SLEEPER - LEATHER - ULTRALEATHER RESTEASY
	P38095-04-P84	EA	COVER/TRUNDLE - SOFA/SLEEPER (P84, P85, P28)
	P38095-04-P86	EA	COVER/TRUNDLE - SOFA/SLEEPER (P86, P87 ,P29)
	P38095-04-P88	EA	COVER/TRUNDLE - SOFA/SLEEPER (P88, P89, P30)
	P38095-08-M62	EA	COVER/TRUNDLE - SOFA/SLEEPER - ULTRALEATHER RESTEASY
13	139716-04-P84	EA	SIGHT SHIELD - 58" - FULL BACK - W/BEVERAGE TRAY (P84, P85, P28)
13	139716-04-P86	EA	SIGHT SHIELD - 58" - FULL BACK - W/BEVERAGE TRAY (P86, P87 ,P29)
13	139716-04-P88	EA	SIGHT SHIELD - 58" - FULL BACK - W/BEVERAGE TRAY (P88, P89, P30)
13	139716-05-N47	EA	SIGHT SHIELD - 58" - FULL BACK - ULTRALEATHER RESTEASY
14*	136534-13-000	EA	BASE - 27.25" X 60" - POWERED CL - W/8" OVER HANG
	136534-33-000	EA	SPRING-7X1/2 W/HOOK ON ENDS
15	116104-04-02B	EA	BRACKET - ZEE W/HOLES - 3.2" - E-COATED

***COMPONENT PARTS LISTED LATER IN THIS GROUP**

CURTAIN & CUSHION GROUP (CONTINUED)
SOFA (CONTINUED)

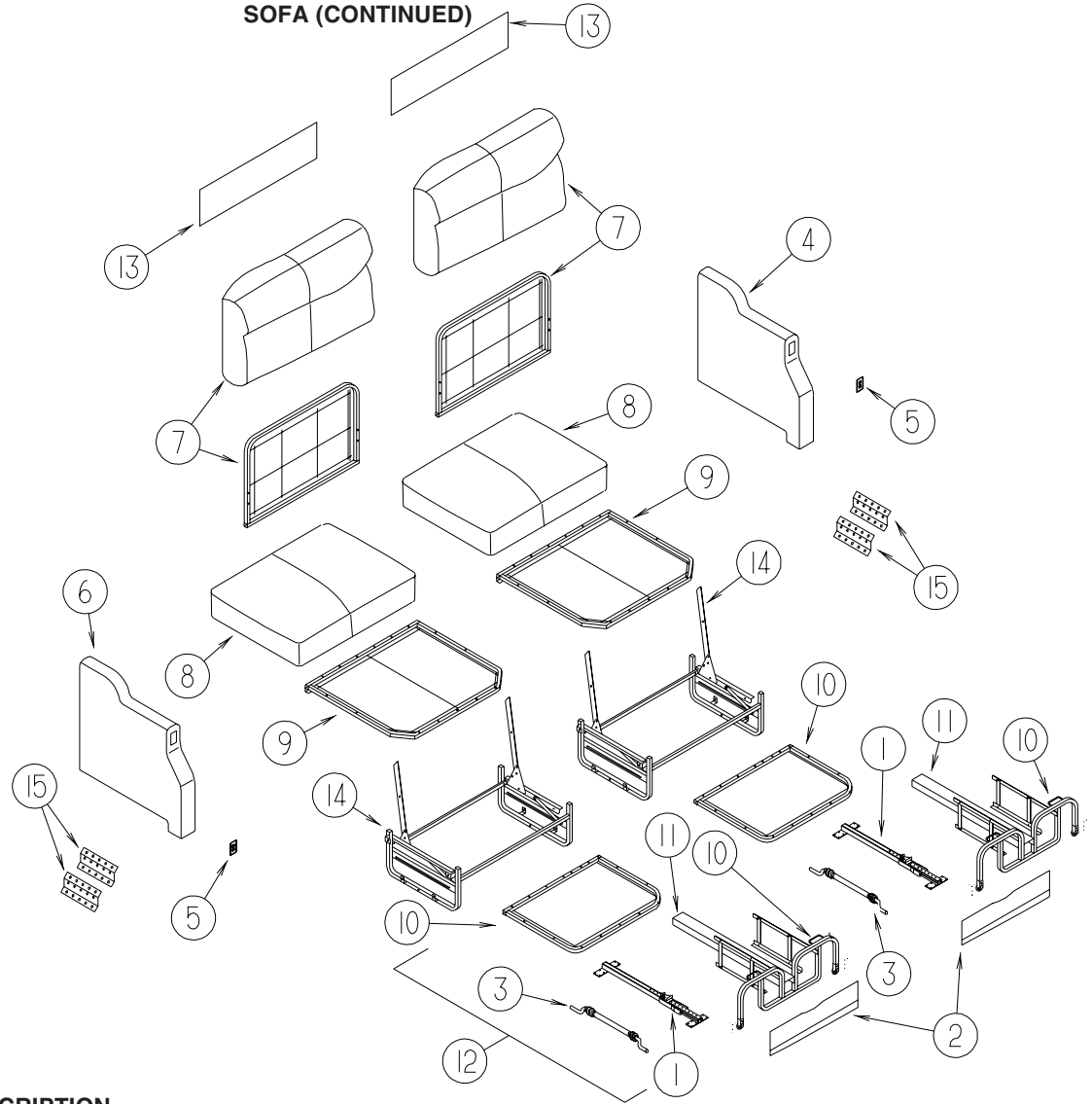

KEY	PART NUMBER	U/M	DESCRIPTION
	139202-05-N84	EA	SOFA/DUAL SLEEPER/TRUNDLE - ULTRALEATHER RESTEASY DUAL CONTROL
1*	136534-24-000	EA	SLIDE RAIL - W/LATCH MECHANISM/PLATES/STOP F/20" RAISED
2	135824-11-N84	EA	PANEL/FRONT KICK - SOFA/SLEEPER - 7.4" X 30.2" - ULTRALEATHER RESTEASY DUAL CONTROL
	121906-01-02B	EA	BRACKET - KICKBOARD - E-COATED
3	136534-19-000	EA	CABLE ONLY - REMOTE - 34" W/Z-ENDS (F/LEVER HANDLE -30-) - DUAL CONTROL
4	135823-19-N84	EA	ARMREST - LEFT HAND - ULTRALEATHER RESTEASY DUAL CONTROL
	P35823-19-N84	EA	COVER/ARMREST - LEFT HAND - ULTRALEATHER RESTEASY DUAL CONTROL
5	136118-01-000	EA	SWITCH - SOFA/RECLINER
6	135823-20-N84	EA	ARMREST - RIGHT HAND - ULTRALEATHER RESTEASY DUAL CONTROL
	P35823-20-N84	EA	COVER/ARMREST - RIGHT HAND - ULTRALEATHER RESTEASY DUAL CONTROL
7	139202-02-N84	EA	BACK - SOFA/DUAL SLEEPER - RECLINER/POWERED - ULTRALEATHER RESTEASY DUAL CONTROL
	P39202-02-N84	EA	COVER/BACK - DUAL SLEEPER - RECLINER - ULTRALEATHER RESTEASY DUAL CONTROL
7	136534-25-000	EA	FRAME/BACK - FOR DUAL REST EASY SOFA - ONE SIDE ONLY - DUAL CONTROL LEATHER
8	139202-03-N84	EA	SEAT - SOFA/DUAL SLEEPER - RECLINER/POWERED - ULTRALEATHER RESTEASY DUAL CONTROL
	P39202-03-N84	EA	COVER/SEAT - DUAL SLEEPER - RECLINER/POWERED- ULTRALEATHER RESTEASY DUAL CONTROL
9	136534-26-000	EA	FRAME/SEAT - FOR DUAL REST EASY SOFA - ONE SIDE ONLY - DUAL CONTROL LEATHER
10	136534-27-000	EA	FRAME - TRUNDEL BED - DUAL
11	136534-31-000	EA	CAP - CABLE COVER
12	139202-04-N84	EA	TRUNDLE - SOFA/DUAL SLEEPER - ULTRALEATHER RESTEASY DUAL CONTROL
	P39202-04-N84	EA	COVER/TRUNDEL - SOFA/DUAL SLEEPER - ULTRALEATHER RESTEASY DUAL CONTROL
13	139716-03-N84	EA	SIGHT SHIELD - 28" - DUAL BACK - ULTRALEATHER RESTEASY DUAL CONTROL
13	139716-06-N84	EA	SIGHT SHIELD - 28" - DUAL BACK - ULTRALEATHER RESTEASY DUAL CONTROL
14*	136534-28-000	EA	BASE - RAISED - DUAL - ULTRALEATHER RESTEASY DUAL CONTROL
	136534-32-000	EA	BRACKET - DUAL BASE
	136534-33-000	EA	SPRING-7X1/2 W/HOOK ON ENDS
15	116104-04-02B	EA	BRACKET - ZEE W/HOLES - 3.2" - E-COATED

*COMPONENT PARTS LISTED LATER IN THIS GROUP

CURTAIN & CUSHION GROUP (CONTINUED)
SOFA (CONTINUED)

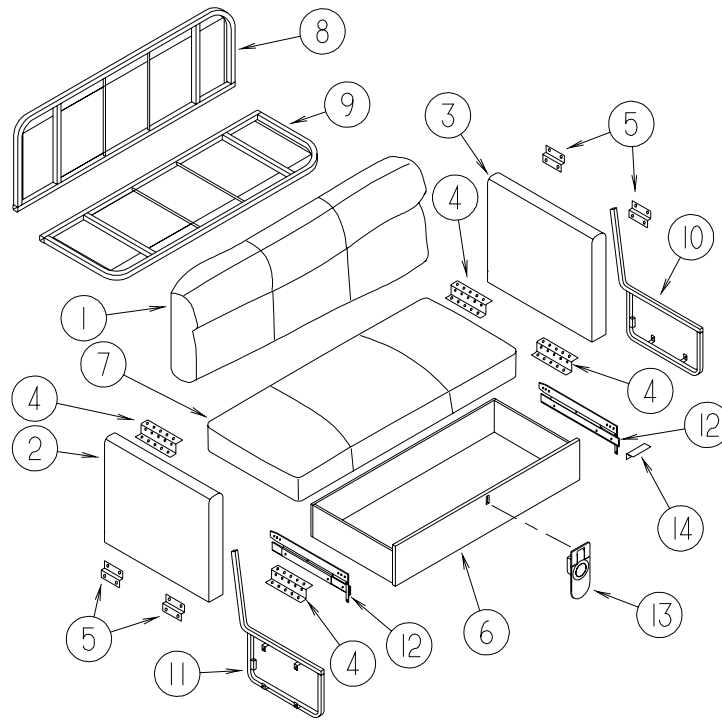

KEY	PART NUMBER	U/M	DESCRIPTION
	145563-17-P84	EA	LOVE SEAT - 40" (P84, P85, P28)
	145563-17-P86	EA	LOVE SEAT - 40" (P86, P87 ,P29)
	145563-17-P88	EA	LOVE SEAT - 40" (P88, P89, P30)
	145563-10-N84	EA	LOVE SEAT - 40" - BANQUETTE - ULTRALEATHER
1	139819-11-P84	EA	BACK - LOVE SEAT - 40" (P84, P85, P28)
1	139819-11-P86	EA	BACK - LOVE SEAT - 40" (P86, P87 ,P29)
1	139819-11-P88	EA	BACK - LOVE SEAT - 40" (P88, P89, P30)
1	139819-18-N84	EA	BACK - LOVE SEAT - 40" - ULTRA - BANQUETTE - ULTRALEATHER
	P39819-11-P84	EA	COVER/BACK - LOVE SEAT - 40" (P84, P85, P28)
	P39819-11-P86	EA	COVER/BACK - LOVE SEAT - 40" (P86, P87 ,P29)
	P39819-11-P88	EA	COVER/BACK - LOVE SEAT - 40" (P88, P89, P30)
	P39819-18-N84	EA	COVER/BACK - LOVE SEAT - 40" - BANQUETTE - ULTRALEATHER
2	138998-09-P84	EA	ARMREST - RIGHT HAND (P84, P85, P28)
2	138998-09-P86	EA	ARMREST - RIGHT HAND (P86, P87 ,P29)
2	138998-09-P88	EA	ARMREST - RIGHT HAND (P88, P89, P30)
2	138998-11-N84	EA	ARMREST - RIGHT HAND - BANQUETTE - ULTRALEATHER
3	138998-10-P84	EA	ARMREST - LEFT HAND (P84, P85, P28)
3	138998-10-P86	EA	ARMREST - LEFT HAND (P86, P87 ,P29)
3	138998-10-P88	EA	ARMREST - LEFT HAND (P88, P89, P30)
3	138998-12-N84	EA	ARMREST - LEFT HAND - BANQUETTE - ULTRALEATHER
4	101926-01-02A	EA	BRACKET - ZEE - 2" - BLACK - MOUNTS SOFA TO FLOOR
5	116104-04-02B	EA	BRACKET - ZEE W/HOLES - E-COATED - MOUNTS ARM TO FLOOR
6	134307-07-P84	EA	DRAWER - 40" - FABRIC COVERED (P84, P85, P28)
6	134307-07-P86	EA	DRAWER - 40" - FABRIC COVERED (P86, P87 ,P29)
6	134307-07-P88	EA	DRAWER - 40" - FABRIC COVERED (P88, P89, P30)
6	134307-09-N84	EA	DRAWER - 40" - FABRIC COVERED - BANQUETTE - ULTRALEATHER
7	139819-10-P84	EA	SEAT - LOVE SEAT - 40" (P84, P85, P28)
7	139819-10-P86	EA	SEAT - LOVE SEAT - 40" (P86, P87 ,P29)
7	139819-10-P88	EA	SEAT - LOVE SEAT - 40" (P88, P89, P30)
7	139819-17-N84	EA	SEAT - LOVE SEAT - 40" - ULTRA - BANQUETTE - ULTRALEATHER
	P39819-10-P84	EA	COVER/SEAT - LOVE SEAT - 40" (P84, P85, P28)
	P39819-10-P86	EA	COVER/SEAT - LOVE SEAT - 40" (P86, P87 ,P29)
	P39819-10-P88	EA	COVER/SEAT - LOVE SEAT - 40" (P88, P89, P30)
	P39819-17-N84	EA	COVER/SEAT - LOVE SEAT - 40" - BANQUETTE - ULTRALEATHER

CURTAIN & CUSHION GROUP (CONTINUED)
SOFA (CONTINUED)

KEY	PART NUMBER	U/M	DESCRIPTION
8	134306-08-000	EA	FRAME ASM-BACK,676,40"
9	134306-07-000	EA	FRAME ASM-SEAT,676,40"
10	134306-04-000	EA	LEG - LEFT W/DRAWER TRACK - 48"
11	134306-03-000	EA	LEG - RIGHT W/DRAWER TRACK - 48"
12	134576-01-000	EA	SLIDE/RAIL KIT - HEAVY DUTY (PAIR) - 22"
13	134511-01-000	EA	LATCH - BANQUETTE
14	128298-01-12B	EA	CATCH - F/LOCK - COMPARTMENT DOORS
	124656-96-000	EA	LOCK - CANADIAN

CURTAIN & CUSHION GROUP (CONTINUED)
COMPONENT PARTS FOR SOFA

136534-13-000, 136534-28-000

KEY	PART NUMBER	U/M	DESCRIPTION	VENDOR NO.
	136534-02-700	EA	MOTOR	9PL-MO-W/T-1
	136534-02-701	EA	CABLE/DRV MTR-REST EASY SOFA	9PL-FCA27.75

136534-24-000

KEY	PART NUMBER	U/M	DESCRIPTION	VENDOR NO.
	136534-14-700	EA	SLIDE MECHANISM - W/LATCH - W/O NYLON GUIDES/SCREWS	PTN-SLD-BUSH
	136534-14-701	EA	BUSHING/GUIDE - BLACK NYLON - F/SLIDE MECHANISM	9TN-SLD-GR-0

CURTAIN & CUSHION GROUP (CONTINUED)
WINDOW TREATMENT

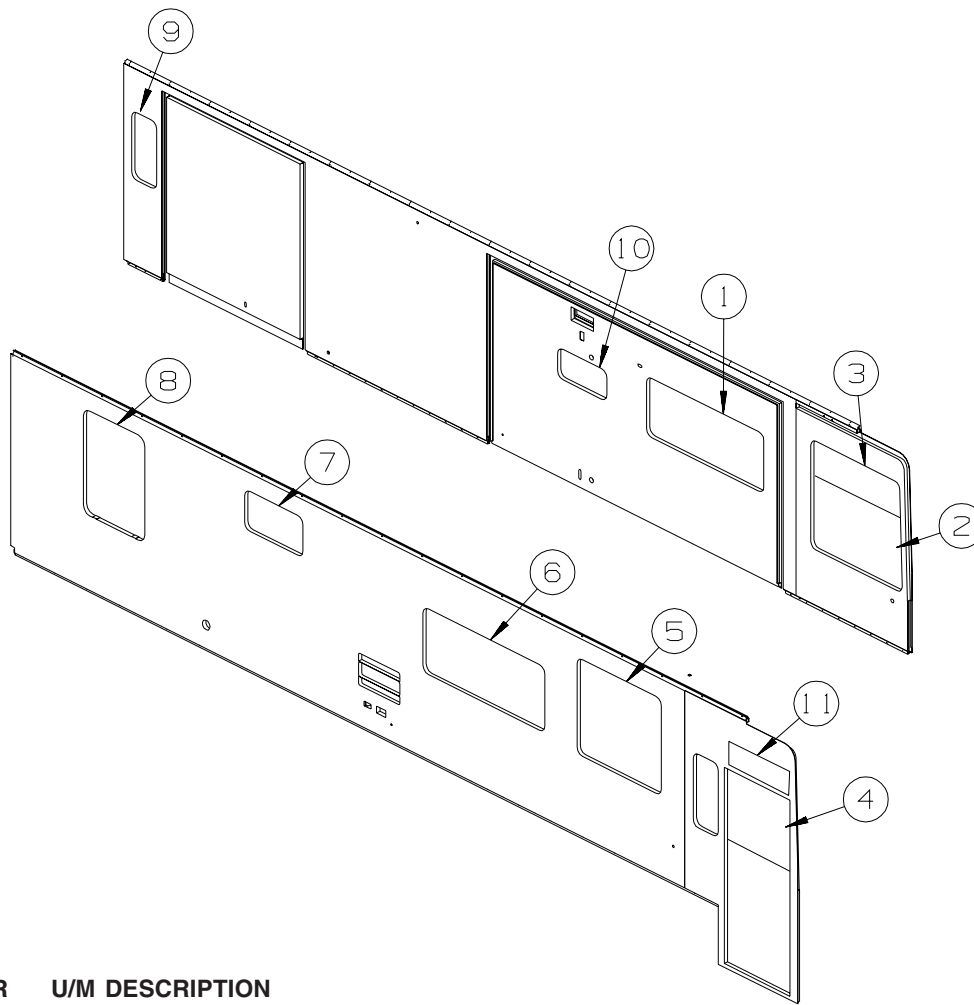

KEY	PART NUMBER	U/M	DESCRIPTION
1	136054-01-P84	EA	LAMBREQUIN - WHITTINGTON - 61" (P84, P85, P28)
1	136054-01-P86	EA	LAMBREQUIN - WHITTINGTON - 61" (P86, P87 ,P29)
1	136054-01-P88	EA	LAMBREQUIN - WHITTINGTON - 61" (P88, P89, P30)
1	140789-08-N44	EA	BLIND - DAY/NIGHTER - 59" X 26.5" (P84, P85, P86, P28, P29)
1	140789-08-N09	EA	BLIND - DAY/NIGHTER - 59" X 26.5" (P88, P89, P30)
2	139479-01-01A	EA	CURTAIN - WRAPAROUND/PRIVACY/PLEATED - 45" X 112" - DRIVER
3	126841-03-000	EA	SHADE - PULL - CHARCOAL MESH - 40.3" X 60"
4	139479-02-01A	EA	CURTAIN - WRAPAROUND/PRIVACY/PLEATED - 42" X 75"- PASS/FRT
4	139479-03-01A	EA	CURTAIN - WRAPAROUND/PRIVACY/PLEATED - 45" X 75"-PASS/REAR
5	136054-17-P84	EA	LAMBREQUIN - WHITTINGTON - 44.5" (P84, P85, P28)
5	136054-17-P86	EA	LAMBREQUIN - WHITTINGTON - 44.5" (P86, P87 ,P29)
5	136054-17-P88	EA	LAMBREQUIN - WHITTINGTON - 44.5" (P88, P89, P30)
5	140789-16-N76	EA	BLIND - DAY/NIGHTER - 42.5" X 41" (P84, P85, P86, P28, P29)
5	140789-16-N74	EA	BLIND - DAY/NIGHTER - 42.5" X 41" (P88, P89, P30)
6	136054-05-P84	EA	LAMBREQUIN - WHITTINGTON - 63" (P84, P85, P28)
6	136054-05-P86	EA	LAMBREQUIN - WHITTINGTON - 63" (P86, P87 ,P29)
6	136054-05-P88	EA	LAMBREQUIN - WHITTINGTON - 63" (P88, P89, P30)
6	140789-14-N72	EA	BLIND - DAY/NIGHTER - 61" X 28.5" (P84, P85, P86, P28, P29)
6	140789-14-N09	EA	BLIND - DAY/NIGHTER - 61" X 28.5" (P88, P89, P30)
7	121410-A2-P84	EA	VALANCE - MODERATE - 32" (P84, P85, P28)
7	121410-A2-P86	EA	VALANCE - MODERATE - 32" (P86, P87 ,P29)
7	121410-A2-P88	EA	VALANCE - MODERATE - 32" (P88, P89, P30)
7	111861-12-02A	EA	BLIND - MINI - 30.5" X 17.5" - WHITE (P84, P85, P86, P28, P29)
7	111861-12-03A	EA	BLIND - MINI - 30.5" X 17.5" - BEIGE (P88, P89, P30)
8	136058-11-P84	EA	LAMBREQUIN - VINEYARD - 35" (P84, P85, P28)
8	136058-18-P86	EA	VALANCE - VINEYARD - 35.5" (P86, P87 ,P29)
8	136058-18-P88	EA	VALANCE - VINEYARD - 35.5" (P88, P89, P30)
8	140789-12-N72	EA	BLIND - DAY/NIGHTER - 32" X 46" (P84, P85, P86, P28, P29)
8	140789-12-N70	EA	BLIND - DAY/NIGHTER - 32" X 46" (P88, P89, P30)

CURTAIN & CUSHION GROUP (CONTINUED)
WINDOW TREATMENT (CONTINUED)

KEY	PART NUMBER	U/M	DESCRIPTION
9	142437-04-P84	EA	VALANCE - ASHWELL - 14.5" (P84, P85, P28)
9	142437-07-P86	EA	VALANCE - ASHWELL - 14.5" (P86, P87 ,P29)
9	142437-07-P88	EA	VALANCE - ASHWELL - 14.5" (P88, P89, P30)
9	140789-10-N54	EA	BLIND - DAY/NIGHTER - 13.5" X 28.5" (P84, P85, P86, P28, P29)
9	140789-10-N66	EA	BLIND - DAY/NIGHTER - 13.5" X 28.5" (P88, P89, P30)
9	136988-61-P84	EA	LEG - RIGHT - 42" (P84, P85, P28)
9	136988-62-P84	EA	LEG - LEFT - 42" (P84, P85, P28)
9	136988-67-P86	EA	LEG - RIGHT - 42" (P86, P87 ,P29)
9	136988-68-P86	EA	LEG - LEFT - 42" (P86, P87 ,P29)
9	136988-67-P88	EA	LEG - RIGHT - 42" (P88, P89, P30)
9	136988-68-P88	EA	LEG - LEFT - 42" (P88, P89, P30)
10	111861-18-03A	EA	BLIND - MINI - 26" X 13.5" (P84, P85, P86, P28, P29)
10	111861-18-02A	EA	BLIND - MINI - 26" X 13.5" (P88, P89, P30)
11	126841-04-000	EA	SHADE - PULL - CHARCOAL MESH - 30.3" X 60"

CURTAIN & CUSHION GROUP (CONTINUED)

HARDWARE

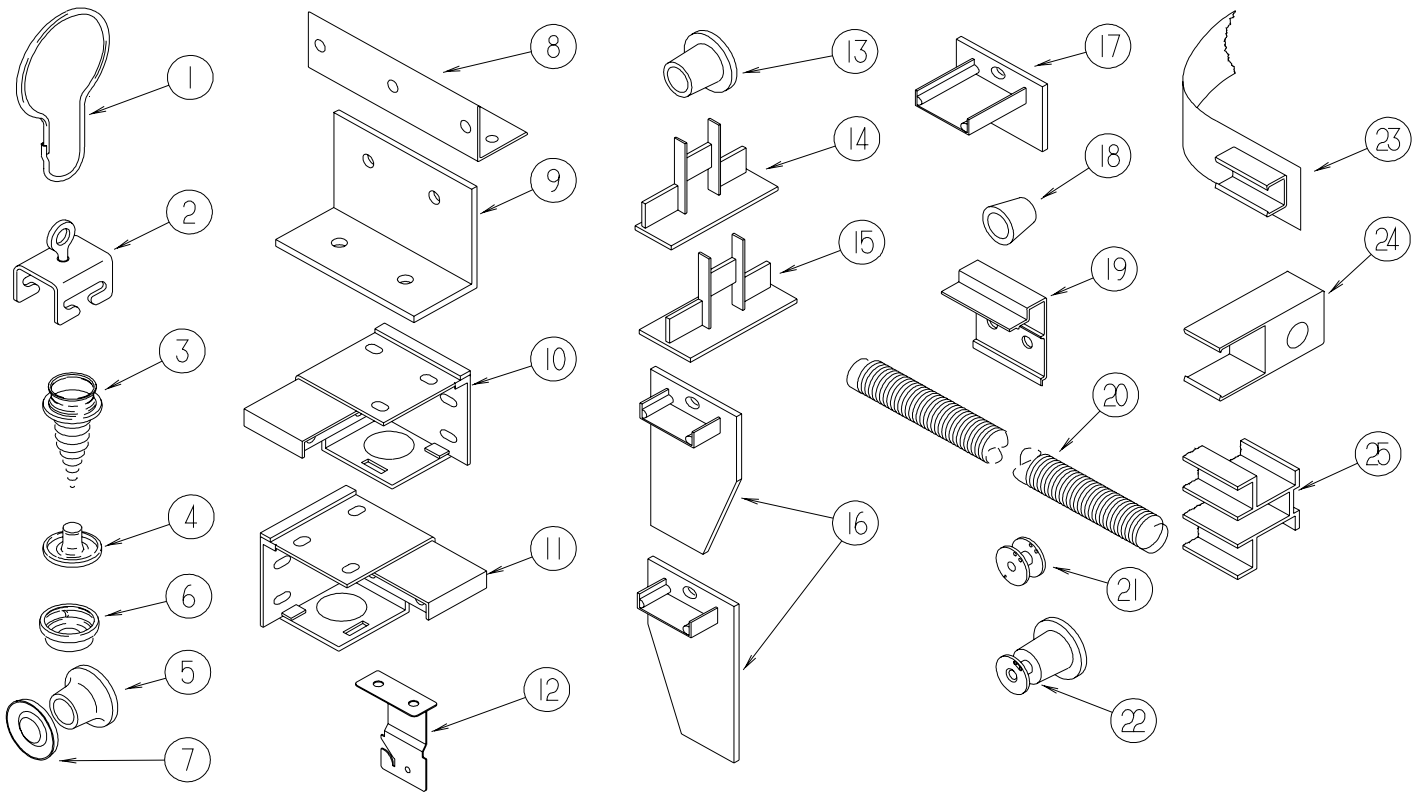

KEY	PART NUMBER	U/M	DESCRIPTION
1	009136-02-000	EA	HANGER - RING - PIN TYPE - CURTAIN - BRASS
2	009702-01-000	EA	END STOP - CURTAIN CARRIER - L - ROD
3	029130-01-000	EA	SCREW - SNAP STUD - #8-16 X 3/8" LONG
3	029130-03-000	EA	SCREW - SNAP STUD - #8-16 X 1" LONG
4	029155-01-000	EA	CAP - SNAP - 5/32" OUTSIDE DIAMETER OF PIN
5	029156-01-000	EA	SOCKET - SNAP - 9/16" O.D.
6	046867-02-000	EA	WASHER - HANDY BUTTON #3
7	046867-03-000	EA	GROMMET - HANDY BUTTON #3
8	075943-10-000	EA	BRACE - VALANCE - 20" - OFF WHITE
9	083125-07-000	EA	BRACE - ANGLE/COUCH - 2.5" - OFF WHITE
9	083125-08-000	EA	BRACE - WINDOW MOUNT - .75" - OFF WHITE
10	083170-01-000	EA	BRACKET/BLIND - LEFT SIDE WHEN FACING WINDOW - CLEAR
11	083170-02-000	EA	BRACKET/BLIND - RIGHT SIDE WHEN FACING WINDOW - CLEAR
12	084434-01-000	EA	BRACKET - MOUNTING - ROLLER SHADE - 1 3/8"
13	094896-02-000	EA	GROMMET - CORD/PLEATED BLIND - NYLON - GRAY
14	094907-02-000	EA	END CAP - PLEATED BLIND/TOP - RH/LH - GRAY PLASTIC
15	094907-04-000	EA	END CAP - PLEATED BLIND/BOTTOM - RH/LH
16	094907-05-000	EA	END CAP - PLEATED BLIND/BOTTOM - PULL TYPE - PLASTIC
17	094907-06-000	EA	END CAP - PLEATED BLIND/TOP
18	097564-99-000	EA	HANDLE - KNOB - E-Z LIFT SHADE - COLORLESS
19	097565-01-000	EA	BRACKET - MOUNTING - PLEATED BLIND
20	097591-01-000	EA	SPRING - EXTENSION - PLEATED BLIND
21	097592-01-000	EA	SPOOL - CORD - ELEVATED BLIND HOLDUP - SMALL - CLEAR
22	097592-02-000	EA	SPOOL - CORD - ELEVATED BLIND HOLDUP - LARGE - CLEAR
	097593-02-000	FT	CORD - BLIND - PLEATED - GRAY
	097593-06-000	FT	CORD - BLIND - PLEATED - PEWTER
	097593-10-000	FT	CORD - BLIND - PLEATED - VANILLA
23	101031-01-000	YD	TAPE/GLIDE - 4.25" SPACING
24	101033-02-000	EA	END CAP - LOW PROFILE TRACK - CLEAR
25	101033-08-000	EA	TRACK/WALL - 75" - FRT BUNK WINDOW 300 SERIES (MINNIE/SPIRIT)
25	101033-09-000	EA	TRACK/WALL - 32" - SIDE BUNK WINDOW 200 SERIES/300 SERIES (VISTA/SUNSTAR /MINNIE/SPIRIT)

CURTAIN & CUSHION GROUP (CONTINUED)
HARDWARE (CONTINUED)

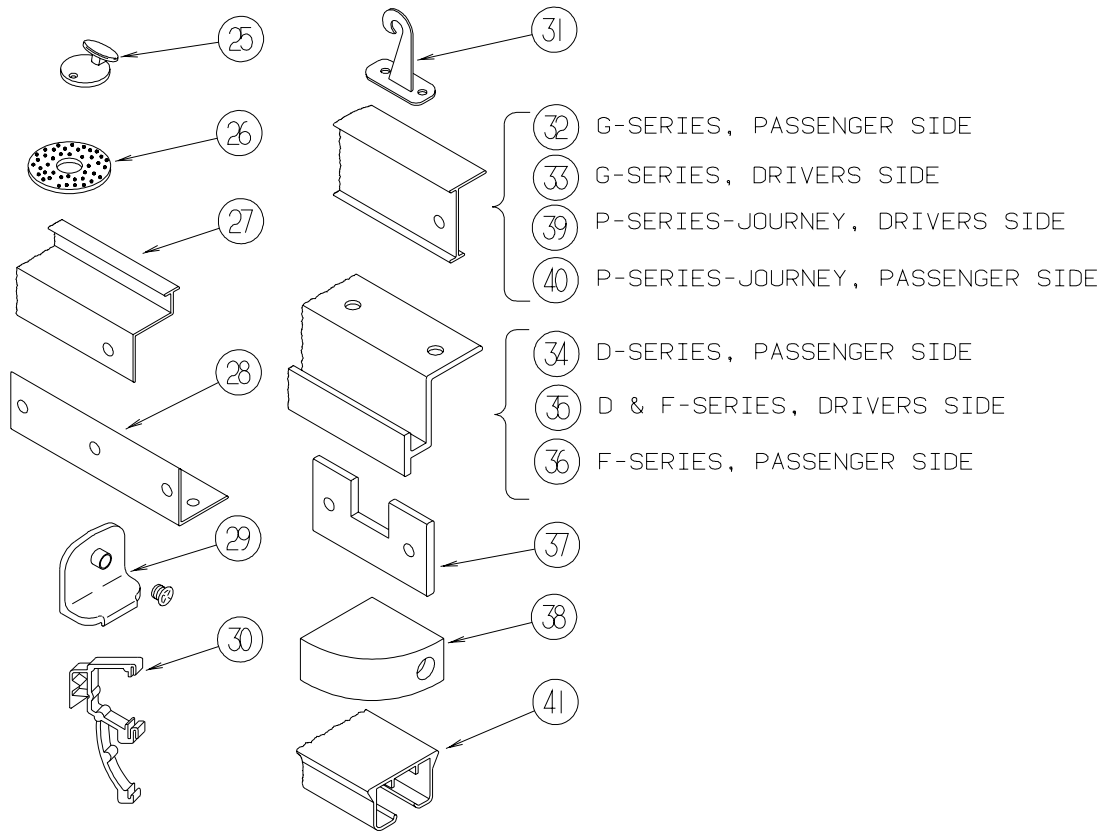

KEY	PART NUMBER	U/M	DESCRIPTION
25	102555-03-000	EA	CLEAT - BLIND CORD - MILKY WHITE - PLASTIC
26	103242-01-000	EA	VELCRO HOOK - BEIGE 7/8" ROUND W/CENTER HOLE
26	103242-02-000	EA	VELCRO HOOK - BLACK 7/8" ROUND W/CENTER HOLE
27	105450-14-01A	EA	TRACK - CURTAIN - 90" - OFF WHITE - FRONT BUNK PRIVACY 300 SERIES (MINNIE/SPIRITE)
27	105450-15-01A	EA	TRACK - CURTAIN - 82.3" - OFF WHITE - FRONT BUNK PRIVACY 200 SERIES (VISTA/SUNSTAR)
28	105648-01-02A	EA	BRACE - VALANCE - OFF/WHITE - 14"
29	106544-01-000	EA	PULL - SHADE/BRASS
	106544-01-001	EA	SCREW - SHADE/BRASS
30	109353-04-000	EA	CLIP - VALANCE SLAT MOUNTING - CLEAR PLASTIC
	109441-02-000	EA	SPACER/BACKET - BLIND HOLD DOWN
31	109441-03-000	EA	BRACKET/HOOK - BLIND HOLD DOWN - CLOUDY
32	126456-03-04A	EA	TRACK/WRAPAROUND - PASSENGER - GLACIER - G SERIES (ADVENTURER/SUNCRUISER)
33	126456-04-04A	EA	TRACK/WRAPAROUND - DRIVER - GLACIER - G SERIES (ADVENTURER/SUNCRUISER)
34	127254-03-05A	EA	TRACK/WRAPAROUND - PASSENGER - GLACIER - D SERIES (SIGHTSEER/SUNOVA)
35	127254-04-05A	EA	TRACK/WRAP - DRIVER - GLACIER - D SERIES/F SERIES (SIGHTSEER/SUNOVA/BRAVE/SUNRISE)
36	127254-14-03A	EA	TRACK/WRAPAROUND - PASSENGER - GLACIER - F SERIES (BRAVE/SUNRISE)
37	130549-01-01A	EA	STOP - CURTAIN TRACK
38	132504-01-N92	EA	BRACKET - SHADE
39	133235-01-04A	EA	TRACK - CURTAIN/LEFT HAND - GLACIER - P SERIES (JOURNEY)
40	133236-01-04A	EA	TRACK - CURTAIN/RIGHT HAND - GLACIER - P SERIES (JOURNEY)
41	138460-01-02A	EA	TRACK/CURTAIN - PASSENGER - WHITE - Q SERIES (ULTIMATE ADVANTAGE/ULTIMATE FREEDOM)
	138460-02-02A	EA	TRACK/CURTAIN - DRIVER - WHITE - Q SERIES (ULTIMATE ADVANTAGE/ULTIMATE FREEDOM)
41	138460-03-02A	EA	TRACK/CURTAIN - PASSENGER - WHITE - P SERIES (JOURNEY DL/HORIZON)
	138460-04-02A	EA	TRACK/CURTAIN - DRIVER - WHITE - P SERIES (JOURNEY DL/HORIZON)
41	138460-05-02A	EA	TRACK/CURTAIN - PASSENGER - WHITE - L SERIES (CHIEFTAIN/SUNFLYER)
	138460-06-02A	EA	TRACK/CURTAIN - DRIVER - WHITE - L SERIES (CHIEFTAIN/SUNFLYER)
	141634-01-000	EA	BOBBIN-PLEATED,ADJUSTABLE

FROM: 06-17-02 THRU: 99-99-99

CURTAIN & CUSHION GROUP (CONTINUED) ACCESSORIES

KEY	PART NUMBER	U/M	DESCRIPTION
	056271-01-000	EA	SEAT BELT - 2" X 102" - BLACK
	129491-01-000	EA	CATCH - SNAP HOOK - 1"
	057534-03-000	EA	TIEBACK - CLEAR PLASTIC - 7.5"
	057534-08-000	EA	TIEBACK - CLEAR PLASTIC - 16"
	099717-13-000	EA	TIEDOWN - STRAP W/BUCKLE

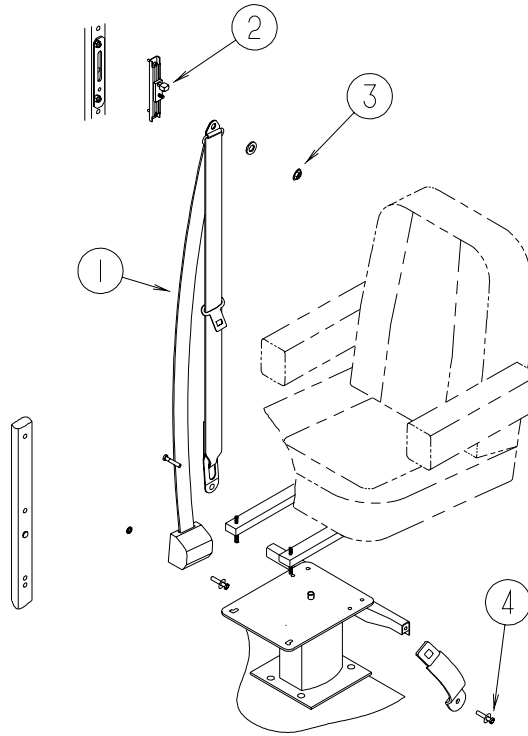

KEY	PART NUMBER	U/M	DESCRIPTION
1*	091990-08-01A	EA	SEAT BELT - 3 POINT - .766" DIAMETER HOLE IN D-LOOP BRKT
2	127598-01-01A	EA	ADJUSTER - SEATBELT - D-LOOP
3	127598-02-000	EA	NUT - HEX FLANGE - M10 X 1.5 - CLASS 10
4	095076-02-000	EA	WASHER - FL - 7/16"ID X 2"OD X .06

*COMPONENT PARTS LISTED LATER IN THIS GROUP

CURTAIN & CUSHION GROUP (CONTINUED)
COMPONENT PARTS FOR ACCESSORIES

091990-08-01A

KEY	PART NUMBER	U/M	DESCRIPTION	VENDOR NO.
	091990-01-701	EA	EXTENDER 9" FOR A8408 3 PT	I-1331-02
	091990-01-703	EA	RECEIVER/FEMALE END-SEATBELT	I-1159-02
	091990-05-700	EA	SLEEVE/BUCKLE COVER-PLASTIC	209S-2
	091990-05-701	EA	CAP/COVER - BOLT HOLE COVER	209SC-02
	091990-05-702	EA	SLEEVE/RETRACTABLE COVER	309C-02

CURTAIN & CUSHION GROUP (CONTINUED)
FABRICS

FAMILY	P84/P85/P28	P86/P87/P29	P88/P89/P30
HORIZON'S	PROVENCE BLUE	HARVEST TAPESTRY	CARRARA CREAM
BUCKET	FLEXSTEEL 407 W/ADJ. ARMS & LUMBAR 126883-P3-000	FLEXSTEEL 407 W/ADJ. ARMS & LUMBAR 126883-M8-000	FLEXSTEEL 407 W/ADJ. ARMS & LUMBAR 126883-D9-000
	*OPT.ULTRA 079680-36/ANT.PEARL	*OPT.ULTRA 079680-36/ANT.PEARL	*OPT.ULTRA 079680-36/ANT.PEARL
DINETTE	2 PILLOW BACK SPRUNG DIN. 126883-P2-000	2 PILLOW BACK SPRUNG DIN. 126883-J5-000	2 PILLOW BACK SPRUNG DIN. 126883-P0-000
DIN.WRAPW/TOE KICK	126883-P3-000/139056-09-000	126883-J5-000/139056-12-000	126883-P1-000/139056-10-000
DINETTE CHAIRS	FLEXSTEEL C1037 CHAIRS	FLEXSTEEL C1037 CHAIRS	FLEXSTEEL C1037 CHAIRS
REM FOLDING & COMPUTER CHAIRS	REM FC200 FOLDING 126883-P3-000	REM FC200 FOLDING 126883-M8-000	REM FC200 FOLDING 126883-P1-000
SOFA	805 4WAY/685 COMFORT LG. 126883-P2-000	805 4WAY/685 COMFORT LG. 126883-J5-000	805 4WAY/685 COMFORT LG. 126883-P0-000
	*OPT.ULTRA 079680-36/ANT.PEARL	*OPT.ULTRA 079680-36/ANT.PEARL	*OPT.ULTRA 079680-36/ANT.PEARL
BANQUETTE	676 BANQ.W/805 BANQ.ARMS 126883-P2-000	676 BANQ.W/805 BANQ.ARMS 126883-J5-000	676 BANQ.W/805 BANQ.ARMS 126883-P0-000
	*OPT.ULTRA 079680-36/ANT.PEARL	*OPT.ULTRA 079680-36/ANT.PEARL	*OPT.ULTRA 079680-36/ANT.PEARL
LOUNGE CHAIR	470 HOOP W/FOOTREST 126883-P3-000	470 HOOP W/FOOTREST 126883-M8-000	470 HOOP W/FOOTREST 126883-P1-000
	*OPT.ULTRA 079680-36/ANT.PEARL	*OPT.ULTRA 079680-36/ANT.PEARL	*OPT.ULTRA 079680-36/ANT.PEARL
LOUNGE WINDOWS	WHITTINGTON LAMBRQUIN 126883-P3-/126883-P2/139041-24	WHITTINGTON LAMBRQUIN 126883-J6-/126883-J5/139041-05	WHITTINGTON LAMBRQUIN 126883-P1-/126883-P0/139041-22
	UNDERLAY/OVERLAY/BRAID	UNDERLAY/OVERLAY/BRAID	UNDERLAY/OVERLAY/BRAID
GALLEY VALANCE	MODERATE 126883-P2-000	MODERATE 126883-J5-000	MODERATE 126883-P0-000
LOUNGE PILLOWS 2 PER SOFA/BANQ.	18" W/FRINGE & OVLY. BODY& WELT 126883-P3-000	18" W/FRINGE & OVLY. BODY& WELT 126883-M8-000	18" W/FRINGE & OVLY. BODY & WELT 126883-D9-000
	OVERLAY 126883-P2-000	OVERLAY 126883-J5-000	OVERLAY 126883-P0-000
	FRINGE 139041-23-000	FRINGE 139041-06-000	FRINGE 139041-21-000
BEDROOM WINDOWS	VINEYARD VALANCE 137813-52-000 COMPLETELY	VINEYARD VALANCE 137813-07-000	VINEYARD VALANCE 137813-50-000
	UNDERLAY/OVERLAY/1.5" BANDS FLUSH LEGS 137813-52-000	UNDERLAY & 1.5" BANDS 137813-08-000	UNDERLAY & 1.5" BANDS 105745-X5-000
	CORD 139041-24-000	FLUSH LEGS & OVERLAYS CORD 139041-05-000	FLUSH LEGS & OVERLAYS CORD 139041-22-000

CURTAIN & CUSHION GROUP (CONTINUED)
FABRICS (CONTINUED)

HORIZONS	P84/P85/P28	P86/P87/P29	P88/P89/P30
	PROVENCE BLUE	HARVEST TAPESTRY	CARRARA CREAM
ASHWELL VAL.	BODY 137813-52-000	BODY 137813-08-000	BODY 105745-X5-000
*WHEN NEEDED	.25" WELT 137813-52-000	.25" WELT 137813-08-000	.25" WELT 105745-X5-000
BEDSPREAD	BEDCAP W/CORD	BEDCAP W/CORD	BEDCAP W/CORD
DIAMOND QUILT	137813-52-000/139041-24-000	137813-07-000/139041-05-000	137813-50-000/139041-22-000
SHAMS	DBL. FLANGED W/CORD INSET	DBL. FLANGED W/CORD INSET	DBL. FLANGED W/CORD INSET
	137813-52-000/139042-24-000	137813-07-000/139041-05-000	137813-50-000/139041-22-000
BEDRM. PILLOW 2 PER MATTRESS	12x20 W/2"BAND,1.5"BOXING, OVLY.,WELTING & TASSELS	12x20 W/2"BAND,1.5"BOXING, OVLY.,WELTING & TASSELS	12x20 W/2"BAND,1.5"BOXING, OVLY.,WELTING & TASSELS
	WELT,BAND&BOXING 137813-53	WELT,BAND&BOXING 137813-08	WELT,BAND&BOXING 105745-X5
	OVERLAY 137813-52-000	OVERLAY 137813-07-000	OVERLAY 137813-50-000
	TASSELS 139727-12-000	TASSELS 139727-09-000	TASSELS 139727-11-000
HEADBOARD	BROOKWOOD W/CORD	BROOKWOOD W/CORD	BROOKWOOD W/CORD
	137813-52-000/139041-24-000	137813-07-000/139041-05-000	137813-50-000/19041-22-000
BEDRM.BED BOARD	137813-53-000	137813-08-000	105745-X5-000
*WHEN NEEDED			
HALLWAY	VALANCE & INSERTS	VALANCE & INSERTS	VALANCE & INSERTS
	126883-P2-000	126883-J5-000	126883-P0-000
BATH VALANCE	MODERATE W/CROWN	MODERATE W/CROWN	MODERATE W/CROWN
	137813-52-000	137813-07-000	137813-50-000
	*IKP34HD MODERATE W/BRAID	*IKP34HD MODERATE W/BRAID	*IKP34HD MODERATE W/BRAID
	137813-52-000/139041-24-000	137813-07-000/139041-05-000	137813-50-000/139041-22-000
DAY-NITERS LGE. & BEDROOM	EGGSHELL/WHT. DECO	EGGSHELL/WHT. DECO	PUTTY/WHT. DECO
	094911-56-000/094911-50-000	094911-56-000/094911-50-000	094911-58-000/094911-50-000
GALLEY&BATH	386 SNO CAP (MICRO MINI)	386 SNO CAP (MICRO MINI)	C011 BEIGE (MICRO MINI)
OVHD. INSERTS LOUNGE&BEDRM.	LOUNGE 126883-P3-000	LOUNGE 126883-M8-000	LOUNGE 126883-P1-000
	BEDROOM 137813-53-000	BEDROOM 137813-08-000	BEDROOM 137813-50-000
FRONT WRAP	PURCHASED PULL CORD	PURCHASED PULL CORD	PURCHASED PULL CORD
SUNVISORS	142380-03-01A POWER VISORS	142380-03-01A POWER VISORS	142380-03-01A POWER VISORS
	GLACIER	GLACIER	GLACIER
STEP WELL	139056-09-000 CARPET	139056-12-000 CARPET	139056-10-000 CARPET
*SENT TO MHP	102695-12-000 TAPE	102695-28-000 TAPE	102695-12-000 TAPE

DINETTE GROUP CABINETS

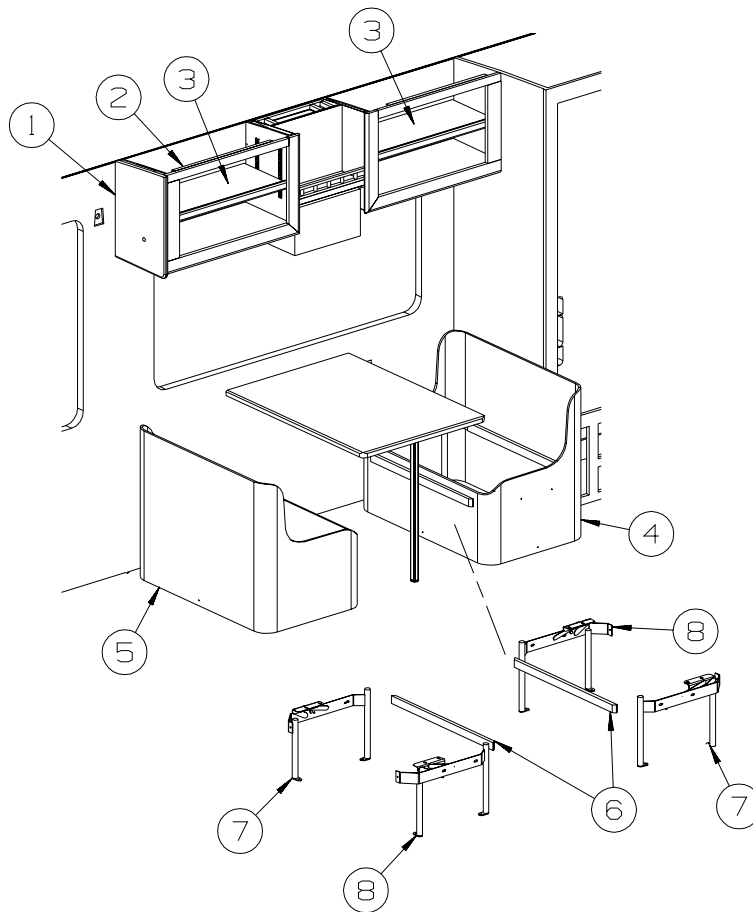

KEY	PART NUMBER	U/M	DESCRIPTION
1	P38119-03-N84	EA	END CAP - OVERHEAD/CABINET - WASHED MAPLE
1	P38119-03-N75	EA	END CAP - OVERHEAD/CABINET - PORTSMOUTH OAK
1	P38119-03-N74	EA	END CAP - OVERHEAD/CABINET - CONCERT CHERRY
2	142242-01-P28	EA	CABINET-OVERHEAD/DINETTE - W/O DOORS/HDW - WASHED MAPLE - W/O DLX SOUND SYS.
2	142242-01-P78	EA	CABINET-OVERHEAD/DINETTE - W/O DOORS/HDW - PORTSMOUTH OAK - W/O DLX SOUND SYS.
2	142242-01-P79	EA	CABINET-OVERHEAD/DINETTE - W/O DOORS/HDW - CONCERT CHERRY - W/O DLX SOUND SYS.
2	142242-02-P28	EA	CABINET-OVERHEAD/DINETTE - W/O DOORS/HDW - WASHED MAPLE - SURROUND SOUND
2	142242-02-P78	EA	CABINET-OVERHEAD/DINETTE - W/O DOORS/HDW - PORTSMOUTH OAK - SURROUND SOUND
2	142242-02-P79	EA	CABINET-OVERHEAD/DINETTE - W/O DOORS/HDW - CONCERT CHERRY - SURROUND SOUND
3	141516-C1-P28	EA	DOOR - ARCHED/PENCIL EDGE - 15.3" X 25.6" - W/O HDW - WASHED MAPLE
3	141516-C1-P84	EA	DOOR - ARCHED/PENCIL EDGE - 15.3" X 25.6" - W/O HDW - PORTSMOUTH OAK
3	141516-C1-P85	EA	DOOR - ARCHED/PENCIL EDGE - 15.3" X 25.6" - W/O HDW - CONCERT CHERRY
4	141859-05-P28	EA	CABINET/BENCH - DINETTE - W/O DOORS/HDW
4	141859-05-P29	EA	CABINET/BENCH - DINETTE - W/O DOORS/HDW
4	141859-05-P30	EA	CABINET/BENCH - DINETTE - W/O DOORS/HDW
4	141859-05-P84	EA	CABINET/BENCH - DINETTE - W/O DOORS/HDW
4	141859-05-P85	EA	CABINET/BENCH - DINETTE - W/O DOORS/HDW
4	141859-05-P86	EA	CABINET/BENCH - DINETTE - W/O DOORS/HDW
4	141859-05-P87	EA	CABINET/BENCH - DINETTE - W/O DOORS/HDW
4	141859-05-P88	EA	CABINET/BENCH - DINETTE - W/O DOORS/HDW
4	141859-05-P89	EA	CABINET/BENCH - DINETTE - W/O DOORS/HDW
5	141859-06-P28	EA	CABINET/BENCH - DINETTE - W/O DOORS/HDW
5	141859-06-P29	EA	CABINET/BENCH - DINETTE - W/O DOORS/HDW
5	141859-06-P30	EA	CABINET/BENCH - DINETTE - W/O DOORS/HDW
5	141859-06-P84	EA	CABINET/BENCH - DINETTE - W/O DOORS/HDW
5	141859-06-P85	EA	CABINET/BENCH - DINETTE - W/O DOORS/HDW
5	141859-06-P86	EA	CABINET/BENCH - DINETTE - W/O DOORS/HDW
5	141859-06-P87	EA	CABINET/BENCH - DINETTE - W/O DOORS/HDW
5	141859-06-P88	EA	CABINET/BENCH - DINETTE - W/O DOORS/HDW
5	141859-06-P89	EA	CABINET/BENCH - DINETTE - W/O DOORS/HDW

DINETTE GROUP (CONTINUED)
CABINETS (CONTINUED)

KEY	PART NUMBER	U/M	DESCRIPTION
6	081295-01-H37	EA	SUPPORT - BED/DINETTE - 28" LONG - WASHED MAPLE
6	081295-01-N70	EA	SUPPORT - BED/DINETTE - 28" LONG - PORTSMOUTH OAK
6	081295-01-M52	EA	SUPPORT - BED/DINETTE - 28" LONG - CONCERT CHERRY
7	142033-02-000	EA	BRACKET - DINETTE - LEFT HAND
8	142033-01-000	EA	BRACKET - DINETTE - RIGHT HAND

DINETTE GROUP (CONTINUED) TABLE

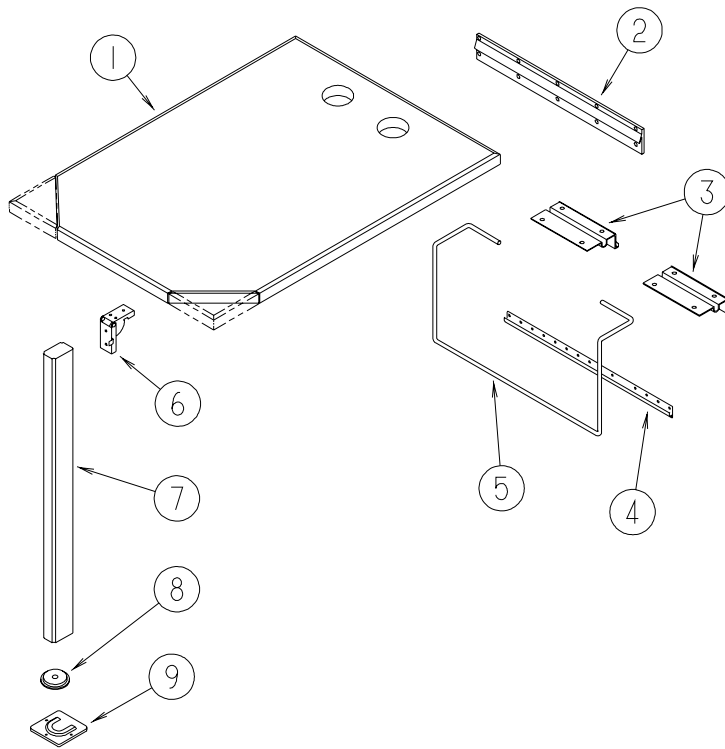

KEY	PART NUMBER	U/M	DESCRIPTION
1	143257-05-P28	EA	TABLE - 29.7" X 41.5" - WOOD EDGE - EGGHELL/WASHED MAPLE(P28, P29, P30)
1	143257-05-P84	EA	TABLE - 29.7" X 41.5" - WOOD EDGE - EGGHELL/PORTSMOUTH OAK (P84, P86, P88)
1	143257-05-P85	EA	TABLE - 29.7" X 41.5" - WOOD EDGE - EGGHELL/CONCERT CHERRY (P85, P87, P89)
2	053200-13-000	EA	SUPPORT - TABLE - 18.5"
			FROM: 00-00-00 THRU: 01-05-03
2	140921-02-01A	EA	SUPPORT - TABLE - 18.5" - OFF WHITE
			FROM: 01-06-03 THRU: 99-99-99
3	088410-02-000	EA	BRACKET - LIFT - TABLE MOUNTED - OFF WHITE
			FROM: 00-00-00 THRU: 01-05-03
3	140921-03-01A	EA	HANGER - TABLE - W/VINYL - OFF WHITE
			FROM: 01-06-03 THRU: 99-99-99
4	024281-15-000	EA	BRACKET/TABLE - LIFT ROD/LOWER WALL MOUNTED - 17.1"
5	024275-13-000	EA	ROD - TABLE LIFT - OFF/WHITE
6	093550-01-000	EA	BRACKET - HINGE - MOUNTS TO LEG & TABLE TOP - 1.7" X 2.6"
7	092707-04-08A	EA	LEG - TABLE - W/O HARDWARE - 27" - WASHED MAPLE
7	092707-04-10A	EA	LEG - TABLE - W/O HARDWARE - 27" - PORTSMOUTH OAK II - PORTSMOUTH OAK
7	092707-04-04A	EA	LEG - TABLE - W/O HARDWARE - 27" - CHERRY - CONCERT CHERRY
8	092593-01-05A	EA	CATCH - TABLE LEG - OFF/WHITE
			FROM: 00-00-00 THRU: 12-04-02
8	143798-02-01A	EA	CATCH - TABLE LEG - BRIGHT WHITE
			FROM: 12-05-02 THRU: 99-99-99
9	049493-12-000	EA	CATCH - TABLE LEG/FLOOR MOUNTED - OFF WHITE
			FROM: 00-00-00 THRU: 12-04-02
9	143798-01-01A	EA	CATCH - FLOOR TO TABLE LEG - BRIGHT WHITE
			FROM: 12-05-02 THRU: 99-99-99

DINETTE GROUP (CONTINUED)
TABLE (CONTINUED)

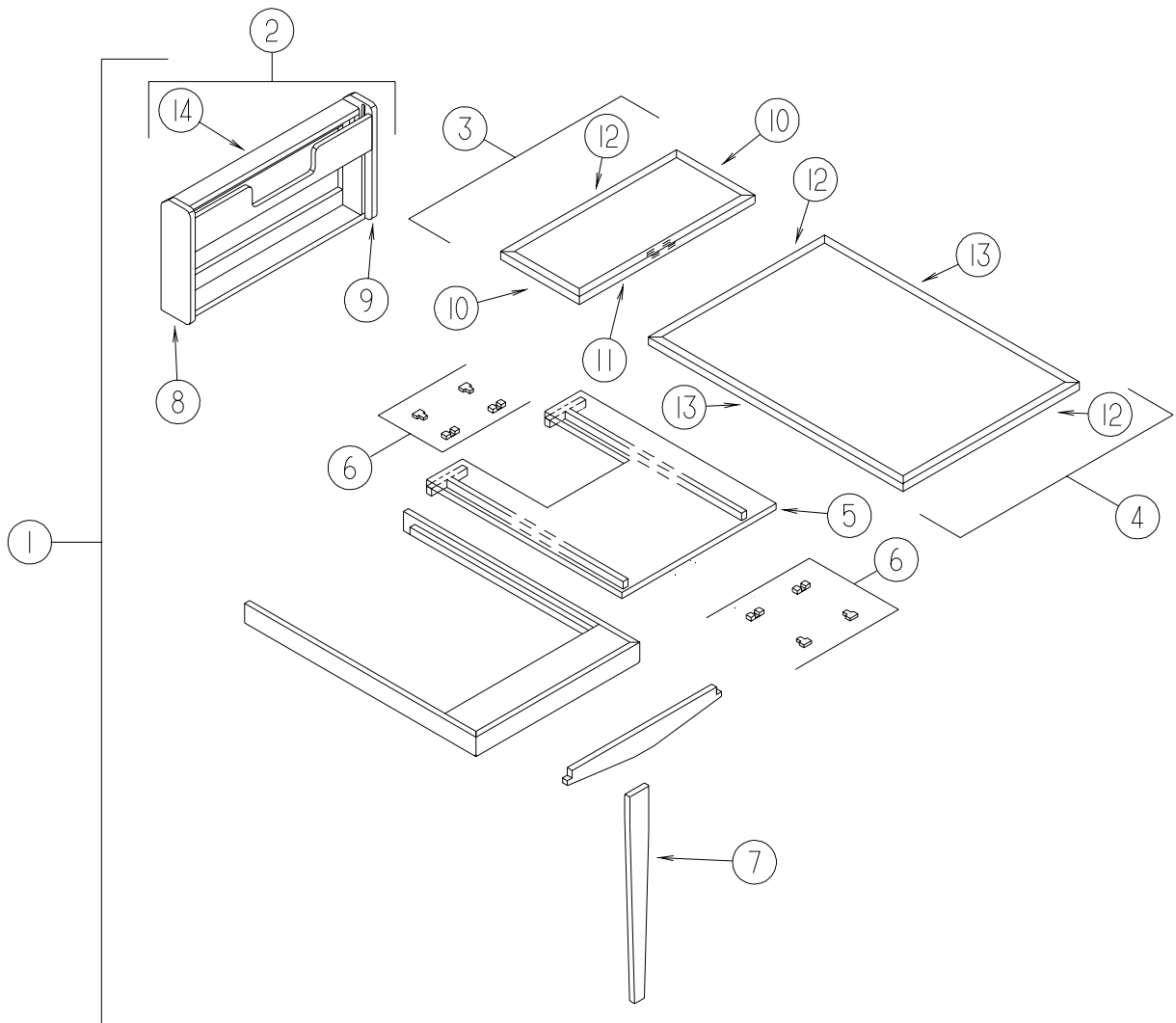

KEY	PART NUMBER	U/M	DESCRIPTION
1	131637-01-K90	EA	TABLE COMPLETE - W/LEG & WALL MOUNT - WASHED MAPLE
1	131637-01-N75	EA	TABLE COMPLETE - W/LEG & WALL MOUNT - PORTSMOUTH OAK
1	131637-01-M94	EA	TABLE COMPLETE - W/LEG & WALL MOUNT - CONCERT CHERRY
2	131637-31-K90	EA	CABINET/WALL - F/TABLE STORAGE - WASHED MAPLE
2	131637-31-N75	EA	CABINET/WALL - F/TABLE STORAGE - PORTSMOUTH OAK
2	131637-31-M94	EA	CABINET/WALL - F/TABLE STORAGE - CONCERT CHERRY
3	131637-12-K90	EA	TABLE TOP - SMALL HINGED SECTION - WASHED MAPLE
3	131637-12-N75	EA	TABLE TOP - SMALL HINGED SECTION - PORTSMOUTH OAK
3	131637-12-M94	EA	TABLE TOP - SMALL HINGED SECTION - CONCERT CHERRY
4	131637-11-K90	EA	TABLE TOP - LARGE HINGED SECTION - WASHED MAPLE
4	131637-11-N75	EA	TABLE TOP - LARGE HINGED SECTION - PORTSMOUTH OAK
4	131637-11-M94	EA	TABLE TOP - LARGE HINGED SECTION - CONCERT CHERRY
5	131637-17-K90	EA	SLIDE - TABLE TOP - WASHED MAPLE
5	131637-17-N75	EA	SLIDE - TABLE TOP - PORTSMOUTH OAK
5	131637-17-M94	EA	SLIDE - TABLE TOP - CONCERT CHERRY
6	009050-02-000	EA	LEVELER - TABLE TOP - MALE END W/4 SCREWS - PLASTIC
6	009050-03-000	EA	LEVELER - TABLE TOP - FEMALE END W/2 SCREWS - PLASTIC
7	131637-28-K90	EA	LEG - TABLE - WASHED MAPLE
7	131637-28-N75	EA	LEG - TABLE - PORTSMOUTH OAK
7	131637-28-M94	EA	LEG - TABLE - CONCERT CHERRY
8	131637-27-K90	EA	END - RIGHT HAND - F/TABLE CABINET - WASHED MAPLE
8	131637-27-N75	EA	END - RIGHT HAND - F/TABLE CABINET - PORTSMOUTH OAK
8	131637-27-M94	EA	END - RIGHT HAND - F/TABLE CABINET - CONCERT CHERRY
9	131637-26-K90	EA	END - LEFT HAND - F/TABLE CABINET - WASHED MAPLE
9	131637-26-N75	EA	END - LEFT HAND - F/TABLE CABINET - PORTSMOUTH OAK
9	131637-26-M94	EA	END - LEFT HAND - F/TABLE CABINET - CONCERT CHERRY

DINETTE GROUP (CONTINUED)
TABLE (CONTINUED)

KEY	PART NUMBER	U/M	DESCRIPTION
10	131637-15-K90	EA	MOLDING - TRIM - TABLE TOP - WASHED MAPLE
10	131637-15-N75	EA	MOLDING - TRIM - TABLE TOP - PORTSMOUTH OAK
10	131637-15-M94	EA	MOLDING - TRIM - TABLE TOP - CONCERT CHERRY
11	131637-16-K90	EA	MOLDING - TRIM - TABLE TOP - WASHED MAPLE
11	131637-16-N75	EA	MOLDING - TRIM - TABLE TOP - PORTSMOUTH OAK
11	131637-16-M94	EA	MOLDING - TRIM - TABLE TOP - CONCERT CHERRY
12	131637-14-K90	EA	MOLDING - TRIM - TABLE TOP - WASHED MAPLE
12	131637-14-N75	EA	MOLDING - TRIM - TABLE TOP - PORTSMOUTH OAK
12	131637-14-M94	EA	MOLDING - TRIM - TABLE TOP - CONCERT CHERRY
13	131637-13-K90	EA	MOLDING - TRIM - TABLE TOP - WASHED MAPLE
13	131637-13-N75	EA	MOLDING - TRIM - TABLE TOP - PORTSMOUTH OAK
13	131637-13-M94	EA	MOLDING - TRIM - TABLE TOP - CONCERT CHERRY
14	131637-23-K90	EA	SHELF - REAR OF TABLE TOP - WASHED MAPLE
14	131637-23-M95	EA	SHELF - REAR OF TABLE TOP - PORTSMOUTH OAK
14	131637-23-M94	EA	SHELF - REAR OF TABLE TOP - CONCERT CHERRY

DRIVERS COMPARTMENT GROUP DASH

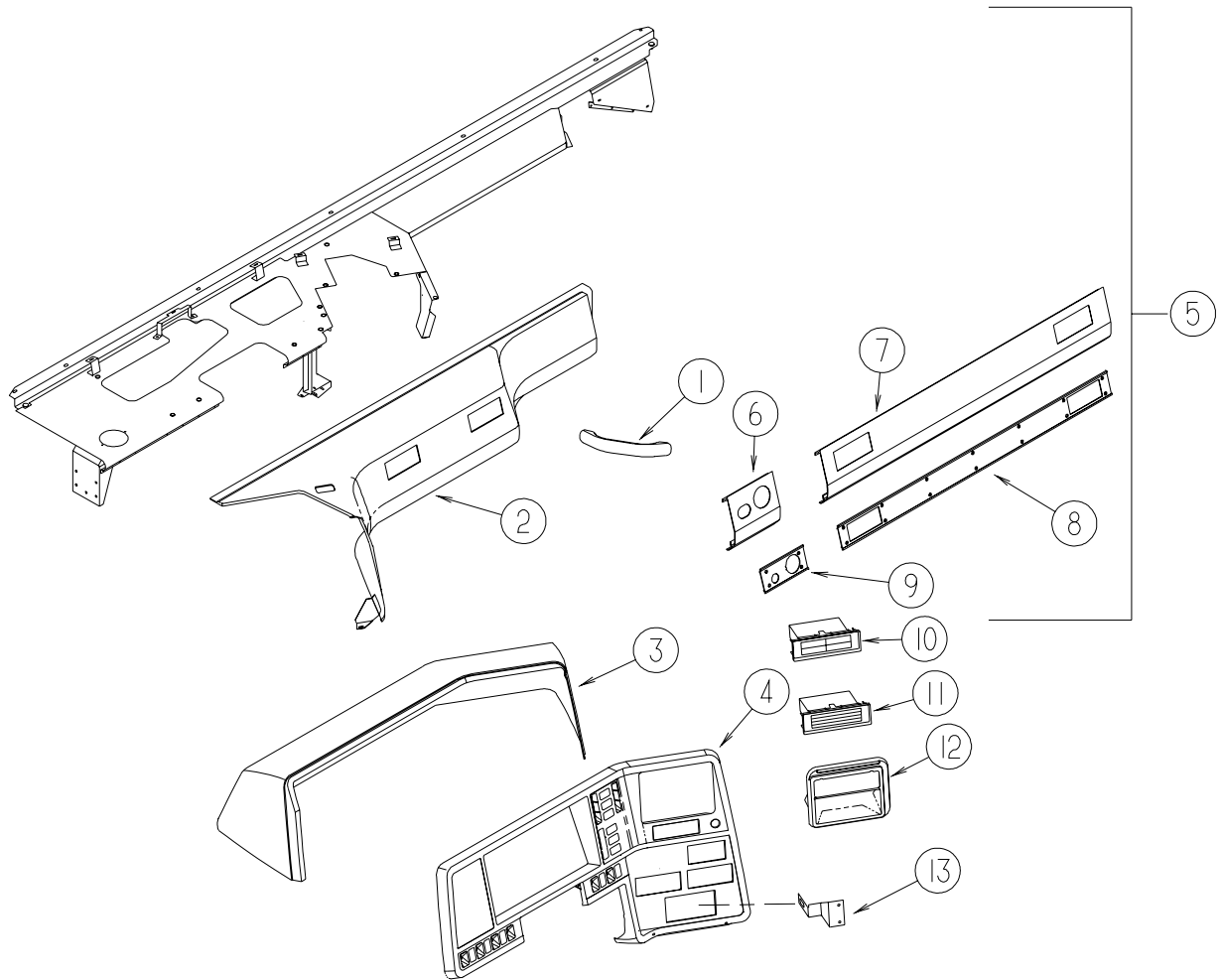

KEY	PART NUMBER	U/M	DESCRIPTION
1	123246-01-05A	EA	HANDLE - GRAB - GLACIER
2	122853-02-N74	EA	TRIM - DASH PANEL/RIGHT HAND - GLACIER
3	107263-03-N74	EA	POD - INSTRUMENT PANEL - GLACIER - REARVIEW MONITOR SYSTEM
3	107263-04-N70	EA	POD - INSTRUMENT PANEL - GLACIER - W/O REARVIEW MONITOR SYSTEM
4	107031-15-01A	EA	BEZEL - INSTRUMENT PANEL
5	P23278-01-000	EA	DASH - W/O VINYL
	106569-09-06A	EA	VINYL - LAMINATE - ALLANTE DOESKIN - 1/4" X 25" X 100"
	106569-10-06A	EA	VINYL - LAMINATE - ALLANTE DOESKIN - 1/4" X 25" X 20"
6	117991-06-01A	EA	EXTENSION - DASH - DRIVER/LOWER/RIGHT HAND
7	117991-05-01A	EA	EXTENSION - DASH - DRIVER/LOWER/LEFT HAND
8	118024-05-06A	EA	TRIM - DASH - DRIVER/LOWER/LEFT HAND - GLACIER
9	118024-06-06A	EA	TRIM - DASH - DRIVER/LOWER/RIGHT HAND - GLACIER
10	096776-02-000	EA	STORAGE BOX - CASSETTE - 4 TAPE HOLDER - W/O REARVIEW MONITOR SYSTEM
11	096776-03-000	EA	STORAGE BOX - CD'S - 4 DISC HOLDER - W/O REARVIEW MONITOR SYSTEM
12	111350-01-01A	EA	POCKET - INSTRUMENT PANEL - UPPER - BLACK - W/O REARVIEW MONITOR SYSTEM
13	138721-01-02B	EA	BRACKET/SUPPORT - RADIO - E-COATED

DRIVERS COMPARTMENT GROUP (CONTINUED)

FRONT INTERIOR

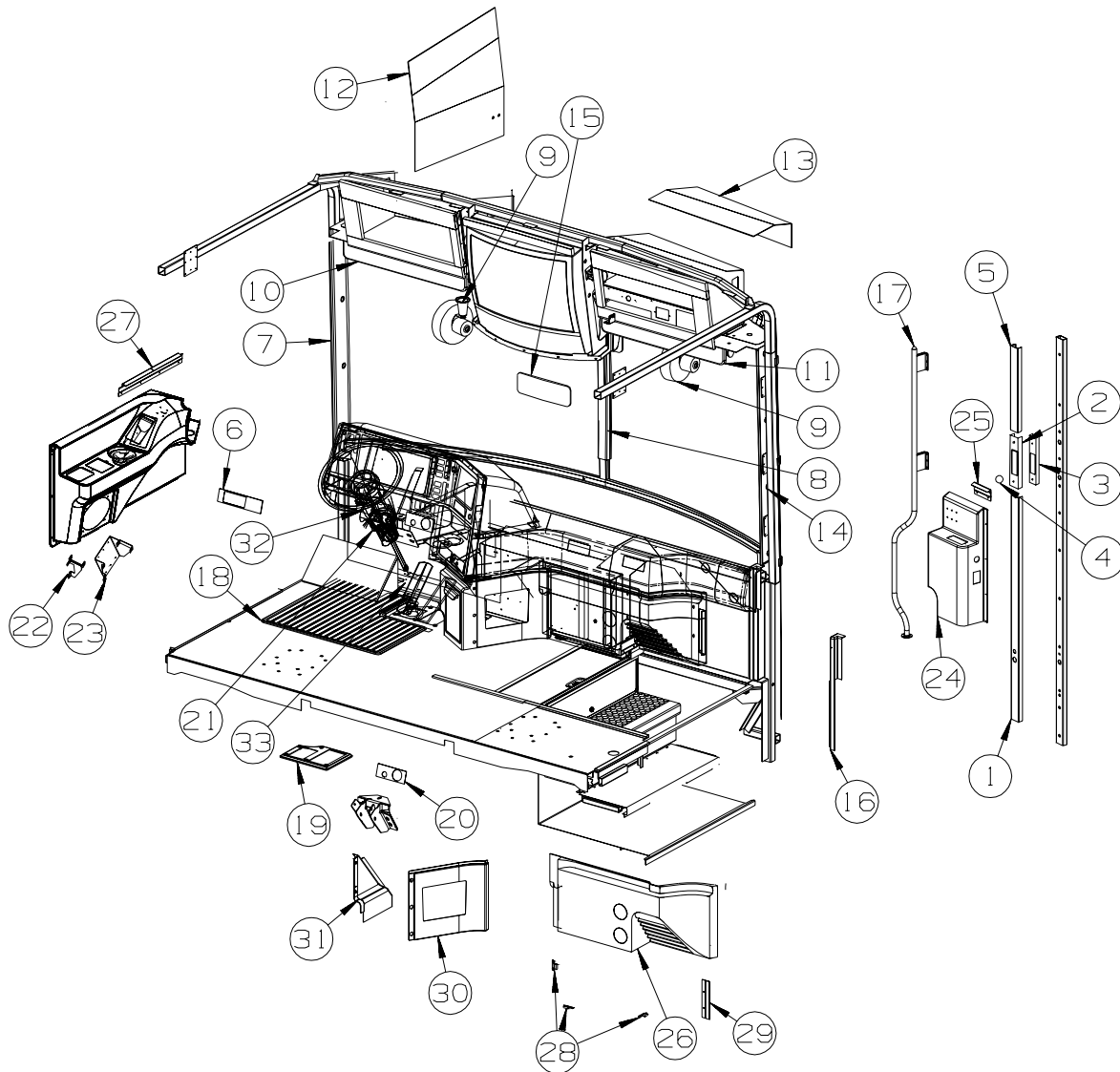

KEY	PART NUMBER	U/M	DESCRIPTION
1	024700-59-000	EA	COVER - ROLL BAR - SIDEWALL - 44.1" - OFF WHITE
2	140151-01-01A	EA	COVER - SEAT BELT - OFF WHITE
3	140151-03-01A	EA	COVER - SEAT BELT SLIDE - BLACK
4	140151-02-01A	EA	COVER - SCREW - OFF WHITE
5	024700-58-000	EA	COVER - ROLL BAR - SIDEWALL - 16.5" - OFF WHITE
6	118377-06-09A	EA	APPLIQUE - LOWER DASH - GM/OSH KOSH/SPARTAN - GLACIER
7	131792-01-04A	EA	TRIM - A-PILLAR - INTERIOR/DRIVER - GLACIER
8	118452-09-04A	EA	TRIM - WINDSHIELD/CENTER - GLACIER
9	122856-01-01A	EA	FAN-DEFROSTER-2 SPEED W/SWIVEL BASE/NON-OSCILLATING-CHROME
10	129004-02-05A	EA	TRIM - WINDSHIELD - INTERIOR/DRIVER TOP - GLACIER
11	129004-01-05A	EA	TRIM - WINDSHIELD - INTERIOR/PASSENGER TOP - GLACIER
12	132909-03-N70	EA	PANEL - VINYL COVERED
13	132909-01-N70	EA	PANEL - VINYL COVERED
14	131791-01-04A	EA	TRIM - A-PILLAR - INTERIOR/PASSENGER - GLACIER
15	134154-01-000	EA	MIRROR - CONVEX - 4" X 11.8"
16	129657-01-05A	EA	TRIM - A-PILLAR - INTERIOR/PASSENGER/LOWER - GLACIER
17	123577-01-01A	EA	HANDRAIL - ASSIST - ENTRY
18	108152-03-000	EA	MAT - FLOOR - DRIVER
19	116993-01-01A	EA	COVER - PEDALS - BLACK
20	118377-05-09A	EA	APPLIQUE - LOWER DASH - FREIGHTLINER - GLACIER
21	109832-03-03A	EA	COVER - STEERING COLUMN - BLACK
22	NOT USED		
23	NOT USED		

DRIVERS COMPARTMENT GROUP (CONTINUED)
FRONT INTERIOR (CONTINUED)

KEY	PART NUMBER	U/M	DESCRIPTION
24	142206-07-P78	EA	PANEL/TRIM - INNER/RIGHT HAND
	130463-03-02B	EA	ANGLE - TRIM/BACKWALL - E-COATED
24	142206-08-P78	EA	PANEL/TRIM - INNER/RIGHT HAND - ELECTRIC AWNING PACKAGE
	130463-03-02B	EA	ANGLE - TRIM/BACKWALL - E-COATED
25	130034-03-02B	EA	CLIP - TRIM - E-COATED
26	133037-01-04A	EA	PANEL - TRIM - HEATER/AC - RIGHT HAND - GLACIER
27	130034-04-02B	EA	CLIP - TRIM - E-COATED
28	073050-03-000	EA	MOUNTING CLIP - VALANCE PANEL
29	130034-02-02B	EA	CLIP - TRIM - E-COATED
30	133163-03-P75	EA	PANEL - BEVERAGE TRAY - RIGHT HAND - W/O TWO-WAY RADIOS
30	133163-04-P75	EA	PANEL - BEVERAGE TRAY/2 WAY RADIO - RIGHT HAND - TWO-WAY RADIOS
31	133164-02-P75	EA	PANEL - BEVERAGE TRAY - LEFT HAND
32	095933-07-000	EA	STOP/TILT - STEERING COLUMN
33	103498-09-000	EA	BOOT - STEERING COLUMN - W/1/2 CIRCLE

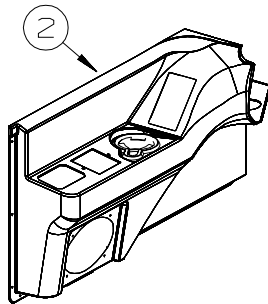

W/SURROUND SOUND

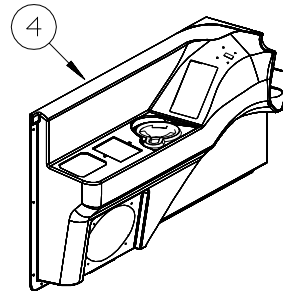

**W/SURROUND SOUND
& TRIP COMPUTER**

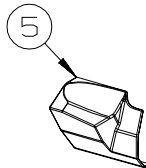
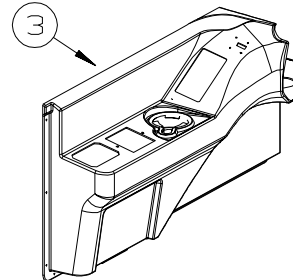
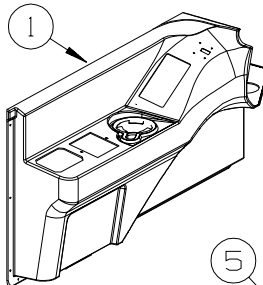

W/TRIP COMPUTER

KEY	PART NUMBER	U/M	DESCRIPTION
1	140578-14-P78	EA	PANEL/TRIM - INNER/LEFT HAND
2	140578-16-P78	EA	PANEL/TRIM - INNER/LEFT HAND
3	140578-22-P78	EA	PANEL/TRIM - INNER/LEFT HAND
4	140578-24-P78	EA	PANEL/TRIM - INNER/LEFT HAND
5	140580-01-01A	EA	PANEL/TRIM - INSERT - LEFT HAND

DRIVERS COMPARTMENT GROUP (CONTINUED)
FRONT INTERIOR (CONTINUED)

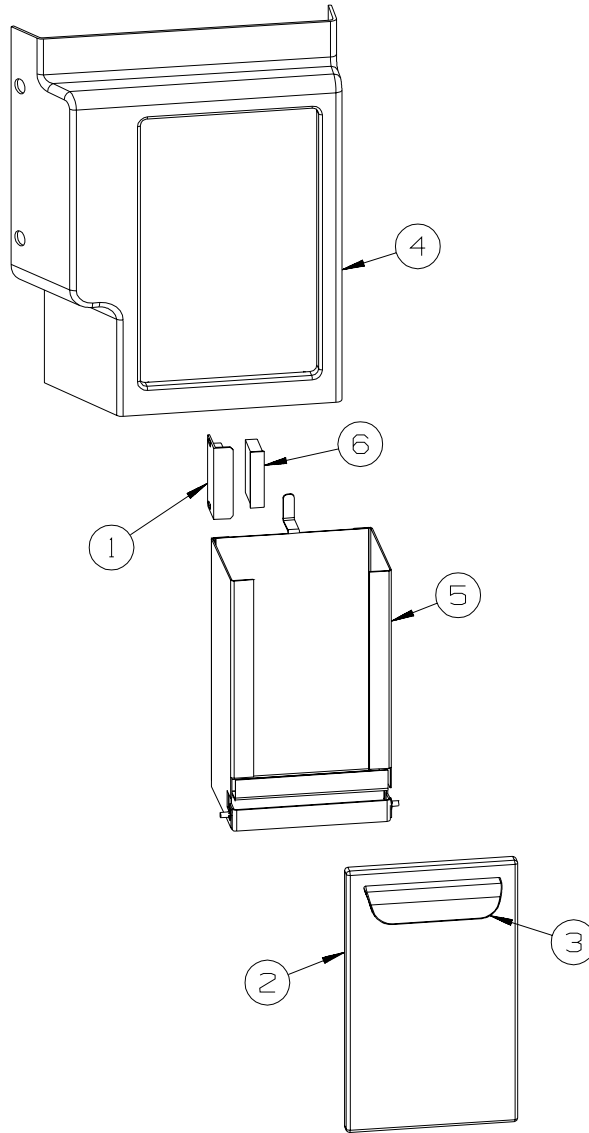

KEY	PART NUMBER	U/M	DESCRIPTION
1	137018-03-01A	EA	BRACKET - MOUNTING - 2"
2	142272-01-04A	EA	PANEL/DOOR - GLACIER
3	074762-01-000	EA	PULL - CABINET - 4.8" X .9" - BLACK PLASTIC
4	142273-01-04A	EA	PANEL - DASH - LOWER - GLACIER
5	142283-01-02B	EA	COMPARTMENT - GLOVE BOX - E-COATED
6	137018-01-01A	EA	CATCH - MAGNETIC - 1.6"

DRIVERS COMPARTMENT GROUP (CONTINUED)
FRONT INTERIOR (CONTINUED)

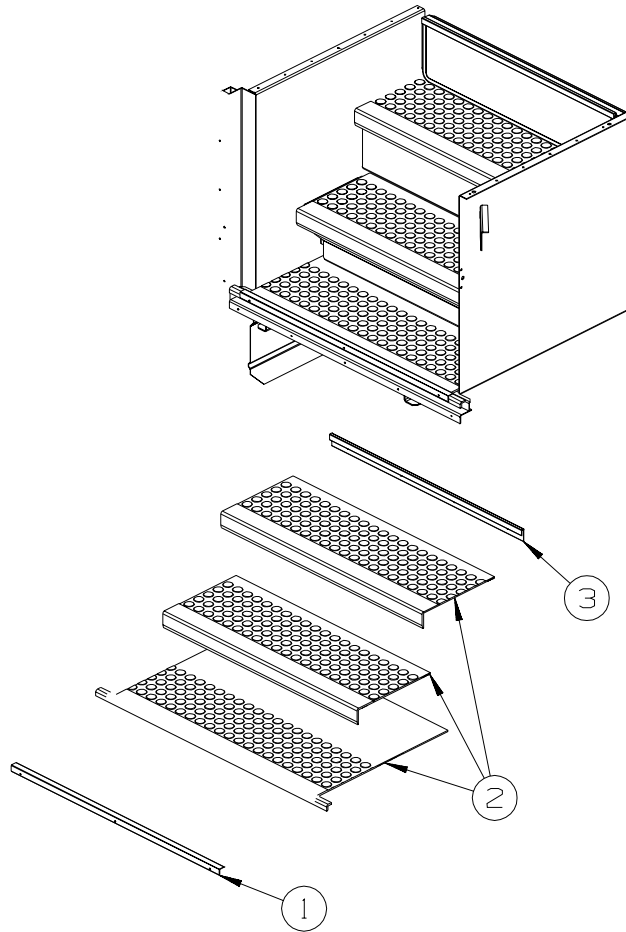

KEY	PART NUMBER	U/M	DESCRIPTION
1	136002-63-02A	EA	ANGLE - W/HOLES - BRIGHT WHITE
2	120231-01-02A	EA	FLOORING - RUBBER - 66.4" X 19.8"
3	136839-07-01A	EA	TRIM-J - CARPET EDGE/SLIDEOUT - 28.3" - BLACK

DRIVERS COMPARTMENT GROUP (CONTINUED)
FRONT INTERIOR (CONTINUED)

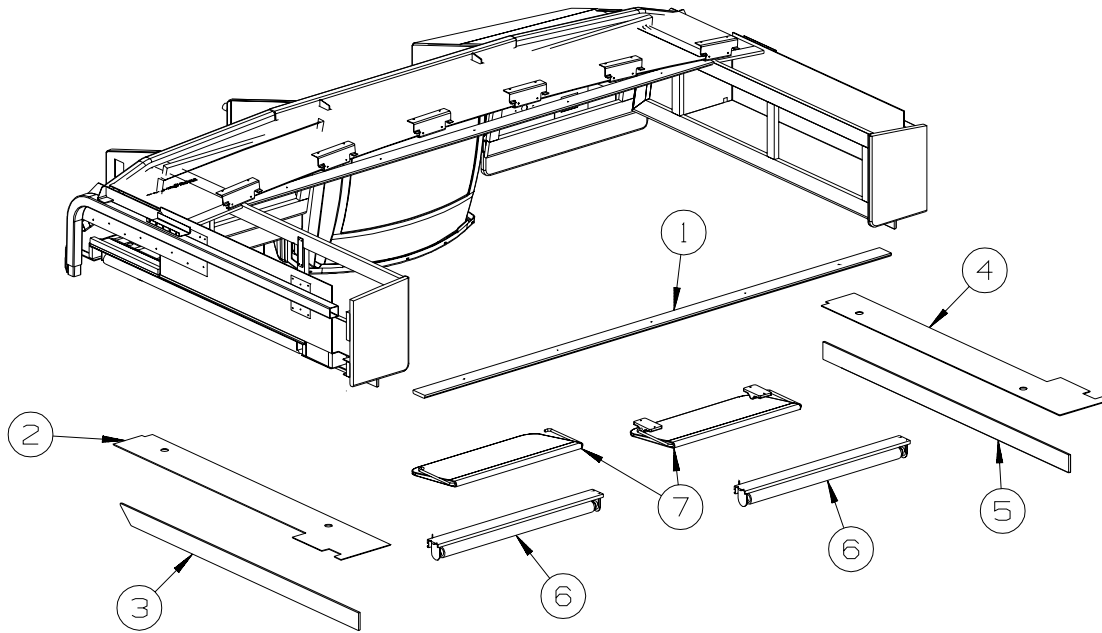

KEY	PART NUMBER	U/M	DESCRIPTION
1	133771-01-N75	EA	MOLDING - CAP - PORTSMOUTH OAK
1	133771-01-L85	EA	MOLDING - CAP - CONCERT CHERRY
1	133771-01-L84	EA	MOLDING - CAP - WASHED MAPLE
2	133230-01-P75	EA	PANEL - OVERHEAD/PASSENGER - W/O HARDWARE - VINYL COVERED
3	132694-05-P78	EA	PANEL - OVERHEAD/FRONT/DRIVER/PASSENGER - VINYL COVERED
4	133230-02-P75	EA	PANEL - OVERHEAD/DRIVER - W/O HARDWARE - VINYL COVERED
5	132694-05-P78	EA	PANEL - OVERHEAD/FRONT/DRIVER/PASSENGER - VINYL COVERED
6	142380-03-01A	EA	SHADE - POWER - 27.8"
7	NOT USED		

DRIVERS COMPARTMENT GROUP (CONTINUED)

CABINETS

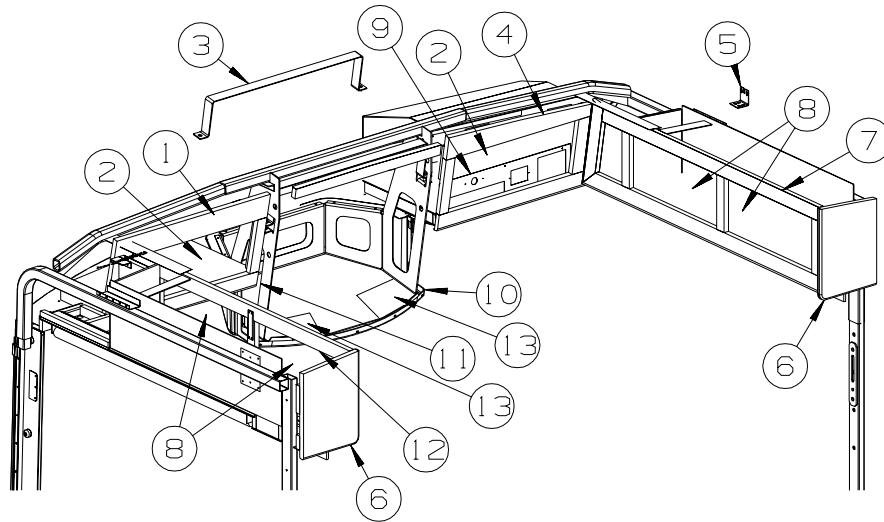

KEY	PART NUMBER	U/M	DESCRIPTION
1	132778-01-N75	EA	CABINET - OVERHEAD/FRONT/LEFT HAND - W/O DOORS/HARDWARE - PORTSMOUTH OAK
1	132778-01-M85	EA	CABINET - OVERHEAD/FRONT/LEFT HAND - W/O DOORS/HARDWARE - CONCERT CHERRY
1	132778-01-M84	EA	CABINET - OVERHEAD/FRONT/LEFT HAND - W/O DOORS/HARDWARE - WASHED MAPLE
2	135238-21-P84	EA	DOOR - RAIL/ARCHED TOP - 9.2" X 21.8" - W/O HARDWARE - PORTSMOUTH OAK
2	135238-21-N85	EA	DOOR - RAIL/ARCHED TOP - 9.2" X 21.8" - W/O HARDWARE - CONCERT CHERRY
2	135238-21-N84	EA	DOOR - RAIL/ARCHED TOP - 9.2" X 21.8" - W/O HARDWARE - WASHED MAPLE
2	100708-23-000	EA	DOOR/GLASS - TV CABINET - 6.4" X 19.1" - W/O HARDWARE
3	133790-02-02B	EA	STRAP - TIEDOWN/TV - E-COATED - 25.3"
4	132779-01-N75	EA	CABINET - OVERHEAD/FRONT/RIGHT HAND - W/O DOORS/HARDWARE - PORTSMOUTH OAK
4	132779-01-M85	EA	CABINET - OVERHEAD/FRONT/RIGHT HAND - W/O DOORS/HARDWARE - CONCERT CHERRY
4	132779-01-M84	EA	CABINET - OVERHEAD/FRONT/RIGHT HAND - W/O DOORS/HARDWARE - WASHED MAPLE
5	109216-03-000	EA	ANGLE - FURNACE DOOR
6	P38119-08-N75	EA	END CAP - OVERHEAD CABINET - PORTSMOUTH OAK
6	P38119-08-N74	EA	END CAP - OVERHEAD CABINET - CONCERT CHERRY
6	P38119-08-N84	EA	END CAP - OVERHEAD CABINET - WASHED MAPLE
7	138377-01-P84	EA	CABINET - OVERHEAD/SIDE/FRONT/RIGHT HAND - W/O DOORS/HDW (P84) - W/O CD CHANGER
7	138377-01-P85	EA	CABINET - OVERHEAD/SIDE/FRONT/RIGHT HAND - W/O DOORS/HDW (P85) - W/O CD CHANGER
7	138377-01-P28	EA	CABINET - OVERHEAD/SIDE/FRONT/RIGHT HAND - W/O DOORS/HDW (P28) - W/O CD CHANGER
7	138377-01-P86	EA	CABINET - OVERHEAD/SIDE/FRONT/RIGHT HAND - W/O DOORS/HDW (P86) - W/O CD CHANGER
7	138377-01-P87	EA	CABINET - OVERHEAD/SIDE/FRONT/RIGHT HAND - W/O DOORS/HDW (P87) - W/O CD CHANGER
7	138377-01-P29	EA	CABINET - OVERHEAD/SIDE/FRONT/RIGHT HAND - W/O DOORS/HDW (P29) - W/O CD CHANGER
7	138377-01-P88	EA	CABINET - OVERHEAD/SIDE/FRONT/RIGHT HAND - W/O DOORS/HDW (P88) - W/O CD CHANGER
7	138377-01-P89	EA	CABINET - OVERHEAD/SIDE/FRONT/RIGHT HAND - W/O DOORS/HDW (P89) - W/O CD CHANGER
7	138377-01-P30	EA	CABINET - OVERHEAD/SIDE/FRONT/RIGHT HAND - W/O DOORS/HDW (P30) - W/O CD CHANGER
7	138377-02-P84	EA	CABINET - OVERHEAD/SIDE/FRONT/RIGHT HAND - W/O DOORS/HDW (P84) - CD CHANGER
7	138377-02-P85	EA	CABINET - OVERHEAD/SIDE/FRONT/RIGHT HAND - W/O DOORS/HDW (P85) - CD CHANGER
7	138377-02-P28	EA	CABINET - OVERHEAD/SIDE/FRONT/RIGHT HAND - W/O DOORS/HDW (P28) - CD CHANGER
7	138377-02-P86	EA	CABINET - OVERHEAD/SIDE/FRONT/RIGHT HAND - W/O DOORS/HDW (P86) - CD CHANGER
7	138377-02-P87	EA	CABINET - OVERHEAD/SIDE/FRONT/RIGHT HAND - W/O DOORS/HDW (P87) - CD CHANGER
7	138377-02-P29	EA	CABINET - OVERHEAD/SIDE/FRONT/RIGHT HAND - W/O DOORS/HDW (P29) - CD CHANGER
7	138377-02-P88	EA	CABINET - OVERHEAD/SIDE/FRONT/RIGHT HAND - W/O DOORS/HDW (P88) - CD CHANGER
7	138377-02-P89	EA	CABINET - OVERHEAD/SIDE/FRONT/RIGHT HAND - W/O DOORS/HDW (P89) - CD CHANGER
7	138377-02-P30	EA	CABINET - OVERHEAD/SIDE/FRONT/RIGHT HAND - W/O DOORS/HDW (P30) - CD CHANGER
8	141516-22-P84	EA	DOOR - ARCHED/PENCIL EDGE 10" X 19.1" - W/O HARDWARE - PORTSMOUTH OAK
8	141516-22-P85	EA	DOOR - ARCHED/PENCIL EDGE 10" X 19.1" - W/O HARDWARE - CONCERT CHERRY
8	141516-22-P28	EA	DOOR - ARCHED/PENCIL EDGE 10" X 19.1" - W/O HARDWARE - WASHED MAPLE
9	133026-04-P75	EA	PANEL - VINYL COVERED - W/NOTCH - 25" COLOR TV
9	133026-05-P75	EA	PANEL - VINYL COVERED - W/NOTCH - 300 WATT DC/AC INVERTER
10	133544-01-N75	EA	CABINET FACE - OVERHEAD/TV - PORTSMOUTH OAK
10	133544-01-L85	EA	CABINET FACE - OVERHEAD/TV - CONCERT CHERRY
10	133544-01-L84	EA	CABINET FACE - OVERHEAD/TV - WASHED MAPLE
	073050-03-000	EA	MOUNTING CLIP - VALANCE PANEL

DRIVERS COMPARTMENT GROUP (CONTINUED)
CABINETS (CONTINUED)

KEY	PART NUMBER	U/M	DESCRIPTION
11	133029-01-04A	EA	COVER - TV/OVERHEAD FRONT - GLACIER
12	138378-01-P84	EA	CABINET - OVERHEAD/SIDE/FRONT/LEFT HAND - W/O DOORS/HDW (P84)
12	138378-01-P85	EA	CABINET - OVERHEAD/SIDE/FRONT/LEFT HAND - W/O DOORS/HDW (P85)
12	138378-01-P28	EA	CABINET - OVERHEAD/SIDE/FRONT/LEFT HAND - W/O DOORS/HDW (P28)
12	138378-01-P86	EA	CABINET - OVERHEAD/SIDE/FRONT/LEFT HAND - W/O DOORS/HDW (P86)
12	138378-01-P87	EA	CABINET - OVERHEAD/SIDE/FRONT/LEFT HAND - W/O DOORS/HDW (P87)
12	138378-01-P29	EA	CABINET - OVERHEAD/SIDE/FRONT/LEFT HAND - W/O DOORS/HDW (P29)
12	138378-01-P88	EA	CABINET - OVERHEAD/SIDE/FRONT/LEFT HAND - W/O DOORS/HDW (P88)
12	138378-01-P89	EA	CABINET - OVERHEAD/SIDE/FRONT/LEFT HAND - W/O DOORS/HDW (P89)
12	138378-01-P30	EA	CABINET - OVERHEAD/SIDE/FRONT/LEFT HAND - W/O DOORS/HDW (P30)
13	140364-01-01A	EA	FOAM - PAD - .5" X 8" X 8"

ELECTRICAL GROUP

12V BODY WIRING

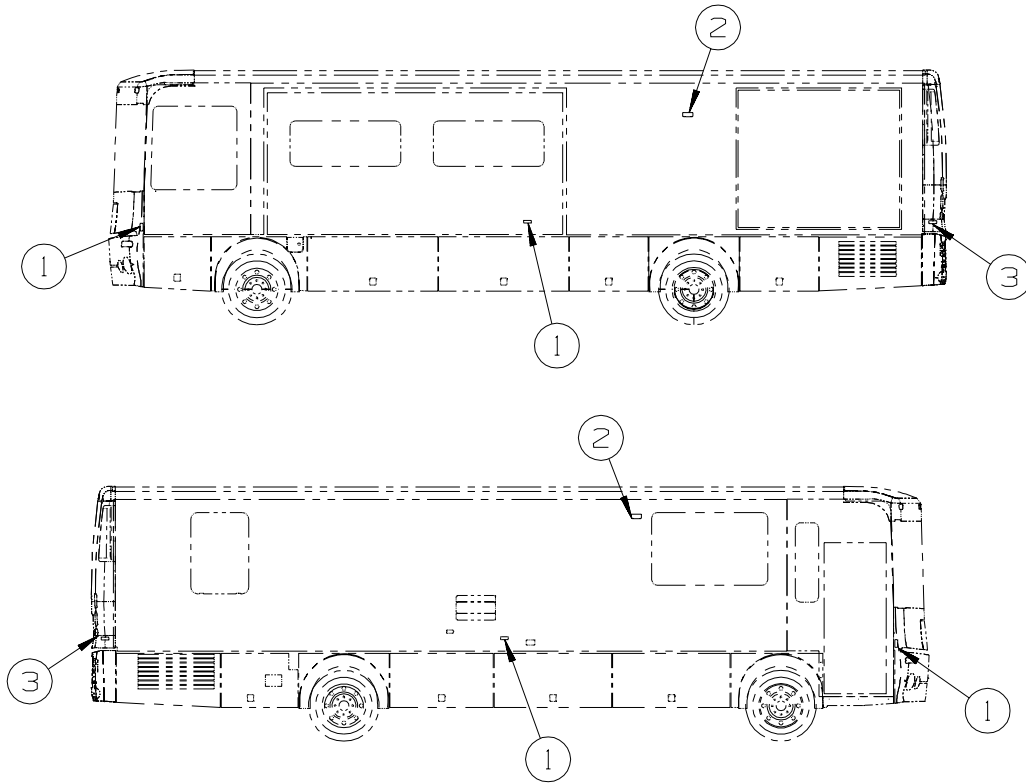

KEY	PART NUMBER	U/M	DESCRIPTION
1	111102-01-000	EA	BASE - MARKER LAMP
1	111102-02-000	EA	LENS - AMBER - MARKER LAMP
	036196-01-000	EA	BULB - 12V - #194 - .27 AMP - BAYONETTE
2*	008089-02-000	EA	LIGHT - PORCH - RECESSED - CANADIAN
2	008214-01-000	EA	BULB - 12 VOLT - #67 - .59 AMP
2	097917-01-08A	EA	LIGHT/PORCH - ENTRY DOOR
3	111102-01-000	EA	BASE - MARKER LAMP
3	111102-03-000	EA	LENS - RED - MARKER LAMP
	036196-01-000	EA	BULB - 12V - #194 - .27 AMP - BAYONETTE
	130672-01-01A	EA	SPOTLIGHT - POWER/REMOTE - WHITE

***COMPONENT PARTS LISTED LATER IN THIS GROUP**

ELECTRICAL GROUP (CONTINUED)

12V BODY WIRING (CONTINUED)

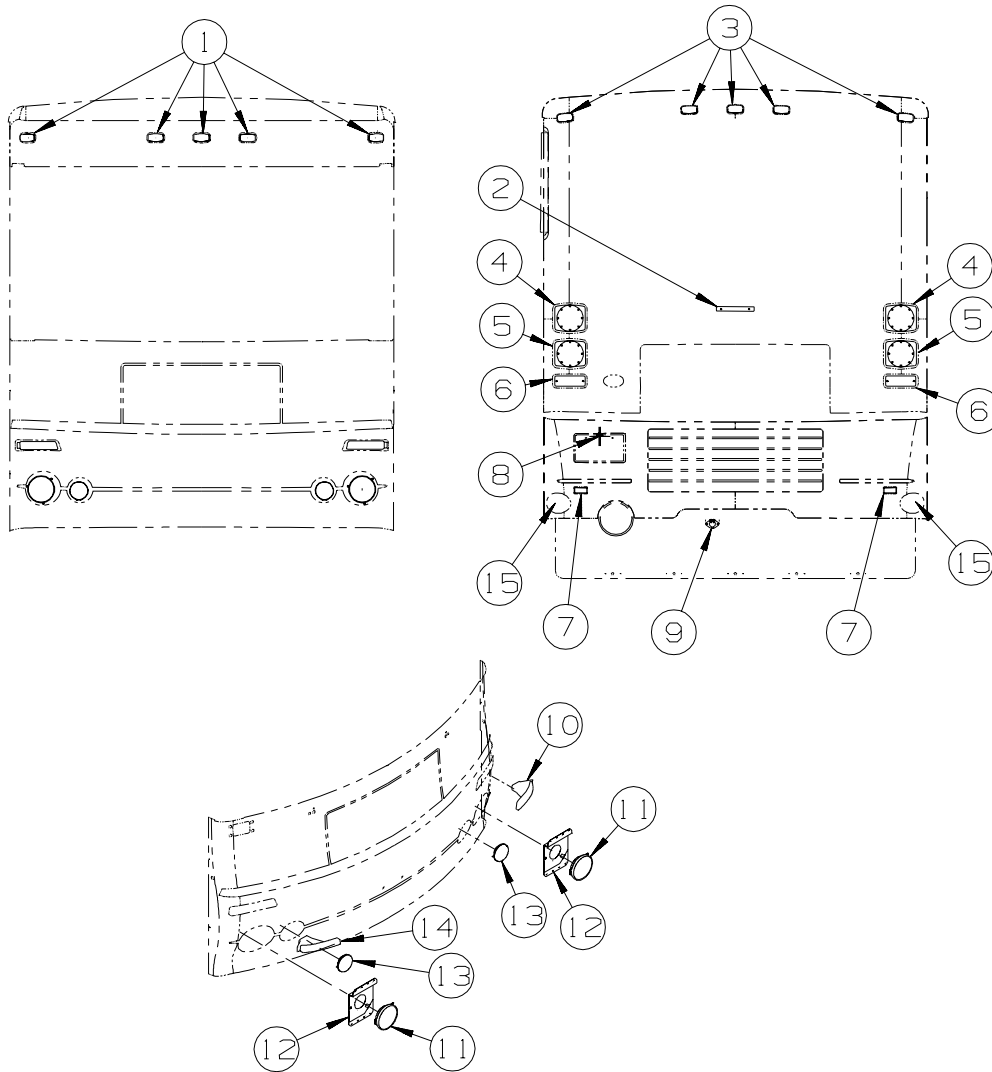

KEY	PART NUMBER	U/M	DESCRIPTION
1	133055-03-000	EA	BASE - F/CLEARANCE/MARKER - WHITE
1	133055-02-000	EA	LENS - AMBER - F/CLEARANCE/MARKER
	036196-01-000	EA	BULB - 12V - #194 - .27 AMP - BAYONETTE
	127536-02-000	EA	SOCKET - LIGHT - 194 WEDGE
2	136917-01-000	EA	LIGHT - BRAKE - CENTER MOUNT - OVAL
3	133055-03-000	EA	BASE - F/CLEARANCE/MARKER - WHITE
3	133055-01-000	EA	LENS - RED - F/CLEARANCE/MARKER
	036196-01-000	EA	BULB - 12V - #194 - .27 AMP - BAYONETTE
	106687-01-000	EA	SOCKET - LIGHT - 2-WIRE
4*	133054-03-000	EA	LIGHT - STOP/TURN/TAILLIGHT - RED
4	037934-01-000	EA	BULB - 12V - #1156 - 2.1 AMP - CLEAR GLASS
5*	133054-04-000	EA	LIGHT - TURN - AMBER
5	037934-01-000	EA	BULB - 12V - #1156 - 2.1 AMP - CLEAR GLASS
6	106688-01-000	EA	LIGHT - BACK-UP W/WHITE LENS (LENS/BACK PAN)
6	037934-01-000	EA	BULB - 12V - #1156 - 2.1 AMP - CLEAR GLASS
7	106646-02-000	EA	REFLECTOR - STICK ON - RED
8	087201-01-000	EA	LIGHT - HALF ROUND - 1" X 1.7" - PLASTIC - BLACK OR WHITE
9	113589-01-000	EA	CONNECTOR - PLUG - TRAILER
9	113589-02-000	EA	CONNECTOR - SOCKET - TRAILER
10	133069-02-000	EA	LENS - PARK/TURN W/O SOCKET - AMBER - DRIVER
10	037935-01-000	EA	BULB - 12V - #1157 OR #2057 - 2.1 AMP - CLEAR GLASS

ELECTRICAL GROUP (CONTINUED)

12V BODY WIRING (CONTINUED)

KEY	PART NUMBER	U/M	DESCRIPTION
11	135625-02-000	EA	HEADLAMP - HIGH/LOW - ROUND - 7" W/BUCKET/TRIM RING- BLACK
11	133069-03-000	EA	SOCKET - LAMP - 3 WIRE
11	049359-01-000	EA	SPRING - RETAINER - HEADLAMP - GM #496096
11	110750-01-000	EA	SCREW - HEADLAMP ADJUSTING
12	137765-01-04B	EA	PLATE - HEADLAMP - 7" ROUND - RIGHT HAND
13	133115-01-000	EA	LAMP/FOG - CLEAR/ROUND
14	133069-01-000	EA	LENS - PARK/TURN W/O SOCKET - AMBER - PASSENGER
14	037935-01-000	EA	BULB - 12V - #1157 OR #2057 - 2.1 AMP - CLEAR GLASS
15	139001-01-000	EA	LIGHT ONLY (DOCKING)
15	117806-01-000	EA	BULB - 12V - #912 - 1.0 AMP

***COMPONENT PARTS LISTED LATER IN THIS GROUP**

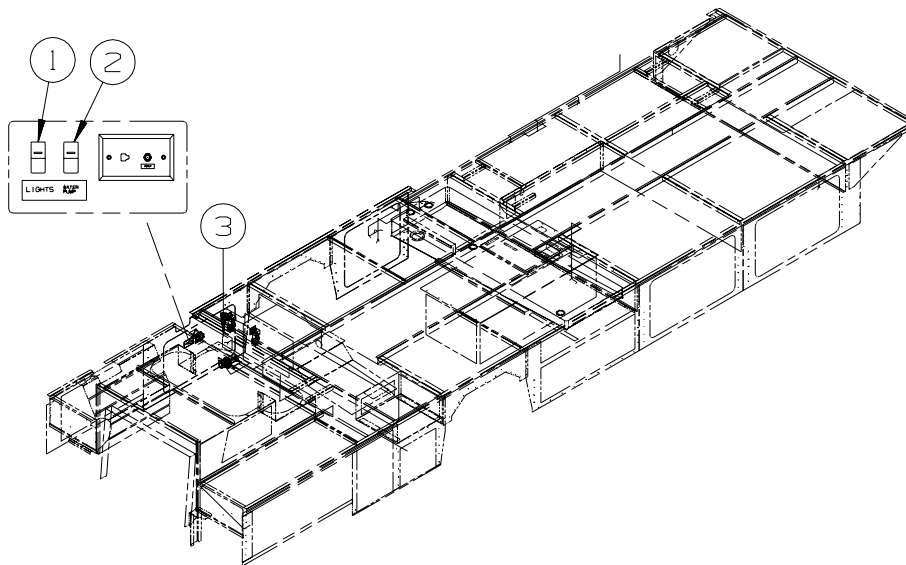

KEY	PART NUMBER	U/M	DESCRIPTION
1	108357-01-000	EA	SWITCH - ROCKER - SPST - ON/OFF - 2 TERMINAL
1	108356-02-01A	EA	COVER/ACTUATOR SWITCH - 2 ROWS DIMPLES- CONTURA II - BLACK
1	108355-01-000	EA	HOUSING - SWITCH
2	108357-15-000	EA	SWITCH - ROCKER - DPDT - ON/NONE/ON - LIGHTED
2	108356-04-01A	EA	COVER/ACTUATOR SWITCH - 2 ROWS DIMPLES W/LENS-CONTURA-BLK
2	108355-01-000	EA	HOUSING - SWITCH
3*	137417-03-01A	EA	LIGHT - DOME - SINGLE - W/FROSTED LENS - W/O SWITCH-WHITE

***COMPONENT PARTS LISTED LATER IN THIS GROUP**

ELECTRICAL GROUP (CONTINUED)

12V BODY WIRING (CONTINUED)

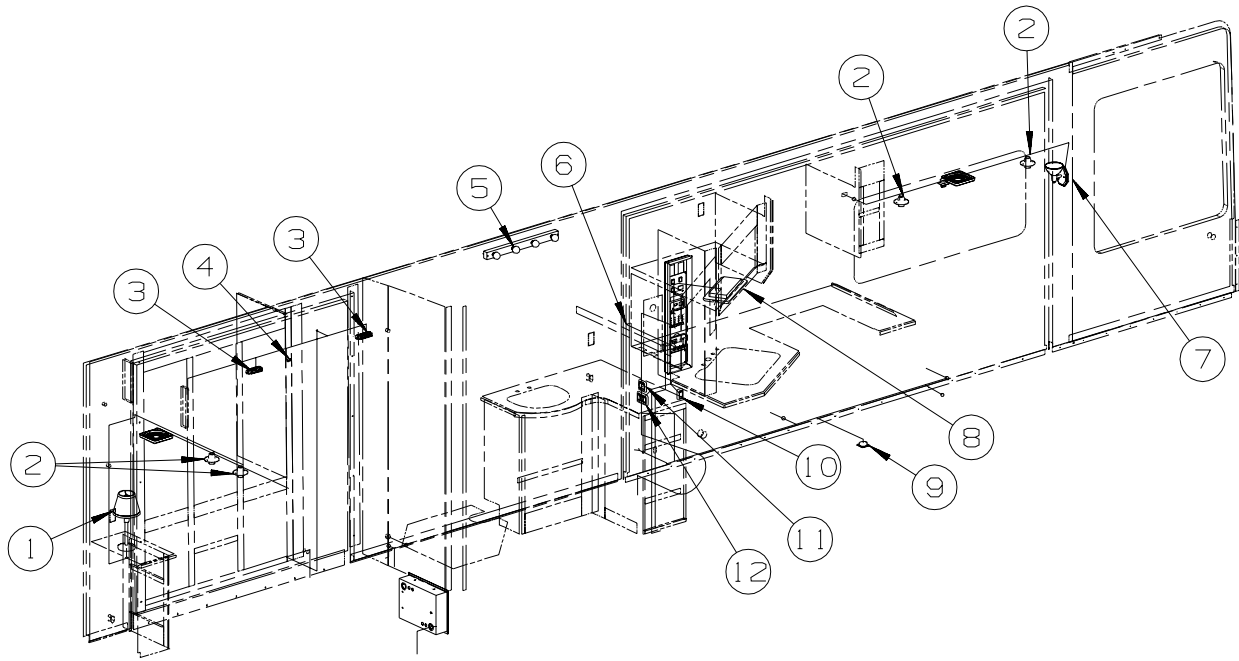

KEY	PART NUMBER	U/M	DESCRIPTION
1	142612-01-01A	EA	LAMP - TABLE - UL/CSA - BRASS
1	065201-09-000	EA	SHADE - LAMP - FABRIC/PARCHMENT - 4.1"T X 6.1"H X 7.1"B
1	067479-01-000	EA	BULB - 12V - #1076 - 1.80 AMP
2	132427-01-01A	EA	LIGHT - READING - SWIVEL/ROUND - BRASS
	123917-01-000	EA	BULB - 12V - HALOGEN SPOT
3*	087694-01-000	EA	LIGHT - WARDROBE/CLOSET - W/SWITCH
4	056264-01-000	EA	SWITCH - LEAF ACTUATOR
5	138116-02-01A	EA	LIGHT/MAKE UP - 4 BULB - CURVED - W/O BULB - BRASS
	123918-01-000	EA	BULB - 12V - MAKEUP WHITE
6*	123775-01-01A	EA	LIGHT - HALOGEN - ROUND
7	119258-43-01A	EA	LAMP - WALL - UL/CSA - BRASS
7	117805-02-000	EA	BULB - 12V - #921 - 1.4 AMPS
8*	091937-09-000	EA	LIGHT-FLOURESCENT-12V/30 WATT RECESSED - W/SWITCH
9*	108354-01-01A	EA	LIGHT - COURTESY
10	135740-01-02A	EA	SWITCH - ROCKER - SPST - ON/OFF - WHITE
10	135741-01-02A	EA	SWITCH - BASE - SINGLE - WHITE
10	135742-07-01A	EA	BEZEL - SWITCH - CEILING - WHITE
11	135740-01-02A	EA	SWITCH - ROCKER - SPST - ON/OFF - WHITE - FAN
11	135741-01-02A	EA	SWITCH - BASE - SINGLE - WHITE
11	135742-12-01A	EA	BEZEL - SWITCH - FAN - WHITE
12	135740-01-02A	EA	SWITCH - ROCKER - SPST - ON/OFF - WHITE - MAKEUP/SHOWER
12	135740-02-02A	EA	SWITCH - ROCKER - SPDT - ON/ON - WHITE - CEILING
12	135741-03-02A	EA	SWITCH - BASE - TRIPLE - WHITE
12	135742-28-01A	EA	BEZEL - SWITCH - CEILING/SHOWER/MAKEUP - WHITE

*COMPONENT PARTS LISTED LATER IN THIS GROUP

ELECTRICAL GROUP (CONTINUED)

12V BODY WIRING (CONTINUED)

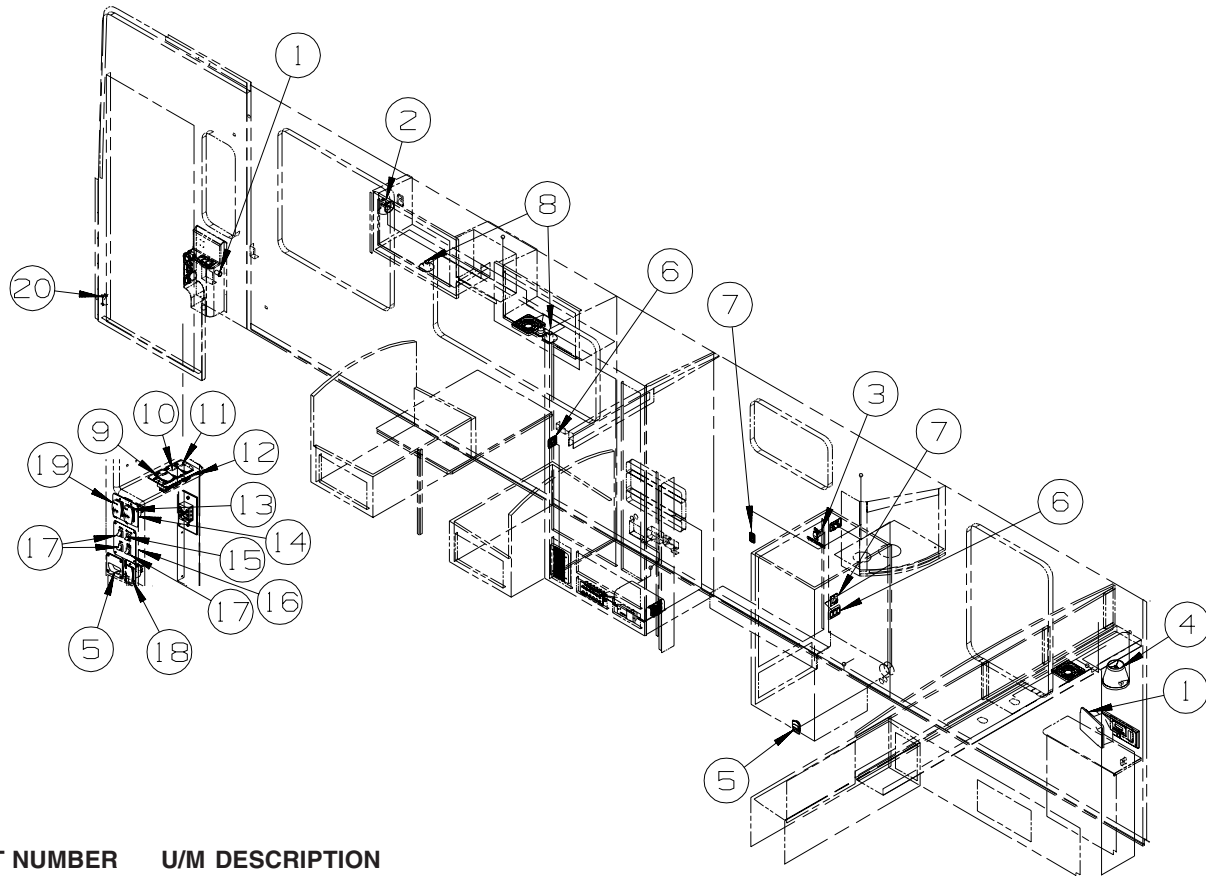

KEY	PART NUMBER	U/M	DESCRIPTION
1	132958-01-000	EA	RECEPTACLE - 12 VOLT - MOUNTING FLANGE - BLACK
2	128786-01-01A	EA	LIGHT - READING/SWIVEL
2	128786-02-01A	EA	LIGHT - READING/SWIVEL - W/O SWITCH - BRASS
			FROM: 00-00-00 THRU: 09-15-02
			FROM: 09-16-02 THRU: 99-99-99
	123917-01-000	EA	BULB - 12V - HALOGEN SPOT
3	108357-06-000	EA	SWITCH - ROCKER - DPDT - MOM/OFF/MOM - 6 TERMINAL
3	108356-02-01A	EA	COVER/ACTUATOR SWITCH - 2 ROWS DIMPLES- CONTURA II - BLACK
3	108355-01-000	EA	HOUSING - SWITCH
4	119258-42-01A	EA	LAMP - WALL - UL/CSA - BRASS
4	119257-19-01A	EA	SHADE - LAMP
4	117805-02-000	EA	BULB - 12V - #921 - 1.4 AMPS
5*	108354-01-01A	EA	LIGHT - COURTESY
6	135740-02-02A	EA	SWITCH - ROCKER - SPDT - ON/ON - WHITE - CEILING/AISLE
6	135741-02-02A	EA	SWITCH - BASE - DOUBLE - WHITE
6	135742-13-02A	EA	BEZEL - SWITCH - CEILING/AISLE - BROWN
7	135740-01-02A	EA	SWITCH - ROCKER - SPST - ON/OFF - WHITE - CEILING
7	135741-01-02A	EA	SWITCH - BASE - SINGLE - WHITE
7	135742-07-01A	EA	BEZEL - SWITCH - CEILING - WHITE
8	132427-01-01A	EA	LIGHT - READING - SWIVEL/ROUND - BRASS
	123917-01-000	EA	BULB - 12V - HALOGEN SPOT
9	108357-06-000	EA	SWITCH - ROCKER - DPDT - MOM/OFF/MOM - 6 TERMINAL
9	108356-01-01A	EA	COVER/ACTUATOR SWITCH - 3 GROOVES - CONTURA III - BLACK
9	108355-01-000	EA	HOUSING - SWITCH
10	108357-06-000	EA	SWITCH - ROCKER - DPDT - MOM/OFF/MOM - 6 TERMINAL - W/POWERED SUNVISOR
10	108356-01-01A	EA	COVER/ACTUATOR SWITCH - 3 GROOVES - CONTURA III - BLACK - W/POWERED SUNVISOR
10	108355-01-000	EA	HOUSING - SWITCH - W/POWERED SUNVISOR
10	096241-03-000	EA	SWITCH - BLANK - BLACK - W/MANUAL SUNVISOR
11	108357-01-000	EA	SWITCH - ROCKER - SPST - ON/OFF - 2 TERMINAL
11	108356-01-01A	EA	COVER/ACTUATOR SWITCH - 3 GROOVES - CONTURA III - BLACK
11	108355-01-000	EA	HOUSING - SWITCH
12	142487-01-02B	EA	PLATE - SWITCH - E-COATED
12	142475-01-01A	EA	APPLIQUE - SWITCH - PASSENGER

ELECTRICAL GROUP (CONTINUED)
12V BODY WIRING (CONTINUED)

KEY	PART NUMBER	U/M	DESCRIPTION
13	108357-06-000	EA	SWITCH - ROCKER - DPDT - MOM/OFF/MOM - 6 TERMINAL
13	108356-12-01A	EA	COVER/ACTUATOR SWITCH - 3 GROOVES
13	108355-01-000	EA	HOUSING - SWITCH
14	098351-22-01A	EA	PLATE/SWITCH - 2 GANG - POLISHED BRASS
15	132180-02-01A	EA	SWITCH - PADDLE - SPDT - ON/ON - BLACK
16	098351-08-01A	EA	PLATE/SWITCH - 4 GANG/BRASS-PORCH/CEILING/STEP/COMPT LAMPS
17	132180-01-01A	EA	SWITCH - PADDLE - SPST - ON/OFF - BLACK
18	108357-07-000	EA	SWITCH - ROCKER - SPDT - MOM/OFF/MOM - 3 TERMINAL - W/POWER DR LOCKS W/REMOTE
18	108356-01-01A	EA	COVER/ACTUATOR SWITCH - 3 GROOVES - CONTURA III - BLACK - W/POWER DR LOCKS W/REMOTE
18	108355-01-000	EA	HOUSING - SWITCH - W/POWER DR LOCKS W/REMOTE
19	108357-08-000	EA	SWITCH - ROCKER - DPDT - 0N/NONE/ON - 6 TERMINAL
19	108356-13-01A	EA	COVER/ACTUATOR SWITCH - 3 GROOVES
19	108355-01-000	EA	HOUSING - SWITCH
20	116995-02-000	EA	SWITCH/MAGNET - ELECTRIC STEP - BLACK/WHITE-CLOSED CIRCUIT

***COMPONENT PARTS LISTED LATER IN THIS GROUP**

ELECTRICAL GROUP (CONTINUED)
12V BODY WIRING (CONTINUED)

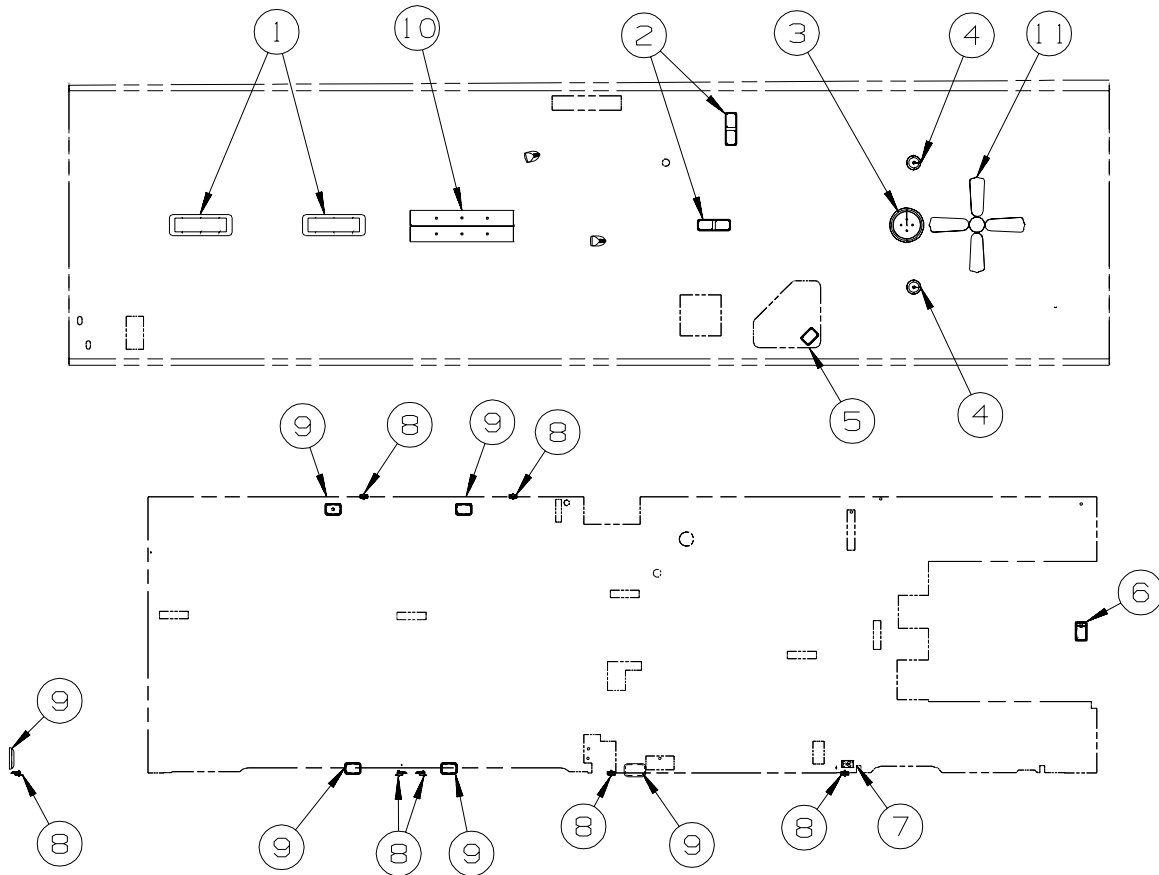

KEY	PART NUMBER	U/M DESCRIPTION
1*	091937-08-000	EA LIGHT-FLOURESCENT-12V/30 WATT RECESSED - W/O SWITCH
	091937-03-000	EA BULB - FLUORESCENT LIGHT - 12 VOLT
2*	137417-06-01A	EA LIGHT - DOME - DOUBLE - W/FROSTED LENS - W/O SWITCH-WHITE
3*	093575-19-01A	EA LIGHT - CEILING/ROUND - BRASS
	117805-02-000	EA BULB - 12V - #921 - 1.4 AMPS
4	093575-27-01A	EA LIGHT - CEILING - ROUND - BRASS - UL/CSA
	117805-02-000	EA BULB - 12V - #921 - 1.4 AMPS
5*	121935-01-01A	EA LIGHT - DOME - SHOWER
6*	137417-01-01A	EA LIGHT - DOME - SINGLE - W/SWITCH/FROSTED LENS - WHITE
7*	086280-01-000	EA LIGHT - SURFACE MOUNT - 12 VOLT
8	041250-01-000	EA SWITCH - PUSH BUTTON/DOOR JAMB - METAL - CHROME
9*	137417-03-01A	EA LIGHT - DOME - SINGLE - W/FROSTED LENS - W/O SWITCH-WHITE
10	133416-02-000	EA LIGHT - FLUORESCENT W/O LENS - 36" - 1 BULB
11*	139134-01-02A	EA FAN - CEILING - 35" - BRIGHT BRASS

***COMPONENT PARTS LISTED LATER IN THIS GROUP**

ELECTRICAL GROUP (CONTINUED)

FRONT END WIRING

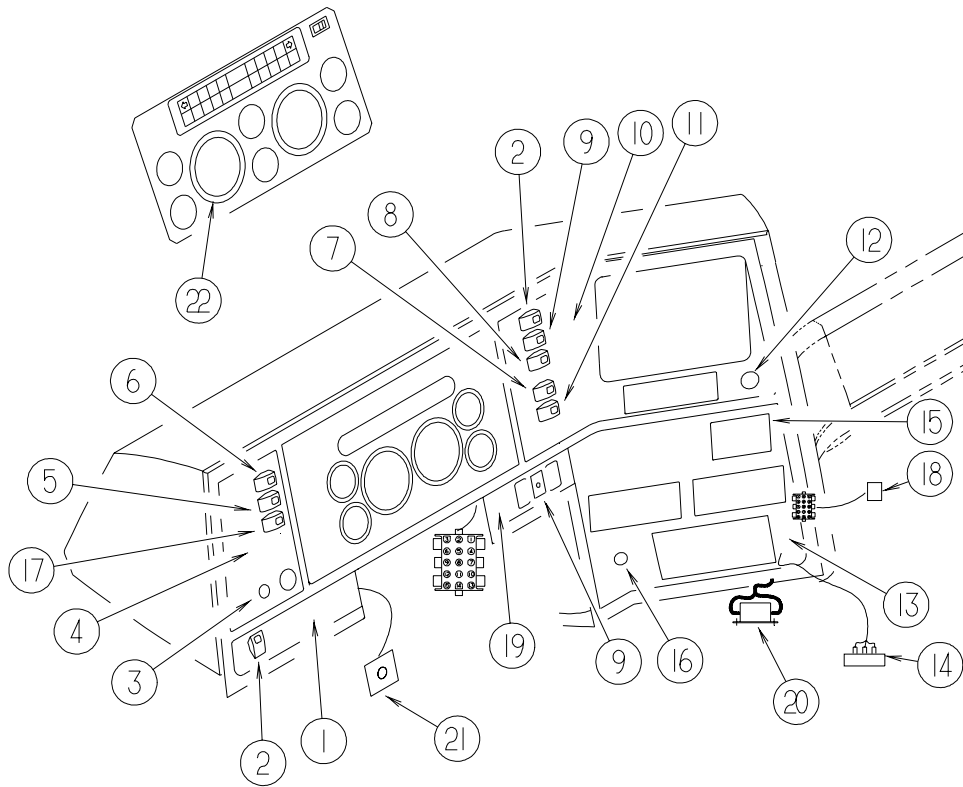

KEY	PART NUMBER	U/M	DESCRIPTION
1	104056-32-01A	EA	APPLIQUE - BEZEL - DRIVER/LOWER - BLACK VELVET
2	108357-08-000	EA	SWITCH - ROCKER DPDT - ON/NONE/ON - 6 TERMINAL - EXHAUST BRAKE - RADIO POWER
2	108356-01-01A	EA	COVER/ACTUATOR SWITCH - 3 GROOVES - CONTURA III - BLACK
2	108355-01-000	EA	HOUSING - SWITCH
3*	091206-04-000	EA	MODULE/WIPER CONTROL KIT - DYNAMIC PARK
4	104056-41-01A	EA	APPLIQUE - BEZEL - DRIVER SWEEP
5	108357-14-000	EA	SWITCH - ROCKER - SPST - W/LIGHT - ON/OFF - 4 TERMINAL - FOG LAMPS
5	108356-03-01A	EA	COVER/ACTUATOR SWITCH -3 GROOVES W/LIGHT-CONTRA III-BLACK
5	108355-01-000	EA	HOUSING - SWITCH
5	096241-03-000	EA	SWITCH - BLANK - BLACK
6	108357-09-000	EA	SWITCH - ROCKER SPDT - ON/NONE/MOM - 3 TERMINAL - AUXILIARY START
6	108356-01-01A	EA	COVER/ACTUATOR SWITCH - 3 GROOVES - CONTURA III - BLACK
6	108355-01-000	EA	HOUSING - SWITCH
7	108357-03-000	EA	SWITCH - ROCKER SPDT - ON/OFF/ON - 3 TERMINAL - AUXILIARY FANS
7	108356-01-01A	EA	COVER/ACTUATOR SWITCH - 3 GROOVES - CONTURA III - BLACK
7	108355-01-000	EA	HOUSING - SWITCH
7	096241-03-000	EA	SWITCH - BLANK - BLACK
8	108357-10-000	EA	SWITCH - ROCKER SPDT - W/LIGHT - MOM/NONE/MOM - 5 TERMINAL - GENERATOR
8	108356-03-01A	EA	COVER/ACTUATOR SWITCH -3 GROOVES W/LIGHT-CONTRA III-BLACK
8	108355-01-000	EA	HOUSING - SWITCH
9	108357-06-000	EA	SWITCH - ROCKER DPDT - MOM/OFF/MOM - 6 TERMINAL - BATTERY DISCONNECT - SLIDEOUT
9	108356-01-01A	EA	COVER/ACTUATOR SWITCH - 3 GROOVES - CONTURA III - BLACK
9	108355-01-000	EA	HOUSING - SWITCH
10	104056-40-01A	EA	APPLIQUE - BEZEL - PASSENGER/UPPER - 6-SWITCH
11	108357-01-000	EA	SWITCH - ROCKER SPST - ON/OFF - 2 TERMINAL - AIR HORN
11	108356-01-01A	EA	COVER/ACTUATOR SWITCH - 3 GROOVES - CONTURA III - BLACK
11	108355-01-000	EA	HOUSING - SWITCH
11	096241-03-000	EA	SWITCH - BLANK - BLACK
12	089294-01-000	EA	LIGHTER - CIGARETTE - W/SOCKET & WIRE
13	104056-52-01A	EA	APPLIQUE - BEZEL - LOWER/RIGHT WING
14	133535-01-000	EA	MODULE - TIMER 20 SECOND
15	136119-01-000	EA	COMPASS/THERMOMETER - ELECTRONIC

ELECTRICAL GROUP (CONTINUED)

FRONT END WIRING (CONTINUED)

KEY	PART NUMBER	U/M	DESCRIPTION
16	133534-02-000	EA	LIGHT - AMBER INDICATOR WITH 1/4" TERMINALS
17	108357-14-000	EA	SWITCH - ROCKER - SPST - W/LIGHT - ON/OFF - 4 TERMINAL - DOCKING LAMPS
17	108356-03-01A	EA	COVER/ACTUATOR SWITCH -3 GROOVES W/LIGHT-CONTRA III-BLACK
17	108355-01-000	EA	HOUSING - SWITCH
18	115539-01-000	EA	RELAY - RADIO/TV SPEAKER - SWITCH
19	104056-42-01A	EA	APPLIQUE - BEZEL - PASSENGER/LOWER - F/SLIDEOUT & JACKS
20	128074-02-000	EA	FILTER - NOISE - 12 VOLT DC W/PLUGS
21	134090-02-000	EA	MODULE - DAY TIME RUNNING LIGHT
22	133196-05-000	EA	SPEEDOMETER - FREIGHTLINER - KILOMETERS - CANADIAN
	077031-03-000	EA	FILM - WHITE - .75" X 1"
	103603-01-000	EA	BULB - 12 VOLT - #74 - .12A WEDGE - GE 22-25 USED IN DASH
	103608-01-000	EA	SOCKET - WEDGE BASE W/LEADS

*COMPONENT PARTS LISTED LATER IN THIS GROUP

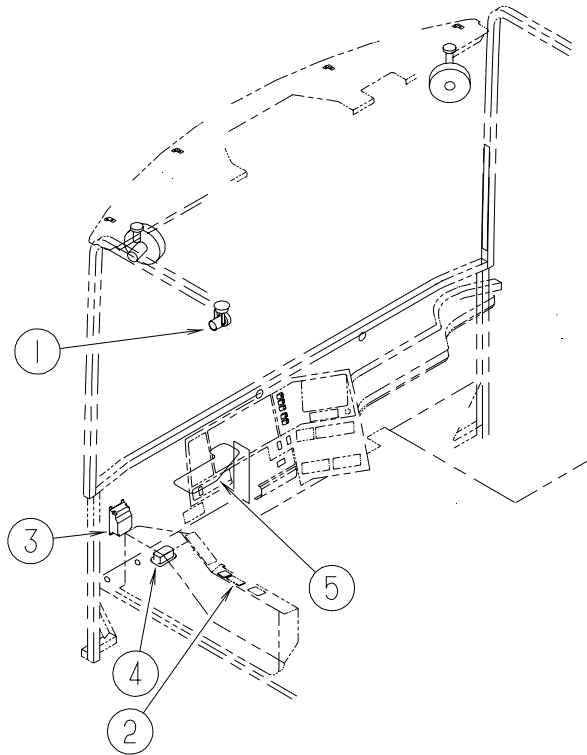

KEY	PART NUMBER	U/M	DESCRIPTION
1	128786-01-01A	EA	LIGHT - READING/SWIVEL
	123917-01-000	EA	BULB - 12V - HALOGEN SPOT
2	118662-14-02B	EA	PLATE - SWITCH - WINDOW - E-COATED - REMOTE POWER DOOR LOCK
2	108357-07-000	EA	SWITCH - ROCKER - SPDT - MOM/OFF/MOM - 3 TERMINAL - REMOTE POWER DOOR LOCK
2	108356-01-01A	EA	COVER/ACTUATOR SWITCH - 3 GROOVES - CONTURA III - BLACK - REMOTE POWER DOOR LOCK
2	108355-01-000	EA	HOUSING - SWITCH - REMOTE POWER DOOR LOCK
2	096241-03-000	EA	SWITCH - BLANK - BLACK
2	143057-01-01A	EA	APPLIQUE/SWITCH - DRIVER - POWERED SUNVISORS
2	108357-06-000	EA	SWITCH - ROCKER - DPDT - MOM/OFF/MOM - 6 TERMINAL - POWERED SUNVISORS
2	108356-01-01A	EA	COVER/ACTUATOR SWITCH - 3 GROOVES - CONTURA III - BLACK - POWERED SUNVISORS
2	108355-01-000	EA	HOUSING - SWITCH - POWERED SUNVISORS
2	088246-01-000	EA	SWITCH/REMOTE MIRROR - W/2PIN & 6 PIN CONNECTORS/PIGTAIL - REMOTE MIRROR
2	108357-14-000	EA	SWITCH - ROCKER SPDT - W/LIGHT - ON/OFF - 4 TERMINAL - MIRROR HEATER
2	108356-03-01A	EA	COVER/ACTUATOR SWITCH -3 GROOVES W/LIGHT-CONTRA III-BLACK - MIRROR HEATER
2	108355-01-000	EA	HOUSING - SWITCH - MIRROR HEATER
3*	091206-04-000	EA	MODULE KIT - WIPER CONTROL - DYNAMIC PARK
4	118571-03-000	EA	BRACKET - MOUNTING
4	118571-04-000	EA	GASKET
5	113452-01-000	FT	SEAL/TRIM - FRONT - VINYL W/WIRE CARRIER - .020"

*COMPONENT PARTS LISTED LATER IN THIS GROUP

ELECTRICAL GROUP (CONTINUED)
FRONT END WIRING (CONTINUED)

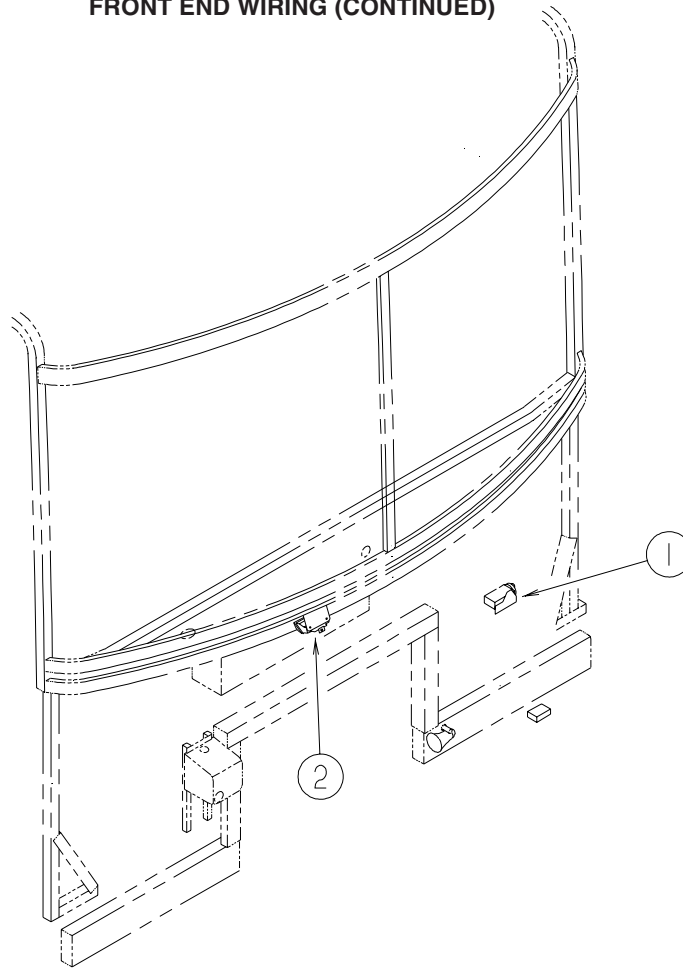

KEY	PART NUMBER	U/M	DESCRIPTION
1	114802-01-000	EA	PUMP - VACUUM - 12V
2*	137417-01-01A	EA	LIGHT - DOME - SINGLE - W/SWITCH/FROSTED LENS - WHITE

*COMPONENT PARTS LISTED LATER IN THIS GROUP

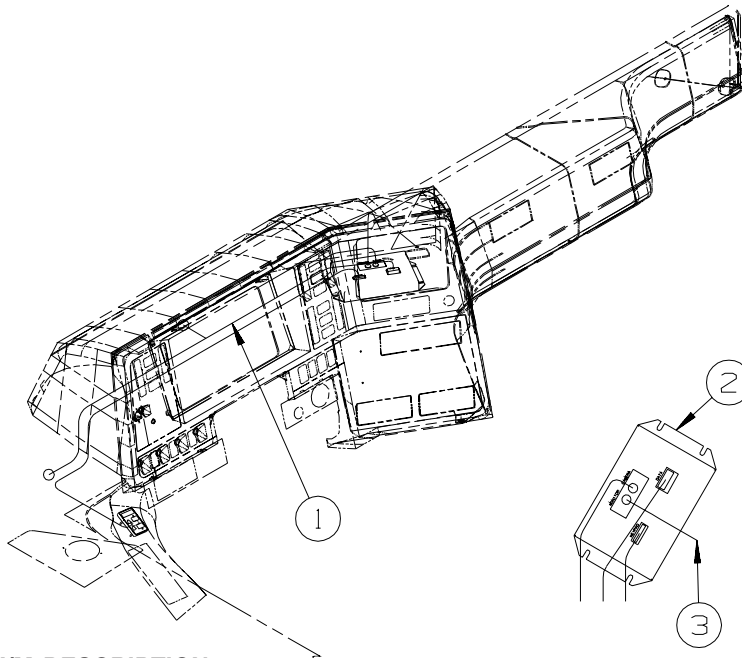

KEY	PART NUMBER	U/M	DESCRIPTION
1	143591-02-000	EA	WIRE LOOM - COMPUTER TRIP/ENGINE MONITOR-TRIP TEK 02-04007
2*	143591-05-000	EA	COMPUTER - TRIP/ENGINE MONITOR - COLOR - TRIP TEK 2500-3
3	143591-04-000	EA	CABLE ASM-CAMERA COLOR INTER , TRIP TEK 02-04009

*COMPONENT PARTS LISTED LATER IN THIS GROUP

ELECTRICAL GROUP (CONTINUED)
COMPONENT PARTS FOR LIGHTS & SWITCHES

			008089-02-000	
KEY	PART NUMBER	U/M	DESCRIPTION	VENDOR NO.
	008089-01-700	EA	LENS/PORCH LIGHT RECESSED	DECO
			086280-01-000	
KEY	PART NUMBER	U/M	DESCRIPTION	VENDOR NO.
	086280-01-700	EA	BULB,12V	ARP1089
			087694-01-000	
KEY	PART NUMBER	U/M	DESCRIPTION	VENDOR NO.
	087694-01-700	EA	BULB	GE561
			091206-04-000	
KEY	PART NUMBER	U/M	DESCRIPTION	VENDOR NO.
	091206-02-700	EA	KNOB-INNER	66C-00019
	091206-02-701	EA	KNOB-OUTER	66C-00020
	091206-04-700	EA	SWITCH ASSEM. ONLY	250-6623
	102362-03-700	EA	MODULE-WIPER CONT., DYNAMIC	66D-00093
			091937-08-000	
KEY	PART NUMBER	U/M	DESCRIPTION	VENDOR NO.
	091937-08-700	EA	LENS - LIGHT - FLUORESCENT	D-766
			091937-09-000	
KEY	PART NUMBER	U/M	DESCRIPTION	VENDOR NO.
	091937-09-700	EA	LENS - LIGHT - FLUORESCENT	D-762
			093575-19-01A	
KEY	PART NUMBER	U/M	DESCRIPTION	VENDOR NO.
	093575-19-700	EA	GLOBE F/55-556X2 LIGHT	9088
			108354-01-01A	
KEY	PART NUMBER	U/M	DESCRIPTION	VENDOR NO.
	108354-01-700	EA	BULB-COURTESY LIGHT	395-B
			121935-01-01A	
KEY	PART NUMBER	U/M	DESCRIPTION	VENDOR NO.
	121935-01-700	EA	LENS ONLY	809511
			123775-01-01A	
KEY	PART NUMBER	U/M	DESCRIPTION	VENDOR NO.
	123775-01-700	EA	BULB - 10 WATT - HALOGEN	71-JC10
	123775-01-701	EA	BEZEL/LENS - RECESSED LIGHT	
			133054-03-000	
KEY	PART NUMBER	U/M	DESCRIPTION	VENDOR NO.
	133054-03-700	EA	LENS	2011-0000-10
	133054-03-701	EA	GASKET - LIGHT MOUNTING	2004-0000-00
	133054-03-702	EA	GASKET - LENS	2003-0000-00
			133054-04-000	
KEY	PART NUMBER	U/M	DESCRIPTION	VENDOR NO.
	133054-03-701	EA	GASKET - LIGHT MOUNTING	2004-0000-00
	133054-03-702	EA	GASKET - LENS	2003-0000-00
	133054-04-700	EA	LENS	2011-0000-20
			137417-01-01A	
KEY	PART NUMBER	U/M	DESCRIPTION	VENDOR NO.
	137417-01-700	EA	LENS - SINGLE (FROSTED)	810868
			137417-03-01A	
KEY	PART NUMBER	U/M	DESCRIPTION	VENDOR NO.
	137417-01-700	EA	LENS - SINGLE (FROSTED)	810868
			137417-06-01A	
KEY	PART NUMBER	U/M	DESCRIPTION	VENDOR NO.
	137417-06-700	EA	LENS - DOUBLE WHITE	810867
			139134-01-02A	
KEY	PART NUMBER	U/M	DESCRIPTION	VENDOR NO.
	139134-01-711	EA	BLADES (36") WHITE MATT	A70050-5W
	139134-01-712	EA	MOTOR	A70050-1
	139134-01-713	EA	HOLDER/BLADE	A70050-4B
	139134-01-714	EA	SWITCH/SLIDE-MOTOR HOUSING	A70050-6
	139134-01-715	EA	HOUSING/MOTOR	A7005202B
	139134-01-716	EA	SWITCH/WALL - ALMOND	A70611

ELECTRICAL GROUP (CONTINUED)
CIRCUIT BREAKERS & FUSES

KEY	PART NUMBER	U/M	DESCRIPTION
	008233-01-000	EA	FUSE - 12 VOLT - 6 AMP
	008235-01-000	EA	FUSE - 15 AMP/12VOLT - AUTOMOTIVE
	008268-01-000	EA	CIRCUIT BREAKER W/MOUNT - 30A, 12V - FASCO 1711-3023
	033573-01-000	EA	CIRCUIT BREAKER W/MOUNT-20A, 12V - FASCO 1711-2026
	062901-02-000	EA	FUSE - 5 AMP - AUTOMOTIVE
	062901-04-000	EA	FUSE - 10 AMP - AUTOMOTIVE
	062901-05-000	EA	FUSE - 15 AMP - AUTOMOTIVE
	062901-06-000	EA	FUSE - 20 AMP - AUTOMOTIVE
	062901-07-000	EA	FUSE - 25 AMP - AUTOMOTIVE
	062901-08-000	EA	FUSE - 30 AMP - AUTOMOTIVE
	083209-01-000	EA	CIRCUIT BREAKER - 15 AMP - 120 VOLT - CANADIAN
	083209-02-000	EA	CIRCUIT BREAKER - 15/15 AMP - 120 VOLT
	083209-03-000	EA	CIRCUIT BREAKER - 15/20 AMP - 120 VOLT
	083209-04-000	EA	CIRCUIT BREAKER - 30 AMP - 120 VOLT
	083209-05-000	EA	CIRCUIT BREAKER - 20 AMP - 120 VOLT
	083209-06-000	EA	CIRCUIT BREAKER - 30/15 AMP - 120 VOLT
	083209-07-000	EA	CIRCUIT BREAKER - 20/20 AMP - 120 VOLT
	083209-10-000	EA	CIRCUIT BREAKER - 20/30 AMP - 120 VOLT
	083209-11-000	EA	CIRCUIT BREAKER - 20/15 AMP - 120 VOLT
	092786-03-000	EA	BUSS BAR - 6.9" LONG
	092786-06-000	EA	BUSS BAR
	093654-01-000	EA	CIRCUIT BREAKER - 6 AMP - 12 VOLT - PUSH BUTTON - WHITE
	093654-02-000	EA	CIRCUIT BREAKER - 15 AMP - 12 VOLT - PUSH BUTTON - WHITE
	093654-03-000	EA	CIRCUIT BREAKER - 20 AMP - 12 VOLT - PUSH BUTTON - WHITE
	093654-11-000	EA	COVER - RESET BUTTON
	093655-01-000	EA	CIRCUIT BREAKER - 25 AMP - 12 VOLT - PUSH BUTTON - WHITE
	093655-02-000	EA	CIRCUIT BREAKER - 30 AMP - 12 VOLT - PUSH BUTTON - WHITE
	093655-03-000	EA	CIRCUIT BREAKER - 40 AMP - 12 VOLT - PUSH BUTTON - WHITE
	097611-01-000	EA	CIRCUIT BREAKER - 10 AMP
	097611-03-000	EA	CIRCUIT BREAKER - 20 AMP
	097611-04-000	EA	CIRCUIT BREAKER - 25 AMP
	106656-01-000	EA	FUSE BLOCK - 4 CAVITY - AUTOFUSE
	108567-01-000	EA	CIRCUIT BREAKER - 40 AMP - 12 VOLT - TYPE II
	108669-01-000	EA	HOUSING - AUTO FUSE HOLDER
	111683-01-000	EA	FUSE - HOLDER - GLASS - 1/4" X 1 1/4"
	113482-01-000	EA	CIRCUIT BREAKER - 55 AMP - MANUAL
	113520-01-000	EA	BREAKER - CIRCUIT - 15AMP - SWITCHED
	115187-01-000	EA	FUSE - 300 AMP - NON-DELAY
	115187-02-000	EA	FUSE HOLDER - BUSS ANN/ANL BLOCK
	118531-05-02B	EA	PLATE - CIRCUIT BREAKER - E-COAT
	122811-01-000	EA	CIRCUIT BREAKER - 20/50/50/20
	125986-04-000	EA	FUSE - 10 AMP - AUTO - MINI BLADE
	125986-05-000	EA	FUSE - 15 AMP - AUTO - MINI BLADE
	134127-01-000	EA	CIRCUIT BREAKER - 10 AMP - MINI

ELECTRICAL GROUP (CONTINUED)
CONVERTER, INVERTER, LOAD CENTERS

KEY	PART NUMBER	U/M	DESCRIPTION
	099048-04-000	EA	INVERTER - 300 WATT
	109677-01-000	EA	LOAD CENTER - 120 VOLT - 40 AMP
	113685-05-000	EA	REMOTE PANEL - INVERTER/CHARGER
	113685-06-000	EA	CABLE - MODULAR JACK - 50'
	113685-07-000	EA	INVERTER/CHARGER - 1500W AC
	123058-01-000	EA	CONVERTER - 55 AMP - ELECTRONIC - 4 1/8"H X 7"W X 12 3/8"L
	127002-05-000	EA	PANEL/MONITOR - ENERGY MANAGEMENT SYSTEMS CTRL - W/PLUG
	127002-07-000	EA	SENSOR - CURRENT
	127002-08-000	EA	MODULE - EMS CENTER - W/REMOTE SENSOR
	141258-01-000	EA	LOAD CENTER - 120/240 - 50 AMP
	141258-02-000	EA	LOAD CENTER - COVER

ELECTRICAL GROUP (CONTINUED)
110V WIRING

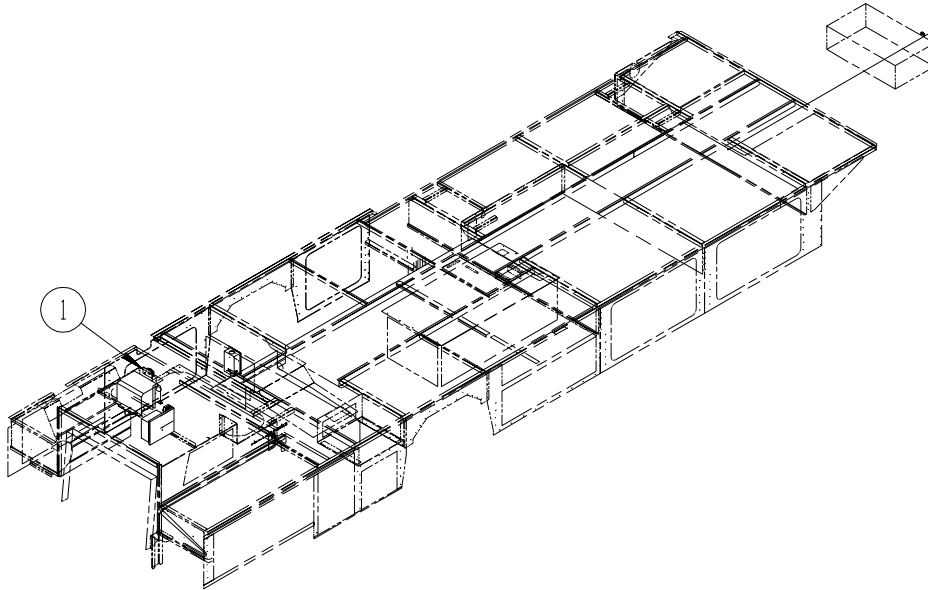

KEY	PART NUMBER	U/M	DESCRIPTION
1	058708-05-000	EA	RECEPTACLE - ELECTRIC - SINGLE - BROWN
1	058708-07-000	EA	RECEPTACLE - SINGLE - WHITE

ELECTRICAL GROUP (CONTINUED)
110V WIRING (CONTINUED)

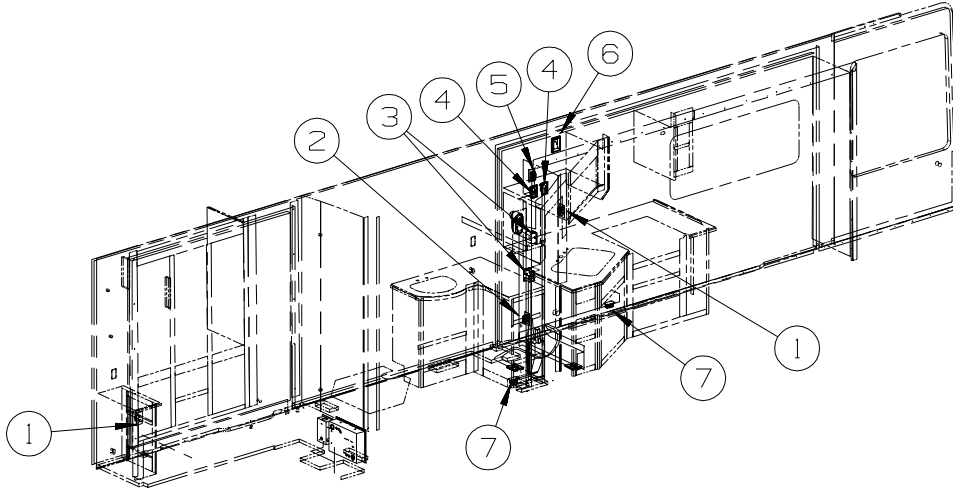

KEY	PART NUMBER	U/M	DESCRIPTION
1	058708-01-000	EA	RECEPTACLE - ELECTRIC - DOUBLE - BROWN
2	058708-06-000	EA	RECEPTACLE - DUPLEX - WHITE
3	084076-05-000	EA	RECEPTACLE - GFI - 15 AMP/125 VOLT - WHITE
4	084420-03-000	EA	SWITCH - TOGGLE - 15 AMP - 120 VOLT - IVORY
5	058708-05-000	EA	RECEPTACLE - ELECTRIC - SINGLE - BROWN
5	058708-07-000	EA	RECEPTACLE - SINGLE - WHITE
6	058708-05-000	EA	RECEPTACLE - ELECTRIC - SINGLE - BROWN
6	058708-07-000	EA	RECEPTACLE - SINGLE - WHITE
6	133713-01-08A	EA	SPACER/RECEPTACLE - VINYL/PORTSMOUTH OAK - PORTSMOUTH OAK
6	133713-01-03A	EA	SPACER/RECEPTACLE - VINYL/SALEM CHERRY - CONCERT CHERRY
6	133713-01-02A	EA	SPACER/RECEPTACLE - VINYL/WASHED MAPLE - WASHED MAPLE
7	058707-02-000	EA	RECEPTACLE - BLANK - JUNCTION BOX

ELECTRICAL GROUP (CONTINUED)
110V WIRING (CONTINUED)

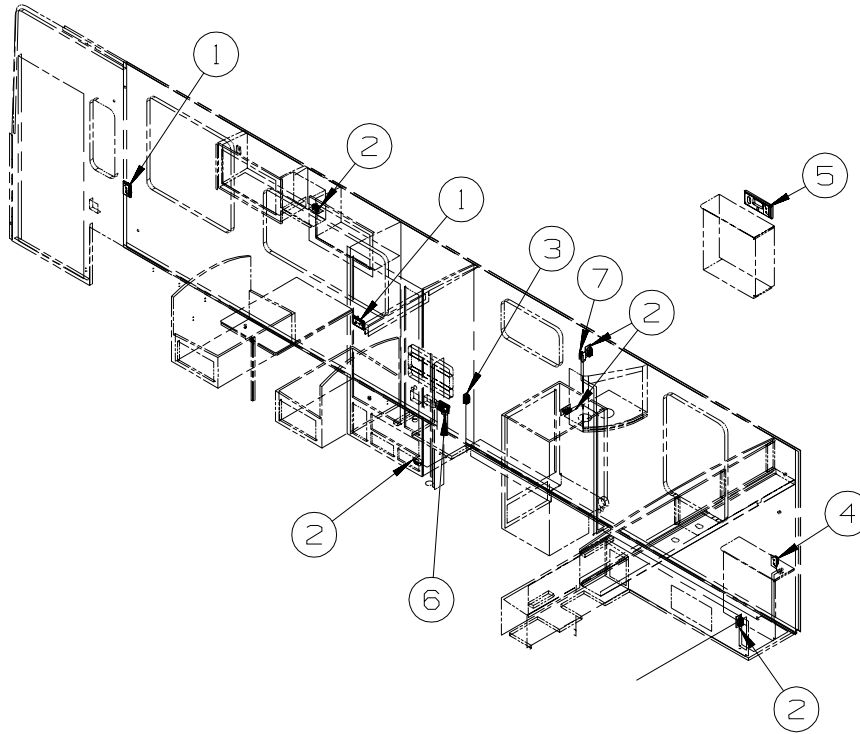

KEY	PART NUMBER	U/M	DESCRIPTION
1	058708-01-000	EA	RECEPTACLE - ELECTRIC - DOUBLE - BROWN
2	058708-06-000	EA	RECEPTACLE - DUPLEX - WHITE
3	084076-05-000	EA	RECEPTACLE - GFI - 15 AMP/125 VOLT - WHITE
4	084420-03-000	EA	SWITCH - TOGGLE - 15 AMP - 120 VOLT - IVORY
5	058708-05-000	EA	RECEPTACLE - ELECTRIC - SINGLE - BROWN
5	058708-07-000	EA	RECEPTACLE - SINGLE - WHITE
6	058708-05-000	EA	RECEPTACLE - ELECTRIC - SINGLE - BROWN
6	058708-07-000	EA	RECEPTACLE - SINGLE - WHITE
6	133713-01-08A	EA	SPACER/RECEPTACLE - VINYL/PORTSMOUTH OAK - PORTSMOUTH OAK
6	133713-01-03A	EA	SPACER/RECEPTACLE - VINYL/SALEM CHERRY - CONCERT CHERRY
6	133713-01-02A	EA	SPACER/RECEPTACLE - VINYL/WASHED MAPLE - WASHED MAPLE
7	058707-02-000	EA	RECEPTACLE - BLANK - JUNCTION BOX

ELECTRICAL GROUP (CONTINUED)
ENTERTAINMENT WIRING

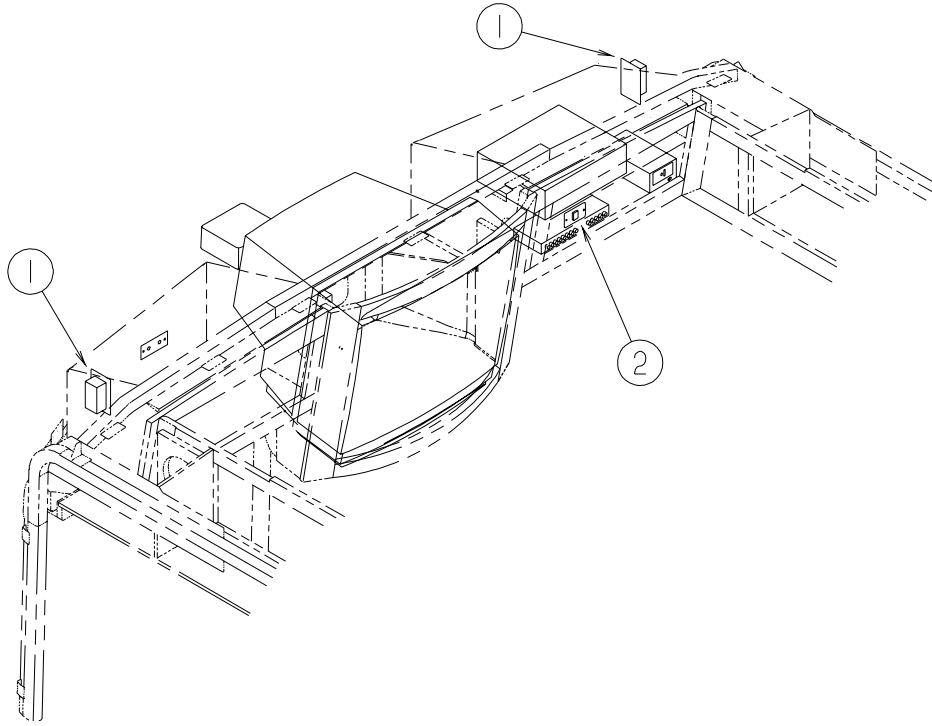

KEY	PART NUMBER	U/M DESCRIPTION
1	058708-01-000	EA RECEPTACLE - ELECTRIC - DOUBLE - BROWN
2	079364-04-000	EA SWITCH - ON/OFF ROCKER - 2 TERMINAL - BLACK
2	098351-09-01A	EA PLATE/SWITCH - 1 GANG - POLISHED BRASS - SPEAKER SELECT/TV

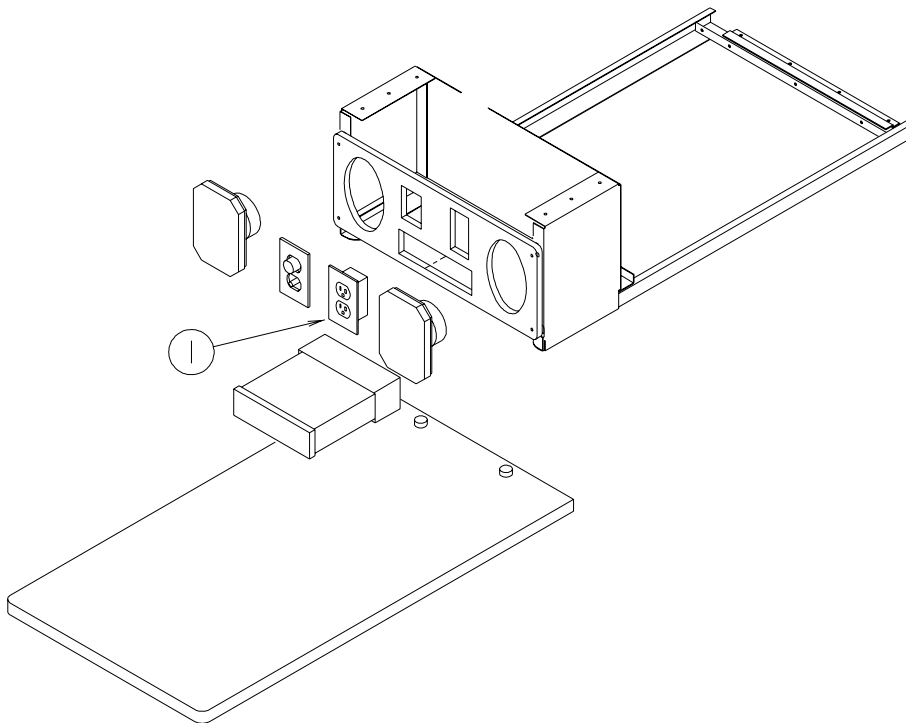

KEY	PART NUMBER	U/M DESCRIPTION
1	058708-05-000	EA RECEPTACLE - ELECTRIC - SINGLE - BROWN
2	058708-07-000	EA RECEPTACLE - SINGLE - WHITE

ELECTRICAL GROUP (CONTINUED)
BOXES & CORDS

KEY	PART NUMBER	U/M	DESCRIPTION
	008054-01-000	EA	CORD - POWER - 10/3 WIRE - 30 AMP - 25'
	008289-01-000	EA	BOX - ELECTRIC/STEEL - 1/2" & 3/4" KNOCKOUTS - 4" X 4" FROM: 00-00-00 THRU: 10-13-02
	008294-01-000	EA	COVER - ELECTRIC BOX - BLANK/STEEL - 4" X 4" - GRAY FROM: 00-00-00 THRU: 10-13-02
	092492-17-000	EA	SEAL - ELECTRICAL BOX
	106071-05-000	EA	SWITCH - AUTOMATIC TRANSFER - 50/70 - MAGNETEK FROM: 00-00-00 THRU: 10-06-02
	106071-06-000	EA	SWITCH - AUTOMATIC TRANSFER FROM: 10-07-02 THRU: 99-99-99
	108934-02-000	EA	CORD - POWER - 50 AMP - 4-WIRE - 36'
	113029-06-02B	EA	PANEL - ELECTRICAL BOX FRONT - E-COATED
	110080-05-000	EA	SEAL - ELECTRICAL BOX
	115832-01-000	FT	CORD - HEAVY DUTY - 14-2W GROUND
	131679-01-000	EA	BOX-ELEC-WATERPROOF SEALED 4" X 4" W/4 3/4"OUTLETS-UL/CSA
	131680-01-000	EA	COVER - W/GASKET FOR WATERPROOF 4" X 4" BOX - UL/CSA
	133070-01-000	EA	BOX - ELECTRIC/PLASTIC - 3" X 2" X 2.8" - UL
	133070-02-000	EA	BOX - ELECTRIC/PLASTIC - 3" X 2" X 2.8" - CSA
	142209-03-02B	EA	DOOR - ELECTRICAL BOX - E-COATED

WIRE ASSEMBLIES

KEY	PART NUMBER	U/M	DESCRIPTION
	096449-02-000	EA	WIRE ASSEMBLY - WATER TANK TO MONITOR PANEL
	096450-05-000	EA	WIRE F/SENSORS - BLACK WATER - 23.6"
	096451-05-000	EA	WIRE F/SENSORS - GREY WATER - 43.2" - IKP39QD
	096451-07-000	EA	WIRE F/SENSORS - GREY WATER - 3.9" - IKP34HD - IKP36LD - IKP39WD
	108029-01-000	EA	WIRE ASSEMBLY - POWER DRIVER SEAT
	108029-04-000	EA	WIRE ASSEMBLY - POWER PASSENGER SEAT
	127002-06-000	EA	WIRE ASSEMBLY - EMS - W/PLUG - IKP36LD FROM: 00-00-00 THRU: 04-08-02
	120233-05-000	EA	WIRE ASSEMBLY - 30" CONNECTS TO WALLPLATE DISPLAY - IKP34HD - IKP36LD - IKP39WD FROM: 00-00-00 THRU: 04-08-02
	137135-03-000	EA	WIRE LOOM - DIGITAL ELEVATION SENSOR - IKP34HD - IKP36LD - IKP39WD FROM: 04-09-02 THRU: 99-99-99
	137135-04-000	EA	WIRE HARNESS - POWER - DIGITAL ELEVATION SENSOR FROM: 04-09-02 THRU: 99-99-99
	142258-02-000	EA	WIRE LOOM - VIDEO SWITCH/POWER SUPPLY FROM: 04-09-02 THRU: 99-99-99
	124336-01-000	EA	WIRE - REAR STEREO - 12 PIN - IKP34HD - IKP36LD
	124843-07-000	EA	WIRE ASSEMBLY - SPEAKER ADAPTER
	124843-08-000	EA	WIRE ASSEMBLY - SPEAKER ADAPTER
	133817-02-000	EA	WIRE ASSEMBLY - SPEAKER/ADAPTER - 117.9" LONG - IKP39QD
	124882-08-000	EA	WIRE LOOM - AMPLIFIER - Q SURROUND
	125853-01-000	EA	WIRE LOOM - ENTERTAINMENT CENTER
	125853-04-000	EA	WIRE LOOM - ENTERTAINMENT CENTER
	129888-01-000	EA	WIRE LOOM - INSTRUMENT PANEL - AIR HORN
	135131-01-000	EA	WIRE LOOM - THERMOSTAT
	135420-02-000	EA	WIRE LOOM - RADIO
	139297-01-000	EA	RESISTOR - 10 OHM/10W CERAMIC - IKP34HD - IKP36LD
	139583-01-000	EA	WIRE LOOM - SOFA/DOUBLE REST EASY
	139583-02-000	EA	WIRE LOOM - SOFA/REAR SWITCH
	140195-01-000	EA	WIRE LOOM - RESISTOR/FAN - IKP34HD - IKP36LD
	141454-02-000	EA	WIRE LOOM - SATELLITE - AUTOMATIC - IKP36LD

ELECTRICAL GROUP (CONTINUED)
CONNECTORS & CONDUIT

KEY	PART NUMBER	U/M	DESCRIPTION
	007956-01-000	EA	RECEPTACLE - HOUSING - 6 POSITION
	007956-05-000	EA	INSULATOR - SHRINK - 1/4" ID X 1 1/2"
	008058-01-000	EA	ADAPTER - POWER CORD - 30 AMP TO 15 AMP
	008311-01-000	EA	CONNECTOR - WIRE NUT - INSULATED - RED
	008312-01-000	EA	CONNECTOR - WIRE NUT - INSULATED - BLUE
	008313-01-000	EA	CONNECTOR - WIRE NUT - INSULATED - YELLOW
	008314-01-000	EA	CONNECTOR - WIRE NUT - INSULATED - GRAY
	008326-01-000	EA	TERMINAL - RING - 16/14 WIRE - 3/8" STUD
	008328-01-000	EA	TERMINAL - RING - 12/10 WIRE - #10 STUD FIT
	008331-01-000	EA	TERMINAL - RING - TONGUE - #4 WIRE - 3/8" STUD - COPPER
	008348-01-000	EA	TERMINAL - RING - 3/8" STUD 2 GA. WIRE
	008355-01-000	EA	CONNECTOR - CABLE CLAMPING - 3/4"
	008356-01-000	EA	CONNECTOR - PLASTIC - 3/8" AVG
	008356-02-000	EA	CONNECTOR - PLASTIC - 21/32
	035416-04-000	EA	TERMINAL - RING - #10 STUD FIT - INSULATED BARREL #16/14
	041953-01-000	FT	CONDUIT - CONVOLUTE SLIT - .5" ID - POLYETHYLENE
	041953-02-000	FT	CONDUIT - CONVOLUTE SLIT - .6" ID - POLYETHYLENE
	041953-03-000	FT	CONDUIT - CONVOLUTE SLIT - 1" ID (CLOTHES ROD COVER)
	041953-05-000	FT	CONDUIT - CONVOLUTE SOLID - .62" ID - POLYETHYLENE
	041953-06-000	FT	CONDUIT - CONVOLUTE SLIT - .4" ID - POLYETHYLENE
	041953-07-000	FT	CONDUIT - CONVOLUTE SLIT - .25" ID - POLYETHYLENE
	041953-08-000	FT	CONDUIT - CONVOLUTE SLIT - 1.5" ID - POLYETHYLENE
	041953-09-000	FT	CONDUIT - CONVOLUTE SLIT - .5" ID - NYLON
	041953-10-000	FT	CONDUIT - CONVOLUTE SLIT - .75" ID - NYLON
	041953-11-000	FT	CONDUIT - CONVOLUTE SLIT - 1.06" ID - NYLON
	041953-12-000	FT	CONDUIT - CONVOLUTE SOLID - 1.1" ID - NYLON
	041953-13-000	FT	CONDUIT - CONVOLUTE SLIT - 1.25
	041953-14-000	FT	CONDUIT - CONVOLUTE SLIT - 1.5
	047443-01-000	EA	TERMINAL - .250 RECEPTACLE FIT - INSULATED - 16/14 AWG
	047443-02-000	EA	TERMINAL - .250 RECEPTACLE FIT - INSULATED - 12/10 AWG
	058028-01-000	EA	CONNECTOR - ELECTRICAL PIGTAIL - NYLON - CLEAR
	062036-01-000	EA	TERMINAL - PACK - CON - 12/10 AWG
	074017-02-000	EA	HOUSING - 5 POSITION - RIGHT ANGLED
	077479-01-000	EA	BOOT - BATTERY TERMINAL - DOUBLE CABLE
	077479-02-000	EA	BOOT - BATTERY TERMINAL - SINGLE CABLE
	080015-02-000	EA	RECEPTACLE - FLAG - .185 - 16/14 GAUGE
	080015-03-000	EA	RECEPTACLE - FLAG - .250 - 14/16 GAUGE
	082109-01-000	EA	HOUSING - CONNECTOR - PACKARD
	082741-01-000	EA	CONNECTOR BODY - 2 CONNECTOR MALE
	087225-01-000	FT	SLEEVING - 1/2" - TYPE H
	087949-01-000	EA	BUSS BAR - 2 POSITION - .6" X 1.5"
	087949-02-000	EA	BUSS BAR - 3 POSITION - .6" X 2.4"
	087949-03-000	EA	BUSS BAR - 4 POSITION
	087949-05-000	EA	BUSS BAR - 7 POSITION
	088267-01-000	EA	TERMINAL - FEMALE - 1/4
	088473-01-000	EA	HOUSING - PIN - 12 CAVITY (3 ROWS OF 4)
	088473-02-000	EA	HOUSING - PIN - 15 CAVITY (3 ROWS OF 5)
	088473-03-000	EA	HOUSING - PIN - 9 CAVITY (3 ROWS OF 3)
	088473-04-000	EA	HOUSING - PIN - 8 CAVITY IN-LINE
	088473-06-000	EA	HOUSING - PIN - 6 CAVITY (2 ROWS OF 3)
	088473-08-000	EA	HOUSING - PIN - 4 CAVITY - IN-LINE
	088473-09-000	EA	HOUSING - PIN - 3 CAVITY - IN-LINE
	088473-10-000	EA	HOUSING - PIN - 2 CAVITY - IN LINE
	088474-01-000	EA	HOUSING - SOCKET - 12 CAVITY
	088474-02-000	EA	HOUSING - SOCKET - 15 CAVITY
	088474-03-000	EA	HOUSING - SOCKET - 9 CAVITY
	088474-06-000	EA	HOUSING - SOCKET - 6 CAVITY
	088474-07-000	EA	HOUSING - SOCKET - 5 CAVITY
	088474-08-000	EA	HOUSING - SOCKET - 4 CAVITY
	088474-09-000	EA	HOUSING - SOCKET - 3 CAVITY
	088474-10-000	EA	HOUSING - SOCKET - 2 CAVITY
	088475-01-000	EA	PIN - CONNECTOR - 14-20 AWG
	088475-02-000	EA	PIN - CONNECTOR - 10-12 AWG
	088476-01-000	EA	TERMINAL - ELECTRICAL

ELECTRICAL GROUP (CONTINUED)
CONNECTORS & CONDUIT (CONTINUED)

KEY	PART NUMBER	U/M	DESCRIPTION
	088476-02-000	EA	SOCKET - CONNECTOR - 12-10 GA - PRE-TIN
	098261-01-000	EA	SOCKET - CONNECTOR - WEATHERPACK - 12 AWG
	098261-02-000	EA	SOCKET - CONNECTOR - WEATHERPACK - 14-18 AWG
	098262-01-000	EA	SEAL - CONNECTOR - WEATHERPACK
	098262-05-000	EA	SEAL - CAVITY
	098262-06-000	EA	SEAL - CONNECTOR - M/P - 10 GAUGE
	098262-07-000	EA	SEAL - CONNECTOR - 12 AWG - 280 SER
	098263-01-000	EA	HOUSING - 3 PIN - WEATHER PACK
	098263-02-000	EA	HOUSING - 3 PIN - WEATHER PACK
	098264-01-000	EA	HOUSING - 2 PIN - WEATHER PACK - MALE W/FEMALE PINS
	098264-02-000	EA	HOUSING - 2 PIN - WEATHER PACK - FEMALE W/MALE PINS
	098265-02-000	EA	PIN - CONNECTOR - WEATHER PACK
	100690-01-000	EA	HOUSING - 5 POSITION - MALE - WEATHER PACK
	100690-02-000	EA	HOUSING - 5 POSITION - FEMALE - WEATHER PACK
	102777-02-000	EA	TERMINAL - RING - #6 STUD - 10 AWG
	104100-01-000	EA	HOUSING - 1 POSITION - 75 AMPS
	104100-03-000	EA	TERMINAL - 75 AMP
	106655-02-000	EA	TERMINAL - FUSE BLOCK - 10-12 AWG
	110178-01-000	EA	HOUSING - WIPER MOTOR
	112823-01-000	EA	SPLICE - REDUCER - 16-14 TO 18-22
	113072-01-000	EA	HOUSING - ELECTRICAL - TURN/TAIL LAMP
	113072-03-000	EA	HOUSING - ELECTRICAL - STOP/MARKER TAILLAMP
	113135-01-000	EA	TERMINAL - FEMALE - M/P - 14-16 - F/SEALED TERMINAL
	113306-01-000	EA	TERMINAL - FEMALE - M/P - 14-16 - F/NON-SEALED TERMINAL
	113306-02-000	EA	TERMINAL - FEMALE - M/P - 10-12 - 480
	113307-01-000	EA	TERMINAL - FEMALE - M/P - 16-20
	113308-01-000	EA	TERMINAL - FEMALE - M/P - 14-16 - 280
	113468-01-000	EA	HOUSING - 2 POSITION-FEMALE-USED ON WIPER/WASHER WIRE ASM
	113638-02-000	EA	CONNECTOR - ACTUATOR
	114667-01-000	FT	HOSE - 2" ID - FLEXIBLE
	115556-01-000	EA	HOUSING - 3 POSITION - FEMALE
	115556-02-000	EA	HOUSING - 2 POSITION - FEMALE/PARALLEL
	115931-02-000	EA	COVER - CONNECTOR - 50 AMP W/LOCKING RING
	115932-02-000	EA	CONNECTOR - FEMALE - 50 AMP/240 VOLT
	116811-01-000	EA	TERMINAL - .110 RECEPTACLE - 16-14 AWG
	118571-01-000	EA	CONNECTOR - 3-WAY - MALE/SEALED
	118571-02-000	EA	CONNECTOR - 3-WAY - FEMALE/SEALED
	118571-05-000	EA	LOCK - SECONDARY - FEMALE
	118571-06-000	EA	LOCK - SECONDARY - MALE
	118597-01-000	EA	TERMINAL - MALE - M/P - 480 - 14-16
	118599-01-000	EA	TERMINAL - MALE - M/P - 280 - 14-16
	118820-01-000	EA	INSULATOR - TERMINAL
	119223-01-000	EA	HOUSING - 6 POSITION - MALE - WEATHERPACK
	119248-02-000	EA	HOUSING - 7 POSITION - FEMALE
	125323-01-000	EA	HOUSING - 10 POSITION - MALE
	125323-02-000	EA	HOUSING - 8 POSITION - MALE
	125323-03-000	EA	LOCK - SECONDARY 8 POSITION
	125323-04-000	EA	LOCK - SECONDARY 10 POSITION
	125323-05-000	EA	HOUSING - 6 POSITION - MALE
	125323-06-000	EA	LOCK - SECONDARY 6 POSITION
	125324-01-000	EA	TERMINAL - MALE - METRI-PACK - 150
	125325-01-000	EA	SEAL - CAVITY
	126403-01-000	EA	CONNECTOR - 2 CIRCUIT
	126403-02-000	EA	CONNECTOR - 3 CIRCUIT
	129233-01-000	EA	HOUSING - 6 POSITION - MALE WEATHERPACK
	129233-02-000	EA	HOUSING - 2-POSITION/FEMALE - 280-SERIES
	129234-01-000	EA	HOUSING - 6-POSITION/FEMALE - 280-SERIES
	129234-02-000	EA	HOUSING - 6-POSITION/FEMALE - 280-SERIES
	129234-03-000	EA	LOCK - SECONDARY - 6-POSITION
	129235-01-000	EA	HOUSING - 2-POSITION/FEMALE - 630-SERIES
	129235-02-000	EA	LOCK - SECONDARY - 2-POSITION
	129236-01-000	EA	TERMINAL - FEMALE - M/P - 630 - 10-12
	131515-01-000	EA	HOUSING - PIN - 2 CAVITY/HIGH AMP

ELECTRICAL GROUP (CONTINUED)
CONNECTORS & CONDUIT (CONTINUED)

KEY	PART NUMBER	U/M	DESCRIPTION
	131515-02-000	EA	TERMINAL - FEMALE JR. POWER TIMER - F/HALOGEN FOG LIGHT
	131515-03-000	EA	SEAL - CAVITY - JR. POWER TIMER
	131681-01-000	EA	CONNECTOR - 3/4" SO CORD - UL/CS
	137207-01-000	EA	HOUSING - PIN - 2 CAVITY/HIGH AMP
	137208-01-000	EA	HOUSING - SOCKET - 2 CAVITY/HIGH AMP
	137209-01-000	EA	PIN - CONNECTOR - 10AWG/HIGH AMP
	137210-01-000	EA	SOCKET - CONNECTOR - 10 AWG/HIGH AMP
	138419-03-000	EA	SOCKET - LAMP - 3 WIRE
	142520-01-000	EA	TERMINAL - FEMALE - MINI FIT 16
	142522-01-000	EA	HOUSING - 4 PIN/MALE - MINI FIT
	142524-01-000	EA	HOUSING - 4 PIN/WEATHER PACK/FEMALE

BOOTS, SOLENOIDS, RELAYS & MISCELLANEOUS

KEY	PART NUMBER	U/M	DESCRIPTION
	008188-02-000	EA	SOLENOID - VENTED - HEAVY DUTY
	063910-01-000	EA	HOUSING - RELAY
	063912-02-000	EA	RELAY - CANISTER - SPDT
	086233-01-000	EA	STUD - ISOLATED - 3/8" X 7/8" LONG
	086273-01-000	EA	RELAY - BATTERY DISCONNECT
	138914-01-02B	EA	STRAP - BATTERY TIE DOWN - E-COATED

FROM: 00-00-00 THRU: 03-19-02

EXTERIOR BODY GROUP

AIR HORN

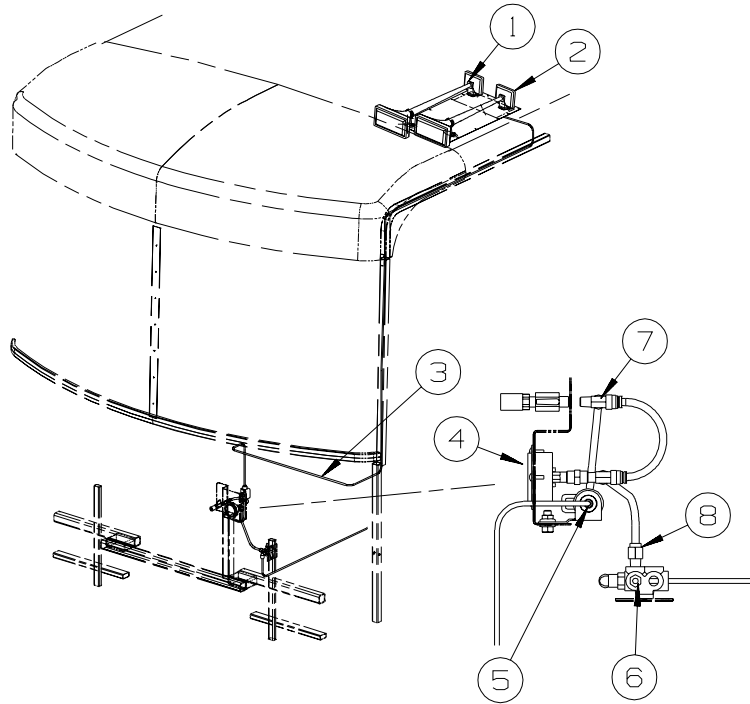

KEY	PART NUMBER	U/M	DESCRIPTION
1*	077497-06-000	EA	HORN - AIR - CHROME - TWIN
2	125123-01-12B	EA	PLATE/MOUNT - AIR HORN - 25" X 13" - BRIGHT WHITE
3	071390-04-000	FT	TUBING - AIR BRAKE - 1/4" OD-BLK WEATHERHEAD(BRKS & HORN)
4	142609-01-000	EA	GAUGE - AIR - 2.5" MOUNTING FLANGE - 1/4" MPT
5	077497-11-000	EA	SOLENOID - HORN - REMOTE MOUNT
6	086241-01-000	EA	VALVE - AIR - 1/4 MPT X TIRE STEM
7	142570-01-000	EA	TEE - 3/8" T X 1/4" P
8	142571-01-000	EA	CONNECTOR - 3/8" T X 1/4" P

***COMPONENT PARTS LISTED LATER IN THIS GROUP**

EXTERIOR BODY GROUP (CONTINUED)
COMPONENT PARTS FOR AIR HORN

077497-06-000

KEY	PART NUMBER	U/M	DESCRIPTION	VENDOR NO.
	077497-01-701	EA	SWITCH - COMPRESSOR	13940-S
	077497-01-702	EA	SWITCH - TOGGLE - W/WIRE	12949-S

EXTERIOR BODY GROUP (CONTINUED)

GRAPHICS & PAINT

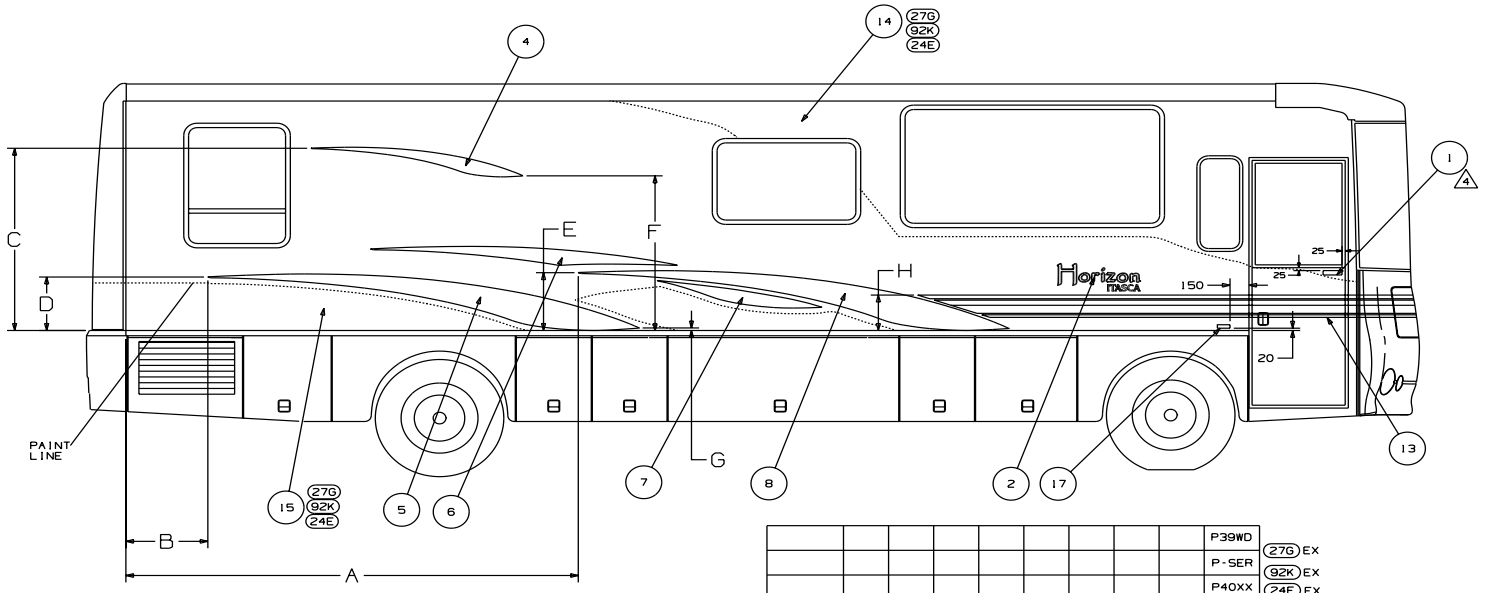

- 1. SUGGESTED VENDOR: SHARPLINE.
- 2. CONTINUE MULTISTRIPES ONTO ENDWALLS OF SLIDEOUT.
- 3. CENTER ON UNIT.
- 4. DECAL IS PUT ON DRIVERS SIDE ALSO.

										P39WD
										P-SER (27G) EX
										P40XX (92K) EX
										(24E) EX
										P390D
										P36LD
										P34HD
										P32TD
										P36C
										P36L
										P34H
										P32T
	279	19.1	1143	705	705	1467	1130	3804		
CHASSIS	H	G	F	E	D	C	B	A		UNIT

NOTES:

KEY	PART NUMBER	U/M	DESCRIPTION
	132664-01-CHT(01A)	EA	DECAL-WINNEBAGO,DOMED - GOLD CHROME/BLACK
(27G)	133691-01-CHT(05A)	EA	DECAL-HORIZON,ITASCA,LG - LT.GOLD/DK.BRT.TEAL
(92K)	133691-01-CHT(06A)	EA	DECAL-HORIZON,ITASCA,LG - STELLAR BLUE/SILVER
	137618-02-CHT(01A)	EA	DECAL-BEZEL,DOMED GRILLE LOGO - BLACK/CHROME
(27G)	138831-01-CHT(02A)	EA	DECAL-TEARDROP,UPPER,RH - LAGO BLUE/SURF GREEN
(92K)	138831-01-CHT(03A)	EA	DECAL-TEARDROP,UPPER,RH - FLINTSTONE/SILVER
(24E)	138831-02-CHT(02A)	EA	DECAL-TEARDROP,UPPER,LH - LAGO BLUE/SURF GREEN
(92K)	138831-02-CHT(03A)	EA	DECAL-TEARDROP,UPPER,LH - FLINTSTONE/SILVER
(27G)	138832-01-CHT(02A)	EA	DECAL-TEARDROP,RR,RH - DK.BRT.TEAL/LAGO BLUE
(92K)	138832-01-CHT(03A)	EA	DECAL-TEARDROP,RR,RH - SILVER/FLINTSTONE
(24E)	138832-02-CHT(02A)	EA	DECAL-TEARDROP,RR,LH - DK.BRT.TEAL/LAGO BLUE
(92K)	138832-02-CHT(03A)	EA	DECAL-TEARDROP,RR,LH - SILVER/FLINTSTONE
(27G)	138833-01-CHT(02A)	EA	DECAL-TAIL,RH - DK.BRT.TEAL/LT.GOLD
(92K)	138833-01-CHT(03A)	EA	DECAL-TAIL,RH - STELLAR BLUE/SILVER BLUE
(24E)	138833-02-CHT(02A)	EA	DECAL-TAIL,LH - DK.BRT.TEAL/LT.GOLD
(92K)	138833-02-CHT(03A)	EA	DECAL-TAIL,LH - STELLAR BLUE/SILVER BLUE
(27G)	138834-01-CHT(02A)	EA	DECAL-TEARDROP,LWR,RH - LT.GOLD
(92K)	138834-01-CHT(03A)	EA	DECAL-TEARDROP,LWR,RH - SILVER BLUE
(24E)	138834-02-CHT(02A)	EA	DECAL-TEARDROP,LWR,LH - LT.GOLD
(92K)	138834-02-CHT(03A)	EA	DECAL-TEARDROP,LWR,LH - SILVER BLUE
(27G)	138835-01-CHT(02A)	EA	DECAL-TEARDROP,FWD,RH - LAGO BLUE/SURF GREEN
(92K)	138835-01-CHT(03A)	EA	DECAL-TEARDROP,FWD,RH - FLINTSTONE/SILVER
(27G)	138835-02-CHT(02A)	EA	DECAL-TEARDROP,FWD,LH - LAGO BLUE/SURF GREEN
(92K)	138835-02-CHT(03A)	EA	DECAL-TEARDROP,FWD,LH - FLINTSTONE/SILVER
(24E)	138836-01-CHT(02A)	EA	DECAL-CORNER,UPPER,RH - SURF GREEN
(92K)	138836-01-CHT(03A)	EA	DECAL-CORNER,UPPER,RH - SILVER BLUE
(27G)	138836-02-CHT(02A)	EA	DECAL-CORNER,UPPER,LH - SURF GREEN
(92K)	138836-02-CHT(03A)	EA	DECAL-CORNER,UPPER,LH - SILVER BLUE
(24E)	138837-01-CHT(02A)	EA	DECAL-CORNER,LWR,RH - DK.BRT.TEAL/LT.GOLD/LAGO BLUE
(92K)	138837-01-CHT(03A)	EA	DECAL-CORNER,LWR,RH - SILVER/STELLAR BLUE/FLINTSTONE
(27G)	138837-02-CHT(02A)	EA	DECAL-CORNER,LWR,LH - DK.BRT.TEAL/LT.GOLD/LAGO BLUE
(92K)	138837-02-CHT(03A)	EA	DECAL-CORNER,LWR,LH - SILVER/STELLAR BLUE/FLINTSTONE
(24E)	138838-02-CHT(01A)	EA	DECAL-HOOD - LAGO BLUE/SURF GREEN/DK.BRT.TEAL/LT.GOLD
(92K)	138838-02-CHT(02A)	EA	DECAL-HOOD - FLINTSTONE/SILVER/SILVER BLUE/STELLAR BLUE
(27G)	138840-02-CHT(01A)	EA	DECAL-TEARDROPS - DK.BRT.TEAL/LT.GOLD/LAGO BLUE/SURF GREEN
(92K)	138840-02-CHT(02A)	EA	DECAL-TEARDROPS - STELLAR BLUE/SILVER BLUE/FLINTSTONE/SILVER
(24E)	138844-01-CHT(02A)	FT	MULTISTRIPES-193.7MM - SURF GREEN/DK.BRT.TEAL/LT.GOLD/LAGO BLUE
(92K)	138844-01-CHT(03A)	FT	MULTISTRIPES-193.7MM - SILVER BLUE/SILVER/STELLAR BLUE/FLINTSTONE
(27G)	141599-04-000	GL	UPPER PAINT - SAND MET - DUPONT #373-P7415
(92K)	141599-14-000	GL	UPPER PAINT - LT.STEEL MET - DUPONT #373-P7448
(24E)	141599-07-000	GL	LOWER PAINT - CYPRESS GREEN - DUPONT #373-P7416
(92K)	141599-01-000	GL	LOWER PAINT - LT.SILVER - DUPONT #373-P6235
(24E)	141599-05-000	GL	LOWER PAINT - OPAL BLUE - DUPONT #373-P6240
	-----	EA	PLATE-FREIGHTLINER,LG - CHASSIS SUPPLIED
(IFR)	135089-02-CHT(01A)	EA	PLATE-FREIGHTLINER,SML - CHASSIS SUPPLIED
(IFO)	135089-03-CHT(01A)	EA	DECAL-DOMED,HORSEPOWER,300
		EA	DECAL-DOMED,HORSEPOWER,300

EXTERIOR BODY GROUP (CONTINUED) GRAPHICS & PAINT (CONTINUED)

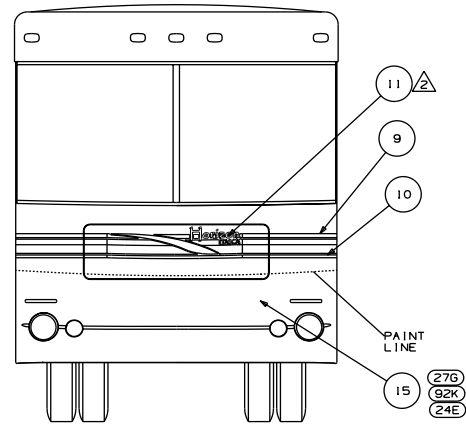
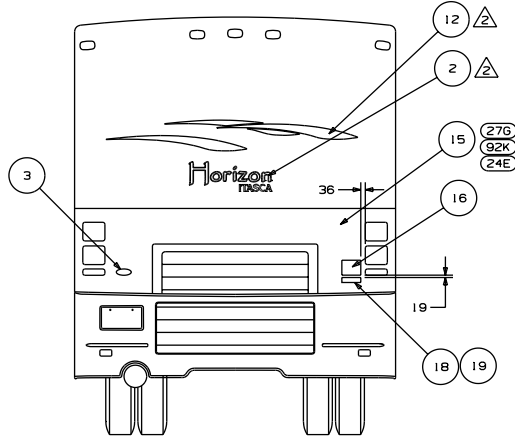

KEY	PART NUMBER	U/M	DESCRIPTION
	132664-01-CHT(01A)	EA	DECAL-WINNEBAGO,DOMED - GOLD CHROME/BLACK
(27G)	133691-01-CHT(05A)	EA	DECAL-HORIZON,ITASCA,LG - LT.GOLD/DK.BRT.TEAL
(24E)(92K)	133691-01-CHT(06A)	EA	DECAL-HORIZON,ITASCA,LG - STELLAR BLUE/SILVER
	137618-02-CHT(01A)	EA	DECAL-BEZEL,DOMED GRILLE LOGO - BLACK/CHROME
(27G)	138831-01-CHT(02A)	EA	DECAL-TEARDROP,UPPER,RH - LAGO BLUE/SURF GREEN
(24E)(92K)	138831-01-CHT(03A)	EA	DECAL-TEARDROP,UPPER,RH - FLINTSTONE/SILVER
(27G)	138831-02-CHT(02A)	EA	DECAL-TEARDROP,UPPER,LH - LAGO BLUE/SURF GREEN
(24E)(92K)	138831-02-CHT(03A)	EA	DECAL-TEARDROP,UPPER,LH - FLINTSTONE/SILVER
(27G)	138832-01-CHT(02A)	EA	DECAL-TEARDROP,RR,RH - DK.BRT.TEAL/LAGO BLUE
(24E)(92K)	138832-01-CHT(03A)	EA	DECAL-TEARDROP,RR,RH - SILVER/FLINTSTONE
(27G)	138832-02-CHT(02A)	EA	DECAL-TEARDROP,RR,LH - DK.BRT.TEAL/LAGO BLUE
(24E)(92K)	138832-02-CHT(03A)	EA	DECAL-TEARDROP,RR,LH - SILVER/FLINTSTONE
(27G)	138833-01-CHT(02A)	EA	DECAL-TAIL,RH - DK.BRT.TEAL/LT.GOLD
(24E)(92K)	138833-01-CHT(03A)	EA	DECAL-TAIL,RH - STELLAR BLUE/SILVER BLUE
(27G)	138833-02-CHT(02A)	EA	DECAL-TAIL,LH - DK.BRT.TEAL/LT.GOLD
(24E)(92K)	138833-02-CHT(03A)	EA	DECAL-TAIL,LH - STELLAR BLUE/SILVER BLUE
(27G)	138834-01-CHT(02A)	EA	DECAL-TEARDROP,LWR,RH - LT.GOLD
(24E)(92K)	138834-01-CHT(03A)	EA	DECAL-TEARDROP,LWR,RH - SILVER BLUE
(27G)	138834-02-CHT(02A)	EA	DECAL-TEARDROP,LWR,LH - LT.GOLD
(24E)(92K)	138834-02-CHT(03A)	EA	DECAL-TEARDROP,LWR,LH - SILVER BLUE
(27G)	138835-01-CHT(02A)	EA	DECAL-TEARDROP,FWD,RH - LAGO BLUE/SURF GREEN
(24E)(92K)	138835-01-CHT(03A)	EA	DECAL-TEARDROP,FWD,RH - FLINTSTONE/SILVER
(27G)	138835-02-CHT(02A)	EA	DECAL-TEARDROP,FWD,LH - LAGO BLUE/SURF GREEN
(24E)(92K)	138835-02-CHT(03A)	EA	DECAL-TEARDROP,FWD,LH - FLINTSTONE/SILVER
(27G)	138836-01-CHT(02A)	EA	DECAL-CORNER,UPPER,RH - SURF GREEN
(24E)(92K)	138836-01-CHT(03A)	EA	DECAL-CORNER,UPPER,RH - SILVER BLUE
(27G)	138836-02-CHT(02A)	EA	DECAL-CORNER,UPPER,LH - SURF GREEN
(24E)(92K)	138836-02-CHT(03A)	EA	DECAL-CORNER,UPPER,LH - SILVER BLUE
(27G)	138837-01-CHT(02A)	EA	DECAL-CORNER,LWR,RH - DK.BRT.TEAL/LT.GOLD/LAGO BLUE
(24E)(92K)	138837-01-CHT(03A)	EA	DECAL-CORNER,LWR,RH - SILVER/STELLAR BLUE/FLINTSTONE
(27G)	138837-02-CHT(02A)	EA	DECAL-CORNER,LWR,LH - DK.BRT.TEAL/LT.GOLD/LAGO BLUE
(24E)(92K)	138837-02-CHT(03A)	EA	DECAL-CORNER,LWR,LH - SILVER/STELLAR BLUE/FLINTSTONE
(27G)	138838-02-CHT(01A)	EA	DECAL-HOOD - LAGO BLUE/SURF GREEN/DK.BRT.TEAL/LT.GOLD
(24E)(92K)	138838-02-CHT(02A)	EA	DECAL-HOOD - FLINTSTONE/SILVER/SILVER BLUE/STELLAR BLUE
(27G)	138840-02-CHT(01A)	EA	DECAL-TEARDROPS - DK.BRT.TEAL/LT.GOLD/LAGO BLUE/SURF GREEN
(24E)(92K)	138840-02-CHT(02A)	EA	DECAL-TEARDROPS - STELLAR BLUE/SILVER BLUE/FLINTSTONE/SILVER
(27G)	138844-01-CHT(02A)	FT	MULTISTRIPE-193.7MM - SURF GREEN/DK.BRT.TEAL/LT.GOLD/LAGO BLUE
(24E)(92K)	138844-01-CHT(03A)	FT	MULTISTRIPE-193.7MM - SILVER BLUE/SILVER/STELLAR BLUE/FLINTSTONE
(27G)	141599-04-000	GL	UPPER PAINT - SAND MET - DUPONT #373-P7415
(24E)(92K)	141599-14-000	GL	UPPER PAINT - LT.STEEL MET - DUPONT #373-P7448
(27G)	141599-07-000	GL	LOWER PAINT - CYPRESS GREEN - DUPONT #373-P7416
(92K)	141599-01-000	GL	LOWER PAINT - LT.SILVER - DUPONT #373-P6235
(24E)	141599-05-000	GL	LOWER PAINT - OPAL BLUE - DUPONT #373-P6240
	16	EA	PLATE-FREIGHTLINER,LG - CHASSIS SUPPLIED
	17	EA	PLATE-FREIGHTLINER,SML - CHASSIS SUPPLIED
(1FR)	135089-02-CHT(01A)	EA	DECAL-DOMED,HORSEPOWER,330
(1FG)	135089-03-CHT(01A)	EA	DECAL-DOMED,HORSEPOWER,300

KEY	PART NUMBER	U/M	DESCRIPTION
	041561-03-000	EA	PAINT - 16 OUNCE SPRAY - OFF WHITE
	099399-23-700	EA	PAINT-SPRAY-BRT WHITE ENAMEL , B8951U DUPONT
	093681-39-01A	FT	FILM - 3.1" - MATTE BLACK

DUPONT COLOR CODES

SURF GREEN METALLIC	
DARK BRIGHT TEAL METALLIC	
LAGO BLUE METALLIC	#W9212
LIGHT GOLD METALLIC	#YM209
CYPRESS GREEN METALLIC	#P7416
SAND METALLIC	#P7415
STELLAR BLUE METALLIC	
SILVER METALLIC	
FLINTSTONE METALLIC	#DM440
LIGHT SILVER METALLIC	#F2573
LIGHT STEEL METALLIC	#P7448K
OPAL BLUE METALLIC	#P6240

EXTERIOR BODY GROUP (CONTINUED)

GRAPHICS & PAINT (CONTINUED)

W/FULL BODY PAINT PACKAGE

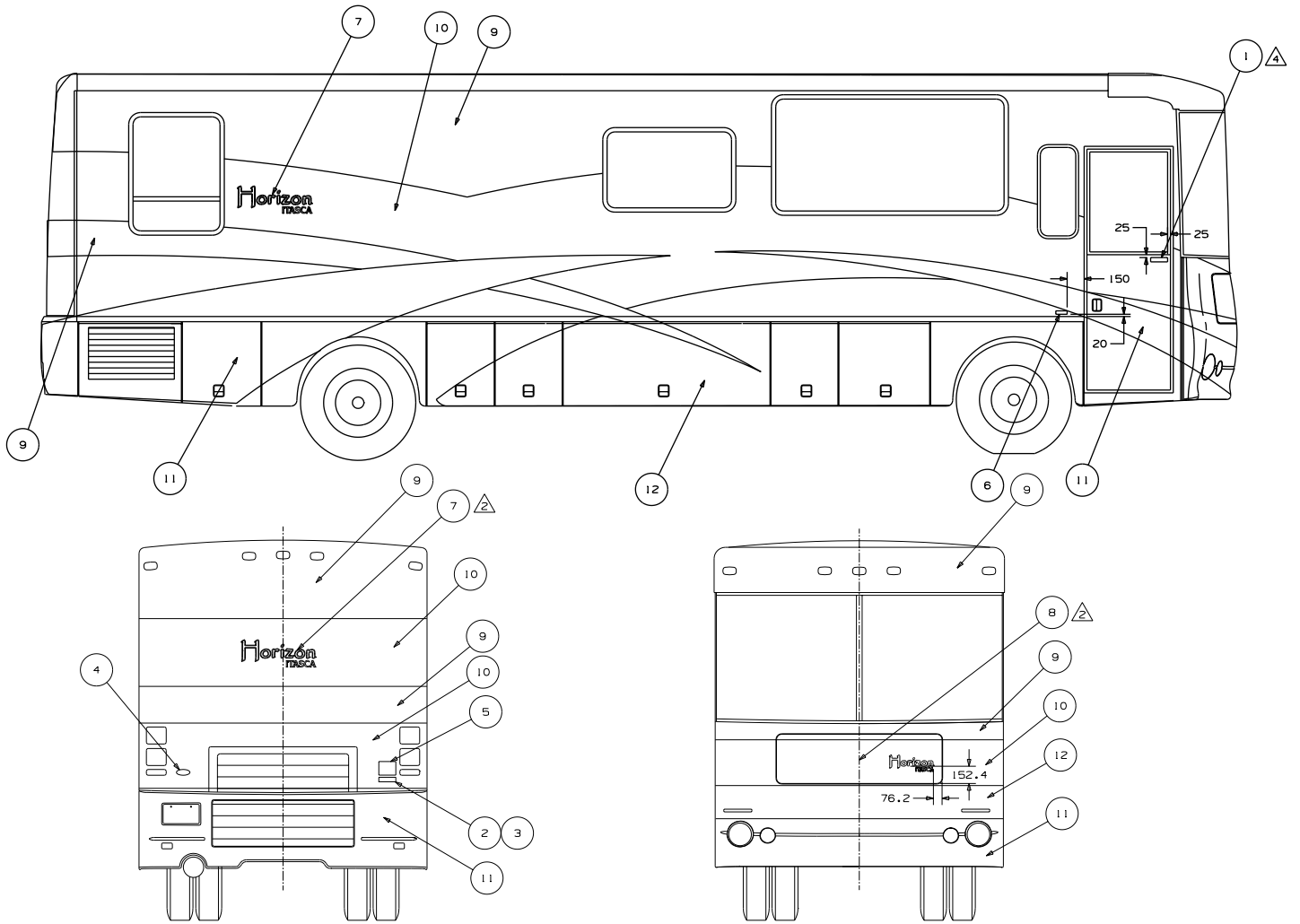

(27A) KEY	PART NUMBER	U/M	DESCRIPTION MOCHA EXTERIOR
1	132664-01-CHT(01A)	EA	DECAL-WINNEBAGO,DOMED - GOLD CHROME/BLACK
2	135089-02-CHT(01A)	EA	DECAL-DOMED HORSEPOWER - 330
3	135089-03-CHT(01A)	EA	DECAL-DOMED HORSEPOWER - 300
4	137618-02-CHT(01A)	EA	DECAL-BEZEL,DOMED,GRILLE,LOGO - BLACK/CHROME
5	EA	DECAL-BEZEL,DOMED,GRILLE,LOGO - BLACK/CHROME
6	EA	PLATE-FREIGHTLINER LG - CHASSIS SUPPLIED
7	EA	PLATE-FREIGHTLINER SML - CHASSIS SUPPLIED
8	144680-01-CHT(01A)	EA	DECAL-HORIZON,DOMED,LG - TRANS BLACK/CHROME/WHITE/TRANS GOLD/TRANS WHITE
9	144680-02-CHT(01A)	EA	DECAL-HORIZON,DOMED,SML - TRANS BLACK/CHROME/WHITE/TRANS GOLD/TRANS WHITE
10	GL	PAINT - MM329
11	GL	PAINT - LM423
12	GL	PAINT - DM077
13	GL	PAINT - YM293
14	LT	PAINT - CLEAR COAT
15	LT	PAINT - CLEAR COAT

(92A) KEY	PART NUMBER	U/M	DESCRIPTION AUBURN EXTERIOR
1	132664-01-CHT(01A)	EA	DECAL-WINNEBAGO,DOMED - GOLD CHROME/BLACK
2	135089-02-CHT(01A)	EA	DECAL-DOMED HORSEPOWER - 330
3	135089-03-CHT(01A)	EA	DECAL-DOMED HORSEPOWER - 300
4	137618-02-CHT(01A)	EA	DECAL-BEZEL,DOMED,GRILLE,LOGO - BLACK/CHROME
5	EA	DECAL-BEZEL,DOMED,GRILLE,LOGO - BLACK/CHROME
6	EA	PLATE-FREIGHTLINER LG - CHASSIS SUPPLIED
7	EA	PLATE-FREIGHTLINER SML - CHASSIS SUPPLIED
8	144680-01-CHT(01A)	EA	DECAL-HORIZON,DOMED,LG - TRANS BLACK/CHROME/WHITE/TRANS GOLD/TRANS WHITE
9	144680-02-CHT(01A)	EA	DECAL-HORIZON,DOMED,SML - TRANS BLACK/CHROME/WHITE/TRANS GOLD/TRANS WHITE
10	GL	PAINT - MM092
11	GL	PAINT - LM423
12	GL	PAINT - RM485
13	GL	PAINT - MM073
14	LT	PAINT - CLEAR COAT

(24C) KEY	PART NUMBER	U/M	DESCRIPTION BLUE LAKE EXTERIOR
1	132664-01-CHT(01A)	EA	DECAL-WINNEBAGO,DOMED - GOLD CHROME/BLACK
2	135089-02-CHT(01A)	EA	DECAL-DOMED HORSEPOWER - 330
3	135089-03-CHT(01A)	EA	DECAL-DOMED HORSEPOWER - 300
4	137618-02-CHT(01A)	EA	DECAL-BEZEL,DOMED,GRILLE,LOGO - BLACK/CHROME
5	EA	DECAL-BEZEL,DOMED,GRILLE,LOGO - BLACK/CHROME
6	EA	PLATE-FREIGHTLINER LG - CHASSIS SUPPLIED
7	EA	PLATE-FREIGHTLINER SML - CHASSIS SUPPLIED
8	144680-01-CHT(01A)	EA	DECAL-HORIZON,DOMED,LG - TRANS BLACK/CHROME/WHITE/TRANS GOLD/TRANS WHITE
9	144680-02-CHT(01A)	EA	DECAL-HORIZON,DOMED,SML - TRANS BLACK/CHROME/WHITE/TRANS GOLD/TRANS WHITE
10	GL	PAINT - MM212
11	GL	PAINT - BM244
12	GL	PAINT - MM251
13	GL	PAINT - MM411
14	LT	PAINT - CLEAR COAT

EXTERIOR BODY GROUP (CONTINUED)

PANELS & TRIMS

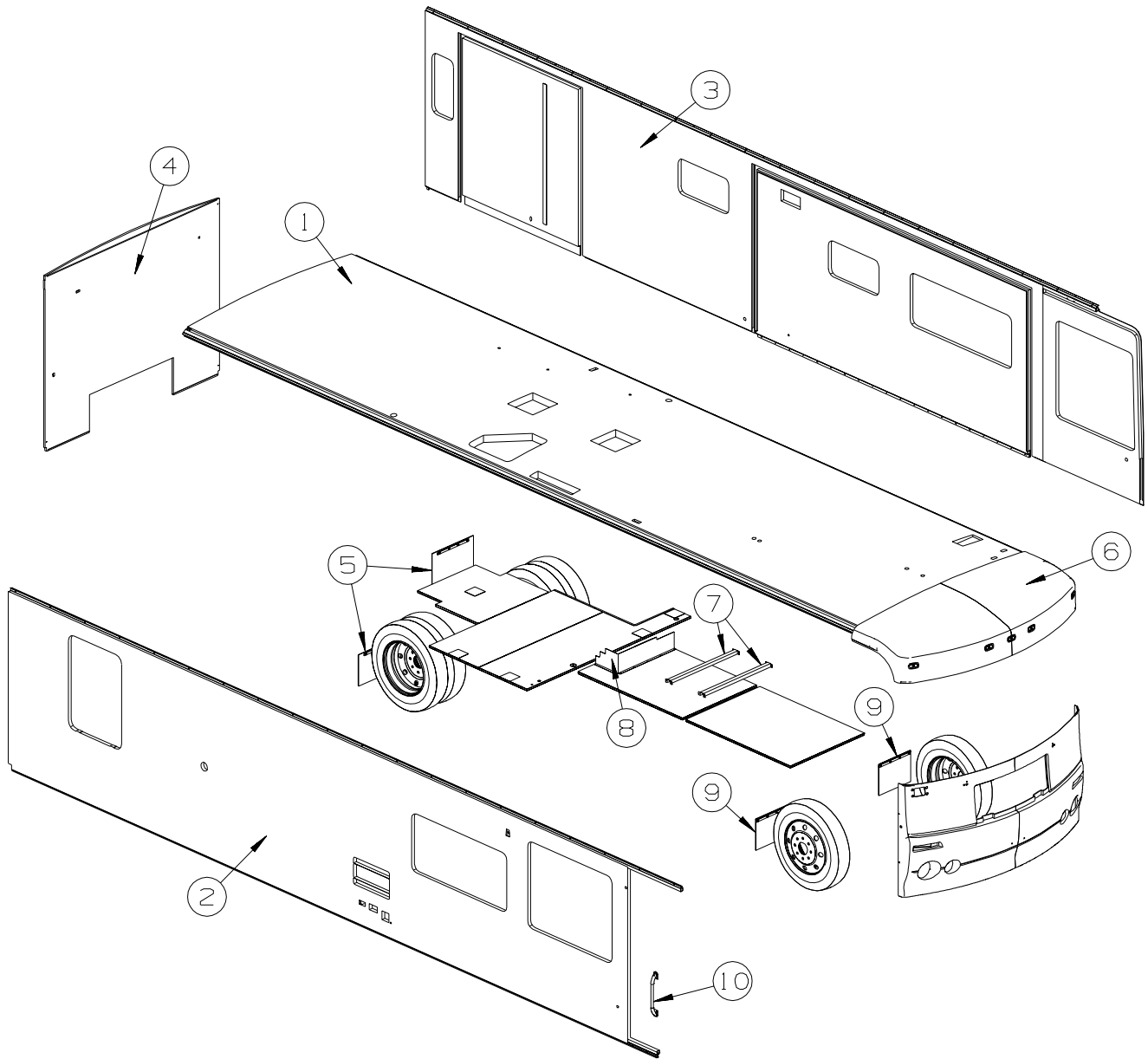

KEY	PART NUMBER	U/M	DESCRIPTION
1	141755-02-P84	EA	ROOF - W/O LIGHTS/VENTS - W/WIRING
2	141692-02-P84	EA	SIDEWALL - PASSENGER - W/O WINDOWS/TRIMS(P84, P85, P28)
2	141692-02-P86	EA	SIDEWALL - PASSENGER - W/O WINDOWS/TRIMS(P86, P87, P88, P89, P29, P30)
3	141693-01-P82	EA	SIDEWALL - DRIVER - W/O WINDOWS/TRIMS(P84, P85, P28)
3	141693-01-P78	EA	SIDEWALL - DRIVER - W/O WINDOWS/TRIMS(P86, P87, P88, P89, P29, P30)
4	143058-01-P77	EA	BACKWALL - W/O WINDOW/TRIMS(P84, P85, P28)
4	143058-01-P76	EA	BACKWALL - W/O WINDOW/TRIMS(P86, P87, P88, P89, P29, P30)
5	017516-07-000	EA	MUD FLAP - 14"H X 23.5"W - BLACK RUBBER
	140922-01-02B	EA	PLATE - MUD FLAP - E-COATED
6	131635-02-L76	EA	CAP - ROOF
7	120524-01-02B	EA	U-CHANNEL/STEEL - 1.8" X 38.2" - E-COATED
8	134811-01-02B	EA	PANEL - COVER - WATER SYSTEM - E-COATED
9	017516-01-000	EA	MUD FLAP - 14"H X 18"W - W/O MOUNTING HOLES - BLACK
	140922-01-02B	EA	PLATE - MUD FLAP - E-COATED
10	132442-03-01A	EA	HANDLE - ASSIST - W/ITASCA LOGO - CHROME ENDS
	105290-01-000	SF	INSULATION - AIR POCKET W/FOIL

EXTERIOR BODY GROUP (CONTINUED)
PANELS & TRIMS (CONTINUED)

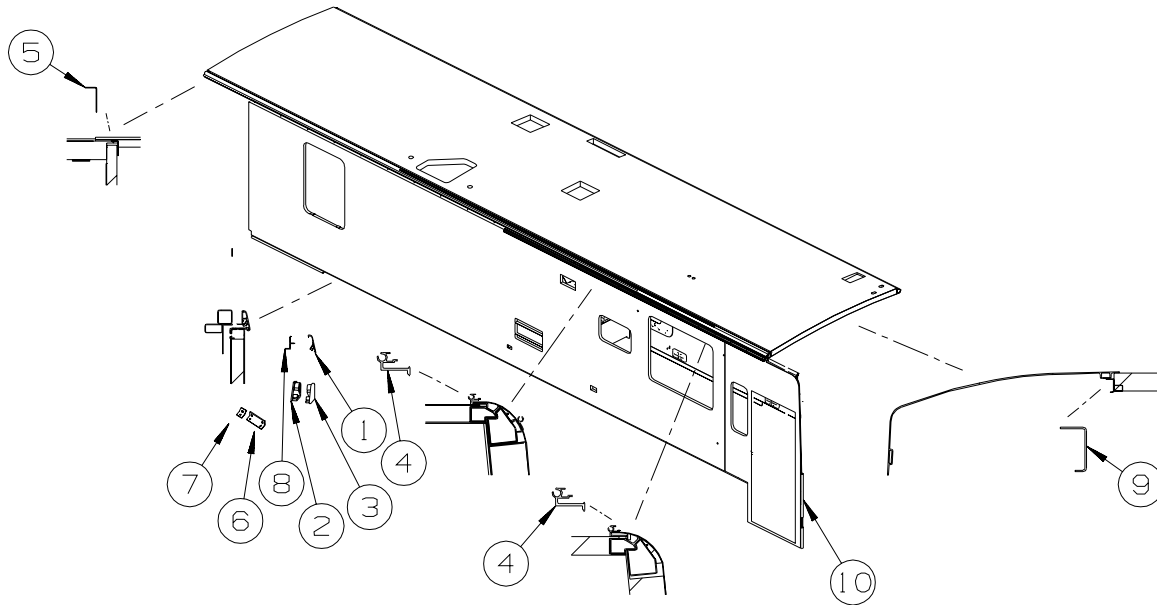

KEY	PART NUMBER	U/M	DESCRIPTION
1	123993-01-03A	EA	TRIM - COVER - 182" ALUMINUM - BRIGHT WHITE FROM: 00-00-00 THRU: 07-28-02
1	123993-01-02A	EA	TRIM - COVER - 182" ALUMINUM - BLACK FROM: 07-29-02 THRU: 99-99-99
2	126775-01-01A	EA	END CAP - VALANCE TRIM - RIGHT HAND FROM: 00-00-00 THRU: 01-01-03
2	126775-01-02A	EA	END CAP - VALANCE TRIM - RIGHT HAND - BLACK FROM: 01-02-03 THRU: 99-99-99
3	126775-02-01A	EA	END CAP - VALANCE TRIM - LEFT HAND FROM: 00-00-00 THRU: 01-01-03
3	126775-02-02A	EA	END CAP - VALANCE TRIM - LEFT HAND - BLACK FROM: 01-02-03 THRU: 99-99-99
4	131483-01-01A	EA	RAIL - AWNING - 192" - BRIGHT WHITE
5	132273-01-02B	EA	BRACKET - REAR TRIM - E-COATED
6	132597-01-02B	EA	ANGLE/SUPPORT/TRIM - 2" - E-COATED FROM: 00-00-00 THRU: 12-31-02
6	143143-02-01A	EA	ANGLE - SUPPORT/TRIM FROM: 01-01-03 THRU: 99-99-99
7	132597-02-02B	EA	ANGLE/SUPPORT/TRIM - .6" - E-COATED FROM: 00-00-00 THRU: 12-31-02
7	143143-01-01A	EA	ANGLE - SUPPORT/TRIM FROM: 01-01-03 THRU: 99-99-99
8	133376-01-01A	EA	TRIM - RETAINER - 144" - MILL
9	134774-01-02B	EA	BRACKET - CAB ATTACHMENT - E-COATED
10	093673-01-06A	FT	TRIM/MOLDING - 1.4" X 8' LONG - BRIGHT WHITE

EXTERIOR BODY GROUP (CONTINUED)
PANELS & TRIMS (CONTINUED)

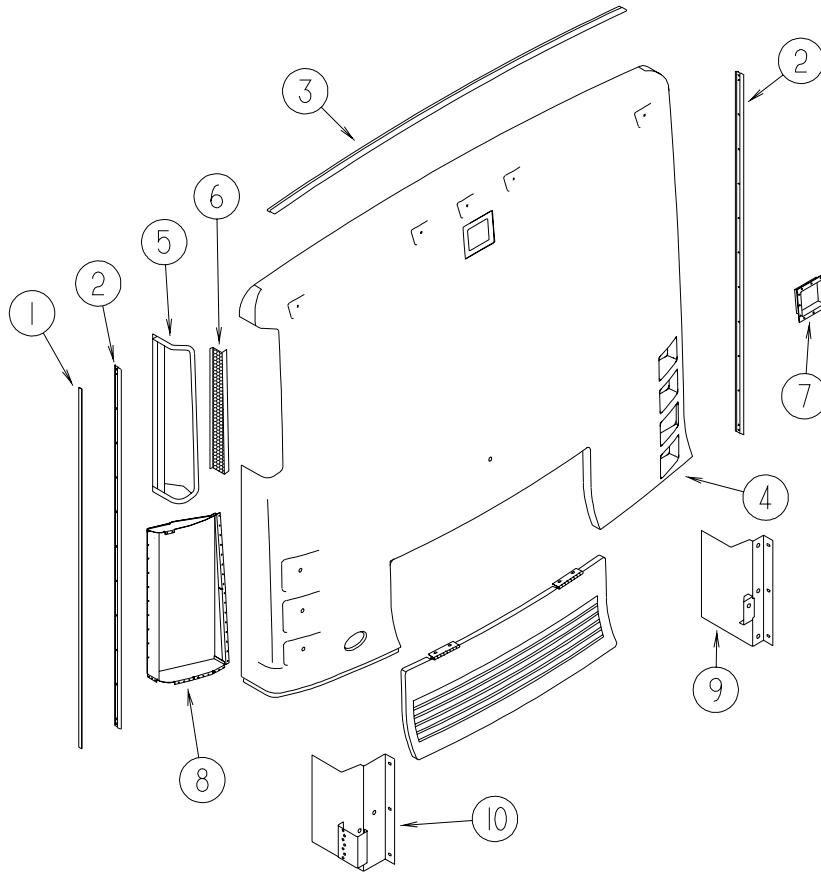

KEY	PART NUMBER	U/M DESCRIPTION
1	091985-01-07A	FT INSERT - TRIM - BRIGHT WHITE - 1"
2	092041-05-01A	EA TRIM - REAR - CAP TO SIDEWALL - BRIGHT WHITE
3	083805-23-000	EA TRIM - ROOF CAP - 92.1" - BRIGHT WHITE
4	131897-04-M76	EA PANEL - REAR CAP
5	131896-01-01A	EA PANEL/AIR SCOOP - BRIGHT WHITE
6	129683-01-02A	EA PANEL - AIR INTAKE - BLACK
7	P23280-01-01A	EA SHROUD - CAMERA - INNER
8	132239-01-02B	EA PANEL/AIR INTAKE - E-COATED
9	134572-01-02B	EA SHIELD/SIDE - ENGINE - RIGHT HAND - E-COATED
10	132636-02-02B	EA SHIELD/SIDE - ENGINE - LEFT HAND - E-COATED

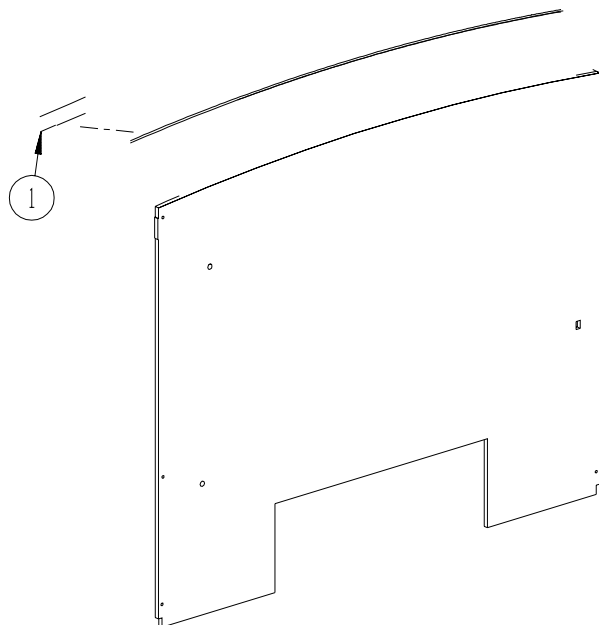

KEY	PART NUMBER	U/M DESCRIPTION
1	114248-02-01A	EA ANGLE - PLASTIC - 96.6"

EXTERIOR BODY GROUP (CONTINUED)

FRONT END

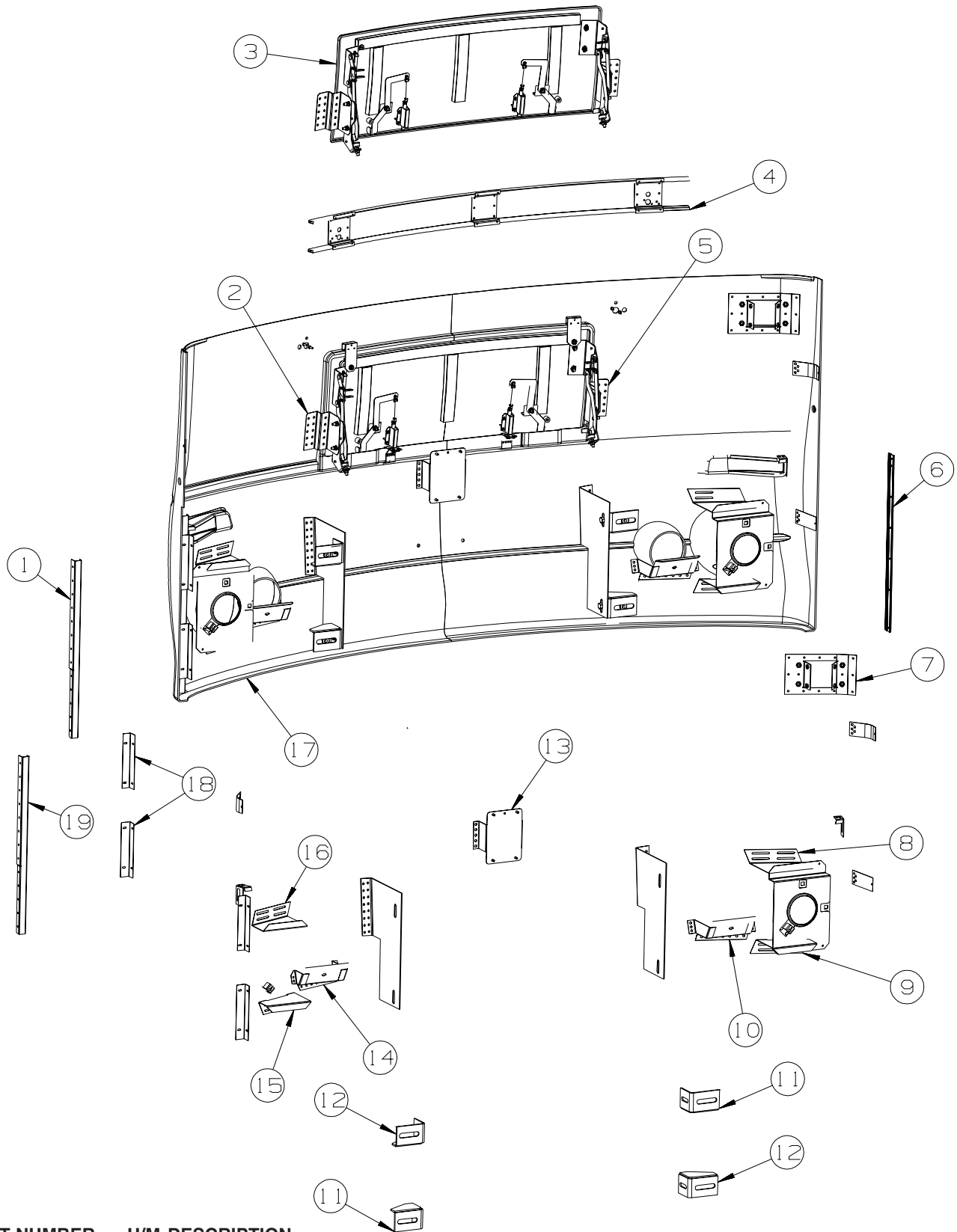

KEY	PART NUMBER	U/M	DESCRIPTION
1	092041-06-01A	EA	TRIM - REAR - CAP TO SIDEWALL - BRIGHT WHITE
1	091985-01-07A	FT	INSERT - TRIM - .65" WIDE - BRIGHT WHITE
2	137703-02-02B	EA	SUPPORT - HINGE - LEFT HAND - E-COATED
3	137771-01-M76	EA	HOOD - FRONT
4	130270-02-L76	EA	SUPPORT - WIPER
5	137703-01-02B	EA	SUPPORT - HINGE - RIGHT HAND - E-COATED

EXTERIOR BODY GROUP (CONTINUED) FRONT END (CONTINUED)

KEY	PART NUMBER	U/M	DESCRIPTION
6	092041-07-01A	EA	TRIM - REAR - CAP TO SIDEWALL - BRIGHT WHITE
6	091985-01-07A	FT	INSERT - TRIM - .65" WIDE - BRIGHT WHITE
7	120850-04-02B	EA	PLATE - SUPPORT/MIRROR - E-COATED
8	137700-01-02B	EA	BRACKET - HEADLAMP - UPPER/RIGHT HAND - E-COATED
9	137701-01-02B	EA	BRACKET - HEADLAMP - LOWER/RIGHT HAND - E-COATED
10	134058-01-02B	EA	BRACKET - FOG LAMP - RIGHT HAND - E-COATED
11	128455-03-02B	EA	BRACKET - BUMPER - RIGHT HAND UPPER/LEFT HAND LOWER
12	128455-04-02B	EA	BRACKET - BUMPER - LEFT HAND UPPER/RIGHT HAND LOWER
13	136446-02-02B	EA	BRACKET - WASHER TANK - E-COATED
14	134058-02-02B	EA	BRACKET - FOG LAMP - LEFT HAND - E-COATED
15	137701-02-02B	EA	BRACKET - HEADLAMP - LOWER/LEFT HAND - E-COATED
16	137700-02-02B	EA	BRACKET - HEADLAMP - UPPER/LEFT HAND - E-COATED
17	137774-02-M76	EA	PANEL - FRONT/LOWER
18	113041-10-02B	EA	ANGLE-MOUNT,E-COAT
19	132071-02-02B	EA	BRACKET - BUMPER - REAR - E-COATED

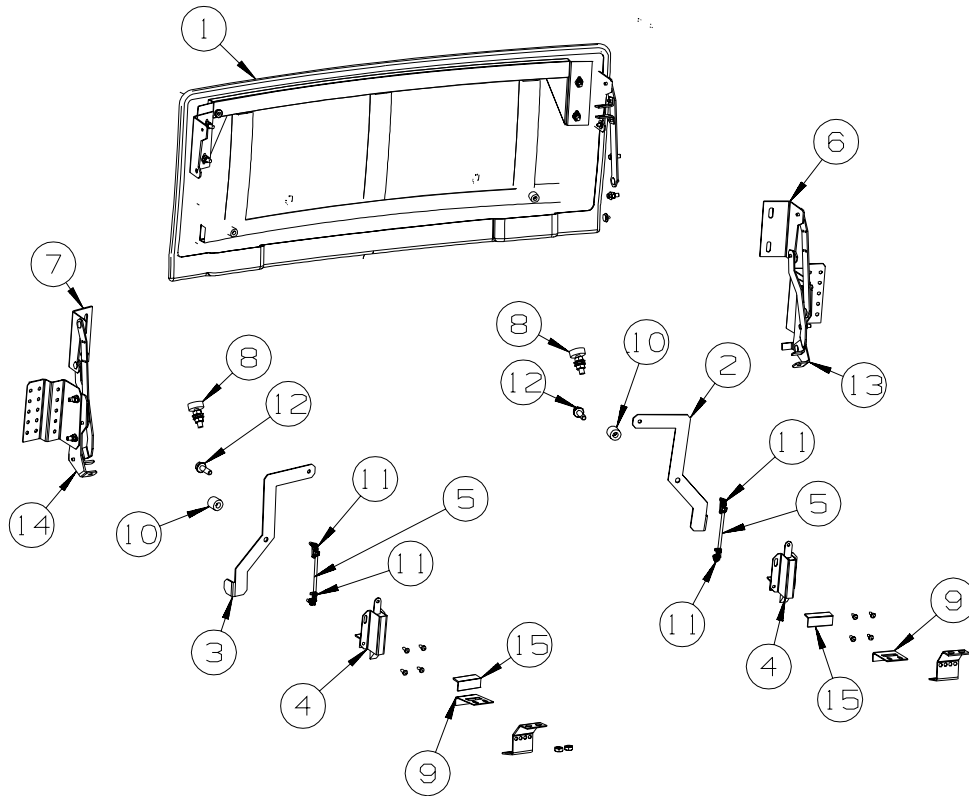

KEY	PART NUMBER	U/M	DESCRIPTION
1	137771-01-M76	EA	HOOD - FRONT
2	131545-01-02B	EA	LATCH-HANDLE,HOOD,RH,E-CT
3	131545-02-02B	EA	LATCH-HANDLE,HOOD,LH,E-CT
4	113908-01-000	EA	LATCH/PLUNGER - F/HOOD
5	131606-01-01A	EA	ROD - HOOD LATCH
6	137761-01-01A	EA	PLATE - HOOD - MOUNTING - RIGHT HAND
7	137761-02-01A	EA	PLATE - HOOD - MOUNTING - LEFT HAND
8	058786-01-000	EA	BOLT - HOOD ADJUSTMENT - 5/16"-18 X 1.5"-2"- W/BLACK PAD
9	134190-01-02B	EA	BRACKET - STRIKER/HOOD - E-COATED
10	120863-07-000	EA	BUMPER - RUBBER - .7" DIA X .7" THICK
11	102265-01-000	EA	CLIP - ROD END - 5/32" - BLACK PLASTIC
12	106730-10-000	EA	PLATE - STUD - F/HOOD
13	137072-03-01A	EA	HINGE - HOOD - RIGHT HAND - BLACK
14	137072-04-01A	EA	HINGE - HOOD - LEFT HAND - BLACK
15	134189-02-02B	EA	BRACKET - MOUNT/STRIKER - E-COATED

EXTERIOR BODY GROUP (CONTINUED)

LADDER

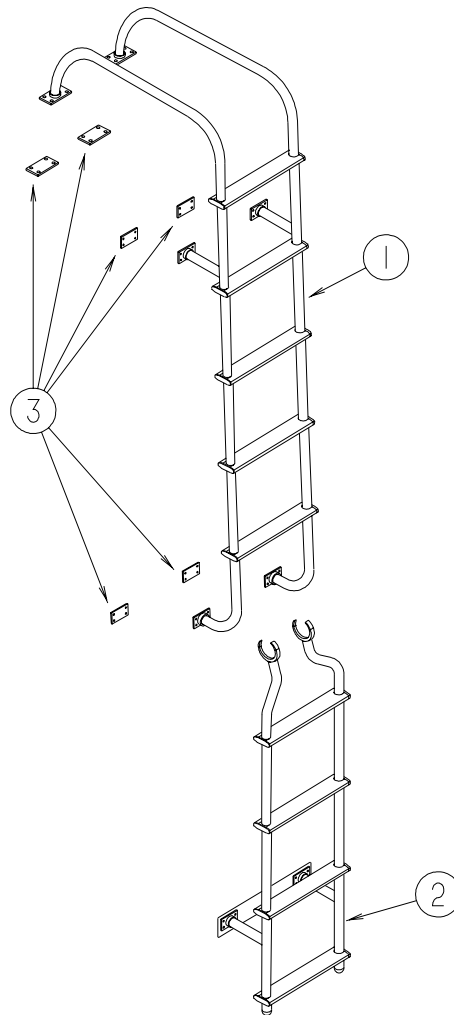

KEY	PART NUMBER	U/M	DESCRIPTION
1	132804-01-01A	EA	LADDER - UPPER - ANODIZED ALUMINUM
2	130163-04-01A	EA	LADDER ASSEMBLY - LOWER - ALUMINUM ANODIZED
3	129375-02-000	EA	SEAL - LADDER BRACKET

MIRRORS

KEY	PART NUMBER	U/M	DESCRIPTION
*	106015-19-01A	EA	MIRROR - EXTERIOR/REMOTE/HEAT - DRIVER
*	131431-06-01A	EA	MIRROR - EXTERIOR REMOTE/HEAT - PASSENGER
	108825-03-000	EA	GASKET - MIRROR
	133379-01-01A	EA	SCREW - MACHINE - 5/16-18 X 2.00 - TORX
	120850-04-02B	EA	PLATE - SUPPORT/MIRROR - E-COATED

***COMPONENT PARTS LISTED LATER IN THIS GROUP**

EXTERIOR BODY GROUP (CONTINUED)

COMPONENT PARTS FOR MIRRORS

106015-18-01A, 106015-19-01A

KEY	PART NUMBER	U/M	DESCRIPTION	VENDOR NO.
	106015-12-702	EA	CAP/SCREW - (PKG OF 4) - BLK	748329 RND
	106015-16-700	EA	GLASS-FLAT W/HEAT ELEMENT	709450
	106015-18-700	EA	GLASS/CONVEX-KIT W/CLIP	709650
	106015-18-701	EA	ACTUATOR - CONVEX GLASS	7475410
	106015-18-702	EA	MOTOR - FLAT GLASS	747118
	106015-18-703	EA	CONVEX REBUILT KIT	709651
	106015-19-700	EA	VIBRATION KIT - MIRROR GLASS, VELVAC	709645

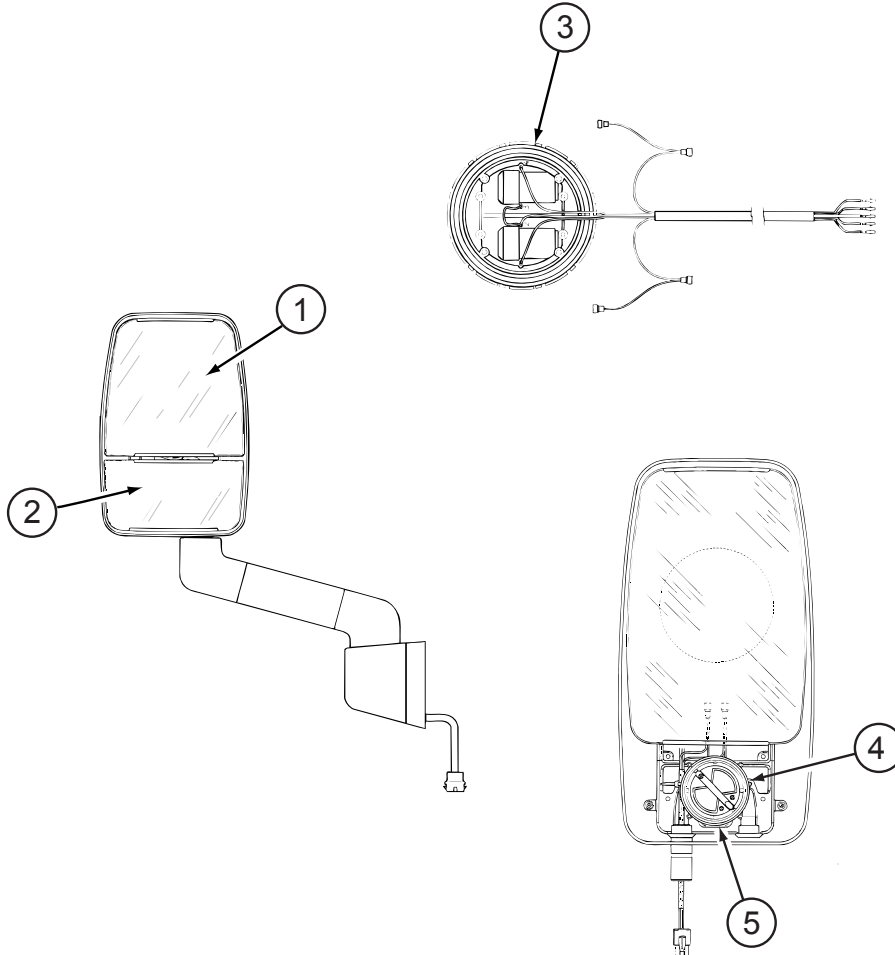

131431-06-01A & 02A

KEY	PART NUMBER	U/M	DESCRIPTION	VENDOR NO.
1	106015-16-700	EA	GLASS-FLAT W/HEAT ELEMENT	709450
2	106015-18-700	EA	GLASS - CONVEX/21"RADIUS	7021220
3	106015-18-702	EA	MOTOR - FLAT GLASS	7476730
5	106015-18-701	EA	ACTUATOR - CONVEX GLASS	7475410
	131431-01-702	EA	KIT(SCREW COVER)ROUND & OVAL	748345

CONTACT WINNEBAGO PART SALES FOR THIS COMPONENT

EXTERIOR BODY GROUP (CONTINUED)
STRUCTURAL COMPONENTS

KEY	PART NUMBER	U/M	DESCRIPTION
	002766-01-001	EA	ANGLE - EXTRUDED - 1" X 1 1/2" X 17'
	068716-01-001	EA	BRACE - 90 DEGREE - L-ANGLE - 16'
	089297-01-000	SF	PLYWOOD - LUAN - OVERLAY GRADE - 4' X 8'
	100619-01-000	BF	FOAM - EXPANDED POLYSTYRENE - 1.34" X 48" X 96"
	100619-02-000	BF	FOAM - EXPANDED POLYSTYRENE - 1.5" X 48" X 96"
	100619-05-000	BF	FOAM - EXPANDED POLYSTYRENE - .75" X 48" X 96"-1.5 DENSITY
	100619-13-000	BF	FOAM - EXPANDED POLYSTYRENE - .34" X 34.65" X 96"
	100619-16-000	BF	FOAM - EXPANDED POLYSTYRENE - .75" X 48" X 96"-2.0 DENSITY
	100619-27-000	BF	FOAM - EXPANDED POLYSTYRENE - 48" X 92.8" X 3"
	105077-08-000	EA	FOAM - PLUG - ROOF CAP
			FROM: 06-24-02 THRU: 99-99-99
	120107-01-000	EA	FOAM - ROOF COVE - 2.8" X 96" LONG
	120107-02-000	EA	FOAM - PLUG - ROOF TUBE - 2.2" X 2.9" X 1.8" LONG
	120107-03-000	EA	FOAM - PLUG - SIDEWALL TUBE - 1.2" X 2.1" X 1.8" LONG
	128782-07-01A	EA	FIBERGLASS SHEET - 79" X 456" - HIGH GLOSS - BRIGHT WHITE
	128782-08-01A	EA	FIBERGLASS SHEET - 22" X 68.3" - HIGH GLOSS - BRIGHT WHITE
	128782-09-01A	EA	FIBERGLASS SHEET - 31" X 68.2" - HIGH GLOSS - BRIGHT WHITE
			FROM: 05-01-02 THRU: 99-99-99
	128782-10-01A	EA	FIBERGLASS SHEET - 25" X 48" - HIGH GLOSS - BRIGHT WHITE

EXTERIOR BODY GROUP (CONTINUED)

AWNINGS

HORIZON PATIO AWNING WITH GRAPHIC PKG.

SERIES HORIZON	MODEL	COLOR DESIGNATION	FABRIC	LENGTH	WEATHER WRAP	PART #	PART #
						MANUAL	ELECTRIC
27G	P32TD	ALPINE GREEN (DY)	VINYL	18'	MTL/BRT WHT	113874-07-28A	143181-07-28A
	P34HD	ALPINE GREEN (DY)	VINYL	18'	MTL/BRT WHT	113874-07-28A	143181-07-28A
	P36LD	ALPINE GREEN (DY)	VINYL	20'	MTL/BRT WHT	113874-09-28A	143181-09-28A
	P39QD	ALPINE GREEN (DY)	VINYL	20'	MTL/BRT WHT	113874-09-28A	143181-09-28A
	P39WD	ALPINE GREEN (DY)	VINYL	20'	MTL/BRT WHT	113874-09-28A	143181-09-28A
92K & 24K	P32TD	GULF BLUE (DX)	VINYL	18'	MTL/BRT WHT	113874-07-39A	143181-07-39A
	P34HD	GULF BLUE (DX)	VINYL	18'	MTL/BRT WHT	113874-07-39A	143181-07-39A
	P36LD	GULF BLUE (DX)	VINYL	20'	MTL/BRT WHT	113874-09-39A	143181-09-39A
	P39QD	GULF BLUE (DX)	VINYL	20'	MTL/BRT WHT	113874-09-39A	143181-09-39A
	P39WD	GULF BLUE (DX)	VINYL	20'	MTL/BRT WHT	113874-09-39A	143181-09-39A

KEY	PART NUMBER	U/M	DESCRIPTION
*	113874-01-02A	EA	HARDWARE KIT - AWNING - W/O STANDOFF BRACKET-BRIGHT WHITE
	143181-01-01A	EA	HARDWARE/AWNING - WEATHERPROOF - BRIGHT WHITE - ELECTRIC
	143181-02-01A	EA	HARDWARE/AWNING - ELECTRICAL KIT
	113874-11-01A	EA	SCREW/LAG - AWNING - 1/4" X 1" STAINLESS STEEL
	113874-12-01A	EA	SCREW/LAG - AWNING - 1/4" X 2 3/4" STAINLESS STEEL
	137054-01-02A	EA	BRACKET - AWNING - BRIGHT WHITE

*COMPONENT PARTS LISTED LATER IN THIS GROUP

HORIZON PATIO AWNINGS WITH FULL BODY PAINT

MODEL	COLOR PAINT PKG #	AWNING COLOR	HARDWARE COLOR	PATIO ROLLER	AWNING LENGTH	PATIO HARDWARE	PATIO ELECTRICAL
P39WD	MOCHA 27A	TRUE BROWN	CHAMPAGNE	143181-09-26E	20'	143181-01-02A	143181-02-01A
P39QD	MOCHA 27A	TRUE BROWN	CHAMPAGNE	143181-09-26E	20'	143181-01-02A	143181-02-01A
P36LD	MOCHA 27A	TRUE BROWN	CHAMPAGNE	143181-09-26E	20'	143181-01-02A	143181-02-01A
P34HD	MOCHA 27A	TRUE BROWN	CHAMPAGNE	143181-07-26E	18'	143181-01-02A	143181-02-01A
P32TD	MOCHA 27A	TRUE BROWN	CHAMPAGNE	143181-07-26E	18'	143181-01-02A	143181-02-01A
P39WD	AUBURN 92A	BURGUNDY	CHAMPAGNE	143181-09-22E	20'	143181-01-02A	143181-02-01A
P39QD	AUBURN 92A	BURGUNDY	CHAMPAGNE	143181-09-22E	20'	143181-01-02A	143181-02-01A
P36LD	AUBURN 92A	BURGUNDY	CHAMPAGNE	143181-09-22E	20'	143181-01-02A	143181-02-01A
P34HD	AUBURN 92A	BURGUNDY	CHAMPAGNE	143181-07-22E	18'	143181-01-02A	143181-02-01A
P32TD	AUBURN 92A	BURGUNDY	CHAMPAGNE	143181-07-22E	18'	143181-01-02A	143181-02-01A
P39WD	BLUE LAKE 24C	BLUE	SILVER	143181-09-52F	20'	143181-01-03A	143181-02-01A
P39QD	BLUE LAKE 24C	BLUE	SILVER	143181-09-52F	20'	143181-01-03A	143181-02-01A
P36LD	BLUE LAKE 24C	BLUE	SILVER	143181-09-52F	20'	143181-01-03A	143181-02-01A
P34HD	BLUE LAKE 24C	BLUE	SILVER	143181-07-52F	18'	143181-01-03A	143181-02-01A
P32TD	BLUE LAKE 24C	BLUE	SILVER	143181-07-52F	18'	143181-01-03A	143181-02-01A

KEY	PART NUMBER	U/M	DESCRIPTION
	113874-11-01A	EA	SCREW/LAG - AWNING - 1/4" X 1" STAINLESS STEEL

EXTERIOR BODY GROUP (CONTINUED)
AWNINGS (CONTINUED)

HORIZON	WHERE	SIZE	HORIZON WINDOW AWNINGS WITH GRAPHIC PKG.	
			GRAPHIC PKG. 27G APLINE GREEN w/ wht mtl wrap PART #	GRAPHIC PKG. 92K & 24E GULF BLUE w/wht mtl wrap PART #
P32TD	RT REAR	42" XL	142199-05-28A	142199-05-39A
	LT MID	42"	142199-04-28A	142199-04-39A
	LT FRONT	66"	142199-06-28A	142199-06-39A
P34HD	RT REAR	42" XL	142199-05-28A	142199-05-39A
	LT FRONT	108"	142199-07-28A	142199-07-39A
P36GD	RT REAR	42"XL	142199-05-28A	142199-05-39A
	LT MID	36"	142199-03-28A	142199-03-39A
	LT FRONT	144"	142199-08-28A	142199-08-39A
P36LD	RT REAR	42" XL	142199-05-28A	142199-05-39A
	LT MID	36"	142199-03-28A	142199-03-39A
	LT FRONT	108"	142199-07-28A	142199-07-39A
P39QD	RT REAR	42" XL	142199-05-28A	142199-05-39A
	LT FRONT	144"	142199-08-28A	142199-08-39A
P39WD	RT REAR	42" XL	142199-05-28A	142199-05-39A
	LT MID	36"	142199-03-28A	142199-03-39A
	LT FRONT	108"	142199-07-28A	142199-07-39A

KEY PART NUMBER	U/M DESCRIPTION
142199-01-01A	EA HARDWARE - WINDOW AWNING - STANDARD LENGTH - BRIGHT WHITE
142199-02-01A	EA HARDWARE - WINDOW AWNING - TALL LENGTH - BRIGHT WHITE

HORIZON WINDOW AWNINGS WITH FULL BODY PAINT

MODEL	COLOR PAINT PKG #	AWNING COLOR	HARDWARE COLOR	WINDOW	WINDOW	WINDOW	WINDOW	WINDOW	WINDOW
				LT FRONT ROLLER	LT FRONT HARDWARE	LT MID ROLLER	LT MID HARDWARE	RT REAR ROLLER	RT REAR HARDWARE
P39WD	MOCHA 27A	TRUE BROWN	CHAMPAGNE	142199-07-26E	142199-01-02A	142199-03-26E	142199-01-02A	142199-05-26E	142199-02-02A
P39QD	MOCHA 27A	TRUE BROWN	CHAMPAGNE	142199-08-26E	142199-01-02A	NA	NA	142199-05-26E	142199-02-02A
P36LD	MOCHA 27A	TRUE BROWN	CHAMPAGNE	142199-07-26E	142199-01-02A	142199-03-26E	142199-01-02A	142199-05-26E	142199-02-02A
P34HD	MOCHA 27A	TRUE BROWN	CHAMPAGNE	142199-07-26E	142199-01-02A	NA	NA	142199-05-26E	142199-02-02A
P32TD	MOCHA 27A	TRUE BROWN	CHAMPAGNE	142199-06-26E	142199-01-02A	142199-04-26E	142199-01-02A	142199-05-26E	142199-02-02A
P39WD	AUBURN 92A	BURGUNDY	CHAMPAGNE	142199-07-22E	142199-01-02A	142199-03-22E	142199-01-02A	142199-05-22E	142199-02-02A
P39QD	AUBURN 92A	BURGUNDY	CHAMPAGNE	142199-08-22E	142199-01-02A	NA	NA	142199-05-22E	142199-02-02A
P36LD	AUBURN 92A	BURGUNDY	CHAMPAGNE	142199-07-22E	142199-01-02A	142199-03-22E	142199-01-02A	142199-05-22E	142199-02-02A
P34HD	AUBURN 92A	BURGUNDY	CHAMPAGNE	142199-07-22E	142199-01-02A	NA	NA	142199-05-22E	142199-02-02A
P32TD	AUBURN 92A	BURGUNDY	CHAMPAGNE	142199-06-22E	142199-01-02A	142199-04-22E	142199-01-02A	142199-05-22E	142199-02-02A
P39WD	BLUE LAKE 24C	BLUE	SILVER	142199-07-52F	142199-01-03A	142199-03-52F	142199-01-03A	142199-05-52F	142199-02-03A
P39QD	BLUE LAKE 24C	BLUE	SILVER	142199-08-52F	142199-01-03A	NA	NA	142199-05-52F	142199-02-03A
P36LD	BLUE LAKE 24C	BLUE	SILVER	142199-07-52F	142199-01-03A	142199-03-52F	142199-01-03A	142199-05-52F	142199-02-03A
P34HD	BLUE LAKE 24C	BLUE	SILVER	142199-07-52F	142199-01-03A	NA	NA	142199-05-52F	142199-02-03A
P32TD	BLUE LAKE 24C	BLUE	SILVER	142199-06-52F	142199-01-03A	142199-04-52F	142199-01-03A	142199-05-52F	142199-02-03A

EXTERIOR BODY GROUP (CONTINUED)
AWNINGS (CONTINUED)

HORIZON ENTRY DOOR AWNINGS					
MODEL	COLOR	AWNING COLOR	HARDWARE COLOR	DOOR ELECTRIC	DOOR MAUAL
ALL	GRAPHIC PKG. 24E,27G,92K	WHITE	BRIGHT WHITE	136767-02-01A	136767-01-01A
	PAINT PKG #				
P39WD	MOCHA 27A	TRUE BROWN	CHAMPAGNE	136767-02-26E	NA
P39QD	MOCHA 27A	TRUE BROWN	CHAMPAGNE	136767-02-26E	NA
P36LD	MOCHA 27A	TRUE BROWN	CHAMPAGNE	136767-02-26E	NA
P34HD	MOCHA 27A	TRUE BROWN	CHAMPAGNE	136767-02-26E	NA
P32TD	MOCHA 27A	TRUE BROWN	CHAMPAGNE	136767-02-26E	NA
P39WD	AUBURN 92A	BURGUNDY	CHAMPAGNE	136767-02-22E	NA
P39QD	AUBURN 92A	BURGUNDY	CHAMPAGNE	136767-02-22E	NA
P36LD	AUBURN 92A	BURGUNDY	CHAMPAGNE	136767-02-22E	NA
P34HD	AUBURN 92A	BURGUNDY	CHAMPAGNE	136767-02-22E	NA
P32TD	AUBURN 92A	BURGUNDY	CHAMPAGNE	136767-02-22E	NA
P39WD	BLUE LAKE 24C	BLUE	SILVER	136767-02-52F	NA
P39QD	BLUE LAKE 24C	BLUE	SILVER	136767-02-52F	NA
P36LD	BLUE LAKE 24C	BLUE	SILVER	136767-02-52F	NA
P34HD	BLUE LAKE 24C	BLUE	SILVER	136767-02-52F	NA
P32TD	BLUE LAKE 24C	BLUE	SILVER	136767-02-52F	NA

KEY	PART NUMBER	U/M	DESCRIPTION
	137029-01-01A	EA	BRACKET - AWNING - BRIGHT WHITE
	136770-03-01A	EA	SPACER - AWNING - 2" - BRIGHT WHITE

EXTERIOR BODY GROUP (CONTINUED)
COMPONENT PARTS FOR AWNINGS

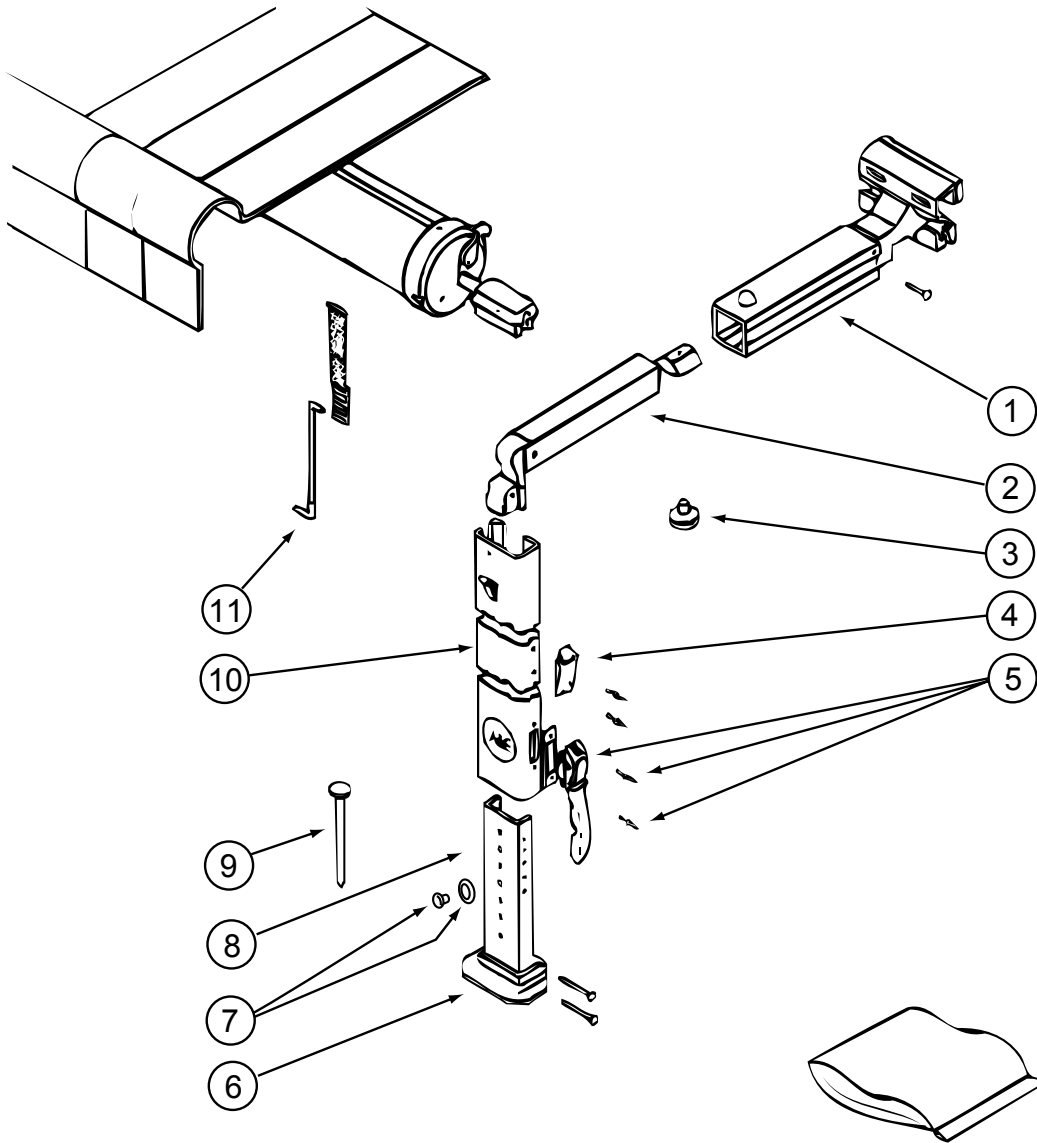

113874-01-02A

KEY	PART NUMBER	U/M	DESCRIPTION	VENDOR NO.
1	113874-01-714	EA	RAFTER - MAIN RH/LH BRT/WHT	830295.536F
2	113874-01-715	EA	RAFTER - SECONDARY BRT/WHT	830463.511F
3	113874-01-702	EA	KNOB - ADJUSTING	3105421.014
4	113874-01-706	EA	LOCK - TRAVEL	830587.001
5	113874-01-707	EA	HANDLE - LIFT W/RIVETS	830644
6	113874-01-712	EA	FOOT - PATIO	730366-001
7	113874-01-710	EA	PLUG-STOP KIT	830456
8	113874-01-717	EA	ARM - ADJUSTABLE BRT/WHT	830467.517/F
9	113874-01-709	EA	NAIL-SPIKE, 8"	113006
10	113874-01-716	EA	ARM - MAIN SUPPORT BRT/WHT	3104502.293/F
11	113874-01-703	EA	ROD-CENTER PULL W/ACCESSORY	830152.102

EXTERIOR DOORS & COMPARTMENTS GROUP

DOOR & COMPARTMENT LAYOUT

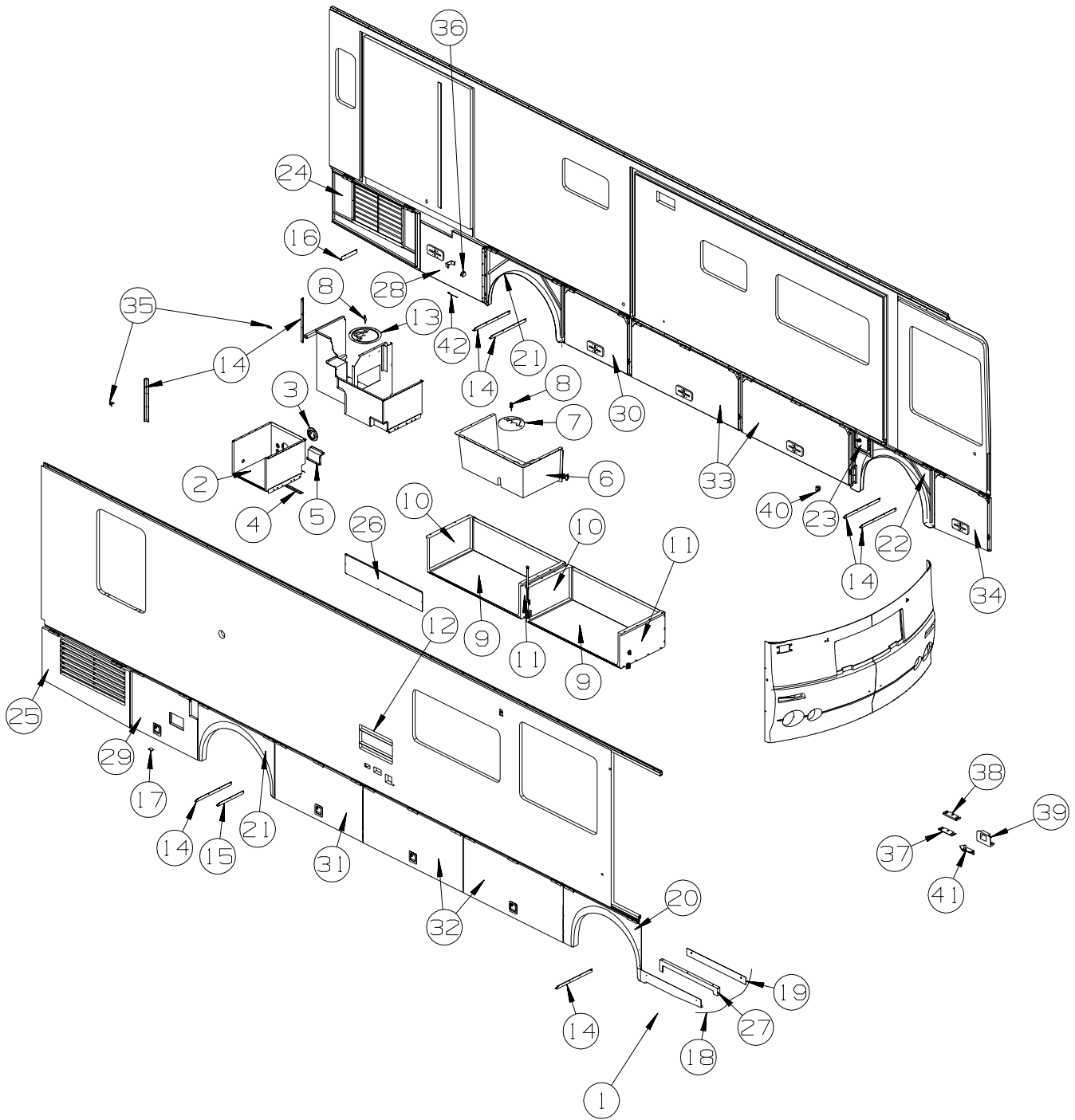

KEY	PART NUMBER	U/M	DESCRIPTION
1 *	094708-03-01A	EA	STEP - ELECTRIC - SINGLE - BLACK CONTROL BOX - KWIKEE
2	132902-02-L76	EA	COMPARTMENT - LUGGAGE
3	092887-03-000	EA	HATCH/PLATE - 6.1" FLANGE/4.5" R.O. - BLACK
4	130034-08-02B	EA	CLIP - TRIM - E-COATED
5	140352-01-02B	EA	PANEL - CLOSEOUT - WATER HEATER - E-COATED
6	133341-01-L76	EA	COMPARTMENT COMPL-DRAINAGE
7	M08628-01-H17	EA	HATCH - W/FOAM INSERT - 3/4" X 11 1/2" DIA.- BLACK PLASTIC
8	121175-02-01A	EA	LATCH - SWELL
9	135927-09-N70	EA	COMPARTMENT - LUGGAGE
10	126397-03-01A	EA	PANEL/COMPARTMENT END - RIGHT HAND
11	126397-04-01A	EA	PANEL/COMPARTMENT END - LEFT HAND
12*	084103-08-000	EA	DOOR - VENT - REFRIGERATOR - W/O JAMB - BRIGHT WHITE
	084104-08-000	EA	JAMB - VENT DOOR/REFRIGERATOR - BRIGHT WHITE

FROM: 02-09-02 THRU: 99-99-99

EXTERIOR DOORS & COMPARTMENTS GROUP (CONTINUED)
DOOR & COMPARTMENT LAYOUT (CONTINUED)

KEY	PART NUMBER	U/M	DESCRIPTION
13	129015-01-K80	EA	PORT W/HATCH - F/ELECTRICAL/DRAIN
14	113904-11-02B	EA	ANGLE - ATTACHMENT/WHEEL LIP - 21.6" - E-COAT FROM: 00-00-00 THRU: 11-11-02
15	113904-13-02B	EA	ANGLE - ATTACHMENT/WHEEL LIP - 15.7" - E-COAT
16	113904-15-02B	EA	ANGLE - ATTACHMENT/WHEEL LIP - 9.4" - E-COAT
17	115620-01-12B	EA	PLATE - BACKING - BRIGHT WHITE
18	131900-02-P75	EA	VALANCE/PANEL - ENTRY DOOR - PLASTIC - BLACK
19	143362-02-02B	EA	CLIP - TRIM - E-COATED
20	131922-01-M70	EA	PANEL/WHEEL LIP - FRONT/PASSENGER - 48.1"
21	131922-03-L76	EA	PANEL/WHEEL LIP - REAR - 47.2"
22	131922-04-N70	EA	PANEL/WHEEL LIP - FRONT/DRIVER - 49" - BLACK
23	131905-05-N70	EA	PANEL/DOOR - FUEL FILL - BLACK
	138290-01-000	EA	CASE - W/CAM - W/O CYLINDER/KEY
24	132197-05-N74	EA	VALANCE/DOOR - DRVR W/GRILLE W/O HDW - 26" X 53.4" X 28.7"
25	132198-01-L76	EA	VALANCE/PANEL - PASSENGER W/GRILLE - 27.8" X 52.6" X 25.2"
26	133386-01-02B	EA	PANEL - CLOSEOUT - HOLDING TANK - E-COATED
27	134125-04-02B	EA	SUPPORT - DOOR/VALANCE - E-COATED
28	138269-16-N74	EA	VALANCE/DOOR - W/O LATCH/HINGE - 41.1" X 28.3"
	132873-80-000	EA	ROD - LATCH - 4.7" W/3/4" DOG LEG
29	140442-02-N70	EA	VALANCE/DOOR - W/O PADDLE LATCH - 40" X 28" W/NOTCH & VENT
	132873-05-000	EA	ROD - LATCH - 18.7" W/3/4" DOG LEG
	132873-06-000	EA	ROD - LATCH - 14.4" W/3/4" DOG LEG
	107796-31-000	EA	SPRING/GAS - 12" COMPRESSED/20" EXTENDED - 100 LB
30	140442-01-N70	EA	VALANCE/DOOR - W/O PADDLE LATCH - 41" X 28"
	132873-07-000	EA	ROD - LATCH - 16.2" W/3/4" DOG LEG
	132873-08-000	EA	ROD - LATCH - 16.2" W/3/4" DOG LEG
	107796-26-000	EA	SPRING/GAS - 12" COMPRESSED/20" EXTENDED - 90 LB.
31	140442-05-N70	EA	VALANCE/DOOR - W/O PADDLE LATCH - 54" X 28"
	132873-11-000	EA	ROD - LATCH - 22.7" W/3/4" DOG LEG
	132873-12-000	EA	ROD - LATCH - 22.7" W/3/4" DOG LEG
	107796-31-000	EA	SPRING/GAS - 12" COMPRESSED/20" EXTENDED - 100 LB
32	140442-06-N70	EA	VALANCE/DOOR - W/O PADDLE LATCH - 61" X 28"
	132873-13-000	EA	ROD - LATCH - 32.4" W/3/4" DOG LEG
	132873-14-000	EA	ROD - LATCH - 26.4" W/3/4" DOG LEG
	107796-31-000	EA	SPRING/GAS - 12" COMPRESSED/20" EXTENDED - 100 LB
33	140442-07-N52	EA	VALANCE/DOOR - W/O PADDLE LATCH - 67" X 28"
	132873-15-000	EA	ROD - LATCH - 27.8" W/3/4" DOG LEG
	132873-16-000	EA	ROD - LATCH - 29.6" W/3/4" DOG LEG
	107796-31-000	EA	SPRING/GAS - 12" COMPRESSED/20" EXTENDED - 100 LB
34	140442-08-N70	EA	VALANCE/DOOR - DRVR FRT W/O PADDLE LATCH - 28" X 34" X 26"
	132873-17-000	EA	ROD - LATCH - 11.3" W/3/4" DOG LEG
	132873-18-000	EA	ROD - LATCH - 13.1" W/3/4" DOG LEG
	107796-31-000	EA	SPRING/GAS - 12" COMPRESSED/20" EXTENDED - 100 LB FROM: 00-00-00 THRU: 02-16-03
	107796-25-000	EA	SPRING/GAS - 11.3" COMPRESSED/18.5" EXTENDED - 90 LB. FROM: 02-17-03 THRU: 99-99-99
35	109216-03-000	EA	ANGLE - FURNACE DOOR FROM: 00-00-00 THRU: 01-13-03
35	140309-03-02B	EA	ANGLE - FURNACE DOOR FROM: 01-14-03 THRU: 99-99-99
36	131383-03-02A	EA	BRACKET - SHOWER HEAD - WHITE
37	120494-03-02B	EA	SHIM - STRIKER - LUGGAGE DOOR - .20 - E-COATED FROM: 00-00-00 THRU: 01-05-03
37	143793-01-01A	EA	SHIM/STRIKER - LUGGAGE - 1.5" - BLACK FROM: 01-06-03 THRU: 99-99-99
38	120494-04-02B	EA	SHIM - STRIKER - LUGGAGE DOOR - .27 - E-COATED
39	130053-01-01A	EA	STRIKER - LUGGAGE DOOR - FLUSH - BLACK
40	130053-02-01A	EA	STRIKER - LUGGAGE DOOR - OFF SET - BLACK
41	126263-02-02B	EA	BRACKET - GAS SPRING W/BALL STUD - E-COATED
42	076767-11-000	EA	CABLE - STAINLESS STEEL - 5.9"
	129041-01-01A	EA	HOLDER - PAPER TOWEL
	132892-02-01A	FT	SEAL - BULB

EXTERIOR DOORS & COMPARTMENTS GROUP (CONTINUED)
DOOR & COMPARTMENT LAYOUT (CONTINUED)

KEY	PART NUMBER	U/M DESCRIPTION
	138292-01-000	EA SEAL - LOCK CYLINDER
	138289-01-000	EA CYLINDER - LOCKING
	138289-02-000	EA CYLINDER - LOCKING
	138289-03-000	EA CYLINDER - LOCKING
	138289-04-000	EA CYLINDER - LOCKING
	138289-05-000	EA CYLINDER - LOCKING
	138289-06-000	EA CYLINDER - LOCKING
	138289-07-000	EA CYLINDER - LOCKING
	138289-08-000	EA CYLINDER - LOCKING
	138289-09-000	EA CYLINDER - LOCKING
	138289-10-000	EA CYLINDER - LOCKING
	138288-01-000	EA KEY - REVERSIBLE - #1151 - T/M 16169-02-3091
	138288-02-000	EA KEY - REVERSIBLE - #1151 - T/M 16169-02-3091
	138288-03-000	EA KEY - REVERSIBLE - #1151 - T/M 16169-02-3091
	138288-04-000	EA KEY - REVERSIBLE - #1151 - T/M 16169-02-3091
	138288-05-000	EA KEY - REVERSIBLE - #1151 - T/M 16169-02-3091
	138288-06-000	EA KEY - REVERSIBLE - #1151 - T/M 16169-02-3091
	138288-07-000	EA KEY - REVERSIBLE - #1151 - T/M 16169-02-3091
	138288-08-000	EA KEY - REVERSIBLE - #1151 - T/M 16169-02-3091
	138288-09-000	EA KEY - REVERSIBLE - #1151 - T/M 16169-02-3091
	138288-10-000	EA KEY - REVERSIBLE - #1151 - T/M 16169-02-3091

***COMPONENT PARTS LISTED LATER IN THIS GROUP**

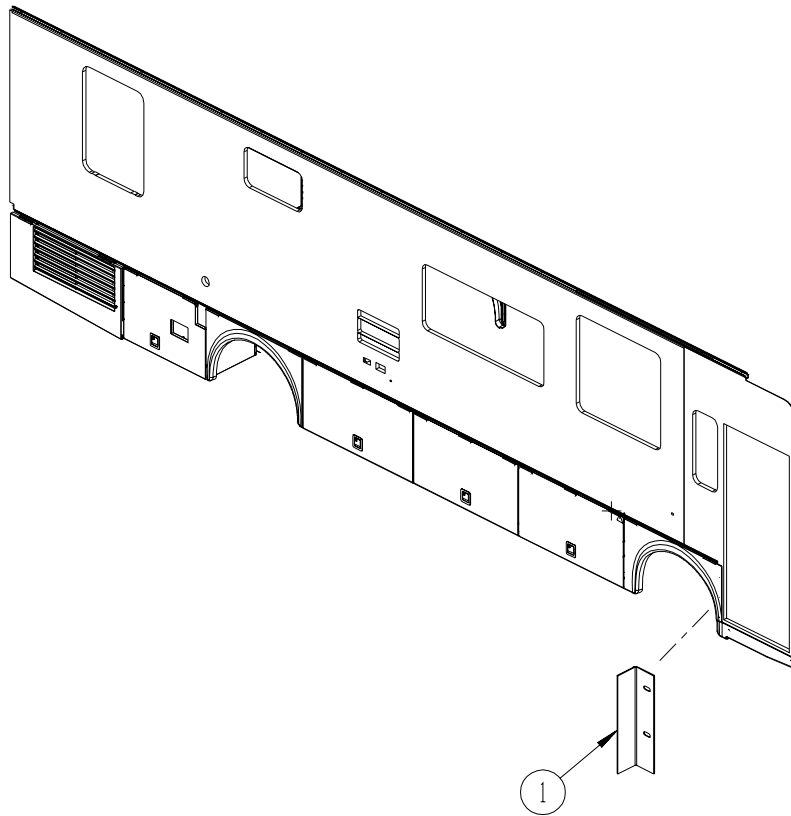

KEY	PART NUMBER	U/M DESCRIPTION
1	113041-15-02B	EA ANGLE - BUMPER MOUNT - E-COATED

EXTERIOR DOORS & COMPARTMENTS GROUP (CONTINUED)
DOOR & COMPARTMENT LAYOUT (CONTINUED)

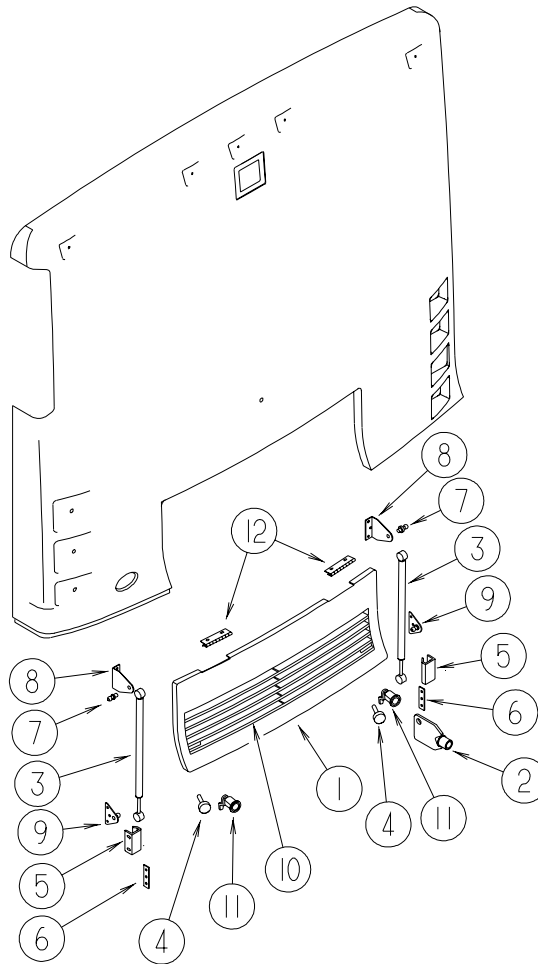

KEY	PART NUMBER	U/M	DESCRIPTION
1	132182-01-L76	EA	DOOR - REAR ENGINE - W/O HARDWARE
2	102328-01-000	EA	KEY - BARREL - NICKEL PLATED
3	107796-23-000	EA	SPRING/GAS - 11.3" COMPRESSED/18.5" EXTENDED - 45 LB.
4	058786-01-000	EA	BOLT - HOOD ADJUSTMENT - 5/16"-18 X 1.5"-2"- W/BLACK PAD
5	107719-01-01A	EA	STRIKE - VALANCE DOOR
6	118931-01-02B	EA	SHIM - STRIKER - DOOR
7	NOT AVAILABLE - CONTACT PART SALES		
8	126263-10-02B	EA	BRACKET - GAS SPRING W/BALL STUD - E-COATED
9	126263-08-02B	EA	BRACKET - GAS SPRING W/CENTERED BALL STUD - E-COATED
10	132412-01-L76	EA	GRILLE/DOOR - TRUNK
11	102330-02-000	EA	LATCH - VISE ACTION/KEY OPERATED
12	102325-02-07A	EA	HINGE/TRUNK DOOR - 6" W/.6" OFF SET - BRIGHT WHITE

EXTERIOR DOORS & COMPARTMENTS GROUP (CONTINUED)
COMPARTMENT DOOR PIECE PARTS

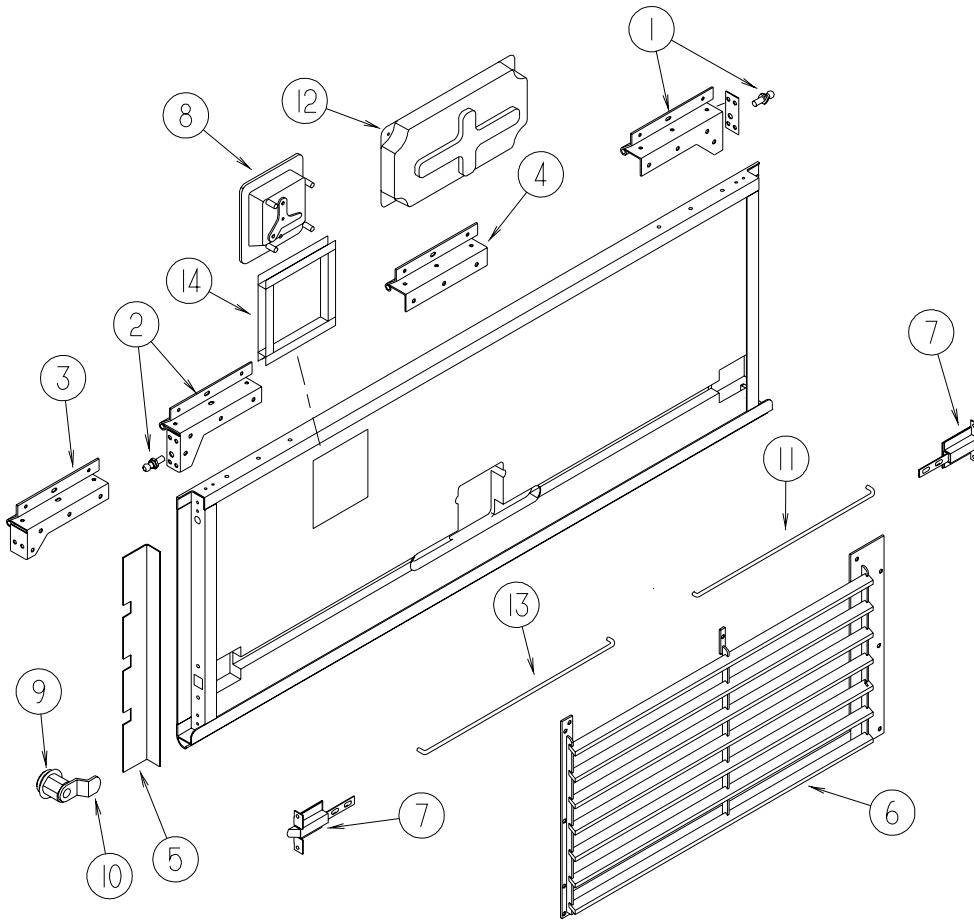

KEY	PART NUMBER	U/M	DESCRIPTION
1	139793-01-01A	EA	HINGE - RIGHT HAND/VALANCE DOOR - W/BALLSTUD
2	139793-02-01A	EA	HINGE - LEFT HAND/VALANCE DOOR - W/BALLSTUD
3	139793-05-01A	EA	HINGE - LEFT HAND/VALANCE DOOR - W/O BALLSTUD
4	139793-03-01A	EA	HINGE - CENTER/VALANCE DOOR - W/O BALLSTUD
5	139207-01-02B	EA	PANEL - SUPPORT - A/C DOOR - E-COATED
6	113333-06-L76	EA	GRILLE/DOOR - A/C
7	121947-01-01A	EA	BOLT - SLIDE W/PLASTIC PLUNGER
8	138277-01-01A	EA	LATCH/PADDLE - COMPARTMENT DOOR - BLACK - KEY ONE
8	112949-02-04A	EA	LATCH - PADDLE NON-LOCKING - BRIGHT WHITE
9	110506-50-000	EA	CASE/CYLINDER - TWIST LATCH - W/O CAM - .65" - 596952
10	110506-76-000	EA	CAM - LOCK
11	132873-01-000	EA	ROD - LATCH (BLANK) - RIGHT HAND
12	137359-01-01A	EA	COVER - LATCH - WHITE
13	132873-02-000	EA	ROD - LATCH (BLANK) - LEFT HAND
14	133049-01-L76	EA	TRIM - COVER - WATER HEATER

EXTERIOR DOORS & COMPARTMENTS GROUP (CONTINUED)

ENTRY

KEY	PART NUMBER	U/M	DESCRIPTION
*	128913-10-02A	EA	DOOR - ENTRY/FRONT - POWER LOCK - WHITE
*	128913-10-01A	EA	DOOR - ENTRY/FRONT - POWER LOCK - W/BLACK OUTER FRAME - FULL BODY PAINT FROM: 00-00-00 THRU: 04-06-03
	128913-12-01A	EA	DOOR - ENTRY/FRONT - POWER LOCK - BLACK - FULL BODY PAINT FROM: 04-07-03 THRU: 99-99-99
	134450-02-01A	EA	TAPE - ANTI SLIP - 1.25" X 29.9" - BLACK
	039715-01-000	EA	NUT-SERT - 1/4" DIAMETER - 20 THREADS
	138287-01-000	EA	CYLINDER/LOCK - ENTRY DOOR (MASTER)
	138287-02-000	EA	CYLINDER/LOCK - ENTRY DOOR (MASTER)
	138287-03-000	EA	CYLINDER/LOCK - ENTRY DOOR (MASTER)
	138287-04-000	EA	CYLINDER/LOCK - ENTRY DOOR (MASTER)
	138287-05-000	EA	CYLINDER/LOCK - ENTRY DOOR (MASTER)
	138287-06-000	EA	CYLINDER/LOCK - ENTRY DOOR (MASTER)
	138287-07-000	EA	CYLINDER/LOCK - ENTRY DOOR (MASTER)
	138287-08-000	EA	CYLINDER/LOCK - ENTRY DOOR (MASTER)
	138287-09-000	EA	CYLINDER/LOCK - ENTRY DOOR (MASTER)
	138287-10-000	EA	CYLINDER/LOCK - ENTRY DOOR (MASTER)
	138288-01-000	EA	KEY - REVERSIBLE - #1151 - T/M 16169-02-3091
	138288-02-000	EA	KEY - REVERSIBLE - #1152 - T/M 16169-02-3092
	138288-03-000	EA	KEY - REVERSIBLE - #1153 - T/M 16169-02-3093
	138288-04-000	EA	KEY - REVERSIBLE - #1154 - T/M 16169-02-3094
	138288-05-000	EA	KEY - REVERSIBLE - #1155 - T/M 16169-02-3095
	138288-06-000	EA	KEY - REVERSIBLE - #1156 - T/M 16169-02-3096
	138288-07-000	EA	KEY - REVERSIBLE - #1157 - T/M 16169-02-3097
	138288-08-000	EA	KEY - REVERSIBLE - #1158 - T/M 16169-02-3098
	138288-09-000	EA	KEY - REVERSIBLE - #1159 - T/M 16169-02-3099
	138288-10-000	EA	KEY - REVERSIBLE - #1150 - T/M 16169-02-3100

*COMPONENT PARTS LISTED LATER IN THIS GROUP

EXTERIOR DOORS & COMPARTMENTS GROUP (CONTINUED)
COMPONENT PARTS FOR ENTRY

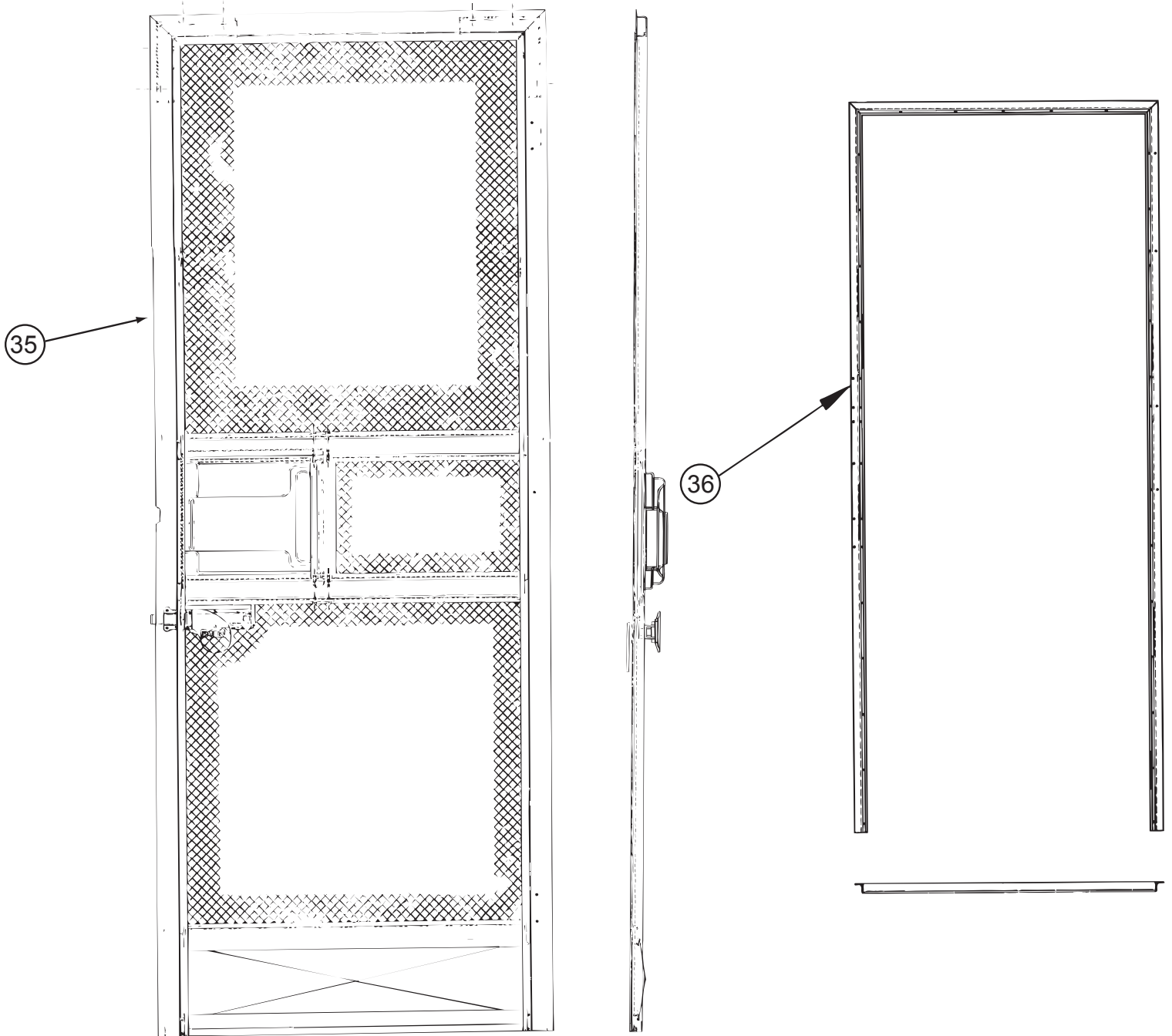

128913-10-02A

KEY	PART NUMBER	U/M	DESCRIPTION	VENDOR NO.
35*	128913-09-700	EA	SCREEN DOOR ASSEMBLY	490056
36	128913-10-700	EA	FRAME/CLAMP - WELD ASM BLACK	490195

***COMPONENT PARTS LISTED LATER IN THIS GROUP**

EXTERIOR DOORS & COMPARTMENTS GROUP (CONTINUED)
COMPONENT PARTS FOR ENTRY (CONTINUED)

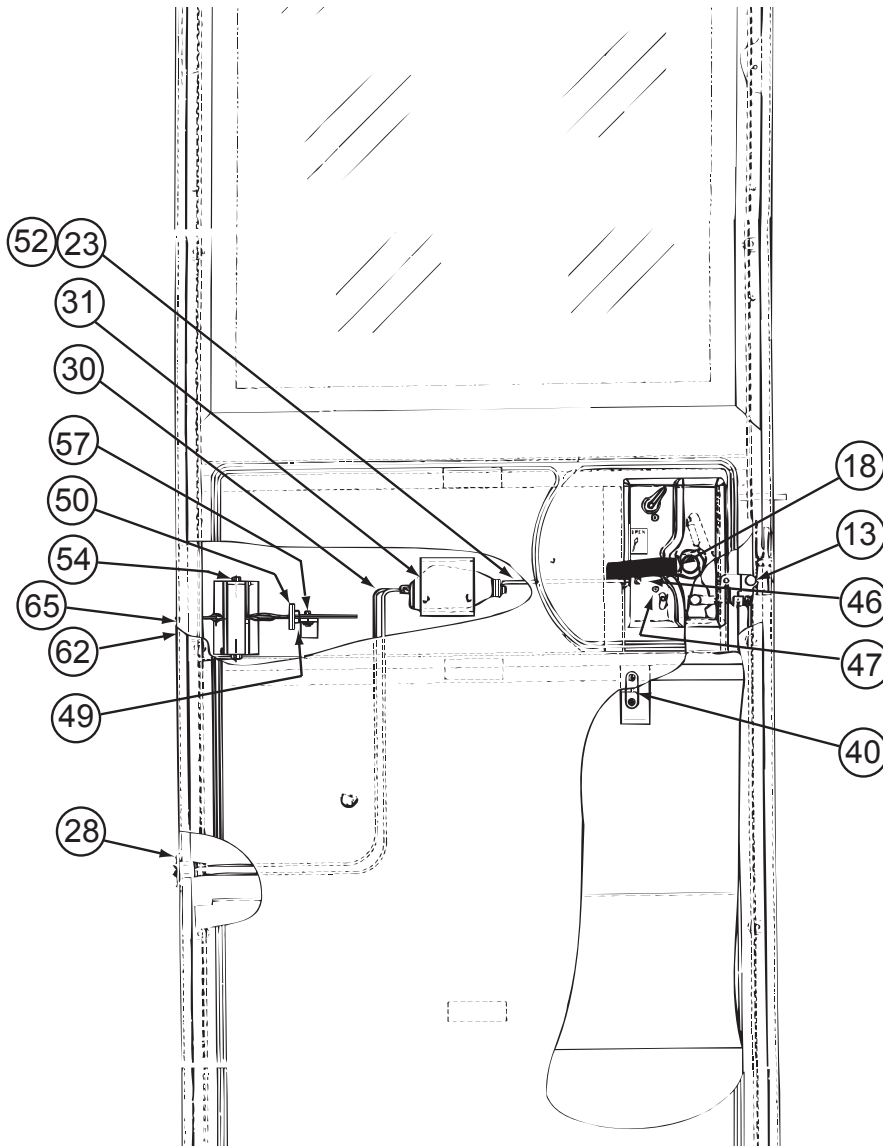

128913-10-02A (CONTINUED)

KEY	PART NUMBER	U/M	DESCRIPTION	VENDOR NO.
13	128913-04-706	EA	LATCH/ROTARY - W/LINKAGE RH	B248-041726/T/M179
18	128913-08-700	EA	HANDLE - INSIDE - REV.	248-041725
23	128913-04-704	EA	ROD/LOCK - (POWER)	17705-01
30	128913-01-712	EA	WIRE HARNESS-POWER DOOR LOCK	400-041935
31	106469-05-701	EA	ACTUATOR, F/ELECTRIC LOCK	410-041096
40	128913-01-710	EA	STRIKER - LATCH/SCREEN DOOR	130-041815
46	128913-02-711	EA	SLIDE BAR ASSEMBLY	V196-29
47	128913-01-746	EA	SCREW #8 X 3/4" OVAL HEAD	276-042030
49	128913-02-712	EA	PIN - COILED SPRING	248-042237
50	128913-02-713	EA	BUMPER STOP	V196-24
54	128913-01-733	EA	DOOR CHECK-SUB ASM ADJUST	V196-04
57	128913-01-705	EA	BOLT - SHOULDER - #10 X 1/4	268-042011
62	128913-02-714	EA	GUIDE BLOCK - DOOR CHECK	146-042045
65	128913-04-709	EA	PIN/CLEVIS-GROOVED W/E-RING	245-042260

CONTACT WINNEBAGO PARTS SALES FOR UNLISTED COMPONENTS

EXTERIOR DOORS & COMPARTMENTS GROUP (CONTINUED)
COMPONENT PARTS FOR ENTRY (CONTINUED)

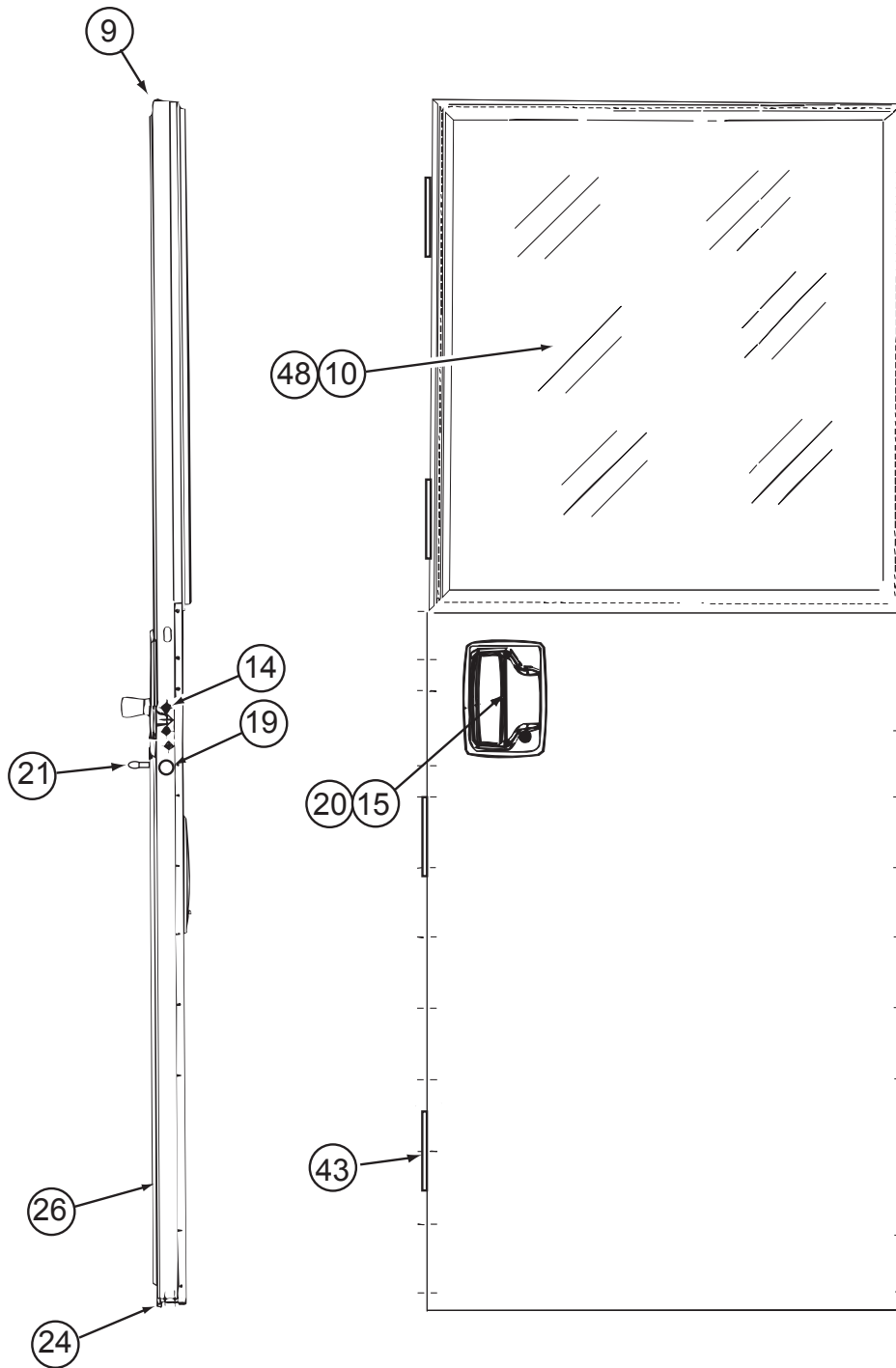

128913-10-02A (CONTINUED)

KEY	PART NUMBER	U/M	DESCRIPTION	VENDOR NO.
9	128913-04-708	EA	DOOR FRAME - SUB ASM - BLACK	V266-90
10	128913-04-707	EA	WINDOW-DUAL PANE	V231-85
14	128913-03-713	EA	BOLT-ROTARY LATCH-1/4"-20	81066-01
15	112782-18-01A	EA	LATCH - EXTERIOR - W/O LOCK CYLINDER W/ICON-REVERSIBLE KEY	
20	128913-04-705	EA	GASKET - OUTSIDE HANDLE	81480
21	112782-05-01A	EA	CAP - VINYL - RED	
24	128913-01-744	EA	SEAL/BULB-STICK ON/THRESHOLD	122-042230
26	128913-04-712	EA	PANEL - INNER PLASTIC	490057
48	128913-04-700	FT	TAPE/BUTYL - FOAM CORE	154-041549

CONTACT WINNEBAGO PARTS SALES FOR UNLISTED COMPONENTS

EXTERIOR DOORS & COMPARTMENTS GROUP (CONTINUED)
COMPONENT PARTS FOR ENTRY (CONTINUED)

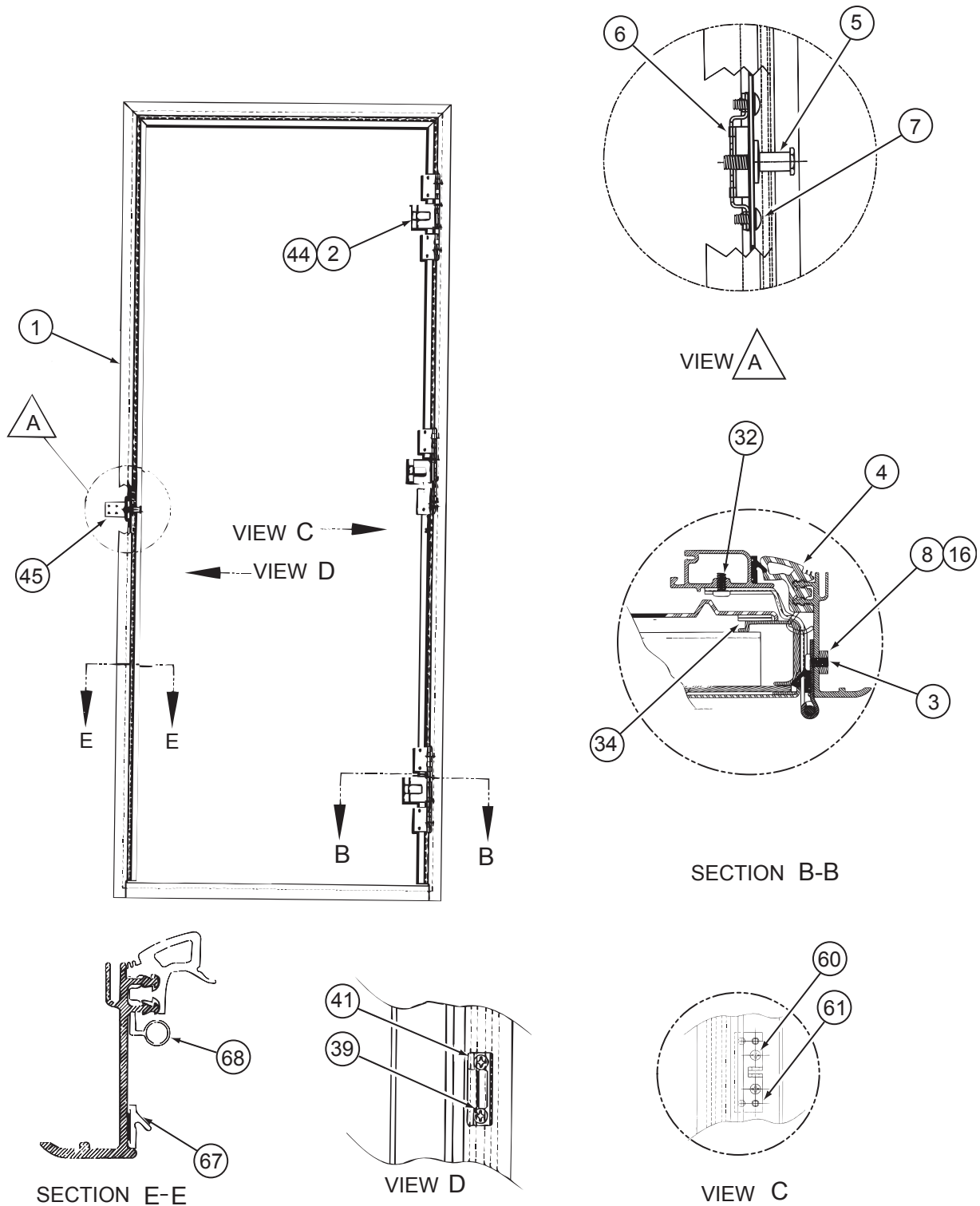

128913-10-02A (CONTINUED)

KEY	PART NUMBER	U/M DESCRIPTION	VENDOR NO.
1	128913-10-702	EA FRAME/OUTER ASM - WHITE	490198
2	128913-01-729	EA HINGE	211-041740
4	128913-01-728	EA SEAL - DOOR/CORNER- MITERED	122-041917
5	128913-01-727	EA STRIKER - BOLT - LONG	11628-16
6	128913-01-726	EA NUT ASSEMBLY-CAGED (STRIKER)	11920-16
41	128913-01-709	EA STRIKER-SCREEN DR/FRAME MT	130-041824
44	128913-03-708	EA SEAL/HINGE (3 PER DOOR)	124-042236
45	128913-02-700	EA LATCH - BRACKET	210-042215
61	128913-01-704	EA BRACKET - PIVOT/BRASS	370-042315
67	128913-01-732	FT SEAL - LAZY T	122-041986

CONTACT WINNEBAGO PARTS SALES FOR UNLISTED COMPONENTS

EXTERIOR DOORS & COMPARTMENTS GROUP (CONTINUED)
COMPONENT PARTS FOR ENTRY (CONTINUED)

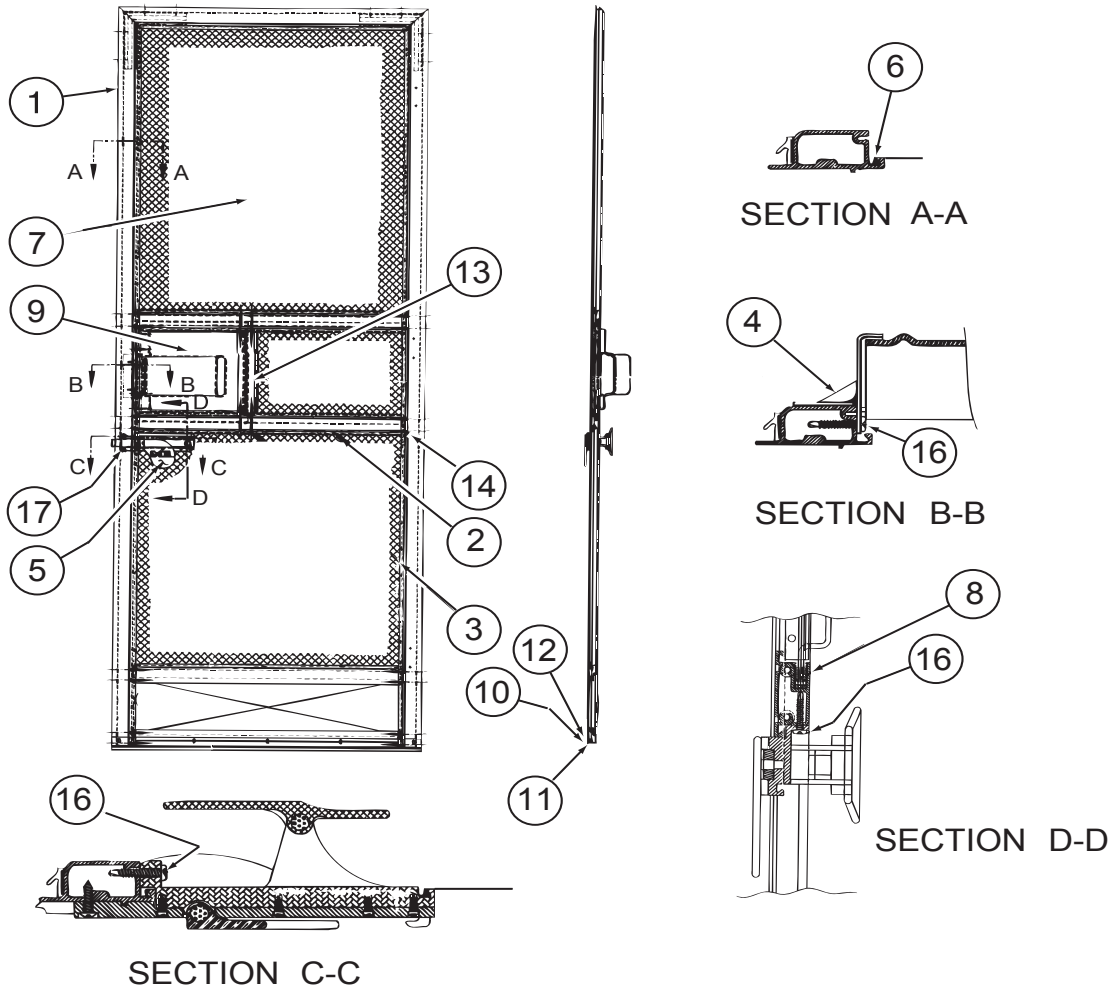

128913-10-01A, 128913-10-02A, 128913-11-01A (CONTINUED)

KEY	PART NUMBER	U/M	DESCRIPTION	VENDOR NO.
2	128913-09-704	EA	RAIL/MID SCREEN-GLACIER BEIG	490054
4	128913-09-703	EA	END CAP - GLACIER BEIGE	490061
5	128913-01-731	EA	LATCH - SCREEN DOOR	146-041950
6	128913-01-742	FT	SPLINE - SCREEN	132-041775
7	128913-01-741	EA	SCREEN ONLY - SCREENDOOR	110-041928
8	128913-01-740	FT	RUN CHANNEL-SCREEN DR SLIDER	170-041263
9	128913-09-702	EA	SLIDER/SCREENDOOR-GLACIER BE	490059
10	128913-09-701	EA	SWEEPER/SCREENDOOR- GLACIER	490052
11	128913-01-736	FT	WEATHERSTRIP-SCREEN DOOR	171-041284
13	128913-01-738	FT	WEATHERSTRIP - SLIDER	171-041285

CONTACT WINNEBAGO PARTS SALES FOR UNLISTED COMPONENTS

EXTERIOR SLIDEOUT GROUP

FRONT LEFT

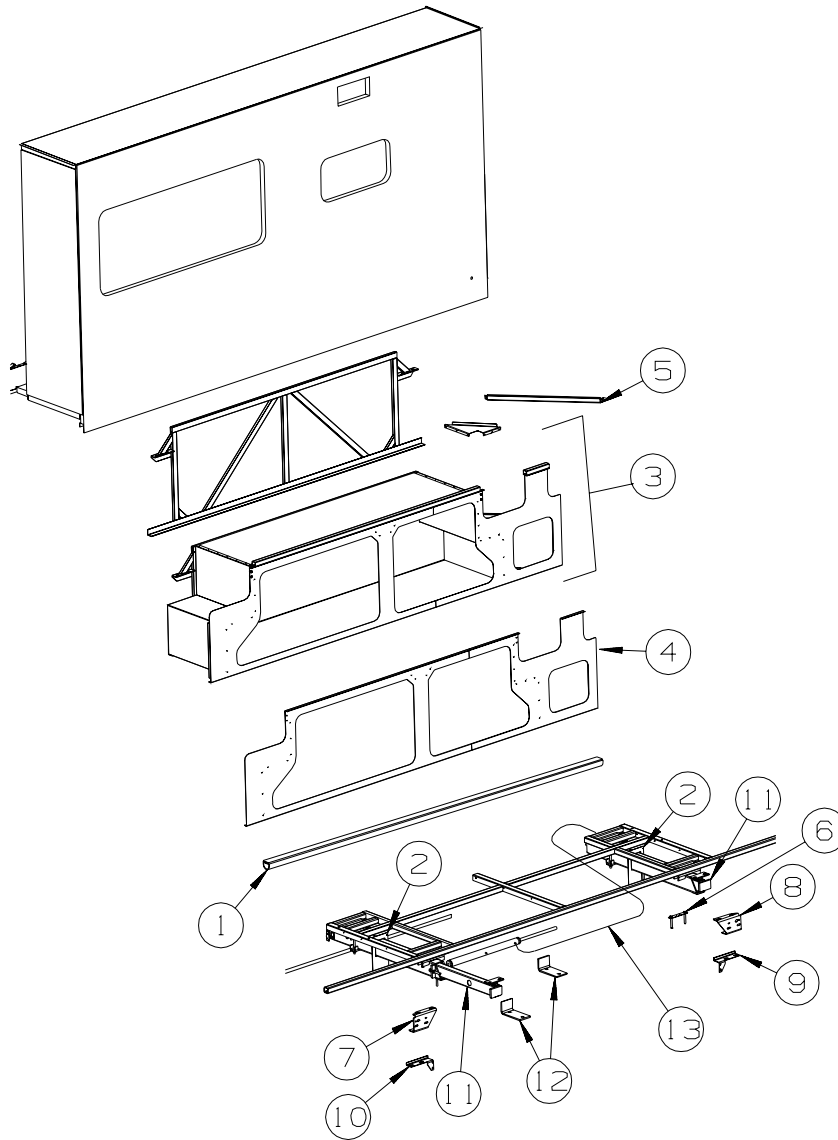

KEY	PART NUMBER	U/M	DESCRIPTION
1	126516-01-01A	EA	TRIM - VINYL/EXTRUDED - 8'
2	125828-03-02B	EA	FILLER/STEEL - SLIDEOUT - E-COATED
3	142588-01-P78	EA	COMPARTMENT - F/SLIDEOUT
4	142589-01-02B	EA	SEAL PLANE
5	126497-10-02B	EA	SUPPORT - VALANCE - E-COATED
6	136995-05-02B	EA	PLATE - E-COATED
7	127030-01-02B	EA	BRACKET - INNER FRONT/SLIDEOUT - E-COATED
8	127030-02-02B	EA	BRACKET - INNER REAR/MOUNT - E-COATED
9	125888-01-02B	EA	BRACKET/SLIDEOUT COMPARTMENT - RIGHT HAND - E-COATED
			FROM: 00-00-00 THRU: 10-27-02
9	125888-05-02B	EA	BRACKET/SLIDEOUT COMPARTMENT - RIGHT HAND - E-COATED
			FROM: 10-28-02 THRU: 99-99-99
10	125888-02-02B	EA	BRACKET/SLIDEOUT COMPARTMENT - LEFT HAND - E-COATED
			FROM: 00-00-00 THRU: 10-27-02
10	125888-06-02B	EA	BRACKET/SLIDEOUT COMPARTMENT - LEFT HAND - E-COATED
			FROM: 10-28-02 THRU: 99-99-99
11*	140121-01-000	EA	SLIDEOUT - HYDRAULIC - 20"
12	122922-02-02B	EA	BRACKET/CYLINDER SUPPORT - E-COATED
13*	100536-44-000	EA	HOSE KIT - PUMP TO SLIDE-OUT VALVE

*COMPONENT PARTS LISTED LATER IN THIS GROUP

EXTERIOR SLIDEOUT GROUP (CONTINUED)
FRONT LEFT (CONTINUED)

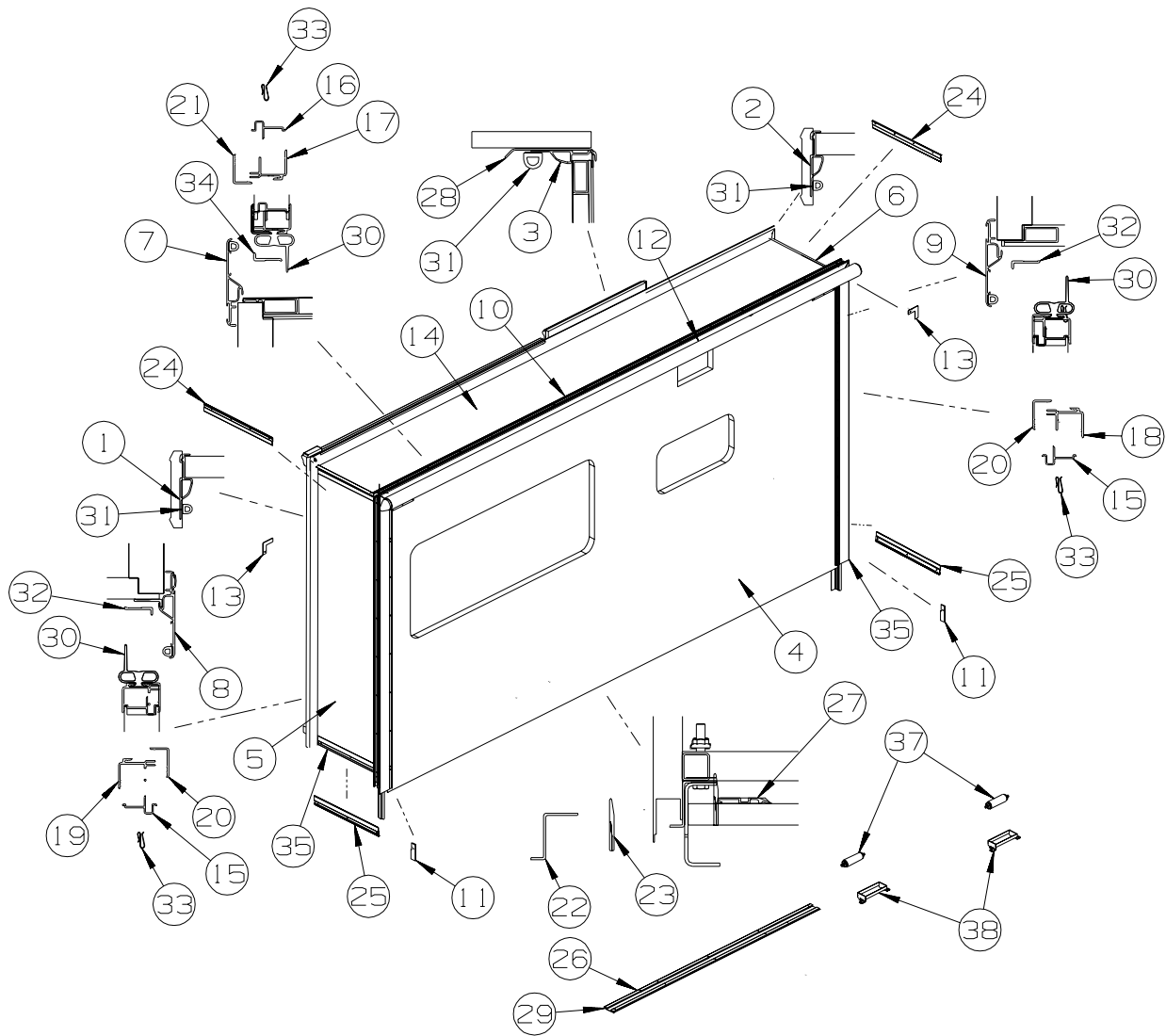

KEY	PART NUMBER	U/M	DESCRIPTION
1	139624-01-01A	EA	TRIM/SEAL - INNER/RIGHT HAND - 73.4" - BRIGHT WHITE
2	139624-02-01A	EA	TRIM/SEAL - INNER/LEFT HAND - 73.4" - BRIGHT WHITE
	130262-02-000	EA	PROTECTOR - CORNER - .7" X .7" X 17.7"
3	139624-06-01A	EA	TRIM/SEAL - INNER/TOP - 145.2" - BRIGHT WHITE
4	142322-11-P82	EA	SLUG - SLIDEOUT (P84,P85,P28)
4	142322-11-P78	EA	SLUG - SLIDEOUT (P86,P87,P88,P89,P29,P30)
5	140825-01-N72	EA	PANEL - F/FRONT SLIDEOUT (P84,P85,P28)
5	140825-01-N71	EA	PANEL - F/FRONT SLIDEOUT (P86,P87,P88,P89,P29,P30)
6	134729-02-N84	EA	PANEL - SLIDEOUT - REAR (P84,P85,P28)
6	134729-02-M76	EA	PANEL - SLIDEOUT - REAR (P86,P87,P88,P89,P29,P30)
7	139625-06-01A	EA	TRIM/SEAL - TOP/W/MITERED ENDS - 147" - BRIGHT WHITE - W/GRAPHICS PACKAGE
7	139625-06-02A	EA	TRIM/SEAL - TOP/W/MITERED ENDS - 147" - BLACK - W/FULL BODY PAINT
	105312-01-07A	FT	INSERT - FEATURE STRIP - VINYL - BRIGHT WHITE - W/GRAPHICS PACKAGE
	105312-01-13A	FT	INSERT - FEATURE STRIP - VINYL - W/FULL BODY PAINT
8	139625-01-01A	EA	TRIM/SEAL - LEFT HAND - 76.4" - BRIGHT WHITE - W/GRAPHICS PACKAGE
8	139625-01-02A	EA	TRIM/SEAL - LEFT HAND - 76.4" - BLACK - W/FULL BODY PAINT
	105312-01-07A	FT	INSERT - FEATURE STRIP - VINYL - BRIGHT WHITE - W/GRAPHICS PACKAGE
	105312-01-13A	FT	INSERT - FEATURE STRIP - VINYL - W/FULL BODY PAINT
9	139625-02-01A	EA	TRIM/SEAL - RIGHT HAND - 76.4" - BRIGHT WHITE - W/GRAPHICS PACKAGE
9	139625-02-02A	EA	TRIM/SEAL - RIGHT HAND - 76.4" - BLACK - W/FULL BODY PAINT
	105312-01-07A	FT	INSERT - FEATURE STRIP - VINYL - BRIGHT WHITE - W/GRAPHICS PACKAGE
	105312-01-13A	FT	INSERT - FEATURE STRIP - VINYL - W/FULL BODY PAINT
10	117058-01-01A	FT	TAPE - LOOP - 3/4" WIDE - ADHESIVE BACKED
11	126546-01-02A	EA	COVER - END/SIDEWALL SLIDEOUT - BRIGHT WHITE

EXTERIOR SLIDEOUT GROUP (CONTINUED)
FRONT LEFT (CONTINUED)

KEY	PART NUMBER	U/M	DESCRIPTION
12	122977-07-03A	EA	AWNING/SLIDEOUT W/COVER - 147" - WHITE - VINYL/VINYL WRAP - W/GRAPHICS PACKAGE
12			SLIDEOUT AWNINGS - W/FULL BODY PAINT

HORIZON SLIDEOUT AWNINGS WITH FULL BODY PAINT

MODEL	COLOR PAINT PKG #	AWNING COLOR	HARDWARE COLOR	SLIDEROOM LT FRONT	SLIDEROOM LT REAR
P39WD	MOCHA 27A	TRUE BROWN	CHAMPAGNE	122977-06-04A	122977-19-04A
P39QD	MOCHA 27A	TRUE BROWN	CHAMPAGNE	122977-06-04A	122977-04-04A
P36LD	MOCHA 27A	TRUE BROWN	CHAMPAGNE	122977-06-04A	122977-18-04A
P34HD	MOCHA 27A	TRUE BROWN	CHAMPAGNE	122977-07-04A	122977-18-04A
P32TD	MOCHA 27A	TRUE BROWN	CHAMPAGNE	122977-11-04A	122977-18-04A
P39WD	AUBURN 92A	BURGUNDY	CHAMPAGNE	122977-06-04A	122977-19-04A
P39QD	AUBURN 92A	BURGUNDY	CHAMPAGNE	122977-06-04A	122977-04-04A
P36LD	AUBURN 92A	BURGUNDY	CHAMPAGNE	122977-06-04A	122977-18-04A
P34HD	AUBURN 92A	BURGUNDY	CHAMPAGNE	122977-07-04A	122977-18-04A
P32TD	AUBURN 92A	BURGUNDY	CHAMPAGNE	122977-11-04A	122977-18-04A
P39WD	BLUE LAKE 24C	BLUE	SILVER	122977-06-05A	122977-19-05A
P39QD	BLUE LAKE 24C	BLUE	SILVER	122977-06-05A	122977-04-05A
P36LD	BLUE LAKE 24C	BLUE	SILVER	122977-06-05A	122977-18-05A
P34HD	BLUE LAKE 24C	BLUE	SILVER	122977-07-05A	122977-18-05A
P32TD	BLUE LAKE 24C	BLUE	SILVER	122977-11-05A	122977-18-05A

KEY	PART NUMBER	U/M	DESCRIPTION
13	116444-04-12B	EA	TRIM/KEY CORNER - SLIDEOUT - 3.1"X3.1" - BRT WHT - W/GRAPHICS PACKAGE
13	116444-04-04B	EA	TRIM/KEY CORNER - SLIDEOUT - 3.1"X3.1" - BLACK - W/FULL BODY PAINT
14	140157-01-N70	EA	ROOF/SLIDEOUT - W/WIRING - W/O LIGHTS/VENTS
15	142718-01-01A	EA	RETAINER - SIDEWALL/SLIDEOUT - 72.8" - MILL
16	142718-02-01A	EA	RETAINER - SIDEWALL/SLIDEOUT - 144.9"
17	142719-01-01A	EA	TRIM/SIDEWALL - TOP/SLIDEOUT - 146.7" - BRIGHT WHITE
18	142720-02-01A	EA	TRIM - SIDEWALL/SLIDEOUT - 74.8" - BRIGHT WHITE
			FROM: 00-00-00 THRU: 10-27-02
18	142720-06-01A	EA	TRIM - SIDEWALL/SLIDEOUT - 74.4" - BRIGHT WHITE
			FROM: 10-28-02 THRU: 99-99-99
19	142720-01-01A	EA	TRIM - SIDEWALL/SLIDEOUT - 74.8" - BRIGHT WHITE
			FROM: 00-00-00 THRU: 10-27-02
19	142720-08-01A	EA	TRIM - SIDEWALL/SLIDEOUT - 74.4" - BRIGHT WHITE
			FROM: 10-28-02 THRU: 99-99-99
20	136824-01-01A	EA	TRIM - SIDEWALL/SLIDEOUT - 74.9" - BRIGHT WHITE - W/GRAPHICS PACKAGE
			FROM: 00-00-00 THRU: 10-27-02
20	136824-01-02A	EA	TRIM - SIDEWALL/SLIDEOUT - 74.9" - BLACK - W/FULL BODY PAINT
			FROM: 00-00-00 THRU: 10-27-02
20	136824-38-01A	EA	TRIM - SIDEWALL/SLIDEOUT - 74.6" - BRIGHT WHITE - W/GRAPHICS PACKAGE
			FROM: 10-28-02 THRU: 99-99-99
20	136824-38-02A	EA	TRIM - SIDEWALL/SLIDEOUT - 74.6" - BLACK - W/FULL BODY PAINT
			FROM: 10-28-02 THRU: 99-99-99
21	136824-05-01A	EA	TRIM - SIDEWALL/SLIDEOUT - 146.4" - BRIGHT WHITE - W/GRAPHICS PACKAGE
21	136824-05-02A	EA	TRIM - SIDEWALL/SLIDEOUT - 146.4" - BLACK - W/FULL BODY PAINT
22	128621-24-01A	EA	BRACKET/ZEE - SLIDEOUT - 140.4" - MILL
23	115075-03-000	FT	SEAL - WIPE - .25" X 2.9"
24	138659-01-01A	EA	TRIM/FEATURE STRIP - 181.7" - BRIGHT WHITE - W/GRAPHICS PACKAGE
24	138659-01-02A	EA	TRIM - FEATURE - UPPER - 181.7" - BLACK - W/FULL BODY PAINT
	105312-01-07A	FT	INSERT - FEATURE STRIP - VINYL - BRIGHT WHITE - W/GRAPHICS PACKAGE
	105312-01-13A	FT	INSERT - FEATURE STRIP - VINYL - W/FULL BODY PAINT
25	125051-01-01A	EA	TRIM - FEATURE STRIP/LOWER - 20.2" - BRIGHT WHITE - W/GRAPHICS PACKAGE
25	125051-01-03A	EA	TRIM - FEATURE STRIP/LOWER - 20.2" - BLACK - W/FULL BODY PAINT
	105312-01-07A	FT	INSERT - FEATURE STRIP - VINYL - BRIGHT WHITE - W/GRAPHICS PACKAGE
	105312-01-13A	FT	INSERT - FEATURE STRIP - VINYL - W/FULL BODY PAINT
26	115325-03-02A	EA	RAIL - FLOOR/SLIDEOUT ROOM - BLACK - 64.5" LONG
27	134837-01-01A	EA	RAMP - SLIDEOUT - BLACK PVC

EXTERIOR SLIDEOUT GROUP (CONTINUED)
FRONT LEFT (CONTINUED)

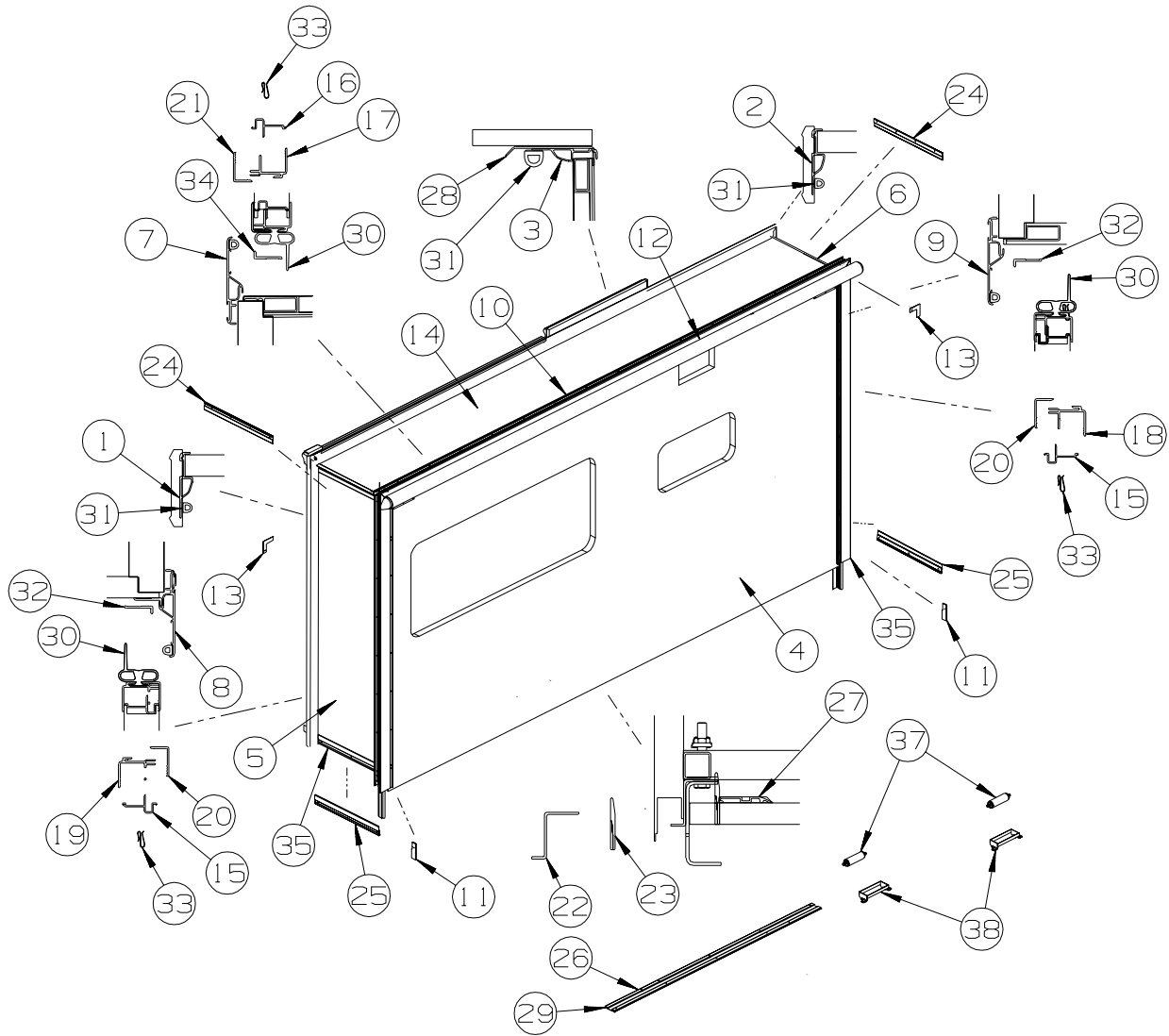

KEY	PART NUMBER	U/M	DESCRIPTION
28	125466-02-02A	EA	SUPPORT - ROOF/INTERIOR - BRIGHT WHITE
29	115661-01-000	FT	SHOE/GLIDE - SLIDEOUT ROOM - 1/16" X 3" - POLYETHYLENE
30	136978-01-01A	FT	SEAL - SLIDEOUT - BLACK
31	112091-01-000	FT	SEAL/D - NEOPRENE - HEAT ACTIVE ADHESIVE - .9"
			FROM: 00-00-00 THRU: 01-12-03
31	146056-01-000	FT	SEAL - TRIANGLE - W/PSA
			FROM: 01-13-03 THRU: 99-99-99
32	133954-09-01A	EA	TRIM/SEAL - W/MITERED ENDS - 71.6" - BRIGHT WHITE - W/GRAPHICS PACKAGE
32	133954-09-02A	EA	TRIM/SEAL - W/MITERED ENDS - 71.6" - BLACK - W/FULL BODY PAINT
33	142549-01-000	EA	CLIP-S TYPE
34	133954-07-01A	EA	TRIM/SEAL - W/MITERED ENDS - 141.8" - BRIGHT WHITE - W/GRAPHICS PACKAGE
34	133954-07-02A	EA	TRIM/SEAL - W/MITERED ENDS - 141.7" - BLACK - W/FULL BODY PAINT
35	075673-05-000	FT	SEAL - PILE - ADHESIVE BACK - BLACK
36	136839-03-01A	EA	TRIM-J - CARPET EDGE/SLIDEOUT - 69.6" - BLACK
37	127033-02-01A	EA	ROLLER - GUIDE
38	140928-01-02B	EA	BRACKET - ROLLER - E-COATED

EXTERIOR SLIDEOUT GROUP (CONTINUED)
FRONT LEFT (CONTINUED)

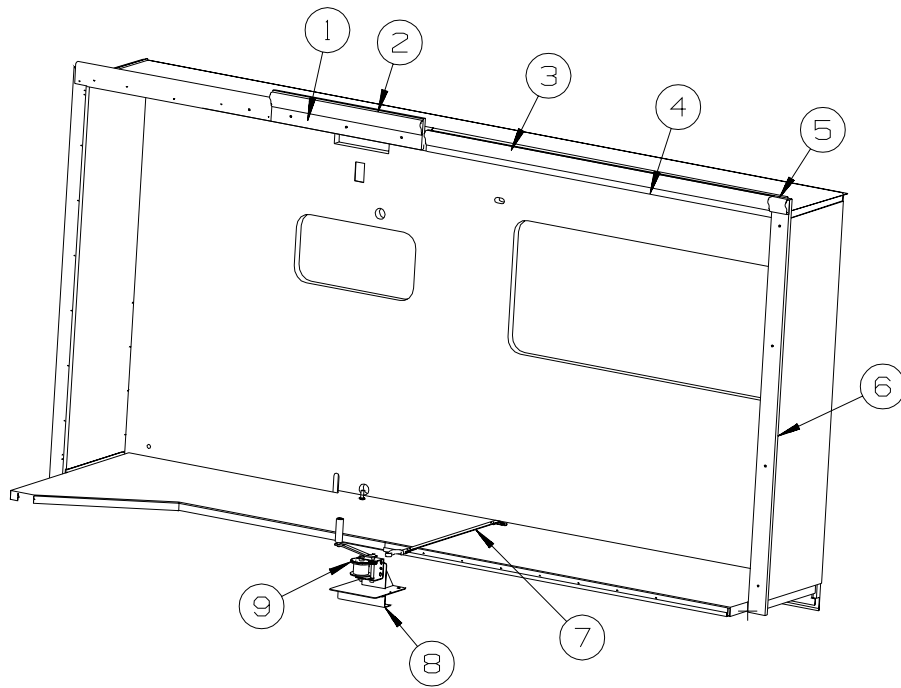

KEY	PART NUMBER	U/M	DESCRIPTION
1	116951-29-N70	EA	MOLDING - TRIM - 5.5" X 30.4" - PORTSMOUTH OAK
1	116951-29-N85	EA	MOLDING - TRIM - 5.5" X 30.4" - CHERRY - CONCERT CHERRY
1	116951-29-N84	EA	MOLDING - TRIM - 5.5" X 30.4" - WASHED MAPLE
2	M09450-59-P78	EA	MOLDING/CROWN - OAK/PORTSMOUTH OAK
2	M09450-59-P79	EA	MOLDING/CROWN - CHERRY/CHERRY IV - CONCERT CHERRY
2	M09450-59-P28	EA	MOLDING - CROWN - HARD WHITE MAPLE - 30.5" - WASHED MAPLE
3	M09450-60-P78	EA	MOLDING/CROWN - OAK/PORTSMOUTH OAK
3	M09450-60-P79	EA	MOLDING/CROWN - CHERRY/CHERRY IV - CONCERT CHERRY
3	M09450-60-P28	EA	MOLDING - CROWN - HARD WHITE MAPLE - 70.2" - WASHED MAPLE
4	116967-19-N75	EA	TRIM - CENTER - WOOD - PORTSMOUTH OAK
4	116967-19-N85	EA	TRIM - CENTER - WOOD - CONCERT CHERRY
4	116967-19-N84	EA	TRIM - CENTER - WOOD - WASHED MAPLE
5	M09450-61-P78	EA	MOLDING/CROWN - OAK/PORTSMOUTH OAK
5	M09450-61-P79	EA	MOLDING/CROWN - CHERRY/CHERRY IV - CONCERT CHERRY
5	M09450-61-P28	EA	MOLDING - CROWN - HARD WHITE MAPLE - 3.5" - WASHED MAPLE
6	116951-16-N75	EA	MOLDING - TRIM - 3.5" X 74.3" - PORTSMOUTH OAK
6	116951-16-K37	EA	MOLDING - TRIM - 3.5" X 74.3" - CHERRY - CONCERT CHERRY
6	116951-16-K90	EA	MOLDING - TRIM - 3.5" X 74.3" - WASHED MAPLE
7	116101-02-F31	EA	STRAP - WINCH - 34" CENTER BRACKET/STRAP END
8	116082-03-02B	EA	BRACKET - WINCH
	069726-02-000	EA	BUMPER - .88" OD X .40" THICK - BLACK
9	115767-02-000	EA	WINCH - SLIDEOUT W/10' STRAP

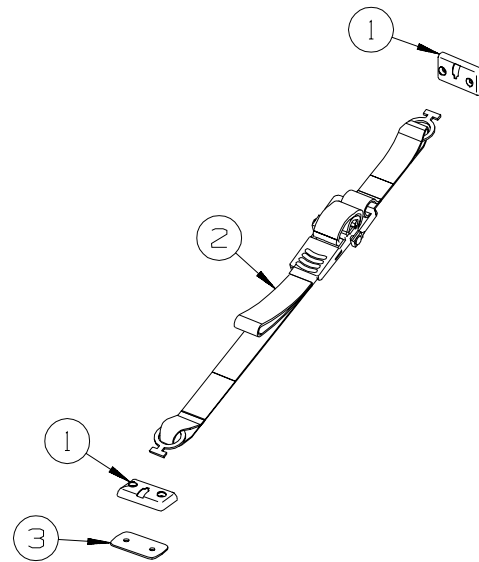

KEY	PART NUMBER	U/M	DESCRIPTION
1	135619-02-01A	EA	PLATE - TIEDOWN - SLIDEOUT ROOM
2	135619-01-01A	EA	STRAP - TIEDOWN - SLIDEOUT ROOM
3	135622-01-01B	EA	PLATE - TIEDOWN - SLIDEOUT ROOM

EXTERIOR SLIDEOUT GROUP (CONTINUED)
COMPONENT PARTS FOR FRONT SLIDEOUT

100536-44-000

KEY	PART NUMBER	U/M	DESCRIPTION	VENDOR NO.
	100536-44-700	EA	HOSE-HYDRAULIC - 1/8" X 172"	AP24649
	131360-01-701	EA	HOSE-HYDRAULIC-1/4" X 125"	AP4906

140121-01-000

KEY	PART NUMBER	U/M	DESCRIPTION	VENDOR NO.
	125687-01-700	EA	CYLINDER/RAM - 21" STROKE	RAP90512
	125687-01-702	EA	CYLINDER - SYNCHRONIZING	RAP90471
	125687-01-704	EA	BOLT - SLIDE ROOM ADJUSTER	RAP90864/P13685
	137196-01-700	EA	HOSE-HYDRAULIC - HP X 120"	AP24642
	137196-01-701	EA	HOSE-HYDRAULIC - 1/2" X 116"	AP5384

EXTERIOR SLIDEOUT GROUP (CONTINUED)

LEFT REAR

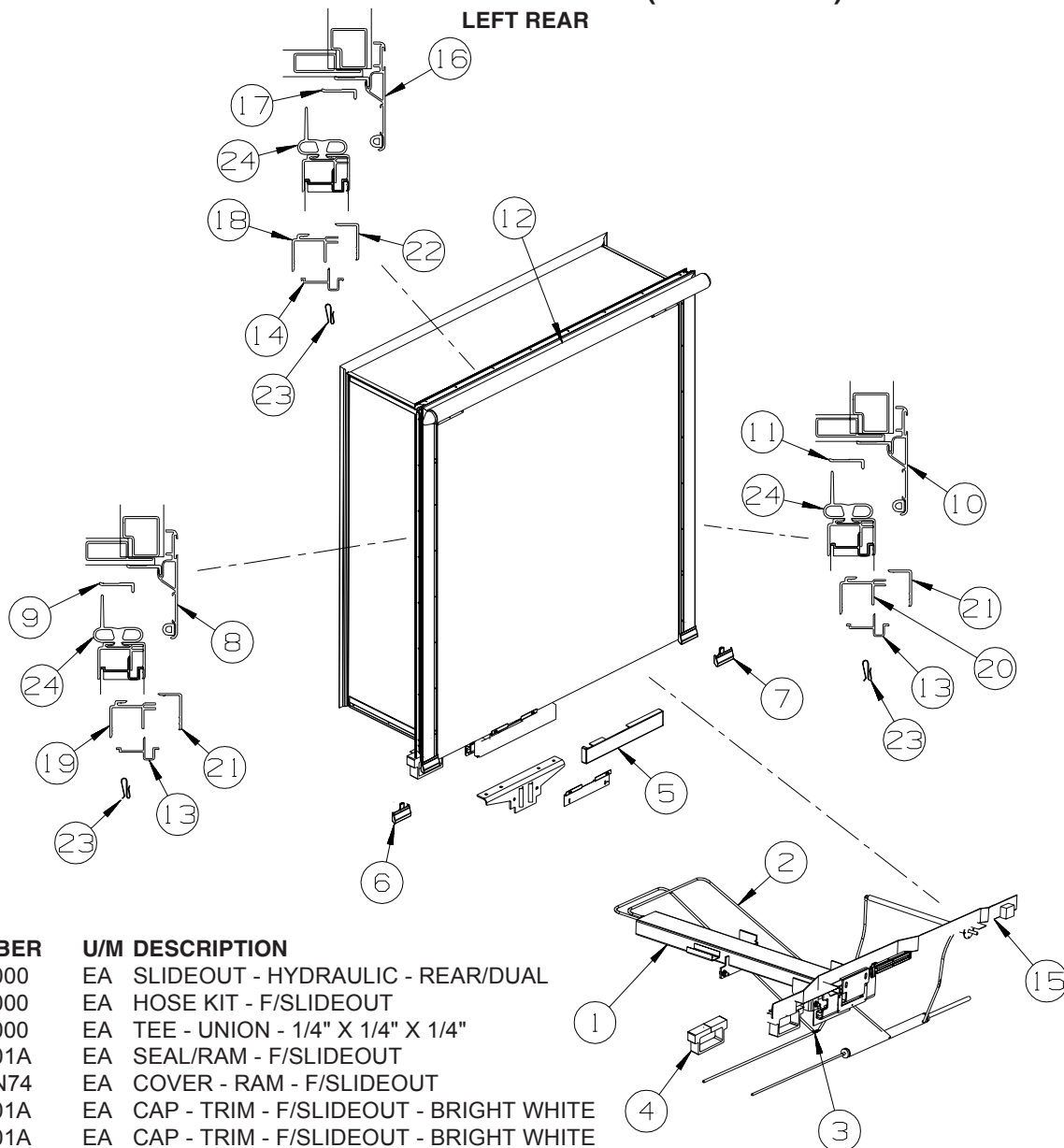

KEY	PART NUMBER	U/M	DESCRIPTION
1*	139507-01-000	EA	SLIDEOUT - HYDRAULIC - REAR/DUAL
2*	100536-52-000	EA	HOSE KIT - F/SLIDEOUT
3	123264-01-000	EA	TEE - UNION - 1/4" X 1/4" X 1/4"
4	140664-01-01A	EA	SEAL/RAM - F/SLIDEOUT
5	137125-04-N74	EA	COVER - RAM - F/SLIDEOUT
6	139182-01-01A	EA	CAP - TRIM - F/SLIDEOUT - BRIGHT WHITE
7	139182-02-01A	EA	CAP - TRIM - F/SLIDEOUT - BRIGHT WHITE
8	139625-01-01A	EA	TRIM/SEAL - LEFT HAND - 76.4" - BRIGHT WHITE - W/GRAPHICS PACKAGE
8	139625-01-02A	EA	TRIM/SEAL - LEFT HAND - 76.4" - BLACK - W/FULL BODY PAINT
	105312-01-07A	FT	INSERT - FEATURE STRIP - VINYL - BRIGHT WHITE - W/GRAPHICS PACKAGE
	105312-01-13A	FT	INSERT - FEATURE STRIP - VINYL - W/FULL BODY PAINT
9	133954-24-01A	EA	TRIM/SEAL - W/MITERED END - 70.4" - BRIGHT WHITE - W/GRAPHICS PACKAGE
			FROM: 00-00-00 THRU: 03-16-03
9	133954-48-01A	EA	TRIM/SEAL - W/MITERED ENDS - 71.7" - BRIGHT WHITE - W/GRAPHICS PACKAGE
			FROM: 03-17-03 THRU: 99-99-99
9	133954-24-02A	EA	TRIM/SEAL - W/MITERED ENDS - 69.3" - BLACK - W/FULL BODY PAINT
			FROM: 00-00-00 THRU: 03-16-03
9	133954-48-02A	EA	TRIM/SEAL - W/MITERED ENDS - 71.7" - BLACK - W/GRAPHICS PACKAGE
			FROM: 03-17-03 THRU: 99-99-99
10	139625-02-01A	EA	TRIM/SEAL - RIGHT HAND - 76.4" - BRIGHT WHITE - W/GRAPHICS PACKAGE
10	139625-02-02A	EA	TRIM/SEAL - RIGHT HAND - 76.4" - BLACK - W/FULL BODY PAINT
	105312-01-07A	FT	INSERT - FEATURE STRIP - VINYL - BRIGHT WHITE - W/GRAPHICS PACKAGE
	105312-01-13A	FT	INSERT - FEATURE STRIP - VINYL - W/FULL BODY PAINT
11	133954-25-01A	EA	TRIM/SEAL - W/MITERED END - 70.4" - BRIGHT WHITE - W/GRAPHICS PACKAGE
			FROM: 00-00-00 THRU: 03-16-03
11	133954-48-01A	EA	TRIM/SEAL - W/MITERED ENDS - 71.7" - BRIGHT WHITE - W/GRAPHICS PACKAGE
			FROM: 03-17-03 THRU: 99-99-99
11	133954-25-02A	EA	TRIM/SEAL - W/MITERED ENDS - 69.3" - BLACK - W/FULL BODY PAINT
			FROM: 00-00-00 THRU: 03-16-03
11	133954-48-02A	EA	TRIM/SEAL - W/MITERED ENDS - 71.7" - BLACK - W/GRAPHICS PACKAGE
			FROM: 03-17-03 THRU: 99-99-99

*COMPONENT PARTS LISTED LATER IN THIS GROUP

EXTERIOR SLIDEOUT GROUP (CONTINUED)
LEFT REAR (CONTINUED)

KEY	PART NUMBER	U/M	DESCRIPTION
12	122977-18-03A	EA	AWNING/SLIDEOUT W/COVER - 71.7" - WHITE -VINYL/VINYL WRAP - W/GRAPHICS PACKAGE
12			SLIDEOUT AWNINGS - W/FULL BODY PAINT

HORIZON SLIDEOUT AWNINGS WITH FULL BODY PAINT

MODEL	COLOR		AWNING	HARDWARE	SLIDEROOM	SLIDEROOM
	PAINT PKG #		COLOR	COLOR	LT FRONT	LT REAR
P39WD	MOCHA	27A	TRUE BROWN	CHAMPAGNE	122977-06-04A	122977-19-04A
P39QD	MOCHA	27A	TRUE BROWN	CHAMPAGNE	122977-06-04A	122977-04-04A
P36LD	MOCHA	27A	TRUE BROWN	CHAMPAGNE	122977-06-04A	122977-18-04A
P34HD	MOCHA	27A	TRUE BROWN	CHAMPAGNE	122977-07-04A	122977-18-04A
P32TD	MOCHA	27A	TRUE BROWN	CHAMPAGNE	122977-11-04A	122977-18-04A
P39WD	AUBURN	92A	BURGUNDY	CHAMPAGNE	122977-06-04A	122977-19-04A
P39QD	AUBURN	92A	BURGUNDY	CHAMPAGNE	122977-06-04A	122977-04-04A
P36LD	AUBURN	92A	BURGUNDY	CHAMPAGNE	122977-06-04A	122977-18-04A
P34HD	AUBURN	92A	BURGUNDY	CHAMPAGNE	122977-07-04A	122977-18-04A
P32TD	AUBURN	92A	BURGUNDY	CHAMPAGNE	122977-11-04A	122977-18-04A
P39WD	BLUE LAKE	24C	BLUE	SILVER	122977-06-05A	122977-19-05A
P39QD	BLUE LAKE	24C	BLUE	SILVER	122977-06-05A	122977-04-05A
P36LD	BLUE LAKE	24C	BLUE	SILVER	122977-06-05A	122977-18-05A
P34HD	BLUE LAKE	24C	BLUE	SILVER	122977-07-05A	122977-18-05A
P32TD	BLUE LAKE	24C	BLUE	SILVER	122977-11-05A	122977-18-05A

KEY	PART NUMBER	U/M	DESCRIPTION
13	142718-01-01A	EA	RETAINER - SIDEWALL/SLIDEOUT - 72.8" - MILL
14	142718-21-01A	EA	RETAINER - SIDEWALL/SLIDEOUT - 69.5"
15	115075-03-000	FT	SEAL - WIPE - .25" X 2.9"
16	139625-09-01A	EA	TRIM/SEAL - TOP/W/MITERED ENDS - 71.8" - BRIGHT WHITE - W/GRAPHICS PACKAGE
16	139625-09-02A	EA	TRIM/SEAL - TOP/W/MITERED ENDS - 71.8" - BLACK - W/FULL BODY PAINT
	105312-01-07A	FT	INSERT - FEATURE STRIP - VINYL - BRIGHT WHITE - W/GRAPHICS PACKAGE
	105312-01-13A	FT	INSERT - FEATURE STRIP - VINYL - W/FULL BODY PAINT
17	133954-20-01A	EA	TRIM/SEAL - W/MITERED ENDS - 68.2" - BRIGHT WHITE
18	142719-07-01A	EA	TRIM/SIDEWALL - TOP/SLIDEOUT - 71.3" - BRIGHT WHITE
19	142720-01-01A	EA	TRIM - SIDEWALL/SLIDEOUT - 74.8" - BRIGHT WHITE
			FROM: 00-00-00 THRU: 10-27-02
19	142720-08-01A	EA	TRIM - SIDEWALL/SLIDEOUT - 74.4" - BRIGHT WHITE
			FROM: 10-28-02 THRU: 99-99-99
20	142720-02-01A	EA	TRIM - SIDEWALL/SLIDEOUT - 74.8" - BRIGHT WHITE
			FROM: 00-00-00 THRU: 10-27-02
20	142720-06-01A	EA	TRIM - SIDEWALL/SLIDEOUT - 74.4" - BRIGHT WHITE
			FROM: 10-28-02 THRU: 99-99-99
21	136824-01-01A	EA	TRIM - SIDEWALL/SLIDEOUT - 74.9" - BRIGHT WHITE - W/GRAPHICS PACKAGE
			FROM: 00-00-00 THRU: 10-27-02
21	136824-01-02A	EA	TRIM - SIDEWALL/SLIDEOUT - 74.9" - BLACK - W/FULL BODY PAINT
			FROM: 00-00-00 THRU: 10-27-02
21	136824-38-01A	EA	TRIM - SIDEWALL/SLIDEOUT - 74.6" - BRIGHT WHITE - W/GRAPHICS PACKAGE
			FROM: 10-28-02 THRU: 99-99-99
21	136824-38-02A	EA	TRIM - SIDEWALL/SLIDEOUT - 74.6" - BLACK - W/FULL BODY PAINT
			FROM: 10-28-02 THRU: 99-99-99
22	136824-12-01A	EA	TRIM - SIDEWALL/SLIDEOUT - 71.5" - BRIGHT WHITE - W/GRAPHICS PACKAGE
22	136824-12-02A	EA	TRIM - SIDEWALL/SLIDEOUT - 71.4" - BRIGHT WHITE - W/FULL BODY PAINT
23	142549-01-000	EA	CLIP-S TYPE
24	136978-01-01A	FT	SEAL - SLIDEOUT - BLACK

EXTERIOR SLIDEOUT GROUP (CONTINUED)
LEFT REAR (CONTINUED)

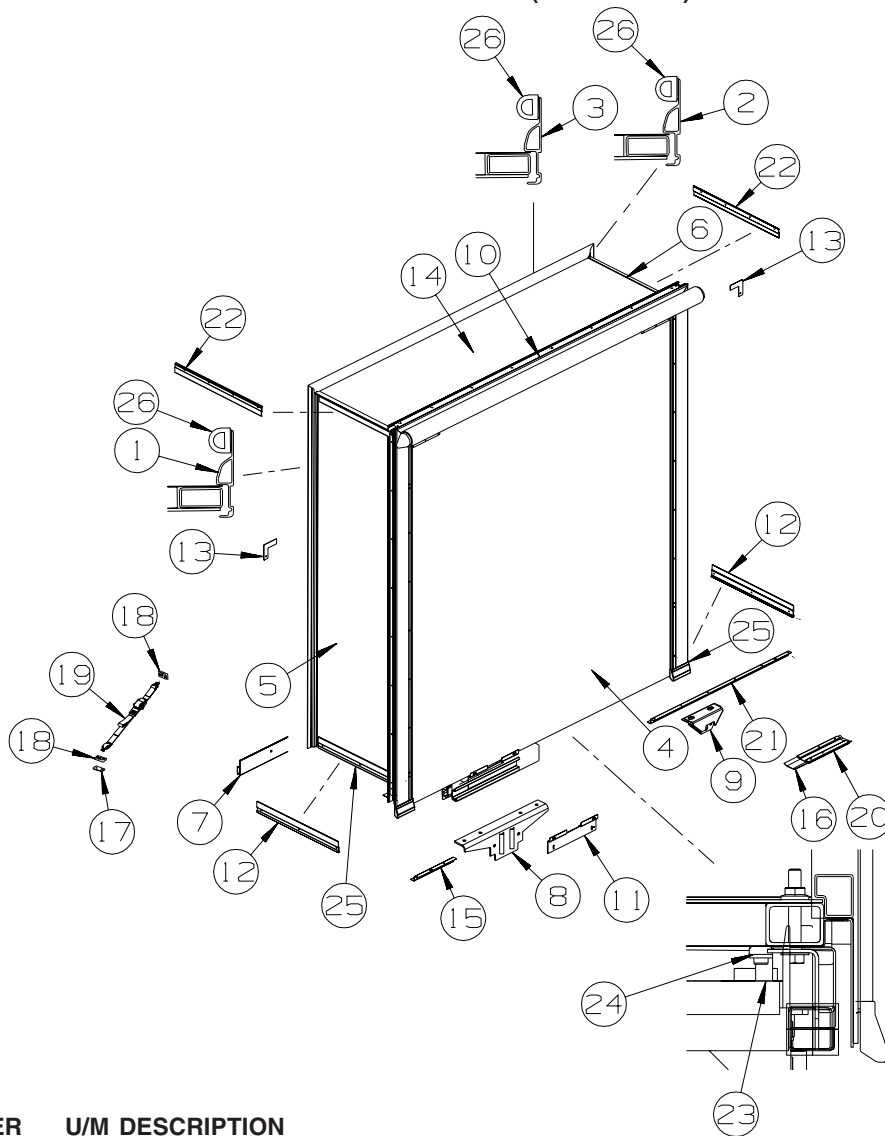

KEY	PART NUMBER	U/M	DESCRIPTION
1	139624-01-01A	EA	TRIM/SEAL - INNER/RIGHT HAND - 73.4" - BRIGHT WHITE
2	139624-02-01A	EA	TRIM/SEAL - INNER/LEFT HAND - 73.4" - BRIGHT WHITE
3	139624-08-01A	EA	TRIM/SEAL - INNER/TOP - 70.1" - BRIGHT WHITE
4	142322-12-P82	EA	SLUG - SLIDEOUT (P84,P85,P28)
4	142322-12-P78	EA	SLUG - SLIDEOUT (P86,P87,P88,P89,P29,P30)
5	134728-02-N84	EA	PANEL - SLIDEOUT - FRONT (P84,P85,P28)
5	134728-02-M76	EA	PANEL - SLIDEOUT - FRONT (P86,P87,P88,P89,P29,P30)
6	134729-02-N84	EA	PANEL - SLIDEOUT - REAR (P84,P85,P28)
6	134729-02-M76	EA	PANEL - SLIDEOUT - REAR (P86,P87,P88,P89,P29,P30)
7	136839-06-01A	EA	TRIM-J - CARPET EDGE/SLIDEOUT - 62.7" - BLACK
8	136963-01-02B	EA	BRACKET - SLIDEOUT - E-COATED
9	139407-02-02B	EA	BRACKET/MOUNT - F/SLIDEOUT - E-COATED
10	117058-01-01A	FT	TAPE - LOOP - 3/4" WIDE - ADHESIVE BACKED
11	137112-02-02B	EA	BRACKET - COVER - SLIDEOUT - E-COATED
12	125051-01-01A	EA	TRIM - FEATURE STRIP/LOWER - 20.2" - BRIGHT WHITE - W/GRAPHICS PACKAGE
12	125051-01-03A	EA	TRIM - FEATURE STRIP/LOWER - 20.2" - BLACK - W/FULL BODY PAINT
	105312-01-07A	FT	INSERT - FEATURE STRIP - VINYL - BRIGHT WHITE - W/GRAPHICS PACKAGE
	105312-01-13A	FT	INSERT - FEATURE STRIP - VINYL - W/FULL BODY PAINT
13	116444-04-12B	EA	TRIM/KEY CORNER - SLIDEOUT - 3.1"X3.1" - BRT WHT - W/GRAPHICS PACKAGE
13	116444-04-04B	EA	TRIM/KEY CORNER - SLIDEOUT - 3.1"X3.1" - BLACK - W/FULL BODY PAINT
14	141228-01-P75	EA	ROOF - W/O LIGHTS/VENTS - W/WIRING - F/SLIDEOUT
15	136968-02-02B	EA	ZEE - F/SLIDEOUT - 9.6" - E-COATED
16	115661-01-000	FT	SHOE/GLIDE - SLIDEOUT ROOM - 1/16" X 3" - POLYETHYLENE
17	135622-01-01B	EA	PLATE - TIEDOWN - SLIDEOUT ROOM
18	135619-02-01A	EA	PLATE - TIEDOWN - SLIDEOUT ROOM
19	135619-01-01A	EA	STRAP - TIEDOWN - SLIDEOUT ROOM

EXTERIOR SLIDEOUT GROUP (CONTINUED)
LEFT REAR (CONTINUED)

KEY	PART NUMBER	U/M	DESCRIPTION
20	115325-16-01A	EA	RAIL - FLOOR/SLIDEOUT ROOM - BLACK
21	136968-03-02B	EA	ZEE - F/SLIDEOUT - 40.2" - E-COATED
22	138659-01-01A	EA	TRIM/FEATURE STRIP - 181.7" - BRIGHT WHITE - W/GRAPHICS PACKAGE
22	138659-01-02A	EA	TRIM/FEATURE STRIP - 181.7" - BLACK - W/FULL BODY PAINT
	105312-01-07A	FT	INSERT - FEATURE STRIP - VINYL - BRIGHT WHITE - W/GRAPHICS PACKAGE
	105312-01-13A	FT	INSERT - FEATURE STRIP - VINYL - W/FULL BODY PAINT
23	126313-09-02B	EA	SUPPORT - ROLLER - E-COATED
24	134855-01-000	EA	BEARING PAD - NARROW
25	075673-05-000	FT	SEAL - PILE - ADHESIVE BACK - BLACK
24	112091-01-000	FT	SEAL/D - NEOPRENE - HEAT ACTIVE ADHESIVE - .9" FROM: 00-00-00 THRU: 01-12-03
24	146056-01-000	FT	SEAL - TRIANGLE - W/PSA FROM: 01-13-03 THRU: 99-99-99

EXTERIOR SLIDEOUT GROUP (CONTINUED)
COMPONENT PARTS FOR LEFT REAR SLIDEOUT

100536-52-000

KEY	PART NUMBER	U/M	DESCRIPTION	VENDOR NO.
	100536-52-700	EA	HOSE-HYDRAULIC - 1/4" X 207"	RAP90119/AP11212
	100536-52-701	EA	HOSE-HYDRAULIC 1/4" X 228"	AP5924

139507-01-000

KEY	PART NUMBER	U/M	DESCRIPTION	VENDOR NO.
	139507-01-700	EA	CYLINDER - SYNCRONIZING	RAP90879/AP24825
	139507-01-701	EA	HOSE - HYDRAULIC 1/8" X 102"	AP23738
	139507-01-702	EA	CYLINDER - ASSIST	RAP90878/AP25743
	139507-01-703	EA	CYLINDER/RAM - MAIN	RAP90877/AP23286

GALLEY GROUP CABINETS

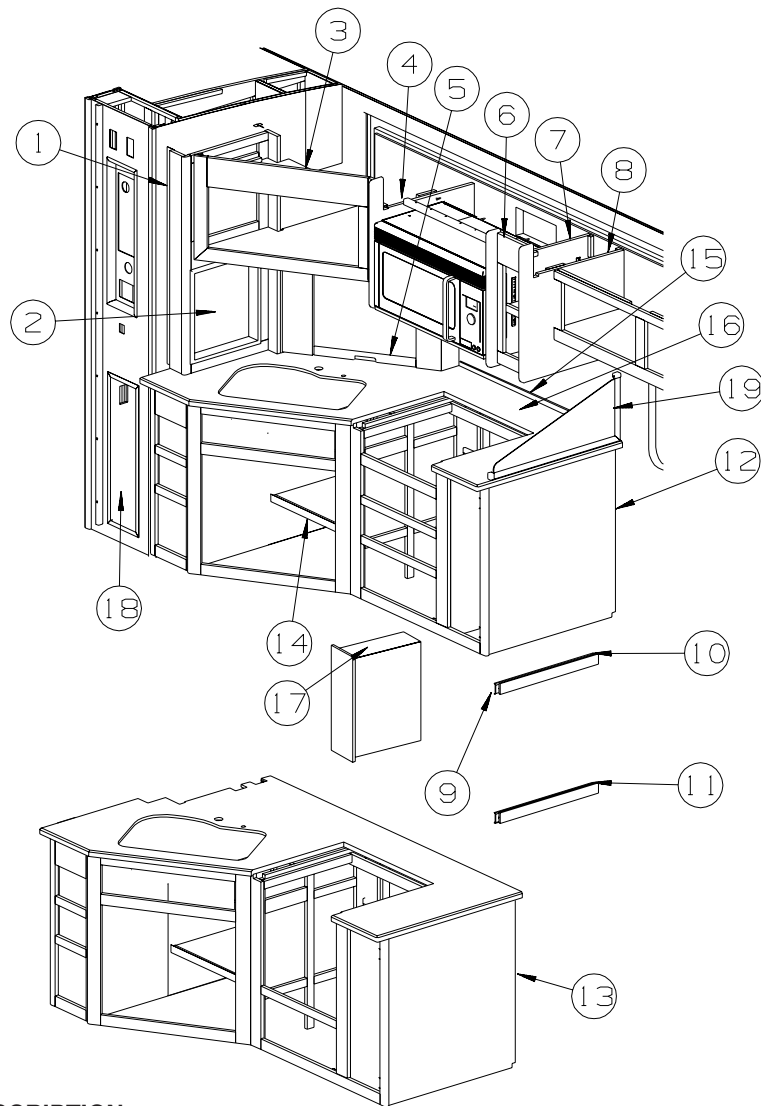

KEY	PART NUMBER	U/M	DESCRIPTION
1	140924-01-N70	EA	CABINET - SPICE RACK - W/O HARDWARE - PORTSMOUTH OAK
1	140924-01-N85	EA	CABINET - SPICE RACK - W/O HARDWARE - CONCERT CHERRY
1	140924-01-N84	EA	CABINET - SPICE RACK - W/O HARDWARE - WASHED MAPLE
2	126847-01-N70	EA	SPICE RACK - PORTSMOUTH OAK
2	126847-01-M52	EA	SPICE RACK - CONCERT CHERRY
2	126847-01-J60	EA	SPICE RACK - WASHED MAPLE
3	P40125-01-N70	EA	CABINET - OVERHEAD/GALLEY - W/O DOORS/HARDWARE - PORTSMOUTH OAK
3	P40125-01-N85	EA	CABINET - OVERHEAD/GALLEY - W/O DOORS/HARDWARE - CONCERT CHERRY
3	P40125-01-N84	EA	CABINET - OVERHEAD/GALLEY - W/O DOORS/HARDWARE - WASHED MAPLE
4	P38119-25-N70	EA	END CAP - OVERHEAD CABINET - PORTSMOUTH OAK
4	P38119-25-N85	EA	END CAP - OVERHEAD CABINET - CONCERT CHERRY
4	P38119-25-N84	EA	END CAP - OVERHEAD CABINET - WASHED MAPLE
5	140892-01-N70	EA	CABINET - STORAGE/APPLIANCE - W/TAMBOUR DOOR - W/O HDW - PORTSMOUTH OAK
5	140892-01-N85	EA	CABINET - STORAGE/APPLIANCE - W/TAMBOUR DOOR - W/O HDW - CONCERT CHERRY
5	140892-01-N84	EA	CABINET - STORAGE/APPLIANCE - W/TAMBOUR DOOR - W/O HDW - WASHED MAPLE
6	P40398-01-N70	EA	CABINET - OVERHEAD/GALLEY - W/O DOORS/HARDWARE - PORTSMOUTH OAK
6	P40398-01-N85	EA	CABINET - OVERHEAD/GALLEY - W/O DOORS/HARDWARE - CONCERT CHERRY
6	P40398-01-N84	EA	CABINET - OVERHEAD/GALLEY - W/O DOORS/HARDWARE - WASHED MAPLE
7	140398-16-N70	EA	END CAP - OVERHEAD CABINET - PORTSMOUTH OAK
7	140398-16-N85	EA	END CAP - OVERHEAD CABINET - CONCERT CHERRY
7	140398-16-N84	EA	END CAP - OVERHEAD CABINET - WASHED MAPLE
8	140398-17-N70	EA	END CAP - OVERHEAD CABINET - PORTSMOUTH OAK
8	140398-17-N85	EA	END CAP - OVERHEAD CABINET - CONCERT CHERRY
8	140398-17-N84	EA	END CAP - OVERHEAD CABINET - WASHED MAPLE

GALLEY GROUP (CONTINUED)

CABINETS (CONTINUED)

KEY	PART NUMBER	U/M	DESCRIPTION
9	123673-01-01A	EA	KNOB - PANTRY SLIDE
10	122360-01-000	EA	SLIDE - PANTRY - W/LOCK - LEFT HAND (FACING PANEL)
11	122360-02-000	EA	SLIDE - PANTRY - W/O LOCK - RIGHT/LEFT HAND
12	140106-01-N70	EA	CABINET - GALLEY - W/O COUNTERTOP/DOORS/DRAWERS/HARDWARE - PORTSMOUTH OAK
12	140106-01-N85	EA	CABINET - GALLEY - W/O COUNTERTOP/DOORS/DRAWERS/HARDWARE - CONCERT CHERRY
12	140106-01-N84	EA	CABINET - GALLEY - W/O COUNTERTOP/DOORS/DRAWERS/HARDWARE - WASHED MAPLE
13	140106-02-N70	EA	CABINET - GALLEY - W/O COUNTERTOP/DOORS/DRAWERS/HARDWARE - PORTSMOUTH OAK
13	140106-02-N85	EA	CABINET - GALLEY - W/O COUNTERTOP/DOORS/DRAWERS/HARDWARE - CONCERT CHERRY
13	140106-02-N84	EA	CABINET - GALLEY - W/O COUNTERTOP/DOORS/DRAWERS/HARDWARE - WASHED MAPLE
14	140106-36-N70	EA	SHELF - W/PLASTIC EDGE MOLDING
15	130813-19-04A	EA	BACKSPLASH - COUNTERTOP - 1/2" VENDURA - QUARRY
			FROM: 00-00-00 THRU: 12-01-02
15	130813-24-04A	EA	BACKSPLASH - COUNTERTOP - 1/2" VENDURA - QUARRY
			FROM: 12-02-02 THRU: 99-99-99
16	137475-06-03A	EA	COUNTERTOP - 1/4" VENDURA - QUARRY
17	130816-04-04A	EA	COUNTERTOP - 1/4" VENDURA - QUARRY
18	140359-01-N70	EA	CABINET - STORAGE - W/O DOORS/HARDWARE - PORTSMOUTH OAK
18	140359-01-N85	EA	CABINET - STORAGE - W/O DOORS/HARDWARE - CONCERT CHERRY
18	140359-01-N84	EA	CABINET - STORAGE - W/O DOORS/HARDWARE - WASHED MAPLE
19	145211-01-P75	EA	SPLASHGUARD - W/GLASS - PORTSMOUTH OAK
19	145211-01-P25	EA	SPLASHGUARD - W/GLASS - CONCERT CHERRY
19	145211-01-P28	EA	SPLASHGUARD - W/GLASS - WASHED MAPLE
19	127117-01-01A	EA	GLASS - STATIONARY - SPLASHGUARD

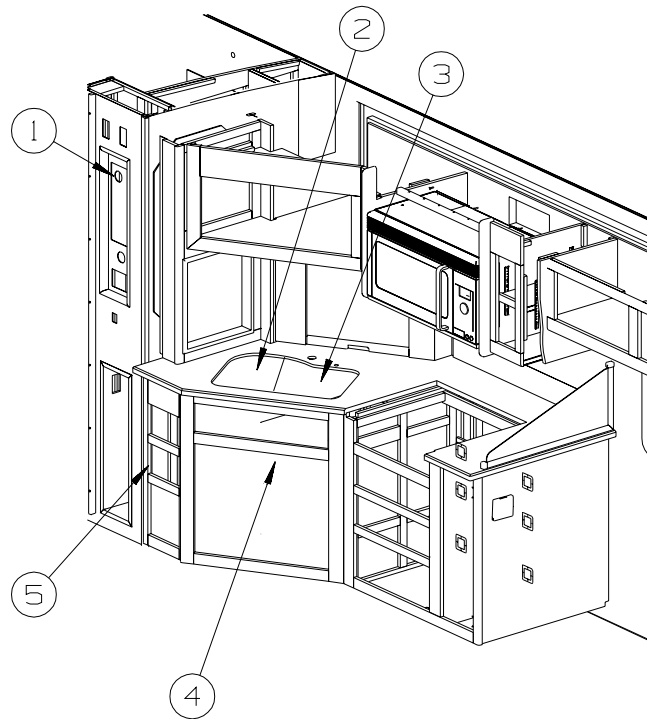

KEY	PART NUMBER	U/M	DESCRIPTION
1	137602-06-N75	EA	POCKET - MONITOR PANEL - PORTSMOUTH OAK - INVERTER/CHARGER - W/O DC/AC
1	137602-06-N74	EA	POCKET - MONITOR PANEL - CONCERT CHERRY - INVERTER/CHARGER - W/O DC/AC
1	137602-06-N84	EA	POCKET - MONITOR PANEL - WASHED MAPLE - INVERTER/CHARGER - W/O DC/AC
1	137602-03-N75	EA	POCKET - MONITOR PANEL - PORTSMOUTH OAK - INVERTER/CHARGER - W/DC/AC
1	137602-03-N74	EA	POCKET - MONITOR PANEL - CONCERT CHERRY - INVERTER/CHARGER - W/DC/AC
1	137602-03-N84	EA	POCKET - MONITOR PANEL - WASHED MAPLE - INVERTER/CHARGER - W/DC/AC
2	137489-03-03A	EA	COVER - SINK/LARGE - 1/4" VENDURA - QUARRY
3	137489-04-03A	EA	COVER - SINK/SMALL - 1/4" VENDURA - QUARRY
4	093605-02-01A	EA	RACK - TOWEL/WIRE - ALMOND
5	100081-01-01A	EA	TRAY - SILVERWARE - 9" X 13.3" RUBBERMAID ALMOND PLASTIC

GALLEY GROUP (CONTINUED)

DOORS & DRAWERS

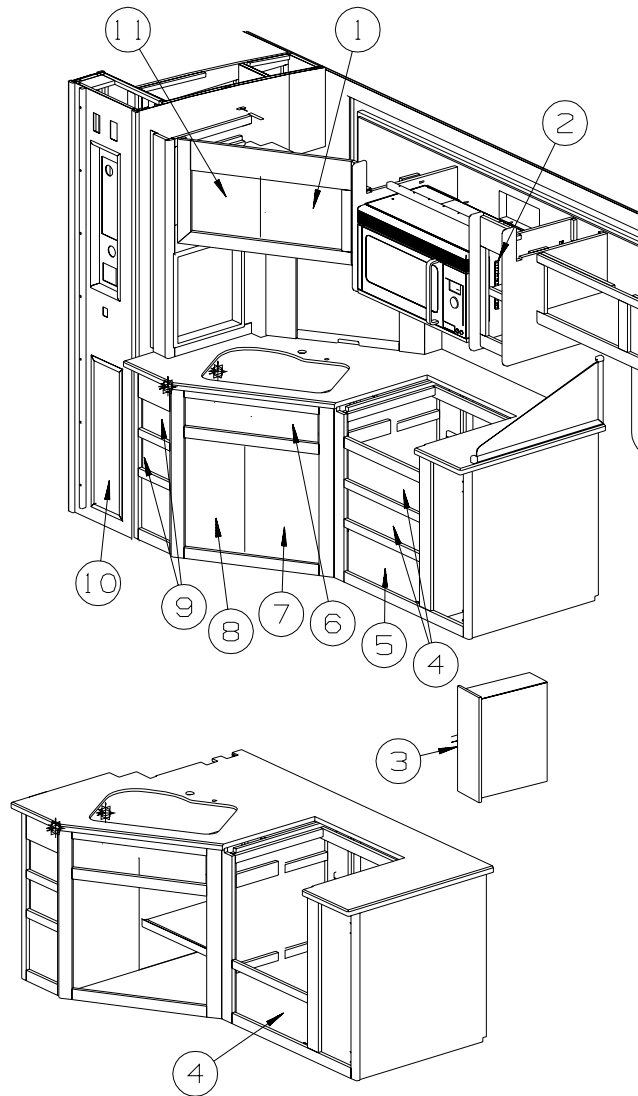

KEY	PART NUMBER	U/M	DESCRIPTION
1	141508-A3-P84	EA	DOOR - ARCHED/PENCIL EDGE - 14.3" X 17.9" - W/O HARDWARE - PORTSMOUTH OAK
1	141508-A3-P85	EA	DOOR - ARCHED/PENCIL EDGE - 14.3" X 17.9" - W/O HARDWARE - CONCERT CHERRY
1	141508-A3-P28	EA	DOOR - ARCHED/PENCIL EDGE - 14.3" X 17.9" - W/O HARDWARE - WASHED MAPLE
2	134783-38-P84	EA	DOOR - RAIL/SOLID PANEL - 6.3" X 23.2" - W/O HARDWARE - PORTSMOUTH OAK
2	134783-38-N63	EA	DOOR - RAIL/SOLID PANEL - 6.3" X 23.2" - W/O HARDWARE - CONCERT CHERRY
2	134783-38-N62	EA	DOOR - RAIL/SOLID PANEL - 6.3" X 23.2" - W/O HARDWARE - WASHED MAPLE
3	134783-U0-P84	EA	DOOR - RAIL/SOLID PANEL - 10" X 29.5" - W/O HARDWARE - PORTSMOUTH OAK
3	134783-U0-N85	EA	DOOR - RAIL/SOLID PANEL - 10" X 29.5" - W/O HARDWARE - CONCERT CHERRY
3	134783-U0-N84	EA	DOOR - RAIL/SOLID PANEL - 10" X 29.5" - W/O HARDWARE - WASHED MAPLE
4	134870-19-P84	EA	DRAWER - PENCIL EDGE - 20.2"W X 21.6"D - W/O SLIDES/HDW - PORTSMOUTH OAK
4	134870-19-N85	EA	DRAWER - PENCIL EDGE - 20.2"W X 21.6"D - W/O SLIDES/HDW - CONCERT CHERRY
4	134870-19-N84	EA	DRAWER - PENCIL EDGE - 20.2"W X 21.6"D - W/O SLIDES/HDW - WASHED MAPLE
5	134870-20-P84	EA	DRAWER - PENCIL EDGE - 20.2"W X 21.6"D - W/O SLIDES/HDW - PORTSMOUTH OAK
5	134870-20-N85	EA	DRAWER - PENCIL EDGE - 20.2"W X 21.6"D - W/O SLIDES/HDW - CONCERT CHERRY
5	134870-20-N84	EA	DRAWER - PENCIL EDGE - 20.2"W X 21.6"D - W/O SLIDES/HDW - WASHED MAPLE
6	134842-07-P84	EA	DRAWER - TIPOUT - W/HIDDEN TRAY - PORTSMOUTH OAK
6	134842-07-N85	EA	DRAWER - TIPOUT - W/HIDDEN TRAY - CONCERT CHERRY
6	134842-07-N84	EA	DRAWER - TIPOUT - W/HIDDEN TRAY - WASHED MAPLE
	108127-01-01A	EA	CAP - TRAY
	108128-01-01A	EA	TRAY - HIDDEN
7	136710-87-P84	EA	DOOR - RAISED PANEL/PENCIL EDGE - 12.8" X 21.8" - W/O HDW - PORTSMOUTH OAK
7	136710-87-P85	EA	DOOR - RAISED PANEL/PENCIL EDGE - 12.8" X 21.8" - W/O HDW - CONCERT CHERRY
7	136710-87-P28	EA	DOOR - RAISED PANEL/PENCIL EDGE - 12.8" X 21.8" - W/O HDW - WASHED MAPLE

GALLEY GROUP (CONTINUED)

DOORS & DRAWERS (CONTINUED)

KEY	PART NUMBER	U/M	DESCRIPTION
8	136710-86-P84	EA	DOOR - RAISED PANEL/PENCIL EDGE - 12.8" X 21.8" - W/O HDW - PORTSMOUTH OAK
8	136710-86-P85	EA	DOOR - RAISED PANEL/PENCIL EDGE - 12.8" X 21.8" - W/O HDW - CONCERT CHERRY
8	136710-86-P28	EA	DOOR - RAISED PANEL/PENCIL EDGE - 12.8" X 21.8" - W/O HDW - WASHED MAPLE
9	134870-05-P84	EA	DRAWER - PENCIL EDGE - 8"W X 15.7"D - W/O SLIDES/HDW - PORTSMOUTH OAK
9	134870-05-M85	EA	DRAWER - PENCIL EDGE - 8"W X 15.7"D - W/O SLIDES/HDW - CONCERT CHERRY
9	134870-05-M84	EA	DRAWER - PENCIL EDGE - 8"W X 15.7"D - W/O SLIDES/HDW - WASHED MAPLE
10	134783-V5-P84	EA	DOOR - RAIL/SOLID PANEL - 9.8" X 33.4" - W/O HARDWARE - PORTSMOUTH OAK
10	134783-V5-N85	EA	DOOR - RAIL/SOLID PANEL - 9.8" X 33.4" - W/O HARDWARE - CONCERT CHERRY
10	134783-V5-N84	EA	DOOR - RAIL/SOLID PANEL - 9.8" X 33.4" - W/O HARDWARE - WASHED MAPLE
11	141285-A3-P84	EA	DOOR - ARCHED/PENCIL EDGE - 14.3" X 17.9" - W/O HARDWARE - PORTSMOUTH OAK
11	141285-A3-P85	EA	DOOR - ARCHED/PENCIL EDGE - 14.3" X 17.9" - W/O HARDWARE - CONCERT CHERRY
11	141285-A3-P28	EA	DOOR - ARCHED/PENCIL EDGE - 14.3" X 17.9" - W/O HARDWARE - WASHED MAPLE

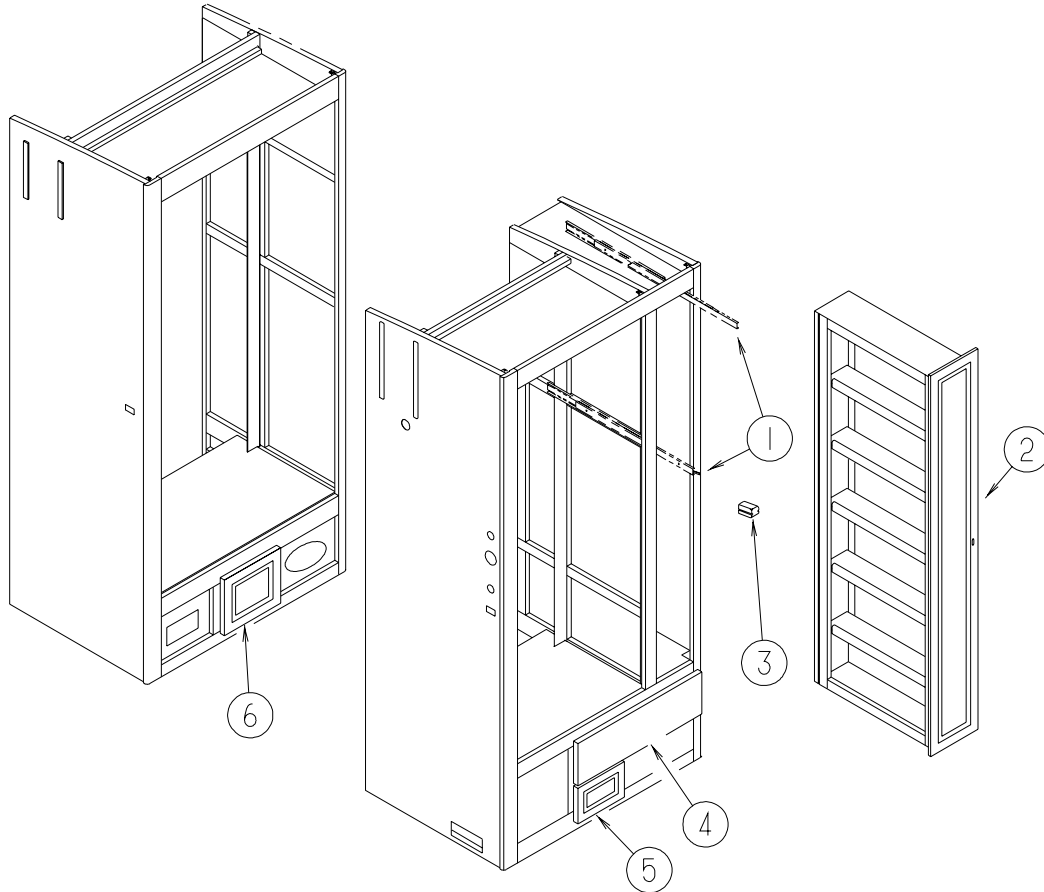

KEY	PART NUMBER	U/M	DESCRIPTION
1	122360-02-000	EA	SLIDE - PANTRY - W/O LOCK - RIGHT/LEFT HAND
1	122360-03-000	EA	SLIDE - PANTRY - W/LOCK - RIGHT HAND (FACING PANEL)
2	134783-86-P84	EA	DOOR - RAIL/SOLID PANEL - 8.1" X 60.7" - W/O HARDWARE - PORTSMOUTH OAK
2	134783-86-N85	EA	DOOR - RAIL/SOLID PANEL - 8.1" X 60.7" - W/O HARDWARE - CONCERT CHERRY
2	134783-86-N84	EA	DOOR - RAIL/SOLID PANEL - 8.1" X 60.7" - W/O HARDWARE - WASHED MAPLE
3	123673-01-01A	EA	KNOB - PANTRY SLIDE
4	P34767-91-P84	EA	DRAWER - PENCIL EDGE - 22.5"W X 17.7"D-W/O SLIDES/HARDWARE - PORTSMOUTH OAK
4	P34767-91-N85	EA	DRAWER - PENCIL EDGE - 22.5"W X 17.7"D-W/O SLIDES/HARDWARE - CONCERT CHERRY
4	P34767-91-N84	EA	DRAWER - PENCIL EDGE - 22.5"W X 17.7"D-W/O SLIDES/HARDWARE - WASHED MAPLE
5	134783-89-P84	EA	DOOR - RAIL/SOLID PANEL - 12.6" X 6.1" - W/O HARDWARE (P84)
5	134783-89-P70	EA	DOOR - RAIL/SOLID PANEL - 12.6" X 6.1" - W/O HARDWARE (P85,P87,P89)
5	134783-89-P69	EA	DOOR - RAIL/SOLID PANEL - 12.6" X 6.1" - W/O HARDWARE (P86,P88)
5	134783-89-P51	EA	DOOR - RAIL/SOLID PANEL - 12.6" X 6.1" - W/O HARDWARE (P28,P29,P30)
6	134783-F0-P84	EA	DOOR - RAIL/SOLID PANEL - 9.2" X 10.2" - W/O HARDWARE - PORTSMOUTH OAK
6	134783-F0-N85	EA	DOOR - RAIL/SOLID PANEL - 9.2" X 10.2" - W/O HARDWARE - CONCERT CHERRY
6	134783-F0-N84	EA	DOOR - RAIL/SOLID PANEL - 9.2" X 10.2" - W/O HARDWARE - WASHED MAPLE

GENERATOR GROUP LPG

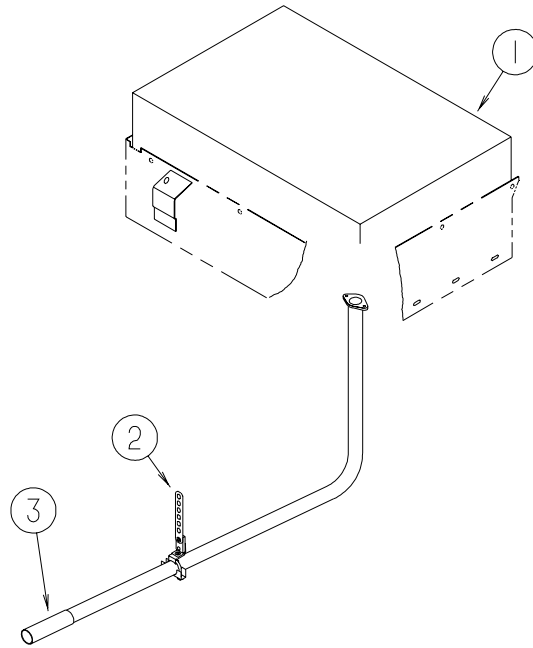

KEY	PART NUMBER	U/M	DESCRIPTION
1	135707-03-000	EA	GENERATOR - 6.5 - 30/30 - LIQUID LP - MARQUIS GOLD
2	007131-01-000	EA	HANGER - TAILPIPE - 6 SLOTS
	007125-03-000	EA	CLAMP - MUFFLER - 1.5" DIAMETER
3	138246-01-01A	EA	EXTENSION - TAILPIPE - 1.6" I.D.
4	137330-02-000	EA	PIPE - EXHAUST - GENERATOR/LP

GENERATOR GROUP (CONTINUED)

DIESEL

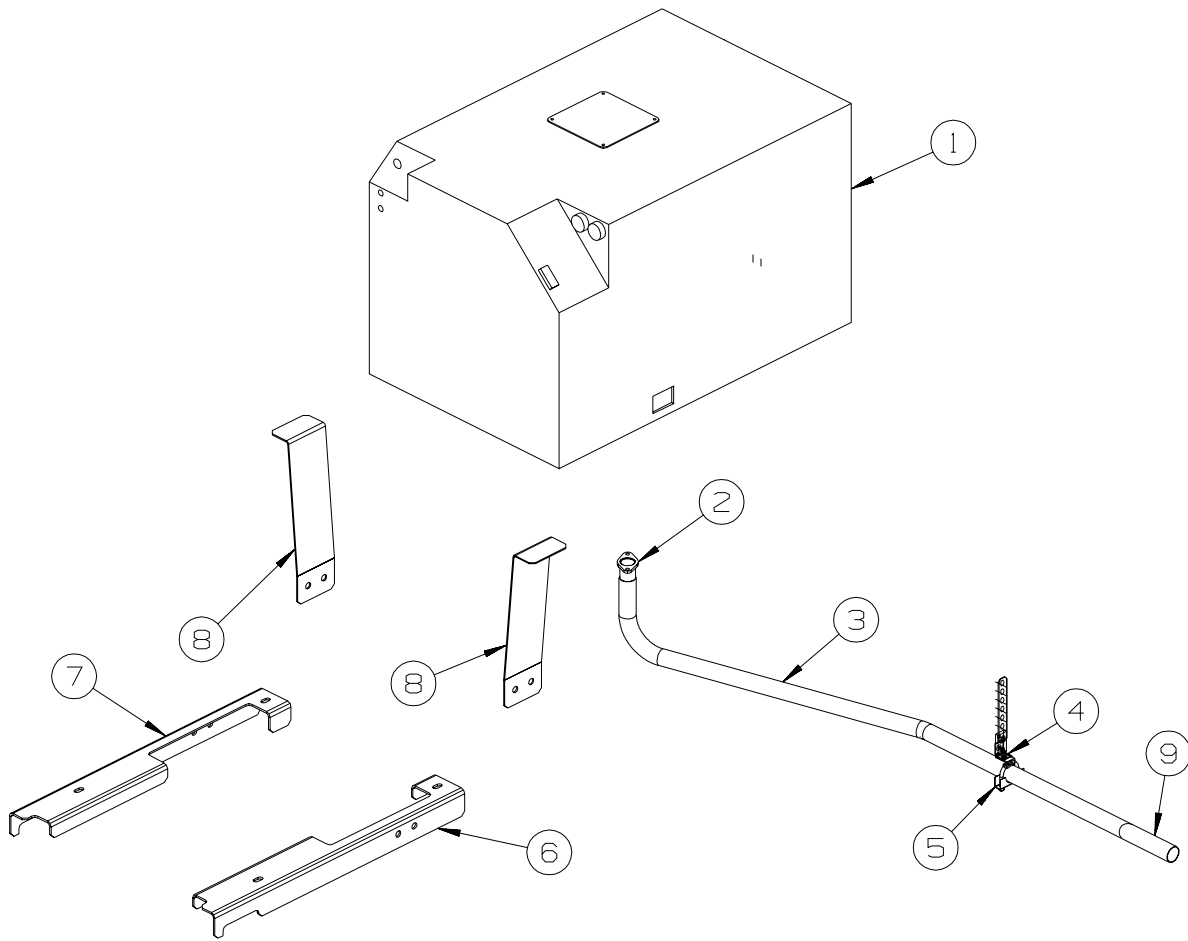

KEY	PART NUMBER	U/M	DESCRIPTION
1	122425-01-000	EA	GENERATOR - DIESEL - 7.5
2	106235-01-000	EA	ADAPTOR - GENERATOR EXHAUST
3	137330-03-000	EA	PIPE - EXHAUST - GENERATOR/DIESEL
4	007131-01-000	EA	HANGER - TAILPIPE - 6 SLOTS
5	007125-03-000	EA	CLAMP - MUFFLER - 1.5" DIAMETER
6	137328-02-02B	EA	SUPPORT - GENERATOR - LH - E-COATED
7	137328-01-02B	EA	SUPPORT - GENERATOR - RH - E-COATED
8	137329-02-02B	EA	BRACKET - HANGAR/GENERATOR - E-COATED
9	138246-01-01A	EA	EXTENSION - TAILPIPE - 1.6"ID X 7.7"

HEATING & A/C GROUP AUTOMOTIVE

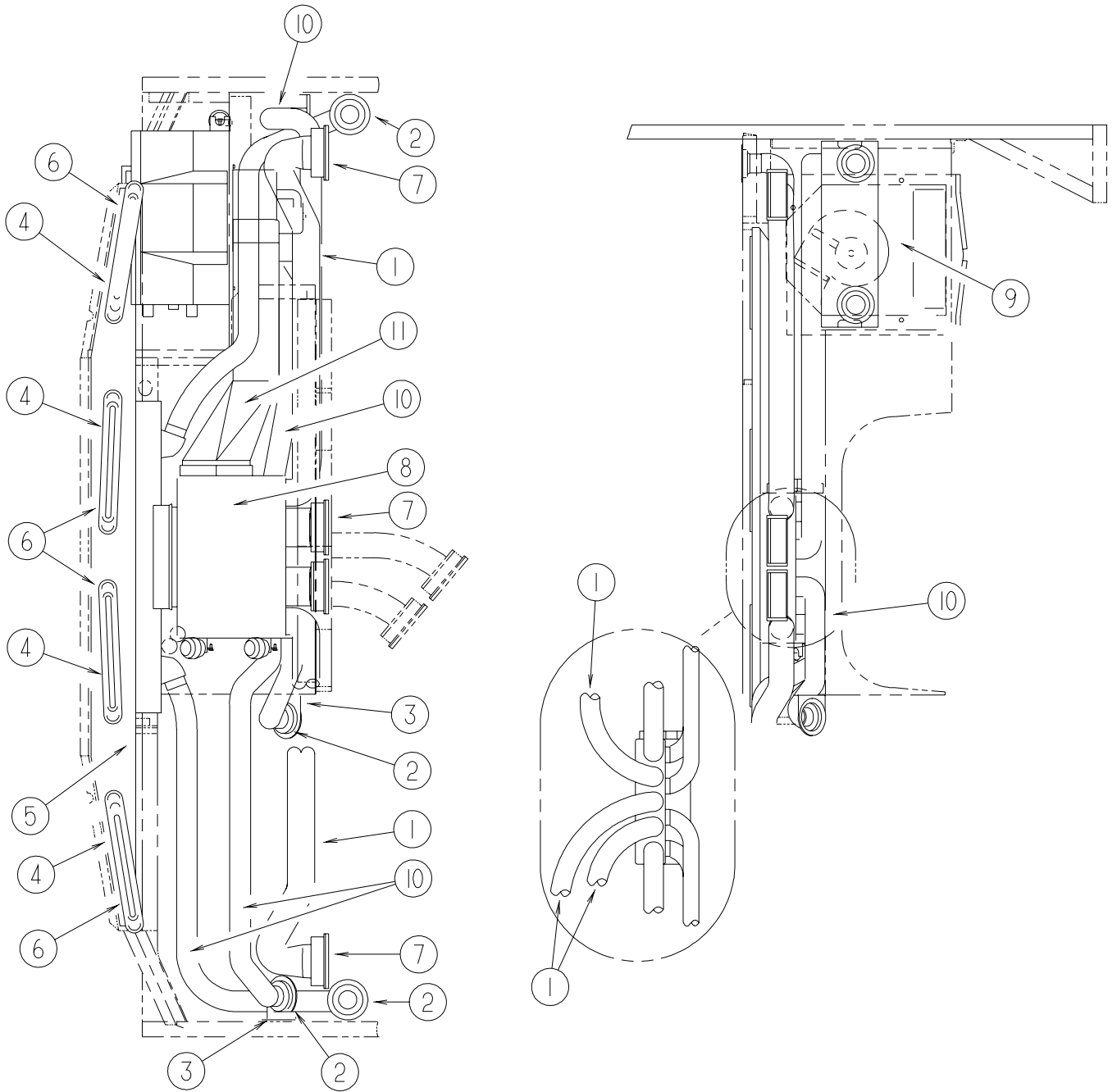

KEY	PART NUMBER	U/M DESCRIPTION
1	007281-01-000	EA HOSE - FLEXIBLE PVC - 2 1/2" ID X 50'
2	024990-05-000	EA OUTLET - DEFROSTER - W/SWIVEL - 2" SLEEVE/4" OD - BLACK - 1 USED
2	024990-12-000	EA OUTLET - DEFROSTER - W/SWIVEL - 2" SLEEVE/4" OD - GLACIER - 3 USED
3	NOT USED	
4	077075-01-000	EA GASKET - INSTRUMENT PANEL/DEFROSTER PLENUM - .6" X 10.2"
5	103017-03-000	EA PLENUM - DEFROSTER
6	135265-01-04A	EA VENT - DEFROSTER - PLASTIC - GLACIER
7	135803-01-01A	EA LOUVER - A/C - 2.5" X 5.2" - BLACK - 3 USED
7	135803-02-01A	EA LOUVER - A/C - 2.5" - 5.7" - W/SCREW HOLES - BLACK - 2 USED
8*	103930-36-000	EA CONTROL/PLENUM - ROTARY CONTROL HEAD
9	103930-55-000	EA EVAPORATOR/HEATER - NONCHARGED - SINGLE OUTPUT
10	007076-01-000	EA HOSE - FLEXIBLE PVC - 2" ID - INCREMENTS OF 50'
11	122822-01-01A	EA PLENUM - TRANSITION
	103930-54-000	EA MANUAL - OWNERS - HEATER/AC

***COMPONENT PARTS LISTED LATER IN THIS GROUP**

HEATING & A/C GROUP (CONTINUED)

AUTOMOTIVE (CONTINUED)

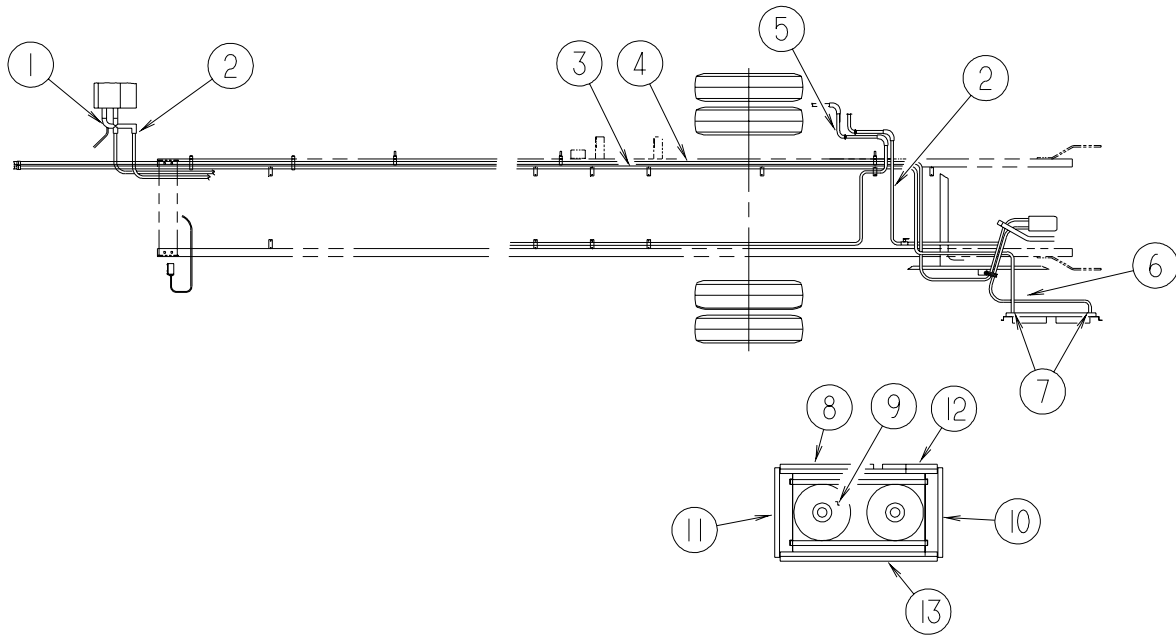

KEY	PART NUMBER	U/M	DESCRIPTION
1	103930-24-000	EA	VALVE - WATER CONTROL - 4 PORT VACUUM CONTROLLED
2	007108-01-000	FT	HOSE - HEATER - 5/8" ID - HI-TEMP
3*	072342-18-000	EA	HOSE - #6 - CONDENSER/EVAPORATOR - 514"
4*	103930-41-000	EA	HOSE KIT - EVAPORATOR/COMPRESSOR #12 - 41.3'- STRAIGHT END
5	079059-01-000	EA	HOSE - 90 DEGREE - 5/8"ID X 4" X 36"
6*	072342-16-000	EA	HOSE - #8 - CONDENSER/COMPRESSOR - 5.2' LONG
7	072368-02-000	EA	TRIM - VINYL - EDGE - BLACK
8	113572-02-02B	EA	BRACKET - CONDENSER - E-COATED
9*	072342-15-000	EA	CONDENSER - W/FAN ON SIDE - NO HOSE
10	113574-02-02B	EA	BRACKET - CONDENSER/SIDE - LH - E-COAT
11	113574-01-02B	EA	BRACKET - CONDENSER/SIDE - RH - E-COAT
12	113572-03-02B	EA	BRACKET - CONDENSER - E-COATED
13	113572-01-02B	EA	BRACKET - CONDENSER - E-COATED

***COMPONENT PARTS LISTED LATER IN THIS GROUP**

HEATING & A/C GROUP (CONTINUED)
COMPONENT PARTS FOR AUTOMOTIVE

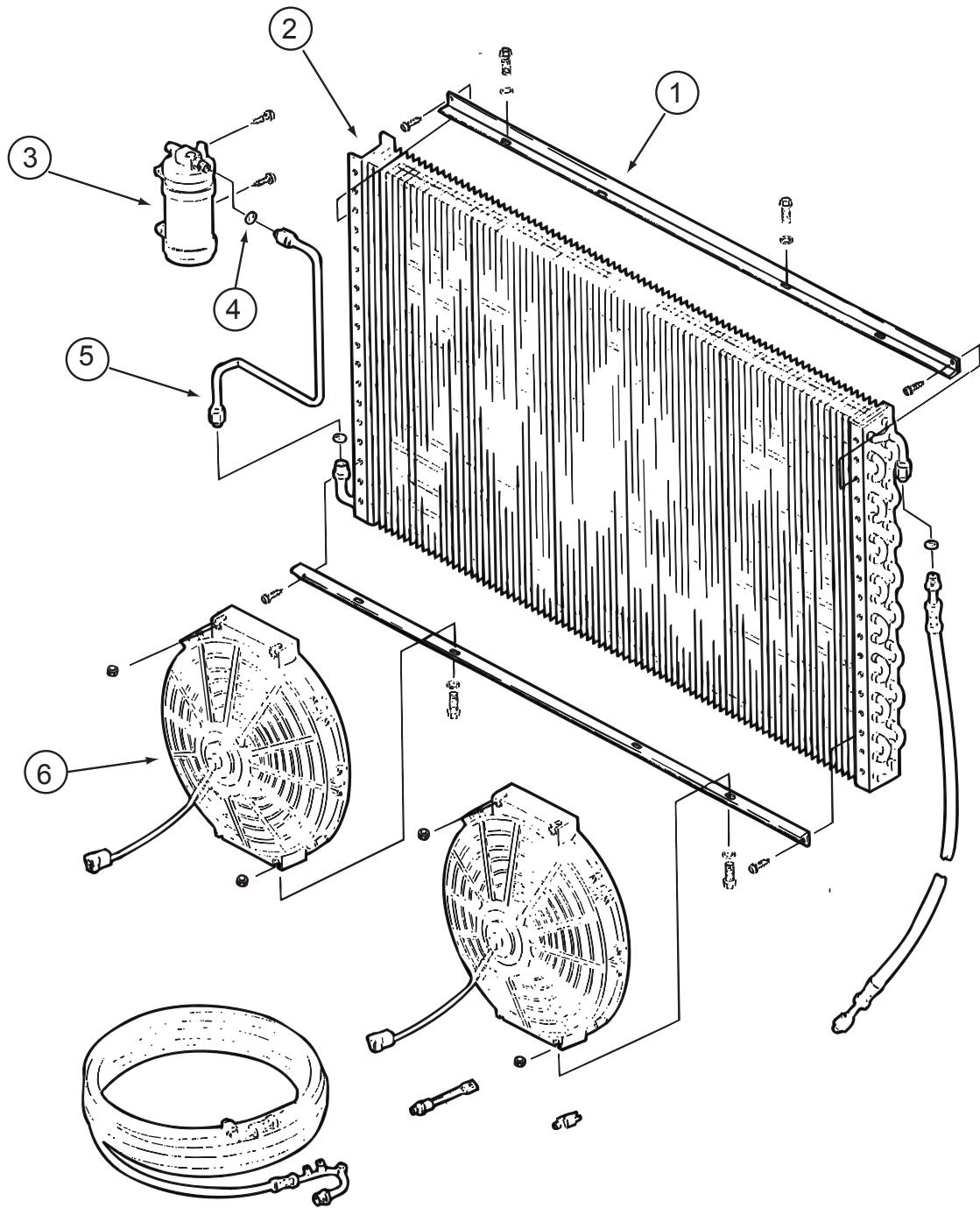

072342-15-000

KEY	PART NUMBER	U/M	DESCRIPTION	VENDOR NO.
1	072342-13-700	EA	BRACKET - CONDENSER FAN	070-0148
2	072342-12-700	EA	COIL-COIL-CONDENSER	040-0027
3	072342-12-703	EA	RECEIVER DRIER	054-0001
4	113245-01-711	EA	O'RING #6	045-0129
5	072342-13-703	EA	TUBE ASM. #6	052-0040
6	072342-08-703	EA	FAN BLADE/MOTOR & SHROUD 11"	062-0097

072342-16-000

KEY	PART NUMBER	U/M	DESCRIPTION	VENDOR NO.
	072342-13-701	EA	HOSE ASM. #8	085-0459
	113245-01-707	EA	O'RING #8	045-0126

HEATING & A/C GROUP (CONTINUED)
COMPONENT PARTS FOR AUTOMOTIVE (CONTINUED)

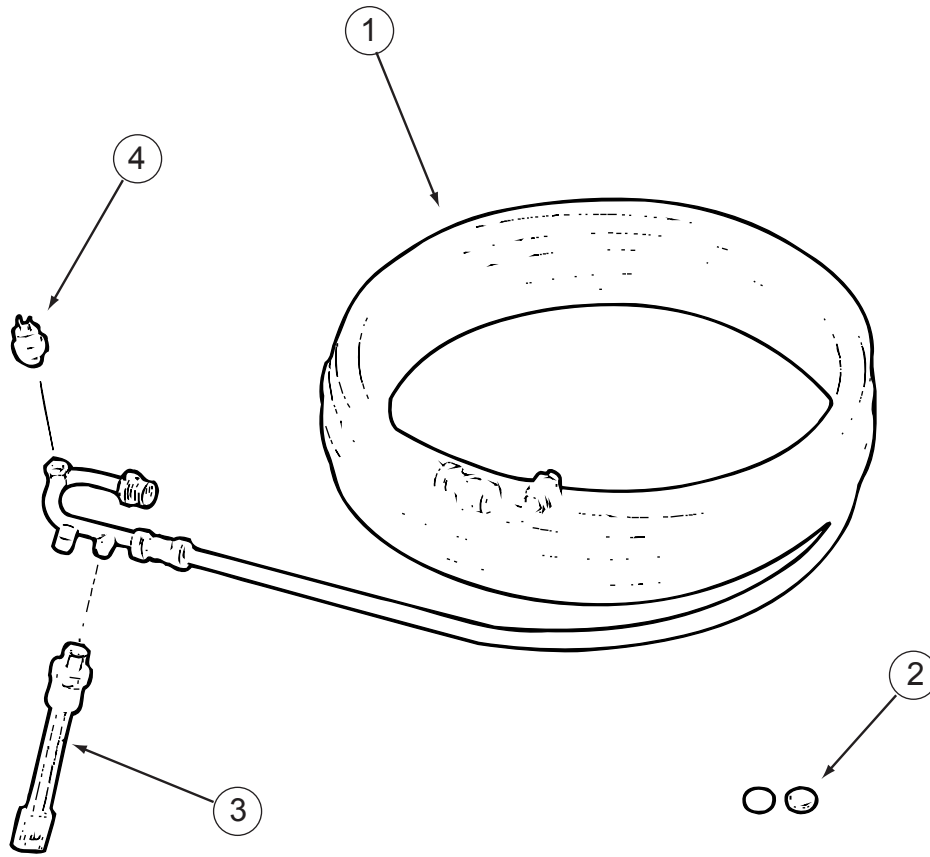

072342-18-000

KEY	PART NUMBER	U/M	DESCRIPTION	VENDOR NO.
1	072342-13-702	EA	HOSE ASM. #6	085-0460
2	113245-01-711	EA	O'RING #6	045-0129
3	103930-01-716	EA	SWITCH - PRESSURE - FAN	032-0036
4	103930-12-708	EA	SWITCH-BINARY-HI/LOW CUTOUT	032-0048

HEATING & A/C GROUP (CONTINUED)
COMPONENT PARTS FOR AUTOMOTIVE (CONTINUED)

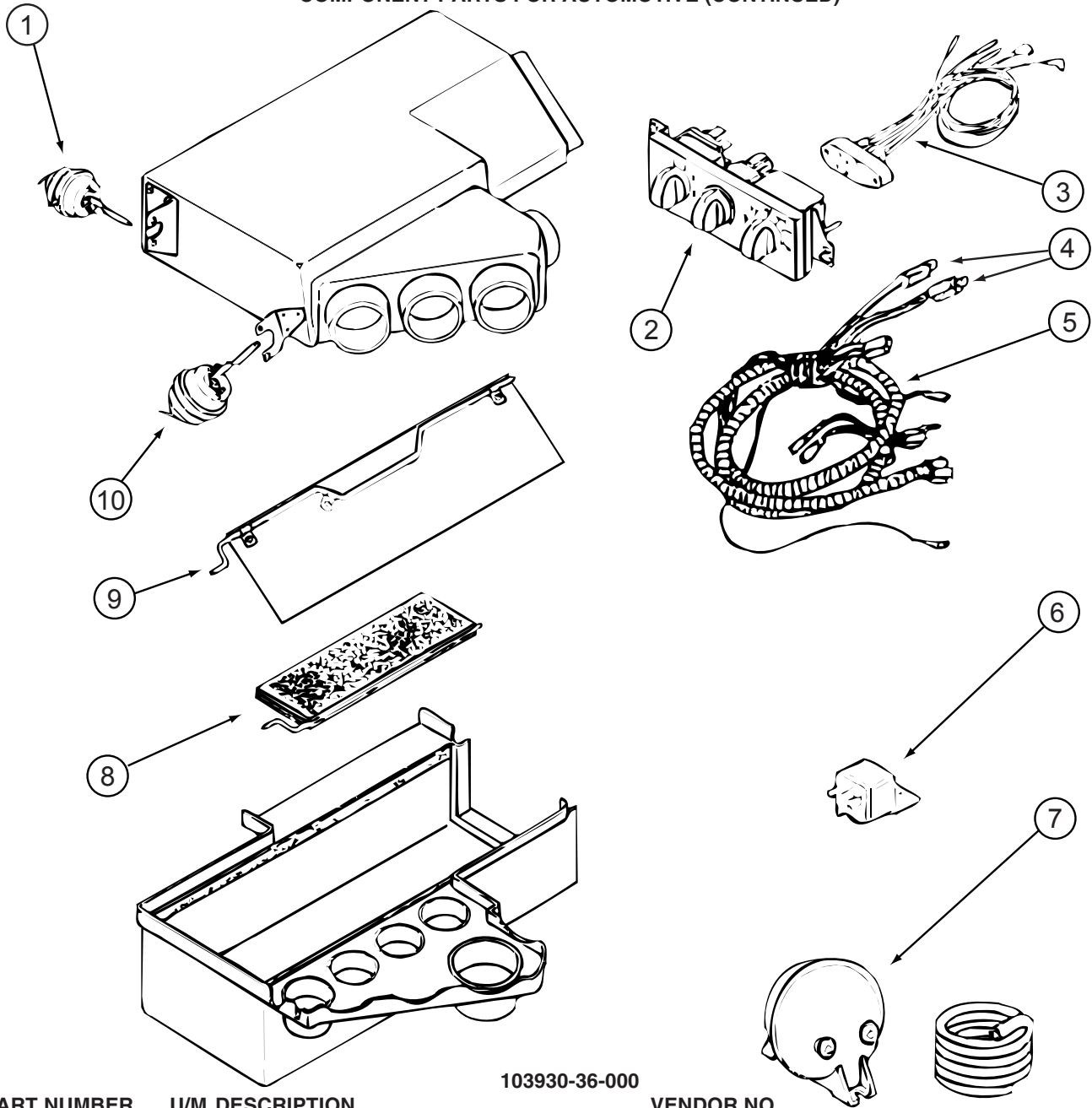

103930-36-000

KEY	PART NUMBER	U/M	DESCRIPTION	VENDOR NO.
	103930-36-000	EA	CONTROL/PLENUM - ROTARY CONTROL HEAD	
1	103930-33-701	EA	MOTOR - VACUUM, 3 STAGE	030-0105
2	103930-33-702	EA	CONTROL PANEL	083-0169
3	103930-33-703	EA	VACUUM HARNESS	036-0466
4	103930-33-705	EA	LIGHT BULBS	035-0030
5	103930-33-711	EA	WIRE HARNESS-W/BULBS(CAVITY)	036-0496
6	103930-02-707	EA	RELAY-BOSCH W/RESISTER	031-0001
7	103930-02-710	EA	CANISTER-VACUUM	054-0002
8	103930-36-701	EA	ROD - DOOR, AC	073-0062
9	103930-36-700	EA	ROD - DOOR, DEFROST	073-0061
10	103930-02-708	EA	MOTOR-VACUUM SERVO, A/C	030-0025
	103930-33-707	EA	SWITCH - BLOWER	032-00066
	103930-33-708	EA	SWITCH - POTENTIOMETER	032-0184
	103930-33-709	EA	SWITCH - VACUUM	032-0183
	103930-33-710	EA	DECAL F/CONTROL HEAD	058-0102
	103930-33-712	EA	KNOB - BLOWER	062-00539
	103930-33-713	EA	KNOB	062-0540
	103930-36-702	EA	PLENUM CASE - UPPER	060-0442
	103930-36-703	EA	PLENUM CASE - LOWER	060-0443
	103930-36-704	EA	SPRING	022-0119

HEATING & A/C GROUP (CONTINUED)
COMPONENT PARTS FOR AUTOMOTIVE (CONTINUED)

103930-41-000

KEY	PART NUMBER	U/M	DESCRIPTION	VENDOR NO.
	103930-17-702	EA	O'RING #10	045-0127

HEATING & A/C GROUP (CONTINUED)
FURNACE

KEY	PART NUMBER	U/M	DESCRIPTION
	093614-11-01A	EA	GRILLE - AIR RETURN - 13.9" X 7.9" - BEIGE - P34HD
	093614-08-02A	EA	GRILLE - AIR RETURN - 9.8" X 13.9" - BEIGE
	098668-14-000	EA	GASKET - FIBERGLASS - .5" X 18" X 18"
	098668-15-000	EA	PLATE - FACE - SUBURBAN FURNACE
	098668-16-000	EA	VENT - INTAKE
	133322-01-02B	EA	PANEL - EXHAUST - FURNACE - E-COATED
	133323-01-01A	EA	SHROUD - FURNACE - BRIGHT WHITE
	137965-01-01A	EA	REGISTER - 2.25" X 10" - W/O DAMPER - ANTIQUE BRASS
	137965-02-01A	EA	REGISTER - 2.25" X 10" - W/DAMPER - ANTIQUE BRASS
	137965-06-01A	EA	REGISTER - 2.25" X 14" - W/O DAMPER - ANTIQUE BRASS
*	139980-04-000	EA	FURNACE - 40000 BTU - SF QUIET - SUBURBAN SF-42 2323J

***COMPONENT PARTS LISTED LATER IN THIS GROUP**

HEATING & A/C GROUP (CONTINUED)
COMPONENT PARTS FOR FURNACE

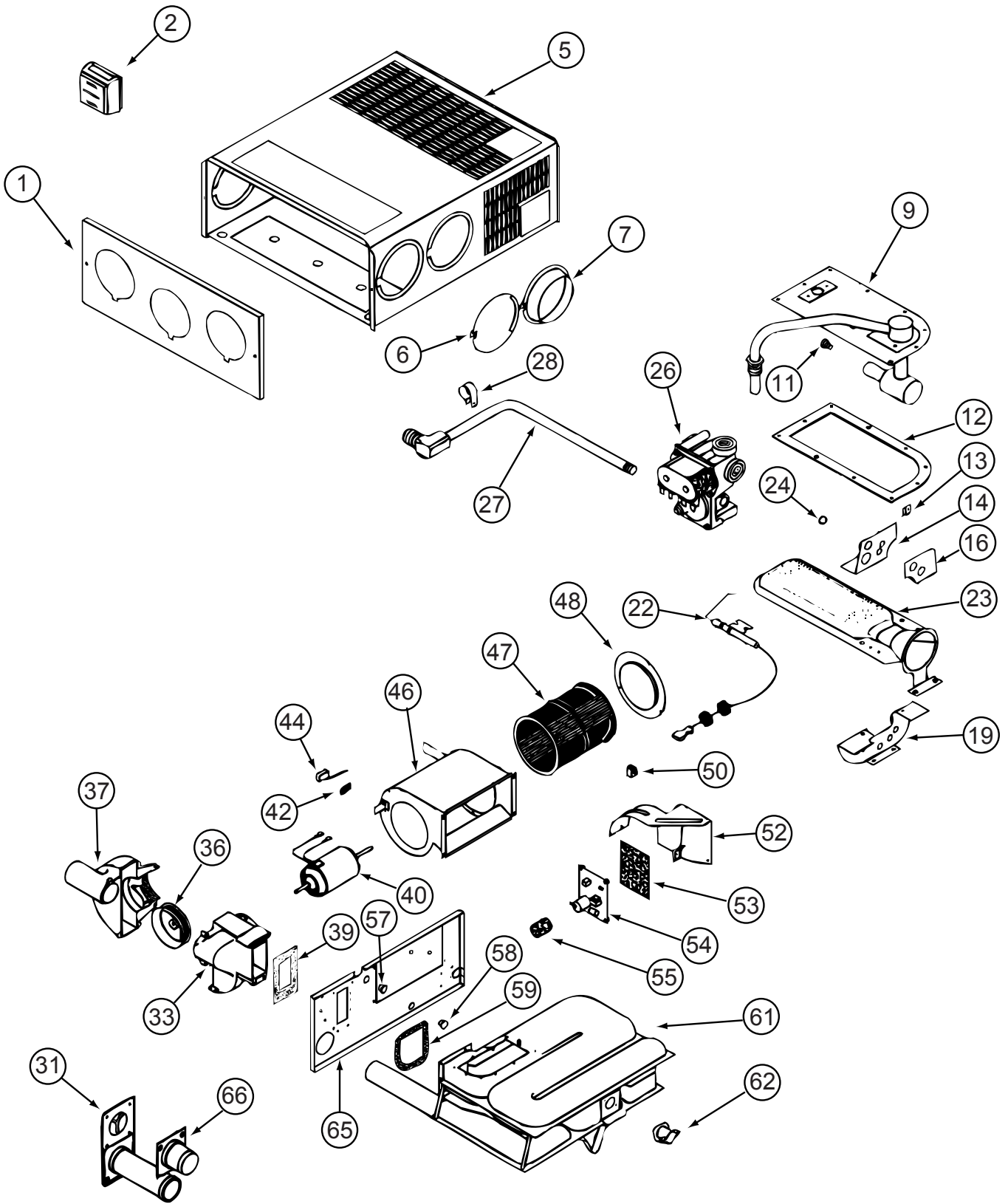

139980-04-000

HEATING & A/C GROUP (CONTINUED)
COMPONENT PARTS FOR FURNACE (CONTINUED)

139980-04-000 (CONTNUED)

KEY	PART NUMBER	U/M	DESCRIPTION	VENDOR NO.
9	098668-20-700	EA	MANIFOLD ASM.	171517
11	139980-04-700	EA	ORFICE - MAIN BURNER	180242
12	098668-22-703	EA	GASKET - BURNER ACCESS COVER	070811
22	139980-01-701	EA	ELECTRODE	232286
23	098668-11-701	EA	BURNER ASSEMBLY,SF-42F	010799
26	098668-01-718	EA	VALVE-GAS SF S.N.974903079	161122
27	139980-01-702	EA	PIPE ASSEMBLY/GAS INLET	171574
31	098668-01-707	EA	TUBE ASSEMBLY, EXHAUST W/CAP	260231
33	139980-01-703	EA	COMBUSTION AIR HOUS FRT/HALF	390852
36	098668-22-702	EA	WHEEL-COMBUSTION AIR	350183
37	139980-01-704	EA	COMBUSTION AIR HOUS RR HALF	390848
39	139980-01-705	EA	GASKET/FIREWALL-COMB AIR	071084
40	139980-04-701	EA	MOTOR ASSEMBLY W/GASKET	232683
42	101990-01-714	EA	GASKET-MICROSWITCH	230877
44	098668-21-700	EA	SWITCH-MICRO-W/O FLAG 3 1/4"	232261
46	139980-04-702	EA	BLOWER ASSEMBLY/ROOM AIR	390740BK
47	098668-01-711	EA	WHEEL-BLOWER, ROOM AIR	350129
48	139980-01-709	EA	ORFICE RING	390696
50	139980-01-710	EA	SWITCH - ON/OFF	232351
52	139980-01-711	EA	PANEL ASSEMBLY-MODULE BD	101663
53	139980-01-712	EA	INSULATOR - MODULE BD	070807
54	098668-22-705	EA	MODULE BD W/RELAY TIME DELAY	520820
55	139980-01-713	EA	CAP/INSULATOR-MODULE BD	070973
57	139980-01-714	EA	BUSHING - UNIVERSAL	070362
58	139980-01-715	EA	BUSHING - STRAIN RELIEF	231809
59	098668-01-716	EA	GASKET-FIREWALL,CHAMBER SIDE	070808
61	139980-04-703	EA	CHAMBER ASSEMBLY FINAL	021150BK
62	098668-22-706	EA	SWITCH/LIMIT - 195 TRIP TEMP	232505
66	098668-01-713	EA	TUBE ASSEMBLY, INTAKE	051248

CONTACT WINNEBAGO PART SALES FOR UNLISTED COMPONENTS

HEATING & A/C GROUP (CONTINUED) CENTRAL

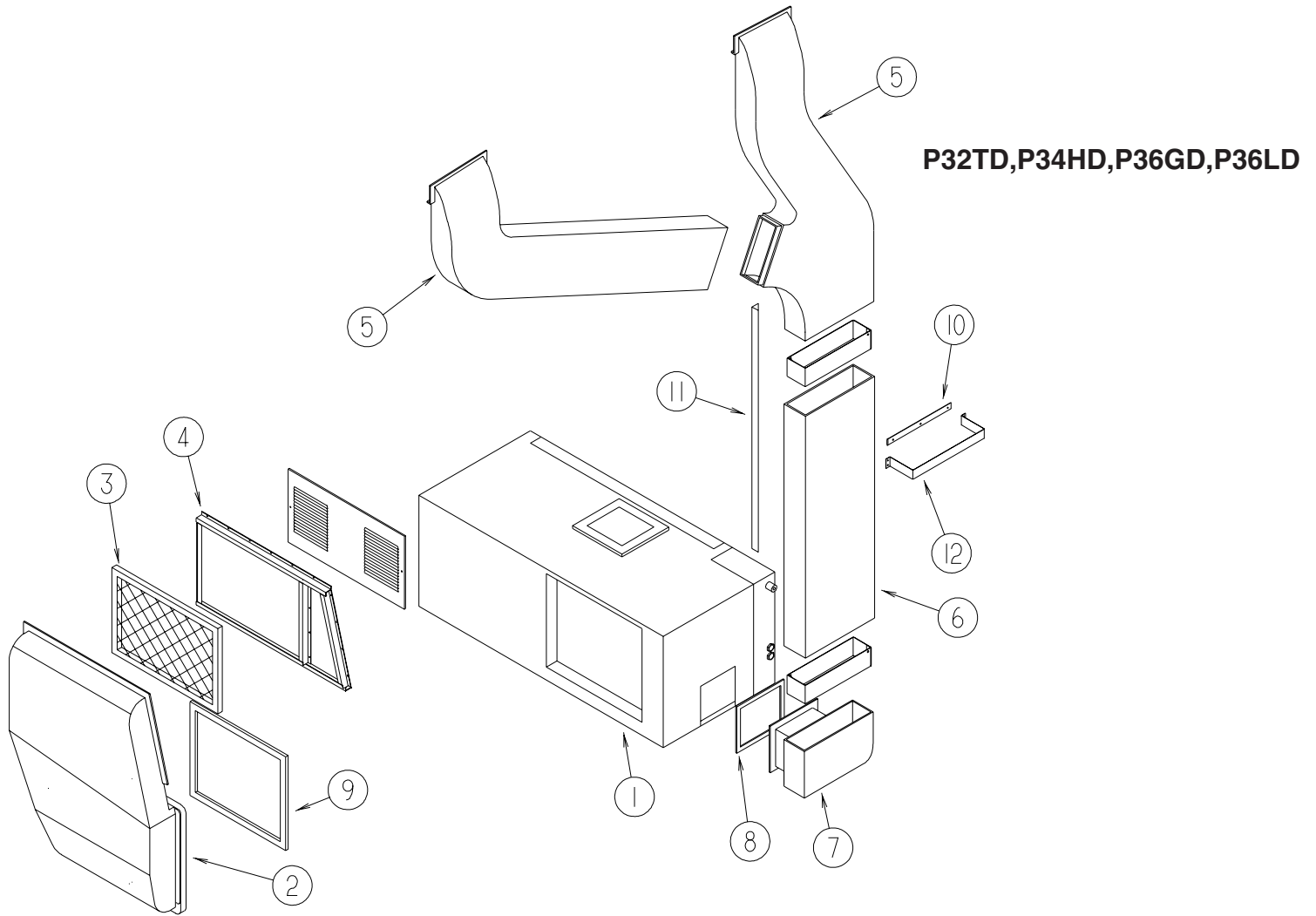

KEY	PART NUMBER	U/M	DESCRIPTION
1*	105620-11-000	EA	A/C CENTRAL PACKAGE - RIGHT HAND POWER SAVER/LARGE BLOWER
2	135036-01-000	EA	DUCT - CENTRAL AIR - RETURN
2	105290-01-000	EA	INSULATION - AIR POCKET W/FOIL
3	109050-02-000	EA	FILTER - FIBERGLASS - 1" X 14" X 20"
4	129604-01-KQ0	EA	FRAME - A/C FILTER
5	M09204-01-000	EA	DUCT/AC - UPPER RIGHT HAND & LEFT HAND
	128862-01-000	EA	DUCT/AIR - UPPER LEFT HAND
	128868-01-000	EA	DUCT/AIR - UPPER RIGHT HAND
5	105290-01-000	EA	INSULATION - AIR POCKET W/FOIL
6	117870-03-01A	EA	PLENUM - A/C
7	P28855-01-000	EA	DUCT/CENTRAL AIR - LOWER
7	105290-01-000	EA	INSULATION - AIR POCKET W/FOIL
8	134588-02-000	EA	GASKET - DUCT - 6.4" X 7.4" IS - 8.3" X 9.4" OS
9	134588-01-000	EA	GASKET - DUCT - 15.5" X 18.2" IS - 17.4" X 20.2" OS
10	115886-11-02A	EA	RETAINER - SIDEWALL - BRIGHT WHITE - 11.8"
11	130262-01-000	EA	PROTECTOR - CORNER SAVER - .7" X .7" X 48"
12	129047-01-02B	EA	STRAP/MOUNTING - AIR DUCT - E-COATED
	120134-01-02A	EA	REGISTER - W/DAMPER - 4" PIPE/7" O.D. FACE - WHITE
*	105620-15-000	EA	THERMOSTAT - FURNACE/HEAT PUMP

*COMPONENT PARTS LISTED LATER IN THIS GROUP

HEATING & A/C GROUP (CONTINUED)
CENTRAL (CONTINUED)

P39QD,P39WD

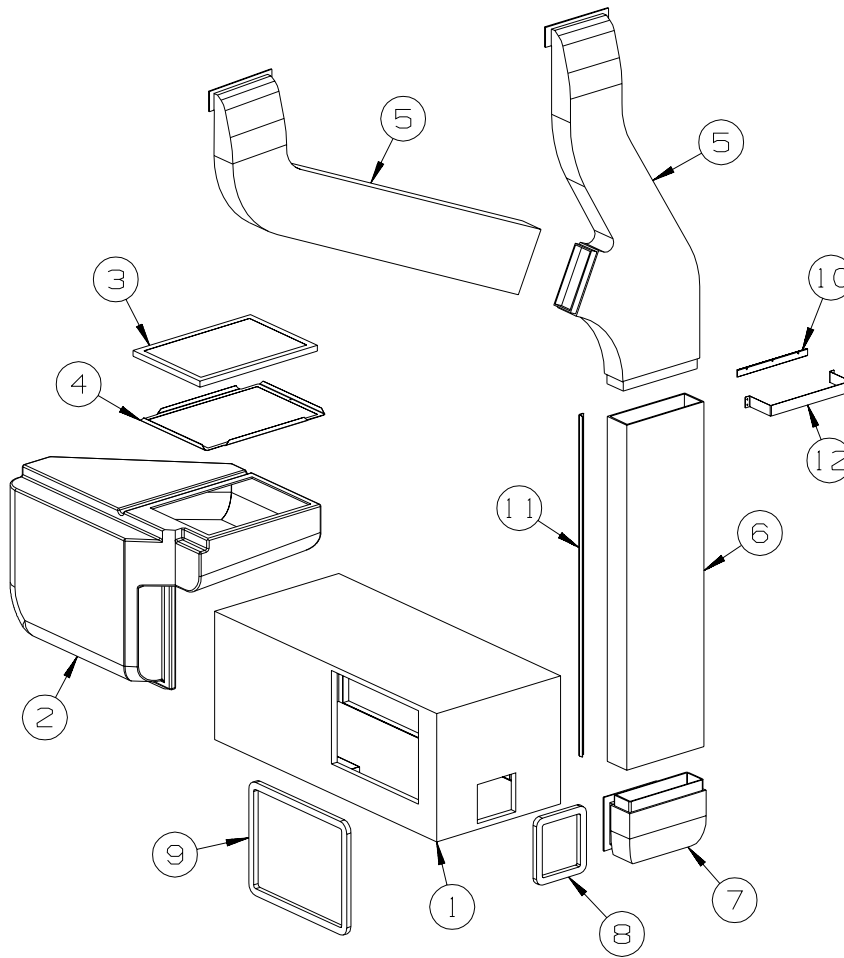

KEY	PART NUMBER	U/M DESCRIPTION
1*	105620-12-000	EA A/C - CONTROL PACK RIGHT HAND/HEAT PUMP - 12,000BTU COMP
2	140289-01-01A	EA DUCT - CENTRAL AIR RETURN
2	105290-01-000	EA INSULATION - AIR POCKET W/FOIL
3	109050-02-000	EA FILTER - FIBERGLASS - 1" X 14" X 20"
4	139757-01-02B	EA PANEL - TRAY - A/C FILTER - E-COATED
5	M09204-01-000	EA DUCT/AC - UPPER RIGHT HAND & LEFT HAND
	128862-01-000	EA DUCT/AIR - UPPER LEFT HAND
	128868-01-000	EA DUCT/AIR - UPPER RIGHT HAND
5	105290-01-000	EA INSULATION - AIR POCKET W/FOIL
6	117870-10-01A	EA PLENUM - A/C - 48.5"
7	P28855-01-000	EA DUCT/CENTRAL AIR - LOWER
7	105290-01-000	EA INSULATION - AIR POCKET W/FOIL
8	134588-02-000	EA GASKET - DUCT - 6.4" X 7.4" IS - 8.3" X 9.4" OS
9	134588-04-000	EA GASKET - DUCT - 13.9" X 18.2" IS - 15.9" X 20.2" OS
10	115886-11-02A	EA RETAINER - SIDEWALL - BRIGHT WHITE - 11.8"
11	130262-01-000	EA PROTECTOR - CORNER SAVER - .7" X .7" X 48"
12	129047-01-02B	EA STRAP/MOUNTING - AIR DUCT - E-COATED
	120134-01-02A	EA REGISTER - W/DAMPER - 4" PIPE/7" O.D. FACE - WHITE
*	105620-15-000	EA THERMOSTAT - FURNACE/HEAT PUMP

***COMPONENT PARTS LISTED LATER IN THIS GROUP**

HEATING & A/C GROUP (CONTINUED)

COMPONENT PARTS FOR CENTRAL

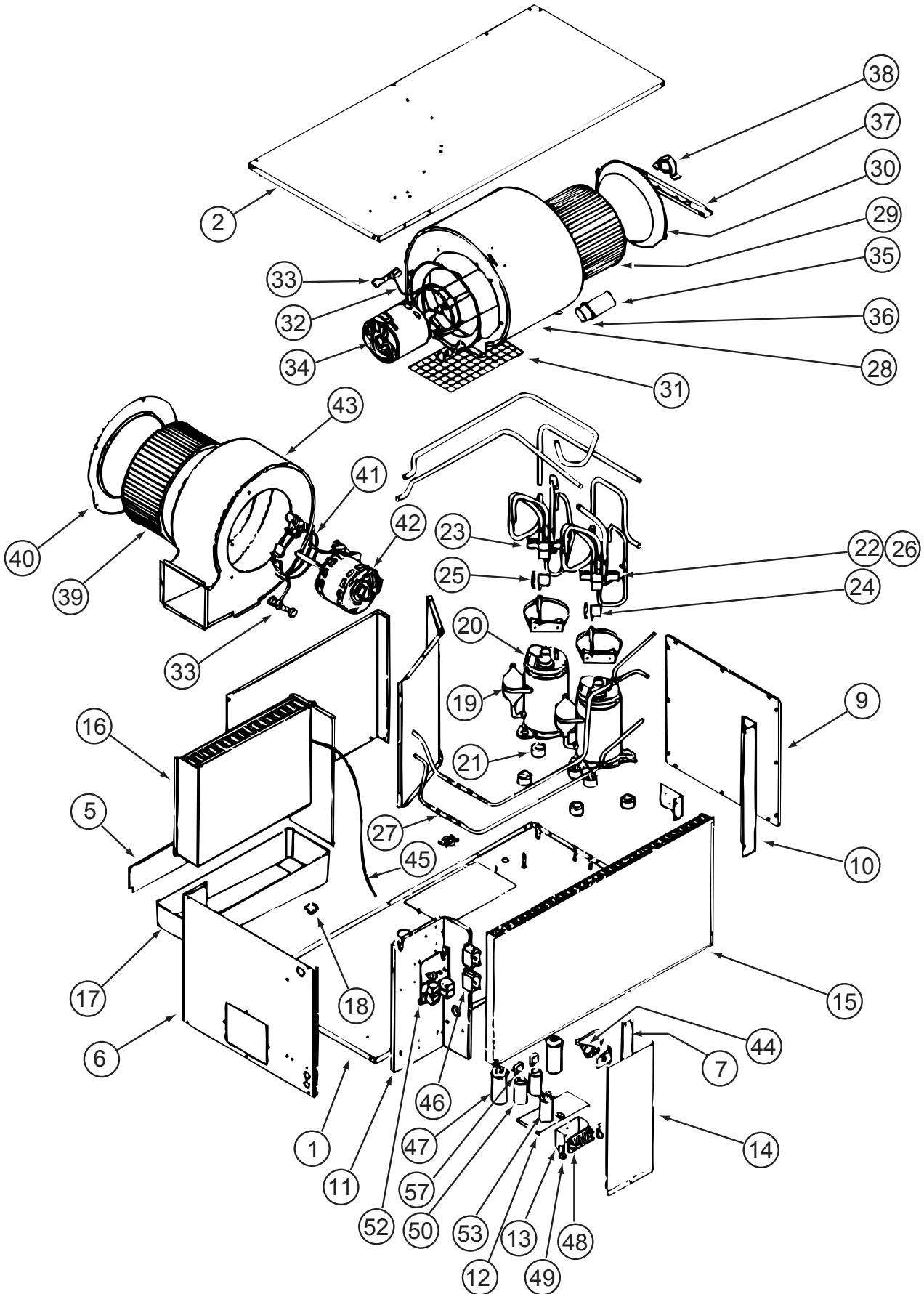

105620-12-000

HEATING & A/C GROUP (CONTINUED)
COMPONENT PARTS FOR CENTRAL A/C SYSTEM (CONTINUED)

105620-12-000 (CONTINUED)

KEY	PART NUMBER	U/M	DESCRIPTION	VENDOR NO.
15	105620-12-701	EA	COIL - CONDENSER	1452-1621
16	105620-12-702	EA	COIL - EVAPORATOR	1452A1611
17	105620-10-709	EA	DRAIN PAN	6636-304
18	105620-12-703	EA	VALVE - DRAIN	6795-200
19	105620-12-704	EA	COMPRESSOR	1450-2149
21	105620-01-706	EA	MOUNTING PKG.,COMP., 3 PER	6759-3081
22	105620-12-706	EA	REVERSING VALVE ASSEMBLY #1	6535A533
23	105620-12-707	EA	REVERSING VALVE ASSEMBLY #2	6535-5321
24	105620-12-708	EA	COIL - SOLENOID	1460-1081
25	105620-12-709	EA	WIRE HARNESS-REVERSING VALVE	6536-111
26	105620-12-710	EA	VALVE - REVERSE ONLY	1454A350
27	105620-12-711	EA	RESTRICTOR - BY FLOW	1454-2521
28	105620-12-712	EA	BLOWER HOUSING/OUTSIDE AIR	6536-515
29	105620-01-713	EA	WHEEL-BLOWER/OUTSIDE AIR	1472-1011
30	105620-01-714	EA	VENTURI-BLOWER/OUTSIDE AIR	6795A150
32	105620-01-715	EA	MOUNT-BLOWER/OUTSIDE AIR	6795A3011
34	105620-10-721	EA	MOTOR/BLOWER-8 3/4" SHAFT	1468A3029
35	105620-01-718	EA	CAPACITOR-FAN, 12.5 MFD/370V	1499-5631
37	105620-12-713	EA	BRACKET/BEARING-O/S AIR BLWR	6536-514
38	105620-10-701	EA	BEARING/PILLOW BLOCK-O/S AIR	6536-3011
39	105620-12-714	EA	WHEEL - BLOWER/INSIDE AIR	1472-1121
40	105620-12-715	EA	BLOWER VENTURI/INSIDE AIR	6535A287
41	105620-01-723	EA	MOUNT-BLOWER MOTOR - I/S AIR	6795-3021
42	105620-12-716	EA	BLOWER MTR/IN AIR/REVERSIBLE	1468-3219
43	105620-12-717	EA	BLOWER HOUSING/INSIDE AIR	6535A589
44	105620-12-718	EA	SWITCH ASSM. - HIGH PRESSURE	6535-5291
45	105620-12-719	EA	COIL SENSOR	7330A3231
46	105620-01-729	EA	RELAY-COMPRESSOR -4 TERMINAL	1460-1131
48	105620-01-738	EA	BOARD-TERMINAL, HIGH VOLTAGE	6795-315
51	105620-10-705	EA	PTCR (START DEVICE) - W/CAP.	8333A9021
52	105620-12-720	EA	KIT-CIRCUIT BD (6535-SERIES)	6535-3209
52	105620-12-721	EA	CIRCUIT BD(6535 A SERIES)	6535-3201
53	093763-01-704	EA	CAPACITOR-FAN	1499-5461
	105620-10-720	EA	FUSE/BUSS(8AMP/250V) 2 PKG	6535-3081
			CONTACT WINNEBAGO PART SALES FOR UNLISTED COMPONENTS	

105620-15-000

KEY	PART NUMBER	U/M	DESCRIPTION	VENDOR NO.
	105620-15-700	EA	FUSE/BUSS (2AMP/250V) 3 PER PK	8330-3343

INTERIOR FINISH GROUP

MOLDINGS & TRIMS

PORTSMOUTH OAK

CONCERT CHERRY

WASHED MAPLE

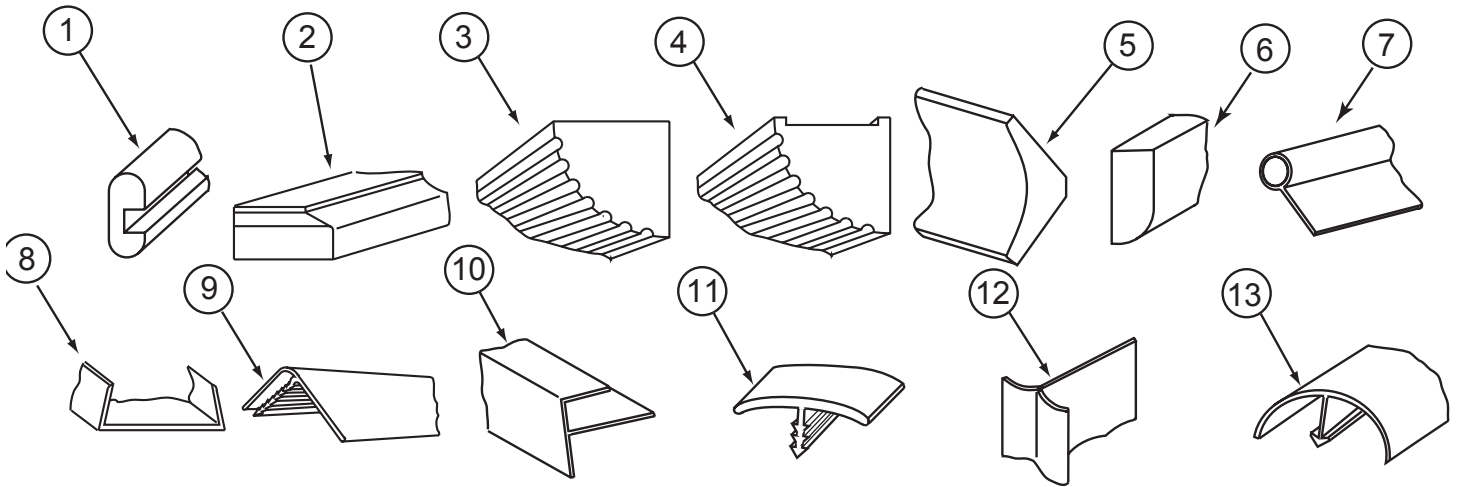

KEY	PART NUMBER	U/M	DESCRIPTION
1	M09412-62-N42	EA	MOLDING/SHELF EDGE - W/.4" NOTCH - PORTSMOUTH II - PORTSMOUTH OAK
1	M09412-62-M62	EA	MOLDING/SHELF EDGE - W/.4" NOTCH - WASHED MAPLE
1	M09412-62-M52	EA	MOLDING/SHELF EDGE - W/.4" NOTCH - CHERRY IV - CONCERT CHERRY
2	P34052-01-N75	EA	TRIM/TABLE - 29.7" - PORTSMOUTH OAK
2	P34052-01-M84	EA	TRIM/TABLE - 29.7" - WASHED MAPLE
2	P34052-01-M52	EA	TRIM/TABLE - 29.7" - SALEM CHERRY - CONCERT CHERRY
2	P34052-02-N47	EA	TRIM/TABLE - 24" - PORTSMOUTH OAK
2	P34052-02-M84	EA	TRIM/TABLE - 24" - WASHED MAPLE
2	P34052-02-M52	EA	TRIM/TABLE - 24" - SALEM CHERRY - CONCERT CHERRY
3	Y00070-22-438	EA	MOLDING/FLUTED - MAPLE - 96" - WASHED MAPLE
3	Y00070-32-438	EA	MOLDING/FLUTED - CHERRY - 96" - CONCERT CHERRY
3	Y00070-42-438	EA	MOLDING/FLUTED - OAK - 96" - PORTSMOUTH OAK
4	Y00071-22-438	EA	MOLDING/FLUTED - W/NOTCH - MAPLE - 96" - WASHED MAPLE
4	Y00071-32-438	EA	MOLDING/FLUTED - W/NOTCH - CHERRY - 96" - CONCERT CHERRY
4	Y00071-42-438	EA	MOLDING/FLUTED - W/NOTCH - OAK - 96" - PORTSMOUTH OAK
5	Y00074-22-438	EA	MOLDING/CROWN - VINYL WRAPPED - MAPLE - 96" - WASHED MAPLE
5	Y00074-62-438	EA	MOLDING/CROWN - VINYL WRAPPED - CONCERT CHERRY - 96" - CONCERT CHERRY
5	Y00074-72-438	EA	MOLDING/CROWN - VINYL WRAPPED - PORTSMOUTH OAK - 96" - PORTSMOUTH OAK
6	Y00086-22-438	EA	MOLDING - VINYL WRAP - 96" - WASHED MAPLE
6	Y00086-62-438	EA	MOLDING - VINYL WRAP - 96" - CONCERT CHERRY
6	Y00086-72-438	EA	MOLDING - VINYL WRAP - 96" - PORTSMOUTH OAK
7	009767-12-000	FT	WELTING - ANTIQUE WHITE
8	009778-25-000	FT	U-CHANNEL - 1" - BEIGE ILLUSION
8	009778-27-000	FT	U-CHANNEL - 1" - WASHED MAPLE
8	009778-30-000	FT	U-CHANNEL - 1" - VILLAGE OAK
8	009778-32-000	FT	U-CHANNEL - 1" - PORTSMOUTH OAK
8	009778-34-000	FT	U-CHANNEL - 1" - CONCERT CHERRY
9	009809-23-000	EA	MOLDING - CORNER - OUTSIDE - 1" X 84" - MODERN IVORY
9	009809-30-000	EA	MOLDING - CORNER - OUTSIDE - 1" X 84" - BEIGE ILLUSION
9	009809-32-000	EA	MOLDING - CORNER - OUTSIDE - 1" X 84" - PORTSMOUTH OAK
9	009809-33-000	EA	MOLDING - CORNER - OUTSIDE - 1" X 84" - CONCERT CHERRY
10	009812-24-000	EA	MOLDING - CORNER - 1/2" W/1/4"CHAN X 84" - IVORY PLASTIC
10	009812-31-000	EA	MOLDING - CORNER - 1/2" W/1/4"CHAN X 84" - BEIGE ILLUSION
10	009812-33-000	EA	MOLDING - CORNER - 1/2" W/1/4"CHAN X 84" - WASHED MAPLE
10	009812-34-000	EA	MOLDING - CORNER - 1/2" W/1/4"CHAN X 84" - VW LIGHT GRAY
10	009812-35-000	EA	MOLDING - CORNER - 1/2" W/1/4"CHAN X 84" - PORTSMOUTH OAK
10	009812-36-000	EA	MOLDING - CORNER - 1/2" W/1/4"CHAN X 84" - CONCERT CHERRY
11	009815-10-000	FT	MOLDING-T - W/EDGE LIP - 3/4" FACE - BEIGE ILLUSION
12	022992-11-000	FT	MOLDING - REVERSE COVE - T-SHAPED - IVORY
12	022992-14-000	FT	MOLDING - REVERSE COVE - T-SHAPED - BRIGHT WHITE
12	022992-15-000	FT	MOLDING - REVERSE COVE - T-SHAPED - VW GRAY
13	042357-25-000	EA	MOLDING - CORNER - RADIUS/PLASTIC - WASHED MAPLE

INTERIOR FINISH GROUP (CONTINUED)
MOLDINGS & TRIMS (CONTINUED)

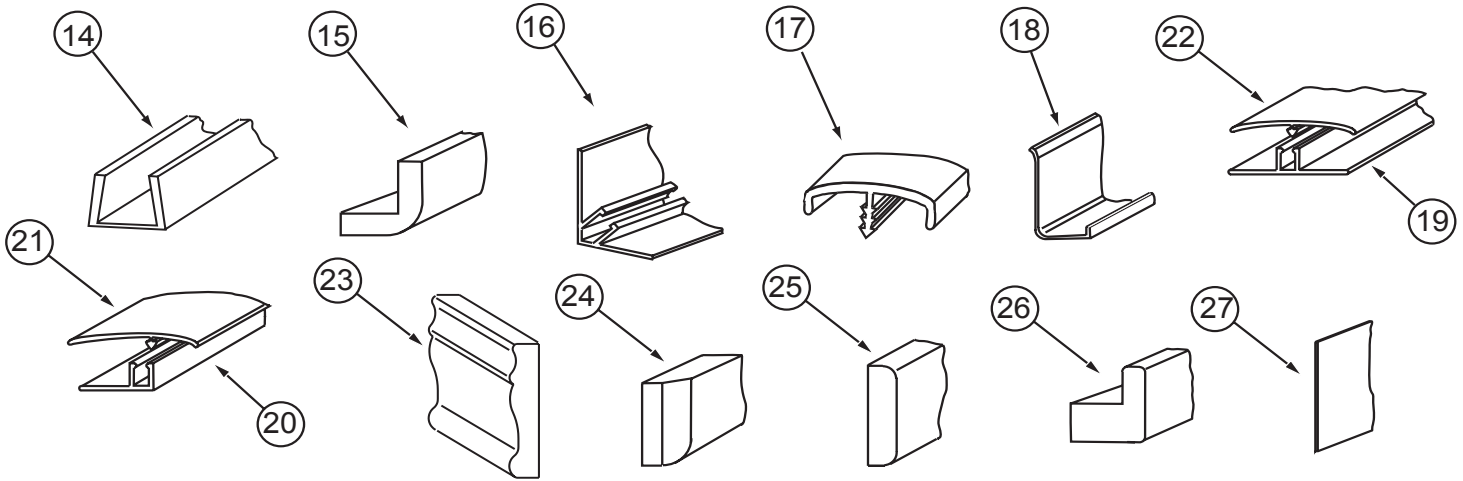

KEY	PART NUMBER	U/M	DESCRIPTION
14	070504-18-000	FT	U-CHANNEL - PLASTIC - .13" X 96" - IVORY
14	070504-35-000	FT	U-CHANNEL - PLASTIC - .13" X 72" - IVORY
14	070504-42-000	FT	U-CHANNEL - PLASTIC - .13" X 84" - BEIGE ILLUSION
14	070504-43-000	FT	U-CHANNEL - PLASTIC - .9" X 96" - BEIGE ILLUSION
14	070504-50-000	FT	U-CHANNEL - PLASTIC - .13" X 96" - WASHED MAPLE
14	070504-54-000	FT	U-CHANNEL - PLASTIC - .9" X 96" - VILLAGE OAK
14	070504-57-000	FT	U-CHANNEL - PLASTIC - .13" X 84" - PORTSMOUTH OAK
14	070504-58-000	FT	U-CHANNEL - PLASTIC - .9" X 84" - PORTSMOUTH OAK
14	070504-60-000	FT	U-CHANNEL - PLASTIC - .13" X 84" - CONCERT CHERRY
14	070504-61-000	FT	U-CHANNEL - PLASTIC - .9" X 84" - CONCERT CHERRY
15	080176-08-000	EA	CAP - CORNER - RADIUS MOLDING - PLASTIC - WASHED MAPLE
16	081521-02-007	EA	MOUNT - METAL MOLDING - F/RADIUS CORNER MOLDING - 151.5"
17	083620-09-000	FT	MOLDING-T - W/EDGE LIP - 7/8" FACE - MODERN IVORY
17	083620-15-000	FT	MOLDING-T - W/EDGE LIP - 7/8" FACE - BEIGE ILLUSION
17	083620-19-000	FT	MOLDING-T - W/EDGE LIP - 7/8" FACE - WASHED MAPLE
17	083620-20-000	FT	MOLDING-T - W/EDGE LIP - 7/8" FACE - PORTSMOUTH OAK
17	083620-21-000	FT	MOLDING-T - W/EDGE LIP - 7/8" FACE - CONCERT CHERRY
18	085746-04-000	FT	TRIM-J - CARPET 1.2" X .5" ANGLE - 10' LONG - OFF WHITE
19	086229-01-000	EA	RETAINER - BATTEN - .75" X 92.1" - ANY COLOR
20	086229-11-000	EA	RETAINER - OFFSET - 97"
21	086229-12-000	EA	BATTEN - 1.5" OFFSET X 96.8" - MODERN IVORY
21	086229-21-000	EA	BATTEN - 1.5" X 83.9" OFFSET - WHITE
22	086229-20-000	EA	BATTEN - 1" X 96" - BEIGE
23	100182-10-J70	EA	TRIM - CHAIR RAIL - 2.5" X 8' EACH - WOOD - WASHED MAPLE
23	100182-10-N47	EA	TRIM/RAIL - PORTSMOUTH OAK
23	100182-10-P85	EA	TRIM - CHAIR RAIL - 2.5" X 8' EACH - WOOD - CONCERT CHERRY
24	100659-30-N75	EA	MOLDING - TRIM - PORTSMOUTH OAK
24	100659-30-N74	EA	MOLDING - TRIM - CHERRY - CONCERT CHERRY
24	100659-30-M84	EA	MOLDING-TRIM,VINYL FLOOR - WASHED MAPLE
25	100818-01-08A	EA	MOLDING - VINYL WRAPPED - 1.6" X .4" X 84"-WASHED MAPLE
25	100818-01-12A	EA	MOLDING - VINYL WRAPPED - 1.6" X .4" X 84"-PORTSMOUTH OAK
25	100818-01-13A	EA	MOLDING - VINYL WRAPPED - 1.6" X .4" X 84" - CHERRY - CONCERT CHERRY
26	100819-01-08A	EA	MOLDING - VINYL WRAPPED-L-SHAPED-1.5"X1.5"X84"- WASHED MAPLE
26	100819-01-12A	EA	MOLDING - VINYL WRAPPED-L-SHAPED - 1.5" X 1.5" X 84" - OAK - PORTSMOUTH OAK
26	100819-01-13A	EA	MOLDING - VINYL WRAPPED-L-SHAPED-1.5"X1.5"X84" - CONCERT CHERRY
27	101957-01-06A	EA	EXTRUDED - PLASTIC - WASHED MAPLE

INTERIOR FINISH GROUP (CONTINUED)
MOLDINGS & TRIMS (CONTINUED)

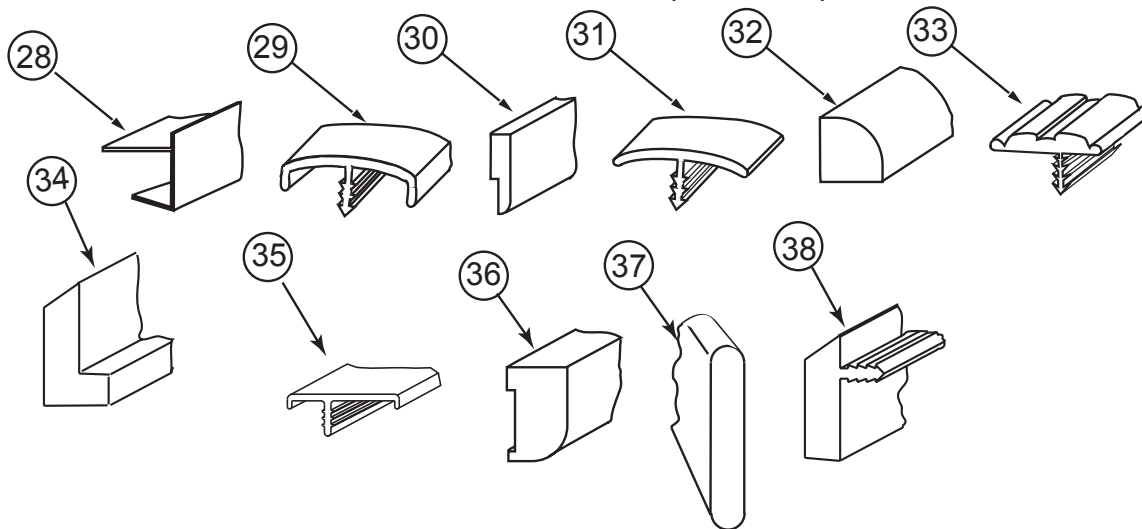

KEY	PART NUMBER	U/M	DESCRIPTION
28	103186-01-07A	FT	MOLDING/PLASTIC - 3/8" U-CHANNEL-3/4"FACE - BEIGE ILLUS 8'
28	103186-01-08A	FT	MOLDING/PLASTIC - 3/8" U-CHANNEL-3/4"FACE-WASHED MAPLE 8' - WASHED MAPLE
28	103186-01-09A	FT	MOLDING/PLASTIC - 3/8" U-CHAN'L-3/4"FACE-PORTSMOUTH OAK 8' - PORTSMOUTH OAK
28	103186-01-10A	FT	MOLDING/PLASTIC-3/8" U-CHAN'L-3/4"FACE-CONCERT CHERRY 8' - CONCERT CHERRY
28	103186-02-07A	FT	MOLDING/PLASTIC-1" U-CHAN'L-1 3/8"FACE-BEIGE ILLUSION - 8'
28	103186-02-08A	FT	MOLDING/PLASTIC - 1" U-CHANNEL-1 3/8"FACE-WASHED MAPLE 8' - WASHED MAPLE
28	103186-02-09A	FT	MOLDING/PLASTIC - 1" U-CHAN'L-1 3/8"FACE-PORTSMOUTH OAK 8' - PORTSMOUTH OAK
28	103186-02-10A	FT	MOLDING/PLASTIC - 1" U-CHAN'L-1 3/8"FACE-CONCERT CHERRY 8' - CONCERT CHERRY
29	104676-02-06A	FT	MOLDING-T - W/EDGE LIP - 11/16" FACE - WASHED MAPLE
29	104676-02-08A	FT	MOLDING-T - W/EDGE LIP - 11/16" FACE - PORTSMOUTH OAK
29	104676-02-09A	FT	MOLDING-T - W/EDGE LIP - 11/16" FACE - CONCERT CHERRY
30	105004-01-08A	EA	MOLDING - VINYL WRAPPED - 1" X 96" - WASHED MAPLE
30	105004-01-12A	EA	MOLDING - VINYL WRAPPED 1" X 96" - PORTSMOUTH OAK
30	105004-01-13A	EA	MOLDING - VINYL WRAPPED 1" X 96" - CONCERT CHERRY
31	105709-02-000	FT	MOLDING-T - W/EDGE LIP - 3/4" FACE - BEIGE ILLUSION
32	109410-01-P25	EA	MOLDING - TRIM - 8' - BLACK CHERRY/CHERRY IV - CONCERT CHERRY
32	109410-01-N75	EA	MOLDING - TRIM - 8' - PORTSMOUTH OAK
32	109410-01-J70	EA	MOLDING - TRIM - 8' - WHITE MAPLE/WASHED MAPLE
33	109736-02-01A	FT	MOLDING-T/OFFSET - W/EDGE LIP - 1" FACE - NAT OAK/BRASS
34	111235-01-H56	EA	MOLDING - COUNTERTOP - 1.4" X 8' - WHITE MAPLE - UNSTAINED - WASHED MAPLE
34	111235-01-N42	EA	MOLDING - COUNTERTOP - 1.4" X 8' - OAK - UNSTAINED - PORTSMOUTH OAK
34	111235-01-P79	EA	MOLDING - COUNTERTOP - 1.4" X 8' - CONCERT CHERRY
35	119520-01-01A	FT	MOLDING-T/OFFSET - W/EDGE LIP - 1"FACE - OFF WHITE
35	119520-01-02A	FT	MOLDING-T/OFFSET - W/EDGE LIP - 1"FACE - CONCERT CHERRY
35	119520-01-03A	FT	MOLDING-T/OFFSET - W/EDGE LIP - 1"FACE - WASHED MAPLE
35	119520-01-04A	FT	MOLDING-T/OFFSET - W/EDGE LIP - 1"FACE - PORTSMOUTH OAK
35	119520-02-01A	FT	MOLDING-T/OFFSET - W/EDGE LIP - 1"FACE
36	126204-D2-134	EA	MOLDING - VINYL WRAPPED - .7" X 1.6" X 84" - WASHED MAPLE
36	126204-F2-134	EA	MOLDING - VINYL WRAPPED - .7" X 2.5" X 84" - WASHED MAPLE
36	137887-D2-134	EA	MOLDING - VINYL WRAPPED - .7" X 1.6" X 96" - CHERRY - CONCERT CHERRY
36	137887-F2-134	EA	MOLDING - VINYL WRAPPED - .7" X 2.5" X 84" - CHERRY - CONCERT CHERRY
36	137887-F2-743	EA	MOLDING - VINYL WRAPPED - .7" X 2.5" X 108" - CHERRY - CONCERT CHERRY
36	137895-D2-134	EA	MOLDING - VINYL WRAPPED - .7" X 1.6" X 84" - PORTSMOUTH OAK
36	137895-F2-134	EA	MOLDING - VINYL WRAPPED - .7" X 2.5" X 84" - PORTSMOUTH OAK
36	137895-F2-743	EA	MOLDING - VINYL WRAPPED - .7" X 2.5" X 108" - PORTSMOUTH OAK
37	127842-01-01A	FT	SEAL - SIGHT SHIELD - 2" BLACK
38	130247-01-05A	FT	MOLDING-T/OFF SET - 1.3" FACE - CONCERT CHERRY
38	130247-01-04A	FT	MOLDING-T/OFF SET - 1.3" FACE - PORTSMOUTH OAK
38	130247-01-02A	FT	MOLDING-T/OFF SET - 1.3" FACE - WASHED MAPLE

INTERIOR FINISH GROUP (CONTINUED)
MOLDINGS & TRIMS (CONTINUED)

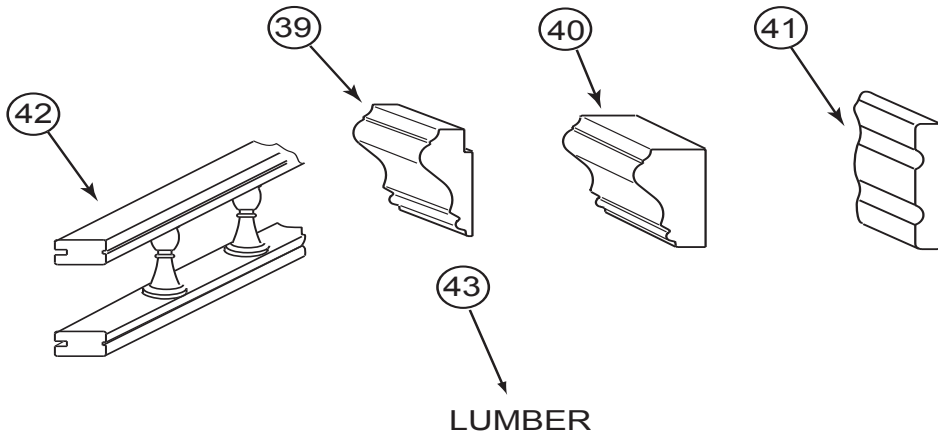

KEY	PART NUMBER	U/M	DESCRIPTION
39	131923-02-04A	FT	MOLDING - PICTURE - OAK - PORTSMOUTH OAK
40	131923-03-03A	FT	MOLDING - CROWN - DIVIDER - WHITE MAPLE - WASHED MAPLE
40	131923-03-02A	FT	MOLDING - CROWN - DIVIDER - CHERRY - CONCERT CHERRY
41	134156-01-03A	EA	MOLDING - VINYL WRAP - .7" X 3.8" X 33.8" - WASHED MAPLE
41	134156-01-08A	EA	MOLDING - VINYL WRAP - .7" X 3.8" X 33.8" - PORTSMOUTH OAK
41	134156-03-03A	EA	MOLDING - VINYL WRAP - .7" X 3.4" X 28.3" - WASHED MAPLE
41	134156-03-07A	EA	MOLDING - VINYL WRAP - .7" X 3.4" X 28.3" - CONCERT CHERRY
41	134156-03-08A	EA	MOLDING - VINYL WRAP - .7" X 3.4" X 28.3" - PORTSMOUTH OAK
41	134156-05-07A	EA	MOLDING - VINYL WRAP - .7" X 3.8" X 34.4" - CONCERT CHERRY
42	137108-01-02A	EA	RAIL - DECORATIVE - SALEM CHERRY - CONCERT CHERRY
42	137108-01-03A	EA	RAIL - DECORATIVE - WASHED MAPLE
42	137108-01-07A	EA	RAIL - DECORATIVE - PORTSMOUTH OAK
43	126205-D2-438	EA	LUMBER - VINYL WRAPPED - .7" X 1.5" X 96" - WASHED MAPLE
43	126205-E2-438	EA	LUMBER - VINYL WRAPPED - .7" X 2" X 96" - WASHED MAPLE
43	126205-F2-438	EA	LUMBER - VINYL WRAPPED - .7" X 2.5" X 96" - WASHED MAPLE
43	126205-G2-438	EA	LUMBER - STAINED - .7" X 3" X 96" - WASHED MAPLE
43	126205-J2-438	EA	LUMBER - VINYL WRAPPED - .7" X 5.5" X 96" - WASHED MAPLE
43	126205-R2-438	EA	LUMBER - LUMBER - VINYL WRAPPED - .7" X 3" X 96" - WASHED MAPLE
43	137885-A2-438	EA	LUMBER - VINYL WRAPPED - .7" X .75" X 96" - CHERRY - CONCERT CHERRY
43	137885-D2-438	EA	LUMBER - VINYL WRAPPED - .7" X 1.5" X 96" - CHERRY - CONCERT CHERRY
43	137885-E2-438	EA	LUMBER - VINYL WRAPPED - .7" X 2" X 96" - CHERRY - CONCERT CHERRY
43	137885-F2-438	EA	LUMBER - VINYL WRAPPED - .7" X 2.5" X 96" - CHERRY - CONCERT CHERRY
43	137885-G2-438	EA	LUMBER - VINYL WRAPPED - .7" X 3" X 96" - CHERRY - CONCERT CHERRY
43	137885-J2-743	EA	LUMBER-018X140X2743 MM VYL - CONCERT CHERRY
43	137885-J2-438	EA	LUMBER - VINYL WRAPPED - .7" X 5.5" X 96" - CHERRY - CONCERT CHERRY
43	137885-R2-438	EA	LUMBER - VINYL WRAPPED - .7" X 3" X 96" - CHERRY - CONCERT CHERRY
43	137894-A2-438	EA	LUMBER - VINYL WRAPPED - .7" X .75 X 96" - PORTSMOUTH OAK
43	137894-D2-438	EA	LUMBER - VINYL WRAPPED - .7" X 1.5" X 96" - PORTSMOUTH OAK
43	137894-E2-438	EA	LUMBER - VINYL WRAPPED - .7" X 2" X 96" - PORTSMOUTH OAK
43	137894-F2-438	EA	LUMBER - VINYL WRAPPED - .7" X 2.5" X 96" - PORTSMOUTH OAK
43	137894-G2-438	EA	LUMBER - VINYL WRAPPED - .7" X 3" X 96" - PORTSMOUTH OAK
43	137894-H2-438	EA	LUMBER - VINYL WRAPPED - .7" X 3.5" X 96" - PORTSMOUTH OAK
43	137894-J2-438	EA	LUMBER - VINYL WRAPPED - .7" X 5.5" X 96" - PORTSMOUTH OAK
43	137894-J2-743	EA	LUMBER - VINYL WRAPPED - .7" X 5.5" X 108" -PORTSMOUTH OAK
43	137894-R2-438	EA	LUMBER - VINYL WRAPPED - .7" X 3" X 96" - PORTSMOUTH OAK
	141260-01-02A	FT	U-CHANNEL - 1" - GRADY BROWN
	141260-01-01A	FT	U-CHANNEL - 1" - VILLAGE OAK

INTERIOR FINISH GROUP (CONTINUED)
PANELING & LAMINATES

KEY	PART NUMBER	U/M	DESCRIPTION
	000885-A1-000	SF	PARTICLE BOARD - 1/2" X 4' X 8' - SALEM CHERRY - 2 SIDED - CONCERT CHERRY
	000885-A2-000	SF	PARTICLE BOARD - 1/2" X 4' X 8' - WASHED MAPLE - 2 SIDED - WASHED MAPLE
	000885-A3-000	SF	PARTICLE BOARD - 3/4" X 4' X 8' - SALEM CHERRY - 2 SIDED - CONCERT CHERRY
	000885-A4-000	SF	PARTICLE BOARD - WASHED MAPLE - 3/4" X 4' X 8' - 2 SIDED - WASHED MAPLE
	000885-A5-000	SF	PARTICLE BOARD - 3/8" X 4' X 8'- WHT PEB EMBOSSED-1 SIDED
	000885-88-000	SF	PART BD-3/8X48/96 - WASHED MAPLE
	000885-89-000	SF	PARTICLE BOARD - 3/8" X 4' X 8' - WASHED MAPLE - 2-SIDED - WASHED MAPLE
	000885-91-000	SF	PARTICLE BOARD - 3/4" X 4' X 8' - WASHED MAPLE - 2-SIDED - WASHED MAPLE
	000885-92-000	SF	PARTICLE BOARD-3/8" X 4' X 8'-PORTSMOUTH OAK-VINYL 1 SIDED - PORTSMOUTH OAK
	000885-93-000	SF	PARTICLE BOARD - 3/8" X 4' X 8' - PORTSMOUTH OAK - 2-SIDED - PORTSMOUTH OAK
	000885-94-000	SF	PARTICLE BOARD - 1/2" X 4' X 8' - PORTSMOUTH OAK - 2-SIDED - PORTSMOUTH OAK
	000885-95-000	SF	PARTICLE BOARD - 3/4" X 4' X 8' - PORTSMOUTH OAK - 2-SIDED - PORTSMOUTH OAK
	000885-96-000	SF	PART BD-PAPER,CONCERT CHERRY, 3/8X48X96 1 SIDE - CONCERT CHERRY
	000885-97-000	SF	PART BD-PAPER,WASHED MAPLE - 3/8X48X96 1 SIDE - WASHED MAPLE
	000885-98-000	SF	PARTICLE BOARD - 3/8" X 4' X 8' - SALEM CHERRY - 2 SIDED - CONCERT CHERRY
	000885-99-000	SF	PARTICLE BOARD - 3/8" X 4' X 8' - WASHED MAPLE - 2-SIDED - WASHED MAPLE
*	057882-04-000	SF	TAMBOUR - 48" X 96" SHEET - UNFINISHED - PORTSMOUTH OAK
*	057882-05-000	SF	TAMBOUR - 48" X 96" SHEET - UNFINISHED - WASHED MAPLE
	057882-06-000	SF	TAMBOUR/ROLL UP - 4' X 8' - CONCERT CHERRY
	074497-39-000	SF	PANELING - WASHED MAPLE - 4' X 8' - WASHED MAPLE
	074497-42-000	SF	PANELING - PORTSMOUTH OAK - 4' X 8' - PORTSMOUTH OAK
	074497-43-000	SF	PANELING - SALEM CHERRY - 4' X 8' - CONCERT CHERRY
	074497-44-000	SF	PANELING - WASHED MAPLE - 4' X 8' - WASHED MAPLE
	076773-14-000	SF	PANELING - 2 SIDED/WASHED MAPLE - 1/8" X 4' X 8' - WASHED MAPLE
	076773-15-000	SF	PANELING - 2 SIDED/PORTSMOUTH OAK - 1/8" X 4' X 8' - PORTSMOUTH OAK
	076773-16-000	SF	PANELING - 2 SIDED/SALEM CHERRY - 1/8" X 4' X 8' - CONCERT CHERRY
	079666-03-000	SF	PANELING - CLOSET - CEDAR - 4' X 7'
	088272-H9-000	SF	PANELING - PEBBLE EMBOSSED - WHITE - 4' X 7'
	088272-K3-000	SF	PANELING - STARLIGHT - 4' X 7' (P84, P85, P28)
	088272-J9-000	SF	PANELING - ALABASTER - 4' X 7' (P86, P87, P29, P88, P89, P30)
	074498-40-000	SF	LAMINATE - PLASTIC - OFF WHITE - 4' X 8'
	074498-82-000	SF	LAMINATE - PLASTIC - WASHED MAPLE - 4' X 8' - WASHED MAPLE
	074498-87-000	SF	LAMINATE - PLASTIC - BEIGE PAMPAS - 5' X 8'
	074498-95-000	SF	LAMINATE - PLASTIC - PORTSMOUTH OAK - 4' X 8' - PORTSMOUTH OAK
	074498-96-000	SF	LAMINATE - PLASTIC - CHERRY - 4' X 8' - CONCERT CHERRY
	076325-73-000	FT	MOLDING - EDGE BAND - .93" X .024" - OFF WHITE
	085284-H4-000	FT	BATT TAPE - ADHESIVE BACKED - DECORATIVE - STARLIGHT (P84, P85, P28)
	085284-G9-000	FT	BATT TAPE - ADHESIVE BACKED - DECORATIVE - ALABASTER (P86, P87, P29, P88, P89, P30)
	088263-H1-000	FT	BATT TAPE - DECORATIVE - STARLIGHT - 8' LONG (P84, P85, P28)
	088263-G9-000	EA	BATT STRIP - DECORATIVE - CORK/ALABASTER - 8' (P86, P87, P29, P88, P89, P30)
	132610-02-07A	FT	WALLPAPER - BORDER - 6 3/4" - SELF-ADHESIVE (P84, P85, P28)
	132610-05-17A	FT	WALLPAPER - BORDER - 7" - SELF-ADHESIVE (P86, P87, P29)
	132610-05-22A	FT	WALLPAPER - BORDER - 7" - SELF-ADHESIVE (P88, P89, P30)

***COMPONENT PARTS LISTED LATER IN THIS GROUP**

INTERIOR FINISH GROUP (CONTINUED)
COMPONENT PARTS FOR PANELING & LAMINATES

057882-04-000

KEY	PART NUMBER	U/M	DESCRIPTION
	057882-04-700	EA	DOOR-TAMBOUR 4'X4' PC WINONA, PART SALES

057882-05-000

KEY	PART NUMBER	U/M	DESCRIPTION
	057882-05-700	EA	DOOR-TAMBOUR 4' X 4' MAPLE, PART SALES

INTERIOR FINISH GROUP (CONTINUED)
ACCESSORIES

KEY	PART NUMBER	U/M	DESCRIPTION
	072852-01-000	EA	DETECTOR - SMOKE - W/9 VOLT BATTERY - US
	072852-02-000	EA	DETECTOR - SMOKE - W/9 VOLT BATTERY - CANADIAN
	125136-02-000	EA	DETECTOR/CO - GAS MODEL - 9 VOLT
	091261-01-000	FT	SLIPNOT - ANTISLIP - 1' WIDE X 12' - BLACK
	096764-02-000	FT	SLIPNOT - ANTISLIP - 1'WIDE (180' ROLLS) - WHITE
	093606-39-000	EA	MIRROR - BEVELED EDGE - 13" X 34"
	093606-43-000	EA	MIRROR - BEVELED EDGE - 7.4" X 12.8"
	113195-17-01A	EA	MIRROR - BEVELED SAFETY GLASS - CLEAR - 16.6" X 26.2"
	131494-03-01A	EA	MIRROR - BEVELED/GLASS - OCTAGON - 1" X 20" X 36"
	133485-01-02A	EA	MIRROR - BEVELED GLASS W/VERTICAL GROOVE - 20" X 20.9"
	133485-02-02A	EA	MIRROR - BEVELED GLASS W/2 VERTICAL GROOVES - 44.9"X 20.9"
	133485-03-02A	EA	MIRROR - BEVELED GLASS W/2 VERTICAL GROOVES - 30" X 20.9"
	140374-36-000	EA	MIRROR - SAFETY GLASS - 20.9" X 25.2"
	094499-03-000	EA	EXTINGUISHER/FIRE - DRY - 10BC - W/GAUGE/BACKET - USA
*	094499-02-000	EA	EXTINGUISHER/FIRE - DRY - 10BC - W/GAUGE - CANADIAN - CANADIAN
	094499-04-000	EA	STRAP - FIRE EXTINGUISHER MOUNTING - METAL
	118718-01-01A	EA	HOLDER/DRINK - COLLAPSIBLE MUG - BLACK PLASTIC
	133831-01-01A	EA	HOLDER - CUP W/THREE CENTERLINE RUBBER FINGERS
	131493-02-05A	EA	PICTURE - DECORATIVE - 13" X 15" - VIOLIN - REFRIGERATOR WALL
	131493-02-12A	EA	PICTURE - DECORATIVE - 13" X 15" - AFRICAN LILY (P84, P85, P28)
	131493-02-13A	EA	PICTURE - DECORATIVE - 13" X 15" - SANDCASTLE (P86, P87, P29)
	131493-02-09A	EA	PICTURE - DECORATIVE - 13" X 15" - MEDITERRANEAN (P88, P89, P30)
	131493-04-02A	EA	PICTURE - DECORATIVE - 16" X 10" - LA CHAMBRE II - QUEEN BEDROOM BACKWALL, P34HD
	132738-01-01A	EA	CLOCK - DIGITAL W/ALARM - 12 VOLT - BLACK
	142631-01-03A	EA	FRAME - MIRROR - 29.5"H X 25.2"W - PORTSMOUTH OAK
	142631-01-01A	EA	FRAME - MIRROR - 29.5"H X 25.2"W - CONCERT CHERRY
	142631-01-02A	EA	FRAME - MIRROR - 29.5"H X 25.2"W - WASHED MAPLE

***COMPONENT PARTS LISTED LATER IN THIS GROUP**

INTERIOR FINISH GROUP (CONTINUED)
COMPONENT PARTS FOR ACCESSORIES

094499-02-000

KEY	PART NUMBER	U/M	DESCRIPTION	VENDOR NO
	094499-01-700	EA	BRACKET MTG. W/PLAS. STRAP	294039

INTERIOR FINISH GROUP (CONTINUED)
FLOOR COVERINGS

KEY	PART NUMBER	U/M	DESCRIPTION
	093486-02-000	SY	CARPET - COMPARTMENT - 72" WIDE - LIGHT GRAY
	096060-H5-000	SY	CARPET - CHARCOAL - INCREMENTS OF 4 SQ YARDS
	096060-K1-000	SY	CARPET - WICKER - INCREMENTS OF 4 SQ YARDS
	139056-09-000	SY	CARPET - WHEAT - 4 SQUARE YARD INCREMENTS (P84, P85, P28)
	139056-12-000	SY	CARPET - BONE - 4 SQUARE YARD INCREMENTS (P86, P87, P29)
	139056-10-000	SY	CARPET - TAUPE - 4 SQUARE YARD INCREMENTS (P88, P89, P30)
	139056-11-000	SY	CARPET - MUSLIN - 4 SQUARE YARD INCREMENTS
	131711-01-06A	EA	TILE/FLOOR - VINYL - 12" X 12" - MUSHROOM

INTERIOR FINISH GROUP (CONTINUED)

HARDWARE

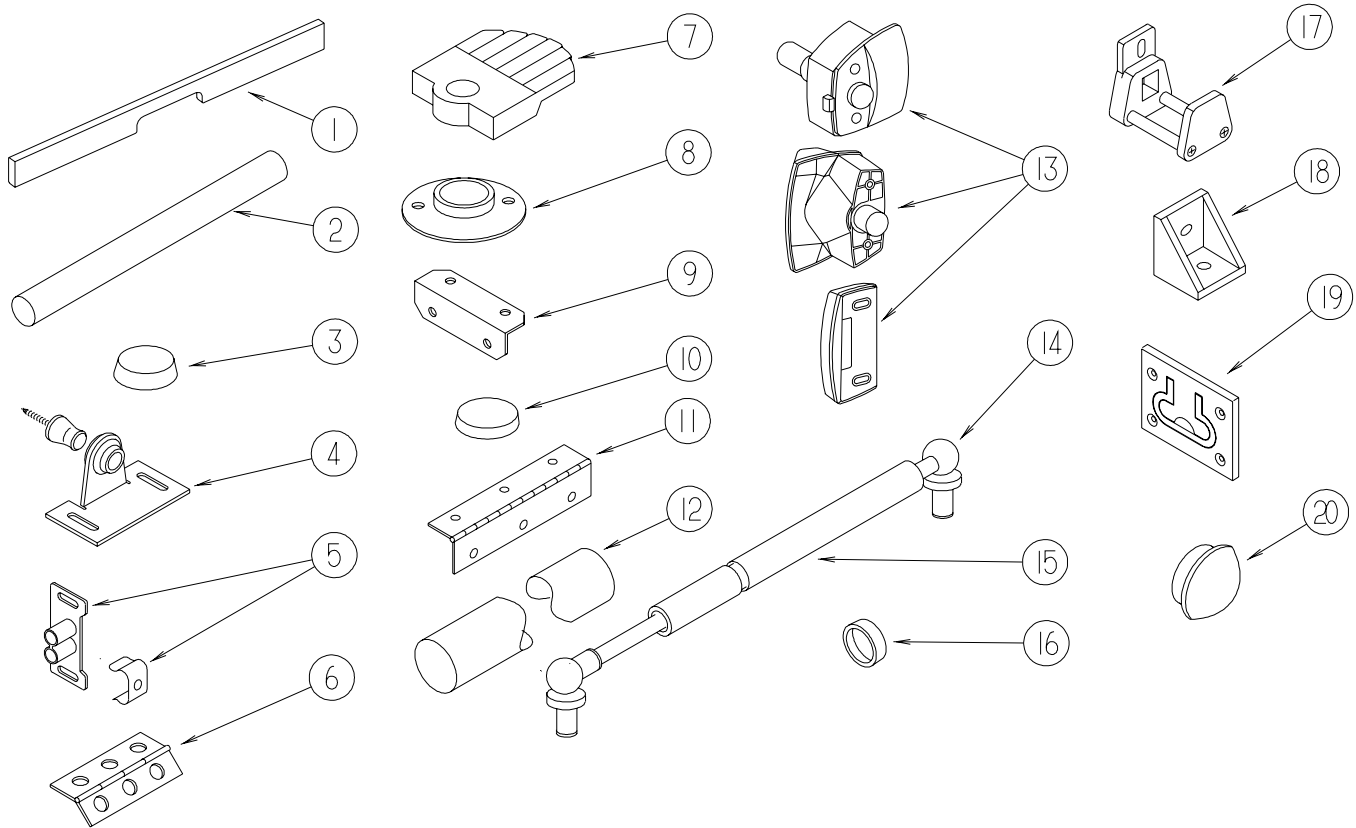

KEY	PART NUMBER	U/M	DESCRIPTION
1	P26866-12-N62	EA	HANDLE - DOOR/TAMBOUR - 14.7" - WASHED MAPLE
1	P26866-12-N63	EA	HANDLE - DOOR/TAMBOUR - 11.6" - CONCERT CHERRY
1	P26866-12-P69	EA	HANDLE - DOOR/TAMBOUR - 11.6" - PORTSMOUTH OAK
2	Y00136-21-218	EA	DOWEL - WOOD - 1" X 4'
3	004354-01-000	EA	BUMPER - RUBBER - .5" DIA - BROWN
4	009013-01-000	EA	CATCH - BULLDOG - MALE/FEMALE
5	009021-01-000	EA	CATCH - GRILLE - NYLON
5	009021-02-000	EA	STRIKE - SPRING STEEL - .68"
6	009059-01-000	EA	HINGE - DOOR - 2" X 1.4" - BRASS
6	009059-02-000	EA	HINGE - DOOR - 2" X 2.7" - BRASS
6	009059-03-000	EA	HINGE - BRASS - 1.75"
7	009089-01-000	EA	CLIP - MIRROR
8	009112-01-000	EA	FLANGE - PLASTIC - 1" CLOTHES ROD - OFF WHITE
9	016604-05-000	EA	BRACE - ANGLE - 2 1/2" - OFF WHITE METAL
9	016604-10-000	EA	BRACE - SEAT ANGLE - 2.5" - BLACK
9	016604-11-000	EA	BRACE - SEAT - ANGLE - 2.5" - CHESTNUT
10	023320-01-000	EA	PAD - FELT 3/8" DIAMETER
11	041389-25-000	EA	HINGE - PIANO - 1 1/2" X 55" - UNPAINTED
12	042438-02-000	EA	DOWEL - WOOD - 2" DIAMETER X 2'
12	042438-06-000	EA	DOWEL - WOOD - CLOTHES ROD - 1.5" X 26"
13	058335-03-000	EA	LATCH W/O LOCK - BATHROOM DOOR BLACK
14	057460-02-000	EA	BALL STUD - F/GAS SPRING .39" - 5/16"-18
15	057460-04-000	EA	SPRING/GAS - BALL STUD STYLE - 120 PI - "SPD6209"
16	057671-01-000	EA	COVER - SCREW - #8 - OFF WHITE
16	057671-15-000	EA	COVER - SCREW - #8 - BRIGHT WHITE
16	057671-16-000	EA	COVER - SCREW - #8 - SOFT WHITE
16	057671-17-000	EA	COVER - SCREW - VW LT GRAY - #8
17	064467-01-000	EA	GUIDE - POCKET - SLIDING DOOR - WALL MOUNTED
18	065740-01-000	EA	BRACE - CABINET/CORNER - PLASTIC
19	072871-01-000	EA	PULL - FLUSH - CHROME
20	074045-08-000	EA	PLUG - OAK - 3/8" DOWEL-1/2" HEAD - SALEM CHERRY - CONCERT CHERRY
20	074045-12-000	EA	PLUG - OAK - 3/8" DOWEL-1/2" HEAD - WASHED MAPLE
20	074045-13-000	EA	PLUG - OAK - 3/8" DOWEL-1/2" HEAD - PORTSMOUTH OAK

INTERIOR FINISH GROUP (CONTINUED)
HARDWARE (CONTINUED)

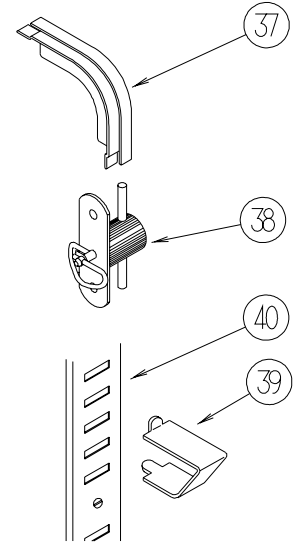
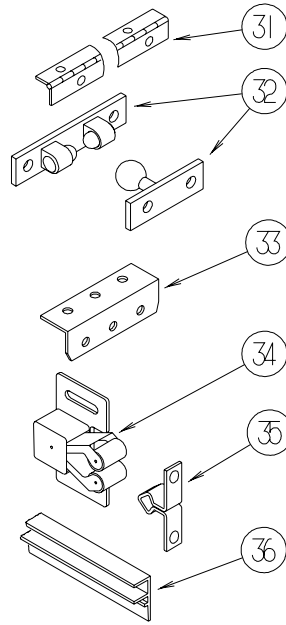
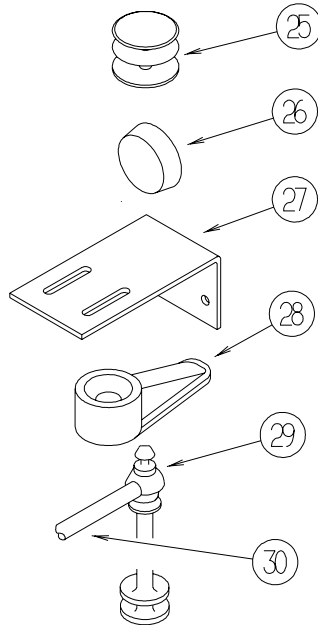
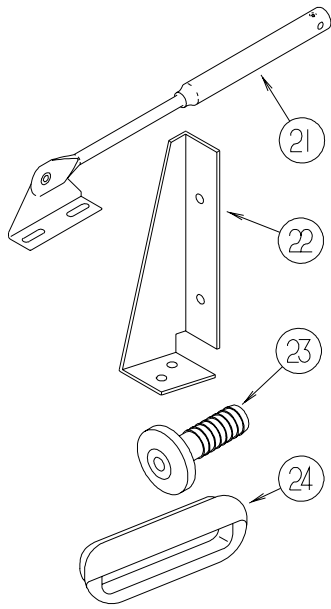

KEY	PART NUMBER	U/M	DESCRIPTION
21	074493-02-000	EA	SUPPORT - PISTON SPRING - CABINET DOOR - 26 LBS
21	074493-03-000	EA	SUPPORT - PISTON SPRING - CABINET DOOR - 12 LBS
21	074493-04-000	EA	SUPPORT - PISTON SPRING - CABINET DOOR - 32 LBS
22	076827-02-000	EA	BRACKET/LEG - 2.9" X 1.8" - TRIANGULAR - LEFT/E-COATED
23	079921-01-000	EA	ROLLER - NYLON - W/STEEL SHAFT - BARBED
24	080736-01-000	EA	PULL - RECESSED - 1.25" X 4" - OAK
25	081114-02-000	EA	CAP - INSERT - ROUND - 1" DIAMETER - WHITE PLASTIC
26	081914-01-000	EA	BUMPER - RUBBER - ROUND - 1/2" DIA. X 1/8" THICK
27	083125-07-000	EA	BRACE - ANGLE/COUCH - 2.5" - OFF WHITE
28	083204-03-000	EA	BUTTON - RETAINING MIRROR 5/16" TIP
29	084070-03-000	EA	POST - END - 2.4" - SHINY BRASS
30	084071-05-000	EA	ROD - BRASS - 15"
30	084071-19-000	EA	ROD - BRASS - 7.1"
30	084071-20-000	EA	ROD - BRASS - 9.8"
30	084071-23-000	EA	ROD - BRASS - 13.1"
30	084071-24-000	EA	ROD - BRASS - 3.8"
30	084071-28-000	EA	ROD - BRASS - 6"
30	084071-30-000	EA	ROD - BRASS - 11.6"
30	084071-31-000	EA	ROD - BRASS - 14.8"
30	084071-33-000	EA	ROD - BRASS - 20.4"
30	084071-34-000	EA	ROD - BRASS - 16.9"
31	084413-01-000	EA	HINGE - 1" X 72" - ALUMINUM - W/HOLES
32	084451-01-000	EA	CATCH & LATCH - 1.7" - BRASS
33	089025-01-000	EA	SUPPORT - SPRING TO BED - ANGLE 1.5" X 11.8"
34	093586-03-000	EA	CATCH - SPRING ROLLER - .377"
34	093586-06-000	EA	CATCH - SPRING ROLLER - .236"
35	093586-04-000	EA	STRIKE - SPRING STEEL - 1.14"
35	093586-05-000	EA	STRIKE - SPRING STEEL - .943"
36	093622-01-000	EA	TRACK - DOOR - TAMBOUR - PLASTIC - 8' LENGTHS
37	093623-01-000	EA	CORNER - TRACK - TAMBOUR DOOR
	097872-04-000	EA	DOWEL - WOOD - 1" DIAMETER X 1.38" LONG - UNFINISHED
38	098196-01-000	EA	LATCH - 1/4 TURN - T-BAR
39	098979-01-000	EA	CLIP - ADJUSTABLE SHELF
40	098980-01-000	EA	PILASTER - ADJUSTABLE SHELF - 18"
40	098980-02-000	EA	PILASTER - ADJUSTABLE SHELF - 12"
40	098980-03-000	EA	PILASTER - ADJUSTABLE SHELF - 9"
40	098980-04-000	EA	PILASTER - ADJUSTABLE SHELF - 48"
40	098980-05-000	EA	PILASTER - ADJUSTABLE SHELF - 15"
40	098980-06-000	EA	PILASTER - ADJUSTABLE SHELF - 24"

INTERIOR FINISH GROUP (CONTINUED)
HARDWARE (CONTINUED)

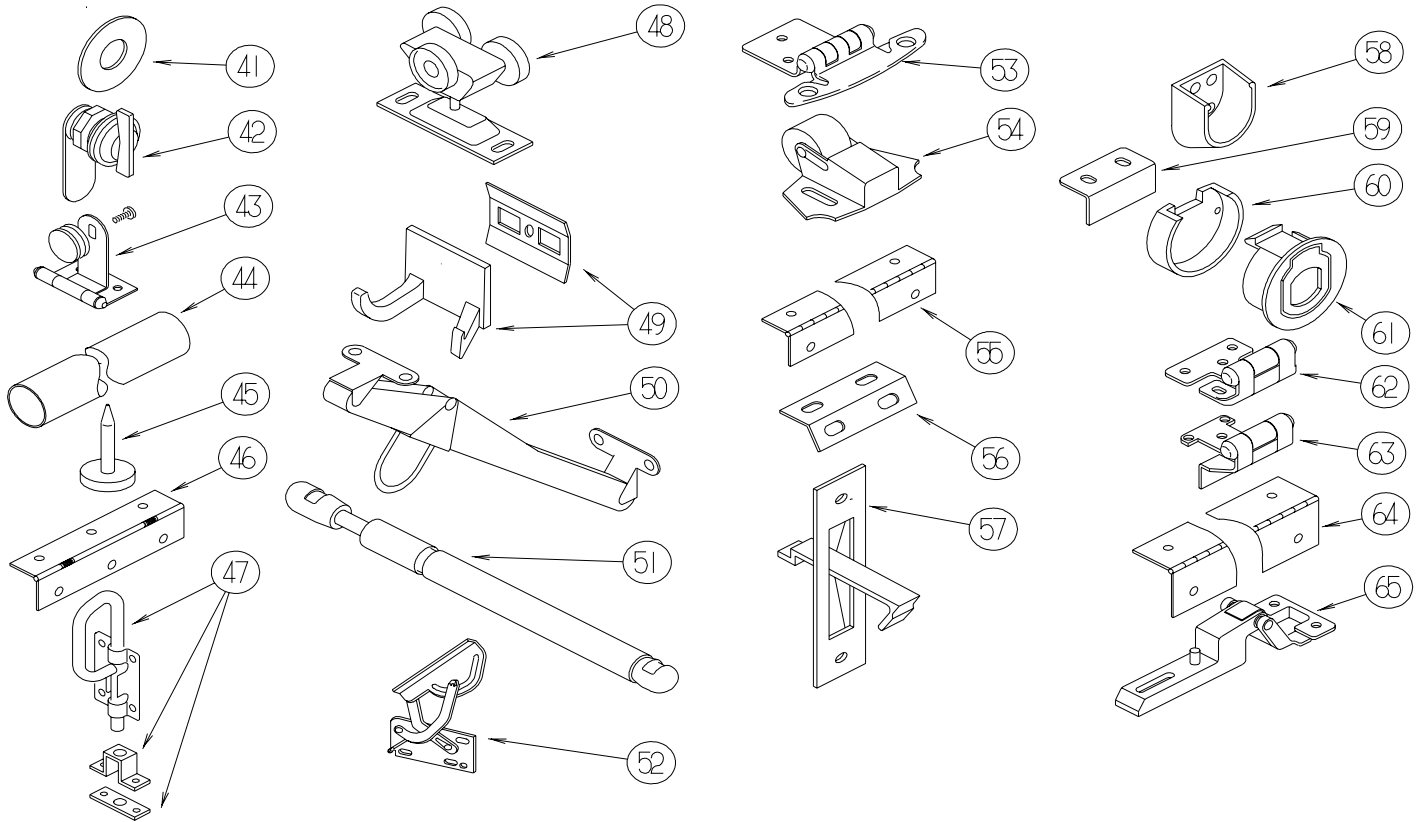

KEY	PART NUMBER	U/M	DESCRIPTION
41	100707-01-000	EA	SPACER - GLASS DOOR - .8" DIA - .3" HOLE - PLASTIC
42	100710-01-01A	EA	LOCK - GLASS DOOR/TWIST TYPE - BRASS
43	100711-01-01A	EA	HINGE - GLASS DOOR
44	102075-06-02A	EA	ROD - SHOWER CURTAIN - 1" OD X 33.5" - SOFT WHITE
44	102075-09-02A	EA	ROD - SHOWER CURTAIN - 3/4"OD X 29.5" - SOFT WHITE
44	102075-16-02A	EA	ROD - SHOWER CURTAIN - 3/4"OD X 34.2" - SOFT WHITE
44	102075-18-02A	EA	ROD - SHOWER CURTAIN - 1" OD X 38.9" - SOFT WHITE
44	102075-20-03A	EA	ROD - SHOWER CURTAIN - 48.8" - MILL
44	102075-21-03A	EA	ROD - SHOWER CURTAIN - 46.1"
45	102194-01-000	EA	GUIDE - PLASTIC - 1" (HEAD/PIN)
46	102920-01-01A	EA	HINGE - SPRING LOADED - BRASS
47	103256-01-000	EA	LATCH COMPLETE (SLIDE)
48	103874-01-000	EA	HANGER - SLIDING DOOR
49	104174-01-000	EA	HOOK - ROBE - DOUBLE
50	104181-01-01A	EA	SUPPORT - LEAF 5.3" EXTENDS TO 7.5" - SAFETY RING - METAL
51	107796-06-000	EA	SPRING/GAS - 12" COMPRESSED/20" EXTENDED - 120 LB.
51	107796-08-000	EA	SPRING/GAS - 11" COMPRESSED/17" EXTENDED - 60 LB
51	107796-15-000	EA	SPRING/GAS - 24" COMPRESSED/40" EXTENDED - 15 LB.
51	107796-16-000	EA	SPRING/GAS - 6.4" COMPRESSED/9.6" EXTENDED - 65 LB.
52	108126-01-000	EA	TRAY HINGE SET (QTY. 2 PER SET)
53	108138-01-000	EA	HINGE - CABINET DOOR - BURNISHED BRASS - Q SERIES (ULTIMATE FREEDOM) ONLY
53	108138-03-000	EA	HINGE - BRIGHT BRASS
54	109403-01-000	EA	CATCH - SINGLE ROLLER - SCREEN DOOR
55	110496-01-01A	EA	HINGE - BRASS
56	111866-01-02A	EA	BRACE - SEAT - ANGLE - OFF WHITE
57	113130-01-01A	EA	PULL - DOOR POCKET
58	113236-01-01A	EA	BRACKET - CLOTHES - ROD
59	113375-02-01A	EA	STRIKE - DOOR - CHROME
60	113375-05-01A	EA	LATCH - SLAM - BACK - .8" THICK
61	113375-06-01A	EA	LATCH - SLAM - FACE - .7" THICK
62	113676-01-01A	EA	HINGE - OVERLAY - VARIABLE - BURNISHED BRASS
63	113677-01-01A	EA	HINGE - SELF CLOSING
64	114278-02-000	EA	HINGE - CONTINUOUS - 3" WIDE
65	114443-01-01A	EA	HINGE - CABINET DOOR

INTERIOR FINISH GROUP (CONTINUED)
HARDWARE (CONTINUED)

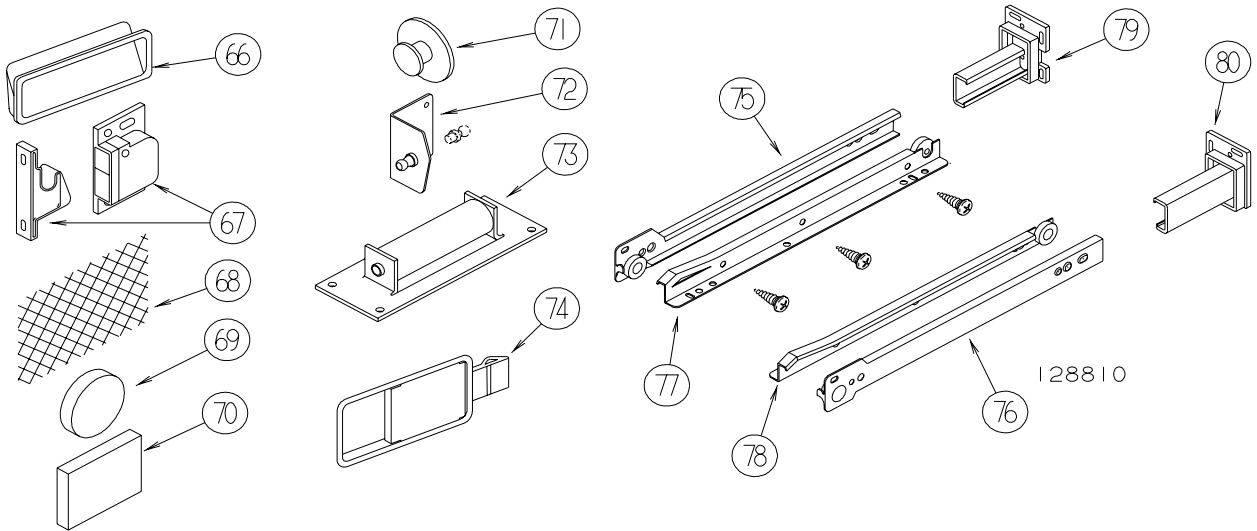

KEY	PART NUMBER	U/M	DESCRIPTION
66	115994-01-01A	EA	HANDLE - POCKET
67	117095-01-01A	EA	LATCH - DOOR - GRABBER W/KEEPER - PLASTIC - BLK-5 LB PULL
67	117095-02-01A	EA	LATCH - DOOR - GRABBER W/KEEPER - PLASTIC - BLK-10 LB PULL
68	118200-01-01A	SF	MESH - PLASTIC 1/2" - 48" X LENGTH = SF - BLACK
69	122717-01-01A	EA	PAD - NON SKID - 4" DIAMETER ROUND
70	122717-06-01A	FT	PAD - NON-SKID - PSA - 5"W
71	125221-01-01A	EA	PULL - MIRROR - W/ROUND HANDLE
72	126263-06-02B	EA	BRACKET - GAS SPRING W/INSIDE BALL STUD - E-COATED
72	126263-08-02B	EA	BRACKET - GAS SPRING W/CENTERED BALL STUD - E-COATED
73	126584-02-000	EA	ROLLER - FLAT
74	127349-01-01A	EA	LATCH - PADDLE
75	128810-01-01A	EA	SLIDE - DRAWER - 12" - LEFT CABINET
75	128810-05-01A	EA	SLIDE - DRAWER - 14" - LEFT CABINET
75	128810-09-01A	EA	SLIDE - DRAWER - 16" - LEFT CABINET
75	128810-13-01A	EA	SLIDE - DRAWER - 18" - LEFT CABINET
75	128810-17-01A	EA	SLIDE - DRAWER - 20" - LEFT CABINET
75	128810-21-01A	EA	SLIDE - DRAWER - 22" - LEFT CABINET
75	128810-25-01A	EA	SLIDE - DRAWER - 24" - LEFT CABINET
75	128810-29-01A	EA	SLIDE - DRAWER - 9" - LEFT CABINET
76	128810-02-01A	EA	SLIDE - DRAWER - 12" - RIGHT CABINET
76	128810-06-01A	EA	SLIDE - DRAWER - 14" - RIGHT CABINET
76	128810-10-01A	EA	SLIDE - DRAWER - 16" - RIGHT CABINET
76	128810-14-01A	EA	SLIDE - DRAWER - 18" - RIGHT CABINET
76	128810-18-01A	EA	SLIDE - DRAWER - 20" - RIGHT CABINET
76	128810-22-01A	EA	SLIDE - DRAWER - 22" - RIGHT CABINET
76	128810-26-01A	EA	SLIDE - DRAWER - 24" - RIGHT CABINET
76	128810-30-01A	EA	SLIDE - DRAWER - 9" - RIGHT CABINET
77	128810-03-01A	EA	SLIDE - DRAWER - 12" - LEFT DRAWER
77	128810-07-01A	EA	SLIDE - DRAWER - 14" - LEFT DRAWER
77	128810-11-01A	EA	SLIDE - DRAWER - 16" - LEFT DRAWER
77	128810-15-01A	EA	SLIDE - DRAWER - 18" - LEFT DRAWER
77	128810-19-01A	EA	SLIDE - DRAWER - 20" - LEFT DRAWER
77	128810-23-01A	EA	SLIDE - DRAWER - 22" - LEFT DRAWER
77	128810-27-01A	EA	SLIDE - DRAWER - 24" - LEFT DRAWER
77	128810-27-01A	EA	SLIDE - DRAWER - 24" - LEFT DRAWER
77	128810-31-01A	EA	SLIDE - DRAWER - 9" - LEFT DRAWER
78	128810-04-01A	EA	SLIDE - DRAWER - 12" - RIGHT DRAWER
78	128810-08-01A	EA	SLIDE - DRAWER - 14" - RIGHT DRAWER
78	128810-12-01A	EA	SLIDE - DRAWER - 16" - RIGHT DRAWER
78	128810-16-01A	EA	SLIDE - DRAWER - 18" - RIGHT DRAWER
78	128810-20-01A	EA	SLIDE - DRAWER - 20" - RIGHT DRAWER
78	128810-24-01A	EA	SLIDE - DRAWER - 22" - RIGHT DRAWER
78	128810-28-01A	EA	SLIDE - DRAWER - 24" - RIGHT DRAWER
78	128810-32-01A	EA	SLIDE - DRAWER - 9" - RIGHT DRAWER
79	128811-01-01A	EA	BACKSOCKET - ADJUSTABLE - LEFT
80	128811-02-01A	EA	BACKSOCKET - ADJUSTABLE - RIGHT

INTERIOR FINISH GROUP (CONTINUED)

HARDWARE (CONTINUED)

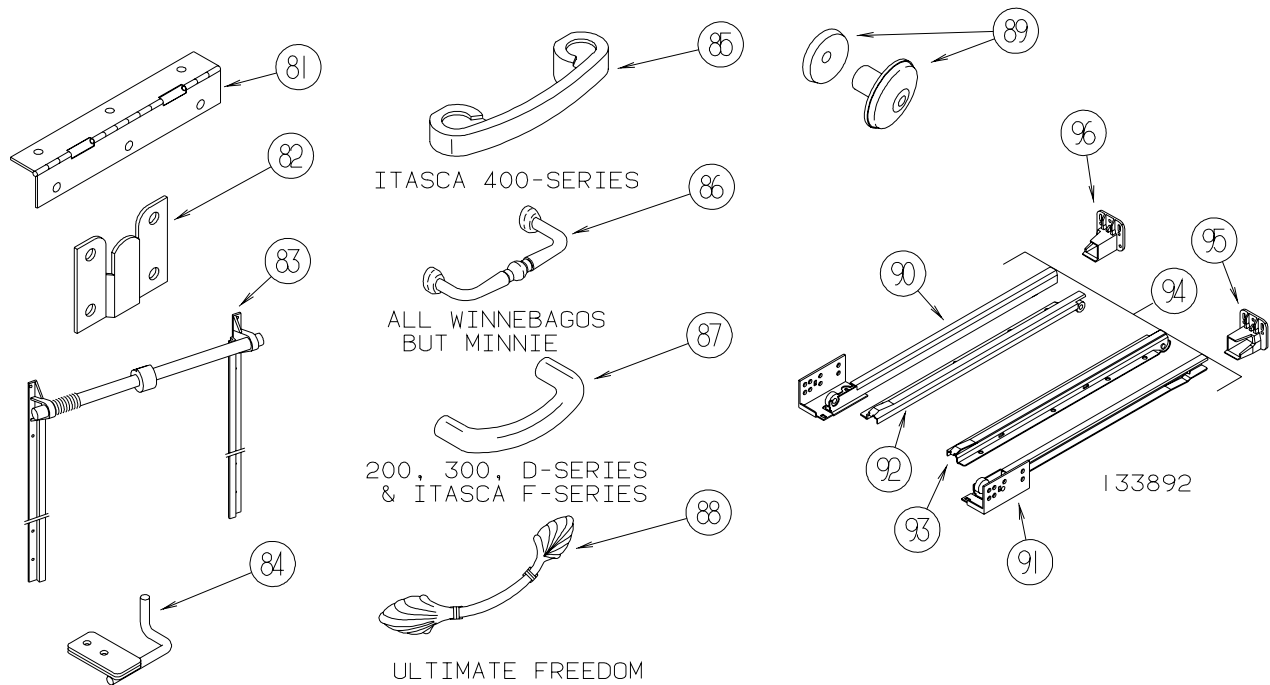

KEY	PART NUMBER	U/M	DESCRIPTION
81	129753-01-01A	EA	HINGE - SPRING LOADED - 19" X 19" - BLACK
82	130120-01-01A	EA	BRACKET - MIRROR
83	130787-01-000	EA	TRACK - TAMBOUR DOOR/SPRING - 15.9"
83	130787-02-000	EA	TRACK - TAMBOUR DOOR/SPRING - 24"
83	130787-04-000	EA	TRACK - TAMBOUR DOOR - SPRING
84	130798-01-02B	EA	GUIDE - POCKET DOOR - E-COATED
85	131962-01-01A	EA	PULL - DOOR/DRAWER - POLISHED BRASS - ITASCA 400 SERIES (SUNDANCER)
86	131963-01-01A	EA	PULL - POLISHED BRASS - WINNEBAGO BRAVE/ADVENTURER/CHIEFTAIN/JOURNEY/MINNIE WINNIE
87	131964-01-01A	EA	PULL - POLISHED BRASS - RIALTA/WINNEBAGO MINNIE/VISTA, ITASCA SPIRIT/SUNOVA
88	131965-01-01A	EA	PULL - DOOR/DRAWER - 6.3" - BURNISHED BRASS - ULTIMATE FREEDOM
89	133313-01-02A	EA	PULL - DOOR/DRAWER - BRIGHT BRASS
89	133313-01-03A	EA	PULL - DOOR/DRAWER - CHROME/BRASS - ITASCA L & P SERIES (SUNFLYER & HORISON) ONLY
90	133892-01-01A	EA	SLIDE - DRAWER - 16" - LEFT CABINET
90	133892-06-01A	EA	SLIDE - DRAWER - 22" - LEFT CABINET
90	133892-10-01A	EA	SLIDE - DRAWER - 12" - LEFT CABINET
90	133892-14-01A	EA	SLIDE - DRAWER - 18" - LEFT CABINET
91	133892-02-01A	EA	SLIDE - DRAWER - 16" - RIGHT CABINET
91	133892-07-01A	EA	SLIDE - DRAWER - 22" - RIGHT CABINET
91	133892-11-01A	EA	SLIDE - DRAWER - 12" - RIGHT CABINET
91	133892-15-01A	EA	SLIDE - DRAWER - 18" - RIGHT CABINET
92	133892-03-01A	EA	SLIDE - DRAWER - 16" - LEFT DRAWER
92	133892-08-01A	EA	SLIDE - DRAWER - 22" - LEFT DRAWER
92	133892-12-01A	EA	SLIDE - DRAWER - 12" - LEFT DRAWER
92	133892-16-01A	EA	SLIDE - DRAWER - 18" - LEFT DRAWER
93	133892-04-01A	EA	SLIDE - DRAWER - 16" - RIGHT DRAWER
93	133892-09-01A	EA	SLIDE - DRAWER - 22" - RIGHT DRAWER
93	133892-13-01A	EA	SLIDE - DRAWER - 12" - RIGHT DRAWER
93	133892-17-01A	EA	SLIDE - DRAWER - 18" - RIGHT DRAWER
94	133892-05-01A	EA	SLIDE - DRAWER - 9" - FULL SET
95	133907-01-01A	EA	BACKSOCKET - RIGHT HAND
96	133907-02-01A	EA	BACKSOCKET - LEFT HAND

INTERIOR FINISH GROUP (CONTINUED)
HARDWARE (CONTINUED)

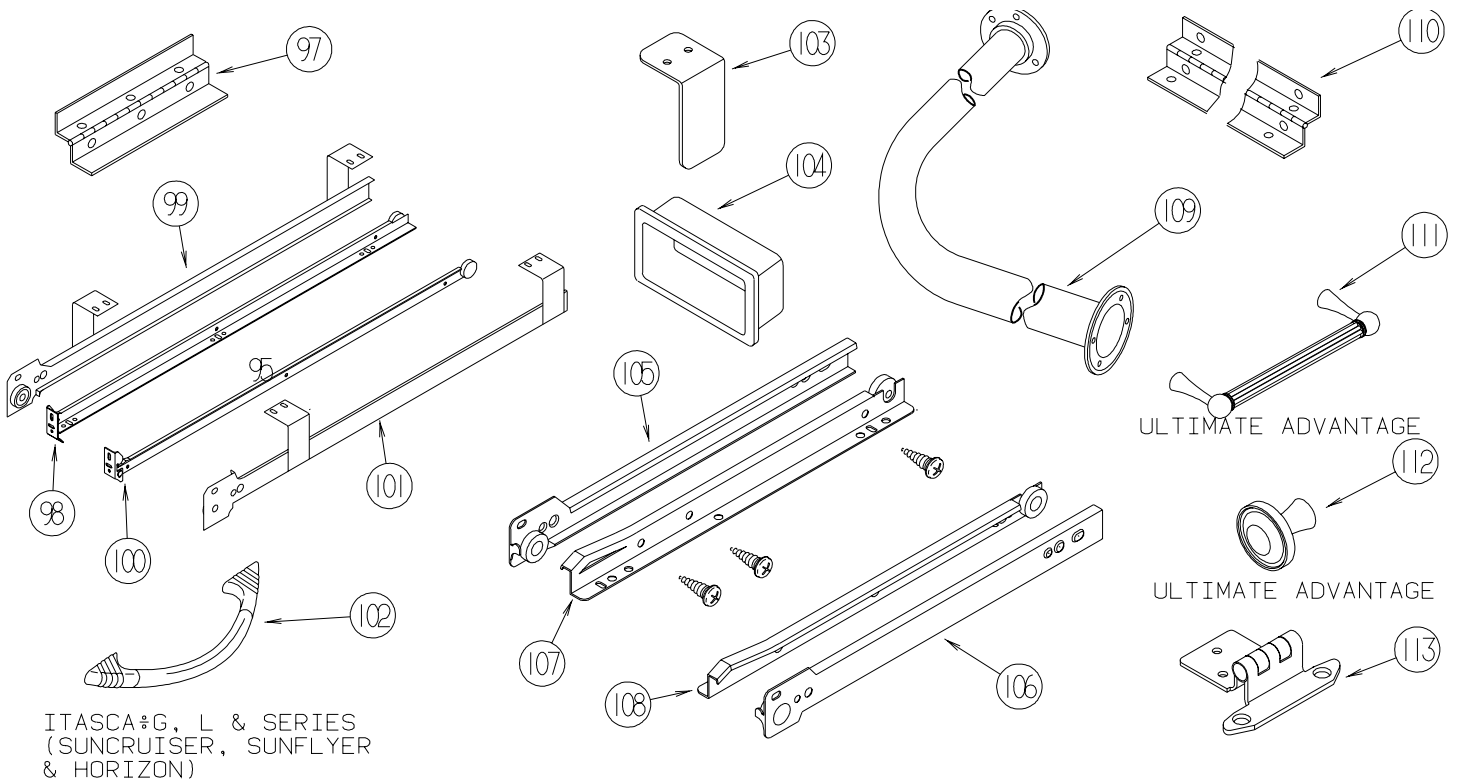

ITASCA G, L & SERIES
(SUNCRUISER, SUNFLYER
& HORIZON)

KEY	PART NUMBER	U/M	DESCRIPTION
97	135538-01-01A	EA	HINGE - PIANO - FULL WRAP - BRASS PLATED
97	135538-03-01A	EA	HINGE - PIANO - FULL WRAP - STOCKER BRASS
98	136944-01-01A	EA	SLIDE - DRAWER/RIGHT HAND - 13.8"
99	136944-02-01A	EA	SLIDE - CABINET/RIGHT HAND - 13.8"
100	136944-03-01A	EA	SLIDE - DRAWER/LEFT HAND - 13.8"
101	136944-04-01A	EA	SLIDE - CABINET/LEFT HAND - 13.8"
102	137446-01-01A	EA	PULL - CABINET - CHROME/BRASS - ITASCA G, L & P SERIES (SUNCRUISER/SUNFLYER/HORIZON)
103	138136-02-02B	EA	GUIDE - DOOR - E-COATED
104	139136-01-01A	EA	HANDLE - RECESSED - 2.9" X 1.3"/2.7" X 1" X .7" C/O- BRASS
104	139136-02-01A	EA	HANDLE - RECESSED - 2.9" X 1.3"/2.7" X 1" X .4" C/O- BRASS
105	139566-01-01A	EA	SLIDE - DRAWER - 37.5" - LEFT CABINET
105	139566-05-01A	EA	SLIDE - DRAWER - 32" - LEFT CABINET
106	139566-02-01A	EA	SLIDE - DRAWER - 37.5" - RIGHT CABINET
106	139566-06-01A	EA	SLIDE - DRAWER - 32" - RIGHT CABINET
107	139566-03-01A	EA	SLIDE - DRAWER - 37.5" - LEFT DRAWER
107	139566-07-01A	EA	SLIDE - DRAWER - 32" - LEFT DRAWER
108	139566-04-01A	EA	SLIDE - DRAWER - 37.5" - RIGHT DRAWER
108	139566-08-01A	EA	SLIDE - DRAWER - 32" - RIGHT DRAWER
109	140494-01-01A	EA	ROD - SHOWER
109	140494-01-02A	EA	ROD - SHOWER - SOFT WHITE
110	142276-01-01A	EA	HINGE - PIANO - FULL WRAP - BRASS
	142569-05-000	EA	SPRING - GAS - 39.9"/15 LB
FROM: 01-18-03 THRU: 99-99-99			
111	142909-01-01A	EA	PULL - CABINET - BRASS - ULTIMATE ADVANTAGE
112	142910-01-01A	EA	KNOB - CABINET - BRASS - ULTIMATE ADVANTAGE
113	143468-01-02A	EA	HINGE - SELF CLOSING - POLISHED BRASS

LABELS GROUP

SEWAGE

KEY PART NUMBER U/M DESCRIPTION
006187-01-000 EA LABEL - SEWAGE

WASTE WATER

KEY PART NUMBER U/M DESCRIPTION
006188-01-000 EA LABEL - WASTE WATER

WARNING

THIS SYSTEM IS DESIGNED FOR USE WITH PROPANE ONLY
DO NOT CONNECT NATURAL GAS TO THIS SYSTEM

BEFORE TURNING ON PROPANE:

- (A) BE CERTAIN APPLIANCES ARE CERTIFIED FOR PROPANE AND ARE EQUIPPED WITH CORRECT BURNING ORIFICES.
- (B) MAKE CERTAIN ALL PROPANE CONNECTIONS ARE TIGHT BY TESTING WITH SOAPY WATER. ALL APPLIANCE VALVES ARE TURNED OFF, AND ANY UNCONNECTED OUTLETS ARE CAPPED.

AFTER TURNING ON PROPANE:

- (A) LIGHT ALL PILOT LIGHTS
- (B) (B) ALL CONNECTIONS, INCLUDING THOSE AT THE APPLIANCES, REGULATORS AND CYLINDERS SHOULD BE LEAK-TESTED PERIODICALLY WITH SOAPY WATER BY THE OCCUPANT. NEVER USE A LIGHTED MATCH OR OTHER FLAME WHEN CHECKING FOR LEAKS.
- (C) DO NOT LEAVE SYSTEM TURNED ON OF CONTAINERS CONNECTED UNTIL THE SYSTEM HAS BEEN PROVEN TO BE FREE OF LEAKS.
- (D) COOKING APPLIANCES SHOULD NOT BE USED FOR SPACE HEATING.
- (E) WHEN THE CONTAINERS ARE DISCONNECTED THE PROPANE SUPPLY LINE SHOULD BE CAPPED OR PLUGGED.

AVERTISSEMENT

CETTE INSTALLATION EST CONÇUE POUR LE PROPANE SEULEMENT
NE PAS L'ALIMENTER EN GAZ NATUREL

AVANT LA MISE EN SERVICE:

- (A) S'ASSURER QUE LES APPAREILS SONT CERTIFIÉS POUR LE PROPANE ET MUNIS D'ORIFICES DE BRULEUR APPROPRIÉS.
- (B) VÉRIFIER L'ÉTANCHEITÉ DE TOUS LES RACCORDEMENTS AU PROPANE. LA PERMÉABILITÉ DE TOUS LES ROBINETS D'APPAREILS ET L'OBTURATION DE TOUTES LES SORTIES NON RACCORDEES.

APRÈS LA MISE EN SERVICE:

- (A) ALLUMER TOUTES LES VEILLEUSES.
- (B) L'OCCUPANT DOIT ÉPROUVER PÉRIODIQUEMENT L'ÉTANCHEITÉ DE TOUS LES RACCORDEMENTS Y COMPRIS CEUX AUX APPAREILS, AUX DÉTENDEURS ET AUX BOUTEILLES, EN Y APPLIQUANT DE L'EAU SAVONNEUSE NE JAMAIS SE SERVIR D'UNE ALLUMETTE OU AUTRE POUR LA DÉTECTION DES FUITES.
- (C) NE PAS LAISSER L'ALIMENTATION OUVERTE NI LES RÉCIPIENTS RACCORDES AVANT D'AVOIR COMPLÉTÉ L'ÉPREUVE D'ÉTANCHEITÉ AU PROPANE DE L'INSTALLATION.
- (D) LES APPAREILS DE CUISSON NE DOIVENT PAS ÊTRE UTILISÉS POUR LE CHAUFFAGE DES LOCAUX.
- (E) LORSQUE LES RÉCIPIENTS SONT DÉCONNECTÉS, L'ALIMENTATION DE PROPANE DOIT ÊTRE OBTURÉE OU SCELLÉE.

KEY PART NUMBER U/M DESCRIPTION
023769-01-000 EA LABEL - WARNING - LPG - CANADIAN

EXIT

KEY PART NUMBER U/M DESCRIPTION
039290-01-000 EA LABEL - WARNING - EXIT

LABELS GROUP (CONTINUED)



KEY PART NUMBER U/M DESCRIPTION
040944-01-000 EA LABEL - ENTRANCE DOOR - "OPEN"

CAUTION

THIS MOTOR HOME HAS BEEN DESIGNED, MANUFACTURED AND TESTED WITH CONCERN FOR THE PROTECTION OF IT'S OCCUPANTS. WE RECOMMEND YOU PERFORM THE FOLLOWING INSPECTIONS FOR YOUR SAFETY AND THE SAFETY OF YOUR PASSENGERS BEFORE STARTING YOUR VEHICLE.

1. LP GAS SYSTEM- TURN OFF AT TANK FOR TRAVELING. TEST FOR LEAKS UPON ARRIVAL AT DESTINATION. BEFORE LIGHTING PILOTS.
2. WHEELS- INSPECT FOR DAMAGE AND CHECK LUG NUTS FOR TIGHTNESS.
3. TIRES- INSPECT FOR WEAR AND DAMAGE AND CHECK FOR RECOMMENDED AIR PRESSURE.
4. LIGHTING- TEST FOR PROPER OPERATION OF ALL INTERIOR AND EXTERIOR LIGHTS INCLUDING DASH LIGHTS, HEADLIGHTS, TAIL LIGHTS, BRAKE LIGHTS, CLEARANCE LIGHTS AND TURN SIGNALS.
5. EXITS- INSPECT RELEASE MECHANISM ON EMERGENCY EXIT WINDOW. TEST BOTH LOCKS ON MAIN ENTRANCE DOOR FOR EASE OF OPERATION AND INSTRUCT PASSENGERS HOW TO USE BOTH MEANS OF EXIT.
6. SEAT BELTS- DIRECT PASSENGERS TO DESIGNATED SEATS AND REQUIRE USE OF SEAT BELTS.
7. APPLIANCES- TURN OFF AND LATCH OR LOCK DOORS WHERE PROVIDED.
8. LOOSE PARCELS- STORE SECURELY.
9. UTILITY SUPPLY LINES- DISCONNECT ALL ELECTRIC, SEWER AND WATER LINES AND SECURE PROPERLY.
10. ENTRANCE DOOR STEP- PLACE IN RETRACTED POSITION FOR TRAVELING.

READ YOUR MOTOR HOME AND CHASSIS OWNER'S
MANUAL FOR FURTHER PRECAUTIONS

KEY PART NUMBER U/M DESCRIPTION
056259-01-000 EA LABEL - SAFETY CHECK LIST

UNLEADED FUEL ONLY

KEY PART NUMBER U/M DESCRIPTION
062043-01-000 EA LABEL - FUEL - UNLEADED

WARNING DISCONNECT BATTERIES BEFORE
CONNECTING EXTERNAL CHARGING EQUIPMENT.

KEY PART NUMBER U/M DESCRIPTION
065748-01-000 EA LABEL - CAUTION - BATTERY CHARGING

AVERTISSEMENT : DEBRANCHER LES BATTERIES AVANT
DE BRANCHER TOUT EQUIPEMENT DE CHARGE EXTERIEUR.

KEY PART NUMBER U/M DESCRIPTION
065748-02-000 EA LABEL - WARNING - BATTERY/FRENCH - CANADIAN

DIESEL FUEL ONLY

KEY PART NUMBER U/M DESCRIPTION
068383-01-000 EA LABEL - DIESEL FUEL

VEHICLE EMISSION CONTROL INFORMATION
THIS VEHICLE CONFORMS TO U.S. EPA
REGULATIONS APPLICABLE TO XXXX MODEL
YEAR NEW VEHICLES.

072887-01-000-7 CATALYST

KEY PART NUMBER U/M DESCRIPTION
072887-14-000 EA LABEL - EPA - 2003 MODEL YEAR

LABELS GROUP (CONTINUED)

IF YOU SMELL GAS

1. EXTINGUISH ANY OPEN FLAME, PILOT LIGHTS AND ALL SMOKING MATERIALS.
2. DO NOT TOUCH ELECTRICAL SWITCHES.
3. SHUT OFF THE GAS SUPPLY AT THE TANK VALVE(S) OR GAS SUPPLY CONNECTION.
4. OPEN DOORS AND OTHER VENTILATING OPENINGS.
5. LEAVE THE AREA UNTIL ODOR CLEARS.
6. HAVE THE GAS SYSTEM CHECKED AND LEAKAGE SOURCE CORRECTED BEFORE USING AGAIN.

KEY PART NUMBER U/M DESCRIPTION
073998-01-000 EA LABEL - LPG ODOR WARNING

WARNING: TEST SMOKE DETECTOR
OPERATION AFTER VEHICLE HAS BEEN IN
STORAGE, BEFORE EACH TRIP AND AT
LEAST ONCE PER WEEK DURING USE.

KEY PART NUMBER U/M DESCRIPTION
077956-01-000 EA LABEL - WARNING - SMOKE DETECTOR

DO NOT FILL
LP-GAS CONTAINER(S)
TO MORE THAN 80%
OF CAPACITY.

KEY PART NUMBER U/M DESCRIPTION
079965-01-000 EA LABEL - LPG - 80% CAPACITY

WARNING
MUST BE STOWED
IN LATCHED POSITION
WHILE VEHICLE IS IN MOTION

KEY PART NUMBER U/M DESCRIPTION
079966-01-000 EA LABEL - WARNING - STOWED - MOTION

W
A
T
E
R
O
N
H
E
A
T
E
R
O
F
F

KEY PART NUMBER U/M DESCRIPTION
083588-01-000 EA LABEL - ON/OFF - WATER HEATER
083588-03-000 EA LABEL - ON/OFF - WATER HEATER

E
N
G
I
N
E
O
N
H
E
A
T
E
R
O
F
F

KEY PART NUMBER U/M DESCRIPTION
083588-02-000 EA LABEL - ON/OFF - ENGINE HEATER
083588-04-000 EA LABEL - ON/OFF - ENGINE HEATER

LABELS GROUP (CONTINUED)

CAUTION	TO HELP AVOID PERSONAL INJURY DURING REMOVAL OF FUEL FILLER CAP, SLOWLY LOOSEN CAP 1/2 TURN TO ALLOW ANY FUEL PRESSURE TO BE RELIEVED BEFORE TURNING CAP FURTHER.
FUEL SPRAY MAY CAUSE PERSONAL INJURY	STOP ADDING FUEL AFTER FIRST SHUTOFF BY AUTOMATIC NOZZLE WHEN TANK IS NEARLY FULL. DO NOT OVERFILL FUEL TANK. SEE OWNERS MANUAL FOR ADDITIONAL INFORMATION. PRINTED IN U.S.A. WLC PT NO 15611763

KEY PART NUMBER U/M DESCRIPTION
087207-05-000 EA LABEL - FUEL CAP REMOVAL



KEY PART NUMBER U/M DESCRIPTION
087236-01-000 EA LABEL - CABLE - INPUT



KEY PART NUMBER U/M DESCRIPTION
087236-02-000 EA LABEL - TV OUTLET

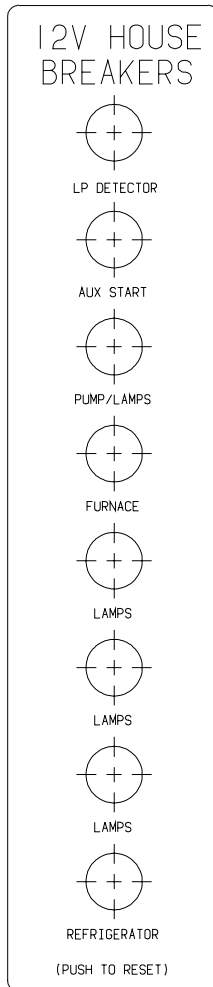

KEY PART NUMBER U/M DESCRIPTION
092547-08-000 EA LABEL - CIRCUIT BREAKER

LABELS GROUP (CONTINUED)

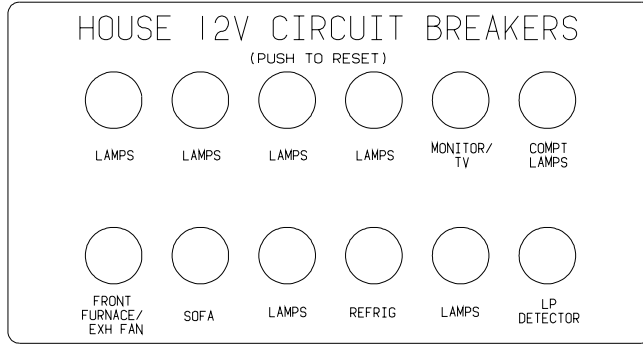

KEY PART NUMBER U/M DESCRIPTION
092547-10-000 EA LABEL - CIRCUIT BREAKER

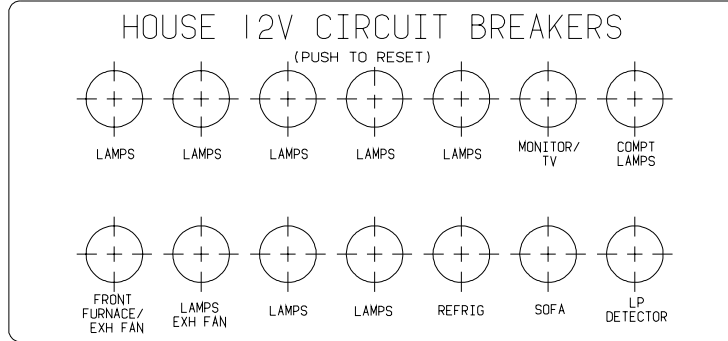

KEY PART NUMBER U/M DESCRIPTION
092547-12-000 EA LABEL - CIRCUIT BREAKER

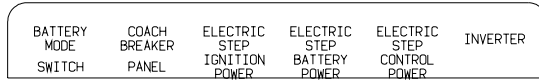

KEY PART NUMBER U/M DESCRIPTION
093236-08-000 EA LABEL - CIRCUIT BREAKER

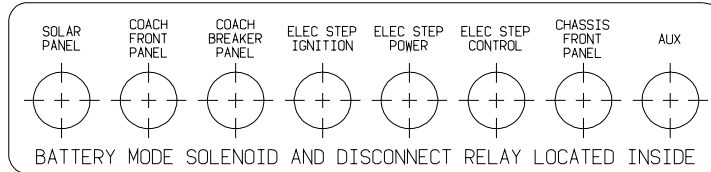

KEY PART NUMBER U/M DESCRIPTION
093236-13-000 EA LABEL - CIRCUIT BREAKER

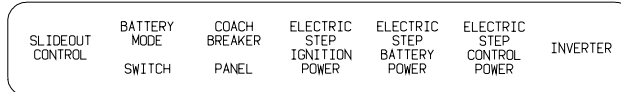

KEY PART NUMBER U/M DESCRIPTION
093236-21-000 EA LABEL - CIRCUIT BREAKER

LABELS GROUP (CONTINUED)

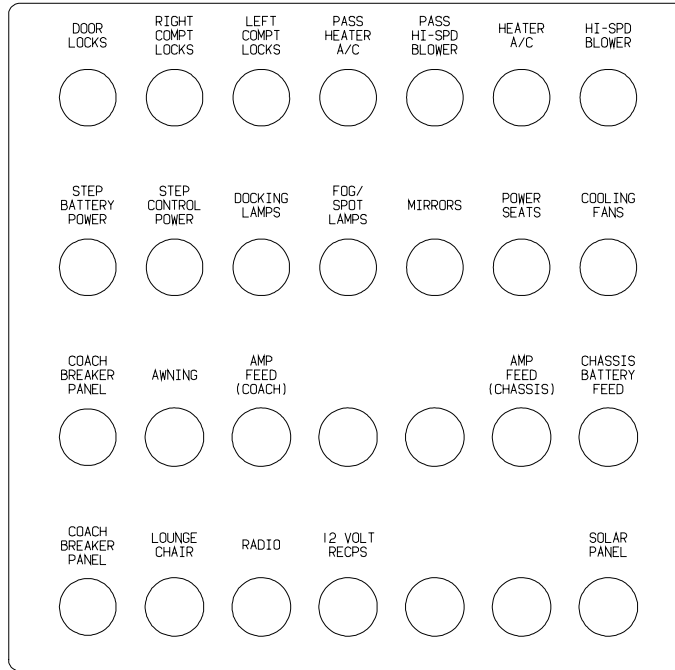

KEY PART NUMBER U/M DESCRIPTION
 093236-22-000 EA LABEL - CIRCUIT BREAKER

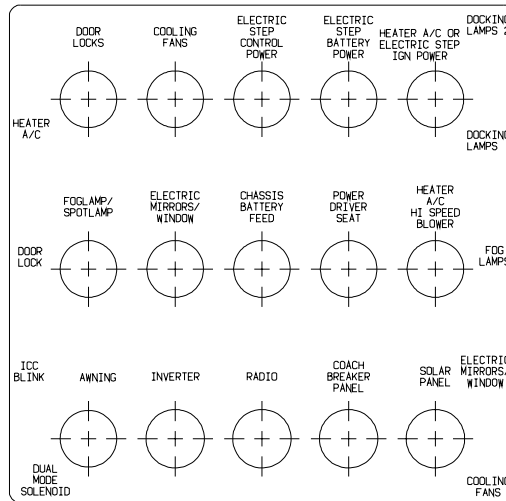

KEY PART NUMBER U/M DESCRIPTION
 093236-23-000 EA LABEL - CIRCUIT BREAKER - MAIN

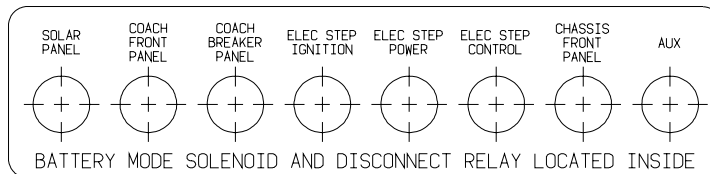

KEY PART NUMBER U/M DESCRIPTION
 093236-24-000 EA LABEL - CIRCUIT BREAKER

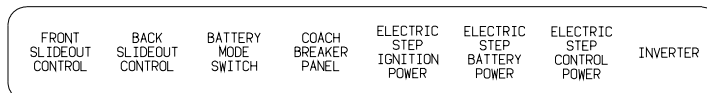

KEY PART NUMBER U/M DESCRIPTION
 093236-28-000 EA LABEL - CIRCUIT BREAKER

LABELS GROUP (CONTINUED)

A / C C I R C U I T 1	M A I N	A / C C I R C U I T 2	R E F F R I G / C O N V	M I C R O W A V E	R E C P S 1	R E C P S 2	R E C P S 3	W A S H E R / D R Y E R	W A T E R H E A T E R	
-----------------------------	---------	-----------------------------	-------------------------	-------------------	----------------	----------------	----------------	-------------------------	--------------------------	--

KEY PART NUMBER 095721-31-000 **U/M DESCRIPTION**
EA LABEL - CONTROL CENTER - 30 AMP - US

A / C C I R C U I T 1	M A I N	M A I N	A / C C I R C U I T 2	R E F F R I G / C O N V	M I C R O W A V E	R E C P S 1	R E C P S 2	R E C P S 3	W A S H E R / D R Y E R	W A T E R H E A T E R
-----------------------------	---------	---------	-----------------------------	-------------------------	-------------------	----------------	----------------	----------------	-------------------------	--------------------------

KEY PART NUMBER 095721-33-000 **U/M DESCRIPTION**
EA LABEL - CONTROL CENTER - 50 AMP - US

A / C	M A I N	R E F F R I G / C O N V	M I C R O W A V E	R E C P S 1	R E C P S 2
-------	---------	-------------------------	-------------------	----------------	----------------

KEY PART NUMBER 095721-40-000 **U/M DESCRIPTION**
EA LABEL - CONTROL CENTER

AUTOMOTIVE AND COACH CIRCUIT BREAKERS
--

KEY PART NUMBER 098379-01-000 **U/M DESCRIPTION**
EA LABEL - CIRCUIT BREAKER - FRONT BOX

CIRCUIT BREAKERS AND AUTOMOTIVE FUSE PANEL
--

KEY PART NUMBER 098379-03-000 **U/M DESCRIPTION**
EA LABEL - ELECTRICAL BOX - FRONT

BATTERY MODE SOLENOID AND RELAYS
--

KEY PART NUMBER 098379-04-000 **U/M DESCRIPTION**
EA LABEL - ELECTRICAL BOX - SIDE

LABELS GROUP (CONTINUED)

UNLEADED
FUEL ONLY

KEY PART NUMBER U/M DESCRIPTION
098641-01-000 EA LABEL - FUEL - UNLEADED - DASH

FOR AWNING INSTALLATION
CONTACT YOUR MOTORHOME
DEALERSHIP

KEY PART NUMBER U/M DESCRIPTION
099509-01-000 EA LABEL - AWNING INSTALLATION

WARNING
THIS VEHICLE, LIKE OTHER
VEHICLES, MAY CONTAIN SMALL
AMOUNTS OF ONE OR MORE
SUBSTANCES WHICH ARE LISTED
BY THE STATE OF CALIFORNIA
FOR CAUSING CANCER OR
REPRODUCTIVE TOXICITY.

KEY PART NUMBER U/M DESCRIPTION
099689-01-000 EA LABEL - WARNING - CANCER/TOXICITY

NOTE: TUNE ANTENNA
PER MANUFACTURER'S
DIRECTIONS. FAILURE TO
COMPLY COULD RESULT IN
DAMAGE TO CB.

CB POWER PROVISION

RED +12 V
BLACK GROUND
COAX ANTENNA
(SEE REVERSE ALSO)

KEY PART NUMBER U/M DESCRIPTION
104678-01-000 EA LABEL - CB PREP



KEY PART NUMBER U/M DESCRIPTION
107571-01-000 EA LABEL - EXIT/ESCAPE WINDOW

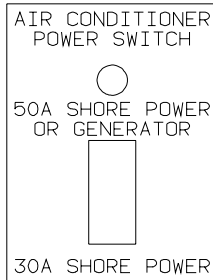

KEY PART NUMBER U/M DESCRIPTION
109051-02-000 EA LABEL - SWITCH - 50 AMP POWER

LABELS GROUP (CONTINUED)

DO NOT USE HITCH BEFORE
READING OWNERS MANUAL REGARDING
VEHICLE LOADING AND TOWING

KEY	PART NUMBER	U/M DESCRIPTION
	111104-01-000	EA LABEL - HITCH - READ MANUAL - WHITE
	111104-02-000	EA LABEL - HITCH - READ MANUAL - BLACK

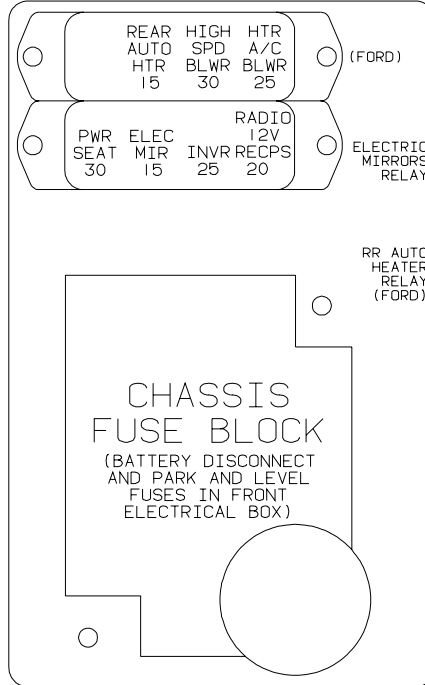

KEY	PART NUMBER	U/M DESCRIPTION
	111537-08-000	EA LABEL - FUSES

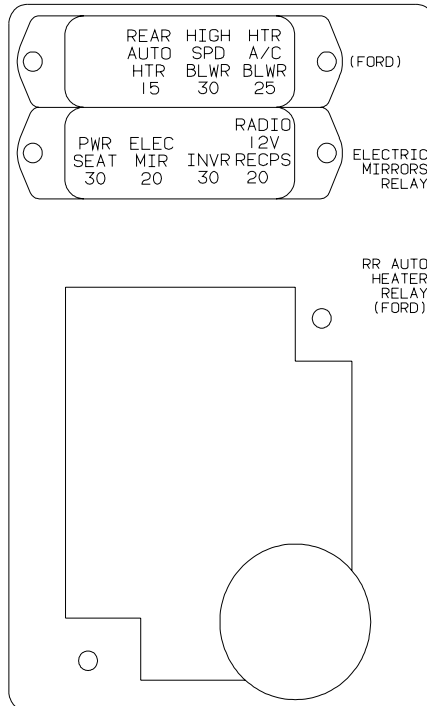

KEY	PART NUMBER	U/M DESCRIPTION
	111537-09-000	EA LABEL - FUSES

LABELS GROUP (CONTINUED)

WARNING: CONTAINS "CFC" A SUBSTANCE WHICH HARMS PUBLIC HEALTH AND ENVIRONMENT BY DESTROYING OZONE IN THE UPPER ATMOSPHERE.

KEY	PART NUMBER	U/M DESCRIPTION
	111802-01-000	EA LABEL - CFC WARNING

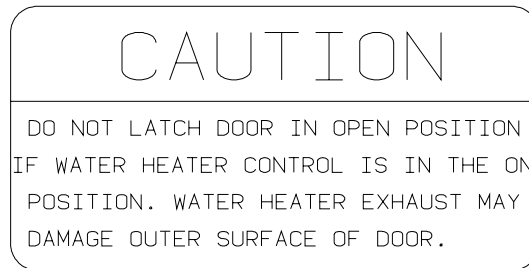

KEY	PART NUMBER	U/M DESCRIPTION
	113402-01-000	EA LABEL - CAUTION - WATER HEATER EXHAUST

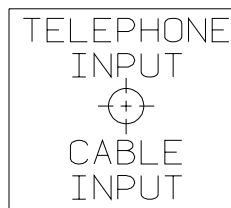

KEY	PART NUMBER	U/M DESCRIPTION
	114866-02-000	EA LABEL - PHONE & CABLE INPUT - WHITE/CLEAR BACKGROUND
	114866-03-000	EA LABEL - PHONE & CABLE INPUT - BLACK/CLEAR BACKGROUND

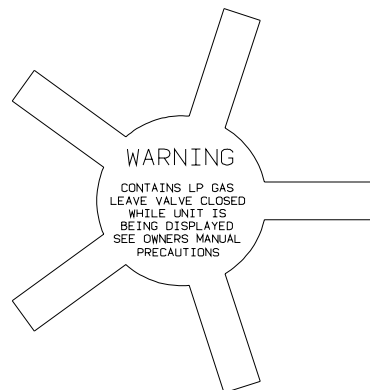

KEY	PART NUMBER	U/M DESCRIPTION
	115600-01-000	EA LABEL - WARNING LPG VALVE

WARNING: REPLACE TIRE ONLY WITH ONE OF EXACTLY SAME TYPE AND RATING. DO NOT REPLACE WITH PASSENGER CAR TIRE. SEE OPERATOR'S MANUAL FOR MORE INFORMATION CALL WINNEBAGO OWNER RELATIONS AT 1-800-537-1885.

KEY	PART NUMBER	U/M DESCRIPTION
	115869-01-000	EA LABEL - WARNING - TIRE

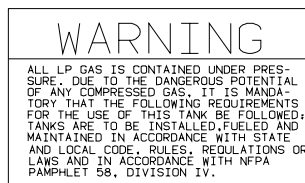

KEY	PART NUMBER	U/M DESCRIPTION
	116112-01-000	EA LABEL - CAUTION - LP

LABELS GROUP (CONTINUED)

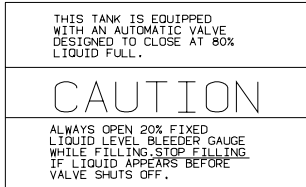

KEY PART NUMBER **U/M DESCRIPTION**
 116113-01-000 EA LABEL - CAUTION - LP

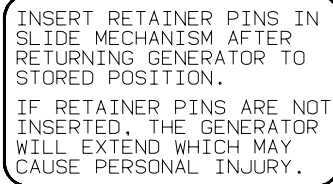

KEY PART NUMBER **U/M DESCRIPTION**
 116273-01-000 EA LABEL - WARNING - GENERATOR

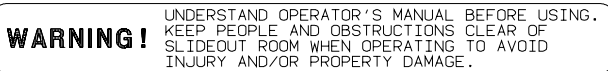

KEY PART NUMBER **U/M DESCRIPTION**
 116549-01-000 EA LABEL - WARNING - SLIDEOUT

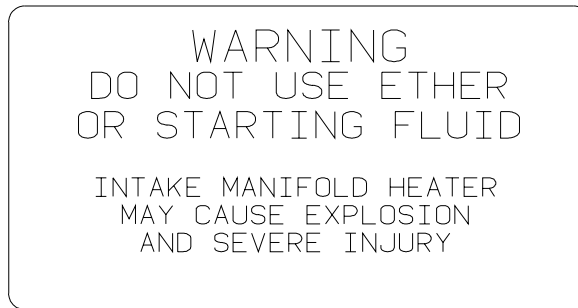

KEY PART NUMBER **U/M DESCRIPTION**
 116756-02-000 EA LABEL - WARNING - ETHER/STARTING

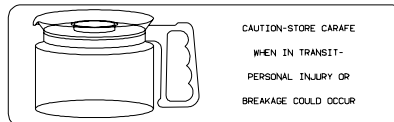

KEY PART NUMBER **U/M DESCRIPTION**
 116829-02-000 EA LABEL - COFFEEMAKER



KEY PART NUMBER **U/M DESCRIPTION**
 117628-02-000 EA LABEL - SWITCH - WATER PUMP/LIGHTS-WHITE/CLEAR BACKGROUND

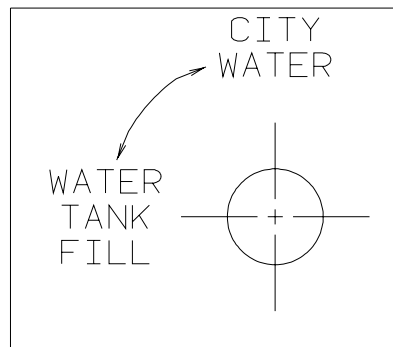

KEY PART NUMBER **U/M DESCRIPTION**
 117629-03-000 EA LABEL - WATER PUMP/FILL-BLK LETTERS/CLEAR BACKGROUND-.31"

LABELS GROUP (CONTINUED)

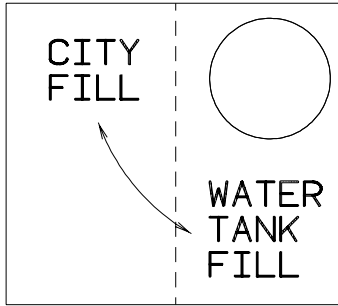

KEY PART NUMBER 117629-04-000
U/M DESCRIPTION EA LABEL - CITY WATER/TANK FILL

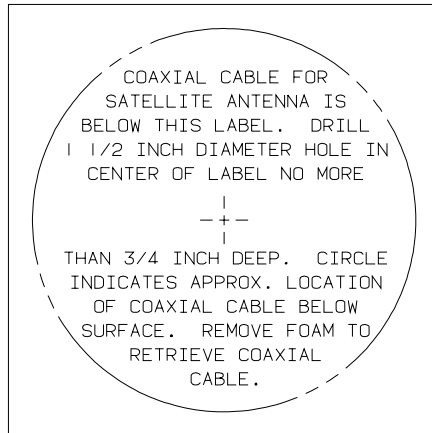

KEY PART NUMBER 120431-01-000
U/M DESCRIPTION EA LABEL - LOCATION - COAXIAL CABLE/SATELLITE ANTENNA

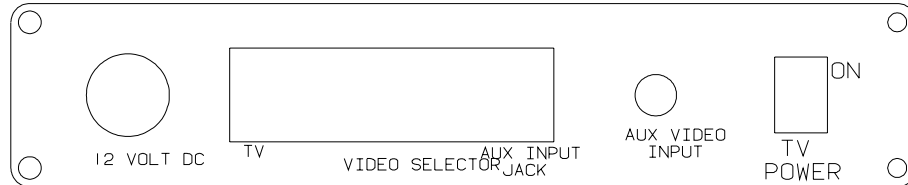

KEY PART NUMBER 120677-01-000
U/M DESCRIPTION EA LABEL - TV

KEEP THE SERVICE INLET ACCESS
 IN THE CLOSED POSITION WHEN
 UTILITY CONNECTIONS ARE NOT IN USE

KEY PART NUMBER 123562-01-000
U/M DESCRIPTION EA LABEL - SERVICE/UTILITY ACCESS

WARNING

ALL PILOT LIGHTS, APPLIANCES AND THEIR
 IGNITORS (SEE OPERATING INSTRUCTIONS) SHALL
 BE TURNED OFF DURING REFUELING OF MOTOR
 FUEL TANKS AND/OR LP GAS CONTAINERS

KEY PART NUMBER 124519-01-01A
 124519-01-02A
U/M DESCRIPTION EA LABEL - WARNING/REFUELING - BLACK ON CLEAR
 EA LABEL - WARNING/REFUELING - WHITE ON CLEAR

LABELS GROUP (CONTINUED)

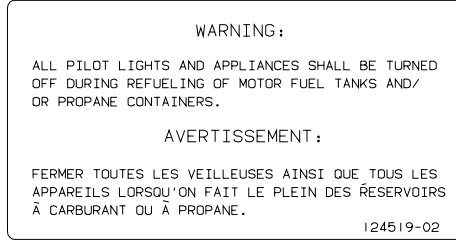

KEY	PART NUMBER	U/M	DESCRIPTION
	124519-02-01A	EA	LABEL - WARNING/REFUELING - BLACK ON CLEAR - CSA
	124519-02-02A	EA	LABEL - WARNING/REFUELING - WHITE ON CLEAR - CSA

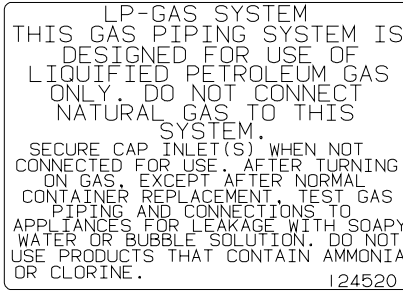

KEY	PART NUMBER	U/M	DESCRIPTION
	124520-01-01A	EA	LABEL - LP GAS ONLY - BLACK ON CLEAR
	124520-01-02A	EA	LABEL - LP GAS ONLY - WHITE ON CLEAR

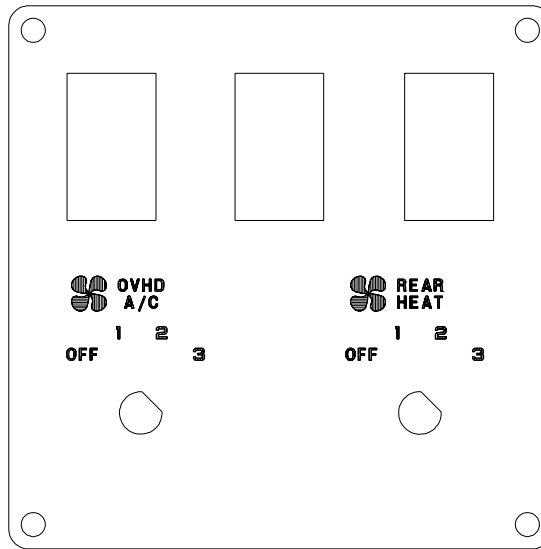

KEY	PART NUMBER	U/M	DESCRIPTION
	124572-01-000	EA	LABEL - SWITCHES

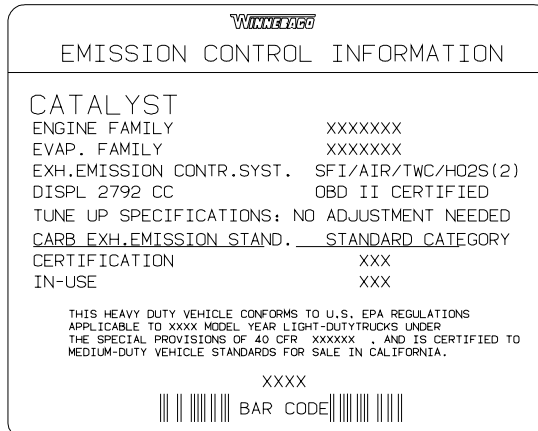

KEY	PART NUMBER	U/M	DESCRIPTION
	124709-07-000	EA	LABEL - EMISSION CONTROL - DUAL

LABELS GROUP (CONTINUED)

THIS CONNECTION IS FOR
 (B) VOLT AC,60 HZ(CYCLES)
 (A) AMPERE SUPPLY

DO NOT CONNECT TO
 HIGHER VOLTAGE

KEY	PART NUMBER	U/M DESCRIPTION
	125306-01-01A	EA LABEL - ELECTRICAL ENTRANCE - 110V 30 AMP - BLACK ON CLEAR
	125306-01-02A	EA LABEL - ELECTRICAL ENTRANCE - 110V 30 AMP - WHITE ON CLEAR

THIS CONNECTION IS FOR
 (B) VOLT AC,3-POLE,4 WIRE
 60 HZ(CYCLES),(A) AMPERE SUPPLY

DO NOT CONNECT TO
 HIGHER VOLTAGE

KEY	PART NUMBER	U/M DESCRIPTION
	125306-04-01A	EA LABEL-ELECTRICAL ENTRANCE-120/240V 50 AMP-BLACK ON CLEAR
	125306-04-02A	EA LABEL - ELECTRICAL ENTRANCE-120/240V 50 AMP-WHITE ON CLEAR

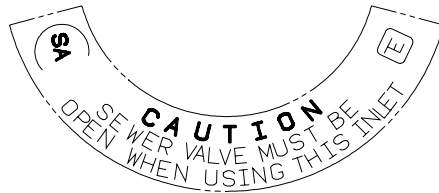

KEY	PART NUMBER	U/M DESCRIPTION
	125697-07-000	EA LABEL - CAUTION - FLUSHING SYSTEM

REMOVE PRIMARY TIRE HANGER BEFORE USING
 SPARE TIRE HOIST-SEE OWNERS MANUAL - PERSONAL
 INJURY MAY RESULT IF NOT FOLLOWED

KEY	PART NUMBER	U/M DESCRIPTION
	126024-01-000	EA LABEL - TIRE HANGER REMOVAL

GRAY HOLDING TANK

KEY	PART NUMBER	U/M DESCRIPTION
	126247-05-000	EA LABEL - GRAY HOLDING TANK-BLACK LETTERS/CLEAR BACKGROUND

BLACK HOLDING TANK

KEY	PART NUMBER	U/M DESCRIPTION
	126247-06-000	EA LABEL - BLACK HOLDING TANK-BLACK LETTERS/CLEAR BACKGROUND

LABELS GROUP (CONTINUED)

EXTERIOR SHOWER

KEY PART NUMBER U/M DESCRIPTION
126248-03-000 EA LABEL - EXTERIOR SHOWER

CITY WATER FILL

KEY PART NUMBER U/M DESCRIPTION
126249-03-000 EA LABEL - CITY WATER FILL-BLK LETTERS/CLEAR BACKGROUND .31"



WARNING

○ **Children Can be KILLED or INJURED
by Passenger Air Bag**

The back seat is the safest place for children 12 and under.
Make sure all children use seat belts or child seats.

KEY PART NUMBER U/M DESCRIPTION
126612-01-000 EA LABEL - HANG TAG - AIR BAG - DASH

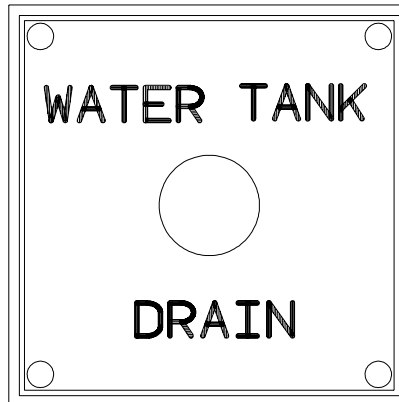

KEY PART NUMBER U/M DESCRIPTION
127170-01-000 EA LABEL - WATER TANK DRAIN

WARNING

ROOF SURFACE MAY BE SLIPPERY
ESPECIALLY WHERE MOISTURE IS PRESENT
SLIPPING MAY RESULT IN PERSONAL INJURY.

128218-01

KEY PART NUMBER U/M DESCRIPTION
128218-01-01A EA LABEL - WARNING - SLIPPERY ROOF

ENTRANCE DOOR PROP ROD

THIS ROD IS DESIGNED TO PROP THE
ENTRANCE DOOR OPEN WHEN THE PATIO
AWNING ARM IS ATTACHED TO THE
SIDEWALL AND THE AWNING IS EX-
TENDED.
HOOK ONE END OF ROD INTO LOOP ON
DOOR AND OTHER END INTO LOOP ON THE
SIDEWALL AS SHOWN.

(THIS LABEL TO BE REMOVED BY RETAIL OWNER ONLY)

KEY PART NUMBER U/M DESCRIPTION
128658-01-000 EA LABEL - PROP ROD - ENTRY DOOR

LABEL GROUP (CONTINUED)

WARNING

POTABLE WATER ONLY
SANITIZE, FLUSH, AND
DRAIN BEFORE USING.
SEE INSTRUCTION MANUAL

KEY PART NUMBER U/M DESCRIPTION
128725-01-01A EA LABEL - POTABLE WATER ONLY - BLACK ON CLEAR

TOW VEHICLE RATING MAY BE LESS THAN HITCH RATING.
MAXIMUM VERTICAL HITCH LOAD: 350 LBS
DO NOT EXCEED REAR AXLE RATING.
SEE OWNER'S MANUAL FOR ADDITIONAL INFORMATION.

KEY PART NUMBER U/M DESCRIPTION
129669-01-01A EA LABEL - HITCH/VEHICLE RATE - 350 - WHITE ON CLEAR
129669-01-02A EA LABEL - HITCH/VEHICLE RATE - 350 - BLACK ON CLEAR
129669-02-01A EA LABEL - HITCH/VEHICLE RATE - 500 - WHITE ON CLEAR
129669-02-02A EA LABEL - HITCH/VEHICLE RATE - 500 - BLACK ON CLEAR

TIRE ROTATION
SEE RIALTA OWNERS MANUAL
SECTION 9

KEY PART NUMBER U/M DESCRIPTION
129684-01-000 EA LABEL - TIRE ROTATION

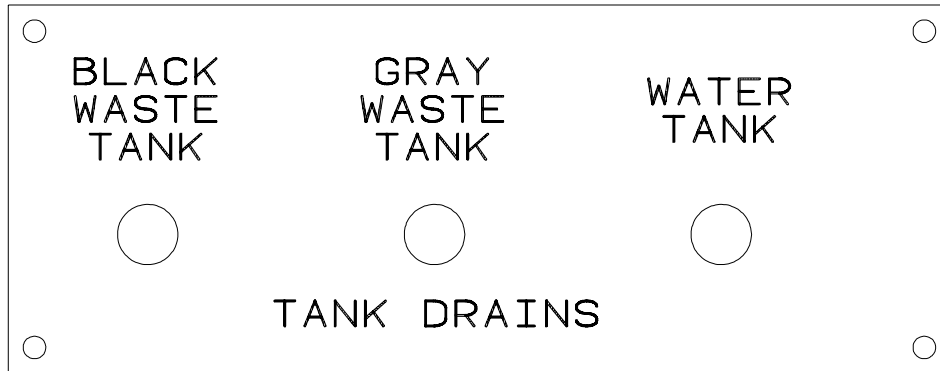

KEY PART NUMBER U/M DESCRIPTION
130166-01-000 EA LABEL - DRAIN

H
O
S
E

S
T
O
R
A
G
E

KEY PART NUMBER U/M DESCRIPTION
130167-02-000 EA LABEL - HOSE STORAGE

LABELS GROUP (CONTINUED)

WASTE TANK FLUSH

KEY PART NUMBER U/M DESCRIPTION
130168-01-000 EA LABEL - WASTE TANK FLUSH

MONITOR WATER
PANEL LIGHT PUMP

KEY PART NUMBER U/M DESCRIPTION
130170-01-000 EA LABEL - SWITCH PANEL - BLK/CLEAR BACKGROUND-1.8"H X 5.9"L

LIGHTS WATER
PUMP

KEY PART NUMBER U/M DESCRIPTION
130170-02-000 EA LABEL - SWITCH PANEL-BLK/CLEAR BACKGROUND-1.4"H X 3.9"L

WATER
PUMP

KEY PART NUMBER U/M DESCRIPTION
130170-03-000 EA LABEL - PANEL SWITCH

CAUTION:
OPEN A WINDOW OR VENT WHILE
OPERATING DRYER. IT IS DANGEROUS
TO CREATE A NEGATIVE AIR PRESSURE
INSIDE A VEHICLE CONTAINING
FUEL-BURNING APPLIANCES

KEY PART NUMBER U/M DESCRIPTION
130670-01-01A EA LABEL - CAUTION DRYER VENTING - BLACK ON CLEAR

PUSH TO
RELEASE
GENERATOR
SLIDE ASM

KEY PART NUMBER U/M DESCRIPTION
131779-01-01A EA LABEL - GENERATOR

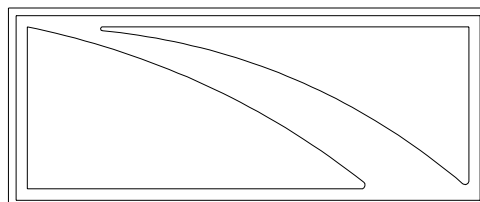

KEY PART NUMBER U/M DESCRIPTION
132651-01-01A EA DECAL - MIRROR/GALLEY

LABELS GROUP (CONTINUED)



KEY PART NUMBER U/M DESCRIPTION
 133423-01-01A EA LABEL - DRAIN



KEY PART NUMBER U/M DESCRIPTION
 133424-01-01A EA LABEL - BYPASS - WATER HEATER



KEY PART NUMBER U/M DESCRIPTION
 133424-02-01A EA LABEL - NORMAL OPERATION



KEY PART NUMBER U/M DESCRIPTION
 133424-03-01A EA LABEL - WATER HEATER BYPASS - BLACK/CLEAR

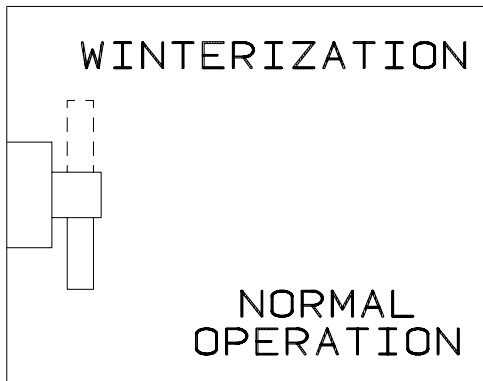

KEY PART NUMBER U/M DESCRIPTION
 133425-01-01A EA LABEL - VALVE - WINTERIZATION



KEY PART NUMBER U/M DESCRIPTION
 133533-01-01A EA LABEL - JACKS DOWN - CLEAR W/WHITE LETTERING



KEY PART NUMBER U/M DESCRIPTION
 133533-02-01A EA LABEL - CHECK ANTENNA - CLEAR W/WHITE LETTERING

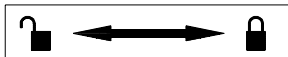

KEY PART NUMBER U/M DESCRIPTION
 133533-03-01A EA LABEL - LOCK/UNLOCK - BLACK/WHITE

LABELS GROUP (CONTINUED)

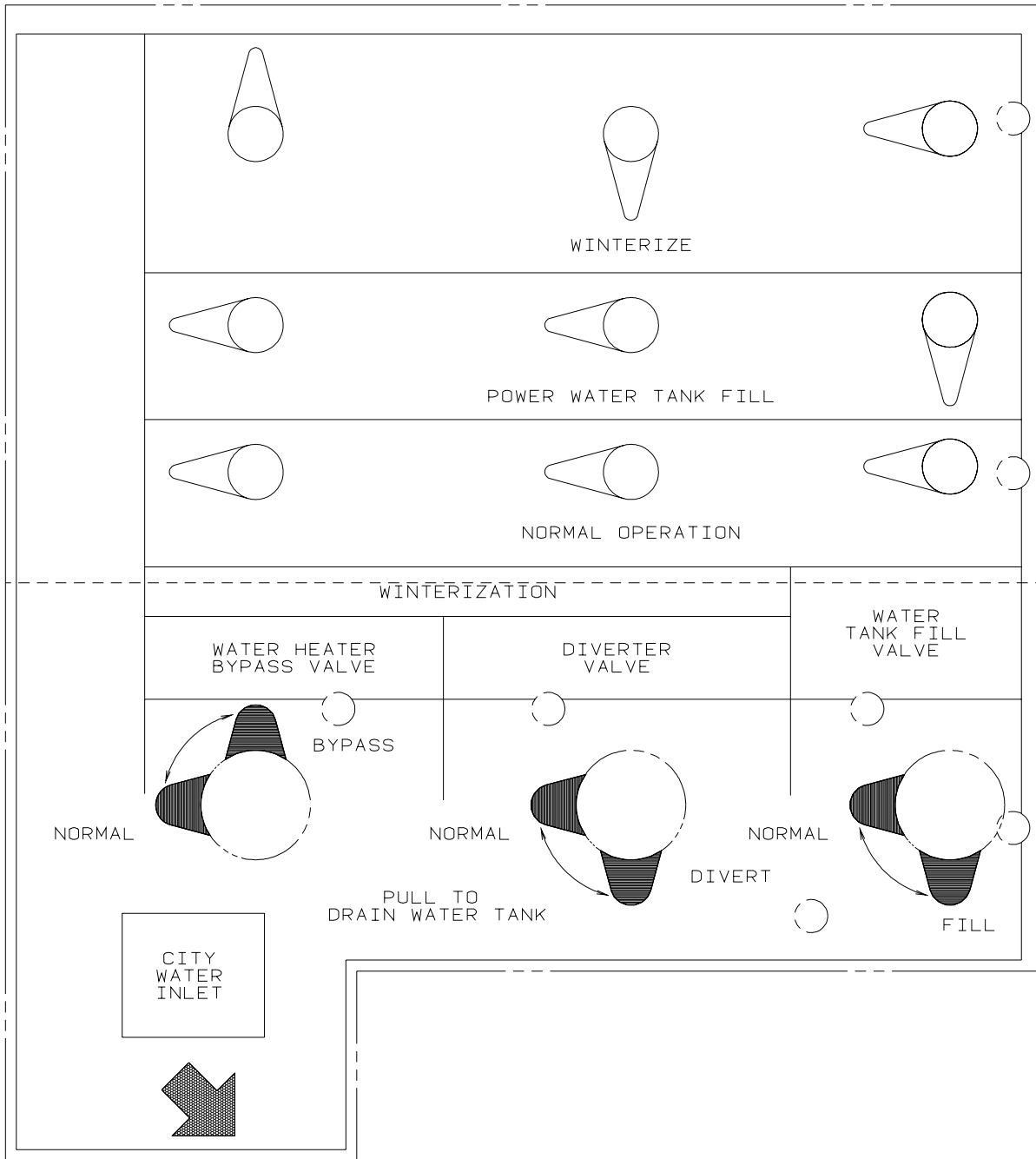

KEY	PART NUMBER	U/M	DESCRIPTION
	133629-01-01A	EA	LABEL - WATER CENTER

LABELS GROUP (CONTINUED)

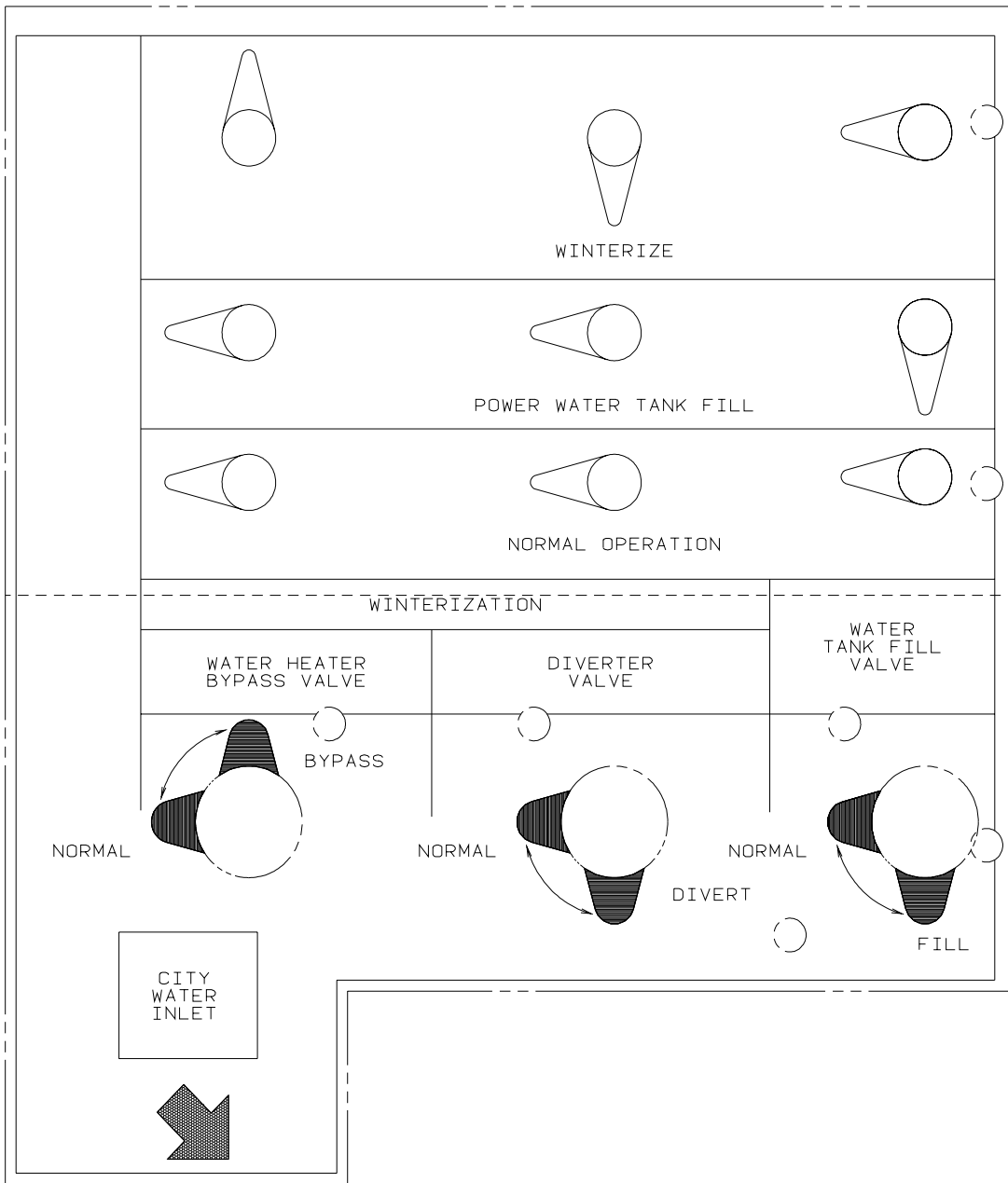

KEY PART NUMBER U/M DESCRIPTION
 133629-02-01A EA LABEL - WATER CENTER - BLACK/CLEAR

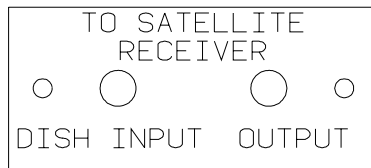

KEY PART NUMBER U/M DESCRIPTION
 134250-01-01A EA LABEL - SATELLITE RECEIVER - BLACK/CLEAR

THIS CHAIR IS NOT INTENDED FOR OCCUPANCY WHEN VEHICLE IS IN MOTION AND MUST BE RETURNED TO STOWED POSITION

DTS ISICE SIEGE N/EST PAS DESTINE A ETRE OCCUPE LORSQUE LE VEHICULE EST IN MOVEMENT ET IL FAUT QUE LE RANGER

THIS CHAIR IS NOT INTENDED FOR OCCUPANCY WHEN VEHICLE IS IN MOTION AND MUST BE RETURNED TO STOWED POSITION

KEY PART NUMBER U/M DESCRIPTION
 134537-01-01A EA LABEL - OCCUPANCY - CHAIR - US

LABELS GROUP (CONTINUED)

THIS SEAT IS NOT INTENDED
FOR OCCUPANCY WHEN
VEHICLE IS IN MOTION

KEY PART NUMBER U/M DESCRIPTION
134538-01-01A EA LABEL - OCCUPANCY - NO SEAT BELT - BLACK ON CLEAR - US

DST ISICE SIEGE N/EST PAS THIS SEAT IS NOT INTENDED
DESTINE A ETRE OCCUPE LORSQUE FOR OCCUPANCY WHILE
LE VEHICULE EST IN MOVUUMENT VEHICLE IS IN MOTION

KEY PART NUMBER U/M DESCRIPTION
134538-02-01A EA LABEL - OCCUPANCY - NO SEAT BELT - BLACK ON CLEAR - CSA

WARNING

IT IS NOT SAFE TO USE COOKING
APPLICANCES FOR COMFORT HEATING

COOKING APPLICANCES NEED FRESH AIR FOR SAFE OPERATION
BEFORE OPERATION.

1. OPEN OVERHEAD VENT OR TURN ON EXHAUST FAN AND;
2. OPEN WINDOW.

KEY PART NUMBER U/M DESCRIPTION
134539-01-01A EA LABEL - WARNING - STOVE/HEATING - US - BLACK ON CLEAR

HOLDING TANK HEATER

TURN OFF WHEN NOT IN USE
SEE OPERATOR'S MANUAL

KEY PART NUMBER U/M DESCRIPTION
134563-01-01A EA LABEL - SWITCH - HEATER

THIS VEHICLE MAY INCLUDE MERCURY-CONTAINING DEVICES INSTALLED BY THE MANUFACTURER:

FLUORESCENT TUBES, RANGES WITH OVEN, HWH LEVEL SENSING UNIT.

REMOVE DEVICES BEFORE VEHICLE DISPOSAL UPON REMOVAL OF
DEVICES: PLEASE REUSE, RECYCLE, OR DISPOSE AS HAZARDOUS WASTE

135869-01A

KEY PART NUMBER U/M DESCRIPTION
135869-01-01A EA LABEL - MERCURY CONTENT - BLACK ON CLEAR
135869-01-02A EA LABEL - MERCURY CONTENT - WHITE ON CLEAR

LIQUID SOAP

KEY PART NUMBER U/M DESCRIPTION
136047-01-01A EA LABEL - LIQUID SOAP

LABELS GROUP (CONTINUED)

DOOR LOCK	DOOR UNLOCK	RIGHT COMPT DOOR LOCK	RIGHT COMPT DOOR UNLOCK	LEFT COMPT DOOR LOCK	LEFT COMPT DOOR UNLOCK	AUX START SOLENOID	AMP SOURCE
POWER MIRRORS	HEATER BLOWER	PASS HEATER BLOWER	FOG LAMPS	DOCKING LAMPS	DOCKING LAMPS SWITCH TRIGGER	COOLING FANS	

KEY PART NUMBER U/M DESCRIPTION
 136161-01-01A EA LABEL - RELAY - MATTE BLACK/WHITE LETTERS



KEY PART NUMBER U/M DESCRIPTION
 136360-01-01A EA LABEL - AIR BAGS

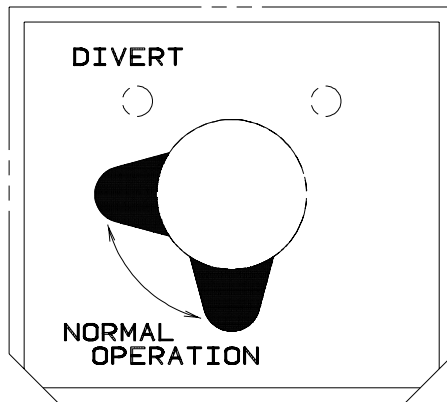

KEY PART NUMBER U/M DESCRIPTION
 137997-01-01A EA LABEL - WINTERIZATION VALVE - BLACK/CLEAR



KEY PART NUMBER U/M DESCRIPTION
 140190-01-01A EA DECAL/LOGO - V6 (DOMED) - CYAN/MAGENTA/YELLOW/BLACK

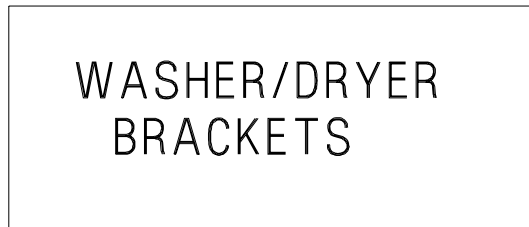

KEY PART NUMBER U/M DESCRIPTION
 141523-01-01A EA LABEL - WASHER/DRYER BRACKETS - BLACK/WHITE

LABELS GROUP (CONTINUED)

INVERTER	SLIDEDOUT CONTROL	BATTERY MODE SWITCH	COACH BREAKER PANEL	ELECTRIC STEP IGNITION POWER	ELECTRIC STEP BATTERY POWER	ELECTRIC STEP CONTROL POWER	SOLAR PANEL
----------	-------------------	---------------------	---------------------	------------------------------	-----------------------------	-----------------------------	-------------

KEY PART NUMBER **U/M DESCRIPTION**
 093236-29-000 EA LABEL - CIRCUIT BREAKER

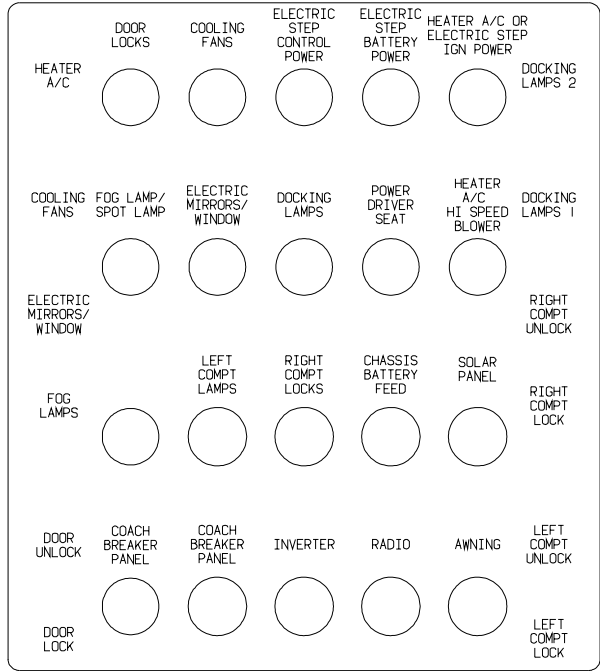

KEY PART NUMBER **U/M DESCRIPTION**
 093236-30-000 EA LABEL - CIRCUIT BREAKER

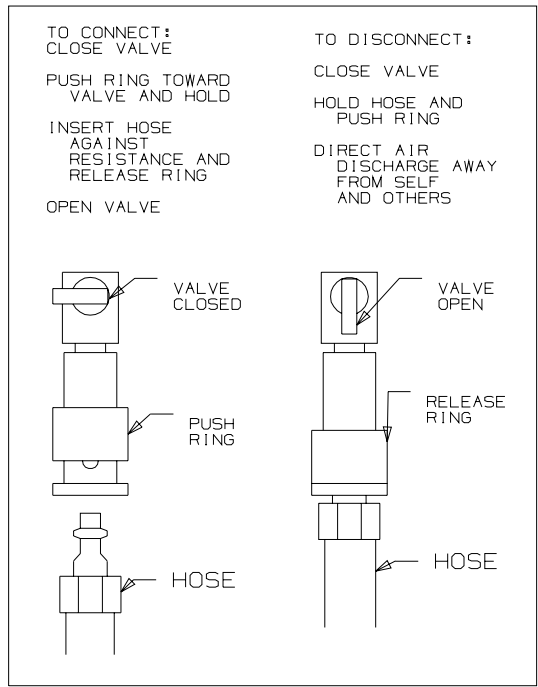

KEY PART NUMBER **U/M DESCRIPTION**
 142773-01-01A EA LABEL - CONNECT/COMPRESS AIR - WHITE LETTERING ON CLEAR

LABELS GROUP (CONTINUED)

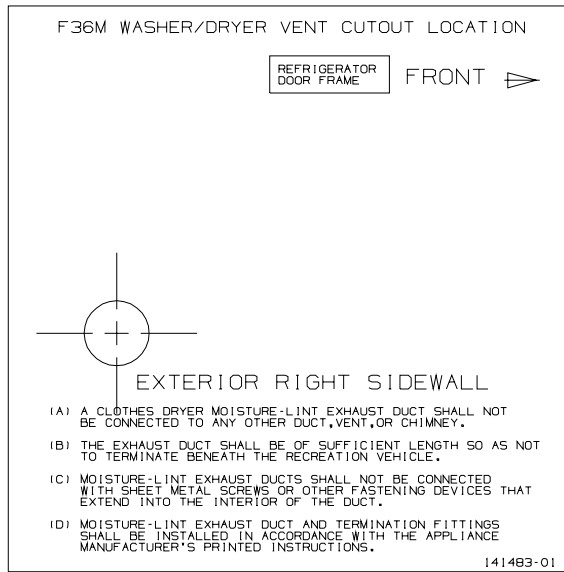

KEY PART NUMBER **U/M DESCRIPTION**
 141483-01-01A EA LABEL - DRYER VENTING - BLACK/WHITE

WARNING : COMPRESSED AIR CAN BE HAZARDOUS.

PROPER EYE PROTECTION MUST BE WORN WHEN CONNECTING, DISCONNECTING OR USING AIR HOSE.

CLOSE VALVE BEHIND CONNECTOR BEFORE CONNECTING OR DISCONNECTING AIR HOSE.

HOSE DISCONNECT WILL PRODUCE AIR DISCHARGE FROM HOSE. DIRECT AIR DISCHARGE AWAY FROM SELF AND OTHERS.

KEY PART NUMBER **U/M DESCRIPTION**
 142771-01-01A EA LABEL - WARNING/COMPRESSED AIR - WHITE LETTERING ON CLEAR

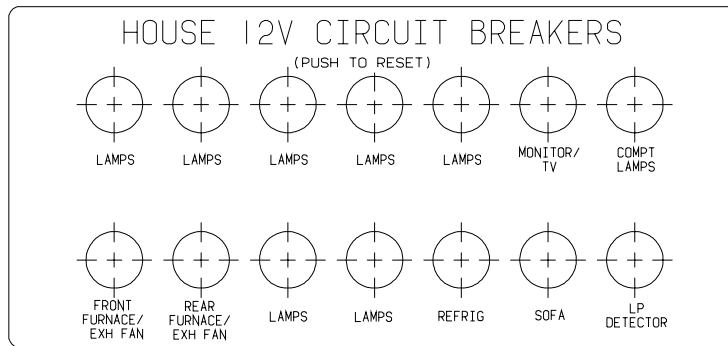

KEY PART NUMBER **U/M DESCRIPTION**
 092547-11-000 EA LABEL - CIRCUIT BREAKER

LP GROUP
LP SYSTEM

KEY	PART NUMBER	U/M	DESCRIPTION
*	088253-05-000	EA	TANK - LP - 130 LB - LIQUID DRAW
*	088253-06-000	EA	TANK - LP - 130 LB
	045703-03-000	EA	HOSE - LP - 3/8"ID X 18" - 3/8"MPT X 1/2"F SWIVEL - U.S.
	045703-09-000	EA	HOSE - LP - 3/8"ID X 24" - 3/8"ID F SWIVEL X 3/8"ID F SWIV
	045703-12-000	EA	HOSE - LP - 3/8"ID X 18" - 3/8"MPT X 1/2"F SWIVEL - CANADA
	045703-13-000	EA	HOSE - LP - 3/8"ID X 120" - 3/8"F SWIVEL X 1/2"F SWIVEL US
	045703-15-000	EA	HOSE - LP - 3/8"ID X 142" - 1/2"F SWIVEL X 3/8"F SWIVEL
	045703-16-000	EA	HOSE - LP - 3/8ID X 109" - 1/2" F SWIV FLR X 3/8" M FLR
	105658-01-000	EA	COMPARTMENT - LP REGULATOR
	106150-01-000	EA	REGULATOR - TWO STAGE-W/90 DEGREE ELBOW & 3/8" FPT OUTLET
	010329-01-000	EA	ADAPTER - BRASS - 1/2"F X 1/2"MPT
	010323-01-000	EA	ADAPTER - BRASS - 3/8"F X 1/2"MPT
	010326-01-000	EA	ADAPTER - FLARE - W/CONE GASKET - 3/8"F X 1/2"F
	010536-02-000	EA	TEE - STEEL - 1/2" - BLACK
	010515-03-000	EA	ELBOW - BLACK - 1/2 X 90 DEGREE STEEL
	010251-02-000	EA	ELBOW - BRASS - 90 DEGREE - 3/8 F X 1/4 MPT
	010265-01-000	EA	ELBOW - BRASS - 90 DEGREE - 3/8"F X 1/2"FPT
	033759-01-000	EA	ELBOW - 90 DEGREE - 3/8" F X 3/8" F
	010380-02-000	EA	NUT - BRASS - 1/2" FLARE - FORGED
	106846-01-000	EA	VALVE - RELIEF
	106871-01-000	EA	BUSHING - 1/2 X 1/4 - BLACK
	040440-03-000	EA	TRANSMITTER - DIAL/SNAP-ON - 0-90 OHM 2 TERM(POWER/GROUND)
	103613-03-000	EA	DETECTOR - LP GAS - W/O SHUT-OFF VALVE

***COMPONENT PARTS LISTED LATER IN THIS GROUP**

LP GROUP (CONTINUED)
COMPONENT PARTS FOR LP SYSTEM

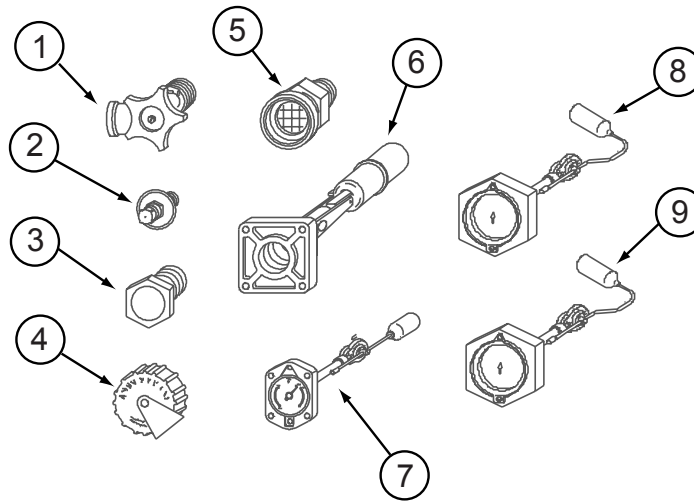

088253-05-000

KEY	PART NUMBER	U/M	DESCRIPTION	VENDOR NO.
1	040421-01-708	EA	HANDWHEEL-SERVICE VALVE	G-1015-A
1	040421-01-710	EA	VALVE-SERVICE, LIQUID	910145
1	040421-01-712	EA	VALVE,SERV. W/O VAPOR RELIEF	29000853
2	040421-01-700	EA	VALVE-LIQUID LEVEL, 20%	G-1013
3	040421-01-713	EA	VALVE-RELIEF 1" W/SPRING 7"	29000587
4	040421-01-702	EA	CAP-FILL VALVE, PLASTIC	G-1014-A
5	040421-01-701	EA	VALVE-FILL-SHORT, LP	7547B
6	040421-01-711	EA	VALVE-80% FILL W/AUTO STOP	LLL/TL3
7			NOT WHAT IS ILLUSTRATED HERE	
8			NOT WHAT IS ILLUSTRATED HERE	
9	088253-01-700	EA	FLOAT/BOLT ON-SCREW ON DIAL	SG16C0000071
9	088253-01-702	EA	FLOAT/SCREW IN-SNAP ON DIAL	SG16C0001442

088253-06-000

KEY	PART NUMBER	U/M	DESCRIPTION	VENDOR NO.
1	040421-01-708	EA	HANDWHEEL-SERVICE VALVE	G-1015-A
1	040421-01-712	EA	VALVE,SERV. W/O VAPOR RELIEF	29000853
2	040421-01-700	EA	VALVE-LIQUID LEVEL, 20%	G-1013
3	040421-01-713	EA	VALVE-RELIEF 1" W/SPRING 7"	29000587
4	040421-01-702	EA	CAP-FILL VALVE, PLASTIC	G-1014-A
5	040421-01-701	EA	VALVE-FILL-SHORT, LP	7547B
6	040421-01-711	EA	VALVE-80% FILL W/AUTO STOP	LLL/TL3
7			NOT WHAT IS ILLUSTRATED HERE	
8			NOT WHAT IS ILLUSTRATED HERE	
9	088253-01-700	EA	FLOAT/BOLT ON-SCREW ON DIAL	SG16C0000071
9	088253-01-702	EA	FLOAT/SCREW IN-SNAP ON DIAL	SG16C0001442

LOUNGE GROUP CABINETS

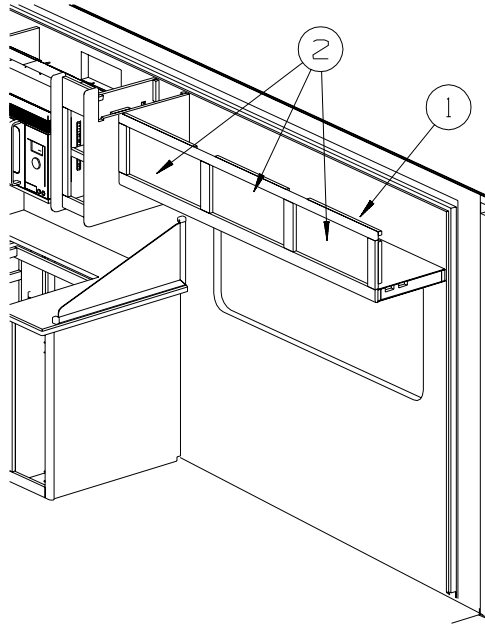

KEY	PART NUMBER	U/M	DESCRIPTION
1	141798-01-P28	EA	CABINET - OVHD/FRONT/LH - W/O DOORS/HARDWARE - WASHED MAPLE - W/O DLX SOUND SYS.
1	141798-01-P78	EA	CABINET - OVHD/FRONT/LH - W/O DOORS/HARDWARE - PORTSMOUTH OAK - W/O DLX SOUND SYS.
1	141798-01-P79	EA	CABINET - OVHD/FRONT/LH - W/O DOORS/HARDWARE - CONCERT CHERRY - W/O DLX SOUND SYS.
1	141798-02-P28	EA	CABINET - OVHD/FRONT/LH - W/O DOORS/HARDWARE - WASHED MAPLE - SURROUND SOUND
1	141798-02-P78	EA	CABINET - OVHD/FRONT/LH - W/O DOORS/HARDWARE - PORTSMOUTH OAK - SURROUND SOUND
1	141798-02-P79	EA	CABINET - OVHD/FRONT/LH - W/O DOORS/HARDWARE - CONCERT CHERRY - SURROUND SOUND
2	141516-43-P28	EA	DOOR - ARCHED/PENCIL EDGE - 10.8" X 23.8" - W/O HARDWARE - WASHED MAPLE
2	141516-43-P84	EA	DOOR - ARCHED/PENCIL EDGE - 10.8" X 23.8" - W/O HARDWARE - PORTSMOUTH OAK
2	141516-43-P85	EA	DOOR - ARCHED/PENCIL EDGE - 10.8" X 23.8" - W/O HARDWARE - CONCERT CHERRY

LOUNGE GROUP (CONTINUED) TABLES

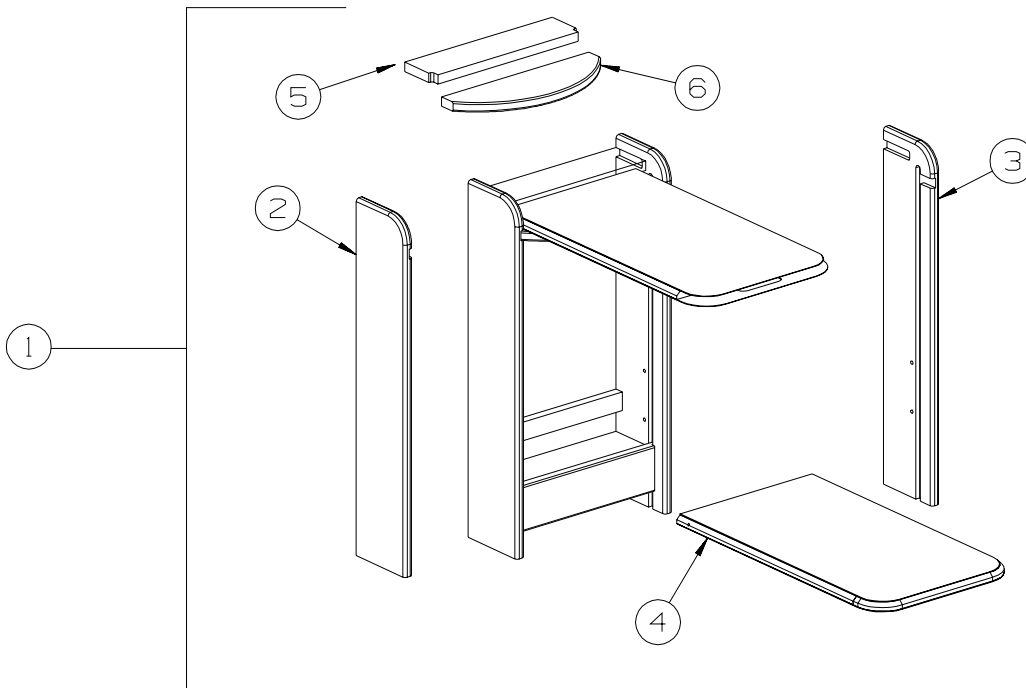

KEY	PART NUMBER	U/M	DESCRIPTION
1	141198-02-P28	EA	TABLE - PULLOUT - WASHED MAPLE
1	141198-02-P78	EA	TABLE - PULLOUT - PORTSMOUTH OAK
1	141198-02-P79	EA	TABLE - PULLOUT - CONCERT CHERRY
2	141198-11-P28	EA	END - TABLE - LEFT - WASHED MAPLE
2	141198-11-P78	EA	END - TABLE - LEFT - PORTSMOUTH OAK
2	141198-11-P79	EA	END - TABLE - LEFT - CONCERT CHERRY
3	141198-12-P28	EA	END - TABLE - RIGHT - WASHED MAPLE
3	141198-12-P78	EA	END - TABLE - RIGHT - PORTSMOUTH OAK
3	141198-12-P79	EA	END - TABLE - RIGHT - CONCERT CHERRY
4	141198-22-P28	EA	TABLE ONLY - WASHED MAPLE
4	141198-22-P78	EA	TABLE ONLY - PORTSMOUTH OAK
4	141198-22-P79	EA	TABLE ONLY - CONCERT CHERRY
5	141198-20-P28	EA	TOP - WALL PORTION - WASHED MAPLE
5	141198-20-P78	EA	TOP - WALL PORTION - PORTSMOUTH OAK
5	141198-20-P79	EA	TOP - WALL PORTION - CONCERT CHERRY
6	141198-19-P78	EA	SHELF - TABLE SUPPORT - WASHED MAPLE
6	141198-19-P78	EA	SHELF - TABLE SUPPORT - PORTSMOUTH OAK
6	141198-19-P79	EA	SHELF - TABLE SUPPORT - CONCERT CHERRY

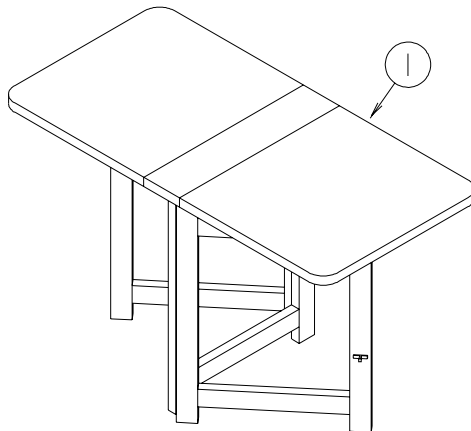

KEY	PART NUMBER	U/M	DESCRIPTION
1	133604-01-L81	EA	TABLE/COFFEE - COMPLETE - PORTSMOUTH OAK
1	133604-01-L52	EA	TABLE/COFFEE - COMPLETE - CHERRY - CONCERT CHERRY
1	133604-01-L58	EA	TABLE/COFFEE - COMPLETE - WASHED MAPLE
	134334-01-000	EA	BAG - COFFEE TABLE

SEALANTS & FASTENERS GROUP
SEALANTS & ADHESIVES

KEY	PART NUMBER	U/M	DESCRIPTION
	002707-02-000	FT	TAPE - SEALER - 5/16" X 1/2" - INCREMENTS OF 50 FT
	004001-02-000	EA	GUN - PLEXUS ADHESIVE - W/O NOZZLE
	004001-05-000	EA	ADHESIVE - SCOTCH-WELD - 3M DP100 - CLEAR - 50ML
	004011-01-000	EA	ADHESIVE-3M-4475 TUBE
	010405-02-000	EA	TAPE - THREAD SEALING - 3/8"
	034552-06-000	EA	SILICONE - TUBE - W/O NOZZLE - OFF WHITE
	034552-15-000	EA	SILICONE - TUBE - W/O NOZZLE - BRIGHT WHITE
	063642-01-000	FT	TAPE - ADHESIVE - .4" X 1.5" X 180'
	064075-07-000	FT	SEAL - BULB - W/WIRED U CHANNEL - .3" X .5" CHANNEL-BLACK
	067788-01-000	EA	ADHESIVE - SPRAY - 3M - 19.5 OZ AEROSOL CAN
	069640-01-000	FT	SEALER - RIBBON - 1/4" DIAMETER X 30' - BLACK OR GRAY
	069640-02-000	FT	SEALER - TAPE - .13" THICK X .5" WIDE X 60' - GRAY
	069640-03-000	FT	SEALER - TAPE - .13" THICK X .75" WIDE X 60' - BLACK
	069640-07-000	FT	SEALER - TAPE - .09" THICK X 2" WIDE X 45' - GRAY
	069640-09-000	FT	SEALER - TAPE - .03" THICK X 2.50"WIDE X 80' - GRAY
	069640-10-000	FT	SEALER - TAPE - .03" THICK X 1.50" WIDE X 90' - GRAY
	069640-11-000	FT	SEALER - TAPE - .19" THICK X .38" WIDE X 40' - BLACK
	069640-13-000	FT	SEALER - TAPE - .03" THICK X 2" WIDE X 45' - BLACK
	069640-14-000	FT	SEALER - TAPE - .06" THICK X 1" WIDE X 100' - GRAY
	069640-15-000	FT	SEALER - TAPE - .06" THICK X .38" WIDE X 100' - GRAY
	069640-17-000	FT	SEALER - TAPE - .03" THICK X 1" WIDE X 90' - GRAY
	069640-18-000	FT	SEALER - TAPE - .50" THICK X .13" WIDE X 60' - BRT WHITE
	069640-19-000	FT	SEALER - TAPE - .75" THICK X .13" WIDE X 60' - BRT WHITE
	069640-20-000	FT	SEALER - TAPE - .50" THICK X 1/8" WIDE X 60' - BLACK
	069640-21-000	FT	SEALER - TAPE - .50" THICK X 1/16" WIDE X 100'-BRIGHT WHT
	069640-23-000	FT	SEALER - TAPE - .06" THICK X 3/4" WIDE X 100' - BRT WHITE
	069640-27-000	FT	SEALER - TAPE - .06" THICK X 2.25" WIDE - BRIGHT WHITE
	069640-28-000	FT	SEALER - TAPE - .25" THICK X 1 7/8" WIDE X 90' - GRAY
	069640-30-000	FT	SEALER - TAPE - 3/8" X 1/32" - GRAY
	069640-31-000	FT	SEALER - TAPE - 25"THICK X 3/4"WIDE X 60' - BLACK
	072889-01-000	EA	SEALANT - URETHANE - BLACK - TUBE W/NOZZLE TIP
	076322-01-000	FT	TAPE-DOUBLE COATED/ADHESIVE BK-.03"THK X .8"W X 216'- WHT
	076322-02-000	FT	TAPE-DOUBLE COATED/ADHESIVE BK-.05"THK X 1"W X 108' - WHT
	076322-03-000	FT	TAPE-DOUBLE COATED/ADHESIVE BK-.05"THK X .5"W X 108' - WHT
	076322-04-000	FT	TAPE-DOUBLE COATED/ADHESIVE BK-.05"THK X .8"W X 108' - WHT
	076322-05-000	FT	TAPE-DOUBLE COATED/ADHESIVE BK-.05"THK X .8"W X 108' - WHT
	076322-11-000	FT	TAPE-DOUBLE COATED/ADHESIVE BK-.02"THK X 1"W X 216' - CLR
	086276-01-000	EA	TAPE - DOUBLE SIDED - 1/2" WIDE X 108' LONG (SOLD BY ROLL)
	088479-01-000	EA	TAPE - ALUMINUM - 3"
	090340-01-000	FT	SEAL - FOAM - CLOSED CELL - 1/4" X 1/2" X 50'
	090340-02-000	FT	SEAL - FOAM - CLOSED CELL - 3/8" X 1/2" X 50'
	091255-02-000	FT	SEAL - ADHESIVE BACKED/FOAM - 3/64" THICK X 3/16"W X 1000'
	091255-03-000	FT	SEAL - ADHESIVE BACKED/FOAM - 1/4" THICK X 1/4"W X 1000'
	094401-01-000	EA	SEALER - BODY SEAM - FLEXICLEAR
	094401-03-000	EA	SEALER - BODY SEAM - BLACK
	094401-04-000	EA	SEALER - BODY SEAM - CLEAR
	098408-01-000	FT	SEAL - SPONGE RUBBER - CLOSED CELL
	099069-01-000	FT	SEAL - RUBBER - CLOSED SPONGE - .5" WIDE X .12" THICK -BLK
	099418-01-000	FT	SEAL - D-SECTION/ADHESIVE BACK - .44" X .44"- BLK RUBBER
	099418-02-000	FT	SEAL - D SECTION - WHITE
	100128-02-000	FT	SEAL - FOAM/ADHESIVE BACK - .37" WIDE X .37" THICK
	104692-01-000	FT	SEAL - ADHESIVE BACKED FOAM - 3/4" THICK X 3/4" WIDE X 25'
	104692-03-000	FT	SEAL - ADHESIVE BACKED FOAM - 1" THICK X 1 3/16"WIDE X 15'
	107828-01-000	EA	SEALANT - SB - 190 EVERSEAL
	108716-01-000	EA	SILICONE - W/O NOZZLE - OFF WHITE - SELF LEVELING
	109506-12-000	EA	FILM/ABRASION-RESISTANT - TRANSPARENT - 1" DIA.
	110274-01-000	FT	TAPE - DOUBLE SIDED/FOAM - .45" X 1" X 216' - BLACK
	112481-02-000	EA	ADHESIVE - PLEXUS ETHACRYLATE - CARTRIDGE
	112864-01-000	FT	SEAL - FOAM/BUTYL COVERED - 3/8" X 35'
	112864-02-000	FT	FOAM - BUTYL COVERED 5/16" X 44'
	112864-03-000	FT	FOAM - BUTYL COVERED - 1/2" X 1/8" X 25'
	112864-04-000	FT	FOAM - BUTYL COVERED - 3/8" X 1/8"
	112901-02-000	EA	ADHESIVE - PLEXUS - MA330 - 50ML - GRAY
	112901-03-000	EA	ADHESIVE - PLEXUS - MA300 - 50ML - WHITE

SEALANTS & FASTENERS GROUP (CONTINUED)

SEALANTS & ADHESIVES (CONTINUED)

KEY	PART NUMBER	U/M	DESCRIPTION
	112902-01-000	EA	NOZZLE - ELEMENT - 3/8 X 24
	112902-02-000	EA	NOZZLE-BELL 3/8X24 - TAH 160-824
	112902-03-000	EA	MIXER NOZZLE - F/GUN #00400102000 - SCOTCH-WELD & PLEXUS
	112902-04-000	EA	NOZZLE - ELEMENT - 1/4" X 3.5"
	113366-01-000	EA	ADHESIVE - INSTANT - 1 OZ
	113452-02-000	FT	SEAL/TRIM - FRONT - VINYL W/WIRE CARRIER - .027"
	115933-01-000	FT	TAPE - 1/64" X 3/8" X 100'
	120074-02-03A	EA	SILICONE - TUBE - W/O NOZZLE - SMOKEY WHITE
	120074-02-02A	EA	SILICONE - TUBE - W/O NOZZLE - LOW ODOR - SOFT WHITE
	120534-01-01A	EA	TAPE - SCOTCH - 3M - 1/2" FINE LINE
	123244-01-000	FT	TAPE - DOUBLE SIDED/FOAM - 5/64" THICK X 3/4" WIDE X 108'
	123816-01-000	FT	TAPE - DOUBLE SIDED - 1" X 3/4" X 200'
	123816-02-000	FT	TAPE - DOUBLE SIDED - 1/2" X 1 1/3" X 200'
	123816-03-000	FT	TAPE - DOUBLE SIDED - 1/2" X 3/4" X 200'
	123816-04-000	FT	TAPE - DOUBLE SIDED - 6" X 750'
	126427-01-000	EA	ADHESIVE - ALL PURPOSE - ABS/PVC
	126427-02-000	EA	PRIMER - CLEANER - FLEX PIPING
	131264-01-08A	EA	SILICONE - TUBE - W/O NOZZLE - BUFF
	131264-01-02A	EA	SILICONE - TUBE - W/O NOZZLE - CLEAR
	131264-01-01A	EA	SILICONE - TUBE - W/O NOZZLE - BLACK
	131264-02-01A	EA	SILICONE - TUBE - W/O NOZZLE - VW GRAY - BATH ONLY
	131264-03-01A	EA	SILICONE - TUBE - W/O NOZZLE- SELF LEVELING - BRIGHT WHITE
	131264-04-01A	EA	SILICONE/SEALANT/ADHESIVE - FAST CURE F/GLASS/VINYL - B/W
	131384-01-000	EA	ADHESIVE - JETWELD
	134651-01-000	FT	SEAL - 1/2" X 3/4" PSA 1 SIDE
	900390-01-000	EA	NOZZLE - SILICONE TUBE - 2.5" LONG
	900390-03-000	EA	NOZZLE - SILICONE TUBE - 4.3" LONG

BOLTS, NUTS AND WASHERS

KEY	PART NUMBER	U/M	DESCRIPTION
	OMC04K-06-016	EA	BOLT - HEX - M06 X 1 X 016
	OMC05K-08-055	EA	BOLT - HEX - M08 X 1.25 X 2.2
	OMC13K-14-110	EA	BOLT - HEX
	OMC13K-14-070	EA	BOLT - HEX - M14 X 2 X 2 3/4
	OMC31K-08-020	EA	BOLT - HEX - SERRATED FLANGE - M8 X 020
	OMC32K-10-030	EA	BOLT - HEX - SERRATED FLANGE - M10 X 1 1/2
	OMD16K-10-000	EA	NUT - HEX PREV TORQUE M10 X 1 1/2 CLASS 8
	OMD39K-12-000	EA	NUT - HEX W/NYLON LOCK - M12 X 1 3/4
	OMD40K-14-000	EA	NUT - HEX W/NYLON LOCK - M14 X 2
	OMD54F-06-000	EA	NUT-HEX SER FLG M6X1,0 SS - DIN6923A2M6
	OME06K-14-280	EA	WASHER - FLAT - 14 ID X 28 OD
	000C12-04-40B	EA	BOLT - HEX - 1/4-20 X 2 1/2 - GRADE 5 ZINC
	000C12-04-08B	EA	BOLT - HEX - 1/4-20 X 1/2 - GRADE #5 - ZINC
	000C12-05-16B	EA	BOLT - HEX - 5/16-18 X 1 - GRADE #5 - ZINC
	000C12-06-24B	EA	BOLT - HEX - 3/8-16 X 1 1/2 - ZINC #5
	000C12-06-16B	EA	BOLT - HEX - 3/8-16 X 1 - GRADE #5 - ZINC
	000C12-06-128	EA	BOLT - HEX - 3/8 - 16 X 8 - ZINC 5
	000C12-06-44B	EA	BOLT - HEX - 3/8-16 X 2 3/4 - GRADE 5 - ZINC
	000C12-08-28B	EA	BOLT - HEX - 1/2-13 X 1 3/4 - GRADE #5 - ZINC
	000C12-08-24B	EA	BOLT - HEX - 1/2-13 X 1 1/2 - GRADE #5 - ZINC
	000C12-08-16B	EA	BOLT - HEX - 1/2-13 X 1 - GRADE #5 - ZINC
	000C12-10-24B	EA	BOLT - HEX - 5/8-11 X 1 1/2 - GRADE #5 - ZINC
	000C13-07-48B	EA	BOLT - HEX - 7/16-20 X 3 - GRADE #5 - ZINC
	000C13-07-40B	EA	BOLT - HEX - 7/16-20 X 2 1/2 - GRADE #5 - ZINC
	000C14-07-28B	EA	BOLT - HEX - 7/16-14 X 1 3/4 - GRADE #8 - ZINC
	000C14-10-32K	EA	BOLT - HEX - 5/8-11 X 2 - GRADE #8 - ZINC
	000C18-05-40A	EA	BOLT - ELEVATOR - 5/16-18 X 2 1/2 - PL
	000C18-06-48B	EA	BOLT - ELEVATOR - 3/8-16 X 3 - GRADE 5 - ZINC
	000C26-04-18B	EA	BOLT - HEX - SERRATED FLANGE - 1/4-20 X 1 1/8 - ZINC
	000C26-04-14B	EA	BOLT - HEX - SERRATED FLANGE - 1/4-20 X 7/8 - ZINC
	000C26-04-10B	EA	BOLT - HEX - SERRATED FLANGE - 1/4-20 X 5/8 - ZINC
	000C26-05-20B	EA	BOLT - HEX - SERRATED FLANGE - 5/16-18 X 1 1/4 - ZINC
	000C26-05-129	EA	BOLT - HEX - SERRATED FLANGE - 5/16-18 X 3/4
	000C26-05-12B	EA	BOLT - HEX - SERRATED FLANGE - 5/16-18 X 3/4 - ZINC

SEALANTS & FASTENERS GROUP (CONTINUED)
BOLTS, NUTS AND WASHERS (CONTINUED)

KEY	PART NUMBER	U/M	DESCRIPTION
	000C26-05-249	EA	BOLT - HEX - SERRATED FLANGE - 5/16-18 X 1 1/2
	000C26-06-28B	EA	BOLT - HEX - SERRATED FLANGE - 3/8-16 X 1 3/4 - ZINC
	000C26-06-20B	EA	BOLT - HEX - SERRATED FLANGE - 3/8-16 X 1 1/4 - ZINC
	000C26-06-12B	EA	BOLT - HEX - SERRATED FLANGE - 3/8-16 X 3/4 - ZINC
	000C26-06-40B	EA	BOLT - HEX - SERRATED FLANGE - 3/8-16 X 2 1/2 - ZINC
	000C26-08-24B	EA	BOLT - HEX - SERRATED FLANGE - 1/2-13 X 1 1/2 - ZINC
	000C27-04-40B	EA	BOLT - CARRIAGE - 1/4-20 X 2 1/2 - ZINC
	000C27-05-44I	EA	BOLT-CARR,5/16-18X2.75" - BLACK ZINC
	000C27-07-40B	EA	BOLT - CARRIAGE - 7/16-14 X 2 1/2 - GRADE #5
	000D16-07-00B	EA	NUT - HEX - 7/16-14 - ZINC
	000D24-10-00B	EA	NUT - HEX - SELF LOCKING - 10-32 ZINC
	000D28-10-00B	EA	NUT - HEX - W/NYLON LOCK - 10-32 ZINC
	000D29-04-00B	EA	NUT - HEX - SELF LOCKING - 1/4 X 20 - ZINC
	000D29-06-00B	EA	NUT - HEX - W/NYLON LOCK - 3/8-16 - ZINC
	000D29-09-00B	EA	NUT - HEX - SELF LOCKING - 9/16-12 - ZINC
	000D30-07-00B	EA	NUT - HEX LOCK - NYLON 7/16 X 20
	000D34-06-00B	EA	NUT - HEX - LOCKING - 3/8-16 GRADE C - ZINC
	000D39-04-00B	EA	NUT - HEX - LOCKING W/SERRATED FLANGE - 1/4-20 - ZINC
	000D39-05-00B	EA	NUT - HEX - LOCKING W/SERRATED FLANGE - 5/16-18 - ZINC
	000D39-06-00B	EA	NUT - HEX - LOCKING W/SERRATED FLANGE - 3/8-18 - ZINC
	000D39-06-00D	EA	NUT - HEX - LOCKING W/SERRATED FLANGE - 3/8"-16 BLACK
	000D39-07-00B	EA	NUT - HEX - LOCKING W/SERRATED FLANGE - 7/16-14 - ZINC
	000D44-04-00B	EA	NUT - HEX - LOCKING W/SERRATED FLANGE - 1/4-28 - ZINC
	000D44-07-00B	EA	NUT - HEX - LOCKING W/SERRATED FLANGE - 7/16-20 - ZINC
	000D44-08-00B	EA	NUT - HEX - LOCKING W/SERRATED FLANGE - 1/2-20 - ZINC
	000D46-04-00A	EA	NUT - HEX - WELD - 1/4-20 - PLAIN
	000D65-08-00B	EA	NUT - HEX - LOCKING W/SERRATED FLANGE - 8-32 - ZINC
	000D67-10-00B	EA	NUT - HEX - LOCK - 5/8-11 - ZINC
	000D73-08-00C	EA	NUT - HEX FLANGE - 1/2-13
	000D75-09-00B	EA	NUT - HEX LOCKING - 9/16-12 - ZINC
	000D76-06-00B	EA	NUT - HEX FLANGE - 3/8-16
	000E11-04-00F	EA	WASHER - LOCKING - 1/4 MED SPLIT - STAINLESS STEEL
	000E11-07-00B	EA	WASHER - LOCKING - 7/16 MED SPLIT - ZINC
	000E11-08-00B	EA	WASHER - LOCKING - 1/2 MED SPLIT - ZINC
	000E13-17-00B	EA	WASHER - FLAT - 3/8 AR - ZINC
	000E13-18-00B	EA	WASHER - FLAT - 3/8 WIDE - ZINC
	000E13-20-00B	EA	WASHER - FLAT - 7/16 WIDE - ZINC
	000E13-22-00B	EA	WASHER - FLAT - 1/2 WIDE - ZINC
	000E13-26-00B	EA	WASHER - FLAT - 5/8 WIDE - ZINC
	000E14-10-00B	EA	WASHER - LOCKING - #10 EXTERNAL TOOTH - ZINC
	000E16-10-00B	EA	WASHER - HARDENED - 5/8 - FLAT - ZINC
	000G45-05-16B	EA	BOLT - LAG - 5/16-9 X 1 - ZINC
	000G62-08-24B	EA	SCREW - SF/DR - 8-18 X 1 1/2 PFH
	002329-01-000	EA	WASHER-FLAT, 9/32" ID X 5/8" OD - NYLON
	005081-01-000	EA	NUT - SPEED - C-TYPE - #8 SCREW
	040921-03-000	EA	NUT - SPEED - U TYPE - #10
	040921-04-000	EA	NUT - SPEED - U TYPE - #8-.59" LENGTH X .44" WIDTH
	040921-05-000	EA	NUT - SPEED - U-TYPE - 8-.67" X .44" WIDE
	041322-01-000	EA	WASHER - FLANGE - 15/32 ID X 2 3/8 OD - F/SEAT BELT MTG
	044364-01-000	EA	NUT - SPEED - FLAT - RECTANGULAR - SELF LOCKING/ONE PIECE
	044364-02-000	EA	NUT - SPEED - FLAT - ROUND
	044533-01-000	EA	WASHER - PLASTIC - 1 3/8 OD - FOR BUTTONS
	046867-04-000	EA	GROMMET - #0
	046867-05-000	EA	WASHER - #0
	051387-06-000	EA	BOLT - CARRIAGE W/O HOLE - 5/16-18 X 9 1/2 - ZINC
	058716-02-000	EA	WASHER - FLAT NYLON
	058716-03-000	EA	WASHER - FLAT/NYLON - .500 X 1 1/4 X 060
	064081-03-000	EA	NUT - WING 3/8-16 - W/WELD NUT
	077071-01-000	EA	WASHER - FENDER - 3/16 ID X 1 OD
	084406-01-000	EA	NUT - CAPPED - CROSS RECESSED - BLACK - 1/4-20 THD
	087234-01-000	EA	NUT - JACK - 1/4 X 20 THD - MOLLY
	087718-01-000	EA	MONOBOLT - STEEL - 3/16 DIAMETER
	088787-12-000	EA	STUD - WELD - 1/4 - 20 X 1.0 LG - MN
	102333-02-01A	EA	BOLT - CARRIAGE - 1/4-20

SEALANTS & FASTENERS GROUP (CONTINUED)
BOLTS, NUTS AND WASHERS (CONTINUED)

KEY	PART NUMBER	U/M	DESCRIPTION
	102540-02-000	EA	SEAL - SCREW
	103020-02-000	EA	BOLT-U - #8-32 - GRADE 5 ZINC
	106166-01-000	EA	BOLT/COLLARED HANGER - 8-32 X 1
	106956-03-000	EA	BOLT - HEX TAP - 1/2-12NC X 3 - GRADE 5 - FULL THREAD/ZINC
	106956-08-000	EA	BOLT - HEX TAP - 1/2-13NC X 4 - GRADE 5 - FULL THREAD/ZINC
	107393-02-000	EA	BOLT - SHOULDER - 3/8" SOCKETHEAD
	107397-01-000	EA	WASHER - FENDER - 3/4 ID X 1 OD
	108067-03-000	EA	STUD - WELD - 1/4 - 20 X 1/2 CD
	109235-01-05A	FT	COVER - SCREW - BRIGHT WHITE
	109235-01-01A	FT	COVER - SCREW - MAT BLACK
	109917-03-000	EA	WASHER - 1" X .50"
	109917-04-000	EA	WASHER - 1" X .75"
	113985-02-000	EA	BOLT - FLANGE - M10-1 1/2 X 30CL 10.9
	114259-05-000	EA	BOLT - 7/16-20 X 1 1/4 W/WASHER
	128444-01-000	EA	WASHER - SPRING - CONICAL
	131377-01-000	EA	NUT-HEX HEAD W/WASHER-1/4-20 X 2" STEEL W/3/4" OD WASHER
	135092-01-01A	EA	BOLT - HEX - SERRATED FLANGE - 1/2-20 X 1 3/4-GRADE 5 ZINC
	135092-02-01A	EA	BOLT - HEX - SERRATED FLANGE - 1/2-20 X 2 1/2-GRADE 5 ZINC

SCREWS

KEY	PART NUMBER	U/M	DESCRIPTION
	0G1106-08-240	EA	SCREW - 6-20 X 1/2 PPH - VW LIGHT GRAY
	0G1108-12-240	EA	SCREW - 8-18 X 3/4 PPH - VW LIGHT GRAY
	0G1208-12-170	EA	SCREW - 8-18 X 3/4 POH - BRIGHT WHITE
	0G1306-08-130	EA	SCREW-6-20X1/2 PFH TAUPE
	0G1308-10-240	EA	SCREW - 8-18 X 5/8 PFH - VW LIGHT GRAY
	0G3804-22-180	EA	SCREW - MACHINE - 1/4-20 X 1 3/8 PFH - BLACK
	0G3908-08-160	EA	SCREW - SF/DR - 8-18 X 1/2 PPH - VW WHITE
	0G3908-08-240	EA	SCREW - SF/DR - 8-18 X 1/2 PPH - VW LIGHT GRAY
	0G3908-08-170	EA	SCREW - SF/DR - 8-18 X 1/2 PPH - BRIGHT WHITE
	0G3908-12-250	EA	SCREW - SF/DR - 8-18 X 3/4 PPH - DARK GRAY
	0G3908-12-240	EA	SCREW - SF/DR - 8-18 X .75 PPH - VW LIGHT GRAY
	0G3908-16-170	EA	SCREW - SF/DR - 8-18 X 1 PPH - BRIGHT WHITE
	0G3908-24-170	EA	SCREW - SF/DR - 8-18 X 1 1/2 PPH - BRIGHT WHITE
	0G3910-10-320	EA	SCREW - SF/DR - 10-16 X 5/8 PPH - GLACIER
	0G3910-10-240	EA	SCREW - SF/DR - 10-16 X 5/8 PPH - VW LIGHT GRAY
	0G3910-10-330	EA	SCREW - SF/DR - 20-16 X 5/8 PPH - PUTTY
	0G3910-12-320	EA	SCREW - SF/DR - 10-16 X .75 PPH - GLACIER
	0G3910-12-240	EA	SCREW - SF/DR - 10-16 X .75 PPH - VW LIGHT GRAY
	0G3910-12-170	EA	SCREW - SF/DR - 10-16 X 3/4 PPH - BRIGHT WHITE
	0G5508-12-270	EA	SCREW - SF/DR - 8-18 X 3/4 PWH - TITANIUM
	0G5508-12-260	EA	SCREW - SF/DR - 8-18 X 3/4 PWH - ALLANTE ANTELOPE
	0G5508-12-240	EA	SCREW - SF/DR - 8-18 X 3/4 PWH - VW LIGHT GRAY
	0G5508-12-170	EA	SCREW - SF/DR - 8-18 X 3/4 PWH - BRIGHT WHITE
	0G5508-12-330	EA	SCREW - SF/DR - 8-18 X 3/4 PWH - PUTTY
	0G5508-12-320	EA	SCREW - SF/DR - 8-18 X 3/4 PWH - GLACIER
	0G5508-16-320	EA	SCREW - SF/DR - 8-18 X 1 PWH - GLACIER
	0G5508-16-250	EA	SCREW - SF/DR - 8-18 X 1 PWH - VW DARK GRAY
	0G6008-16-170	EA	SCREW - SF/DR - 8-18 X 1 POH - BRIGHT WHITE
	0G6710-08-240	EA	SCREW - 10-12 X 1/2 PPH TAUPE - VW LIGHT GRAY
	0G6710-08-170	EA	SCREW - 10-12 X 1/2 PPH - BRIGHT WHITE
	0G6710-08-130	EA	SCREW - 10-12 X 1/2 PPH - TAUPE
	0G6710-12-170	EA	SCREW - 10-12 X 3/4 PPH - BRIGHT WHITE
	0G6806-16-170	EA	SCREW - 6-18 X 1 POH - BRIGHT WHITE
	0G6810-24-280	EA	SCREW - 10-12 X 1 1/2 POH - SOFT WHITE
	000C20-04-16A	EA	SCREW - 1/4-20X 1 - FLAT SOCKET HEAD
	000C20-05-28F	EA	SCREW - 5/16-18 X 1 3/4 FLAT SOC - STAINLESS STEEL
	000C20-06-24T	EA	SCREW - 3/8-16 X 1 1/2 - FLAT SOCKET
	000G11-06-10J	EA	SCREW - 6-20 X 5/8 PPH - BRASS
	000G11-06-08B	EA	SCREW - 6-20 X 1/2 PPH - ZINC
	000G11-07-08B	EA	SCREW - 7-19 X 1/2 PPH - ZINC
	000G11-08-12B	EA	SCREW - 8-18 X 3/4 PPH - ZINC
	000G11-08-08T	EA	SCREW - 8-18 X 1/2 PPH - FLUOROCARBON COATING

SEALANTS & FASTENERS GROUP (CONTINUED)
SCREWS (CONTINUED)

KEY	PART NUMBER	U/M	DESCRIPTION
	000G11-08-06B	EA	SCREW - 8-18 X 3/8 PPH - ZINC
	000G11-08-20G	EA	SCREW - 8-18 X 1 1/4 - ANTIQUE BRASS
	000G11-08-20B	EA	SCREW - 8-18 X 1 1/4 PPH - ZINC
	000G11-08-16B	EA	SCREW - 8-18 X 1 PPH - ZINC
	000G11-08-12T	EA	SCREW - 8-18 X 3/4 PPH - BLACK MAGNESIUM
	000G11-08-12P	EA	SCREW - 8-18 X 3/4 PPH - DARK BROWN
	000G11-10-12D	EA	SCREW - 10-16 X 3/4 PPH - BLACK
	000G12-06-12J	EA	SCREW - 6-20 X .75 POH - BRASS
	000G12-06-08T	EA	SCREW - 6-20 X 1/2 POH - BLACK
	000G12-08-12S	EA	SCREW - 8-18 X 3/4 POH - OFF WHITE
	000G13-05-10B	EA	SCREW - 5-12 X 5/8 PFH - ZINC
	000G13-06-08B	EA	SCREW - 6-20 X 1/2 PFH - ZINC
	000G13-06-06I	EA	SCREW - 6-20 X 3/8 PFH - BLACK ZINC
	000G13-06-16J	EA	SCREW - 6-20 X 1 PFH - BRASS
	000G13-06-10J	EA	SCREW - 6-20 X 5/8 PFH - BRASS
	000G13-06-10G	EA	SCREW - 6-20 X 5/8 PFH - ANTIQUE BRASS
	000G13-06-08G	EA	SCREW - 6-20 X 1/2 PFH - ANTIQUE BRASS
	000G13-06-24J	EA	SCREW - 6-20 X 1 1/2 PFH - BRASS
	000G13-07-12B	EA	SCREW - 7-19 X 3/4 PFH - ZINC
	000G13-07-10H	EA	SCREW - 7-19 X 5/8 PFH - BLACK
	000G13-08-10B	EA	SCREW - 8-18 X 5/8 PFH - ZINC
	000G13-08-24B	EA	SCREW - 8-18 X 1 1/2 PFH - ZINC
	000G13-08-16B	EA	SCREW - 8-18 X 1 PFH - ZINC
	000G13-08-109	EA	SCREW - 8-18 X 5/8 PFH
	000G13-10-16I	EA	SCREW - 10-16 X 1 PFH - BLACK
	000G16-04-24B	EA	SCREW - MACHINE - 1/4-20 X 1 1/2 PPH
	000G18-08-22B	EA	SCREW - MACHINE - 8-32 X 1 3/8 PPH - ZINC
	000G18-08-16B	EA	SCREW - MACHINE - 8-32 X 1 PPH - ZINC
	000G18-08-12B	EA	SCREW - MACHINE - 8-32 X 3/4 PPH - ZINC
	000G18-08-24B	EA	SCREW - MACHINE - 8-32 X 1 1/2 PPH - ZINC
	000G19-10-12F	EA	SCREW - MACHINE - 10-32 X 3/4 PPH - STAINLESS STEEL
	000G19-10-10B	EA	SCREW - MACHINE - 10-32 X 5/8 - PPH - ZINC
	000G19-10-08B	EA	SCREW - MACHINE - 10-32 X 1/2 PPH - ZINC
	000G19-10-20B	EA	SCREW - MACHINE - 10-32 X 1 1/2 PPH - ZINC
	000G36-10-12T	EA	SCREW - 10-24X 3/4 PFH TYPE 23 - BLACK
	000G39-06-16T	EA	SCREW - SF/DR - 6-20 X 1 PPH - BLACK
	000G39-06-10T	EA	SCREW - SF/DR - 6-20 X 5/8 PPH - BLACK
	000G39-08-32B	EA	SCREW - SF/DR - 8-18 X 2 PPH - ZINC
	000G39-08-24T	EA	SCREW - SF/DR - 8-18 X 1 1/2 PPH - BLACK
	000G39-08-24S	EA	SCREW - SF/DR - 8-18 X 1 1/2 - OFF WHITE
	000G39-08-24B	EA	SCREW - SF/DR - 8-18 X 1 1/2 PPH - ZINC
	000G39-08-16T	EA	SCREW - SF/DR - 6-20 X 1 PPH - BLACK
	000G39-08-16B	EA	SCREW - SF/DR - 8-18 X 1 PPH - ZINC
	000G39-08-12B	EA	SCREW - SF/DR - 8-18 X 3/4 PPH - ZINC
	000G39-08-08T	EA	SCREW - SF/DR - 8-18 X 1/2 PPH - BLACK
	000G39-08-08S	EA	SCREW - SF/DR - 8-18 X 1/2 PPH - OFF WHITE
	000G39-08-08B	EA	SCREW - SF/DR - 8-18 X 1/2 PPH - ZINC
	000G39-08-06B	EA	SCREW - SF/DR - 8-18 X 3/8 PPH - ZINC
	000G39-10-08B	EA	SCREW - SF/DR - 10-16 X 1/2 PPH - ZINC
	000G39-10-48T	EA	SCREW - SF/DR - 10-16 X 3 PPH - BLACK
	000G39-10-48B	EA	SCREW - SF/DR - 10-16 X 3 - PPH - ZINC
	000G39-10-32B	EA	SCREW - SF/DR - 10-16 X 2 - PPH - ZINC
	000G39-10-20T	EA	SCREW - SF/DR - 10-16 X 1 1/4 PPH - BLACK
	000G39-10-20B	EA	SCREW - SF/DR - 10-16 X 1 1/4 PPH - ZINC
	000G39-10-169	EA	SCREW - SF/DR - 10-16 X 1 PPH - FLUOROCARBON SILVER
	000G39-10-129	EA	SCREW - SF/DR - 10-16 X 3/4 PPH - FLUOROCARBON SILVER
	000G39-10-12T	EA	SCREW - SF/DR - 10-16 X 3/4 - BLACK
	000G39-10-10T	EA	SCREW - SF/DR - 10-16 X 5/8 - BLACK
	000G39-10-10B	EA	SCREW - SF/DR - 10-16 X 5/8 - ZINC
	000G39-12-12E	EA	SCREW - SF/DR - 12-14 X 3/4 PPH - CHROME
	000G42-04-16B	EA	SCREW - SF/DR - 1/4-14 X 1 HWH - ZINC
	000G42-04-24B	EA	SCREW - SF/DR - 1/4-14 X 1 1/2 - ZINC
	000G46-08-24T	EA	SCREW - MACHINE - 8-32 X 1 1/2 PFH - BLACK
	000G50-04-08B	EA	SCREW - MACHINE - 1/4-20 X 1/2 PTH - ZINC

SEALANTS & FASTENERS GROUP (CONTINUED)
SCREWS (CONTINUED)

KEY	PART NUMBER	U/M	DESCRIPTION
	000G51-06-12B	EA	SCREW - 6-20 X 3/4 PTH - ZINC
	000G52-06-05B	EA	SCREW - MACHINE - 6-32 X 5/16 PTH ZINC
	000G52-08-18B	EA	SCREW - MACHINE - 8-32 X 1 1/8 PTH - ZINC
	000G54-04-14B	EA	SCREW - 1/4-20 X 7/8 PTH - TYPE 23 - ZINC PLATED
	000G55-08-16S	EA	SCREW - SF/DR - 8-18 X 1 PWH - WILLOW
	000G55-08-16T	EA	SCREW - SF/DR - 8-18 X 1 PWH - BLACK
	000G55-08-16S	EA	SCREW - SF/DR - 8-18 X 1.00 - PWH - OFF WHITE
	000G55-08-124	EA	SCREW - SF/DR - 8-18 X 3/4 PWH - ASH GRAY
	000G55-08-12M	EA	SCREW - SF/DR - 8-19 X .75 PWH - GRAY
	000G56-12-48B	EA	SCREW - WOOD - 12-11 X 3 POH - SPECIAL HARDENED
	000G57-14-72B	EA	SCREW-14-10-X4 1/2 PFH ZN GENERAL MOTORHOMES
	000G57-14-64B	EA	SCREW - 14-10 X 4 PFH ZINC
	000G60-08-22B	EA	SCREW - SF/DR - 8-18 X 1.38 POH - ZINC
	000G60-08-20F	EA	SCREW - SF/DR - 8-19X1.25 POH
	000G60-08-16E	EA	SCREW - SF/DR - 8-1 X 1 POH - CHROME
	000G60-10-20B	EA	SCREW - SF/DR - 10-16 X 1 1/4 POH - ZINC
	000G60-10-28T	EA	SCREW - SF/DR - 10-16 X 1 3/4 - BLACK
	000G60-10-209	EA	SCREW - SF/DR - 10-16 X 1 1/4 POH - SILVER STALGAARD
	000G67-08-32B	EA	SCREW - 8-15 X 2 PPH - ZINC
	000G67-10-24S	EA	SCREW - 10-12 X 1 1/2 PPH - OFF WHITE
	000G67-10-24B	EA	SCREW - 10-12 X 1 1/2 PPH - ZINC
	000G67-10-20D	EA	SCREW - 10-12 X 1 1/4 PPH - BLACK
	000G67-10-125	EA	SCREW - 10-12 X 3/4 PPH - WILLOW
	000G67-10-12S	EA	SCREW - 10-12 X 3/4 PPH - OFF WHITE
	000G67-10-12P	EA	SCREW - 10-12 X 3/4 PPH - DARK BROWN
	000G67-10-12B	EA	SCREW - 10-12 X 3/4 PPH - ZINC
	000G67-10-10T	EA	SCREW - 10-12 X 5/8 PPH - BLACK
	000G67-10-10S	EA	SCREW - 10-12 X 5/8 PPH - OFF WHITE
	000G67-10-10P	EA	SCREW - 10-12 X 5/8 PPH - DARK BROWN
	000G67-10-10B	EA	SCREW - 10-12 X 5/8 PPH - ZINC - TYPE A
	000G67-10-08B	EA	SCREW - 10-12 X 1/2 PPH - ZINC
	000G67-10-36T	EA	SCREW - 10-12 X 2 1/4 - PPH - BLACK
	000G68-06-12J	EA	SCREW - 6-18 X 3/4 POH - BRASS
	000G68-06-10J	EA	SCREW - 6-18 X 5/8 POH - BRASS
	000G68-06-10G	EA	SCREW - 6-18 X 5/8 POH - ANTIQUE BRASS
	029130-01-000	EA	SCREW - SNAP STUD - #8-16 X 5/8" LONG
	029130-03-000	EA	SCREW - SNAP STUD - #8-16 X 1" LONG
	049465-01-000	EA	SCREW - 10-16 PTH W/WASHER - DARK BROWN
	049465-03-000	EA	SCREW - 10-16 X 1 POH W/WASHER - OFF WHITE
	049465-04-000	EA	SCREW - 10-16 X 1 PTH W/WASHER - BEIGE
	049465-13-000	EA	SCREW-10+16X1 PTH W/WASHER - *ASH GRAY
	049465-17-000	EA	SCREW - 10-16 X 1 POH W/WASHER - BRIGHT WHITE
	049465-23-000	EA	SCREW - 10-16 X 1.5 POH W/WASHER - VW LIGHT GRAY
	054434-03-000	EA	SCREW - SF/DR - 10-16 X 2 - PWH - ZINC - W/O WINGS
	075908-01-000	EA	SCREW - MACHINE - 10-32 X .56 PTH - EXTERNAL TOOTH - ZINC
	076790-01-000	EA	SCREW - 6-20 X 1 1/4 PPH - BLACK
	076790-05-000	EA	SCREW - 6-20 X 1/2 PPH - BLACK - THREAD CUTTING/WOOD
	083554-01-000	EA	SCREW - DRYWALL - 8 X 1 1/4
	083554-04-000	EA	SCREW - DRYWALL - 8 X 2 1/2
	087721-01-000	EA	SCREW - FLAT HEAD - TAPPING - 1/4 X 1 1/4 LONG - ZINC
	090033-02-000	EA	SCREW - 1/4-20 X 5/8 - ROUND WASHER HEAD - OFF/WHITE
	097974-01-000	EA	SCREW - PARTICLE BOARD - 7-9 X 3/4 PPH
	101618-01-000	EA	SCREW - 1/4-20 X 3/4 HEX - TAPPING - STALGARD TYPE F
	110460-05-02A	EA	SCREW - MACHINE - 10-24 X 2 1/2 PFH - WHITE
	113563-01-01A	EA	SCREW - 8 X 5/8 LONG SHOULDER/WASHER HEAD
	117478-01-04A	EA	SCREW - 8-18 X 3/4 PPH W/WASHER - VW LIGHT GRAY
	118383-01-04A	EA	RETAINER/RECESSED - F/.22" SCREW - BRIGHT WHITE
	118383-01-05A	EA	RETAINER/RECESSED - F/.22" SCREW - VW LIGHT GRAY
	118383-01-09A	EA	RETAINER/RECESSED - F/.22" SCREW - GLACIER
	118383-02-09A	EA	RETAINER/RECESSED - F/.27" SCREW - GLACIER
	118383-02-05A	EA	RETAINER/RECESSED - F/.27" SCREW - VW LIGHT GRAY
	118383-03-09A	EA	RETAINER/RECESSED - F/.32" SCREW - GLACIER

SEALANTS & FASTENERS GROUP (CONTINUED)
SCREWS (CONTINUED)

KEY	PART NUMBER	U/M	DESCRIPTION
	118383-04-09A	EA	CAP - F/RECESSED RETAINER - GLACIER
	118383-04-05A	EA	CAP - F/RECESSED RETAINER - VW LIGHT GRAY
	118383-04-04A	EA	CAP - F/RECESSED RETAINER - BRIGHT WHITE
	126458-01-01A	EA	SCREW - 8-18 X 1/2 - PRWH - BLACK
	134126-01-01A	EA	SCREW/NAIL - HEX HEAD - 3/4"
	140040-01-000	EA	SCREW - 1/4-20 X 1 - BUTTON HEAD/SOCKET - W/LOCTITE

CLAMPS, CLIPS, GROMMETS, RIVETS & PLUGS

KEY	PART NUMBER	U/M	DESCRIPTION
	000F10-06-32B	EA	PIN - COTTER - 3/16" X 2" - ZINC
	000H14-06-06R	EA	RIVET-MANDREL BLIND,3/16 AL - CHERRY BSP-66
	000H14-06-03R	EA	RIVET - MANDREL BLIND - 3/16 ALUMINUM
	000H16-04-06R	EA	RIVET - POP ALUMINUM - 1/8 X .313 - .375
	000H16-06-10R	EA	RIVET - POP ALUMINUM - 3/16 X .501-.625
	007161-01-000	EA	CLAMP - HOSE - SPRING TYPE - 1/2"
	010495-01-000	EA	CLAMP - CABLE - 9/16"ID
	010495-02-000	EA	CLAMP - CABLE - 3/8"ID
	010495-04-000	EA	CLAMP - CABLE - 11/16" - WHITE
	010497-01-000	EA	CLAMP - CLOSED - 5/8"ID
	010497-03-000	EA	CLAMP - CLOSED - 1"ID - CUSHIONED
	010497-04-000	EA	CLAMP - CLOSED - 1 5/8"ID
	010497-05-000	EA	CLAMP - CLOSED - 1/2"ID
	010497-07-000	EA	CLAMP - CLOSED - 3/8"ID
	010497-10-000	EA	CLAMP - CLOSED
	010499-01-000	EA	CLAMP - CLOSED - 3/8"ID
	016188-03-000	EA	GROMMET - L/P LINE - 3/8"HOLE X 2 1/2"LONG - RUBBER
	016188-04-000	EA	GROMMET - L/P LINE - 1/2"HOLE X 2 1/2"LONG - RUBBER
	016188-05-000	EA	GROMMET - L/P LINE - 3/8"HOLE X 1 1/4"LONG - RUBBER
	016188-06-000	EA	GROMMET - L/P LINE - 3/8"HOLE X 3 1/4"LONG
	016188-07-000	EA	GROMMET - L/P LINE - 1/2"HOLE X 3 1/4"LONG
	023942-01-000	EA	GROMMET - RUBBER - 2" OD
	034141-02-000	EA	PLUG/NYLON - .38" - BLACK
	061420-04-000	EA	PLUG/PLASTIC - 1 1/4" DIAMETER
	061420-05-000	EA	PLUG/PLASTIC - 1 1/2" DIAMETER
	061420-08-000	EA	PLUG/PLASTIC - 2 1/2" DIAMETER
	061420-09-000	EA	PLUG/PLASTIC - 1.00" - DIAMETER
	061420-10-000	EA	PLUG/PLASTIC - 1 1/2" DIAMETER - BLACK
	061420-14-000	EA	PLUG/PLASTIC - .034" DIAMETER
	061420-15-000	EA	PLUG/PLASTIC - 2" DIAMETER - BLACK
	061420-16-000	EA	PLUG/PLASTIC - 2 1/8" DIAMETER
	062401-01-000	EA	CLAMP - HOSE - WORMGEAR - .25" - 1"
	062401-02-000	EA	CLAMP - HOSE - WORMGEAR - 1.56" - 2.5"
	062401-03-000	EA	CLAMP - HOSE - WORMGEAR - .22" - 1"
	062401-04-000	EA	CLAMP - HOSE - WORMGEAR - .69" - 1.25"
	062401-05-000	EA	CLAMP - HOSE - WORMGEAR - 2" - 3" ID
	062401-06-000	EA	CLAMP - HOSE - WORMGEAR - .22" - .62" ID
	062401-09-000	EA	CLAMP - HOSE - WORMGEAR - 2.8" - 3.75"
	062401-11-000	EA	CLAMP - HOSE - WORMGEAR - 3.50" - 4.50"
	062401-12-000	EA	CLAMP - HOSE - WORMGEAR - .79" X 1.26"
	071015-11-000	EA	GROMMET - RUBBER - 1"ID FITS .12 MATERIAL - BLACK
	071015-19-000	EA	GROMMET - RUBBER - .38 ID - FITS .06 MATERIAL - BLACK
	071015-26-000	EA	GROMMET - RUBBER - 1.5" ID X 2.1" OD W/.06" GROOVE-BLACK
	071015-30-000	EA	GROMMET - RUBBER - .31" ID X .81" OD W/.12" GROOVE-BLACK
	071015-39-000	EA	GROMMET - .75 ID FITS .06 MTL
	071015-41-000	EA	GROMMET - .125 ID FITS .188 MTL
	075148-02-000	EA	CLAMP - GROUNDING - BRONZE SCREWS
	077955-01-000	EA	CLIP/J - 3/8" - VINYL COATED
	080734-02-000	EA	CLIP - WIRE NYLON
	081211-03-000	EA	PLUG/PLASTIC - .50 DIAMETER - BLACK
	081211-04-000	EA	PLUG/PLASTIC - .46 DIAMETER - BLACK

SEALANTS & FASTENERS GROUP (CONTINUED)
CLAMPS, CLIPS, GROMMETS, RIVETS & PLUGS (CONTINUED)

KEY	PART NUMBER	U/M	DESCRIPTION
	083609-01-000	EA	CLAMP - WIRE - DUAL - EQUAL DIAMETERS - 5/8"
	083610-01-000	EA	CLAMP - WIRE - DUAL - UNEQUAL DIAMETERS - 3/4" & 1 1/4"
	083610-02-000	EA	CLAMP - WIRE - DUAL - UNEQUAL DIAMETERS - 3/4" & 2"
	083610-03-000	EA	CLAMP - WIRE - DUAL - EQUAL DIAMETERS - 2"
	088756-01-000	EA	GROMMET - WEB - 1 1/8 " I.D.
	091952-01-000	EA	CLIP - GRIPPER - 1"
	091952-02-000	EA	CLIP - GRIPPER - 3/4"
	094362-02-000	EA	CLIP - XMAS TREE - BINDER HEAD - .9" LONG
	114208-04-000	EA	GROMMET - EDGE LINER - FITS 1"
	114208-05-000	EA	GROMMET - EDGE LINER - FITS 2"
	118626-01-02A	EA	RIVET - POP - ALUMINUM - 3/16 X .08 - .375
	118626-01-01A	EA	RIVET - POP - ALUMINUM - 3/16 X .08 - .375
	118626-02-01A	EA	RIVET - POP - ALUMINUM - 3/16 X .500 - .750
	137014-01-01A	EA	GROMMET - CABLE - ALMOND
	137014-01-02A	EA	GROMMET - CABLE - BROWN
	139118-01-01A	EA	GROMMET - PLASTIC/SCREW
	139118-02-01A	EA	GROMMET - SCREW - PLASTIC
	140171-02-000	EA	CLAMP - HOSE - STEPLESS EAR - .250

MISCELLANEOUS FASTENERS

KEY	PART NUMBER	U/M	DESCRIPTION
	008343-01-000	EA	TIE - WIRE - 6"
	008343-02-000	EA	TIE - WIRE - 14"
	008343-03-000	EA	TIE - WIRE - 7 1/2" - BLACK
	029094-04-000	YD	VELCRO TAPE - LOOP - 1" WIDE - BLACK
	029094-06-000	YD	VELCRO TAPE - LOOP - 2" WIDE - BLACK
	029096-03-000	YD	VELCRO TAPE - HOOK - 1" WIDE - BLACK
	029096-04-000	YD	VELCRO TAPE - HOOK - 1" WIDE - BLACK
	048394-02-000	YD	VELCRO TAPE - HOOK - ADHESIVE BACK - 3/4" WIDE - BEIGE
	085774-01-000	FT	FASTENER - DUAL LOCK - 1" WIDE - ADHESIVE BACK - BLACK
	085774-02-000	FT	FASTENER - DUAL HOOK - 1" WIDE - ADHESIVE BACK - BLACK
	085774-03-000	FT	FASTENER - DUAL LOCK - 1/2" WIDE - ADHESIVE BACK - BLACK
	085774-04-000	FT	FASTENER - DUAL HOOK - 1/2" WIDE - ADHESIVE BACK - BLACK
	088792-02-000	YD	VELCRO TAPE - LOOP - 3/4" - ADHESIVE BACK - BEIGE
	088792-04-000	YD	VELCRO TAPE - HOOK - 5/8" - NON-ADHESIVE BACK - WHITE
	088792-05-000	YD	VELCRO TAPE - LOOP - 5/8" - NON-ADHESIVE BACK - WHITE
	108046-02-000	EA	CABLE TIE - SCREW MOUNT 15"
	110943-02-000	FT	FELT STRIP - 3/8" - ADHESIVE BACK - WHITE
	113133-02-01A	EA	RIVET - POP - ALUMINUM - 3/16 X .252 - .504 - BLACK
	127960-01-01A	EA	RETAINER - 3/8" - STAINLESS STEEL

WATER & SEWAGE GROUP DRAINAGE SYSTEM

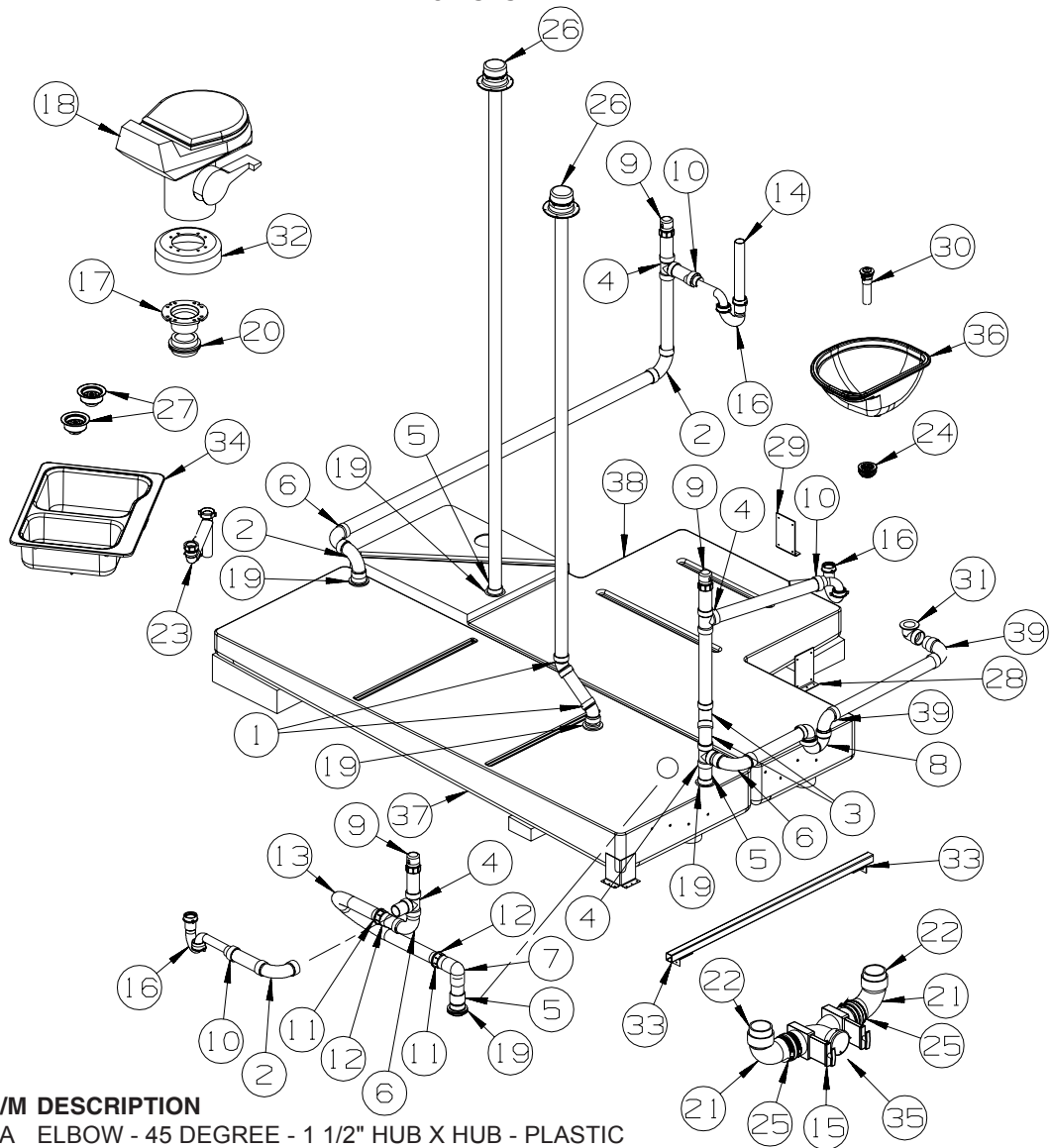

KEY	PART NUMBER	U/M	DESCRIPTION
1	010006-01-000	EA	ELBOW - 45 DEGREE - 1 1/2" HUB X HUB - PLASTIC
2	010008-01-000	EA	ELBOW - 90 DEGREE - 1 1/2" HUB X HUB - PLASTIC
3	010051-01-000	EA	ELBOW - 45 DEGREE - 1 1/2" SPIGOT X HUB - PLASTIC
4	010071-01-000	EA	TEE - SANITARY - 1 1/2" HUB X HUB X HUB - PLASTIC
5	010115-01-000	EA	COUPLING - 1 1/2" HUB X HUB - PLASTIC
6	033761-01-000	EA	ELBOW - 90 DEGREE - TURN - 1 1/2" HUB X 1 1/2" SPIGOT
7	034250-01-000	EA	ELBOW - 90 DEGREE - LONG TURN - 1 1/2" HUB X HUB - ABS
8	037763-01-000	EA	P-TRAP - PLASTIC - 1 1/2 HXH W/UNION
9	079968-01-000	EA	VENT - MECHANICAL/TRAP ARM - ANTI-SIPHON-2" X 7.3" PLASTIC
10	109571-01-000	EA	ADAPTER - P-TRAP - 1 1/2"P X 1 1/4"MPT
11	126424-01-000	EA	ADAPTER - 1 1/2" MPT X 1 1/2" HUB
12	126425-02-000	EA	ADAPTER - SWIVEL - 1 1/2 FPT X SPIGOT
13	126426-01-000	FT	PIPE - 1 1/2" FLEXIBLE
14	126588-02-000	EA	ARM - WASTE - 1 1/2 X 20" - FEMALE
15	136143-01-000	EA	VALVE - DUAL - 3" X 3"
16	107538-01-000	EA	P-TRAP - PLASTIC - 1 1/4" W/EXTENSION ARM - USA
16	011071-01-000	EA	P-TRAP - PLASTIC - 1 1/2" - CSA - CANADIAN
17	116644-01-000	EA	FLANGE/CLOSET - 3" FEMALE - 4 BOLT
18*	136729-01-01A	EA	TOILET - CHINA - STANDARD W/SPRAYER - WHITE
19	061607-01-000	EA	GROMMET - HOLDING TANK - 1 1/2" NPS
20	061607-02-000	EA	GROMMET - HOLDING TANK - 3" NPS
21	010062-01-000	EA	ELBOW - ST PLASTIC - 3 90 SPGXH
22	010129-03-000	EA	NIPPLE - PLASTIC - 3" X 3" TOE
23	011091-02-000	EA	WASTE - CONTINUOUS - DOUBLE SINK
24	066440-01-000	EA	STRAINER - SHOWER DRAIN - W/RUBBER WASHER
	127440-02-01A	EA	WASHER - RUBBER - 1.8" X .1"
	130403-01-000	EA	NUT - SLIP - W/WINGS 1 1/2"

WATER & SEWAGE GROUP (CONTINUED)
DRAINAGE SYSTEM (CONTINUED)

KEY	PART NUMBER	U/M	DESCRIPTION
25	078406-01-000	EA	COUPLER - RUBBER - W/CLAMPS - 3" X 3"
26	083558-06-000	EA	VENT - PLUMBING - ROOF PIPE COVERED - VW WHITE
27	092303-01-000	EA	STRAINER - W/BASKET - GALLEY SINK - 4" OD
	127440-02-01A	EA	WASHER - RUBBER - 1.8" X .1"
28	094756-01-01A	EA	BRACKET/ANGLE - W/HOLES
			FROM: 00-00-00 THRU: 10-29-02
28	094756-02-01A	EA	BRACKET - L - 6.1" LONG X 3.9" WIDE - STEEL
			FROM: 10-30-02 THRU: 99-99-99
29	094756-02-01A	EA	BRACKET - L - 6.1" LONG X 3.9" WIDE - STEEL
30	141491-01-01A	EA	WASTE - LAVATORY - W/O OVERFLOW
31	131486-01-000	EA	ELBOW - DRAIN - 1 1/2 LOW PROFILE - TUB DRAIN
32	131786-05-01A	EA	SPACER - TOILET - SOFT WHITE
33	132871-03-02B	EA	BRACKET/L ANGLE W/HOLES - 1.2" X 2.8" - E-COATED
34	134851-01-01A	EA	SINK - DOUBLE/GALLEY - LARGE/SMALL - 25" X 18" X 6.9"D-WHT
35	139513-01-000	EA	HOSE - SEWER - 3" X 10' - W/ADAPTER
36	142285-01-01A	EA	SINK - LAVATORY
37	132407-01-700	EA	TANK - HOLDING
	010232-01-000	EA	FITTING - SPINWELD - PLASTIC 3FPT
	049032-01-000	EA	PATCH - SPINWELD - 3/8" - PLASTIC
38	140050-01-700	EA	TANK - HOLDING
	010232-01-000	EA	FITTING - SPINWELD - PLASTIC 3FPT
	049032-01-000	EA	PATCH - SPINWELD - 3/8" - PLASTIC
39	010009-01-000	EA	ELBOW - 90 DEGREE - 1/4 BEND - 1 1/2" PLASTIC

***COMPONENT PARTS LISTED LATER IN THIS GROUP**

WATER & SEWAGE GROUP (CONTINUED)
COMPONENT PARTS FOR DRAINAGE SYSTEM

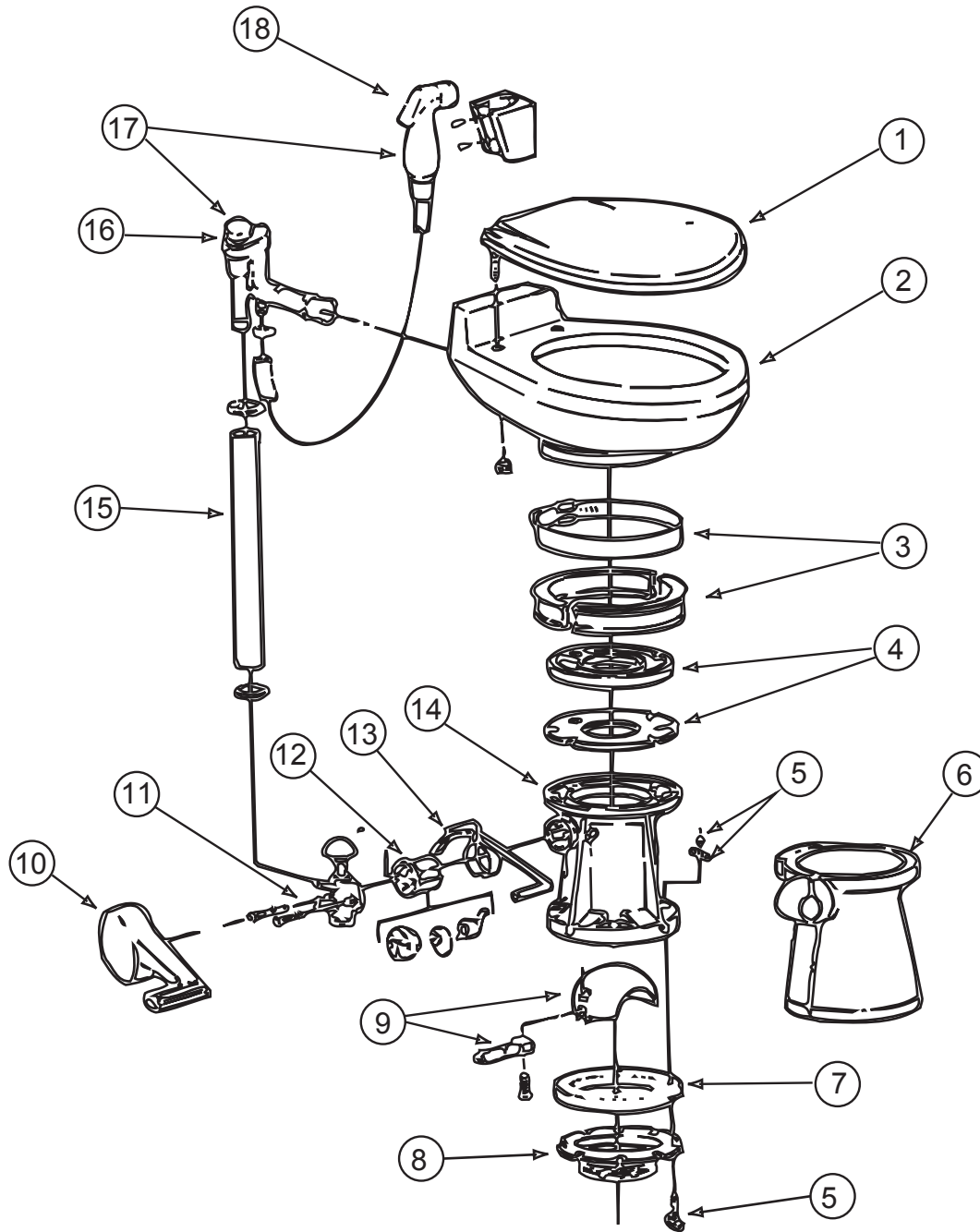

136729-01-01A

KEY	PART NUMBER	U/M	DESCRIPTION	VENDOR NO.
1	136729-01-700	EA	SEAT ASSEMBLY - WHITE	343829
2	136729-01-701	EA	BOWL/CHINA - WHITE	310739
3	085330-01-703	EA	RING & HALF CLAMPS, BONE	385310048
4	085330-01-704	EA	TEFLON & RUBBER SEAL KIT	385316140
5	085330-01-717	EA	HARDWARE KIT - BASE MOUNTING	310064
6	085330-09-704	EA	PEDESTAL COVER - WHITE	310111
7	085330-01-714	EA	SEAL-FLANGE, FLOOR	390343892
8	085330-01-716	EA	FLANGE-FLOOR, 3" MPT	345889
10	085330-09-702	EA	COVER/PEDAL KIT - WHITE	310114
11	085330-01-709	EA	VALVE-WATER	385314349
12	085330-01-707	EA	CARTRIDGE SPRING ASSEMBLY	381236096
13	085330-06-703	EA	LEVER-FLUSH	340873
14	085330-09-703	EA	BASE KIT - WHITE	310120
16	085330-06-701	EA	BREAKER-VACUUM/DIVERTER(900)	230335
18	085330-04-701	EA	HAND SPRAY W/HOSE(500 & 900)	340683

CONTACT WINNEBAGO PART SALES FOR UNLISTED COMPONENTS

WATER & SEWAGE GROUP (CONTINUED)
WATER SYSTEM

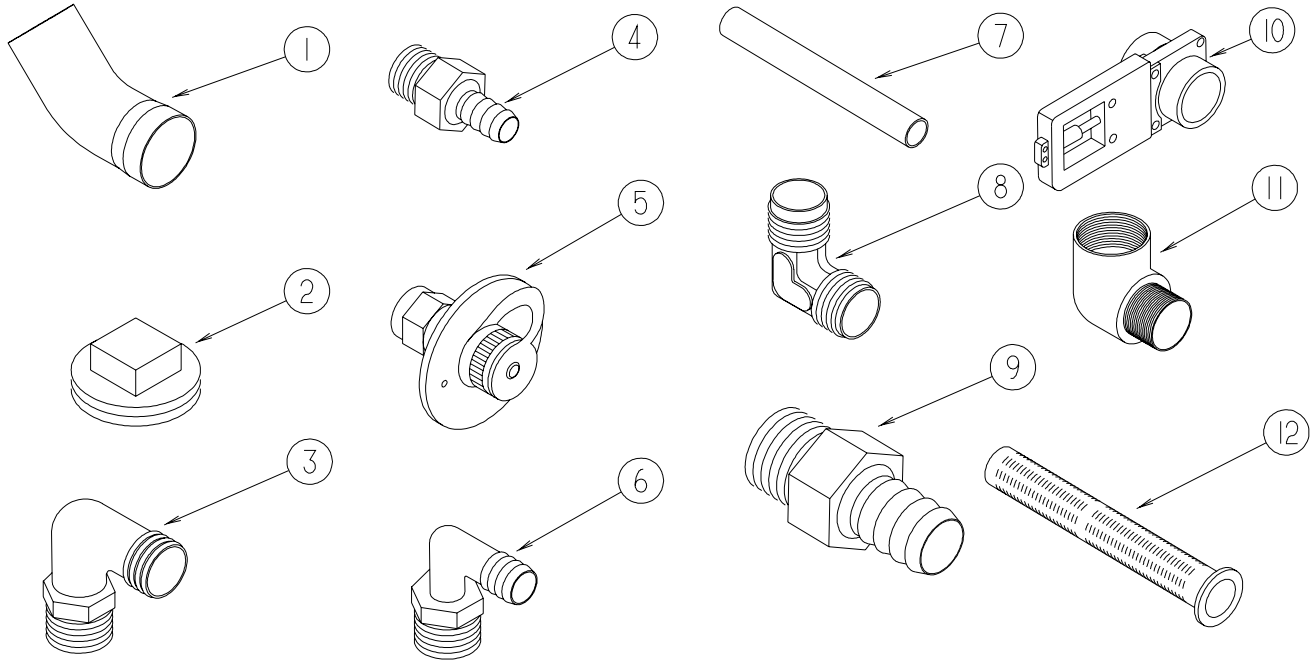

KEY	PART NUMBER	U/M	DESCRIPTION
1	010009-01-000	EA	ELBOW - 90 DEGREE - 1/4 BEND - 1 1/2" PLASTIC
2	010166-01-000	EA	PLUG/THREADED - 1 1/4"MPT - PLASTIC - BLACK - UL
3	010219-01-000	EA	ELBOW - 1 1/4 MPT X 1 1/4 BARB - WATER FILL - PLASTIC
4	010224-01-000	EA	ADAPTER - HOSE TO PIPE - 3/8 MPT X 3/8 BARB - PLASTIC
5	010230-06-000	EA	FILL - CITY WATER - W/CHECK VALVE - MPT - BRUSHED ALUM
6	035539-01-000	EA	ELBOW - 3/8 MPT X 3/8 BARB - PLASTIC
7	039800-04-000	FT	TUBING - POLYBUTYL - 1/4"OD
7	074462-02-000	FT	TUBING - VINYL - 3/8 ID X 20' - CLEAR
7	112176-01-000	FT	TUBING - VINYL - REINFORCED - 1/2" ID
7	124188-01-000	FT	TUBING - PEX - 1/2" ID X 20' - BLUE(COLD)
7	124188-02-000	FT	TUBING - PEX - 1/2" ID X 20' - RED(HOT)
8	039808-03-000	EA	ELBOW - 1/2" MPT X 1/2" MPT - PLASTIC
9	044927-01-000	EA	ADAPTER - HOSE TO PIPE-1 1/4 MPTX1 1/4 BARB-BLACK PLASTIC
10	062421-03-000	EA	VALVE/DUMP W/O HANDLE - 1 1/2" X 1 1/2" HUB
11	065318-02-000	EA	ELBOW - 90 DEGREE - 3/8" MPT TO 3/8" FPT
12	077954-02-000	EA	FILTER - WATER TANK - W/SCREEN IN TANK

WATER & SEWAGE GROUP (CONTINUED)
WATER SYSTEM (CONTINUED)

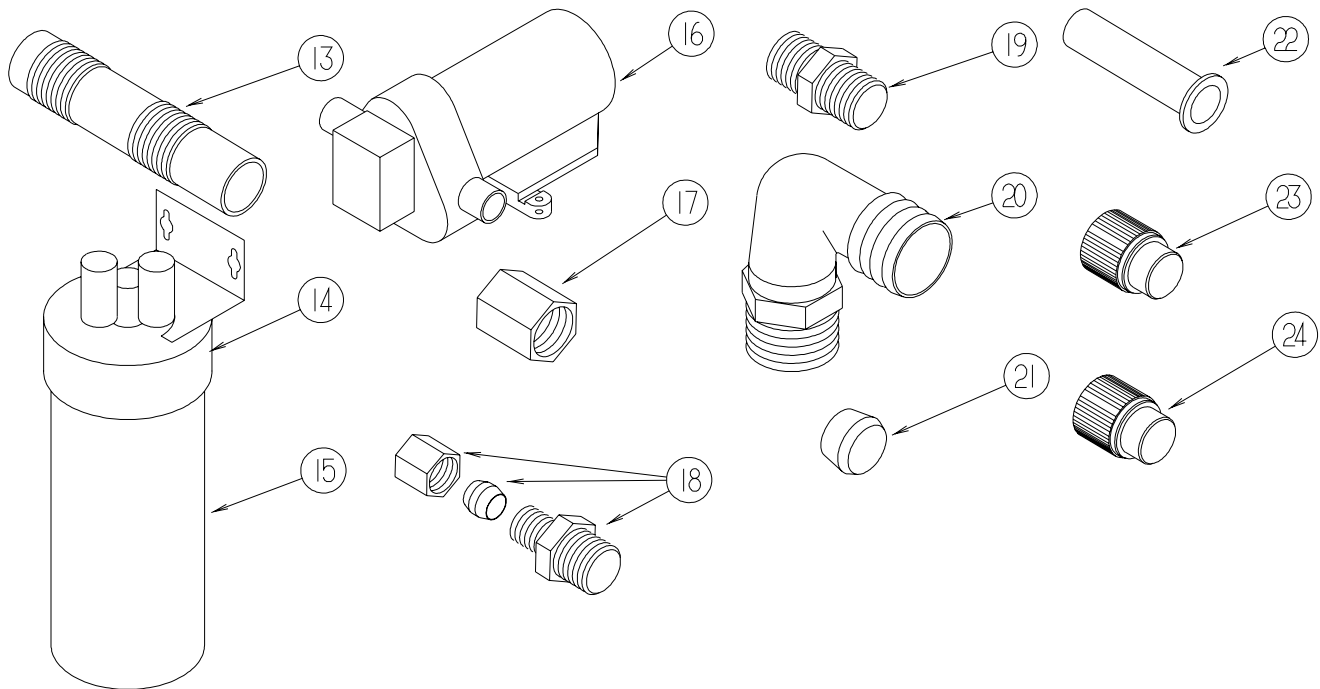

KEY	PART NUMBER	U/M	DESCRIPTION
13	079381-01-000	FT	TUBING - RIBBED FLEXIBLE - WATER FILL - 1.4" ID
14	087200-01-000	EA	FILTER-WATER PURIFICATION, EVERPURE QC2-AC
15	087200-02-000	EA	CARTRIDGE-WATER FILTER, AC - EVERPURE 9601-11
16*	098607-01-000	EA	PUMP - WATER - W/.5" MPT FITTING - FLOW 2.8 GPM
17	101814-01-000	EA	COUPLING - FEMALE - 1/2" X 1/2" FPT - GRAY
18	103798-01-000	EA	CONNECTOR - 1/4 OD X 3/8 MPT
19	110438-02-000	EA	VALVE - CHECK - BRASS - 1/2 MPT X 1/2 MPT
20	111223-02-000	EA	ELBOW - 1/2" MPT X 3/8" BARB - PLASTIC
20	111223-03-000	EA	ELBOW - 3/4" MPT X 1/2" BARB - PLASTIC
20	111223-04-000	EA	ELBOW - 1/2" MPT X 1/2" BARB - PLASTIC
21	111888-01-000	EA	FERRULE - PLASTIC - .250 ID X .375 OD
22	111888-02-000	EA	INSERT - BRASS - 1/4 COMP
23	113697-01-000	EA	CAP - 3/8"P
24	114427-01-000	EA	CAP - 1/2"P

WATER & SEWAGE GROUP (CONTINUED)
WATER SYSTEM (CONTINUED)

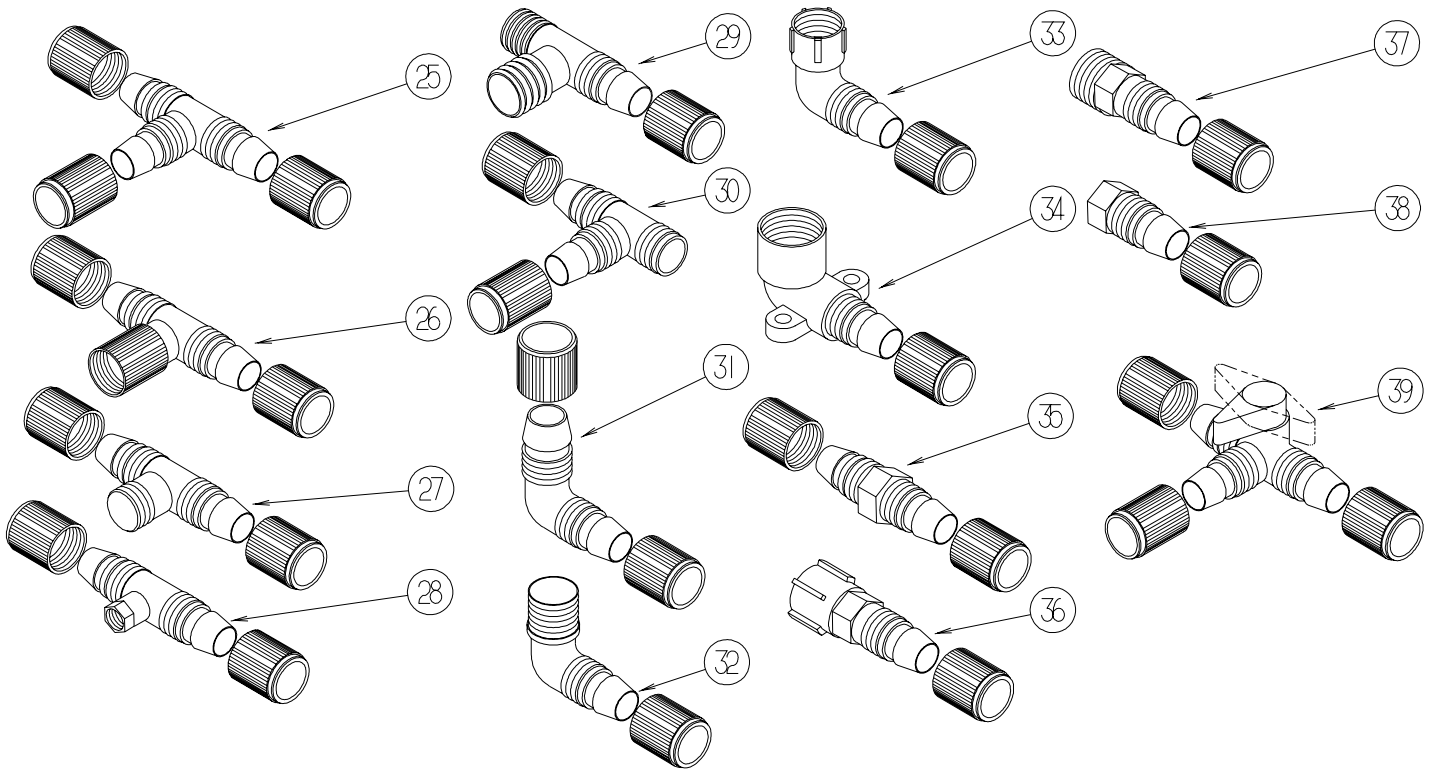

KEY	PART NUMBER	U/M	DESCRIPTION
25	114428-01-000	EA	TEE - 1/2"P X 1/2"P X 1/2"P
26	114428-02-000	EA	TEE - SWIVEL - 1/2"P X 1/2"P X 1/2"FPT
27	114428-03-000	EA	TEE - 1/2"P X 1/2"P X 1/2"MPT
28	114428-04-000	EA	TEE - 1/2"P X 1/2"P X 1/8"FPT
29	114428-06-000	EA	TEE - 1/2" P X 1/2" MPT X 1/2" MPT
30	114428-07-000	EA	TEE - 1/2" P X 1/2" MPT X 1/2" P
31	114429-01-000	EA	ELBOW - 1/2"P X 1/2"P
32	114429-02-000	EA	ELBOW - 1/2"P X 1/2"MPT
32	114429-04-000	EA	ELBOW - 1/2"P X 3/8"MPT
32	114429-05-000	EA	ELBOW - 1/2"P X 3/4"MPT
33	114429-03-000	EA	ELBOW - SWIVEL - 1/2"P X 1/2"FPT
33	114429-06-000	EA	ELBOW - SWIVEL - 1/2"P X 3/4"FPT
33	114429-08-000	EA	ELBOW - SWIVEL - 1/2"P X 1/2"FPT
34	114429-09-000	EA	ELBOW - 1/2"P X 1/2"FPT DROP EAR
35	114430-01-000	EA	ADAPTER - 1/2"P X 1/2"P
36	114430-02-000	EA	ADAPTER - SWIVEL - 1/2"P X 1/2"FPT
37	114430-03-000	EA	ADAPTER - 1/2"P X 1/2"MPT
38	114430-06-000	EA	ADAPTER - 1/2"P X 3/8"FPT
39	114431-01-000	EA	VALVE - 180 DEGREE/CENTER DRAIN - 1/2"P - THREE WAY

WATER & SEWAGE GROUP (CONTINUED)
WATER SYSTEM (CONTINUED)

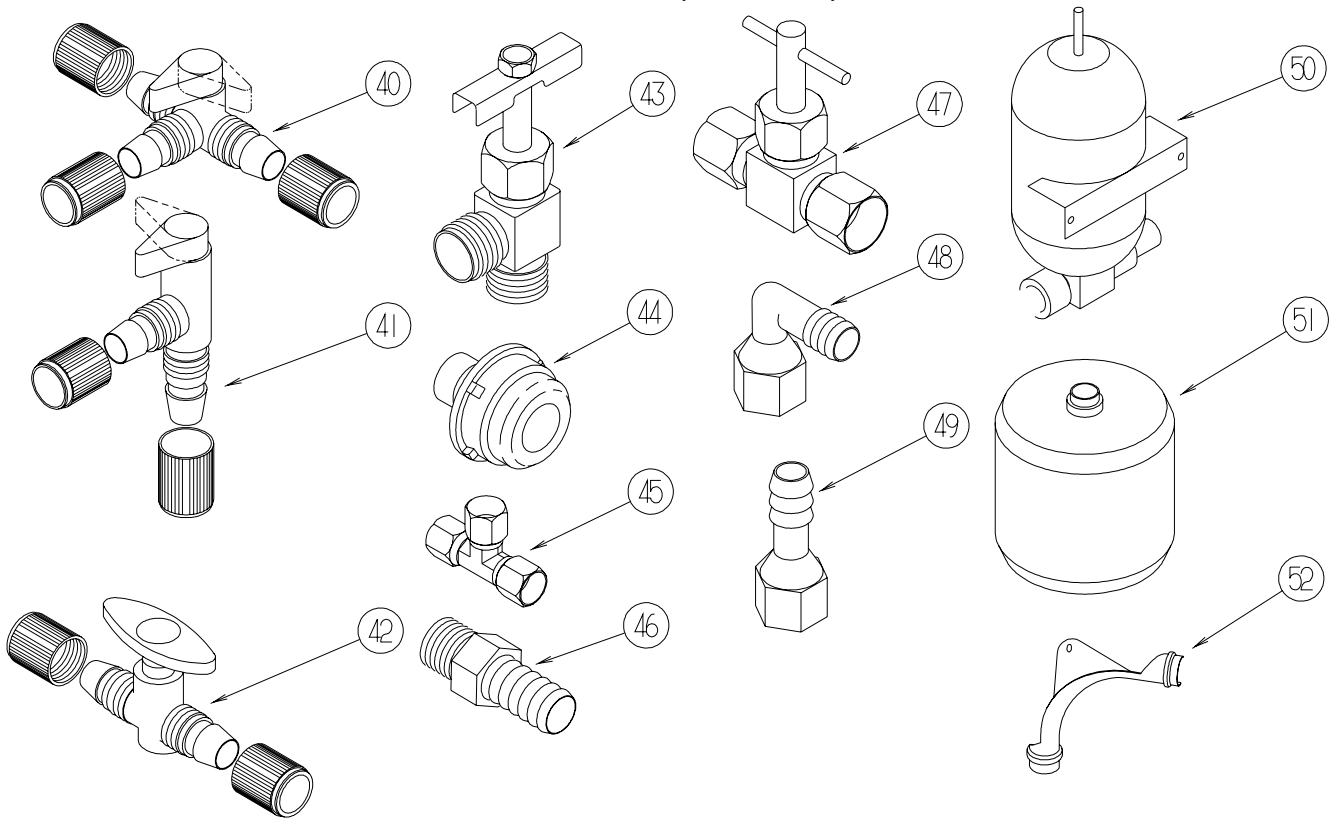

KEY	PART NUMBER	U/M	DESCRIPTION
40	114431-02-000	EA	VALVE - WATER BYPASS - 1/2"P - THREE WAY (WATER HEATER)
41	114431-03-000	EA	VALVE - 90 DEGREE DRAIN - 1/2"P
42	114431-04-000	EA	VALVE - "INLINE SHUT-OFF" - 1/2"P
43	114431-05-000	EA	VALVE - NEEDLE - 1/8" MPT X 1/4" COMPRESSION (ICE MAKER)
44	114966-01-000	EA	FILTER - IN LINE - TWIST ON - 1/2"
45	118423-01-000	EA	FITTING - BRASS-TEE - 1/4C X 1/4C X 1/4C
46	118809-02-000	EA	ADAPTER - 1/2" MPT X 1/2" BARB - PLASTIC
47	120868-01-000	EA	VALVE - NEEDLE - 1/4" COMPRESSION X 1/4" COMPRESSION
48	123150-01-000	EA	ELBOW - 1/2 FPT X 1/2 BARB - SWIVEL
49	123152-01-000	EA	ADAPTER - 1/2 FPT X 1/2 BARB - SWIVEL
50	123243-01-000	EA	TANK - ACCUMULATOR - 24 OZ
51	123317-01-000	EA	TANK - ACCUMULATOR - 2 GALLON
52	124184-01-000	EA	SUPPORT - WATER LINE - BEND

WATER & SEWAGE GROUP (CONTINUED)
WATER SYSTEM (CONTINUED)

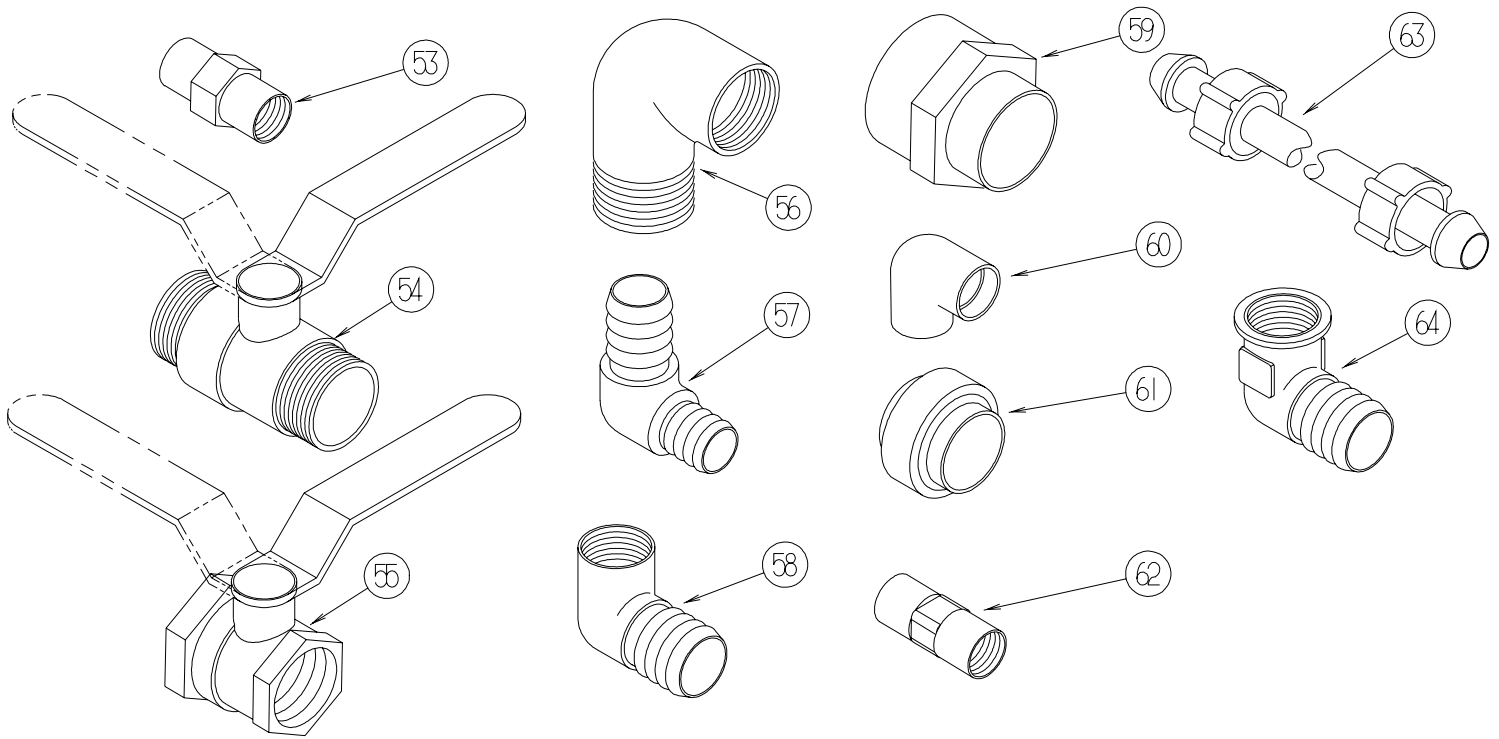

KEY	PART NUMBER	U/M	DESCRIPTION
53	132148-01-000	EA	CONNECTOR - 1/2" X 1/2"MPT - BRASS
54	132483-01-000	EA	VALVE/BALL - 1" - THREADED ENDS
55	132483-02-000	EA	VALVE/BALL - 1/2" - BRASS - FPT
56	132484-01-000	EA	ELBOW - 90 DEGREE - 1MPT X 1FPT - PLASTIC
57	132781-01-000	EA	ELBOW - 1.3" BARB X 1.3" BARB - 90 DEGREE - PLASTIC
58	132782-01-000	EA	ELBOW - 1"FPT X 1.3" BARB - 90 DEGREE - PLASTIC
59	133835-01-000	EA	ADAPTER - REDUCING - 1 1/2" X 1 1/4"
60	133837-01-000	EA	ELBOW - 1 1/2" X 90 DEGREE - DOUBLE SLIP
61	133889-01-000	EA	UNION - 1 1/2 DOUBLE SLIP - PVC
62	135386-01-000	EA	NIPPLE - 1/2"
63	140821-01-000	EA	TUBE - WATER SUPPLY - 3/8" X 24"
63	140821-02-000	EA	TUBE - WATER SUPPLY - 3/8" X 30"
63	140821-03-000	EA	TUBE - WATER SUPPLY - 3/8" X 36"
63	140821-04-000	EA	TUBE - WATER SUPPLY - 3/8" X 48"
63	140821-05-000	EA	TUBE - WATER SUPPLY - 3/8" X 54"
63	140821-06-000	EA	TUBE - WATER SUPPLY - 3/8" X 60"
63	140821-07-000	EA	TUBE - WATER SUPPLY - 3/8" X 72"
64	142812-01-000	EA	ELBOW - BRASS - 1/2"MPT X 1/2"FPT

***COMPONENT PARTS LISTED LATER IN THIS GROUP**

WATER & SEWAGE GROUP (CONTINUED)
WATER SYSTEM (CONTINUED)

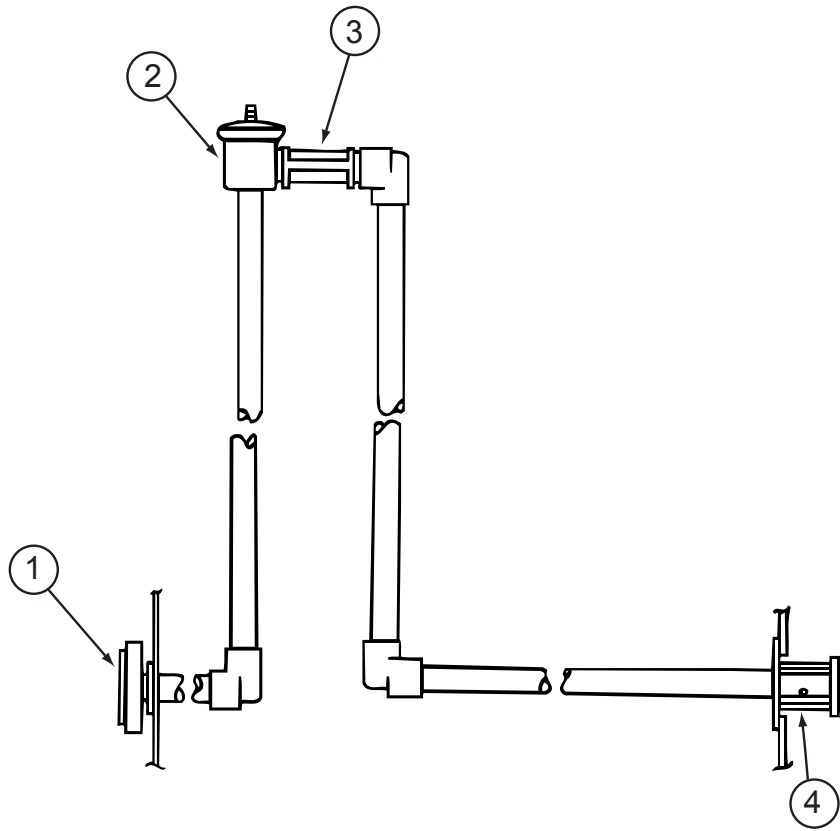

KEY	PART NUMBER	U/M	DESCRIPTION
1	125697-05-000	EA	INLET - WATER - FLUSHING SYSTEM
2	125697-04-000	EA	BREAKER - VACUUM - FLUSHING SYSTEM
3	125697-03-000	EA	CHECK VALVE - FLUSHING SYSTEM
4	125697-02-000	EA	NOZZLE - WELD-A-FLUSH
	125697-06-000	EA	INSTRUCTIONS - USER - FLUSHING SYSTEM

WATER & SEWAGE GROUP (CONTINUED)
WATER SYSTEM (CONTINUED)

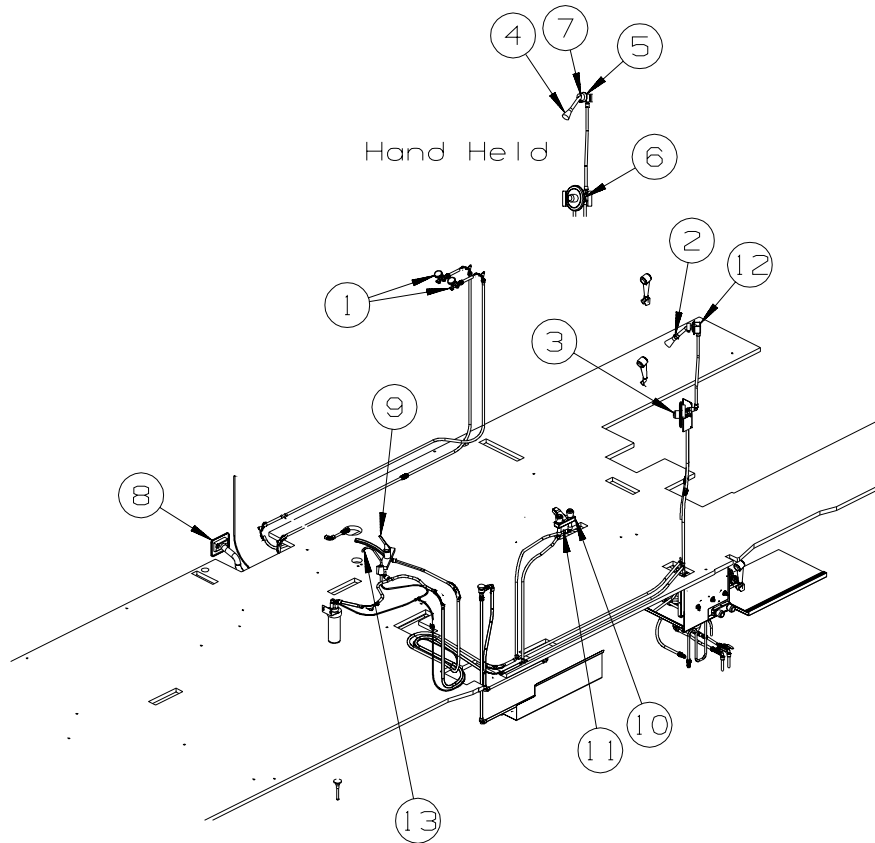

KEY	PART NUMBER	U/M	DESCRIPTION
1	098419-01-000	EA	FAUCET - WASHER - 90 DEGREE
2	128974-01-01A	EA	VALVE - SHOWER HEAD/WATER SAVER (ON/OFF) - BRIGHT BRASS
3*	131340-01-01A	EA	FAUCET - W/SHOWER HEAD- SINGLE LEVER-W/O WATER SAVER-BRASS
4	129390-03-01A	EA	SHOWER HEAD - W/HOSE & BRACKET - BRASS
5	130041-01-02A	EA	SPACER/SHOWER HEAD - SOFT WHITE
6*	131340-02-01A	EA	FAUCET ONLY - W/O SHOWER HEAD/ARM EXTENSION - BRASS
7	135028-01-01A	EA	DROP ELL - F/SHOWER HOSE - BRASS - 1/2"
8	137169-01-01A	EA	WATER FILL/GRAVITY - W/DOOR - W/O LOCK - BRIGHT WHITE
	138290-03-000	EA	CASE - W/CAM - W/O CYLINDER/KEY
9*	123744-03-01A	EA	FAUCET - GALLEY/SINGLE CONTROL W/SPRAYER HEAD - CHROME
10*	141490-01-01A	EA	FAUCET - LAVATORY - W/STOP - CHROME/POLISHED BRASS
11	105218-01-01A	EA	SPACER - FAUCET/LAVATORY SINK - 2" X 5.9" - ABS PLASTIC
12	143101-01-01A	EA	BRACKET - SHOWER HEAD
13	103635-01-000	EA	FAUCET - SINGLE CONTROL/DRINKING WATER

*COMPONENT PARTS LISTED LATER IN THIS GROUP

WATER & SEWAGE GROUP (CONTINUED)

WATER SYSTEM (CONTINUED)

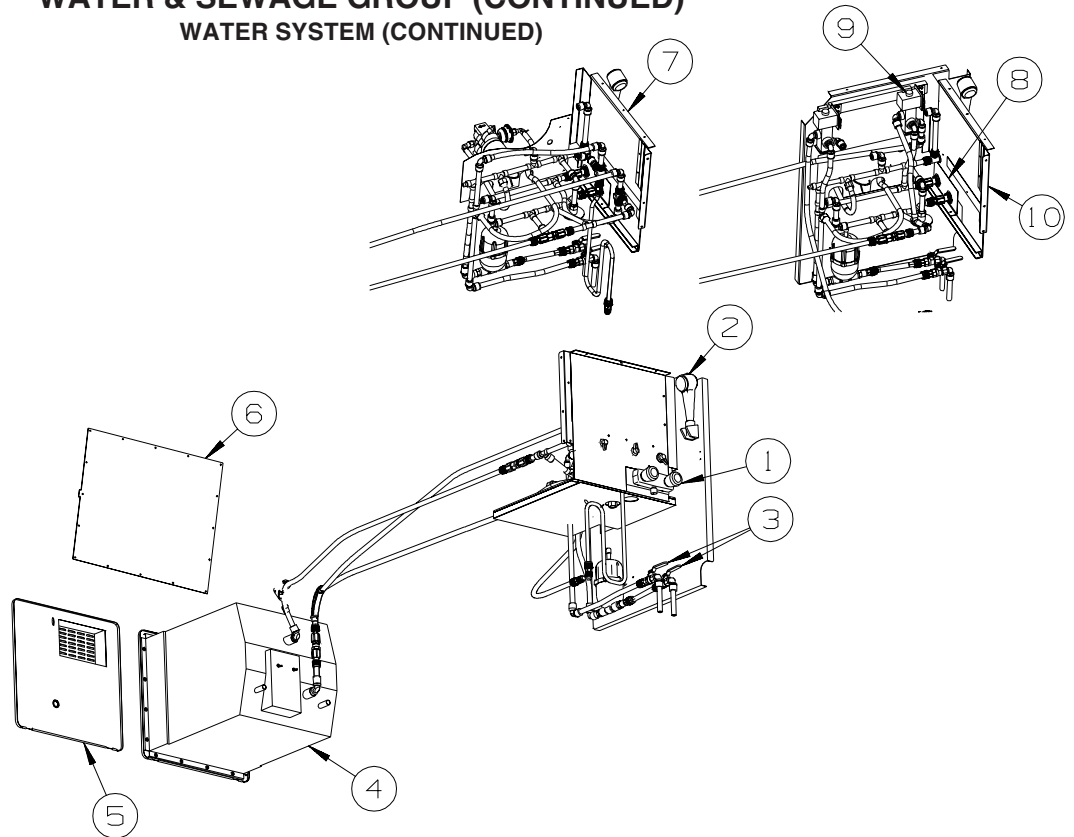

KEY	PART NUMBER	U/M	DESCRIPTION
1*	072541-06-000	EA	FAUCET - SHOWER/BRIGHT WHITE - .5" MPT W/1.9" INLET PIPES
2	131383-01-02A	EA	SHOWER HEAD - W/60" HOSE & BRACKET - WHITE - USA
2	131383-02-02A	EA	SHOWER HEAD - W/60" HOSE & BRACKET - CSA - WHITE - CANADIAN
3	132483-02-000	EA	VALVE/BALL - 1/2"FPT - BRASS
4*	051391-05-000	EA	WATER HEATER/MOTOR AID-GAS/ELECT IGN - GCH10A-9E - 10 GAL
5*	125420-01-02A	EA	DOOR - WATER HEATER - 10 GALLON - BRIGHT WHITE
5*	125420-01-03A	EA	DOOR - WATER HEATER - 10 GALLON - BLACK W/BLACK GRILLE
6	133224-01-02B	EA	PLATE - WATER HEATER - E-COATED
7	143023-01-12B	EA	PANEL - SERVICE CENTER - BRIGHT WHITE
8	143021-01-12B	EA	BRACKET - EXTERIOR SHOWER - BRIGHT WHITE
9*	118569-03-000	EA	WINTERIZATION SYSTEM - W/O TANK
10	143023-02-12B	EA	PANEL - SERVICE CENTER - BRIGHT WHITE

***COMPONENT PARTS LISTED LATER IN THIS GROUP**

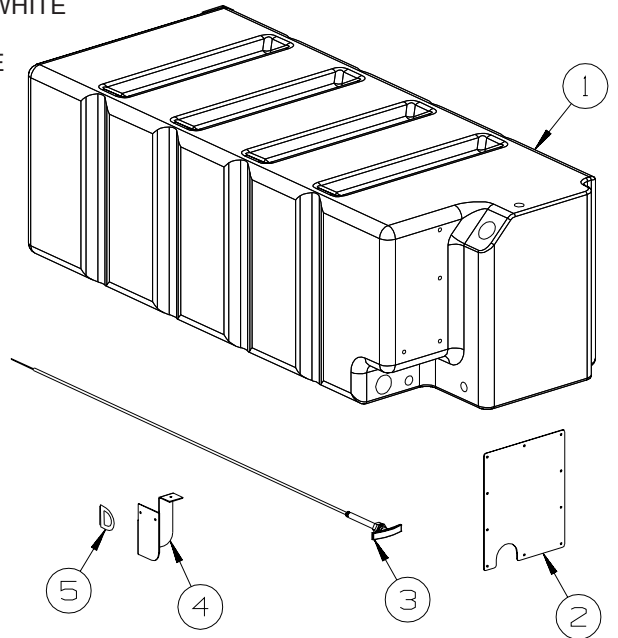

KEY	PART NUMBER	U/M	DESCRIPTION
1	132678-02-000	EA	TANK - WATER - 85 GALLON - W/FITTINGS
	042989-05-000	EA	FITTING - SPINWELD - 1/2"FPT - PLASTIC
	042989-03-000	EA	FITTING - SPINWELD - 1 1/4"NPT - PLASTIC
	049032-01-000	EA	PATCH - SPINWELD - 3/8" - PLASTIC
	132678-01-000	EA	TANK - WATER - 85 GALLON - W/O FITTINGS
2	133352-01-02B	EA	PANEL - ACCESS - WATER TANK - E-COATED
3	062421-05-000	EA	CABLE/ROD - F/DUMP VALVE - W/HANDLE - 48"
4	143994-01-12B	EA	BRACKET/MOUNTING - VALVE - BRIGHT WHITE
5	112091-01-000	FT	SEAL/D - NEOPRENE - HEAT ACTIVE ADHESIVE - .9" X .7"

WATER & SEWAGE GROUP (CONTINUED)
COMPONENT PARTS FOR WATER SYSTEM

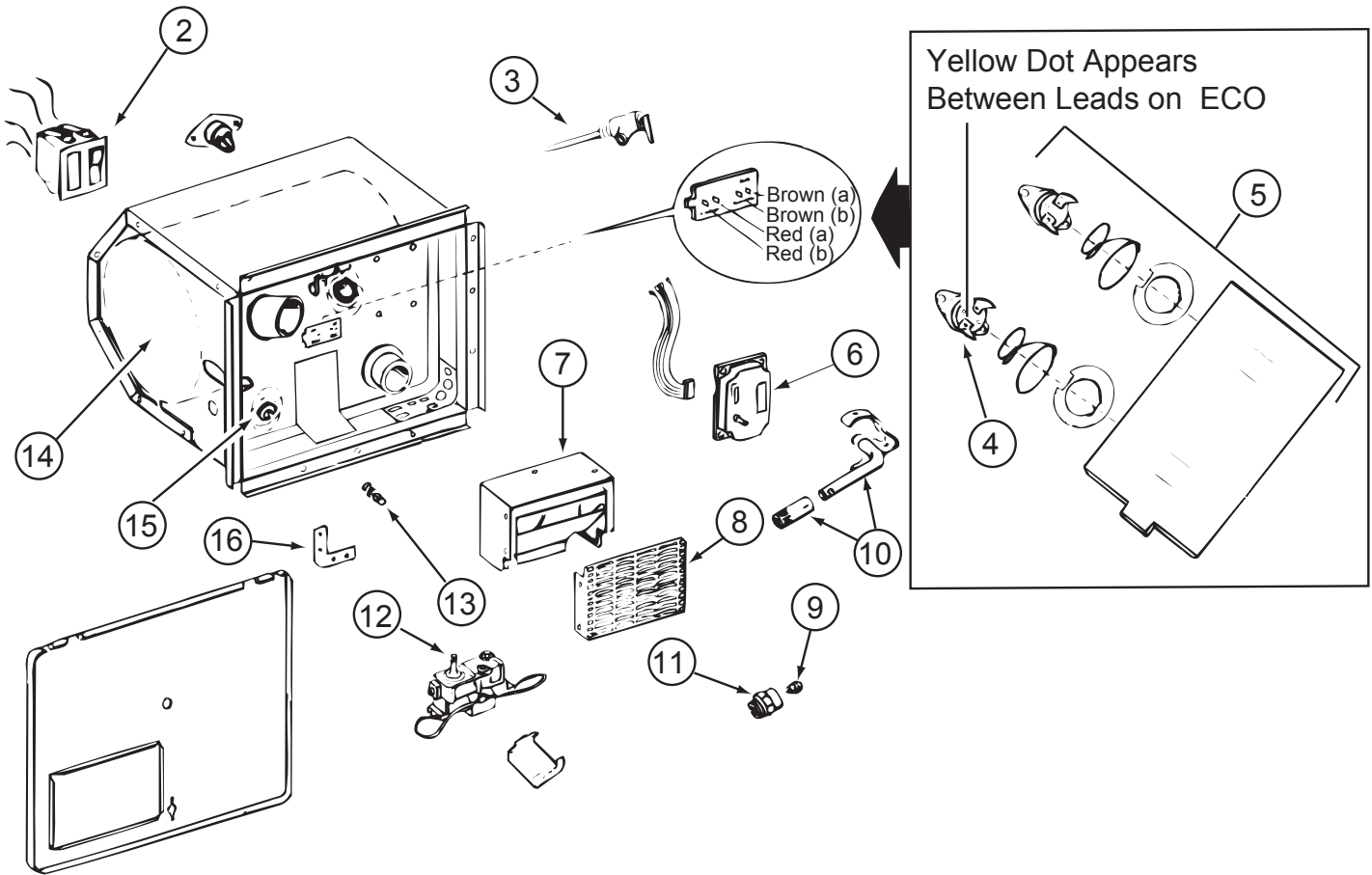

051391-05-000

KEY	PART NUMBER	U/M	DESCRIPTION	VENDOR NO.
2	051393-01-701	EA	SWITCH - REMOTE - W/LIGHT	91959
3	051391-01-704	EA	VALVE-RELIEF, 1/2" FITTING	91604
4	051391-04-701	EA	THERMOSTAT 12V DC-120 PRESET	91470
5	051391-05-707	EA	THERMOSTAT & ECO - 110 VOLT	91873
6	051393-01-704	EA	BOARD-CIRCUIT	93865
7	051391-04-707	EA	KIT-EXHAUST, (FLUE & GASKET)	90960
8	051391-01-717	EA	GRILLE-WATER HEATER DOOR	92640
9	051391-05-701	EA	ORIFICE-MAIN BURNER	93914
10	051391-05-700	EA	BURNER-MAIN	93221
11	051391-03-700	EA	HOLDER-ORIFICE	91563
12	051393-01-726	EA	VALVE-SOLENOID, W/O BRACKET	93870
13	051391-01-715	EA	PLUG-DRAIN, 1 EA = 2 PER PKG	91857
14	051391-05-704	EA	TANK-INNER	93593
15	051391-05-706	EA	ELEMENT-HEATING 1500 WATT	91160 W/GASKET
16	111129-01-711	EA	BRACKET-CORNER, SET OF FOUR	91928
	051391-05-703	EA	HARDWARE KIT-DOOR	91858
	051391-05-705	EA	SWITCH - ON/OFF SWITCH - BOX	91182
	051393-01-721	EA	THERMOSTAT W/ECO, 140 FRT MT	91447
	051393-01-723	EA	SWITCH - THERMAL CUTOUT 2/PK	93866
	051393-01-725	EA	ELECTRODE-SGL SPADE CONNECT.	93868
	051393-01-730	EA	BRACKET - F/10 GAL SYSTEM	93862

CONTACT WINNEBAGO PARTS SALES FOR UNLISTED COMPONENTS

075241-04-000, 075241-05-000, 075241-06-000

KEY	PART NUMBER	U/M	DESCRIPTION	VENDOR NO.
	075240-05-700	EA	CARTRIDGE - WASHERLESS	9-P42

WATER & SEWAGE GROUP (CONTINUED)
COMPONENT PARTS FOR WATER SYSTEM (CONTINUED)

118569-03-000

KEY	PART NUMBER	U/M	DESCRIPTION	VENDOR NO
	118569-01-700	EA	VALVE/SOLENOID-ELECT CONTROL	NO VDR#
	118569-01-701	EA	SWITCH - ELECTRIC	EA1-31
	118569-01-702	EA	PLATE - SWITCH	ERUS-1
	118569-01-704	EA	PLUG - 3/4 MPT	NO VDR#
	118569-01-705	EA	PLUG - 1/2 MPT	NO VDR#
	118569-01-706	EA	SCREEN - WHITE	NO VDR#

123744-03-01A

KEY	PART NUMBER	U/M	DESCRIPTION	VENDOR NO.
	135027-01-700	EA	CLIP - RETAINER	883
	135027-01-705	EA	CARTRIDGE F/SGL LEVER FAUCET	1225

125420-01-02A, 125420-01-03A, 125420-04-03A

KEY	PART NUMBER	U/M	DESCRIPTION	VENDOR NO.
	051391-01-705	EA	FASTENER - CAMLOCK	92609

128997-01-01A

KEY	PART NUMBER	U/M	DESCRIPTION	VENDOR NO.
	119677-01-712	EA	AERATOR - SPOUT - BATHTUB	50-19PB
	131340-01-700	EA	BUTTON - HOT/COLD	N1201-16
	131340-01-701	EA	KNOB - CLEAR	N1201-9
	131340-02-700	EA	CARTRIDGE	6-1201-5-0WB

131340-01-01A

KEY	PART NUMBER	U/M	DESCRIPTION	VENDOR NO.
	119677-01-701	EA	SHOWER HEAD ONLY 1/2"	34PB
	131340-01-700	EA	BUTTON - HOT/COLD	N1201-16
	131340-01-701	EA	KNOB - CLEAR	N1201-9

131340-02-01A

KEY	PART NUMBER	U/M	DESCRIPTION	VENDOR NO.
	131340-02-700	EA	CARTRIDGE	6-1201-5-0

WINDOW & VENTS GROUP

WINDOW & VENT LAYOUT

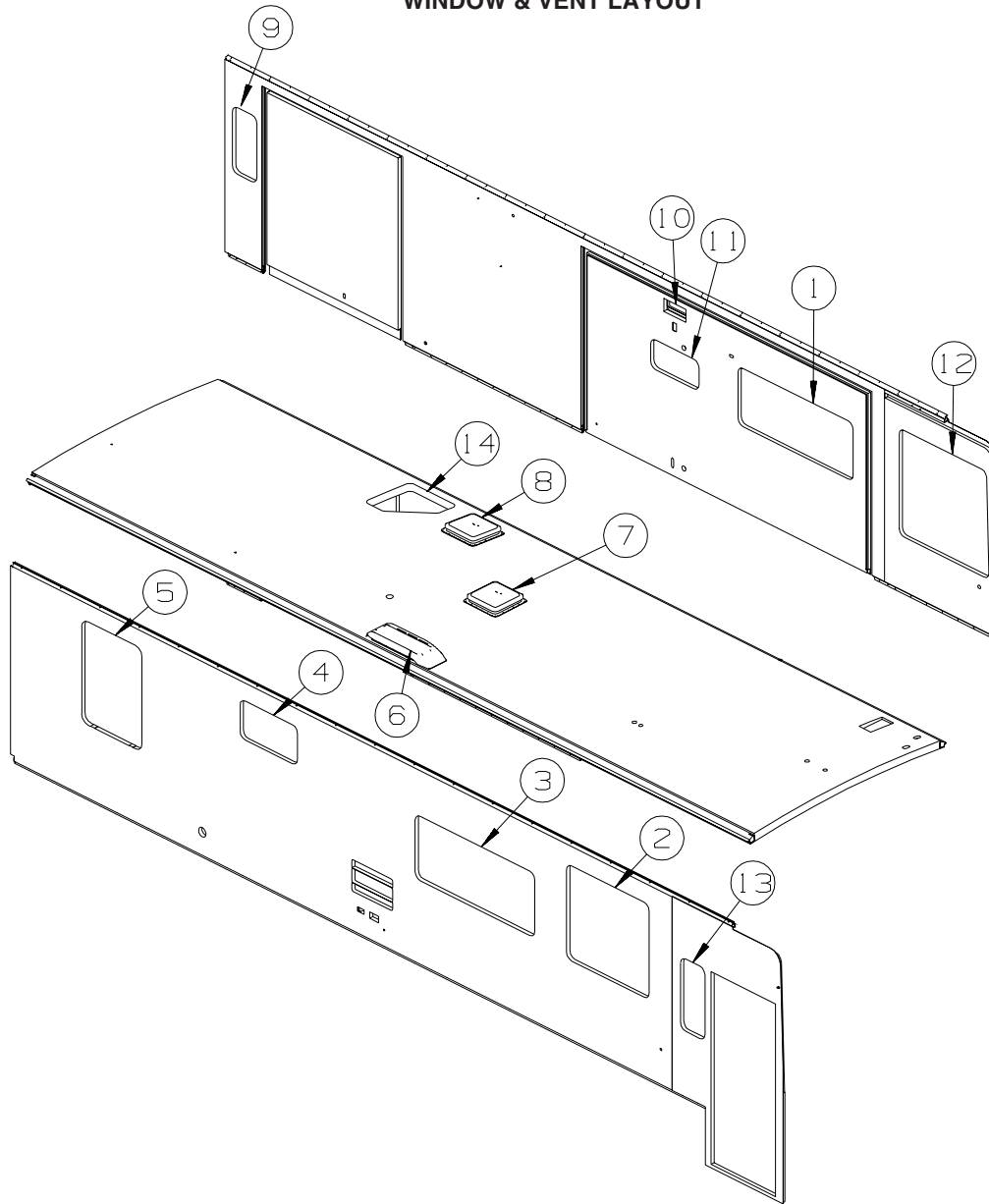

KEY	PART NUMBER	U/M	DESCRIPTION
1*	112795-81-01A	EA	WINDOW - DRVR HORIZ SLIDER/ESCAPE - THERMO - 23.8" X 57.7" - DUAL PANE
2*	112795-83-01A	EA	WINDOW - PASSENGER HORIZ SLIDER - THERMO - 39" X 41.4" - DUAL PANE
3*	112795-69-01A	EA	WINDOW - PASSENGER HORIZ SLIDER - THERMO - 26.3" X 60" - DUAL PANE
4*	112795-72-01A	EA	WINDOW - PASSENGER HORIZ SLIDER - THERMO - 28.5" X 15.7" - DUAL PANE
5*	129929-08-01A	EA	WINDOW - TORQUE - THERMO/ESCAPE - 42.2" X 30.2" - DUAL PANE
6	084073-04-000	EA	BASE/VENT - ROOF/REFRIGERATOR - BLACK - NORCOLD
6	084073-07-000	EA	CAP - ROOF/REFRIGERATOR VENT - 10" X 32" - BRIGHT WHITE
7*	123780-09-01A	EA	FANTASTIC VENT-4"ROOF- W/FAN/DBL DOME-W/O THERM/PWR LIFT - HOME COMFORT PLUS PKG.
7	009440-01-000	EA	GEAR/ARM - LIFT - ROOF VENT COVER
8*	123780-10-01A	EA	FANTASTIC VENT-4"ROOF-W/FAN/PWR LIFT/DBL DOME-W/O THERM - INSULATED POWERED VENT
8	009440-01-000	EA	GEAR/ARM - LIFT - ROOF VENT COVER
9*	137867-04-01A	EA	WINDOW - DOUBLE TIPOUT - THERMO - 12.3" X 27.2" - DUAL PANE
10	138983-01-01A	EA	VENT - MICROWAVE OUTER - BRIGHT WHITE
10	138983-03-01A	EA	COVER - VENT MICROWAVE OUTER - BRIGHT WHITE
11*	112795-85-01A	EA	WINDOW - DRIVER HORIZONTAL SLIDER - THERMO- 12.3" X 24.2" - DUAL PANE
12*	106466-14-01A	EA	WINDOW - CAB/DRVR THERMO W/RETAINER-44.6"T X 44.7"H X 46"B - DUAL PANE
13*	112898-27-01A	EA	WINDOW - VERTICAL SLIDER - THERMO - 12" X 29.4" - BLACK - DUAL PANE
14	122214-01-02A	EA	PANEL - SKYLITE - INNER - W/ANGLED CORNER - WHITE
14	138372-01-12B	EA	TRIM - CORNER - SKYLIGHT - BRIGHT WHITE
14	139411-01-01A	EA	PANEL/SKYLITE - OUTER - NEO ANGLE - WHITE

*COMPONENT PARTS LISTED LATER IN THIS GROUP

WINDOW & VENTS GROUP (CONTINUED)
COMPONENT PARTS FOR WINDOWS & VENT LAYOUT

106466-14-01A

KEY	PART NUMBER	U/M	DESCRIPTION	VENDOR NO.
1	112795-01-704	FT	PLUG FILLER (DOUBLE GLAZED)	122-018737
2	112795-01-705	FT	VINYL - GLAZING	132-027331
3	098644-01-706	FT	WEATHERSTRIP - GLASS	171-010668
4	098644-01-713	EA	CLIP - SCREEN - METAL	226-016966
4	125582-01-701	EA	CLIP - SCREEN - PLASTIC	130-005153
5	112795-01-701	EA	SLIDE-STOP	132-019092
6	098644-01-710	FT	TRACK - SCREEN SPACER 12'	132-017135
7	112795-01-700	EA	LATCH ASM., BLK.,(BOLT ON)	DH287-CK
8	112795-01-703	IN	CHANNEL-RUN (INCHES)	122-027566
9	075673-05-000	FT	SEAL-PILE ADH BACK,BLK	AMESBURY
10	106466-14-701	EA	GLASS - STATIONERY - LOWER	390-027478
11	106466-14-702	EA	GLASS-SLIDING W/SASH & LATCH	DH567-A9L
12	125582-04-701	EA	SCREEN ASM - W/SEALS & CLIPS	410-026544
13	106466-13-703	EA	RETAINER - TRIM	H671-66L
14	106466-14-700	EA	GLASS - STATIONERY - UPPER	390-027477
	098644-01-717	FT	SPLINE - SCREEN	132-004716
	125582-01-708	EA	WEEPHOLE COVER - RIGHT HAND	130-026598
	125582-01-709	EA	WEEPHOLE COVER - LEFT HAND	130-026599

WINDOW & VENTS GROUP (CONTINUED)
COMPONENT PARTS FOR WINDOWS & VENT LAYOUT (CONTINUED)

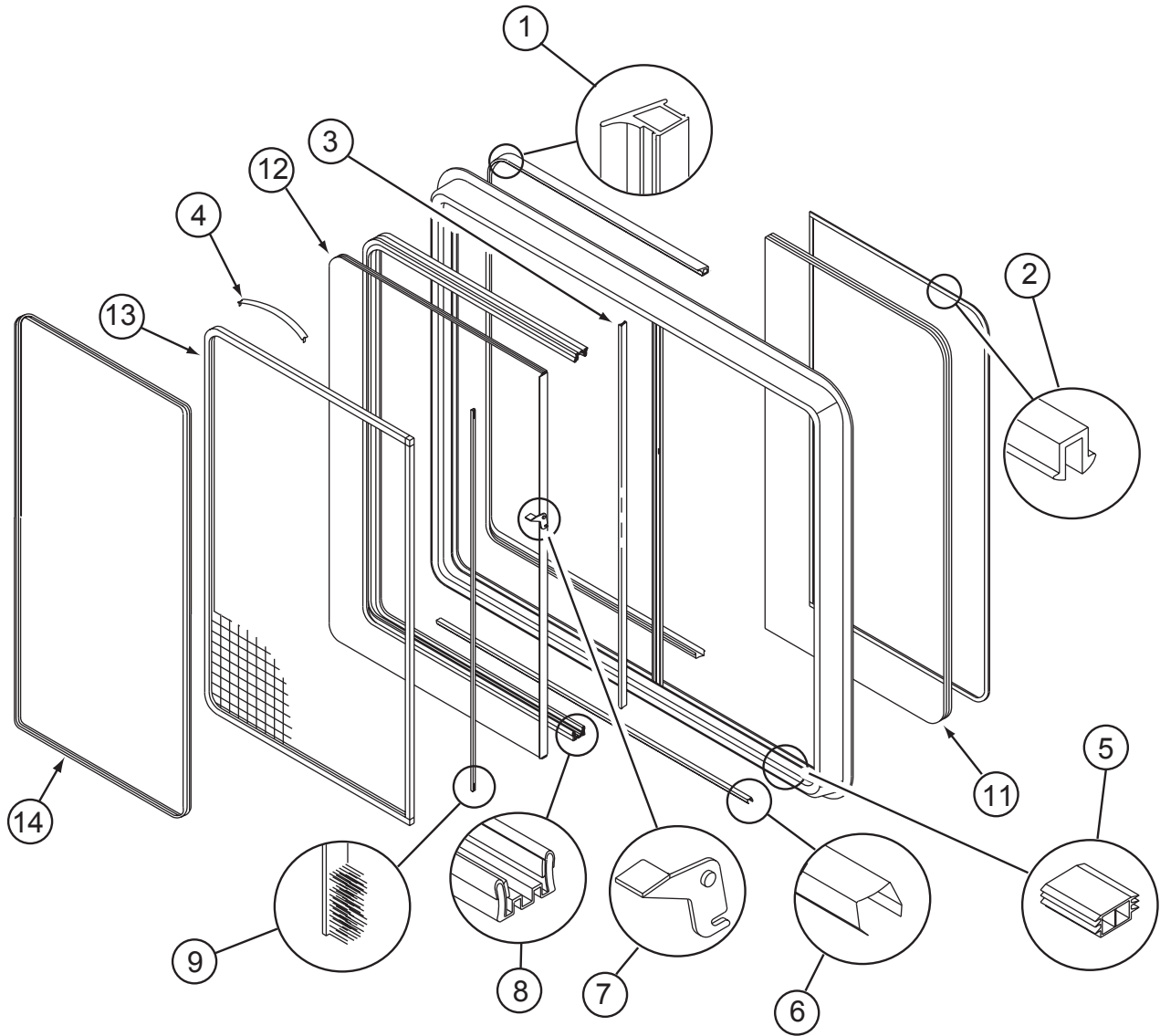

112795-69-01A

KEY	PART NUMBER	U/M	DESCRIPTION	VENDOR NO.
1	112795-01-704	FT	PLUG FILLER (DOUBLE GLAZED)	122-018737
2	112795-01-705	FT	VINYL - GLAZING	132-025736
3	098644-01-706	FT	WEATHERSTRIP - GLASS	171-010668
4	098644-01-713	EA	CLIP - SCREEN - METAL	226-016966
4	125582-01-701	EA	CLIP - SCREEN - PLASTIC	130-005153
	098644-01-717	FT	SPLINE - SCREEN	132-004716
5	112795-01-701	EA	SLIDE-STOP	132-019092
6	098644-01-710	FT	TRACK - SCREEN SPACER 12'	132-017135
7	112795-01-700	EA	LATCH ASM., BLK.,(BOLT ON)	DH287-CK
8	112795-01-703	IN	CHANNEL-RUN (INCHES)	122-018736
9	098644-01-711	FT	WEATHERSTRIP - SCREEN BLACK	171-016965
11	112795-68-700	EA	GLASS - STATIONARY	390-028353
12	112795-68-701	EA	GLASS - SLIDING W/SASH LATCH	390-028353
13	098647-23-704	EA	SCREEN ASSY - W/SEAL & CLIPS	410-019066
14	098647-27-704	EA	RETAINER - TRIM	H287-66

WINDOW & VENTS GROUP (CONTINUED)
COMPONENT PARTS FOR WINDOWS & VENT LAYOUT (CONTINUED)

112795-72-01A

KEY	PART NUMBER	U/M	DESCRIPTION	VENDOR NO.
1	112795-01-704	FT	PLUG FILLER (DOUBLE GLAZED)	122-018737
2	112795-01-705	FT	VINYL - GLAZING	132-025736
3	098644-01-706	FT	WEATHERSTRIP - GLASS	171-010668
4	098644-01-713	EA	CLIP - SCREEN - METAL	226-016966
4	125582-01-701	EA	CLIP - SCREEN - PLASTIC	130-005153
	098644-01-717	FT	SPLINE - SCREEN	132-004716
5	112795-01-701	EA	SLIDE-STOP	132-019092
6	098644-01-710	FT	TRACK - SCREEN SPACER 12'	132-017135
7	112795-01-700	EA	LATCH ASM., BLK.,(BOLT ON)	DH287-CK
8	112795-01-703	IN	CHANNEL-RUN (INCHES)	122-018736
9	098644-01-711	FT	WEATHERSTRIP - SCREEN BLACK	171-016965
11	112795-72-700	EA	GLASS - STATIONARY	390-028307
12	112795-72-701	EA	GLASS - SLIDING W/SASH LATCH	DC29-G8
13	098647-31-704	EA	SCREEN ASSY - W/SEAL & CLIPS	410-019128
14	098647-31-705	EA	RETAINER - TRIM	CH29-66

112795-81-01A

KEY	PART NUMBER	U/M	DESCRIPTION	VENDOR NO.
1	112795-01-704	FT	PLUG FILLER (DOUBLE GLAZED)	122-018737
2	112795-01-705	FT	VINYL - GLAZING	132-025736
3	098644-01-706	FT	WEATHERSTRIP - GLASS	171-010668
4	098644-01-713	EA	CLIP - SCREEN - METAL	226-016966
4	125582-01-701	EA	CLIP - SCREEN - PLASTIC	130-005153
	098644-01-717	FT	SPLINE - SCREEN	132-004716
5	112795-01-701	EA	SLIDE-STOP	132-019092
6	098644-01-710	FT	TRACK - SCREEN SPACER 12'	132-017135
7	112795-01-700	EA	LATCH ASM., BLK.,(BOLT ON)	DH287-CK
8	112795-01-703	IN	CHANNEL-RUN (INCHES)	122-018736
9	098644-01-711	FT	WEATHERSTRIP - SCREEN BLACK	171-016965
11	112795-77-700	EA	GLASS - STATIONARY	390-28313
12	112795-77-701	EA	GLASS - SLIDING W/SASH LATCH	DH493-G8
13	098647-47-702	EA	SCREEN ASSY - W/SEAL & CLIPS	410-025226
14	098647-47-704	EA	RETAINER - TRIM	H493-66

112795-83-01A

KEY	PART NUMBER	U/M	DESCRIPTION	VENDOR NO.
1	112795-01-704	FT	PLUG FILLER (DOUBLE GLAZED)	122-018737
2	112795-01-705	FT	VINYL - GLAZING	132-025736
3	098644-01-706	FT	WEATHERSTRIP - GLASS	171-010668
4	098644-01-713	EA	CLIP - SCREEN - METAL	226-016966
4	125582-01-701	EA	CLIP - SCREEN - PLASTIC	130-005153
	098644-01-717	FT	SPLINE - SCREEN	132-004716
5	112795-01-701	EA	SLIDE-STOP	132-019092
6	098644-01-710	FT	TRACK - SCREEN SPACER 12'	132-017135
7	112795-01-700	EA	LATCH ASM., BLK.,(BOLT ON)	DH287-CK
8	112795-01-703	IN	CHANNEL-RUN (INCHES)	122-018736
9	098644-01-711	FT	WEATHERSTRIP - SCREEN BLACK	171-016965
11	112795-83-700	EA	GLASS - STATIONARY	390-028332
12	112795-83-701	EA	GLASS - SLIDING W/SASH LATCH	DH650-G8
13	112795-67-702	EA	SCREEN ASSY - W/SEAL & CLIPS	410-027134
14	112795-67-700	EA	RETAINER - TRIM	H650-66

WINDOW & VENTS GROUP (CONTINUED)
COMPONENT PARTS FOR WINDOWS & VENT LAYOUT (CONTINUED)

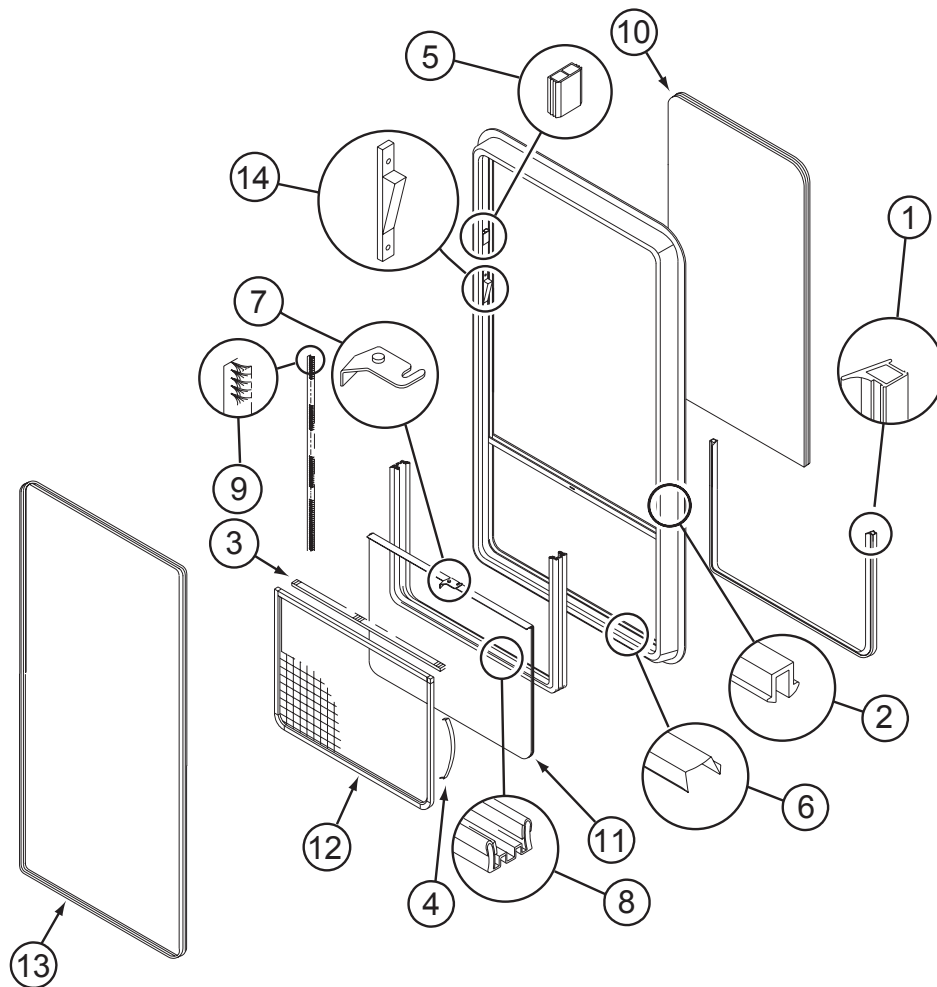

112898-27-01A

KEY	PART NUMBER	U/M	DESCRIPTION	VENDOR NO.
1	112795-01-704	FT	PLUG FILLER (DOUBLE GLAZED)	122-018737
2	112795-01-705	FT	VINYL - GLAZING	132-027331
3	098644-01-706	FT	WEATHERSTRIP - GLASS	171-010668
4	098644-01-713	EA	CLIP - SCREEN - METAL	226-016966
4	125582-01-701	EA	CLIP - SCREEN - PLASTIC	130-005153
5	112795-01-701	EA	SLIDE-STOP	132-019092
6	098644-01-710	FT	TRACK - SCREEN SPACER 12'	132-017135
7	112795-01-700	EA	LATCH ASM., BLK.,(BOLT ON)	DH287-CK
8	112795-01-703	IN	CHANNEL-RUN (INCHES)	122-027566
9	075673-05-000	FT	SEAL-PILE ADH BACK,BLK	AMESBURY
10	112898-27-700	EA	GLASS - STATIONARY	390-029191
11	112898-27-701	EA	GLASS-SLIDING W/SASH & LATCH	DH755-G8
12	112898-27-702	EA	SCREEN ASM W/SEALS & CLIPS	410-029193
13	113733-13-701	EA	RETAINER - TRIM	H754-66
	098644-01-717	FT	SPLINE - SCREEN	132-004716

WINDOW & VENTS GROUP (CONTINUED)
COMPONENT PARTS FOR WINDOWS & VENT LAYOUT (CONTINUED)

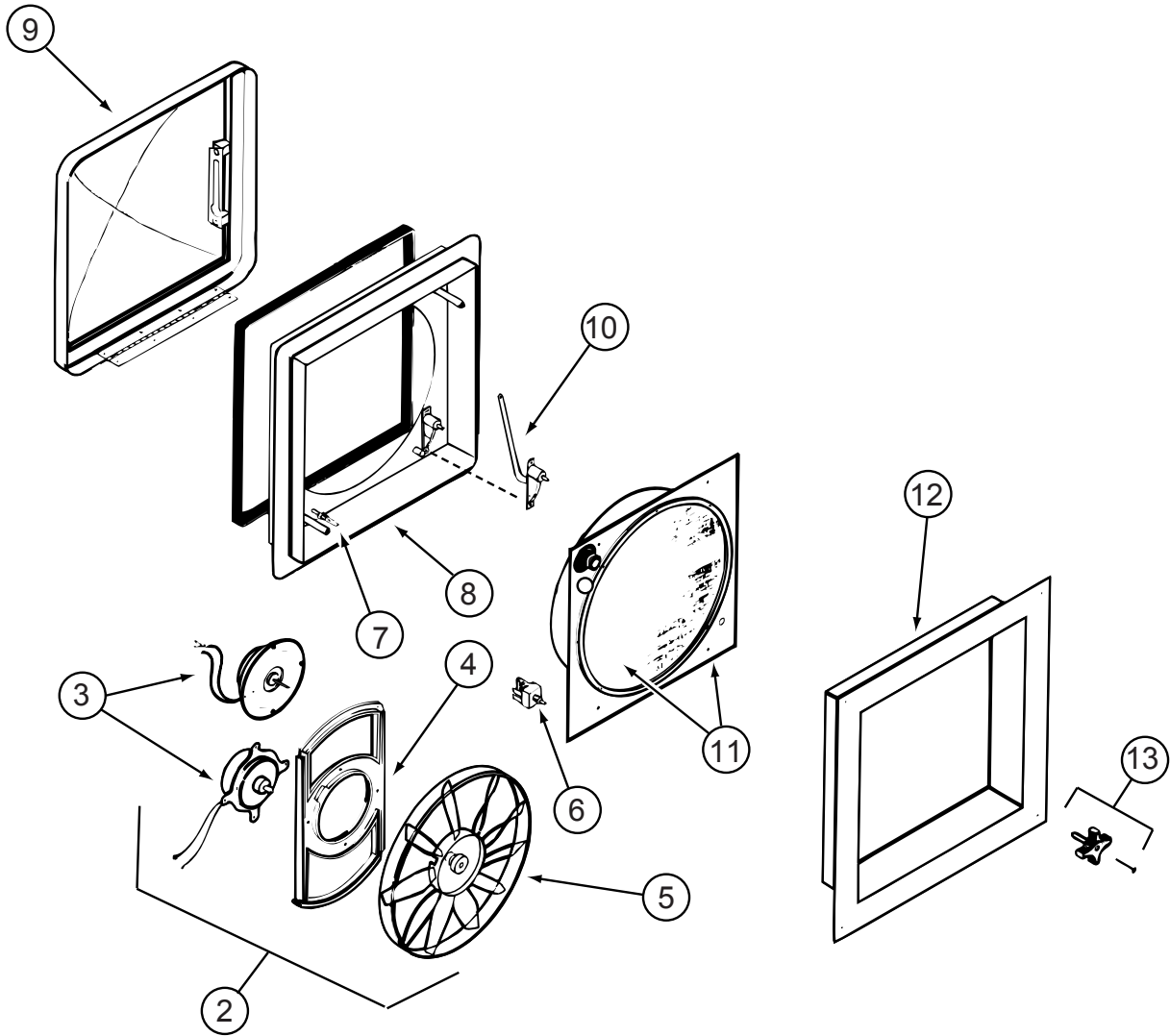

123780-09-01A

KEY	PART NUMBER	U/M	DESCRIPTION	VENDOR NO.
2	084079-11-700	EA	MOTOR & FAN BLADE W/BRACKET	K4017-09
3	084079-01-705	EA	MOTOR/EXT BRKT/FAN BLADE KIT	1080-00
5	084079-01-704	EA	BLADE-FAN	1138-00
6	084079-01-709	EA	SWITCH - MAIN - 3 SPEED	1031-05
7	084079-01-707	EA	SWITCH - SAFETY	1122-05
8	123780-05-700	EA	BASE/MAIN-BRT WHT W/GASKET	1010-81
9	123780-09-700	EA	DOMES (DOUBLE)WHT TRANSPARENT	K2020-82
10	009440-01-000	EA	GEAR-ARM-ROOF VENT	705221K38
11	123780-03-701	EA	SCREEN ASM 78-100MM W/SWITCH	1030BT-81
12	123780-03-700	EA	GARNISH - INT. 3"-4" BRT/WHT	2040-81
13	084079-01-703	EA	KNOB-LIFT, W/EXT.	1140K-00
	123780-01-702	EA	SCREEN INSERT (SCREEN RING)	K1035-81

CONTACT WINNEBAGO PART SALES FOR UNLISTED COMPONENTS

WINDOW & VENTS GROUP (CONTINUED)
COMPONENT PARTS FOR WINDOWS & VENT LAYOUT (CONTINUED)

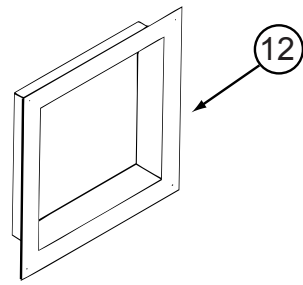
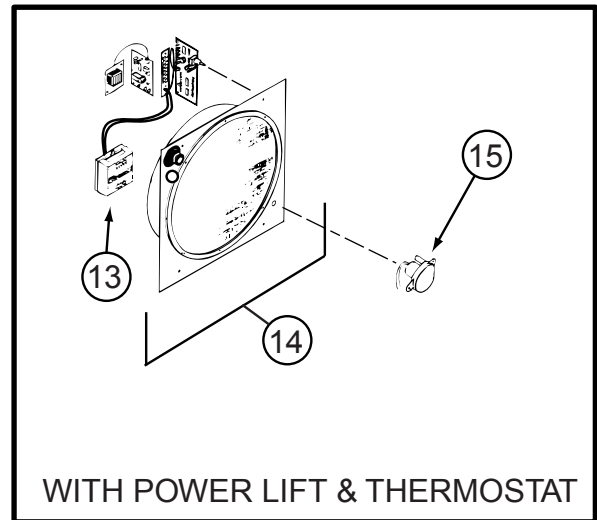
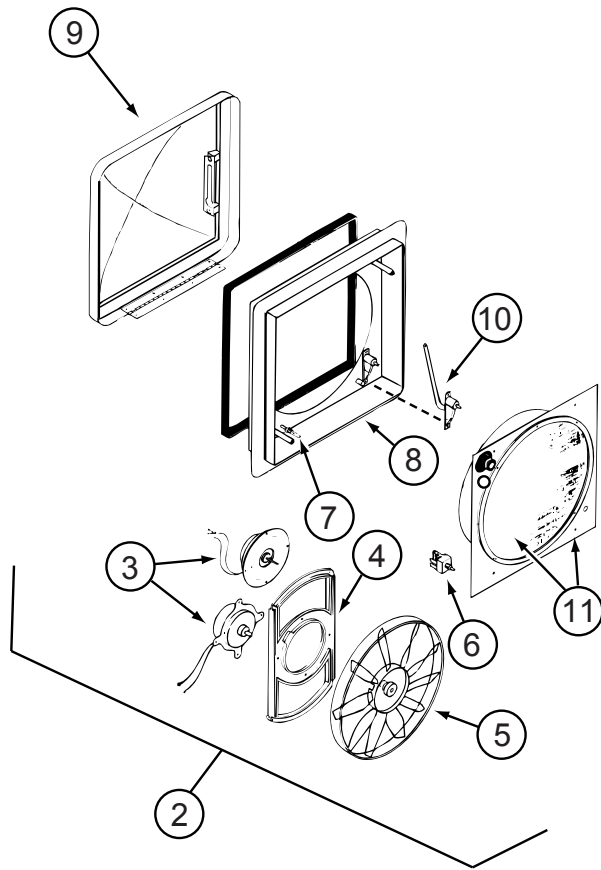

123780-10-01A				
KEY	PART NUMBER	U/M	DESCRIPTION	VENDOR NO.
2	084079-11-700	EA	MOTOR & FAN BLADE W/BRACKET	K4017-09
3	084079-01-705	EA	MOTOR/EXT BRKT/FAN BLADE KIT	1080-00
5	084079-01-704	EA	BLADE-FAN	1138-00
6	084079-01-709	EA	SWITCH - MAIN - 3 SPEED	1031-05
7	084079-01-707	EA	SWITCH - SAFETY	1122-05
8	123780-05-700	EA	BASE/MAIN-BRT WHT W/GASKET	1010-81
9	123780-09-700	EA	DOME (DOUBLE)WHT TRANSPARENT	K2020-82
10	009440-01-000	EA	GEAR-ARM-ROOF VENT	705221K38
12	123780-03-700	EA	GARNISH - INT. 3"-4" BRT/WHT	2040-81
13	084079-01-710	EA	THERMOSTAT(WALL MT)ANY COLOR	9988-81
14	123780-05-701	EA	SCREEN INT W/ALL SWITCHES	KIT-81
15	084079-11-703	EA	MOTOR/AUTO LIFT OFF/WHT CAP	6050-80 OS
15	084079-11-705	EA	MOTOR - LIFT (BC MOTOR)	5050-40
15	084079-11-707	EA	MOTOR-AUTO LIFT-WHT CAP NS	6050-81 NS
	123780-01-702	EA	SCREEN INSERT (SCREEN RING)	K1035-81

CONTACT WINNEBAGO PART SALES FOR UNLISTED COMPONENTS

WINDOW & VENTS GROUP (CONTINUED)
COMPONENT PARTS FOR WINDOWS & VENT LAYOUT (CONTINUED)

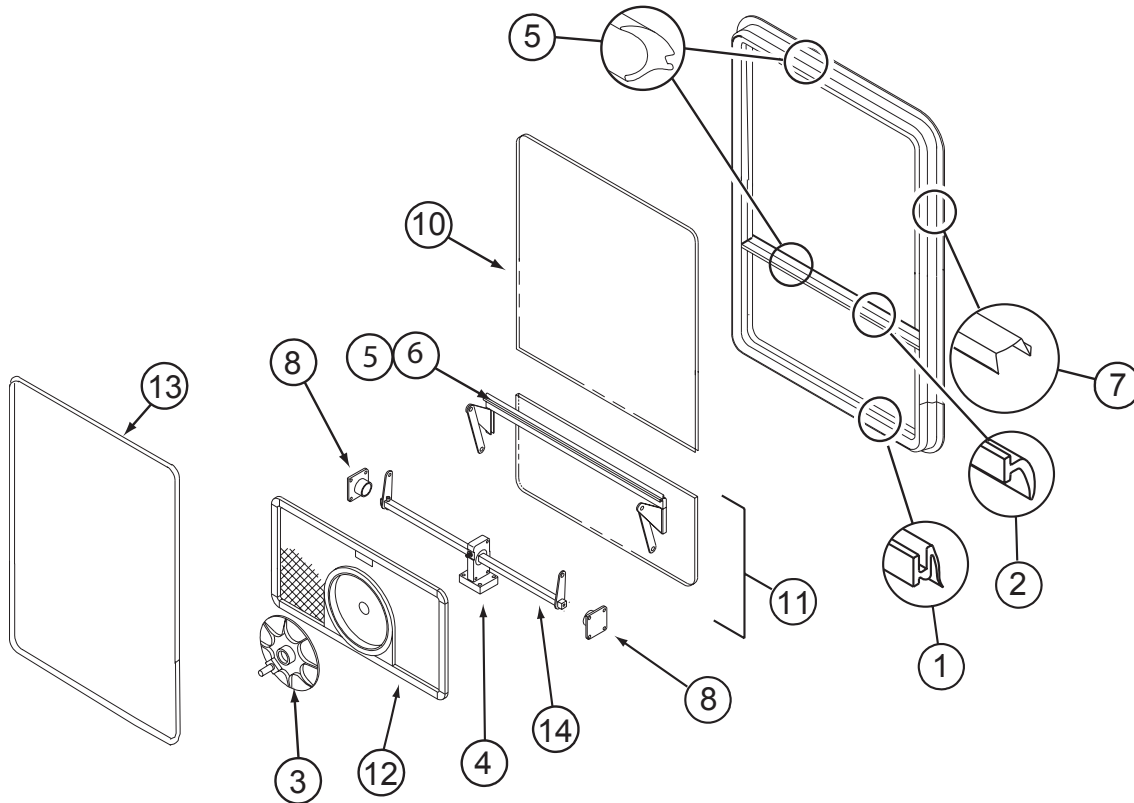

129929-08-01A

KEY	PART NUMBER	U/M	DESCRIPTION	VENDOR NO .
1	100322-01-701	FT	SEAL-VENT	122-016071
3	100322-01-718	EA	HANDLE-DIAL	410-016081
4	129929-01-710	EA	TORQUE-CTR SUPPORT (2 HOLE)	410-026806
5	129929-01-705	FT	GLAZING VINYL	132-026811
6	129929-01-707	FT	COVER/SCREW-FILLER STRIP	132-026808
8	129929-01-708	EA	SUPPORT - TORQUE BAR - RT/LT	130-026804
10	129929-08-700	EA	GLASS - STATIONARY	390-028303
11	129929-10-701	EA	VENT GLASS ASSEMBLY	DTH002-G8
12	129929-02-702	EA	SCREEN ASM - W/SEALS & CLIPS	410-026861
13	129929-02-707	EA	RETAINER - TRIM	CH10162
14	129929-02-704	EA	OPERATOR BAR ASSEMBLY	DTH002-15
	100322-01-717	FT	SEAL - VENT	122-016071
	129929-01-706	FT	SEAL - TOP F/CENTER EGRESS	132-026811
	129929-02-706	FT	SEAL - FOAM	140-027022

CONTACT WINNEBAGO PART SALES FOR UNLISTED COMPONENTS

WINDOW & VENTS GROUP (CONTINUED)
COMPONENT PARTS FOR WINDOWS & VENT LAYOUT (CONTINUED)

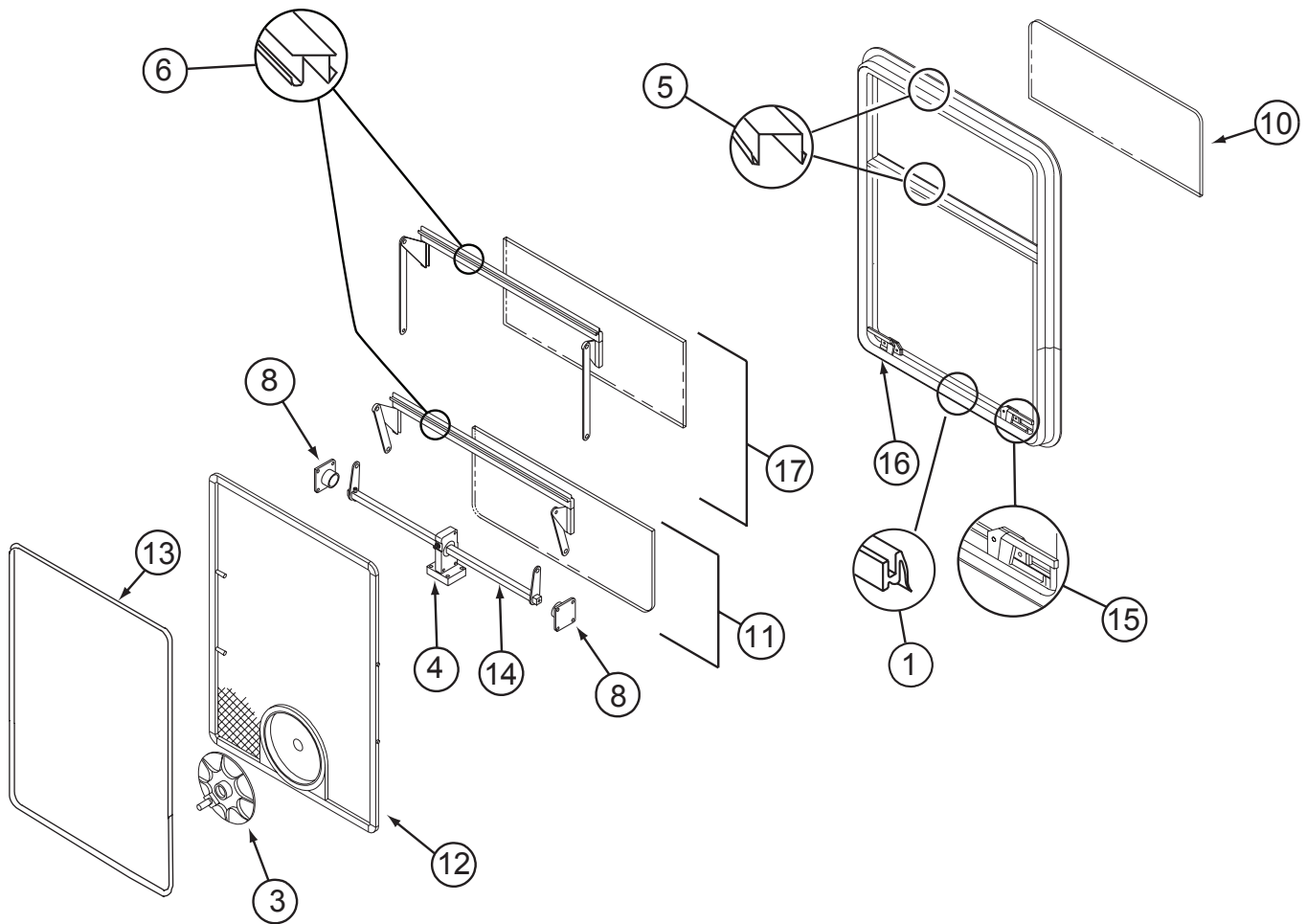

137867-04-01A

KEY	PART NUMBER	U/M	DESCRIPTION	VENDOR NO.
1	100322-01-701	FT	SEAL-VENT	122-016071
3	100322-01-718	EA	HANDLE-DIAL	410-016081
4	129929-01-710	EA	TORQUE-CTR SUPPORT (2 HOLE)	410-026806
5	129929-01-705	FT	GLAZING VINYL	132-026811
6	129929-01-707	FT	COVER/SCREW-FILLER STRIP	132-026808
8	129929-01-708	EA	SUPPORT - TORQUE BAR - RT/LT	130-026804
10	137867-04-700	EA	GLASS - STATIONARY (DBL GLZ)	390-029416
10	137867-04-704	EA	RETAINER - TRIM	H298-62
11	137867-04-701	EA	VENT ASSEMBLY LWR (DBL GLZ)	DTH025-G8
12	137867-04-703	EA	SCREEN ASSEMBLY W/SEAL/CLIPS	410-029417
13	137867-03-703	EA	RETAINER - TRIM	DTH023-62
14	137867-03-704	EA	OPERATOR BAR ASSEMBLY	DTH025-15
15	NOT USED			
16	NOT USED			
17	137867-04-702	EA	VENT ASSEMBLY UPR (DBL GLZ)	DTH025-G6
	100322-01-717	EA	E-RING	245-015975
	129929-01-706	IN	SEAL - TOP F/CENTER EGRESS	132-026811
	129929-02-706	FT	SEAL - FOAM	140-027022

CONTACT WINNEBAGO PART SALES FOR UNLISTED COMPONENTS

WINDSHIELD & WIPER GROUP

WINDSHIELD

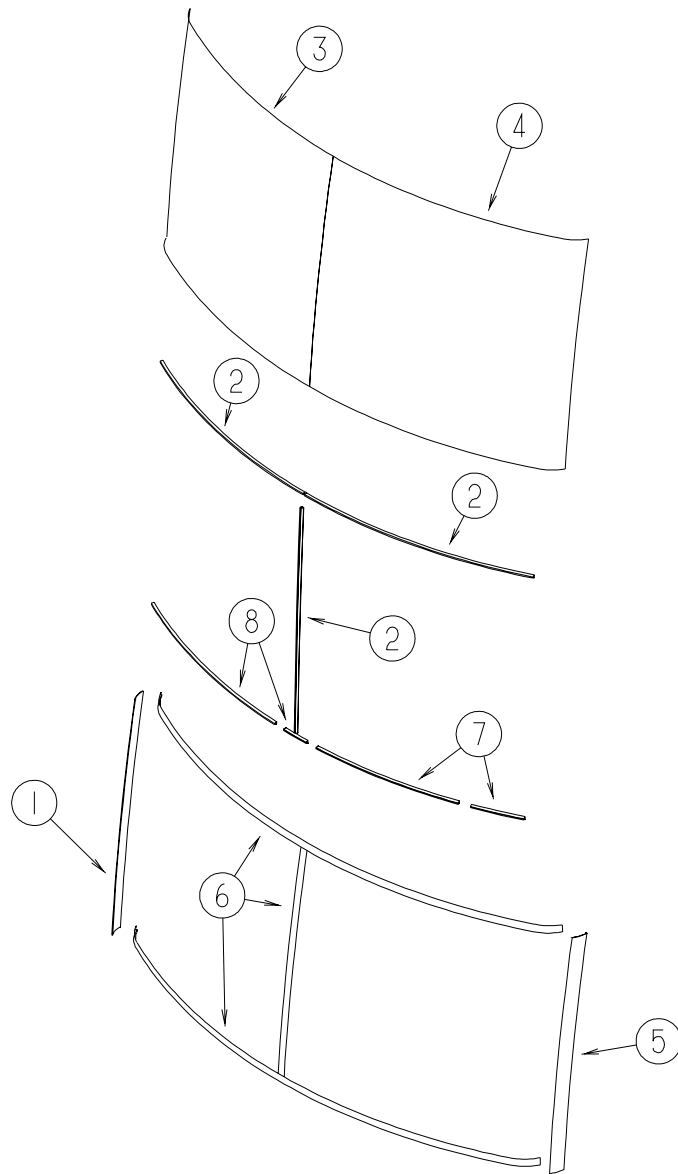

KEY	PART NUMBER	U/M	DESCRIPTION
1	129497-05-03A	EA	TRIM - WINDSHIELD - PASSENGER A-PILLAR - BRIGHT WHITE FROM: 00-00-00 THRU: 07-28-02
1	129497-05-02A	EA	TRIM - PASSENGER A-PILLAR - BLACK FROM: 07-29-02 THRU: 99-99-99
2	127862-01-000	EA	CARRIER - REVEAL - WINDSHIELD - 47.2"
3	131244-01-000	EA	WINDSHIELD - PASSENGER - 52.5" X 44.4" (CURVED)
4	131244-02-000	EA	WINDSHIELD - DRIVER - 52.5" X 44.4" (CURVED)
5	129497-06-03A	EA	TRIM - WINDSHIELD - DRIVER A-PILLAR - BRIGHT WHITE FROM: 00-00-00 THRU: 07-28-02
5	129497-06-02A	EA	TRIM - DRIVER A-PILLAR - BLACK FROM: 07-29-02 THRU: 99-99-99
6	120533-01-000	FT	MOLDING - REVEAL - WINDSHIELD
7	117335-01-000	EA	CARRIER/REVEAL - 94.6" W/ADHESIVE BACKING
8	132375-02-000	EA	CARRIER - REVEAL/WINDSHIELD - 10
	081914-02-000	EA	BUMPER - RUBBER - ROUND - 5/16" DIA. X 13/64" THICK

WINDSHIELD & WIPER GROUP (CONTINUED)

WIPER

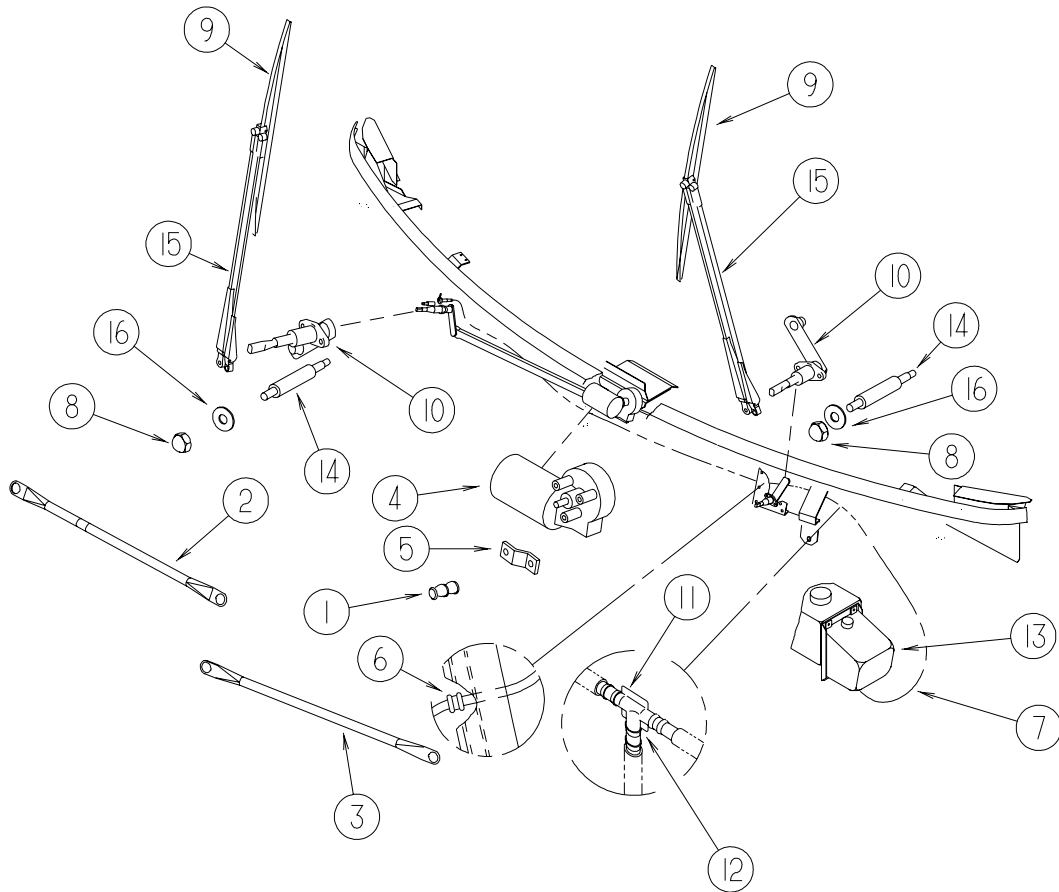

KEY	PART NUMBER	U/M	DESCRIPTION
1	067188-01-000	EA	STUD - CRANK - WIPER MOTOR
	117322-01-000	EA	SCREW - 1/4-28 UNFINISHED - 2A - TORX
2	117770-01-000	EA	LINK - CONNECTING - 24" - CLOSED GROMMET/OPEN GROMMET
3	117770-02-000	EA	LINK - CONNECTING - 24" - CLOSED GROMMET/CLOSED GROMMET
4	104346-05-000	EA	WIPER MOTOR - W/INTERNAL BREAKER - DYNAMIC PARK - FORD
5	104347-04-000	EA	ARM - DRIVE - WIPER MOTOR
6	061603-01-000	EA	GROMMET - SNAP - 3/16"ID - 3/8" HOLE - PLASTIC BLACK
7	045794-01-000	FT	HOSE - WASHER - WINDSHIELD - 5/32" ID - BLACK
8	077049-02-000	EA	NUT - ACORN - 10-32 BLACK/ANODIZED
9*	095964-01-000	EA	BLADE - WINDSHIELD WIPER - 24"
10*	096505-09-000	EA	SHAFT/PIVOT - WINDSHIELD WIPER
11	110605-01-000	EA	TEE - PLASTIC - BARBED - 1/8" X 1/8" X 3/16"
12	117765-03-000	EA	CONNECTOR - 5/32" - WINDSHIELD WASHER
13	117766-02-000	EA	RESERVOIR/PUMP - WINDSHIELD WASHER
14	117768-01-000	EA	SHAFT - ADAPTER - PANTOGRAPH ARM
15*	117769-01-000	EA	ARM - WIPER - PANTOGRAPH - 28"
16	110742-02-000	EA	GASKET - NEOPRENE - WIPER ADAPTER SHAFT - .5" ID X .9" OD

*COMPONENT PARTS LISTED LATER IN THIS GROUP

WINDSHIELD & WIPER GROUP (CONTINUED)
COMPONENT PARTS FOR WIPER

095964-01-000

KEY	PART NUMBER	U/M	DESCRIPTION	VENDOR NO.
	095964-01-700	EA	BLADE-REFILL 24" EA= 1 PAIR	12360

096505-09-000

KEY	PART NUMBER	U/M	DESCRIPTION	VENDOR NO.
	096505-02-700	EA	DRIVER-KNURLED,(HD) BRL .687	NT721017
	096505-02-701	EA	NUT-HEX (HD) W/.687 BARREL	NT721021
	096505-02-702	EA	CAP-RUBBER (HD) BARREL .687	CP721084
	096505-02-703	EA	NUT/ACORN - HD W/.687 BRL	51065-40-NT27WC

117769-01-000

KEY	PART NUMBER	U/M	DESCRIPTION	VENDOR NO.
	096931-01-700	FT	HOSE - WASHER - 1/8" ID	XTU-66-0001
	117769-01-700	EA	RETAINER CLIP - HOSE	