

**2003**  
**ULTIMATE ADVANTAGE**  
**USQ40K**  
**Q-SERIES**  
**PORTSMOUTH OAK**  
**PA0 BLUE CALAIS - BLUE**  
**PA3 TAJ MAHAL - NEUTRAL**  
**PA6 GEORGIAN ROSEWOOD - GREEN**  
**CONCERT CHERRY**  
**PA1 BLUE CALAIS - BLUE**  
**PA4 TAJ MAHAL - NEUTRAL**  
**PA7 GEORGIAN ROSEWOOD - GREEN**  
**WASHED MAPLE**  
**PA2 BLUE CALAIS - BLUE**  
**PA5 TAJ MAHAL - NEUTRAL**  
**PA8 GEORGIAN ROSEWOOD - GREEN**

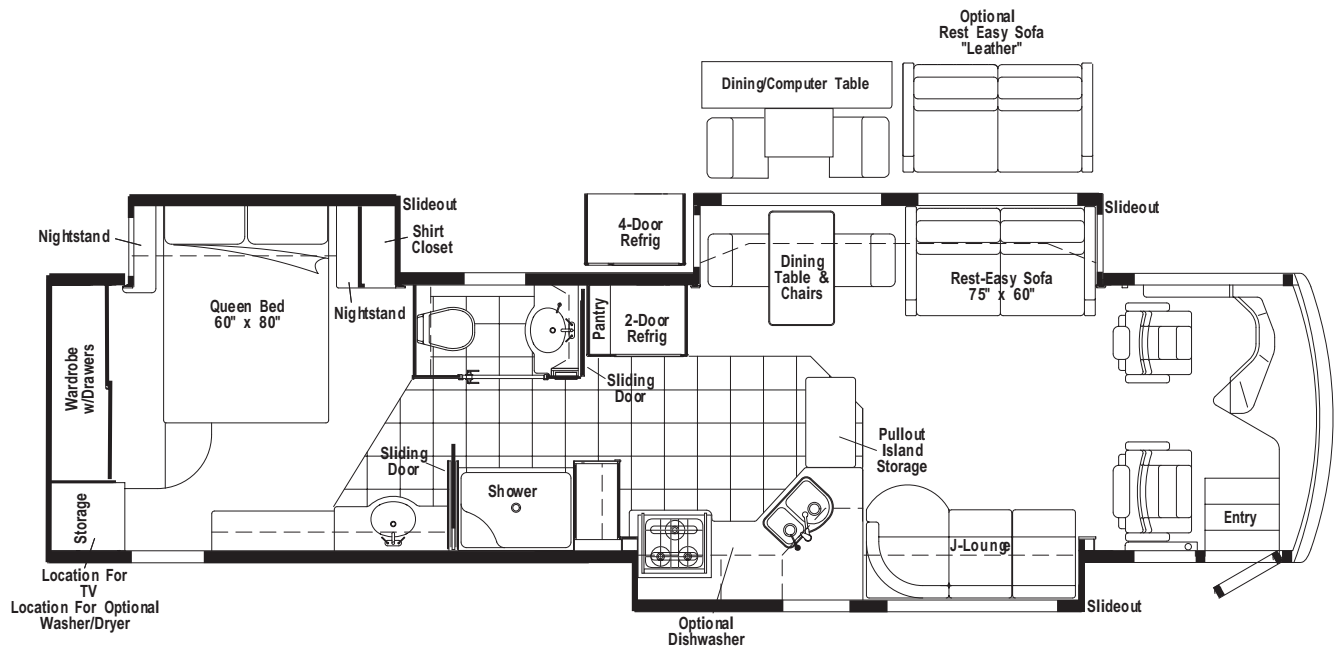

**FLOORPLAN**

# CONTENTS

<b>FLOORPLAN</b> .....	<b>1</b>
<b>ACCESSORIES GROUP</b> .....	<b>6</b>
OPERATORS MANUAL .....	6
<b>APPLIANCE GROUP</b> .....	<b>7</b>
APPLIANCES .....	7
COMPONENT PARTS FOR APPLIANCE .....	13
108186-02-000 .....	13
108186-03-000 .....	13
115504-01-000 .....	13
119267-06-01A .....	13
120075-13-01A, 120075-14-01A, 120075-15-01A .....	14
125242-02-01A .....	20
129561-01-01A .....	28
133004-02-01A .....	28
133004-04-01A .....	29
135065-01-01A, 135065-01-02A, 135065-02-01A .....	29
135066-02-01A .....	31
<b>AUDIO VIDEO GROUP</b> .....	<b>34</b>
RADIO SYSTEM .....	34
COMPONENT PARTS FOR RADIO SYSTEM .....	35
127517-12-000 .....	35
REAR VIEW MONITOR .....	36
TELEPHONE .....	36
TV & VCR .....	37
COMPONENT PARTS FOR TV & VCR .....	38
076319-23-000 .....	38
076319-25-000 .....	38
124073-11-000 .....	39
124073-12-000 .....	39
124075-06-000 .....	39
130121-06-000 .....	39
130121-07-000 .....	39
137135-01-000 .....	40
141454-01-01A .....	41
EXTERIOR ENTERTAINMENT .....	42
<b>BATH GROUP</b> .....	<b>43</b>
CABINETS .....	43
SHOWER .....	46
COMPONENT PARTS FOR SHOWER DOOR .....	47
139047-06-01A & -02A .....	47
<b>BEDROOM GROUP</b> .....	<b>48</b>
QUEEN CABINETS .....	48
TV & RADIO CABINETS .....	54
<b>CHASSIS GROUP</b> .....	<b>56</b>
FRAME .....	56
FRONT END .....	58
AIR INTAKE .....	59
INSULATION .....	60
STEPWELL COVER .....	63
EXHAUST .....	64
HITCH .....	64
REAR BUMPER .....	65
FUEL .....	66
HYDRAULIC LEVELING .....	67
COMPONENT PARTS FOR HYDRAULIC LEVELING .....	68
107889-03-000 .....	68
131306-28-000 .....	68
131306-31-000 .....	68
WHEEL, TIRE, COVERS &/OR LINERS .....	69

## CONTENTS (CONTINUED)

<b>CURTAIN &amp; CUSHION GROUP</b> .....	<b>70</b>
NOTICE .....	70
CUSHION LAYOUT .....	71
BUCKET SEATS .....	73
WINDOW TREATMENT .....	74
HARDWARE .....	76
ACCESSORIES .....	78
COMPONENT PARTS FOR ACCESSORIES .....	79
091990-08-01A .....	79
FABRICS .....	80
<b>DINETTE GROUP</b> .....	<b>82</b>
CABINETS .....	82
TABLE .....	83
<b>DRIVERS COMPARTMENT GROUP</b> .....	<b>85</b>
DASH .....	85
BEVERAGE TRAY .....	86
FRONT INTERIOR .....	87
CABINETS .....	89
<b>ELECTRICAL GROUP</b> .....	<b>91</b>
12V BODY WIRING .....	91
FRONT END WIRING .....	98
COMPONENT PARTS FOR LIGHTS & SWITCHES .....	101
008089-02-000 .....	101
087694-01-000 .....	101
091206-04-000 .....	101
091937-09-000 .....	101
091937-10-000 .....	101
093575-22-01A .....	101
097917-01-06A .....	101
098024-01-03A .....	101
102756-03-000 .....	101
108354-01-01A .....	101
121935-01-01A .....	101
123775-01-01A .....	101
130051-01-000 .....	101
136119-01-000 .....	102
137417-01-01A .....	102
137417-03-01A .....	102
137424-01-000 .....	102
CIRCUIT BREAKERS & FUSES .....	103
CONVERTER, INVERTER, LOAD CENTERS .....	103
110V WIRING .....	104
ENTERTAINMENT WIRING .....	107
BOXES & CORDS .....	108
WIRE ASSEMBLIES .....	108
CONNECTORS & CONDUIT .....	109
BOOTS, SOLENOIDS, RELAYS & MISCELLANEOUS .....	111
COMPONENT PARTS FOR BOOTS, SOLENOIDS, RELAYS & MISCELLANEOUS .....	112
113832-02-01A .....	112
113832-03-01A .....	112

# CONTENTS (CONTINUED)

<b>EXTERIOR BODY GROUP .....</b>	<b>113</b>
AIR HORN .....	113
COMPONENT PARTS FOR AIR HORN .....	114
077497-06-000 .....	114
GRAPHICS & PAINT .....	115
PANELS & TRIMS .....	118
FRONT END .....	120
COMPONENT PARTS FOR FRONT END .....	122
091955-02-000 .....	122
138827-01-000 .....	122
LADDER .....	123
MIRRORS .....	123
COMPONENT PARTS FOR MIRRORS .....	124
129656-01-01A .....	124
129656-02-01A .....	124
STRUCTURAL COMPONENTS .....	125
AWNINGS .....	126
COMPONENT PARTS FOR AWNINGS .....	129
130483-01-01A .....	129
<b>EXTERIOR DOORS &amp; COMPARTMENTS GROUP .....</b>	<b>130</b>
DOOR & COMPARTMENT LAYOUT .....	130
COMPONENT PARTS FOR DOOR & COMPARTMENT LAYOUT .....	135
084103-08-000 .....	135
094708-03-01A .....	135
110506-A1-000, 110506-A2-000, 110506-26-000, 110506-27-000 .....	135
COMPARTMENT DOOR PIECE PARTS .....	136
ENTRY .....	137
COMPONENT PARTS FOR ENTRY .....	138
128913-10-01A .....	138
<b>EXTERIOR SLIDEOUT GROUP .....</b>	<b>142</b>
LEFT FRONT .....	142
COMPONENT PARTS FOR LEFT FRONT .....	147
143625-02-000 .....	147
143625-03-000 .....	147
RIGHT FRONT .....	148
LEFT REAR .....	152
COMPONENT PARTS FOR LEFT REAR .....	156
100536-54-000 .....	156
137390-01-000 .....	156
143071-01-000 .....	156
<b>GALLEY GROUP .....</b>	<b>157</b>
CABINETS .....	157
DOORS & DRAWERS .....	160
<b>GENERATOR GROUP .....</b>	<b>162</b>
DIESEL .....	162
<b>HEATING &amp; A/C GROUP .....</b>	<b>163</b>
AUTOMOTIVE .....	163
COMPONENT PARTS FOR AUTOMOTIVE .....	165
072342-15-000 .....	165
072342-17-000 .....	165
072342-18-000 .....	166
072342-22-000 .....	166
072342-23-000 .....	166
103930-51-000 .....	166
103930-52-000 .....	167
FURNACE .....	168
COMPONENT PARTS FOR FURNACE .....	169
143563-01-000 .....	169
CENTRAL .....	171
COMPONENT PARTS FOR CENTRAL .....	173
105620-12-000 .....	173
105620-15-000 .....	174

# CONTENTS (CONTINUED)

<b>INTERIOR FINISH GROUP</b> .....	<b>175</b>
MOLDINGS & TRIMS .....	175
PANELING & LAMINATES .....	179
ACCESSORIES .....	180
COMPONENT PARTS FOR ACCESSORIES .....	181
094499-02-000 .....	181
FLOOR COVERINGS .....	182
HARDWARE .....	183
<b>LABELS GROUP</b> .....	<b>189</b>
<b>LP GROUP</b> .....	<b>212</b>
LP SYSTEM .....	212
COMPONENT PARTS FOR LP SYSTEM .....	213
117432-03-000 .....	213
<b>LOUNGE GROUP</b> .....	<b>214</b>
CABINETS .....	214
<b>SEALANTS &amp; FASTENERS GROUP</b> .....	<b>215</b>
SEALANTS & ADHESIVES .....	215
BOLTS, NUTS AND WASHERS .....	216
SCREWS .....	218
CLAMPS, CLIPS, GROMMETS, RIVETS & PLUGS .....	221
MISCELLANEOUS FASTENERS .....	222
<b>WATER &amp; SEWAGE GROUP</b> .....	<b>223</b>
DRAINAGE SYSTEM .....	223
COMPONENT PARTS FOR DRAINAGE SYSTEM .....	225
062415-01-000 .....	225
136729-01-01A .....	225
WATER SYSTEM .....	226
COMPONENT PARTS FOR WATER SYSTEM .....	235
051391-05-000 .....	235
075241-04-000, 075241-05-000, 075241-06-000 .....	235
098607-01-000 .....	236
118569-03-000 .....	236
125420-01-02A, 125420-01-03A, 125420-04-03A .....	236
131340-02-01A .....	236
134735-01-01A .....	236
135027-01-01A .....	236
136915-01-000 .....	236
141682-01-01A .....	236
144596-01-01A .....	236
<b>WINDOW &amp; VENTS GROUP</b> .....	<b>237</b>
WINDOW & VENT LAYOUT .....	237
COMPONENT PARTS FOR WINDOW & VENT LAYOUT .....	238
106466-16-01A .....	238
106467-09-01A .....	238
112795-73-01A .....	239
112795-77-01A .....	240
112795-80-01A .....	240
112795-81-01A .....	240
112795-86-01A .....	241
123780-09-01A .....	242
123780-16-01A .....	243
129929-13-01A .....	244
134004-03-01A .....	245
140069-01-01A .....	246
<b>WINDSHIELD &amp; WIPER GROUP</b> .....	<b>247</b>
WINDSHIELD .....	247
WIPER .....	248
COMPONENT PARTS FOR WIPER .....	249
095964-01-000 .....	249
096505-09-000 .....	249
117769-01-000 .....	249

**ACCESSORIES GROUP**  
**OPERATORS MANUAL**

<b>KEY</b>	<b>PART NUMBER</b>	<b>U/M</b>	<b>DESCRIPTION</b>
	137943-01-000	EA	SAFE-STEEL
	141736-01-000	DW	TOP LEVEL-Q,2003
	129079-03-01A	EA	CASE - VINYL/BLK-EXPANDABLE ACCORDION SIDES-11"WX9"HX14"L
	132000-11-003	EA	MANUAL/OWNER - ULTIMATE ADVANTAGE - 2003

## APPLIANCE GROUP APPLIANCES

KEY	PART NUMBER	U/M	DESCRIPTION
	135066-03-01A	EA	RANGE - 3 BURNER W/OVEN - 22" - W/BLACK GLASS DOOR - RANGE W/OVEN - US
*	135066-02-01A	EA	RANGE - 3 BURNER W/OVEN - SEALED BURNERS - 22" - RANGE W/OVEN - CSA
	135065-03-01A	EA	RANGE - 3 BURNER W/O OVEN - SEALED BURNERS - BLACK TOP - RANGE TOP - US
*	135065-02-01A	EA	RANGE - 3 BURNER W/O OVEN - SEALED BURNERS - CSA - RANGE TOP - CSA
	136382-03-04B	EA	BRACKET - TIEDOWN/OVEN - BLACK - RANGE W/OVEN - Q38K, Q40E
	136382-04-04B	EA	BRACKET - TIEDOWN/OVEN - BLACK - RANGE W/OVEN - Q38K, Q40E
	136382-06-04B	EA	BRACKET - TIEDOWN/OVEN - REAR - BLACK - RANGE W/OVEN - Q36C
	136382-07-04B	EA	BRACKET - TIEDOWN/OVEN - BLACK - RANGE W/OVEN - Q36C
	136382-10-04B	EA	BRACKET/TIEDOWN - OVEN - REAR - BLACK - RANGE W/OVEN - Q40K
	136382-11-04B	EA	BRACKET/TIEDOWN - OVEN - FRONT - BLACK - RANGE W/OVEN - Q40K
	106936-29-04B	EA	BRACKET-TIEDOWN,STOVE FRT BK - RANGE TOP - Q38K, Q40E
	106936-30-04B	EA	BRACKET-TIEDOWN,STOVE FRT,BK - RANGE TOP - Q38K, Q40E
	106936-36-04B	EA	BRACKET - STOVE TIEDOWN/REAR - BLACK - RANGE TOP - Q36C
	106936-37-04B	EA	BRACKET - STOVE TIEDOWN/FRONT - BLACK - RANGE TOP - Q36C
	106936-40-04B	EA	BRACKET/TIEDOWN - STOVE - FRONT - BLACK - RANGE TOP - Q40K
	106936-41-04B	EA	BRACKET/TIEDOWN - STOVE - REAR - BLACK - RANGE TOP - Q40K
	M05904-05-PA0	EA	COVER - STOVE - W/SOLID COUNTERTOP
*	126022-01-01A	EA	COVER - RANGE/BI-FOLD - 16" & 22" - BLACK TEXTURED
	107752-04-01A	EA	DISHWASHER - 18" - BLACK - Q38K, Q40E, Q40K
*	108186-02-000	EA	TOOL SET - VACUUM - W/O POWER BRUSH W/30' HOSE
*	108186-03-000	EA	VACUUM CLEANER - BUILT IN
	108186-05-000	EA	BAG/CANVAS - CADDY W/POCKETS
	108186-06-000	EA	RACK - VACUUM HOSE/CADDY
	108187-01-000	EA	PIPE - 2" X 8' PVC - VACUUM SYSTEM
	108187-02-000	EA	ELBOW - 90 DEGREE STREET PVC - VACUUM SYSTEM - Q38K, Q40E, Q40K
	108187-08-000	EA	ELBOW - 45 DEGREE - 2" - Q36C
	108187-03-000	EA	COUPLING - 2" PVC - VACUUM SYSTEM - Q36C
	108187-04-000	EA	COUPLING - STOP - MALE - Q38K, Q40E, Q40K
	108187-06-000	EA	INLET - REDUCER
	108187-10-000	EA	TEE - 90 DEGREE - TY 2" - Q36C
	108187-11-000	EA	TEE - 90 DEGREE - 3 WAY ELBOW 2" - Q38K, Q40E, Q40K
	108187-13-000	EA	VALVE/INLET - VACUUM CLEANER - WHITE
	138584-01-01A	EA	COFFEE MAKER/CARAFE - BLACK - NO TIMER - KRUPS
*	115504-01-000	EA	PANEL - SOLAR 10 WATT - 12.2"W X 26.9"L X 1.2"H
*	133004-02-01A	EA	PANEL - MONITOR - 2 TANK DIGITAL VOLT METER - SOLAR
*	133004-04-01A	EA	PANEL/MONITOR-2 TANK-DIGITAL VOLT MT/SOLAR-NO WATER HTR SW
*	129561-01-01A	EA	PANEL/MONITOR - READ OUT ONLY - HOLDING/WATER TANK
	130818-02-01A	EA	TRASH CONTAINER - 20 QUART ALMOND

\*COMPONENT PARTS LISTED LATER IN THIS GROUP

**APPLIANCE GROUP (CONTINUED)**  
**APPLIANCES (CONTINUED)**

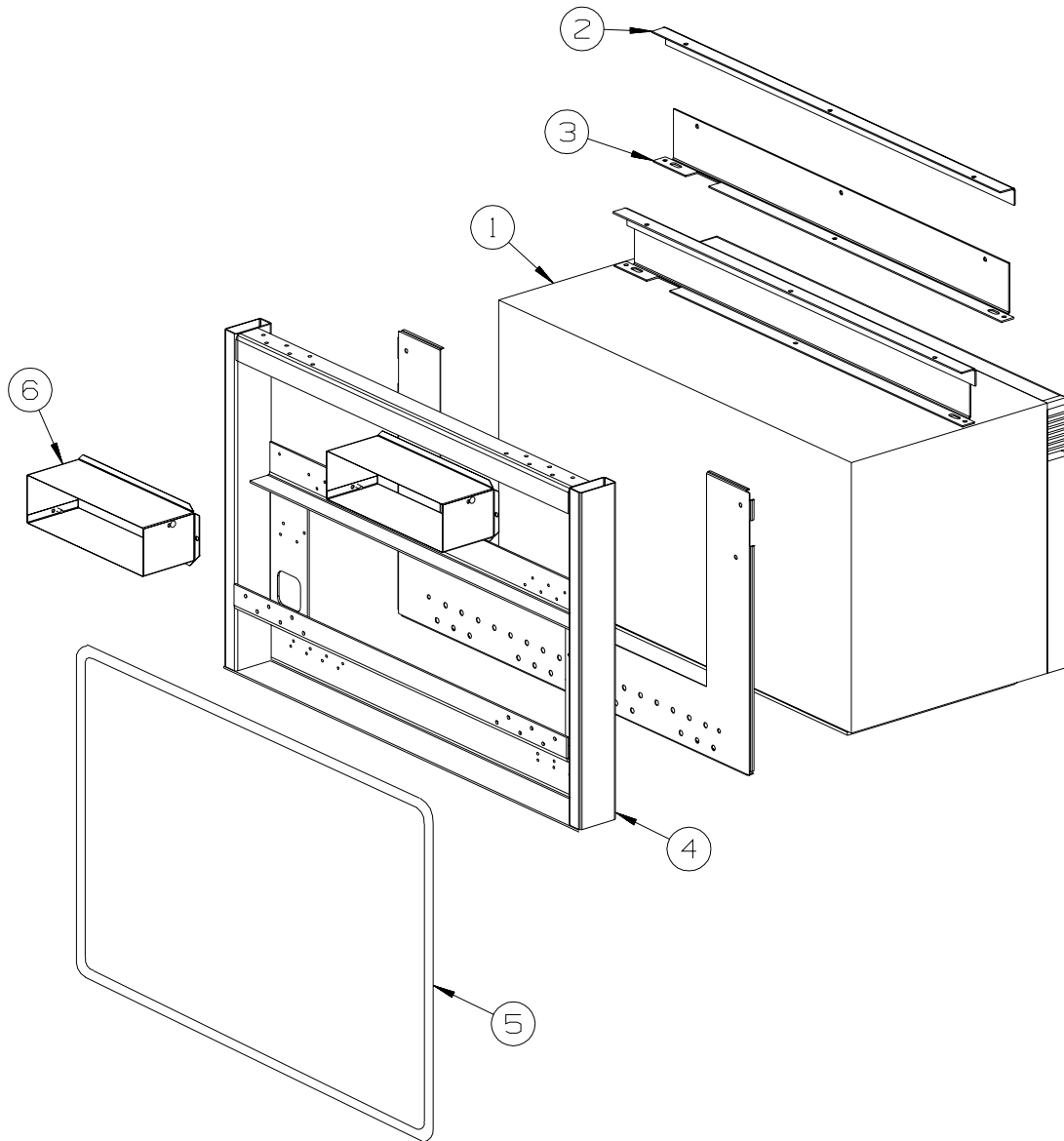

**Q38K, Q40E, Q40K**

KEY	PART NUMBER	U/M	DESCRIPTION
1	140147-01-01A	EA	OVEN/MICROWAVE - 1.4 CUBIC FT - 30" CONVECTION/BLK FACE - CONVECTION USA
1*	119267-13-01A	EA	OVEN - MICROWAVE/CONVECTION W/HOOD CSA - #R-1875A - CONVECTION CANADIAN
1	140147-02-01A	EA	OVEN/MICROWAVE - 1.4 CUBIC FT - STAINLESS STEEL FACE - SPEEDCOOK
2	129836-02-02B	EA	ANGLE - W/HOLES - .7" X 1" X 28.3" - E-COATED - LH
3	129836-04-02B	EA	ANGLE - W/HOLES - .7" X 2.2" X 28.3" - E-COATED
3	140225-02-02B	EA	ANGLE-W/HOLES ,E-CT FROM: 00-00-00 THRU: 08-11-02
4	137824-04-02B	EA	BRACKET - MICROWAVE - E-COATED FROM: 08-12-02 THRU: 99-99-99
4	137824-05-02B	EA	BRACKET - MICROWAVE - E-COATED FROM: 00-00-00 THRU: 08-15-02
4	137824-05-02B	EA	BRACKET - MICROWAVE - E-COATED FROM: 08-16-02 THRU: 99-99-99
5	093305-01-01A	FT	TRIM - EDGE C-TYPE - WIRE CARRIER - .35" X .24" - VINYL
6	140093-05-02B	EA	DUCT ASM, E-CT

\*COMPONENT PARTS LISTED LATER IN THIS GROUP

**Q36C**

KEY	PART NUMBER	U/M	DESCRIPTION
	140147-01-01A	EA	OVEN/MICROWAVE - 1.4 CUBIC FT - 30" CONVECTION/BLK FACE - CONVECTION USA
*	119267-06-01A	EA	OVEN - MICROWAVE/CONVECTION W/HOOD - CSA - CONVECTION CANADIAN
	140147-02-01A	EA	OVEN/MICROWAVE - 1.4 CUBIC FT - STAINLESS STEEL FACE - SPEEDCOOK

\*COMPONENT PARTS LISTED LATER IN THIS GROUP



**APPLIANCE GROUP (CONTINUED)**  
**APPLIANCES (CONTINUED)**

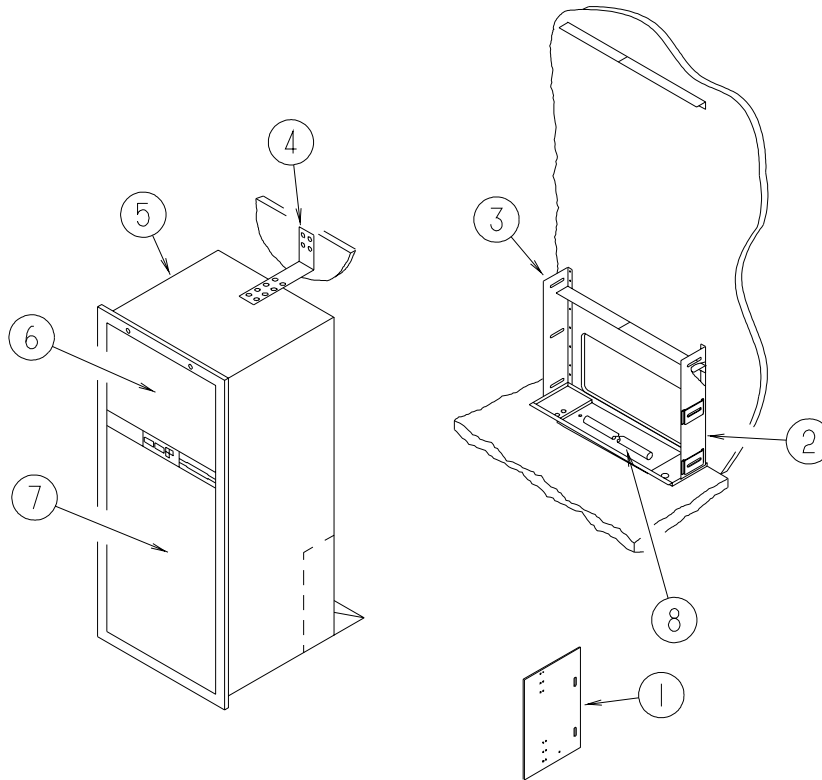

KEY	PART NUMBER	U/M	DESCRIPTION
1	065225-04-000	EA	PLATE - TIEDOWN/REFRIGERATOR
2	093646-01-000	EA	BRACKET - TIEDOWN/REFRIGERATOR - RIGHT HAND
3	093646-02-000	EA	BRACKET - TIEDOWN/REFRIGERATOR - LEFT HAND
4	093369-02-000	EA	STRAP - REFRIGERATOR
5*	120075-13-01A	EA	REFRIGERATOR-LARGE DOUBLE DOOR/RH - 2-WAY -ICE MAKER-BLACK - <b>W/ICE MAKER</b>
6	140113-14-PA0	EA	PANEL/INSERT - REFRIGERATOR - PORTSMOUTH
6	140113-14-PA1	EA	PANEL/INSERT - REFRIGERATOR - CONCERT CHERRY
6	140113-14-PA2	EA	PANEL/INSERT - REFRIGERATOR - WASHED MAPLE
7	140113-16-PA0	EA	PANEL/INSERT - REFRIGERATOR - PORTSMOUTH
7	140113-16-PA1	EA	PANEL/INSERT - REFRIGERATOR - CONCERT CHERRY
7	140113-16-PA2	EA	PANEL/INSERT - REFRIGERATOR - WASHED MAPLE
8	112176-01-000	FT	TUBING - VINYL - REINFORCED - 1/2" ID
	116751-02-01A	EA	TRAY - REFRIGERATOR - BLACK - <b>Q36C</b>
	118871-02-01A	EA	TRAY - REFRIGERATOR - SIDE/SIDE - BLACK - 34.4" LONG - <b>Q38K, Q40J, Q40E</b>
	090329-01-000	FT	SEAL/T - REFRIGERATOR CABINET
	054450-01-000	EA	LEVEL - REFRIGERATOR

**\*COMPONENT PARTS LISTED LATER IN THIS GROUP**

**APPLIANCE GROUP (CONTINUED)**  
**APPLIANCES (CONTINUED)**

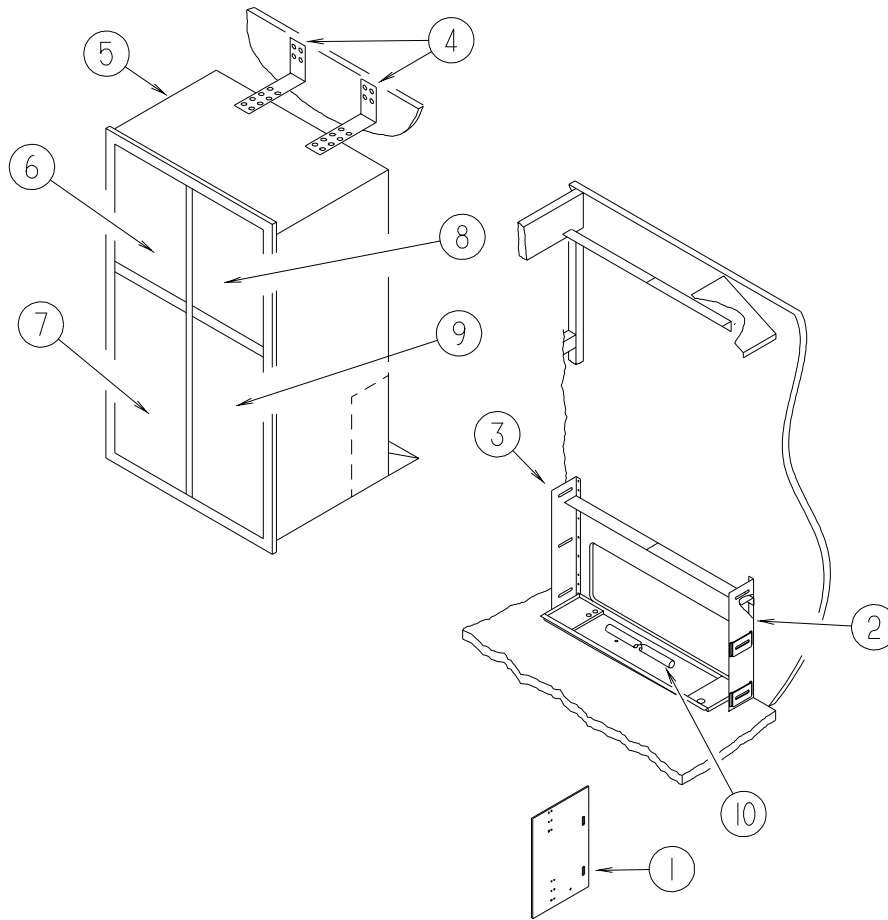

KEY	PART NUMBER	U/M	DESCRIPTION
1	065225-01-000	EA	PLATE - TIEDOWN/REFRIGERATOR
2	093646-01-000	EA	BRACKET - TIEDOWN/REFRIGERATOR - RIGHT HAND
3	093646-02-000	EA	BRACKET - TIEDOWN/REFRIGERATOR - LEFT HAND
4	093369-02-000	EA	STRAP - REFRIGERATOR
5*	125242-02-01A	EA	REFRIGERATOR-4 DR-W/ICE MKR-W/CONTOURED HANDLE-NORCOLD1201
6	140113-03-P69	EA	PANEL/INSERT - REFRIGERATOR - 16.5" X 19.3" - PORTSMOUTH OAK
6	140113-03-N63	EA	PANEL/INSERT - REFRIGERATOR - 16.5" X 19.3" - CONCERT CHERRY
6	140113-03-N62	EA	PANEL/INSERT - REFRIGERATOR - 16.5" X 19.3" - WASHED MAPLE
7	140113-05-P69	EA	PANEL/INSERT - REFRIGERATOR - 16.5" X 42.1" - PORTSMOUTH OAK
7	140113-05-N63	EA	PANEL/INSERT - REFRIGERATOR - 16.5" X 42.1" - CONCERT CHERRY
7	140113-05-N62	EA	PANEL/INSERT - REFRIGERATOR - 16.5" X 42.1" - WASHED MAPLE
8	140113-04-P69	EA	PANEL/INSERT - REFRIGERATOR - 16.5" X 19.3" - PORTSMOUTH OAK
8	140113-04-N63	EA	PANEL/INSERT - REFRIGERATOR - 16.5" X 19.3" - CONCERT CHERRY
8	140113-04-N62	EA	PANEL/INSERT - REFRIGERATOR - 16.5" X 19.3" - WASHED MAPLE
9	140113-06-P69	EA	PANEL/INSERT - REFRIGERATOR - 16.5" X 42.1" - PORTSMOUTH OAK
9	140113-06-N63	EA	PANEL/INSERT - REFRIGERATOR - 16.5" X 42.1" - CONCERT CHERRY
9	140113-06-N62	EA	PANEL/INSERT - REFRIGERATOR - 16.5" X 42.1" - WASHED MAPLE
10	112176-01-000	FT	TUBING - VINYL - REINFORCED - 1/2" ID
	090329-01-000	FT	SEAL/T - REFRIGERATOR CABINET
	054450-01-000	EA	LEVEL - REFRIGERATOR
	118871-02-01A	EA	TRAY - REFRIGERATOR - SIDE/SIDE - BLACK - 34.4" LONG - Q36C
	118871-05-01A	EA	TRAY - REFRIGERATOR - SIDE/SIDE - BLACK - 35.5" LONG - Q38K, Q40J, Q40E

\*COMPONENT PARTS LISTED LATER IN THIS GROUP

**APPLIANCE GROUP (CONTINUED)**  
**APPLIANCES (CONTINUED)**

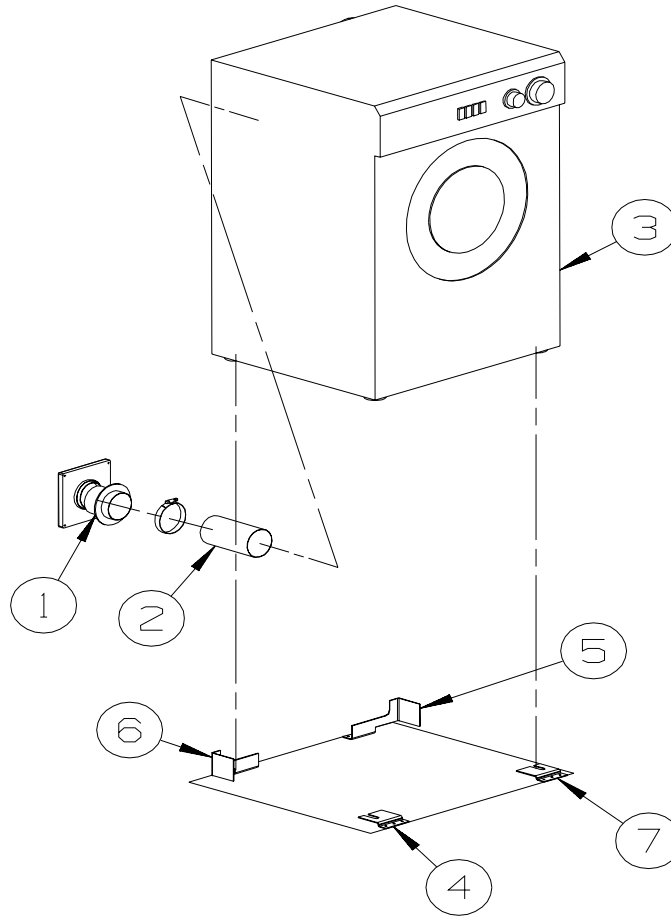

**Q36C & Q38K**

KEY	PART NUMBER	U/M	DESCRIPTION
1	111947-02-01A	EA	VENT - DRYER - 3"
2	116653-02-000	FT	DUCT - FLEXIBLE - 3' COMPRESSED/8' EXTENDED
3	107753-03-01A	EA	WASHER - DRYER - VENTED - UL/CSA - WHITE
			FROM: 00-00-00 THRU: 10-21-02
3	107753-04-01A	EA	WASHER - DRYER - VENTED - UL/CSA - WHITE
			FROM: 10-22-02 THRU: 99-99-99
4	111913-01-01A	EA	BRACKET - WASHER - TIE DOWN
			FROM: 00-00-00 THRU: 11-10-02
4	111913-02-04B	EA	BRACKET/WASHER - TIE DOWN - BLACK
			FROM: 11-11-02 THRU: 99-99-99
5	113795-03-02B	EA	BRACKET - WASHER - E-COATED
6	113795-04-02B	EA	BRACKET - WASHER - E-COATED
7	111913-01-01A	EA	BRACKET - WASHER - TIE DOWN
			FROM: 00-00-00 THRU: 11-10-02
7	111913-03-04B	EA	BRACKET/WASHER - TIE DOWN - BLACK
			FROM: 11-11-02 THRU: 99-99-99

**APPLIANCE GROUP (CONTINUED)**  
**APPLIANCES (CONTINUED)**

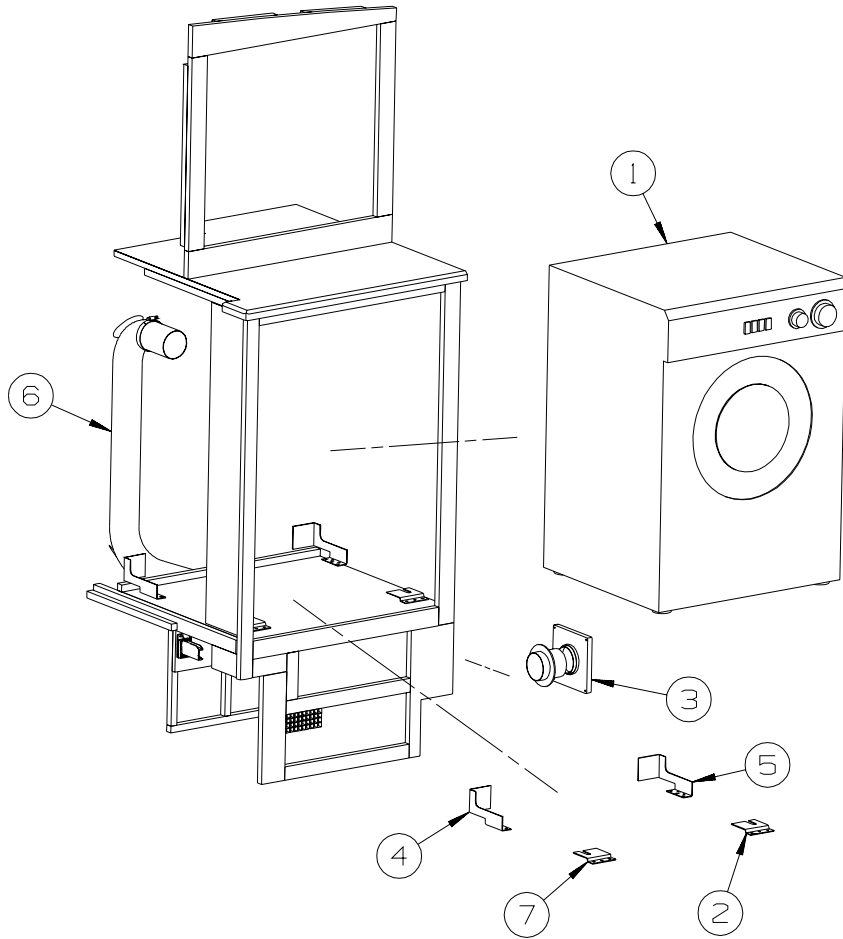

**Q40E & Q40K**

KEY	PART NUMBER	U/M	DESCRIPTION
1	107753-03-01A	EA	WASHER - DRYER - VENTED - UL/CSA - WHITE FROM: 00-00-00 THRU: 10-21-02
1	107753-04-01A	EA	WASHER - DRYER - VENTED - UL/CSA - WHITE FROM: 10-22-02 THRU: 99-99-99
2	111913-01-01A	EA	BRACKET - WASHER - TIE DOWN FROM: 00-00-00 THRU: 11-10-02
2	111913-03-04B	EA	BRACKET/WASHER - TIE DOWN - BLACK FROM: 11-11-02 THRU: 99-99-99
3	111947-02-01A	EA	VENT - DRYER - 3"
4	113795-03-02B	EA	BRACKET - WASHER - E-COATED
5	113795-04-02B	EA	BRACKET - WASHER - E-COATED
6	116653-02-000	FT	DUCT - FLEXIBLE - 3' COMPRESSED/8' EXTENDED
7	111913-01-01A	EA	BRACKET - WASHER - TIE DOWN FROM: 00-00-00 THRU: 11-10-02
7	111913-02-04B	EA	BRACKET/WASHER - TIE DOWN - BLACK FROM: 11-11-02 THRU: 99-99-99

**APPLIANCE GROUP (CONTINUED)**  
**COMPONENT PARTS FOR APPLIANCE**

**108186-02-000**

<b>KEY</b>	<b>PART NUMBER</b>	<b>U/M</b>	<b>DESCRIPTION</b>	<b>VENDOR NO.</b>
	092304-02-702	EA	TOOL-RUG	4982
	092304-02-707	EA	TOOL-UPHOLSTERY	7029
	092304-02-708	EA	WAND-PLASTIC	4978
	092304-02-709	EA	HOSE ASM., 30' COMPLETE	4988-30-G

**108186-03-000**

<b>KEY</b>	<b>PART NUMBER</b>	<b>U/M</b>	<b>DESCRIPTION</b>	<b>VENDOR NO.</b>
	092304-02-700	EA	BRUSH-POWER, VACUUM (RUGRAT)	6970
	092304-02-702	EA	TOOL-RUG	4982
	092304-02-707	EA	TOOL-UPHOLSTERY	7029
	092304-02-708	EA	WAND-PLASTIC	4978
	092304-02-709	EA	HOSE ASM., 30' COMPLETE	4988-30-G
	092304-02-710	EA	SECONDARY FILTER	4929
	108186-03-700	EA	PAPER BAG - 3-PKG	7767
	108186-03-701	EA	MOTOR F/RV2000	7756
	108186-03-702	EA	REDUCER	5531
	108186-03-703	EA	VALVE - INLET - WHITE	4935
	108186-03-704	EA	BRUSH - TURBINE (HAND HELD)	7834-B

**115504-01-000**

<b>KEY</b>	<b>PART NUMBER</b>	<b>U/M</b>	<b>DESCRIPTION</b>	<b>VENDOR NO.</b>
	115504-01-700	EA	PLUG & CABLE, 10 WATT PANEL	600-016

**119267-06-01A**

<b>KEY</b>	<b>PART NUMBER</b>	<b>U/M</b>	<b>DESCRIPTION</b>	<b>VENDOR NO.</b>
	119267-04-700	EA	FILTER-GREASE	BOO2
	119267-04-703	EA	PLATE-MOUNTING W/2 SCREWS	FANGTB003MRV0

**APPLIANCE GROUP (CONTINUED)**  
**COMPONENT PARTS FOR APPLIANCE (CONTINUED)**

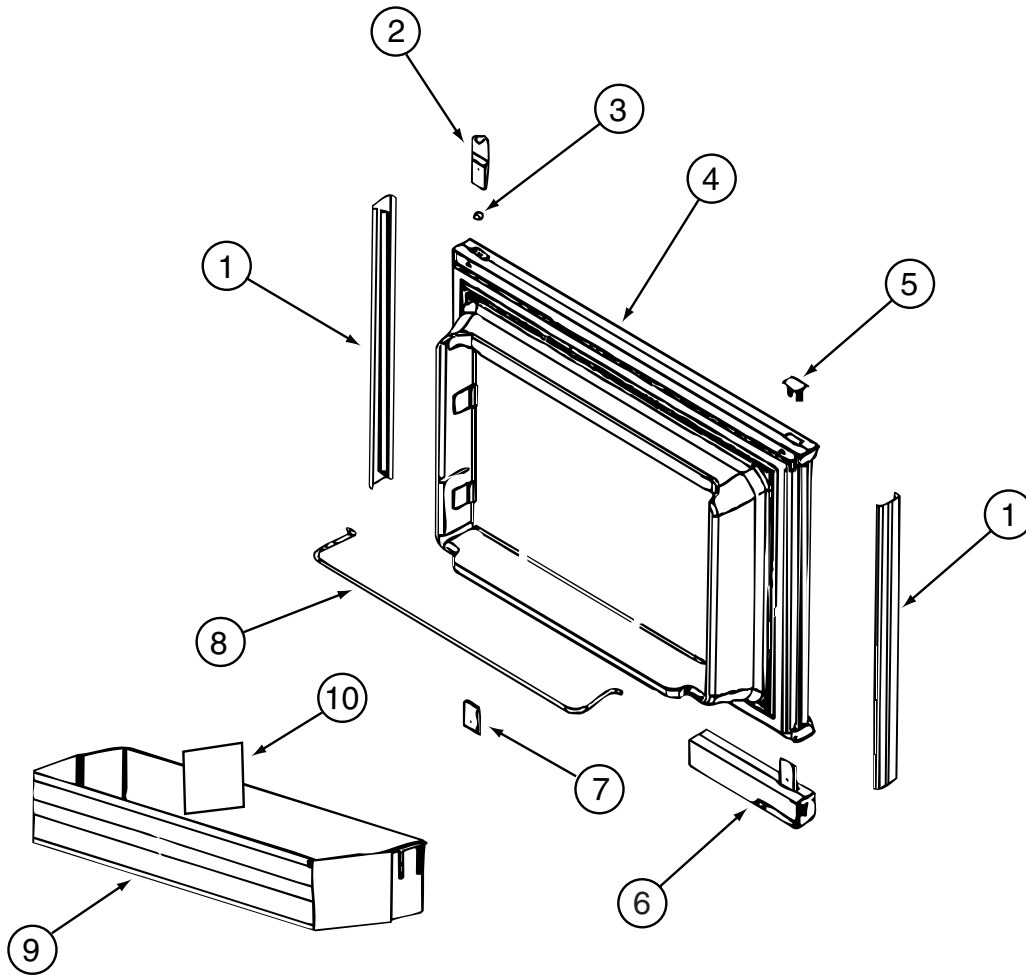

120075-13-01A, 120075-14-01A, 120075-15-01A

KEY	PART NUMBER	U/M	DESCRIPTION	VENDOR NO.
1	121568-03-700	EA	RETAINER - DOOR PANEL/BLACK	619558
2	120075-01-701	EA	HINGE-TOP RH/BOTTOM LH(DOOR)	618511
3	121568-03-701	EA	BUSHING - HINGE PIN/GRAY	619671
4	121568-03-702	EA	DOOR LINER - W/TRIM/BLACK	619627 - SMALL DOOR
5	120075-01-702	EA	CAP, (HINGE PLUG)	618160
6	120075-12-700	EA	HANDLE(CONTOUR)TOP LH/BTM RH	621105
6	120075-12-702	EA	HANDLE/HOUSING-TOP-LH/BTM RH	618159GEN
6	120075-12-701	EA	HANDLE(CONTOUR)TOP RH/BTM LH	621104
	120075-12-707	EA	LATCH	619648
	120075-12-709	EA	HANDLE/HOUSING-BTM LH/TOP RH	618122GEN
6	121568-03-703	EA	HANDLE/FLUSH-TOP/RH-LWR/LH	619865
6	121568-03-708	EA	HANDLE/FLUSH-TOP/LH-LWR/RH	619866
7	120075-01-705	EA	HINGE-TOP LH/BOTTOM RH(DOOR)	618510
8	121568-01-700	EA	RAIL - DOOR UPPER	618618
9	120075-07-700	EA	DOOR BIN - CLEAR	619006
10	120075-07-701	EA	DIVIDER/DOOR BIN CLEAR	619008
	121568-03-704	EA	TRAVEL LATCH - GRAY	619647
	121568-03-705	EA	STORAGE LATCH - GRAY	619648

**APPLIANCE GROUP (CONTINUED)**  
**COMPONENT PARTS FOR APPLIANCE (CONTINUED)**

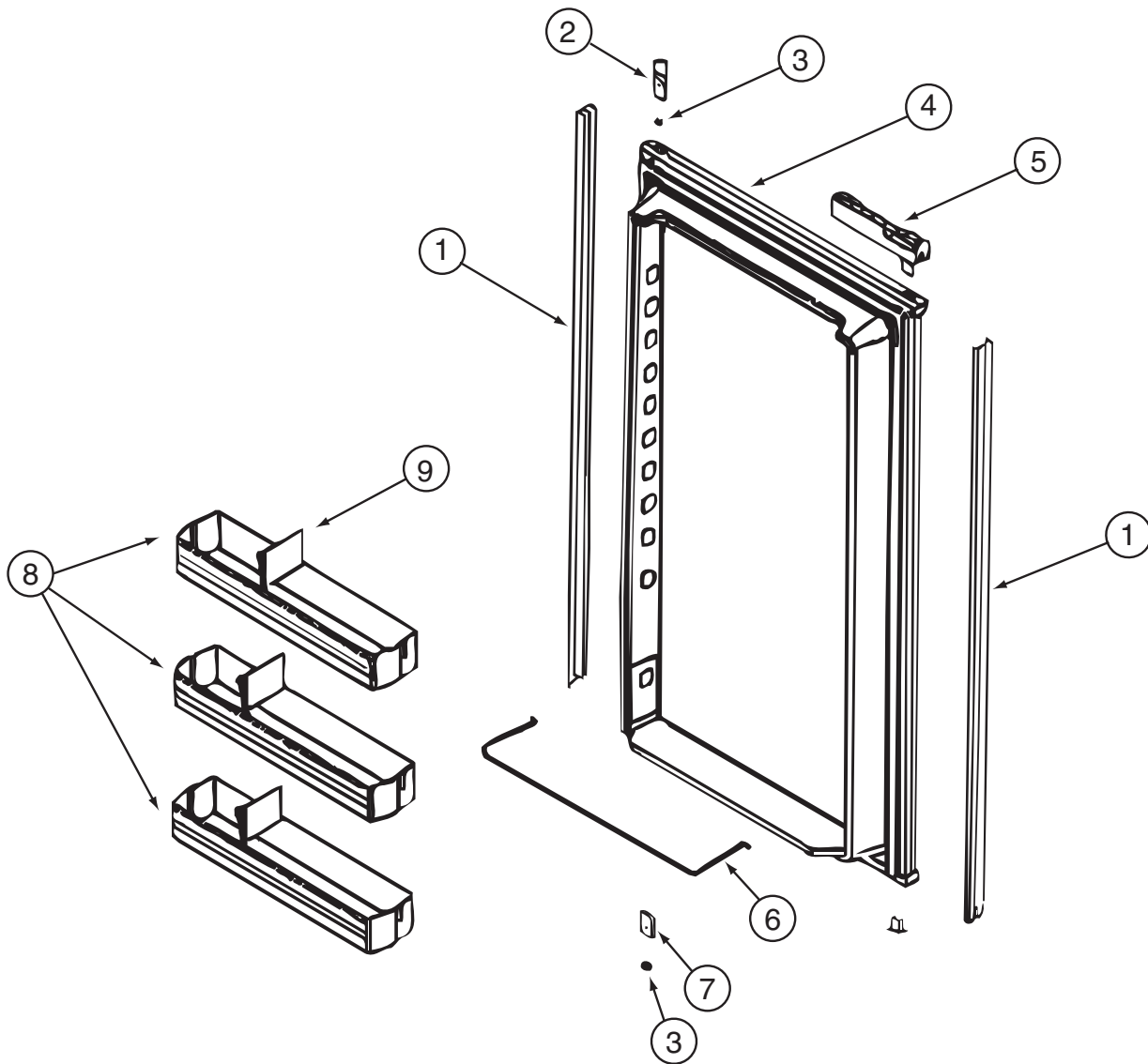

**120075-13-01A, 120075-14-01A, 120075-15-01A (CONTINUED)**

KEY	PART NUMBER	U/M	DESCRIPTION	VENDOR NO.
1	120075-07-702	EA	RETAINER - DOOR PANEL/BLACK	619560
2	120075-01-701	EA	HINGE-TOP RH/BOTTOM LH(DOOR)	618511
3	121568-03-701	EA	BUSHING - HINGE PIN/GRAY	619671
4	120075-07-703	EA	DOOR LINER - BLACK	619631 - LARGE DOOR
5	120075-12-700	EA	HANDLE(CONTOUR)TOP LH/BTM RH	621105
	120075-12-702	EA	HANDLE/HOUSING-TOP-LH/BTM RH	618159GEN
5	120075-12-701	EA	HANDLE(CONTOUR)TOP RH/BTM LH	621104
	120075-12-707	EA	LATCH	619648
	120075-12-709	EA	HANDLE/HOUSING-BTM LH/TOP RH	618122GEN
5	121568-03-703	EA	HANDLE/FLUSH-TOP/RH-LWR/LH	619865
5	121568-03-708	EA	HANDLE/FLUSH-TOP/LH-LWR/RH	619866
6	121568-01-704	EA	RAIL - DOOR LOWER	618578
7	120075-01-705	EA	HINGE-TOP LH/BOTTOM RH(DOOR)	618510
8	120075-07-700	EA	DOOR BIN - CLEAR	619006
8	120075-07-704	EA	DOOR BIN - LARGE/CLEAR	619005
9	120075-07-701	EA	DIVIDER/DOOR BIN CLEAR	619008
	121568-03-704	EA	TRAVEL LATCH - GRAY	619647
	121568-03-705	EA	STORAGE LATCH - GRAY	619648

**APPLIANCE GROUP (CONTINUED)**  
**COMPONENT PARTS FOR APPLIANCE (CONTINUED)**

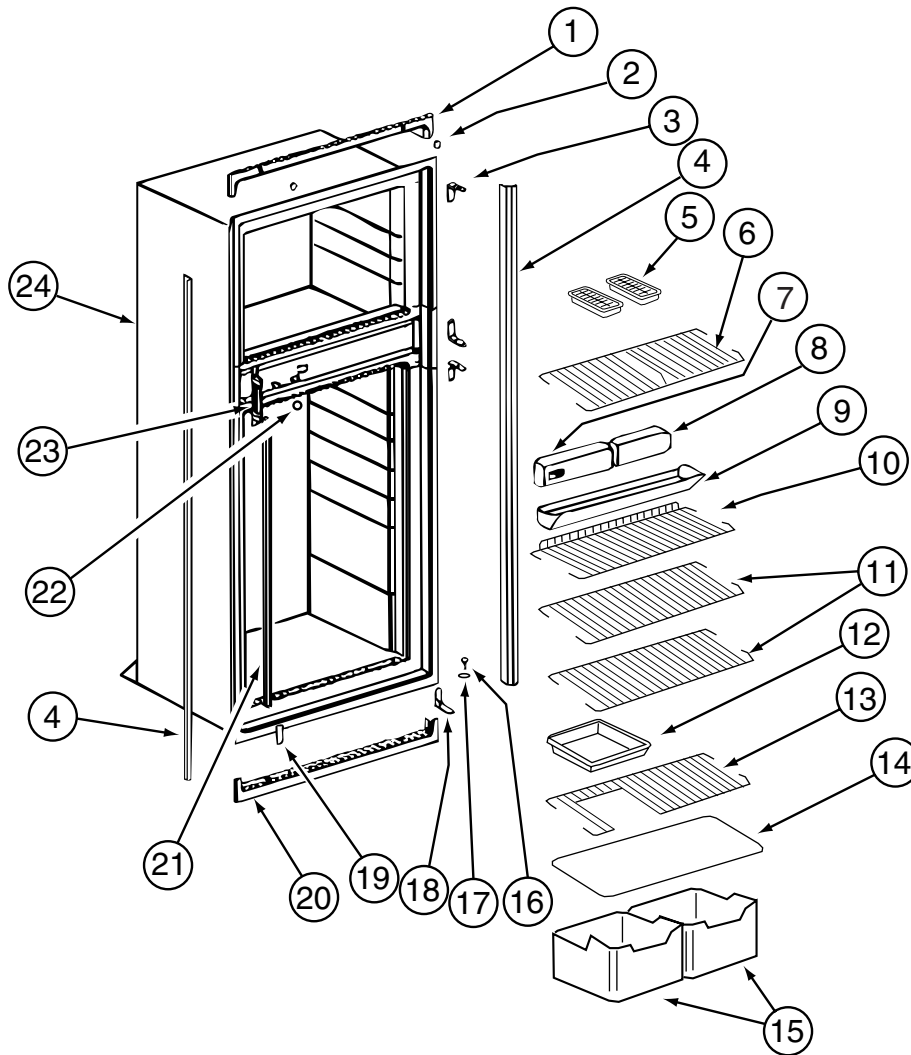

**120075-13-01A, 120075-14-01A, 120075-15-01A (CONTINUED)**

KEY	PART NUMBER	U/M	DESCRIPTION	VENDOR NO.
1	121568-03-709	EA	TRIM - TOP/BLACK	619687
2	120075-01-714	EA	PLUG-HOLE (BLACK)	618170
3	121568-03-710	EA	HINGE/CABINET-TOP/RH-LWR/LH	619335
4	120075-07-705	EA	TRIM - SIDE - BLACK	622296
5	104137-06-724	EA	ICE TRAY	61630422
6	120075-07-706	EA	SHELF - WIRE/FREEZER	620249
7	120075-07-707	EA	CONTROL BOX - BLACK	619665
8	121568-03-713	EA	FRONT BOX/DECORATIVE-BLACK	619282
9	120075-01-720	EA	TRAY-DRIP	618137
10	120075-01-722	EA	SHELF-WIRE, SHORT	620269
11	120075-01-723	EA	SHELF-WIRE	620270
12	104137-06-718	EA	SHELF-TRAY, WHITE, W/CUTOUT	617756
13	120075-01-724	EA	SHELF-WIRE, W/CUTOUT	618177
14	120075-01-725	EA	COVER-CRISPER	618158
15	120075-07-708	EA	CRISPER/ICE BIN	619007
16	120075-01-727	EA	PIN-HINGE	618145
17	121568-03-701	EA	BUSHING - HINGE PIN/GRAY	619671
18	121568-03-715	EA	HINGE/CABINET-TOP/LH-LWR/RH	619336
19	121568-03-716	EA	COVER - HINGE HOLES	619301
20	120075-01-729	EA	TRIM-BOTTOM PIECE	620958
21	120075-01-730	EA	RETAINER-SHELF(SER#926684 DN	618181
22	121568-03-717	EA	HOLE PLUG - WHITE	619561
23	120075-01-732	EA	PLATE-STRIKE	618167
24	120075-09-700	EA	CABINET - FOAMED	619660
	120075-01-721	EA	LOUVER-DRIP TRAY	618176



**APPLIANCE GROUP (CONTINUED)**  
**COMPONENT PARTS FOR APPLIANCE (CONTINUED)**

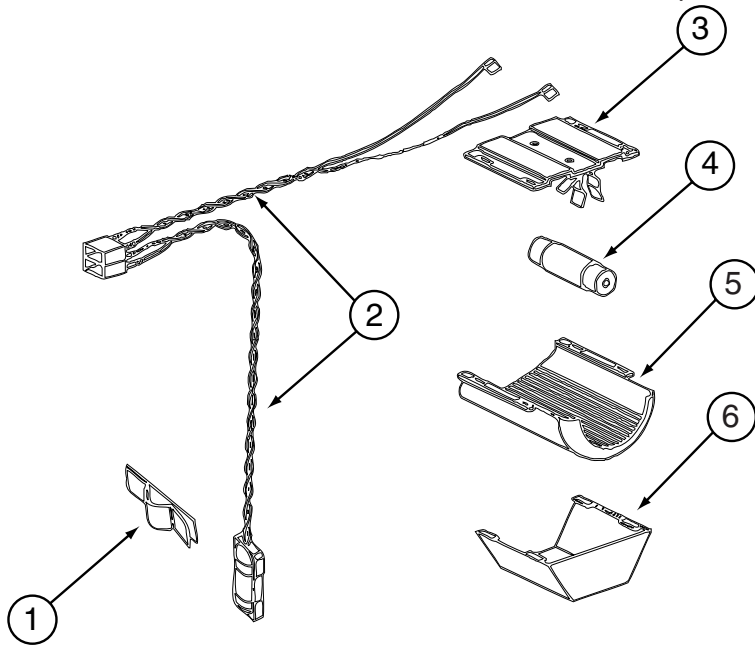

**120075-13-01A, 120075-14-01A, 120075-15-01A (CONTINUED)**

KEY	PART NUMBER	U/M	DESCRIPTION	VENDOR NO.
1	084880-01-760	EA	CLIP (THERMISTER)	61689122
2	120075-01-735	EA	THERMISTER W/LAMP & WIRE/ASM	618548
3	084880-03-705	EA	BRACKET-LIGHT-INTERIOR	61629722
4	084880-03-706	EA	BULB-LAMP	61628922
5	120075-01-734	EA	COVER-LENS	618190
6	084880-03-707	EA	COVER-LAMP, LENS	61627922

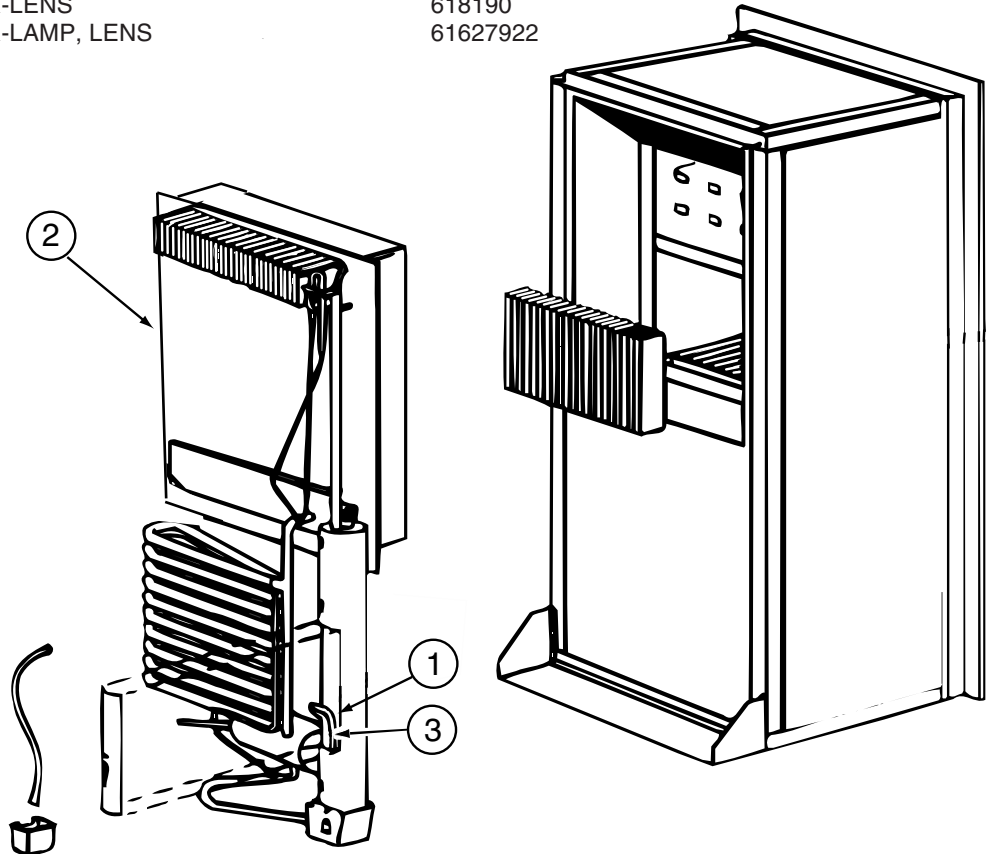

**120075-13-01A, 120075-14-01A, 120075-15-01A (CONTINUED)**

KEY	PART NUMBER	U/M	DESCRIPTION	VENDOR NO.
1	088248-01-710	EA	HEATER DC (HORIZONTAL)	61562822
2	120075-01-736	EA	COOLING UNIT, SERVICE PACK	618542
3	088248-01-709	EA	HEATER-AC (HORIZONTAL)	61562722

**APPLIANCE GROUP (CONTINUED)**  
**COMPONENT PARTS FOR APPLIANCE (CONTINUED)**

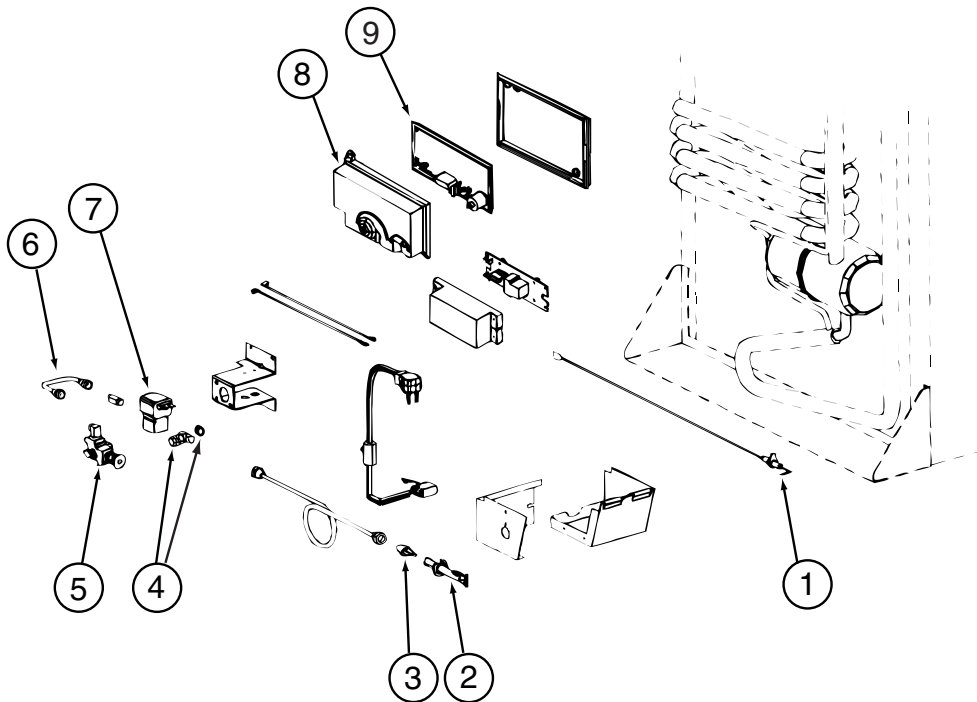

**120075-13-01A, 120075-14-01A, 120075-15-01A (CONTINUED)**

KEY	PART NUMBER	U/M	DESCRIPTION	VENDOR NO.
1	104137-06-715	EA	ELECTRODE-SPARK/SENSOR, SGL	61692222
2	104137-06-714	EA	BURNER ASSEMBLY, 5-SLOT	61705222
3	120075-01-737	EA	ORIFICE - JEWEL - .0155	618284
4	113737-01-702	EA	PLUG 1/8" F/PRESSURE TAP	61445322
4	113737-01-716	EA	TAP-PRESSURE	61594422
5	104137-06-734	EA	VALVE-SHUT OFF/MAN-OLD STYLE	61694922
6	113737-01-750	EA	TUBE-UNION	61694622
7	084880-01-718	EA	VALVE-GAS, (ASCO)	621447
8	120075-01-738	EA	COVER-POWER BOARD	618185
9	120075-07-710	EA	POWER - BOARD - 2-WAY	619360 = 621269
	104137-06-734	EA	VALVE-SHUT OFF/MAN-NEW STYLE	618696
	120075-01-744	EA	KIT - GAS VALVE/BURNER TUBE	620609

**APPLIANCE GROUP (CONTINUED)**  
**COMPONENT PARTS FOR APPLIANCE (CONTINUED)**

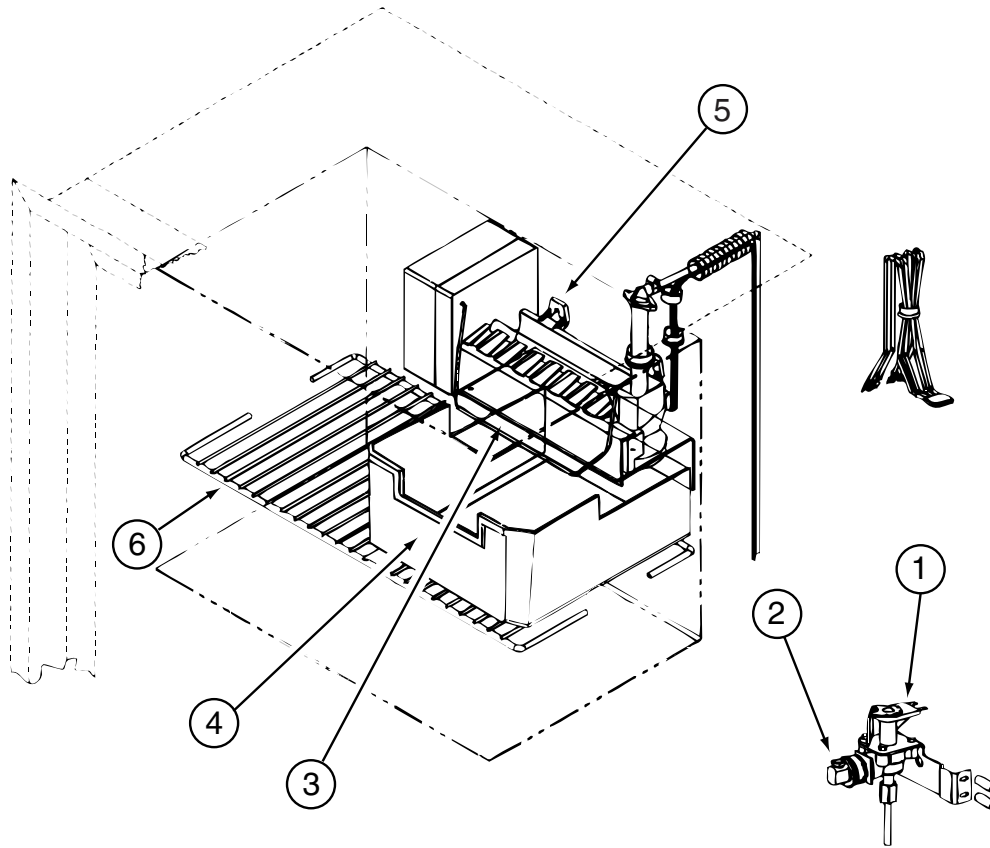

**120075-13-01A, 120075-14-01A (CONTINUED)**

KEY	PART NUMBER	U/M	DESCRIPTION	VENDOR NO.
1	120075-09-701	EA	WATER VALVE W/BRACKET	618253
2	120075-03-702	EA	NUT/COMPRESSION - FITTING	61678722
3	120075-03-703	EA	ARM-SHUT OFF	61656922
4	120075-03-704	EA	BIN-ICE CUBE	618154
5	094039-07-706	EA	ICE MAKER W/O PLATES	61656522
6	120075-01-717	EA	SHELF-FREEZER, WIRE	618172
	120075-09-702	EA	RELAY - 12 VOLT	620239

**APPLIANCE GROUP (CONTINUED)**  
**COMPONENT PARTS FOR APPLIANCE (CONTINUED)**

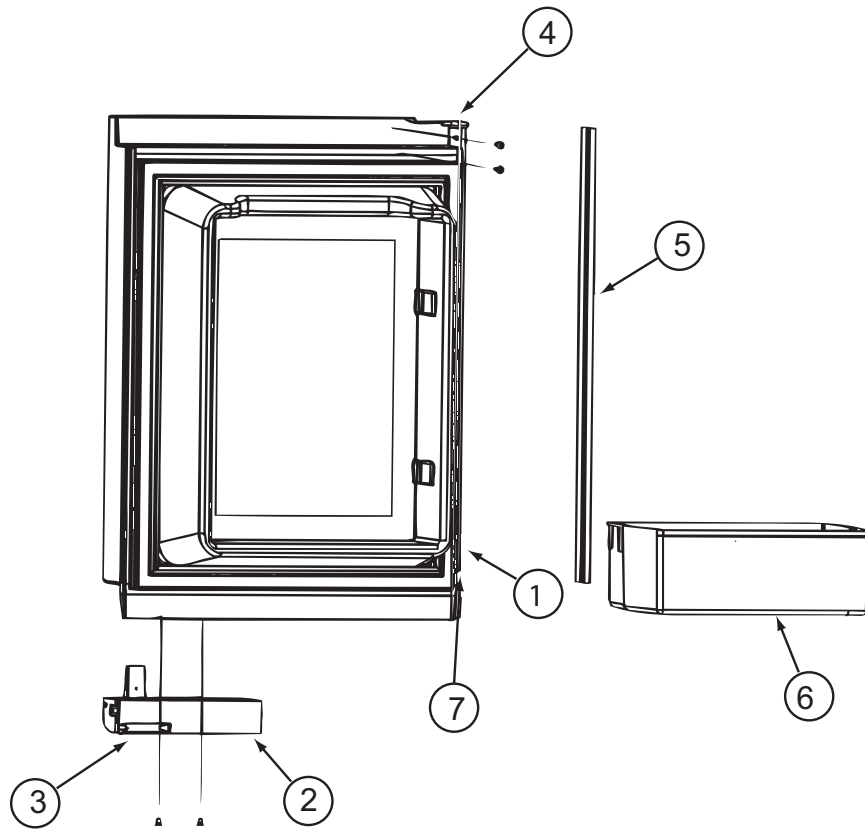

125242-02-01A

KEY	PART NUMBER	U/M	DESCRIPTION	VENDOR NO.
1	125242-01-762	EA	LINER/FOAMED-UPPER/LH-WHITE	619839
2	125242-02-700	EA	HANDLE(CONTOUR)TOP LH BTM RH	621107
3	125242-02-722	EA	LATCH-STORAGE DR/BLK POINTED	619374
4	125242-02-724	EA	HINGE - DOOR	618792
5	125242-02-723	EA	RETAINER/PANEL-UPPER DOOR	621974
6	125242-01-711	EA	DOOR BIN	618765
7	125242-01-704	EA	BUSHING-HINGE MIDDLE	618746
	125242-02-725	EA	DOOR ASM/UPR LH/WHITE GASKET	621148

**APPLIANCE GROUP (CONTINUED)**  
**COMPONENT PARTS FOR APPLIANCE (CONTINUED)**

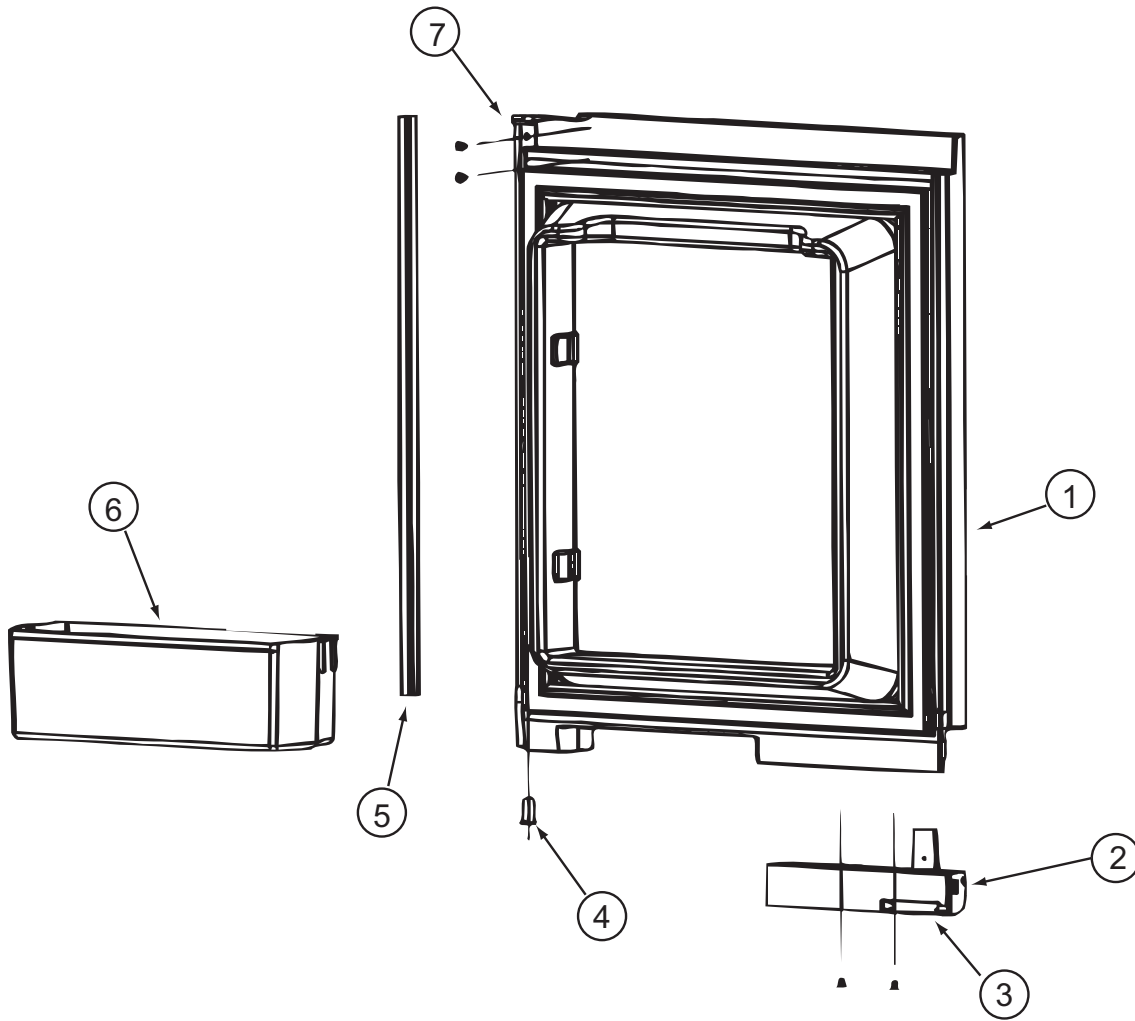

**125242-02-01A (CONTINUED)**

KEY	PART NUMBER	U/M	DESCRIPTION	VENDOR NO.
1	125242-01-763	EA	LINER/FOAMED-UPPER/RH-WHITE	619840
2	125242-02-701	EA	HANDLE(CONTOUR)TOP RH LWR LH	621106
3	125242-02-722	EA	LATCH-STORAGE DR/BLK POINTED	619374
4	125242-01-704	EA	BUSHING-HINGE MIDDLE	618746
5	125242-02-723	EA	RETAINER/PANEL-UPPER DOOR	621974
6	125242-01-711	EA	DOOR BIN	618765
7	125242-02-724	EA	HINGE - DOOR	618792
	125242-02-721	EA	DOOR ASM-UPR/RH/WHITE GASKET	621149

**APPLIANCE GROUP (CONTINUED)**  
**COMPONENT PARTS FOR APPLIANCE (CONTINUED)**

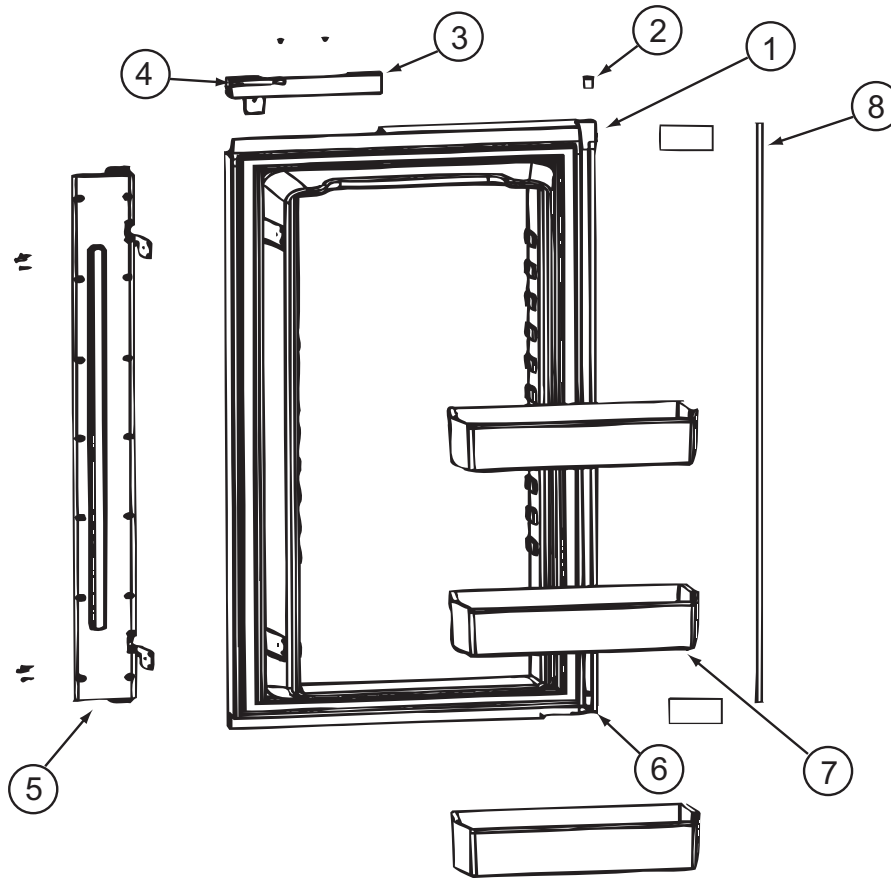

**125242-02-01A (CONTINUED)**

KEY	PART NUMBER	U/M	DESCRIPTION	VENDOR NO.
1	125242-01-765	EA	LINER/FOAMED-LOWER-LH-WHITE	619837
2	125242-01-704	EA	BUSHING-HINGE MIDDLE	618746
3	125242-02-701	EA	HANDLE(CONTOUR)TOP RH LWR LH	621106
4	125242-02-722	EA	LATCH-STORAGE DR/BLK POINTED	619374
5	125242-02-727	EA	FLAPPER ASM DOUBLE POLE	619845
6	125242-02-724	EA	HINGE - DOOR	618792
7	125242-01-711	EA	DOOR BIN	618765
8	125242-02-728	EA	RETAINER/PANEL - LOWER	621973
	125242-01-736	EA	CONTACT-PROBE PIN	618886
	125242-02-726	EA	DOOR ASM-LWR LH/WHITE GASKET	621150

**APPLIANCE GROUP (CONTINUED)**  
**COMPONENT PARTS FOR APPLIANCE (CONTINUED)**

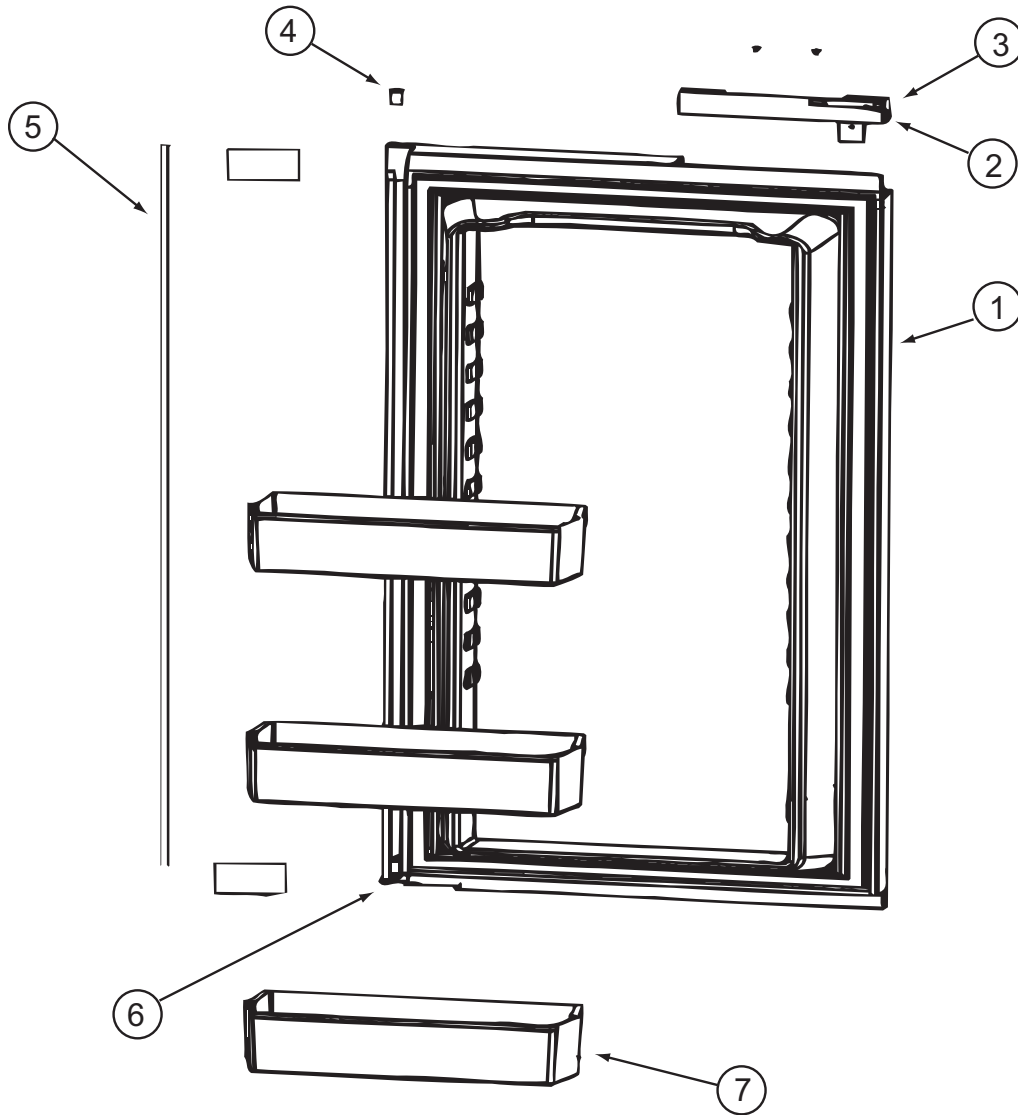

**125242-02-01A (CONTINUED)**

KEY	PART NUMBER	U/M	DESCRIPTION	VENDOR NO.
1	125242-01-764	EA	LINER/FOAMED-LOWER/RH-WHITE	619838
2	125242-02-700	EA	HANDLE(CONTOUR)TOP LH BTM RH	621107
3	125242-02-722	EA	LATCH-STORAGE DR/BLK POINTED	619374
4	125242-01-704	EA	BUSHING-HINGE MIDDLE	618746
5	125242-02-728	EA	RETAINER/PANEL - LOWER	621973
6	125242-02-724	EA	HINGE - DOOR	618792
7	125242-01-711	EA	DOOR BIN	618765
	125242-01-729	EA	FAN-EXTERNAL DC	618856
	125242-02-716	EA	GUIDE ASM LWR(SER#540294 DN)	620042
	125242-02-717	EA	GUIDE ASM LWR(SER#540295 UP)	620043

**APPLIANCE GROUP (CONTINUED)**  
**COMPONENT PARTS FOR APPLIANCE (CONTINUED)**

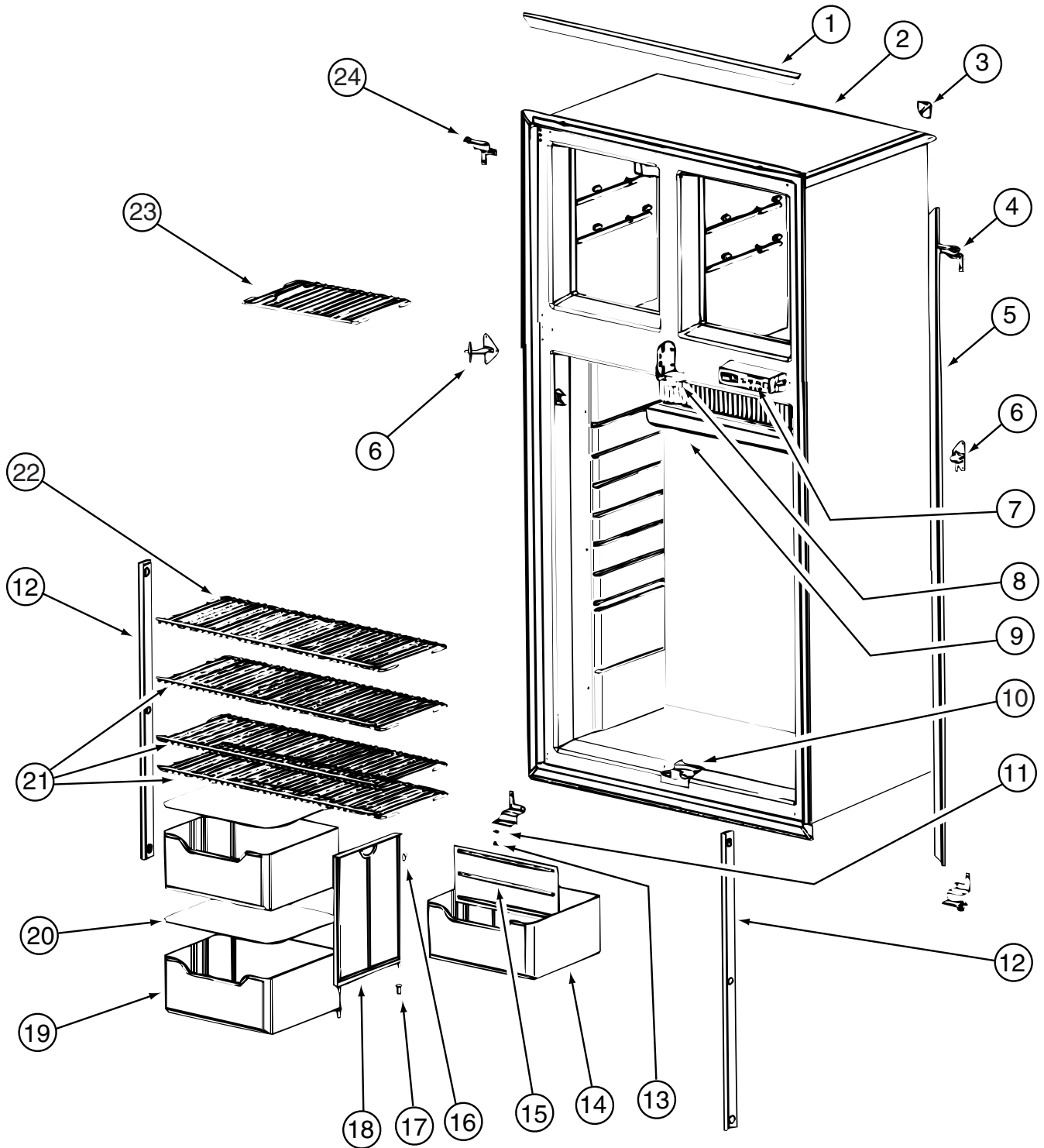

125242-02-01A (CONTINUED)



**APPLIANCE GROUP (CONTINUED)**  
**COMPONENT PARTS FOR APPLIANCE (CONTINUED)**

**125242-02-01A (CONTINUED)**

KEY	PART NUMBER	U/M	DESCRIPTION	VENDOR NO.
1	125242-01-723	EA	TRIM-HORIZONTAL-FRT SNAP ON	618845
2	125242-01-748	EA	CABINET/FOAMED ASSEMBLY	618748
3	125242-01-722	EA	TRIM - CORNER	618844
4	125242-01-715	EA	HINGE - TOP RH/BOTTOM LH	618798
5	125242-01-724	EA	RIM-LT/RT-FRT VERT SNAPON	618846
6	125242-01-713	EA	HINGE-MIDDLE (PAINTED)	618794
7	125242-02-704	EA	DISPLAY ASM (SER#832172) UP	621188
8	125242-01-751	EA	BLOCK - GUIDE - UPPER	618789
9	125242-01-712	EA	DRIP TRAY	618774
10	125242-01-752	EA	BLOCK - GUIDE - LOWER	618788
11	120075-01-708	EA	BUSHING - DOOR HINGE	618144
12	120075-01-730	EA	RETAINER - SHELF(SER#926684 DN	618181
13	120075-01-727	EA	PIN - HINGE	618145
14	125242-01-734	EA	CRISPER/BOTTLE BIN	618878
15	125242-01-733	EA	DIVIDER - BOTTLE CRISPER	618877
16	125242-01-750	EA	CLIP	61409622
17	113737-01-701	EA	BUSHING - HINGE	61742022
18	125242-01-749	EA	SUPPORT - WALL	618840
19	125242-01-734	EA	CRISPER/BOTTLE BIN	618878
20	125242-01-706	EA	COVER - CRISPER	618757
21	125242-01-726	EA	SHELF - WIRE (LONG)	618848
22	125242-01-727	EA	SHELF - WIRE (SHORT)	618849
23	125242-01-725	EA	SHELF - FREEZER (WIRE)	618847
24	125242-01-714	EA	HINGE - TOP LH/BOTTOM RH	618796
	125242-01-735	EA	SWITCH - DOOR LIGHT	618884

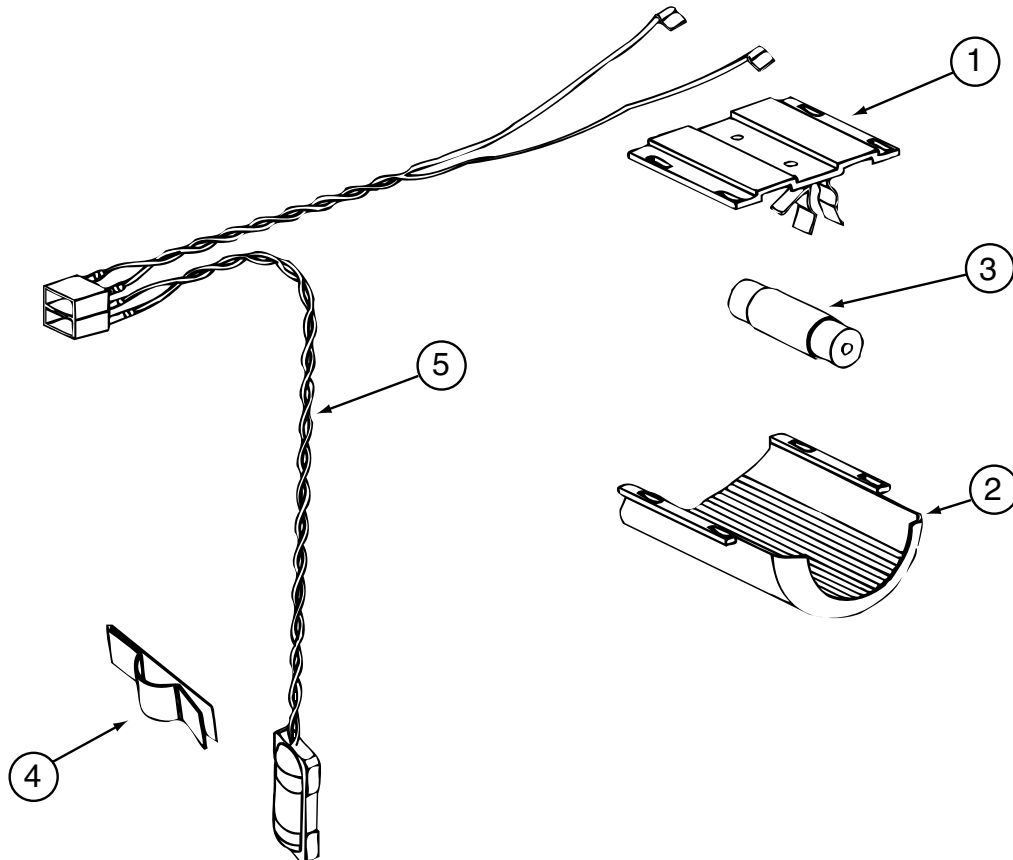

**125242-02-01A (CONTINUED)**

KEY	PART NUMBER	U/M	DESCRIPTION	VENDOR NO.
1	084880-03-705	EA	BRACKET - LIGHT - INTERIOR	61629722
2	120075-01-734	EA	COVER - LENS	618190
3	084880-03-706	EA	BULB - LAMP	61628922
4	084880-01-760	EA	CLIP (THERMISTER)	61689122
5	120075-01-735	EA	THERMISTER W/LAMP & WIRE/ASM	618548

**APPLIANCE GROUP (CONTINUED)**  
**COMPONENT PARTS FOR APPLIANCE (CONTINUED)**

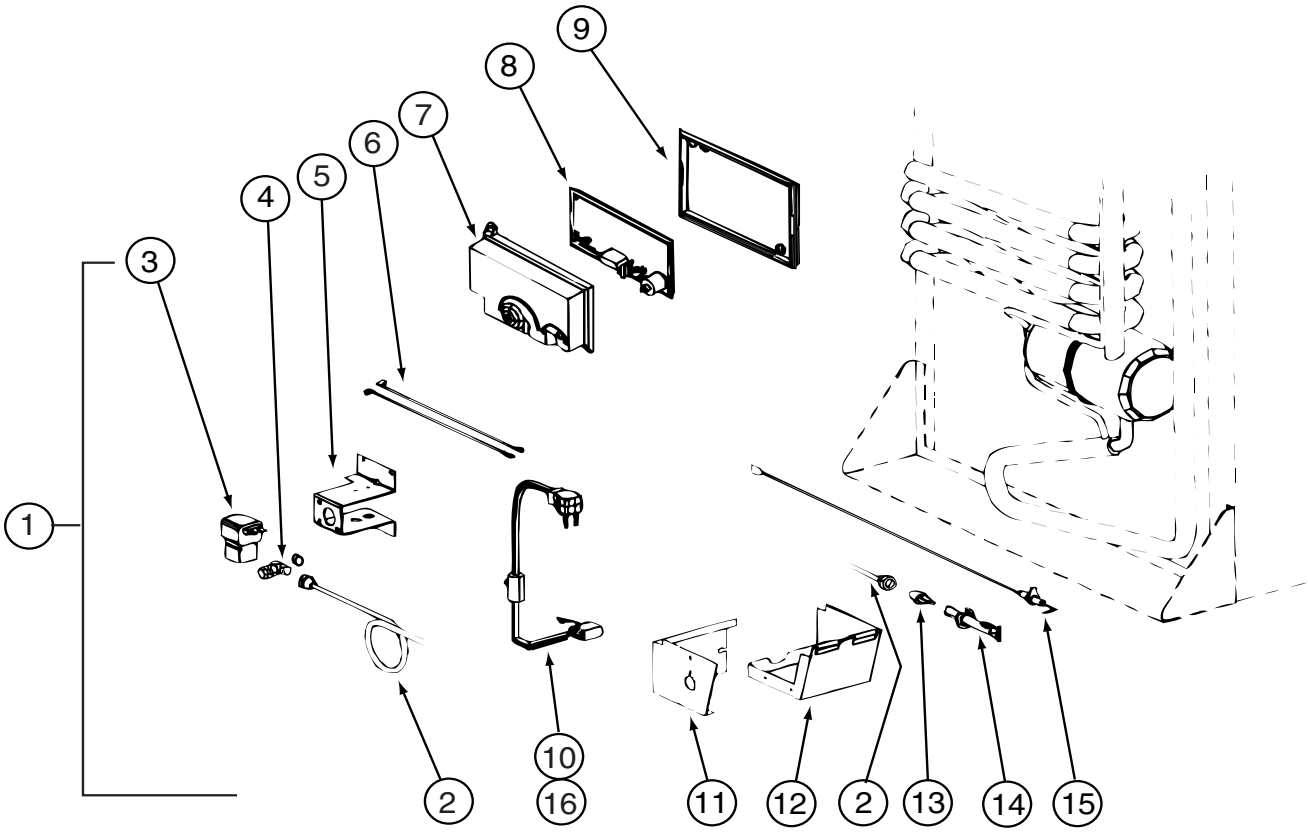

125242-02-01A (CONTINUED)

**APPLIANCE GROUP (CONTINUED)**  
**COMPONENT PARTS FOR APPLIANCE (CONTINUED)**

KEY	PART NUMBER	U/M	DESCRIPTION	VENDOR NO.
1	125242-01-753	EA	KIT - GAS VALVE/BURNER TUBE	620610
2	125242-01-744	EA	BURNER TUBE	618937
4	113737-01-716	EA	TAP-PRESSURE	61594422
7	120075-01-738	EA	COVER-POWER BOARD	618185
8	125242-02-703	EA	POWER BOARD	621271
9	120075-01-740	EA	COVER-BASE, POWER BOARD	618186
11	125242-01-739	EA	BASE-BURNER BOX	618902
12	125242-01-740	EA	COVER-BURNER BOX	618910
13	125242-01-717	EA	ORIFICE-JEWELED	618814
14	125242-01-743	EA	BURNER - 8 SLOT	618932
15	104137-06-715	EA	ELECTRODE-SPARK/SENSOR, SGL	61692222

CONTACT WINNEBAGO PART SALES FOR UNLISTED COMPONENTS

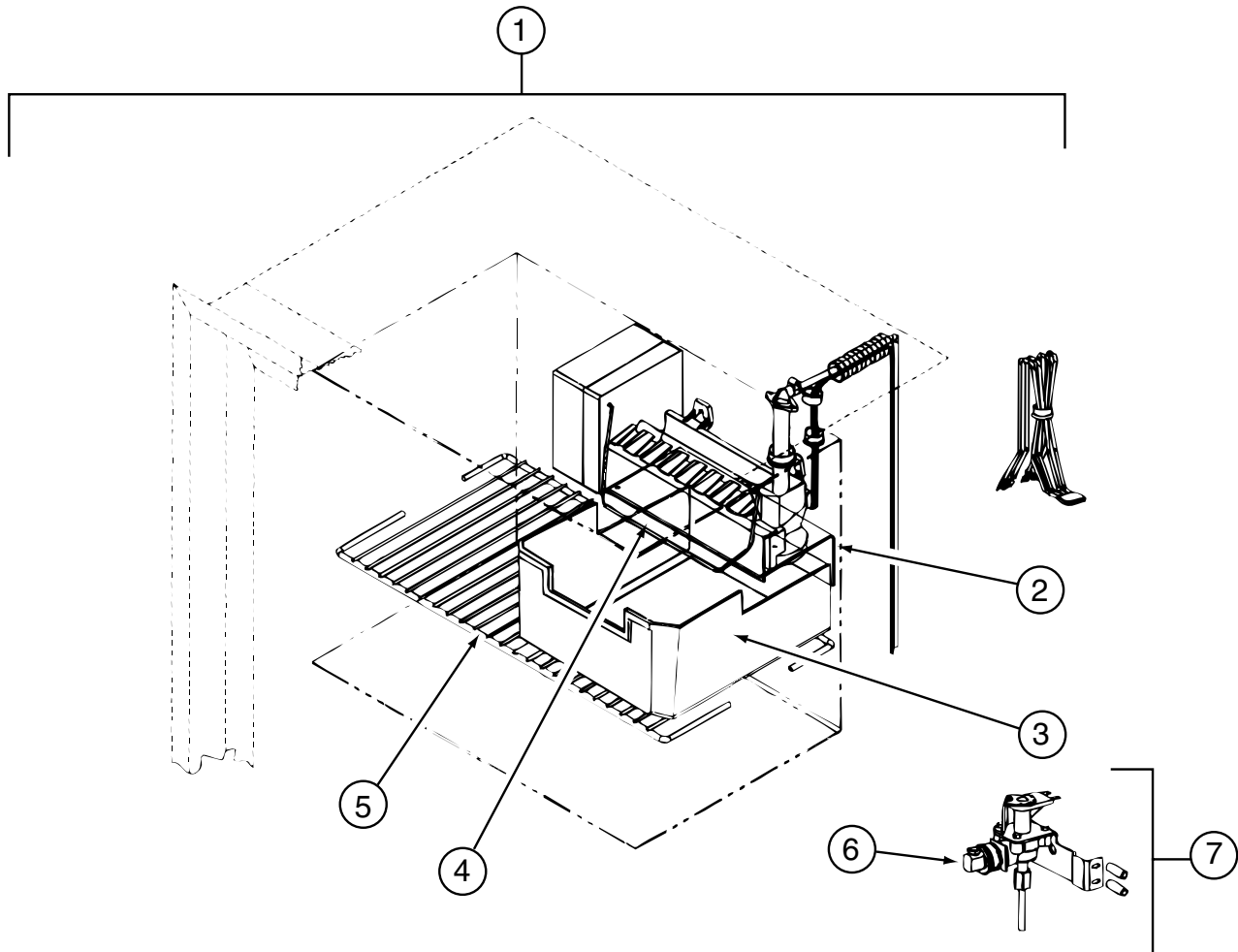

**125242-02-01A (CONTINUED)**

KEY	PART NUMBER	U/M	DESCRIPTION	VENDOR NO.
1	094039-07-706	EA	ICE MAKER W/O PLATES	61656522
2	125242-01-737	EA	BRACKET - MOUNTING (ICE MAKER)	618894
3	125242-01-716	EA	ICE BIN	618803
4	120075-03-703	EA	ARM - SHUT OFF	61656922
5	125242-01-725	EA	SHELF - FREEZER (WIRE)	618847
6	120075-03-702	EA	NUT/COMPRESSION - FITTING	61678722
7	120075-03-701	EA	VALVE - WATER - W/BRACKET	618523

**APPLIANCE GROUP (CONTINUED)**  
**COMPONENT PARTS FOR APPLIANCE (CONTINUED)**

129561-01-01A

KEY	PART NUMBER	U/M	DESCRIPTION	VENDOR NO.
	129561-01-700	EA	PC BOARD	L5097-09
	129561-01-701	EA	CHASSIS SCREENED	C00399
	129561-01-702	EA	LABEL	L0451-0
	129561-01-703	EA	HARNESS	L7694-00

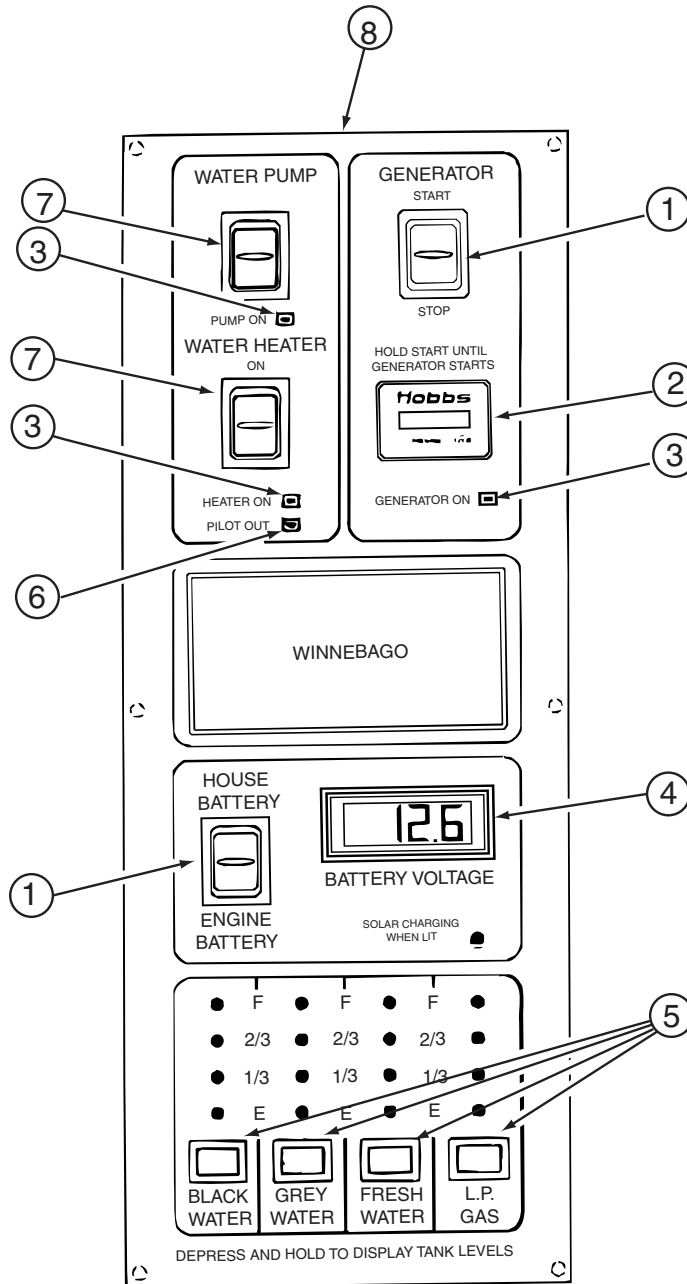

133004-02-01A

KEY	PART NUMBER	U/M	DESCRIPTION	VENDOR NO.
1	133004-01-702	EA	SWITCH/DPDT MOM=ON-OFF-ON	L1011-00
2	100258-10-701	EA	GAUGE-HR METER ONLY (LCD)	L0775-00
3	133004-01-706	EA	L.E.D. GREEN-PANEL MOUNT	L0785
4	133004-01-704	EA	METER/VOLT-DIGITAL - LCD	L1008-00
5	133004-01-705	EA	SWITCH/MOM ON - PUSH BUTTON	L0950-00
6	133004-01-703	EA	L.E.D. RED-PANEL MOUNT	L1009-00
7	133004-01-701	EA	SWITCH/DPDT ON-ON/MAINTAINED	L1025-00
8	133004-02-701	EA	SCREENED - CHASSIS	CC0547-00
	133004-02-700	EA	BOARD - PC	L5113-03

**APPLIANCE GROUP (CONTINUED)**  
**COMPONENT PARTS FOR APPLIANCE (CONTINUED)**

133004-04-01A

KEY	PART NUMBER	U/M	DESCRIPTION	VENDOR NO.
1	133004-01-702	EA	SWITCH/DPDT MOM=ON-OFF-ON	L1011-00
2	100258-10-701	EA	GAUGE-HOUR MTR-CLIP ON (LCD)	L0775-00
3	133004-01-706	EA	L.E.D. GREEN-PANEL MOUNT	L0785
4	133004-01-704	EA	METER/VOLT-DIGITAL - LCD	L1008-00
5	133004-01-705	EA	SWITCH/MOM ON - PUSH BUTTON	L0950-00
7	133004-01-701	EA	SWITCH/DPDT ON-ON/MAINTAINED	L1025-00
8	133004-04-700	EA	SCREENED CHASSIS/SUB ASSY	CE0287
	133004-02-700	EA	BOARD - PC	L5113-03

CONTACT WINNEBAGO PARTS SALES FOR MISSING COMPONENTS

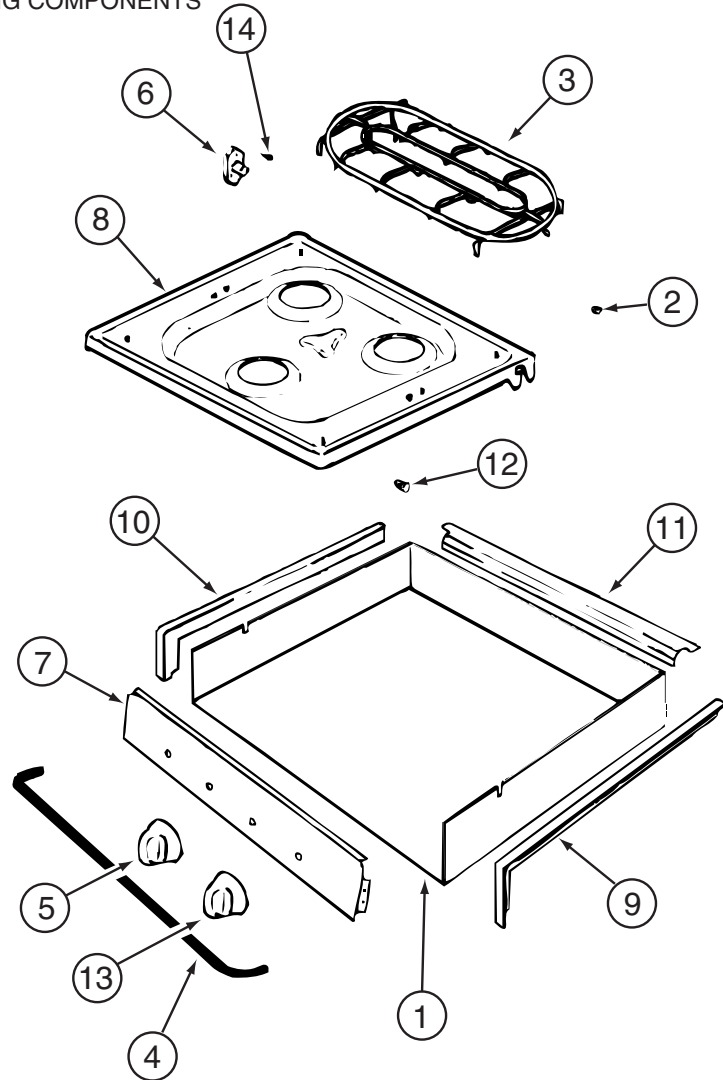

135065-01-01A, 135065-01-02A, 135065-02-01A

KEY	PART NUMBER	U/M	DESCRIPTION	VENDOR NO.
2	102020-01-709	EA	BUMPER-GRATE	8007-P020-60
3	128728-01-700	EA	GRATE - BURNER	74003948
4	114030-02-700	EA	GUARD/FABRIC - TOWEL BAR	3609F006-70
5	112881-01-705	EA	KNOB-TOP BURNER	7733P072-60
5	112881-01-718	EA	KNOB - TOP BURNER HI-OUTPUT	74001794
6	128728-01-703	EA	PIN/T-NUT F/HINGE	7103P109-60
7	135065-01-700	EA	PANEL/MANIFOLD	74003354
8	128728-01-705	EA	TOP - MAIN - BLACK	74003928
8	135066-01-700	EA	TOP - MAIN - BISQUE	74005332
9	114030-01-704	EA	TRIM - RIGHT/BLACK TEXTURED	74002839
10	114030-01-705	EA	TRIM - LEFT/BLACK TEXTURED	74002840
11	114030-01-706	EA	TRIM - REAR/BLACK TEXTURED	74002841
12	102020-01-724	EA	BUMPER-MAIN TOP	8003P008-60
13	126023-01-720	EA	KNOB - IGNITER	74002414

CONTACT WINNEBAGO PART SALES FOR UNLISTED COMPONENTS

**APPLIANCE GROUP (CONTINUED)**  
**COMPONENT PARTS FOR APPLIANCE (CONTINUED)**

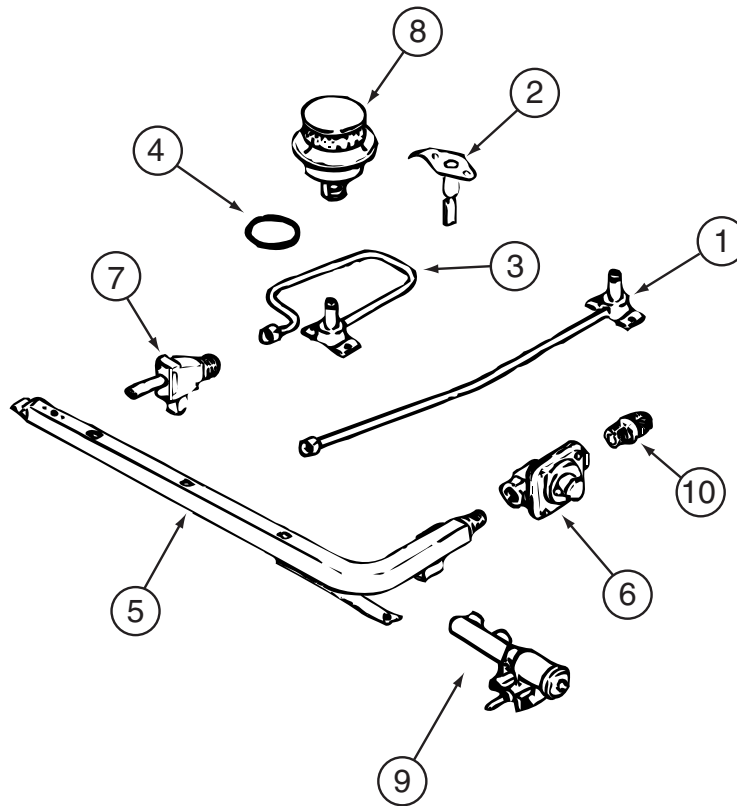

**135065-01-01A, 135065-01-02A, 135065-02-01A (CONTINUED)**

KEY	PART NUMBER	U/M	DESCRIPTION	VENDOR NO.
1	128728-01-708	EA	FITTING W/ORFICE/TUBE - REAR	74003931
2	135065-01-701	EA	IGNITOR/PORCELAIN-TOP BURNER	74004053
3	128728-01-710	EA	FITTING W/ORFICE/TUBE - FRT	74003930
4	128728-01-711	EA	GASKET - BURNER	74002745
5	135065-01-702	EA	PIPE/MANIFOLD	74004642
6	126023-02-703	EA	REGULATOR - PRESSURE	74004235
7	135065-01-703	EA	VALVE/BURNER - REAR	74004643
7	135065-01-704	EA	VALVE/BURNER-FRT-HI	74004644
8	135065-01-705	EA	BURNER/SEALED ASSEMBLY	12001497
9	128728-01-716	EA	BURNER - IGNITOR	74003946
9	128728-01-717	EA	WIRES - IGNITOR	74003947

**APPLIANCE GROUP (CONTINUED)**  
**COMPONENT PARTS FOR APPLIANCE (CONTINUED)**

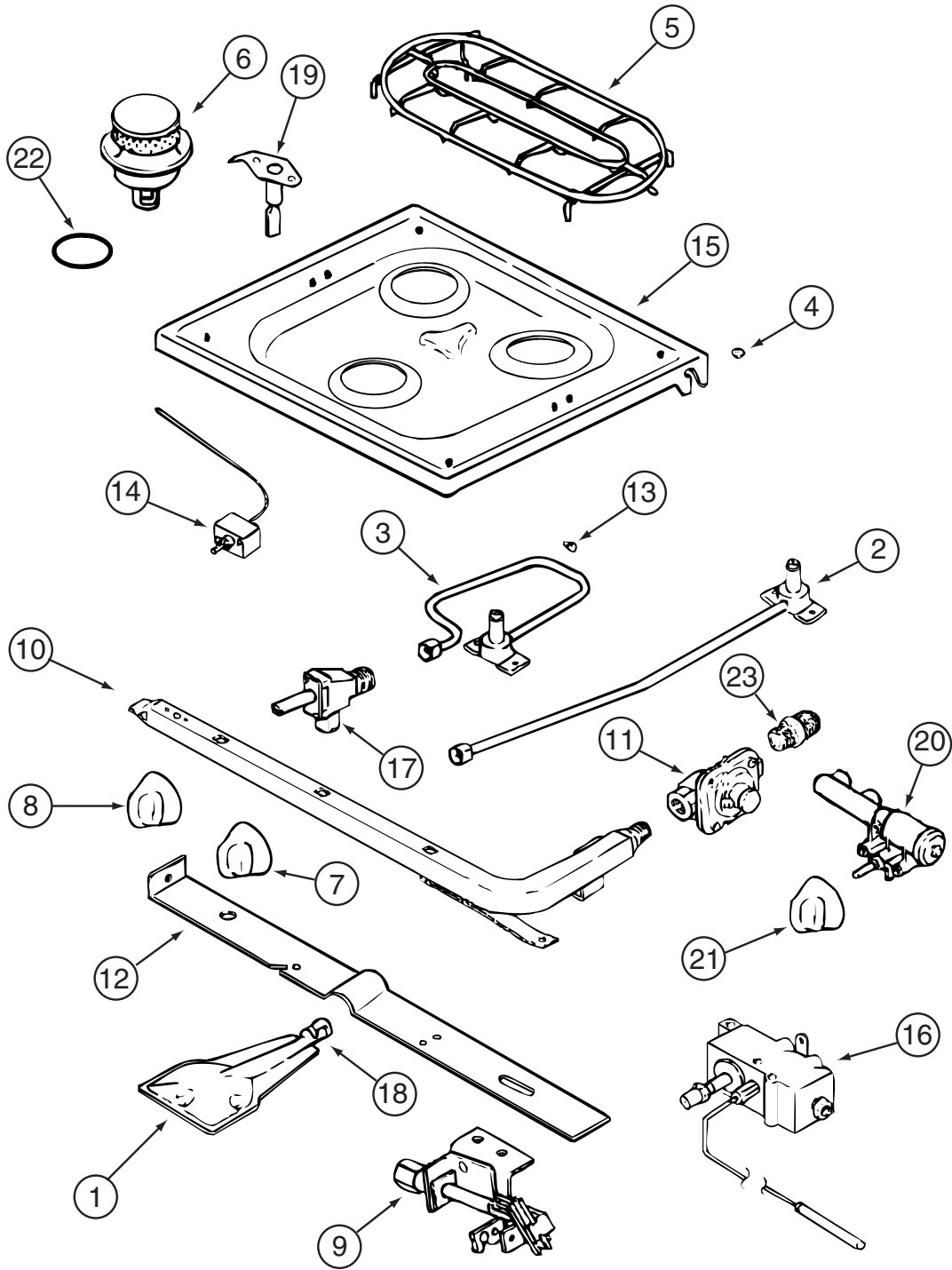

135066-02-01A

**APPLIANCE GROUP (CONTINUED)**  
**COMPONENT PARTS FOR APPLIANCE (CONTINUED)**  
**135066-02-01A (CONTINUED)**

KEY	PART NUMBER	U/M	DESCRIPTION	VENDOR NO.
1	126023-01-717	EA	BURNER - OVEN	74003343
2	128728-01-708	EA	FITTING W/ORFICE/TUBE - REAR	74003931
3	128728-01-710	EA	FITTING W/ORFICE/TUBE - FRT	74003930
4	102020-01-709	EA	BUMPER-GRATE	8007-P020-60
5	128728-01-700	EA	GRATE - BURNER	74003948
6	135065-01-705	EA	BURNER/SEALED ASSEMBLY	12001497
7	112881-01-705	EA	KNOB-TOP BURNER	7733P072-60
7	112881-01-718	EA	KNOB - TOP BURNER HI-OUTPUT	74001794
8	135656-01-700	EA	KNOB/THERMOSTAT	74002529
9	126023-02-701	EA	PILOT - OVEN	74004586
10	126023-02-702	EA	PIPE - MANIFOLD	74004360
11	135066-02-700	EA	REGULATOR - PRESSURE	74004236
13	102020-01-724	EA	BUMPER-MAIN TOP	8003P008-60
14	126023-01-734	EA	THERMOSTAT/OVEN SERIES #11	74006332
15	128728-01-705	EA	TOP - MAIN - BLACK	74003928
16	126023-02-704	EA	VALVE/OVEN - MERCURY	74004585
17	135065-01-703	EA	VALVE/BURNER - REAR	74004643
17	135065-01-704	EA	VALVE/BURNER-FRT-HI	74004644
18	135656-01-701	EA	MIXER/AIR	3411F003-34
19	135065-01-701	EA	IGNITOR/PORCELAIN-TOP BURNER	74004053
20	128728-01-716	EA	BURNER - IGNITOR	74003946
20	128728-01-717	EA	WIRES - IGNITOR	74003947
21	126023-01-720	EA	KNOB - IGNITER	74002414

CONTACT WINNEBAGO PART SALES FOR UNLISTED COMPONENTS

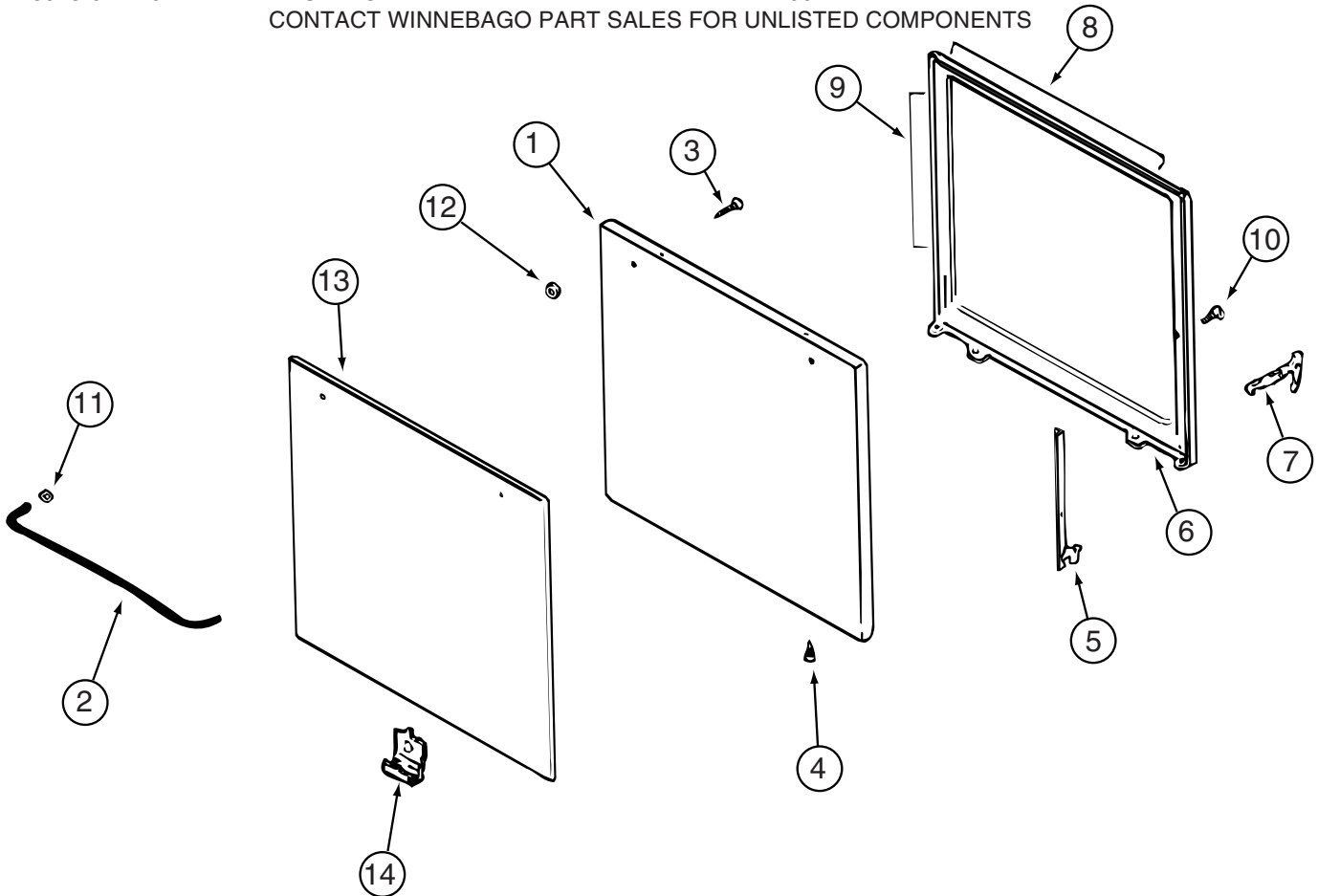

**135066-01-01A, 135066-01-02A, 135066-02-01A (CONTINUED)**

KEY	PART NUMBER	U/M	DESCRIPTION	VENDOR NO.
1	126023-01-712	EA	PANEL - DOOR (BLACK)	74001190
2	102020-01-701	EA	HANDLE,DOOR	7701P092-60
8	126023-01-732	EA	SEAL/OVEN DR TOP	7212P014-60
9	126023-01-733	EA	SEAL/OVEN DR SIDES(2PCS)	7212P038-60
13	102020-01-725	EA	GLASS OUTER	7902P266-60

CONTACT WINNEBAGO PART SALES FOR UNLISTED COMPONENTS



**APPLIANCE GROUP (CONTINUED)**  
**COMPONENT PARTS FOR APPLIANCE (CONTINUED)**

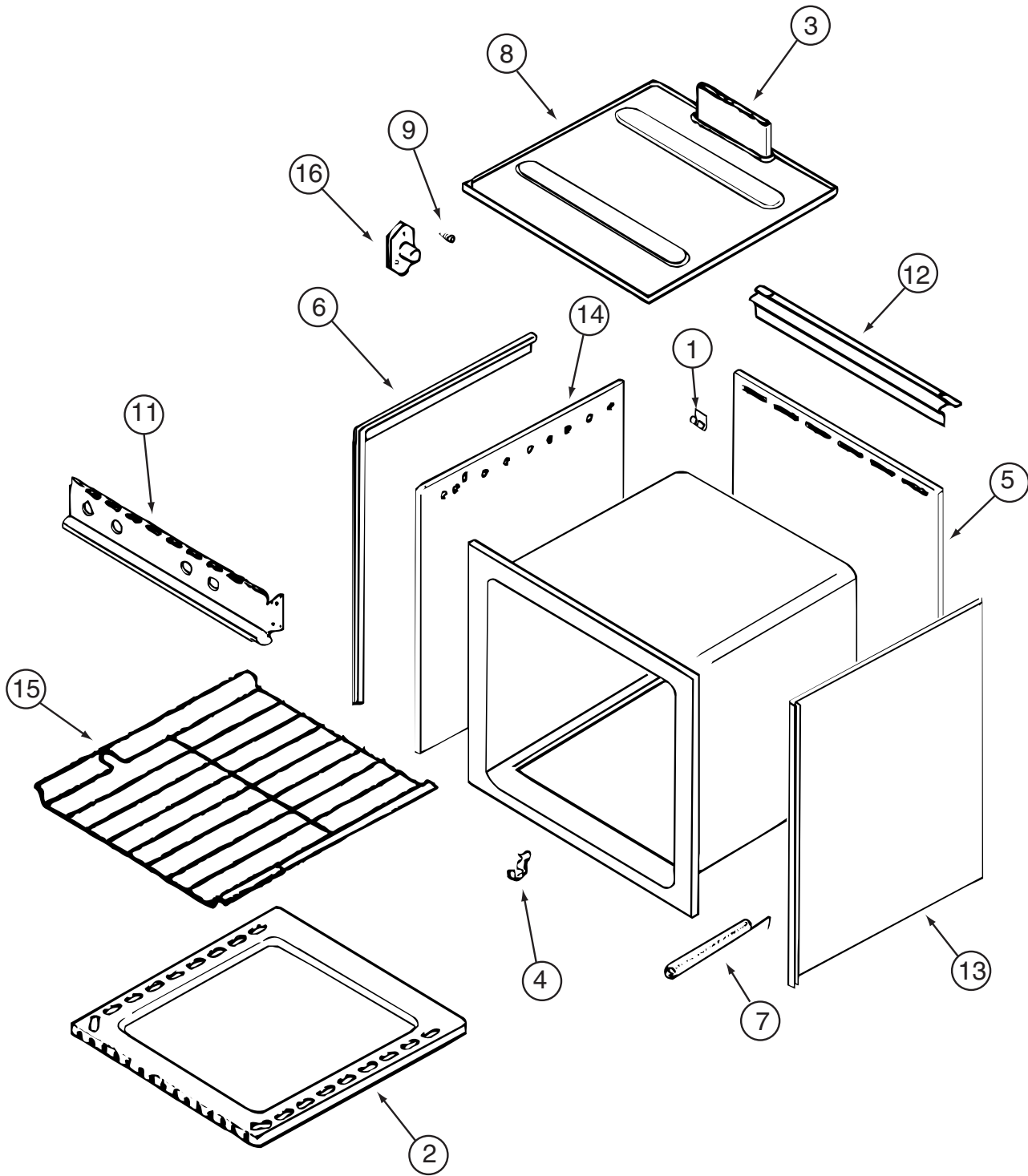

**135066-01-01A, 135066-01-02A, 135066-02-01A (CONTINUED)**

KEY	PART NUMBER	U/M	DESCRIPTION	VENDOR NO.
1	112881-03-702	EA	CLIP - MAIN TOP	74003998
2	126023-01-731	EA	BOTTOM - OVEN	2205F016-19
3	126023-01-718	EA	FLUE BOX ASSEMBLY	4006W075-80
6	126023-01-713	EA	TRIM - SIDE (RIGHT)	74002827
6	126023-01-714	EA	TRIM - SIDE (LEFT)	74002828
11	126023-01-729	EA	PANEL - MANIFOLD	74003351
15	126023-01-716	EA	RACK - OVEN	74003106

CONTACT WINNEBAGO PART SALES FOR UNLISTED COMPONENTS

**AUDIO VIDEO GROUP**  
**RADIO SYSTEM**

KEY	PART NUMBER	U/M	DESCRIPTION
*	127517-12-000	EA	RADIO - AM/FM/CD - REMOTE CONTROL - SONY CDX-CA400 - EXTERIOR ENTERTAINMENT W/CD
	133307-02-000	EA	RADIO - WALL MOUNT - CD W/ALARM - AUDIOVOX AWN-930 - REAR STEREO
	136543-02-000	EA	RADIO - AM/FM CD6 - XU3F-18C815-NA - DASH
	110469-01-000	EA	SPEAKER - 4" X 6" OVAL - COAXIAL - EXTERIOR ENTERTAINMENT
	124883-02-000	EA	SPEAKER - CUBE - W/BRACKET - SURROUND SOUND
	124883-03-000	EA	CUBE/SPEAKER - W/O CASE - SURROUND SOUND
	124884-01-000	EA	SPEAKER - 6" X 9" - SUB-WOOFER - SURROUND SOUND
	094097-01-000	EA	SPEAKER - RADIO/TV - W/O GRILLE - 5.25" DIAMETER
	110470-01-01A	EA	GRILLE - 4" X 6" OVAL SPEAKER - BLACK - EXTERIOR ENTERTAINMENT
	124883-04-000	EA	GRILLE/SPEAKER - F/CUBE - SURROUND SOUND
	124885-01-000	EA	GRILLE - SPEAKER - 6" X 9" - SUB-WOOFER - SURROUND SOUND
	089340-02-000	EA	GRILLE - SPEAKER - 6.5" SQUARE
	124881-02-000	EA	AMPLIFIER - AUDIO - MTS Q SURROUND - ORANGE LABEL (LATEST) - SURROUND SOUND
	090944-01-000	EA	ANTENNA - RADIO - 16" RUBBER - W/72" LEAD WIRE FROM: 00-00-00 THRU: 01-05-03
	090944-02-000	EA	ANTENNA - RADIO - 16" RUBBER - W/O LEAD WIRE FROM: 01-06-03 THRU: 99-99-99
	090944-03-000	EA	CABLE - ANTENNA FROM: 01-06-03 THRU: 99-99-99
	077069-02-000	EA	CABLE/EXTENSION - RADIO ANTENNA - 96"
	108847-01-000	EA	BRACKET - ANTENNA GROUND
	109889-04-000	EA	EXTENDER - ANTENNA SHAFT - 3.7"
	123256-01-000	EA	ANTENNA - CB - W/O CABLE
	123256-02-000	EA	CABLE - CB - COAX

\*COMPONENT PARTS LISTED LATER IN THIS GROUP

**AUDIO VIDEO GROUP (CONTINUED)**  
**COMPONENT PARTS FOR RADIO SYSTEM**

127517-12-000

<b>KEY</b>	<b>PART NUMBER</b>	<b>U/M</b>	<b>DESCRIPTION</b>	<b>VENDOR NO.</b>
	127517-12-700	EA	REMOTE	RMX114

**AUDIO VIDEO GROUP (CONTINUED)**  
**REAR VIEW MONITOR**

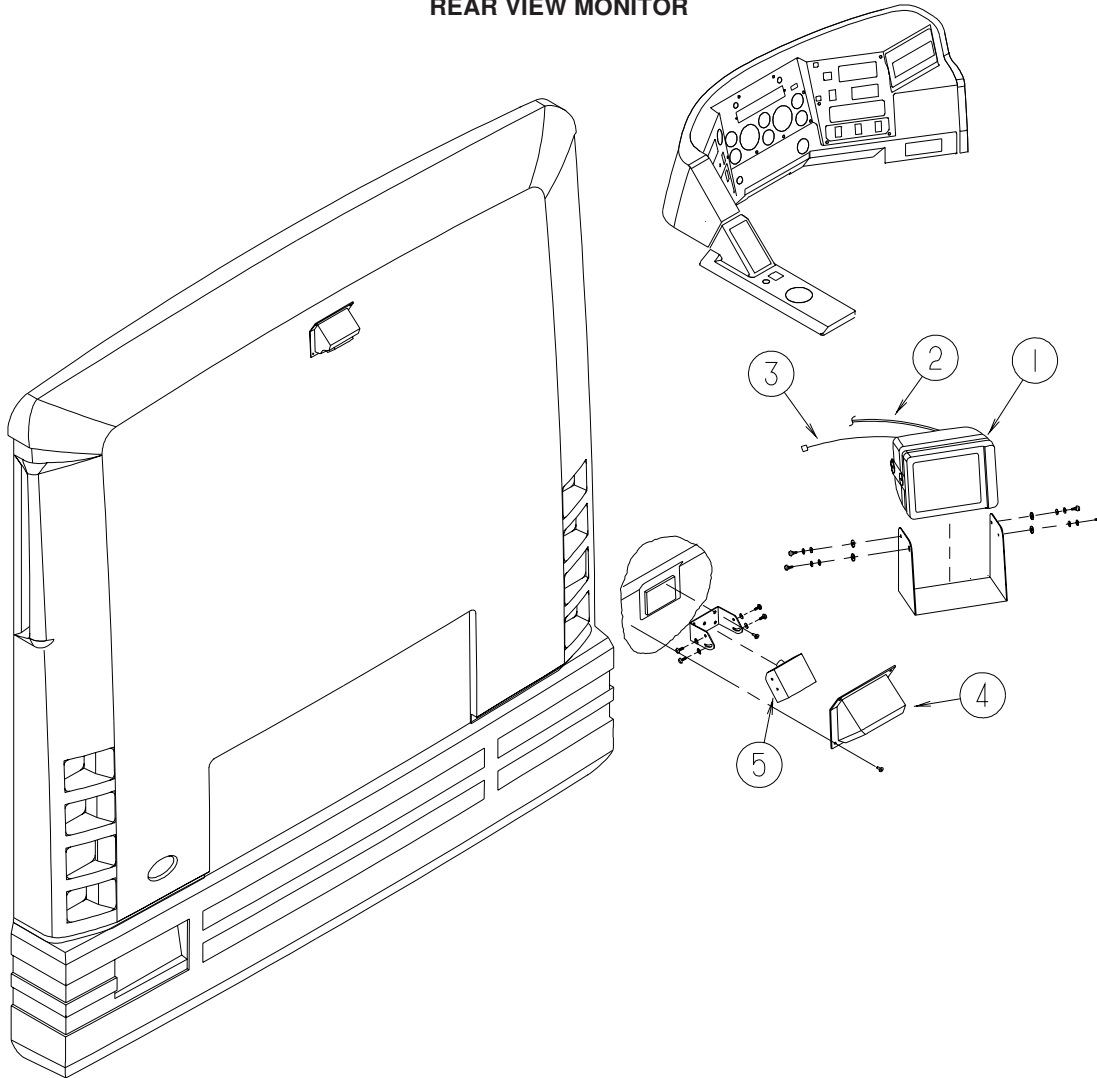

KEY	PART NUMBER	U/M	DESCRIPTION
1	143363-01-000	EA	MONITOR/REAR - COLOR - W/BRACKET - SONY VCB-MH1
2	143363-03-000	EA	CABLE - MONITOR/CAMERA - COLOR - SONY VCB-MHC20
3	143545-01-000	EA	WIRE ASSEMBLY - REAR MONITOR
4	123281-01-01A	EA	SHROUD - CAMERA/OUTER - BRIGHT WHITE
5	143363-02-000	EA	CAMERA/REAR - COLOR - W/BRACKET - SONY VCB-MHD1

**TELEPHONE**

KEY	PART NUMBER	U/M	DESCRIPTION
	093253-01-02A	EA	PLATE - WALL - TELEPHONE - BROWN
	093253-01-03A	EA	PLATE - WALL - TELEPHONE - WHITE
	130686-01-01A	EA	PLATE - WALL - TELEPHONE/COAX - WHITE

**AUDIO VIDEO GROUP (CONTINUED)**  
TV & VCR

KEY	PART NUMBER	U/M	DESCRIPTION
*	076319-23-000	EA	ANTENNA - TV ROOF MOUNT - 44.5" MAST
*	076319-25-000	EA	KIT - HARDWARE INTERIOR
	136860-01-000	EA	CABLE - RCA - #3 MALE TO #12F MALE CONNECTOR
	120233-03-000	EA	CERTIFICATE - SATELLITE RECEIVER
*	137135-01-000	EA	ANTENNA - SATELLITE DSS - W/SENSOR - <b>SATELLITE DISH</b> FROM: 00-00-00 THRU: 04-08-02
	137135-02-000	EA	ANTENNA - SATELLITE DSS - W/SENSOR - <b>SATELLITE DISH</b> FROM: 04-09-02 THRU: 99-99-99
*	141454-01-01A	EA	ANTENNA - SATELLITE - <b>AUTOMATIC SATELLITE DISH</b>
	144377-01-000	EA	ANTENNA - SATELLITE - IN MOTION - - <b>IN-MOTION SATELLITE SYSTEM</b>
	076319-09-000	EA	WALLPLATE - CABLE RECEPTACLE - TV - SINGLE - BROWN
	076319-03-000	FT	CABLE - COAXIAL - 75 OHM
	076319-12-000	EA	CONNECTOR - COAXIAL - ONE PIECE
	142258-01-000	EA	SWITCH - VIDEO/ANTENNA POWER SUPPLY
*	124075-06-000	EA	TV - 19" - 1/8 JACK - UL/CSA - RCA F19424M - <b>19" TV W/REMOTE</b>
*	130121-06-000	EA	TV - 25" - COLOR/STEREO W/5 JACKS - RCA F25649 - <b>25" COLOR STEREO TV</b> FROM: 00-00-00 THRU: 09-11-02
*	130121-07-000	EA	TV - 25" - COLOR/STEREO W/5 JACKS - RCA F25442A0 - <b>25" COLOR STEREO TV</b> FROM: 09-18-02 THRU: 12-01-02
	130121-08-000	EA	TV - 25" - COLOR/STEREO W/5 JACKS - RCA F25441A0 - <b>25" COLOR STEREO TV</b> FROM: 12-02-02 THRU: 99-99-99
	082134-01-000	EA	ADAPTER - TV - CABLE TO CABLE
	082136-01-000	EA	NUT - HEX JAM - 3/8-32
	086756-01-000	EA	SPLITTER - TV/2 WAY
	114870-02-000	EA	PLUG - AUDIO W/LEADS - 10"
	123324-01-000	EA	FILTER - GROUND LOOP
	134006-01-03B	EA	PLATE - COAXIAL CABLE/OFF WHITE
*	124073-11-000	EA	VCR-VHS/HI-FI STEREO - SILVER CASE - RCA VR651HF FROM: 00-00-00 THRU: 05-16-02
*	124073-12-000	EA	VCR-VHS/HI-FI STEREO - SILVER CASE - RCA VR637HF FROM: 05-17-02 THRU: 99-99-99
	136764-02-000	EA	DVD PLAYER - RCA RC524OP FROM: 00-00-00 THRU: 07-21-02
	136764-03-000	EA	DVD PLAYER - RCA DRC220N FROM: 07-22-02 THRU: 99-99-99

\*COMPONENT PARTS LISTED LATER IN THIS GROUP

**AUDIO VIDEO GROUP (CONTINUED)**  
**COMPONENT PARTS FOR TV & VCR**

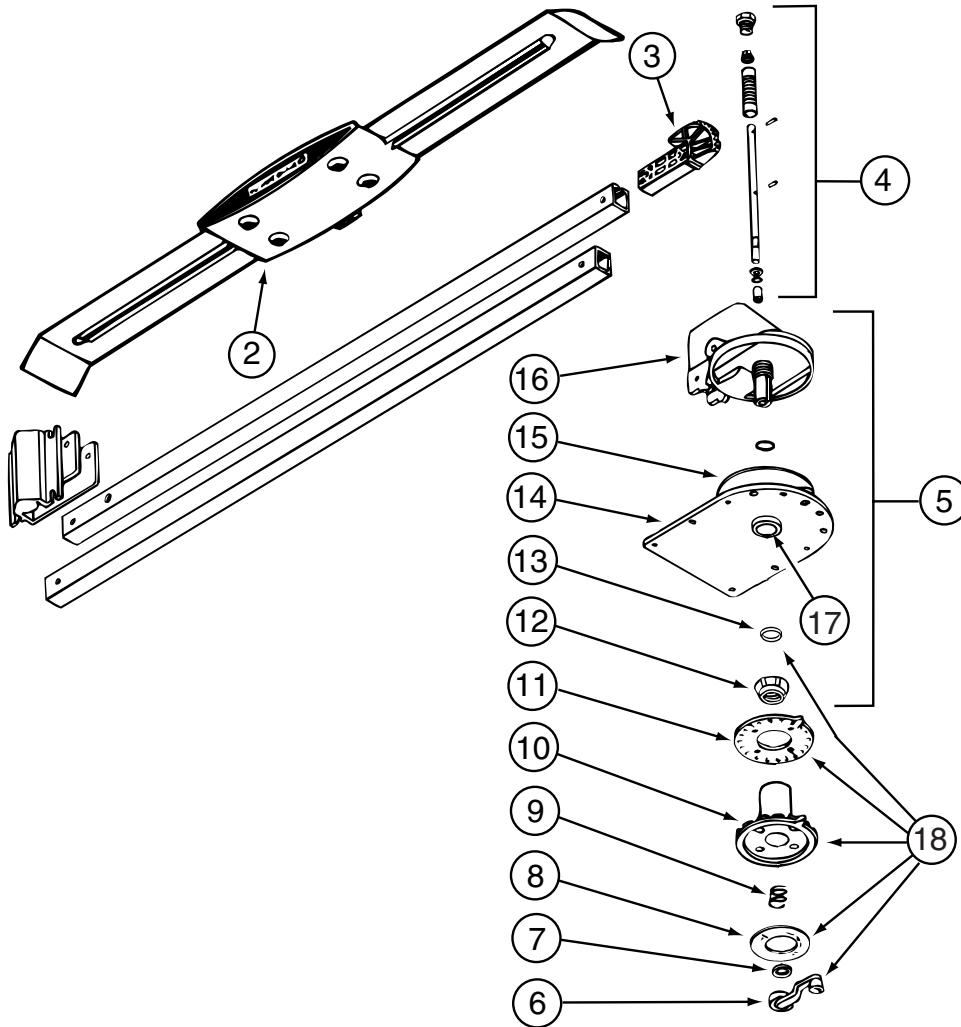

**076319-23-000**

KEY	PART NUMBER	U/M	DESCRIPTION	VENDOR NO.
2	076319-01-700	EA	HEAD-ANTENNA, AMPLIFIED	RVSA U/V
3	076319-01-701	EA	GEAR-ELEVATING, PLASTIC	2200046
4	076319-01-702	EA	SHAFT ASM-ELEVATING	RP-4000
5	076319-01-711	EA	BASE & LIFT ASM	2762802
7	076319-01-705	EA	GROMMET-NYLON, 7/8"ID	3200658
8	076319-01-708	EA	DECAL-CRANK	5413002
9	076319-01-707	EA	SPRING-HANDLE	2160822
11	076319-01-712	EA	PLATE - CEILING	3200608
12	076319-01-715	EA	NUT (GEAR HOUSING)	2200047
14	076319-01-713	EA	BASE-PLATE, STEEL	3100523
15	076319-01-703	EA	BEARING-NYLON, 5"OD	3200656
16	076319-01-714	EA	HOUSING, ROTATING GEAR	2200049
	076319-01-716	EA	TUBING, ELEVATING	RP-2900
17	076319-01-704	EA	BEARING-NYLON, 1.25"OD	3200657

CONTACT WINNEBAGO PART SALES FOR UNLISTED COMPONENT

**076319-25-000**

KEY	PART NUMBER	U/M	DESCRIPTION	VENDOR NO.
6	076319-01-706	EA	CRANK-W/SET SCREW UNIV/BEIGE	2750897
6	120233-01-710	EA	HANDLE-CRANK W/SCREW - WHITE	RP-6795
8	076319-01-708	EA	DECAL-CRANK	5413002
10	076319-25-700	EA	DIRECTIONAL HANDLE(WHITE)	3200612
11	076319-25-701	EA	PLATE - CEILING(WHITE)	3200609
13	120233-01-709	EA	WASHER-NYLON	RP-2658

CONTACT WINNEBAGO PART SALES FOR UNLISTED COMPONENTS

**AUDIO VIDEO GROUP (CONTINUED)**  
**COMPONENT PARTS FOR TV & VCR (CONTINUED)**

			<b>124073-11-000</b>	
<b>KEY</b>	<b>PART NUMBER</b>	<b>U/M DESCRIPTION</b>		<b>VENDOR NO.</b>
	126697-04-700	EA REMOTE		239040
			<b>124073-12-000</b>	
<b>KEY</b>	<b>PART NUMBER</b>	<b>U/M DESCRIPTION</b>		<b>VENDOR NO.</b>
	126697-04-700	EA REMOTE		239040
			<b>124075-06-000</b>	
<b>KEY</b>	<b>PART NUMBER</b>	<b>U/M DESCRIPTION</b>		<b>VENDOR NO.</b>
	124075-05-700	EA REMOTE		242778
			<b>130121-06-000</b>	
<b>KEY</b>	<b>PART NUMBER</b>	<b>U/M DESCRIPTION</b>		<b>VENDOR NO.</b>
	130121-05-700	EA REMOTE		242524
			<b>130121-07-000</b>	
<b>KEY</b>	<b>PART NUMBER</b>	<b>U/M DESCRIPTION</b>		<b>VENDOR NO.</b>
	124075-05-700	EA REMOTE		242778

**AUDIO VIDEO GROUP (CONTINUED)**  
**COMPONENT PARTS FOR TV & VCR (CONTINUED)**

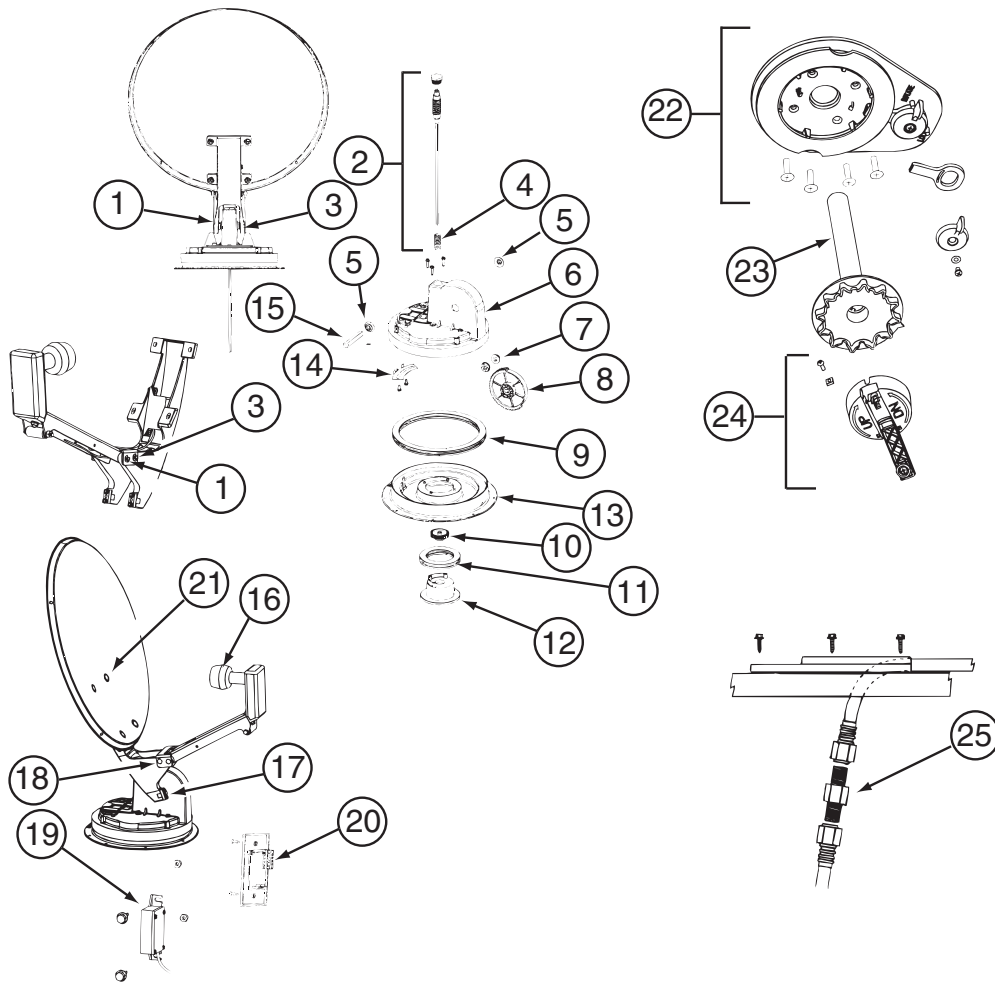

137135-01-000

KEY	PART NUMBER	U/M	DESCRIPTION	VENDOR NO.
1	120233-01-714	EA	CLIP-E	5160818
2	137135-01-703	EA	SHAFT-ELEVATING(SPRING/PLUG)	RP-4400
3	137135-01-704	EA	PIN - 1/4" X 3.25"	2160813
4	137135-01-705	EA	SPRING	2160818
5	137135-01-707	EA	SEAL - PIVOT SHAFT	2200852
6	137135-01-708	EA	TURRET	3100728
7	137135-01-709	EA	PIVOT BEARING	2200470
8	137135-01-711	EA	GEAR - ELEVATING	2200464
9	137135-01-712	EA	BEARING - OUTER	2590347
10	137135-01-714	EA	GEAR - ELEVATING SHAFT	2200465
11	137135-01-715	EA	BEARING - INNER	2590348
12	137135-01-716	EA	HUB	3100731
13	137135-01-713	EA	TURRET BASE	3100730
14	137135-01-710	EA	PLATE - ROTATE LIMIT	3720052
15	137135-01-706	EA	KIT-TURRET/SEAL/BEARING/GEAR	RP-RM30
16	120233-01-734	EA	LOW NOISE BLOCK FILTER (SGL)	LB10003
17	137135-01-722	EA	CLAMP	2590343
18	137135-01-719	EA	BRACKET - PIVOT	2744945
19	137135-01-720	EA	DE-SENSOR UNIT W/43" CABLE	276342
20	137135-01-721	EA	WALL PLATE	3200213
21	137135-01-717	EA	BOLT - FLAT HEAD	216032
22	120233-01-722	EA	PLATE ASSEMBLY (CEILING)	2762826
23	120233-01-704	EA	DIAL - DIRECTIONAL	3200364
24	120233-01-721	EA	CRANK HANDLE ASSEMBLY	2762825
25	137135-01-701	EA	CONNECTOR - F - MALE TO MALE	FS-8100
	137135-01-700	EA	ROOF WEDGE W/GASKET	RW-5000
	137135-01-718	EA	REFLECTOR/WHITE - 46CM	2745282



**AUDIO VIDEO GROUP (CONTINUED)**  
**COMPONENT PARTS FOR TV & VCR (CONTINUED)**

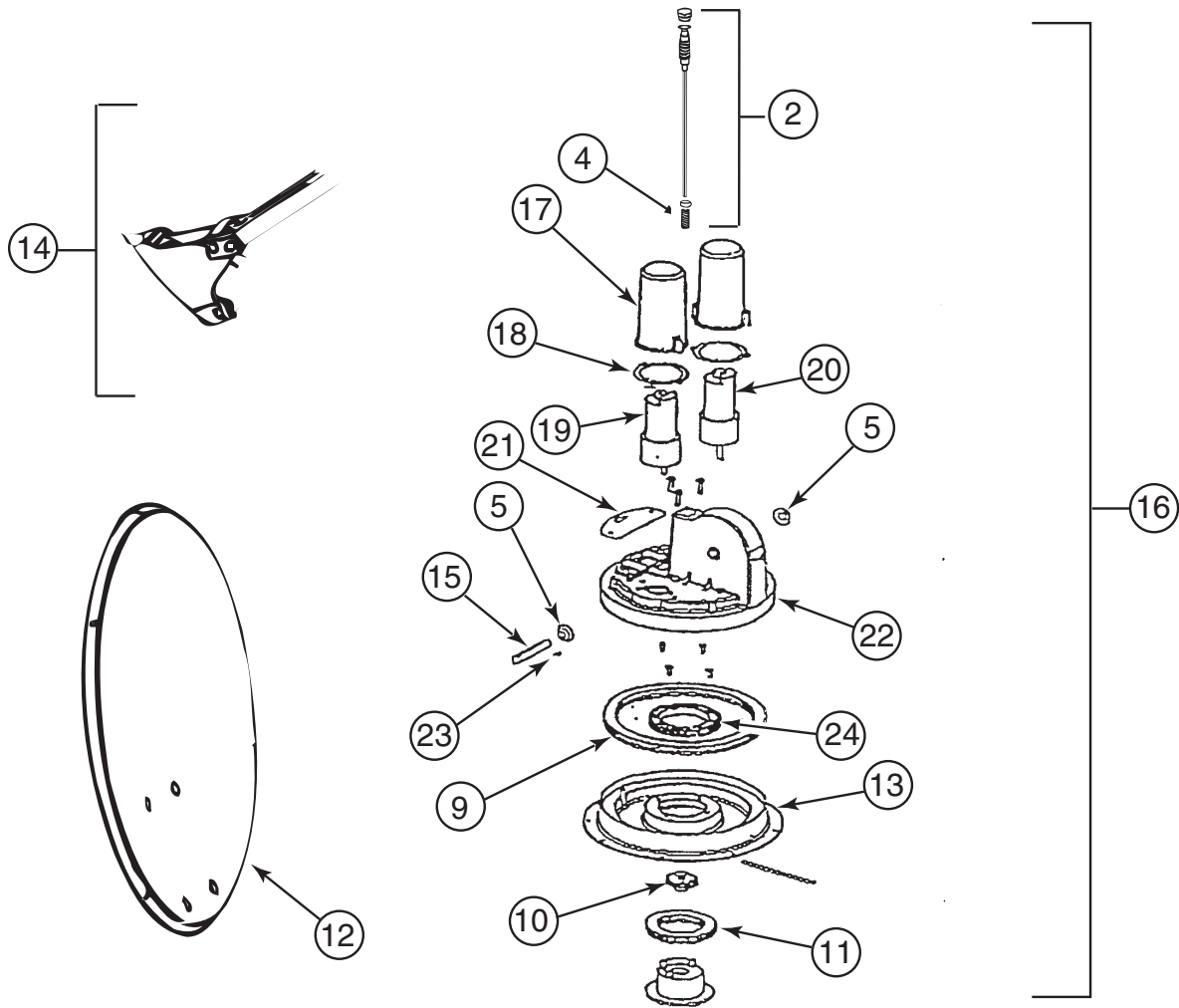

**141454-01-01A**

KEY	PART NUMBER	U/M	DESCRIPTION	VENDOR NO.
2	141454-01-700	EA	KIT ELEV-SHAFT/GEARS/SPRING	RP-RM20
5	137135-01-707	EA	SEAL - PIVOT SHAFT	2200852
9	137135-01-712	EA	BEARING - OUTER	2590347
10	137135-01-714	EA	GEAR - ELEVATING SHAFT	2200465
11	137135-01-715	EA	BEARING - INNER	2590348
12	137135-01-718	EA	REFLECTOR/WHITE-46CM W/HDWE	RP-35RM
13	137135-01-713	EA	TURRET BASE	3100730
14	137135-01-723	EA	SUPPORT/FRAME-BACKUP-W/HDWE	RP-RM00
15	137135-01-706	EA	KIT-TURRET/SEAL/BEARING/GEAR	RP-RM30
16	141454-01-704	EA	KIT LIFT ASSEMBLY COMPLETE	RP-RM05
17	141454-01-705	EA	HOUSING - MOTOR	3200260
18	141454-01-706	EA	GASKET - MOTOR HOUSING	2240054
19	141454-01-707	EA	MOTOR - AZIMUTH	2665039
20	141454-01-708	EA	MOTOR - ELEVATION	2665038
21	141454-01-709	EA	GASKET	2240056
22	141454-01-710	EA	TURRET	3100729
23	141454-01-711	EA	ROLL PIN	2160842
24	141454-01-712	EA	GEAR - ROTATE	2200469
	141454-01-701	EA	KIT - GEAR/MOTOR-GEAR/ROTATE	RP-RM25
	141454-01-702	EA	HOUSING/ELECTRONICS - UPPER	RP-RM10
	141454-01-703	EA	HOUSING/ELECTRONICS - LOWER	RP-RM15
	141454-01-713	EA	PANEL/FRT-W/DIGITAL READOUT	2764586

CONTACT WINNEBAGO PART SALES FOR UNLISTED COMPONENT

**AUDIO VIDEO GROUP (CONTINUED)**  
**EXTERIOR ENTERTAINMENT**

<b>KEY</b>	<b>PART NUMBER</b>	<b>U/M</b>	<b>DESCRIPTION</b>
	126123-01-K30	EA	PLATE - RADIO MOUNTING - WHITE LAMINATE

## BATH GROUP CABINETS

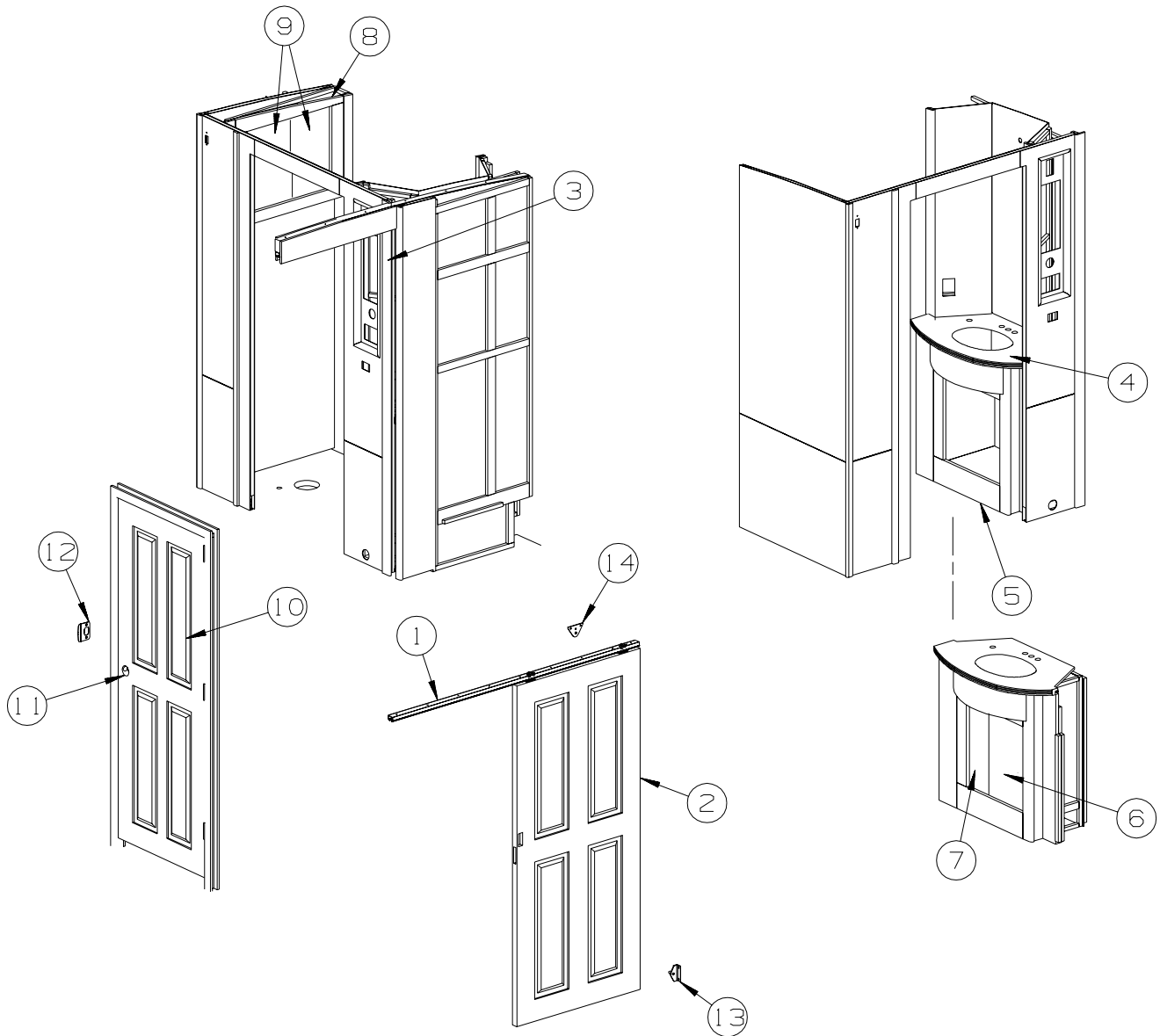

KEY	PART NUMBER	U/M	DESCRIPTION
1	103868-17-01A	EA	TRACK - SLIDING DOOR - 62.9" - OFF WHITE FROM: 00-00-00 THRU: 01-16-03
1	137422-18-01A	EA	TRACK - DOOR - OFF WHITE FROM: 01-17-03 THRU: 99-99-99
2	142371-03-07A	EA	DOOR - SLIDING - 31.4" X 72.7" - W/O HARDWARE - PTSM OAK - PORTSMOUTH OAK
2	142371-03-05A	EA	DOOR - SLIDING - 31.4" X 72.7" - W/O HARDWARE - CHERRY - CONCERT CHERRY
2	142371-03-06A	EA	DOOR - SLIDING - 31.4" X 72.7" - W/O HARDWARE - MAPLE - WASHED MAPLE
3	137602-73-PC0	EA	POCKET - MONITOR PANEL - PORTSMOUTH OAK FROM: 00-00-00 THRU: 08-18-02
3	137602-09-N95	EA	POCKET - MONITOR PANEL - PORTSMOUTH OAK FROM: 08-19-02 THRU: 99-99-99
3	137602-73-PC1	EA	POCKET - MONITOR PANEL - CONCERT CHERRY FROM: 00-00-00 THRU: 08-18-02
3	137602-09-N94	EA	POCKET - MONITOR PANEL - CONCERT CHERRY FROM: 08-19-02 THRU: 99-99-99
3	137602-73-PC2	EA	POCKET - MONITOR PANEL - WASHED MAPLE FROM: 00-00-00 THRU: 08-18-02
3	137602-09-PC2	EA	POCKET - MONITOR PANEL - WASHED MAPLE FROM: 08-19-02 THRU: 99-99-99
4	138786-12-01A	EA	COUNTERTOP - 1/2" CORIAN - MAGNA SAVANNA
5	143216-01-PA0	EA	CABINET - LAVATORY - W/O COUNTERTOP/DOORS/DRAWERS/HARDWARE - PORTSMOUTH OAK
5	143216-01-PA1	EA	CABINET - LAVATORY - W/O COUNTERTOP/DOORS/DRAWERS/HARDWARE - CONCERT CHERRY
5	143216-01-PA2	EA	CABINET - LAVATORY - W/O COUNTERTOP/DOORS/DRAWERS/HARDWARE - WASHED MAPLE

**BATH GROUP (CONTINUED)**  
**CABINETS (CONTINUED)**

<b>KEY</b>	<b>PART NUMBER</b>	<b>U/M</b>	<b>DESCRIPTION</b>
6	141286-09-PA0	EA	DOOR - DBL ARCH/VERT PENCIL EDGE-9.2" X 21.8" - W/O HDW - PORTSMOUTH OAK FROM: 00-00-00 THRU: 07-19-02
6	136710-09-PA0	EA	DOOR - RAISED PANEL/PENCIL EDGE - 9.2" X 21.8" - W/O HDW - PORTSMOUTH OAK FROM: 07-20-02 THRU: 99-99-99
6	141286-09-PA1	EA	DOOR - DBL ARCH/VERT PENCIL EDGE-9.2" X 21.8" - W/O HDW - CONCERT CHERRY FROM: 00-00-00 THRU: 07-19-02
6	136710-09-PA1	EA	DOOR - RAISED PANEL/PENCIL EDGE - 9.2" X 21.8" - W/O HDW - CONCERT CHERRY FROM: 07-20-02 THRU: 99-99-99
6	141286-09-PA2	EA	DOOR - DBL ARCH/VERT PENCIL EDGE-9.2" X 21.8" - W/O HDW - WASHED MAPLE FROM: 00-00-00 THRU: 07-19-02
6	136710-09-PA2	EA	DOOR - RAISED PANEL/PENCIL EDGE - 9.2" X 21.8" - W/O HDW - WASHED MAPLE FROM: 07-20-02 THRU: 99-99-99
7	141286-08-PA0	EA	DOOR - DBL ARCH/VERT PENCIL EDGE-9.2" X 21.8" - W/O HDW - PORTSMOUTH OAK FROM: 00-00-00 THRU: 07-19-02
7	136710-08-PA0	EA	DOOR - RAISED PANEL/PENCIL EDGE - 9.2" X 21.8" - W/O HDW - PORTSMOUTH OAK FROM: 07-20-02 THRU: 99-99-99
7	141286-08-PA1	EA	DOOR - DBL ARCH/VERT PENCIL EDGE-9.2" X 21.8" - W/O HDW - CONCERT CHERRY FROM: 00-00-00 THRU: 07-19-02
7	136710-08-PA1	EA	DOOR - RAISED PANEL/PENCIL EDGE - 9.2" X 21.8" - W/O HDW - CONCERT CHERRY FROM: 07-20-02 THRU: 99-99-99
7	141286-08-PA2	EA	DOOR - DBL ARCH/VERT PENCIL EDGE-9.2" X 21.8" - W/O HDW - WASHED MAPLE FROM: 00-00-00 THRU: 07-19-02
7	136710-08-PA2	EA	DOOR - RAISED PANEL/PENCIL EDGE - 9.2" X 21.8" - W/O HDW - WASHED MAPLE FROM: 07-20-02 THRU: 99-99-99
8	143342-01-PA0	EA	CABINET - OVERHEAD/LINEN - W/O DOORS/HARDWARE - PORTSMOUTH OAK
8	143342-01-PA1	EA	CABINET - OVERHEAD/LINEN - W/O DOORS/HARDWARE - CONCERT CHERRY
8	143342-01-PA2	EA	CABINET - OVERHEAD/LINEN - W/O DOORS/HARDWARE - WASHED MAPLE
9	141286-64-PA0	EA	DOOR - DBL ARCH/VERT PENCIL EDGE-12" X 18.7" - W/O HDW - PORTSMOUTH OAK
9	141286-64-PA1	EA	DOOR - DBL ARCH/VERT PENCIL EDGE-12" X 18.7" - W/O HDW - CONCERT CHERRY
9	141286-64-PA2	EA	DOOR - DBL ARCH/VERT PENCIL EDGE-12" X 18.7" - W/O HDW - WASHED MAPLE
10	142401-02-07A	EA	DOOR - W/JAMB/RH HINGED - 27.5" X 72.7" - W/O HDW-PTSM OAK - PORTSMOUTH OAK FROM: 00-00-00 THRU: 08-18-02
10	142401-06-07A	EA	DOOR - W/JAMB/RH HINGED - 27.5" X 72.7" - W/O HDW-PTSM OAK - PORTSMOUTH OAK FROM: 08-19-02 THRU: 99-99-99
10	142401-02-05A	EA	DOOR - W/JAMB/RH HINGED - 27.5" X 72.7" - W/O HDW-CHERRY - CONCERT CHERRY FROM: 00-00-00 THRU: 08-18-02
10	142401-06-05A	EA	DOOR - W/JAMB/RH HINGED - 27.5" X 72.7" - W/O HDW-CHERRY - CONCERT CHERRY FROM: 08-19-02 THRU: 99-99-99
10	142401-02-06A	EA	DOOR - W/JAMB/RH HINGED - 27.5" X 72.7" - W/O HDW-MAPLE - WASHED MAPLE FROM: 00-00-00 THRU: 08-18-02
10	142401-06-06A	EA	DOOR - W/JAMB/RH HINGED - 27.5" X 72.7" - W/O HDW-MAPLE - WASHED MAPLE FROM: 08-19-02 THRU: 99-99-99
11	111155-09-01A	EA	LOCK - PRIVACY
12	144909-01-01A	EA	PLATE - STRIKE - DOOR LATCH - POLISHED BRASS FROM: 10-01-02 THRU: 99-99-99
13	126263-02-02B	EA	BRACKET - GAS SPRING W/BALL STUD - E-COATED
14	126263-08-02B	EA	BRACKET - GAS SPRING W/CENTERED BALL STUD - E-COATED

**BATH GROUP (CONTINUED)**  
**CABINETS (CONTINUED)**

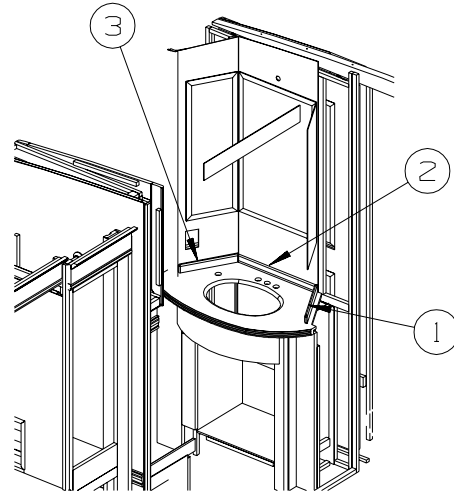
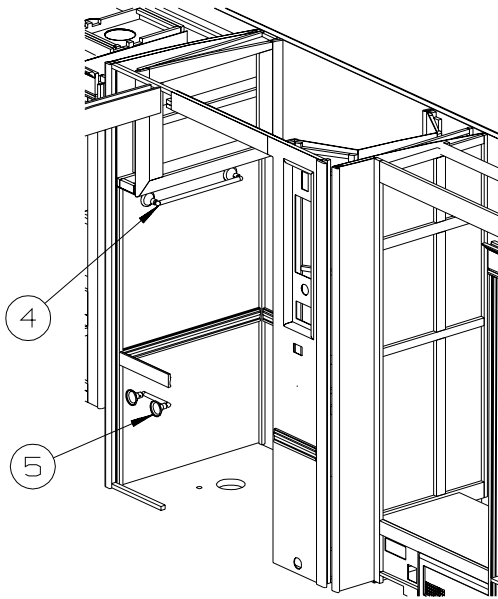

KEY	PART NUMBER	U/M	DESCRIPTION
1	144403-01-02A	EA	BACKSPLASH - COUNTERTOP - CORIAN - MAGNA SAVANNAH FROM: 09-25-02 THRU: 99-99-99
2	139855-07-02A	EA	BACKSPLASH - COUNTERTOP - CORIAN - MAGNA SAVANNAH FROM: 09-25-02 THRU: 99-99-99
3	144403-02-02A	EA	BACKSPLASH - COUNTERTOP - CORIAN - MAGNA SAVANNAH FROM: 09-25-02 THRU: 99-99-99
4	142068-01-01A	EA	TOWEL BAR - 18"
5	142069-01-01A	EA	TISSUE HOLDER

**BATH GROUP (CONTINUED)**  
**SHOWER**

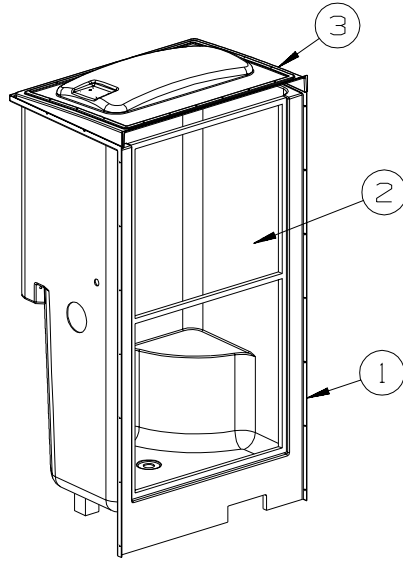

<b>KEY</b>	<b>PART NUMBER</b>	<b>U/M</b>	<b>DESCRIPTION</b>
1	141978-01-01A	EA	SHOWER - FIBERGLASS - W/SEAT - WHITE
2*	139047-06-01A	EA	DOOR - SHOWER - STRAIGHT - RAIN TEXTURE
3	141797-01-01A	EA	PANEL - SKYLITE - INNER

**\*COMPONENT PARTS LISTED LATER IN THIS GROUP**

**BATH GROUP (CONTINUED)**  
**COMPONENT PARTS FOR SHOWER DOOR**

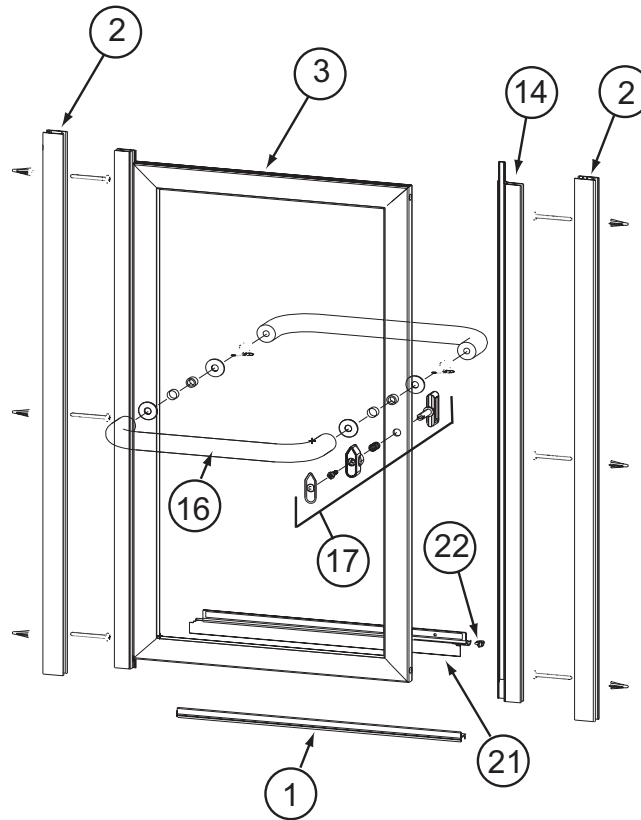

**139047-06-01A & -02A**

KEY	PART NUMBER	U/M	DESCRIPTION	VENDOR NO.
1	139047-01-701	EA	DAM STRIP-TOP/BOTTOM-35.4"	901
2	139047-01-702	EA	JAMB - WALL - 65.9"	903
3	139047-01-705	EA	HINGE/POST - DOOR - 64.5"	920
14	139047-01-704	EA	STRIKE - JAMB - 64.6"	926
16	139047-06-700	EA	TOWEL BAR ASM (KIT)	
17	139047-06-701	EA	TRAVEL LATCH KIT	
21	139047-01-710	FT	VINYL SWEEP	C176G
22	139047-01-711	EA	PLUG - DRIP CAP (SET)	CP933
	139047-01-706	EA	HINGE PINS	CP932
	139047-01-707	EA	WASHERS - HINGE	CP148TW
	139047-01-708	EA	HINGE - SLEEVE - 61.5"	C921B
	139047-01-709	EA	STRIP - MAGNETIC- 55"	98-42

CONTACT WINNEBAGO PART SALES FOR UNLISTED COMPONENT

## BEDROOM GROUP QUEEN CABINETS

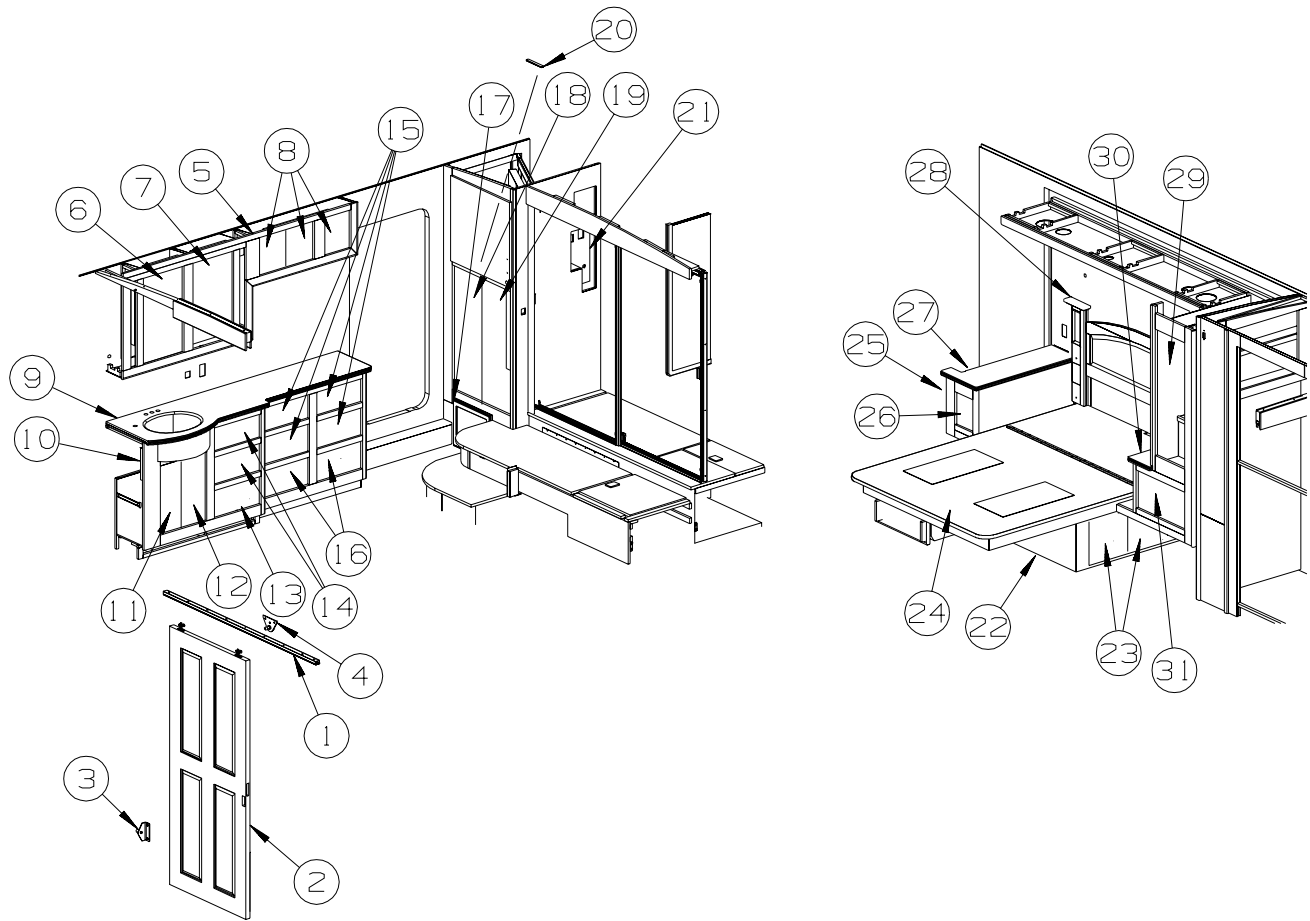

KEY	PART NUMBER	U/M	DESCRIPTION
1	103868-01-01A	EA	TRACK - SLIDING DOOR - 60.8" - OFF WHITE FROM: 00-00-00 THRU: 01-16-03
1	137422-10-01A	EA	TRACK/DOOR - OFF WHITE FROM: 01-17-03 THRU: 99-99-99
2	142371-03-07A	EA	DOOR - SLIDING - 31.4" X 72.7" - W/O HARDWARE - PTSM OAK - PORTSMOUTH OAK
2	142371-03-05A	EA	DOOR - SLIDING - 31.4" X 72.7" - W/O HARDWARE - CHERRY - CONCERT CHERRY
2	142371-03-06A	EA	DOOR - SLIDING - 31.4" X 72.7" - W/O HARDWARE - MAPLE - WASHED MAPLE
3	126263-02-02B	EA	BRACKET - GAS SPRING W/BALL STUD - E-COATED
4	126263-08-02B	EA	BRACKET - GAS SPRING W/CENTERED BALL STUD - E-COATED
5	143419-01-PA0	EA	CABINET - OVERHEAD/VANITY - W/O DOORS/HARDWARE - PORTSMOUTH OAK
5	143419-01-PA1	EA	CABINET - OVERHEAD/VANITY - W/O DOORS/HARDWARE - CONCERT CHERRY
5	143419-01-PA2	EA	CABINET - OVERHEAD/VANITY - W/O DOORS/HARDWARE - WASHED MAPLE
6	115237-17-PA0	EA	DOOR - MIRRORED/MEDICINE CABINET - 14.5" X 25.9" - W/O HDW - PORTSMOUTH OAK
6	115237-17-M94	EA	DOOR - MIRRORED/MEDICINE CABINET - 14.5" X 25.9" - W/O HDW - CONCERT CHERRY
6	115237-17-PC2	EA	DOOR - MIRRORED/MEDICINE CABINET - 14.5" X 25.9" - W/O HDW - WASHED MAPLE
	093606-30-000	EA	MIRROR - BEVELED EDGE - 14.5" X 25.9"
	137463-01-01A	EA	LIFT - HOOK - SATIN BRASS
7	115237-07-PA0	EA	DOOR - MIRRORED/MEDICINE CABINET - W/O HARDWARE - PORTSMOUTH OAK
7	115237-07-M94	EA	DOOR - MIRRORED/MEDICINE CABINET - W/O HARDWARE - CONCERT CHERRY
7	115237-07-K80	EA	DOOR - MIRRORED/MEDICINE CABINET - W/O HARDWARE - WASHED MAPLE
	093606-30-000	EA	MIRROR - BEVELED EDGE - 14.5" X 25.9"
	137463-01-01A	EA	LIFT - HOOK - SATIN BRASS
8	141286-10-PA0	EA	DOOR - DBL ARCH/VERT PENCIL EDGE-9.8" X 12" - W/O HDW - PORTSMOUTH OAK
8	141286-10-PA1	EA	DOOR - DBL ARCH/VERT PENCIL EDGE-9.8" X 12" - W/O HDW - CONCERT CHERRY
8	141286-10-PA2	EA	DOOR - DBL ARCH/VERT PENCIL EDGE-9.8" X 12" - W/O HDW - WASHED MAPLE
9	138786-11-01A	EA	COUNTERTOP - 1/2" CORIAN - MAGNA SAVANNA
	124236-01-000	EA	DISPENSER - SOAP/HAND LOTION - POLISHED BRASS
10	143242-01-PA0	EA	CABINET - VANITY - W/O COUNTERTOP/DRAWR/HARDWARE - PORTSMOUTH OAK
10	143242-01-PA1	EA	CABINET - VANITY - W/O COUNTERTOP/DRAWR/HARDWARE - CONCERT CHERRY
10	143242-01-PA2	EA	CABINET - VANITY - W/O COUNTERTOP/DRAWR/HARDWARE - WASHED MAPLE



**BEDROOM GROUP (CONTINUED)**  
**QUEEN CABINETS (CONTINUED)**

<b>KEY</b>	<b>PART NUMBER</b>	<b>U/M</b>	<b>DESCRIPTION</b>
11	141286-08-PA0	EA	DOOR - DBL ARCH/VERT PENCIL EDGE-9.2" X 21.8" - W/O HDW - PORTSMOUTH OAK FROM: 00-00-00 THRU: 07-19-02
11	136710-08-PA0	EA	DOOR - RAISED PANEL/PENCIL EDGE - 9.2" X 21.8" - W/O HDW - PORTSMOUTH OAK FROM: 07-20-02 THRU: 99-99-99
11	141286-08-PA1	EA	DOOR - DBL ARCH/VERT PENCIL EDGE-9.2" X 21.8" - W/O HDW - CONCERT CHERRY FROM: 00-00-00 THRU: 07-19-02
11	136710-08-PA1	EA	DOOR - RAISED PANEL/PENCIL EDGE - 9.2" X 21.8" - W/O HDW - CONCERT CHERRY FROM: 07-20-02 THRU: 99-99-99
11	141286-08-PA2	EA	DOOR - DBL ARCH/VERT PENCIL EDGE-9.2" X 21.8" - W/O HDW - WASHED MAPLE FROM: 00-00-00 THRU: 07-19-02
11	136710-08-PA2	EA	DOOR - RAISED PANEL/PENCIL EDGE - 9.2" X 21.8" - W/O HDW - WASHED MAPLE FROM: 07-20-02 THRU: 99-99-99
12	141286-09-PA0	EA	DOOR - DBL ARCH/VERT PENCIL EDGE-9.2" X 21.8" - W/O HDW - PORTSMOUTH OAK FROM: 00-00-00 THRU: 07-19-02
12	136710-09-PA0	EA	DOOR - RAISED PANEL/PENCIL EDGE - 9.2" X 21.8" - W/O HDW - PORTSMOUTH OAK FROM: 07-20-02 THRU: 99-99-99
12	141286-09-PA1	EA	DOOR - DBL ARCH/VERT PENCIL EDGE-9.2" X 21.8" - W/O HDW - CONCERT CHERRY FROM: 00-00-00 THRU: 07-19-02
12	136710-09-PA1	EA	DOOR - RAISED PANEL/PENCIL EDGE - 9.2" X 21.8" - W/O HDW - CONCERT CHERRY FROM: 07-20-02 THRU: 99-99-99
12	141286-09-PA2	EA	DOOR - DBL ARCH/VERT PENCIL EDGE-9.2" X 21.8" - W/O HDW - WASHED MAPLE FROM: 00-00-00 THRU: 07-19-02
12	136710-09-PA2	EA	DOOR - RAISED PANEL/PENCIL EDGE - 9.2" X 21.8" - W/O HDW - WASHED MAPLE FROM: 07-20-02 THRU: 99-99-99
13	P40787-32-PA0	EA	DRAWER - SOLID PANEL - 15.1"W X 9.8"D - W/O SLIDES/HDW - PORTSMOUTH OAK
13	P40787-32-PA1	EA	DRAWER - SOLID PANEL - 15.1"W X 9.8"D - W/O SLIDES/HDW - CONCERT CHERRY
13	P40787-32-PA2	EA	DRAWER - SOLID PANEL - 15.1"W X 9.8"D - W/O SLIDES/HDW - WASHED MAPLE
14	P40787-33-PA0	EA	DRAWER - SOLID PANEL - 15.1"W X 9.8"D - W/O SLIDES/HDW - PORTSMOUTH OAK
14	P40787-33-PA1	EA	DRAWER - SOLID PANEL - 15.1"W X 9.8"D - W/O SLIDES/HDW - CONCERT CHERRY
14	P40787-33-PA2	EA	DRAWER - SOLID PANEL - 15.1"W X 9.8"D - W/O SLIDES/HDW - WASHED MAPLE
15	P40787-31-PA0	EA	DRAWER - SOLID PANEL - 14.7"W X 9.8"D - W/O SLIDES/HDW - PORTSMOUTH OAK
15	P40787-31-PA1	EA	DRAWER - SOLID PANEL - 14.7"W X 9.8"D - W/O SLIDES/HDW - CONCERT CHERRY
15	P40787-31-PA2	EA	DRAWER - SOLID PANEL - 14.7"W X 9.8"D - W/O SLIDES/HDW - WASHED MAPLE
16	P40787-30-PA0	EA	DRAWER - SOLID PANEL - 14.7"W X 9.8"D - W/O SLIDES/HDW - PORTSMOUTH OAK
16	P40787-30-PA1	EA	DRAWER - SOLID PANEL - 14.7"W X 9.8"D - W/O SLIDES/HDW - CONCERT CHERRY
16	P40787-30-PA2	EA	DRAWER - SOLID PANEL - 14.7"W X 9.8"D - W/O SLIDES/HDW - WASHED MAPLE
17	140594-06-01A	EA	GRILLE - RETURN AIR - 12.3" X 14.9" - BLACK
18	134847-04-PA0	EA	DOOR - LH LOUVERED/ACCESS - 12" X 36" - W/O HARDWARE - PORTSMOUTH OAK FROM: 00-00-00 THRU: 11-24-02
18	134847-12-PA0	EA	DOOR - LH LOUVERED ACCESS - 12.4" X 36" - W/O HARDWARE - PORTSMOUTH OAK FROM: 11-25-02 THRU: 99-99-99
18	134847-04-PA1	EA	DOOR - LH LOUVERED/ACCESS - 12" X 36" - W/O HARDWARE - CONCERT CHERRY FROM: 00-00-00 THRU: 11-24-02
18	134847-12-PA1	EA	DOOR - LH LOUVERED ACCESS - 12.4" X 36" - W/O HARDWARE - CONCERT CHERRY FROM: 11-25-02 THRU: 99-99-99
18	134847-04-PA2	EA	DOOR - LH LOUVERED/ACCESS - 12" X 36" - W/O HARDWARE - WASHED MAPLE FROM: 00-00-00 THRU: 11-24-02
18	134847-12-PA2	EA	DOOR - LH LOUVERED ACCESS - 12.4" X 36" - W/O HARDWARE - WASHED MAPLE FROM: 11-25-02 THRU: 99-99-99
19	134847-06-PA0	EA	DOOR - RH LOUVERED/ACCESS - 12" X 36" - W/O HARDWARE - PORTSMOUTH OAK
19	134847-06-PA1	EA	DOOR - RH LOUVERED/ACCESS - 12" X 36" - W/O HARDWARE - CONCERT CHERRY
19	134847-06-PA2	EA	DOOR - RH LOUVERED/ACCESS - 12" X 36" - W/O HARDWARE - WASHED MAPLE
20	113797-02-01A	EA	STRIP - BLACK PLASTIC W/SELF ADHESIVE-.25" X .75" X 6.45"

**BEDROOM GROUP (CONTINUED)**  
**QUEEN CABINETS (CONTINUED)**

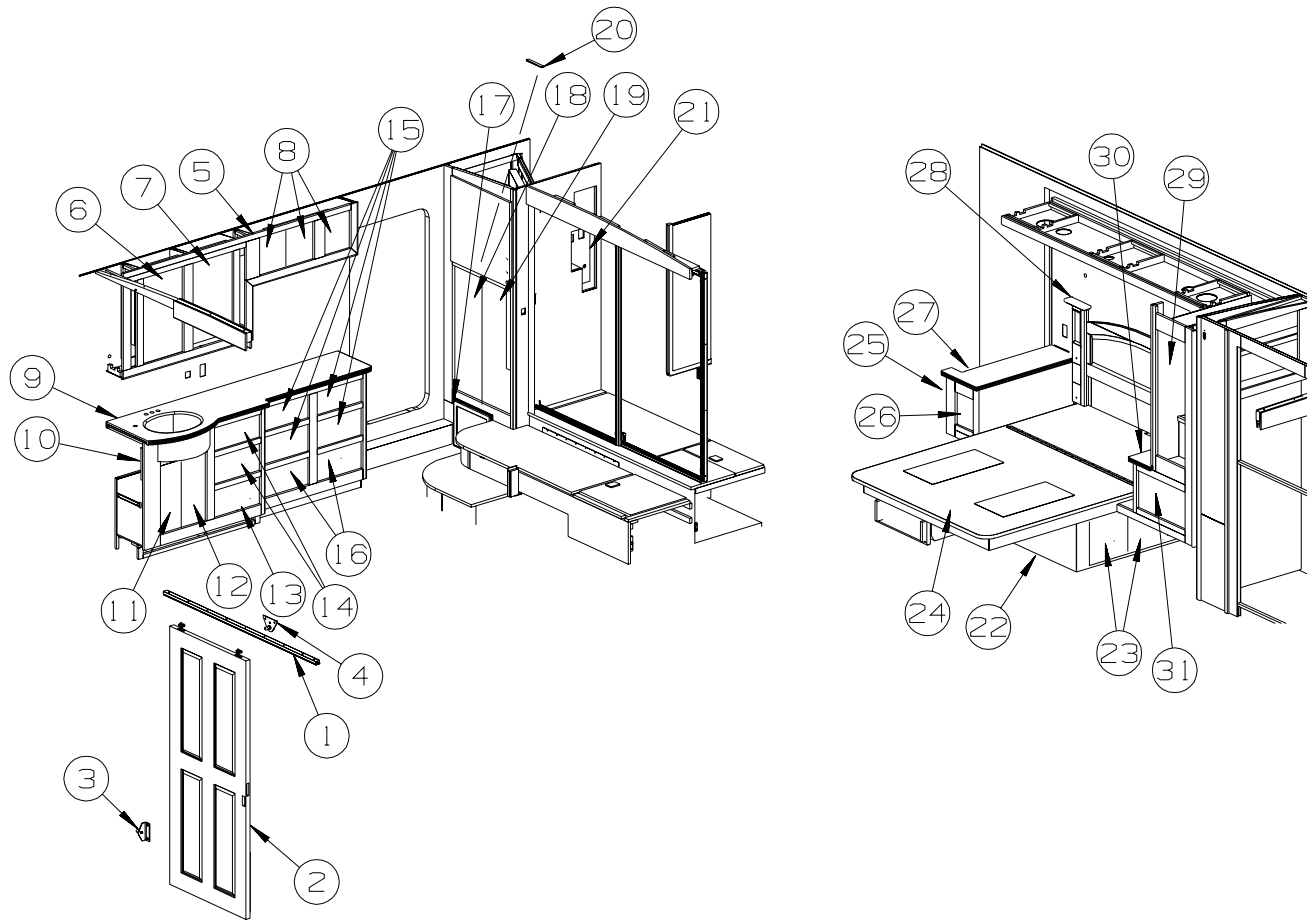

KEY	PART NUMBER	U/M	DESCRIPTION
21	141286-22-PA0	EA	DOOR - DBL ARCH/VERT PENCIL EDGE-10" X 19.1" - W/O HDW - PORTSMOUTH OAK FROM: 00-00-00 THRU: 07-19-02
21	136710-22-PA0	EA	DOOR - RAISED PANEL/PENCIL EDGE - 10" X 19.1" - W/O HDW - PORTSMOUTH OAK FROM: 07-20-02 THRU: 99-99-99
21	141286-22-PA1	EA	DOOR - DBL ARCH/VERT PENCIL EDGE-10" X 19.1" - W/O HDW - CONCERT CHERRY FROM: 00-00-00 THRU: 07-19-02
21	136710-22-PA1	EA	DOOR - RAISED PANEL/PENCIL EDGE - 10" X 19.1" - W/O HDW - CONCERT CHERRY FROM: 07-20-02 THRU: 99-99-99
21	141286-22-PA2	EA	DOOR - DBL ARCH/VERT PENCIL EDGE-10" X 19.1" - W/O HDW - WASHED MAPLE FROM: 00-00-00 THRU: 07-19-02
21	136710-22-PA2	EA	DOOR - RAISED PANEL/PENCIL EDGE - 10" X 19.1" - W/O HDW - WASHED MAPLE FROM: 07-20-02 THRU: 99-99-99
22	141626-01-PC0	EA	CABINET/BASE - QUEEN BED - W/O DOOR/DRAWER/HARDWARE - PORTSMOUTH OAK FROM: 00-00-00 THRU: 11-17-02
22	145094-01-PC0	EA	CABINET/BASE - F/QUEEN BED - W/O DOORS/HARDWARE - PORTSMOUTH OAK FROM: 11-18-02 THRU: 99-99-99
22	141626-01-PC1	EA	CABINET/BASE - QUEEN BED - W/O DOOR/DRAWER/HARDWARE - CONCERT CHERRY FROM: 00-00-00 THRU: 11-17-02
22	145094-01-PC1	EA	CABINET/BASE - F/QUEEN BED - W/O DOORS/HARDWARE - CONCERT CHERRY FROM: 11-18-02 THRU: 99-99-99
22	141626-01-PC2	EA	CABINET/BASE - QUEEN BED - W/O DOOR/DRAWER/HARDWARE - WASHED MAPLE FROM: 00-00-00 THRU: 11-17-02
22	145094-01-PC2	EA	CABINET/BASE - F/QUEEN BED - W/O DOORS/HARDWARE - WASHED MAPLE FROM: 11-18-02 THRU: 99-99-99

**BEDROOM GROUP (CONTINUED)**  
**QUEEN CABINETS (CONTINUED)**

<b>KEY</b>	<b>PART NUMBER</b>	<b>U/M</b>	<b>DESCRIPTION</b>
23	143106-02-PA0	EA	DOOR-DBLE ARCH PANEL/PENCIL EDGE/HDWD-17.7" X12" - W/O HDW - PORTSMOUTH OAK FROM: 00-00-00 THRU: 07-19-02
23	143959-01-PA0	EA	DOOR - RAISED PANEL/PENCIL EDGE-18.7" X 12.8"-W/O HDW - PORTSMOUTH OAK FROM: 07-20-02 THRU: 99-99-99
23	143106-02-PA1	EA	DOOR-DBLE ARCH PANEL/PENCIL EDGE/HDWD-17.7" X12" - W/O HDW - CONCERT CHERRY FROM: 00-00-00 THRU: 07-19-02
23	143959-01-PA1	EA	DOOR - RAISED PANEL/PENCIL EDGE-18.7" X 12.8"-W/O HDW - CONCERT CHERRY FROM: 07-20-02 THRU: 99-99-99
23	143106-02-PA2	EA	DOOR-DBLE ARCH PANEL/PENCIL EDGE/HDWD-17.7" X12" - W/O HDW - WASHED MAPLE FROM: 00-00-00 THRU: 07-19-02
23	143959-01-PA2	EA	DOOR - RAISED PANEL/PENCIL EDGE-18.7" X 12.8"-W/O HDW - WASHED MAPLE FROM: 07-20-02 THRU: 99-99-99
24	137406-04-N52	EA	BEDBOARD - W/HINGE/T-MOLDING/SLIPNOT - FLIP-UP
25	136885-A8-PA0	EA	CABINET - NIGHTSTAND/RH - W/O COUNTERTOP/DOOR/DRAWER/HDW - PORTSMOUTH OAK
25	136885-A8-PA1	EA	CABINET - NIGHTSTAND/RH - W/O COUNTERTOP/DOOR/DRAWER/HDW - CONCERT CHERRY
25	136885-A8-PA2	EA	CABINET - NIGHTSTAND/RH - W/O COUNTERTOP/DOOR/DRAWER/HDW - WASHED MAPLE
26	P40787-26-PA0	EA	DRAWER - SOLID PANEL - 6.8"W X 21.6"D - W/O SLIDES/HDW - PORTSMOUTH OAK
26	P40787-26-PA1	EA	DRAWER - SOLID PANEL - 6.8"W X 21.6"D - W/O SLIDES/HDW - CONCERT CHERRY
26	P40787-26-PA2	EA	DRAWER - SOLID PANEL - 6.8"W X 21.6"D - W/O SLIDES/HDW - WASHED MAPLE
27	133655-80-PA0	EA	COUNTERTOP - LAMINATED (PA0, PA3, PA6)
27	133655-80-PA1	EA	COUNTERTOP - LAMINATED - PLANK CHERRY/CHERRY (PA1, PA4, PA7)
27	133655-80-PA2	EA	COUNTERTOP - LAMINATED - WASHED MAPLE/WASHED MAPLE (PA2, PA5, PA8)
28	140843-01-N95	EA	CABINET/HEADBOARD - W/O HARDWARE - PORTSMOUTH OAK
28	140843-01-N94	EA	CABINET/HEADBOARD - W/O HARDWARE - CONCERT CHERRY
28	140843-01-PC2	EA	CABINET/HEADBOARD - W/O HARDWARE - WASHED MAPLE
29	141286-B5-PA0	EA	DOOR - DBL ARCH/VERT PENCIL EDGE-14.3" X 36.4" - W/O HDW - PORTSMOUTH OAK
29	141286-B5-PA1	EA	DOOR - DBL ARCH/VERT PENCIL EDGE-14.3" X 36.4" - W/O HDW - CONCERT CHERRY
29	141286-B5-PA2	EA	DOOR - DBL ARCH/VERT PENCIL EDGE-14.3" X 36.4" - W/O HDW - WASHED MAPLE
30	133655-79-PA0	EA	COUNTERTOP - LAMINATED (PA0, PA3, PA6)
30	133655-79-PA1	EA	COUNTERTOP - LAMINATED - PLANK CHERRY/CHERRY (PA1, PA4, PA7)
30	133655-79-PA2	EA	COUNTERTOP - LAMINATED - WASHED MAPLE/WASHED MAPLE (PA2, PA5, PA8)
31	P40787-27-PA0	EA	DRAWER - SOLID PANEL - 19.4"W X 21.6"D - W/O SLIDES/HDW - PORTSMOUTH OAK
31	P40787-27-PA1	EA	DRAWER - SOLID PANEL - 19.4"W X 21.6"D - W/O SLIDES/HDW - CONCERT CHERRY
31	P40787-27-PA2	EA	DRAWER - SOLID PANEL - 19.4"W X 21.6"D - W/O SLIDES/HDW - WASHED MAPLE

## BEDROOM GROUP (CONTINUED) QUEEN CABINETS (CONTINUED)

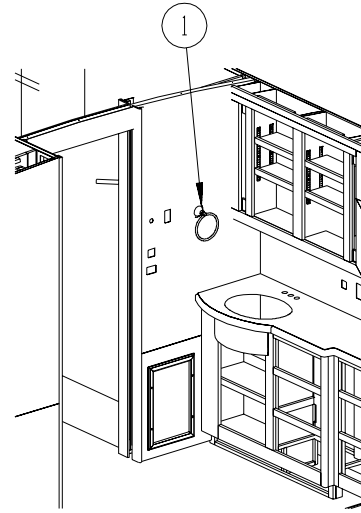
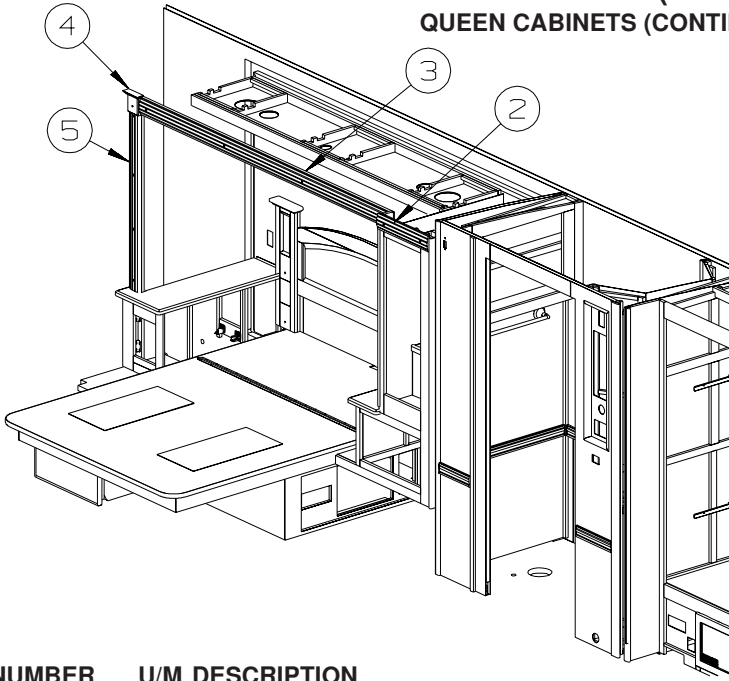

KEY	PART NUMBER	U/M	DESCRIPTION
1	142066-01-01A	EA	TOWEL RING
2	P39129-17-PA0	EA	MOLDING - FLUTED/CURVED - 16.7" - PORTSMOUTH OAK
2	P39129-17-PA1	EA	MOLDING - FLUTED/CURVED - 16.7" - CONCERT CHERRY
2	P39129-17-PA2	EA	MOLDING - FLUTED/CURVED - 16.7" - WASHED MAPLE
3	P39129-16-PA0	EA	MOLDING - FLUTED/CURVED - 81.7" - PORTSMOUTH OAK
			FROM: 00-00-00 THRU: 09-27-02
3	P39129-30-PA0	EA	MOLDING - FLUTED/CURVED - 82" - PORTSMOUTH OAK - PORTSMOUTH OAK
			FROM: 09-28-02 THRU: 99-99-99
3	P39129-16-PA1	EA	MOLDING - FLUTED/CURVED - 81.7" - CONCERT CHERRY
			FROM: 00-00-00 THRU: 09-27-02
3	P39129-30-PA1	EA	MOLDING - FLUTED/CURVED - 82" - CHERRY - CONCERT CHERRY
			FROM: 09-28-02 THRU: 99-99-99
3	P39129-16-PA2	EA	MOLDING - FLUTED/CURVED - 81.7" - WASHED MAPLE
			FROM: 00-00-00 THRU: 09-27-02
3	P39129-30-PA2	EA	MOLDING - FLUTED/CURVED - 82" - WASHED MAPLE - WASHED MAPLE
			FROM: 09-28-02 THRU: 99-99-99
4	141303-03-N53	EA	MOLDING - CROWN/BLOCK - PORTSMOUTH OAK
4	141303-03-N52	EA	MOLDING - CROWN/BLOCK - CONCERT CHERRY
4	141303-03-N62	EA	MOLDING - CROWN/BLOCK - WASHED MAPLE
5	P39129-14-PA0	EA	MOLDING - FLUTED/CURVED - 40.8" - PORTSMOUTH OAK
5	P39129-14-PA1	EA	MOLDING - FLUTED/CURVED - 40.8" - CONCERT CHERRY
5	P39129-14-PA2	EA	MOLDING - FLUTED/CURVED - 40.8" - WASHED MAPLE

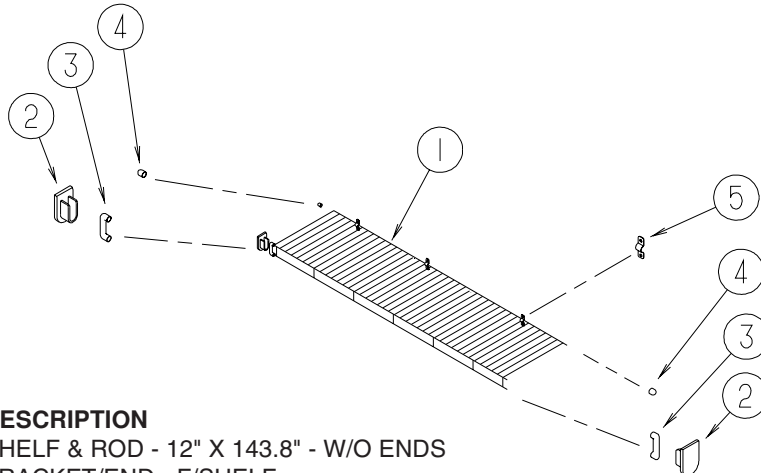

KEY	PART NUMBER	U/M	DESCRIPTION
1	136891-01-01A	EA	SHELF & ROD - 12" X 143.8" - W/O ENDS
2	136891-50-01A	EA	BRACKET/END - F/SHELF
3	136891-51-01A	EA	END CAP - LARGE - F/SHELF
4	136891-52-01A	EA	END CAP - SMALL - F/SHELF
5	136891-53-01A	EA	BRACKET - U/CLAMP MOUNTING - F/SHELF

**BEDROOM GROUP (CONTINUED)**  
**QUEEN CABINETS (CONTINUED)**

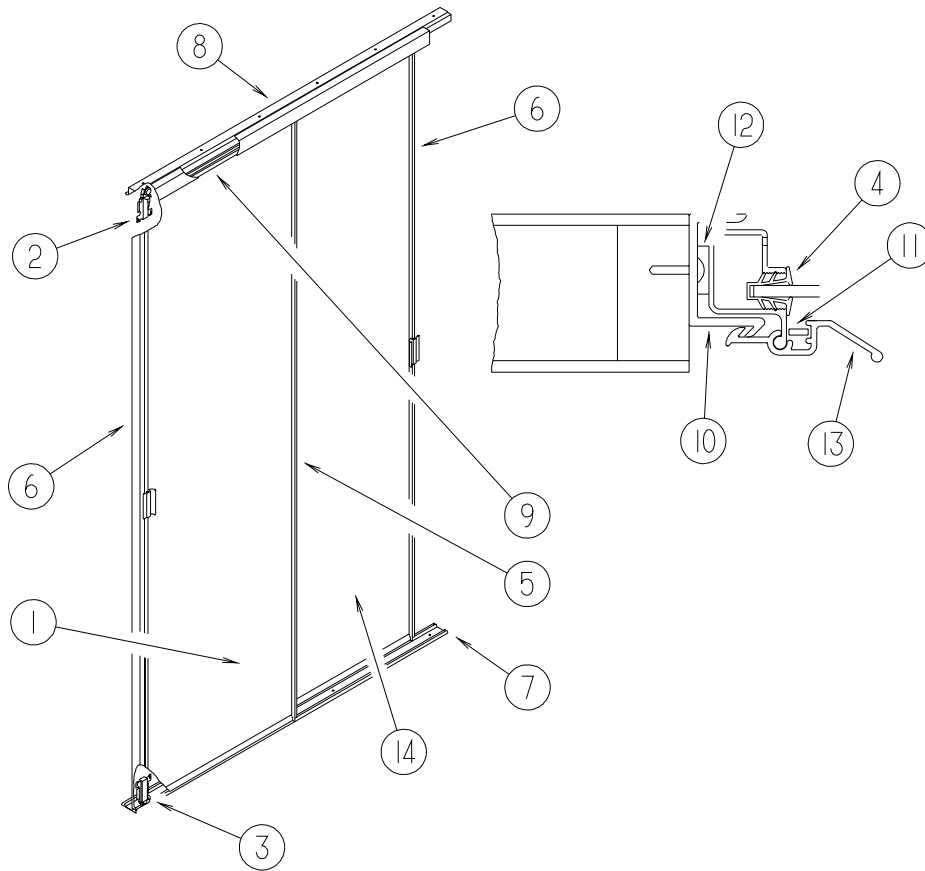

KEY	PART NUMBER	U/M DESCRIPTION
1	136681-21-N84	EA DOOR - MIRRORED/WARDROBE - LH - W/HANGERS/GUIDES/LATCH
	140374-57-000	EA MIRROR - SAFETY GLASS - 34.7" X 57.9"
2	107390-02-000	EA CORNER HANGER (DOUBLE ROLLER W/BACKET) (SOLD AS 1 EACH)
3	107391-01-000	EA GUIDE - BOTTOM - BY-PASS (4 USED PER DOOR)
4	111575-01-01A	FT CHANNEL - GLAZING - SWING DOOR
5	114104-21-01A	EA STILE - DOOR - SLIDING - 57.9" - TERRATONE
6	114104-22-01A	EA STILE - DOOR - SLIDING - 57.9" - TERRATONE
7	114105-18-01A	EA TRACK - SLIDING DOOR - LOWER - 67.2" - TERRATONE
8	114106-18-01A	EA TRACK - SLIDING DOOR - UPPER - 67.2" - TERRATONE
9	114107-03-01A	EA RAIL - DOOR/SLIDING - UPPER/LOWER - 34.1" - TERRATONE
10	115538-10-01A	EA JAMB - DOOR - WARDROBE/MIRRORED - 58.6" - BLACK
11	115541-01-000	EA SPRING - DOOR - SLIDING
12	123655-01-000	FT SEAL - CLOSED CELL/FOAM
13	132038-01-01A	EA LATCH - DOOR/WARDROBE - TERRATONE
14	136680-21-N84	EA DOOR - MIRRORED/WARDROBE - RH - W/HANGERS/GUIDES/LATCH
	140374-57-000	EA MIRROR - SAFETY GLASS - 34.7" X 57.9"

## BEDROOM GROUP (CONTINUED)

### TV & RADIO CABINETS

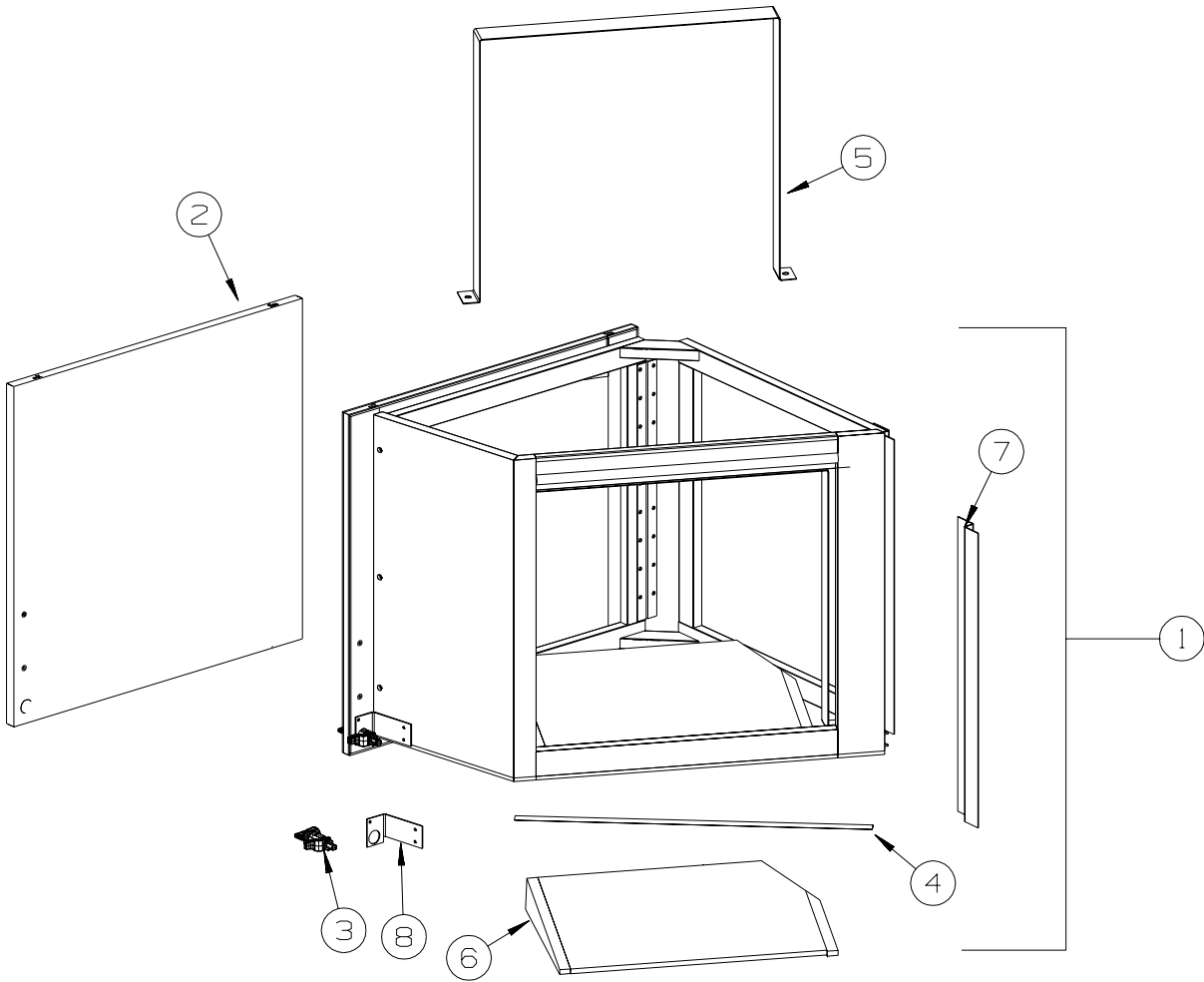

KEY	PART NUMBER	U/M	DESCRIPTION
1	141628-03-P84	EA	CABINET/TV - SWINGOUT - W/O DOORS/HARDWARE - PORTSMOUTH OAK
1	141628-03-P85	EA	CABINET/TV - SWINGOUT - W/O DOORS/HARDWARE - CONCERT CHERRY
1	141628-03-P28	EA	CABINET/TV - SWINGOUT - W/O DOORS/HARDWARE - WASHED MAPLE
2	141628-23-P84	EA	DOOR - 24.3" X 24" - W/LATCH/PULL - PORTSMOUTH OAK
2	141628-23-P85	EA	DOOR - 24.3" X 24" - W/LATCH/PULL - CONCERT CHERRY
2	141628-23-P28	EA	DOOR - 24.3" X 24" - W/LATCH/PULL - WASHED MAPLE
3	135231-01-01A	EA	LATCH - COMPRESSION - BLACK
4	113797-07-01A	EA	STRIP - RECTANGULAR - .2" X 23.4"
5	115466-26-02B	EA	STRAP - TIEDOWN/TV - E-COATED
6	133023-04-P78	EA	WEDGE - TV SHELF - PORTSMOUTH OAK
6	133023-04-P79	EA	WEDGE - TV SHELF - CONCERT CHERRY
6	133023-04-PC2	EA	WEDGE - TV SHELF - WASHED MAPLE
7	116104-08-02B	EA	BRACKET - ZEE W/HOLES - E-COATED
8	144050-01-02B	EA	ANGLE/SUPPORT - TV - E-COATED

FROM: 08-12-02 THRU: 99-99-99

**BEDROOM GROUP (CONTINUED)**  
**TV & RADIO CABINETS (CONTINUED)**

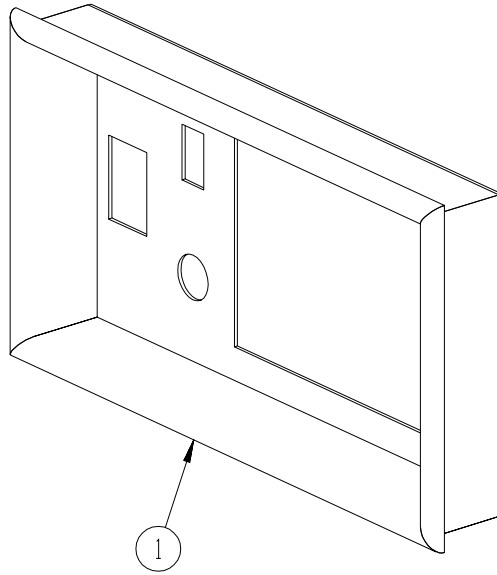

KEY	PART NUMBER	U/M	DESCRIPTION
1	137602-70-PC0	EA	POCKET - RADIO - PORTSMOUTH OAK
1	137602-70-PC1	EA	POCKET - RADIO - CONCERT CHERRY
1	137602-70-PC2	EA	POCKET - RADIO - WASHED MAPLE

## CHASSIS GROUP FRAME

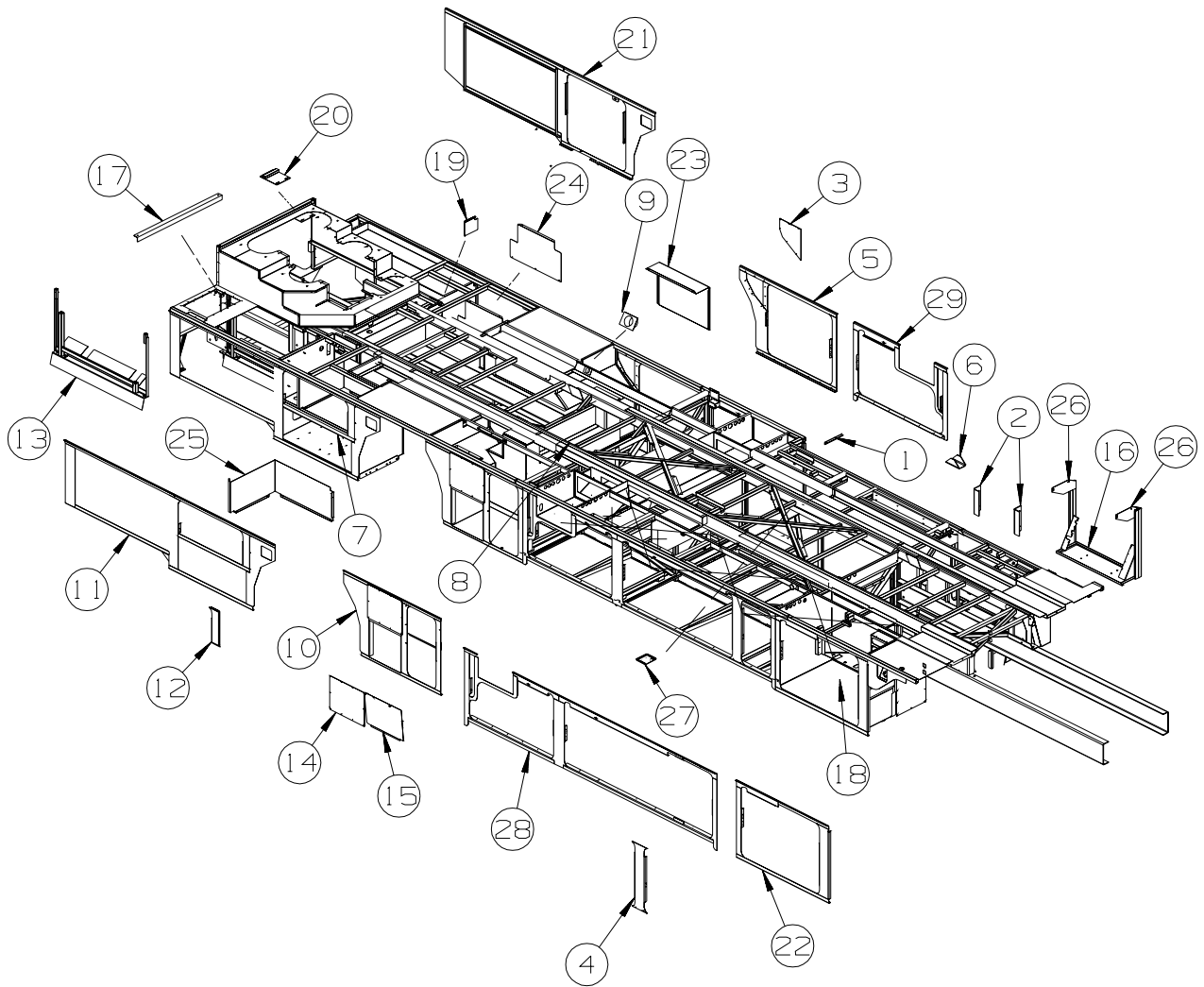

KEY	PART NUMBER	U/M	DESCRIPTION
1	127635-07-02B	EA	ANGLE - FORMED - W/HOLES - E-COATED
2	128087-01-02B	EA	BRACKET - MOUNTING - LP TANK
3	128140-01-02B	EA	SEAL PLANE - E-COATED
4	128140-04-02B	EA	SEAL PLANE - E-COATED
5	129870-01-02B	EA	SEAL PLANE - DRAIN/LEFT HAND - E-COATED
6	135727-01-02B	EA	BRACKET - SPLICE - TUBE - E-COATED
7	137942-01-02B	EA	COMPARTMENT - WATER - E-COATED
8	137944-01-02B	EA	COMPARTMENT - HOLDING TANK - E-COATED
	138238-01-02B	EA	PANEL- COMPARTMENT BOTTOM
9	092776-01-000	EA	ADAPTER - DUCT - 2"
10	138050-01-02B	EA	SEAL PLANE - WATER/RIGHT HAND - E-COATED
11	138051-01-02B	EA	SEAL PLANE - RIGHT HAND/REAR - E-COATED
12	138200-01-02B	EA	PLATE - SEAL - E-COATED
13	138481-01-02B	EA	HANGER - A/C COACH - E-COATED
14	138489-01-02B	EA	PANEL - ACCESS - WATER HEATER - E-COATED
15	138489-02-02B	EA	PANEL/ACCESS - ELECTRICAL - E-COATED
16	139915-03-02B	EA	BRACKET - CONDENSER - E-COATED
17	139946-01-02B	EA	BRACKET - MUDFLAP - E-COATED
18	140192-03-02B	EA	COMPARTMENT - ENTERTAINMENT CTR - E-COATED
			FROM: 00-00-00 THRU: 10-09-02
18	144264-02-02B	EA	COMPARTMENT - ENTERTAINMENT CENTER - E-COATED
			FROM: 10-10-02 THRU: 99-99-99
19	141122-01-02B	EA	PANEL - CLOSEOUT - E-COATED
20	141664-01-02B	EA	BRACKET - AIR FILTER - E-COATED
			FROM: 02-25-02 THRU: 99-99-99



**CHASSIS GROUP (CONTINUED)**  
**FRAME (CONTINUED)**

KEY	PART NUMBER	U/M	DESCRIPTION
21	141282-01-02B	EA	SEAL PLANE - LEFT HAND/REAR - E-COATED
22	141283-01-02B	EA	SEAL PLANE - ENTERTAINMENT CENTER - E-COATED
23	141683-01-02B	EA	PANEL/CLOSEOUT - ELECTRICAL - E-COATED
24	141683-02-02B	EA	PANEL/CLOSEOUT - ELECTRIC - E-COATED
25	141683-04-02B	EA	PANEL/CLOSEOUT - ELECTRICAL - E-COATED
26	141740-01-02B	EA	BRACKET - CONDENSER - FRAME - E-COATED
27	138799-01-02B	EA	SHIM - BODY - E-COATED
			FROM: 00-00-00 THRU: 12-22-02
27	144724-01-02B	EA	BRACKET - SENSOR/LEVELING - E-COATED
			FROM: 12-23-02 THRU: 99-99-99
28	143156-13-02B	EA	SEAL PLANE - E-COATED
29	143156-14-02B	EA	SEAL PLANE - E-COATED

# CHASSIS GROUP (CONTINUED)

## FRONT END

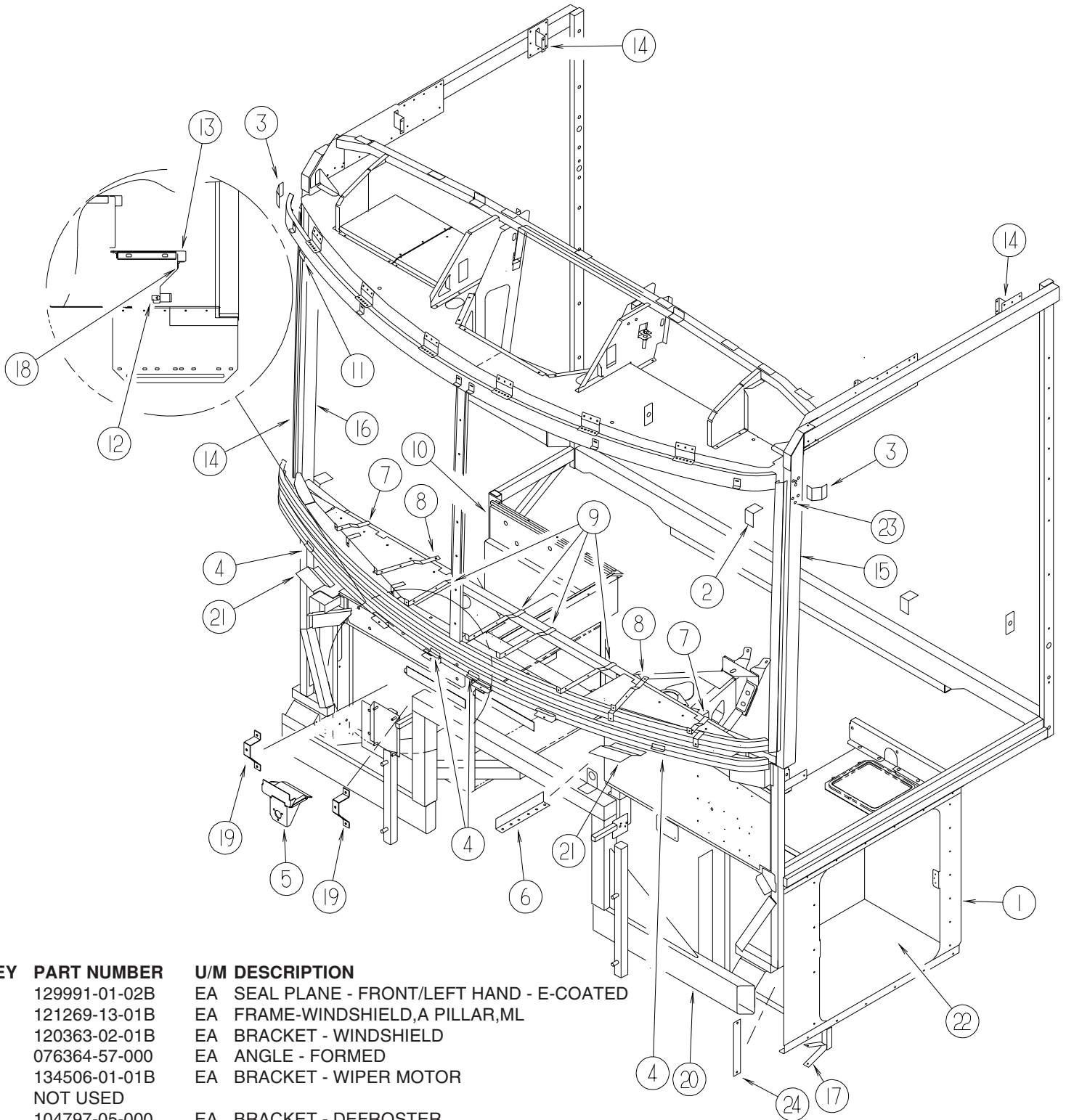

KEY	PART NUMBER	U/M	DESCRIPTION
1	129991-01-02B	EA	SEAL PLANE - FRONT/LEFT HAND - E-COATED
2	121269-13-01B	EA	FRAME-WINDSHIELD,A PILLAR,ML
3	120363-02-01B	EA	BRACKET - WINDSHIELD
4	076364-57-000	EA	ANGLE - FORMED
5	134506-01-01B	EA	BRACKET - WIPER MOTOR
6	NOT USED		
7	104797-05-000	EA	BRACKET - DEFROSTER
8	104797-04-000	EA	BRACKET - DEFROSTER
9	104797-03-000	EA	BRACKET - DEFROSTER
10	132987-04-02B	EA	STEP - ENTRY DOOR - E-COATED
11	120363-01-01B	EA	BRACKET - WINDSHIELD
12	120863-08-000	EA	BUMPER - RUBBER - W/INSERT
13	131519-04-PC0	EA	STEP - FOLD UP - ENTRY DOOR
14	139383-01-02B	EA	PLATE/MOUNT - SIDEWALL - E-COATED
15	129420-01-01B	EA	TUBE-MITERED,A PILLAR,MILL
16	129420-02-01B	EA	TUBE-MITERED,A PILLAR,MILL
17	114761-01-01B	EA	BRACKET-EXHAUST,GENERATOR,ML
18	129753-01-01A	EA	HINGE - SPRING LOADED - 19" X 19" - BLACK

## CHASSIS GROUP (CONTINUED)

### FRONT END (CONTINUED)

KEY	PART NUMBER	U/M	DESCRIPTION
19	110429-06-02B	EA	BRACKET - SQUEEGEE - E-COATED
20	135808-02-02B	EA	SUPPORT - FRONT - E-COATED
21	134202-01-01B	EA	REINFORCEMENT - SUPPORT - LOWER WINDSHIELD/MIDDLE
22	140614-02-02B	EA	COMPARTMENT - LUGGAGE - E-COATED
23	063729-12-000	EA	RIVNUT - 5/16 - 18 UNCUT - FLATHEAD - STAINLESS
24	115023-01-000	EA	ISOLATOR - RUBBER

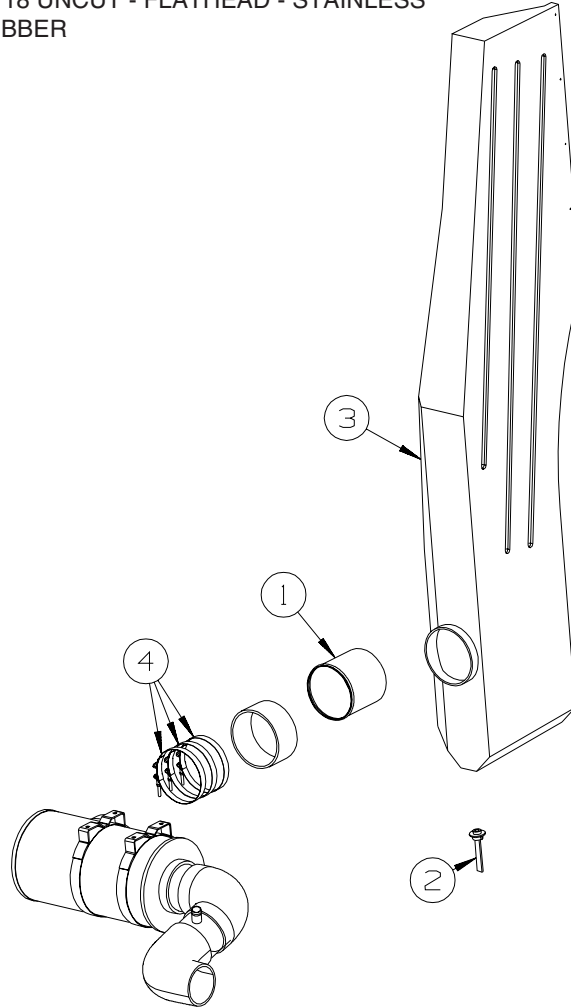

**AIR INTAKE**

KEY	PART NUMBER	U/M	DESCRIPTION
1	124497-02-000	EA	SLEEVE - RUBBER - 6"ID X 3"L
2	130377-01-000	EA	TUBE/DRAIN - KAZOO - 1 1/4" X 4"
	135386-01-000	EA	NIPPLE - 1/2"
3	140408-02-01A	EA	DUCT - AIR INTAKE
4	125083-01-01A	EA	CLAMP - T BOLT - 6"

## CHASSIS GROUP (CONTINUED) INSULATION

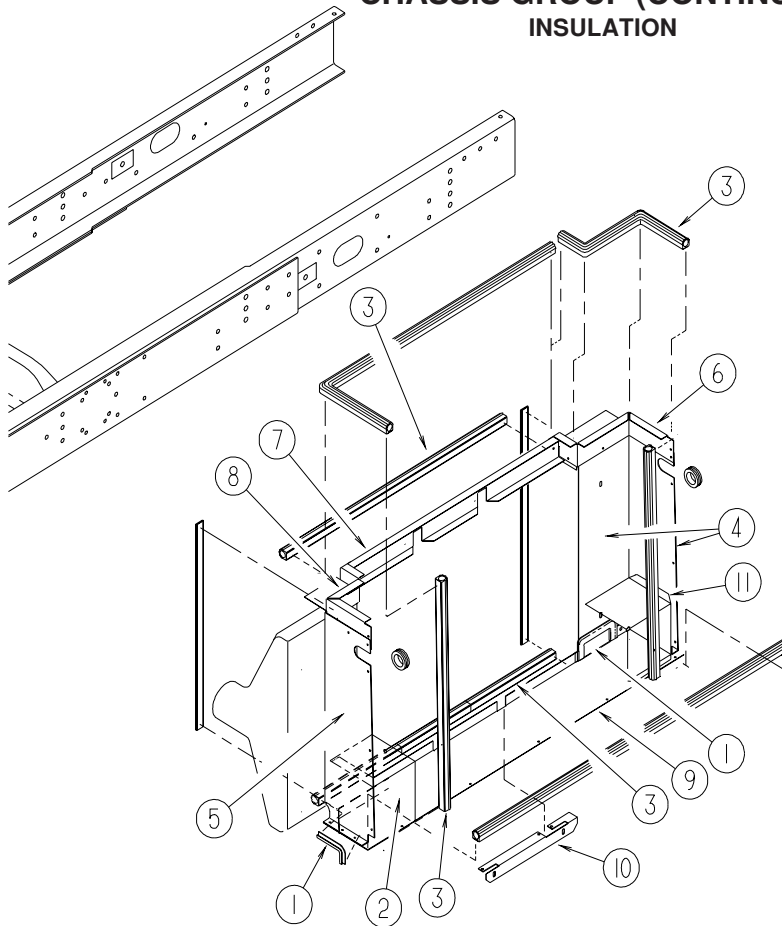

KEY	PART NUMBER	U/M	DESCRIPTION
1	072368-02-000	FT	TRIM - VINYL - EDGE - BLACK
2	140505-01-02B	EA	COVER/HOSE - OIL COOLER - E-COATED
3	107721-07-000	FT	SEAL - ACCESS DOOR - .9" WIDE X 1.1" HIGH
4	131125-03-02B	EA	BAFFLE - RADIATOR - RT - SPT - E-COATED
5	131125-05-02B	EA	BAFFLE - RADIATOR - LT - SPT - E-COATED
6	134558-02-02B	EA	BAFFLE - RADIATOR - E-COATED
7	134558-04-02B	EA	BAFFLE - RADIATOR/SIDE - E-COATED
8	134558-05-02B	EA	BAFFLE - RADIATOR/SIDE - E-COATED
9	134558-06-02B	EA	BAFFLE - RADIATOR/SIDE - E-COATED
10	134598-01-02B	EA	MOUNT - BAFFLE - E-COATED
11	140505-02-02B	EA	COVER/HOSE - OIL COOLER - E - COATED

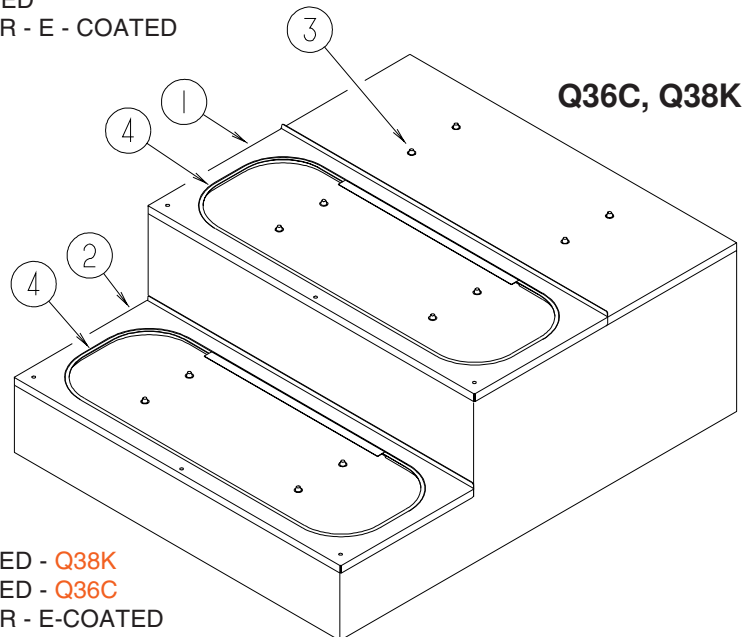

KEY	PART NUMBER	U/M	DESCRIPTION
1	138525-01-02B	EA	COVER - ENGINE - E-COATED - Q38K
1	134340-01-02B	EA	COVER - ENGINE - E-COATED - Q36C
2	140505-01-02B	EA	COVER/HOSE - OIL COOLER - E-COATED
3	106648-01-000	EA	CAP - STUD - .120 TO .130 DIAMETER
4	039623-01-000	EA	SEAL - MOTOR COVER - RUBBER BULB TYPE

**CHASSIS GROUP (CONTINUED)**  
**INSULATION (CONTINUED)**

**Q40E**

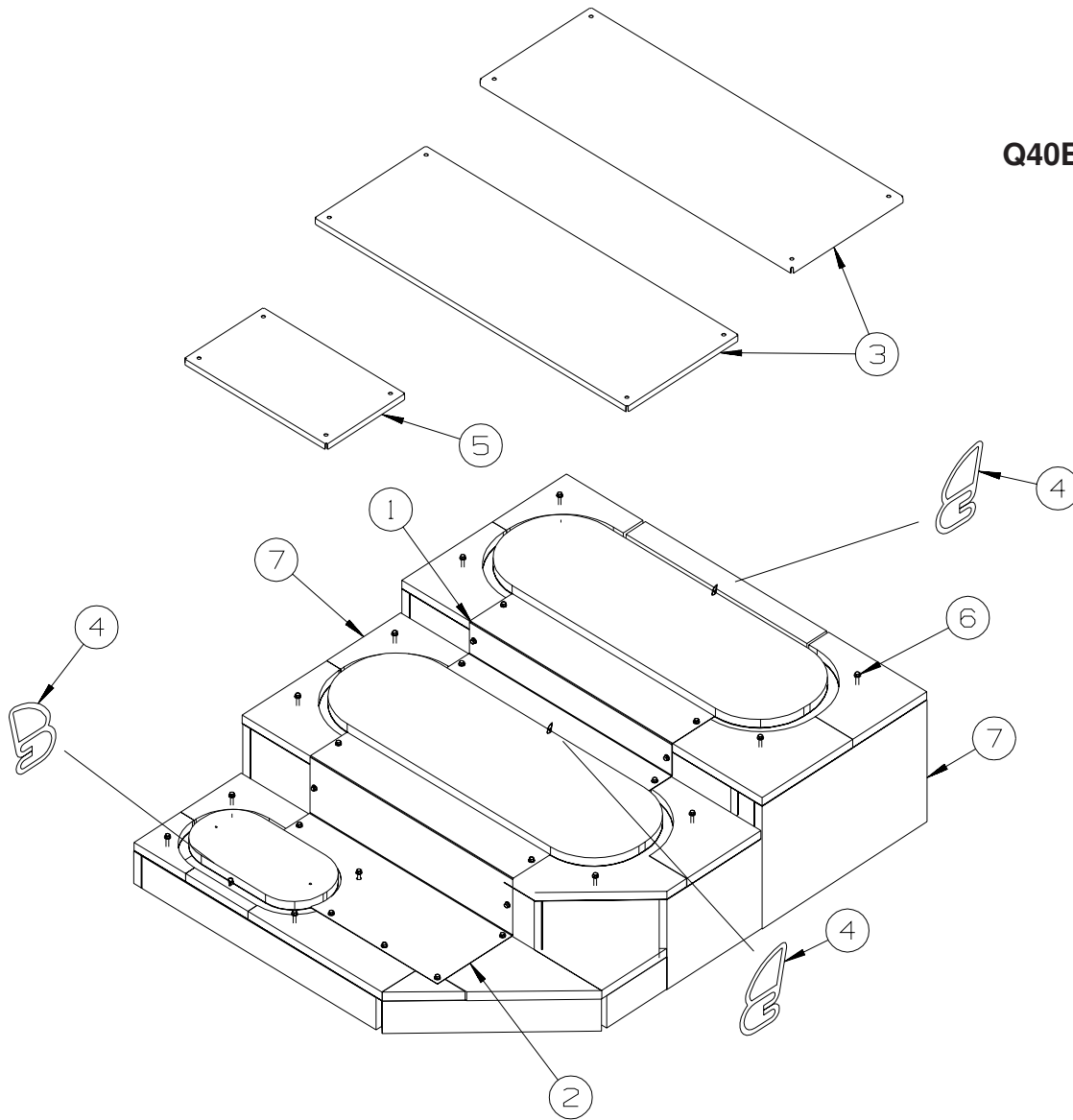

KEY	PART NUMBER	U/M	DESCRIPTION
1	140351-02-02B	EA	PANEL - ACCESS/COMPARTMENT - E-COATED
2	140388-02-02B	EA	PANEL - ACCESS/COMPARTMENT - E-COATED
3	140399-01-02B	EA	COVER - ENGINE - E-COATED
4	039623-01-000	EA	SEAL - MOTOR COVER - RUBBER BULB TYPE
5	140420-01-02B	EA	COVER - ENGINE - E-COATED
6	106648-01-000	EA	CAP - STUD - .120 TO .130 DIAMETER
7	072877-03-000	EA	INSULATION - SOUND BARRIER- 1" X 36" X 57" - ADHESIVE BACK

**CHASSIS GROUP (CONTINUED)**  
**INSULATION (CONTINUED)**

**Q40K**

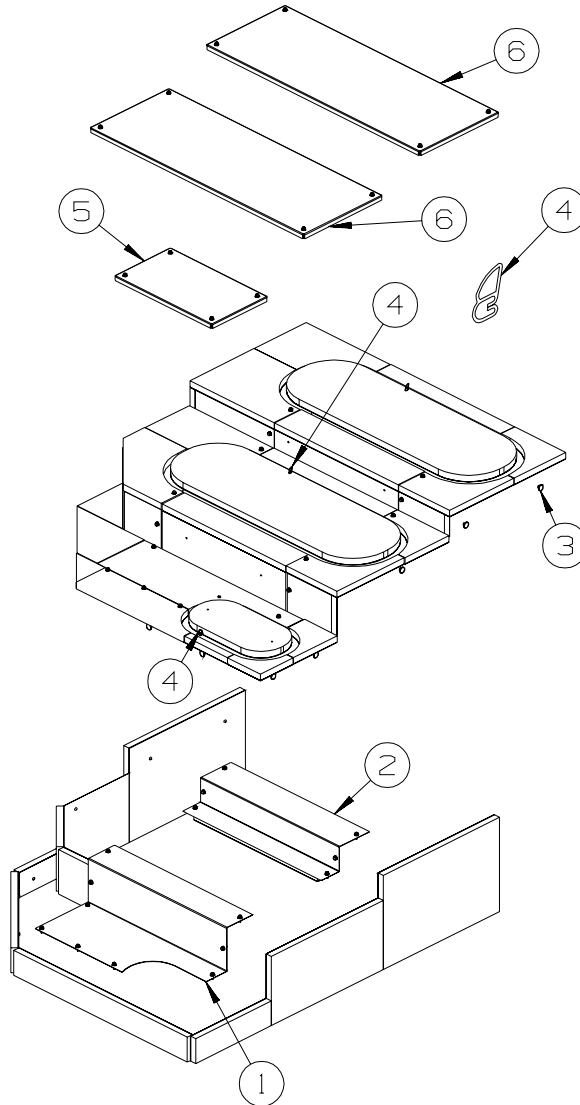

KEY	PART NUMBER	U/M	DESCRIPTION
1	140564-02-02B	EA	PANEL/ACCESS - ENGINE COMPARTMENT - E-COATED
2	140351-02-02B	EA	PANEL - ACCESS/COMPARTMENT - E-COATED
3	106648-01-000	EA	CAP - STUD - .120 TO .130 DIAMETER
4	039623-01-000	EA	SEAL - MOTOR COVER - RUBBER BULB TYPE
5	140420-01-02B	EA	COVER - ENGINE - E-COATED
6	140399-01-02B	EA	COVER - ENGINE - E-COATED
	072877-03-000	EA	INSULATION - SOUND BARRIER- 1" X 36" X 57" - ADHESIVE BACK

**CHASSIS GROUP (CONTINUED)**  
**INSULATION (CONTINUED)**

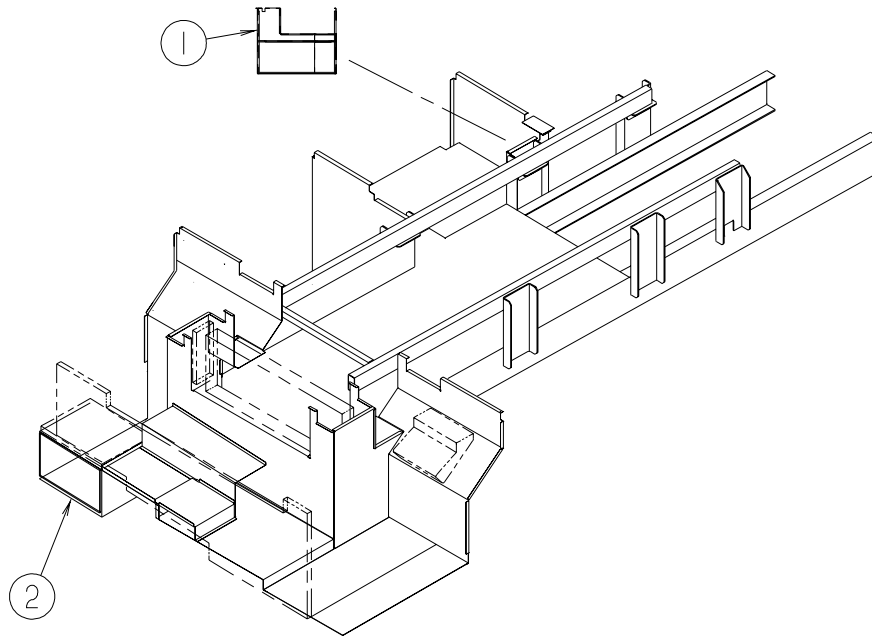

**Q40E, Q40K**

KEY	PART NUMBER	U/M DESCRIPTION
1	105290-01-000	SF INSULATION - AIR POCKET W/FOIL
2	138497-03-N94	EA PANEL - WATER CENTER

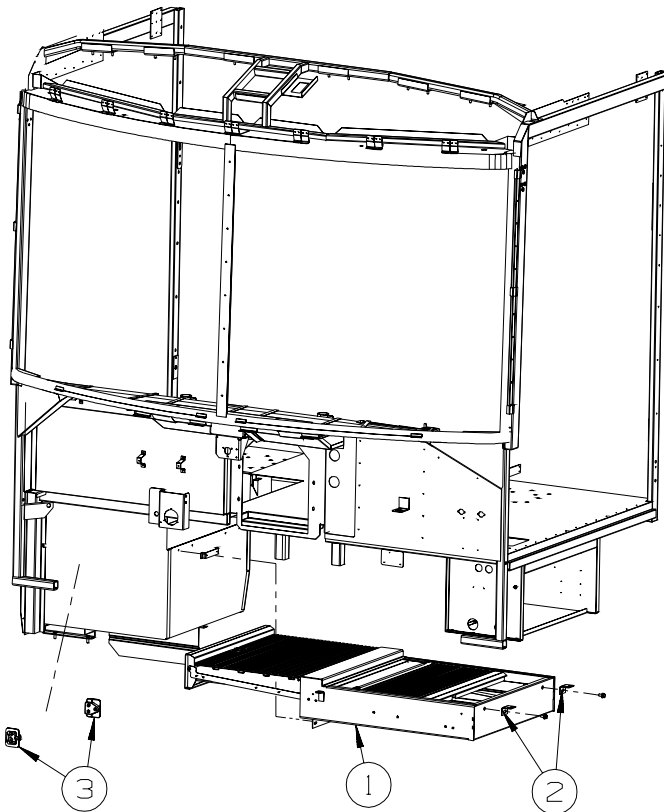

**STEPWELL COVER**

KEY	PART NUMBER	U/M DESCRIPTION
1*	141691-01-01A	EA STEP COVER - SLIDING
2	142274-01-02B	EA BRACKET - STEP COVER - E-COATED
3	142499-01-01A	EA BLOCK/SUPPORT (STEP COVER)

**\*COMPONENT PARTS LISTED LATER IN THIS GROUP**

**CHASSIS GROUP (CONTINUED)**  
**EXHAUST**

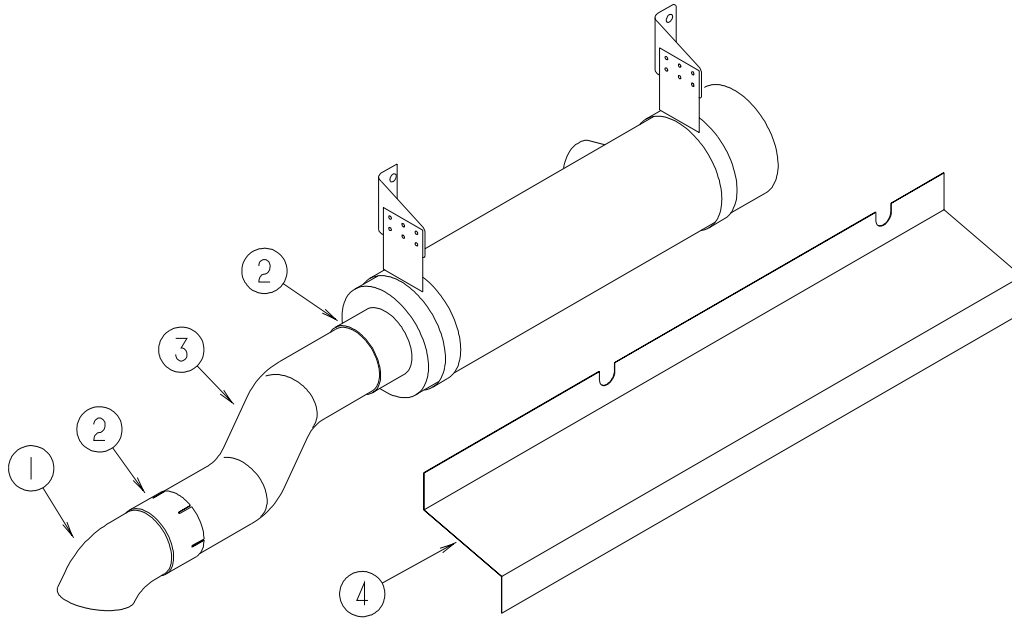

KEY	PART NUMBER	U/M DESCRIPTION
1	116425-02-000	EA EXTENSION - EXHAUST - CHROMED - 5"
2	094918-08-000	EA CLAMP - EXHAUST - 5"
3	114869-11-000	EA PIPE - EXHAUST
4	NOT USED	

**HITCH**

KEY	PART NUMBER	U/M DESCRIPTION
	134016-01-01A	EA HITCH RECEIVER - BOLT ON CLASS III - 10,000#
	133706-02-02B	EA SHIM - HITCH



## CHASSIS GROUP (CONTINUED)

### REAR BUMPER

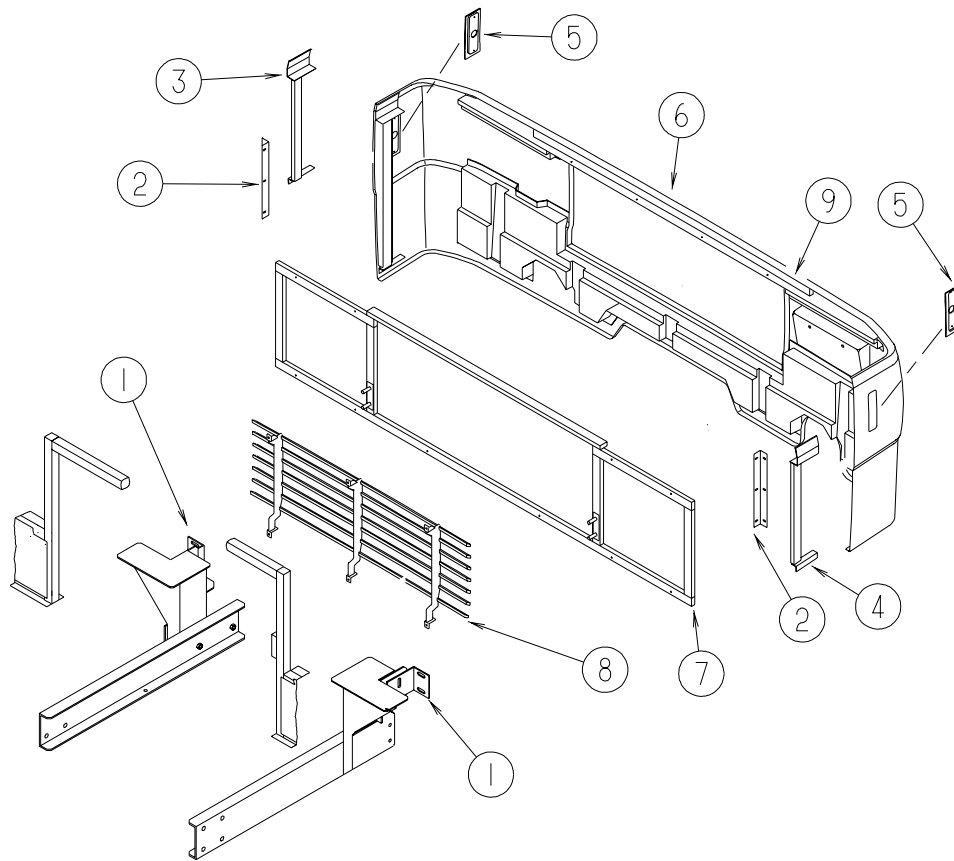

KEY	PART NUMBER	U/M	DESCRIPTION
1	107524-04-000	EA	ANGLE - BUMPER - INNER/RIGHT & LEFT HAND
2	113041-03-02B	EA	ANGLE - BUMPER MOUNT - 14.9"
3	124837-05-01A	EA	SUPPORT - BUMPER - REAR/PASSENGER - BLACK
4	124837-06-01A	EA	SUPPORT - BUMPER - REAR/DRIVER - BLACK
5	118374-01-01A	EA	POCKET - SIDE MARKER LIGHT - BLACK - FLAT WALL
6	P29397-02-KQ0	EA	PANEL - BUMPER/REAR
7	NO LONGER AVAILABLE - CONTACT PART SALES		
8	129377-01-KQ0	EA	GRILLE - BUMPER/REAR
9	124861-01-02A	EA	SUPPORT - BUMPER - REAR/PASSENGER/UPPER - BLACK

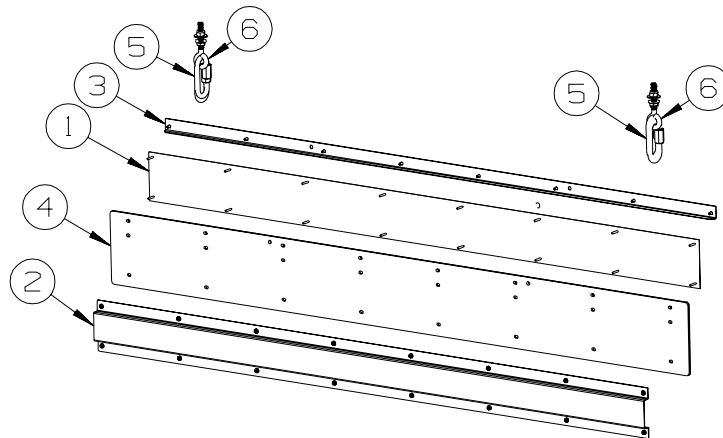

KEY	PART NUMBER	U/M	DESCRIPTION
1	139238-02-01A	EA	PLATE - MUD FLAP - ADVANTAGE LOGO
2	139416-01-02B	EA	STIFFENER - MUDFLAP - E-COATED
3	139417-01-04B	EA	ANGLE - FORMED - MUDFLAP - E-COATED
4	139635-01-01A	EA	MUD FLAP - FULL WIDTH
5	139818-01-01A	EA	LINK - QUICK - STAINLESS STEEL
6	139820-02-01A	EA	BOLT - HANGER EYE - 5/16" - STAINLESS STEEL

## CHASSIS GROUP (CONTINUED)

### FUEL

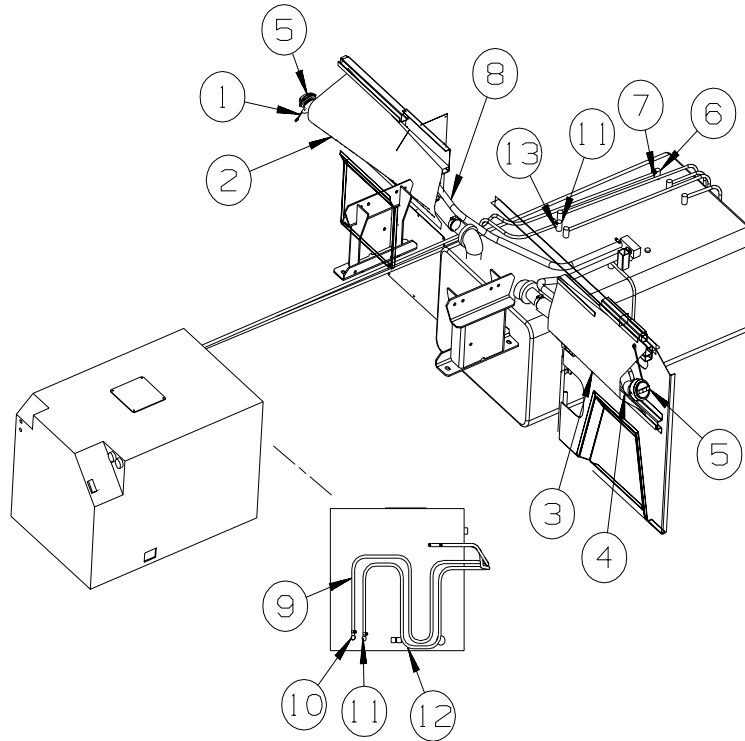

KEY	PART NUMBER	U/M	DESCRIPTION
1	143097-02-000	EA	NECK - FUEL FILL - RIGHT HAND
2	118726-04-000	EA	BAFFLE - FUEL FILL - RIGHT HAND
3	118726-03-000	EA	BAFFLE - FUEL FILL - LEFT HAND
3	118726-06-000	EA	BAFFLE - FUEL FILL - LEFT HAND
			FROM: 00-00-00 THRU: 03-09-03
4	143097-01-000	EA	NECK - FUEL FILL - LEFT HAND
5	073220-04-000	EA	CAP - FUEL FILL - NON LOCKING DIESEL
6	114253-02-000	EA	ELBOW - 5/16 SINGLE BARB X 1/4 MPT
7	068382-01-000	EA	BUSHING - BRASS - 1/2"MPT X 1/4"FPT
8	066732-01-000	FT	HOSE - FUEL - .62"ID
9	024138-01-000	FT	HOSE - FUEL - 5/16" ID
10	114254-02-000	EA	ADAPTER - 5/16 SINGLE BARB X 1/8 MPT
			FROM: 00-00-00 THRU: 08-19-02
10	114253-04-000	EA	ELBOW - 5/16 SINGLE BARB X 1/8 MPT
			FROM: 08-20-02 THRU: 99-99-99
11	114254-01-000	EA	ADAPTER - 1/4 BARB X 1/8 MPT
			FROM: 00-00-00 THRU: 08-19-02
11	114253-01-000	EA	ELBOW - 1/4 SINGLE BARB X 1/8 MPT
			FROM: 08-20-02 THRU: 99-99-99
12	128139-03-000	EA	HOSE - FUEL - LOW PERMEABILITY - 1/4" DIAMETER
13	068382-06-000	EA	BUSHING - BRASS - 3/8"MPT X 1/8"FPT

## CHASSIS GROUP (CONTINUED)

### HYDRAULIC LEVELING

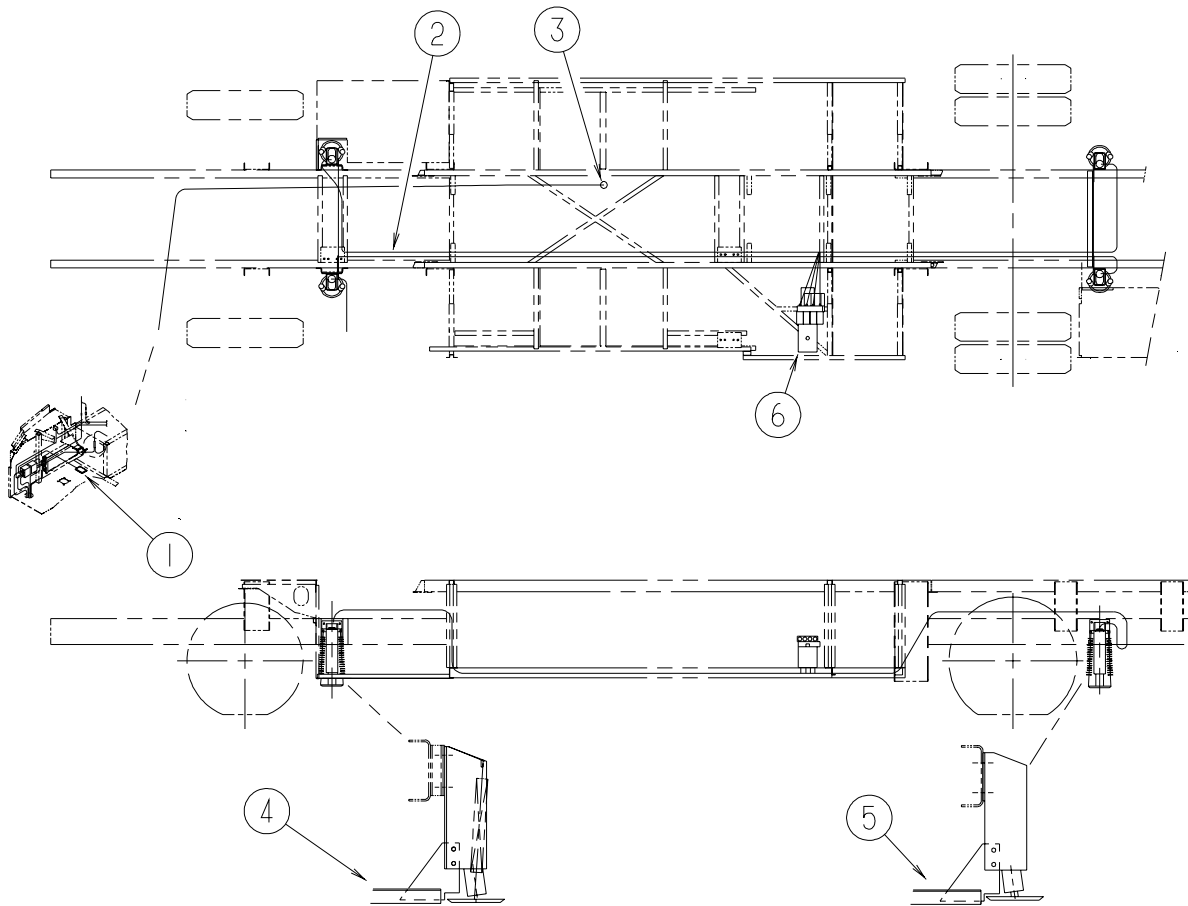

KEY	PART NUMBER	U/M	DESCRIPTION
1*	107889-03-000	EA	PANEL - CONTROL - TOUCH - AIR DUMP
2	100536-53-000	EA	HOSE KIT - LEVELING JACKS
3	117183-01-02B	EA	COVER - SENSOR - LEVELING
4	128411-01-02B	EA	BRACKET - JACK - E-COATED
5	128411-04-02B	EA	BRACKET - JACK - E-COATED
6*	131306-28-000	EA	LEVELING SYSTEM - 610 SYSTEM - F/2 ROOM SLIDE - SPARTAN - Q36C, Q38K
6*	131306-31-000	EA	LEVELING SYSTEM - 610 - 2 SLIDEOUT - Q40E
6	131306-32-000	EA	LEVELING SYSTEM - 610 - 3 SLIDEOUT - Q40K

\*COMPONENT PARTS LISTED LATER IN THIS GROUP

**CHASSIS GROUP (CONTINUED)**  
**COMPONENT PARTS FOR HYDRAULIC LEVELING**

**107889-03-000**

KEY	PART NUMBER	U/M	DESCRIPTION	VENDOR NO.
	100532-09-702	EA	CABLE-MODULAR 5'	RAP1020
	107889-03-700	EA	PANEL-TOUCH	RAP1088

**131306-28-000**

KEY	PART NUMBER	U/M	DESCRIPTION	VENDOR NO.
	100532-01-713	EA	PUMP/MOTOR/TANK - MONARCH	RAP90014/AP2260
	100532-03-715	EA	CAP-BREATHER W/DIPSTICK	RAP7876
	100532-03-716	EA	SOLENOID-CONTINUOUS DUTY	RAP7505
	100532-03-717	EA	VALVE-PRESS., RETURN SHUTTLE	RAP7964
	100532-03-719	EA	TUBE ASM. (SHORT SHUTTLE)	RAP8088
	100532-03-721	EA	VALVE-CHECK KIT (SGL)	RAP7944
	100532-03-722	EA	O-RING KIT-SOLENOID/MANIFOLD	R7430
	100532-03-723	EA	O-RING/SEAL KIT	RAP9171
	100532-03-726	EA	SWITCH - PRESSURE	RAP8003
	100532-09-704	EA	VALVE-PRESS SOLENOID(LARGE)	RAP0642
	100532-09-705	EA	SWITCH-PRESS - 3000 LB.	RAP0993
	100532-09-710	EA	SOLENOID-INTERMITENT DUTY	RAP0533
	100532-12-703	EA	SENSING UNIT BI-AXIS-27'	RAP6800
	100532-12-706	EA	SWITCH - WARNING/MAGNETIC	RAP1008
	100532-12-707	EA	SPRING KIT (PAIR)	R3847
	100532-25-702	EA	CYLINDER ONLY (12,000# JACK)	RAP9517
	100532-31-701	EA	CHECK VALVE & KIT	RAP10021
	100532-31-702	EA	O-RING/SEAL KIT - MANIFOLD	RAP90127
	100532-34-700	EA	CONTROL BOX - 610 W/AIR DMP	RAP90304/AP12209
	107889-03-700	EA	PANEL-TOUCH	RAP1088/AP1088
	131306-02-701	EA	FOOT - 9K JACK	RAP8464/AP17525
	131306-09-700	EA	VELOCITY VALVE ASM.W/4 VALVE	RAP90280
	131306-09-701	EA	VELOCITY VALVE - SINGLE	RAP90279/AP11578
	131306-12-702	EA	VALVE-PRESS SOLENOID (SMALL)	RAP90729/AP24604
	131306-26-700	EA	MANIFOLD ASM. - 2 ROOM	RAP90870/AP20550
	131306-27-700	EA	JACK - 12K STRAIGHT ACTING	RAP90780/AP18310
	131306-27-701	EA	CABLE ASM. - F/610 CONTROL	RAP90527/AP11224

**131306-31-000**

KEY	PART NUMBER	U/M	DESCRIPTION	VENDOR NO.
	100532-01-713	EA	PUMP/MOTOR/TANK - MONARCH	RAP90014/AP2260
	100532-03-715	EA	CAP-BREATHER W/DIPSTICK	RAP7876
	100532-03-716	EA	SOLENOID-CONTINUOUS DUTY	RAP7505
	100532-03-717	EA	VALVE-PRESS., RETURN SHUTTLE	RAP7964
	100532-03-719	EA	TUBE ASM. (SHORT SHUTTLE)	RAP8088
	100532-03-721	EA	VALVE-CHECK KIT (SGL)	RAP7944
	100532-03-722	EA	O-RING KIT-SOLENOID/MANIFOLD	R7430
	100532-03-723	EA	O-RING/SEAL KIT	RAP9171
	100532-03-726	EA	SWITCH - PRESSURE	RAP8003
	100532-09-704	EA	VALVE-PRESS SOLENOID(LARGE)	RAP0642
	100532-09-705	EA	SWITCH-PRESS - 3000 LB.	RAP0993
	100532-09-710	EA	SOLENOID-INTERMITENT DUTY	RAP0533
	100532-12-703	EA	SENSING UNIT BI-AXIS-27'	RAP6800
	100532-12-706	EA	SWITCH - WARNING/MAGNETIC	RAP1008
	100532-12-707	EA	SPRING KIT (PAIR)	R3847
	100532-25-702	EA	CYLINDER ONLY (12,000# JACK)	RAP9517
	100532-31-701	EA	CHECK VALVE & KIT	RAP10021
	100532-31-702	EA	O-RING/SEAL KIT - MANIFOLD	RAP90127
	100532-34-700	EA	CONTROL BOX - 610 W/AIR DMP	RAP90304/AP12209
	131306-02-701	EA	FOOT - 9K JACK	RAP8464/AP17525
	131306-09-701	EA	VELOCITY VALVE - SINGLE	RAP90279/AP11578
	131306-12-702	EA	VALVE-PRESS SOLENOID (SMALL)	RAP90729/AP24604
	131306-26-700	EA	MANIFOLD ASM. - 2 ROOM	RAP90870/AP20550
	131306-27-700	EA	JACK - 12K STRAIGHT ACTING	RAP90780/AP18310
	131306-27-701	EA	CABLE ASM. - F/610 CONTROL	RAP90527/AP11224

## CHASSIS GROUP (CONTINUED)

### WHEEL, TIRE, COVERS &/OR LINERS

KEY	PART NUMBER	U/M	DESCRIPTION
	129058-10-000	EA	COVER - NUT - 1.9"H X 2"BASE X 1.4" NUT
	129058-11-000	EA	COVER - NUT - 2.24"H X 2" BASE X 1.4" NUT (REAR WHEELS) FROM: 00-00-00 THRU: 02-19-02
	129058-14-000	EA	COVER - FRONT AXLE - 10 BOLT FRONT - W/LOGO FROM: 02-20-02 THRU: 99-99-99
	129058-15-000	EA	COVER - REAR AXLE - 10 BOLT REAR - W/LOGO FROM: 02-20-02 THRU: 99-99-99
	129058-16-000	EA	CAP - REAR - THREADED - W/LOGO FROM: 02-20-02 THRU: 99-99-99
	129058-17-000	EA	BRACKET - REAR - THREADED FROM: 02-20-02 THRU: 99-99-99
	133429-01-000	EA	WHEEL - ALUMINUM - 22.5" X 8.25" - POLISHED/OUTSIDE
	133429-02-000	EA	WHEEL - ALUMINUM - 22.5" X 8.25" - POLISHED/INSIDE
	077030-02-000	EA	EXTENSION - VALVE STEM - 1.25"
	080208-04-000	EA	LUG WRENCH - 1 3/16" - OSHKOSH/SPARTAN
	080208-05-000	EA	BAR - LEVERAGE - LUG WRENCH - .75"DIA. - OSHKOSH/SPARTAN

## CURTAIN & CUSHION GROUP

### NOTICE

IN ORDER TO ASSIST OUR PARTS SALES DEPT. IN PROVIDING INTERIOR SOFTWARE ITEMS, PLEASE INCLUDE THE SERIAL NUMBER AND THE COLOR CODE NUMBER FROM THE VEHICLE CERTIFICATION LABEL WHEN ORDERING. THIS LABEL IS LOCATED ON THE LEFT SIDEWALL AT THE END OF THE DASH (A-BODY), OR ON THE DRIVER'S DOOR LATCH PLATE (C-BODY).

AN EXAMPLE OF A COLOR CODE NUMBER IS B07, WHICH DESIGNATES AN OVERALL COLOR SCHEME OF A PARTICULAR UNIT. THE COLOR LISTED AFTER THE ITEM DESCRIPTION ON THE MICROFICHE, INDICATES THE OVERALL UNIT COLOR. ORDER THE ITEM YOU DESIRE ACCORDING TO UNIT COLOR CODE. IF ALL COLORS USE THE SAME ITEM NO COLOR CODE WILL BE NOTED.

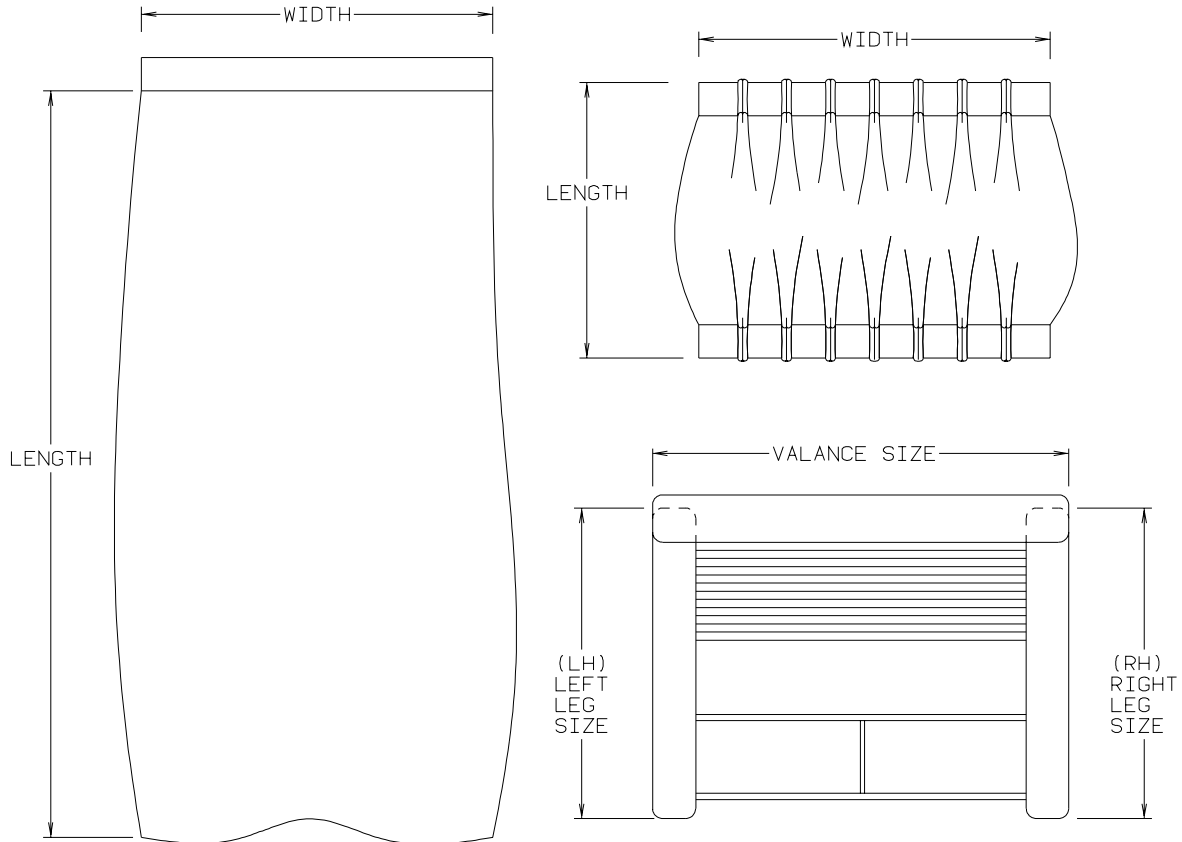

NOTE: USE THIS ILLUSTRATION WHEN DETERMINING LENGTH AND WIDTH MEASUREMENTS FOR CURTAINS. YOU WILL NOTE THE WIDTH MEASUREMENT IS TAKEN ON THE TOP OF THE CURTAIN WITH THE CURTAIN FULLY EXTENDED. THE LENGTH MEASUREMENT IS TAKEN FROM TOP TO BOTTOM. LEFT AND RIGHT WINDOW LEGS ARE DETERMINED WHEN FACING THE WINDOW.

**CURTAIN & CUSHION GROUP (CONTINUED)**  
**CUSHION LAYOUT**

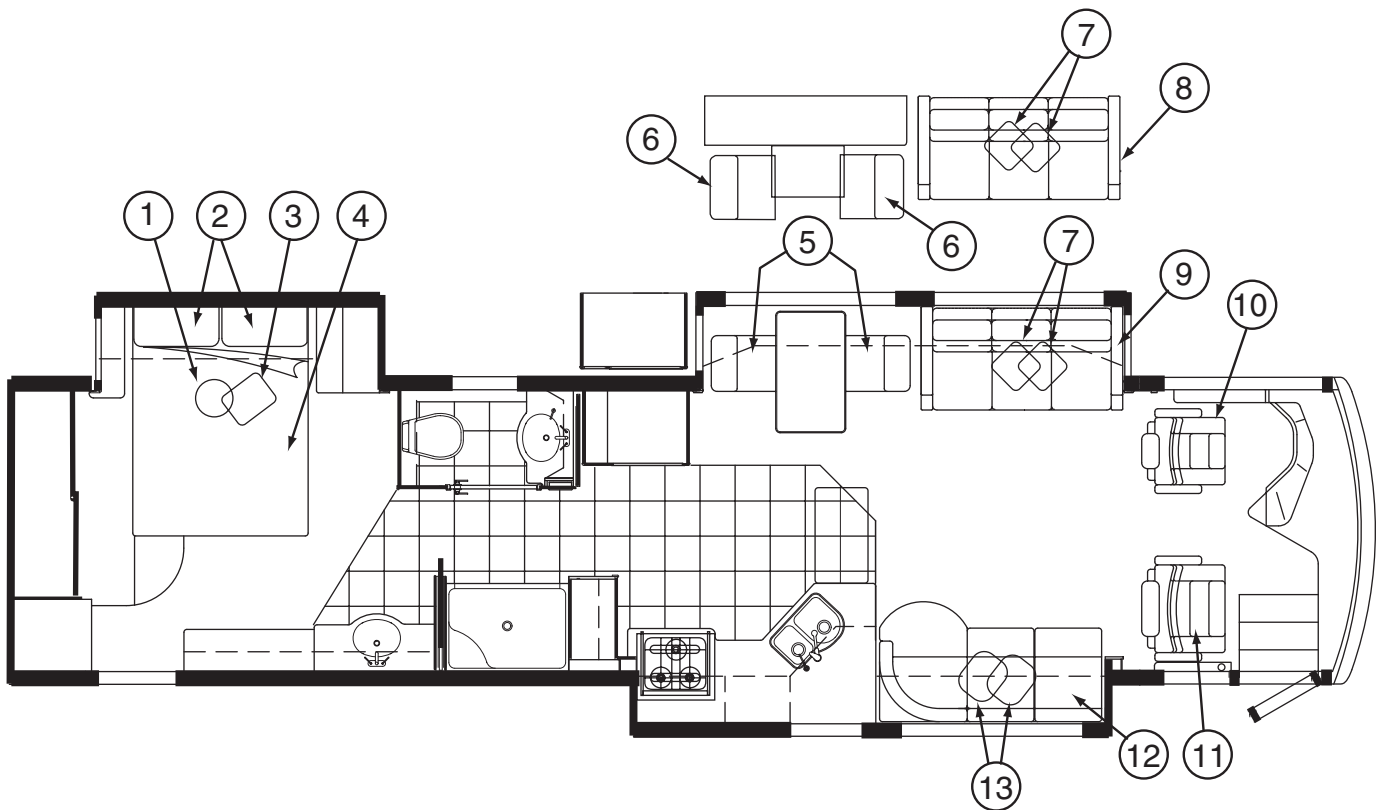

KEY	PART NUMBER	U/M DESCRIPTION
1	139766-01-PA0	EA PILLOW - 16" - ROUND (PA0, PA1, PA2)
1	139766-01-N96	EA PILLOW - 16" - ROUND (PA3, PA4, PA5)
1	139766-03-PA6	EA PILLOW - 16" - ROUND (PA6, PA7, PA8)
2	126211-06-PA0	EA PILLOW SHAM - 20" X 33" (PA0, PA1, PA2)
2	126211-06-PA3	EA PILLOW SHAM - 20" X 33" (PA3, PA4, PA5)
2	126211-06-PA6	EA PILLOW SHAM - 20" X 33" (PA6, PA7, PA8)
2	119249-01-000	EA PILLOW CASE - 20" X 33" - QUEEN
3	139679-05-PA0	EA PILLOW - 15" X 15" (PA0, PA1, PA2)
3	139679-05-N96	EA PILLOW - 15" X 15" (PA3, PA4, PA5)
3	139679-08-PA6	EA PILLOW - 15" X 15" - W/BOXING (PA6, PA7, PA8)
4	143141-03-PA0	EA BEDSPREAD - 60" X 80" (PA0, PA1, PA2)
4	143141-04-PA3	EA BEDSPREAD - 60" X 80" (PA3, PA4, PA5)
4	143141-04-PA6	EA BEDSPREAD - 60" X 80" (PA6, PA7, PA8)
4	142411-02-000	EA MATTRESS/AIR - 60" X 80" - SELECT COMFORT
4	142411-03-000	EA AIR PUMP W/CONTROLS - F/SELECT COMFORT MATTRESS
5	139218-07-000	EA CHAIR - DINETTE - PORTSMOUTH OAK (PA0)
5	139218-08-000	EA CHAIR - DINETTE - CHERRY (PA1)
5	139218-09-000	EA CHAIR - DINETTE - WASHED MAPLE (PA2)
5	139218-04-000	EA CHAIR - DINETTE - PORTSMOUTH OAK (PA3)
5	139218-03-000	EA CHAIR - DINETTE - CHERRY (PA4)
5	139218-10-000	EA CHAIR - DINETTE - WASHED MAPLE (PA5)
5	139218-11-000	EA CHAIR - DINETTE - PORTSMOUTH OAK (PA6)
5	139218-12-000	EA CHAIR - DINETTE - CHERRY (PA7)
5	139218-13-000	EA CHAIR - DINETTE - WASHED MAPLE (PA8)
5	135600-E0-000	EA CHAIR - FOLDING - PORTSMOUTH OAK (PA0)
5	135600-E1-000	EA CHAIR - FOLDING - CHERRY (PA1)
5	135600-E2-000	EA CHAIR - FOLDING - WASHED MAPLE (PA2)
5	135600-61-000	EA CHAIR - FOLDING - PORTSMOUTH OAK (PA3)
5	135600-60-000	EA CHAIR - FOLDING - CHERRY (PA4)
5	135600-E3-000	EA CHAIR - FOLDING - WASHED MAPLE (PA5)
5	135600-E4-000	EA CHAIR - FOLDING - PORTSMOUTH OAK (PA6)
5	135600-E5-000	EA CHAIR - FOLDING - CHERRY (PA7)
5	135600-E6-000	EA CHAIR - FOLDING - WASHED MAPLE (PA8)
5	105402-04-000	EA STRAP - DINING CHAIR/TIEDOWN - 35"

**CURTAIN & CUSHION GROUP (CONTINUED)**  
**CUSHION LAYOUT (CONTINUED)**

<b>KEY</b>	<b>PART NUMBER</b>	<b>U/M</b>	<b>DESCRIPTION</b>
6	141091-58-000	EA	CHAIR - COMPUTER - PORTSMOUTH OAK (PA0)
6	141091-59-000	EA	CHAIR - COMPUTER - CONCERT CHERRY (PA1)
6	141091-60-000	EA	CHAIR - COMPUTER - WASHED MAPLE (PA2)
6	141091-16-000	EA	CHAIR - COMPUTER - PORTSMOUTH OAK (PA3)
6	141091-15-000	EA	CHAIR - COMPUTER - CONCERT CHERRY (PA4)
6	141091-61-000	EA	CHAIR - COMPUTER - WASHED MAPLE (PA5)
6	141091-62-000	EA	CHAIR - COMPUTER - PORTSMOUTH OAK (PA6)
6	141091-63-000	EA	CHAIR - COMPUTER - CONCERT CHERRY (PA7)
6	141091-64-000	EA	CHAIR - COMPUTER - WASHED MAPLE (PA8)
6	135600-E1-000	EA	CHAIR - FOLDING - CHERRY (PA1)
6	135600-E2-000	EA	CHAIR - FOLDING - WASHED MAPLE (PA2)
6	135600-61-000	EA	CHAIR - FOLDING - PORTSMOUTH OAK (PA3)
6	135600-60-000	EA	CHAIR - FOLDING - CHERRY (PA4)
6	135600-E3-000	EA	CHAIR - FOLDING - WASHED MAPLE (PA5)
6	135600-E4-000	EA	CHAIR - FOLDING - PORTSMOUTH OAK (PA6)
6	135600-E5-000	EA	CHAIR - FOLDING - CHERRY (PA7)
6	135600-E6-000	EA	CHAIR - FOLDING - WASHED MAPLE (PA8)
6	105402-04-000	EA	STRAP - DINING CHAIR/TIEDOWN - 35"
7	139680-03-PA0	EA	PILLOW - 13" X 20" - W/BOXING & OVERLAY (PA0, PA1, PA2)
7	139680-03-N96	EA	PILLOW - 13" X 20" - W/BOXING & OVERLAY (PA3, PA4, PA5)
7	139680-03-PA6	EA	PILLOW - 13" X 20" - W/BOXING & OVERLAY (PA6, PA7, PA8)
8	143802-04-000	EA	SOFA/FINLEY - ELECTRIC - 69" - <b>LEATHER RESTEASY</b>
9	143802-01-000	EA	SOFA/FINLEY - ELECTRIC - 69" (PA0, PA1, PA2)
9	143802-02-000	EA	SOFA/FINLEY - ELECTRIC - 69" (PA3, PA4, PA5)
9	143802-03-000	EA	SOFA/FINLEY - ELECTRIC - 69" (PA6, PA7, PA8)
10	139205-01-000	EA	BUCKET - FINLEY - PILOT - 6 WAY POWER - GLACIER LEATHER
11	139205-03-000	EA	BUCKET - FINLEY - PASS - 6 WAY POWER - GLACIER LEATHER
12	143801-02-000	EA	SOFA/LOVE SEAT - W/HEAT EXCHANGE - 74" (PA0, PA1, PA2)
12	143801-03-000	EA	SOFA/LOVE SEAT - W/HEAT EXCHANGE - 74" (PA3, PA4, PA5)
12	143801-04-000	EA	SOFA/LOVE SEAT - W/HEAT EXCHANGE - 74" (PA6, PA7, PA8)
12	143801-01-000	EA	SOFA/LOVE SEAT - W/HEAT EXCHANGE - 74" - <b>LEATHER LOVE SEAT</b>
13	139679-03-PA0	EA	PILLOW - 15" X 15" - W/BOXING & OVERLAY (PA0, PA1, PA2)
13	139679-03-N96	EA	PILLOW - 15" X 15" - W/BOXING & OVERLAY (PA3, PA4, PA5)
13	139679-03-PA6	EA	PILLOW - 15" X 15" - W/BOXING & OVERLAY (PA6, PA7, PA8)



**CURTAIN & CUSHION GROUP (CONTINUED)**  
**BUCKET SEATS**

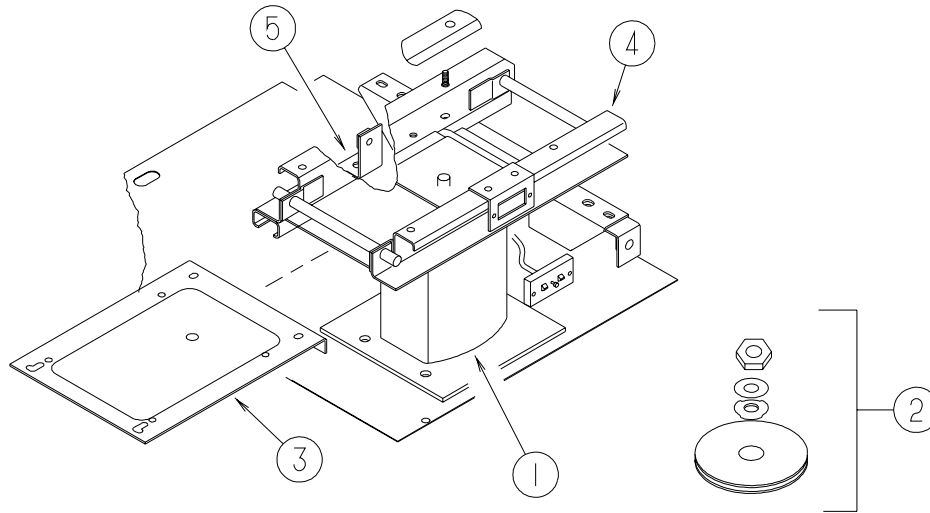

KEY	PART NUMBER	U/M	DESCRIPTION
	139205-01-000	EA	BUCKET - FINLEY - PILOT - 6 WAY POWER - GLACIER LEATHER
	139205-03-000	EA	BUCKET - FINLEY - PASS - 6 WAY POWER - GLACIER LEATHER
1	139167-03-000	EA	PEDESTAL - DRIVER/PASSENGER - VILLA
2	139167-01-000	EA	BEARING KIT - SWIVEL - VILLAE BELT
3	139167-02-000	EA	TOP PLATE - VILLA
4*	NOT USED		
5	139167-05-000	EA	SEAT BELT FLOOR BRACKET - VILLA

**\*COMPONENT PARTS LISTED LATER IN THIS GROUP**

**CURTAIN & CUSHION GROUP (CONTINUED)**  
**WINDOW TREATMENT**

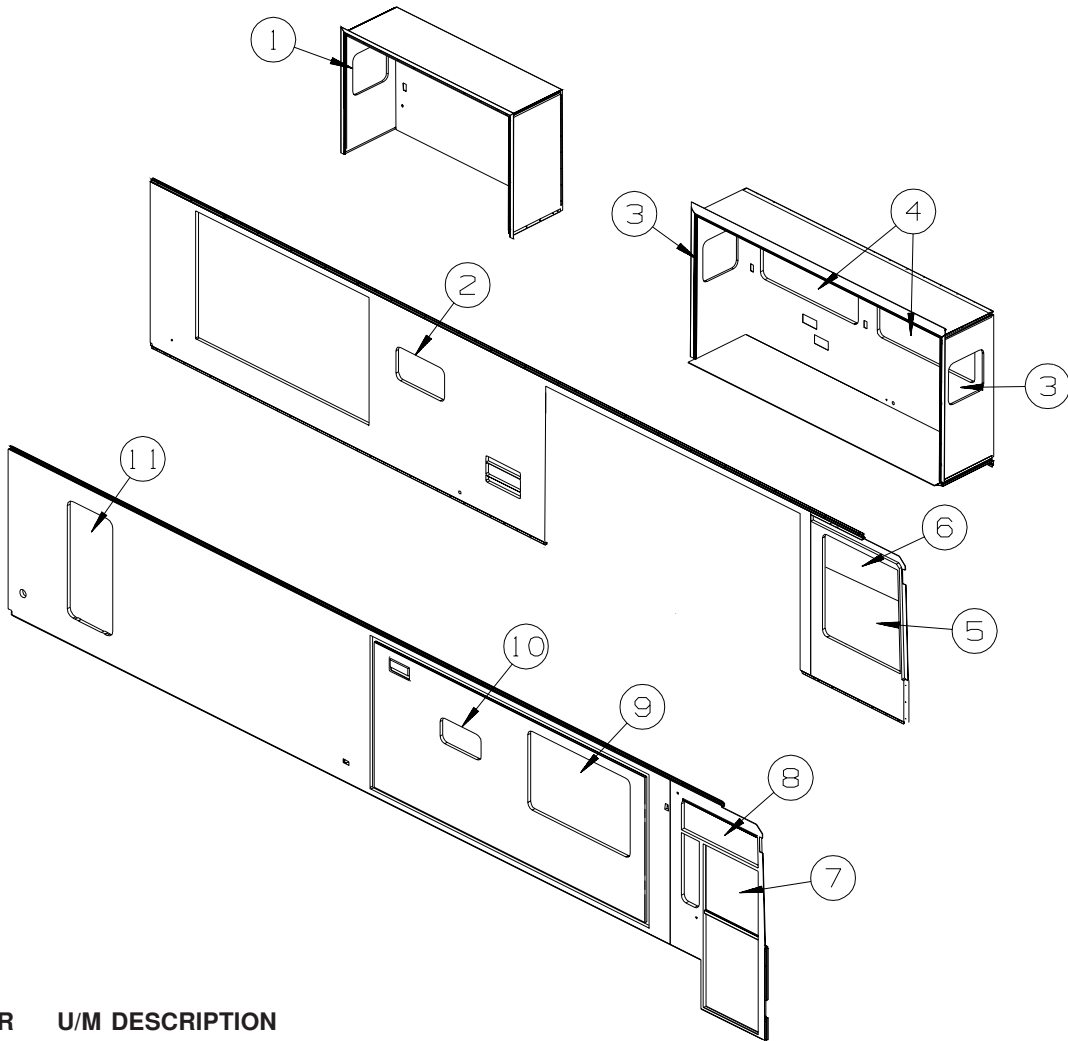

KEY	PART NUMBER	U/M	DESCRIPTION
1	136029-06-PA0	EA	VALANCE - TRELLIS - 26" (PA0, PA1, PA2)
1	136029-06-PA3	EA	VALANCE - TRELLIS - 26" (PA3, PA4, PA5)
1	136029-06-PA6	EA	VALANCE - TRELLIS - 26" (PA6, PA7, PA8)
1	140789-07-N44	EA	BLIND - DAY/NIGHTER - 22.5" X 23" (PA0, PA1, PA2, PA6, PA7, PA8)
1	140789-07-N42	EA	BLIND - DAY/NIGHTER - 22.5" X 23" (PA3, PA4, PA5)
1	136988-59-PA0	EA	LEG - RIGHT - 22" (PA0, PA1, PA2)
1	136988-59-N96	EA	LEG - RIGHT - 22" (PA3, PA4, PA5)
1	136988-59-PA6	EA	LEG - RIGHT - 22" (PA6, PA7, PA8)
1	136988-60-PA0	EA	LEG - LEFT - 22" (PA0, PA1, PA2)
1	136988-60-N96	EA	LEG - LEFT - 22" (PA3, PA4, PA5)
1	136988-60-PA6	EA	LEG - LEFT - 22" (PA6, PA7, PA8)
2	121410-D1-PA0	EA	VALANCE - MODERATE - 32" (PA0, PA1, PA2)
2	121410-D1-PA3	EA	VALANCE - MODERATE - 32" (PA3, PA4, PA5)
2	121410-D1-PA6	EA	VALANCE - MODERATE - 32" (PA6, PA7, PA8)
2	143829-01-PC0	EA	TRIM/WINDOW - U-SHAPED - 2.8" X 32.3"
2	111861-09-01A	EA	BLIND - MINI - 30.5" X 18"
3	139256-14-PA0	EA	VALANCE - WOODMARK - 26"
3	139256-14-PA1	EA	VALANCE - WOODMARK - 26"
3	139256-14-PA2	EA	VALANCE - WOODMARK - 26"
3	139256-14-PA3	EA	VALANCE - WOODMARK - 26"
3	139256-14-PA4	EA	VALANCE - WOODMARK - 26"
3	139256-14-PA5	EA	VALANCE - WOODMARK - 26"
3	139256-14-PA6	EA	VALANCE - WOODMARK - 26"
3	139256-14-PA7	EA	VALANCE - WOODMARK - 26"
3	139256-14-PA8	EA	VALANCE - WOODMARK - 26"
3	140789-07-N44	EA	BLIND - DAY/NIGHTER - 22.5" X 23" (PA0, PA1, PA2, PA6, PA7, PA8)
3	140789-07-N42	EA	BLIND - DAY/NIGHTER - 22.5" X 23" (PA3, PA4, PA5)

**CURTAIN & CUSHION GROUP (CONTINUED)**  
**WINDOW TREATMENT (CONTINUED)**

KEY	PART NUMBER	U/M	DESCRIPTION
3	136988-33-PA0	EA	LEG - RIGHT - 22" (PA0, PA1, PA2)
3	136988-33-PA3	EA	LEG - RIGHT - 22" (PA3, PA4, PA5)
3	136988-33-PA6	EA	LEG - RIGHT - 22" (PA6, PA7, PA8)
3	136988-34-PA0	EA	LEG - LEFT - 22" (PA0, PA1, PA2)
3	136988-34-PA3	EA	LEG - LEFT - 22" (PA3, PA4, PA5)
3	136988-34-PA6	EA	LEG - LEFT - 22" (PA6, PA7, PA8)
4	139256-11-PA0	EA	LAMBREQUIN - WOODMARK - 61"
4	139256-11-PA1	EA	LAMBREQUIN - WOODMARK - 61"
4	139256-11-PA2	EA	LAMBREQUIN - WOODMARK - 61"
4	139256-11-PA3	EA	LAMBREQUIN - WOODMARK - 61"
4	139256-11-PA4	EA	LAMBREQUIN - WOODMARK - 61"
4	139256-11-PA5	EA	LAMBREQUIN - WOODMARK - 61"
4	139256-11-PA6	EA	LAMBREQUIN - WOODMARK - 61"
4	139256-11-PA7	EA	LAMBREQUIN - WOODMARK - 61"
4	139256-11-PA8	EA	LAMBREQUIN - WOODMARK - 61"
4	140789-08-N44	EA	BLIND - DAY/NIGHTER - 59" X 26.5" (PA0, PA1, PA2, PA6, PA7, PA8)
4	140789-08-N09	EA	BLIND - DAY/NIGHTER - 59" X 26.5" (PA3, PA4, PA5)
5	139479-04-01A	EA	CURTAIN - WRAPAROUND/PRIVACY/PLEATED - 47" X 108" - DRIVER
6	126841-01-000	EA	SHADE - PULL - CHARCOAL MESH - 45" X 60"
7	126841-08-000	EA	SHADE - PULL - SUNSCREEN - 33" X 60"
8	139479-05-01A	EA	CURTAIN - WRAPAROUND/PRIVACY/PLEATED - 42" X 75"-PASS/FRONT
8	139479-06-01A	EA	CURTAIN - WRAPAROUND/PRIVACY/PLEATED - 42" X 75"-PASS/REAR
9	139256-13-PA0	EA	LAMBREQUIN - WOODMARK - 63"
9	139256-13-PA1	EA	LAMBREQUIN - WOODMARK - 63"
9	139256-13-PA2	EA	LAMBREQUIN - WOODMARK - 63"
9	139256-13-PA3	EA	LAMBREQUIN - WOODMARK - 63"
9	139256-13-PA4	EA	LAMBREQUIN - WOODMARK - 63"
9	139256-13-PA5	EA	LAMBREQUIN - WOODMARK - 63"
9	139256-13-PA6	EA	LAMBREQUIN - WOODMARK - 63"
9	139256-13-PA7	EA	LAMBREQUIN - WOODMARK - 63"
9	139256-13-PA8	EA	LAMBREQUIN - WOODMARK - 63"
9	140789-08-N44	EA	BLIND - DAY/NIGHTER - 59" X 26.5" (PA0, PA1, PA2, PA6, PA7, PA8)
9	140789-08-N09	EA	BLIND - DAY/NIGHTER - 59" X 26.5" (PA3, PA4, PA5)
10	143828-01-PC0	EA	TRIM - WINDOW - PORTSMOUTH OAK
10	143828-01-PC1	EA	TRIM - WINDOW - CONCERT CHERRY
10	143828-01-PC2	EA	TRIM - WINDOW - WASHED MAPLE
10	143828-02-PC0	EA	TRIM - WINDOW - PORTSMOUTH OAK
10	143828-02-PC1	EA	TRIM - WINDOW - CONCERT CHERRY
10	143828-02-PC2	EA	TRIM - WINDOW - WASHED MAPLE
10	111861-18-01A	EA	BLIND - MINI - 26" X 13.5" - ALABASTER PEARL
11	136029-07-PA0	EA	VALANCE - TRELIS - 32.5" (PA0, PA1, PA2)
11	136029-07-PA3	EA	VALANCE - TRELIS - 32.5" (PA3, PA4, PA5)
11	136029-07-PA6	EA	VALANCE - TRELIS - 32.5" (PA6, PA7, PA8)
11	140789-30-PA0	EA	BLIND - DAY/NIGHTER - 29" X 57" (PA0, PA1, PA2, PA6, PA7, PA8)
11	140789-30-PA3	EA	BLIND - DAY/NIGHTER - 29" X 57" (PA3, PA4, PA5)
11	136988-83-PA0	EA	LEG - RIGHT - 57" (PA0, PA1, PA2)
11	136988-83-PA3	EA	LEG - RIGHT - 57" (PA3, PA4, PA5)
11	136988-83-PA6	EA	LEG - RIGHT - 57" (PA6, PA7, PA8)
11	136988-84-PA0	EA	LEG - LEFT - 57" (PA0, PA1, PA2)
11	136988-84-PA3	EA	LEG - LEFT - 57" (PA3, PA4, PA5)
11	136988-84-PA6	EA	LEG - LEFT - 57" (PA6, PA7, PA8)

## CURTAIN & CUSHION GROUP (CONTINUED) HARDWARE

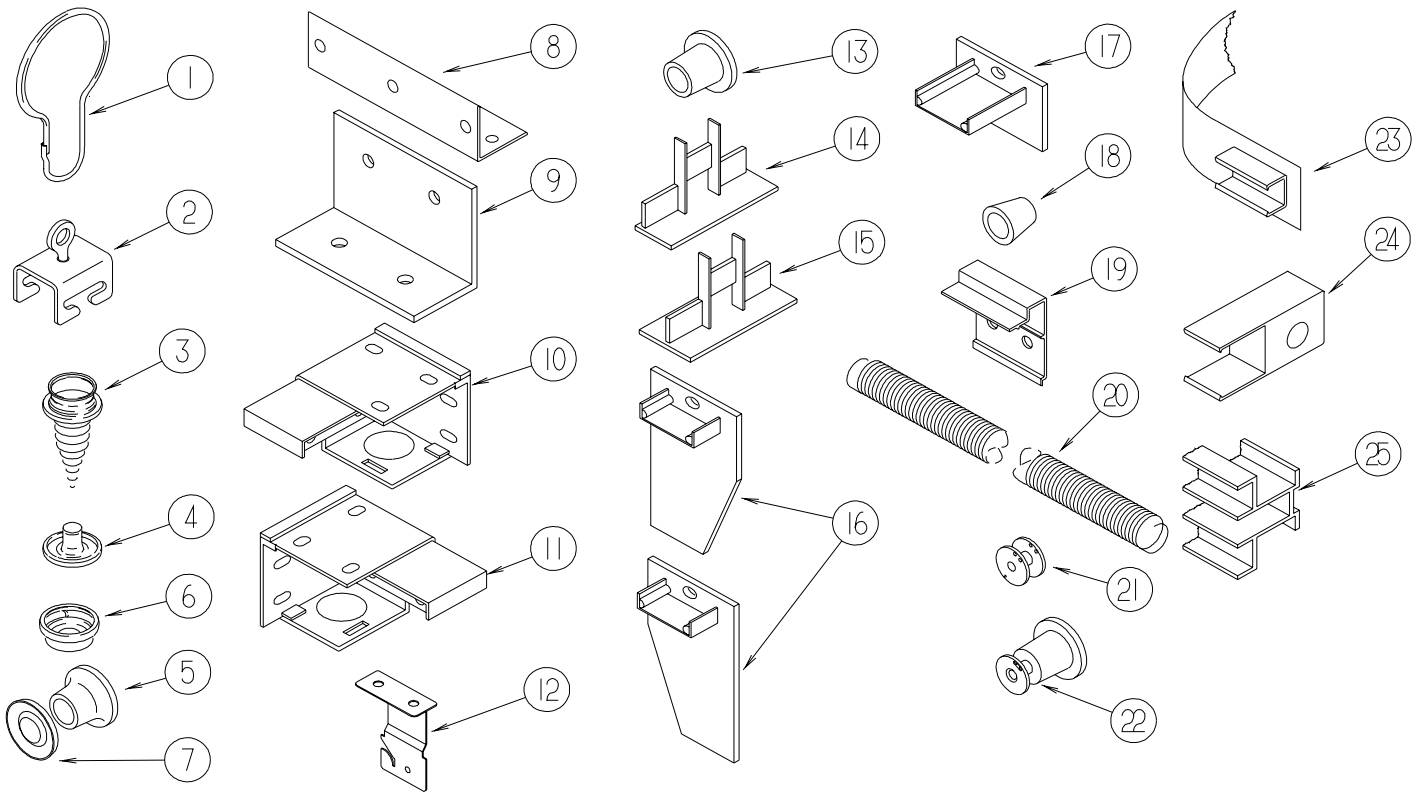

KEY	PART NUMBER	U/M	DESCRIPTION
1	009136-02-000	EA	HANGER - RING - PIN TYPE - CURTAIN - BRASS
2	009702-01-000	EA	END STOP - CURTAIN CARRIER - L - ROD
3	029130-01-000	EA	SCREW - SNAP STUD - #8-16 X 3/8" LONG
3	029130-03-000	EA	SCREW - SNAP STUD - #8-16 X 1" LONG
4	029155-01-000	EA	CAP - SNAP - 5/32" OUTSIDE DIAMETER OF PIN
5	029156-01-000	EA	SOCKET - SNAP - 9/16" O.D.
6	046867-02-000	EA	WASHER - HANDY BUTTON #3
7	046867-03-000	EA	GROMMET - HANDY BUTTON #3
8	075943-10-000	EA	BRACE - VALANCE - 20" - OFF WHITE
9	083125-07-000	EA	BRACE - ANGLE/COUCH - 2.5" - OFF WHITE
9	083125-08-000	EA	BRACE - WINDOW MOUNT - .75" - OFF WHITE
10	083170-01-000	EA	BRACKET/BLIND - LEFT SIDE WHEN FACING WINDOW - CLEAR
11	083170-02-000	EA	BRACKET/BLIND - RIGHT SIDE WHEN FACING WINDOW - CLEAR
12	084434-01-000	EA	BRACKET - MOUNTING - ROLLER SHADE - 1 3/8"
13	094896-02-000	EA	GROMMET - CORD/PLEATED BLIND - NYLON - GRAY
14	094907-02-000	EA	END CAP - PLEATED BLIND/TOP - RH/LH - GRAY PLASTIC
15	094907-04-000	EA	END CAP - PLEATED BLIND/BOTTOM - RH/LH
16	094907-05-000	EA	END CAP - PLEATED BLIND/BOTTOM - PULL TYPE - PLASTIC
17	094907-06-000	EA	END CAP - PLEATED BLIND/TOP
18	097564-99-000	EA	HANDLE - KNOB - E-Z LIFT SHADE - COLORLESS
19	097565-01-000	EA	BRACKET - MOUNTING - PLEATED BLIND
20	097591-01-000	EA	SPRING - EXTENSION - PLEATED BLIND
21	097592-01-000	EA	SPOOL - CORD - ELEVATED BLIND HOLDUP - SMALL - CLEAR
22	097592-02-000	EA	SPOOL - CORD - ELEVATED BLIND HOLDUP - LARGE - CLEAR
	097593-02-000	FT	CORD - BLIND - PLEATED - GRAY
	097593-06-000	FT	CORD - BLIND - PLEATED - PEWTER
	097593-10-000	FT	CORD - BLIND - PLEATED - VANILLA
23	101031-01-000	YD	TAPE/GLIDE - 4.25" SPACING
24	101033-02-000	EA	END CAP - LOW PROFILE TRACK - CLEAR
25	101033-08-000	EA	TRACK/WALL - 75" - FRT BUNK WINDOW 300 SERIES (MINNIE/SPIRIT)
25	101033-09-000	EA	TRACK/WALL - 32" - SIDE BUNK WINDOW 200 SERIES/300 SERIES (VISTA/SUNSTAR /MINNIE/SPIRIT)

## CURTAIN & CUSHION GROUP (CONTINUED) HARDWARE (CONTINUED)

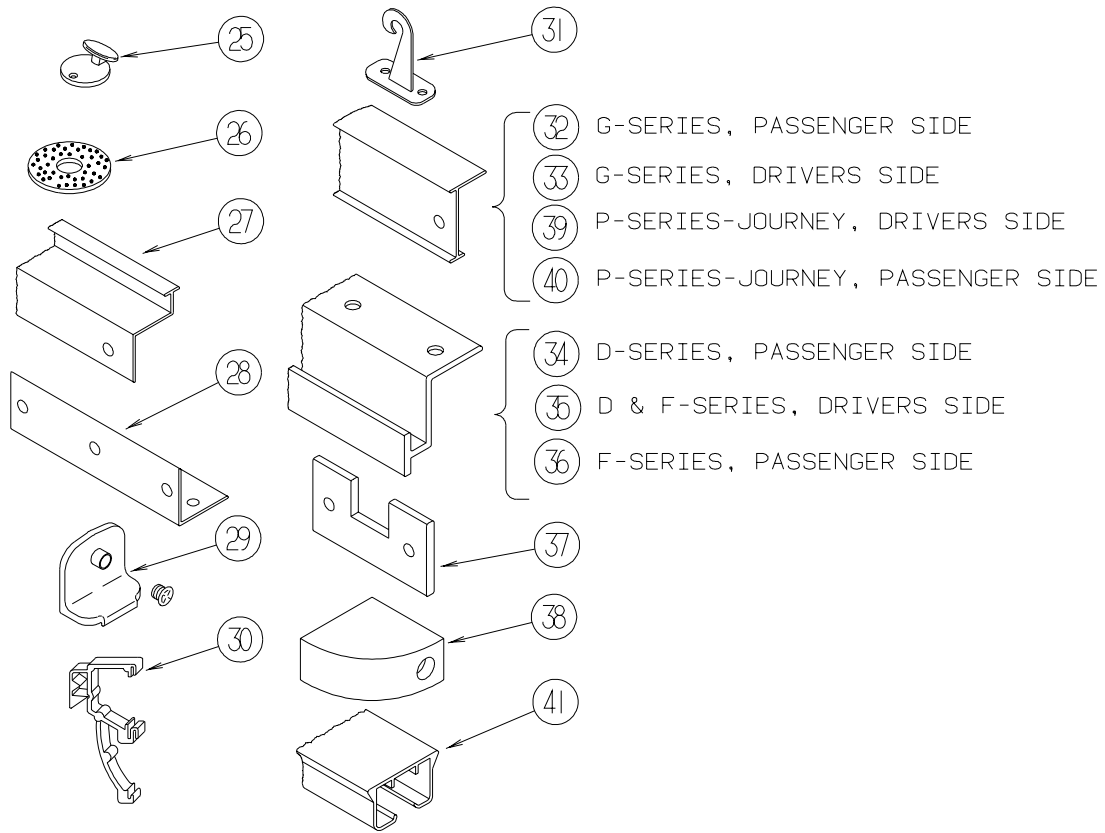

KEY	PART NUMBER	U/M	DESCRIPTION
25	102555-03-000	EA	CLEAT - BLIND CORD - MILKY WHITE - PLASTIC
26	103242-01-000	EA	VELCRO HOOK - BEIGE 7/8" ROUND W/CENTER HOLE
26	103242-02-000	EA	VELCRO HOOK - BLACK 7/8" ROUND W/CENTER HOLE
27	105450-14-01A	EA	TRACK - CURTAIN - 90" - OFF WHITE - FRONT BUNK PRIVACY 300 SERIES (MINNIE/SPIRITE)
27	105450-15-01A	EA	TRACK - CURTAIN - 82.3" - OFF WHITE - FRONT BUNK PRIVACY 200 SERIES (VISTA/SUNSTAR)
28	105648-01-02A	EA	BRACE - VALANCE - OFF/WHITE - 14"
29	106544-01-000	EA	PULL - SHADE/BRASS
	106544-01-001	EA	SCREW - SHADE/BRASS
30	109353-04-000	EA	CLIP - VALANCE SLAT MOUNTING - CLEAR PLASTIC
	109441-02-000	EA	SPACER/BACKET - BLIND HOLD DOWN
31	109441-03-000	EA	BRACKET/HOOK - BLIND HOLD DOWN - CLOUDY
32	126456-03-04A	EA	TRACK/WRAPAROUND - PASSENGER - GLACIER - G SERIES (ADVENTURER/SUNCRUISER)
33	126456-04-04A	EA	TRACK/WRAPAROUND - DRIVER - GLACIER - G SERIES (ADVENTURER/SUNCRUISER)
34	127254-03-05A	EA	TRACK/WRAPAROUND - PASSENGER - GLACIER - D SERIES (SIGHTSEER/SUNOVA)
35	127254-04-05A	EA	TRACK/WRAP - DRIVER - GLACIER - D SERIES/F SERIES (SIGHTSEER/SUNOVA/BRAVE/SUNRISE)
36	127254-14-03A	EA	TRACK/WRAPAROUND - PASSENGER - GLACIER - F SERIES (BRAVE/SUNRISE)
37	130549-01-01A	EA	STOP - CURTAIN TRACK
38	132504-01-N92	EA	BRACKET - SHADE
39	133235-01-04A	EA	TRACK - CURTAIN/LEFT HAND - GLACIER - P SERIES (JOURNEY)
40	133236-01-04A	EA	TRACK - CURTAIN/RIGHT HAND - GLACIER - P SERIES (JOURNEY)
41	138460-01-02A	EA	TRACK/CURTAIN - PASSENGER - WHITE - Q SERIES (ULTIMATE ADVANTAGE/ULTIMATE FREEDOM)
	138460-02-02A	EA	TRACK/CURTAIN - DRIVER - WHITE - Q SERIES (ULTIMATE ADVANTAGE/ULTIMATE FREEDOM)
41	138460-03-02A	EA	TRACK/CURTAIN - PASSENGER - WHITE - P SERIES (JOURNEY DL/HORIZON)
	138460-04-02A	EA	TRACK/CURTAIN - DRIVER - WHITE - P SERIES (JOURNEY DL/HORIZON)
41	138460-05-02A	EA	TRACK/CURTAIN - PASSENGER - WHITE - L SERIES (CHIEFTAIN/SUNFLYER)
	138460-06-02A	EA	TRACK/CURTAIN - DRIVER - WHITE - L SERIES (CHIEFTAIN/SUNFLYER)
	141634-01-000	EA	BOBBIN-PLEATED,ADJUSTABLE

FROM: 06-17-02 THRU: 99-99-99

## CURTAIN & CUSHION GROUP (CONTINUED)

### ACCESSORIES

KEY	PART NUMBER	U/M	DESCRIPTION
	007021-01-000	EA	SEAT BELT - 2" X 90" - BLACK
	057534-08000	EA	TIEBACK - CLEAR PLASTIC - 16"
	057534-03-000	EA	TIEBACK - CLEAR PLASTIC - 7.5"
	056271-01-000	EA	SEAT BELT - 2" X 102" - BLACK
	095076-02-000	EA	WASHER - FL - 7/16"ID X 2"OD X .06
	129491-01-000	EA	CATCH - SNAP HOOK - 1"

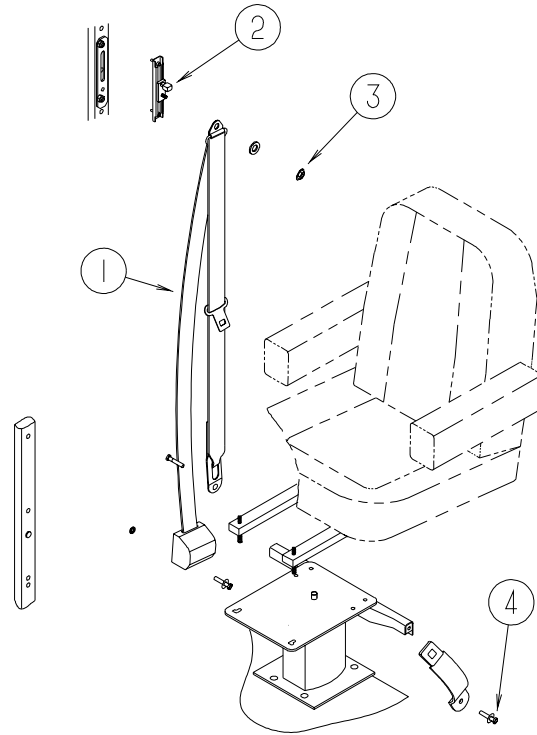

KEY	PART NUMBER	U/M	DESCRIPTION
1*	091990-08-01A	EA	SEAT BELT - 3 POINT - .766" DIAMETER HOLE IN D-LOOP BRKT
2	127598-01-01A	EA	ADJUSTER - SEATBELT - D-LOOP
3	127598-02-000	EA	NUT - HEX FLANGE - M10 X 1.5 - CLASS 10
4	095076-02-000	EA	WASHER - FL - 7/16"ID X 2"OD X .06

\*COMPONENT PARTS LISTED LATER IN THIS GROUP

# CURTAIN & CUSHION GROUP (CONTINUED)

## COMPONENT PARTS FOR ACCESSORIES

091990-08-01A

KEY	PART NUMBER	U/M	DESCRIPTION	VENDOR NO.
	091990-01-701	EA	EXTENDER 9" FOR A8408 3 PT	I-1331-02
	091990-01-703	EA	RECEIVER/FEMALE END-SEATBELT	I-1159-02
	091990-05-700	EA	SLEEVE/BUCKLE COVER-PLASTIC	209S-2
	091990-05-701	EA	CAP/COVER - BOLT HOLE COVER	209SC-02
	091990-05-702	EA	SLEEVE/RETRACTABLE COVER	309C-02

**CURTAIN & CUSHION GROUP (CONTINUED)**  
FABRICS

<b>2003 FAMILY</b>	<b>PA0/PA1/PA2 BLUE CALAIS</b>	<b>PA3/PA4/PA5 TAJ MAHAL</b>	<b>PA6/PA7/PA8 GEORGIAN ROSEWOOD</b>
<b>BUCKET</b>	FINLEY STYLE GLACIER	FINLEY STYLE GLACIER	FINLEY STYLE GLACIER
<b>DINING CHAIRS</b>	(2) FINLEY STYLE 126883-R1-000 (2) REM STYLE (Q36C ONLY) 126883-R1-000	(2) FINLEY STYLE 126883-J3-000 (2) REM STYLE (Q36C ONLY) 126883-J3-000	(2) FINLEY STYLE 126883-R3-000 (2) REM STYLE (Q36C ONLY) 126883-R3-000
<b>FOLDING CHAIRS</b>	(2) REM 126883-R1-000	(2) REM 126883-J3-000	(2) REM 126883-R3-000
<b>SOFA</b>	FINLEY ELECTRIC SOFA 126883-R0-000 *OPTIONAL LEATHER PRESTWICK GLACIER	FINLEY ELECTRIC SOFA 126883-J2-000 *OPTIONAL LEATHER PRESTWICK GLACIER	FINLEY ELECTRIC SOFA 126883-R2-000 *OPTIONAL LEATHER PRESTWICK GLACIER
<b>LOUNGE PILLOW</b>	(2) 12X20 RECTANGLE PILLOW W/BOXING & TASSEL 126883-R0-000/126883-R1-000 BUTTON TASSEL - 139730-08-000	(2) 12X20 RECTANGLE PILLOW W/BOXING & TASSEL 126883-J2-000/126883-J3-000 BUTTON TASSEL - 139730-02-000	(2) 12X20 RECTANGLE PILLOW W/BOXING & TASSEL 126883-R2-000/126883-R3-000 BUTTON TASSEL - 139730-07-000
<b>BANQUETTE PILLOW</b>	(2) 17" SQUARE PILLOW W/CTR. BUTT. TASSEL &FRG 126883-R1-000/139041-04-000 BUTTON TASSEL - 139730-08-000	(2) 17" SQUARE PILLOW W/CTR. BUTT. TASSEL &FRG 126883-J3-000/08441-E2-000 BUTTON TASSEL - 139730-02-000	(2) 17" SQUARE PILLOW W/CTR. BUTT. TASSEL &FRG 126883-R3-000/139041-26-000 BUTTON TASSEL - 139730-07-000
<b>LOUNGE CHAIR</b>	FINLEY STYLE RECLINER 126883-R1-000 *OPTIONAL LEATHER PRESTWICK GLACIER	FINLEY STYLE RECLINER 126883-J3-000 *OPTIONAL LEATHER PRESTWICK GLACIER	FINLEY STYLE RECLINER 126883-R4-000 *OPTIONAL LEATHER PRESTWICK GLACIER
<b>"J" LOVE SEAT</b>	FINLEY LOVE SEAT GLACIER	FINLEY LOVE SEAT GLACIER	FINLEY LOVE SEAT GLACIER
<b>LOUNGE WINDOWS</b>	WOODMARK LAMBREQUIN 126883-R1-000/126883-R0-000 UNDERLAY/OVERLAY	WOODMARK LAMBREQUIN 126883-J3-000/126883-J2-000 UNDERLAY/OVERLAY	WOODMARK LAMBREQUIN 126883-R3-000/126883-R2-000 UNDERLAY/OVERLAY
<b>FRONT WRAP</b>	PURCHASED PLEATED	PURCHASED PLEATED	PURCHASED PLEATED
<b>DAY/NIGHTER</b>	094911-56-000/126883-50-000 EGGSHELL/WT. DECO	094911-58-000/126883-50-000 PUTTY/WT. DECO	094911-56-000/126883-50-000 EGGSHELL/WT. DECO
<b>GALLEY BLINDS</b>	ALABASTER PEARL	ALABASTER PEARL	ALABASTER PEARL



**CURTAIN & CUSHION GROUP (CONTINUED)**  
**FABRICS (CONTINUED)**

<b>2003 FAMILY</b>	<b>PA0/PA1/PA2 BLUE CALAIS</b>	<b>PA3/PA4/PA5 TAJ MAHAL</b>	<b>PA6/PA7/PA8 GEORGIAN ROSEWOOD</b>
<b>BEDROOM WDO TREATMENT</b>	TRELLIS VALANCE 137813-62-000/137813-58-000 LEGS - 137813-62-000	TRELLIS VALANCE 137813-03-000/137813-04-000 LEGS - 137813-03-000	TRELLIS VALANCE 137813-59-000/126883-R3-000 LEGS - 137813-59-000
<b>BEDCOVER</b>	THROW W/TIE DOWNS & WLT 137813-62-000 TRIM - 137813-58-000	THROW W/TIE DOWNS & WLT 137813-03-000/137813-04-000 TRIM - 137813-04-000	THROW W/TIE DOWNS & WLT 137813-59-000/126883-R3-000 TRIM - 139041-25-000
<b>SHAMS</b>	FLANGED W/CORD INSET 137813-58-000/139041-03-000	FLANGED W/CORD INSET 137813-04-000/139041-D8-000	FLANGED W/CORD INSET 126883-R3-000/139041-25-000
<b>BED PILLOW</b>	(2) 17" W/BOXING 137813-62-000/137813-58-000	(2) 17" W/BOXING 137813-03-000/137813-04-000	(2) 17" W/BOXING 137813-59-000/137813-61-000
	(1) ROUND W/½ WELT BOXING 137813-62-000/137813-58-000 BUTTON TASSEL - 139730-08-000	(1) ROUND W/½ WELT BOXING 137813-03-000/137813-04-000 BUTTON TASSEL - 139730-02-000	(1) ROUND W/½ WELT BOXING 137813-59-000/137813-61-000 BUTTON TASSEL - 139730-07-000
<b>HEADBOARD</b>	PRINCE (CHANNEL) WRAP - 137813-58-000 2" SURROUND - 137813-62-000 ¼" WELT - 137813-62-000	PRINCE (CHANNEL) WRAP - 137813-04-000 2" SURROUND - 137813-03-000 ¼" WELT - 137813-03-000	PRINCE (CHANNEL) WRAP - 126883-R3-000 2" SURROUND - 137813-59-000 ¼" WELT - 137813-59-000
<b>BEDBOARD</b>	137813-58-000	137813-04-000	126883-R3-000
<b>CARPET</b>	139056-14-000 BLUSH BEIGE	139056-16-000 SWISS COCOA	139056-13-000 CASTILLE
<b>CEILING MATERIAL</b>	113979-12-01A SOFT CLOUD - 102" PEARL CR	113979-12-01A SOFT CLOUD - 102" PEARL CR	113979-12-01A SOFT CLOUD - 102" PEARL CR
<b>VINYL</b>	079680-50-000 ALLANTE DOESKIN	079680-50-000 ALLANTE DOESKIN	079680-50-000 ALLANTE DOESKIN

## DINETTE GROUP CABINETS

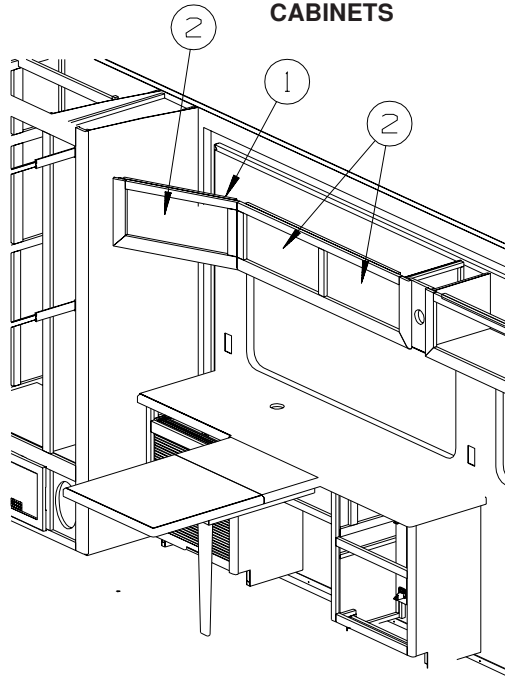

KEY	PART NUMBER	U/M	DESCRIPTION
1	143417-01-PA0	EA	CABINET - OVERHEAD/DINETTE - W/O DOORS/HARDWARE - PORTSMOUTH OAK
1	143417-01-PA1	EA	CABINET - OVERHEAD/DINETTE - W/O DOORS/HARDWARE - CONCERT CHERRY
1	143417-01-PA2	EA	CABINET - OVERHEAD/DINETTE - W/O DOORS/HARDWARE - WASHED MAPLE
2	136957-40-PA0	EA	DOOR - RAIL/ARCHED TOP - 10.8" X 21.8" - W/O HARDWARE - PORTSMOUTH OAK
2	136957-40-PA1	EA	DOOR - RAIL/ARCHED TOP - 10.8" X 21.8" - W/O HARDWARE - CONCERT CHERRY
2	136957-40-PA2	EA	DOOR - RAIL/ARCHED TOP - 10.8" X 21.8" - W/O HARDWARE - WASHED MAPLE

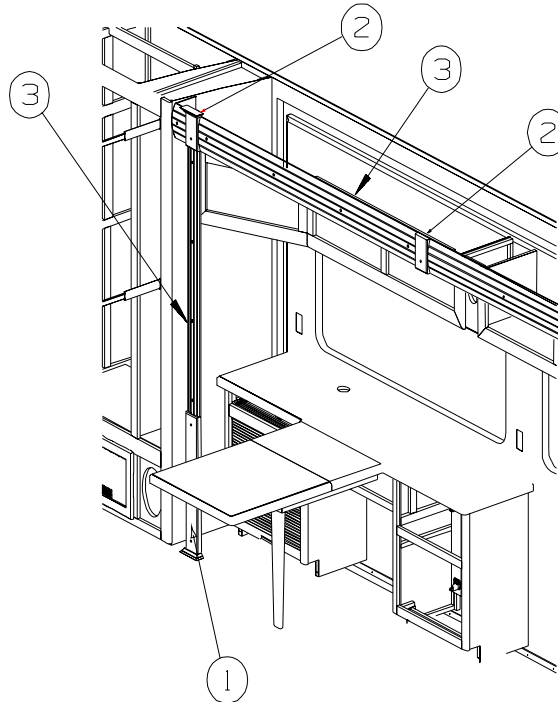

KEY	PART NUMBER	U/M	DESCRIPTION
1	141303-02-N53	EA	MOLDING - CROWN/BLOCK - PORTSMOUTH OAK
1	141303-02-N52	EA	MOLDING - CROWN/BLOCK - CONCERT CHERRY
1	141303-02-N62	EA	MOLDING - CROWN/BLOCK - WASHED MAPLE
2	141303-01-N53	EA	MOLDING - CROWN/BLOCK - PORTSMOUTH OAK
2	141303-01-N52	EA	MOLDING - CROWN/BLOCK - CONCERT CHERRY
2	141303-01-N62	EA	MOLDING - CROWN/BLOCK - WASHED MAPLE
3	P39129-08-N53	EA	MOLDING - FLUTED/CURVED - 3.5" X 44.5" - PORTSMOUTH OAK - PORTSMOUTH OAK
3	P39129-08-N52	EA	MOLDING - FLUTED/CURVED - 3.5" X 44.5" - PORTSMOUTH OAK - CONCERT CHERRY
3	P39129-08-N63	EA	MOLDING - FLUTED/CURVED - 3.5" X 44.5" - PORTSMOUTH OAK - WASHED MAPLE

## DINETTE GROUP (CONTINUED) TABLE

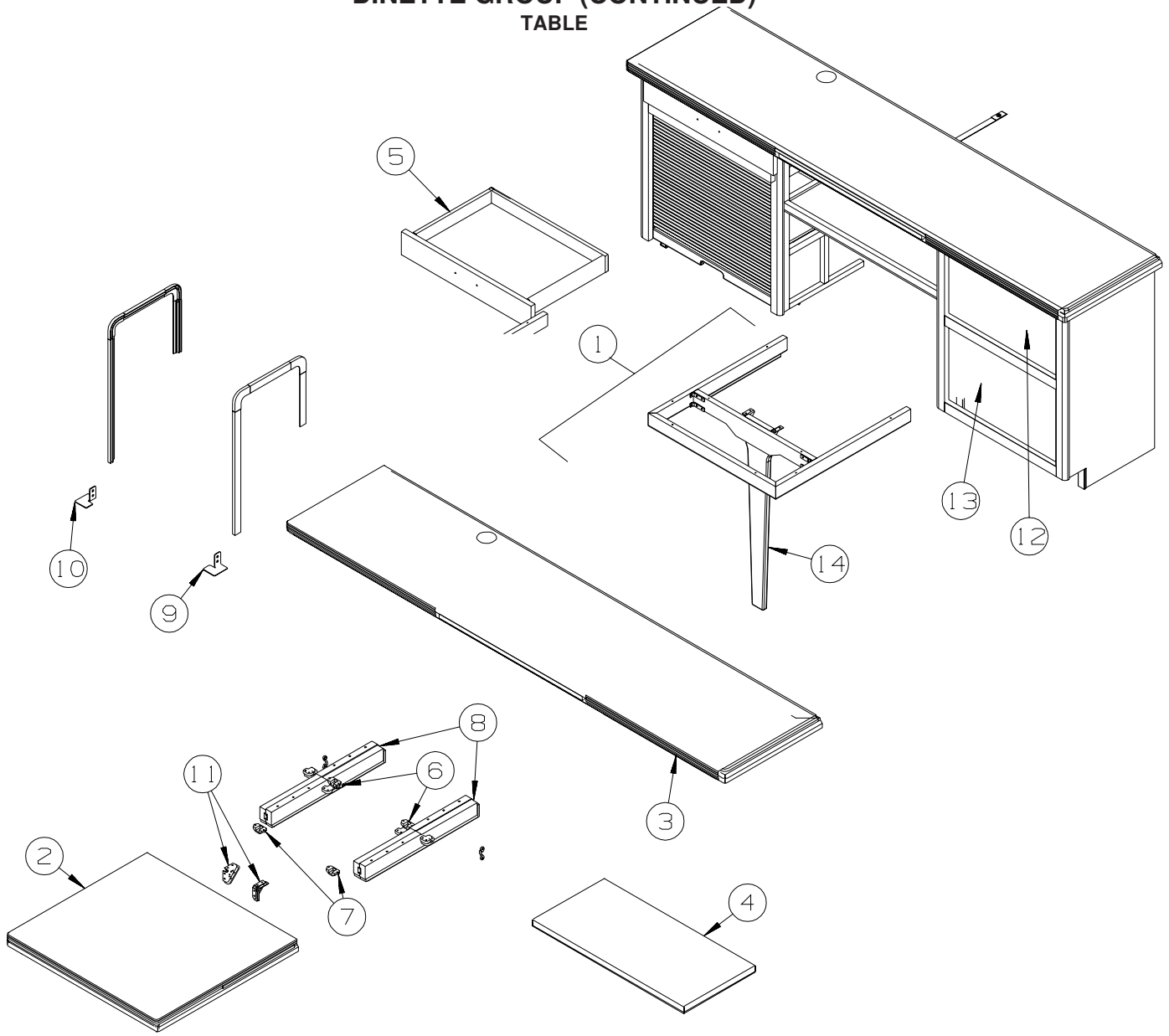

KEY	PART NUMBER	U/M	DESCRIPTION
	143782-02-PA0	EA	CABINET - DINETTE/COMPUTER - W/O COUNTERTOPS/DRAWERS/HDW - PORTSMOUTH OAK
	143782-02-PA1	EA	CABINET - DINETTE/COMPUTER - W/O COUNTERTOPS/DRAWERS/HDW - CONCERT CHERRY
	143782-02-PA2	EA	CABINET - DINETTE/COMPUTER - W/O COUNTERTOPS/DRAWERS/HDW - WASHED MAPLE
1	P43782-34-PA0	EA	SUPPORT/FRAME - W/LEG - W/O TOP - PORTSMOUTH OAK
1	P43782-34-PA1	EA	SUPPORT/FRAME - W/LEG - W/O TOP - CONCERT CHERRY
1	P43782-34-PA2	EA	SUPPORT/FRAME - W/LEG - W/O TOP - WASHED MAPLE
2	133539-56-02A	EA	COUNTERTOP - 1/2" CORIAN - MAGNA SAVANNA
3	133539-54-02A	EA	COUNTERTOP - 1/2" CORIAN - MAGNA SAVANNA
4	133539-55-02A	EA	COUNTERTOP - 1/2" CORIAN - MAGNA SAVANNA
5	P36353-03-PA0	EA	DRAWER - KEYBOARD - W/SLIDES - PORTSMOUTH OAK
5	P36353-03-PA1	EA	DRAWER - KEYBOARD - W/SLIDES - CONCERT CHERRY
5	P36353-03-PA2	EA	DRAWER - KEYBOARD - W/SLIDES - WASHED MAPLE
6	009050-03-000	EA	LEVELER - TABLE TOP - FEMALE END W/2 SCREWS - PLASTIC
7	009050-02-000	EA	LEVELER - TABLE TOP - MALE END W/4 SCREWS - PLASTIC
8	110749-01-000	EA	SLIDE/EXTENSION - 19 3/4" TO 33 1/4"
9	139264-01-02B	EA	STOP - DOOR - TAMBOUR - E-COATED
10	139264-02-02B	EA	STOP - DOOR - TAMBOUR - E-COATED
11	102810-01-04A	EA	BRACE - TABLE LEG - BLACK
12	P40787-41-PA0	EA	DRAWER - SOLID PANEL - 19"W X 11.8"D - W/O SLIDES/HARDWARE - PORTSMOUTH OAK
12	P40787-41-PA1	EA	DRAWER - SOLID PANEL - 19"W X 11.8"D - W/O SLIDES/HARDWARE - CONCERT CHERRY
12	P40787-41-PA2	EA	DRAWER - SOLID PANEL - 19"W X 11.8"D - W/O SLIDES/HARDWARE - WASHED MAPLE

**DINETTE GROUP (CONTINUED)**  
**TABLE (CONTINUED)**

KEY	PART NUMBER	U/M	DESCRIPTION
13	P40787-42-PA0	EA	DRAWER - SOLID PANEL - 19"W X 11.8"D - W/O SLIDES/HARDWARE - PORTSMOUTH OAK
13	P40787-42-PA1	EA	DRAWER - SOLID PANEL - 19"W X 11.8"D - W/O SLIDES/HARDWARE - CONCERT CHERRY
13	P40787-42-PA2	EA	DRAWER - SOLID PANEL - 19"W X 11.8"D - W/O SLIDES/HARDWARE - WASHED MAPLE
14	143782-39-PA0	EA	LEG - TABLE - PORTSMOUTH OAK
14	143782-39-PA1	EA	LEG - TABLE - CONCERT CHERRY
14	143782-39-PA2	EA	LEG - TABLE - WASHED MAPLE

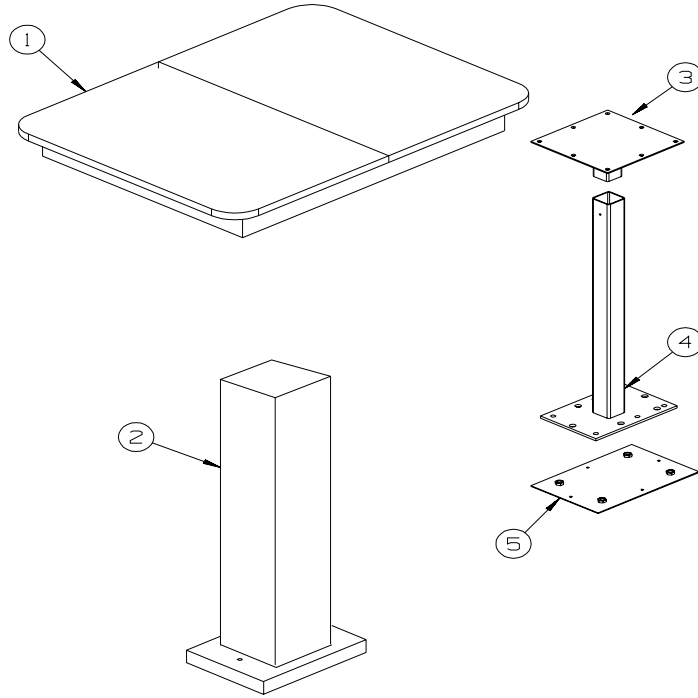

KEY	PART NUMBER	U/M	DESCRIPTION
1	139294-01-04A	EA	TABLE - DINETTE - FREE STANDING - OAK - PORTSMOUTH OAK
1	139294-01-03A	EA	TABLE - DINETTE - FREE STANDING - CHERRY - CONCERT CHERRY
1	139294-01-02A	EA	TABLE - DINETTE - FREE STANDING - WASHED MAPLE
2	139294-02-04A	EA	TABLE BASE - DINETTE - OAK - PORTSMOUTH OAK
2	139294-02-03A	EA	TABLE BASE - DINETTE - CHERRY - CONCERT CHERRY
2	139294-02-02A	EA	TABLE BASE - DINETTE - WASHED MAPLE
3	139466-01-02B	EA	SUPPORT - TABLE - UPPER - E-COATED
4	139459-01-02B	EA	SUPPORT/TABLE - DINETTE - E-COATED
5	139469-02-02B	EA	PLATE/BASE - TABLE - DINETTE - E-COATED - Q40E
			FROM: 00-00-00 THRU: 12-01-02
5	139469-04-02B	EA	PLATE/BASE - TABLE - DINETTE - E-COATED - Q40E
			FROM: 12-02-02 THRU: 99-99-99
5	141071-02-02B	EA	PLATE/BASE - TABLE - DINETTE - E-COATED - Q36C, Q38K, Q40K

## DRIVERS COMPARTMENT GROUP DASH

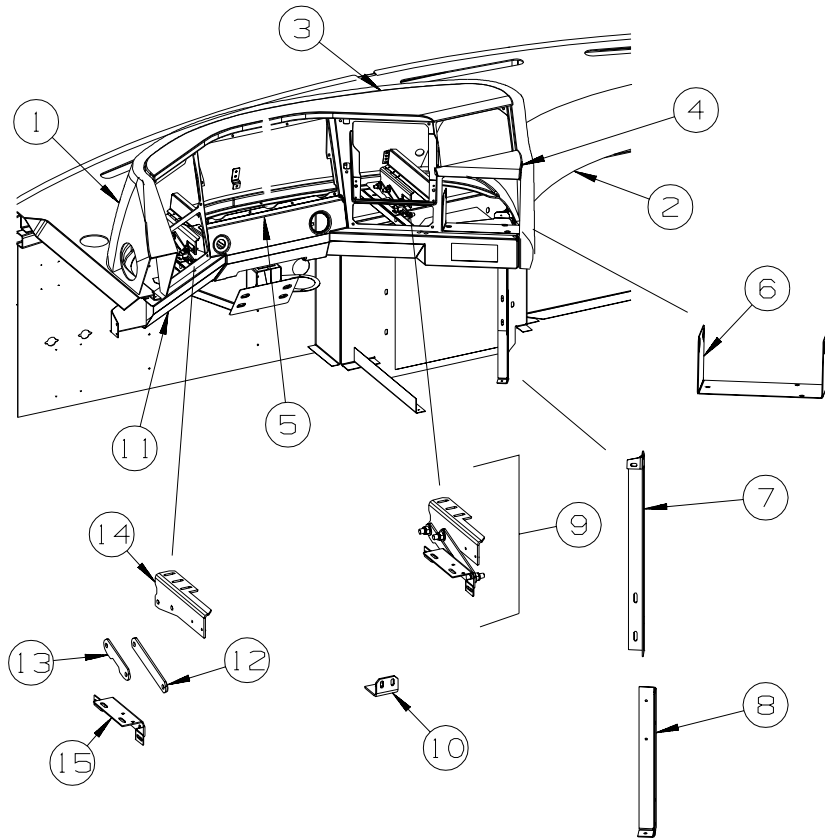

KEY	PART NUMBER	U/M	DESCRIPTION
1	134554-02-02A	EA	POD - DASH - ALLANTE DOESKIN
			FROM: 00-00-00 THRU: 03-02-03
1	134554-03-02A	EA	POD - DASH - ALLANTE DOESKIN
			FROM: 03-03-03 THRU: 99-99-99
2	134586-01-03A	EA	EXTENSION - DASH POD - RIGHT HAND - ALLANTE DOESKIN
3	P35573-01-N95	EA	PANEL TRIM - DASH POD - UPPER - PORTSMOUTH OAK
3	P35573-01-M94	EA	PANEL TRIM - DASH POD - UPPER - CONCERT CHERRY
3	P35573-01-MQ0	EA	PANEL TRIM - DASH POD - UPPER - WASHED MAPLE
4	P35573-02-N95	EA	PANEL TRIM - DASH POD - LOWER - PORTSMOUTH OAK
4	P35573-02-M94	EA	PANEL TRIM - DASH POD - LOWER - CONCERT CHERRY
4	P35573-02-MQ0	EA	PANEL TRIM - DASH POD - LOWER - WASHED MAPLE
5	115870-01-000	FT	SEAL - TRIM - EDGE
6	134742-02-02B	EA	MOUNT - MONITOR - E-COATED
7	134804-01-02B	EA	SUPPORT - DASH - UPPER/CENTER - E-COATED
8	134805-01-02B	EA	SUPPORT - DASH - LOWER/CENTER - E-COATED
9	134856-01-M94	EA	HINGE - DASH POD
10	135229-01-02B	EA	ANGLE - DASH SUPPORT - LEFT HAND - E-COATED
11	136513-01-03A	EA	COVER - DASH/LOWER LEFT - VINYL - ALLANTE DOESKIN
	106569-12-03A	YD	VINYL - LAMINATE - 1/4" X 54" - ALLANTE DOESKIN
	106569-10-06A	EA	VINYL - LAMINATE - 1/4" X 25" X 20" - ALLANTE DOESKIN
	106569-09-06A	EA	VINYL - LAMINATE - 1/4" X 25" X 100" - ALLANTE DOESKIN
12	134858-01-02B	EA	LINK - HINGE - E-COATED
13	134858-02-02B	EA	LINK - HINGE - E-COATED
14	134859-02-02B	EA	BRACKET - HINGE/LINK - E-COATED
15	134860-02-02B	EA	BRACKET - HINGE/LINK - E-COATED

## DRIVERS COMPARTMENT GROUP (CONTINUED)

### BEVERAGE TRAY

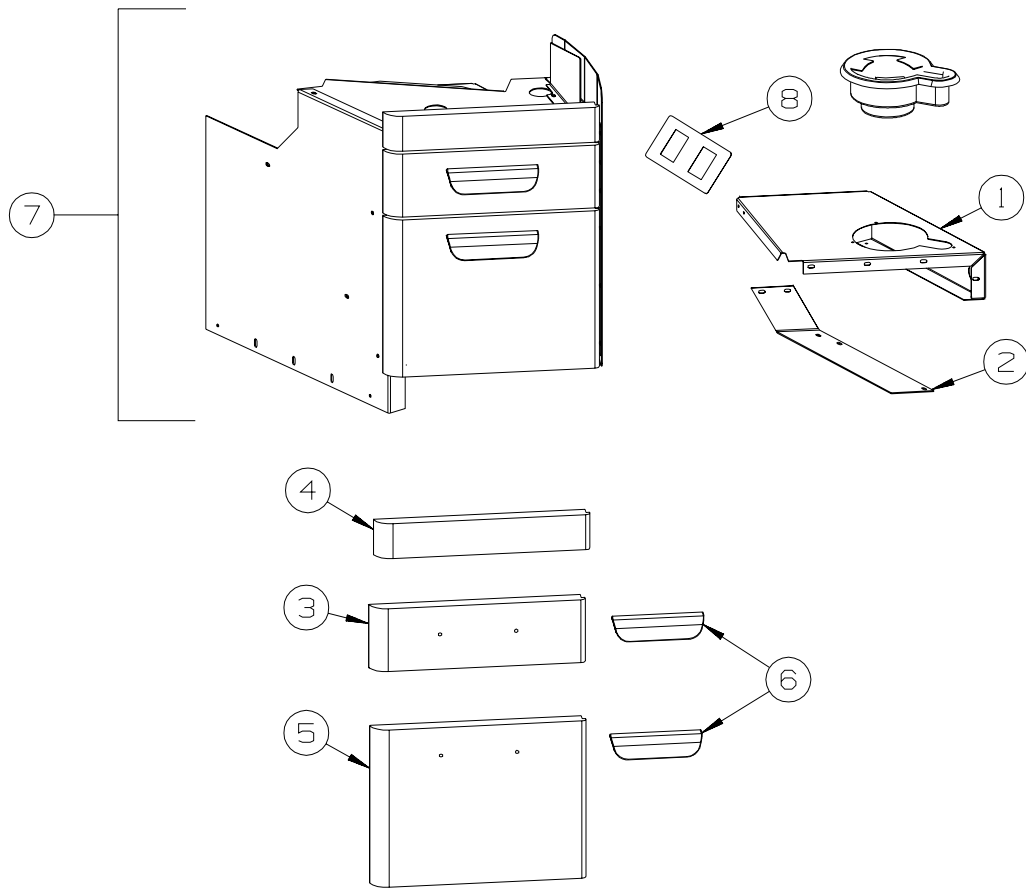

KEY	PART NUMBER	U/M	DESCRIPTION
1	P41847-01-PC0	EA	TRAY/BEVERAGE - STEEL - VINYL WRAPPED - DOESKIN
2	141850-01-02B	EA	MOUNT/CATCH - PRESSURE - E-COATED
3	P35708-04-PC0	EA	DOOR - CONSOLE - 3.5" - PORTSMOUTH OAK
3	P35708-04-PC1	EA	DOOR - CONSOLE - 3.5" - CONCERT CHERRY
3	P35708-04-PC2	EA	DOOR - CONSOLE - 3.5" - WASHED MAPLE
4	P35708-05-PC0	EA	DOOR - CONSOLE - 2" - PORTSMOUTH OAK
4	P35708-05-PC1	EA	DOOR - CONSOLE - 2" - CONCERT CHERRY
4	P35708-05-PC2	EA	DOOR - CONSOLE - 2" - WASHED MAPLE
5	P35708-03-PC0	EA	DOOR - CONSOLE - 8.8" - PORTSMOUTH OAK
5	P35708-03-PC1	EA	DOOR - CONSOLE - 8.8" - CONCERT CHERRY
5	P35708-03-PC2	EA	DOOR - CONSOLE - 8.8" - WASHED MAPLE
6	074762-01-000	EA	PULL - CABINET - 4.8" X .9" - BLACK PLASTIC
7	P41823-01-PC0	EA	CONSOLE/CENTER - STEEL - VINYL WRAPPED - DOESKIN
	134759-01-01B	EA	PANEL - CONSOLE - SWEPT - E-COATED
	106569-12-03A	YD	VINYL - LAMINATE - ALLANTE DOESKIN - 1/4" X 54"
8	132946-04-01A	EA	APPLIQUE - SWITCH - F/SLIDEOUT

## DRIVERS COMPARTMENT GROUP (CONTINUED)

### FRONT INTERIOR

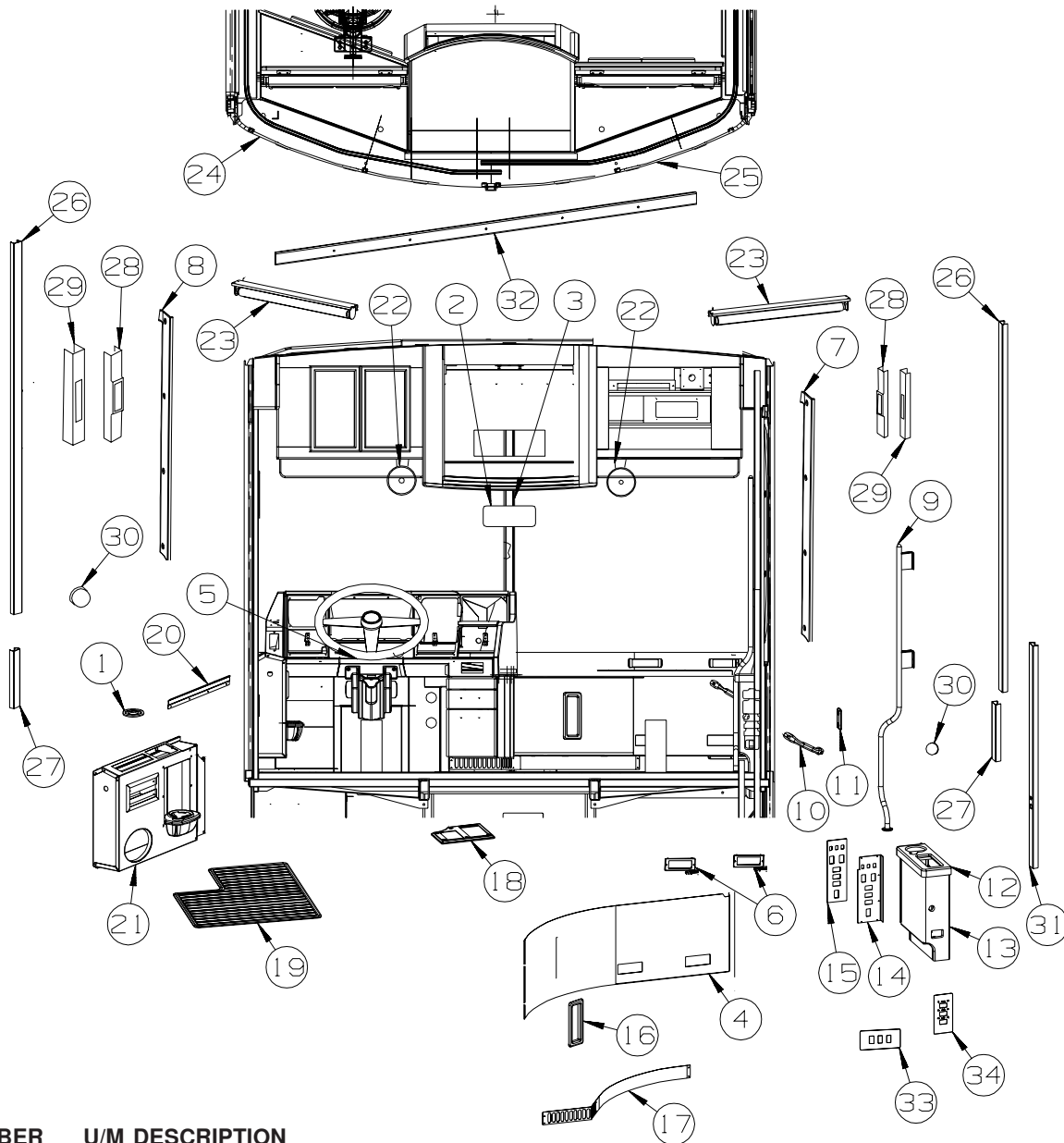

KEY	PART NUMBER	U/M DESCRIPTION
1	136457-01-02A	EA PROTECTOR - VINYL - PARK BRAKE - GLACIER
2	134154-01-000	EA MIRROR - CONVEX - 4" X 11.8"
3	118452-08-05A	EA TRIM - WINDSHIELD/CENTER - GLACIER
4	P34764-02-PC0	EA PANEL/TRIM - DASH/PASSENGER - VINYL COVERED
5	095933-07-000	EA STOP/TILT - STEERING COLUMN
6	135803-03-01A	EA LOUVER - A/C - OPEN FRAME
7	136351-01-02A	EA TRIM - A-PILLAR - INTERIOR/PASSENGER - GLACIER
8	136351-02-02A	EA TRIM - A-PILLAR - INTERIOR/DRIVER - GLACIER
8	143745-01-01A	EA TRIM - A PILLAR - INTERIOR/DRIVER - GLACIER FROM: 00-00-00 THRU: 07-08-02 FROM: 07-09-02 THRU: 99-99-99
9	123577-01-01A	EA HANDRAIL - ASSIST - ENTRY
10	123246-01-05A	EA HANDLE - GRAB - GLACIER
11	136456-01-02A	EA COVER - BRACKET - STRIKER BOLT - GLACIER
12	133539-03-02A	EA COUNTERTOP - 1/2" CORIAN - MAGNA-SAVANNAH
13	143311-01-PC0	EA CABINET - CONSOLE/RIGHT HAND - PORTSMOUTH OAK
13	143311-01-PC1	EA CABINET - CONSOLE/RIGHT HAND - CONCERT CHERRY
13	143311-01-PC2	EA CABINET - CONSOLE/RIGHT HAND - WASHED MAPLE
14	135119-01-02B	EA PLATE - SWITCH - CONSOLE/RIGHT HAND - E-COATED
15	135429-01-01A	EA PLATE/SWITCH - W/APPLIQUE - 3.7"W X 12.3"H
15	135429-03-01A	EA PLATE/SWITCH - W/APPLIQUE - 3.7"W X 12.3"H - <b>ELECTRIC AWNING</b>

**DRIVERS COMPARTMENT GROUP (CONTINUED)**  
**FRONT INTERIOR (CONTINUED)**

KEY	PART NUMBER	U/M	DESCRIPTION
16	NOT USED		
17	134758-02-11B	EA	PANEL - TOE KICK - RIGHT HAND - BLACK
18	116993-01-01A	EA	COVER - PEDALS - BLACK
19	108152-03-000	EA	MAT - FLOOR - DRIVER
20	130034-04-02B	EA	CLIP - TRIM - E-COATED
21	140794-01-PC0	EA	CONSOLE COMPL-DRIVER - PORTSMOUTH OAK
21	140794-01-PC1	EA	CONSOLE COMPL-DRIVER - CONCERT CHERRY
21	140794-01-PC2	EA	CONSOLE COMPL-DRIVER - WASHED MAPLE
	131358-03-02A	EA	RETAINER - UCHANNEL - 14.8" - GLACIER
22	122856-01-01A	EA	FAN-DEFROSTER-2 SPEED W/SWIVEL BASE/NON-OSCILLATING-CHROME
23	142380-01-01A	EA	SHADE - POWER - 25.7"
			FROM: 00-00-00 THRU: 05-27-02
23	142380-04-01A	EA	SHADE - POWER - 27.5"
			FROM: 05-28-02 THRU: 99-99-99
24	129004-01-05A	EA	TRIM - WINDSHIELD - INTERIOR/PASSENGER TOP - GLACIER
25	129004-02-05A	EA	TRIM - WINDSHIELD - INTERIOR/DRIVER TOP - GLACIER
26	NOT USED		
27	024700-60-000	EA	COVER - ROLL BAR - SIDEWALL - 11.3" - OFF WHITE
28	140151-01-01A	EA	COVER - SEAT BELT - OFF WHITE
29	140151-03-01A	EA	COVER - SEAT BELT SLIDE - BLACK
30	140151-02-01A	EA	COVER - SCREW - OFF WHITE
31	024700-59-000	EA	COVER - ROLL BAR - SIDEWALL - 44.1" - OFF WHITE
32	133771-02-N95	EA	MOLDING - CAP - PORTSMOUTH OAK
32	133771-02-M94	EA	MOLDING - CAP - CONCERT CHERRY
32	133771-02-MQ0	EA	MOLDING - CAP - WASHED MAPLE
33	142487-02-02B	EA	PLATE - SWITCH - E-COATED
34	142475-02-01A	EA	APPLIQUE - SWITCH - PASSENGER



# DRIVERS COMPARTMENT GROUP (CONTINUED)

## CABINETS

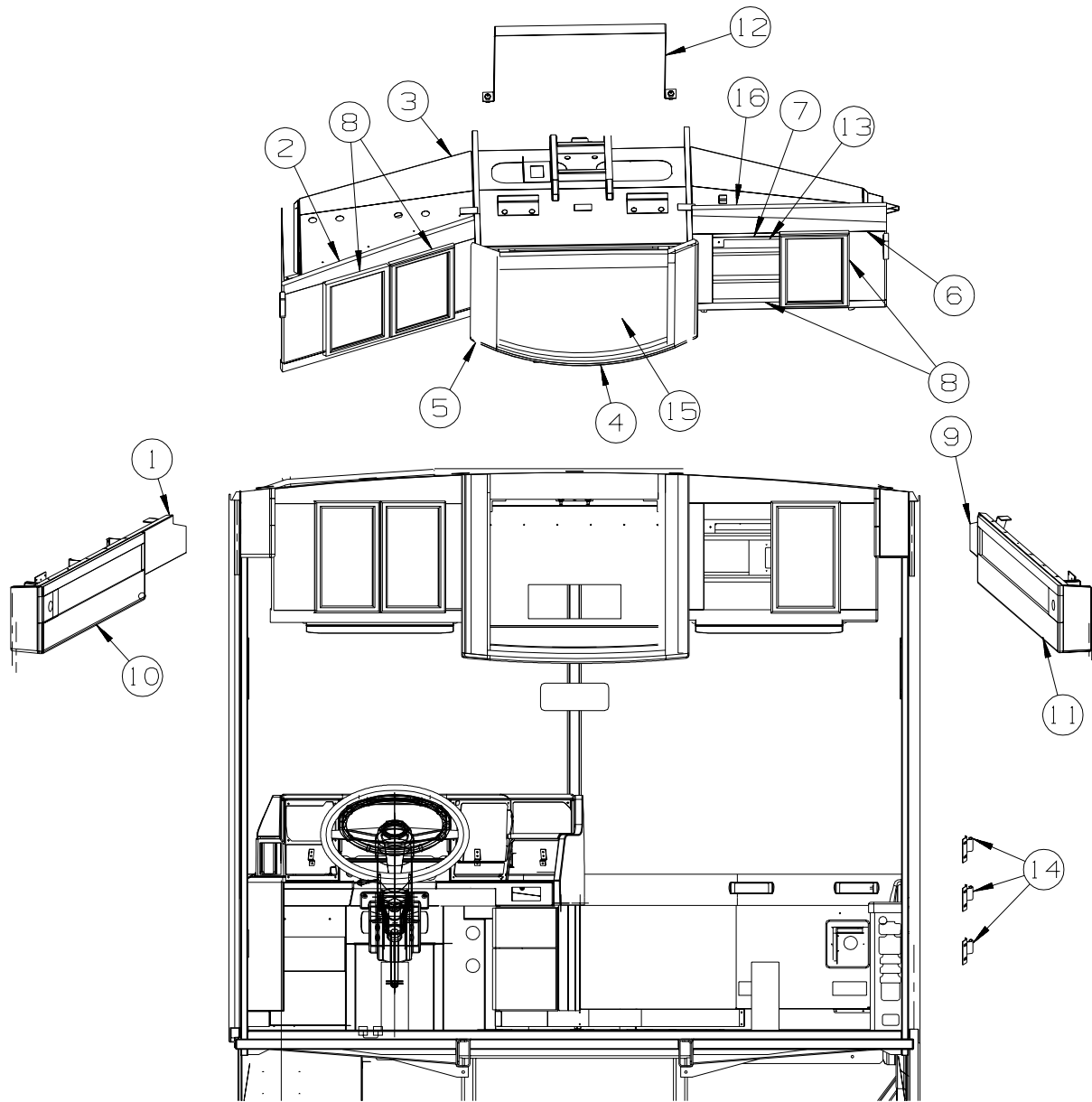

KEY	PART NUMBER	U/M	DESCRIPTION
1	P35582-02-PC0	EA	PANEL - OVERHEAD/LEFT HAND - VINYL COVERED
	135582-02-02B	EA	PANEL - OVERHEAD/LEFT HAND - E-COATED
	106569-12-03A	YD	VINYL - LAMINATE - ALLANTE DOESKIN - 1/4" X 54"
2	135503-03-PC0	EA	CABINET/FACE - ENTERTAINMENT CENTER - DRIVER - PORTSMOUTH OAK
2	135503-03-PC1	EA	CABINET/FACE - ENTERTAINMENT CENTER - DRIVER - CONCERT CHERRY
2	135503-03-PC2	EA	CABINET/FACE - ENTERTAINMENT CENTER - DRIVER - WASHED MAPLE
3	135493-02-02B	EA	PANEL - ENTERTAINMENT CENTER/LEFT HAND - E-COATED
4	135527-01-PC0	EA	CABINET - ENTERTAINMENT CENTER/TV
5	133544-04-N95	EA	CABINET FACE - OVERHEAD/TV - PORTSMOUTH OAK
5	133544-04-N94	EA	CABINET FACE - OVERHEAD/TV - CONCERT CHERRY
5	133544-04-PA2	EA	CABINET FACE - OVERHEAD/TV - WASHED MAPLE
6	135503-01-N95	EA	CABINET/FACE - ENTERTAINMENT CENTER - PASSENGER - PORTSMOUTH OAK
6	135503-01-M94	EA	CABINET/FACE - ENTERTAINMENT CENTER - PASSENGER - CONCERT CHERRY
6	135503-01-N95	EA	CABINET/FACE - ENTERTAINMENT CENTER - PASSENGER - WASHED MAPLE
7	136392-01-02B	EA	PANEL - COVER - SWITCHBOX - E-COATED - <b>SATELLITE DISH</b>
8	134783-K3-PA0	EA	DOOR - RAIL/SOLID PANEL - 10.8" X 16.5" - W/O HARDWARE - PORTSMOUTH OAK
8	134783-K3-PA1	EA	DOOR - RAIL/SOLID PANEL - 10.8" X 16.5" - W/O HARDWARE - CONCERT CHERRY
8	134783-K3-PA2	EA	DOOR - RAIL/SOLID PANEL - 10.8" X 16.5" - W/O HARDWARE - WASHED MAPLE
	100708-25-000	EA	DOOR - GLASS - TV CABINET - W/O HARDWARE
9	P35582-01-PC0	EA	PANEL - OVERHEAD/RIGHT HAND - VINYL COVERED
	135582-01-02B	EA	PANEL - OVERHEAD/RIGHT HAND - E-COATED
	106569-12-03A	YD	VINYL - LAMINATE - ALLANTE DOESKIN - 1/4" X 54"

**DRIVERS COMPARTMENT GROUP (CONTINUED)**  
**CABINETS (CONTINUED)**

<b>KEY</b>	<b>PART NUMBER</b>	<b>U/M</b>	<b>DESCRIPTION</b>
10	135532-02-N95	EA	FACE - CABINET - OVERHEAD/LEFT HAND - W/O HARDWARE - PORTSMOUTH OAK
10	135532-02-M94	EA	FACE - CABINET - OVERHEAD/LEFT HAND - W/O HARDWARE - CONCERT CHERRY
10	135532-02-MQ0	EA	FACE - CABINET - OVERHEAD/LEFT HAND - W/O HARDWARE - WASHED MAPLE
11	135532-01-N95	EA	FACE - CABINET - OVERHEAD/RIGHT HAND - W/O HARDWARE - PORTSMOUTH OAK
11	135532-01-M94	EA	FACE - CABINET - OVERHEAD/RIGHT HAND - W/O HARDWARE - CONCERT CHERRY
11	135532-01-MQ0	EA	FACE - CABINET - OVERHEAD/RIGHT HAND - W/O HARDWARE - WASHED MAPLE
12	136441-01-02B	EA	STRAP - TV - E-COATED
13	136387-01-PC0	EA	PANEL - VINYL COVERED
	136386-01-02B	EA	PANEL - COVER/FRONT - E-COATED
	106569-10-06A	EA	VINYL - LAMINATE - ALLANTE DOESKIN - 1/4" X 25" X 20"
14	073050-03-000	EA	MOUNTING CLIP - VALANCE PANEL
15	140364-01-01A	EA	FOAM - PAD - 5" X 8" X 8"
16	P35505-02-PC0	EA	PANEL - ENTERTAINMENT CENTER/RIGHT HAND - E- COATED

# ELECTRICAL GROUP

## 12V BODY WIRING

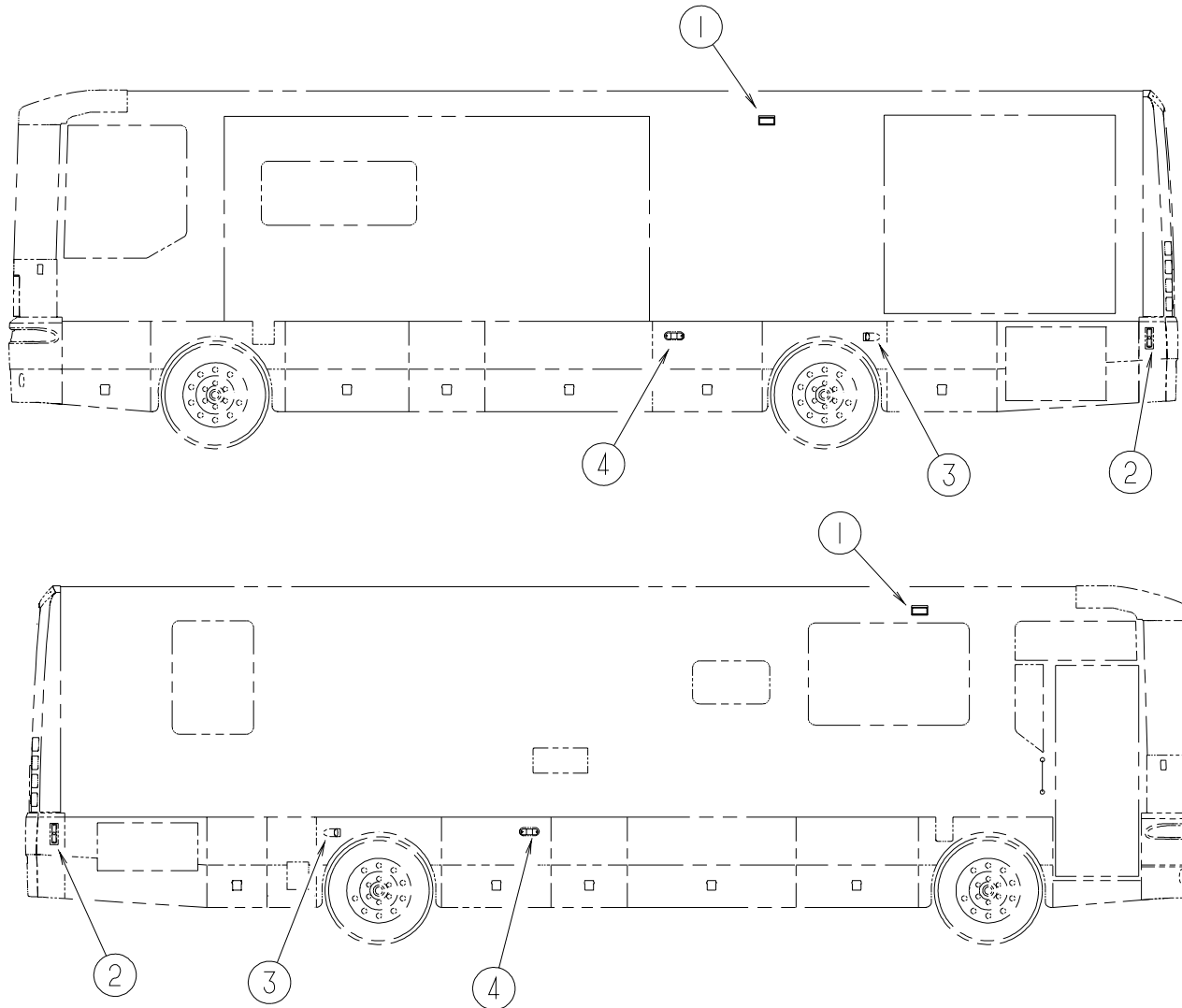

KEY	PART NUMBER	U/M	DESCRIPTION
1*	097917-01-06A	EA	LIGHT - PORCH - BRIGHT WHITE - USA
	008215-01-000	EA	BULB - 12 VOLT - #1003 - .94 AMP - USA
1	097917-01-08A	EA	LIGHT/PORCH - ENTRY DOOR - USA, FULL BODY PAINT
	008215-01-000	EA	BULB - 12 VOLT - #1003 - .94 AMP - USA
1*	008089-02-000	EA	LIGHT/PORCH - RECESSED - CANADIAN - CANADIAN
	008214-01-000	EA	BULB - 12 VOLT - #67 - .59 AMP - CANADIAN
2	117826-01-000	EA	SIDE MARKER LAMP ASSEMBLY - RED
2	117826-03-000	EA	GASKET - MARKER LIGHT
2	036196-01-000	EA	BULB - 12V - #194 - .27 AMP - BAYONETTE
2	067789-02-000	EA	SOCKET - LAMP
3	129746-01-000	EA	LAMP - DOCKING/DRIVING W/MOUNT BRACKET
3	120494-03-02B	EA	SHIM - STRIKER - LUGGAGE DOOR - .20 - E-COATED
4	113293-01-000	EA	LAMP - (LENS/BASE) SIDEMARKER/TURN SIGNAL - AMBER
4	037935-01-000	EA	BULB - 12V - #1157 OR #2057 - 2.1 AMP - CLEAR GLASS
4	106687-02-000	EA	SOCKET - LIGHT - 3-WIRE
	130672-01-01A	EA	SPOTLIGHT - POWER/REMOTE - WHITE
	130672-01-02A	EA	SPOTLIGHT - POWER/REMOTE - BLACK

FROM: 00-00-00 THRU: 03-23-03  
FROM: 03-24-03 THRU: 99-99-99

\*COMPONENT PARTS LISTED LATER IN THIS GROUP

## ELECTRICAL GROUP (CONTINUED)

### 12V BODY WIRING (CONTINUED)

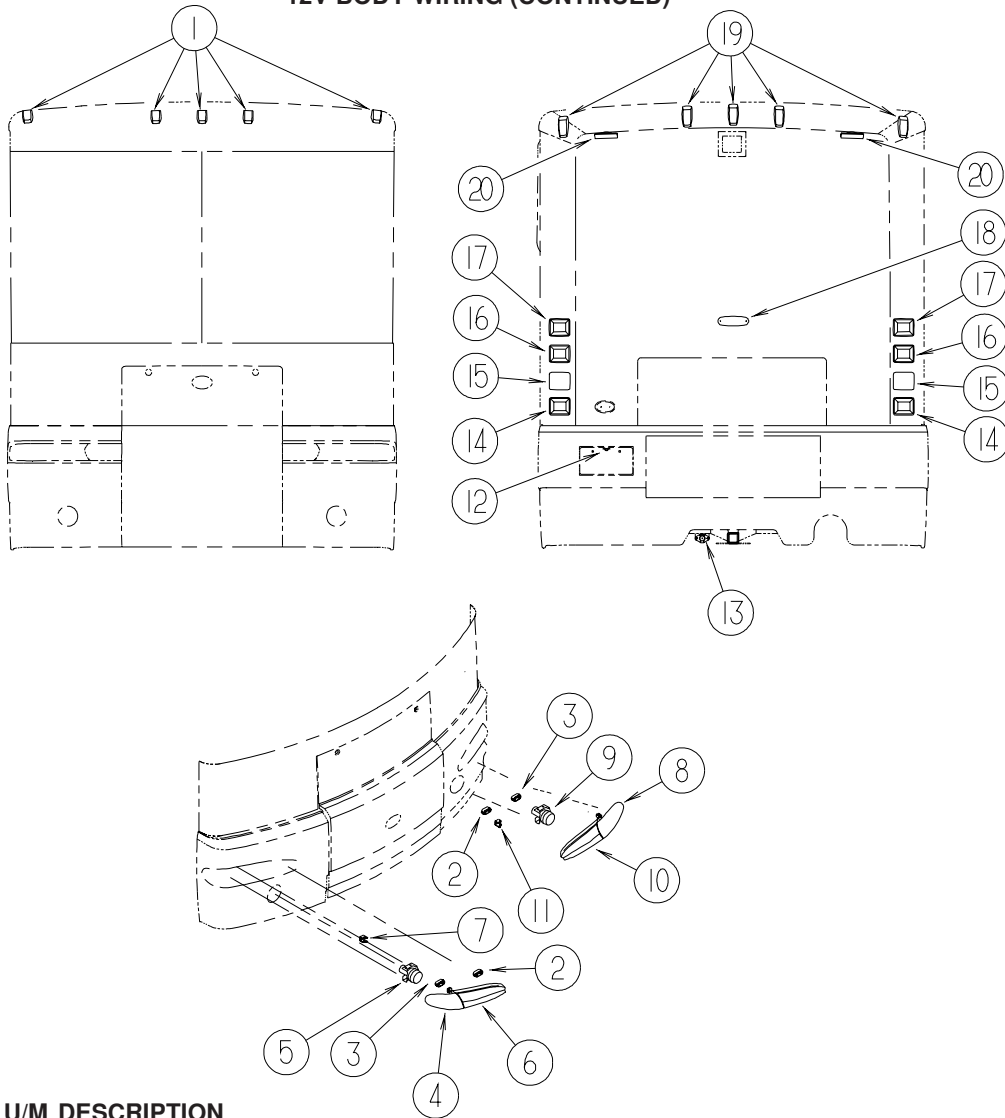

KEY	PART NUMBER	U/M	DESCRIPTION
1	129942-01-000	EA	LAMP - CLEARANCE - AMBER
2	124187-01-000	EA	SOCKET/HOUSING - LOW BEAM HEADLAMP
3	124187-02-000	EA	SOCKET/HOUSING - HIGH BEAM HEADLAMP
4	124161-01-000	EA	LAMP - PASSENGER PARK/TURN
5*	130051-01-000	EA	LAMP - FOG W/BRACKET - CLEAR/ROUND - PASSENGER
6	129927-01-000	EA	HEADLAMP - W/HALOGEN - RIGHT HAND - FORD
6	124163-01-000	EA	CLIP - HEADLAMP/MOUNTING BRACKET - FORD #E9DZ-13N129A
7	135879-02-02B	EA	BRACKET - PARKLAMP/RIGHT HAND - E-COATED
8	124161-02-000	EA	LAMP - DRIVER PARK/TURN
9	130051-02-000	EA	LAMP - FOG W/BRACKET - CLEAR/ROUND - DRIVER
10	129927-02-000	EA	HEADLAMP - W/HALOGEN - LEFT HAND - FORD
10	124163-01-000	EA	CLIP - HEADLAMP/MOUNTING BRACKET - FORD #E9DZ-13N129A
11	135879-03-02B	EA	BRACKET - PARKLAMP/LEFT HAND - E-COATED
12	087201-01-000	EA	LIGHT - HALF ROUND - 1" X 1.7" - PLASTIC - BLACK OR WHITE
13	113589-01-000	EA	CONNECTOR - PLUG - TRAILER
13	113589-02-000	EA	CONNECTOR - SOCKET - TRAILER
14	124186-01-000	EA	LIGHT - BACKUP (WHITE/CLEAR)
14	124220-01-000	EA	BULB - 12 VOLT/1.75 AMP/21 WATT - #7506
15	124186-04-000	EA	REFLECTOR - RED
16	124186-02-000	EA	LIGHT - TURN/AMBER
16	124220-01-000	EA	BULB - 12 VOLT/1.75 AMP/21 WATT - #7506
17	124186-03-000	EA	LIGHT - STOP/TAIL - RED
17	124234-01-000	EA	BULB - 12 VOLT/1.7-.42AMP #7528
18	136917-01-000	EA	LIGHT - BRAKE - CENTER MOUNT - OVAL
19	129942-02-000	EA	LAMP - CLEARANCE - RED
20	NOT USED		

\*COMPONENT PARTS LISTED LATER IN THIS GROUP

**ELECTRICAL GROUP (CONTINUED)**  
**12V BODY WIRING (CONTINUED)**

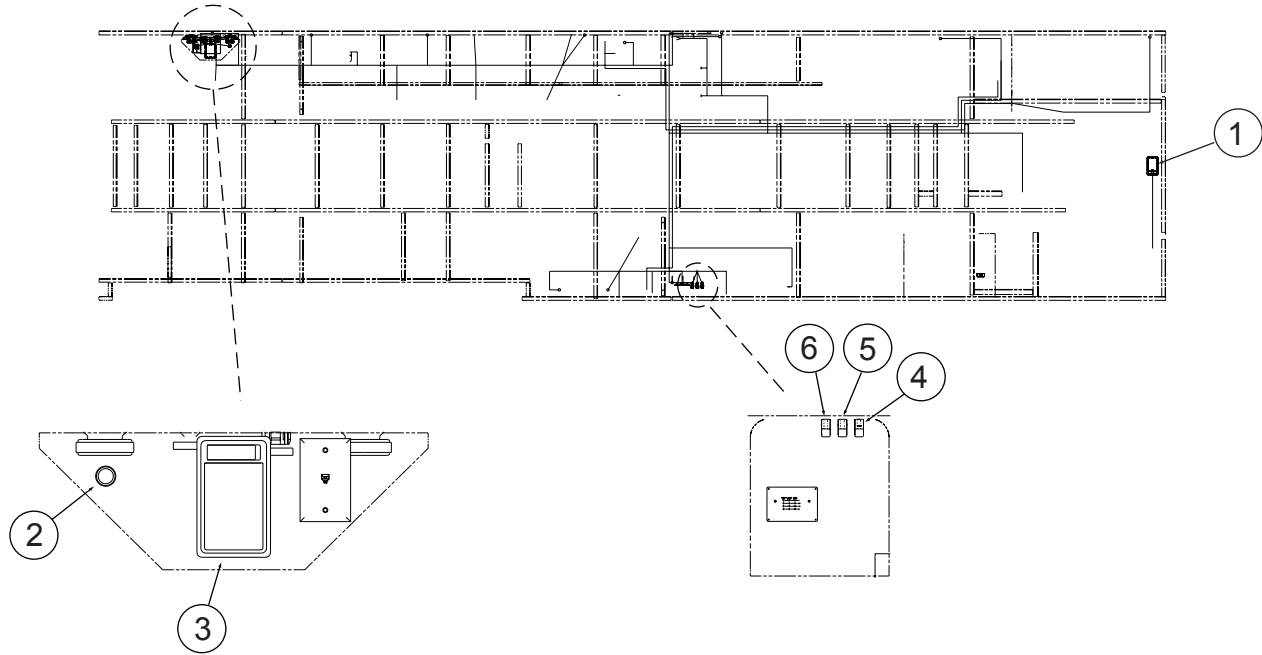

KEY	PART NUMBER	U/M	DESCRIPTION
1*	137417-01-01A	EA	LIGHT - DOME - SINGLE - W/SWITCH/FROSTED LENS - WHITE
2	111414-01-000	EA	RECEPTACLE/SOCKET - 12 VOLT
3*	098024-01-03A	EA	LIGHT - DOME - 1 BULB - WHITE
4	108357-15-000	EA	SWITCH - ROCKER - DPDT - ON/NONE/ON - LIGHTED
4	108356-02-01A	EA	COVER/ACTUATOR SWITCH - 2 ROWS DIMPLES- CONTURA II - BLACK
4	108355-01-000	EA	HOUSING - SWITCH
5	108357-09-000	EA	SWITCH - ROCKER - SPDT - ON/NONE/MOM - 3 TERMINAL
5	108356-02-01A	EA	COVER/ACTUATOR SWITCH - 2 ROWS DIMPLES- CONTURA II - BLACK
5	108355-01-000	EA	HOUSING - SWITCH
6	108357-01-000	EA	SWITCH - ROCKER - SPST - ON/OFF - 2 TERMINAL
6	108356-02-01A	EA	COVER/ACTUATOR SWITCH - 2 ROWS DIMPLES- CONTURA II - BLACK
6	108355-01-000	EA	HOUSING - SWITCH

**\*COMPONENT PARTS LISTED LATER IN THIS GROUP**

## ELECTRICAL GROUP (CONTINUED)

### 12V BODY WIRING (CONTINUED)

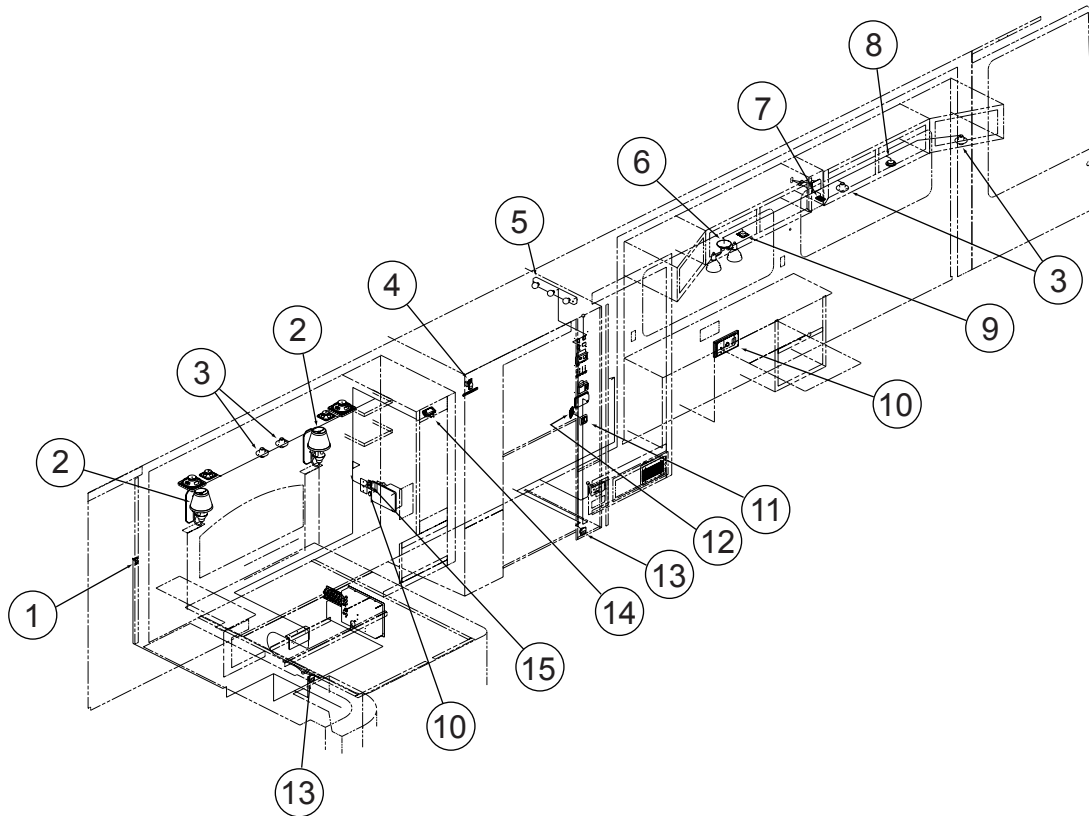

KEY	PART NUMBER	U/M	DESCRIPTION
1	041250-01-000	EA	SWITCH - PUSH BUTTON/DOOR JAMB - METAL - CHROME
2	119258-40-01A	EA	LAMP - WALL - UL/CSA - BRASS
2	065201-09-000	EA	SHADE - LAMP - FABRIC/PARCHMENT - 4.1"T X 6.1"H X 7.1"B
2	117805-02-000	EA	BULB - 12V - #921 - 1.4 AMPS
3	132427-01-01A	EA	LIGHT - READING - SWIVEL/ROUND - BRASS
	123917-01-000	EA	BULB - 12V - HALOGEN SPOT
4	081994-10-000	EA	PLATE/SWITCH - SLIDEOUT
4	108357-06-000	EA	SWITCH - ROCKER - DPDT - MOM/OFF/MOM - 6 TERMINAL
4	108356-02-01A	EA	COVER/ACTUATOR SWITCH - 2 ROWS DIMPLES- CONTURA II - BLACK
4	108355-01-000	EA	HOUSING - SWITCH
5	123774-03-01A	EA	LIGHT - MAKE UP - 3 BULB
	123918-01-000	EA	BULB - 12V - MAKEUP WHITE
6	093575-28-01A	EA	LIGHT-CEILING,TRIPLE BRASS
6	117806-01-000	EA	BULB - 12V - #912 - 1.0 AMP
7	135740-01-02A	EA	SWITCH - ROCKER - SPST - ON/OFF - WHITE
7	135741-01-02A	EA	SWITCH - BASE - SINGLE - WHITE
7	135742-01-02A	EA	BEZEL - SWITCH - SINGLE - WHITE
8*	123775-01-01A	EA	LIGHT - HALOGEN - ROUND
8	123917-01-000	EA	BULB - 12V - HALOGEN SPOT
9	137889-01-000	EA	SWITCH - LIGHT DIMMER
10	132958-01-000	EA	RECEPTACLE - 12 VOLT - MOUNTING FLANGE - BLACK
11	135740-01-02A	EA	SWITCH - ROCKER - SPST - ON/OFF - WHITE
11	135741-02-02A	EA	SWITCH - BASE - DOUBLE - WHITE
11	135742-15-01A	EA	BEZEL - SWITCH - CEILING/SHOWER - WHITE
12	135740-01-02A	EA	SWITCH - ROCKER - SPST - ON/OFF - WHITE
12	135741-02-02A	EA	SWITCH - BASE - DOUBLE - WHITE
12	135742-14-01A	EA	BEZEL - SWITCH - MAKEUP/CEILING - WHITE
13*	108354-01-01A	EA	LIGHT - COURTESY
14*	087694-01-000	EA	LIGHT - WARDROBE/CLOSET - W/SWITCH
15	098351-07-01A	EA	PLATE/SWITCH - 1 GANG - POLISHED BRASS - GENERATOR
15	108357-10-000	EA	SWITCH - ROCKER - SPDT - MOM/NONE/MOM-5 TERMINAL-W/LIGHT
15	108356-05-01A	EA	COVER/ACTUATOR SWITCH-3 GROOVES W/LENS-GEN SET-CONTURA III
15	108355-01-000	EA	HOUSING - SWITCH

\*COMPONENT PARTS LISTED LATER IN THIS GROUP

## ELECTRICAL GROUP (CONTINUED)

### 12V BODY WIRING (CONTINUED)

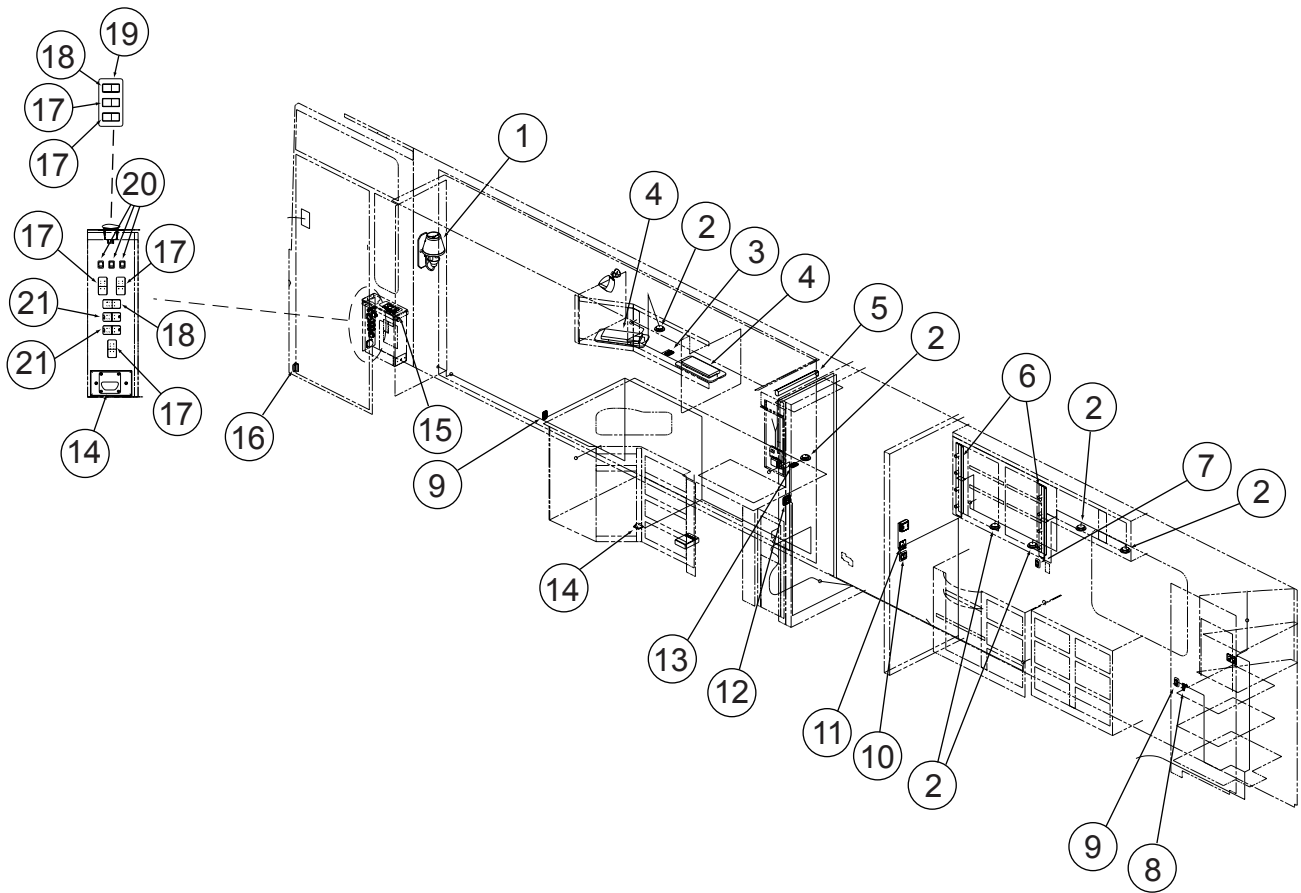

KEY	PART NUMBER	U/M	DESCRIPTION
1	119258-40-01A	EA	LAMP - WALL - UL/CSA - BRASS
1	065201-09-000	EA	SHADE - LAMP - FABRIC/PARCHMENT - 4.1"T X 6.1"H X 7.1"B
1	117805-02-000	EA	BULB - 12V - #921 - 1.4 AMPS
2*	123775-01-01A	EA	LIGHT - HALOGEN - ROUND
2	123917-01-000	EA	BULB - 12V - HALOGEN SPOT
3	135740-01-02A	EA	SWITCH - ROCKER - SPST - ON/OFF - WHITE
3	135741-01-02A	EA	SWITCH - BASE - SINGLE - WHITE
3	135742-07-01A	EA	BEZEL - SWITCH - CEILING - WHITE
4*	091937-09-000	EA	LIGHT-FLOURESCENT-12V/16 WATT RECESSED - W/SWITCH
5	113371-02-000	EA	LIGHT-FLUORESCENT 24", STRIP
6	123774-02-01A	EA	LIGHT - MAKE UP - 4 BULB
6	123918-01-000	EA	BULB - 12V - MAKEUP WHITE
7	135740-01-02A	EA	SWITCH - ROCKER - SPST - ON/OFF - WHITE
7	135741-01-02A	EA	SWITCH - BASE - SINGLE - WHITE
7	135742-08-01A	EA	BEZEL - SWITCH - MAKEUP - WHITE
8	041250-01-000	EA	SWITCH - PUSH BUTTON/DOOR JAMB - METAL - CHROME
9	135740-01-02A	EA	SWITCH - ROCKER - SPST - ON/OFF - WHITE
9	135741-01-02A	EA	SWITCH - BASE - SINGLE - WHITE
9	135742-06-01A	EA	BEZEL - SWITCH - AISLE - WHITE

**ELECTRICAL GROUP (CONTINUED)**  
**12V BODY WIRING (CONTINUED)**

KEY	PART NUMBER	U/M	DESCRIPTION
10	135740-01-02A	EA	SWITCH - ROCKER - SPST - ON/OFF - WHITE - <b>READING</b>
10	135740-02-02A	EA	SWITCH - ROCKER - SPDT - ON/ON - WHITE - <b>AISLE</b>
10	135741-02-02A	EA	SWITCH - BASE - DOUBLE - WHITE
10	135742-21-02A	EA	BEZEL - SWITCH - AISLE/READING - BROWN
11	137889-01-000	EA	SWITCH - LIGHT DIMMER
12	135740-01-02A	EA	SWITCH - ROCKER - SPST - ON/OFF - WHITE - <b>GALLEY</b>
12	135740-02-02A	EA	SWITCH - ROCKER - SPDT - ON/ON - WHITE - <b>LOUNGE</b>
12	135741-02-02A	EA	SWITCH - BASE - DOUBLE - WHITE
12	135742-18-01A	EA	BEZEL - SWITCH - LOUNGE/GALLEY - WHITE
13	135740-01-02A	EA	SWITCH - ROCKER - SPST - ON/OFF - WHITE
13	135741-01-02A	EA	SWITCH - BASE - SINGLE - WHITE
13	135742-01-02A	EA	BEZEL - SWITCH - SINGLE - WHITE
14*	108354-01-01A	EA	LIGHT - COURTESY
15	132958-01-000	EA	RECEPTACLE - 12 VOLT - MOUNTING FLANGE - BLACK
16	116995-02-000	EA	SWITCH/MAGNET - ELECTRIC STEP - BLACK/WHITE-CLOSED CIRCUIT
17	108357-06-000	EA	SWITCH - ROCKER - DPDT - MOM/OFF/MOM - 6 TERMINAL
17	108356-01-01A	EA	COVER/ACTUATOR SWITCH - 3 GROOVES - CONTURA III - BLACK
17	108355-01-000	EA	HOUSING - SWITCH
18	108357-01-000	EA	SWITCH - ROCKER - SPST - ON/OFF - 2 TERMINAL
18	108356-01-01A	EA	COVER/ACTUATOR SWITCH - 3 GROOVES - CONTURA III - BLACK
18	108355-01-000	EA	HOUSING - SWITCH
19	142487-02-02B	EA	PLATE - SWITCH - E-COATED
19	142475-02-01A	EA	APPLIQUE - SWITCH - PASSENGER
20	132180-01-01A	EA	SWITCH - PADDLE - SPST - ON/OFF - BLACK
21	108357-06-000	EA	SWITCH - ROCKER - DPDT - MOM/OFF/MOM - 6 TERMINAL
21	108356-12-01A	EA	COVER/ACTUATOR SWITCH - 3 GROOVES
21	108355-01-000	EA	HOUSING - SWITCH

**\*COMPONENT PARTS LISTED LATER IN THIS GROUP**



## ELECTRICAL GROUP (CONTINUED)

### 12V BODY WIRING (CONTINUED)

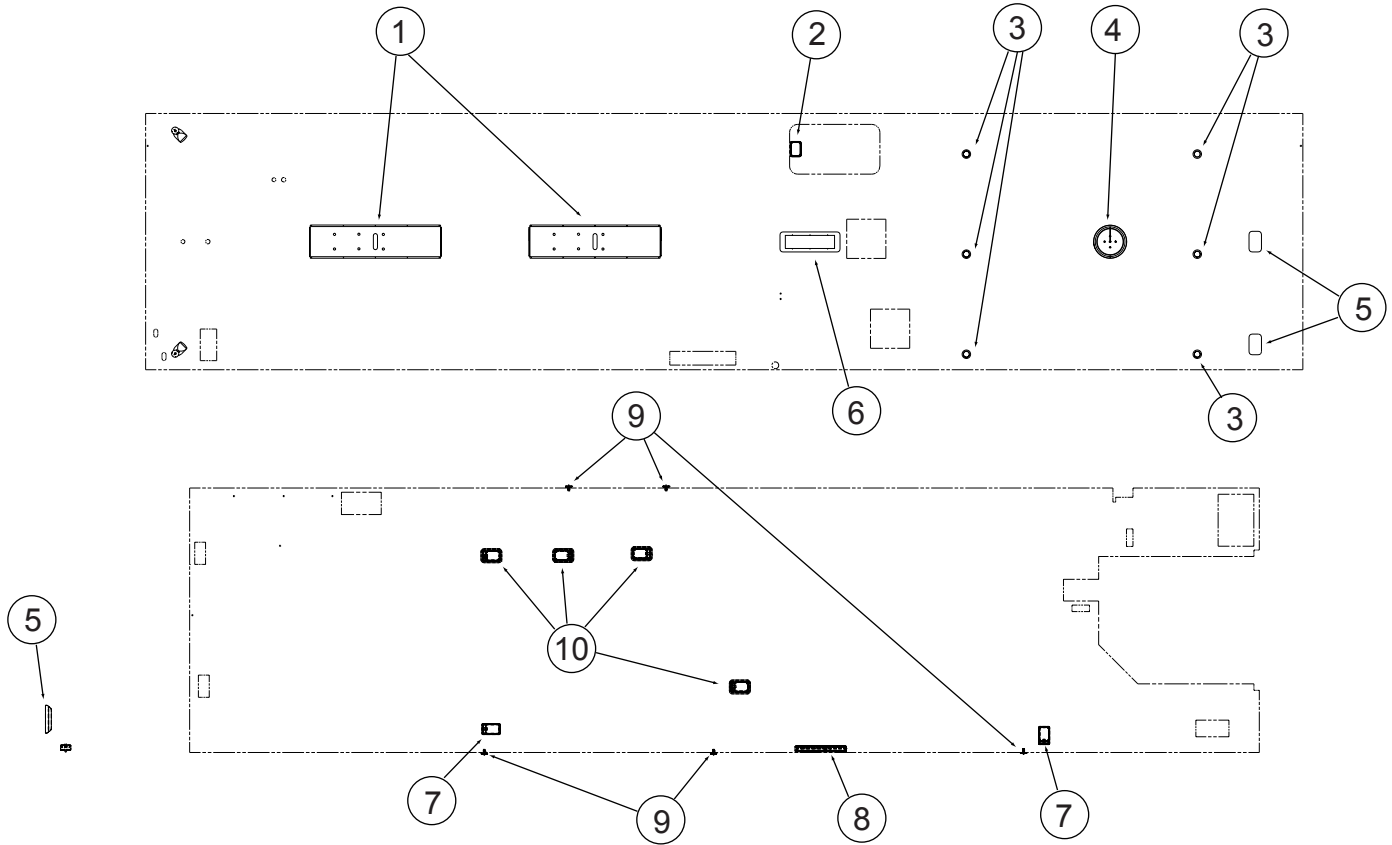

KEY	PART NUMBER	U/M	DESCRIPTION
1	133416-01-000	EA	LIGHT - FLOURESCENT W/O LENS - 48" - 1 BULB
2*	121935-01-01A	EA	LIGHT - DOME - SHOWER
3*	123775-01-01A	EA	LIGHT - HALOGEN - ROUND
3	123917-01-000	EA	BULB - 12V - HALOGEN SPOT
4*	093575-22-01A	EA	LIGHT - CEILING/ROUND - BRASS - UL/CSA
	117806-01-000	EA	BULB - 12V - #912 - 1.0 AMP
5*	137417-03-01A	EA	LIGHT - DOME - SINGLE - W/FROSTED LENS - W/O SWITCH-WHITE
6*	091937-10-000	EA	LIGHT-FLOURESCENT-12V/16 WATT RECESSED - W/O SWITCH
7*	098024-01-03A	EA	LIGHT - DOME - 1 BULB - WHITE
7	008218-01-000	EA	BULB - 12 VOLT - #1141 - 1.44 AMP
8	127327-01-01A	EA	LAMP - FLUORESCENT - BLACK/THIN LITE
9	041250-01-000	EA	SWITCH - PUSH BUTTON/DOOR JAMB - METAL - CHROME
10*	098024-01-03A	EA	LIGHT - DOME - 1 BULB - WHITE
10	008218-01-000	EA	BULB - 12 VOLT - #1141 - 1.44 AMP
10	098023-01-02A	EA	SHROUD - CEILING LIGHT - SINGLE WHITE

\*COMPONENT PARTS LISTED LATER IN THIS GROUP

## ELECTRICAL GROUP (CONTINUED)

### FRONT END WIRING

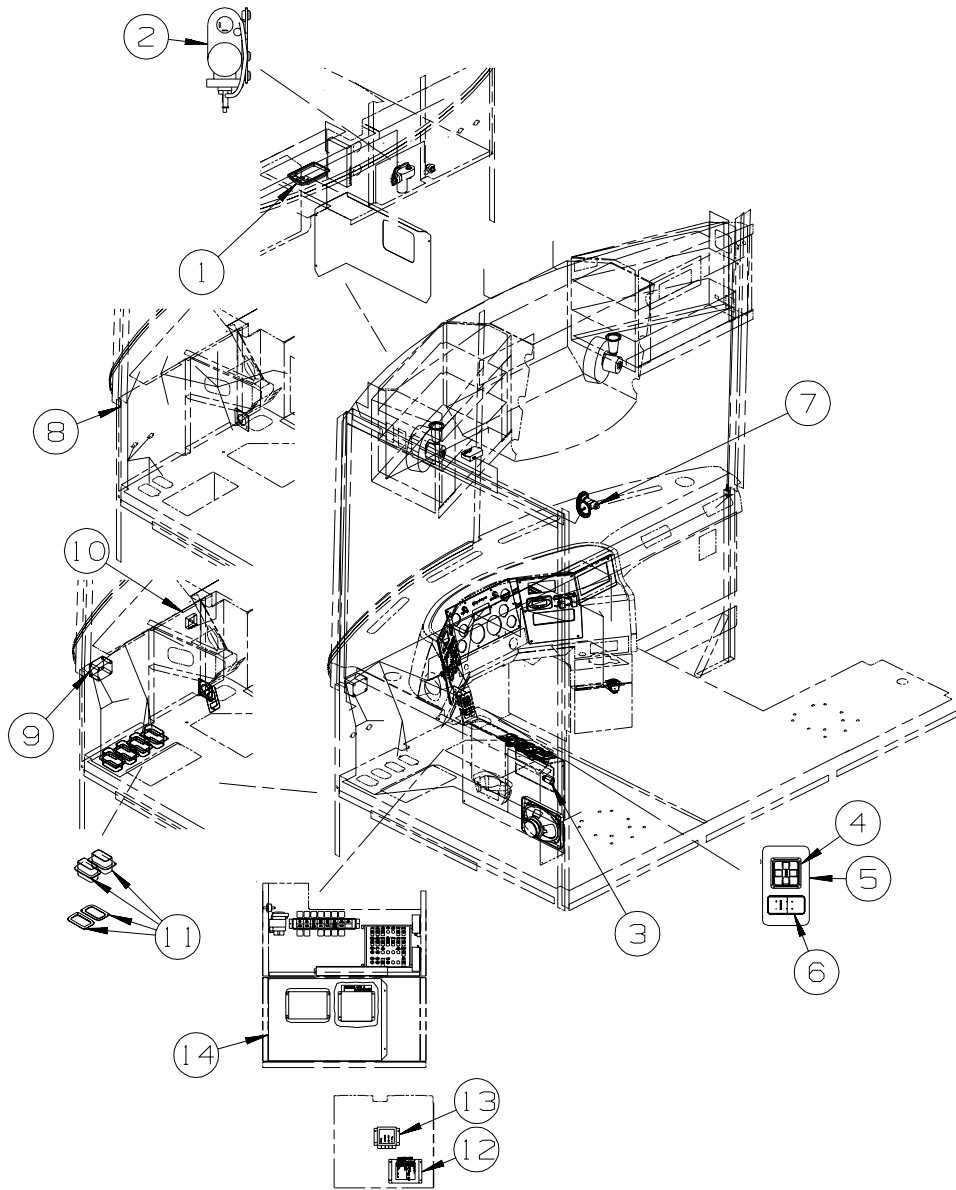

KEY	PART NUMBER	U/M	DESCRIPTION
1*	098024-01-03A	EA	LIGHT - DOME - 1 BULB - WHITE
	008218-01-000	EA	BULB - 12 VOLT - #1141 - 1.44 AMP
2	114802-01-000	EA	PUMP - VACUUM - 12V
3	132958-01-000	EA	RECEPTACLE - 12 VOLT - MOUNTING FLANGE - BLACK
4	088246-01-000	EA	SWITCH/REMOTE MIRROR - W/2PIN & 6 PIN CONNECTORS/PIGTAIL
5	099982-06-02B	EA	PLATE - SWITCH - E-COATED
6	108357-14-000	EA	SWITCH - ROCKER - SPST - W/LIGHT - ON/OFF - 4 TERMINAL
6	108356-03-01A	EA	COVER/ACTUATOR SWITCH -3 GROOVES W/LIGHT-CONTRA III-BLACK
6	108355-01-000	EA	HOUSING - SWITCH
7	128786-01-01A	EA	LIGHT - READING/SWIVEL9
			FROM: 00-00-00 THRU: 09-18-02
7	128786-02-01A	EA	LIGHT - READING/SWIVEL - W/O SWITCH - BRASS
			FROM: 09-19-02 THRU: 99-99-99
	123917-01-000	EA	BULB - 12V - HALOGEN SPOT
8	113452-01-000	FT	SEAL/TRIM - FRONT - VINYL W/WIRE CARRIER - .020"
9	128074-02-000	EA	FILTER - NOISE - 12 VOLT DC W/PLUGS
10	133535-01-000	EA	MODULE - TIMER 20 SECOND - WARNING LIGHT - TS61120P
11	118571-03-000	EA	BRACKET - MOUNTING
11	118571-04-000	EA	GASKET
12*	102756-03-000	EA	REMOTE - KEYLESS ENTRY CARGO
13	130366-01-000	EA	MODULE - CHARGE CNTRL/BI-DIRECTIONAL ISOLATOR RELAY DELAY
14	141683-03-02B	EA	PANEL/CLOSEOUT - ELECTRICAL - E-COATED

\*COMPONENT PARTS LISTED LATER IN THIS GROUP

## ELECTRICAL GROUP (CONTINUED)

### FRONT END WIRING (CONTINUED)

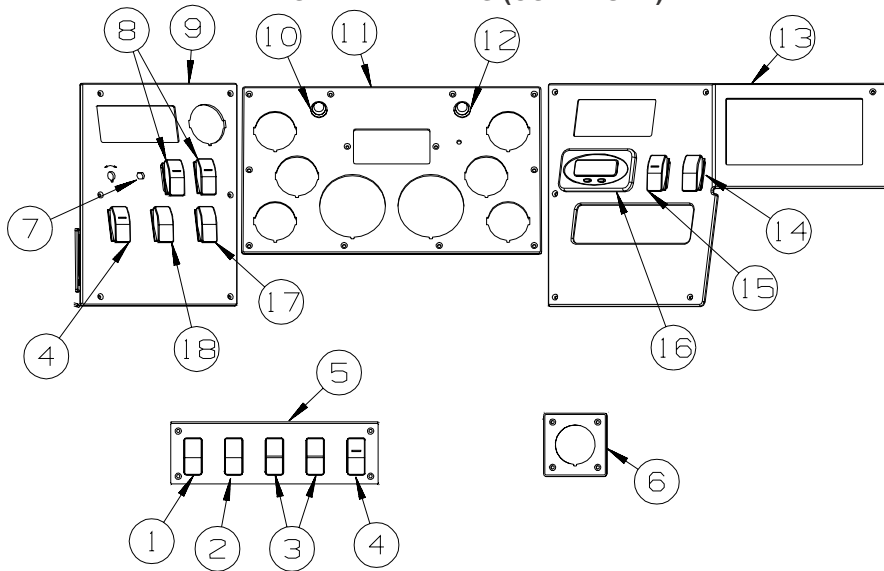

#### KEY PART NUMBER

#### U/M DESCRIPTION

1	096241-03-000	EA SWITCH - BLANK - BLACK
2	108357-07-000	EA SWITCH - ROCKER - SPDT - MOM/OFF/MOM - 3 TERMINAL
2	108356-01-01A	EA COVER/ACTUATOR SWITCH - 3 GROOVES - CONTURA III - BLACK
2	108355-01-000	EA HOUSING - SWITCH
3	108357-06-000	EA SWITCH - ROCKER - DPDT - MOM/OFF/MOM - 6 TERMINAL
3	108356-01-01A	EA COVER/ACTUATOR SWITCH - 3 GROOVES - CONTURA III - BLACK
3	108355-01-000	EA HOUSING - SWITCH
4	108357-15-000	EA SWITCH - ROCKER - DPDT - ON/NONE/ON - LIGHTED
4	108356-03-01A	EA COVER/ACTUATOR SWITCH - 3 GROOVES W/LIGHT-CONTRA III-BLACK
4	108355-01-000	EA HOUSING - SWITCH
5	139046-04-01A	EA PANEL/SWITCH - INSTRUMENT PANEL - MATTE BLACK(ILLUMINATED)
6	143527-01-01A	EA BEZEL - GAUGE - SINGLE - MATT BLACK
7*	091206-04-000	EA MODULE KIT - WIPER CONTROL - DYNAMIC PARK
8	108357-14-000	EA SWITCH - ROCKER - SPST - W/LIGHT - ON/OFF - 4 TERMINAL
8	108356-03-01A	EA COVER/ACTUATOR SWITCH - 3 GROOVES W/LIGHT-CONTRA III-BLACK
8	108355-01-000	EA HOUSING - SWITCH
9	134553-05-01A	EA PANEL/SWITCH - INSTRUMENT (DRVR)-MATTE BLACK(ILLUMINATED)
10	133534-01-000	EA LIGHT - RED INDICATOR WITH 1/4" TERMINALS
11	134552-04-01A	EA BEZEL/DASH - CENTER - MATTE BLACK - SPARTAN
		FROM: 00-00-00 THRU: 07-07-02
11	134552-05-01A	EA BEZEL/DASH - CENTER - MATTE BLACK
		FROM: 07-08-02 THRU: 99-99-99
12	133534-02-000	EA LIGHT - AMBER INDICATOR WITH 1/4" TERMINALS
13	134556-05-01A	EA BEZEL/DASH - RIGHT HAND - <b>W/O TRIP TEK/TRIP COMPUTER</b>
13	134556-06-01A	EA BEZEL/DASH - RH - W/CIRCUIT TAPE - F/TRIP COMPUTER - BLK - <b>TRIP TEK/TRIP COMPUTER</b>
14	108357-08-000	EA SWITCH - ROCKER - DPDT - ON/NONE/ON - 6 TERMINAL
14	108356-01-01A	EA COVER/ACTUATOR SWITCH - 3 GROOVES - CONTURA III - BLACK
14	108355-01-000	EA HOUSING - SWITCH
15	108357-10-000	EA SWITCH - ROCKER - SPDT - W/LIGHT - MOM/NONE/MOM-5 TERMINAL
15	108356-03-01A	EA COVER/ACTUATOR SWITCH - 3 GROOVES W/LIGHT-CONTRA III-BLACK
15	108355-01-000	EA HOUSING - SWITCH
16*	136119-01-000	EA COMPASS/THERMOMETER - ELECTRONIC- 4.5" X 2.3" DISPLAY FACE
17	108357-09-000	EA SWITCH - ROCKER - SPDT - ON/NONE/MOM - 3 TERMINAL
17	108356-01-01A	EA COVER/ACTUATOR SWITCH - 3 GROOVES - CONTURA III - BLACK
17	108355-01-000	EA HOUSING - SWITCH
18	108357-03-000	EA SWITCH - ROCKER - SPDT - ON/OFF/ON - 3 TERMINAL
18	108356-01-01A	EA COVER/ACTUATOR SWITCH - 3 GROOVES - CONTURA III - BLACK
18	108355-01-000	EA HOUSING - SWITCH
*	137424-01-000	EA GPS-NAVIGATION SYS-W/DVD DIVIT/MAPS/GPS ANT & WIRE HARNESS - <b>MAPPING SYSTEM</b>
	137424-02-000	EA MONITOR/LCD - COLOR - 6.5" - W/INTERFACE BOX & HARNESS - <b>MAPPING SYSTEM</b>
		FROM: 00-00-00 THRU: 06-06-02
	137424-03-000	EA MONITOR/LCD - COLOR - <b>MAPPING SYSTEM</b>
		FROM: 06-07-02 THRU: 99-99-99

\*COMPONENT PARTS LISTED LATER IN THIS GROUP

**ELECTRICAL GROUP (CONTINUED)**  
**FRONT END WIRING (CONTINUED)**

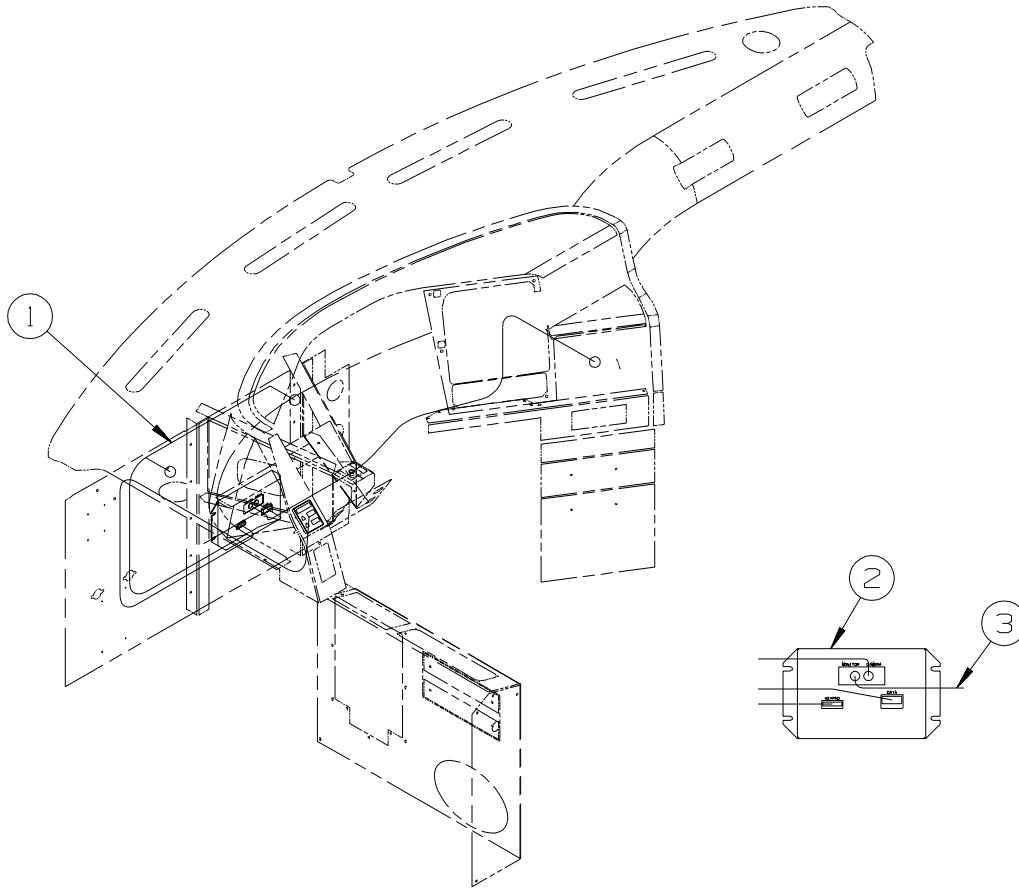

KEY	PART NUMBER	U/M	DESCRIPTION
1	143591-02-000	EA	WIRE LOOM - COMPUTER TRIP/ENGINE MONITOR-TRIP TEK 02-04007
2	143591-05-000	EA	COMPUTER - TRIP/ENGINE MONITOR - COLOR - TRIP TEK 2500-3
3	143591-04-000	EA	CABLE ASM-CAMERA COLOR INTER - TRIP TEK 02-04009

**ELECTRICAL GROUP (CONTINUED)**  
**COMPONENT PARTS FOR LIGHTS & SWITCHES**

008089-02-000

KEY	PART NUMBER	U/M	DESCRIPTION	VENDOR NO.
	008089-01-700	EA	LENS/PORCH LIGHT RECESSED	DECO

087694-01-000

KEY	PART NUMBER	U/M	DESCRIPTION	VENDOR NO.
	087694-01-700	EA	BULB	GE561

091206-04-000

KEY	PART NUMBER	U/M	DESCRIPTION	VENDOR NO.
	091206-02-700	EA	KNOB-INNER	66C-00019
	091206-02-701	EA	KNOB-OUTER	66C-00020
	091206-04-700	EA	SWITCH ASSEM. ONLY	250-6623
	102362-03-700	EA	MODULE-WIPER CONT., DYNAMIC	66D-00093

091937-09-000

KEY	PART NUMBER	U/M	DESCRIPTION	VENDOR NO.
	091937-09-700	EA	LENS - LIGHT - FLUORESCENT	D-762

091937-10-000

KEY	PART NUMBER	U/M	DESCRIPTION	VENDOR NO.
	091937-09-700	EA	LENS - LIGHT - FLUORESCENT	D-762

093575-22-01A

KEY	PART NUMBER	U/M	DESCRIPTION	VENDOR NO.
	093575-19-700	EA	GLOBE F/55-556X2 LIGHT	9088

097917-01-06A

KEY	PART NUMBER	U/M	DESCRIPTION	VENDOR NO.
	097917-01-700	EA	LENS-LIGHT, CLEAR	30-78-021

098024-01-03A

KEY	PART NUMBER	U/M	DESCRIPTION	VENDOR NO.
	098024-01-700	EA	LENS-LIGHT	807877

102756-03-000

KEY	PART NUMBER	U/M	DESCRIPTION	VENDOR NO.
	102756-02-702	EA	BATTERY-12 VOLT	402-1002
	102756-03-700	EA	MODULE BOARD	202-3219
	102756-03-701	EA	REMOTE-KEYLESS ENTRY	412-1115
	102756-03-702	EA	RELAY- 30AMP - SPDT	463-1000
	102756-03-703	EA	WIRE HARNESS - KEYLESS ENTRY	203-6879

108354-01-01A

KEY	PART NUMBER	U/M	DESCRIPTION	VENDOR NO.
	108354-01-700	EA	BULB-COURTESY LIGHT	395-B

121935-01-01A

KEY	PART NUMBER	U/M	DESCRIPTION	VENDOR NO.
	121935-01-700	EA	LENS ONLY	809511

123775-01-01A

KEY	PART NUMBER	U/M	DESCRIPTION	VENDOR NO.
	123775-01-700	EA	BULB - 10 WATT - HALOGEN	71-JC10
	123775-01-701	EA	BEZEL/LENS - RECESSED LIGHT	

130051-01-000

KEY	PART NUMBER	U/M	DESCRIPTION	VENDOR NO.
	130051-01-700	EA	BULB/REPLACEMENT	689D

**ELECTRICAL GROUP (CONTINUED)**  
**COMPONENT PARTS FOR LIGHTS & SWITCHES (CONTINUED)**

**136119-01-000**

<b>KEY</b>	<b>PART NUMBER</b>	<b>U/M</b>	<b>DESCRIPTION</b>	<b>VENDOR NO.</b>
	136119-01-700	EA	COMPASS SENSOR (BLACK BOX )	AP-SUB-005
	136119-01-701	EA	PROBE/TEMPERATURE SENSOR(V1)	AP-SUB-004A
	136119-01-702	EA	DISPLAY MODULE-LED (V1)	AP-SUB-004B
	136119-01-703	EA	HARNESS - COMPASS POWER	AP-HRN-175
	136119-01-704	EA	HARNESS - COMPASS ENGINE	AP-HRN-176
	136119-01-705	EA	HRNSS-COMP.TEMP SENSOR V1	AP-HRN-177
	136119-01-706	EA	PROBE/TEMPERATURE SENSOR (V2)	AP-SUB-006
	136119-01-707	EA	DISPLAY MODULE - VISUAL (V2)	AP-SUB-007
	136119-01-708	EA	HARNESS/COMP. COMP/THERM(V2)	AP-HRN-239 W/PACKRD

**137417-01-01A**

<b>KEY</b>	<b>PART NUMBER</b>	<b>U/M</b>	<b>DESCRIPTION</b>	<b>VENDOR NO.</b>
	137417-01-700	EA	LENS - SINGLE (FROSTED)	810868

**137417-03-01A**

<b>KEY</b>	<b>PART NUMBER</b>	<b>U/M</b>	<b>DESCRIPTION</b>	<b>VENDOR NO.</b>
	137417-01-700	EA	LENS - SINGLE (FROSTED)	810868

**137424-01-000**

<b>KEY</b>	<b>PART NUMBER</b>	<b>U/M</b>	<b>DESCRIPTION</b>	<b>VENDOR NO.</b>
	137424-01-700	EA	DISC - SETUP - DVD	NVD-A131

**ELECTRICAL GROUP (CONTINUED)**  
**CIRCUIT BREAKERS & FUSES**

<b>KEY</b>	<b>PART NUMBER</b>	<b>U/M</b>	<b>DESCRIPTION</b>
	008233-01-000	EA	FUSE - 12 VOLT - 6 AMP
	008235-01-000	EA	FUSE - 15 AMP/12VOLT - AUTOMOTIVE
	008268-01-000	EA	CIRCUIT BREAKER W/MOUNT - 30A, 12V - FASCO 1711-3023
	033573-01-000	EA	CIRCUIT BREAKER W/MOUNT-20A, 12V - FASCO 1711-2026
	062901-02-000	EA	FUSE - 5 AMP - AUTOMOTIVE
	062901-04-000	EA	FUSE - 10 AMP - AUTOMOTIVE
	062901-05-000	EA	FUSE - 15 AMP - AUTOMOTIVE
	062901-06-000	EA	FUSE - 20 AMP - AUTOMOTIVE
	062901-07-000	EA	FUSE - 25 AMP - AUTOMOTIVE
	062901-08-000	EA	FUSE - 30 AMP - AUTOMOTIVE
	083209-01-000	EA	CIRCUIT BREAKER - 15 AMP - 120 VOLT - CANADIAN
	083209-02-000	EA	CIRCUIT BREAKER - 15/15 AMP - 120 VOLT
	083209-03-000	EA	CIRCUIT BREAKER - 15/20 AMP - 120 VOLT
	083209-04-000	EA	CIRCUIT BREAKER - 30 AMP - 120 VOLT
	083209-05-000	EA	CIRCUIT BREAKER - 20 AMP - 120 VOLT
	083209-06-000	EA	CIRCUIT BREAKER - 30/15 AMP - 120 VOLT
	083209-07-000	EA	CIRCUIT BREAKER - 20/20 AMP - 120 VOLT
	083209-10-000	EA	CIRCUIT BREAKER - 20/30 AMP - 120 VOLT
	083209-11-000	EA	CIRCUIT BREAKER - 20/15 AMP - 120 VOLT
	092786-03-000	EA	BUSS BAR - 6.9" LONG
	092786-06-000	EA	BUSS BAR
	093654-01-000	EA	CIRCUIT BREAKER - 6 AMP - 12 VOLT - PUSH BUTTON - WHITE
	093654-02-000	EA	CIRCUIT BREAKER - 15 AMP - 12 VOLT - PUSH BUTTON - WHITE
	093654-03-000	EA	CIRCUIT BREAKER - 20 AMP - 12 VOLT - PUSH BUTTON - WHITE
	093654-11-000	EA	COVER - RESET BUTTON
	093655-01-000	EA	CIRCUIT BREAKER - 25 AMP - 12 VOLT - PUSH BUTTON - WHITE
	093655-02-000	EA	CIRCUIT BREAKER - 30 AMP - 12 VOLT - PUSH BUTTON - WHITE
	093655-03-000	EA	CIRCUIT BREAKER - 40 AMP - 12 VOLT - PUSH BUTTON - WHITE
	097611-01-000	EA	CIRCUIT BREAKER - 10 AMP
	097611-03-000	EA	CIRCUIT BREAKER - 20 AMP
	097611-04-000	EA	CIRCUIT BREAKER - 25 AMP
	106656-01-000	EA	FUSE BLOCK - 4 CAVITY - AUTOFUSE
	108567-01-000	EA	CIRCUIT BREAKER - 40 AMP - 12 VOLT - TYPE II
	108669-01-000	EA	HOUSING - AUTO FUSE HOLDER
	111683-01-000	EA	FUSE - HOLDER - GLASS - 1/4" X 1 1/4"
	113482-01-000	EA	CIRCUIT BREAKER - 55 AMP - MANUAL
	113520-01-000	EA	BREAKER - CIRCUIT - 15AMP - SWITCHED
	115187-01-000	EA	FUSE - 300 AMP - NON-DELAY
	115187-02-000	EA	FUSE HOLDER - BUSS ANN/ANL BLOCK
	118531-05-02B	EA	PLATE - CIRCUIT BREAKER - E-COAT
	122811-01-000	EA	CIRCUIT BREAKER - 20/50/50/20
	125986-04-000	EA	FUSE - 10 AMP - AUTO - MINI BLADE
	125986-05-000	EA	FUSE - 15 AMP - AUTO - MINI BLADE
	134127-01-000	EA	CIRCUIT BREAKER - 10 AMP - MINI

**CONVERTER, INVERTER, LOAD CENTERS**

<b>KEY</b>	<b>PART NUMBER</b>	<b>U/M</b>	<b>DESCRIPTION</b>
	109677-01-000	EA	LOAD CENTER - 120 VOLT - 40 AMP
	113685-05-000	EA	REMOTE PANEL - INVERTER/CHARGER
	113685-06-000	EA	CABLE/HEART INVERTOR - W/MODULAR CONNECTORS - 50'
	113685-07-000	EA	INVERTER/CHARGER - 1500W AC
	127002-05-000	EA	PANEL/MONITOR - ENERGY MANAGEMENT SYSTEMS CTRL - W/PLUG
	127002-07-000	EA	SENSOR - CURRENT
	127002-08-000	EA	MODULE - EMS CENTER - W/REMOTE SENSOR
	141258-01-000	EA	LOAD CENTER - 120/240 - 50 AMP
	141258-02-000	EA	LOAD CENTER - COVER

# ELECTRICAL GROUP (CONTINUED)

## 110V WIRING

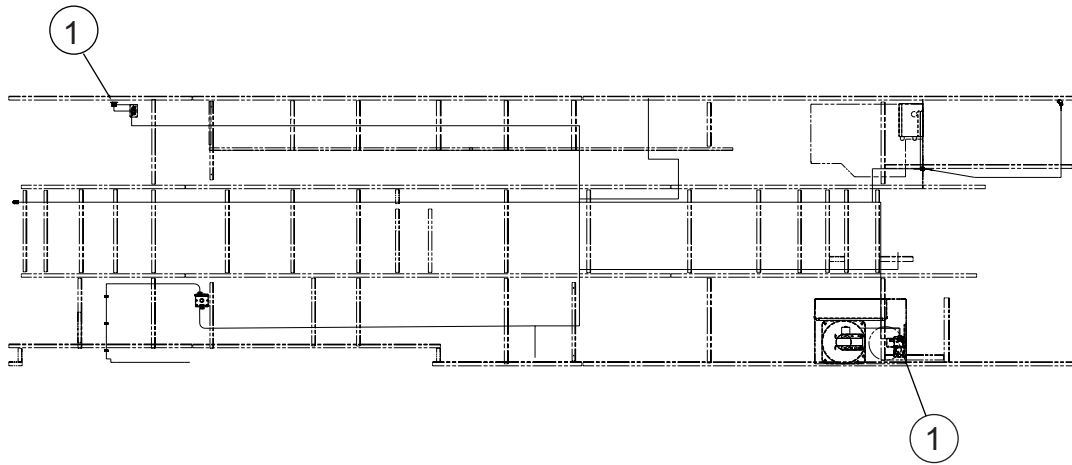

KEY	PART NUMBER	U/M	DESCRIPTION
1	058708-05-000	EA	RECEPTACLE - ELECTRIC - SINGLE - BROWN
1	058708-07-000	EA	RECEPTACLE - SINGLE - WHITE



**ELECTRICAL GROUP (CONTINUED)**  
**110V WIRING (CONTINUED)**

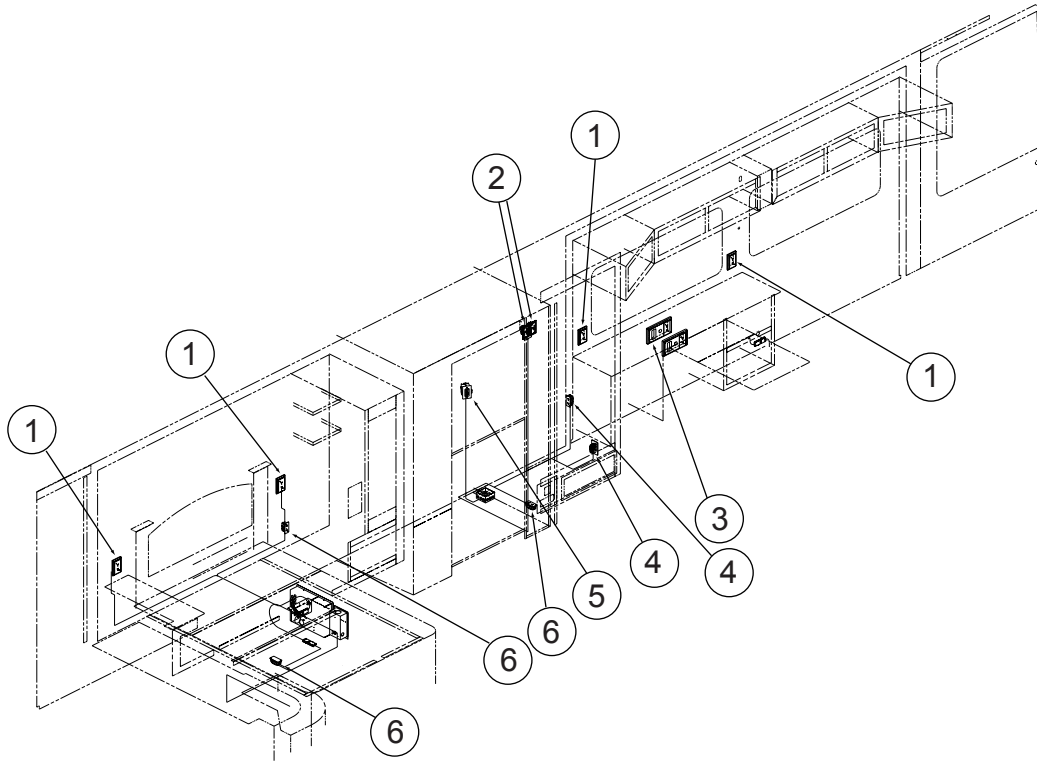

KEY	PART NUMBER	U/M	DESCRIPTION
1	058708-06-000	EA	RECEPTACLE - DUPLEX - WHITE
1	133713-01-20A	EA	SPACER/RECEPTACLE - WHITE VINYL
2	084420-01-000	EA	SWITCH - TOGGLE - 15 AMP - 120 VOLT - BROWN
3	058708-06-000	EA	RECEPTACLE - DUPLEX - WHITE
3	133713-01-20A	EA	SPACER/RECEPTACLE - WHITE VINYL
4	058708-01-000	EA	RECEPTACLE - ELECTRIC - DOUBLE - BROWN
5	084076-05-000	EA	RECEPTACLE - GFI - 15 AMP/125 VOLT - WHITE - W/COVER
6	058707-01-000	EA	RECEPTACLE - ELECTRIC - SINGLE - BROWN

**ELECTRICAL GROUP (CONTINUED)**  
**110V WIRING (CONTINUED)**

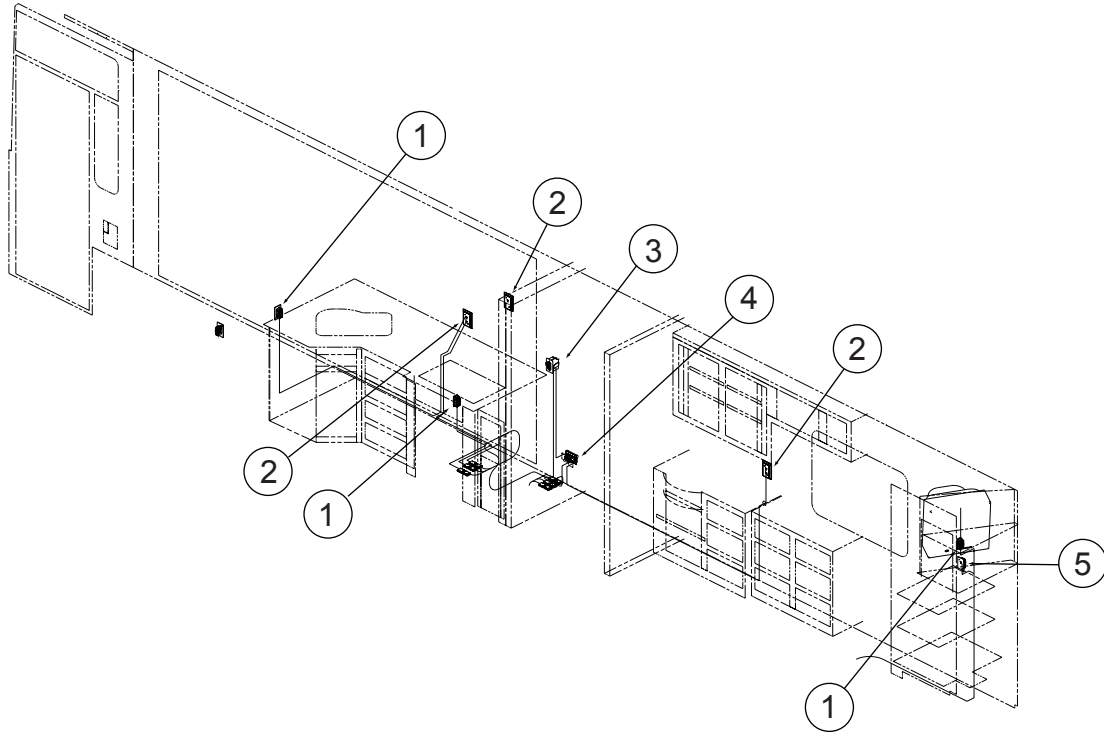

KEY	PART NUMBER	U/M	DESCRIPTION
1	058708-01-000	EA	RECEPTACLE - ELECTRIC - DOUBLE - BROWN
2	058708-06-000	EA	RECEPTACLE - DUPLEX - WHITE
2	133713-01-20A	EA	SPACER/RECEPTACLE - WHITE VINYL
3	084076-05-000	EA	RECEPTACLE - GFI - 15 AMP/125 VOLT - WHITE - W/COVER
4	131826-01-01A	EA	RECEPTACLE - EXTERIOR - W/COVER/GASKET - WHITE
5	058708-05-000	EA	RECEPTACLE - ELECTRIC - SINGLE - BROWN
5	058708-07-000	EA	RECEPTACLE - SINGLE - WHITE

**ELECTRICAL GROUP (CONTINUED)**  
**ENTERTAINMENT WIRING**

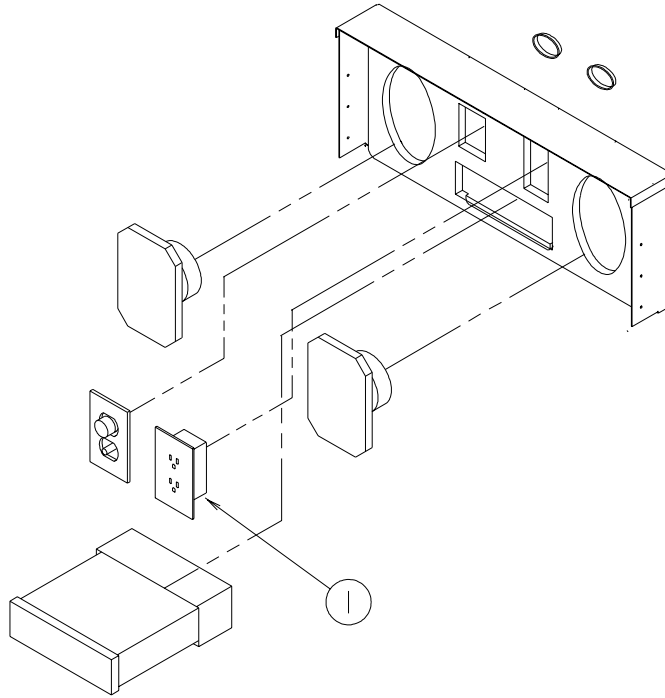

KEY	PART NUMBER	U/M DESCRIPTION
1	058708-01-000	EA RECEPTACLE - ELECTRIC - DOUBLE - BROWN

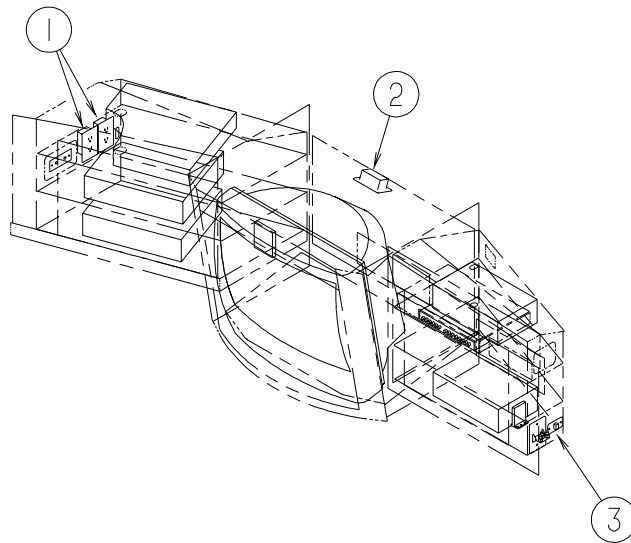

KEY	PART NUMBER	U/M DESCRIPTION
1	058708-01-000	EA RECEPTACLE - ELECTRIC - DOUBLE - BROWN
2	058708-05-000	EA RECEPTACLE - ELECTRIC - SINGLE - BROWN
3	079364-04-000	EA SWITCH - ON/OFF ROCKER - 2 TERMINAL - BLACK
3	098351-09-01A	EA PLATE/SWITCH - 1 GANG - POLISHED BRASS - SPEAKER SELECT/TV

## ELECTRICAL GROUP (CONTINUED)

### BOXES & CORDS

KEY	PART NUMBER	U/M	DESCRIPTION
	008289-01-000	EA	BOX - ELECTRIC/STEEL - 4" X 4" - 1/2" & 3/4" KNOCKOUTS
	008289-02-000	EA	BOX - ELECTRIC/STEEL - 1/2" & 3/4" KNOCKOUTS - 4" X 4"-CAN
	091910-01-000	EA	BOX - ELECTRIC - 3.8" X 3.5" X 1.8" - PLASTIC
	091910-02-000	EA	BOX - ELECTRIC - 2.2" X 3.5" X 1.8" - PLASTIC
	131679-01-000	EA	BOX-ELEC-WATERPROOF SEALED 4" X 4" W/4 3/4"OUTLETS-UL/CSA
	133070-01-000	EA	BOX - ELECTRIC/PLASTIC - 3" X 2" X 2.8" - UL
	133070-02-000	EA	BOX - ELECTRIC/PLASTIC - 3" X 2" X 2.8" - CSA
	008294-01-000	EA	COVER - ELECTRIC BOX - BLANK/STEEL - 4" X 4" - GRAY
	008294-02-000	EA	COVER - ELECTRICAL BOX - BLANK/STEEL - 4" X 4" - CANADIAN
	131680-01-000	EA	COVER - W/GASKET FOR WATERPROOF 4" X 4" BOX - UL/CSA
	106071-05-000	EA	SWITCH - AUTOMATIC TRANSFER - 50/70 - MAGNETEK FROM: 00-00-00 THRU: 10-06-02
	106071-06-000	EA	SWITCH - AUTOMATIC TRANSFER FROM: 10-07-02 THRU: 99-99-99
	108934-02-000	EA	CORD - POWER - 50 AMP - 4-WIRE - 36'
	109172-01-000	EA	CORD - POWER - 13 AMP - 3-WIRE - 4'
	115832-01-000	FT	CORD - HEAVY DUTY - 14-2W GROUND
	121470-01-000	EA	CORD/EXTENSION - 6 FOOT - 16-2 WIRE
	144858-01-000	EA	REEL - POWERED/36'-50 AMP POWERCORD INSTALLED

### WIRE ASSEMBLIES

KEY	PART NUMBER	U/M	DESCRIPTION
	097618-01-000	EA	WIRE ASSEMBLY - MONITOR PANEL- W/3 WIRES & ORANGE RESISTOR
	124842-03-000	EA	WIRE ASSEMBLY - SPEAKER/ADAPTOR
	124864-04-000	EA	WIRE - SPEAKER - DELUXE EXTENSION
	124882-09-000	EA	WIRE LOOM - AMPLIFIER - Q SURROUND
	125853-04-000	EA	WIRE LOOM - ENTERTAINMENT CENTER
	129365-02-000	EA	WIRE ASSEMBLY - CLEARANCE LAMPS - REAR
	129560-01-000	EA	WIRE LOOM - 2 MONITOR PANEL
	135131-01-000	EA	WIRE LOOM - THERMOSTAT
	136543-03-000	EA	WIRE - RADIO - CD6
	137135-03-000	EA	WIRE LOOM - DIGITAL ELEVATION SENSOR
	137135-04-000	EA	WIRE HARNESS - POWER - DIGITAL ELEVATION SENSOR
	140167-01-000	EA	WIRE LOOM - GPS ADAPTER
	141454-02-000	EA	WIRE LOOM - SATELLITE - AUTOMATIC
	142258-02-000	EA	WIRE LOOM - VIDEO SWITCH/POWER SUPPLY
	143363-04-000	EA	WIRE - MONITOR - 12 VOLT COLOR - SONY VM-HRN7W

**ELECTRICAL GROUP (CONTINUED)**  
**CONNECTORS & CONDUIT**

KEY	PART NUMBER	U/M	DESCRIPTION
	007956-01-000	EA	RECEPTACLE - HOUSING - 6 POSITION
	007956-05-000	EA	INSULATOR - SHRINK - 1/4" ID X 1 1/2"
	008058-01-000	EA	ADAPTER - POWER CORD - 30 AMP TO 15 AMP
	008311-01-000	EA	CONNECTOR - WIRE NUT - INSULATED - RED
	008312-01-000	EA	CONNECTOR - WIRE NUT - INSULATED - BLUE
	008313-01-000	EA	CONNECTOR - WIRE NUT - INSULATED - YELLOW
	008314-01-000	EA	CONNECTOR - WIRE NUT - INSULATED - GRAY
	008326-01-000	EA	TERMINAL - RING - 16/14 WIRE - 3/8" STUD
	008328-01-000	EA	TERMINAL - RING - 12/10 WIRE - #10 STUD FIT
	008331-01-000	EA	TERMINAL - RING - TONGUE - #4 WIRE - 3/8" STUD - COPPER
	008348-01-000	EA	TERMINAL - RING - 3/8" STUD 2 GA. WIRE
	008355-01-000	EA	CONNECTOR - CABLE CLAMPING - 3/4"
	008356-01-000	EA	CONNECTOR - PLASTIC - 3/8" AVG
	008356-02-000	EA	CONNECTOR - PLASTIC - 21/32
	035416-04-000	EA	TERMINAL - RING - #10 STUD FIT - INSULATED BARREL #16/14
	041953-01-000	FT	CONDUIT - CONVOLUTE SLIT - .5" ID - POLYETHYLENE
	041953-02-000	FT	CONDUIT - CONVOLUTE SLIT - .6" ID - POLYETHYLENE
	041953-03-000	FT	CONDUIT - CONVOLUTE SLIT - 1" ID (CLOTHES ROD COVER)
	041953-05-000	FT	CONDUIT - CONVOLUTE SOLID - .62" ID - POLYETHYLENE
	041953-06-000	FT	CONDUIT - CONVOLUTE SLIT - .4" ID - POLYETHYLENE
	041953-07-000	FT	CONDUIT - CONVOLUTE SLIT - .25" ID - POLYETHYLENE
	041953-08-000	FT	CONDUIT - CONVOLUTE SLIT - 1.5" ID - POLYETHYLENE
	041953-09-000	FT	CONDUIT - CONVOLUTE SLIT - .5" ID - NYLON
	041953-10-000	FT	CONDUIT - CONVOLUTE SLIT - .75" ID - NYLON
	041953-11-000	FT	CONDUIT - CONVOLUTE SLIT - 1.06" ID - NYLON
	041953-12-000	FT	CONDUIT - CONVOLUTE SOLID - 1.1" ID - NYLON
	041953-13-000	FT	CONDUIT - CONVOLUTE SLIT - 1.25
	041953-14-000	FT	CONDUIT - CONVOLUTE SLIT - 1.5
	047443-01-000	EA	TERMINAL - .250 RECEPTACLE FIT - INSULATED - 16/14 AWG
	047443-02-000	EA	TERMINAL - .250 RECEPTACLE FIT - INSULATED - 12/10 AWG
	058028-01-000	EA	CONNECTOR - ELECTRICAL PIGTAIL - NYLON - CLEAR
	062036-01-000	EA	TERMINAL - PACK - CON - 12/10 AWG
	074017-02-000	EA	HOUSING - 5 POSITION - RIGHT ANGLED
	077479-01-000	EA	BOOT - BATTERY TERMINAL - DOUBLE CABLE
	077479-02-000	EA	BOOT - BATTERY TERMINAL - SINGLE CABLE
	080015-02-000	EA	RECEPTACLE - FLAG - .185 - 16/14 GAUGE
	080015-03-000	EA	RECEPTACLE - FLAG - .250 - 14/16 GAUGE
	082109-01-000	EA	HOUSING - CONNECTOR - PACKARD
	082741-01-000	EA	CONNECTOR BODY - 2 CONNECTOR MALE
	087225-01-000	FT	SLEEVING - 1/2" - TYPE H
	087949-01-000	EA	BUSS BAR - 2 POSITION - .6" X 1.5"
	087949-02-000	EA	BUSS BAR - 3 POSITION - .6" X 2.4"
	087949-03-000	EA	BUSS BAR - 4 POSITION
	087949-05-000	EA	BUSS BAR - 7 POSITION
	088267-01-000	EA	TERMINAL - FEMALE - 1/4
	088473-01-000	EA	HOUSING - PIN - 12 CAVITY (3 ROWS OF 4)
	088473-02-000	EA	HOUSING - PIN - 15 CAVITY (3 ROWS OF 5)
	088473-03-000	EA	HOUSING - PIN - 9 CAVITY (3 ROWS OF 3)
	088473-04-000	EA	HOUSING - PIN - 8 CAVITY IN-LINE
	088473-06-000	EA	HOUSING - PIN - 6 CAVITY (2 ROWS OF 3)
	088473-08-000	EA	HOUSING - PIN - 4 CAVITY - IN-LINE
	088473-09-000	EA	HOUSING - PIN - 3 CAVITY - IN-LINE
	088473-10-000	EA	HOUSING - PIN - 2 CAVITY - IN LINE
	088474-01-000	EA	HOUSING - SOCKET - 12 CAVITY
	088474-02-000	EA	HOUSING - SOCKET - 15 CAVITY
	088474-03-000	EA	HOUSING - SOCKET - 9 CAVITY
	088474-06-000	EA	HOUSING - SOCKET - 6 CAVITY
	088474-07-000	EA	HOUSING - SOCKET - 5 CAVITY
	088474-08-000	EA	HOUSING - SOCKET - 4 CAVITY
	088474-09-000	EA	HOUSING - SOCKET - 3 CAVITY
	088474-10-000	EA	HOUSING - SOCKET - 2 CAVITY
	088475-01-000	EA	PIN - CONNECTOR - 14-20 AWG
	088475-02-000	EA	PIN - CONNECTOR - 10-12 AWG
	088476-01-000	EA	TERMINAL - ELECTRICAL

**ELECTRICAL GROUP (CONTINUED)**  
**CONNECTORS & CONDUIT (CONTINUED)**

KEY	PART NUMBER	U/M	DESCRIPTION
	088476-02-000	EA	SOCKET - CONNECTOR - 12-10 GA - PRE-TIN
	098261-01-000	EA	SOCKET - CONNECTOR - WEATHERPACK - 12 AWG
	098261-02-000	EA	SOCKET - CONNECTOR - WEATHERPACK - 14-18 AWG
	098262-01-000	EA	SEAL - CONNECTOR - WEATHERPACK
	098262-05-000	EA	SEAL - CAVITY
	098262-06-000	EA	SEAL - CONNECTOR - M/P - 10 GAUGE
	098262-07-000	EA	SEAL - CONNECTOR - 12 AWG - 280 SER
	098263-01-000	EA	HOUSING - 3 PIN - WEATHER PACK
	098263-02-000	EA	HOUSING - 3 PIN - WEATHER PACK
	098264-01-000	EA	HOUSING - 2 PIN - WEATHER PACK - MALE W/FEMALE PINS
	098264-02-000	EA	HOUSING - 2 PIN - WEATHER PACK - FEMALE W/MALE PINS
	098265-02-000	EA	PIN - CONNECTOR - WEATHER PACK
	100690-01-000	EA	HOUSING - 5 POSITION - MALE - WEATHER PACK
	100690-02-000	EA	HOUSING - 5 POSITION - FEMALE - WEATHER PACK
	102777-02-000	EA	TERMINAL - RING - #6 STUD - 10 AWG
	104100-01-000	EA	HOUSING - 1 POSITION - 75 AMPS
	104100-03-000	EA	TERMINAL - 75 AMP
	106655-02-000	EA	TERMINAL - FUSE BLOCK - 10-12 AWG
	110178-01-000	EA	HOUSING - WIPER MOTOR
	112823-01-000	EA	SPLICE - REDUCER - 16-14 TO 18-22
	113072-01-000	EA	HOUSING - ELECTRICAL - TURN/TAIL LAMP
	113072-03-000	EA	HOUSING - ELECTRICAL - STOP/MARKER TAILLAMP
	113135-01-000	EA	TERMINAL - FEMALE - M/P - 14-16 - F/SEALED TERMINAL
	113306-01-000	EA	TERMINAL - FEMALE - M/P - 14-16 - F/NON-SEALED TERMINAL
	113306-02-000	EA	TERMINAL - FEMALE - M/P - 10-12 - 480
	113307-01-000	EA	TERMINAL - FEMALE - M/P - 16-20
	113308-01-000	EA	TERMINAL - FEMALE - M/P - 14-16 - 280
	113468-01-000	EA	HOUSING - 2 POSITION-FEMALE-USED ON WIPER/WASHER WIRE ASM
	113638-02-000	EA	CONNECTOR - ACTUATOR
	114667-01-000	FT	HOSE - 2" ID - FLEXIBLE
	115556-01-000	EA	HOUSING - 3 POSITION - FEMALE
	115556-02-000	EA	HOUSING - 2 POSITION - FEMALE/PARALLEL
	115931-02-000	EA	COVER - CONNECTOR - 50 AMP W/LOCKING RING
	115932-02-000	EA	CONNECTOR - FEMALE - 50 AMP/240 VOLT
	116811-01-000	EA	TERMINAL - .110 RECEPTACLE - 16-14 AWG
	118571-01-000	EA	CONNECTOR - 3-WAY - MALE/SEALED
	118571-02-000	EA	CONNECTOR - 3-WAY - FEMALE/SEALED
	118571-05-000	EA	LOCK - SECONDARY - FEMALE
	118571-06-000	EA	LOCK - SECONDARY - MALE
	118597-01-000	EA	TERMINAL - MALE - M/P - 480 - 14-16
	118599-01-000	EA	TERMINAL - MALE - M/P - 280 - 14-16
	118820-01-000	EA	INSULATOR - TERMINAL
	119223-01-000	EA	HOUSING - 6 POSITION - MALE - WEATHERPACK
	119248-02-000	EA	HOUSING - 7 POSITION - FEMALE
	125323-01-000	EA	HOUSING - 10 POSITION - MALE
	125323-02-000	EA	HOUSING - 8 POSITION - MALE
	125323-03-000	EA	LOCK - SECONDARY 8 POSITION
	125323-04-000	EA	LOCK - SECONDARY 10 POSITION
	125323-05-000	EA	HOUSING - 6 POSITION - MALE
	125323-06-000	EA	LOCK - SECONDARY 6 POSITION
	125324-01-000	EA	TERMINAL - MALE - METRI-PACK - 150
	125325-01-000	EA	SEAL - CAVITY
	126403-01-000	EA	CONNECTOR - 2 CIRCUIT
	126403-02-000	EA	CONNECTOR - 3 CIRCUIT
	129233-01-000	EA	HOUSING - 6 POSITION - MALE WEATHERPACK
	129233-02-000	EA	HOUSING - 2-POSITION/FEMALE - 280-SERIES
	129234-01-000	EA	HOUSING - 6-POSITION/FEMALE - 280-SERIES
	129234-02-000	EA	HOUSING - 6-POSITION/FEMALE - 280-SERIES
	129234-03-000	EA	LOCK - SECONDARY - 6-POSITION
	129235-01-000	EA	HOUSING - 2-POSITION/FEMALE - 630-SERIES
	129235-02-000	EA	LOCK - SECONDARY - 2-POSITION
	129236-01-000	EA	TERMINAL - FEMALE - M/P - 630 - 10-12
	131515-01-000	EA	HOUSING - PIN - 2 CAVITY/HIGH AMP

**ELECTRICAL GROUP (CONTINUED)**  
**CONNECTORS & CONDUIT (CONTINUED)**

<b>KEY</b>	<b>PART NUMBER</b>	<b>U/M</b>	<b>DESCRIPTION</b>
	131515-02-000	EA	TERMINAL - FEMALE JR. POWER TIMER - F/HALOGEN FOG LIGHT
	131515-03-000	EA	SEAL - CAVITY - JR. POWER TIMER
	131681-01-000	EA	CONNECTOR - 3/4" SO CORD - UL/CS
	137207-01-000	EA	HOUSING - PIN - 2 CAVITY/HIGH AMP
	137208-01-000	EA	HOUSING - SOCKET - 2 CAVITY/HIGH AMP
	137209-01-000	EA	PIN - CONNECTOR - 10AWG/HIGH AMP
	137210-01-000	EA	SOCKET - CONNECTOR - 10 AWG/HIGH AMP
	138419-03-000	EA	SOCKET - LAMP - 3 WIRE
	142520-01-000	EA	TERMINAL - FEMALE - MINI FIT 16
	142522-01-000	EA	HOUSING - 4 PIN/MALE - MINI FIT
	142524-01-000	EA	HOUSING - 4 PIN/WEATHER PACK/FEMALE

**BOOTS, SOLENOIDS, RELAYS & MISCELLANEOUS**

<b>KEY</b>	<b>PART NUMBER</b>	<b>U/M</b>	<b>DESCRIPTION</b>
	008188-02-000	EA	SOLENOID - VENTED - HEAVY DUTY
	063910-01-000	EA	HOUSING - RELAY
	063912-02-000	EA	RELAY - CANISTER - SPDT
	086273-01-000	EA	RELAY - BATTERY DISCONNECT
	086233-01-000	EA	STUD - ISOLATED - 3/8" X 7/8" LONG
*	113832-02-01A	EA	SLIDE - BATTERY TRAY - HEAVY DUTY
*	113832-03-01A	EA	SLIDE - BATTERY TRAY

**\*COMPONENT PARTS LISTED LATER IN THIS GROUP**

**ELECTRICAL GROUP (CONTINUED)**  
**COMPONENT PARTS FOR BOOTS, SOLENOIDS, RELAYS & MISCELLANEOUS**

113832-02-01A

<b>KEY</b>	<b>PART NUMBER</b>	<b>U/M</b>	<b>DESCRIPTION</b>	<b>VENDOR NO.</b>
	113832-01-700	EA	STRAP-FLAT W/J-HOOK & LATCH	8323

113832-03-01A

<b>KEY</b>	<b>PART NUMBER</b>	<b>U/M</b>	<b>DESCRIPTION</b>	<b>VENDOR NO.</b>
	113832-01-700	EA	STRAP-FLAT W/J-HOOK & LATCH	8323



# EXTERIOR BODY GROUP

## AIR HORN

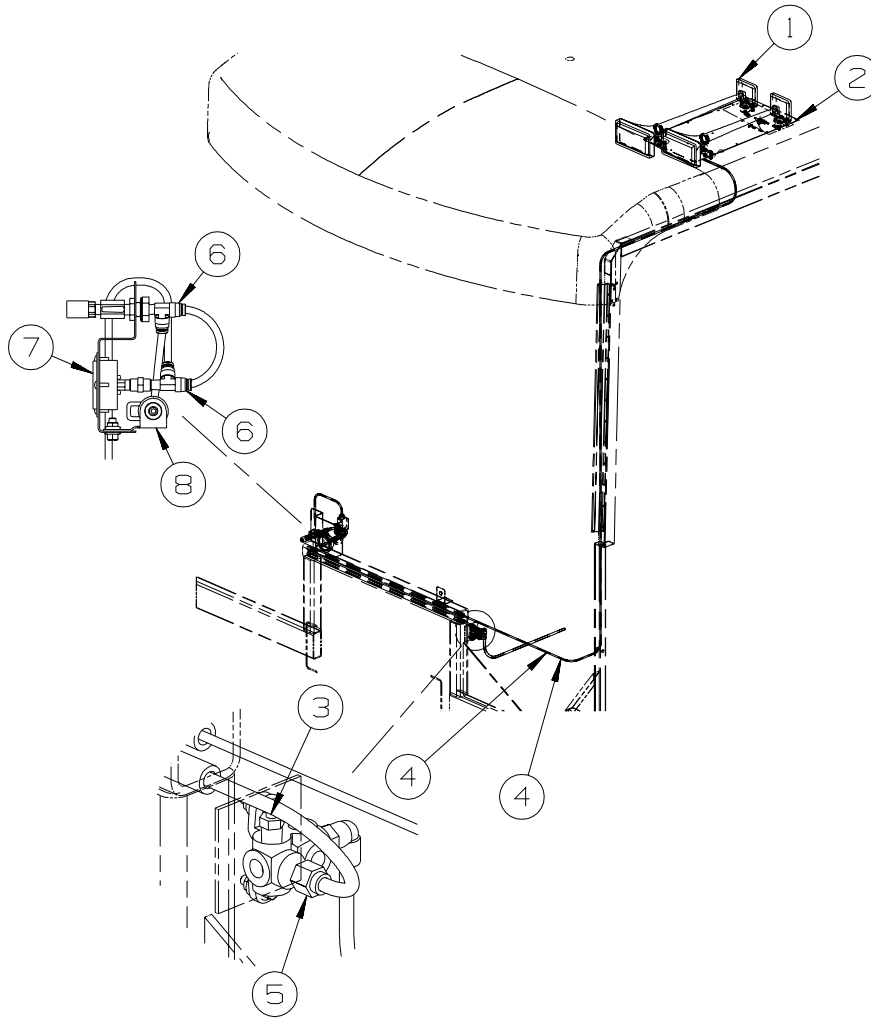

KEY	PART NUMBER	U/M	DESCRIPTION
1*	077497-06-000	EA	HORN - AIR CHROME - TWIN
2	125123-01-12B	EA	PLATE/MOUNT - AIR HORN - 25" X 13" - BRIGHT WHITE
3	086241-01-000	EA	VALVE - AIR - 1/4 MPT X TIRE STEM
4	071390-04-000	FT	TUBING - AIR BRAKE - 1/4" OD-BLK WEATHERHEAD(BRKS & HORN)
5	142571-01-000	EA	CONNECTOR - 3/8" T X 1/4" P
6	142570-01-000	EA	TEE - 3/8" T X 1/4" P
7	142609-01-000	EA	GAUGE - AIR - 2.5" MOUNTING FLANGE - 1/4" MPT
8	077497-11-000	EA	SOLENOID - HORN - REMOTE MOUNT

**\*COMPONENT PARTS LISTED LATER IN THIS GROUP**

**EXTERIOR BODY GROUP (CONTINUED)**  
**COMPONENT PARTS FOR AIR HORN**

077497-06-000

<b>KEY</b>	<b>PART NUMBER</b>	<b>U/M</b>	<b>DESCRIPTION</b>	<b>VENDOR NO.</b>
	077497-01-701	EA	SWITCH - COMPRESSOR	13940-S
	077497-01-702	EA	SWITCH - TOGGLE - W/WIRE	12949-S

# EXTERIOR BODY GROUP (CONTINUED)

## GRAPHICS & PAINT

### GRAPHICS PACKAGE

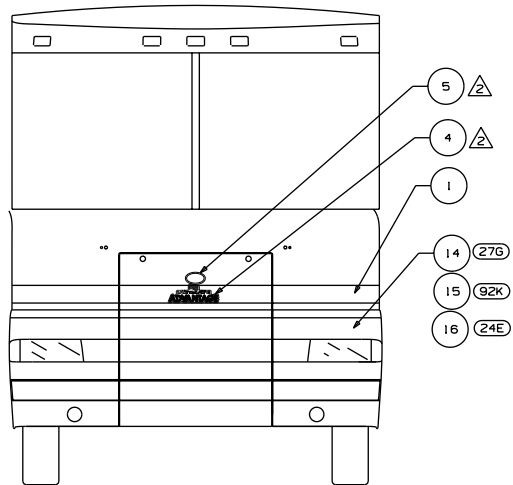
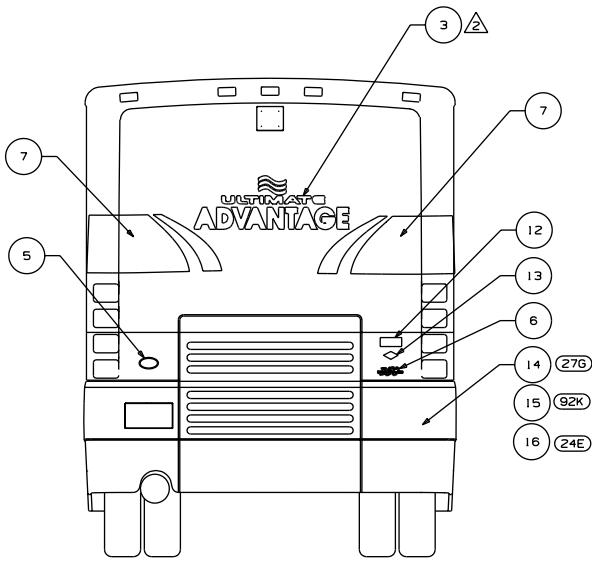

KEY	PART NUMBER	U/M	DESCRIPTION
(27G) 1	093681-72-CHT(01A)	FT	FILM-120.6MM - WIN GREEN
(92K) 1	093681-72-CHT(02A)	FT	FILM-120.6MM - BERRYWOOD
(24E) 1	093681-72-CHT(03A)	FT	FILM-120.6MM - CANYON RED
2	132664-01-CHT(01A)	EA	DECAL-LOGO,DOMED,W/INNEBAGO - GOLD CHROME/BLACK
3	136180-01-CHT(01A)	EA	DECAL-ULTIMATE ADVANTAGE,LG - HOT RED/BLACK/CHROME/TRANS GOLD/BRT WHITE
4	136180-02-CHT(01A)	EA	DECAL-ULTIMATE ADVANTAGE,SML - HOT RED/BLACK/CHROME/TRANS GOLD/BRT WHITE/SAND
5	137618-03-CHT(01A)	EA	DECAL/BEZEL - DOMED GRILLE LOGO - BLACK/GOLD
6	135089-01-CHT(01A)	EA	DECAL-DOMED,HORSEPOWER,350 - BRT WHITE/CHROME/BLACK
(27G) 7	143178-01-CHT(01A)	EA	DECAL-CORNER,RR,RH - FLINTSTONE
(92K) 7	143178-01-CHT(02A)	EA	DECAL-CORNER,RR,RH - LT.ROSE
(24E) 7	143178-01-CHT(03A)	EA	DECAL-CORNER,RR,RH - MOSS GREEN
(27G) 7	143178-02-CHT(01A)	EA	DECAL-CORNER,RR,LH - FLINTSTONE
(92K) 7	143178-02-CHT(02A)	EA	DECAL-CORNER,RR,LH - LT.ROSE
(24E) 7	143178-02-CHT(03A)	EA	DECAL-CORNER,RR,LH - MOSS GREEN
(27G) 8	143186-01-CHT(01A)	EA	DECAL-SWEEP,RR,RH - FLINTSTONE
(92K) 8	143186-01-CHT(02A)	EA	DECAL-SWEEP,RR,RH - LT.ROSE
(24E) 8	143186-01-CHT(03A)	EA	DECAL-SWEEP,RR,RH - MOSS GREEN
(27G) 8	143186-02-CHT(01A)	EA	DECAL-SWEEP,RR,LH - FLINTSTONE
(92K) 8	143186-02-CHT(02A)	EA	DECAL-SWEEP,RR,LH - LT.ROSE
(24E) 8	143186-02-CHT(03A)	EA	DECAL-SWEEP,RR,LH - MOSS GREEN
(27G) 9	143187-01-CHT(01A)	EA	DECAL-TIP,RH - FLINTSTONE
(92K) 9	143187-01-CHT(02A)	EA	DECAL-TIP,RH - LT.ROSE
(24E) 9	143187-01-CHT(03A)	EA	DECAL-TIP,RH - MOSS GREEN
(27G) 9	143187-02-CHT(01A)	EA	DECAL-TIP,LH - FLINTSTONE
(92K) 9	143187-02-CHT(02A)	EA	DECAL-TIP,LH - LT.ROSE
(24E) 9	143187-02-CHT(03A)	EA	DECAL-TIP,LH - MOSS GREEN
(27G) 10	143188-01-CHT(01A)	EA	DECAL-HOOK,RH - WIN GREEN
(92K) 10	143188-01-CHT(02A)	EA	DECAL-HOOK,RH - BERRYWOOD
(24E) 10	143188-01-CHT(03A)	EA	DECAL-HOOK,RH - CANYON RED
(27G) 10	143188-02-CHT(01A)	EA	DECAL-HOOK,LH - WIN GREEN
(92K) 10	143188-02-CHT(02A)	EA	DECAL-HOOK,LH - BERRYWOOD
(24E) 10	143188-02-CHT(03A)	EA	DECAL-HOOK,LH - CANYON RED
(27G) 11	143190-01-CHT(01A)	EA	DECAL-SWEEP,FRT,RH - WIN GREEN
(92K) 11	143190-01-CHT(02A)	EA	DECAL-SWEEP,FRT,RH - BERRYWOOD
(24E) 11	143190-01-CHT(03A)	EA	DECAL-SWEEP,FRT,RH - CANYON RED
(27G) 11	143190-02-CHT(01A)	EA	DECAL-SWEEP,FRT,LH - WIN GREEN
(92K) 11	143190-02-CHT(02A)	EA	DECAL-SWEEP,FRT,LH - BERRYWOOD
(24E) 11	143190-02-CHT(03A)	EA	DECAL-SWEEP,FRT,LH - CANYON RED
12	143566-01-000(01A)	EA	DECAL-LOGO ULTI-BAY - CHROME/BLACK/WHITE/RED
13	-----	EA	DECAL-SPARTAN (CHASSIS SUPPLIED)
(27G) 14	141599-02-000	GL	PAINT-JAGUAR BLUE MET - DUPONT #373-P7414
(92K) 15	141599-51-000	GL	PAINT-WINEBERRY MET - DUPONT #373-P7449
(24E) 16	141599-06-000	GL	PAINT-TITANIUM MET - DUPONT #373-6236

# EXTERIOR BODY GROUP (CONTINUED)

## GRAPHICS & PAINT (CONTINUED)

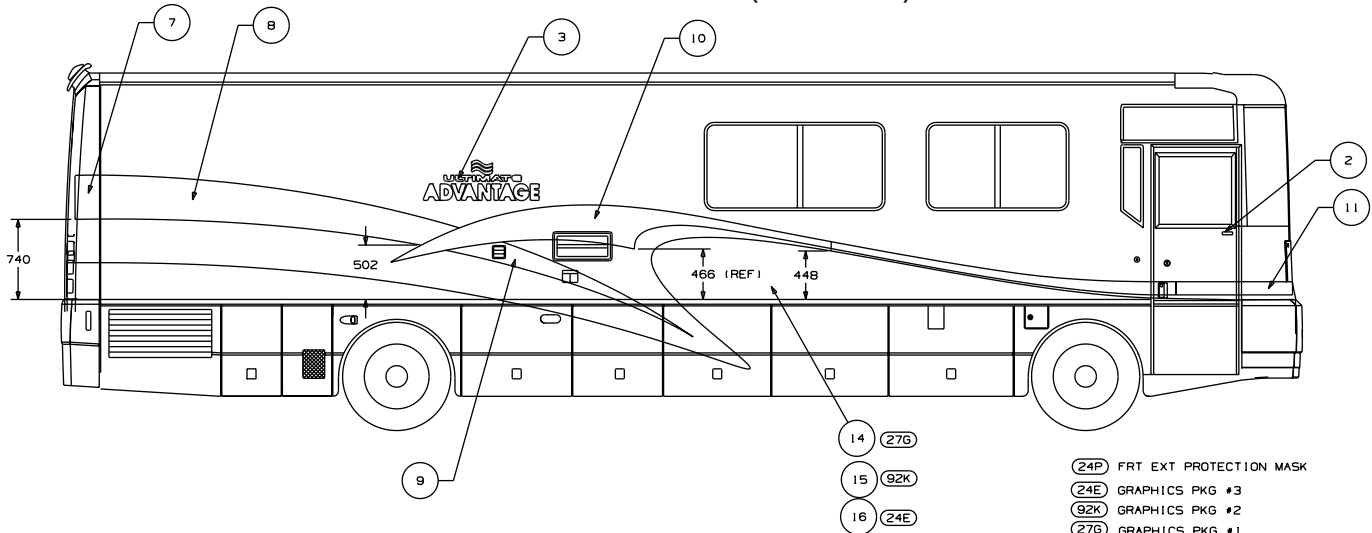

- (24P) FRT EXT PROTECTION MASK
- (24E) GRAPHICS PKG #3
- (92K) GRAPHICS PKG #2
- (27G) GRAPHICS PKG #1

		G40XD
		G40ED
		G40K
		G40E
		G38K
		G36C
B	A	UNIT

- △ DIE CUT ACRYLIC 3M FILM USED TO PROTECT FULL BODY PAINTED UNITS.
- 4. ON FULL BODY PAINT UNITS, USE 145487-01-000 (100 FT) TO COVER UNSEALED ROOF SEAMS.
- △ CLEAR COAT TO BE PAINTED ON ENTIRE UNIT.
- △ CENTER ON UNIT.
- 1. APPLY PROTECTOR 116424-01 TO WATER HEATER LATCH.

NOTES:

KEY	PART NUMBER	U/M	DESCRIPTION
(27G) 1	093681-72-CHT(01A)	FT	FILM-120.6MM - WIN GREEN
(92K) 1	093681-72-CHT(02A)	FT	FILM-120.6MM - BERRYWOOD
(24E) 1	093681-72-CHT(03A)	FT	FILM-120.6MM - CANYON RED
2	132664-01-CHT(01A)	EA	DECAL-LOGO,DOMED,WINNEBAGO - GOLD CHROME/BLACK
3	136180-01-CHT(01A)	EA	DECAL-ULTIMATE ADVANTAGE,LG - HOT RED/BLACK/CHROME/TRANS GOLD/BRT WHITE
4	136180-02-CHT(01A)	EA	DECAL-ULTIMATE ADVANTAGE,SML - HOT RED/BLACK/CHROME/TRANS GOLD/BRT WHITE/SAND
5	137618-03-CHT(01A)	EA	DECAL/BEZEL - DOMED GRILLE LOGO - BLACK/GOLD
6	135089-01-CHT(01A)	EA	DECAL-DOMED,HORSEPOWER,350 - BRT WHITE/CHROME/BLACK
(27G) 7	143178-01-CHT(01A)	EA	DECAL-CORNER,RR,RH - FLINTSTONE
(92K) 7	143178-01-CHT(02A)	EA	DECAL-CORNER,RR,RH - LT.ROSE
(24E) 7	143178-01-CHT(03A)	EA	DECAL-CORNER,RR,RH - MOSS GREEN
(27G) 7	143178-02-CHT(01A)	EA	DECAL-CORNER,RR,LH - FLINTSTONE
(92K) 7	143178-02-CHT(02A)	EA	DECAL-CORNER,RR,LH - LT.ROSE
(24E) 7	143178-02-CHT(03A)	EA	DECAL-CORNER,RR,LH - MOSS GREEN
(27G) 8	143186-01-CHT(01A)	EA	DECAL-SWEEP,RR,RH - FLINTSTONE
(92K) 8	143186-01-CHT(02A)	EA	DECAL-SWEEP,RR,RH - LT.ROSE
(24E) 8	143186-01-CHT(03A)	EA	DECAL-SWEEP,RR,RH - MOSS GREEN
(27G) 8	143186-02-CHT(01A)	EA	DECAL-SWEEP,RR,LH - FLINTSTONE
(92K) 8	143186-02-CHT(02A)	EA	DECAL-SWEEP,RR,LH - LT.ROSE
(24E) 8	143186-02-CHT(03A)	EA	DECAL-SWEEP,RR,LH - MOSS GREEN
(27G) 9	143187-01-CHT(01A)	EA	DECAL-TIP,RH - FLINTSTONE
(92K) 9	143187-01-CHT(02A)	EA	DECAL-TIP,RH - LT.ROSE
(24E) 9	143187-01-CHT(03A)	EA	DECAL-TIP,RH - MOSS GREEN
(27G) 9	143187-02-CHT(01A)	EA	DECAL-TIP,LH - FLINTSTONE
(92K) 9	143187-02-CHT(02A)	EA	DECAL-TIP,LH - LT.ROSE
(24E) 9	143187-02-CHT(03A)	EA	DECAL-TIP,LH - MOSS GREEN
(27G) 10	143188-01-CHT(01A)	EA	DECAL-HOOK,RH - WIN GREEN
(92K) 10	143188-01-CHT(02A)	EA	DECAL-HOOK,RH - BERRYWOOD
(24E) 10	143188-01-CHT(03A)	EA	DECAL-HOOK,RH - CANYON RED
(27G) 10	143188-02-CHT(01A)	EA	DECAL-HOOK,LH - WIN GREEN
(92K) 10	143188-02-CHT(02A)	EA	DECAL-HOOK,LH - BERRYWOOD
(24E) 10	143188-02-CHT(03A)	EA	DECAL-HOOK,LH - CANYON RED
(27G) 11	143190-01-CHT(01A)	EA	DECAL-SWEEP,FRT,RH - WIN GREEN
(92K) 11	143190-01-CHT(02A)	EA	DECAL-SWEEP,FRT,RH - BERRYWOOD
(24E) 11	143190-01-CHT(03A)	EA	DECAL-SWEEP,FRT,RH - CANYON RED
(27G) 11	143190-02-CHT(01A)	EA	DECAL-SWEEP,FRT,LH - WIN GREEN
(92K) 11	143190-02-CHT(02A)	EA	DECAL-SWEEP,FRT,LH - BERRYWOOD
(24E) 11	143190-02-CHT(03A)	EA	DECAL-SWEEP,FRT,LH - CANYON RED
12	143566-01-000(01A)	EA	DECAL-LOGO ULTI-BAY - CHROME/BLACK/WHITE/RED
13	-----	EA	DECAL-SPARTAN (CHASSIS SUPPLIED)
(27G) 14	141599-02-000	GL	PAINT-JAGUAR BLUE MET - DUPONT #373-P7414
(92K) 15	141599-51-000	GL	PAINT-WINEBERRY MET - DUPONT #373-P7449
(24E) 16	141599-06-000	GL	PAINT-TITANIUM MET - DUPONT #373-6236

<b>KEY</b>	<b>PART NUMBER</b>	<b>U/M</b>	<b>DESCRIPTION</b>
	041561-03-000	EA	PAINT - 16 OUNCE SPRAY - OFF WHITE
			<b>DUPONT COLOR CODES</b>
			BERRYWOOD MET RM055
			WINEBERRY MET. P7449
			FLINTSTONE MET DM440
			WIND. GREEN MET. GM198
			JAGUAR BLUE MET. P7414
			MED. TITANIUM MET. P6236

# EXTERIOR BODY GROUP (CONTINUED)

## GRAPHICS & PAINT (CONTINUED)

### FULL BODY PAINT

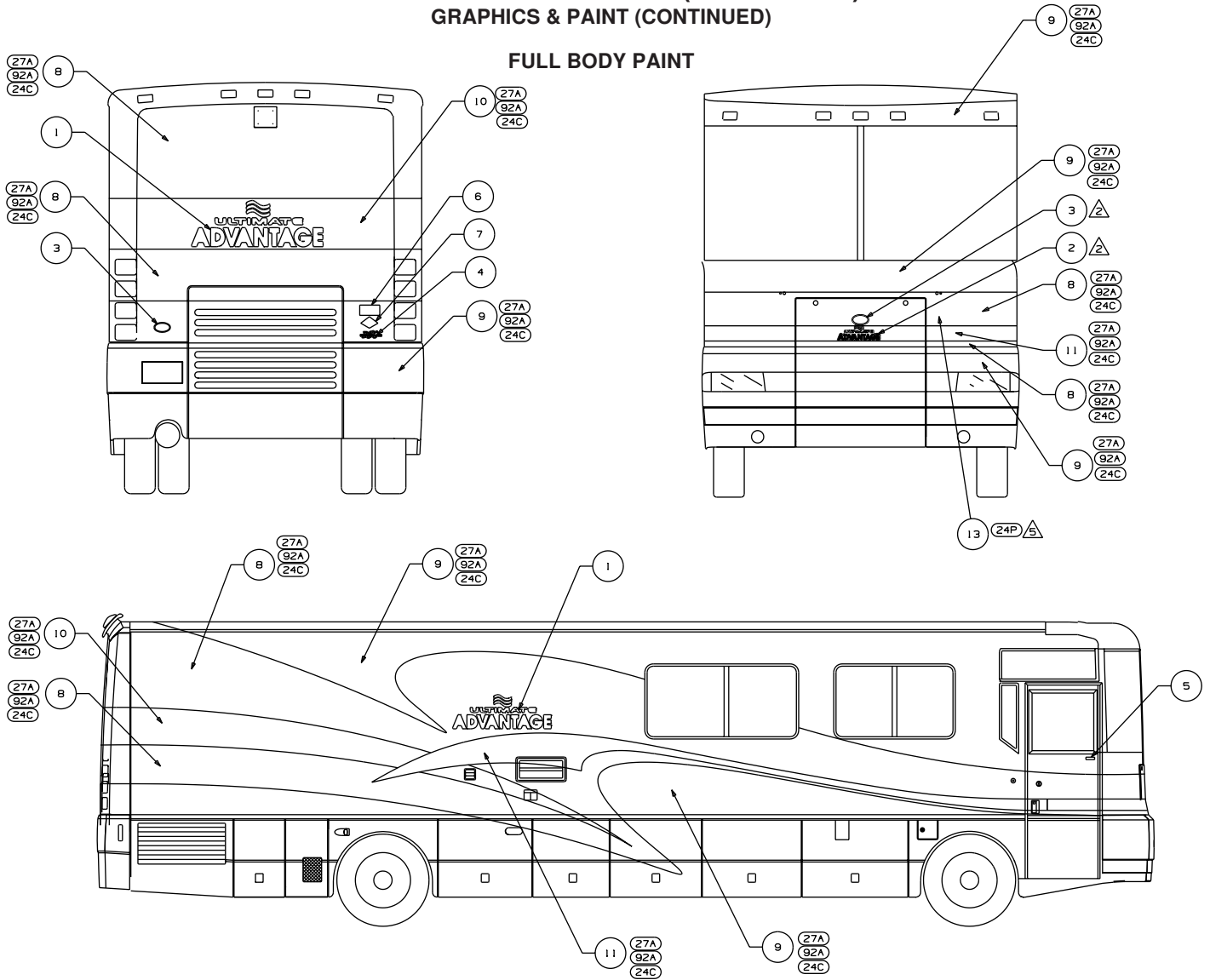

(27A) KEY	PART NUMBER	U/M	DESCRIPTION SLATE BLUE
1	136180-01-CHT(01A)	EA	DECAL-ULTIMATE ADVANTAGE,LG - HOT RED/BLACK/CHROME/TRNS.GOLD/BRT WHITE
2	136180-02-CHT(02A)	EA	DECAL-ULTIMATE ADVANTAGE,SML - HOT RED/BLACK/CHROME/TRNS.GOLD/BRT WHITE/SAND
3	137618-03-CHT(01A)	EA	DECAL-BEZEL - DOMED GRILLE LOGO - BLACK/GOLD
4	135089-01-CHT(01A)	EA	DECAL-DOMED,HORSEPOWER 350 - BRT WHITE/CHROME/BLACK
5	132664-01-CHT(01A)	EA	DECAL-LOGO,DOMED,WINNEBAGO - GOLD CHROME/BLACK
6	143566-01-000(01A)	EA	DECAL-LOGO ULTI-BAY - CHROME/BLACK/WHITE/RED
7	-----	EA	DECAL-SPARTAN (CHASSIS SUPPLIED)
8	143755-11-000	GL	PAINT-CHAMPAGNE-MET DUPONT/SPIES 70544
9	143755-15-000	GL	PAINT-BLAGRA-MET DUPONT/SPIES 95564
10	143755-16-000	GL	PAINT-MOUSY GREY-MET DUPONT/SPIES 80717
11	143755-17-000	GL	PAINT-TURQUOISE-MET DUPONT/SPIES 62474
12	143366-68-000	LT	PAINT-VARIO CLEAR
(24P) 13	143369-01-000	EA	KIT-3M PAINT PROTECTION

(92A) KEY	PART NUMBER	U/M	DESCRIPTION ROSEWOOD
1	136180-01-CHT(01A)	EA	DECAL-ULTIMATE ADVANTAGE,LG - HOT RED/BLACK/CHROME/TRNS.GOLD/BRT WHITE
2	136180-02-CHT(02A)	EA	DECAL-ULTIMATE ADVANTAGE,SML - HOT RED/BLACK/CHROME/TRNS.GOLD/BRT WHITE/SAND
3	137618-03-CHT(01A)	EA	DECAL-BEZEL - DOMED GRILLE LOGO - BLACK/GOLD
4	135089-01-CHT(01A)	EA	DECAL-DOMED,HORSEPOWER 350 - BRT WHITE/CHROME/BLACK
5	132664-01-CHT(01A)	EA	DECAL-LOGO,DOMED,WINNEBAGO - GOLD CHROME/BLACK
6	143566-01-000(01A)	EA	DECAL-LOGO ULTI-BAY - CHROME/BLACK/WHITE/RED
7	-----	EA	DECAL-SPARTAN (CHASSIS SUPPLIED)
8	143755-11-000	GL	PAINT-CHAMPAGNE-MET DUPONT/SPIES 70544
9	143755-12-000	GL	PAINT-WINE BERRY MET DUPONT/SPIES 30926
10	143755-13-000	GL	PAINT-RED NIGHTMIST PEARL MET DUPONT/SPIES 40158
11	143755-14-000	GL	PAINT-CAMELLIA RED MET DUPONT/SPIES 30351
12	143366-68-000	LT	PAINT-VARIO CLEAR
(24P) 13	143369-01-000	EA	KIT-3M PAINT PROTECTION

(24C) KEY	PART NUMBER	U/M	DESCRIPTION HARVEST
1	136180-01-CHT(01A)	EA	DECAL-ULTIMATE ADVANTAGE,LG - HOT RED/BLACK/CHROME/TRNS.GOLD/BRT WHITE
2	136180-02-CHT(02A)	EA	DECAL-ULTIMATE ADVANTAGE,SML - HOT RED/BLACK/CHROME/TRNS.GOLD/BRT WHITE/SAND
3	137618-03-CHT(01A)	EA	DECAL-BEZEL - DOMED GRILLE LOGO - BLACK/GOLD
4	135089-01-CHT(01A)	EA	DECAL-DOMED,HORSEPOWER 350 - BRT WHITE/CHROME/BLACK
5	132664-01-CHT(01A)	EA	DECAL-LOGO,DOMED,WINNEBAGO - GOLD CHROME/BLACK
6	143566-01-000(01A)	EA	DECAL-LOGO ULTI-BAY - CHROME/BLACK/WHITE/RED
7	-----	EA	DECAL-SPARTAN (CHASSIS SUPPLIED)
8	143755-11-000	GL	PAINT-CHAMPAGNE-MET DUPONT/SPIES 70544
9	143755-18-000	GL	PAINT-MEDIUM TITANIUM-MET DUPONT/SPIES 70153
10	143755-19-000	GL	PAINT-SMARAGDGRUEN-MET DUPONT/SPIES 96443
11	143755-20-000	GL	PAINT-DEEP RED MET DUPONT/SPIES 95046
12	143366-68-000	LT	PAINT-VARIO CLEAR
(24P) 13	143369-01-000	EA	KIT-3M PAINT PROTECTION

## EXTERIOR BODY GROUP (CONTINUED)

### PANELS & TRIMS

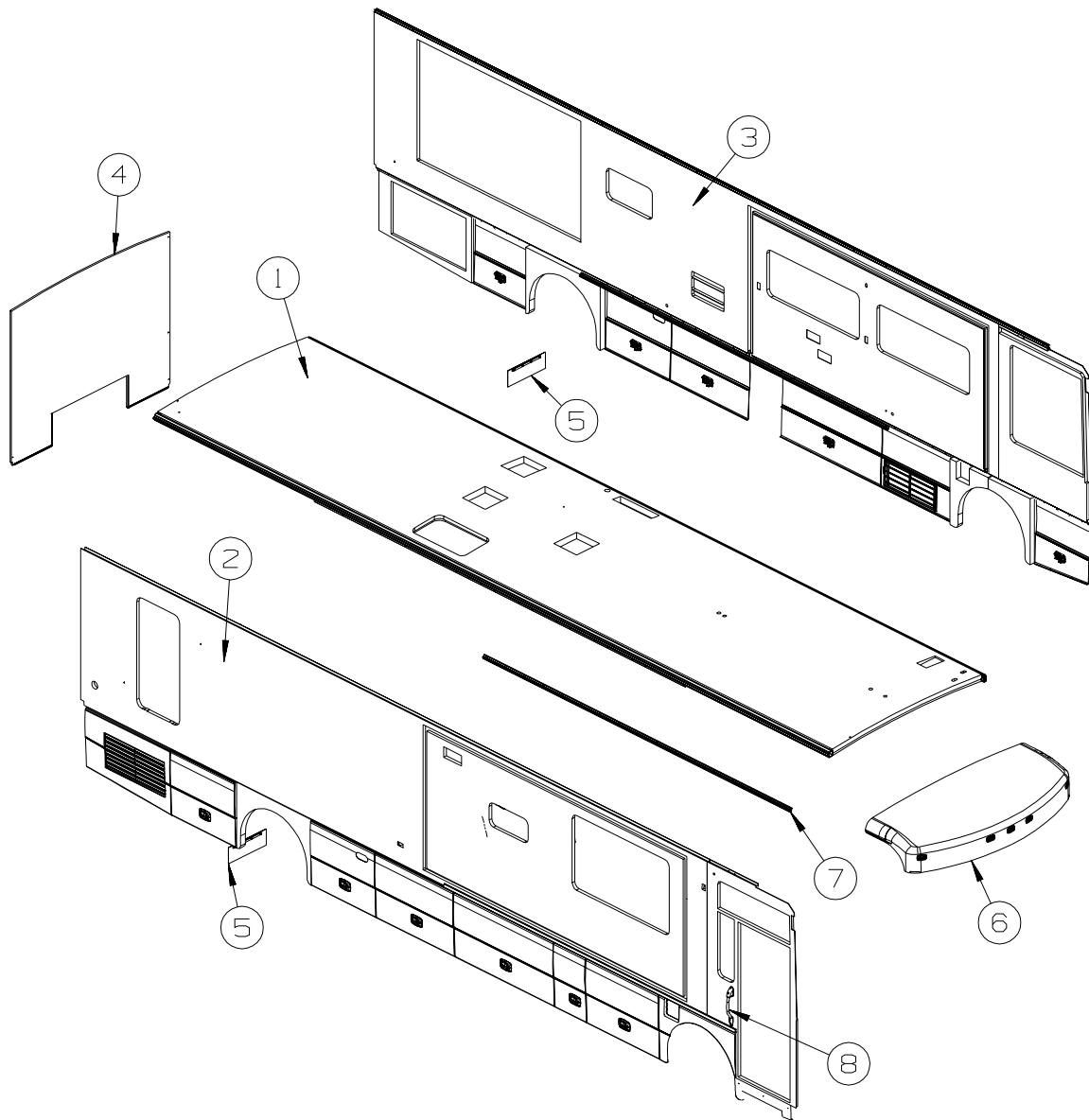

KEY	PART NUMBER	U/M	DESCRIPTION
1	143182-01-PA0	EA	ROOF - W/O LIGHTS/VENTS - W/WIRING
2	141896-01-PC0	EA	SIDEWALL - PASSENGER - W/O WINDOWS/TRIMS(PA0, PA1, PA2)
2	141896-01-PA3	EA	SIDEWALL - PASSENGER - W/O WINDOWS/TRIMS(PA3, PA4, PA5)
2	141896-01-PC3	EA	SIDEWALL - PASSENGER - W/O WINDOWS/TRIMS(PA6, PA7, PA8)
3	141897-01-PC0	EA	SIDEWALL - DRIVER - W/O WINDOWS/TRIMS(PA0, PA1, PA2)
3	141897-01-PA3	EA	SIDEWALL - DRIVER - W/O WINDOWS/TRIMS(PA3, PA4, PA5)
3	141897-01-PC3	EA	SIDEWALL - DRIVER - W/O WINDOWS/TRIMS(PA6, PA7, PA8)
4	141898-01-PC0	EA	BACKWALL - W/O WINDOWS/TRIMS(PA0, PA1, PA2)
4	141898-01-PA3	EA	BACKWALL - W/O WINDOWS/TRIMS(PA3, PA4, PA5)
4	141898-01-PC3	EA	BACKWALL - W/O WINDOWS/TRIMS(PA6, PA7, PA8)
5	017516-04-000	EA	MUD FLAP - BLACK - 16.5"H X 23.5"W - W/NOTCH
			FROM: 00-00-00 THRU: 02-19-02
5	141594-01-01A	EA	MUD FLAP - BLACK
			FROM: 02-20-02 THRU: 99-99-99
	140922-01-02B	EA	PLATE - MUD FLAP - E-COATED
6	128342-02-KQ0	EA	PANEL - ROOF CAP - W/O LIGHTS/WIRING
7	142123-01-01A	EA	RAIL - AWNING - 239.6" - BRIGHT WHITE
8*	138827-01-000	EA	BELL/DOOR - W/EXTERIOR "ULTIMATE" ENGRAVED/LIGHTED HANDLE

\*COMPONENT PARTS LISTED LATER IN THIS GROUP

**EXTERIOR BODY GROUP (CONTINUED)**  
**PANELS & TRIMS (CONTINUED)**

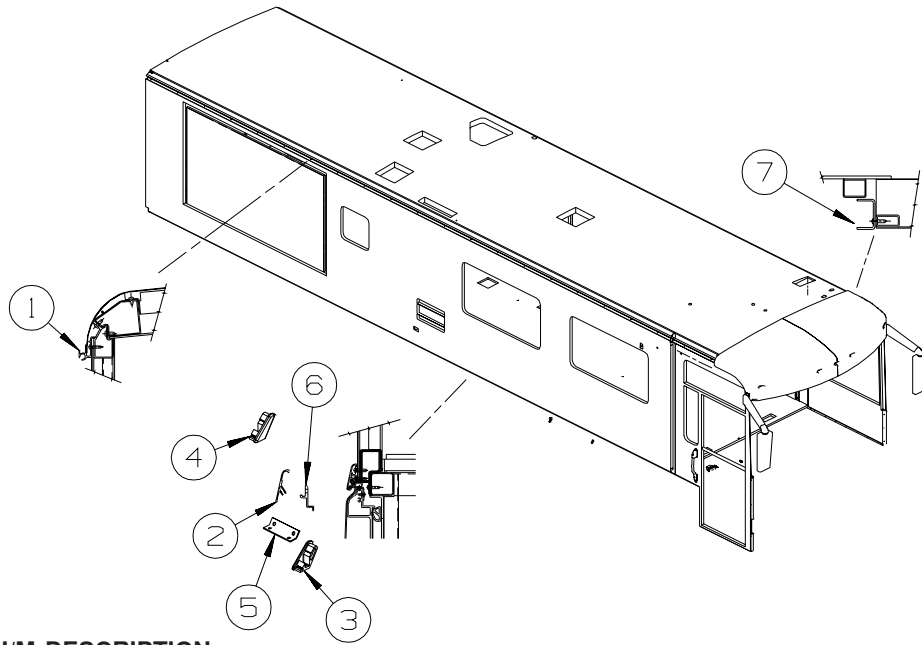

KEY	PART NUMBER	U/M	DESCRIPTION
1	131483-0101A	EA	RAIL - AWNING - 192" - BRIGHT WHITE
2	123993-01-03A	EA	TRIM - COVER - 182" ALUMINUM - BRIGHT WHITE
3	126775-01-01A	EA	END CAP - VALANCE TRIM - RIGHT HAND
4	126775-02-01A	EA	END CAP - VALANCE TRIM - LEFT HAND
5	132597-01-02B	EA	ANGLE/SUPPORT/TRIM - E-COATED
6	133376-01-01A	EA	TRIM - RETAINER - 144" - MILL
7	134774-01-02B	EA	BRACKET - CAB ATTACHMENT - E-COATED

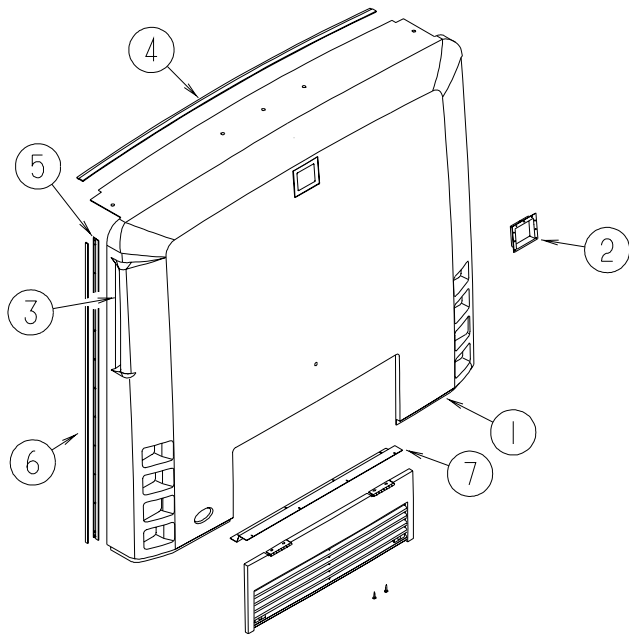

KEY	PART NUMBER	U/M	DESCRIPTION
1	128928-04-K90	EA	PANEL - REAR CAP - W/DOOR - W/O HARDWARE
2	P23280-01-01A	EA	SHROUD - CAMERA - INNER
3	129683-01-02A	EA	PANEL - AIR INTAKE - BLACK
4	083805-23-000	EA	TRIM - ROOF CAP - 92.1" - BRIGHT WHITE
5	092041-02-03A	EA	TRIM - BACKWALL/SIDEWALL - 77.1" - BRIGHT WHITE
6	091985-01-07A	FT	INSERT - TRIM - .65" WIDE - BRIGHT WHITE
7	118741-06-02B	EA	SHIELD - ENGINE/UPPER - E-COATED

## EXTERIOR BODY GROUP (CONTINUED)

### FRONT END

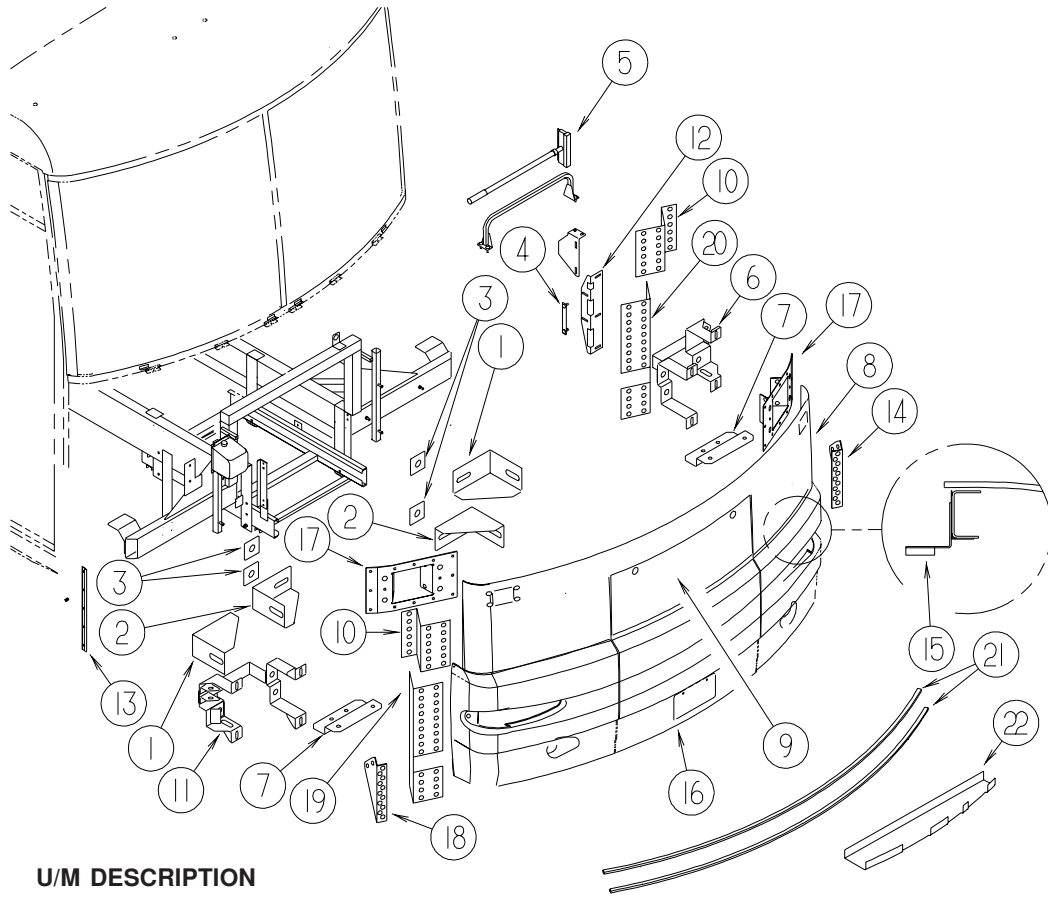

KEY	PART NUMBER	U/M	DESCRIPTION
1	128455-01-02B	EA	BRACKET - BUMPER
2	128455-02-02B	EA	BRACKET - BUMPER
3	116617-02-02B	EA	SPACER - BUMPER
4	106730-04-000	EA	PLATE - STUD
5*	091955-02-000	EA	SQUEEGEE - EXTENDED HANDLE
6	129273-02-02B	EA	FRAME - HEADLAMP/LEFT HAND - E-COATED
7	131497-01-02B	EA	BRACKET - FOG LAMP - MOUNT - E-COATED
8	131293-04-M94	EA	PANEL - FRONT/LOWER - W/O DOOR/BUMPER/HEADLIGHTS
9	129271-01-KQ0	EA	HOOD - FRONT - Q-SERIES
10	113495-05-02B	EA	SUPPORT - HINGE
11	129273-01-02B	EA	FRAME - HEADLAMP/RIGHT HAND - E-COATED
12	114396-05-02B	EA	ANGLE - BUMPER MOUNT/PASSENGER - E-COATED
12	114396-06-02B	EA	ANGLE - BUMPER MOUNT/DRIVER - E-COATED
13	092041-06-01A	EA	TRIM - REAR - CAP TO SIDEWALL - BRIGHT WHITE
13	091985-01-07A	FT	INSERT - TRIM - BRIGHT WHITE - 1"
14	131498-02-02B	EA	BRACKET - FOG LAMP - SUPPORT - E-COATED
15	134417-01-02B	EA	PLATE/SPACER - FRONT - E-COATED
16	131294-02-KQ0	EA	PANEL/BUMPER - FRONT/CENTER ACCESS F/GENERATOR
17			NOT USED
18	131498-01-02B	EA	BRACKET - FOG LAMP - SUPPORT - E-COATED
19	131304-01-02B	EA	SUPPORT - BUMPER - FRONT/PASSENGER - E-COATED
20	131304-02-02B	EA	SUPPORT - BUMPER - FRONT/DRIVER - E-COATED
21			NO LONGER AVAILABLE - CONTACT PART SALES
22	131305-01-02B	EA	SUPPORT-BUMPER,FRONT,SIDE,EC

\*COMPONENT PARTS LISTED LATER IN THIS GROUP



**EXTERIOR BODY GROUP (CONTINUED)**  
**FRONT END (CONTINUED)**

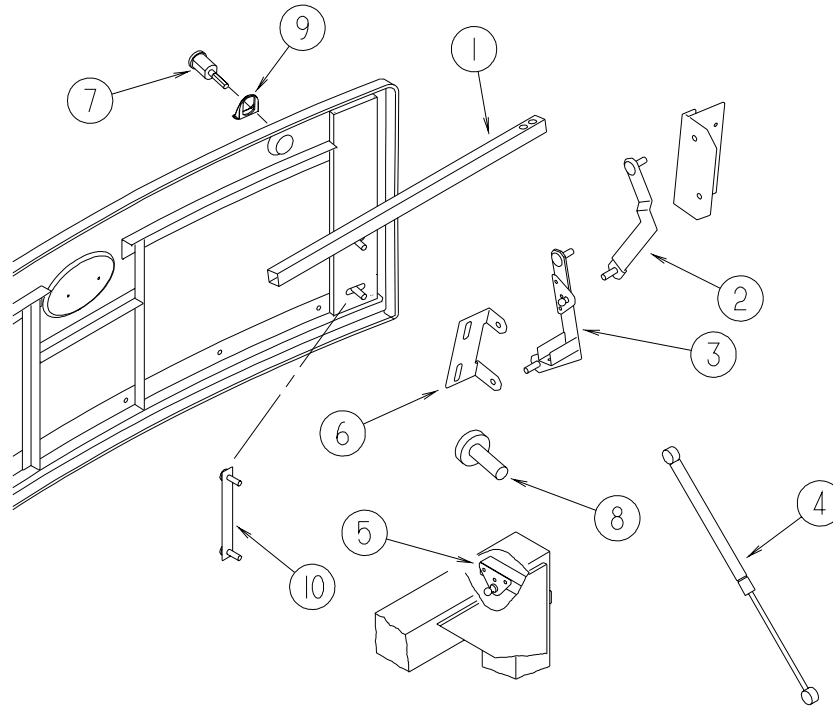

KEY	PART NUMBER	U/M	DESCRIPTION
1	138814-08-02B	EA	TUBE-TIMING - HOOD HINGE - 39.2" - E-COATED
2	131661-01-02B	EA	LINK - HINGE - UPPER HOOD - E-COATED
	131661-02-02B	EA	LINK - HINGE - UPPER HOOD - E-COATED
3	131662-01-02B	EA	LINK - HINGE - LOWER HOOD - E-COATED
	131662-02-02B	EA	LINK - HINGE - LOWER HOOD - E-COATED
4	107796-04-000	EA	SPRING/GAS - 12" COMPRESSED/20" EXTENDED - 20LB. FROM: 00-00-00 THRU: 05-31-02
4	142569-07-000	EA	SPRING - GAS - 20"/20 LB FROM: 06-01-02 THRU: 99-99-99
5	126263-08-02B	EA	BRACKET - GAS SPRING W/CENTERED BALL STUD - E-COATED
6	113505-01-02B	EA	ANGLE - HOOD LINK - PASSENGER - E-COATED
	113505-02-02B	EA	ANGLE - HOOD LINK - DRIVER - E-COATED
7	102330-02-000	EA	LATCH - VISE ACTION/KEY OPERATED
8	058786-01-000	EA	BOLT - HOOD ADJUSTMENT - 5/16"-18 X 1.5"-2" - W/BLACK PAD
9	131664-01-01A	EA	PULL-LOCK, BLACK
10	106730-10-000	EA	PLATE - STUD - F/HOOD

**EXTERIOR BODY GROUP (CONTINUED)**  
**COMPONENT PARTS FOR FRONT END**

091955-02-000

<b>KEY</b>	<b>PART NUMBER</b>	<b>U/M</b>	<b>DESCRIPTION</b>	<b>VENDOR NO.</b>
	091955-01-701	EA	HANDLE-EXTENSION 24" TO 40"	

138827-01-000

<b>KEY</b>	<b>PART NUMBER</b>	<b>U/M</b>	<b>DESCRIPTION</b>	<b>VENDOR NO.</b>
	138827-01-700	EA	HANDLE - ULTIMATE	71211AU
	138827-01-701	EA	CHIME BOX	71211CB
	138827-01-702	EA	TOP BRACKET-SS W/TRANSMITTER	71211BA

## EXTERIOR BODY GROUP (CONTINUED)

### LADDER

KEY	PART NUMBER	U/M	DESCRIPTION
	130163-01-01A	EA	LADDER EXTENSION/LOWER - 47.6" - 4 STEP - BRUSHED ALUMINUM
	130164-01-01A	EA	LADDER - UPPER - BRUSHED ALUMINUM
	129375-02-000	EA	SEAL - LADDER BRACKET

### MIRRORS

KEY	PART NUMBER	U/M	DESCRIPTION
*	129656-01-01A	EA	MIRROR - EXTERIOR REMOTE/HEAT - PASSENGER - SMOOTH SURFACE
*	129656-02-01A	EA	MIRROR - EXTERIOR REMOTE/HEAT - DRIVER - SMOOTH SURFACE
	129486-01-01A	EA	SPACER/MIRROR - BLACK
	129607-03-01A	EA	BRACKET - MOUNTING/MIRROR
			FROM: 00-00-00 THRU: 04-15-03
	129607-04-01A	EA	WIRE - MIRROR - EUROPEAN
			FROM: 00-00-00 THRU: 04-15-03
	129607-05-01A	EA	BRACKET - WIRE MOUNT
			FROM: 04-16-03 THRU: 99-99-99

\*COMPONENT PARTS LISTED LATER IN THIS GROUP

**EXTERIOR BODY GROUP (CONTINUED)**  
**COMPONENT PARTS FOR MIRRORS**

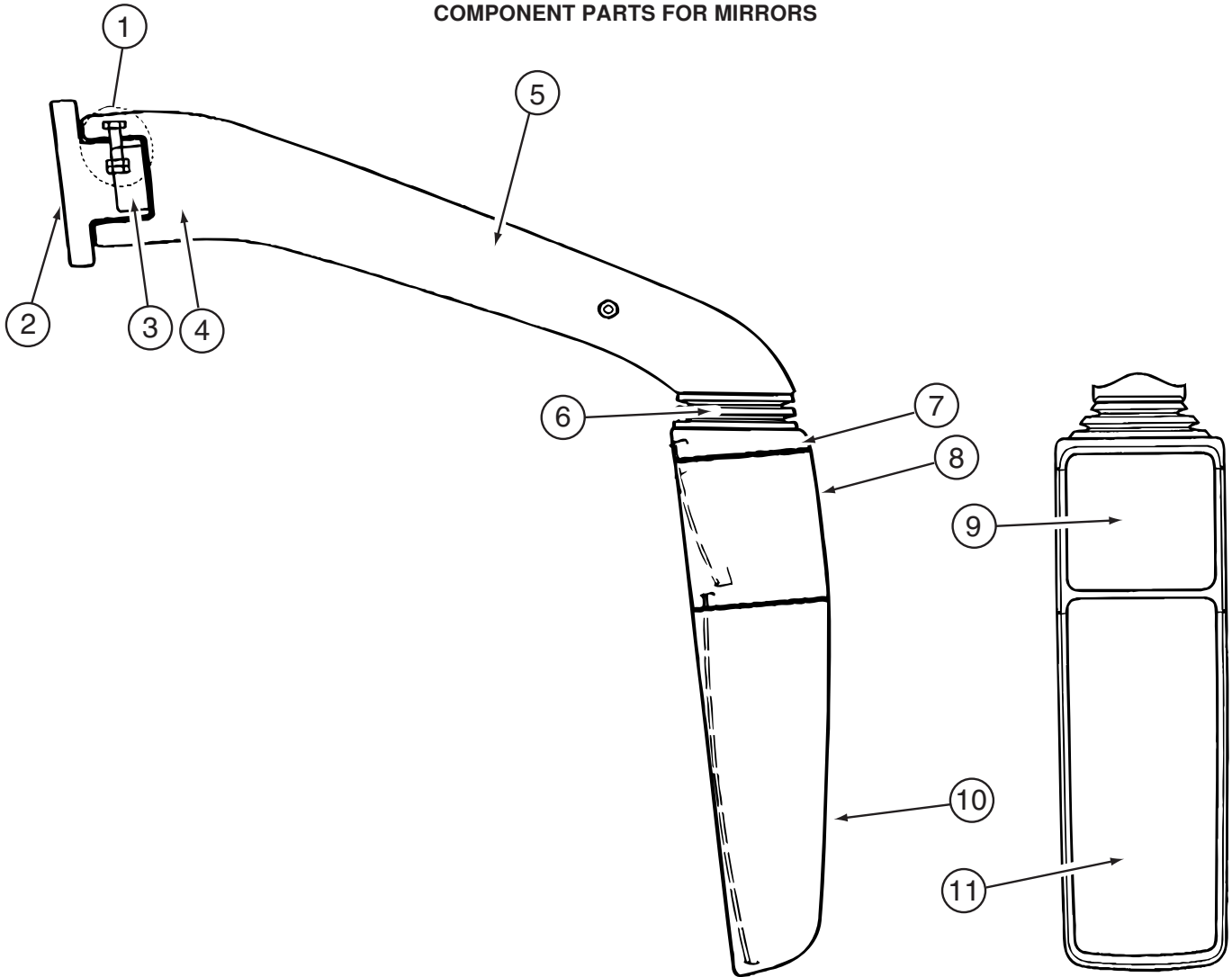

**129656-01-01A**

KEY	PART NUMBER	U/M	DESCRIPTION	VENDOR NO.
1	129656-01-700	EA	HARDWARE-FASTENING F/HOLDER8HS	563 390-00
2	129656-01-703	EA	HOLDER ASSEMBLY	9XD 563 637-01
3	129656-01-702	EA	CAP	9HD 562 802-01
4	129656-01-701	EA	HOLDER/SUPPORT ASSEMBLY	9BP 563 482-00
5	129656-01-704	EA	COVER - F/ARM ASSEMBLY 551MM	8SB 501 246
6	129656-01-705	EA	BELLOWS	9GH 562 803-00
7	129656-01-706	EA	HOUSING-MIRROR/UPPER SUPPORT	9BG 562 812-00
8	129656-01-707	EA	HOUSING-MIRROR/CTR SUPPORT	9BG 562 813-00
9	129656-01-709	EA	MIRROR-CONVEX GLASS/CARRIER	9MX 562 846-01
10	129656-01-708	EA	HOUSING-MIRROR/LWR SUPPORT	9GB 562 814-00
11	129656-01-710	EA	MIRROR-FLAT GLASS/CARRIER -PASS	9MX 562 841-05

**129656-02-01A**

KEY	PART NUMBER	U/M	DESCRIPTION	VENDOR NO.
1	129656-01-700	EA	HARDWARE-FASTENING F/HOLDER	8HS 563 390-00
2	129656-01-703	EA	HOLDER ASSEMBLY	9XD 563 637-01
3	129656-01-702	EA	CAP	9HD 562 802-01
4	129656-01-701	EA	HOLDER/SUPPORT ASSEMBLY	9BP 563 482-00
5	129656-01-704	EA	COVER - F/ARM ASSEMBLY 551MM	9HB 562 824-02
6	129656-01-705	EA	BELLOWS	9GH 562 803-00
7	129656-01-706	EA	HOUSING-MIRROR/UPPER SUPPORT	9BG 562 812-00
8	129656-01-707	EA	HOUSING-MIRROR/CTR SUPPORT	9BG 562 813-00
9	129656-01-709	EA	MIRROR-CONVEX GLASS/CARRIER	9MX 562 846-01
10	129656-01-708	EA	HOUSING-MIRROR/LWR SUPPORT	9GB 562 814-00
11	129656-02-700	EA	MIRROR-CONVEX	9MX 562 841-01

**EXTERIOR BODY GROUP (CONTINUED)**  
**STRUCTURAL COMPONENTS**

<b>KEY</b>	<b>PART NUMBER</b>	<b>U/M</b>	<b>DESCRIPTION</b>
	068716-01-001	EA	BRACE - 90 DEGREE - L-ANGLE - 16'
	076054-Y2-000	EA	FIBERGLASS SHEET - 102" X 320.9" - BRIGHT WHITE
	089297-01-000	SF	PLYWOOD - LUAN - OVERLAY GRADE - 4' X 8'
	100619-01-000	BF	FOAM - EXPANDED POLYSTYRENE - 1.34" X 48" X 96"
	100619-02-000	BF	FOAM - EXPANDED POLYSTYRENE - 1.5" X 48" X 96"
	100619-04-000	BF	FOAM - EXPANDED POLYSTYRENE - .5" X 48" X 96"
	100619-05-000	BF	FOAM - EXPANDED POLYSTYRENE - .75" X 48" X 96"-1.5 DENSITY
	100619-11-000	BF	FOAM - EXPANDED POLYSTYRENE - 2" X 48" X 96"
	100619-13-000	BF	FOAM - EXPANDED POLYSTYRENE - .34" X 34.65" X 96"
	100619-16-000	BF	FOAM - EXPANDED POLYSTYRENE - .75" X 48" X 96"-2.0 DENSITY
	100619-27-000	BF	FOAM - EXPANDED POLYSTYRENE - 48" X 92.8" X 3"
	108535-05-03A	SF	FIBERGLASS SHEET - 108" X 500' ROLL - BRIGHT WHITE
	113192-06-01A	EA	FIBERGLASS/LUAN LAMINATED SHEET-79"X446" - HIGH GLOSS-B/W
	116942-03-01A	LB	ALUMINUM - .7" X 40" X 158"
	128782-03-01A	EA	FIBERGLASS SHEET - 26.1" X 68.2" - HIGH GLOSS/SLIDEOUT-B/W
	128782-07-01A	EA	FIBERGLASS SHEET - 79" X 456" - HIGH GLOSS - BRIGHT WHITE FROM: 00-00-00 THRU: 04-30-02
	128782-09-01A	EA	FIBERGLASS SHEET - 31" X 68.2" - HIGH GLOSS - BRIGHT WHITE FROM: 05-01-02 THRU: 99-99-99
	128782-08-01A	EA	FIBERGLASS SHEET - 22" X 68.3" - HIGH GLOSS - BRIGHT WHITE

**EXTERIOR BODY GROUP (CONTINUED)**  
**AWNINGS**

**PATIO AWNINGS WITH GRAPHIC PACKAGES**

**ADVANTAGE PATIO AWNINGS WITH GRAPHIC PACKAGE**

MODEL	PACKAGE	COLOR	AWNING	AWNING	WEATHER	AWNING #	AWNING #
		DESIGNATION	FABRIC	LENGTH	WRAP	MANUAL	ELECTRIC
Q36C	<b>92K</b> ROSEWOOD	BLACK CHERRY	ACRYLIC	18'	MTL/BRT WHT	130483-06-14A	137148-06-14A
Q36C	<b>27G</b> SLATE BLUE	NAVY	ACRYLIC	18'	MTL/BRT WHT	130483-06-17A	137148-06-17A
Q36C	<b>24E</b> HARVEST	TAUPE	ACRYLIC	18'	MTL/BRT WHT	130483-06-11A	137148-06-11A
Q38K	<b>92K</b> ROSEWOOD	BLACK CHERRY	ACRYLIC	20'	MTL/BRT WHT	130483-04-14A	137148-04-14A
Q38K	<b>27G</b> SLATE BLUE	NAVY	ACRYLIC	20'	MTL/BRT WHT	130483-04-17A	137148-04-17A
Q38K	<b>24E</b> HARVEST	TAUPE	ACRYLIC	20'	MTL/BRT WHT	130483-04-11A	137148-04-11A
Q40E	<b>92K</b> ROSEWOOD	BLACK CHERRY	ACRYLIC	20'	MTL/BRT WHT	130483-04-14A	137148-04-14A
Q40E	<b>27G</b> SLATE BLUE	NAVY	ACRYLIC	20'	MTL/BRT WHT	130483-04-17A	137148-04-17A
Q40E	<b>24E</b> HARVEST	TAUPE	ACRYLIC	20'	MTL/BRT WHT	130483-04-11A	137148-04-11A
<b>Q40K UP TO 08-25-02</b>							
Q40K	<b>92K</b> ROSEWOOD	BLACK CHERRY	ACRYLIC	20'	MTL/BRT WHT	130483-04-14A	137148-04-14A
Q40K	<b>27G</b> SLATE BLUE	NAVY	ACRYLIC	20'	MTL/BRT WHT	130483-04-17A	137148-04-17A
Q40K	<b>24E</b> HARVEST	TAUPE	ACRYLIC	20'	MTL/BRT WHT	130483-04-11A	137148-04-11A
<b>Q40K AFTER 08-26-02</b>							
Q40K	<b>92K</b> ROSEWOOD	BLACK CHERRY	ACRYLIC	21'	MTL/BRT WHT	130483-08-14A	137148-08-14A
Q40K	<b>27G</b> SLATE BLUE	NAVY	ACRYLIC	21'	MTL/BRT WHT	130483-08-17A	137148-08-17A
Q40K	<b>24E</b> HARVEST	TAUPE	ACRYLIC	21'	MTL/BRT WHT	130483-08-11A	137148-08-11A

KEY	PART NUMBER	U/M	DESCRIPTION
	113874-11-01A	EA	SCREW/LAG - AWNING - 1/4" X 1" STAINLESS STEEL
	113874-12-01A	EA	SCREW/LAG - AWNING - 1/4" X 2 3/4" STAINLESS STEEL
	136770-03-01A	EA	SPACER - AWNING - 2" - BRIGHT WHITE
*	130483-01-01A	EA	AWNING HARDWARE - PATIO - BRIGHT WHITE - <b>MANUAL</b>
	137148-01-01A	EA	HARDWARE KIT - F/1 TOUCH AWNING - BRIGHT WHITE - <b>ELECTRIC</b>
			FROM: 00-00-00 THRU: 10-27-02
	137148-09-01A	EA	HARDWARE KIT-F/1 TOUCH W/AUTO RETRACT/REMOTE-BRT WHT - <b>ELECTRIC</b>
			FROM: 10-28-02 THRU: 99-99-99
	137148-07-01A	EA	HARDWARE (SPECIAL) PATIO AWNING/SLIDEOUT ROOM-BRT WHT - <b>ELECTRIC - Q40K ONLY</b>
			FROM: 00-00-00 THRU: 10-27-02
	137148-10-01A	EA	HARDWARE KIT-F/1 TOUCH W/AUTO RETRACT/REMOTE-F-S/O ROOM - <b>ELECTRIC - Q40K ONLY</b>
			FROM: 10-28-02 THRU: 99-99-99
	137148-02-01A	EA	ELECTRICAL KIT - F/1 TOUCH AWNING - <b>ELECTRIC</b>
			FROM: 00-00-00 THRU: 10-27-02
	137148-11-01A	EA	ELECTRICAL OUTLET ASM(CONTROL BOX KIT) AUTO RETRACT/REWIND
			FROM: 10-28-02 THRU: 99-99-99
	137148-03-01A	EA	ELECTRICAL OUTLET ASSEMBLY - F/1 TOUCH AWNING

\*COMPONENT PARTS LISTED LATER IN THIS GROUP

**EXTERIOR BODY GROUP (CONTINUED)**  
**AWNINGS (CONTINUED)**

**PATIO AWNINGS WITH FULL BODY PAINT**

**ADVANTAGE PATIO AWNINGS WITH FULL BODY PAINT**

MODEL	COLOR CODE	AWNING COLOR	HARDWARE COLOR	PATIO ROLLER	AWNING LENGTH	EARLY	LATER	EARLY	LATER
						PATIO HARDWARE	PATIO HARDWARE	ELECTRICAL KIT	ELECTRICAL KIT
						UP TO 10-27-02	AFTER 10-28-02	UP TO 10-27-02	AFTER 10-28-02
Q36C	ROSEWOOD 92A	BLACK CHERRY	CHAMPAGNE	137148-06-14E	18'	137148-01-05A	137148-09-05A	137148-02-01A	137148-11-01A
Q36C	SLATE BLUE 27A	NAVY	CHAMPAGNE	137148-06-17E	18'	137148-01-05A	137148-09-05A	137148-02-01A	137148-11-01A
Q36C	HARVEST 24C	TAUPE	CHAMPAGNE	137148-06-11E	18'	137148-01-05A	137148-09-05A	137148-02-01A	137148-11-01A
Q38K	ROSEWOOD 92A	BLACK CHERRY	CHAMPAGNE	137148-04-14E	20'	137148-01-05A	137148-09-05A	137148-02-01A	137148-11-01A
Q38K	SLATE BLUE 27A	NAVY	CHAMPAGNE	137148-04-17E	20'	137148-01-05A	137148-09-05A	137148-02-01A	137148-11-01A
Q38K	HARVEST 24C	TAUPE	CHAMPAGNE	137148-04-11E	20'	137148-01-05A	137148-09-05A	137148-02-01A	137148-11-01A
Q40E	ROSEWOOD 92A	BLACK CHERRY	CHAMPAGNE	137148-04-14E	20'	137148-01-05A	137148-09-05A	137148-02-01A	137148-11-01A
Q40E	SLATE BLUE 27A	NAVY	CHAMPAGNE	137148-04-17E	20'	137148-01-05A	137148-09-05A	137148-02-01A	137148-11-01A
Q40E	HARVEST 24C	TAUPE	CHAMPAGNE	137148-04-11E	20'	137148-01-05A	137148-09-05A	137148-02-01A	137148-11-01A
<b>Q40K UP TO 08-25-02</b>									
Q40K	ROSEWOOD 92A	BLACK CHERRY	CHAMPAGNE	137148-04-14E	20'	137148-07-05A	137148-10-05A	137148-02-01A	137148-11-01A
Q40K	SLATE BLUE 27A	NAVY	CHAMPAGNE	137148-04-17E	20'	137148-07-05A	137148-10-05A	137148-02-01A	137148-11-01A
Q40K	HARVEST 24C	TAUPE	CHAMPAGNE	137148-04-11E	20'	137148-07-05A	137148-10-05A	137148-02-01A	137148-11-01A
<b>Q40K AFTER 08-26-02</b>									
Q40K	ROSEWOOD 92A	BLACK CHERRY	CHAMPAGNE	137148-08-14E	21'	137148-07-05A	137148-10-05A	137148-02-01A	137148-11-01A
Q40K	SLATE BLUE 27A	NAVY	CHAMPAGNE	137148-08-17E	21'	137148-07-05A	137148-10-05A	137148-02-01A	137148-11-01A
Q40K	HARVEST 24C	TAUPE	CHAMPAGNE	137148-08-11E	21'	137148-07-05A	137148-10-05A	137148-02-01A	137148-11-01A

KEY	PART NUMBER	U/M DESCRIPTION
	113874-11-01A	EA SCREW/LAG - AWNING - 1/4" X 1" STAINLESS STEEL
	113874-12-01A	EA SCREW/LAG - AWNING - 1/4" X 2 3/4" STAINLESS STEEL
	136770-03-02A	EA SPACER - AWNING - 2" - BLACK
	137148-01-01A	EA HARDWARE KIT - F/1 TOUCH AWNING - BRIGHT WHITE
		FROM: 00-00-00 THRU: 10-27-02
	137148-09-01A	EA HARDWARE KIT-F/1 TOUCH W/AUTO RETRACT/REMOTE-BRT WHT
		FROM: 10-28-02 THRU: 99-99-99
	137148-07-01A	EA HARDWARE (SPECIAL) PATIO AWNING/SLIDEOUT ROOM-BRT WHT - Q40K ONLY
		FROM: 00-00-00 THRU: 10-27-02
	137148-10-01A	EA HARDWARE KIT-F/1 TOUCH W/AUTO RETRACT/REMOTE-F/S/O ROOM - Q40K ONLY
		FROM: 10-28-02 THRU: 99-99-99
	137148-03-01A	EA ELECTRICAL OUTLET ASSEMBLY - F/1 TOUCH AWNING

**ENTRY DOOR AWNINGS**

**ADVANTAGE ENTRY DOOR AWNINGS**

MODEL	COLOR CODE	AWNING COLOR	HARDWARE COLOR	MANUAL AWNING	ELECTRIC AWNING
<b>GRAPHIC PKG.</b>					
ALL	SLATE BLUE 27G	NAVY	BRIGHT WHITE	143185-01-17A	143185-02-17A
ALL	ROSEWOOD 92K	BLACK CHERRY	BRIGHT WHITE	143185-01-14A	143185-02-14A
ALL	HARVEST 24E	TAUPE	BRIGHT WHITE	143185-01-11A	143185-02-11A
<b>FULL BODY PAINT</b>					
ALL	ROSEWOOD 92A	BLACK CHERRY	CHAMPAGNE	NA	143185-02-14E
ALL	SLATE BLUE 27A	NAVY	CHAMPAGNE	NA	143185-02-17E
ALL	HARVEST 24C	TAUPE	CHAMPAGNE	NA	143185-02-11E

KEY	PART NUMBER	U/M DESCRIPTION
	136770-03-01A	EA SPACER - AWNING - 2" - BRIGHT WHITE
	137029-02-01A	EA BRACKET - AWNING - BRIGHT WHITE - MANUAL
	137029-02-02A	EA BRACKET - AWNING - BLACK - ELECTRIC

**EXTERIOR BODY GROUP (CONTINUED)**  
**AWNINGS (CONTINUED)**

**WINDOW AWNINGS WITH GRAPHIC PACKAGES**

		<b>ADVANTAGE WINDOW AWNINGS WITH GRAPHICS PKG.</b>					
<b>COLOR CODE</b>		<b>ROSEWOOD 92K</b>		<b>SLATE BLUE 27G</b>		<b>HARVEST 24E</b>	
<b>AWNING COLOR</b>		<b>BLACK CHERRY</b>		<b>NAVY</b>		<b>TAUPE</b>	
		<b>WHITE MTL WRAP</b>		<b>WHITE MTL WRAP</b>		<b>WHITE MTL WRAP</b>	
Q36C	RT REAR	42" XL	134483-02-14A	134483-02-17A	134483-02-11A		
	LT FRONT	144"	130485-05-14A	130485-05-17A	130485-05-11A		
Q38K	LT REAR	42" XL	134483-02-14A	134483-02-17A	134483-02-11A		
	LT FRONT	108"	130485-04-14A	130485-04-17A	130485-04-11A		
Q40E	LT REAR	42" XL	134483-02-14A	134483-02-17A	134483-02-11A		
	LT FRONT	132"	130485-06-14A	130485-06-17A	130485-06-11A		
Q40K	RT REAR	48" XL	134483-02-14A	134483-02-17A	134483-02-11A		
	LT MID	42"	130485-02-14A	130485-02-17A	130485-02-11A		
	LT FRONT	132"	130485-06-14A	130485-06-17A	130485-06-11A		

<b>KEY</b>	<b>PART NUMBER</b>	<b>U/M</b>	<b>DESCRIPTION</b>
	130485-01-01A	EA	HARDWARE KIT - WINDOW AWNING - BRIGHT WHITE
	134483-01-01A	EA	AWNING HARDWARE - WINDOW/XL - BRIGHT WHITE

**WINDOW AWNINGS WITH FULL BODY PAINT**

<b>ADVANTAGE WINDOW AWNINGS WITH FULL BODY PAINT</b>												
<b>MODEL</b>	<b>COLOR CODE</b>	<b>AWNING COLOR</b>	<b>HARDWARE COLOR</b>	<b>WINDOW LT FRONT ROLLER</b>	<b>WINDOW LT FRONT HARDWARE</b>	<b>WINDOW LT MID ROLLER</b>	<b>WINDOW LT MID HARDWARE</b>	<b>WINDOW LT REAR ROLLER</b>	<b>WINDOW LT REAR HARDWARE</b>	<b>WINDOW RT REAR ROLLER</b>	<b>WINDOW RT REAR HARDWARE</b>	<b>WINDOW RT REAR HARDWARE</b>
Q36C	ROSEWOOD 92A	BLACK CHERRY	CHAMPAGNE	130485-05-14E	130485-01-05A	NA	NA	NA	NA	134483-02-14E	134483-01-05A	134483-01-05A
Q36C	SLATE BLUE 27A	NAVY	CHAMPAGNE	130485-05-17E	130485-01-05A	NA	NA	NA	NA	134483-02-17E	134483-01-05A	134483-01-05A
Q36C	HARVEST 24C	TAUPE	CHAMPAGNE	130485-05-11E	130485-01-05A	NA	NA	NA	NA	134483-02-11E	134483-01-05A	134483-01-05A
Q38K	ROSEWOOD 92A	BLACK CHERRY	CHAMPAGNE	130485-04-14E	130485-01-05A	NA	NA	134483-02-14E	134483-01-05A	NA	NA	NA
Q38K	SLATE BLUE 27A	NAVY	CHAMPAGNE	130485-04-17E	130485-01-05A	NA	NA	134483-02-17E	134483-01-05A	NA	NA	NA
Q38K	HARVEST 24C	TAUPE	CHAMPAGNE	130485-04-11E	130485-01-05A	NA	NA	134483-02-11E	134483-01-05A	NA	NA	NA
Q40E	ROSEWOOD 92A	BLACK CHERRY	CHAMPAGNE	130485-06-14E	130485-01-05A	NA	NA	134483-02-14E	134483-01-05A	NA	NA	NA
Q40E	SLATE BLUE 27A	NAVY	CHAMPAGNE	130485-06-17E	130485-01-05A	NA	NA	134483-02-17E	134483-01-05A	NA	NA	NA
Q40E	HARVEST 24C	TAUPE	CHAMPAGNE	130485-06-11E	130485-01-05A	NA	NA	134483-02-11E	134483-01-05A	NA	NA	NA
Q40K	ROSEWOOD 92A	BLACK CHERRY	CHAMPAGNE	130485-06-14E	130485-01-05A	130485-02-14E	130485-01-05A	NA	NA	134483-02-14E	134483-04-05A	134483-04-05A
Q40K	SLATE BLUE 27A	NAVY	CHAMPAGNE	130485-06-17E	130485-01-05A	130485-02-17E	130485-01-05A	NA	NA	134483-02-17E	134483-04-05A	134483-04-05A
Q40K	HARVEST 24C	TAUPE	CHAMPAGNE	130485-06-11E	130485-01-05A	130485-02-11E	130485-01-05A	NA	NA	134483-02-11E	134483-04-05A	134483-04-05A



**EXTERIOR BODY GROUP (CONTINUED)**  
**COMPONENT PARTS FOR AWNINGS**

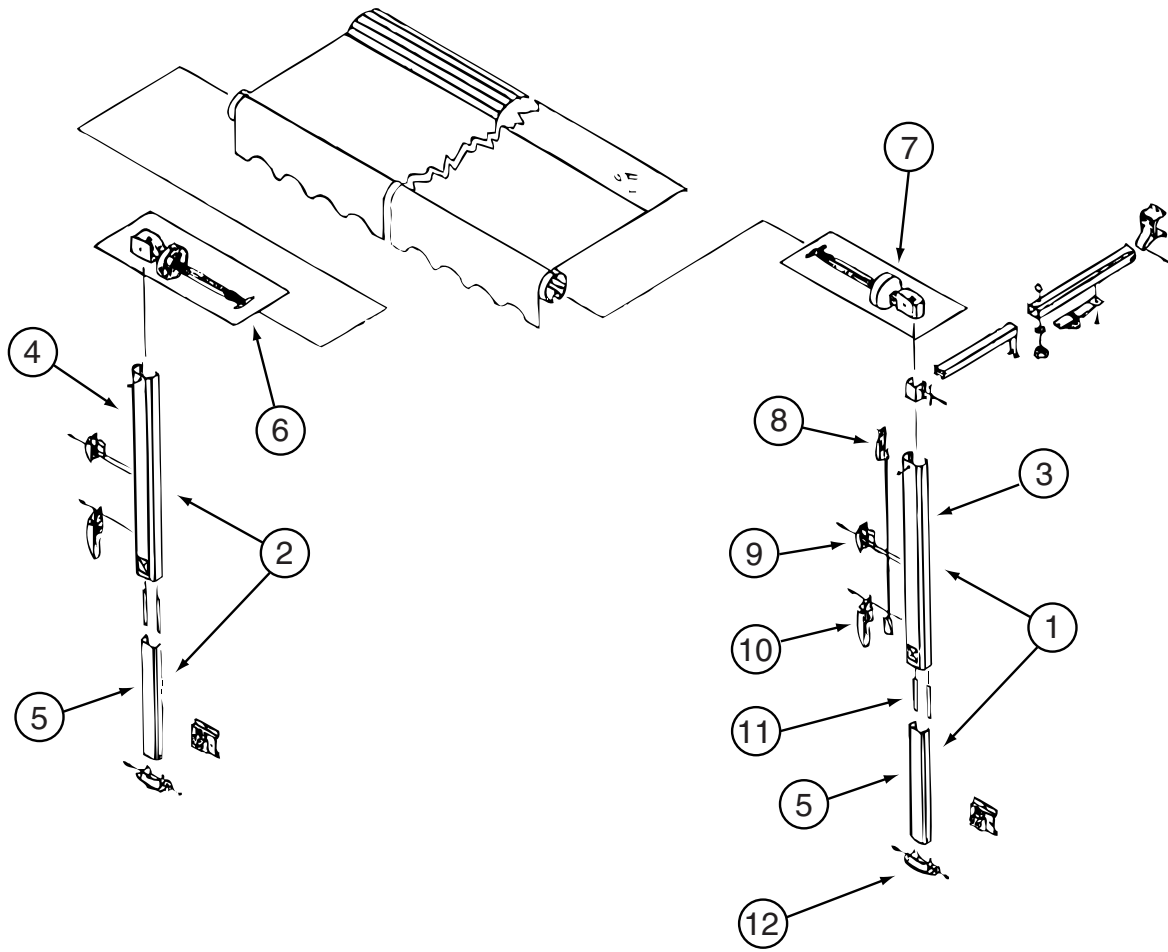

**130483-01-01A**

KEY	PART NUMBER	U/M	DESCRIPTION	VENDOR NO.
1	130483-01-700	EA	HARDWARE SET/FRONT 1/2 (WW)	R00415-101-55
2	130483-01-701	EA	HARDWARE SET/REAR 1/2 (WW)	R00416-101-55
3	130483-01-702	EA	ARM/UPPER - FRONT - UNI (WW)	R00410-101-55
4	130483-01-703	EA	ARM/UPPER - REAR - UNI (WW)	R00411-101-55
5	130483-01-704	EA	ARM/LOWER - RT/LT - UNI (WW)	R00412-101-55
6	130483-01-705	EA	SPRINGS/ REAR - (WW)	R012408WHT
7	130483-01-706	EA	SPRINGS/FRONT - (WW)	R012407WHT
8	130483-01-707	EA	LOCK/REMOTE - UNIVERSAL	R00631W
9	130483-01-708	EA	LOCK/TRAVEL	901017W
10	130483-01-709	EA	HANDLE	901015W
11	130483-01-710	EA	GLIDE - PLASTIC	041178-001
12	130483-01-711	EA	FOOT/CARPORT	901020W
	130483-01-712	EA	STANDOFF/TOP BRACKET (WW)	249153WHT
	130483-01-713	EA	BRACKET/BOTTOM-CARPORT BRKT	90109W

# EXTERIOR DOORS & COMPARTMENTS GROUP

## DOOR & COMPARTMENT LAYOUT

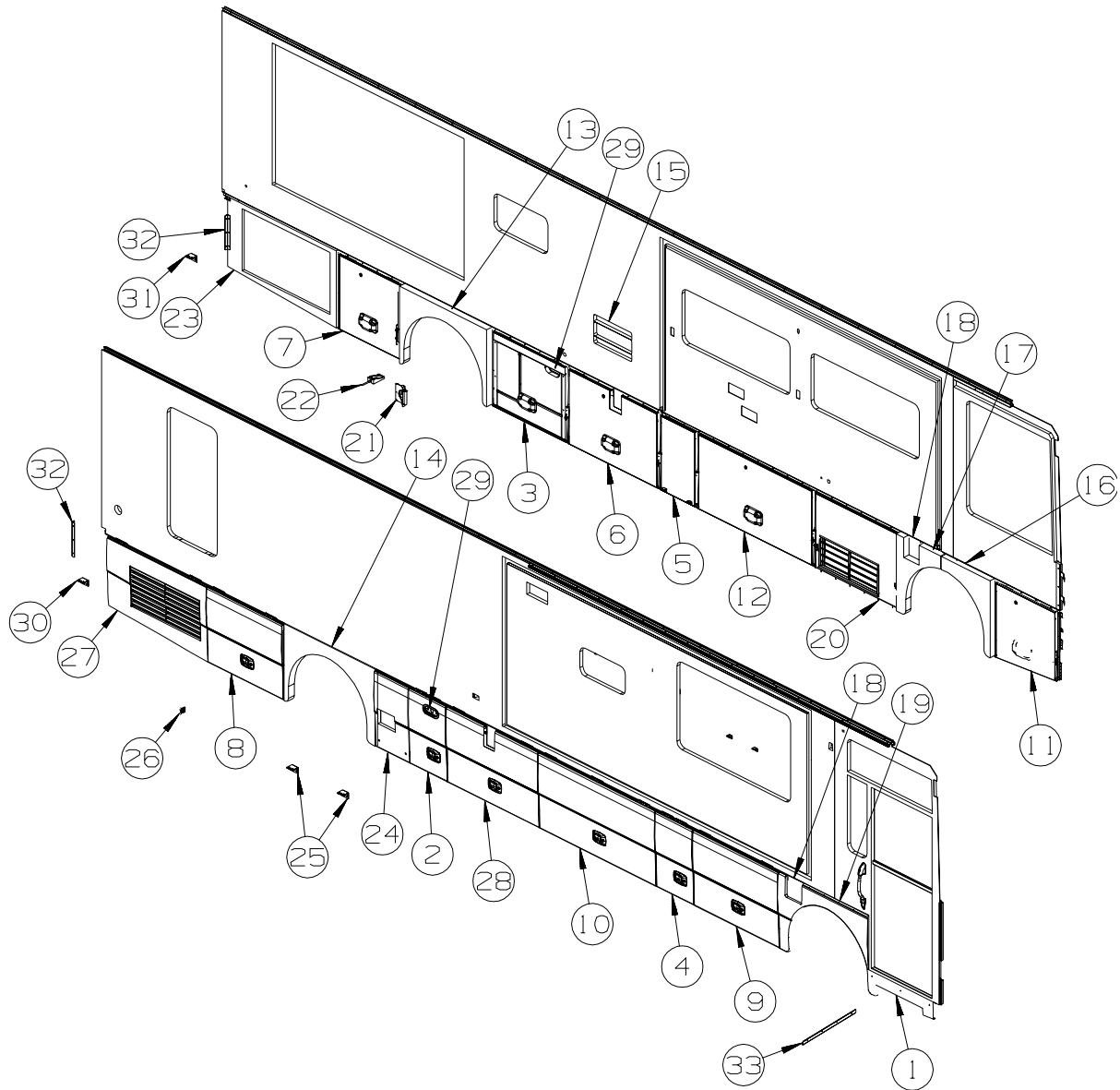

KEY	PART NUMBER	U/M	DESCRIPTION
1*	094708-03-01A	EA	STEP - ELECTRIC - SINGLE - BLACK CONTROL BOX - KWIKEE
2	141909-01-PC0	EA	VALANCE/DOOR - W/O PAD LATCH 21.7" X 33.6"-W/LIGHT POCKET - BLACK
	142569-04-000	EA	SPRING - GAS - 21"/45 LB
2	141909-01-PA0	EA	VALANCE/DOOR - W/O PAD LATCH 21.7" X 33.6"-W/LIGHT POCKET - WHITE
	142569-04-000	EA	SPRING - GAS - 21"/45 LB
3	141909-06-PC0	EA	VALANCE/DOOR-DRVR W/O PAD LATCH-40" X 33.6"-W/LIGHT POCKET - BLACK
	142569-04-000	EA	SPRING - GAS - 21"/45 LB
3	141909-06-PA0	EA	VALANCE/DOOR-DRVR W/O PAD LATCH-40" X 33.6"-W/LIGHT POCKET - WHITE
	142569-04-000	EA	SPRING - GAS - 21"/45 LB
4	141909-14-PC0	EA	VALANCE/DOOR - W/O PADDLE LATCH - 19.7" X 33.6" - BLACK
	142569-02-000	EA	SPRING - GAS - 21"/45 LB
4	141909-14-PA0	EA	VALANCE/DOOR - W/O PADDLE LATCH - 19.7" X 33.6" - WHITE
	142569-02-000	EA	SPRING - GAS - 21"/45 LB
5	141909-16-PC0	EA	VALANCE/DOOR - W/O PADDLE LATCH - 19.7" X 33.6" - BLACK
5	141909-16-PA0	EA	VALANCE/DOOR - W/O PADDLE LATCH - 19.7" X 33.6" - WHITE
6	141909-17-PC0	EA	VALANCE/DOOR - W/O PADDLE LATCH - 48.6" X 33.6" - BLACK
	142569-04-000	EA	SPRING - GAS - 21"/45 LB
6	141909-17-PA0	EA	VALANCE/DOOR - W/O PADDLE LATCH - 48.6" X 33.6" - WHITE
	142569-04-000	EA	SPRING - GAS - 21"/45 LB
7	141909-04-PC0	EA	VALANCE/DOOR - W/O PADDLE LATCH - 34.9" X 33.6" - BLACK
	142569-02-000	EA	SPRING - GAS - 21"/45 LB

**EXTERIOR DOORS & COMPARTMENTS GROUP (CONTINUED)**  
**DOOR & COMPARTMENT LAYOUT (CONTINUED)**

KEY	PART NUMBER	U/M	DESCRIPTION
8	141909-05-PC0	EA	VALANCE/DOOR - W/O PADDLE LATCH - 40" X 33.6" - BLACK
	142569-10-000	EA	SPRING - GAS - 18.6"/45LBS
9	141909-09-PC0	EA	VALANCE/DOOR - W/O PADDLE LATCH - 45.2" X 33.6" - BLACK
	142569-02-000	EA	SPRING - GAS - 21"/45 LB
10	141909-10-PC0	EA	VALANCE/DOOR - W/O PADDLE LATCH - 62" X 33.6" - BLACK
	142569-01-000	EA	SPRING - GAS - 21"/60 LB
11	141909-12-PC0	EA	VALANCE/DOOR - DRVR W/O PAD LATCH - 33.6" X 33.2" X 30.8" - BLACK
	142569-04-000	EA	SPRING - GAS - 21"/45 LB
12	141909-10-PC0	EA	VALANCE/DOOR - W/O PADDLE LATCH - 62" X 33.6" - BLACK
	142569-04-000	EA	SPRING - GAS - 21"/45 LB
13	P28911-05-PC0	EA	WHEEL LIP - REAR - W/LIGHT
	129116-01-01A	EA	HINGE - SINGLE PIVOT - MILL
14	P28911-06-PC0	EA	WHEEL LIP - REAR - W/LIGHT
	129116-01-01A	EA	HINGE - SINGLE PIVOT - MILL
15*	084103-08-000	EA	DOOR - VENT - REFRIGERATOR - W/O JAMB - BRIGHT WHITE
	084104-08-000	EA	JAMB - VENT DOOR/REFRIGERATOR - BRIGHT WHITE
16	128912-09-PC0	EA	WHEEL LIP - FRONT
	129116-01-01A	EA	HINGE - SINGLE PIVOT - MILL
17	128912-21-PC0	EA	WHEEL LIP - FRONT
	129116-01-01A	EA	HINGE - SINGLE PIVOT - MILL
18	128910-03-N94	EA	DOOR - FUEL FILL
	121677-01-01A	EA	HINGE - SINGLE PIVOT
	138290-01-000	EA	CASE - W/CAM - W/O CYLINDER/KEY
19	128912-22-PC0	EA	WHEEL LIP - FRONT
	128910-03-N94	EA	DOOR - FUEL FILL
	121677-01-01A	EA	HINGE - SINGLE PIVOT
	138290-01-000	EA	CASE - W/CAM - W/O CYLINDER/KEY
20	139995-01-NQ0	EA	VALANCE/DOOR
	140060-01-01A	EA	LATCH/DOOR - COMPRESSION
	129116-01-01A	EA	HINGE - SINGLE PIVOT - MILL
	142569-04-000	EA	SPRING - GAS - 21"/45 LB
21	129015-01-K80	EA	PORT W/HATCH - F/ELECTRICAL/DRAIN
			FROM: 00-00-00 THRU: 08-15-02
21	142226-01-01A	EA	HATCH - POWER
			FROM: 08-16-02 THRU: 99-99-99
22	121175-02-01A	EA	LATCH - SWELL
23	134737-01-L94	EA	VALANCE/PANEL - DRIVER W/GRILLE - 30.1" X 56.6" X 33.2"
	121677-01-01A	EA	HINGE - SINGLE PIVOT
24	132057-02-K90	EA	VALANCE/PANEL - W/O LATCH/HINGE - 18" X 33.6"
*	110506-A1-000	EA	LOCK ASM-TWIST,17.65MM
	110506-50-000	EA	CASE/CYLINDER - TWIST LATCH - W/O CAM - .65" - 596952
	110506-60-000	EA	CAM - LATCHING - STRAIGHT 2.4"
	129116-01-01A	EA	HINGE - SINGLE PIVOT - MILL
25	132585-01-02B	EA	BRACKET - CATCH - VALANCE DOOR - E-COATED
26	107721-08-000	FT	SEAL - ACCESS DOOR - .9" WIDE X .9" HIGH
27	138059-01-N94	EA	VALANCE/DOOR
	121677-01-01A	EA	HINGE - SINGLE PIVOT
28	141909-17-PC0	EA	VALANCE/DOOR - W/O PADDLE LATCH - 48.6" X 33.6" - BLACK
	142569-02-000	EA	SPRING - GAS - 21"/45 LB
28	141909-17-PA0	EA	VALANCE/DOOR - W/O PADDLE LATCH - 48.6" X 33.6" - WHITE
	142569-02-000	EA	SPRING - GAS - 21"/45 LB
29	115792-03-02A	EA	COVER - WIRE - WHITE
30	109216-03-000	EA	ANGLE - FURNACE DOOR
31	140309-03-02B	EA	ANGLE - FURNACE DOOR - E-COATED
32	113041-03-02B	EA	ANGLE - BUMPER MOUNT - E-COATED
33	136839-07-01A	EA	TRIM-J - CARPET EDGE/SLIDEOUT - 28.3" - BLACK

**EXTERIOR DOORS & COMPARTMENTS GROUP (CONTINUED)**  
**DOOR & COMPARTMENT LAYOUT (CONTINUED)**

<b>KEY</b>	<b>PART NUMBER</b>	<b>U/M</b>	<b>DESCRIPTION</b>
	138292-01-000	EA	SEAL - LOCK CYLINDER
	138289-01-000	EA	CYLINDER - LOCKING
	138289-02-000	EA	CYLINDER - LOCKING
	138289-03-000	EA	CYLINDER - LOCKING
	138289-04-000	EA	CYLINDER - LOCKING
	138289-05-000	EA	CYLINDER - LOCKING
	138289-06-000	EA	CYLINDER - LOCKING
	138289-07-000	EA	CYLINDER - LOCKING
	138289-08-000	EA	CYLINDER - LOCKING
	138289-09-000	EA	CYLINDER - LOCKING
	138289-10-000	EA	CYLINDER - LOCKING
	138288-01-000	EA	KEY - REVERSIBLE - #1151 - T/M 16169-02-3091
	138288-02-000	EA	KEY - REVERSIBLE - #1152 - T/M 16169-02-3092
	138288-03-000	EA	KEY - REVERSIBLE - #1153 - T/M 16169-02-3093
	138288-04-000	EA	KEY - REVERSIBLE - #1154 - T/M 16169-02-3094
	138288-05-000	EA	KEY - REVERSIBLE - #1155 - T/M 16169-02-3095
	138288-06-000	EA	KEY - REVERSIBLE - #1156 - T/M 16169-02-3096
	138288-07-000	EA	KEY - REVERSIBLE - #1157 - T/M 16169-02-3097
	138288-08-000	EA	KEY - REVERSIBLE - #1158 - T/M 16169-02-3098
	138288-09-000	EA	KEY - REVERSIBLE - #1159 - T/M 16169-02-3099
	138288-10-000	EA	KEY - REVERSIBLE - #1150 - T/M 16169-02-3100

**\*COMPONENT PARTS LISTED LATER IN THIS GROUP**

**EXTERIOR DOORS & COMPARTMENTS GROUP (CONTINUED)**  
**DOOR & COMPARTMENT LAYOUT (CONTINUED)**

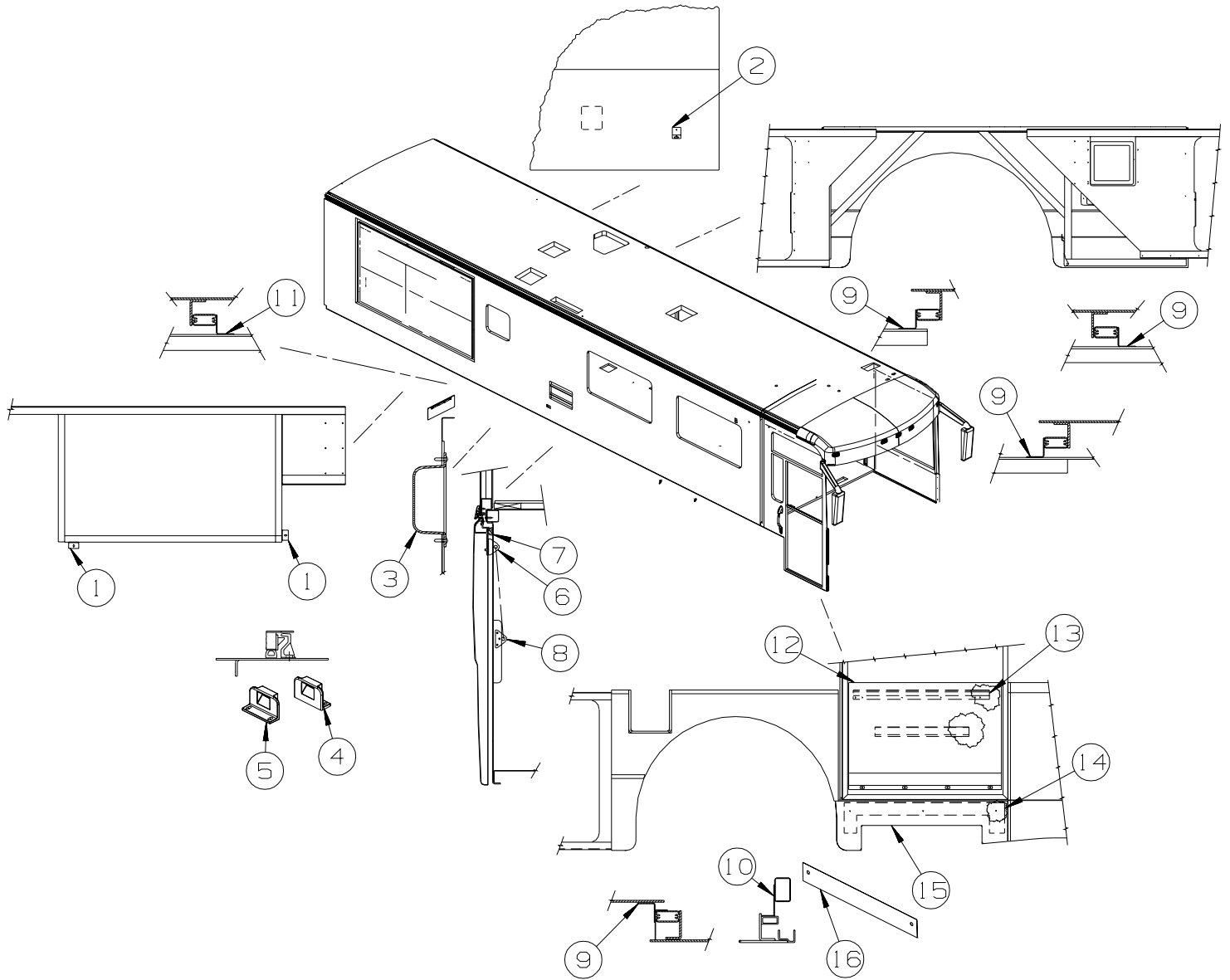

KEY	PART NUMBER	U/M	DESCRIPTION
1	140309-03-02B	EA	ANGLE - FURNACE DOOR - E-COATED
2	131383-03-02A	EA	BRACKET - SHOWER HEAD - WHITE
3	129301-02-01A	EA	COVER - DOCKING LIGHT - BLACK
4	130053-01-01A	EA	STRIKER - LUGGAGE DOOR - FLUSH - BLACK
5	130053-02-01A	EA	STRIKER - LUGGAGE DOOR - OFF SET - BLACK
6	126263-05-02B	EA	BRACKET - GAS SPRING W/BALL STUD - E-COATED
7	107721-08-000	FT	SEAL - ACCESS DOOR - .9" WIDE X .9" HIGH
8	126263-08-02B	EA	BRACKET - GAS SPRING W/CENTERED BALL STUD - E-COATED
9	113041-03-02B	EA	ANGLE - BUMPER MOUNT - E-COATED
10	113041-12-02B	EA	ANGLE - BUMPER MOUNT - E-COATED
11	113904-07-02B	EA	ANGLE - ATTACHMENT/WHEEL LIP - 8" - E-COAT
12	130044-02-KQ0	EA	PANEL/VALANCE - ENTRY DOOR - W/O HARDWARE
13	130034-01-02B	EA	CLIP - TRIM - E-COATED
14	134125-03-02B	EA	SUPPORT - DOOR/VALANCE - E-COATED
15	133078-03-PC0	EA	PANEL - ENTRY DOOR/LOWER
16	143362-01-02B	EA	CLIP - TRIM - E-COATED

**EXTERIOR DOORS & COMPARTMENT GROUP (CONTINUED)**  
**DOOR & COMPARTMENT LAYOUT (CONTINUED)**

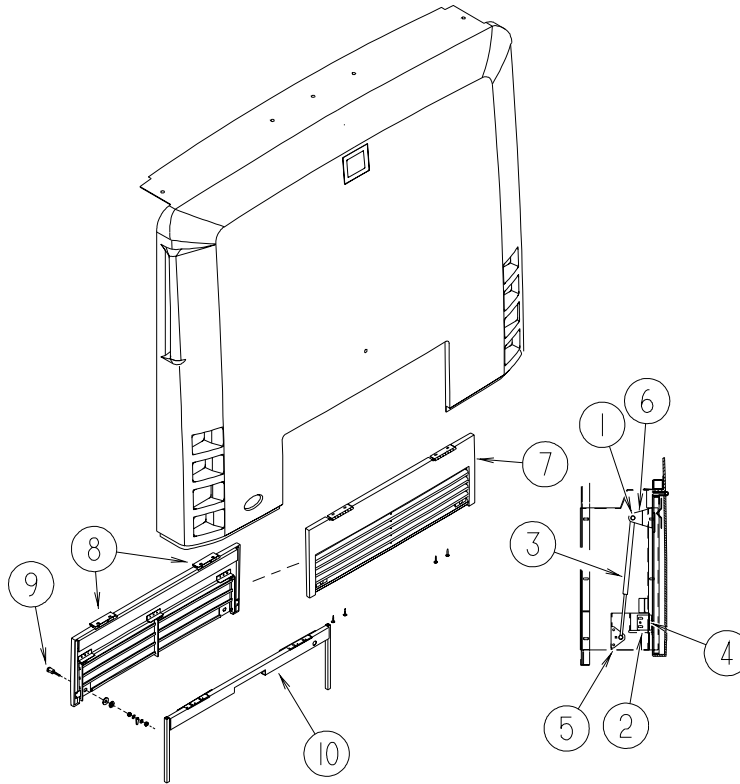

KEY	PART NUMBER	U/M	DESCRIPTION
1	057460-02-000	EA	BALL STUD - F/GAS SPRING .39" - 5/16"-18
2	107719-01-01A	EA	STRIKE - VALANCE DOOR
3	107796-23-000	EA	SPRING/GAS - 11.3" COMPRESSED/18.5" EXTENDED - 45 LB. FROM: 00-00-00 THRU: 05-31-02
3	142569-08-000	EA	SPRING - GAS - 18.5"/45 LB FROM: 06-01-02 THRU: 99-99-99
4	118931-01-02B	EA	SHIM - STRIKER - DOOR
5	126263-08-02B	EA	BRACKET - GAS SPRING W/CENTERED BALL STUD - E-COATED
6	126263-10-02B	EA	BRACKET - GAS SPRING W/BALL STUD - E-COATED
7	129786-01-K90	EA	DOOR - REAR ENGINE
8	102325-02-07A	EA	HINGE/TRUNK DOOR - 6" W/.6" OFF SET - BRIGHT WHITE
9	102330-02-000	EA	LATCH - VISE ACTION/KEY OPERATED
10	113310-03-02B	EA	FRAME - DOOR/REAR ENGINE - E-COATED

# EXTERIOR DOORS & COMPARTMENTS GROUP (CONTINUED)

## COMPONENT PARTS FOR DOOR & COMPARTMENT LAYOUT

084103-08-000

KEY	PART NUMBER	U/M DESCRIPTION	VENDOR NO.
	084104-01-700	EA LOCK-MALE, FASTENER	201-721-010
	084104-01-701	EA LOCK-FEMALE, FASTENER	201-802-010

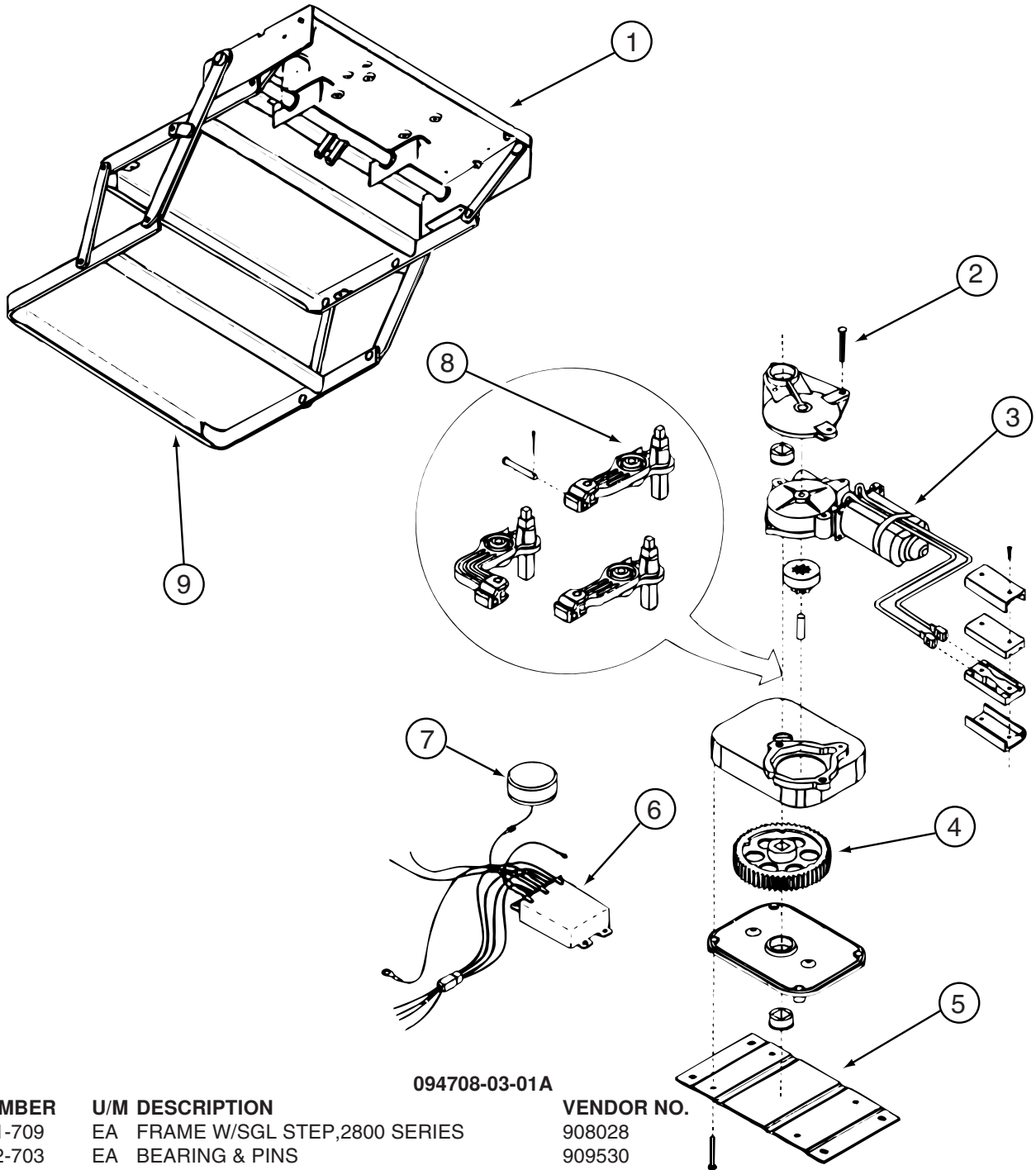

094708-03-01A

KEY	PART NUMBER	U/M DESCRIPTION	VENDOR NO.
1	088746-01-709	EA FRAME W/SGL STEP,2800 SERIES	908028
2	094707-02-703	EA BEARING & PINS	909530
3	094707-02-700	EA MOTOR ASM.,W/BEARINGS & PINS	909520
4	094707-02-702	EA GEAR KIT(GEAR-BEARING-PINS)	909525
5	094707-02-704	EA CONNECTOR-MOTOR ASM.W/PLATES	909537
6	094707-03-700	EA KIT CONTROL/SWITCH-RETROFIT	909506005
7	088733-01-700	EA BULB	9004
7	088746-01-705	EA LIGHT-UNDER STEP	9004
8	094708-03-700	EA LINKAGE ASSEMBLY-SERIES 28	909533
9	094707-02-707	EA TREAD - NON-SKID - BLACK	909333
	094707-03-701	EA PLUG - 4-WAY - PACKARD	909306

110506-A1-000, 110506-A2-000, 110506-26-000, 110506-27-000

KEY	PART NUMBER	U/M DESCRIPTION	VENDOR NO.
	110506-40-700	EA HARDWARE PACKAGE-CYLINDER/CASE	596950AAL

**EXTERIOR DOORS & COMPARTMENTS GROUP (CONTINUED)**  
**COMPARTMENT DOOR PIECE PARTS**

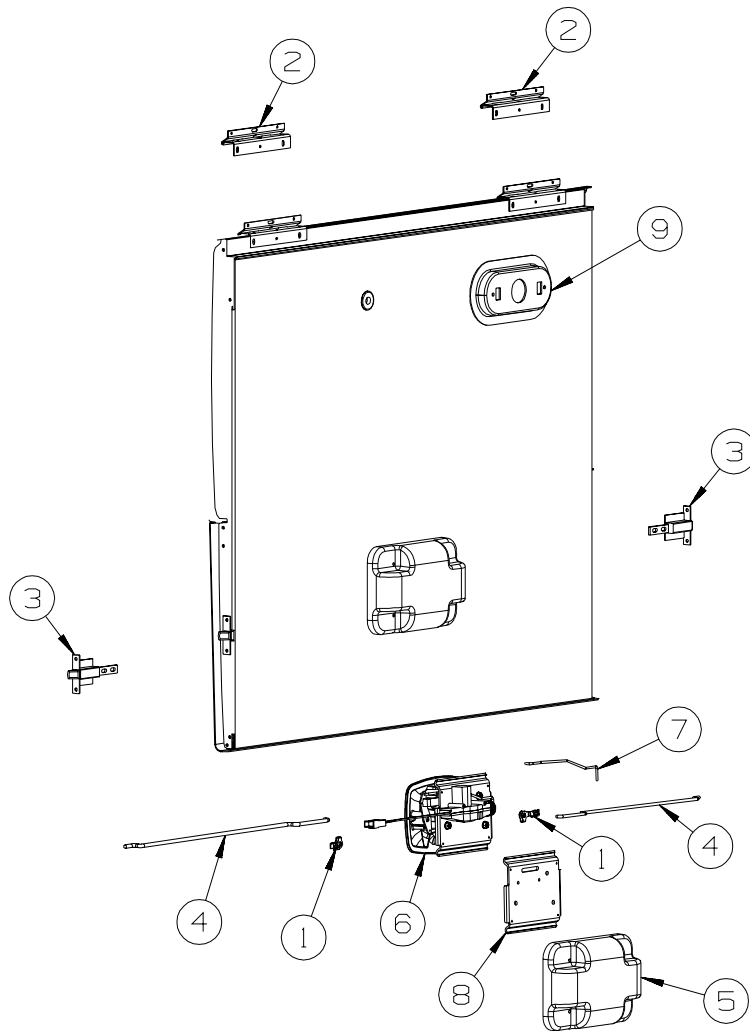

KEY	PART NUMBER	U/M DESCRIPTION
1	102265-03-000	EA CLIP-ROD END, LEFT HAND - .18" - METAL
2	121677-01-01A	EA HINGE - SINGLE PIVOT
3	121947-01-01A	EA BOLT - SLIDE W/PLASTIC PLUNGER
4	132873-01-000	EA ROD - LATCH (BLANK)
5	141856-01-01A	EA COVER - LATCH/VALANCE DOOR - BRIGHT WHITE
6	141940-01-01A	EA LATCH - PADDLE - BLACK
7	141940-03-01A	EA ROD - PADDLE LATCH
8	141940-04-01A	EA BRACKET - PADDLE LATCH
9	113598-02-01A	EA POCKET - LIGHT - SIDE MARKER



## EXTERIOR DOORS & COMPARTMENTS GROUP (CONTINUED)

### ENTRY

KEY	PART NUMBER	U/M	DESCRIPTION
	116111-02-01A	EA	SCREW - TAPTITE - 1/4-20 X 3/8 PPH - ZINC
*	128913-10-01A	EA	DOOR - ENTRY/FRONT - POWER LOCK - BLACK
	134450-02-01A	EA	TAPE - ANTI SLIP - 1.25" X 29.9" - BLACK
	138287-01-000	EA	CYLINDER/LOCK - ENTRY DOOR (MASTER)
	138287-02-000	EA	CYLINDER/LOCK - ENTRY DOOR (MASTER)
	138287-03-000	EA	CYLINDER/LOCK - ENTRY DOOR (MASTER)
	138287-04-000	EA	CYLINDER/LOCK - ENTRY DOOR (MASTER)
	138287-05-000	EA	CYLINDER/LOCK - ENTRY DOOR (MASTER)
	138287-06-000	EA	CYLINDER/LOCK - ENTRY DOOR (MASTER)
	138287-07-000	EA	CYLINDER/LOCK - ENTRY DOOR (MASTER)
	138287-08-000	EA	CYLINDER/LOCK - ENTRY DOOR (MASTER)
	138287-09-000	EA	CYLINDER/LOCK - ENTRY DOOR (MASTER)
	138287-10-000	EA	CYLINDER/LOCK - ENTRY DOOR (MASTER)
	138288-01-000	EA	KEY - REVERSIBLE - #1151 - T/M 16169-02-3091
	138288-02-000	EA	KEY - REVERSIBLE - #1152 - T/M 16169-02-3092
	138288-03-000	EA	KEY - REVERSIBLE - #1153 - T/M 16169-02-3093
	138288-04-000	EA	KEY - REVERSIBLE - #1154 - T/M 16169-02-3094
	138288-05-000	EA	KEY - REVERSIBLE - #1155 - T/M 16169-02-3095
	138288-06-000	EA	KEY - REVERSIBLE - #1156 - T/M 16169-02-3096
	138288-07-000	EA	KEY - REVERSIBLE - #1157 - T/M 16169-02-3097
	138288-08-000	EA	KEY - REVERSIBLE - #1158 - T/M 16169-02-3098
	138288-09-000	EA	KEY - REVERSIBLE - #1159 - T/M 16169-02-3099
	138288-10-000	EA	KEY - REVERSIBLE - #1150 - T/M 16169-02-3100
	138898-01-000	EA	ACTUATOR/LOCK - ELECTRIC

\*COMPONENT PARTS LISTED LATER IN THIS GROUP

**EXTERIOR DOORS & COMPARTMENTS GROUP (CONTINUED)**  
**COMPONENT PARTS FOR ENTRY**

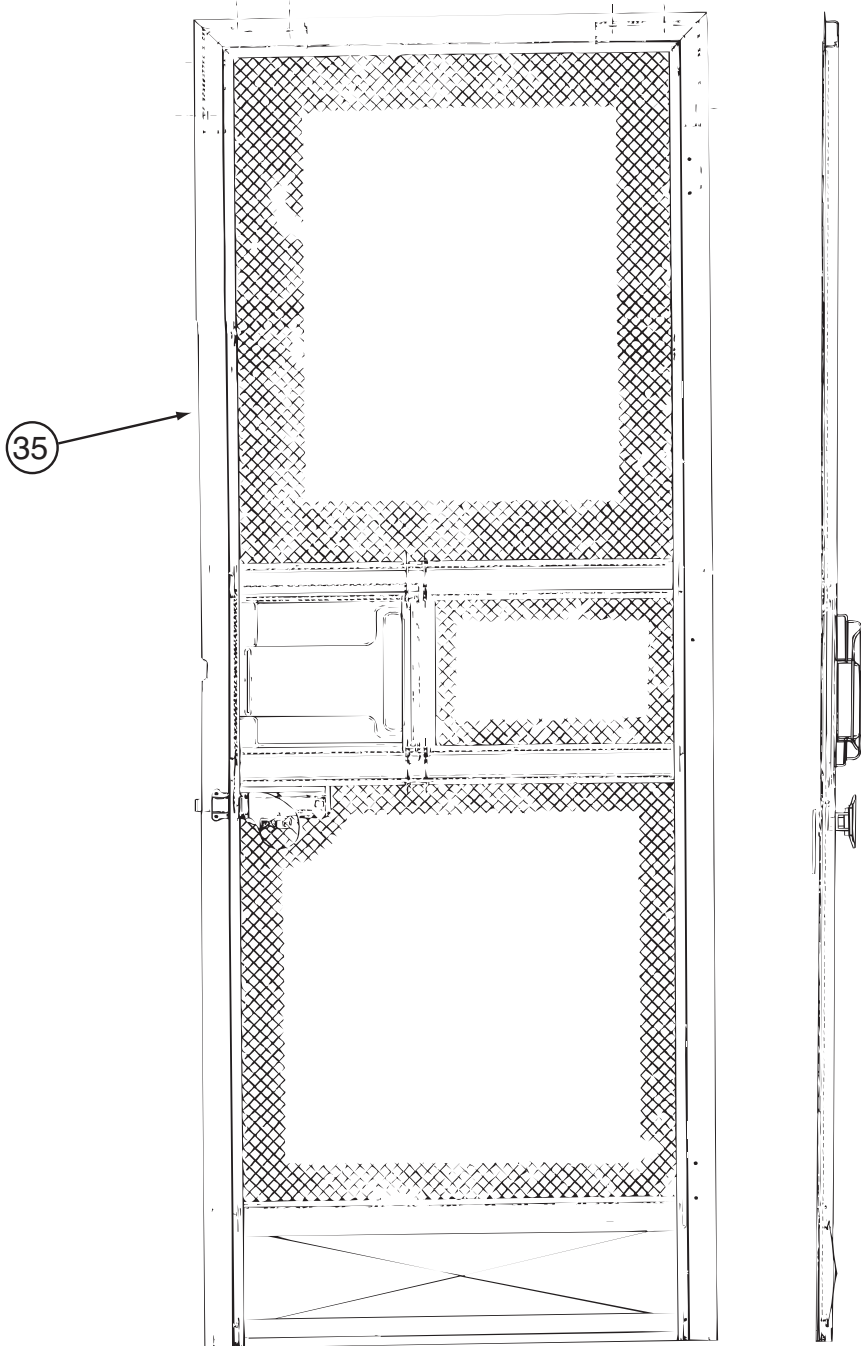

KEY	PART NUMBER	U/M	DESCRIPTION	128913-10-01A	VENDOR NO.
35	128913-09-700	EA	SCREEN DOOR ASSEMBLY		490056

**EXTERIOR DOORS & COMPARTMENTS GROUP (CONTINUED)**  
**COMPONENT PARTS FOR ENTRY (CONTINUED)**

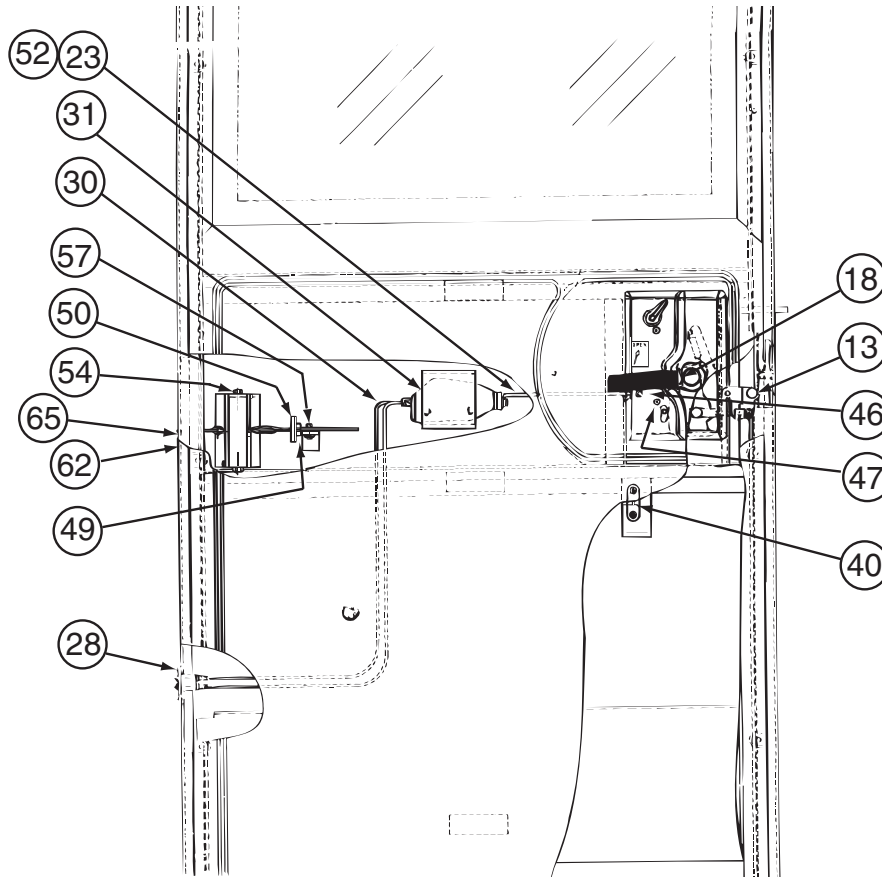

**128913-10-01A (CONTINUED)**

KEY	PART NUMBER	U/M	DESCRIPTION	VENDOR NO.
13	128913-04-706	FT	LATCH/ROTARY - W/LINKAGE RH	B248-041726/T/M1799
18	128913-08-700	EA	HANDLE - INSIDE - REV.	248-041725
23	128913-04-704	EA	ROD/LOCK - (POWER)	17705-01
28	128913-01-714	EA	CONTACT - MALE/2-POSITION	400-041934
30	128913-01-712	EA	WIRE HARNESS-POWER DOOR LOCK	400-041935
31	106469-05-701	EA	ACTUATOR, F/ELECTRICE LOCK	4110-041096
40	128913-01-710	EA	STRIKER - LATCH/SCREEN DOOR	130-041815
46	128913-02-711	EA	SLIDE BAR ASSEMBLY	V196-29
47	128913-01-746	EA	SCREW #8 X 3/4" OVAL HEAD	276-042030
49	128913-02-712	EA	PIN - COILED SPRING	248-042237
50	128913-02-713	EA	BUMPER STOP	V196-24
54	128913-01-733	EA	DOOR CHECK-SUB ASM ADJUST	V196-04
57	128913-01-705	EA	BOLT - SHOULDER - #10 X 1/4	268-042011
62	128913-02-714	EA	GUIDE BLOCK - DOOR CHECK	146-042045
65	128913-04-709	EA	PIN/CLEVIS-GROOVED W/E-RING	245-042260

CONTACT WINNEBAGO PARTS SALES FOR UNLISTED COMPONENTS

**EXTERIOR DOORS & COMPARTMENTS GROUP (CONTINUED)**  
**COMPONENT PARTS FOR ENTRY (CONTINUED)**

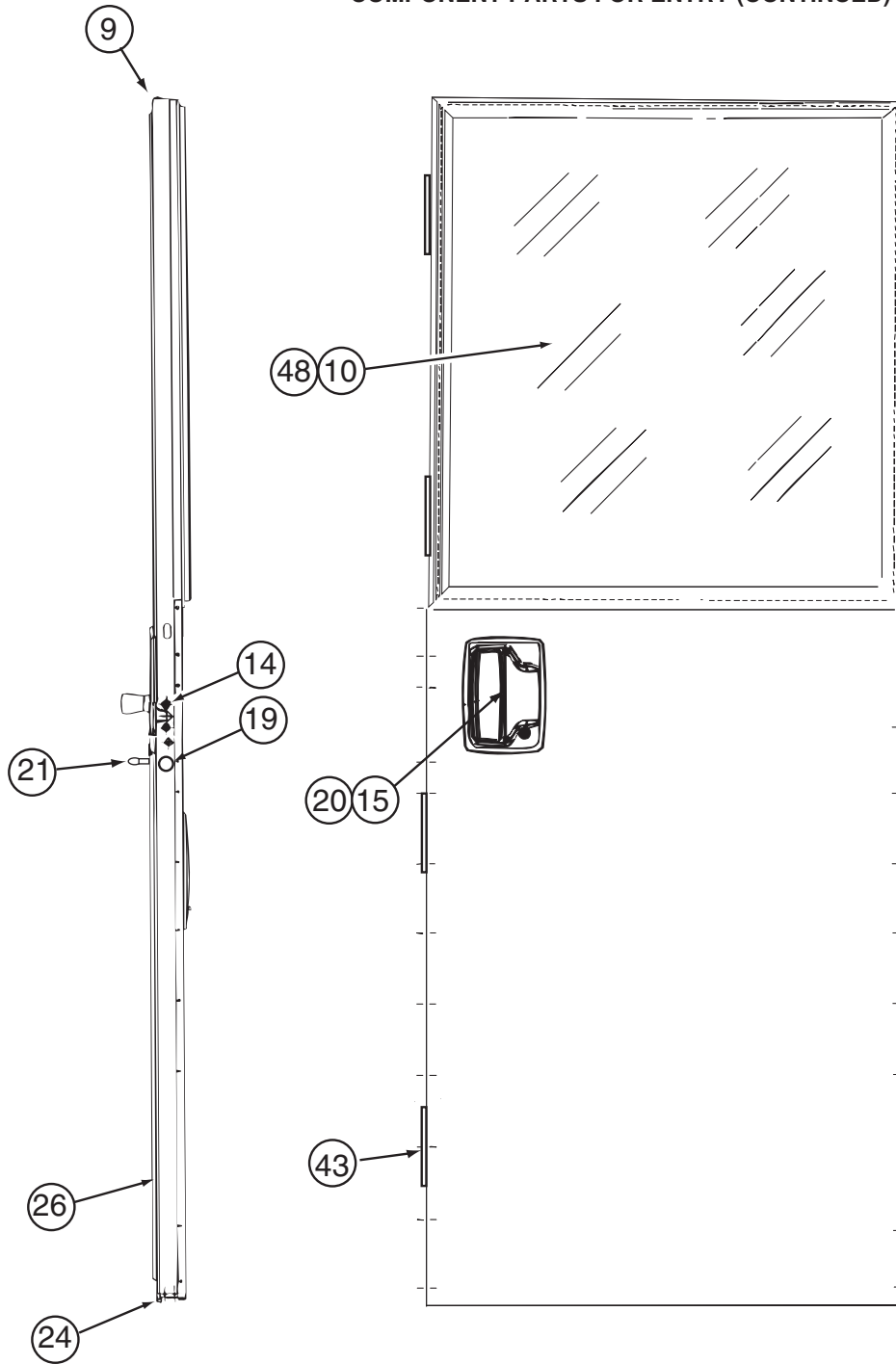

**128913-10-01A (CONTINUED)**

KEY	PART NUMBER	U/M	DESCRIPTION	VENDOR NO.
9	128913-04-708	EA	DOOR FRAME - SUB ASM - BLACK	V266-90
10	128913-04-707	EA	WINDOW-DUAL PANE	V231-85
14	128913-03-713	EA	BOLT-ROTARY LATCH - 1/4" -20	81066-01
15	128913-08-701	EA	PADDLE ASM - OUTSIDE	490060
20	128913-04-705	EA	GASKET - OUTSIDE HANDLE	81480
21	128913-04-717	EA	CAP - VINYL- RED	130-042257
24	128913-01-744	EA	SEAL/BULB-STICK ON/THRESHOLD	122-042230
26	128913-04-712	EA	PANEL - INNER PLASTIC	490057
48	128913-04-700	FT	TAPE/BUTYL - FOAM CORE	154-041549

CONTACT WINNEBAGO PARTS SALES FOR UNLISTED COMPONENTS

**EXTERIOR DOORS & COMPARTMENTS GROUP (CONTINUED)**  
**COMPONENT PARTS FOR ENTRY (CONTINUED)**

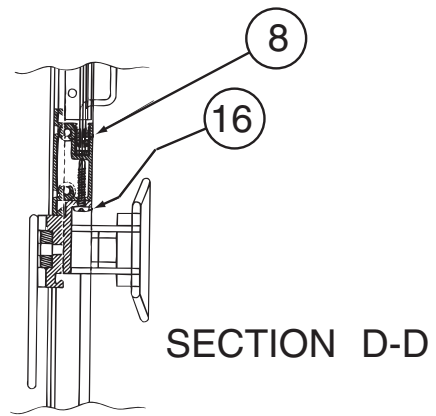
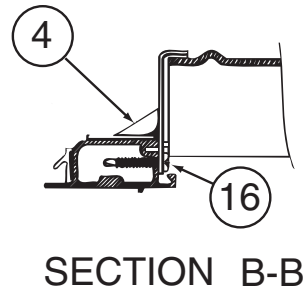
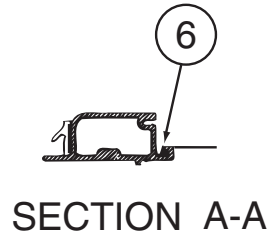
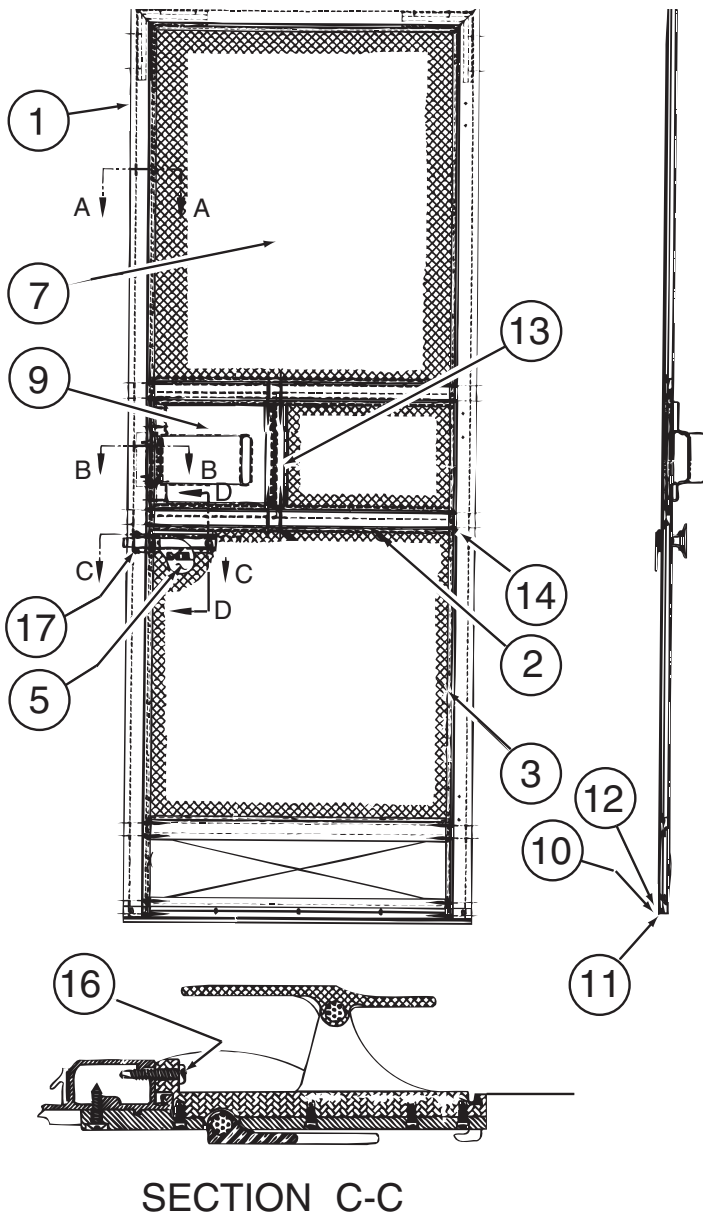

**SECTION C-C**

**128913-10-01A, 128913-10-02A, 128913-11-01A (CONTINUED)**

KEY	PART NUMBER	U/M	DESCRIPTION	VENDOR NO.
2	128913-09-704	EA	RAIL/MID SCREEN-GLACIER BEIG	490054
4	128913-09-703	EA	END CAP - GLACIER BEIGE	490061
5	128913-01-731	EA	LATCH - SCREEN DOOR	146-041950
6	128913-01-742	FT	SPLINE - SCREEN	132-041775
7	128913-01-741	EA	SCREEN ONLY - SCREENDOOR	110-041928
8	128913-01-740	FT	RUN CHANNEL-SCREEN DR SLIDER	170-041263
9	128913-09-702	EA	SLIDER/SCREENDOOR-GLACIER BE	490059
10	128913-09-701	EA	SWEEPER/SCREENDOOR- GLACIER	490052
11	128913-01-736	FT	WEATHERSTRIP-SCREEN DOOR	171-041284
13	128913-01-738	FT	WEATHERSTRIP - SLIDER	171-041285

CONTACT WINNEBAGO PARTS SALES FOR UNLISTED COMPONENTS

## EXTERIOR SLIDEOUT GROUP LEFT FRONT

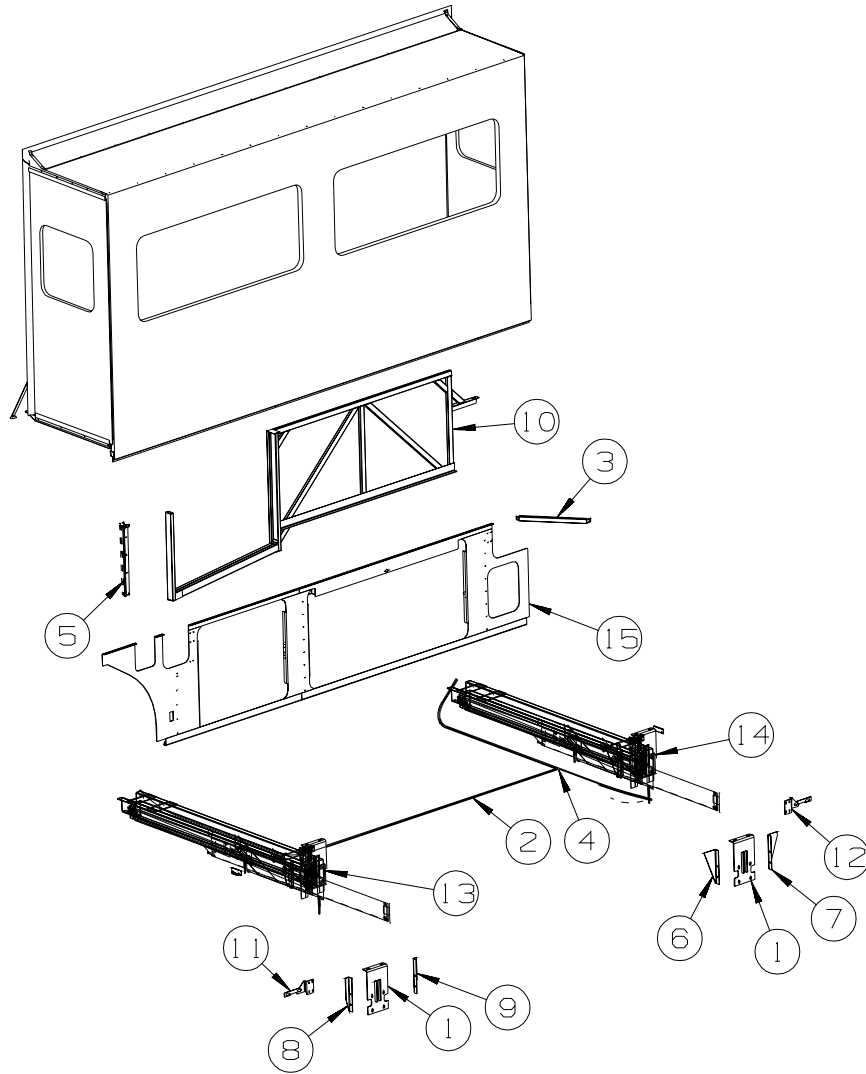

KEY	PART NUMBER	U/M	DESCRIPTION
1	131529-01-02B	EA	BRACKET - MOUNTING - F/SLIDEOUT COMPARTMENT - C-COATED
2	100536-15-000	EA	HOSE KIT - JACKS/SLIDEOUT ROOM - HWH #AP0043
3	135788-04-02B	EA	SUPPORT - VALANCE - E-COATED
4	123264-01-000	EA	TEE - UNION - 1/4" X 1/4" X 1/4"
5	126591-02-02B	EA	CARRIER - WIRE LOOM - F/SLIDEOUT ROOM
6	131531-02-02B	EA	GUSSET - SLIDEOUT - E-COATED
7	131531-03-02B	EA	GUSSET - SLIDEOUT - E-COATED
8	131531-04-02B	EA	GUSSET - SLIDEOUT - E-COATED
9	131531-07-02B	EA	GUSSET - SLIDEOUT - E-COATED
10	141151-01-02B	EA	SUPPORT - SLIDEOUT - E-COATED
11	143183-01-02B	EA	BRACKET - SLIDEOUT COMPARTMENT - E-COATED
12	143183-02-02B	EA	BRACKET - SLIDEOUT COMPARTMENT - E-COATED
13*	143625-02-000	EA	SLIDEOUT-HYDRAULIC,FLAT,29"
14*	143625-03-000	EA	SLIDEOUT-HYDRAULIC KIT
15	142010-01-02B	EA	PANEL/SEAL - F/SLIDEOUT - E-COATE
	143738-01-000	EA	WRENCH - RATCHET - 13/16" X 7/8"

\*COMPONENT PARTS LISTED LATER IN THIS GROUP

**EXTERIOR SLIDEOUT GROUP (CONTINUED)**  
**LEFT FRONT (CONTINUED)**

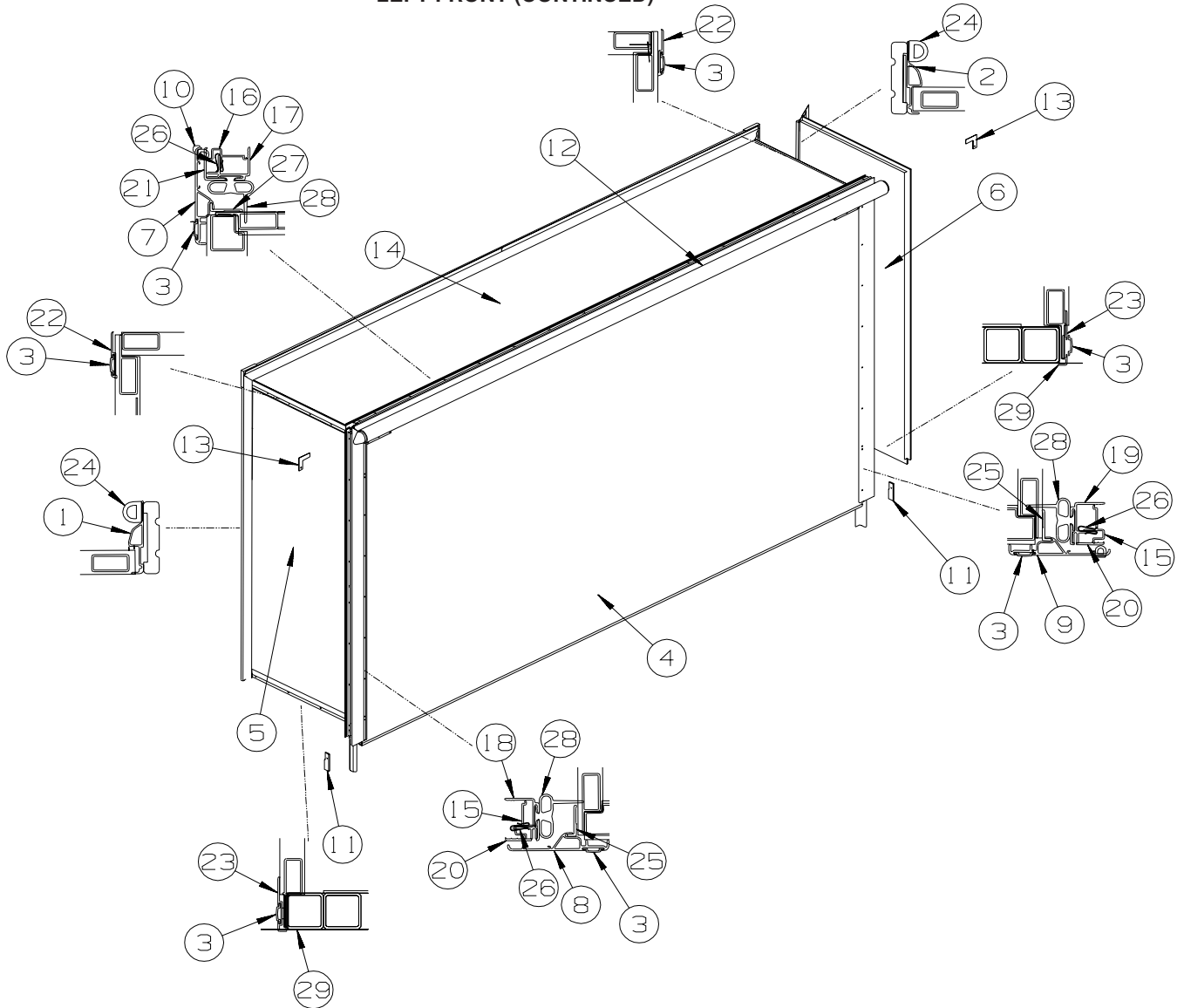

KEY	PART NUMBER	U/M	DESCRIPTION
1	139624-18-01A	EA	TRIM/SEAL - INNER/RIGHT HAND - 71.3" - BRIGHT WHITE
2	139624-19-01A	EA	TRIM/SEAL - INNER/LEFT HAND - 71.3" - BRIGHT WHITE
3	105312-01-07A	FT	INSERT - FEATURE STRIP - VINYL - BRIGHT WHITE
3	105312-01-13A	FT	INSERT - FEATURE STRIP - VINYL - BLACK - <b>FULL BODY PAINT</b>
4	141897-11-PC0	EA	SLUG - SLIDEOUT (PA0, PA1, PA2)
4	141897-11-PA3	EA	SLUG - SLIDEOUT (PA3, PA4, PA5)
4	141897-11-PC3	EA	SLUG - SLIDEOUT (PA6, PA7, PA8)
5	141972-02-N94	EA	PANEL - SLIDEOUT - FRONT (PA0, PA1, PA2)
5	141972-02-N96	EA	PANEL - SLIDEOUT - FRONT (PA3, PA4, PA5)
5	141972-02-N98	EA	PANEL - SLIDEOUT - FRONT (PA6, PA7, PA8)
6	141973-02-N94	EA	PANEL - SLIDEOUT - REAR (PA0, PA1, PA2)
6	141973-02-N96	EA	PANEL - SLIDEOUT - REAR (PA3, PA4, PA5)
6	141973-02-N98	EA	PANEL - SLIDEOUT - REAR (PA6, PA7, PA8)
7	139625-20-01A	EA	TRIM/SEAL - TOP/W/MITERED ENDS - 151.3" - BRIGHT WHITE
7	139625-20-02A	EA	TRIM/SEAL - TOP/W/MITERED ENDS - 151.3" - BLACK - <b>FULL BODY PAINT</b>
8	139625-33-01A	EA	TRIM/SEAL - LEFT HAND - 75.3" - BRIGHT WHITE
8	139625-33-02A	EA	TRIM/SEAL - LEFT HAND - 75.3" - BLACK - <b>FULL BODY PAINT</b>
9	139625-34-01A	EA	TRIM/SEAL - RIGHT HAND - 75.3" - BRIGHT WHITE
9	139625-34-02A	EA	TRIM/SEAL - RIGHT HAND - 75.3" - BLACK - <b>FULL BODY PAINT</b>
10	117058-01-01A	FT	TAPE - LOOP - 3/4" WIDE - ADHESIVE BACKED
11	126546-02-02A	EA	COVER - END/SIDEWALL SLIDEOUT - BRIGHT WHITE
12			AWNING - SEE FOLLOWING AWNING CHART
	137331-01-01A	EA	SLIDE - COVER - CENTER/BRIGHT WHITE
	137331-01-02A	EA	COVER/SLIDE - CENTER - F/SLIDEOUT - <b>FULL BODY PAINT</b>

**EXTERIOR SLIDEOUT GROUP (CONTINUED)**  
**LEFT FRONT (CONTINUED)**

KEY	PART NUMBER	U/M	DESCRIPTION
13	116444-04-12B	EA	TRIM/KEY CORNER - SLIDEOUT - 3.1"X3.1" - BRT WHT
13	116444-04-02B	EA	TRIM/KEY CORNER - SLIDEOUT - 3.1"X3.1" - BLACK - FULL BODY PAINT
14	141155-01-PC0	EA	ROOF - W/O WIRING - F/SLIDEOUT
15	142718-01-01A	EA	RETAINER - SIDEWALL/SLIDEOUT - 72.8" - MILL
16	142718-18-01A	EA	RETAINER - SIDEWALL/SLIDEOUT - 149"
17	142719-15-01A	EA	TRIM/SIDEWALL - TOP/SLIDEOUT - 150.8" - BRIGHT WHITE
18	142720-01-01A	EA	TRIM - SIDEWALL/SLIDEOUT - 74.8" - BRIGHT WHITE
19	142720-02-01A	EA	TRIM - SIDEWALL/SLIDEOUT - 74.8" - BRIGHT WHITE
20	136824-35-01A	EA	TRIM - SIDEWALL/SLIDEOUT - 74" - BRIGHT WHITE
20	136824-35-02A	EA	TRIM - SIDEWALL/SLIDEOUT - 74" - BLACK - FULL BODY PAINT
21	136824-25-01A	EA	TRIM - SIDEWALL/SLIDEOUT - 150.9" - BRIGHT WHITE
21	136824-25-02A	EA	TRIM - SIDEWALL/SLIDEOUT - 150.9" - BLACK - FULL BODY PAINT
22	138659-01-01A	EA	TRIM/FEATURE STRIP - 181.7" - BRIGHT WHITE
22	138659-01-02A	EA	TRIM/FEATURE STRIP - 181.7" - BLACK - FULL BODY PAINT
23	125051-03-01A	EA	TRIM - FEATURE STRIP/LOWER - 29.3" - BRIGHT WHITE
23	125051-03-02A	EA	TRIM - FEATURE STRIP/LOWER - 29.3" - BLACK - FULL BODY PAINT
24	112091-01-000	FT	SEAL/D - NEOPRENE - HEAT ACTIVE ADHESIVE - .9" FROM: 00-00-00 THRU: 01-12-03
24	146056-01-000	FT	SEAL - TRIANGLE - W/PSA FROM: 01-13-03 THRU: 99-99-99
25	133954-16-01A	EA	TRIM/SEAL - W/MITERED ENDS - 71.2" - BRIGHT WHITE
25	133954-16-02A	EA	TRIM/SEAL - W/MITERED ENDS - 71.2" - BLACK - FULL BODY PAINT
26	142549-01-000	EA	CLIP-S TYPE
27	133954-36-01A	EA	TRIM/SEAL - W/MITERED ENDS - 145.6" - BRIGHT WHITE
27	133954-36-02A	EA	TRIM/SEAL - W/MITERED ENDS - 145.6" - BLACK - FULL BODY PAINT
28	136978-01-01A	FT	SEAL - SLIDEOUT - BLACK
29	075673-05-000	FT	SEAL - PILE - ADHESIVE BACK - BLACK

**ADVANTAGE SLIDEOUT ROOM AWNINGS**

MODEL	COLOR CODE	AWNING COLOR	HARDWARE COLOR	SLIDEROOM LT FRONT	SLIDEROOM LT REAR	SLIDEROOM RT FRONT	SLIDEROOM RT REAR
<b>FULL BODY PAINT</b>							
Q36C	ROSEWOOD <b>92A</b>	BLACK CHERRY	CHAMPAGNE	140019-03-05A	NA	NA	140019-05-05A
Q36C	SLATE BLUE <b>27A</b>	NAVY	CHAMPAGNE	140019-03-05A	NA	NA	140019-05-05A
Q36C	HARVEST <b>24C</b>	TAUPE	CHAMPAGNE	140019-03-05A	NA	NA	140019-05-05A
Q38K	ROSEWOOD <b>92A</b>	BLACK CHERRY	CHAMPAGNE	140019-02-05A	NA	NA	140019-05-05A
Q38K	SLATE BLUE <b>27A</b>	NAVY	CHAMPAGNE	140019-02-05A	NA	NA	140019-05-05A
Q38K	HARVEST <b>24C</b>	TAUPE	CHAMPAGNE	140019-02-05A	NA	NA	140019-05-05A
Q40E	ROSEWOOD <b>92A</b>	BLACK CHERRY	CHAMPAGNE	140019-04-05A	NA	NA	140019-06-05A
Q40E	SLATE BLUE <b>27A</b>	NAVY	CHAMPAGNE	140019-04-05A	NA	NA	140019-06-05A
Q40E	HARVEST <b>24C</b>	TAUPE	CHAMPAGNE	140019-04-05A	NA	NA	140019-06-05A
Q40K	ROSEWOOD <b>92A</b>	BLACK CHERRY	CHAMPAGNE	140019-08-05A	140019-07-05A	140019-09-05A	NA
Q40K	SLATE BLUE <b>27A</b>	NAVY	CHAMPAGNE	140019-08-05A	140019-07-05A	140019-09-05A	NA
Q40K	HARVEST <b>24C</b>	TAUPE	CHAMPAGNE	140019-08-05A	140019-07-05A	140019-09-05A	NA
<b>GRAPHIC PKG.</b>							
Q36C	<b>27G,92K,24E</b>	WHITE	BRIGHT WHITE	140019-03-01A	NA	NA	140019-05-01A
Q38K	<b>27G,92K,24E</b>	WHITE	BRIGHT WHITE	140019-02-01A	NA	NA	140019-05-01A
Q40E	<b>27G,92K,24E</b>	WHITE	BRIGHT WHITE	140019-04-01A	NA	NA	140019-06-01A
Q40K	<b>27G,92K,24E</b>	WHITE	BRIGHT WHITE	140019-08-01A	140019-07-01A	140019-09-01A	NA



**EXTERIOR SLIDEOUT GROUP (CONTINUED)**  
**LEFT FRONT (CONTINUED)**

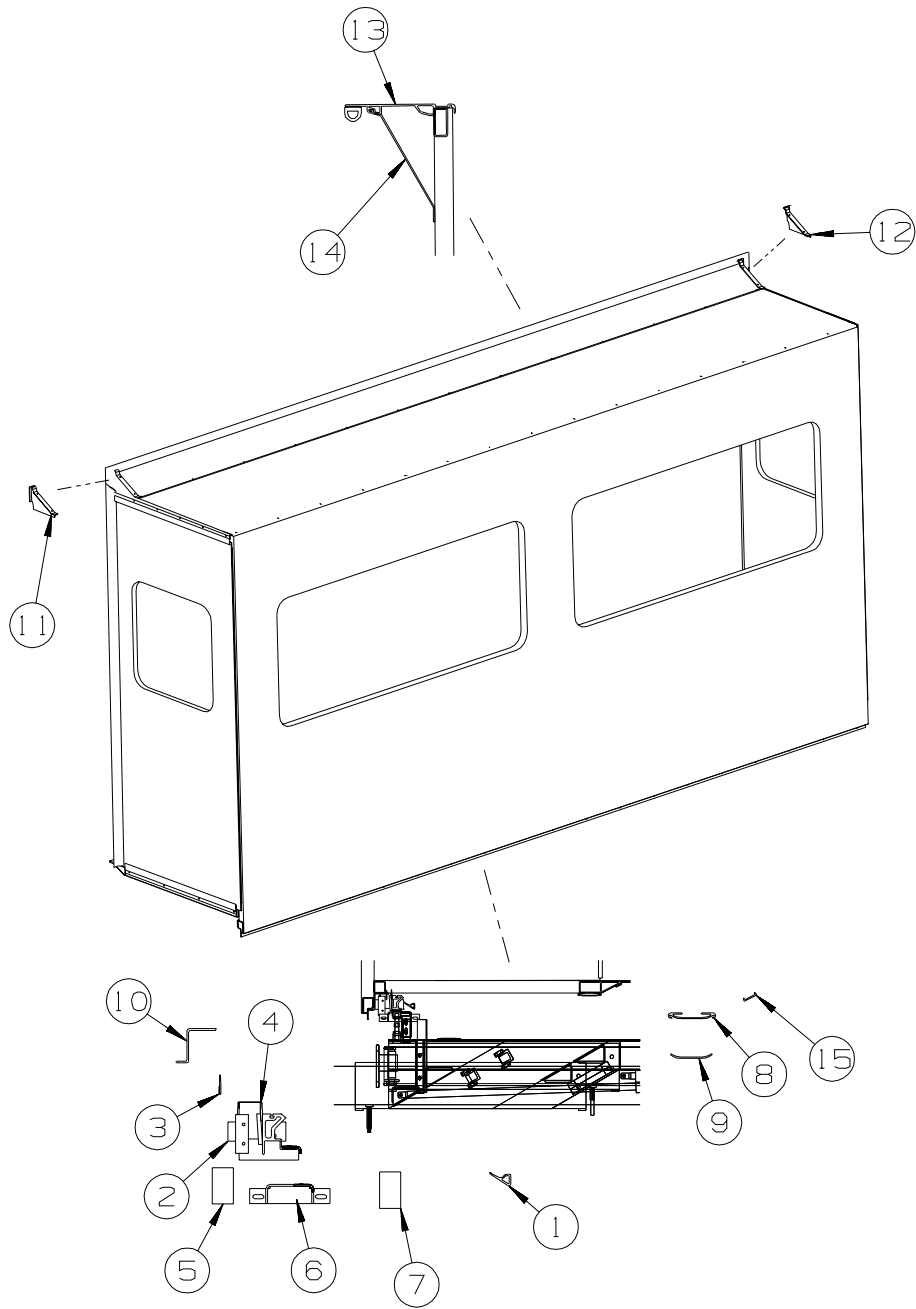

KEY	PART NUMBER	U/M DESCRIPTION
1	131611-01-000	FT SEAL - SLIDEOUT/LOWER
2	131659-07-PC0	EA TUBE/SUPPORT - SLIDEOUT - 144.9"
3	123012-01-000	FT SEAL - SLIDEOUT - .09"/.13" THICK X 1.25" - W/ADHESIVE
4	137343-04-02B	EA PLATE - W/HOLES - E-COATED
5	137408-02-000	EA SEAL - BLOCK - F/SLIDEOUT - 1.4"
6	133233-01-02B	EA BRACKET - SLIDEOUT - E-COATED
7	137408-01-000	EA SEAL - BLOCK - F/SLIDEOUT - 2.2"
8	115325-04-02A	EA RAIL - FLOOR/SLIDEOUT ROOM - BLACK
9	115661-01-000	FT SHOE/GLIDE - SLIDEOUT ROOM - 1/16" X 3" - POLYETHYLENE
10	131520-11-01A	EA EXTRUSION/ZEE - F/SLIDEOUT - 141.7"
11	131584-01-01A	EA COVER - TRIM - SLIDEOUT - FRONT - BRIGHT WHITE
11	131584-01-02A	EA COVER - TRIM - SLIDEOUT - FRONT - BLACK - <b>FULL BODY PAINT</b>
12	131584-02-01A	EA COVER - TRIM - SLIDEOUT - REAR - BRIGHT WHITE
12	131584-02-02A	EA COVER - TRIM - SLIDEOUT - REAR - BLACK - <b>FULL BODY PAINT</b>
13	141893-04-01A	EA TRIM/SEAL - F/SLIDEOUT - BRIGHT WHITE
14	131579-04-01A	EA TRIM/RETAINER - BRIGHT WHITE
14	131579-04-02A	EA TRIM/RETAINER - BLACK - <b>FULL BODY PAINT</b>
15	131358-05-01A	EA RETAINER - U-CHANNEL - 144.7" - BLACK

**EXTERIOR SLIDEOUT GROUP (CONTINUED)**  
**LEFT FRONT (CONTINUED)**

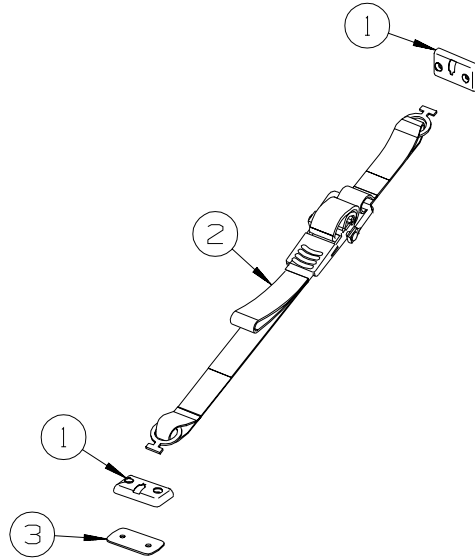

KEY	PART NUMBER	U/M	DESCRIPTION
1	135619-02-01A	EA	PLATE - TIEDOWN - SLIDEOUT ROOM
2	135619-01-01A	EA	STRAP - TIEDOWN - SLIDEOUT ROOM
3	NOT USED		

**EXTERIOR SLIDEOUT GROUP (CONTINUED)**  
**COMPONENT PARTS FOR LEFT FRONT**

**143625-02-000**

<b>KEY</b>	<b>PART NUMBER</b>	<b>U/M</b>	<b>DESCRIPTION</b>	<b>VENDOR NO.</b>
	128599-06-703	EA	HOSE/HYDRAULIC - 1/8" X 72"	AP24635
	131360-01-700	EA	CYLINDER - HYDRAULIC (RAM)	RAP90696/AP19256
	131360-01-706	EA	HOSE-HYDRAULIC - 1/8" X 42"	AP24631

**143625-03-000**

<b>KEY</b>	<b>PART NUMBER</b>	<b>U/M</b>	<b>DESCRIPTION</b>	<b>VENDOR NO.</b>
	100536-44-700	EA	HOSE-HYDRAULIC - 1/8" X 172"	AP24649
	131360-01-701	EA	HOSE-HYDRAULIC-1/4" X 125"	AP4906
	132540-01-701	EA	CYLINDER - SYNCRONIZING	RAP90690/AP17966

## EXTERIOR SLIDEOUT GROUP (CONTINUED)

### RIGHT FRONT

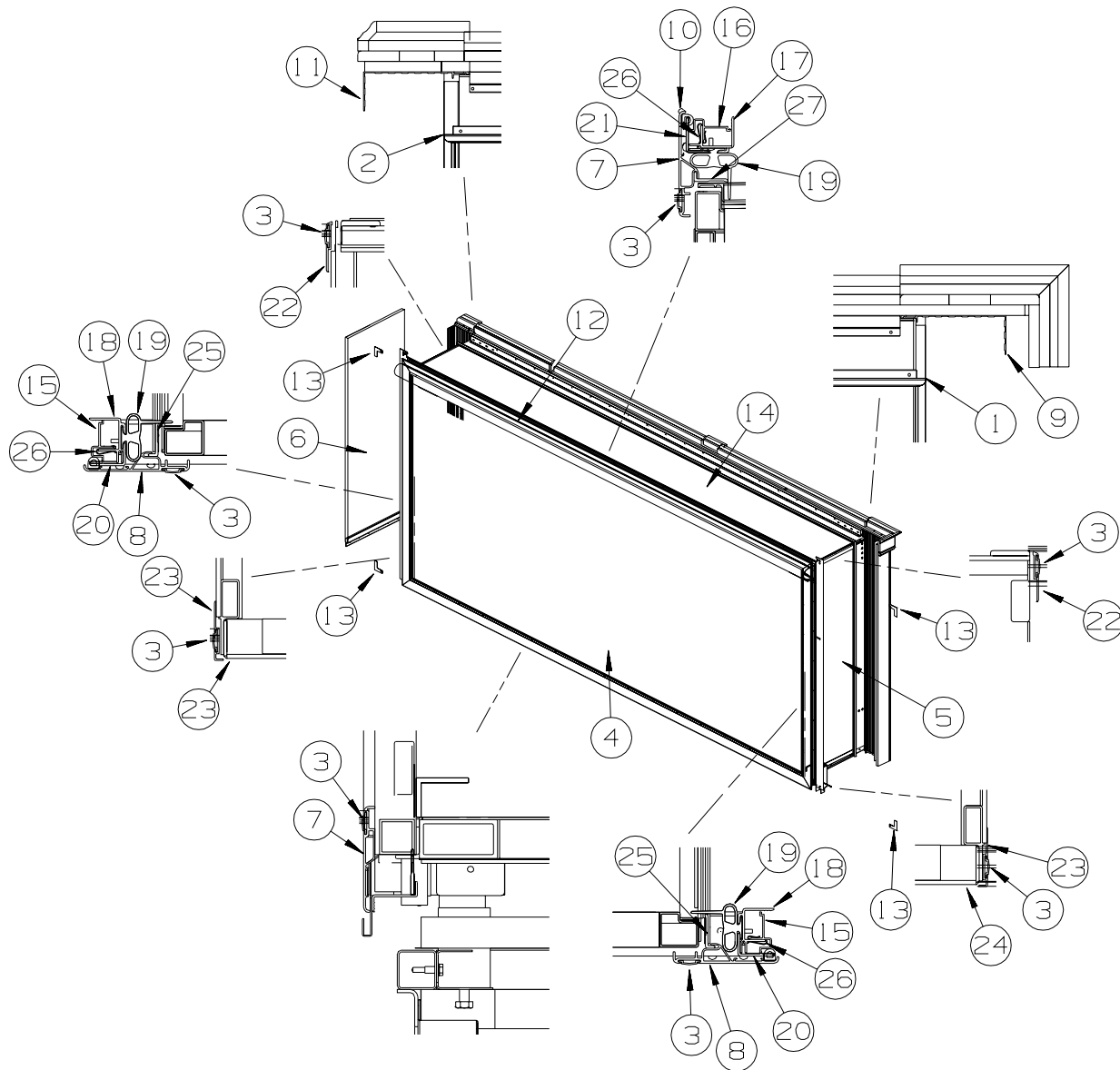

KEY	PART NUMBER	U/M	DESCRIPTION
1	141429-02-01A	EA	TRIM/SEAL - INNER - W/MITERED ENDS - 71.8"
2	141429-01-01A	EA	TRIM/SEAL - INNER - W/MITERED ENDS - 71.8"
3	105312-01-07A	FT	INSERT - FEATURE STRIP - VINYL - BRIGHT WHITE
3	105312-01-13A	FT	INSERT - FEATURE STRIP - VINYL - BLACK - <b>FULL BODY PAINT</b>
4	141896-11-PC0	EA	SLUG - SLIDEOUT (PA0, PA1, PA2)
4	141896-11-PA3	EA	SLUG - SLIDEOUT (PA3, PA4, PA5)
4	141896-11-PC3	EA	SLUG - SLIDEOUT (PA6, PA7, PA8)
5	142479-01-PC0	EA	PANEL/SLIDEOUT - FRONT (PA0, PA1, PA2)
5	142479-01-PA3	EA	PANEL/SLIDEOUT - FRONT (PA3, PA4, PA5)
5	142479-01-PC3	EA	PANEL/SLIDEOUT - FRONT (PA6, PA7, PA8)
6	142480-01-PC0	EA	PANEL/SLIDEOUT - REAR (PA0, PA1, PA2)
6	142480-01-PA3	EA	PANEL/SLIDEOUT - REAR (PA3, PA4, PA5)
6	142480-01-PC3	EA	PANEL/SLIDEOUT - REAR (PA6, PA7, PA8)
7	139625-24-01A	EA	TRIM/SEAL - W/MITERED ENDS - 167.8" - BRIGHT WHITE
7	139625-24-02A	EA	TRIM/SEAL - W/MITERED ENDS - 167.8" - BLACK - <b>FULL BODY PAINT</b>
8	139625-35-01A	EA	TRIM/SEAL - W/MITERED ENDS - 75.1" - BRIGHT WHITE
8	139625-35-02A	EA	TRIM/SEAL - W/MITERED ENDS - 75.1" - BLACK - <b>FULL BODY PAINT</b>
9	142982-01-01A	EA	TRIM - SLIDEOUT/INNER - 72.5" - BRIGHT WHITE
10	117058-01-01A	FT	TAPE - LOOP - 3/4" WIDE - ADHESIVE BACKED
11	142982-02-01A	EA	TRIM - SLIDEOUT/INNER - 72.5" - BRIGHT WHITE
12			AWNING - SEE FOLLOWING AWNING CHART
13	116444-04-12B	EA	TRIM/KEY CORNER - SLIDEOUT - 3.1"X3.1" - BRT WHT
13	116444-04-02B	EA	TRIM/KEY CORNER - SLIDEOUT - 3.1"X3.1" - BLACK - <b>FULL BODY PAINT</b>

**EXTERIOR SLIDEOUT GROUP (CONTINUED)**  
**RIGHT FRONT (CONTINUED)**

KEY	PART NUMBER	U/M	DESCRIPTION
14	142481-01-PC0	EA	PANEL/ROOF - SLIDEOUT - W/O VENTS/WIRING
15	142718-14-01A	EA	RETAINER - SIDEWALL/SLIDEOUT - 75"
16	142718-25-01A	EA	RETAINER - SIDEWALL/SLIDEOUT - 15.4"
17	136824-28-01A	EA	TRIM - SIDEWALL/SLIDEOUT - 167.6" - BRIGHT WHITE
17	136824-28-02A	EA	TRIM - SIDEWALL/SLIDEOUT - 167.6" - BLACK - <b>FULL BODY PAINT</b>
18	142720-11-01A	EA	TRIM - SIDEWALL/SLIDEOUT - 72.9" - BRIGHT WHITE
19	136978-01-01A	FT	SEAL - SLIDEOUT - BLACK
20	136824-16-01A	EA	TRIM - SIDEWALL/SLIDEOUT - 72.7" - BRIGHT WHITE
20	136824-16-02A	EA	TRIM - SIDEWALL/SLIDEOUT - 72.7" - BLACK - <b>FULL BODY PAINT</b>
21	142719-17-01A	EA	TRIM/SIDEWALL - TOP/SLIDEOUT - 167.3" - BRIGHT WHITE
22	138659-01-01A	EA	TRIM/FEATURE STRIP - 181.7" - BRIGHT WHITE
22	138659-01-02A	EA	TRIM/FEATURE STRIP - 181.7" - BLACK - <b>FULL BODY PAINT</b>
23	125051-05-01A	EA	TRIM - FEATURE STRIP/LOWER -17.7" - BRIGHT WHITE
23	125051-05-02A	EA	TRIM - FEATURE STRIP/LOWER -17.7" - BLACK - <b>FULL BODY PAINT</b>
24	075673-05-000	FT	SEAL - PILE - ADHESIVE BACK - BLACK
25	133954-23-01A	EA	TRIM/SEAL - W/MITERED ENDS - 68.3" - BRIGHT WHITE
25	133954-23-02A	EA	TRIM/SEAL - W/MITERED ENDS - 68.3" - BLACK - <b>FULL BODY PAINT</b>
26	142549-01-000	EA	CLIP-S TYPE
27	133954-38-01A	EA	TRIM/SEAL - W/MITERED ENDS - 160.4" - BRIGHT WHITE
27	133954-38-02A	EA	TRIM/SEAL - W/MITERED ENDS - 160.4" - BLACK - <b>FULL BODY PAINT</b>

**ADVANTAGE SLIDEOUT ROOM AWNINGS**

MODEL	COLOR CODE	AWNING COLOR	HARDWARE COLOR	SLIDEROOM LT FRONT	SLIDEROOM LT REAR	SLIDEROOM RT FRONT	SLIDEROOM RT REAR
<b>FULL BODY PAINT</b>							
Q36C	ROSEWOOD <b>92A</b>	BLACK CHERRY	CHAMPAGNE	140019-03-05A	NA	NA	140019-05-05A
Q36C	SLATE BLUE <b>27A</b>	NAVY	CHAMPAGNE	140019-03-05A	NA	NA	140019-05-05A
Q36C	HARVEST <b>24C</b>	TAUPE	CHAMPAGNE	140019-03-05A	NA	NA	140019-05-05A
Q38K	ROSEWOOD <b>92A</b>	BLACK CHERRY	CHAMPAGNE	140019-02-05A	NA	NA	140019-05-05A
Q38K	SLATE BLUE <b>27A</b>	NAVY	CHAMPAGNE	140019-02-05A	NA	NA	140019-05-05A
Q38K	HARVEST <b>24C</b>	TAUPE	CHAMPAGNE	140019-02-05A	NA	NA	140019-05-05A
Q40E	ROSEWOOD <b>92A</b>	BLACK CHERRY	CHAMPAGNE	140019-04-05A	NA	NA	140019-06-05A
Q40E	SLATE BLUE <b>27A</b>	NAVY	CHAMPAGNE	140019-04-05A	NA	NA	140019-06-05A
Q40E	HARVEST <b>24C</b>	TAUPE	CHAMPAGNE	140019-04-05A	NA	NA	140019-06-05A
Q40K	ROSEWOOD <b>92A</b>	BLACK CHERRY	CHAMPAGNE	140019-08-05A	140019-07-05A	140019-09-05A	NA
Q40K	SLATE BLUE <b>27A</b>	NAVY	CHAMPAGNE	140019-08-05A	140019-07-05A	140019-09-05A	NA
Q40K	HARVEST <b>24C</b>	TAUPE	CHAMPAGNE	140019-08-05A	140019-07-05A	140019-09-05A	NA
<b>GRAPHIC PKG.</b>							
Q36C	<b>27G,92K,24E</b>	WHITE	BRIGHT WHITE	140019-03-01A	NA	NA	140019-05-01A
Q38K	<b>27G,92K,24E</b>	WHITE	BRIGHT WHITE	140019-02-01A	NA	NA	140019-05-01A
Q40E	<b>27G,92K,24E</b>	WHITE	BRIGHT WHITE	140019-04-01A	NA	NA	140019-06-01A
Q40K	<b>27G,92K,24E</b>	WHITE	BRIGHT WHITE	140019-08-01A	140019-07-01A	140019-09-01A	NA

**EXTERIOR SLIDEOUT GROUP (CONTINUED)**  
**RIGHT FRONT (CONTINUED)**

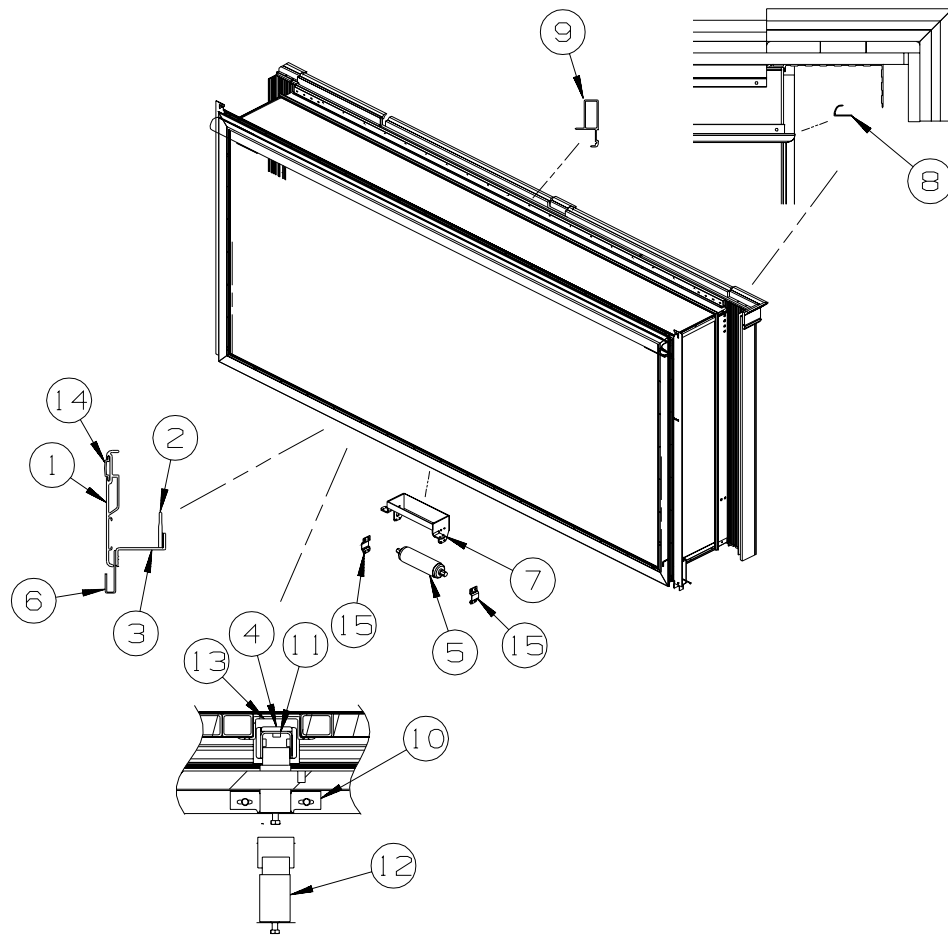

KEY	PART NUMBER	U/M	DESCRIPTION
1	142233-08-01A	EA	TRIM/SEAL - W/MITERED ENDS - 167.8" - BRIGHT WHITE
1	142233-08-02A	EA	TRIM/SEAL - W/MITERED ENDS - 167.8" - BLACK - FULL BODY PAINT
2	123012-03-000	FT	SEAL - F/SLIDEOUT
3	141174-06-02A	EA	TRIM/ZEE - SIDEWALL - 165.6" - BRIGHT WHITE
3	141174-06-03A	EA	TRIM/ZEE - SIDEWALL - 165.6" - BLACK - FULL BODY PAINT
4	128599-03-000	EA	PAD - F/SLIDEOUT
5	127033-02-01A	EA	ROLLER - GUIDE
6	136839-01-01A	EA	TRIM-J - CARPET EDGE/SLIDEOUT - 79.5" - BLACK
7	140928-02-02B	EA	BRACKET - ROLLER - E-COATED
8	141429-03-01A	EA	TRIM/SEAL - INNER - W/MITERED ENDS - 163.6"
9	141927-01-01A	EA	TRIM - SLIDEOUT - INNER/TOP - BRIGHT WHITE
10	142488-01-02B	EA	ADJUSTER - SLIDE - E-COATED
11	142529-01-02B	EA	GUIDE - F/SLIDEOUT ROOM - E-COATED
12	142881-01-01B	EA	CHANNEL/GUIDE - SLIDEOUT
13	143240-01-000	EA	SEAL - SPONGE RUBBER
14	105312-01-07A	FT	INSERT - FEATURE STRIP - VINYL - BRIGHT WHITE
14	105312-01-13A	FT	INSERT - FEATURE STRIP - VINYL - BLACK - FULL BODY PAINT
15	143017-01-02B	EA	ZEE - FORMED/RETAINER - ROLLER - E-COATED

**EXTERIOR SLIDEOUT GROUP (CONTINUED)**  
**RIGHT FRONT (CONTINUED)**

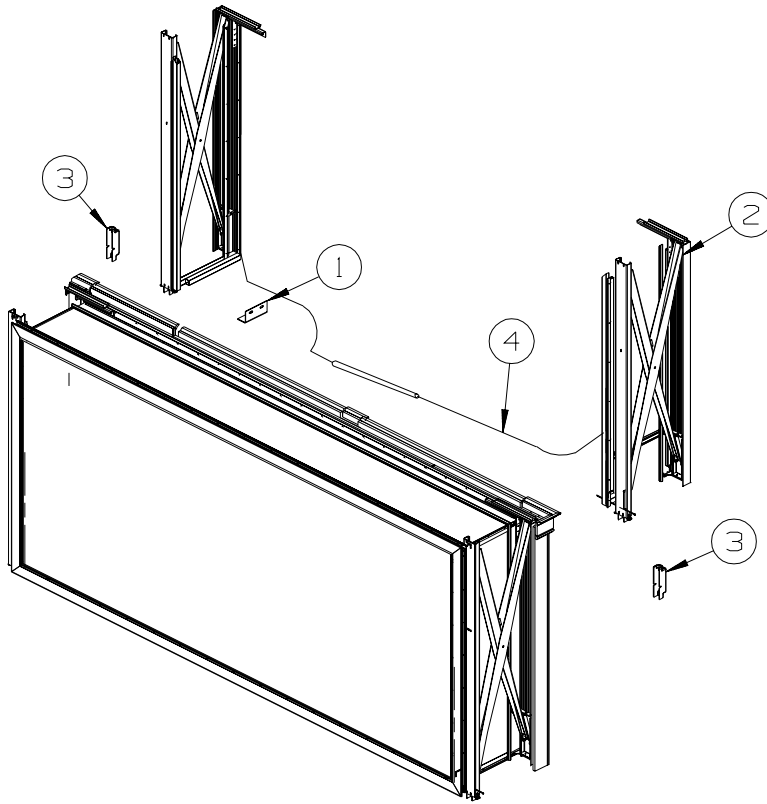

KEY	PART NUMBER	U/M	DESCRIPTION
1	128252-01-02B	EA	BRACKET/ANGLE - SLIDEOUT - E-COAT
2*	143071-01-000	EA	SLIDEOUT - "X" ARM - 18"
3	NOT USED		
4	100536-49-000	EA	HOSE KIT - F/SLIDEOUT - F/PUMP TO S/O ROOM CYLINDER

# EXTERIOR SLIDEOUT GROUP (CONTINUED)

## LEFT REAR

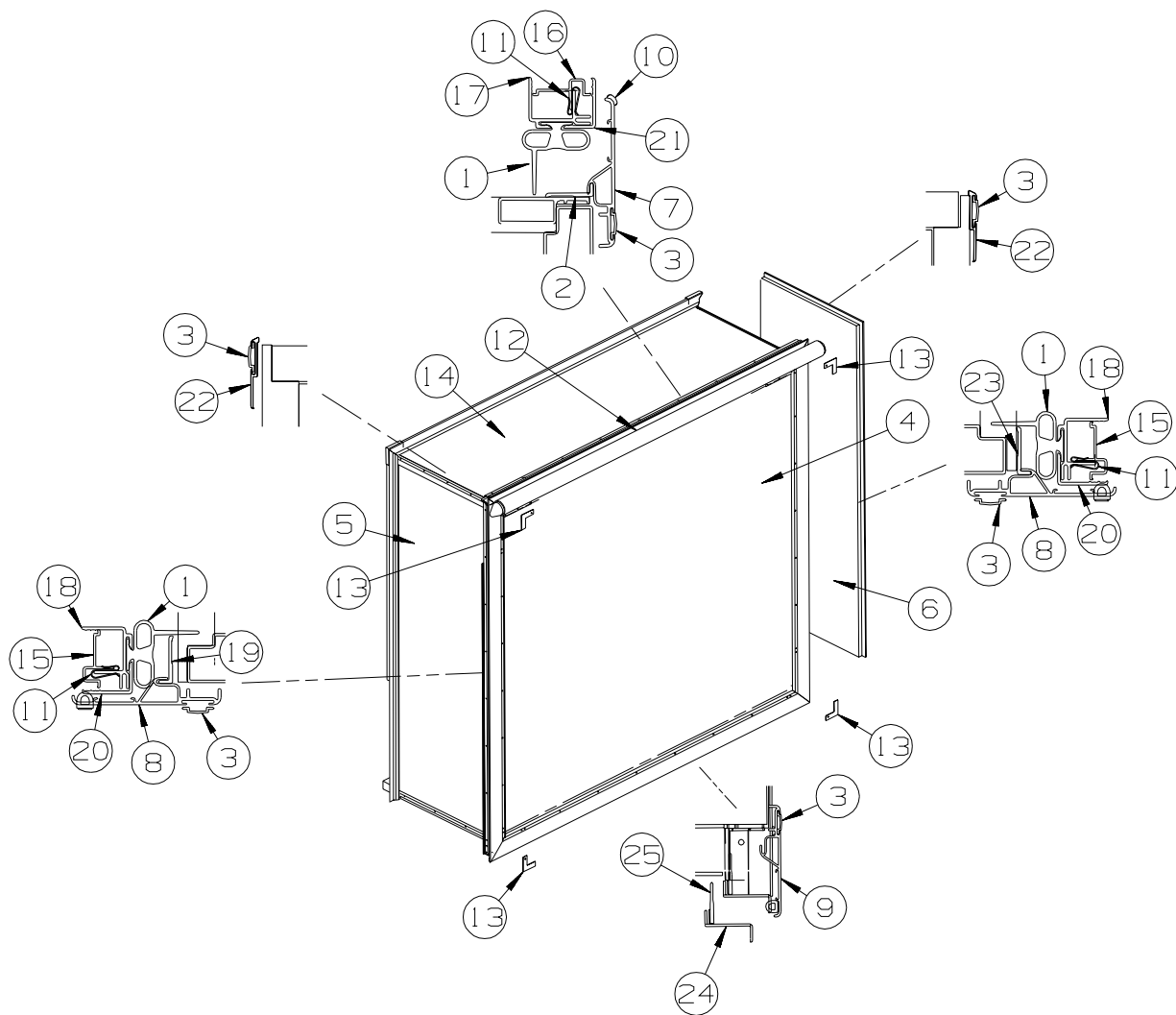

KEY	PART NUMBER	U/M DESCRIPTION
1	136978-01-01A	FT SEAL - SLIDEOUT - BLACK
2	133954-35-01A	EA TRIM/SEAL - W/MITERED ENDS - 98.1" - BRIGHT WHITE
2	133954-35-02A	EA TRIM/SEAL - W/MITERED ENDS - 98.1" - BLACK - <b>FULL BODY PAINT</b>
3	105312-01-07A	FT INSERT - FEATURE STRIP - VINYL - BRIGHT WHITE
3	105312-01-13A	FT INSERT - FEATURE STRIP - VINYL - BLACK - <b>FULL BODY PAINT</b>
4	141897-12-PC0	EA SLUG - SLIDEOUT (PA0, PA1, PA2)
4	141897-12-PA3	EA SLUG - SLIDEOUT (PA3, PA4, PA5)
4	141897-12-PC3	EA SLUG - SLIDEOUT (PA6, PA7, PA8)
5	141913-01-P82	EA PANEL - FRONT - LEFT/REAR SLIDEOUT (PA0, PA1, PA2)
5	141913-01-PA3	EA PANEL - FRONT - LEFT/REAR SLIDEOUT (PA3, PA4, PA5)
5	141913-01-P78	EA PANEL - FRONT - LEFT/REAR SLIDEOUT (PA6, PA7, PA8)
6	141912-01-PC0	EA PANEL - FRONT - LEFT/REAR SLIDEOUT (PA0, PA1, PA2)
6	141912-01-PA3	EA PANEL - FRONT - LEFT/REAR SLIDEOUT (PA3, PA4, PA5)
6	141912-01-PC3	EA PANEL - FRONT - LEFT/REAR SLIDEOUT (PA6, PA7, PA8)
7	139625-19-01A	EA TRIM/SEAL - TOP/W/MITERED ENDS - 103.5" - BRIGHT WHITE
7	139625-19-02A	EA TRIM/SEAL - TOP/W/MITERED ENDS - 103.5" - BLACK - <b>FULL BODY PAINT</b>
8	139625-26-01A	EA TRIM/SEAL - TOP/W/MITERED ENDS - 63.3" - BRIGHT WHITE
8	139625-26-02A	EA TRIM/SEAL - TOP/W/MITERED ENDS - 63.3" - BLACK - <b>FULL BODY PAINT</b>
9	142233-07-01A	EA TRIM/SEAL - W/MITERED ENDS - 103.5" - BRIGHT WHITE
9	142233-07-02A	EA TRIM/SEAL - W/MITERED ENDS - 103.5" - BLACK - <b>FULL BODY PAINT</b>
10	117058-01-01A	FT TAPE - LOOP - 3/4" WIDE - ADHESIVE BACKED
11	142549-01-000	EA CLIP-S TYPE
12		AWNING - SEE FOLLOWING AWNING CHART
	137321-01-02A	EA SPACER - SLIDE COVER - BLACK
13	116444-04-12B	EA TRIM/KEY CORNER - SLIDEOUT - 3.1"X3.1" - BRT WHT
13	116444-04-02B	EA TRIM/KEY CORNER - SLIDEOUT - 3.1"X3.1" - BLACK - <b>FULL BODY PAINT</b>



**EXTERIOR SLIDEOUT GROUP (CONTINUED)**  
**LEFT REAR (CONTINUED)**

KEY	PART NUMBER	U/M	DESCRIPTION
14	142063-01-PC0	EA	ROOF - LEFT/REAR SLIDEOUT - W/O LIGHTS/VENTS - W/WIRING
15	142718-26-01A	EA	RETAINER - SIDEWALL/SLIDEOUT - 60.2"
16	142718-17-01A	EA	RETAINER - SIDEWALL/SLIDEOUT - 100.2"
17	142719-21-01A	EA	TRIM/SIDEWALL - TOP/SLIDEOUT
18	142720-13-01A	EA	TRIM - SIDEWALL/SLIDEOUT - 60.5" - BRIGHT WHITE
19	133954-34-01A	EA	TRIM/SEAL - W/MITERED ENDS - 56.7" - BRIGHT WHITE
19	133954-34-02A	EA	TRIM/SEAL - W/MITERED ENDS - 56.7" - BLACK - FULL BODY PAINT
20	136824-19-01A	EA	TRIM - SIDEWALL/SLIDEOUT - 60.6" - BRIGHT WHITE
20	136824-19-02A	EA	TRIM - SIDEWALL/SLIDEOUT - 60.6" - BLACK - FULL BODY PAINT
21	136824-36-01A	EA	TRIM - SIDEWALL/SLIDEOUT - 109" - BRIGHT WHITE
21	136824-36-02A	EA	TRIM - SIDEWALL/SLIDEOUT - 109" - BLACK - FULL BODY PAINT
22	138659-01-01A	EA	TRIM/FEATURE STRIP - 181.7" - BRIGHT WHITE
22	138659-01-02A	EA	TRIM/FEATURE STRIP - 181.7" - BLACK - FULL BODY PAINT
23	133954-31-01A	EA	TRIM/SEAL - W/MITERED ENDS - 56.7" - BRIGHT WHITE
23	133954-31-02A	EA	TRIM/SEAL - W/MITERED ENDS - 56.7" - BLACK - FULL BODY PAINT
24	141174-03-02A	EA	TRIM/ZEE - SIDEWALL - 103.1" - BRIGHT WHITE
24	141174-03-03A	EA	TRIM/ZEE - SIDEWALL - 103.1" - BLACK - FULL BODY PAINT
25	123012-01-000	FT	SEAL - SLIDEOUT - .09"/.13" THICK X 1.25" - W/ADHESIVE

**ADVANTAGE SLIDEOUT ROOM AWNINGS**

MODEL	COLOR CODE	AWNING COLOR	HARDWARE COLOR	SLIDEROOM LT FRONT	SLIDEROOM LT REAR	SLIDEROOM RT FRONT	SLIDEROOM RT REAR
<b>FULL BODY PAINT</b>							
Q36C	ROSEWOOD <b>92A</b>	BLACK CHERRY	CHAMPAGNE	140019-03-05A	NA	NA	140019-05-05A
Q36C	SLATE BLUE <b>27A</b>	NAVY	CHAMPAGNE	140019-03-05A	NA	NA	140019-05-05A
Q36C	HARVEST <b>24C</b>	TAUPE	CHAMPAGNE	140019-03-05A	NA	NA	140019-05-05A
Q38K	ROSEWOOD <b>92A</b>	BLACK CHERRY	CHAMPAGNE	140019-02-05A	NA	NA	140019-05-05A
Q38K	SLATE BLUE <b>27A</b>	NAVY	CHAMPAGNE	140019-02-05A	NA	NA	140019-05-05A
Q38K	HARVEST <b>24C</b>	TAUPE	CHAMPAGNE	140019-02-05A	NA	NA	140019-05-05A
Q40E	ROSEWOOD <b>92A</b>	BLACK CHERRY	CHAMPAGNE	140019-04-05A	NA	NA	140019-06-05A
Q40E	SLATE BLUE <b>27A</b>	NAVY	CHAMPAGNE	140019-04-05A	NA	NA	140019-06-05A
Q40E	HARVEST <b>24C</b>	TAUPE	CHAMPAGNE	140019-04-05A	NA	NA	140019-06-05A
Q40K	ROSEWOOD <b>92A</b>	BLACK CHERRY	CHAMPAGNE	140019-08-05A	140019-07-05A	140019-09-05A	NA
Q40K	SLATE BLUE <b>27A</b>	NAVY	CHAMPAGNE	140019-08-05A	140019-07-05A	140019-09-05A	NA
Q40K	HARVEST <b>24C</b>	TAUPE	CHAMPAGNE	140019-08-05A	140019-07-05A	140019-09-05A	NA
<b>GRAPHIC PKG.</b>							
Q36C	<b>27G,92K,24E</b>	WHITE	BRIGHT WHITE	140019-03-01A	NA	NA	140019-05-01A
Q38K	<b>27G,92K,24E</b>	WHITE	BRIGHT WHITE	140019-02-01A	NA	NA	140019-05-01A
Q40E	<b>27G,92K,24E</b>	WHITE	BRIGHT WHITE	140019-04-01A	NA	NA	140019-06-01A
Q40K	<b>27G,92K,24E</b>	WHITE	BRIGHT WHITE	140019-08-01A	140019-07-01A	140019-09-01A	NA

**EXTERIOR SLIDEOUT GROUP (CONTINUED)**  
**LEFT REAR (CONTINUED)**

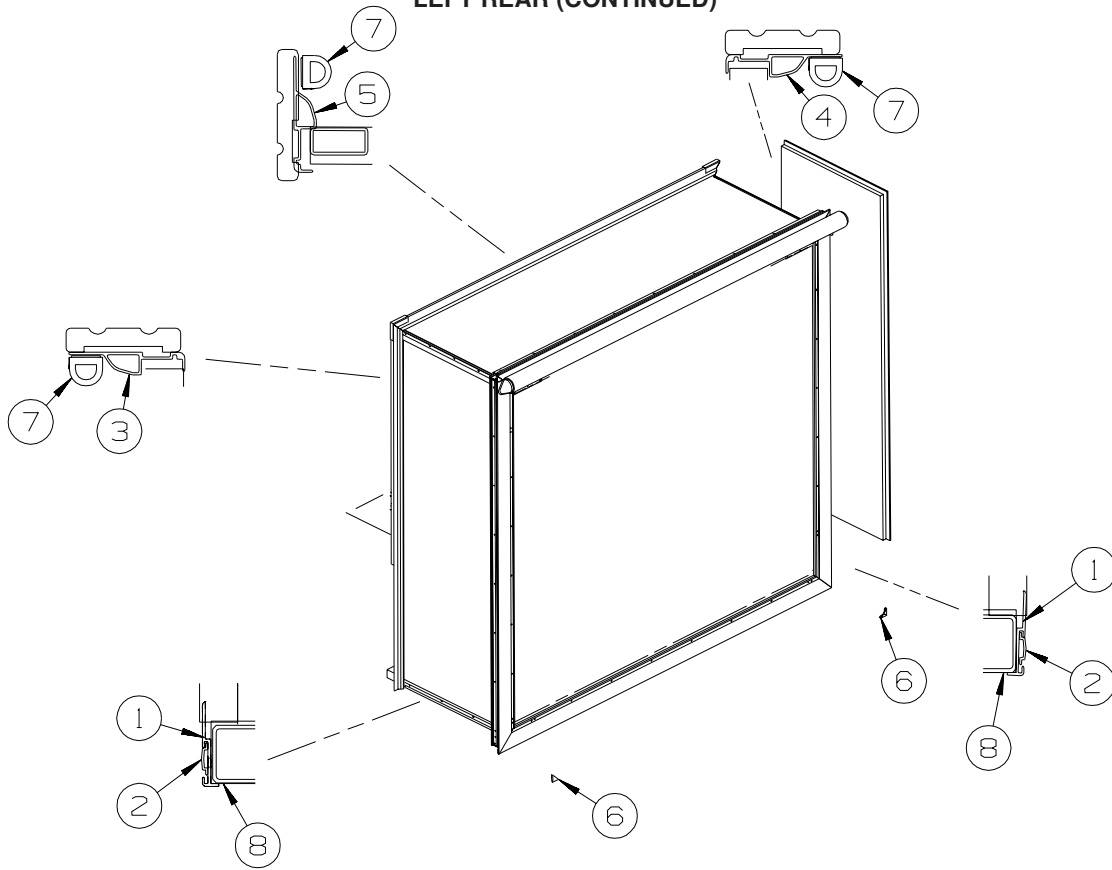

KEY	PART NUMBER	U/M	DESCRIPTION
1	125051-03-01A	EA	TRIM - FEATURE STRIP/LOWER - 29.3" - BRIGHT WHITE
1	125051-03-02A	EA	TRIM - FEATURE STRIP/LOWER - 29.3" - BLACK - <b>FULL BODY PAINT</b>
2	105312-01-07A	FT	INSERT - FEATURE STRIP - VINYL - BRIGHT WHITE
2	105312-01-13A	FT	INSERT - FEATURE STRIP - VINYL - BLACK - <b>FULL BODY PAINT</b>
3	139624-20-01A	EA	TRIM/SEAL - INNER/RIGHT HAND W/NOTCH - 60.6" - BRIGHT WHITE
4	139624-21-01A	EA	TRIM/SEAL - INNER/LEFT HAND W/NOTCH - 60.6" - BRIGHT WHITE
5	139624-22-01A	EA	TRIM/SEAL - INNER/TOP - 101.8" - BRIGHT WHITE
6	135275-01-01A	EA	PROTECTOR - CORNER - SLIDEOUT - WHITE
7	112091-01-000	FT	SEAL/D - NEOPRENE - HEAT ACTIVE ADHESIVE - .9" FROM: 00-00-00 THRU: 04-25-03
7	146056-01-000	FT	SEAL - TRIANGLE - W/PSA FROM: 04-26-03 THRU: 99-99-99
8	075673-05-000	FT	SEAL - PILE - ADHESIVE BACK - BLACK

**EXTERIOR SLIDEOUT GROUP (CONTINUED)**  
**LEFT REAR (CONTINUED)**

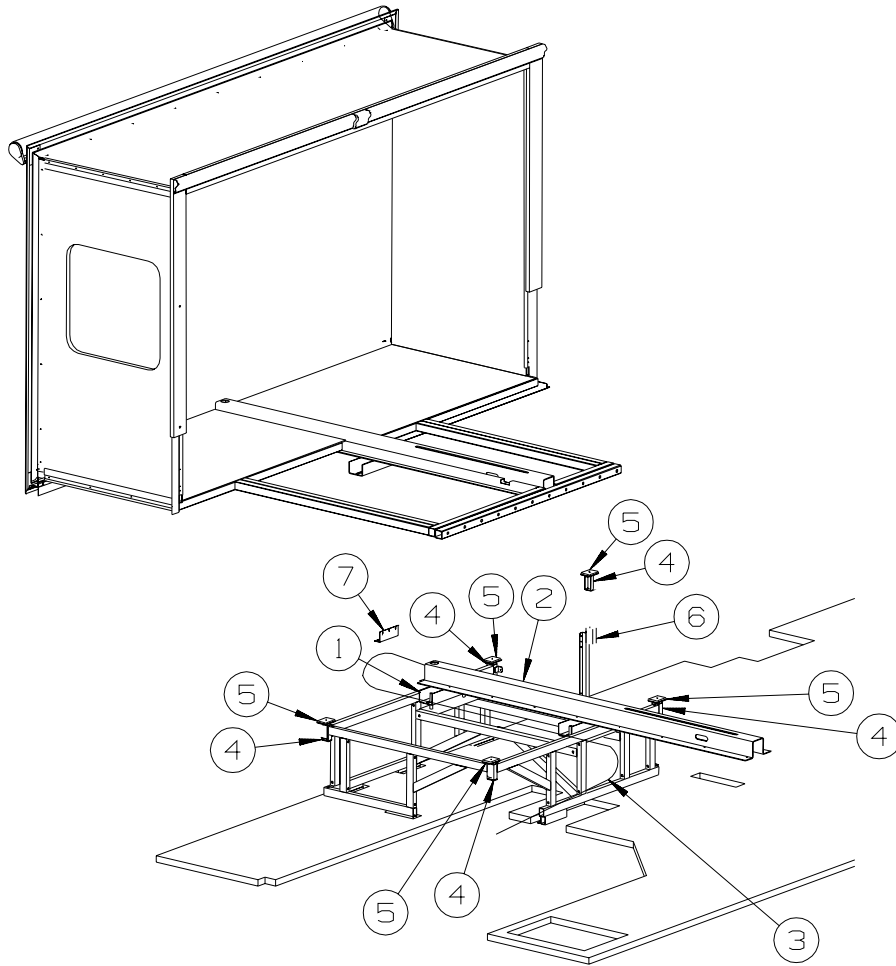

KEY	PART NUMBER	U/M	DESCRIPTION
1*	137390-01-000	EA	HYDRAULIC/BED - F/SLIDEOUT
2	137390-02-000	EA	CHANNEL - HYDRAULIC - F/SLIDEOUT
3*	100536-54-000	EA	HOSE KIT - F/SLIDEOUT
4	126313-02-02B	EA	SUPPORT - ROLLER - E-COATED
5	128599-03-000	EA	PAD - F/SLIDEOUT
6	140484-01-02B	EA	ADJUSTMENT - F/SLIDEOUT - E-COATED
7	113904-16-02B	EA	ANGLE - ATTACHMENT/WHEEL LIP - 5.1" - E-COAT

**\*COMPONENT PARTS LISTED LATER IN THIS GROUP**

**EXTERIOR SLIDEOUT GROUP (CONTINUED)**  
**COMPONENT PARTS FOR LEFT REAR**

**100536-54-000**

<b>KEY</b>	<b>PART NUMBER</b>	<b>U/M DESCRIPTION</b>	<b>VENDOR NO.</b>
	100536-14-702	EA HOSE-HYDRAULIC-264"	RAP6216
	100536-35-701	EA HOSE - HYDRAULIC 1/4" X 252"	RAP90121

**137390-01-000**

<b>KEY</b>	<b>PART NUMBER</b>	<b>U/M DESCRIPTION</b>	<b>VENDOR NO.</b>
	128599-06-700	EA HOSE/HYDRAULIC -1/8" X 72"	AP24635
	128599-06-701	EA HOSE/HYDRAULIC - 1/8" X 84"	AP24636
	128599-06-703	EA BEARING KIT - SLIDE-OUT TUBE	RAP90698
	128599-06-704	EA BEARING PAD - SLIDE-OUT	P14811
	137390-01-700	EA RAM/CYLINDER - SLIDEOUT ROOM	RAP90876/AP23425
	137390-01-701	EA CYLINDER NUT KIT - SLIDEOUT	RAP90947
	137390-01-702	EA SLOT COVER ASM. - RUBBER	AP26959

**143071-01-000**

<b>KEY</b>	<b>PART NUMBER</b>	<b>U/M DESCRIPTION</b>	<b>VENDOR NO.</b>
	143071-01-700	EA HOSE - HYDRAULIC 1/8" X 192"	RAP90821/AP24652
	143071-01-701	EA CYLINDER - SYNCRONIZING	RAP91006/AP27302
	143071-01-702	EA HOSE - HYDRAULIC 1/8" X 196"	AP26471
	143071-01-703	EA HOSE - HYDRAULI 1/8" X 18.8"	AP25732
	143071-01-704	EA HOSE - HYDRAULI 1/8" X 15.8"	AP25957
	143071-01-705	EA CYLINDER/RAM - SLIDEOUT ROOM	RAP91007/AP27723

## GALLEY GROUP CABINETS

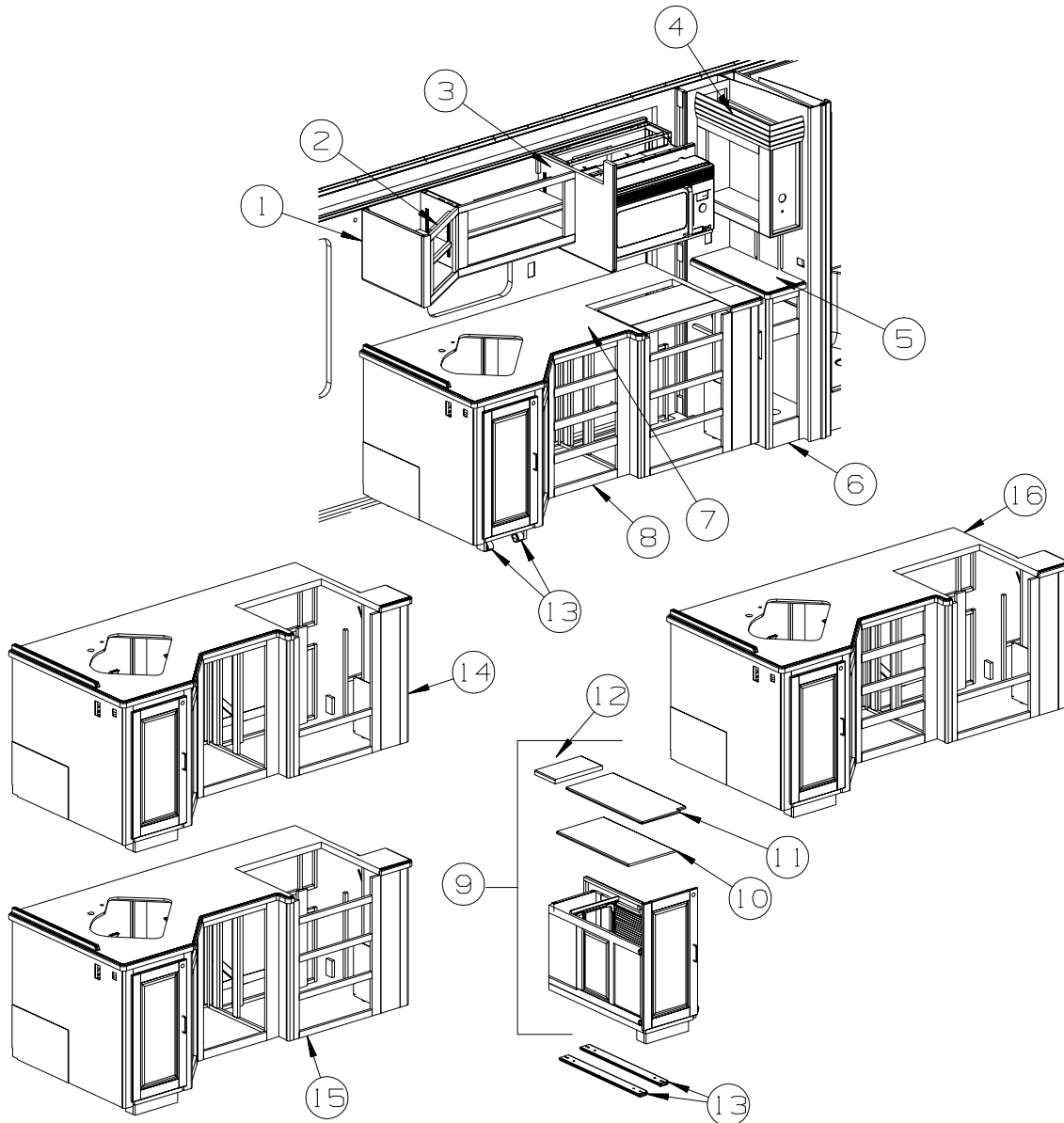

KEY	PART NUMBER	U/M	DESCRIPTION
1	142476-14-PC0	EA	END CAP - OVERHEAD CABINET - PORTSMOUTH OAK
1	142476-14-PC1	EA	END CAP - OVERHEAD CABINET - CONCERT CHERRY
1	142476-14-PC2	EA	END CAP - OVERHEAD CABINET - WASHED MAPLE
2	142476-02-PA0	EA	CABINET - OVERHEAD/GALLEY - W/O DOORS/HARDWARE - PORTSMOUTH OAK
2	142476-02-PA1	EA	CABINET - OVERHEAD/GALLEY - W/O DOORS/HARDWARE - CONCERT CHERRY
2	142476-02-PA2	EA	CABINET - OVERHEAD/GALLEY - W/O DOORS/HARDWARE - WASHED MAPLE
3	142476-36-PC0	EA	END CAP - OVERHEAD CABINET - PORTSMOUTH OAK
3	142476-36-PC1	EA	END CAP - OVERHEAD CABINET - CONCERT CHERRY
3	142476-36-PC2	EA	END CAP - OVERHEAD CABINET - WASHED MAPLE
4	141710-02-PA0	EA	CABINET - OVERHEAD/STORAGE - W/O DOORS/HARDWARE - PORTSMOUTH OAK
4	141710-02-PA1	EA	CABINET - OVERHEAD/STORAGE - W/O DOORS/HARDWARE - CONCERT CHERRY
4	141710-02-PA2	EA	CABINET - OVERHEAD/STORAGE - W/O DOORS/HARDWARE - WASHED MAPLE
5	133539-53-01A	EA	COUNTERTOP - 1/2" CORIAN - MAGNA SAVANNA
6	143245-01-PA0	EA	CABINET - STORAGE/PANTRY - W/O DOORS/HARDWARE - PORTSMOUTH OAK
6	143245-01-PA1	EA	CABINET - STORAGE/PANTRY - W/O DOORS/HARDWARE - CONCERT CHERRY
6	143245-01-PA2	EA	CABINET - STORAGE/PANTRY - W/O DOORS/HARDWARE - WASHED MAPLE
7	133537-17-01A	EA	COUNTERTOP - 1/2" CORIAN - MAGNA SAVANNA

## GALLEY GROUP (CONTINUED)

### CABINETS (CONTINUED)

KEY	PART NUMBER	U/M	DESCRIPTION
8	143258-01-PA0	EA	CABINET - GALLEY - W/O COUNTERTOP/DOORS/DRAWERS/HARDWARE - PORTSMOUTH OAK
8	143258-01-PA1	EA	CABINET - GALLEY - W/O COUNTERTOP/DOORS/DRAWERS/HARDWARE - CONCERT CHERRY
8	143258-01-PA2	EA	CABINET - GALLEY - W/O COUNTERTOP/DOORS/DRAWERS/HARDWARE - WASHED MAPLE
9	142678-02-PA0	EA	CABINET - GALLEY/PULLOUT - W/O COUNTERTOP - W/ROLL-UP DOOR - PORTSMOUTH OAK
9	142678-02-PA1	EA	CABINET - GALLEY/PULLOUT - W/O COUNTERTOP - W/ROLL-UP DOOR - CONCERT CHERRY
9	142678-02-PA2	EA	CABINET - GALLEY/PULLOUT - W/O COUNTERTOP - W/ROLL-UP DOOR - WASHED MAPLE
10	133539-49-01A	EA	COUNTERTOP - 1/2" CORIAN - MAGNA SAVANNA
11	133539-48-01A	EA	COUNTERTOP - 1/2" CORIAN - MAGNA SAVANNA
12	133539-50-01A	EA	COUNTERTOP - 1/2" CORIAN - MAGNA SAVANNA
13	143913-01-000	EA	SLIDE - PANTRY - 28"
14	143258-04-PA0	EA	CABINET - GALLEY - W/O COUNTERTOP/DOORS/DRAWERS/HARDWARE - PORTSMOUTH OAK
14	143258-04-PA1	EA	CABINET - GALLEY - W/O COUNTERTOP/DOORS/DRAWERS/HARDWARE - CONCERT CHERRY
14	143258-04-PA2	EA	CABINET - GALLEY - W/O COUNTERTOP/DOORS/DRAWERS/HARDWARE - WASHED MAPLE
15	143258-03-PA0	EA	CABINET - GALLEY - W/O COUNTERTOP/DOORS/DRAWERS/HARDWARE - PORTSMOUTH OAK
15	143258-03-PA1	EA	CABINET - GALLEY - W/O COUNTERTOP/DOORS/DRAWERS/HARDWARE - CONCERT CHERRY
15	143258-03-PA2	EA	CABINET - GALLEY - W/O COUNTERTOP/DOORS/DRAWERS/HARDWARE - WASHED MAPLE
16	143258-02-PA0	EA	CABINET - GALLEY - W/O COUNTERTOP/DOORS/DRAWERS/HARDWARE - PORTSMOUTH OAK
16	143258-02-PA1	EA	CABINET - GALLEY - W/O COUNTERTOP/DOORS/DRAWERS/HARDWARE - CONCERT CHERRY
16	143258-02-PA2	EA	CABINET - GALLEY - W/O COUNTERTOP/DOORS/DRAWERS/HARDWARE - WASHED MAPLE

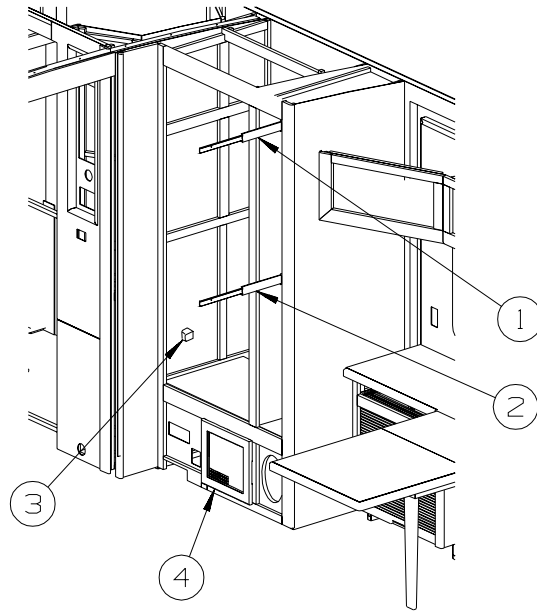

KEY	PART NUMBER	U/M	DESCRIPTION
1	122360-02-000	EA	SLIDE - PANTRY - W/O LOCK - RIGHT/LEFT HAND
2	122360-03-000	EA	SLIDE - PANTRY - W/LOCK - RIGHT HAND (FACING PANEL)
3	123673-01-01A	EA	KNOB - PANTRY SLIDE
4	140594-09-01A	EA	GRILL - RETURN AIR - 1/2" X 11.8" X 12" - BLACK

## GALLEY GROUP (CONTINUED) CABINETS (CONTINUED)

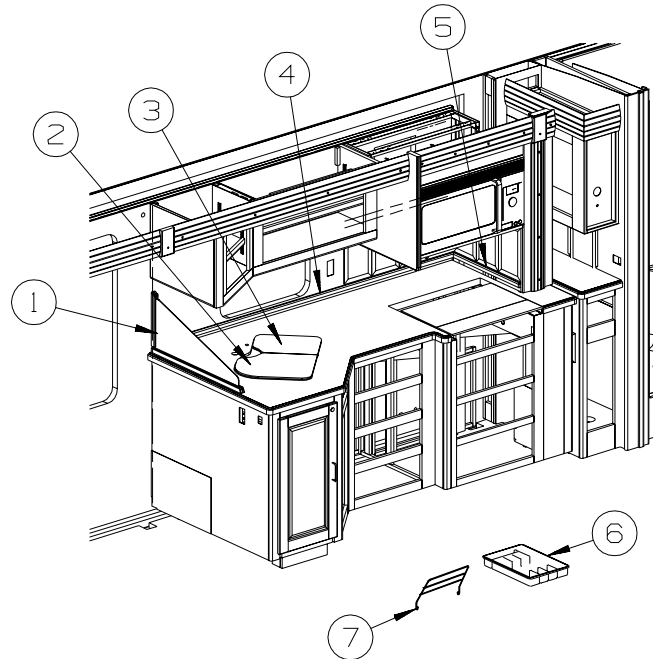

KEY	PART NUMBER	U/M	DESCRIPTION
1	128828-02-PC0	EA	MOLDING - SPLASHGUARD - MAGNA SAVANNAH
1	127117-01-01A	EA	GLASS - STATIONARY - SPLASHGUARD
2	107044-10-01A	EA	COVER - RECESSED SINK - 13.2" X 16.4" - CORIAN
3	107044-09-01A	EA	COVER - RECESSED SINK - 10.1" X 14" - CORIAN
4	142772-05-02A	EA	BACKSPLASH - COUNTERTOP - CORIAN - MAGNA SAVANNAH
5	142772-06-02A	EA	BACKSPLASH - COUNTERTOP - CORIAN - MAGNA SAVANNAH
6	100081-01-01A	EA	TRAY - SILVERWARE - 9" X 13.3" RUBBERMAID ALMOND PLASTIC
7	093605-02-01A	EA	RACK - TOWEL/WIRE - ALMOND

## GALLEY GROUP (CONTINUED)

### DOORS & DRAWERS

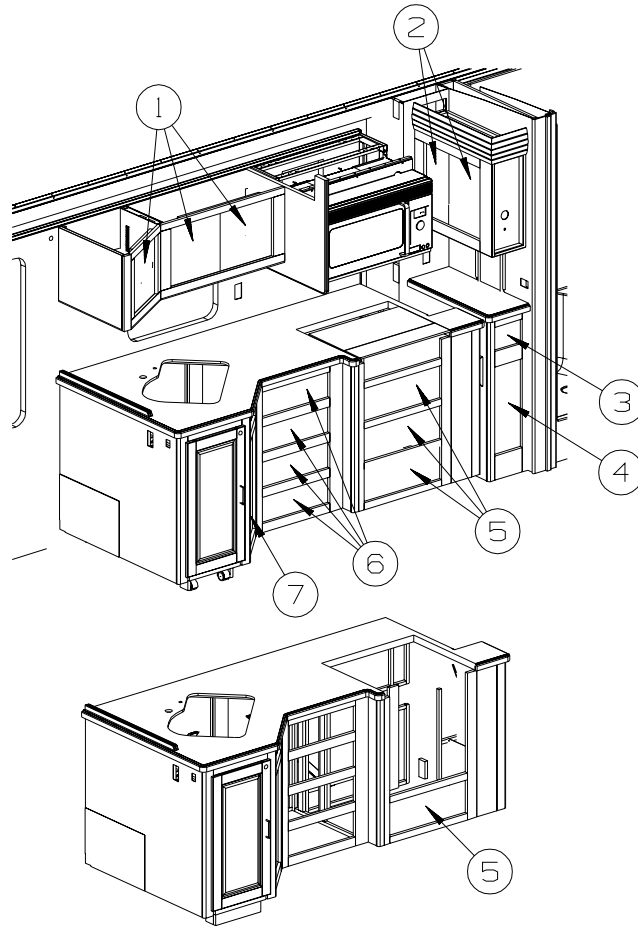

KEY	PART NUMBER	U/M	DESCRIPTION
1	141286-A0-PA0	EA	DOOR - DBL ARCH/VERT PENCIL EDGE-14.3" X 14.3" - W/O HDW - PORTSMOUTH OAK
1	141286-A0-PA1	EA	DOOR - DBL ARCH/VERT PENCIL EDGE-14.3" X 14.3" - W/O HDW - CONCERT CHERRY
1	141286-A0-PA2	EA	DOOR - DBL ARCH/VERT PENCIL EDGE-14.3" X 14.3" - W/O HDW - WASHED MAPLE
2	141286-22-PA0	EA	DOOR - DBL ARCH/VERT PENCIL EDGE-10" X 19.1" - W/O HDW - PORTSMOUTH OAK
2	141286-22-PA1	EA	DOOR - DBL ARCH/VERT PENCIL EDGE-10" X 19.1" - W/O HDW - CONCERT CHERRY
2	141286-22-PA2	EA	DOOR - DBL ARCH/VERT PENCIL EDGE-10" X 19.1" - W/O HDW - WASHED MAPLE
3	P40787-35-PA0	EA	DRAWER - SOLID PANEL - 6.8"W X 21.6"D - W/O SLIDES/HDW - PORTSMOUTH OAK
3	P40787-35-PA1	EA	DRAWER - SOLID PANEL - 6.8"W X 21.6"D - W/O SLIDES/HDW - CONCERT CHERRY
3	P40787-35-PA2	EA	DRAWER - SOLID PANEL - 6.8"W X 21.6"D - W/O SLIDES/HDW - WASHED MAPLE
4	143106-03-PA0	EA	DOOR-DBLE ARCH PANEL/PENCIL EDGE/HDWD-9.2"X21.8"-W/O HDW - PORTSMOUTH OAK FROM: 00-00-00 THRU: 07-19-02
4	143959-02-PA0	EA	DOOR - RAISED PANEL/PENCIL EDGE/HDWD-9.2" X 21.8"-W/O HDW - PORTSMOUTH OAK FROM: 07-20-02 THRU: 99-99-99
4	143106-03-PA1	EA	DOOR-DBLE ARCH PANEL/PENCIL EDGE/HDWD-9.2"X21.8"-W/O HDW - CONCERT CHERRY FROM: 00-00-00 THRU: 07-19-02
4	143959-02-PA1	EA	DOOR - RAISED PANEL/PENCIL EDGE/HDWD-9.2" X 21.8"-W/O HDW - CONCERT CHERRY FROM: 07-20-02 THRU: 99-99-99
4	143106-03-PA2	EA	DOOR-DBLE ARCH PANEL/PENCIL EDGE/HDWD-9.2"X21.8"-W/O HDW - WASHED MAPLE FROM: 00-00-00 THRU: 07-19-02
4	143959-02-PA3	EA	DOOR - RAISED PANEL/PENCIL EDGE/HDWD-9.2" X 21.8"-W/O HDW - WASHED MAPLE FROM: 07-20-02 THRU: 99-99-99



**GALLEY GROUP (CONTINUED)**  
**DOORS & DRAWERS (CONTINUED)**

KEY	PART NUMBER	U/M	DESCRIPTION
5	P40787-34-PA0	EA	DRAWER - SOLID PANEL - 20.2"W X 21.6"D - W/O SLIDES/HDW - PORTSMOUTH OAK
5	P40787-34-PA1	EA	DRAWER - SOLID PANEL - 20.2"W X 21.6"D - W/O SLIDES/HDW - CONCERT CHERRY
5	P40787-34-PA2	EA	DRAWER - SOLID PANEL - 20.2"W X 21.6"D - W/O SLIDES/HDW - WASHED MAPLE
6	P40787-03-PA0	EA	DRAWER - SOLID PANEL - 17.5"W X 21.6"D - W/O SLIDES/HDW - PORTSMOUTH OAK
6	P40787-03-PA1	EA	DRAWER - SOLID PANEL - 17.5"W X 21.6"D - W/O SLIDES/HDW - CONCERT CHERRY
6	P40787-03-PA2	EA	DRAWER - SOLID PANEL - 17.5"W X 21.6"D - W/O SLIDES/HDW - WASHED MAPLE
7	141286-96-PA0	EA	DOOR - DBL ARCH/VERT PENCIL EDGE-13.6" X 30.3" - W/O HDW - PORTSMOUTH OAK FROM: 00-00-00 THRU: 07-19-02
7	136710-96-PA0	EA	DOOR - RAISED PANEL/PENCIL EDGE - 13.6" X 30.3" - W/O HDW - PORTSMOUTH OAK FROM: 07-20-02 THRU: 99-99-99
7	141286-96-PA1	EA	DOOR - DBL ARCH/VERT PENCIL EDGE-13.6" X 30.3" - W/O HDW - CONCERT CHERRY FROM: 00-00-00 THRU: 07-19-02
7	136710-96-PA1	EA	DOOR - RAISED PANEL/PENCIL EDGE - 13.6" X 30.3" - W/O HDW - CONCERT CHERRY FROM: 07-20-02 THRU: 99-99-99
7	141286-96-PA2	EA	DOOR - DBL ARCH/VERT PENCIL EDGE-13.6" X 30.3" - W/O HDW - WASHED MAPLE FROM: 00-00-00 THRU: 07-19-02
7	136710-96-PA2	EA	DOOR - RAISED PANEL/PENCIL EDGE - 13.6" X 30.3" - W/O HDW - WASHED MAPLE FROM: 07-20-02 THRU: 99-99-99

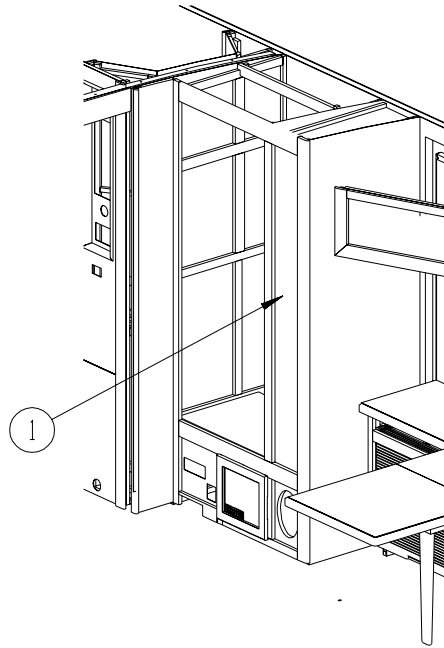

KEY	PART NUMBER	U/M	DESCRIPTION
1	143106-05-PA0	EA	DOOR-DBLE ARCH PANEL/PENCIL EDGE/HDWD-8.1"X60.7" - W/O HDW - PORTSMOUTH OAK FROM: 00-00-00 THRU: 07-19-02
1	143959-04-PA0	EA	DOOR - RAISED PANEL/PENCIL EDGE/HDWD-8.1" X 60.7"-W/O HDW - PORTSMOUTH OAK FROM: 07-20-02 THRU: 99-99-99
1	143106-05-PA1	EA	DOOR-DBLE ARCH PANEL/PENCIL EDGE/HDWD-8.1"X60.7" - W/O HDW - CONCERT CHERRY FROM: 00-00-00 THRU: 07-19-02
1	143959-04-PA1	EA	DOOR - RAISED PANEL/PENCIL EDGE/HDWD-8.1" X 60.7"-W/O HDW - CONCERT CHERRY FROM: 07-20-02 THRU: 99-99-99
1	143106-05-PA2	EA	DOOR-DBLE ARCH PANEL/PENCIL EDGE/HDWD-8.1"X60.7" - W/O HDW - WASHED MAPLE FROM: 00-00-00 THRU: 07-19-02
1	143959-04-PA2	EA	DOOR - RAISED PANEL/PENCIL EDGE/HDWD-8.1" X 60.7"-W/O HDW - WASHED MAPLE FROM: 07-20-02 THRU: 99-99-99

## GENERATOR GROUP DIESEL

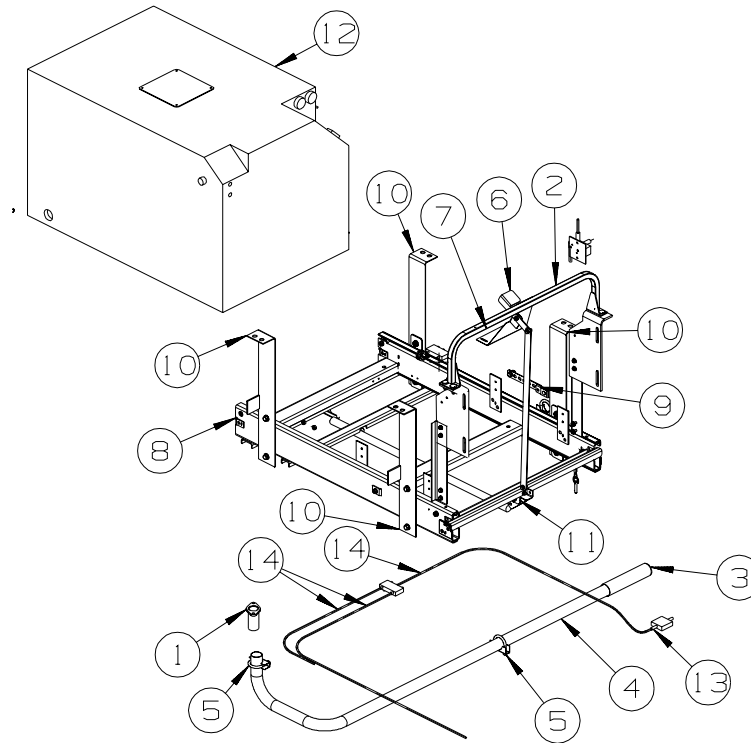

KEY	PART NUMBER	U/M	DESCRIPTION
1	106235-01-000	EA	ADAPTOR - GENERATOR EXHAUST
2	114169-02-02B	EA	HANDLE - BUMPER MOUNT - E-COATED
3	138246-01-01A	EA	EXTENSION - TAILPIPE - 1.6"ID X 7.7"
4	116381-09-000	EA	PIPE - EXHAUST - GENERATOR
5	007125-03-000	EA	CLAMP - MUFFLER - 1.5" DIAMETER
6	131696-01-02B	EA	BRACKET - GENERATOR - E-COATED
7	131507-01-02B	EA	BRACKET - GENERATOR - E-COATED
8	130294-02-01A	EA	SLIDE - GENERATOR - NON-POWERED
9	007131-01-000	EA	HANGER - TAILPIPE - 6 SLOTS
10	123141-05-02B	EA	BRACKET/HANGER - GENERATOR - E-COATED
11	131696-02-02B	EA	BRACKET - GENERATOR - E-COATED
12	122425-01-000	EA	GENERATOR - DIESEL - 7.5
13	071386-06-000	EA	CONNECTOR - MALE - 1/4 TUBE X 1/4
14	071390-04-000	FT	TUBING - AIR BRAKE - 1/4" OD-BLK WEATHERHEAD(BRKS & HORN)

## HEATING & A/C GROUP AUTOMOTIVE

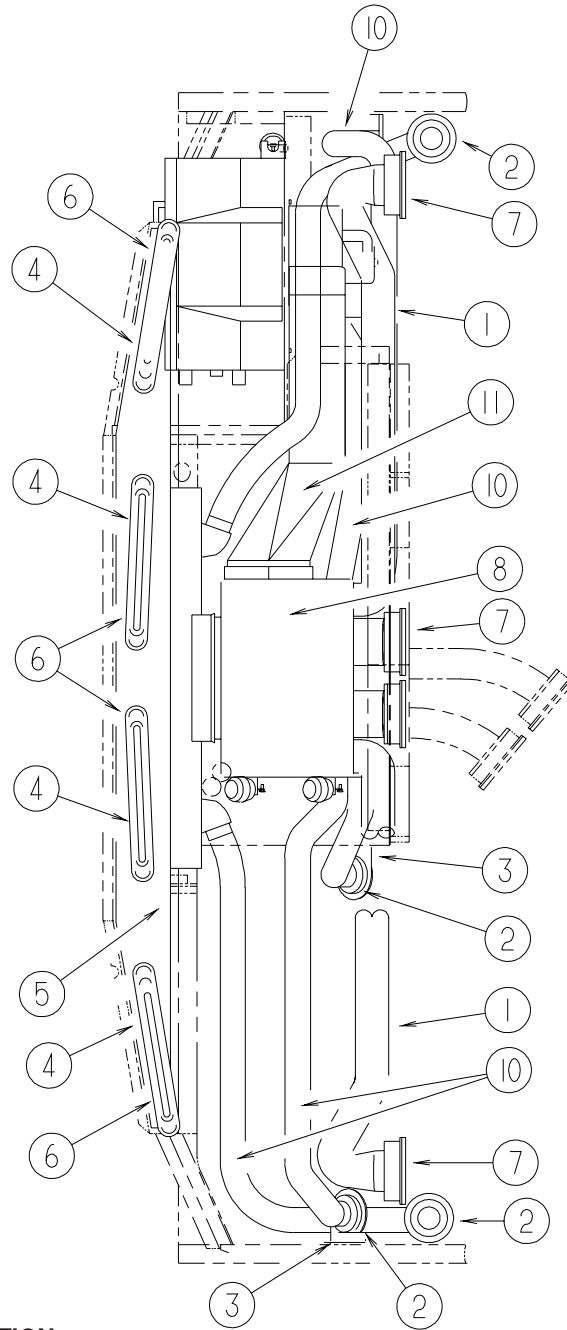

KEY	PART NUMBER	U/M	DESCRIPTION
1	007281-01-000	EA	HOSE - FLEXIBLE PVC - 2 1/2" ID X 50'
2	024990-05-000	EA	OUTLET - DEFROSTER - W/SWIVEL - 2" SLEEVE/4" OD - BLACK - 2 USED
2	024990-12-000	EA	OUTLET - DEFROSTER - W/SWIVEL - 2" SLEEVE/4" OD - GLACIER - 3 USED
3	136157-03-02B	EA	BRACKET - HEATER - E-COATED - 1 USED
4	077075-01-000	EA	GASKET - INSTRUMENT PANEL/DEFROSTER PLENUM - .6" X 10.2"
5	103017-03-000	EA	PLENUM - DEFROSTER
6	135265-01-04A	EA	VENT - DEFROSTER - PLASTIC - GLACIER
7	135803-01-01A	EA	LOUVER - A/C - 2.5" X 5.2" - BLACK - 3 USED
7	135803-02-01A	EA	LOUVER - A/C - 2.5" - 5.7" - W/SCREW HOLES - BLACK - 2 USED
8*	103930-52-000	EA	CONTROL/PLENUM - LARGE ROTARY
9*	103930-55-000	EA	EVAPORATOR/HEATER - NONCHARGED - SINGLE OUTPUT
10	007076-01-000	EA	HOSE - FLEXIBLE PVC - 2" ID - INCREMENTS OF 50'
11	134275-01-01A	EA	PLENUM - TRANSITION
	103930-54-000	EA	MANUAL - OWNERS - HEATER/AC

\*COMPONENT PARTS LISTED LATER IN THIS GROUP

## HEATING & A/C GROUP (CONTINUED)

### AUTOMOTIVE (CONTINUED)

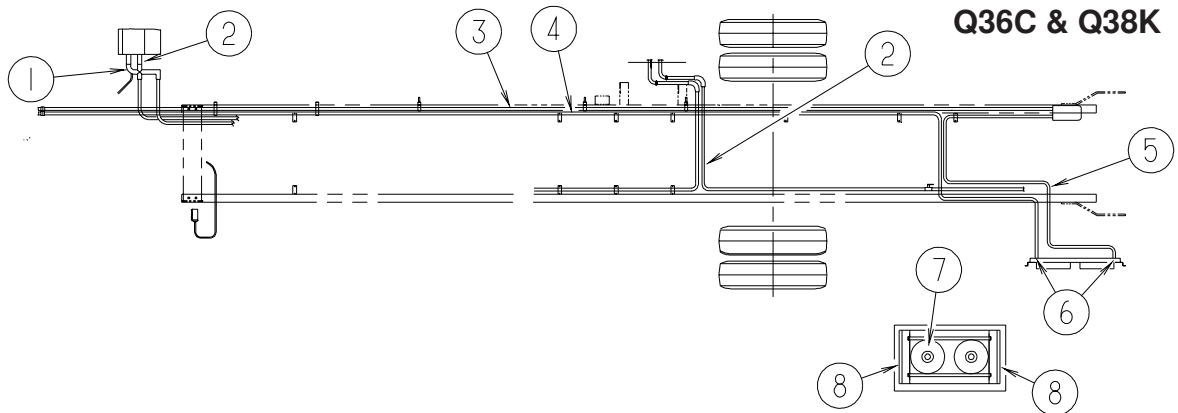

KEY	PART NUMBER	U/M	DESCRIPTION
1	103930-24-000	EA	VALVE - WATER CONTROL - 4 PORT VACUUM CONTROLLED
2	007108-01-000	FT	HOSE - HEATER - 5/8" ID - HI-TEMP
3*	103930-51-000	EA	HOSE KIT - #12 496" 90 DEGREE BEND - COMPRESSOR/EVAPORATOR
4*	072342-18-000	EA	HOSE - #6 - REC DRIER/EVAPORATOR - 42.8' LONG W/SWITCHES
5*	072342-17-000	EA	HOSE - #8 - STRAIGHT END - CONDENSER/COMPRESSOR - 62"
6	072368-02-000	EA	TRIM - VINYL - EDGE - BLACK
7*	072342-15-000	EA	CONDENSER - W/FAN SIDE - NO HOSE
8	113574-05-02B	EA	BRACKET - A/C CONDENSOR/SIDE - RH/LH - E-COAT

**\*COMPONENT PARTS LISTED LATER IN THIS GROUP**

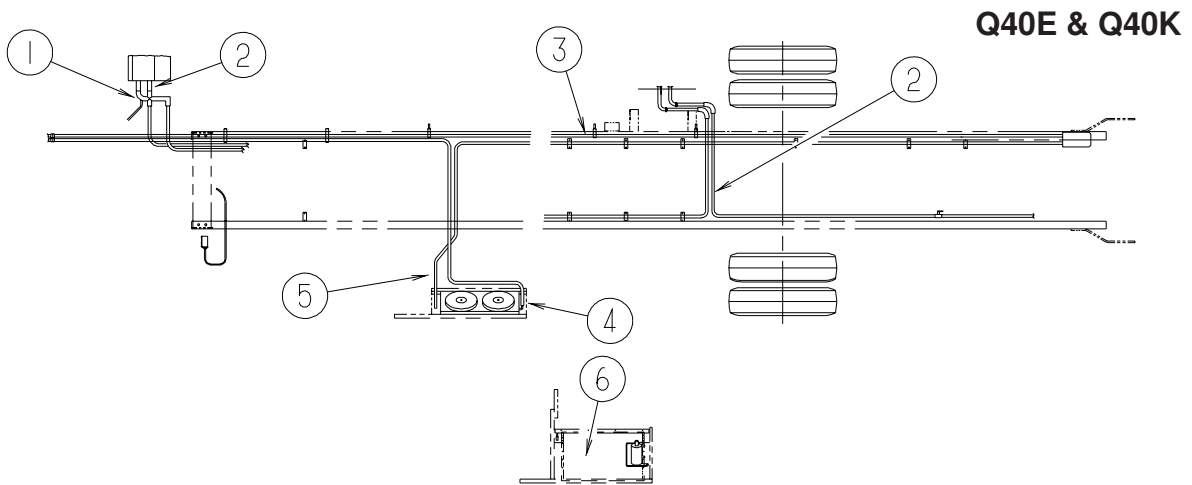

KEY	PART NUMBER	U/M	DESCRIPTION
1	103930-24-000	EA	VALVE - WATER CONTROL - 4 PORT VACUUM CONTROLLED
2	007108-01-000	FT	HOSE - HEATER - 5/8" ID - HI-TEMP
3*	103930-51-000	EA	HOSE KIT - #12 496" 90 DEGREE BEND - COMPRESSOR/EVAPORATOR
4*	072342-23-000	EA	HOSE - #6 - 175" LONG
5*	072342-22-000	EA	HOSE - #8/90 DEGREE END - 465" LONG
6*	072342-15-000	EA	CONDENSER - W/FAN SIDE - NO HOSE

**\*COMPONENT PARTS LISTED LATER IN THIS GROUP**

**HEATING & A/C GROUP (CONTINUED)**  
**COMPONENT PARTS FOR AUTOMOTIVE**

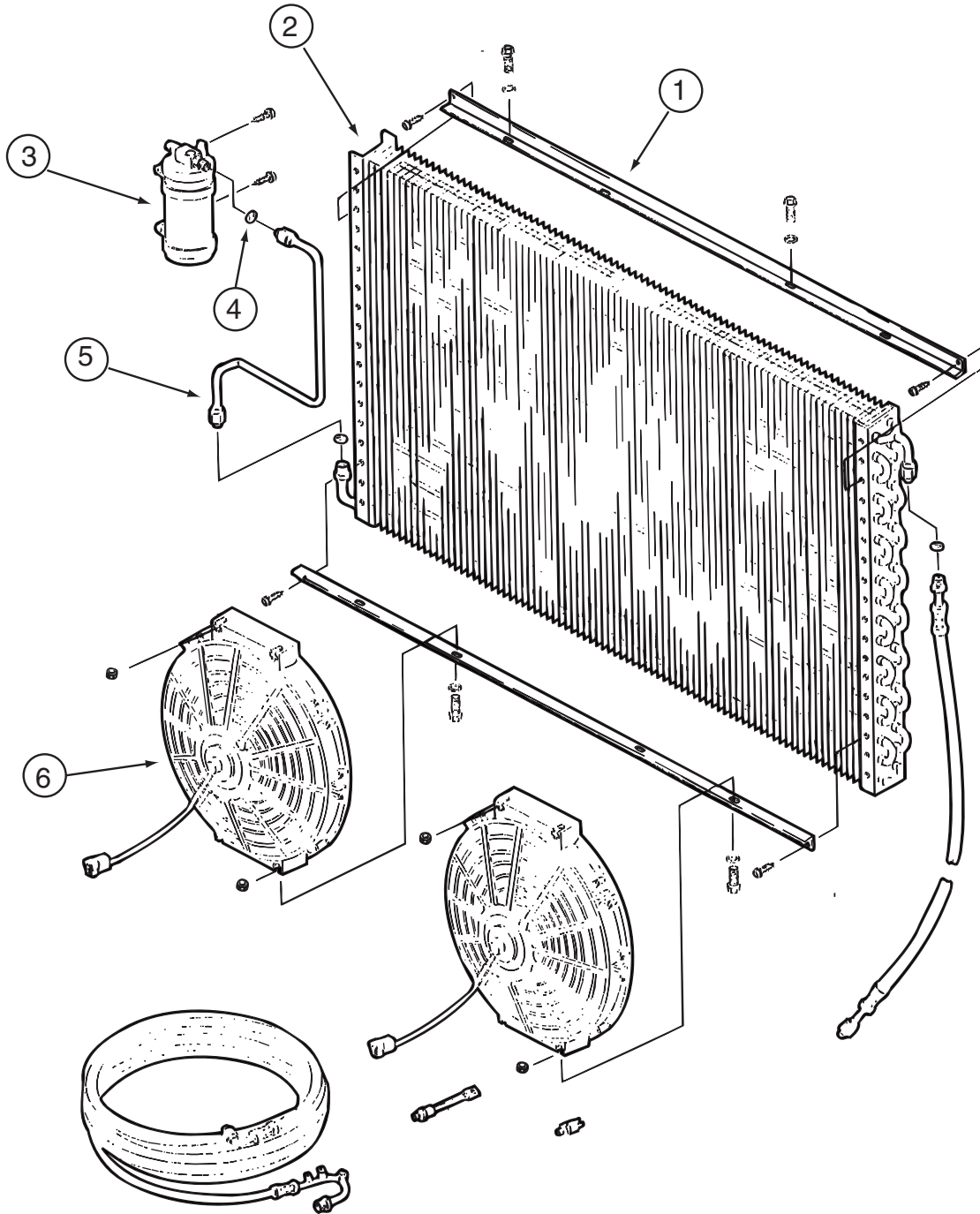

**072342-15-000**

KEY	PART NUMBER	U/M	DESCRIPTION	VENDOR NO.
1	072342-13-700	EA	BRACKET - CONDENSER FAN	070-0148
2	072342-12-700	EA	COIL-CONDENSER	040-0027
3	072342-12-703	EA	RECEIVER DRIER	054-0001
4	113245-01-711	EA	O'RING #6	045-0129
5	072342-13-703	EA	TUBE ASM. #6	052-0040
6	072342-08-703	EA	FAN BLADE/MOTOR & SHROUD 11"	062-0097

**072342-17-000**

KEY	PART NUMBER	U/M	DESCRIPTION	VENDOR NO.
	072342-12-701	EA	HOSE ASM #8 CONDENSER/COMP	085-0142
	113245-01-707	EA	O'RING #8	045-0126

**HEATING & A/C GROUP (CONTINUED)**  
**COMPONENT PARTS FOR AUTOMOTIVE (CONTINUED)**

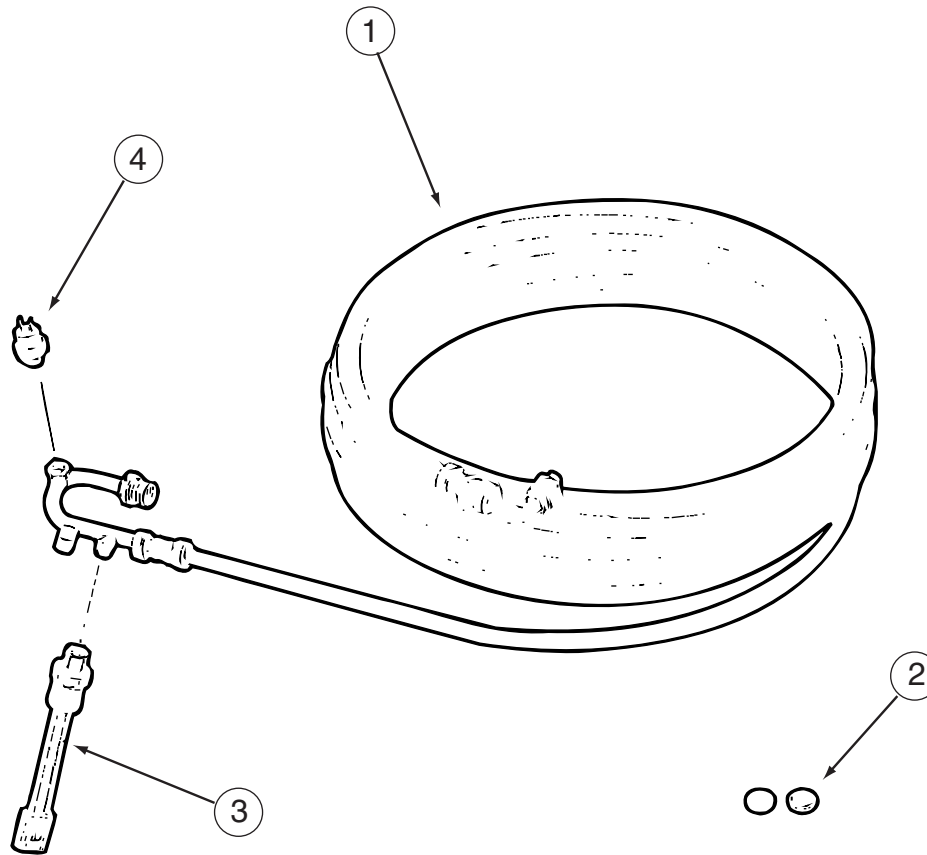

**072342-18-000**

KEY	PART NUMBER	U/M DESCRIPTION	VENDOR NO.
1	072342-13-702	EA HOSE ASM. #6	085-0460
2	113245-01-711	EA O'RING #6	045-0129
3	103930-01-716	EA SWITCH - PRESSURE - FAN	032-0036
4	103930-12-708	EA SWITCH-BINARY-HI/LOW CUTOUT	032-0048

**072342-22-000**

KEY	PART NUMBER	U/M DESCRIPTION	VENDOR NO.
	072342-22-700	EA HOSE - #8 COMP/COND - 38.8'	085-0541
	113245-01-707	EA O'RING #8	045-0126

**072342-23-000**

KEY	PART NUMBER	U/M DESCRIPTION	VENDOR NO.
	072342-23-700	EA HOSE - #6 EVAP/DRIER - 14.6'	085-0540
	103930-01-716	EA SWITCH-PRESSURE-PIGTAILED	032-0036
	103930-12-708	EA SWITCH-BINARY-HI/LOW CUTOUT	032-0048
	113245-01-711	EA O'RING #6	045-0129
	103930-51-000	EA HOSE KIT - #12 - COMPRESSOR/EVAPORATOR - 41.5' LONG 10	

**103930-51-000**

KEY	PART NUMBER	U/M DESCRIPTION	VENDOR NO.
	103930-17-702	EA O'RING #10	045-0127

**HEATING & A/C GROUP (CONTINUED)**  
**COMPONENT PARTS FOR AUTOMOTIVE (CONTINUED)**

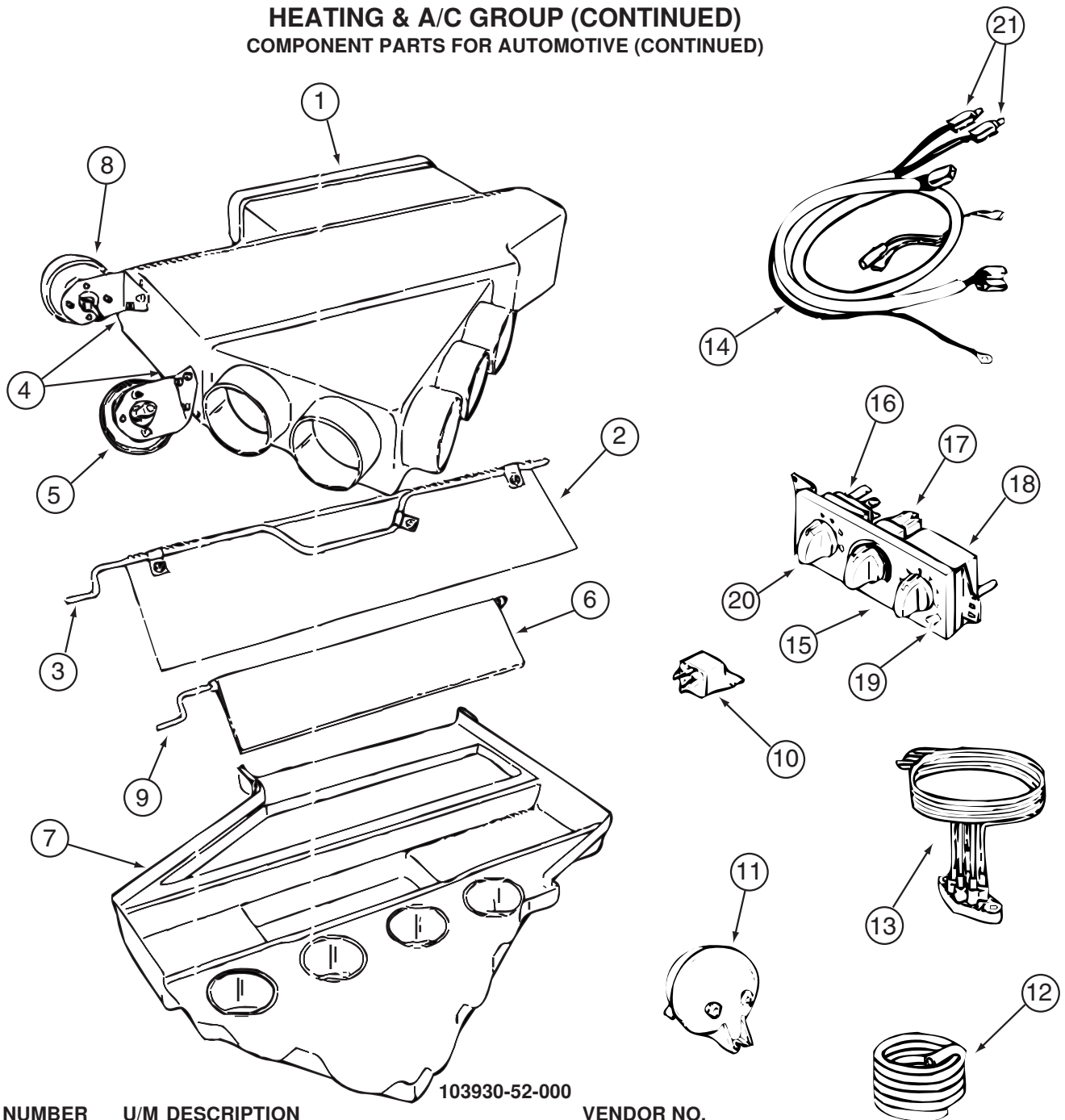

103930-52-000

KEY	PART NUMBER	U/M	DESCRIPTION	VENDOR NO.
1	103930-52-700	EA	PLENUM/TOP	060-0580
2	103930-52-701	EA	PLATE/DEFROST DOOR	071-0728
3	103930-52-702	EA	ROD/DEFROST DOOR	073-0072
5	103930-02-708	EA	MOTOR-VACUUM SERVO, A/C	030-0025
6	103930-52-703	EA	PLATE/DOOR-AC/HEAT	071-0729
7	103930-52-704	EA	PLENUM/BOTTOM	060-0581
8	103930-33-701	EA	MOTOR - VACUUM, 3 STAGE	030-0105
9	103930-52-705	EA	ROOD/DOOR-A/C HEAT	073-0073
10	103930-02-707	EA	RELAY-BOSCH W/RESISTER	031-0001
11	103930-02-710	EA	CANISTER-VACUUM	054-0002
13	103930-33-703	EA	VACUUM HARNESS	036-0466
14	103930-49-701	EA	HARNESS - WIRE W/BULBS	036-0557
15	103930-49-703	EA	CONTROL PANEL - NON RECESSED	083-0223
16	103930-49-704	EA	SWITCH - BLOWER	032-0332
17	103930-49-705	EA	POTENTIOMETER	032-0182
18	103930-49-706	EA	SWITCH - VACUUM	032-0185
19	103930-49-707	EA	DECAL CONTROL PANEL-N/RECESS	058-0144
20	103930-49-708	EA	KNOB - BLOWER - NONRECESSED	062-0620
21	103930-33-705	EA	LIGHT BULBS	035-0030

CONTACT WINNEBAGO PARTS SALES FOR UNLISTED COMPONENTS

**HEATING & A/C GROUP (CONTINUED)**  
**FURNACE**

<b>KEY</b>	<b>PART NUMBER</b>	<b>U/M</b>	<b>DESCRIPTION</b>
	124643-02-01A	EA	SHROUD - FURNACE
	112091-01-000	FT	SEAL/D - NEOPRENE - HEAT ACTIVE ADHESIVE - .9"
	128080-04-02B	EA	PANEL - EXHAUST/FURNACE - E-COATED
*	143563-01-000	EA	FURNACE - 35000 BTU/HIGH QUIET - SUBURBAN SH-35 2322
	143563-05-000	EA	GASKET - FIBERGLASS - SUBURBAN #071018
	143563-04-000	EA	PLATE END - COLLAR
	098668-16-000	EA	VENT - INTAKE
	137965-03-01A	EA	REGISTER - 2.25" X 10" - W/O DAMPER - ANTIQUE BRASS
	137965-04-01A	EA	REGISTER - 2.25" X 10" - W/DAMPER - ANTIQUE BRASS
	137965-07-01A	EA	REGISTER - 3.5" X 8" - W/O DAMPER - ANTIQUE BRASS
	142290-19-02A	EA	GRILLE - HEATER/HURRICANE - 11" X 4" - OFF WHITE
	142290-19-01A	EA	GRILLE - HEATER/HURRICANE - 11" X 4"
	093614-09-01A	EA	GRILLE - AIR RETURN - 21.9" X 11.9" - BEIGE
			FROM: 00-00-00 THRU: 08-12-02
	107721-08-000	FT	SEAL - ACCESS DOOR - .9" WIDE X .9" HIGH
	115764-01-01A	EA	THERMOSTAT - FURNACE

**\*COMPONENT PARTS LISTED LATER IN THIS GROUP**



HEATING & A/C GROUP (CONTINUED)  
COMPONENT PARTS FOR FURNACE

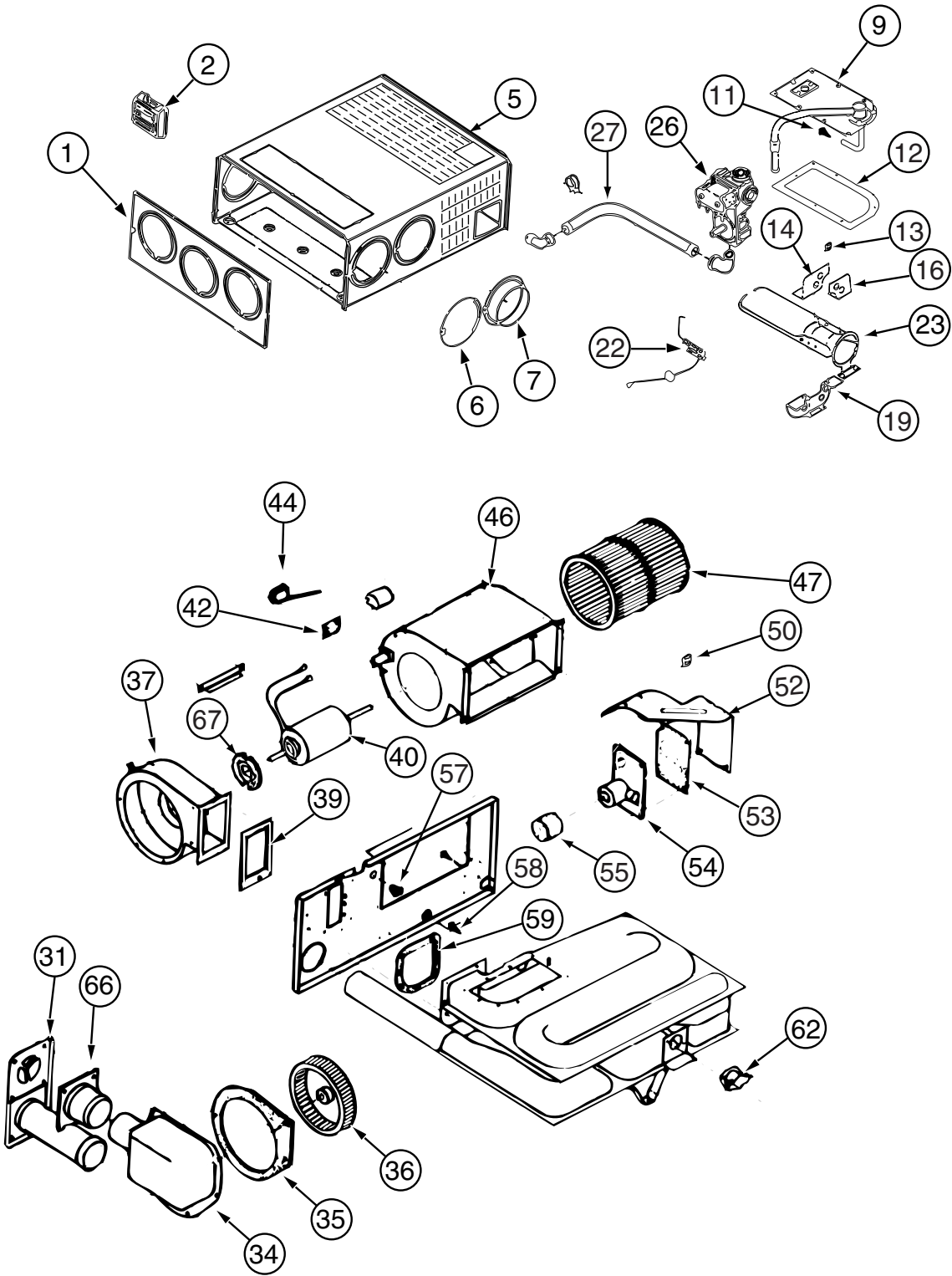

143563-01-000

**HEATING & A/C GROUP (CONTINUED)**  
**COMPONENT PARTS FOR FURNACE (CONTINUED)**

143563-01-000 (CONTINUED)

KEY	PART NUMBER	U/M	DESCRIPTION	VENDOR NO.
1	143563-01-700	EA	CABINET - FRONT	101907
2	115764-01-01A	EA	THERMOSTAT - FURNACE	161154
5	143563-01-701	EA	CABINET	101921
7	075696-02-703	EA	COLLAR - DUCT	050715
9	143563-01-702	EA	MANIFOLD ASSEMBLY	171599
11	143563-01-703	EA	ORFICE - MAIN BURNER	180308
12	098668-22-703	EA	GASKET - BURNER ACCESS COVER	070811
14	143563-01-704	EA	PLATE - SECONDARY AIR/TOP BACK	063199
16	143563-01-705	EA	PLATE - SECONDARY AIR/TOP FRT	062936
19	143563-01-706	EA	PLATE - SECONDARY AIR/BOTTOM	062938
22	139980-01-701	EA	ELECTRODE	232286
23	098668-02-700	EA	BURNER ASSEMBLY,SF-30 & SF35	010745
26	098668-01-718	EA	VALVE-GAS SF S.N.974903079	161122
27	143563-01-707	EA	PIPE ASSEMBLY (GAS INLET)	171603
31	098668-01-707	EA	TUBE ASSEMBLY, EXHAUST W/CAP	260231
34	143563-01-708	EA	BOX ASM (COMB. AIR INTAKE)	051430BK
35	143563-01-709	EA	GASKET (COMB. AIR HOUSING)	071108
36	143563-01-710	EA	WHEEL (COMBUSTION AIR)	350199
37	143563-01-711	EA	HOUSING (COMBUSTION AIR)	390862BK
39	143563-01-715	EA	GASKET-FIREWALL/COMB. AIR	071107
40	143563-01-712	EA	MOTOR ASSEMBLY	232727
42	098668-01-712	EA	BOARD-MODULE	520741
44	098668-21-700	EA	SWITCH-MICRO-W/O FLAG 3 1/4"	232261
46	143563-01-713	EA	BLOWER ASSEMBLY(ROOM AIR)	390867BK
47	143563-01-714	EA	WHEEL - ROOM AIR	350198
50	139980-01-710	EA	SWITCH - ON/OFF	232351
52	139980-01-711	EA	PANEL ASSEMBLY-MODULE BD	101663
53	139980-01-712	EA	INSULATOR - MODULE BD	070807
54	098668-22-705	EA	MODULE BD W/RELAY TIME DELAY	520820
55	139980-01-713	EA	CAP/INSULATOR-MODULE BD	070973
57	139980-01-714	EA	BUSHING - UNIVERSAL	070362
58	139980-01-715	EA	BUSHING - STRAIN RELIEF	231809
59	098668-01-716	EA	GASKET-FIREWALL,CHAMBER SIDE	070808
62	098668-21-701	EA	SWITCH - LIMIT	232504
66	098668-01-713	EA	TUBE ASSEMBLY, INTAKE	051248
67	075697-07-703	EA	GASKET - MOTOR	070448

CONTACT WINNEBAGO PART SALES FOR UNLISTED COMPONENTS

## HEATING & A/C GROUP (CONTINUED) CENTRAL

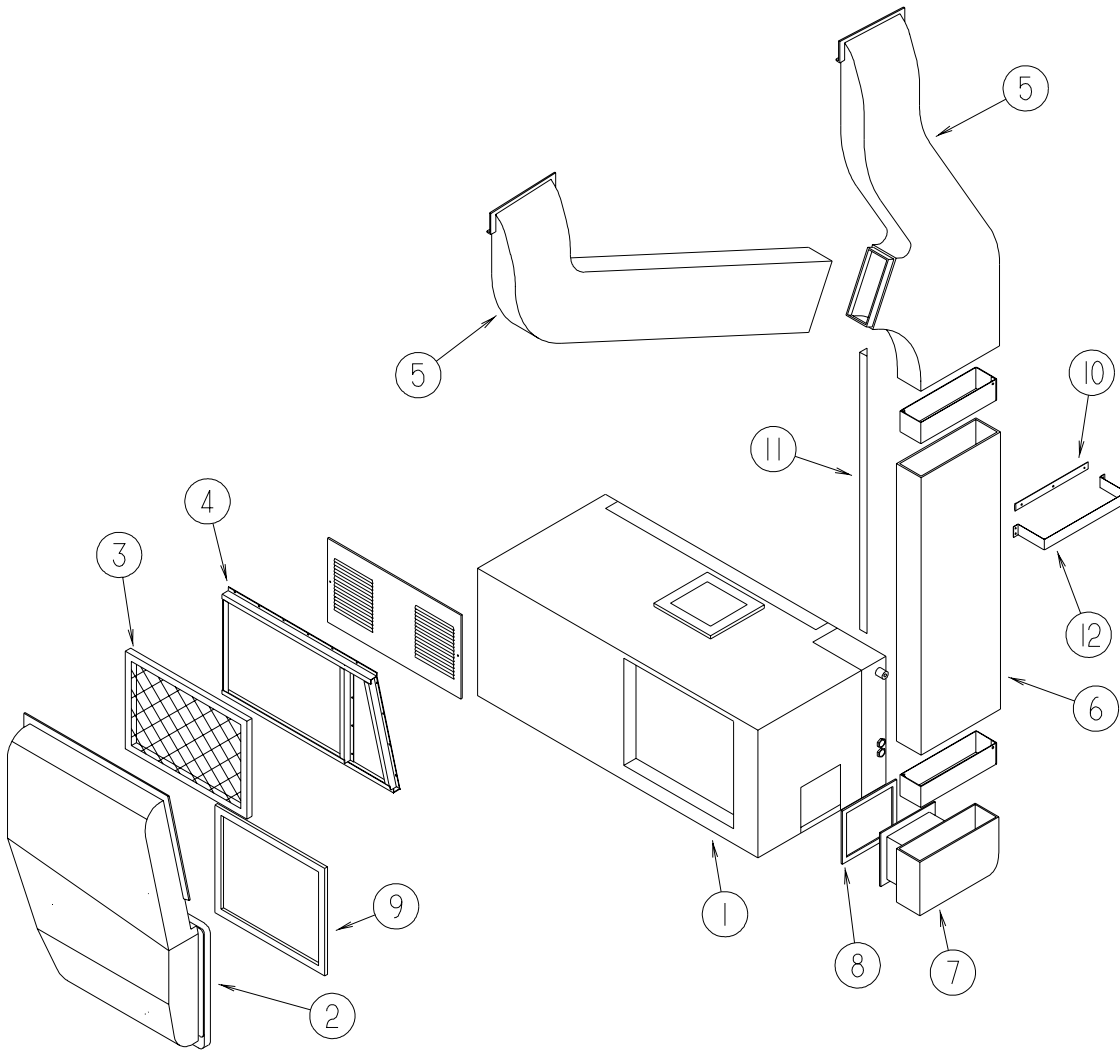

**Q36C**

KEY	PART NUMBER	U/M	DESCRIPTION
1*	105620-11-000	EA	A/C CENTRAL PACKAGE - RIGHT HAND POWER SAVER/LARGE BLOWER - CENTRAL A/C
1*	105620-12-000	EA	A/C - CONTROL PACK RIGHT HAND/HEAT PUMP - 12,000BTU COMP - CENTRAL A/C W/HEAT PUMP
2	135036-01-000	EA	DUCT - CENTRAL AIR - RETURN - REAR RADIATOR
2	128859-01-000	EA	DUCT - RETURN - CENTRAL AIR - SIDE RADIATOR
3	109050-02-000	EA	FILTER - FIBERGLASS - 1" X 14" X 20"
4	129604-01-KQ0	EA	FRAME - A/C FILTER
5	M09204-01-000	EA	DUCT/AC - UPPER RIGHT HAND & LEFT HAND
	128862-01-000	EA	DUCT/AIR - UPPER LEFT HAND
	128868-01-000	EA	DUCT/AIR - UPPER RIGHT HAND
5	105290-01-000	EA	INSULATION - AIR POCKET W/FOIL
6	117870-03-01A	EA	PLENUM - A/C - 42.3"
7	P28855-01-000	EA	DUCT/CENTRAL AIR - LOWER
	128855-01-000	EA	DUCT/LOWER - CENTRAL FORCED AIR
7	105290-01-000	EA	INSULATION - AIR POCKET W/FOIL
8	134588-02-000	EA	GASKET - DUCT - 6.4" X 7.4" IS - 8.3" X 9.4" OS
9	134588-01-000	EA	GASKET - DUCT - 15.5" X 18.2" IS - 17.4" X 20.2" OS
10	115886-11-02A	EA	RETAINER - SIDEWALL - BRIGHT WHITE - 11.8"
11	130262-01-000	EA	PROTECTOR - CORNER SAVER - .7" X .7" X 48"
12	129047-01-02B	EA	STRAP/MOUNTING - AIR DUCT - E-COATED
	120134-01-02A	EA	REGISTER - W/DAMPER - 4" PIPE/7" O.D. FACE - WHITE
	105620-14-000	EA	THERMOSTAT - A/C AND FURNACE
*	105620-15-000	EA	THERMOSTAT - FURNACE/HEAT PUMP-A/C

\*COMPONENT PARTS LISTED LATER IN THIS GROUP

**HEATING & A/C GROUP (CONTINUED)**  
**CENTRAL (CONTINUED)**

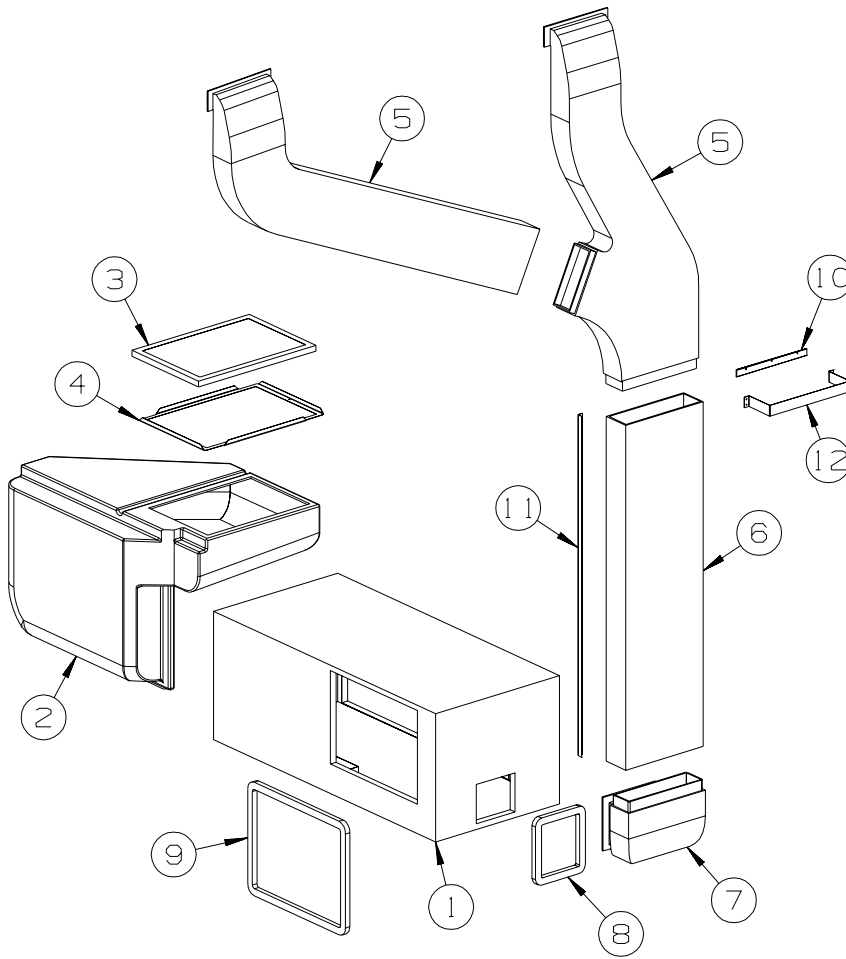

**Q38K, Q40E, Q40K**

KEY	PART NUMBER	U/M DESCRIPTION
1*	105620-12-000	EA A/C - CONTROL PACK RIGHT HAND/HEAT PUMP - 12,000BTU COMP
2	138052-01-01A	EA DUCT - CENTRAL AIR RETURN
3	109050-02-000	EA FILTER - FIBERGLASS - 1" X 14" X 20"
4	139757-01-02B	EA PANEL - TRAY - A/C FILTER - E-COATED
5	M09204-01-000	EA DUCT/AC - UPPER RIGHT HAND & LEFT HAND
	128862-01-000	EA DUCT/AIR - UPPER LEFT HAND
	128868-01-000	EA DUCT/AIR - UPPER RIGHT HAND
5	105290-01-000	EA INSULATION - AIR POCKET W/FOIL
6	117870-10-01A	EA PLENUM - A/C - 48.5"
7	P28855-01-000	EA DUCT/CENTRAL AIR - LOWER
	128855-01-000	EA DUCT/LOWER - CENTRAL FORCED AIR
7	105290-01-000	EA INSULATION - AIR POCKET W/FOIL
8	134588-02-000	EA GASKET - DUCT - 6.4" X 7.4" IS - 8.3" X 9.4" OS
9	134588-04-000	EA GASKET - DUCT - 13.9" X 18.2" IS - 15.9" X 20.2" OS
10	115886-11-02A	EA RETAINER - SIDEWALL - BRIGHT WHITE - 11.8"
11	130262-01-000	EA PROTECTOR - CORNER SAVER - .7" X .7" X 48"
12	129047-01-02B	EA STRAP/MOUNTING - AIR DUCT - E-COATED
	120134-01-02A	EA REGISTER - W/DAMPER - 4" PIPE/7" O.D. FACE - WHITE
*	105620-15-000	EA THERMOSTAT - FURNACE/HEAT PUMP

**\*COMPONENT PARTS LISTED LATER IN THIS GROUP**

HEATING & A/C GROUP (CONTINUED)  
COMPONENT PARTS FOR CENTRAL

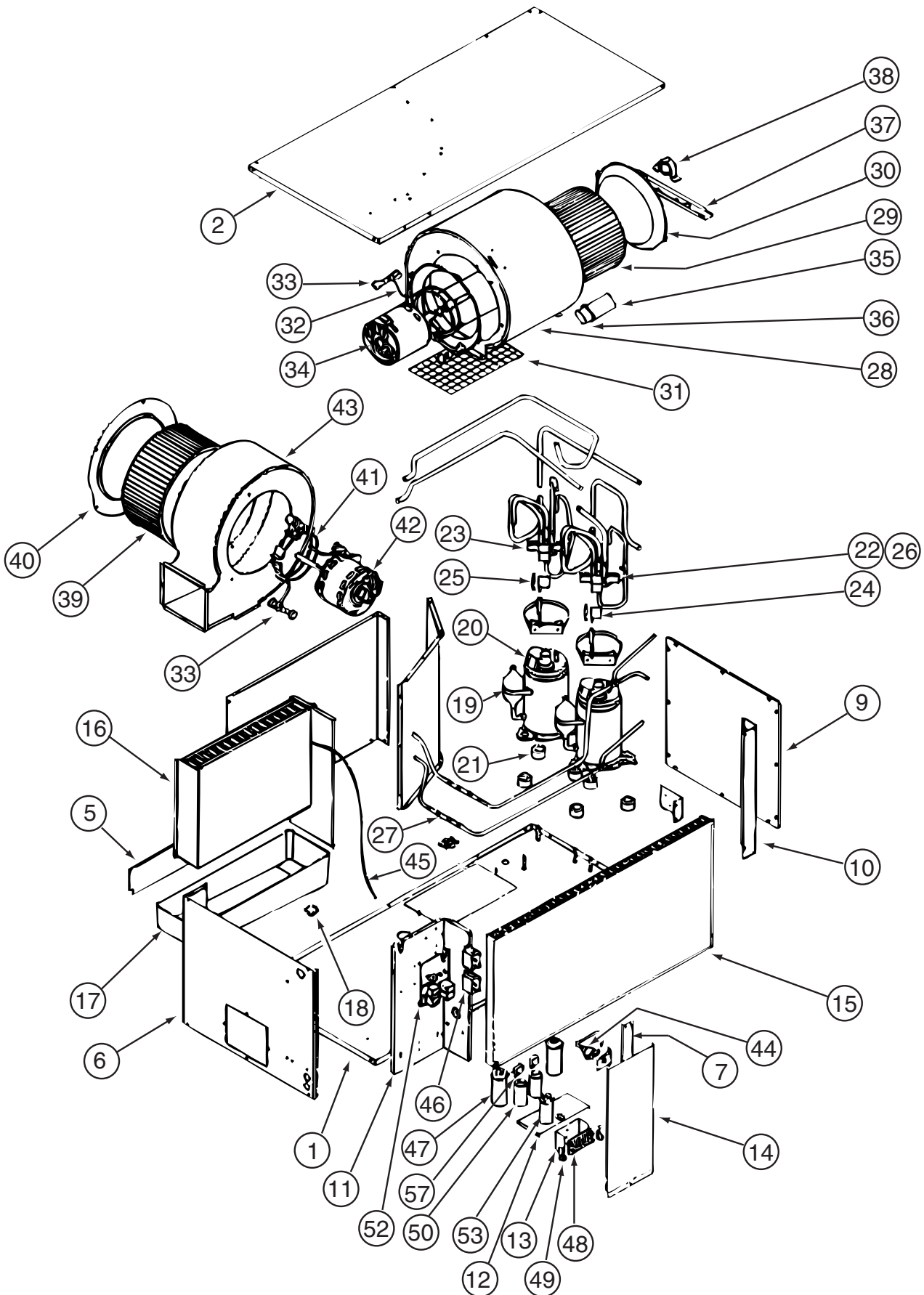

105620-12-000

**HEATING & A/C GROUP (CONTINUED)**  
**COMPONENT PARTS FOR CENTRAL (CONTINUED)**

**105620-12-000 (CONTINUED)**

<b>KEY</b>	<b>PART NUMBER</b>	<b>U/M</b>	<b>DESCRIPTION</b>	<b>VENDOR NO.</b>
15	105620-12-701	EA	COIL - CONDENSER	1452-1621
16	105620-12-702	EA	COIL - EVAPORATOR	1452A1611
17	105620-10-709	EA	DRAIN PAN	6636-304
18	105620-12-703	EA	VALVE - DRAIN	6795-200
19	105620-12-704	EA	COMPRESSOR	1450-2149
21	105620-01-706	EA	MOUNTING PKG.,COMP., 3 PER	6759-3081
22	105620-12-706	EA	REVERSING VALVE ASSEMBLY #1	6535A533
23	105620-12-707	EA	REVERSING VALVE ASSEMBLY #2	6535-5321
24	105620-12-708	EA	COIL - SOLENOID	1460-1081
25	105620-12-709	EA	WIRE HARNESS-REVERSING VALVE	6536-111
26	105620-12-710	EA	VALVE - REVERSE ONLY	1454A350
27	105620-12-711	EA	RESTRICTOR - BY FLOW	1454-2521
28	105620-12-712	EA	HOUSING/OUTSIDE AIR	6536-515
29	105620-01-713	EA	WHEEL-BLOWER/OUTSIDE AIR	1472-1011
30	105620-01-714	EA	VENTURI-BLOWER/OUTSIDE AIR	6795A150
32	105620-01-715	EA	MOUNT-BLOWER/OUTSIDE AIR	6795A3011
34	105620-10-721	EA	MOTOR/BLOWER-8 3/4" SHAFT	1468A3029
35	105620-01-718	EA	CAPACITOR-FAN, 12.5 MFD/370V	1499-5631
37	105620-12-713	EA	BRACKET/BEARING-O/S AIR BLWR	6536-514
38	105620-10-701	EA	BEARING/PILLOW BLOCK-O/S AIR	6536-3011
39	105620-12-714	EA	WHEEL - BLOWER/INSIDE AIR	1472-1121
40	105620-12-715	EA	BLOWER VENTURI/INSIDE AIR	6535A287
41	105620-01-723	EA	MOUNT-BLOWER MOTOR - I/S AIR	6795-3021
42	105620-12-716	EA	BLOWER MTR/IN AIR/REVERSIBLE	1468-3219
43	105620-12-717	EA	BLOWER HOUSING/INSIDE AIR	6535A589
44	105620-12-718	EA	SWITCH ASSM. - HIGH PRESSURE	6535-5291
45	105620-12-719	EA	COIL SENSOR	7330A3231
46	105620-01-729	EA	RELAY-COMPRESSOR -4 TERMINAL	1460-1131
48	105620-01-738	EA	BOARD-TERMINAL, HIGH VOLTAGE	6795-315
51	105620-10-705	EA	PTCR (START DEVICE) - W/CAP.	8333A9021
52	105620-12-720	EA	KIT-CIRCUIT BD (6535-SERIES)	6535-3209
52	105620-12-721	EA	CIRCUIT BD(6535 A SERIES)	6535-3201
53	093763-01-704	EA	CAPACITOR-FAN	1499-5461
	105620-10-720	EA	FUSE/BUSS(8AMP/250V) 2 PKG	6535-3081
			CONTACT WINNEBAGO PART SALES FOR UNLISTED COMPONENTS	

**105620-15-000**

<b>KEY</b>	<b>PART NUMBER</b>	<b>U/M</b>	<b>DESCRIPTION</b>	<b>VENDOR NO.</b>
	105620-15-700	EA	FUSE/BUSS (2AMP/250V) 3 PER PK	8330-3343

# INTERIOR FINISH GROUP

MOLDINGS & TRIMS  
 PORTSMOUTH OAK  
 CONCERT CHERRY  
 WASHED MAPLE

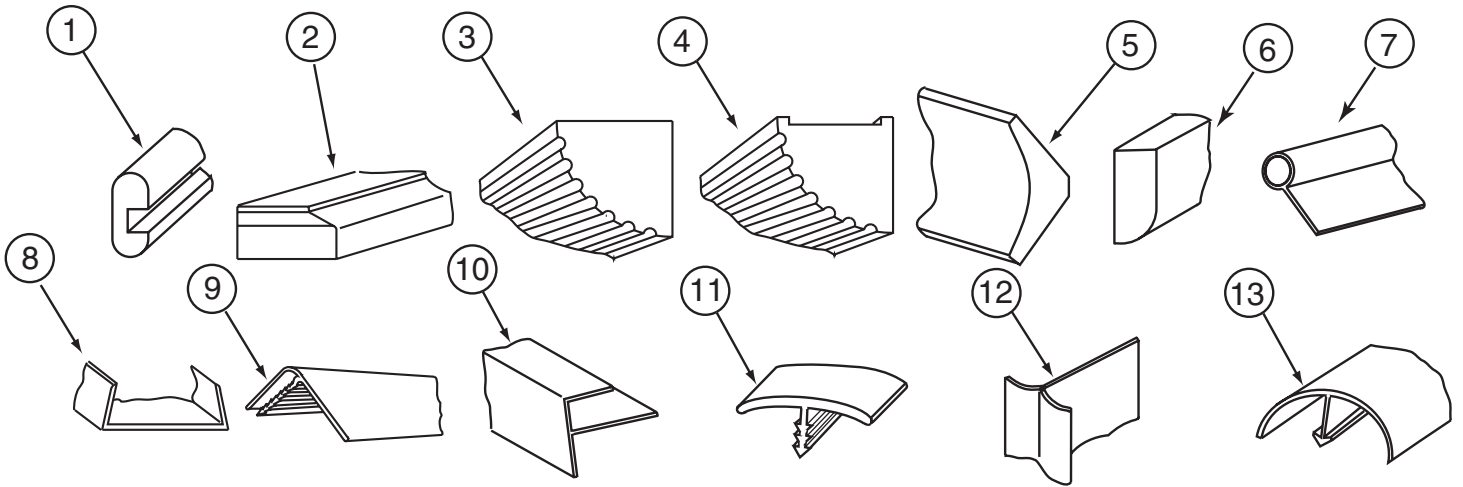

KEY	PART NUMBER	U/M	DESCRIPTION
1	M09412-62-N42	EA	MOLDING/SHELF EDGE - W/.4" NOTCH - PORTSMOUTH II - PORTSMOUTH OAK
1	M09412-62-M62	EA	MOLDING/SHELF EDGE - W/.4" NOTCH - WASHED MAPLE
1	M09412-62-M52	EA	MOLDING/SHELF EDGE - W/.4" NOTCH - CHERRY IV - CONCERT CHERRY
2	P34052-01-N75	EA	TRIM/TABLE - 29.7" - PORTSMOUTH OAK
2	P34052-01-M84	EA	TRIM/TABLE - 29.7" - WASHED MAPLE
2	P34052-01-M52	EA	TRIM/TABLE - 29.7" - SALEM CHERRY - CONCERT CHERRY
2	P34052-02-N47	EA	TRIM/TABLE - 24" - PORTSMOUTH OAK
2	P34052-02-M84	EA	TRIM/TABLE - 24" - WASHED MAPLE
2	P34052-02-M52	EA	TRIM/TABLE - 24" - SALEM CHERRY - CONCERT CHERRY
3	Y00070-22-438	EA	MOLDING/FLUTED - MAPLE - 96" - WASHED MAPLE
3	Y00070-32-438	EA	MOLDING/FLUTED - CHERRY - 96" - CONCERT CHERRY
3	Y00070-42-438	EA	MOLDING/FLUTED - OAK - 96" - PORTSMOUTH OAK
4	Y00071-22-438	EA	MOLDING/FLUTED - W/NOTCH - MAPLE - 96" - WASHED MAPLE
4	Y00071-32-438	EA	MOLDING/FLUTED - W/NOTCH - CHERRY - 96" - CONCERT CHERRY
4	Y00071-42-438	EA	MOLDING/FLUTED - W/NOTCH - OAK - 96" - PORTSMOUTH OAK
5	Y00074-22-438	EA	MOLDING/CROWN - VINYL WRAPPED - MAPLE - 96" - WASHED MAPLE
5	Y00074-62-438	EA	MOLDING/CROWN - VINYL WRAPPED - CONCERT CHERRY - 96" - CONCERT CHERRY
5	Y00074-72-438	EA	MOLDING/CROWN - VINYL WRAPPED - PORTSMOUTH OAK - 96" - PORTSMOUTH OAK
6	Y00086-22-438	EA	MOLDING - VINYL WRAP - 96" - WASHED MAPLE
6	Y00086-62-438	EA	MOLDING - VINYL WRAP - 96" - CONCERT CHERRY
6	Y00086-72-438	EA	MOLDING - VINYL WRAP - 96" - PORTSMOUTH OAK
7	009767-12-000	FT	WELTING - ANTIQUE WHITE
8	009778-25-000	FT	U-CHANNEL - 1" - BEIGE ILLUSION
8	009778-27-000	FT	U-CHANNEL - 1" - WASHED MAPLE
8	009778-30-000	FT	U-CHANNEL - 1" - VILLAGE OAK
8	009778-32-000	FT	U-CHANNEL - 1" - PORTSMOUTH OAK
8	009778-34-000	FT	U-CHANNEL - 1" - CONCERT CHERRY
9	009809-23-000	EA	MOLDING - CORNER - OUTSIDE - 1" X 84" - MODERN IVORY
9	009809-30-000	EA	MOLDING - CORNER - OUTSIDE - 1" X 84" - BEIGE ILLUSION
9	009809-32-000	EA	MOLDING - CORNER - OUTSIDE - 1" X 84" - PORTSMOUTH OAK
9	009809-33-000	EA	MOLDING - CORNER - OUTSIDE - 1" X 84" - CONCERT CHERRY
10	009812-24-000	EA	MOLDING - CORNER - 1/2" W/1/4"CHAN X 84" - IVORY PLASTIC
10	009812-31-000	EA	MOLDING - CORNER - 1/2" W/1/4"CHAN X 84" - BEIGE ILLUSION
10	009812-33-000	EA	MOLDING - CORNER - 1/2" W/1/4"CHAN X 84" - WASHED MAPLE
10	009812-34-000	EA	MOLDING - CORNER - 1/2" W/1/4"CHAN X 84" - VW LIGHT GRAY
10	009812-35-000	EA	MOLDING - CORNER - 1/2" W/1/4"CHAN X 84" - PORTSMOUTH OAK
10	009812-36-000	EA	MOLDING - CORNER - 1/2" W/1/4"CHAN X 84" - CONCERT CHERRY
11	009815-10-000	FT	MOLDING-T - W/EDGE LIP - 3/4" FACE - BEIGE ILLUSION
12	022992-11-000	FT	MOLDING - REVERSE COVE - T-SHAPED - IVORY
12	022992-14-000	FT	MOLDING - REVERSE COVE - T-SHAPED - BRIGHT WHITE
12	022992-15-000	FT	MOLDING - REVERSE COVE - T-SHAPED - VW GRAY
13	042357-25-000	EA	MOLDING - CORNER - RADIUS/PLASTIC - WASHED MAPLE

**INTERIOR FINISH GROUP (CONTINUED)**  
**MOLDINGS & TRIMS (CONTINUED)**

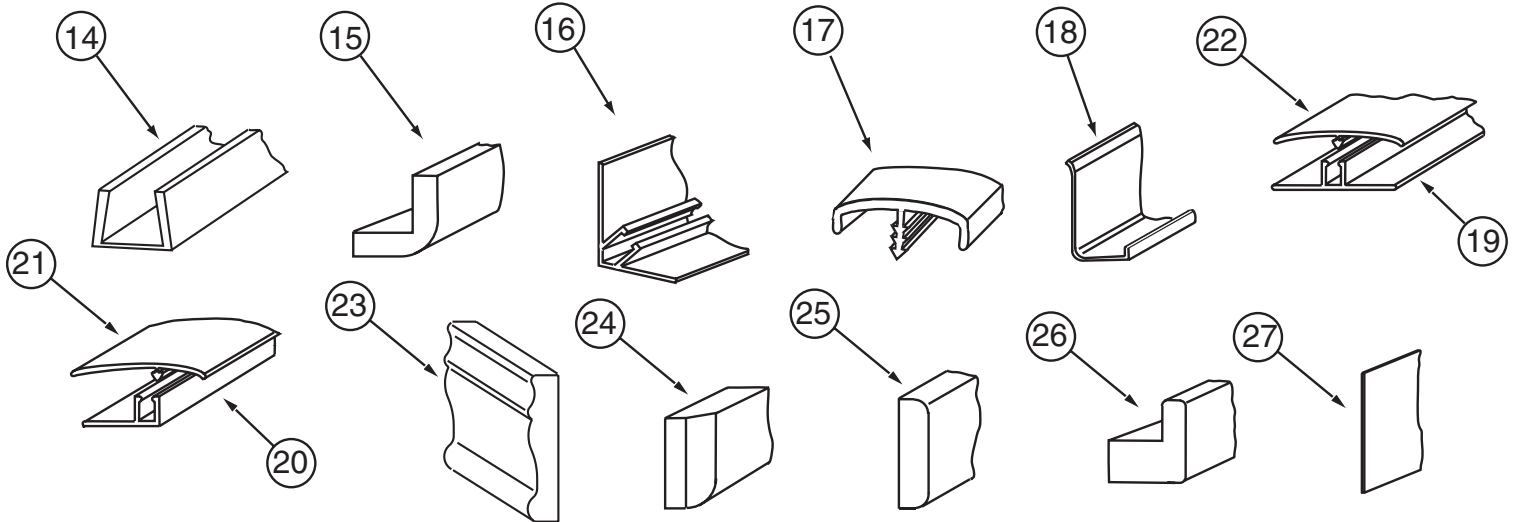

KEY	PART NUMBER	U/M	DESCRIPTION
14	070504-18-000	FT	U-CHANNEL - PLASTIC - .13" X 96" - IVORY
14	070504-35-000	FT	U-CHANNEL - PLASTIC - .13" X 72" - IVORY
14	070504-42-000	FT	U-CHANNEL - PLASTIC - .13" X 84" - BEIGE ILLUSION
14	070504-43-000	FT	U-CHANNEL - PLASTIC - .9" X 96" - BEIGE ILLUSION
14	070504-50-000	FT	U-CHANNEL - PLASTIC - .13" X 96" - WASHED MAPLE
14	070504-54-000	FT	U-CHANNEL - PLASTIC - .9" X 96" - VILLAGE OAK
14	070504-57-000	FT	U-CHANNEL - PLASTIC - .13" X 84" - PORTSMOUTH OAK
14	070504-58-000	FT	U-CHANNEL - PLASTIC - .9" X 84" - PORTSMOUTH OAK
14	070504-60-000	FT	U-CHANNEL - PLASTIC - .13" X 84" - CONCERT CHERRY
14	070504-61-000	FT	U-CHANNEL - PLASTIC - .9" X 84" - CONCERT CHERRY
15	080176-08-000	EA	CAP - CORNER - RADIUS MOLDING - PLASTIC - WASHED MAPLE
16	081521-02-007	EA	MOUNT - METAL MOLDING - F/RADIUS CORNER MOLDING - 151.5"
17	083620-09-000	FT	MOLDING-T - W/EDGE LIP - 7/8" FACE - MODERN IVORY
17	083620-15-000	FT	MOLDING-T - W/EDGE LIP - 7/8" FACE - BEIGE ILLUSION
17	083620-19-000	FT	MOLDING-T - W/EDGE LIP - 7/8" FACE - WASHED MAPLE
17	083620-20-000	FT	MOLDING-T - W/EDGE LIP - 7/8" FACE - PORTSMOUTH OAK
17	083620-21-000	FT	MOLDING-T - W/EDGE LIP - 7/8" FACE - CONCERT CHERRY
18	085746-04-000	FT	TRIM-J - CARPET 1.2" X .5" ANGLE - 10' LONG - OFF WHITE
19	086229-01-000	EA	RETAINER - BATTEN - .75" X 92.1" - ANY COLOR
20	086229-11-000	EA	RETAINER - OFFSET - 97"
21	086229-12-000	EA	BATTEN - 1.5" OFFSET X 96.8" - MODERN IVORY
21	086229-21-000	EA	BATTEN - 1.5" X 83.9" OFFSET - WHITE
22	086229-20-000	EA	BATTEN - 1" X 96" - BEIGE
23	100182-10-J70	EA	TRIM - CHAIR RAIL - 2.5" X 8' EACH - WOOD - WASHED MAPLE
23	100182-10-N47	EA	TRIM/RAIL - PORTSMOUTH OAK
23	100182-10-P85	EA	TRIM - CHAIR RAIL - 2.5" X 8' EACH - WOOD - CONCERT CHERRY
24	100659-30-N75	EA	MOLDING - TRIM - PORTSMOUTH OAK
24	100659-30-N74	EA	MOLDING - TRIM - CHERRY - CONCERT CHERRY
24	100659-30-M84	EA	MOLDING-TRIM,VINYL FLOOR - WASHED MAPLE
25	100818-01-08A	EA	MOLDING - VINYL WRAPPED - 1.6" X .4" X 84"-WASHED MAPLE
25	100818-01-12A	EA	MOLDING - VINYL WRAPPED - 1.6" X .4" X 84"-PORTSMOUTH OAK
25	100818-01-13A	EA	MOLDING - VINYL WRAPPED - 1.6" X .4" X 84" - CHERRY - CONCERT CHERRY
26	100819-01-08A	EA	MOLDING - VINYL WRAPPED-L-SHAPED-1.5"X1.5"X84"- WASHED MAPLE
26	100819-01-12A	EA	MOLDING - VINYL WRAPPED-L-SHAPED - 1.5" X 1.5" X 84" - OAK - PORTSMOUTH OAK
26	100819-01-13A	EA	MOLDING - VINYL WRAPPED-L-SHAPED-1.5"X1.5"X84" - CONCERT CHERRY
27	101957-01-06A	EA	EXTRUDED - PLASTIC - WASHED MAPLE



**INTERIOR FINISH GROUP (CONTINUED)**  
**MOLDINGS & TRIMS (CONTINUED)**

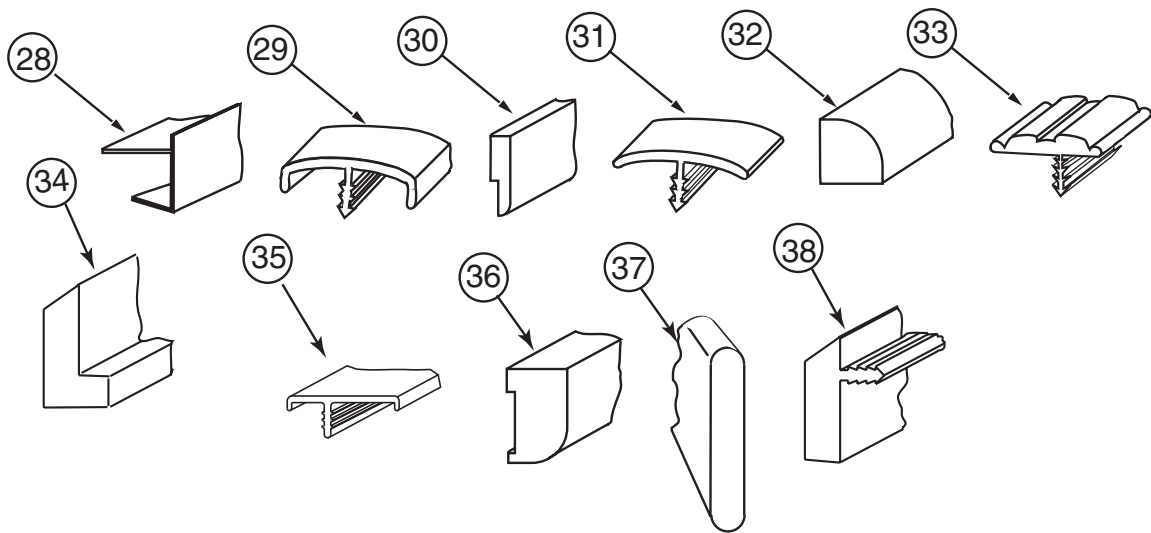

KEY	PART NUMBER	U/M	DESCRIPTION
28	103186-01-07A	FT	MOLDING/PLASTIC - 3/8" U-CHANNEL-3/4"FACE - BEIGE ILLUS 8'
28	103186-01-08A	FT	MOLDING/PLASTIC - 3/8" U-CHANNEL-3/4"FACE-WASHED MAPLE 8' - WASHED MAPLE
28	103186-01-09A	FT	MOLDING/PLASTIC - 3/8" U-CHAN'L-3/4"FACE-PORTSMOUTH OAK 8' - PORTSMOUTH OAK
28	103186-01-10A	FT	MOLDING/PLASTIC-3/8" U-CHAN'L-3/4"FACE-CONCERT CHERRY 8' - CONCERT CHERRY
28	103186-02-07A	FT	MOLDING/PLASTIC-1" U-CHAN'L-1 3/8"FACE-BEIGE ILLUSION - 8'
28	103186-02-08A	FT	MOLDING/PLASTIC - 1" U-CHANNEL-1 3/8"FACE-WASHED MAPLE 8' - WASHED MAPLE
28	103186-02-09A	FT	MOLDING/PLASTIC - 1" U-CHAN'L-1 3/8"FACE-PORTSMOUTH OAK 8' - PORTSMOUTH OAK
28	103186-02-10A	FT	MOLDING/PLASTIC - 1" U-CHAN'L-1 3/8"FACE-CONCERT CHERRY 8' - CONCERT CHERRY
29	104676-02-06A	FT	MOLDING-T - W/EDGE LIP - 11/16" FACE - WASHED MAPLE
29	104676-02-08A	FT	MOLDING-T - W/EDGE LIP - 11/16" FACE - PORTSMOUTH OAK
29	104676-02-09A	FT	MOLDING-T - W/EDGE LIP - 11/16" FACE - CONCERT CHERRY
30	105004-01-08A	EA	MOLDING - VINYL WRAPPED - 1" X 96" - WASHED MAPLE
30	105004-01-12A	EA	MOLDING - VINYL WRAPPED 1" X 96" - PORTSMOUTH OAK
30	105004-01-13A	EA	MOLDING - VINYL WRAPPED 1" X 96" - CONCERT CHERRY
31	105709-02-000	FT	MOLDING-T - W/EDGE LIP - 3/4" FACE - BEIGE ILLUSION
32	109410-01-P25	EA	MOLDING - TRIM - 8' - BLACK CHERRY/CHERRY IV - CONCERT CHERRY
32	109410-01-N75	EA	MOLDING - TRIM - 8' - PORTSMOUTH OAK
32	109410-01-J70	EA	MOLDING - TRIM - 8' - WHITE MAPLE/WASHED MAPLE
33	109736-02-01A	FT	MOLDING-T/OFFSET - W/EDGE LIP - 1" FACE - NAT OAK/BRASS
34	111235-01-H56	EA	MOLDING - COUNTERTOP - 1.4" X 8' - WHITE MAPLE - UNSTAINED - WASHED MAPLE
34	111235-01-N42	EA	MOLDING - COUNTERTOP - 1.4" X 8' - OAK - UNSTAINED - PORTSMOUTH OAK
34	111235-01-P79	EA	MOLDING - COUNTERTOP - 1.4" X 8' - CONCERT CHERRY
35	119520-01-01A	FT	MOLDING-T/OFFSET - W/EDGE LIP - 1"FACE - OFF WHITE
35	119520-01-02A	FT	MOLDING-T/OFFSET - W/EDGE LIP - 1"FACE - CONCERT CHERRY
35	119520-01-03A	FT	MOLDING-T/OFFSET - W/EDGE LIP - 1"FACE - WASHED MAPLE
35	119520-01-04A	FT	MOLDING-T/OFFSET - W/EDGE LIP - 1"FACE - PORTSMOUTH OAK
35	119520-02-01A	FT	MOLDING-T/OFFSET - W/EDGE LIP - 1"FACE
36	126204-D2-134	EA	MOLDING - VINYL WRAPPED - .7" X 1.6" X 84" - WASHED MAPLE
36	126204-F2-134	EA	MOLDING - VINYL WRAPPED - .7" X 2.5" X 84" - WASHED MAPLE
36	137887-D2-134	EA	MOLDING - VINYL WRAPPED - .7" X 1.6" X 96" - CHERRY - CONCERT CHERRY
36	137887-F2-134	EA	MOLDING - VINYL WRAPPED - .7" X 2.5" X 84" - CHERRY - CONCERT CHERRY
36	137887-F2-743	EA	MOLDING - VINYL WRAPPED - .7" X 2.5" X 108" - CHERRY - CONCERT CHERRY
36	137895-D2-134	EA	MOLDING - VINYL WRAPPED - .7" X 1.6" X 84" - PORTSMOUTH OAK
36	137895-F2-134	EA	MOLDING - VINYL WRAPPED - .7" X 2.5" X 84" - PORTSMOUTH OAK
36	137895-F2-743	EA	MOLDING - VINYL WRAPPED - .7" X 2.5" X 108" - PORTSMOUTH OAK
37	127842-01-01A	FT	SEAL - SIGHT SHIELD - 2" BLACK
38	130247-01-05A	FT	MOLDING-T/OFF SET - 1.3" FACE - CONCERT CHERRY
38	130247-01-04A	FT	MOLDING-T/OFF SET - 1.3" FACE - PORTSMOUTH OAK
38	130247-01-02A	FT	MOLDING-T/OFF SET - 1.3" FACE - WASHED MAPLE

**INTERIOR FINISH GROUP (CONTINUED)**  
**MOLDINGS & TRIMS (CONTINUED)**

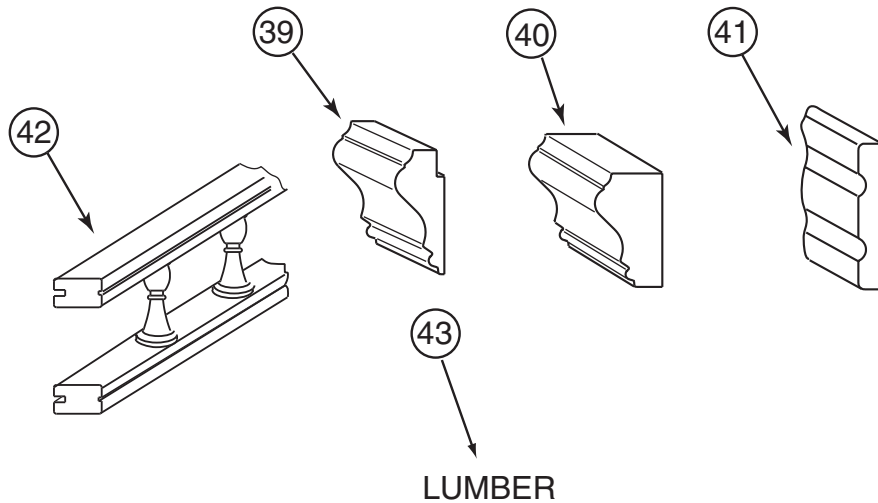

KEY	PART NUMBER	U/M	DESCRIPTION
39	131923-02-04A	FT	MOLDING - PICTURE - OAK - PORTSMOUTH OAK
40	131923-03-03A	FT	MOLDING - CROWN - DIVIDER - WHITE MAPLE - WASHED MAPLE
40	131923-03-02A	FT	MOLDING - CROWN - DIVIDER - CHERRY - CONCERT CHERRY
41	134156-01-03A	EA	MOLDING - VINYL WRAP - .7" X 3.8" X 33.8" - WASHED MAPLE
41	134156-01-08A	EA	MOLDING - VINYL WRAP - .7" X 3.8" X 33.8" - PORTSMOUTH OAK
41	134156-03-03A	EA	MOLDING - VINYL WRAP - .7" X 3.4" X 28.3" - WASHED MAPLE
41	134156-03-07A	EA	MOLDING - VINYL WRAP - .7" X 3.4" X 28.3" - CONCERT CHERRY
41	134156-03-08A	EA	MOLDING - VINYL WRAP - .7" X 3.4" X 28.3" - PORTSMOUTH OAK
41	134156-05-07A	EA	MOLDING - VINYL WRAP - .7" X 3.8" X 34.4" - CONCERT CHERRY
42	137108-01-02A	EA	RAIL - DECORATIVE - SALEM CHERRY - CONCERT CHERRY
42	137108-01-03A	EA	RAIL - DECORATIVE - WASHED MAPLE
42	137108-01-07A	EA	RAIL - DECORATIVE - PORTSMOUTH OAK
43	126205-D2-438	EA	LUMBER - VINYL WRAPPED - .7" X 1.5" X 96" - WASHED MAPLE
43	126205-E2-438	EA	LUMBER - VINYL WRAPPED - .7" X 2" X 96" - WASHED MAPLE
43	126205-F2-438	EA	LUMBER - VINYL WRAPPED - .7" X 2.5" X 96" - WASHED MAPLE
43	126205-G2-438	EA	LUMBER - STAINED - .7" X 3" X 96" - WASHED MAPLE
43	126205-J2-438	EA	LUMBER - VINYL WRAPPED - .7" X 5.5" X 96" - WASHED MAPLE
43	126205-R2-438	EA	LUMBER - LUMBER - VINYL WRAPPED - .7" X 3" X 96" - WASHED MAPLE
43	137885-A2-438	EA	LUMBER - VINYL WRAPPED - .7" X .75" X 96" - CHERRY - CONCERT CHERRY
43	137885-D2-438	EA	LUMBER - VINYL WRAPPED - .7" X 1.5" X 96" - CHERRY - CONCERT CHERRY
43	137885-E2-438	EA	LUMBER - VINYL WRAPPED - .7" X 2" X 96" - CHERRY - CONCERT CHERRY
43	137885-F2-438	EA	LUMBER - VINYL WRAPPED - .7" X 2.5" X 96" - CHERRY - CONCERT CHERRY
43	137885-G2-438	EA	LUMBER - VINYL WRAPPED - .7" X 3" X 96" - CHERRY - CONCERT CHERRY
43	137885-J2-743	EA	LUMBER-018X140X2743 MM VYL - CONCERT CHERRY
43	137885-J2-438	EA	LUMBER - VINYL WRAPPED - .7" X 5.5" X 96" - CHERRY - CONCERT CHERRY
43	137885-R2-438	EA	LUMBER - VINYL WRAPPED - .7" X 3" X 96" - CHERRY - CONCERT CHERRY
43	137894-A2-438	EA	LUMBER - VINYL WRAPPED - .7" X .75 X 96" - PORTSMOUTH OAK
43	137894-D2-438	EA	LUMBER - VINYL WRAPPED - .7" X 1.5" X 96" - PORTSMOUTH OAK
43	137894-E2-438	EA	LUMBER - VINYL WRAPPED - .7" X 2" X 96" - PORTSMOUTH OAK
43	137894-F2-438	EA	LUMBER - VINYL WRAPPED - .7" X 2.5" X 96" - PORTSMOUTH OAK
43	137894-G2-438	EA	LUMBER - VINYL WRAPPED - .7" X 3" X 96" - PORTSMOUTH OAK
43	137894-H2-438	EA	LUMBER - VINYL WRAPPED - .7" X 3.5" X 96" - PORTSMOUTH OAK
43	137894-J2-438	EA	LUMBER - VINYL WRAPPED - .7" X 5.5" X 96" - PORTSMOUTH OAK
43	137894-J2-743	EA	LUMBER - VINYL WRAPPED - .7" X 5.5" X 108" -PORTSMOUTH OAK
43	137894-R2-438	EA	LUMBER - VINYL WRAPPED - .7" X 3" X 96" - PORTSMOUTH OAK
	141260-01-02A	FT	U-CHANNEL - 1" - GRADY BROWN
	141260-01-01A	FT	U-CHANNEL - 1" - VILLAGE OAK

**INTERIOR FINISH GROUP (CONTINUED)**  
**PANELING & LAMINATES**

<b>KEY</b>	<b>PART NUMBER</b>	<b>U/M</b>	<b>DESCRIPTION</b>
	000885-A3-000	SF	PARTICLE BOARD - 3/4" X 4' X 8' - SALEM CHERRY - 2 SIDED - CONCERT CHERRY
	000885-A5-000	SF	PARTICLE BOARD - 3/8" X 4' X 8'- WHT PEB EMBOSSED-1 SIDED
	000885-88-000	SF	PART BD-3/8X48X96 WASHED MAP - WASHED MAPLE
	000885-89-000	SF	PARTICLE BOARD - 3/8" X 4' X 8' - WASHED MAPLE - 2-SIDED
	000885-91-000	SF	PARTICLE BOARD - 3/4" X 4' X 8' - WASHED MAPLE - 2-SIDED
	000885-92-000	SF	PARTICLE BOARD-3/8" X 4' X 8'-PORTSMOUTH OAK-VINYL 1 SIDED
	000885-93-000	SF	PARTICLE BOARD - 3/8" X 4' X 8' - PORTSMOUTH OAK - 2-SIDED
	000885-95-000	SF	PARTICLE BOARD - 3/4" X 4' X 8' - PORTSMOUTH OAK - 2-SIDED
	000885-96-000	SF	PART BD-PAPER,CONCERT CHERRY
	000885-98-000	SF	PARTICLE BOARD - 3/8" X 4' X 8' - SALEM CHERRY - 2 SIDED- CONCERT CHERRY
	057882-04-000	SF	TAMBOUR - 48" X 96" SHEET - UNFINISHED (PA0, PA3, PA6)
	057882-05-000	SF	TAMBOUR - 48" X 96" SHEET - UNFINISHED (PA2, PA5, PA8)
	057882-06-000	SF	TAMBOUR/ROLL UP - 4' X 8' (PA1, PA4, PA7)
	074497-39-000	SF	PANELING - WASHED MAPLE - 4' X 8'
	074497-42-000	SF	PANELING - PORTSMOUTH OAK - 4' X 8'
	074497-43-000	SF	PANELING - SALEM CHERRY - 4' X 8' - CONCERT CHERRY
	074498-82-000	SF	LAMINATE - PLASTIC - WASHED MAPLE - 4' X 8'
	074498-95-000	SF	LAMINATE - PLASTIC - PORTSMOUTH OAK - 4' X 8'
	074498-96-000	SF	LAMINATE - PLASTIC - CHERRY - 4' X 8' - CONCERT CHERRY
	076773-14-000	SF	PANELING - 2 SIDED/WASHED MAPLE - 1/8" X 4' X 8'
	076773-15-000	SF	PANELING - 2 SIDED/PORTSMOUTH OAK - 1/8" X 4' X 8'
	076773-16-000	SF	PANELING - 2 SIDED/SALEM CHERRY - 1/8" X 4' X 8' - CONCERT CHERRY
	079666-03-000	SF	PANELING - CLOSET - CEDAR - 4' X 7'
	085284-F5-000	FT	BATT TAPE - ADHESIVE BACKED - WASHED MAPLE
	085284-G8-000	FT	BATT TAPE - ADHESIVE BACKED - PORTSMOUTH OAK
	085284-G9-000	FT	BATT TAPE - ADHESIVE BACKED - DECORATIVE - ALABASTER (PA6, PA7, PA8)
	085284-H1-000	FT	BATT TAPE - ADHESIVE BACKED - DECORATIVE - GRAY (PA3, PA4, PA5)
	085284-H2-000	FT	BATT TAPE - ADHESIVE BACKED - SALEM CHERRY- CONCERT CHERRY
	085284-H4-000	FT	BATT TAPE - ADHESIVE BACKED - DECORATIVE - STARLIGHT (PA0, PA1, PA2)
	088263-H1-000	EA	BATT STRIP - DECORATIVE - STARLIGHT - 8' LONG (PA0, PA1, PA2)
	088263-H0-000	EA	BATT STRIP - DECORATIVE - VILLA/GRAY - 8' LONG (PA3, PA4, PA5)
	088262-G9-000	EA	BATT STRIP - DECORATIVE - CORK/ALABASTER - 8'
	069733-86-000	EA	BATT STRIP - WOODGRAINED/WASHED MAPLE - 8'
	069733-87-000	EA	BATT STRIP - WOODGRAINED/PORTSMOUTH OAK - 8'
	069733-88-000	EA	BATT STRIP - WOODGRAINED/SALEM CHERRY - 8' - CONCERT CHERRY
	088272-H9-000	SF	PANELING - PEBBLE EMBOSSED - WHITE - 4' X 7'
	088272-J9-000	SF	PANELING - ALABASTER - 4' X 7' (PA6, PA7, PA8)
	088272-K1-000	SF	PANELING - GRAY - 4' X 7' (PA3, PA4, PA5)
	088272-K3-000	SF	PANELING - STARLIGHT - 4' X 7' (PA0, PA1, PA2)

**INTERIOR FINISH GROUP (CONTINUED)**  
**ACCESSORIES**

<b>KEY</b>	<b>PART NUMBER</b>	<b>U/M</b>	<b>DESCRIPTION</b>
	072852-01-000	EA	DETECTOR - SMOKE - W/9 VOLT BATTERY - US
	094499-03-000	EA	EXTINGUISHER/FIRE - DRY - 10BC - W/GAUGE/BRACKET
	072852-02-000	EA	DETECTOR - SMOKE - W/9 VOLT BATTERY - CANADIAN
*	094499-02-000	EA	EXTINGUISHER/FIRE - DRY - 10BC - W/GAUGE - CANADIAN
	096764-02-000	FT	SLIPNOT - ANTISLIP - 1'WIDE (180' ROLLS) - WHITE
	091261-01-000	FT	SLIPNOT - ANTISLIP - 1' WIDE X 12' - BLACK
	133831-01-01A	EA	HOLDER - CUP W/THREE CENTERLINE RUBBER FINGERS
	094499-04-000	EA	STRAP - FIRE EXTINGUISHER MOUNTING - METAL
	P02786-04-N95	EA	HAND-RAIL ONLY - W/O BRACKETS - PORTSMOUTH OAK
	P02786-04-K29	EA	HAND-RAIL ONLY - W/O BRACKETS - WASHED MAPLE
	P02786-04-K37	EA	HAND-RAIL ONLY - W/O BRACKETS - CONCERT CHERRY
	099682-01-01A	EA	BRACKET - MOUNTING/HAND RAIL - ROUND BASE
	093606-30-000	EA	MIRROR - BEVELED EDGE - 14.5" X 25.9"
	113195-17-01A	EA	MIRROR - BEVELED SAFETY GLASS - CLEAR - 16.6" X 26.2"
	113195-42-01A	EA	MIRROR - BEVELED SAFETY GLASS - 11.6" X 36.8"
	113195-43-02A	EA	MIRROR - BEVELED SAFETY GLASS - 7.4" X 12.6"
	113195-44-02A	EA	MIRROR - BEVELED SAFETY GLASS - 9.6" X 27.9"
	113195-45-02A	EA	MIRROR - BEVELED SAFETY GLASS - 17.3" X 27.9"
	131494-03-01A	EA	MIRROR - BEVELED/GLASS - OCTAGON - 1" X 20" X 36"
	133485-01-01A	EA	GLASS MIRROR - 1" BEVEL W/VERTICAL GROOVE - 20" X 20.9"
	133485-02-01A	EA	GLASS MIRROR - BEVELED W/2 VERTICAL GROOVES - 44.9"X20.9"
	133485-03-01A	EA	GLASS MIRROR - 1" BEVEL/W/2 VERTICAL GROOVES - 30" X 20.9"
	140374-57-000	EA	MIRROR - SAFETY GLASS - 34.7" X 57.9"
	125136-02-000	EA	DETECTOR/CO - GAS MODEL - 9 VOLT
	131493-02-12A	EA	PICTURE - DECORATIVE - 13" X 15" - AFRICAN LILY

**\*COMPONENT PARTS LISTED LATER IN THIS GROUP**

**INTERIOR FINISH GROUP (CONTINUED)**  
**COMPONENT PARTS FOR ACCESSORIES**

094499-02-000

<b>KEY</b>	<b>PART NUMBER</b>	<b>U/M</b>	<b>DESCRIPTION</b>	<b>VENDOR NO</b>
	094499-01-700	EA	BRACKET MTG. W/PLAS. STRAP	294039

**INTERIOR FINISH GROUP (CONTINUED)**  
**FLOOR COVERINGS**

<b>KEY</b>	<b>PART NUMBER</b>	<b>U/M</b>	<b>DESCRIPTION</b>
	093486-02-000	SY	CARPET - COMPARTMENT - 72" WIDE - LIGHT GRAY
	123994-01-08A	EA	TILE/CERAMIC FLOOR - 13" X 13" - DINGO (PA0, PA1, PA2, PA3, PA4, PA5)
	123994-01-07A	EA	TILE/CERAMIC FLOOR - 13" X 13" - DUNDEE (PA6, PA7, PA8)
	124742-01-02A	EA	MOLDING - TRIM - TILE - SOFT WHITE
	139056-14-000	SY	CARPET - BLUSH BEIGE - 4 SQUARE YARD INCREMENTS (PA0, PA1, PA2)
	139056-16-000	SY	CARPET - SWISS MOCHA - 4 SQUARE YARD INCREMENTS (PA3, PA4, PA5)
	139056-13-000	SY	CARPET - CASTILLE - 4 SQUARE YARD INCREMENTS (PA6, PA7, PA8)

## INTERIOR FINISH GROUP (CONTINUED) HARDWARE

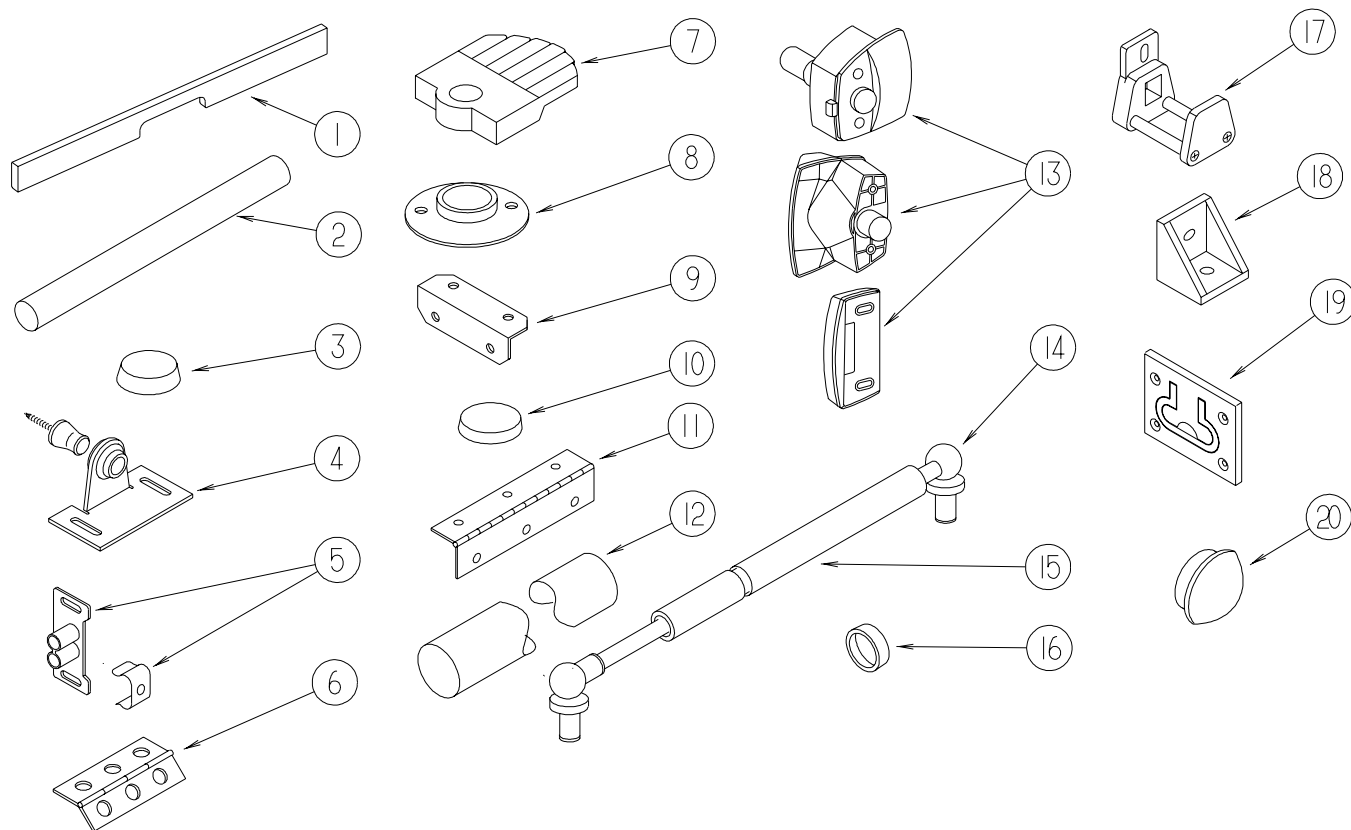

KEY	PART NUMBER	U/M	DESCRIPTION
1	P26866-12-N62	EA	HANDLE - DOOR/TAMBOUR - 14.7" - WASHED MAPLE
1	P26866-12-N63	EA	HANDLE - DOOR/TAMBOUR - 11.6" - CONCERT CHERRY
1	P26866-12-P69	EA	HANDLE - DOOR/TAMBOUR - 11.6" - PORTSMOUTH OAK
2	Y00136-21-218	EA	DOWEL - WOOD - 1" X 4"
3	004354-01-000	EA	BUMPER - RUBBER - .5" DIA - BROWN
4	009013-01-000	EA	CATCH - BULLDOG - MALE/FEMALE
5	009021-01-000	EA	CATCH - GRILLE - NYLON
5	009021-02-000	EA	STRIKE - SPRING STEEL - .68"
6	009059-01-000	EA	HINGE - DOOR - 2" X 1.4" - BRASS
6	009059-02-000	EA	HINGE - DOOR - 2" X 2.7" - BRASS
6	009059-03-000	EA	HINGE - BRASS - 1.75"
7	009089-01-000	EA	CLIP - MIRROR
8	009112-01-000	EA	FLANGE - PLASTIC - 1" CLOTHES ROD - OFF WHITE
9	016604-05-000	EA	BRACE - ANGLE - 2 1/2" - OFF WHITE METAL
9	016604-10-000	EA	BRACE - SEAT ANGLE - 2.5" - BLACK
9	016604-11-000	EA	BRACE - SEAT - ANGLE - 2.5" - CHESTNUT
10	023320-01-000	EA	PAD - FELT 3/8" DIAMETER
11	041389-25-000	EA	HINGE - PIANO - 1 1/2" X 55" - UNPAINTED
12	042438-02-000	EA	DOWEL - WOOD - 2" DIAMETER X 2'
12	042438-06-000	EA	DOWEL - WOOD - CLOTHES ROD - 1.5" X 26"
13	058335-03-000	EA	LATCH W/O LOCK - BATHROOM DOOR BLACK
14	057460-02-000	EA	BALL STUD - F/GAS SPRING .39" - 5/16"-18
15	057460-04-000	EA	SPRING/GAS - BALL STUD STYLE - 120 PI - "SPD6209"
16	057671-01-000	EA	COVER - SCREW - #8 - OFF WHITE
16	057671-15-000	EA	COVER - SCREW - #8 - BRIGHT WHITE
16	057671-16-000	EA	COVER - SCREW - #8 - SOFT WHITE
16	057671-17-000	EA	COVER - SCREW - VW LT GRAY - #8
17	064467-01-000	EA	GUIDE - POCKET - SLIDING DOOR - WALL MOUNTED
18	065740-01-000	EA	BRACE - CABINET/CORNER - PLASTIC
19	072871-01-000	EA	PULL - FLUSH - CHROME
20	074045-08-000	EA	PLUG - OAK - 3/8" DOWEL-1/2" HEAD - SALEM CHERRY - CONCERT CHERRY
20	074045-12-000	EA	PLUG - OAK - 3/8" DOWEL-1/2" HEAD - WASHED MAPLE
20	074045-13-000	EA	PLUG - OAK - 3/8" DOWEL-1/2" HEAD - PORTSMOUTH OAK

## INTERIOR FINISH GROUP (CONTINUED) HARDWARE (CONTINUED)

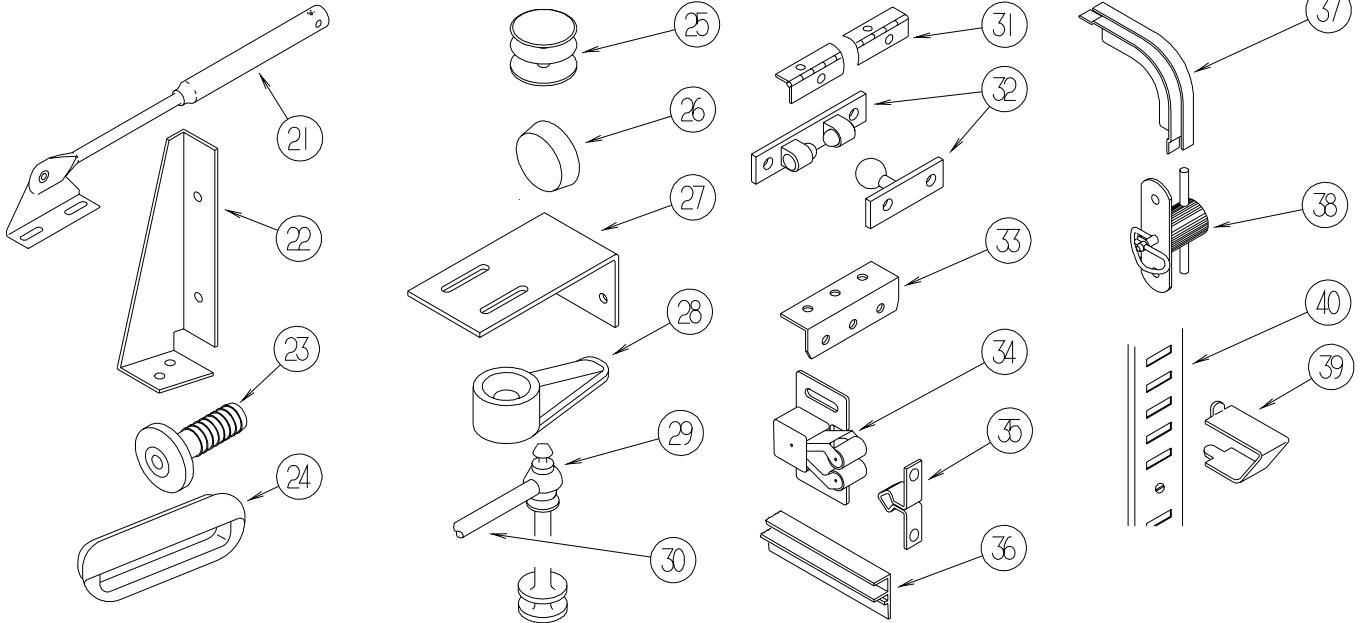

KEY	PART NUMBER	U/M	DESCRIPTION
21	074493-02-000	EA	SUPPORT - PISTON SPRING - CABINET DOOR - 26 LBS
21	074493-03-000	EA	SUPPORT - PISTON SPRING - CABINET DOOR - 12 LBS
21	074493-04-000	EA	SUPPORT - PISTON SPRING - CABINET DOOR - 32 LBS
22	076827-02-000	EA	BRACKET/LEG - 2.9" X 1.8" - TRIANGULAR - LEFT/E-COATED
23	079921-01-000	EA	ROLLER - NYLON - W/STEEL SHAFT - BARBED
24	080736-01-000	EA	PULL - RECESSED - 1.25" X 4" - OAK
25	081114-02-000	EA	CAP - INSERT - ROUND - 1" DIAMETER - WHITE PLASTIC
26	081914-01-000	EA	BUMPER - RUBBER - ROUND - 1/2" DIA. X 1/8" THICK
27	083125-07-000	EA	BRACE - ANGLE/COUCH - 2.5" - OFF WHITE
28	083204-03-000	EA	BUTTON - RETAINING MIRROR 5/16" TIP
29	084070-03-000	EA	POST - END - 2.4" - SHINY BRASS
30	084071-05-000	EA	ROD - BRASS - 15"
30	084071-19-000	EA	ROD - BRASS - 7.1"
30	084071-20-000	EA	ROD - BRASS - 9.8"
30	084071-23-000	EA	ROD - BRASS - 13.1"
30	084071-24-000	EA	ROD - BRASS - 3.8"
30	084071-28-000	EA	ROD - BRASS - 6"
30	084071-30-000	EA	ROD - BRASS - 11.6"
30	084071-31-000	EA	ROD - BRASS - 14.8"
30	084071-33-000	EA	ROD - BRASS - 20.4"
30	084071-34-000	EA	ROD - BRASS - 16.9"
31	084413-01-000	EA	HINGE - 1" X 72" - ALUMINUM - W/HOLES
32	084451-01-000	EA	CATCH & LATCH - 1.7" - BRASS
33	089025-01-000	EA	SUPPORT - SPRING TO BED - ANGLE 1.5" X 11.8"
34	093586-03-000	EA	CATCH - SPRING ROLLER - .377"
34	093586-06-000	EA	CATCH - SPRING ROLLER - .236"
35	093586-04-000	EA	STRIKE - SPRING STEEL - 1.14"
35	093586-05-000	EA	STRIKE - SPRING STEEL - .943"
36	093622-01-000	EA	TRACK - DOOR - TAMBOUR - PLASTIC - 8' LENGTHS
37	093623-01-000	EA	CORNER - TRACK - TAMBOUR DOOR
	097872-04-000	EA	DOWEL - WOOD - 1" DIAMETER X 1.38" LONG - UNFINISHED
38	098196-01-000	EA	LATCH - 1/4 TURN - T-BAR
39	098979-01-000	EA	CLIP - ADJUSTABLE SHELF
40	098980-01-000	EA	PILASTER - ADJUSTABLE SHELF - 18"
40	098980-02-000	EA	PILASTER - ADJUSTABLE SHELF - 12"
40	098980-03-000	EA	PILASTER - ADJUSTABLE SHELF - 9"
40	098980-04-000	EA	PILASTER - ADJUSTABLE SHELF - 48"
40	098980-05-000	EA	PILASTER - ADJUSTABLE SHELF - 15"
40	098980-06-000	EA	PILASTER - ADJUSTABLE SHELF - 24"



**INTERIOR FINISH GROUP (CONTINUED)**  
**HARDWARE (CONTINUED)**

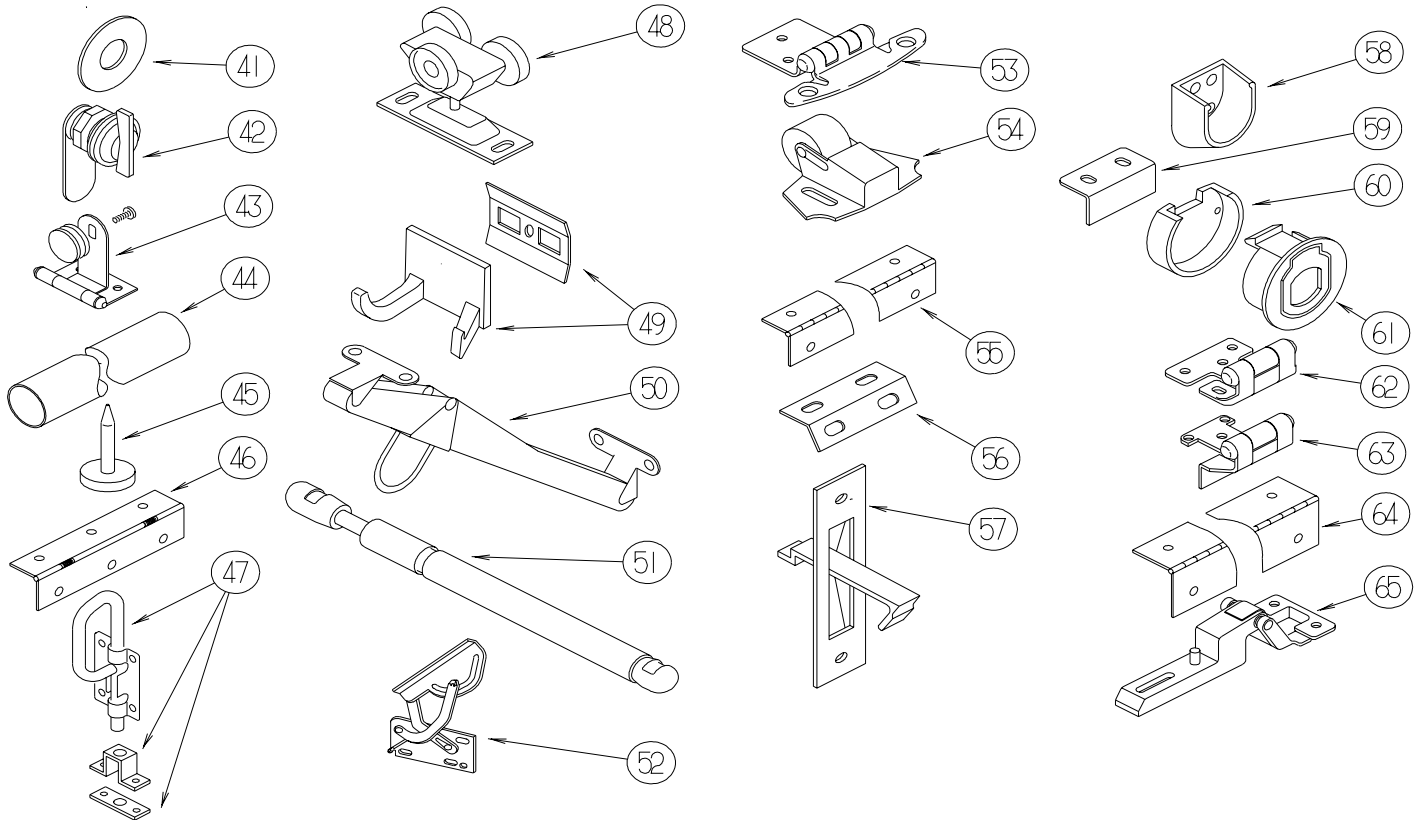

KEY	PART NUMBER	U/M	DESCRIPTION
41	100707-01-000	EA	SPACER - GLASS DOOR - .8" DIA - .3" HOLE - PLASTIC
42	100710-01-01A	EA	LOCK - GLASS DOOR/TWIST TYPE - BRASS
43	100711-01-01A	EA	HINGE - GLASS DOOR
44	102075-06-02A	EA	ROD - SHOWER CURTAIN - 1" OD X 33.5" - SOFT WHITE
44	102075-09-02A	EA	ROD - SHOWER CURTAIN - 3/4"OD X 29.5" - SOFT WHITE
44	102075-16-02A	EA	ROD - SHOWER CURTAIN - 3/4"OD X 34.2" - SOFT WHITE
44	102075-18-02A	EA	ROD - SHOWER CURTAIN - 1" OD X 38.9" - SOFT WHITE
44	102075-20-03A	EA	ROD - SHOWER CURTAIN - 48.8" - MILL
44	102075-21-03A	EA	ROD - SHOWER CURTAIN - 46.1"
45	102194-01-000	EA	GUIDE - PLASTIC - 1" (HEAD/PIN)
46	102920-01-01A	EA	HINGE - SPRING LOADED - BRASS
47	103256-01-000	EA	LATCH COMPLETE (SLIDE)
48	103874-01-000	EA	HANGER - SLIDING DOOR
49	104174-01-000	EA	HOOK - ROBE - DOUBLE
50	104181-01-01A	EA	SUPPORT - LEAF 5.3" EXTENDS TO 7.5" - SAFETY RING - METAL
51	107796-06-000	EA	SPRING/GAS - 12" COMPRESSED/20" EXTENDED - 120 LB.
51	107796-08-000	EA	SPRING/GAS - 11" COMPRESSED/17" EXTENDED - 60 LB
51	107796-15-000	EA	SPRING/GAS - 24" COMPRESSED/40" EXTENDED - 15 LB.
51	107796-16-000	EA	SPRING/GAS - 6.4" COMPRESSED/9.6" EXTENDED - 65 LB.
52	108126-01-000	EA	TRAY HINGE SET (QTY. 2 PER SET)
53	108138-01-000	EA	HINGE - CABINET DOOR - BURNISHED BRASS - Q SERIES (ULTIMATE FREEDOM) ONLY
53	108138-03-000	EA	HINGE - BRIGHT BRASS
54	109403-01-000	EA	CATCH - SINGLE ROLLER - SCREEN DOOR
55	110496-01-01A	EA	HINGE - BRASS
56	111866-01-02A	EA	BRACE - SEAT - ANGLE - OFF WHITE
57	113130-01-01A	EA	PULL - DOOR POCKET
58	113236-01-01A	EA	BRACKET - CLOTHES - ROD
59	113375-02-01A	EA	STRIKE - DOOR - CHROME
60	113375-05-01A	EA	LATCH - SLAM - BACK - .8" THICK
61	113375-06-01A	EA	LATCH - SLAM - FACE - .7" THICK
62	113676-01-01A	EA	HINGE - OVERLAY - VARIABLE - BURNISHED BRASS
63	113677-01-01A	EA	HINGE - SELF CLOSING
64	114278-02-000	EA	HINGE - CONTINUOUS - 3" WIDE
65	114443-01-01A	EA	HINGE - CABINET DOOR

**INTERIOR FINISH GROUP (CONTINUED)**  
**HARDWARE (CONTINUED)**

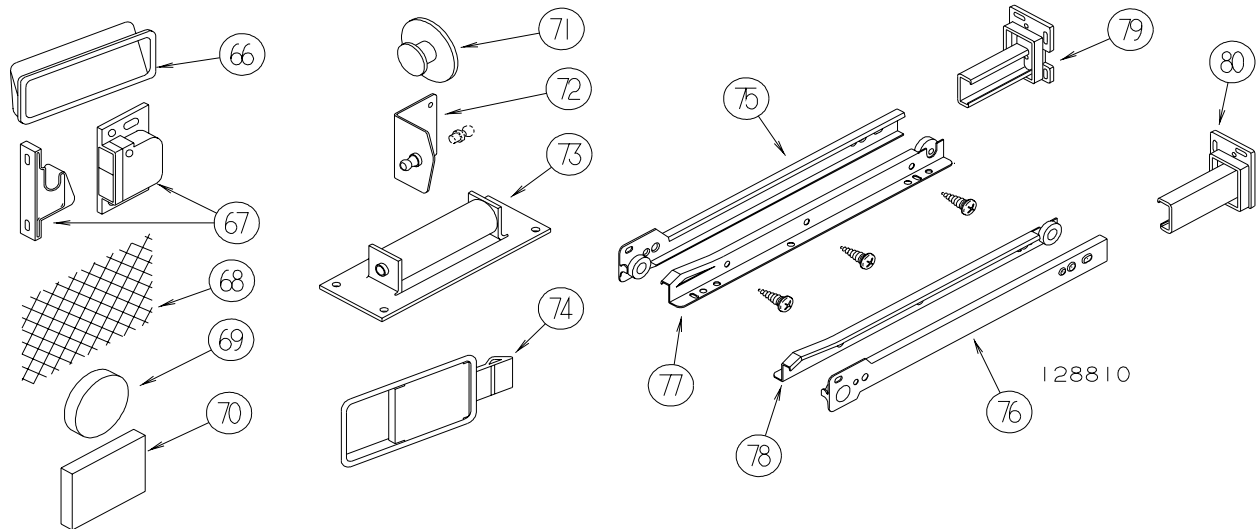

KEY	PART NUMBER	U/M	DESCRIPTION
66	115994-01-01A	EA	HANDLE - POCKET
67	117095-01-01A	EA	LATCH - DOOR - GRABBER W/KEEPER - PLASTIC - BLK-5 LB PULL
67	117095-02-01A	EA	LATCH - DOOR - GRABBER W/KEEPER - PLASTIC - BLK-10 LB PULL
68	118200-01-01A	SF	MESH - PLASTIC 1/2" - 48" X LENGTH = SF - BLACK
69	122717-01-01A	EA	PAD - NON SKID - 4" DIAMETER ROUND
70	122717-06-01A	FT	PAD - NON-SKID - PSA - 5"W
71	125221-01-01A	EA	PULL - MIRROR - W/ROUND HANDLE
72	126263-06-02B	EA	BRACKET - GAS SPRING W/INSIDE BALL STUD - E-COATED
	126263-08-02B	EA	BRACKET - GAS SPRING W/CENTERED BALL STUD - E-COATED
73	126584-02-000	EA	ROLLER - FLAT
74	127349-01-01A	EA	LATCH - PADDLE
75	128810-01-01A	EA	SLIDE - DRAWER - 12" - LEFT CABINET
75	128810-05-01A	EA	SLIDE - DRAWER - 14" - LEFT CABINET
75	128810-09-01A	EA	SLIDE - DRAWER - 16" - LEFT CABINET
75	128810-13-01A	EA	SLIDE - DRAWER - 18" - LEFT CABINET
75	128810-17-01A	EA	SLIDE - DRAWER - 20" - LEFT CABINET
75	128810-21-01A	EA	SLIDE - DRAWER - 22" - LEFT CABINET
75	128810-25-01A	EA	SLIDE - DRAWER - 24" - LEFT CABINET
75	128810-29-01A	EA	SLIDE - DRAWER - 9" - LEFT CABINET
76	128810-02-01A	EA	SLIDE - DRAWER - 12" - RIGHT CABINET
76	128810-06-01A	EA	SLIDE - DRAWER - 14" - RIGHT CABINET
76	128810-10-01A	EA	SLIDE - DRAWER - 16" - RIGHT CABINET
76	128810-14-01A	EA	SLIDE - DRAWER - 18" - RIGHT CABINET
76	128810-18-01A	EA	SLIDE - DRAWER - 20" - RIGHT CABINET
76	128810-22-01A	EA	SLIDE - DRAWER - 22" - RIGHT CABINET
76	128810-26-01A	EA	SLIDE - DRAWER - 24" - RIGHT CABINET
76	128810-30-01A	EA	SLIDE - DRAWER - 9" - RIGHT CABINET
77	128810-03-01A	EA	SLIDE - DRAWER - 12" - LEFT DRAWER
77	128810-07-01A	EA	SLIDE - DRAWER - 14" - LEFT DRAWER
77	128810-11-01A	EA	SLIDE - DRAWER - 16" - LEFT DRAWER
77	128810-15-01A	EA	SLIDE - DRAWER - 18" - LEFT DRAWER
77	128810-19-01A	EA	SLIDE - DRAWER - 20" - LEFT DRAWER
77	128810-23-01A	EA	SLIDE - DRAWER - 22" - LEFT DRAWER
77	128810-27-01A	EA	SLIDE - DRAWER - 24" - LEFT DRAWER
77	128810-27-01A	EA	SLIDE - DRAWER - 24" - LEFT DRAWER
77	128810-31-01A	EA	SLIDE - DRAWER - 9" - LEFT DRAWER
78	128810-04-01A	EA	SLIDE - DRAWER - 12" - RIGHT DRAWER
78	128810-08-01A	EA	SLIDE - DRAWER - 14" - RIGHT DRAWER
78	128810-12-01A	EA	SLIDE - DRAWER - 16" - RIGHT DRAWER
78	128810-16-01A	EA	SLIDE - DRAWER - 18" - RIGHT DRAWER
78	128810-20-01A	EA	SLIDE - DRAWER - 20" - RIGHT DRAWER
78	128810-24-01A	EA	SLIDE - DRAWER - 22" - RIGHT DRAWER
78	128810-28-01A	EA	SLIDE - DRAWER - 24" - RIGHT DRAWER
78	128810-32-01A	EA	SLIDE - DRAWER - 9" - RIGHT DRAWER
79	128811-01-01A	EA	BACKSOCKET - ADJUSTABLE - LEFT
80	128811-02-01A	EA	BACKSOCKET - ADJUSTABLE - RIGHT

**INTERIOR FINISH GROUP (CONTINUED)**  
**HARDWARE (CONTINUED)**

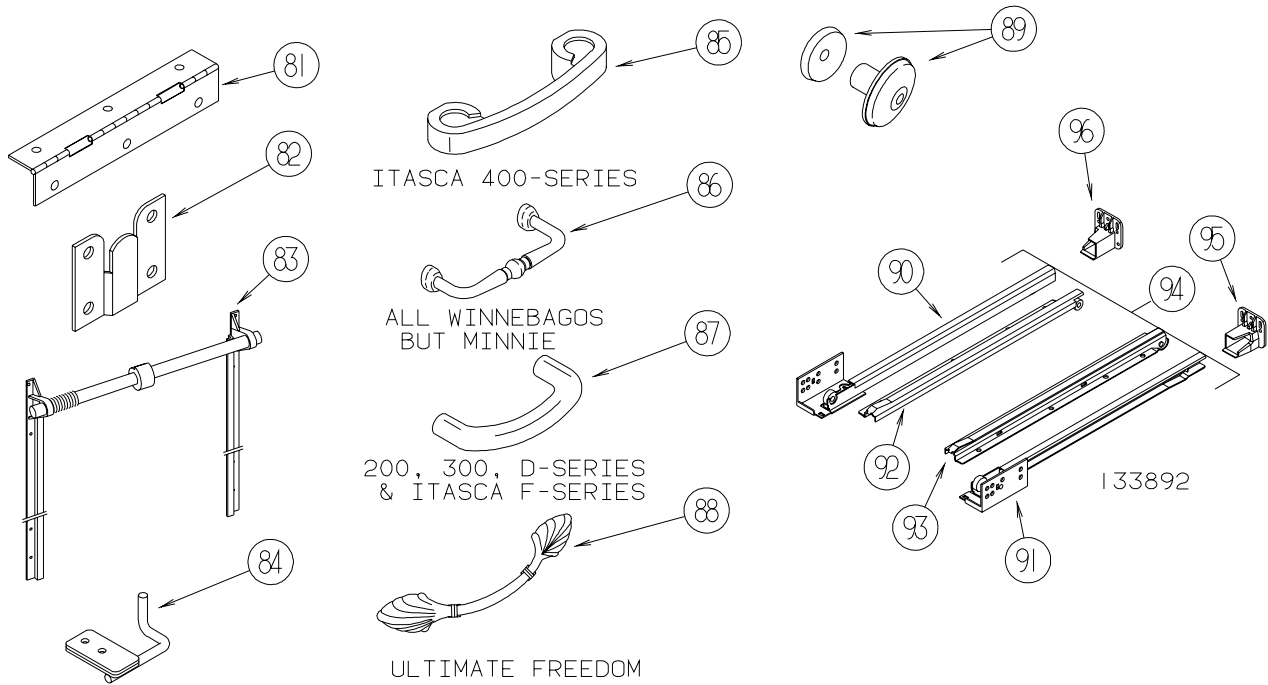

KEY	PART NUMBER	U/M	DESCRIPTION
81	129753-01-01A	EA	HINGE - SPRING LOADED - 19" X 19" - BLACK
82	130120-01-01A	EA	BRACKET - MIRROR
83	130787-01-000	EA	TRACK - TAMBOUR DOOR/SPRING - 15.9"
83	130787-02-000	EA	TRACK - TAMBOUR DOOR/SPRING - 24"
83	130787-04-000	EA	TRACK - TAMBOUR DOOR - SPRING
84	130798-01-02B	EA	GUIDE - POCKET DOOR - E-COATED
85	131962-01-01A	EA	PULL - DOOR/DRAWER - POLISHED BRASS - <b>ITASCA 400 SERIES (SUNDANCER)</b>
86	131963-01-01A	EA	PULL - POLISHED BRASS - <b>WINNEBAGO BRAVE/ADVENTURER/CHIEFTAIN/JOURNEY/MINNIE WINNIE</b>
87	131964-01-01A	EA	PULL - POLISHED BRASS - <b>RIALTA/WINNEBAGO MINNIE/VISTA, ITASCA SPIRIT/SUNOVA</b>
88	131965-01-01A	EA	PULL - DOOR/DRAWER - 6.3" - BURNISHED BRASS - <b>ULTIMATE FREEDOM</b>
89	133313-01-02A	EA	PULL - DOOR/DRAWER - BRIGHT BRASS
89	133313-01-03A	EA	PULL - DOOR/DRAWER - CHROME/BRASS - <b>ITASCA L &amp; P SERIES (SUNFLYER &amp; HORISON) ONLY</b>
90	133892-01-01A	EA	SLIDE - DRAWER - 16" - LEFT CABINET
90	133892-06-01A	EA	SLIDE - DRAWER - 22" - LEFT CABINET
90	133892-10-01A	EA	SLIDE - DRAWER - 12" - LEFT CABINET
90	133892-14-01A	EA	SLIDE - DRAWER - 18" - LEFT CABINET
91	133892-02-01A	EA	SLIDE - DRAWER - 16" - RIGHT CABINET
91	133892-07-01A	EA	SLIDE - DRAWER - 22" - RIGHT CABINET
91	133892-11-01A	EA	SLIDE - DRAWER - 12" - RIGHT CABINET
91	133892-15-01A	EA	SLIDE - DRAWER - 18" - RIGHT CABINET
92	133892-03-01A	EA	SLIDE - DRAWER - 16" - LEFT DRAWER
92	133892-08-01A	EA	SLIDE - DRAWER - 22" - LEFT DRAWER
92	133892-12-01A	EA	SLIDE - DRAWER - 12" - LEFT DRAWER
92	133892-16-01A	EA	SLIDE - DRAWER - 18" - LEFT DRAWER
93	133892-04-01A	EA	SLIDE - DRAWER - 16" - RIGHT DRAWER
93	133892-09-01A	EA	SLIDE - DRAWER - 22" - RIGHT DRAWER
93	133892-13-01A	EA	SLIDE - DRAWER - 12" - RIGHT DRAWER
93	133892-17-01A	EA	SLIDE - DRAWER - 18" - RIGHT DRAWER
94	133892-05-01A	EA	SLIDE - DRAWER - 9" - FULL SET
95	133907-01-01A	EA	BACKSOCKET - RIGHT HAND
96	133907-02-01A	EA	BACKSOCKET - LEFT HAND

**INTERIOR FINISH GROUP (CONTINUED)**  
**HARDWARE (CONTINUED)**

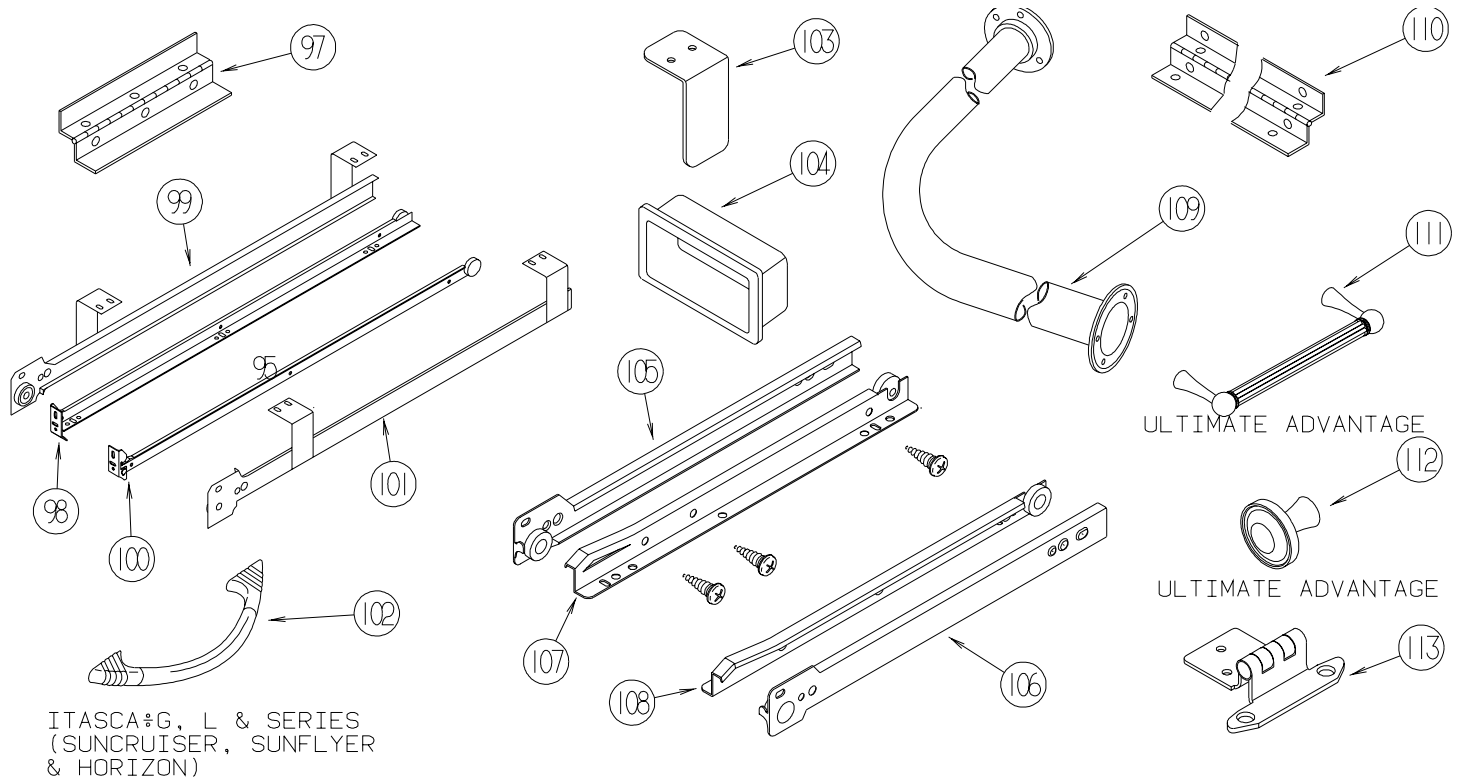

KEY	PART NUMBER	U/M	DESCRIPTION
97	135538-01-01A	EA	HINGE - PIANO - FULL WRAP - BRASS PLATED
97	135538-03-01A	EA	HINGE - PIANO - FULL WRAP - STOCKER BRASS
98	136944-01-01A	EA	SLIDE - DRAWER/RIGHT HAND - 13.8"
99	136944-02-01A	EA	SLIDE - CABINET/RIGHT HAND - 13.8"
100	136944-03-01A	EA	SLIDE - DRAWER/LEFT HAND - 13.8"
101	136944-04-01A	EA	SLIDE - CABINET/LEFT HAND - 13.8"
102	137446-01-01A	EA	PULL - CABINET - CHROME/BRASS - <b>ITASCA G, L &amp; P SERIES (SUNCRUISER/SUNFLYER/HORIZON)</b>
103	138136-02-02B	EA	GUIDE - DOOR - E-COATED
104	139136-01-01A	EA	HANDLE - RECESSED - 2.9" X 1.3"/2.7" X 1" X .7" C/O- BRASS
104	139136-02-01A	EA	HANDLE - RECESSED - 2.9" X 1.3"/2.7" X 1" X .4" C/O- BRASS
105	139566-01-01A	EA	SLIDE - DRAWER - 37.5" - LEFT CABINET
105	139566-05-01A	EA	SLIDE - DRAWER - 32" - LEFT CABINET
106	139566-02-01A	EA	SLIDE - DRAWER - 37.5" - RIGHT CABINET
106	139566-06-01A	EA	SLIDE - DRAWER - 32" - RIGHT CABINET
107	139566-03-01A	EA	SLIDE - DRAWER - 37.5" - LEFT DRAWER
107	139566-07-01A	EA	SLIDE - DRAWER - 32" - LEFT DRAWER
108	139566-04-01A	EA	SLIDE - DRAWER - 37.5" - RIGHT DRAWER
108	139566-08-01A	EA	SLIDE - DRAWER - 32" - RIGHT DRAWER
109	140494-01-01A	EA	ROD - SHOWER
109	140494-01-02A	EA	ROD - SHOWER - SOFT WHITE
110	142276-01-01A	EA	HINGE - PIANO - FULL WRAP - BRASS
	142569-05-000	EA	SPRING - GAS - 39.9"/15 LB
FROM: 01-18-03 THRU: 99-99-99			
111	142909-01-01A	EA	PULL - CABINET - BRASS - <b>ULTIMATE ADVANTAGE</b>
112	142910-01-01A	EA	KNOB - CABINET - BRASS - <b>ULTIMATE ADVANTAGE</b>
113	143468-01-02A	EA	HINGE - SELF CLOSING - POLISHED BRASS

## LABELS GROUP

SEWAGE

**KEY PART NUMBER U/M DESCRIPTION**  
006187-01-000 EA LABEL - SEWAGE

WASTE WATER

**KEY PART NUMBER U/M DESCRIPTION**  
006188-01-000 EA LABEL - WASTE WATER

### WARNING

THIS SYSTEM IS DESIGNED FOR USE WITH PROPANE ONLY  
DO NOT CONNECT NATURAL GAS TO THIS SYSTEM

BEFORE TURNING ON PROPANE:

- (A) BE CERTAIN APPLIANCES ARE CERTIFIED FOR PROPANE AND ARE EQUIPPED WITH CORRECT BURNING ORIFICES.
- (B) MAKE CERTAIN ALL PROPANE CONNECTIONS ARE TIGHT BY TESTING WITH SOAPY WATER. ALL APPLIANCE VALVES ARE TURNED OFF, AND ANY UNCONNECTED OUTLETS ARE CAPPED.

AFTER TURNING ON PROPANE:

- (A) LIGHT ALL PILOT LIGHTS
- (B) (B) ALL CONNECTIONS, INCLUDING THOSE AT THE APPLIANCES, REGULATORS AND CYLINDERS SHOULD BE LEAK-TESTED PERIODICALLY WITH SOAPY WATER BY THE OCCUPANT. NEVER USE A LIGHTED MATCH OR OTHER FLAME WHEN CHECKING FOR LEAKS.
- (C) DO NOT LEAVE SYSTEM TURNED ON OF CONTAINERS CONNECTED UNTIL THE SYSTEM HAS BEEN PROVEN TO BE FREE OF LEAKS.
- (D) COOKING APPLIANCES SHOULD NOT BE USED FOR SPACE HEATING.
- (E) WHEN THE CONTAINERS ARE DISCONNECTED THE PROPANE SUPPLY LINE SHOULD BE CAPPED OR PLUGGED.

### AVERTISSEMENT

CETTE INSTALLATION EST CONCUE POUR LE PROPANE SEULEMENT  
NE PAS L'ALIMENTER EN GAZ NATUREL

AVANT LA MISE EN SERVICE:

- (A) S'ASSURER QUE LES APPAREILS SONT CERTIFIES POUR LE PROPANE ET MUNIS D'ORIFICES DE BRULEUR APPROPRIES.
- (B) VERIFIER L'ETANCHEITE DE TOUS LES RACCORDEMENTS AU PROPANE. LA PERMETURE DE TOUS LES ROBINETS D'APPAREILS ET L'OBTURATION DE TOUTES LES SORTIES NON RACCORDEES.

APRES LA MISE EN SERVICE:

- (A) ALLUMER TOUTES LES VEILLEUSES.
- (B) L'OCCUPANT DOIT EPROUVER PERIODIQUEMENT L'ETANCHEITE DE TOUS LES RACCORDEMENTS Y COMPRIS CEUX AUX APPAREILS, AUX DETENDEURS ET AUX BOUTEILLES, EN Y APPLIQUANT DE L'EAU SAVONNEUSE NE JAMA'S SE SERVIR D'UNE ALLUMETTE OU AUTRE POUR LA DETECTION DES FUITES.
- (C) NE PAS LAISSER L'ALIMENTATION OUVERTE NI LES RECIPIENTS RACCORDES AVANT D'AVOIR COMPLETE L'EPREUVE D'ETANCHEITE AU PROPANE DE L'INSTALLATION.
- (D) LES APPAREILS DE CUISSON NE DOIVENT PAS ETRE UTILISES POUR LE CHAUFFAGE DES LOCAUX.
- (E) LORSQUE LES RECIPIENTS SONT DECONNECTES, L'ALIMENTATION DE PROPANE DOIT ETRE OBTUREE OU SCHELLEE.

**KEY PART NUMBER U/M DESCRIPTION**  
023769-01-000 EA LABEL - WARNING - LPG - CANADIAN

EXIT

**KEY PART NUMBER U/M DESCRIPTION**  
039290-01-000 EA LABEL - WARNING - EXIT

## LABELS GROUP (CONTINUED)



**KEY PART NUMBER U/M DESCRIPTION**  
040944-01-000 EA LABEL - ENTRANCE DOOR - "OPEN"

### CAUTION

THIS MOTOR HOME HAS BEEN DESIGNED, MANUFACTURED AND TESTED WITH CONCERN FOR THE PROTECTION OF IT'S OCCUPANTS. WE RECOMMEND YOU PERFORM THE FOLLOWING INSPECTIONS FOR YOUR SAFETY AND THE SAFETY OF YOUR PASSENGERS BEFORE STARTING YOUR VEHICLE.

1. LP GAS SYSTEM- TURN OFF AT TANK FOR TRAVELING. TEST FOR LEAKS UPON ARRIVAL AT DESTINATION. BEFORE LIGHTING PILOTS.
2. WHEELS- INSPECT FOR DAMAGE AND CHECK LUG NUTS FOR TIGHTNESS.
3. TIRES- INSPECT FOR WEAR AND DAMAGE AND CHECK FOR RECOMMENDED AIR PRESSURE.
4. LIGHTING- TEST FOR PROPER OPERATION OF ALL INTERIOR AND EXTERIOR LIGHTS INCLUDING DASH LIGHTS, HEADLIGHTS, TAIL LIGHTS, BRAKE LIGHTS, CLEARANCE LIGHTS AND TURN SIGNALS.
5. EXITS- INSPECT RELEASE MECHANISM ON EMERGENCY EXIT WINDOW. TEST BOTH LOCKS ON MAIN ENTRANCE DOOR FOR EASE OF OPERATION AND INSTRUCT PASSENGERS HOW TO USE BOTH MEANS OF EXIT.
6. SEAT BELTS- DIRECT PASSENGERS TO DESIGNATED SEATS AND REQUIRE USE OF SEAT BELTS.
7. APPLIANCES- TURN OFF AND LATCH OR LOCK DOORS WHERE PROVIDED.
8. LOOSE PARCELS- STORE SECURELY.
9. UTILITY SUPPLY LINES- DISCONNECT ALL ELECTRIC, SEWER AND WATER LINES AND SECURE PROPERLY.
10. ENTRANCE DOOR STEP- PLACE IN RETRACTED POSITION FOR TRAVELING.

READ YOUR MOTOR HOME AND CHASSIS OWNER'S  
MANUAL FOR FURTHER PRECAUTIONS

**KEY PART NUMBER U/M DESCRIPTION**  
056259-01-000 EA LABEL - SAFETY CHECK LIST

UNLEADED FUEL ONLY

**KEY PART NUMBER U/M DESCRIPTION**  
062043-01-000 EA LABEL - FUEL - UNLEADED

**WARNING** DISCONNECT BATTERIES BEFORE  
CONNECTING EXTERNAL CHARGING EQUIPMENT.

**KEY PART NUMBER U/M DESCRIPTION**  
065748-01-000 EA LABEL - CAUTION - BATTERY CHARGING

AVERTISSEMENT : DEBRANCHER LES BATTERIES AVANT  
DE BRANCHER TOUT EQUIPEMENT DE CHARGE EXTERIEUR.

**KEY PART NUMBER U/M DESCRIPTION**  
065748-02-000 EA LABEL - WARNING - BATTERY/FRENCH - CANADIAN

DIESEL FUEL ONLY

**KEY PART NUMBER U/M DESCRIPTION**  
068383-01-000 EA LABEL - DIESEL FUEL

VEHICLE EMISSION CONTROL INFORMATION  
THIS VEHICLE CONFORMS TO U.S. EPA  
REGULATIONS APPLICABLE TO XXXX MODEL  
YEAR NEW VEHICLES.

072887-01-000-7 CATALYST

**KEY PART NUMBER U/M DESCRIPTION**  
072887-14-000 EA LABEL - EPA - 2003 MODEL YEAR

## LABELS GROUP (CONTINUED)

### IF YOU SMELL GAS

1. EXTINGUISH ANY OPEN FLAME, PILOT LIGHTS AND ALL SMOKING MATERIALS.
2. DO NOT TOUCH ELECTRICAL SWITCHES.
3. SHUT OFF THE GAS SUPPLY AT THE TANK VALVE(S) OR GAS SUPPLY CONNECTION.
4. OPEN DOORS AND OTHER VENTILATING OPENINGS.
5. LEAVE THE AREA UNTIL ODOR CLEARS.
6. HAVE THE GAS SYSTEM CHECKED AND LEAKAGE SOURCE CORRECTED BEFORE USING AGAIN.

**KEY PART NUMBER U/M DESCRIPTION**  
073998-01-000 EA LABEL - LPG ODOR WARNING

WARNING: TEST SMOKE DETECTOR  
OPERATION AFTER VEHICLE HAS BEEN IN  
STORAGE, BEFORE EACH TRIP AND AT  
LEAST ONCE PER WEEK DURING USE.

**KEY PART NUMBER U/M DESCRIPTION**  
077956-01-000 EA LABEL - WARNING - SMOKE DETECTOR

DO NOT FILL  
LP-GAS CONTAINER(S)  
TO MORE THAN 80%  
OF CAPACITY.

**KEY PART NUMBER U/M DESCRIPTION**  
079965-01-000 EA LABEL - LPG - 80% CAPACITY

WARNING  
MUST BE STOWED  
IN LATCHED POSITION  
WHILE VEHICLE IS IN MOTION

**KEY PART NUMBER U/M DESCRIPTION**  
079966-01-000 EA LABEL - WARNING - STOWED - MOTION

W  
A  
T  
E  
R  
H  
E  
A  
T  
E  
R  
O  
N  
O  
F  
F

**KEY PART NUMBER U/M DESCRIPTION**  
083588-01-000 EA LABEL - ON/OFF - WATER HEATER  
083588-03-000 EA LABEL - ON/OFF - WATER HEATER

E  
N  
G  
I  
N  
E  
H  
E  
A  
T  
E  
R  
O  
N  
O  
F  
F

**KEY PART NUMBER U/M DESCRIPTION**  
083588-02-000 EA LABEL - ON/OFF - ENGINE HEATER  
083588-04-000 EA LABEL - ON/OFF - ENGINE HEATER

## LABELS GROUP (CONTINUED)

CAUTION	TO HELP AVOID PERSONAL INJURY DURING REMOVAL OF FUEL FILLER CAP, SLOWLY LOOSEN CAP 1/2 TURN TO ALLOW ANY FUEL PRESSURE TO BE RELIEVED BEFORE TURNING CAP FURTHER.
FUEL SPRAY MAY CAUSE PERSONAL INJURY	STOP ADDING FUEL AFTER FIRST SHUTOFF BY AUTOMATIC NOZZLE WHEN TANK IS NEARLY FULL. DO NOT OVERFILL FUEL TANK.  SEE OWNERS MANUAL FOR ADDITIONAL INFORMATION.  PRINTED IN U.S.A. <span style="float: right;">WLC PT NO 15611763</span>

**KEY PART NUMBER U/M DESCRIPTION**  
087207-05-000 EA LABEL - FUEL CAP REMOVAL



**KEY PART NUMBER U/M DESCRIPTION**  
087236-01-000 EA LABEL - CABLE - INPUT



**KEY PART NUMBER U/M DESCRIPTION**  
087236-02-000 EA LABEL - TV OUTLET

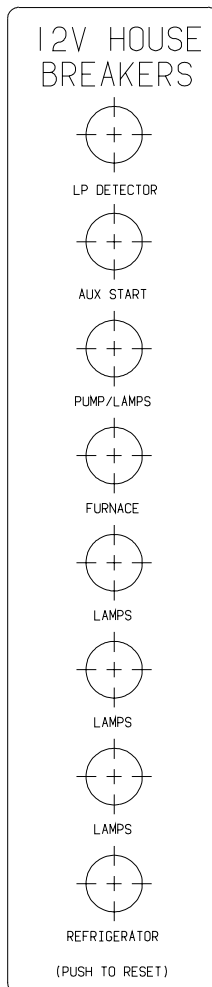

**KEY PART NUMBER U/M DESCRIPTION**  
092547-08-000 EA LABEL - CIRCUIT BREAKER



## LABELS GROUP (CONTINUED)

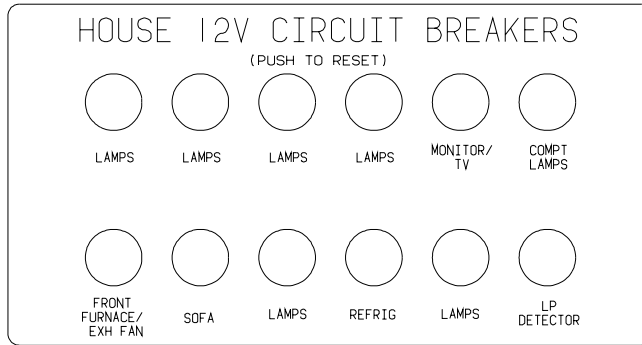

**KEY PART NUMBER** 092547-10-000 **U/M DESCRIPTION**  
EA LABEL - CIRCUIT BREAKER

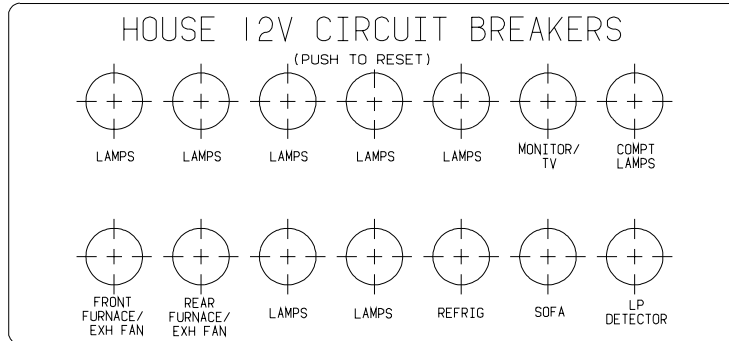

**KEY PART NUMBER** 092547-11-000 **U/M DESCRIPTION**  
EA LABEL - CIRCUIT BREAKER

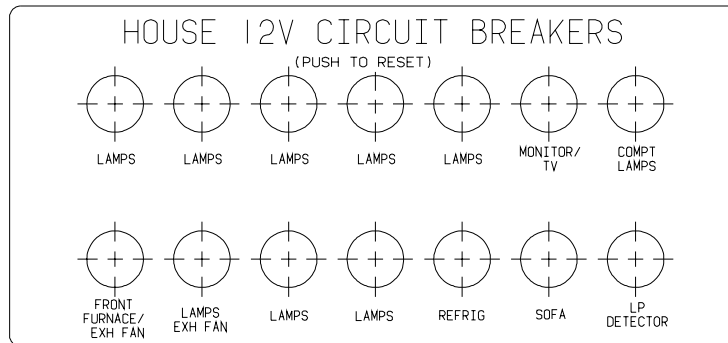

**KEY PART NUMBER** 092547-12-000 **U/M DESCRIPTION**  
EA LABEL - CIRCUIT BREAKER

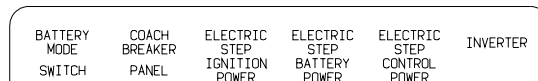

**KEY PART NUMBER** 093236-08-000 **U/M DESCRIPTION**  
EA LABEL - CIRCUIT BREAKER

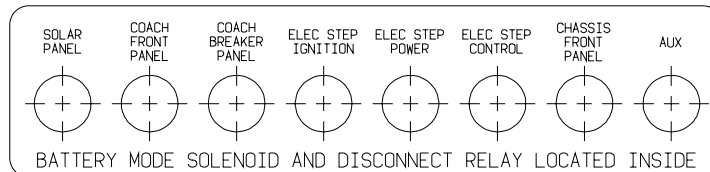

**KEY PART NUMBER** 093236-13-000 **U/M DESCRIPTION**  
EA LABEL - CIRCUIT BREAKER

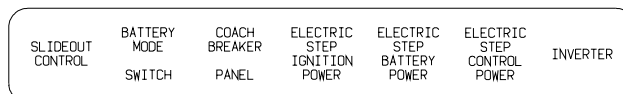

**KEY PART NUMBER** 093236-21-000 **U/M DESCRIPTION**  
EA LABEL - CIRCUIT BREAKER

## LABELS GROUP (CONTINUED)

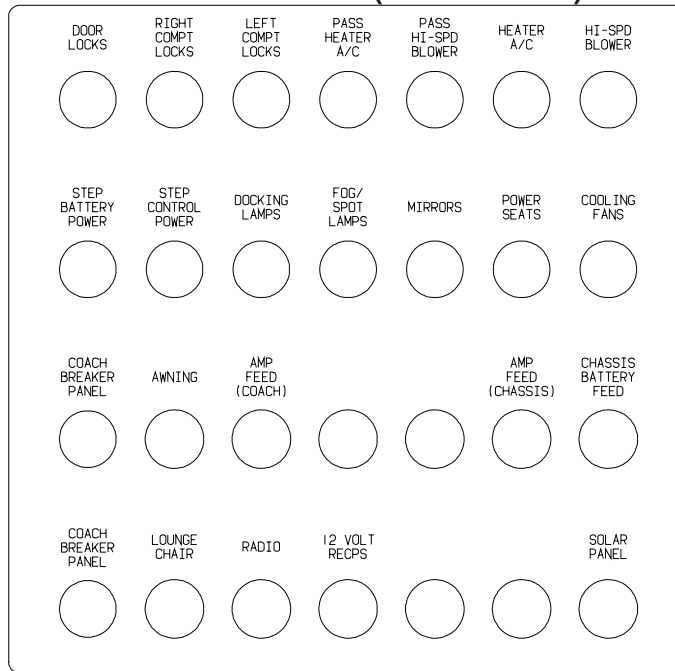

**KEY PART NUMBER**  
093236-22-000

**U/M DESCRIPTION**  
EA LABEL - CIRCUIT BREAKER

**KEY PART NUMBER**  
093236-23-000

**U/M DESCRIPTION**  
EA LABEL - CIRCUIT BREAKER - MAIN

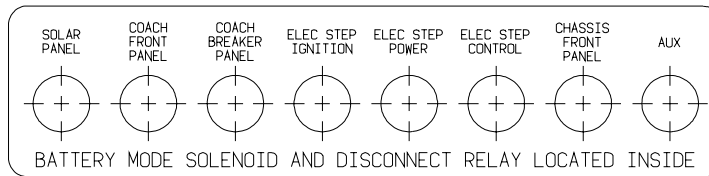
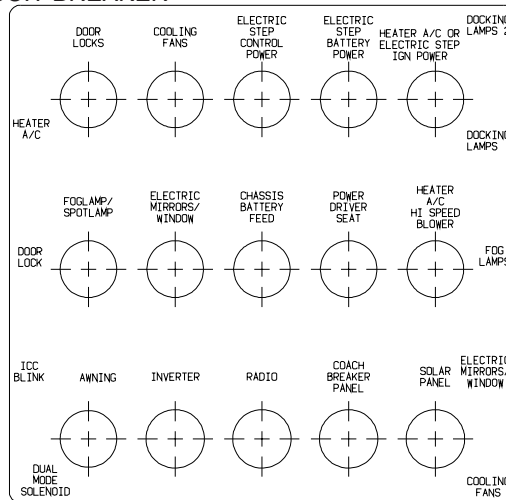

**KEY PART NUMBER**  
093236-24-000

**U/M DESCRIPTION**  
EA LABEL - CIRCUIT BREAKER

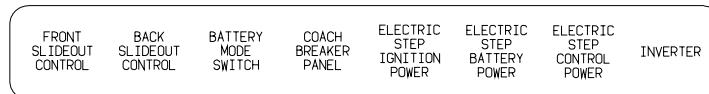

**KEY PART NUMBER**  
093236-28-000

**U/M DESCRIPTION**  
EA LABEL - CIRCUIT BREAKER

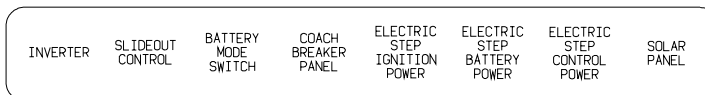

**KEY PART NUMBER**  
093236-29-000

**U/M DESCRIPTION**  
EA LABEL - CIRCUIT BREAKER

## LABELS GROUP (CONTINUED)

A / C C I R C U I T 1	M A I N	A / C C I R C U I T 2	R E F F R I G / C O N V	M I C R O W A V E	R E C P S 1	R E C P S 2	R E C P S 3	W A S H E R / D R Y E R	W A T E R H E A T E R	
-----------------------------	---------	-----------------------------	-------------------------	-------------------	----------------	----------------	----------------	-------------------------	--------------------------	--

**KEY PART NUMBER** 095721-31-000 **U/M DESCRIPTION**  
EA LABEL - CONTROL CENTER - 30 AMP - US

A / C C I R C U I T 1	M A I N	M A I N	A / C C I R C U I T 2	R E F F R I G / C O N V	M I C R O W A V E	R E C P S 1	R E C P S 2	R E C P S 3	W A S H E R / D R Y E R	W A T E R H E A T E R
-----------------------------	---------	---------	-----------------------------	-------------------------	-------------------	----------------	----------------	----------------	-------------------------	--------------------------

**KEY PART NUMBER** 095721-33-000 **U/M DESCRIPTION**  
EA LABEL - CONTROL CENTER - 50 AMP - US

A / C	M A I N	R E F F R I G / C O N V	M I C R O W A V E	R E C P S 1	R E C P S 2
-------	---------	-------------------------	-------------------	----------------	----------------

**KEY PART NUMBER** 095721-40-000 **U/M DESCRIPTION**  
EA LABEL - CONTROL CENTER

AUTOMOTIVE AND COACH  
CIRCUIT BREAKERS

**KEY PART NUMBER** 098379-01-000 **U/M DESCRIPTION**  
EA LABEL - CIRCUIT BREAKER - FRONT BOX

CIRCUIT BREAKERS  
AND AUTOMOTIVE  
FUSE PANEL

**KEY PART NUMBER** 098379-03-000 **U/M DESCRIPTION**  
EA LABEL - ELECTRICAL BOX - FRONT

BATTERY MODE  
SOLENOID AND  
RELAYS

**KEY PART NUMBER** 098379-04-000 **U/M DESCRIPTION**  
EA LABEL - ELECTRICAL BOX - SIDE

## LABELS GROUP (CONTINUED)

UNLEADED  
FUEL ONLY

**KEY PART NUMBER U/M DESCRIPTION**  
098641-01-000 EA LABEL - FUEL - UNLEADED - DASH

FOR AWNING INSTALLATION  
CONTACT YOUR MOTORHOME  
DEALERSHIP

**KEY PART NUMBER U/M DESCRIPTION**  
099509-01-000 EA LABEL - AWNING INSTALLATION

WARNING  
THIS VEHICLE, LIKE OTHER  
VEHICLES, MAY CONTAIN SMALL  
AMOUNTS OF ONE OR MORE  
SUBSTANCES WHICH ARE LISTED  
BY THE STATE OF CALIFORNIA  
FOR CAUSING CANCER OR  
REPRODUCTIVE TOXICITY.

**KEY PART NUMBER U/M DESCRIPTION**  
099689-01-000 EA LABEL - WARNING - CANCER/TOXICITY

NOTE: TUNE ANTENNA  
PER MANUFACTURER'S  
DIRECTIONS. FAILURE TO  
COMPLY COULD RESULT IN  
DAMAGE TO CB.

CB POWER PROVISION

RED +12 V  
BLACK GROUND  
COAX ANTENNA  
(SEE REVERSE ALSO)

**KEY PART NUMBER U/M DESCRIPTION**  
104678-01-000 EA LABEL - CB PREP

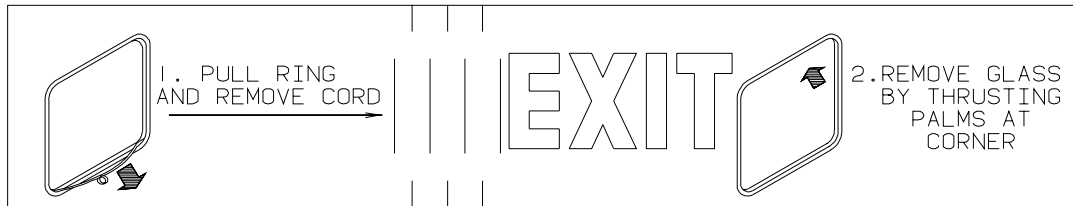

**KEY PART NUMBER U/M DESCRIPTION**  
107571-01-000 EA LABEL - EXIT/ESCAPE WINDOW

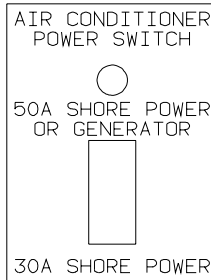

**KEY PART NUMBER U/M DESCRIPTION**  
109051-02-000 EA LABEL - SWITCH - 50 AMP POWER

## LABELS GROUP (CONTINUED)

DO NOT USE HITCH BEFORE  
READING OWNERS MANUAL REGARDING  
VEHICLE LOADING AND TOWING

KEY	PART NUMBER	U/M DESCRIPTION
	111104-01-000	EA LABEL - HITCH - READ MANUAL - WHITE
	111104-02-000	EA LABEL - HITCH - READ MANUAL - BLACK

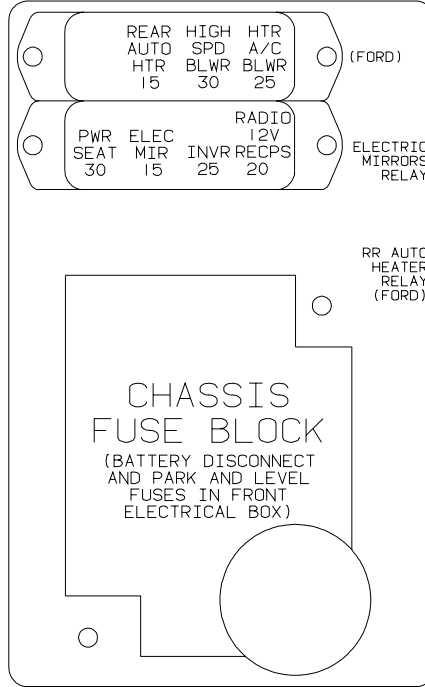

KEY	PART NUMBER	U/M DESCRIPTION
	111537-08-000	EA LABEL - FUSES

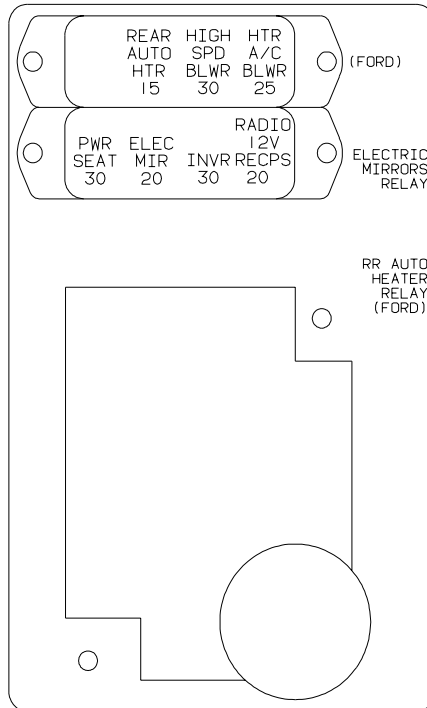

KEY	PART NUMBER	U/M DESCRIPTION
	111537-09-000	EA LABEL - FUSES

## LABELS GROUP (CONTINUED)

WARNING: CONTAINS "CFC" A SUBSTANCE WHICH HARMS PUBLIC HEALTH AND ENVIRONMENT BY DESTROYING OZONE IN THE UPPER ATMOSPHERE.

KEY	PART NUMBER	U/M DESCRIPTION
	111802-01-000	EA LABEL - CFC WARNING

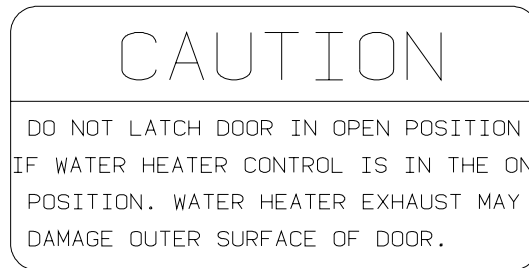

KEY	PART NUMBER	U/M DESCRIPTION
	113402-01-000	EA LABEL - CAUTION - WATER HEATER EXHAUST

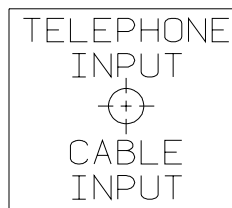

KEY	PART NUMBER	U/M DESCRIPTION
	114866-02-000	EA LABEL - PHONE & CABLE INPUT - WHITE/CLEAR BACKGROUND
	114866-03-000	EA LABEL - PHONE & CABLE INPUT - BLACK/CLEAR BACKGROUND

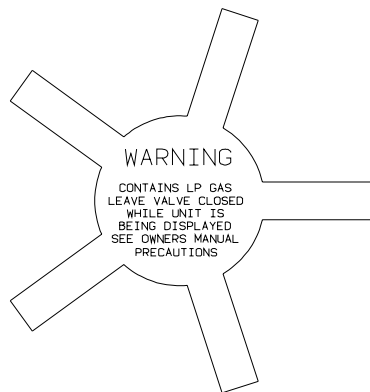

KEY	PART NUMBER	U/M DESCRIPTION
	115600-01-000	EA LABEL - WARNING LPG VALVE

WARNING: REPLACE TIRE ONLY WITH ONE OF EXACTLY SAME TYPE AND RATING. DO NOT REPLACE WITH PASSENGER CAR TIRE. SEE OPERATOR'S MANUAL FOR MORE INFORMATION CALL WINNEBAGO OWNER RELATIONS AT 1-800-537-1885.

KEY	PART NUMBER	U/M DESCRIPTION
	115869-01-000	EA LABEL - WARNING - TIRE

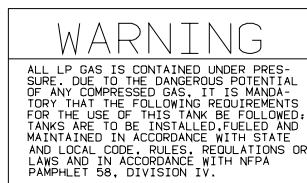

KEY	PART NUMBER	U/M DESCRIPTION
	116112-01-000	EA LABEL - CAUTION - LP

## LABELS GROUP (CONTINUED)

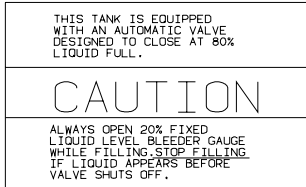

**KEY PART NUMBER**      **U/M DESCRIPTION**  
 116113-01-000      EA LABEL - CAUTION - LP

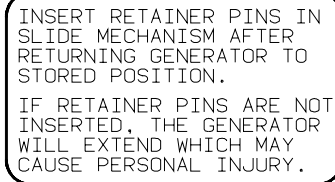

**KEY PART NUMBER**      **U/M DESCRIPTION**  
 116273-01-000      EA LABEL - WARNING - GENERATOR

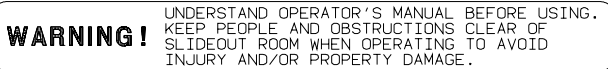

**KEY PART NUMBER**      **U/M DESCRIPTION**  
 116549-01-000      EA LABEL - WARNING - SLIDEOUT

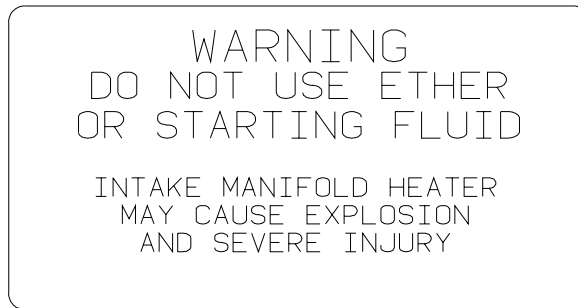

**KEY PART NUMBER**      **U/M DESCRIPTION**  
 116756-02-000      EA LABEL - WARNING - ETHER/STARTING

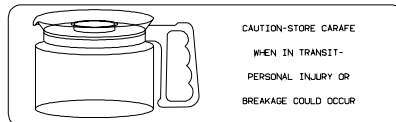

**KEY PART NUMBER**      **U/M DESCRIPTION**  
 116829-02-000      EA LABEL - COFFEEMAKER



**KEY PART NUMBER**      **U/M DESCRIPTION**  
 117628-02-000      EA LABEL - SWITCH - WATER PUMP/LIGHTS-WHITE/CLEAR BACKGROUND

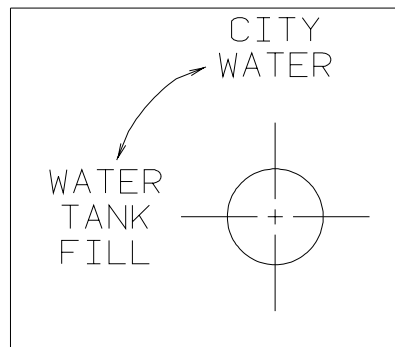

**KEY PART NUMBER**      **U/M DESCRIPTION**  
 117629-03-000      EA LABEL - WATER PUMP/FILL-BLK LETTERS/CLEAR BACKGROUND-.31"

## LABELS GROUP (CONTINUED)

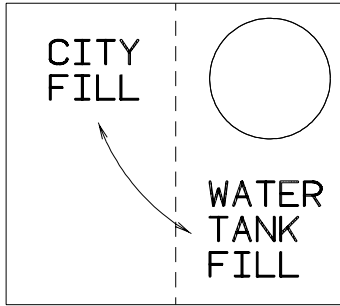

**KEY PART NUMBER**      **U/M DESCRIPTION**  
 117629-04-000      EA LABEL - CITY WATER/TANK FILL

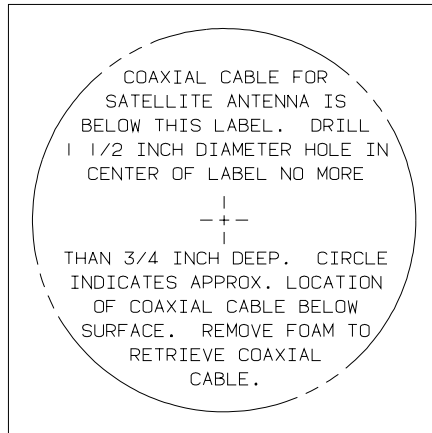

**KEY PART NUMBER**      **U/M DESCRIPTION**  
 120431-01-000      EA LABEL - LOCATION - COAXIAL CABLE/SATELLITE ANTENNA

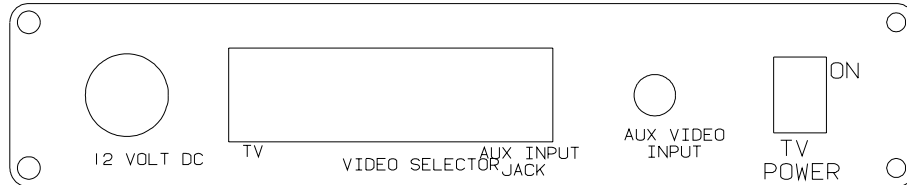

**KEY PART NUMBER**      **U/M DESCRIPTION**  
 120677-01-000      EA LABEL - TV

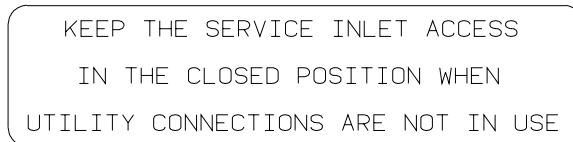

**KEY PART NUMBER**      **U/M DESCRIPTION**  
 123562-01-000      EA LABEL - SERVICE/UTILITY ACCESS

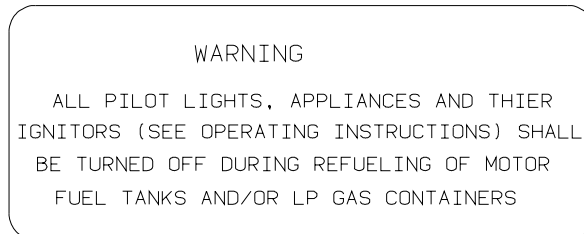

**KEY PART NUMBER**      **U/M DESCRIPTION**  
 124519-01-01A      EA LABEL - WARNING/REFUELING - BLACK ON CLEAR  
 124519-01-02A      EA LABEL - WARNING/REFUELING - WHITE ON CLEAR



## LABELS GROUP (CONTINUED)

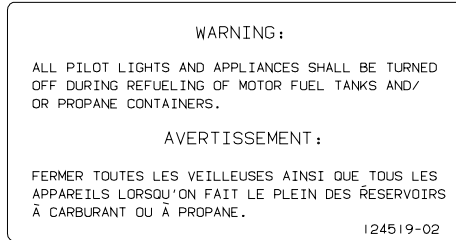

KEY	PART NUMBER	U/M DESCRIPTION
	124519-02-01A	EA LABEL - WARNING/REFUELING - BLACK ON CLEAR - CSA
	124519-02-02A	EA LABEL - WARNING/REFUELING - WHITE ON CLEAR - CSA

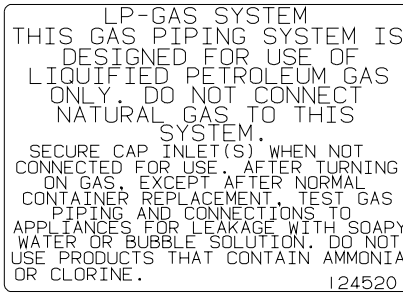

KEY	PART NUMBER	U/M DESCRIPTION
	124520-01-01A	EA LABEL - LP GAS ONLY - BLACK ON CLEAR
	124520-01-02A	EA LABEL - LP GAS ONLY - WHITE ON CLEAR

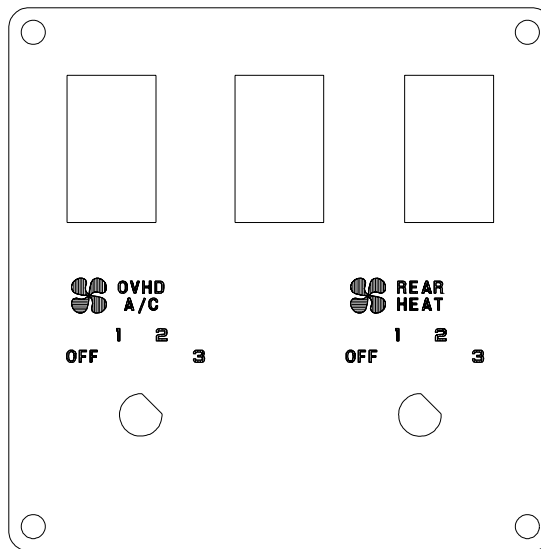

KEY	PART NUMBER	U/M DESCRIPTION
	124572-01-000	EA LABEL - SWITCHES

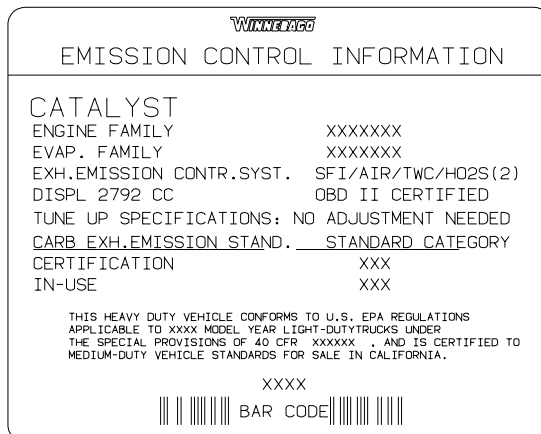

KEY	PART NUMBER	U/M DESCRIPTION
	124709-07-000	EA LABEL - EMISSION CONTROL - DUAL

## LABELS GROUP (CONTINUED)

THIS CONNECTION IS FOR  
 (B) VOLT AC,60 HZ(CYCLES)  
 (A) AMPERE SUPPLY

DO NOT CONNECT TO  
 HIGHER VOLTAGE

KEY	PART NUMBER	U/M DESCRIPTION
	125306-01-01A	EA LABEL - ELECTRICAL ENTRANCE - 110V 30 AMP - BLACK ON CLEAR
	125306-01-02A	EA LABEL - ELECTRICAL ENTRANCE - 110V 30 AMP - WHITE ON CLEAR

THIS CONNECTION IS FOR  
 (B) VOLT AC,3-POLE,4 WIRE  
 60 HZ(CYCLES),(A) AMPERE SUPPLY

DO NOT CONNECT TO  
 HIGHER VOLTAGE

KEY	PART NUMBER	U/M DESCRIPTION
	125306-04-01A	EA LABEL-ELECTRICAL ENTRANCE-120/240V 50 AMP-BLACK ON CLEAR
	125306-04-02A	EA LABEL - ELECTRICAL ENTRANCE-120/240V 50 AMP-WHITE ON CLEAR

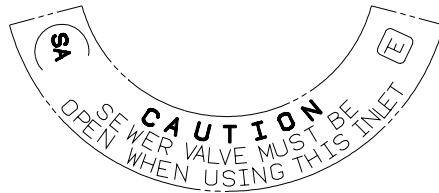

KEY	PART NUMBER	U/M DESCRIPTION
	125697-07-000	EA LABEL - CAUTION - FLUSHING SYSTEM

REMOVE PRIMARY TIRE HANGER BEFORE USING  
 SPARE TIRE HOIST-SEE OWNERS MANUAL - PERSONAL  
 INJURY MAY RESULT IF NOT FOLLOWED

KEY	PART NUMBER	U/M DESCRIPTION
	126024-01-000	EA LABEL - TIRE HANGER REMOVAL

# GRAY HOLDING TANK

KEY	PART NUMBER	U/M DESCRIPTION
	126247-05-000	EA LABEL - GRAY HOLDING TANK-BLACK LETTERS/CLEAR BACKGROUND

# BLACK HOLDING TANK

KEY	PART NUMBER	U/M DESCRIPTION
	126247-06-000	EA LABEL - BLACK HOLDING TANK-BLACK LETTERS/CLEAR BACKGROUND

**LABELS GROUP (CONTINUED)**

EXTERIOR SHOWER

**KEY PART NUMBER U/M DESCRIPTION**  
126248-03-000 EA LABEL - EXTERIOR SHOWER

CITY WATER FILL

**KEY PART NUMBER U/M DESCRIPTION**  
126249-03-000 EA LABEL - CITY WATER FILL-BLK LETTERS/CLEAR BACKGROUND .31"



**WARNING**

○ **Children Can be KILLED or INJURED  
by Passenger Air Bag**

The back seat is the safest place for children 12 and under.  
Make sure all children use seat belts or child seats.

**KEY PART NUMBER U/M DESCRIPTION**  
126612-01-000 EA LABEL - HANG TAG - AIR BAG - DASH

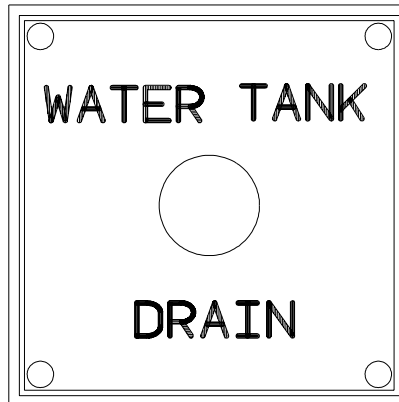

**KEY PART NUMBER U/M DESCRIPTION**  
127170-01-000 EA LABEL - WATER TANK DRAIN

**WARNING**

ROOF SURFACE MAY BE SLIPPERY  
ESPECIALLY WHERE MOISTURE IS PRESENT  
SLIPPING MAY RESULT IN PERSONAL INJURY.

128218-01

**KEY PART NUMBER U/M DESCRIPTION**  
128218-01-01A EA LABEL - WARNING - SLIPPERY ROOF

ENTRANCE DOOR PROP ROD

THIS ROD IS DESIGNED TO PROP THE  
ENTRANCE DOOR OPEN WHEN THE PATIO  
AWNING ARM IS ATTACHED TO THE  
SIDEWALL AND THE AWNING IS EX-  
TENDED.  
HOOK ONE END OF ROD INTO LOOP ON  
DOOR AND OTHER END INTO LOOP ON THE  
SIDEWALL AS SHOWN.

(THIS LABEL TO BE REMOVED BY RETAIL OWNER ONLY)

**KEY PART NUMBER U/M DESCRIPTION**  
128658-01-000 EA LABEL - PROP ROD - ENTRY DOOR

**LABEL GROUP (CONTINUED)**

**WARNING**  
POTABLE WATER ONLY  
SANITIZE, FLUSH, AND  
DRAIN BEFORE USING.  
SEE INSTRUCTION MANUAL

**KEY PART NUMBER U/M DESCRIPTION**  
128725-01-01A EA LABEL - POTABLE WATER ONLY - BLACK ON CLEAR

TOW VEHICLE RATING MAY BE LESS THAN HITCH RATING.  
MAXIMUM VERTICAL HITCH LOAD: 350 LBS  
DO NOT EXCEED REAR AXLE RATING.  
SEE OWNER'S MANUAL FOR ADDITIONAL INFORMATION.

**KEY PART NUMBER U/M DESCRIPTION**  
129669-01-01A EA LABEL - HITCH/VEHICLE RATE - 350 - WHITE ON CLEAR  
129669-01-02A EA LABEL - HITCH/VEHICLE RATE - 350 - BLACK ON CLEAR  
129669-02-01A EA LABEL - HITCH/VEHICLE RATE - 500 - WHITE ON CLEAR  
129669-02-02A EA LABEL - HITCH/VEHICLE RATE - 500 - BLACK ON CLEAR

TIRE ROTATION  
SEE RIALTA OWNERS MANUAL  
SECTION 9

**KEY PART NUMBER U/M DESCRIPTION**  
129684-01-000 EA LABEL - TIRE ROTATION

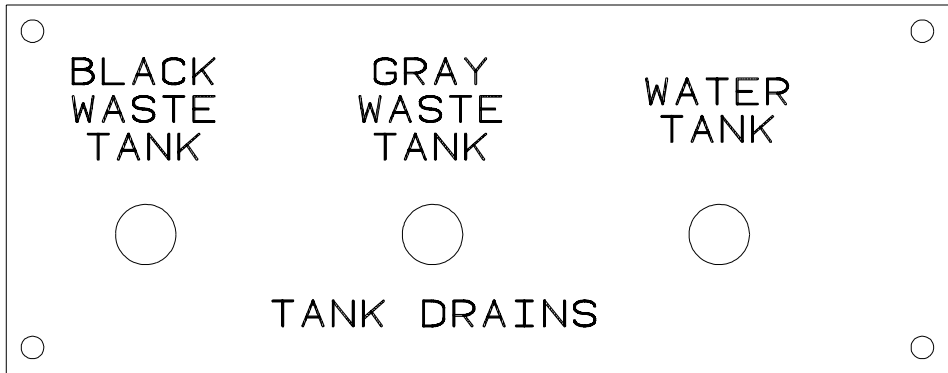

**KEY PART NUMBER U/M DESCRIPTION**  
130166-01-000 EA LABEL - DRAIN

H  
O  
S  
E  
  
S  
T  
O  
R  
A  
G  
E

**KEY PART NUMBER U/M DESCRIPTION**  
130167-02-000 EA LABEL - HOSE STORAGE

**LABELS GROUP (CONTINUED)**

WASTE TANK FLUSH

**KEY PART NUMBER U/M DESCRIPTION**  
130168-01-000 EA LABEL - WASTE TANK FLUSH

MONITOR WATER  
PANEL LIGHT PUMP

**KEY PART NUMBER U/M DESCRIPTION**  
130170-01-000 EA LABEL - SWITCH PANEL - BLK/CLEAR BACKGROUND-1.8"H X 5.9"L

LIGHTS WATER  
PUMP

**KEY PART NUMBER U/M DESCRIPTION**  
130170-02-000 EA LABEL - SWITCH PANEL-BLK/CLEAR BACKGROUND-1.4"H X 3.9"L

WATER  
PUMP

**KEY PART NUMBER U/M DESCRIPTION**  
130170-03-000 EA LABEL - PANEL SWITCH

CAUTION:  
OPEN A WINDOW OR VENT WHILE  
OPERATING DRYER. IT IS DANGEROUS  
TO CREATE A NEGATIVE AIR PRESSURE  
INSIDE A VEHICLE CONTAINING  
FUEL-BURNING APPLIANCES

**KEY PART NUMBER U/M DESCRIPTION**  
130670-01-01A EA LABEL - CAUTION DRYER VENTING - BLACK ON CLEAR

PUSH TO  
RELEASE  
GENERATOR  
SLIDE ASM

**KEY PART NUMBER U/M DESCRIPTION**  
131779-01-01A EA LABEL - GENERATOR

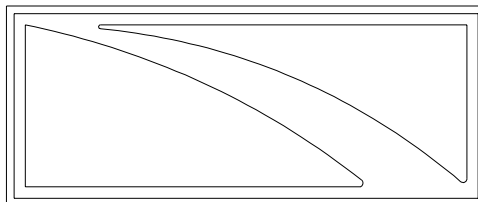

**KEY PART NUMBER U/M DESCRIPTION**  
132651-01-01A EA DECAL - MIRROR/GALLEY

## LABELS GROUP (CONTINUED)



**KEY PART NUMBER U/M DESCRIPTION**  
133424-01-01A EA LABEL - BYPASS - WATER HEATER



**KEY PART NUMBER U/M DESCRIPTION**  
133424-01-01A EA LABEL - BYPASS - WATER HEATER



**KEY PART NUMBER U/M DESCRIPTION**  
133424-02-01A EA LABEL - NORMAL OPERATION



**KEY PART NUMBER U/M DESCRIPTION**  
133424-03-01A EA LABEL - WATER HEATER BYPASS - BLACK/CLEAR

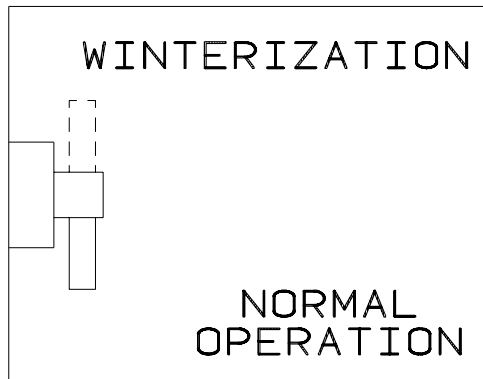

**KEY PART NUMBER U/M DESCRIPTION**  
133425-01-01A EA LABEL - VALVE - WINTERIZATION



**KEY PART NUMBER U/M DESCRIPTION**  
133533-01-01A EA LABEL - JACKS DOWN - CLEAR W/WHITE LETTERING



**KEY PART NUMBER U/M DESCRIPTION**  
133533-02-01A EA LABEL - CHECK ANTENNA - CLEAR W/WHITE LETTERING

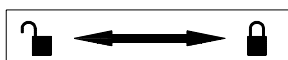

**KEY PART NUMBER U/M DESCRIPTION**  
133533-03-01A EA LABEL - LOCK/UNLOCK - BLACK/WHITE

# LABELS GROUP (CONTINUED)

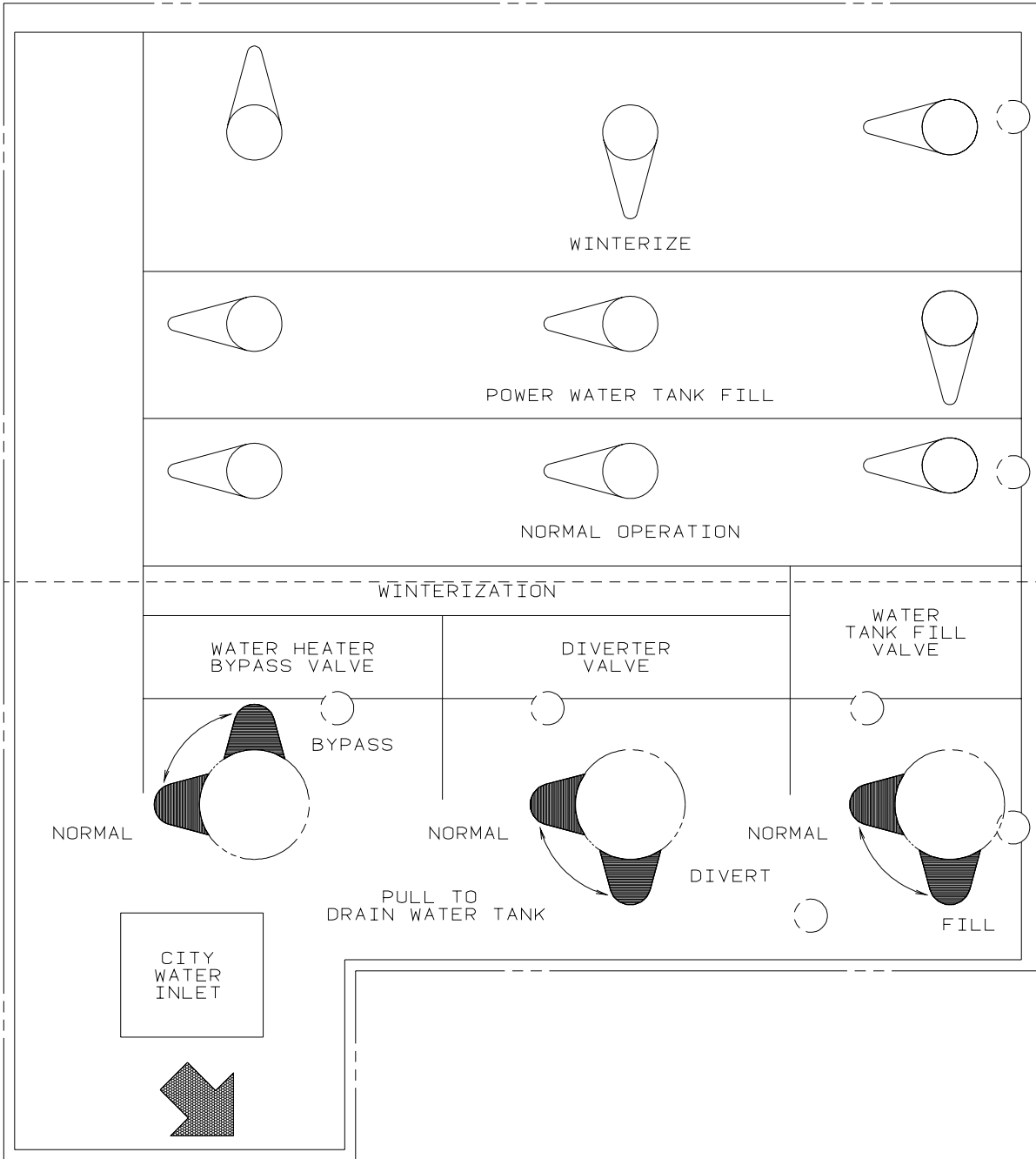

KEY	PART NUMBER	U/M	DESCRIPTION
	133629-01-01A	EA	LABEL - WATER CENTER

# LABELS GROUP (CONTINUED)

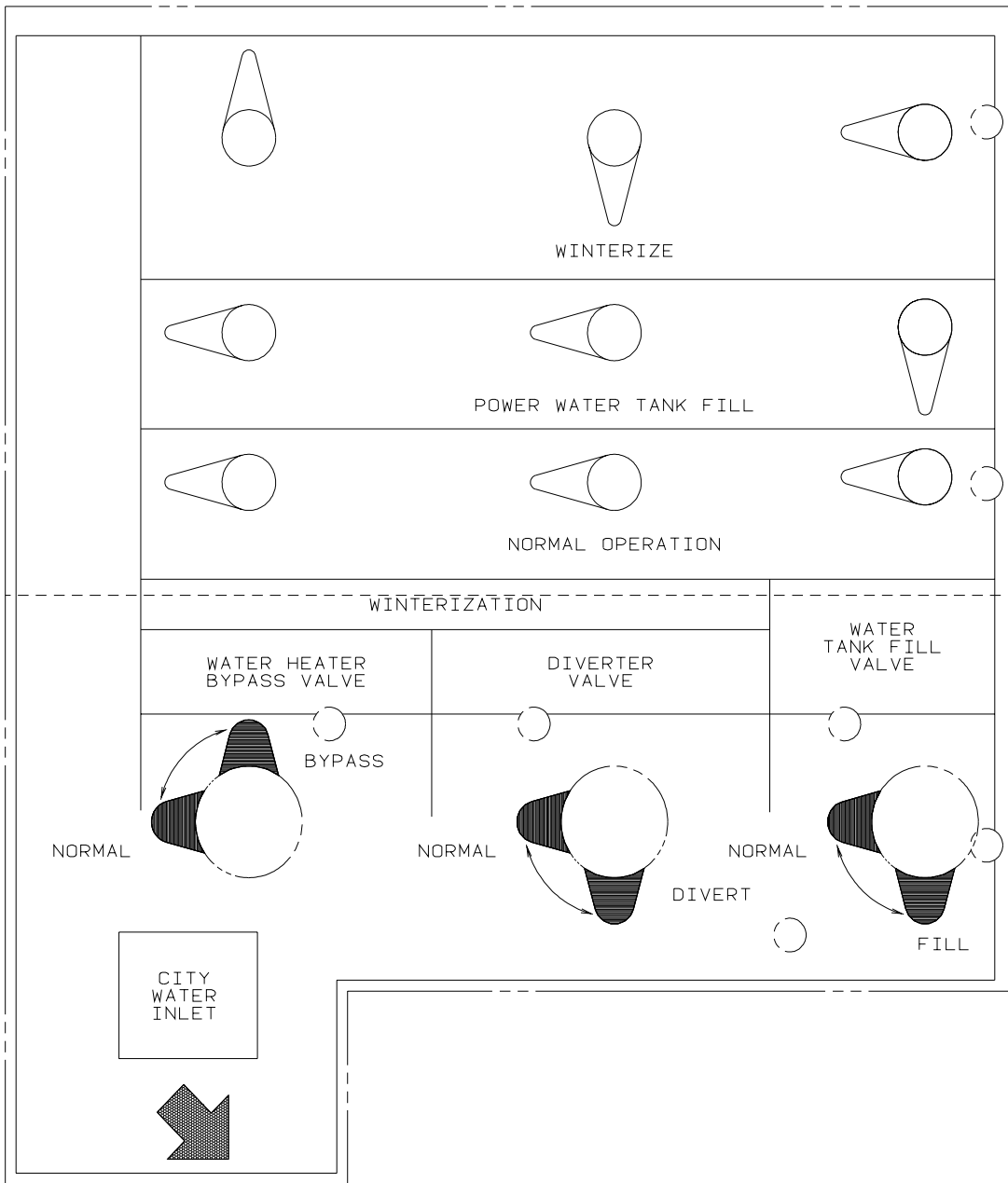

**KEY PART NUMBER U/M DESCRIPTION**  
 133629-02-01A EA LABEL - WATER CENTER - BLACK/CLEAR

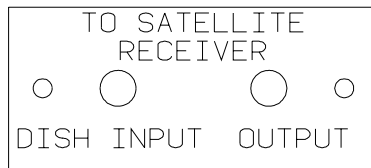

**KEY PART NUMBER U/M DESCRIPTION**  
 134250-01-01A EA LABEL - SATELLITE RECEIVER - BLACK/CLEAR

THIS CHAIR IS NOT INTENDED FOR OCCUPANCY WHEN VEHICLE IS IN MOTION AND MUST BE RETURNED TO STOWED POSITION

DTS ISICE SIEGE N/EST PAS DESTINE A ETRE OCCUPE LORSQUE LE VEHICULE EST IN MOVEMENT ET IL FAUT QUE LE RANGER

THIS CHAIR IS NOT INTENDED FOR OCCUPANCY WHEN VEHICLE IS IN MOTION AND MUST BE RETURNED TO STOWED POSITION

**KEY PART NUMBER U/M DESCRIPTION**  
 134537-01-01A EA LABEL - OCCUPANCY - CHAIR - US



## LABELS GROUP (CONTINUED)

THIS SEAT IS NOT INTENDED  
FOR OCCUPANCY WHEN  
VEHICLE IS IN MOTION

**KEY PART NUMBER U/M DESCRIPTION**  
134538-01-01A EA LABEL - OCCUPANCY - NO SEAT BELT - BLACK ON CLEAR - US

DST ISICE SIEGE N/EST PAS THIS SEAT IS NOT INTENDED  
DESTINE A ETRE OCCUPE LORSQUE FOR OCCUPANCY WHILE  
LE VEHICULE EST IN MOVUUMENT VEHICLE IS IN MOTION

**KEY PART NUMBER U/M DESCRIPTION**  
134538-02-01A EA LABEL - OCCUPANCY - NO SEAT BELT - BLACK ON CLEAR - CSA

### WARNING

IT IS NOT SAFE TO USE COOKING  
APPLICANCES FOR COMFORT HEATING

COOKING APPLICANCES NEED FRESH AIR FOR SAFE OPERATION  
BEFORE OPERATION.

1. OPEN OVERHEAD VENT OR TURN ON EXHAUST FAN AND;
2. OPEN WINDOW.

**KEY PART NUMBER U/M DESCRIPTION**  
134539-01-01A EA LABEL - WARNING - STOVE/HEATING - US - BLACK ON CLEAR

### HOLDING TANK HEATER

TURN OFF WHEN NOT IN USE  
SEE OPERATOR'S MANUAL

**KEY PART NUMBER U/M DESCRIPTION**  
134563-01-01A EA LABEL - SWITCH - HEATER

THIS VEHICLE MAY INCLUDE MERCURY-CONTAINING DEVICES INSTALLED BY THE MANUFACTURER:

FLUORESCENT TUBES, RANGES WITH OVEN, HWH LEVEL SENSING UNIT.

REMOVE DEVICES BEFORE VEHICLE DISPOSAL UPON REMOVAL OF  
DEVICES: PLEASE REUSE, RECYCLE, OR DISPOSE AS HAZARDOUS WASTE

135869-01A

**KEY PART NUMBER U/M DESCRIPTION**  
135869-01-01A EA LABEL - MERCURY CONTENT - BLACK ON CLEAR  
135869-01-02A EA LABEL - MERCURY CONTENT - WHITE ON CLEAR

### LIQUID SOAP

**KEY PART NUMBER U/M DESCRIPTION**  
136047-01-01A EA LABEL - LIQUID SOAP

## LABELS GROUP (CONTINUED)

DOOR LOCK	DOOR UNLOCK	RIGHT COMPT DOOR LOCK	RIGHT COMPT DOOR UNLOCK	LEFT COMPT DOOR LOCK	LEFT COMPT DOOR UNLOCK	AUX START SOLENOID	AMP SOURCE
POWER MIRRORS	HEATER BLOWER	PASS HEATER BLOWER	FOG LAMPS	DOCKING LAMPS	DOCKING LAMPS SWITCH TRIGGER	COOLING FANS	

**KEY PART NUMBER U/M DESCRIPTION**  
 136161-01-01A EA LABEL - RELAY - MATTE BLACK/WHITE LETTERS



**KEY PART NUMBER U/M DESCRIPTION**  
 136360-01-01A EA LABEL - AIR BAGS

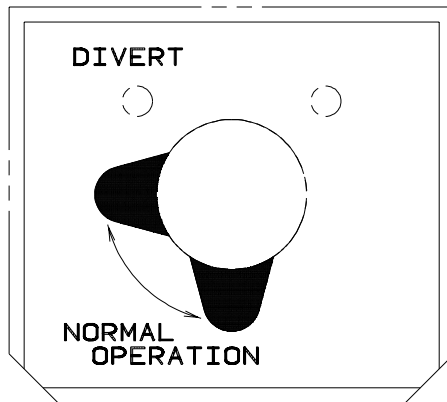

**KEY PART NUMBER U/M DESCRIPTION**  
 137997-01-01A EA LABEL - WINTERIZATION VALVE - BLACK/CLEAR



**KEY PART NUMBER U/M DESCRIPTION**  
 140190-01-01A EA DECAL/LOGO - V6 (DOMED) - CYAN/MAGENTA/YELLOW/BLACK



**KEY PART NUMBER U/M DESCRIPTION**  
 141523-01-01A EA LABEL - WASHER/DRYER BRACKETS - BLACK/WHITE

## LABELS GROUP (CONTINUED)

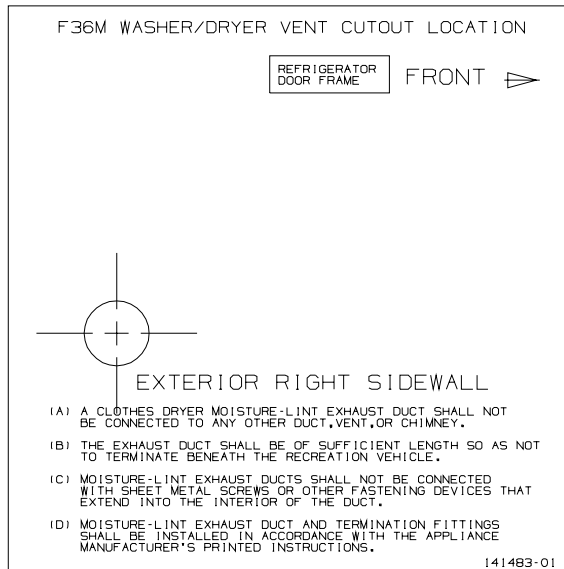

<b>KEY PART NUMBER</b>	<b>U/M DESCRIPTION</b>
141483-01-01A	EA LABEL - DRYER VENTING - BLACK/WHITE

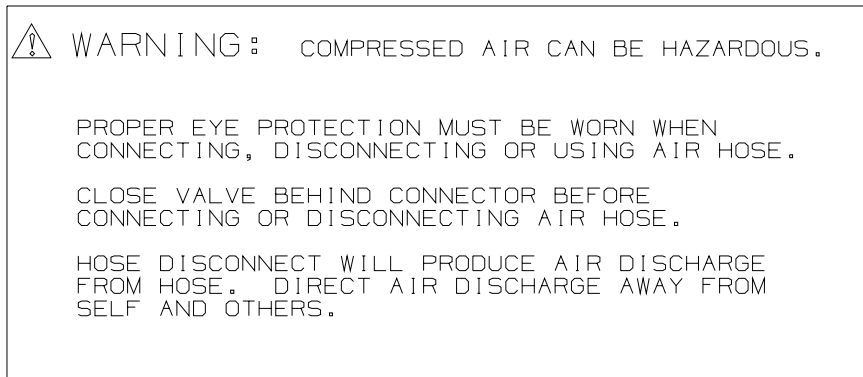

<b>KEY PART NUMBER</b>	<b>U/M DESCRIPTION</b>
142771-01-01A	EA LABEL - WARNING/COMPRESSED AIR - WHITE LETTERING ON CLEAR

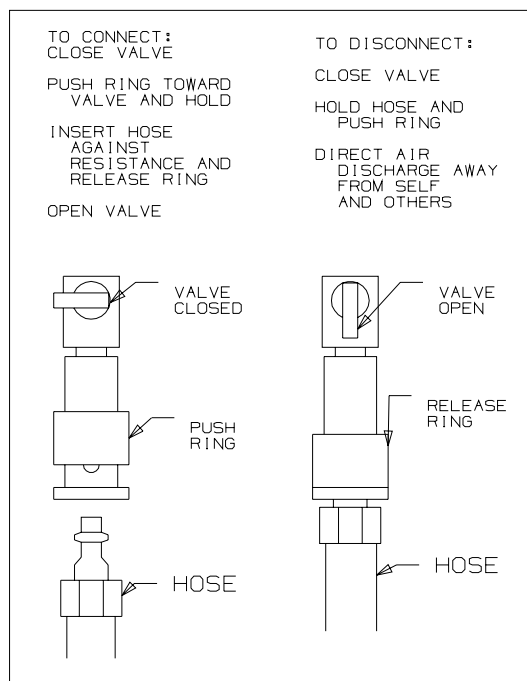

<b>KEY PART NUMBER</b>	<b>U/M DESCRIPTION</b>
142773-01-01A	EA LABEL - CONNECT/COMPRESS AIR - WHITE LETTERING ON CLEAR

**LP GROUP**  
**LP SYSTEM**

KEY	PART NUMBER	U/M	DESCRIPTION
	045703-03-000	EA	HOSE - LP - 3/8"ID X 18" - 3/8"MPT X 1/2"F SWIVEL - USA
	045703-12-000	EA	HOSE - LP - 3/8"ID X 18" - 3/8"MPT X 1/2"F SWIVEL - CANADAIN
	045703-18-000	EA	HOSE - LP - 3/8"ID X 28" W/1/2" FEMALE SWIVELS - Q36C
			FROM: 00-00-00 THRU: 10-20-02
	045703-22-000	EA	HOSE - LP 3/8"ID X 60"-US/CGA - 1/2F SWIVEL X 1/2F SWIVEL - Q36C
			FROM: 10-21-02 THRU: 99-99-99
	045703-15-000	EA	HOSE - LP - 3/8"ID X 142" - 1/2"F SWIVEL X 3/8"F SWIVEL - Q38K
	045703-17-000	EA	HOSE - LP - 3/8"ID X 24" US - 1/2"F SWIVEL X 3/8"F SWIVEL - Q38K
			FROM: 00-00-00 THRU: 10-20-02
	045703-21-000	EA	HOSE - LP 3/8"ID X 60"-US/CGA - 1/2F SWIVEL X 3/8F SWIVEL - Q38K
			FROM: 10-21-02 THRU: 99-99-99
	045703-21-000	EA	HOSE - LP 3/8"ID X 60"-US/CGA - 1/2F SWIVEL X 3/8F SWIVEL - Q40E
	105658-01-000	EA	COMPARTMENT - LP REGULATOR
	106150-01-000	EA	REGULATOR - TWO STAGE-W/90 DEGREE ELBOW & 3/8" FPT OUTLET
	010323-01-000	EA	ADAPTER - BRASS - 3/8"F X 1/2"MPT
	010329-01-000	EA	ADAPTER - BRASS - 1/2"F X 1/2"MPT
	040440-03-000	EA	TRANSMITTER - DIAL/SNAP-ON - 0-90 OHM 2 TERM(POWER/GROUND)
*	117432-03-000	EA	TANK - LP - 130 LB - 20" DIAMETER X 35" - VAPOR DRAW ONLY
	129741-01-02B	EA	BRACKET - LP
	103613-03-000	EA	DETECTOR - LP GAS - W/O SHUT-OFF VALVE
	010377-02-000	EA	NUT - BRASS - 3/8" FLARE - FORGED
	010380-02-000	EA	NUT - BRASS - 1/2" FLARE - FORGED

\*COMPONENT PARTS LISTED LATER IN THIS GROUP

**LP GROUP (CONTINUED)**  
**COMPONENT PARTS FOR LP SYSTEM**

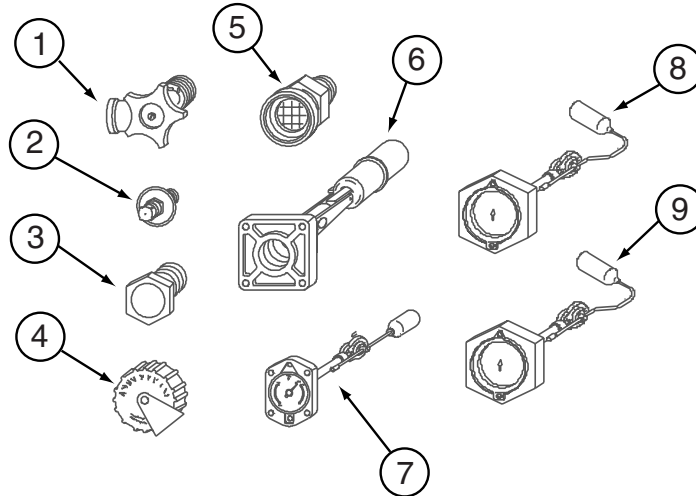

117432-03-000

KEY	PART NUMBER	U/M	DESCRIPTION	VENDOR NO.
1	040421-01-708	EA	HANDWHEEL-SERVICE VALVE	G-1015-A
1	040421-01-712	EA	VALVE,SERV. W/O VAPOR RELIEF	29000853
2	040421-01-700	EA	VALVE-LIQUID LEVEL, 20%	G-1013
3	040421-01-713	EA	VALVE-RELIEF 1" W/SPRING 7"	29000587
4	040421-01-702	EA	CAP-FILL VALVE, PLASTIC	G-1014-A
5	040421-01-701	EA	VALVE-FILL-SHORT, LP	7547B
6	040421-01-711	EA	VALVE-80% FILL W/AUTO STOP	LLL/TL3
7			NOT WHAT IS ILLUSTRATED HERE	
8			NOT WHAT IS ILLUSTRATED HERE	
9			NOT WHAT IS ILLUSTRATED HERE	
	091970-01-700	EA	FLOAT/BOLT ON-SCREW ON DIAL	SG20C0000801
	091970-01-701	EA	FLOAT/SCREW IN-SNAP ON DIAL	SG20C0001595

## LOUNGE GROUP CABINETS

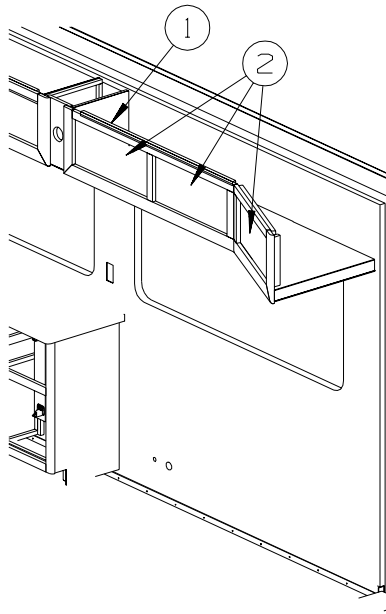

KEY	PART NUMBER	U/M	DESCRIPTION
1	143416-01-PA0	EA	CABINET - OVERHEAD/DINETTE - W/O DOORS/HARDWARE - PORTSMOUTH OAK
1	143416-01-PA1	EA	CABINET - OVERHEAD/DINETTE - W/O DOORS/HARDWARE - CONCERT CHERRY
1	143416-01-PA2	EA	CABINET - OVERHEAD/DINETTE - W/O DOORS/HARDWARE - WASHED MAPLE
2	136957-40-PA0	EA	DOOR - RAIL/ARCHED TOP - 10.8" X 21.8" - W/O HARDWARE - PORTSMOUTH OAK
2	136957-40-PA1	EA	DOOR - RAIL/ARCHED TOP - 10.8" X 21.8" - W/O HARDWARE - CONCERT CHERRY
2	136957-40-PA2	EA	DOOR - RAIL/ARCHED TOP - 10.8" X 21.8" - W/O HARDWARE - WASHED MAPLE

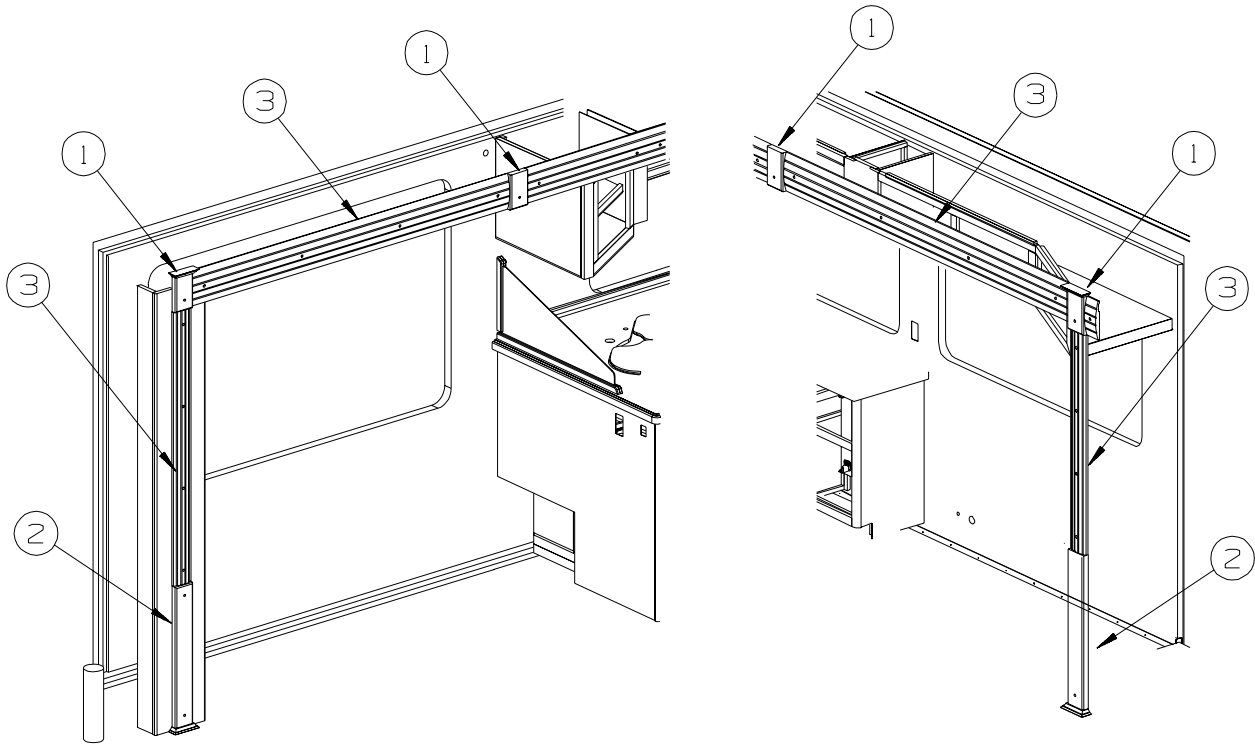

KEY	PART NUMBER	U/M	DESCRIPTION
1	141303-01-N53	EA	MOLDING - CROWN/BLOCK - PORTSMOUTH OAK
1	141303-01-N52	EA	MOLDING - CROWN/BLOCK - CONCERT CHERRY
1	141303-01-N62	EA	MOLDING - CROWN/BLOCK - WASHED MAPLE
2	141303-02-N53	EA	MOLDING - CROWN/BLOCK - PORTSMOUTH OAK
2	141303-02-N52	EA	MOLDING - CROWN/BLOCK - CONCERT CHERRY
2	141303-02-N62	EA	MOLDING - CROWN/BLOCK - WASHED MAPLE
3	P39129-08-N53	EA	MOLDING - FLUTED/CURVED - 3.5" X 44.5" - PORTSMOUTH OAK - PORTSMOUTH OAK
3	P39129-08-N52	EA	MOLDING - FLUTED/CURVED - 3.5" X 44.5" - PORTSMOUTH OAK - CONCERT CHERRY
3	P39129-08-N63	EA	MOLDING - FLUTED/CURVED - 3.5" X 44.5" - PORTSMOUTH OAK - WASHED MAPLE

**SEALANTS & FASTENERS GROUP**  
**SEALANTS & ADHESIVES**

KEY	PART NUMBER	U/M	DESCRIPTION
	002707-02-000	FT	TAPE - SEALER - 5/16" X 1/2" - INCREMENTS OF 50 FT
	004001-02-000	EA	GUN - PLEXUS ADHESIVE - W/O NOZZLE
	004001-05-000	EA	ADHESIVE - SCOTCH-WELD - 3M DP100 - CLEAR - 50ML
	004011-01-000	EA	ADHESIVE-3M-4475 TUBE
	010405-02-000	EA	TAPE - THREAD SEALING - 3/8"
	034552-06-000	EA	SILICONE - TUBE - W/O NOZZLE - OFF WHITE
	034552-15-000	EA	SILICONE - TUBE - W/O NOZZLE - BRIGHT WHITE
	063642-01-000	FT	TAPE - ADHESIVE - .4" X 1.5" X 180'
	064075-07-000	FT	SEAL - BULB - W/WIRED U CHANNEL - .3" X .5" CHANNEL-BLACK
	067788-01-000	EA	ADHESIVE - SPRAY - 3M - 19.5 OZ AEROSOL CAN
	069640-01-000	FT	SEALER - RIBBON - 1/4" DIAMETER X 30' - BLACK OR GRAY
	069640-02-000	FT	SEALER - TAPE - .13" THICK X .5" WIDE X 60' - GRAY
	069640-03-000	FT	SEALER - TAPE - .13" THICK X .75" WIDE X 60' - BLACK
	069640-07-000	FT	SEALER - TAPE - .09" THICK X 2" WIDE X 45' - GRAY
	069640-09-000	FT	SEALER - TAPE - .03" THICK X 2.50"WIDE X 80' - GRAY
	069640-10-000	FT	SEALER - TAPE - .03" THICK X 1.50" WIDE X 90' - GRAY
	069640-11-000	FT	SEALER - TAPE - .19" THICK X .38" WIDE X 40' - BLACK
	069640-13-000	FT	SEALER - TAPE - .03" THICK X 2" WIDE X 45' - BLACK
	069640-14-000	FT	SEALER - TAPE - .06" THICK X 1" WIDE X 100' - GRAY
	069640-15-000	FT	SEALER - TAPE - .06" THICK X .38" WIDE X 100' - GRAY
	069640-17-000	FT	SEALER - TAPE - .03" THICK X 1" WIDE X 90' - GRAY
	069640-18-000	FT	SEALER - TAPE - .50" THICK X .13" WIDE X 60' - BRT WHITE
	069640-19-000	FT	SEALER - TAPE - .75" THICK X .13" WIDE X 60' - BRT WHITE
	069640-20-000	FT	SEALER - TAPE - .50" THICK X 1/8" WIDE X 60' - BLACK
	069640-21-000	FT	SEALER - TAPE - .50" THICK X 1/16" WIDE X 100'-BRIGHT WHT
	069640-23-000	FT	SEALER - TAPE - .06" THICK X 3/4" WIDE X 100' - BRT WHITE
	069640-27-000	FT	SEALER - TAPE - .06" THICK X 2.25" WIDE - BRIGHT WHITE
	069640-28-000	FT	SEALER - TAPE - .25" THICK X 1 7/8" WIDE X 90' - GRAY
	069640-30-000	FT	SEALER - TAPE - 3/8" X 1/32" - GRAY
	069640-31-000	FT	SEALER - TAPE - 25"THICK X 3/4"WIDE X 60' - BLACK
	072889-01-000	EA	SEALANT - URETHANE - BLACK - TUBE W/NOZZLE TIP
	076322-01-000	FT	TAPE-DOUBLE COATED/ADHESIVE BK-.03"THK X .8"W X 216'- WHT
	076322-02-000	FT	TAPE-DOUBLE COATED/ADHESIVE BK-.05"THK X 1"W X 108' - WHT
	076322-03-000	FT	TAPE-DOUBLE COATED/ADHESIVE BK-.05"THK X .5"W X 108' - WHT
	076322-04-000	FT	TAPE-DOUBLE COATED/ADHESIVE BK-.05"THK X .8"W X 108' - WHT
	076322-05-000	FT	TAPE-DOUBLE COATED/ADHESIVE BK-.05"THK X .8"W X 108' - WHT
	076322-11-000	FT	TAPE-DOUBLE COATED/ADHESIVE BK-.02"THK X 1"W X 216' - CLR
	086276-01-000	EA	TAPE - DOUBLE SIDED - 1/2" WIDE X 108' LONG (SOLD BY ROLL)
	088479-01-000	EA	TAPE - ALUMINUM - 3"
	090340-01-000	FT	SEAL - FOAM - CLOSED CELL - 1/4" X 1/2" X 50'
	090340-02-000	FT	SEAL - FOAM - CLOSED CELL - 3/8" X 1/2" X 50'
	091255-02-000	FT	SEAL - ADHESIVE BACKED/FOAM - 3/64" THICK X 3/16"W X 1000'
	091255-03-000	FT	SEAL - ADHESIVE BACKED/FOAM - 1/4" THICK X 1/4"W X 1000'
	094401-01-000	EA	SEALER - BODY SEAM - FLEXICLEAR
	094401-03-000	EA	SEALER - BODY SEAM - BLACK
	094401-04-000	EA	SEALER - BODY SEAM - CLEAR
	098408-01-000	FT	SEAL - SPONGE RUBBER - CLOSED CELL
	099069-01-000	FT	SEAL - RUBBER - CLOSED SPONGE - .5" WIDE X .12" THICK -BLK
	099418-01-000	FT	SEAL - D-SECTION/ADHESIVE BACK - .44" X .44"- BLK RUBBER
	099418-02-000	FT	SEAL - D SECTION - WHITE
	100128-02-000	FT	SEAL - FOAM/ADHESIVE BACK - .37" WIDE X .37" THICK
	104692-01-000	FT	SEAL - ADHESIVE BACKED FOAM - 3/4" THICK X 3/4" WIDE X 25'
	104692-03-000	FT	SEAL - ADHESIVE BACKED FOAM - 1" THICK X 1 3/16"WIDE X 15'
	107828-01-000	EA	SEALANT - SB - 190 EVERSEAL
	108716-01-000	EA	SILICONE - W/O NOZZLE - OFF WHITE - SELF LEVELING
	109506-12-000	EA	FILM/ABRASION-RESISTANT - TRANSPARENT - 1" DIA.
	110274-01-000	FT	TAPE - DOUBLE SIDED/FOAM - .45" X 1" X 216' - BLACK
	112481-02-000	EA	ADHESIVE - PLEXUS ETHACRYLATE - CARTRIDGE
	112864-01-000	FT	SEAL - FOAM/BUTYL COVERED - 3/8" X 35'
	112864-02-000	FT	FOAM - BUTYL COVERED 5/16" X 44'
	112864-03-000	FT	FOAM - BUTYL COVERED - 1/2" X 1/8" X 25'
	112864-04-000	FT	FOAM - BUTYL COVERED - 3/8" X 1/8"
	112901-02-000	EA	ADHESIVE - PLEXUS - MA330 - 50ML - GRAY
	112901-03-000	EA	ADHESIVE - PLEXUS - MA300 - 50ML - WHITE

## SEALANTS & FASTENERS GROUP (CONTINUED)

### SEALANTS & ADHESIVES (CONTINUED)

KEY	PART NUMBER	U/M	DESCRIPTION
	112902-01-000	EA	NOZZLE - ELEMENT - 3/8 X 24
	112902-02-000	EA	NOZZLE-BELL 3/8X24 - TAH 160-824
	112902-03-000	EA	MIXER NOZZLE - F/GUN #00400102000 - SCOTCH-WELD & PLEXUS
	112902-04-000	EA	NOZZLE - ELEMENT - 1/4" X 3.5"
	113366-01-000	EA	ADHESIVE - INSTANT - 1 OZ
	113452-02-000	FT	SEAL/TRIM - FRONT - VINYL W/WIRE CARRIER - .027"
	115933-01-000	FT	TAPE - 1/64" X 3/8" X 100'
	120074-02-03A	EA	SILICONE - TUBE - W/O NOZZLE - SMOKEY WHITE
	120074-02-02A	EA	SILICONE - TUBE - W/O NOZZLE - LOW ODOR - SOFT WHITE
	120534-01-01A	EA	TAPE - SCOTCH - 3M - 1/2" FINE LINE
	123244-01-000	FT	TAPE - DOUBLE SIDED/FOAM - 5/64" THICK X 3/4" WIDE X 108'
	123816-01-000	FT	TAPE - DOUBLE SIDED - 1" X 3/4" X 200'
	123816-02-000	FT	TAPE - DOUBLE SIDED - 1/2" X 1 1/3" X 200'
	123816-03-000	FT	TAPE - DOUBLE SIDED - 1/2" X 3/4" X 200'
	123816-04-000	FT	TAPE - DOUBLE SIDED - 6" X 750'
	126427-01-000	EA	ADHESIVE - ALL PURPOSE - ABS/PVC
	126427-02-000	EA	PRIMER - CLEANER - FLEX PIPING
	131264-01-08A	EA	SILICONE - TUBE - W/O NOZZLE - BUFF
	131264-01-02A	EA	SILICONE - TUBE - W/O NOZZLE - CLEAR
	131264-01-01A	EA	SILICONE - TUBE - W/O NOZZLE - BLACK
	131264-02-01A	EA	SILICONE - TUBE - W/O NOZZLE - VW GRAY - BATH ONLY
	131264-03-01A	EA	SILICONE - TUBE - W/O NOZZLE- SELF LEVELING - BRIGHT WHITE
	131264-04-01A	EA	SILICONE/SEALANT/ADHESIVE - FAST CURE F/GLASS/VINYL - B/W
	131384-01-000	EA	ADHESIVE - JETWELD
	134651-01-000	FT	SEAL - 1/2" X 3/4" PSA 1 SIDE
	900390-01-000	EA	NOZZLE - SILICONE TUBE - 2.5" LONG
	900390-03-000	EA	NOZZLE - SILICONE TUBE - 4.3" LONG

### BOLTS, NUTS AND WASHERS

KEY	PART NUMBER	U/M	DESCRIPTION
	OMC04K-06-016	EA	BOLT - HEX - M06 X 1 X 016
	OMC05K-08-055	EA	BOLT - HEX - M08 X 1.25 X 2.2
	OMC13K-14-110	EA	BOLT - HEX
	OMC13K-14-070	EA	BOLT - HEX - M14 X 2 X 2 3/4
	OMC31K-08-020	EA	BOLT - HEX - SERRATED FLANGE - M8 X 020
	OMC32K-10-030	EA	BOLT - HEX - SERRATED FLANGE - M10 X 1 1/2
	OMD16K-10-000	EA	NUT - HEX PREV TORQUE M10 X 1 1/2 CLASS 8
	OMD39K-12-000	EA	NUT - HEX W/NYLON LOCK - M12 X 1 3/4
	OMD40K-14-000	EA	NUT - HEX W/NYLON LOCK - M14 X 2
	OMD54F-06-000	EA	NUT-HEX SER FLG M6X1,0 SS - DIN6923A2M6
	OME06K-14-280	EA	WASHER - FLAT - 14 ID X 28 OD
	000C12-04-40B	EA	BOLT - HEX - 1/4-20 X 2 1/2 - GRADE 5 ZINC
	000C12-04-08B	EA	BOLT - HEX - 1/4-20 X 1/2 - GRADE #5 - ZINC
	000C12-05-16B	EA	BOLT - HEX - 5/16-18 X 1 - GRADE #5 - ZINC
	000C12-06-24B	EA	BOLT - HEX - 3/8-16 X 1 1/2 - ZINC #5
	000C12-06-16B	EA	BOLT - HEX - 3/8-16 X 1 - GRADE #5 - ZINC
	000C12-06-128	EA	BOLT - HEX - 3/8 - 16 X 8 - ZINC 5
	000C12-06-44B	EA	BOLT - HEX - 3/8-16 X 2 3/4 - GRADE 5 - ZINC
	000C12-08-28B	EA	BOLT - HEX - 1/2-13 X 1 3/4 - GRADE #5 - ZINC
	000C12-08-24B	EA	BOLT - HEX - 1/2-13 X 1 1/2 - GRADE #5 - ZINC
	000C12-08-16B	EA	BOLT - HEX - 1/2-13 X 1 - GRADE #5 - ZINC
	000C12-10-24B	EA	BOLT - HEX - 5/8-11 X 1 1/2 - GRADE #5 - ZINC
	000C13-07-48B	EA	BOLT - HEX - 7/16-20 X 3 - GRADE #5 - ZINC
	000C13-07-40B	EA	BOLT - HEX - 7/16-20 X 2 1/2 - GRADE #5 - ZINC
	000C14-07-28B	EA	BOLT - HEX - 7/16-14 X 1 3/4 - GRADE #8 - ZINC
	000C14-10-32K	EA	BOLT - HEX - 5/8-11 X 2 - GRADE #8 - ZINC
	000C18-05-40A	EA	BOLT - ELEVATOR - 5/16-18 X 2 1/2 - PL
	000C18-06-48B	EA	BOLT - ELEVATOR - 3/8-16 X 3 - GRADE 5 - ZINC
	000C26-04-18B	EA	BOLT - HEX - SERRATED FLANGE - 1/4-20 X 1 1/8 - ZINC
	000C26-04-14B	EA	BOLT - HEX - SERRATED FLANGE - 1/4-20 X 7/8 - ZINC
	000C26-04-10B	EA	BOLT - HEX - SERRATED FLANGE - 1/4-20 X 5/8 - ZINC
	000C26-05-20B	EA	BOLT - HEX - SERRATED FLANGE - 5/16-18 X 1 1/4 - ZINC
	000C26-05-129	EA	BOLT - HEX - SERRATED FLANGE - 5/16-18 X 3/4
	000C26-05-12B	EA	BOLT - HEX - SERRATED FLANGE - 5/16-18 X 3/4 - ZINC



**SEALANTS & FASTENERS GROUP (CONTINUED)**  
**BOLTS, NUTS AND WASHERS (CONTINUED)**

KEY	PART NUMBER	U/M	DESCRIPTION
	000C26-05-249	EA	BOLT - HEX - SERRATED FLANGE - 5/16-18 X 1 1/2
	000C26-06-28B	EA	BOLT - HEX - SERRATED FLANGE - 3/8-16 X 1 3/4 - ZINC
	000C26-06-20B	EA	BOLT - HEX - SERRATED FLANGE - 3/8-16 X 1 1/4 - ZINC
	000C26-06-12B	EA	BOLT - HEX - SERRATED FLANGE - 3/8-16 X 3/4 - ZINC
	000C26-06-40B	EA	BOLT - HEX - SERRATED FLANGE - 3/8-16 X 2 1/2 - ZINC
	000C26-08-24B	EA	BOLT - HEX - SERRATED FLANGE - 1/2-13 X 1 1/2 - ZINC
	000C27-04-40B	EA	BOLT - CARRIAGE - 1/4-20 X 2 1/2 - ZINC
	000C27-05-44I	EA	BOLT-CARR,5/16-18X2.75" - BLACK ZINC
	000C27-07-40B	EA	BOLT - CARRIAGE - 7/16-14 X 2 1/2 - GRADE #5
	000D16-07-00B	EA	NUT - HEX - 7/16-14 - ZINC
	000D24-10-00B	EA	NUT - HEX - SELF LOCKING - 10-32 ZINC
	000D28-10-00B	EA	NUT - HEX - W/NYLON LOCK - 10-32 ZINC
	000D29-04-00B	EA	NUT - HEX - SELF LOCKING - 1/4 X 20 - ZINC
	000D29-06-00B	EA	NUT - HEX - W/NYLON LOCK - 3/8-16 - ZINC
	000D29-09-00B	EA	NUT - HEX - SELF LOCKING - 9/16-12 - ZINC
	000D30-07-00B	EA	NUT - HEX LOCK - NYLON 7/16 X 20
	000D34-06-00B	EA	NUT - HEX - LOCKING - 3/8-16 GRADE C - ZINC
	000D39-04-00B	EA	NUT - HEX - LOCKING W/SERRATED FLANGE - 1/4-20 - ZINC
	000D39-05-00B	EA	NUT - HEX - LOCKING W/SERRATED FLANGE - 5/16-18 - ZINC
	000D39-06-00B	EA	NUT - HEX - LOCKING W/SERRATED FLANGE - 3/8-18 - ZINC
	000D39-06-00D	EA	NUT - HEX - LOCKING W/SERRATED FLANGE - 3/8"-16 BLACK
	000D39-07-00B	EA	NUT - HEX - LOCKING W/SERRATED FLANGE - 7/16-14 - ZINC
	000D44-04-00B	EA	NUT - HEX - LOCKING W/SERRATED FLANGE - 1/4-28 - ZINC
	000D44-07-00B	EA	NUT - HEX - LOCKING W/SERRATED FLANGE - 7/16-20 - ZINC
	000D44-08-00B	EA	NUT - HEX - LOCKING W/SERRATED FLANGE - 1/2-20 - ZINC
	000D46-04-00A	EA	NUT - HEX - WELD - 1/4-20 - PLAIN
	000D65-08-00B	EA	NUT - HEX - LOCKING W/SERRATED FLANGE - 8-32 - ZINC
	000D67-10-00B	EA	NUT - HEX - LOCK - 5/8-11 - ZINC
	000D73-08-00C	EA	NUT - HEX FLANGE - 1/2-13
	000D75-09-00B	EA	NUT - HEX LOCKING - 9/16-12 - ZINC
	000D76-06-00B	EA	NUT - HEX FLANGE - 3/8-16
	000E11-04-00F	EA	WASHER - LOCKING - 1/4 MED SPLIT - STAINLESS STEEL
	000E11-07-00B	EA	WASHER - LOCKING - 7/16 MED SPLIT - ZINC
	000E11-08-00B	EA	WASHER - LOCKING - 1/2 MED SPLIT - ZINC
	000E13-17-00B	EA	WASHER - FLAT - 3/8 AR - ZINC
	000E13-18-00B	EA	WASHER - FLAT - 3/8 WIDE - ZINC
	000E13-20-00B	EA	WASHER - FLAT - 7/16 WIDE - ZINC
	000E13-22-00B	EA	WASHER - FLAT - 1/2 WIDE - ZINC
	000E13-26-00B	EA	WASHER - FLAT - 5/8 WIDE - ZINC
	000E14-10-00B	EA	WASHER - LOCKING - #10 EXTERNAL TOOTH - ZINC
	000E16-10-00B	EA	WASHER - HARDENED - 5/8 - FLAT - ZINC
	000G45-05-16B	EA	BOLT - LAG - 5/16-9 X 1 - ZINC
	000G62-08-24B	EA	SCREW - SF/DR - 8-18 X 1 1/2 PFH
	002329-01-000	EA	WASHER-FLAT, 9/32" ID X 5/8" OD - NYLON
	005081-01-000	EA	NUT - SPEED - C-TYPE - #8 SCREW
	040921-03-000	EA	NUT - SPEED - U TYPE - #10
	040921-04-000	EA	NUT - SPEED - U TYPE - #8-.59" LENGTH X .44" WIDTH
	040921-05-000	EA	NUT - SPEED - U-TYPE - 8-.67" X .44" WIDE
	041322-01-000	EA	WASHER - FLANGE - 15/32 ID X 2 3/8 OD - F/SEAT BELT MTG
	044364-01-000	EA	NUT - SPEED - FLAT - RECTANGULAR - SELF LOCKING/ONE PIECE
	044364-02-000	EA	NUT - SPEED - FLAT - ROUND
	044533-01-000	EA	WASHER - PLASTIC - 1 3/8 OD - FOR BUTTONS
	046867-04-000	EA	GROMMET - #0
	046867-05-000	EA	WASHER - #0
	051387-06-000	EA	BOLT - CARRIAGE W/O HOLE - 5/16-18 X 9 1/2 - ZINC
	058716-02-000	EA	WASHER - FLAT NYLON
	058716-03-000	EA	WASHER - FLAT/NYLON - .500 X 1 1/4 X 060
	064081-03-000	EA	NUT - WING 3/8-16 - W/WELD NUT
	077071-01-000	EA	WASHER - FENDER - 3/16 ID X 1 OD
	084406-01-000	EA	NUT - CAPPED - CROSS RECESSED - BLACK - 1/4-20 THD
	087234-01-000	EA	NUT - JACK - 1/4 X 20 THD - MOLLY
	087718-01-000	EA	MONOBOLT - STEEL - 3/16 DIAMETER
	088787-12-000	EA	STUD - WELD - 1/4 - 20 X 1.0 LG - MN
	102333-02-01A	EA	BOLT - CARRIAGE - 1/4-20

**SEALANTS & FASTENERS GROUP (CONTINUED)**  
**BOLTS, NUTS AND WASHERS (CONTINUED)**

KEY	PART NUMBER	U/M	DESCRIPTION
	102540-02-000	EA	SEAL - SCREW
	103020-02-000	EA	BOLT-U - #8-32 - GRADE 5 ZINC
	106166-01-000	EA	BOLT/COLLARED HANGER - 8-32 X 1
	106956-03-000	EA	BOLT - HEX TAP - 1/2-12NC X 3 - GRADE 5 - FULL THREAD/ZINC
	106956-08-000	EA	BOLT - HEX TAP - 1/2-13NC X 4 - GRADE 5 - FULL THREAD/ZINC
	107393-02-000	EA	BOLT - SHOULDER - 3/8" SOCKETHEAD
	107397-01-000	EA	WASHER - FENDER - 3/4 ID X 1 OD
	108067-03-000	EA	STUD - WELD - 1/4 - 20 X 1/2 CD
	109235-01-05A	FT	COVER - SCREW - BRIGHT WHITE
	109235-01-01A	FT	COVER - SCREW - MAT BLACK
	109917-03-000	EA	WASHER - 1" X .50"
	109917-04-000	EA	WASHER - 1" X .75"
	113985-02-000	EA	BOLT - FLANGE - M10-1 1/2 X 30CL 10.9
	114259-05-000	EA	BOLT - 7/16-20 X 1 1/4 W/WASHER
	128444-01-000	EA	WASHER - SPRING - CONICAL
	131377-01-000	EA	NUT-HEX HEAD W/WASHER-1/4-20 X 2" STEEL W/3/4" OD WASHER
	135092-01-01A	EA	BOLT - HEX - SERRATED FLANGE - 1/2-20 X 1 3/4-GRADE 5 ZINC
	135092-02-01A	EA	BOLT - HEX - SERRATED FLANGE - 1/2-20 X 2 1/2-GRADE 5 ZINC

**SCREWS**

KEY	PART NUMBER	U/M	DESCRIPTION
	0G1106-08-240	EA	SCREW - 6-20 X 1/2 PPH - VW LIGHT GRAY
	0G1108-12-240	EA	SCREW - 8-18 X 3/4 PPH - VW LIGHT GRAY
	0G1208-12-170	EA	SCREW - 8-18 X 3/4 POH - BRIGHT WHITE
	0G1306-08-130	EA	SCREW-6-20X1/2 PFH TAUPE
	0G1308-10-240	EA	SCREW - 8-18 X 5/8 PFH - VW LIGHT GRAY
	0G3804-22-180	EA	SCREW - MACHINE - 1/4-20 X 1 3/8 PFH - BLACK
	0G3908-08-160	EA	SCREW - SF/DR - 8-18 X 1/2 PPH - VW WHITE
	0G3908-08-240	EA	SCREW - SF/DR - 8-18 X 1/2 PPH - VW LIGHT GRAY
	0G3908-08-170	EA	SCREW - SF/DR - 8-18 X 1/2 PPH - BRIGHT WHITE
	0G3908-12-250	EA	SCREW - SF/DR - 8-18 X 3/4 PPH - DARK GRAY
	0G3908-12-240	EA	SCREW - SF/DR - 8-18 X .75 PPH - VW LIGHT GRAY
	0G3908-16-170	EA	SCREW - SF/DR - 8-18 X 1 PPH - BRIGHT WHITE
	0G3908-24-170	EA	SCREW - SF/DR - 8-18 X 1 1/2 PPH - BRIGHT WHITE
	0G3910-10-320	EA	SCREW - SF/DR - 10-16 X 5/8 PPH - GLACIER
	0G3910-10-240	EA	SCREW - SF/DR - 10-16 X 5/8 PPH - VW LIGHT GRAY
	0G3910-10-330	EA	SCREW - SF/DR - 20-16 X 5/8 PPH - PUTTY
	0G3910-12-320	EA	SCREW - SF/DR - 10-16 X .75 PPH - GLACIER
	0G3910-12-240	EA	SCREW - SF/DR - 10-16 X .75 PPH - VW LIGHT GRAY
	0G3910-12-170	EA	SCREW - SF/DR - 10-16 X 3/4 PPH - BRIGHT WHITE
	0G5508-12-270	EA	SCREW - SF/DR - 8-18 X 3/4 PWH - TITANIUM
	0G5508-12-260	EA	SCREW - SF/DR - 8-18 X 3/4 PWH - ALLANTE ANTELOPE
	0G5508-12-240	EA	SCREW - SF/DR - 8-18 X 3/4 PWH - VW LIGHT GRAY
	0G5508-12-170	EA	SCREW - SF/DR - 8-18 X 3/4 PWH - BRIGHT WHITE
	0G5508-12-330	EA	SCREW - SF/DR - 8-18 X 3/4 PWH - PUTTY
	0G5508-12-320	EA	SCREW - SF/DR - 8-18 X 3/4 PWH - GLACIER
	0G5508-16-320	EA	SCREW - SF/DR - 8-18 X 1 PWH - GLACIER
	0G5508-16-250	EA	SCREW - SF/DR - 8-18 X 1 PWH - VW DARK GRAY
	0G6008-16-170	EA	SCREW - SF/DR - 8-18 X 1 POH - BRIGHT WHITE
	0G6710-08-240	EA	SCREW - 10-12 X 1/2 PPH TAUPE - VW LIGHT GRAY
	0G6710-08-170	EA	SCREW - 10-12 X 1/2 PPH - BRIGHT WHITE
	0G6710-08-130	EA	SCREW - 10-12 X 1/2 PPH - TAUPE
	0G6710-12-170	EA	SCREW - 10-12 X 3/4 PPH - BRIGHT WHITE
	0G6806-16-170	EA	SCREW - 6-18 X 1 POH - BRIGHT WHITE
	0G6810-24-280	EA	SCREW - 10-12 X 1 1/2 POH - SOFT WHITE
	000C20-04-16A	EA	SCREW - 1/4-20X 1 - FLAT SOCKET HEAD
	000C20-05-28F	EA	SCREW - 5/16-18 X 1 3/4 FLAT SOC - STAINLESS STEEL
	000C20-06-24T	EA	SCREW - 3/8-16 X 1 1/2 - FLAT SOCKET
	000G11-06-10J	EA	SCREW - 6-20 X 5/8 PPH - BRASS
	000G11-06-08B	EA	SCREW - 6-20 X 1/2 PPH - ZINC
	000G11-07-08B	EA	SCREW - 7-19 X 1/2 PPH - ZINC
	000G11-08-12B	EA	SCREW - 8-18 X 3/4 PPH - ZINC
	000G11-08-08T	EA	SCREW - 8-18 X 1/2 PPH - FLUOROCARBON COATING

**SEALANTS & FASTENERS GROUP (CONTINUED)**  
**SCREWS (CONTINUED)**

KEY	PART NUMBER	U/M	DESCRIPTION
	000G11-08-06B	EA	SCREW - 8-18 X 3/8 PPH - ZINC
	000G11-08-20G	EA	SCREW - 8-18 X 1 1/4 - ANTIQUE BRASS
	000G11-08-20B	EA	SCREW - 8-18 X 1 1/4 PPH - ZINC
	000G11-08-16B	EA	SCREW - 8-18 X 1 PPH - ZINC
	000G11-08-12T	EA	SCREW - 8-18 X 3/4 PPH - BLACK MAGNESIUM
	000G11-08-12P	EA	SCREW - 8-18 X 3/4 PPH - DARK BROWN
	000G11-10-12D	EA	SCREW - 10-16 X 3/4 PPH - BLACK
	000G12-06-12J	EA	SCREW - 6-20 X .75 POH - BRASS
	000G12-06-08T	EA	SCREW - 6-20 X 1/2 POH - BLACK
	000G12-08-12S	EA	SCREW - 8-18 X 3/4 POH - OFF WHITE
	000G13-05-10B	EA	SCREW - 5-12 X 5/8 PFH - ZINC
	000G13-06-08B	EA	SCREW - 6-20 X 1/2 PFH - ZINC
	000G13-06-06I	EA	SCREW - 6-20 X 3/8 PFH - BLACK ZINC
	000G13-06-16J	EA	SCREW - 6-20 X 1 PFH - BRASS
	000G13-06-10J	EA	SCREW - 6-20 X 5/8 PFH - BRASS
	000G13-06-10G	EA	SCREW - 6-20 X 5/8 PFH - ANTIQUE BRASS
	000G13-06-08G	EA	SCREW - 6-20 X 1/2 PFH - ANTIQUE BRASS
	000G13-06-24J	EA	SCREW - 6-20 X 1 1/2 PFH - BRASS
	000G13-07-12B	EA	SCREW - 7-19 X 3/4 PFH - ZINC
	000G13-07-10H	EA	SCREW - 7-19 X 5/8 PFH - BLACK
	000G13-08-10B	EA	SCREW - 8-18 X 5/8 PFH - ZINC
	000G13-08-24B	EA	SCREW - 8-18 X 1 1/2 PFH - ZINC
	000G13-08-16B	EA	SCREW - 8-18 X 1 PFH - ZINC
	000G13-08-109	EA	SCREW - 8-18 X 5/8 PFH
	000G13-10-16I	EA	SCREW - 10-16 X 1 PFH - BLACK
	000G16-04-24B	EA	SCREW - MACHINE - 1/4-20 X 1 1/2 PPH
	000G18-08-22B	EA	SCREW - MACHINE - 8-32 X 1 3/8 PPH - ZINC
	000G18-08-16B	EA	SCREW - MACHINE - 8-32 X 1 PPH - ZINC
	000G18-08-12B	EA	SCREW - MACHINE - 8-32 X 3/4 PPH - ZINC
	000G18-08-24B	EA	SCREW - MACHINE - 8-32 X 1 1/2 PPH - ZINC
	000G19-10-12F	EA	SCREW - MACHINE - 10-32 X 3/4 PPH - STAINLESS STEEL
	000G19-10-10B	EA	SCREW - MACHINE - 10-32 X 5/8 - PPH - ZINC
	000G19-10-08B	EA	SCREW - MACHINE - 10-32 X 1/2 PPH - ZINC
	000G19-10-20B	EA	SCREW - MACHINE - 10-32 X 1 1/2 PPH - ZINC
	000G36-10-12T	EA	SCREW - 10-24X 3/4 PFH TYPE 23 - BLACK
	000G39-06-16T	EA	SCREW - SF/DR - 6-20 X 1 PPH - BLACK
	000G39-06-10T	EA	SCREW - SF/DR - 6-20 X 5/8 PPH - BLACK
	000G39-08-32B	EA	SCREW - SF/DR - 8-18 X 2 PPH - ZINC
	000G39-08-24T	EA	SCREW - SF/DR - 8-18 X 1 1/2 PPH - BLACK
	000G39-08-24S	EA	SCREW - SF/DR - 8-18 X 1 1/2 - OFF WHITE
	000G39-08-24B	EA	SCREW - SF/DR - 8-18 X 1 1/2 PPH - ZINC
	000G39-08-16T	EA	SCREW - SF/DR - 6-20 X 1 PPH - BLACK
	000G39-08-16B	EA	SCREW - SF/DR - 8-18 X 1 PPH - ZINC
	000G39-08-12B	EA	SCREW - SF/DR - 8-18 X 3/4 PPH - ZINC
	000G39-08-08T	EA	SCREW - SF/DR - 8-18 X 1/2 PPH - BLACK
	000G39-08-08S	EA	SCREW - SF/DR - 8-18 X 1/2 PPH - OFF WHITE
	000G39-08-08B	EA	SCREW - SF/DR - 8-18 X 1/2 PPH - ZINC
	000G39-08-06B	EA	SCREW - SF/DR - 8-18 X 3/8 PPH - ZINC
	000G39-10-08B	EA	SCREW - SF/DR - 10-16 X 1/2 PPH - ZINC
	000G39-10-48T	EA	SCREW - SF/DR - 10-16 X 3 PPH - BLACK
	000G39-10-48B	EA	SCREW - SF/DR - 10-16 X 3 - PPH - ZINC
	000G39-10-32B	EA	SCREW - SF/DR - 10-16 X 2 - PPH - ZINC
	000G39-10-20T	EA	SCREW - SF/DR - 10-16 X 1 1/4 PPH - BLACK
	000G39-10-20B	EA	SCREW - SF/DR - 10-16 X 1 1/4 PPH - ZINC
	000G39-10-169	EA	SCREW - SF/DR - 10-16 X 1 PPH - FLUOROCARBON SILVER
	000G39-10-129	EA	SCREW - SF/DR - 10-16 X 3/4 PPH - FLUOROCARBON SILVER
	000G39-10-12T	EA	SCREW - SF/DR - 10-16 X 3/4 - BLACK
	000G39-10-10T	EA	SCREW - SF/DR - 10-16 X 5/8 - BLACK
	000G39-10-10B	EA	SCREW - SF/DR - 10-16 X 5/8 - ZINC
	000G39-12-12E	EA	SCREW - SF/DR - 12-14 X 3/4 PPH - CHROME
	000G42-04-16B	EA	SCREW - SF/DR - 1/4-14 X 1 HWH - ZINC
	000G42-04-24B	EA	SCREW - SF/DR - 1/4-14 X 1 1/2 - ZINC
	000G46-08-24T	EA	SCREW - MACHINE - 8-32 X 1 1/2 PFH - BLACK
	000G50-04-08B	EA	SCREW - MACHINE - 1/4-20 X 1/2 PTH - ZINC

**SEALANTS & FASTENERS GROUP (CONTINUED)**  
**SCREWS (CONTINUED)**

KEY	PART NUMBER	U/M	DESCRIPTION
	000G51-06-12B	EA	SCREW - 6-20 X 3/4 PTH - ZINC
	000G52-06-05B	EA	SCREW - MACHINE - 6-32 X 5/16 PTH ZINC
	000G52-08-18B	EA	SCREW - MACHINE - 8-32 X 1 1/8 PTH - ZINC
	000G54-04-14B	EA	SCREW - 1/4-20 X 7/8 PTH - TYPE 23 - ZINC PLATED
	000G55-08-165	EA	SCREW - SF/DR - 8-18 X 1 PWH - WILLOW
	000G55-08-16T	EA	SCREW - SF/DR - 8-18 X 1 PWH - BLACK
	000G55-08-16S	EA	SCREW - SF/DR - 8-18 X 1.00 - PWH - OFF WHITE
	000G55-08-124	EA	SCREW - SF/DR - 8-18 X 3/4 PWH - ASH GRAY
	000G55-08-12M	EA	SCREW - SF/DR - 8-19 X .75 PWH - GRAY
	000G56-12-48B	EA	SCREW - WOOD - 12-11 X 3 POH - SPECIAL HARDENED
	000G57-14-72B	EA	SCREW-14-10-X4 1/2 PFH ZN                   GENERAL MOTORHOMES
	000G57-14-64B	EA	SCREW - 14-10 X 4 PFH ZINC
	000G60-08-22B	EA	SCREW - SF/DR - 8-18 X 1.38 POH - ZINC
	000G60-08-20F	EA	SCREW - SF/DR - 8-19X1.25 POH
	000G60-08-16E	EA	SCREW - SF/DR - 8-1 X 1 POH - CHROME
	000G60-10-20B	EA	SCREW - SF/DR - 10-16 X 1 1/4 POH - ZINC
	000G60-10-28T	EA	SCREW - SF/DR - 10-16 X 1 3/4 - BLACK
	000G60-10-209	EA	SCREW - SF/DR - 10-16 X 1 1/4 POH - SILVER STALGAARD
	000G67-08-32B	EA	SCREW - 8-15 X 2 PPH - ZINC
	000G67-10-24S	EA	SCREW - 10-12 X 1 1/2 PPH - OFF WHITE
	000G67-10-24B	EA	SCREW - 10-12 X 1 1/2 PPH - ZINC
	000G67-10-20D	EA	SCREW - 10-12 X 1 1/4 PPH - BLACK
	000G67-10-125	EA	SCREW - 10-12 X 3/4 PPH - WILLOW
	000G67-10-12S	EA	SCREW - 10-12 X 3/4 PPH - OFF WHITE
	000G67-10-12P	EA	SCREW - 10-12 X 3/4 PPH - DARK BROWN
	000G67-10-12B	EA	SCREW - 10-12 X 3/4 PPH - ZINC
	000G67-10-10T	EA	SCREW - 10-12 X 5/8 PPH - BLACK
	000G67-10-10S	EA	SCREW - 10-12 X 5/8 PPH - OFF WHITE
	000G67-10-10P	EA	SCREW - 10-12 X 5/8 PPH - DARK BROWN
	000G67-10-10B	EA	SCREW - 10-12 X 5/8 PPH - ZINC - TYPE A
	000G67-10-08B	EA	SCREW - 10-12 X 1/2 PPH - ZINC
	000G67-10-36T	EA	SCREW - 10-12 X 2 1/4 - PPH - BLACK
	000G68-06-12J	EA	SCREW - 6-18 X 3/4 POH - BRASS
	000G68-06-10J	EA	SCREW - 6-18 X 5/8 POH - BRASS
	000G68-06-10G	EA	SCREW - 6-18 X 5/8 POH - ANTIQUE BRASS
	029130-01-000	EA	SCREW - SNAP STUD - #8-16 X 5/8" LONG
	029130-03-000	EA	SCREW - SNAP STUD - #8-16 X 1" LONG
	049465-01-000	EA	SCREW - 10-16 PTH W/WASHER - DARK BROWN
	049465-03-000	EA	SCREW - 10-16 X 1 POH W/WASHER - OFF WHITE
	049465-04-000	EA	SCREW - 10-16 X 1 PTH W/WASHER - BEIGE
	049465-13-000	EA	SCREW-10+16X1 PTH W/WASHER - *ASH GRAY
	049465-17-000	EA	SCREW - 10-16 X 1 POH W/WASHER - BRIGHT WHITE
	049465-23-000	EA	SCREW - 10-16 X 1.5 POH W/WASHER - VW LIGHT GRAY
	054434-03-000	EA	SCREW - SF/DR - 10-16 X 2 - PWH - ZINC - W/O WINGS
	075908-01-000	EA	SCREW - MACHINE - 10-32 X .56 PTH - EXTERNAL TOOTH - ZINC
	076790-01-000	EA	SCREW - 6-20 X 1 1/4 PPH - BLACK
	076790-05-000	EA	SCREW - 6-20 X 1/2 PPH - BLACK - THREAD CUTTING/WOOD
	083554-01-000	EA	SCREW - DRYWALL - 8 X 1 1/4
	083554-04-000	EA	SCREW - DRYWALL - 8 X 2 1/2
	087721-01-000	EA	SCREW - FLAT HEAD - TAPPING - 1/4 X 1 1/4 LONG - ZINC
	090033-02-000	EA	SCREW - 1/4-20 X 5/8 - ROUND WASHER HEAD - OFF/WHITE
	097974-01-000	EA	SCREW - PARTICLE BOARD - 7-9 X 3/4 PPH
	101618-01-000	EA	SCREW - 1/4-20 X 3/4 HEX - TAPPING - STALGARD TYPE F
	110460-05-02A	EA	SCREW - MACHINE - 10-24 X 2 1/2 PFH - WHITE
	113563-01-01A	EA	SCREW - 8 X 5/8 LONG SHOULDER/WASHER HEAD
	117478-01-04A	EA	SCREW - 8-18 X 3/4 PPH W/WASHER - VW LIGHT GRAY
	118383-01-04A	EA	RETAINER/RECESSED - F/.22" SCREW - BRIGHT WHITE
	118383-01-05A	EA	RETAINER/RECESSED - F/.22" SCREW - VW LIGHT GRAY
	118383-01-09A	EA	RETAINER/RECESSED - F/.22" SCREW - GLACIER
	118383-02-09A	EA	RETAINER/RECESSED - F/.27" SCREW - GLACIER
	118383-02-05A	EA	RETAINER/RECESSED - F/.27" SCREW - VW LIGHT GRAY
	118383-03-09A	EA	RETAINER/RECESSED - F/.32" SCREW - GLACIER

**SEALANTS & FASTENERS GROUP (CONTINUED)**  
**SCREWS (CONTINUED)**

KEY	PART NUMBER	U/M	DESCRIPTION
	118383-04-09A	EA	CAP - F/RECESSED RETAINER - GLACIER
	118383-04-05A	EA	CAP - F/RECESSED RETAINER - VW LIGHT GRAY
	118383-04-04A	EA	CAP - F/RECESSED RETAINER - BRIGHT WHITE
	126458-01-01A	EA	SCREW - 8-18 X 1/2 - PRWH - BLACK
	134126-01-01A	EA	SCREW/NAIL - HEX HEAD - 3/4"
	140040-01-000	EA	SCREW - 1/4-20 X 1 - BUTTON HEAD/SOCKET - W/LOCTITE

**CLAMPS, CLIPS, GROMMETS, RIVETS & PLUGS**

KEY	PART NUMBER	U/M	DESCRIPTION
	000F10-06-32B	EA	PIN - COTTER - 3/16" X 2" - ZINC
	000H14-06-06R	EA	RIVET-MANDREL BLIND,3/16 AL - CHERRY BSP-66
	000H14-06-03R	EA	RIVET - MANDREL BLIND - 3/16 ALUMINUM
	000H16-04-06R	EA	RIVET - POP ALUMINUM - 1/8 X .313 - .375
	000H16-06-10R	EA	RIVET - POP ALUMINUM - 3/16 X .501-.625
	007161-01-000	EA	CLAMP - HOSE - SPRING TYPE - 1/2"
	010495-01-000	EA	CLAMP - CABLE - 9/16"ID
	010495-02-000	EA	CLAMP - CABLE - 3/8"ID
	010495-04-000	EA	CLAMP - CABLE - 11/16" - WHITE
	010497-01-000	EA	CLAMP - CLOSED - 5/8"ID
	010497-03-000	EA	CLAMP - CLOSED - 1"ID - CUSHIONED
	010497-04-000	EA	CLAMP - CLOSED - 1 5/8"ID
	010497-05-000	EA	CLAMP - CLOSED - 1/2"ID
	010497-07-000	EA	CLAMP - CLOSED - 3/8"ID
	010497-10-000	EA	CLAMP - CLOSED
	010499-01-000	EA	CLAMP - CLOSED - 3/8"ID
	016188-03-000	EA	GROMMET - L/P LINE - 3/8"HOLE X 2 1/2"LONG - RUBBER
	016188-04-000	EA	GROMMET - L/P LINE - 1/2"HOLE X 2 1/2"LONG - RUBBER
	016188-05-000	EA	GROMMET - L/P LINE - 3/8"HOLE X 1 1/4"LONG - RUBBER
	016188-06-000	EA	GROMMET - L/P LINE - 3/8"HOLE X 3 1/4"LONG
	016188-07-000	EA	GROMMET - L/P LINE - 1/2"HOLE X 3 1/4"LONG
	023942-01-000	EA	GROMMET - RUBBER - 2" OD
	034141-02-000	EA	PLUG/NYLON - .38" - BLACK
	061420-04-000	EA	PLUG/PLASTIC - 1 1/4" DIAMETER
	061420-05-000	EA	PLUG/PLASTIC - 1 1/2" DIAMETER
	061420-08-000	EA	PLUG/PLASTIC - 2 1/2" DIAMETER
	061420-09-000	EA	PLUG/PLASTIC - 1.00" - DIAMETER
	061420-10-000	EA	PLUG/PLASTIC - 1 1/2" DIAMETER - BLACK
	061420-14-000	EA	PLUG/PLASTIC - .034" DIAMETER
	061420-15-000	EA	PLUG/PLASTIC - 2" DIAMETER - BLACK
	061420-16-000	EA	PLUG/PLASTIC - 2 1/8" DIAMETER
	062401-01-000	EA	CLAMP - HOSE - WORMGEAR - .25" - 1"
	062401-02-000	EA	CLAMP - HOSE - WORMGEAR - 1.56" - 2.5"
	062401-03-000	EA	CLAMP - HOSE - WORMGEAR - .22" - 1"
	062401-04-000	EA	CLAMP - HOSE - WORMGEAR - .69" - 1.25"
	062401-05-000	EA	CLAMP - HOSE - WORMGEAR - 2" - 3" ID
	062401-06-000	EA	CLAMP - HOSE - WORMGEAR - .22" - .62" ID
	062401-09-000	EA	CLAMP - HOSE - WORMGEAR - 2.8" - 3.75"
	062401-11-000	EA	CLAMP - HOSE - WORMGEAR - 3.50" - 4.50"
	062401-12-000	EA	CLAMP - HOSE - WORMGEAR - .79" X 1.26"
	071015-11-000	EA	GROMMET - RUBBER - 1"ID FITS .12 MATERIAL - BLACK
	071015-19-000	EA	GROMMET - RUBBER - .38 ID - FITS .06 MATERIAL - BLACK
	071015-26-000	EA	GROMMET - RUBBER - 1.5" ID X 2.1" OD W/.06" GROOVE-BLACK
	071015-30-000	EA	GROMMET - RUBBER - .31" ID X .81" OD W/.12" GROOVE-BLACK
	071015-39-000	EA	GROMMET - .75 ID FITS .06 MTL
	071015-41-000	EA	GROMMET - .125 ID FITS .188 MTL
	075148-02-000	EA	CLAMP - GROUNDING - BRONZE SCREWS
	077955-01-000	EA	CLIP/J - 3/8" - VINYL COATED
	080734-02-000	EA	CLIP - WIRE NYLON
	081211-03-000	EA	PLUG/PLASTIC - .50 DIAMETER - BLACK
	081211-04-000	EA	PLUG/PLASTIC - .46 DIAMETER - BLACK

**SEALANTS & FASTENERS GROUP (CONTINUED)**  
**CLAMPS, CLIPS, GROMMETS, RIVETS & PLUGS (CONTINUED)**

KEY	PART NUMBER	U/M	DESCRIPTION
	083609-01-000	EA	CLAMP - WIRE - DUAL - EQUAL DIAMETERS - 5/8"
	083610-01-000	EA	CLAMP - WIRE - DUAL - UNEQUAL DIAMETERS - 3/4" & 1 1/4"
	083610-02-000	EA	CLAMP - WIRE - DUAL - UNEQUAL DIAMETERS - 3/4" & 2"
	083610-03-000	EA	CLAMP - WIRE - DUAL - EQUAL DIAMETERS - 2"
	088756-01-000	EA	GROMMET - WEB - 1 1/8" I.D.
	091952-01-000	EA	CLIP - GRIPPER - 1"
	091952-02-000	EA	CLIP - GRIPPER - 3/4"
	094362-02-000	EA	CLIP - XMAS TREE - BINDER HEAD - .9" LONG
	114208-04-000	EA	GROMMET - EDGE LINER - FITS 1"
	114208-05-000	EA	GROMMET - EDGE LINER - FITS 2"
	118626-01-02A	EA	RIVET - POP - ALUMINUM - 3/16 X .08 - .375
	118626-01-01A	EA	RIVET - POP - ALUMINUM - 3/16 X .08 - .375
	118626-02-01A	EA	RIVET - POP - ALUMINUM - 3/16 X .500 - .750
	137014-01-01A	EA	GROMMET - CABLE - ALMOND
	137014-01-02A	EA	GROMMET - CABLE - BROWN
	139118-01-01A	EA	GROMMET - PLASTIC/SCREW
	139118-02-01A	EA	GROMMET - SCREW - PLASTIC
	140171-02-000	EA	CLAMP - HOSE - STEPLESS EAR - .250

**MISCELLANEOUS FASTENERS**

KEY	PART NUMBER	U/M	DESCRIPTION
	008343-01-000	EA	TIE - WIRE - 6"
	008343-02-000	EA	TIE - WIRE - 14"
	008343-03-000	EA	TIE - WIRE - 7 1/2" - BLACK
	029094-04-000	YD	VELCRO TAPE - LOOP - 1" WIDE - BLACK
	029094-06-000	YD	VELCRO TAPE - LOOP - 2" WIDE - BLACK
	029096-03-000	YD	VELCRO TAPE - HOOK - 1" WIDE - BLACK
	029096-04-000	YD	VELCRO TAPE - HOOK - 1" WIDE - BLACK
	048394-02-000	YD	VELCRO TAPE - HOOK - ADHESIVE BACK - 3/4" WIDE - BEIGE
	085774-01-000	FT	FASTENER - DUAL LOCK - 1" WIDE - ADHESIVE BACK - BLACK
	085774-02-000	FT	FASTENER - DUAL HOOK - 1" WIDE - ADHESIVE BACK - BLACK
	085774-03-000	FT	FASTENER - DUAL LOCK - 1/2" WIDE - ADHESIVE BACK - BLACK
	085774-04-000	FT	FASTENER - DUAL HOOK - 1/2" WIDE - ADHESIVE BACK - BLACK
	088792-02-000	YD	VELCRO TAPE - LOOP - 3/4" - ADHESIVE BACK - BEIGE
	088792-04-000	YD	VELCRO TAPE - HOOK - 5/8" - NON-ADHESIVE BACK - WHITE
	088792-05-000	YD	VELCRO TAPE - LOOP - 5/8" - NON-ADHESIVE BACK - WHITE
	108046-02-000	EA	CABLE TIE - SCREW MOUNT 15"
	110943-02-000	FT	FELT STRIP - 3/8" - ADHESIVE BACK - WHITE
	113133-02-01A	EA	RIVET - POP - ALUMINUM - 3/16 X .252 - .504 - BLACK
	127960-01-01A	EA	RETAINER - 3/8" - STAINLESS STEEL

## WATER & SEWAGE GROUP DRAINAGE SYSTEM

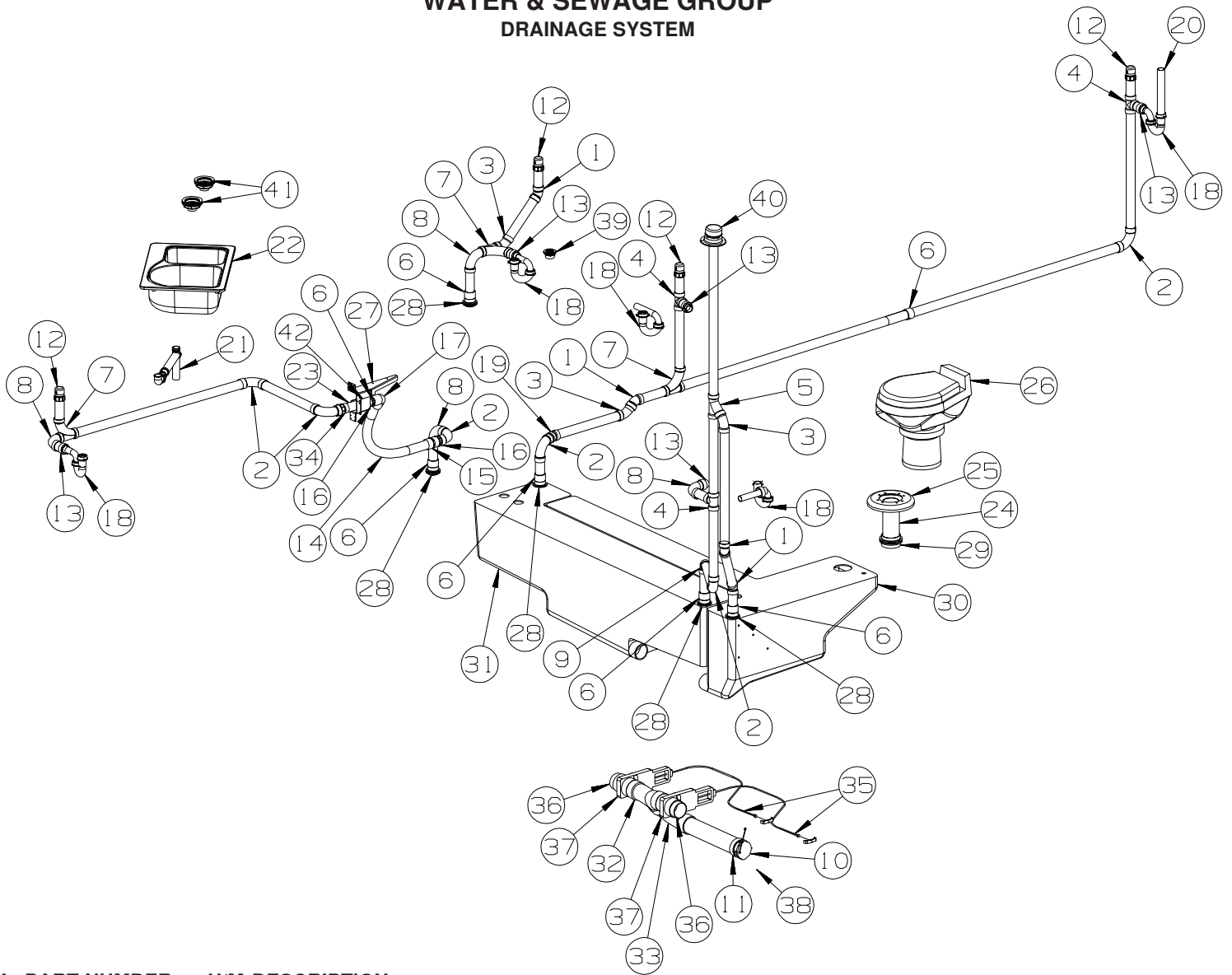

KEY	PART NUMBER	U/M	DESCRIPTION
1	010006-01-000	EA	ELBOW - 45 DEGREE - 1 1/2" HUB X HUB - PLASTIC
2	010008-01-000	EA	ELBOW - 90 DEGREE - 1 1/2" HUB X HUB - PLASTIC
3	010051-01-000	EA	ELBOW - 45 DEGREE - 1 1/2" SPIGOT X HUB - PLASTIC
4	010071-01-000	EA	TEE - SANITARY - 1 1/2" HUB X HUB X HUB - PLASTIC
5	010073-01-000	EA	WYE - 45 DEGREE - 1 1/2" HUB X HUB X HUB - PLASTIC
6	010115-01-000	EA	COUPLING - 1 1/2" HUB X HUB - PLASTIC
7	031365-02-000	EA	TEE - PLASTIC - 1 1/2" EXTRA LONG TURN
8	033761-01-000	EA	ELBOW - 90 DEGREE - TURN - 1 1/2" HUB X 1 1/2" SPIGOT
9	034250-01-000	EA	ELBOW - 90 DEGREE - LONG TURN - 1 1/2" HUB X HUB - ABS
10*	062415-01-000	EA	CAP - SEWER - 3" DIAMETER
11	062417-01-000	EA	ADAPTER - TERMINATION - 3"
12	079968-01-000	EA	VENT - MECHANICAL/TRAP ARM - ANTI-SIPHON-2" X 7.3" PLASTIC
13	109571-01-000	EA	ADAPTER - P-TRAP - 1 1/2"P X 1 1/4"MPT
14	126426-01-000	FT	PIPE - 1 1/2" FLEXIBLE
15	130685-01-000	EA	ADAPTER - 1 7/8" FEMALE SLIP X 1 1/2" FEMALE THREAD/O-RING
16	130685-03-000	EA	ADAPTER - 1 7/8" MALE SLIP X 1 1/2" MALE THREAD/O-RING
17	136111-01-000	EA	ELBOW-1 1/2, SOCKETXSLIP FIT - LASCO
18	107538-01-000	EA	P-TRAP - PLASTIC - 1 1/4" W/EXTENSION ARM - USA
18	011071-01-000	EA	P-TRAP - PLASTIC - 1 1/2" - CSA - CANADIAN
19	010005-01-000	EA	ELBOW - 22.5 DEGREE - 1 1/2" HUB X HUB - PLASTIC
20	126588-02-000	EA	ARM - WASTE - 1 1/2 X 20" - FEMALE
21	011091-04-000	EA	WASTE - CONTINUOUS - DOUBLE SINK - DISHWASHER - W/DISHWASHER
21	011091-02-000	EA	WASTE - CONTINUOUS - DOUBLE SINK - W/O DISHWASHER
22	134851-01-01A	EA	SINK - DOUBLE/GALLEY - LARGE/SMALL - 25" X 18" X 6.9"D-WHT
23	142527-01-02B	EA	BRACKET/CARRIER - PLUMBING - E-COATED

**WATER & SEWAGE GROUP (CONTINUED)**  
**DRAINAGE SYSTEM (CONTINUED)**

<b>KEY</b>	<b>PART NUMBER</b>	<b>U/M</b>	<b>DESCRIPTION</b>
24	116644-01-000	EA	FLANGE/CLOSET - 3" FEMALE - 4 BOLT
25	131786-03-01A	EA	SPACER - TOILET - ROUND - 10" DIAM. X 1.3" HIGH - SOFT WHT
26*	136729-01-01A	EA	TOILET - CHINA - STANDARD W/SPRAYER - WHITE
27	142526-01-02B	EA	BRACKET/COVER - PLUMBING - E-COATED
28	061607-01-000	EA	GROMMET - HOLDING TANK - 1 1/2" NPS
29	061607-02-000	EA	GROMMET - HOLDING TANK - 3" NPS
30	128993-01-000	EA	TANK - HOLDING - 60 GALLON - W/O FITTINGS
31	128996-01-000	EA	TANK - HOLDING - 70 GALLON - W/O FITTINGS
32	010065-01-000	EA	TEE - PLASTIC - 3" FEMALE
33	041956-01-000	EA	ELBOW - 3" STREET - 90 DEGREE PLASTIC
34	062417-01-000	EA	ADAPTER - TERMINATION - 3"
35	062421-04-000	EA	CABLE/ROD - F/DUMP VALVE - W/HANDLE - 36"
36	078406-01-000	EA	COUPLER - RUBBER - W/CLAMPS - 3" X 3"
37	129147-01-000	EA	VALVE - 3" HUB X 3" HUB - REMOTE
38	139513-02-000	EA	HOSE - SEWER - 3" X 20' - W/ADAPTER
39	066440-01-000	EA	STRAINER - SHOWER DRAIN - W/RUBBER WASHER
	011069-06-000	EA	TAILPIECE - 1 1/2" X 1 1/4" X 2 1/2"
	130403-01-000	EA	NUT - SLIP - W/WINGS 1 1/2"
	132376-01-01A	EA	GASKET - FOAM - 1 1/2" - TUB STRAINER
40	083558-03-000	EA	VENT - PLUMBING - ROOF PIPE COVERED - OFF WHITE
41	092303-01-000	EA	STRAINER - W/BASKET - GALLEY SINK - 4" OD
	127440-02-01A	EA	WASHER - RUBBER - 1.8" X .1"
42	142527-01-02B	EA	BRACKET/CARRIER - PLUMBING - E-COATED

**\*COMPONENT PARTS LISTED LATER IN THIS GROUP**



**WATER & SEWAGE GROUP (CONTINUED)**  
**COMPONENT PARTS FOR DRAINAGE SYSTEM**

062415-01-000

**KEY PART NUMBER**  
062415-01-700

**U/M DESCRIPTION**  
EA STRING-SEWER CAP

**VENDOR NO.**  
V#SV7 STRAP

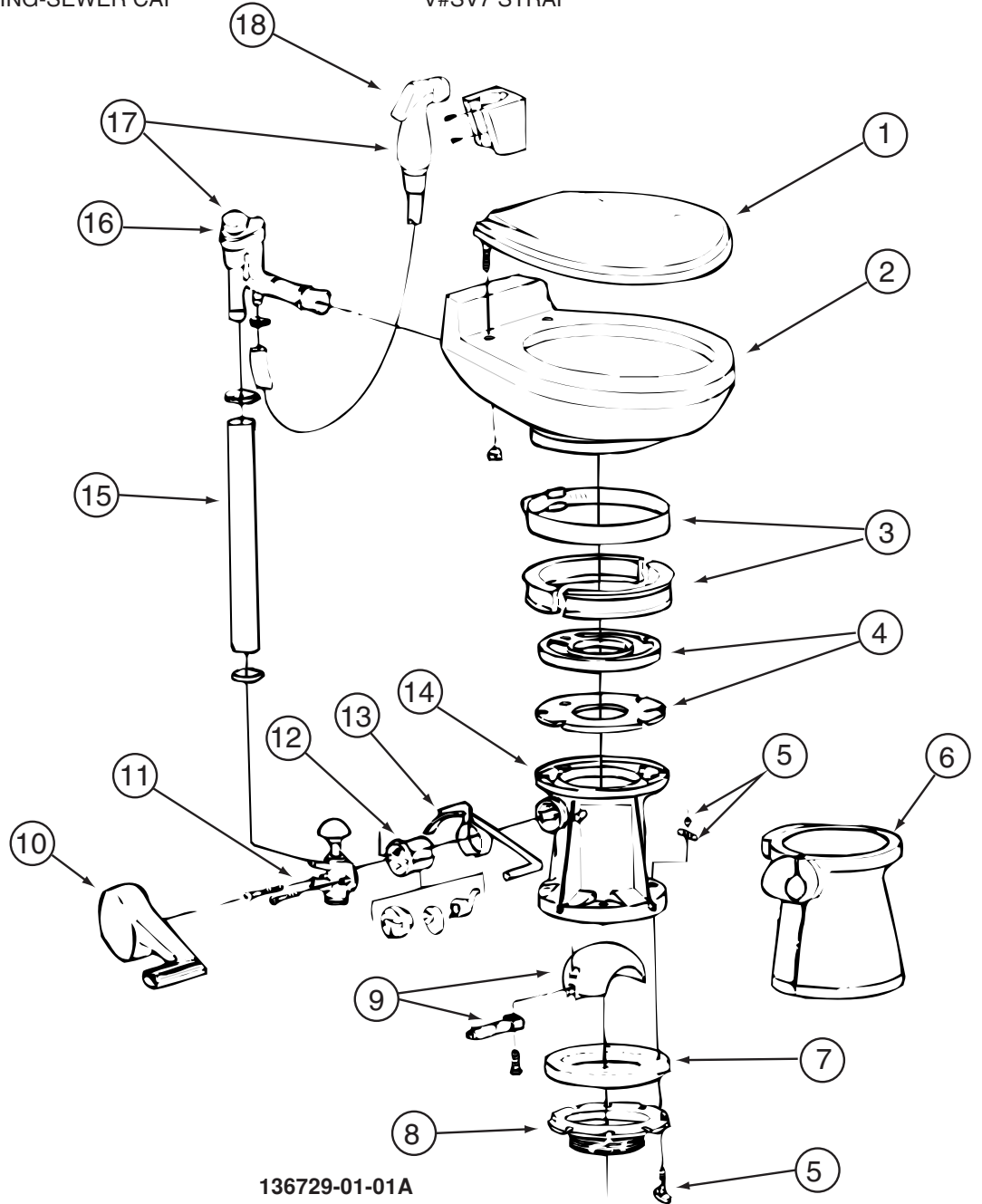

136729-01-01A

**KEY PART NUMBER**  
 1 136729-01-700  
 2 136729-01-701  
 3 085330-01-703  
 4 085330-01-704  
 5 085330-01-717  
 6 085330-09-704  
 7 085330-01-714  
 8 085330-01-716  
 10 085330-09-702  
 11 085330-01-709  
 12 085330-01-707  
 13 085330-06-703  
 14 085330-09-703  
 16 085330-06-701  
 18 085330-04-701

**U/M DESCRIPTION**  
 EA SEAT ASSEMBLY - WHITE  
 EA BOWL/CHINA - WHITE  
 EA RING & HALF CLAMPS, BONE  
 EA TEFLON & RUBBER SEAL KIT  
 EA HARDWARE KIT - BASE MOUNTING  
 EA PEDESTAL COVER - WHITE  
 EA SEAL-FLANGE, FLOOR  
 EA FLANGE-FLOOR, 3" MPT  
 EA COVER/PEDAL KIT - WHITE  
 EA VALVE-WATER  
 EA CARTRIDGE SPRING ASSEMBLY  
 EA LEVER-FLUSH  
 EA BASE KIT - WHITE  
 EA BREAKER-VACUUM/DIVERTER(900)  
 EA HAND SPRAY W/HOSE(500 & 900)

**VENDOR NO.**  
 343829  
 310739  
 385310048  
 385316140  
 310064  
 310111  
 390343892  
 345889  
 310114  
 385314349  
 381236096  
 340873  
 310120  
 230335  
 340683

CONTACT WINNEBAGO PART SALES FOR UNLISTED COMPONENTS

**WATER & SEWAGE GROUP (CONTINUED)**  
**WATER SYSTEM**

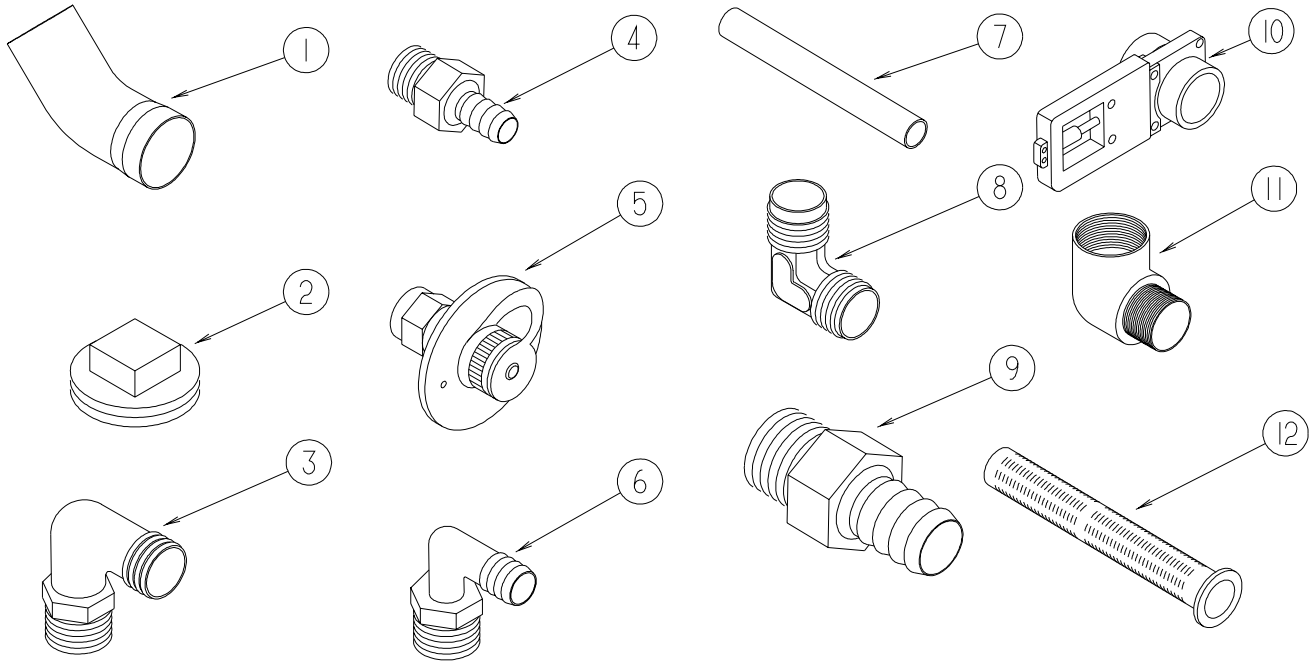

KEY	PART NUMBER	U/M	DESCRIPTION
1	010009-01-000	EA	ELBOW - 90 DEGREE - 1/4 BEND - 1 1/2" PLASTIC
2	010166-01-000	EA	PLUG/THREADED - 1 1/4"MPT - PLASTIC - BLACK - UL
3	010219-01-000	EA	ELBOW - 1 1/4 MPT X 1 1/4 BARB - WATER FILL - PLASTIC
4	010224-01-000	EA	ADAPTER - HOSE TO PIPE - 3/8 MPT X 3/8 BARB - PLASTIC
5	010230-06-000	EA	FILL - CITY WATER - W/CHECK VALVE - MPT - BRUSHED ALUM
6	035539-01-000	EA	ELBOW - 3/8 MPT X 3/8 BARB - PLASTIC
7	039800-04-000	FT	TUBING - POLYBUTYL - 1/4"OD
7	074462-02-000	FT	TUBING - VINYL - 3/8 ID X 20' - CLEAR
7	112176-01-000	FT	TUBING - VINYL - REINFORCED - 1/2" ID
7	124188-01-000	FT	TUBING - PEX - 1/2" ID X 20' - BLUE(COLD)
7	124188-02-000	FT	TUBING - PEX - 1/2" ID X 20' - RED(HOT)
8	039808-03-000	EA	ELBOW - 1/2" MPT X 1/2" MPT - PLASTIC
9	044927-01-000	EA	ADAPTER - HOSE TO PIPE-1 1/4 MPTX1 1/4 BARB-BLACK PLASTIC
10	062421-03-000	EA	VALVE/DUMP W/O HANDLE - 1 1/2" X 1 1/2" HUB
11	065318-02-000	EA	ELBOW - 90 DEGREE - 3/8" MPT TO 3/8" FPT
12	077954-02-000	EA	FILTER - WATER TANK - W/SCREEN IN TANK

**WATER & SEWAGE GROUP (CONTINUED)**  
**WATER SYSTEM (CONTINUED)**

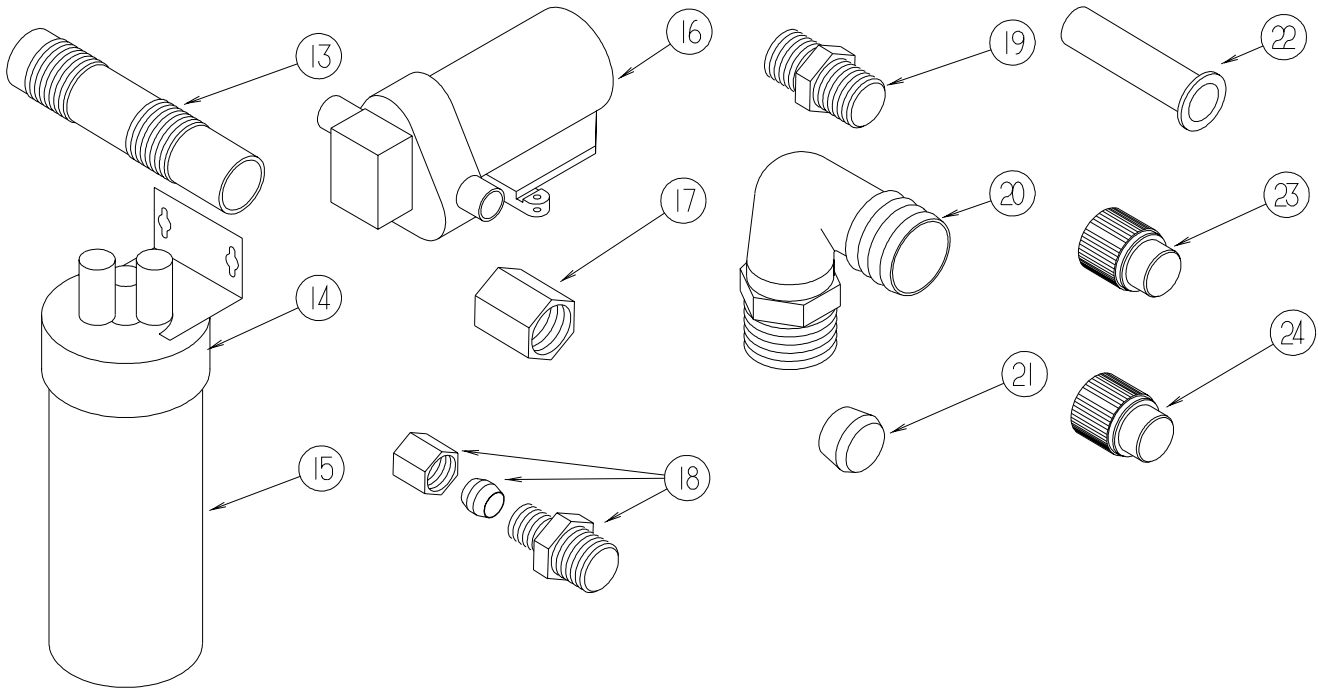

KEY	PART NUMBER	U/M	DESCRIPTION
13	079381-01-000	FT	TUBING - RIBBED FLEXIBLE - WATER FILL - 1.4" ID
14	087200-01-000	EA	FILTER-WATER PURIFICATION, EVERPURE QC2-AC
15	087200-02-000	EA	CARTRIDGE-WATER FILTER, AC - EVERPURE 9601-11
16*	098607-01-000	EA	PUMP - WATER - W/.5" MPT FITTING - FLOW 2.8 GPM
17	101814-01-000	EA	COUPLING - FEMALE - 1/2" X 1/2" FPT - GRAY
18	103798-01-000	EA	CONNECTOR - 1/4 OD X 3/8 MPT
19	110438-02-000	EA	VALVE - CHECK - BRASS - 1/2 MPT X 1/2 MPT
20	111223-02-000	EA	ELBOW - 1/2" MPT X 3/8" BARB - PLASTIC
20	111223-03-000	EA	ELBOW - 3/4" MPT X 1/2" BARB - PLASTIC
20	111223-04-000	EA	ELBOW - 1/2" MPT X 1/2" BARB - PLASTIC
21	111888-01-000	EA	FERRULE - PLASTIC - .250 ID X .375 OD
22	111888-02-000	EA	INSERT - BRASS - 1/4 COMP
23	113697-01-000	EA	CAP - 3/8"P
24	114427-01-000	EA	CAP - 1/2"P

**WATER & SEWAGE GROUP (CONTINUED)**  
**WATER SYSTEM (CONTINUED)**

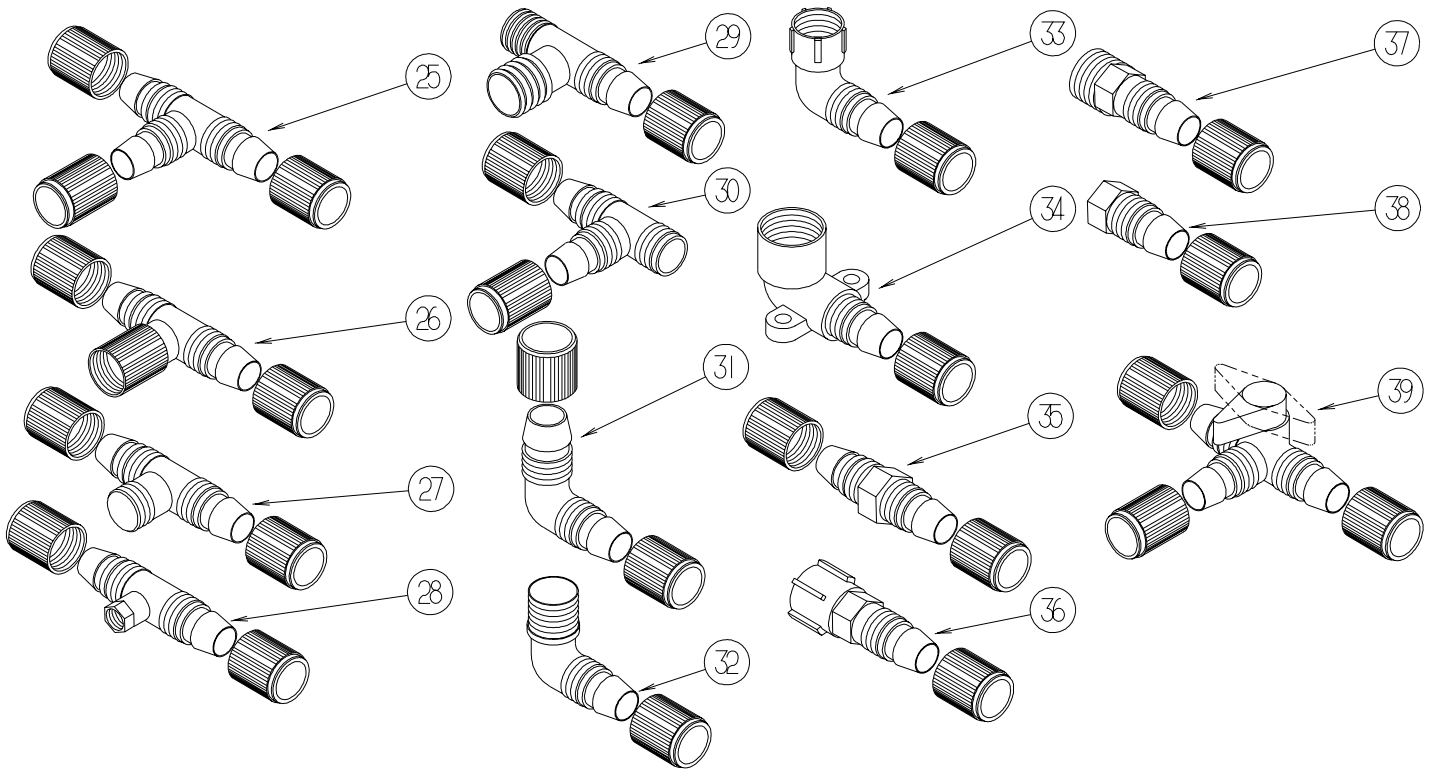

KEY	PART NUMBER	U/M	DESCRIPTION
25	114428-01-000	EA	TEE - 1/2"P X 1/2"P X 1/2"P
26	114428-02-000	EA	TEE - SWIVEL - 1/2"P X 1/2"P X 1/2"FPT
27	114428-03-000	EA	TEE - 1/2"P X 1/2"P X 1/2"MPT
28	114428-04-000	EA	TEE - 1/2"P X 1/2"P X 1/8"FPT
29	114428-06-000	EA	TEE - 1/2" P X 1/2" MPT X 1/2" MPT
30	114428-07-000	EA	TEE - 1/2" P X 1/2" MPT X 1/2" P
31	114429-01-000	EA	ELBOW - 1/2"P X 1/2"P
32	114429-02-000	EA	ELBOW - 1/2"P X 1/2"MPT
32	114429-04-000	EA	ELBOW - 1/2"P X 3/8"MPT
32	114429-05-000	EA	ELBOW - 1/2"P X 3/4"MPT
33	114429-03-000	EA	ELBOW - SWIVEL - 1/2"P X 1/2"FPT
33	114429-06-000	EA	ELBOW - SWIVEL - 1/2"P X 3/4"FPT
33	114429-08-000	EA	ELBOW - SWIVEL - 1/2"P X 1/2"FPT
34	114429-09-000	EA	ELBOW - 1/2"P X 1/2"FPT DROP EAR
35	114430-01-000	EA	ADAPTER - 1/2"P X 1/2"P
36	114430-02-000	EA	ADAPTER - SWIVEL - 1/2"P X 1/2"FPT
37	114430-03-000	EA	ADAPTER - 1/2"P X 1/2"MPT
38	114430-06-000	EA	ADAPTER - 1/2"P X 3/8"FPT
39	114431-01-000	EA	VALVE - 180 DEGREE/CENTER DRAIN - 1/2"P - THREE WAY

**WATER & SEWAGE GROUP (CONTINUED)**  
**WATER SYSTEM (CONTINUED)**

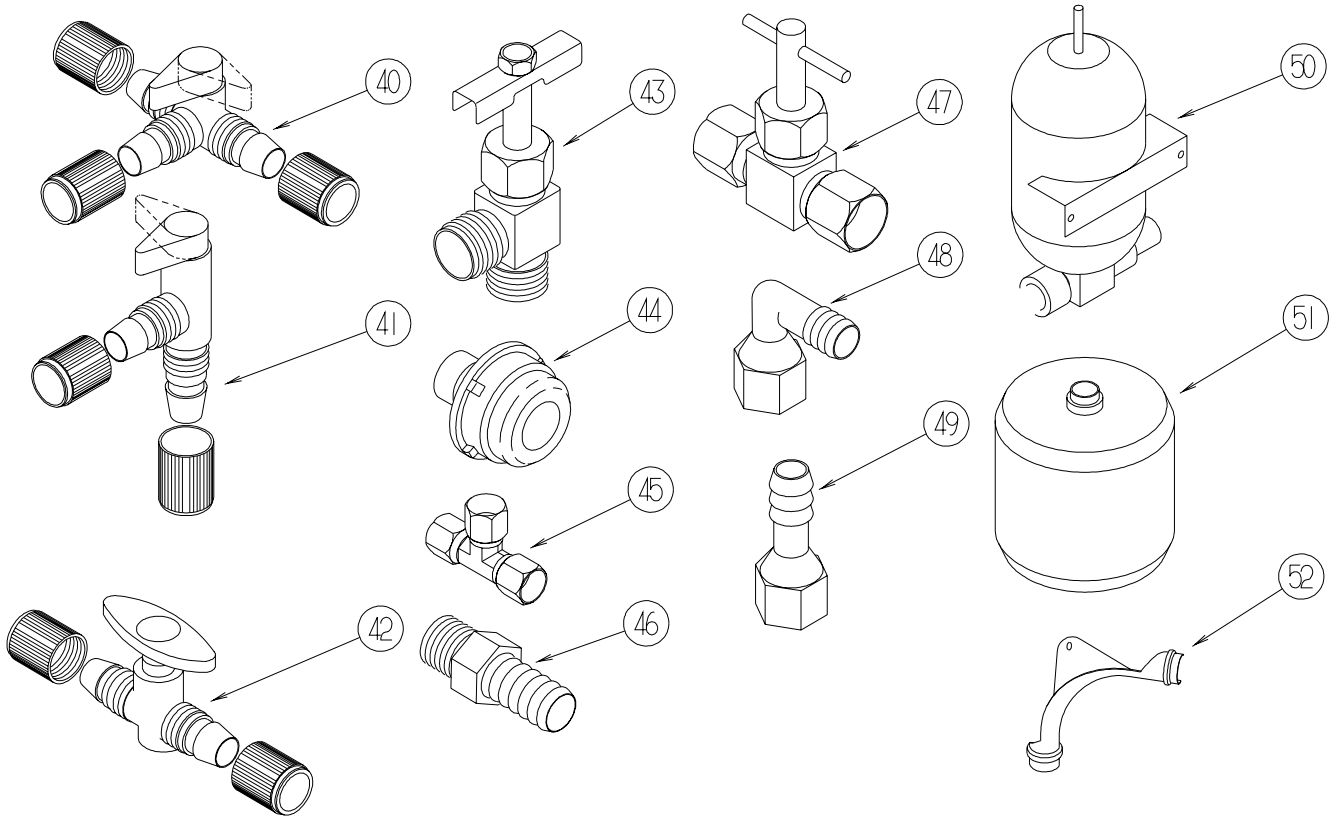

KEY	PART NUMBER	U/M	DESCRIPTION
40	114431-02-000	EA	VALVE - WATER BYPASS - 1/2"P - THREE WAY (WATER HEATER)
41	114431-03-000	EA	VALVE - 90 DEGREE DRAIN - 1/2"P
42	114431-04-000	EA	VALVE - "INLINE SHUT-OFF" - 1/2"P
43	114431-05-000	EA	VALVE - NEEDLE - 1/8" MPT X 1/4" COMPRESSION (ICE MAKER)
44	114966-01-000	EA	FILTER - IN LINE - TWIST ON - 1/2"
45	118423-01-000	EA	FITTING - BRASS-TEE - 1/4C X 1/4C X 1/4C
46	118809-02-000	EA	ADAPTER - 1/2" MPT X 1/2" BARB - PLASTIC
47	120868-01-000	EA	VALVE - NEEDLE - 1/4" COMPRESSION X 1/4" COMPRESSION
48	123150-01-000	EA	ELBOW - 1/2 FPT X 1/2 BARB - SWIVEL
49	123152-01-000	EA	ADAPTER - 1/2 FPT X 1/2 BARB - SWIVEL
50	123243-01-000	EA	TANK - ACCUMULATOR - 24 OZ
51	123317-01-000	EA	TANK - ACCUMULATOR - 2 GALLON
52	124184-01-000	EA	SUPPORT - WATER LINE - BEND

**WATER & SEWAGE GROUP (CONTINUED)**  
**WATER SYSTEM (CONTINUED)**

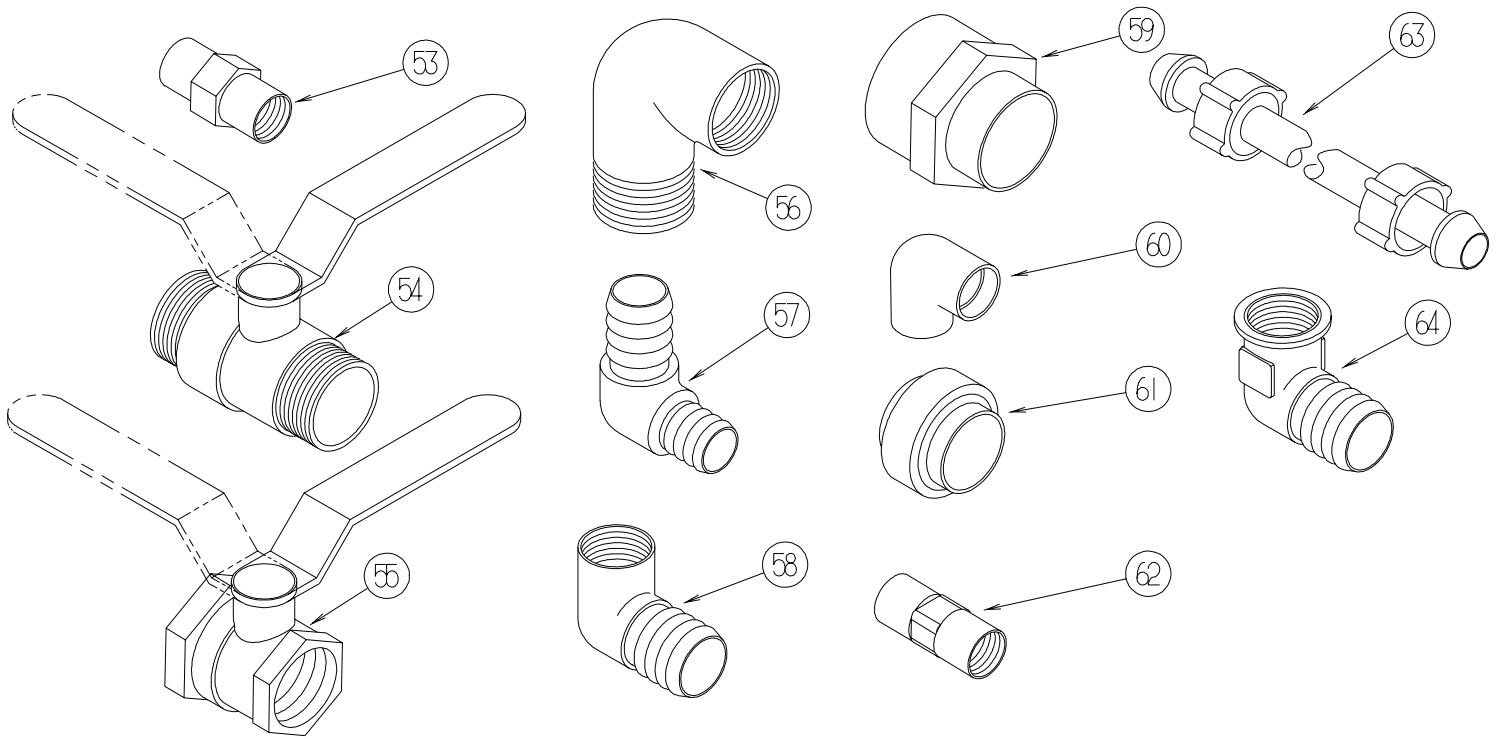

KEY	PART NUMBER	U/M	DESCRIPTION
53	132148-01-000	EA	CONNECTOR - 1/2" X 1/2"MPT - BRASS
54	132483-01-000	EA	VALVE/BALL - 1" - THREADED ENDS
55	132483-02-000	EA	VALVE/BALL - 1/2" - BRASS - FPT
56	132484-01-000	EA	ELBOW - 90 DEGREE - 1MPT X 1FPT - PLASTIC
57	132781-01-000	EA	ELBOW - 1.3" BARB X 1.3" BARB - 90 DEGREE - PLASTIC
58	132782-01-000	EA	ELBOW - 1"FPT X 1.3" BARB - 90 DEGREE - PLASTIC
59	133835-01-000	EA	ADAPTER - REDUCING - 1 1/2" X 1 1/4"
60	133837-01-000	EA	ELBOW - 1 1/2" X 90 DEGREE - DOUBLE SLIP
61	133889-01-000	EA	UNION - 1 1/2 DOUBLE SLIP - PVC
62	135386-01-000	EA	NIPPLE - 1/2"
63	140821-01-000	EA	TUBE - WATER SUPPLY - 3/8" X 24"
63	140821-02-000	EA	TUBE - WATER SUPPLY - 3/8" X 30"
63	140821-03-000	EA	TUBE - WATER SUPPLY - 3/8" X 36"
63	140821-04-000	EA	TUBE - WATER SUPPLY - 3/8" X 48"
63	140821-05-000	EA	TUBE - WATER SUPPLY - 3/8" X 54"
63	140821-06-000	EA	TUBE - WATER SUPPLY - 3/8" X 60"
63	140821-07-000	EA	TUBE - WATER SUPPLY - 3/8" X 72"
64	142812-01-000	EA	ELBOW - BRASS - 1/2"MPT X 1/2"FPT

**\*COMPONENT PARTS LISTED LATER IN THIS GROUP**

**WATER & SEWAGE GROUP (CONTINUED)**  
**WATER SYSTEM (CONTINUED)**

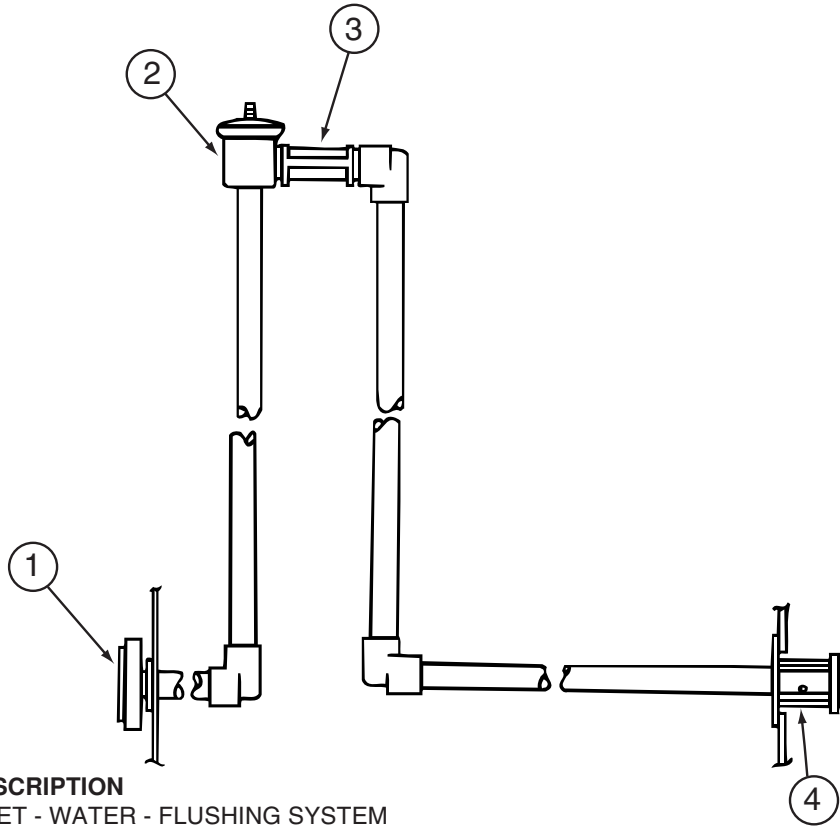

KEY	PART NUMBER	U/M DESCRIPTION
1	125697-05-000	EA INLET - WATER - FLUSHING SYSTEM
2	125697-04-000	EA BREAKER - VACUUM - FLUSHING SYSTEM
3	125697-03-000	EA CHECK VALVE - FLUSHING SYSTEM
4	125697-02-000	EA NOZZLE - WELD-A-FLUSH
	125697-06-000	EA INSTRUCTIONS - USER - FLUSHING SYSTEM

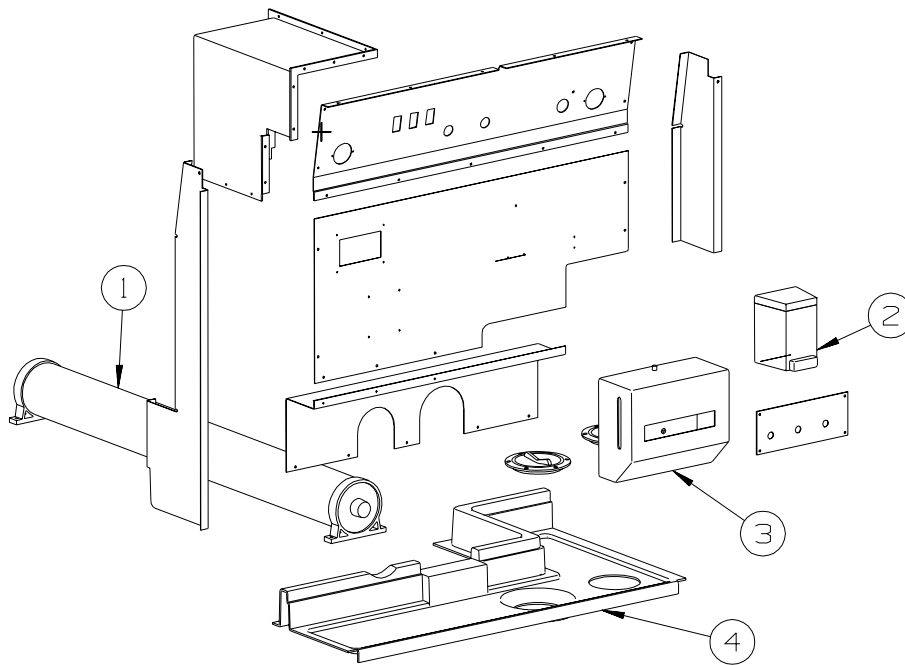

KEY	PART NUMBER	U/M DESCRIPTION
1	129850-01-01A	EA COMPARTMENT - SEWER HOSE
2	136909-01-000	EA DISPENSER - SOAP/LIQUID
3*	136915-01-000	EA DISPENSER - TOWEL/PAPER - 9"H X 10.8"L X 4.8"D - WHITE
4	134740-01-01A	EA PLATE - ACCESS - 4"

\*COMPONENT PARTS LISTED LATER IN THIS GROUP

**WATER & SEWAGE GROUP (CONTINUED)**  
**WATER SYSTEM (CONTINUED)**

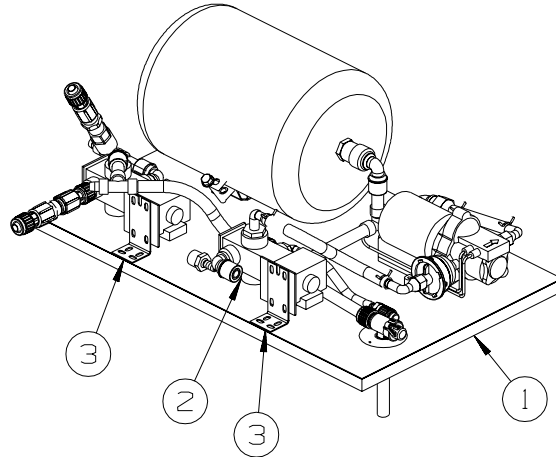

KEY	PART NUMBER	U/M	DESCRIPTION
1	138497-01-N94	EA	PANEL - WATER CENTER
2*	118569-03-000	EA	WINTERIZATION SYSTEM - W/O TANK
3	140309-05-02B	EA	ANGLE - FURNACE DOOR - E-COATED

**\*COMPONENT PARTS LISTED LATER IN THIS GROUP**



## WATER & SEWAGE GROUP (CONTINUED)

### WATER SYSTEM (CONTINUED)

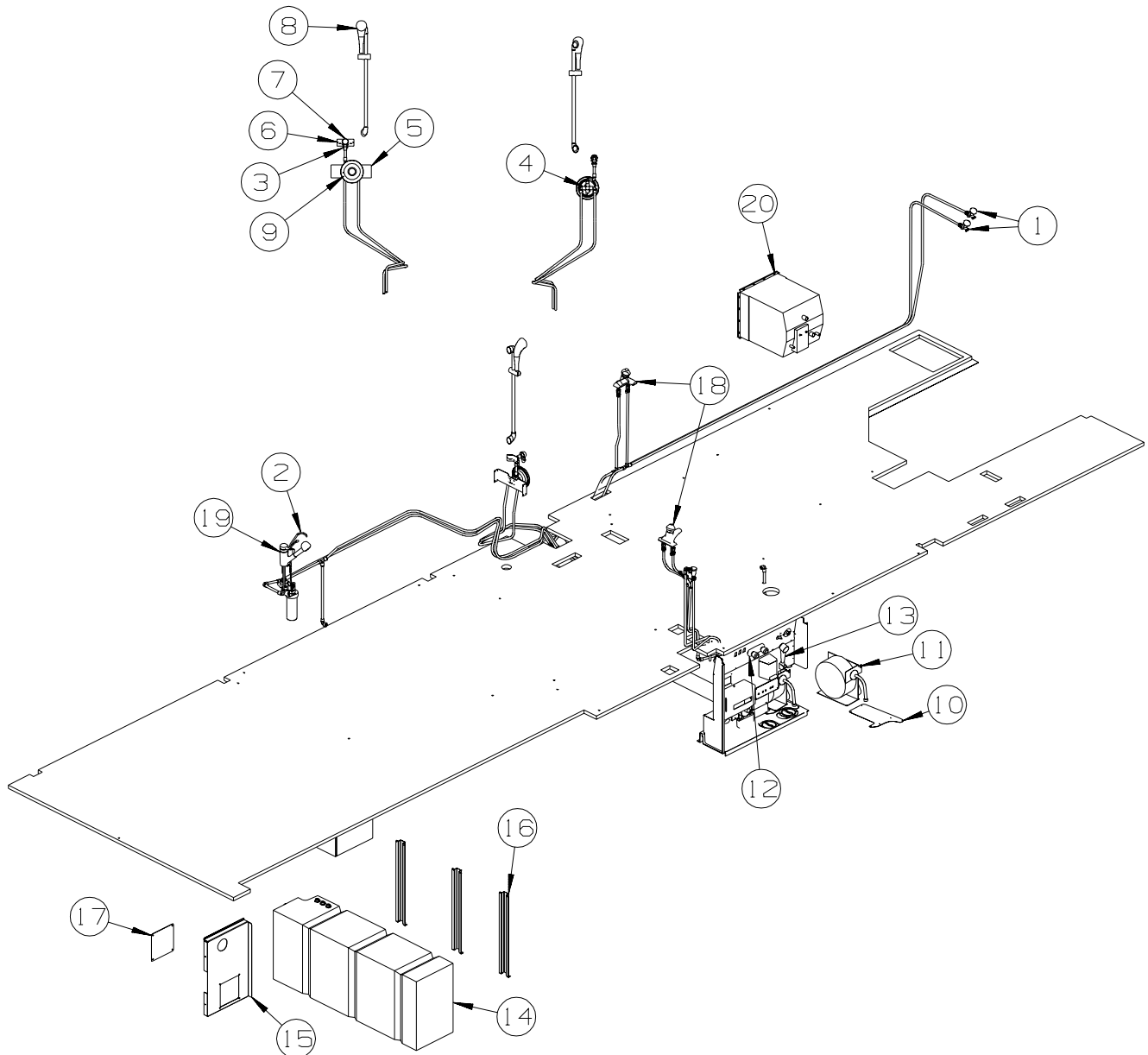

KEY	PART NUMBER	U/M	DESCRIPTION
1	098419-01-000	EA	FAUCET - 90 DEGREE
2	103635-03-000	EA	FAUCET - WATER PURIFIER - WHITE
3	128974-01-01A	EA	VALVE - SHOWER HEAD/WATER SAVER (ON/OFF) - BRIGHT BRASS
4*	131340-02-01A	EA	FAUCET ONLY - W/O SHOWER HEAD/ARM EXTENSION - BRASS
4*	144596-01-01A	EA	FAUCET/VALVE - SHOWER - POSI-TEMP - MOEN 62300
			FROM: 00-00-00 THRU: 10-15-02
5	133721-01-02B	EA	BRACKET - SHOWER CONTROL - E-COATED
			FROM: 00-00-00 THRU: 11-24-02
5	133721-02-02B	EA	BRACKET - SHOWER CONTROL - E-COATED
			FROM: 11-25-02 THRU: 99-99-99
6	133726-01-02B	EA	BRACKET - SHOWER HEAD - E-COATED
7	135028-01-01A	EA	DROP ELL - F/SHOWER HOSE - BRASS - 1/2"
8	143525-01-01A	EA	SHOWER - HAND HELD - W/SLIDE BAR - BRASS
9*	144596-02-01A	EA	FAUCET - TRIM KIT - CHATEAU - POLISHED BRASS
			FROM: 10-16-02 THRU: 99-99-99
10	142667-01-02B	EA	BRACKET - HOSE REEL - WATER - E-COATED
11	142675-01-01A	EA	HOSE REEL/WATER - POWERED
12*	075241-06-000	EA	FAUCET - SHOWER/BRIGHT WHITE - .5" MPT W/1.9" INLET PIPES
13	131383-01-02A	EA	SHOWER HEAD - W/60" HOSE & BRACKET - WHITE - USA
13	131383-02-02A	EA	SHOWER HEAD - W/60" HOSE & BRACKET - CSA - WHITE - CANADIAN

**WATER & SEWAGE GROUP (CONTINUED)**  
**WATER SYSTEM (CONTINUED)**

KEY	PART NUMBER	U/M	DESCRIPTION
14	143652-02-000	EA	TANK - WATER - 95 GALLONS - W/FITTINGS
	042989-03-000	EA	FITTING - SPINWELD - 1 1/4"NPT - PLASTIC
	042989-05-000	EA	FITTING - SPINWELD - 1/2"FPT - PLASTIC
	042989-08-000	EA	FITTING - SPINWELD - 1"FPT - PLASTIC
	049032-01-000	EA	PATCH - SPINWELD - 3/8" - PLASTIC
	143652-01-000	EA	TANK - WATER - 95 GALLONS - W/O FITTINGS
15	143670-01-02B	EA	PANEL/CLOSEOUT - WATER - E-COATED
			FROM: 00-00-00 THRU: 08-05-02
15	143670-02-02B	EA	PANEL/CLOSEOUT - WATER - E-COATED
			FROM: 08-06-02 THRU: 09-08-02
15	144216-02-02B	EA	PANEL/CLOSEOUT - WATER - E-COATED
			FROM: 09-09-02 THRU: 99-99-99
16	143671-01-02B	EA	BRACKET/TIEDOWN - WATER - E-COATED
17	144110-01-02B	EA	PANEL/CLOSEOUT - WATER - E-COATED
			FROM: 08-06-02 THRU: 99-99-99
18*	134735-01-01A	EA	FAUCET - LAVATORY - SINGLE CONTROL - BRASS
19*	141682-01-01A	EA	FAUCET - GALLEY - W/PULLOUT SPOUT - WHITE
20*	051391-05-000	EA	WATER HEATER/MOTOR AID-GAS/ELECT IGN - GCH10A-9E - 10 GAL
20*	125420-01-03A	EA	DOOR - WATER HEATER - 10 GALLON - BLACK W/BLACK GRILLE

**\*COMPONENT PARTS LISTED LATER IN THIS GROUP**

**WATER & SEWAGE GROUP (CONTINUED)**  
**COMPONENT PARTS FOR WATER SYSTEM**

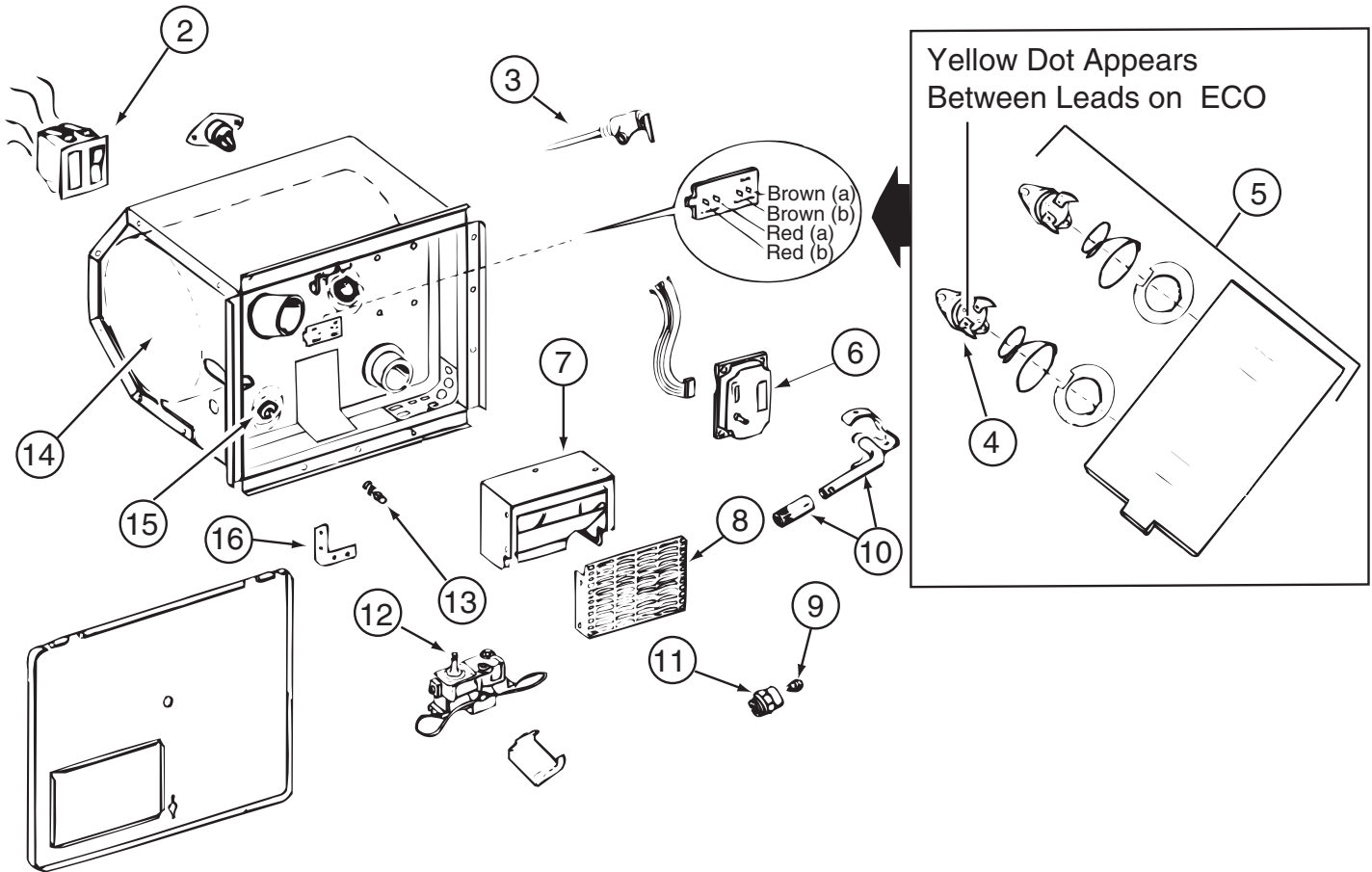

051391-05-000

KEY	PART NUMBER	U/M	DESCRIPTION	VENDOR NO.
2	051393-01-701	EA	SWITCH - REMOTE - W/LIGHT	91959
3	051391-01-704	EA	VALVE-RELIEF, 1/2" FITTING	91604
4	051391-04-701	EA	THERMOSTAT 12V DC-120 PRESET	91470
5	051391-05-707	EA	THERMOSTAT & ECO - 110 VOLT	91873
6	051393-01-704	EA	BOARD-CIRCUIT	93865
7	051391-04-707	EA	KIT-EXHAUST, (FLUE & GASKET)	90960
8	051391-01-717	EA	GRILLE-WATER HEATER DOOR	92640
9	051391-05-701	EA	ORIFICE-MAIN BURNER	93914
10	051391-05-700	EA	BURNER-MAIN	93221
11	051391-03-700	EA	HOLDER-ORIFICE	91563
12	051393-01-726	EA	VALVE-SOLENOID, W/O BRACKET	93870
13	051391-01-715	EA	PLUG-DRAIN, 1 EA = 2 PER PKG	91857
14	051391-05-704	EA	TANK-INNER	93593
15	051391-05-706	EA	ELEMENT-HEATING 1500 WATT	91160 W/GASKET
16	111129-01-711	EA	BRACKET-CORNER, SET OF FOUR	91928
	051391-05-703	EA	HARDWARE KIT-DOOR	91858
	051391-05-705	EA	SWITCH - ON/OFF SWITCH - BOX	91182
	051393-01-721	EA	THERMOSTAT W/ECO, 140 FRT MT	91447
	051393-01-723	EA	SWITCH - THERMAL CUTOUT 2/PK	93866
	051393-01-725	EA	ELECTRODE-SGL SPADE CONNECT.	93868
	051393-01-730	EA	BRACKET - F/10 GAL SYSTEM	93862

CONTACT WINNEBAGO PARTS SALES FOR UNLISTED COMPONENTS

075241-04-000, 075241-05-000, 075241-06-000

KEY	PART NUMBER	U/M	DESCRIPTION	VENDOR NO.
	075240-05-700	EA	CARTRIDGE - WASHERLESS	9-P42

**WATER & SEWAGE GROUP (CONTINUED)**  
**COMPONENT PARTS FOR WATER SYSTEM (CONTINUED)**

**098607-01-000**

<b>KEY</b>	<b>PART NUMBER</b>	<b>U/M</b>	<b>DESCRIPTION</b>	<b>VENDOR NO.</b>
	098607-01-702	EA	DIAPHRAGM/DRIVE ASSEMBLY KIT	94-238-04
	098607-01-703	EA	VALVE KIT	94-232-00
	098607-01-705	EA	VALVE-CHECK, KIT	94-237-00
	098607-01-706	EA	HOUSING, W/SWITCH ONLY	94-231-20
	098607-01-707	EA	MOTOR W/BASEPLATE	11-148-04

**118569-03-000**

<b>KEY</b>	<b>PART NUMBER</b>	<b>U/M</b>	<b>DESCRIPTION</b>	<b>VENDOR NO</b>
	118569-01-700	EA	VALVE/SOLENOID-ELECT CONTROL	NO VDR#
	118569-01-701	EA	SWITCH - ELECTRIC	EA1-31
	118569-01-702	EA	PLATE - SWITCH	ERUS-1
	118569-01-704	EA	PLUG - 3/4 MPT	NO VDR#
	118569-01-705	EA	PLUG - 1/2 MPT	NO VDR#
	118569-01-706	EA	SCREEN - WHITE	NO VDR#

**125420-01-02A, 125420-01-03A, 125420-04-03A**

<b>KEY</b>	<b>PART NUMBER</b>	<b>U/M</b>	<b>DESCRIPTION</b>	<b>VENDOR NO.</b>
	051391-01-705	EA	FASTENER - CAMLOCK	92609

**131340-02-01A**

<b>KEY</b>	<b>PART NUMBER</b>	<b>U/M</b>	<b>DESCRIPTION</b>	<b>VENDOR NO.</b>
	131340-02-700	EA	CARTRIDGE	6-1201-5-0

**134735-01-01A**

<b>KEY</b>	<b>PART NUMBER</b>	<b>U/M</b>	<b>DESCRIPTION</b>	<b>VENDOR NO.</b>
	135027-01-705	EA	CARTRIDGE F/SGL LEVER FAUCET	1225

**135027-01-01A**

<b>KEY</b>	<b>PART NUMBER</b>	<b>U/M</b>	<b>DESCRIPTION</b>	<b>VENDOR NO.</b>
1	135027-01-700	EA	CLIP - RETAINER	883
2	135027-01-701	EA	STOP-CHECK VALVE KIT CHROME	12318
3	135027-01-702	EA	DIVERTER-PUSH BUTTON-CHROME	1394
4	135027-01-703	EA	HANDLE/EXT - 1" - CHROME	1136
5	135027-01-704	EA	BALANCING SPOON	1423
6	135027-01-705	EA	CARTRIDGE REPLACEMENT	1200-1225
7	135027-01-706	EA	ESCUTCHEON - GOLD	150T
8	135027-01-707	EA	KNOB KIT - CLEAR PLASTIC	13094

**136915-01-000**

<b>KEY</b>	<b>PART NUMBER</b>	<b>U/M</b>	<b>DESCRIPTION</b>	<b>VENDOR NO.</b>
	136915-01-700	EA	TOWEL - PAPER/FOLDING PKG.	1999

**141682-01-01A**

<b>KEY</b>	<b>PART NUMBER</b>	<b>U/M</b>	<b>DESCRIPTION</b>	<b>VENDOR NO.</b>
	135027-01-705	EA	CARTRIDGE F/SGL LEVER FAUCET	1225

**144596-01-01A**

<b>KEY</b>	<b>PART NUMBER</b>	<b>U/M</b>	<b>DESCRIPTION</b>	<b>VENDOR NO.</b>
	144596-01-700	EA	CARTRIDGE (REPLACEMENT)	1222

## WINDOW & VENTS GROUP

### WINDOW & VENT LAYOUT

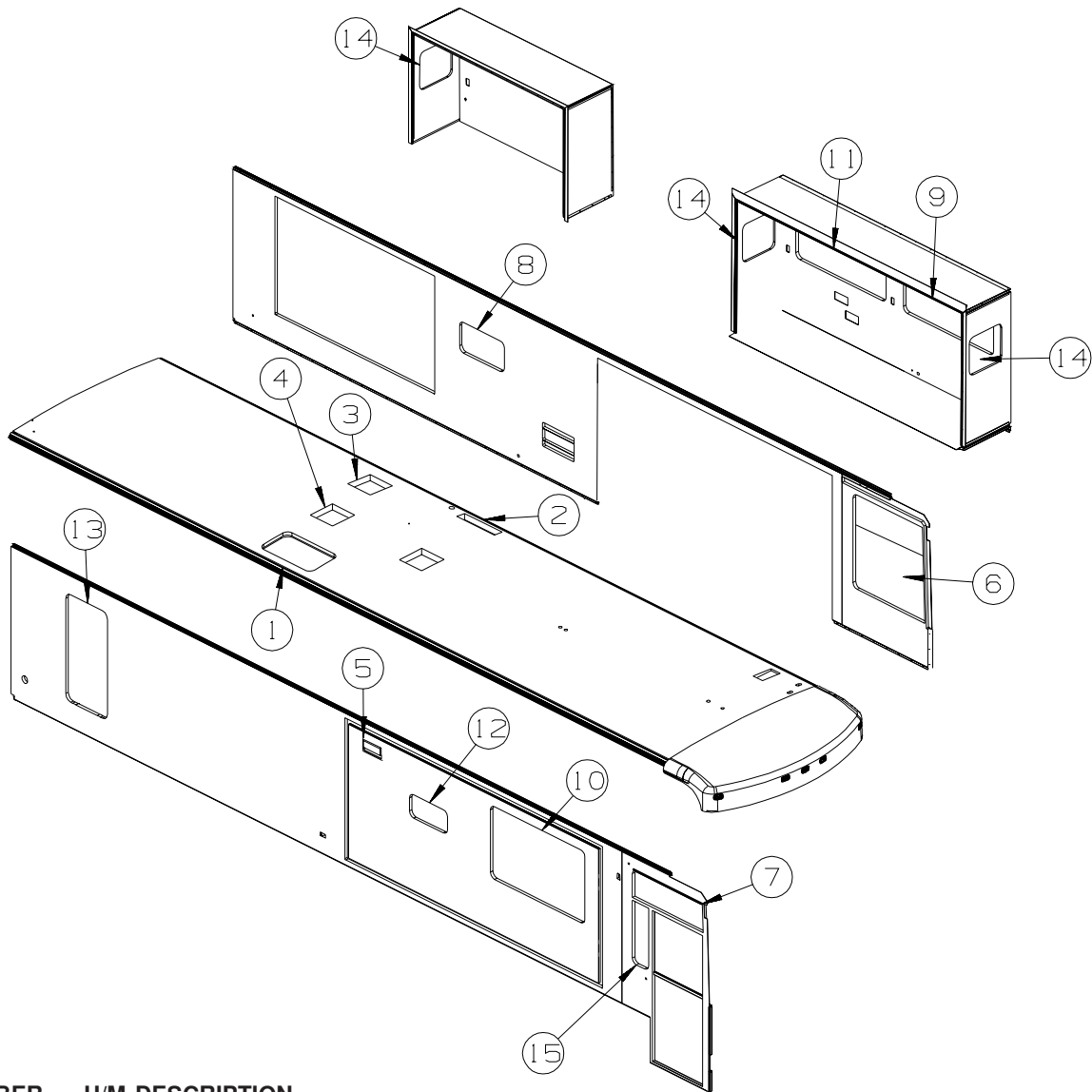

KEY	PART NUMBER	U/M	DESCRIPTION
1	138372-01-12B	EA	TRIM - CORNER - SKYLIGHT - BRIGHT WHITE FROM: 00-00-00 THRU: 12-18-02
1	138372-01-02B	EA	TRIM - CORNER - SKYLIGHT FROM: 12-19-02 THRU: 99-99-99
1	138380-01-01A	EA	PANEL/SKYLIGHT - LARGE/OUTER - RECTANGULAR - WHITE
2	084073-04-000	EA	BASE/VENT - ROOF/REFRIGERATOR - BLACK - NORCOLD
2	084073-07-000	EA	CAP - ROOF/REFRIGERATOR VENT - 10" X 32" - BRIGHT WHITE
3	122882-07-01A	EA	GARNISH - ROOF VENT - 2.5" TO 4.1"
3*	123780-09-01A	EA	FANTASTIC VENT-4"ROOF- W/FAN/DBL DOME-W/O THERM/PWR LIFT
	009440-01-000	EA	GEAR/ARM - LIFT - ROOF VENT COVER
4*	123780-16-01A	EA	FANTASTIC VENT-4"ROOF-W/FAN/PWR LIFT/THERM/DBL DOMED
	009440-01-000	EA	GEAR/ARM - LIFT - ROOF VENT COVER
5	138983-01-01A	EA	VENT - MICROWAVE OUTER - BRIGHT WHITE
5	138983-03-01A	EA	COVER - VENT MICROWAVE OUTER - BRIGHT WHITE
6*	106466-16-01A	EA	WINDOW - CAB/DRVR/THERMO-45.1"T X 50.3"H X 46.7"B
7*	106467-09-01A	EA	WINDOW - PASSENGER VISTA/THERMO - 45.1"T X 45.7"B X 15.6"H
8*	112795-73-01A	EA	WINDOW - DRIVER HORIZONTAL SLIDER - THERMO - 28.7" X 15.7"
9*	112795-77-01A	EA	WINDOW - DRVR HORIZ SLIDER W/RET. - THERMO - 57.4" X 23.6"
10*	112795-80-01A	EA	WINDOW - PASSENGER HORIZ SLIDER - THERMO - 37.9" X 60.4"
11	112795-81-01A	EA	WINDOW - DRVR HORIZ SLIDER/ESCAPE - THERMO - 23.8" X 57.7"
12*	112795-86-01A	EA	WINDOW - DRIVER HORIZONTAL SLIDER - THERMO - 12.3" X 24.2"
13*	129929-13-01A	EA	WINDOW - TIPOUT/THERMO/ESCAPE W/RETAINER - 56.1" X 26.7"
14	134004-03-01A	EA	WINDOW - VERT SLIDER/FLUSH O/S-THERMO - 21" X 19.8"
15	140069-01-01A	EA	WINDOW - VERTICAL SLIDER - THERMO - 32.7" X 10.5"

\*COMPONENT PARTS LISTED LATER IN THIS GROUP

**WINDOW & VENTS GROUP (CONTINUED)**  
**COMPONENT PARTS FOR WINDOW & VENT LAYOUT**

**106466-16-01A**

<b>KEY</b>	<b>PART NUMBER</b>	<b>U/M</b>	<b>DESCRIPTION</b>	<b>VENDOR NO.</b>
	098644-01-706	FT	WEATHERSTRIP - GLASS	171-010668
	098644-01-710	FT	TRACK - SCREEN SPACER 12'	132-017135
	098644-01-713	EA	CLIP - SCREEN - METAL	226-016966
	098644-01-717	FT	SPLINE - SCREEN	132-004716
	112795-01-700	EA	LATCH ASM., BLK.,(BOLT ON)	DH287-CK
	112795-01-701	EA	SLIDE-STOP	132-019092
	112795-01-703	IN	CHANNEL-RUN (INCHES)	122-027566
	112795-01-704	FT	PLUG FILLER (DOUBLE GLAZED)	122-018737
	112795-01-705	FT	VINYL - GLAZING	132-027331
	125582-01-701	EA	CLIP - SCREEN - PLASTIC	130-005153

**106467-09-01A**

<b>KEY</b>	<b>PART NUMBER</b>	<b>U/M</b>	<b>DESCRIPTION</b>	<b>VENDOR NO.</b>
	106467-09-700	EA	GLASS - STATIONARY	390-026726
	116000-01-704	FT	VINYL - GLAZING	132-018161
	106467-09-701	EA	RETAINER - TRIM	H619-27R

**WINDOW & VENTS GROUP (CONTINUED)**  
**COMPONENT PARTS FOR WINDOW & VENT LAYOUT (CONTINUED)**

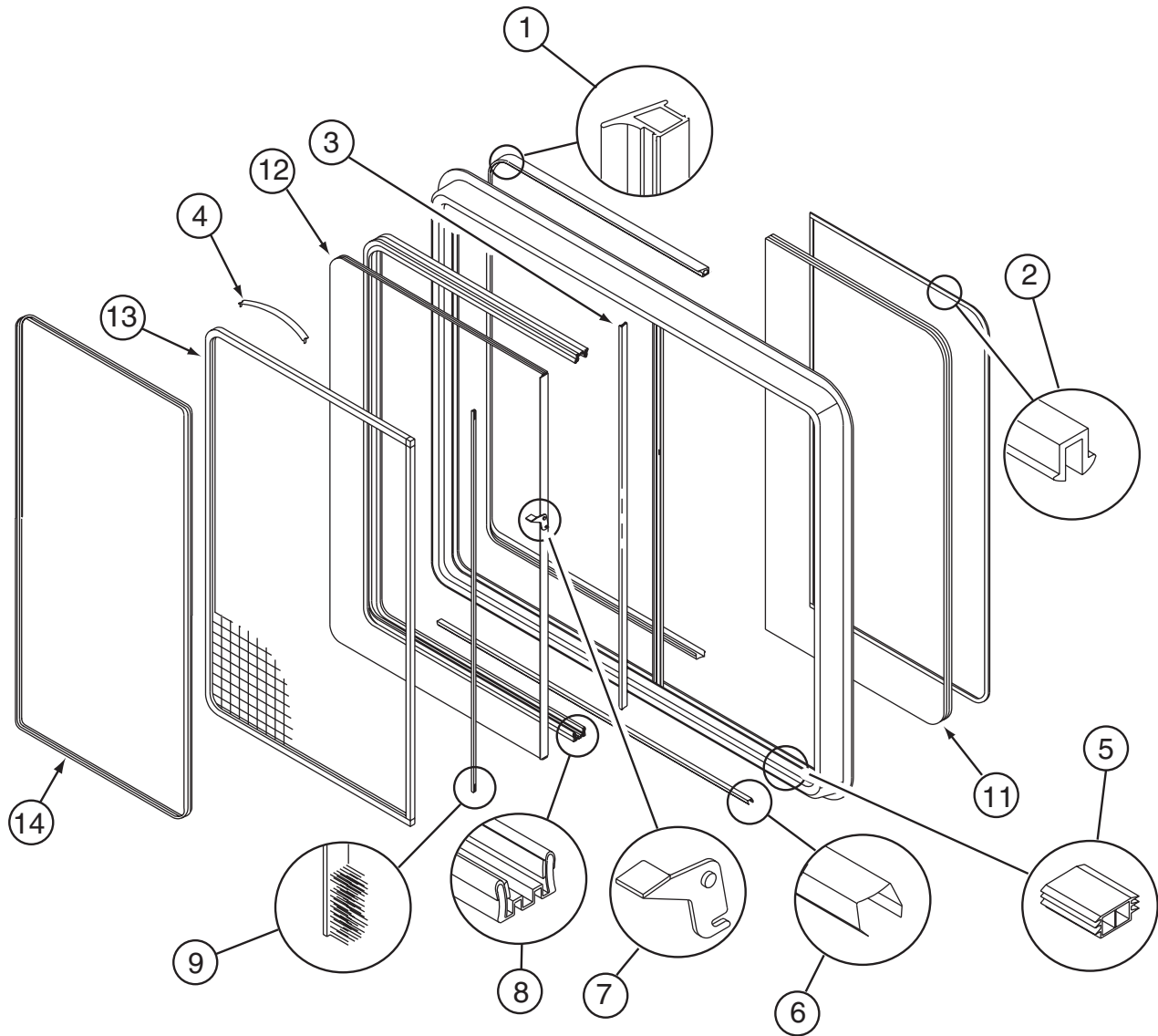

112795-73-01A

KEY	PART NUMBER	U/M	DESCRIPTION	VENDOR NO.
1	112795-01-704	FT	PLUG FILLER (DOUBLE GLAZED)	122-018737
2	112795-01-705	FT	VINYL - GLAZING	132-025736
3	098644-01-706	FT	WEATHERSTRIP - GLASS	171-010668
4	098644-01-713	EA	CLIP - SCREEN - METAL	226-016966
4	125582-01-701	EA	CLIP - SCREEN - PLASTIC	130-005153
	098644-01-717	FT	SPLINE - SCREEN	132-004716
5	112795-01-701	EA	SLIDE-STOP	132-019092
6	098644-01-710	FT	TRACK - SCREEN SPACER 12'	132-017135
7	112795-01-700	EA	LATCH ASM., BLK.,(BOLT ON)	DH287-CK
8	112795-01-703	IN	CHANNEL-RUN (INCHES)	122-018736
9	098644-01-711	FT	WEATHERSTRIP - SCREEN BLACK	171-016965
11	112795-72-700	EA	GLASS - STATIONARY	390-028307
12	112795-72-701	EA	GLASS - SLIDING W/SASH LATCH	DC29-G8
13	098647-31-704	EA	SCREEN ASSY - W/SEAL & CLIPS	410-019128
14	098647-31-705	EA	RETAINER - TRIM	CH29-66

**WINDOW & VENTS GROUP (CONTINUED)**  
**COMPONENT PARTS FOR WINDOW & VENT LAYOUT (CONTINUED)**

**112795-77-01A**

<b>KEY</b>	<b>PART NUMBER</b>	<b>U/M</b>	<b>DESCRIPTION</b>	<b>VENDOR NO.</b>
1	112795-01-704	FT	PLUG FILLER (DOUBLE GLAZED)	122-018737
2	112795-01-705	FT	VINYL - GLAZING	132-025736
3	098644-01-706	FT	WEATHERSTRIP - GLASS	171-010668
4	098644-01-713	EA	CLIP - SCREEN - METAL	226-016966
4	125582-01-701	EA	CLIP - SCREEN - PLASTIC	130-005153
5	112795-01-701	EA	SLIDE-STOP	132-019092
6	098644-01-710	FT	TRACK - SCREEN SPACER 12'	132-017135
7	112795-01-700	EA	LATCH ASM., BLK.,(BOLT ON)	DH287-CK
8	112795-01-703	IN	CHANNEL-RUN (INCHES)	122-018736
9	098644-01-711	FT	WEATHERSTRIP - SCREEN BLACK	171-016965
11	112795-77-700	EA	GLASS - STATIONARY	390-28313
12	112795-77-701	EA	GLASS - SLIDING W/SASH LATCH	DH493-G8
13	098647-47-702	EA	SCREEN ASSY - W/SEAL & CLIPS	410-025226
14	098647-47-704	EA	RETAINER - TRIM	H493-66
	098644-01-717	FT	SPLINE - SCREEN	132-004716

**112795-80-01A**

<b>KEY</b>	<b>PART NUMBER</b>	<b>U/M</b>	<b>DESCRIPTION</b>	<b>VENDOR NO.</b>
1	112795-01-704	FT	PLUG FILLER (DOUBLE GLAZED)	122-018737
2	112795-01-705	FT	VINYL - GLAZING	132-025736
3	098644-01-706	FT	WEATHERSTRIP - GLASS	171-010668
4	098644-01-713	EA	CLIP - SCREEN - METAL	226-016966
4	125582-01-701	EA	CLIP - SCREEN - PLASTIC	130-005153
	098644-01-717	FT	SPLINE - SCREEN	132-004716
5	112795-01-701	EA	SLIDE-STOP	132-019092
6	098644-01-710	FT	TRACK - SCREEN SPACER 12'	132-017135
7	112795-01-700	EA	LATCH ASM., BLK.,(BOLT ON)	DH287-CK
8	112795-01-703	IN	CHANNEL-RUN (INCHES)	122-018736
9	098644-01-711	FT	WEATHERSTRIP - SCREEN BLACK	171-016965
11	112795-80-700	EA	GLASS - STATIONARY	390-028379
12	112795-80-701	EA	GLASS - SLIDING W/SASH LATCH	DH442-G8
13	112795-80-702	EA	SCREEN ASSY - W/SEAL & CLIPS	410-019057
14	112795-64-700	EA	RETAINER - TRIM	H442-66

**112795-81-01A**

<b>KEY</b>	<b>PART NUMBER</b>	<b>U/M</b>	<b>DESCRIPTION</b>	<b>VENDOR NO.</b>
1	112795-01-704	FT	PLUG FILLER (DOUBLE GLAZED)	122-018737
2	112795-01-705	FT	VINYL - GLAZING	132-025736
3	098644-01-706	FT	WEATHERSTRIP - GLASS	171-010668
4	098644-01-713	EA	CLIP - SCREEN - METAL	226-016966
4	125582-01-701	EA	CLIP - SCREEN - PLASTIC	130-005153
	098644-01-717	FT	SPLINE - SCREEN	132-004716
5	112795-01-701	EA	SLIDE-STOP	132-019092
6	098644-01-710	FT	TRACK - SCREEN SPACER 12'	132-017135
7	112795-01-700	EA	LATCH ASM., BLK.,(BOLT ON)	DH287-CK
8	112795-01-703	IN	CHANNEL-RUN (INCHES)	122-018736
9	098644-01-711	FT	WEATHERSTRIP - SCREEN BLACK	171-016965
11	112795-77-700	EA	GLASS - STATIONARY	390-28313
12	112795-77-701	EA	GLASS - SLIDING W/SASH LATCH	DH493-G8
13	098647-47-702	EA	SCREEN ASSY - W/SEAL & CLIPS	410-025226
14	098647-47-704	EA	RETAINER - TRIM	H493-66



**WINDOW & VENTS GROUP (CONTINUED)**  
**COMPONENT PARTS FOR WINDOW & VENT LAYOUT (CONTINUED)**

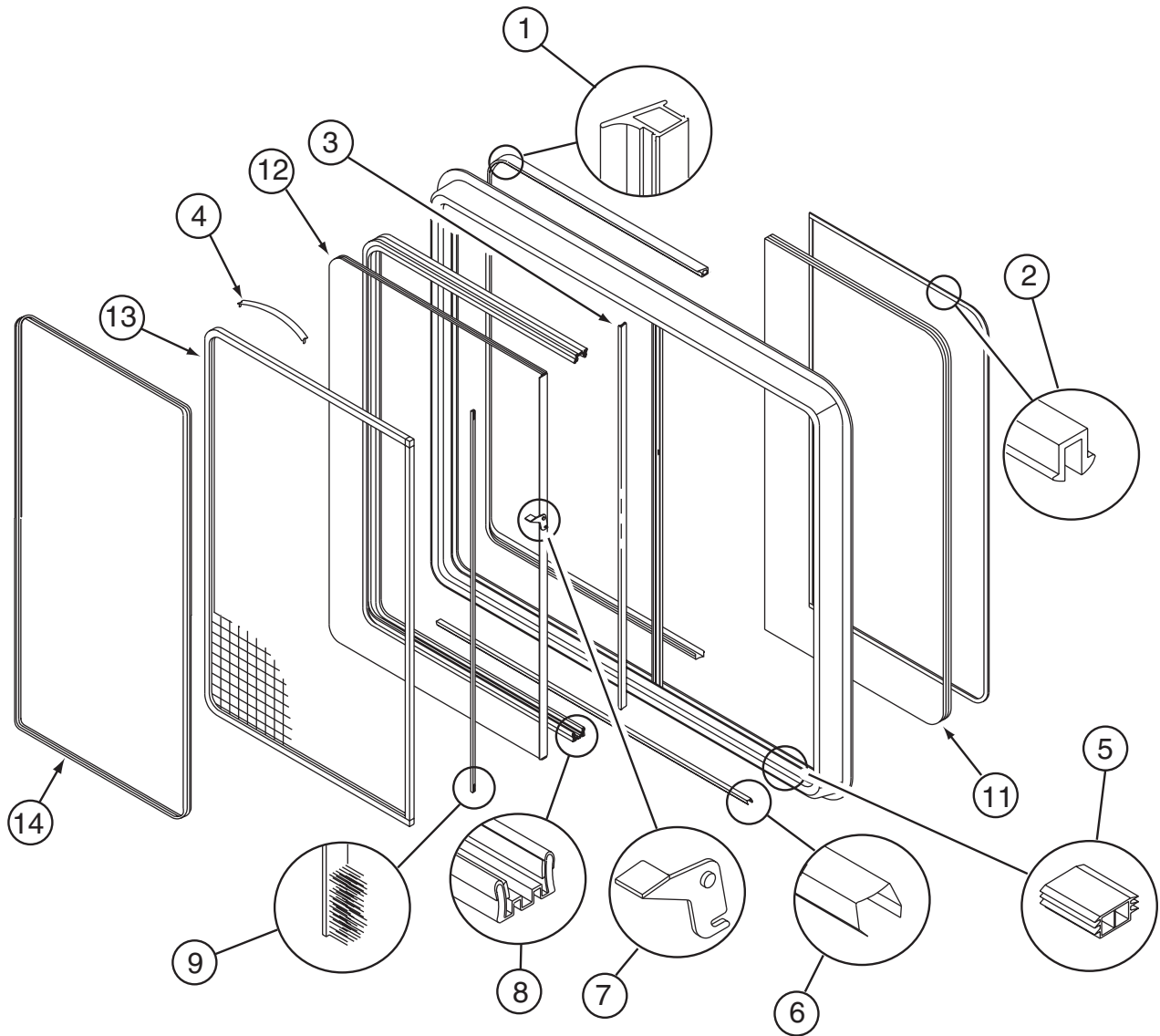

112795-86-01A

KEY	PART NUMBER	U/M	DESCRIPTION	VENDOR NO.
	112795-01-704	FT	PLUG FILLER (DOUBLE GLAZED)	122-018737
	112795-01-705	FT	VINYL - GLAZING	132-027331
	098644-01-706	FT	WEATHERSTRIP - GLASS	171-010668
	125582-01-701	EA	CLIP - SCREEN - PLASTIC	130-005153
	098644-01-713	EA	CLIP - SCREEN - METAL	226-016966
	112795-01-701	EA	SLIDE-STOP	132-019092
	098644-01-710	FT	TRACK - SCREEN SPACER 12'	132-017135
	112795-01-700	EA	LATCH ASM., BLK.,(BOLT ON)	DH287-CK
	112795-01-703	IN	CHANNEL-RUN (INCHES)	122-027566
	098644-01-711	FT	WEATHERSTRIP - SCREEN BLACK	171-016965
	112795-86-700	EA	GLASS - STATIONARY	390-030058
	112795-86-701	EA	GLASS-SLIDING W/SASH & LATCH	DB951-G8
	112795-86-702	EA	SCREEN ASM W/SEALS & CLIPS	410-030059
	112795-86-703	EA	RETAINER - TRIM	B951-66
	098644-01-717	FT	SPLINE - SCREEN	132-004716

**WINDOW & VENTS GROUP (CONTINUED)**  
**COMPONENT PARTS FOR WINDOW & VENT LAYOUT (CONTINUED)**

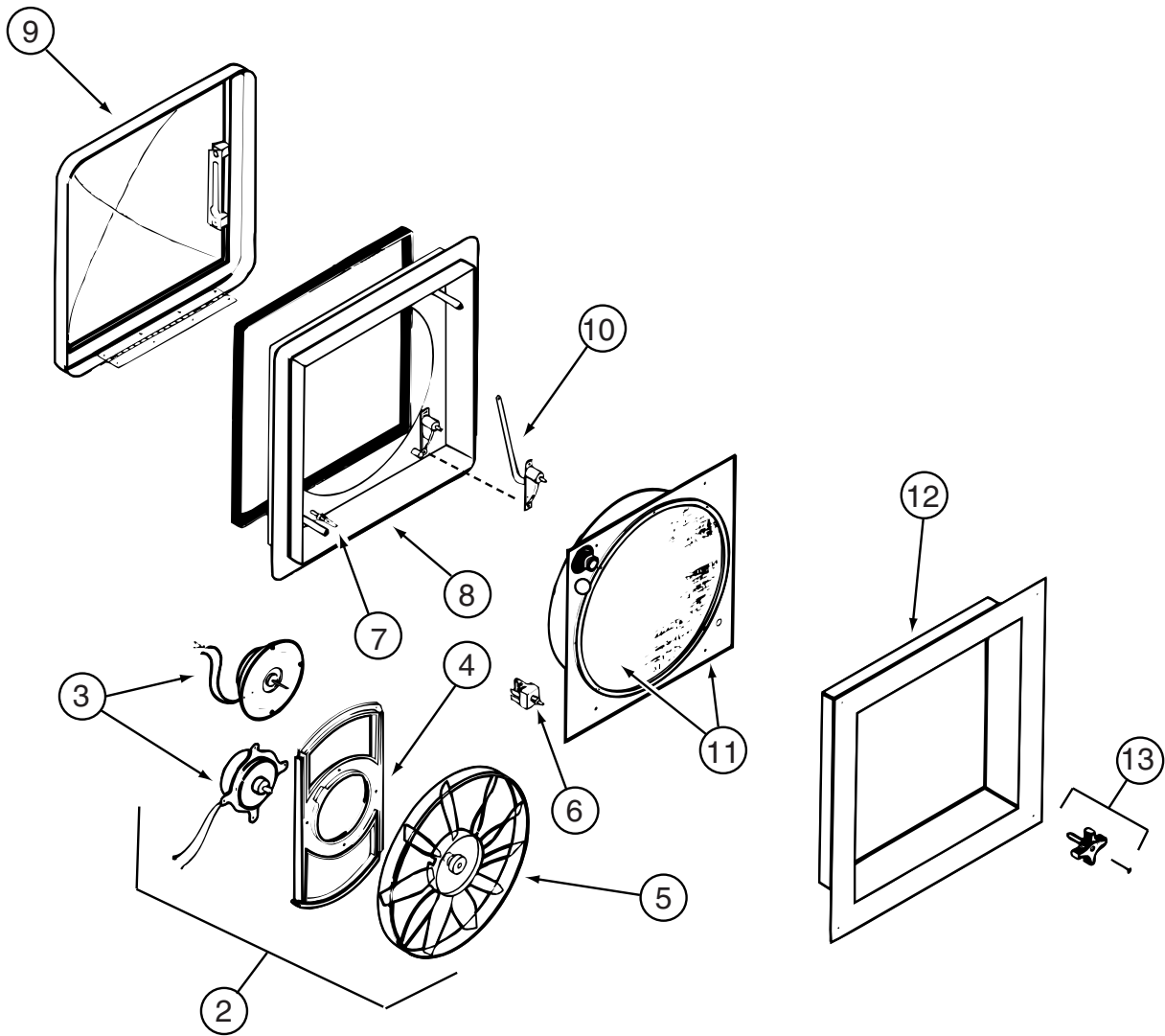

123780-09-01A

KEY	PART NUMBER	U/M	DESCRIPTION	VENDOR NO.
2	084079-11-700	EA	MOTOR & FAN BLADE W/BRACKET	K4017-09
3	084079-01-705	EA	MOTOR/EXT BRKT/FAN BLADE KIT	1080-00
5	084079-01-704	EA	BLADE-FAN	1138-00
6	084079-01-709	EA	SWITCH - MAIN - 3 SPEED	1031-05
7	084079-01-707	EA	SWITCH - SAFETY	1122-05
8	123780-05-700	EA	BASE/MAIN-BRT WHT W/GASKET	1010-81
9	123780-09-700	EA	DOME (DOUBLE)WHT TRANSPARENT	K2020-82
10	009440-01-000	EA	GEAR-ARM-ROOF VENT	705221K38
11	123780-03-701	EA	SCREEN ASM 78-100MM W/SWITCH	1030BT-81
12	123780-03-700	EA	GARNISH - INT. 3"-4" BRT/WHT	2040-81
13	084079-01-703	EA	KNOB-LIFT, W/EXT.	1140K-00
	123780-01-702	EA	SCREEN INSERT (SCREEN RING)	K1035-81

CONTACT WINNEBAGO PART SALES FOR UNLISTED COMPONENTS

**WINDOW & VENTS GROUP (CONTINUED)**  
**COMPONENT PARTS FOR WINDOW & VENT LAYOUT (CONTINUED)**

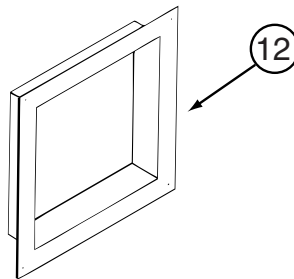
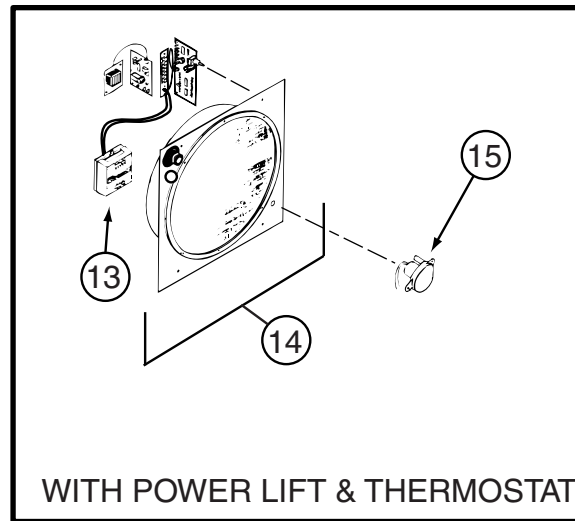
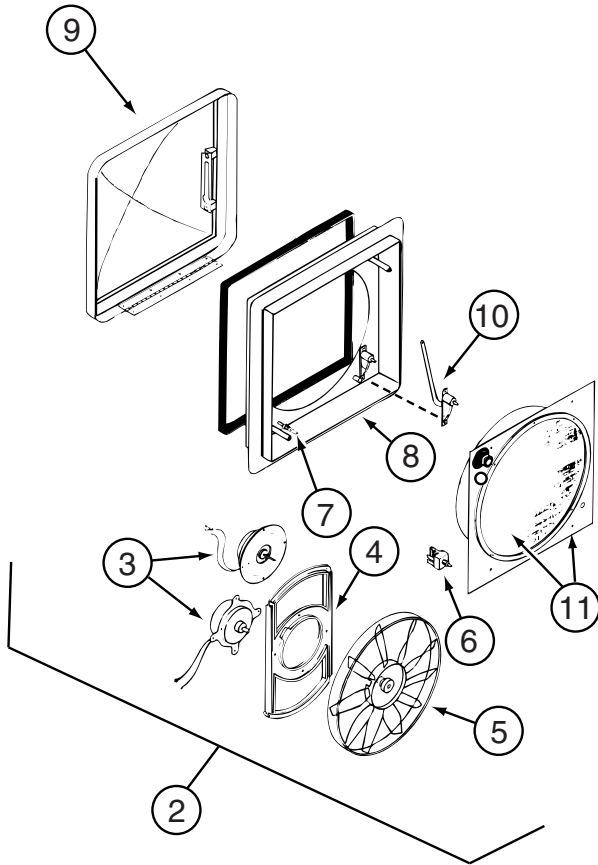

**123780-16-01A**

KEY	PART NUMBER	U/M	DESCRIPTION	VENDOR NO.
2	084079-11-700	EA	MOTOR & FAN BLADE W/BRACKET	K4017-09
5	084079-01-704	EA	BLADE-FAN	1138-00
6	084079-01-709	EA	SWITCH - MAIN - 3 SPEED	1031-05
7	084079-01-707	EA	SWITCH - SAFETY	1122-05
8	123780-05-700	EA	BASE/MAIN-BRT WHT W/GASKET	1010-81
9	123780-09-700	EA	DOME (DOUBLE)WHT TRANSPARENT	K2020-82
10	009440-01-000	EA	GEAR-ARM-ROOF VENT	705221K38
12	123780-03-700	EA	GARNISH - INT. 3"-4" BRT/WHT	2040-81
13	084079-01-710	EA	THERMOSTAT(WALL MT)ANY COLOR	9988-81
14	123780-05-701	EA	SCREEN INT W/ALL SWITCHES	KIT-81
15	084079-11-703	EA	MOTOR/AUTO LIFT OFF/WHT CAP	6050-80 OS
15	084079-11-705	EA	MOTOR - LIFT (BC MOTOR)	5050-40
	123780-01-702	EA	SCREEN INSERT (SCREEN RING)	K1035-81
	123780-16-700	EA	KNOB-BLK/AUTOMATIC LIFT MTR	K1140-09
	123780-16-701	EA	THERMAL PROTECTOR	1031-00
	123780-16-702	EA	SWITCH-ROCKER-OFF/ON BLACK	9023-09

CONTACT WINNEBAGO PART SALES FOR UNLISTED COMPONENTS

**WINDOW & VENTS GROUP (CONTINUED)**  
**COMPONENT PARTS FOR WINDOW & VENT LAYOUT (CONTINUED)**

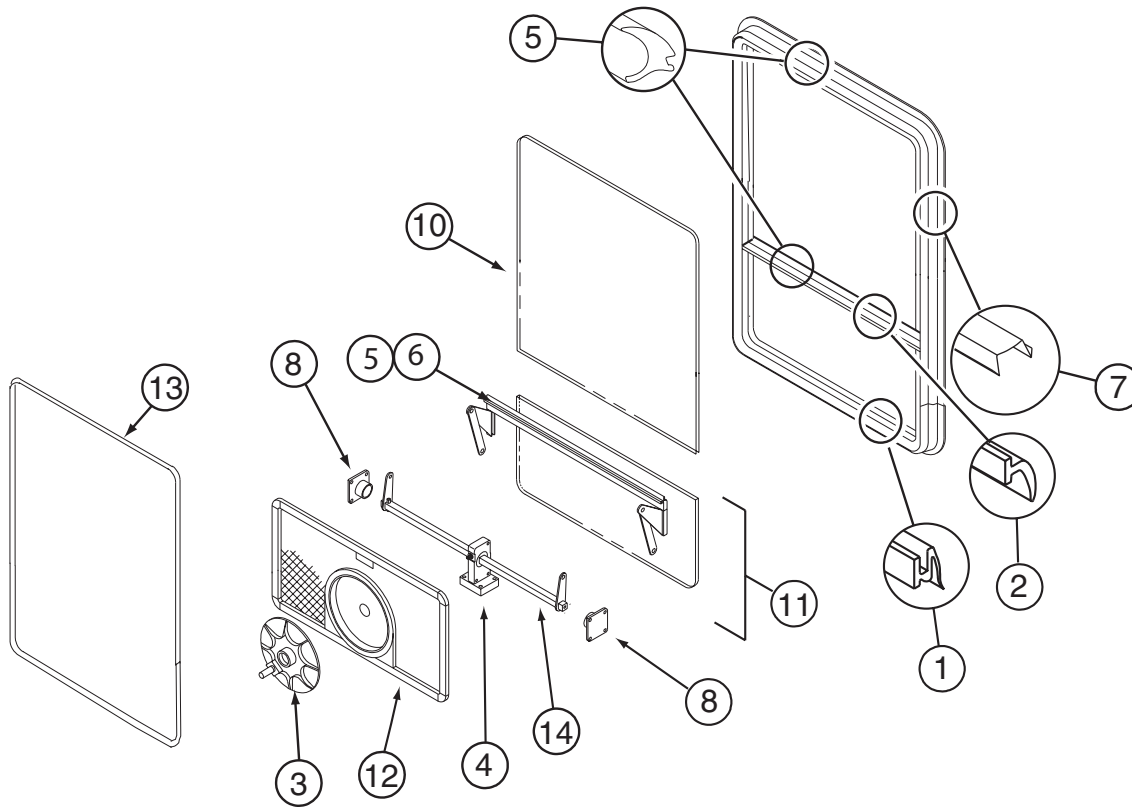

**129929-13-01A**

KEY	PART NUMBER	U/M	DESCRIPTION	VENDOR NO .
1	100322-01-701	FT	SEAL-VENT	122-016071
3	100322-01-718	EA	HANDLE-DIAL	410-016081
4	129929-01-710	EA	TORQUE-CTR SUPPORT (2 HOLE)	410-026806
5	129929-01-705	FT	GLAZING VINYL	132-026811
6	129929-01-707	FT	COVER/SCREW-FILLER STRIP	132-026808
8	129929-01-708	EA	SUPPORT - TORQUE BAR - RT/LT	130-026804
10	129929-13-700	EA	GLASS - STATIONARY	390-030042
11	129929-13-701	EA	VENT GLASS ASSEMBLY	DTH028-G8
12	129929-13-702	EA	SCREEN ASM - W/SEALS & CLIPS	410-030044
13	129929-13-703	EA	RETAINER - TRIM	DTH028-62
14	129929-13-704	EA	OPERATOR BAR ASSEMBLY	DTH028-18
	100322-01-717	FT	SEAL - VENT	122-016071
	129929-01-706	FT	SEAL - TOP F/CENTER EGRESS	132-026811
	129929-02-706	FT	SEAL - FOAM	140-027022

CONTACT WINNEBAGO PART SALES FOR UNLISTED COMPONENTS

**WINDOW & VENTS GROUP (CONTINUED)**  
**COMPONENT PARTS FOR WINDOW & VENT LAYOUT (CONTINUED)**

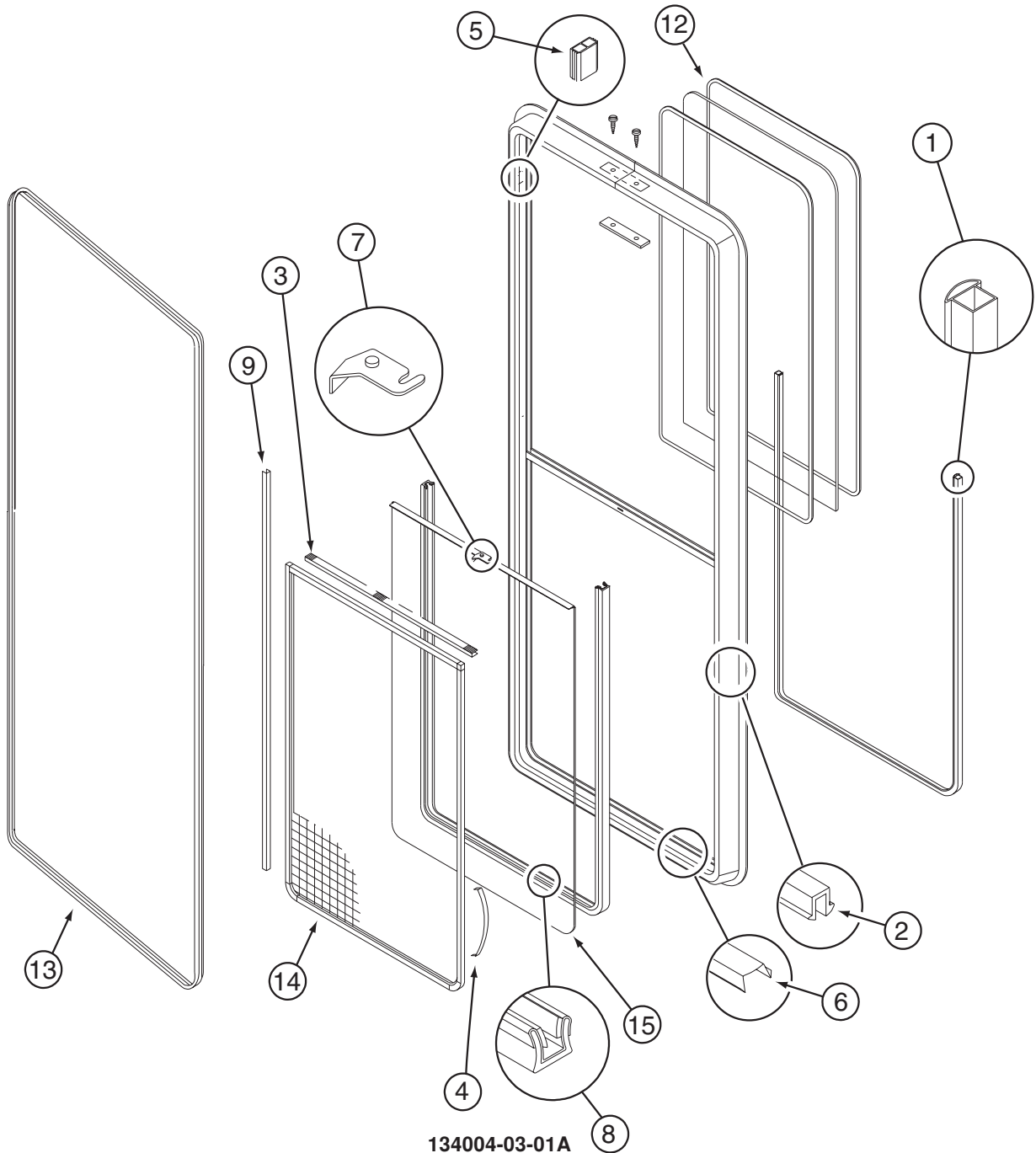

134004-03-01A

KEY	PART NUMBER	U/M	DESCRIPTION	VENDOR NO
1	112795-01-704	FT	PLUG FILLER (DOUBLE GLAZED)	122-018737
2	112795-01-705	FT	VINYL - GLAZING	132-027331
3	098644-01-706	FT	WEATHERSTRIP - GLASS	171-010668
4	098644-01-713	EA	CLIP - SCREEN - METAL	226-016966
4	125582-01-701	EA	CLIP - SCREEN - PLASTIC	130-005153
5	112795-01-701	EA	SLIDE-STOP	132-019092
6	098644-01-710	FT	TRACK - SCREEN SPACER 12'	132-017135
7	112795-01-700	EA	LATCH ASM., BLK.,(BOLT ON)	DH287-CK
8	112795-01-703	IN	CHANNEL-RUN (INCHES)	122-027566
9	075673-05-000	FT	SEAL-PILE ADH BACK,BLK	AMESBURY
12	134004-03-700	EA	GLASS - STATIONARY	390-028662
13	134004-03-702	EA	RETAINER - TRIM	H702-56
14	098644-13-702	EA	SCREEN ASM W/SEALS & CLIPS	410-028663
15	134004-03-701	EA	GLASS-SLIDING W/SASH & LATCH	DH702-G8
	098644-01-717	FT	SPLINE - SCREEN	132-004716
	112898-04-703	EA	VERTICAL LATCH (SASH KIT)	DH343-CK

**WINDOW & VENTS GROUP (CONTINUED)**  
**COMPONENT PARTS FOR WINDOW & VENT LAYOUT (CONTINUED)**

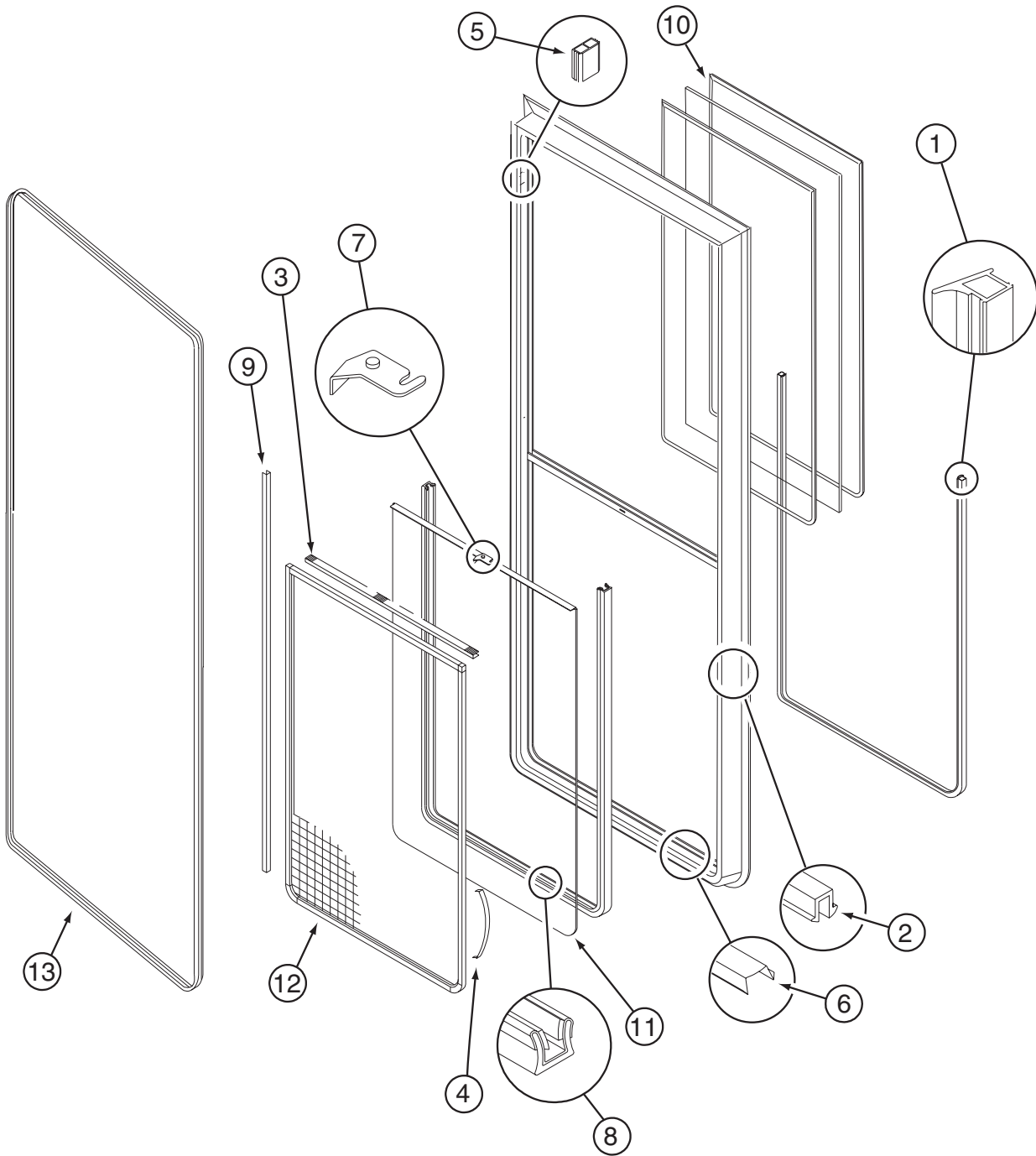

140069-01-01A

KEY	PART NUMBER	U/M	DESCRIPTION	VENDOR NO
1	112795-01-704	FT	PLUG FILLER (DOUBLE GLAZED)	122-018737
2	112795-01-705	FT	VINYL - GLAZING	132-027331
3	098644-01-706	FT	WEATHERSTRIP - GLASS	171-010668
4	098644-01-713	EA	CLIP - SCREEN - METAL	226-016966
4	125582-01-701	EA	CLIP - SCREEN - PLASTIC	130-005153
5	112795-01-701	EA	SLIDE-STOP	132-019092
6	098644-01-710	FT	TRACK - SCREEN SPACER 12'	132-017135
7	112795-01-700	EA	LATCH ASM., BLK.,(BOLT ON)	DH287-CK
8	112795-01-703	IN	CHANNEL-RUN (INCHES)	122-027566
9	098644-01-711	FT	WEATHERSTRIP - SCREEN BLACK	171-016965
10	140069-01-700	EA	GLASS - STATIONARY	390-029541
11	140069-01-701	EA	GLASS-SLIDING W/SASH & LATCH	DH788-A9
12	140069-01-702	EA	SCREEN ASM W/SEALS & CLIPS	410-029458
13	140069-01-703	EA	RETAINER - TRIM	H788-41
	098644-01-717	FT	SPLINE - SCREEN	132-004716

# WINDSHIELD & WIPER GROUP

## WINDSHIELD

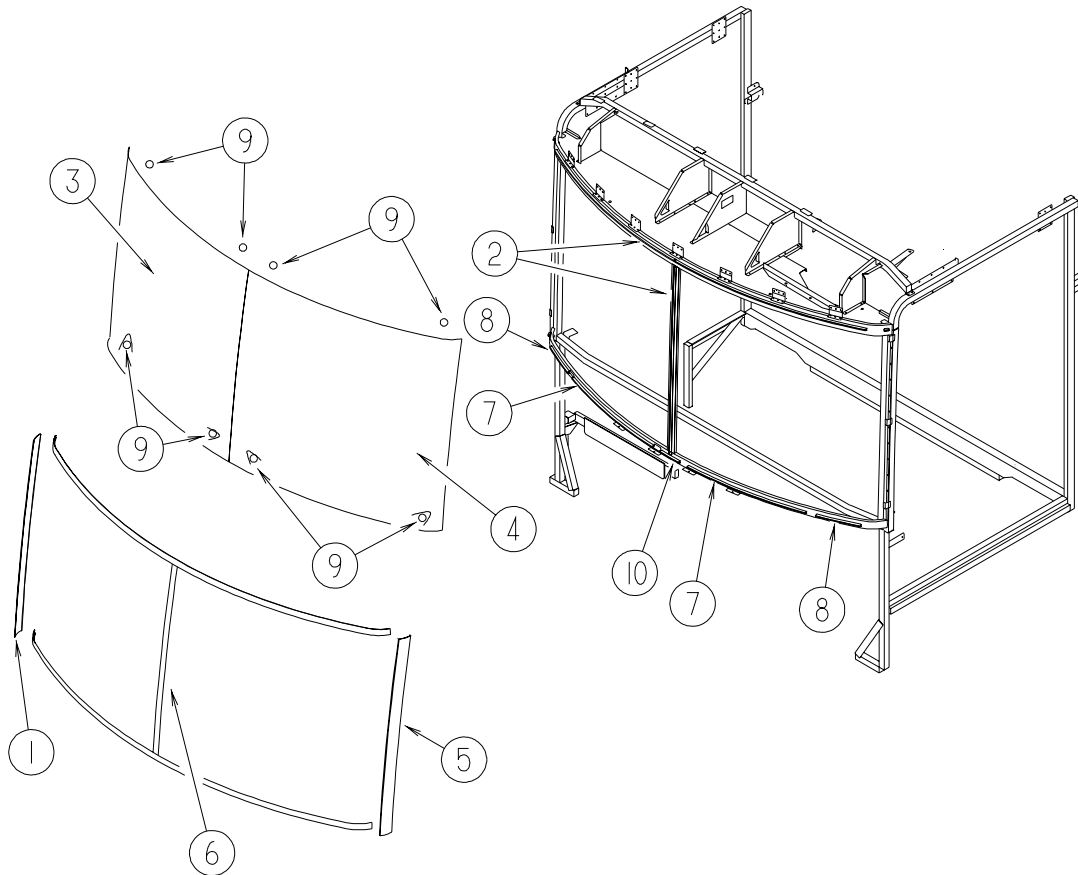

KEY	PART NUMBER	U/M	DESCRIPTION
1	129497-01-02A	EA	TRIM - A-PILLAR - PASSENGER - BLACK
2	127862-01-000	EA	CARRIER - REVEAL - WINDSHIELD - 47.2"
3	124591-01-000	EA	WINDSHIELD - PASSENGER - CURVED - 52.3" X 48.8"
4	124591-02-000	EA	WINDSHIELD - DRIVER - CURVED - 52.3" X 48.8"
5	129497-02-02A	EA	TRIM - WINDSHIELD - A-PILLAR - DRIVER - BLACK
6	120533-01-000	FT	MOLDING - REVEAL - WINDSHIELD
7	117335-06-000	EA	CARRIER - REVEAL - 29.8"
8	132375-02-000	EA	CARRIER/REVEAL/WINDSHIELD - 10"
9	081914-02-000	EA	BUMPER - RUBBER - ROUND - 5/16" DIA. X 13/64" THICK
10	132375-01-000	EA	CARRIER/REVEAL - WINDSHIELD - 5.5"
	002328-02-000	EA	BLOCK - WINDSHIELD - .062" X .5" X .98"

# WINDSHIELD & WIPER GROUP (CONTINUED)

## WIPER

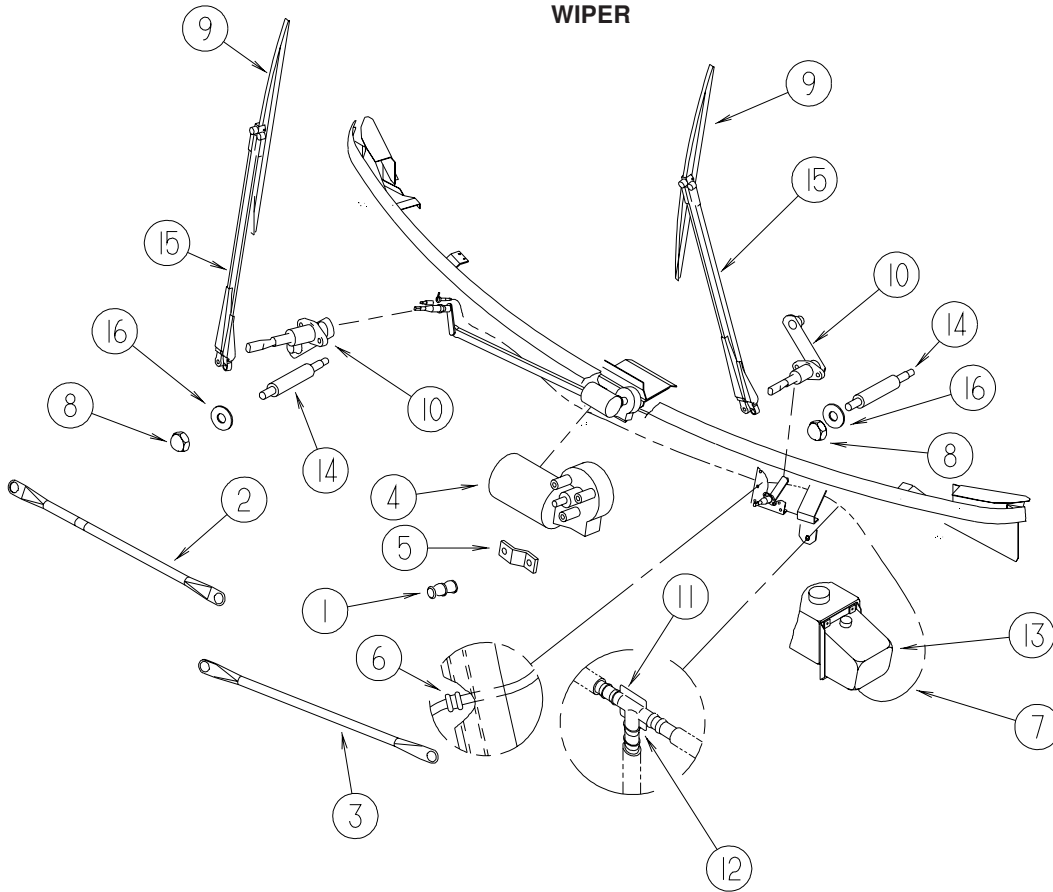

KEY	PART NUMBER	U/M	DESCRIPTION
1	067188-01-000	EA	STUD - CRANK - WIPER MOTOR
	117322-01-000	EA	SCREW - 1/4-28 UNFINISHED - 2A - TORX
2	117770-02-000	EA	LINK - CONNECTING - 24" - CLOSED GROMMET/CLOSED GROMMET
3	117770-01-000	EA	LINK - CONNECTING - 24" - CLOSED GROMMET/OPEN GROMMET
4	104346-05-000	EA	WIPER MOTOR - "DYNAMIC PARK" - W/INTERNAL BREAKER
5	104347-04-000	EA	ARM - DRIVE - WIPER MOTOR
6	061603-01-000	EA	GROMMET - SNAP - 3/16"ID - 3/8" HOLE - PLASTIC BLACK
7	045794-01-000	FT	HOSE - WASHER - WINDSHIELD - 5/32" ID - BLACK
8	077049-02-000	EA	NUT - ACORN - 10-32 BLACK/ANODIZED
9*	095964-01-000	EA	BLADE - WINDSHIELD WIPER - 24"
10*	096505-09-000	EA	SHAFT/PIVOT - WINDSHIELD WIPER
11	110605-01-000	EA	TEE - PLASTIC - BARBED - 1/8" X 1/8" X 3/16"
12	117765-03-000	EA	CONNECTOR - 5/32" - WINDSHIELD WASHER
	045794-02-000	FT	HOSE - WINDSHIELD WASHER - 3/32" ID - BLACK
13	117766-02-000	EA	RESERVOIR/PUMP - WINDSHIELD WASHER
14	117768-01-000	EA	SHAFT - ADAPTER - PANTOGRAPH ARM
15*	117769-01-000	EA	ARM - WIPER - PANTOGRAPH - 28"
16	110742-02-000	EA	GASKET - NEOPRENE - WIPER ADAPTER SHAFT - .5" ID X .9" OD

\*COMPONENT PARTS LISTED LATER IN THIS GROUP



**WINDSHIELD & WIPER GROUP (CONTINUED)**  
**COMPONENT PARTS FOR WIPER**

095964-01-000

<b>KEY</b>	<b>PART NUMBER</b>	<b>U/M</b>	<b>DESCRIPTION</b>	<b>VENDOR NO.</b>
	095964-01-700	EA	BLADE-REFILL 24" EA= 1 PAIR	12360

096505-09-000

<b>KEY</b>	<b>PART NUMBER</b>	<b>U/M</b>	<b>DESCRIPTION</b>	<b>VENDOR NO.</b>
	096505-02-700	EA	DRIVER-KNURLED,(HD) BRL .687	NT721017
	096505-02-701	EA	NUT-HEX (HD) W/.687 BARREL	NT721021
	096505-02-702	EA	CAP-RUBBER (HD) BARREL .687	CP721084
	096505-02-703	EA	NUT/ACORN - HD W/.687 BRL	51065-40-NT27WC

117769-01-000

<b>KEY</b>	<b>PART NUMBER</b>	<b>U/M</b>	<b>DESCRIPTION</b>	<b>VENDOR NO.</b>
	096931-01-700	FT	HOSE - WASHER - 1/8" ID	XTU-66-0001
	117769-01-700	EA	RETAINER CLIP - HOSE	