

2003
SUNDANCER
IF430V
400 SERIES
PORTSMOUTH OAK
P19 CHAMBRAY BLUE - BLUE
P21 FERN GARDEN
P23 SAND CASTLE
CONCERT CHERRY
P20 CHAMBRAY BLUE - BLUE
P22 FERN GARDEN
P24 SAND CASTLE
WASHED MAPLE
P33 CHAMBRAY BLUE - BLUE
P36 FERN GARDEN
P40 SAND CASTLE

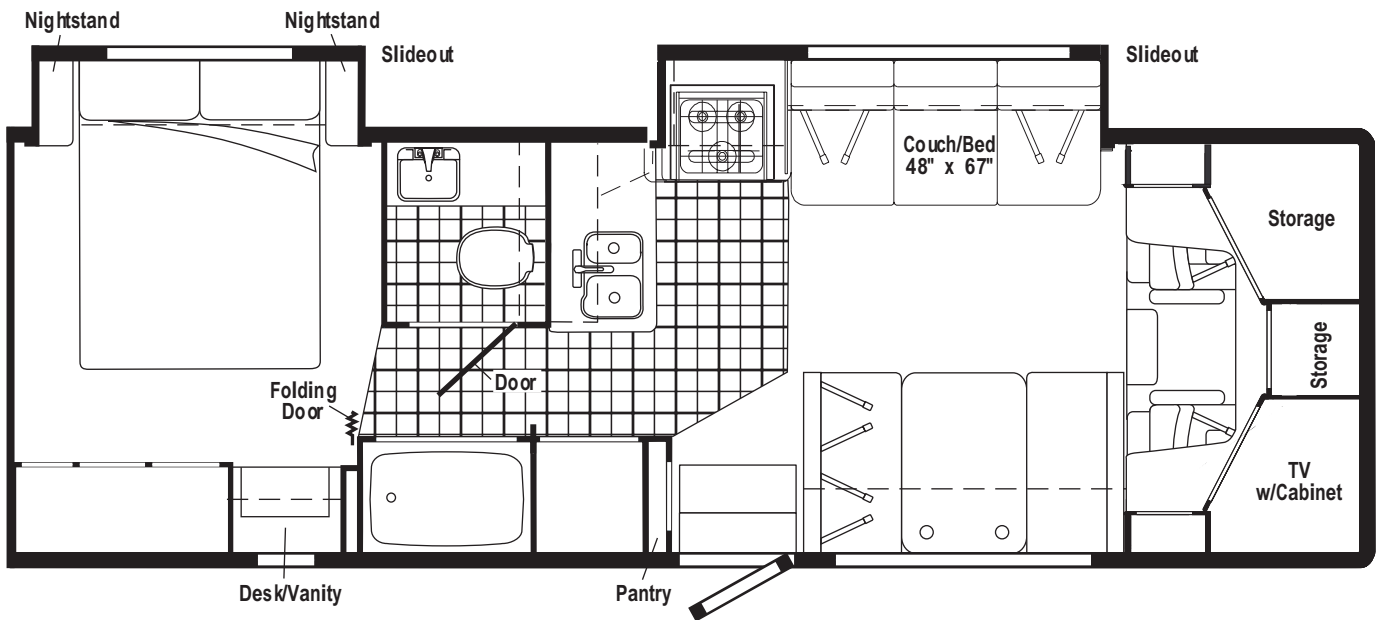

FLOORPLAN

CONTENTS

ACCESSORIES GROUP	6
OPERATORS MANUAL	6
APPLIANCE GROUP	7
APPLIANCES	7
COMPONENT PARTS FOR APPLIANCE	10
112881-03-01A	10
115504-01-000	12
121569-05-01A, 121569-07-01A	13
134940-01-01A	19
134940-02-01A	20
134940-04-01A	21
135656-01-01A	22
137354-01-000	24
AUDIO VIDEO GROUP	25
RADIO SYSTEM	25
COMPONENT PARTS FOR RADIO SYSTEM	26
143509-01-000	26
REAR VIEW MONITOR	27
TELEPHONE	27
TV & VCR	27
COMPONENT PARTS FOR TV & VCR	28
076319-23-000	28
076319-25-000	28
126697-07-000	29
133377-01-000 & 133377-02-000	29
137135-01-000	30
EXTERIOR ENTERTAINMENT	31
BATH GROUP	32
CABINETS	32
SHOWER	34
COMPONENT PARTS FOR SHOWER DOOR	35
115011-03-01A	35
BEDROOM GROUP	36
CABINETS	36
COMPONENT PARTS FOR CABINETS	40
131595-01-01A	40
CHASSIS GROUP	41
FRAME	41
DRIVETRAIN	42
EXHAUST	42
HITCH	43
FUEL	43
SPARE TIRE	45
SUSPENSION	45
COMPONENT PARTS FOR SUSPENSION	46
135674-01-000	46
WHEEL, TIRE, COVERS &/OR LINERS	47
COMPONENT PARTS FOR WHEEL, TIRE, COVERS &/OR LINERS	48
109443-05-000	48
110435-13-000	48
BRAKELINE	49

CONTENTS (CONTINUED)

CURTAIN & CUSHION GROUP	50
NOTICE	50
CUSHION LAYOUT	51
BUCKET SEATS	53
COMPONENT PARTS FOR BUCKET SEATS	55
122611-02-000	55
SOFA	56
WINDOW TREATMENT	57
HARDWARE	58
ACCESSORIES	60
FABRICS	61
DINETTE GROUP	63
CABINETS	63
TABLE	65
DRIVERS COMPARTMENT GROUP	66
FRONT INTERIOR	66
CABINETS	67
ELECTRICAL GROUP	69
12V BODY WIRING	69
FRONT END WIRING	74
COMPONENT PARTS FOR LIGHTS & SWITCHES	75
008089-01-000	75
087202-01-000	75
087694-01-000	75
097917-01-06A	75
121935-01-01A	75
137417-01-01A	75
137417-02-01A	75
137417-03-01A	75
137417-05-01A	75
137417-06-01A	75
CIRCUIT BREAKERS & FUSES	76
CONVERTER, INVERTER, LOAD CENTERS	76
110V WIRING	77
ENTERTAINMENT WIRING	79
ENTERTAINMENT WIRING COMPONENTS	80
123775-01-01A	80
BOXES & CORDS	81
WIRE ASSEMBLIES	81
CONNECTORS & CONDUIT	82
BOOTS, SOLENOIDS, RELAYS & MISCELLANEOUS	84
EXTERIOR BODY GROUP	85
GRAPHICS & PAINT	85
PANELS & TRIMS	87
COMPONENT PARTS FOR PANELS & TRIMS	91
132442-01-01A	91
LADDER	92
RUNNING BOARDS	92
MIRRORS	92
COMPONENT PARTS FOR MIRRORS	93
120269-07-01A	93
133908-01-01A, 133908-01-02A, 133908-02-01A, 133908-03-01A, 133908-03-02A, 133908-04-01A, 133908-05-01A, 133908-06-01A,	93
133908-07-01A, 133908-08-01A, 133908-10-01A, 133908-11-01A, 133908-12-01A, 133908-13-01A	93
STRUCTURAL COMPONENTS	94
AWNINGS	94
COMPONENT PARTS FOR AWNINGS	95
113874-01-02A	95

CONTENTS (CONTINUED)

EXTERIOR DOORS & COMPARTMENTS GROUP	96
DOOR & COMPARTMENT LAYOUT	96
COMPARTMENT DOOR PIECE PARTS	100
ENTRY	102
SCREEN	103
LATCH - ENTRY	104
EXTERIOR SLIDEOUT GROUP	105
FRONT LEFT	105
COMPONENT PARTS FOR FRONT SLIDEOUT	110
136747-01-000	110
143394-01-000	110
LEFT REAR	111
COMPONENT PARTS FOR REAR SLIDEOUT	115
100536-42-000	115
128599-02-000	115
128599-04-000	115
GALLEY GROUP	116
CABINETS	116
DOORS & DRAWERS	118
GENERATOR GROUP	121
GAS	121
HEATING & A/C GROUP	122
FURNACE	122
COMPONENT PARTS FOR FURNACE	123
139980-02-000	123
REAR HEATER	125
COMPONENT PARTS FOR REAR HEATER	126
084405-01-000	126
ROOF	127
COMPONENT PARTS FOR ROOF	128
131184-03-01A	128
131184-05-01A	129
131188-03-01A	130
131188-04-01A	131
INTERIOR FINISH GROUP	132
MOLDINGS & TRIMS	132
PANELING & LAMINATES	136
ACCESSORIES	136
COMPONENT PARTS FOR ACCESSORIES	137
094499-02-000	137
FLOOR COVERINGS	138
HARDWARE	139
LABELS GROUP	145
LP GROUP	168
LP SYSTEM	168
COMPONENT PARTS FOR LP SYSTEM	169
097821-03-000	169
LOUNGE GROUP	170
CABINETS	170
SEALANTS & FASTENERS GROUP	171
SEALANTS & ADHESIVES	171
BOLTS, NUTS AND WASHERS	172
SCREWS	174
CLAMPS, CLIPS, GROMMETS, RIVETS & PLUGS	178
MISCELLANEOUS FASTENERS	179

CONTENTS (CONTINUED)

WATER & SEWAGE GROUP	180
DRAINAGE SYSTEM	180
COMPONENT PARTS FOR DRAINAGE SYSTEM	182
062415-01-000	182
067487-04-000	182
096927-01-02A	183
WATER SYSTEM	184
COMPONENT PARTS FOR WATER SYSTEM	191
051391-03-000	191
051391-07-000	192
075240-05-000	193
075241-04-000, 075241-05-000, 075241-06-000	193
141432-01-01A	193
WINDOW & VENTS GROUP	194
WINDOW & VENT LAYOUT	194
COMPONENT PARTS FOR WINDOW & VENT LAYOUT	196
098644-07-02A	196
098647-07-03A	197
098647-23-02A	198
098647-47-02A	198
112795-69-01A	199
112795-77-01A	200
112795-84-01A	200
112898-22-01A	201
113500-09-02A	202
113733-04-01A, 113733-10-01A, 113733-11-01A	203
122882-01-01A	203
122882-02-01A, 122882-03-01A	203
123780-03-01A	204
123780-09-01A	205
123780-11-01A	205
129929-12-01A	206
129929-10-01A	207

ACCESSORIES GROUP
OPERATORS MANUAL

KEY	PART NUMBER	U/M	DESCRIPTION
	132000-13-003	EA	MANUAL/OWNER - SUNDANCER - 2003
	129079-01-01A	EA	CASE - VINYL/BLACK-EXPANDABLE ACCORDION SIDES-7"WX9"HX14"L
	140492-01-000	EA	TOP LEVEL-C,2003

APPLIANCE GROUP APPLIANCES

KEY	PART NUMBER	U/M	DESCRIPTION
*	135656-03-01A	EA	RANGE - 16" - 3 BURNER W/OVEN/NEW STYLE KNOBS-GRATES - BLK
*	112881-03-01A	EA	RANGE - 16"/3 BURNER/NEW STYLE KNOBS-GRATES-HANDLE - BLK - 430V CANADIAN ONLY
	140176-03-01B	EA	BRACKET/TIEDOWN - STOVE
	140176-04-01B	EA	BRACKET/TIEDOWN - STOVE
	124649-02-01A	EA	COFFEEMAKER - 10 CUP/DEEP BREW - BLACK - UL
	138584-03-01A	EA	COFFEE MAKER/CARAFE - NO TIMER - KRUPS #536-42 - BLACK
			FROM: 00-00-00 THRU: 11-17-02
			FROM: 11-18-02 THRU: 99-99-99
*	115504-01-000	EA	PANEL - SOLAR 10 WATT - 12.2"W X 26.9"L X 1.2"H
*	134940-01-01A	EA	PANEL - MONITOR - 2 TANK - W/GENERATOR SWITCH/HOUR METER
*	134940-02-01A	EA	PANEL - MONITOR - 2 TANK - W/O GENERATOR SWITCH/HOUR METER
*	134940-04-01A	EA	PANEL - MONITOR - 2 TANK-W/GENERATOR SWITCH/SOLAR CHARGER

***COMPONENT PARTS LISTED LATER IN THIS GROUP**

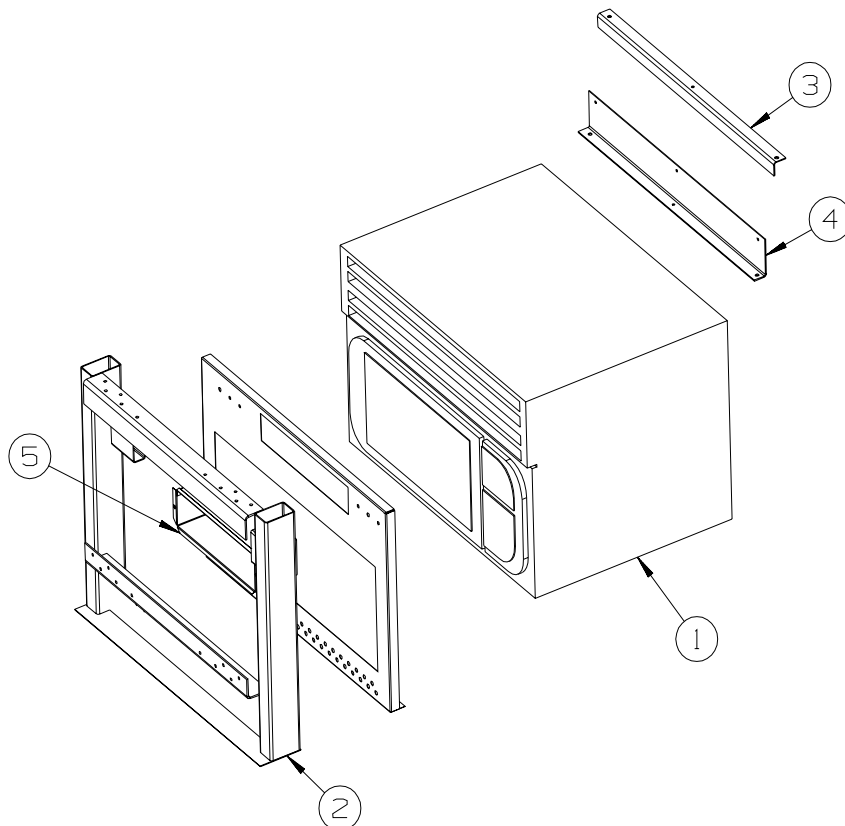

KEY	PART NUMBER	U/M	DESCRIPTION
1*	137354-01-000	EA	OVEN - MICROWAVE - 1.2 OTR - W/VENT
2	NOT USED		
3	138230-02-02B	EA	ANGLE - W/HOLES - E - COATED - 430V
4	138230-01-02B	EA	ANGLE - W/HOLES - E - COATED - 430V
5	NOT USED		

***COMPONENT PARTS LISTED LATER IN THIS GROUP**

APPLIANCE GROUP (CONTINUED)
APPLIANCES (CONTINUED)

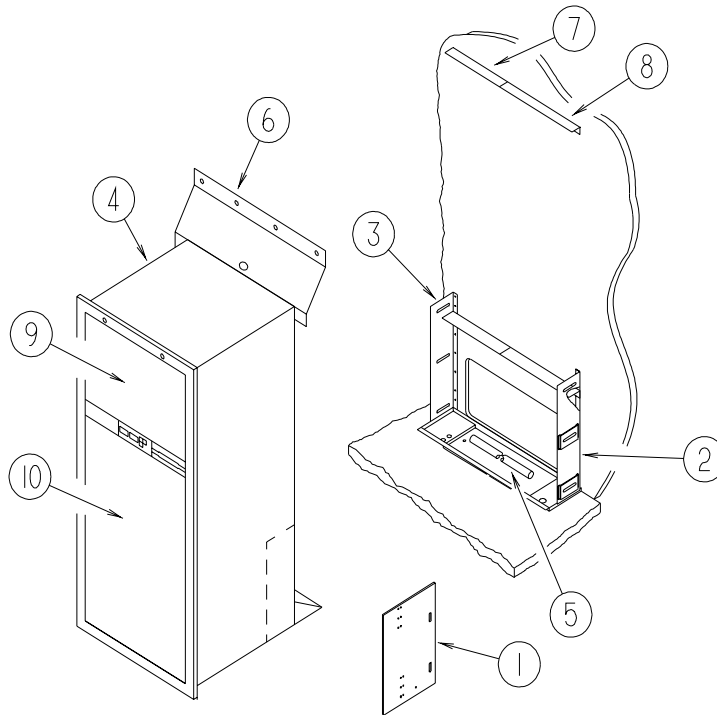

427P

KEY	PART NUMBER	U/M	DESCRIPTION
1	065225-04-000	EA	PLATE - TIEDOWN/REFRIGERATOR
2	093646-01-000	EA	BRACKET - TIEDOWN/REFRIGERATOR - RIGHT HAND
3	093646-02-000	EA	BRACKET - TIEDOWN/REFRIGERATOR - LEFT HAND
4*	121569-07-01A	EA	REFRIGERATOR - LARGE DBL DOOR/LEFT HAND -2 WAY- F/SLIDEOUT
5	112176-01-000	FT	TUBING - VINYL - REINFORCED - 1/2" ID
6	136966-01-02B	EA	BAFFLE - REFRIGERATOR - E-COATED
7	143195-02-02B	EA	BAFFLE - REFRIGERATOR - E-COATED
			FROM: 04-29-02 THRU: 99-99-99
8	143195-01-02B	EA	BAFFLE - REFRIGERATOR - E-COATED
			FROM: 04-29-02 THRU: 99-99-99
9	P34457-03-N47	EA	PANEL - INSERT RAISED MEMBRANE - 21.5" X 14.5" - PORTSMOUTH OAK
9	P34457-03-L85	EA	PANEL - INSERT RAISED MEMBRANE - 21.5" X 14.5" - CONCERT CHERRY
9	P34457-03-L94	EA	PANEL - INSERT RAISED MEMBRANE - 21.5" X 14.5" - WASHED MAPLE
10	P34457-04-N47	EA	PANEL - INSERT RAISED MEMBRANE - 21.5" X 38.5" - PORTSMOUTH OAK
10	P34457-04-L85	EA	PANEL - INSERT RAISED MEMBRANE - 21.5" X 38.5" - CONCERT CHERRY
10	P34457-04-N47	EA	PANEL - INSERT RAISED MEMBRANE - 21.5" X 38.5" - WASHED MAPLE
	090329-01-000	FT	SEAL/T - REFRIGERATOR CABINET
	054450-01-000	EA	LEVEL - REFRIGERATOR
	136907-01-01A	EA	TRAY - REFRIGERATOR - BLACK

***COMPONENT PARTS LISTED LATER IN THIS GROUP**

APPLIANCE GROUP (CONTINUED)
APPLIANCES (CONTINUED)

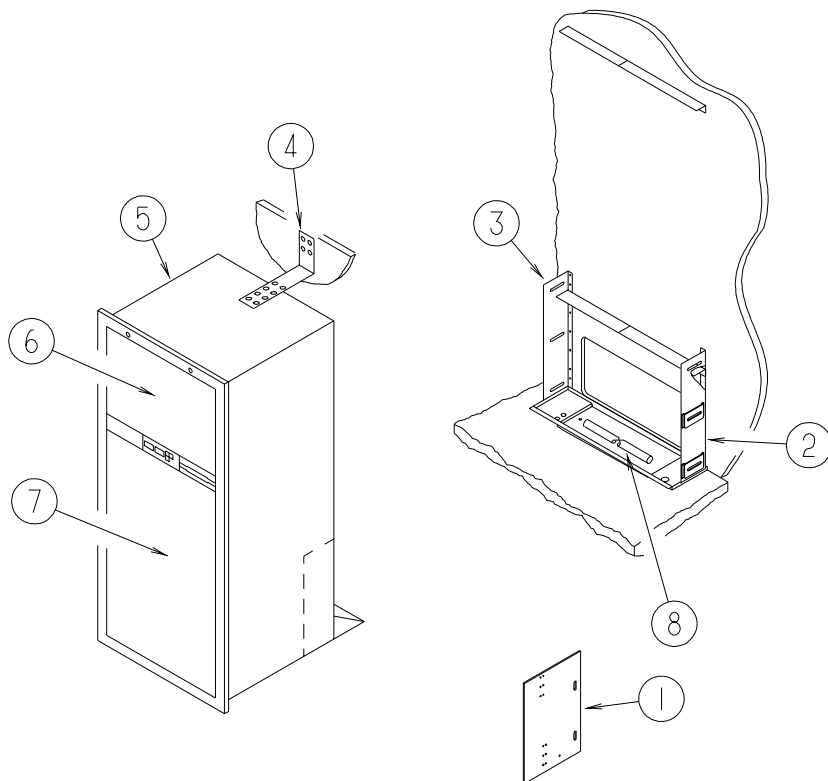

430V AND 431C

KEY	PART NUMBER	U/M	DESCRIPTION
1	065225-04-000	EA	PLATE - TIEDOWN/REFRIGERATOR
2	093646-01-000	EA	BRACKET - TIEDOWN/REFRIGERATOR - RIGHT HAND
3	093646-02-000	EA	BRACKET - TIEDOWN/REFRIGERATOR - LEFT HAND
4	093369-02-000	EA	STRAP - REFRIGERATOR
5*	121569-05-01A	EA	REFRIGERATOR - LARGE DOUBLE DOOR/RH - 2-WAY - BLACK
6	P34457-03-N47	EA	PANEL - INSERT RAISED MEMBRANE - 21.5" X 14.5" - PORTSMOUTH OAK
6	P34457-03-L85	EA	PANEL - INSERT RAISED MEMBRANE - 21.5" X 14.5" - CONCERT CHERRY
6	P34457-03-L94	EA	PANEL - INSERT RAISED MEMBRANE - 21.5" X 14.5" - WASHED MAPLE
7	P34457-04-N47	EA	PANEL - INSERT RAISED MEMBRANE - 21.5" X 38.5 - PORTSMOUTH OAK
7	P34457-04-L85	EA	PANEL - INSERT RAISED MEMBRANE - 21.5" X 38.5 - CONCERT CHERRY
7	P34457-04-L94	EA	PANEL - INSERT RAISED MEMBRANE - 21.5" X 38.5 - WASHED MAPLE
8	112176-01-000	FT	TUBING - VINYL - REINFORCED - 1/2" ID
	116751-02-01A	EA	TRAY - REFRIGERATOR - BLACK - 431C
	116751-05-01A	EA	TRAY - REFRIGERATOR - BLACK - 430V
	090329-01-000	FT	SEAL/T - REFRIGERATOR CABINET
	054450-01-000	EA	LEVEL - REFRIGERATOR

***COMPONENT PARTS LISTED LATER IN THIS GROUP**

APPLIANCE GROUP (CONTINUED)
COMPONENT PARTS FOR APPLIANCE

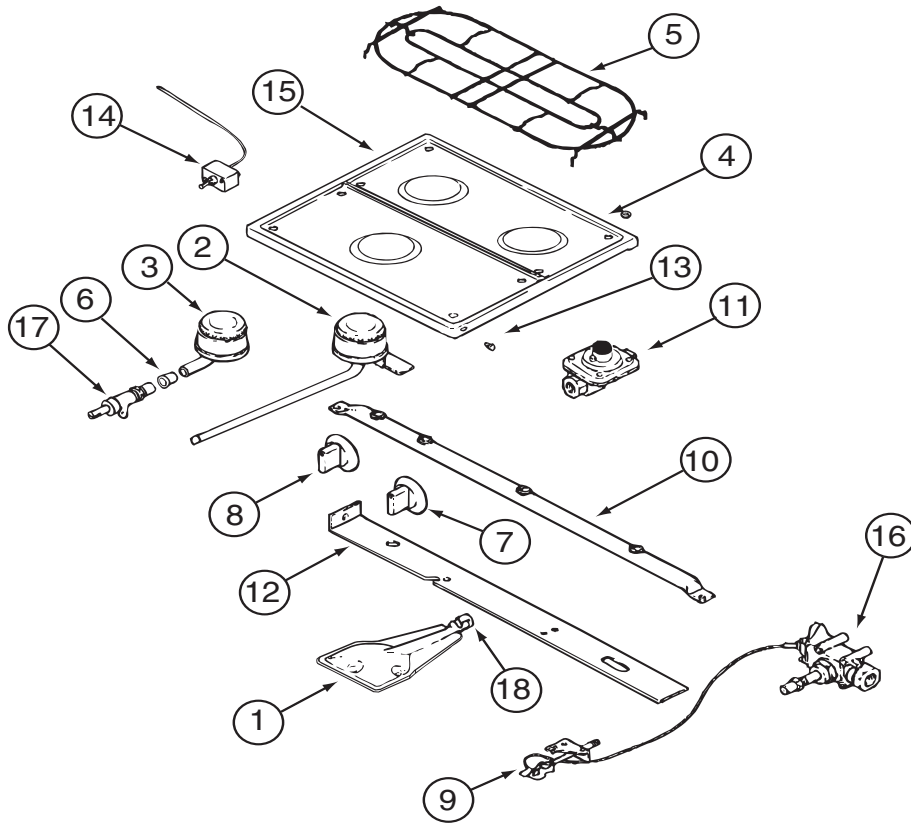

112881-03-01A

KEY	PART NUMBER	U/M	DESCRIPTION	VENDOR NO.
1	126023-01-717	EA	BURNER - OVEN	74003343
2	112881-01-717	EA	BURNER, TOP REAR	7505P181-60
3	112881-02-703	EA	BURNER - FRONT HIGH OUTPUT	7505P142-60
4	102020-01-709	EA	BUMPER-GRATE	8007-P020-60
5	126023-01-730	EA	GRATE - TOP	74003358
6	098507-02-701	EA	INSERT-BURNER, SLOTTED VENT	7214P015-60
7	112881-01-718	EA	KNOB - TOP BURNER HI-OUTPUT	74001794
7	112881-01-705	EA	KNOB-TOP BURNER	7733P072-60
8	112881-03-700	EA	KNOB - THERMOSTAT - BLACK	74004155
9	102020-01-714	EA	PILOT-OVEN	968-143
10	126023-01-705	EA	PIPE - MANIFOLD	7513P161-60
11	112881-03-701	EA	REGULATOR KIT W/FITTINGS	12001285
13	102020-01-724	EA	BUMPER-MAIN TOP	8003P008-60
14	112881-01-722	EA	THERMOSTAT SER.# CHECK 12/13	7515P029-60K
15	126023-01-728	EA	TOP - MAIN (BLACK)	74003323
16	102020-01-720	EA	VALVE-MERCURY CONTROL	7501P056-60
	128728-01-712	EA	FITTING - HALF UNION	7507P083-60

CONTACT WINNEBAGO PART SALES FOR UNLISTED COMPONENTS

APPLIANCE GROUP (CONTINUED)
COMPONENT PARTS FOR APPLIANCE (CONTINUED)

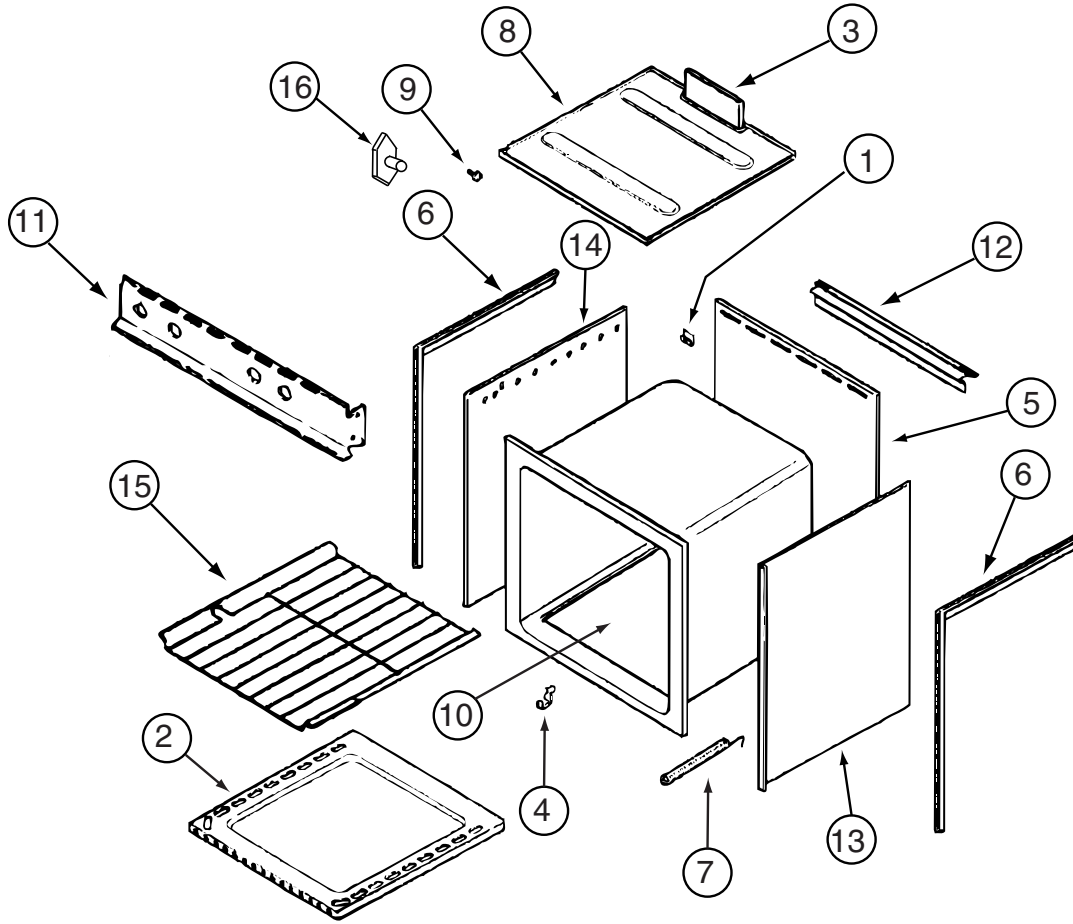

112881-03-01A (CONTINUED)

KEY	PART NUMBER	U/M	DESCRIPTION	VENDOR NO.
1	112881-02-701	EA	CLIP - MAIN TOP (REAR)	7112P071-60
2	126023-01-731	EA	BOTTOM - OVEN	2205F016-19
3	126023-01-718	EA	FLUE BOX ASSEMBLY	4006W075-80
6	112881-01-720	EA	TRIM-FLAT RH BLACK TEXTURED	4002812
6	112881-01-719	EA	TRIM-FLAT LH BLACK TEXTURED	74002813
7	112881-02-704	EA	SPRING-OVEN DOOR F/1641 MOD	7803P052-60
7	112881-02-702	EA	SPRING - OVEN DOOR	7803P051-60
11	126023-01-715	EA	PANEL - MANIFOLD	74003350
12	112881-01-721	EA	DEFLECTOR FLUE BLACK TEXTURE	74002809
15	126023-01-716	EA	RACK - OVEN	74003106
16	128728-01-703	EA	T-NUT - F/HINGE	7103P109-60
	112881-03-702	EA	CLIP - MAIN TOP	74003998

CONTACT WINNEBAGO PART SALES FOR UNLISTED COMPONENTS

APPLIANCE GROUP (CONTINUED)
COMPONENT PARTS FOR APPLIANCE (CONTINUED)

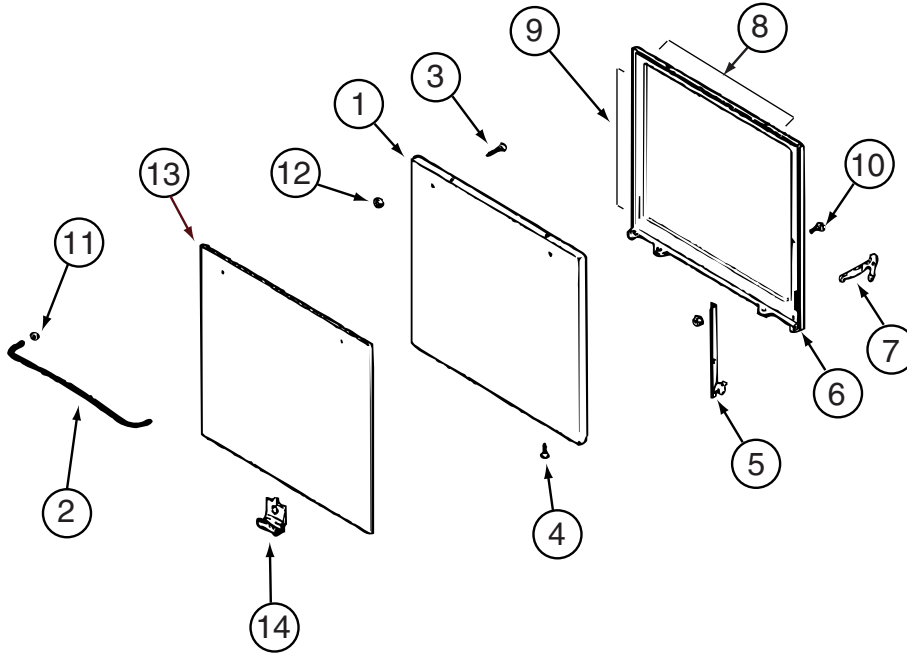

112881-03-01A (CONTINUED)

KEY	PART NUMBER	U/M	DESCRIPTION	VENDOR NO.
1	112881-02-705	EA	DOOR/OVEN-TEXT/BLK-F/WINDOW	74001273
1	112881-01-713	EA	DOOR/OVEN-TEXT/BLK NO WINDOW	2401F126-70
2	102020-01-701	EA	HANDLE,DOOR	7701P092-60
8	126023-01-732	EA	SEAL/OVEN DR TOP	7212P014-60
9	126023-01-733	EA	SEAL/OVEN DR SIDES(2PCS)	7212P038-60
13	102022-01-704	EA	GLASS-OUTER	7902P261-60

CONTACT WINNEBAGO PART SALES FOR UNLISTED COMPONENTS

115504-01-000

KEY	PART NUMBER	U/M	DESCRIPTION	VENDOR NO.
	115504-01-700	EA	PLUG & CABLE, 10 WATT PANEL	600-016

APPLIANCE GROUP (CONTINUED)
COMPONENT PARTS FOR APPLIANCE (CONTINUED)

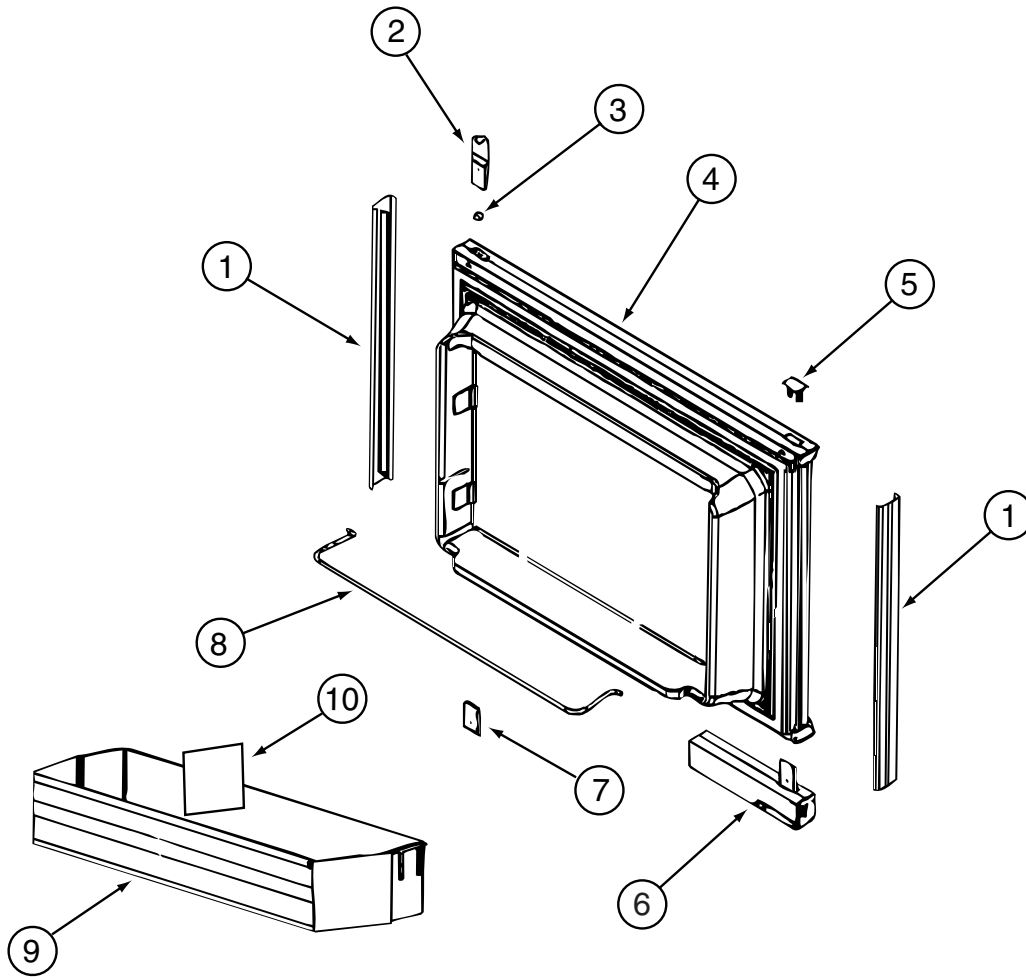

121569-05-01A, 121569-07-01A

KEY	PART NUMBER	U/M	DESCRIPTION	VENDOR NO.
1	121568-03-700	EA	RETAINER - DOOR PANEL/BLACK	619558
2	120075-01-701	EA	HINGE-TOP RH/BOTTOM LH(DOOR)	618511
3	121568-03-701	EA	BUSHING - HINGE PIN/GRAY	619671
4	121568-03-702	EA	DOOR LINER - W/TRIM/BLACK	619627 - SMALL DOOR
5	120075-01-702	EA	CAP, (HINGE PLUG)	618160
6	120075-12-700	EA	HANDLE(CONTOUR)TOP LH/BTM RH	621105
7	120075-01-705	EA	HINGE-TOP LH/BOTTOM RH(DOOR)	618510
8	121568-01-700	EA	RAIL - DOOR UPPER	618618
9	120075-07-700	EA	DOOR BIN - CLEAR	619006
10	120075-07-701	EA	DIVIDER/DOOR BIN CLEAR	619008
	121568-03-705	EA	STORAGE LATCH - GRAY	619648

APPLIANCE GROUP (CONTINUED)
COMPONENT PARTS FOR APPLIANCE (CONTINUED)

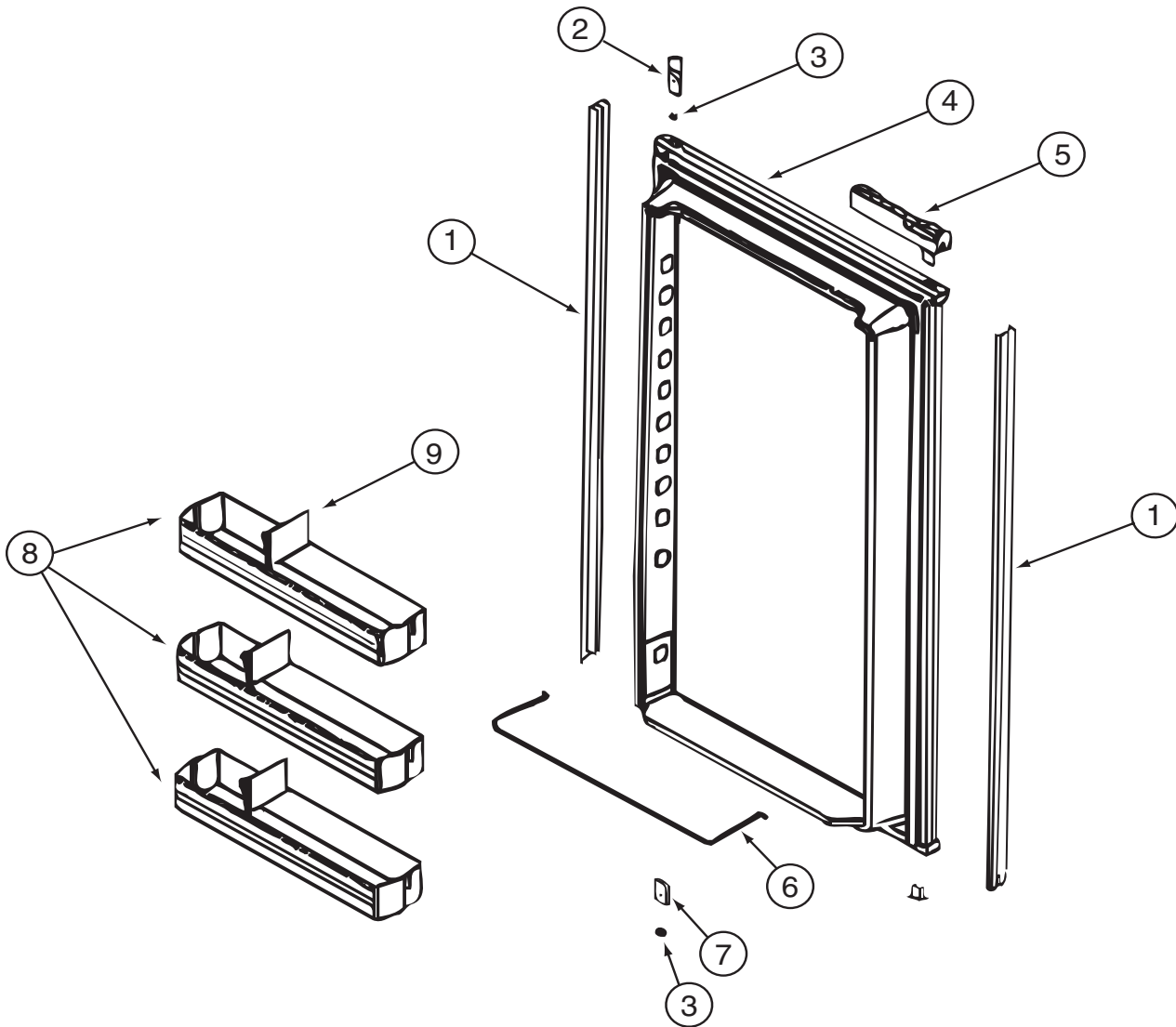

121569-05-01A, 121569-07-01A (CONTINUED)

KEY	PART NUMBER	U/M	DESCRIPTION	VENDOR NO.
1	120075-07-702	EA	RETAINER - DOOR PANEL/BLACK	619560
2	120075-01-701	EA	HINGE-TOP RH/BOTTOM LH(DOOR)	618511
3	121568-03-701	EA	BUSHING - HINGE PIN/GRAY	619671
4	121568-03-707	EA	DOOR LINER - W/BLACK TRIM	619629
5	120075-12-701	EA	HANDLE(CONTOUR)TOP RH/BTM LH	621104
6	121568-01-704	EA	RAIL - DOOR LOWER	618578
7	120075-01-705	EA	HINGE-TOP LH/BOTTOM RH(DOOR)	618510
8	121568-01-701	EA	BIN - DOOR WHITE	618619
9	120075-07-701	EA	DIVIDER/DOOR BIN CLEAR	619008
	121568-03-705	EA	STORAGE LATCH - GRAY	619648

APPLIANCE GROUP (CONTINUED)
COMPONENT PARTS FOR APPLIANCE (CONTINUED)

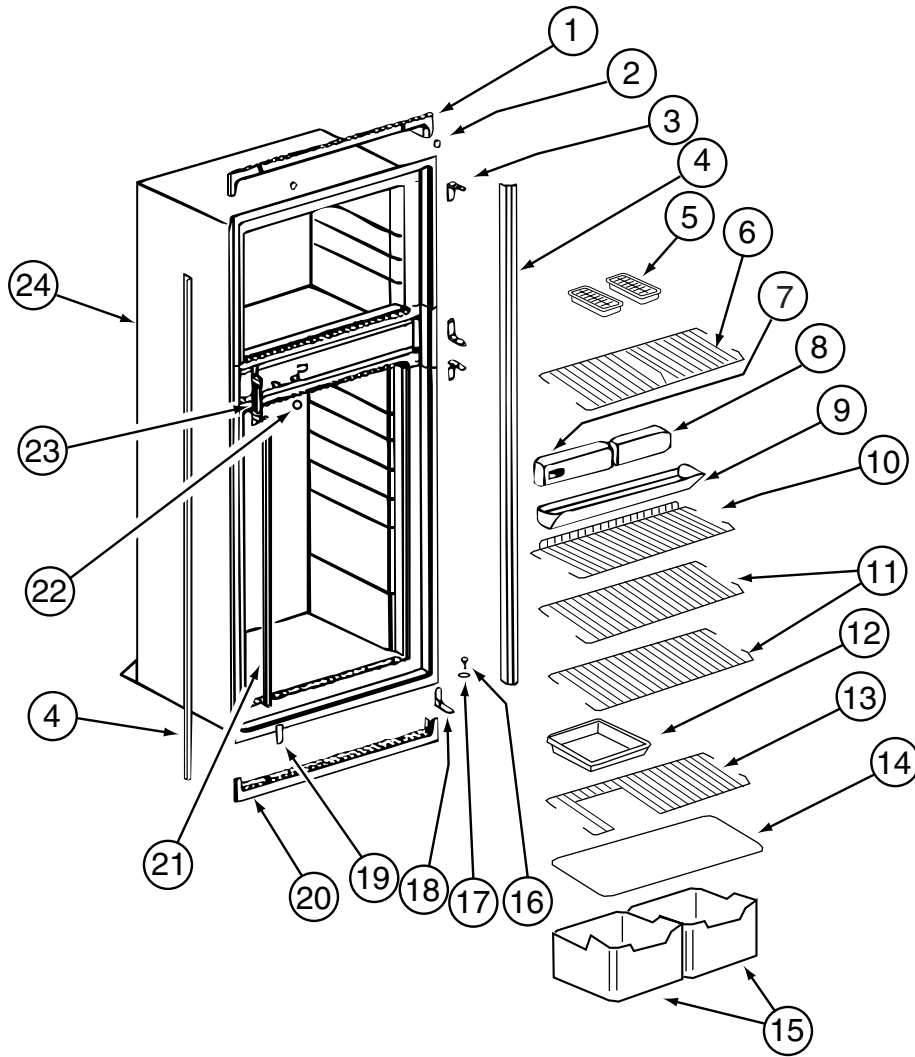

121569-05-01A, 121569-07-01A (CONTINUED)

KEY	PART NUMBER	U/M	DESCRIPTION	VENDOR NO.
1	121568-03-709	EA	TRIM - TOP/BLACK	619687
2	120075-01-714	EA	PLUG-HOLE	618170
3	121568-03-710	EA	HINGE/CABINET-TOP/RH-LWR/LH	619335
4	120075-07-705	EA	TRIM - SIDE - BLACK	619802
6	121568-03-712	EA	SHELF - WIRE/FREEZER	620250
7	121568-03-714	EA	CONTROL ASM - 2 WAY BLACK	619350
8	121568-03-713	EA	FRONT BOX/DECORATIVE-BLACK	619282
9	120075-01-720	EA	TRAY-DRIP	618137
10	121568-01-707	EA	SHELF - WIRE - SHORT	618624
11	121568-01-708	EA	SHELF - WIRE	618589
14	120075-01-725	EA	COVER-CRISPER	618158
15	121568-01-709	EA	CRISPER	618571
16	120075-01-727	EA	PIN-HINGE	618145
18	121568-03-715	EA	HINGE/CABINET-TOP/LH-LWR/RH	619336
19	121568-03-716	EA	COVER - HINGE HOLES	619301
20	120075-01-729	EA	TRIM-BOTTOM PIECE	618136
21	120075-01-730	EA	RETAINER-SHELF	618181
22	121568-03-717	EA	HOLE PLUG - WHITE	619561
23	120075-01-732	EA	PLATE-STRIKE	618167
24	120075-07-709	EA	CABINET - FOAMED	619347
	120075-01-721	EA	LOUVER-DRIP TRAY	618176

CONTACT WINNEBAGO PART SALES FOR UNLISTED COMPONENTS

APPLIANCE GROUP (CONTINUED)
COMPONENT PARTS FOR APPLIANCE (CONTINUED)

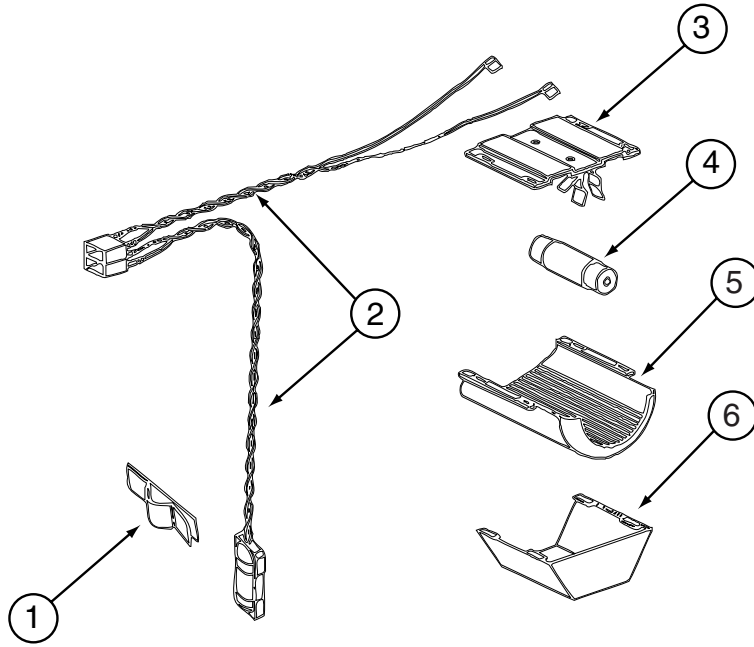

121569-05-01A, 121569-07-01A (CONTINUED)

KEY	PART NUMBER	U/M	DESCRIPTION	VENDOR NO.
1	084880-01-760	EA	CLIP (THERMISTER)	61689122
2	120075-01-735	EA	THERMISTER W/LAMP & WIRE/ASM	618548
3	084880-03-705	EA	BRACKET-LIGHT-INTERIOR	61629722
4	084880-03-706	EA	BULB-LAMP	61628922
6	084880-03-707	EA	COVER-LAMP, LENS	61627922

CONTACT WINNEBAGO PART SALES FOR UNLISTED COMPONENTS

APPLIANCE GROUP (CONTINUED)
COMPONENT PARTS FOR APPLIANCE (CONTINUED)

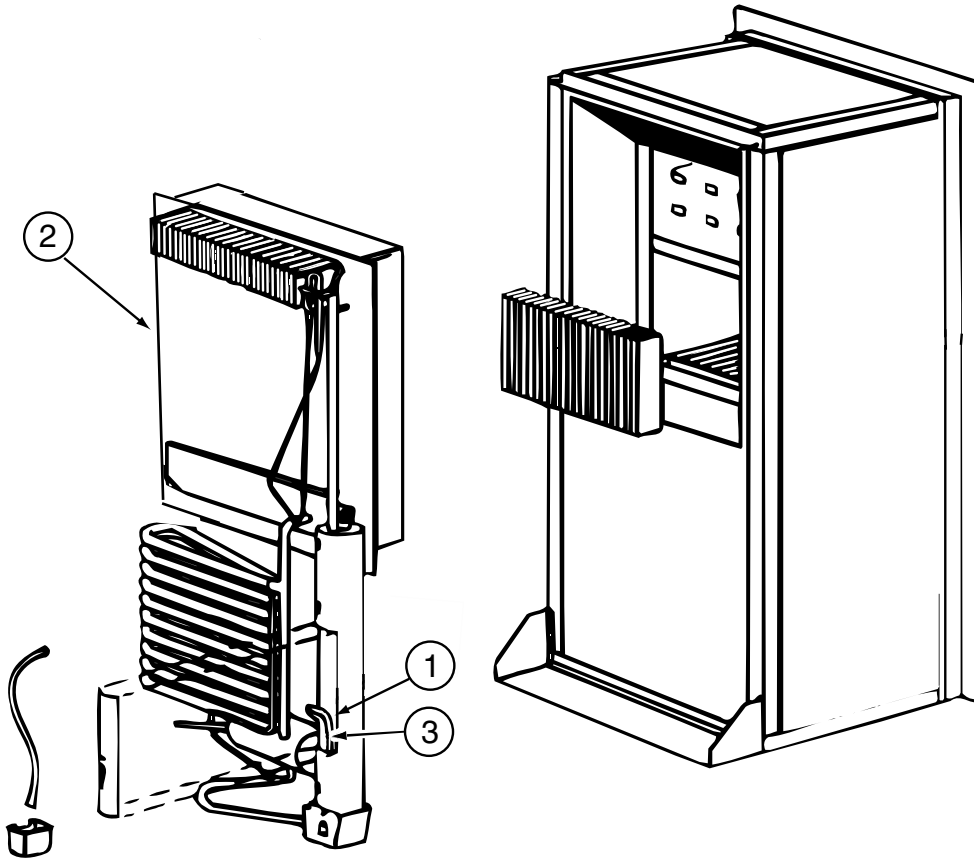

121569-05-01A, 121569-07-01A (CONTINUED)

KEY	PART NUMBER	U/M	DESCRIPTION	VENDOR NO.
2	120075-01-736	EA	COOLING UNIT, SERVICE PACK	618542
3	088248-01-709	EA	HEATER-AC (HORIZONTAL)	61562722
	120075-01-744	EA	KIT - GAS VALVE/BURNER TUBE	620609

CONTACT WINNEBAGO PART SALES FOR UNLISTED COMPONENTS

APPLIANCE GROUP (CONTINUED)
COMPONENT PARTS FOR APPLIANCE (CONTINUED)

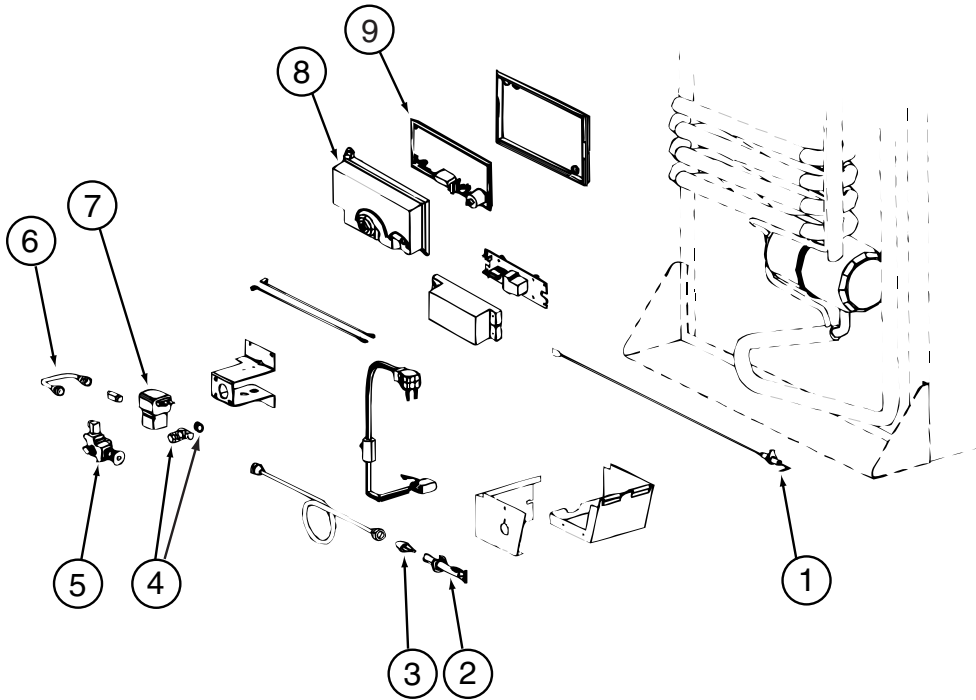

121569-05-01A, 121569-07-01A (CONTINUED)

KEY	PART NUMBER	U/M	DESCRIPTION	VENDOR NO.
1	104137-06-715	EA	ELECTRODE-SPARK/SENSOR, SGL	61692222
2	104137-06-714	EA	BURNER ASSEMBLY, 5-SLOT	61705222
3	120075-01-737	EA	ORIFICE - JEWEL - .0155	618284
4	113737-01-702	EA	PLUG 1/8" F/PRESSURE TAP	61445322
4	113737-01-716	EA	TAP-PRESSURE	61594422
6	113737-01-750	EA	TUBE-UNION	61694622
7	084880-01-718	EA	VALVE-GAS, (ASCO)	61551822
8	120075-01-738	EA	COVER-POWER BOARD	618185
9	121568-03-719	EA	POWER - BOARD - 2-WAY	619353
	121568-03-720	EA	VALVE/SHUT OF-MANUAL ELECT.	618696

CONTACT WINNEBAGO PART SALES FOR UNLISTED COMPONENTS

121569-07-01A (CONTINUED)

KEY	PART NUMBER	U/M	DESCRIPTION	VENDOR NO.
	125242-01-729	EA	FAN-EXTERNAL DC	618856
	125242-01-730	EA	BRACKET- DC FAN	618857
	125242-01-741	EA	SUPPORT-DC FAN	618912

APPLIANCE GROUP (CONTINUED)
COMPONENT PARTS FOR APPLIANCE (CONTINUED)

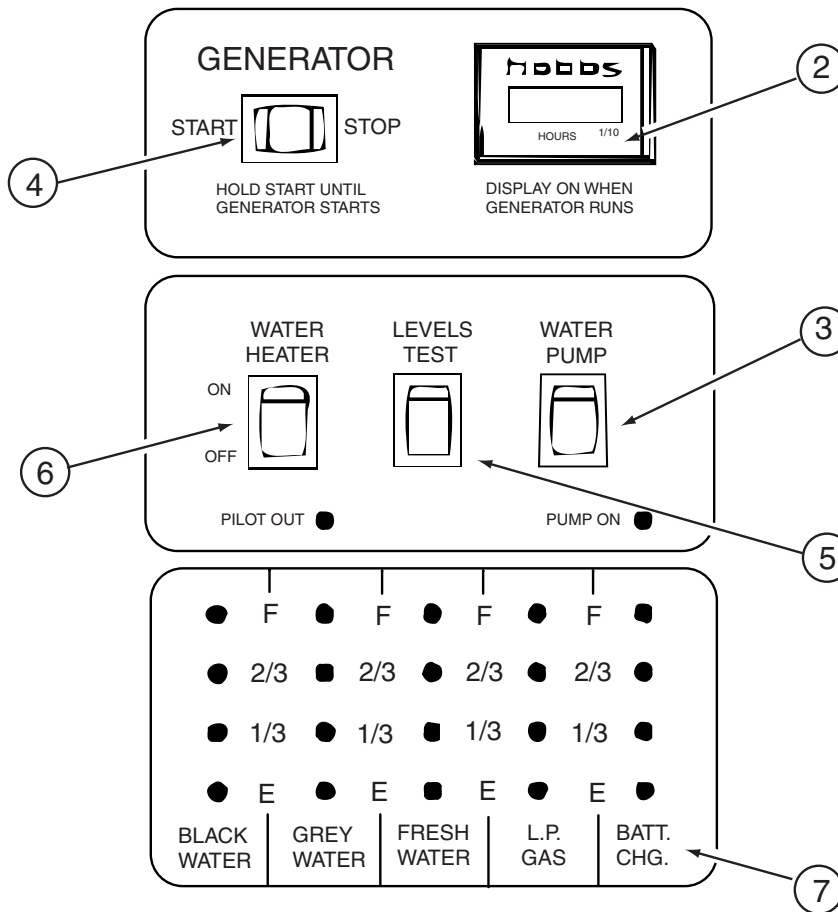

134940-01-01A

KEY	PART NUMBER	U/M	DESCRIPTION	VENDOR NO.
	134940-01-700	EA	BOARD - PC	L5118-01
2	100258-10-701	EA	GAUGE-HR METER ONLY (LCD)	L0775-00
3	096983-01-703	EA	SWITCH - ON/ON	L0115-00
4	096983-01-702	EA	SWITCH - MOM/OFF/MOM/3 TERM	L0112-00
5	096983-01-701	EA	SWITCH - SPST/MOM 2 TERMINAL	L0111-00
6	134940-01-701	EA	SWITCH-SPST/ON-OFF/BLK W/LGT	L0109
7	134940-01-702	EA	CHASSIS - SILKSCREENED	CC0558-00
	100258-10-702	EA	HOUR METER(CLIP ON)SW & WIRE	L4441-00

APPLIANCE GROUP (CONTINUED)
COMPONENT PARTS FOR APPLIANCE (CONTINUED)

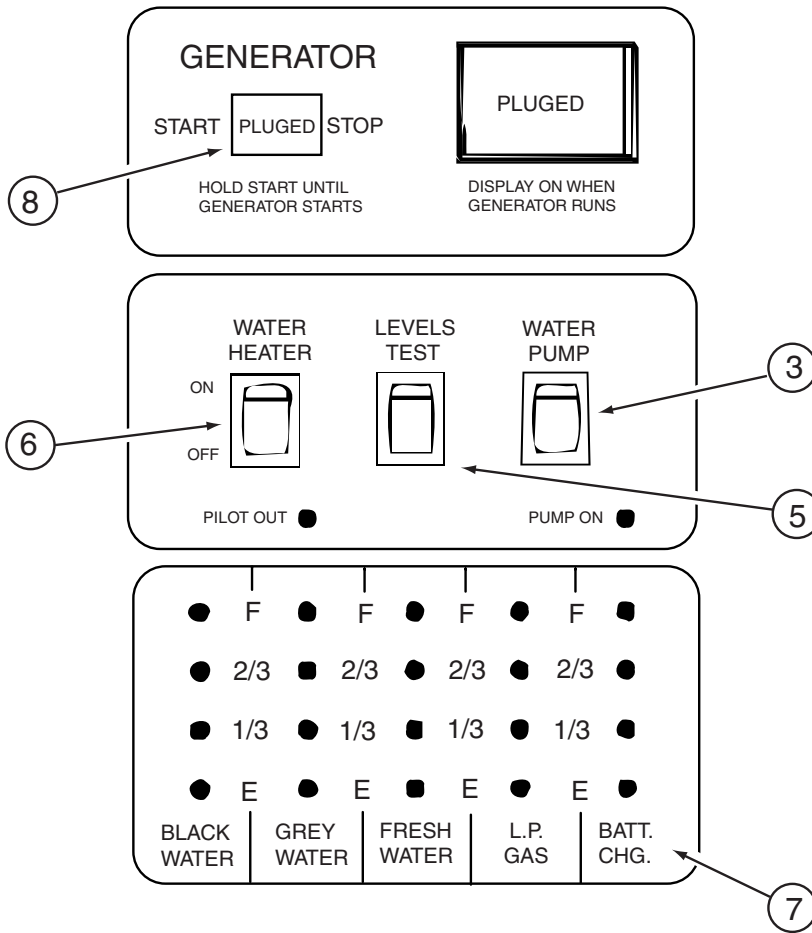

134940-02-01A

KEY	PART NUMBER	U/M	DESCRIPTION	VENDOR NO.
	134940-01-700	EA	BOARD - PC	L5118-01
3	096983-01-703	EA	SWITCH - ON/ON	L0115-00
5	096983-01-701	EA	SWITCH - SPST/MOM 2 TERMINAL	L0111-00
6	134940-01-701	EA	SWITCH-SPST/ON-OFF/BLK W/LGT	L0109
7	134940-01-702	EA	CHASSIS - SILKSCREENED	CC0558-00
8	134940-02-700	EA	SWITCH - DUMMY	L0118

APPLIANCE GROUP (CONTINUED)
COMPONENT PARTS FOR APPLIANCE (CONTINUED)

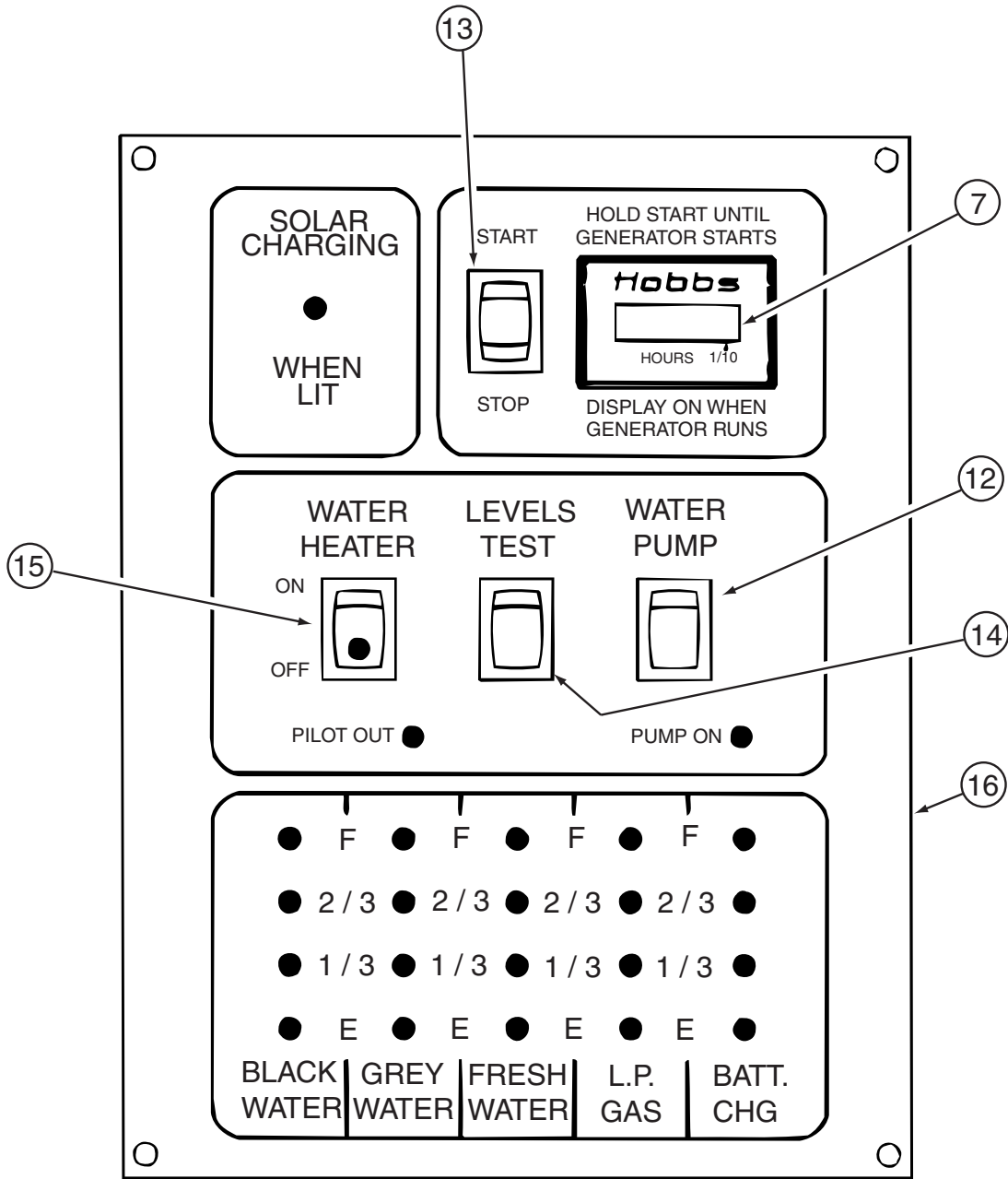

134940-04-01A

KEY	PART NUMBER	U/M	DESCRIPTION	VENDOR NO.
7	100258-10-701	EA	GAUGE/HOUR METER-CLIP ON LCD	L0775-00
12	096983-01-703	EA	SWITCH - ON/ON	L0115-00
13	096983-01-702	EA	SWITCH - MOM/OFF/MOM/3 TERM	L0112-00
14	096983-01-701	EA	SWITCH - SPST/MOM 2 TERMINAL	L0111-00
15	134940-01-701	EA	SWITCH-SPST/ON-OFF/BLK W/LGT	L0109
16	134940-04-700	EA	CHASSIS - SILKSCREENED	CE0136-00

APPLIANCE GROUP (CONTINUED)
COMPONENT PARTS FOR APPLIANCE (CONTINUED)

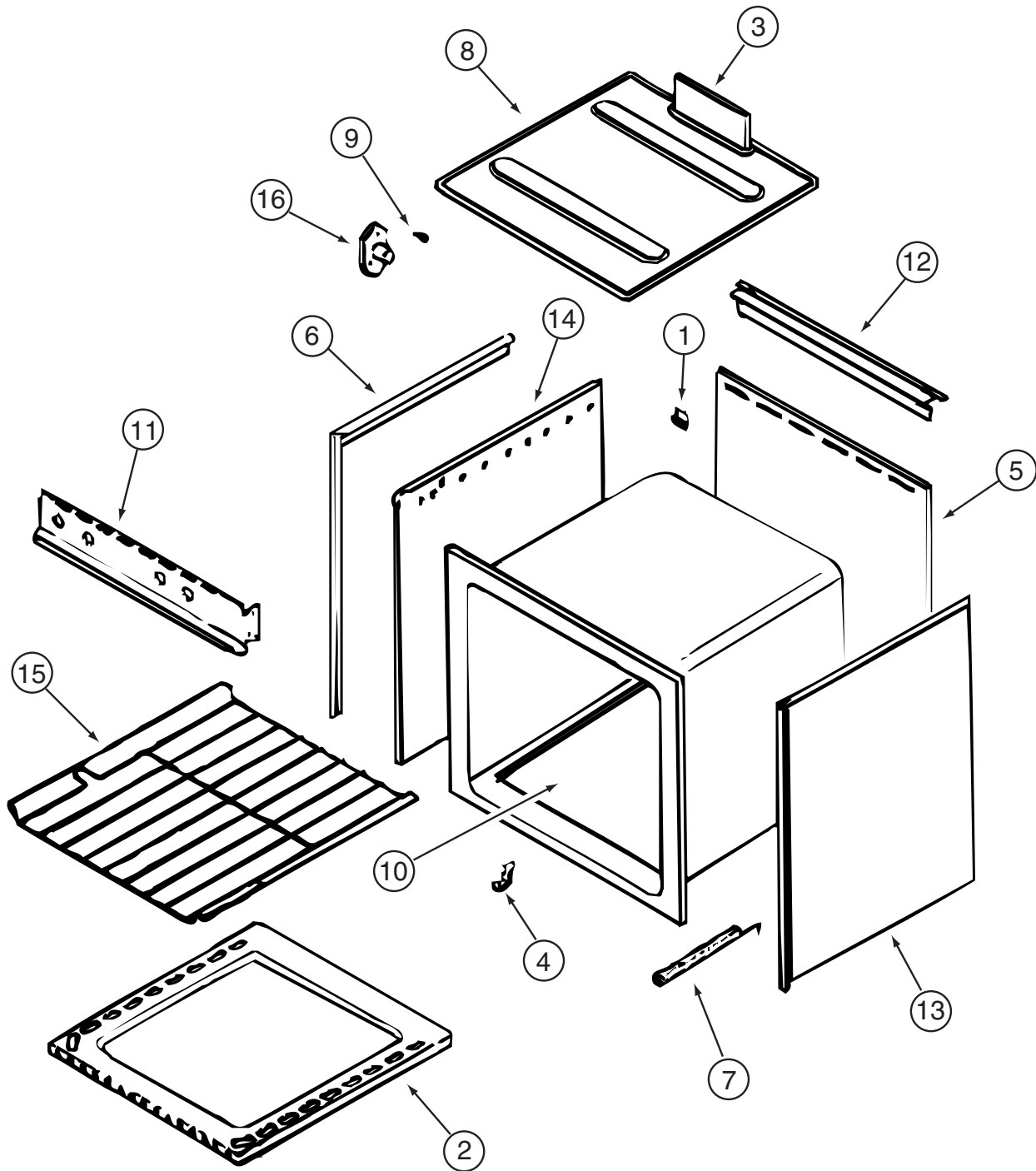

135656-01-01A

KEY	PART NUMBER	U/M	DESCRIPTION	VENDOR NO.
1	112881-03-702	EA	CLIP - MAIN TOP	74003998
2	126023-01-731	EA	BOTTOM - OVEN	2205F016-19
3	126023-01-718	EA	FLUE BOX ASSEMBLY	4006W075-80
6	112881-01-719	EA	TRIM-FLAT LH BLACK TEXTURED	74002813
6	112881-01-720	EA	TRIM-FLAT RH BLACK TEXTURED	74002812
11	126023-01-729	EA	PANEL - MANIFOLD	74003351
12	112881-01-721	EA	DEFLECTOR FLUE BLACK TEXTURE	74002809
15	126023-01-716	EA	RACK - OVEN	74003106
16	128728-01-703	EA	T-NUT - F/HINGE	7103P109-60

CONTACT WINNEBAGO PART SALES FOR UNLISTED COMPONENTS

APPLIANCE GROUP (CONTINUED)
COMPONENT PARTS FOR APPLIANCE (CONTINUED)

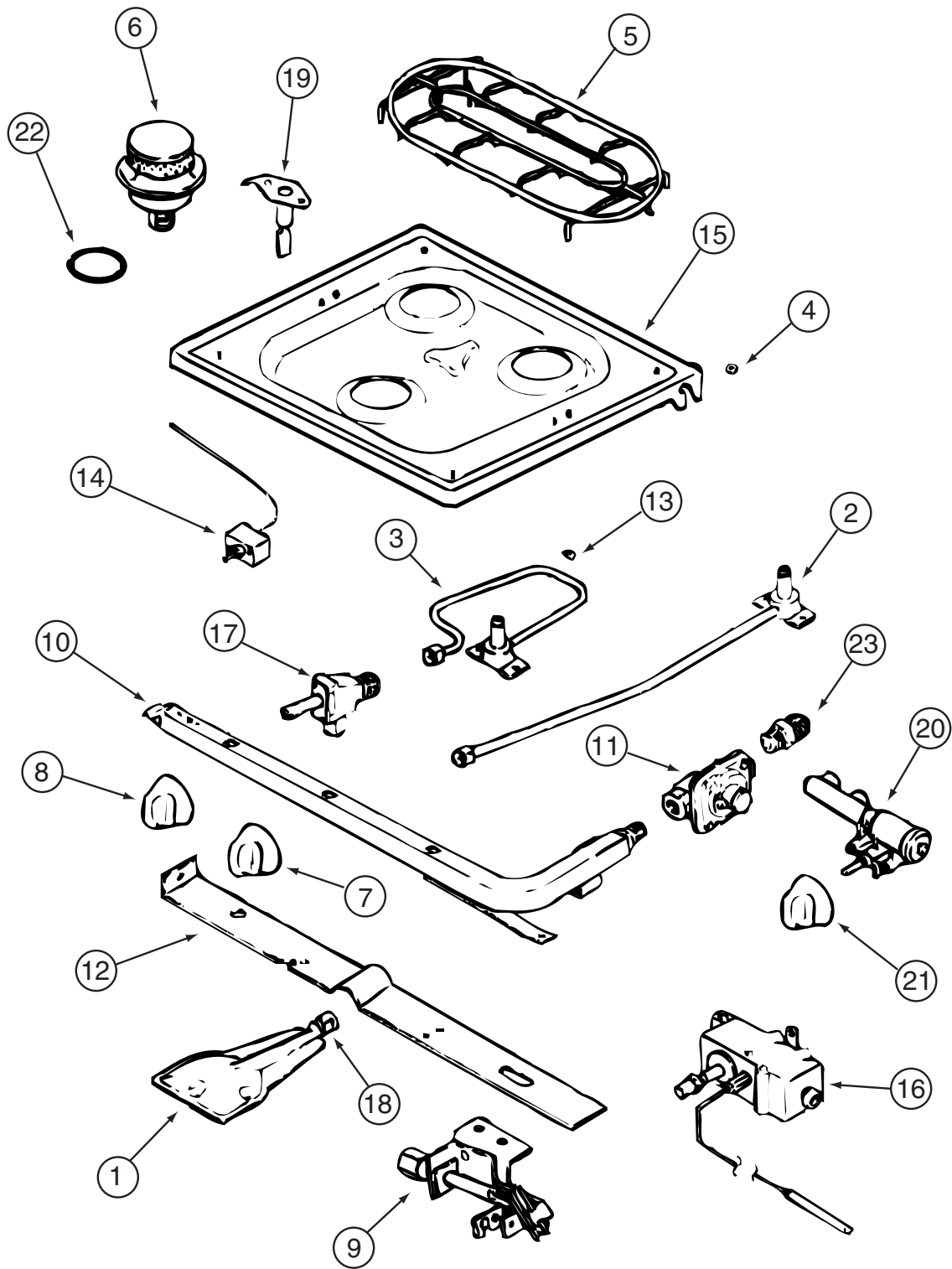

135656-01-01A (CONTINUED)

APPLIANCE GROUP (CONTINUED)
COMPONENT PARTS FOR APPLIANCE (CONTINUED)

135656-01-01A (CONTINUED)

KEY	PART NUMBER	U/M	DESCRIPTION	VENDOR NO.
1	126023-01-717	EA	BURNER - OVEN	74003343
2	128728-01-708	EA	FITTING - ORFICE TUBE - REAR	74003931
3	128728-01-710	EA	FITTING - ORFICE TUBE - FRT	74003930
4	102020-01-709	EA	BUMPER-GRATE	8007-P020-60
5	128728-01-700	EA	GRATE - BURNER	74003948
6	135065-01-705	EA	BURNER/SEALED ASSEMBLY	74003967
7	112881-01-705	EA	KNOB-TOP BURNER	7733P072-60
7	112881-01-718	EA	KNOB - TOP BURNER HI-OUTPUT	74001794
8	135656-01-700	EA	KNOB/THERMOSTAT	74002529
9	126023-02-701	EA	PILOT - OVEN	74004586
10	126023-02-702	EA	PIPE - MANIFOLD	74004360
11	126023-02-703	EA	REGULATOR - PRESSURE	74004235
13	102020-01-724	EA	BUMPER-MAIN TOP	8003P008-60
14	126023-01-734	EA	THERMOSTAT OVEN 11/CLY MODEL	74004361
15	128728-01-705	EA	TOP - MAIN - BLACK	74003928
16	126023-02-704	EA	VALVE - OVEN	74004585

CONTACT WINNEBAGO PART SALES FOR UNLISTED COMPONENTS

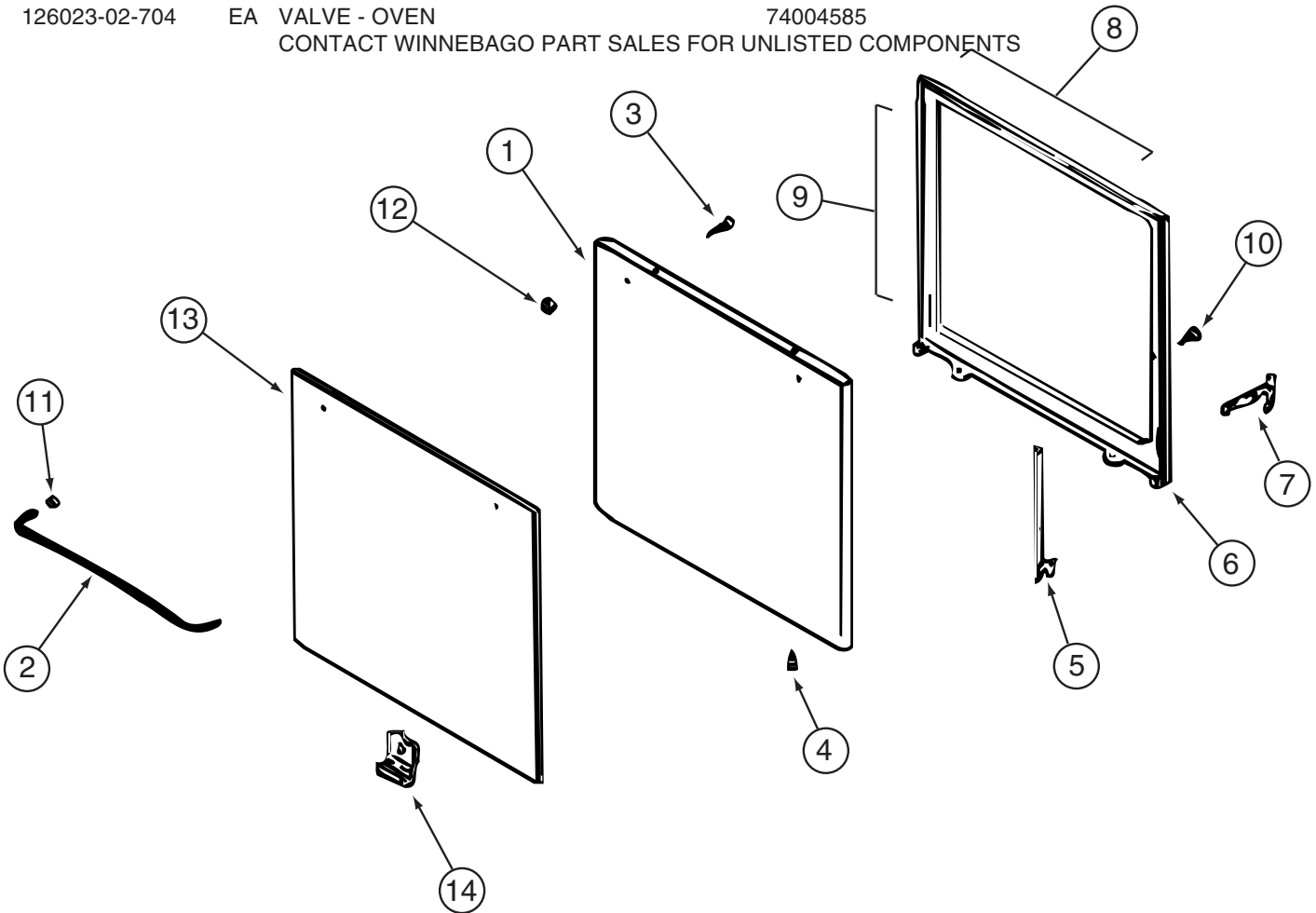

135656-01-01A (CONTINUED)

KEY	PART NUMBER	U/M	DESCRIPTION	VENDOR NO.
1	112881-02-705	EA	PANEL - OVEN DOOR (BLACK)	74001273
2	102020-01-701	EA	HANDLE, DOOR	7701P092-60
8	126023-01-732	EA	SEAL/OVEN DR TOP	7212P014-60
9	126023-01-733	EA	SEAL/OVEN DR SIDES(2PCS)	7212P038-60
13	102022-01-704	EA	GLASS-OUTER	7902P261-60

CONTACT WINNEBAGO PART SALES FOR UNLISTED COMPONENTS

137354-01-000

KEY	PART NUMBER	U/M	DESCRIPTION	VENDOR NO.
	137354-01-700	EA	FILTER	UN38

AUDIO VIDEO GROUP
RADIO SYSTEM

KEY	PART NUMBER	U/M	DESCRIPTION
	110469-01-000	EA	SPEAKER - 4" X 6" OVAL - COAXIAL
	110470-01-01A	EA	GRILLE - 4" X 6" OVAL SPEAKER - BLACK
	127517-11-000	EA	RADIO - AM/FM STEREO/CD PLAYER - SONY CDX-L300 - EXTERIOR ENTERTAINMENT FROM: 00-00-00 THRU: 06-02-02
*	143509-01-000	EA	RADIO - AM/FM CD - W/REMOTE - JENSEN CD3010X-W - EXTERIOR ENTERTAINMENT FROM: 06-03-02 THRU: 99-99-99
	125322-02-000	EA	RADIO-AM/FM STEREO/CASSETTE-AUDIOVOX-MS-306-EXT ENT W/CASS - EXT ENTERTAINMENT
	135420-01-000	EA	RADIO - AM/FM CASSETTE/CD COMBO - M9900 - 7.2" X 3.3" R.O. - DASH
	135420-05-000	EA	RADIO - MOUNTING KIT - FORD
	077069-02-000	EA	CABLE/EXTENSION - RADIO ANTENNA - 96"
	090944-01-000	EA	ANTENNA - RADIO - 16" RUBBER - W/72" LEAD WIRE
	108847-01-000	EA	BRACKET - ANTENNA GROUND
	124881-02-000	EA	AMPLIFIER - AUDIO - MTS Q SURROUND - ORANGE LABEL (LATEST)
	124883-02-000	EA	SPEAKER - CUBE - W/BRACKET
	124883-03-000	EA	SPEAKER - CUBE - W/O CASE
	124883-04-000	EA	SPEAKER - GRILLE - F/CUBE
	124884-01-000	EA	SPEAKER - 6" X 9" - SUB-WOOFER
	124885-01-000	EA	GRILLE - SPEAKER - 6" X 9" - SUB-WOOFER
	109889-02-000	EA	EXTENDER - ANTENNA SHAFT - 2.1"
	109889-05-000	EA	EXTENDER - ANTENNA SHAFT - 3"
	109889-04-000	EA	EXTENDER - ANTENNA SHAFT - 3.7"
	108137-01-000	EA	PLUG - ANTENNA

***COMPONENT PARTS LISTED LATER IN THIS GROUP**

AUDIO VIDEO GROUP (CONTINUED)
COMPONENT PARTS FOR RADIO SYSTEM

143509-01-000

KEY	PART NUMBER	U/M	DESCRIPTION	VENDOR NO.
	143509-01-700	EA	REMOTE - RADIO	VG70A0

AUDIO VIDEO GROUP (CONTINUED)

REAR VIEW MONITOR

KEY	PART NUMBER	U/M	DESCRIPTION
	136514-01-000	EA	MONITOR ONLY - 6" - REAR VIEW/VISOR MOUNT FROM: 00-00-00 THRU: 07-28-02
	136514-04-000	EA	MONITOR ONLY - 6" - REAR VIEW/VISOR MOUNT FROM: 07-29-02 THRU: 99-99-99
	136514-03-000	EA	CAMERA ONLY - REAR VIEW W/BRACKET FROM: 00-00-00 THRU: 07-28-02
	136514-05-000	EA	CAMERA ONLY - REAR VIEW W/BRACKET FROM: 07-29-02 THRU: 99-99-99
	136514-02-000	EA	CABLE - MONITOR/CAMERA
	143999-01-01A	EA	SPACER - MONITOR - BLACK FROM: 07-29-02 THRU: 99-99-99

TELEPHONE

KEY	PART NUMBER	U/M	DESCRIPTION
	093253-01-03A	EA	PLATE - WALL - TELEPHONE - WHITE
	130686-01-01A	EA	PLATE - WALL - TELEPHONE/COAX - WHITE

TV & VCR

KEY	PART NUMBER	U/M	DESCRIPTION
	082134-01-000	EA	ADAPTER - TV - CABLE TO CABLE
	086756-01-000	EA	SPLITTER - TV/2 WAY
	136764-02-000	EA	DVD PLAYER - RCA RC5240P FROM: 00-00-00 THRU: 07-21-02
	136764-03-000	EA	DVD PLAYER - RCA DRC220N FROM: 07-22-02 THRU: 99-99-99
	082136-01-000	EA	NUT - HEX JAM - 3/8-32
	134006-01-03B	EA	PLATE - COAXIAL CABLE/OFF WHITE
	123324-01-000	EA	FILTER - GROUND LOOP
	142258-01-000	EA	SWITCH - VIDEO/ANTENNA POWER SUPPLY
*	133377-02-000	EA	TV - 25" - COLOR - W/O 1/8" JACK - UL/CSA - GE 25GT240
	136162-01-000	EA	TV - 27" STEREO W/5 JACKS - RCA F27648 - DELUXE ENTERTAINMENT FROM: 00-00-00 THRU: 04-22-02
	136162-02-000	EA	TV - 27" STEREO W/5 JACKS - RCA F27689 - DELUXE ENTERTAINMENT FROM: 04-23-02 THRU: 01-19-03
	136162-03-000	EA	TV - 27" STEREO W/5 JACKS - RCA F27440M - DELUXE ENTERTAINMENT FROM: 01-20-03 THRU: 99-99-99
*	126697-07-000	EA	VCR - VHS/CABLE READY - W/REMOTE - GE VG4045 FROM: 00-00-00 THRU: 08-04-02
	124073-13-000	EA	VCR-VHS/CABLE READY - W/AUDIO/VIDEO PORT - RCA VR546 FROM: 08-05-02 THRU: 99-99-99
*	124073-11-000	EA	VCR-VHS/HI-FI STEREO - SILVER CASE - RCA VR651HF - DELUXE ENTERTAINMENT FROM: 00-00-00 THRU: 05-16-02
*	124073-12-000	EA	VCR-VHS/HI-FI STEREO - SILVER CASE - RCA VR637HF - DELUXE ENTERTAINMENT FROM: 05-17-02 THRU: 99-99-99
	076319-09-000	EA	WALLPLATE - CABLE RECEPTACLE - TV - SINGLE - BROWN
	076319-03-000	FT	CABLE - COAXIAL - 75 OHM
	076319-12-000	EA	CONNECTOR - COAXIAL - ONE PIECE
*	076319-23-000	EA	ANTENNA - TV ROOF MOUNT - 44.5" MAST
*	076319-25-000	EA	KIT - HARDWARE INTERIOR
	076319-26-000	EA	WEDGE/ROOF - F/TV ANTENNA
	120233-03-000	EA	CERTIFICATE - SATELLITE RECEIVER
*	137135-01-000	EA	ANTENNA - SATELLITE DSS - W/SENSOR FROM: 09-18-00 THRU: 04-08-02
	137135-02-000	EA	ANTENNA - SATELLITE DSS - W/SENSOR FROM: 04-09-02 THRU: 99-99-99
	136860-01-000	EA	CABLE - RCA - #3 MALE TO #12F MALE CONNECTOR
	076319-27-000	EA	WALLPLATE/RECEPTACLE - WHITE

*COMPONENT PARTS LISTED LATER IN THIS GROUP

AUDIO VIDEO GROUP (CONTINUED)
COMPONENT PARTS FOR TV & VCR

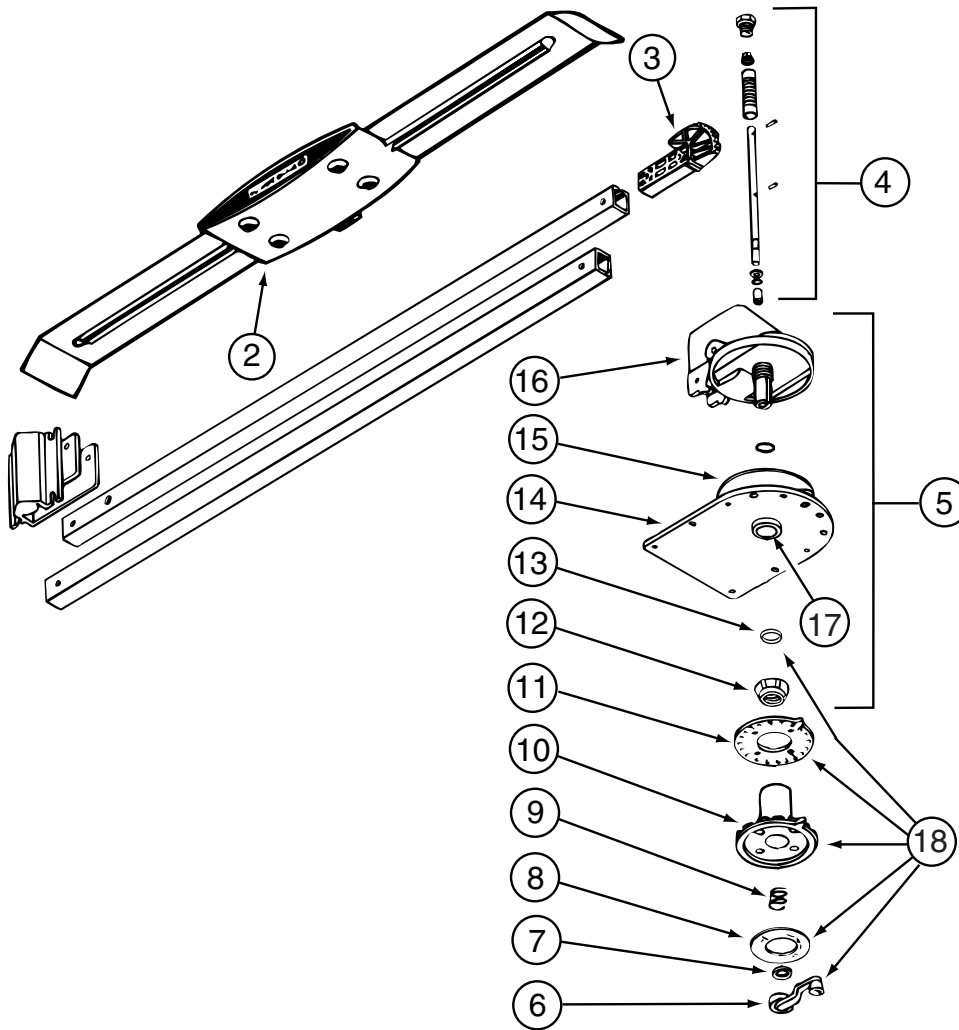

076319-23-000

KEY	PART NUMBER	U/M	DESCRIPTION	VENDOR NO.
2	076319-01-700	EA	HEAD-ANTENNA, AMPLIFIED	RVSA U/V
3	076319-01-701	EA	GEAR-ELEVATING, PLASTIC	2200046
4	076319-01-702	EA	SHAFT ASM-ELEVATING	RP-4000
5	076319-01-711	EA	BASE & LIFT ASM	2762802
7	076319-01-705	EA	GROMMET-NYLON, 7/8"ID	3200658
8	076319-01-708	EA	DECAL-CRANK	5413002
9	076319-01-707	EA	SPRING-HANDLE	2160822
11	076319-01-712	EA	PLATE - CEILING	3200608
12	076319-01-715	EA	NUT (GEAR HOUSING)	2200047
14	076319-01-713	EA	BASE-PLATE, STEEL	3100523
15	076319-01-703	EA	BEARING-NYLON, 5"OD	3200656
16	076319-01-714	EA	HOUSING, ROTATING GEAR	2200049
17	076319-01-716	EA	TUBING, ELEVATING	RP-2900
17	076319-01-704	EA	BEARING-NYLON, 1.25"OD	3200657

CONTACT WINNEBAGO PART SALES FOR UNLISTED COMPONENT

076319-25-000

KEY	PART NUMBER	U/M	DESCRIPTION	VENDOR NO.
6	076319-01-706	EA	CRANK-W/SET SCREW UNIV/BEIGE	2750897
6	120233-01-710	EA	HANDLE-CRANK W/SCREW - WHITE	RP-6795
8	076319-01-708	EA	DECAL-CRANK	5413002
10	076319-25-700	EA	DIRECTIONAL HANDLE(WHITE)	3200612
11	076319-25-701	EA	PLATE - CEILING(WHITE)	3200609
13	120233-01-709	EA	WASHER-NYLON	RP-2658

CONTACT WINNEBAGO PART SALES FOR UNLISTED COMPONENTS

AUDIO VIDEO GROUP (CONTINUED)
COMPONENT PARTS FOR TV & VCR (CONTINUED)

126697-07-000

KEY	PART NUMBER	U/M	DESCRIPTION	VENDOR NO.
	126697-07-700	EA	REMOTE	248687

133377-01-000 & 133377-02-000

KEY	PART NUMBER	U/M	DESCRIPTION	VENDOR NO.
	133377-01-700	EA	REMOTE	240961

AUDIO VIDEO GROUP (CONTINUED)
COMPONENT PARTS FOR TV & VCR (CONTINUED)

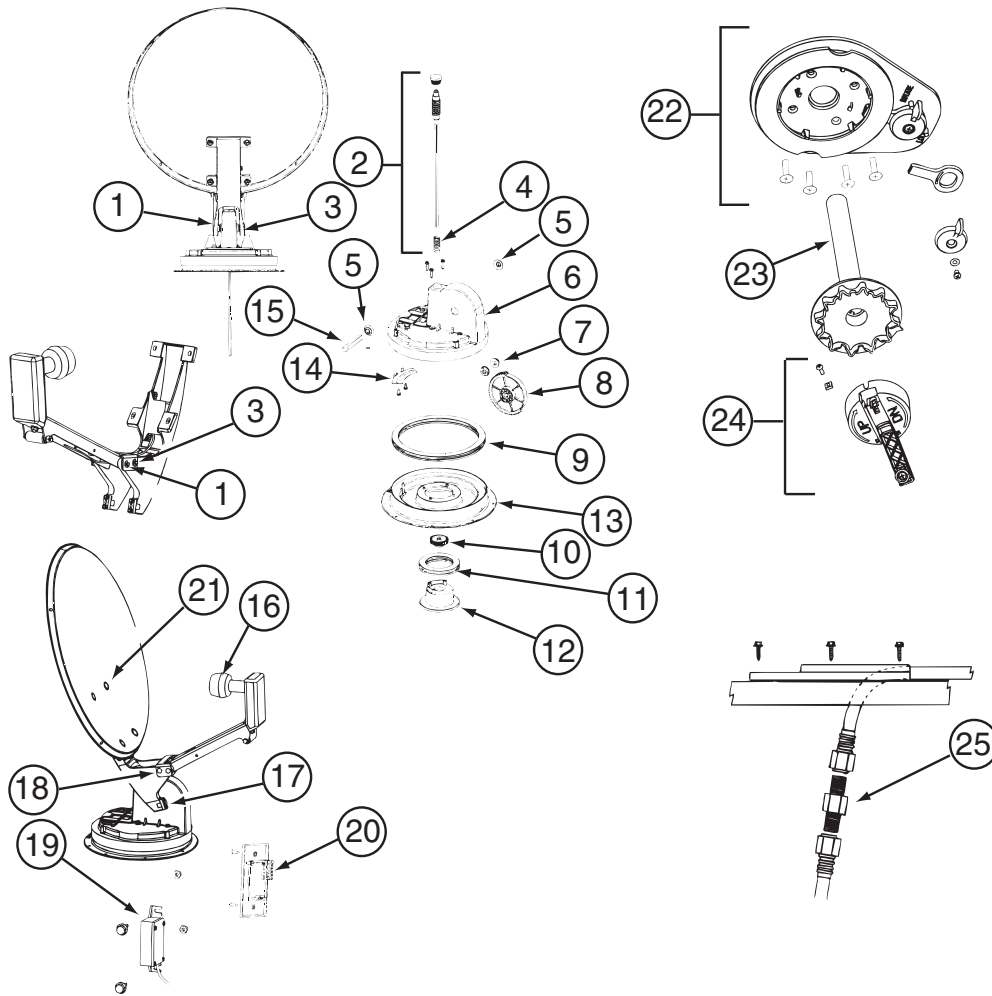

137135-01-000

KEY	PART NUMBER	U/M	DESCRIPTION	VENDOR NO.
1	120233-01-714	EA	CLIP-E	5160818
2	137135-01-703	EA	SHAFT-ELEVATING(SPRING/PLUG)	RP-4400
3	137135-01-704	EA	PIN - 1/4" X 3.25"	2160813
4	137135-01-705	EA	SPRING	2160818
5	137135-01-707	EA	SEAL - PIVOT SHAFT	2200852
6	137135-01-708	EA	TURRET	3100728
7	137135-01-709	EA	PIVOT BEARING	2200470
8	137135-01-711	EA	GEAR - ELEVATING	2200464
9	137135-01-712	EA	BEARING - OUTER	2590347
10	137135-01-714	EA	GEAR - ELEVATING SHAFT	2200465
11	137135-01-715	EA	BEARING - INNER	2590348
12	137135-01-716	EA	HUB	3100731
13	137135-01-713	EA	TURRET BASE	3100730
14	137135-01-710	EA	PLATE - ROTATE LIMIT	3720052
15	137135-01-706	EA	KIT-TURRET/SEAL/BEARING/GEAR	RP-RM30
16	120233-01-734	EA	LOW NOISE BLOCK FILTER (SGL)	LB10003
17	137135-01-722	EA	CLAMP	2590343
18	137135-01-719	EA	BRACKET - PIVOT	2744945
19	137135-01-720	EA	DE-SENSOR UNIT W/43" CABLE	276342
20	137135-01-721	EA	WALL PLATE	3200213
21	137135-01-717	EA	BOLT - FLAT HEAD	216032
22	120233-01-722	EA	PLATE ASSEMBLY (CEILING)	2762826
23	120233-01-704	EA	DIAL - DIRECTIONAL	3200364
24	120233-01-721	EA	CRANK HANDLE ASSEMBLY	2762825
25	137135-01-701	EA	CONNECTOR - F - MALE TO MALE	FS-8100
	137135-01-700	EA	ROOF WEDGE W/GASKET	RW-5000
	137135-01-718	EA	REFLECTOR/WHITE - 46CM	2745282

AUDIO VIDEO GROUP (CONTINUED)
EXTERIOR ENTERTAINMENT

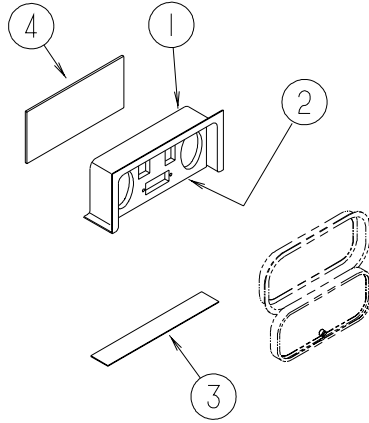

KEY	PART NUMBER	U/M	DESCRIPTION
1	104897-02-02A	EA	BOX - EXTERIOR ENTERTAINMENT CENTER
2	127409-01-L07	EA	PLATE - RADIO MOUNTING
3	104898-01-02A	EA	PLATE - PLASTIC BOTTOM - BRIGHT WHITE
4	NOT USED		

BATH GROUP CABINETS

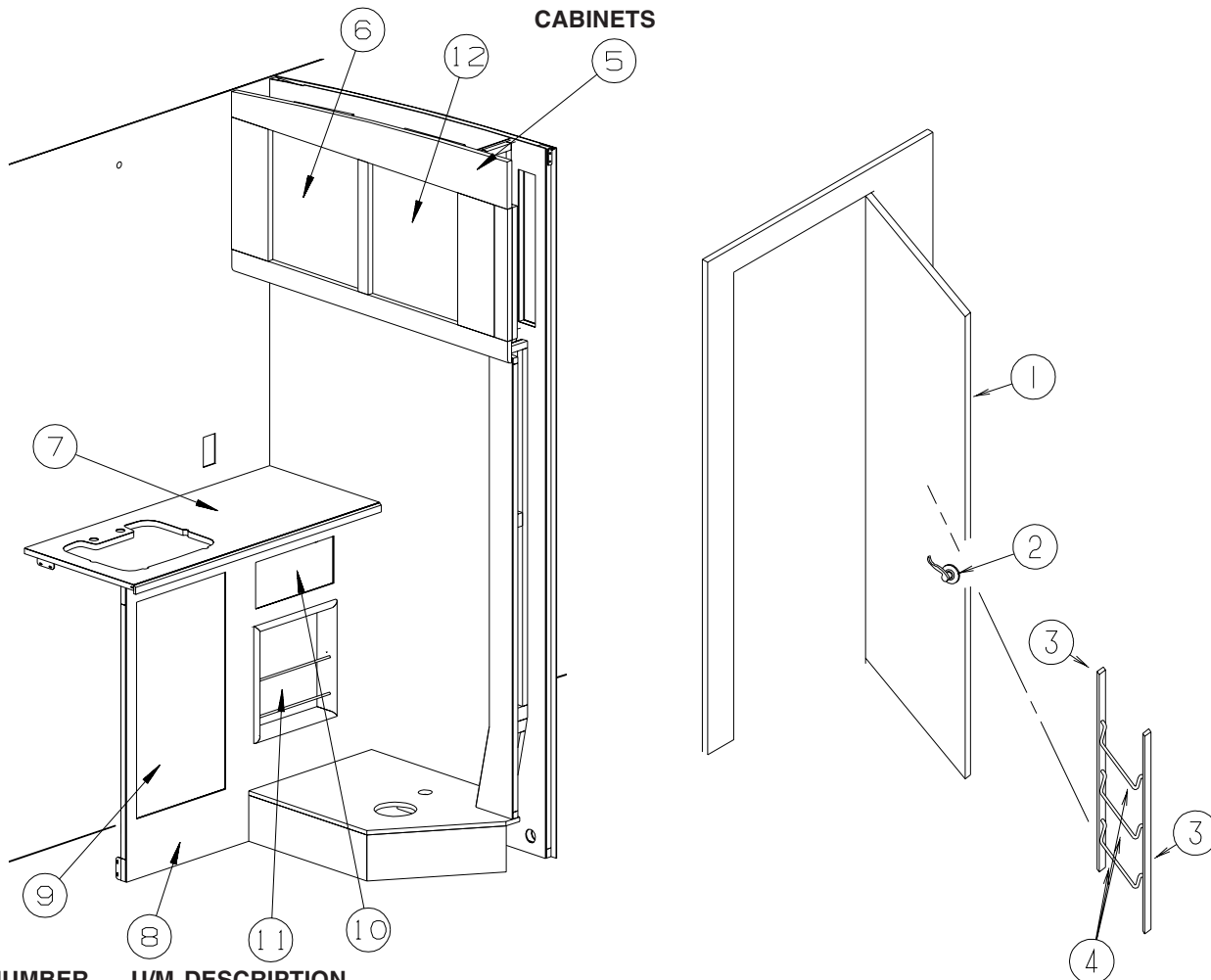

KEY	PART NUMBER	U/M	DESCRIPTION
1	131933-07-L81	EA	DOOR - BATH - W/O HARDWAR - PORTSMOUTH OAK
1	131933-07-M08	EA	DOOR - BATH - W/O HARDWARE - CONCERT CHERRY
1	131933-07-M15	EA	DOOR - BATH - W/O HARDWARE - WASHED MAPLE
2	111155-05-01A	EA	LOCK - PRIVACY/LOCKING - POLISHED BRASS - "S" SHAPE HANDLE FROM: 00-00-00 THRU: 01-26-03
2	146064-01-01A	EA	LOCK - PRIVACY HANDLE - POLISHED BRASS FROM: 01-27-03 THRU: 99-99-99
3	P34509-01-N01	EA	RAIL END - RH/LH - TOWEL RACK - PORTSMOUTH OAK - PORTSMOUTH OAK
3	P34509-01-P14	EA	RAIL END - RH/LH - TOWEL RACK - CHERRY - CONCERT CHERRY
3	P34509-01-J70	EA	RAIL END - RH/LH - TOWEL RACK - WASHED MAPLE - WASHED MAPLE
4	100357-01-000	EA	ROD - F/TOWEL BAR - BRASS
5	141607-01-P13	EA	CABINET - OVERHEAD/MEDICINE - W/O DOORS/HARDWARE - PORTSMOUTH OAK
5	141607-01-P14	EA	CABINET - OVERHEAD/MEDICINE - W/O DOORS/HARDWARE - CONCERT CHERRY
5	141607-01-P33	EA	CABINET - OVERHEAD/MEDICINE - W/O DOORS/HARDWARE - WASHED MAPLE
6	134868-40-P19	EA	DOOR - RAIL/ARCHED TOP - 14.3" X 17.9" - W/O HARDWARE - PORTSMOUTH OAK FROM: 00-00-00 THRU: 11-10-02
6	141518-A3-P19	EA	DOOR - ARCHED/PENCIL EDGE - 14.3" X 17.9" - W/O HARDWARE - PORTSMOUTH OAK FROM: 11-11-02 THRU: 99-99-99
6	134868-40-P20	EA	DOOR - RAIL/ARCHED TOP - 14.3" X 17.9" - W/O HARDWARE - CONCERT CHERRY FROM: 00-00-00 THRU: 11-10-02
6	141518-A3-P20	EA	DOOR - ARCHED/PENCIL EDGE - 14.3" X 17.9" - W/O HARDWARE - CONCERT CHERRY FROM: 11-11-02 THRU: 99-99-99
6	134868-40-P33	EA	DOOR - RAIL/ARCHED TOP - 14.3" X 17.9" - W/O HARDWARE - WASHED MAPLE FROM: 00-00-00 THRU: 11-10-02
6	141518-A3-P33	EA	DOOR - ARCHED/PENCIL EDGE - 14.3" X 17.9" - W/O HARDWARE - WASHED MAPLE FROM: 11-11-02 THRU: 99-99-99
7	133654-21-P13	EA	COUNTERTOP - LAMINATED - GRAY TRANQUILITY (P19)
7	133654-21-P14	EA	COUNTERTOP - LAMINATED - GRAY TRANQUILITY (P20)
7	133654-21-P15	EA	COUNTERTOP - LAMINATED - EGGSHELL (P21, P23)
7	133654-21-P16	EA	COUNTERTOP - LAMINATED - EGGSHELL (P22, P24)
7	133654-21-P33	EA	COUNTERTOP - LAMINATED - GRAY TRANQUILITY (P33)
7	133654-21-P36	EA	COUNTERTOP - LAMINATED - EGGSHELL (P36, P40)

BATH GROUP (CONTINUED)

CABINETS (CONTINUED)

KEY	PART NUMBER	U/M	DESCRIPTION
8	141605-01-P13	EA	CABINET - LAVATORY - W/O COUNTERTOP/DOORS/DRAWERS/HARDWARE - PORTSMOUTH OAK
8	141605-01-P14	EA	CABINET - LAVATORY - W/O COUNTERTOP/DOORS/DRAWERS/HARDWARE - CONCERT CHERRY
8	141605-01-P33	EA	CABINET - LAVATORY - W/O COUNTERTOP/DOORS/DRAWERS/HARDWARE - WASHED MAPLE
9	136919-B0-P19	EA	DOOR - FLAT/PENCIL EDGE - 14.3" X 26.7" - W/O HARDWARE - PORTSMOUTH OAK
9	136919-B0-P20	EA	DOOR - FLAT/PENCIL EDGE - 14.3" X 26.7" - W/O HARDWARE - CONCERT CHERRY
9	136919-B0-P33	EA	DOOR - FLAT/PENCIL EDGE - 14.3" X 26.7" - W/O HARDWARE - WASHED MAPLE
10	P34767-61-P19	EA	DRAWER - PENCIL EDGE - 10.7"W X 13.7"D-W/O SLIDES/HARDWARE - PORTSMOUTH OAK
10	P34767-61-M16	EA	DRAWER - PENCIL EDGE - 10.7"W X 13.7"D-W/O SLIDES/HARDWARE - CONCERT CHERRY
10	P34767-61-M15	EA	DRAWER - PENCIL EDGE - 10.7"W X 13.7"D-W/O SLIDES/HARDWARE - WASHED MAPLE
11	137602-07-N01	EA	POCKET - MAGAZINE - PORTSMOUTH OAK
11	137602-07-P46	EA	POCKET - MAGAZINE - CONCERT CHERRY
11	137602-07-P33	EA	POCKET - MAGAZINE - WASHED MAPLE
12	134868-39-P19	EA	DOOR - RAIL/ARCHED TOP - 14.3" X 17.9" - W/O HARDWARE - PORTSMOUTH OAK FROM: 00-00-00 THRU: 11-10-02
12	141520-A3-P19	EA	DOOR - ARCHED/PENCIL EDGE/RIGHT HAND-14.3" X 17.9"-W/O HDW - PORTSMOUTH OAK FROM: 11-11-02 THRU: 99-99-99
12	134868-39-P20	EA	DOOR - RAIL/ARCHED TOP - 14.3" X 17.9" - W/O HARDWARE - CONCERT CHERRY FROM: 00-00-00 THRU: 11-10-02
12	141520-A3-P20	EA	DOOR - ARCHED/PENCIL EDGE/RIGHT HAND-14.3" X 17.9"-W/O HDW - CONCERT CHERRY FROM: 11-11-02 THRU: 99-99-99
12	134868-39-P33	EA	DOOR - RAIL/ARCHED TOP - 14.3" X 17.9" - W/O HARDWARE - WASHED MAPLE FROM: 00-00-00 THRU: 11-10-02
12	141520-A3-P33	EA	DOOR - ARCHED/PENCIL EDGE/RIGHT HAND-14.3" X 17.9"-W/O HDW - WASHED MAPLE FROM: 11-11-02 THRU: 99-99-99

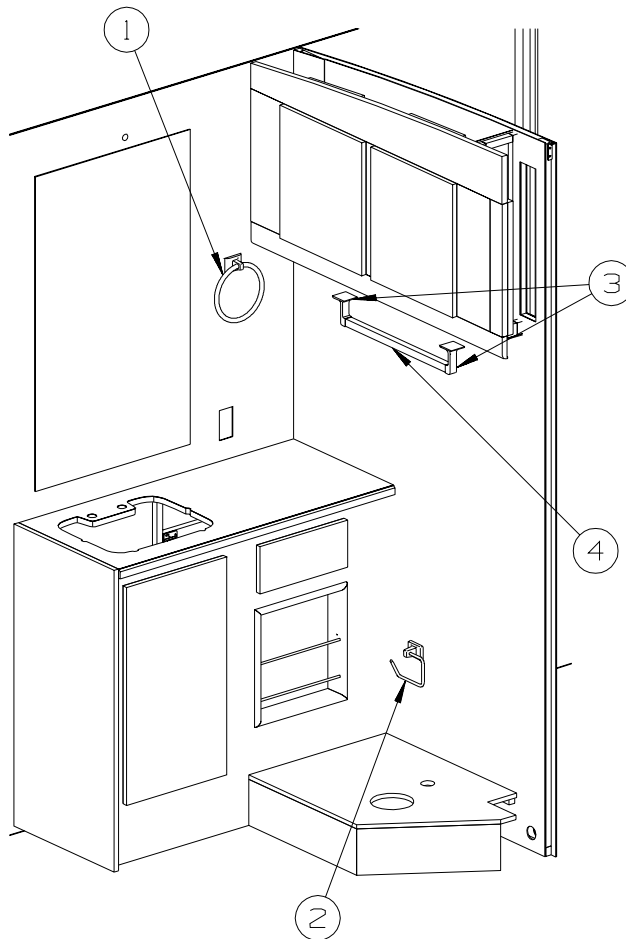

KEY	PART NUMBER	U/M	DESCRIPTION
1	132046-02-01A	EA	RING - TOWEL - BRASS
2	132533-02-01A	EA	HOLDER - PAPER - BRASS & CHROME
3	075453-03-000	EA	BRACKET - TOWEL BAR - BRASS - 2 PER PACK
4	075453-04-000	EA	ROD - F/TOWEL BAR - 18" BRASS - W/O END BRACKETS

BATH GROUP (CONTINUED)
SHOWER

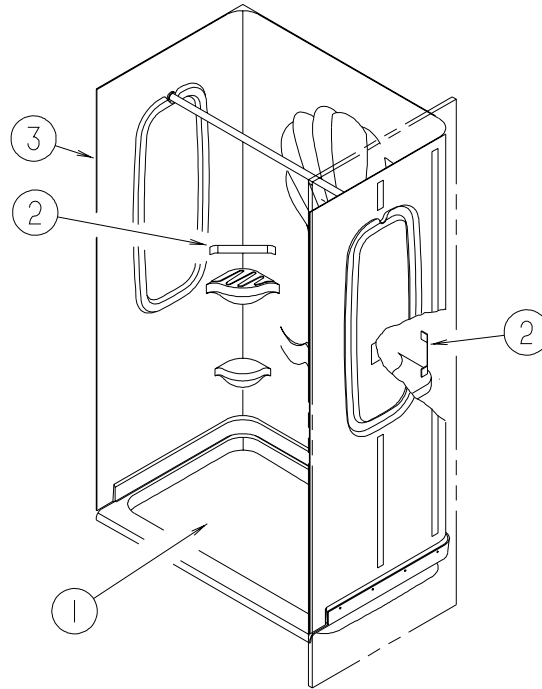

KEY	PART NUMBER	U/M	DESCRIPTION
1	M02630-66-N09	EA	SHOWER PAN - W/STRAINER
2	113714-04-02A	EA	RETAINER - SHELF/SHOWER - SOFT WHITE
3	132216-02-01A	EA	SHOWER - SURROUND - SOFT WHITE
*	115011-03-01A	EA	DOOR - SHOWER/BYPASS - 39.3" X 65" - W/HARDWARE & LOCK

***COMPONENT PARTS LISTED LATER IN THIS GROUP**

BATH GROUP (CONTINUED)
COMPONENT PARTS FOR SHOWER DOOR

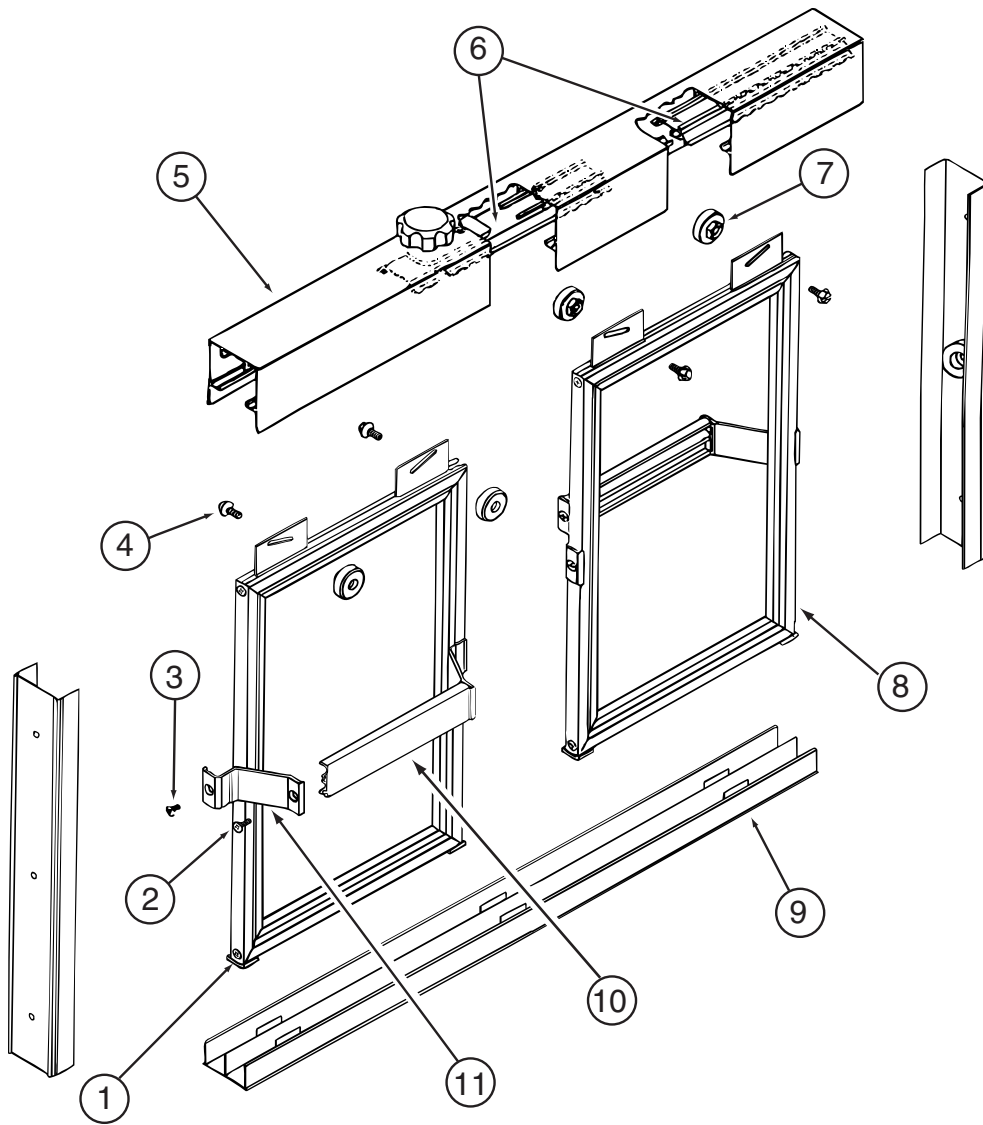

115011-03-01A

KEY	PART NUMBER	U/M	DESCRIPTION	VENDOR NO.
1	115011-01-701	EA	GUIDE-NYLON, (W-TRACK)	1104
2	115011-01-707	EA	SCREW F/TOWEL BAR	612F
3	115011-01-708	EA	SCREW F/TOWEL BAR BRKTS	638F
4	115011-01-705	EA	SCREW-ROLLER, (HEX HEAD)	832HEX
5	115011-01-700	EA	HEADER, W/O ANTI JUMP GUARD	120G
6	115011-01-710	EA	HEADER LOCK (ANTI JUMP) ADJ	130MIDDLE
6	115011-01-716	EA	GUARD-ANTI JUMP-W/O TENSION	130END
7	115011-01-704	EA	ROLLERS	PN193
8	115011-01-706	FT	GLAZING VINYL	C 169
9	115011-01-709	EA	TRACK-BOTTOM- 50"	90
10	115011-01-703	EA	BAR-TOWEL	136
11	115011-01-702	EA	BRACKET-TOWEL BAR	135
	115011-01-711	EA	KNOB-TENSION, (HEADER W/BOLT)	1420K-1420S
	115011-01-714	EA	BUMPER - RATTLE/SHOWER DOOR	5168S
	115011-01-715	EA	PAD - FOAM	116R

BEDROOM GROUP CABINETS

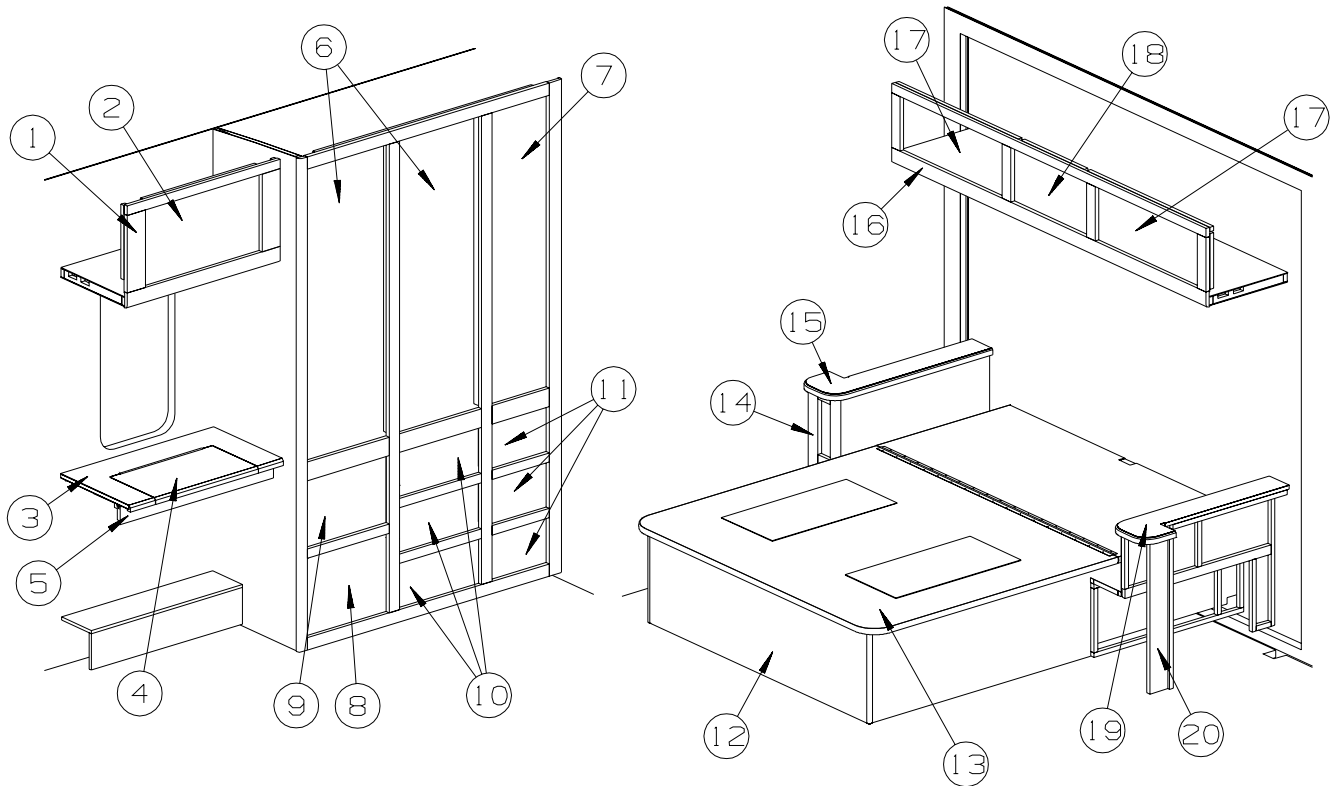

KEY	PART NUMBER	U/M	DESCRIPTION
1	141320-01-P13	EA	CABINET - OVERHEAD/VANITY - W/O DOORS/HARDWARE - PORTSMOUTH OAK
1	141320-01-P14	EA	CABINET - OVERHEAD/VANITY - W/O DOORS/HARDWARE - CONCERT CERRY
1	141320-01-P33	EA	CABINET - OVERHEAD/VANITY - W/O DOORS/HARDWARE - WASHED MAPLE
2	134868-07-P19	EA	DOOR - RAIL/ARCHED TOP - 13.7" X 23.2" - W/O HARDWARE - PORTSMOUTH OAK FROM: 00-00-00 THRU: 11-10-02
2	141522-97-P19	EA	DOOR - ARCHED/PENCIL EDGE/HORIZ - 13.8" X 23.2" - W/O HDW - PORTSMOUTH OAK FROM: 11-11-02 THRU: 99-99-99
2	134868-07-P20	EA	DOOR - RAIL/ARCHED TOP - 13.7" X 23.2" - W/O HARDWARE - CONCERT CHERRY FROM: 00-00-00 THRU: 11-10-02
2	141522-97-P20	EA	DOOR - ARCHED/PENCIL EDGE/HORIZ - 13.8" X 23.2" - W/O HDW - CONCERT CHERRY FROM: 11-11-02 THRU: 99-99-99
2	134868-07-P33	EA	DOOR - RAIL/ARCHED TOP - 13.7" X 23.2" - W/O HARDWARE - WASHED MAPLE FROM: 00-00-00 THRU: 11-10-02
2	141522-97-P33	EA	DOOR - ARCHED/PENCIL EDGE/HORIZ - 13.8" X 23.2" - W/O HDW - WASHED MAPLE FROM: 11-11-02 THRU: 99-99-99
3	140889-03-P13	EA	COUNTERTOP - LAMINATED - GRAY TRANQUILITY/PORTSMOUTH OAK (P19)
3	140889-03-P14	EA	COUNTERTOP - LAMINATED - GRAY TRANQUILITY/CHERRY (P20)
3	140889-03-P15	EA	COUNTERTOP - LAMINATED - EGGSHELL/PORTSMOUTH OAK (P21, P23)
3	140889-03-P16	EA	COUNTERTOP - LAMINATED (P22, P24)
3	140889-03-P33	EA	COUNTERTOP - LAMINATED (P33)
3	140889-03-P36	EA	COUNTERTOP - LAMINATED - EGGSHELL/WASHED MAPLE (P36, P40)
4	140889-04-P13	EA	COUNTERTOP - LAMINATED - GRAY TRANQUILITY/PORTSMOUTH OAK (P19)
4	140889-04-P14	EA	COUNTERTOP - LAMINATED - GRAY TRANQUILITY/CHERRY (P20)
4	140889-04-P15	EA	COUNTERTOP - LAMINATED - EGGSHELL/PORTSMOUTH OAK (P21, P23)
4	140889-04-P16	EA	COUNTERTOP - LAMINATED (P22, P24)
4	140889-04-P33	EA	COUNTERTOP - LAMINATED (P33)
4	140889-04-P36	EA	COUNTERTOP - LAMINATED - EGGSHELL/WASHED MAPLE (P36, P40)
5	136937-01-M07	EA	DRAWER/VANITY - W/O COUNTERTOP - W/CABLE - PORTSMOUTH OAK
5	136937-01-M08	EA	DRAWER/VANITY - W/O COUNTERTOP - W/CABLE - CONCERT CHERRY
5	136937-01-M15	EA	DRAWER/VANITY - W/O COUNTERTOP - W/CABLE - WASHED MAPLE
	140374-04-000	EA	MIRROR - SAFETY GLASS - 8.7" X 12.5"
6	134786-02-N04	EA	DOOR - MIRROR/MITERED CORNERS - 16.7" X 47.9"-W/O HARDWARE - PORTSMOUTH OAK
6	134786-02-M16	EA	DOOR - MIRROR/MITERED CORNERS - 16.7" X 47.9"-W/O HARDWARE - CONCERT CHERRY
6	134786-02-M15	EA	DOOR - MIRROR/MITERED CORNERS - 16.7" X 47.9"-W/O HARDWARE - WASHED MAPLE
	076767-04-000	EA	CABLE - STAINLESS STEEL - 5.9"

BEDROOM GROUP (CONTINUED)
CABINETS (CONTINUED)

KEY	PART NUMBER	U/M	DESCRIPTION
7	134868-11-P19	EA	DOOR - RAIL/ARCHED TOP - 12" X 48" - W/O HARDWARE - PORTSMOUTH OAK FROM: 00-00-00 THRU: 11-10-02
7	141520-76-P19	EA	DOOR - ARCHED/PENCIL EDGE/RIGHT HAND -12"X48"- W/O HDW - PORTSMOUTH OAK FROM: 11-11-02 THRU: 99-99-99
7	134868-11-P20	EA	DOOR - RAIL/ARCHED TOP - 12" X 48" - W/O HARDWARE - CONCERT CHERRY FROM: 00-00-00 THRU: 11-10-02
7	141520-76-P20	EA	DOOR - ARCHED/PENCIL EDGE/RIGHT HAND -12"X48"- W/O HDW - CONCERT CHERRY FROM: 11-11-02 THRU: 99-99-99
7	134868-11-P33	EA	DOOR - RAIL/ARCHED TOP - 12" X 48" - W/O HARDWARE - WASHED MAPLE FROM: 00-00-00 THRU: 11-10-02
7	141520-76-P33	EA	DOOR - ARCHED/PENCIL EDGE/RIGHT HAND -12"X48"- W/O HDW - WASHED MAPLE FROM: 11-11-02 THRU: 99-99-99
8	P34767-C2-P19	EA	DRAWER - PENCIL EDGE - 14.7"W X 17.7"D-W/O SLIDES/HARDWARE - PORTSMOUTH OAK FROM: 00-00-00 THRU: 08-18-02
8	134870-42-P19	EA	DRAWER - PENCIL EDGE - 15.1"W X 13.8"D - W/O SLIDES/HDW - PORTSMOUTH OAK FROM: 08-19-02 THRU: 99-99-99
8	P34767-C2-P20	EA	DRAWER - PENCIL EDGE - 14.7"W X 17.7"D-W/O SLIDES/HARDWARE - CONCERT CHERRY FROM: 00-00-00 THRU: 08-18-02
8	134870-42-P20	EA	DRAWER - PENCIL EDGE - 15.1"W X 13.8"D - W/O SLIDES/HDW - CONCERT CHERRY FROM: 08-19-02 THRU: 99-99-99
8	P34767-C2-P33	EA	DRAWER - PENCIL EDGE - 14.7"W X 17.7"D-W/O SLIDES/HARDWARE - WASHED MAPLE FROM: 00-00-00 THRU: 08-18-02
8	134870-42-P33	EA	DRAWER - PENCIL EDGE - 15.1"W X 13.8"D - W/O SLIDES/HDW - WASHED MAPLE FROM: 08-19-02 THRU: 99-99-99
9	P34767-C2-P19	EA	DRAWER - PENCIL EDGE - 14.7"W X 17.7"D-W/O SLIDES/HARDWARE - PORTSMOUTH OAK FROM: 00-00-00 THRU: 08-18-02
9	P34767-J6-P19	EA	DRAWER - PENCIL EDGE - 14.7"W X 17.7"D-W/O SLIDES HARDWARE - PORTSMOUTH OAK FROM: 08-19-02 THRU: 99-99-99
9	P34767-C2-P20	EA	DRAWER - PENCIL EDGE - 14.7"W X 17.7"D-W/O SLIDES/HARDWARE - CONCERT CHERRY FROM: 00-00-00 THRU: 08-18-02
9	P34767-J6-P20	EA	DRAWER - PENCIL EDGE - 14.7"W X 17.7"D-W/O SLIDES HARDWARE - CONCERT CHERRY FROM: 08-19-02 THRU: 99-99-99
9	P34767-C2-P33	EA	DRAWER - PENCIL EDGE - 14.7"W X 17.7"D-W/O SLIDES/HARDWARE - WASHED MAPLE FROM: 00-00-00 THRU: 08-18-02
9	P34767-J6-P33	EA	DRAWER - PENCIL EDGE - 14.7"W X 17.7"D-W/O SLIDES HARDWARE - WASHED MAPLE FROM: 08-19-02 THRU: 99-99-99
10	P34767-B9-N37	EA	DRAWER - PENCIL EDGE - 14.7"W X 17.7"D-W/O SLIDES/HARDWARE - PORTSMOUTH OAK
10	P34767-B9-P55	EA	DRAWER - PENCIL EDGE - 14.7"W X 17.7"D-W/O SLIDES/HARDWARE - CONCERT CHERRY
10	P34767-B9-P56	EA	DRAWER - PENCIL EDGE - 14.7"W X 17.7"D-W/O SLIDES/HARDWARE - WASHED MAPLE
11	P34767-B8-N04	EA	DRAWER - PENCIL EDGE - 9.9"W X 17.7"D-W/O SLIDES/HARDWARE - PORTSMOUTH OAK
11	P34767-B8-M16	EA	DRAWER - PENCIL EDGE - 9.9"W X 17.7"D-W/O SLIDES/HARDWARE - CONCERT CHERRY
11	P34767-B8-M15	EA	DRAWER - PENCIL EDGE - 9.9"W X 17.7"D-W/O SLIDES/HARDWARE - WASHED MAPLE
12	140655-02-P13	EA	CABINET/BASE - W/O DOORS/HARDWARE - F/QUEEN BED - PORTSMOUTH OAK
12	140655-02-P14	EA	CABINET/BASE - W/O DOORS/HARDWARE - F/QUEEN BED - CONCERT CHERRY
12	140655-02-P33	EA	CABINET/BASE - W/O DOORS/HARDWARE - F/QUEEN BED - WASHED MAPLE
13	137406-05-P13	EA	BEDBOARD - W/HINGE/T-MOLDING/SLIPNOT - FLIP-UP
14	136885-10-N09	EA	CABINET - NIGHTSTAND - W/O DOORS/DRAWERS/HARDWARE - PORTSMOUTH OAK
14	136885-10-N10	EA	CABINET - NIGHTSTAND - W/O COUNTERTOP/DOOR/DRAWER/HARDWARE - CONCERT CHERRY
14	136885-10-N15	EA	CABINET - NIGHTSTAND - W/O COUNTERTOP/DOOR/DRAWER/HARDWARE - WASHED MAPLE
15	140888-08-P13	EA	COUNTERTOP - LAMINATED - GRAY TRANQUILITY/PORTSMOUTH OAK (P19)
15	140888-08-P14	EA	COUNTERTOP - LAMINATED - GRAY TRANQUILITY/CHERRY (P20)
15	140888-08-P15	EA	COUNTERTOP - LAMINATED - EGGSHELL/PORTSMOUTH OAK (P21, P23)
15	140888-08-P16	EA	COUNTERTOP - LAMINATED - EGGSHELL/CHERRY (P22, P24)
15	140888-08-P33	EA	COUNTERTOP - LAMINATED (P33)
15	140888-08-P36	EA	COUNTERTOP - LAMINATED - EGGSHELL/WASHED MAPLE (P36, P40)
16	136936-01-P13	EA	CABINET - OVERHEAD/REAR - W/O DOORS/HARDWARE - PORTSMOUTH OAK
16	136936-01-P14	EA	CABINET - OVERHEAD/REAR - W/O DOORS/HARDWARE - CONCERT CHERRY
16	136936-01-P33	EA	CABINET - OVERHEAD/REAR - W/O DOORS/HARDWARE - WASHED MAPLE

BEDROOM GROUP (CONTINUED)
CABINETS (CONTINUED)

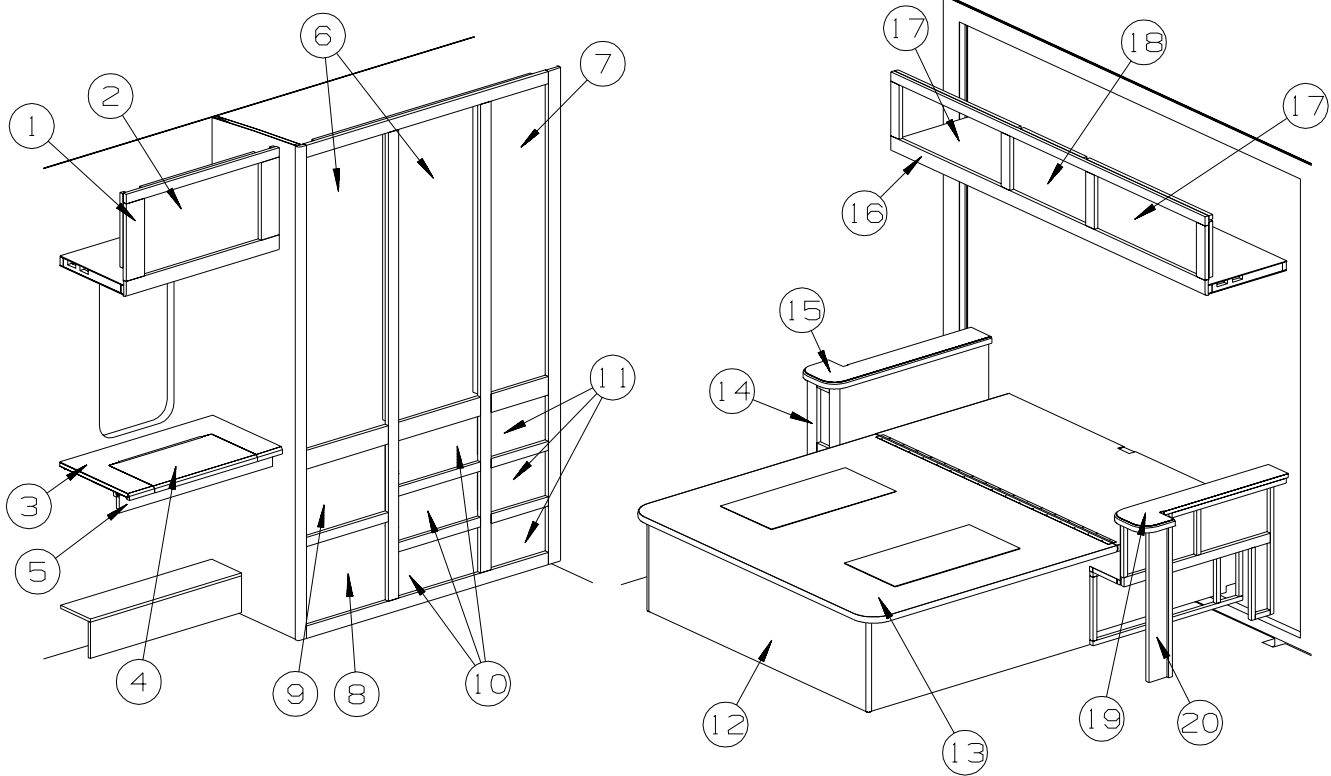

KEY	PART NUMBER	U/M	DESCRIPTION
17	134868-26-P19	EA	DOOR - RAIL/ARCHED TOP - 10" X 25.1" - W/O HARDWARE - PORTSMOUTH OAK FROM: 00-00-00 THRU: 11-10-02
17	141522-25-P19	EA	DOOR - ARCHED/PENCIL EDGE/HORIZ - 10" X 25.2" - W/O HDW - PORTSMOUTH OAK FROM: 11-11-02 THRU: 99-99-99
17	134868-26-P20	EA	DOOR - RAIL/ARCHED TOP - 10" X 25.1" - W/O HARDWARE - CONCERT CHERRY FROM: 00-00-00 THRU: 11-10-02
17	141522-25-P20	EA	DOOR - ARCHED/PENCIL EDGE/HORIZ - 10" X 25.2" - W/O HDW - CONCERT CHERRY FROM: 11-11-02 THRU: 99-99-99
17	134868-26-P33	EA	DOOR - RAIL/ARCHED TOP - 10" X 25.1" - W/O HARDWARE - WASHED MAPLE FROM: 00-00-00 THRU: 11-10-02
17	141522-25-P33	EA	DOOR - ARCHED/PENCIL EDGE/HORIZ - 10" X 25.2" - W/O HDW - WASHED MAPLE FROM: 11-11-02 THRU: 99-99-99
18	134868-25-P19	EA	DOOR - RAIL/ARCHED TOP - 10" X 19.1" - W/O HARDWARE - PORTSMOUTH OAK FROM: 00-00-00 THRU: 11-10-02
18	141522-22-P19	EA	DOOR - ARCHED/PENCIL EDGE/HORIZ - 10" X 19.1" - W/O HDW - PORTSMOUTH OAK FROM: 11-11-02 THRU: 99-99-99
18	134868-25-P20	EA	DOOR - RAIL/ARCHED TOP - 10" X 19.1" - W/O HARDWARE - CONCERT CHERRY FROM: 00-00-00 THRU: 11-10-02
18	141522-22-P20	EA	DOOR - ARCHED/PENCIL EDGE/HORIZ - 10" X 19.1" - W/O HDW - CONCERT CHERRY FROM: 11-11-02 THRU: 99-99-99
18	134868-25-P33	EA	DOOR - RAIL/ARCHED TOP - 10" X 19.1" - W/O HARDWARE - WASHED MAPLE FROM: 00-00-00 THRU: 11-10-02
18	141522-22-P33	EA	DOOR - ARCHED/PENCIL EDGE/HORIZ - 10" X 19.1" - W/O HDW - WASHED MAPLE FROM: 11-11-02 THRU: 99-99-99
19	140888-09-P13	EA	COUNTERTOP - LAMINATED - GRAY TRANQUILITY/PORTSMOUTH OAK (P19)
19	140888-09-P14	EA	COUNTERTOP - LAMINATED - GRAY TRANQUILITY/CHERRY (P20)
19	140888-09-P15	EA	COUNTERTOP - LAMINATED - EGGSHELL/PORTSMOUTH OAK (P21, P23)
19	140888-09-P16	EA	COUNTERTOP - LAMINATED - EGGSHELL/CHERRY (P22, P24)
19	140888-09-P33	EA	COUNTERTOP - LAMINATED (P33)
19	140888-09-P36	EA	COUNTERTOP - LAMINATED - EGGSHELL/WASHED MAPLE (P36, P40)
20	136885-A0-N09	EA	CABINET - NIGHTSTAND - W/O COUNTERTOP/DOOR/DRAWER/HARDWARE - PORTSMOUTH OAK
20	136885-A0-N10	EA	CABINET - NIGHTSTAND - W/O COUNTERTOP/DOOR/DRAWER/HARDWARE - CONCERT CHERRY
20	136885-A0-N15	EA	CABINET - NIGHTSTAND - W/O COUNTERTOP/DOOR/DRAWER/HARDWARE - WASHED MAPLE

BEDROOM GROUP (CONTINUED)
CABINETS (CONTINUED)

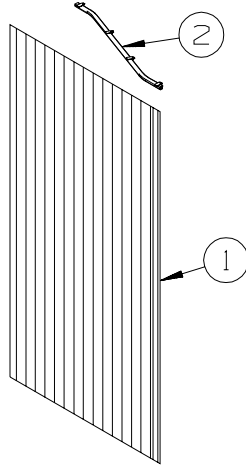

KEY	PART NUMBER	U/M	DESCRIPTION
1*	131595-01-01A	EA	DOOR - FOLDING-36.9" X 74.9"-W/4 CEILING MOUNTED BRACKETS
2	131595-07-01A	EA	TRACK - DOOR - CURVED/RIGHT - 28.5"

***COMPONENT PARTS LISTED LATER IN THIS GROUP**

BEDROOM GROUP (CONTINUED)
COMPONENT PARTS FOR CABINETS

131595-01-01A

KEY	PART NUMBER	U/M	DESCRIPTION	VENDOR NO.
	117431-01-707	EA	CATCH/PIN - PLASTIC	
	131595-01-700	EA	END STOP ONLY	
	131595-01-701	EA	BRACKET/MOUNTING	908956
	131595-01-702	EA	TRACK/STRAIGHT - 37"	

CHASSIS GROUP FRAME

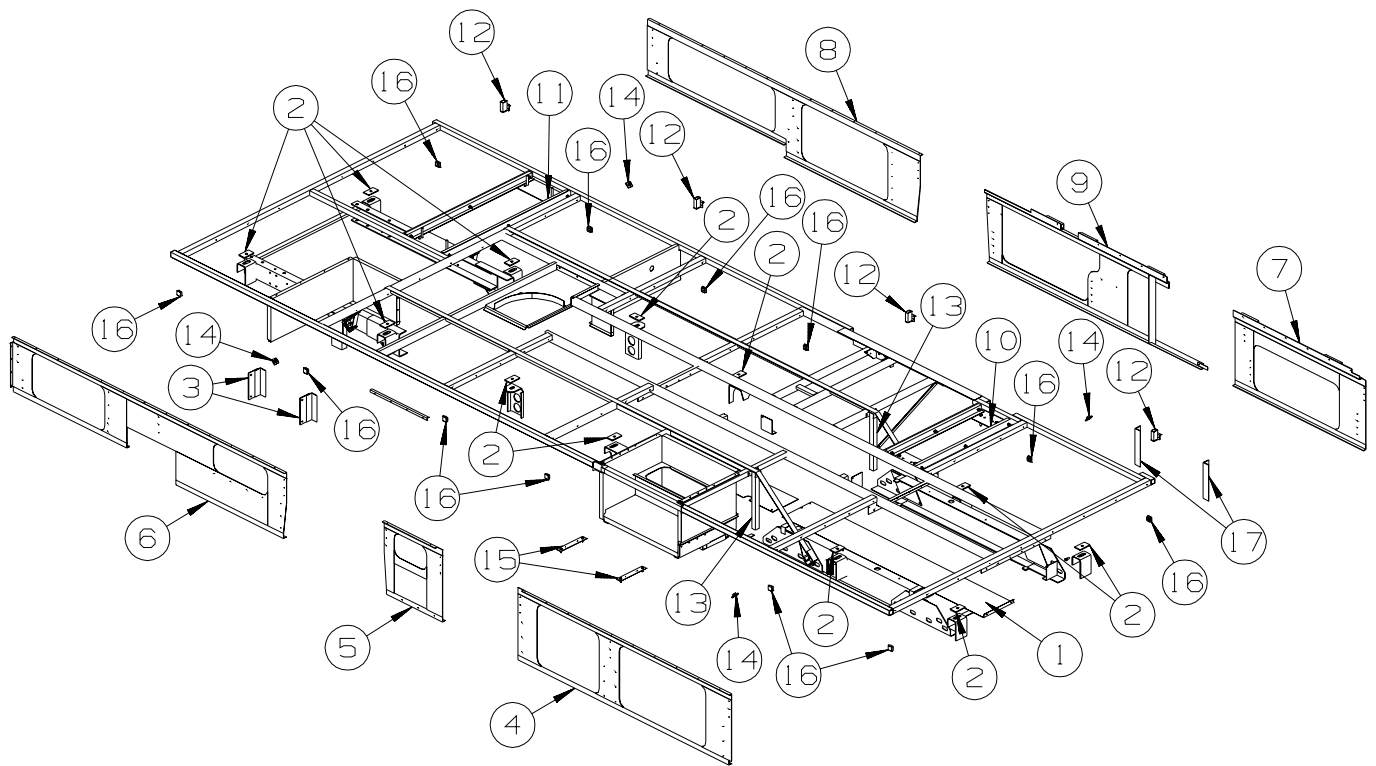

KEY	PART NUMBER	U/M	DESCRIPTION
1	135676-04-02B	EA	SHIELD - HEAT - E-COAT
2	135712-01-02B	EA	PLATE - BODY MOUNT - E-COATED
3	136042-01-02B	EA	BRACKET - LP SUPPORT - E-COATED
4	141344-13-01A	EA	SEAL PLANE
5	141344-14-01A	EA	SEAL PLANE
6	141344-15-01A	EA	SEAL PLANE
7	141344-16-01A	EA	SEAL PLANE
8	141344-17-01A	EA	SEAL PLANE
9	141344-18-01A	EA	SEAL PLANE
10	143020-01-02B	EA	FRAME - SLIDEOUT/MECHANISM - E-COATED
	143019-01-01B	EA	ZEE - BRACKET - SLIDEOUT
11	143020-02-02B	EA	FRAME - F/SLIDEOUT MECHANISM - E-COATED
	143019-01-01B	EA	ZEE - BRACKET - SLIDEOUT
12	136780-02-02B	EA	ADJUSTER - SLIDE - E-COATED
13	143275-01-02B	EA	TRUSS SUPPORT - E-COATED
14	141901-02-02B	EA	PLATE - TIE DOWN - E-COATED
15	143130-01-02B	EA	PLATE - BACKING - RIGHT - E-COATED
			FROM: 00-00-00 THRU: 06-18-02
15	143131-01-02B	EA	PLATE - BACKING - LEFT - E-COATED
			FROM: 00-00-00 THRU: 06-18-02
15	143130-02-02B	EA	PLATE - BACKING - RIGHT/LEFT - E-COATED
			FROM: 06-19-02 THRU: 99-99-99
16	119845-01-01A	EA	PLUG/PLASTIC - 1 1/2" SQUARE - BLACK
17	143953-01-02B	EA	ANGLE - GENERATOR MOUNT - E-COATED

CHASSIS GROUP (CONTINUED)

DRIVETRAIN

KEY	PART NUMBER	U/M	DESCRIPTION
	103653-23-000	EA	BOLT - U- JOINT - 5/6-24 X .75 - 430V, 431C
	103653-24-000	EA	STRAP - U- JOINT - 430V, 431C
	131695-07-000	EA	DRIVESHAFT - 3 BALANCED - 219" WHEELBASE - 431C
	131695-09-000	EA	DRIVESHAFT ASSEMBLY - BALANCED PAIR - 190" WHEELBASE - 427P
	131695-05-000	EA	DRIVESHAFT - 3 BALANCED - 205" WHEELBASE - 430V

EXHAUST

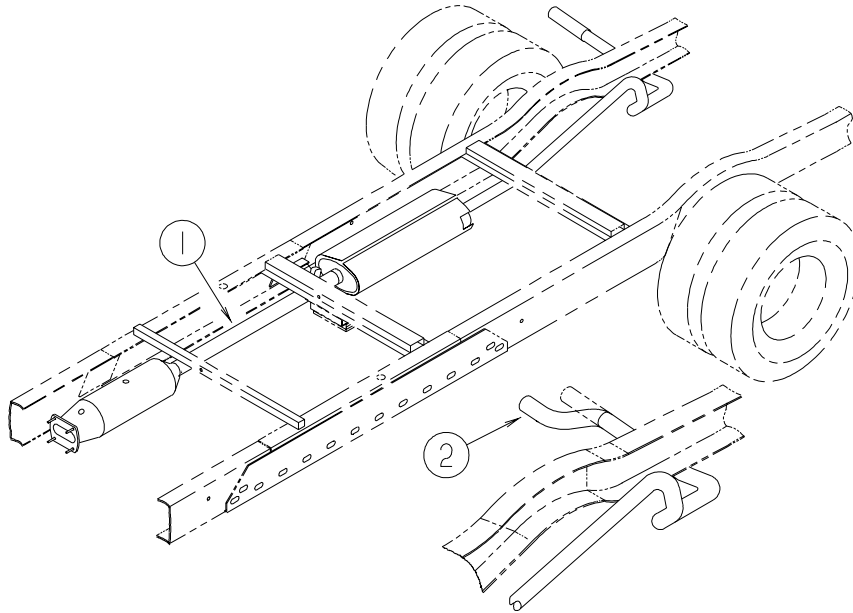

427P AND 431C

KEY	PART NUMBER	U/M	DESCRIPTION
1	111478-02-000	EA	EXHAUST PIPE - DOUBLE WALL STAINLESS STEEL - 34" - GAS - 427P
1	111478-05-000	EA	EXHAUST PIPE - DOUBLE WALL STAINLESS STEEL - 431C
	094918-06-000	EA	CLAMP - EXHAUST - 3" - HEAVY DUTY
2	129846-02-000	EA	PIPE - EXHAUST - TAIL - 3" - 427P

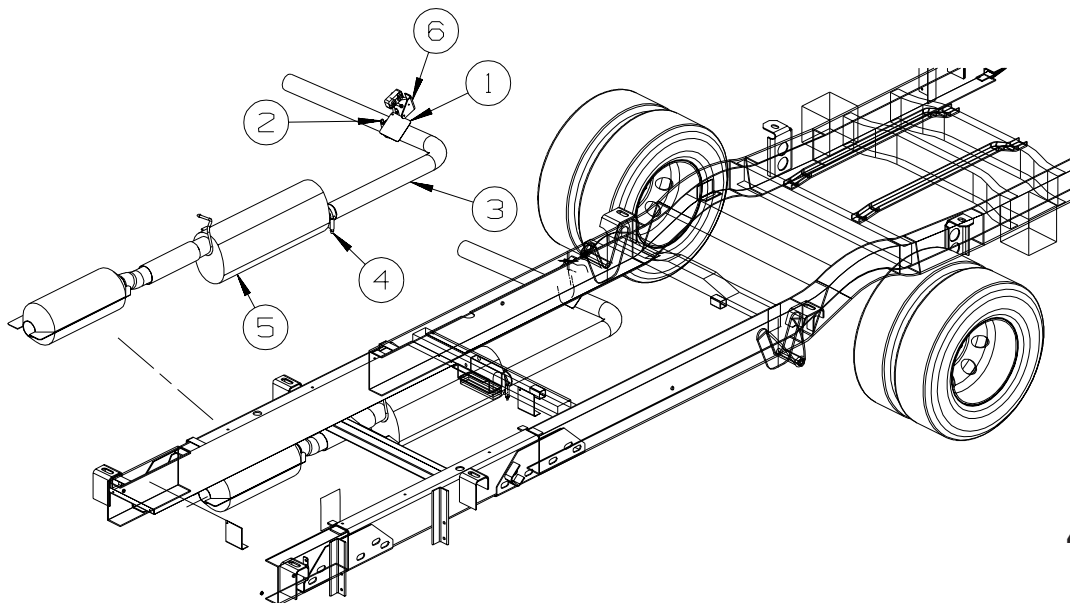

430V

KEY	PART NUMBER	U/M	DESCRIPTION
1	143138-02-02B	EA	SHIELD - EXHAUST - E-COATED
2	122392-02-02B	EA	HANGER - TAILPIPE - E-COATED
3	143927-01-000	EA	PIPE - EXHAUST - TAIL
4	094918-01-000	EA	CLAMP - EXHAUST - 3" - GUILLOTINE STYLE
5	143929-01-000	EA	MUFFLER - EXHAUST
6	143811-02-000	EA	HANGER - EXHAUST - FORD F53

CHASSIS GROUP (CONTINUED)

HITCH

KEY	PART NUMBER	U/M	DESCRIPTION
	130339-04-000	EA	HITCH RECEIVER - BOLT ON CLASS II
			FROM: 00-00-00 THRU: 12-18-02
	130339-04-000	EA	HITCH RECEIVER - BOLT ON CLASS II
			FROM: 12-19-02 THRU: 99-99-99
	034513-01-000	EA	PIN - HITCH - 3/16" WIRE

FUEL

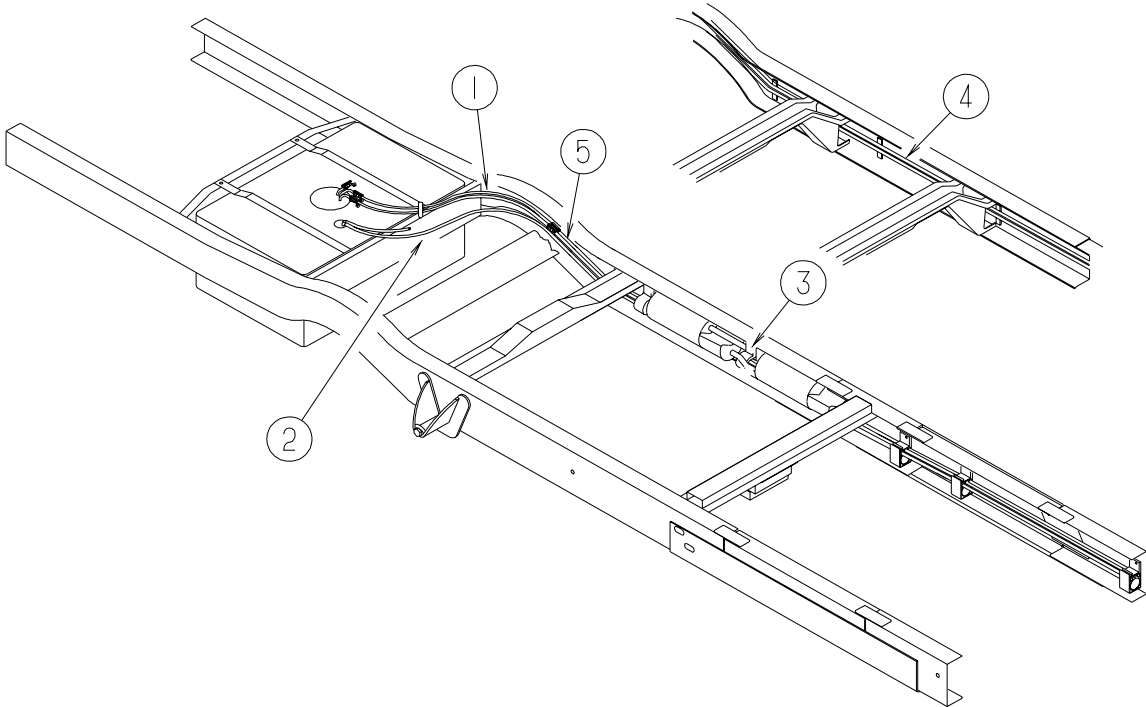

KEY	PART NUMBER	U/M	DESCRIPTION
1	106389-10-000	EA	FUEL LINE - FORD - 3/8 HP - FORD - 427P
1	106389-11-000	EA	FUEL LINE - FORD - 3/8 HP - FORD - 430V
1	106389-12-000	EA	FUEL LINE - FORD - 3/8 HP - FORD - 431C
2	125187-01-000	FT	HOSE - FUEL - LOW PERMEABILITY - 11.1 ID - FORD
3	125187-02-000	FT	HOSE - FUEL - LOW PERMEABILITY - 12.7" ID - FORD
	128139-03-000	FT	HOSE - FUEL - LOW PERMEABILITY - 1/4" DIAMETER
4	NOT USED		
5	106388-10-000	EA	FUEL LINE - FORD - 5/16 HP - FORD - 427P
5	106388-11-000	EA	FUEL LINE - FORD - 5/16 HP - FORD - 430V
5	106388-12-000	EA	FUEL LINE - FORD - 5/16 HP - FORD - 431C

CHASSIS GROUP (CONTINUED) FUEL (CONTINUED)

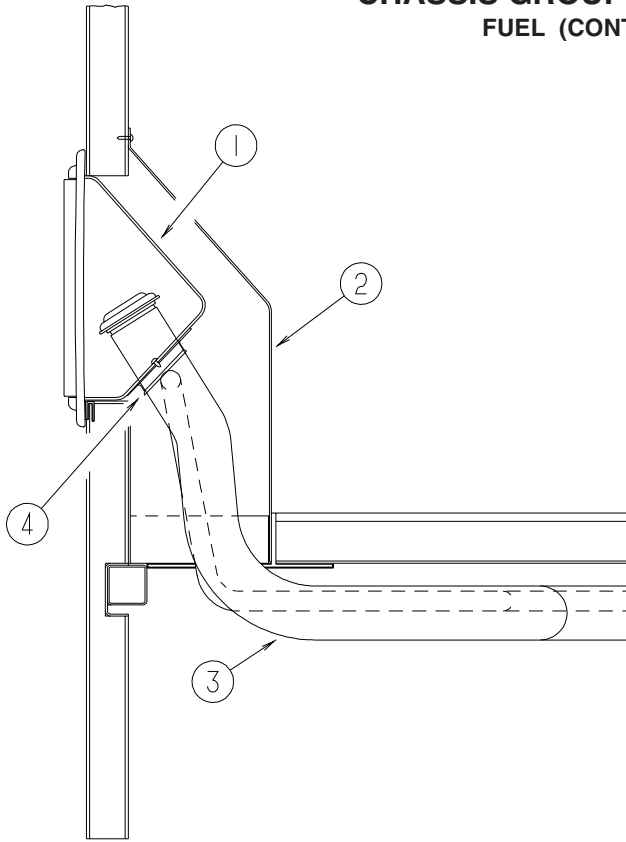

430V

KEY	PART NUMBER	U/M	DESCRIPTION
1	127291-02-01A	EA	SHROUD - FUEL FILL - BRIGHT WHITE
2	078040-09-000	EA	SHROUD - FUEL FILL - UPPER - RECTANGULAR
3	144751-01-000	EA	NECK - FUEL FILL
4	078200-01-000	EA	GASKET - FUEL FILL - 3.5"OD X 2"ID

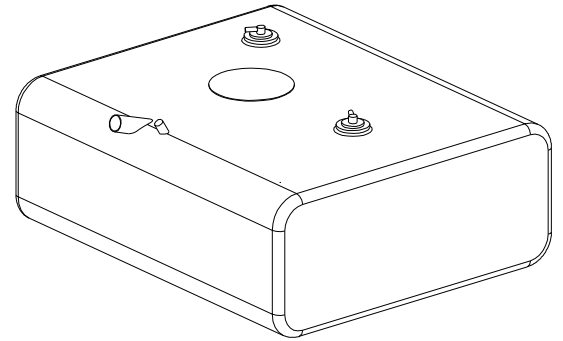

427P, 431C

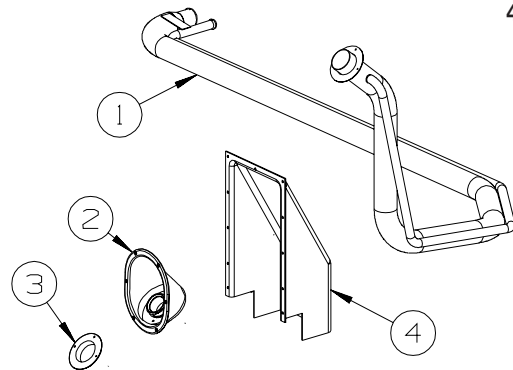

KEY	PART NUMBER	U/M	DESCRIPTION
1	135543-01-000	EA	NECK - FUEL FILL - 431C
1	135543-02-000	EA	NECK - FUEL FILL - 427P
2	127291-02-01A	EA	SHROUD - FUEL FILL - BRIGHT WHITE
2	095854-01-04A	EA	SHROUD - FUEL FILL - RADIUS - BRIGHT WHITE
3	078200-01-000	EA	GASKET - FUEL FILL - 3.5"OD X 2"ID
4	135557-01-01A	EA	SHROUD - FULE FILL/UPPER

FROM: 00-00-00 THRU: 01-06-02
FROM: 01-07-02 THRU: 99-99-99

CHASSIS GROUP (CONTINUED)

SPARE TIRE

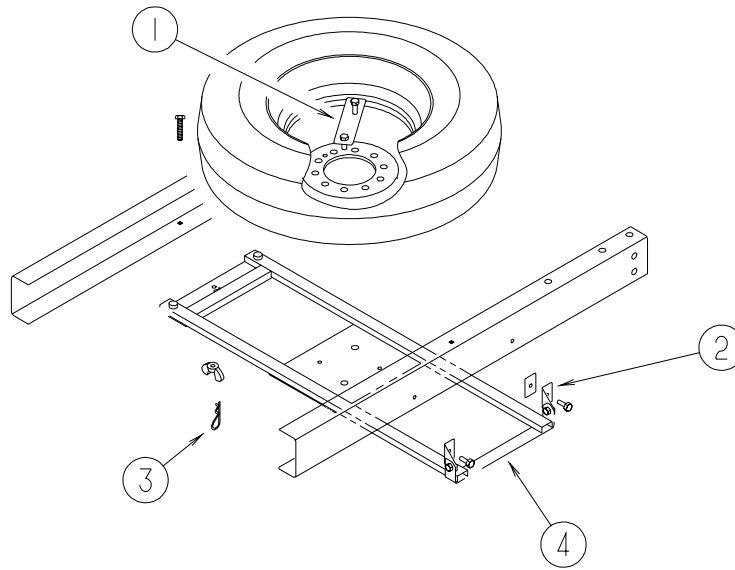

KEY	PART NUMBER	U/M	DESCRIPTION
1	116338-02-02B	EA	BRACKET/CLAMP - SPARE TIRE - E-COATED
2	116349-03-02B	EA	BRACKET/HINGE - SPARE TIRE - 2.4" - E-COATED - 427P, 431C
2	116349-04-02B	EA	BRACKET - HINGE - SPARE TIRE - E-COATED - 430V
3	034513-01-000	EA	PIN - HITCH - 3/16" WIRE
4	141986-01-02B	EA	CRADLE - SPARE TIRE - E-COATED
	069726-02-000	EA	BUMPER - .88" OD X .40" THICK - BLACK

SUSPENSION

KEY	PART NUMBER	U/M	DESCRIPTION
*	135674-01-000	EA	AIRSPRING - AIR BAG KIT - FORD 450 SUPER DUTY CHASSIS FROM: 00-00-00 THRU: 01-05-03
*	144887-01-000	EA	AIRSPRING - 4" DIAMETER TWIN FROM: 01-06-03 THRU: 99-99-99

*COMPONENT PARTS LISTED LATER IN THIS GROUP

CHASSIS GROUP (CONTINUED)
COMPONENT PARTS FOR SUSPENSION

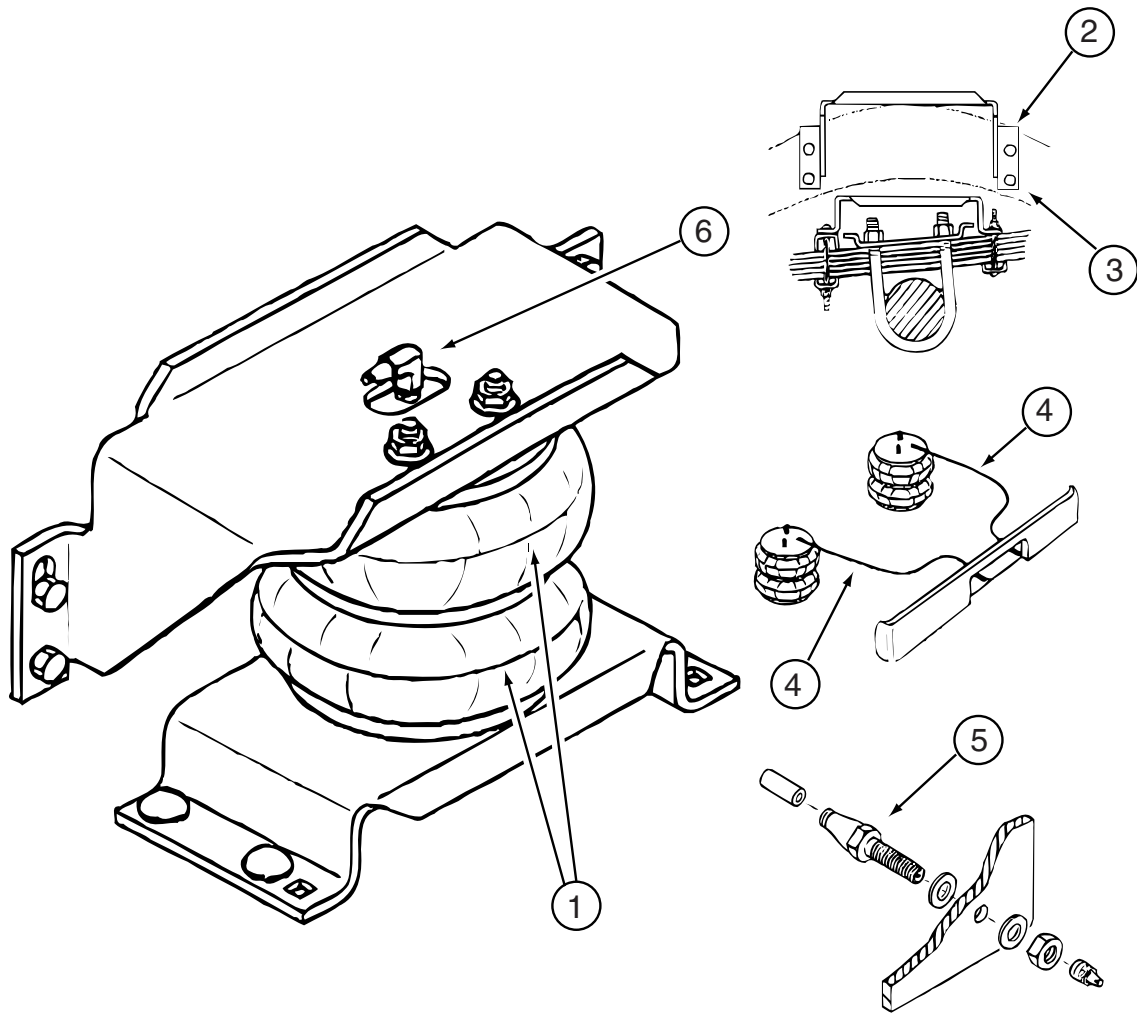

135674-01-000

KEY	PART NUMBER	U/M	DESCRIPTION	VENDOR NO.
1	135674-01-700	EA	AIR SPRING	W21-760-6957
2	135674-01-701	EA	BRACKET - UPPER/RT & LT	5187
3	135674-01-702	EA	BRACKET - LOWER/RT & LT	5092
4	084086-01-701	EA	TUBING, DOT 1/4"X22'	21-0937
5	084086-05-706	EA	VALVE-INFLATION, PUSH TO CONN	3032
6	084086-04-703	EA	BRASS ELBOW	21-3028
	084086-01-705	EA	PROTECTOR-TUBING	21-0899
	084086-05-704	EA	BRACKET CLAMP	5086
	135674-01-703	EA	STRAP/SHIM - F/BRACKET	5093

CHASSIS GROUP (CONTINUED)

WHEEL, TIRE, COVERS &/OR LINERS

KEY	PART NUMBER	U/M	DESCRIPTION
*	109443-05-000	EA	WHEEL COVER - 4/SET - 16" STAINLESS STEEL - 8 LUG
	051377-04-000	EA	VALVE STEM - .5" X 2"
	070917-06-000	EA	TIRE - LT225/75R16E - R4S M/S - FIRESTONE
			FROM: 00-00-00 THRU: 05-17-02
	143401-01-000	EA	TIRE - LT225/75R16 LRE - GOODYEAR WRANGLER HT
			FROM: 05-18-02 THRU: 06-16-02
	083425-14-000	EA	TIRE - LT225/75R16 LRE - MICHELIN LTX M/S
			FROM: 06-17-02 THRU: 99-99-99
	083617-04-000	EA	WHEEL - STEEL - 6" X 16" - FORD
	095012-05-000	EA	EXTENSION - VALVE STEM - LIVE - 5"
	095012-06-000	EA	STABILIZER - VALVE EXTENSION - LIVE - 2"
*	110435-13-000	EA	LINER - WHEEL - SET OF 4 - 16" (8 HOLE)
	112358-01-000	EA	WRENCH - LUG - 7/8" - L-SHAPE

*COMPONENT PARTS LISTED LATER IN THIS GROUP

CHASSIS GROUP (CONTINUED)
COMPONENT PARTS FOR WHEEL, TIRE, COVERS &/OR LINERS

109443-05-000

KEY	PART NUMBER	U/M	DESCRIPTION	VENDOR NO.
	098532-01-700	EA	COVER-LUG NUT (CHROME)	SHAU-LNC
	109443-05-700	EA	COVER-WHEEL, 16" SS EA=1	SHFM16-CVR

110435-13-000

KEY	PART NUMBER	U/M	DESCRIPTION	VENDOR NO.
	110435-01-711	EA	DECAL-CENTER CAP, 2"	2" DECAL
	110435-10-705	EA	TOOL - INSTALLATION	V195P7-TOL
	110435-13-700	EA	LINER - WHEEL - FRONT	V160F7-FWC
	110435-13-701	EA	LINER - WHEEL - REAR	V160F7-RWC
	110435-13-702	EA	COVER-LUG NUT W/JAMB NUT FT	V160F7-EJN

CHASSIS GROUP (CONTINUED)

BRAKELINE

KEY	PART NUMBER	U/M	DESCRIPTION
	088498-01-000	EA	UNION - INVERTED FLARE - BRASS - 3/16

CURTAIN & CUSHION GROUP

NOTICE

IN ORDER TO ASSIST OUR PARTS SALES DEPT. IN PROVIDING INTERIOR SOFTWARE ITEMS, PLEASE INCLUDE THE SERIAL NUMBER AND THE COLOR CODE NUMBER FROM THE VEHICLE CERTIFICATION LABEL WHEN ORDERING. THIS LABEL IS LOCATED ON THE LEFT SIDEWALL AT THE END OF THE DASH (A-BODY), OR ON THE DRIVER'S DOOR LATCH PLATE (C-BODY).

AN EXAMPLE OF A COLOR CODE NUMBER IS B07, WHICH DESIGNATES AN OVERALL COLOR SCHEME OF A PARTICULAR UNIT. THE COLOR LISTED AFTER THE ITEM DESCRIPTION ON THE MICROFICHE, INDICATES THE OVERALL UNIT COLOR. ORDER THE ITEM YOU DESIRE ACCORDING TO UNIT COLOR CODE. IF ALL COLORS USE THE SAME ITEM NO COLOR CODE WILL BE NOTED.

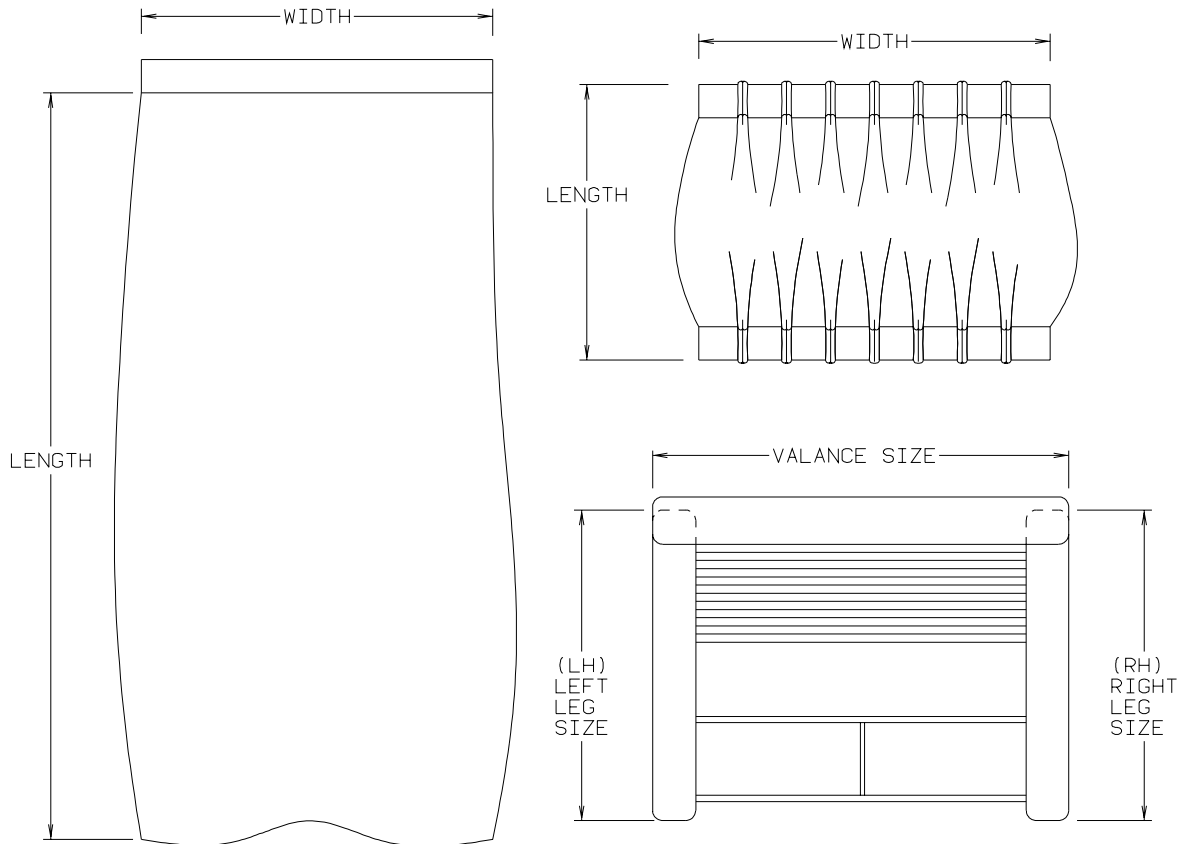

NOTE: USE THIS ILLUSTRATION WHEN DETERMINING LENGTH AND WIDTH MEASUREMENTS FOR CURTAINS. YOU WILL NOTE THE WIDTH MEASUREMENT IS TAKEN ON THE TOP OF THE CURTAIN WITH THE CURTAIN FULLY EXTENDED. THE LENGTH MEASUREMENT IS TAKEN FROM TOP TO BOTTOM. LEFT AND RIGHT WINDOW LEGS ARE DETERMINED WHEN FACING THE WINDOW.

CURTAIN & CUSHION GROUP (CONTINUED)

CUSHION LAYOUT

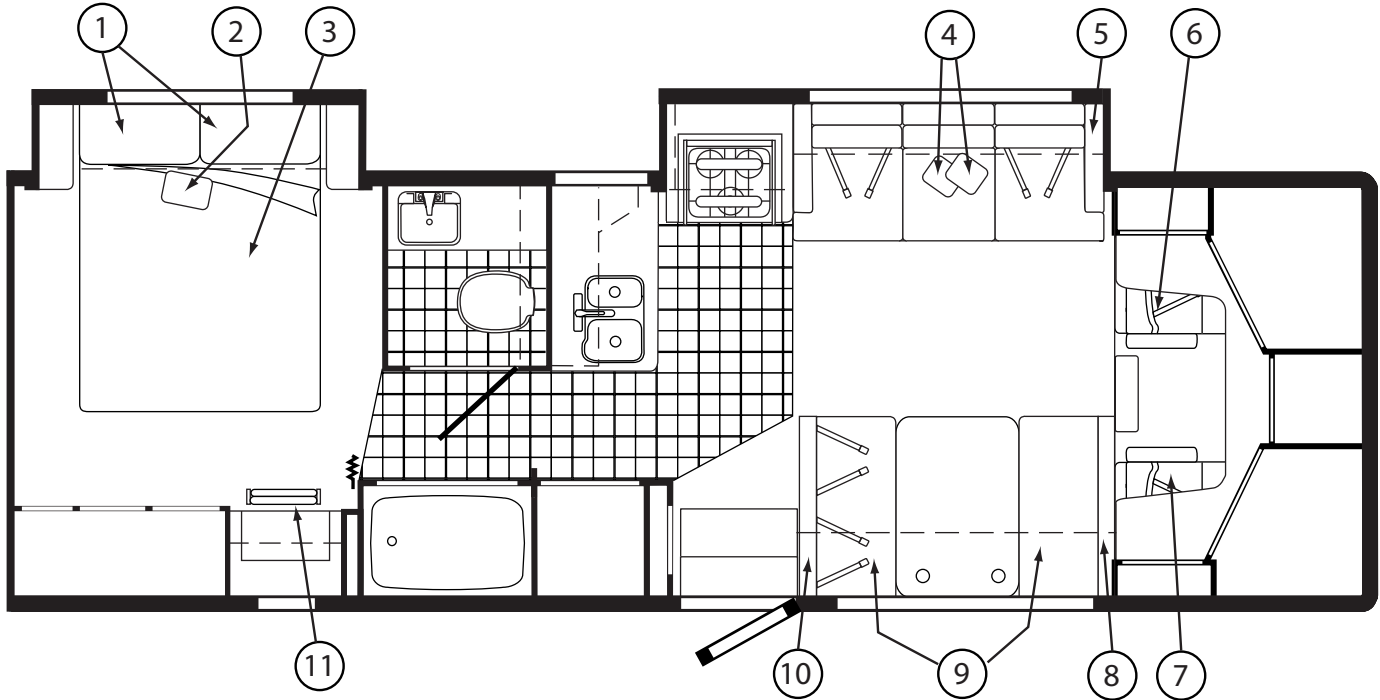

KEY	PART NUMBER	U/M	DESCRIPTION
1	142405-02-P19	EA	SHAM - PILLOW (P19, P20, P33)
1	142405-02-P21	EA	SHAM - PILLOW (P21, P22, P36)
1	142405-02-P23	EA	SHAM - PILLOW (P23, P24, P40)
2	132338-28-P19	EA	PILLOW - 10" X 17" (P19, P20, P33)
2	132338-28-P21	EA	PILLOW - 10" X 17" (P21, P22, P36)
2	132338-28-P23	EA	PILLOW - 10" X 17" (P23, P24, P40)
3	132336-09-P19	EA	BEDSPREAD/CAP - 60" X 75" (P19, P20, P33)
3	132336-09-P21	EA	BEDSPREAD/CAP - 60" X 75" (P21, P22, P36)
3	132336-09-P23	EA	BEDSPREAD/CAP - 60" X 75" (P23, P24, P40)
3	123015-06-000	EA	MATTRESS - INNERSPRING - 60" X 74.5"
4	132319-48-P19	EA	PILLOW - 17" - W/"V" OVERLAY (P19, P20, P33)
4	132319-48-P21	EA	PILLOW - 17" - W/"V" OVERLAY (P21, P22, P36)
4	132319-48-P23	EA	PILLOW - 17" - W/"V" OVERLAY (P23, P24, P40)
5		EA	SOFA/BED - SEE SOFA AREA
6	136590-15-P19	EA	BUCKET SEAT - DRIVER - W/LUMBAR (P19, P20, P33)
6	136590-15-P21	EA	BUCKET SEAT - DRIVER - W/LUMBAR (P21, P22, P36)
6	136590-15-P23	EA	BUCKET SEAT - DRIVER - W/LUMBAR (P23, P24, P40)
6	136590-17-P19	EA	BUCKET SEAT - DRIVER - W/LUMBAR - ULTRA LEATHER CAB SEATS
7	136590-16-P19	EA	BUCKET SEAT - PASSENGER (P19, P20, P33)
7	136590-16-P21	EA	BUCKET SEAT - PASSENGER (P21, P22, P36)
7	136590-16-P23	EA	BUCKET SEAT - PASSENGER (P23, P24, P40)
7	136590-18-P19	EA	BUCKET SEAT - PASSENGER - ULTRA LEATHER CAB SEATS
8	142291-04-P19	EA	BACK - DINETTE CUSHION - LEFT - 12.5" X 42" (P19, P20, P33)
8	142291-04-P21	EA	BACK - DINETTE CUSHION - LEFT - 12.5" X 42" (P21, P22, P36)
8	142291-04-P23	EA	BACK - DINETTE CUSHION - LEFT - 12.5" X 42" (P23, P24, P40)
	P42291-04-P19	EA	COVER/BACK - DINETTE CUSHION - LEFT - 12.5" X 42" (P19, P20, P33)
	P42291-04-P21	EA	COVER/BACK - DINETTE CUSHION - LEFT - 12.5" X 42" (P21, P22, P36)
	P42291-04-P23	EA	COVER/BACK - DINETTE CUSHION - LEFT - 12.5" X 42" (P23, P24, P40)
9	142292-06-P19	EA	SEAT - DINETTE CUSHION (SPRUNG) - 22" X 37" (P19, P20, P33)
9	142292-06-P21	EA	SEAT - DINETTE CUSHION (SPRUNG) - 22" X 37" (P21, P22, P36)
9	142292-06-P23	EA	SEAT - DINETTE CUSHION (SPRUNG) - 22" X 37" (P23, P24, P40)
	P42292-06-P19	EA	COVER/SEAT - DINETTE CUSHION (SPRUNG) - 22" X 37" (P19, P20, P33)
	P42292-06-P21	EA	COVER/SEAT - DINETTE CUSHION (SPRUNG) - 22" X 37" (P21, P22, P36)
	P42292-06-P23	EA	COVER/SEAT - DINETTE CUSHION (SPRUNG) - 22" X 37" (P23, P24, P40)
	142366-03-000	EA	FRAME - SPRUNG - DINETTE SEAT

CURTAIN & CUSHION GROUP (CONTINUED)
CUSHION LAYOUT (CONTINUED)

KEY	PART NUMBER	U/M	DESCRIPTION
10	142291-03-P19	EA	BACK - DINETTE CUSHION - RIGHT - 12.5" X 42" (P19, P20, P33)
10	142291-03-P21	EA	BACK - DINETTE CUSHION - RIGHT - 12.5" X 42" (P21, P22, P36)
10	142291-03-P23	EA	BACK - DINETTE CUSHION - RIGHT - 12.5" X 42" (P23, P24, P40)
	P42291-03-P19	EA	COVER/BACK - DINETTE CUSHION - RIGHT - 12.5" X 42" (P19, P20, P33)
	P42291-03-P21	EA	COVER/BACK - DINETTE CUSHION - RIGHT - 12.5" X 42" (P21, P22, P36)
	P42291-03-P23	EA	COVER/BACK - DINETTE CUSHION - RIGHT - 12.5" X 42" (P23, P24, P40)
11	135600-92-000	EA	CHAIR - FOLDING - LEGHORN/PORTSMOUTH OAK (P19)
11	135600-93-000	EA	CHAIR - FOLDING - LEGHORN/CHERRY (P20)
11	135600-95-000	EA	CHAIR - FOLDING - DESTIN/PORTSMOUTH OAK (P21)
11	135600-96-000	EA	CHAIR - FOLDING - DESTIN/CHERRY (P22)
11	135600-12-000	EA	CHAIR - FOLDING - IVORY MULTI/PORTSMOUTH OAK (P23)
11	135600-98-000	EA	CHAIR - FOLDING - IVORY MULTI/CHERRY (P24)
11	135600-94-000	EA	CHAIR - FOLDING - LEGHORN/WASHED MAPLE (P33)
11	135600-97-000	EA	CHAIR - FOLDING - DESTIN/WASHED MAPLE (P36)
11	135600-99-000	EA	CHAIR - FOLDING - IVORY/WASHED MAPLE (P40)

CURTAIN & CUSHION GROUP (CONTINUED)

BUCKET SEATS

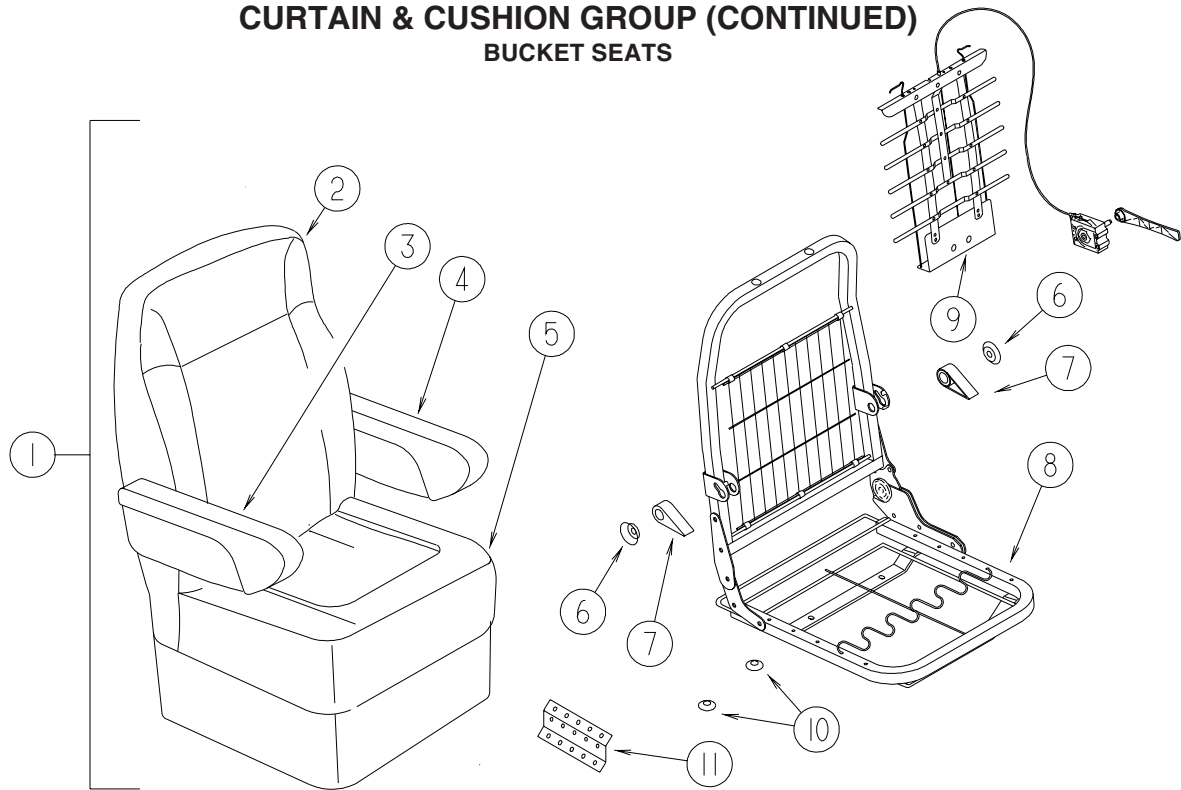

KEY	PART NUMBER	U/M	DESCRIPTION
1	136590-15-P19	EA	BUCKET SEAT - DRIVER - W/LUMBAR (P19, P20, P33)
1	136590-15-P21	EA	BUCKET SEAT - DRIVER - W/LUMBAR (P21, P22, P36)
1	136590-15-P23	EA	BUCKET SEAT - DRIVER - W/LUMBAR (P23, P24, P40)
1	136590-17-P19	EA	BUCKET SEAT - DRIVER - W/LUMBAR - LEATHER FACED CAB SEATS
1	136590-16-P19	EA	BUCKET SEAT - PASSENGER (P19, P20, P33)
1	136590-16-P21	EA	BUCKET SEAT - PASSENGER (P21, P22, P36)
1	136590-16-P23	EA	BUCKET SEAT - PASSENGER (P23, P24, P40)
1	136590-18-P19	EA	BUCKET SEAT - PASSENGER - LEATHER FACED CAB SEATS
2	M05962-F0-P19	EA	COVER - BACK (P19, P20, P33)
2	M05962-F0-P21	EA	COVER - BACK (P21, P22, P36)
2	M05962-F0-P23	EA	COVER - BACK (P23, P24, P40)
2	M05962-F2-M15	EA	COVER - BACK - LEATHER FACED CAB SEATS
3	129666-07-P19	EA	ARMREST - RIGHT HAND (P19, P20, P33)
3	129666-07-P21	EA	ARMREST - RIGHT HAND (P21, P22, P36)
3	129666-07-P37	EA	ARMREST - RIGHT HAND (P23, P24, P40)
3	129666-09-N06	EA	ARMREST - RIGHT HAND - LEATHER FACED CAB SEATS
	P29666-07-P19	EA	COVER - ARMREST/RIGHT HAND (P19, P20, P33)
	P29666-07-P21	EA	COVER - ARMREST/RIGHT HAND (P21, P22, P36)
	P29666-07-P37	EA	COVER - ARMREST/RIGHT HAND (P23, P24, P40)
	P29666-09-N06	EA	COVER - ARMREST/RIGHT HAND - LEATHER FACED CAB SEATS
	130698-01-000	EA	ARMREST-99 RT, MOLDED - CARPENTER
4	129666-08-P19	EA	ARMREST - LEFT HAND (P19, P20, P33)
4	129666-08-P21	EA	ARMREST - LEFT HAND (P21, P22, P36)
4	129666-08-P37	EA	ARMREST - LEFT HAND (P23, P24, P40)
4	129666-10-N06	EA	ARMREST - LEFT HAND - LEATHER FACED CAB SEATS
	P29666-08-P19	EA	COVER - ARMREST/LEFT HAND (P19, P20, P33)
	P29666-08-P21	EA	COVER - ARMREST/LEFT HAND (P21, P22, P36)
	P29666-08-P37	EA	COVER - ARMREST/LEFT HAND (P23, P24, P40)
	P29666-10-N06	EA	COVER - ARMREST/LEFT HAND - LEATHER FACED CAB SEATS
	130698-02-000	EA	ARMREST-99 LT, MOLDED - CARPENTER
5	M05962-F1-P19	EA	COVER - SEAT (P19, P20, P33)
5	M05962-F1-P21	EA	COVER - SEAT (P21, P22, P36)
5	M05962-F1-P23	EA	COVER - SEAT (P23, P24, P40)
5	M05962-F3-M15	EA	COVER - SEAT - LEATHER FACED CAB SEATS
6	130802-03-000	EA	SCREW F/LEVER
7	130802-02-000	EA	LEVER - RIGHT HAND
7	130802-01-000	EA	LEVER - LEFT HAND

CURTAIN & CUSHION GROUP (CONTINUED)
BUCKET SEATS (CONTINUED)

KEY	PART NUMBER	U/M	DESCRIPTION
8	132875-04-000	EA	FRAME - LEFT HAND CHAIR/TAPERED BACK
8	132875-03-000	EA	FRAME - RIGHT HAND CHAIR/TAPERED BACK
9*	122611-02-000	EA	LUMBAR - W/LEVER
10	007221-01-000	EA	SPACER - SEAT/ADJUSTER
11	116104-04-02B	EA	BRACKET - ZEE W/HOLES - 3.2" - E-COATED
	029134-01-000	EA	CLIP - FINISH - K2915 - UPHOLSTERY

***COMPONENT PARTS LISTED LATER IN THIS GROUP**

CURTAIN & CUSHION GROUP (CONTINUED)
COMPONENT PARTS FOR BUCKET SEATS

122611-02-000

KEY	PART NUMBER	U/M	DESCRIPTION	VENDOR NO.
	122611-02-701	EA	LUMBAR - LEVER	412
	122611-02-702	EA	LUMBAR MECHANISM	24395-FLEXSTEEL

CURTAIN & CUSHION GROUP (CONTINUED)

SOFA

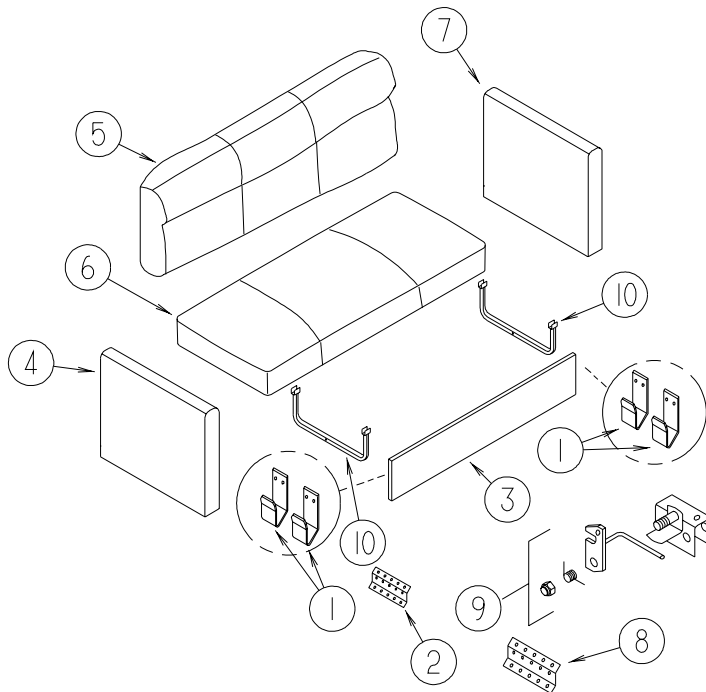

KEY	PART NUMBER	U/M	DESCRIPTION
1	121906-01-02B	EA	BRACKET - KICKBOARD - E-COATED
2	116104-04-02B	EA	BRACKET - ZEE - 2" - BLACK - MOUNTS ARM TO FLOOR
3	120992-34-P19	EA	PANEL/FRONT KICK - SOFA/BED - FABRIC COVERED - 67.5" (P19, P20, P33)
3	120992-34-P21	EA	PANEL/FRONT KICK - SOFA/BED - FABRIC COVERED - 67.5" (P21, P22, P36)
3	120992-34-P23	EA	PANEL/FRONT KICK - SOFA/BED - FABRIC COVERED - 67.5" (P23, P24, P40)
4	123381-05-P19	EA	ARMREST - RIGHT HAND (P19, P20, P33)
4	123381-05-P21	EA	ARMREST - RIGHT HAND (P21, P22, P36)
4	123381-05-P23	EA	ARMREST - RIGHT HAND (P23, P24, P40)
	P23381-05-P19	EA	COVER/ARMREST - RIGHT HAND (P19, P20, P33)
	P23381-05-P21	EA	COVER/ARMREST - RIGHT HAND (P21, P22, P36)
	P23381-05-P23	EA	COVER/ARMREST - RIGHT HAND (P23, P24, P40)
	123499-04-000	EA	SOFA/ARM - WOOD - RIGHT HAND
5	140142-01-P19	EA	BACK - SOFA/BED - 67.5" (P19, P20, P33)
5	140142-01-P21	EA	BACK - SOFA/BED - 67.5" (P21, P22, P36)
5	140142-01-P23	EA	BACK - SOFA/BED - 67.5" (P23, P24, P40)
	P40142-01-P19	EA	COVER/BACK - SOFA/BED - 67.5" (P19, P20, P33)
	P40142-01-P21	EA	COVER/BACK - SOFA/BED - 67.5" (P21, P22, P36)
	P40142-01-P23	EA	COVER/BACK - SOFA/BED - 67.5" (P23, P24, P40)
6	135138-03-P19	EA	SEAT - SOFA/BED - 67.5" (P19, P20, P33)
6	135138-03-P21	EA	SEAT - SOFA/BED - 67.5" (P21, P22, P36)
6	135138-03-P23	EA	SEAT - SOFA/BED - 67.5" (P21, P22, P36)
	P35318-03-P19	EA	COVER - SEAT - SOFA/BED - 66.5" (P19, P20, P33)
	P35318-03-P21	EA	COVER - SEAT - SOFA/BED - 66.5" (P21, P22, P36)
	P35318-03-P23	EA	COVER - SEAT - SOFA/BED - 66.5" (P21, P22, P36)
7	123381-06-P19	EA	ARMREST - LEFT HAND (P19, P20, P33)
7	123381-06-P21	EA	ARMREST - LEFT HAND (P21, P22, P36)
7	123381-06-P23	EA	ARMREST - LEFT HAND (P23, P24, P40)
	P23381-06-P19	EA	COVER/ARMREST - LEFT HAND (P19, P20, P33)
	P23381-06-P21	EA	COVER/ARMREST - LEFT HAND (P21, P22, P36)
	P23381-06-P23	EA	COVER/ARMREST - LEFT HAND (P23, P24, P40)
	123499-05-000	EA	SOFA/ARM - WOOD - LEFT HAND
8	101926-01-02A	EA	BRACKET - ZEE - 2" - BLACK - MOUNTS SOFA TO FLOOR
9	127335-10-000	EA	BRACKET - CANADIAN LATCH
10	127335-07-000	EA	LEG - SOFA/BED - 8"

CURTAIN & CUSHION GROUP (CONTINUED)
WINDOW TREATMENT

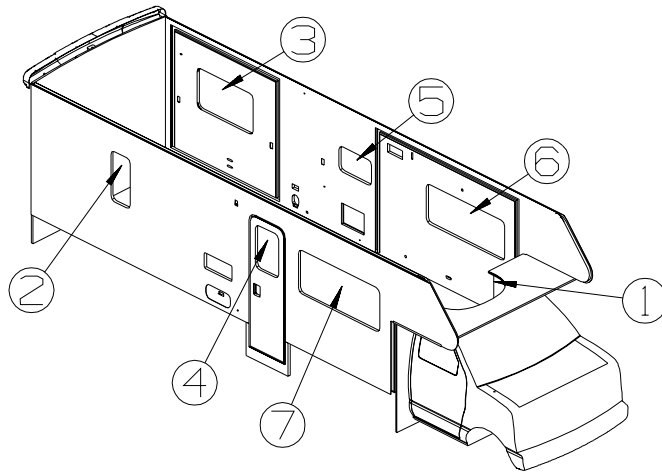

KEY	PART NUMBER	U/M	DESCRIPTION
1	076892-28-P19	EA	CURTAIN - CAB PRIVACY - 42" X 74"
2	142266-02-P19	EA	VALANCE - BEL AIR - 19" (P19, P20, P33)
2	142266-02-P21	EA	VALANCE - BEL AIR - 19" (P21, P22, P36)
2	142266-02-P23	EA	VALANCE - BEL AIR - 19" (P23, P24, P40)
2	136988-A6-P19	EA	LEG - RIGHT - 32" (P19, P20, P33)
2	136988-A6-P21	EA	LEG - RIGHT - 32" (P21, P22, P36)
2	136988-A6-P23	EA	LEG - RIGHT - 32" (P23, P24, P40)
2	136988-A7-P19	EA	LEG - LEFT - 32" (P19, P20, P33)
2	136988-A7-P21	EA	LEG - LEFT - 32" (P21, P22, P36)
2	136988-A7-P23	EA	LEG ASM-FLUSH,LT.32" (P23, P24, P40)
2	140789-23-P13	EA	BLIND - DAY/NIGHTER - 15.5" X 33" (P19, P20, P33, P21, P22, P36)
2	140789-23-N09	EA	BLIND - DAY/NIGHTER - 15.5" X 33" (P23, P24, P40)
3	142266-01-P19	EA	VALANCE - BEL AIR - 46" (P19, P20, P33)
3	142266-01-P21	EA	VALANCE - BEL AIR - 46" (P21, P22, P36)
3	142266-01-P23	EA	VALANCE - BEL AIR - 46" (P23, P24, P40)
3	136988-17-P19	EA	LEG - RIGHT - 26" (P19, P20, P33)
3	136988-17-P21	EA	LEG - RIGHT - 26" (P21, P22, P36)
3	136988-17-P23	EA	LEG - RIGHT - 26" (P23, P24, P40)
3	136988-18-P19	EA	LEG - LEFT - 26" (P19, P20, P33)
3	136988-18-P21	EA	LEG - LEFT - 26" (P21, P22, P36)
3	136988-18-P23	EA	LEG - LEFT - 26" (P23, P24, P40)
3	140789-02-N94	EA	BLIND - DAY/NIGHTER - 43" X 28" (P19, P20, P33, P21, P22, P36)
3	140789-02-N09	EA	BLIND - DAY/NIGHTER - 43" X 28" (P23, P24, P40)
4	121410-B4-P19	EA	VALANCE - MODERATE - 31.75" (P19, P20, P33)
4	121410-B4-P21	EA	VALANCE - MODERATE - 31.75" (P21, P22, P36)
4	121410-B4-P23	EA	VALANCE - MODERATE - 31.75" (P23, P24, P40)
4	084755-57-E07	EA	SHADE - PULL - 27.25"
5	109041-57-03A	EA	BLIND-MINI,26X17"
6	142259-02-P19	EA	LAMBREQUIN - PALM COURT - 61" (P19, P20, P33)
6	142259-02-P21	EA	LAMBREQUIN - PALM COURT - 61" (P21, P22, P36)
6	142259-02-P23	EA	LAMBREQUIN - PALM COURT - 61" (P23, P24, P40)
6	140789-08-N44	EA	BLIND - DAY/NIGHTER - 59" X 26.5" (P19, P20, P33, P21, P22, P36)
6	140789-08-N09	EA	BLIND - DAY/NIGHTER - 59" X 26.5" (P23, P24, P40)
7	142259-07-P19	EA	LAMBREQUIN - PALM COURT - 63" (P19, P20, P33)
7	142259-07-P21	EA	LAMBREQUIN - PALM COURT - 63" (P21, P22, P36)
7	142259-07-P23	EA	LAMBREQUIN - PALM COURT - 63" (P23, P24, P40)
7	140789-14-N72	EA	BLIND - DAY/NIGHTER - 61" X 28.5" (P19, P20, P33, P21, P22, P36)
7	140789-14-N09	EA	BLIND - DAY/NIGHTER - 61" X 28.5" (P23, P24, P40)

CURTAIN & CUSHION GROUP (CONTINUED) HARDWARE

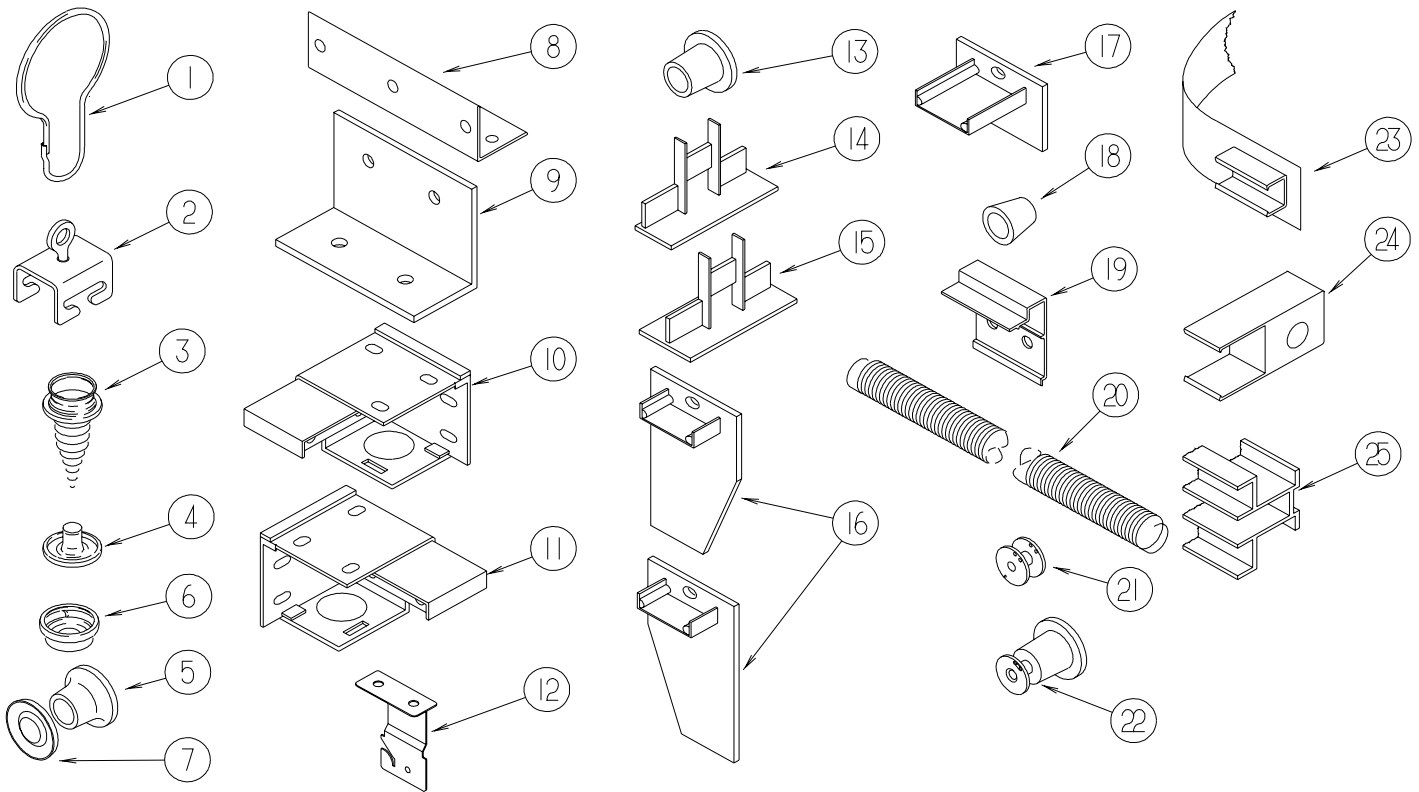

KEY	PART NUMBER	U/M	DESCRIPTION
1	009136-02-000	EA	HANGER - RING - PIN TYPE - CURTAIN - BRASS
2	009702-01-000	EA	END STOP - CURTAIN CARRIER - L - ROD
3	029130-01-000	EA	SCREW - SNAP STUD - #8-16 X 3/8" LONG
3	029130-03-000	EA	SCREW - SNAP STUD - #8-16 X 1" LONG
4	029155-01-000	EA	CAP - SNAP - 5/32" OUTSIDE DIAMETER OF PIN
5	029156-01-000	EA	SOCKET - SNAP - 9/16" O.D.
6	046867-02-000	EA	WASHER - HANDY BUTTON #3
7	046867-03-000	EA	GROMMET - HANDY BUTTON #3
8	075943-10-000	EA	BRACE - VALANCE - 20" - OFF WHITE
9	083125-07-000	EA	BRACE - ANGLE/COUCH - 2.5" - OFF WHITE
9	083125-08-000	EA	BRACE - WINDOW MOUNT - .75" - OFF WHITE
10	083170-01-000	EA	BRACKET/BLIND - LEFT SIDE WHEN FACING WINDOW - CLEAR
11	083170-02-000	EA	BRACKET/BLIND - RIGHT SIDE WHEN FACING WINDOW - CLEAR
12	084434-01-000	EA	BRACKET - MOUNTING - ROLLER SHADE - 1 3/8"
13	094896-02-000	EA	GROMMET - CORD/PLEATED BLIND - NYLON - GRAY
14	094907-02-000	EA	END CAP - PLEATED BLIND/TOP - RH/LH - GRAY PLASTIC
15	094907-04-000	EA	END CAP - PLEATED BLIND/BOTTOM - RH/LH
16	094907-05-000	EA	END CAP - PLEATED BLIND/BOTTOM - PULL TYPE - PLASTIC
17	094907-06-000	EA	END CAP - PLEATED BLIND/TOP
18	097564-99-000	EA	HANDLE - KNOB - E-Z LIFT SHADE - COLORLESS
19	097565-01-000	EA	BRACKET - MOUNTING - PLEATED BLIND
20	097591-01-000	EA	SPRING - EXTENSION - PLEATED BLIND
21	097592-01-000	EA	SPOOL - CORD - ELEVATED BLIND HOLDUP - SMALL - CLEAR
22	097592-02-000	EA	SPOOL - CORD - ELEVATED BLIND HOLDUP - LARGE - CLEAR
	097593-02-000	FT	CORD - BLIND - PLEATED - GRAY
	097593-06-000	FT	CORD - BLIND - PLEATED - PEWTER
	097593-10-000	FT	CORD - BLIND - PLEATED - VANILLA
23	101031-01-000	YD	TAPE/GLIDE - 4.25" SPACING
24	101033-02-000	EA	END CAP - LOW PROFILE TRACK - CLEAR
25	101033-08-000	EA	TRACK/WALL - 75" - FRT BUNK WINDOW 300 SERIES (MINNIE/SPIRIT)
25	101033-09-000	EA	TRACK/WALL - 32" - SIDE BUNK WINDOW 200 SERIES/300 SERIES (VISTA/SUNSTAR /MINNIE/SPIRIT)

CURTAIN & CUSHION GROUP (CONTINUED) HARDWARE (CONTINUED)

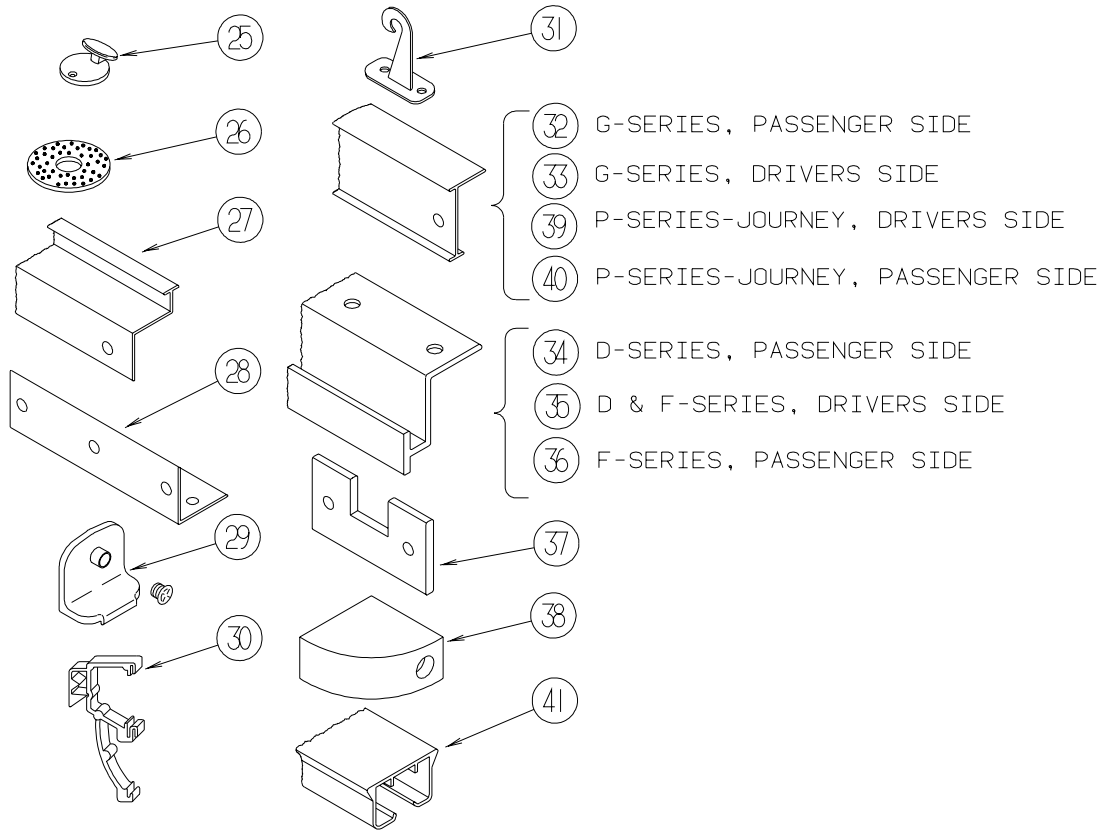

KEY	PART NUMBER	U/M	DESCRIPTION
25	102555-03-000	EA	CLEAT - BLIND CORD - MILKY WHITE - PLASTIC
26	103242-01-000	EA	VELCRO HOOK - BEIGE 7/8" ROUND W/CENTER HOLE
26	103242-02-000	EA	VELCRO HOOK - BLACK 7/8" ROUND W/CENTER HOLE
27	105450-14-01A	EA	TRACK - CURTAIN - 90" - OFF WHITE - FRONT BUNK PRIVACY 300 SERIES (MINNIE/SPIRITE)
27	105450-15-01A	EA	TRACK - CURTAIN - 82.3" - OFF WHITE - FRONT BUNK PRIVACY 200 SERIES (VISTA/SUNSTAR)
28	105648-01-02A	EA	BRACE - VALANCE - OFF/WHITE - 14"
29	106544-01-000	EA	PULL - SHADE/BRASS
	106544-01-001	EA	SCREW - SHADE/BRASS
30	109353-04-000	EA	CLIP - VALANCE SLAT MOUNTING - CLEAR PLASTIC
	109441-02-000	EA	SPACER/BRACKET - BLIND HOLD DOWN
31	109441-03-000	EA	BRACKET/HOOK - BLIND HOLD DOWN - CLOUDY
32	126456-03-04A	EA	TRACK/WRAPAROUND - PASSENGER - GLACIER - G SERIES (ADVENTURER/SUNCRUISER)
33	126456-04-04A	EA	TRACK/WRAPAROUND - DRIVER - GLACIER - G SERIES (ADVENTURER/SUNCRUISER)
34	127254-03-05A	EA	TRACK/WRAPAROUND - PASSENGER - GLACIER - D SERIES (SIGHTSEER/SUNOVA)
35	127254-04-05A	EA	TRACK/WRAP - DRIVER - GLACIER - D SERIES/F SERIES (SIGHTSEER/SUNOVA/BRAVE/SUNRISE)
36	127254-14-03A	EA	TRACK/WRAPAROUND - PASSENGER - GLACIER - F SERIES (BRAVE/SUNRISE)
37	130549-01-01A	EA	STOP - CURTAIN TRACK
38	132504-01-N92	EA	BRACKET - SHADE
39	133235-01-04A	EA	TRACK - CURTAIN/LEFT HAND - GLACIER - P SERIES (JOURNEY)
40	133236-01-04A	EA	TRACK - CURTAIN/RIGHT HAND - GLACIER - P SERIES (JOURNEY)
41	138460-01-02A	EA	TRACK/CURTAIN - PASSENGER - WHITE - Q SERIES (ULTIMATE ADVANTAGE/ULTIMATE FREEDOM)
	138460-02-02A	EA	TRACK/CURTAIN - DRIVER - WHITE - Q SERIES (ULTIMATE ADVANTAGE/ULTIMATE FREEDOM)
41	138460-03-02A	EA	TRACK/CURTAIN - PASSENGER - WHITE - P SERIES (JOURNEY DL/HORIZON)
	138460-04-02A	EA	TRACK/CURTAIN - DRIVER - WHITE - P SERIES (JOURNEY DL/HORIZON)
41	138460-05-02A	EA	TRACK/CURTAIN - PASSENGER - WHITE - L SERIES (CHIEFTAIN/SUNFLYER)
	138460-06-02A	EA	TRACK/CURTAIN - DRIVER - WHITE - L SERIES (CHIEFTAIN/SUNFLYER)
	141634-01-000	EA	BOBBIN-PLEATED,ADJUSTABLE

FROM: 06-17-02 THRU: 99-99-99

CURTAIN & CUSHION GROUP (CONTINUED)

ACCESSORIES

KEY	PART NUMBER	U/M	DESCRIPTION
	007021-01-000	EA	SEAT BELT - 2" X 90" - BLACK
	056271-01-000	EA	SEAT BELT - 2" X 102" - BLACK
	057534-03-000	EA	TIEBACK - CLEAR PLASTIC - 7.5"

CURTAIN & CUSHION GROUP (CONTINUED)
FABRICS

2003 FAMILY	P19/P20/P33	P21/P22/P36	P23/P24/P40
	CHAMBRAY BLUE	FERN GARDEN	SAND CASTLE
BUCKET	566H STYLE	566H STYLE	566H STYLE
	126883-N0-000	126883-K9-000	126883-H4-000
	*OPT. LEATH/COBRA SILVER	*OPT. LEATH/COBRA SILVER	*OPT. LEATH/COBRA SILVER
	079680-39-000 (BOXING)	079680-39-000 (BOXING)	079680-39-000 (BOXING)
DINETTE (PARTIAL WRAP)	CLUB	CLUB	CLUB
	126883-M9-000	126883-K8-000	126883-H3-000
DINETTE PADS & BOMERANGS	126883-N0-000	126883-K9-000	126883-H4-000
SOFA	696 /K.E. JACK KNIFE	696/K.E. JACK KNIFE	696/K.E. JACK KNIFE
	126883-M9-000	126883-K8-000	126883-H3-000
LOUNGE CHAIR	#465	#465	#465
	126883-N0-000	126883-K9-000	126883-H4-000
LOUNGE WINDOWS	PALM COURT LAMBREQUIN	PALM COURT LAMBREQUIN	PALM COURT LAMBREQUIN
	126883-NO-000/126883-M9-000	126883-K9-000/126883-K8-000	126883-H4-000/126883-H3-000
	UNDERLAY/OVERLAY	UNDERLAY/OVERLAY	UNDERLAY/OVERLAY
	BRAID - 139041-11-000	BRAID - 084415-F2-000	BRAID - 084415-F2-000
LOUNGE PILLOW	(2) 17" PALM COURT	(2) 17" PALM COURT	(2) 17" PALM COURT
	126883-N0-000/125883-M9-000	126883-K9-000/125883-K8-000	126883-H4-000/126883-H3-000
	CORD TRIM - 139041-14-000	CORD TRIM - 139041-15-000	CORD TRIM - 139041-15-000
FWA, BLACKOUT & PRIVACY CURTAIN	0732333-85-000	0732333-85-000	0732333-85-000
	CLOUDS MUSHROOM	CLOUDS MUSHROOM	CLOUDS MUSHROOM
OVERHEAD CURTS	137813-40-000	137813-21-000	137813-41-000
OVERHEAD BUNK	126883-N0-000	126883-K9-000	126883-H4-000
DAY/NIGHTER	094911-56/126883-50	094911-56/126883-50	094911-58/126883-50
	EGGSHELL/WT. DECO	EGGSHELL/WT. DECO	PUTTY/WT. DECO
GALLEY BLINDS	386 SNOCAP	386 SNOCAP	386 SNOCAP
CEILING MATERIA	113979-12-01A	113979-12-01A	113979-12-01A
	SOFT CLOUD - 102"	SOFT CLOUD - 102"	SOFT CLOUD - 102"

CURTAIN & CUSHION GROUP (CONTINUED)
FABRICS (CONTINUED)

2003 FAMILY	P19/P20/P33	P21/P22/P36	P23/P24/P40
	CHAMBRAY BLUE	FERN GARDEN	SAND CASTLE
BEDROOM WDO TREATMENT	BEL-AIR VALANCE 137813-31-000/137813-40-000	BEL-AIR VALANCE 137813-20-000/137813-21-000	BEL-AIR VALANCE 137813-22-000/137813-41-000
	UNDERLAY/OVERLAY LEGS - 137813-31-000	UNDERLAY/OVERLAY LEGS - 137813-20-000	UNDERLAY/OVERLAY LEGS - 137813-22-000
	CORD - 139041-11-000	CORD - 084415-F2-000	CORD - 084415-F2-000
BEDCOVER	BEDCAP W/½ N-G WELT 137813-31-000/137813-40-000	BEDCAP W/½ N-G WELT 137813-20-000/137813-21-000	BEDCAP W/½ N-G WELT 137813-22-000/137813-41-000
QUILT PATTERN	LARGE DIAMOND	LARGE DIAMOND	LARGE DIAMOND
SHAMS	SHAM W/2" GATH. BAND 137813-31-000/137813-40-000	SHAM W/2" GATH. BAND 137813-20-000/137813-21-000	SHAM W/2" GATH. BAND 137813-22-000/137813-41-000
	CORD - 139041-11-000	CORD - 084415-F2-000	CORD - 084415-F2-000
BED PILLOW	(2) 10X17" W/1½" GATH. BAND BODY - 137813-40-000	(2) 10X17" W/1½" GATH. BAND BODY - 137813-21-000	(2) 10X17" W/1½" GATH. BAND BODY - 137813-41-000
	GATH. BAND - 137813-31-000	GATH. BAND - 137813-20-000	GATH. BAND - 137813-22-000
	BRAID - 139041-11-000	BRAID - 084415-F2-000	BRAID - 084415-F2-000
HEADBOARD	CAMEO CTR - 137813-31-000	CAMEO STYLE CTR - 137813-20-000	CAMEO CTR - 137813-22-000
	SIDES - 137813-40-000	SIDES - 137813-21-000	SIDES - 137813-41-000
	CORD - 139041-11-000	CORD - 084415-F2-000	CORD - 084415-F2-000
BEDROOM VANITY CHAIR	REM 126883-N0-000	REM 126883-K9-000	REM 126883-H4-000
CARPET	139056-06-000 CRYSTAL LAKE	096060-F0-000 PALE SAGE	139056-04-000 SORREL
VINYL	079680-39-000 SMOKE GRAY	079680-39-000 SMOKE GRAY	079680-39-000 SMOKE GRAY
	103907-01-06A	103907-01-06A	103907-01-06A
	VW DARK GREY	VW DARK GREY	VW DARK GREY

DINETTE GROUP CABINETS

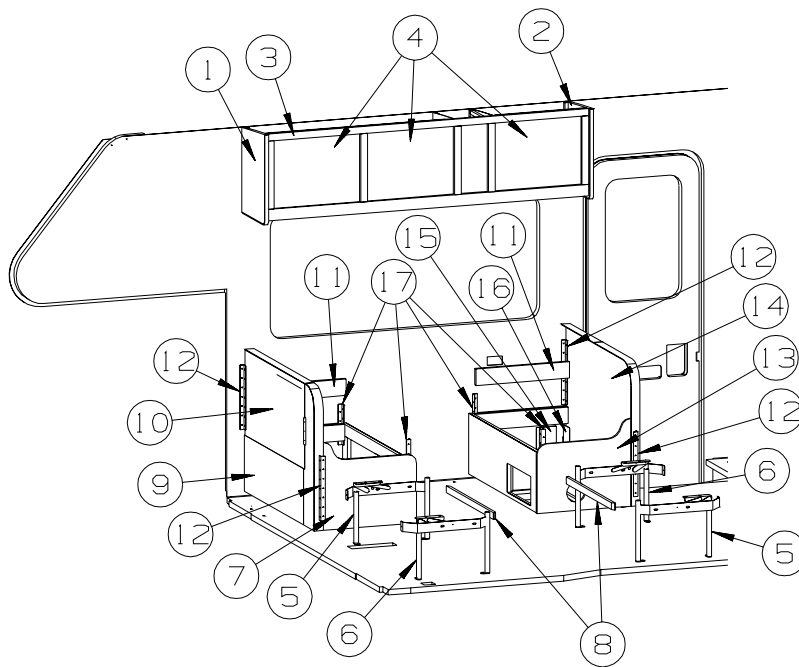

KEY	PART NUMBER	U/M	DESCRIPTION
1	141565-18-P13	EA	END CAP - OVERHEAD CABINET - PORTSMOUTH OAK
1	141565-18-P14	EA	END CAP - OVERHEAD CABINET - CONCERT CHERRY
1	141565-18-P33	EA	END CAP - OVERHEAD CABINET - WASHED MAPLE
2	141565-19-P13	EA	END CAP - OVERHEAD CABINET - PORTSMOUTH OAK
2	141565-19-P14	EA	END CAP - OVERHEAD CABINET - CONCERT CHERRY
2	141565-19-P33	EA	END CAP - OVERHEAD CABINET - WASHED MAPLE
3	141565-01-P19	EA	CABINET - OVERHEAD/FRONT - W/O DOORS/HARDWARE
3	141565-01-P20	EA	CABINET - OVERHEAD/FRONT - W/O DOORS/HARDWARE
3	141565-01-P21	EA	CABINET - OVERHEAD/FRONT - W/O DOORS/HARDWARE
3	141565-01-P22	EA	CABINET - OVERHEAD/FRONT - W/O DOORS/HARDWARE
3	141565-01-P23	EA	CABINET - OVERHEAD/FRONT - W/O DOORS/HARDWARE
3	141565-01-P24	EA	CABINET - OVERHEAD/FRONT - W/O DOORS/HARDWARE
3	141565-01-P33	EA	CABINET - OVERHEAD/FRONT - W/O DOORS/HARDWARE
3	141565-01-P36	EA	CABINET - OVERHEAD/FRONT - W/O DOORS/HARDWARE
3	141565-01-P40	EA	CABINET - OVERHEAD/FRONT - W/O DOORS/HARDWARE
4	141522-D0-P19	EA	DOOR - ARCHED/PENCIL EDGE/HORIZ - 15.7" X 20.4" - W/O HDW - PORTSMOUTH OAK
4	141522-D0-P20	EA	DOOR - ARCHED/PENCIL EDGE/HORIZ - 15.7" X 20.4" - W/O HDW - CONCERT CHERRY
4	141522-D0-P33	EA	DOOR - ARCHED/PENCIL EDGE/HORIZ - 15.7" X 20.4" - W/O HDW - WASHED MAPLE
5	142033-01-000	EA	BRACKET - DINETTE - RIGHT HAND
6	142033-02-000	EA	BRACKET - DINETTE - LEFT HAND
7	142046-09-P19	EA	CABINET/BASE - DINETTE/FLIP UP - LEFT HAND - W/O BACK
7	142046-09-P20	EA	CABINET/BASE - DINETTE/FLIP UP - LEFT HAND - W/O BACK
7	142046-09-P21	EA	CABINET/BASE - DINETTE/FLIP UP - LEFT HAND - W/O BACK
7	142046-09-P22	EA	CABINET/BASE - DINETTE/FLIP UP - LEFT HAND - W/O BACK
7	142046-09-P23	EA	CABINET/BASE - DINETTE/FLIP UP - LEFT HAND - W/O BACK
7	142046-09-P24	EA	CABINET/BASE - DINETTE/FLIP UP - LEFT HAND - W/O BACK
7	142046-09-P33	EA	CABINET/BASE - DINETTE/FLIP UP - LEFT HAND - W/O BACK
7	142046-09-P36	EA	CABINET/BASE - DINETTE/FLIP UP - LEFT HAND - W/O BACK
7	142046-09-P40	EA	CABINET/BASE - DINETTE/FLIP UP - LEFT HAND - W/O BACK
8	081295-01-G01	EA	SUPPORT - BED/DINETTE - 28" LONG - PORTSMOUTH OAK
8	081295-01-M52	EA	SUPPORT - BED/DINETTE - 28" LONG - CONCERT CHERRY
8	081295-01-H37	EA	SUPPORT - BED/DINETTE - 28" LONG - WASHED MAPLE
9	142046-72-P19	EA	PANEL/BACK - DINETTE SEAT/W/O HINGED PORTION - LEFT HAND
9	142046-72-P20	EA	PANEL/BACK - DINETTE SEAT/W/O HINGED PORTION - LEFT HAND
9	142046-72-P21	EA	PANEL/BACK - DINETTE SEAT/W/O HINGED PORTION - LEFT HAND
9	142046-72-P22	EA	PANEL/BACK - DINETTE SEAT/W/O HINGED PORTION - LEFT HAND
9	142046-72-P23	EA	PANEL/BACK - DINETTE SEAT/W/O HINGED PORTION - LEFT HAND
9	142046-72-P24	EA	PANEL/BACK - DINETTE SEAT/W/O HINGED PORTION - LEFT HAND
9	142046-72-P33	EA	PANEL/BACK - DINETTE SEAT/W/O HINGED PORTION - LEFT HAND
9	142046-72-P36	EA	PANEL/BACK - DINETTE SEAT/W/O HINGED PORTION - LEFT HAND
9	142046-72-P40	EA	PANEL/BACK - DINETTE SEAT/W/O HINGED PORTION - LEFT HAND

DINETTE GROUP (CONTINUED)
CABINETS (CONTINUED)

KEY	PART NUMBER	U/M	DESCRIPTION
10	142046-75-P13	EA	PANEL - BACK/HINGED - PORTSMOUTH OAK
10	142046-75-P14	EA	PANEL - BACK/HINGED - CONCERT CHERRY
10	142046-75-P14	EA	PANEL - BACK/HINGED - WASHED MAPLE
11	142046-62-P19	EA	SPACER/BASE - DINETTE SEAT (P19,P20,P19)
11	142046-62-P21	EA	SPACER/BASE - DINETTE SEAT (P21,P22,P21)
11	142046-62-P37	EA	SPACER/BASE - DINETTE SEAT (P23,P24,P40)
12	122021-02-02A	EA	ANGLE - W/HOLES - 13.7" LONG - OFF WHITE
13	142046-01-P19	EA	CABINET/BASE - DINETTE/FLIP UP - RIGHT HAND - W/O BACK (P19)
13	142046-01-P20	EA	CABINET/BASE - DINETTE/FLIP UP - RIGHT HAND - W/O BACK (P20)
13	142046-01-P21	EA	CABINET/BASE - DINETTE/FLIP UP - RIGHT HAND - W/O BACK (P21)
13	142046-01-R23	EA	CABINET/BASE - DINETTE/FLIP UP - RIGHT HAND - W/O BACK (P22)
13	142046-01-P37	EA	CABINET/BASE - DINETTE/FLIP UP - RIGHT HAND - W/O BACK (P23)
13	142046-01-P24	EA	CABINET/BASE - DINETTE/FLIP UP - RIGHT HAND - W/O BACK (P24)
13	142046-01-P33	EA	CABINET/BASE - DINETTE/FLIP UP - RIGHT HAND - W/O BACK (P33)
13	142046-01-R24	EA	CABINET/BASE - DINETTE/FLIP UP - RIGHT HAND - W/O BACK (P36)
13	142046-01-P40	EA	CABINET/BASE - DINETTE/FLIP UP - RIGHT HAND - W/O BACK (P40)
13	142046-04-P19	EA	CABINET/BASE - DINETTE/FLIP UP - RIGHT HAND - W/O BACK - HOME COMFORT PLUS PKG
13	142046-04-P20	EA	CABINET/BASE - DINETTE/FLIP UP - RIGHT HAND - W/O BACK - HOME COMFORT PLUS PKG
13	142046-04-P21	EA	CABINET/BASE - DINETTE/FLIP UP - RIGHT HAND - W/O BACK - HOME COMFORT PLUS PKG
13	142046-04-P22	EA	CABINET/BASE - DINETTE/FLIP UP - RIGHT HAND - W/O BACK - HOME COMFORT PLUS PKG
13	142046-04-P23	EA	CABINET/BASE - DINETTE/FLIP UP - RIGHT HAND - W/O BACK - HOME COMFORT PLUS PKG
13	142046-04-P24	EA	CABINET/BASE - DINETTE/FLIP UP - RIGHT HAND - W/O BACK - HOME COMFORT PLUS PKG
13	142046-04-P33	EA	CABINET/BASE - DINETTE/FLIP UP - RIGHT HAND - W/O BACK - HOME COMFORT PLUS PKG
13	142046-04-P36	EA	CABINET/BASE - DINETTE/FLIP UP - RIGHT HAND - W/O BACK - HOME COMFORT PLUS PKG
13	142046-04-P40	EA	CABINET/BASE - DINETTE/FLIP UP - RIGHT HAND - W/O BACK - HOME COMFORT PLUS PKG
14	142046-16-P19	EA	PANEL/BACK - DINETTE SEAT - RIGHT HAND
14	142046-16-P20	EA	PANEL/BACK - DINETTE SEAT - RIGHT HAND
14	142046-16-P21	EA	PANEL/BACK - DINETTE SEAT - RIGHT HAND
14	142046-16-P22	EA	PANEL/BACK - DINETTE SEAT - RIGHT HAND
14	142046-16-P23	EA	PANEL/BACK - DINETTE SEAT - RIGHT HAND
14	142046-16-P24	EA	PANEL/BACK - DINETTE SEAT - RIGHT HAND
14	142046-16-P33	EA	PANEL/BACK - DINETTE SEAT - RIGHT HAND
14	142046-16-P36	EA	PANEL/BACK - DINETTE SEAT - RIGHT HAND
14	142046-16-P40	EA	PANEL/BACK - DINETTE SEAT - RIGHT HAND
15	142046-35-P13	EA	PANEL/SWITCH SIDE (P19,P21,P23)
15	142046-35-P14	EA	PANEL/SWITCH SIDE (P20,P22,P24)
15	142046-35-P33	EA	PANEL/SWITCH SIDE (P33,P36,P40)
16	142046-37-P13	EA	PANEL/SWITCH FACE (P19,P21,P23)
16	142046-37-P14	EA	PANEL/SWITCH FACE (P20,P22,P24)
16	142046-37-P33	EA	PANEL/SWITCH FACE (P33,P36,P40)
17	122021-01-02A	EA	ANGLE - W/HOLES - 8.6" LONG - OFF WHITE

DINETTE GROUP (CONTINUED)

TABLE

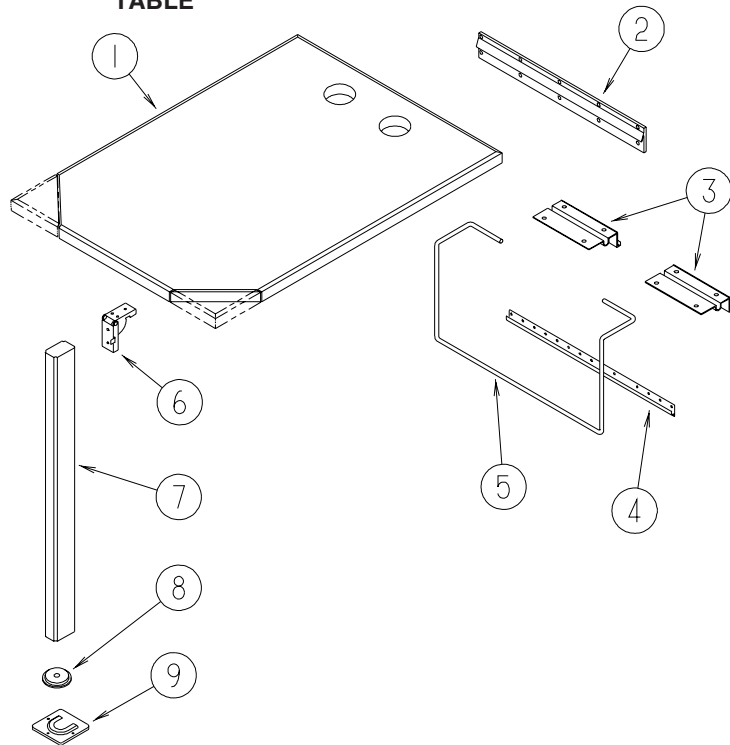

KEY	PART NUMBER	U/M	DESCRIPTION
1	132034-18-P13	EA	TABLE TOP ONLY - 37.7" X 29.2" (P19) - 427P
1	132034-18-P14	EA	TABLE TOP ONLY - 37.7" X 29.2" (P20) - 427P
1	132034-18-P15	EA	TABLE TOP ONLY - 37.7" X 29.2" (P21, P23) - 427P
1	132034-18-P16	EA	TABLE TOP ONLY - 37.7" X 29.2" (P22, P24) - 427P
1	132034-18-P33	EA	TABLE TOP ONLY - 37.7" X 29.2" (P33) - 427P
1	132034-18-P36	EA	TABLE TOP ONLY - 37.7" X 29.2" (P36, P40) - 427P
1	132034-09-P13	EA	TABLE TOP ONLY - 27.8" X 41.6" (P19) - 430V
1	132034-09-P14	EA	TABLE TOP ONLY - 27.8" X 41.6" (P20) - 430V
1	132034-09-P15	EA	TABLE TOP ONLY - 27.8" X 41.6" (P21, P23) - 430V
1	132034-09-P16	EA	TABLE TOP ONLY - 27.8" X 41.6" (P22, P24) - 430V
1	132034-09-P33	EA	TABLE TOP ONLY - 27.8" X 41.6" (P33) - 430V
1	132034-09-P36	EA	TABLE TOP ONLY - 27.8" X 41.6" (P36,P40) - 430V
1	132034-11-P13	EA	TABLE TOP ONLY - 41.5" X 24" (P19) -431C
1	132034-11-P14	EA	TABLE TOP ONLY - 41.5" X 24" (P20) -431C
1	132034-11-P31	EA	TABLE TOP ONLY - 41.5" X 24" (P21, P23) -431C
1	132034-11-P16	EA	TABLE TOP ONLY - 41.5" X 24" (P22, P24) -431C
1	132034-11-M15	EA	TABLE TOP ONLY - 41.5" X 24" (P33) -431C
1	132034-11-P36	EA	TABLE TOP ONLY - 41.5" X 24" (P36, P40) -431C
2	053200-13-000	EA	SUPPORT - TABLE - 18.5"
			FROM: 00-00-00 THRU: 11-10-02
2	140921-02-01A	EA	SUPPORT - TABLE - 18.5" - OFF WHITE
			FROM: 11-11-02 THRU: 99-99-99
3	088410-02-000	EA	BRACKET - LIFT - TABLE MOUNTED
			FROM: 00-00-00 THRU: 11-10-02
3	140921-03-01A	EA	HANGER - TABLE - W/VINYL - OFF WHITE
			FROM: 11-11-02 THRU: 99-99-99
4	024281-15-000	EA	BRACKET/TABLE - LIFT ROD/LOWER WALL MOUNTED - 17.1"
5	024275-13-000	EA	ROD - TABLE LIFT - OFF/WHITE
6	093550-01-000	EA	BRACKET - HINGE - MOUNTS TO LEG & TABLE TOP - 1.7" X 2.6"
7	092707-04-10A	EA	LEG - TABLE - W/O HARDWARE - 27" - PORTSMOUTH OAK II
7	092707-04-04A	EA	LEG - TABLE - W/O HARDWARE - 27" - CHERRY
7	092707-04-08A	EA	LEG - TABLE - W/O HARDWARE - 27" - WASHED MAPLE
8	092593-01-05A	EA	CATCH - TABLE LEG - OFF/WHITE
			FROM: 00-00-00 THRU: 12-04-02
8	143798-02-01A	EA	CATCH - TABLE LEG - BRIGHT WHITE
			FROM: 12-05-02 THRU: 99-99-99
9	049493-12-000	EA	CATCH - TABLE LEG/FLOOR MOUNTED - OFF WHITE
			FROM: 00-00-00 THRU: 12-04-02
9	143798-01-01A	EA	CATCH - FLOOR TO TABLE LEG - BRIGHT WHITE
			FROM: 12-05-02 THRU: 99-99-99

DRIVERS COMPARTMENT GROUP FRONT INTERIOR

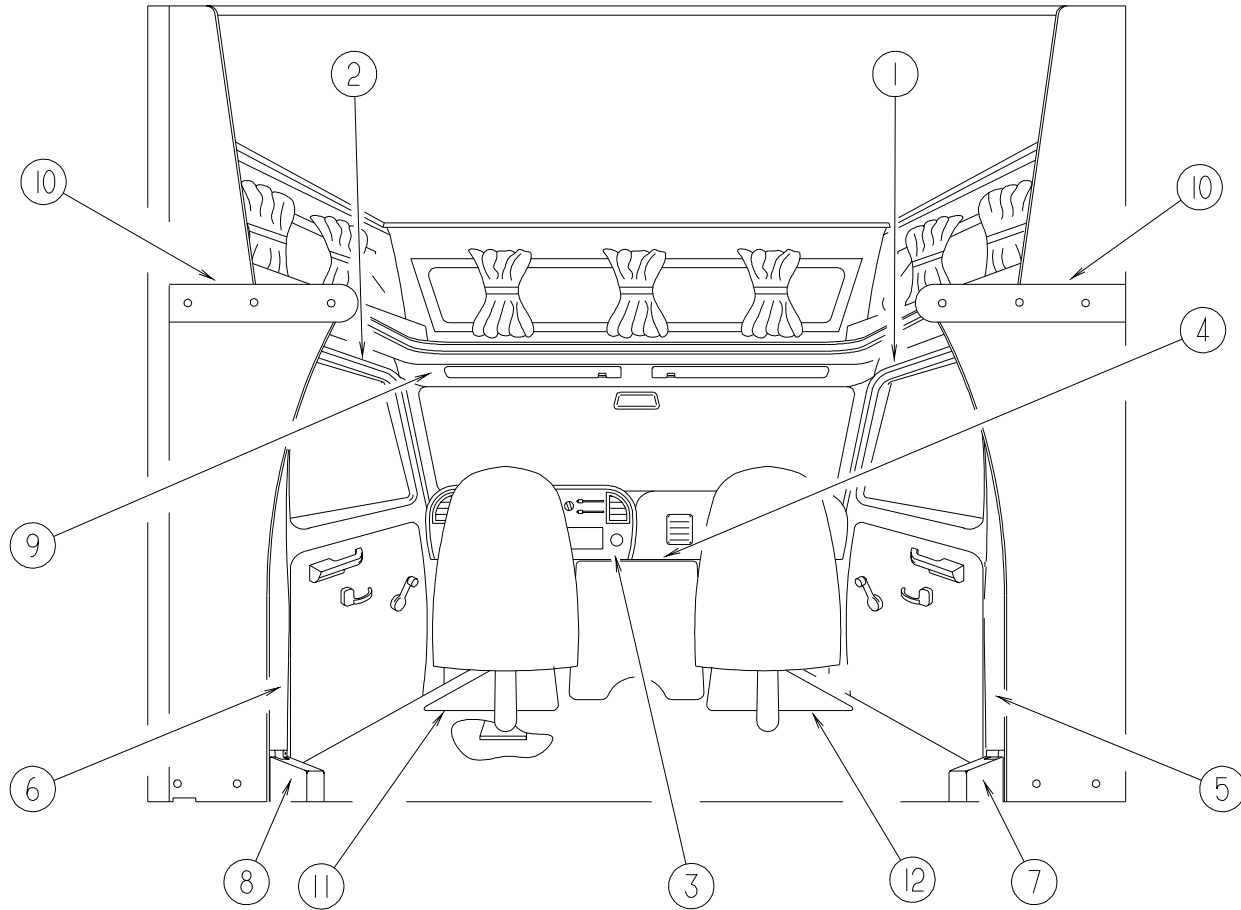

KEY	PART NUMBER	U/M	DESCRIPTION
1	106447-05-N09	EA	TRIM - CAB DOOR - UPPER/RIGHT HAND FROM: 00-00-00 THRU: 10-09-02
1	106447-09-P13	EA	TRIM - CAB DOOR - UPPER/RIGHT HAND FROM: 10-10-02 THRU: 99-99-99
2	106447-06-N09	EA	TRIM - CAB DOOR - UPPER/LEFT HAND FROM: 00-00-00 THRU: 10-09-02
2	106447-10-P13	EA	TRIM - CAB DOOR - UPPER/LEFT HAND FROM: 10-10-02 THRU: 99-99-99
3	136524-03-01A	EA	APPLIQUE - BEZEL - MOTOR COVER - WOOD GRAINED
4	136524-04-01A	EA	APPLIQUE - BEZEL - DASH - WOOD GRAINED
5	125031-01-H04	EA	TRIM - CAB - B-PILLAR - PASSENGER SIDE
6	125031-02-H04	EA	TRIM - CAB - B-PILLAR - DRIVER SIDE
7	106431-01-02A	EA	COVER - SEATBELT RECOIL - DRIVER SIDE - VW GRAY
8	106431-02-02A	EA	COVER - SEATBELT RECOIL - PASSENGER SIDE - VW GRAY
9	106448-02-M07	EA	HEADLINER - W/VINYL FROM: 00-00-00 THRU: 07-28-02
9	106448-04-P13	EA	HEADLINER - W/VINYL FROM: 07-29-02 THRU: 10-09-02
9	106448-06-P13	EA	HEADLINER - W/VINYL FROM: 10-10-02 THRU: 99-99-99
10	142374-01-P13	EA	CAP - SLEEPERBOARD - PORTSMOUTH OAK
10	142374-01-P14	EA	CAP - SLEEPERBOARD - CONCERT CHERRY
10	142374-01-P33	EA	CAP - SLEEPERBOARD - WASHED MAPLE
11	125780-04-000	EA	MAT - FLOOR - FRONT DRIVER - "1" - FORD
12	125780-03-000	EA	MAT - FLOOR - FRONT PASSENGER - "1" - FORD

DRIVERS COMPARTMENT GROUP (CONTINUED)

CABINETS

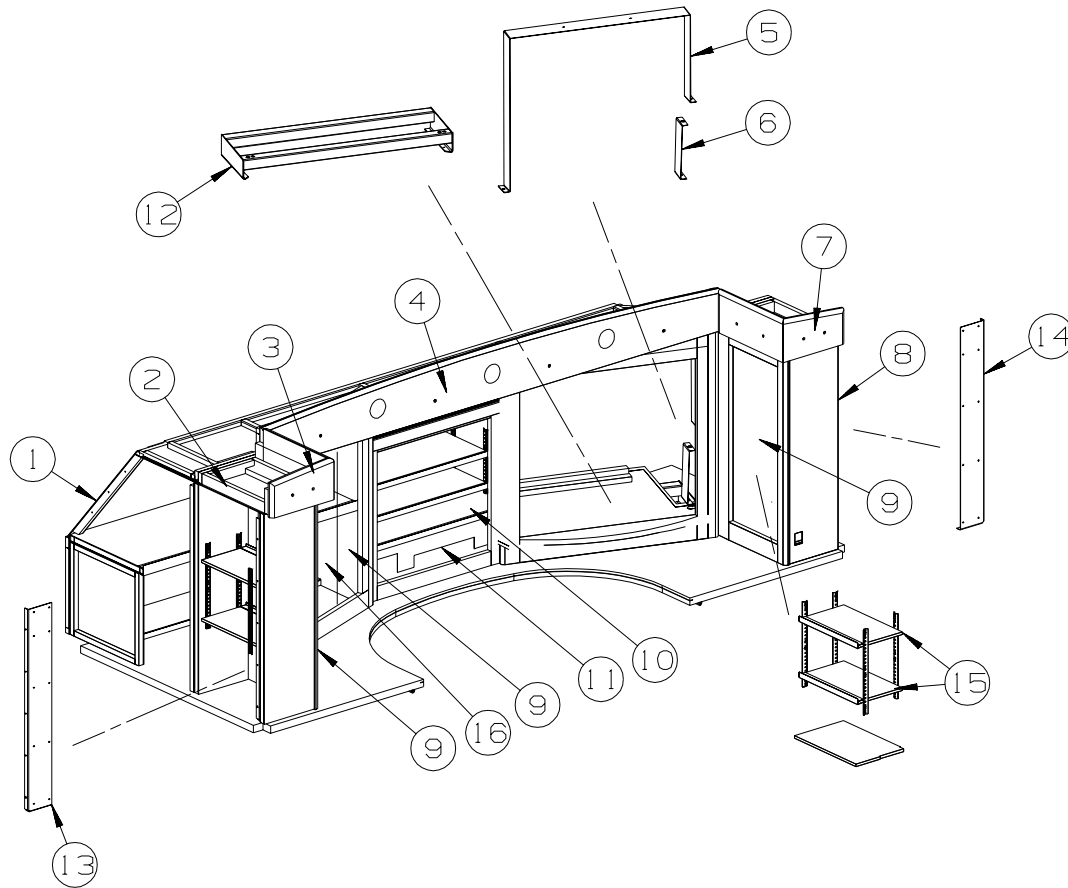

KEY	PART NUMBER	U/M	DESCRIPTION
1	142076-01-P07	EA	CABINET - ENTERTAINMENT CENTER - LEFT HAND - W/O DOORS/HDW - PORTSMOUTH OAK
1	142076-01-P14	EA	CABINET - ENTERTAINMENT CENTER - LEFT HAND - W/O DOORS/HDW - CONCERT CHERRY
1	142076-01-P33	EA	CABINET - ENTERTAINMENT CENTER - LEFT HAND - W/O DOORS/HDW - WASHED MAPLE
2	142079-01-P13	EA	CABINET - ENTERTAINMENT CENTER/TOP - W/O DOORS/HARDWARE
3	142078-07-P13	EA	TRIM/FACE - ENTERTAINMENT CENTER - PORTSMOUTH OAK
3	142078-07-P14	EA	TRIM/FACE - ENTERTAINMENT CENTER - CONCERT CHERRY
3	142078-07-P33	EA	TRIM/FACE - ENTERTAINMENT CENTER - WASHED MAPLE
4	142078-03-P13	EA	TRIM/FACE - ENTERTAINMENT CENTER - PORTSMOUTH OAK - DELUXE ENTERTAINMENT
4	142078-03-P14	EA	TRIM/FACE - ENTERTAINMENT CENTER - CONCERT CHERRY - DELUXE ENTERTAINMENT
4	142078-03-P33	EA	TRIM/FACE - ENTERTAINMENT CENTER - WASHED MAPLE - DELUXE ENTERTAINMENT
4	142078-06-P13	EA	TRIM/FACE - ENTERTAINMENT CENTER - PORTSMOUTH OAK
4	142078-06-P14	EA	TRIM/FACE - ENTERTAINMENT CENTER - CONCERT CHERRY
4	142078-06-P33	EA	TRIM/FACE - ENTERTAINMENT CENTER - WASHED MAPLE
5	136269-05-02B	EA	BRACKET/TIEDOWN - TV - E-COATED - DELUXE ENTERTAINMENT
			FROM: 00-00-00 THRU: 09-03-02
5	144148-01-02B	EA	BRACKET - TV TIEDOWN - E-COATED
			FROM: 09-04-02 THRU: 99-99-99
5	136269-06-02B	EA	BRACKET/TIEDOWN - TV - E-COATED
			FROM: 00-00-00 THRU: 09-03-02
5	144148-02-02B	EA	BRACKET/TIEDOWN - TV - E-COATED
			FROM: 09-04-02 THRU: 99-99-99
6	136269-08-02B	EA	BRACKET/TIEDOWN - TV - E-COATED
7	142078-08-P13	EA	TRIM/FACE - ENTERTAINMENT CENTER - PORTSMOUTH OAK
7	142078-08-P14	EA	TRIM/FACE - ENTERTAINMENT CENTER - CONCERT CHERRY
7	142078-08-P33	EA	TRIM/FACE - ENTERTAINMENT CENTER - WASHED MAPLE

DRIVERS COMPARTMENT GROUP (CONTINUED)
CABINETS (CONTINUED)

KEY	PART NUMBER	U/M	DESCRIPTION
8	142077-01-P13	EA	CABINET - ENTR CTR/RT HAND - W/O DOORS/HDW - PORTSMOUTH OAK - DELUXE ENTERTAINMENT FROM: 00-00-00 THRU: 01-19-02
8	142077-05-P13	EA	CABINET - ENTR CTR/RT HAND - W/O DOORS/HDW - PORTSMOUTH OAK - DELUXE ENTERTAINMENT FROM: 01-20-03 THRU: 99-99-99
8	142077-01-P14	EA	CABINET - ENTR CTR/RT HAND - W/O DOORS/HDW - CONCERT CHERRY - DELUXE ENTERTAINMENT FROM: 00-00-00 THRU: 01-19-02
8	142077-05-P14	EA	CABINET - ENTR CTR/RT HAND - W/O DOORS/HDW - CONCERT CHERRY - DELUXE ENTERTAINMENT FROM: 01-20-03 THRU: 99-99-99
8	142077-01-P33	EA	CABINET - ENTR CTR/RT HAND - W/O DOORS/HDW - WASHED MAPLE - DELUXE ENTERTAINMENT FROM: 00-00-00 THRU: 01-19-02
8	142077-05-P33	EA	CABINET - ENTR CTR/RT HAND - W/O DOORS/HDW - WASHED MAPLE - DELUXE ENTERTAINMENT FROM: 01-20-03 THRU: 99-99-99
8	142077-02-P07	EA	CABINET - ENTERTAINMENT CENTER/RIGHT HAND - W/O DOORS/HDW - PORTSMOUTH OAK
8	142077-02-P14	EA	CABINET - ENTERTAINMENT CENTER/RIGHT HAND - W/O DOORS/HDW - CONCERT CHERRY
8	142077-02-P33	EA	CABINET - ENTERTAINMENT CENTER/RIGHT HAND - W/O DOORS/HDW - WASHED MAPLE
	136268-03-03B	EA	BRACKET - WINDWALL - OFF WHITE
9	134868-37-P19	EA	DOOR - RAIL/ARCHED TOP - 15.7" X 25.2" - W/O HARDWARE - PORTSMOUTH OAK
9	134868-37-P20	EA	DOOR - RAIL/ARCHED TOP - 15.7" X 25.2" - W/O HARDWARE - CONCERT CHERRY
9	134868-37-P33	EA	DOOR - RAIL/ARCHED TOP - 15.7" X 25.2" - W/O HARDWARE - WASHED MAPLE
10	100708-30-000	EA	DOOR - GLASS - F/TV CABINET
11	142200-01-P07	EA	PANEL - VINYL COVERED
11	142200-02-P07	EA	PANEL - VINYL COVERED - INVERTER-DC/AC - 130 WATT
11	142200-03-P07	EA	PANEL - VINYL COVERED - INVERTER-DC/AC - 300 WATT
12	142119-01-02B	EA	BRACKET - ENTERTAINMENT CENTER - E-COATED
13	136268-04-03B	EA	BRACKET - WINGWALL - OFF WHITE
14	136268-03-03B	EA	BRACKET - WINGWALL - OFF WHITE
15	142077-17-P07	EA	SHELF - W/PLASTIC EDGE TRIM - PORTSMOUTH OAK
15	142077-17-P14	EA	SHELF - W/PLASTIC EDGE TRIM - CONCERT CHERRY
15	142077-17-P33	EA	SHELF - W/PLASTIC EDGE TRIM - WASHED MAPLE
16	134868-38-P19	EA	DOOR - RAIL/ARCHED TOP - 15.7" X 25.2" - W/O HARDWARE - PORTSMOUTH OAK
16	134868-38-P20	EA	DOOR - RAIL/ARCHED TOP - 15.7" X 25.2" - W/O HARDWARE - CONCERT CHERRY
16	134868-38-P33	EA	DOOR - RAIL/ARCHED TOP - 15.7" X 25.2" - W/O HARDWARE - WASHED MAPLE

ELECTRICAL GROUP

12V BODY WIRING

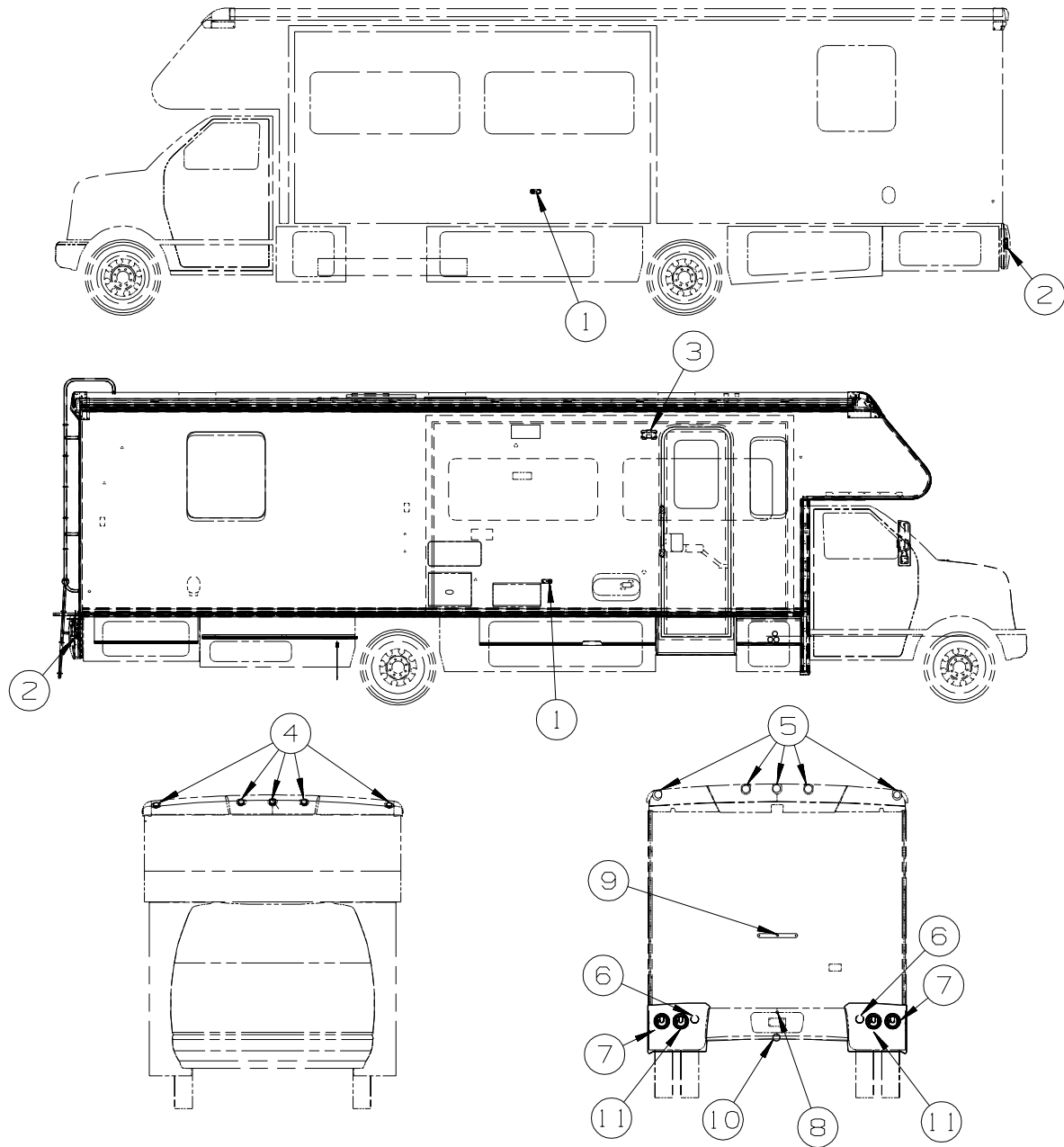

KEY	PART NUMBER	U/M DESCRIPTION
1	111102-02-000	EA LENS - AMBER - MARKER LAMP
	111102-01-000	EA BASE - MARKER LAMP
	036196-01-000	EA BULB - 12V - #194 - .27 AMP - BAYONETTE
2	111102-03-000	EA LENS - RED - MARKER LAMP
	111102-01-000	EA BASE - MARKER LAMP
	036196-01-000	EA BULB - 12V - #194 - .27 AMP - BAYONETTE
3*	097917-01-06A	EA LIGHT - PORCH - BRIGHT WHITE
	008215-01-000	EA BULB - 12 VOLT - #1003 - .94 AMP
3*	008089-02-000	EA LIGHT - PORCH - RECESSED - CANADIAN
	008214-01-000	EA BULB - 12 VOLT - #67 - .59 AMP
4	138996-01-000	EA LAMP - CLEARANCE - AMBER
	138996-03-000	EA BRACKET - CLEARANCE LIGHT
5	138996-02-000	EA LAMP - CLEARANCE - RED
	138996-03-000	EA BRACKET - CLEARANCE LIGHT
6	141514-01-000	EA REFLECTOR - ROUND/RED
7	138441-01-000	EA LAMP - BRAKE/TAIL/TURN - 4 1/2" ROUND
	126403-01-000	EA CONNECTOR - 2 CIRCUIT
	126403-02-000	EA CONNECTOR - 3 CIRCUIT
8	087201-01-000	EA LIGHT - HALF ROUND - 1" X 1.7" - PLASTIC - BLACK OR WHITE
9	136916-01-000	EA LIGHT - CENTER BRAKE - L.E.D.

ELECTRICAL GROUP (CONTINUED)
12V BODY WIRING (CONTINUED)

KEY	PART NUMBER	U/M	DESCRIPTION
10	113589-01-000	EA	CONNECTOR - PLUG - TRAILER
10	113589-02-000	EA	CONNECTOR - SOCKET - TRAILER
11	138441-02-000	EA	LAMP - BACKUP - 4 1/2" ROUND
	126403-01-000	EA	CONNECTOR - 2 CIRCUIT
	126403-02-000	EA	CONNECTOR - 3 CIRCUIT

***COMPONENT PARTS LISTED LATER IN THIS GROUP**

ELECTRICAL GROUP (CONTINUED)

12V BODY WIRING (CONTINUED)

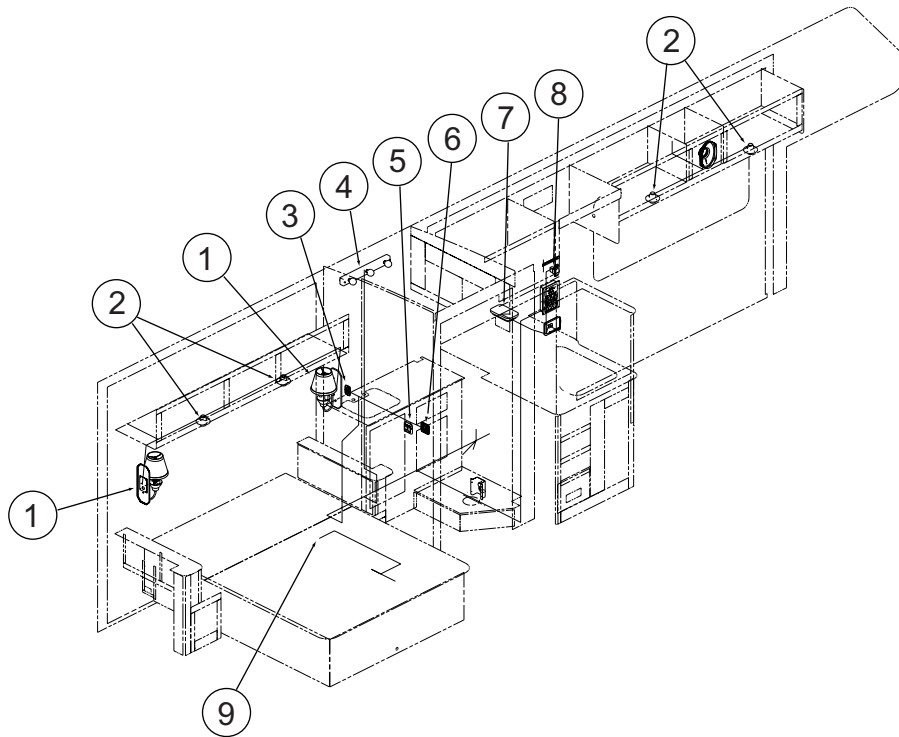

KEY	PART NUMBER	U/M	DESCRIPTION
1	119258-27-01A	EA	LAMP - WALL - BRASS - UL/CSA
1	119257-14-01A	EA	SHADE - LAMP - WAFFLE WEAVE FABRIC
1	067479-01-000	EA	BULB - 12V - #1076 - 1.80 AMP
2	132427-01-01A	EA	LIGHT - READING - SWIVEL/ROUND - BRASS
	123917-01-000	EA	BULB - 12V - HALOGEN SPOT
3	135740-01-02A	EA	SWITCH - ROCKER - SPST - ON/OFF - WHITE
3	135741-01-02A	EA	SWITCH - BASE - SINGLE - WHITE
3	135742-08-01A	EA	BEZEL - SWITCH - MAKEUP - WHITE
4	138116-01-01A	EA	LIGHT/MAKE UP - 3 BULB - CURVED - W/O BULB - BRASS
	123918-01-000	EA	BULB - 12V - MAKEUP WHITE
5	135740-01-02A	EA	SWITCH - ROCKER - SPST - ON/OFF - WHITE - CEILING
5	135740-02-02A	EA	SWITCH - ROCKER - SPDT - ON/ON - WHITE - AISLE
5	135741-02-02A	EA	SWITCH - BASE - DOUBLE - WHITE
5	135742-13-01A	EA	BEZEL - SWITCH - CEILING/AISLE - WHITE
6	135740-01-02A	EA	SWITCH - ROCKER - SPST - ON/OFF - WHITE
6	135741-02-02A	EA	SWITCH - BASE - DOUBLE - WHITE
6	135742-15-01A	EA	BEZEL - SWITCH - CEILING/SHOWER - WHITE
7*	137417-02-01A	EA	LIGHT - DOME - SINGLE - W/SWITCH/OPTIC LENS - WHITE
8	081994-10-000	EA	PLATE/SWITCH - SLIDEOUT
8	108357-06-000	EA	SWITCH - ROCKER - DPDT - MOM/OFF/MOM - 6 TERMINAL
8	108356-02-01A	EA	COVER/ACTUATOR SWITCH - 2 ROWS DIMPLES- CONTURA II - BLACK
8	108355-01-000	EA	HOUSING - SWITCH
9	108357-15-000	EA	SWITCH - ROCKER - DPDT - ON/NONE/ON - W/LIGHT W/O COVER
9	108356-04-01A	EA	COVER/ACTUATOR SWITCH - 2 ROWS DIMPLES W/LENS-CONTURA-BLK
9	108355-01-000	EA	HOUSING - SWITCH

*COMPONENT PARTS LISTED LATER IN THIS GROUP

ELECTRICAL GROUP (CONTINUED)

12V BODY WIRING (CONTINUED)

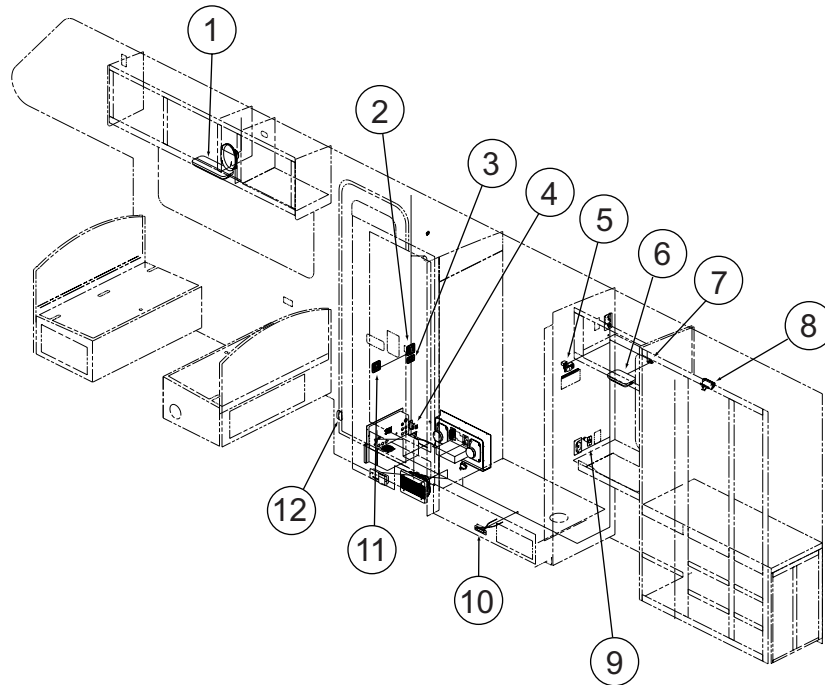

KEY	PART NUMBER	U/M	DESCRIPTION
1*	137417-05-01A	EA	LIGHT - DOME - DOUBLE - W/SWITCH/OPTIC LENS - WHITE
2	135740-01-01A	EA	SWITCH - ROCKER - SPST - ON/OFF - BROWN - PORCH & CEILING
2	135741-02-01A	EA	SWITCH - BASE - DOUBLE - BROWN
2	135742-19-02A	EA	BEZEL - SWITCH - PORCH/CEILING - BROWN
3	135740-01-01A	EA	SWITCH - ROCKER - SPST - ON/OFF - BROWN - STEP
3	135741-01-01A	EA	SWITCH - BASE - SINGLE - BROWN
3	135742-11-02A	EA	BEZEL - SWITCH - STEP - BROWN
4	098351-07-01A	EA	PLATE/SWITCH - 1 GANG - POLISHED BRASS - GENERATOR
4	108357-06-000	EA	SWITCH - ROCKER - DPDT - MOM/OFF/MOM - 6 TERMINAL
4	108356-11-01A	EA	COVER/ACTUATOR SWITCH - 3 GROOVES - AUX BATT - BLACK
4	108355-01-000	EA	HOUSING - SWITCH
5	081994-10-000	EA	PLATE/SWITCH - SLIDEOUT
5	108357-06-000	EA	SWITCH - ROCKER - DPDT - MOM/OFF/MOM - 6 TERMINAL
5	108356-02-01A	EA	COVER/ACTUATOR SWITCH - 2 ROWS DIMPLES- CONTURA II - BLACK
5	108355-01-000	EA	HOUSING - SWITCH
6*	137417-02-01A	EA	LIGHT - DOME - SINGLE - W/SWITCH/OPTIC LENS - WHITE
7	056264-01-000	EA	SWITCH - LEAF ACTUATOR
8*	087694-01-000	EA	LIGHT - WARDROBE/CLOSET - W/SWITCH
9	111414-01-000	EA	RECEPTACLE/SOCKET - 12 VOLT
9	111386-01-04B	EA	PLATE - RECEPTACLE - 12 VOLT - BLACK
10	061424-01-000	EA	LIGHT - AISLE - 12 VOLT - RECTANGULAR
11	135740-01-01A	EA	SWITCH - ROCKER - SPST - ON/OFF - BROWN - CEILING
11	135740-02-01A	EA	SWITCH - ROCKER - SPDT - ON/ON - BROWN - AISLE
11	135741-02-01A	EA	SWITCH - BASE - DOUBLE - BROWN
11	135742-13-02A	EA	BEZEL - SWITCH - CEILING/AISLE - BROWN
12	116995-02-000	EA	SWITCH/MAGNET - ELECTRIC STEP - BLACK/WHITE-CLOSED CIRCUIT

*COMPONENT PARTS LISTED LATER IN THIS GROUP

ELECTRICAL GROUP (CONTINUED)
12V BODY WIRING (CONTINUED)

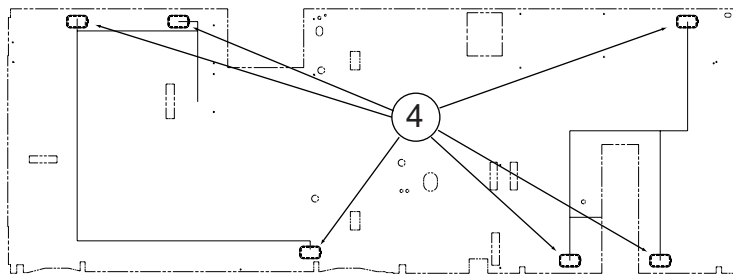
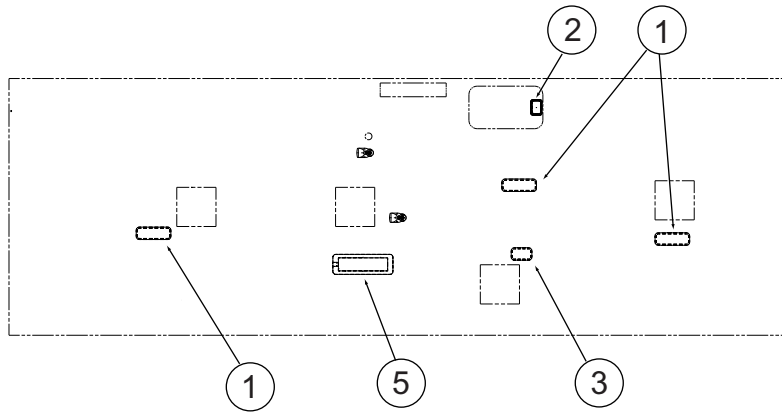

KEY	PART NUMBER	U/M	DESCRIPTION
1*	137417-06-01A	EA	LIGHT - DOME - DOUBLE - W/FROSTED LENS - W/O SWITCH-WHITE
2*	121935-01-01A	EA	LIGHT - DOME - SHOWER
3*	137417-03-01A	EA	LIGHT - DOME - SINGLE - W/FROSTED LENS - W/O SWITCH-WHITE
4*	137417-01-01A	EA	LIGHT - DOME - SINGLE - W/SWITCH/FROSTED LENS - WHITE
5	130338-01-01A	EA	LIGHT - FLUORESCENT 18" - THIN LITE
5	091937-03-000	EA	BULB - FLUORESCENT LIGHT - 12 VOLT

***COMPONENT PARTS LISTED LATER IN THIS GROUP**

ELECTRICAL GROUP (CONTINUED)
FRONT END WIRING

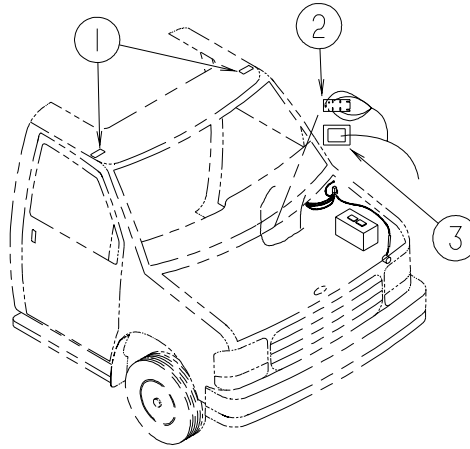

KEY	PART NUMBER	U/M	DESCRIPTION
1	112643-01-000	EA	LIGHT - SINGLE - SWIVEL
	112642-01-06A	EA	TRIM RING - SINGLE LIGHT - BLACK
2*	087202-01-000	EA	SWITCH - 4 POSITION - W/KNOB/BEZEL - 5 TERMINAL
3	108357-09-000	EA	SWITCH - ROCKER - SPDT - ON/NONE/MOM - 3 TERMINAL
	108356-07-01A	EA	COVER/ACTUATOR SWITCH - 2 ROWS DIMPLES - AUX START - BLACK
	081994-07-000	EA	PLATE - SWITCH - "AUXILIARY START"

*COMPONENT PARTS LISTED LATER IN THIS GROUP

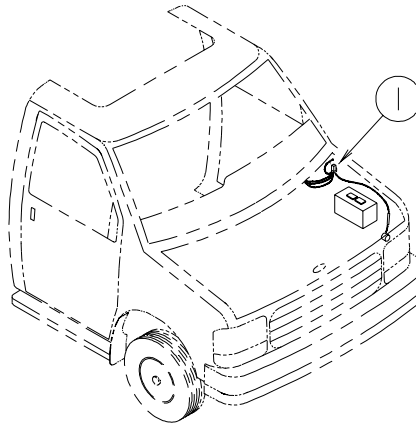

KEY	PART NUMBER	U/M	DESCRIPTION
1	100138-01-000	EA	MODULE - DAYTIME/RUNNING LIGHT - HAMSAR DRL #H8005B

ELECTRICAL GROUP (CONTINUED)
COMPONENT PARTS FOR LIGHTS & SWITCHES

008089-01-000

KEY	PART NUMBER	U/M	DESCRIPTION	VENDOR NO.
	008089-01-700	EA	LENS/PORCH LIGHT RECESSED	DECO

087202-01-000

KEY	PART NUMBER	U/M	DESCRIPTION	VENDOR NO.
	087202-01-701	EA	KNOB-SWITCH, ROTARY	062-0104
	087202-01-702	EA	PLATE F/ROTARY SWITCH	062-0105

087694-01-000

KEY	PART NUMBER	U/M	DESCRIPTION	VENDOR NO.
	087694-01-700	EA	BULB	GE561

097917-01-06A

KEY	PART NUMBER	U/M	DESCRIPTION	VENDOR NO.
	097917-01-700	EA	LENS-LIGHT, CLEAR	30-78-021

121935-01-01A

KEY	PART NUMBER	U/M	DESCRIPTION	VENDOR NO.
	121935-01-700	EA	LENS ONLY	809511

137417-01-01A

KEY	PART NUMBER	U/M	DESCRIPTION	VENDOR NO.
	137417-01-700	EA	LENS - SINGLE (FROSTED)	810868

137417-02-01A

KEY	PART NUMBER	U/M	DESCRIPTION	VENDOR NO.
	137417-02-700	EA	LENS - SINGLE OPTIC	810844

137417-03-01A

KEY	PART NUMBER	U/M	DESCRIPTION	VENDOR NO.
	137417-01-700	EA	LENS - SINGLE (FROSTED)	810868

137417-05-01A

KEY	PART NUMBER	U/M	DESCRIPTION	VENDOR NO.
	137417-05-700	EA	LENS - DOUBLE OPTIC	810845

137417-06-01A

KEY	PART NUMBER	U/M	DESCRIPTION	VENDOR NO.
	137417-06-700	EA	LENS - DOUBLE WHITE	810867

ELECTRICAL GROUP (CONTINUED)
CIRCUIT BREAKERS & FUSES

KEY	PART NUMBER	U/M	DESCRIPTION
	008233-01-000	EA	FUSE - 12 VOLT - 6 AMP
	008235-01-000	EA	FUSE - 15 AMP/12VOLT - AUTOMOTIVE
	008268-01-000	EA	CIRCUIT BREAKER W/MOUNT - 30A, 12V - FASCO 1711-3023
	033573-01-000	EA	CIRCUIT BREAKER W/MOUNT-20A, 12V - FASCO 1711-2026
	062901-02-000	EA	FUSE - 5 AMP - AUTOMOTIVE
	062901-04-000	EA	FUSE - 10 AMP - AUTOMOTIVE
	062901-05-000	EA	FUSE - 15 AMP - AUTOMOTIVE
	062901-06-000	EA	FUSE - 20 AMP - AUTOMOTIVE
	062901-07-000	EA	FUSE - 25 AMP - AUTOMOTIVE
	062901-08-000	EA	FUSE - 30 AMP - AUTOMOTIVE
	083209-01-000	EA	CIRCUIT BREAKER - 15 AMP - 120 VOLT - CANADIAN
	083209-02-000	EA	CIRCUIT BREAKER - 15/15 AMP - 120 VOLT
	083209-03-000	EA	CIRCUIT BREAKER - 15/20 AMP - 120 VOLT
	083209-04-000	EA	CIRCUIT BREAKER - 30 AMP - 120 VOLT
	083209-05-000	EA	CIRCUIT BREAKER - 20 AMP - 120 VOLT
	083209-06-000	EA	CIRCUIT BREAKER - 30/15 AMP - 120 VOLT
	083209-07-000	EA	CIRCUIT BREAKER - 20/20 AMP - 120 VOLT
	083209-10-000	EA	CIRCUIT BREAKER - 20/30 AMP - 120 VOLT
	083209-11-000	EA	CIRCUIT BREAKER - 20/15 AMP - 120 VOLT
	092786-03-000	EA	BUSS BAR - 6.9" LONG
	092786-06-000	EA	BUSS BAR
	093654-01-000	EA	CIRCUIT BREAKER - 6 AMP - 12 VOLT - PUSH BUTTON - WHITE
	093654-02-000	EA	CIRCUIT BREAKER - 15 AMP - 12 VOLT - PUSH BUTTON - WHITE
	093654-03-000	EA	CIRCUIT BREAKER - 20 AMP - 12 VOLT - PUSH BUTTON - WHITE
	093654-11-000	EA	COVER - RESET BUTTON
	093655-01-000	EA	CIRCUIT BREAKER - 25 AMP - 12 VOLT - PUSH BUTTON - WHITE
	093655-02-000	EA	CIRCUIT BREAKER - 30 AMP - 12 VOLT - PUSH BUTTON - WHITE
	093655-03-000	EA	CIRCUIT BREAKER - 40 AMP - 12 VOLT - PUSH BUTTON - WHITE
	097611-01-000	EA	CIRCUIT BREAKER - 10 AMP
	097611-03-000	EA	CIRCUIT BREAKER - 20 AMP
	097611-04-000	EA	CIRCUIT BREAKER - 25 AMP
	106656-01-000	EA	FUSE BLOCK - 4 CAVITY - AUTOFUSE
	108567-01-000	EA	CIRCUIT BREAKER - 40 AMP - 12 VOLT - TYPE II
	108669-01-000	EA	HOUSING - AUTO FUSE HOLDER
	111683-01-000	EA	FUSE - HOLDER - GLASS - 1/4" X 1 1/4"
	113482-01-000	EA	CIRCUIT BREAKER - 55 AMP - MANUAL
	113520-01-000	EA	BREAKER - CIRCUIT - 15AMP - SWITCHED
	115187-01-000	EA	FUSE - 300 AMP - NON-DELAY
	115187-02-000	EA	FUSE HOLDER - BUSS ANN/ANL BLOCK
	118531-05-02B	EA	PLATE - CIRCUIT BREAKER - E-COAT
	122811-01-000	EA	CIRCUIT BREAKER - 20/50/50/20
	125986-04-000	EA	FUSE - 10 AMP - AUTO - MINI BLADE
	125986-05-000	EA	FUSE - 15 AMP - AUTO - MINI BLADE
	134127-01-000	EA	CIRCUIT BREAKER - 10 AMP - MINI

CONVERTER, INVERTER, LOAD CENTERS

KEY	PART NUMBER	U/M	DESCRIPTION
	083208-06-000	EA	CONTROL CENTER - 45 AMP/120V/12V - W/O BREAKERS/ELECTRONIC
	099048-03-000	EA	INVERTER - 130 WATT

ELECTRICAL GROUP (CONTINUED)

110V WIRING

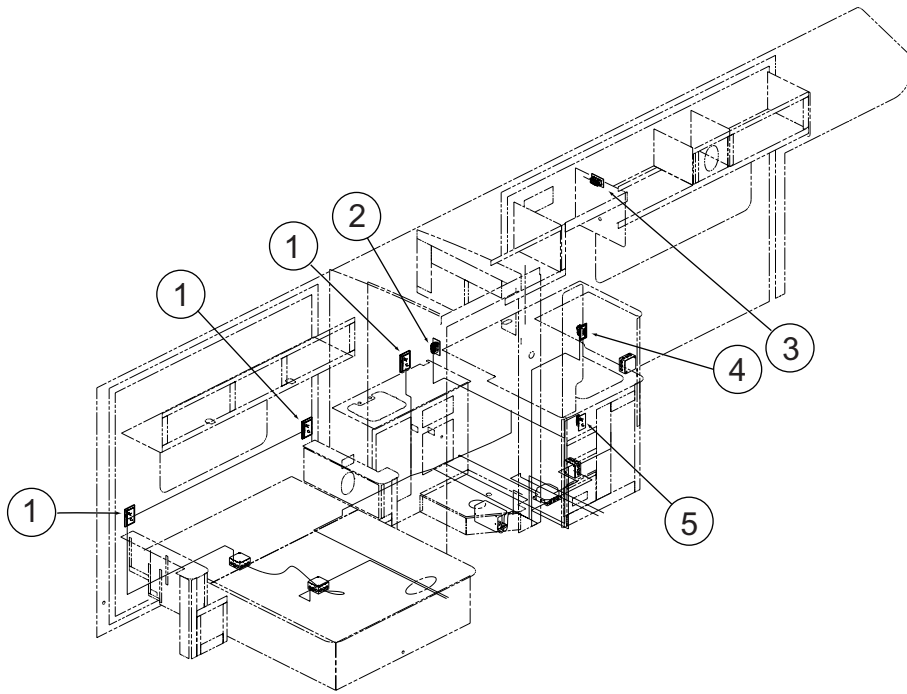

KEY	PART NUMBER	U/M	DESCRIPTION
1	058708-06-000	EA	RECEPTACLE - DUPLEX - WHITE
1	133713-01-20A	EA	SPACER/RECEPTACLE - WHITE VINYL
2	058708-06-000	EA	RECEPTACLE - DUPLEX - WHITE
2	133713-11-20A	EA	SPACER - RECEPTACLE - VINYL WHITE
3	058708-05-000	EA	RECEPTACLE - ELECTRIC - SINGLE - BROWN
3	058708-07-000	EA	RECEPTACLE - SINGLE - WHITE
4	084420-01-000	EA	SWITCH - TOGGLE - 15 AMP - 120 VOLT - BROWN
5	058708-01-000	EA	RECEPTACLE - ELECTRIC - DOUBLE - BROWN

ELECTRICAL GROUP (CONTINUED)
110V WIRING (CONTINUED)

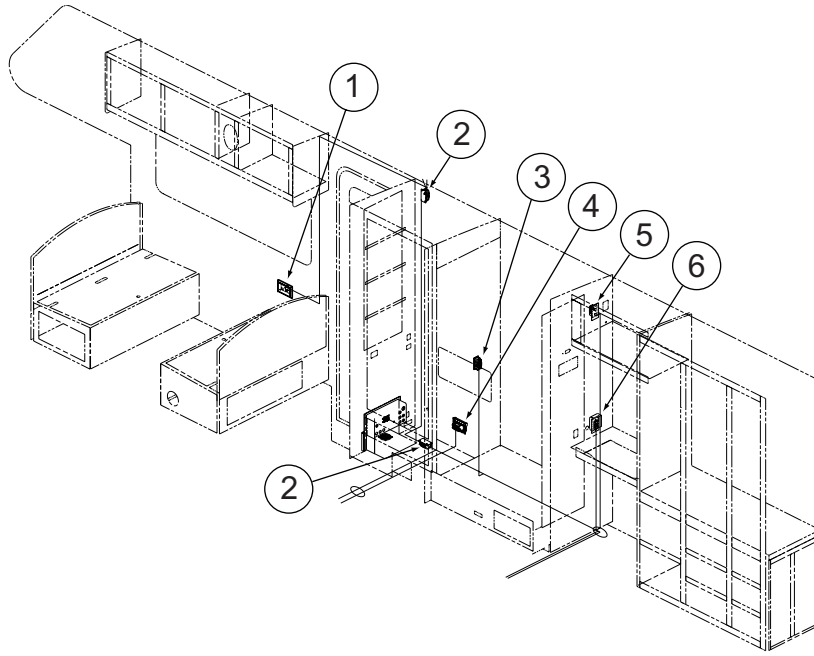

KEY	PART NUMBER	U/M	DESCRIPTION
1	058708-06-000	EA	RECEPTACLE - DUPLEX - WHITE
1	133713-01-20A	EA	SPACER/RECEPTACLE - WHITE VINYL
2	058707-02-000	EA	RECEPTACLE - BLANK - JUNCTION BOX
3	058707-01-000	EA	RECEPTACLE - ELECTRIC - SINGLE - BROWN
4	131826-01-01A	EA	RECEPTACLE - EXTERIOR - W/COVER/GASKET - WHITE
5	058708-01-000	EA	RECEPTACLE - ELECTRIC - DOUBLE - BROWN
6	084076-05-000	EA	RECEPTACLE - GFI - 15 AMP/125 VOLT - WHITE - W/COVER

ELECTRICAL GROUP (CONTINUED) ENTERTAINMENT WIRING

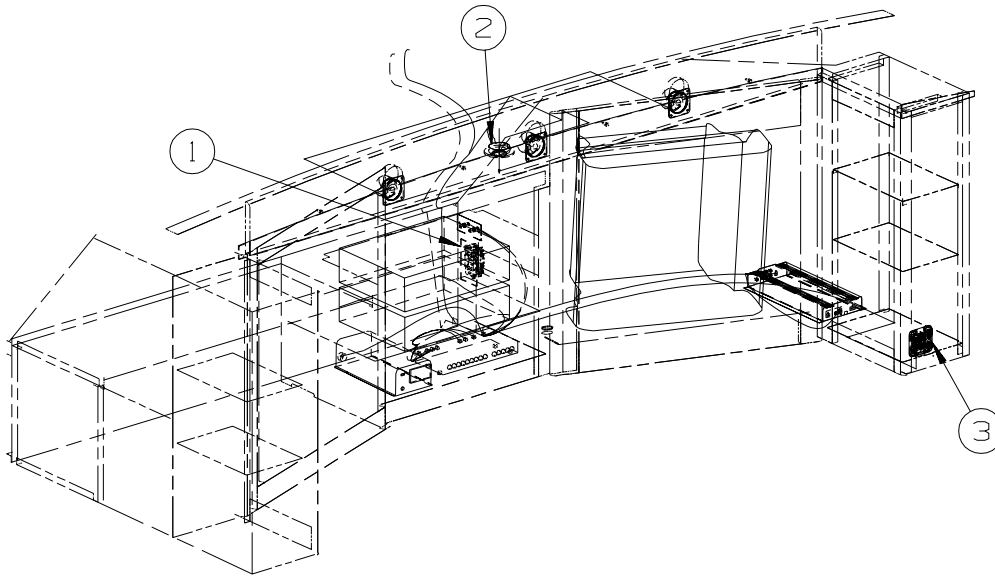

KEY	PART NUMBER	U/M	DESCRIPTION
1	058708-01-000	EA	RECEPTACLE - ELECTRIC - DOUBLE - BROWN
2*	123775-01-01A	EA	LIGHT - HALOGEN - ROUND
3	135740-01-01A	EA	SWITCH - ROCKER - SPST - ON/OFF - BROWN
	135741-01-01A	EA	SWITCH - BASE - SINGLE - BROWN
	135742-07-02A	EA	BEZEL - SWITCH - CEILING - BROWN

*COMPONENT PARTS LISTED LATER IN THIS GROUP

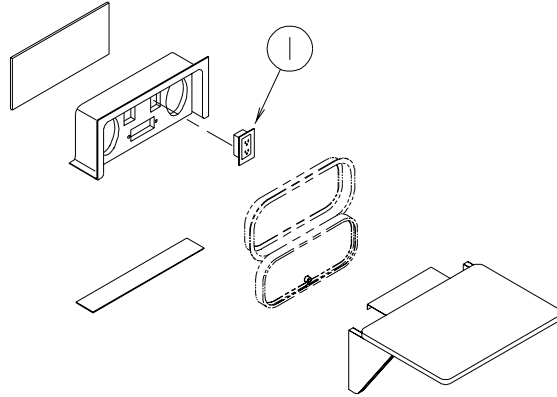

KEY	PART NUMBER	U/M	DESCRIPTION
1	058708-01-000	EA	RECEPTACLE - ELECTRIC - DOUBLE - BROWN

ELECTRICAL GROUP (CONTINUED)

ENTERTAINMENT WIRING COMPONENTS

123775-01-01A

KEY	PART NUMBER	U/M	DESCRIPTION	VENDOR NO
	123775-01-700	EA	BULB - 10 WATT - HALOGEN	71-JC10
	123775-01-701	EA	BEZEL/LENS - RECESSED LIGHT	

ELECTRICAL GROUP (CONTINUED)

BOXES & CORDS

KEY	PART NUMBER	U/M	DESCRIPTION
	008054-01-000	EA	CORD - POWER - 10/3 WIRE - 30 AMP - 25'
	008289-01-000	EA	BOX - ELECTRIC/STEEL - 1/2" & 3/4" KNOCKOUTS - 4" X 4"
	008294-01-000	EA	COVER - ELECTRIC BOX - BLANK/STEEL - 4" X 4" - GRAY
	008294-02-000	EA	COVER- ELECTRIC BOX - BLANK/STEEL - 4" X 4" - GRAY
	091910-01-000	EA	BOX - ELECTRIC - 3.8" X 3.5" X 1.8" - PLASTIC
	091910-02-000	EA	BOX - ELECTRIC - 2.2" X 3.5" X 1.8" - PLASTIC
	092492-16-000	EA	SEAL - ELECTRICAL BOX
	115832-01-000	FT	CORD - HEAVY DUTY - 14-2W GROUND
	133070-01-000	EA	BOX - ELECTRIC/PLASTIC - 3" X 2" X 2.8" - UL
	133070-02-000	EA	BOX - ELECTRIC/PLASTIC - 3" X 2" X 2.8" - CSA

WIRE ASSEMBLIES

KEY	PART NUMBER	U/M	DESCRIPTION
	090986-02-000	EA	WIRE ASSEMBLY - ELECTRIC STEP
	096449-01-000	EA	WIRE ASSEMBLY - WATER TANK TO MONITOR PANEL
	096450-05-000	EA	WIRE F/SENSORS - BLACK WATER - 23.6"
	096451-06-000	EA	WIRE F/SENSORS - GREY WATER - 23.6"
	106851-01-000	EA	WIRE ASSEMBLY - RUNNING LIGHTS - FUSE
	116894-01-000	EA	WIRE ASSEMBLY - SPEED SENSORE EXTENDED
	120233-05-000	EA	WIRE ASSEMBLY - 30" CONNECTS TO WALLPLATE DISPLAY
	124882-10-000	EA	WIRE LOOM - AMPLIFIER - Q SURROUND
	125853-01-000	EA	WIRE LOOM - ENTERTAINMENT CENTER
	125853-04-000	EA	WIRE LOOM - ENTERTAINMENT CENTER
	135420-03-000	EA	WIRE ASSEMBLY - RADIO - FORD C-BODY
	137135-03-000	EA	WIRE LOOM - DIGITAL ELEVATION SENSOR
	137135-04-000	EA	WIRE HARNESS - POWER - DIGITAL ELEVATION SENSOR
	142258-02-000	EA	WIRE LOOM - VIDEO SWITCH/POWER SUPPLY

ELECTRICAL GROUP (CONTINUED)
CONNECTORS & CONDUIT

KEY	PART NUMBER	U/M	DESCRIPTION
	007956-01-000	EA	RECEPTACLE - HOUSING - 6 POSITION
	007956-05-000	EA	INSULATOR - SHRINK - 1/4" ID X 1 1/2"
	008058-01-000	EA	ADAPTER - POWER CORD - 30 AMP TO 15 AMP
	008311-01-000	EA	CONNECTOR - WIRE NUT - INSULATED - RED
	008312-01-000	EA	CONNECTOR - WIRE NUT - INSULATED - BLUE
	008313-01-000	EA	CONNECTOR - WIRE NUT - INSULATED - YELLOW
	008314-01-000	EA	CONNECTOR - WIRE NUT - INSULATED - GRAY
	008326-01-000	EA	TERMINAL - RING - 16/14 WIRE - 3/8" STUD
	008328-01-000	EA	TERMINAL - RING - 12/10 WIRE - #10 STUD FIT
	008331-01-000	EA	TERMINAL - RING - TONGUE - #4 WIRE - 3/8" STUD - COPPER
	008348-01-000	EA	TERMINAL - RING - 3/8" STUD 2 GA. WIRE
	008355-01-000	EA	CONNECTOR - CABLE CLAMPING - 3/4"
	008356-01-000	EA	CONNECTOR - PLASTIC - 3/8" AVG
	008356-02-000	EA	CONNECTOR - PLASTIC - 21/32
	035416-04-000	EA	TERMINAL - RING - #10 STUD FIT - INSULATED BARREL #16/14
	041953-01-000	FT	CONDUIT - CONVOLUTE SLIT - .5" ID - POLYETHYLENE
	041953-02-000	FT	CONDUIT - CONVOLUTE SLIT - .6" ID - POLYETHYLENE
	041953-03-000	FT	CONDUIT - CONVOLUTE SLIT - 1" ID (CLOTHES ROD COVER)
	041953-05-000	FT	CONDUIT - CONVOLUTE SOLID - .62" ID - POLYETHYLENE
	041953-06-000	FT	CONDUIT - CONVOLUTE SLIT - .4" ID - POLYETHYLENE
	041953-07-000	FT	CONDUIT - CONVOLUTE SLIT - .25" ID - POLYETHYLENE
	041953-08-000	FT	CONDUIT - CONVOLUTE SLIT - 1.5" ID - POLYETHYLENE
	041953-09-000	FT	CONDUIT - CONVOLUTE SLIT - .5" ID - NYLON
	041953-10-000	FT	CONDUIT - CONVOLUTE SLIT - .75" ID - NYLON
	041953-11-000	FT	CONDUIT - CONVOLUTE SLIT - 1.06" ID - NYLON
	041953-12-000	FT	CONDUIT - CONVOLUTE SOLID - 1.1" ID - NYLON
	041953-13-000	FT	CONDUIT - CONVOLUTE SLIT - 1.25
	041953-14-000	FT	CONDUIT - CONVOLUTE SLIT - 1.5
	047443-01-000	EA	TERMINAL - .250 RECEPTACLE FIT - INSULATED - 16/14 AWG
	047443-02-000	EA	TERMINAL - .250 RECEPTACLE FIT - INSULATED - 12/10 AWG
	058028-01-000	EA	CONNECTOR - ELECTRICAL PIGTAIL - NYLON - CLEAR
	062036-01-000	EA	TERMINAL - PACK - CON - 12/10 AWG
	074017-02-000	EA	HOUSING - 5 POSITION - RIGHT ANGLED
	077479-01-000	EA	BOOT - BATTERY TERMINAL - DOUBLE CABLE
	077479-02-000	EA	BOOT - BATTERY TERMINAL - SINGLE CABLE
	080015-02-000	EA	RECEPTACLE - FLAG - .185 - 16/14 GAUGE
	080015-03-000	EA	RECEPTACLE - FLAG - .250 - 14/16 GAUGE
	082109-01-000	EA	HOUSING - CONNECTOR - PACKARD
	082741-01-000	EA	CONNECTOR BODY - 2 CONNECTOR MALE
	087225-01-000	FT	SLEEVING - 1/2" - TYPE H
	087949-01-000	EA	BUSS BAR - 2 POSITION - .6" X 1.5"
	087949-02-000	EA	BUSS BAR - 3 POSITION - .6" X 2.4"
	087949-03-000	EA	BUSS BAR - 4 POSITION
	087949-05-000	EA	BUSS BAR - 7 POSITION
	088267-01-000	EA	TERMINAL - FEMALE - 1/4
	088473-01-000	EA	HOUSING - PIN - 12 CAVITY (3 ROWS OF 4)
	088473-02-000	EA	HOUSING - PIN - 15 CAVITY (3 ROWS OF 5)
	088473-03-000	EA	HOUSING - PIN - 9 CAVITY (3 ROWS OF 3)
	088473-04-000	EA	HOUSING - PIN - 8 CAVITY IN-LINE
	088473-06-000	EA	HOUSING - PIN - 6 CAVITY (2 ROWS OF 3)
	088473-08-000	EA	HOUSING - PIN - 4 CAVITY - IN-LINE
	088473-09-000	EA	HOUSING - PIN - 3 CAVITY - IN-LINE
	088473-10-000	EA	HOUSING - PIN - 2 CAVITY - IN LINE
	088474-01-000	EA	HOUSING - SOCKET - 12 CAVITY
	088474-02-000	EA	HOUSING - SOCKET - 15 CAVITY
	088474-03-000	EA	HOUSING - SOCKET - 9 CAVITY
	088474-06-000	EA	HOUSING - SOCKET - 6 CAVITY
	088474-07-000	EA	HOUSING - SOCKET - 5 CAVITY
	088474-08-000	EA	HOUSING - SOCKET - 4 CAVITY
	088474-09-000	EA	HOUSING - SOCKET - 3 CAVITY
	088474-10-000	EA	HOUSING - SOCKET - 2 CAVITY
	088475-01-000	EA	PIN - CONNECTOR - 14-20 AWG
	088475-02-000	EA	PIN - CONNECTOR - 10-12 AWG
	088476-01-000	EA	TERMINAL - ELECTRICAL

ELECTRICAL GROUP (CONTINUED)
CONNECTORS & CONDUIT (CONTINUED)

KEY	PART NUMBER	U/M	DESCRIPTION
	088476-02-000	EA	SOCKET - CONNECTOR - 12-10 GA - PRE-TIN
	098261-01-000	EA	SOCKET - CONNECTOR - WEATHERPACK - 12 AWG
	098261-02-000	EA	SOCKET - CONNECTOR - WEATHERPACK - 14-18 AWG
	098262-01-000	EA	SEAL - CONNECTOR - WEATHERPACK
	098262-05-000	EA	SEAL - CAVITY
	098262-06-000	EA	SEAL - CONNECTOR - M/P - 10 GAUGE
	098262-07-000	EA	SEAL - CONNECTOR - 12 AWG - 280 SER
	098263-01-000	EA	HOUSING - 3 PIN - WEATHER PACK
	098263-02-000	EA	HOUSING - 3 PIN - WEATHER PACK
	098264-01-000	EA	HOUSING - 2 PIN - WEATHER PACK - MALE W/FEMALE PINS
	098264-02-000	EA	HOUSING - 2 PIN - WEATHER PACK - FEMALE W/MALE PINS
	098265-02-000	EA	PIN - CONNECTOR - WEATHER PACK
	100690-01-000	EA	HOUSING - 5 POSITION - MALE - WEATHER PACK
	100690-02-000	EA	HOUSING - 5 POSITION - FEMALE - WEATHER PACK
	102777-02-000	EA	TERMINAL - RING - #6 STUD - 10 AWG
	104100-01-000	EA	HOUSING - 1 POSITION - 75 AMPS
	104100-03-000	EA	TERMINAL - 75 AMP
	106655-02-000	EA	TERMINAL - FUSE BLOCK - 10-12 AWG
	110178-01-000	EA	HOUSING - WIPER MOTOR
	112823-01-000	EA	SPLICE - REDUCER - 16-14 TO 18-22
	113072-01-000	EA	HOUSING - ELECTRICAL - TURN/TAIL LAMP
	113072-03-000	EA	HOUSING - ELECTRICAL - STOP/MARKER TAILLAMP
	113135-01-000	EA	TERMINAL - FEMALE - M/P - 14-16 - F/SEALED TERMINAL
	113306-01-000	EA	TERMINAL - FEMALE - M/P - 14-16 - F/NON-SEALED TERMINAL
	113306-02-000	EA	TERMINAL - FEMALE - M/P - 10-12 - 480
	113307-01-000	EA	TERMINAL - FEMALE - M/P - 16-20
	113308-01-000	EA	TERMINAL - FEMALE - M/P - 14-16 - 280
	113468-01-000	EA	HOUSING - 2 POSITION-FEMALE-USED ON WIPER/WASHER WIRE ASM
	113638-02-000	EA	CONNECTOR - ACTUATOR
	114667-01-000	FT	HOSE - 2" ID - FLEXIBLE
	115556-01-000	EA	HOUSING - 3 POSITION - FEMALE
	115556-02-000	EA	HOUSING - 2 POSITION - FEMALE/PARALLEL
	115931-02-000	EA	COVER - CONNECTOR - 50 AMP W/LOCKING RING
	115932-02-000	EA	CONNECTOR - FEMALE - 50 AMP/240 VOLT
	116811-01-000	EA	TERMINAL - .110 RECEPTACLE - 16-14 AWG
	118571-01-000	EA	CONNECTOR - 3-WAY - MALE/SEALED
	118571-02-000	EA	CONNECTOR - 3-WAY - FEMALE/SEALED
	118571-05-000	EA	LOCK - SECONDARY - FEMALE
	118571-06-000	EA	LOCK - SECONDARY - MALE
	118597-01-000	EA	TERMINAL - MALE - M/P - 480 - 14-16
	118599-01-000	EA	TERMINAL - MALE - M/P - 280 - 14-16
	118820-01-000	EA	INSULATOR - TERMINAL
	119223-01-000	EA	HOUSING - 6 POSITION - MALE - WEATHERPACK
	119248-02-000	EA	HOUSING - 7 POSITION - FEMALE
	125323-01-000	EA	HOUSING - 10 POSITION - MALE
	125323-02-000	EA	HOUSING - 8 POSITION - MALE
	125323-03-000	EA	LOCK - SECONDARY 8 POSITION
	125323-04-000	EA	LOCK - SECONDARY 10 POSITION
	125323-05-000	EA	HOUSING - 6 POSITION - MALE
	125323-06-000	EA	LOCK - SECONDARY 6 POSITION
	125324-01-000	EA	TERMINAL - MALE - METRI-PACK - 150
	125325-01-000	EA	SEAL - CAVITY
	126403-01-000	EA	CONNECTOR - 2 CIRCUIT
	126403-02-000	EA	CONNECTOR - 3 CIRCUIT
	129233-01-000	EA	HOUSING - 6 POSITION - MALE WEATHERPACK
	129233-02-000	EA	HOUSING - 2-POSITION/FEMALE - 280-SERIES
	129234-01-000	EA	HOUSING - 6-POSITION/FEMALE - 280-SERIES
	129234-02-000	EA	HOUSING - 6-POSITION/FEMALE - 280-SERIES
	129234-03-000	EA	LOCK - SECONDARY - 6-POSITION
	129235-01-000	EA	HOUSING - 2-POSITION/FEMALE - 630-SERIES
	129235-02-000	EA	LOCK - SECONDARY - 2-POSITION
	129236-01-000	EA	TERMINAL - FEMALE - M/P - 630 - 10-12
	131515-01-000	EA	HOUSING - PIN - 2 CAVITY/HIGH AMP

ELECTRICAL GROUP (CONTINUED)
CONNECTORS & CONDUIT (CONTINUED)

KEY	PART NUMBER	U/M	DESCRIPTION
	131515-02-000	EA	TERMINAL - FEMALE JR. POWER TIMER - F/HALOGEN FOG LIGHT
	131515-03-000	EA	SEAL - CAVITY - JR. POWER TIMER
	131681-01-000	EA	CONNECTOR - 3/4" SO CORD - UL/CS
	137207-01-000	EA	HOUSING - PIN - 2 CAVITY/HIGH AMP
	137208-01-000	EA	HOUSING - SOCKET - 2 CAVITY/HIGH AMP
	137209-01-000	EA	PIN - CONNECTOR - 10AWG/HIGH AMP
	137210-01-000	EA	SOCKET - CONNECTOR - 10 AWG/HIGH AMP
	138419-03-000	EA	SOCKET - LAMP - 3 WIRE
	142520-01-000	EA	TERMINAL - FEMALE - MINI FIT 16
	142522-01-000	EA	HOUSING - 4 PIN/MALE - MINI FIT
	142524-01-000	EA	HOUSING - 4 PIN/WEATHER PACK/FEMALE

BOOTS, SOLENOIDS, RELAYS & MISCELLANEOUS

KEY	PART NUMBER	U/M	DESCRIPTION
	008188-01-000	EA	SOLENOID - 3 POST - BATTERY CHANGE OVER
	063910-01-000	EA	HOUSING - RELAY
	063912-02-000	EA	RELAY - CANISTER - SPDT
	065451-05-000	EA	BRACKET/TIEDOWN - BATTERY - 7.7" FROM BRKT TO BRKT
	065450-05-000	EA	TIEDOWN - BATTERY - 8.4" TUBE
	086273-01-000	EA	RELAY - BATTERY DISCONNECT

EXTERIOR BODY GROUP GRAPHICS & PAINT

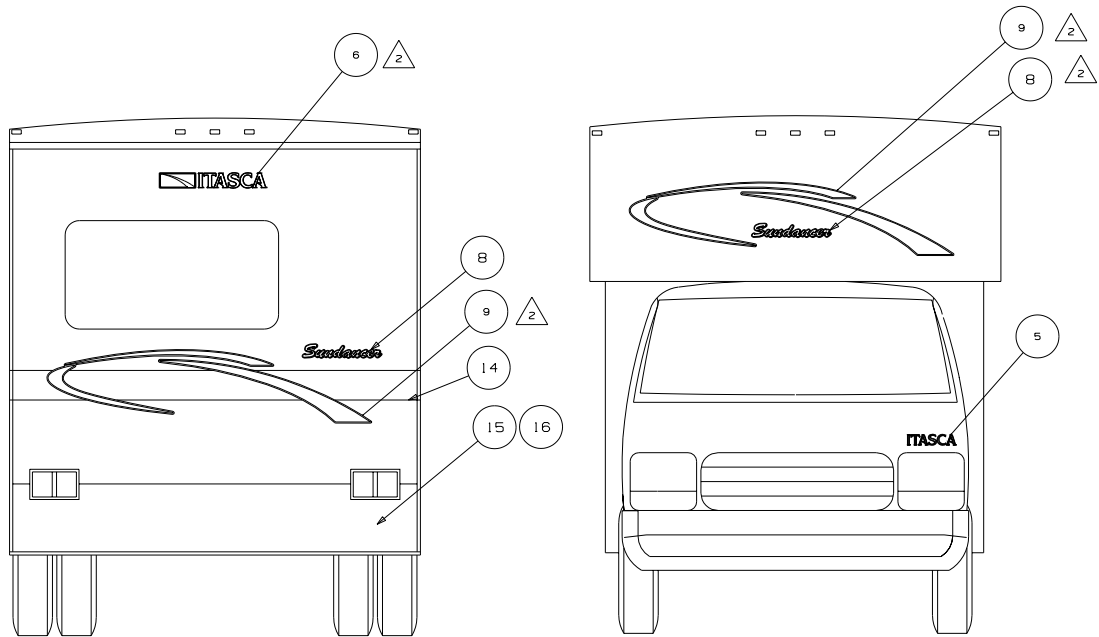

KEY	PART NUMBER	U/M	DESCRIPTION
1	105781-86-CHT (02A)	FT	MULTISTRIPE-69.9MM - DK.ROSE/LT.GREEN
2	94443-72-CHT (03A)	FT	MULTISTRIPE-120.7MM - LT.GREEN/SILVER/DK.ROSE
3	132664-01-CHT (01A)	EA	DECAL-WINNEBAGO,DOMED - CHROME/BLACK
4	124811-01-CHT (24A)	EA	DECAL-ITASCA - LT.GREEN/BRT.WHITE
5	124811-02-CHT (05A)	EA	DECAL-ITASCA,SML,HOOD - LT.GREEN/BRT.WHITE
6	124806-01-CHT (24A)	EA	DECAL-ITASCA W/ICON - LT.GREEN/BRT.WHITE
7	125103-01-CHT (07A)	EA	DECAL-SUNDANCER - BRT.WHITE/DK.ROSE/SILVER/GREEN MOSS
8	125103-02-CHT (03A)	EA	DECAL-SUNDANCER,SML - BRT.WHITE/DK.ROSE/SILVR/GREEN MOSS
9	138370-01-CHT (02A)	EA	DECAL-SWEEPS - BRT.WHITE/LT.GREEN/SILVER/DK.ROSE
10	138371-01-CHT (03A)	EA	DECAL-CAB-DOOR,RH - LT.GREEN/SILVER/DK.ROSE
10	138371-02-CHT (03A)	EA	DECAL-CAB-DOOR,LH - LT.GREEN/SILVER/DK.ROSE
11	138373-01-CHT (02A)	EA	DECAL-SWEEP #1,RH - LT.GREEN
11	138373-02-CHT (02A)	EA	DECAL-SWEEP #1,LH - LT.GREEN
12	138374-01-CHT (02A)	EA	DECAL-SWEEP #2,RH - LT.GREEN/DK.ROSE
12	138374-02-CHT (02A)	EA	DECAL-SWEEP #2,LH - LT.GREEN/DK.ROSE
13	138375-01-CHT (03A)	EA	DECAL-SWEEP #3,RH - SILVER/DK.ROSE
13	138375-02-CHT (03A)	EA	DECAL-SWEEP #3,LH - SILVER/DK.ROSE
14	093681-69-CHT (02A)	FT	FILM-171.4MM - DK.ROSE
92K	141599-02-000	GL	PAINT: JAGUAR BLUE MET - DUPONT #F4194F
27G	141599-01-000	GL	PAINT: LT.SILVER MET - DUPONT #F2573
27G	141568-01-CHT (02A)	EA	DECAL-SWEEP #4,RH - GREEN MOSS/SILVER
27G	141568-02-CHT (02A)	EA	DECAL-SWEEP #4,LH - GREEN MOSS/SILVER
92K	141568-01-CHT (01A)	EA	DECAL-SWEEP #4,RH - SILVER/GREEN MOSS
92K	141568-02-CHT (01A)	EA	DECAL-SWEEP #4,LH - SILVER/GREEN MOSS

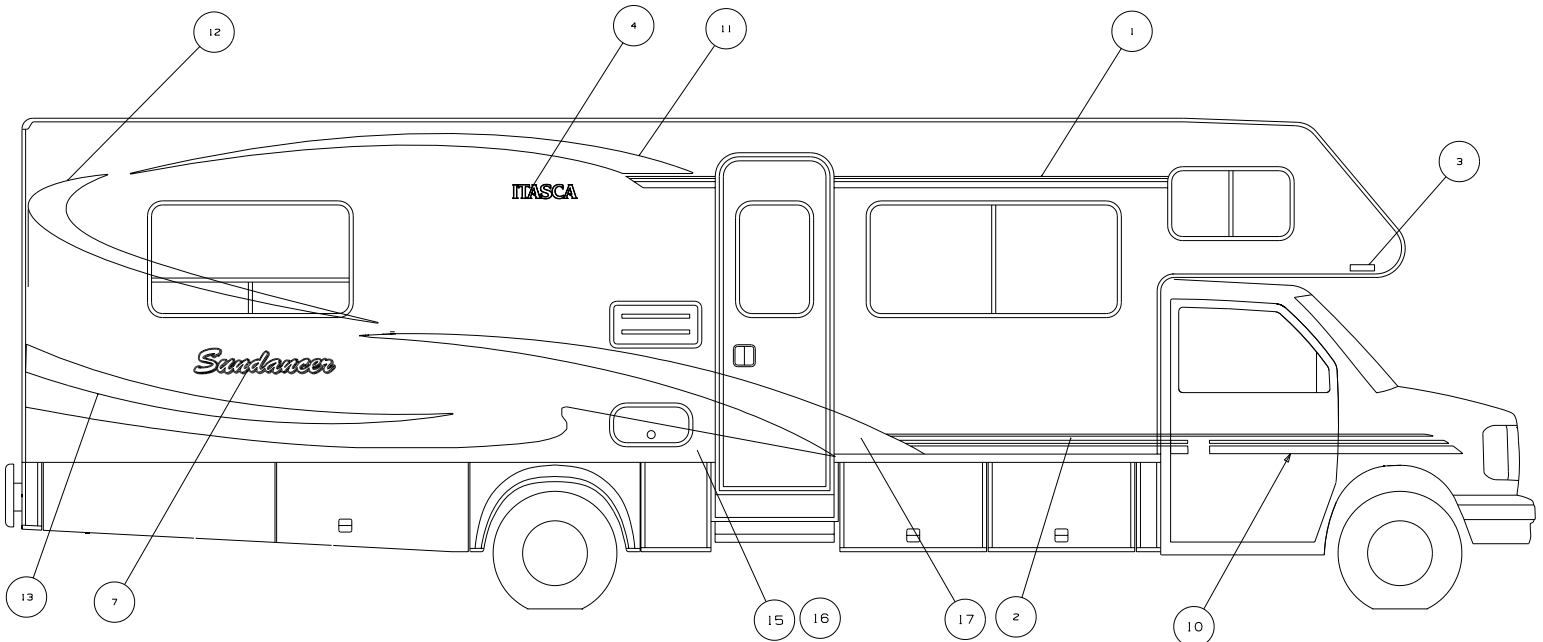

3. CONTINUE MULTISTRIPE ONTO WINDWALLS OF SLIDEOUT.

△ CENTER ON UNIT.

1. APPLY PROTECTOR 116424-01-000 TO WATER HEATER DOOR LATCH.

EXTERIOR BODY GROUP (CONTINUED)

GRAPHICS & PAINT (CONTINUED)

KEY	PART NUMBER	U/M	DESCRIPTION
	041561-03-000	EA	PAINT - 16 OUNCE SPRAY - OFF WHITE
	099399-23-700	EA	PAINT-SPRAY - BRIGHT WHITE ENAMEL - 12 OZ.

DUPONT COLOR CODES

LT. GREEN MET	#GM185
BRIGHT WHITE	#B8915
SILVER MET	#F2573
JAGUAR BLUE MET	#P7414
LT. SILVER MET	#P6235

EXTERIOR BODY GROUP (CONTINUED)

PANELS & TRIMS

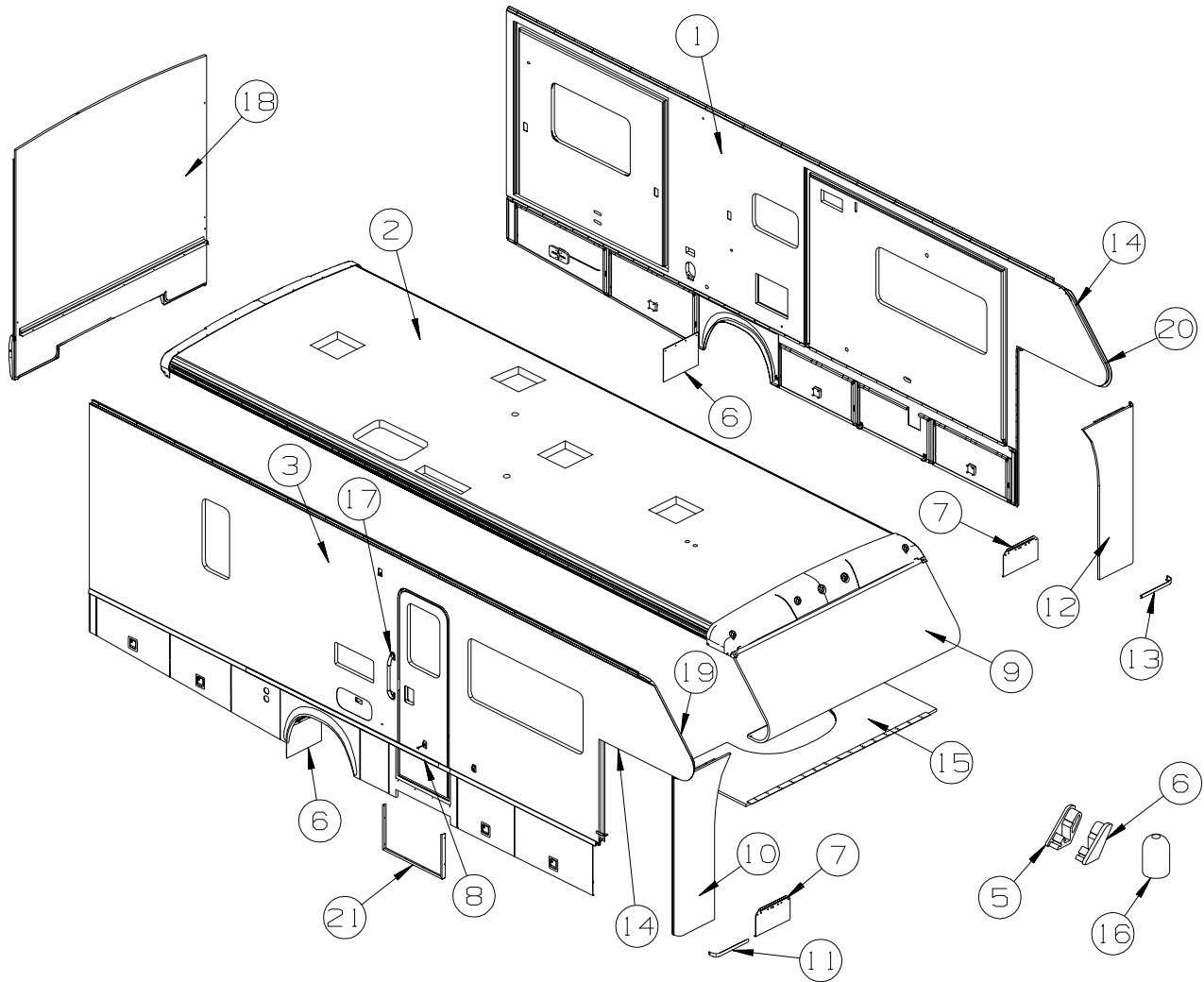

KEY	PART NUMBER	U/M	DESCRIPTION
1	P41510-01-P13	EA	SIDEWALL - DRIVER - W/O WINDOWS/TRIMS(P19, P20, P33)
1	P41510-01-P15	EA	SIDEWALL - DRIVER - W/O WINDOWS/TRIMS(P21, P22, P36)
1	P41510-01-P17	EA	SIDEWALL - DRIVER - W/O WINDOWS/TRIMS(P23, P24, P40)
2	141511-01-P13	EA	ROOF - W/O LIGHTS/VENTS - W/WIRING
3	P41509-01-P13	EA	SIDEWALL - PASSENGER - W/O WINDOWS/TRIMS(P19, P20, P33)
3	P41509-01-P15	EA	SIDEWALL - PASSENGER - W/O WINDOWS/TRIMS(P21, P22, P36)
3	P41509-01-P17	EA	SIDEWALL - PASSENGER - W/O WINDOWS/TRIMS(P23, P24, P40)
4	126775-01-01A	EA	END CAP - VALANCE TRIM - RIGHT HAND
5	126775-02-01A	EA	END CAP - VALANCE TRIM - LEFT HAND
6	017516-01-000	EA	MUD FLAP - 14"H X 18"W - W/O MOUNTING HOLES - BLACK
	140922-01-02B	EA	PLATE - MUD FLAP - E-COATED
7	136389-01-02B	EA	GUARD/ROCK - STEEL - W/BEND - 18"W X 10.9"H - E-COATED
8	133045-02-01A	EA	TRIM - W/HOLES - 23.1" - BRIGHT WHITE
9	141436-01-P13	EA	ROOF - W/O LIGHTS/VENTS - W/WIRING - FRONT SECTION
10	141437-01-P13	EA	WINGWALL ASM
11	122910-02-G07	EA	COVER - WINGWALL - DRIVER
12	141437-02-P13	EA	WINGWALL ASM
13	122910-01-G07	EA	COVER - WINGWALL - PASSENGER
14	105312-01-07A	FT	INSERT - FEATURE STRIP - VINYL - BRIGHT WHITE
15	125129-03-P13	EA	SLEEPERBOARD(P13, P15, P17)
15	125129-03-P14	EA	SLEEPERBOARD(P14, P16, P18)
16	117046-02-000	EA	BUMPER - RUBBER/ROUND END - 1.5"
17*	132442-01-01A	EA	HANDLE - ASSIST - WHITE METAL HANDLE W/WHITE ENDS
18	141353-01-P13	EA	BACKWALL - W/O WINDOWS/TRIMS(P19, P20, P33)
18	141353-01-P15	EA	BACKWALL - W/O WINDOWS/TRIMS(P21, P22, P36)
18	141353-01-P17	EA	BACKWALL - W/O WINDOWS/TRIMS(P23, P24, P40)

EXTERIOR BODY GROUP (CONTINUED)
PANELS & TRIMS (CONTINUED)

KEY	PART NUMBER	U/M	DESCRIPTION
19	136826-15-01A	EA	TRIM - CONTOUR - 83.5"
20	136826-16-01A	EA	TRIM - CONTOUR - 83.5"
21	136228-01-01A	EA	ANGLE - DOOR/ENTRY - BRIGHT WHITE FROM: 00-00-00 THRU: 09-02-02
21	136228-02-01A	EA	ANGLE - DOOR/ENTRY - BRIGHT WHITE FROM: 00-00-00 THRU: 09-02-02
21	136228-03-01A	EA	ANGLE - DOOR/ENTRY - BRIGHT WHITE FROM: 00-00-00 THRU: 09-02-02
21	144153-02-P13	EA	ANGLE ASM - "U" F/ENTRANCE DOOR - 31" X 18.9" FROM: 09-03-02 THRU: 99-99-99

***COMPONENT PARTS LISTED LATER IN THIS GROUP**

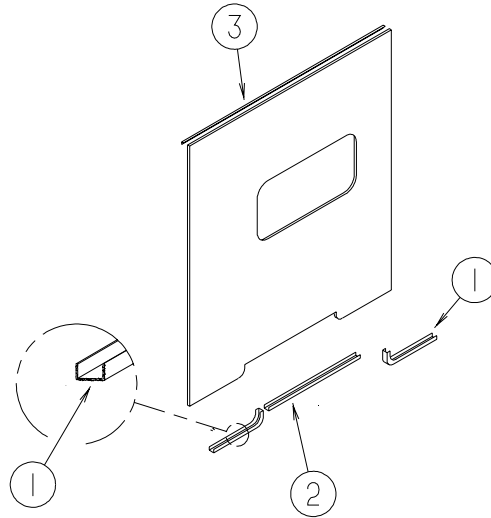

KEY	PART NUMBER	U/M	DESCRIPTION
1	103334-06-02A	EA	TRIM - BACKWALL/LOWER - 20.4" - BRIGHT WHITE FROM: 00-00-00 THRU: 08-06-02
1	103334-08-02A	EA	TRIM - BACKWALL/LOWER - 20.4" - BRIGHT WHITE FROM: 08-07-02 THRU: 99-99-99
2	103335-09-02A	EA	TRIM - BACKWALL/LOWER - 56.9" - BRIGHT WHITE
3	114248-02-01A	EA	ANGLE - PLASTIC - 96.6"

EXTERIOR BODY GROUP (CONTINUED)
PANELS & TRIMS (CONTINUED)

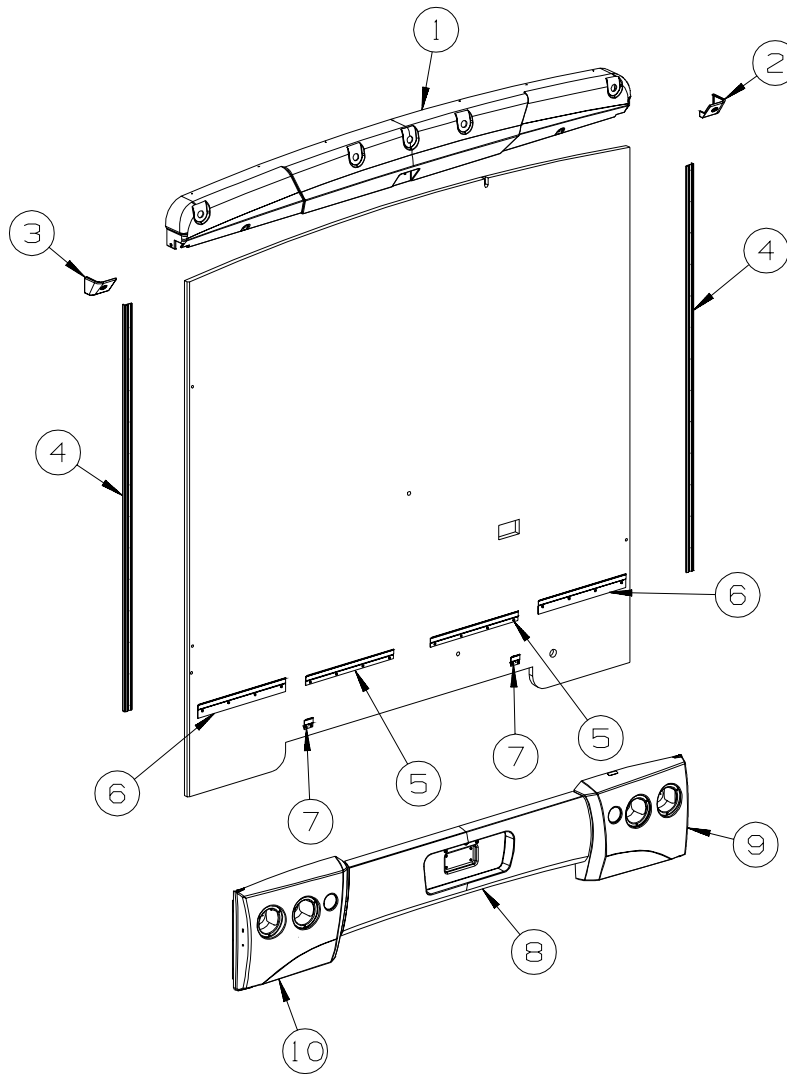

KEY	PART NUMBER	U/M	DESCRIPTION
1	140596-02-P07	EA	CAP - ROOF - W/O LIGHTS/VENTS/WIRING-W/STEEL REINFORCEMENT
2	140620-01-01A	EA	CAP - TRIM - REAR/RIGHT - BRIGHT WHITE
3	140620-02-01A	EA	CAP - TRIM - REAR/LEFT - BRIGHT WHITE
4	096854-13-02B	EA	TRIM - CONTOUR - 76.3" - BRIGHT WHITE
5	130034-04-02B	EA	CLIP - TRIM - E-COATED
6	130034-05-02B	EA	CLIP - TRIM - E-COATED
7	130034-07-02B	EA	CLIP - TRIM - E-COATED
8	140459-02-P13	EA	BUMPER - REAR - BLACK - W/DUMP VALVE LIGHT
9	140460-03-P19	EA	TRIM/BACKWALL - LOWER/PASSENGER - W/BACKWALL SUPT BRACKETS
10	140460-04-P19	EA	TRIM/BACKWALL - LOWER/DRIVER - W/BACKWALL SUPT BRACKETS

EXTERIOR BODY GROUP (CONTINUED)
PANELS & TRIMS (CONTINUED)

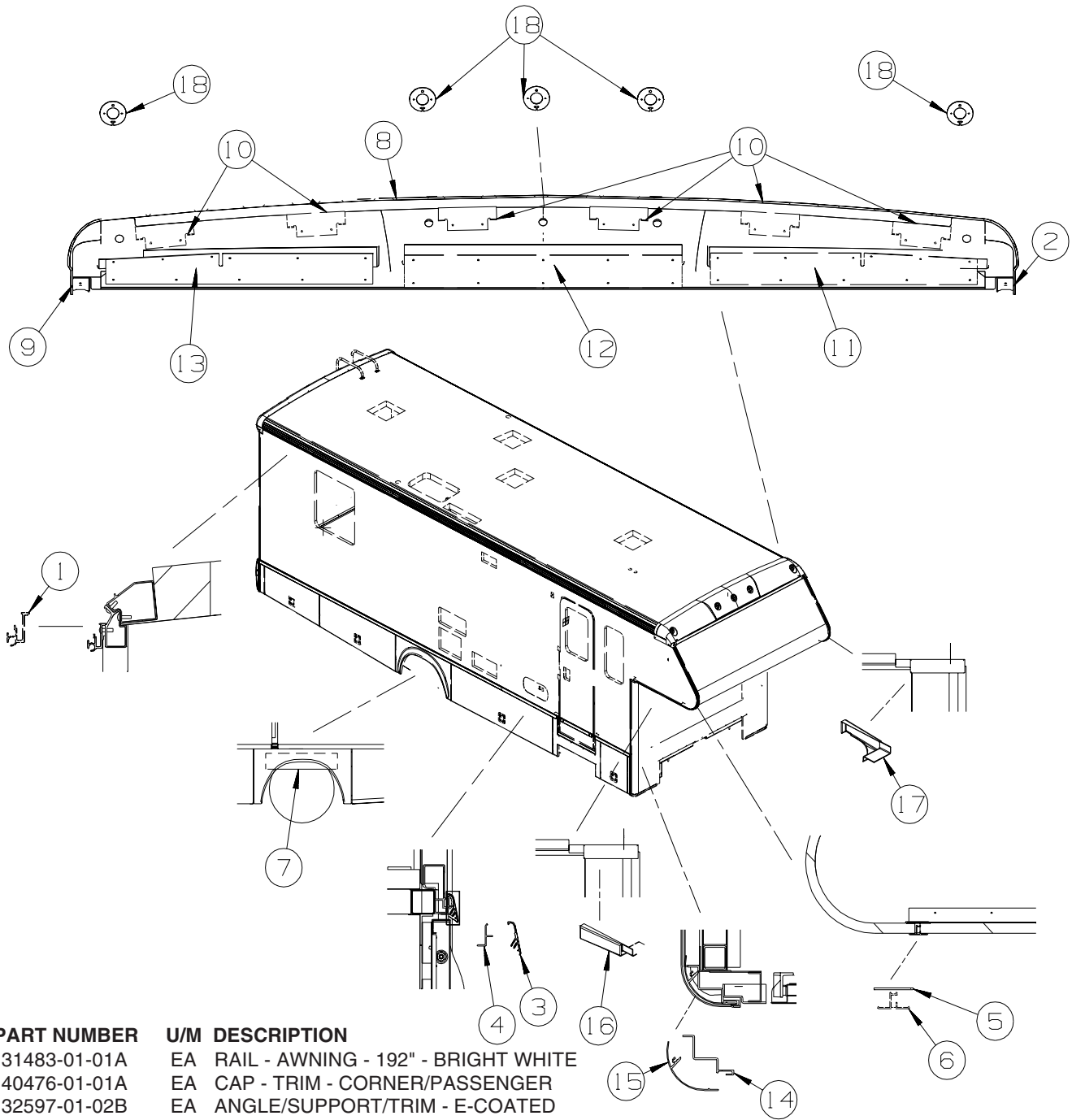

KEY	PART NUMBER	U/M	DESCRIPTION
1	131483-01-01A	EA	RAIL - AWNING - 192" - BRIGHT WHITE
2	140476-01-01A	EA	CAP - TRIM - CORNER/PASSENGER
3	132597-01-02B	EA	ANGLE/SUPPORT/TRIM - E-COATED
3	143143-02-01A	EA	ANGLE SUPPORT/TRIM FROM: 99-99-99 THRU: 01-31-03
3	143143-02-01A	EA	ANGLE SUPPORT/TRIM FROM: 02-01-03 THRU: 99-99-99
4	133376-01-01A	EA	TRIM - RETAINER - 144" - MILL
5	100085-05-01A	EA	TRIM/STRAP - SLEEPERBOARD - OFF/WHITE - 92.9"
6	100086-04-01A	EA	TRIM - SLEEPERBOARD/ROOF/LOWER - BRIGHT WHITE - 96.5"
7	121948-02-000	EA	SHIELD - SIGHT
8	140443-02-P07	EA	CAP - ROOF - W/O LIGHTS/VENTS - W/WIRING
9	140476-02-01A	EA	CAP - TRIM - CORNER/DRIVER
10	134774-01-02B	EA	BRACKET - CAB ATTACHMENT - E - COATED
11	141718-01-02B	EA	BRACKET - ROOF CAP - END/RIGHT HAND - E-COATED
12	140805-01-02B	EA	BRACKET - ROOF CAP/Front - E - COATED
13	141718-02-02B	EA	BRACKET - ROOF CAP - END/LEFT HAND - E-COATED
14	105015-03-02A	EA	TRIM - WINGWALL/SIDEWALL CURVED - INNER SUPT BRKT - B/W
15	108037-03-02A	EA	COVER - WINGWALL OUTER/CURVED - BRIGHT WHITE
16	104444-01-02A	EA	COVER - WINGWALL TRIM - UPPER PASSENGER - BRIGHT WHITE
17	104444-02-02A	EA	COVER - WINGWALL TRIM - UPPER DRIVER - BRIGHT WHITE
18	138423-01-12B	EA	PLATE/BACKING - LITE - BRIGHT WHITE

EXTERIOR BODY GROUP (CONTINUED)
COMPONENT PARTS FOR PANELS & TRIMS

132442-01-01A

KEY	PART NUMBER	U/M DESCRIPTION	VENDOR NO.
	132442-01-700	EA BULB/ROPE - F/ASSIST HANDLE	ST012-0C/12MLX

EXTERIOR BODY GROUP (CONTINUED)

LADDER

KEY	PART NUMBER	U/M	DESCRIPTION
	129639-07-01A	EA	LADDER - 81.7" - 6 STEP - BRUSHED ALUMINUM
	130163-10-01A	EA	LADDER EXTENSION/LOWER - 35.6" - 3 STEP - BRUSHED ALUMINUM

RUNNING BOARDS

KEY	PART NUMBER	U/M	DESCRIPTION
	106461-03-000	EA	HARDWARE KIT - RUNNING BOARD
	106461-10-01A	EA	RUNNING BOARD - PASSENGER/FORD - PRIMED
	106461-11-01A	EA	RUNNING BOARD - DRIVER/FORD - PRIMED

MIRRORS

KEY	PART NUMBER	U/M	DESCRIPTION
*	120269-07-01A	EA	PANEL/CONTROL-DRIVERS DOOR MIRROR - W/SWITCH & PIGTAIL
*	133908-03-01A	EA	MIRROR/PASSENGER - 102" W/B FORD - HEATED/REMOTE - BRT WHT FROM: 00-00-00 THRU: 10-13-02
	133908-12-01A	EA	MIRROR/PASS - 102" FORD C BODY - HEATED/REMOTE - BRT WHT FROM: 10-14-02 THRU: 99-99-99
*	133908-04-01A	EA	MIRROR/DRIVER - 102" W/B FORD - HEATED/REMOTE - BRT WHITE FROM: 00-00-00 THRU: 10-13-02
	133908-13-01A	EA	MIRROR/DRIVER - 102" FORD C BODY - HEATED/REMOTE - BRT WHT FROM: 10-14-02 THRU: 99-99-99
	120269-08-000	EA	HARNES/WIRE - F/ELECTRIC MIRRORS FROM: 09-01-02 THRU: 99-99-99

*COMPONENT PARTS LISTED LATER IN THIS GROUP

EXTERIOR BODY GROUP (CONTINUED)
COMPONENT PARTS FOR MIRRORS

120269-07-01A

KEY	PART NUMBER	U/M	DESCRIPTION	VENDOR NO.
	120269-07-700	EA	SWITCH - REMOTE	7475720
	133908-09-700	EA	SWITCH-MIRROR HEATER	7475150

133908-01-01A, 133908-01-02A, 133908-02-01A, 133908-03-01A, 133908-03-02A, 133908-04-01A, 133908-05-01A, 133908-06-01A,
 133908-07-01A, 133908-08-01A, 133908-10-01A, 133908-11-01A, 133908-12-01A, 133908-13-01A

KEY	PART NUMBER	U/M	DESCRIPTION	VENDOR NO.
	117051-01-700	EA	MIRROR-CONVEX	723068-4
	120269-05-701	EA	GLASS ONLY REPLACEMENT RH/LH	709411
	133908-03-700	EA	CAP - RECT/BLACK-W/O LIGHT	7095570
	133908-04-700	EA	CAP-MIRROR/ROUND - W/O LIGHT	7095470

EXTERIOR BODY GROUP (CONTINUED)
STRUCTURAL COMPONENTS

KEY	PART NUMBER	U/M	DESCRIPTION
	002726-01-001	EA	GARNISH - U-CHANNEL - 1.38" X 19' - SERRATED
	076054-AC-000	EA	FIBERGLASS SHEET - 20" X 99.8" - OFF WHITE
	076054-P9-000	EA	FIBERGLASS SHEET - 37.4" X 99.3" - BRIGHT WHITE
	076054-U6-000	EA	FIBERGLASS SHEET - 102" X 361" - BRIGHT WHITE
	076054-U8-000	EA	FIBERGLASS SHEET - 100" X 105" - BRIGHT WHITE
	076054-W2-000	EA	FIBERGLASS SHEET - 85" X 339" - BRIGHT WHITE
	076054-X9-000	EA	FIBERGLASS SHEET - 22.1" X 70.6" - BRIGHT WHITE
	077517-62-000	EA	FIBERGLASS SHEET - 48" X 96" - BRIGHT WHITE
	089297-01-000	SF	PLYWOOD - LUAN - OVERLAY GRADE - 4' X 8'
	089297-02-000	SF	PLYWOOD - LUAN - OVERLAY GRADE - 4' X 9'
	100619-01-000	BF	FOAM - EXPANDED POLYSTYRENE - 1.34" X 48" X 96"
	100619-02-000	BF	FOAM - EXPANDED POLYSTYRENE - 1.5" X 48" X 96"
	100619-04-000	BF	FOAM - EXPANDED POLYSTYRENE - .5" X 48" X 96"
	100619-05-000	BF	FOAM - EXPANDED POLYSTYRENE - .75" X 48" X 96"-1.5 DENSITY
	100619-11-000	BF	FOAM - EXPANDED POLYSTYRENE - 2" X 48" X 96"
	100619-13-000	BF	FOAM - EXPANDED POLYSTYRENE - .34" X 34.65" X 96"
	100619-16-000	BF	FOAM - EXPANDED POLYSTYRENE - .75" X 48" X 96"-2.0 DENSITY
	100619-27-000	BF	FOAM - EXPANDED POLYSTYRENE - 48" X 92.8" X 3"
	105077-10-000	EA	PLUG - ROOF CAP
	108535-05-03A	SF	FIBERGLASS SHEET - 108" X 500' ROLL - BRIGHT WHITE
	108535-07-01A	SF	FIBERGLASS SHEET - 100" X 500' - BRIGHT WHITE
	117754-03-01A	EA	FIBERGLASS SHEET - 10.5" X 96" LONG
	120107-01-000	EA	FOAM - ROOF COVE - 2.8" X 96" LONG
	120107-02-000	EA	FOAM - PLUG - ROOF TUBE - 2.2" X 2.9" X 1.8" LONG
	120107-03-000	EA	FOAM - PLUG - SIDEWALL TUBE - 1.2" X 2.1" X 1.8" LONG
	135926-02-01A	EA	FIBERGLASS - SHEET - 80.8" X 308.7" - BRIGHT WHITE
	135926-04-01A	EA	FIBERGLASS - SHEET - 26.1" X 68.2" - BRIGHT WHITE
	135926-06-01A	EA	FIBERGLASS - SHEET - 79" X 346" - BRIGHT WHITE
	135926-13-01A	EA	FIBERGLASS - SHEET - 27.4" X 67.2" - BRIGHT WHITE

AWNINGS

PATIO AWNINGS

SERIES	MODEL	COLOR DESIGNATION	AWNING FABRIC	AWNING LENGTH	WEATHER WRAP	PART # MANUAL
SUN-	427P	ALPINE GREEN (DY)	VINYL	11.5'	VYL/BRT WHT	113874-03-45A
DANCER	430V	ALPINE GREEN (DY)	VINYL	14'	VYL/BRT WHT	113874-05-45A
	431C	ALPINE GREEN (DY)	VINYL	14'	VYL/BRT WHT	113874-05-45A

KEY	PART NUMBER	U/M	DESCRIPTION
*	113874-01-02A	EA	HARDWARE KIT - AWNING - W/O STANDOFF BRACKET-BRIGHT WHITE
	113874-11-01A	EA	SCREW/LAG - AWNING - 1/4" X 1" STAINLESS STEEL
	113874-12-01A	EA	SCREW/LAG - AWNING - 1/4" X 2 3/4" STAINLESS STEEL
	127647-02-01A	EA	ROD/AWNING GUARD - ENTRANCE DOOR - 12.7" LONG
	137054-01-02A	EA	BRACKET - AWNING - BRIGHT WHITE

*COMPONENT PARTS LISTED LATER IN THIS GROUP

EXTERIOR BODY GROUP (CONTINUED)
COMPONENT PARTS FOR AWNINGS

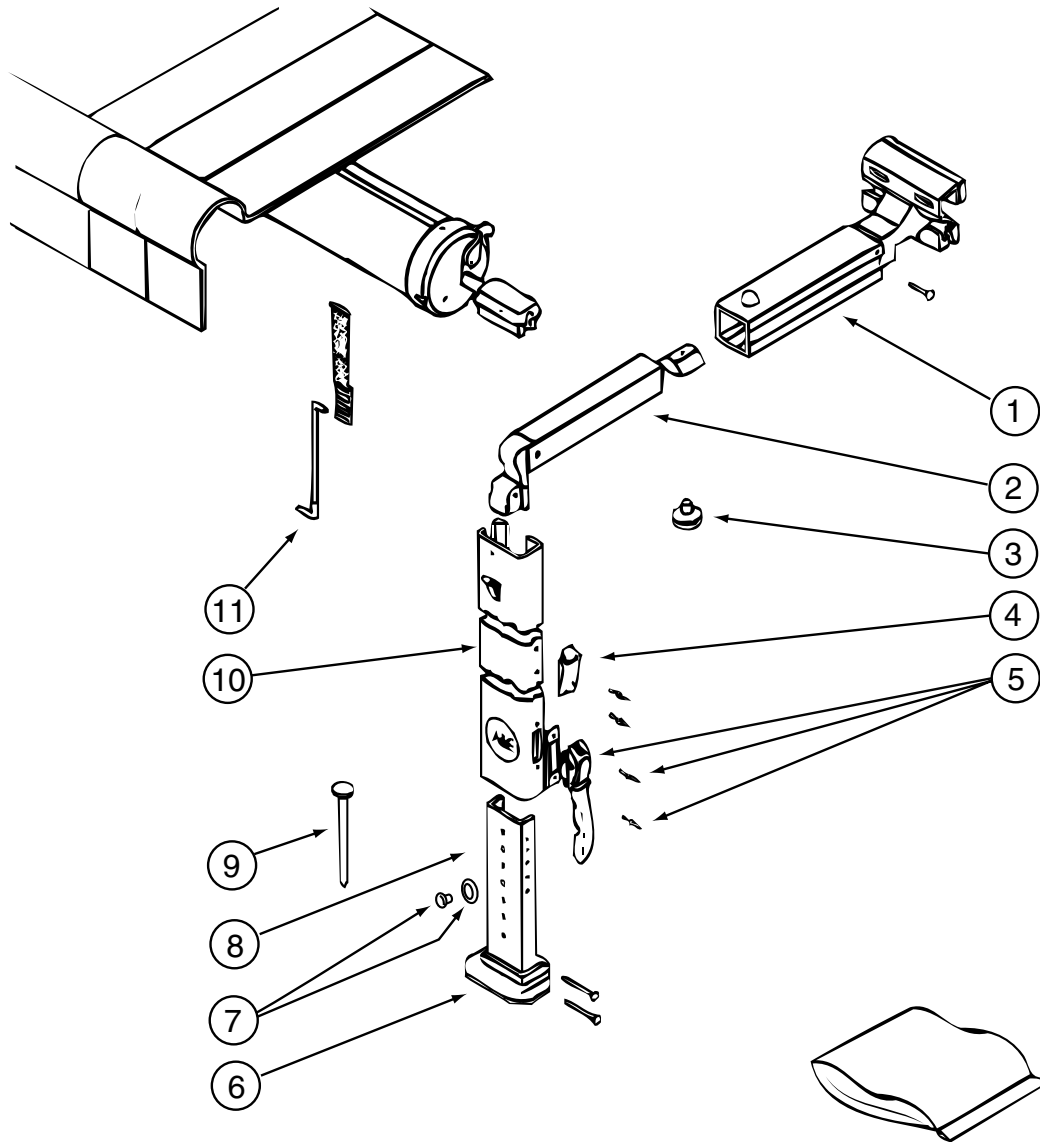

113874-01-02A

KEY	PART NUMBER	U/M	DESCRIPTION	VENDOR NO.
1	113874-01-714	EA	RAFTER - MAIN RH/LH BRT/WHT	830295.536F
2	113874-01-715	EA	RAFTER - SECONDARY BRT/WHT	830463.511F
3	113874-01-702	EA	KNOB - ADJUSTING	3105421.014
4	113874-01-706	EA	LOCK - TRAVEL	830587.001
5	113874-01-707	EA	HANDLE - LIFT W/RIVETS	830644
6	113874-01-712	EA	FOOT - PATIO	730366-001
7	113874-01-710	EA	PLUG-STOP KIT	830456
8	113874-01-717	EA	ARM - ADJUSTABLE BRT/WHT	830467.517/F
9	113874-01-709	EA	NAIL-SPIKE, 8"	113006
10	113874-01-716	EA	ARM - MAIN SUPPORT BRT/WHT	3104502.293/F
11	113874-01-703	EA	ROD-CENTER PULL W/ACCESSORY	830152.102

EXTERIOR DOORS & COMPARTMENTS GROUP

DOOR & COMPARTMENT LAYOUT

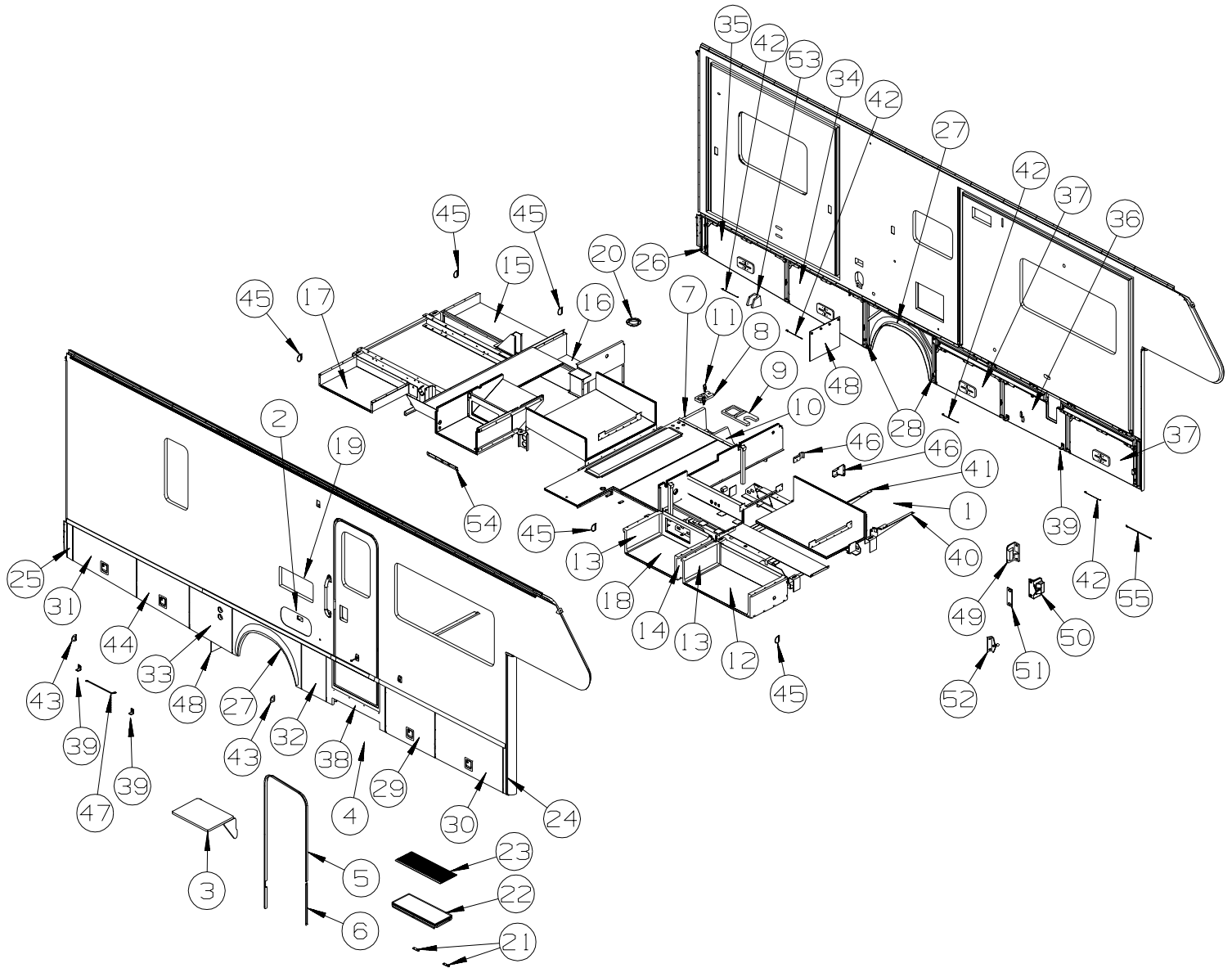

KEY	PART NUMBER	U/M	DESCRIPTION
1	147453-01-02B	EA	COMPARTMENT - STORAGE - E-COATED
2	126945-09-N42	EA	DOOR/STORAGE - W/O HARDWARE - 18" X 8.3"
	081801-V3-000	EA	HINGE - ALUMINUM - 2" X 96" - BRIGHT WHITE
	138290-02-000	EA	CASE - W/CAM - W/O CYLINDER/KEY
	139325-01-000	EA	SPACER - LOCK - 6MM
	139337-01-000	EA	GASKET - LOCK
3	142034-02-01A	EA	SHELF - F/EXTERIOR TV - BRIGHT WHITE
4*	094707-03-01A	EA	STEP - ELECTRIC DOUBLE - W/BLACK CONTROL BOX - KWIKEE
5	139100-07-01A	EA	GARNISH/RADIUS - ENTRY DOOR
6	139101-06-01A	EA	GARNISH/STRAIGHT - ENTRY DOOR
7	117186-07-P13	EA	COMPARTMENT - SEWER/POWER CORD
8	M06991-02-FQ0	EA	HATCH - F/POWER CORD/SEWER HOSE COMPT - 8.3"W X 3.9"H
9	M06991-04-FB1	EA	HATCH - F/POWER CORD/SEWER HOSE COMPT - 7.2"W X 15.4"H
10	116926-01-01A	EA	COMPARTMENT - SEWER - PLASTIC
11	121175-01-01A	EA	LATCH - SWELL - BLACK
12	135927-18-P13	EA	COMPARTMENT - LUGGAGE
13	126397-05-01A	EA	PANEL - END - COMPARTMENT/RIGHT HAND

EXTERIOR DOORS & COMPARTMENTS GROUP (CONTINUED)
DOOR & COMPARTMENT LAYOUT (CONTINUED)

KEY	PART NUMBER	U/M	DESCRIPTION
14	126397-06-01A	EA	PANEL - END - COMPARTMENT/LEFT HAND
15	135929-04-P13	EA	COMPARTMENT - LUGGAGE
16	135929-05-P13	EA	COMPARTMENT - LUGGAGE
17	135929-07-P13	EA	COMPARTMENT - LUGGAGE
			FROM: 00-00-00 THRU: 08-25-02
17	135929-08-P13	EA	COMPARTMENT - LUGGAGE
			FROM: 08-26-02 THRU: 99-99-99
18	142456-01-P13	EA	COMPARTMENT - LUGGAGE
19 *	084103-08-000	EA	DOOR - VENT - REFRIGERATOR - W/O JAMB - BRIGHT WHITE
	084104-08-000	EA	JAMB - VENT DOOR/REFRIGERATOR - BRIGHT WHITE
20	092887-03-000	EA	HATCH/PLATE - 6.1" FLANGE/4.5" R.O. - BLACK
21	101222-01-02A	EA	BRACKET - CATCH - LID - OFF WHITE
22	P14437-02-000	EA	CABINET - LID/ENTRY STEP - W/O CARPET
23	133114-03-03A	EA	TREAD - STEP/RUBBER - 27.1" - GRAY(P19, P20,P33)
23	133114-03-01A	EA	TREAD - STEP - RUBBER - 27.1" - TAUPE(P21, P22, P23, P24, P36, P40)
24	135764-02-P13	EA	PANEL/FILLER - VALANCE
			FROM: 00-00-00 THRU: 10-03-02
24	135764-01-M07	EA	PANEL/FILLER - VALANCE
			FROM: 10-04-02 THRU: 99-99-99
25	135764-03-M07	EA	PANEL/FILLER - VALANCE
26	135764-04-M07	EA	PANEL/FILLER - VALANCE
27	135983-02-P13	EA	PANEL - WHEEL LIP - REAR
28	113904-12-02B	EA	ANGLE - ATTACHMENT/WHEEL LIP - 17.7" - E-COAT
			FROM: 00-00-00 THRU: 10-23-02
28	134533-01-02B	EA	BRACKET - MOUNT - TRIM/LOWER - E-COATED
			FROM: 10-24-02 THRU: 11-03-02
28	123512-06-02B	EA	BRACKET - DOOR/VALANCE - E-COATED
			FROM: 11-04-02 THRU: 99-99-99
29	140552-18-P13	EA	VALANCE/DOOR - W/O PADDLE LATCH - 29.4" X 22.4"
	132873-A7-000	EA	ROD - LATCH - 8.6" W/3/4" DOG LEG
	132873-73-000	EA	ROD - LATCH - 10.4" W/3/4" DOG LEG
			FROM: 00-00-00 THRU: 10-22-02
	132873-24-000	EA	ROD - LATCH - 10.3" W/3/4" DOG LEG
			FROM: 10-23-02 THRU: 99-99-99
	107796-32-000	EA	SPRING/GAS - 9.5" COMPRESSED/15" EXTENDED - 90 LB - BLACK
30	140552-19-P13	EA	VALANCE/DOOR - W/O PADDLE LATCH - 40.6" X 22.4"
	132873-A8-000	EA	ROD - LATCH - 14.1" W/3/4" DOG LEG
	132873-A9-000	EA	ROD - LATCH - 16" W/3/4" DOG LEG
	107796-32-000	EA	SPRING/GAS - 9.5" COMPRESSED/15" EXTENDED - 90 LB - BLACK
31	140552-24-P13	EA	VALANCE/DOOR - PASS W/O PAD LATCH - 17.4" X 48.6" X 19.9"
			FROM: 00-00-00 THRU: 10-06-02
	132873-B1-000	EA	ROD - LATCH - 18.1" W/3/4" DOG LEG
	132873-82-000	EA	ROD - LATCH - 24.3" W/3/4" DOG LEG
	107796-27-000	EA	SPRING/GAS - 8.5" COMPRESSED/12" EXTENDED - 90 LB
31	140552-07-N09	EA	VALANCE/DOOR - PASS W/O PADDLE LATCH - 19.4" X 38" X 17.3"
			FROM: 10-07-02 THRU: 99-99-99
	132873-56-000	EA	ROD - LATCH - 12.9" W/3/4" DOG LEG
	132873-57-000	EA	ROD - LATCH - 14.6" W/3/4" DOG LEG
	107796-27-000	EA	SPRING/GAS - 8.5" COMPRESSED/12" EXTENDED - 90 LB
32	140552-20-P13	EA	VALANCE/DOOR - W/O PADDLE LATCH - 14.6" X 22.4"
	112091-01-000	FT	SEAL/D - NEOPRENE - HEAT ACTIVE ADHESIVE - .9" X .7"
33	140552-21-P13	EA	VALANCE/DOOR - PASS W/O PADDLE LATCH - 22.4" X 46.6" X 20"
	112091-01-000	FT	SEAL/D - NEOPRENE - HEAT ACTIVE ADHESIVE - .9" X .7"
34	140552-22-P13	EA	VALANCE/DOOR - DRVR W/O PADDLE LATCH - 22.4" X 46.6" X 20"
	132873-68-000	EA	ROD - LATCH - 17.2" W/3/4" DOG LEG
	132873-69-000	EA	ROD - LATCH - 19" W/3/4" DOG LEG
	107796-32-000	EA	SPRING/GAS - 9.5" COMPRESSED/15" EXTENDED - 90 LB - BLACK
35	140552-23-P13	EA	VALANCE/DOOR - DRVR W/O PAD LATCH - 17.4" X 48.6" X 19.9"
	132873-B1-000	EA	ROD - LATCH - 18.1" W/3/4" DOG LEG
	132873-B2-000	EA	ROD - LATCH - 20.1" W/3/4" DOG LEG
	107796-27-000	EA	SPRING/GAS - 8.5" COMPRESSED/12" EXTENDED - 90 LB

EXTERIOR DOORS & COMPARTMENTS GROUP (CONTINUED)
DOOR & COMPARTMENT LAYOUT (CONTINUED)

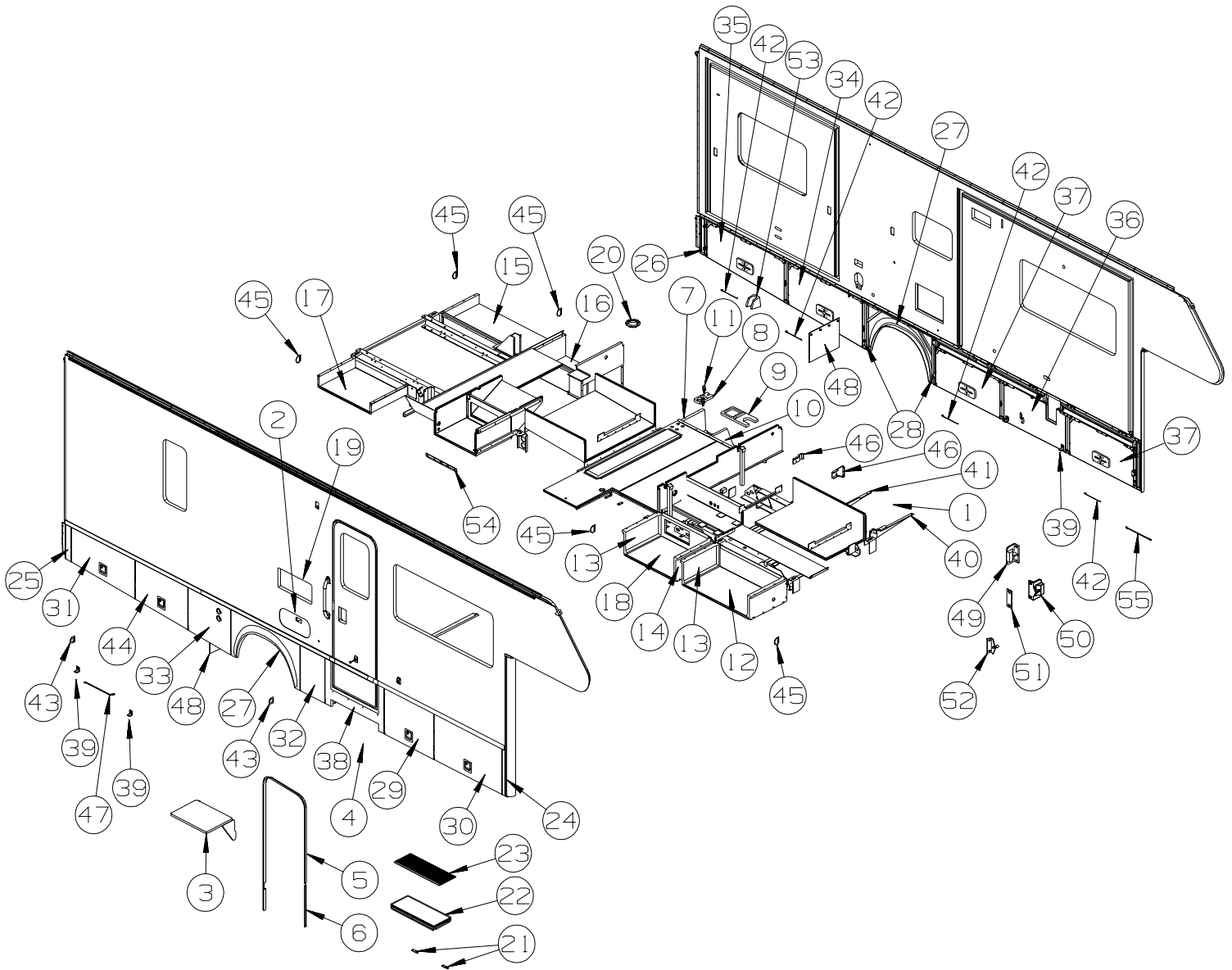

KEY	PART NUMBER	U/M	DESCRIPTION	
36	140552-25-P13	EA	VALANCE/DOOR - W/O PADDLE LATCH - W/NOTCH - 39.2" X 18.5"	
37	140552-26-P13	EA	VALANCE/DOOR - W/O PADDLE LATCH - 40.6" X 18.5"	
	132873-A8-000	EA	ROD - LATCH - 14.1" W/3/4" DOG LEG	
	132873-A9-000	EA	ROD - LATCH - 16" W/3/4" DOG LEG	
	107796-36-000	EA	SPRING/GAS - 12" EXTENDED - 45 LBS	
38	143065-01-P13	EA	VALANCE/PANEL - ENTRY DOOR - HORSESHOE - 35.4" - BLACK	
39	119568-01-01A	EA	STANDOFF - VALANCE PANEL - BLACK	
40	143938-01-02B	EA	BRACKET - GENERATOR - E-COATED	
41	143938-02-02B	EA	BRACKET - GENERATOR - E-COATED	
42	076767-15-000	EA	CABLE - STAINLESS STEEL - 9.8"	
43	112091-01-000	FT	SEAL/D - NEOPRENE - HEAT ACTIVE ADHESIVE - .9" X .7"	
44	140552-27-P13	EA	VALANCE/DOOR - PASS W/O PAD LATCH - 21.1" X 31.5" X 19.4"	
	107796-27-000	EA	SPRING/GAS - 8.5" COMPRESSED/12" EXTENDED - 90 LB	
45	126516-01-01A	FT	TRIM - VINYL/EXTRUDED - 8'	
				FROM: 00-00-00 THRU: 12-27-02
45	143749-01-01A	EA	EXTRUDED - VINYL - TRIM	FROM: 12-28-02 THRU: 99-99-99
46	143491-01-02B	EA	BRACKET/SUPPORT - E-COATED	FROM: 00-00-00 THRU: 08-25-02
46	143490-01-02B	EA	BRACKET/SUPPORT - E-COATED	FROM: 08-26-02 THRU: 99-99-99

EXTERIOR DOORS & COMPARTMENTS GROUP (CONTINUED)
DOOR & COMPARTMENT LAYOUT (CONTINUED)

KEY	PART NUMBER	U/M	DESCRIPTION
47	107865-01-000	EA	ROD - SUPPORT - VALANCE PANEL - 14.3"
48	136389-03-02B	EA	GUARD/ROCK - STEEL - W/BEND - 18"W X 7.1"H - E-COATED FROM: 00-00-00 THRU: 11-03-02
48	136389-01-02B	EA	GUARD/ROCK - STEEL - W/BEND - 18"W X 10.9"H - E-COATED FROM: 11-04-02 THRU: 99-99-99
49	130053-01-01A	EA	STRIKER - LUGGAGE DOOR - FLUSH - BLACK
50	130053-02-01A	EA	STRIKER - LUGGAGE DOOR - OFF SET - BLACK
51	120494-03-02B	EA	SHIM - STRIKER - LUGGAGE DOOR - .20 - E-COATED FROM: 00-00-00 THRU: 01-05-03
51	143793-01-01A	EA	SHIM/STRIKER - LUGGAGE - 1.5" - BLACK FROM: 01-06-03 THRU: 99-99-99
52	126263-02-02B	EA	BRACKET - GAS SPRING W/BALL STUD - E-COATED
53	131383-03-02A	EA	BRACKET - SHOWER HEAD - WHITE
54	143627-01-02B	EA	ANGLE - W/HOLES - E-COATED
55	107865-06-000	EA	ROD - SUPPORT - VALANCE PANEL - 15"
	116975-01-01A	EA	LATCH - W/O STRIKE - BLACK - NEW STYLE
	116800-55-005	EA	EXTRUDED CHANNEL - 192" - BRIGHT WHITE
	138292-01-000	EA	SEAL - LOCK CYLINDER
	132892-03-01A	EA	SEAL - BULB - W/LEG
	138289-01-000	EA	CYLINDER - LOCKING
	138289-02-000	EA	CYLINDER - LOCKING
	138289-03-000	EA	CYLINDER - LOCKING
	138289-04-000	EA	CYLINDER - LOCKING
	138289-05-000	EA	CYLINDER - LOCKING
	138289-06-000	EA	CYLINDER - LOCKING
	138289-07-000	EA	CYLINDER - LOCKING
	138289-08-000	EA	CYLINDER - LOCKING
	138289-09-000	EA	CYLINDER - LOCKING
	138289-10-000	EA	CYLINDER - LOCKING
	138288-01-000	EA	KEY - REVERSIBLE - #1151 - T/M 16169-02-3091
	138288-02-000	EA	KEY - REVERSIBLE - #1151 - T/M 16169-02-3091
	138288-03-000	EA	KEY - REVERSIBLE - #1151 - T/M 16169-02-3091
	138288-04-000	EA	KEY - REVERSIBLE - #1151 - T/M 16169-02-3091
	138288-05-000	EA	KEY - REVERSIBLE - #1151 - T/M 16169-02-3091
	138288-06-000	EA	KEY - REVERSIBLE - #1151 - T/M 16169-02-3091
	138288-07-000	EA	KEY - REVERSIBLE - #1151 - T/M 16169-02-3091
	138288-08-000	EA	KEY - REVERSIBLE - #1151 - T/M 16169-02-3091
	138288-09-000	EA	KEY - REVERSIBLE - #1151 - T/M 16169-02-3091
	138288-10-000	EA	KEY - REVERSIBLE - #1151 - T/M 16169-02-3091

***COMPONENT PARTS LISTED LATER IN THIS GROUP**

EXTERIOR DOORS & COMPARTMENTS GROUP (CONTINUED)
COMPARTMENT DOOR PIECE PARTS

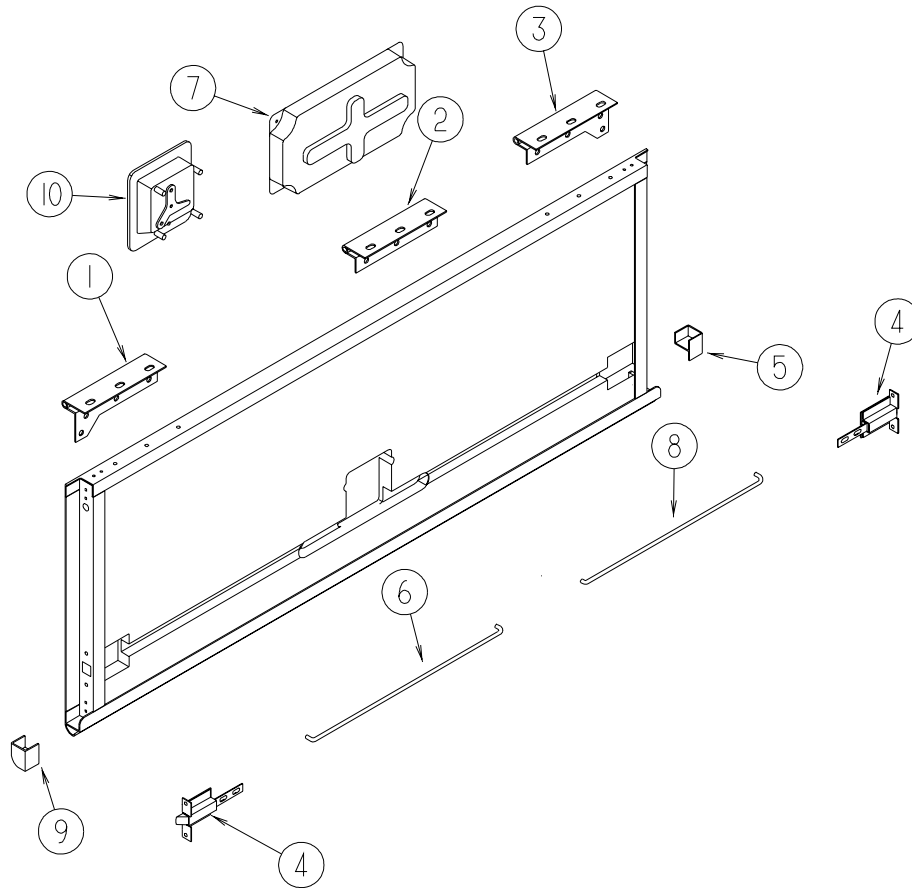

KEY	PART NUMBER	U/M	DESCRIPTION
1	139793-02-01A	EA	HINGE - LEFT HAND/VALANCE DOOR - W/BALLSTUD
2	139793-03-01A	EA	HINGE - CENTER/VALANCE DOOR - W/O BALLSTUD
3	139793-04-01A	EA	HINGE - RIGHT HAND/VALANCE DOOR - W/O BALLSTUD
4	121947-01-01A	EA	BOLT - SLIDE W/PLASTIC PLUNGER
5	135276-01-01A	EA	REINFORCEMENT - CORNER - RIGHT HAND
6	132873-02-000	EA	ROD - LATCH (BLANK)
6			SEE DOOR & COMPARTMENT LAYOUT FOR ROD-LATCH
7	137359-01-01A	EA	COVER - LATCH - WHITE
8	132873-01-000	EA	ROD - LATCH (BLANK)
8			SEE DOOR & COMPARTMENT LAYOUT FOR ROD-LATCH
9	135276-02-01A	EA	REINFORCEMENT - CORNER - LEFT HAND
10	138277-01-01A	EA	LATCH/PADDLE - COMPARTMENT DOOR - BLACK - KEY ONE
			FROM: 00-00-00 THRU: 10-22-02
10	112949-02-05A	EA	LATCH - PADDLE NON-LOCKING - BLACK
			FROM: 10-23-02 THRU: 99-99-99

EXTERIOR DOORS & COMPARTMENTS GROUP (CONTINUED)
COMPARTMENT DOOR PIECE PARTS (CONTINUED)

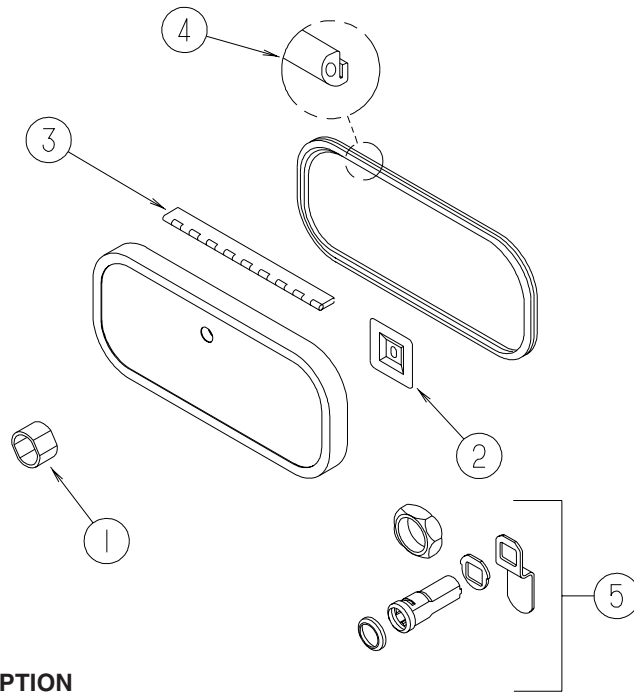

KEY	PART NUMBER	U/M	DESCRIPTION
1	139325-01-000	EA	SPACER - LOCK - 6MM
	139337-01-000	EA	GASKET - LOCK
2	097111-02-04A	EA	POCKET - LOCK - VALANCE
3	081801-V3-000	EA	HINGE - ALUMINUM - 2" X 96" - BRIGHT WHITE
4	106850-02-000	FT	SEAL-E - SPONGE RUBBER - .43" X .75"
5	138290-02-000	EA	CASE - W/CAM - W/O CYLINDER/KEY

EXTERIOR DOORS & COMPARTMENTS GROUP (CONTINUED)

ENTRY

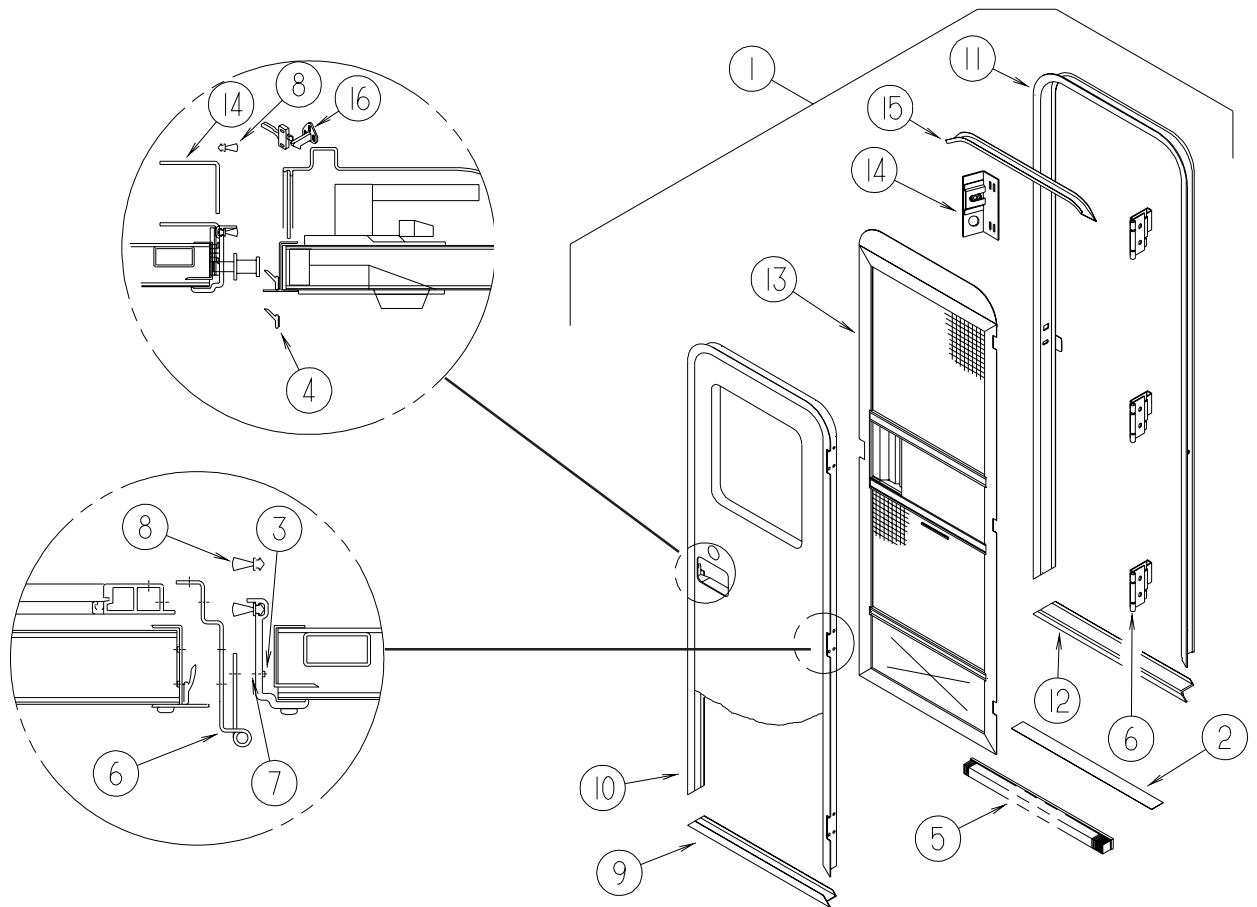

KEY	PART NUMBER	U/M	DESCRIPTION
1	P32206-10-N02	EA	DOOR - ENTRY W/SCREEN DOOR - W/O WINDOW LATCH (P19, P20, P33)
1	P32206-10-P15	EA	DOOR - ENTRY W/SCREEN DOOR - W/O WINDOW LATCH (P21, P22, P36)
1	P32206-10-N09	EA	DOOR - ENTRY W/SCREEN DOOR - W/O WINDOW LATCH (P23, P24, P40)
2	038327-01-000	FT	TAPE - ANTI-SLIP - 2" X 60'
3	039715-01-000	EA	NUT-SERT - 1/4" DIAMETER - 20 THREADS
4	075671-04-000	FT	SEAL - SPONGE - LAZY T - W/ADHESIVE STRIP - .5" WIDE
5	075673-05-000	FT	SEAL - PILE - ADHESIVE BACK - BLACK
6	106719-01-05A	EA	HINGE - ENTRY DOOR - BRIGHT WHITE
7	116111-02-01A	EA	SCREW - TAPTITE - 1/4-20 X 3/8 PPH 0 ZINC
8	118929-01-01A	FT	SEAL - PILE - PUSH ON
9	121893-01-01A	EA	FRAME - ENTRY DOOR/BOTTOM - BRIGHT WHITE
10	121894-23-01A	EA	FRAME - ENTRY DOOR - BRIGHT WHITE
11	121898-18-01A	EA	JAMB - ENTRY DOOR - BRIGHT WHITE
12	051049-01-000	EA	JAMB/DOOR - BOTTOM - 25.9" - UNPAINTED
13	132208-04-L07	EA	DOOR - SCREEN - W/O HARDWARE
14	137401-01-03B	EA	BRACKET - DOOR ANGLE - OFF WHITE
15	044582-44-000	EA	CAP - DRIP - JAMB - BRIGHT WHITE
			FROM: 00-00-00 THRU: 08-04-02
15	139054-01-01A	EA	CAP - TRIM - CORNER/PASSENGER
			FROM: 08-05-02 THRU: 99-99-99
16	132915-01-01A	EA	LATCH - SCREEN DOOR - BLACK
	138287-01-000	EA	CYLINDER/LOCK - ENTRY DOOR (MASTER)
	138287-02-000	EA	CYLINDER/LOCK - ENTRY DOOR (MASTER)
	138287-03-000	EA	CYLINDER/LOCK - ENTRY DOOR (MASTER)
	138287-04-000	EA	CYLINDER/LOCK - ENTRY DOOR (MASTER)
	138287-05-000	EA	CYLINDER/LOCK - ENTRY DOOR (MASTER)
	138287-06-000	EA	CYLINDER/LOCK - ENTRY DOOR (MASTER)
	138287-07-000	EA	CYLINDER/LOCK - ENTRY DOOR (MASTER)
	138287-08-000	EA	CYLINDER/LOCK - ENTRY DOOR (MASTER)
	138287-09-000	EA	CYLINDER/LOCK - ENTRY DOOR (MASTER)
	138287-10-000	EA	CYLINDER/LOCK - ENTRY DOOR (MASTER)

EXTERIOR DOORS & COMPARTMENTS GROUP (CONTINUED)
ENTRY (CONTINUED)

KEY	PART NUMBER	U/M	DESCRIPTION
	138288-01-000	EA	KEY - REVERSIBLE - #1151 - T/M 16169-02-3091
	138288-02-000	EA	KEY - REVERSIBLE - #1152 - T/M 16169-02-3092
	138288-03-000	EA	KEY - REVERSIBLE - #1153 - T/M 16169-02-3093
	138288-04-000	EA	KEY - REVERSIBLE - #1154 - T/M 16169-02-3094
	138288-05-000	EA	KEY - REVERSIBLE - #1155 - T/M 16169-02-3095
	138288-06-000	EA	KEY - REVERSIBLE - #1156 - T/M 16169-02-3096
	138288-07-000	EA	KEY - REVERSIBLE - #1157 - T/M 16169-02-3097
	138288-08-000	EA	KEY - REVERSIBLE - #1158 - T/M 16169-02-3098
	138288-09-000	EA	KEY - REVERSIBLE - #1159 - T/M 16169-02-3099
	138288-10-000	EA	KEY - REVERSIBLE - #1150 - T/M 16169-02-3100

SCREEN

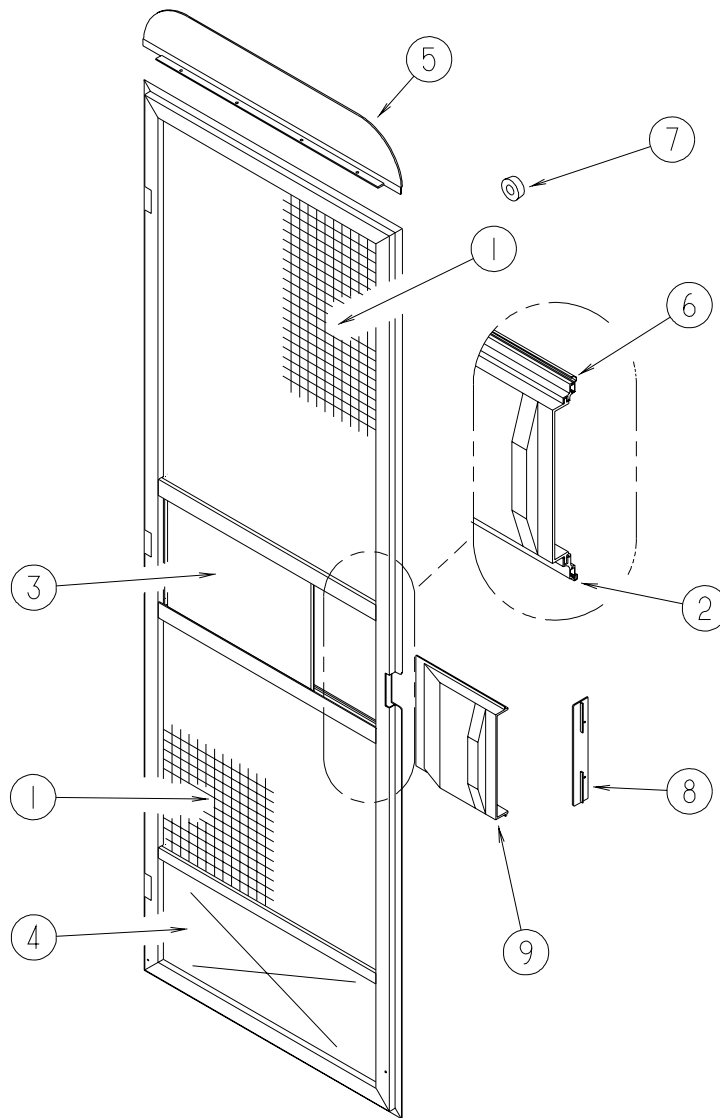

KEY	PART NUMBER	U/M	DESCRIPTION
1	002293-02-000	SF	SCREEN - 26" - CHARCOAL
2	002294-01-000	FT	SPLINE - SCREENING - .13" X .14"
3	016454-21-000	EA	INSERT - SCREEN DOOR - CENTER
4	078552-03-000	EA	KICK PANEL - SCREEN DOOR - LOWER INSERT - UNPAINTED
5	078595-01-000	EA	TOP PLATE - SCREEN DOOR - CURVED TOP - 4.7" X 25.35"
6	078777-08-000	FT	CHANNEL - SLIDER
7	120863-06-000	EA	BUMPER - RUBBER - 3/4" X 3/8"
8	132081-01-01A	EA	STRIKE - SLIDER - SCREEN DOOR - BRIGHT WHITE
9	132082-01-01A	EA	SLIDER - SCREEN DOOR - BRIGHT WHITE

EXTERIOR DOORS & COMPARTMENTS GROUP (CONTINUED)

LATCH - ENTRY

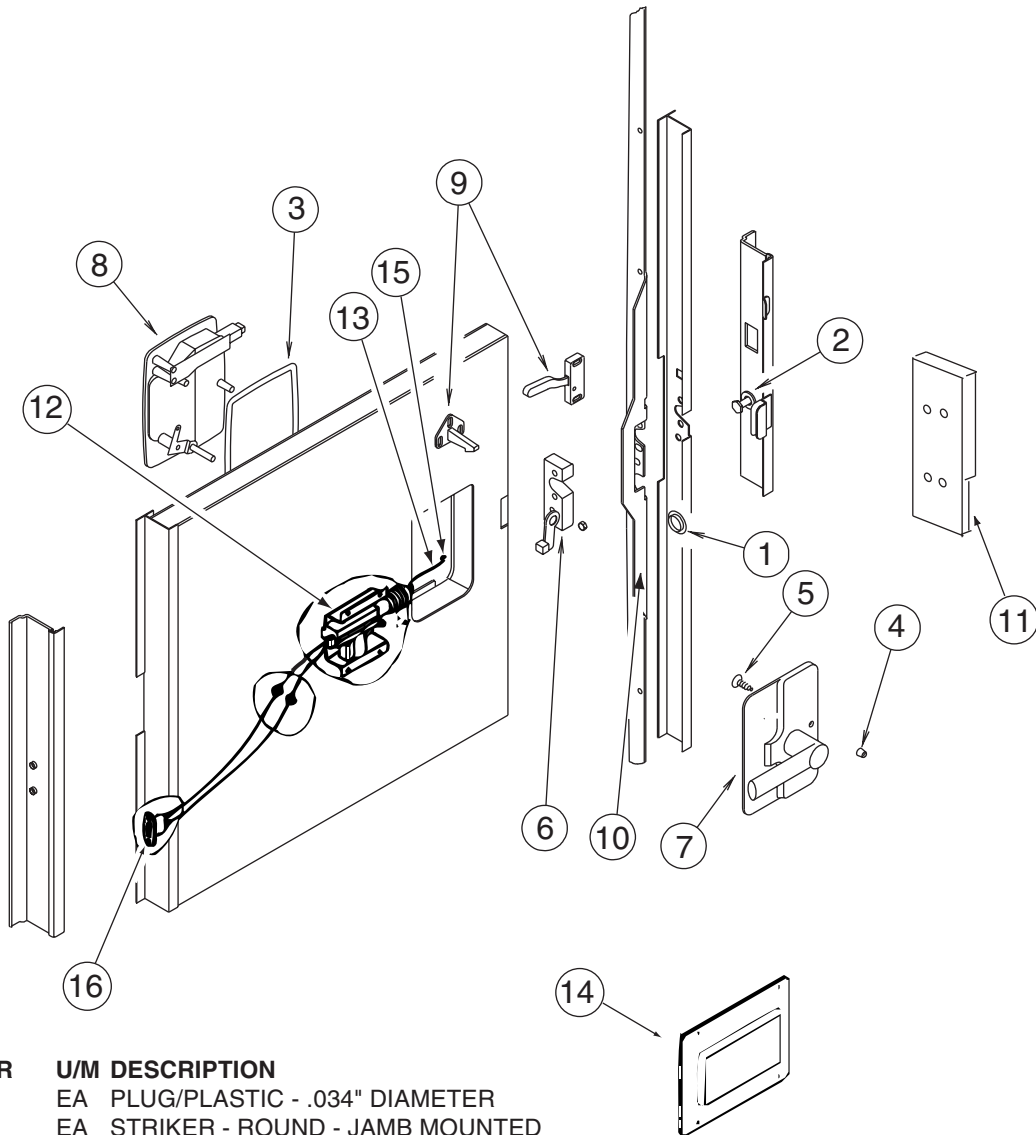

KEY	PART NUMBER	U/M	DESCRIPTION
1	061420-14-000	EA	PLUG/PLASTIC - .034" DIAMETER
2	092927-14-000	EA	STRIKER - ROUND - JAMB MOUNTED
3	112782-04-01A	EA	GASKET
4	112782-05-01A	EA	CAP - VINYL - RED
5	112782-08-01A	EA	SCREW - MOUNTING/PLATE - ZINC
6	112782-15-01A	EA	LATCH - SINGLE ROTOR
7	112782-16-01A	EA	LATCH - INTERIOR PLATE
8	112782-18-01A	EA	LATCH - EXTERIOR - W/O LOCK CYLINDER W/ICON-REVERSIBLE KEY
9	132915-01-01A	EA	LATCH - SCREEN DOOR
10	132207-01-02B	EA	STIFFENER/DOOR - FORMED - E-COATED
	072893-04-000	EA	NUTSERT - 10-32
11	139102-01-01A	EA	COVER - BRACKET - STRIKE - BRIGHT WHITE
12	113650-02-02B	EA	BRACKET - ACTUATOR - ELECTRIC - E-COATED
	138898-01-000	EA	ACTUATOR/LOCK - ELECTRIC
13	113651-01-01A	EA	ROD - CONTROL - MOTOR/LOCK
14	113960-01-01A	EA	COVER - ACTUATOR - POWER LOCK
15	114209-01-01A	EA	PUSHNUT - CAP - 1/8" - WHITE
16	138897-01-000	EA	CONTACT/PIN - 2 POSITION

EXTERIOR SLIDEOUT GROUP FRONT LEFT

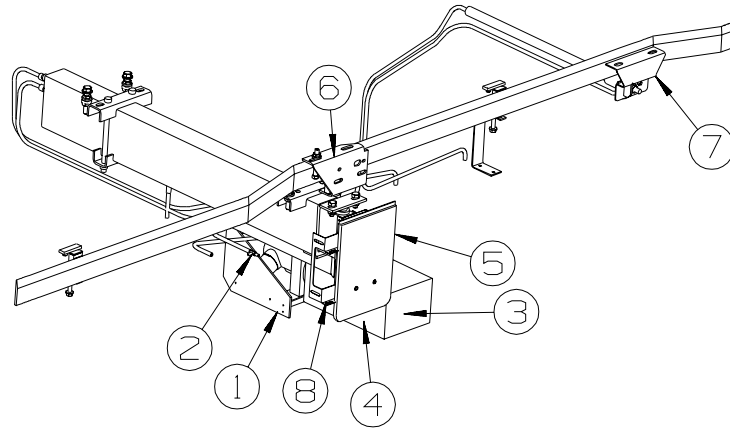

KEY	PART NUMBER	U/M	DESCRIPTION
1	107938-08-000	EA	BRACKET - PUMP
2	123264-01-000	EA	TEE - UNION - 1/4" X 1/4" X 1/4"
3*	136747-01-000	EA	PUMP - SLIDEOUT - 2 ROOM
4*	143394-01-000	EA	SLIDEOUT - HYDRAULIC KIT
5	138077-04-P13	EA	COVER - RAM
	138077-03-01A	EA	COVER - RAM - BRIGHT WHITE
6	127030-02-02B	EA	BRACKET - INNER REAR/MOUNT - E-COATED
7	143198-01-02B	EA	BRACKET/MOUNT - F/SLIDEOUT - E-COATED
8	145262-01-02B	EA	BRACKET - RAM - E-COATED

***COMPONENT PARTS LISTED LATER IN THIS GROUP**

EXTERIOR SLIDEOUT GROUP (CONTINUED)
FRONT LEFT (CONTINUED)

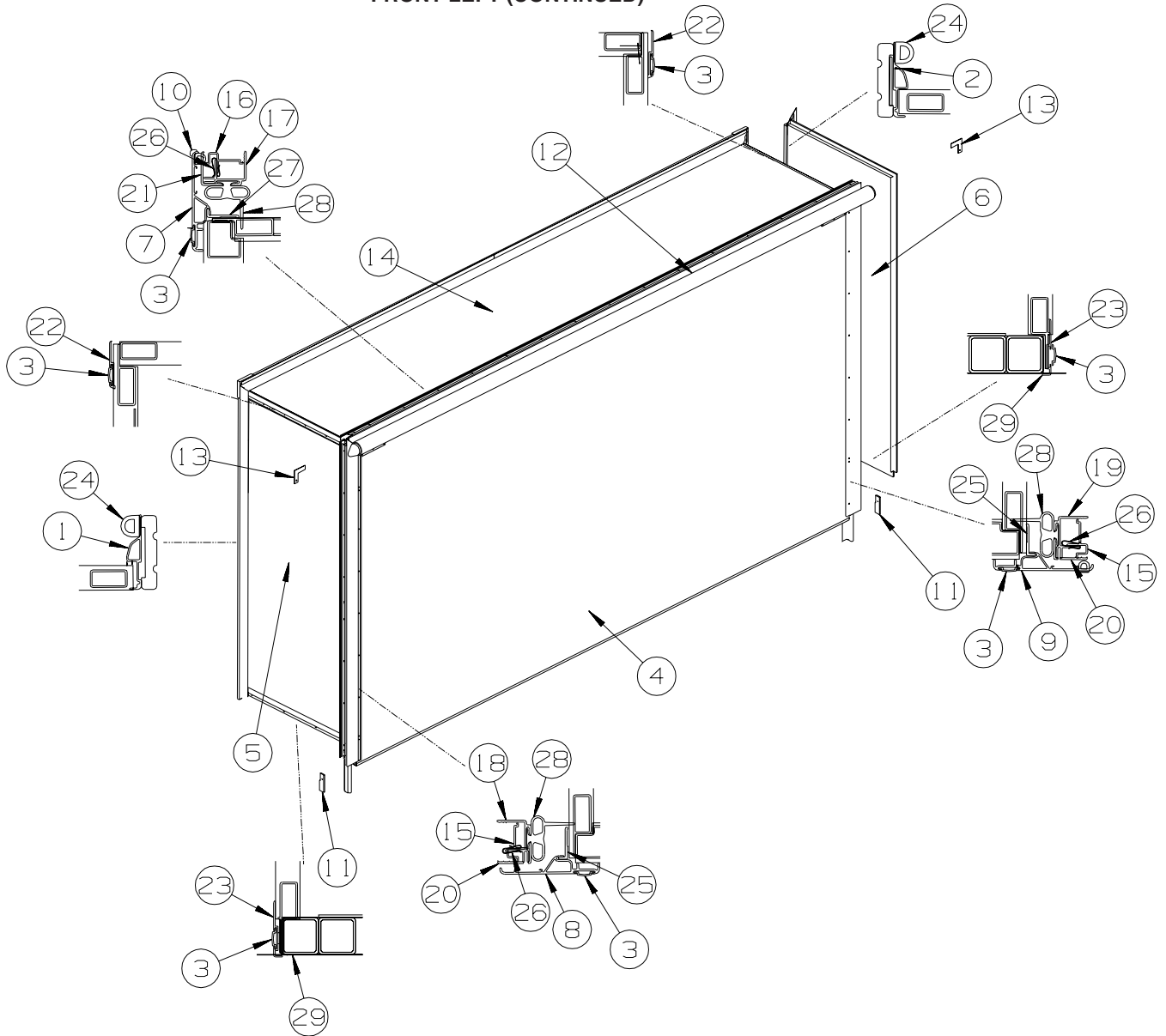

KEY	PART NUMBER	U/M	DESCRIPTION
1	139624-01-01A	EA	TRIM/SEAL - INNER/RIGHT HAND - 73.4" - BRIGHT WHITE
2	139624-02-01A	EA	TRIM/SEAL - INNER/LEFT HAND - 73.4" - BRIGHT WHITE
3	105312-01-07A	FT	INSERT - FEATURE STRIP - VINYL - BRIGHT WHITE
4	141510-11-P13	EA	SLUG - SLIDEOUT (P19, P20, P33)
4	141510-11-P15	EA	SLUG - SLIDEOUT (P21, P22, P36)
4	141510-11-P17	EA	SLUG - SLIDEOUT (P23, P24, P40)
5	121401-07-N32	EA	PANEL - SLIDEOUT - FRONT (P19, P20, P33)
5	121401-07-P38	EA	PANEL - SLIDEOUT - FRONT (P21, P22, P36)
5	121401-07-P37	EA	PANEL - SLIDEOUT - FRONT (P23, P24, P40)
6	121402-05-P13	EA	PANEL - SLIDEOUT - REAR (P19, P20, P33)
6	121402-05-P15	EA	PANEL - SLIDEOUT - REAR (P21, P22, P36)
6	121402-05-P17	EA	PANEL - SLIDEOUT - REAR (P23, P24, P40)
7	139625-25-01A	EA	TRIM/SEAL - TOP/W/MITERED ENDS - 107" - BRIGHT WHITE
8	139625-13-01A	EA	TRIM/SEAL - LEFT HAND - 79.4" - BRIGHT WHITE
9	139625-13-01A	EA	TRIM/SEAL - RIGHT HAND - 79.4" - BRIGHT WHITE
10	117058-01-01A	FT	TAPE - LOOP - 3/4" WIDE - ADHESIVE BACKED
11	126546-01-02A	EA	COVER - END/SIDEWALL SLIDEOUT - BRIGHT WHITE
12	122977-11-03A	EA	AWNING/SLIDEOUT W/COVER - 120" - WHITE - VINYL/VINYL WRAP
13	116444-04-12B	EA	TRIM/KEY CORNER - SLIDEOUT - 3.1"X3.1" - BRT WHT
14	136559-01-M76	EA	ROOF - W/O LIGHTS/VENTS - W/WIRING - F/SLIDEOUT
15	142718-01-01A	EA	RETAINER - SIDEWALL/SLIDEOUT - 72.8" - MILL
16	142718-16-01A	EA	RETAINER - SIDEWALL/SLIDEOUT - 104.7"
17	142719-16-01A	EA	TRIM/SIDEWALL - TOP/SLIDEOUT - 106.3" - BRIGHT WHITE

EXTERIOR SLIDEOUT GROUP (CONTINUED)
FRONT LEFT (CONTINUED)

KEY	PART NUMBER	U/M	DESCRIPTION
18	142720-01-01A	EA	TRIM - SIDEWALL/SLIDEOUT - 74.8" - BRIGHT WHITE FROM: 00-00-00 THRU: 10-27-02
18	142720-08-01A	EA	TRIM - SIDEWALL/SLIDEOUT - 74.4" - BRIGHT WHITE FROM: 10-28-02 THRU: 99-99-99
19	142720-02-01A	EA	TRIM - SIDEWALL/SLIDEOUT - 74.8" - BRIGHT WHITE FROM: 00-00-00 THRU: 10-27-02
19	142720-06-01A	EA	TRIM - SIDEWALL/SLIDEOUT - 74.4" - BRIGHT WHITE FROM: 10-28-02 THRU: 99-99-99
20	136824-01-01A	EA	TRIM - SIDEWALL/SLIDEOUT - 74.9" - BRIGHT WHITE FROM: 00-00-00 THRU: 10-27-02
20	136824-38-01A	EA	TRIM - SIDEWALL/SLIDEOUT - 74.6" - BRIGHT WHITE FROM: 10-28-02 THRU: 99-99-99
21	136824-24-01A	EA	TRIM - SIDEWALL/SLIDEOUT - 60.5" - BRIGHT WHITE
22	138659-01-01A	EA	TRIM/FEATURE STRIP - 181.7" - BRIGHT WHITE
23	125051-01-01A	EA	TRIM - FEATURE STRIP/LOWER - 20.2" - BRIGHT WHITE
24	112091-01-000	FT	SEAL/D - NEOPRENE - HEAT ACTIVE ADHESIVE - .9" FROM: 00-00-00 THRU: 01-12-03
24	146056-01-000	FT	SEAL - TRIANGLE - W/PSA FROM: 01-13-03 THRU: 99-99-99
25	133954-09-01A	EA	TRIM/SEAL - W/MITERED ENDS - 71.6" - BRIGHT WHITE
26	142549-01-000	EA	CLIP-S TYPE
27	133954-32-01A	EA	TRIM/SEAL - W/MITERED ENDS - 107.1" - BRIGHT WHITE
28	136978-01-01A	FT	SEAL - SLIDEOUT - BLACK
29	075673-05-000	FT	SEAL - PILE - ADHESIVE BACK - BLACK

EXTERIOR SLIDEOUT GROUP (CONTINUED)
FRONT LEFT (CONTINUED)

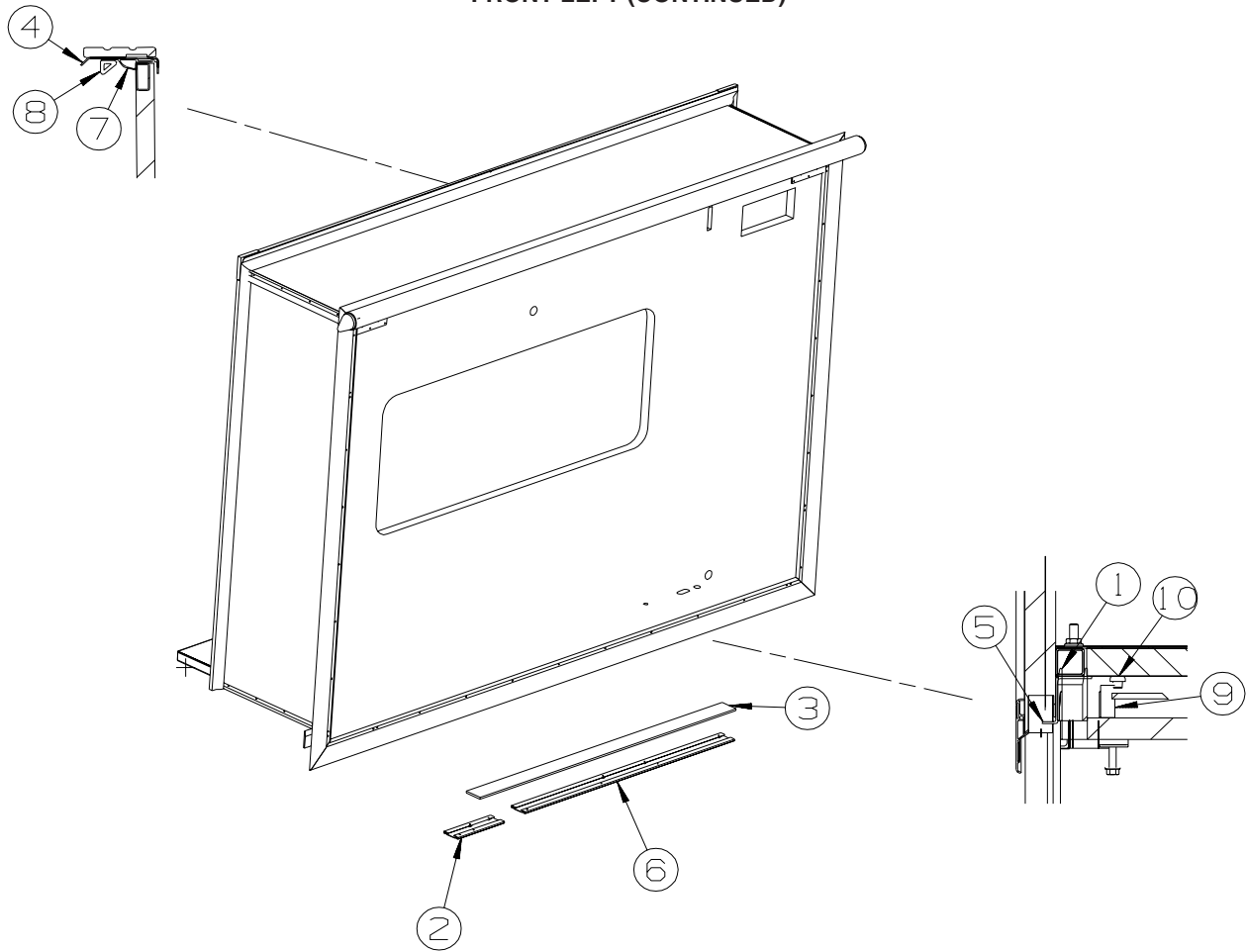

KEY	PART NUMBER	U/M	DESCRIPTION
1	115075-03-000	FT	SEAL - WIPE - .25" X 2.9"
2	115325-06-02A	EA	RAIL - FLOOR/SLIDEOUT ROOM - BLACK - 19.6" LONG
3	115661-01-000	FT	SHOE/GLIDE - SLIDEOUT ROOM - 1/16" X 3" - POLYETHYLENE
4	125466-07-01A	EA	SUPPORT - ROOF/INTERIOR - OFF WHITE
5	128621-31-01A	EA	BRACKET/ZEE - SLIDEOUT - 113.1" - MILL
6	115325-08-02A	EA	RAIL - FLOOR/SLIDEOUT ROOM - BLACK
7	139624-03-01A	EA	TRIM/SEAL - INNER/TOP - 117.7" - BRIGHT WHITE
8	112091-01-000	FT	SEAL/D - NEOPRENE - HEAT ACTIVE ADHESIVE - .9"
			FROM: 00-00-00 THRU: 01-12-03
8	146056-01-000	FT	SEAL - TRIANGLE - W/PSA
			FROM: 01-13-03 THRU: 99-99-99
9	126313-09-02B	EA	SUPPORT - ROLLER - E-COATED
10	134855-01-000	EA	BEARING PAD - NARROW

EXTERIOR SLIDEOUT GROUP (CONTINUED)
FRONT LEFT (CONTINUED)

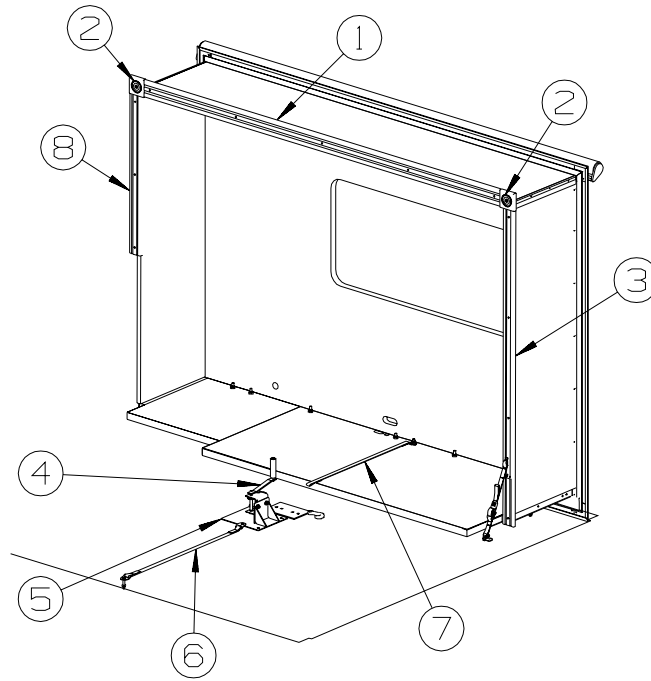

KEY	PART NUMBER	U/M	DESCRIPTION
1	132663-25-08A	EA	MOLDING-VINYL,014X97X2480 - PORTSMOUTH OAK
1	132663-25-07A	EA	MOLDING-VINYL,014X97X2480 - CONCERT CHERRY
1	132663-25-07A	EA	MOLDING-VINYL,014X97X2480 - WASHED MAPLE
2	132844-01-08A	EA	BLOCK - CORNER - 3.9" X 3.9" - PORTSMOUTH OAK
2	132844-01-02A	EA	BLOCK - CORNER - 3.9" X 3.9" - SALEM CHERRY - CONCERT CHERRY
2	132844-01-03A	EA	BLOCK - CORNER - 3.9" X 3.9" - WASHED MAPLE
3	132663-04-08A	EA	MOLDING-VINYL WRAP/PRE DRILLED - .6" X 3" X 70.4" - OAK - PORTSMOUTH OAK
3	132663-04-07A	EA	MOLDING-VINYL WRAP/PRE DRILLED-.6"X3"X70.4" - CHERRY - CONCERT CHERRY
3	132663-04-03A	EA	MOLDING-VINYL WRAP/PRE DRILLED-.6"X3"X70.4" - WASHED MAPLE
4	115767-02-000	EA	WINCH - SLIDEOUT W/10' STRAP
5	116082-01-02B	EA	BRACKET - WINCH
	069726-02-000	EA	BUMPER - .88" OD X .40" THICK - BLACK
6	116101-03-H13	EA	STRAP - WINCH - 39.5" CENTER BRACKET/CENTER
	140221-01-02B	EA	WASHER - SEAT BELT - E-COAT
7	116101-02-F31	EA	STRAP - WINCH - 34" CENTER BRACKET/STRAP END
8	132663-13-08A	EA	MOLDING-VINYL WRAP/PRE DRILLED-.6"X3"X35.7" - OAK - PORTSMOUTH OAK
8	132663-13-07A	EA	MOLDING-VINYL WRAP/PRE DRILLED- .6" X 3" X 35.7" - CONCERT CHERRY
8	132663-13-03A	EA	MOLDING-VINYL WRAP/PRE DRILLED- .6" X 3" X 35.7" - WASHED MAPLE

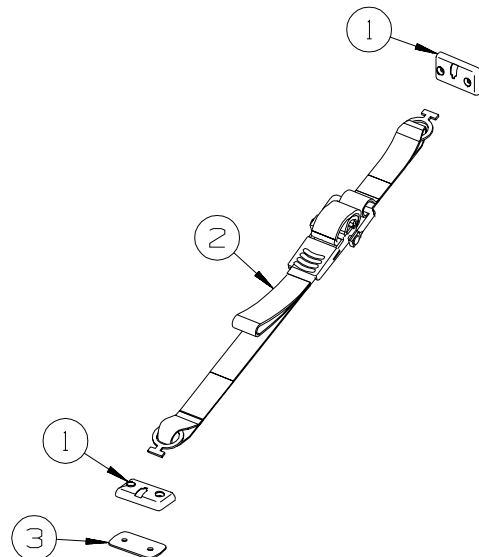

KEY	PART NUMBER	U/M	DESCRIPTION
1	135619-02-01A	EA	PLATE - TIEDOWN - SLIDEOUT ROOM
2	135619-01-01A	EA	STRAP - TIEDOWN - SLIDEOUT ROOM
3	135622-01-01B	EA	PLATE - TIEDOWN - SLIDEOUT ROOM

EXTERIOR SLIDEOUT GROUP (CONTINUED)
COMPONENT PARTS FOR FRONT SLIDEOUT

136747-01-000

KEY	PART NUMBER	U/M	DESCRIPTION	VENDOR NO.
	100532-01-713	EA	PUMP/MOTOR/TANK - MONARCH	RAP90014/AP2260 & AP21255
	100532-03-715	EA	CAP-BREATHER W/DIPSTICK	RAP7876
	100532-03-723	EA	O-RING/SEAL KIT	RAP9171
	100532-09-710	EA	SOLENOID-INTERMITENT DUTY	RAP0533
	131306-12-702	EA	VALVE - PRESSURE SOLENOID - 3.3"X1.6"	RAP90729/AP24604

143394-01-000

KEY	PART NUMBER	U/M	DESCRIPTION	VENDOR NO.
	132540-01-706	EA	BOLT - SLIDE ROOM ADJUSTER	RAP90865/P19611

EXTERIOR SLIDEOUT GROUP (CONTINUED)

LEFT REAR

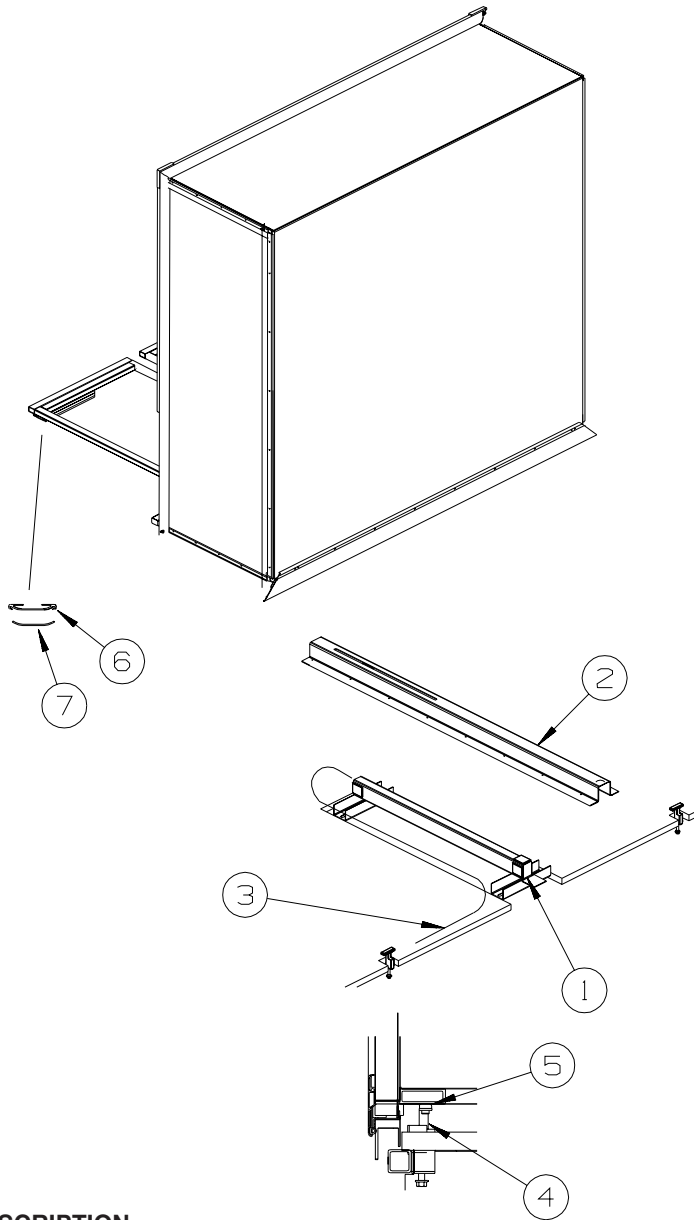

KEY	PART NUMBER	U/M	DESCRIPTION
1*	128599-04-000	EA	CYLINDER/HYDRAULIC - F/SLIDEOUT
2*	128599-02-000	EA	CHANNEL - F/SLIDEOUT
3*	100536-42-000	EA	HOSE KIT - PUMP TO SLIDE-OUT VALVE
4	126313-09-02B	EA	SUPPORT - ROLLER - E-COATED
5	134855-01-000	EA	BEARING PAD - NARROW
6	115325-08-01A	EA	RAIL - FLOOR/SLIDEOUT ROOM - BLACK
7	115661-01-000	FT	SHOE/GLIDE - SLIDEOUT ROOM - 1/16" X 3" - POLYETHYLENE

***COMPONENT PARTS LISTED LATER IN THIS GROUP**

EXTERIOR SLIDEOUT GROUP (CONTINUED)
LEFT REAR (CONTINUED)

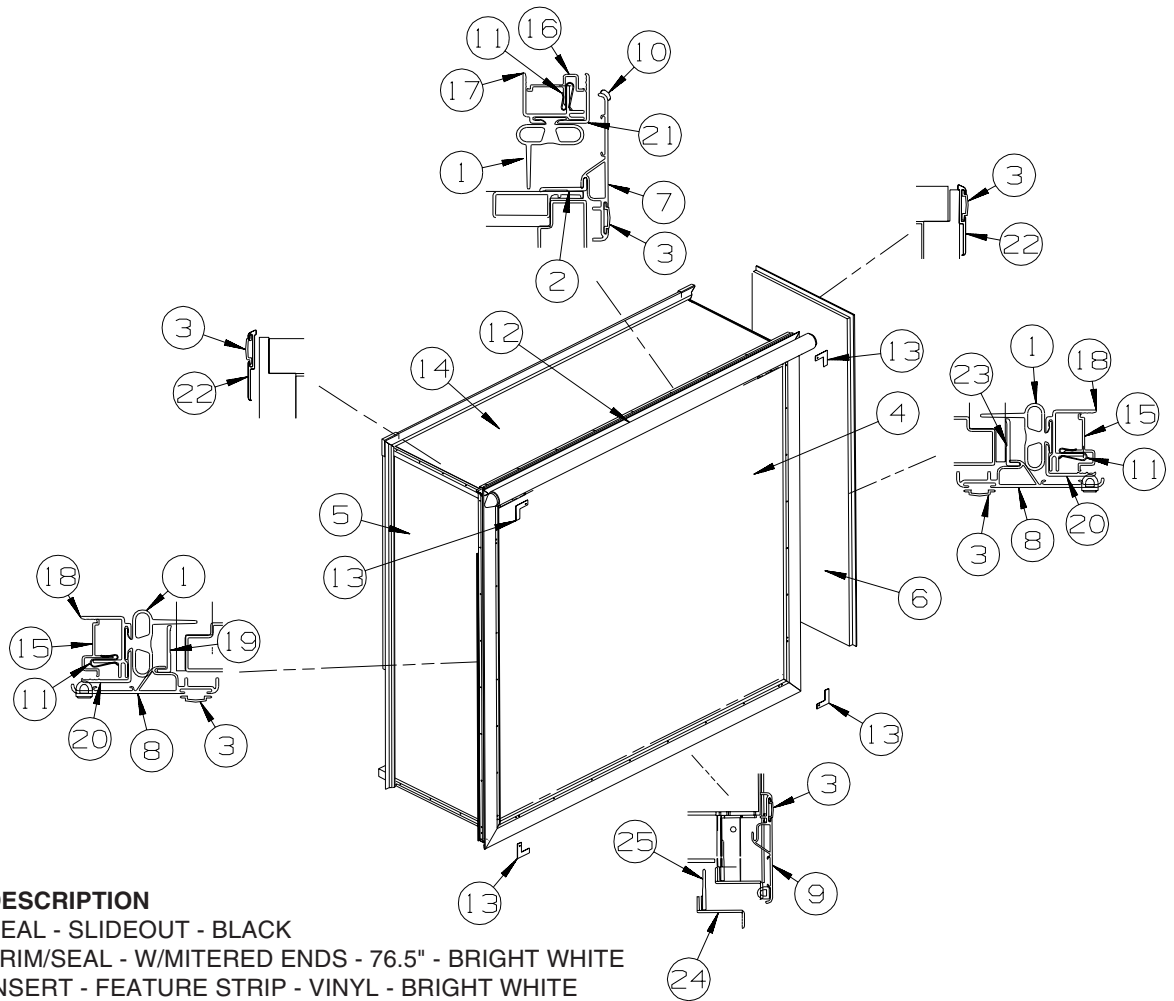

KEY	PART NUMBER	U/M	DESCRIPTION
1	136978-01-01A	FT	SEAL - SLIDEOUT - BLACK
2	133954-18-01A	EA	TRIM/SEAL - W/MITERED ENDS - 76.5" - BRIGHT WHITE
3	105312-01-07A	FT	INSERT - FEATURE STRIP - VINYL - BRIGHT WHITE
4	141510-12-P13	EA	SLUG - SLIDEOUT (P19, P20, P33)
4	141510-12-P15	EA	SLUG - SLIDEOUT (P21, P22, P36)
4	141510-12-P17	EA	SLUG - SLIDEOUT (P23, P24, P40)
5	143039-01-P13	EA	PANEL - REAR - REAR SLIDEOUT (P19, P20, P33)
5	143039-01-P15	EA	PANEL - REAR - REAR SLIDEOUT (P21, P22, P36)
5	143039-01-P17	EA	PANEL - REAR - REAR SLIDEOUT (P23, P24, P40)
6	143041-01-P13	EA	PANEL - FRONT - REAR SLIDEOUT (P19, P20, P33)
6	143041-01-P15	EA	PANEL - FRONT - REAR SLIDEOUT (P21, P22, P36)
6	143041-01-P17	EA	PANEL - FRONT - REAR SLIDEOUT (P23, P24, P40)
7	139625-03-01A	EA	TRIM/SEAL - TOP/W/MITERED ENDS - 81.8" - BRIGHT WHITE
8	139625-11-01A	EA	TRIM/SEAL - TOP/W/MITERED ENDS - 75.6" - BRIGHT WHITE
9	142233-04-01A	EA	TRIM/SEAL - W/MITERED ENDS - 81.8" - BRIGHT WHITE
10	117058-01-01A	FT	TAPE - LOOP - 3/4" WIDE - ADHESIVE BACKED
11	142549-01-000	EA	CLIP-S TYPE
12	122977-12-03A	EA	AWNING/SLIDEOUT W/COVER - 81.8" - WHITE - VINYL/VINYL WRAP
13	116444-04-12B	EA	TRIM/KEY CORNER - SLIDEOUT - 3.1"X3.1" - BRT WHT
14	136557-01-M07	EA	ROOF - LEFT/REAR SLIDEOUT - W/O LIGHTS/VENTS - W/WIRING
15	142718-01-01A	EA	RETAINER - SIDEWALL/SLIDEOUT - 72.8"
16	142718-23-01A	EA	RETAINER - SIDEWALL/SLIDEOUT - 79.9"
17	142719-05-01A	EA	TRIM/SIDEWALL - TOP/SLIDEOUT - 81.3" - BRIGHT WHITE
18	142720-11-01A	EA	TRIM - SIDEWALL/SLIDEOUT - 72.9" - BRIGHT WHITE
19	133954-37-01A	EA	TRIM/SEAL - W/MITERED ENDS - 67.1" - BRIGHT WHITE
20	136824-16-01A	EA	TRIM - SIDEWALL/SLIDEOUT - 72.7" - BRIGHT WHITE
21	136824-02-01A	EA	TRIM - SIDEWALL/SLIDEOUT - 81.2" - BRIGHT WHITE
22	138659-01-01A	EA	TRIM/FEATURE STRIP - 181.7" - BRIGHT WHITE
23	133954-37-01A	EA	TRIM/SEAL - W/MITERED ENDS - 67.1" - BRIGHT WHITE
23	133954-46-01A	EA	TRIM/SEAL - W/MITERED ENDS - 68.8" - BRIGHT WHITE
			FROM: 00-00-00 THRU: 01-26-03
24	141174-01-02A	EA	TRIM/ZEE - SIDEWALL - 81.4" - BRIGHT WHITE
25	123012-04-000	FT	SEAL - F/SLIDEOUT

EXTERIOR SLIDEOUT GROUP (CONTINUED)
LEFT REAR (CONTINUED)

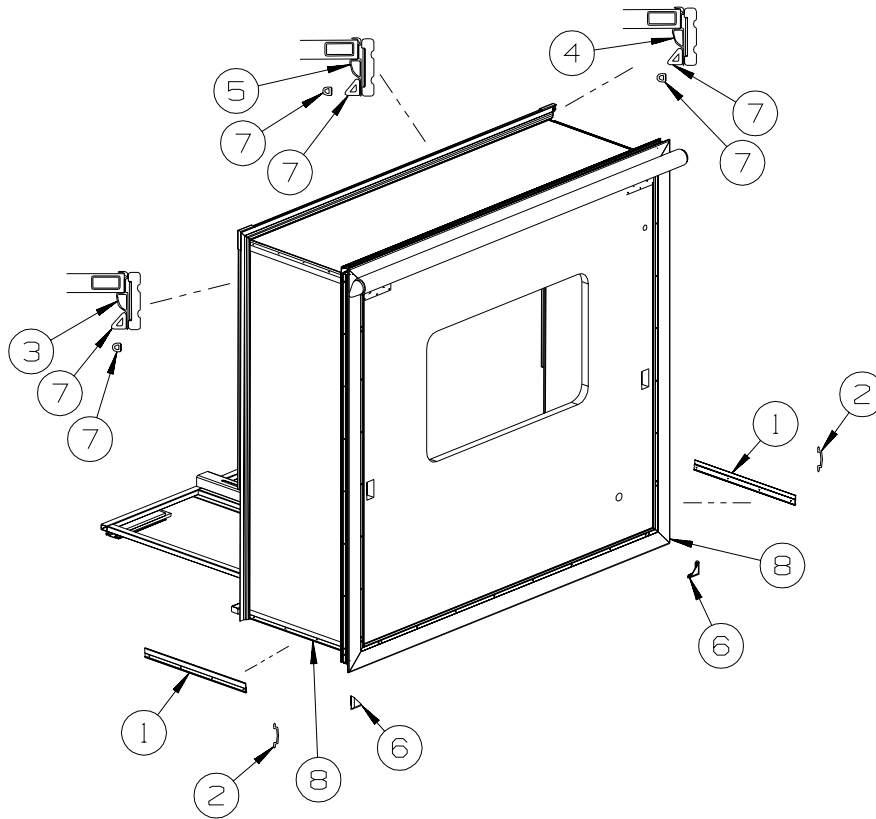

KEY	PART NUMBER	U/M	DESCRIPTION
1	141435-02-01A	EA	TRIM - FEATURE STRIP/LOWER - 25.2" - BRIGHT WHITE FROM: 00-00-00 THRU: 01-26-03
1	141435-04-01A	EA	TRIM - FEATURE - LOWER - 24" - BRIGHT WHITE FROM: 01-27-03 THRU: 99-99-99
	141434-51-001	EA	TRIM - FLOOR/SIDEWALL - 16'
2	105312-01-07A	FT	INSERT - FEATURE STRIP - VINYL - BRIGHT WHITE
3	139624-15-01A	EA	TRIM/SEAL - INNER/RIGHT HAND W/NOTCH - 72.9" -BRIGHT WHITE
4	139624-16-01A	EA	TRIM/SEAL - INNER/LEFT HAND W/NOTCH - 72.7" - BRIGHT WHITE
5	139624-04-01A	EA	TRIM/SEAL - INNER/TOP - 80.2" - BRIGHT WHITE
6	135275-01-01A	EA	PROTECTOR - CORNER - SLIDEOUT - WHITE
7	112091-01-000	FT	SEAL/D - NEOPRENE - HEAT ACTIVE ADHESIVE - .9" FROM: 00-00-00 THRU: 01-12-03
7	146056-01-000	FT	SEAL - TRIANGLE - W/PSA FROM: 01-13-03 THRU: 99-99-99
8	075673-05-000	FT	SEAL - PILE - ADHESIVE BACK - BLACK

EXTERIOR SLIDEOUT GROUP (CONTINUED)
LEFT REAR (CONTINUED)

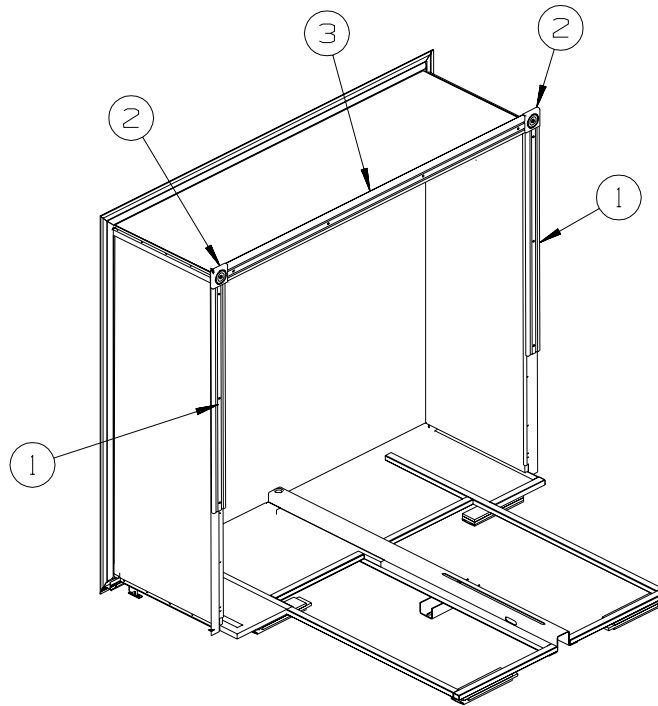

KEY	PART NUMBER	U/M	DESCRIPTION
1	132663-17-08A	EA	MOLDING-VINYL WRAP/PRE DRILLED-.6"X3.8"X45.5" - OAK - PORTSMOUTH OAK
1	132663-17-07A	EA	MOLDING-VINYL WRAP/PRE DRILLED-.6"X3.8"X45.5" - CHERRY - CONCERT CHERRY
1	132663-17-03A	EA	MOLDING-VINYL WRAP/PRE DRILLED-.6"X3.8"X45.5" - WASHED MAPLE
2	132844-01-08A	EA	BLOCK - CORNER - 3.9" X 3.9" - PORTSMOUTH OAK
2	132844-01-02A	EA	BLOCK - CORNER - 3.9" X 3.9" - SALEM CHERRY - CONCERT CHERRY
2	132844-01-03A	EA	BLOCK - CORNER - 3.9" X 3.9" - WASHED MAPLE
3	132663-18-08A	EA	MOLDING-VINYL WRAP/PRE DRILLED - .6" X 3" X 73.2" - OAK - PORTSMOUTH OAK
3	132663-18-07A	EA	MOLDING-VINYL WRAP/PRE DRILLED-.6"X3"X73.2" - CHERRY - CONCERT CHERRY
3	132663-18-03A	EA	MOLDING-VINYL WRAP/PRE DRILLED-.6"X3"X73.2" - WASHED MAPLE

EXTERIOR SLIDEOUT GROUP (CONTINUED)
COMPONENT PARTS FOR REAR SLIDEOUT

100536-42-000

KEY	PART NUMBER	U/M DESCRIPTION	VENDOR NO.
	100536-42-700	EA HOSE/HYDRAULIC - 180" - PRESS	RAP90120/AP5965
	100536-42-701	EA HOSE/HYDRAULIC - 175" - RETURN	RAP90350/AP7358

128599-02-000

KEY	PART NUMBER	U/M DESCRIPTION	VENDOR NO.
	128599-06-703	EA BEARING KIT - SLIDE-OUT TUBE	RAP90698
	128599-06-704	EA BEARING PAD - SLIDE-OUT	P14811

128599-04-000

KEY	PART NUMBER	U/M DESCRIPTION	VENDOR NO.
	128599-05-700	EA RAM/CYLINDER - SLIDEOUT	RAP90688
	137390-01-701	EA CYLINDER NUT KIT - SLIDEOUT	RAP90947

GALLEY GROUP CABINETS

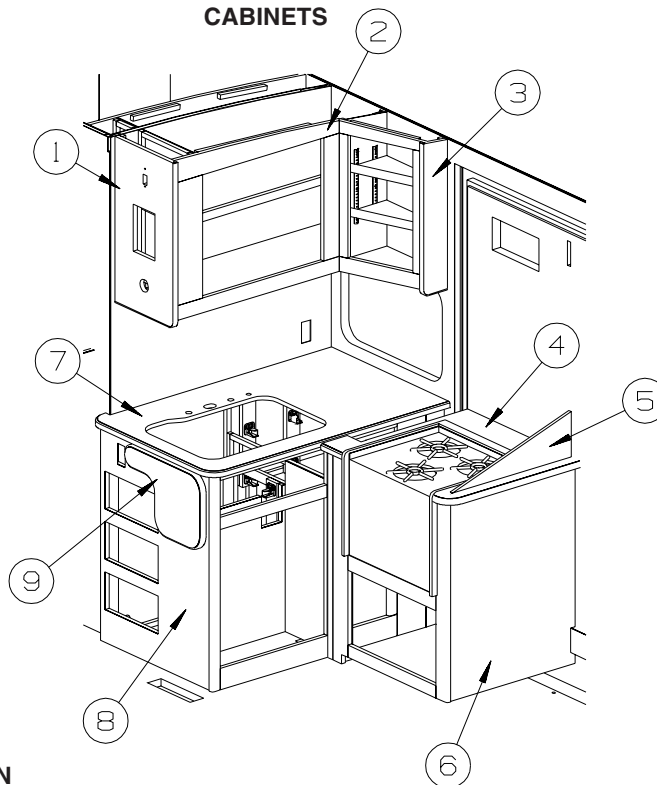

KEY	PART NUMBER	U/M	DESCRIPTION
1	143060-16-P13	EA	END CAP - OVERHEAD CABINET - PORTSMOUTH OAK - WATER HEATER - ELEC. IGNITION
1	143060-16-P14	EA	END CAP - OVERHEAD CABINET - CONCERT CHERRY - WATER HEATER - ELEC. IGNITION
1	143060-16-P33	EA	END CAP - OVERHEAD CABINET - WASHED MAPLE - WATER HEATER - ELEC. IGNITION
1	143060-30-P13	EA	END CAP - OVERHEAD CABINET - PORTSMOUTH OAK - WTR. HTR. - 6 GAL/ELEC/LP/MOTORAID
1	143060-30-P14	EA	END CAP - OVERHEAD CABINET - CONCERT CHERRY - WTR. HTR. - 6 GAL/ELEC/LP/MOTORAID
1	143060-30-P33	EA	END CAP - OVERHEAD CABINET - WASHED MAPLE - WTR. HTR. - 6 GAL/ELEC/LP/MOTORAID
2	143060-01-P13	EA	CABINET - OVERHEAD/GALLEY - W/O DRS/HDW - PORTSMOUTH OAK - WTR HTR - ELEC. IGNITION
2	143060-01-P14	EA	CABINET - OVERHEAD/GALLEY - W/O DRS/HDW - CONCERT CHERRY - WTR HTR - ELEC. IGNITION
2	143060-01-P33	EA	CABINET - OVERHEAD/GALLEY - W/O DRS/HDW - WASHED MAPLE - WTR HTR - ELEC. IGNITION
2	143060-02-P13	EA	CABINET - OVERHEAD/GALLEY - W/O DRS/HDW - PORTSMOUTH OAK - 6 GAL/ELEC/LP/MOTORAID
2	143060-02-P14	EA	CABINET - OVERHEAD/GALLEY - W/O DRS/HDW - CONCERT CHERRY - 6 GAL/ELEC/LP/MOTORAID
2	143060-02-P33	EA	CABINET - OVERHEAD/GALLEY - W/O DRS/HDW - WASHED MAPLE - 6 GAL/ELEC/LP/MOTORAID
3	143060-15-P13	EA	END CAP - OVERHEAD CABINET - PORTSMOUTH OAK
3	143060-15-P14	EA	END CAP - OVERHEAD CABINET - CONCERT CHERRY
3	143060-15-P33	EA	END CAP - OVERHEAD CABINET - WASHED MAPLE
4	133653-25-P13	EA	COUNTERTOP - LAMINATED - GRAY TRANQUILITY (P19)
4	133653-25-P14	EA	COUNTERTOP - LAMINATED - GRAY TRANQUILITY (P20)
4	133653-25-P15	EA	COUNTERTOP - LAMINATED - EGG SHELL (P21,P23)
4	133653-25-P16	EA	COUNTERTOP - LAMINATED - EGG SHELL (P22,P24)
4	133653-25-P33	EA	COUNTERTOP - LAMINATED - GRAY TRANQUILITY (P33)
4	133653-25-P36	EA	COUNTERTOP - LAMINATED - EGG SHELL (P36,P40)
5	126875-02-N70	EA	FRAME ONLY - F/SPLASHGUARD - PORTSMOUTH OAK
5	126875-02-K13	EA	FRAME ONLY - F/SPLASHGUARD - CONCERT CHERRY
5	126875-02-M15	EA	FRAME ONLY - F/SPLASHGUARD - WASHED MAPLE
5	127117-02-01A	EA	GLASS - STATIONARY - SPLASHGUARD
6	143062-01-P13	EA	CABINET - GALLEY/SLIDEOUT - W/O DOORS/DRAWERS/HARDWARE - PORTSMOUTH OAK FROM: 00-00-00 THRU: 08-25-02
6	P43062-02-P13	EA	CABINET - GALLEY/SLIDEOUT - W/O DOORS/DRAWERS/HARDWARE - PORTSMOUTH OAK FROM: 08-26-02 THRU: 99-99-99
6	143062-01-P14	EA	CABINET - GALLEY/SLIDEOUT - W/O DOORS/DRAWERS/HARDWARE - CONCERT CHERRY FROM: 00-00-00 THRU: 08-25-02
6	P43062-02-P14	EA	CABINET - GALLEY/SLIDEOUT - W/O DOORS/DRAWERS/HARDWARE - CONCERT CHERRY FROM: 08-26-02 THRU: 99-99-99
6	143062-01-P33	EA	CABINET - GALLEY/SLIDEOUT - W/O DOORS/DRAWERS/HARDWARE - WASHED MAPLE FROM: 00-00-00 THRU: 08-25-02
6	P43062-02-P33	EA	CABINET - GALLEY/SLIDEOUT - W/O DOORS/DRAWERS/HARDWARE - WASHED MAPLE FROM: 08-26-02 THRU: 99-99-99

GALLEY GROUP (CONTINUED)

CABINETS (CONTINUED)

KEY	PART NUMBER	U/M	DESCRIPTION
7	133653-22-P13	EA	COUNTERTOP - LAMINATED - GRAY TRANQUILITY (P19) - W/O WATER PURIFIER
7	133653-22-P14	EA	COUNTERTOP - LAMINATED - GRAY TRANQUILITY (P20) - W/O WATER PURIFIER
7	133653-22-P15	EA	COUNTERTOP - LAMINATED - EGGSHELL (P21,P23) - W/O WATER PURIFIER
7	133653-22-P16	EA	COUNTERTOP - LAMINATED - EGGSHELL (P22,P24) - W/O WATER PURIFIER
7	133653-22-P33	EA	COUNTERTOP - LAMINATED - GRAY TRANQUILITY (P33) - W/O WATER PURIFIER
7	133653-22-P36	EA	COUNTERTOP - LAMINATED - EGGSHELL (P36,P40) - W/O WATER PURIFIER
7	133653-21-P13	EA	COUNTERTOP - LAMINATED - GRAY TRANQUILITY (P19) - W/WATER PURIFIER
7	133653-21-P14	EA	COUNTERTOP - LAMINATED - GRAY TRANQUILITY (P20) - W/WATER PURIFIER
7	133653-21-P15	EA	COUNTERTOP - LAMINATED - EGGSHELL (P21,P23) - W/WATER PURIFIER
7	133653-21-P16	EA	COUNTERTOP - LAMINATED - EGGSHELL (P22,P24) - W/WATER PURIFIER
7	133653-21-P33	EA	COUNTERTOP - LAMINATED - GRAY TRANQUILITY (33) - W/WATER PURIFIER
7	133653-21-P36	EA	COUNTERTOP - LAMINATED - EGGSHELL (P36,P40) - W/WATER PURIFIER
8	143061-01-P13	EA	CABINET - GALLEY - W/O COUNTERTOP/DOORS/DRAWERS/HARDWARE - PORTSMOUTH OAK
8	143061-01-P14	EA	CABINET - GALLEY - W/O COUNTERTOP/DOORS/DRAWERS/HARDWARE - CONCERT CHERRY
8	143061-01-P33	EA	CABINET - GALLEY - W/O COUNTERTOP/DOORS/DRAWERS/HARDWARE - WASHED MAPLE
9	143175-01-P13	EA	EXTENSION - GALLEY - LAMINATED - GRAY TRANQUILITY (P19)
9	143175-01-P14	EA	EXTENSION - GALLEY - LAMINATED - GRAY TRANQUILITY (P20)
9	143175-01-P15	EA	EXTENSION - GALLEY - LAMINATED - EGGSHELL (P21,P23)
9	143175-01-P16	EA	EXTENSION - GALLEY - LAMINATED - EGGSHELL (P22,P24)
9	143175-01-P33	EA	EXTENSION - GALLEY - LAMINATED - GRAY TRANQUILITY (P33)
9	143175-01-P36	EA	EXTENSION - GALLEY - LAMINATED - EGGSHELL (P36,P40)

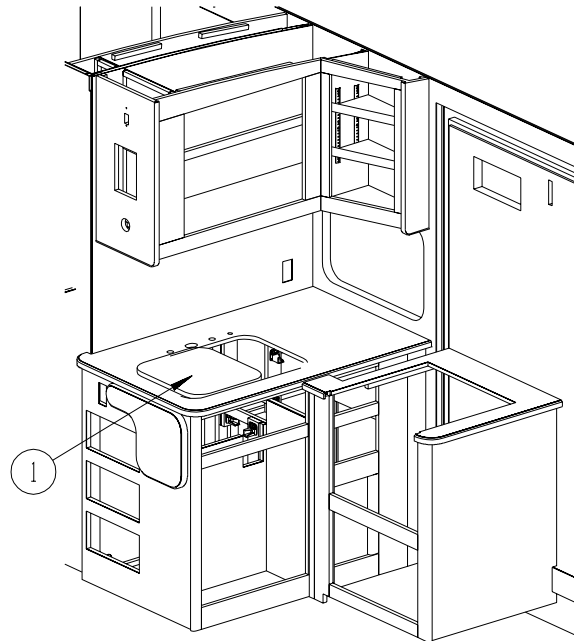

KEY	PART NUMBER	U/M	DESCRIPTION
1	103610-04-N30	EA	COVER - SINK - 15.7" X 13.8" - GRAY TRANQUILITY (P19,P20,P33)
1	103610-04-P17	EA	COVER - SINK - 15.7" X 13.8" - EGGSHELL MOSAIC (P21,P22,P23,P24,P36,P40)

GALLEY GROUP (CONTINUED)

DOORS & DRAWERS

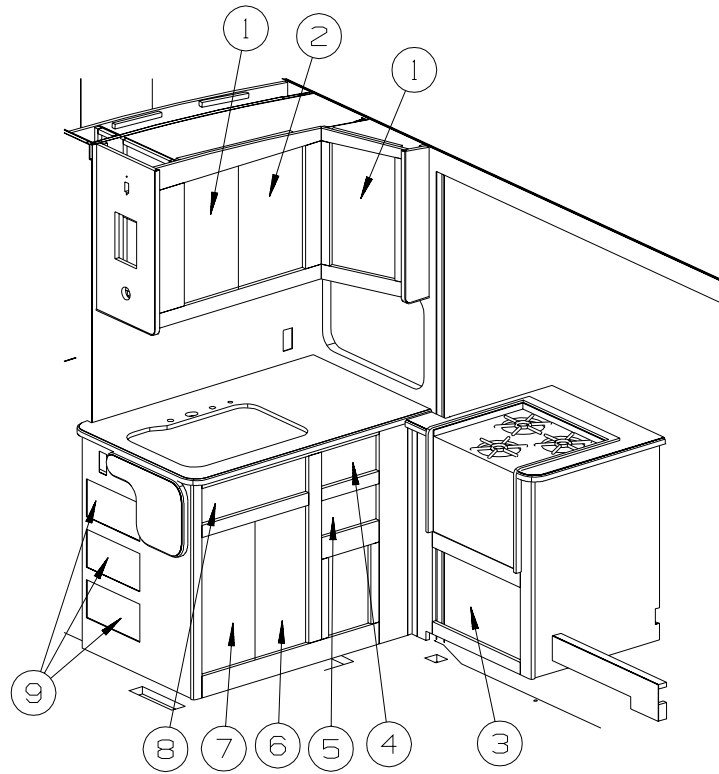

KEY	PART NUMBER	U/M	DESCRIPTION
1	134868-30-P19	EA	DOOR - RAIL/ARCHED TOP - 12" X 21.8" - W/O HARDWARE - PORTSMOUTH OAK FROM: 00-00-00 THRU: 11-10-02
1	141518-67-P19	EA	DOOR - ARCHED/PENCIL EDGE/LEFT HAND-12" X 21.8"-W/O HDW - PORTSMOUTH OAK FROM: 11-11-02 THRU: 99-99-99
1	134868-30-P20	EA	DOOR - RAIL/ARCHED TOP - 12" X 21.8" - W/O HARDWARE - CONCERT CHERRY FROM: 00-00-00 THRU: 11-10-02
1	141518-67-P20	EA	DOOR - ARCHED/PENCIL EDGE/LEFT HAND-12" X 21.8"-W/O HDW - CONCERT CHERRY FROM: 11-11-02 THRU: 99-99-99
1	134868-30-P33	EA	DOOR - RAIL/ARCHED TOP - 12" X 21.8" - W/O HARDWARE - WASHED MAPLE FROM: 00-00-00 THRU: 11-10-02
1	141518-67-P33	EA	DOOR - ARCHED/PENCIL EDGE/LEFT HAND-12" X 21.8"-W/O HDW - WASHED MAPLE FROM: 11-11-02 THRU: 99-99-99
2	134868-31-P19	EA	DOOR - RAIL/ARCHED TOP - 12" X 21.8" - W/O HARDWARE - PORTSMOUTH OAK FROM: 00-00-00 THRU: 11-10-02
2	141520-67-P19	EA	DOOR - ARCHED/PENCIL EDGE/RIGHT HAND -12"X21.8"- W/O HDW - PORTSMOUTH OAK FROM: 11-11-02 THRU: 99-99-99
2	134868-31-P20	EA	DOOR - RAIL/ARCHED TOP - 12" X 21.8" - W/O HARDWARE - CONCERT CHERRY FROM: 00-00-00 THRU: 11-10-02
2	141520-67-P20	EA	DOOR - ARCHED/PENCIL EDGE/RIGHT HAND -12"X21.8"- W/O HDW - CONCERT CHERRY FROM: 11-11-02 THRU: 99-99-99
2	134868-31-P33	EA	DOOR - RAIL/ARCHED TOP - 12" X 21.8" - W/O HARDWARE - WASHED MAPLE FROM: 00-00-00 THRU: 11-10-02
2	141520-67-P33	EA	DOOR - ARCHED/PENCIL EDGE/RIGHT HAND -12"X21.8"- W/O HDW - WASHED MAPLE FROM: 11-11-02 THRU: 99-99-99
2	076767-04-000	EA	CABLE - STAINLESS STEEL - 5.9"
3	134870-31-P19	EA	DRAWER - PENCIL EDGE - 20.2"W X 21.6"D - W/O SLIDES/HDW - PORTSMOUTH OAK
3	134870-31-P20	EA	DRAWER - PENCIL EDGE - 20.2"W X 21.6"D - W/O SLIDES/HDW - CONCERT CHERRY
3	134870-31-P33	EA	DRAWER - PENCIL EDGE - 20.2"W X 21.6"D - W/O SLIDES/HDW - WASHED MAPLE
4	134870-33-P19	EA	DRAWER - PENCIL EDGE - 10.4"W X 15.7"D - W/O HARDWARE - PORTSMOUTH OAK
4	134870-33-P20	EA	DRAWER - PENCIL EDGE - 10.4"W X 15.7"D - W/O HARDWARE - CONCERT CHERRY
4	134870-33-P33	EA	DRAWER - PENCIL EDGE - 10.4"W X 15.7"D - W/O HARDWARE - WASHED MAPLE
5	134870-30-P19	EA	DRAWER - PENCIL EDGE - 10.4"W X 21.6"D - W/O SLIDES/HDW - PORTSMOUTH OAK
5	134870-30-P20	EA	DRAWER - PENCIL EDGE - 10.4"W X 21.6"D - W/O SLIDES/HDW - CONCERT CHERRY
5	134870-30-P33	EA	DRAWER - PENCIL EDGE - 10.4"W X 21.6"D - W/O SLIDES/HDW - WASHED MAPLE
6	136919-45-P19	EA	DOOR - FLAT/PENCIL EDGE - 10.8" X 23.8" - W/O HARDWARE - PORTSMOUTH OAK
6	136919-45-P20	EA	DOOR - FLAT/PENCIL EDGE - 10.8" X 23.8" - W/O HARDWARE - CONCERT CHERRY
6	136919-45-P33	EA	DOOR - FLAT/PENCIL EDGE - 10.8" X 23.8" - W/O HARDWARE - WASHED MAPLE

GALLEY GROUP (CONTINUED)
DOORS & DRAWERS (CONTINUED)

KEY	PART NUMBER	U/M	DESCRIPTION
7	136919-44-P19	EA	DOOR - FLAT/PENCIL EDGE - 10.8" X 23.8" - W/O HARDWARE - PORTSMOUTH OAK
7	136919-44-P20	EA	DOOR - FLAT/PENCIL EDGE - 10.8" X 23.8" - W/O HARDWARE - CONCERT CHERRY
7	136919-44-P33	EA	DOOR - FLAT/PENCIL EDGE - 10.8" X 23.8" - W/O HARDWARE - WASHED MAPLE
8	134842-11-P19	EA	DRAWER - TIPOUT - W/HIDDEN TRAY - PORTSMOUTH OAK
8	134842-11-P20	EA	DRAWER - TIPOUT - W/HIDDEN TRAY - CONCERT CHERRY
8	134842-11-P33	EA	DRAWER - TIPOUT - W/HIDDEN TRAY - WASHED MAPLE
	108127-01-01A	EA	CAP - TRAY
	108128-01-01A	EA	TRAY - HIDDEN
9	134870-32-P19	EA	DRAWER - PENCIL EDGE - 11.4"W X 19.7"D - W/O SLIDES/HDW - PORTSMOUTH OAK
9	134870-32-P20	EA	DRAWER - PENCIL EDGE - 11.4"W X 19.7"D - W/O SLIDES/HDW - CONCERT CHERRY
9	134870-32-P33	EA	DRAWER - PENCIL EDGE - 11.4"W X 19.7"D - W/O SLIDES/HDW - WASHED MAPLE

GALLEY GROUP (CONTINUED)
DOORS & DRAWERS (CONTINUED)

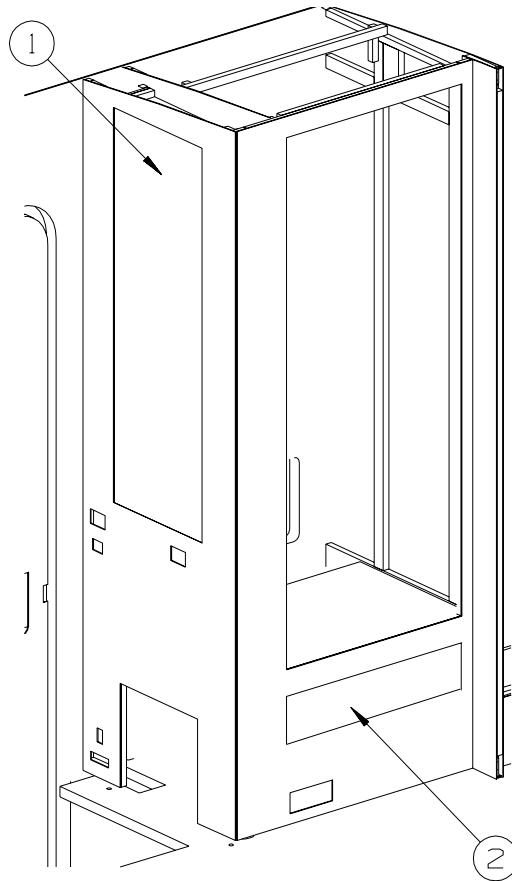

KEY	PART NUMBER	U/M	DESCRIPTION
1	134868-44-P19	EA	DOOR - RAIL/ARCHED TOP - 15.5" X 45.4" - W/O HARDWARE - PORTSMOUTH OAK FROM: 00-00-00 THRU: 11-10-02
1	141518-C7-P19	EA	DOOR - ARCHED/PENCIL EDGE - 15.5" X 45.4" - W/O HARDWARE - PORTSMOUTH OAK FROM: 11-11-02 THRU: 99-99-99
1	134868-44-P20	EA	DOOR - RAIL/ARCHED TOP - 15.5" X 45.4" - W/O HARDWARE - CONCERT CHERRY FROM: 00-00-00 THRU: 11-10-02
1	141518-C7-P20	EA	DOOR - ARCHED/PENCIL EDGE - 15.5" X 45.4" - W/O HARDWARE - CONCERT CHERRY FROM: 11-11-02 THRU: 99-99-99
1	134868-44-P33	EA	DOOR - RAIL/ARCHED TOP - 15.5" X 45.4" - W/O HARDWARE - WASHED MAPLE FROM: 00-00-00 THRU: 11-10-02
1	141518-C7-P33	EA	DOOR - ARCHED/PENCIL EDGE - 15.5" X 45.4" - W/O HARDWARE - WASHED MAPLE FROM: 11-11-02 THRU: 99-99-99
1	076767-04-000	EA	CABLE - STAINLESS STEEL - 5.9"
2	P34767-60-P19	EA	DRAWER - PENCIL EDGE - 22.5" X 13.7"-W/O SLIDES/HARDWARE - PORTSMOUTH OAK
2	P34767-60-M16	EA	DRAWER - PENCIL EDGE - 22.5" X 13.7"-W/O SLIDES/HARDWARE - CONCERT CHERRY
2	P34767-60-M15	EA	DRAWER - PENCIL EDGE - 22.5" X 13.7"-W/O SLIDES/HARDWARE - WASHED MAPLE

GENERATOR GROUP
GAS

KEY	PART NUMBER	U/M	DESCRIPTION
	007125-04-000	EA	CLAMP - MUFFLER - 1.12" DIAMETER
	007131-01-000	EA	HANGER - TAILPIPE - 6 SLOTS
	109982-03-000	EA	GENERATOR - 4.0 MICROLITE
	105958-26-000	EA	PIPE - EXHAUST - GENERATOR - 427P, 431C
	143954-01-000	EA	PIPE - EXHAUST - GENERATOR - 430V

HEATING & A/C GROUP
FURNACE

KEY	PART NUMBER	U/M	DESCRIPTION
*	139980-02-000	EA	FURNACE - 30000 BTU - SF QUIET - SUBURBAN SF-30 2321J
	009200-01-000	EA	TAPE - FURNACE - 1 1/2"
	093741-01-000	EA	BOX - BOOT - FLOOR REGISTER
	137965-01-01A	EA	REGISTER - 2.25" X 10" - W/O DAMPER - ANTIQUE BRASS
	098668-26-000	EA	BOTTOM DUCT KIT - 40,000 BTU
			FROM: 00-00-00 THRU: 07-21-02
	098668-15-000	EA	PLATE - FACE - SUBURBAN FURNACE
			FROM: 07-22-02 THRU: 99-99-99
	137965-02-01A	EA	REGISTER - 2.25" X 10" - W/DAMPER - ANTIQUE BRASS

***COMPONENT PARTS LISTED LATER IN THIS GROUP**

HEATING & A/C GROUP (CONTINUED)

COMPONENT PARTS FOR FURNACE

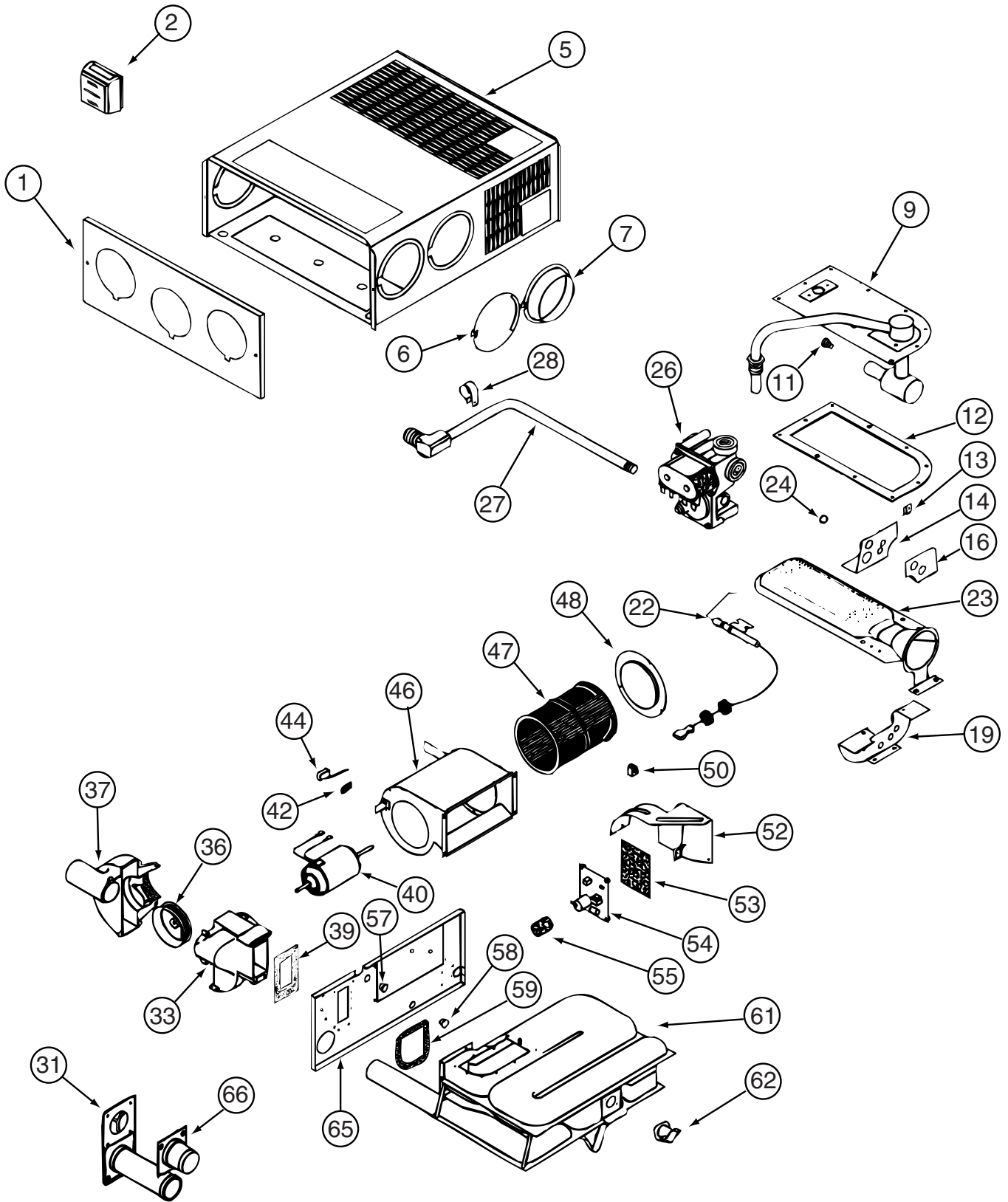

139980-02-000

HEATING & A/C GROUP (CONTINUED)
COMPONENT PARTS FOR FURNACE (CONTINUED)

139980-02-000 (CONTNUED)

KEY	PART NUMBER	U/M	DESCRIPTION	VENDOR NO.
9	139980-01-700	EA	MANIFOLD ASSEMBLY	171571
11	092300-02-701	EA	ORIFICE-MAIN BURNER (NT-30BW	180214
12	098668-22-703	EA	GASKET - BURNER ACCESS COVER	070811
22	139980-01-701	EA	ELECTRODE	232286
23	098668-02-700	EA	BURNER ASSEMBLY,SF-30 & SF35	010745
26	098668-01-718	EA	VALVE-GAS SF S.N.974903079	161122
27	139980-01-702	EA	PIPE ASSEMBLY/GAS INLET	171574
31	098668-01-707	EA	TUBE ASSEMBLY, EXHAUST W/CAP	260231
33	139980-01-703	EA	COMBUSTION AIR HOUS FRT/HALF	390852
36	098668-01-706	EA	WHEEL-COMBUSTION AIR	350184
37	139980-01-704	EA	COMBUSTION AIR HOUS RR HALF	390848
39	139980-01-705	EA	GASKET/FIREWALL-COMB AIR	071084
40	139980-01-706	EA	MOTOR ASSEMBLY W/GASKET	232682
42	101990-01-714	EA	GASKET-MICROSWITCH	230877
44	098668-21-700	EA	SWITCH-MICRO-W/O FLAG 3 1/4"	232261
46	139980-01-708	EA	BLOWER ASSEMBLY - ROOM AIR	390739BK
47	098668-01-711	EA	WHEEL-BLOWER, ROOM AIR	350129
48	139980-01-709	EA	ORFICE RING	390696
50	139980-01-710	EA	SWITCH - ON/OFF	232351
52	139980-01-711	EA	PANEL ASSEMBLY-MODULE BD	101663
53	139980-01-712	EA	INSULATOR - MODULE BD	070807
54	098668-22-705	EA	MODULE BD W/RELAY TIME DELAY	520820
55	139980-01-713	EA	CAP/INSULATOR-MODULE BD	070973
57	139980-01-714	EA	BUSHING - UNIVERSAL	070362
58	139980-01-715	EA	BUSHING - STRAIN RELIEF	231809
59	098668-01-716	EA	GASKET-FIREWALL,CHAMBER SIDE	070808
61	139980-01-716	EA	CHAMBER ASSEMBLY - FINAL	021149BK
62	098668-21-701	EA	SWITCH - LIMIT	232504
66	098668-01-713	EA	TUBE ASSEMBLY, INTAKE	051248
			CONTACT WINNEBAGO PART SALES FOR UNLISTED COMPONENTS	

HEATING & A/C GROUP (CONTINUED)

REAR HEATER

KEY	PART NUMBER	U/M	DESCRIPTION
*	084405-01-000	EA	HEATER - REAR/DUCTED - W/MOTOR AID
	118761-01-000	EA	REDUCER - 4' - 2" - GALVANIZED - 430V
	137965-01-01A	EA	REGISTER - 2.25" X 10" - W/O DAMPER - ANTIQUE BRASS - 427P, 431C
	009198-01-000	FT	DUCT - HEAT - FLEXIBLE - 4" ID X 25'
	009198-02-000	FT	DUCT - HEAT - FLEXIBLE - 2" ID X 25' - 430V
	007108-01-000	FT	HOSE - HEATER - 5/8" ID - HI-TEMP - 427P, 431C
	069636-02-000	EA	CONNECTOR - DUCT - 4" ID
	079059-01-000	EA	HOSE - 90 DEGREE - 5/8" ID X 4" X 36"
	079059-02-000	EA	HOSE - 90 DEGREE - .61" ID X 4" X 6" - 427P, 431C
	093741-01-000	EA	BOX - BOOT - FLOOR REGISTER - 427P, 431C
	093614-01-02A	EA	GRILLE - AIR RETURN - 15.9" X 7.9" - BEIGE - 430V
	076776-01-000	EA	TEE - BEADED - 5/8" X 5/8" X 5/8"

*COMPONENT PARTS LISTED LATER IN THIS GROUP

HEATING & A/C GROUP (CONTINUED)
COMPONENT PARTS FOR REAR HEATER

084405-01-000

KEY	PART NUMBER	U/M	DESCRIPTION	VENDOR NO.
	084405-01-700	EA	CORE-HEATER	FT200229
	084405-01-701	EA	FAN BLADES	HV029931
	084405-01-702	EA	MOTOR ASSEMBLY, 12 VOLT	RV010348

HEATING & A/C GROUP (CONTINUED)
ROOF

KEY	PART NUMBER	U/M	DESCRIPTION
*	131184-03-01A	EA	CEILING ASSEMBLY - A/C DUCTED - C-BODY - WHITE
*	131188-03-01A	EA	A/C - ROOF - 14,800 BTU - MACH 15 - WHITE
	135618-03-01A	EA	THERMOSTAT - A/C & FURNACE - WHITE
	131184-02-01A	EA	BOARD - DIVIDER - SILVER
*	131184-05-01A	EA	CEILING - HEAT PUMP - WHITE
*	131188-04-01A	EA	A/C - ROOF - 14,800 BTU - HEAT PUMP - WHITE
	135618-01-01A	EA	THERMOSTAT - HEAT PUMP/FURNACE - WHITE
	120134-01-02A	EA	REGISTER - W/DAMPER - 4" PIPE/7" O.D. FACE - WHITE

***COMPONENT PARTS LISTED LATER IN THIS GROUP**

HEATING & A/C GROUP (CONTINUED)

COMPONENT PARTS FOR ROOF

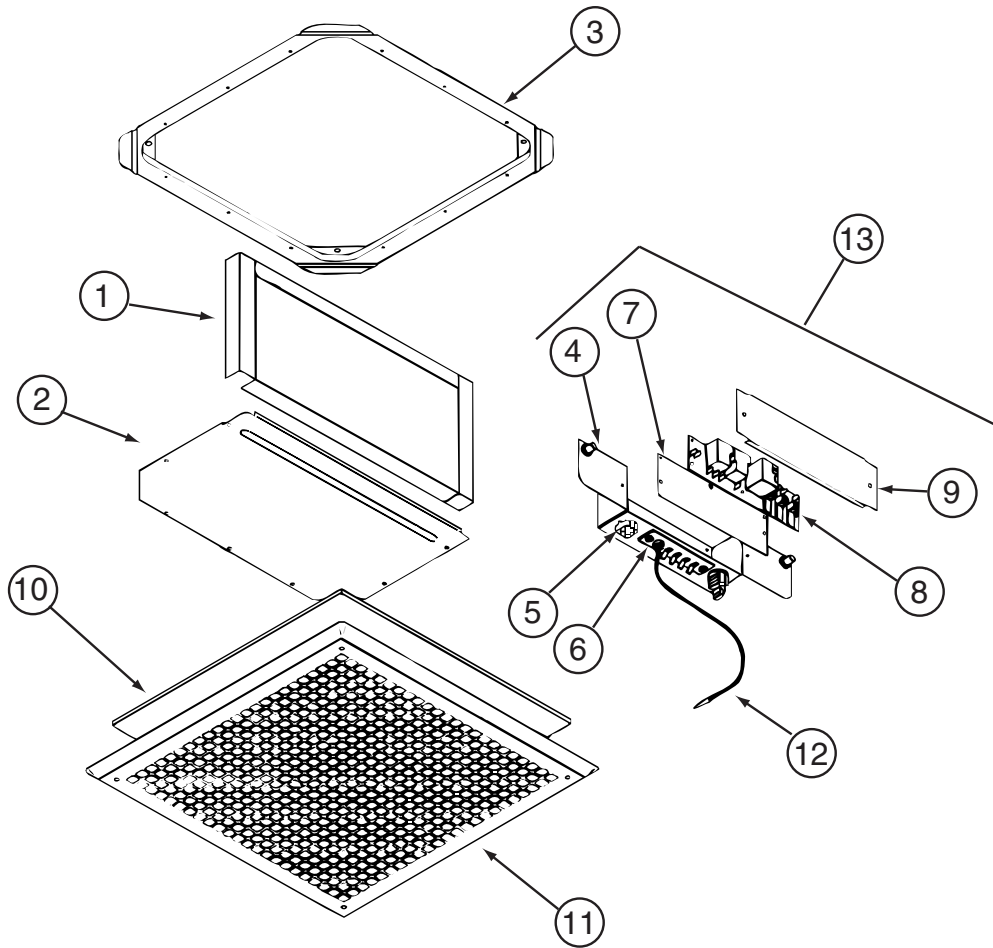

131184-03-01A

KEY	PART NUMBER	U/M	DESCRIPTION	VENDOR NO.
5	131184-01-700	EA	PLUG ASSEMBLY	7330A389
6	131184-01-701	EA	TERMINAL BOARD	7330B3201
7	131184-01-702	EA	ISOLATOR - BLANK	7330C365
8	131184-03-700	EA	BOARD - P.C.	7330D3211
10	108892-01-703	EA	FILTER	6798A3761
11	108892-01-704	EA	GRILLE 16 3/8X16 3/8 RETURN	6798-3041
12	131184-01-704	EA	COIL SENSOR	7330-6111
13	131184-01-705	EA	JUNCTION BOX ASSEMBLY	7330B5551
	131184-01-703	EA	SMALL PARTS PKG	8330-5961

CONTACT WINNEBAGO PART SALES FOR UNLISTED COMPONENT

HEATING & A/C GROUP (CONTINUED)
COMPONENT PARTS FOR ROOF (CONTINUED)

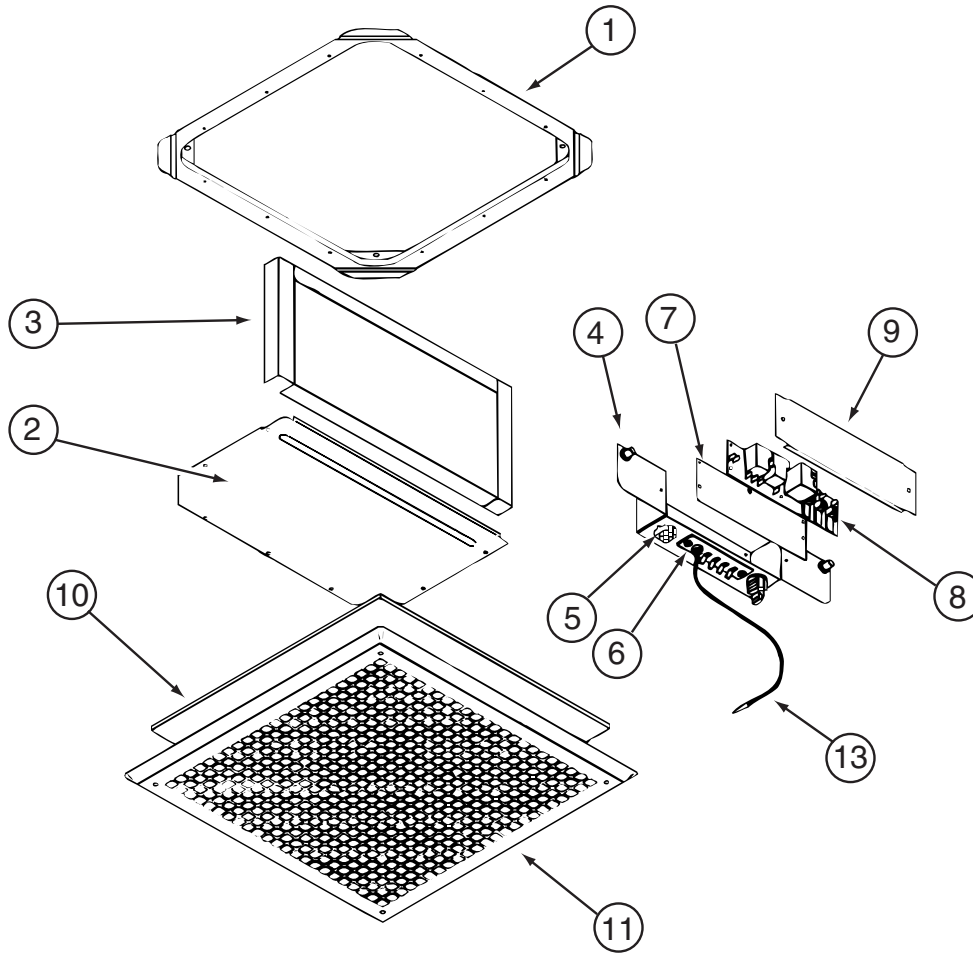

131184-05-01A

KEY	PART NUMBER	U/M	DESCRIPTION	VENDOR NO.
4	131184-04-703	EA	BOX - JUNCTION	7330-113
5	131184-04-700	EA	PLUG ASSEMBLY	7530A340
6	131184-04-702	EA	BOARD - TERMINAL	7530B3201
7	131184-01-702	EA	ISOLATOR - BLANK	7330C365
8	131184-04-705	EA	BOARD - P.C.	7330B3311
10	108892-01-703	EA	FILTER	6798A3761
11	108892-01-704	EA	GRILLE 16 3/8X16 3/8 RETURN	6798-3041
13	105620-12-719	EA	COIL SENSOR	7330A3231
	131184-01-703	EA	SMALL PARTS PKG	8330-5961

CONTACT WINNEBAGO PART SALES FOR UNLISTED COMPONENT

HEATING & A/C GROUP (CONTINUED)

COMPONENT PARTS FOR ROOF (CONTINUED)

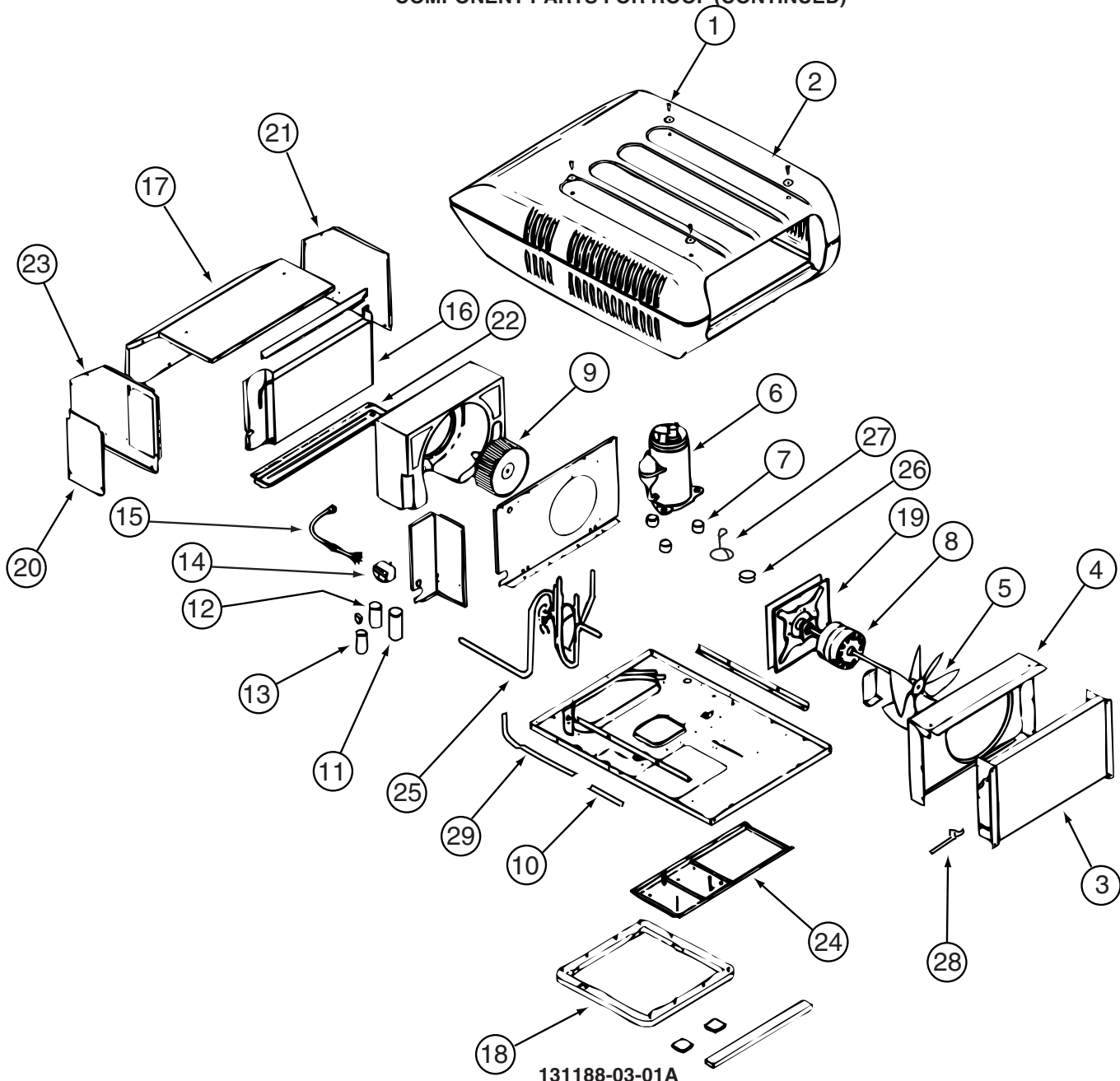

131188-03-01A

KEY	PART NUMBER	U/M	DESCRIPTION	VENDOR NO.
2	108889-05-700	EA	SHROUD-BRIGHT/WHT. W/O LOGO	7333-4601
3	115219-01-700	EA	COIL-CONDENSER	1452A1321
5	093763-01-712	EA	BLADE-FAN-CONDENSER	6733-3221
6	131188-01-700	EA	COMPRESSOR - TECUMSEH	1450A2609
7	105620-01-706	EA	MOUNTING PKG.,COMP., 3 PER	6759-3081
8	131185-01-701	EA	MOTOR (115V, 60HZ)	1468-3069
9	131185-01-702	EA	BLOWER WHEEL PACKAGE	1472-1091
11	131188-01-701	EA	RUN CAP. (COMP-40MFD/370V)	1499-5721
12	108889-01-708	EA	CAPACITOR-FAN, 7.5MFD. 370U	1499-5461
13	126859-01-704	EA	CAPACITOR - START	1497-0871
14	091225-01-709	EA	RELAY-START	1497-4131
16	131186-01-701	EA	EVAPORATOR COIL	1452-1521
18	037648-01-714	EA	GASKET PACKAGE	8332-3301
19	131185-01-704	EA	MOTOR MOUNT & SEAL KIT	8333-5151
	093306-01-701	EA	DECAL PACKAGE, LEFT & RIGHT	6798B3591
	108889-01-710	EA	PAD-FILLER, CONDENSER SEAL	6759B3971
	131188-01-702	EA	LINE - SUCTION	7335A134
	131188-01-703	EA	LINE - DISCHARGE	7335A135

CONTACT WINNEBAGO PART SALES FOR UNLISTED COMPONENT

HEATING & A/C GROUP (CONTINUED)
COMPONENT PARTS FOR ROOF (CONTINUED)

131188-04-01A

KEY	PART NUMBER	U/M	DESCRIPTION	VENDOR NO.
3	131188-02-700	EA	CONDENSER COIL	1452-1441
5	093763-01-712	EA	BLADE-FAN-CONDENSER	6733-3221
6	131188-02-701	EA	COMPRESSOR(TECUMSEH-RK225AT)	1450A2069
7	105620-01-706	EA	MOUNTING PKG.,COMP., 3 PER	6759-3081
8	131185-01-701	EA	MOTOR (115V, 60HZ)	1468-3069
9	131185-01-702	EA	BLOWER WHEEL PACKAGE	1472-1091
10	131188-02-702	EA	RESTRICTOR - BY FLOW	1454-2501
11	131188-01-701	EA	RUN CAP. (COMP-40MFD/370V)	1499-5721
12	093763-01-704	EA	CAPACITOR-FAN	1499-5461
13	131188-02-703	EA	CAPACITOR-START(21-25MFD)	1497-0211
14	091225-01-709	EA	RELAY-START	1497-4131
16	131186-01-701	EA	EVAPORATOR COIL	1452-1521
18	037648-01-714	EA	GASKET PACKAGE	8332-3301
19	131185-01-704	EA	MOTOR MOUNT & SEAL KIT	8333-5151
25	131188-02-704	EA	VALVE/REVERSE ASSEMBLY	7535A5301
26	105620-12-708	EA	COIL - SOLENOID	1460-1081
27	131188-02-705	EA	WIRE HARNESS F/SOLENOID	7535-109
28	131188-02-706	EA	SWITCH - FREEZE	1460-2041
29	131188-02-707	EA	LIQUID LINE	7535-135
			CONTACT WINNEBAGO PART SALES FOR UNLISTED COMPONENT	

INTERIOR FINISH GROUP
MOLDINGS & TRIMS
PORTSMOUTH OAK
CONCERT CHERRY
WASHED MAPLE

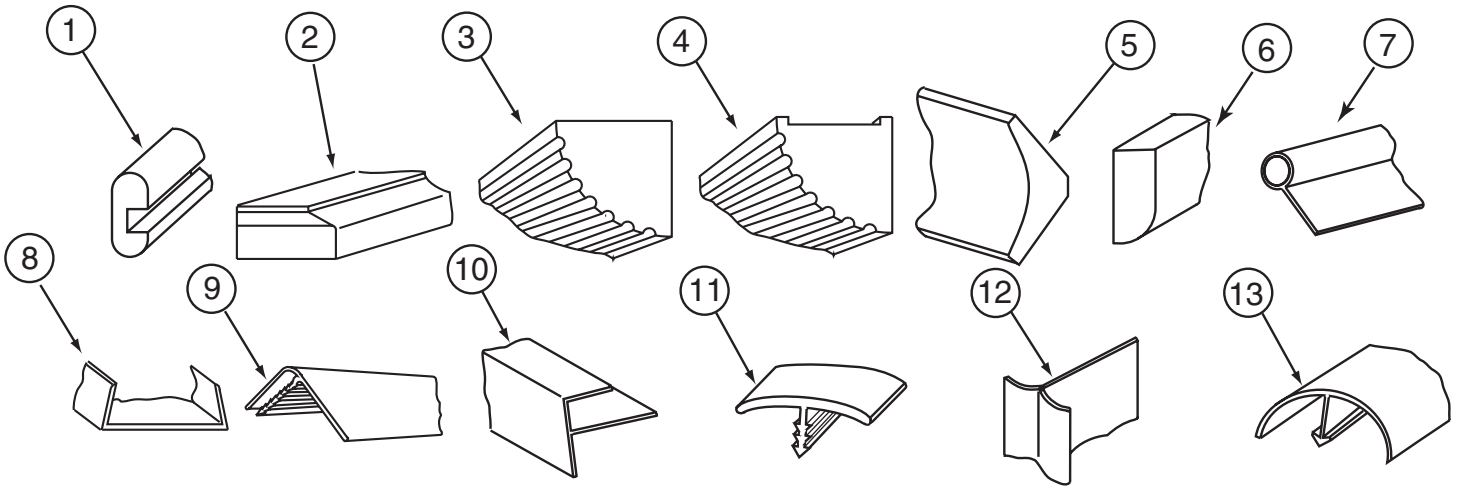

KEY	PART NUMBER	U/M	DESCRIPTION
1	M09412-62-N42	EA	MOLDING/SHELF EDGE - W/.4" NOTCH - PORTSMOUTH II - PORTSMOUTH OAK
1	M09412-62-M62	EA	MOLDING/SHELF EDGE - W/.4" NOTCH - WASHED MAPLE
1	M09412-62-M52	EA	MOLDING/SHELF EDGE - W/.4" NOTCH - CHERRY IV - CONCERT CHERRY
2	P34052-01-N75	EA	TRIM/TABLE - 29.7" - PORTSMOUTH OAK
2	P34052-01-M84	EA	TRIM/TABLE - 29.7" - WASHED MAPLE
2	P34052-01-M52	EA	TRIM/TABLE - 29.7" - SALEM CHERRY - CONCERT CHERRY
2	P34052-02-N47	EA	TRIM/TABLE - 24" - PORTSMOUTH OAK
2	P34052-02-M84	EA	TRIM/TABLE - 24" - WASHED MAPLE
2	P34052-02-M52	EA	TRIM/TABLE - 24" - SALEM CHERRY - CONCERT CHERRY
3	Y00070-22-438	EA	MOLDING/FLUTED - MAPLE - 96" - WASHED MAPLE
3	Y00070-32-438	EA	MOLDING/FLUTED - CHERRY - 96" - CONCERT CHERRY
3	Y00070-42-438	EA	MOLDING/FLUTED - OAK - 96" - PORTSMOUTH OAK
4	Y00071-22-438	EA	MOLDING/FLUTED - W/NOTCH - MAPLE - 96" - WASHED MAPLE
4	Y00071-32-438	EA	MOLDING/FLUTED - W/NOTCH - CHERRY - 96" - CONCERT CHERRY
4	Y00071-42-438	EA	MOLDING/FLUTED - W/NOTCH - OAK - 96" - PORTSMOUTH OAK
5	Y00074-22-438	EA	MOLDING/CROWN - VINYL WRAPPED - MAPLE - 96" - WASHED MAPLE
5	Y00074-62-438	EA	MOLDING/CROWN - VINYL WRAPPED - CONCERT CHERRY - 96" - CONCERT CHERRY
5	Y00074-72-438	EA	MOLDING/CROWN - VINYL WRAPPED - PORTSMOUTH OAK - 96" - PORTSMOUTH OAK
6	Y00086-22-438	EA	MOLDING - VINYL WRAP - 96" - WASHED MAPLE
6	Y00086-62-438	EA	MOLDING - VINYL WRAP - 96" - CONCERT CHERRY
6	Y00086-72-438	EA	MOLDING - VINYL WRAP - 96" - PORTSMOUTH OAK
7	009767-12-000	FT	WELTING - ANTIQUE WHITE
8	009778-25-000	FT	U-CHANNEL - 1" - BEIGE ILLUSION
8	009778-27-000	FT	U-CHANNEL - 1" - WASHED MAPLE
8	009778-30-000	FT	U-CHANNEL - 1" - VILLAGE OAK
8	009778-32-000	FT	U-CHANNEL - 1" - PORTSMOUTH OAK
8	009778-34-000	FT	U-CHANNEL - 1" - CONCERT CHERRY
9	009809-23-000	EA	MOLDING - CORNER - OUTSIDE - 1" X 84" - MODERN IVORY
9	009809-30-000	EA	MOLDING - CORNER - OUTSIDE - 1" X 84" - BEIGE ILLUSION
9	009809-32-000	EA	MOLDING - CORNER - OUTSIDE - 1" X 84" - PORTSMOUTH OAK
9	009809-33-000	EA	MOLDING - CORNER - OUTSIDE - 1" X 84" - CONCERT CHERRY
10	009812-24-000	EA	MOLDING - CORNER - 1/2" W/1/4"CHAN X 84" - IVORY PLASTIC
10	009812-31-000	EA	MOLDING - CORNER - 1/2" W/1/4"CHAN X 84" - BEIGE ILLUSION
10	009812-33-000	EA	MOLDING - CORNER - 1/2" W/1/4"CHAN X 84" - WASHED MAPLE
10	009812-34-000	EA	MOLDING - CORNER - 1/2" W/1/4"CHAN X 84" - VW LIGHT GRAY
10	009812-35-000	EA	MOLDING - CORNER - 1/2" W/1/4"CHAN X 84" - PORTSMOUTH OAK
10	009812-36-000	EA	MOLDING - CORNER - 1/2" W/1/4"CHAN X 84" - CONCERT CHERRY
11	009815-10-000	FT	MOLDING-T - W/EDGE LIP - 3/4" FACE - BEIGE ILLUSION
12	022992-11-000	FT	MOLDING - REVERSE COVE - T-SHAPED - IVORY
12	022992-14-000	FT	MOLDING - REVERSE COVE - T-SHAPED - BRIGHT WHITE
12	022992-15-000	FT	MOLDING - REVERSE COVE - T-SHAPED - VW GRAY
13	042357-25-000	EA	MOLDING - CORNER - RADIUS/PLASTIC - WASHED MAPLE

INTERIOR FINISH GROUP (CONTINUED)
MOLDINGS & TRIMS (CONTINUED)

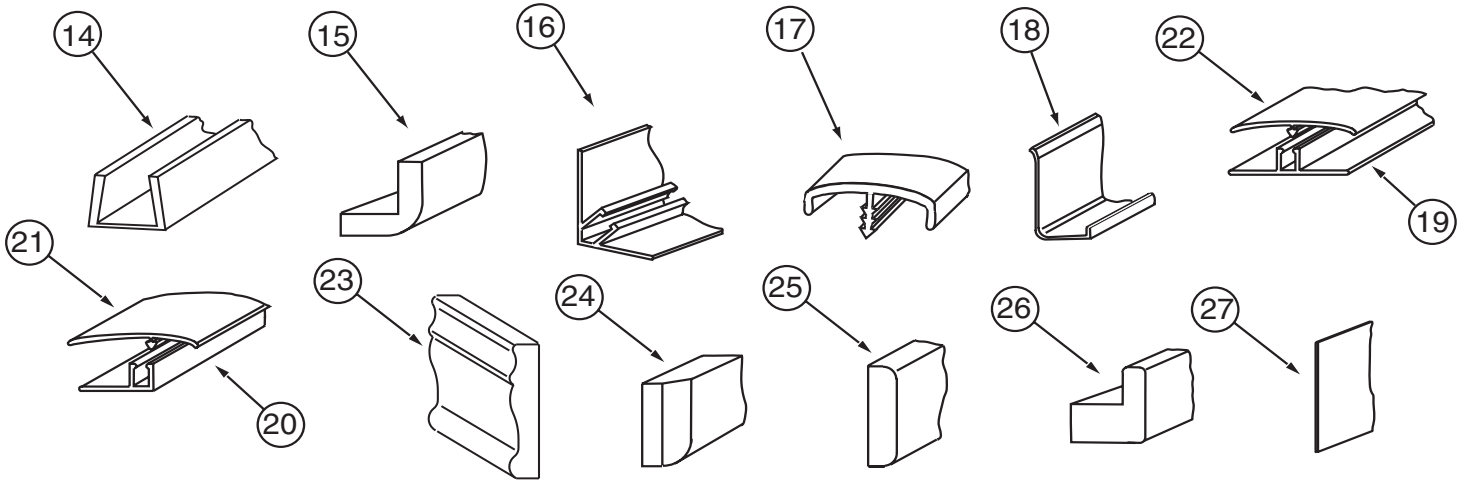

KEY	PART NUMBER	U/M	DESCRIPTION
14	070504-18-000	FT	U-CHANNEL - PLASTIC - .13" X 96" - IVORY
14	070504-35-000	FT	U-CHANNEL - PLASTIC - .13" X 72" - IVORY
14	070504-42-000	FT	U-CHANNEL - PLASTIC - .13" X 84" - BEIGE ILLUSION
14	070504-43-000	FT	U-CHANNEL - PLASTIC - .9" X 96" - BEIGE ILLUSION
14	070504-50-000	FT	U-CHANNEL - PLASTIC - .13" X 96" - WASHED MAPLE
14	070504-54-000	FT	U-CHANNEL - PLASTIC - .9" X 96" - VILLAGE OAK
14	070504-57-000	FT	U-CHANNEL - PLASTIC - .13" X 84" - PORTSMOUTH OAK
14	070504-58-000	FT	U-CHANNEL - PLASTIC - .9" X 84" - PORTSMOUTH OAK
14	070504-60-000	FT	U-CHANNEL - PLASTIC - .13" X 84" - CONCERT CHERRY
14	070504-61-000	FT	U-CHANNEL - PLASTIC - .9" X 84" - CONCERT CHERRY
15	080176-08-000	EA	CAP - CORNER - RADIUS MOLDING - PLASTIC - WASHED MAPLE
16	081521-02-007	EA	MOUNT - METAL MOLDING - F/RADIUS CORNER MOLDING - 151.5"
17	083620-09-000	FT	MOLDING-T - W/EDGE LIP - 7/8" FACE - MODERN IVORY
17	083620-15-000	FT	MOLDING-T - W/EDGE LIP - 7/8" FACE - BEIGE ILLUSION
17	083620-19-000	FT	MOLDING-T - W/EDGE LIP - 7/8" FACE - WASHED MAPLE
17	083620-20-000	FT	MOLDING-T - W/EDGE LIP - 7/8" FACE - PORTSMOUTH OAK
17	083620-21-000	FT	MOLDING-T - W/EDGE LIP - 7/8" FACE - CONCERT CHERRY
18	085746-04-000	FT	TRIM-J - CARPET 1.2" X .5" ANGLE - 10' LONG - OFF WHITE
19	086229-01-000	EA	RETAINER - BATTEN - .75" X 92.1" - ANY COLOR
20	086229-11-000	EA	RETAINER - OFFSET - 97"
21	086229-12-000	EA	BATTEN - 1.5" OFFSET X 96.8" - MODERN IVORY
21	086229-21-000	EA	BATTEN - 1.5" X 83.9" OFFSET - WHITE
22	086229-20-000	EA	BATTEN - 1" X 96" - BEIGE
23	100182-10-J70	EA	TRIM - CHAIR RAIL - 2.5" X 8' EACH - WOOD - WASHED MAPLE
23	100182-10-N47	EA	TRIM/RAIL - PORTSMOUTH OAK
23	100182-10-P85	EA	TRIM - CHAIR RAIL - 2.5" X 8' EACH - WOOD - CONCERT CHERRY
24	100659-30-N75	EA	MOLDING - TRIM - PORTSMOUTH OAK
24	100659-30-N74	EA	MOLDING - TRIM - CHERRY - CONCERT CHERRY
24	100659-30-M84	EA	MOLDING-TRIM,VINYL FLOOR - WASHED MAPLE
25	100818-01-08A	EA	MOLDING - VINYL WRAPPED - 1.6" X .4" X 84"-WASHED MAPLE
25	100818-01-12A	EA	MOLDING - VINYL WRAPPED - 1.6" X .4" X 84"-PORTSMOUTH OAK
25	100818-01-13A	EA	MOLDING - VINYL WRAPPED - 1.6" X .4" X 84" - CHERRY - CONCERT CHERRY
26	100819-01-08A	EA	MOLDING - VINYL WRAPPED-L-SHAPED-1.5"X1.5"X84"- WASHED MAPLE
26	100819-01-12A	EA	MOLDING - VINYL WRAPPED-L-SHAPED - 1.5" X 1.5" X 84" - OAK - PORTSMOUTH OAK
26	100819-01-13A	EA	MOLDING - VINYL WRAPPED-L-SHAPED-1.5"X1.5"X84" - CONCERT CHERRY
27	101957-01-06A	EA	EXTRUDED - PLASTIC - WASHED MAPLE

INTERIOR FINISH GROUP (CONTINUED)
MOLDINGS & TRIMS (CONTINUED)

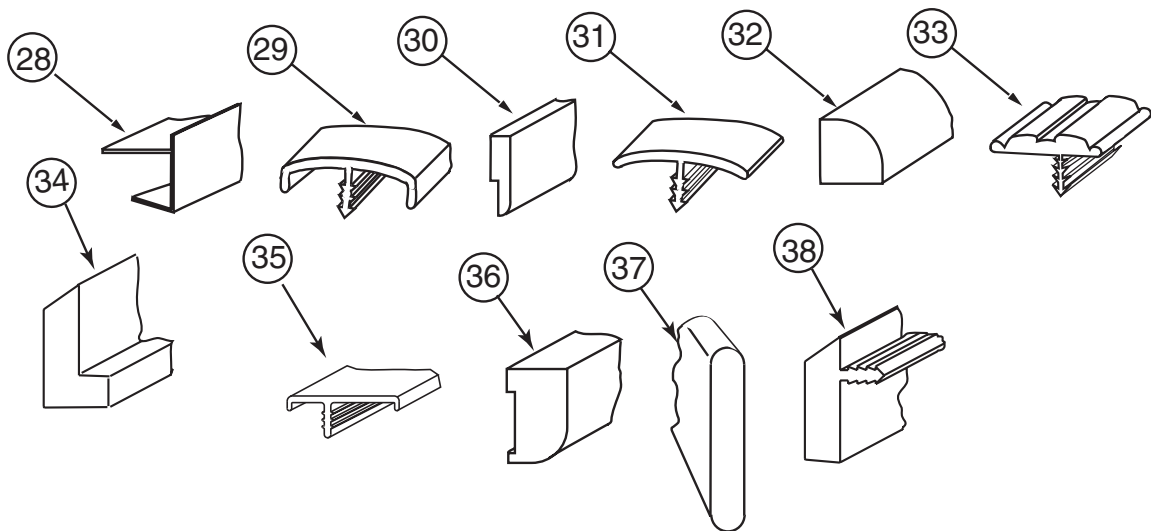

KEY	PART NUMBER	U/M	DESCRIPTION
28	103186-01-07A	FT	MOLDING/PLASTIC - 3/8" U-CHANNEL-3/4"FACE - BEIGE ILLUS 8'
28	103186-01-08A	FT	MOLDING/PLASTIC - 3/8" U-CHANNEL-3/4"FACE-WASHED MAPLE 8' - WASHED MAPLE
28	103186-01-09A	FT	MOLDING/PLASTIC - 3/8" U-CHAN'L-3/4"FACE-PORTSMOUTH OAK 8' - PORTSMOUTH OAK
28	103186-01-10A	FT	MOLDING/PLASTIC-3/8" U-CHAN'L-3/4"FACE-CONCERT CHERRY 8' - CONCERT CHERRY
28	103186-02-07A	FT	MOLDING/PLASTIC-1" U-CHAN'L-1 3/8"FACE-BEIGE ILLUSION - 8'
28	103186-02-08A	FT	MOLDING/PLASTIC - 1" U-CHANNEL-1 3/8"FACE-WASHED MAPLE 8' - WASHED MAPLE
28	103186-02-09A	FT	MOLDING/PLASTIC - 1" U-CHAN'L-1 3/8"FACE-PORTSMOUTH OAK 8' - PORTSMOUTH OAK
28	103186-02-10A	FT	MOLDING/PLASTIC - 1" U-CHAN'L-1 3/8"FACE-CONCERT CHERRY 8' - CONCERT CHERRY
29	104676-02-06A	FT	MOLDING-T - W/EDGE LIP - 11/16" FACE - WASHED MAPLE
29	104676-02-08A	FT	MOLDING-T - W/EDGE LIP - 11/16" FACE - PORTSMOUTH OAK
29	104676-02-09A	FT	MOLDING-T - W/EDGE LIP - 11/16" FACE - CONCERT CHERRY
30	105004-01-08A	EA	MOLDING - VINYL WRAPPED - 1" X 96" - WASHED MAPLE
30	105004-01-12A	EA	MOLDING - VINYL WRAPPED 1" X 96" - PORTSMOUTH OAK
30	105004-01-13A	EA	MOLDING - VINYL WRAPPED 1" X 96" - CONCERT CHERRY
31	105709-02-000	FT	MOLDING-T - W/EDGE LIP - 3/4" FACE - BEIGE ILLUSION
32	109410-01-P25	EA	MOLDING - TRIM - 8' - BLACK CHERRY/CHERRY IV - CONCERT CHERRY
32	109410-01-N75	EA	MOLDING - TRIM - 8' - PORTSMOUTH OAK
32	109410-01-J70	EA	MOLDING - TRIM - 8' - WHITE MAPLE/WASHED MAPLE
33	109736-02-01A	FT	MOLDING-T/OFFSET - W/EDGE LIP - 1" FACE - NAT OAK/BRASS
34	111235-01-H56	EA	MOLDING - COUNTERTOP - 1.4" X 8' - WHITE MAPLE - UNSTAINED - WASHED MAPLE
34	111235-01-N42	EA	MOLDING - COUNTERTOP - 1.4" X 8' - OAK - UNSTAINED - PORTSMOUTH OAK
34	111235-01-P79	EA	MOLDING - COUNTERTOP - 1.4" X 8' - CONCERT CHERRY
35	119520-01-01A	FT	MOLDING-T/OFFSET - W/EDGE LIP - 1"FACE - OFF WHITE
35	119520-01-02A	FT	MOLDING-T/OFFSET - W/EDGE LIP - 1"FACE - CONCERT CHERRY
35	119520-01-03A	FT	MOLDING-T/OFFSET - W/EDGE LIP - 1"FACE - WASHED MAPLE
35	119520-01-04A	FT	MOLDING-T/OFFSET - W/EDGE LIP - 1"FACE - PORTSMOUTH OAK
35	119520-02-01A	FT	MOLDING-T/OFFSET - W/EDGE LIP - 1"FACE
36	126204-D2-134	EA	MOLDING - VINYL WRAPPED - .7" X 1.6" X 84" - WASHED MAPLE
36	126204-F2-134	EA	MOLDING - VINYL WRAPPED - .7" X 2.5" X 84" - WASHED MAPLE
36	137887-D2-134	EA	MOLDING - VINYL WRAPPED - .7" X 1.6" X 96" - CHERRY - CONCERT CHERRY
36	137887-F2-134	EA	MOLDING - VINYL WRAPPED - .7" X 2.5" X 84" - CHERRY - CONCERT CHERRY
36	137887-F2-743	EA	MOLDING - VINYL WRAPPED - .7" X 2.5" X 108" - CHERRY - CONCERT CHERRY
36	137895-D2-134	EA	MOLDING - VINYL WRAPPED - .7" X 1.6" X 84" - PORTSMOUTH OAK
36	137895-F2-134	EA	MOLDING - VINYL WRAPPED - .7" X 2.5" X 84" - PORTSMOUTH OAK
36	137895-F2-743	EA	MOLDING - VINYL WRAPPED - .7" X 2.5" X 108" - PORTSMOUTH OAK
37	127842-01-01A	FT	SEAL - SIGHT SHIELD - 2" BLACK
38	130247-01-05A	FT	MOLDING-T/OFF SET - 1.3" FACE - CONCERT CHERRY
38	130247-01-04A	FT	MOLDING-T/OFF SET - 1.3" FACE - PORTSMOUTH OAK
38	130247-01-02A	FT	MOLDING-T/OFF SET - 1.3" FACE - WASHED MAPLE

INTERIOR FINISH GROUP (CONTINUED)
MOLDINGS & TRIMS (CONTINUED)

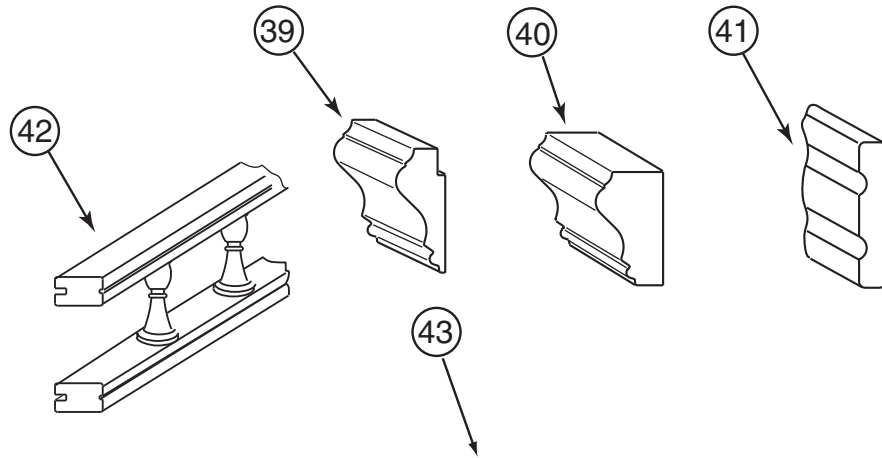

LUMBER

KEY	PART NUMBER	U/M	DESCRIPTION
39	131923-02-04A	FT	MOLDING - PICTURE - OAK - PORTSMOUTH OAK
40	131923-03-03A	FT	MOLDING - CROWN - DIVIDER - WHITE MAPLE - WASHED MAPLE
40	131923-03-02A	FT	MOLDING - CROWN - DIVIDER - CHERRY - CONCERT CHERRY
41	134156-01-03A	EA	MOLDING - VINYL WRAP - .7" X 3.8" X 33.8" - WASHED MAPLE
41	134156-01-08A	EA	MOLDING - VINYL WRAP - .7" X 3.8" X 33.8" - PORTSMOUTH OAK
41	134156-03-03A	EA	MOLDING - VINYL WRAP - .7" X 3.4" X 28.3" - WASHED MAPLE
41	134156-03-07A	EA	MOLDING - VINYL WRAP - .7" X 3.4" X 28.3" - CONCERT CHERRY
41	134156-03-08A	EA	MOLDING - VINYL WRAP - .7" X 3.4" X 28.3" - PORTSMOUTH OAK
41	134156-05-07A	EA	MOLDING - VINYL WRAP - .7" X 3.8" X 34.4" - CONCERT CHERRY
42	137108-01-02A	EA	RAIL - DECORATIVE - SALEM CHERRY - CONCERT CHERRY
42	137108-01-03A	EA	RAIL - DECORATIVE - WASHED MAPLE
42	137108-01-07A	EA	RAIL - DECORATIVE - PORTSMOUTH OAK
43	126205-D2-438	EA	LUMBER - VINYL WRAPPED - .7" X 1.5" X 96" - WASHED MAPLE
43	126205-E2-438	EA	LUMBER - VINYL WRAPPED - .7" X 2" X 96" - WASHED MAPLE
43	126205-F2-438	EA	LUMBER - VINYL WRAPPED - .7" X 2.5" X 96" - WASHED MAPLE
43	126205-G2-438	EA	LUMBER - STAINED - .7" X 3" X 96" - WASHED MAPLE
43	126205-J2-438	EA	LUMBER - VINYL WRAPPED - .7" X 5.5" X 96" - WASHED MAPLE
43	126205-R2-438	EA	LUMBER - LUMBER - VINYL WRAPPED - .7" X 3" X 96" - WASHED MAPLE
43	137885-A2-438	EA	LUMBER - VINYL WRAPPED - .7" X .75" X 96" - CHERRY - CONCERT CHERRY
43	137885-D2-438	EA	LUMBER - VINYL WRAPPED - .7" X 1.5" X 96" - CHERRY - CONCERT CHERRY
43	137885-E2-438	EA	LUMBER - VINYL WRAPPED - .7" X 2" X 96" - CHERRY - CONCERT CHERRY
43	137885-F2-438	EA	LUMBER - VINYL WRAPPED - .7" X 2.5" X 96" - CHERRY - CONCERT CHERRY
43	137885-G2-438	EA	LUMBER - VINYL WRAPPED - .7" X 3" X 96" - CHERRY - CONCERT CHERRY
43	137885-J2-743	EA	LUMBER-018X140X2743 MM VYL - CONCERT CHERRY
43	137885-J2-438	EA	LUMBER - VINYL WRAPPED - .7" X 5.5" X 96" - CHERRY - CONCERT CHERRY
43	137885-R2-438	EA	LUMBER - VINYL WRAPPED - .7" X 3" X 96" - CHERRY - CONCERT CHERRY
43	137894-A2-438	EA	LUMBER - VINYL WRAPPED - .7" X .75" X 96" - PORTSMOUTH OAK
43	137894-D2-438	EA	LUMBER - VINYL WRAPPED - .7" X 1.5" X 96" - PORTSMOUTH OAK
43	137894-E2-438	EA	LUMBER - VINYL WRAPPED - .7" X 2" X 96" - PORTSMOUTH OAK
43	137894-F2-438	EA	LUMBER - VINYL WRAPPED - .7" X 2.5" X 96" - PORTSMOUTH OAK
43	137894-G2-438	EA	LUMBER - VINYL WRAPPED - .7" X 3" X 96" - PORTSMOUTH OAK
43	137894-H2-438	EA	LUMBER - VINYL WRAPPED - .7" X 3.5" X 96" - PORTSMOUTH OAK
43	137894-J2-438	EA	LUMBER - VINYL WRAPPED - .7" X 5.5" X 96" - PORTSMOUTH OAK
43	137894-J2-743	EA	LUMBER - VINYL WRAPPED - .7" X 5.5" X 108" -PORTSMOUTH OAK
43	137894-R2-438	EA	LUMBER - VINYL WRAPPED - .7" X 3" X 96" - PORTSMOUTH OAK
	141260-01-02A	FT	U-CHANNEL - 1" - GRADY BROWN
	141260-01-01A	FT	U-CHANNEL - 1" - VILLAGE OAK

INTERIOR FINISH GROUP (CONTINUED)
PANELING & LAMINATES

KEY	PART NUMBER	U/M	DESCRIPTION
	000885-A3-000	SF	PARTICLE BOARD - 3/4" X 4' X 8' - SALEM CHERRY - 2 SIDED
	000885-A5-000	SF	PARTICLE BOARD - 3/8" X 4' X 8'- WHT PEB EMBOSSED-1 SIDED
	000885-88-000	SF	PARTICLE BOARD - 3/8" X 4' X 8' - WASHED MAPLE - 1-SIDED
	000885-89-000	SF	PARTICLE BOARD - 3/8" X 4' X 8' - WASHED MAPLE - 2-SIDED
	000885-91-000	SF	PARTICLE BOARD - 3/4" X 4' X 8' - WASHED MAPLE - 2-SIDED
	000885-96-000	SF	PARTICLE BOARD - 3/8" X 4' X 8' - CONCERT CHERRY - 1-SIDED
	000885-98-000	SF	PARTICLE BOARD - 3/8" X 4' X 8' - SALEM CHERRY - 2 SIDED
	000885-92-000	SF	PARTICLE BOARD-3/8" X 4' X 8'-PORTSMOUTH OAK-VINYL 1 SIDED
	000885-93-000	SF	PARTICLE BOARD - 3/8" X 4' X 8' - PORTSMOUTH OAK - 2-SIDED
	000885-94-000	SF	PARTICLE BOARD - 1/2" X 4' X 8' - PORTSMOUTH OAK - 2-SIDED
	000885-95-000	SF	PARTICLE BOARD - 3/4" X 4' X 8' - PORTSMOUTH OAK - 2-SIDED
	069733-87-000	EA	BATT STRIP - WOODGRAINED/PORTSMOUTH OAK - 8'
	069733-88-000	EA	BATT STRIP - WOODGRAINED/SALEM CHERRY - 8'
	069733-89-000	EA	BATT STRIP - WOODGRAINED/WASHED MAPLE - 8'
	074497-41-000	SF	PANELING - CEILING/IMPACT PEARL - 4' X 9'
	074497-42-000	SF	PANELING - PORTSMOUTH OAK - 4' X 8'
	074497-43-000	SF	PANELING - SALEM CHERRY - 4' X 8'
	074497-39-000	SF	PANELING - WASHED MAPLE - 4' X 8'
	074498-97-000	SF	LAMINATE - PLASTIC - GRAY TRANQUILITY - 4' X 8'
	074498-99-000	SF	LAMINATE - PLASTIC - EGGSHELL - 4' X 8'
	076325-40-000	FT	MOLDING - EDGE BAND - .93" X .024" - ALMOND
	076773-15-000	SF	PANELING - 2 SIDED/PORTSMOUTH OAK - 1/8" X 4' X 8'
	076773-16-000	SF	PANELING - 2 SIDED/SALEM CHERRY - 1/8" X 4' X 8'
	076773-17-000	SF	PANELING - 2 SIDED/WASHED MAPLE - 1/8" X 4' X 8'
	088263-G9-000	EA	BATT STRIP - DECORATIVE - CORK/ALABASTER - 8' (P23, P24, P40)
	088263-H1-000	EA	BATT STRIP - DECORATIVE - STARLIGHT - 8' LONG (P19, P20, P33)
	088263-H2-000	EA	BATT STRIP - DECORATIVE - MULTI - 8' LONG (P21, P22, P36)
	085284-G8-000	FT	BATT TAPE - ADHESIVE BACKED - PORTSMOUTH OAK
	085284-H2-000	FT	BATT TAPE - ADHESIVE BACKED - SALEM CHERRY
	085284-H3-000	FT	BATT TAPE - ADHESIVE BACKED - DECORATIVE - WASHED MAPLE
	085284-H4-000	FT	BATT TAPE - ADHESIVE BACKED - DECORATIVE - STARLIGHT (P19, P20, P33)
	085284-H6-000	FT	BATT TAPE - ADHESIVE BACKED - DECORATIVE - MULTI (P21, P22, P36)
	085284-G9-000	FT	BATT TAPE - ADHESIVE BACKED - DECORATIVE - ALABASTER (P23, P24, P40)
	088263-H1-000	EA	BATT STRIP - DECORATIVE - STARLIGHT - 8' LONG
	088272-H9-000	SF	PANELING - PEBBLE EMBOSSED - WHITE - 4' X 7'
	088272-K3-000	SF	PANELING - STARLIGHT - 4' X 7' (P19, P20, P33)
	088272-K4-000	SF	PANELING - MULTI - 4' X 7' (P21, P22, P36)
	088272-J9-000	SF	PANELING - ALABASTER - 4' X 7' (P23, P24, P40)
	126339-01-000	SF	BOARD - WHEAT - 60" X 72"
	132610-10-14A	FT	WALLPAPER - BORDER - 5 3/4" - SELF ADHESIVE (P19, P20, P33)
	132610-10-06A	FT	WALLPAPER - BORDER - 5 3/4" - SELF ADHESIVE (P21, P22, P36)
	132610-05-18A	FT	WALLPAPER - BORDER - 7" - SELF-ADHESIVE (P23, P24, P40)

ACCESSORIES

KEY	PART NUMBER	U/M	DESCRIPTION
	072852-01-000	EA	DETECTOR - SMOKE - W/9 VOLT BATTERY - US
	094499-03-000	EA	EXTINGUISHER/FIRE - DRY - 10BC - W/GAUGE/BRACKET
	064781-06-000	EA	HOLDER/CUP - TWO STEP - OFF WHITE
	072852-02-000	EA	DETECTOR - SMOKE - W/9 VOLT BATTERY - CANADIAN
*	094499-02-000	EA	EXTINGUISHER/FIRE - DRY - 10BC - W/GAUGE - CANADIAN
	096764-02-000	FT	SLIPNOT - ANTISLIP - 1"WIDE (180' ROLLS) - WHITE
	118718-01-01A	EA	HOLDER/DRINK - COLLAPSIBLE MUG - BLACK PLASTIC
	142368-02-01A	EA	CLOCK - 8" SQUARE - BRASS
	094499-04-000	EA	STRAP - FIRE EXTINGUISHER MOUNTING - METAL
	125136-02-000	EA	DETECTOR/CO - GAS MODEL - 9 VOLT
	131493-02-12A	EA	PICTURE - DECORATIVE - 13" X 15" - AFRICAN LILY (P19,P20,P33)
	131493-02-11A	EA	PICTURE - DECORATIVE - 13" X 15" - RHODODENDRON (P,21,P22.P36)
	131493-02-13A	EA	PICTURE - DECORATIVE - 13" X 15" - SANDCASTLE (P23,P24,P40)
	131494-05-01A	EA	MIRROR - ARCHED TOP - 20" X 30"
	137605-01-01A	EA	RAIL - HAND - INTERIOR ENTRY DOOR
	140374-36-000	EA	MIRROR - SAFETY GLASS - 20.9" X 25.2"
	140374-14-000	EA	MIRROR - SAFETY GLASS - 20.8" X 35.4"

*COMPONENT PARTS LISTED LATER IN THIS GROUP

INTERIOR FINISH GROUP (CONTINUED)
COMPONENT PARTS FOR ACCESSORIES

094499-02-000

KEY	PART NUMBER	U/M	DESCRIPTION	VENDOR NO
	094499-01-700	EA	BRACKET MTG. W/PLAS. STRAP	294039

INTERIOR FINISH GROUP (CONTINUED)

FLOOR COVERINGS

KEY	PART NUMBER	U/M	DESCRIPTION
	042720-28-000	SY	VINYL - FLOOR COVERING - 14' WIDE - OPTIMATION
	093486-02-000	SY	CARPET - COMPARTMENT - 72" WIDE - LIGHT GRAY
	139056-06-000	SY	CARPET - CRYSTAL LAKE - 4 SQUARE YARD INCREMENTS (P19, P20, P33)
	096060-F0-000	SY	CARPET - PALE SAGE - INCREMENTS OF 4 SQ YARDS (P21, P22, P36)
	139056-04-000	SY	CARPET - 4 SQUARE YARD INCREMENTS (P23, P24, P40)

INTERIOR FINISH GROUP (CONTINUED) HARDWARE

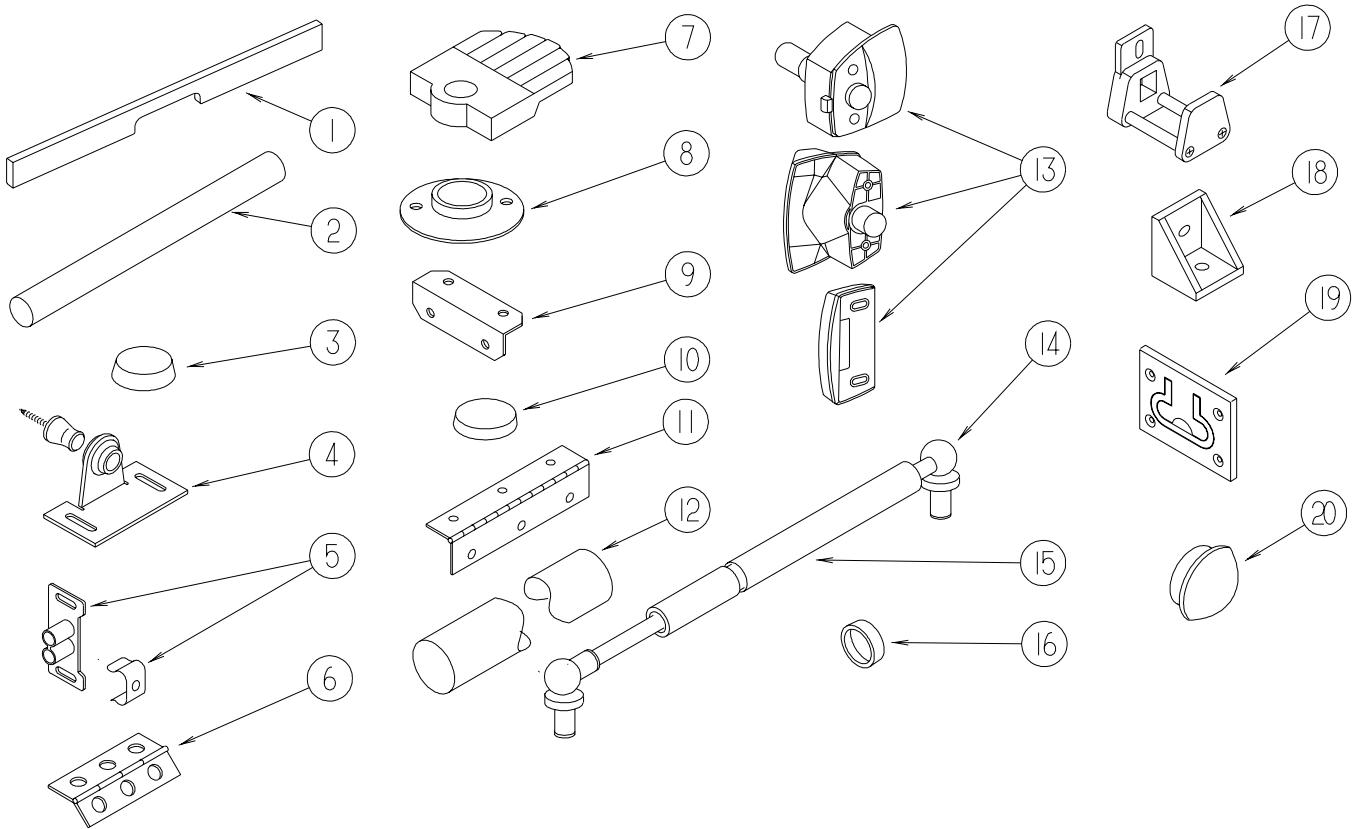

KEY	PART NUMBER	U/M	DESCRIPTION
1	P26866-12-N62	EA	HANDLE - DOOR/TAMBOUR - 14.7" - WASHED MAPLE
1	P26866-12-N63	EA	HANDLE - DOOR/TAMBOUR - 11.6" - CONCERT CHERRY
1	P26866-12-P69	EA	HANDLE - DOOR/TAMBOUR - 11.6" - PORTSMOUTH OAK
2	Y00136-21-218	EA	DOWEL - WOOD - 1" X 4'
3	004354-01-000	EA	BUMPER - RUBBER - .5" DIA - BROWN
4	009013-01-000	EA	CATCH - BULLDOG - MALE/FEMALE
5	009021-01-000	EA	CATCH - GRILLE - NYLON
5	009021-02-000	EA	STRIKE - SPRING STEEL - .68"
6	009059-01-000	EA	HINGE - DOOR - 2" X 1.4" - BRASS
6	009059-02-000	EA	HINGE - DOOR - 2" X 2.7" - BRASS
6	009059-03-000	EA	HINGE - BRASS - 1.75"
7	009089-01-000	EA	CLIP - MIRROR
8	009112-01-000	EA	FLANGE - PLASTIC - 1" CLOTHES ROD - OFF WHITE
9	016604-05-000	EA	BRACE - ANGLE - 2 1/2" - OFF WHITE METAL
9	016604-10-000	EA	BRACE - SEAT ANGLE - 2.5" - BLACK
9	016604-11-000	EA	BRACE - SEAT - ANGLE - 2.5" - CHESTNUT
10	023320-01-000	EA	PAD - FELT 3/8" DIAMETER
11	041389-25-000	EA	HINGE - PIANO - 1 1/2" X 55" - UNPAINTED
12	042438-02-000	EA	DOWEL - WOOD - 2" DIAMETER X 2'
12	042438-06-000	EA	DOWEL - WOOD - CLOTHES ROD - 1.5" X 26"
13	058335-03-000	EA	LATCH W/O LOCK - BATHROOM DOOR BLACK
14	057460-02-000	EA	BALL STUD - F/GAS SPRING .39" - 5/16"-18
15	057460-04-000	EA	SPRING/GAS - BALL STUD STYLE - 120 PI - "SPD6209"
16	057671-01-000	EA	COVER - SCREW - #8 - OFF WHITE
16	057671-15-000	EA	COVER - SCREW - #8 - BRIGHT WHITE
16	057671-16-000	EA	COVER - SCREW - #8 - SOFT WHITE
16	057671-17-000	EA	COVER - SCREW - VW LT GRAY - #8
17	064467-01-000	EA	GUIDE - POCKET - SLIDING DOOR - WALL MOUNTED
18	065740-01-000	EA	BRACE - CABINET/CORNER - PLASTIC
19	072871-01-000	EA	PULL - FLUSH - CHROME
20	074045-08-000	EA	PLUG - OAK - 3/8" DOWEL-1/2" HEAD - SALEM CHERRY - CONCERT CHERRY
20	074045-12-000	EA	PLUG - OAK - 3/8" DOWEL-1/2" HEAD - WASHED MAPLE
20	074045-13-000	EA	PLUG - OAK - 3/8" DOWEL-1/2" HEAD - PORTSMOUTH OAK

INTERIOR FINISH GROUP (CONTINUED)
HARDWARE (CONTINUED)

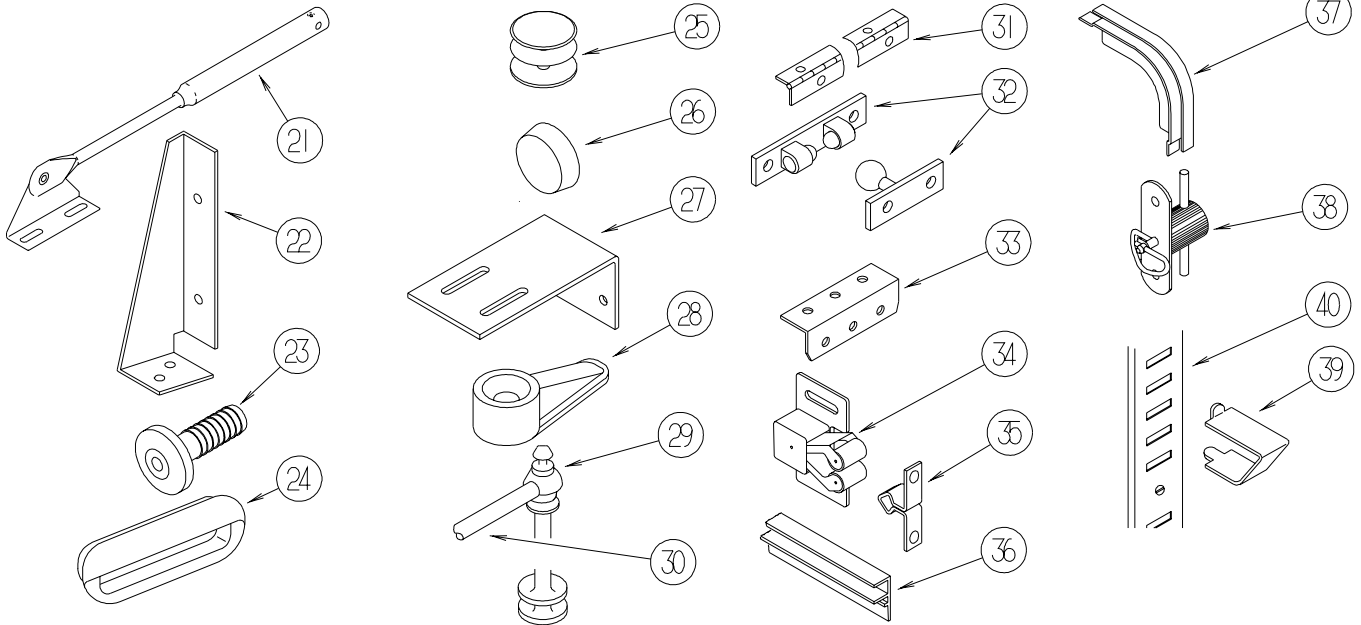

KEY	PART NUMBER	U/M	DESCRIPTION
21	074493-02-000	EA	SUPPORT - PISTON SPRING - CABINET DOOR - 26 LBS
21	074493-03-000	EA	SUPPORT - PISTON SPRING - CABINET DOOR - 12 LBS
21	074493-04-000	EA	SUPPORT - PISTON SPRING - CABINET DOOR - 32 LBS
22	076827-02-000	EA	BRACKET/LEG - 2.9" X 1.8" - TRIANGULAR - LEFT/E-COATED
23	079921-01-000	EA	ROLLER - NYLON - W/STEEL SHAFT - BARBED
24	080736-01-000	EA	PULL - RECESSED - 1.25" X 4" - OAK
25	081114-02-000	EA	CAP - INSERT - ROUND - 1" DIAMETER - WHITE PLASTIC
26	081914-01-000	EA	BUMPER - RUBBER - ROUND - 1/2" DIA. X 1/8" THICK
27	083125-07-000	EA	BRACE - ANGLE/COUCH - 2.5" - OFF WHITE
28	083204-03-000	EA	BUTTON - RETAINING MIRROR 5/16" TIP
29	084070-03-000	EA	POST - END - 2.4" - SHINY BRASS
30	084071-05-000	EA	ROD - BRASS - 15"
30	084071-19-000	EA	ROD - BRASS - 7.1"
30	084071-20-000	EA	ROD - BRASS - 9.8"
30	084071-23-000	EA	ROD - BRASS - 13.1"
30	084071-24-000	EA	ROD - BRASS - 3.8"
30	084071-28-000	EA	ROD - BRASS - 6"
30	084071-30-000	EA	ROD - BRASS - 11.6"
30	084071-31-000	EA	ROD - BRASS - 14.8"
30	084071-33-000	EA	ROD - BRASS - 20.4"
30	084071-34-000	EA	ROD - BRASS - 16.9"
31	084413-01-000	EA	HINGE - 1" X 72" - ALUMINUM - W/HOLES
32	084451-01-000	EA	CATCH & LATCH - 1.7" - BRASS
33	089025-01-000	EA	SUPPORT - SPRING TO BED - ANGLE 1.5" X 11.8"
34	093586-03-000	EA	CATCH - SPRING ROLLER - .377"
34	093586-06-000	EA	CATCH - SPRING ROLLER - .236"
35	093586-04-000	EA	STRIKE - SPRING STEEL - 1.14"
35	093586-05-000	EA	STRIKE - SPRING STEEL - .943"
36	093622-01-000	EA	TRACK - DOOR - TAMBOUR - PLASTIC - 8' LENGTHS
37	093623-01-000	EA	CORNER - TRACK - TAMBOUR DOOR
	097872-04-000	EA	DOWEL - WOOD - 1" DIAMETER X 1.38" LONG - UNFINISHED
38	098196-01-000	EA	LATCH - 1/4 TURN - T-BAR
39	098979-01-000	EA	CLIP - ADJUSTABLE SHELF
40	098980-01-000	EA	PILASTER - ADJUSTABLE SHELF - 18"
40	098980-02-000	EA	PILASTER - ADJUSTABLE SHELF - 12"
40	098980-03-000	EA	PILASTER - ADJUSTABLE SHELF - 9"
40	098980-04-000	EA	PILASTER - ADJUSTABLE SHELF - 48"
40	098980-05-000	EA	PILASTER - ADJUSTABLE SHELF - 15"
40	098980-06-000	EA	PILASTER - ADJUSTABLE SHELF - 24"

INTERIOR FINISH GROUP (CONTINUED)

HARDWARE (CONTINUED)

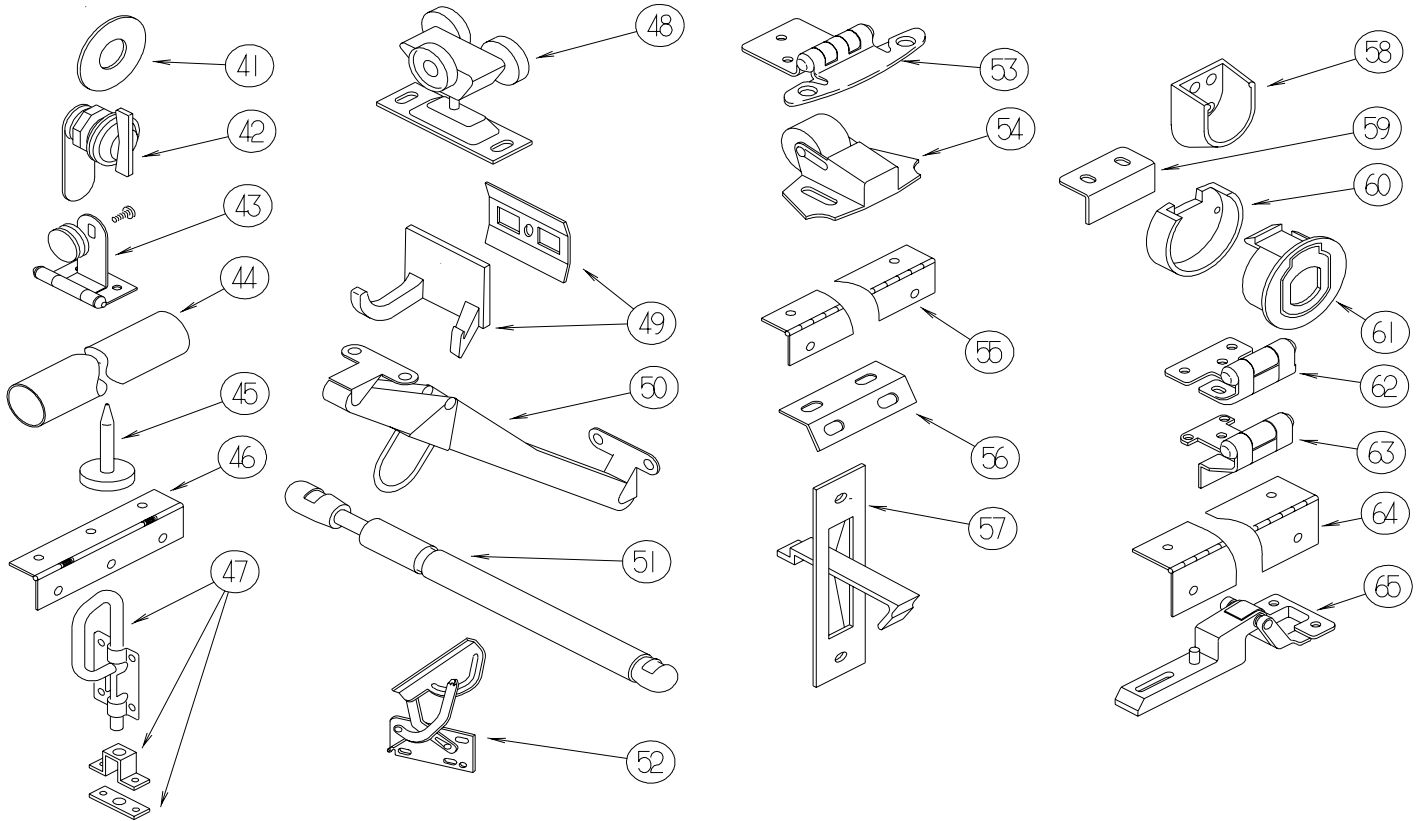

KEY	PART NUMBER	U/M	DESCRIPTION
41	100707-01-000	EA	SPACER - GLASS DOOR - .8" DIA - .3" HOLE - PLASTIC
42	100710-01-01A	EA	LOCK - GLASS DOOR/TWIST TYPE - BRASS
43	100711-01-01A	EA	HINGE - GLASS DOOR
44	102075-06-02A	EA	ROD - SHOWER CURTAIN - 1" OD X 33.5" - SOFT WHITE
44	102075-09-02A	EA	ROD - SHOWER CURTAIN - 3/4"OD X 29.5" - SOFT WHITE
44	102075-16-02A	EA	ROD - SHOWER CURTAIN - 3/4"OD X 34.2" - SOFT WHITE
44	102075-18-02A	EA	ROD - SHOWER CURTAIN - 1" OD X 38.9" - SOFT WHITE
44	102075-20-03A	EA	ROD - SHOWER CURTAIN - 48.8" - MILL
44	102075-21-03A	EA	ROD - SHOWER CURTAIN - 46.1"
45	102194-01-000	EA	GUIDE - PLASTIC - 1" (HEAD/PIN)
46	102920-01-01A	EA	HINGE - SPRING LOADED - BRASS
47	103256-01-000	EA	LATCH COMPLETE (SLIDE)
48	103874-01-000	EA	HANGER - SLIDING DOOR
49	104174-01-000	EA	HOOK - ROBE - DOUBLE
50	104181-01-01A	EA	SUPPORT - LEAF 5.3" EXTENDS TO 7.5" - SAFETY RING - METAL
51	107796-06-000	EA	SPRING/GAS - 12" COMPRESSED/20" EXTENDED - 120 LB.
51	107796-08-000	EA	SPRING/GAS - 11" COMPRESSED/17" EXTENDED - 60 LB
51	107796-15-000	EA	SPRING/GAS - 24" COMPRESSED/40" EXTENDED - 15 LB.
51	107796-16-000	EA	SPRING/GAS - 6.4" COMPRESSED/9.6" EXTENDED - 65 LB.
52	108126-01-000	EA	TRAY HINGE SET (QTY. 2 PER SET)
53	108138-01-000	EA	HINGE - CABINET DOOR - BURNISHED BRASS - Q SERIES (ULTIMATE FREEDOM) ONLY
53	108138-03-000	EA	HINGE - BRIGHT BRASS
54	109403-01-000	EA	CATCH - SINGLE ROLLER - SCREEN DOOR
55	110496-01-01A	EA	HINGE - BRASS
56	111866-01-02A	EA	BRACE - SEAT - ANGLE - OFF WHITE
57	113130-01-01A	EA	PULL - DOOR POCKET
58	113236-01-01A	EA	BRACKET - CLOTHES - ROD
59	113375-02-01A	EA	STRIKE - DOOR - CHROME
60	113375-05-01A	EA	LATCH - SLAM - BACK - .8" THICK
61	113375-06-01A	EA	LATCH - SLAM - FACE - .7" THICK
62	113676-01-01A	EA	HINGE - OVERLAY - VARIABLE - BURNISHED BRASS
63	113677-01-01A	EA	HINGE - SELF CLOSING
64	114278-02-000	EA	HINGE - CONTINUOUS - 3" WIDE
65	114443-01-01A	EA	HINGE - CABINET DOOR

INTERIOR FINISH GROUP (CONTINUED)
HARDWARE (CONTINUED)

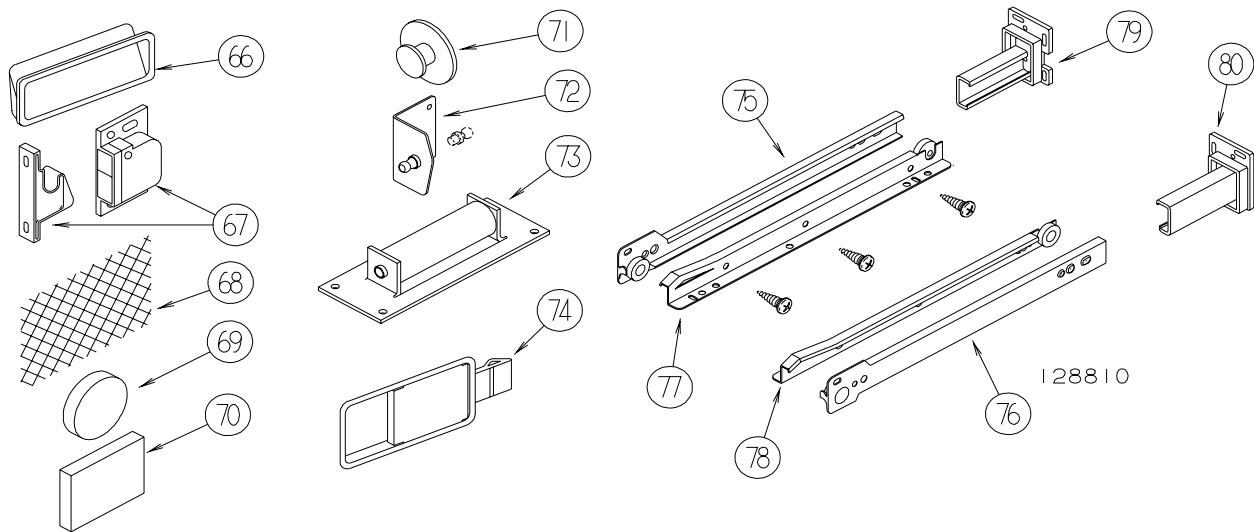

KEY	PART NUMBER	U/M	DESCRIPTION
66	115994-01-01A	EA	HANDLE - POCKET
67	117095-01-01A	EA	LATCH - DOOR - GRABBER W/KEEPER - PLASTIC - BLK-5 LB PULL
67	117095-02-01A	EA	LATCH - DOOR - GRABBER W/KEEPER - PLASTIC - BLK-10 LB PULL
68	118200-01-01A	SF	MESH - PLASTIC 1/2" - 48" X LENGTH = SF - BLACK
69	122717-01-01A	EA	PAD - NON SKID - 4" DIAMETER ROUND
70	122717-06-01A	FT	PAD - NON-SKID - PSA - 5"W
71	125221-01-01A	EA	PULL - MIRROR - W/ROUND HANDLE
72	126263-06-02B	EA	BRACKET - GAS SPRING W/INSIDE BALL STUD - E-COATED
72	126263-08-02B	EA	BRACKET - GAS SPRING W/CENTERED BALL STUD - E-COATED
73	126584-02-000	EA	ROLLER - FLAT
74	127349-01-01A	EA	LATCH - PADDLE
75	128810-01-01A	EA	SLIDE - DRAWER - 12" - LEFT CABINET
75	128810-05-01A	EA	SLIDE - DRAWER - 14" - LEFT CABINET
75	128810-09-01A	EA	SLIDE - DRAWER - 16" - LEFT CABINET
75	128810-13-01A	EA	SLIDE - DRAWER - 18" - LEFT CABINET
75	128810-17-01A	EA	SLIDE - DRAWER - 20" - LEFT CABINET
75	128810-21-01A	EA	SLIDE - DRAWER - 22" - LEFT CABINET
75	128810-25-01A	EA	SLIDE - DRAWER - 24" - LEFT CABINET
75	128810-29-01A	EA	SLIDE - DRAWER - 9" - LEFT CABINET
76	128810-02-01A	EA	SLIDE - DRAWER - 12" - RIGHT CABINET
76	128810-06-01A	EA	SLIDE - DRAWER - 14" - RIGHT CABINET
76	128810-10-01A	EA	SLIDE - DRAWER - 16" - RIGHT CABINET
76	128810-14-01A	EA	SLIDE - DRAWER - 18" - RIGHT CABINET
76	128810-18-01A	EA	SLIDE - DRAWER - 20" - RIGHT CABINET
76	128810-22-01A	EA	SLIDE - DRAWER - 22" - RIGHT CABINET
76	128810-26-01A	EA	SLIDE - DRAWER - 24" - RIGHT CABINET
76	128810-30-01A	EA	SLIDE - DRAWER - 9" - RIGHT CABINET
77	128810-03-01A	EA	SLIDE - DRAWER - 12" - LEFT DRAWER
77	128810-07-01A	EA	SLIDE - DRAWER - 14" - LEFT DRAWER
77	128810-11-01A	EA	SLIDE - DRAWER - 16" - LEFT DRAWER
77	128810-15-01A	EA	SLIDE - DRAWER - 18" - LEFT DRAWER
77	128810-19-01A	EA	SLIDE - DRAWER - 20" - LEFT DRAWER
77	128810-23-01A	EA	SLIDE - DRAWER - 22" - LEFT DRAWER
77	128810-27-01A	EA	SLIDE - DRAWER - 24" - LEFT DRAWER
77	128810-27-01A	EA	SLIDE - DRAWER - 24" - LEFT DRAWER
77	128810-31-01A	EA	SLIDE - DRAWER - 9" - LEFT DRAWER
78	128810-04-01A	EA	SLIDE - DRAWER - 12" - RIGHT DRAWER
78	128810-08-01A	EA	SLIDE - DRAWER - 14" - RIGHT DRAWER
78	128810-12-01A	EA	SLIDE - DRAWER - 16" - RIGHT DRAWER
78	128810-16-01A	EA	SLIDE - DRAWER - 18" - RIGHT DRAWER
78	128810-20-01A	EA	SLIDE - DRAWER - 20" - RIGHT DRAWER
78	128810-24-01A	EA	SLIDE - DRAWER - 22" - RIGHT DRAWER
78	128810-28-01A	EA	SLIDE - DRAWER - 24" - RIGHT DRAWER
78	128810-32-01A	EA	SLIDE - DRAWER - 9" - RIGHT DRAWER
79	128811-01-01A	EA	BACKSOCKET - ADJUSTABLE - LEFT
80	128811-02-01A	EA	BACKSOCKET - ADJUSTABLE - RIGHT

INTERIOR FINISH GROUP (CONTINUED) HARDWARE (CONTINUED)

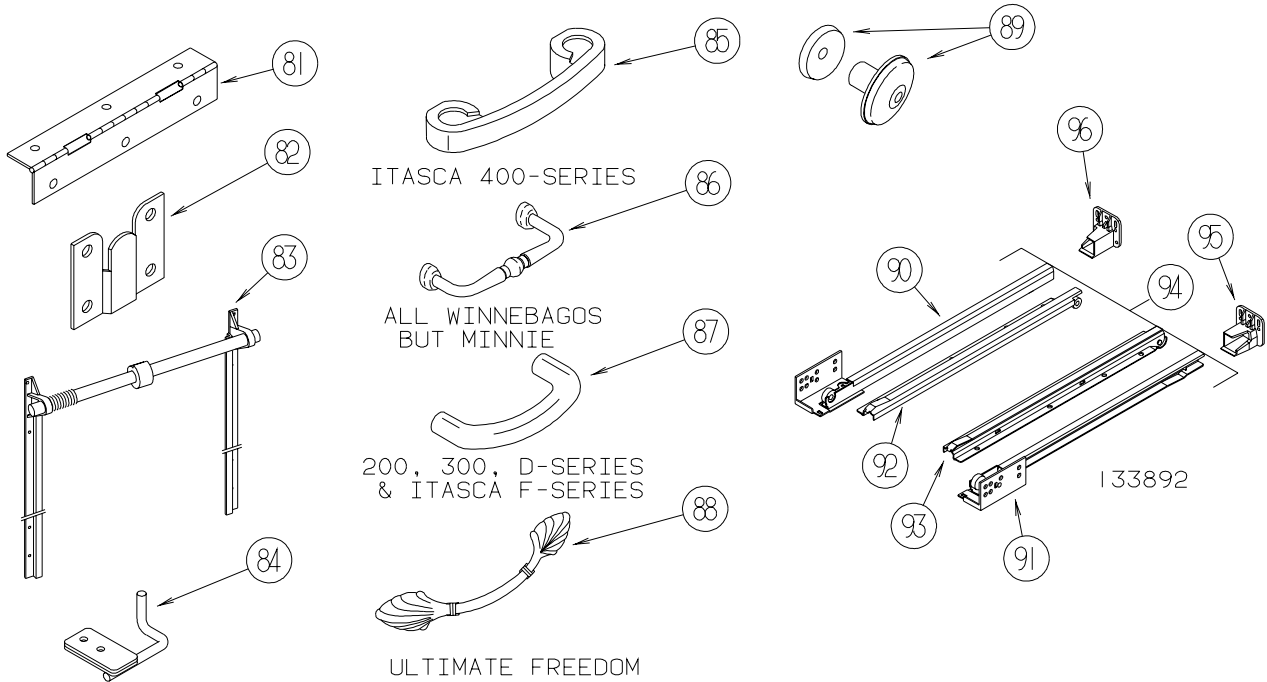

KEY	PART NUMBER	U/M	DESCRIPTION
81	129753-01-01A	EA	HINGE - SPRING LOADED - 19" X 19" - BLACK
82	130120-01-01A	EA	BRACKET - MIRROR
83	130787-01-000	EA	TRACK - TAMBOUR DOOR/SPRING - 15.9"
83	130787-02-000	EA	TRACK - TAMBOUR DOOR/SPRING - 24"
83	130787-04-000	EA	TRACK - TAMBOUR DOOR - SPRING
84	130798-01-02B	EA	GUIDE - POCKET DOOR - E-COATED
85	131962-01-01A	EA	PULL - DOOR/DRAWER - POLISHED BRASS - ITASCA 400 SERIES (SUNDANCER)
86	131963-01-01A	EA	PULL - POLISHED BRASS - WINNEBAGO BRAVE/ADVENTURER/CHIEFTAIN/JOURNEY/MINNIE WINNIE
87	131964-01-01A	EA	PULL - POLISHED BRASS - RIALTA/WINNEBAGO MINNIE/VISTA, ITASCA SPIRIT/SUNOVA
88	131965-01-01A	EA	PULL - DOOR/DRAWER - 6.3" - BURNISHED BRASS - ULTIMATE FREEDOM
89	133313-01-02A	EA	PULL - DOOR/DRAWER - BRIGHT BRASS
89	133313-01-03A	EA	PULL - DOOR/DRAWER - CHROME/BRASS - ITASCA L & P SERIES (SUNFLYER & HORISON) ONLY
90	133892-01-01A	EA	SLIDE - DRAWER - 16" - LEFT CABINET
90	133892-06-01A	EA	SLIDE - DRAWER - 22" - LEFT CABINET
90	133892-10-01A	EA	SLIDE - DRAWER - 12" - LEFT CABINET
90	133892-14-01A	EA	SLIDE - DRAWER - 18" - LEFT CABINET
91	133892-02-01A	EA	SLIDE - DRAWER - 16" - RIGHT CABINET
91	133892-07-01A	EA	SLIDE - DRAWER - 22" - RIGHT CABINET
91	133892-11-01A	EA	SLIDE - DRAWER - 12" - RIGHT CABINET
91	133892-15-01A	EA	SLIDE - DRAWER - 18" - RIGHT CABINET
92	133892-03-01A	EA	SLIDE - DRAWER - 16" - LEFT DRAWER
92	133892-08-01A	EA	SLIDE - DRAWER - 22" - LEFT DRAWER
92	133892-12-01A	EA	SLIDE - DRAWER - 12" - LEFT DRAWER
92	133892-16-01A	EA	SLIDE - DRAWER - 18" - LEFT DRAWER
93	133892-04-01A	EA	SLIDE - DRAWER - 16" - RIGHT DRAWER
93	133892-09-01A	EA	SLIDE - DRAWER - 22" - RIGHT DRAWER
93	133892-13-01A	EA	SLIDE - DRAWER - 12" - RIGHT DRAWER
93	133892-17-01A	EA	SLIDE - DRAWER - 18" - RIGHT DRAWER
94	133892-05-01A	EA	SLIDE - DRAWER - 9" - FULL SET
95	133907-01-01A	EA	BACKSOCKET - RIGHT HAND
96	133907-02-01A	EA	BACKSOCKET - LEFT HAND

INTERIOR FINISH GROUP (CONTINUED)
HARDWARE (CONTINUED)

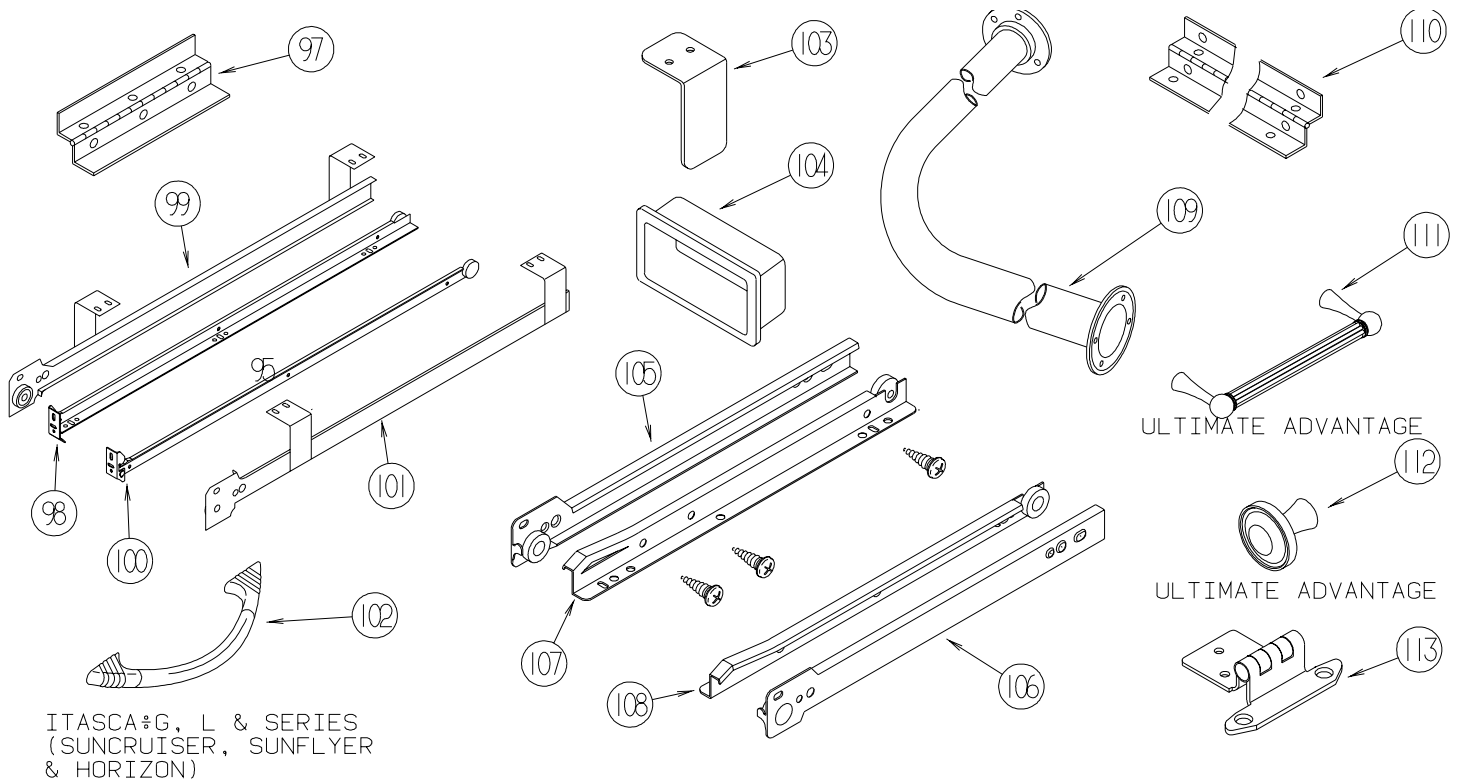

ITASCA G, L & SERIES
(SUNCRUISER, SUNFLYER
& HORIZON)

KEY	PART NUMBER	U/M	DESCRIPTION
97	135538-01-01A	EA	HINGE - PIANO - FULL WRAP - BRASS PLATED
97	135538-03-01A	EA	HINGE - PIANO - FULL WRAP - STOCKER BRASS
98	136944-01-01A	EA	SLIDE - DRAWER/RIGHT HAND - 13.8"
99	136944-02-01A	EA	SLIDE - CABINET/RIGHT HAND - 13.8"
100	136944-03-01A	EA	SLIDE - DRAWER/LEFT HAND - 13.8"
101	136944-04-01A	EA	SLIDE - CABINET/LEFT HAND - 13.8"
102	137446-01-01A	EA	PULL - CABINET - CHROME/BRASS - ITASCA G, L & P SERIES (SUNCRUISER/SUNFLYER/HORIZON)
103	138136-02-02B	EA	GUIDE - DOOR - E-COATED
104	139136-01-01A	EA	HANDLE - RECESSED - 2.9" X 1.3"/2.7" X 1" X .7" C/O- BRASS
104	139136-02-01A	EA	HANDLE - RECESSED - 2.9" X 1.3"/2.7" X 1" X .4" C/O- BRASS
105	139566-01-01A	EA	SLIDE - DRAWER - 37.5" - LEFT CABINET
105	139566-05-01A	EA	SLIDE - DRAWER - 32" - LEFT CABINET
106	139566-02-01A	EA	SLIDE - DRAWER - 37.5" - RIGHT CABINET
106	139566-06-01A	EA	SLIDE - DRAWER - 32" - RIGHT CABINET
107	139566-03-01A	EA	SLIDE - DRAWER - 37.5" - LEFT DRAWER
107	139566-07-01A	EA	SLIDE - DRAWER - 32" - LEFT DRAWER
108	139566-04-01A	EA	SLIDE - DRAWER - 37.5" - RIGHT DRAWER
108	139566-08-01A	EA	SLIDE - DRAWER - 32" - RIGHT DRAWER
109	140494-01-01A	EA	ROD - SHOWER
109	140494-01-02A	EA	ROD - SHOWER - SOFT WHITE
110	142276-01-01A	EA	HINGE - PIANO - FULL WRAP - BRASS
	142569-05-000	EA	SPRING - GAS - 39.9"/15 LB
			FROM: 01-18-03 THRU: 99-99-99
111	142909-01-01A	EA	PULL - CABINET - BRASS - ULTIMATE ADVANTAGE
112	142910-01-01A	EA	KNOB - CABINET - BRASS - ULTIMATE ADVANTAGE
113	143468-01-02A	EA	HINGE - SELF CLOSING - POLISHED BRASS

LABELS GROUP

SEWAGE

KEY PART NUMBER U/M DESCRIPTION
006187-01-000 EA LABEL - SEWAGE

WASTE WATER

KEY PART NUMBER U/M DESCRIPTION
006188-01-000 EA LABEL - WASTE WATER

WARNING

THIS SYSTEM IS DESIGNED FOR USE WITH PROPANE ONLY
DO NOT CONNECT NATURAL GAS TO THIS SYSTEM

BEFORE TURNING ON PROPANE:

- (A) BE CERTAIN APPLIANCES ARE CERTIFIED FOR PROPANE AND ARE EQUIPPED WITH CORRECT BURNING ORIFICES.
- (B) MAKE CERTAIN ALL PROPANE CONNECTIONS ARE TIGHT BY TESTING WITH SOAPY WATER. ALL APPLIANCE VALVES ARE TURNED OFF, AND ANY UNCONNECTED OUTLETS ARE CAPPED.

AFTER TURNING ON PROPANE:

- (A) LIGHT ALL PILOT LIGHTS
- (B) (B) ALL CONNECTIONS, INCLUDING THOSE AT THE APPLIANCES, REGULATORS AND CYLINDERS SHOULD BE LEAK-TESTED PERIODICALLY WITH SOAPY WATER BY THE OCCUPANT. NEVER USE A LIGHTED MATCH OR OTHER FLAME WHEN CHECKING FOR LEAKS.
- (C) DO NOT LEAVE SYSTEM TURNED ON OF CONTAINERS CONNECTED UNTIL THE SYSTEM HAS BEEN PROVEN TO BE FREE OF LEAKS.
- (D) COOKING APPLIANCES SHOULD NOT BE USED FOR SPACE HEATING.
- (E) WHEN THE CONTAINERS ARE DISCONNECTED THE PROPANE SUPPLY LINE SHOULD BE CAPPED OR PLUGGED.

AVERTISSEMENT

CETTE INSTALLATION EST CONÇUE POUR LE PROPANE SEULEMENT
NE PAS L'ALIMENTER EN GAZ NATUREL

AVANT LA MISE EN SERVICE:

- (A) S'ASSURER QUE LES APPAREILS SONT CERTIFIÉS POUR LE PROPANE ET MUNIS D'ORIFICES DE BRULEUR APPROPRIÉS.
- (B) VÉRIFIER L'ÉTANCHEITÉ DE TOUS LES RACCORDEMENTS AU PROPANE. LA PERMÉTURE DE TOUS LES ROBINETS D'APPAREILS ET L'OBTURATION DE TOUTES LES SORTIES NON RACCORDEES.

APRÈS LA MISE EN SERVICE:

- (A) ALLUMER TOUTES LES VEILLEUSES.
- (B) L'OCCUPANT DOIT ÉPROUVER PÉRIODIQUEMENT L'ÉTANCHEITÉ DE TOUS LES RACCORDEMENTS Y COMPRIS CEUX AUX APPAREILS, AUX DÉTENDEURS ET AUX BOUTEILLES, EN Y APPLIQUANT DE L'EAU SAVONNEUSE NE JAMAIS SE SERVIR D'UNE ALLUMETTE OU AUTRE POUR LA DÉTECTION DES FUITES.
- (C) NE PAS LAISSER L'ALIMENTATION OUVERTE NI LES RÉCIPIENTS RACCORDES AVANT D'AVOIR COMPLÉTÉ L'ÉPREUVE D'ÉTANCHEITÉ AU PROPANE DE L'INSTALLATION.
- (D) LES APPAREILS DE CUISSON NE DOIVENT PAS ÊTRE UTILISÉS POUR LE CHAUFFAGE DES LOCAUX.
- (E) LORSQUE LES RÉCIPIENTS SONT DÉCONNECTÉS, L'ALIMENTATION DE PROPANE DOIT ÊTRE OBTURÉE OU SCELLÉE.

KEY PART NUMBER U/M DESCRIPTION
023769-01-000 EA LABEL - WARNING - LPG - CANADIAN

EXIT

KEY PART NUMBER U/M DESCRIPTION
039290-01-000 EA LABEL - WARNING - EXIT

LABELS GROUP (CONTINUED)



KEY PART NUMBER U/M DESCRIPTION
040944-01-000 EA LABEL - ENTRANCE DOOR - "OPEN"

CAUTION

THIS MOTOR HOME HAS BEEN DESIGNED, MANUFACTURED AND TESTED WITH CONCERN FOR THE PROTECTION OF IT'S OCCUPANTS. WE RECOMMEND YOU PERFORM THE FOLLOWING INSPECTIONS FOR YOUR SAFETY AND THE SAFETY OF YOUR PASSENGERS BEFORE STARTING YOUR VEHICLE.

1. LP GAS SYSTEM- TURN OFF AT TANK FOR TRAVELING. TEST FOR LEAKS UPON ARRIVAL AT DESTINATION. BEFORE LIGHTING PILOTS.
2. WHEELS- INSPECT FOR DAMAGE AND CHECK LUG NUTS FOR TIGHTNESS.
3. TIRES- INSPECT FOR WEAR AND DAMAGE AND CHECK FOR RECOMMENDED AIR PRESSURE.
4. LIGHTING- TEST FOR PROPER OPERATION OF ALL INTERIOR AND EXTERIOR LIGHTS INCLUDING DASH LIGHTS, HEADLIGHTS, TAIL LIGHTS, BRAKE LIGHTS, CLEARANCE LIGHTS AND TURN SIGNALS.
5. EXITS- INSPECT RELEASE MECHANISM ON EMERGENCY EXIT WINDOW. TEST BOTH LOCKS ON MAIN ENTRANCE DOOR FOR EASE OF OPERATION AND INSTRUCT PASSENGERS HOW TO USE BOTH MEANS OF EXIT.
6. SEAT BELTS- DIRECT PASSENGERS TO DESIGNATED SEATS AND REQUIRE USE OF SEAT BELTS.
7. APPLIANCES- TURN OFF AND LATCH OR LOCK DOORS WHERE PROVIDED.
8. LOOSE PARCELS- STORE SECURELY.
9. UTILITY SUPPLY LINES- DISCONNECT ALL ELECTRIC, SEWER AND WATER LINES AND SECURE PROPERLY.
10. ENTRANCE DOOR STEP- PLACE IN RETRACTED POSITION FOR TRAVELING.

READ YOUR MOTOR HOME AND CHASSIS OWNER'S
MANUAL FOR FURTHER PRECAUTIONS

KEY PART NUMBER U/M DESCRIPTION
056259-01-000 EA LABEL - SAFETY CHECK LIST

UNLEADED FUEL ONLY

KEY PART NUMBER U/M DESCRIPTION
062043-01-000 EA LABEL - FUEL - UNLEADED

WARNING DISCONNECT BATTERIES BEFORE
CONNECTING EXTERNAL CHARGING EQUIPMENT.

KEY PART NUMBER U/M DESCRIPTION
065748-01-000 EA LABEL - CAUTION - BATTERY CHARGING

AVERTISSEMENT : DEBRANCHER LES BATTERIES AVANT
DE BRANCHER TOUT EQUIPEMENT DE CHARGE EXTERIEUR.

KEY PART NUMBER U/M DESCRIPTION
065748-02-000 EA LABEL - WARNING - BATTERY/FRENCH - CANADIAN

DIESEL FUEL ONLY

KEY PART NUMBER U/M DESCRIPTION
068383-01-000 EA LABEL - DIESEL FUEL

VEHICLE EMISSION CONTROL INFORMATION

THIS VEHICLE CONFORMS TO U.S. EPA
REGULATIONS APPLICABLE TO XXXX MODEL
YEAR NEW VEHICLES.

072887-01-000-7 CATALYST

KEY PART NUMBER U/M DESCRIPTION
072887-14-000 EA LABEL - EPA - 2003 MODEL YEAR

LABELS GROUP (CONTINUED)

IF YOU SMELL GAS

1. EXTINGUISH ANY OPEN FLAME, PILOT LIGHTS AND ALL SMOKING MATERIALS.
2. DO NOT TOUCH ELECTRICAL SWITCHES.
3. SHUT OFF THE GAS SUPPLY AT THE TANK VALVE(S) OR GAS SUPPLY CONNECTION.
4. OPEN DOORS AND OTHER VENTILATING OPENINGS.
5. LEAVE THE AREA UNTIL ODOR CLEARS.
6. HAVE THE GAS SYSTEM CHECKED AND LEAKAGE SOURCE CORRECTED BEFORE USING AGAIN.

KEY PART NUMBER U/M DESCRIPTION
073998-01-000 EA LABEL - LPG ODOR WARNING

WARNING: TEST SMOKE DETECTOR OPERATION AFTER VEHICLE HAS BEEN IN STORAGE, BEFORE EACH TRIP AND AT LEAST ONCE PER WEEK DURING USE.

KEY PART NUMBER U/M DESCRIPTION
077956-01-000 EA LABEL - WARNING - SMOKE DETECTOR

DO NOT FILL LP-GAS CONTAINER(S) TO MORE THAN 80% OF CAPACITY.

KEY PART NUMBER U/M DESCRIPTION
079965-01-000 EA LABEL - LPG - 80% CAPACITY

WARNING
MUST BE STOWED
IN LATCHED POSITION
WHILE VEHICLE IS IN MOTION

KEY PART NUMBER U/M DESCRIPTION
079966-01-000 EA LABEL - WARNING - STOWED - MOTION

W
A
T
E
R
H
E
A
T
E
R
ON
OFF

KEY PART NUMBER U/M DESCRIPTION
083588-01-000 EA LABEL - ON/OFF - WATER HEATER
083588-03-000 EA LABEL - ON/OFF - WATER HEATER

E
N
G
I
N
E
H
E
A
T
E
R
ON
OFF

KEY PART NUMBER U/M DESCRIPTION
083588-02-000 EA LABEL - ON/OFF - ENGINE HEATER
083588-04-000 EA LABEL - ON/OFF - ENGINE HEATER

LABELS GROUP (CONTINUED)

CAUTION	TO HELP AVOID PERSONAL INJURY DURING REMOVAL OF FUEL FILLER CAP, SLOWLY LOOSEN CAP 1/2 TURN TO ALLOW ANY FUEL PRESSURE TO BE RELIEVED BEFORE TURNING CAP FURTHER.
FUEL SPRAY MAY CAUSE PERSONAL INJURY	STOP ADDING FUEL AFTER FIRST SHUTOFF BY AUTOMATIC NOZZLE WHEN TANK IS NEARLY FULL. DO NOT OVERFILL FUEL TANK. SEE OWNERS MANUAL FOR ADDITIONAL INFORMATION. PRINTED IN U.S.A. WLC PT NO 15611763

KEY PART NUMBER U/M DESCRIPTION
087207-05-000 EA LABEL - FUEL CAP REMOVAL



KEY PART NUMBER U/M DESCRIPTION
087236-01-000 EA LABEL - CABLE - INPUT



KEY PART NUMBER U/M DESCRIPTION
087236-02-000 EA LABEL - TV OUTLET

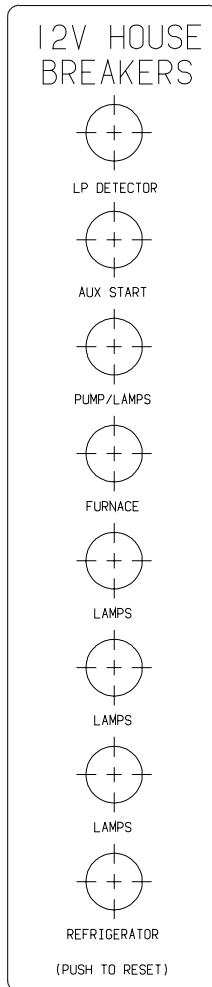

KEY PART NUMBER U/M DESCRIPTION
092547-08-000 EA LABEL - CIRCUIT BREAKER

LABELS GROUP (CONTINUED)

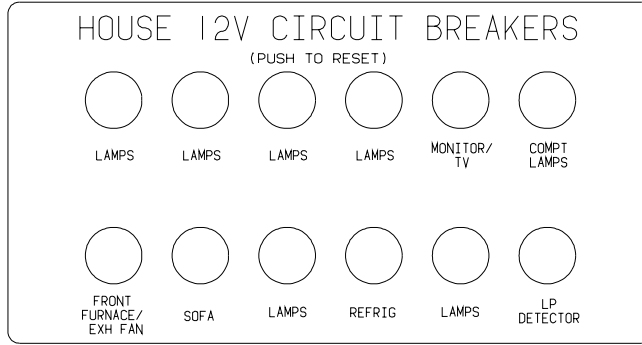

KEY PART NUMBER U/M DESCRIPTION
 092547-10-000 EA LABEL - CIRCUIT BREAKER

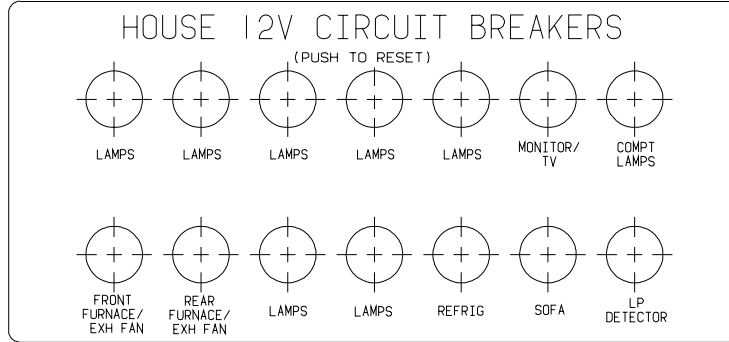

KEY PART NUMBER U/M DESCRIPTION
 092547-11-000 EA LABEL - CIRCUIT BREAKER

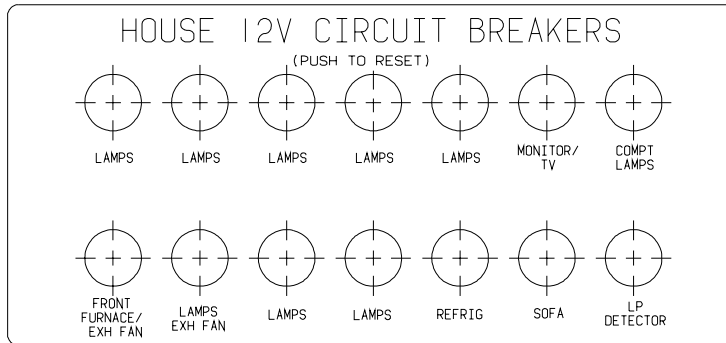

KEY PART NUMBER U/M DESCRIPTION
 092547-12-000 EA LABEL - CIRCUIT BREAKER

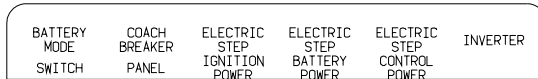

KEY PART NUMBER U/M DESCRIPTION
 093236-08-000 EA LABEL - CIRCUIT BREAKER

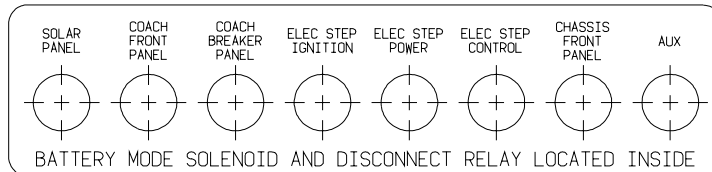

KEY PART NUMBER U/M DESCRIPTION
 093236-13-000 EA LABEL - CIRCUIT BREAKER

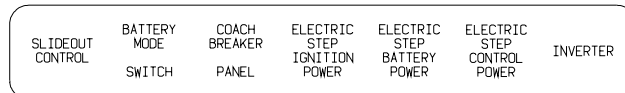

KEY PART NUMBER U/M DESCRIPTION
 093236-21-000 EA LABEL - CIRCUIT BREAKER

LABELS GROUP (CONTINUED)

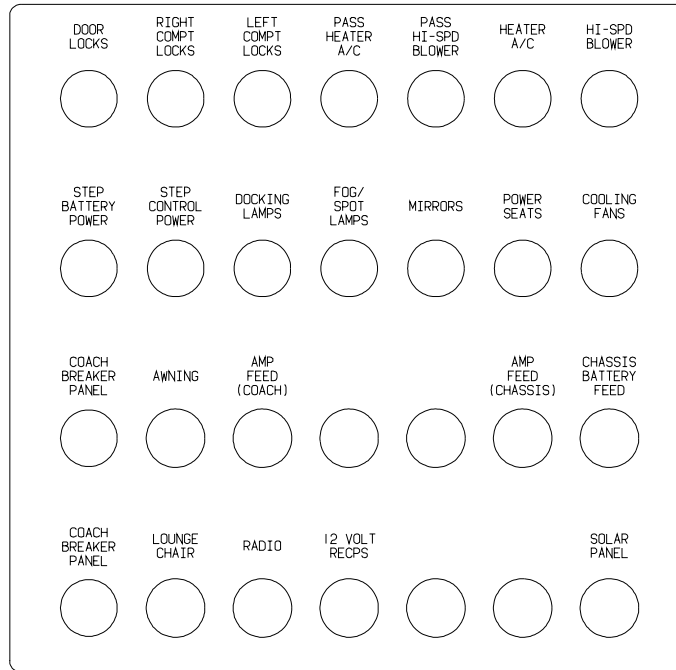

KEY PART NUMBER U/M DESCRIPTION
 093236-22-000 EA LABEL - CIRCUIT BREAKER

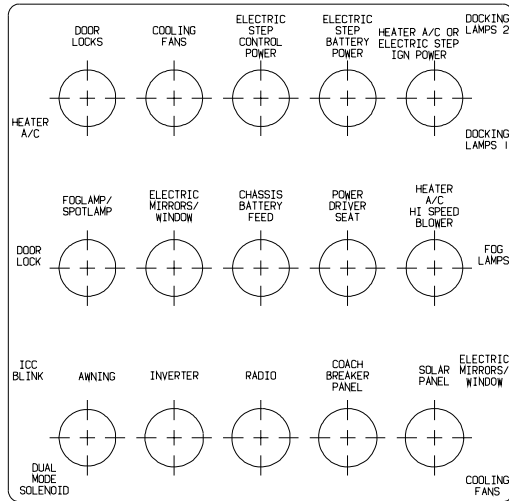

KEY PART NUMBER U/M DESCRIPTION
 093236-23-000 EA LABEL - CIRCUIT BREAKER - MAIN

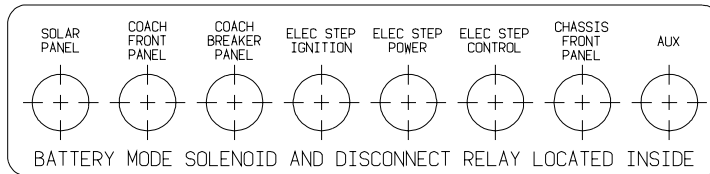

KEY PART NUMBER U/M DESCRIPTION
 093236-24-000 EA LABEL - CIRCUIT BREAKER

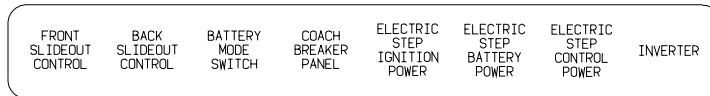

KEY PART NUMBER U/M DESCRIPTION
 093236-28-000 EA LABEL - CIRCUIT BREAKER

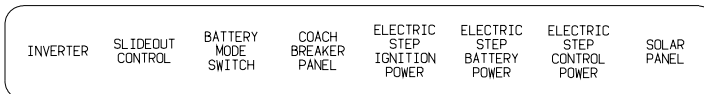

KEY PART NUMBER U/M DESCRIPTION
 093236-29-000 EA LABEL - CIRCUIT BREAKER

LABELS GROUP (CONTINUED)

A / C C I R C U I T 1	M A I N	A / C C I R C U I T 2	R E F F R I G / C O N V	M I C R O W A V E	R E C P S 1	R E C P S 2	R E C P S 3	W A S H E R / D R Y E R	W A T E R H E A T E R	
-----------------------------	---------	-----------------------------	-------------------------	-------------------	----------------	----------------	----------------	-------------------------	--------------------------	--

KEY PART NUMBER 095721-31-000 **U/M DESCRIPTION**
EA LABEL - CONTROL CENTER - 30 AMP - US

A / C C I R C U I T 1	M A I N	M A I N	A / C C I R C U I T 2	R E F F R I G / C O N V	M I C R O W A V E	R E C P S 1	R E C P S 2	R E C P S 3	W A S H E R / D R Y E R	W A T E R H E A T E R
-----------------------------	---------	---------	-----------------------------	-------------------------	-------------------	----------------	----------------	----------------	-------------------------	--------------------------

KEY PART NUMBER 095721-33-000 **U/M DESCRIPTION**
EA LABEL - CONTROL CENTER - 50 AMP - US

A / C	M A I N	R E F F R I G / C O N V	M I C R O W A V E	R E C P S 1	R E C P S 2
-------	---------	-------------------------	-------------------	----------------	----------------

KEY PART NUMBER 095721-40-000 **U/M DESCRIPTION**
EA LABEL - CONTROL CENTER

AUTOMOTIVE AND COACH
CIRCUIT BREAKERS

KEY PART NUMBER 098379-01-000 **U/M DESCRIPTION**
EA LABEL - CIRCUIT BREAKER - FRONT BOX

CIRCUIT BREAKERS
AND AUTOMOTIVE
FUSE PANEL

KEY PART NUMBER 098379-03-000 **U/M DESCRIPTION**
EA LABEL - ELECTRICAL BOX - FRONT

BATTERY MODE
SOLENOID AND
RELAYS

KEY PART NUMBER 098379-04-000 **U/M DESCRIPTION**
EA LABEL - ELECTRICAL BOX - SIDE

LABELS GROUP (CONTINUED)

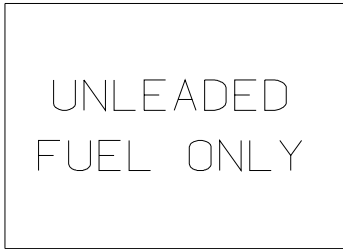

KEY PART NUMBER U/M DESCRIPTION
098641-01-000 EA LABEL - FUEL - UNLEADED - DASH



KEY PART NUMBER U/M DESCRIPTION
099509-01-000 EA LABEL - AWNING INSTALLATION

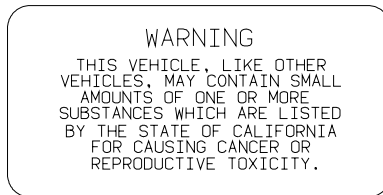

KEY PART NUMBER U/M DESCRIPTION
099689-01-000 EA LABEL - WARNING - CANCER/TOXICITY

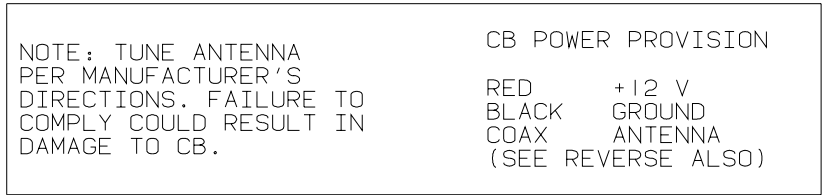

KEY PART NUMBER U/M DESCRIPTION
104678-01-000 EA LABEL - CB PREP

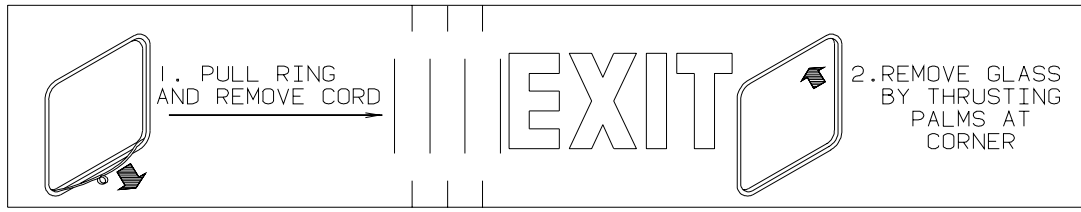

KEY PART NUMBER U/M DESCRIPTION
107571-01-000 EA LABEL - EXIT/ESCAPE WINDOW

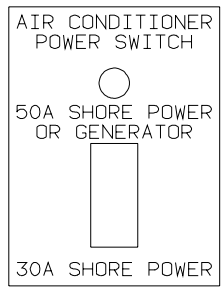

KEY PART NUMBER U/M DESCRIPTION
109051-02-000 EA LABEL - SWITCH - 50 AMP POWER

LABELS GROUP (CONTINUED)

DO NOT USE HITCH BEFORE
READING OWNERS MANUAL REGARDING
VEHICLE LOADING AND TOWING

KEY	PART NUMBER	U/M DESCRIPTION
	111104-01-000	EA LABEL - HITCH - READ MANUAL - WHITE
	111104-02-000	EA LABEL - HITCH - READ MANUAL - BLACK

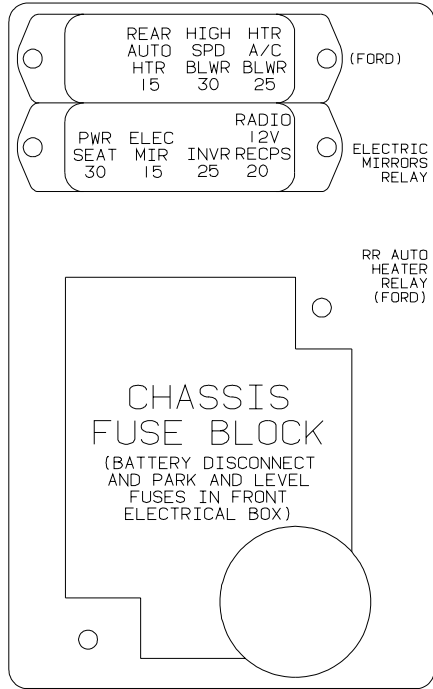

KEY	PART NUMBER	U/M DESCRIPTION
	111537-08-000	EA LABEL - FUSES

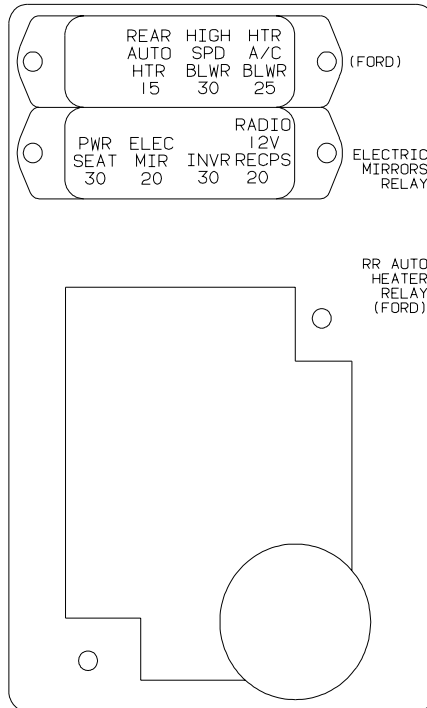

KEY	PART NUMBER	U/M DESCRIPTION
	111537-09-000	EA LABEL - FUSES

LABELS GROUP (CONTINUED)

WARNING: CONTAINS "CFC" A SUBSTANCE WHICH HARMS PUBLIC HEALTH AND ENVIRONMENT BY DESTROYING OZONE IN THE UPPER ATMOSPHERE.

KEY	PART NUMBER	U/M DESCRIPTION
	111802-01-000	EA LABEL - CFC WARNING

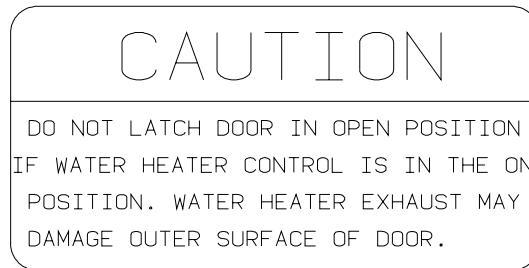

KEY	PART NUMBER	U/M DESCRIPTION
	113402-01-000	EA LABEL - CAUTION - WATER HEATER EXHAUST

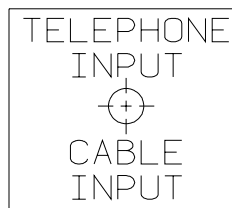

KEY	PART NUMBER	U/M DESCRIPTION
	114866-02-000	EA LABEL - PHONE & CABLE INPUT - WHITE/CLEAR BACKGROUND
	114866-03-000	EA LABEL - PHONE & CABLE INPUT - BLACK/CLEAR BACKGROUND

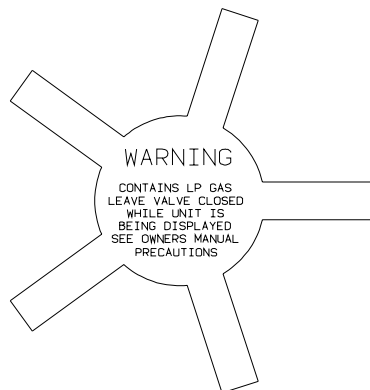

KEY	PART NUMBER	U/M DESCRIPTION
	115600-01-000	EA LABEL - WARNING LPG VALVE

WARNING: REPLACE TIRE ONLY WITH ONE OF EXACTLY SAME TYPE AND RATING. DO NOT REPLACE WITH PASSENGER CAR TIRE. SEE OPERATOR'S MANUAL FOR MORE INFORMATION CALL WINNEBAGO OWNER RELATIONS AT 1-800-537-1885.

KEY	PART NUMBER	U/M DESCRIPTION
	115869-01-000	EA LABEL - WARNING - TIRE

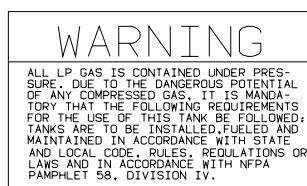

KEY	PART NUMBER	U/M DESCRIPTION
	116112-01-000	EA LABEL - CAUTION - LP

LABELS GROUP (CONTINUED)

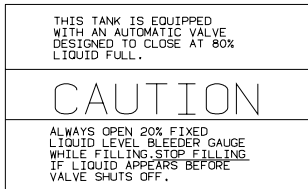

KEY PART NUMBER **U/M DESCRIPTION**
 116113-01-000 EA LABEL - CAUTION - LP

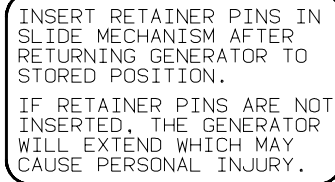

KEY PART NUMBER **U/M DESCRIPTION**
 116273-01-000 EA LABEL - WARNING - GENERATOR

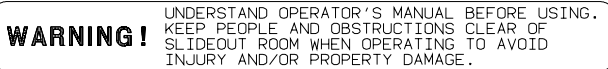

KEY PART NUMBER **U/M DESCRIPTION**
 116549-01-000 EA LABEL - WARNING - SLIDEOUT

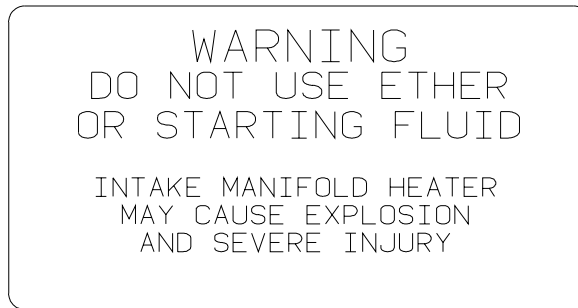

KEY PART NUMBER **U/M DESCRIPTION**
 116756-02-000 EA LABEL - WARNING - ETHER/STARTING

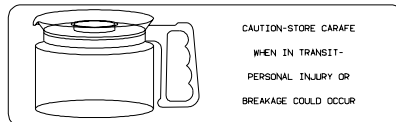

KEY PART NUMBER **U/M DESCRIPTION**
 116829-02-000 EA LABEL - COFFEEMAKER



KEY PART NUMBER **U/M DESCRIPTION**
 117628-02-000 EA LABEL - SWITCH - WATER PUMP/LIGHTS-WHITE/CLEAR BACKGROUND

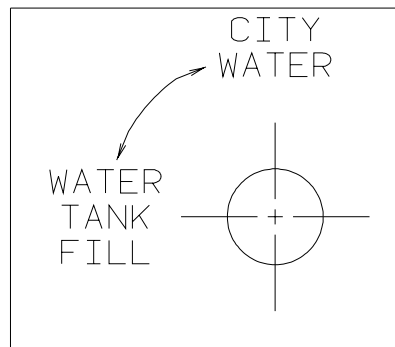

KEY PART NUMBER **U/M DESCRIPTION**
 117629-03-000 EA LABEL - WATER PUMP/FILL-BLK LETTERS/CLEAR BACKGROUND-.31"

LABELS GROUP (CONTINUED)

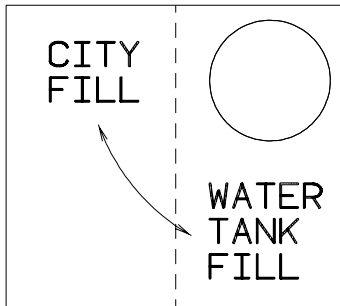

KEY PART NUMBER **U/M DESCRIPTION**
 117629-04-000 EA LABEL - CITY WATER/TANK FILL

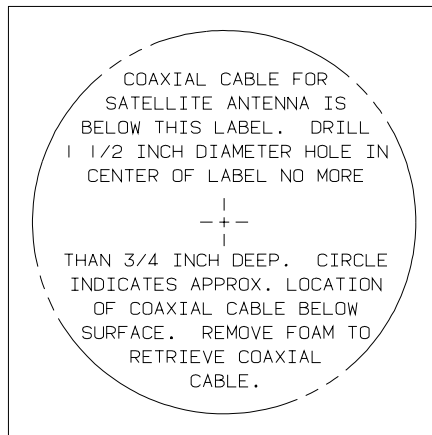

KEY PART NUMBER **U/M DESCRIPTION**
 120431-01-000 EA LABEL - LOCATION - COAXIAL CABLE/SATELLITE ANTENNA

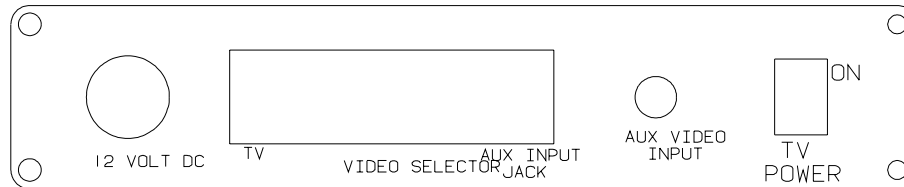

KEY PART NUMBER **U/M DESCRIPTION**
 120677-01-000 EA LABEL - TV

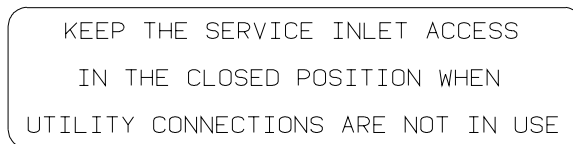

KEY PART NUMBER **U/M DESCRIPTION**
 123562-01-000 EA LABEL - SERVICE/UTILITY ACCESS

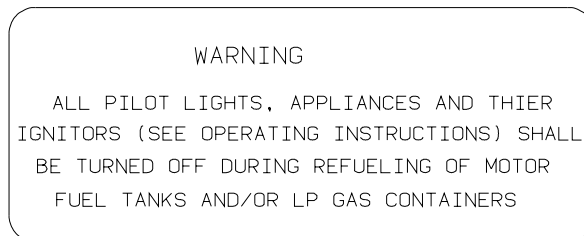

KEY PART NUMBER **U/M DESCRIPTION**
 124519-01-01A EA LABEL - WARNING/REFUELING - BLACK ON CLEAR
 124519-01-02A EA LABEL - WARNING/REFUELING - WHITE ON CLEAR

LABELS GROUP (CONTINUED)

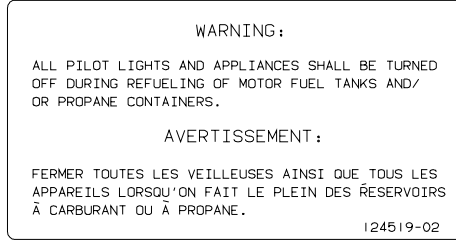

KEY	PART NUMBER	U/M	DESCRIPTION
	124519-02-01A	EA	LABEL - WARNING/REFUELING - BLACK ON CLEAR - CSA
	124519-02-02A	EA	LABEL - WARNING/REFUELING - WHITE ON CLEAR - CSA

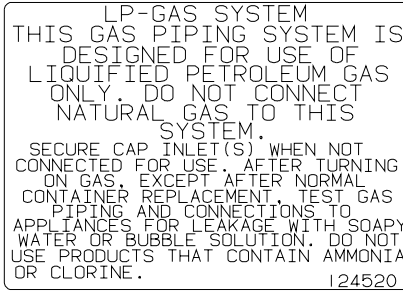

KEY	PART NUMBER	U/M	DESCRIPTION
	124520-01-01A	EA	LABEL - LP GAS ONLY - BLACK ON CLEAR
	124520-01-02A	EA	LABEL - LP GAS ONLY - WHITE ON CLEAR

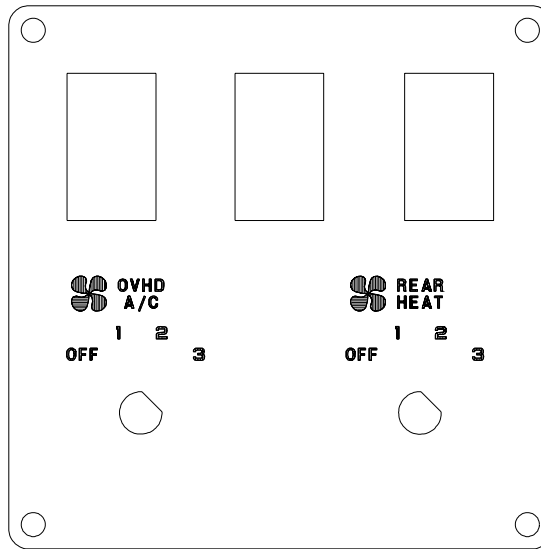

KEY	PART NUMBER	U/M	DESCRIPTION
	124572-01-000	EA	LABEL - SWITCHES

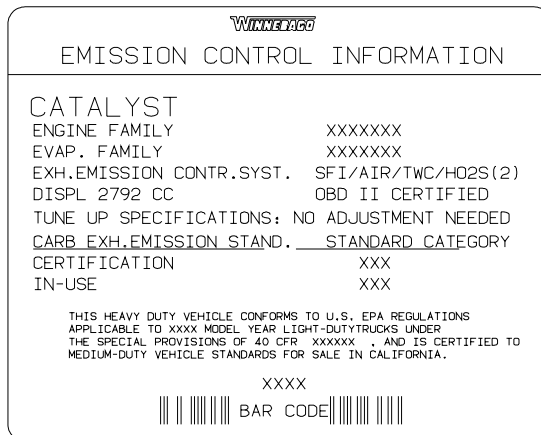

KEY	PART NUMBER	U/M	DESCRIPTION
	124709-07-000	EA	LABEL - EMISSION CONTROL - DUAL

LABELS GROUP (CONTINUED)

THIS CONNECTION IS FOR
 (B) VOLT AC,60 HZ(CYCLES)
 (A) AMPERE SUPPLY

DO NOT CONNECT TO
 HIGHER VOLTAGE

KEY	PART NUMBER	U/M	DESCRIPTION
	125306-01-01A	EA	LABEL - ELECTRICAL ENTRANCE - 110V 30 AMP - BLACK ON CLEAR
	125306-01-02A	EA	LABEL - ELECTRICAL ENTRANCE - 110V 30 AMP - WHITE ON CLEAR

THIS CONNECTION IS FOR
 (B) VOLT AC,3-POLE,4 WIRE
 60 HZ(CYCLES),(A) AMPERE SUPPLY

DO NOT CONNECT TO
 HIGHER VOLTAGE

KEY	PART NUMBER	U/M	DESCRIPTION
	125306-04-01A	EA	LABEL-ELECTRICAL ENTRANCE-120/240V 50 AMP-BLACK ON CLEAR
	125306-04-02A	EA	LABEL - ELECTRICAL ENTRANCE-120/240V 50 AMP-WHITE ON CLEAR

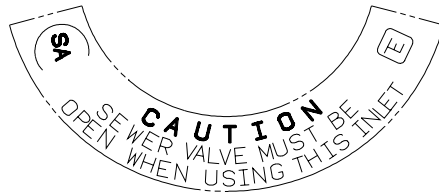

KEY	PART NUMBER	U/M	DESCRIPTION
	125697-07-000	EA	LABEL - CAUTION - FLUSHING SYSTEM

REMOVE PRIMARY TIRE HANGER BEFORE USING
 SPARE TIRE HOIST-SEE OWNERS MANUAL - PERSONAL
 INJURY MAY RESULT IF NOT FOLLOWED

KEY	PART NUMBER	U/M	DESCRIPTION
	126024-01-000	EA	LABEL - TIRE HANGER REMOVAL

GRAY HOLDING TANK

KEY	PART NUMBER	U/M	DESCRIPTION
	126247-05-000	EA	LABEL - GRAY HOLDING TANK-BLACK LETTERS/CLEAR BACKGROUND

BLACK HOLDING TANK

KEY	PART NUMBER	U/M	DESCRIPTION
	126247-06-000	EA	LABEL - BLACK HOLDING TANK-BLACK LETTERS/CLEAR BACKGROUND

LABELS GROUP (CONTINUED)

EXTERIOR SHOWER

KEY PART NUMBER U/M DESCRIPTION
126248-03-000 EA LABEL - EXTERIOR SHOWER

CITY WATER FILL

KEY PART NUMBER U/M DESCRIPTION
126249-03-000 EA LABEL - CITY WATER FILL-BLK LETTERS/CLEAR BACKGROUND .31"



WARNING

○ **Children Can be KILLED or INJURED
by Passenger Air Bag**

The back seat is the safest place for children 12 and under.
Make sure all children use seat belts or child seats.

KEY PART NUMBER U/M DESCRIPTION
126612-01-000 EA LABEL - HANG TAG - AIR BAG - DASH

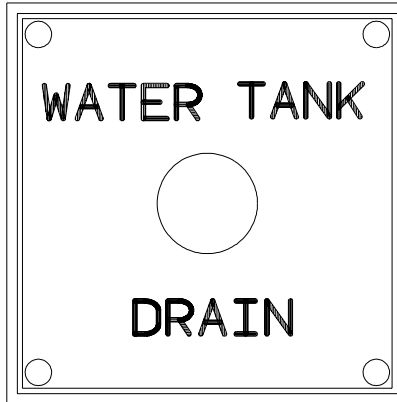

KEY PART NUMBER U/M DESCRIPTION
127170-01-000 EA LABEL - WATER TANK DRAIN

WARNING

ROOF SURFACE MAY BE SLIPPERY
ESPECIALLY WHERE MOISTURE IS PRESENT
SLIPPING MAY RESULT IN PERSONAL INJURY.

128218-01

KEY PART NUMBER U/M DESCRIPTION
128218-01-01A EA LABEL - WARNING - SLIPPERY ROOF

ENTRANCE DOOR PROP ROD

THIS ROD IS DESIGNED TO PROP THE
ENTRANCE DOOR OPEN WHEN THE PATIO
AWNING ARM IS ATTACHED TO THE
SIDEWALL AND THE AWNING IS EX-
TENDED.
HOOK ONE END OF ROD INTO LOOP ON
DOOR AND OTHER END INTO LOOP ON THE
SIDEWALL AS SHOWN.

(THIS LABEL TO BE REMOVED BY RETAIL OWNER ONLY)

KEY PART NUMBER U/M DESCRIPTION
128658-01-000 EA LABEL - PROP ROD - ENTRY DOOR

LABEL GROUP (CONTINUED)

WARNING
POTABLE WATER ONLY
SANITIZE, FLUSH, AND
DRAIN BEFORE USING.
SEE INSTRUCTION MANUAL

KEY PART NUMBER U/M DESCRIPTION
128725-01-01A EA LABEL - POTABLE WATER ONLY - BLACK ON CLEAR

TOW VEHICLE RATING MAY BE LESS THAN HITCH RATING.
MAXIMUM VERTICAL HITCH LOAD: 350 LBS
DO NOT EXCEED REAR AXLE RATING.
SEE OWNER'S MANUAL FOR ADDITIONAL INFORMATION.

KEY PART NUMBER U/M DESCRIPTION
129669-01-01A EA LABEL - HITCH/VEHICLE RATE - 350 - WHITE ON CLEAR
129669-01-02A EA LABEL - HITCH/VEHICLE RATE - 350 - BLACK ON CLEAR
129669-02-01A EA LABEL - HITCH/VEHICLE RATE - 500 - WHITE ON CLEAR
129669-02-02A EA LABEL - HITCH/VEHICLE RATE - 500 - BLACK ON CLEAR

TIRE ROTATION
SEE RIALTA OWNERS MANUAL
SECTION 9

KEY PART NUMBER U/M DESCRIPTION
129684-01-000 EA LABEL - TIRE ROTATION

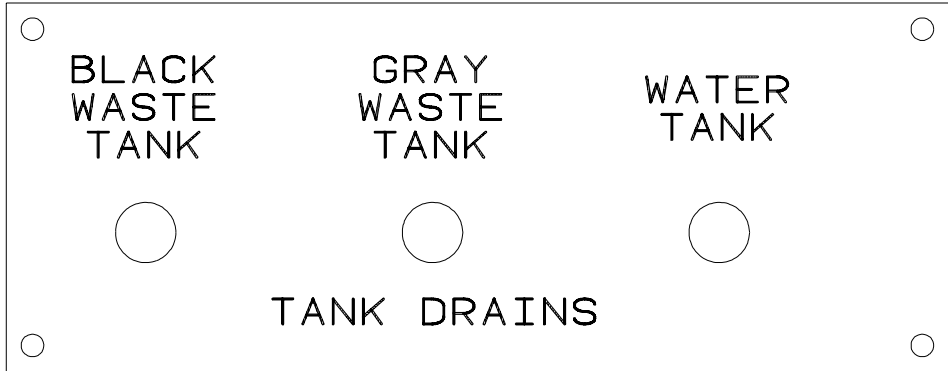

KEY PART NUMBER U/M DESCRIPTION
130166-01-000 EA LABEL - DRAIN

H
O
S
E

S
T
O
R
A
G
E

KEY PART NUMBER U/M DESCRIPTION
130167-02-000 EA LABEL - HOSE STORAGE

LABELS GROUP (CONTINUED)

WASTE TANK FLUSH

KEY PART NUMBER U/M DESCRIPTION
130168-01-000 EA LABEL - WASTE TANK FLUSH

MONITOR WATER
PANEL LIGHT PUMP

KEY PART NUMBER U/M DESCRIPTION
130170-01-000 EA LABEL - SWITCH PANEL - BLK/CLEAR BACKGROUND-1.8"H X 5.9"L

LIGHTS WATER
PUMP

KEY PART NUMBER U/M DESCRIPTION
130170-02-000 EA LABEL - SWITCH PANEL-BLK/CLEAR BACKGROUND-1.4"H X 3.9"L

WATER
PUMP

KEY PART NUMBER U/M DESCRIPTION
130170-03-000 EA LABEL - PANEL SWITCH

CAUTION:
OPEN A WINDOW OR VENT WHILE
OPERATING DRYER. IT IS DANGEROUS
TO CREATE A NEGATIVE AIR PRESSURE
INSIDE A VEHICLE CONTAINING
FUEL-BURNING APPLIANCES

KEY PART NUMBER U/M DESCRIPTION
130670-01-01A EA LABEL - CAUTION DRYER VENTING - BLACK ON CLEAR

PUSH TO
RELEASE
GENERATOR
SLIDE ASM

KEY PART NUMBER U/M DESCRIPTION
131779-01-01A EA LABEL - GENERATOR

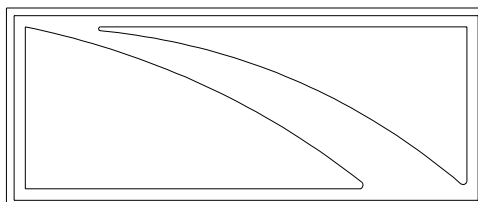

KEY PART NUMBER U/M DESCRIPTION
132651-01-01A EA DECAL - MIRROR/GALLEY

LABELS GROUP (CONTINUED)

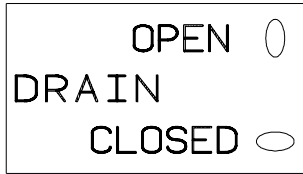

KEY PART NUMBER U/M DESCRIPTION
 133423-01-01A EA LABEL - DRAIN



KEY PART NUMBER U/M DESCRIPTION
 133424-01-01A EA LABEL - BYPASS - WATER HEATER



KEY PART NUMBER U/M DESCRIPTION
 133424-02-01A EA LABEL - NORMAL OPERATION



KEY PART NUMBER U/M DESCRIPTION
 133424-03-01A EA LABEL - WATER HEATER BYPASS - BLACK/CLEAR

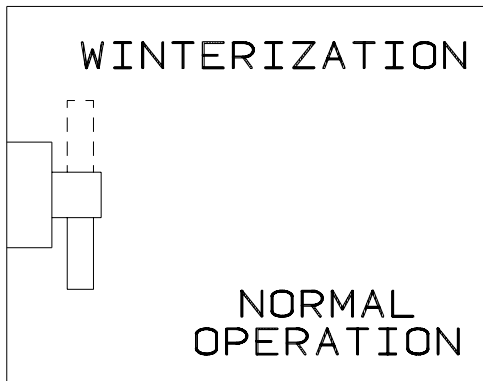

KEY PART NUMBER U/M DESCRIPTION
 133425-01-01A EA LABEL - VALVE - WINTERIZATION



KEY PART NUMBER U/M DESCRIPTION
 133533-01-01A EA LABEL - JACKS DOWN - CLEAR W/WHITE LETTERING



KEY PART NUMBER U/M DESCRIPTION
 133533-02-01A EA LABEL - CHECK ANTENNA - CLEAR W/WHITE LETTERING

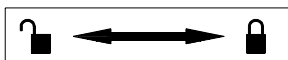

KEY PART NUMBER U/M DESCRIPTION
 133533-03-01A EA LABEL - LOCK/UNLOCK - BLACK/WHITE

LABELS GROUP (CONTINUED)

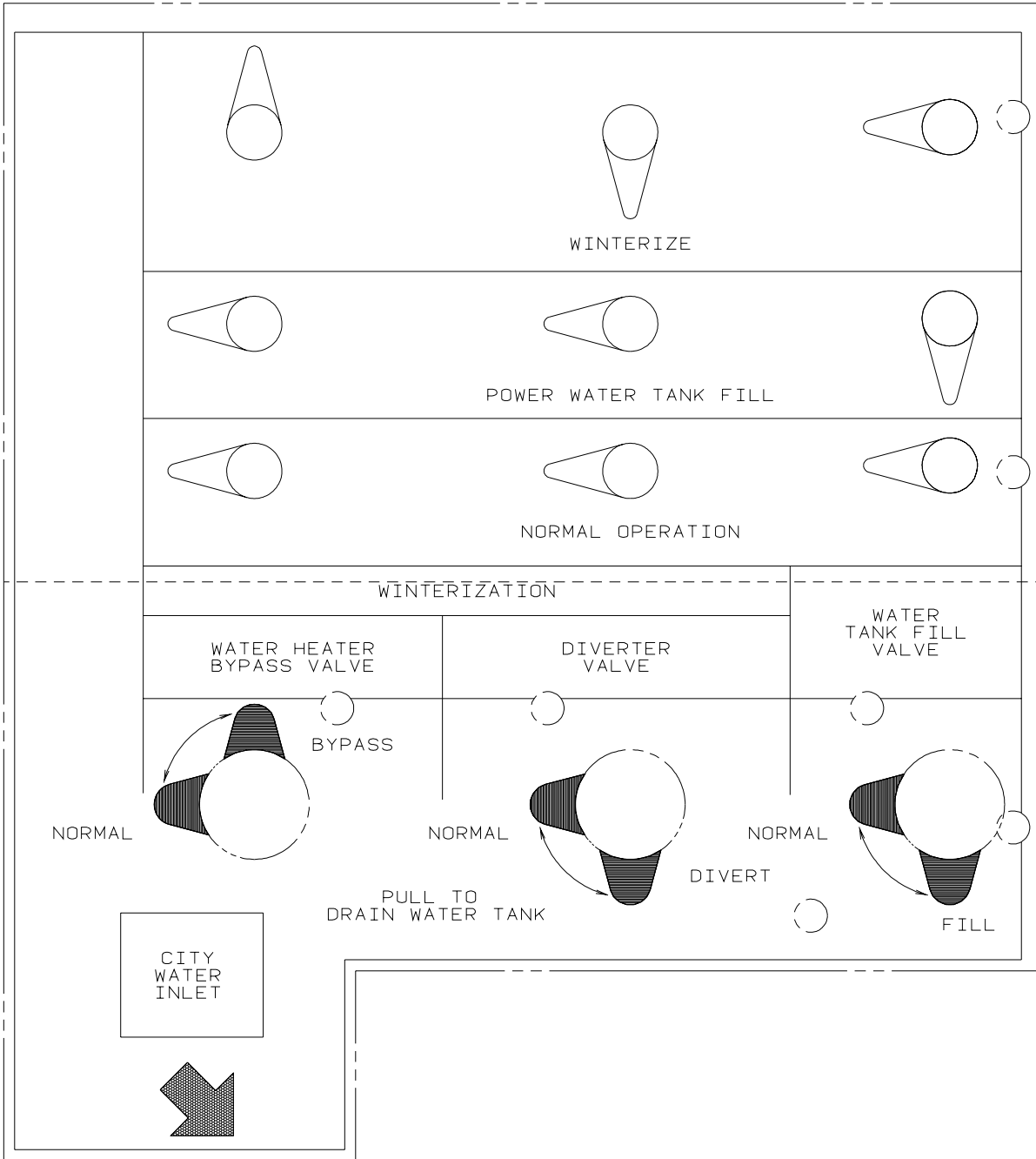

KEY	PART NUMBER	U/M	DESCRIPTION
	133629-01-01A	EA	LABEL - WATER CENTER

LABELS GROUP (CONTINUED)

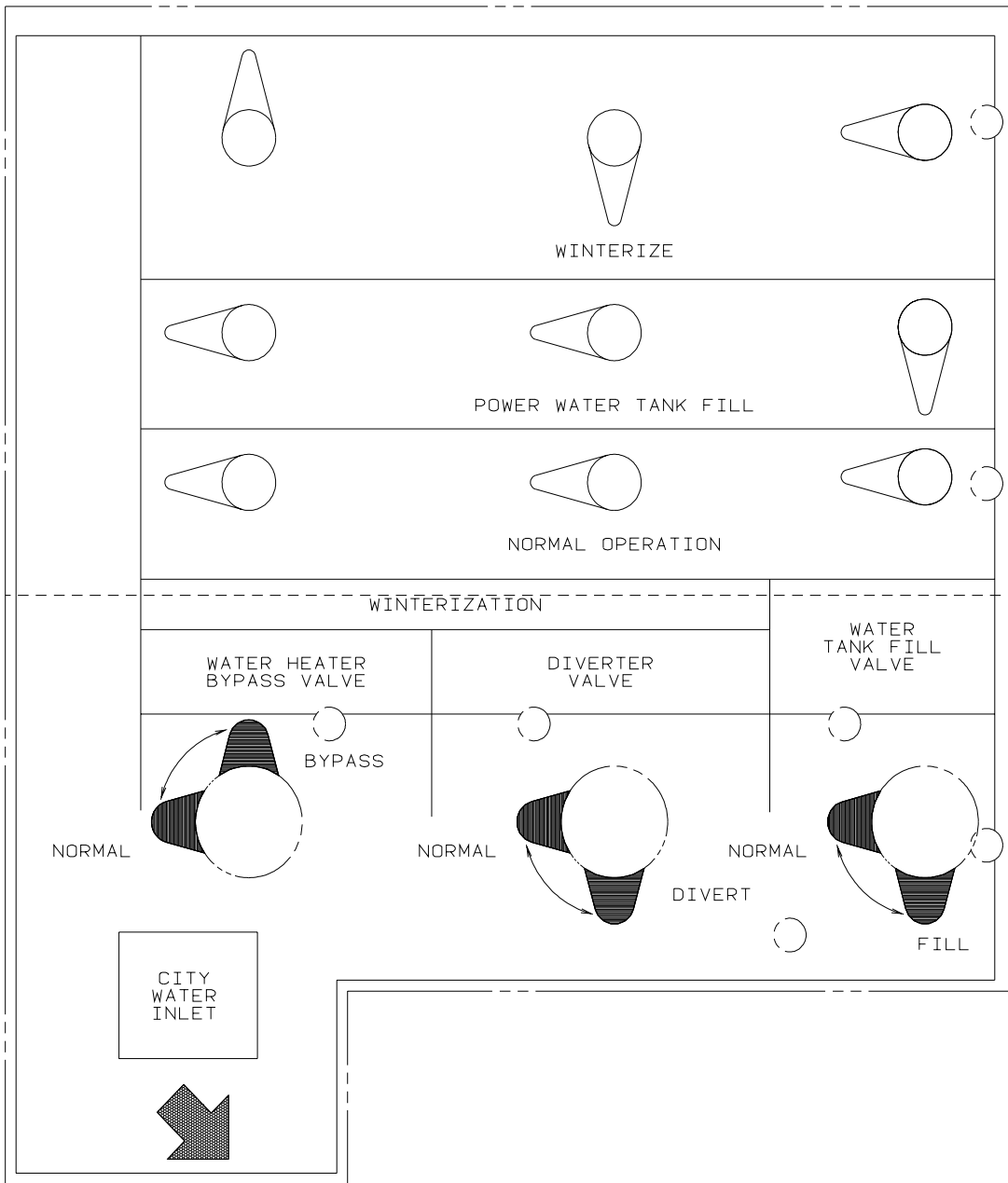

KEY PART NUMBER U/M DESCRIPTION
 133629-02-01A EA LABEL - WATER CENTER - BLACK/CLEAR

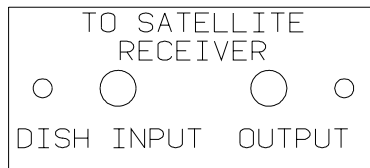

KEY PART NUMBER U/M DESCRIPTION
 134250-01-01A EA LABEL - SATELLITE RECEIVER - BLACK/CLEAR

THIS CHAIR IS NOT INTENDED FOR OCCUPANCY WHEN VEHICLE IS IN MOTION AND MUST BE RETURNED TO STOWED POSITION

DTS ISICE SIEGE N/EST PAS DESTINE A ETRE OCCUPE LORSQUE LE VEHICULE EST IN MOVEMENT ET IL FAUT QUE LE RANGER

THIS CHAIR IS NOT INTENDED FOR OCCUPANCY WHEN VEHICLE IS IN MOTION AND MUST BE RETURNED TO STOWED POSITION

KEY PART NUMBER U/M DESCRIPTION
 134537-01-01A EA LABEL - OCCUPANCY - CHAIR - US

LABELS GROUP (CONTINUED)

THIS SEAT IS NOT INTENDED
FOR OCCUPANCY WHEN
VEHICLE IS IN MOTION

KEY PART NUMBER U/M DESCRIPTION
134538-01-01A EA LABEL - OCCUPANCY - NO SEAT BELT - BLACK ON CLEAR - US

DST ISICE SIEGE N/EST PAS THIS SEAT IS NOT INTENDED
DESTINE A ETRE OCCUPE LORSQUE FOR OCCUPANCY WHILE
LE VEHICULE EST IN MOVUUMENT VEHICLE IS IN MOTION

KEY PART NUMBER U/M DESCRIPTION
134538-02-01A EA LABEL - OCCUPANCY - NO SEAT BELT - BLACK ON CLEAR - CSA

WARNING

IT IS NOT SAFE TO USE COOKING
APPLICANCES FOR COMFORT HEATING

COOKING APPLICANCES NEED FRESH AIR FOR SAFE OPERATION
BEFORE OPERATION.

1. OPEN OVERHEAD VENT OR TURN ON EXHAUST FAN AND;
2. OPEN WINDOW.

KEY PART NUMBER U/M DESCRIPTION
134539-01-01A EA LABEL - WARNING - STOVE/HEATING - US - BLACK ON CLEAR

HOLDING TANK HEATER

TURN OFF WHEN NOT IN USE
SEE OPERATOR'S MANUAL

KEY PART NUMBER U/M DESCRIPTION
134563-01-01A EA LABEL - SWITCH - HEATER

THIS VEHICLE MAY INCLUDE MERCURY-CONTAINING DEVICES INSTALLED BY THE MANUFACTURER:

FLUORESCENT TUBES, RANGES WITH OVEN, HWH LEVEL SENSING UNIT.

REMOVE DEVICES BEFORE VEHICLE DISPOSAL UPON REMOVAL OF
DEVICES: PLEASE REUSE, RECYCLE, OR DISPOSE AS HAZARDOUS WASTE

135869-01A

KEY PART NUMBER U/M DESCRIPTION
135869-01-01A EA LABEL - MERCURY CONTENT - BLACK ON CLEAR
135869-01-02A EA LABEL - MERCURY CONTENT - WHITE ON CLEAR

LIQUID SOAP

KEY PART NUMBER U/M DESCRIPTION
136047-01-01A EA LABEL - LIQUID SOAP

LABELS GROUP (CONTINUED)

DOOR LOCK	DOOR UNLOCK	RIGHT COMPT DOOR LOCK	RIGHT COMPT DOOR UNLOCK	LEFT COMPT DOOR LOCK	LEFT COMPT DOOR UNLOCK	AUX START SOLENOID	AMP SOURCE
POWER MIRRORS	HEATER BLOWER	PASS HEATER BLOWER	FOG LAMPS	DOCKING LAMPS	DOCKING LAMPS SWITCH TRIGGER	COOLING FANS	

KEY PART NUMBER U/M DESCRIPTION
 136161-01-01A EA LABEL - RELAY - MATTE BLACK/WHITE LETTERS



KEY PART NUMBER U/M DESCRIPTION
 136360-01-01A EA LABEL - AIR BAGS

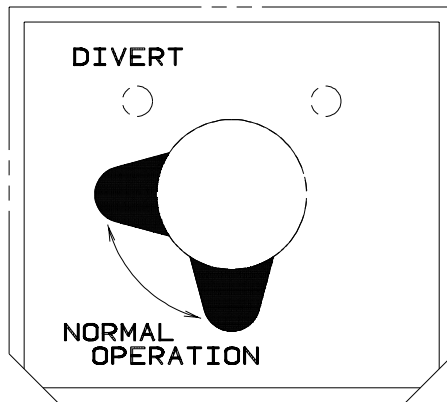

KEY PART NUMBER U/M DESCRIPTION
 137997-01-01A EA LABEL - WINTERIZATION VALVE - BLACK/CLEAR



KEY PART NUMBER U/M DESCRIPTION
 140190-01-01A EA DECAL/LOGO - V6 (DOMED) - CYAN/MAGENTA/YELLOW/BLACK

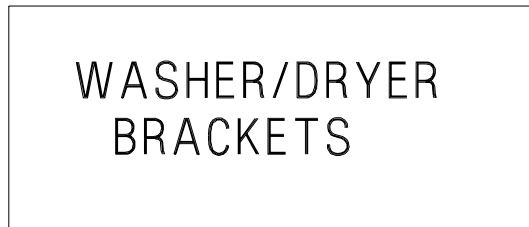

KEY PART NUMBER U/M DESCRIPTION
 141523-01-01A EA LABEL - WASHER/DRYER BRACKETS - BLACK/WHITE

LABELS GROUP (CONTINUED)

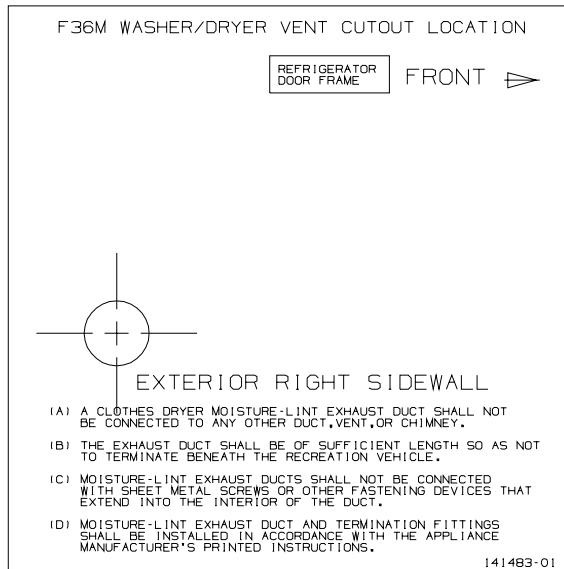

KEY PART NUMBER	U/M DESCRIPTION
141483-01-01A	EA LABEL - DRYER VENTING - BLACK/WHITE

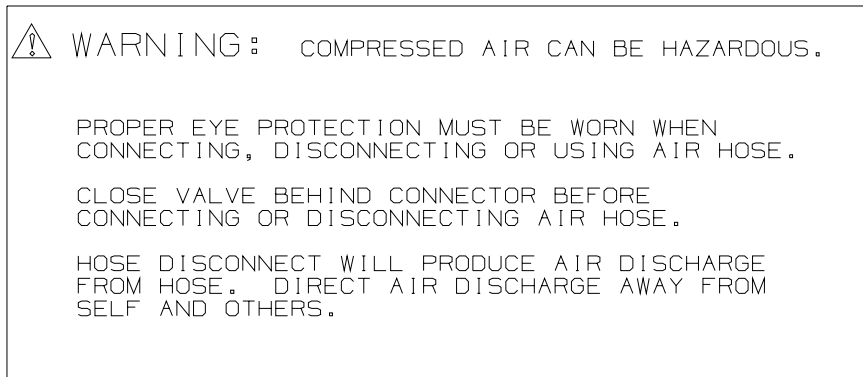

KEY PART NUMBER	U/M DESCRIPTION
142771-01-01A	EA LABEL - WARNING/COMPRESSED AIR - WHITE LETTERING ON CLEAR

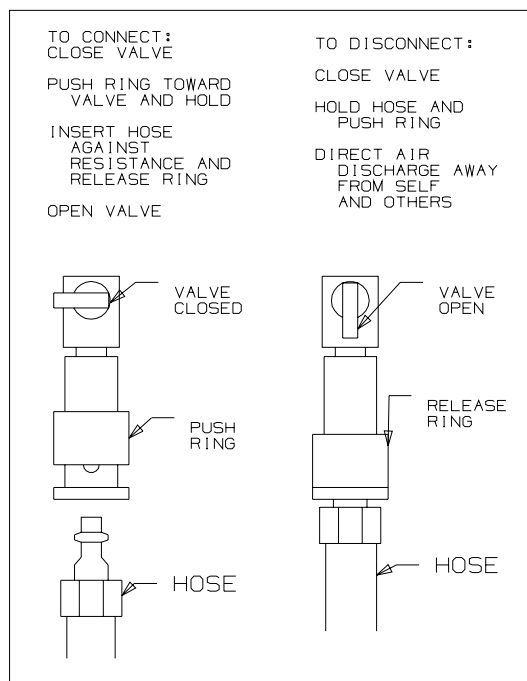

KEY PART NUMBER	U/M DESCRIPTION
142773-01-01A	EA LABEL - CONNECT/COMPRESS AIR - WHITE LETTERING ON CLEAR

LP GROUP
LP SYSTEM

KEY	PART NUMBER	U/M	DESCRIPTION
	045703-03-000	EA	HOSE - LP - 3/8"ID X 18" - 3/8"MPT X 1/2"F SWIVEL - U.S.
	106150-01-000	EA	REGULATOR - TWO STAGE-W/90 DEGREE ELBOW & 3/8" FPT OUTLET
	105658-01-000	EA	COMPARTMENT - LP REGULATOR
	106150-01-000	EA	REGULATOR - TWO STAGE-W/90 DEGREE ELBOW & 3/8" FPT OUTLET
	010323-01-000	EA	ADAPTER - BRASS - 3/8"F X 1/2"MPT
	010329-01-000	EA	ADAPTER - BRASS - 1/2"F X 1/2"MPT
	040440-03-000	EA	TRANSMITTER - DIAL/SNAP-ON - 0-90 OHM 2 TERM(POWER/GROUND)
	045703-01-000	EA	HOSE - LP - 3/8"ID X 24" - 3/8"MPT X 1/2"F SWIVEL - U.S. - 431C
	045703-02-000	EA	HOSE - LP - 3/8"ID X 24" - 3/8"MPT X 1/2"F SWIVEL - CANADA - 431C
	045703-05-000	EA	HOSE - LP - 3/8"ID X 28" - 3/8"MPT X 1/2"F SWIVEL - U.S. - 430V
	045703-06-000	EA	HOSE - LP - 3/8"ID X 28" - 3/8"MPT X 1/2"F SWIVEL - CANADA - 430V
	045703-05-000	EA	HOSE - LP - 3/8"ID X 28" - 3/8"MPT X 1/2"F SWIVEL - U.S. - 427P FROM: 00-00-00 THRU: 08-04-02
	045703-06-000	EA	HOSE - LP - 3/8"ID X 28" - 3/8"MPT X 1/2"F SWIVEL - CANADA - 427P FROM: 00-00-00 THRU: 08-04-02
	045703-03-000	EA	HOSE - LP - 3/8"ID X 18" - 3/8"MPT X 1/2"F SWIVEL - U.S. - 427P FROM: 08-05-02 THRU: 99-99-99
	045703-12-000	EA	HOSE - LP - 3/8"ID X 18" - 3/8"MPT X 1/2"F SWIVEL - CANADA - 427P FROM: 08-05-02 THRU: 99-99-99
	045703-14-000	EA	HOSE - LP - 3/8"ID X 157.5" - 1/2"F SWIVEL X 1/2"F SWIVEL - 430V
	045703-19-000	EA	HOSE - LP 3/8"ID X 120"-US/CGA - 1/2F SWIVEL X 3/8F SWIVEL - 427P
*	097821-03-000	EA	TANK - LP - 60 LB - 14" X 30"
	010323-01-000	EA	ADAPTER - BRASS - 3/8"F X 1/2"MPT
	010326-01-000	EA	ADAPTER - FLARE - W/CONE GASKET - 3/8"F X 1/2"F
	010377-02-000	EA	NUT - BRASS - 3/8" FLARE - FORGED
	010380-02-000	EA	NUT - BRASS - 1/2" FLARE - FORGED
	103613-03-000	EA	DETECTOR - LP GAS - W/O SHUT-OFF VALVE

*COMPONENT PARTS LISTED LATER IN THIS GROUP

LP GROUP (CONTINUED)
COMPONENT PARTS FOR LP SYSTEM

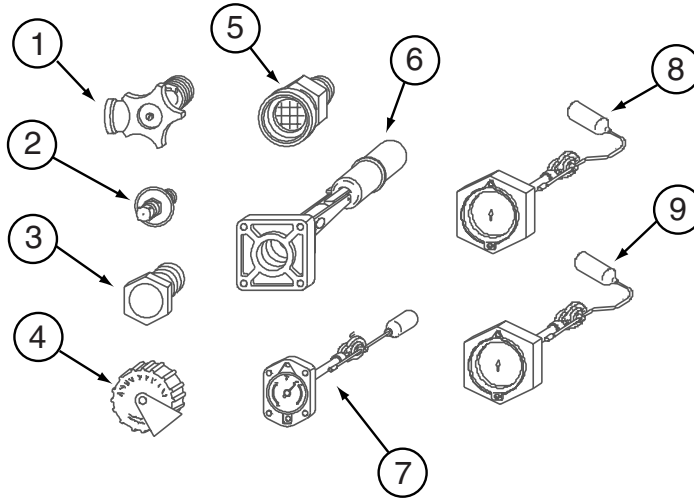

097821-03-000

KEY	PART NUMBER	U/M	DESCRIPTION	VENDOR NO.
1	040421-01-708	EA	HANDWHEEL-SERVICE VALVE	G-1015-A
1	040421-01-712	EA	VALVE,SERV. W/O VAPOR RELIEF	29000853
2	040421-01-700	EA	VALVE-LIQUID LEVEL, 20%	G-1013
3	040421-01-713	EA	VALVE-RELIEF 1" W/SPRING 7"	29000587
3	040421-01-714	EA	VALVE RELIEF 3/4"W/SPRING 7"	LVRF29000400
4	040421-01-702	EA	CAP-FILL VALVE, PLASTIC	G-1014-A
5	040421-01-701	EA	VALVE-FILL-SHORT, LP	7547B
6	040421-01-711	EA	VALVE-80% FILL W/AUTO STOP	LLL/TL3
7	040421-01-707	EA	FLOAT/BOLT ON-SCREW ON DIAL	14C
7	088253-09-700	EA	FLOAT/SCREW IN-SNAP ON DIAL	SG14C0001466
8			NOT WHAT IS ILLUSTRATED HERE	
9			NOT WHAT IS ILLUSTRATED HERE	

LOUNGE GROUP CABINETS

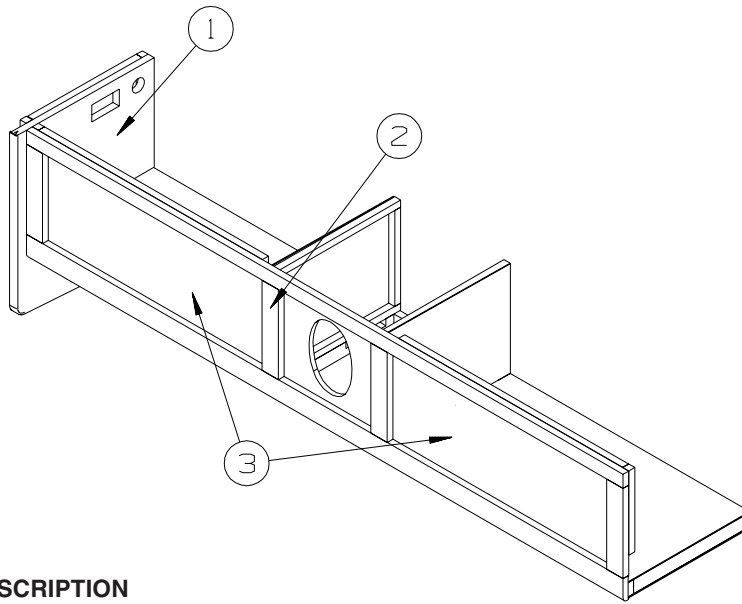

KEY	PART NUMBER	U/M	DESCRIPTION
1	142038-21-P13	EA	END CAP - OVERHEAD CABINET - PORTSMOUTH OAK
1	142038-21-P14	EA	END CAP - OVERHEAD CABINET - CONCERT CHERRY
1	142038-21-P33	EA	END CAP - OVERHEAD CABINET - WASHED MAPLE
2	142038-01-P19	EA	CABINET - OVERHEAD/FRONT/LEFT HAND - W/O DOORS/HARDWARE
2	142038-01-P20	EA	CABINET - OVERHEAD/FRONT/LEFT HAND - W/O DOORS/HARDWARE
2	142038-01-P21	EA	CABINET - OVERHEAD/FRONT/LEFT HAND - W/O DOORS/HARDWARE
2	142038-01-P22	EA	CABINET - OVERHEAD/FRONT/LEFT HAND - W/O DOORS/HARDWARE
2	142038-01-P23	EA	CABINET - OVERHEAD/FRONT/LEFT HAND - W/O DOORS/HARDWARE
2	142038-01-P24	EA	CABINET - OVERHEAD/FRONT/LEFT HAND - W/O DOORS/HARDWARE
2	142038-01-P33	EA	CABINET - OVERHEAD/FRONT/LEFT HAND - W/O DOORS/HARDWARE
2	142038-01-P36	EA	CABINET - OVERHEAD/FRONT/LEFT HAND - W/O DOORS/HARDWARE
2	142038-01-P40	EA	CABINET - OVERHEAD/FRONT/LEFT HAND - W/O DOORS/HARDWARE
3	141522-46-P19	EA	DOOR - ARCHED/PENCIL EDGE/HORIZ - 10.8" X 27.9" - W/O HDW - PORTSMOUTH OAK
3	141522-46-P20	EA	DOOR - ARCHED/PENCIL EDGE/HORIZ - 10.8" X 27.9" - W/O HDW - CONCERT CHERRY
3	141522-46-P33	EA	DOOR - ARCHED/PENCIL EDGE/HORIZ - 10.8" X 27.9" - W/O HDW - WASHED MAPLE

SEALANTS & FASTENERS GROUP
SEALANTS & ADHESIVES

KEY	PART NUMBER	U/M	DESCRIPTION
	002707-02-000	FT	TAPE - SEALER - 5/16" X 1/2" - INCREMENTS OF 50 FT
	004001-02-000	EA	GUN - PLEXUS ADHESIVE - W/O NOZZLE
	004001-05-000	EA	ADHESIVE - SCOTCH-WELD - 3M DP100 - CLEAR - 50ML
	004011-01-000	EA	ADHESIVE-3M-4475 TUBE
	010405-02-000	EA	TAPE - THREAD SEALING - 3/8"
	034552-06-000	EA	SILICONE - TUBE - W/O NOZZLE - OFF WHITE
	034552-15-000	EA	SILICONE - TUBE - W/O NOZZLE - BRIGHT WHITE
	063642-01-000	FT	TAPE - ADHESIVE - .4" X 1.5" X 180'
	064075-07-000	FT	SEAL - BULB - W/WIRED U CHANNEL - .3" X .5" CHANNEL-BLACK
	067788-01-000	EA	ADHESIVE - SPRAY - 3M - 19.5 OZ AEROSOL CAN
	069640-01-000	FT	SEALER - RIBBON - 1/4" DIAMETER X 30' - BLACK OR GRAY
	069640-02-000	FT	SEALER - TAPE - .13" THICK X .5" WIDE X 60' - GRAY
	069640-03-000	FT	SEALER - TAPE - .13" THICK X .75" WIDE X 60' - BLACK
	069640-07-000	FT	SEALER - TAPE - .09" THICK X 2" WIDE X 45' - GRAY
	069640-09-000	FT	SEALER - TAPE - .03" THICK X 2.50"WIDE X 80' - GRAY
	069640-10-000	FT	SEALER - TAPE - .03" THICK X 1.50" WIDE X 90' - GRAY
	069640-11-000	FT	SEALER - TAPE - .19" THICK X .38" WIDE X 40' - BLACK
	069640-13-000	FT	SEALER - TAPE - .03" THICK X 2" WIDE X 45' - BLACK
	069640-14-000	FT	SEALER - TAPE - .06" THICK X 1" WIDE X 100' - GRAY
	069640-15-000	FT	SEALER - TAPE - .06" THICK X .38" WIDE X 100' - GRAY
	069640-17-000	FT	SEALER - TAPE - .03" THICK X 1" WIDE X 90' - GRAY
	069640-18-000	FT	SEALER - TAPE - .50" THICK X .13" WIDE X 60' - BRT WHITE
	069640-19-000	FT	SEALER - TAPE - .75" THICK X .13" WIDE X 60' - BRT WHITE
	069640-20-000	FT	SEALER - TAPE - .50" THICK X 1/8" WIDE X 60' - BLACK
	069640-21-000	FT	SEALER - TAPE - .50" THICK X 1/16" WIDE X 100'-BRIGHT WHT
	069640-23-000	FT	SEALER - TAPE - .06" THICK X 3/4" WIDE X 100' - BRT WHITE
	069640-27-000	FT	SEALER - TAPE - .06" THICK X 2.25" WIDE - BRIGHT WHITE
	069640-28-000	FT	SEALER - TAPE - .25" THICK X 1 7/8" WIDE X 90' - GRAY
	069640-30-000	FT	SEALER - TAPE - 3/8" X 1/32" - GRAY
	069640-31-000	FT	SEALER - TAPE - 25"THICK X 3/4"WIDE X 60' - BLACK
	072889-01-000	EA	SEALANT - URETHANE - BLACK - TUBE W/NOZZLE TIP
	076322-01-000	FT	TAPE-DOUBLE COATED/ADHESIVE BK-.03"THK X .8"W X 216'- WHT
	076322-02-000	FT	TAPE-DOUBLE COATED/ADHESIVE BK-.05"THK X 1"W X 108' - WHT
	076322-03-000	FT	TAPE-DOUBLE COATED/ADHESIVE BK-.05"THK X .5"W X 108' - WHT
	076322-04-000	FT	TAPE-DOUBLE COATED/ADHESIVE BK-.05"THK X .8"W X 108' - WHT
	076322-05-000	FT	TAPE-DOUBLE COATED/ADHESIVE BK-.05"THK X .8"W X 108' - WHT
	076322-11-000	FT	TAPE-DOUBLE COATED/ADHESIVE BK-.02"THK X 1"W X 216' - CLR
	086276-01-000	EA	TAPE - DOUBLE SIDED - 1/2" WIDE X 108' LONG (SOLD BY ROLL)
	088479-01-000	EA	TAPE - ALUMINUM - 3"
	090340-01-000	FT	SEAL - FOAM - CLOSED CELL - 1/4" X 1/2" X 50'
	090340-02-000	FT	SEAL - FOAM - CLOSED CELL - 3/8" X 1/2" X 50'
	091255-02-000	FT	SEAL - ADHESIVE BACKED/FOAM - 3/64" THICK X 3/16"W X 1000'
	091255-03-000	FT	SEAL - ADHESIVE BACKED/FOAM - 1/4" THICK X 1/4"W X 1000'
	094401-01-000	EA	SEALER - BODY SEAM - FLEXICLEAR
	094401-03-000	EA	SEALER - BODY SEAM - BLACK
	094401-04-000	EA	SEALER - BODY SEAM - CLEAR
	098408-01-000	FT	SEAL - SPONGE RUBBER - CLOSED CELL
	099069-01-000	FT	SEAL - RUBBER - CLOSED SPONGE - .5" WIDE X .12" THICK -BLK
	099418-01-000	FT	SEAL - D-SECTION/ADHESIVE BACK - .44" X .44"- BLK RUBBER
	099418-02-000	FT	SEAL - D SECTION - WHITE
	100128-02-000	FT	SEAL - FOAM/ADHESIVE BACK - .37" WIDE X .37" THICK
	104692-01-000	FT	SEAL - ADHESIVE BACKED FOAM - 3/4" THICK X 3/4" WIDE X 25'
	104692-03-000	FT	SEAL - ADHESIVE BACKED FOAM - 1" THICK X 1 3/16"WIDE X 15'
	107828-01-000	EA	SEALANT - SB - 190 EVERSEAL
	108716-01-000	EA	SILICONE - W/O NOZZLE - OFF WHITE - SELF LEVELING
	109506-12-000	EA	FILM/ABRASION-RESISTANT - TRANSPARENT - 1" DIA.
	110274-01-000	FT	TAPE - DOUBLE SIDED/FOAM - .45" X 1" X 216' - BLACK
	112481-02-000	EA	ADHESIVE - PLEXUS ETHACRYLATE - CARTRIDGE
	112864-01-000	FT	SEAL - FOAM/BUTYL COVERED - 3/8" X 35'
	112864-02-000	FT	FOAM - BUTYL COVERED 5/16" X 44'
	112864-03-000	FT	FOAM - BUTYL COVERED - 1/2" X 1/8" X 25'
	112864-04-000	FT	FOAM - BUTYL COVERED - 3/8" X 1/8"
	112901-02-000	EA	ADHESIVE - PLEXUS - MA330 - 50ML - GRAY
	112901-03-000	EA	ADHESIVE - PLEXUS - MA300 - 50ML - WHITE

SEALANTS & FASTENERS GROUP (CONTINUED)

SEALANTS & ADHESIVES (CONTINUED)

KEY	PART NUMBER	U/M	DESCRIPTION
	112902-01-000	EA	NOZZLE - ELEMENT - 3/8 X 24
	112902-02-000	EA	NOZZLE-BELL 3/8X24 - TAH 160-824
	112902-03-000	EA	MIXER NOZZLE - F/GUN #00400102000 - SCOTCH-WELD & PLEXUS
	112902-04-000	EA	NOZZLE - ELEMENT - 1/4" X 3.5"
	113366-01-000	EA	ADHESIVE - INSTANT - 1 OZ
	113452-02-000	FT	SEAL/TRIM - FRONT - VINYL W/WIRE CARRIER - .027"
	115933-01-000	FT	TAPE - 1/64" X 3/8" X 100'
	120074-02-03A	EA	SILICONE - TUBE - W/O NOZZLE - SMOKEY WHITE
	120074-02-02A	EA	SILICONE - TUBE - W/O NOZZLE - LOW ODOR - SOFT WHITE
	120534-01-01A	EA	TAPE - SCOTCH - 3M - 1/2" FINE LINE
	123244-01-000	FT	TAPE - DOUBLE SIDED/FOAM - 5/64" THICK X 3/4" WIDE X 108'
	123816-01-000	FT	TAPE - DOUBLE SIDED - 1" X 3/4" X 200'
	123816-02-000	FT	TAPE - DOUBLE SIDED - 1/2" X 1 1/3" X 200'
	123816-03-000	FT	TAPE - DOUBLE SIDED - 1/2" X 3/4" X 200'
	123816-04-000	FT	TAPE - DOUBLE SIDED - 6" X 750'
	126427-01-000	EA	ADHESIVE - ALL PURPOSE - ABS/PVC
	126427-02-000	EA	PRIMER - CLEANER - FLEX PIPING
	131264-01-08A	EA	SILICONE - TUBE - W/O NOZZLE - BUFF
	131264-01-02A	EA	SILICONE - TUBE - W/O NOZZLE - CLEAR
	131264-01-01A	EA	SILICONE - TUBE - W/O NOZZLE - BLACK
	131264-02-01A	EA	SILICONE - TUBE - W/O NOZZLE - VW GRAY - BATH ONLY
	131264-03-01A	EA	SILICONE - TUBE - W/O NOZZLE- SELF LEVELING - BRIGHT WHITE
	131264-04-01A	EA	SILICONE/SEALANT/ADHESIVE - FAST CURE F/GLASS/VINYL - B/W
	131384-01-000	EA	ADHESIVE - JETWELD
	134651-01-000	FT	SEAL - 1/2" X 3/4" PSA 1 SIDE
	900390-01-000	EA	NOZZLE - SILICONE TUBE - 2.5" LONG
	900390-03-000	EA	NOZZLE - SILICONE TUBE - 4.3" LONG

BOLTS, NUTS AND WASHERS

KEY	PART NUMBER	U/M	DESCRIPTION
	OMC04K-06-016	EA	BOLT - HEX - M06 X 1 X 016
	OMC05K-08-055	EA	BOLT - HEX - M08 X 1.25 X 2.2
	OMC13K-14-110	EA	BOLT - HEX
	OMC13K-14-070	EA	BOLT - HEX - M14 X 2 X 2 3/4
	OMC31K-08-020	EA	BOLT - HEX - SERRATED FLANGE - M8 X 020
	OMC32K-10-030	EA	BOLT - HEX - SERRATED FLANGE - M10 X 1 1/2
	OMD16K-10-000	EA	NUT - HEX PREV TORQUE M10 X 1 1/2 CLASS 8
	OMD39K-12-000	EA	NUT - HEX W/NYLON LOCK - M12 X 1 3/4
	OMD40K-14-000	EA	NUT - HEX W/NYLON LOCK - M14 X 2
	OMD54F-06-000	EA	NUT-HEX SER FLG M6X1,0 SS - DIN6923A2M6
	OME06K-14-280	EA	WASHER - FLAT - 14 ID X 28 OD
	000C12-04-40B	EA	BOLT - HEX - 1/4-20 X 2 1/2 - GRADE 5 ZINC
	000C12-04-08B	EA	BOLT - HEX - 1/4-20 X 1/2 - GRADE #5 - ZINC
	000C12-05-16B	EA	BOLT - HEX - 5/16-18 X 1 - GRADE #5 - ZINC
	000C12-06-24B	EA	BOLT - HEX - 3/8-16 X 1 1/2 - ZINC #5
	000C12-06-16B	EA	BOLT - HEX - 3/8-16 X 1 - GRADE #5 - ZINC
	000C12-06-128	EA	BOLT - HEX - 3/8 - 16 X 8 - ZINC 5
	000C12-06-44B	EA	BOLT - HEX - 3/8-16 X 2 3/4 - GRADE 5 - ZINC
	000C12-08-28B	EA	BOLT - HEX - 1/2-13 X 1 3/4 - GRADE #5 - ZINC
	000C12-08-24B	EA	BOLT - HEX - 1/2-13 X 1 1/2 - GRADE #5 - ZINC
	000C12-08-16B	EA	BOLT - HEX - 1/2-13 X 1 - GRADE #5 - ZINC
	000C12-10-24B	EA	BOLT - HEX - 5/8-11 X 1 1/2 - GRADE #5 - ZINC
	000C13-07-48B	EA	BOLT - HEX - 7/16-20 X 3 - GRADE #5 - ZINC
	000C13-07-40B	EA	BOLT - HEX - 7/16-20 X 2 1/2 - GRADE #5 - ZINC
	000C14-07-28B	EA	BOLT - HEX - 7/16-14 X 1 3/4 - GRADE #8 - ZINC
	000C14-10-32K	EA	BOLT - HEX - 5/8-11 X 2 - GRADE #8 - ZINC
	000C18-05-40A	EA	BOLT - ELEVATOR - 5/16-18 X 2 1/2 - PL
	000C18-06-48B	EA	BOLT - ELEVATOR - 3/8-16 X 3 - GRADE 5 - ZINC
	000C26-04-18B	EA	BOLT - HEX - SERRATED FLANGE - 1/4-20 X 1 1/8 - ZINC
	000C26-04-14B	EA	BOLT - HEX - SERRATED FLANGE - 1/4-20 X 7/8 - ZINC
	000C26-04-10B	EA	BOLT - HEX - SERRATED FLANGE - 1/4-20 X 5/8 - ZINC
	000C26-05-20B	EA	BOLT - HEX - SERRATED FLANGE - 5/16-18 X 1 1/4 - ZINC
	000C26-05-129	EA	BOLT - HEX - SERRATED FLANGE - 5/16-18 X 3/4
	000C26-05-12B	EA	BOLT - HEX - SERRATED FLANGE - 5/16-18 X 3/4 - ZINC

SEALANTS & FASTENERS GROUP (CONTINUED)
BOLTS, NUTS AND WASHERS (CONTINUED)

KEY	PART NUMBER	U/M	DESCRIPTION
	000C26-05-249	EA	BOLT - HEX - SERRATED FLANGE - 5/16-18 X 1 1/2
	000C26-06-28B	EA	BOLT - HEX - SERRATED FLANGE - 3/8-16 X 1 3/4 - ZINC
	000C26-06-20B	EA	BOLT - HEX - SERRATED FLANGE - 3/8-16 X 1 1/4 - ZINC
	000C26-06-12B	EA	BOLT - HEX - SERRATED FLANGE - 3/8-16 X 3/4 - ZINC
	000C26-06-40B	EA	BOLT - HEX - SERRATED FLANGE - 3/8-16 X 2 1/2 - ZINC
	000C26-08-24B	EA	BOLT - HEX - SERRATED FLANGE - 1/2-13 X 1 1/2 - ZINC
	000C27-04-40B	EA	BOLT - CARRIAGE - 1/4-20 X 2 1/2 - ZINC
	000C27-05-44I	EA	BOLT-CARR,5/16-18X2.75" - BLACK ZINC
	000C27-07-40B	EA	BOLT - CARRIAGE - 7/16-14 X 2 1/2 - GRADE #5
	000D16-07-00B	EA	NUT - HEX - 7/16-14 - ZINC
	000D24-10-00B	EA	NUT - HEX - SELF LOCKING - 10-32 ZINC
	000D28-10-00B	EA	NUT - HEX - W/NYLON LOCK - 10-32 ZINC
	000D29-04-00B	EA	NUT - HEX - SELF LOCKING - 1/4 X 20 - ZINC
	000D29-06-00B	EA	NUT - HEX - W/NYLON LOCK - 3/8-16 - ZINC
	000D29-09-00B	EA	NUT - HEX - SELF LOCKING - 9/16-12 - ZINC
	000D30-07-00B	EA	NUT - HEX LOCK - NYLON 7/16 X 20
	000D34-06-00B	EA	NUT - HEX - LOCKING - 3/8-16 GRADE C - ZINC
	000D39-04-00B	EA	NUT - HEX - LOCKING W/SERRATED FLANGE - 1/4-20 - ZINC
	000D39-05-00B	EA	NUT - HEX - LOCKING W/SERRATED FLANGE - 5/16-18 - ZINC
	000D39-06-00B	EA	NUT - HEX - LOCKING W/SERRATED FLANGE - 3/8-18 - ZINC
	000D39-06-00D	EA	NUT - HEX - LOCKING W/SERRATED FLANGE - 3/8"-16 BLACK
	000D39-07-00B	EA	NUT - HEX - LOCKING W/SERRATED FLANGE - 7/16-14 - ZINC
	000D44-04-00B	EA	NUT - HEX - LOCKING W/SERRATED FLANGE - 1/4-28 - ZINC
	000D44-07-00B	EA	NUT - HEX - LOCKING W/SERRATED FLANGE - 7/16-20 - ZINC
	000D44-08-00B	EA	NUT - HEX - LOCKING W/SERRATED FLANGE - 1/2-20 - ZINC
	000D46-04-00A	EA	NUT - HEX - WELD - 1/4-20 - PLAIN
	000D65-08-00B	EA	NUT - HEX - LOCKING W/SERRATED FLANGE - 8-32 - ZINC
	000D67-10-00B	EA	NUT - HEX - LOCK - 5/8-11 - ZINC
	000D73-08-00C	EA	NUT - HEX FLANGE - 1/2-13
	000D75-09-00B	EA	NUT - HEX LOCKING - 9/16-12 - ZINC
	000D76-06-00B	EA	NUT - HEX FLANGE - 3/8-16
	000E11-04-00F	EA	WASHER - LOCKING - 1/4 MED SPLIT - STAINLESS STEEL
	000E11-07-00B	EA	WASHER - LOCKING - 7/16 MED SPLIT - ZINC
	000E11-08-00B	EA	WASHER - LOCKING - 1/2 MED SPLIT - ZINC
	000E13-17-00B	EA	WASHER - FLAT - 3/8 AR - ZINC
	000E13-18-00B	EA	WASHER - FLAT - 3/8 WIDE - ZINC
	000E13-20-00B	EA	WASHER - FLAT - 7/16 WIDE - ZINC
	000E13-22-00B	EA	WASHER - FLAT - 1/2 WIDE - ZINC
	000E13-26-00B	EA	WASHER - FLAT - 5/8 WIDE - ZINC
	000E14-10-00B	EA	WASHER - LOCKING - #10 EXTERNAL TOOTH - ZINC
	000E16-10-00B	EA	WASHER - HARDENED - 5/8 - FLAT - ZINC
	000G45-05-16B	EA	BOLT - LAG - 5/16-9 X 1 - ZINC
	000G62-08-24B	EA	SCREW - SF/DR - 8-18 X 1 1/2 PFH
	002329-01-000	EA	WASHER-FLAT, 9/32" ID X 5/8" OD - NYLON
	005081-01-000	EA	NUT - SPEED - C-TYPE - #8 SCREW
	040921-03-000	EA	NUT - SPEED - U TYPE - #10
	040921-04-000	EA	NUT - SPEED - U TYPE - #8-.59" LENGTH X .44" WIDTH
	040921-05-000	EA	NUT - SPEED - U-TYPE - 8-.67" X .44" WIDE
	041322-01-000	EA	WASHER - FLANGE - 15/32 ID X 2 3/8 OD - F/SEAT BELT MTG
	044364-01-000	EA	NUT - SPEED - FLAT - RECTANGULAR - SELF LOCKING/ONE PIECE
	044364-02-000	EA	NUT - SPEED - FLAT - ROUND
	044533-01-000	EA	WASHER - PLASTIC - 1 3/8 OD - FOR BUTTONS
	046867-04-000	EA	GROMMET - #0
	046867-05-000	EA	WASHER - #0
	051387-06-000	EA	BOLT - CARRIAGE W/O HOLE - 5/16-18 X 9 1/2 - ZINC
	058716-02-000	EA	WASHER - FLAT NYLON
	058716-03-000	EA	WASHER - FLAT/NYLON - .500 X 1 1/4 X 060
	064081-03-000	EA	NUT - WING 3/8-16 - W/WELD NUT
	077071-01-000	EA	WASHER - FENDER - 3/16 ID X 1 OD
	084406-01-000	EA	NUT - CAPPED - CROSS RECESSED - BLACK - 1/4-20 THD
	087234-01-000	EA	NUT - JACK - 1/4 X 20 THD - MOLLY
	087718-01-000	EA	MONOBOLT - STEEL - 3/16 DIAMETER
	088787-12-000	EA	STUD - WELD - 1/4 - 20 X 1.0 LG - MN
	102333-02-01A	EA	BOLT - CARRIAGE - 1/4-20

SEALANTS & FASTENERS GROUP (CONTINUED)
BOLTS, NUTS AND WASHERS (CONTINUED)

KEY	PART NUMBER	U/M	DESCRIPTION
	102540-02-000	EA	SEAL - SCREW
	103020-02-000	EA	BOLT-U - #8-32 - GRADE 5 ZINC
	106166-01-000	EA	BOLT/COLLARED HANGER - 8-32 X 1
	106956-03-000	EA	BOLT - HEX TAP - 1/2-12NC X 3 - GRADE 5 - FULL THREAD/ZINC
	106956-08-000	EA	BOLT - HEX TAP - 1/2-13NC X 4 - GRADE 5 - FULL THREAD/ZINC
	107393-02-000	EA	BOLT - SHOULDER - 3/8" SOCKETHEAD
	107397-01-000	EA	WASHER - FENDER - 3/4 ID X 1 OD
	108067-03-000	EA	STUD - WELD - 1/4 - 20 X 1/2 CD
	109235-01-05A	FT	COVER - SCREW - BRIGHT WHITE
	109235-01-01A	FT	COVER - SCREW - MAT BLACK
	109917-03-000	EA	WASHER - 1" X .50"
	109917-04-000	EA	WASHER - 1" X .75"
	113985-02-000	EA	BOLT - FLANGE - M10-1 1/2 X 30CL 10.9
	114259-05-000	EA	BOLT - 7/16-20 X 1 1/4 W/WASHER
	128444-01-000	EA	WASHER - SPRING - CONICAL
	131377-01-000	EA	NUT-HEX HEAD W/WASHER-1/4-20 X 2" STEEL W/3/4" OD WASHER
	135092-01-01A	EA	BOLT - HEX - SERRATED FLANGE - 1/2-20 X 1 3/4-GRADE 5 ZINC
	135092-02-01A	EA	BOLT - HEX - SERRATED FLANGE - 1/2-20 X 2 1/2-GRADE 5 ZINC

SCREWS

KEY	PART NUMBER	U/M	DESCRIPTION
	0G1106-08-240	EA	SCREW - 6-20 X 1/2 PPH - VW LIGHT GRAY
	0G1108-12-240	EA	SCREW - 8-18 X 3/4 PPH - VW LIGHT GRAY
	0G1208-12-170	EA	SCREW - 8-18 X 3/4 POH - BRIGHT WHITE
	0G1306-08-130	EA	SCREW-6-20X1/2 PFH TAUPE
	0G1308-10-240	EA	SCREW - 8-18 X 5/8 PFH - VW LIGHT GRAY
	0G3804-22-180	EA	SCREW - MACHINE - 1/4-20 X 1 3/8 PFH - BLACK
	0G3908-08-160	EA	SCREW - SF/DR - 8-18 X 1/2 PPH - VW WHITE
	0G3908-08-240	EA	SCREW - SF/DR - 8-18 X 1/2 PPH - VW LIGHT GRAY
	0G3908-08-170	EA	SCREW - SF/DR - 8-18 X 1/2 PPH - BRIGHT WHITE
	0G3908-12-250	EA	SCREW - SF/DR - 8-18 X 3/4 PPH - DARK GRAY
	0G3908-12-240	EA	SCREW - SF/DR - 8-18 X .75 PPH - VW LIGHT GRAY
	0G3908-16-170	EA	SCREW - SF/DR - 8-18 X 1 PPH - BRIGHT WHITE
	0G3908-24-170	EA	SCREW - SF/DR - 8-18 X 1 1/2 PPH - BRIGHT WHITE
	0G3910-10-320	EA	SCREW - SF/DR - 10-16 X 5/8 PPH - GLACIER
	0G3910-10-240	EA	SCREW - SF/DR - 10-16 X 5/8 PPH - VW LIGHT GRAY
	0G3910-10-330	EA	SCREW - SF/DR - 20-16 X 5/8 PPH - PUTTY
	0G3910-12-320	EA	SCREW - SF/DR - 10-16 X .75 PPH - GLACIER
	0G3910-12-240	EA	SCREW - SF/DR - 10-16 X .75 PPH - VW LIGHT GRAY
	0G3910-12-170	EA	SCREW - SF/DR - 10-16 X 3/4 PPH - BRIGHT WHITE
	0G5508-12-270	EA	SCREW - SF/DR - 8-18 X 3/4 PWH - TITANIUM
	0G5508-12-260	EA	SCREW - SF/DR - 8-18 X 3/4 PWH - ALLANTE ANTELOPE
	0G5508-12-240	EA	SCREW - SF/DR - 8-18 X 3/4 PWH - VW LIGHT GRAY
	0G5508-12-170	EA	SCREW - SF/DR - 8-18 X 3/4 PWH - BRIGHT WHITE
	0G5508-12-330	EA	SCREW - SF/DR - 8-18 X 3/4 PWH - PUTTY
	0G5508-12-320	EA	SCREW - SF/DR - 8-18 X 3/4 PWH - GLACIER
	0G5508-16-320	EA	SCREW - SF/DR - 8-18 X 1 PWH - GLACIER
	0G5508-16-250	EA	SCREW - SF/DR - 8-18 X 1 PWH - VW DARK GRAY
	0G6008-16-170	EA	SCREW - SF/DR - 8-18 X 1 POH - BRIGHT WHITE
	0G6710-08-240	EA	SCREW - 10-12 X 1/2 PPH TAUPE - VW LIGHT GRAY
	0G6710-08-170	EA	SCREW - 10-12 X 1/2 PPH - BRIGHT WHITE
	0G6710-08-130	EA	SCREW - 10-12 X 1/2 PPH - TAUPE
	0G6710-12-170	EA	SCREW - 10-12 X 3/4 PPH - BRIGHT WHITE
	0G6806-16-170	EA	SCREW - 6-18 X 1 POH - BRIGHT WHITE
	0G6810-24-280	EA	SCREW - 10-12 X 1 1/2 POH - SOFT WHITE
	000C20-04-16A	EA	SCREW - 1/4-20X 1 - FLAT SOCKET HEAD
	000C20-05-28F	EA	SCREW - 5/16-18 X 1 3/4 FLAT SOC - STAINLESS STEEL
	000C20-06-24T	EA	SCREW - 3/8-16 X 1 1/2 - FLAT SOCKET
	000G11-06-10J	EA	SCREW - 6-20 X 5/8 PPH - BRASS
	000G11-06-08B	EA	SCREW - 6-20 X 1/2 PPH - ZINC
	000G11-07-08B	EA	SCREW - 7-19 X 1/2 PPH - ZINC
	000G11-08-12B	EA	SCREW - 8-18 X 3/4 PPH - ZINC
	000G11-08-08T	EA	SCREW - 8-18 X 1/2 PPH - FLUOROCARBON COATING

SEALANTS & FASTENERS GROUP (CONTINUED)
SCREWS (CONTINUED)

KEY	PART NUMBER	U/M	DESCRIPTION
	000G11-08-06B	EA	SCREW - 8-18 X 3/8 PPH - ZINC
	000G11-08-20G	EA	SCREW - 8-18 X 1 1/4 - ANTIQUE BRASS
	000G11-08-20B	EA	SCREW - 8-18 X 1 1/4 PPH - ZINC
	000G11-08-16B	EA	SCREW - 8-18 X 1 PPH - ZINC
	000G11-08-12T	EA	SCREW - 8-18 X 3/4 PPH - BLACK MAGNESIUM
	000G11-08-12P	EA	SCREW - 8-18 X 3/4 PPH - DARK BROWN
	000G11-10-12D	EA	SCREW - 10-16 X 3/4 PPH - BLACK
	000G12-06-12J	EA	SCREW - 6-20 X .75 POH - BRASS
	000G12-06-08T	EA	SCREW - 6-20 X 1/2 POH - BLACK
	000G12-08-12S	EA	SCREW - 8-18 X 3/4 POH - OFF WHITE
	000G13-05-10B	EA	SCREW - 5-12 X 5/8 PFH - ZINC
	000G13-06-08B	EA	SCREW - 6-20 X 1/2 PFH - ZINC
	000G13-06-06I	EA	SCREW - 6-20 X 3/8 PFH - BLACK ZINC
	000G13-06-16J	EA	SCREW - 6-20 X 1 PFH - BRASS
	000G13-06-10J	EA	SCREW - 6-20 X 5/8 PFH - BRASS
	000G13-06-10G	EA	SCREW - 6-20 X 5/8 PFH - ANTIQUE BRASS
	000G13-06-08G	EA	SCREW - 6-20 X 1/2 PFH - ANTIQUE BRASS
	000G13-06-24J	EA	SCREW - 6-20 X 1 1/2 PFH - BRASS
	000G13-07-12B	EA	SCREW - 7-19 X 3/4 PFH - ZINC
	000G13-07-10H	EA	SCREW - 7-19 X 5/8 PFH - BLACK
	000G13-08-10B	EA	SCREW - 8-18 X 5/8 PFH - ZINC
	000G13-08-24B	EA	SCREW - 8-18 X 1 1/2 PFH - ZINC
	000G13-08-16B	EA	SCREW - 8-18 X 1 PFH - ZINC
	000G13-08-109	EA	SCREW - 8-18 X 5/8 PFH
	000G13-10-16I	EA	SCREW - 10-16 X 1 PFH - BLACK
	000G16-04-24B	EA	SCREW - MACHINE - 1/4-20 X 1 1/2 PPH
	000G18-08-22B	EA	SCREW - MACHINE - 8-32 X 1 3/8 PPH - ZINC
	000G18-08-16B	EA	SCREW - MACHINE - 8-32 X 1 PPH - ZINC
	000G18-08-12B	EA	SCREW - MACHINE - 8-32 X 3/4 PPH - ZINC
	000G18-08-24B	EA	SCREW - MACHINE - 8-32 X 1 1/2 PPH - ZINC
	000G19-10-12F	EA	SCREW - MACHINE - 10-32 X 3/4 PPH - STAINLESS STEEL
	000G19-10-10B	EA	SCREW - MACHINE - 10-32 X 5/8 - PPH - ZINC
	000G19-10-08B	EA	SCREW - MACHINE - 10-32 X 1/2 PPH - ZINC
	000G19-10-20B	EA	SCREW - MACHINE - 10-32 X 1 1/2 PPH - ZINC
	000G36-10-12T	EA	SCREW - 10-24X 3/4 PFH TYPE 23 - BLACK
	000G39-06-16T	EA	SCREW - SF/DR - 6-20 X 1 PPH - BLACK
	000G39-06-10T	EA	SCREW - SF/DR - 6-20 X 5/8 PPH - BLACK
	000G39-08-32B	EA	SCREW - SF/DR - 8-18 X 2 PPH - ZINC
	000G39-08-24T	EA	SCREW - SF/DR - 8-18 X 1 1/2 PPH - BLACK
	000G39-08-24S	EA	SCREW - SF/DR - 8-18 X 1 1/2 - OFF WHITE
	000G39-08-24B	EA	SCREW - SF/DR - 8-18 X 1 1/2 PPH - ZINC
	000G39-08-16T	EA	SCREW - SF/DR - 6-20 X 1 PPH - BLACK
	000G39-08-16B	EA	SCREW - SF/DR - 8-18 X 1 PPH - ZINC
	000G39-08-12B	EA	SCREW - SF/DR - 8-18 X 3/4 PPH - ZINC
	000G39-08-08T	EA	SCREW - SF/DR - 8-18 X 1/2 PPH - BLACK
	000G39-08-08S	EA	SCREW - SF/DR - 8-18 X 1/2 PPH - OFF WHITE
	000G39-08-08B	EA	SCREW - SF/DR - 8-18 X 1/2 PPH - ZINC
	000G39-08-06B	EA	SCREW - SF/DR - 8-18 X 3/8 PPH - ZINC
	000G39-10-08B	EA	SCREW - SF/DR - 10-16 X 1/2 PPH - ZINC
	000G39-10-48T	EA	SCREW - SF/DR - 10-16 X 3 PPH - BLACK
	000G39-10-48B	EA	SCREW - SF/DR - 10-16 X 3 - PPH - ZINC
	000G39-10-32B	EA	SCREW - SF/DR - 10-16 X 2 - PPH - ZINC
	000G39-10-20T	EA	SCREW - SF/DR - 10-16 X 1 1/4 PPH - BLACK
	000G39-10-20B	EA	SCREW - SF/DR - 10-16 X 1 1/4 PPH - ZINC
	000G39-10-169	EA	SCREW - SF/DR - 10-16 X 1 PPH - FLUOROCARBON SILVER
	000G39-10-129	EA	SCREW - SF/DR - 10-16 X 3/4 PPH - FLUOROCARBON SILVER
	000G39-10-12T	EA	SCREW - SF/DR - 10-16 X 3/4 - BLACK
	000G39-10-10T	EA	SCREW - SF/DR - 10-16 X 5/8 - BLACK
	000G39-10-10B	EA	SCREW - SF/DR - 10-16 X 5/8 - ZINC
	000G39-12-12E	EA	SCREW - SF/DR - 12-14 X 3/4 PPH - CHROME
	000G42-04-16B	EA	SCREW - SF/DR - 1/4-14 X 1 HWH - ZINC
	000G42-04-24B	EA	SCREW - SF/DR - 1/4-14 X 1 1/2 - ZINC
	000G46-08-24T	EA	SCREW - MACHINE - 8-32 X 1 1/2 PFH - BLACK
	000G50-04-08B	EA	SCREW - MACHINE - 1/4-20 X 1/2 PTH - ZINC

SEALANTS & FASTENERS GROUP (CONTINUED)
SCREWS (CONTINUED)

KEY	PART NUMBER	U/M	DESCRIPTION
	000G51-06-12B	EA	SCREW - 6-20 X 3/4 PTH - ZINC
	000G52-06-05B	EA	SCREW - MACHINE - 6-32 X 5/16 PTH ZINC
	000G52-08-18B	EA	SCREW - MACHINE - 8-32 X 1 1/8 PTH - ZINC
	000G54-04-14B	EA	SCREW - 1/4-20 X 7/8 PTH - TYPE 23 - ZINC PLATED
	000G55-08-165	EA	SCREW - SF/DR - 8-18 X 1 PWH - WILLOW
	000G55-08-16T	EA	SCREW - SF/DR - 8-18 X 1 PWH - BLACK
	000G55-08-16S	EA	SCREW - SF/DR - 8-18 X 1.00 - PWH - OFF WHITE
	000G55-08-124	EA	SCREW - SF/DR - 8-18 X 3/4 PWH - ASH GRAY
	000G55-08-12M	EA	SCREW - SF/DR - 8-19 X .75 PWH - GRAY
	000G56-12-48B	EA	SCREW - WOOD - 12-11 X 3 POH - SPECIAL HARDENED
	000G57-14-72B	EA	SCREW-14-10-X4 1/2 PFH ZN GENERAL MOTORHOMES
	000G57-14-64B	EA	SCREW - 14-10 X 4 PFH ZINC
	000G60-08-22B	EA	SCREW - SF/DR - 8-18 X 1.38 POH - ZINC
	000G60-08-20F	EA	SCREW - SF/DR - 8-19X1.25 POH
	000G60-08-16E	EA	SCREW - SF/DR - 8-1 X 1 POH - CHROME
	000G60-10-20B	EA	SCREW - SF/DR - 10-16 X 1 1/4 POH - ZINC
	000G60-10-28T	EA	SCREW - SF/DR - 10-16 X 1 3/4 - BLACK
	000G60-10-209	EA	SCREW - SF/DR - 10-16 X 1 1/4 POH - SILVER STALGAARD
	000G67-08-32B	EA	SCREW - 8-15 X 2 PPH - ZINC
	000G67-10-24S	EA	SCREW - 10-12 X 1 1/2 PPH - OFF WHITE
	000G67-10-24B	EA	SCREW - 10-12 X 1 1/2 PPH - ZINC
	000G67-10-20D	EA	SCREW - 10-12 X 1 1/4 PPH - BLACK
	000G67-10-125	EA	SCREW - 10-12 X 3/4 PPH - WILLOW
	000G67-10-12S	EA	SCREW - 10-12 X 3/4 PPH - OFF WHITE
	000G67-10-12P	EA	SCREW - 10-12 X 3/4 PPH - DARK BROWN
	000G67-10-12B	EA	SCREW - 10-12 X 3/4 PPH - ZINC
	000G67-10-10T	EA	SCREW - 10-12 X 5/8 PPH - BLACK
	000G67-10-10S	EA	SCREW - 10-12 X 5/8 PPH - OFF WHITE
	000G67-10-10P	EA	SCREW - 10-12 X 5/8 PPH - DARK BROWN
	000G67-10-10B	EA	SCREW - 10-12 X 5/8 PPH - ZINC - TYPE A
	000G67-10-08B	EA	SCREW - 10-12 X 1/2 PPH - ZINC
	000G67-10-36T	EA	SCREW - 10-12 X 2 1/4 - PPH - BLACK
	000G68-06-12J	EA	SCREW - 6-18 X 3/4 POH - BRASS
	000G68-06-10J	EA	SCREW - 6-18 X 5/8 POH - BRASS
	000G68-06-10G	EA	SCREW - 6-18 X 5/8 POH - ANTIQUE BRASS
	029130-01-000	EA	SCREW - SNAP STUD - #8-16 X 5/8" LONG
	029130-03-000	EA	SCREW - SNAP STUD - #8-16 X 1" LONG
	049465-01-000	EA	SCREW - 10-16 PTH W/WASHER - DARK BROWN
	049465-03-000	EA	SCREW - 10-16 X 1 POH W/WASHER - OFF WHITE
	049465-04-000	EA	SCREW - 10-16 X 1 PTH W/WASHER - BEIGE
	049465-13-000	EA	SCREW-10+16X1 PTH W/WASHER - *ASH GRAY
	049465-17-000	EA	SCREW - 10-16 X 1 POH W/WASHER - BRIGHT WHITE
	049465-23-000	EA	SCREW - 10-16 X 1.5 POH W/WASHER - VW LIGHT GRAY
	054434-03-000	EA	SCREW - SF/DR - 10-16 X 2 - PWH - ZINC - W/O WINGS
	075908-01-000	EA	SCREW - MACHINE - 10-32 X .56 PTH - EXTERNAL TOOTH - ZINC
	076790-01-000	EA	SCREW - 6-20 X 1 1/4 PPH - BLACK
	076790-05-000	EA	SCREW - 6-20 X 1/2 PPH - BLACK - THREAD CUTTING/WOOD
	083554-01-000	EA	SCREW - DRYWALL - 8 X 1 1/4
	083554-04-000	EA	SCREW - DRYWALL - 8 X 2 1/2
	087721-01-000	EA	SCREW - FLAT HEAD - TAPPING - 1/4 X 1 1/4 LONG - ZINC
	090033-02-000	EA	SCREW - 1/4-20 X 5/8 - ROUND WASHER HEAD - OFF/WHITE
	097974-01-000	EA	SCREW - PARTICLE BOARD - 7-9 X 3/4 PPH
	101618-01-000	EA	SCREW - 1/4-20 X 3/4 HEX - TAPPING - STALGARD TYPE F
	110460-05-02A	EA	SCREW - MACHINE - 10-24 X 2 1/2 PFH - WHITE
	113563-01-01A	EA	SCREW - 8 X 5/8 LONG SHOULDER/WASHER HEAD
	117478-01-04A	EA	SCREW - 8-18 X 3/4 PPH W/WASHER - VW LIGHT GRAY
	118383-01-04A	EA	RETAINER/RECESSED - F/.22" SCREW - BRIGHT WHITE
	118383-01-05A	EA	RETAINER/RECESSED - F/.22" SCREW - VW LIGHT GRAY
	118383-01-09A	EA	RETAINER/RECESSED - F/.22" SCREW - GLACIER
	118383-02-09A	EA	RETAINER/RECESSED - F/.27" SCREW - GLACIER
	118383-02-05A	EA	RETAINER/RECESSED - F/.27" SCREW - VW LIGHT GRAY
	118383-03-09A	EA	RETAINER/RECESSED - F/.32" SCREW - GLACIER

SEALANTS & FASTENERS GROUP (CONTINUED)
SCREWS (CONTINUED)

KEY	PART NUMBER	U/M	DESCRIPTION
	118383-04-09A	EA	CAP - F/RECESSED RETAINER - GLACIER
	118383-04-05A	EA	CAP - F/RECESSED RETAINER - VW LIGHT GRAY
	118383-04-04A	EA	CAP - F/RECESSED RETAINER - BRIGHT WHITE
	126458-01-01A	EA	SCREW - 8-18 X 1/2 - PRWH - BLACK
	134126-01-01A	EA	SCREW/NAIL - HEX HEAD - 3/4"
	140040-01-000	EA	SCREW - 1/4-20 X 1 - BUTTON HEAD/SOCKET - W/LOCTITE

SEALANTS & FASTENERS GROUP (CONTINUED)
CLAMPS, CLIPS, GROMMETS, RIVETS & PLUGS

KEY	PART NUMBER	U/M	DESCRIPTION
	000F10-06-32B	EA	PIN - COTTER - 3/16" X 2" - ZINC
	000H14-06-06R	EA	RIVET-MANDREL BLIND,3/16 AL - CHERRY BSP-66
	000H14-06-03R	EA	RIVET - MANDREL BLIND - 3/16 ALUMINUM
	000H16-04-06R	EA	RIVET - POP ALUMINUM - 1/8 X .313 - .375
	000H16-06-10R	EA	RIVET - POP ALUMINUM - 3/16 X .501-.625
	007161-01-000	EA	CLAMP - HOSE - SPRING TYPE - 1/2"
	010495-01-000	EA	CLAMP - CABLE - 9/16"ID
	010495-02-000	EA	CLAMP - CABLE - 3/8"ID
	010495-04-000	EA	CLAMP - CABLE - 11/16" - WHITE
	010497-01-000	EA	CLAMP - CLOSED - 5/8"ID
	010497-03-000	EA	CLAMP - CLOSED - 1"ID - CUSHIONED
	010497-04-000	EA	CLAMP - CLOSED - 1 5/8"ID
	010497-05-000	EA	CLAMP - CLOSED - 1/2"ID
	010497-07-000	EA	CLAMP - CLOSED - 3/8"ID
	010497-10-000	EA	CLAMP - CLOSED
	010499-01-000	EA	CLAMP - CLOSED - 3/8"ID
	016188-03-000	EA	GROMMET - L/P LINE - 3/8"HOLE X 2 1/2"LONG - RUBBER
	016188-04-000	EA	GROMMET - L/P LINE - 1/2"HOLE X 2 1/2"LONG - RUBBER
	016188-05-000	EA	GROMMET - L/P LINE - 3/8"HOLE X 1 1/4"LONG - RUBBER
	016188-06-000	EA	GROMMET - L/P LINE - 3/8"HOLE X 3 1/4"LONG
	016188-07-000	EA	GROMMET - L/P LINE - 1/2"HOLE X 3 1/4"LONG
	023942-01-000	EA	GROMMET - RUBBER - 2" OD
	034141-02-000	EA	PLUG/NYLON - .38" - BLACK
	061420-04-000	EA	PLUG/PLASTIC - 1 1/4" DIAMETER
	061420-05-000	EA	PLUG/PLASTIC - 1 1/2" DIAMETER
	061420-08-000	EA	PLUG/PLASTIC - 2 1/2" DIAMETER
	061420-09-000	EA	PLUG/PLASTIC - 1.00" - DIAMETER
	061420-10-000	EA	PLUG/PLASTIC - 1 1/2" DIAMETER - BLACK
	061420-14-000	EA	PLUG/PLASTIC - .034" DIAMETER
	061420-15-000	EA	PLUG/PLASTIC - 2" DIAMETER - BLACK
	061420-16-000	EA	PLUG/PLASTIC - 2 1/8" DIAMETER
	062401-01-000	EA	CLAMP - HOSE - WORMGEAR - .25" - 1"
	062401-02-000	EA	CLAMP - HOSE - WORMGEAR - 1.56" - 2.5"
	062401-03-000	EA	CLAMP - HOSE - WORMGEAR - .22" - 1"
	062401-04-000	EA	CLAMP - HOSE - WORMGEAR - .69" - 1.25"
	062401-05-000	EA	CLAMP - HOSE - WORMGEAR - 2" - 3" ID
	062401-06-000	EA	CLAMP - HOSE - WORMGEAR - .22" - .62" ID
	062401-09-000	EA	CLAMP - HOSE - WORMGEAR - 2.8" - 3.75"
	062401-11-000	EA	CLAMP - HOSE - WORMGEAR - 3.50" - 4.50"
	062401-12-000	EA	CLAMP - HOSE - WORMGEAR - .79" X 1.26"
	071015-11-000	EA	GROMMET - RUBBER - 1"ID FITS .12 MATERIAL - BLACK
	071015-19-000	EA	GROMMET - RUBBER - .38 ID - FITS .06 MATERIAL - BLACK
	071015-26-000	EA	GROMMET - RUBBER - 1.5" ID X 2.1" OD W/.06" GROOVE-BLACK
	071015-30-000	EA	GROMMET - RUBBER - .31" ID X .81" OD W/.12" GROOVE-BLACK
	071015-39-000	EA	GROMMET - .75 ID FITS .06 MTL
	071015-41-000	EA	GROMMET - .125 ID FITS .188 MTL
	075148-02-000	EA	CLAMP - GROUNDING - BRONZE SCREWS
	077955-01-000	EA	CLIP/J - 3/8" - VINYL COATED
	080734-02-000	EA	CLIP - WIRE NYLON
	081211-03-000	EA	PLUG/PLASTIC - .50 DIAMETER - BLACK
	081211-04-000	EA	PLUG/PLASTIC - .46 DIAMETER - BLACK

SEALANTS & FASTENERS GROUP (CONTINUED)
CLAMPS, CLIPS, GROMMETS, RIVETS & PLUGS (CONTINUED)

KEY	PART NUMBER	U/M	DESCRIPTION
	083609-01-000	EA	CLAMP - WIRE - DUAL - EQUAL DIAMETERS - 5/8"
	083610-01-000	EA	CLAMP - WIRE - DUAL - UNEQUAL DIAMETERS - 3/4" & 1 1/4"
	083610-02-000	EA	CLAMP - WIRE - DUAL - UNEQUAL DIAMETERS - 3/4" & 2"
	083610-03-000	EA	CLAMP - WIRE - DUAL - EQUAL DIAMETERS - 2"
	088756-01-000	EA	GROMMET - WEB - 1 1/8" I.D.
	091952-01-000	EA	CLIP - GRIPPER - 1"
	091952-02-000	EA	CLIP - GRIPPER - 3/4"
	094362-02-000	EA	CLIP - XMAS TREE - BINDER HEAD - .9" LONG
	114208-04-000	EA	GROMMET - EDGE LINER - FITS 1"
	114208-05-000	EA	GROMMET - EDGE LINER - FITS 2"
	118626-01-02A	EA	RIVET - POP - ALUMINUM - 3/16 X .08 - .375
	118626-01-01A	EA	RIVET - POP - ALUMINUM - 3/16 X .08 - .375
	118626-02-01A	EA	RIVET - POP - ALUMINUM - 3/16 X .500 - .750
	137014-01-01A	EA	GROMMET - CABLE - ALMOND
	137014-01-02A	EA	GROMMET - CABLE - BROWN
	139118-01-01A	EA	GROMMET - PLASTIC/SCREW
	139118-02-01A	EA	GROMMET - SCREW - PLASTIC
	140171-02-000	EA	CLAMP - HOSE - STEPLESS EAR - .250

MISCELLANEOUS FASTENERS

KEY	PART NUMBER	U/M	DESCRIPTION
	008343-01-000	EA	TIE - WIRE - 6"
	008343-02-000	EA	TIE - WIRE - 14"
	008343-03-000	EA	TIE - WIRE - 7 1/2" - BLACK
	029094-04-000	YD	VELCRO TAPE - LOOP - 1" WIDE - BLACK
	029094-06-000	YD	VELCRO TAPE - LOOP - 2" WIDE - BLACK
	029096-03-000	YD	VELCRO TAPE - HOOK - 1" WIDE - BLACK
	029096-04-000	YD	VELCRO TAPE - HOOK - 1" WIDE - BLACK
	048394-02-000	YD	VELCRO TAPE - HOOK - ADHESIVE BACK - 3/4" WIDE - BEIGE
	085774-01-000	FT	FASTENER - DUAL LOCK - 1" WIDE - ADHESIVE BACK - BLACK
	085774-02-000	FT	FASTENER - DUAL HOOK - 1" WIDE - ADHESIVE BACK - BLACK
	085774-03-000	FT	FASTENER - DUAL LOCK - 1/2" WIDE - ADHESIVE BACK - BLACK
	085774-04-000	FT	FASTENER - DUAL HOOK - 1/2" WIDE - ADHESIVE BACK - BLACK
	088792-02-000	YD	VELCRO TAPE - LOOP - 3/4" - ADHESIVE BACK - BEIGE
	088792-04-000	YD	VELCRO TAPE - HOOK - 5/8" - NON-ADHESIVE BACK - WHITE
	088792-05-000	YD	VELCRO TAPE - LOOP - 5/8" - NON-ADHESIVE BACK - WHITE
	108046-02-000	EA	CABLE TIE - SCREW MOUNT 15"
	110943-02-000	FT	FELT STRIP - 3/8" - ADHESIVE BACK - WHITE
	113133-02-01A	EA	RIVET - POP - ALUMINUM - 3/16 X .252 - .504 - BLACK
	127960-01-01A	EA	RETAINER - 3/8" - STAINLESS STEEL

WATER & SEWAGE GROUP DRAINAGE SYSTEM

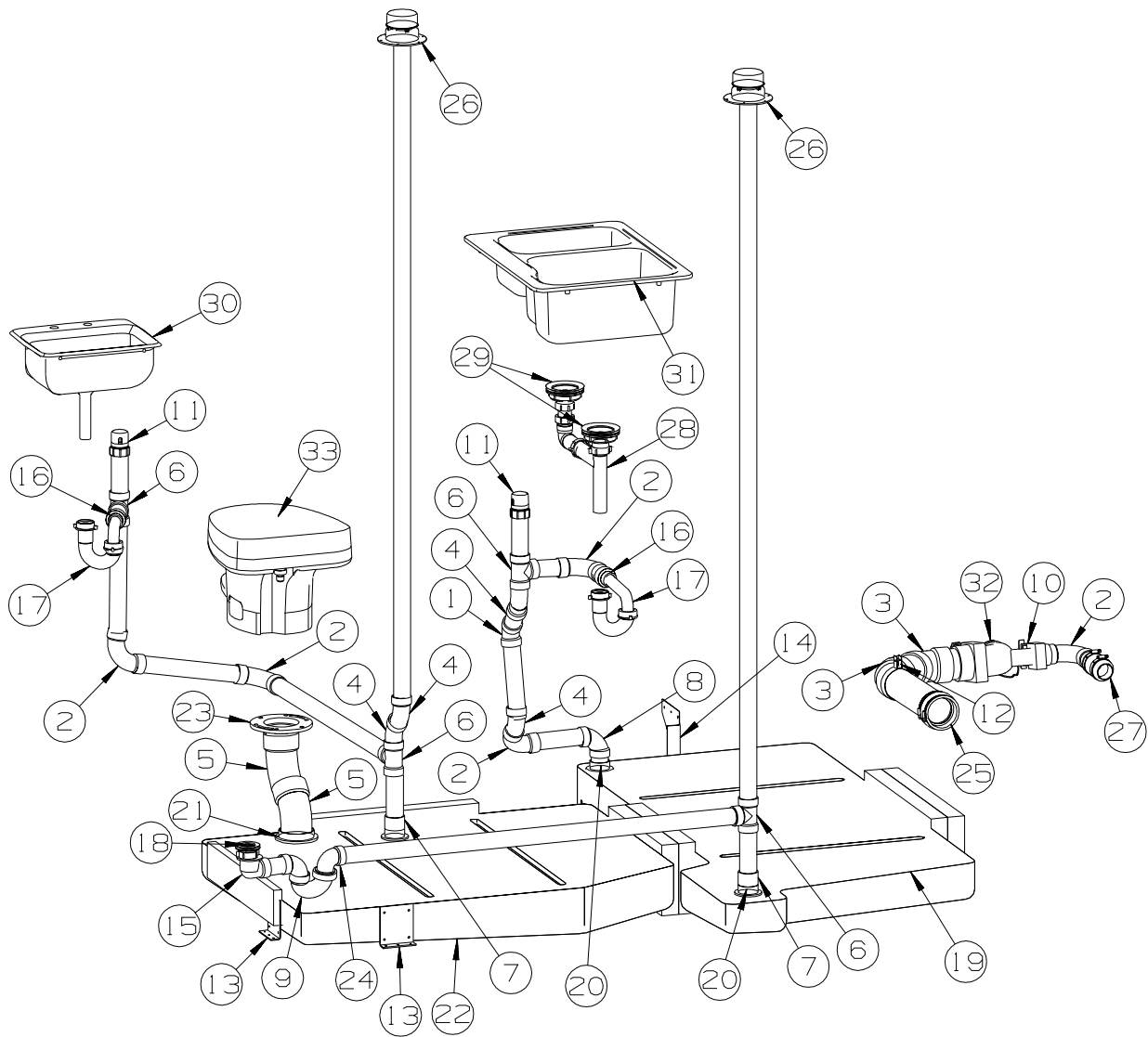

KEY	PART NUMBER	U/M	DESCRIPTION
1	010006-01-000	EA	ELBOW - 45 DEGREE - 1 1/2" HUB X HUB - PLASTIC
2	010008-01-000	EA	ELBOW - 90 DEGREE - 1 1/2" HUB X HUB - PLASTIC
3	010024-01-000	EA	ELBOW - 45 DEGREE - 3" HUB X HUB - PLASTIC
4	010051-01-000	EA	ELBOW - 45 DEGREE - 1 1/2" SPIGOT X HUB - PLASTIC
5	010061-01-000	EA	ELBOW - 45 DEGREE ST - 3" SPIGOT & HUB - PLASTIC
6	010071-01-000	EA	TEE - SANITARY - 1 1/2" HUB X HUB X HUB - PLASTIC
7	010115-01-000	EA	COUPLING - 1 1/2" HUB X HUB - PLASTIC
8	034250-01-000	EA	ELBOW - 90 DEGREE - LONG TURN - 1 1/2" HUB X HUB - ABS
9	037763-01-000	EA	P-TRAP - PLASTIC - 1 1/2" HXH W/UNION
10*	070916-01-000	EA	VALVE - DUAL DUMP - W/CAP - 3" X 1 1/2"
11	079968-01-000	EA	VENT - MECHANICAL/TRAP ARM - ANTI-SIPHON-2" X 7.3" PLASTIC
12	141443-01-02B	EA	HOLDER - RING - E-COATED
13	094756-01-01A	EA	BRACKET/ANGLE - W/HOLES
14	112628-05-02B	EA	BRACKET/TIEDOWN - WATER TANK - E-COATED
15	131486-01-000	EA	ELBOW - DRAIN - 1 1/2" LOW PROFILE - TUB DRAIN
16	109571-01-000	EA	ADAPTER - P-TRAP - 1 1/2" P X 1 1/4" MPT
17	107538-01-000	EA	P-TRAP - PLASTIC - 1 1/4" W/EXTENSION ARM - USA
17	011071-01-000	EA	P-TRAP - PLASTIC - 1 1/2" - CSA - CANADIAN
18	066440-01-000	EA	STRAINER - SHOWER DRAIN - W/RUBBER WASHER
	011069-02-000	EA	TAILPIECE - TUB/SHOWER - 1 1/2" X 1 1/4" X 4" - BRASS
	127440-02-01A	EA	WASHER - RUBBER - 1.8" X .1"
	130403-01-000	EA	NUT - SLIP - W/WINGS 1 1/2"
19	129966-01-000	EA	TANK - HOLDING - 40 GALLON - W/O FITTINGS
20	061607-01-000	EA	GROMMET - HOLDING TANK - 1 1/2" NPS
21	061607-02-000	EA	GROMMET - HOLDING TANK - 3" NPS
22	129964-01-000	EA	TANK - HOLDING - 38 GALLON - W/O FITTINGS

WATER & SEWAGE GROUP (CONTINUED)
DRAINAGE SYSTEM (CONTINUED)

KEY	PART NUMBER	U/M	DESCRIPTION
23	063641-01-000	EA	FLANGE - CLOSET - 4" X 3"
24	010009-01-000	EA	ELBOW - 90 DEGREE - 1/4 BEND - 1 1/2" PLASTIC
25	078406-01-000	EA	COUPLER - RUBBER - W/CLAMPS - 3" X 3"
26	083558-06-000	EA	VENT - PLUMBING - ROOF PIPE COVERED - VW WHITE
27	089355-01-000	EA	COUPLER - RUBBER - 1 1/2" X 1 1/2"
28	091980-01-000	EA	WASTE - CONTINUOUS
29	092303-01-000	EA	STRAINER - W/BASKET - GALLEY SINK - 4" OD
	127440-02-01A	EA	WASHER - RUBBER - 1.8" X .1"
30*	096927-01-02A	EA	SINK - LAVATORY - RECTANGLE - SOFT WHITE
31	136828-01-01A	EA	SINK/DBL - LGE/SM BASIN-25"X19"X7" W/O NOTCH/FAUCET HOLES
32	139513-01-000	EA	HOSE - SEWER - 3" X 10' - W/ADAPTER
33*	067487-04-000	EA	TOILET - LOW - FOOTFLUSH - WHITE

***COMPONENT PARTS LISTED LATER IN THIS GROUP**

WATER & SEWAGE GROUP (CONTINUED)
COMPONENT PARTS FOR DRAINAGE SYSTEM

062415-01-000

KEY	PART NUMBER	U/M	DESCRIPTION	VENDOR NO.
	062415-01-700	EA	STRING-SEWER CAP	V#SV7 STRAP

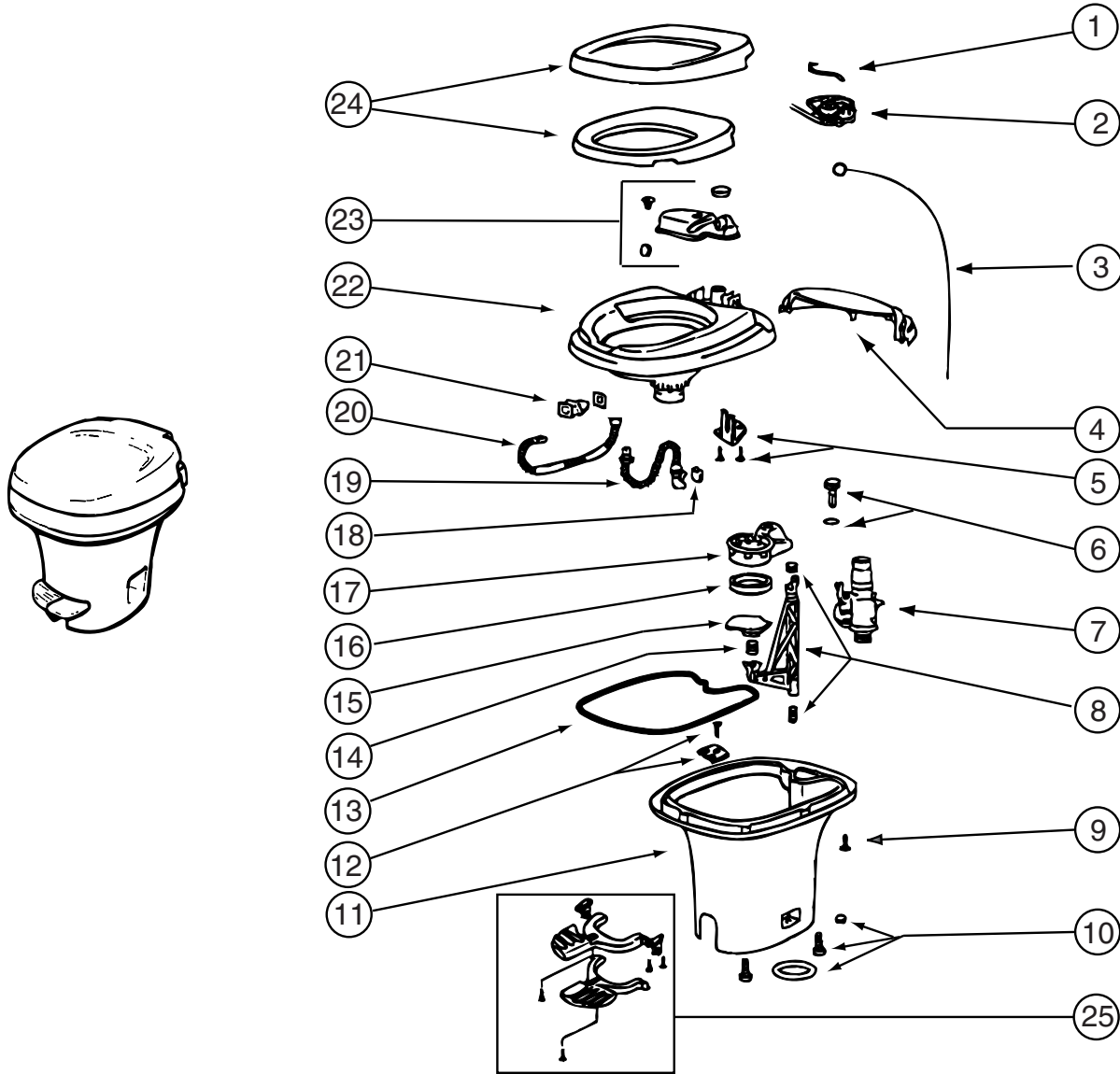

067487-04-000

KEY	PART NUMBER	U/M	DESCRIPTION	VENDOR NO.
2	063740-02-703	EA	KIT-LEVER/WIRE ASSM FOOT FL	24571
4	131932-02-701	EA	COVER -MECHANISM- WHITE	2086562
7	063740-01-714	EA	VALVE ASM (VALVE-BALL SEAL)	13168
10	063740-01-706	EA	BOLT PACKAGE-FLOOR FLANGE	12524THETFORD
15	063740-01-721	EA	BLADE ONLY	1248262
16	063740-01-722	EA	SEAL - BLADE	12481
20	063740-01-717	EA	TUBE-FLUSH	12509
23	063740-02-701	EA	RESERVOIR (TANK ASM.)	24630
24	131932-01-701	EA	SEAT/COVER ASSMBLY - WHITE	2464162
25	131932-02-702	EA	PEDAL PACKAGE(WHITE)	2082162

CONTACT WINNEBAGO PART SALES FOR UNLISTED COMPONENT

WATER & SEWAGE GROUP (CONTINUED)
COMPONENT PARTS FOR DRAINAGE SYSTEM (CONTINUED)

096927-01-02A

KEY	PART NUMBER	U/M	DESCRIPTION	VENDOR NO.
	096927-01-700	EA	SINK STOPPER	M9801
	096927-01-701	EA	TAILPIECE-DRAIN-LAVATORY	M9802

WATER & SEWAGE GROUP (CONTINUED)
WATER SYSTEM

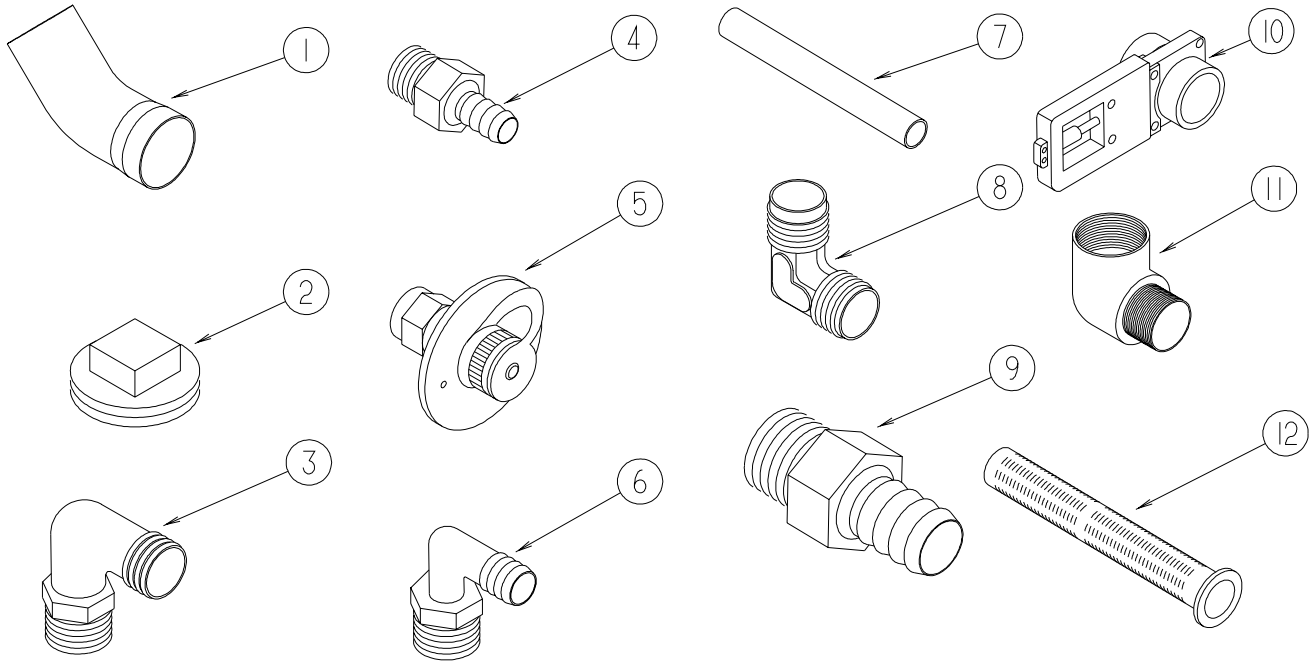

KEY	PART NUMBER	U/M	DESCRIPTION
1	010009-01-000	EA	ELBOW - 90 DEGREE - 1/4 BEND - 1 1/2" PLASTIC
2	010166-01-000	EA	PLUG/THREADED - 1 1/4"MPT - PLASTIC - BLACK - UL
3	010219-01-000	EA	ELBOW - 1 1/4 MPT X 1 1/4 BARB - WATER FILL - PLASTIC
4	010224-01-000	EA	ADAPTER - HOSE TO PIPE - 3/8 MPT X 3/8 BARB - PLASTIC
5	010230-06-000	EA	FILL - CITY WATER - W/CHECK VALVE - MPT - BRUSHED ALUM
6	035539-01-000	EA	ELBOW - 3/8 MPT X 3/8 BARB - PLASTIC
7	039800-04-000	FT	TUBING - POLYBUTYL - 1/4"OD
7	074462-02-000	FT	TUBING - VINYL - 3/8 ID X 20' - CLEAR
7	112176-01-000	FT	TUBING - VINYL - REINFORCED - 1/2" ID
7	124188-01-000	FT	TUBING - PEX - 1/2" ID X 20' - BLUE(COLD)
7	124188-02-000	FT	TUBING - PEX - 1/2" ID X 20' - RED(HOT)
8	039808-03-000	EA	ELBOW - 1/2" MPT X 1/2" MPT - PLASTIC
9	044927-01-000	EA	ADAPTER - HOSE TO PIPE-1 1/4 MPTX1 1/4 BARB-BLACK PLASTIC
10	062421-03-000	EA	VALVE/DUMP W/O HANDLE - 1 1/2" X 1 1/2" HUB
11	065318-02-000	EA	ELBOW - 90 DEGREE - 3/8" MPT TO 3/8" FPT
12	077954-02-000	EA	FILTER - WATER TANK - W/SCREEN IN TANK

WATER & SEWAGE GROUP (CONTINUED)
WATER SYSTEM (CONTINUED)

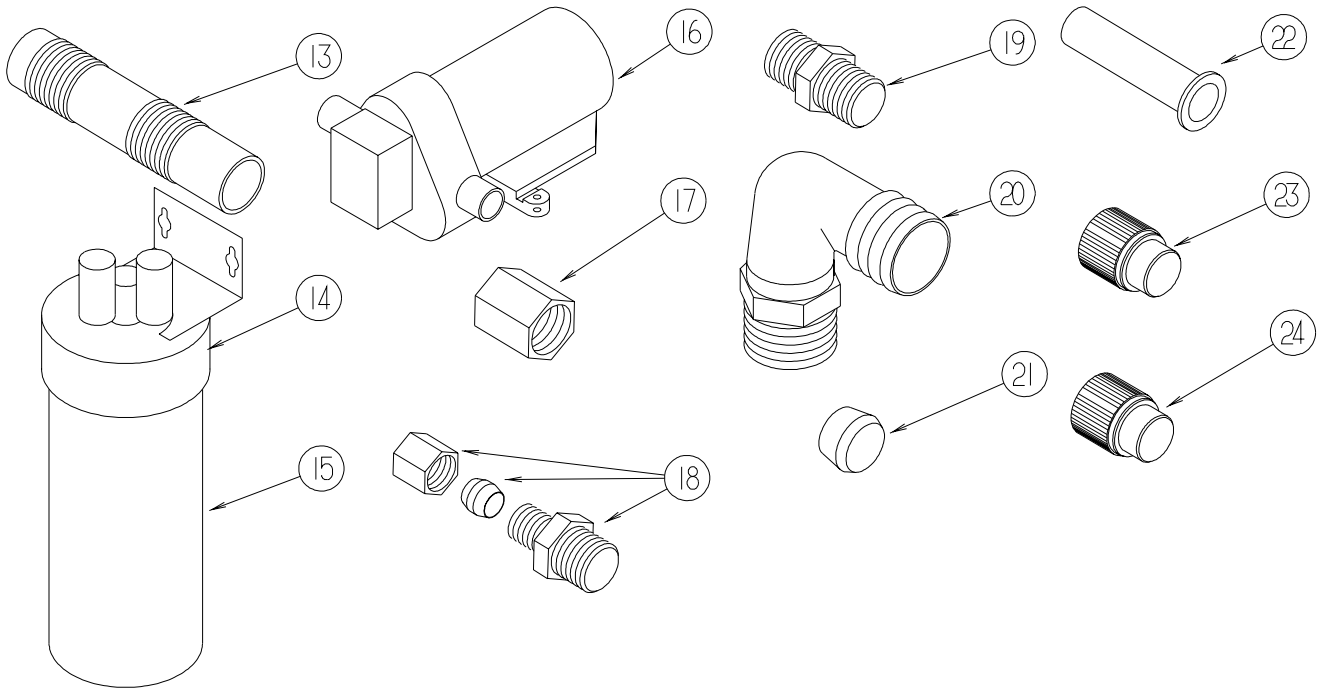

KEY	PART NUMBER	U/M	DESCRIPTION
13	079381-01-000	FT	TUBING - RIBBED FLEXIBLE - WATER FILL - 1.4" ID
14	087200-01-000	EA	FILTER-WATER PURIFICATION, EVERPURE QC2-AC
15	087200-02-000	EA	CARTRIDGE-WATER FILTER, AC - EVERPURE 9601-11
16*	098607-01-000	EA	PUMP - WATER - W/.5" MPT FITTING - FLOW 2.8 GPM
17	101814-01-000	EA	COUPLING - FEMALE - 1/2" X 1/2" FPT - GRAY
18	103798-01-000	EA	CONNECTOR - 1/4 OD X 3/8 MPT
19	110438-02-000	EA	VALVE - CHECK - BRASS - 1/2 MPT X 1/2 MPT
20	111223-02-000	EA	ELBOW - 1/2" MPT X 3/8" BARB - PLASTIC
20	111223-03-000	EA	ELBOW - 3/4" MPT X 1/2" BARB - PLASTIC
20	111223-04-000	EA	ELBOW - 1/2" MPT X 1/2" BARB - PLASTIC
21	111888-01-000	EA	FERRULE - PLASTIC - .250 ID X .375 OD
22	111888-02-000	EA	INSERT - BRASS - 1/4 COMP
23	113697-01-000	EA	CAP - 3/8"P
24	114427-01-000	EA	CAP - 1/2"P

WATER & SEWAGE GROUP (CONTINUED)
WATER SYSTEM (CONTINUED)

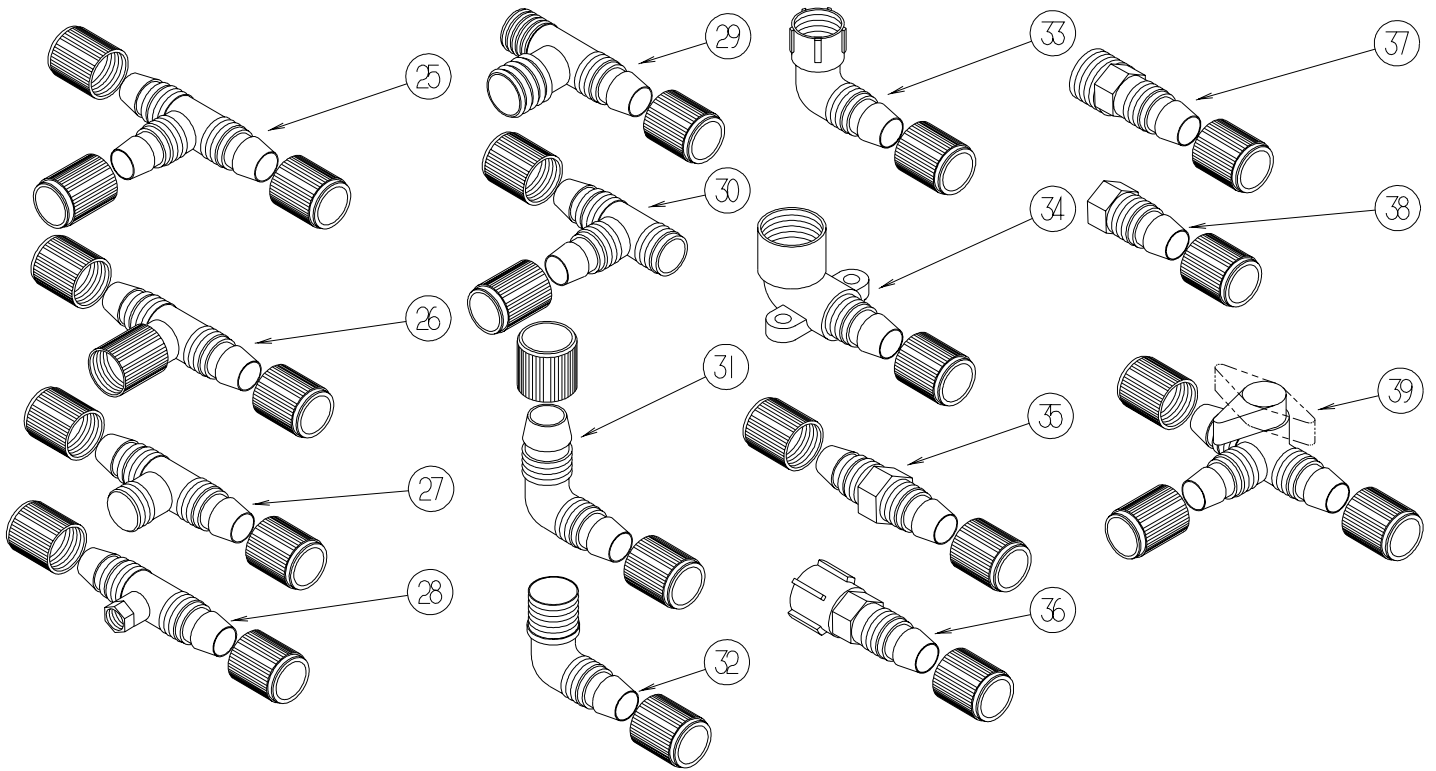

KEY	PART NUMBER	U/M	DESCRIPTION
25	114428-01-000	EA	TEE - 1/2"P X 1/2"P X 1/2"P
26	114428-02-000	EA	TEE - SWIVEL - 1/2"P X 1/2"P X 1/2"FPT
27	114428-03-000	EA	TEE - 1/2"P X 1/2"P X 1/2"MPT
28	114428-04-000	EA	TEE - 1/2"P X 1/2"P X 1/8"FPT
29	114428-06-000	EA	TEE - 1/2" P X 1/2" MPT X 1/2" MPT
30	114428-07-000	EA	TEE - 1/2" P X 1/2" MPT X 1/2" P
31	114429-01-000	EA	ELBOW - 1/2"P X 1/2"P
32	114429-02-000	EA	ELBOW - 1/2"P X 1/2"MPT
32	114429-04-000	EA	ELBOW - 1/2"P X 3/8"MPT
32	114429-05-000	EA	ELBOW - 1/2"P X 3/4"MPT
33	114429-03-000	EA	ELBOW - SWIVEL - 1/2"P X 1/2"FPT
33	114429-06-000	EA	ELBOW - SWIVEL - 1/2"P X 3/4"FPT
33	114429-08-000	EA	ELBOW - SWIVEL - 1/2"P X 1/2"FPT
34	114429-09-000	EA	ELBOW - 1/2"P X 1/2"FPT DROP EAR
35	114430-01-000	EA	ADAPTER - 1/2"P X 1/2"P
36	114430-02-000	EA	ADAPTER - SWIVEL - 1/2"P X 1/2"FPT
37	114430-03-000	EA	ADAPTER - 1/2"P X 1/2"MPT
38	114430-06-000	EA	ADAPTER - 1/2"P X 3/8"FPT
39	114431-01-000	EA	VALVE - 180 DEGREE/CENTER DRAIN - 1/2"P - THREE WAY

WATER & SEWAGE GROUP (CONTINUED)
WATER SYSTEM (CONTINUED)

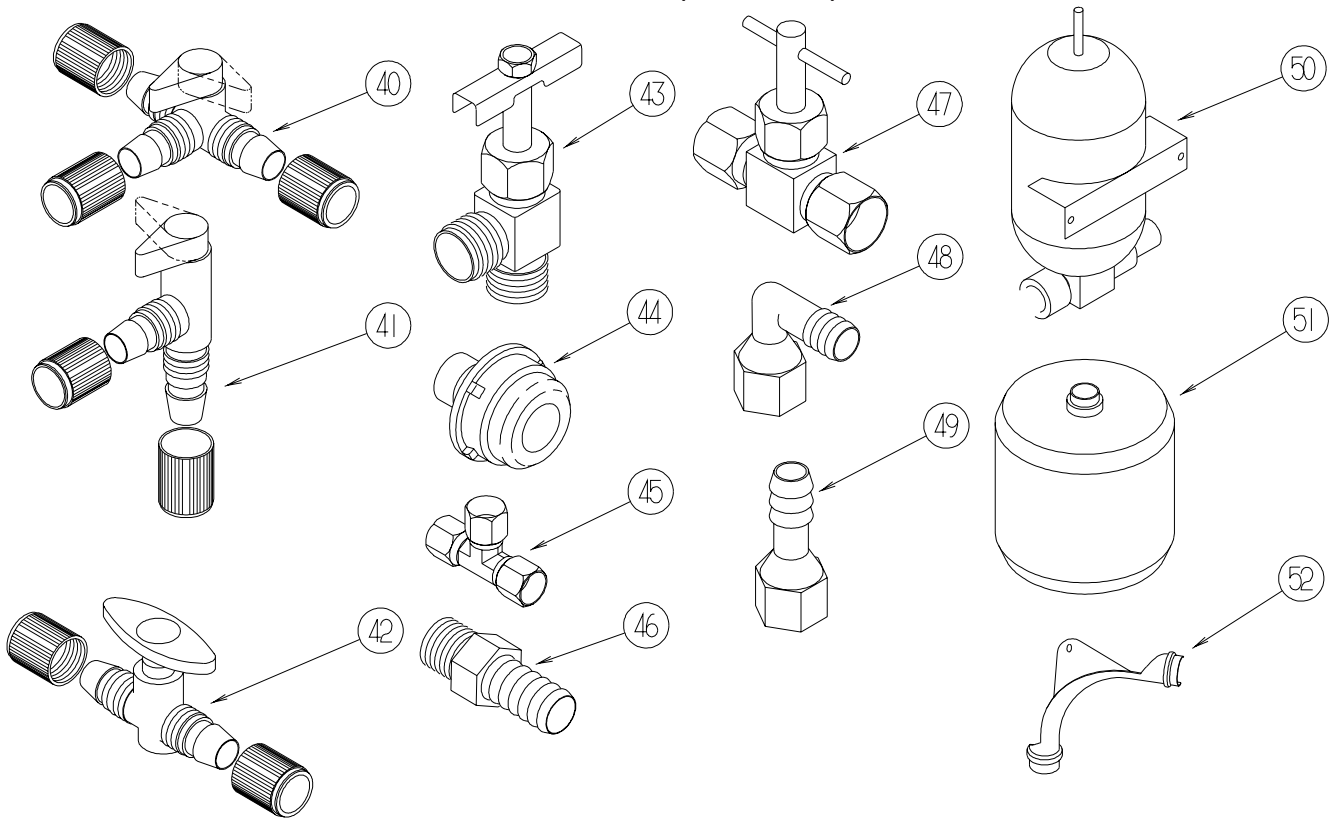

KEY	PART NUMBER	U/M	DESCRIPTION
40	114431-02-000	EA	VALVE - WATER BYPASS - 1/2"P - THREE WAY (WATER HEATER)
41	114431-03-000	EA	VALVE - 90 DEGREE DRAIN - 1/2"P
42	114431-04-000	EA	VALVE - "INLINE SHUT-OFF" - 1/2"P
43	114431-05-000	EA	VALVE - NEEDLE - 1/8" MPT X 1/4" COMPRESSION (ICE MAKER)
44	114966-01-000	EA	FILTER - IN LINE - TWIST ON - 1/2"
45	118423-01-000	EA	FITTING - BRASS-TEE - 1/4C X 1/4C X 1/4C
46	118809-02-000	EA	ADAPTER - 1/2" MPT X 1/2" BARB - PLASTIC
47	120868-01-000	EA	VALVE - NEEDLE - 1/4" COMPRESSION X 1/4" COMPRESSION
48	123150-01-000	EA	ELBOW - 1/2 FPT X 1/2 BARB - SWIVEL
49	123152-01-000	EA	ADAPTER - 1/2 FPT X 1/2 BARB - SWIVEL
50	123243-01-000	EA	TANK - ACCUMULATOR - 24 OZ
51	123317-01-000	EA	TANK - ACCUMULATOR - 2 GALLON
52	124184-01-000	EA	SUPPORT - WATER LINE - BEND

WATER & SEWAGE GROUP (CONTINUED)
WATER SYSTEM (CONTINUED)

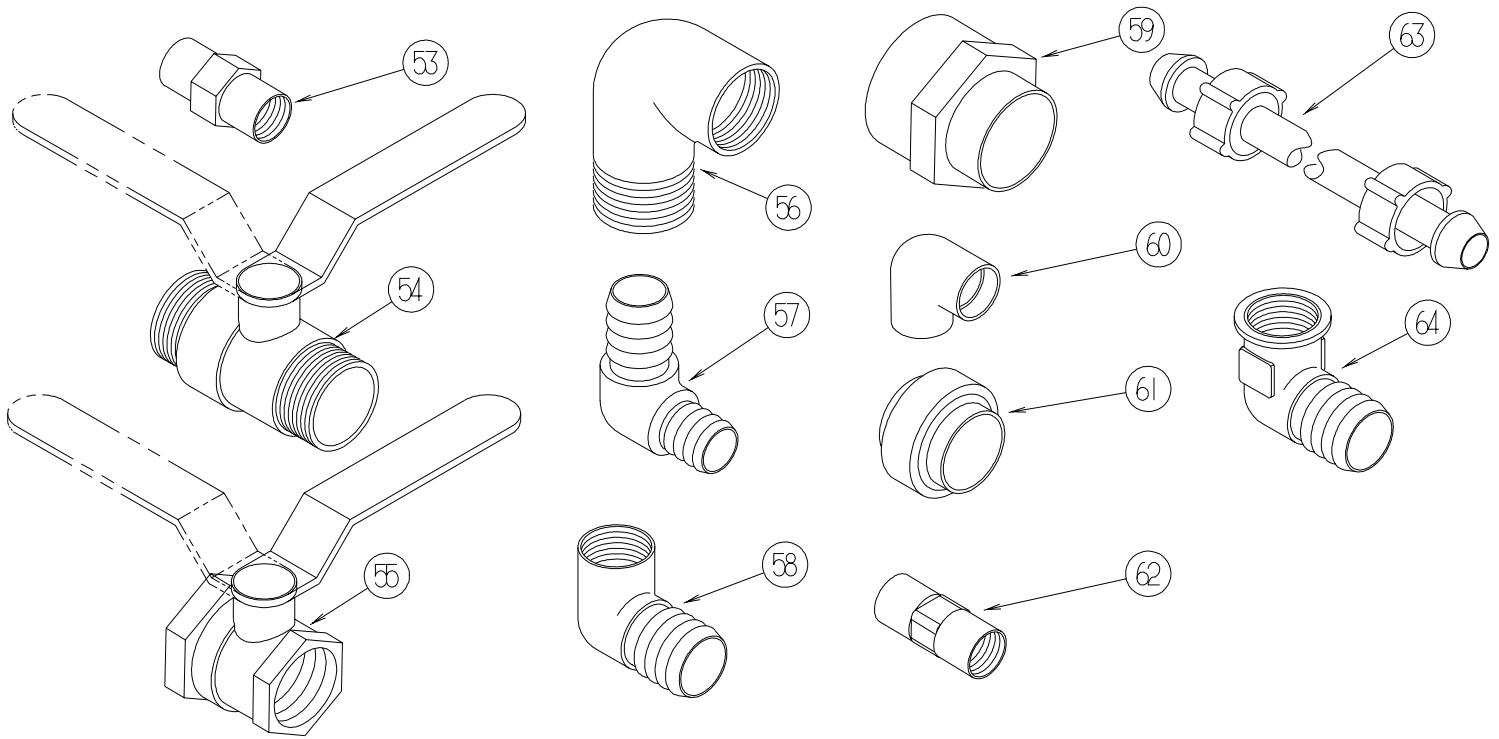

KEY	PART NUMBER	U/M	DESCRIPTION
53	132148-01-000	EA	CONNECTOR - 1/2" X 1/2"MPT - BRASS
54	132483-01-000	EA	VALVE/BALL - 1" - THREADED ENDS
55	132483-02-000	EA	VALVE/BALL - 1/2" - BRASS - FPT
56	132484-01-000	EA	ELBOW - 90 DEGREE - 1MPT X 1FPT - PLASTIC
57	132781-01-000	EA	ELBOW - 1.3" BARB X 1.3" BARB - 90 DEGREE - PLASTIC
58	132782-01-000	EA	ELBOW - 1"FPT X 1.3" BARB - 90 DEGREE - PLASTIC
59	133835-01-000	EA	ADAPTER - REDUCING - 1 1/2" X 1 1/4"
60	133837-01-000	EA	ELBOW - 1 1/2" X 90 DEGREE - DOUBLE SLIP
61	133889-01-000	EA	UNION - 1 1/2 DOUBLE SLIP - PVC
62	135386-01-000	EA	NIPPLE - 1/2"
63	140821-01-000	EA	TUBE - WATER SUPPLY - 3/8" X 24"
63	140821-02-000	EA	TUBE - WATER SUPPLY - 3/8" X 30"
63	140821-03-000	EA	TUBE - WATER SUPPLY - 3/8" X 36"
63	140821-04-000	EA	TUBE - WATER SUPPLY - 3/8" X 48"
63	140821-05-000	EA	TUBE - WATER SUPPLY - 3/8" X 54"
63	140821-06-000	EA	TUBE - WATER SUPPLY - 3/8" X 60"
63	140821-07-000	EA	TUBE - WATER SUPPLY - 3/8" X 72"
64	142812-01-000	EA	ELBOW - BRASS - 1/2"MPT X 1/2"FPT

***COMPONENT PARTS LISTED LATER IN THIS GROUP**

WATER & SEWAGE GROUP (CONTINUED)
WATER SYSTEM (CONTINUED)

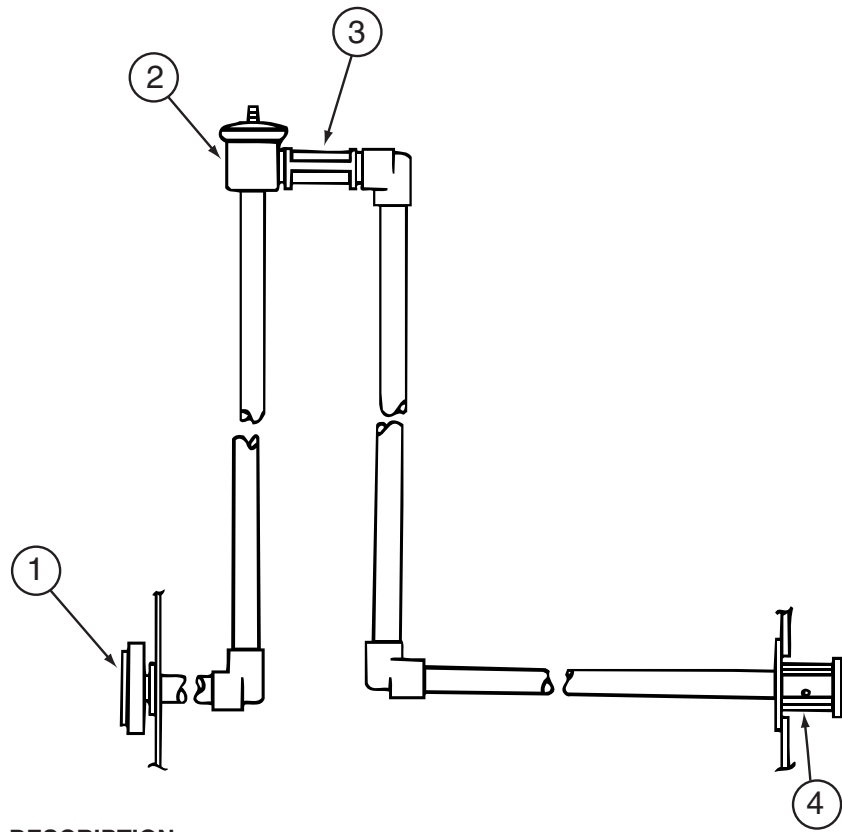

KEY	PART NUMBER	U/M	DESCRIPTION
1	125697-05-000	EA	INLET - WATER - FLUSHING SYSTEM
2	125697-04-000	EA	BREAKER - VACUUM - FLUSHING SYSTEM
3	125697-03-000	EA	CHECK VALVE - FLUSHING SYSTEM
4	125697-02-000	EA	NOZZLE - WELD-A-FLUSH
	125697-06-000	EA	INSTRUCTIONS - USER - FLUSHING SYSTEM

WATER & SEWAGE GROUP (CONTINUED)
WATER SYSTEM (CONTINUED)

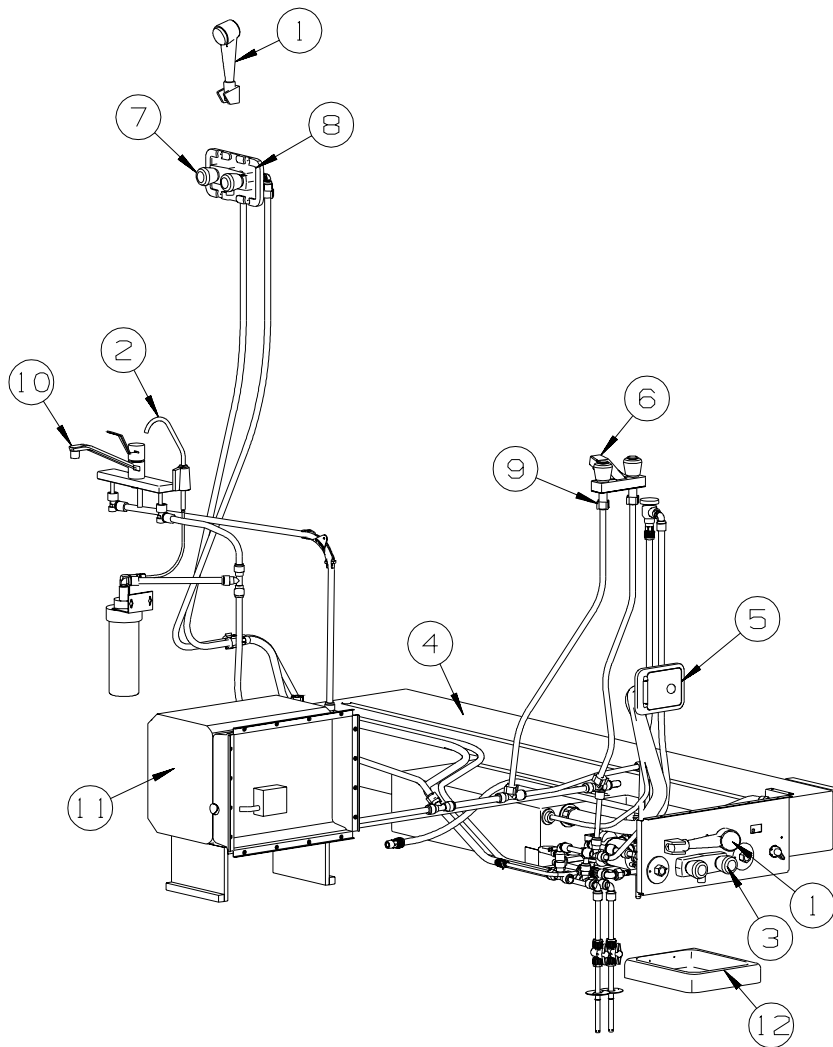

KEY	PART NUMBER	U/M	DESCRIPTION
1	131383-01-02A	EA	SHOWER HEAD - W/60" HOSE & BRACKET - WHITE - USA
1	131383-02-02A	EA	SHOWER HEAD - W/60" HOSE & BRACKET - CSA - WHITE - CANADIAN
2	103635-01-000	EA	FAUCET - SINGLE CONTROL/DRINKING WATER
3*	075241-06-000	EA	FAUCET - SHOWER/BRIGHT WHITE - .5" MPT W/1.9" INLET PIPES
4	142250-02-01A	EA	TANK - WATER - W/FITTINGS
	042989-03-000	EA	FITTING - SPINWELD - 1 1/4"NPT - PLASTIC
	042989-04-000	EA	FITTING - SPINWELD - 3/8"FPT - PLASTIC
	042989-05-000	EA	FITTING - SPINWELD - 1/2"FPT - PLASTIC
	042989-08-000	EA	FITTING - SPINWELD - 1"FPT - PLASTIC
	049032-01-000	EA	PATCH - SPINWELD - 3/8" - PLASTIC
	142250-01-01A	EA	TANK - WATER - W/O FITTINGS
5	137169-01-01A	EA	WATER FILL/GRAVITY - W/DOOR - W/O LOCK - BRIGHT WHITE
	138290-03-000	EA	CASE - W/CAM - W/O CYLINDER/KEY
6*	075240-05-000	EA	FAUCET - LAVATORY/BRASS
7*	075241-04-000	EA	FAUCET - SHOWER/BRASS
8	075606-03-000	EA	PANEL - FAUCET SHOWER - SOFT WHITE
9	091253-01-000	EA	GASKET - FAUCET - LAVATORY/GALLEY
10*	141432-01-01A	EA	FAUCET - GALLEY - SINGLE CONTROL
11*	051391-07-000	EA	WATER HEATER/MOTOR AID-GAS/ELECT IGN - GCH6A-9E - 6 GAL
11*	051391-07-000	EA	WATER HEATER/MOTOR AID-GAS/ELECT IGN - GCH6A-9E - 6 GAL
11	052009-06-000	EA	DOOR - WATER HEATER - BRIGHT WHITE - 18" X 14.6"
12	114293-01-02B	EA	PAN - DRIP - EXTERIOR - OFF WHITE

***COMPONENT PARTS LISTED LATER IN THIS GROUP**

WATER & SEWAGE GROUP (CONTINUED)
COMPONENT PARTS FOR WATER SYSTEM

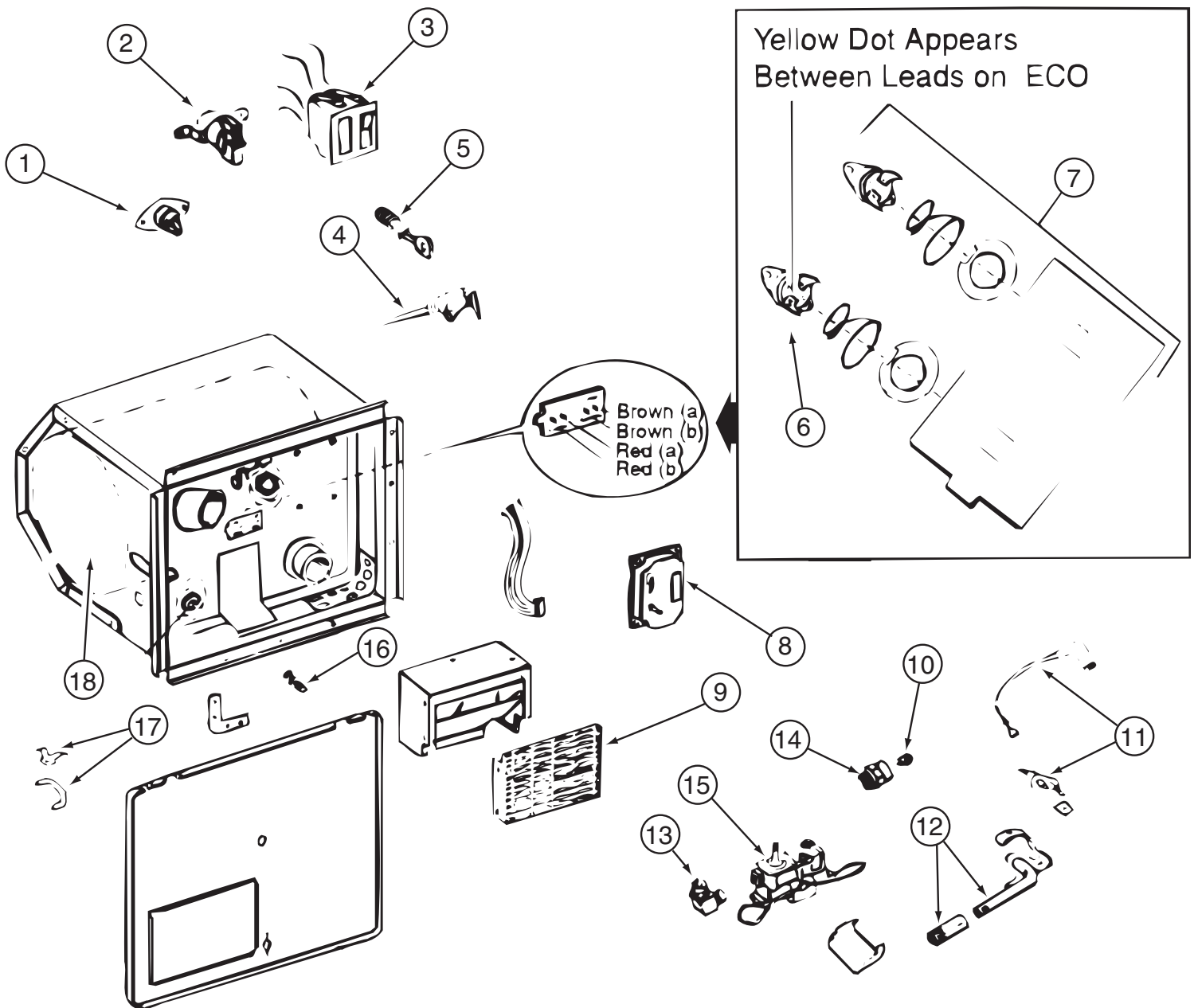

051391-03-000

KEY	PART NUMBER	U/M	DESCRIPTION	VENDOR NO.
3	051393-01-701	EA	SWITCH - REMOTE - W/LIGHT	91959
4	051391-01-704	EA	VALVE-RELIEF, 1/2" FITTING	91604
5	051391-01-705	EA	FASTENER-CAMLOCK	92609
6	051391-04-701	EA	THERMOSTAT 12V DC-120 PRESET	91470
7	051393-01-721	EA	THERMOSTAT W/ECO, 140 FRT MT	91447
9	051391-04-707	EA	KIT-EXHAUST, (FLUE & GASKET)	90960
10	051391-01-710	EA	ORIFICE-MAIN BURNER	92742
12	051391-04-703	EA	BURNER-MAIN/ELECTRONIC	91638
13	051391-01-714	EA	FITTING-ELBOW 45,3/8F X 3/8	MPT 1044
14	051391-03-700	EA	HOLDER-ORIFICE	91563
16	051391-01-715	EA	PLUG-DRAIN, 1 EA = 2 PER PKG	91857
17	051391-01-700	EA	HINGE KIT, (PIN & CLIP)	92568&92559
18	051391-04-706	EA	TANK-INNER,G6A-4E&6E FRT. MT	91641
	051391-01-717	EA	GRILLE-WATER HEATER DOOR	92640
	051393-01-723	EA	SWITCH - THERMAL CUTOUT 2/PK	93866
	051393-01-724	EA	BOARD-CIRCUIT,SPADE TERMINAL	93865
	051393-01-725	EA	ELECTRODE-SGL SPADE CONNECT.	93868
	051393-01-726	EA	VALVE-SOLENOID, W/O BRACKET	93870
	111129-01-711	EA	BRACKET-CORNER, SET OF FOUR	91928

CONTACT WINNEBAGO PARTS SALES FOR UNLISTED COMPONENTS

WATER & SEWAGE GROUP (CONTINUED)
COMPONENT PARTS FOR WATER SYSTEM (CONTINUED)

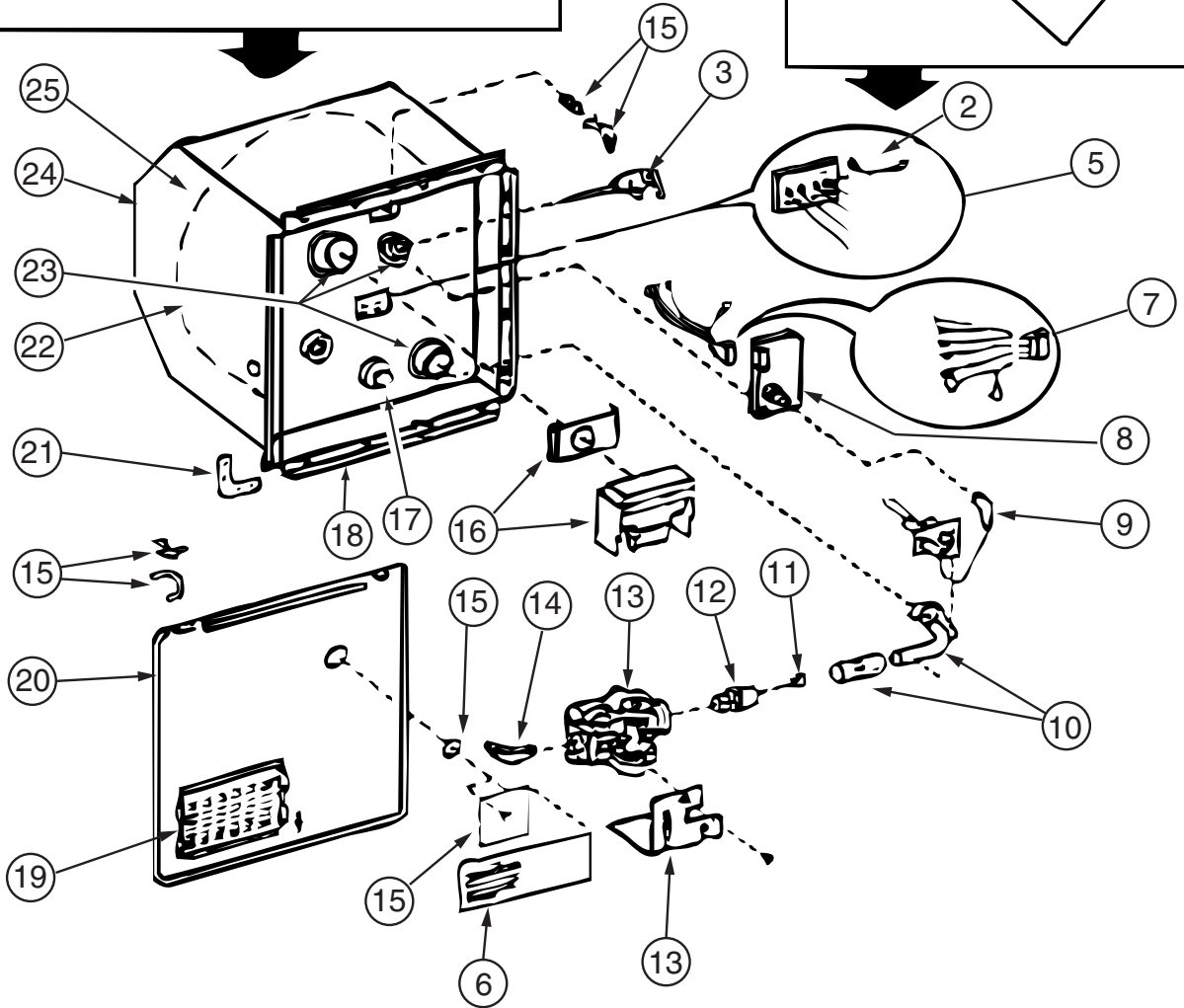
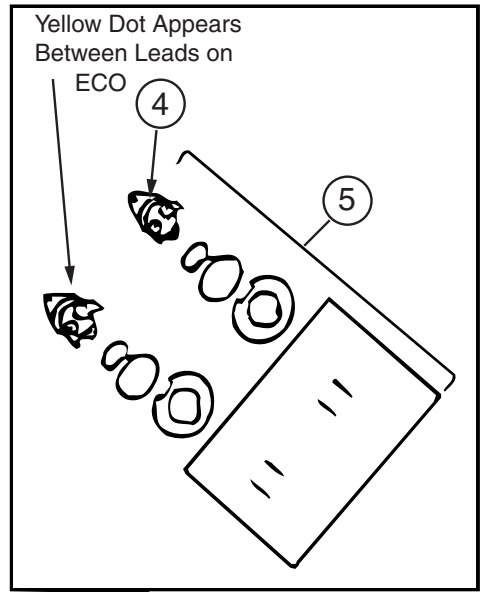
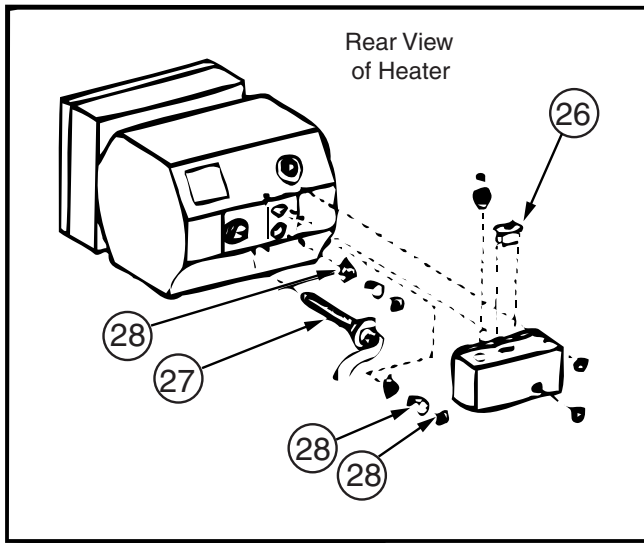

051391-07-000

WATER & SEWAGE GROUP (CONTINUED)
COMPONENT PARTS FOR WATER SYSTEM (CONTINUED)

051391-07-000 (CONTINUED)

KEY	PART NUMBER	U/M	DESCRIPTION	VENDOR NO.
1	051393-01-701	EA	SWITCH - REMOTE - W/LIGHT	91959
2	051393-01-723	EA	SWITCH - THERMAL CUTOUT 2/PK	93866
3	051391-01-704	EA	VALVE-RELIEF, 1/2" FITTING	91604
4	051391-04-701	EA	THERMOSTAT 12V DC-120 PRESET	91470
5	051393-01-721	EA	THERMOSTAT W/ECO, 140 FRT MT	91447
9	051393-01-725	EA	ELECTRODE-SGL SPADE CONNECT.	93868
10	051391-04-703	EA	BURNER-MAIN/ELECTRONIC IG	91638
11	051391-01-710	EA	ORIFICE-MAIN BURNER	92742
12	051391-03-700	EA	HOLDER-ORIFICE	91563
13	051393-01-726	EA	VALVE-SOLENOID, W/O BRACKET	93870
15	051391-05-703	EA	HARDWARE KIT-DOOR	91858
16	051391-04-707	EA	KIT-EXHAUST, (FLUE & GASKET)	90960
17	051391-01-715	EA	PLUG-DRAIN, 1 EA = 2 PER PKG	91857
19	051391-01-717	EA	GRILLE-WATER HEATER DOOR	92640
21	111129-01-711	EA	BRACKET-CORNER, SET OF FOUR	91928
22	051391-07-701	EA	TANK-INNER W/JACKET/INSUL	91592
26	051391-07-700	EA	SWITCH ON/OFF - 110 VAC	92857
27	051391-05-706	EA	ELEMENT-HEATING 1500 WATT	91160 W/GASKET
28	051391-05-707	EA	THERMOSTAT & ECO - 110 VOLT	91873
			CONTACT WINNEBAGO PART SALES FOR UNLISTED COMPONENT	

075240-05-000

KEY	PART NUMBER	U/M	DESCRIPTION	VENDOR NO.
	075240-05-700	EA	CARTRIDGE - WASHERLESS	9-P42

075241-04-000, 075241-05-000, 075241-06-000

KEY	PART NUMBER	U/M	DESCRIPTION	VENDOR NO.
	075240-05-700	EA	CARTRIDGE - WASHERLESS	9-P42

141432-01-01A

KEY	PART NUMBER	U/M	DESCRIPTION	VENDOR NO.
	135027-01-705	EA	CARTRIDGE F/SGL LEVER FAUCET,	1225

WINDOW & VENTS GROUP

WINDOW & VENT LAYOUT

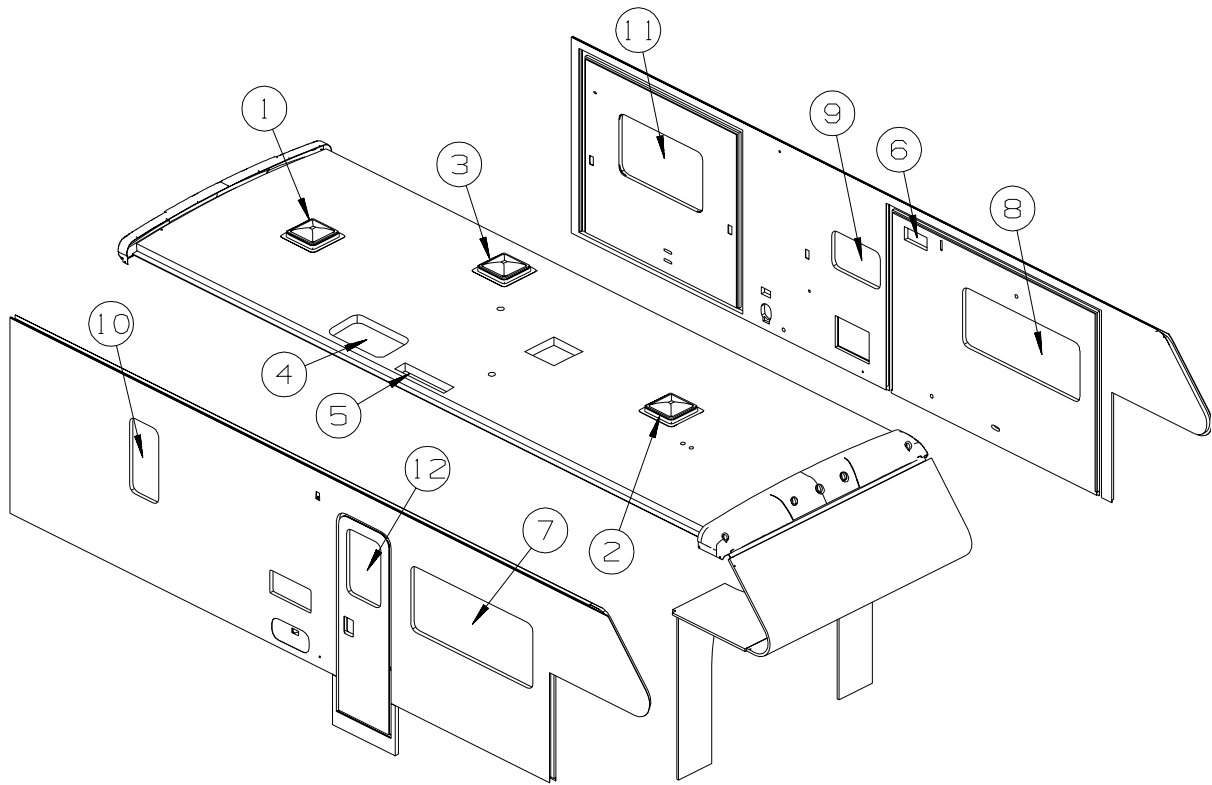

KEY	PART NUMBER	U/M	DESCRIPTION
1*	122882-01-01A	EA	VENT - ROOF - NONPOWERED - W/O INSIDE GARNISH
	009440-01-000	EA	GEAR/ARM - LIFT - ROOF VENT COVER
1	122882-07-01A	EA	GARNISH - ROOF VENT - 2.5" TO 4.1"
1*	123780-11-01A	EA	FANTASTIC VENT-4"ROOF-DBL DOME-W/O FAN/THERM/PWR LIFT - COMFORT PLUS PKG.
	009440-01-000	EA	GEAR/ARM - LIFT - ROOF VENT COVER
2*	122882-01-01A	EA	VENT - ROOF - NONPOWERED - W/O INSIDE GARNISH
	009440-01-000	EA	GEAR/ARM - LIFT - ROOF VENT COVER
2	122882-07-01A	EA	GARNISH - ROOF VENT - 2.5" TO 4.1"
2*	123780-03-01A	EA	FANTASTIC VENT-3"/4"ROOF-W/FAN-W/O THERM/PWR LIFT/WHT CVR - POWER VENTILAT
	009440-01-000	EA	GEAR/ARM - LIFT - ROOF VENT COVER
2*	123780-09-01A	EA	FANTASTIC VENT-4"ROOF- W/FAN/DBL DOME-W/O THERM/PWR LIFT - COMFORT PLUS PKG.
	009440-01-000	EA	GEAR/ARM - LIFT - ROOF VENT COVER
3*	122882-02-01A	EA	VENT - ROOF - W/FAN - W/O INSIDE GARNISH - UL - U.S. POWER VENT
3*	122882-03-01A	EA	VENT - ROOF - W/FAN - W/O INSIDE GARNISH - CSA - CANADIAN POWER VENT
	009440-01-000	EA	GEAR/ARM - LIFT - ROOF VENT COVER
	048648-01-000	EA	MOTOR/ROOF VENT - W/RESISTER - 1/8 SHAFT - 12VOLT
	048649-01-000	EA	FAN BLADE - ROOF VENT - 6 BLADES - 6"
3	122882-07-01A	EA	GARNISH - ROOF VENT - 2.5" TO 4.1"
3*	123780-09-01A	EA	FANTASTIC VENT-4"ROOF- W/FAN/DBL DOME-W/O THERM/PWR LIFT - COMFORT PLUS PKG.
	009440-01-000	EA	GEAR/ARM - LIFT - ROOF VENT COVER
4	122192-01-02A	EA	PANEL - SKYLITE - OUTER - 18.6" X 30" BASE MEASUREMENTS FROM: 00-00-00 THRU: 04-18-02
4	138379-02-01A	EA	PANEL/SKYLIGHT OTR - RECT/4"H CTR DOME-18.4" X 29.5 - WHT FROM: 04-19-02 THRU: 99-99-99
4	138372-01-12B	EA	TRIM - CORNER - SKYLIGHT - BRIGHT WHITE FROM: 04-19-02 THRU: 12-18-02
4	138372-01-02B	EA	TRIM - CORNER - SKYLIGHT FROM: 12-19-02 THRU: 99-99-99
4	122193-01-02A	EA	PANEL - SKYLITE - INNER
5	084073-04-000	EA	BASE/VENT - ROOF/REFRIGERATOR - BLACK - NORCOLD
5	084073-07-000	EA	CAP - ROOF/REFRIGERATOR VENT - 10" X 32" - BRIGHT WHITE
6	138983-01-01A	EA	VENT - MICROWAVE OUTER - BRIGHT WHITE
6	138983-02-01A	EA	COVER - VENT MICROWAVE OUTER - BRIGHT WHITE FROM: 00-00-00 THRU: 11-11-02
6	138983-03-01A	EA	COVER - VENT MICROWAVE OUTER - BRIGHT WHITE FROM: 11-12-02 THRU: 99-99-99

WINDOW & VENTS GROUP (CONTINUED)
WINDOW & VENT LAYOUT (CONTINUED)

KEY	PART NUMBER	U/M	DESCRIPTION
7*	098647-23-02A	EA	WINDOW - PASS HORIZ SLIDER TINTED W/RETAINER-26.1" X 59.7"
7*	112795-69-01A	EA	WINDOW - PASSENGER HORIZ SLIDER - THERMO - 26.3" X 60" - DUAL PANE
8*	098647-47-02A	EA	WINDOW - DRVR HORIZ SLIDER W/TRIM - TINTED - 57.4" X 23.6"
8*	112795-77-01A	EA	WINDOW - DRVR HORIZ SLIDER W/RET. - THERMO - 57.4" X 23.6" - DUAL PANE
9*	098647-07-03A	EA	WINDOW - DRIVER HORIZ SLIDER W/TRIM - TINTED - 15" X 23.7"
9*	112795-84-01A	EA	WINDOW - DRIVER HORIZONTAL SLIDER - THERMO - 27" X 24" - DUAL PANE
10*	098644-07-02A	EA	WINDOW - VERTICAL SLIDER W/TRIM - TINTED - 14" X 30"
10*	112898-22-01A	EA	WINDOW - VERTICAL SLIDER - THERMOPANE - 14.1" X 29.9" - DUAL PANE
11*	113500-09-02A	EA	WINDOW - DOUBLE TIPOUT ESCAPE - TINTED - 27.2" X 12.3"
11*	129929-12-01A	EA	WINDOW - TIPOUT/THERMO/ESCAPE W/RETAINER - 24.4" X 41.3" - DUAL PANE
12	117053-02-F36	EA	WINDOW - PICTURE - 60% TINTING - 26.4" X 17"
	002181-25-000	EA	GLASS - PICTURE WINDOW - 25.8"W X 16.4"H
	087561-01-000	FT	SEAL - GLASS - EXTERIOR - .5" WIDE - VINYL BLACK
12	117054-02-02A	EA	RETAINER - TRIM - BRIGHT WHITE
12*	113733-10-01A	EA	WINDOW - STATIONARY - THERMO/EUROPEAN W/RET. - 26.3" X 17" - DUAL PANE

***COMPONENT PARTS LISTED LATER IN THIS GROUP**

WINDOW & VENTS GROUP (CONTINUED)
COMPONENT PARTS FOR WINDOW & VENT LAYOUT

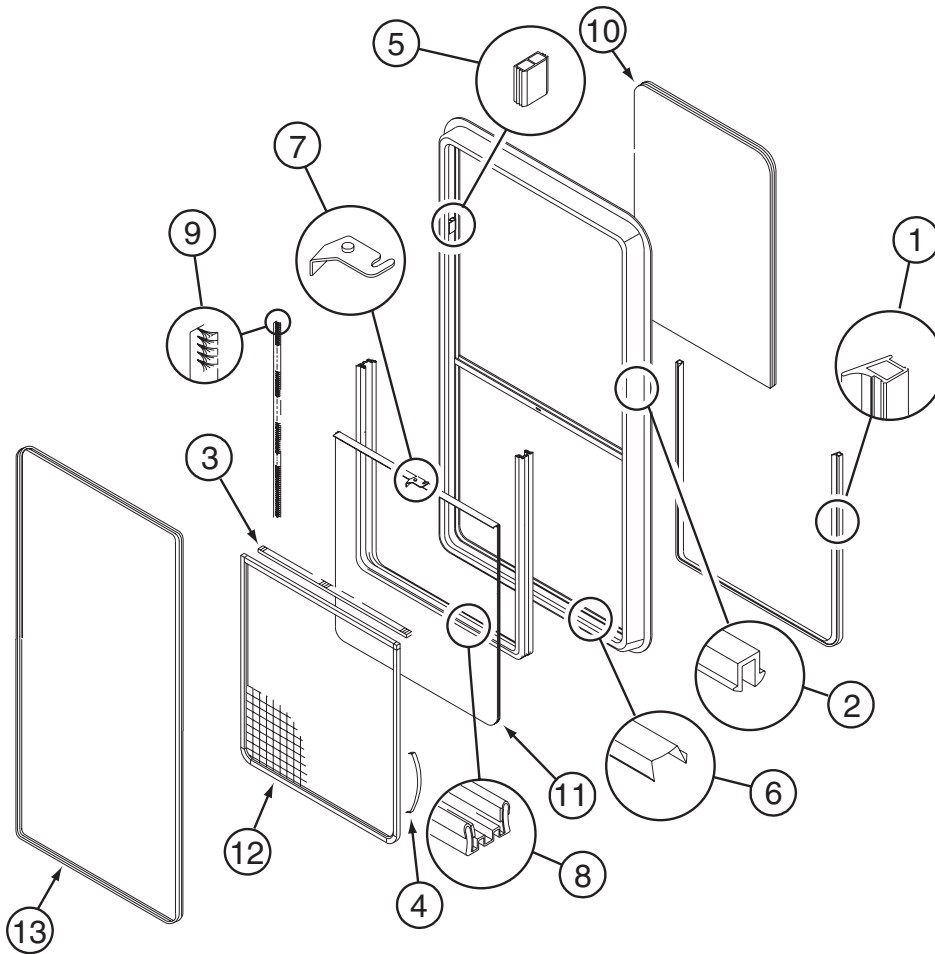

098644-07-02A

KEY	PART NUMBER	U/M	DESCRIPTION	VENDOR NO.
1	098644-01-716	FT	PLUG - FILLER	132-014470
2	098644-01-705	FT	GLAZING - STRIP	132-010231
3	098644-01-706	FT	WEATHERSTRIP - GLASS	171-010668
4	098644-01-713	EA	CLIP - SCREEN - METAL	226-016966
4	125582-01-701	EA	CLIP - SCREEN - PLASTIC	130-005153
5	098644-01-719	EA	STOP - SLIDER GLASS	132-014203
6	098644-01-710	FT	TRACK - SCREEN SPACER 12'	132-017135
7	098644-01-700	EA	LATCH - REPAIR KIT (BLACK)	B801-CK
8	098644-01-708	FT	CHANNEL - RUN PIERCED	122-016543
9	098644-01-711	FT	WEATHERSTRIP - SCREEN BLACK	171-016965
10	098644-07-702	EA	GLASS - STATIONARY	106-015777
11	098644-07-703	EA	GLASS-SLIDING W/SASH & LATCH	H170-G9
12	098644-07-704	EA	SCREEN ASM - W/SEALS & CLIPS	410-018863
13	098644-07-705	EA	RETAINER - TRIM	CH02-66
	098644-01-717	FT	SPLINE - SCREEN	132-004716

WINDOW & VENTS GROUP (CONTINUED)
COMPONENT PARTS FOR WINDOW & VENT LAYOUT (CONTINUED)

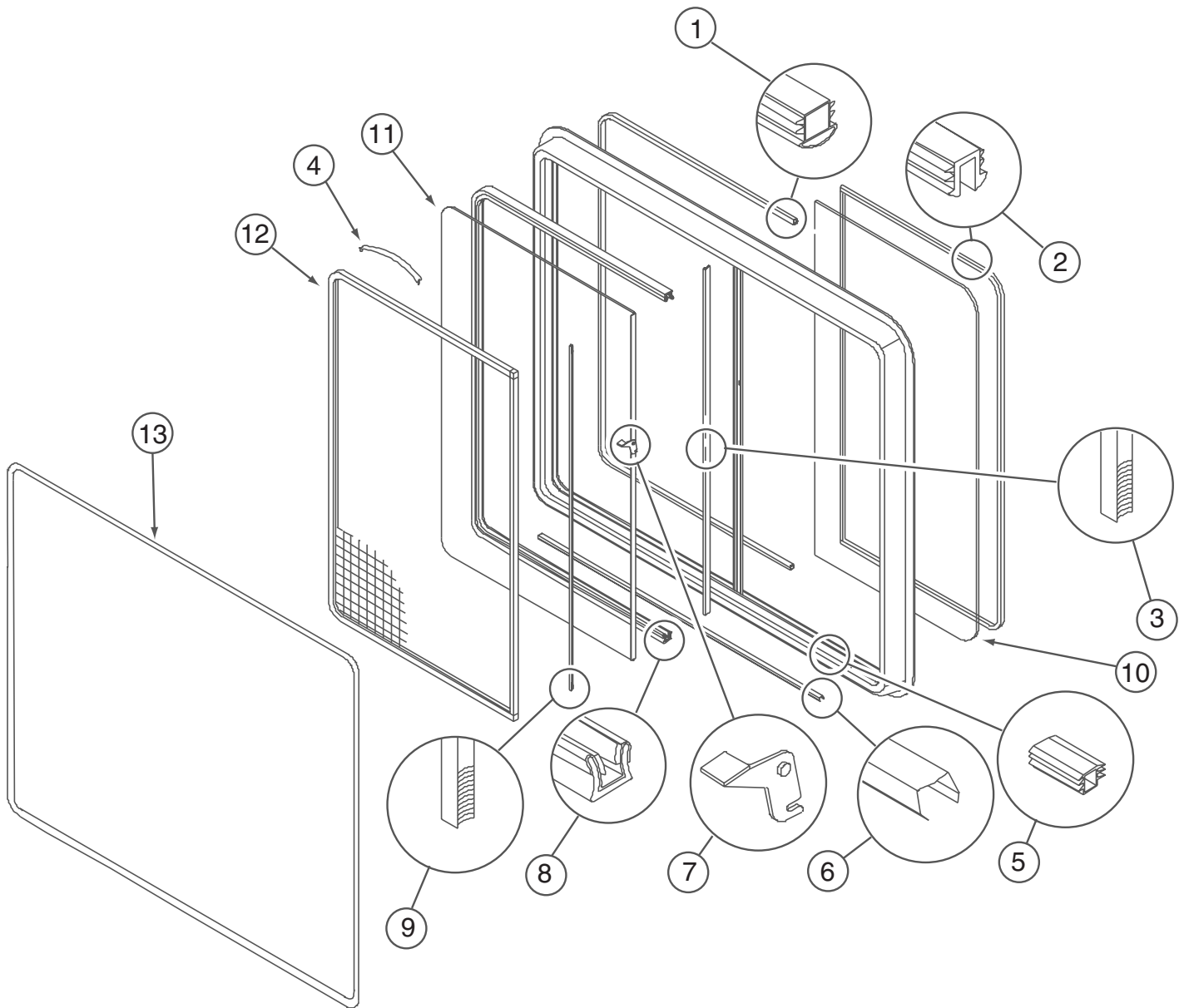

098647-07-03A

KEY	PART NUMBER	U/M	DESCRIPTION	VENDOR NO.
1	098644-01-716	FT	PLUG - FILLER	132-014470
2	098644-01-705	FT	GLAZING - STRIP	132-010231
3	098644-01-706	FT	WEATHERSTRIP - GLASS	171-010668
4	098644-01-713	EA	CLIP - SCREEN - METAL	226-016966
4	125582-01-701	EA	CLIP - SCREEN - PLASTIC	130-005153
5	098644-01-719	EA	STOP - SLIDER GLASS	132-014203
6	098644-01-710	FT	TRACK - SCREEN SPACER 12'	132-017135
7	098644-01-700	EA	LATCH - REPAIR KIT (BLACK)	B801-CK
8	098644-01-708	FT	CHANNEL - RUN PIERCED	122-016543
9	098644-01-711	FT	WEATHERSTRIP - SCREEN BLACK	171-016965
10	098647-06-700	EA	GLASS - STATIONARY 10.9X13.8	106-016921
11	098647-06-702	EA	GLASS-SLIDING W/SASH & LATCH	B969-G9
12	098647-06-703	EA	SCREEN ASM - W/SEALS & CLIPS	410-016477
13	098647-07-701	EA	RETAINER - TRIM	H969-67
	098644-01-717	FT	SPLINE - SCREEN	132-004716

WINDOW & VENTS GROUP (CONTINUED)
COMPONENT PARTS FOR WINDOW & VENT LAYOUT (CONTINUED)

098647-23-02A

KEY	PART NUMBER	U/M	DESCRIPTION	VENDOR NO.
1	098644-01-716	FT	PLUG - FILLER	132-014470
2	098644-01-705	FT	GLAZING - STRIP	132-010231
3	098644-01-706	FT	WEATHERSTRIP - GLASS	171-010668
4	098644-01-713	EA	CLIP - SCREEN - METAL	226-016966
4	125582-01-701	EA	CLIP - SCREEN - PLASTIC	130-005153
5	098644-01-719	EA	STOP - SLIDER GLASS	132-014203
6	098644-01-710	FT	TRACK - SCREEN SPACER 12'	132-017135
7	098644-01-700	EA	LATCH - REPAIR KIT (BLACK)	B801-CK
8	098644-01-708	FT	CHANNEL - RUN PIERCED	122-016543
9	098644-01-711	FT	WEATHERSTRIP - SCREEN BLACK	171-016965
10	098647-23-703	EA	GLASS - STATIONARY	106-017622
11	098647-23-700	EA	GLASS SLIDING W/SASH & LATCH	H287-G9
12	098647-23-704	EA	SCREEN ASM - W/SEALS & CLIPS	410-019066
13	098647-22-701	EA	RETAINER - TRIM	H287-67
	098644-01-717	FT	SPLINE - SCREEN	132-004716

098647-47-02A

KEY	PART NUMBER	U/M	DESCRIPTION	VENDOR NO.
1	098644-01-716	FT	PLUG - FILLER	132-014470
2	098644-01-705	FT	GLAZING - STRIP	132-010231
3	098644-01-706	FT	WEATHERSTRIP - GLASS	171-010668
4	098644-01-713	EA	CLIP - SCREEN - METAL	226-016966
4	125582-01-701	EA	CLIP - SCREEN - PLASTIC	130-0
5	098644-01-719	EA	STOP - SLIDER GLASS	132-014203
6	098644-01-710	FT	TRACK - SCREEN SPACER 12'	132-017135
7	098644-01-700	EA	LATCH - REPAIR KIT (BLACK)	B801-CK
8	098644-01-708	FT	CHANNEL - RUN PIERCED	122-016543
9	098644-01-711	FT	WEATHERSTRIP - SCREEN BLACK	171-016965
10	098647-47-700	EA	GLASS - STATIONARY	106-025224
11	098647-47-701	EA	GLASS-SLIDING W/SASH & LATCH	H493-G9
12	098647-47-702	EA	SCREEN ASM - W/SEALS & CLIPS	410-025226
13	098647-47-704	EA	RETAINER - TRIM	H493-66
	098644-01-717	FT	SPLINE - SCREEN	132-004716

WINDOW & VENTS GROUP (CONTINUED)
COMPONENT PARTS FOR WINDOW & VENT LAYOUT (CONTINUED)

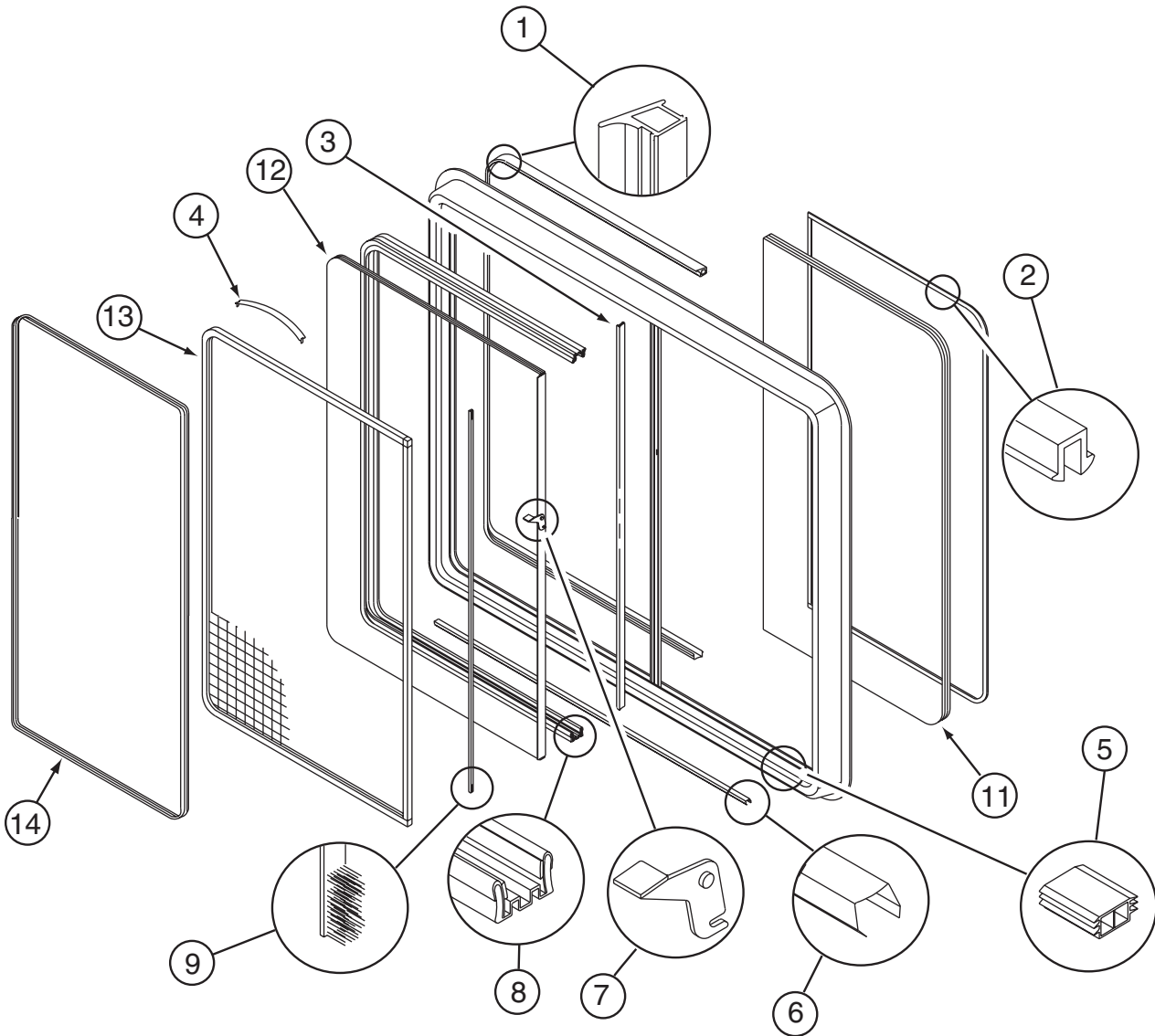

112795-69-01A

KEY	PART NUMBER	U/M	DESCRIPTION	VENDOR NO.
1	112795-01-704	FT	PLUG FILLER (DOUBLE GLAZED)	122-018737
2	112795-01-705	FT	VINYL - GLAZING	132-025736
3	098644-01-706	FT	WEATHERSTRIP - GLASS	171-010668
4	098644-01-713	EA	CLIP - SCREEN - METAL	226-016966
4	125582-01-701	EA	CLIP - SCREEN - PLASTIC	130-005153
	098644-01-717	FT	SPLINE - SCREEN	132-004716
5	112795-01-701	EA	SLIDE-STOP	132-019092
6	098644-01-710	FT	TRACK - SCREEN SPACER 12'	132-017135
7	112795-01-700	EA	LATCH ASM., BLK.,(BOLT ON)	DH287-CK
8	112795-01-703	IN	CHANNEL-RUN (INCHES)	122-018736
9	098644-01-711	FT	WEATHERSTRIP - SCREEN BLACK	171-016965
11	112795-68-700	EA	GLASS - STATIONARY	390-028353
12	112795-68-701	EA	GLASS - SLIDING W/SASH LATCH	390-028353
13	098647-23-704	EA	SCREEN ASSY - W/SEAL & CLIPS	410-019066
14	098647-27-704	EA	RETAINER - TRIM	H287-66

WINDOW & VENTS GROUP (CONTINUED)
COMPONENT PARTS FOR WINDOW & VENT LAYOUT (CONTINUED)

112795-77-01A

KEY	PART NUMBER	U/M	DESCRIPTION	VENDOR NO.
1	112795-01-704	FT	PLUG FILLER (DOUBLE GLAZED)	122-018737
2	112795-01-705	FT	VINYL - GLAZING	132-025736
3	098644-01-706	FT	WEATHERSTRIP - GLASS	171-010668
4	098644-01-713	EA	CLIP - SCREEN - METAL	226-016966
4	125582-01-701	EA	CLIP - SCREEN - PLASTIC	130-005153
5	112795-01-701	EA	SLIDE-STOP	132-019092
6	098644-01-710	FT	TRACK - SCREEN SPACER 12'	132-017135
7	112795-01-700	EA	LATCH ASM., BLK.,(BOLT ON)	DH287-CK
8	112795-01-703	IN	CHANNEL-RUN (INCHES)	122-018736
9	098644-01-711	FT	WEATHERSTRIP - SCREEN BLACK	171-016965
11	112795-77-700	EA	GLASS - STATIONARY	390-28313
12	112795-77-701	EA	GLASS - SLIDING W/SASH LATCH	DH493-G8
13	098647-47-702	EA	SCREEN ASSY - W/SEAL & CLIPS	410-025226
14	098647-47-704	EA	RETAINER - TRIM	H493-66
	098644-01-717	FT	SPLINE - SCREEN	132-004716

112795-84-01A

KEY	PART NUMBER	U/M	DESCRIPTION	VENDOR NO.
1	112795-01-704	FT	PLUG FILLER (DOUBLE GLAZED)	122-018737
2	112795-01-705	FT	VINYL - GLAZING	132-025736
3	098644-01-706	FT	WEATHERSTRIP - GLASS	171-010668
4	098644-01-713	EA	CLIP - SCREEN - METAL	226-016966
4	125582-01-701	EA	CLIP - SCREEN - PLASTIC	130-005153
	098644-01-717	FT	SPLINE - SCREEN	132-004716
5	112795-01-701	EA	SLIDE-STOP	132-019092
6	098644-01-710	FT	TRACK - SCREEN SPACER 12'	132-017135
7	112795-01-700	EA	LATCH ASM., BLK.,(BOLT ON)	DH287-CK
8	112795-01-703	IN	CHANNEL-RUN (INCHES)	122-018736
9	098644-01-711	FT	WEATHERSTRIP - SCREEN BLACK	171-016965
11	112795-78-700	EA	GLASS - STATIONARY	390-028338
12	112795-78-701	EA	GLASS - SLIDING W/SASH LATCH	DB969-G8
13	112795-56-702	EA	SCREEN ASSY - W/SEAL & CLIPS	410-019414
14	112795-56-704	EA	RETAINER - TRIM	390-028338

WINDOW & VENTS GROUP (CONTINUED)
COMPONENT PARTS FOR WINDOW & VENT LAYOUT (CONTINUED)

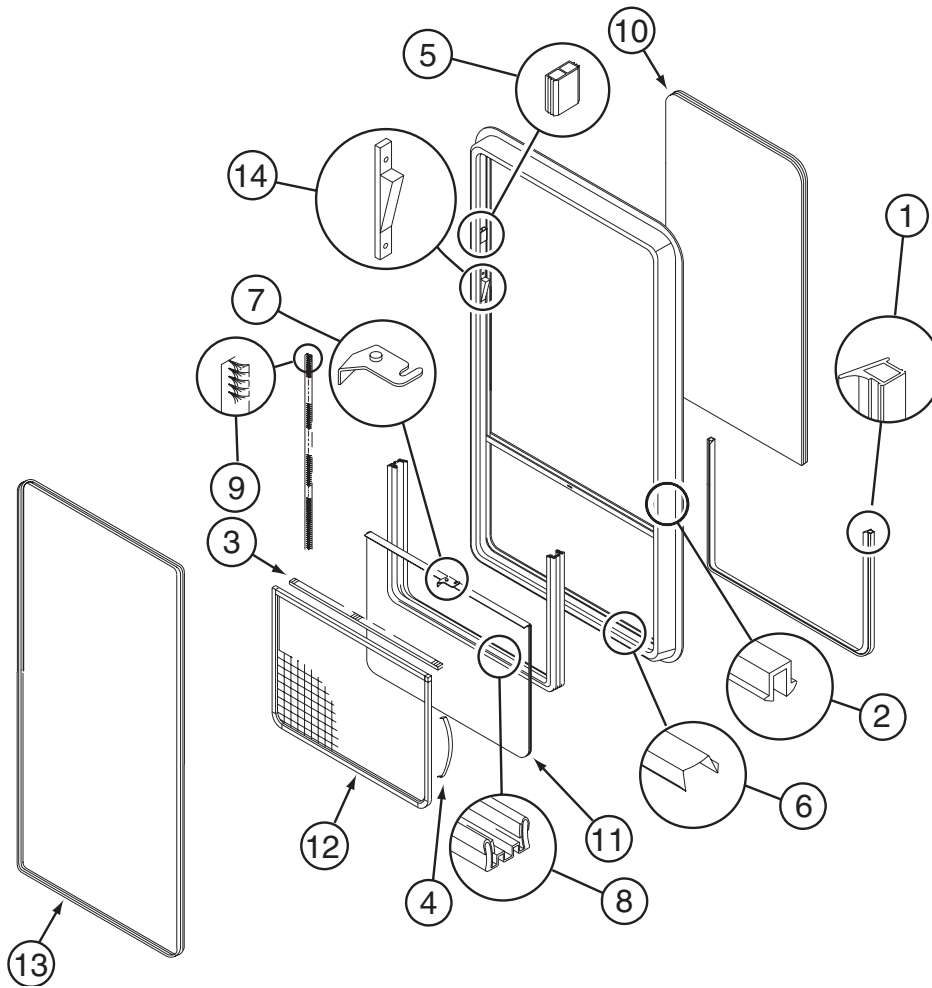

112898-22-01A

KEY	PART NUMBER	U/M	DESCRIPTION	VENDOR NO.
1	112795-01-704	FT	PLUG FILLER (DOUBLE GLAZED)	122-018737
2	112795-01-705	FT	VINYL - GLAZING	132-025736
3	098644-01-706	FT	WEATHERSTRIP - GLASS	171-010668
4	098644-01-713	EA	CLIP - SCREEN - METAL	226-016966
4	125582-01-701	EA	CLIP - SCREEN - PLASTIC	130-005153
5	112795-01-701	EA	SLIDE-STOP	132-019092
6	098644-01-710	FT	TRACK - SCREEN SPACER 12'	132-017135
7	112795-01-700	EA	LATCH ASM., BLK.,(BOLT ON)	DH287-CK
8	112795-01-703	IN	CHANNEL-RUN (INCHES)	122-018736
9	098644-01-711	FT	WEATHERSTRIP - SCREEN BLACK	171-016965
10	112898-22-700	EA	GLASS - STATIONARY	390-028345
11	112898-22-701	EA	GLASS-SLIDING-W/SASH & LATCH	DC02-G8
12	098644-07-704	EA	SCREEN ASM - W/SEALS & CLIPS	410-018863
13	098644-07-705	EA	RETAINER - TRIM	CH02-66
14	112898-04-703	EA	VERTICAL LATCH (SASH KIT)	DH343-CK
	098644-01-717	FT	SPLINE - SCREEN	132-004716

WINDOW & VENTS GROUP (CONTINUED)
COMPONENT PARTS FOR WINDOW & VENT LAYOUT (CONTINUED)

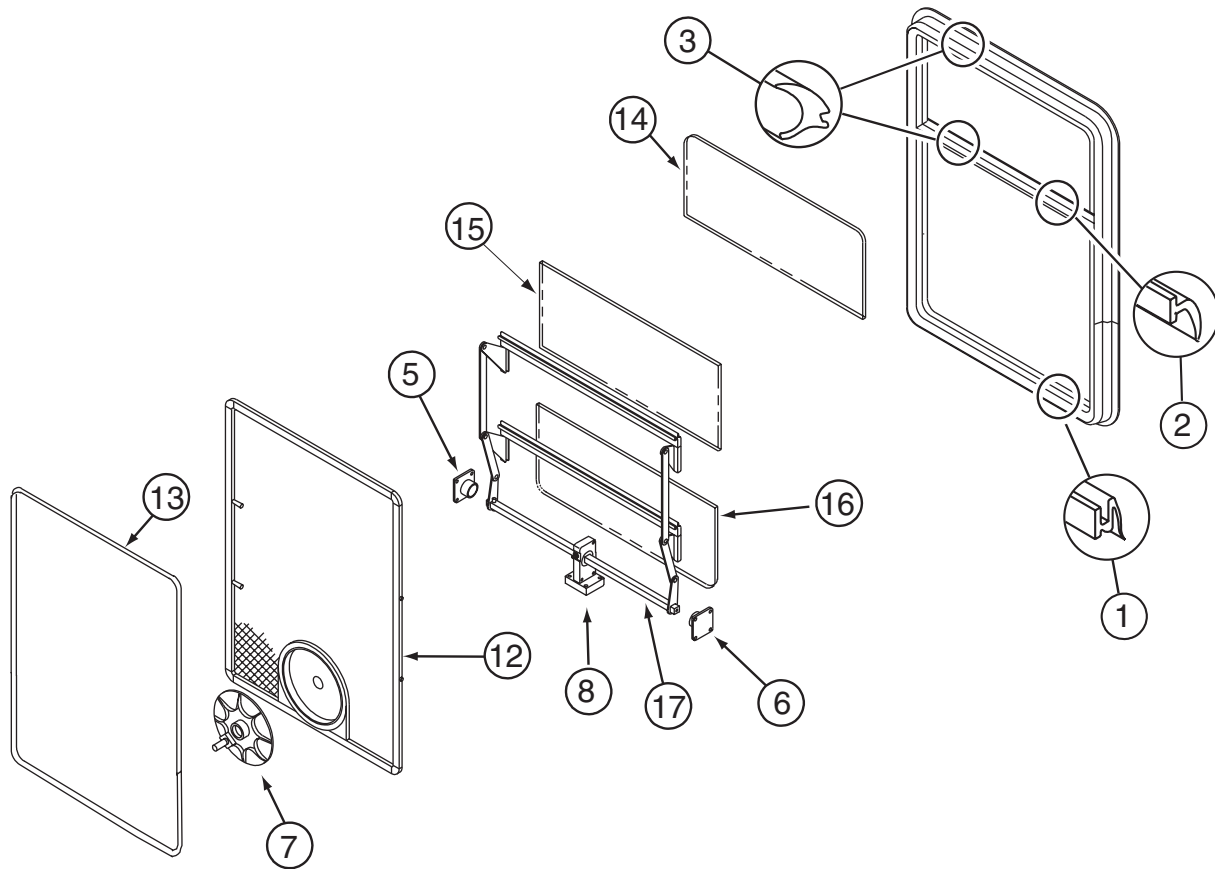

113500-09-02A

KEY	PART NUMBER	U/M	DESCRIPTION	VENDOR NO.
1	116976-01-702	FT	FILLER PLUG	132-016065
2	100322-01-701	FT	SEAL-VENT	122-016071
3	100322-01-702	EA	WEATHERSTRIP-HORIZ RAIL-148"	132-019631
	100322-01-703	FT	VINYL-GLAZING, BUTYL	132-010723
5	100322-01-714	EA	SUPPORT-TORQUE BAR, LH	130-015978
6	100322-01-715	EA	SUPPORT-TORQUE BAR, RH	130-015979
7	100322-01-718	EA	HANDLE-DIAL	410-016081
8	112519-01-702	EA	TORQUE-CTR SUPPORT (4 HOLE)	410-016123
12	113500-09-705	EA	SCREEN - W/SEAL & CLIPS	410-018794
14	113500-09-701	EA	GLASS - STATIONARY	106-018772
15	113500-09-702	EA	GLASS - UPPER VENT ASSEMBLY	CH73G7
16	113500-09-703	EA	GLASS - LOWER VENT ASSEMBLY	CH73G9L
17	113500-09-704	EA	OPERATOR BAR ASSEMBLY	CH73-15L
	112898-06-704	EA	HANDLE-LATCH/RED-RH (TIPOUT)	182-11293
	112898-06-705	EA	HANDLE-LATCH/RED-LH (TIPOUT)	182-11294
	100322-01-717	EA	E-RING	245-015975
	112463-02-706	FT	SEAL - FOAM RUBBER	140-014727

CONTACT WINNEBAGO PART SALES FOR UNLISTED COMPONENTS

WINDOW & VENTS GROUP (CONTINUED)
COMPONENT PARTS FOR WINDOW & VENT LAYOUT (CONTINUED)

113733-04-01A, 113733-10-01A, 113733-11-01A

KEY	PART NUMBER	U/M	DESCRIPTION	VENDOR NO.
	112795-01-705	FT	VINYL - GLAZING	132-025736
	113733-10-700	EA	GLASS-STATIONARY	390-028306
	113733-10-701	EA	RETAINER-TRIM	H416-66

122882-01-01A

KEY	PART NUMBER	U/M	DESCRIPTION	VENDOR NO.
	009440-01-000	EA	GEAR-ARM-ROOF VENT	705221K38
	064470-01-700	EA	COVER - VENT - W/O SLIDE BAR	J7291
	064470-01-701	EA	SLIDE BAR - VENT LID	JRP1291B
	122882-01-701	EA	SCREEN	JRP-1124-B
	122882-01-702	EA	HANDLE - CRANK - WHITE	JRP1031B

122882-02-01A, 122882-03-01A

KEY	PART NUMBER	U/M	DESCRIPTION	VENDOR NO.
	064470-01-700	EA	COVER - VENT - W/O SLIDE BAR	J7291
	009440-01-000	EA	GEAR-ARM-ROOF VENT	705221K38
	048648-01-000	EA	MOTOR-12V NONVENTED 1/8 SFT	
	048649-01-000	EA	FAN-PLAS-6 IN 6 BLADED	
	122882-01-701	EA	SCREEN	JRP-1124-B
	122882-01-702	EA	HANDLE - CRANK - WHITE	JRP1031B
	064470-01-701	EA	SLIDE BAR - VENT LID	JRP1291B
	110051-03-700	EA	SWITCH-BLACK/PUSH BUTTON	27-0164

WINDOW & VENTS GROUP (CONTINUED)
COMPONENT PARTS FOR WINDOW & VENT LAYOUT (CONTINUED)

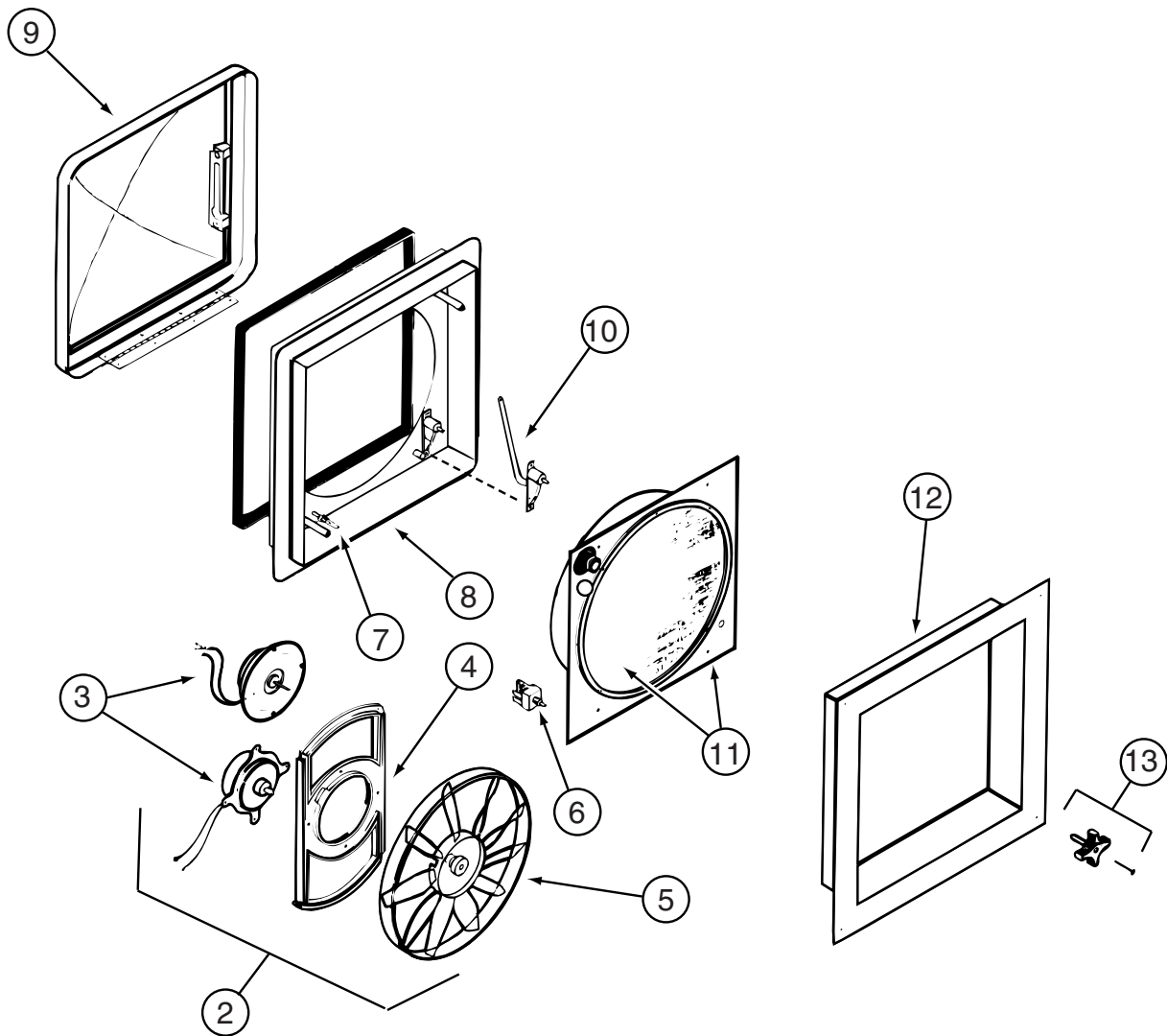

123780-03-01A

KEY	PART NUMBER	U/M	DESCRIPTION	VENDOR NO.
2	084079-11-700	EA	MOTOR & FAN BLADE W/BRACKET	K4017-09
3	084079-01-705	EA	MOTOR/EXT BRKT/FAN BLADE KIT	1080-00
5	084079-01-704	EA	BLADE-FAN	1138-00
6	084079-01-709	EA	SWITCH - MAIN - 3 SPEED	1031-05
7	084079-01-707	EA	SWITCH - SAFETY	1122-05
8	123780-05-700	EA	BASE/MAIN-BRT WHT W/GASKET	1010-81
9	123780-01-700	EA	COVER - VENT W/HINGE & SLIDE	1020K-81
10	009440-01-000	EA	GEAR-ARM-ROOF VENT	705221K38
11	123780-03-701	EA	SCREEN ASM 78-100MM W/SWITCH	1030BT-81
12	123780-03-700	EA	GARNISH - INT. 3"-4" BRT/WHT	2040-81
13	084079-01-703	EA	KNOB-LIFT, W/EXT.	1140K-00
	123780-01-702	EA	SCREEN INSERT (SCREEN RING)	K1035-81

CONTACT WINNEBAGO PART SALES FOR UNLISTED COMPONENTS

WINDOW & VENTS GROUP (CONTINUED)
COMPONENT PARTS FOR WINDOW & VENT LAYOUT (CONTINUED)

123780-09-01A

KEY	PART NUMBER	U/M	DESCRIPTION	VENDOR NO.
2	084079-11-700	EA	MOTOR & FAN BLADE W/BRACKET	K4017-09
3	084079-01-705	EA	MOTOR/EXT BRKT/FAN BLADE KIT	1080-00
5	084079-01-704	EA	BLADE-FAN	1138-00
6	084079-01-709	EA	SWITCH - MAIN - 3 SPEED	1031-05
7	084079-01-707	EA	SWITCH - SAFETY	1122-05
8	123780-05-700	EA	BASE/MAIN-BRT WHT W/GASKET	1010-81
9	123780-09-700	EA	DOME (DOUBLE)WHT TRANSPARENT	K2020-82
10	009440-01-000	EA	GEAR-ARM-ROOF VENT	705221K38
11	123780-03-701	EA	SCREEN ASM 78-100MM W/SWITCH	1030BT-81
12	123780-03-700	EA	GARNISH - INT. 3"-4" BRT/WHT	2040-81
13	084079-01-703	EA	KNOB-LIFT, W/EXT.	1140K-00
	123780-01-702	EA	SCREEN INSERT (SCREEN RING)	K1035-81

CONTACT WINNEBAGO PART SALES FOR UNLISTED COMPONENTS

123780-11-01A

KEY	PART NUMBER	U/M	DESCRIPTION	VENDOR NO.
8	123780-05-700	EA	BASE/MAIN-BRT WHT W/GASKET	1010-81
9	123780-09-700	EA	DOME (DOUBLE)WHT TRANSPARENT	K2020-82
10	009440-01-000	EA	GEAR-ARM-ROOF VENT	705221K38
12	123780-03-700	EA	GARNISH - INT. 3"-4" BRT/WHT	2040-81
13	084079-01-703	EA	KNOB-LIFT, W/EXT.	1140K-00
	123780-01-702	EA	SCREEN INSERT (SCREEN RING)	K1035-81

CONTACT WINNEBAGO PART SALES FOR UNLISTED COMPONENTS

WINDOW & VENTS GROUP (CONTINUED)
COMPONENT PARTS FOR WINDOW & VENT LAYOUT (CONTINUED)

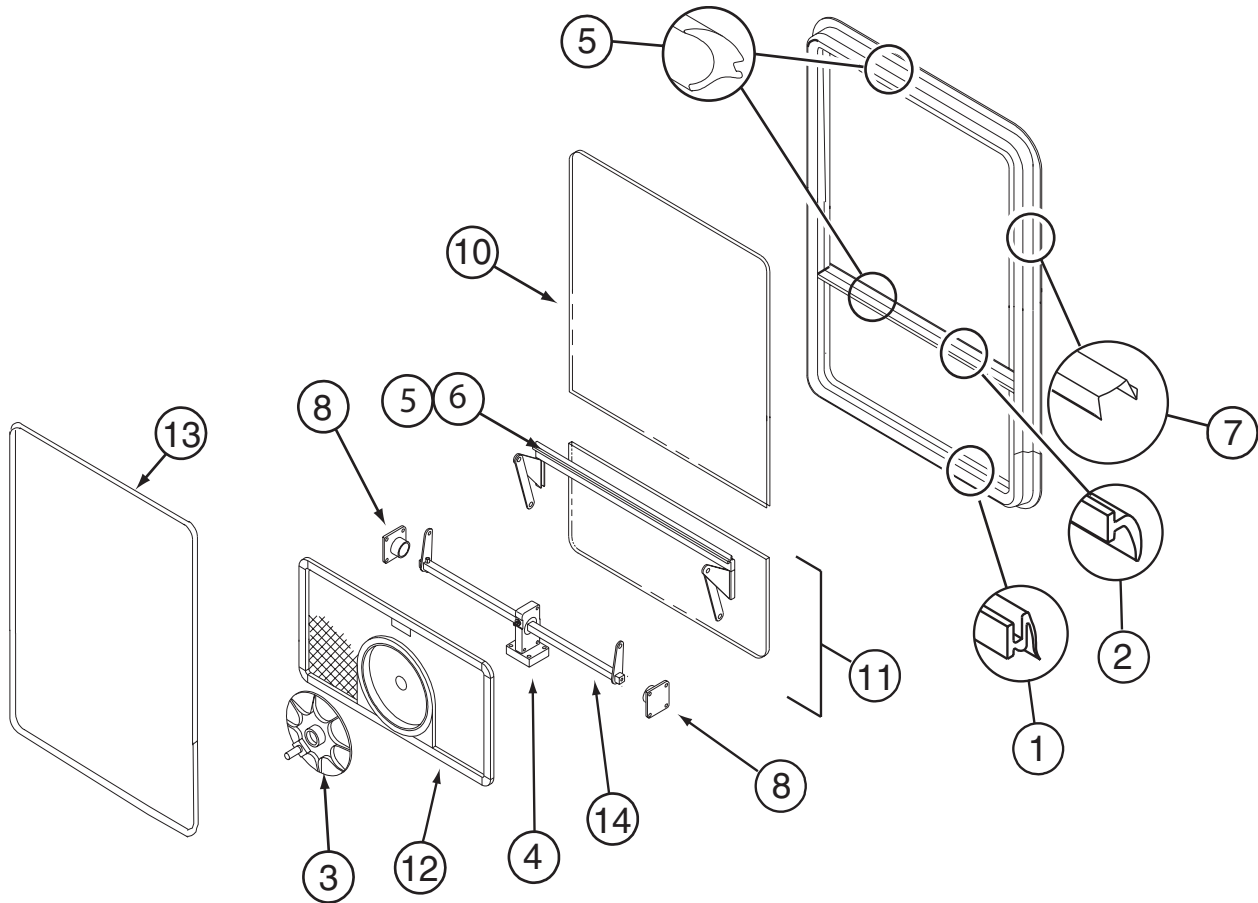

129929-12-01A

KEY	PART NUMBER	U/M	DESCRIPTION	VENDOR NO .
1	100322-01-701	FT	SEAL-VENT	122-016071
3	100322-01-718	EA	HANDLE-DIAL	410-016081
4	129929-01-710	EA	TORQUE-CTR SUPPORT (2 HOLE)	410-026806
5	129929-01-705	FT	GLAZING VINYL	132-026811
6	129929-01-707	FT	COVER/SCREW-FILLER STRIP	132-026808
8	129929-01-708	EA	SUPPORT - TORQUE BAR - RT/LT	130-026804
10	129929-12-700	EA	GLASS - STATIONARY	390-029808
11	129929-12-701	EA	VENT GLASS ASSEMBLY	DTH011-G8
12	129929-12-702	EA	SCREEN ASM - W/SEALS & CLIPS	410-028632
13	129929-12-703	EA	RETAINER - TRIM	DTH011-62
14	129929-12-704	EA	OPERATOR BAR ASSEMBLY	DTH011-18
	100322-01-717	FT	SEAL - VENT	122-016071
	129929-01-706	FT	SEAL - TOP F/CENTER EGRESS	132-026811
	129929-02-706	FT	SEAL - FOAM	140-027022

CONTACT WINNEBAGO PART SALES FOR UNLISTED COMPONENTS

WINDOW & VENTS GROUP (CONTINUED)
COMPONENT PARTS FOR WINDOW & VENT LAYOUT (CONTINUED)

129929-10-01A

KEY	PART NUMBER	U/M	DESCRIPTION	VENDOR NO .
1	100322-01-701	FT	SEAL-VENT	122-016071
3	100322-01-718	EA	HANDLE-DIAL	410-016081
4	129929-01-710	EA	TORQUE-CTR SUPPORT (2 HOLE)	410-026806
5	129929-01-705	FT	GLAZING VINYL	132-026811
6	129929-01-707	FT	COVER/SCREW-FILLER STRIP	132-026808
8	129929-01-708	EA	SUPPORT - TORQUE BAR - RT/LT	130-026804
10	129929-10-700	EA	GLASS - STATIONARY	390-028300
11	129929-10-701	EA	VENT GLASS ASSEMBLY	DTH002-G8
12	129929-02-702	EA	SCREEN ASM - W/SEALS & CLIPS	410-026861
13	129929-02-707	EA	RETAINER - TRIM	CH10162
14	129929-02-704	EA	OPERATOR BAR ASSEMBLY	DTH002-15
	100322-01-717	FT	SEAL - VENT	122-016071
	129929-01-706	FT	SEAL - TOP F/CENTER EGRESS	132-026811
	129929-02-706	FT	SEAL - FOAM	140-027022

CONTACT WINNEBAGO PART SALES FOR UNLISTED COMPONENTS