

2000 WKP34B

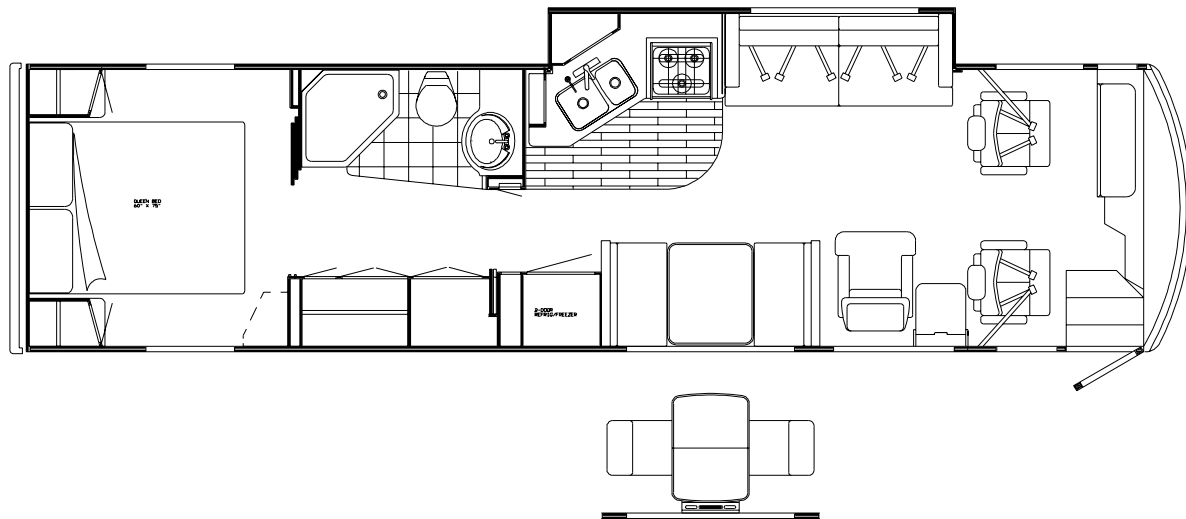
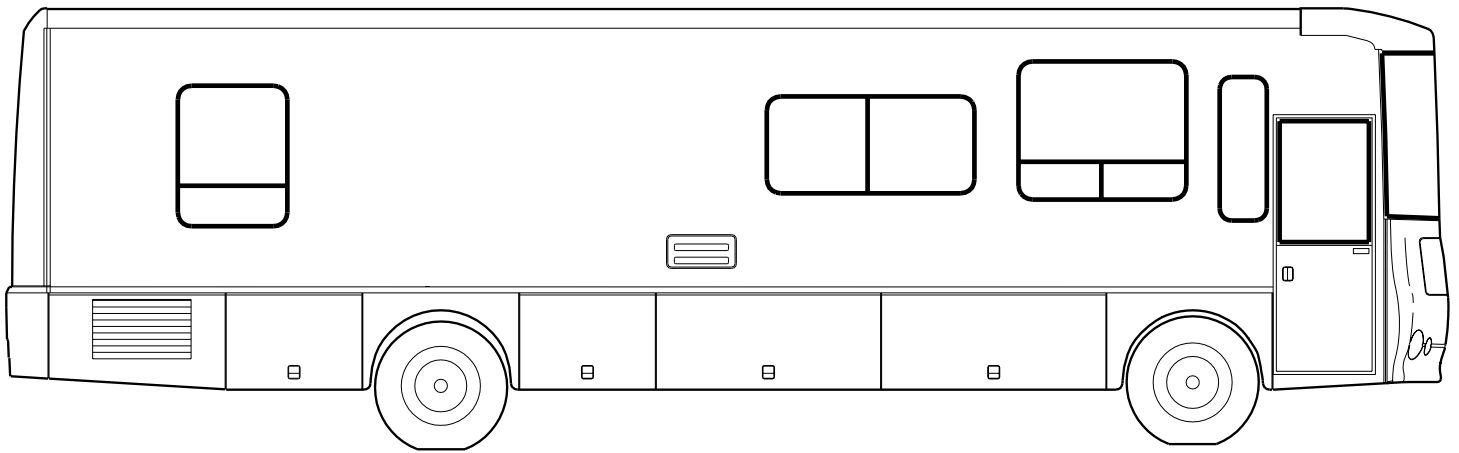

FLOORPLAN

2000 WKP34B

**JOURNEY
P-SERIES**

WATERFORD OAK

L76 IVORY COAST (BEIGE)

L78 WINDSPRAY (GREEN)

L80 AMETHYST FROST (PALE PLUM)

CONTENTS

FLOORPLAN	2
ACCESSORIES GROUP	8
OPERATORS MANUAL	8
APPLIANCE GROUP	9
APPLIANCE	9
AUDIO VIDEO GROUP	12
RADIO SYSTEM	12
REAR VIEW MONITOR	12
TELEPHONE SYSTEM	13
TV & VCR SYSTEMS	13
EXTERIOR ENTERTAINMENT	14
BATH GROUP	15
CABINETS	15
SHOWER	17
BEDROOM GROUP	18
CABINETS	18
CHASSIS GROUP	19
FRAME	19
FRONT END	20
INSULATION	22
EXHAUST	23
HITCH	23
REAR BUMPER	24
FUEL	25
HYDRAULIC LEVELING	26
WHEEL, TIRE, COVERS &/OR LINERS	26

CONTENTS (CONTINUED)

CURTAIN & CUSHION GROUP	27
NOTICE	27
CUSHION LAYOUT	28
BUCKET SEAT	31
LOUNGE CHAIR	35
WINDOW TREATMENT	37
HARDWARE	39
ACCESSORIES	41
FABRICS	42
DINETTE GROUP	44
CABINETS	44
TABLE	45
DRIVERS COMPARTMENT GROUP	47
INSTRUMENT PANEL	47
DASH	48
BEVERAGE TRAY	49
FRONT INTERIOR	49
CABINETS	51
ELECTRICAL GROUP	52
LIGHTS	52
CIRCUIT BREAKERS & FUSES	57
CONVERTER, INVERTER, LOAD CENTER	57
RECEPTACLES	58
SWITCHES	60
BOXES & CORDS	62
WIRE ASSEMBLIES	62
CONNECTORS & CONDUIT	63
BOOTS, SOLENOIDS, RELAYS & MISCELLANOUS	64

CONTENTS (CONTINUED)

EXTERIOR BODY GROUP	65
AIR HORN INSTL	65
GRAPHICS & PAINT	66
PANELS	68
FRONT END	70
LADDER	72
MIRRORS	72
BODY PANELS COMPONENTS	72
AWNINGS	72
EXTERIOR DOORS & COMPARTMENTS GROUP	73
DOOR & COMPARTMENT LAYOUT	73
COMPARTMENT DOOR COMPONENTS	75
ENTRY DOOR	76
EXTERIOR SLIDEOUT INSTALLATION GROUP	77
FRONT LEFT	77
GALLEY GROUP	82
CABINETS	82
GENERATOR GROUP	85
LPG	85
DIESEL	86
HEATING & A/C GROUP	87
AUTOMOTIVE	87
FURNACE	89
CENTRAL	90
INTERIOR FINISH GROUP	91
MOLDINGS & TRIMS	91
PANELING, LAMINATES, BATT & EDGEBANDING	95
ACCESSORIES	96
FLOOR COVERINGS	96
HARDWARE	97

CONTENTS (CONTINUED)

LABELS GROUP	105
LP GROUP	123
LP SYSTEM	123
LOUNGE GROUP	124
CABINETS	124
TABLES	125
SEALANTS & ADHESIVES	126
SEALANTS & FASTENERS GROUP	126
BOLTS, NUTS AND WASHERS	127
SCREWS	129
CLAMPS, CLIPS, GROMMETS, RIVETS & PLUGS	133
MISCELLANEOUS FASTENERS	135
WATER & SEWAGE GROUP	136
DRAINAGE SYSTEM	136
WATER SYSTEM	138
WINDOW & VENTS GROUP	145
WINDOW & VENT LAYOUT	145
WINDSHIELD & WIPER GROUP	147
WINDSHIELD	147
WIPER	148

ACCESSORIES GROUP

OPERATORS MANUAL

KEY	PART NUMBER	U/M	DESCRIPTION
	129079-02-01A	EA	CASE - VINYL - OWNER MANUAL - 8.5" X 9" X 14"- BLACK
	132000-09-000	EA	MANUAL/OWNER - JOURNEY - 2000
	132390-01-000	DW	TOP LEVEL - P - 2000

APPLIANCE GROUP

APPLIANCE

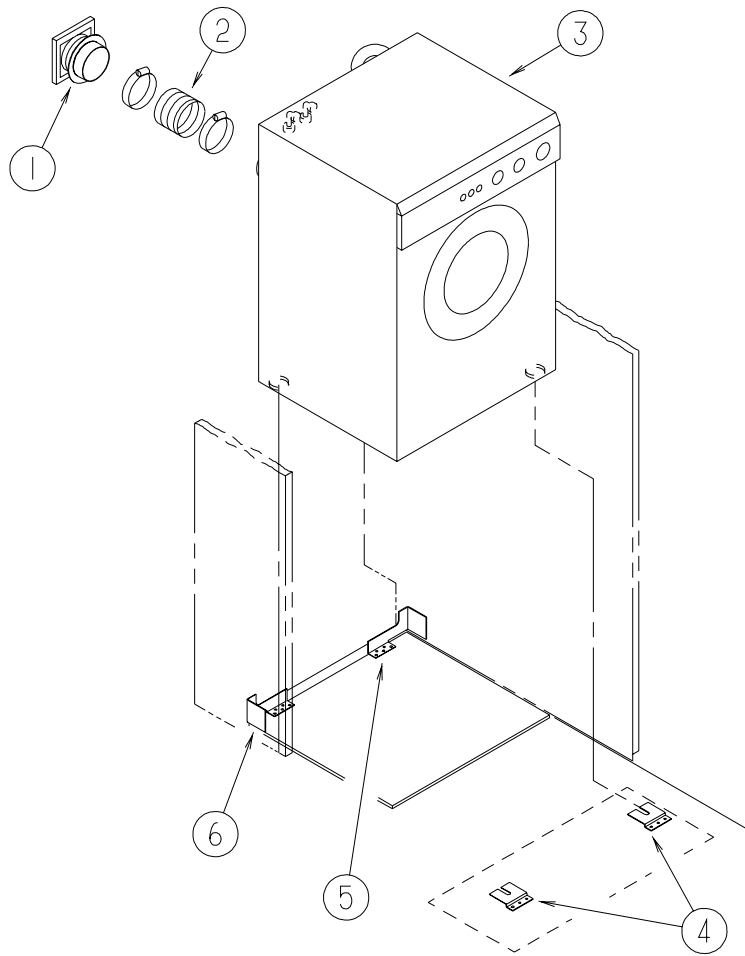

WASHER/DRYER

KEY	PART NUMBER	U/M	DESCRIPTION
1	111947-02-01A	EA	VENT - DRYER - 3"
2	116653-02-000	EA	DUCT - FLEXIBLE
	062401-09-000	EA	CLAMP - HOSE - WORMGEAR - 2.8" - 3.75"
3	107753-03-01A	EA	WASHER - DRYER - VENTED - UL/CSA - WHITE
4	111913-01-01A	EA	BRACKET - WASHER - TIE DOWN
5	113795-01-02B	EA	BRACKET - WASHER - E-COATED
6	113795-02-02B	EA	BRACKET - WASHER - E-COATED

MICROWAVE OVEN

KEY	PART NUMBER	U/M	DESCRIPTION
*	119267-04-01A	EA	OVEN - MICROWAVE/CONVECTION - W/HOOD - US
*	119267-06-01A	EA	OVEN - MICROWAVE/CONVECTION W/HOOD - CSA
*	119267-07-01A	EA	OVEN - MICROWAVE/NON/CONVECTION W/HOOD - US
*	119267-08-01A	EA	OVEN - MICROWAVE/NON/CONVECTION W/HOOD - #R-1480C - CSA
	129552-03-02B	EA	BRACKET - MICROWAVE
	129836-02-02B	EA	ANGLE - W/HOLES - .7" X 1" X 28.3" - E-COATED
	129836-03-02B	EA	ANGLE - W/HOLES - 3.3" X 2.9" X 28.3" - E-COATED
	119267-05-000	EA	FILTER - HOOD - CHARCOAL

*COMPONENT PARTS FOUND IN SERVICE PARTS LIBRARY

APPLIANCE GROUP (CONTINUED)

APPLIANCE (CONTINUED)

RANGE

KEY	PART NUMBER	U/M	DESCRIPTION
*	126023-01-01A	EA	RANGE - W/OVEN 22" - 3 BURNER/BLACK GLASS DOOR
	107109-21-04B	EA	BRACKET - TIEDOWN
	107109-22-04B	EA	BRACKET - TIEDOWN
*	126023-02-01A	EA	RANGE - W/OVEN - 22" - 3 BURNER/TEXTURED TOP - BLACK
	106936-21-04B	EA	BRACKET - STOVE TIEDOWN - BLACK
	106936-22-04B	EA	BRACKET - STOVE TIEDOWN - BLACK
*	114030-02-01A	EA	RANGE - 3 BURNER TOP - W/O OVEN - BLACK - UL
*	114030-03-01A	EA	RANGE - 3 BURNER TOP - W/O OVEN - BLACK - CSA
	M05904-03-L76	EA	COVER - STOVE/LAMINATED COUNTERTOP
*	126022-01-01A	EA	COVER - RANGE/BI-FOLD - 16" & 22" - BLACK TEXTURED
	130816-01-01A	EA	COVER - RANGE - JAMAICAN SAND - 1/4" X 5.4" X 24.3"
	130816-02-01A	EA	COVER - RANGE - JAMAICAN SAND - 1/4" X 11.7" X 24.3"

*COMPONENT PARTS FOUND IN SERVICE PARTS LIBRARY

REFRIGERATOR

KEY	PART NUMBER	U/M	DESCRIPTION
*	120075-07-01A	EA	REFRIGERATOR - LARGE DOUBLE DOOR/RIGHT HAND - BLACK 2-WAY FROM: 00-00-00 THRU: 08-26-99
*	121569-03-01A	EA	REFRIGERATOR - LARGE DOUBLE DOOR/RIGHT HAND - 2-WAY-BLACK FROM: 08-27-99 THRU: 01-02-00
*	121569-05-01A	EA	REFRIGERATOR - LARGE DBL DOOR/2 WAY - BLK-NON-FLUSH HANDLE FROM: 01-03-00 THRU: 99-99-99
	065225-04-000	EA	PLATE - TIEDOWN/REFRIGERATOR
	093369-02-000	EA	STRAP - REFRIGERATOR
	093646-01-000	EA	BRACKET - TIEDOWN/REFRIGERATOR - RIGHT HAND
	093646-02-000	EA	BRACKET - TIEDOWN/REFRIGERATOR - LEFT HAND
	103251-07-01A	EA	INSERT/REFRIGERATOR DOOR - BLACK ACRYLIC - 21.6" X 14.5"
	103251-09-01A	EA	INSERT/REFRIGERATOR DOOR - BLACK ACRYLIC - 21.6" X 38.6"
	116751-02-01A	EA	TRAY - REFRIGERATOR - BLACK
*	120075-09-01A	EA	REFRIGERATOR - LARGE DBL DOOR RH - W/ICE MAKER-BLACK 2-WAY FROM: 00-00-00 THRU: 01-02-00
*	120075-13-01A	EA	REFRIGERATOR-LARGE DBL DOOR- 2-WAY/ICE MKR-BLK-FLUSH HNDL FROM: 01-03-00 THRU: 99-99-99
	090329-01-000	FT	SEAL/T - REFRIGERATOR CABINET
	054450-01-000	EA	LEVEL - REFRIGERATOR

*COMPONENT PARTS FOUND IN SERVICE PARTS LIBRARY

COFFEEMAKER

KEY	PART NUMBER	U/M	DESCRIPTION
*	126019-01-01A	EA	COFFEEMAKER - OPTIMA - W/BRACKETS - BLACK & DECKER

*COMPONENT PARTS FOUND IN SERVICE PARTS LIBRARY

APPLIANCE GROUP (CONTINUED)

APPLIANCE (CONTINUED)

VACUUM CLEANER

KEY	PART NUMBER	U/M DESCRIPTION
	133139-01-000	EA VACUUM CLEANER - RECHARGEABLE

MONITOR

KEY	PART NUMBER	U/M DESCRIPTION
*	133004-02-01A	EA PANEL - MONITOR - 2 TANK DIGITAL VOLT METER - SOLAR
*	133004-01-01A	EA PANEL - MONITOR - 2 TANK DIGITAL VOLT METER

*COMPONENT PARTS FOUND IN SERVICE PARTS LIBRARY

FLASHLIGHT & TRASH CONTAINER

KEY	PART NUMBER	U/M DESCRIPTION
	133140-01-000	EA FLASHLIGHT - RECHARGEABLE
	130818-02-01A	EA TRASH CONTAINER - 20 QUART ALMOND

HAIR DRYER

KEY	PART NUMBER	U/M DESCRIPTION
	133068-01-000	EA HAIR DRYER - 3 SPEED W/NIGHT LIGHT - WALL MOUNT

SOLAR PANELS

KEY	PART NUMBER	U/M DESCRIPTION
*	115504-01-000	EA PANEL - SOLAR 10 WATT - 12.2"W X 26.9"L X 1.2"H
	115505-01-000	EA LIGHT - MONITOR/SOLAR PANEL - RED LED INDICATOR

*COMPONENT PARTS FOUND IN SERVICE PARTS LIBRARY

AUDIO VIDEO GROUP RADIO SYSTEM

KEY	PART NUMBER	U/M	DESCRIPTION
	077069-02-000	EA	CABLE - ANTENNA/EXTENSION - RADIO - 96"
	090944-01-000	EA	ANTENNA - RADIO - 16" RUBBER
	094097-01-000	EA	SPEAKER - RADIO/TV - W/O GRILLE - 5.25" DIAMETER
	108847-01-000	EA	BRACKET - ANTENNA GROUND
	109889-04-000	EA	EXTENDER - ANTENNA SHAFT - 3.7"
	124883-02-000	EA	SPEAKER - CUBE - W/BRACKET (DELUXE SOUND)
	126387-01-000	EA	BRACKET - SPEAKER MOUNTING (DELUXE SOUND)
	124884-01-000	EA	SPEAKER - 6" X 9" - SUB-WOOFER (DELUXE SOUND)
	124885-01-000	EA	GRILLE - SPEAKER - 6" X 9" - SUB-WOOFER (DELUXE SOUND)
	110469-01-000	EA	SPEAKER - 4" X 6" OVAL - COAXIAL
	110470-01-01A	EA	GRILLE - 4" X 6" OVAL - BLACK
	123256-01-000	EA	ANTENNA - CB - W/O CABLE
	123256-02-000	EA	CABLE - CB - COAX
	128074-02-000	EA	FILTER - NOISE - 12 VOLT D.C. W/PLUGS
	124881-01-000	EA	AMPLIFIER - AUDIO
	133089-01-000	EA	CONTROL - VOLUME - SPEAKER
*	102080-09-000	EA	CHANGER - CONTROL/FM MOD & REM FROM: 00-00-00 THRU: 03-26-00
	102080-08-000	EA	CHANGER - COMPACT DISC - W/CARTRIDGE - CDX-525
	102080-12-000	EA	CHANGER - REMOTE CONTROL/FM MODULATOR FROM: 03-27-00 THRU: 99-99-99
	102080-11-000	EA	CHANGER - COMPACT DISC - 530RF
	127517-03-000	EA	RADIO - AM/FM STEREO - CD PLAYER - SONY CDX-2250 FROM: 00-00-00 THRU: 05-14-00
	127517-05-000	EA	RADIO - AM/FM STEREO - CD PLAYER - SONY CDX-C4005X FROM: 05-15-00 THRU: 99-99-99
	097460-12-000	EA	RADIO - AM/FM STEREO - CASSETTE - SONY XR-4890
	127516-05-000	EA	RADIO - AM/FM STEREO - CD PLAYER - PANASONIC CQ-DP22 (EXTERIOR) FROM: 00-00-00 THRU: 04-02-00
	127516-06-000	EA	RADIO - AM/FM STEREO - CD PLAYER - PANASONIC CQ-DP202 (EXTERIOR) FROM: 04-03-00 THRU: 99-99-99
	125322-02-000	EA	RADIO - AM/FM STEREO - CASSETTE - AUDIOVOX - MS-306 (EXTERIOR)

***COMPONENT PARTS FOUND IN SERVICE PARTS LIBRARY**

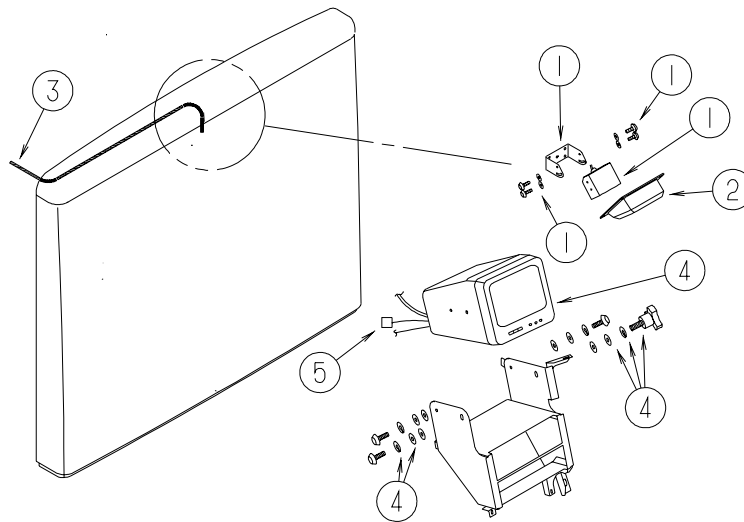

REAR VIEW MONITOR

KEY	PART NUMBER	U/M	DESCRIPTION
1	093040-09-000	EA	CAMERA - REAR VIEW - W/BRACKET - SONY
2	123281-01-01A	EA	SHROUD - CAMERA/OUTER - BRIGHT WHITE
3	093041-01-000	EA	CABLE - MONITOR/CAMERA - INTERNAL USE - 65.6'
4*	093040-10-000	EA	MONITOR - 7" REAR VIEW - W/BRACKET - SONY
5	096717-04-000	EA	WIRE ASSEMBLY - REAR MONITOR - UPPER
	114870-01-000	EA	PLUG - AUDIO W/LEADS - 48.5"
	098819-01-000	EA	SPEAKER - 4" - 2 WATT - 8 OHM
	093214-01-01A	EA	GRILL - SPEAKER - 4" - BLACK

***COMPONENT PARTS FOUND IN SERVICE PARTS LIBRARY**

AUDIO VIDEO GROUP (CONTINUED)

TELEPHONE SYSTEM

KEY	PART NUMBER	U/M	DESCRIPTION
	093253-01-01A	EA	PLATE - WALL - TELEPHONE - BEIGE
	130686-01-01A	EA	PLATE - WALL - TELEPHONE/COAX - WHITE
	133713-06-01A	EA	SPACER - RECEPTACLE - 110/12V - PHONE - WATERFORD OAK

TV & VCR SYSTEMS

KEY	PART NUMBER	U/M	DESCRIPTION
*	086231-10-000	EA	TV - 13" COLOR - AUDIOVOX AVT-1498/DC
*	133377-01-000	EA	TV - 25" - 1/8" JACK - UL/CSA - GE 25GT240
*	126697-03-000	EA	VCR - VHS - CABLE READY - REMOTE - GE V62051 FROM: 00-00-00 THRU: 02-20-00
*	126697-05-000	EA	VCR/VHS - CABLE READY - REMOTE - GE VG4052 FROM: 02-21-00 THRU: 05-28-00
*	126697-06-000	EA	VCR/VHS - CABLE READY - W/REMOTE - GE VG4060 FROM: 05-29-00 THRU: 99-99-99
	086777-06-000	EA	WALLPLATE - TV CABLE - ANTENNA BOOSTER/1 OUTPUT - BROWN
	115540-01-000	EA	AMPLIFIER - TV SPEAKERS
	114870-02-000	EA	PLUG - AUDIO W/LEADS - 10"
	086757-04-000	EA	CONTROL CENTER - SWITCH - VCR/TV - 5 INPUTS
	082134-01-000	EA	ADAPTER - TV - CABLE TO CABLE
	082136-01-000	EA	NUT - HEX JAM - 3/8-32
	115539-01-000	EA	RELAY - RADIO/TV SPEAKER - SWITCH
	093214-01-02A	EA	GRILLE - SPEAKER - 4" BROWN
	098819-01-000	EA	SPEAKER - 4" - 2 WATT - 8 OHM
	086756-01-000	EA	SPLITTER - TV - 2 WAY
	076319-09-000	EA	WALLPLATE - CABLE RECEPTACLE - TV - SINGLE - BROWN
	076319-03-000	FT	CABLE - COAXIAL - 75 OHM
	076319-12-000	EA	CONNECTOR - COAXIAL - ONE PIECE

*COMPONENT PARTS FOUND IN SERVICE PARTS LIBRARY

SATELLITE DISH

KEY	PART NUMBER	U/M	DESCRIPTION
*	120233-04-000	EA	ANTENNA - SATELLITE - W/DIGITAL SENSOR/READ OUT DISPLAY

*COMPONENT PARTS FOUND IN SERVICE PARTS LIBRARY

TV ANTENNA

KEY	PART NUMBER	U/M	DESCRIPTION
*	076319-23-000	EA	ANTENNA-TV - ROOF MOUNT - 44.5" MAST
*	076319-25-000	EA	KIT - HARDWARE INTERIOR

*COMPONENT PARTS FOUND IN SERVICE PARTS LIBRARY

AUDIO VIDEO GROUP (CONTINUED)
EXTERIOR ENTERTAINMENT

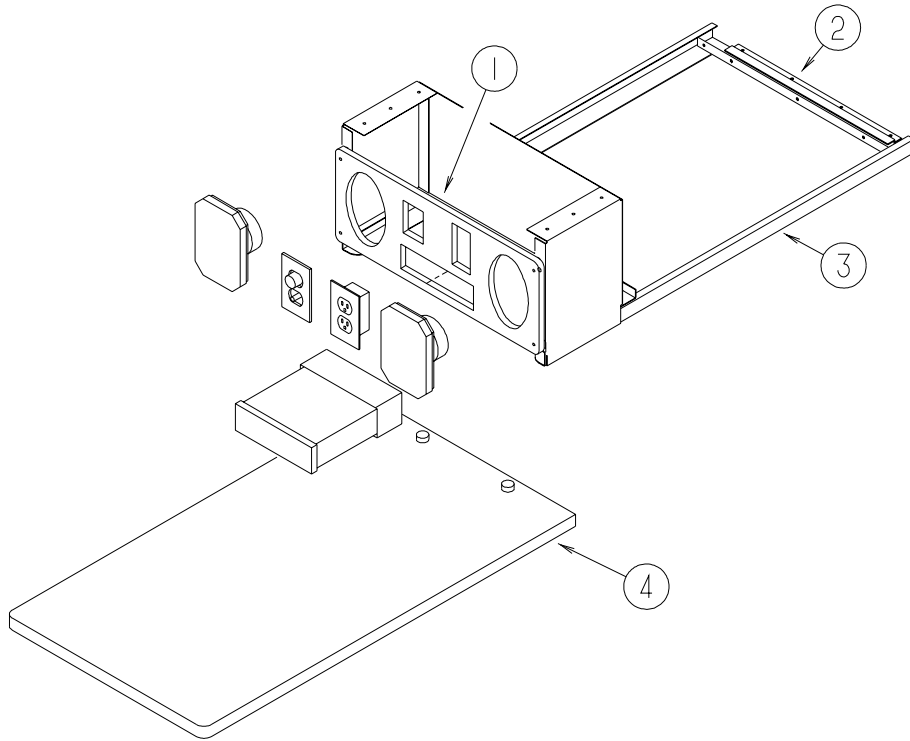

KEY	PART NUMBER	U/M	DESCRIPTION
1	126123-01-K30	EA	PLATE - RADIO MOUNTING - WHITE LAMINATE
2	130284-01-01A	EA	CLIP-MOUNTING, MILL
3	126119-03-02B	EA	FRAME - ENTERTAINMENT CNTR - EXTERIOR - 24.6" X 10.3" - GM
4	126125-01-K30	EA	TABLE - ENTERTAINMENT CENTER

BATH GROUP

CABINETS

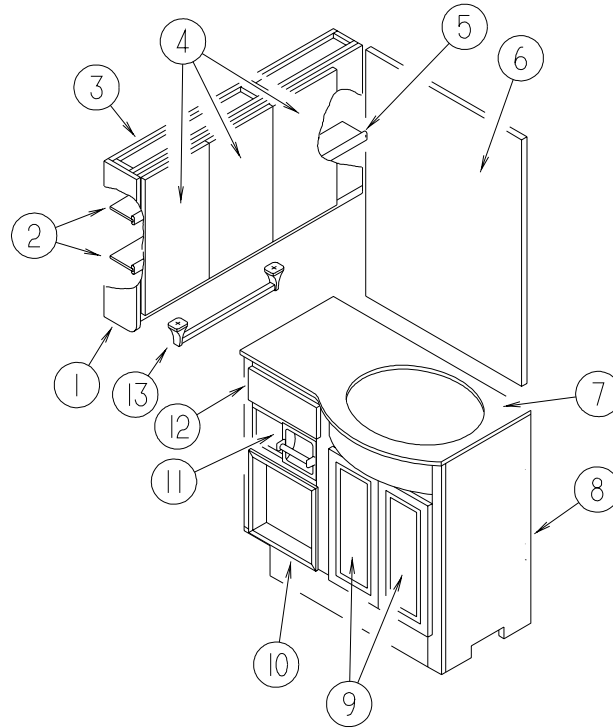

KEY	PART NUMBER	U/M	DESCRIPTION
1	103128-68-L76	EA	END CAP - OVERHEAD
2	134211-12-L76	EA	SHELF - W/WOOD MOLDING
3	134211-01-L76	EA	CABINET - OVERHEAD/MEDICINE - W/O DOORS/HARDWARE
4	132141-C1-L76	EA	DOOR - RAIL/VENEER - 11.4" X 21.8" - W/O HARDWARE
5	134211-13-L76	EA	SHELF - W/WOOD MOLDING
6	113195-04-01A	EA	MIRROR - BEVELED SAFETY GLASS - CLEAR - 28.1" X 36"
7	133132-09-L76	EA	COUNTERTOP - LAVATORY - LAMINATED
8	134212-01-L76	EA	CABINET - LAVATORY - W/COUNTERTOP - W/O DOORS/DRAWERS/HDW
9	132141-C2-L76	EA	DOOR - RAIL/VENEER - 9.2" X 21.8" - W/O HARDWARE
10	131096-01-K07	EA	WALL POCKET - MAGAZINE RACK
11	085278-01-000	EA	HOLDER - TOILET PAPER - RECESSED - BRASS
12	M09316-59-L07	EA	DRAWER - OGEE EDGE - 10.7"W X 13.7"D - W/O SLIDES/HARDWARE
13	075453-03-000	EA	BRACKET - TOWEL BAR - BRASS - 2 PER PACK
	075453-04-000	EA	ROD - F/TOWEL BAR - 18" BRASS - W/O END BRACKETS
	130859-01-01A	EA	TOWEL RING - BRASS

BATH GROUP (CONTINUED)

CABINETS (CONTINUED)

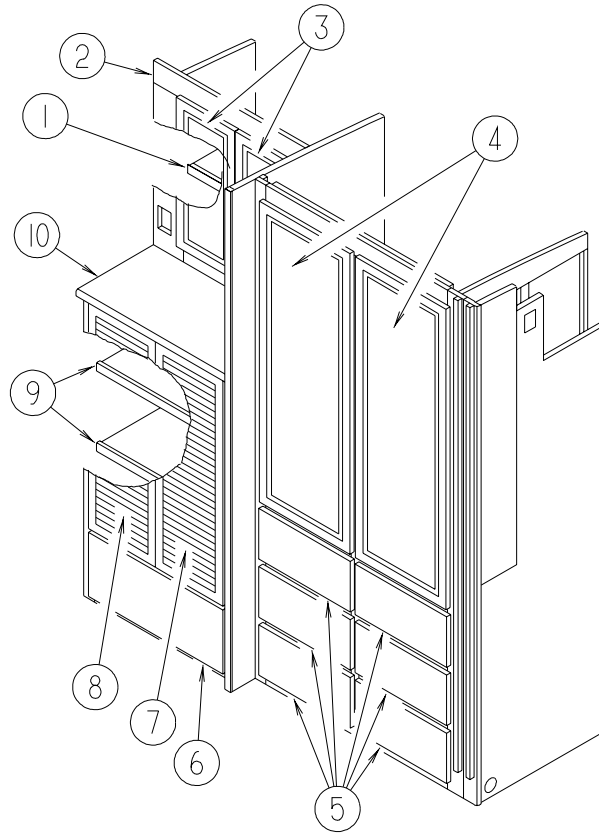

KEY	PART NUMBER	U/M	DESCRIPTION
1	134247-18-L76	EA	SHELF - W/PLASTIC EDGE MOLDING
2	134247-01-L76	EA	CABINET - LINEN - W/CTRTP - W/O DOR/DRAWERS/HDW (W/O WASHER/DRYER)
2	134247-02-L76	EA	CABINET - LINEN - W/CTRTP - W/O DOR/DRAWERS/HDW (W/O WASHER/DRYER,W/10 GL.HEATER)
2	134247-04-L76	EA	CABINET - LINEN - W/CTRTP -W/O DOR/DRAWERS/HDW (W/10 GL.HEATER,W/WASHER/DRYER PREP)
2	134247-07-L76	EA	CABINET - LINEN - W/CTRTP - W/O DOR/DRAWERS/HDW(W/WASHER/DRYER)
2	134247-08-L76	EA	CABINET - LINEN - W/CTRTP - W/O DOR/DRAWERS/HDW (W/WASHER/DRYER,W/10 GL.HEATER)
2	134247-09-L76	EA	CABINET - LINEN - W/CTRTP - W/O DOR/DRAWERS/HDW (W/WASHER/DRYERPREP)
3	132141-38-L76	EA	DOOR - RAIL/VENEER - 10.8" X 23.8" - W/O HARDWARE
4	132006-05-L32	EA	DOOR - MIRRORED/MITERED RAIL - 16.7" X 47.9" - W/O HDW
	058331-A3-000	EA	MIRROR - SAFETY GLASS - 13.4" X 44.7"
5	M09316-F3-L76	EA	DRAWER - OGEE EDGE - 14.7"W X 21.6"D - W/O SLIDES/HARDWARE
6	M09316-A9-L32	EA	DRAWER - OGEE EDGE - 22.9"W X 19.6"D - W/O SLIDES/HARDWARE
7	132850-07-L76	EA	DOOR/LOUVERED - 12.4" X 36" - W/O HARDWARE
8	132850-09-L76	EA	DOOR/LOUVERED - 12.4" X 36" - W/O HARDWARE
9	134247-19-L76	EA	SHELF - W/PLASTIC EDGE MOLDING
10	133131-09-L76	EA	COUNTERTOP - LAMINATED

BATH GROUP (CONTINUED)

CABINETS (CONTINUED)

SLIDING DOORS

KEY	PART NUMBER	U/M	DESCRIPTION
	M09366-06-L76	EA	DOOR/PANEL - SLIDING - W/O PULL (BETWEEN BATH & BEDROOM)
	M09366-05-L76	EA	DOOR/PANEL - SLIDING - W/PULL (BETWEEN BATH & BEDROOM)
	104013-18-L76	EA	DOOR - SLIDING - W/O HARDWARE (BETWEEN GALLEY & BATH)

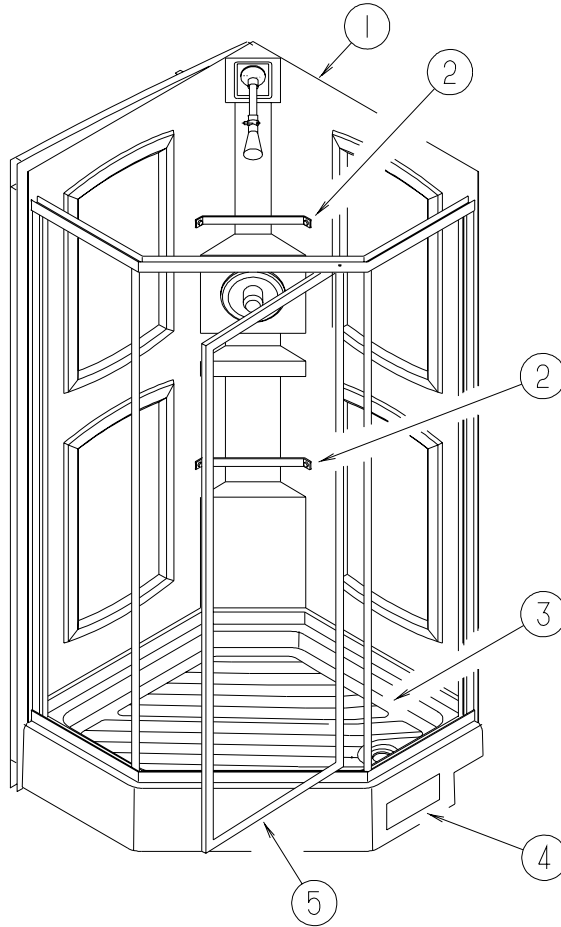

SHOWER

KEY	PART NUMBER	U/M	DESCRIPTION
1	131311-01-01A	EA	ENCLOSURE - SHOWER - SIDES/BACK - 1 PIECE
2	113714-02-01A	EA	RETAINER - SHELF/SHOWER - 10.6" - OFF WHITE
3	M02630-52-L52	EA	SHOWER PAN - W/TIP TOE DRAIN
4	089326-02-000	EA	GRILL - FLOOR - HEATING - 9.3" X 8.4" - SOFT WHITE
5*	131618-01-01A	EA	DOOR - SHOWER - SOLID W/PANEL

*COMPONENT PARTS FOUND IN SERVICE PARTS LIBRARY

BEDROOM GROUP

CABINETS

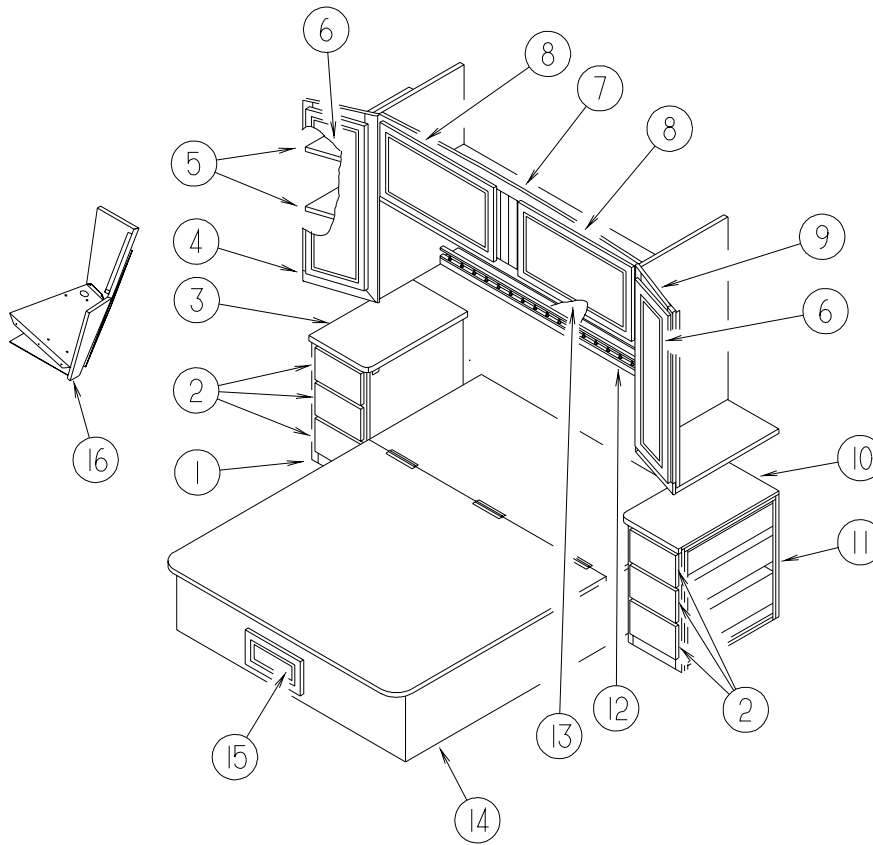

KEY	PART NUMBER	U/M	DESCRIPTION
1	129251-65-L76	EA	CABINET - NIGHTSTAND/RH - W/CTRTP - W/O DOORS/DRAWERS/HDW
2	M09316-14-L07	EA	DRAWER - OGEE EDGE - 10.7"W X 19.7"D - W/O SLIDES/HARDWARE
3	129251-31-L76	EA	COUNTERTOP - LAMINATED
			FROM: 00-00-00 THRU: 01-31-00
3	133131-29-L76	EA	COUNTERTOP - LAMINATED
			FROM: 02-01-00 THRU: 99-99-99
4	133092-01-L76	EA	CABINET - SHIRT CLOSET - W/O DOORS/HARDWARE
5	133092-21-L76	EA	SHELF - W/PLASTIC EDGE MOLDING
6	132006-02-L07	EA	DOOR - MIRROR/MITERED RAIL - 14.3" X 36.4" - W/O HARDWARE
7	133091-01-L76	EA	CABINET - OVERHEAD/REAR - W/O DOORS/HARDWARE
8	132141-14-L07	EA	DOOR - RAIL/VENEER - 15.7" X 27.9" - W/O HARDWARE
9	133092-02-L32	EA	CABINET - SHIRT CLOSET - W/O DOORS/HARDWARE
10	129251-32-L76	EA	COUNTERTOP - NIGHTSTAND
			FROM: 00-00-00 THRU: 01-31-00
10	133131-29-L76	EA	COUNTERTOP - LAMINATED
			FROM: 02-01-00 THRU: 99-99-99
11	129251-66-L76	EA	CABINET - NIGHTSTAND/LH - W/COUNTERTOP - W/O DRS/DWRS/HDW
12	133090-01-L76	EA	SHELF - COUNTERTOP
13	058331-K1-000	EA	MIRROR - SAFETY GLASS - 18.9" X 63.5"
14	P32910-01-L76	EA	CABINET/BASE - QUEEN BED - W/O DOORS/DRAWERS/HARDWARE
	126066-01-01A	EA	SUPPORT - BEDBOARD - BLACK
15	132141-56-L07	EA	DOOR - RAIL/VENEER - 14.3" X 26.7" - W/O HARDWARE
16	133087-01-L76	EA	CABINET - OVERHEAD/TV - W/O DOORS/HARDWARE

CHASSIS GROUP FRAME

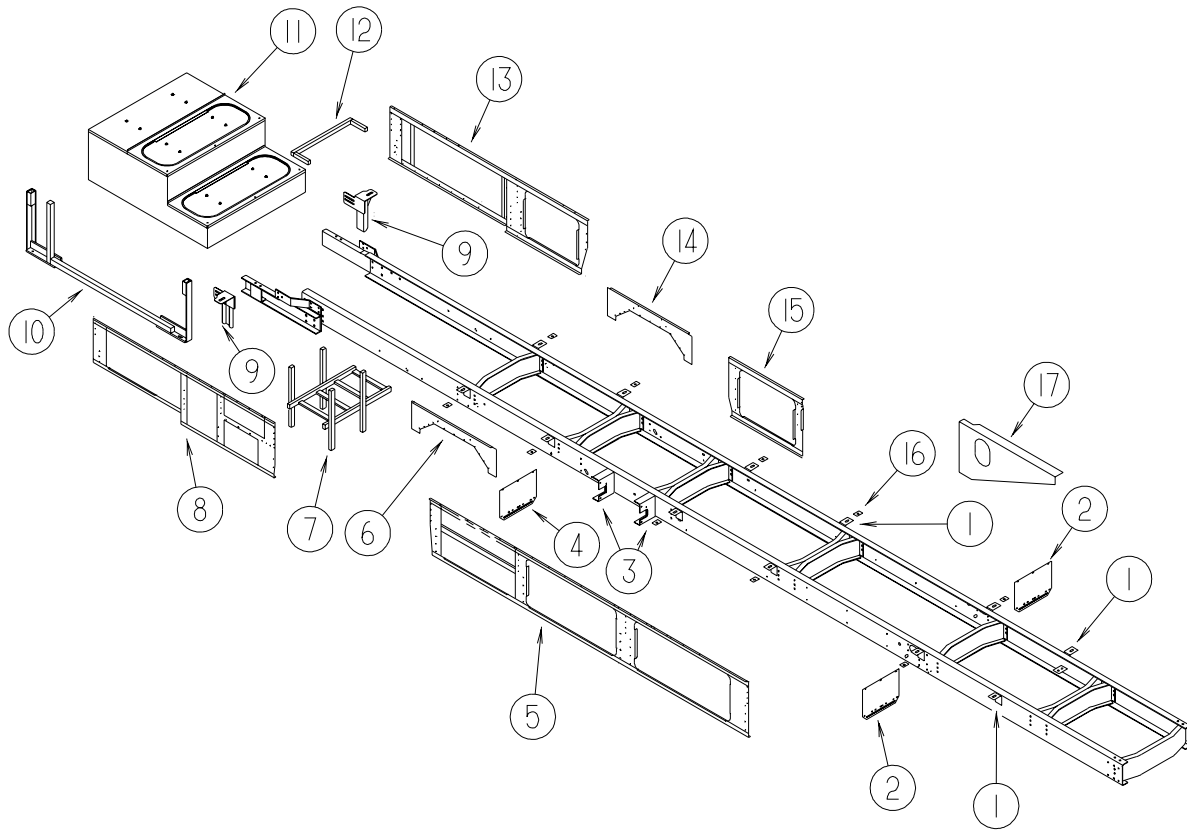

KEY	PART NUMBER	U/M	DESCRIPTION
1	117154-07-02B	EA	MOUNT - FRAME RAIL/FLOOR
2	136391-01-02B	EA	GUARD - ROCK - E-COATED
	017516-01-000	EA	MUD FLAP - 14" X 18" - W/O MOUNTING HOLES - BLACK
3	120867-01-02B	EA	MOUNT - LP TANK
4	136391-01-02B	EA	GUARD - ROCK - E-COATED
	017516-07-000	EA	MUD FLAP - BLACK - RUBBER - 23.5"W X 14"H
5	133146-02-02B	EA	SEAL PLANE - E-COATED
6	119750-04-02B	EA	SEAL PLANE/WHEEL WELL - RIGHT HAND - E-COATED
7	132568-01-02B	EA	SUPPORT - BATTERY TRAY - E-COATED
8	133147-01-02B	EA	SEAL PLANE - E-COATED
9	131328-03-02B	EA	SUPPORT - REAR RISER - RIGHT HAND - E-COATED
9	131328-04-02B	EA	SUPPORT - REAR RISER - LEFT HAND - E-COATED
10	134993-01-02B	EA	HANGER - A/C - COACH/E-COATED
11	134341-01-02B	EA	COMPARTMENT - ENGINE - E-COATED
12	134225-01-02B	EA	SUPPORT - CONDENSOR SHIELD - E-COATED
13	133149-01-02B	EA	SEAL PLANE - E-COATED
			FROM: 00-00-00 THRU: 04-09-00
13	135640-01-02B	EA	SEAL PLANE - E-COATED
			FROM: 04-10-00 THRU: 99-99-99
14	119750-05-02B	EA	SEAL PLANE/WHEEL WELL - LEFT HAND - E-COATED
15	133148-02-02B	EA	SEAL PLANE - E-COATED
16	135712-01-02B	EA	PLATE - BODY MOUNT - E-COATED
17	132752-01-02B	EA	PANEL - FUEL FILL - LEFT HAND - E-COATED
			FROM: 00-00-00 THRU: 10-01-99
17	134755-01-02B	EA	PANEL - FUEL FILL - LEFT HAND - E-COATED
			FROM: 10-02-99 THRU: 99-99-99

CHASSIS GROUP (CONTINUED)

FRONT END

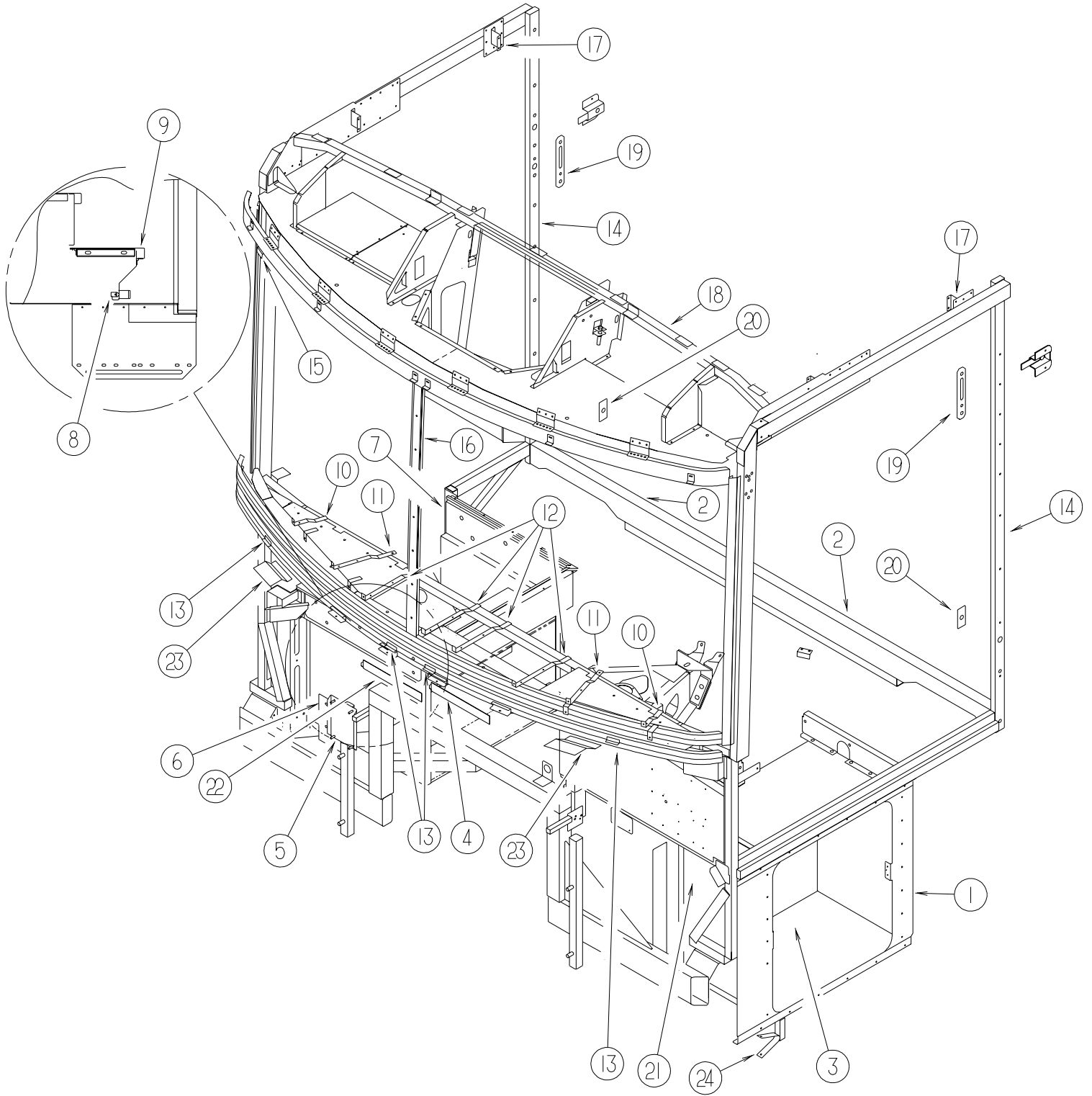

CHASSIS GROUP (CONTINUED)

FRONT END (CONTINUED)

KEY	PART NUMBER	U/M	DESCRIPTION
1	136332-01-02B	EA	SEAL PLANE - FRONT/LEFT HAND - E-COATED
2	117154-04-02B	EA	MOUNT-BODY,E-COAT
3	123764-03-02B	EA	COMPARTMENT - LUGGAGE - E- COATED
4	134371-01-01B	EA	ANGLE-MOUNT,WIPER MOTOR,MILL
5	119656-02-02B	EA	BRACKET - RESERVOIR/WASHER - E-COATED
6	115024-01-01B	EA	BRACKET - TANK - AIR HORN
7	131471-01-02B	EA	STEP - ENTRY DOOR - E-COATED
8	120863-08-000	EA	BUMPER - RUBBER - W/INSERT
9	131519-01-L76	EA	STEP - FOLD UP/ENTRY DOOR
10	104797-05-000	EA	BRACKET-DEFROSTER
11	104797-04-000	EA	BRACKET-DEFROSTER
12	104797-03-000	EA	BRACKET-DEFROSTER
13	076364-57-000	EA	ANGLE - FORMED
14	127874-02-01B	EA	TUBE-B PILLAR,MILL
15	120363-01-01B	EA	BRACKET - WINDSHIELD
16	120840-06-01B	EA	STRAP-W/HOLES,MILL
17	104409-01-000	EA	PLATE-MOUNT,SIDEWALL
18	130043-01-01B	EA	SUPPORT - CABINET/TV - FRONT
19	127461-02-01B	EA	PLATE - ANCHOR - SEAT BELT - UPPER - MILL
20	133576-02-01B	EA	PLATE - ANCHOR - SEAT BELT - LOWER - MILL
21	125212-12-01B	EA	BOX ASM-ELECTRICAL,MILL
22	134371-02-01B	EA	ANGLE-MOUNT,WIPER MOTOR,MILL
23	134202-01-01B	EA	REINFORCEMENT - SUPPORT - LOWER WINDSHIELD/MIDDLE
24	115023-01-000	EA	ISOLATOR - RUBBER

CHASSIS GROUP (CONTINUED)

INSULATION

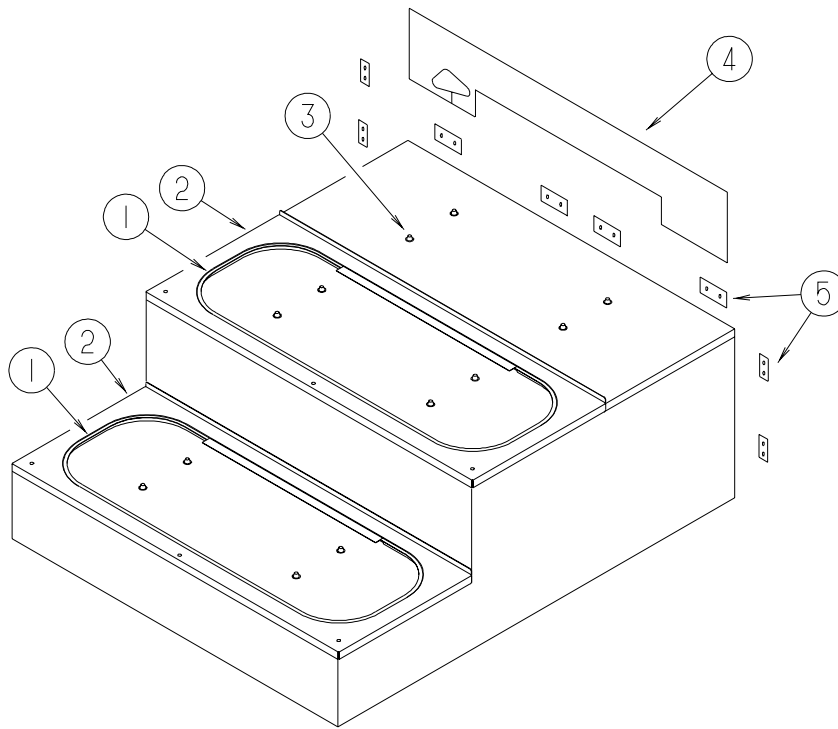

KEY	PART NUMBER	U/M	DESCRIPTION
1	039623-01-000	FT	SEAL - MOTOR COVER - RUBBER BULB TYPE
2	134340-01-02B	EA	COVER - ENGINE - E-COATED
3	106648-01-000	EA	CAP - STUD - .120 TO .130 DIAMETER
4	131292-02-000	EA	BAFFLE - RADIATOR - TOP/REAR
5	110277-02-000	EA	STRAP - W/HOLES

CHASSIS GROUP (CONTINUED)

EXHAUST

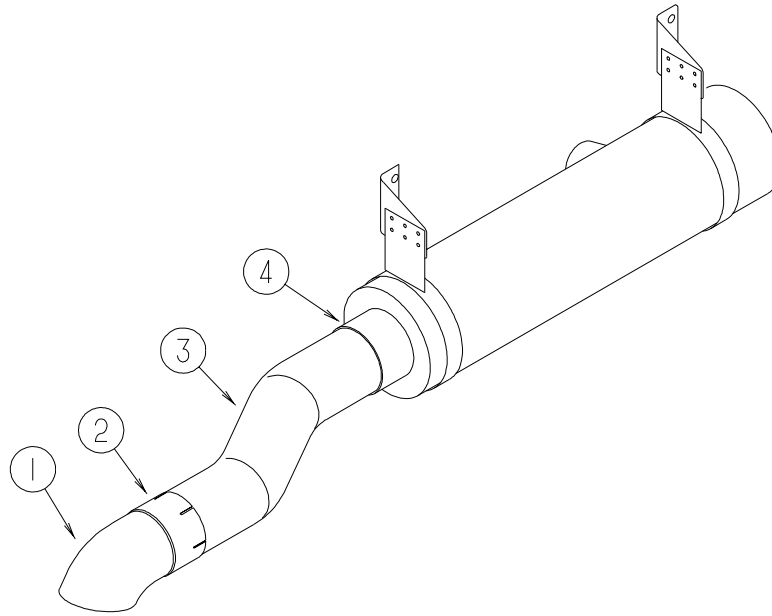

KEY	PART NUMBER	U/M DESCRIPTION
1	116425-03-000	EA EXTENSION - EXHAUST - CHROMED - 4"
2	094918-05-000	EA CLAMP - EXHAUST - 4 7/16" - GUILLOTINE STYLE
3	114869-06-000	EA PIPE - EXHAUST
4	094918-08-000	EA CLAMP - EXHAUST - 5"

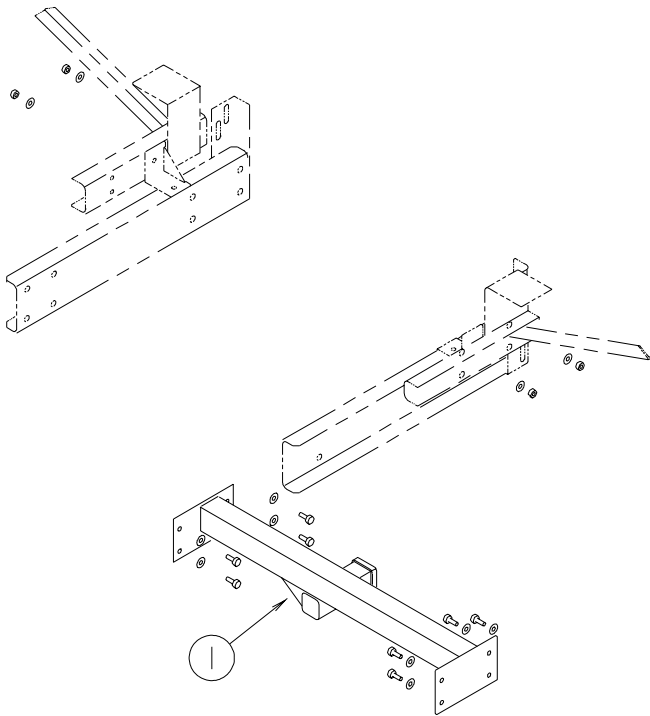

HITCH

KEY	PART NUMBER	U/M DESCRIPTION
1	130339-03-000	EA HITCH RECEIVER - BOLT ON CLASS III
	113589-02-000	EA CONNECTOR - SOCKET - TRAILER
	113589-01-000	EA CONNECTOR - PLUG - TRAILER

CHASSIS GROUP (CONTINUED)

REAR BUMPER

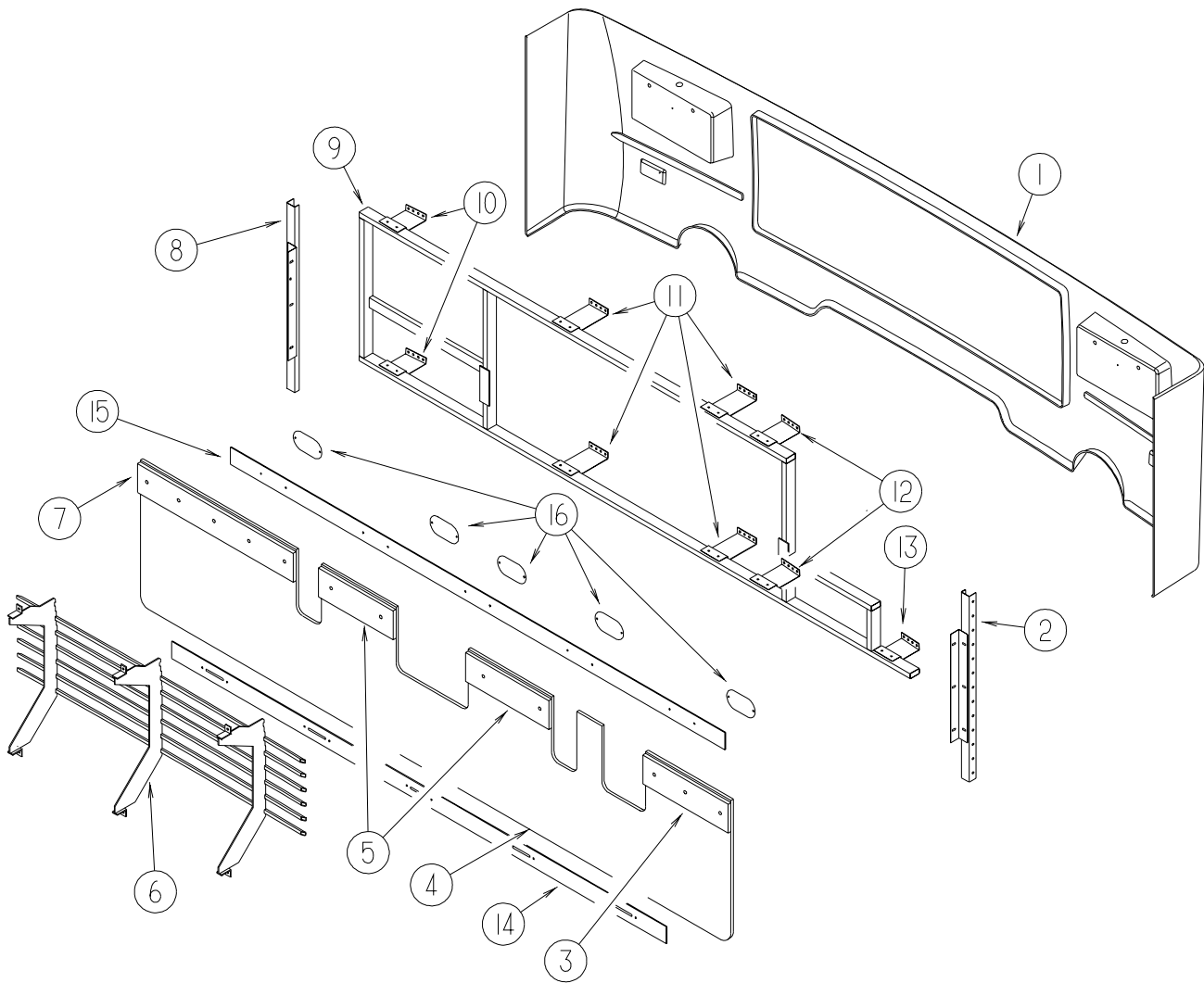

KEY	PART NUMBER	U/M	DESCRIPTION
1	131898-02-L76	EA	PANEL - BUMPER - REAR
2	132071-01-02B	EA	BRACKET - REAR BUMPER - E-COATED
3	N/A	EA	STRAP - W/HOLES - 12"
4	130464-07-01A	EA	MUD FLAP - REAR/RADIATOR (SIDE)
5	N/A	EA	STRAP - W/HOLES - E-COATED
6	132447-01-L76	EA	GRILL ASSEMBLY - REAR BUMPER
7	N/A	EA	STRAP - W/HOLES - E-COATED
8	132071-01-02B	EA	BRACKET - REAR BUMPER - E-COATED
9	132446-03-L76	EA	FRAME - BUMPER/REAR
10	132070-01-02B	EA	BRACKET - BUMPER SUPPORT - E-COATED
11	132070-03-02B	EA	BRACKET - BUMPER SUPPORT
12	132070-09-02B	EA	BRACKET - BUMPER SUPPORT - E-COATED
13	132070-02-02B	EA	BRACKET - BUMPER SUPPORT
14	135067-01-02B	EA	ANGLE - MUDFLAP - E-COATED
15	130464-03-01A	EA	TRIM & FASTENER PKG - REAR MUD FLAP
16	130464-04-01A	EA	REFLECTOR ONLY - REAR MUD FLAP (1 PKG = 5 REFLECTORS)

CHASSIS GROUP (CONTINUED)

FUEL

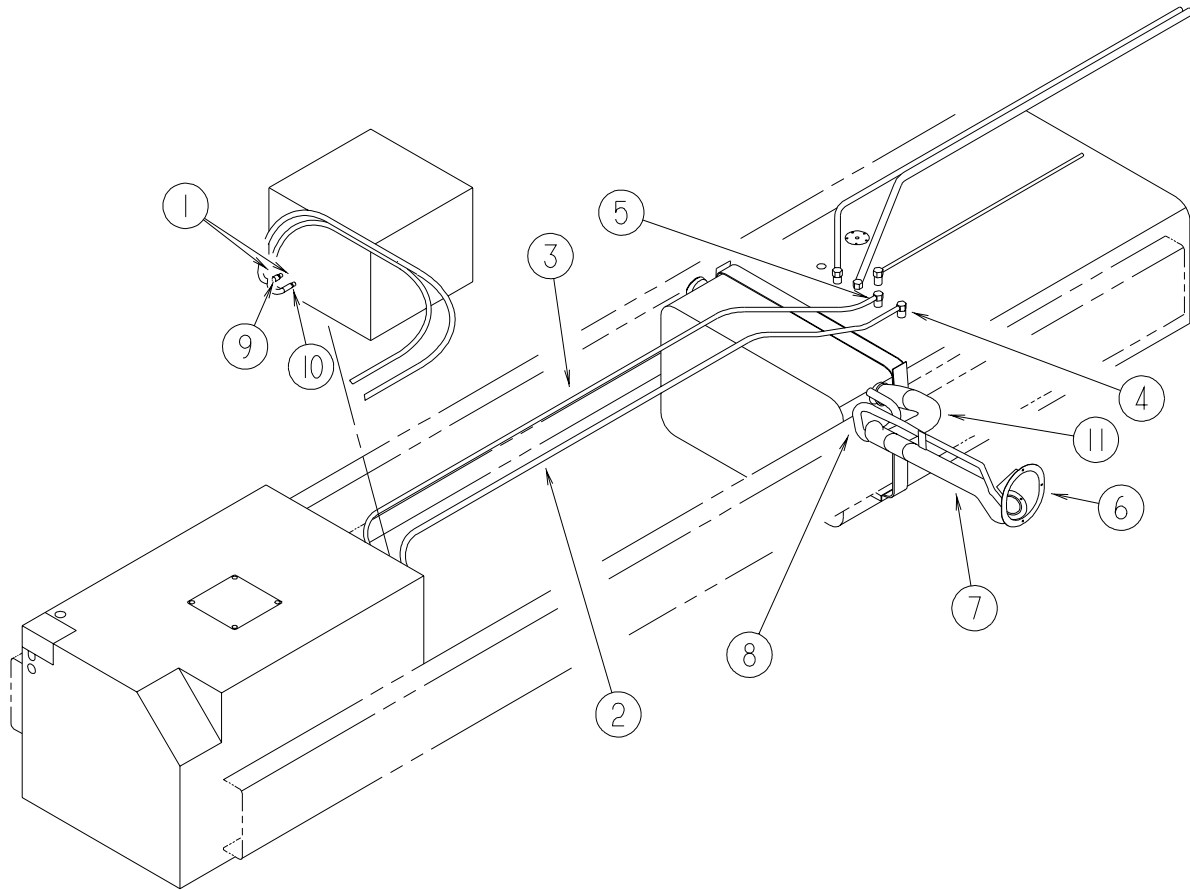

KEY	PART NUMBER	U/M	DESCRIPTION
1	010497-03-000	EA	CLAMP - CLOSED - 1" ID - CUSHIONED
2	024138-01-000	FT	HOSE - FUEL - 5/16" ID
2	062401-06-000	EA	CLAMP - HOSE - WORMGEAR - .22" - .62" ID
3	128139-03-000	FT	HOSE - FUEL - LOW PERMEABILITY - 1/4" DIAMETER
3	062401-06-000	EA	CLAMP - HOSE - WORMGEAR - .22" - .62" ID
4	114253-02-000	EA	ELBOW - 5/16 SINGLE BARB X 1/4 MPT
5	114253-01-000	EA	ELBOW - 1/4 SINGLE BARB X 1/8 MPT
5	068382-06-000	EA	BUSHING - BRASS - 3/8"MPT X 1/8"FPT
6	128299-01-01A	EA	SHROUD - FUEL FILL
7	132108-01-000	EA	NECK ASSEMBLY - FUEL FILL/DRIVER
8	066732-01-000	FT	HOSE - FUEL - .62"ID
8	062401-02-000	EA	CLAMP - HOSE - WORMGEAR - 1.56" - 2.5"
9	114254-02-000	EA	ADAPTER - 5/16 SINGLE BARB X 1/8 MPT
9	062401-06-000	EA	CLAMP - HOSE - WORMGEAR - .22" - .62" ID
10	114254-01-000	EA	ADAPTER - 1/4 BARB X 1/8 MPT
10	062401-06-000	EA	CLAMP - HOSE - WORMGEAR - .22" - .62" ID
11	132405-01-000	EA	TUBE - FUEL INLET

CHASSIS GROUP (CONTINUED)

HYDRAULIC LEVELING

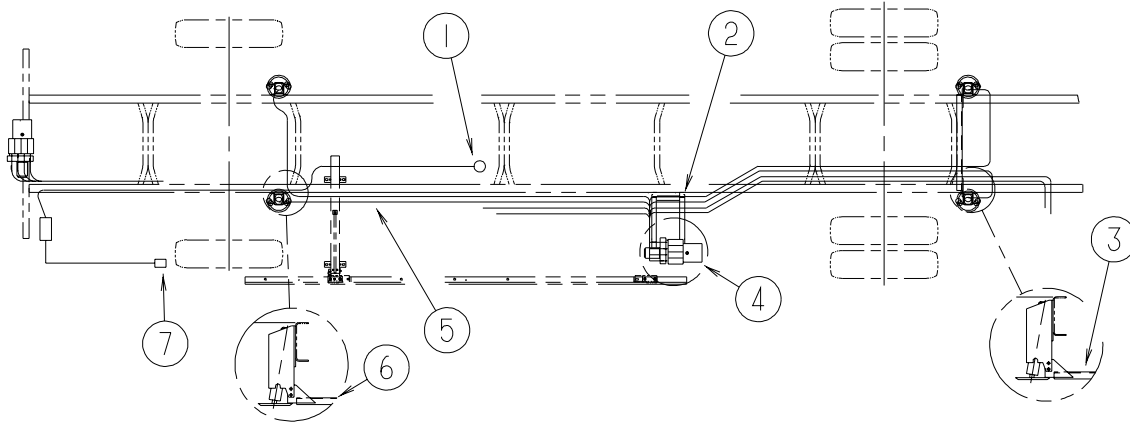

KEY	PART NUMBER	U/M	DESCRIPTION
	1	EA	COVER - SENSOR - LEVELING
	2	EA	BRACKET - PUMP - LEVELING - E-COATED
	3	EA	BRACKET - JACKS/REAR - E-COATED
	4*	EA	LEVELING SYSTEM - FREIGHTLINER W/AIR DUMP - 310 F/SLIDE
	5	EA	HOSE KIT - LEVELING JACKS
	6	EA	CROSSMEMBER - REAR JACK MOUNTING
	7	EA	PANEL - CONTROL - 310 AIR DUMP
	100536-44-000	EA	HOSE KIT - SLIDEOUT
	071387-04-000	EA	ELBOW - MALE - BRAKE TUBE 3/8 X 1/4

*COMPONENT PARTS FOUND IN SERVICE PARTS LIBRARY

WHEEL, TIRE, COVERS &/OR LINERS

WHEELS

FROM: 00-00-00 THRU: 10-03-99

KEY	PART NUMBER	U/M	DESCRIPTION
	128689-01-000	EA	WHEEL - ALUMINUM - 22.5" X 7.5" - 8 BOLT - FRONT AXLE
	128689-02-000	EA	WHEEL - ALUMINUM - 22.5" X 7.5" - 8 BOLT - REAR AXLE
	129058-01-000	EA	COVER - FRONT AXLE
	129058-02-000	EA	COVER - WHEEL HUB/REAR
	129058-03-000	EA	COVER - WHEEL NUT
	129058-06-000	EA	EXTENSION - VALVE STEM - 4" LONG
	129058-07-000	EA	STABILIZER - VALVE STEM

WHEELS

FROM: 10-04-99 THRU: 99-99-99

KEY	PART NUMBER	U/M	DESCRIPTION
	134439-01-000	EA	WHEEL - ALUMINUM - 7.5" X 22.5"/10 BOLT - FRONT
	134439-02-000	EA	WHEEL - ALUMINUM - 7.5" X 22.5"/10 BOLT - REAR
	129058-10-000	EA	COVER - NUT - 10 BOLT - 33 HEX (FRONT 2 WHEELS)
	129058-11-000	EA	COVER - NUT - 10 BOLT - 33 HEX (REAR OUTSIDE 2 WHEELS)
	129058-12-000	EA	COVER - AXLE - 10B REAR W/O FLANGE
	129058-13-000	EA	COVER - AXLE - 10B FRONT
	077030-07-000	EA	EXTENSION - VALVE STEM - 5.9" LONG

WHEEL LINERS

KEY	PART NUMBER	U/M	DESCRIPTION
*	110435-05-000	EA	LINER - WHEEL - SET/4 - 22.5" - 8 BOLT FROM: 00-00-00 THRU: 09-30-99
*	110435-17-000	EA	LINER - WHEEL - SET/4 - 22.5" - 10 BOLT FROM: 10-01-99 THRU: 99-99-99

*COMPONENT PARTS FOUND IN SERVICE PARTS LIBRARY

LUG WRENCH & BAR

KEY	PART NUMBER	U/M	DESCRIPTION
	080208-04-000	EA	LUG WRENCH - 1 3/16" - OSHKOSH/SPARTAN
	080208-05-000	EA	BAR - LEVERAGE - LUG WRENCH - .75"DIA. - OSHKOSH/SPARTAN

CURTAIN & CUSHION GROUP

NOTICE

IN ORDER TO ASSIST OUR PARTS SALES DEPT. IN PROVIDING INTERIOR SOFTWARE ITEMS, PLEASE INCLUDE THE SERIAL NUMBER AND THE COLOR CODE NUMBER FROM THE VEHICLE CERTIFICATION LABEL WHEN ORDERING. THIS LABEL IS LOCATED ON THE LEFT SIDEWALL AT THE END OF THE DASH (A-BODY), OR ON THE DRIVER'S DOOR LATCH PLATE (C-BODY).

AN EXAMPLE OF A COLOR CODE NUMBER IS B07, WHICH DESIGNATES AN OVERALL COLOR SCHEME OF A PARTICULAR UNIT. THE COLOR LISTED AFTER THE ITEM DESCRIPTION ON THE MICROFICHE, INDICATES THE OVERALL UNIT COLOR. ORDER THE ITEM YOU DESIRE ACCORDING TO UNIT COLOR CODE. IF ALL COLORS USE THE SAME ITEM NO COLOR CODE WILL BE NOTED.

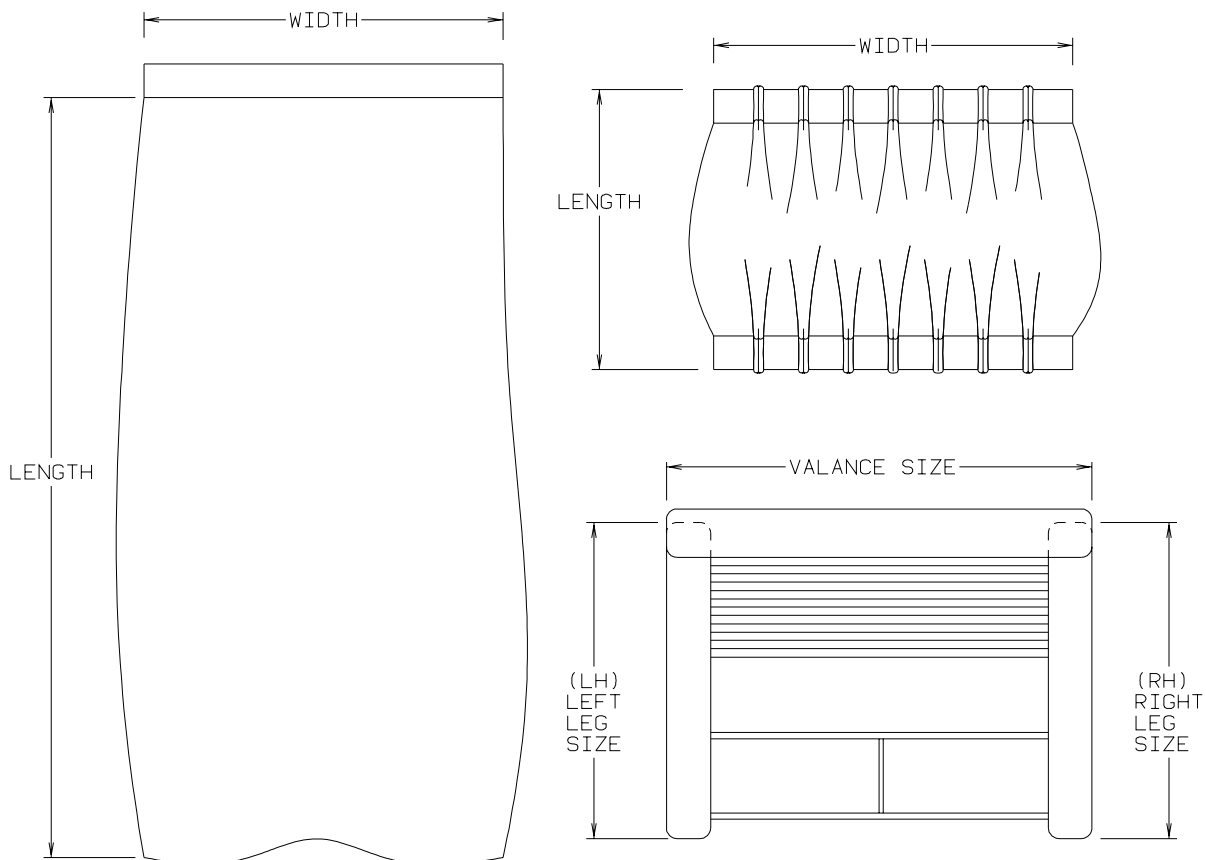

NOTE: USE THIS ILLUSTRATION WHEN DETERMINING LENGTH AND WIDTH MEASUREMENTS FOR CURTAINS. YOU WILL NOTE THE WIDTH MEASUREMENT IS TAKEN ON THE TOP OF THE CURTAIN WITH THE CURTAIN FULLY EXTENDED. THE LENGTH MEASUREMENT IS TAKEN FROM TOP TO BOTTOM. LEFT AND RIGHT WINDOW LEGS ARE DETERMINED WHEN FACING THE WINDOW.

CURTAIN & CUSHION GROUP (CONTINUED)

CUSHION LAYOUT

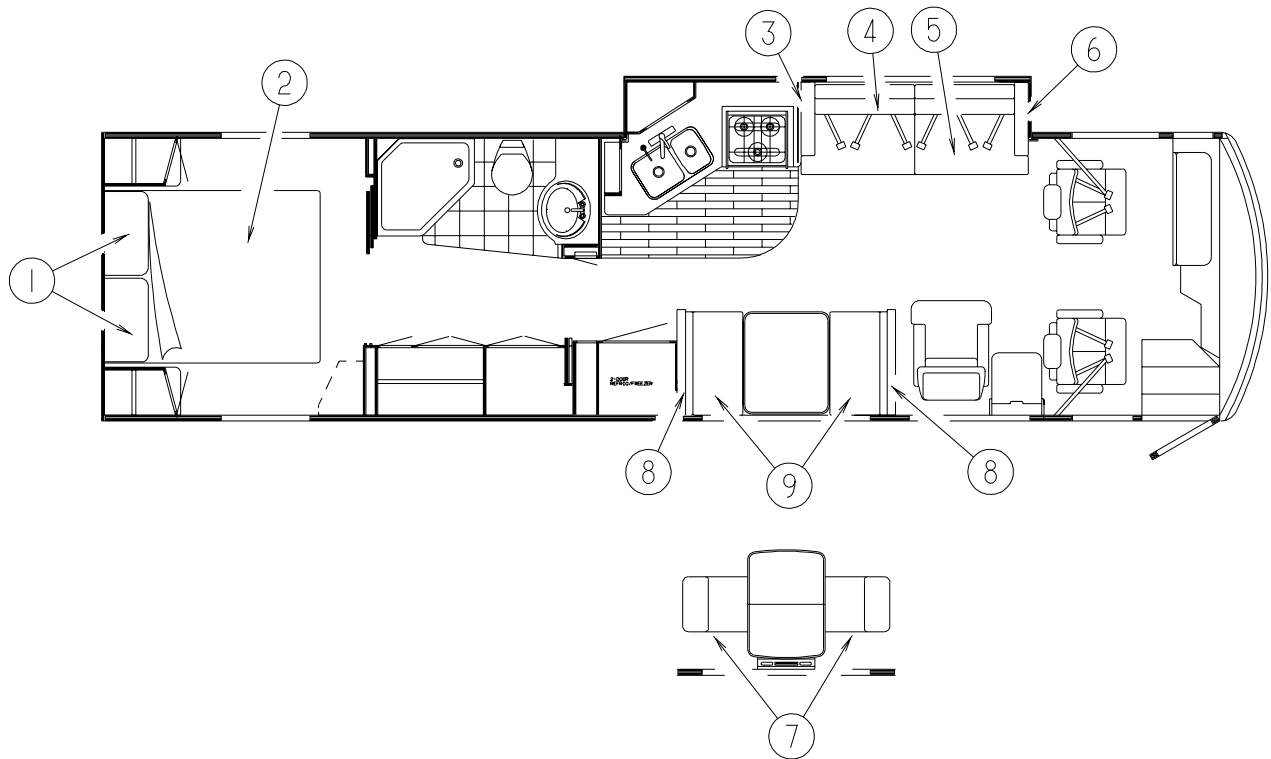

QUEEN BED

KEY	PART NUMBER	U/M	DESCRIPTION
1	104565-21-L76	EA	PILLOW SHAM - 2" FLANGE & BRAID
1	104565-21-L78	EA	PILLOW SHAM - 2" FLANGE & BRAID
1	104565-21-L80	EA	PILLOW SHAM - 2" FLANGE & BRAID
	132319-08-L76	EA	PILLOW - 17" - W/HALF MOON OVERLAY (L76)
	132319-08-L78	EA	PILLOW - 17" - W/HALF MOON OVERLAY (L78)
	132319-08-LA8	EA	PILLOW - 17" - W/HALF MOON OVERLAY (L78) FROM: 00-00-00 THRU: 03-05-00
	132319-08-L80	EA	PILLOW - 17" - W/HALF MOON OVERLAY (L80) FROM: 03-06-00 THRU: 99-99-99
2	123015-06-000	EA	MATTRESS - INNERSPRING - 60" X 74.5"
2	132336-06-L76	EA	BEDSPREAD/CAP - 60" X 75"
2	132336-06-L78	EA	BEDSPREAD/CAP - 60" X 75"
2	132336-06-L80	EA	BEDSPREAD/CAP - 60" X 75"

DRIVERS SIDE SOFA

KEY	PART NUMBER	U/M	DESCRIPTION
3	133346-05-L76	EA	ARMREST/RIGHT HAND - SOFA/BED
3	133346-05-L78	EA	ARMREST/RIGHT HAND - SOFA/BED
3	133346-05-L80	EA	ARMREST/RIGHT HAND - SOFA/BED
3	133346-07-L76	EA	ARMREST/RIGHT HAND - SOFA/BED - LEATHER
3	133346-07-L78	EA	ARMREST/RIGHT HAND - SOFA/BED - LEATHER
3	133346-07-L80	EA	ARMREST/RIGHT HAND - SOFA/BED - LEATHER
3	134235-03-000	EA	ARMREST/RIGHT HAND - SOFA/BED - W/O COVER
4	133344-02-L76	EA	BACK ONLY - SOFA/BED - 70"
4	133344-02-L78	EA	BACK ONLY - SOFA/BED - 70"
4	133344-02-L80	EA	BACK ONLY - SOFA/BED - 70"
4	P33344-02-L76	EA	COVER/BACK - SOFA/BED - 70"
4	P33344-02-L78	EA	COVER/BACK - SOFA/BED - 70"
4	P33344-02-L80	EA	COVER/BACK - SOFA/BED - 70"
4	133349-02-L76	EA	BACK ONLY - SOFA/BED - 70" - LEATHER
4	133349-02-L78	EA	BACK ONLY - SOFA/BED - 70" - LEATHER
4	133349-02-L80	EA	BACK ONLY - SOFA/BED - 70" - LEATHER

CURTAIN & CUSHION GROUP (CONTINUED)

CUSHION LAYOUT (CONTINUED)

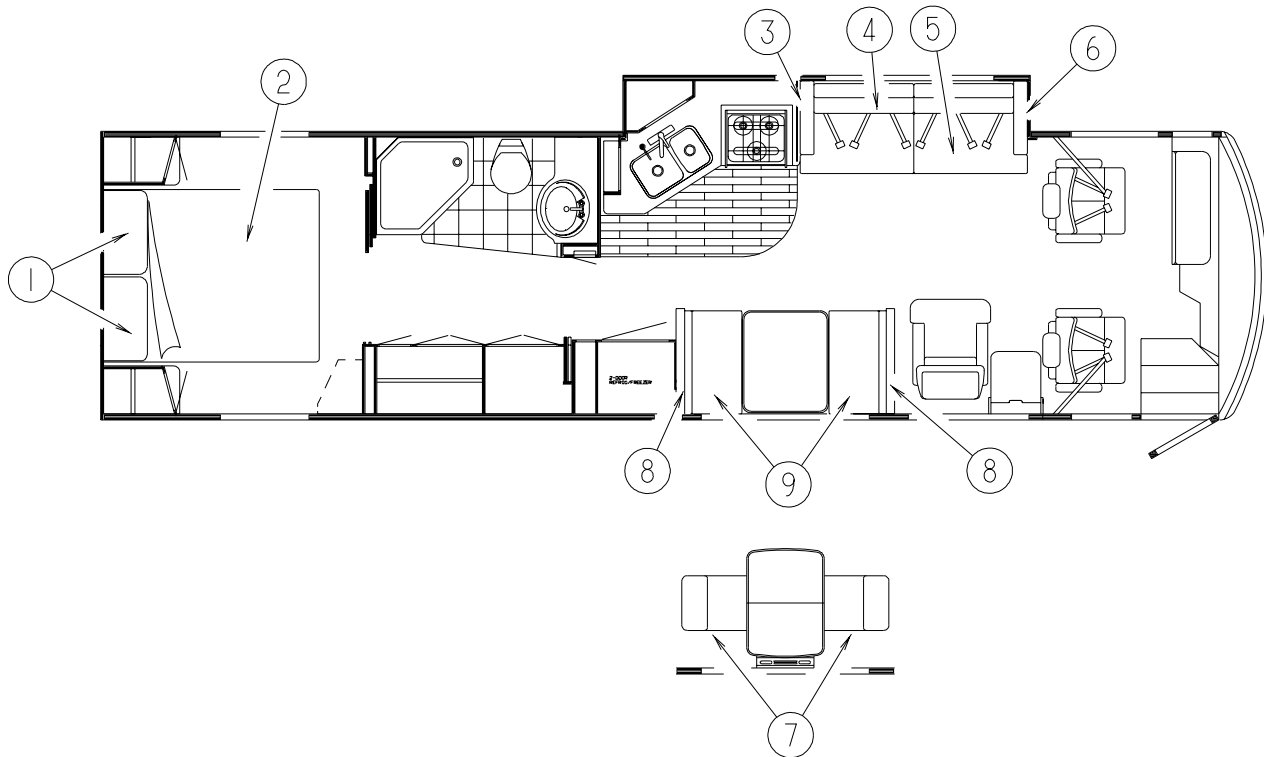

DRIVERS SIDE SOFA (CONTINUED)

KEY	PART NUMBER	U/M	DESCRIPTION
4	P33349-02-L76	EA	COVER/BACK - SOFA/BED - 70" - LEATHER
4	P33349-02-L78	EA	COVER/BACK - SOFA/BED - 70" - LEATHER
4	P33349-02-L80	EA	COVER/BACK - SOFA/BED - 70" - LEATHER
5	133344-01-L76	EA	SEAT ONLY - SOFA/BED - 70"
5	133344-01-L78	EA	SEAT ONLY - SOFA/BED - 70"
5	133344-01-L80	EA	SEAT ONLY - SOFA/BED - 70"
5	P33344-01-L76	EA	COVER/SEAT - SOFA/BED - 70"
5	P33344-01-L78	EA	COVER/SEAT - SOFA/BED - 70"
5	P33344-01-L80	EA	COVER/SEAT - SOFA/BED - 70"
5	133349-01-L76	EA	SEAT ONLY - SOFA/BED - 70" - LEATHER
5	133349-01-L78	EA	SEAT ONLY - SOFA/BED - 70" - LEATHER
5	133349-01-L80	EA	SEAT ONLY - SOFA/BED - 70" - LEATHER
5	P33349-01-L76	EA	COVER/SEAT - SOFA/BED - 70" - LEATHER
5	P33349-01-L78	EA	COVER/SEAT - SOFA/BED - 70" - LEATHER
5	P33349-01-L80	EA	COVER/SEAT - SOFA/BED - 70" - LEATHER
6	133346-06-L76	EA	ARMREST/LEFT HAND - SOFA/BED
6	133346-06-L78	EA	ARMREST/LEFT HAND - SOFA/BED
6	133346-06-L80	EA	ARMREST/LEFT HAND - SOFA/BED
6	133346-08-L76	EA	ARMREST/LEFT HAND - SOFA/BED - LEATHER
6	133346-08-L78	EA	ARMREST/LEFT HAND - SOFA/BED - LEATHER
6	133346-08-L80	EA	ARMREST/LEFT HAND - SOFA/BED - LEATHER
6	134235-04-000	EA	ARMREST/LEFT HAND - SOFA/BED - W/O COVER
	132319-07-L76	EA	PILLOW - 17" - W/HALF MOON OVERLAY
	132319-07-L78	EA	PILLOW - 17" - W/HALF MOON OVERLAY
	132319-07-L80	EA	PILLOW - 17" - W/HALF MOON OVERLAY
	127335-07-000	EA	LEG - SOFA/BED
	132870-03-000	EA	FRAME - 70" SOFA BASE - CUSTOM LOUNGE
	124656-96-000	EA	LOCK - CANADIAN - #3380EZLK
	116104-03-02B	EA	BRACKET - ZEE W/HOLES - 5.9"
	116104-04-02B	EA	BRACKET - ZEE W/HOLES - 3.2"

CURTAIN & CUSHION GROUP (CONTINUED)

CUSHION LAYOUT (CONTINUED)

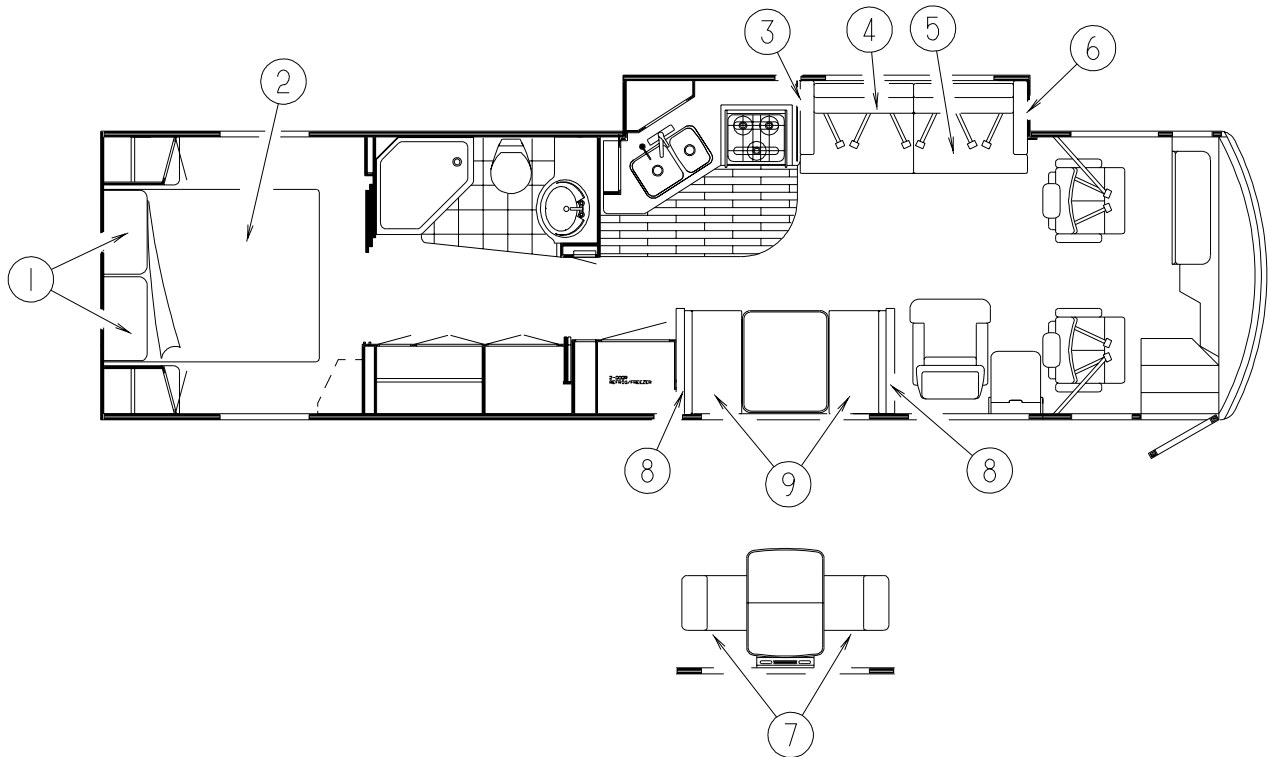

DINETTE CHAIR

KEY	PART NUMBER	U/M	DESCRIPTION
7	134017-01-000	EA	CHAIR - DINETTE - WATERFORD OAK (L76)
7	134017-08-000	EA	CHAIR - DINETTE - WATERFORD OAK (L78)
7	134017-09-000	EA	CHAIR - DINETTE - WATERFORD OAK (L80)
	101604-01-03A	EA	CHAIR - FOLDING/DINETTE - LINEN FABRIC - WATERFORD OAK

DINETTE

KEY	PART NUMBER	U/M	DESCRIPTION
8	111880-09-L76	EA	CUSHION - BACK - 13.5" X 36" X 5"
8	111880-09-L78	EA	CUSHION - BACK - 13.5" X 36" X 5"
8	111880-09-L80	EA	CUSHION - BACK - 13.5" X 36" X 5"
8	P11880-09-L32	EA	COVER - BACK - 13.5" X 36" X 5" (L76)
8	P11880-09-L34	EA	COVER - BACK - 13.5" X 36" X 5" (L78)
8	P11880-09-L36	EA	COVER - BACK - 13.5" X 36" X 5" (L80)
9	105603-01-L32	EA	CUSHION - SEAT - 23" X 36" X 5" (L76)
9	105603-01-L34	EA	CUSHION - SEAT - 23" X 36" X 5" (L78)
9	105603-01-L36	EA	CUSHION - SEAT - 23" X 36" X 5" (L80)
9	P05603-01-L32	EA	COVER - SEAT - 23" X 36" X 5" (L76)
9	P05603-01-L34	EA	COVER - SEAT - 23" X 36" X 5" (L78)
9	P05603-01-L36	EA	COVER - SEAT - 23" X 36" X 5" (L80)

CURTAIN & CUSHION GROUP (CONTINUED)

BUCKET SEAT

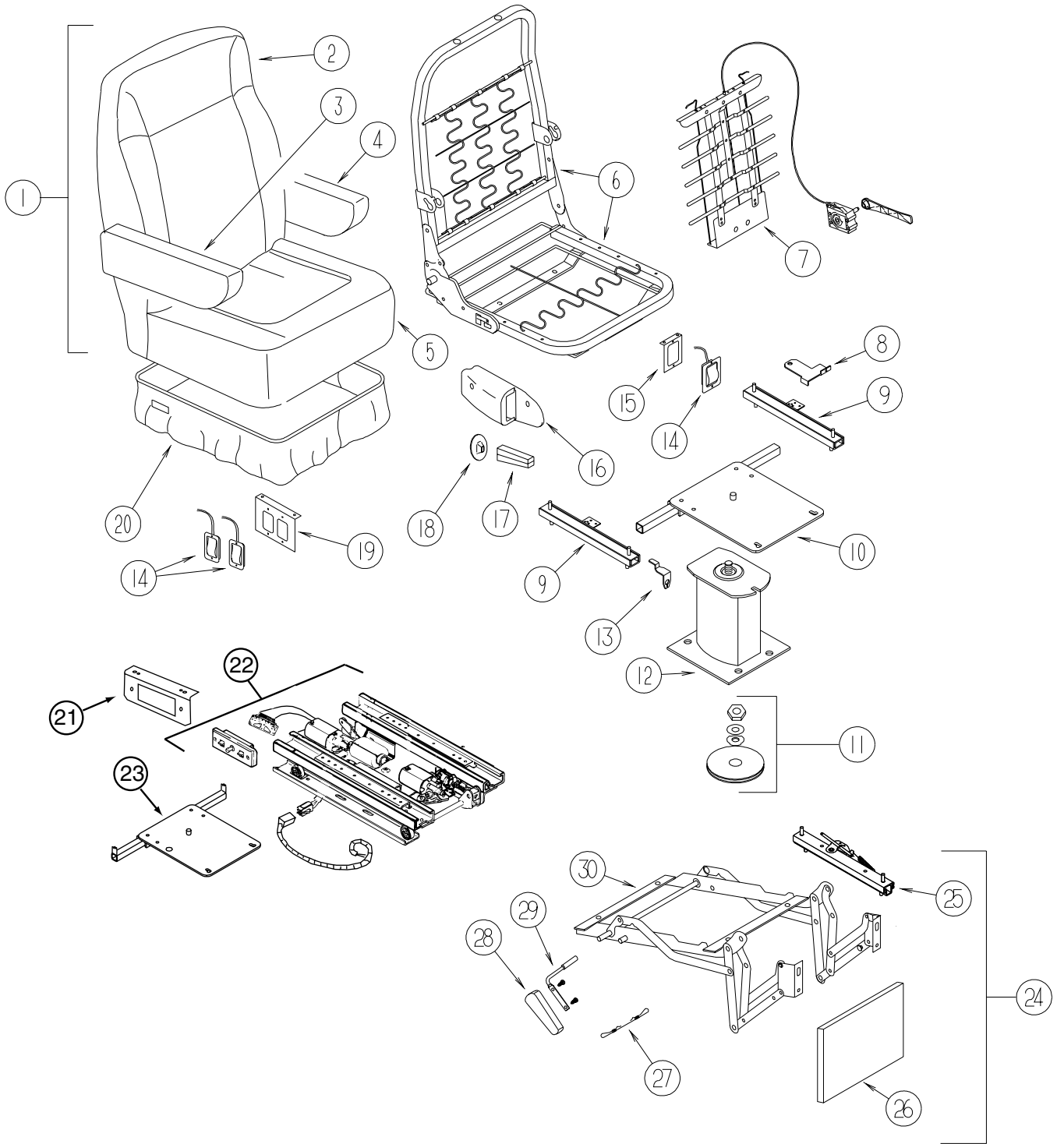

CURTAIN & CUSHION GROUP (CONTINUED)

BUCKET SEAT (CONTINUED)

KEY	PART NUMBER	U/M	DESCRIPTION
1	129715-03-L76	EA	SEAT - BUCKET - W/FOOTREST
1	129715-03-L78	EA	SEAT - BUCKET - W/FOOTREST
1	129715-03-L80	EA	SEAT - BUCKET - W/FOOTREST
1	129715-06-L76	EA	SEAT - BUCKET - W/ADJUSTABLE ARMS/FOOTREST - LEATHER (L76)
1	129715-12-L78	EA	SEAT - BUCKET - W/ADJUSTABLE ARMS/FOOTREST - LEATHER (L78)
1	129715-12-L52	EA	SEAT - BUCKET - W/ADJUSTABLE ARMS/FOOTREST - LEATHER (L80)
1	129715-01-L76	EA	SEAT - BUCKET - W/LUMBAR SUPPORT
1	129715-01-L78	EA	SEAT - BUCKET - W/LUMBAR SUPPORT
1	129715-01-L80	EA	SEAT - BUCKET - W/LUMBAR SUPPORT
1	129715-04-L76	EA	SEAT - BUCKET - LUMBAR W/ADJUSTABLE ARMS - LEATHER
1	129715-10-L78	EA	SEAT - BUCKET - LUMBAR W/ADJUSTABLE ARMS - LEATHER
1	129715-10-L80	EA	SEAT - BUCKET - LUMBAR W/ADJUSTABLE ARMS - LEATHER
1	129715-02-L76	EA	SEAT - BUCKET - W/ADJUSTABLE ARMRESTS
1	129715-02-L78	EA	SEAT - BUCKET - W/ADJUSTABLE ARMRESTS
1	129715-02-L80	EA	SEAT - BUCKET - W/ADJUSTABLE ARMRESTS
1	129715-05-L76	EA	SEAT - BUCKET - W/ADJUSTABLE ARMS - LEATHER
1	129715-11-L78	EA	SEAT - BUCKET - W/ADJUSTABLE ARMS - LEATHER
1	129715-11-L80	EA	SEAT - BUCKET - W/ADJUSTABLE ARMS - LEATHER
2	M05962-82-L76	EA	COVER - BACK
2	M05962-82-L78	EA	COVER - BACK
2	M05962-82-L80	EA	COVER - BACK
2	M05962-98-L76	EA	COVER - BACK - LEATHER (L76)
2	M05962-A3-L78	EA	COVER - BACK - LEATHER (L78)
2	M05962-A3-L52	EA	COVER - BACK - LEATHER (L80)
3	129716-01-L76	EA	ARMREST - ADJUSTABLE RIGHT HAND
3	P29716-01-L76	EA	COVER - ARMREST/RIGHT HAND
3	129716-01-L78	EA	ARMREST - ADJUSTABLE RIGHT HAND
3	P29716-01-L78	EA	COVER - ARMREST/RIGHT HAND
3	129716-01-L80	EA	ARMREST - ADJUSTABLE RIGHT HAND
3	P29716-01-L80	EA	COVER - ARMREST/RIGHT HAND
3	129716-05-L76	EA	ARMREST - ADJUSTABLE RIGHT HAND - LEATHER
3	P29716-05-L76	EA	COVER - ARMREST/RIGHT HAND - LEATHER
	130699-01-000	EA	ARMREST - MOLDED/RIGHT HAND
	122622-04-000	EA	BRACKET - ADJUSTABLE/ARMREST - RIGHT HAND
	122622-06-000	EA	KNOB - W/3/8" THREAD INSERT
4	129716-02-L76	EA	ARMREST - ADJUSTABLE LEFT HAND
4	P29716-02-L76	EA	COVER - ARMREST/LEFT HAND
4	129716-02-L78	EA	ARMREST - ADJUSTABLE LEFT HAND
4	P29716-02-L78	EA	COVER - ARMREST/LEFT HAND
4	129716-02-L80	EA	ARMREST - ADJUSTABLE LEFT HAND
4	P29716-02-L80	EA	COVER - ARMREST/LEFT HAND
4	129716-06-L76	EA	ARMREST - ADJUSTABLE LEFT HAND - LEATHER
4	P29716-06-L76	EA	COVER - ARMREST/LEFT HAND - LEATHER
	130699-02-000	EA	ARMREST - MOLDED/LEFT HAND
	122622-05-000	EA	BRACKET - ADJUSTABLE/ARMREST - LEFT HAND
	122622-06-000	EA	KNOB - W/3/8" THREAD INSERT
5	M05962-83-L76	EA	COVER - SEAT
5	M05962-83-L78	EA	COVER - SEAT
5	M05962-83-L80	EA	COVER - SEAT
5	M05962-99-L76	EA	COVER - SEAT - LEATHER
5	M05962-A4-L78	EA	COVER - SEAT - LEATHER
5	M05962-A4-L80	EA	COVER - SEAT - LEATHER
6	122695-04-01B	EA	FRAME - SEAT/HIGH BACK
			FROM: 00-00-00 THRU: 09-05-99
6	134532-01-000	EA	FRAME/SEAT - HI BACK/WIDE
			FROM: 09-06-99 THRU: 99-99-99
7	122611-02-000	EA	LUMBAR - W/LEVER
8	117125-01-02B	EA	BRACKET - CABLE MOUNT - ADJUSTER W/LOCK
9	119952-04-000	EA	SLIDE/SEAT - HEAVY DUTY LOCKING - 4 STUDS
			FROM: 00-00-00 THRU: 09-12-99
9	131566-04-000	EA	SLIDE - DOUBLE LOCKING
			FROM: 09-13-99 THRU: 99-99-99
	119952-07-000	EA	WIRE - LATCH RELEASE/ROTARY

CURTAIN & CUSHION GROUP (CONTINUED)

BUCKET SEAT (CONTINUED)

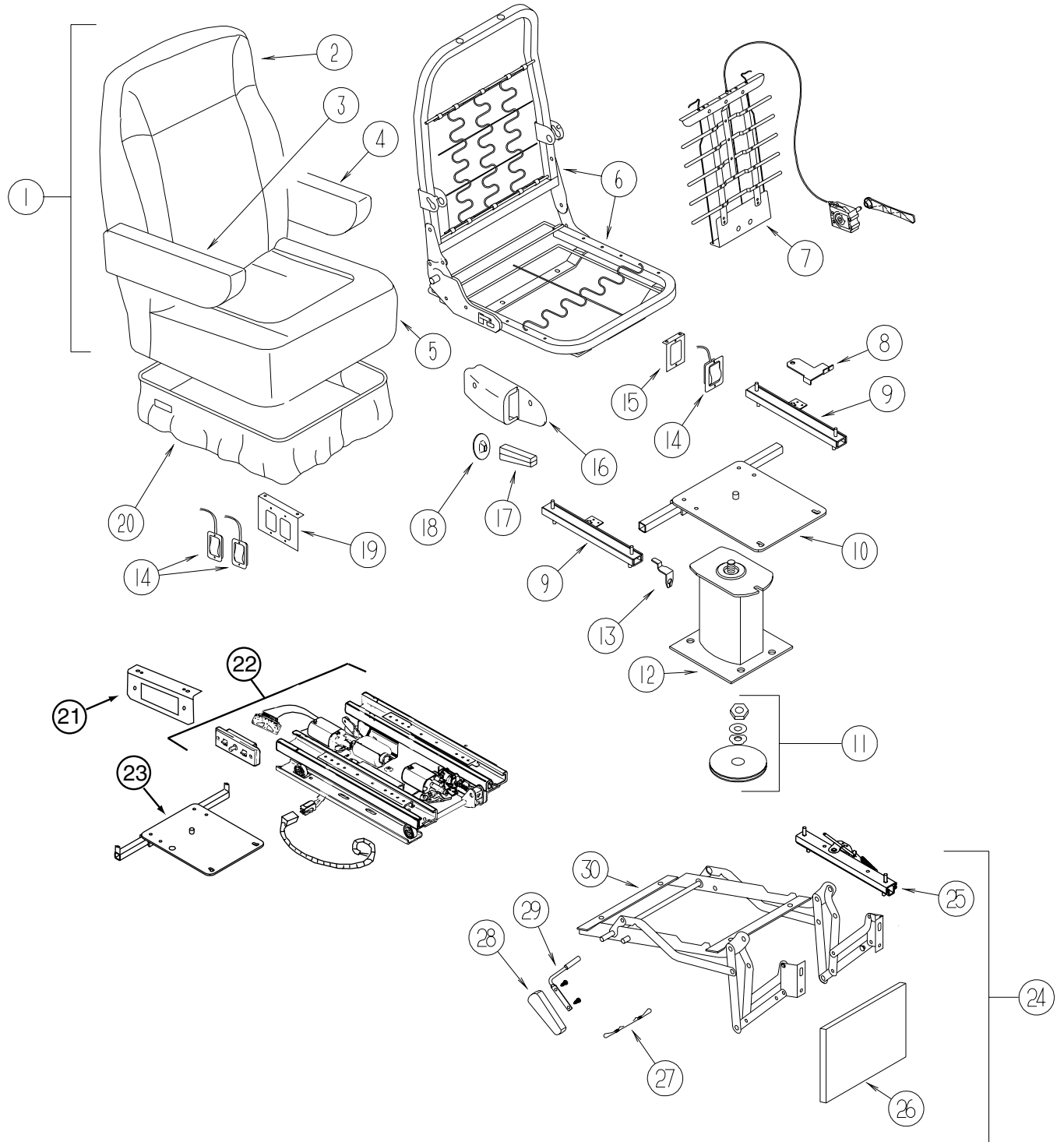

CURTAIN & CUSHION GROUP (CONTINUED)

BUCKET SEAT (CONTINUED)

KEY	PART NUMBER	U/M	DESCRIPTION
10	107921-05-000	EA	PLATE - TOP - W/SEAT BELT BAR
11	107921-06-000	EA	BEARING KIT - PEDESTAL
12	107921-01-000	EA	PEDESTAL/FLOOR MOUNTED - W/9.75" EXTENSION
12	107921-14-000	EA	PEDESTAL/FLOOR MOUNTED - W/5.75" EXTENSION (POWER)
13	108049-02-000	EA	CLIP - CABLE/PEDESTAL
14	108049-04-000	EA	CABLE - W/MINI LEVER ACTION SWITCH - 28" SHEATH/30" CABLE
15	127159-01-02B	EA	BRACKET - SEAT RELEASE - SINGLE REMOTE
16	080730-09-000	EA	SHIELD - RECLINER HANDLE
17	080730-08-000	EA	HANDLE - RECLINER
18	080730-11-000	EA	SHIELD - RUBBER BOOT
19	127159-02-02B	EA	BRACKET - SEAT RELEASE - DUAL REMOTE
20	071126-72-L76	EA	SKIRT - 10.5" (FOOTREST)
20	071126-72-L78	EA	SKIRT - 10.5" (FOOTREST)
20	071126-72-L80	EA	SKIRT - 10.5" (FOOTREST)
20	071126-79-L76	EA	SKIRT - WIDE - 10.5" - LEATHER
20	071126-68-L32	EA	SKIRT - WIDE - 10.5" OPEN CORNER (STANDARD/6-WAY POWER) (L76)
20	071126-68-L34	EA	SKIRT - WIDE - 10.5" OPEN CORNER (STANDARD/6-WAY POWER) (L78)
20	071126-68-L36	EA	SKIRT - WIDE - 10.5" OPEN CORNER (STANDARD/6-WAY POWER) (L80)
20	071126-77-L76	EA	SKIRT - WIDE - 10.5" OPEN CORNER (STANDARD/6-WAY POWER) - LEATHER
21	128699-01-02B	EA	BRACKET - SEAT SWITCH - E-COATED
22*	081373-03-000	EA	SEAT - POWER 6 WAY
23	107921-18-000	EA	PLATE - TOP - POWER - 6-WAY
24	131613-01-L76	EA	FOOTREST - PASSENGER BUCKET SEAT
24	131613-01-L78	EA	FOOTREST - PASSENGER BUCKET SEAT
24	131613-01-L80	EA	FOOTREST - PASSENGER BUCKET SEAT
24	131613-04-L52	EA	FOOTREST - PASSENGER BUCKET SEAT - LEATHER
25	131566-04-000	EA	SLIDE - DOUBLE LOCKING
	131566-05-000	EA	WASHER - SLIDE SPACER
	131566-07-000	EA	5" DOUBLE LOCKING SLIDE W/TAB
26	131613-99-000	EA	FOOTREST/WOOD - W/T-NUT
27	131566-06-000	EA	WIRE - LATCH/RELEASE - 5"
28	131566-03-000	EA	WOOD HANDLE
29	131566-02-000	EA	ROD/LEVER - FOOT-REST EXTENSION
30	131566-01-000	EA	FOOTREST - MECHANICAL
	130184-01-01A	EA	PROTECTOR - SEAT - CLEAR

*COMPONENT PARTS FOUND IN SERVICE PARTS LIBRARY

CURTAIN & CUSHION GROUP (CONTINUED)

LOUNGE CHAIR

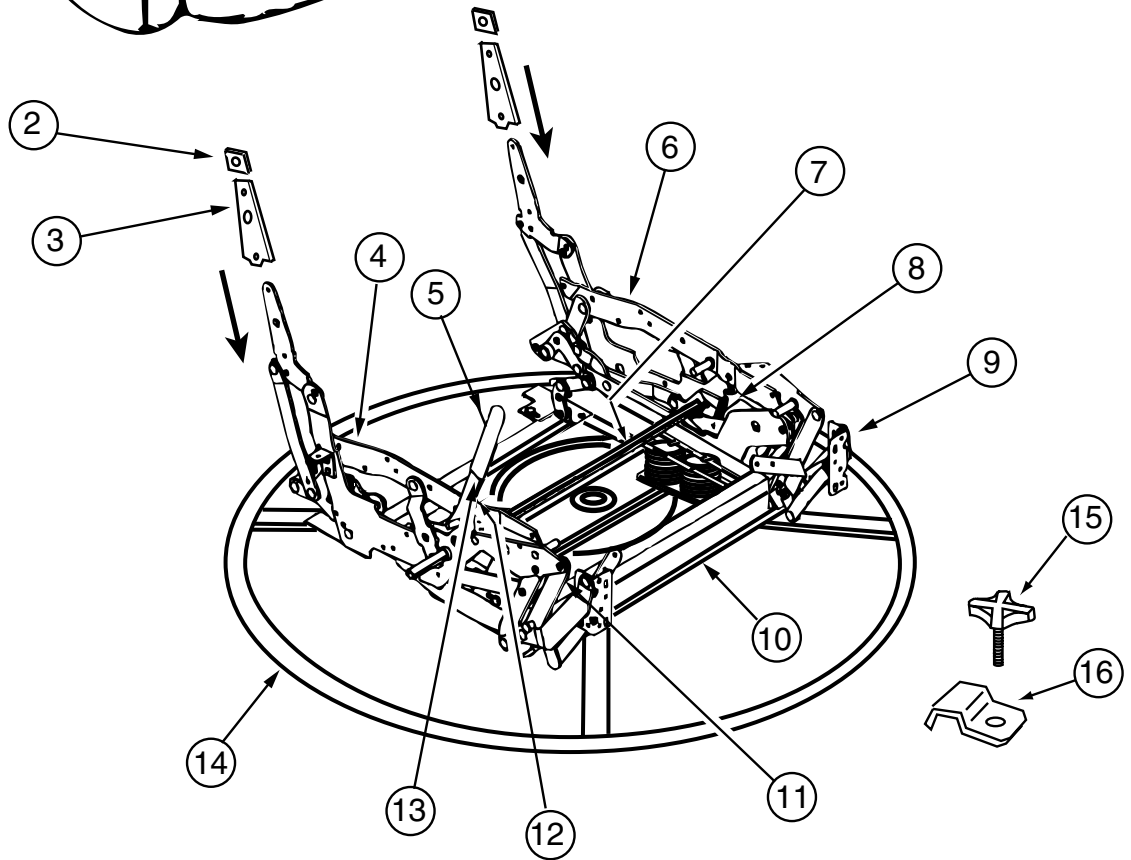
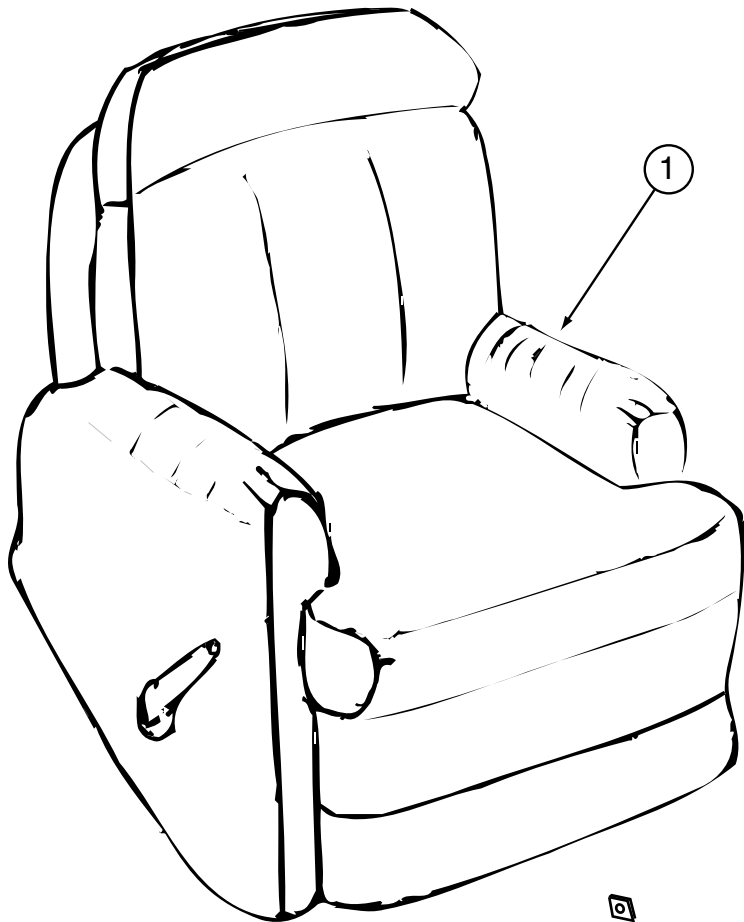

CURTAIN & CUSHION GROUP (CONTINUED)

LOUNGE CHAIR (CONTINUED)

KEY	PART NUMBER	U/M	DESCRIPTION
1	133130-01-L32	EA	CHAIR - RECLINER W/FOOTREST (L76)
1	133130-01-L34	EA	CHAIR - RECLINER W/FOOTREST (L78)
1	133130-01-L36	EA	CHAIR - RECLINER W/FOOTREST (L80)
1	133130-02-L32	EA	CHAIR - RECLINER W/FOOTREST - LEATHER (L76)
1	133130-02-L34	EA	CHAIR - RECLINER W/FOOTREST - LEATHER (L78)
1	133130-02-L80	EA	CHAIR - RECLINER W/FOOTREST - LEATHER (L80)
	P33130-01-L32	EA	COVER - RECLINER W/FOOTREST (L76)
	P33130-01-L34	EA	COVER - RECLINER W/FOOTREST (L78)
	P33130-01-L36	EA	COVER - RECLINER W/FOOTREST (L80)
	P33130-02-L32	EA	COVER - RECLINER W/FOOTREST - LEATHER (L76)
	P33130-02-L34	EA	COVER - RECLINER W/FOOTREST - LEATHER (L78)
	P33130-02-L80	EA	COVER - RECLINER W/FOOTREST - LEATHER (L80)
	133128-01-000	EA	FRAME - (CB-120 BACK)
	133128-02-000	EA	FRAME - (CS-120 SEAT)
2	133126-13-000	EA	RECLINER - (BACK KD CLIP)
3	133126-12-000	EA	RECLINER - (BACK KD SLEEVE)
4	133126-01-000	EA	RECLINER - (LEFT HARDWARE)
5	133126-11-000	EA	RECLINER - (PLASTIC HANDLE)
6	133126-02-000	EA	RECLINER - (RIGHT HARDWARE)
7	133126-10-000	EA	RECLINER - (HANDLE MOUNTING TUBE)
8	133126-08-000	EA	RECLINER - (LOCK SPRING)
9	133126-07-000	EA	RECLINER - (FIXED OTTOMAN) - RIGHT
10	133126-03-000	EA	RECLINER - (SWIVEL ROCKER)
11	133126-06-000	EA	RECLINER - (FIXED OTTOMAN) - LEFT
12	133126-09-000	EA	RECLINER - (PLASTIC BUSHING)
13	133126-05-000	EA	RECLINER - (HANDLE TUBE)
14	133126-04-000	EA	RECLINER - (RECLINER/GLIDER 24" RING)
	134324-01-000	EA	E-CLIP - PHOSPHORUS FINISH
15	134194-01-01A	EA	KNOB - HOLD DOWN - RECLINER - BLACK
16	134057-01-11B	EA	BRACKET - RECLINER - FLAT BLACK

CURTAIN & CUSHION GROUP (CONTINUED)
WINDOW TREATMENT

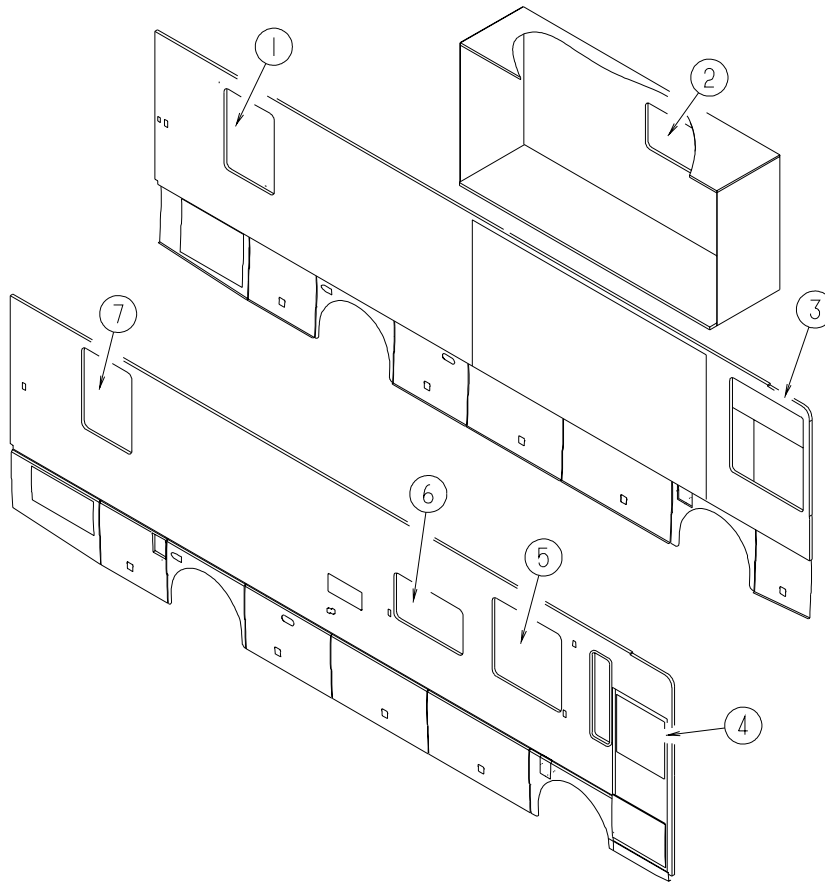

KEY	PART NUMBER	U/M	DESCRIPTION	
1	133050-08-L76	EA	VALANCE - CORONADO - 34" (L76)	
1	133050-08-L78	EA	VALANCE - CORONADO - 34" (L78)	
1	133050-08-LA8	EA	VALANCE - CORONADO - 34" (L78)	FROM: 00-00-00 THRU: 03-05-00
				FROM: 03-06-00 THRU: 99-99-99
1	133050-08-L80	EA	VALANCE - CORONADO - 34" (L80)	
1	123910-19-L32	EA	LEG - RIGHT - 34" (L76)	
1	123910-19-L34	EA	LEG - RIGHT - 34" (L78)	
				FROM: 00-00-00 THRU: 03-05-00
1	123910-19-LA8	EA	LEG - RIGHT - 34" (L78)	FROM: 03-06-00 THRU: 99-99-99
1	123910-19-L36	EA	LEG - RIGHT - 34" (L80)	
1	123910-20-L32	EA	LEG - LEFT - 34" (L76)	
1	123910-20-L34	EA	LEG - LEFT - 34" (L78)	
				FROM: 00-00-00 THRU: 03-05-00
1	123910-20-LA8	EA	LEG - LEFT - 34" (L78)	FROM: 03-06-00 THRU: 99-99-99
1	123910-20-L36	EA	LEG - LEFT - 34" (L80)	
1	111910-58-L76	EA	BLIND - DAY/NIGHTER - 31" X 37"	
1	111910-58-L78	EA	BLIND - DAY/NIGHTER - 31" X 37"	
1	111910-58-L80	EA	BLIND - DAY/NIGHTER - 31" X 37"	
2	133050-05-L76	EA	VALANCE - CORONADO - 62.5"	
2	133050-05-L78	EA	VALANCE - CORONADO - 62.5"	
2	133050-05-L80	EA	VALANCE - CORONADO - 62.5"	
2	127017-41-L76	EA	LEG - RIGHT - 23.5"	
2	127017-43-L78	EA	LEG - RIGHT - 23.5"	
2	127017-41-L80	EA	LEG - RIGHT - 23.5"	
2	127017-42-L76	EA	LEG - LEFT - 23.5"	
2	127017-44-L78	EA	LEG - LEFT - 23.5"	
2	127017-42-L80	EA	LEG - LEFT - 23.5"	

CURTAIN & CUSHION GROUP (CONTINUED)

WINDOW TREATMENT (CONTINUED)

KEY	PART NUMBER	U/M	DESCRIPTION
2	111910-55-L76	EA	BLIND - DAY/NIGHTER - 59" X 26.5"
2	111910-55-L78	EA	BLIND - DAY/NIGHTER - 59" X 26.5"
2	111910-55-L80	EA	BLIND - DAY/NIGHTER - 59" X 26.5"
3	130872-03-L76	EA	CURTAIN - DRIVER - 45" X 112"
3	073260-42-C18	EA	TIEBACK - 6" X 18"
3	126841-03-000	EA	SHADE - PULL - CHARCOAL MESH - 40.3" X 60"
3	084434-01-000	EA	BRACKET - MOUNTING - ROLLER SHADE - 1 3/8"
4	130872-04-L76	EA	CURTAIN - PASSENGER - 45" X 112"
4	073260-42-C18	EA	TIEBACK - 6" X 18"
4	126841-03-000	EA	SHADE - PULL - CHARCOAL MESH - 40.3" X 60"
4	084434-01-000	EA	BRACKET - MOUNTING - ROLLER SHADE - 1 3/8"
4	084755-57-E07	EA	SHADE - PULL - 27.25"
5	133050-16-L76	EA	VALANCE - CORONADO - 46"
5	133050-16-L78	EA	VALANCE - CORONADO - 46"
5	133050-16-L80	EA	VALANCE - CORONADO - 46"
5	127017-25-L76	EA	LEG - RIGHT - 38"
5	127017-81-L78	EA	LEG - RIGHT - 38"
5	127017-25-L80	EA	LEG - RIGHT - 38"
5	127017-26-L76	EA	LEG - LEFT - 38"
5	127017-82-L78	EA	LEG - LEFT - 38"
5	127017-26-L80	EA	LEG - LEFT - 38"
5	111910-71-L76	EA	BLIND - DAY/NIGHTER - 42.5" X 41" (L76,L78)
5	111910-71-L80	EA	BLIND - DAY/NIGHTER - 42.5" X 41" (L80)
6	133050-01-L76	EA	VALANCE - CORONADO - 64.5"
6	133050-01-L78	EA	VALANCE - CORONADO - 64.5"
6	133050-01-L80	EA	VALANCE - CORONADO - 64.5"
6	127017-01-L76	EA	LEG - RIGHT - 25"
6	127017-11-L78	EA	LEG - RIGHT - 25"
6	127017-01-L80	EA	LEG - RIGHT - 25"
6	127017-02-L76	EA	LEG - LEFT - 25"
6	127017-12-L78	EA	LEG - LEFT - 25"
6	127017-02-L80	EA	LEG - LEFT - 25"
6	111910-57-L76	EA	BLIND - DAY/NIGHTER - 61" X 28.5"
6	111910-57-L78	EA	BLIND - DAY/NIGHTER - 61" X 28.5"
6	111910-57-L80	EA	BLIND - DAY/NIGHTER - 61" X 28.5"
7	133050-07-L76	EA	VALANCE - CORONADO - 34" (L76)
7	133050-07-L78	EA	VALANCE - CORONADO - 34" (L78)
7	133050-07-LA8	EA	VALANCE - CORONADO - 34" (L78)
7	133050-07-L80	EA	VALANCE - CORONADO - 34" (L80)
7	127017-17-L32	EA	LEG - RIGHT - 34" (L76)
7	127017-17-L34	EA	LEG - RIGHT - 34" (L78)
7	127017-17-LA8	EA	LEG - RIGHT - 34" (L78)
7	127017-17-L36	EA	LEG - RIGHT - 34" (L80)
7	127017-18-L32	EA	LEG - LEFT - 34" (L76)
7	127017-18-L34	EA	LEG - LEFT - 34" (L78)
7	127017-18-LA8	EA	LEG - LEFT - 34" (L78)
7	127017-18-L36	EA	LEG - LEFT - 34" (L80)
7	111910-58-L76	EA	BLIND - DAY/NIGHTER - 31" X 37"
7	111910-58-L78	EA	BLIND - DAY/NIGHTER - 31" X 37"
7	111910-58-L80	EA	BLIND - DAY/NIGHTER - 31" X 37"

FROM: 00-00-00 THRU: 03-05-00

FROM: 03-06-00 THRU: 99-99-99

FROM: 00-00-00 THRU: 03-05-00

FROM: 03-06-00 THRU: 99-99-99

FROM: 00-00-00 THRU: 03-05-00

FROM: 03-06-00 THRU: 99-99-99

CURTAIN & CUSHION GROUP (CONTINUED)

HARDWARE

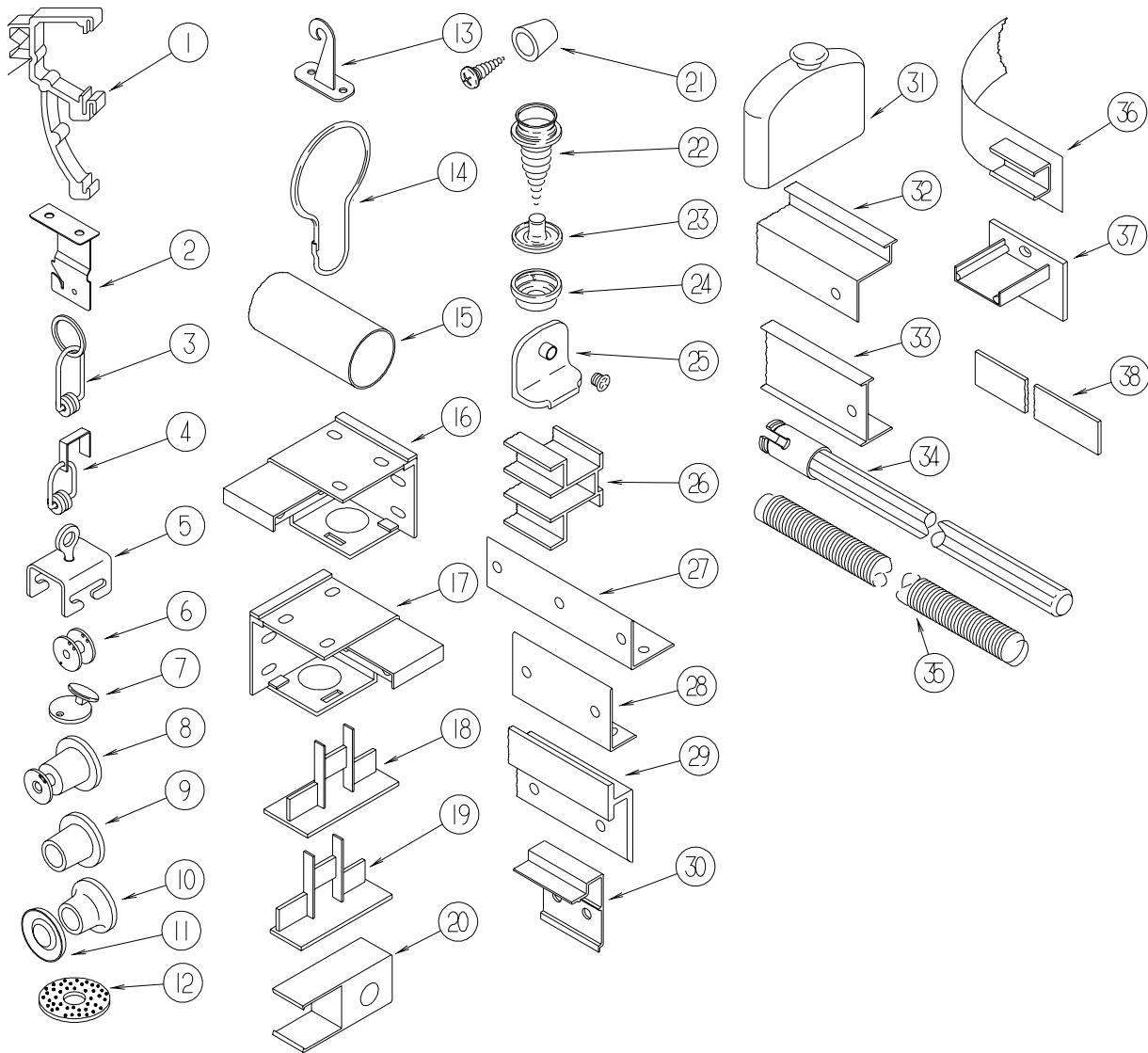

**BLIND PARTS ARE COLOR COORDINATED TO MATCH THE COLOR OF THE BLINDS
HAMPTON TAN COLORS ARE USED BY THE ULTIMATE FREEDOM & ADVANTAGE
TITANIUM IS USED BY ALL ITASCAS
ANTELOPE IS USED BY ALL WINNEBAGOS**

KEY	PART NUMBER	U/M	DESCRIPTION
1	109353-04-000	EA	CLIP - VALANCE SLAT MOUNTING - CLEAR PLASTIC
2	084434-01-000	EA	BRACKET - MOUNTING - ROLLER SHADE - 1 3/8"
	096843-01-000	EA	SPRING - REWIND/ROLLER SHADE
	086276-01-000	EA	TAPE - DOUBLE SIDED - 1/2"
3	009701-01-000	EA	CARRIER - CURTAIN - L ROD
4	093487-91-000	EA	ROLLER/CLIP
5	009702-01-000	EA	END STOP - CURTAIN CARRIER - L ROD
6	097592-01-000	EA	SPOOL - CORD - ELEVATED BLIND HOLDUP - SMALL - CLEAR
7	102555-03-000	EA	CLEAT - BLIND CORD - MILKY WHITE PLASTIC
8	097592-02-000	EA	SPOOL - CORD - ELEVATED BLIND HOLDUP - LARGE - CLEAR
9	094896-02-000	EA	GROMMET - CORD/PLEATED BLIND - NYLON - GRAY
10	046867-03-000	EA	GROMMET - HANDY BUTTON #3
11	046867-02-000	EA	WASHER - HANDY BUTTON #3
12	103242-01-000	EA	VELCRO HOOK - BEIGE 7/8" ROUND W/CENTER HOLE
12	103242-02-000	EA	VELCRO HOOK - BLACK 7/8" ROUND W/CENTER HOLE
13	109441-03-000	EA	HOLD DOWN - BLIND (CLOUDY)
	109441-02-000	EA	HOLD DOWN - SPACER
14	009136-02-000	EA	HANGER - RING - PIN TYPE - CURTAIN - BRASS

CURTAIN & CUSHION GROUP (CONTINUED)

HARDWARE (CONTINUED)

KEY	PART NUMBER	U/M	DESCRIPTION
15	102075-01-02A	EA	ROD - SHOWER CURTAIN - 1" OD X 30.9" - SOFT WHITE
15	102075-06-02A	EA	ROD - SHOWER CURTAIN - 1" OD X 33.5" - SOFT WHITE
15	102075-09-01A	EA	ROD - SHOWER CURTAIN - 3/4"OD X 29.5" - OFF WHITE
15	102075-09-02A	EA	ROD - SHOWER CURTAIN - 3/4"OD X 29.5" - SOFT WHITE
15	102075-10-02A	EA	ROD - SHOWER CURTAIN - 1" OD X 46.3" - SOFT WHITE
15	102075-16-02A	EA	ROD - SHOWER CURTAIN - 3/4"OD X 34.2" - SOFT WHITE
15	102075-17-02A	EA	ROD - SHOWER CURTAIN - 1" OD X 39.3" - SOFT WHITE
15	102075-18-02A	EA	ROD - SHOWER CURTAIN - 1" OD X 38.9" - SOFT WHITE
15	102075-19-02A	EA	ROD - SHOWER CURTAIN - 3/4"OD X 39.2" - SOFT WHITE
16	083170-01-000	EA	BRACKET - BLIND - LEFT SIDE WHEN FACING WINDOW
17	083170-02-000	EA	BRACKET - BLIND - RIGHT SIDE WHEN FACING WINDOW
18	094907-04-000	EA	END CAP - BOTTOM/PLEATED BLIND (RH & LH)
19	094907-02-000	EA	END CAP - TOP/PLEATED BLIND - PLASTIC - GRAY
	094907-05-700	EA	END CAP-RH BOTTOM BLIND
	094907-05-701	EA	END CAP-LH BOTTOM BLIND
20	101033-02-000	EA	END CAP - TRACK/CLEAR
21	097564-03-000	EA	HANDLE - KNOB - E-Z LIFT SHADE - TAN
21	097564-04-000	EA	HANDLE - KNOB - E-Z LIFT SHADE - NAVY
21	097564-05-000	EA	HANDLE - KNOB - E-Z LIFT SHADE - TEAL
21	097564-06-000	EA	HANDLE - KNOB - E-Z LIFT SHADE - ALABASTER
21	097564-07-000	EA	HANDLE - KNOB - E-Z LIFT SHADE - SILVER
21	000G68-06-12J	EA	SCREW 6-18X.75 POH BRASS
22	029130-01-000	EA	SCREW - SNAP SOCKET - #8 PH X 5/8"
22	029130-03-000	EA	SCREW - SNAP SOCKET - #8 PH X 1"
23	029155-01-000	EA	CAP - SNAP - 5/32" OUTSIDE DIAMETER OF PIN
24	029156-01-000	EA	SOCKET - SNAP - 9/16" O.D.
24	029156-02-000	EA	SOCKET - SNAP - 27/64" O.D.
25	106544-01-000	EA	PULL - SHADE/BRASS
25	106544-01-001	EA	SCREW - SHADE/BRASS
26	101033-08-000	EA	TRACK - WALL - 75"
26	101033-09-000	EA	TRACK - WALL - 32"
27	105648-01-02A	EA	BRACE - VALANCE - OFF/WHITE - 14"
27	075943-10-000	EA	BRACE - VALANCE - 20"
28	083125-07-000	EA	BRACE - WINDOW MOUNT - 2.5" - OFF WHITE
28	083125-08-000	EA	BRACE - WINDOW MOUNT - 3/4 - OFF WHITE
29	127254-03-02A	EA	TRACK - CURTAIN/RIGHT HAND - ANTELOPE - F & G SERIES
29	127254-03-03A	EA	TRACK - CURTAIN/RIGHT HAND - TITANIUM - F & G SERIES
29	133236-01-02A	EA	TRACK - CURTAIN/RIGHT HAND - TITANIUM - P SERIES
29	133236-01-01A	EA	TRACK - CURTAIN/RIGHT HAND - ANTELOPE - P SERIES
29	127254-04-02A	EA	TRACK - CURTAIN/LEFT HAND - ANTELOPE - F & G SERIES
29	127254-04-03A	EA	TRACK - CURTAIN/LEFT HAND - TITANIUM - F & G SERIES
29	133235-01-02A	EA	TRACK - CURTAIN/LEFT HAND - TITANIUM - P SERIES
29	133235-01-01A	EA	TRACK - CURTAIN/LEFT HAND - ANTELOPE - P SERIES
30	097565-01-000	EA	BRACKET - MOUNTING/PLEATED BLIND
31	093475-01-701	EA	CAP-END, WITH INVERTED STUD
32	105450-14-01A	EA	TRACK - CURTAIN - 90" - OFF WHITE
33	009700-04-002	EA	TRACK - CURTAIN - L SHAPED - 15.5' - OFF WHITE
33	118896-05-02A	EA	TRACK - CURTAIN/RIGHT HAND - HAMPTON TAN - Q-SERIES
33	118897-04-02A	EA	TRACK - CURTAIN/LEFT HAND - HAMPTON TAN - Q-SERIES
33	126456-01-03A	EA	TRACK - CURTAIN/RIGHT HAND - TITANIUM - L-SERIES
33	126456-02-03A	EA	TRACK - CURTAIN/LEFT HAND - TITANIUM - L-SERIES
33	126456-03-02A	EA	TRACK - CURTAIN/RIGHT HAND - ANTELOPE - L-SERIES
33	126456-04-02A	EA	TRACK - CURTAIN/LEFT HAND - ANTELOPE - L-SERIES
34	093487-90-000	EA	WAND - 30" - FRONT WRAP AROUND
35	097591-01-000	EA	SPRING - EXTENSION/PLEATED BLIND
36	101031-01-000	YD	TAPE - GLIDE/CURTAIN - 4.25" SPACING
37	094907-06-000	EA	HARDWARE - END CAP - E-Z LIFT - TOP
38	089275-01-000	FT	STRIP - 3/4" X 96" - CLEAR POLYETHYLENE
	094908-03-000	FT	HARDWARE - SEMI-RIDGED PVC - EZ LIFT
	094908-04-000	FT	STRAP - FLAT POLY VINYL
	095567-01-000	EA	TACK - STRIP - .5" X 625' ROLL
	097593-02-000	FT	CORD - BLIND - PLEATED - GRAY
	097593-06-000	FT	CORD - BLIND - PLEATED - PEWTER
	097593-07-000	FT	CORD - BLIND - PLEATED - PALE JADE
	097593-10-000	FT	CORD - BLIND - PLEATED - VANILLA

CURTAIN & CUSHION GROUP (CONTINUED)

ACCESSORIES

KEY	PART NUMBER	U/M	DESCRIPTION
	057759-01-000	EA	WASHER - FLAT F/SEAT BELT - 4" DIAMETER
	007021-01-000	EA	SEAT BELT - 2" X 90" - BLACK
*	091990-08-01A	EA	SEAT BELT - 3 POINT - .766" DIAMETER HOLE IN D-LOOP BRKT
	095076-02-000	EA	WASHER-FL-7/16IDX 50.8ODX.06
			FROM: 01-13-00 THRU: 99-99-99
	127598-02-000	EA	NUT - HEX FLANGE - M10 X 1.5 - CLASS 10
	129529-02-000	EA	STRAP - CHAIR RETAINING - 81.9"
	129491-01-000	EA	CATCH - SNAP HOOK - 1"
	057534-03-000	EA	TIEBACK - CLEAR PLASTIC - 7.5"
	127598-01-01A	EA	ADJUSTER - SEATBELT - D-LOOP - ADJUSTER
	079349-04-L07	YD	WELT - NARROW (L76)
	079349-04-L78	YD	WELT - NARROW (L78)
	079349-04-L80	YD	WELT - NARROW (L80)
	127960-01-01A	EA	RETAINER - 3/8" - STAINLESS STEEL

*COMPONENT PARTS FOUND IN SERVICE PARTS LIBRARY

CURTAIN & CUSHION GROUP (CONTINUED)

FABRICS

COLOR CODES	L76 IVORY COAST	L78 WINDSPRAY	L80 AMETHYST FROST
BUCKET SEAT	108446-T5-000 079680-31-000	126883-40-000 079680-31-000 079680-32-000	126883-50-000 079680-31-000 079680-33-000
DINETTE PADS	108446-T5-000	126883-40-000	126883-50-000
BATHROOM VALANCE	105745-L3-000	105745-L5-000	105745-M0-000
LOUNGE WINDOW	126883-38-000 108446-T5-000	126883-39-000 126883-40-000	126883-49-000 126883-50-000
FRONT WRAP AROUND	072333-85-000	072333-85-000	072333-85-000
BEDROOM WINDOW	105745-L3-000 105745-L4-000	105745-L5-000 105745-L6-000	105745-M0-000 105745-M1-000
BEDSPREAD	105745-L3-000	105745-L5-000	105745-M0-000
BEDROOM PILLOW	105745-L3-000 105745-L4-000	105745-L5-000 105745-L6-000 084415-A8-000	105745-M0-000 105745-M1-000
SHAM	105745-L3-000	105745-L5-000	105745-M0-000
DRAPERY LINING	087272-03-000	087272-03-000	087272-03-000
VINYL 54"	103907-01-07A	103907-01-07A	103907-01-07A
VINYL 15"	103907-02-07A	103907-02-07A	103907-02-07A
CEILING MATERIAL 102"	113979-09-01A	113979-09-01A	113979-09-01A

NOTE: FABRIC LISTED FIRST IN A BLOCK, IS THE LARGEST QUANTITY OF FABRIC USED

CURTAIN & CUSHION GROUP (CONTINUED)
FABRICS (CONTINUED)

COLOR CODES	L76 IVORY COAST	L78 WINDSPRAY	L80 AMETHYST FROST
FLOOR MAT	096060-E4-000	096060-E4-000	096060-E3-000
DINETTE	126883-38-000	126883-39-000	126883-49-000
SOFA	126883-38-000 079680-31-000	126883-39-000 079680-32-000	126883-49-000 079680-33-000
LOUNGE CHAIR	108446-T5-000 079680-31-000	126883-40-000 079680-32-000	126883-50-000 079680-33-000
DINETTE CHAIR	108446-T5-000	126883-40-000	126883-50-000
BANQUETTE	126883-38-000 079680-31-000	126883-39-000 079680-32-000	126833-49-000 079680-33-000
LOUNGE PILLOW	126883-38-000 108446-T5-000	126883-39-000 126883-40-000 084415-A8-000	126883-49-000 126883-50-000
OVHD. INSERT LGE/BEDROOM	108446-T5-000 105745-L4-000	126883-40-000 105745-L6-000	126883-50-000 105745-M1-000
FOLDING CHAIR	108446-T5-000	126883-40-000	126883-50-000
MAP POCKETS	108446-T5-000	126883-40-000	126883-50-000
HEADBOARD	105745-L3-000 105745-L4-000	105745-L5-000 105745-L6-000	105745-M0-000 105745-M1-000
CEILING MATERIAL 21.5"	113979-10-01A	113979-10-01A	113979-10-01A

NOTE: FABRIC LISTED FIRST IN A BLOCK, IS THE LARGEST QUANTITY OF FABRIC USED

DINETTE GROUP CABINETS

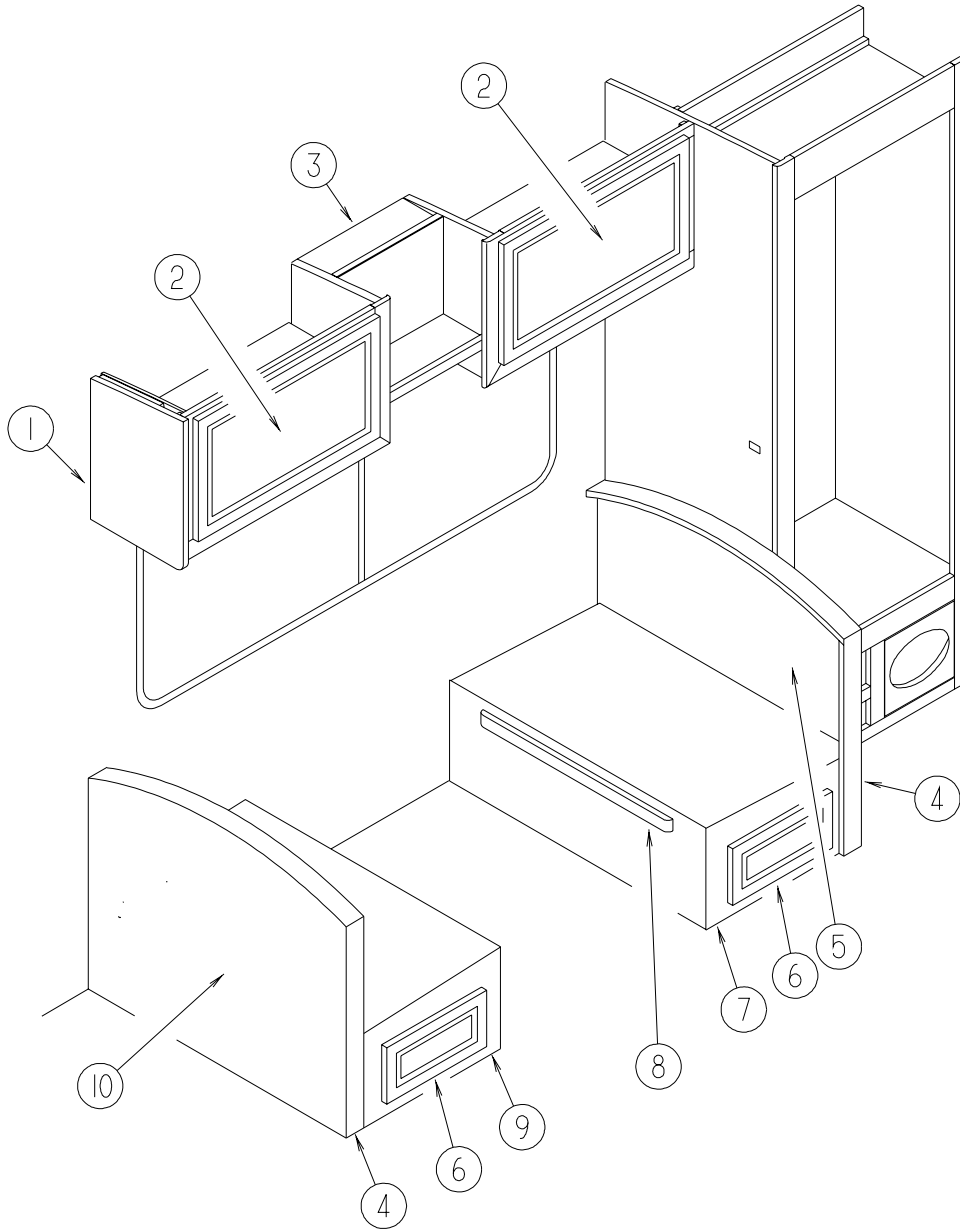

KEY	PART NUMBER	U/M	DESCRIPTION
1	103128-52-L76	EA	END CAP - OVERHEAD CABINET/LEFT HAND
2	132141-14-L07	EA	DOOR - RAIL/VENEER - 15.7" X 27.9" - W/O HARDWARE
3	133085-01-L76	EA	CABINET - OVERHEAD/DINETTE - W/O DOORS/HARDWARE
4	104787-17-L32	EA	PAD - DINETTE SEATBACK (L76)
4	104787-17-L34	EA	PAD - DINETTE SEATBACK (L78)
4	104787-17-L36	EA	PAD - DINETTE SEATBACK (L80)
5	M08755-09-L53	EA	CABINET - SEATBACK/RIGHT HAND - W/O HARDWARE
6	M09316-H2-L53	EA	DRAWER - OGEE EDGE - 16.6"W X 31.4"D - W/O SLIDES/HARDWARE
7	M08756-11-L53	EA	CABINET - SEATBASE/RIGHT HAND - W/O DOOR/DRAWER/HARDWARE
8	081295-01-G01	EA	SUPPORT - BED/DINETTE - 28" LONG
9	M08755-12-L53	EA	CABINET - SEATBASE/LEFT HAND - W/O DOOR/DRAWER/HARDWARE
10	M08755-10-L53	EA	CABINET - SEATBASE/LEFT HAND - W/O HARDWARE
	122021-01-02A	EA	ANGLE - W/HOLES - 8.6" LONG - OFF WHITE
	122021-02-02A	EA	ANGLE - W/HOLES - 13.7" LONG - OFF WHITE
	132871-02-02B	EA	ANGLE - FORMED - W/HOLES - E-COATED

DINETTE GROUP (CONTINUED)

TABLE

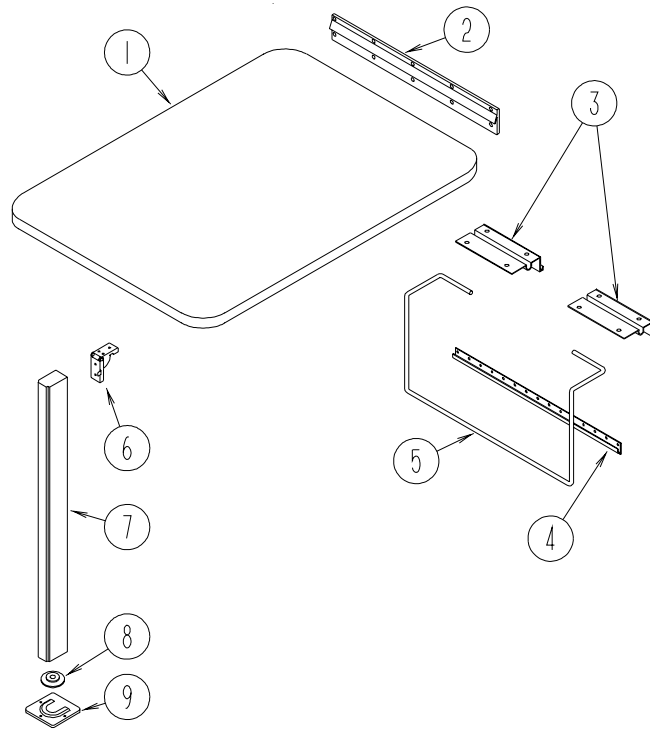

DINETTE TABLE

KEY	PART NUMBER	U/M	DESCRIPTION
1	132783-03-01A	EA	TABLE - WHITE ETHOS/WOOD EDGE-WATERFORD - 29.8" X 35.7"
2	053200-13-000	EA	SUPPORT - TABLE - 18.5"
3	088410-02-000	EA	BRACKET - LIFT - TABLE MOUNTED
4	024281-15-000	EA	BRACKET/TABLE - LIFT ROD/LOWER WALL MOUNTED - 17.1"
5	024275-13-000	EA	ROD - TABLE LIFT - OFF/WHITE
6	093550-01-000	EA	BRACKET - HINGE - MOUNTS TO LEG & TABLE TOP - 1.7" X 2.6"
7	092707-04-05A	EA	LEG - TABLE - W/O HARDWARE - 27" - WATERFORD OAK
8	092593-01-05A	EA	CATCH - TABLE LEG - OFF/WHITE
9	049493-12-000	EA	CATCH - TABLE LEG/FLOOR MOUNTED - OFF WHITE

DINETTE GROUP (CONTINUED)

TABLE (CONTINUED)

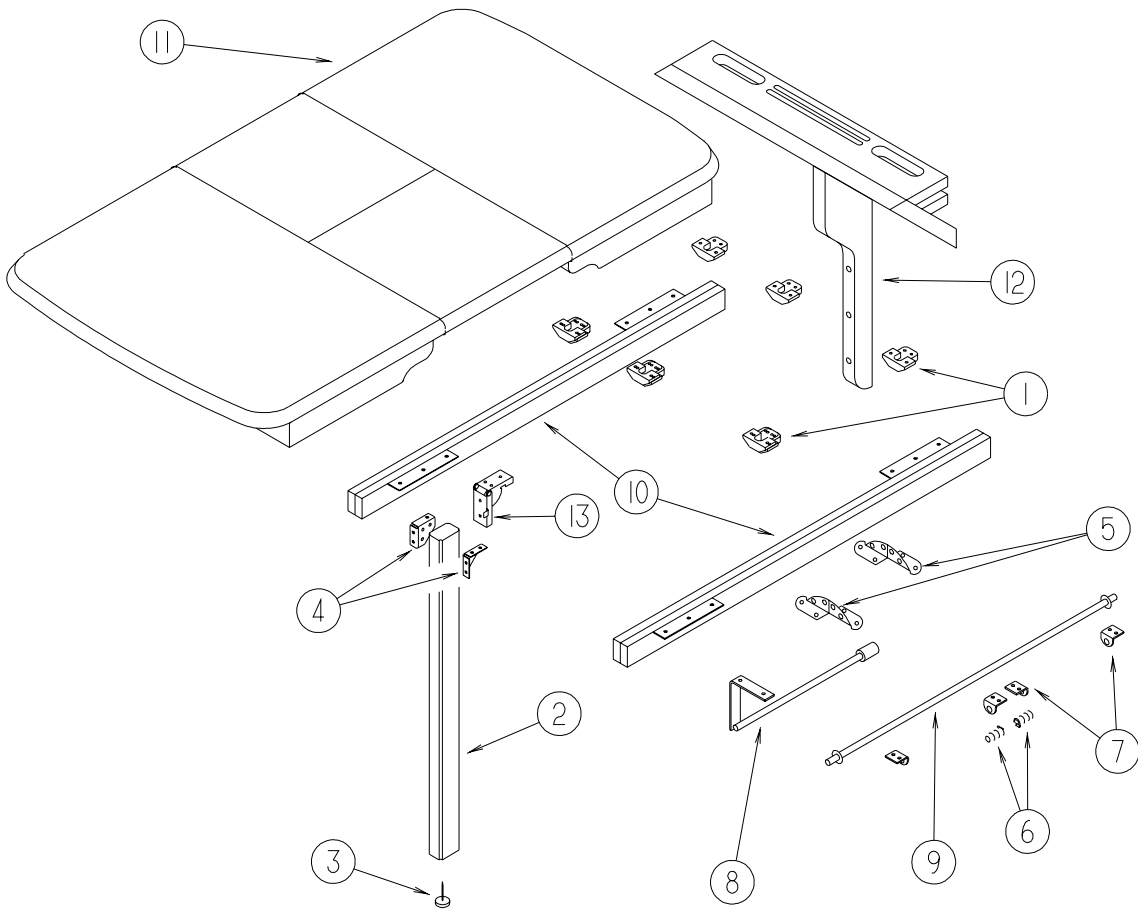

PULLOUT TABLE

KEY	PART NUMBER	U/M	DESCRIPTION
1	009050-02-000	EA	LEVELER - TABLE TOP - MALE END W/4 SCREWS - PLASTIC
1	009050-03-000	EA	LEVELER - TABLE TOP - FEMALE END W/2 SCREWS - PLASTIC
2	092707-07-05A	EA	LEG - TABLE - W/O HARDWARE - 27.8" - WATERFORD OAK
3	102194-01-000	EA	GUIDE - PLASTIC
4	102810-01-04A	EA	BRACE - TABLE LEG - BLACK
4	102810-01-03A	EA	BRACE - TABLE LEG - MILL
5	108663-01-000	EA	HINGE - LEAF - FOLDING
6	108664-01-000	EA	SPRING - COMPRESSION - .51" X 1.96"
7	108874-01-000	EA	BRACKET - HINGE - TABLE LEAF
8	108905-01-000	EA	SUPPORT - TABLE LEAF
9	108932-01-000	EA	ROD - PIVOT
10	110749-01-000	EA	SLIDE/EXTENSION - 19 3/4" TO 33 1/4"
11	P18322-02-L53	EA	TABLE - PULLOUT/SELF STORING LEAF - W/O LEG
12	118322-16-L76	EA	MOUNT - WALL - DROP LEAF TABLE
13	092593-01-05A	EA	CATCH - TABLE LEG - OFF/WHITE

DRIVERS COMPARTMENT GROUP INSTRUMENT PANEL

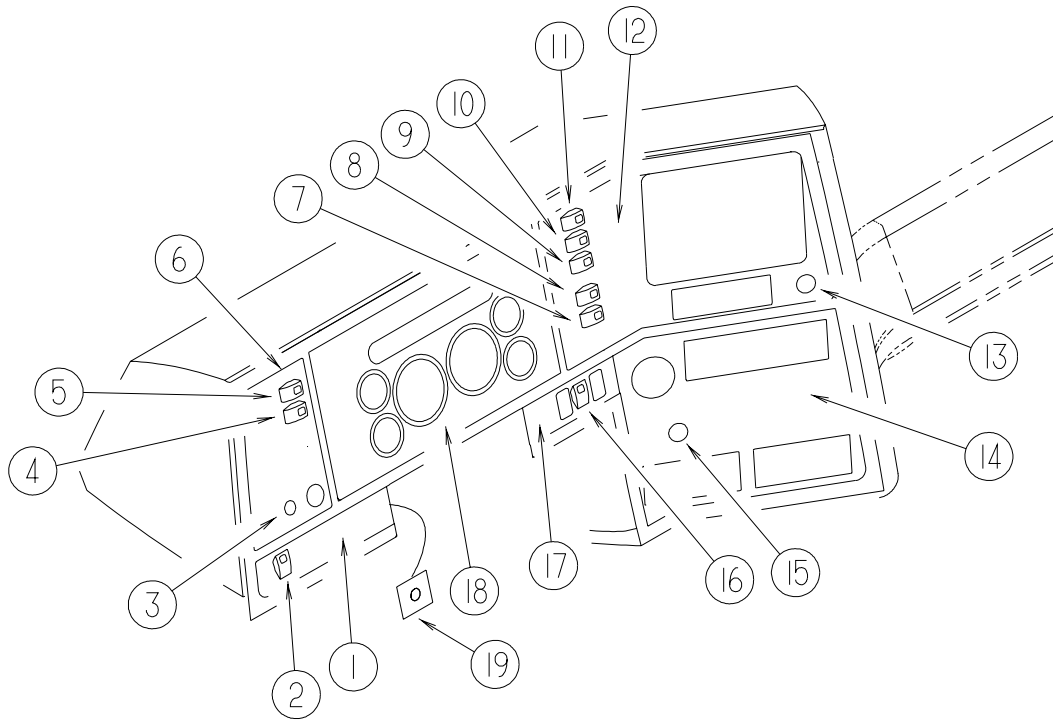

KEY	PART NUMBER	U/M	DESCRIPTION
1	104056-32-01A	EA	APPLIQUE - BEZEL - DRIVER/LOWER - BLACK VELVET
2	108357-08-000	EA	SWITCH - ROCKER DPDT - ON/NONE/ON - 6 TERMINAL
	108356-01-01A	EA	COVER/ACTUATOR SWITCH - 3 GROOVES - CONTURA III - BLACK
3*	091206-04-000	EA	MODULE/WIPER CONTROL KIT - DYNAMIC PARK
4	108357-01-000	EA	SWITCH - ROCKER SPST - ON/OFF - 2 TERMINAL
	108356-01-01A	EA	COVER/ACTUATOR SWITCH - 3 GROOVES - CONTURA III - BLACK
5	108357-09-000	EA	SWITCH - ROCKER SPDT - ON/NONE/MOM - 3 TERMINAL
	108356-01-01A	EA	COVER/ACTUATOR SWITCH - 3 GROOVES - CONTURA III - BLACK
6	104056-50-01A	EA	APPLIQUE - BEZEL - DRIVER SIDEWALL
7	108357-01-000	EA	SWITCH - ROCKER SPST - ON/OFF - 2 TERMINAL
	108356-01-01A	EA	COVER/ACTUATOR SWITCH - 3 GROOVES - CONTURA III - BLACK
7	096241-03-000	EA	SWITCH - BLANK - BLACK
8	108357-03-000	EA	SWITCH - ROCKER SPDT - ON/OFF/ON - 3 TERMINAL
	108356-01-01A	EA	COVER/ACTUATOR SWITCH - 3 GROOVES - CONTURA III - BLACK
8	096241-03-000	EA	SWITCH - BLANK - BLACK
9	108357-10-000	EA	SWITCH - ROCKER SPDT - W/LIGHT - MOM/NONE/MOM - 5 TERMINAL
	108356-03-01A	EA	COVER/ACTUATOR SWITCH - 3 GROOVES W/LENS-CONTURA III-BLACK
10	108357-06-000	EA	SWITCH - ROCKER DPDT - MOM/OFF/MOM - 6 TERMINAL
	108356-01-01A	EA	COVER/ACTUATOR SWITCH - 3 GROOVES - CONTURA III - BLACK
11	108357-08-000	EA	SWITCH - ROCKER DPDT - ON/NONE/ON - 6 TERMINAL
	108356-01-01A	EA	COVER/ACTUATOR SWITCH - 3 GROOVES - CONTURA III - BLACK
12	104056-40-01A	EA	APPLIQUE - BEZEL - PASSENGER/UPPER - 6-SWITCH
13	089294-01-000	EA	LIGHTER - CIGARETTE - W/SOCKET & WIRE
14	104056-14-01A	EA	APPLIQUE - BEZEL - PASSENGER/LOWER WING
15	133534-02-000	EA	LIGHT - AMBER INDICATOR WITH 1/4" TERMINALS
16	108357-06-000	EA	SWITCH - ROCKER DPDT - MOM/OFF/MOM - 6 TERMINAL
	108356-01-01A	EA	COVER/ACTUATOR SWITCH - 3 GROOVES - CONTURA III - BLACK
17	104056-42-01A	EA	APPLIQUE - BEZEL - PASSENGER/LOWER - F/SLIDEOUT & JACKS
18	121868-25-000	EA	CLUSTER - KILOMETERS - 4 SPEED
19	133535-01-000	EA	MODULE - TIMER 20 SECOND
	077031-01-000	EA	FILM - BLACK - 1" X 1.75"
	077031-03-000	EA	FILM - WHITE - .75" X 1"

***COMPONENT PARTS FOUND IN SERVICE PARTS LIBRARY**

DRIVERS COMPARTMENT GROUP (CONTINUED)

DASH

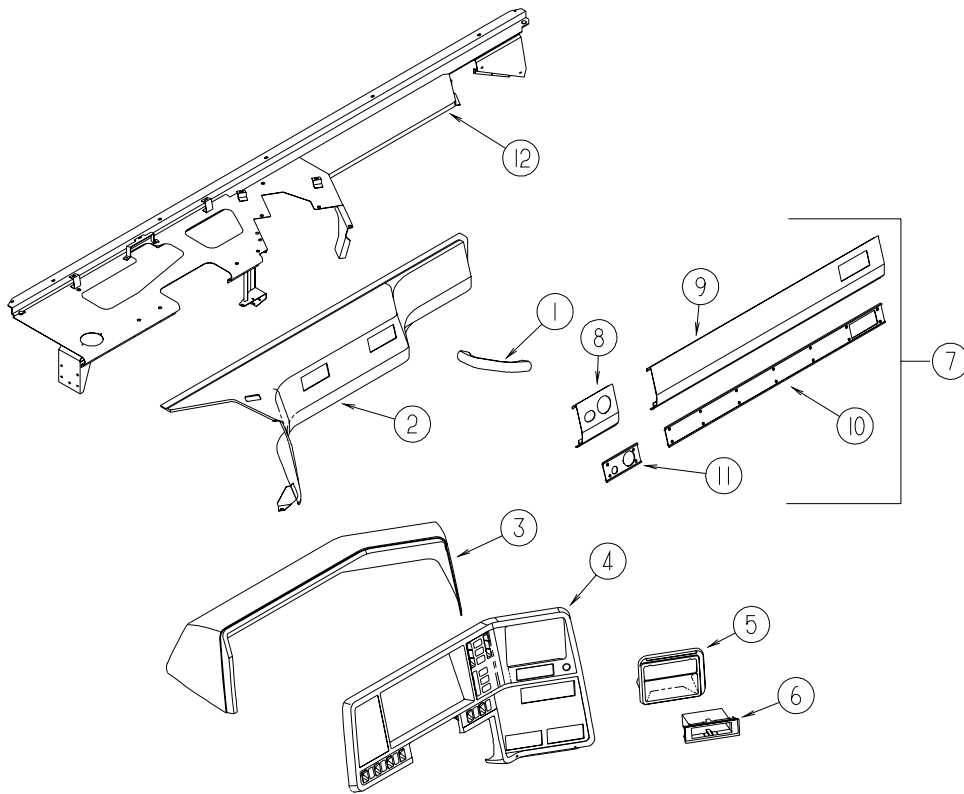

KEY	PART NUMBER	U/M	DESCRIPTION
1	123246-01-01A	EA	HANDLE - GRAB
2	122853-02-L76	EA	TRIM - DASH PANEL - RIGHT HAND
3	107263-03-L76	EA	POD - INSTRUMENT PANEL - W/SPEAKER CUT-OUT
3	107263-04-L76	EA	POD - INSTRUMENT PANEL
4	107031-08-02A	EA	BEZEL - INSTRUMENT - HAMPTON TAN
5	111350-01-01A	EA	POCKET - INSTRUMENT PANEL - UPPER - BLACK
6	096776-03-000	EA	STORAGE BOX - CD'S - 4 DISC HOLDER
6	096776-02-000	EA	STORAGE BOX - CASSETTE - 4 TAPE HOLDER
7	P23278-01-000	EA	DASH COMPLETE W/O VINYL
	106569-09-02A	EA	VINYL - LAMINATE - 25" X 100" - ALLANTE ANTELOPE
8	117991-06-01A	EA	EXTENSION - DASH - DRIVER - LOWER/RIGHT HAND
9	117991-05-01A	EA	EXTENSION - DASH - DRIVER - LOWER/LEFT HAND
10	118024-05-02A	EA	TRIM - DASH - DRIVER - LOWER/LEFT HAND - ANTELOPE
11	118024-06-02A	EA	TRIM - DASH - DRIVER/LOWER/RIGHT HAND - ANTELOPE
12	123277-01-02B	EA	DASH - STEEL - E-COATED

DRIVERS COMPARTMENT GROUP (CONTINUED)

BEVERAGE TRAY

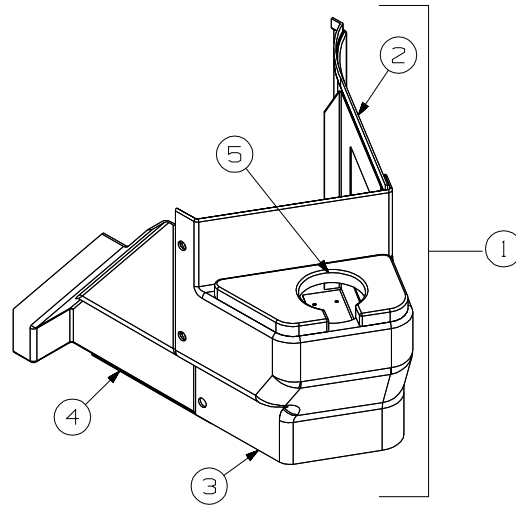

KEY	PART NUMBER	U/M	DESCRIPTION
1	132964-01-L76	EA	TRAY - BEVERAGE
2	M09393-01-L76	EA	PANEL - TRAY/BEVERAGE - RIGHT HAND SIDE
3	M09393-03-L76	EA	PANEL - TRAY/CUPHOLDER
4	M09393-02-L76	EA	PANEL - TRAY/BEVERAGE - LEFT HAND SIDE
5	134566-01-01A	EA	HOLDER - CUP - TWO STEP - BLACK

FRONT INTERIOR

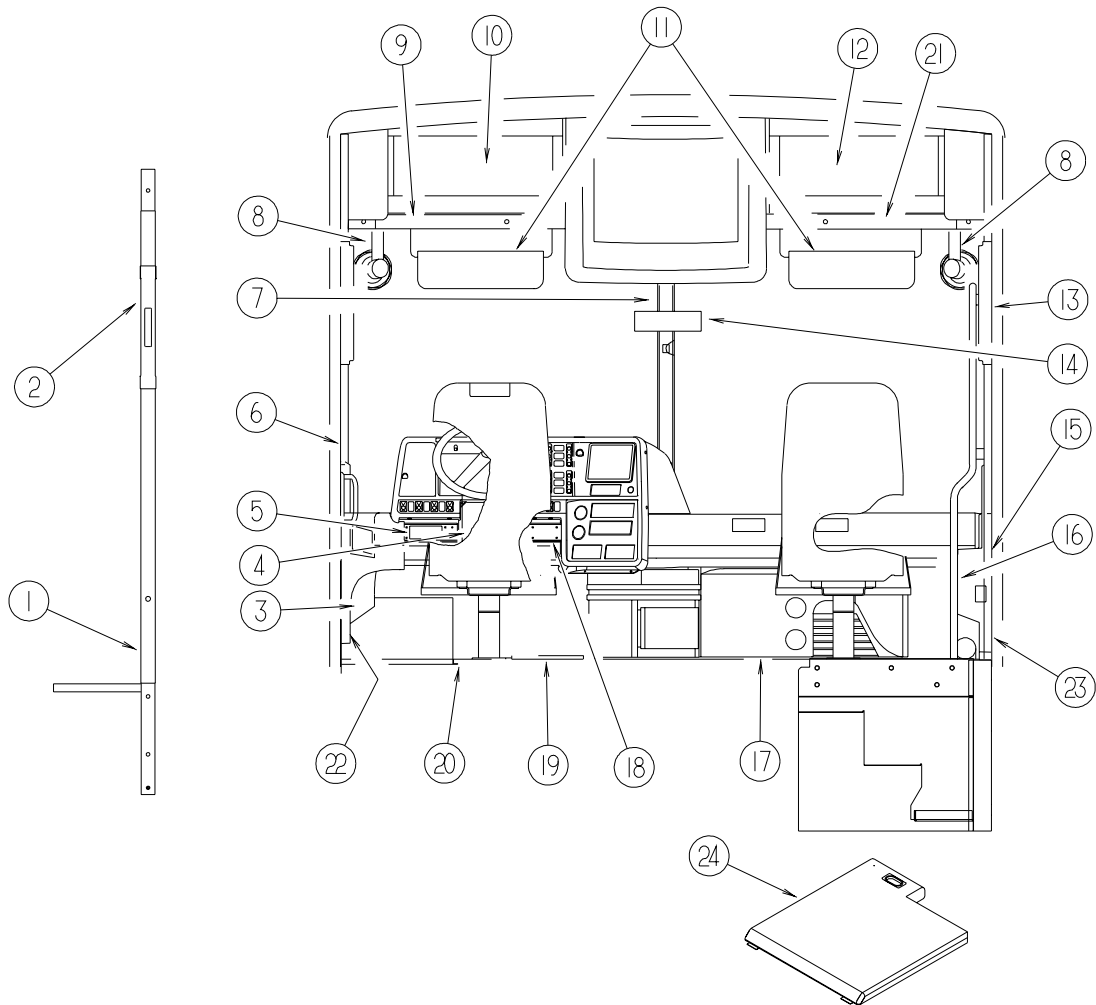

DRIVERS COMPARTMENT GROUP (CONTINUED)
FRONT INTERIOR (CONTINUED)

KEY	PART NUMBER	U/M	DESCRIPTION
1	024700-51-000	EA	COVER - ROLL BAR - 88" - OFF WHITE
2	127721-01-01A	EA	COVER - SLIDE - OFF WHITE
2	127798-01-01A	EA	COVER - SLIDE - INNER - BLACK - 1.5" X 11.4"
3	086120-12-L76	EA	PAD - MAP POCKET
3	086120-12-L78	EA	PAD - MAP POCKET
3	086120-12-L80	EA	PAD - MAP POCKET
4	109832-03-03A	EA	COVER - STEERING COLUMN - BLACK
5	118377-06-07A	EA	APPLIQUE - LOWER DASH - DRIVER - FREIGHTLINER - ANTELOPE
6	131792-01-01A	EA	TRIM - A PILLAR - INTERIOR/DRIVER - ALANTE
7	118452-09-01A	EA	TRIM - WINDSHIELD/CENTER - ANTELOPE
8	122856-01-01A	EA	FAN-DEFROSTER-2 SPEED W/SWIVEL BASE/NON-OSCILLATING-CHROME
9	129004-02-02A	EA	TRIM - WINDSHIELD - INTERIOR/TOP - ANTELOPE
10	133230-02-L76	EA	PANEL - OVERHEAD/LEFT HAND - W/O HARDWARE
11	123298-04-01A	EA	SUNVISOR - 10.5" X 21" - DRIVER/PASSENGER-ALLANTE ANTELOPE
12	133230-01-L76	EA	PANEL - OVERHEAD/RIGHT HAND - W/O HARDWARE
13	131791-01-01A	EA	TRIM - A PILLAR - INTERIOR/PASSENGER - ALANTE
14	040714-01-000	EA	MIRROR - REAR VIEW/ARM MOUNT & SET SCREW
			FROM: 00-00-00 THRU: 09-05-99
14	067490-01-000	EA	BUTTON - MIRROR/REAR VIEW
			FROM: 00-00-00 THRU: 09-05-99
14	134154-01-000	EA	MIRROR - CONVEX - 4" X 11.8"
			FROM: 09-06-99 THRU: 99-99-99
15	129657-01-02A	EA	TRIM - A-PILLAR - INTERIOR/PASSENGER LOWER - ANTELOPE
16	123577-01-01A	EA	HANDRAIL - ASSIST - ENTRANCE
17	105924-01-L32	EA	MAT - FLOOR - 18" X 27" (L76,L78)
17	105924-01-L36	EA	MAT - FLOOR - 18" X 27" (L80)
18	118377-05-07A	EA	APPLIQUE - LOWER DASH - DRIVER - FREIGHTLINER - ANTELOPE
19	116993-01-01A	EA	COVER - PEDALS - BLACK
20	108152-03-000	EA	MAT - FLOOR - DRIVER
21	129004-01-02A	EA	TRIM - WINDSHIELD - INTERIOR/TOP PASSENGER - ANTELOPE
22	132846-07-L76	EA	PANEL ASM-TRIM,INNER,LH (W/O DELUXE SOUND)
22	132846-08-L76	EA	PANEL ASM-TRIM,INNER,LH (W/DELUXE SOUND)
	118718-01-01A	EA	HOLDER - DRINK - COLLAPSIBLE MUG - BLACK PLASTIC
23	133614-02-L76	EA	PANEL - TRIM - INNER/PASSENGER
24	131458-01-L76	EA	COVER/ENTRANCE DOOR STEP - W/PULL LATCH (L76,L78)
24	131458-01-L80	EA	COVER/ENTRANCE DOOR STEP - W/PULL LATCH (L80)

DRIVERS COMPARTMENT GROUP (CONTINUED)

CABINETS

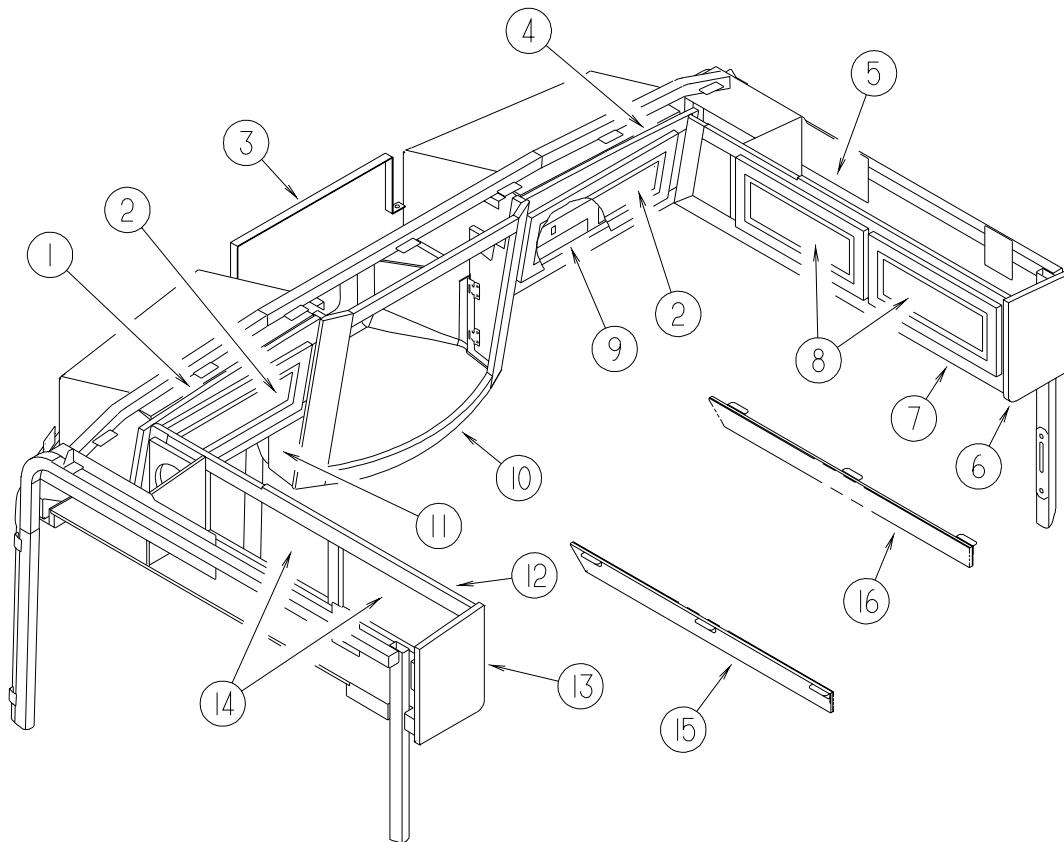

KEY	PART NUMBER	U/M	DESCRIPTION
1	132778-01-L76	EA	CABINET - OVERHEAD/FRONT/LEFT HAND - W/O DOORS/HARDWARE
2	131995-V4-L76	EA	DOOR - RAIL/SOLID PANEL - 9.2" X 21.8" - W/O HARDWARE
3	133790-02-02B	EA	STRAP - TIEDOWN/TV - E-COATED
	132796-01-01B	EA	SUPPORT - CABINET/TV - FRONT MIDDLE
	132792-01-01B	EA	SUPPORT - TV - MILL
4	132779-01-L76	EA	CABINET - OVERHEAD - FRONT/RIGHT HAND - W/O DOORS/HARDWARE
5	126681-10-L76	EA	PANEL - CLOSEOUT/RIGHT HAND - W/O HARDWARE
6	103128-52-L76	EA	END CAP - OVERHEAD CABINET/RIGHT HAND
7	132776-01-L76	EA	CABINET - OVERHEAD/SIDE FRONT/RIGHT HAND - W/O DOORS/HDW
8	132141-74-L07	EA	DOOR - RAIL/VENEER - 10" X 19.1" - W/O HARDWARE
9	133026-02-L76	EA	PANEL - VINYL COVERED - W/O NOTCH
9	133026-01-L76	EA	PANEL - VINYL COVERED - W/NOTCH
10	133544-01-L76	EA	CABINET - OVERHEAD/TV FACE - W/O HARDWARE
11	133029-01-01A	EA	COVER - TV - OVERHEAD/FRONT - ANTELOPE
12	132777-01-L76	EA	CABINET - OVERHEAD/SIDE/FRONT/RIGHT HAND - W/O DOORS/HDW
13	103128-56-L76	EA	END CAP - OVERHEAD CABINET/LEFT HAND
14	132141-74-L07	EA	DOOR - RAIL/VENEER - 10" X 19.1" - W/O HARDWARE
15	132694-04-L76	EA	PANEL - OVERHEAD/FRONT/LEFT HAND
15	133230-02-L76	EA	PANEL - OVERHEAD/LEFT HAND - W/O HARDWARE
16	132694-03-L76	EA	PANEL - OVERHEAD/FRONT/RIGHT HAND
16	133230-01-L76	EA	PANEL - OVERHEAD/RIGHT HAND - W/O HARDWARE

ELECTRICAL GROUP

LIGHTS

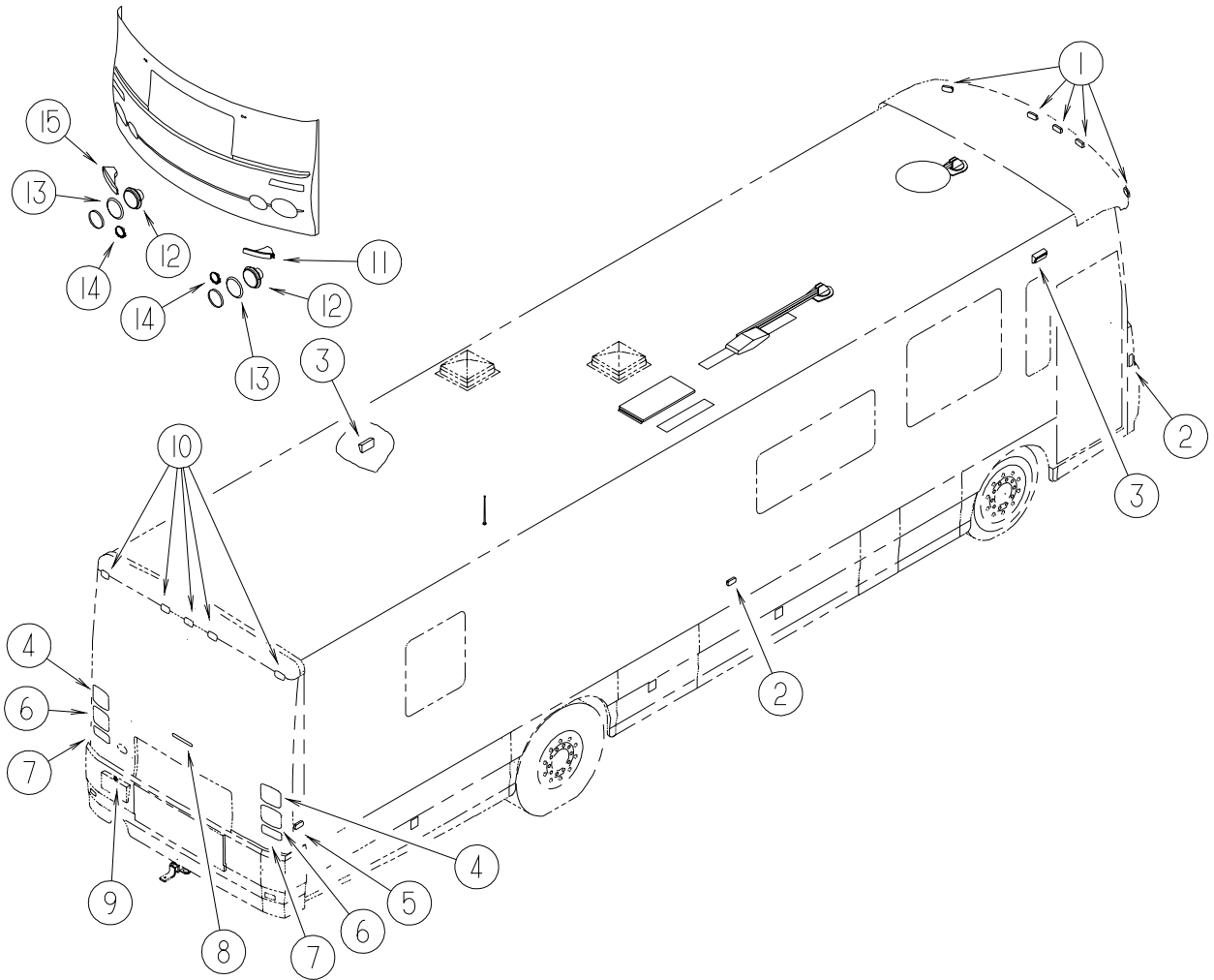

EXTERIOR

ELECTRICAL GROUP (CONTINUED)

LIGHTS (CONTINUED)

EXTERIOR (CONTINUED)

KEY	PART NUMBER	U/M	DESCRIPTION
1	133055-02-000	EA	LENS - CLEARANCE/MARKER - AMBER FROM: 00-00-00 THRU: 08-04-99
1	133055-03-000	EA	BASE - CLEARANCE/MARKER - WHITE FROM: 00-00-00 THRU: 08-04-99
1	111102-02-000	EA	LENS - AMBER - MARKER LAMP FROM: 08-05-99 THRU: 99-99-99
1	111102-01-000	EA	BASE - MARKER LAMP FROM: 08-05-99 THRU: 99-99-99
1	036196-01-000	EA	BULB - 12V - #194 - .27 AMP - BAYONETTE
1	127536-02-000	EA	SOCKET - LIGHT - 194 WEDGE
2	111102-02-000	EA	LENS - AMBER - MARKER LAMP
2	111102-01-000	EA	BASE - MARKER LAMP
2	036196-01-000	EA	BULB - 12V - #194 - .27 AMP - BAYONETTE
3*	097917-01-06A	EA	LIGHT - PORCH - BRIGHT WHITE
3	008215-01-000	EA	BULB - 12 VOLT - #1003 - .94 AMP
3*	008089-02-000	EA	LIGHT - PORCH - RECESSED - CANADIAN
3	008214-01-000	EA	BULB - 12 VOLT - #67 - .59 AMP
3	091981-01-000	EA	GASKET - PORCH LIGHT
4	133054-01-000	EA	LIGHT - STOP/TURN/TAILLIGHT - RED FROM: 00-00-00 THRU: 02-27-00
4	133054-03-000	EA	LIGHT - STOP/TURN/TAILLIGHT - RED FROM: 02-28-00 THRU: 99-99-99
4	037935-01-000	EA	BULB - 12V - #1157 OR #2057 - 2.1 AMP - CLEAR GLASS
5	111102-03-000	EA	LENS - RED - MARKER LAMP
5	111102-01-000	EA	BASE - MARKER LAMP
5	036196-01-000	EA	BULB - 12V - #194 - .27 AMP - BAYONETTE
6	133054-02-000	EA	LIGHT - AMBER TURN FROM: 00-00-00 THRU: 02-27-00
6	133054-04-000	EA	LIGHT - TURN - AMBER FROM: 02-28-00 THRU: 99-99-99
6	037934-01-000	EA	BULB - 12V - #1156 - 2.1 AMP - CLEAR GLASS
7	106688-01-000	EA	LIGHT - BACK-UP W/WHITE LENS (LENS/BACK PAN)
7	037934-01-000	EA	BULB - 12V - #1156 - 2.1 AMP - CLEAR GLASS
8	121950-01-000	EA	LIGHT - BRAKE - CENTER MOUNT
9	087201-01-000	EA	LIGHT - HALF ROUND - 1" X 1.7" - PLASTIC - BLACK
10	133055-01-000	EA	LAMP - CLEARANCE/MARKER - RED
10	133055-03-000	EA	BASE - CLEARANCE/MARKER - WHITE
10	036196-01-000	EA	BULB - 12V - #194 - .27 AMP - BAYONETTE
11	133069-02-000	EA	LAMP - AMBER PARK/TURN W/O SOCKET - DRIVER
12	133053-01-000	EA	HEADLAMP - 7" ROUND HALOGEN W/BLACK RING - HIGH/LOW FROM: 00-00-00 THRU: 01-27-00
12	135625-01-000	EA	HEADLAMP - HIGH/LOW - ROUND 7" FROM: 01-28-00 THRU: 99-99-99
13	135661-01-02B	EA	ADAPTER/RING - HEADLAMP - E-COATED
	135662-01-02B	EA	BRACKET - HEADLAMP - RIGHT HAND - E-COATED
	135662-02-02B	EA	BRACKET - HEADLAMP - LEFT HAND - E-COATED
14	133115-01-000	EA	LAMP - FOG - CLEAR ROUND
15	133069-01-000	EA	LAMP - AMBER PARK/TURN W/O SOCKET - PASSENGER

*COMPONENT PARTS FOUND IN SERVICE PARTS LIBRARY

ELECTRICAL GROUP (CONTINUED)

LIGHTS (CONTINUED)

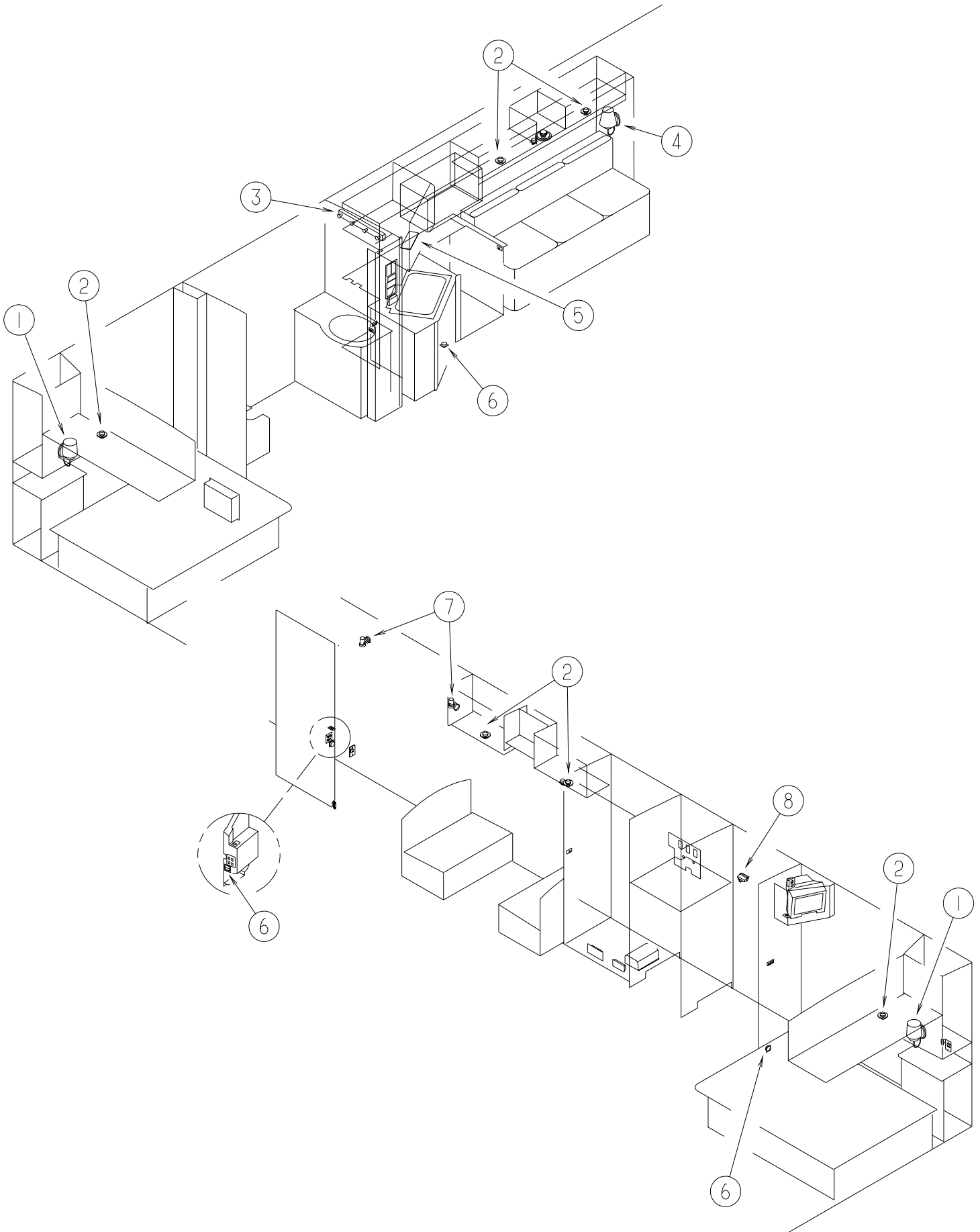

ELECTRICAL GROUP (CONTINUED)

LIGHTS (CONTINUED)

INTERIOR

KEY	PART NUMBER	U/M	DESCRIPTION
1	119258-08-01A	EA	LAMP - WALL - UL/CSA - BRASS
1	117806-01-000	EA	BULB - 12 VOLT #912 - 1.0 AMPS
2	132427-01-01A	EA	LIGHT - READING - SWIVEL/ROUND - BRASS
2	123917-01-000	EA	BULB - 12V - HALOGEN SPOT
3*	110235-02-01A	EA	LIGHT - MAKE UP - 4 BULB PANLESS
4	119258-12-01A	EA	LAMP - WALL - UL/CSA - BRASS
			FROM: 00-00-00 THRU: 12-12-99
4	119258-18-01A	EA	LAMP - WALL - W/O BULB OR SHADE - UL/CSA
			FROM: 12-13-99 THRU: 99-99-99
4	119257-05-01A	EA	SHADE - LAMP - WHITE HARDBACK - 4"T X 6.3"H X 7.3"B
5*	098024-06-02A	EA	LIGHT - DOME - 2 BULB - SKYLITE/OPTI CLEAR
5	008218-01-000	EA	BULB - 12 VOLT - #1141 - 1.44 AMP
6*	108354-01-01A	EA	LIGHT - COURTESY
7	128786-01-01A	EA	LIGHT - READING/SWIVEL
7	123917-01-000	EA	BULB - 12V - HALOGEN SPOT
8*	087694-01-000	EA	LIGHT - WARDROBE/CLOSET - W/SWITCH

*COMPONENT PARTS FOUND IN SERVICE PARTS LIBRARY

ELECTRICAL GROUP (CONTINUED)

LIGHTS (CONTINUED)

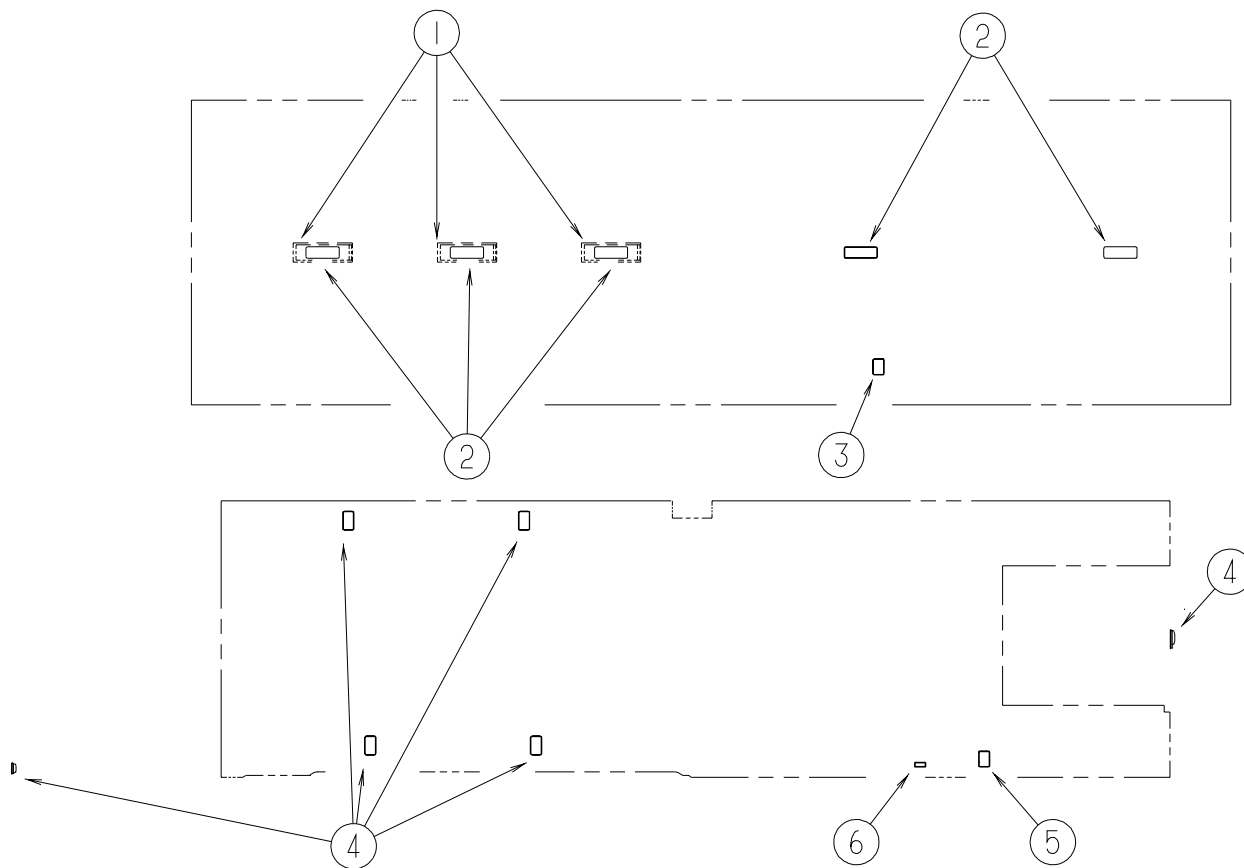

CEILING & COMPARTMENT

KEY	PART NUMBER	U/M	DESCRIPTION
1	091937-06-000	EA	LIGHT - FLOURESCENT-12 VOLT - RECESSED/THIN-LITE
2	098024-08-02A	EA	LIGHT - DOME W/O SWITCH - 2 BULB
			FROM: 00-00-00 THRU: 03-05-00
2	098024-09-02A	EA	LIGHT - DOME - 1 LENS/2 BULB FIXTURE - W/O SWITCH
			FROM: 03-06-00 THRU: 99-99-99
3*	121935-01-01A	EA	LIGHT - DOME - SHOWER
4*	098024-01-03A	EA	LIGHT - DOME - 1 BULB - WHITE
4	008218-01-000	EA	BULB - 12 VOLT - #1141 - 1.44 AMP
5	098024-07-02A	EA	LIGHT - DOME W/O SWITCH - 1 BULB
6*	086280-01-000	EA	LIGHT - SURFACE MOUNT - 12 VOLT

*COMPONENT PARTS FOUND IN SERVICE PARTS LIBRARY

ELECTRICAL GROUP (CONTINUED)

CIRCUIT BREAKERS & FUSES

KEY	PART NUMBER	U/M	DESCRIPTION
	062901-02-000	EA	FUSE - 5 AMP - AUTOMOTIVE
	083209-01-000	EA	CIRCUIT BREAKER - 15 AMP - 120 VOLT - CANADIAN
	083209-02-000	EA	CIRCUIT BREAKER - 15/15 AMP - 120 VOLT
	083209-03-000	EA	CIRCUIT BREAKER - 15/20 AMP - 120 VOLT
	083209-04-000	EA	CIRCUIT BREAKER - 30 AMP - 120 VOLT
	083209-05-000	EA	CIRCUIT BREAKER - 20 AMP - 120 VOLT
	083209-07-000	EA	CIRCUIT BREAKER - 20/20 AMP - 120 VOLT
	083209-10-000	EA	CIRCUIT BREAKER - 20/30 AMP - 120 VOLT
	083209-11-000	EA	CIRCUIT BREAKER - 20/15 AMP - 120 VOLT
	093654-01-000	EA	CIRCUIT BREAKER - 6 AMP - 12 VOLT
	093654-02-000	EA	CIRCUIT BREAKER - 15 AMP - 12 VOLT
	093654-03-000	EA	CIRCUIT BREAKER - 20 AMP - 12 VOLT
	093655-01-000	EA	CIRCUIT BREAKER - 25 AMP - 12 VOLT
	093655-02-000	EA	CIRCUIT BREAKER - 30 AMP - 12 VOLT
	097611-01-000	EA	CIRCUIT BREAKER - 10 AMP - 12 VOLT
	108916-01-000	EA	CIRCUIT BREAKER - 50 AMP - 12 VOLT - 2 POLE
	113482-01-000	EA	CIRCUIT BREAKER - 55 AMP - MANUAL
	122811-01-000	EA	CIRCUIT BREAKER - 20/50/50/20

CONVERTER, INVERTER, LOAD CENTER

KEY	PART NUMBER	U/M	DESCRIPTION
	099048-03-000	EA	INVERTER - 130 WATT
	108915-03-000	EA	LOAD CENTER - 120/240 - 100 AMP
	113132-01-000	EA	LOAD CENTER - 120/240 VOLT - 60 AMP
	123058-01-000	EA	CONVERTER - 55 AMP - ELECTRONIC - 4 1/8"H X 7"W X 12 3/8"L
	127002-01-000	EA	MODULE/CIRCUIT BOARD - ENERGY MANAGEMENT SYSTEM CONTROL
	127002-02-000	EA	PANEL/MONITOR - ENERGY MANAGEMENT SYSTEM

ELECTRICAL GROUP (CONTINUED)
RECEPTACLES

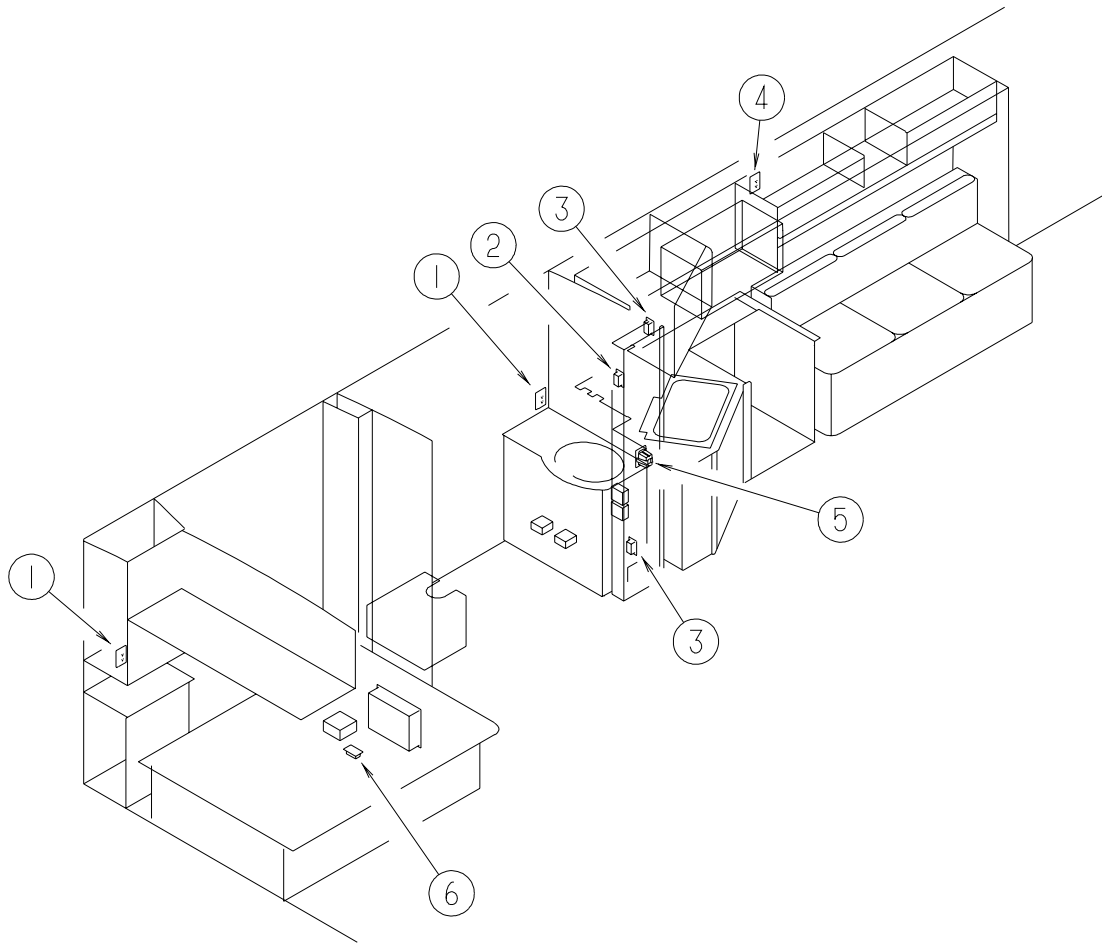

DRIVER

KEY	PART NUMBER	U/M	DESCRIPTION
1	058708-02-000	EA	RECEPTACLE - ELECTRIC - DOUBLE - IVORY
1	133713-01-01A	EA	SPACER - RECEPTACLE - WATERFORD OAK
2	058708-02-000	EA	RECEPTACLE - ELECTRIC - DOUBLE - IVORY
3	058708-01-000	EA	RECEPTACLE - ELECTRIC - DOUBLE - BROWN
4	058708-05-000	EA	RECEPTACLE - ELECTRIC - SINGLE - BROWN
4	133713-01-01A	EA	SPACER - RECEPTACLE - WATERFORD OAK
5	084076-01-000	EA	RECEPTACLE - GFI - 15 AMP/125 VOLT - IVORY - W/COVER
6	058707-02-000	EA	RECEPTACLE - BLANK - JUNCTION BOX

ELECTRICAL GROUP (CONTINUED)
RECEPTACLES (CONTINUED)

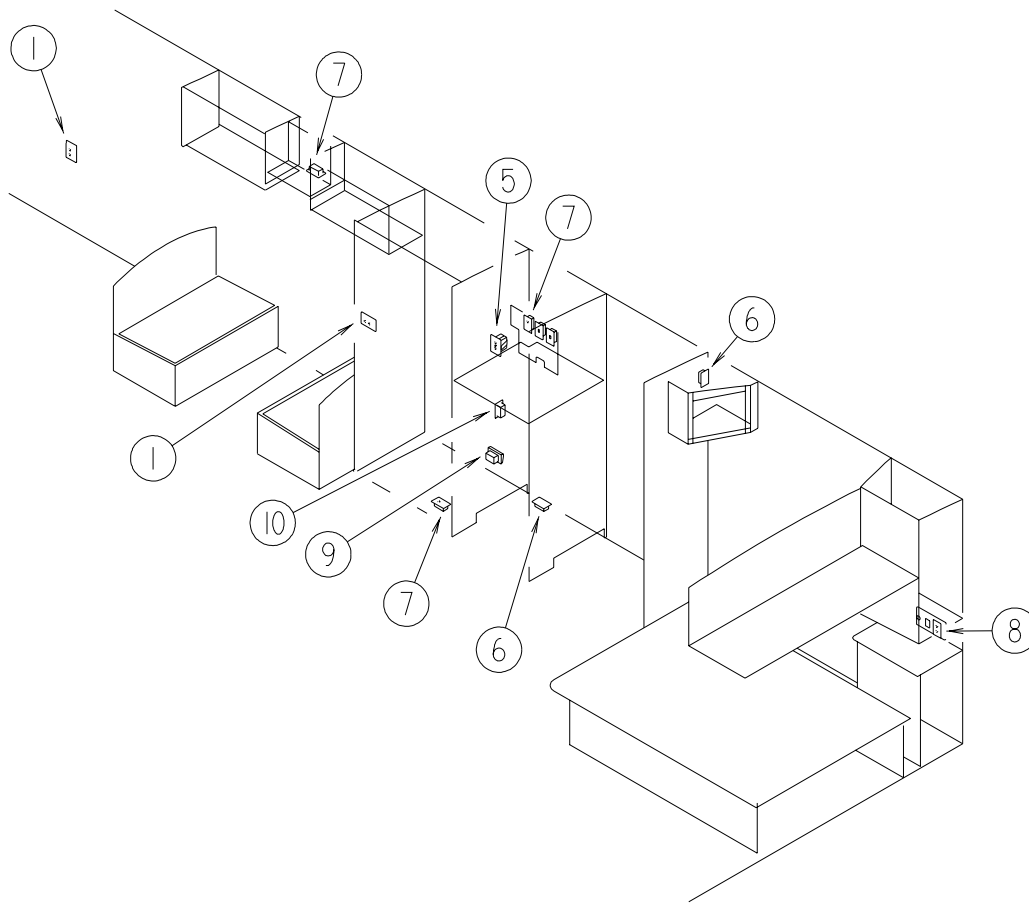

KEY	PART NUMBER	U/M	DESCRIPTION
1	058708-02-000	EA	RECEPTACLE - ELECTRIC - DOUBLE - IVORY
1	133713-01-01A	EA	SPACER - RECEPTACLE - WATERFORD OAK
2	058708-02-000	EA	RECEPTACLE - ELECTRIC - DOUBLE - IVORY
3	058708-01-000	EA	RECEPTACLE - ELECTRIC - DOUBLE - BROWN
4	058708-05-000	EA	RECEPTACLE - ELECTRIC - SINGLE - BROWN
4	133713-01-01A	EA	SPACER - RECEPTACLE - WATERFORD OAK
5	084076-01-000	EA	RECEPTACLE - GFI - 15 AMP/125 VOLT - IVORY - W/COVER
6	058707-02-000	EA	RECEPTACLE - BLANK - JUNCTION BOX
7	058708-05-000	EA	RECEPTACLE - ELECTRIC - SINGLE - BROWN
8	058708-02-000	EA	RECEPTACLE - ELECTRIC - DOUBLE - IVORY
8	133713-06-01A	EA	SPACER - RECEPTACLE - 110/12V - PHONE - WATERFORD OAK
9	131826-01-01A	EA	RECEPTACLE - EXTERIOR - W/COVER/GASKET - WHITE
10	058707-01-000	EA	RECEPTACLE - ELECTRIC - SINGLE - BROWN

ELECTRICAL GROUP (CONTINUED)

SWITCHES

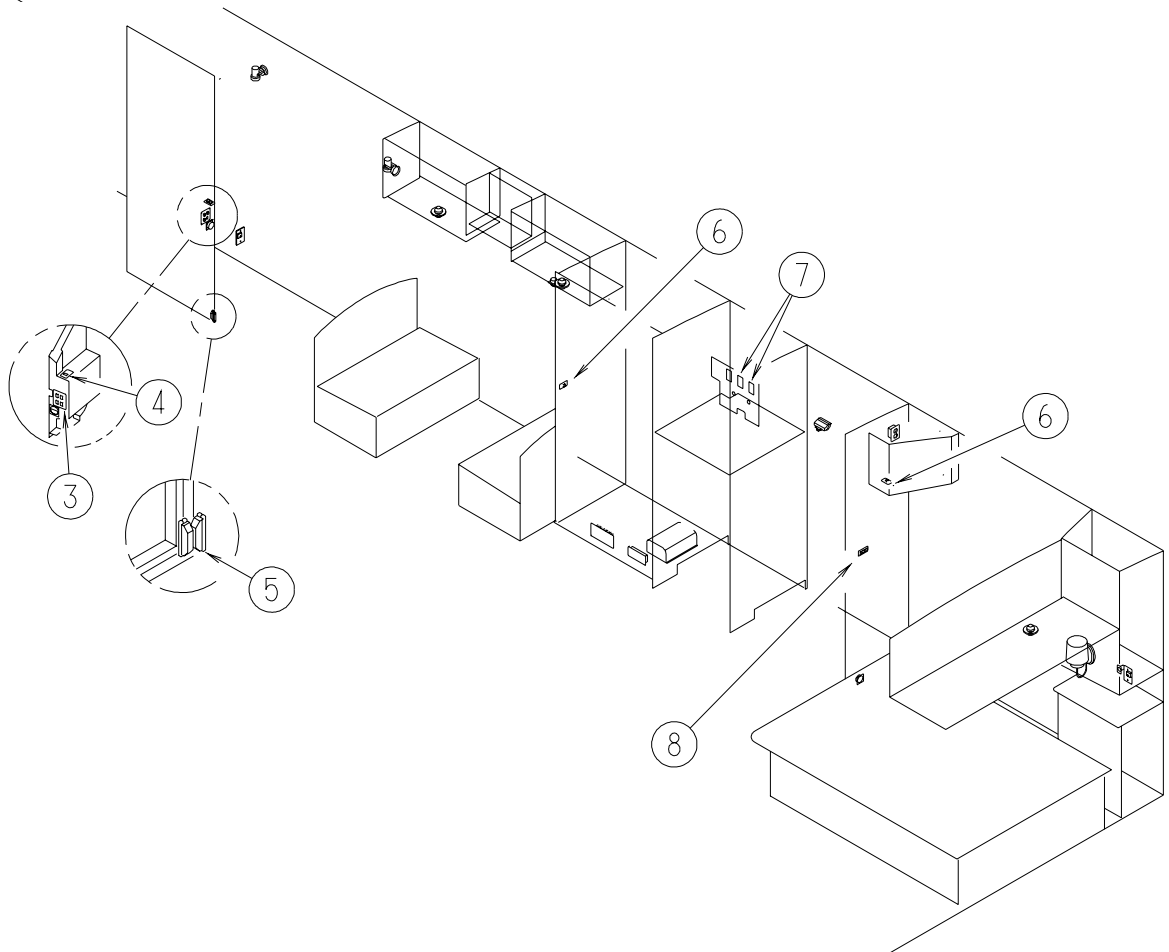
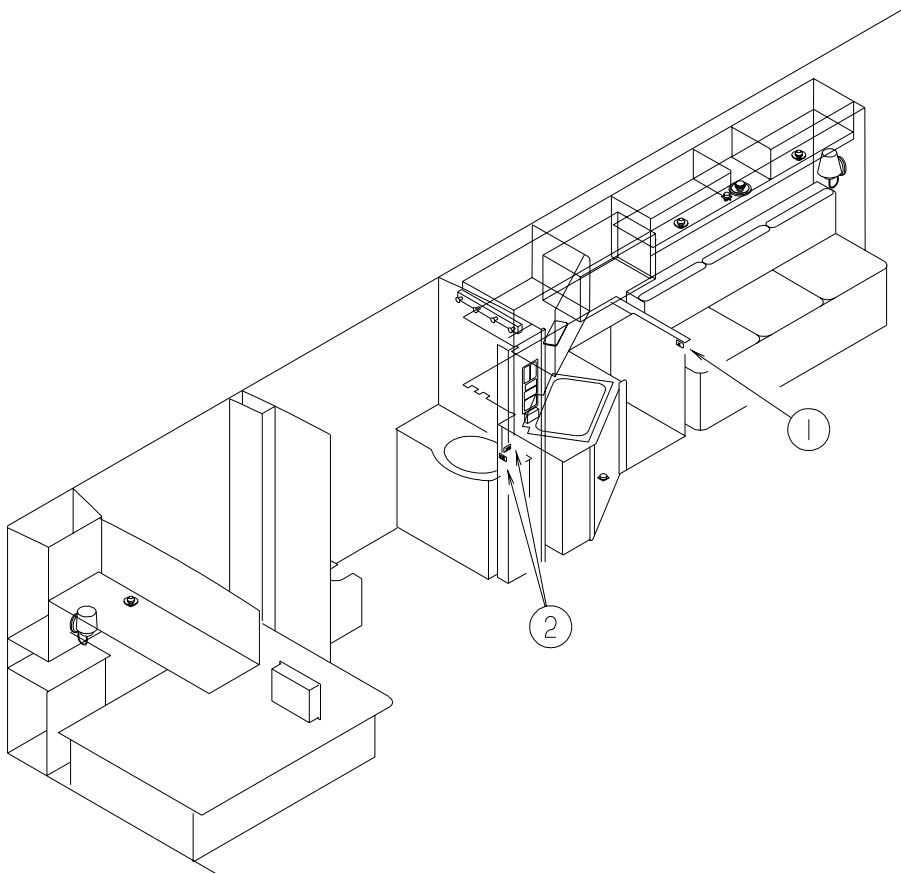

ELECTRICAL GROUP (CONTINUED)

SWITCHES (CONTINUED)

KEY	PART NUMBER	U/M	DESCRIPTION
1	132180-02-01A	EA	SWITCH - PADDLE - SPDT - ON/OFF - BLACK
1	098351-01-01A	EA	PLATE/SWITCH - 1 GANG - POLISHED BRASS - W/O LABEL
1	095188-01-01A	EA	SPACER - SWITCH - 2.3" X 3.4" - PLASTIC - DARK BROWN
2	132180-01-01A	EA	SWITCH - PADDLE - SPST - ON/OFF - BLACK
2	132180-02-01A	EA	SWITCH - PADDLE - SPDT - ON/OFF - BLACK
2	098351-02-01A	EA	PLATE/SWITCH - 2 GANG - POLISHED BRASS - W/O LABEL
2	095188-01-01A	EA	SPACER - SWITCH - 2.3" X 3.4" - PLASTIC - DARK BROWN
3	132180-01-01A	EA	SWITCH - PADDLE - SPST - ON/OFF - BLACK
3	098351-08-01A	EA	PLATE/SWITCH - 4 GANG/BRASS-PORCH/CEILING/STEP/COMPT LAMPS
4	079364-04-000	EA	SWITCH - ON/OFF ROCKER - 2 TERMINAL - BLACK
4	098351-01-01A	EA	PLATE/SWITCH - 1 GANG - POLISHED BRASS - W/O LABEL
5	116995-02-000	EA	SWITCH/MAGNET - ELECTRIC STEP - BLACK/WHITE-CLOSED CIRCUIT
6	132180-01-01A	EA	SWITCH - PADDLE - SPST - ON/OFF - BLACK
6	098351-14-01A	EA	PLATE/SWITCH - 1 GANG - POLISHED BRASS - TV
7	084420-01-000	EA	SWITCH - TOGGLE - 15 AMP - 120 VOLT - BROWN
8	132180-01-01A	EA	SWITCH - PADDLE - SPST - ON/OFF - BLACK
8	132180-02-01A	EA	SWITCH - PADDLE - SPDT - ON/OFF - BLACK
8	098351-03-01A	EA	PLATE/SWITCH - 3 GANG - POLISHED BRASS - W/O LABEL
8	095188-03-01A	EA	SPACER - SWITCH - DARK BROWN

ELECTRICAL GROUP (CONTINUED)

BOXES & CORDS

KEY	PART NUMBER	U/M	DESCRIPTION
	008054-01-000	EA	CORD - POWER - 10/3 WIRE - 30 AMP - 25'
	008289-01-000	EA	BOX - ELECTRIC/STEEL - 1/2" & 3/4" KNOCKOUTS - 4" X 4"
	008289-02-000	EA	BOX - ELECTRIC/STEEL - 1/2" & 3/4" KNOCKOUTS - 4" X 4"-CAN
	008294-01-000	EA	COVER - ELECTRICAL BOX - BLANK/STEEL - 4" X 4" - GRAY
	008294-02-000	EA	COVER - ELECTRICAL BOX - BLANK STEEL - 4" X 4" - CANADIAN
	092492-14-000	EA	SEAL - ELECTRICAL BOX
*	106071-04-000	EA	SWITCH - AUTOMATIC TRANSFER W/CONNECTION LUGS
	108934-02-000	EA	CORD - POWER - 50 AMP - 4-WIRE - 36'
	113029-05-02B	EA	PANEL - ELECTRICAL BOX - FRONT - E-COATED
	131679-01-000	EA	BOX-ELEC-WATERPROOF SEALED 4" X 4" W/4 3/4"OUTLETS-UL/CSA
	131680-01-000	EA	COVER - W/GASKET FOR WATERPROOF 4" X 4" BOX - UL/CSA
	109925-05-000	EA	DOOR - ELECTRICAL BOX
	133070-01-000	EA	BOX - ELECTRICAL - PLASTIC - 3" X 2" X 2.8" - UL
	133070-02-000	EA	BOX - ELECTRICAL - PLASTIC - 3" X 2" X 2.8" - CSA

*COMPONENT PARTS FOUND IN SERVICE PARTS LIBRARY

WIRE ASSEMBLIES

KEY	PART NUMBER	U/M	DESCRIPTION
	090986-01-000	EA	WIRE ASSEMBLY - ELECTRIC STEP FROM: 00-00-00 THRU: 06-01-99
	090986-02-000	EA	WIRE ASSEMBLY - ELECTRIC STEP FROM: 06-02-99 THRU: 99-99-99
	096449-02-000	EA	WIRE ASSEMBLY - WATER TANK TO MONITOR PANEL
	096717-04-000	EA	WIRE ASSEMBLY - REAR MONITOR - UPPER
	108029-01-000	EA	WIRE ASSEMBLY - POWER DRIVER SEAT
	113639-01-000	FT	CABLE - 3/0 AWG STRANDED - RED
	113639-02-000	FT	CABLE - 3/0 AWG STRANDED - BLACK
	120233-05-000	EA	WIRE ASSEMBLY - 30" CONNECTS TO WALLPLATE DISPLAY
	124842-01-000	EA	WIRE ASSEMBLY - SPEAKER ADAPTER/TV
	124843-07-000	EA	WIRE ASSEMBLY - SPEAKER ADAPTER
	124843-08-000	EA	WIRE ASSEMBLY - SPEAKER ADAPTER
	124882-01-000	EA	WIRE ASSEMBLY - AMPLIFIER
	125266-09-000	EA	WIRE ASSEMBLY - COMPARTMENT LAMPS
	125853-01-000	EA	WIRE ASSEMBLY - ENTERTAINMENT CENTER
	127002-03-000	EA	WIRE ASSEMBLY - ENERGY MANAGEMENT SYSTEM
	133542-01-000	EA	WIRE ASSEMBLY - HEADLAMP/FLOOD
	133543-01-000	EA	WIRE ASSEMBLY - INSTRUMENT PANEL - MAIN/FLOOD
	105620-07-000	EA	WIRE ASSEMBLY - THERMOSTAT FROM: 00-00-00 THRU: 01-02-00
	135131-01-000	EA	WIRE ASSEMBLY - THERMOSTAT FROM: 01-03-00 THRU: 99-99-99

ELECTRICAL GROUP (CONTINUED)

CONNECTORS & CONDUIT

KEY	PART NUMBER	U/M	DESCRIPTION
	007956-05-000	EA	INSULATOR - SHRINK - .25 ID X 1.50
	008311-01-000	EA	CONNECTOR - WIRE NUT - INSULATED - RED
	008313-01-000	EA	CONNECTOR - WIRE NUT - INSULATED - YELLOW
	008314-01-000	EA	CONNECTOR - WIRE NUT - INSULATED - GRAY
	008326-01-000	EA	TERMINAL - RING - 16/14 WIRE - 3/8" STUD
	008331-01-000	EA	TERMINAL - RING - TONGUE - #4 WIRE - 3/8" STUD - COPPER
	008348-01-000	EA	TERMINAL - RING - 3/8" STUD 2 GA. WIRE
	008355-01-000	EA	CONNECTOR - CABLE CLAMPING - 3/4"
	008356-01-000	EA	CONNECTOR - PLASTIC - 3/8" AVG
	008356-02-000	EA	CONNECTOR - PLASTIC - 21/32
	035416-04-000	EA	TERMINAL - RING - #10 STUD FIT - INSULATED BARREL #16/14
	041953-01-000	FT	CONDUIT - CONVOLUTE SLIT - .5" ID - POLYETHYLENE
	041953-03-000	FT	CONDUIT - CONVOLUTE SLIT - 1" ID (CLOTHES ROD COVER)
	041953-05-000	FT	CONDUIT - CONVOLUTE SOLID - .62" ID - POLYETHYLENE
	041953-06-000	FT	CONDUIT - CONVOLUTE SLIT - .375" ID - POLYETHYLENE
	041953-07-000	FT	CONDUIT - CONVOLUTE SLIT - .25" ID - POLYETHYLENE
	041953-08-000	FT	CONDUIT - CONVOLUTE SLIT - 1.50" ID - POLYETHYLENE
	041953-09-000	FT	CONDUIT - CONVOLUTE SLIT - .50" ID - NYLON
	041953-10-000	FT	CONDUIT - CONVOLUTE SLIT - .75" ID - NYLON
	041953-11-000	FT	CONDUIT - CONVOLUTE SLIT - 1.06" ID - NYLON
	041953-12-000	FT	CONDUIT - CONVOLUTE SOLID - 1.1" ID - NYLON
	041953-13-000	FT	CONDUIT - CONVOLUTE SLIT - 1.25
	047443-01-000	EA	TERMINAL - .250 RECEPTACLE FIT - INSULATED - 16/14 AWG
	047443-02-000	EA	TERMINAL - .250 RECEPTACLE FIT - INSULATED - 12/10 AWG
	058028-01-000	EA	CONNECTOR - ELECTRICAL PIGTAIL - NYLON - CLEAR
	062036-01-000	EA	TERMINAL - PACK - CON - 12/10 AWG
	077479-01-000	EA	BOOT - BATTERY TERMINAL - DOUBLE CABLE
	077479-02-000	EA	BOOT - BATTERY TERMINAL - SINGLE CABLE
	080015-02-000	EA	RECEPTACLE - FLAG - .185 - 16/14 GAUGE
	080015-03-000	EA	RECEPTACLE - FLAG - .250 - 14/16 GAUGE
	082109-01-000	EA	HOUSING - CONNECTOR - PACKARD
	082741-01-000	EA	CONNECTOR BODY - 2 CONNECTOR MALE
	087225-01-000	FT	SLEEVING - 1/2" - TYPE H
	087949-01-000	EA	BUSS BAR - 2 POSITION - .6" X 1.5"
	087949-02-000	EA	BUSS BAR - 3 POSITION - .6" X 2.4"
	088267-01-000	EA	TERMINAL - FEMALE - 1/4
	088473-01-000	EA	HOUSING - PIN - 12 CAVITY (3 ROWS OF 4)
	088473-02-000	EA	HOUSING - PIN - 15 CAVITY (3 ROWS OF 5)
	088473-03-000	EA	HOUSING - PIN - 9 CAVITY (3 ROWS OF 3)
	088473-04-000	EA	HOUSING - PIN - 8 CAVITY IN-LINE
	088473-06-000	EA	HOUSING - PIN - 6 CAVITY (2 ROWS OF 3)
	088473-07-000	EA	HOUSING - PIN - 5 CAVITY - IN-LINE
	088473-08-000	EA	HOUSING - PIN - 4 CAVITY - IN-LINE
	088473-09-000	EA	HOUSING - PIN - 3 CAVITY - IN-LINE
	088473-10-000	EA	HOUSING - PIN - 2 CAVITY - IN LINE
	088474-01-000	EA	HOUSING - SOCKET - 12 CAVITY
	088474-02-000	EA	HOUSING - SOCKET - 15 CAVITY
	088474-03-000	EA	HOUSING - SOCKET - 9 CAVITY
	088474-06-000	EA	HOUSING - SOCKET - 6 CAVITY
	088474-08-000	EA	HOUSING - SOCKET - 4 CAVITY
	088474-09-000	EA	HOUSING - SOCKET - 3 CAVITY
	088474-10-000	EA	HOUSING - SOCKET - 2 CAVITY
	088475-01-000	EA	PIN - CONNECTOR - 14-20 AWG
	088475-02-000	EA	PIN - CONNECTOR - 10-12 AWG
	088476-01-000	EA	TERMINAL - ELECTRICAL
	088476-02-000	EA	SOCKET - CONNECTOR - 12-10 GA - PRE-TIN
	098261-02-000	EA	SOCKET - CONNECTOR - WEATHERPACK - 14-18 AWG
	098262-01-000	EA	SEAL - CONNECTOR - WEATHERPACK
	098262-05-000	EA	SEAL - CAVITY
	098263-01-000	EA	HOUSING - 3 PIN - WEATHER PACK
	098264-01-000	EA	HOUSING - 2 PIN - WEATHER PACK - MALE W/FEMALE PINS
	098265-02-000	EA	PIN - CONNECTOR - WEATHERPACK

ELECTRICAL GROUP (CONTINUED)

CONNECTORS & CONDUIT (CONTINUED)

KEY	PART NUMBER	U/M	DESCRIPTION
	100690-01-000	EA	HOUSING - 5 POSITON - MALE - WEATHERPACK
	100690-02-000	EA	HOUSING - 5 POSITION - FEMALE - WEATHERPACK
	101751-01-000	EA	HOUSING - 1 PIN - WEATHER PACK
	101751-02-000	EA	HOUSING - 1 PIN - WEATHERPACK
	102777-02-000	EA	TERMINAL - RING - #6 STUD - 10 AWG
	104100-01-000	EA	HOUSING - 1 POSITION - 75 AMPS
	104100-02-000	EA	TERMINAL - 75 AMP
	104100-03-000	EA	TERMINAL - 75 AMP
	110178-01-000	EA	HOUSING - WIPER MOTOR
	112823-01-000	EA	SPLICE - REDUCER - 16-14 TO 18-22
	113306-01-000	EA	TERMINAL - FEMALE - M/P - 14-16 - F/NON-SEALED TERMINAL
	113306-02-000	EA	TERMINAL - FEMALE - M/P - 10-12 - 480
	113308-01-000	EA	TERMINAL - FEMALE - M/P - 14-16 - 280
	113452-01-000	FT	SEAL/TRIM - FRONT - VINYL W/WIRE CARRIER - .020"
	113452-02-000	FT	SEAL/TRIM - FRONT - VINYL W/WIRE CARRIER - .027"
	113468-01-000	EA	HOUSING - 2 POSITION - FEMALE USED ON WIPER/WASHER WIRE ASM
	116811-01-000	EA	TERMINAL - .110 RECEPTACLE - 16-14 AWG
	118571-01-000	EA	CONNECTOR - 3-WAY - MALE/SEALED
	118571-02-000	EA	CONNECTOR - 3-WAY - FEMALE/SEALED
	118571-03-000	EA	BRACKET - MOUNTING
	118571-04-000	EA	GASKET
	118571-05-000	EA	LOCK - SECONDARY - FEMALE
	118571-06-000	EA	LOCK - SECONDARY - MALE
	118599-01-000	EA	TERMINAL - MALE - M/P - 280 - 14-16
	119223-01-000	EA	HOUSING - 6 POSITION - MALE - WEATHERPACK
	125323-01-000	EA	HOUSING - 10 POSITION - MALE
	125323-02-000	EA	HOUSING - 8 POSITION - MALE
	125323-03-000	EA	LOCK - SECONDARY 8 POSITION
	125323-04-000	EA	LOCK - SECONDARY 10 POSITION
	125323-05-000	EA	HOUSING - 6 POSITION - MALE
	125323-06-000	EA	LOCK - SECONDARY - 6 POSITION
	125324-01-000	EA	TERMINAL - MALE - METRI-PACK - 150
	125325-01-000	EA	SEAL - CAVITY

BOOTS, SOLENOIDS, RELAYS & MISCELLANOUS

KEY	PART NUMBER	U/M	DESCRIPTION
	007093-01-000	EA	SIGNAL FLASHER
	008188-02-000	EA	SOLENOID - SEALED - HEAVY DUTY
	063910-01-000	EA	HOUSING - RELAY
	063912-02-000	EA	RELAY - CANISTER - SPDT
	086233-01-000	EA	STUD - ISOLATED - 3/8" X 7/8" LONG
	086273-01-000	EA	RELAY - BATTERY DISCONNECT
*	113832-02-01A	EA	SLIDE - BATTERY TRAY - HEAVY DUTY
*	113832-03-01A	EA	SLIDE - BATTERY TRAY
	131832-01-000	EA	RELAY - 25 AMP/120 VOLT AC/6 TERM - CUTLER-HAMMER D8PR7TEA
	131832-02-000	EA	HOUSING - RELAY

*COMPONENT PARTS FOUND IN SERVICE PARTS LIBRARY

EXTERIOR BODY GROUP

AIR HORN INSTL.

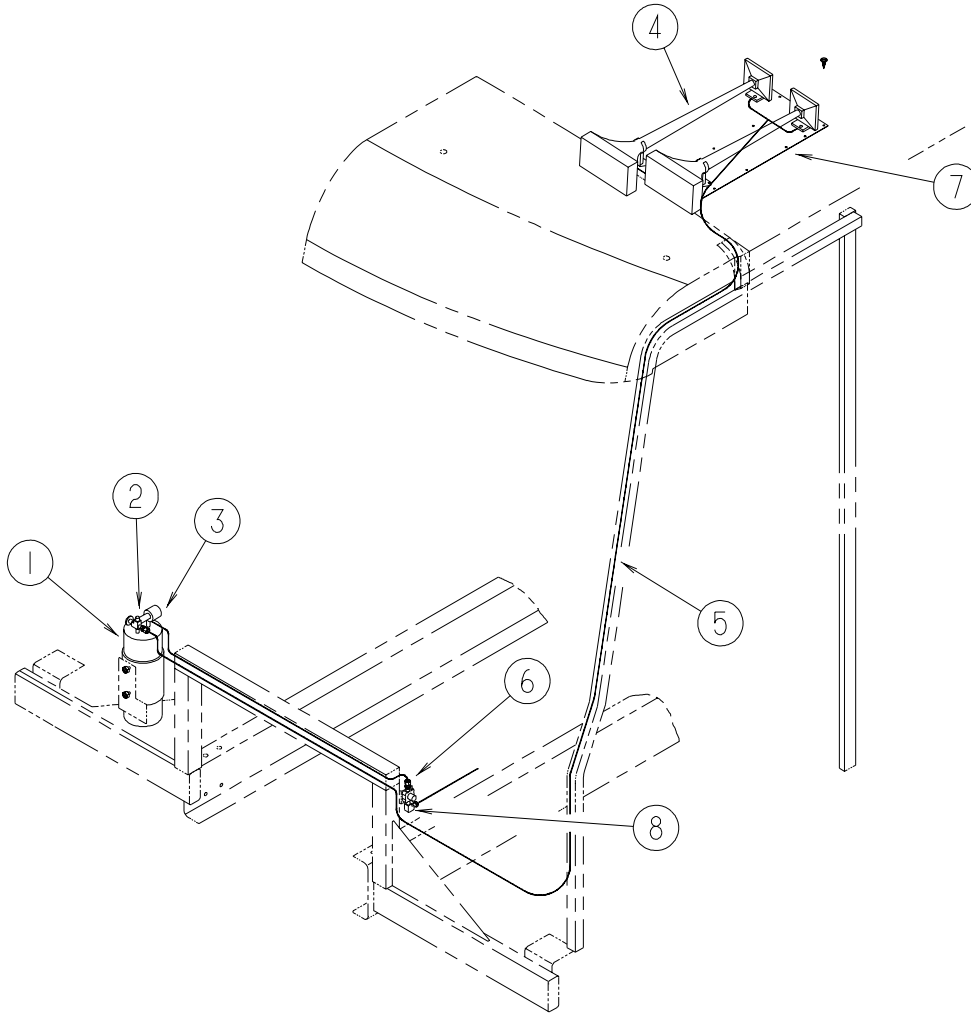

KEY	PART NUMBER	U/M	DESCRIPTION
1*	077497-09-000	EA	TANK - AIR - SOLENOID KIT - AUXILIARY HORN
2	071387-07-000	EA	ELBOW - MALE - BRAKE TUBE - 1/4" X 1/8"
3*	077497-03-000	EA	FITTING KIT - HOSE/HOSE FITTING/AIR GAUGE - F/AUX HORN
4*	077497-06-000	EA	HORN - AIR - CHROME - TWIN
5	071390-04-000	FT	TUBING - AIR BRAKE - 1/4" OD-BLK WEATHERHEAD (BRKS & HORN)
6	071386-06-000	EA	CONNECTOR - MALE - 1/4 TUBE X 1/4
	077497-02-000	EA	HOSE - AUXILIARY AIR HORN
7	125123-01-12B	EA	PLATE/MOUNTING - AIR HORN - 25" X 13" - BRIGHT WHITE
8	071387-04-000	EA	ELBOW - MALE - BRAKE TUBE 3/8 X 1/4

*COMPONENT PARTS FOUND IN SERVICE PARTS LIBRARY

EXTERIOR BODY GROUP (CONTINUED)
GRAPHICS & PAINT

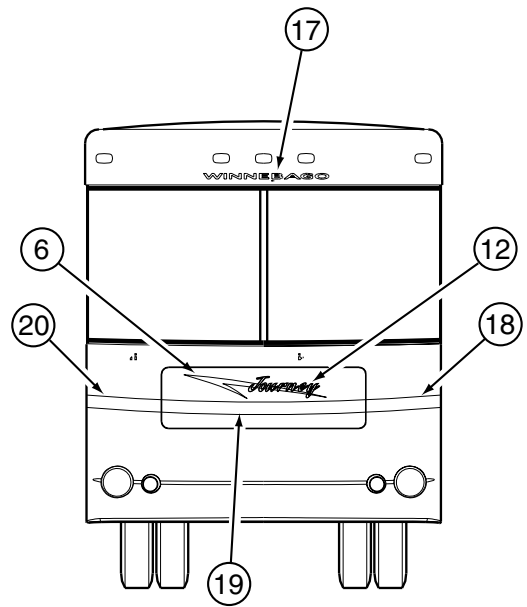
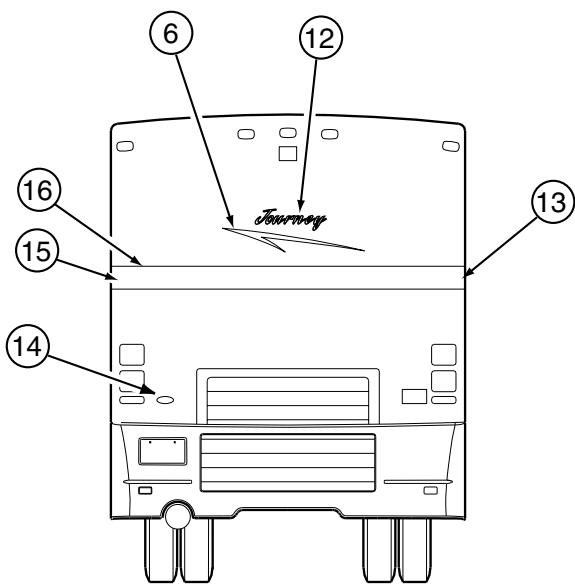
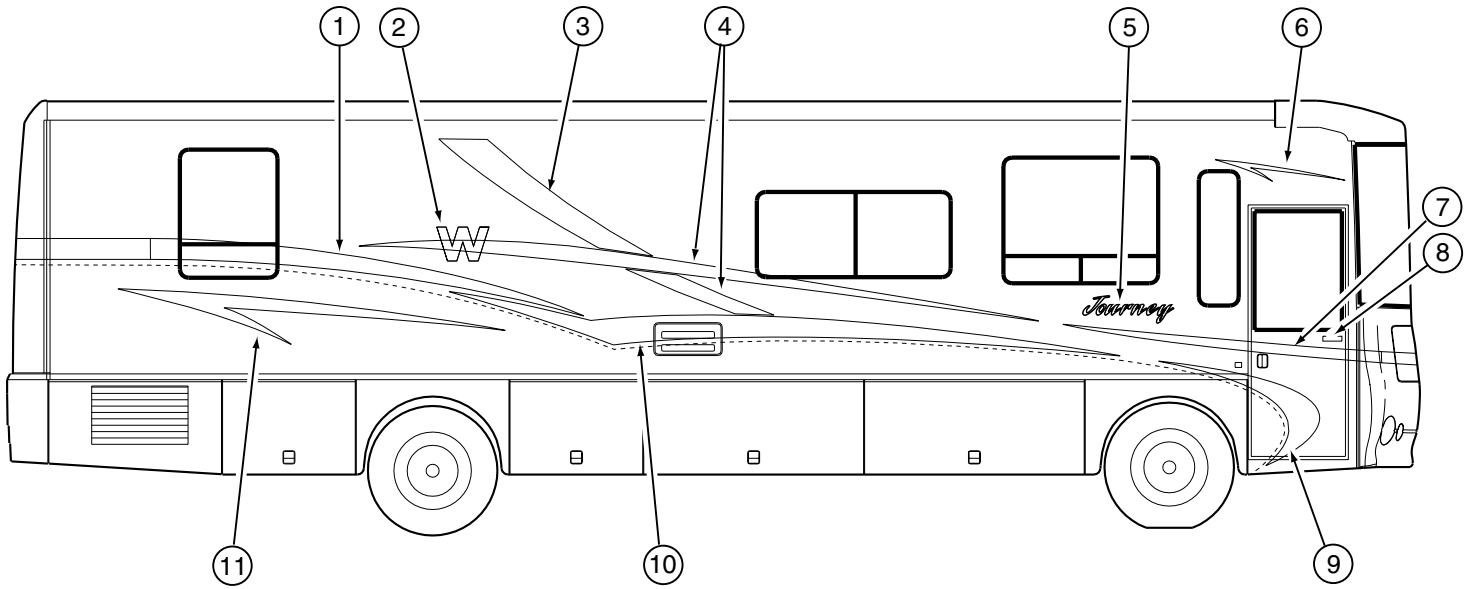

EXTERIOR BODY GROUP (CONTINUED)

GRAPHICS & PAINT (CONTINUED)

KEY	PART NUMBER	U/M	DESCRIPTION
1	131939-01-01A	EA	DECAL - SWEEP - REAR/PASSENGER FROM: 00-00-00 THRU: 02-27-00
1	131939-02-01A	EA	DECAL - SWEEP - REAR/DRIVER FROM: 00-00-00 THRU: 02-27-00
1	135972-01-01A	EA	DECAL - SWEEP - REAR/PASSENGER - WINE FROM: 02-28-00 THRU: 99-99-99
1	135972-02-01A	EA	DECAL - SWEEP - REAR/DRIVER - WINE FROM: 02-28-00 THRU: 99-99-99
2	120700-08-01A	EA	DECAL - LOGO - "W"
3	131941-01-01A	EA	DECAL - SLASH - UPPER REAR/PASSENGER
3	131941-02-01A	EA	DECAL - SLASH - UPPER REAR/DRIVER
4	131951-01-01A	EA	DECAL - SLASH - LOWER REAR/RIGHT HAND
4	131951-02-01A	EA	DECAL - SLASH - LOWER REAR/LEFT HAND
5	131947-01-01A	EA	DECAL - LOGO - VECTRA JOURNEY
6	131948-01-01A	EA	DECAL - CHECK - FRONT/REAR
7	131944-01-01A	EA	DECAL - SLASH - FRONT/PASSENGER
7	131944-02-01A	EA	DECAL - SLASH - FRONT/DRIVER
8	132664-01-01A	EA	DECAL - LOGO/DOMED - WINNEBAGO - GOLD/BLACK - PLASTIC
9	131943-01-01A	EA	DECAL - SWEEP - FRONT/PASSENGER
9	131943-02-01A	EA	DECAL - SWEEP - FRONT/DRIVER
10	131942-01-01A	EA	DECAL - SWEEP - MIDDLE/PASSENGER
10	131942-02-01A	EA	DECAL - SWEEP - MIDDLE/DRIVER
11	131940-01-01A	EA	DECAL - CHECK - REAR/PASSENGER
11	131940-02-01A	EA	DECAL - CHECK - REAR/DRIVER
12	131947-02-01A	EA	DECAL - LOGO - VECTRA JOURNEY - SMALL
13	131949-01-01A	EA	DECAL - CORNER - REAR/PASSENGER
14	120875-01-01A	EA	DECAL - "WINNEBAGO INDUSTRIES"-OVAL DOMED-GRILLE-BLK/GOLD
14	120994-01-01A	EA	BEZEL - DOMED GRILLE LOGO
15	131949-02-01A	EA	DECAL - CORNER - REAR/DRIVER
16	093681-63-01A	FT	FILM - 6.4"
17	120702-03-16A	EA	DECAL - WINNEBAGO - 35.4"
18	131945-02-01A	EA	DECAL - CORNER/DRIVER
19	131946-01-01A	EA	DECAL - HOOD
20	131945-01-01A	EA	DECAL - CORNER/PASSENGER
	041561-03-000	EA	PAINT - 16 OUNCE SPRAY - OFF WHITE

DUPONT COLORS

PEPPERBERRY MET.	DUPONT RM329
WINE MET.	DUPONT RM022
DK. JADESTONE MET.	DUPONT MM171
SAHARA MET	DUPONT M1024U
JADESTONE MET	DUPONT M3264U
BRIGHT WHITE	DUPONT B8951

EXTERIOR BODY GROUP (CONTINUED)

PANELS

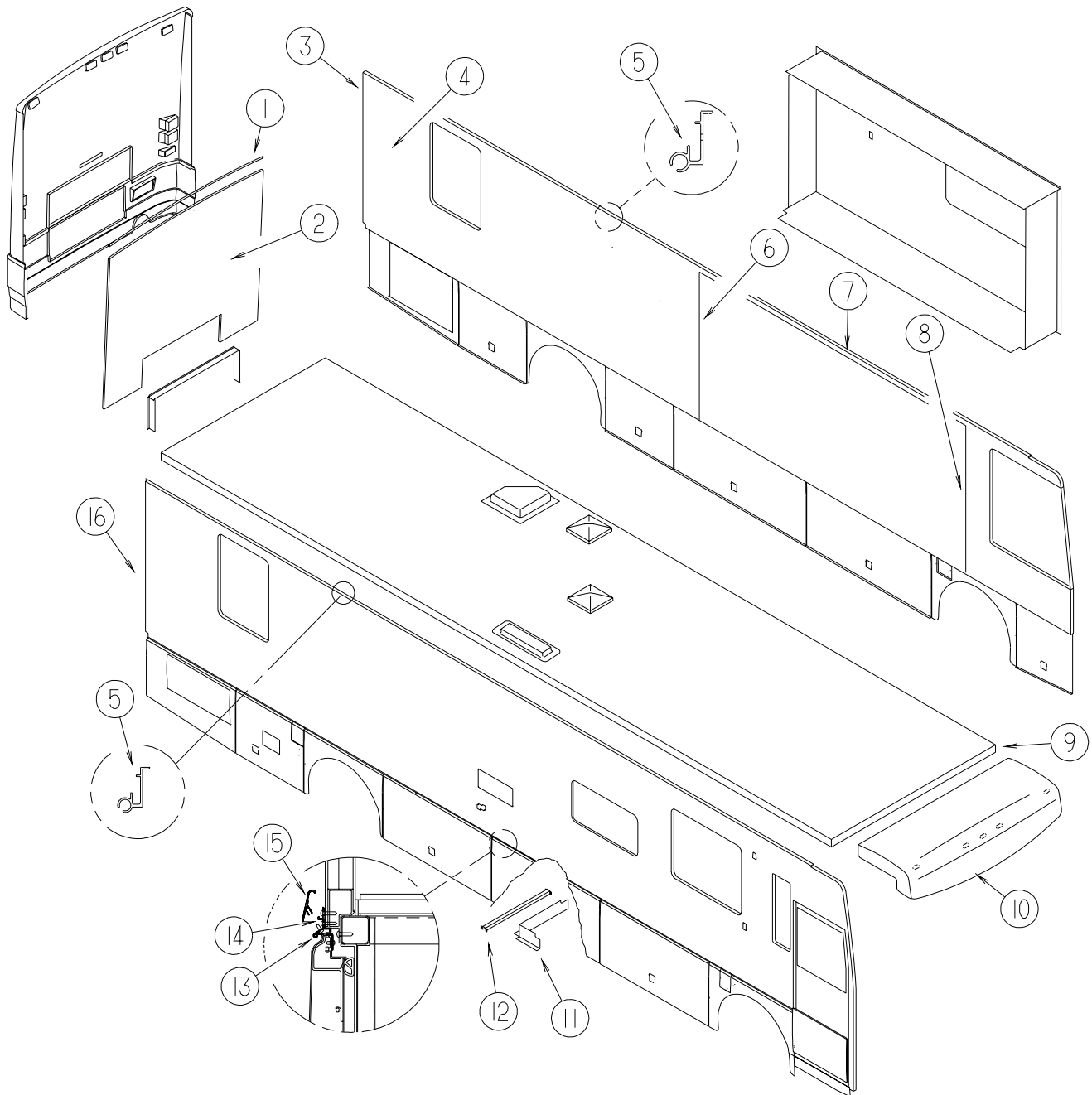

KEY	PART NUMBER	U/M	DESCRIPTION
1	114248-02-01A	EA	ANGLE - PLASTIC - 96.6"
2	132784-01-L76	EA	BACKWALL - W/O WINDOW/TRIM (L76,L78)
2	132784-01-L80	EA	BACKWALL - W/O WINDOW/TRIM (L80)
3	115886-09-01A	EA	RETAINER - SIDEWALL - BRIGHT WHITE
4	133734-01-L76	EA	SIDEWALL - DRIVER - W/O WINDOWS/TRIMS (L76,L78)
4	133734-01-L80	EA	SIDEWALL - DRIVER - W/O WINDOWS/TRIMS (L80)
5	131483-01-01A	EA	RAIL - AWNING - 192" - BRIGHT WHITE
6	115863-18-01A	EA	TRIM - SIDEWALL/SLIDEOUT - RIGHT HAND - 76.1" - BRT WHT
6	115886-09-01A	EA	RETAINER - SIDEWALL - BRIGHT WHITE
7	115863-03-03A	EA	TRIM - SIDEWALL/SLIDEOUT - TOP - 159.4" - BRT WHT
7	115886-09-01A	EA	RETAINER - SIDEWALL - BRIGHT WHITE

EXTERIOR BODY GROUP (CONTINUED)

PANELS (CONTINUED)

KEY	PART NUMBER	U/M	DESCRIPTION
8	115863-17-01A	EA	TRIM - SIDEWALL/SLIDEOUT - LEFT HAND - 76.1" - BRT WHT
8	115886-09-01A	EA	RETAINER - SIDEWALL - BRIGHT WHITE
9	133735-01-L76	EA	ROOF - W/O LIGHTS/VENTS - W/WIRING
10	131635-02-L76	EA	CAP - ROOF
11	134811-01-02B	EA	PANEL - COVER - WATER SYSTEM - E-COATED
12	115392-01-01A	EA	STRAP - VELCRO (LUG WRENCH HOLDER)
13	133376-01-01A	EA	TRIM - RETAINER - MILL
14	124046-02-02B	EA	BRACKET - ANCHOR - E-COATED
15	123993-01-03A	EA	COVER - TRIM - 182" ALUMINUM - BRIGHT WHITE
	126775-01-01A	EA	END CAP - VALANCE TRIM - RIGHT HAND
	126775-02-01A	EA	END CAP - VALANCE TRIM - LEFT HAND
	105312-01-07A	FT	INSERT - VINYL FEATURE STRIP - BRIGHT WHITE
16	133733-01-L76	EA	SIDEWALL - PASSENGER - W/O WINDOWS/TRIMS (L76,L78)
16	133733-01-L80	EA	SIDEWALL - PASSENGER - W/O WINDOWS/TRIMS (L80)

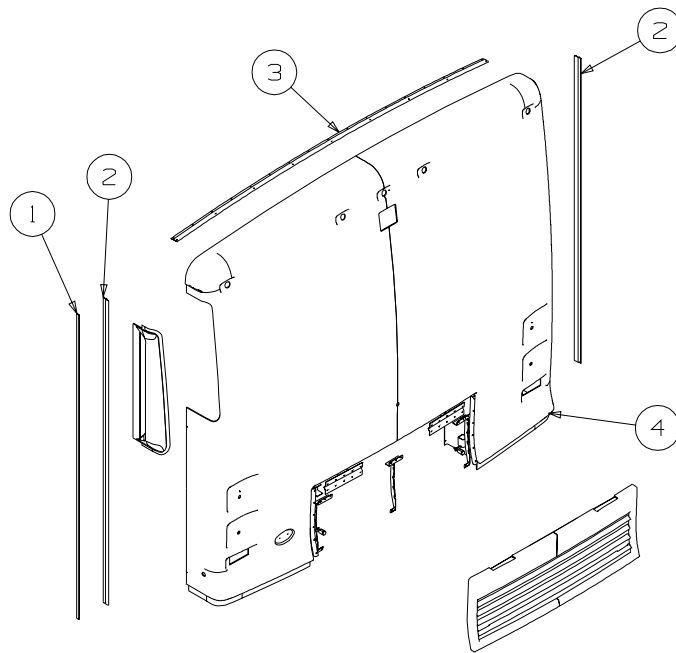

REAR CAP

KEY	PART NUMBER	U/M	DESCRIPTION
1	091985-01-07A	FT	MOLDING - TRIM - BRIGHT WHITE
2	092041-01-02A	EA	TRIM - BACKWALL/SIDEWALL - 83.1" - OFF WHITE
3	083805-23-000	EA	TRIM - ROOF CAP - 92.1" - BRIGHT WHITE
4	131897-02-L76	EA	PANEL - REAR CAP
	131896-01-01A	EA	PANEL/AIR SCOOP - BRIGHT WHITE
	129683-01-02A	EA	PANEL - AIR INTAKE - BLACK
	P23280-01-01A	EA	SHROUD - CAMERA - INNER

EXTERIOR BODY GROUP (CONTINUED)

FRONT END

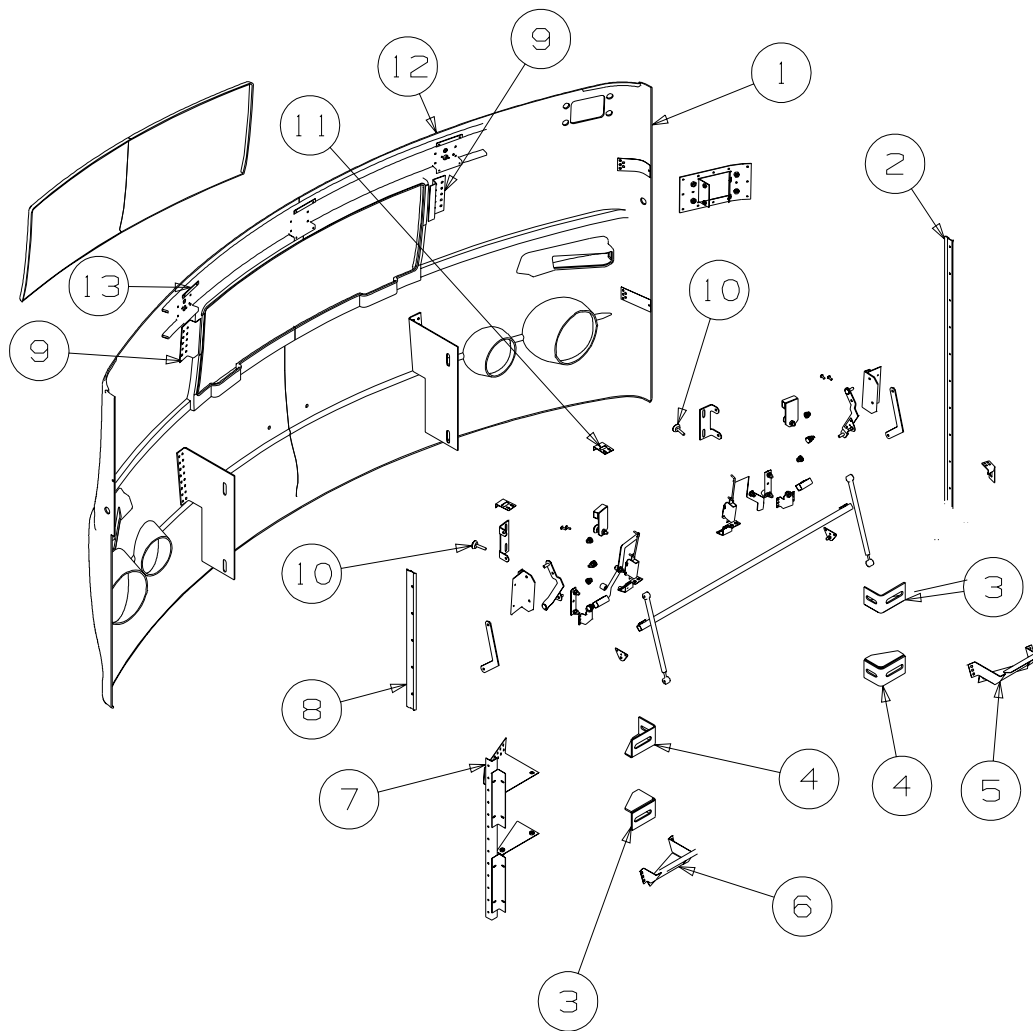

KEY	PART NUMBER	U/M	DESCRIPTION
1	131442-02-L76	EA	PANEL - FRONT LOWER W/NEW STYLE HEADLAMP BRACKETS
2	125818-04-01A	EA	TRIM - FIBERGLASS PANEL - BRIGHT WHITE
	091985-01-07A	FT	INSERT - TRIM - BRIGHT WHITE - 1"
3	128455-01-02B	EA	BRACKET - BUMPER
			FROM: 00-00-00 THRU: 08-01-99
3	128455-03-02B	EA	BRACKET - BUMPER - RIGHT HAND UPPER/LEFT HAND LOWER
			FROM: 08-02-99 THRU: 99-99-99
4	128455-02-02B	EA	BRACKET - BUMPER
			FROM: 00-00-00 THRU: 08-01-99
4	128455-04-02B	EA	BRACKET - BUMPER - LEFT HAND UPPER/RIGHT HAND LOWER
			FROM: 08-02-99 THRU: 99-99-99
5	134058-01-02B	EA	BRACKET - FOGLAMP - E-COATED
6	134058-02-02B	EA	BRACKET - FOGLAMP - E-COATED
7	132071-01-02B	EA	BRACKET - BUMPER - E-COATED
8	125818-04-01A	EA	TRIM - FIBERGLASS PANEL - BRIGHT WHITE
	091985-01-07A	FT	INSERT - TRIM - BRIGHT WHITE - 1"
9	113495-05-02B	EA	SUPPORT - HINGE
10	058786-01-000	EA	BOLT - HOOD ADJUSTMENT - 5/16"-18 X 1.5"-2"- W/BLACK PAD
11	134189-02-02B	EA	BRACKET - MOUNT/STRIKER - E-COATED
12	125847-17-02B	EA	SUPPORT/PIVOT SHAFT - PASSENGER - E-COATED
13	125847-19-02B	EA	SUPPORT/PIVOT SHAFT - DRIVERS - E-COATED

EXTERIOR BODY GROUP (CONTINUED)

FRONT END (CONTINUED)

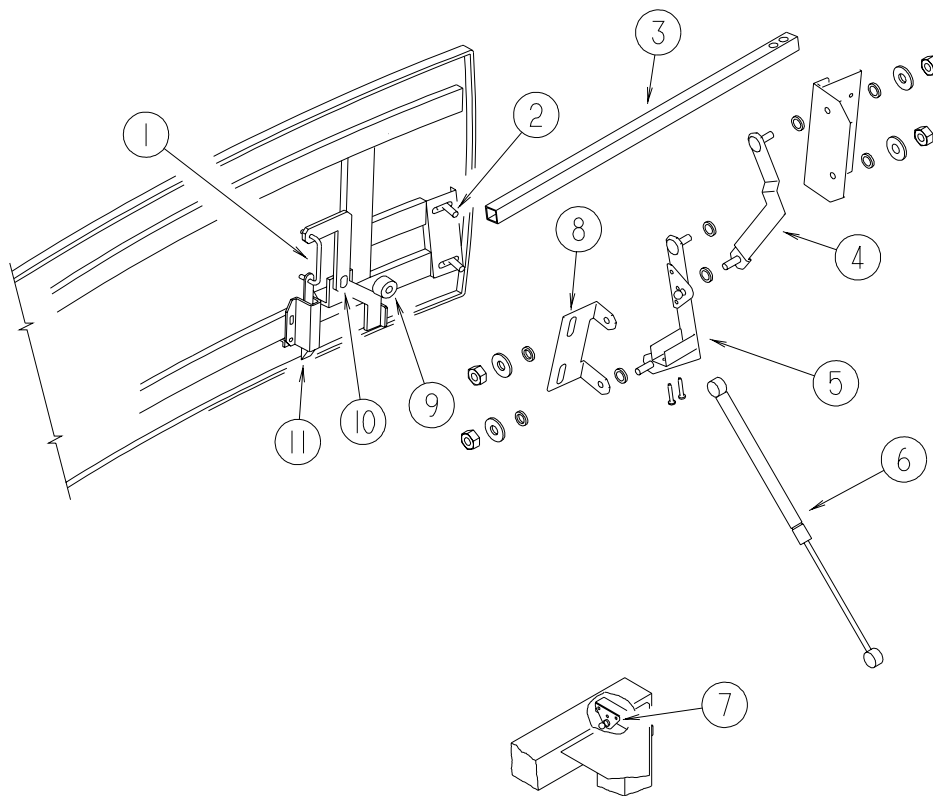

HOOD

KEY	PART NUMBER	U/M	DESCRIPTION
1	131606-01-01A	EA	ROD - HOOD LATCH
2	106730-10-000	EA	PLATE - STUD - F/HOOD
3	105096-08-000	EA	TUBE - HOOD HINGE TIMING W/WELDNUTS
4	131662-01-02B	EA	LINK - HINGE - LOWER HOOD - E-COATED (PASSENGER)
4	131662-02-02B	EA	LINK - HINGE - LOWER HOOD - E-COATED (DRIVER)
5	131661-01-02B	EA	LINK - HINGE - UPPER HOOD - E-COATED (PASSENGER)
5	131661-02-02B	EA	LINK - HINGE - UPPER HOOD - E-COATED (DRIVER)
6	107796-04-000	EA	SPRING/GAS - 12" COMPRESSED/20" EXTENDED - 20LB.
7	126263-08-02B	EA	BRACKET - GAS SPRING W/BALL STUD - E-COATED
8	113505-01-02B	EA	ANGLE - HOOD LINK - PASSENGER - E-COATED
8	113505-02-02B	EA	ANGLE - HOOD LINK - DRIVER - E-COATED
9	120863-07-000	EA	BUMPER - RUBBER - .7" DIA X .7" THICK
10	058716-02-000	EA	WASHER - FLAT NYLON
11	113908-01-000	EA	LATCH/PLUNGER - F/HOOD

EXTERIOR BODY GROUP (CONTINUED)

LADDER

KEY	PART NUMBER	U/M DESCRIPTION
	129375-02-000	EA SEAL - LADDER BRACKET
	130163-04-01A	EA LADDER ASSEMBLY - LOWER - ALUMINUM ANODIZED
	132804-01-01A	EA LADDER - UPPER - ANODIZED ALUMINUM
	038327-05-000	EA TAPE - ANTI SLIP - 5/8"X 60' - BLACK

MIRRORS

KEY	PART NUMBER	U/M DESCRIPTION
*	106015-13-01A	EA MIRROR - EXTERIOR REMOTE/HEAT - DRIVER
	108825-03-000	EA GASKET - MIRROR
*	131431-05-01A	EA MIRROR - EXTERIOR REMOTE/HEAT - PASSENGER - BLACK
	120850-04-02B	EA PLATE - SUPPORT/MIRROR - E-COATED

*COMPONENT PARTS FOUND IN SERVICE PARTS LIBRARY

BODY PANELS COMPONENTS

KEY	PART NUMBER	U/M DESCRIPTION
	068716-01-001	EA BRACE - 90 DEGREE - L-ANGLE - 16'
	089297-01-000	SF PLYWOOD - LUAN - OVERLAY GRADE - 48" X 96"
	100619-01-000	BF FOAM - EXPANDED POLYSTYRENE - 1.34" X 48" X 96"
	100619-02-000	BF FOAM - EXPANDED POLYSTYRENE - 1.5" X 48" X 96"
	100619-05-000	BF FOAM - EXPANDED POLYSTYRENE - .75" X 48" X 96"-1.5 DENSITY
	100619-11-000	BF FOAM - EXPANDED POLYSTYRENE - 2" X 48" X 96"
	100619-13-000	BF FOAM - EXPANDED POLYSTYRENE - .34" X 34.65" X 96"
	100619-16-000	BF FOAM - EXPANDED POLYSTYRENE - .75" X 48" X 96"-2.0 DENSITY
	100619-22-000	BF FOAM - EXPANDED POLYSTYRENE - 48" X 120" X 1.34"
	100619-25-000	BF FOAM - EXPANDED POLYSTYRENE - 48" X 100" X .75"
	100619-27-000	BF FOAM - EXPANDED POLYSTYRENE - 48" X 92.80" X 3.0"
	120107-01-000	EA FOAM - ROOF COVE - 2.8" X 96" LONG
	120107-02-000	EA FOAM - PLUG - ROOF TUBE - 2.2" X 2.9" X 1.8" LONG
	120107-03-000	EA FOAM - PLUG - SIDEWALL TUBE - 1.2" X 2.1" X 1.8" LONG
	128782-02-01A	EA FIBERGLASS SHEET - 79" X 428"/HIGH GLOSS - BRIGHT WHITE
	076054-W5-000	EA FIBERGLASS SHEET - 101.4" X 108.7" - BRIGHT WHITE (ROOF)
	002754-01-001	EA ANGLE - EXTRUDED - .75" X .75" X 16' - MILL ALUMINUM
	002766-01-001	EA ANGLE - EXTRUDED - 1" X 1.5" X 17'

*COMPONENT PARTS FOUND IN SERVICE PARTS LIBRARY

AWNINGS

KEY	PART NUMBER	U/M DESCRIPTION
*	113874-01-02A	EA HARDWARE KIT - AWNING - W/O STANDOFF BRACKET-BRIGHT WHITE
	113874-07-28A	EA AWNING - 18' ALPINE GREEN VINYL - BRT/WHT METAL WRAP FROM: 00-00-00 THRU: 12-19-99
	113874-07-34A	EA AWNING - 18' BURGUNDY/ROSE VINYL - BRT/WHT METAL WRAP FROM: 12-20-99 THRU: 99-99-99
	113874-12-01A	EA SCREW/LAG - AWNING - 1/4" X 2 3/4" STAINLESS STEEL
	113874-11-01A	EA SCREW/LAG - AWNING - 1/4" X 1" STAINLESS STEEL
	130320-01-02A	EA BRACKET - AWNING - F/A&E INSTALLATION - BRIGHT WHITE

*COMPONENT PARTS FOUND IN SERVICE PARTS LIBRARY

EXTERIOR DOORS & COMPARTMENTS GROUP

DOOR & COMPARTMENT LAYOUT

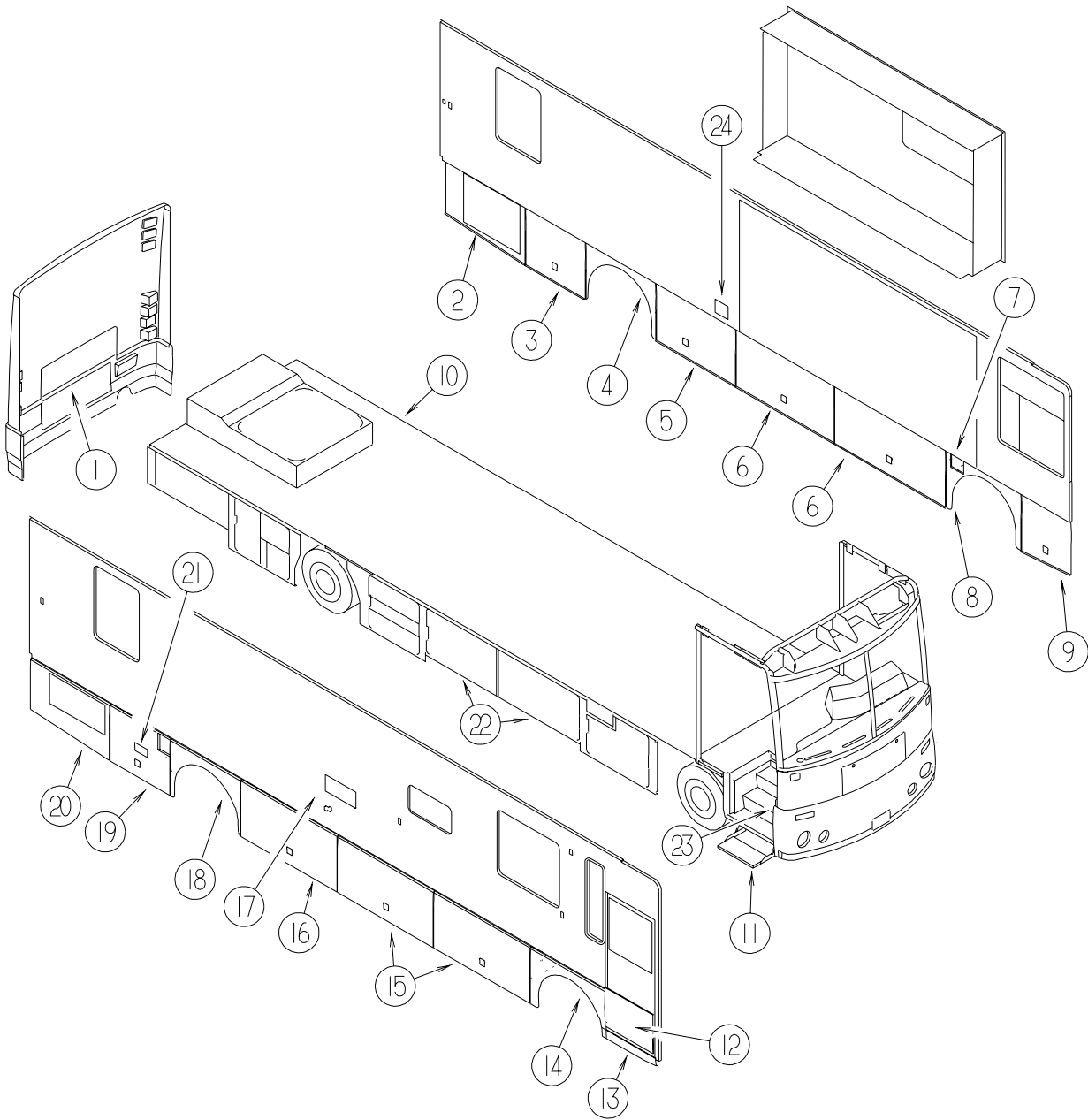

EXTERIOR DOORS & COMPARTMENTS GROUP (CONTINUED)

DOOR & COMPARTMENT LAYOUT (CONTINUED)

KEY	PART NUMBER	U/M	DESCRIPTION
1	132182-01-L76	EA	DOOR - REAR ENGINE - W/O HARDWARE
	132412-01-L76	EA	GRILLE ASM-DOOR,TRUNK
	102330-02-000	EA	LATCH - VISE ACTION/KEY OPERATED
	107719-01-01A	EA	STRIKE - VALANCE DOOR
	107796-23-000	EA	SPRING/GAS - 11.3" COMPRESSED/18.5" EXTENDED - 45 LB.
	118931-01-02B	EA	SHIM - STRIKER - DOOR
	126263-10-02B	EA	BRACKET - GAS SPRING W/BALL STUD - E-COATED
	102325-02-07A	EA	HINGE/TRUNK DOOR - 6" W/.6" OFF SET - BRIGHT WHITE
	102325-02-01A	EA	HINGE/TRUNK DOOR - 6" W/.6" OFF SET - UNFINISHED
2	132197-01-L76	EA	PANEL/VALANCE - DEPARTURE/LEFT HAND- W/O HARDWARE
3	J33099-03-L76	EA	VALANCE/DOOR - W/LATCH/HINGE - 41.1" X 28.7"
	132873-07-000	EA	ROD - LATCH - 16.2"
	132873-08-000	EA	ROD - LATCH - 16.2"
4	131922-03-L76	EA	PANEL/WHEEL LIP - REAR - 47.2"
5	J33099-01-L76	EA	VALANCE/DOOR - W/LATCH/HINGE - 34.1" X 28.7"
	132873-03-000	EA	ROD - LATCH - 10.9"
	132873-04-000	EA	ROD - LATCH - 12.7"
6	J33099-06-L76	EA	VALANCE/DOOR - W/LATCH/HINGE - 61.5" X 28.7"
	132873-13-000	EA	ROD - LATCH - 32.4"
	132873-14-000	EA	ROD - LATCH - 26.4"
7	131905-02-L76	EA	PANEL - FUEL FILL DOOR - BRIGHT WHITE
	009065-01-000	EA	HINGE - ALUMINUM - 1 1/2" X 96" - UNPAINTED
	130005-01-000	EA	LOCK - W/O CYLINDER & KEYS - W/CAM - F/KEY ONE SYSTEM
8	131922-02-L76	EA	PANEL/WHEEL LIP - FRONT/DRIVER - 50"
9	J33099-08-L76	EA	VALANCE/DOOR- PASS W/LATCH/HINGE - 34.9" X 28.7" X 26.7"
	132873-17-000	EA	ROD - LATCH - 11.3"
	132873-18-000	EA	ROD - LATCH - 13.1"
9	123764-03-02B	EA	COMPARTMENT - LUGGAGE - E- COATED
10	129015-01-K80	EA	PORT COMPLETE - F/ELECTRICAL/DRAIN
	121175-02-01A	EA	LATCH - SWELL
	M08628-01-H17	EA	HATCH W/FOAM INSERT
	061420-04-000	EA	PLUG/PLASTIC - 1.25" DIAMETER
	128298-01-12B	EA	CATCH - F/LOCK - COMPARTMENT DOORS
11*	094708-03-01A	EA	STEP - ELECTRIC - SINGLE - BLACK CONTROL BOX - KWIKEE
12*	128913-03-01A	EA	DOOR/ENTRY - FRONT/PASS - NON/POWER - W/O DEADBOLT/WHT ANT
	132442-02-01A	EA	HANDLE - ASSIST
13	131900-01-02A	EA	PANEL - VALANCE DOOR
14	131922-01-L76	EA	PANEL/WHEEL LIP - FRONT/PASSENGER - 48.1"
15	J33099-04-L76	EA	VALANCE/DOOR - W/LATCH/HINGE - 51.5" X 28.7"
	132873-09-000	EA	ROD - LATCH - 19.6"
	132873-10-000	EA	ROD - LATCH - 21.4"
16	J33099-05-L76	EA	VALANCE/DOOR - W/LATCH/HINGE - 54.1" X 28.7"
	132873-11-000	EA	ROD - LATCH - 22.7"
	132873-12-000	EA	ROD - LATCH - 22.7"
17*	084103-08-000	EA	DOOR - VENT/REFRIGERATOR - W/O JAMB - BRIGHT WHITE
	084104-08-000	EA	JAMB - VENT DOOR/REFRIGERATOR - BRIGHT WHITE
18	131922-03-L76	EA	PANEL/WHEEL LIP - REAR - 47.2"
19	J33099-09-L76	EA	VALANCE/DOOR - W/LATCH/HINGE - 40.2" X 28.7" (W/6 GAL WATER HEATER)
	132873-05-000	EA	ROD - LATCH - 18.7"
	132873-06-000	EA	ROD - LATCH - 14.4"
19	J33099-02-L76	EA	VALANCE/DOOR - W/LATCH/HINGE - 40.2" X 28.7" (W/10 GAL WATER HEATER)
	132873-05-000	EA	ROD - LATCH - 18.7"
	132873-06-000	EA	ROD - LATCH - 14.4"
20	132198-01-L76	EA	PANEL/VALANCE - DEPARTURE/RIGHT HAND - W/O HARDWARE
21	133049-01-L76	EA	TRIM - COVER - WATER HEATER
22	126386-50-L76	EA	COMPARTMENT - LUGGAGE
	126397-03-01A	EA	PANEL/COMPARTMENT END - RIGHT HAND
	126397-04-01A	EA	PANEL/COMPARTMENT END - LEFT HAND
23	120231-01-01A	EA	FLOORING - RUBBER - 66.4" X 19.8"
24	081240-20-000	EA	WATER FILL W/DOOR - W/O LOCK - BRIGHT WHITE

*COMPONENT PARTS FOUND IN SERVICE PARTS LIBRARY

EXTERIOR DOORS & COMPARTMENTS GROUP (CONTINUED)

COMPARTMENT DOOR COMPONENTS

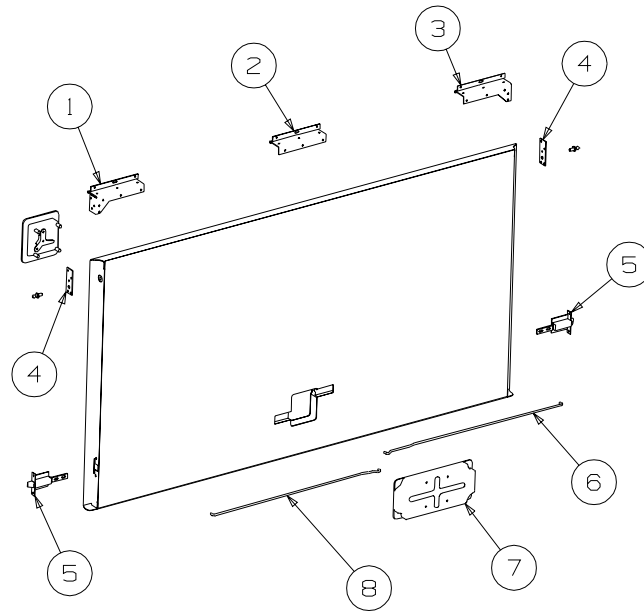

KEY	PART NUMBER	U/M	DESCRIPTION
1	131790-02-01A	EA	HINGE - SINGLE/PIVOT
2	131790-03-01A	EA	HINGE - SINGLE/PIVOT
3	131790-01-01A	EA	HINGE - SINGLE/PIVOT
4	134033-01-04B	EA	PLATE - HINGE - BLACK
5	121947-01-01A	EA	BOLT - SLIDE W/PLASTIC PLUNGER
6		EA	SEE DOOR & COMPARTMENT LAYOUT FOR ROD-LATCH
	124304-01-000	EA	CLIP - ROUND PUSH ON
7	122277-05-02A	EA	COVER - LATCH - WHITE
8		EA	SEE DOOR & COMPARTMENT LAYOUT FOR ROD-LATCH
	107796-04-000	EA	SPRING/GAS - 12" COMPRESSED/20" EXTENDED - 20LB.
	107796-23-000	EA	SPRING/GAS - 11.3" COMPRESSED/18.5" EXTENDED - 45 LB.
	107796-31-000	EA	SPRING/GAS - 20" EXTENDED X 12" COMPRESSED - 100 LB
	107721-08-000	FT	SEAL - ACCESS DOOR
	120494-03-02B	EA	SHIM - STRIKER - LUGGAGE DOOR - E-COATED
	130053-01-01A	EA	STRIKER - LUGGAGE DOOR - FLUSH - BLACK
	130053-02-01A	EA	STRIKER - LUGGAGE DOOR - OFF SET - BLACK
	129686-01-000	EA	CYLINDER - LOCK ASSEMBLY - COMPARTMENT/DRIVER DOOR
	129686-02-000	EA	CYLINDER - LOCK ASSEMBLY - COMPARTMENT/DRIVER DOOR
	129686-03-000	EA	CYLINDER - LOCK ASSEMBLY - COMPARTMENT/DRIVER DOOR
	129686-04-000	EA	CYLINDER - LOCK ASSEMBLY - COMPARTMENT/DRIVER DOOR
	129686-05-000	EA	CYLINDER - LOCK ASSEMBLY - COMPARTMENT/DRIVER DOOR
	129686-06-000	EA	CYLINDER - LOCK ASSEMBLY - COMPARTMENT/DRIVER DOOR
	129686-07-000	EA	CYLINDER - LOCK ASSEMBLY - COMPARTMENT/DRIVER DOOR
	129686-08-000	EA	CYLINDER - LOCK ASSEMBLY - COMPARTMENT/DRIVER DOOR
	129686-09-000	EA	CYLINDER - LOCK ASSEMBLY - COMPARTMENT/DRIVER DOOR
	129686-10-000	EA	CYLINDER - LOCK ASSEMBLY - COMPARTMENT/DRIVER DOOR

EXTERIOR DOORS & COMPARTMENTS GROUP (CONTINUED)

ENTRY DOOR ONE KEY SYSTEM

KEY	PART NUMBER	U/M	DESCRIPTION
*	129676-01-000	EA	KEY - T/M 14472-07-1431
*	129676-02-000	EA	KEY - T/M 14472-07-1432
*	129676-03-000	EA	KEY - T/M 14472-07-1443
*	129676-04-000	EA	KEY - T/M 14472-07-1434
*	129676-05-000	EA	KEY - T/M 14472-07-1435
*	129676-06-000	EA	KEY - T/M 14472-07-1436
*	129676-07-000	EA	KEY - T/M 14472-07-1437
*	129676-08-000	EA	KEY - T/M 14472-07-1438
*	129676-09-000	EA	KEY - T/M 14472-07-1439
*	129676-10-000	EA	KEY - T/M 14472-07-1440
*	129685-01-000	EA	CYLINDER - LOCK ASSEMBLY - ENTRANCE DOOR (J)
*	129685-02-000	EA	CYLINDER - LOCK ASSEMBLY - ENTRANCE DOOR (J)
*	129685-03-000	EA	CYLINDER - LOCK ASSEMBLY - ENTRANCE DOOR (J)
*	129685-04-000	EA	CYLINDER - LOCK ASSEMBLY - ENTRANCE DOOR (J)
*	129685-05-000	EA	CYLINDER - LOCK ASSEMBLY - ENTRANCE DOOR (J)
*	129685-06-000	EA	CYLINDER - LOCK ASSEMBLY - ENTRANCE DOOR (J)
*	129685-07-000	EA	CYLINDER - LOCK ASSEMBLY - ENTRANCE DOOR (J)
*	129685-08-000	EA	CYLINDER - LOCK ASSEMBLY - ENTRANCE DOOR (J)
*	129685-09-000	EA	CYLINDER - LOCK ASSEMBLY - ENTRANCE DOOR (J)
*	129685-10-000	EA	CYLINDER - LOCK ASSEMBLY - ENTRANCE DOOR (J)
*	101145-01-06A	EA	DEADBOLT - ENTRY DOOR W/O SECURITY BOLT W/2 KEYS - BLACK
*	101147-01-000	EA	BOLT - SECURITY - 4.12"

***COMPONENT PARTS FOUND IN SERVICE PARTS LIBRARY**

EXTERIOR SLIDEOUT INSTALLATION GROUP

FRONT LEFT

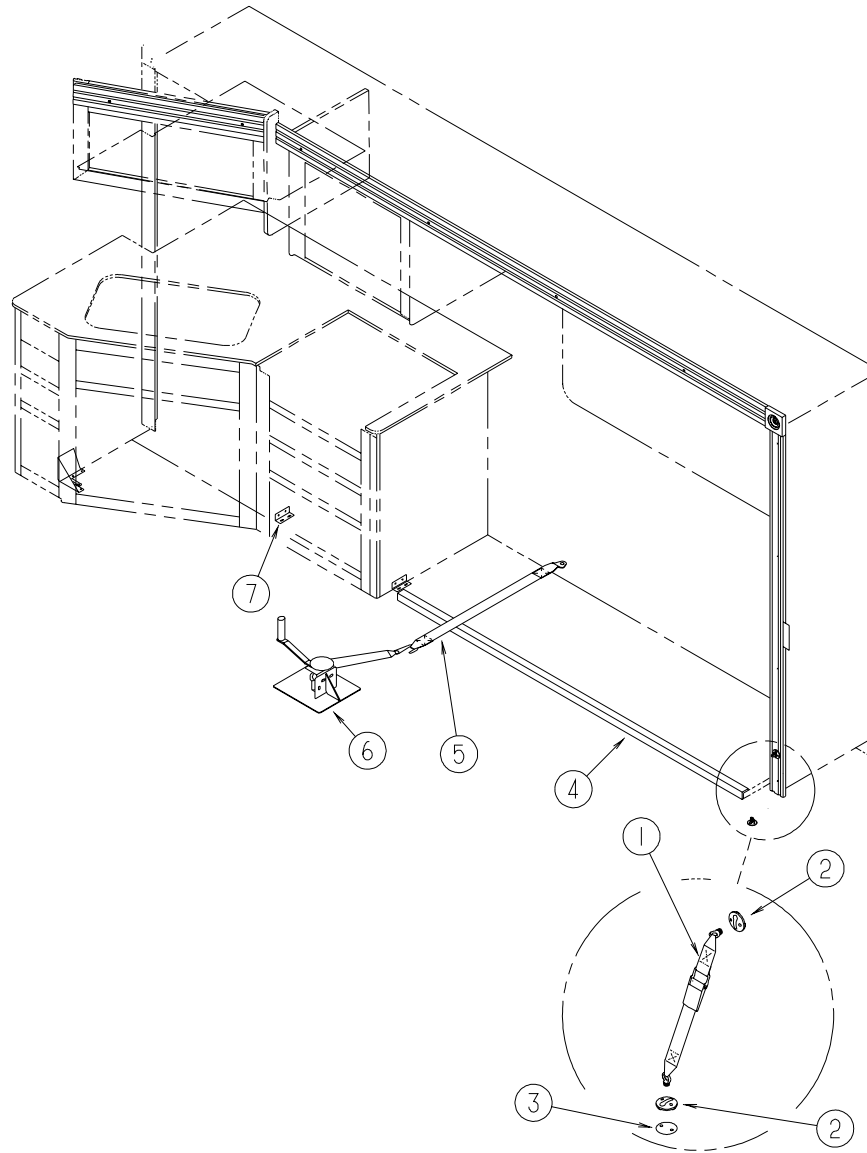

WINCH & TIEDOWNS

KEY	PART NUMBER	U/M	DESCRIPTION	
1	133067-01-01A	EA	STRAP - TIE DOWN - SLIDE	FROM: 00-00-00 THRU: 03-31-00
1	135619-01-01A	EA	STRAP - SLIDE-OUT ROOM TIEDOWN	FROM: 04-01-00 THRU: 99-99-99
2	133067-02-01A	EA	PLATE - TIE-DOWN - SLIDE	FROM: 00-00-00 THRU: 03-31-00
2	135619-02-01A	EA	PLATE - TIEDOWN/SLIDE	FROM: 04-01-00 THRU: 99-99-99
3	133374-01-09B	EA	PLATE - TIEDOWN	FROM: 00-00-00 THRU: 03-31-00
3	135622-01-01B	EA	PLATE - SLIDE-OUT ROOM TIEDOWN	FROM: 04-01-00 THRU: 99-99-99
4	124624-04-02A	EA	ANGLE - TRIM - BLACK	
5	116101-02-F31	EA	STRAP - WINCH	
6	115767-02-000	EA	WINCH - SLIDEOUT	
6	116082-03-02B	EA	BRACKET - WINCH	
7	128252-01-02B	EA	BRACKET-ANGLE,E-COAT	

EXTERIOR SLIDEOUT INSTALLATION GROUP (CONTINUED)

FRONT LEFT (CONTINUED)

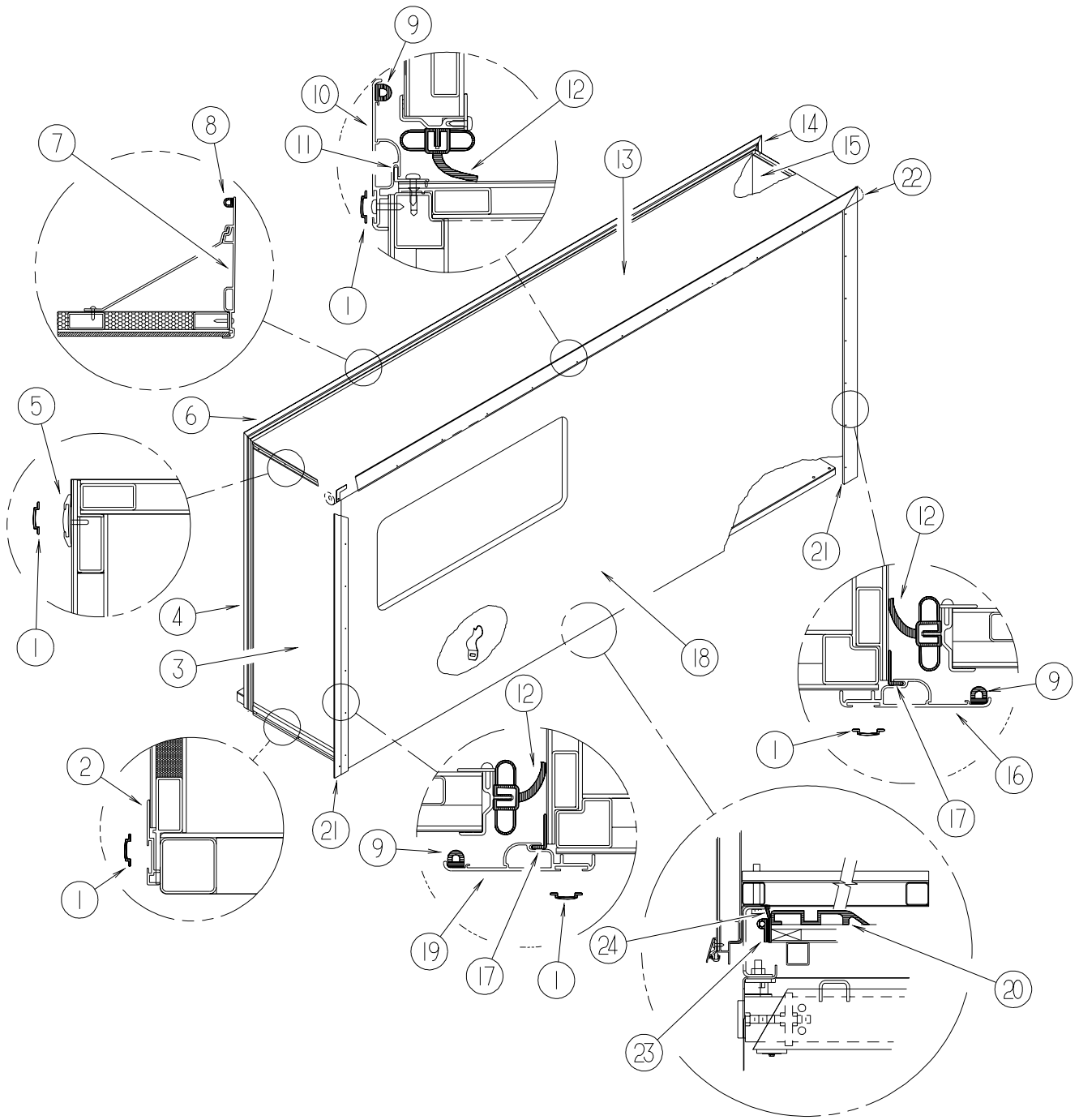

EXTERIOR SLIDEOUT INSTALLATION GROUP (CONTINUED)

FRONT LEFT (CONTINUED)

ROOM

KEY	PART NUMBER	U/M DESCRIPTION
1	105312-01-07A	FT INSERT - VINYL FEATURE STRIP - BRIGHT WHITE
2	125051-01-01A	EA STRIP - FEATURE - LOWER - BRIGHT WHITE
3	121401-06-L76	EA PANEL - SLIDEOUT/FRONT - W/O HARDWARE (L76,L78)
3	121401-06-L80	EA PANEL - SLIDEOUT/FRONT - W/O HARDWARE (L80)
4	117004-01-03A	EA TRIM - SEAL/INNER VERTICAL-W/MITERED ENDS-73.5"- BRT WHT
5	108688-01-03A	EA STRIP - FEATURE - 15'
6	117004-08-03A	EA TRIM - SEAL/INNER UPPER-W/MITERED ENDS-145"-BRIGHT WHITE
7	125466-02-01A	EA SUPPORT - ROOF/INTERIOR - OFF WHITE
8	112091-01-000	FT D-SEAL - NEOPRENE - TRUNK - HEAT ACTIVE ADHESIVE
9	099418-01-000	FT SEAL - D-SECTION/ADHESIVE BACK - .44" X .44"- BLK RUBBER
10	133955-01-01A	EA TRIM - SEAL W/MITERED ENDS - 160" - BRIGHT WHITE
11	133954-01-01A	EA TRIM - SEAL W/MITERED ENDS - 154.3" - BRIGHT WHITE
12	115076-03-000	FT SEAL - SLIDEOUT
13	133011-01-L58	EA ROOF - SLIDEOUT - W/O LIGHTS/VENTS - W/WIRING
14	117004-02-03A	EA TRIM - SEAL/INNER HORIZONTAL W/MITERED ENDS-73.5 - BRT WHT
15	121402-03-L76	EA PANEL - SLIDEOUT/REAR - W/O HARDWARE (L76,L78)
15	121402-03-L80	EA PANEL - SLIDEOUT/REAR - W/O HARDWARE
16	133955-12-01A	EA TRIM - SEAL W/MITERED ENDS - 76.4" - BRIGHT WHITE
17	133954-09-01A	EA TRIM/SEAL - W/MITERED ENDS - BRIGHT WHITE - 71.6"
18	133734-11-L76	EA SLUG-SLIDEOUT (L76,L78)
18	133734-11-L80	EA SLUG-SLIDEOUT (L80)
19	133955-11-01A	EA TRIM - SEAL W/MITERED ENDS - 76.4" - BRIGHT WHITE
20	134837-01-01A	EA RAMP - SLIDEOUT - BLACK PVC
21	126546-01-02A	EA COVER - END/SIDEWALL SLIDEOUT - BRIGHT WHITE
22	122977-07-01A	EA AWNING/SLIDEOUT W/COVER - 147" - BRIGHT WHITE
22	117058-01-01A	FT TAPE - LOOP - 3/4" WIDE - ADHESIVE BACKED
23	121283-01-000	FT SEAL - P SHAPED
24	115075-02-000	FT SEAL - WIPE - .25" X 2.9"

EXTERIOR SLIDEOUT INSTALLATION GROUP (CONTINUED)

FRONT LEFT (CONTINUED)

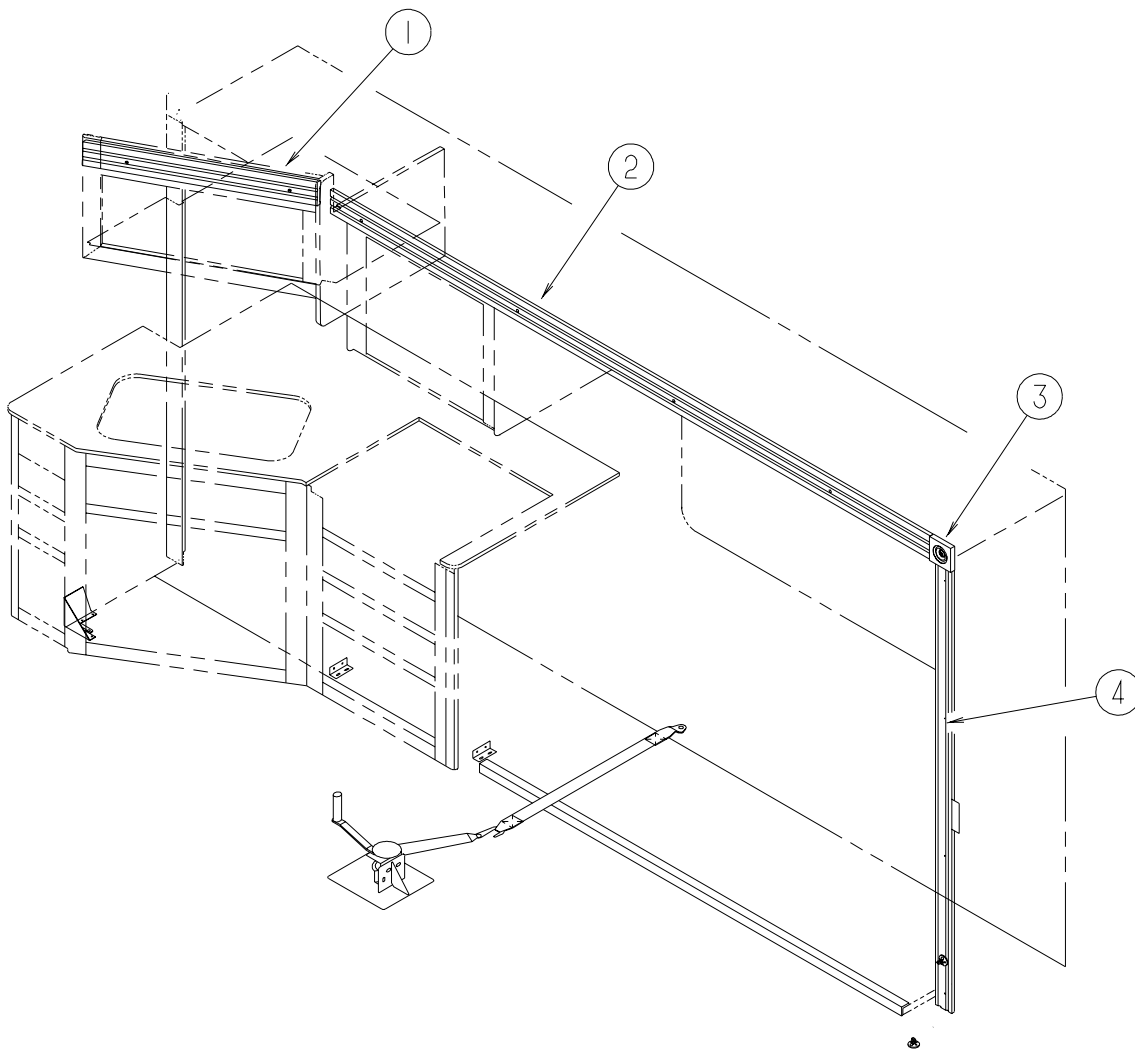

TRIMS

KEY	PART NUMBER	U/M	DESCRIPTION
1	134156-04-01A	EA	MOLDING-019X097X0859,VINYL-WATERFORD OAK
2	132663-11-01A	EA	MOLDING - VINYL WRAPPED-.6" X 3.8" X 110.4"-WATERFORD OAK
3	132844-01-01A	EA	BLOCK - CORNER - 3.9" X 3.9" - WATERFORD OAK
4	132663-04-01A	EA	MOLDING - VINYL WRAPPED - .6" X 3" X 70.4"-WATERFORD OAK

EXTERIOR SLIDEOUT INSTALLATION GROUP (CONTINUED)

FRONT LEFT (CONTINUED)

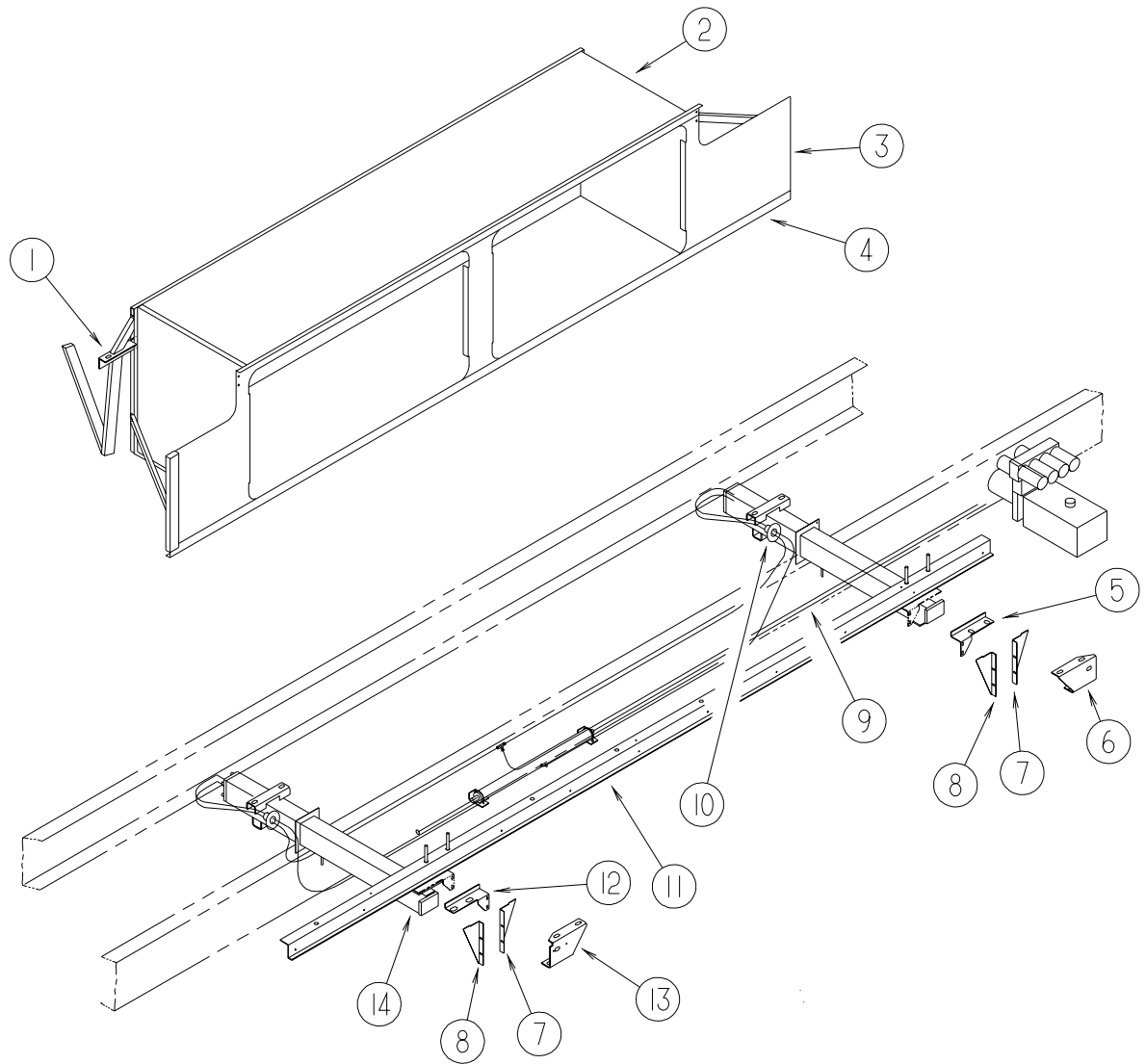

HYDRAULIC & SEAL PANEL

KEY	PART NUMBER	U/M	DESCRIPTION
1	126050-20-L76	EA	SUPPORT - SLIDEOUT COMPARTMENT
2	126390-23-000	EA	COMPARTMENT - SLIDEOUT
3	133051-02-02B	EA	SEAL PLANE - SLIDEOUT - E-COATED
3	135632-01-02B	EA	SEAL PLANE - SLIDEOUT - E-COATED
			FROM: 00-00-00 THRU: 05-21-00
			FROM: 05-22-00 THRU: 99-99-99
4	126516-01-01A	FT	TRIM - VINYL/EXTRUDED - 96"
5	125888-01-02B	EA	BRACKET - SLIDEOUT COMPARTMENT - E-COATED - RIGHT HAND
6	127030-02-02B	EA	BRACKET - INNER FRONT/SLIDEOUT - E-COATED
7	131531-04-02B	EA	GUSSET - SLIDEOUT - E-COATED
8	131531-06-02B	EA	GUSSET - SLIDEOUT - E-COAT
9	100536-44-000	EA	HOSE KIT - SLIDEOUT
10	088756-01-000	EA	GROMMET - WEB - 1 1/8" I.D.
11	128621-12-01A	EA	ZEE-SLIDEOUT, W/HOLES, MILL
12	125888-02-02B	EA	BRACKET - SLIDEOUT COMPARTMENT - E-COATED - LEFT HAND
13	127030-01-02B	EA	BRACKET - INNER REAR/SLIDEOUT - E-COATED
14*	125687-01-000	EA	SLIDEOUT - HYDRAULIC

*COMPONENT PARTS FOUND IN SERVICE PARTS LIBRARY

GALLEY GROUP

CABINETS

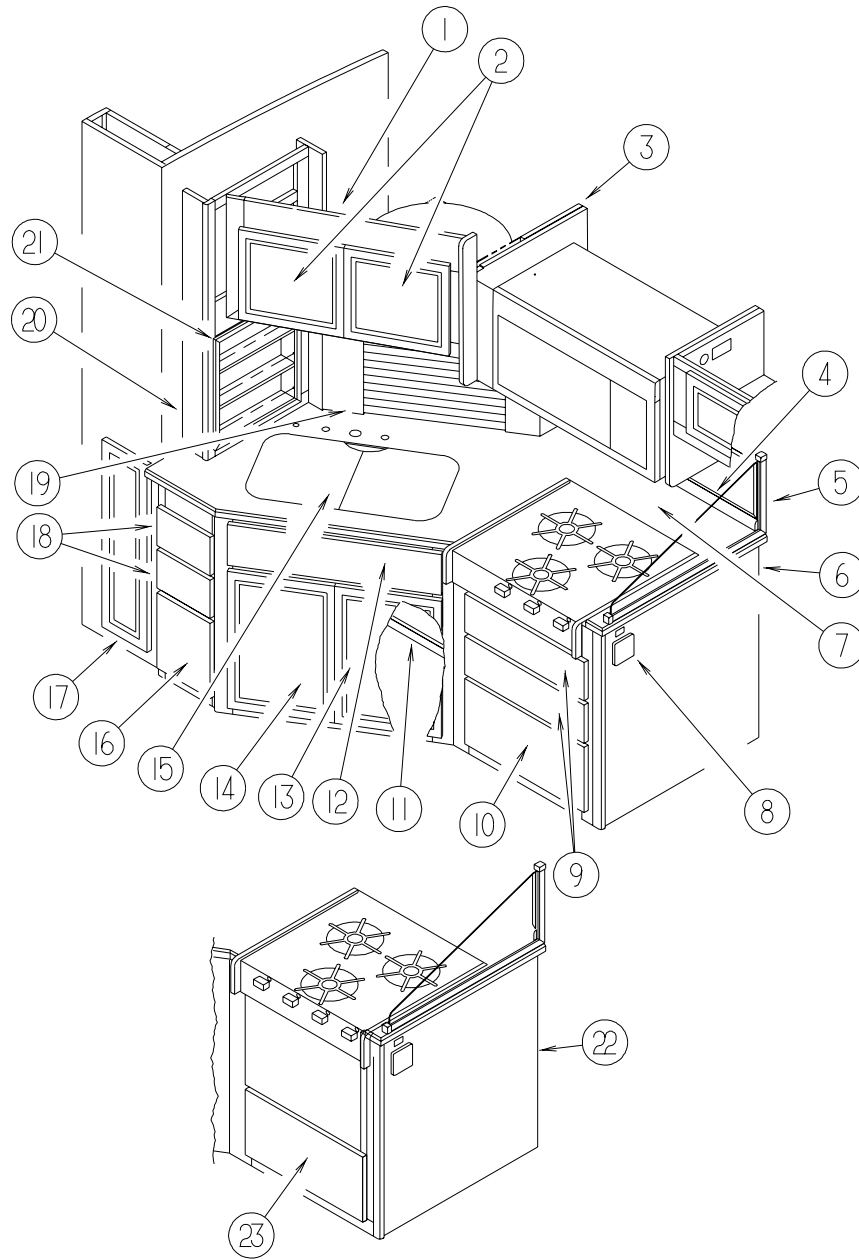

GALLEY GROUP (CONTINUED)

CABINETS (CONTINUED)

KEY	PART NUMBER	U/M	DESCRIPTION
1	133363-06-L76	EA	CABINET - OVERHEAD/GALLEY - W/O DOORS/HARDWARE
2	132141-C5-L76	EA	DOOR - RAIL/VENEER - 12.9" X 9.8" - W/O HARDWARE
3	103128-64-L76	EA	END CAP - OVERHEAD CABINET - RIGHT HAND FROM: 00-00-00 THRU: 02-23-00
3	103128-69-L76	EA	END CAP - OVERHEAD CABINET - RIGHT HAND FROM: 02-24-00 THRU: 99-99-99
4	132601-18-L76	EA	BACKSPLASH - GALLEY COUNTERTOP
5	126875-01-J94	EA	SPLASHGUARD - L-SHAPED W/GLASS
	127117-01-01A	EA	GLASS - STATIONARY - SPLASHGUARD
6	133356-01-L53	EA	CABINET - GALLEY - W/COUNTERTOP - W/O DOORS/DRAWERS/HDW
7	132601-06-L76	EA	COUNTERTOP - GALLEY CABINET - LAMINATED
7	130812-02-01A	EA	COUNTERTOP - JAMAICAN SAND - 1/4" VENDURA
8	131333-01-01A	EA	HOLDER - CUP - VERTICAL DROP/FLUSH MOUNT - BLACK
	118718-01-01A	EA	HOLDER - DRINK - COLLAPSIBLE MUG - BLACK PLASTIC
9	M09316-F0-L53	EA	DRAWER - OGEE EDGE - 19.8"W X 23.6"D - W/O SLIDES/HARDWARE
10	M09316-F1-L53	EA	DRAWER - OGEE EDGE - 19.8"W X 23.6"D - W/O SLIDES/HARDWARE
11	133356-14-L53	EA	SHELF - W/PLASTIC EDGE MOLDING
12	110941-13-L53	EA	DRAWER - TIPOUT - W/O HARDWARE
	108127-01-01A	EA	CAP - TRAY
	108128-01-01A	EA	TRAY - HIDDEN
13	132141-01-L76	EA	DOOR - RAIL/VENEER - 14.3" X 21.8" - W/O HARDWARE
14	132141-03-L76	EA	DOOR - RAIL/VENEER - 14.3" X 21.8" - W/O HARDWARE
	093605-02-01A	EA	RACK - TOWEL/WIRE - ALMOND
15	108464-03-L76	EA	COVER - SINK - 15" X 11" - LAMINATED ON BOTH SIDES
15	108464-04-L76	EA	COVER - SINK - 15" X 15" - LAMINATED ON BOTH SIDES
15	130815-01-01A	EA	COVER/SINK - LARGE - JAMAICAN SAND - 1/4" VENDURA
15	130815-02-01A	EA	COVER/SINK - SMALL - JAMAICAN SAND - 1/4" VENDURA
16	132141-C3-L76	EA	DOOR - RAIL/VENEER - 9.8" X 12" - W/O HARDWARE
17	131995-Y0-L76	EA	DOOR - RAIL/SOLID PANEL - 7.4" X 29.8" - W/O HARDWARE
18	M09316-H7-L76	EA	DRAWER - OGEE EDGE - 7.6"W X 17.7"D - W/O SLIDES/HARDWARE
19	128763-03-L76	EA	CABINET - STORAGE/APPLIANCE - W/TAMBOUR DOOR/TRACK
	126866-01-J94	EA	HANDLE - DOOR - TAMBOUR
20	128762-01-J94	EA	CABINET - SPICE RACK - W/O DOORS/HARDWARE
21	126847-01-J94	EA	SPICE RACK
22	133356-02-L53	EA	CABINET - GALLEY - W/COUNTERTOP - W/O DOORS/DRAWERS/HDW
23	M09316-F0-L53	EA	DRAWER - OGEE EDGE - 19.8"W X 23.6"D - W/O SLIDES/HARDWARE

GALLEY GROUP (CONTINUED)

CABINETS (CONTINUED)

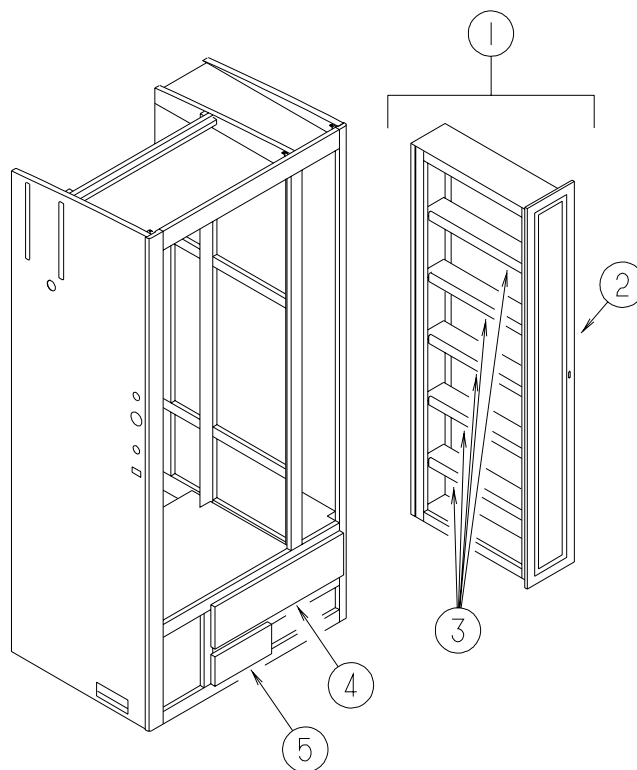

PANTRY

KEY	PART NUMBER	U/M	DESCRIPTION
1	122325-01-H17	EA	CABINET - PANTRY/RIGHT HAND SLIDING - W/O SLIDES/HARDWARE
	122360-02-000	EA	SLIDE - PANTRY - W/O LOCK - RIGHT/LEFT HAND
	122360-03-000	EA	SLIDE - PANTRY - W/LOCK - RIGHT HAND (FACING PANEL)
	123673-01-01A	EA	KNOB - PANTRY SLIDE
2	131995-J3-L32	EA	DOOR - RAIL/SOLID PANEL - 8" X 60.7" - W/O HARDWARE
3	122325-11-H17	EA	SHELF - W/EDGE MOLDING
4	M09316-F2-L76	EA	DRAWER - OGEE EDGE - 22.5"W X 17.7"D - W/O SLIDES/HARDWARE
5	131995-L7-L53	EA	DOOR - RAIL/SOLID PANEL - 12.6" X 8.1" - W/O HARDWARE

GENERATOR GROUP

LPG

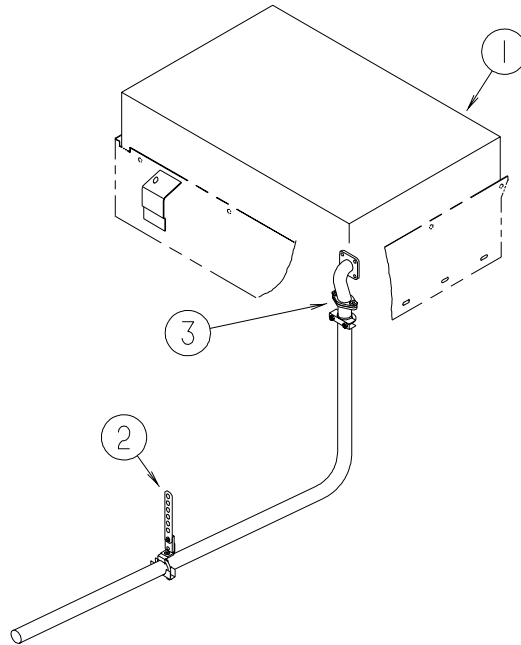

KEY	PART NUMBER	U/M	DESCRIPTION
1	105559-02-000	EA	MARQUIS GENERATOR-7KW W/MUFFLER/TRAY - LP FUELED
1	105559-04-000	EA	GENERATOR-6.5 KW W/MUFLER/TRAY - LP 30/30
2	007131-01-000	EA	HANGER - TAILPIPE - 6 SLOTS
	007125-03-000	EA	CLAMP - MUFLER - 1.5" DIAMETER
3	106235-01-000	EA	ADAPTOR - GENERATOR EXHAUST

GENERATOR GROUP (CONTINUED)

DIESEL

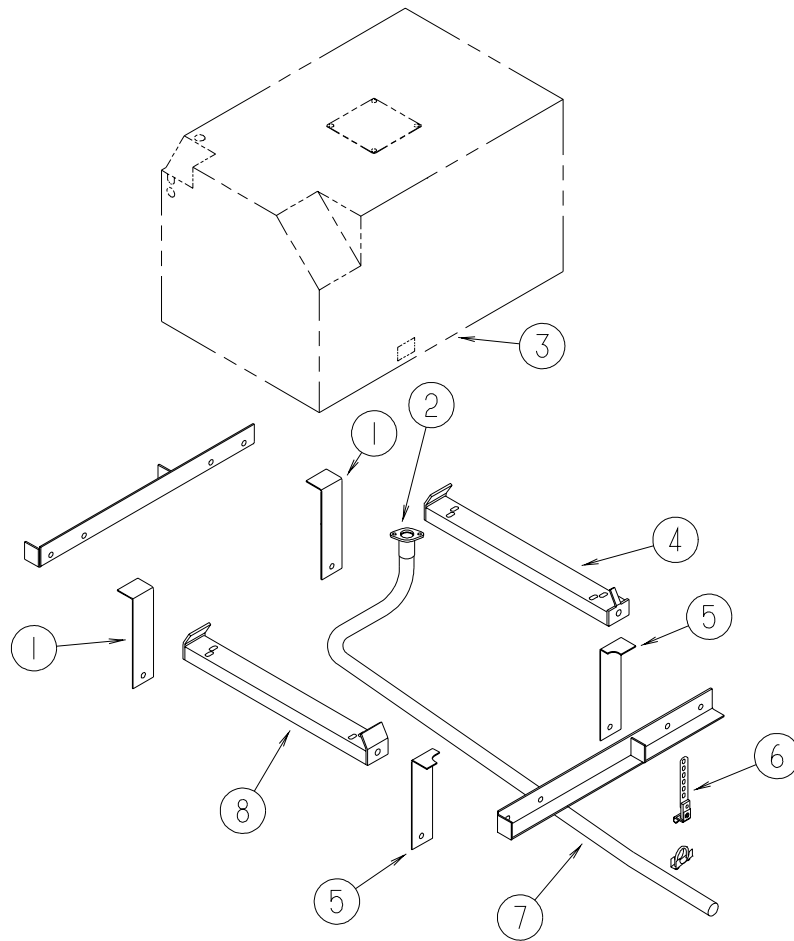

KEY	PART NUMBER	U/M	DESCRIPTION
1	123142-03-02B	EA	HANGER - GENERATOR - E-COATED
2	106235-01-000	EA	ADAPTOR - GENERATOR EXHAUST
3	122425-01-000	EA	GENERATOR - DIESEL - 7.5
4	115656-05-02B	EA	SUPPORT - GENERATOR - E-COATED
5	123142-04-02B	EA	HANGER - GENERATOR - E-COATED
6	007131-01-000	EA	HANGER - TAILPIPE - 6 SLOTS
7	116381-03-000	EA	PIPE - EXHAUST - GENERATOR
	007125-03-000	EA	CLAMP - MUFFLER - 1.5" DIAMETER
8	115656-04-02B	EA	SUPPORT - GENERATOR - E-COATED

HEATING & A/C GROUP AUTOMOTIVE

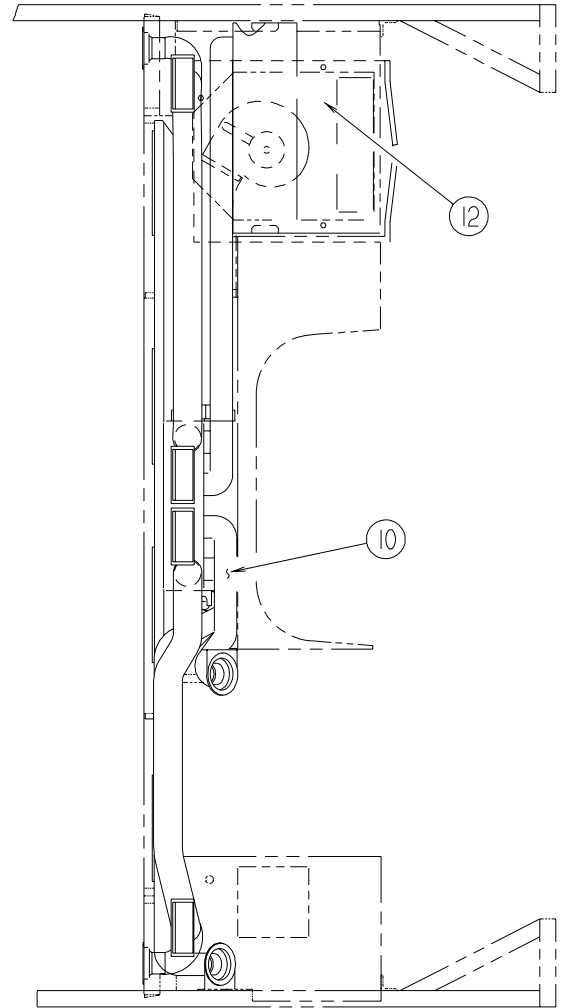
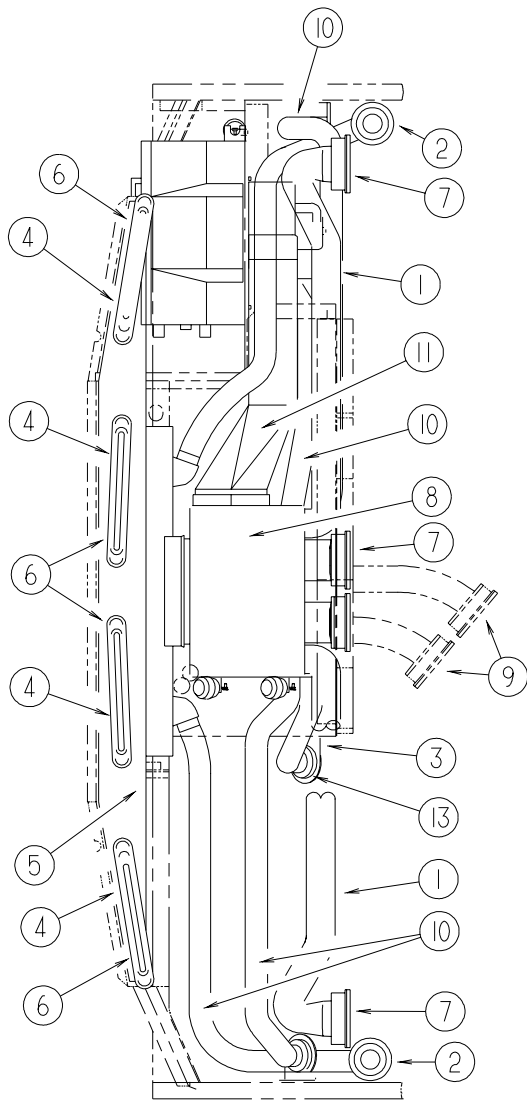

KEY	PART NUMBER	U/M DESCRIPTION
1	007281-01-000	FT HOSE - FLEXIBLE PVC - 2.5" ID X 50'
2	024990-09-000	EA OUTLET - DEFROSTER - W/SWIVEL - ANTELOPE
3	136157-03-02B	EA BRACKET - HEATER - E-COATED
4	103558-04-03A	EA VENT - DEFROSTER - 1.4" X 14.4" X 1.1" - ANTELOPE
		FROM: 00-00-00 THRU: 05-07-00
4	135265-01-01A	EA VENT - DEFROSTER - ANTELOPE
		FROM: 05-08-00 THRU: 99-99-99
5	103017-03-000	EA PLENUM - DEFROSTER
6	077075-01-000	EA GASKET - INSTRUMENT PANEL/DEFROSTER PLENUM - .6" X 10.2"
7	103796-01-01A	EA LOUVER - A/C-ADJUSTABLE - 2.2" X 5.4" F/2.5" HOSE - BLACK
		FROM: 00-00-00 THRU: 03-26-00
7	135803-01-01A	EA LOUVER - A/C - 2.5" - BLACK
		FROM: 03-27-00 THRU: 99-99-99
8*	103930-36-000	EA CONTROL/PLENUM - ROTARY CONTROL HEAD
9	103796-02-01A	EA LOUVER - A/C-ADJ W/MOUNT HOLES - 2.5" X 5.8" F/2.5"HOSE
		FROM: 00-00-00 THRU: 03-26-00
9	135803-02-01A	EA LOUVER - A/C - 2.5" - W/HOLES
		FROM: 03-27-00 THRU: 99-99-99
10	007076-01-000	EA HOSE - FLEXIBLE PVC - 2" ID - INCREMENTS OF 50'
11	122822-01-01A	EA PLENUM-TRANSITION GRY
12*	103930-43-000	EA EVAPORATOR/HEATER ASSEMBLY - NON-CHARGED
13	024990-05-000	EA OUTLET - DEFROSTER - 2" SLEEVE/4" OD - W/SWIVEL DEFLECTORS
	103930-37-000	EA MANUAL - OWNERS - HEATER/A/C

***COMPONENT PARTS FOUND IN SERVICE PARTS LIBRARY**

HEATING & A/C GROUP (CONTINUED)

AUTOMOTIVE (CONTINUED)

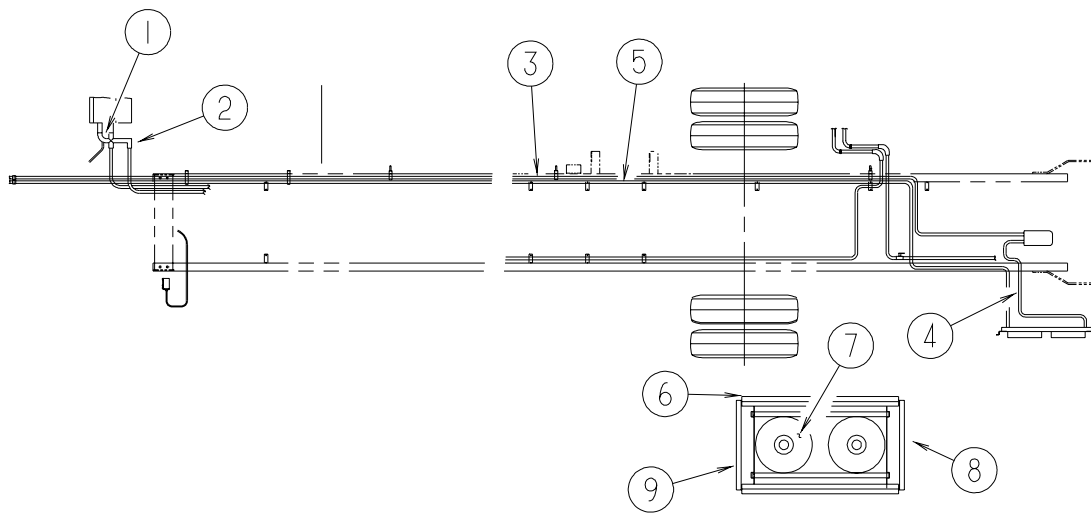

KEY	PART NUMBER	U/M	DESCRIPTION
1	103930-24-000	EA	VALVE - WATER CONTROL - 4 PORT VACUUM CONTROLLED
2	062401-04-000	EA	CLAMP - HOSE - WORMGEAR - .69" - 1.25"
3*	103930-51-000	EA	HOSE KIT - #12 496" 90 DEGREE BEND
4*	072342-17-000	EA	HOSE - #8 - 90 DEGREE END - CONDENSER/COMPRESSOR - 95"
5*	072342-18-000	EA	HOSE - #6 - CONDENSER/EVAPORATOR - 514"
6	113572-01-02B	EA	BRACKET - CONDENSER - E-COAT
7*	072342-15-000	EA	CONDENSER - W/FAN SIDE - NO HOSE
8	113574-02-02B	EA	BRACKET - CONDENSER/SIDE - E-COAT
9	113574-01-02B	EA	BRACKET - CONDENSER/SIDE - E-COAT

*COMPONENT PARTS FOUND IN SERVICE PARTS LIBRARY

HEATING & A/C GROUP (CONTINUED)

FURNACE

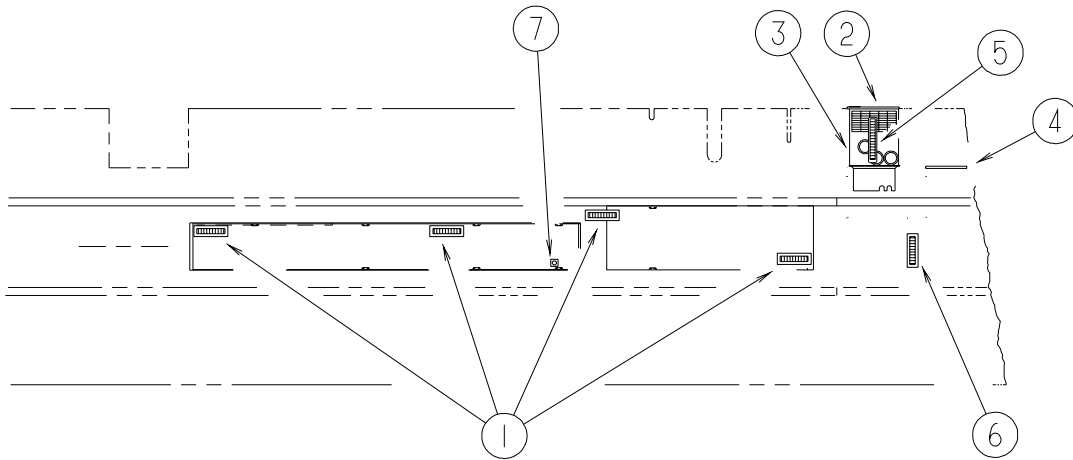

KEY	PART NUMBER	U/M	DESCRIPTION
1	094600-05-01A	EA	REGISTER W/O DAMPER-3.6" X 11.3" FACE/2.1" X 9.9" RO-BEIGE
2	133322-01-02B	EA	PANEL - EXHAUST - FURNACE - E-COATED
2	133323-01-01A	EA	SHROUD - FURNACE - BRIGHT WHITE
3*	098668-22-000	EA	FURNACE - 40,000 BTU
3	098668-14-000	EA	GASKET - FIBERGLASS - .5" X 18" X 18"
3	098668-15-000	EA	PLATE-FACE
3	098668-16-000	EA	VENT-INTAKE
4	093614-08-02A	EA	GRILLE - RETURN AIR - 8" X 12" - BEIGE
5	094600-10-01A	EA	REGISTER - HEAT - W/O DAMPER - 2.25" X 14"
6	094600-06-01A	EA	REGISTER W/DAMPER-3.6" X 11.3" FACE/2.1" X 9.9" RO-BEIGE
7	092776-01-000	EA	ADAPTER - DUCT - 2"
	115764-01-01A	EA	THERMOSTAT - FURNACE

***COMPONENT PARTS FOUND IN SERVICE PARTS LIBRARY**

HEATING & A/C GROUP (CONTINUED)

CENTRAL

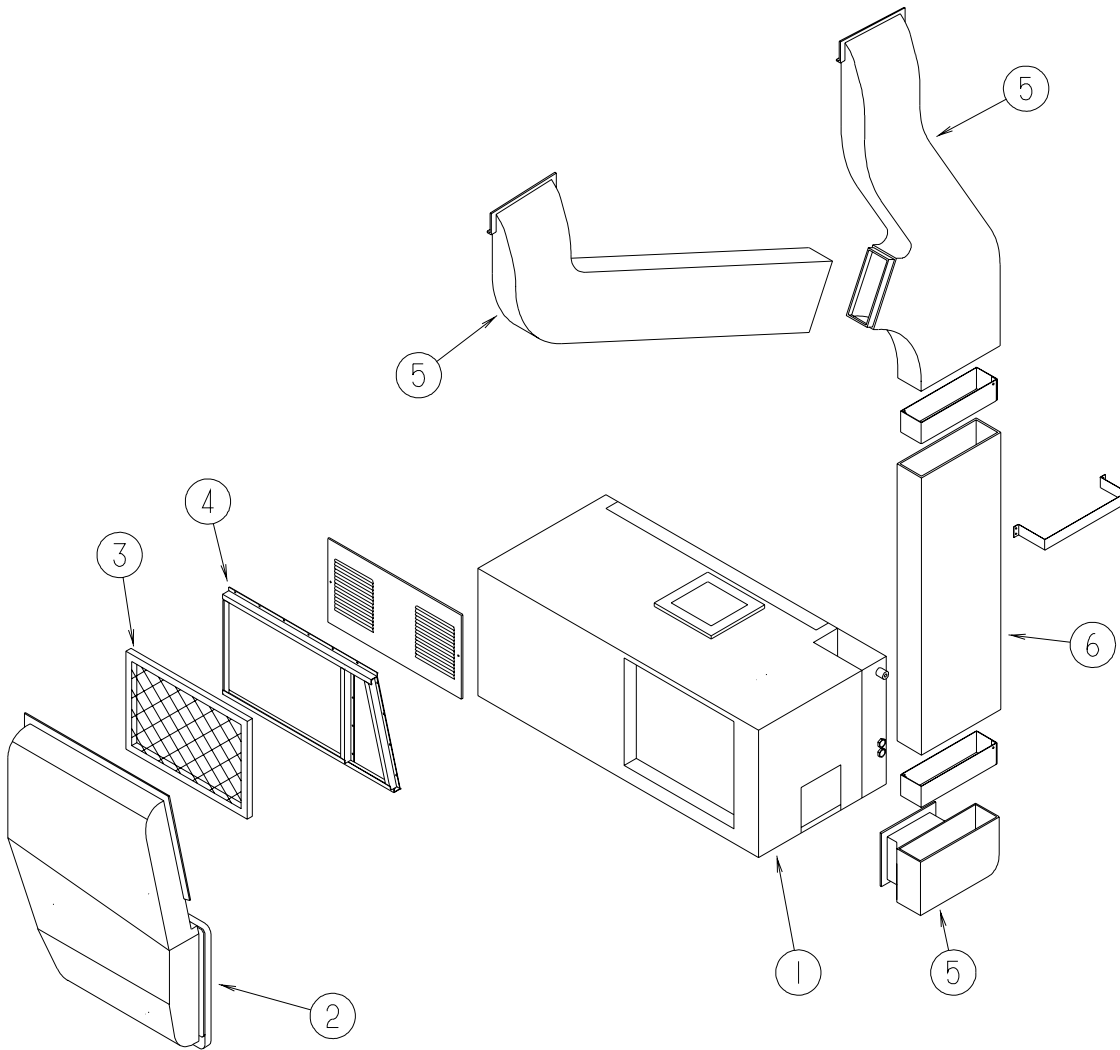

KEY	PART NUMBER	U/M DESCRIPTION
1*	105620-10-000	EA A/C-CENTRAL PKG RH,POWER SAV - COLEMAN 6636-871 FROM: 00-00-00 THRU: 07-11-99
1*	105620-11-000	EA A/C CENTRAL PACKAGE - RIGHT HAND POWER SAVER/LARGE BLOWER FROM: 07-12-99 THRU: 99-99-99
1*	105620-12-000	EA A/C - CONTROL PACK RIGHT HAND/HEAT PUMP - 12,000BTU COMP
2	135036-01-000	EA DUCT - CENTRAL AIR - RETURN
3	109050-02-000	EA FILTER - FIBERGLASS - 1" X 14" X 20"
4	129604-01-KQ0	EA FRAME - A/C FILTER
5	105290-01-000	EA INSULATION - AIR POCKET W/FOIL
6	117870-03-01A	EA PLENUM - A/C
	105620-09-000	EA THERMOSTAT - A/C & FURNACE - HORIZONTAL MOUNT 4.25" X 2.5" FROM: 00-00-00 THRU: 04-02-00
	105620-14-000	EA THERMOSTAT - A/C AND FURNACE FROM: 04-03-00 THRU: 99-99-99
	105620-13-000	EA THERMOSTAT - FURNACE/HEAT PUMP FROM: 00-00-00 THRU: 05-21-00
	105620-15-000	EA THERMOSTAT - FURNACE/HEAT PUMP FROM: 05-22-00 THRU: 99-99-99
	120134-01-02A	EA REGISTER - W/DAMPER - 4" PIPE/7" O.D. FACE - WHITE
	105620-07-000	EA WIRE ASSEMBLY - THERMOSTAT

*COMPONENT PARTS FOUND IN SERVICE PARTS LIBRARY

INTERIOR FINISH GROUP

MOLDINGS & TRIMS WATERFORD OAK

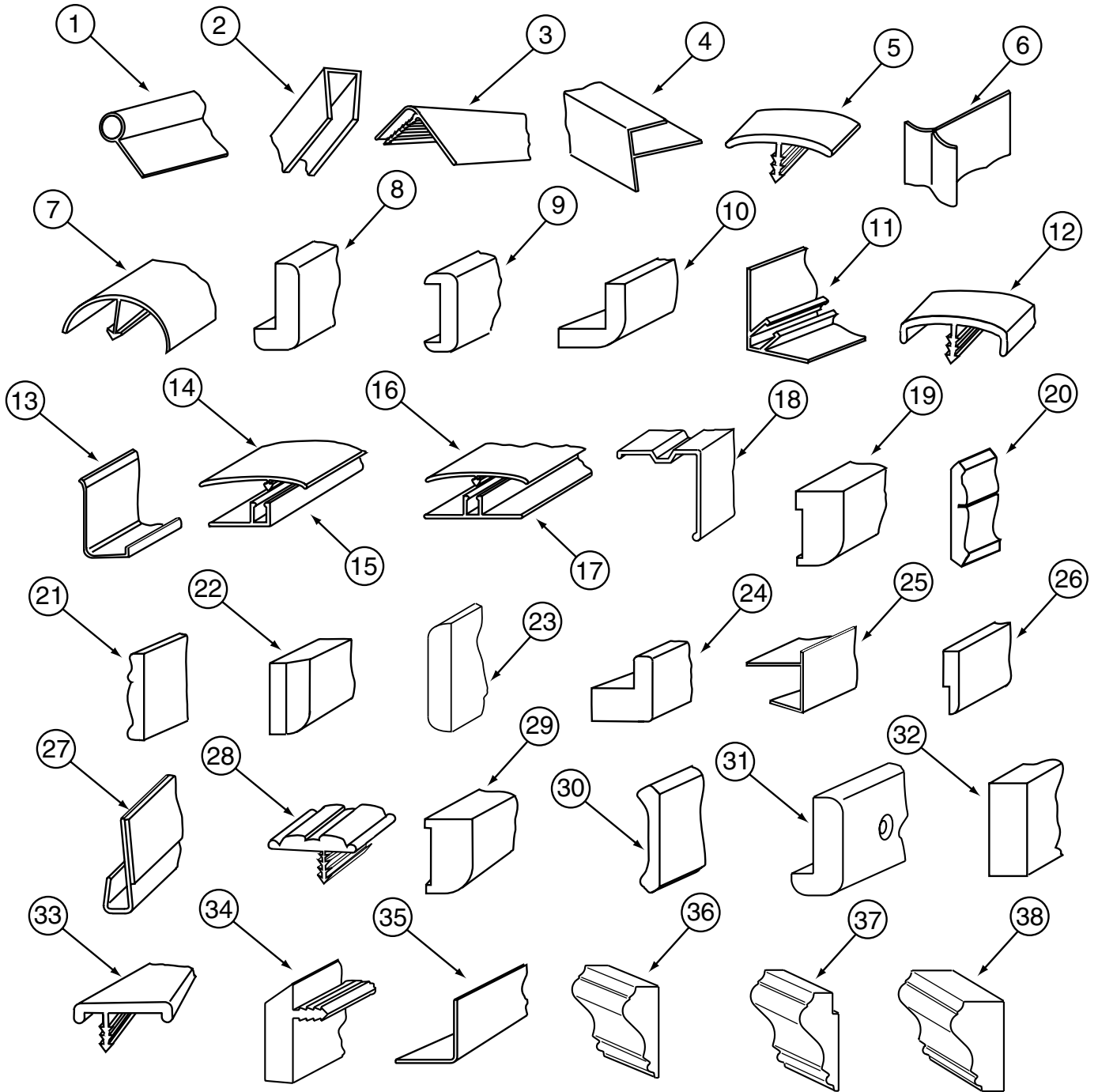

KEY	PART NUMBER	U/M	DESCRIPTION
1	009767-12-000	FT	WELTING - SIDEWALL/CEILING/CABINET - OFF/WHT
1	009767-14-000	FT	WELTING - CHERRY
1	009767-15-000	FT	WELTING - WATERFORD OAK
1	009767-16-000	FT	WELTING - REBER BIRCH
1	009778-16-000	FT	U-CHANNEL - 1" - PICKLED ASH
2	009778-18-000	FT	U-CHANNEL - 1" - CHERRY-CHERRY
2	009778-21-000	FT	U-CHANNEL - 1" - WATERFORD OAK
2	009778-25-000	FT	U-CHANNEL - 1" - BEIGE ILLUSION
2	009778-27-000	FT	U-CHANNEL - 1" - WASHED MAPLE
2	009778-31-000	FT	U-CHANNEL - 1" - GRADY BROWN

INTERIOR FINISH GROUP (CONTINUED)

MOLDINGS & TRIMS (CONTINUED)

KEY	PART NUMBER	U/M	DESCRIPTION
2	070504-03-000	FT	U-CHANNEL - PLASTIC - .9" X 96" - GRADY BROWN
2	070504-18-000	FT	U-CHANNEL - PLASTIC - .13" X 84" - IVORY
2	070504-30-000	FT	U-CHANNEL - PLASTIC - .13" X 84" - CHERRY
2	070504-31-000	FT	U-CHANNEL - PLASTIC - .9" X 84" - CHERRY
2	070504-36-000	FT	U-CHANNEL - PLASTIC - .13" X 72" - WATERFORD OAK
2	070504-37-000	FT	U-CHANNEL - PLASTIC - .9" X 84" - WATERFORD OAK
2	070504-38-000	FT	U-CHANNEL - PLASTIC - .9" X 65" - WATERFORD OAK
2	070504-42-000	FT	U-CHANNEL - PLASTIC - .13" X 84" - BEIGE ILLUSION
2	070504-50-000	FT	U-CHANNEL - PLASTIC - .13" X 84" - WASHED MAPLE
2	070504-51-000	FT	U-CHANNEL - PLASTIC - .9" X 84" - WASHED MAPLE
2	070504-54-000	FT	U-CHANNEL - PLASTIC - .9" X 84" - VILLAGE OAK
3	009809-27-000	EA	MOLDING - CORNER - OUTSIDE - 1" X 84" - CHERRY
3	009809-28-000	EA	MOLDING - CORNER - OUTSIDE - 1" X 84" - WATERFORD OAK
3	009809-30-000	EA	MOLDING - CORNER - OUTSIDE - 1" X 84" - BEIGE ILLUSION
3	009809-31-000	EA	MOLDING - CORNER - OUTSIDE - 1" X 84" - WASHED MAPLE
3	009809-32-000	EA	MOLDING - CORNER - OUTSIDE - 1" X 84" - PORTSMOUTH OAK
4	009812-24-000	EA	MOLDING - CORNER - 1/2" W/1/4" CHAN X 84" - IVORY
4	009812-26-000	EA	MOLDING - CORNER - 1/2" W/1/4" CHAN X 84" - CHERRY
4	009812-27-000	EA	MOLDING - CORNER - 1/2" W/1/4" CHAN X 84" - PICKLED ASH
4	009812-29-000	EA	MOLDING - CORNER - 1/2" W/1/4" CHAN X 84" - WATERFORD OAK
4	009812-31-000	EA	MOLDING - CORNER - 1/2" W/1/4" CHAN X 84" - BEIGE ILLUSION
4	009812-33-000	EA	MOLDING - CORNER - 1/2" W/1/4" CHAN X 84" - WASHED MAPLE
4	009812-34-000	EA	MOLDING - CORNER - 1/2" W/1/4" CHAN X 84" - VW LIGHT GRAY
4	009812-35-000	EA	MOLDING - CORNER - 1/2" W/1/4" CHAN X 84" - PORTSMOUTH OAK
5	009815-09-000	FT	MOLDING-T - .75" IVORY
5	105709-01-000	FT	MOLDING-T - 1" - MODERN IVORY
5	105709-02-000	FT	MOLDING-T - 1" - BEIGE ILLUSION
6	022992-11-000	FT	MOLDING - REVERSE COVE - T-SHAPED VINYL - IVORY
6	022992-14-000	FT	MOLDING - REVERSE COVE
6	022992-15-000	FT	MOLDING - REVERSE COVE - VW GRAY
7	042357-18-000	EA	MOLDING - CORNER - RADIUS/PLASTIC - PICKLED ASH
7	042357-19-000	EA	MOLDING - CORNER - RADIUS/PLASTIC - CHERRY
7	042357-20-000	EA	MOLDING - CORNER - RADIUS/PLASTIC - WATERFORD OAK
7	042357-25-000	EA	MOLDING - CORNER - RADIUS/PLASTIC - WASHED MAPLE
7	042357-26-000	EA	MOLDING - CORNER - RADIUS/PLASTIC - PORTSMOUTH OAK
8	077840-01-E41	EA	MOLDING - WALL CAP - 8' - SALEM CHERRY
8	077840-01-G01	EA	MOLDING - WALL CAP - 8' - WATERFORD OAK
8	077840-01-J70	EA	MOLDING - WALL CAP - 8' - WASHED MAPLE
9	078323-06-G15	EA	MOLDING - CAP/WALL - 79.6" - WATERFORD OAK
10	080176-08-000	EA	CAP - CORNER - RADIUS MOLDING - PLASTIC - WASHED MAPLE
11	081521-02-007	EA	MOUNT - METAL MOLDING - F/RADIUS CORNER MOLDING - 151.5"
12	083620-09-000	FT	MOLDING-T - W/EDGE LIP - 7/8" FACE - MODERN IVORY
12	083620-11-000	FT	MOLDING-T - W/EDGE LIP - 7/8" FACE - CHERRY
12	083620-12-000	FT	MOLDING-T - W/EDGE LIP - 7/8" FACE - WATERFORD OAK
12	083620-15-000	FT	MOLDING-T - W/EDGE LIP - 7/8" FACE - BEIGE ILLUSION
12	083620-19-000	FT	MOLDING-T - W/EDGE LIP - 7/8" FACE - WASHED MAPLE
12	104676-02-02A	FT	MOLDING-T - 1/2" - PICKLED ASH
12	104676-02-03A	FT	MOLDING-T - 1/2" - CHERRY
12	104676-02-04A	FT	MOLDING-T - 1/2" - WATERFORD OAK
12	104676-02-06A	FT	MOLDING-T - 1/2" - WASHED MAPLE
12	104676-02-08A	FT	MOLDING-T - 1/2" - PORTSMOUTH OAK
13	085746-04-000	FT	TRIM-J - CARPET 1.2" X .5" ANGLE - 12' LONG - OFF WHITE
14	086229-12-000	EA	BATTEN - 1.5" OFFSET X 97.01" IVORY
15	086229-11-000	EA	RETAINER - OFFSET - 97.01"
16	086229-13-000	EA	RETAINER - 1" X 96" - IVORY
16	086229-15-000	EA	BATTEN - 1" X 96" - MODERN IVORY
16	086229-19-000	EA	BATTEN - 1" X 98.43" - OFF WHITE
16	086229-20-000	EA	BATTEN - 1" X 96" - BEIGE
17	086229-01-000	EA	RETAINER - BATTEN - .75" X 92.3" - ANY COLOR
17	086229-14-000	EA	RETAINER - .75" X 98.43" - ANY COLOR
18	093873-01-01A	EA	TRIM - CARPET - L-ANGLE 1.1" X 1.3" X 12' - GRAY VINYL
19	126204-D2-134	EA	MOLDING - VINYL WRAPPED - .7" X 1.6" X 84" - WASHED MAPLE
19	126204-F2-134	EA	MOLDING - VINYL WRAPPED - .7" X 2.5" X 84" - WASHED MAPLE

INTERIOR FINISH GROUP (CONTINUED)

MOLDINGS & TRIMS (CONTINUED) WATERFORD OAK

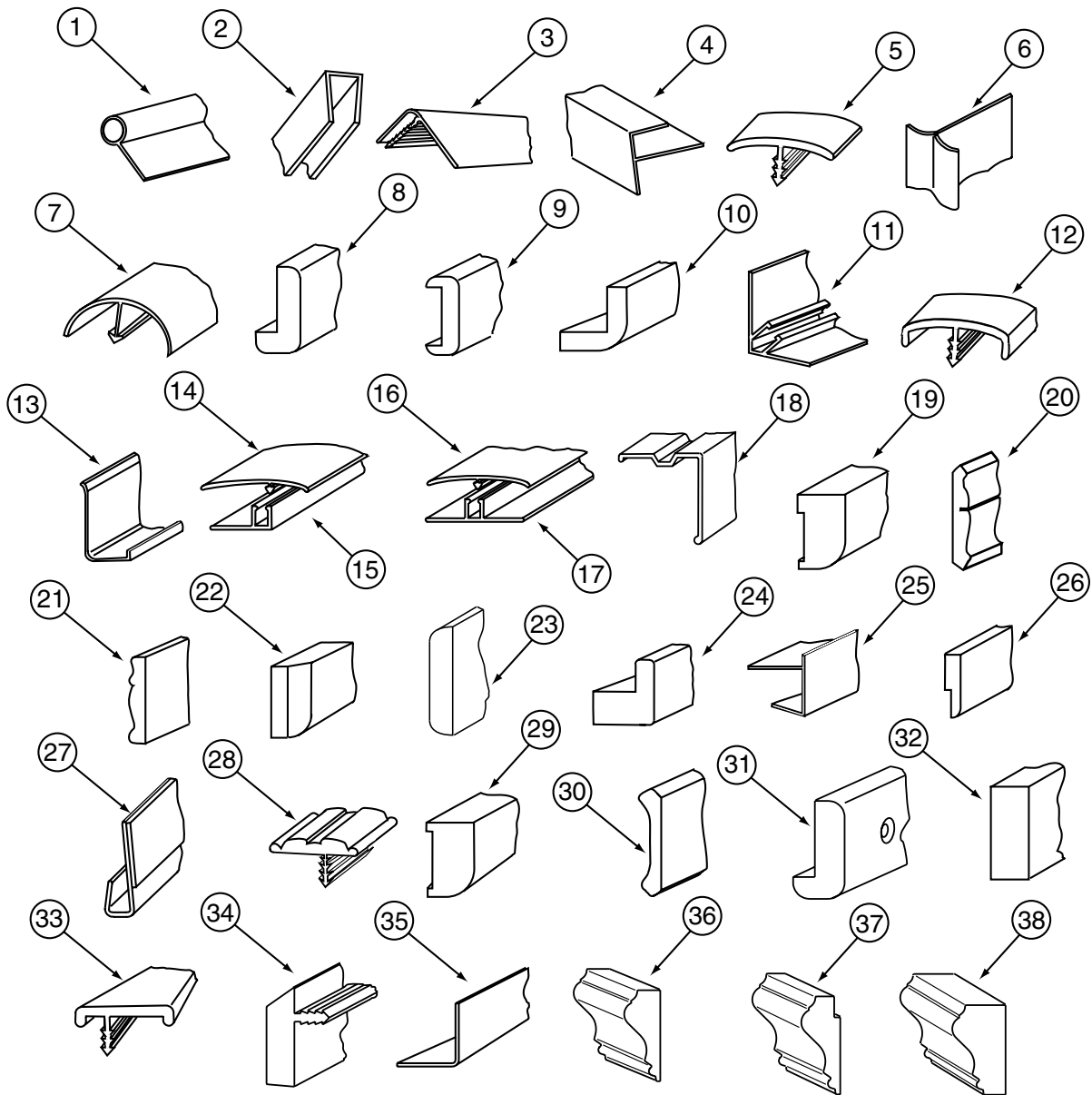

KEY	PART NUMBER	U/M	DESCRIPTION
19	126204-F2-438	EA	MOLDING - VINYL WRAPPED - .7" X 2.6" X 84" - WASHED MAPLE
20	111136-D2-134	EA	MOLDING - VINYL WRAPPED - .7" X 1.6" X 7' - CHERRY
20	111136-D2-438	EA	MOLDING - VINYL WRAPPED - .7" X 1.6" X 8' - CHERRY
20	111136-F2-134	EA	MOLDING - VINYL WRAPPED - .7" X 2.6" X 84" - CHERRY
20	111136-F2-438	EA	MOLDING - VINYL WRAPPED - .7" X 2.5" X 8' - CHERRY
21	100182-01-G15	EA	TRIM - RAIL
22	100659-01-E74	EA	MOLDING - TRIM - SALEM CHERRY
22	100659-01-G09	EA	MOLDING - TRIM - WATERFORD OAK
22	100659-01-J40	EA	MOLDING - TRIM - WASHED MAPLE
22	100659-01-M42	EA	MOLDING - TRIM - PORTSMOUTH OAK
22	100659-27-G15	EA	MOLDING - TRIM
23	100818-01-03A	EA	MOLDING - VINYL WRAPPED - 1.6" X .4" X 84" - PICKLED ASH
23	100818-01-04A	EA	MOLDING - VINYL WRAPPED - 1.6" X .4" X 84" - WATERFORD OAK
23	100818-01-05A	EA	MOLDING - VINYL WRAPPED - 1.6" X .4" X 84" - CHERRY
23	100818-01-08A	EA	MOLDING - VINYL WRAPPED - 1.6" X .4" X 84" - WASHED MAPLE
23	100818-01-09A	EA	MOLDING - VINYL WRAPPED - 1.6" X .4" X 84" - PORTSMOUTH OAK
24	100819-01-03A	EA	MOLDING - VINYL WRAPPED - L-SHAPED - 1.5"X1.5"X84" - PICKLED ASH
24	100819-01-04A	EA	MOLDING - VINYL WRAPPED - L-SHAPED - 1.5"X1.5"X84" - CHERRY
24	100819-01-05A	EA	MOLDING - VINYL WRAPPED - L-SHAPED - 1.5"X1.5"X84" - OAK
24	100819-01-08A	EA	MOLDING - VINYL WRAPPED - L-SHAPED - 1.5"X1.5"X84" - WASHED MAPLE

INTERIOR FINISH GROUP (CONTINUED)

MOLDINGS & TRIMS (CONTINUED)

WATERFORD OAK

KEY	PART NUMBER	U/M	DESCRIPTION
24	100819-01-09A	EA	MOLDING - VINYL WRAPPED - L-SHAPED - 1.5"X1.5"X84" - PORTSMOUTH OAK
25	103186-01-04A	FT	MOLDING - PLASTIC 3/8" U-CHANNEL W/3/4" FACE - CHERRY
25	103186-01-03A	FT	MOLDING - PLASTIC 3/8" U-CHANNEL W/3/4" FACE - PICKLED ASH
25	103186-01-05A	FT	MOLDING - PLASTIC 3/8" U-CHANNEL W/3/4" FACE - WATERFORD OAK
25	103186-01-07A	FT	MOLDING - PLASTIC 3/8" U-CHANNEL W/3/4" FACE - BEIGE ILLUSION
25	103186-01-09A	FT	MOLDING - PLASTIC 3/8" U-CHANNEL W/3/4" FACE - PORTSMOUTH OAK
25	103186-01-08A	FT	MOLDING - PLASTIC 3/8" U-CHANNEL W/3/4" FACE - WASHED MAPLE
25	103186-02-03A	FT	MOLDING - PLASTIC - 1" U-CHANNEL 1 3/8" FACE - PICKLED ASH
25	103186-02-04A	FT	MOLDING - PLASTIC - 1" U-CHANNEL 1 3/8" FACE - CHERRY
25	103186-02-05A	FT	MOLDING - PLASTIC - 1" U-CHANNEL 1 3/8" FACE - WATERFORD OAK
25	103186-02-07A	FT	MOLDING - PLASTIC - 1" U-CHANNEL 1 3/8" FACE - BEIGE ILLUSION
25	103186-02-08A	FT	MOLDING - PLASTIC - 1" U-CHANNEL 1 3/8" FACE - WASHED MAPLE
25	103186-02-09A	FT	MOLDING - PLASTIC - 1" U-CHANNEL 1 3/8" FACE - PORTSMOUTH OAK
26	105004-01-03A	EA	MOLDING - VINYL WRAPPED - 1" X 96" - PICKLED ASH
26	105004-01-04A	EA	MOLDING - VINYL WRAPPED - 1" X 96" - CHERRY
26	105004-01-05A	EA	MOLDING - VINYL WRAPPED - 1" X 96" - WATERFORD OAK
26	105004-01-08A	EA	MOLDING - VINYL WRAPPED - 1" X 96" - WASHED MAPLE
26	105004-01-09A	EA	MOLDING - VINYL WRAPPED - 1" X 96" - PORTSMOUTH OAK
27	109332-02-03A	FT	TRIM-J - W/O ADHESIVE - SALEM CHERRY
27	109332-02-05A	FT	TRIM-J - W/O ADHESIVE - WASHED MAPLE
27	109332-02-06A	EA	TRIM-J - W/O ADHESIVE - PORTSMOUTH OAK
28	109736-02-01A	FT	MOLDING-T/OFFSET - W/EDGE LIP - 1" FACE - NATURAL OAK
29	117268-D2-134	EA	MOLDING - VINYL WRAPPED - .7" X 1.6" X 84" - WATERFORD OAK
29	117268-F2-134	EA	MOLDING - VINYL WRAPPED - .7" X 2.7" X 84" - WATERFORD OAK
29	117268-F2-438	EA	MOLDING - VINYL WRAPPED - .7" X 2.6" X 96" - WATERFORD OAK
30	113794-01-03A	FT	MOLDING - CROWN - 3.45" - MAPLE
30	113794-02-03A	FT	MOLDING - CROWN - 3.45" - MAPLE
31	116280-02-GV0	EA	MOLDING - CAP - PICKLED ASH
31	116280-02-GV1	EA	MOLDING - CAP - SALEM CHERRY
31	116280-02-J70	EA	MOLDING - CAP - WASHED MAPLE
31	116280-02-L95	EA	MOLDING - CAP - WATERFORD OAK
32	111134-D2-438	EA	LUMBER - VINYL WRAPPED - .7" X 1.5" X 96" - CHERRY
32	111134-E2-438	EA	LUMBER - VINYL WRAPPED - .7" X 2" X 96" - CHERRY
32	111134-F2-438	EA	LUMBER - VINYL WRAPPED - .7" X 2.5" X 96" - CHERRY
32	111134-G2-438	EA	LUMBER - VINYL WRAPPED - .7" X 3" X 96" - CHERRY
32	111134-J2-438	EA	LUMBER - VINYL WRAPPED - .7" X 5.5" X 96" - CHERRY
32	117267-D2-438	EA	LUMBER - VINYL WRAPPED - .7" X 1.5" X 96" - WATERFORD OAK
32	117267-E2-438	EA	LUMBER - VINYL WRAPPED - .7" X 2" X 96" - WATERFORD OAK
32	117267-F2-438	EA	LUMBER - VINYL WRAPPED - .7" X 2.5" X 96" - WATERFORD OAK
32	117267-J2-438	EA	LUMBER - VINYL WRAPPED - .7" X 5.5" X 96" - WATERFORD OAK
32	117267-R2-438	EA	LUMBER - VINYL WRAPPED - .7" X 3" X 96" - WATERFORD OAK
32	126205-D2-438	EA	LUMBER - VINYL WRAPPED - .7" X 1.5" X 96" - WASHED MAPLE
32	126205-E2-438	EA	LUMBER - VINYL WRAPPED - .7" X 2" X 96" - WASHED MAPLE
32	126205-F2-438	EA	LUMBER - VINYL WRAPPED - .7" X 2.5" X 96" - WASHED MAPLE
32	126205-J2-438	EA	LUMBER - VINYL WRAPPED - .7" X 5.5" X 96" - WASHED MAPLE
32	126205-R2-438	EA	LUMBER - VINYL WRAPPED - .7" X 3" X 96" - WASHED MAPLE
32	126205-G2-438	EA	LUMBER - VINYL WRAPPED - .7" X 3" X 96" - WASHED MAPLE
33	119520-01-01A	FT	MOLDING-T - 1" - W/EDGE LIPS (OFF/WHITE-CREAM)
34	130247-01-01A	FT	T-MOLDING - 1.3" - WATERFORD OAK
34	130247-01-02A	FT	T-MOLDING - 1.3" - WASHED MAPLE
34	130247-01-03A	FT	T-MOLDING - 1.3" - SALEM CHERRY
34	130247-01-04A	FT	T-MOLDING - 1.3" - PORTSMOUTH OAK
35	130262-01-000	EA	PROTECTOR - CORNER SAVER - .7" X .7"
36	131923-01-01A	FT	MOLDING - CROWN - ASH
36	131923-01-02A	FT	MOLDING - CROWN - CHERRY
36	131923-01-03A	FT	MOLDING - CROWN - HARD WHITE MAPLE
37	131923-02-01A	FT	MOLDING - PICTURE - CHERRY
37	131923-02-02A	FT	MOLDING - PICTURE - ASH
37	131923-02-03A	FT	MOLDING - PICTURE - HARD WHITE MAPLE
38	131923-03-01A	FT	MOLDING - CROWN - DIVIDER - ASH
38	131923-03-02A	FT	MOLDING - CROWN - DIVIDER - CHERRY
38	131923-03-03A	FT	MOLDING - CROWN - DIVIDER - HARD WHITE MAPLE
38	131923-03-02A	FT	MOLDING - CROWN - DIVIDER - CHERRY

INTERIOR FINISH GROUP (CONTINUED)

PANELING, LAMINATES, BATT & EDGEBANDING

KEY	PART NUMBER	U/M	DESCRIPTION
	000846-01-000	SF	PLYWOOD - 5/16" X 48" X 96" - CD GRADE
	000846-02-000	SF	PLYWOOD/UNDERLAYMENT - 5/16" X 48" X 96"
	000885-76-000	SF	PARTICLE BOARD-3/8" X 48" X 96"-WATERFORD OAK-VINYL 1 SIDE
	000885-77-000	SF	PARTICLE BOARD-3/8" X 48" X 96"-WATERFORD OAK-VINYL 2 SIDE
	000885-79-000	SF	PARTICLE BOARD-3/4" X 48" X 96"-WATERFORD OAK-VINYL 2 SIDE
	074497-28-000	SF	PANELING - WATERFORD OAK - 4' X 8'
	088272-J3-000	SF	PANELING - PHOENIX/NEUTRAL - 4' X 7' (L76,L78)
	088272-J6-000	SF	PANELING - CIRRUS - 4' X 7' (L80)
	074498-40-000	SF	LAMINATE - PLASTIC - OFF WHITE - 5' X 8'
	074498-52-000	SF	LAMINATE - PLASTIC - WHITE ETHOS - 5' X 8'
	074498-62-000	SF	LAMINATE - PLASTIC - GREY FINESSE - 5' X 8'
	074498-77-000	SF	LAMINATE - PLASTIC - ART CABIN (WATERFORD OAK) - 4' X 8'
	076325-39-000	FT	MOLDING - EDGE BAND - 1 5/16" X .030" - ALMOND
	076325-67-000	FT	MOLDING - EDGE BAND - .93" X .024" - WATERFORD OAK
	076325-73-000	FT	MOLDING - EDGE BAND - .93" X .024" - OFF WHITE
	085284-G2-000	FT	BATT TAPE - ADHESIVE BACKED - DECORATIVE - PHOENIX/NEUTRAL (L76,L78)
	085284-G5-000	FT	BATT TAPE - ADHESIVE BACKED - CIRRUS (L80)
	085284-B5-000	FT	BATT TAPE - ADHESIVE BACKED - WOODGRAINED-WATERFORD OAK
	088263-G3-000	EA	BATT STRIP - DECORATIVE - PHOENIX/NEUTRAL - 8' (L76,L78)
	088263-G6-000	EA	BATT STRIP - DECORATIVE - CIRRUS - 8' (L80)
	069733-83-000	EA	BATT STRIP - WOODGRAINED/WATERFORD OAK - 8'
	126339-01-000	SF	BOARD - WHEAT - 60" X 72"
	132610-04-02A	FT	WALLPAPER - BORDER - 5" (L76)
			FROM: 09-13-99 THRU: 09-29-99
	132610-05-02A	FT	WALLPAPER - BORDER - 7" (L76)
			FROM: 09-30-99 THRU: 99-99-99
	132610-03-01A	FT	BORDER - WALLPAPER - 6 7/8" - SELF ADHESIVE (L78)
			FROM: 00-00-00 THRU: 09-20-99
	132610-05-03A	FT	BORDER - WALLPAPER - 7" (L78)
			FROM: 09-21-99 THRU: 99-99-99
	122481-20-000	FT	WALLPAPER - 6.8" BORDER (L80)

INTERIOR FINISH GROUP (CONTINUED)

ACCESSORIES

KEY	PART NUMBER	U/M	DESCRIPTION
	072852-01-000	EA	DETECTOR - SMOKE - W/9 VOLT BATTERY - US
	094499-03-000	EA	EXTINGUISHER/FIRE - DRY - 10BC - W/GAUGE - W/O BRACKET
	094499-04-000	EA	BRACKET - FIRE EXTINGUISHER
	072852-02-000	EA	DETECTOR - SMOKE - W/9 VOLT BATTERY - CANADIAN
*	094499-02-000	EA	EXTINGUISHER/FIRE - DRY - 1A10BC - CANADIAN
	094499-04-000	EA	BRACKET - FIRE EXTINGUISHER
	133713-02-01A	EA	SPACER - CUP HOLDER - WATERFORD OAK
			FROM: 09-13-99 THRU: 99-99-99
	125136-01-000	EA	CO DETECTOR - GAS - ROUND W/2 SCREWS - 9 VOLT
			FROM: 00-00-00 THRU: 11-21-99
	125136-02-000	EA	CO DETECTOR - GAS MODEL - 9 VOLT
			FROM: 11-22-99 THRU: 99-99-99
	131493-02-01A	EA	PICTURE - 13" X 15" - HOMESTEAD
			FROM: 00-00-00 THRU: 11-16-99
	131493-02-04A	EA	PICTURE - DECORATIVE - 13" X 15" - FLORAL
			FROM: 11-17-99 THRU: 99-99-99
	131333-01-01A	EA	HOLDER - CUP - VERTICAL DROP/FLUSH MOUNT - BLACK
	133713-02-01A	EA	SPACER - CUPHOLDER - WATERFORD OAK

*COMPONENT PARTS FOUND IN SERVICE PARTS LIBRARY

FLOOR COVERINGS

KEY	PART NUMBER	U/M	DESCRIPTION
	042720-25-000	SY	VINYL - FLOOR COVERING - 14' WIDE - MODULATION
	091261-01-000	FT	SLIPNOT - ANTISLIP - 1' WIDE X 12' - BLACK
	093486-01-000	SY	CARPET - COMPARTMENT - 72" WIDE - DARK GRAY
	096060-E4-000	SY	CARPET - LT BAROQUE - INCREMENTS OF 4 SY YDS (L76,L78)
			FROM: 00-00-00 THRU: 10-24-99
	096060-G8-000	SY	CARPET - CAMEL - INCREMENTS OF 4 SQ YDS (3' X 12') (L76,L78)
			FROM: 10-25-99 THRU: 99-99-99
	096060-E3-000	SY	CARPET - BARELY PLUM - INCREMENTS OF 4 SY YDS (L80)
	096764-02-000	FT	SLIPNOT - ANTISLIP - 1' WIDE (180' ROLLS) - WHITE
	120231-01-02A	EA	FLOORING - RUBBER - 66.4" X 19.8"
	120231-01-01A	EA	FLOORING - RUBBER - 66.4" X 19.8"
	124253-01-02A	EA	VINYL - FLOOR PLANK - 3" X 12" - MAPLE

INTERIOR FINISH GROUP (CONTINUED)

HARDWARE

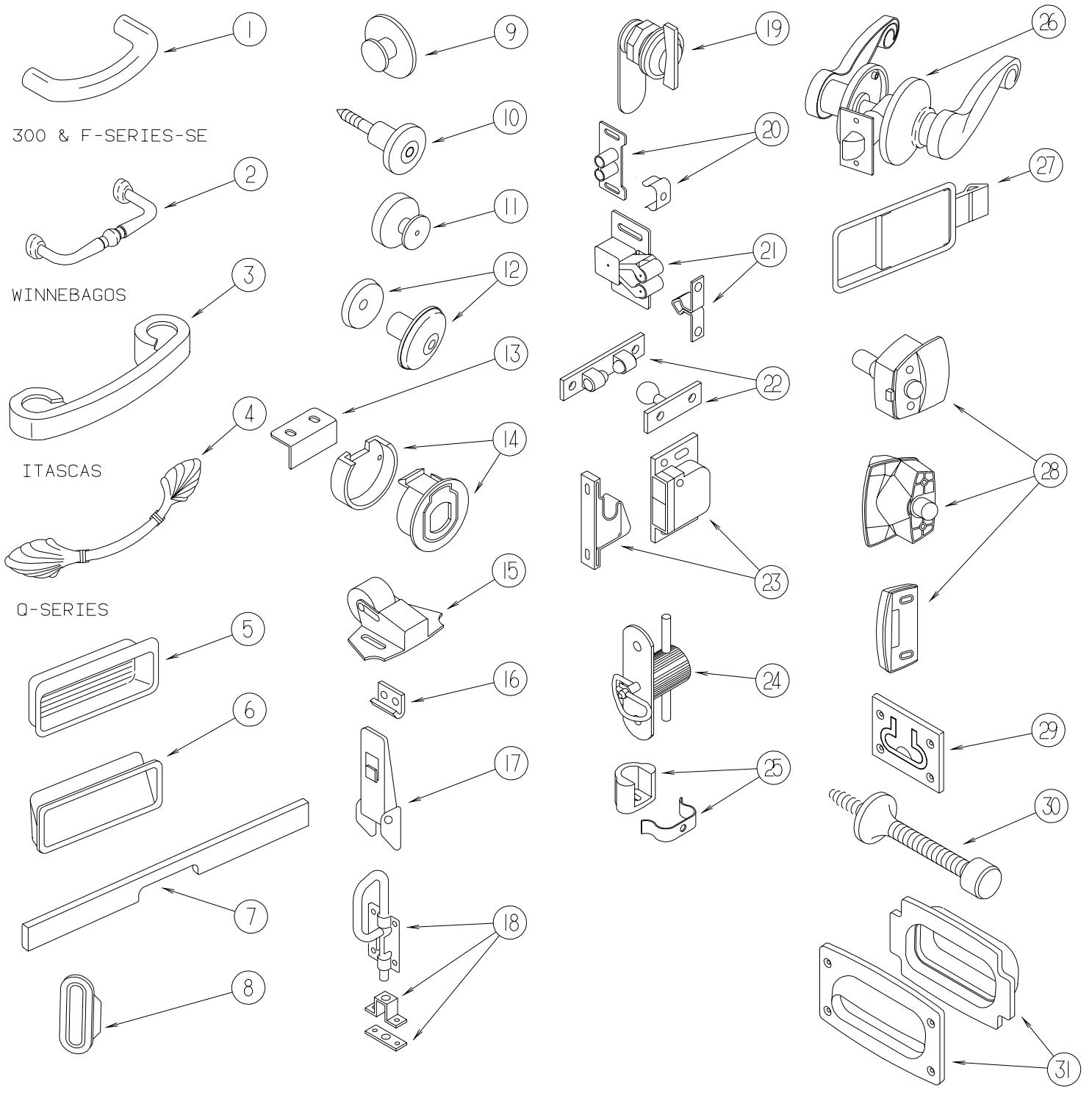

INTERIOR FINISH GROUP (CONTINUED)

HARDWARE (CONTINUED)

KEY	PART NUMBER	U/M	DESCRIPTION
1	131964-01-01A	EA	PULL - CABINET - POLISHED BRASS
2	131963-01-01A	EA	PULL - CABINET - POLISHED BRASS
3	131962-01-01A	EA	PULL - CABINET - POLISHED BRASS
4	117923-01-01A	EA	PULL - CABINET - BURNISHED BRASS - 5.5"
4	131965-01-01A	EA	PULL - CABINET - BURNISHED BRASS - 6.3"
5	124311-01-01A	EA	HANDLE - RECESSED - BRASS
6	115994-01-01A	EA	HANDLE - POCKET
7	126866-01-L81	EA	HANDLE - DOOR - TAMBOUR - 18.6"
7	126866-04-KQ0	EA	HANDLE - TAMBOUR DOOR - 14.7"
7	126866-04-KQ1	EA	HANDLE - TAMBOUR DOOR - 14.7"
7	126866-04-L95	EA	HANDLE - TAMBOUR DOOR - 14.7"
7	126866-05-K07	EA	HANDLE - TAMBOUR DOOR - 11.5"
7	126866-05-K09	EA	HANDLE - TAMBOUR DOOR - 11.5"
8	098410-01-01A	EA	PULL - FINGER - OVAL - BRASS
9	125221-01-01A	EA	PULL - MIRROR - W/ROUND HANDLE
10	113800-01-000	EA	KNOB - CABINET - BRASS
11	133313-01-01A	EA	PULL - DRAWER KNOB - BURNISHED BRASS
11	133313-01-02A	EA	PULL - DRAWER KNOB - BRIGHT BRASS
12	117978-01-01A	EA	KNOB - DOOR - BRIGHT BRASS
13	113375-02-01A	EA	STRIKE - DOOR - CHROME
14	113375-05-01A	EA	LATCH - SLAM - BACK - .8" THICK
14	113375-06-01A	EA	LATCH - SLAM - FACE - .7" THICK
15	109403-01-000	EA	CATCH - SINGLE ROLLER - SCREEN DOOR
16	116975-02-01A	EA	KEEPER/STRIKE - BLACK - NEW STYLE
17	116975-01-01A	EA	LATCH - W/O STRIKE - BLACK - NEW STYLE
18	103256-01-000	EA	LATCH - SLIDE
19	100710-01-01A	EA	LOCK - GLASS DOOR/TWIST TYPE - BRASS
20	009021-01-000	EA	CATCH - GRILLE - NYLON
20	009021-02-000	EA	STRIKE - SPRING STEEL
21	093586-04-000	EA	STRIKE - SPRING STEEL - 1.14"
21	093586-05-000	EA	STRIKE - SPRING STEEL - .943"
21	093586-03-000	EA	CATCH - SPRING ROLLER - .377"
21	093586-06-000	EA	CATCH - SPRING - ROLLER - .236"
22	084451-01-000	EA	CATCH - BRASS
23	117095-01-01A	EA	CATCH - DOOR - GRABBER W/KEEPER - PLASTIC - BLK - 5LB PULL
23	117095-02-01A	EA	LATCH - DOOR - GRABBER W/KEEPER - PLASTIC - BLK-10LB PULL
24	098196-01-000	EA	LATCH - 1/4 TURN - T-BAR
25	129703-01-01A	EA	CATCH ASSEMBLY
26	111155-03-01A	EA	LOCK - PRIVACY/LOCKING - POLISHED BRASS/PLAIN HANDLE
26	111155-05-01A	EA	LOCK - PRIVACY/LOCKING - S SHAPED - POLISHED BRASS
27	127349-01-01A	EA	LATCH - PADDLE
28	058335-03-000	EA	LATCH W/O LOCK - BATHROOM DOOR BLACK
29	072871-01-000	EA	PULL - FLUSH - CHROME
30	103194-01-000	EA	STOP - BATH DOOR
31	133607-01-01A	EA	PULL - LATCH - BLACK PLASTIC

INTERIOR FINISH GROUP (CONTINUED)

HARDWARE (CONTINUED)

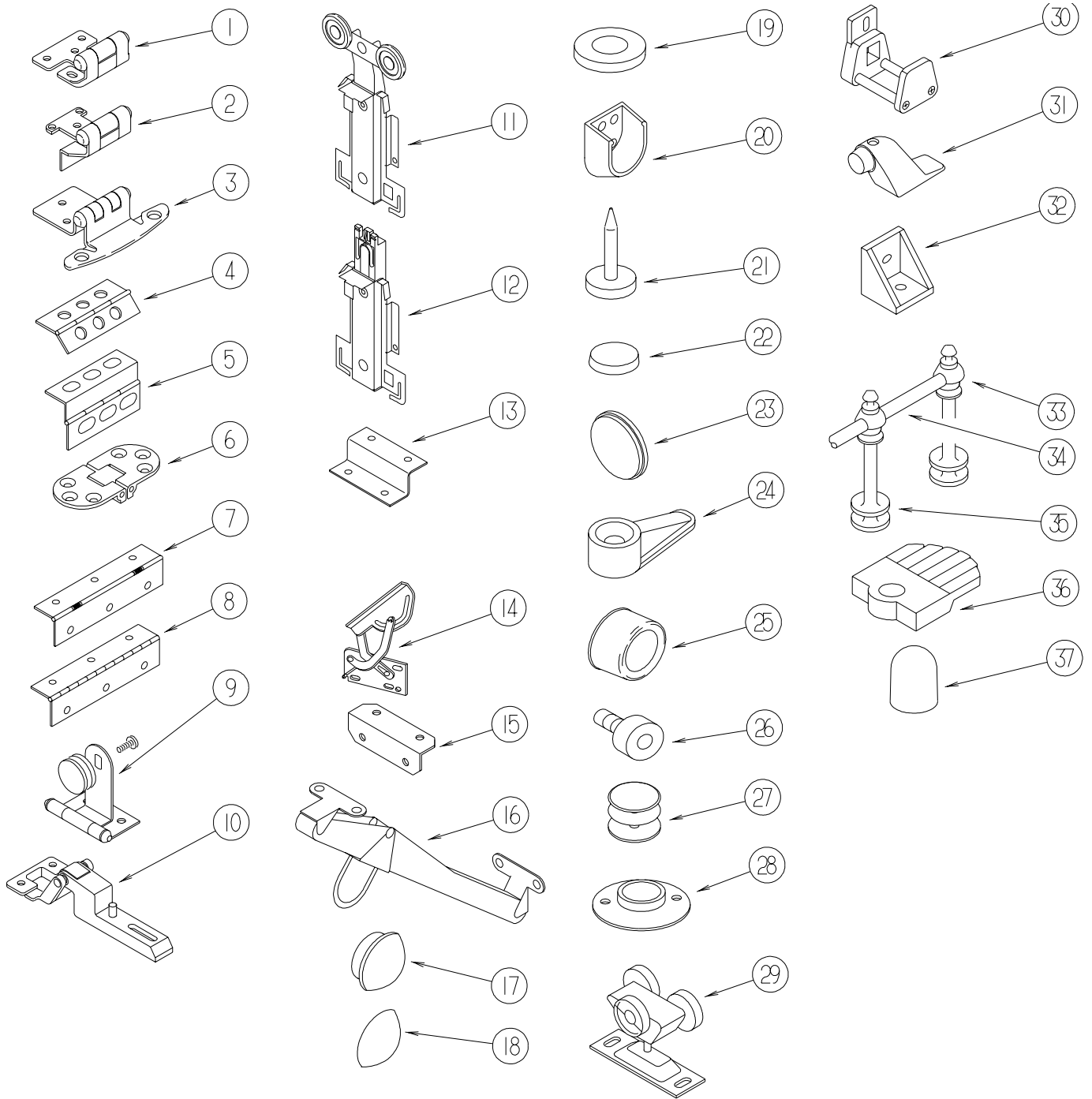

KEY	PART NUMBER	U/M DESCRIPTION
1	113676-01-01A	EA HINGE - OVERLAY - VARIABLE
2	113677-01-01A	EA HINGE - SELF CLOSING
3	108138-03-000	EA HINGE - BRIGHT BRASS
	000G13-06-08G	EA SCREW - 6-20 X .50 PFH - ANTIQUE BRASS
4	009059-01-000	EA HINGE - DOOR - 2" X 1.4" - BRASS
4	009059-02-000	EA HINGE - DOOR - 2" X 2.7" - BRASS
4	041389-18-000	EA HINGE - PIANO - 1 1/2" X 19" - OFF WHITE
4	041389-25-000	EA HINGE - PIANO - 1 1/2" X 55"
4	041389-35-000	EA HINGE - PIANO - OFF WHITE - 31"
5	118802-01-02A	EA HINGE - DOOR - CABINET - HAMPTON TAN
6	111535-01-000	EA HINGE - TABLE/FOLDING

INTERIOR FINISH GROUP (CONTINUED)
HARDWARE (CONTINUED)

KEY	PART NUMBER	U/M	DESCRIPTION
7	102920-01-01A	EA	HINGE/SPRING LOADED - BRASS
8	084413-01-000	EA	HINGE/CONTINUOUS - ALUMINUM 1" X 72" - W/HOLES
8	110496-01-01A	EA	HINGE - BRASS
9	100711-01-01A	EA	HINGE - GLASS DOOR
10	114443-01-01A	EA	HINGE - CABINET DOOR
11	107390-02-000	EA	CORNER HANGER (DOUBLE ROLLER W/BRACKET) (SOLD AS 1 EACH)
12	107391-01-000	EA	GUIDE - BOTTOM - BY-PASS (4 USED PER DOOR)
13	101926-01-02A	EA	BRACKET - ZEE - BLACK
14	108126-01-000	EA	TRAY HINGE SET (QTY. 2 PER SET)
15	016604-01-000	EA	BRACE - CABINET - ANGLE - 2.5" - UNPAINTED METAL
15	016604-05-000	EA	BRACE - CABINET - ANGLE - 2.5" - OFF WHITE METAL
16	104181-01-01A	EA	SUPPORT - LEAF 5.3" EXTENDS TO 7.5" - SAFETY RING - METAL
17	074045-01-000	EA	PLUG - OAK - 1/2" DIAMETER
17	074045-08-000	EA	PLUG - OAK - 1/2" DIAMETER - SALEM CHERRY
17	042356-01-000	EA	PLUG - BUTTON - MAHOGANY - 3/8" DIAMETER - WOOD
18	057671-01-000	EA	COVER - SCREW - OFF WHITE - #8
18	057671-11-000	EA	COVER - SCREW - HAMPTON TAN - #8
18	057671-13-000	EA	COVER - SCREW - DARK GRAY - #8
18	057671-15-000	EA	COVER - SCREW - BRIGHT WHITE
18	057671-16-000	EA	COVER - SCREW - SOFT WHITE
19	100707-01-000	EA	SPACER - GLASS DOOR - .8" DIA - .3" HOLE - PLASTIC
20	113236-01-01A	EA	BRACKET - CLOTHES - ROD
21	102194-01-000	EA	GUIDE - PLASTIC
22	004354-01-000	EA	BUMPER - RUBBER - .5" DIA - BROWN
23	120760-01-000	EA	BUMPER - RUBBER - CLEAR
24	083204-03-000	EA	BUTTON - RETAINING MIRROR 5/16" TIP
25	069726-02-000	EA	BUMPER - .88" OD X .40" THICK - BLACK
26	079921-01-000	EA	ROLLER - NYLON - W/STEEL SHAFT - BARBED
27	081114-02-000	EA	CAP - INSERT - ROUND 1" DIAMETER - WHITE
28	009112-01-000	EA	FLANGE - PLASTIC - 1" CLOTHES ROD - OFF WHITE
29	103874-01-000	EA	HANGER - SLIDING DOOR
30	064467-01-000	EA	GUIDE - POCKET - SLIDING DOOR - WALL MOUNTED
31	103257-01-000	EA	STOP - DOOR
32	065740-01-000	EA	BRACE - CABINET/CORNER - PLASTIC
33	084070-03-000	EA	POST - END - 2.4" - BRASS
34	084071-05-000	EA	ROD - BRASS - 15"
34	084071-08-000	EA	ROD - BRASS - 9.3" LONG
34	084071-12-000	EA	ROD - BRASS - 4.1" LONG
34	084071-19-000	EA	ROD - BRASS - 7.1"
34	084071-20-000	EA	ROD - BRASS - 9.8" LONG
34	084071-22-000	EA	ROD - BRASS - 15.3"
34	084071-23-000	EA	ROD - BRASS - 13.12"
34	084071-24-000	EA	ROD - BRASS - 3.8"
34	084071-27-000	EA	ROD - BRASS - 2.7"
34	084071-28-000	EA	ROD - BRASS - 6" LONG
34	084071-30-000	EA	ROD - BRASS - 11.6" LONG
34	084071-31-000	EA	ROD - BRASS - 14.08" LONG
34	084071-32-000	EA	ROD - BRASS - 13.6" LONG
35	084070-01-000	EA	POST - CENTER - 2.4" - BRASS
36	009089-01-000	EA	CLIP - MIRROR
37	039984-01-000	EA	CAP - ROUND - VINYL - .28" ID X .62" - BLACK

INTERIOR FINISH GROUP (CONTINUED)

HARDWARE (CONTINUED)

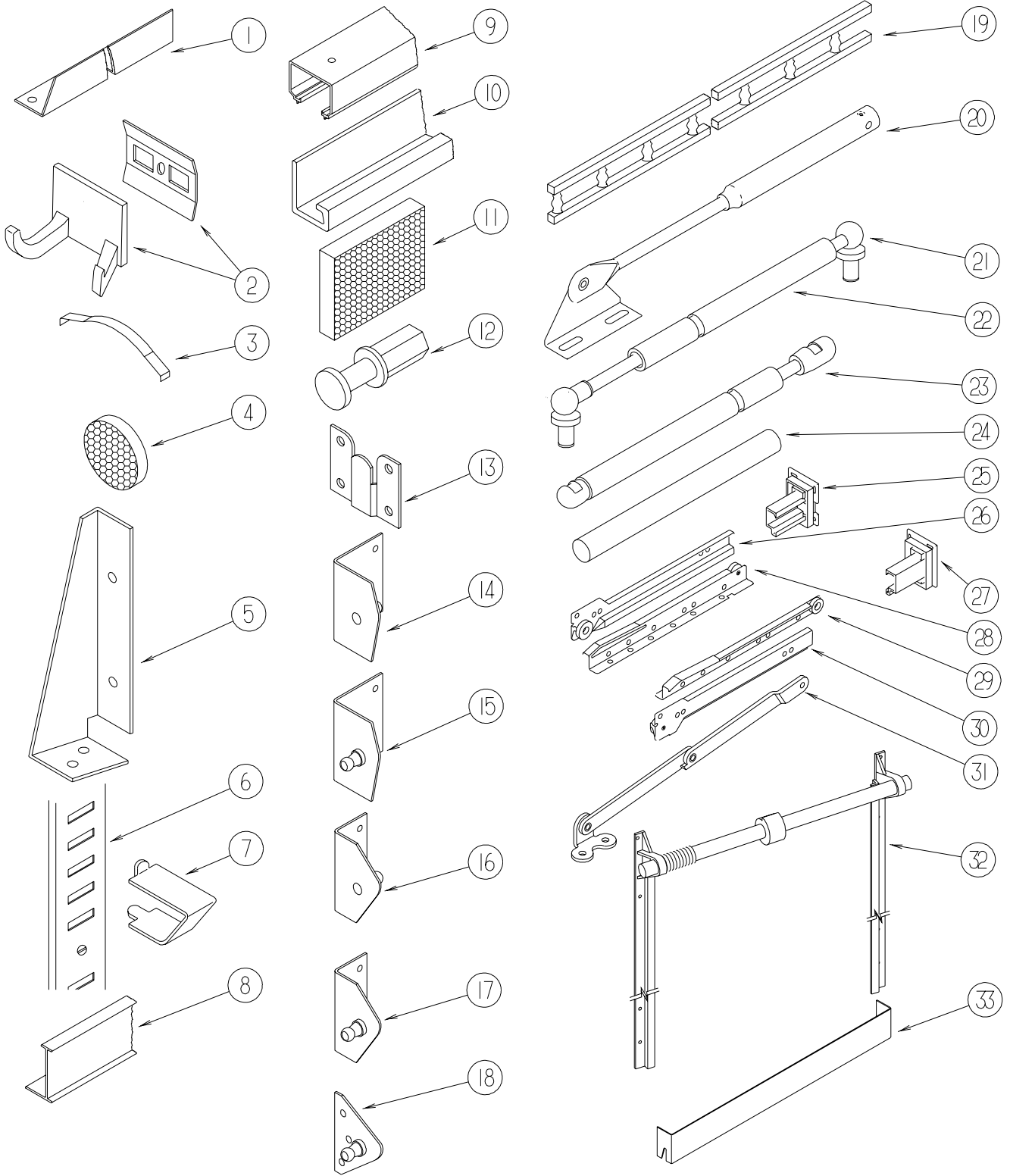

INTERIOR FINISH GROUP (CONTINUED)

HARDWARE (CONTINUED)

KEY	PART NUMBER	U/M	DESCRIPTION
1	114693-01-01A	EA	SUPPORT - BLACK - RIGHT HAND
1	114693-02-01A	EA	SUPPORT - BLACK - LEFT HAND
2	104174-01-000	EA	HOOK - ROBE - DOUBLE
3	115541-01-000	EA	SPRING - DOOR - SLIDING
4	122717-01-01A	EA	PAD - NON SKID - 4" DIAMETER ROUND
4	122717-01-01A	EA	PAD - NON SKID - 3" DIA. ROUND
5	076827-02-000	EA	BRACKET - 2.9" X 1.8" - TRIANGLE
6	098980-01-000	EA	PILASTER - ADJUSTABLE SHELF - 18"
6	098980-02-000	EA	PILASTER - ADJUSTABLE SHELF - 12"
6	098980-03-000	EA	PILASTER - ADJUSTABLE SHELF - 09"
6	098980-04-000	EA	PILASTER - ADJUSTABLE SHELF - 48"
6	098980-05-000	EA	PILASTER - ADJUSTABLE SHELF - 15"
6	098980-06-000	EA	PILASTER - ADJUSTABLE SHELF - 24"
7	098979-01-000	EA	CLIP - ADJUSTABLE SHELF
8	094856-10-01A	EA	TRACK - FOLDING DOOR - OFF WHITE
9	103868-09-01A	EA	TRACK - SLIDING DOOR - 64.3" - OFF WHITE
9	103868-15-01A	EA	TRACK - SLIDING DOOR - 76" - OFF WHITE
10	118933-01-01A	EA	SUPPORT - HINGE LOCK
11	122717-06-01A	FT	PAD - NON-SKID - PSA - 5"W
	122717-08-01A	EA	PAD - NON-SKID - PSA - 7.2"W
12	092652-01-000	EA	GUIDE WHEEL/DOOR - TOP MOUNT
13	130120-01-01A	EA	BRACKET - MOUNTING/MIRROR
14	126263-06-02B	EA	BRACKET - GAS SPRING - E-COATED
15	126263-05-02B	EA	BRACKET - GAS SPRING - UPPER - E-COATED
16	107796-10-000	EA	BRACKET - GAS SPRING - 90 DEGREE SMALL
17	126263-02-02B	EA	BRACKET - GAS SPRING
18	126263-08-02B	EA	BRACKET - GAS SPRING - E-COATED
19	075249-01-000	EA	RAILING - OAK - 72" UNFINISHED
19	111775-01-03A	EA	RAIL - DECORATIVE/PLASTIC SPINDLES - 71.9" - SALEM CHERRY
19	111775-01-04A	EA	RAIL - DECORATIVE - 6' - WATERFORD OAK
19	111775-01-06A	EA	RAIL - DECORATIVE/PLASTIC SPINDLES - 71.9" - WASHED MAPLE
19	111775-01-07A	EA	RAIL - DECORATIVE/PLASTIC SPINDLES - 71.9"-PORTSMOUTH OAK
20	074493-02-000	EA	SUPPORT - PISTON SPRING - CABINET DOOR - 26 LBS
21	057460-02-000	EA	STUD BALL - GAS SPRING - .39" - 5/16"-18
22	057460-04-000	EA	SPRING - GAS - BALL STUD STYLE - 120 PI - "SPD6209"
23	107796-06-000	EA	SPRING/GAS - 12" COMPRESSED/20" EXTENDED - 120 LB.
23	107796-08-000	EA	SPRING/GAS - 11" COMPRESSED/17" EXTENDED - 60 LB
23	107796-15-000	EA	SPRING/GAS - 24" COMPRESSED/40" EXTENDED - 15 LB.
23	107796-16-000	EA	SPRING/GAS - 6.4" COMPRESSED/9.6" EXTENDED - 65 LB.
23	107796-26-000	EA	SPRING/GAS - 12" COMPRESSED/20" EXTENDED - 90 LB.
24	042438-02-000	EA	DOWEL - WOOD - 2" X 2"
24	042438-01-000	EA	DOWEL - WOOD - CLOTHES ROD - 1" DIAMETER X 4'
	133426-01-02B	EA	BRACKET - MIRROR - MOUNTING - E-COATED

INTERIOR FINISH GROUP (CONTINUED)

HARDWARE (CONTINUED)

KEY	PART NUMBER	U/M	DESCRIPTION
25	128811-01-01A	EA	BACKSOCKET - ADJUSTABLE - LEFT
26	128810-01-01A	EA	SLIDE - DRAWER - 12" - LEFT CABINET
26	128810-05-01A	EA	SLIDE - DRAWER - 14" - LEFT CABINET
26	128810-09-01A	EA	SLIDE - DRAWER - 16" - LEFT CABINET
26	128810-13-01A	EA	SLIDE - DRAWER - 18" - LEFT CABINET
26	128810-17-01A	EA	SLIDE - DRAWER - 20" - LEFT CABINET
26	128810-21-01A	EA	SLIDE - DRAWER - 22" - LEFT CABINET
26	128810-25-01A	EA	SLIDE - DRAWER - 24" - LEFT CABINET
27	128811-02-01A	EA	BACKSOCKET - ADJUSTABLE RIGHT
28	128810-03-01A	EA	SLIDE - DRAWER - 12" - LEFT DRAWER
28	128810-07-01A	EA	SLIDE - DRAWER - 14" - LEFT DRAWER
28	128810-11-01A	EA	SLIDE - DRAWER - 16" - LEFT DRAWER
28	128810-15-01A	EA	SLIDE - DRAWER - 18" - LEFT DRAWER
28	128810-19-01A	EA	SLIDE - DRAWER - 20" - LEFT DRAWER
28	128810-23-01A	EA	SLIDE - DRAWER - 22" - LEFT DRAWER
28	128810-27-01A	EA	SLIDE - DRAWER - 24" - LEFT DRAWER
29	128810-04-01A	EA	SLIDE - DRAWER - 12" - RIGHT DRAWER
29	128810-08-01A	EA	SLIDE - DRAWER - 14" - RIGHT DRAWER
29	128810-12-01A	EA	SLIDE - DRAWER - 16" - RIGHT DRAWER
29	128810-16-01A	EA	SLIDE - DRAWER - 18" - RIGHT DRAWER
29	128810-20-01A	EA	SLIDE - DRAWER - 20" - RIGHT DRAWER
29	128810-24-01A	EA	SLIDE - DRAWER - 22" - RIGHT DRAWER
29	128810-28-01A	EA	SLIDE - DRAWER - 24" - RIGHT DRAWER
30	128810-02-01A	EA	SLIDE - DRAWER - 12" - RIGHT CABINET
30	128810-06-01A	EA	SLIDE - DRAWER - 14" - RIGHT CABINET
30	128810-10-01A	EA	SLIDE - DRAWER - 16" - RIGHT CABINET
30	128810-14-01A	EA	SLIDE - DRAWER - 18" - RIGHT CABINET
30	128810-18-01A	EA	SLIDE - DRAWER - 20" - RIGHT CABINET
30	128810-22-01A	EA	SLIDE - DRAWER - 22" - RIGHT CABINET
30	128810-26-01A	EA	SLIDE - DRAWER - 24" - RIGHT CABINET
31	084412-01-000	EA	SUPPORT/HINGE KIT (LEFT & RIGHT HINGES)
32	130787-01-000	EA	TRACK - TAMBOUR DOOR/SPRING - 15.9"
32	130787-02-000	EA	TRACK - TAMBOUR DOOR/SPRING - 24"
32	130787-03-000	EA	TRACK - TAMBOUR DOOR/SPRING - 30"
33	133426-01-02B	EA	BRACKET - MIRROR - MOUNTING - E-COATED

LABELS GROUP

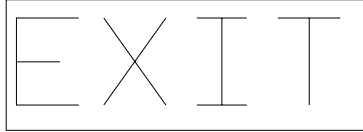

KEY PART NUMBER 039290-01-000
U/M DESCRIPTION EA LABEL - WARNING - EXIT

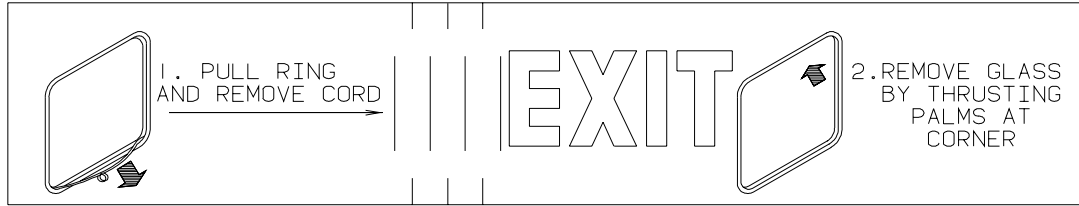

KEY PART NUMBER 107571-01-000
U/M DESCRIPTION EA LABEL - EXIT/ESCAPE WINDOW

FOR AWNING INSTALLATION
CONTACT YOUR MOTORHOME
DEALERSHIP

KEY PART NUMBER 099509-01-000
U/M DESCRIPTION EA LABEL - AWNING INSTALLATION



KEY PART NUMBER 040944-01-000
U/M DESCRIPTION EA LABEL - ENTRANCE DOOR - "OPEN"

WARNING
MUST BE STOWED
IN LATCHED POSITION
WHILE VEHICLE IS IN MOTION

KEY PART NUMBER 079966-01-000
U/M DESCRIPTION EA LABEL - WARNING - STOWED - MOTION

WARNING DISCONNECT BATTERIES BEFORE
CONNECTING EXTERNAL CHARGING EQUIPMENT.

KEY PART NUMBER 065748-01-000
U/M DESCRIPTION EA LABEL - CAUTION - BATTERY CHARGING

AVERTISSEMENT : DEBRANCHER LES BATTERIES AVANT
DE BRANCHER TOUT EQUIPEMENT DE CHARGE EXTERIEUR.

KEY PART NUMBER 065748-02-000
U/M DESCRIPTION EA LABEL - WARNING - BATTERY/FRENCH - CANADIAN

LABELS GROUP (CONTINUED)

WASTE WATER

KEY PART NUMBER U/M DESCRIPTION
006188-01-000 EA LABEL - WASTE WATER

SEWAGE

KEY PART NUMBER U/M DESCRIPTION
006187-01-000 EA LABEL - SEWAGE

IF YOU SMELL GAS

1. EXTINGUISH ANY OPEN FLAME, PILOT LIGHTS AND ALL SMOKING MATERIALS.
2. DO NOT TOUCH ELECTRICAL SWITCHES.
3. SHUT OFF THE GAS SUPPLY AT THE TANK VALVE(S) OR GAS SUPPLY CONNECTION.
4. OPEN DOORS AND OTHER VENTILATING OPENINGS.
5. LEAVE THE AREA UNTIL ODOR CLEARS.
6. HAVE THE GAS SYSTEM CHECKED AND LEAKAGE SOURCE CORRECTED BEFORE USING AGAIN.

KEY PART NUMBER U/M DESCRIPTION
073998-01-000 EA LABEL - LPG ODOR WARNING

WARNING: TEST SMOKE DETECTOR OPERATION AFTER VEHICLE HAS BEEN IN STORAGE, BEFORE EACH TRIP AND AT LEAST ONCE PER WEEK DURING USE.

KEY PART NUMBER U/M DESCRIPTION
077956-01-000 EA LABEL - WARNING - SMOKE DETECTOR

CAUTION	TO HELP AVOID PERSONAL INJURY DURING REMOVAL OF FUEL FILLER CAP, SLOWLY LOOSEN CAP 1/2 TURN TO ALLOW ANY FUEL PRESSURE TO BE RELIEVED BEFORE TURNING CAP FURTHER.
FUEL SPRAY MAY CAUSE PERSONAL INJURY	STOP ADDING FUEL AFTER FIRST SHUTOFF BY AUTOMATIC NOZZLE WHEN TANK IS NEARLY FULL. DO NOT OVERFILL FUEL TANK. SEE OWNERS MANUAL FOR ADDITIONAL INFORMATION. PRINTED IN U.S.A. WLC PT NO 15611763

KEY PART NUMBER U/M DESCRIPTION
087207-05-000 EA LABEL - FUEL CAP REMOVAL

UNLEADED FUEL ONLY

KEY PART NUMBER U/M DESCRIPTION
062043-01-000 EA LABEL - FUEL - UNLEADED

UNLEADED
FUEL ONLY

KEY PART NUMBER U/M DESCRIPTION
098641-01-000 EA LABEL - FUEL - UNLEADED - DASH

LABELS GROUP (CONTINUED)

LP-GAS SYSTEM
THIS GAS PIPING SYSTEM IS
DESIGNED FOR USE OF
LIQUIFIED PETROLEUM GAS
ONLY. DO NOT CONNECT
NATURAL GAS TO THIS
SYSTEM.
SECURE CAP INLET(S) WHEN NOT
CONNECTED FOR USE. AFTER TURNING
ON GAS, EXCEPT AFTER NORMAL
CONTAINER REPLACEMENT, TEST GAS
PIPING AND CONNECTIONS TO
APPLIANCES FOR LEAKAGE WITH SOAPY
WATER OR BUBBLE SOLUTION. DO NOT
USE PRODUCTS THAT CONTAIN AMMONIA
OR CLORINE.

124520

KEY	PART NUMBER	U/M	DESCRIPTION
	124520-01-01A	EA	LABEL - LP GAS ONLY - BLACK ON CLEAR
	124520-01-02A	EA	LABEL - LP GAS ONLY - WHITE ON CLEAR

WARNING

THIS SYSTEM IS DESIGNED FOR USE WITH PROPANE ONLY
DO NOT CONNECT NATURAL GAS TO THIS SYSTEM

BEFORE TURNING ON PROPANE:

- (A) BE CERTAIN APPLIANCES ARE CERTIFIED FOR PROPANE AND ARE EQUIPPED WITH CORRECT BURNING DRIFICES.
- (B) MAKE CERTAIN ALL PROPANE CONNECTIONS ARE TIGHT BY TESTING WITH SOAPY WATER. ALL APPLIANCE VALVES ARE TURNED OFF. AND ANY UNCONNECTED OUTLETS ARE CAPPED.

AFTER TURNING ON PROPANE:

- (A) LIGHT ALL PILOT LIGHTS
- (B) (B) ALL CONNECTIONS, INCLUDING THOSE AT THE APPLIANCES, REGULATORS AND CYLINDERS SHOULD BE LEAK-TESTED PERIODICALLY WITH SOAPY WATER BY THE OCCUPANT. NEVER USE A LIGHTED MATCH OR OTHER FLAME WHEN CHECKING FOR LEAKS.
- (C) DO NOT LEAVE SYSTEM TURNED ON OF CONTAINERS CONNECTED UNTIL THE SYSTEM HAS BEEN PROVEN TO BE FREE OF LEAKS.
- (D) COOKING APPLIANCES SHOULD NOT BE USED FOR SPACE HEATING.
- (E) WHEN THE CONTAINERS ARE DISCONNECTED THE PROPANE SUPPLY LINE SHOULD BE CAPPED OR PLUGGED.

AVERTISSEMENT

CETTE INSTALLATION EST CONCUE POUR LE PROPANE SEULEMENT
NE PAS L'ALIMENTER EN GAZ NATUREL

AVANT LA MISE EN SERVICE:

- (A) S'ASSURER QUE LES APPAREILS SONT CERTIFIES POUR LE PROPANE ET MUNIS D'ORIFICES DE BRULEUR APPROPRIES.
- (B) VERIFIER L'ETANCHEITE DE TOUS LES RACCORDEMENTS AU PROPANE. LA PERMETURE DE TOUS LES ROBINETS D'APPAREILS ET L'OBTUTATION DE TOUTES LES SORTIES NON RACCORDEES.

APHES LA MISE EN SERVICE:

- (A) ALLUMER TOUTES LES VEILLEUSES.
- (B) L'OCCUPANT DOIT EPROUVER PERIODIQUEMENT L'ETANCHEITE DE TOUS LES RACCORDEMENTS Y COMPRIS CEUX AUX APPAREILS, AUX DETENDEURS ET AUX BOUTEEILLES. EN Y APPLIQUANT DE L'EAU SAVONNEUSE NE JAMA'S SE SERVIR D'UNE ALLUMETTE OU AUTRE POUR LA DETECTION DES FUITES.
- (C) NE PAS LAISSER L'ALIMENTATION OUVERTE NI LES RECIPIENTS RACCORDES AVANT D'AVOIR COMPLETE L'EPREUVE D'ETANCHEITE AU PROPANE DE L'INSTALLATION.
- (D) LES APPAREILS DE CUISSON NE DOIVENT PAS ETRE UTILISES POUR LE CHAUFFAGE DES LOCAUX.
- (E) LORSQUE LES RECIPIENTS SONT DECONNECTES, L'ALIMENTATION DE PROPANE DOIT ETRE OBTUREE OU SCHELLEE.

KEY	PART NUMBER	U/M	DESCRIPTION
	023769-01-000	EA	LABEL - WARNING - LPG - CANADIAN

THIS CONNECTION IS FOR
(B) VOLT AC, 60 HZ (CYCLES)
(A) AMPERE SUPPLY

DO NOT CONNECT TO
HIGHER VOLTAGE

KEY	PART NUMBER	U/M	DESCRIPTION
	125306-01-01A	EA	LABEL - ELECTRICAL ENTRANCE - 110VOLT 30AMP
	125306-03-01A	EA	LABEL - ELECTRICAL ENTRANCE - 100 VOLT 30 AMP

LABELS GROUP (CONTINUED)

THIS CONNECTION IS FOR
(B) VOLT AC,3-POLE,4 WIRE
60 HZ(CYCLES),(A) AMPERE SUPPLY

DO NOT CONNECT TO
HIGHER VOLTAGE

KEY PART NUMBER U/M DESCRIPTION
125306-04-01A EA LABEL - ELECTRICAL ENTRANCE - 120 VOLT - 240 AMP

THIS CONNECTION IS FOR
(B) VOLT AC,50 HZ(CYCLES)
(A) AMPERE SUPPLY

DO NOT CONNECT TO
HIGHER VOLTAGE

KEY PART NUMBER U/M DESCRIPTION
125306-05-01A EA LABEL - ELECTRICAL ENTRANCE - 220 VOLT 25 AMP

"TO ENSURE A SUPPLY OF FRESH AIR TO
OCCUPANTS, OPEN VENTILATORS WHEN
FUEL BURNING RANGE, FUEL BURNING
CARRY-ON APPLIANCES AND/OR FUEL -
BURNING LIGHTS ARE IN OPERATION."

DE MANIERE A ASSURE UNE ALIMENTATION
EN AIR FRAIS AUX OCCUPANTS,OUVRIR
LES VENTILATEURS LORSQUE LA CUISINIERE,
LES APPAREILS DE CHAUFFAGE PORTABLES
ET/OU LES LAMPES DE COMBUSTION
D'HUILE SONT EN FONCTIONNEMENT.

"COOKING APPLIANCES SHOULD NOT BE
USED FOR SPACE HEATING PURPOSES"

LES APPAREILS DE CUSSON NE DOIVENT
PAS SERVIR AU CHAUFFAGES DES LOCAUX.

KEY PART NUMBER U/M DESCRIPTION
050222-01-000 EA LABEL - STOVE VENT - CANADIAN

WARNING

THIS VEHICLE, LIKE OTHER
VEHICLES, MAY CONTAIN SMALL
AMOUNTS OF ONE OR MORE
SUBSTANCES WHICH ARE LISTED
BY THE STATE OF CALIFORNIA
FOR CAUSING CANCER OR
REPRODUCTIVE TOXICITY.

KEY PART NUMBER U/M DESCRIPTION
099689-01-000 EA LABEL - WARNING - CANCER/TOXICITY

WATER HEATER NORMAL
BY-PASS OPERATION

KEY PART NUMBER U/M DESCRIPTION
133424-01-01A EA LABEL - BYPASS - WATER HEATER

REMOVE PRIMARY TIRE HANGER BEFORE USING
SPARE TIRE HOIST-SEE OWNERS MANUAL- PERSONAL
INJURY MAY RESULT IF NOT FOLLOWED

KEY PART NUMBER U/M DESCRIPTION
126024-01-01A EA LABEL - TIRE HANGER REMOVAL

DO NOT USE HITCH BEFORE
READING OWNERS MANUAL REGARDING
VEHICLE LOADING AND TOWING

KEY PART NUMBER U/M DESCRIPTION
111104-01-000 EA LABEL - HITCH - READ MANUAL - WHITE
111104-02-000 EA LABEL - HITCH - READ MANUAL - BLACK

LABELS GROUP (CONTINUED)

CAUTION

THIS MOTOR HOME HAS BEEN DESIGNED, MANUFACTURED AND TESTED WITH CONCERN FOR THE PROTECTION OF IT'S OCCUPANTS. WE RECOMMEND YOU PERFORM THE FOLLOWING INSPECTIONS FOR YOUR SAFETY AND THE SAFETY OF YOUR PASSENGERS BEFORE STARTING YOUR VEHICLE.

1. LP GAS SYSTEM- TURN OFF AT TANK FOR TRAVELING. TEST FOR LEAKS UPON ARRIVAL AT DESTINATION. BEFORE LIGHTING PILOTS.
2. WHEELS- INSPECT FOR DAMAGE AND CHECK LUG NUTS FOR TIGHTNESS.
3. TIRES- INSPECT FOR WEAR AND DAMAGE AND CHECK FOR RECOMMENDED AIR PRESSURE.
4. LIGHTING- TEST FOR PROPER OPERATION OF ALL INTERIOR AND EXTERIOR LIGHTS INCLUDING DASH LIGHTS, HEADLIGHTS, TAIL LIGHTS, BRAKE LIGHTS, CLEARANCE LIGHTS AND TURN SIGNALS.
5. EXITS- INSPECT RELEASE MECHANISM ON EMERGENCY EXIT WINDOW. TEST BOTH LOCKS ON MAIN ENTRANCE DOOR FOR EASE OF OPERATION AND INSTRUCT PASSENGERS HOW TO USE BOTH MEANS OF EXIT.
6. SEAT BELTS- DIRECT PASSENGERS TO DESIGNATED SEATS AND REQUIRE USE OF SEAT BELTS.
7. APPLIANCES- TURN OFF AND LATCH OR LOCK DOORS WHERE PROVIDED.
8. LOOSE PARCELS- STORE SECURELY.
9. UTILITY SUPPLY LINES- DISCONNECT ALL ELECTRIC, SEWER AND WATER LINES AND SECURE PROPERLY.
10. ENTRANCE DOOR STEP- PLACE IN RETRACTED POSITION FOR TRAVELING.

READ YOUR MOTOR HOME AND CHASSIS OWNER'S MANUAL FOR FURTHER PRECAUTIONS

KEY PART NUMBER **U/M DESCRIPTION**
056259-01-000 EA LABEL - SAFETY CHECK LIST

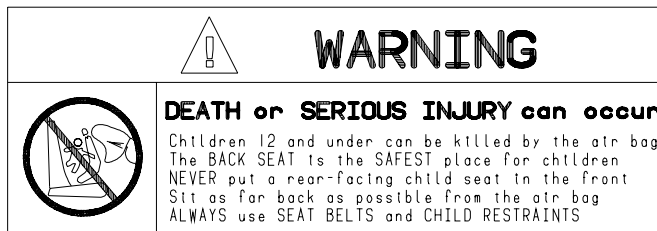

KEY PART NUMBER **U/M DESCRIPTION**
126611-01-000 EA LABEL - AIR BAG - VISOR

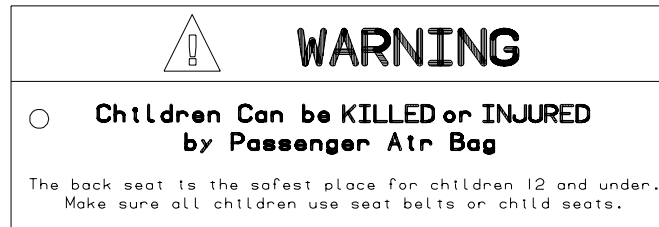

KEY PART NUMBER **U/M DESCRIPTION**
126612-01-000 EA LABEL - HANG TAG - AIR BAG - DASH

AIR CONDITIONING CIRCUIT.
THIS CONNECTION IS FOR
AIR CONDITIONERS RATED 110-
125 VOLT AC, 60 HZ, 16
AMPERES MAXIMUM. DO NOT
EXCEED CIRCUIT RATING.

KEY PART NUMBER **U/M DESCRIPTION**
091243-01-000 EA LABEL - A/C COVER "AIR CONDITIONING CIRCUIT ETC."

WARNING: CONTAINS "CFC" A SUBSTANCE WHICH HARMS PUBLIC HEALTH AND ENVIRONMENT BY DESTROYING OZONE IN THE UPPER ATMOSPHERE.

KEY PART NUMBER **U/M DESCRIPTION**
111802-01-000 EA LABEL - CFC WARNING

LABELS GROUP (CONTINUED)

WARNING

WHEN ADDING A GENERATOR SET:

HIGH VOLTAGE-USE EXTREME CAUTION WHEN WORKING ON ELECTRICAL COMPONENTS.
HAVE ALL ELECTRICAL INSTALLATION PERFORMED BY A QUALIFIED LICENSED ELECTRICIAN-FOLLOW ALL STATE AND LOCAL CODES.
ONLY INSTALL GENERATOR SET APPROVED FOR R.V. APPLICATION. HAVE INSTALLED BY QUALIFIED TECHNICIAN.
TO AVOID HEAT BUILD-UP AND TO GUARANTEE AN ADEQUATE AIR SUPPLY TO THE GENERATOR CARBURETOR, FOLLOW INSTALLATION INSTRUCTIONS.
GENERATOR ENGINE EXHAUST GASES ARE TOXIC AND MUST NOT TERMINATE UNDER THE VEHICLE-DISCHARGE EXHAUST AWAY FROM VEHICLE.

KEY PART NUMBER U/M DESCRIPTION
077510-01-000 EA LABEL - GENERATOR PREP

CAUTION

DO NOT LATCH DOOR IN OPEN POSITION
IF WATER HEATER CONTROL IS IN THE ON
POSITION. WATER HEATER EXHAUST MAY
DAMAGE OUTER SURFACE OF DOOR.

KEY PART NUMBER U/M DESCRIPTION
113402-01-000 EA LABEL - CAUTION - WATER HEATER EXHAUST
113402-02-000 EA LABEL - CAUTION - FURNACE EXHAUST

WARNING!

UNDERSTAND OPERATOR'S MANUAL BEFORE USING.
KEEP PEOPLE AND OBSTRUCTIONS CLEAR OF
SLIDEOUT ROOM WHEN OPERATING TO AVOID
INJURY AND/OR PROPERTY DAMAGE.

KEY PART NUMBER U/M DESCRIPTION
116549-01-000 EA LABEL - WARNING - SLIDEOUT

MISE EN GARDE

POUR VOTRE SECURITE PERSONNELLE RANGEZ,
TOUT OBJECT DE FAÇON SECURITAIRE LORSQUE
LE VEHICULE EST EN MOUVEMENT.

CAUTION

FOR YOUR PERSONAL SAFETY, SECURELY STOW
OBJECTS AWAY WHILE VEHICLE IS IN MOTION

KEY PART NUMBER U/M DESCRIPTION
131341-01-000 EA LABEL - STOW OBJECTS - US

DIESEL FUEL ONLY

KEY PART NUMBER U/M DESCRIPTION
068383-01-000 EA LABEL - DIESEL FUEL

OPEN ○
DRAIN
CLOSED ○

KEY PART NUMBER U/M DESCRIPTION
133423-01-01A EA LABEL - DRAIN

WARNING

IT IS NOT SAFE TO USE COOKING
APPLIANCES FOR COMFORT HEATING
COOKING APPLIANCES NEED FRESH AIR FOR SAFE OPERATION
BEFORE OPERATION:

1. OPEN OVERHEAD VENT OR TURN ON EXHAUST FAN AND;
2. OPEN WINDOW.

KEY PART NUMBER U/M DESCRIPTION

LABELS GROUP (CONTINUED)

WARNING

ALL PILOT LIGHTS, APPLIANCES AND THIER
IGNITORS (SEE OPERATING INSTRUCTIONS) SHALL
BE TURNED OFF DURING REFUELING OF MOTOR
FUEL TANKS AND/OR LP GAS CONTAINERS

KEY	PART NUMBER	U/M DESCRIPTION
	124519-01-01A	EA LABEL - WARNING/REFUELING - BLACK ON CLEAR
	124519-01-02A	EA LABEL - WARNING/REFUELING - WHITE ON CLEAR

WARNING :

ALL PILOT LIGHTS AND APPLIANCES SHALL BE TURNED
OFF DURING REFUELING OF MOTOR FUEL TANKS AND/
OR PROPANE CONTAINERS.

AVERTISSEMENT :

FERMER TOUTES LES VEILLEUSES AINSI QUE TOUTS LES
APPAREILS LORSQU'ON FAIT LE PLEIN DES RESERVOIRS
À CARBURANT OU À PROPANE.

124519-02

KEY	PART NUMBER	U/M DESCRIPTION
	124519-02-01A	EA LABEL - WARNING/REFUELING - BLACK ON CLEAR - CSA
	124519-02-02A	EA LABEL - WARNING/REFUELING - WHITE ON CLEAR - CSA

ENTRANCE DOOR PROP ROD

THIS ROD IS DESIGNED TO PROP THE
ENTRANCE DOOR OPEN WHEN THE PATIO
AWNING ARM IS ATTACHED TO THE
SIDEWALL AND THE AWNING IS EX-
TENDED.
HOOK ONE END OF ROD INTO LOOP ON
DOOR AND OTHER END INTO LOOP ON THE
SIDEWALL AS SHOWN.

(THIS LABEL TO BE REMOVED BY RETAIL OWNER ONLY)

KEY	PART NUMBER	U/M DESCRIPTION
	128658-01-000	EA LABEL - PROP ROD - ENTRY DOOR

INPUT

KEY	PART NUMBER	U/M DESCRIPTION
	087236-01-000	EA LABEL - CABLE - INPUT

OUTLET

KEY	PART NUMBER	U/M DESCRIPTION
	087236-02-000	EA LABEL - TV OUTLET

DTS' ISI CE SIEGE N'EST PAS
DESTINE A ETRE OCCUPE LORSQUE
LE VEHICULE EST EN MOUVEMENT

THIS SEAT IS NOT INTENDED
FOR OCCUPANCY WHILE
VEHICLE IS IN MOTION

KEY	PART NUMBER	U/M DESCRIPTION
	006064-01-000	EA LABEL - SEAT W/O SEATBELT
	006064-02-000	EA LABEL - SEAT W/O SEATBELT - CANADIAN

LABELS GROUP (CONTINUED)

CAUTION:
OPEN A WINDOW OR VENT WHILE
OPERATING DRYER. IT IS DANGEROUS
TO CREATE A NEGATIVE AIR PRESSURE
INSIDE A VEHICLE CONTAINING
FUEL-BURNING APPLIANCES

KEY PART NUMBER U/M DESCRIPTION
130670-01-01A EA LABEL - CAUTION DRYER VENTING - BLACK ON CLEAR

FUEL

KEY PART NUMBER U/M DESCRIPTION
061417-01-000 EA LABEL - FUEL - ON FUEL FILL DOOR

INSERT RETAINER PINS IN
SLIDE MECHANISM AFTER
RETURNING GENERATOR TO
STORED POSITION.
IF RETAINER PINS ARE NOT
INSERTED, THE GENERATOR
WILL EXTEND WHICH MAY
CAUSE PERSONAL INJURY.

KEY PART NUMBER U/M DESCRIPTION
116273-01-000 EA LABEL - WARNING - GENERATOR

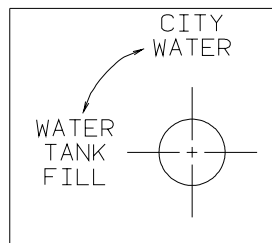

KEY PART NUMBER U/M DESCRIPTION
117629-02-000 EA LABEL - WATER PUMP/FILL-WHITE LETTER/CLEAR BACKGROUND-.24"
117629-03-000 EA LABEL - WATER PUMP/FILL-BLK LETTERS/CLEAR BACKGROUND-.31"

KEEP THE SERVICE INLET ACCESS
IN THE CLOSED POSITION WHEN
UTILITY CONNECTIONS ARE NOT IN USE

KEY PART NUMBER U/M DESCRIPTION
123562-01-000 EA LABEL - SERVICE/UTILITY ACCESS

CITY WATER FILL

KEY PART NUMBER U/M DESCRIPTION
126249-01-000 EA LABEL - CITY WATER FILL - WHITE LETTERS/CLEAR BACKGROUND
126249-02-000 EA LABEL - CITY WATER FILL-BLK LETTER/CLEAR BACKGROUND-.24"H
126249-03-000 EA LABEL - CITY WATER FILL-BLK LETTER/CLEAR BACKGROUND-.31"H

LABELS GROUP (CONTINUED)

WARNING

ROOF SURFACE MAY BE SLIPPERY
ESPECIALLY WHERE MOISTURE IS PRESENT
SLIPPING MAY RESULT IN PERSONAL INJURY.

128218-01

KEY	PART NUMBER	U/M DESCRIPTION
	128218-01-01A	EA LABEL - WARNING - SLIPPERY ROOF

WASTE TANK FLUSH

KEY	PART NUMBER	U/M DESCRIPTION
	130168-01-000	EA LABEL - WASTE TANK FLUSH

LIGHTS WATER
PUMP

KEY	PART NUMBER	U/M DESCRIPTION
	130170-02-000	EA LABEL - SWITCH PANEL - BLK/CLEAR BACKGROUND-1.4H X 3.9"L
	117628-02-000	EA LABEL - SWITCH - WATER PUMP/LIGHTS-WHITE/CLEAR BACKGROUND

MONITOR WATER
PANEL PUMP
LIGHT

KEY	PART NUMBER	U/M DESCRIPTION
	130170-01-000	EA LABEL - SWITCH PANEL - BLK/CLEAR BACKGROUND-1.8"H X 5.9"L

PUSH TO
RELEASE
GENERATOR
SLIDE ASM

KEY	PART NUMBER	U/M DESCRIPTION
	131779-01-01A	EA LABEL - GENERATOR

WARNING

ALL LP GAS IS CONTAINED UNDER PRES-
SURE. DUE TO THE DANGEROUS POTENTIAL
OF ANY COMPRESSED GAS, IT IS MANDA-
TORY THAT THE FOLLOWING REQUIREMENTS
FOR THE USE OF THIS TANK BE FOLLOWED:
TANKS ARE TO BE INSTALLED, FUELED AND
MAINTAINED IN ACCORDANCE WITH STATE
AND LOCAL CODE, RULES, REGULATIONS OR
LAWS AND IN ACCORDANCE WITH NFPA
PAMPHLET 58, DIVISION IV.

KEY	PART NUMBER	U/M DESCRIPTION
	116112-01-000	EA LABEL - SWITCH PANEL - BLK/CLEAR BACKGROUND-1.8"H X 5.9"L

LABELS GROUP (CONTINUED)

TOW VEHICLE RATING MAY BE LESS THAN HITCH RATING.
 MAXIMUM VERTICAL HITCH LOAD: 350 LBS
 DO NOT EXCEED REAR AXLE RATING.
 SEE OWNER'S MANUAL FOR ADDITIONAL INFORMATION.

KEY	PART NUMBER	U/M DESCRIPTION
	129669-01-01A	EA LABEL - HITCH/VEHICLE RATE - 350 - WHITE ON CLEAR
	129669-01-02A	EA LABEL - HITCH/VEHICLE RATE - 350 - BLACK ON CLEAR
	129669-02-01A	EA LABEL - HITCH/VEHICLE RATE - 500 - WHITE ON CLEAR
	129669-02-02A	EA LABEL - HITCH/VEHICLE RATE - 500 - BLACK ON CLEAR

THIS CHAIR IS NOT INTENDED FOR OCCUPANCY WHEN VEHICLE IS IN MOTION AND MUST BE RETURNED TO STOWED POSITION

KEY	PART NUMBER	U/M DESCRIPTION
	102267-01-000	EA LABEL - NO OCCUPANCY - US

DTS ISICE SIEGE N'EST PAS DESTINE A ETRE OCCUPE LORSQUE LE VEHICULE EST EN MOUVEMENT ET IL FAUT QUE LE RANGER

THIS CHAIR IS NOT INTENDED FOR OCCUPANCY WHEN VEHICLE IS IN MOTION AND MUST BE RETURNED TO STOWED POSITION

KEY	PART NUMBER	U/M DESCRIPTION
	102267-02-000	EA LABEL - NO OCCUPANCY - CSA

EXTERIOR SHOWER

KEY	PART NUMBER	U/M DESCRIPTION
	126248-03-000	EA LABEL - EXTERIOR SHOWER

W
A
T
E
R

ON

|

H
E
A
T
E
R

OFF

KEY	PART NUMBER	U/M DESCRIPTION
	083588-01-000	EA LABEL - ON/OFF - WATER HEATER

E
N
G
I
N
E

ON

|

H
E
A
T
E
R

OFF

KEY	PART NUMBER	U/M DESCRIPTION
	083588-02-000	EA LABEL - ON/OFF - ENGINE HEATER

LABELS GROUP (CONTINUED)

NOTE: TUNE ANTENNA
PER MANUFACTURER'S
DIRECTIONS. FAILURE TO
COMPLY COULD RESULT IN
DAMAGE TO CB.

CB POWER PROVISION

RED +12 V
BLACK GROUND
COAX ANTENNA
(SEE REVERSE ALSO)

KEY PART NUMBER U/M DESCRIPTION
104678-01-000 EA LABEL - CB PREP

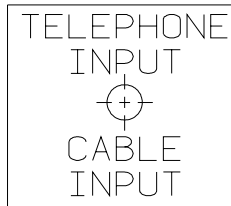

KEY PART NUMBER U/M DESCRIPTION
114886-02-000 EA LABEL - PHONE & CABLE INPUT - WHITE/CLEAR BACKGROUND
114866-03-000 EA LABEL - PHONE & CABLE INPUT - BLACK/CLEAR BACKGROUND

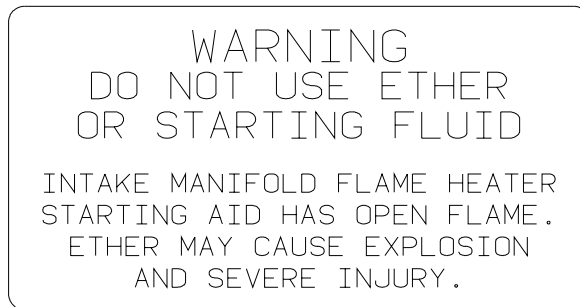

KEY PART NUMBER U/M DESCRIPTION
116756-01-000 EA LABEL - WARNING ER/STARTING



KEY PART NUMBER U/M DESCRIPTION
126247-01-000 EA LABEL - GRAY HOLDING TANK-WHITE LETTERS/CLEAR BACKGROUND
126247-05-000 EA LABEL - GRAY HOLDING TANK-BLACK LETTERS/CLEAR BACKGROUND



KEY PART NUMBER U/M DESCRIPTION
126247-02-000 EA LABEL - BLACK HOLDING TANK-WHITE LETTERS/BLACK BACKGROUND
126247-06-000 EA LABEL - BLACK HOLDING TANK-BLACK LETTERS/CLEAR BACKGROUND

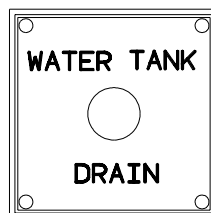

KEY PART NUMBER U/M DESCRIPTION
127170-01-000 EA LABEL - WATER TANK DRAIN

LABELS GROUP (CONTINUED)

WARNING

POTABLE WATER ONLY
SANITIZE, FLUSH, AND
DRAIN BEFORE USING.
SEE INSTRUCTION MANUAL

KEY	PART NUMBER	U/M DESCRIPTION
	128725-01-01A	EA LABEL - POTABLE WATER ONLY - BLACK ON CLEAR
	128725-01-02A	EA LABEL - POTABLE WATER ONLY - WHITE ON CLEAR

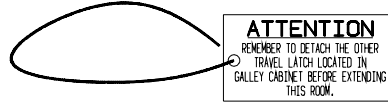

KEY	PART NUMBER	U/M DESCRIPTION
	129033-01-000	EA LABEL - HANG TAG - TRAVEL LATCH - 1.5" X3"

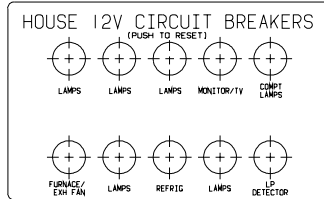

KEY	PART NUMBER	U/M DESCRIPTION
	092547-06-000	EA LABEL - CIRCUIT BREAKER

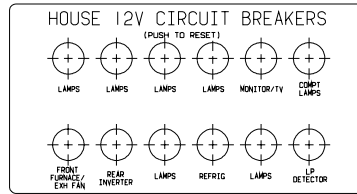

KEY	PART NUMBER	U/M DESCRIPTION
	092547-09-000	EA LABEL - CIRCUIT BREAKER

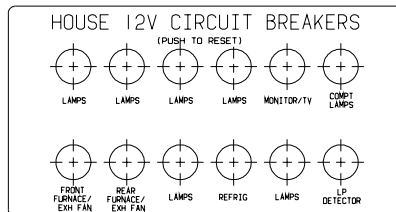

KEY	PART NUMBER	U/M DESCRIPTION
	092547-07-000	EA LABEL - CIRCUIT BREAKER

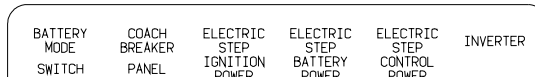

KEY	PART NUMBER	U/M DESCRIPTION
	093236-08-000	EA LABEL - CIRCUIT BREAKER

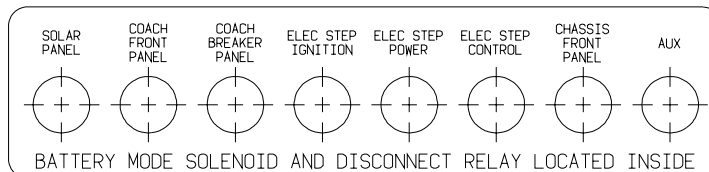

KEY	PART NUMBER	U/M DESCRIPTION
	093236-13-000	EA LABEL - CIRCUIT BREAKER

LABELS GROUP (CONTINUED)

SLIDEOUT DRIVE	INVERTER	ELECTRIC STEP CONTROL POWER	ELECTRIC STEP BATTERY POWER	ELECTRIC STEP IGNITION POWER	COACH BREAKER PANEL	BATTERY MODE SWITCH
-------------------	----------	--------------------------------------	--------------------------------------	---------------------------------------	---------------------------	---------------------------

KEY PART NUMBER U/M DESCRIPTION
 093236-15-000 EA LABEL - CIRCUIT BREAKER

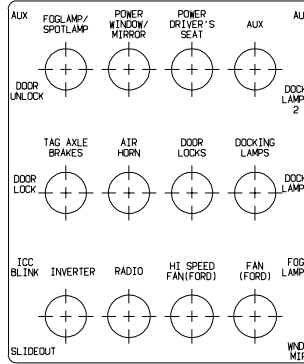

KEY PART NUMBER U/M DESCRIPTION
 093236-16-000 EA LABEL - CIRCUIT BREAKER

BATTERY MODE SWITCH	COACH BREAKER PANEL	ELECTRIC STEP IGNITION POWER	ELECTRIC STEP BATTERY POWER	ELECTRIC STEP CONTROL POWER	INVERTER	SLIDEOUT POWER
---------------------------	---------------------------	---------------------------------------	--------------------------------------	--------------------------------------	----------	-------------------

KEY PART NUMBER U/M DESCRIPTION
 093236-18-000 EA LABEL - CIRCUIT BREAKER

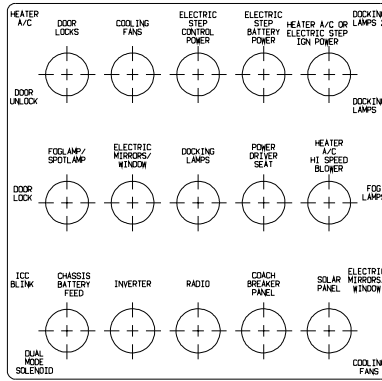

KEY PART NUMBER U/M DESCRIPTION
 093236-19-000 EA LABEL - CIRCUIT BREAKER



KEY PART NUMBER U/M DESCRIPTION
 093237-10-000 EA LABEL - CIRCUIT BREAKER - FRONT - COOLING FANS

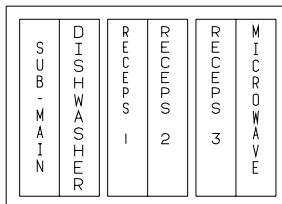

KEY PART NUMBER U/M DESCRIPTION
 095721-20-000 EA LABEL - CONTROL CENTER W/INVERTER

LABELS GROUP (CONTINUED)

SUB - MAIN	APPLIANCE 1	APPLIANCE 2	RECEPS 1	RECEPS 2	MICROWAVE
------------	-------------	-------------	----------	----------	-----------

KEY PART NUMBER 095721-21-000 **U/M DESCRIPTION**
EA LABEL - CONTROL CENTER W/INVERTER

A/C CIRCUIT 1	MAIN	MAIN	A/C CIRCUIT 2	INVERTER / CHARGER	REFRIG / VACUUM	WASHER / DRYER	WATER HEATER	
---------------	------	------	---------------	--------------------	-----------------	----------------	--------------	--

KEY PART NUMBER 095721-22-000 **U/M DESCRIPTION**
EA LABEL - CONTROL CENTER - 50AMP

A/C CIRCUIT 1	MAIN		REFRIG / COND V	MICROWAVE		STOVE 1	STOVE 2	
---------------	------	--	-----------------	-----------	--	---------	---------	--

KEY PART NUMBER 095721-25-000 **U/M DESCRIPTION**
EA LABEL - CONTROL CENTER - 30 AMP

A/C CIRCUIT 1	MAIN	REFRIG / COND V	MICROWAVE	STOVE 1	STOVE 2	APPLIANCE		
---------------	------	-----------------	-----------	---------	---------	-----------	--	--

KEY PART NUMBER 095721-26-000 **U/M DESCRIPTION**
EA LABEL - CONTROL CENTER - 30 AMP - CANADIAN

A/C CIRCUIT 1	MAIN	A/C CIRCUIT 2	REFRIG / COND V	MICROWAVE	STOVE 1	STOVE 2	STOVE 3		
---------------	------	---------------	-----------------	-----------	---------	---------	---------	--	--

KEY PART NUMBER 095721-27-000 **U/M DESCRIPTION**
EA LABEL - CONTROL CENTER - 30 AM

A/C CIRCUIT 1	MAIN	A/C CIRCUIT 2	REFRIG / COND V	MICROWAVE	STOVE 1	STOVE 2	APPLIANCE		
---------------	------	---------------	-----------------	-----------	---------	---------	-----------	--	--

KEY PART NUMBER 095721-28-000 **U/M DESCRIPTION**
EA LABEL - CONTROL CENTER - 30 AMP - CANADIAN

LABELS GROUP (CONTINUED)

A/C CIRCUIT 1	MAIN	MAIN	A/C CIRCUIT 2	REFRIG/CONV	MICROWAVE	RECP 1	RECP 2	RECP 3	WASHER/DRYER	
------------------	------	------	------------------	-------------	-----------	-----------	-----------	-----------	--------------	--

KEY PART NUMBER **U/M DESCRIPTION**
 095721-29-000 EA LABEL - CONTROL CENTER - 50 AMP

A/C CIRCUIT 1	MAIN	MAIN	A/C CIRCUIT 2	REFRIG/CONV	MICROWAVE	RECP 1	RECP 2	RECP 3	APPLIANCE 1	APPLIANCE 2	WASHER DRYER
------------------	------	------	------------------	-------------	-----------	-----------	-----------	-----------	----------------	----------------	-----------------

KEY PART NUMBER **U/M DESCRIPTION**
 095721-30-000 EA LABEL - CONTROL CENTER - 50 AMP - CANADIAN

A/C CIRCUIT 1	MAIN	A/C CIRCUIT 2	REFRIG/CONV	MICROWAVE	RECP 1	RECP 2	RECP 3	WASHER/DRYER	WATER HEATER	
------------------	------	------------------	-------------	-----------	-----------	-----------	-----------	--------------	-----------------	--

KEY PART NUMBER **U/M DESCRIPTION**
 095721-31-000 EA LABEL - CONTROL CENTER - 30 AMP - US

A/C CIRCUIT 1	MAIN	MAIN	A/C CIRCUIT 2	REFRIG/CONV	MICROWAVE	RECP 1	RECP 2	RECP 3	WASHER/DRYER	WATER HEATER
------------------	------	------	------------------	-------------	-----------	-----------	-----------	-----------	--------------	-----------------

KEY PART NUMBER **U/M DESCRIPTION**
 095721-33-000 EA LABEL - CONTROL CENTER - 50 AMP - US

A/C CIRCUIT 1	MAIN	MAIN	A/C CIRCUIT 2	INVERTER/ CHARGER	REFRIGERATOR	WASHER/DRYER	WATER HEATER	
------------------	------	------	------------------	----------------------	--------------	--------------	-----------------	--

KEY PART NUMBER **U/M DESCRIPTION**
 095721-34-000 EA LABEL - CONTROL CENTER - 50 AMP

AUTOMOTIVE AND COACH CIRCUIT BREAKERS
--

KEY PART NUMBER **U/M DESCRIPTION**
 098379-01-000 EA LABEL - FRONT BOX - CIRCUIT BREAKER

LABELS GROUP (CONTINUED)

A / C CIRCUIT 1	M A I N	A / C CIRCUIT 2	R E F R I G / C O N V	M I C R O W A V E	R E C P S 1	R E C P S 2	R E C P S 3	A P P L I A N C E	W A S H E R D R Y E R	W A T E R H E A T E R
-----------------------	------------------	-----------------------	---	---	--------------------------------	--------------------------------	--------------------------------	---	---	---

KEY PART NUMBER 095721-35-000 **U/M DESCRIPTION**
EA LABEL - CONTROL CENTER - 30 AMP - CSA

A / C CIRCUIT 1	M A I N	M A I N	A / C CIRCUIT 2	R E F R I G / C O N V	M I C R O W A V E	R E C P S 1	R E C P S 2	A P P L I A N C E 1	A P P L I A N C E 2	W A S H E R / D R Y E R	W A T E R H E A T E R
-----------------------	------------------	------------------	-----------------------	---	---	--------------------------------	--------------------------------	--	--	--	---

KEY PART NUMBER 095721-36-000 **U/M DESCRIPTION**
EA LABEL - CONTROL CENTER - 50 AMP - CSA

M A I N	M I C R O W A V E	G F I / R E C E P S	R E F E R / C O N V	W A T E R H T R	A / C
------------------	---	--	--	--	-------------

KEY PART NUMBER 095721-38-000 **U/M DESCRIPTION**
EA LABEL - CONTROL CENTER - 30 AMP - US

M A I N	A P P L I A N C E	G F I / R E C E P S	R E F E R / M I C R O	W A T E R H T R	A / C
------------------	---	--	---	--	-------------

KEY PART NUMBER 095721-39-000 **U/M DESCRIPTION**
EA LABEL - CONTROL CENTER - 30 AMP - CANADIAN

BATTERY MODE SOLENOID AND RELAYS
--

KEY PART NUMBER 098379-04-000 **U/M DESCRIPTION**
EA LABEL - ELECTRICAL BOX - SIDE

FRONT TIRE PRESSURE AT UNLOADED VEHICLE WEIGHT: 75 PSI							
REAR TIRE PRESSURE AT UNLOADED VEHICLE WEIGHT: 75 PSI							
FOR LOADED VEHICLE, WEIGH UNIT AND REFER TO TABLE:							
TIRE PRESSURE	75	80	85	90	95	100	
FRONT LOAD-LBS	7185	7630	8070	8555	9085	9350*	
REAR LOAD-LBS	13580	14375	15255	15500*			
TIRE: MICHELIN XRV 235/80R22.5, LOAD RANGE F							
*GAWR = 9350 **GAWR = 15500							
FOR BEST PERFORMANCE, MATCH TIRE PRESSURE TO YOUR AXLE LOAD							

KEY PART NUMBER 131775-03-01A **U/M DESCRIPTION**
EA LABEL - TIRE PRESSURE - BROWN/BLACK

LABELS GROUP (CONTINUED)

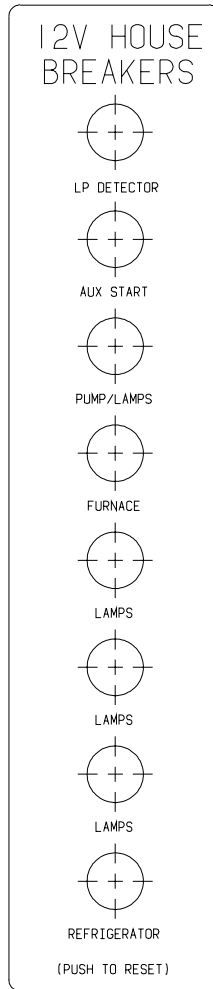

KEY PART NUMBER U/M DESCRIPTION
092547-08-000 EA LABEL - CIRCUIT BREAKER

DO NOT FILL
LP-GAS CONTAINER(S)
TO MORE THAN 80%
OF CAPACITY.

KEY PART NUMBER U/M DESCRIPTION
079965-01-000 EA LABEL - LPG - 80% CAPACITY

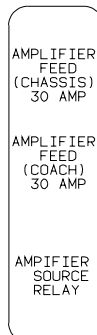

KEY PART NUMBER U/M DESCRIPTION
111537-06-000 EA LABEL - AMPLIFIER POWER

LABELS GROUP (CONTINUED)

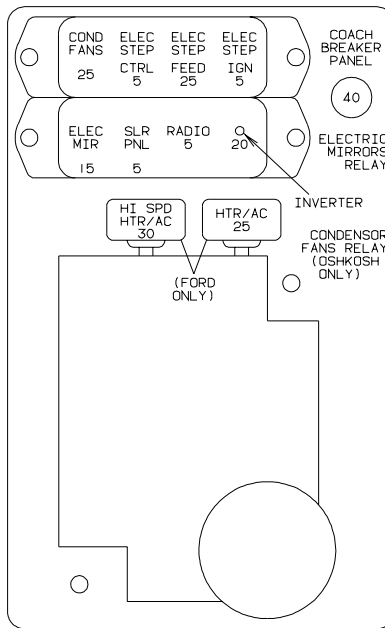

KEY	PART NUMBER	U/M DESCRIPTION
	111537-07-000	EA LABEL - FUSES

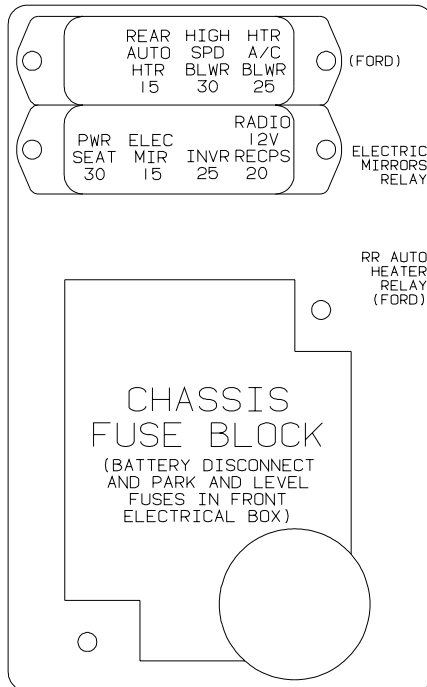

KEY	PART NUMBER	U/M DESCRIPTION
	111537-08-000	EA LABEL - FUSES

KEY	PART NUMBER	U/M DESCRIPTION
	133533-02-01A	EA LABEL - CHECK ANTENNA - CLEAR W/WHITE LETTERING
	133629-01-01A	EA LABEL - WATER CENTER
	134250-01-01A	EA LABEL - SATELLITE RECEIVER - BLACK/CLEAR
	134539-01-01A	EA LABEL - WARNING - STOVE/HEATING - BLACK ON CLEAR
		FROM: 01-01-00 THRU: 99-99-99
	134540-01-01A	EA LABEL - WARNING - STOVE/HEATING - BLACK ON CLEAR
		FROM: 01-01-00 THRU: 99-99-99

LP GROUP

LP SYSTEM

KEY	PART NUMBER	U/M	DESCRIPTION
*	088253-05-000	EA	TANK - LP - 130 LB - LIQUID DRAW
*	088253-06-000	EA	TANK - LP - 130 LB
	045703-03-000	EA	HOSE - LP - 3/8"ID X 18" - 3/8"MPT X 1/2"F SWIVEL - U.S.
	045703-11-000	EA	HOSE - LP - 3/8"ID X 36" - 3/8"MPT X 3/8"F SWIVEL - UL/CSA
	065318-02-000	EA	ELBOW - 90 DEGREE - 3/8" MPT TO 3/8" FPT
	105658-01-000	EA	COMPARTMENT - LP REGULATOR
	106150-01-000	EA	REGULATOR - TWO STAGE -W/90 DEGREE ELBOW & 3/8" FPT OUTLET
	010252-01-000	EA	ELBOW - BRASS - 90 DEGREE - 3/8"F X 1/2"MPT
	010265-01-000	EA	ELBOW - BRASS - 90 DEGREE - 3/8"F X 1/2"FPT
	010515-03-000	EA	ELBOW - BLACK - 1/2 X 90 DEGREE STEEL
	010536-02-000	EA	TEE - STEEL BLACK - 1/2"
	106846-01-000	EA	VALVE - RELIEF
	106871-01-000	EA	BUSHING - 1/2 X 1/4 - BLACK
	010329-01-000	EA	ADAPTER - BRASS - 1/2"F X 1/2"MPT
	040440-02-000	EA	TRANSMITTER - DIAL/BOLT-ON - 0-90 OHM 2 TERM(POWER/GROUND)
	040440-03-000	EA	TRANSMITTER - DIAL/SNAP-ON - 0-90 OHM 2 TERM(POWER/GROUND)
	103613-03-000	EA	DETECTOR - LP GAS - W/O SHUT-OFF VALVE
	010377-02-000	EA	NUT - BRASS - 3/8" FLARE - FORGED
	010380-02-000	EA	NUT - BRASS - 1/2" FLARE - FORGED
	045703-14-000	EA	HOSE - LP - 3/8"ID X 157.5" - 1/2"F SWIVEL X 1/2"F SWIVEL
	045703-09-000	EA	HOSE - LP - 3/8"ID X 24" - 3/8"ID F SWIVEL X 3/8"ID F SWIV

***COMPONENT PARTS FOUND IN SERVICE PARTS LIBRARY**

LOUNGE GROUP CABINETS

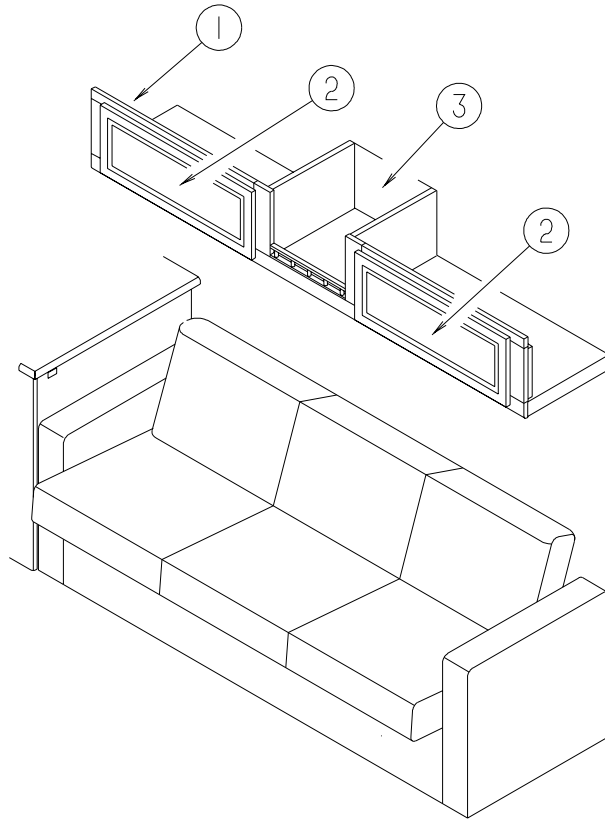

KEY	PART NUMBER	U/M	DESCRIPTION
1	133082-01-L76	EA	CABINET - OVERHEAD/FRONT/LEFT HAND - W/O DOORS/HARDWARE
2	132141-20-L07	EA	DOOR - RAIL/VENEER - 10.8" X 27.9" - W/O HARDWARE
3	058331-K0-000	EA	MIRROR - SAFETY GLASS - 10.3" X 14.1"
4	120992-18-L76	EA	PANEL - FRONT KICK - SOFA/BED - 70" - FABRIC COVERED
4	120992-18-L78	EA	PANEL - FRONT KICK - SOFA/BED - 70" - FABRIC COVERED
4	120992-18-L80	EA	PANEL - FRONT KICK - SOFA/BED - 70" - FABRIC COVERED
4	120992-19-L76	EA	PANEL - FRONT KICK - SOFA/BED - 70" - FABRIC COVERED - LEATHER
4	120992-19-L78	EA	PANEL - FRONT KICK - SOFA/BED - 70" - FABRIC COVERED - LEATHER
4	120992-19-L80	EA	PANEL - FRONT KICK - SOFA/BED - 70" - FABRIC COVERED - LEATHER
	121906-01-02B	EA	BRACKET - KICKBOARD - E-COATED
	134334-01-000	EA	BAG - COFFEE TABLE
	133604-01-L53	EA	TABLE/COFFEE - COMPLETE - WATERFORD OAK

LOUNGE GROUP (CONTINUED)

TABLES

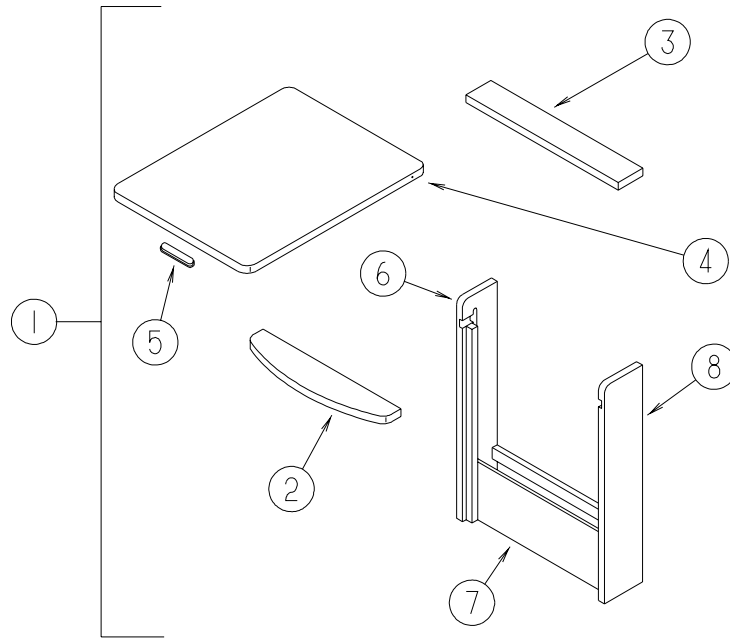

KEY	PART NUMBER	U/M	DESCRIPTION
1	119559-04-L32	EA	CABINET - W/PULLOUT TABLE
2	119559-27-L32	EA	SHELF - SUPPORT - F/PULLOUT TABLE
3	119559-26-L32	EA	WALL CABINET/TOP - F/PULLOUT TABLE
4	119559-29-L32	EA	TABLE TOP ONLY
5	080736-01-000	EA	PULL - RECESSED - 1.25" X 4" - OAK
6	119559-11-G35	EA	CABINET/RIGHT SIDE - F/PULLOUT TABLE - 5.7" X 28.7"
7	119559-28-L32	EA	PANEL - BOTTOM KICK - CABINET
8	119559-12-G35	EA	CABINET/LEFT SIDE - F/PULLOUT TABLE - 5.7" X 28.7"

SEALANTS & FASTENERS GROUP

SEALANTS & ADHESIVES

KEY	PART NUMBER	U/M	DESCRIPTION
	069640-01-000	FT	SEALER - RIBBON - 1/4" DIAMETER X 30' - BLACK
	069640-02-000	FT	SEALER - TAPE - .13"THICK X .5"WIDE X 60' - GRAY
	069640-03-000	FT	SEALER - TAPE - .13"THICK X .75"WIDE X 60' - BLACK
	069640-07-000	FT	SEALER - TAPE - .09"THICK X 2"WIDE X 45' - GRAY
	069640-09-000	FT	SEALER - TAPE - .032"THICK X 2.50"WIDE X 80' - GRAY
	069640-10-000	FT	SEALER - TAPE - .03"THICK X 1.50"WIDE X 90' - GRAY
	069640-11-000	FT	SEALER - TAPE - .19"THICK X .38"WIDE X 40' - BLACK
	069640-13-000	FT	SEALER - TAPE - .03"THICK X 2"WIDE X 45' - BLACK
	069640-14-000	FT	SEALER - TAPE - .06"THICK X 1"WIDE X 100' - GRAY
	069640-15-000	FT	SEALER - TAPE - .06"THICK X .38"WIDE X 100' - GRAY
	069640-17-000	FT	SEALER - TAPE - .03"THICK X 1"WIDE X 90' - GRAY
	069640-18-000	FT	SEALER - TAPE - .50"THICK X 1/8"WIDE X 60' - BRIGHT WHITE
	069640-19-000	FT	SEALER - TAPE - .75"THICK X 1/8" WIDE X 60'- BRIGHT WHITE
	069640-20-000	FT	SEALER - TAPE - .50" THICK X 1/8" WIDE X 60'-BRIGHT WHITE
	069640-21-000	FT	SEALER - TAPE - .50" THICK X 1/16" WIDE X 100'-BRIGHT WHT
	069640-22-000	FT	SEALER - TAPE - .25" THICK X 1/32" WIDE X 100'- BRIGHT WHT
	069640-23-000	FT	SEALER - TAPE - 1/16" THICK X .75" WIDE X 100'- BRIGHT WHT
	069640-25-000	FT	SEALER - TAPE - .06" THICK X 3.5" WIDE X 50' - GRAY
	072889-01-000	EA	SEALANT - URETHANE - BLACK - TUBE
	072889-10-000	EA	SEALANT - URETHANE - BRIGHT WHITE - TUBE
	072889-11-000	EA	SEALANT - URETHANE - GRAY - TUBE
	072889-13-000	EA	SEALANT - URETHANE - VW WHITE - TUBE
	072889-14-000	EA	SEALANT - URETHANE - SABLE - TUBE
	116767-01-01A	EA	SEALANT - WATERBASE - CLEAR
	053766-02-000	EA	BEDDING COMPOUND - TUBE - WHITE
	053766-06-000	EA	BEDDING COMPOUND - TUBE - CLEAR
	053766-08-000	EA	BEDDING COMPOUND - TUBE - GRAY
	131264-01-02A	EA	SILICONE - W/O NOZZLE - CLEAR
	131264-01-01A	EA	SILICONE - W/O NOZZLE - BLACK
	131264-01-08A	EA	SILICONE - W/O NOZZLE - BUFF
	131264-02-01A	EA	SILICONE - W/O NOZZLE - VW GRAY - BATH ONLY
	131264-03-01A	EA	SILICONE - SELF LEVELING - W/O NOZZLE - BRIGHT WHITE
	108716-01-000	EA	SILICONE - W/O NOZZLE - OFF WHITE - SELF LEVELING
	108716-02-000	EA	SILICONE - W/O NOZZLE - BUFF - SELF LEVELING
	102352-01-000	EA	SEALER - PUMPABLE - TUBE - BLACK
	102352-02-000	EA	SEALER - PUMPABLE - TUBE - CLEAR
	094401-01-000	EA	SEALER - BODY SEAM - FLEXICLEAR
	067788-01-000	EA	ADHESIVE - SPRAY - 3M - 19.5 AEROSOL CAN
	900390-01-000	EA	NOZZLE - SILICONE TUBE - 2.5" LONG
	900390-03-000	EA	NOZZLE - SILICONE TUBE - 4.3" LONG
	112902-01-000	EA	NOZZLE - ELEMENT - 3/8 X 24
	112902-02-000	EA	NOZZLE - BELL - 3/8 X 24
	112902-03-000	EA	MIXER NOZZLE - F/GUN #00400102000 - SCOTCH-WELD & PLEXUS
	076322-01-000	FT	TAPE-DOUBLE COATED/ADHESIVE BK-.03"THK X .8"W X 216'- WHT
	076322-02-000	FT	TAPE-DOUBLE COATED/ADHESIVE BK-.05"THK X 1"W X 108' - WHT
	076322-03-000	FT	TAPE-DOUBLE COATED/ADHESIVE BK-.05"THK X .5"W X 108' - WHT
	076322-05-000	FT	TAPE-DOUBLE COATED/ADHESIVE BK-.05"THK X .8"W X 108' - WHT
	076322-06-000	FT	TAPE-DOUBLE COATED/ADHESIVE BK-.05"THK X 1"W - BLK
	076322-07-000	FT	TAPE-DOUBLE COATED/ADHESIVE BK-.05"THK X .5"W X 200' - BLK
	076322-11-000	FT	TAPE-DOUBLE COATED/ADHESIVE BK-.02"THK X 1"W X 216' - CLR
	076322-12-000	FT	TAPE-DOUBLE COATED/ADHESIVE BK-.05"THK X .8"W X 108' - CLR
	123816-01-000	FT	TAPE - DOUBLE SIDED - 1" X 100'
	123816-02-000	FT	TAPE - DOUBLE SIDED - 1/2" X 1 1/3" X 100'
	123816-03-000	FT	TAPE - DOUBLE SIDED - 1/2" X 3/4" X 100'
	123816-04-000	FT	TAPE - DOUBLE SIDED - 6" X 750'

SEALANTS & FASTENERS GROUP (CONTINUED)

SEALANTS & ADHESIVES (CONTINUED)

KEY	PART NUMBER	U/M	DESCRIPTION
	120534-01-01A	EA	TAPE - SCOTCH - 3M - 1/2" FINE LINE
	063642-01-000	FT	TAPE - ADHESIVE - .4" X 1.5" X 180"
	123244-02-000	FT	TAPE - DOUBLE SIDED/FOAM - 5/64" THICK X 1/2" WIDE X 108'
	076314-02-000	FT	TAPE - CARPET SEAM - HEAT-BOND - 4" WIDE
	088479-01-000	EA	TAPE - ALUMINUM - 3"
	103202-02-000	FT	TAPE - FOAM/ADHESIVE ONE SIDE - 1/16" X 200'
	110274-01-000	FT	TAPE - DOUBLE SIDED/FOAM - .45" X 1" X 216' - BLACK
	004363-01-000	FT	TAPE - ADHESIVE FOAM/1 SIDE - 3/16" X 1/2" X 50' - GRAY
	115933-01-000	FT	TAPE - 1/64" X 3/8" X 100'
	123816-04-000	FT	TAPE - DOUBLE SIDED - 6" X 750'
	109215-01-000	FT	TAPE - SHIELD 1"
	002707-02-000	FT	TAPE - SEALER - 5/16" X 1/2" - INCREMENTS OF 50 FT
	091255-02-000	FT	SEAL - ADHESIVE BACKED/FOAM - 3/64" THICK X 3/16"W X 1000'
	091255-03-000	FT	SEAL - ADHESIVE BACKED/FOAM - 1/4" THICK X 1/4"W X 1000'
	104692-01-000	FT	SEAL - ADHESIVE BACKED FOAM - 3/4" THICK X 3/4" WIDE X 25'
	104692-03-000	FT	SEAL - ADHESIVE BACKED FOAM - 1" THICK X 1 3/4" WIDE X 15'
	108353-01-000	FT	SEAL - FOAM - 5/16" X 1/2" - ADHESIVE BACKED
	108353-03-000	FT	SEAL - FOAM - .19" X .25"
	112864-01-000	FT	SEAL - FOAM/BUTYL COVERED - 3/8" X 35'
	106206-01-000	EA	SEALER - PUMPABLE - TUBE - BLACK - MANUS
	120074-02-01A	EA	SILICONE - W/O NOZZLE - LOW ODOR - OFF WHITE
	120074-02-02A	EA	SEALANT - W/O NOZZLE - SOFT WHITE
	107828-01-000	EA	SEALANT - SB - 190 EVERSEAL
	112864-02-000	FT	FOAM - BUTYL COVERED 5/16" X 44'
	087211-01-000	GL	PROMOTER - ADHESIVE - GALLON
	004006-05-700	EA	ADHESIVE - 5 GALLON - NATIONAL STARCH
	004020-01-000	QT	ADHESIVE - ABS CEMENT - QUART
	112901-01-000	EA	ADHESIVE - PLEXUS - 400 ML CARTRIDGE
	112901-02-000	EA	ADHESIVE - PLEXUS - MA330 - 50ML - GRAY
	131384-01-000	EA	ADHESIVE - JETWELD
	113366-01-000	EA	ADHESIVE - INSTANT - 1 OZ
	062917-03-000	EA	ADHESIVE - LOCTITE 242
	004001-02-000	EA	GUN - PLEXUS ADHESIVE - W/O NOZZLE
	004001-03-000	EA	MIXER NOZZLE (EPX)
	004001-03-001	EA	EPOXY MIXER NOZZLE 12"
	004001-03-002	EA	TUBE/MIXER - GRACO EPOXY
	004001-04-000	EA	PLUNGER ACCESSORY (EPX)
	004001-05-000	EA	ADHESIVE - SCOTCH-WELD - 3M DP100 - CLEAR - 50ML

BOLTS, NUTS AND WASHERS

KEY	PART NUMBER	U/M	DESCRIPTION
	000C12-04-12A	EA	BOLT - HEX - 1/4-20 X .75 - PLAIN 5
	000C12-05-16B	EA	BOLT - HEX - 5/16-18 X 1 - GRADE #5 - ZINC
	000C12-05-12B	EA	BOLT - HEX - 5/16-18 X 3/4 - ZINC 5
	000C12-06-16B	EA	BOLT - HEX - 3/8-16 X 1 - GRADE #5 - ZINC
	000C12-06-20B	EA	BOLT - HEX - 3/8 - 16 X 1 1/4 - ZINC #5
	000C12-06-44B	EA	BOLT - HEX - 3/8-16 X 2 3/4 - ZINC 5
	000C12-07-20B	EA	BOLT - HEX - 7/16-14 X 1 1/4 - ZINC 5
	000C12-08-24B	EA	BOLT - HEX - 1/2-13 X 1.5 - GRADE #3 - ZINC
	000C12-08-28B	EA	BOLT - HEX - 1/2-13 X 1.8" - GRADE #5 - ZIN
	000C12-08-16B	EA	BOLT - HEX - 1/2-13 X 1" - GRADE #5 - ZINC
	OMC04K-06-016	EA	BOLT - HEX - M06 X 1 X 016
	OMC05K-08-055	EA	BOLT - HEX M.3 X 1.25 X 2.2
	OMC13K-14-070	EA	BOLT - HEX M14 X 2.00 X 2.75
	OMC31K-08-020	EA	BOLT - HEX - SERRATED FLANGE - M8 X 020
	OMC32K-10-030	EA	BOLT - HEX - SERRATED FLANGE - M10 X 1.50

SEALANTS & FASTENERS GROUP (CONTINUED)

BOLTS, NUTS AND WASHERS (CONTINUED)

KEY	PART NUMBER	U/M	DESCRIPTION
	0MC53K-12-050	EA	BOLT - HEX - M12 X 1.75 X 050
	000C12-04-40B	EA	BOLT - HEX - 1/4-20 X 2 1/2 - GRADE 5 ZINC
	000C12-05-64B	EA	BOLT - HEX - 5/16-18 X 4
	000C12-06-24B	EA	BOLT - HEX - 3/8-16 X 1 1/2 - ZINC #5
	000C12-10-24B	EA	BOLT - HEX - 5/8-11 X 1.5" - GRADE #5 - ZINC
	000C13-07-40B	EA	BOLT - HEX - 7/16-20 X 2.5" - GRADE #5 - ZINC
	000C13-07-48B	EA	BOLT - HEX - 7/16-20 X 3" - GRADE #5 - ZINC
	000C13-08-40B	EA	BOLT - HEX - 1/2-20 X 2 1/2 - GRADE #5 - ZINC
	000C13-08-28B	EA	BOLT - HEX - 1/2-20 X 1 3/4 - GRADE #5 - ZINC
	000C14-07-28B	EA	BOLT - HEX - 7/16-14 X 1.75 - GRADE 8 ZINC
	000C14-07-20B	EA	BOLT - HEX - 7/16-14 X 1.25 - GRADE 8 ZINC
	000C14-10-24K	EA	BOLT - HEX - 5/8-11 X 1.50 - GRADE #8 - ZINC
	000C14-10-32K	EA	BOLT - HEX - 5/8"-11 X 2 - GRADE #8 - ZINC
	000C18-05-40A	EA	BOLT - ELEVATOR - 5/16-18 X 2.50 - PL
	000C18-06-48B	EA	BOLT - ELEVATOR - 3/8-16 X 3 - GRADE 5 - ZINC
	000C18-06-56A	EA	BOLT - ELEVATOR - 3/8-16 X 3 1/2 - GRADE 5
	000C26-04-18B	EA	BOLT - HEX - SERRATED FLANGE - 1/4-20 X 1 1/8 - ZINC
	000C26-04-14B	EA	BOLT - HEX - SERRATED FLANGE - 1/4-20 X 7/8 - ZINC
	000C26-04-10B	EA	BOLT - HEX - SERRATED FLANGE - 1/4-20 X 5/8 - ZINC
	000C26-05-16B	EA	BOLT - HEX - SERRATED FLANGE - 5/16-18 X 1 - ZINC
	000C26-05-20B	EA	BOLT - HEX - SERRATED FLANGE - 5/16-18 X 1 1/4 - ZINC
	000C26-05-12B	EA	BOLT - HEX - SERRATED FLANGE - 5/16-18 X 3/4 - ZINC
	000C26-05-16B	EA	BOLT - HEX - SERRATED FLANGE - 5/16-18 X 1 - ZINC
	000C26-05-129	EA	BOLT - HEX - SERRATED FLANGE - 5/16-18 X 3/4
	000C26-05-249	EA	BOLT - HEX - SERRATED FLANGE 5/16-18 X 1.5"
	000C26-06-16B	EA	BOLT - HEX - SERRATED FLANGE - 3/8-16 X 1 - ZINC
	000C26-06-12B	EA	BOLT - HEX - SERRATED FLANGE - 3/8-16 X 3/4 - ZINC
	000C26-06-28B	EA	BOLT - HEX - SERRATED FLANGE - 3/8-16 X 1 3/4 - ZINC
	000C26-06-40B	EA	BOLT - HEX - SERRATED FLANGE - 3/8-16 X 1 3/4 - ZINC
	000C26-06-12B	EA	BOLT - HEX - SERRATED FLANGE - 3/8-16 X 3/4 - ZINC
	000C26-06-20B	EA	BOLT - HEX, SER FLG 3/8 - 16 X 1 1/4 - ZN
	000C26-08-24B	EA	BOLT - HEX - SERRATED FLANGE - 1/2-13 X 1 1/2 - ZINC
	000C27-04-40B	EA	BOLT - CARRIAGE 1/4-20 X 2.50 - ZINC
	000C27-08-64B	EA	BOLT - CARRIAGE - 1/2-13 X 4. - GRS
	106166-01-000	EA	BOLT/COLLARED HANGER - 8-32 X 1"
	000G45-04-24B	EA	BOLT - LAG - 1/4-9 X 1 1/2 - ZINC
	000G45-04-24F	EA	BOLT - LAG - 1/4" #9 X 1 1/2SS
	000G45-05-16B	EA	BOLT - LAG - 5/16-9 X 1 - ZINC
	106956-03-000	EA	BOLT - HEX TAP - 1/2-12NC X 3 - GRADE 5 - FULL THREAD/ZINC
	051387-06-000	EA	BOLT - CARRIAGE W/O HOLE - 5/16-18 X 9.5 - ZINC
	091274-03-000	EA	BOLT - J - 3/8-16 X 12.0
	106956-08-000	EA	BOLT - HEX TAP - 1/2-13NC X 4 - GRADE 5 - FULL THREAD/ZINC
	087718-01-000	EA	MONOBOLT - STEEL - 3/16 DIAMETER
	102333-02-01A	EA	BOLT - CARRIAGE - 1/4-20
	103020-02-000	EA	BOLT-U - #8-32 - GRADE 5 ZINC
	107393-02-000	EA	BOLT - SHOULDER - 3/8" SOCKETHEAD
	113985-02-000	EA	BOLT - FLANGE - M10-1.5 X 30CL10.9
	114259-05-000	EA	BOLT - 7/16-20X1.25 W/WASHER
	0MD16K-10-000	EA	NUT - HEX PREV TORQUE M10 X 1.50 CLASS 8
	0MD39K-12-000	EA	NUT - HEX W/NYLON LOCK - M12 X 1.75
	000D24-10-00B	EA	NUT - HEX - SELF LOCKING - 10-32 ZINC
	000D29-05-00B	EA	NUT - HEX - LOCKING W/SERRATED FLANGE-NYLON WASHER INSERT
	000D29-09-00B	EA	NUT - HEX - SELF LOCKING - 9/16-12 - ZINC
	000D29-06-00B	EA	NUT - HEX - W/NYLON LOCK - 3/8-16 - ZINC
	000D30-07-00B	EA	NUT - HEX LOCK,NYLON 7/16X20
	000D34-04-00B	EA	NUT - HEX - LOCKING - 1/4-20 ZINC
	000D34-06-00B	EA	NUT - HEX - LOCKING - 3/8-16 GRADE C - ZINC
	000D39-04-00B	EA	NUT - HEX - LOCKING W/SERRATED FLANGE - 1/4-20 - ZINC
	000D39-05-00B	EA	NUT - HEX - LOCKING W/SERRATED FLANGE - 5/16-18 - ZINC
	000D39-06-00B	EA	NUT - HEX - LOCKING W/SERRATED FLANGE - 3/8-18 - ZINC
	000D39-07-00B	EA	NUT - HEX - LOCKING W/SERRATED FLANGE - 7/16-14 - ZINC
	000D39-08-00B	EA	NUT - HEX - LOCKING W/SERRATED FLANGE - 1/2-13 - ZINC

SEALANTS & FASTENERS GROUP (CONTINUED)

BOLTS, NUTS AND WASHERS (CONTINUED)

KEY	PART NUMBER	U/M	DESCRIPTION
	000D44-04-00B	EA	NUT - HEX - LOCKING W/SERRATED FLANGE - 1/4-28 - ZINC
	000D44-07-00B	EA	NUT - HEX - LOCKING W/SERRATED FLANGE - 7/16-20 - ZINC
	000D44-08-00B	EA	NUT - HEX - SERRATED FLANGE - 1/2-20 - GRADE #5 - ZINC
	000D46-04-00A	EA	NUT - HEX - WELD - 1/4-20 - PLAIN
	000D58-06-00A	EA	NUT - HEX - WELD 3/8-16 - PLAIN
	000D65-08-00B	EA	NUT - HEX - LOCKING W/SERRATED FLANGE - 8-32 - ZINC
	000D67-10-00B	EA	NUT - HEX - LOCK - 5/8-11 - ZINC
	000D73-07-00C	EA	NUT - HEX FLANGE - 7/16-14 - GRADE 6
	000D73-08-00C	EA	NUT - HEX FLANGE - 1/2-13
	000D76-06-00B	EA	NUT - HEX FLANGE - 3/8-16
	044364-02-000	EA	NUT - SPEED - FLAT - ROUND
	063253-07-000	EA	NUT - J - #8A - .120 - .130 PNL THK
	087234-01-000	EA	NUT - JACK - 1/4 X 20 THD - MOLLY
	040921-01-000	EA	NUT - SPEED - U TYPE - #10-24 - BLACK
	104369-01-000	EA	NUT - HEX - HEAVY - 5/8-11 UNC
	000D29-04-00B	EA	NUT - HEX - SELF LOCKING - 1/4 X 20 - ZINC
	005081-01-000	EA	NUT - SPEED - C-TYPE - #8 SCREW
	040921-04-000	EA	NUT - SPEED - U TYPE - #8-.59" LENGTH X .44" WIDTH
	040921-09-000	EA	NUT - SPEED - U TYPE - #8
	044364-01-000	EA	NUT - SPEED - FLAT - RECTANGULAR - SELF LOCKING/ONE PIECE
	083163-06-000	EA	PUSHNUT - FLAT TYPE 3/8 STUD - FORD ONLY
	0ME06K-14-280	EA	WASHER - FLAT - 14 ID X 28.00 OD
	000E11-07-00B	EA	WASHER - LOCKING - 7/16 MED SPLIT - ZINC
	000E11-08-00B	EA	WASHER - LOCKING - 1/2 MED SPLIT - ZINC
	000E13-14-00B	EA	WASHER - FLAT - 1/4 WIDE - ZINC
	000E13-17-00B	EA	WASHER - FLAT - 3/8 AR - ZINC
	000E13-18-00B	EA	WASHER - FLAT - 3/8 WIDE - ZINC
	000E13-20-00B	EA	WASHER - FLAT - 7/16 WIDE - ZINC
	000E13-21-00B	EA	WASHER - FLAT - 1/2 NARROW - ZINC
	000E13-22-00B	EA	WASHER - FLAT - 1/2 WIDE - ZINC
	000E13-26-00B	EA	WASHER - FLAT - 5/8 WIDE - ZINC
	000E14-10-00B	EA	WASHER - LOCKING - #10 EXTERNAL TOOTH - ZINC
	000E16-10-00B	EA	WASHER - HARDENED - 5/8 - FLAT - ZINC
	058716-02-000	EA	WASHER - FLAT NYLON
	077071-01-000	EA	WASHER - FENDER - 3/16"ID X 1" OD
	107397-01-000	EA	WASHER - FENDER - .25" ID X 1" OD
	041322-01-000	EA	WASHER - FLANGE - 15/32 ID X 2 3/8 OD - F/SEAT BELT MTG
	044533-01-000	EA	WASHER - PLASTIC - 1 3/8" OD - FOR BUTTONS
	046867-05-000	EA	WASHER - #0
	058716-03-000	EA	WASHER - FLAT/NYLON - .500 X 1.25 X .060
	128444-01-000	EA	WASHER - SPRING - CONICAL
	088787-12-000	EA	STUD - WELD - 1/4 - 20 X 1.0 LG - MN
	108067-03-000	EA	STUD - WELD - 1/4 - 20 X 1/2 CD
	102540-02-000	EA	SEAL - SCREW
	106648-01-000	EA	CAP - STUD - .120 TO .130 DIAMETER

SCREWS

KEY	PART NUMBER	U/M	DESCRIPTION
	0G1108-12-170	EA	SCREW - 8-18 X .75 PPH - BRIGHT WHITE
	0G1106-08-240	EA	SCREW - 6-20 X 1/2 PPH - VW LIGHT GRAY
	0G1108-12-140	EA	SCREW - 8-18 X .75 PPH
	0G1108-12-240	EA	SCREW - 8-18 X .75 PPH - VW LIGHT GRAY
	0G1208-12-170	EA	SCREW - 8-18 X .75 POH - BRIGHT WHITE
	0G3908-08-160	EA	SCREW - SF/DR-8-18X1/2 PPH
	0G3908-08-170	EA	SCREW - SF/DR - 8-18 X .50 PPH - BRIGHT WHITE
	0G3908-08-240	EA	SCREW - SF/DR - 8-18 X 1/2 PPH - VW LIGHT GRAY
	0G3908-12-250	EA	SCREW - SF/DR - 8-18 X .75 PPH - DARK GRAY
	0G3908-16-170	EA	SCREW - SF/DR - 8-18 X 1.00 PPH - BRIGHT WHITE
	0G3908-20-170	EA	SCREW - SF/DR - 8-18 X 1.25 PPH - BRIGHT WHITE
	0G3908-24-170	EA	SCREW - SF/DR - 8-18 X 1.50 PPH - BRIGHT WHITE

SEALANTS & FASTENERS GROUP (CONTINUED)

SCREWS (CONTINUED)

KEY	PART NUMBER	U/M	DESCRIPTION
	0G3910-10-160	EA	SCREW - SF/DR - 10-16 X .62 PPH
	0G3910-10-240	EA	SCREW - SF/DR - 10-16 X .62 PPH - VW LIGHT GRAY
	0G5508-12-110	EA	SCREW - SF/DR-8-18 X .75 PWH
	0G3910-12-260	EA	SCREW - SF/DR - 10-16 X .75 PPH - ALLANTE ANTELOPE
	0G3910-12-170	EA	SCREW - SF/DR - 10-16 X .75 PPH - BRIGHT WHITE
	0G5508-12-170	EA	SCREW - SF/DR - 8-18 X .75 PWH - BRIGHT WHITE
	0G5508-12-270	EA	SCREW - SF/DR - 8-18 X .75 PWH - TITANIUM
	0G5508-12-260	EA	SCREW - SF/DR - 8-18 X .75 PWH - ALLANTE ANTELOPE
	0G5508-16-250	EA	SCREW - SF/DR - 8-18 X 1.00 PWH - VW DARK GRAY
	0G6008-16-170	EA	SCREW - SF/DR - 8-18 X 1.00 POH - BRIGHT WHITE
	0G5508-16-260	EA	SCREW - SF/DR - 8-18 X 1.00 PWH ZINC - INTERIOR ANTELOPE
	0G5508-16-270	EA	SCREW - SF/DR - 8-18 X 1.00 PWH ZINC - INTERIOR TITANIUM
	0G6710-08-130	EA	SCREW - 10-12 X .50 PPH TAUPE
	0G6710-08-170	EA	SCREW - 10-12 X 1/2 PPH - BRIGHT WHITE
	0G6710-08-240	EA	SCREW - 10-12 X .50 PPH TAUPE - VW LIGHT GRAY
	0G6710-12-170	EA	SCREW - 10-12 X .75 PPH - BRIGHT WHITE
	0G6710-16-230	EA	SCREW - 10-12 X 1 PPH - BEIGE
	000G11-05-08B	EA	SCREW - 5-20 X .50 PPH - ZINC
	000G11-06-06B	EA	SCREW - 6-20 X 3/8 PPH - ZINC
	000G11-06-10B	EA	SCREW - 6-20 X 5/8 PPH - ZINC
	000G11-06-12B	EA	SCREW - 6-20 X 3/4" PPH - ZINC
	000G11-06-10J	EA	SCREW - 6-20 X 5/8 PPH - BRASS
	000G11-06-A4B	EA	SCREW - 6-20 X 1.5 PPH ZINC
	000G11-06-08B	EA	SCREW - 6-20 X 1/2 PPH - ZINC
	000G11-07-08B	EA	SCREW - 7-19 X 1/2 PPH - ZINC
	000G11-07-08T	EA	SCREW - 7-19 X 1/2 PPH - BLACK
	000G11-08-06B	EA	SCREW - 8-18 X 3/8 PPH - ZINC
	000G11-08-06J	EA	SCREW - 8-18 X 3/8 PPH BRASS
	000G11-08-12B	EA	SCREW - 8-18 X 3/4 PPH - ZINC
	000G11-08-12S	EA	SCREW - 8-18 X 3/4 PPH - OFF WHITE
	000G11-08-08T	EA	SCREW - 8-18 X 1/2 PPH - FLUOROCARBON COATING
	000G11-08-08B	EA	SCREW - 8-18 X 1/2 PPH - ZINC
	000G11-08-20B	EA	SCREW - 8-18 X 1 1/4 PPH - ZINC
	000G11-08-16S	EA	SCREW - 8-18 X 1 PPH - OFF WHITE
	000G11-08-16B	EA	SCREW - 8-18 X 1 PPH - ZINC
	000G11-08-12P	EA	SCREW - 8-18 X 3/4 PPH - DARK BROWN
	000G11-08-12D	EA	SCREW - 8-18 X 3/4 PPH - BLACK
	000G11-08-12T	EA	SCREW - 8-18 X 3/4 PPH - BLACK
	000G11-10-12S	EA	SCREW - 10-16 X 3/4 PPH - OFF WHITE
	000G11-10-12D	EA	SCREW - 10-16 X 3/4 PPH - BLACK
	000G11-10-16B	EA	SCREW - 10-16 X 1 PPH - ZINC
	000G11-10-40B	EA	SCREW - 10-16 X 2 1/2 PPH CAD - 34927-01-000
	000G12-06-08T	EA	SCREW - 6-20 X 1/2 POH - BLACK
	000G12-08-12S	EA	SCREW - 8-18 X 3/4 POH - OFF WHITE
	000G13-05-10B	EA	SCREW - 5-12 X 5/8 PFH - ZINC
	000G13-06-16S	EA	SCREW - 6-20 X 1.00 PFH - OFF WHITE
	000G13-06-10G	EA	SCREW - 6-20 X 5/8 PFH - ANTIQUE BRASS
	000G13-06-08B	EA	SCREW - 6-20 X 1/2 PFH - ZINC
	000G13-06-08G	EA	SCREW - 6-20 X .50 PFH - ANTIQUE BRASS
	000G13-06-24J	EA	SCREW - 6-20 X 1 1/2 PFH - BRASS
	000G13-06-10J	EA	SCREW - 6-20 X .62 PFH - BRASS
	000G13-06-16E	EA	SCREW - 6-20 X 1.00 PFH - CHROME
	000G13-06-16J	EA	SCREW - 6-20 X 1 PFH - BRASS
	000G13-06-06I	EA	SCREW - 6-20 X 3/8 PFH BLACK ZINC
	000G13-06-06B	EA	SCREW - 6-20 X 3/8 PFH ZINC
	000G13-07-12B	EA	SCREW - 7-19 X 3/4 PFH - ZINC
	000G13-07-10H	EA	SCREW - 7-19 X 5/8 PFH - BLACK
	000G13-07-089	EA	SCREW - 7-19 X 1.2 PPH - SILVER
	000G13-08-10B	EA	SCREW - 8-18 X 5/8 PFH - ZINC
	000G13-08-16B	EA	SCREW - 8-18 X 1 PFH - ZINC
	000G13-08-109	EA	SCREW - 8-18 X 5/8 PFH
	000G16-04-24B	EA	SCREW - MACHINE - 1/4-20 X 1 1/2 PPH

SEALANTS & FASTENERS GROUP (CONTINUED)

SCREWS (CONTINUED)

KEY	PART NUMBER	U/M	DESCRIPTION
	000G18-08-22B	EA	SCREW - MACHINE - 8-32 X 1 3/8 PPH - ZINC
	000G18-08-20B	EA	SCREW - MACHINE - 8-32 X 1 1/4 PPH - ZINC
	000G18-08-24B	EA	SCREW - MACH-8-32X1 1/2PPH ZN
	000G13-08-24B	EA	SCREW - #8, 18X1 1/2 PFH ZN
	000G19-10-10B	EA	SCREW - MACHINE - 10-32 X 5/8 - PPH - ZINC
	000G19-10-20B	EA	SCREW - MACHINE - 10-32 X 1 1/2 PPH - ZINC
	000G19-10-12F	EA	SCREW - MACHINE - 10-32 X 3/4 PPH - STAINLESS STEEL
	000G19-10-08B	EA	SCREW - MACHINE - 10-32 X 1/2 PPH - ZINC
	000G32-10-06B	EA	SCREW - 10-32 X 3/8 PPH - ZINC
	000G13-10-16I	EA	SCREW - 10-16X1.00 PFH,BLK
	000G34-05-12B	EA	SCREW - HEX HEAD TAPPING - 5/16 X 3/4 LONG
	000G37-08-12B	EA	SCREW - 8-18 X 3/4 PPH
	000G37-08-089	EA	SCREW - 8 X 18 X 1/2 PPH - FLUOROCARBON SILVER
	000G36-10-12T	EA	SCREW - 10-24X 3/4 PFH TYPE 23 - BLACK
	000G38-04-16D	EA	SCREW - MACHINE - 1/4-20 X 1 PFN - BLACK
	000G39-06-10T	EA	SCREW - SF/DR - 6-20 X 5/8 PPH - BLACK
	000G39-06-16T	EA	SCREW - SF/DR - 6-20 X 1 PPH - BLACK
	000G39-06-08B	EA	SCREW - SF/DR - 6-18 X 1/2 - ZINC
	000G39-08-16S	EA	SCREW - SF/DR - 8-18 X 1 PPH - OFF WHITE
	000G39-08-32B	EA	SCREW - SF/DR - 8-18 X 2 PPH - ZINC
	000G39-08-24B	EA	SCREW - SF/DR - 8-18 X 1 1/2 PPH - ZINC
	000G39-08-24S	EA	SCREW - SF/DR - 8-18 X 1 1/2 - OFF WHITE
	000G39-08-24T	EA	SCREW - SF/DR - 8-18 X 1.50 PPH - BLACK
	000G39-08-16T	EA	SCREW - SF/DR - 6-20 X 1 PPH - BLACK
	000G39-08-16B	EA	SCREW - SF/DR - 8-18 X 1 PPH - ZINC
	000G39-08-12B	EA	SCREW - SF/DR - 8-18 X 3/4 PPH - ZINC
	000G39-08-12T	EA	SCREW - SF/DR - 8-18 X 3/4 PPH - BLACK
	000G39-08-08T	EA	SCREW - SF/DR - 8-18 X 1/2 PPH - BLACK
	000G39-08-08S	EA	SCREW - SF/DR - 8-18 X 1/2 PPH - OFF WHITE
	000G39-08-08B	EA	SCREW - SF/DR - 8-18 X 1/2 PPH - ZINC
	000G39-08-06B	EA	SCREW - SF/DR - 8-18 X 3/8 PPH - ZINC
	000G39-10-10B	EA	SCREW - SF/DR - 10-16 X 5/8 - ZINC
	000G39-10-12P	EA	SCREW - SF/DR, 10-16 X .75 PPH - DARK BROWN
	000G39-10-088	EA	SCREW - SF/DR - 10-16 X 1/2 PPH - FLEX FLUOROCARBON
	000G39-10-08B	EA	SCREW - SF/DR - 10-16 X 1/2 PPH - ZINC
	000G39-10-40D	EA	SCREW - SF/DR - 10-16 X 2 1/2 PPH - BLACK
	000G39-10-32B	EA	SCREW - SF/DR - 10-16 X 2 - PPH - ZINC
	000G39-10-209	EA	SCREW - SF/DR - 10-16 X 1 1/4 PPH - FLUOROCARBON SILVER
	000G39-10-20T	EA	SCREW - SF/DR - 10-16 X 1.25 PPH
	000G39-10-20B	EA	SCREW - SF/DR - 10-16 X 1 1/4 PPH - ZINC
	000G39-10-12T	EA	SCREW - SELF TAPPING 10-16 X 3/4"
	000G39-10-12D	EA	SCREW - SF/DR - 10-16 X 3/4 PPH - BLACK
	000G39-10-12B	EA	SCREW - SF/DR - 10-16 X 3/4 PPH - ZINC
	000G39-10-10T	EA	SCREW - SF/DR - 10-16 X .625 - BLACK
	000G39-10-129	EA	SCREW - SF/DR - 10-16 X 3/4 PPH - FLUOROCARBON SILVER
	000G39-10-48B	EA	SCREW - SF/DR - 10-16 X 3 - PPH - ZINC
	000G39-10-48T	EA	SCREW - SF/DR - 10-16 X 3.00 PPH - BLACK
	000G39-10-24B	EA	SCREW - SF/DR - 10-16 X 1.50 PPH - ZINC
	000G39-10-32I	EA	SCREW - SELF TAPPING - 10-16 X 2" PPH - BLACK
	000G39-12-12E	EA	SCREW - SF/DR - 12-14 X 3/4 PPH - CHROME
	000G42-04-16B	EA	SCREW - SF/DR - 1/4-14 X 1 HWH - ZINC
	000G42-04-12B	EA	SCREW - SF/DR - 1/4-14 X 3/4 HWH - ZINC
	000G42-04-24B	EA	SCREW - SF/DR 1/4-14X1 1/2 ZN
	000G46-08-24T	EA	SCREW - MACHINE - 8-32 X 1 1/2 PFH - BLACK
	000G46-08-28T	EA	SCREW - MACHINE - 8-32 X 1 3/4 PHILLIPS FLAT HEAD - BLACK
	000G50-04-12B	EA	SCREW - MACHINE - 1/4-20 X 3/4 PPH - ZINC
	000G50-04-06B	EA	SCREW - MACHINE - 1/4-20 X 38 PTH - ZINC
	000G50-04-08B	EA	SCREW - MACHINE - 1/4-20 X 1/2 PTH - ZIN
	000G51-08-08B	EA	SCREW - 8-18 X 1/2 PTH - ZINC
	000G51-06-12B	EA	SCREW - 6-20 X 3/4 PTH - ZINC
	000G52-08-18B	EA	SCREW - MACHINE - 8-32 X 1 1/8 PTH - ZINC
	000G54-04-20B	EA	SCREW - 1/4-20 X 1.25 PTH - TYPE 23 - ZINC PLATED

SEALANTS & FASTENERS GROUP (CONTINUED)

SCREWS (CONTINUED)

KEY	PART NUMBER	U/M	DESCRIPTION
	000G55-08-125	EA	SCREW - SF/DR - 8-18 X 3/4 PWH - WILLOW
	000G55-08-12S	EA	SCREW - SF/DR - 8-18 X 3/4 PWH - OFF WHITE
	000G55-08-124	EA	SCREW - SF/DR-8-18X.75 PWH - ASH GRAY
	000G55-08-165	EA	SCREW - SF/DR-8-18X1.00 PWH - WILLOW
	000G56-12-48B	EA	SCREW - WOOD - 12-11 X 3 POH - SPECIAL HARDENED
	000G57-05-16J	EA	SCREW - 5-20 X 1 PFH - BRASS
	000G57-14-64B	EA	SCREW - 14-10 X 4 PFH ZINC
	000G57-14-72B	EA	SCREW - 14-10-X4-1/2 PFH ZN
	000G60-08-22B	EA	SCREW - SF/DR, 8 - 18 X 1.38 POH - ZN
	000G60-10-28T	EA	SCREW - SF/DR - 10-16 X 1 3/4 - BLACK
	000G60-10-20I	EA	SCREW - SF/DR - 10-16 X 1.25 POH - BLACK
	000G60-10-20B	EA	SCREW - SF/DR - 10-16 X 1 1/4 POH - ZINC
	000G60-10-209	EA	SCREW - SF/DR - 10-16 X 1.25 POH - SILVER STALGAARD
	000G62-10-24I	EA	SCREW - SF/DR - 10-16 X 1/5 PFH - BLACK ZINC
	000G67-08-32B	EA	SCREW - 8-15 X 2 PPH - ZINC
	000G67-10-08S	EA	SCREW - 10-12 X 1/2 PPH - OFF WHITE
	000G67-10-08R	EA	SCREW - 10-12 X 1/2 PPH - BEIGE - TYPE A
	000G67-10-08B	EA	SCREW - 10-12 X 1/2 PPH - ZINC
	000G67-10-16B	EA	SCREW - 10-12 X 1 PPH - ZINC
	000G67-10-120	EA	SCREW - 10-12 X 3/4 PPH - TAN
	000G67-10-12B	EA	SCREW - 10-12 X 3/4 PPH - ZINC
	000G67-10-12R	EA	SCREW - 10-12 X .75 PPH - BEIGE
	000G67-10-12P	EA	SCREW - 10-12 X 3/4 PPH - DARK BROWN
	000G67-10-10S	EA	SCREW - 10-12 X 5/8 PPH - OFF WHITE
	000G67-10-10P	EA	SCREW - 10-12X.62 PPH - DARK BROWN
	000G67-10-10D	EA	SCREW - 10-12 X 5/8 PPH - BLACK - TYPE A
	000G67-10-10T	EA	SCREW - 10-12 X 5/8 PPH BLACK
	000G67-10-10B	EA	SCREW - 10-12 X 5/8 PPH - ZINC - TYPE A
	000G67-10-20D	EA	SCREW - 10-12 X 1.25 PPH - BLACK
	000G67-10-36T	EA	SCREW - 10-12 X 2 1/4 - PPH - BLACK
	000G67-10-32B	EA	SCREW - 10-12 X 2 1/4 - PPH - BLACK
	000G67-10-24B	EA	SCREW - 10-12 X 1.50 PPH - ZINC
	000G67-10-24S	EA	SCREW - 10-12X1.5PPH OFF WHITE
	000G67-10-125	EA	SCREW - 10-12 X .75 PPH WILLOW
	000G67-10-28B	EA	SCREW - 10-12 X 1.75 PPH - ZINC
	000G67-10-48B	EA	SCREW - 10-12 X 3 PPH - ZINC
	000G68-06-12B	EA	SCREW - 6-18 X .75 POH - ZINC & CLEAR
	000G68-06-12J	EA	SCREW - 6-18X.75 POH BRASS
	000G68-06-10G	EA	SCREW - 6-18 X 5/8 POH - ANTIQUE BRASS
	000G68-10-20I	EA	SCREW - 10-12 X 1 1/4 POH - BLACK
	000G68-10-36T	EA	SCREW - 10-12 X 2.25 POH BLACK
	049465-01-000	EA	SCREW - 10-16 PTH W/WASHER - DARK BROWN
	049465-13-000	EA	SCREW - 10-16X1 PTH W/WASHER - ASH GRAY
	049465-17-000	EA	SCREW - 10-16 X 1 POH W/WASHER - BRIGHT WHITE
	049465-22-000	EA	SCREW - 10-16 X 1 1/2 POH W/WASHER - SABLE
	054434-02-000	EA	SCREW - SF/DR - 10-16 X 2 - ZINC
	054434-03-000	EA	SCREW - SF/DR - 10-16 X 2 - PWH - ZINC - W/O WINGS
	057671-01-000	EA	COVER - SCREW - OFF WHITE - #8
	057671-11-000	EA	COVER - SCREW - HAMPTON TAN - #8
	057671-15-000	EA	COVER - SCREW - BRIGHT WHITE
	057671-16-000	EA	COVER - SCREW - SOFT WHITE
	057671-17-000	EA	COVER - SCREW - VW LT GRAY #8
	075908-01-000	EA	SCREW - MACHINE - 10-32 X .56 PTH - EXTERNAL TOOTH - ZINC
	076790-01-000	EA	SCREW - 6-20 X 1 1/4 PPH - BLACK
	076790-03-000	EA	SCREW - 6-20 X 1 PPH - BLACK
	076790-05-000	EA	SCREW - 6-20 X 1/2 PPH BLACK - THREADCUTTING - WOOD
	083554-01-000	EA	SCREW - DRYWALL - 8 X 1.25
	083554-04-000	EA	SCREW - DRYWALL - 8 X 2.50
	086256-01-000	EA	SCREW - SF/DR - 8 X 3/4 HWH
	087721-01-000	EA	SCREW - FLAT HEAD - TAPPING - 1/4" X 1 1/4" LONG - ZINC
	097974-01-000	EA	SCREW - PARTICLE BOARD - 7-9 X 3/4 PPH
	090033-02-000	EA	SCREW - 1/4-20 X 5/8 - ROUND WASHER HEAD - OFF/WHITE

SEALANTS & FASTENERS GROUP (CONTINUED)

SCREWS (CONTINUED)

KEY	PART NUMBER	U/M	DESCRIPTION
	101618-01-000	EA	SCREW - 1/4-20 X 3/4 HEX - TAPPING - STALGARD TYPE F
	101289-01-01A	EA	SCREW - MACHINE - 8-32 X 3.75 POH - BRASS -F/EXTENDED KNOB
	105126-01-000	EA	SCREW - MACHINE - 8-32 X 1 PPH TAPTIT
	110460-05-02A	EA	SCREW - MACHINE - 10-24 X 2.5 PFH - WHITE
	112782-08-01A	EA	SCREW - MOUNTING/PLATE - ZINC
	113563-01-01A	EA	SCREW - 8 X .62 LONG SHOULDER/WASHER HEAD
	117478-01-04A	EA	SCREW - 8-18 X .75 PPH W/WASHER - VW LIGHT GRAY
	126458-01-01A	EA	SCREW - 8-18 X .50 PRWH BLACK
	134126-01-01A	EA	SCREW/NAIL - HEX HEAD - 3/4"

CLAMPS, CLIPS, GROMMETS, RIVETS & PLUGS

KEY	PART NUMBER	U/M	DESCRIPTION
	010495-01-000	EA	CLAMP - CABLE - 9/16"
	010495-02-000	EA	CLAMP - CABLE - 3/8
	010495-04-000	EA	CLAMP - CABLE - 11/16" - WHITE
	010495-05-000	EA	CLAMP - CABLE - 1/2
	010497-01-000	EA	CLAMP - CLOSED - 5/8" ID
	010497-03-000	EA	CLAMP - CLOSED - 1" ID - CUSHIONED
	010497-04-000	EA	CLAMP - CLOSED - 1.62" ID
	010497-05-000	EA	CLAMP - CLOSED - 1/2 ID
	010497-06-000	EA	CLAMP - CLOSED - 11/16" ID
	010497-07-000	EA	CLAMP - CLOSED - 3/8" ID
	010497-08-000	EA	CLAMP - CLOSED - .125" ID
	062401-01-000	EA	CLAMP - HOSE - WORMGEAR - .25" - 1"
	062401-02-000	EA	CLAMP - HOSE - WORMGEAR - 1.56" - 2.5"
	062401-03-000	EA	CLAMP - HOSE - WORMGEAR - .22" - 1"
	062401-04-000	EA	CLAMP - HOSE - WORMGEAR - .69" - 1.25"
	062401-05-000	EA	CLAMP - HOSE - WORMGEAR - 2" TO 3" ID
	062401-06-000	EA	CLAMP - HOSE - WORMGEAR - .22" - .62" ID
	062401-07-000	EA	CLAMP - HOSE - WORMGEAR - 5"-7"
	062401-08-000	EA	CLAMP - HOSE - WORMGEAR 4.06" - 5.0"
	062401-09-000	EA	CLAMP - HOSE - WORMGEAR - 2.8" - 3.75"
	062401-11-000	EA	CLAMP - HOSE - WORMGEAR - 3.50" - 4.50"
	062401-12-000	EA	CLAMP - HOSE - WORMGEAR - .79" X 1.26"
	083610-01-000	EA	CLAMP - WIRE - DUAL - UNEQUAL DIAMETERS - 3/4" & 1 1/4"
	083610-02-000	EA	CLAMP - WIRE - DUAL - UNEQUAL DIAMETERS - 3/4" & 2"
	083610-03-000	EA	CLAMP - DUAL WIRE
	083609-01-000	EA	CLAMP - WIRE - DUAL - EQUAL DIAMETERS - 5/8"
	007161-01-000	EA	CLAMP - HOSE - SPRING TYPE - 1/2"
	10499-01-000	EA	CLAMP - CLOSED - 3/8" ID
	075148-02-000	EA	CLAMP - GROUNDING - BRONZE SCREWS
	008386-01-000	EA	GROMMET - SNAP - 3/8"
	023942-01-000	EA	GROMMET - RUBBER - 2" OD
	071015-07-000	EA	GROMMET - RUBBER - 1"ID X 2.25" OD W/.06" GROOVE - BLACK
	071015-11-000	EA	GROMMET - 1.00 ID - FITS .12 MATERIAL
	071015-13-000	EA	GROMMET - RUBBER - .62" ID X 1" OD W/.09" GROOVE - BLACK
	071015-19-000	EA	GROMMET - .38 ID - FITS .06 MATERIAL
	071015-21-000	EA	GROMMET - RUBBER - 1/2 ID X 1.06 OD - W/.19 GROOVE - BLACK
	071015-22-000	EA	GROMMET - RUBBER - .62"ID X 1.12"OD W/.19" GROOVE - BLACK
	071015-26-000	EA	GROMMET - RUBBER - 1.5" ID X 2.1" OD W/.06" GROOVE-BLACK
	071015-29-000	EA	GROMMET - RUBBER - .3" ID X 1.3"OD W/.12" GROOVE - BLACK
	071015-30-000	EA	GROMMET - RUBBER - .31" ID X .81" OD W/.12" GROOVE - BLK
	071015-32-000	EA	GROMMET - RUBBER - .75" ID X 1.375" OD W/.187" GROOVE-BLK
	071015-33-000	EA	GROMMET - RUBBER - .875" ID X 1.625" OD W/.187" GROOVE - BLK
	071015-35-000	EA	GROMMET - 1.25 ID,FITS .187MAT
	071015-37-000	EA	GROMMET - .81 ID FITS .56 MTL
	071015-39-000	EA	GROMMET - .75 ID FITS .06 MTL
	088756-01-000	EA	GROMMET - WEB - 1 1/8 " I.D.
	114208-01-000	EA	GROMMET - EDGE LINER - FITS 1 3/4"
	114208-02-000	EA	GROMMET - EDGE LINER - FITS .625
	114208-03-000	EA	GROMMET - EDGE LINER - FITS 2.50"

SEALANTS & FASTENERS GROUP (CONTINUED)

CLAMPS, CLIPS, GROMMETS, RIVETS & PLUGS (CONTINUED)

KEY	PART NUMBER	U/M	DESCRIPTION
	114208-04-000	EA	GROMMET - EDGE LINER - FITS 1.00"
	114208-05-000	EA	GROMMET - EDGE LINER - FITS 2"
	016188-03-000	EA	GROMMET - L/P LINE - 3/8" HOLE X 2 1/2" LONG - RUBBER
	016188-04-000	EA	GROMMET - GAS LINE - 1/2" HOLE X 2 1/2" LONG - RUBBER
	016188-05-000	EA	GROMMET - L/P LINE - 3/8" HOLE X 1 1/4" LONG - RUBBER
	008380-01-000	EA	GROMMET - RUBBER - 5/8" HOLE X 1 1/2" DIAMETER - BLACK
	008384-01-000	EA	GROMMET - SNAP - 3/4 DIAMETER - NYLON
	077953-01-000	EA	GROMMET - EDGE LINER - FITS 1"
	099637-01-000	EA	GROMMET - RUBBER - .37" X .94" DIAMETER - BLACK
	000F10-04-16B	EA	PIN - COTTER - 1/8" X 1" - ZINC
	000F10-06-32B	EA	PIN - COTTER - 3/16" X 2" - ZINC
	000H14-04-08R	EA	RIVET - MANDREL BLIND - 4/32 ALUMINUM
	000H14-06-03R	EA	RIVET - MANDREL BLIND - 3/16 - CHERRY
	000H15-06-02R	EA	RIVET - POP - STEEL - 3/16 X .063-.125
	000H16-06-10R	EA	RIVET - POP ALUMINUM - 3/16 X .501-.625
	000H14-04-04A	EA	RIVET - MANDREL BLIND - 1/8 X .400
	000H16-04-06R	EA	RIVET - POP ALUMINUM - 1/8 X .313 - .375
	000H14-06-14R	EA	RIVET - MANDREL BLIND - 3/16 - CHERRY
	118626-01-01A	EA	RIVET - POP - ALUMINUM 3/16 X .08-.375
	118626-02-01A	EA	RIVET - POP - ALUMINUM - 3/16 X .500-.750
	061420-01-000	EA	PLUG/PLASTIC - 1.75" DIAMETER - BROWN
	061420-03-000	EA	PLUG/PLASTIC - 3.00" DIAMETER
	061420-04-000	EA	PLUG/PLASTIC - 1.25" DIAMETER
	061420-05-000	EA	PLUG/PLASTIC - 1.8" DIAMETER
	061420-07-000	EA	PLUG/PLASTIC - 1.8" DIAMETER
	061420-08-000	EA	PLUG/PLASTIC - 2.5" DIAMETER
	061420-09-000	EA	PLUG/PLASTIC - 1.00" - DIAMETER
	061420-10-000	EA	PLUG/PLASTIC - 1.50" DIAMETER - BLACK
	061420-11-000	EA	PLUG/PLASTIC - .50" DIAMETER
	061420-12-000	EA	PLUG/PLASTIC - 1.50" DIAMETER - RED
	061420-14-000	EA	PLUG/PLASTIC - .034" DIAMETER
	061420-15-000	EA	PLUG/PLASTIC - 2" DIAMETER - BLACK
	061420-16-000	EA	PLUG/PLASTIC - 2 1/8" DIAMETER
	081211-03-000	EA	PLUG/PLASTIC - .50 DIAMETER - BLACK
	081211-04-000	EA	PLUG/PLASTIC - .46 DIAMETER - BLACK
	081211-05-000	EA	PLUG/PLASTIC - .188 DIAMETER - NATURAL
	034141-02-000	EA	PLUG - HOLE - 3/8" NYLON/BLACK
	115361-01-01A	EA	PLUG - PLASTIC - 1/2" DIAMETER
	077955-01-000	EA	J-CLIP - 3/8" - VINYL COATED
	080211-03-000	EA	CLIP - XMAS TREE W/PANEL RETAINING HEAD - 3/4" SHANK
	094362-02-000	EA	CLIP - XMAS TREE - BINDER HEAD - .9" LONG
	119392-01-000	EA	CLIP - U/TYPE - OFFSET LEG
	129962-01-01A	EA	CLIP - U/TYPE - BLACK
	091952-01-000	EA	CLIP - GRIPPER - 1"
	091952-02-000	EA	CLIP - GRIPPER - 3/4"
	080734-02-000	EA	CLIP - WIRE NYLON
	056134-01-000	EA	HOLDER - RING - 3.6" DIAMETER - METAL
	056134-02-000	EA	HOLDER - RING - 1.8" DIAMETER - METAL

SEALANTS & FASTENERS GROUP (CONTINUED)

MISCELLANEOUS FASTENERS

KEY	PART NUMBER	U/M	DESCRIPTION
	008343-01-000	EA	TIE - WIRE - 6"
	008343-02-000	EA	TIE - WIRE - 14"
	008343-03-000	EA	TIE - WIRE - 7 1/2" - BLACK
	029096-03-000	YD	VELCRO TAPE - HOOK - 1" WIDE - BLACK
	029096-04-000	YD	VELCRO TAPE - HOOK - 1" WIDE - BLACK
	029094-04-000	YD	VELCRO TAPE - LOOP - 1" WIDE - BLACK
	029094-06-000	YD	VELCRO TAPE - LOOP - 2" WIDE - BLACK
	048394-02-000	YD	VELCRO TAPE - HOOK - ADHESIVE BACK - .75" WIDE - BEIGE
	085774-01-000	FT	FASTENER - DUAL LOCK - 1" WIDE - ADHESIVE BACK - BLACK
	085774-02-000	FT	FASTENER - DUAL HOOK - 1" WIDE - ADHESIVE BACK - BLACK
	085774-03-000	FT	FASTENER - DUAL LOCK - 1/2" WIDE - ADHESIVE BACK - BLACK
	085774-04-000	FT	FASTENER - DUAL HOOK - 1/2" WIDE - ADHESIVE BACK - BLACK
	088792-02-000	YD	VELCRO TAPE - LOOP - 3/4" - ADHESIVE BACK - BEIGE
	088792-04-000	YD	VELCRO TAPE - LOOP - 5/8" - NON-ADHESIVE BACK - WHITE
	088792-05-000	YD	VELCRO TAPE - LOOP - 5/8" - NON-ADHESIVE BACK - WHITE
	108046-01-000	EA	CABLE TIE - SCREW MOUNT 8"
	108046-02-000	EA	CABLE TIE - SCREW MOUNT 15"
	110943-01-000	FT	FELTSTRIP - 3/8" - ADHESIVE BACK - BLACK
	110943-02-000	FT	FELTSTRIP - 3/8" - ADHESIVE BACK - WHITE
	099856-11-000	EA	STRAP - TIEDOWN - 78.6"
	086285-01-000	EA	SPACER - NYLON - .5" OD X .257" ID

WATER & SEWAGE GROUP

DRAINAGE SYSTEM

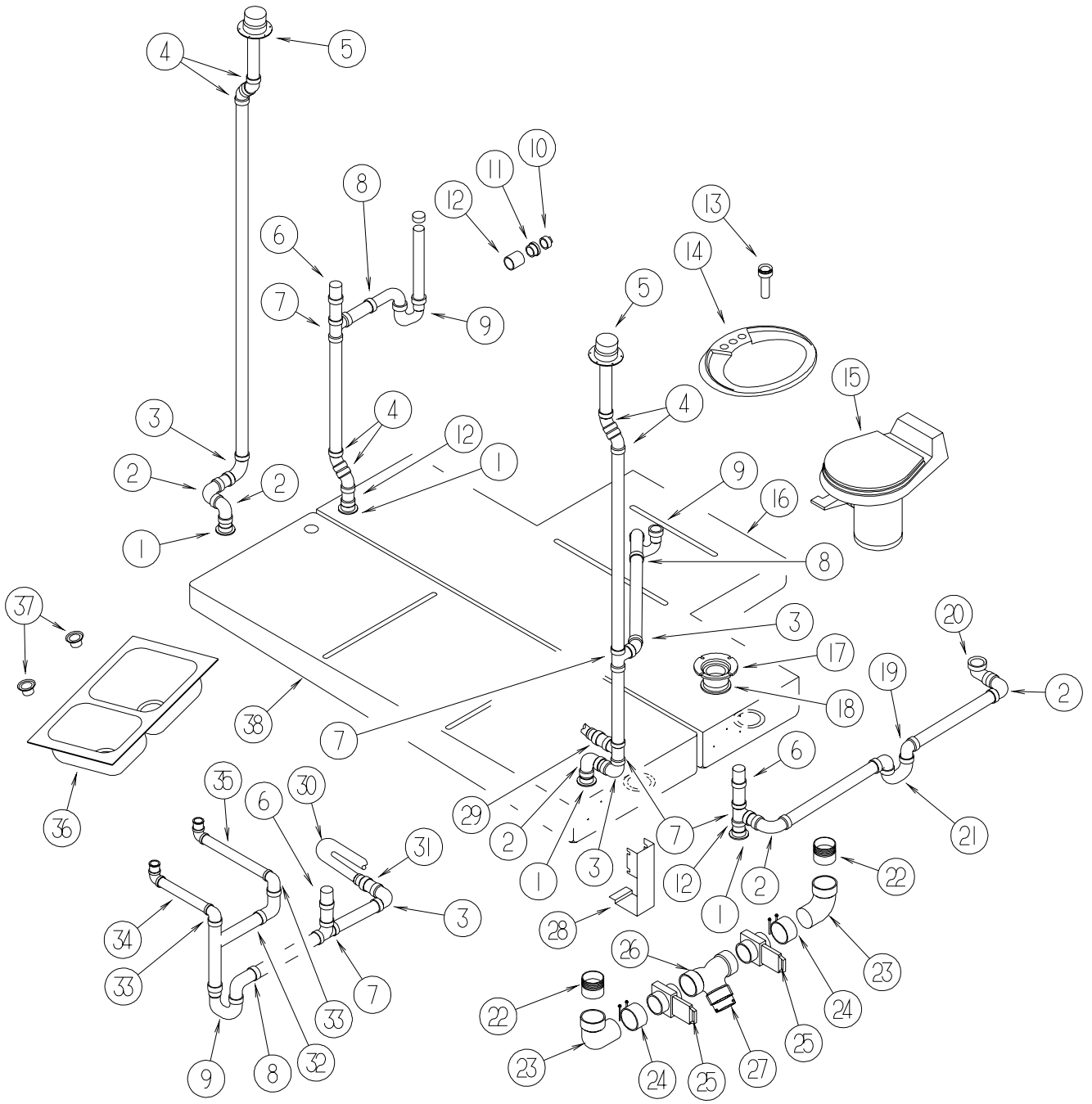

WATER & SEWAGE GROUP (CONTINUED)

DRAINAGE SYSTEM (CONTINUED)

KEY	PART NUMBER	U/M	DESCRIPTION
1	061607-01-000	EA	GROMMET - HOLDING TANK - 1 1/2" NPS
2	010008-01-000	EA	ELBOW - 90 DEGREE - 1 1/2" HUB X HUB - PLASTIC
3	033761-01-000	EA	ELBOW - TURN - 90 DEGREE 1 1/2" HUB X 1 1/2" SPIGOT
4	010006-01-000	EA	ELBOW - 45 DEGREE - 1 1/2" HUB X HUB - PLASTIC
5	083558-06-000	EA	VENT - ROOF PLUMBING PIPE - COVERED
6	079968-01-000	EA	VENT - MECHANICAL/TRAP ARM - ANTI-SIPHON - 2" X 7.3" PLASTIC
7	010071-01-000	EA	TEE - SANITARY - 1 1/2" HUB X HUB X HUB - PLASTIC
8	109571-01-000	EA	ADAPTER - P TRAP - 1 1/2" P X 1 1/4" MPT
9	107538-01-000	EA	P TRAP - PLASTIC - 1 1/4" W/EXTENSION ARM - US
9	011071-01-000	EA	P-TRAP - PLASTIC - 1 1/2" - CSA
10	010166-01-000	EA	PLUG - THREADED - 1 1/4" DIAMETER - PLASTIC - BLACK (W/O WASHER/DRYER)
11	010122-01-000	EA	BUSHING - REDUCER - 1 1/2 SMTH X 1 1/4 THD - BLACK PLASTIC (W/O WASHER/DRYER)
11	010123-01-000	EA	BUSHING - 2" X 1 1/2" HUB - PLASTIC (W/O WASHER/DRYER)
12	010115-01-000	EA	COUPLING - 1 1/2" HUB X HUB - PLASTIC
13	106116-01-02A	EA	STRAINER/PLASTIC - STOPPER/TAILPIECE/GASKET & NUT-LAVATORY
14	105921-01-02A	EA	SINK - LAVATORY - LARGE OVAL - 17" X 20" - WHITE
14	105218-01-01A	EA	SPACER - FAUCET/LAVATORY SINK - 2" X 5.9" - ABS PLASTIC
15*	085330-09-000	EA	TOILET - CHINA - STANDARD W.HAND SPRAYER - WHITE
15	131786-01-01A	EA	SPACER - TOILET - SOFT WHITE
16	132408-05-000	EA	TANK ASM-HOLDING
17	116644-01-000	EA	FLANGE - CLOSET - 4" X 3"
18	061607-02-000	EA	GROMMET - HOLDING TANK - 3" NPS
19	010009-01-000	EA	ELBOW - 90 DEGREE - 1/4 BEND - 1 1/2" PLASTIC
20	132150-01-01A	EA	STRAINER - SHOWER - BRASS
20	132376-01-01A	EA	GASKET - FOAM - 1 1/2" - TUB STRAINER
20	131486-01-000	EA	ELBOW - DRAIN - 1 1/2 LOW PROFILE - TUB DRAIN
21	037763-01-000	EA	P-TRAP - PLASTIC - 1 1/2 HXH W/UNION
22	062401-09-000	EA	CLAMP - HOSE - WORMGEAR - 2.8" - 3.75"
22	010129-03-000	EA	NIPPLE - PLASTIC - 3" X 3" TOE
23	010062-01-000	EA	ELBOW - ST PLASTIC - 3 90 SPGXH
24	078406-01-000	EA	COUPLER - RUBBER - W/CLAMPS - 3" X 3"
25	062418-03-000	EA	VALVE- 3" SPIGOT X 3" SPIGOT
26	010065-01-000	EA	TEE - PLASTIC - 3" FEMALE
27*	062415-01-000	EA	CAP - SEWER - 3" DIAMETER
27	062417-01-000	EA	ADAPTER - TERMINATION - 3"
27	062416-01-000	EA	ADAPTER - SEWER HOSE TO 3" PIPE
	010201-01-000	EA	HOSE - SEWER - 3" ID X 8'
28	134703-01-02B	EA	BRACKET - DRAINAGE - E-COATED
29	130685-03-000	EA	ADAPTER - SWIVEL - 1 1/2 ACME X SPG
29	130685-01-000	EA	ADAPTER - SWIVEL - 1 1/2 ACME X SOC
30	126426-01-000	FT	PIPE - 1 1/2" FLEXIBLE
30	126427-01-000	EA	ADHESIVE - ALL PURPOSE - ABS/PVC
30	126427-02-000	EA	PRIMER - CLEANER - FLEX PIPING
31	126424-01-000	EA	ADAPTER - 1 1/2" MPT X 1 1/2" HUB
31	126425-02-000	EA	ADAPTER - SWIVEL - 1 1/2 FPT X SPIGOT
32	011091-02-000	EA	WASTE - CONTINUOUS - DOUBLE SINK
33	125569-01-000	EA	ELBOW - 1 1/2" X 90 DEGREE - DOUBLE SLIP
34	126588-01-000	EA	ARM - WASTE - 1 1/2" X 9 1/2" - FEMALE
35	126588-02-000	EA	ARM - WASTE - 1 1/2 X 20 - FEMALE
36	110654-01-000	EA	SINK - STAINLESS STEEL/DOUBLE BASIN (1 LG-1 SM BASIN)
37	092303-01-000	EA	STRAINER - SINK
38	132407-01-000	EA	TANK - HOLDING - W/O FITTINGS

*COMPONENT PARTS FOUND IN SERVICE PARTS LIBRARY

WATER & SEWAGE GROUP (CONTINUED)

WATER SYSTEM

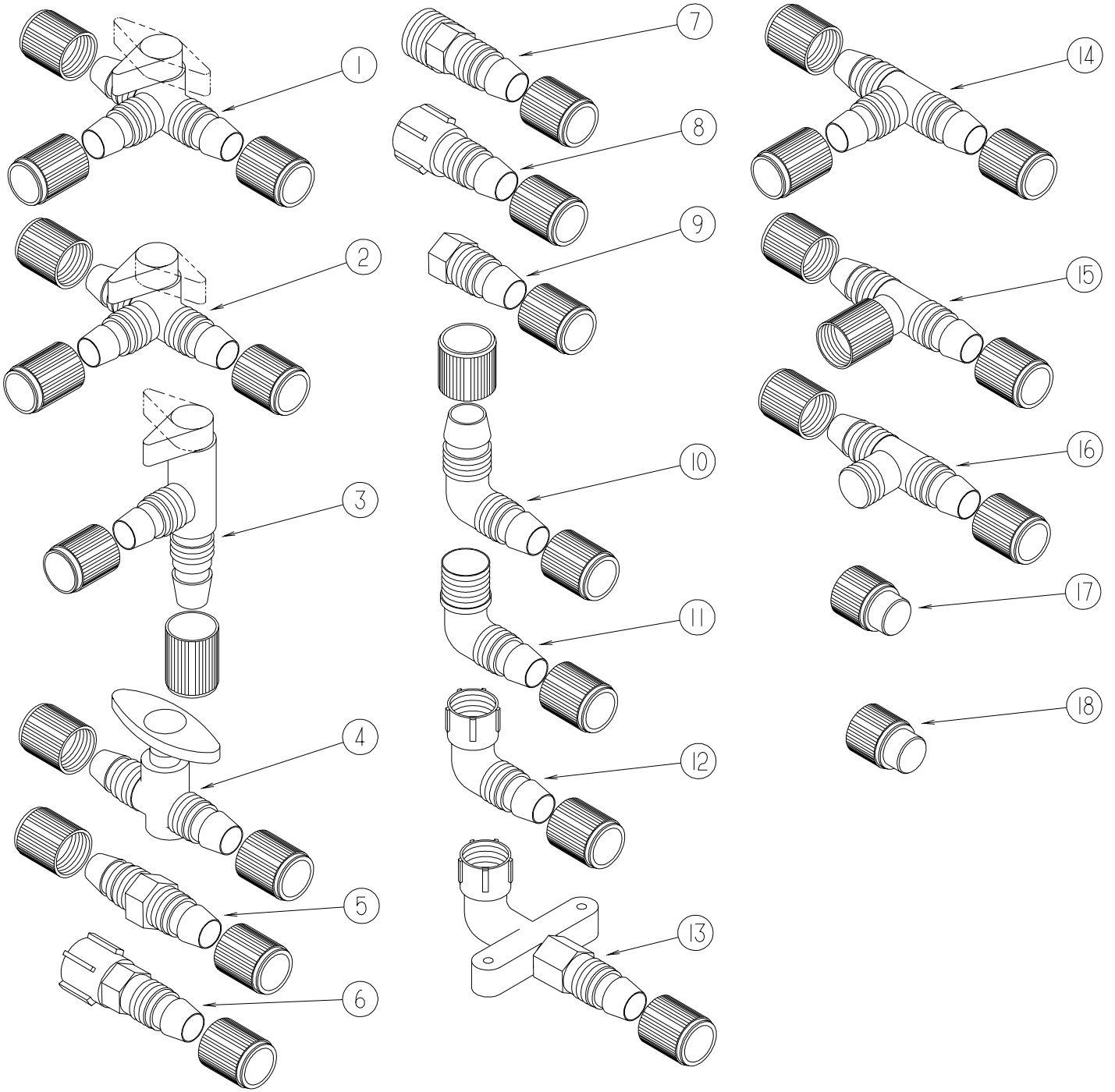

FITTINGS

WATER & SEWAGE GROUP (CONTINUED)

WATER SYSTEM (CONTINUED)

FITTINGS (CONTINUED)

KEY	PART NUMBER	U/M	DESCRIPTION
1	114431-01-000	EA	VALVE - 180 DEGREE/CENTER DRAIN - 1/2"P - THREE WAY
2	114431-02-000	EA	VALVE - WATER BYPASS - 1/2"P - THREE WAY (WATER HEATER)
3	114431-03-000	EA	VALVE - 90 DEGREE DRAIN - 1/2"P
4	114431-04-000	EA	VALVE - "INLINE SHUT-OFF" - 1/2"P
5	114430-01-000	EA	ADAPTER - 1/2"P X 1/2"P
6	114430-02-000	EA	ADAPTER - SWIVEL - 1/2"P X 1/2"FPT
7	114430-03-000	EA	ADAPTER - 1/2"P X 1/2"MPT
8	114427-02-000	EA	PLUG - W/COMP NUT - 1/2" PLASTIC PIPE/1/2" FLAIR-IT
9	114430-06-000	EA	ADAPTER - 1/2"P X 3/8"FPT
10	114429-01-000	EA	ELBOW - 1/2"P X 1/2"P
11	114429-02-000	EA	ELBOW - 1/2"P X 1/2"MPT
11	114429-04-000	EA	ELBOW - 1/2"P X 3/8"MPT
11	114429-05-000	EA	ELBOW - 1/2"P X 3/4"MPT
12	114429-03-000	EA	ELBOW - SWIVEL - 1/2"P X 1/2"FPT
12	114429-06-000	EA	ELBOW - SWIVEL - 1/2"P X 3/4"FPT
12	114429-08-000	EA	ELBOW - SWIVEL - 1/2"MPT X 1/2"FPT SWIVEL
13	114429-07-000	EA	ELBOW - 1/2"P X 1/2"FPT
14	114428-01-000	EA	TEE - 1/2"P X 1/2"P X 1/2"P
15	114428-02-000	EA	TEE - SWIVEL - 1/2"P X 1/2"P X 1/2"FPT
16	114428-03-000	EA	TEE - 1/2"P X 1/2"P X 1/2"MPT
17	113697-01-000	EA	CAP - 3/8 FTG
18	114427-01-000	EA	CAP - 1/2"P

WATER & SEWAGE GROUP (CONTINUED)
WATER SYSTEM (CONTINUED)

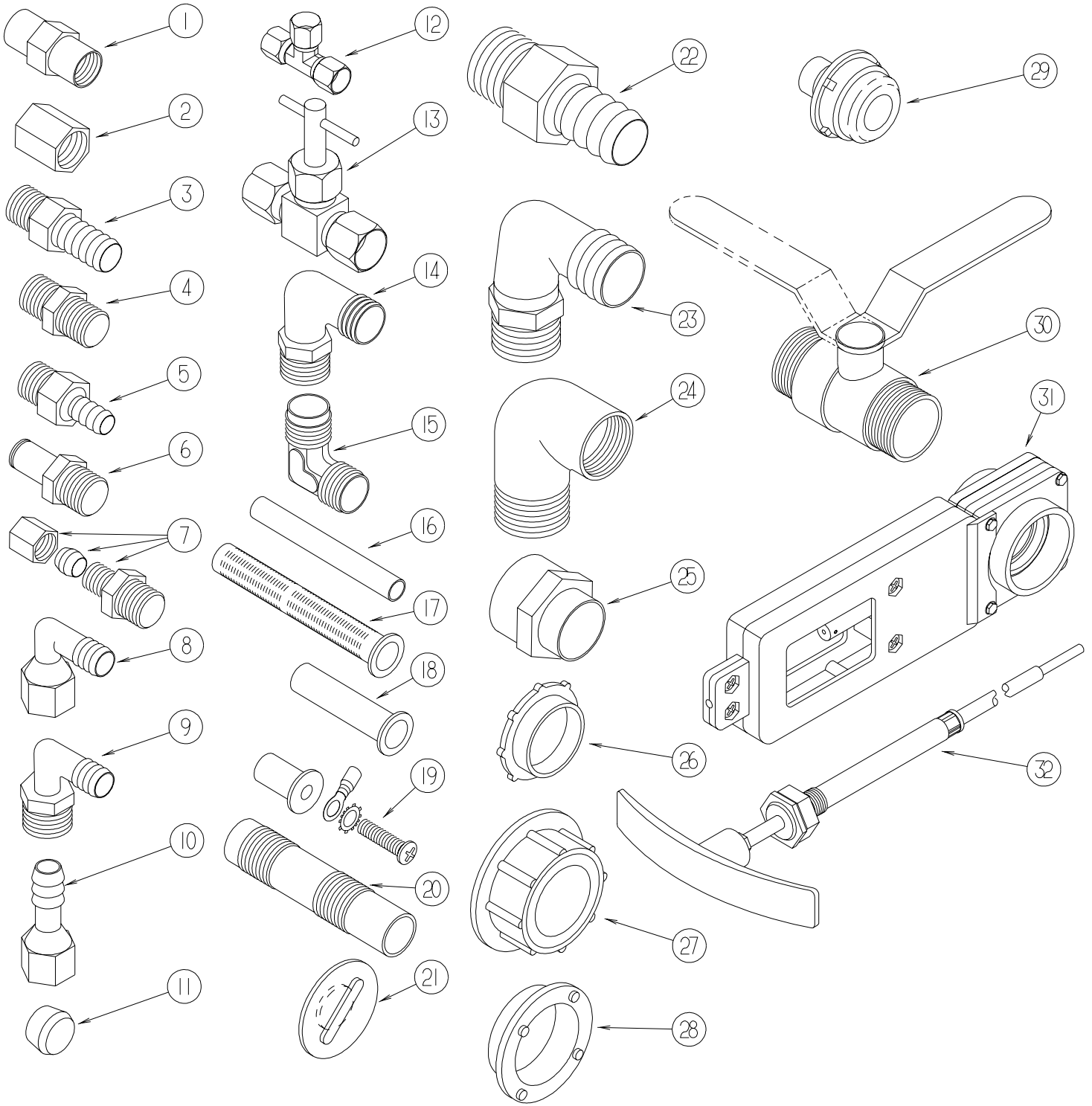

FITTINGS (CONTINUED)

WATER & SEWAGE GROUP (CONTINUED)

WATER SYSTEM (CONTINUED)

FITTINGS (CONTINUED)

KEY	PART NUMBER	U/M	DESCRIPTION
1	132148-01-000	EA	CONNECTOR - 1/2" X 1/2" MPT - BRASS
2	101814-01-000	EA	COUPLING - FEMALE - 1/2" X 1/2" FPT - GRAY
3	118809-02-000	EA	ADAPTER - 1/2" MPT X 1/2" BARB - PLASTIC
4	110438-02-000	EA	VALVE - CHECK - BRASS - 1/2 MPT X 1/2 MPT
5	010224-01-000	EA	ADAPTER - HOSE TO PIPE - 3/8 MPT X 3/8 BARB - PLASTIC
6	090338-03-000	EA	FITTING - HOSE - .75"ID - 2" LENGTH - BRASS
7	103798-01-000	EA	CONNECTOR - 1/4 OD X 3/8 MPT
8	123150-01-000	EA	ELBOW - 1/2 FPT X 1/2 BARB - SWIVEL
9	035539-01-000	EA	ELBOW - 3/8 MPT X 3/8 BARB - PLASTIC
10	123152-01-000	EA	ADAPTER - 1/2 FPT X 1/2 BARB - SWIVEL
11	111888-01-000	EA	FERRULE - PLASTIC - .250 ID X .375 OD
12	118423-01-000	EA	FITTING - BRASS-TEE - 1/4C X 1/4C X 1/4C
13	120868-01-000	EA	VALVE - NEEDLE - 1/4" COMPRESSION X 1/4" COMPRESSION
14	111223-02-000	EA	ELBOW - 1/2MPT X 3/8 BARB - PLASTIC
14	111223-03-000	EA	ELBOW - 3/4" MPT X 1/2" BARB - PLASTIC
14	111223-04-000	EA	ELBOW - 1/2" MPT X 1/2" BARB - PLASTIC
15	039808-03-000	EA	ELBOW - 1/2" MPT X 1/2" MPT - PLASTIC
16	124188-01-000	FT	TUBING - PEX - 1/2" ID X 20' - BLUE(COLD)
16	124188-02-000	FT	TUBING - PEX - 1/2" ID X 20' - RED(HOT)
16	112176-01-000	FT	TUBING - VINYL - REINFORCED - 1/2" ID
16	074462-02-000	FT	TUBING - VINYL - 3/8 ID X 20' - CLEAR
16	039800-04-000	FT	TUBING - POLYBUTYL - 1/4"OD
17	077954-02-000	EA	FILTER - WATER TANK - W/SCREEN IN TANK
18	111888-02-000	EA	INSERT - BRASS - 1/4 COMP
19	039861-01-000	EA	SENDING UNIT - W/SCREW - WASHER - WELL NUT/TERMINAL RING
20	079381-01-000	FT	TUBING - RIBBED FLEXIBLE - WATER FILL - 1.4" I.D.
21	049032-01-000	EA	PATCH - SPINWELD - 3/8" - PLASTIC
22	044927-01-000	EA	ADAPTER - HOSE TO PIPE-1 1/4 MPTX1 1/4 BARB-BLACK PLASTIC
23	010219-01-000	EA	ELBOW - 1 1/4 MPT X 1 1/4 BARB - WATER FILL - PLASTIC
24	132484-01-000	EA	ELBOW - 90 DEGREE - 1MPT X 1FPT - PLASTIC
25	133835-01-000	EA	ADAPTER - REDUCING - 1 1/2" X 1 1/4"
26	120069-01-000	EA	PLUG - 3" - POLYETHYLENE MPT
27	042989-03-000	EA	FITTING - SPINWELD - 1 1/4"NPT - PLASTIC
27	042989-04-000	EA	FITTING - SPINWELD - 3/8"FPT - PLASTIC
27	042989-05-000	EA	FITTING - SPINWELD - 1/2"FPT - PLASTIC
27	042989-07-000	EA	FITTING - SPINWELD - 1 1/2"FPT - PLASTIC
27	042989-08-000	EA	FITTING - SPINWELD - 1"FPT - PLASTIC
28	120070-01-000	EA	FITTING - SPINWELD - PLASTIC 3" FPT
29	114966-01-000	EA	FILTER - IN LINE - TWIST ON - 1/2"
30	132483-01-000	EA	VALVE - BALL - 1" - THREADED ENDS
31	062421-03-000	EA	VALVE - DUMP - 1 1/2" HUB X 1 1/2" HUB - REMOTE
32	062421-04-000	EA	CABLE - DUMP VALVE W/HANDLE - 36"
32	062421-05-000	EA	CABLE - DUMP VALVE W/HANDLE - 48"
32	062421-06-000	EA	CABLE - DUMP VALVE W/HANDLE - 144"

WATER & SEWAGE GROUP (CONTINUED)

WATER SYSTEM (CONTINUED)

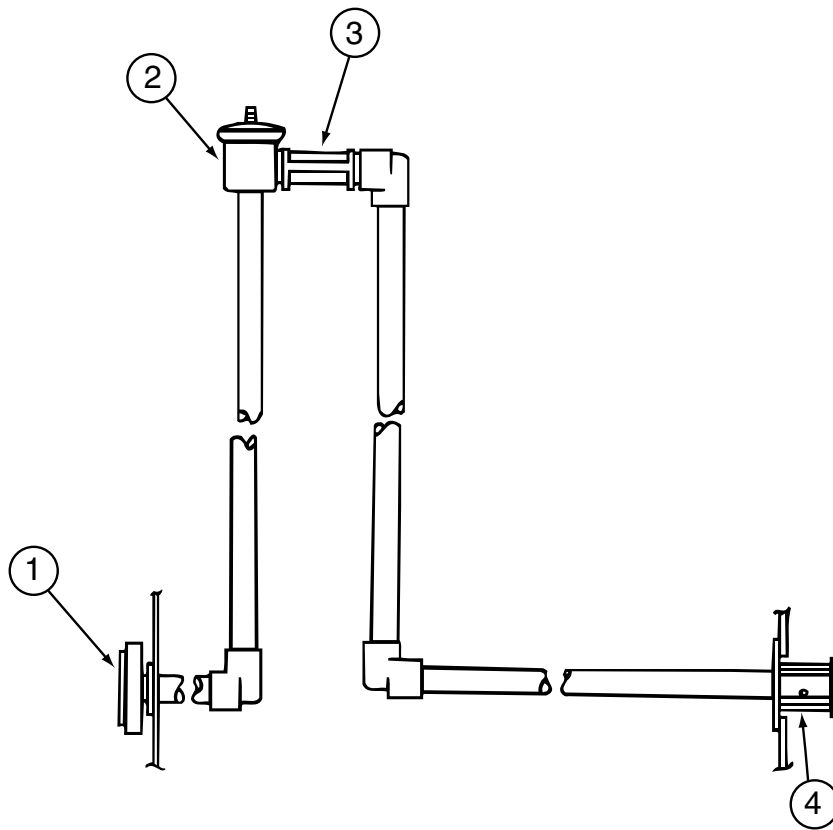

WELD-A-FLUSH SEWAGE TANK FLUSHING SYSTEM

KEY	PART NUMBER	U/M	DESCRIPTION
1	125697-05-000	EA	INLET - WATER - FLUSHING SYSTEM
2	125697-04-000	EA	BREAKER - VACUUM - FLUSHING SYSTEM
3	125697-03-000	FT	CHECK VALVE - FLUSHING SYSTEM
4	125697-02-000	FT	NOZZLE - WELD-A-FLUSH
	125697-06-000	EA	INSTRUCTIONS - USER - FLUSHING SYSTEM
	125697-07-000	EA	LABEL - CAUTION - FLUSHING SYSTEM

WATER & SEWAGE GROUP (CONTINUED)

WATER SYSTEM (CONTINUED)

TANKS

KEY	PART NUMBER	U/M	DESCRIPTION
	132678-01-000	EA	TANK - WATER - 85 GALLON - W/O FITTINGS
	132678-02-000	EA	TANK - WATER - 85 GALLON - W/FITTINGS
	123243-01-000	EA	TANK - ACCUMULATOR - 24 OZ

HEATER, PUMP & FAUCETS

KEY	PART NUMBER	U/M	DESCRIPTION
*	051391-05-000	EA	WATER HEATER/MOTOR AID-GAS/ELECT IGN - GCH10A-3E - 10 GAL
	097967-01-000	EA	SWITCH - WATER HEATER - REMOTE W/LIGHT
	125420-01-02A	EA	DOOR - WATER HEATER - BRIGHT WHITE
	133224-01-02B	EA	PLATE - WATER HEATER - E-COATED
*	051391-03-000	EA	WATER HEATER G6A-8E ELECTRONIC IGNITION
	097967-01-000	EA	SWITCH - WATER HEATER - REMOTE W/LIGHT
	125420-02-02A	EA	DOOR - WATER HEATER - 6 GALLON - BRIGHT WHITE
	133224-02-02B	EA	PLATE - WATER HEATER - E-COATED
*	098607-01-000	EA	PUMP - WATER - W/.5" MPT FITTING - FLOW 2.8 GPM
*	103635-01-000	EA	FAUCET - SINGLE CONTROL/DRINKING WATER (GALLEY)
*	131340-01-01A	EA	FAUCET/SHOWER HEAD W/O WATER SAVER - SINGLE LEVER - BRASS (SHOWER)
	131551-01-02B	EA	BRACKET - SHOWER HEAD
	075240-05-000	EA	FAUCET - LAVATORY - BRASS
	104114-02-01A	EA	FAUCET - GALLEY - SINGLE CONTROL
	128974-01-01A	EA	VALVE - SHOWER HEAD/WATER SAVER (ON/OFF) - BRIGHT BRASS
	098419-01-000	EA	FAUCET - WASHER - 90 DEGREE (WASHER)
	081240-20-000	EA	WATER FILL - W/DOOR - LOCKABLE - W/O LOCK - BRT WHT

*COMPONENT PARTS FOUND IN SERVICE PARTS LIBRARY

WATER PURIFICATION

KEY	PART NUMBER	U/M	DESCRIPTION
	701069-01-000	EA	WATER PURIFICATION SYSTEM

WATER & SEWAGE GROUP (CONTINUED)

WATER SYSTEM (CONTINUED) SERVICE CENTER

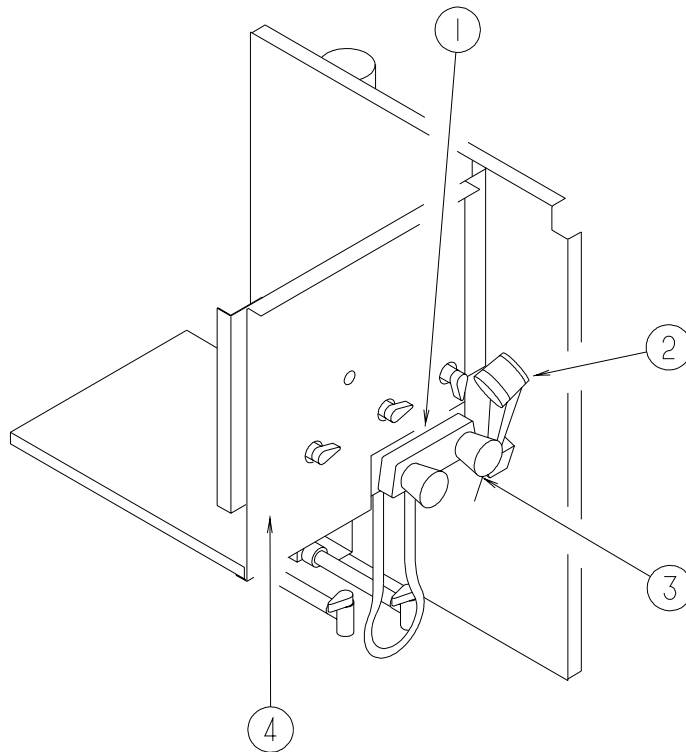

KEY	PART NUMBER	U/M	DESCRIPTION
1	075241-06-000	EA	FAUCET/SHOWER - BRIGHT WHITE - 1/2"MPT X 1.9" INLET PIPES
2	131383-01-02A	EA	SHOWER HEAD - W/60" HOSE & BRACKET - WHITE
2	131383-02-02A	EA	SHOWER HEAD - W/60" HOSE & BRACKET - WHITE - CSA
3	133047-01-12B	EA	BRACKET - SHOWER - EXTERIOR - BRIGHT WHITE
4	133523-02-12B	EA	PANEL - SERVICE CENTER - BRIGHT WHITE

WINDOW & VENTS GROUP
WINDOW & VENT LAYOUT

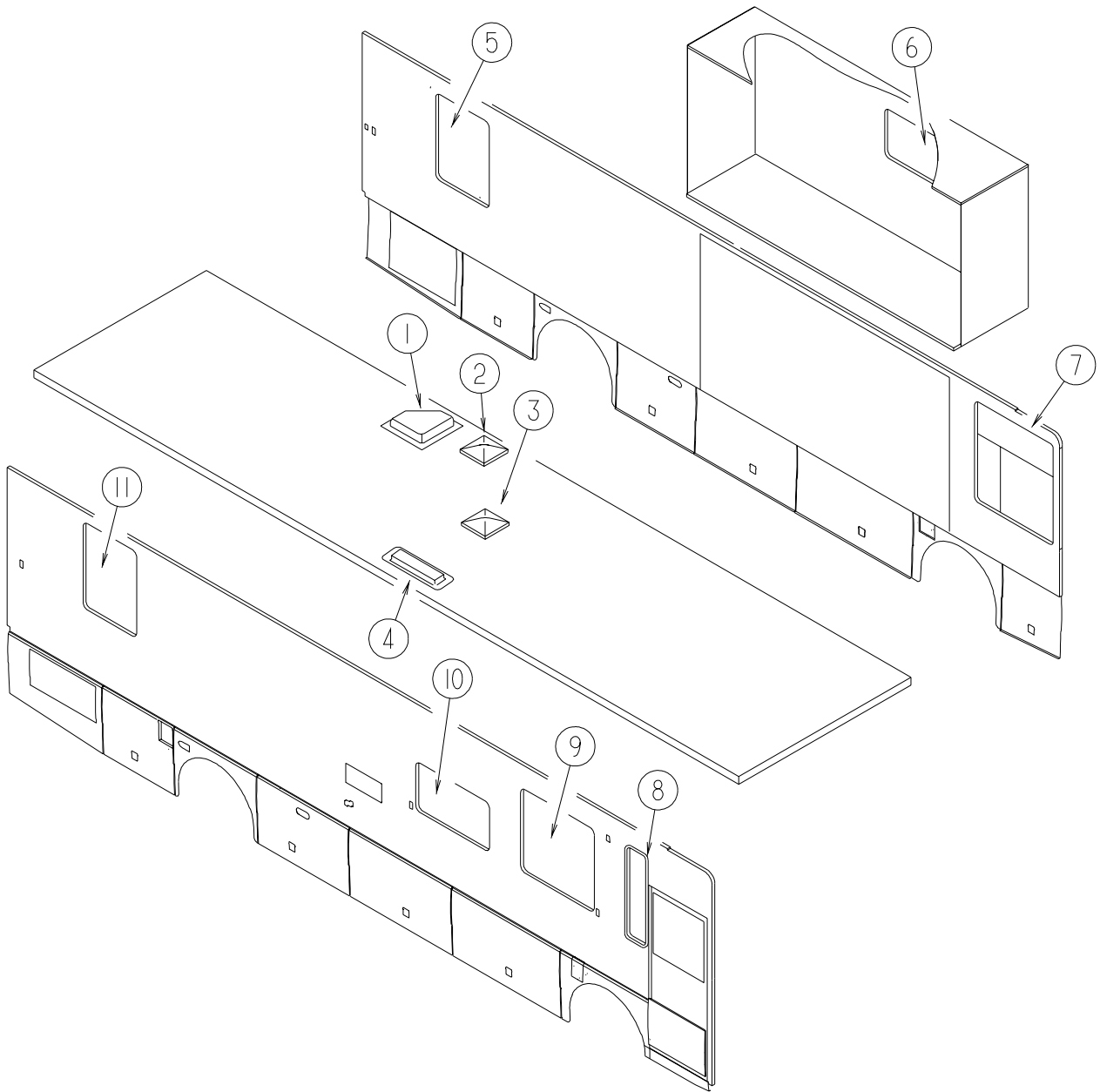

WINDOW & VENTS GROUP (CONTINUED)

WINDOW & VENT LAYOUT (CONTINUED)

KEY	PART NUMBER	U/M	DESCRIPTION
1	122214-01-02A	EA	PANEL - SKYLITE - INNER
1	122215-01-02A	EA	PANEL - SKYLITE - OUTER
2*	122882-02-01A	EA	VENT - ROOF - W/FAN - W/O INSIDE GARNISH - UL
2*	122882-03-01A	EA	VENT - ROOF - W/FAN - W/O INSIDE GARNISH - CSA
	009440-01-000	EA	GEAR/ARM - LIFT - ROOF VENT COVER
	048648-01-000	EA	MOTOR - ROOF VENT - 1/8 SHAFT - 12VOLT
	048649-01-000	EA	FAN BLADE - ROOF VENT - 6 BLADES - 6"
	122882-07-01A	EA	GARNISH - ROOF VENT - 2.5" TO 4"
3*	123780-03-01A	EA	VENT - ROOF - 3" TO 4" - W/FAN/POWER LIFT - W/O THERMOSTAT
	009440-01-000	EA	GEAR/ARM - LIFT - ROOF VENT COVER
3*	122882-01-01A	EA	VENT - ROOF - NONPOWERED - W/O INSIDE GARNISH
	009440-01-000	EA	GEAR/ARM - LIFT - ROOF VENT COVER
	122882-07-01A	EA	GARNISH - ROOF VENT - 2.5" TO 4"
4	084073-04-000	EA	BASE - ROOF VENT/REFRIGERATOR - BLACK - NORCOLD
4	084073-07-000	EA	VENT - ROOF/REFRIGERATOR - BRIGHT WHITE - NORCOLD
5*	112463-05-02A	EA	WINDOW - TIPOUT/ESCAPE W/RETAINER RING - 33.3" X 30.2"
5*	129929-02-02A	EA	WINDOW - TORQUE - THERMO - 33.2" X 30.2"
6*	098647-47-02A	EA	WINDOW - DRIVER HORIZ SLIDER W/TRIM - TINTED-23.6" X 57.5"
6*	112795-54-02A	EA	WINDOW - DRIVER HORIZONTAL SLIDER - THERMO - 23.9" X 57.8"
7*	106466-13-01A	EA	WINDOW - CAB/DRIVER - 44.6"T X 44.7"H X 46"B
7*	106466-14-01A	EA	WINDOW - CAB/DRIVER - THERMAL - 44.6"T X 44.7"H X 46"B
8	132460-01-01A	EA	WINDOW - CAB/PASSENGER W/RETAINER - 12.3" X 41.6"
8*	113733-08-01A	EA	WINDOW - STATIONARY THERMOPANE - 12.3"W X 41.6"H
9*	098647-55-01A	EA	WINDOW - PASS HORIZONTAL SLIDER - 41.3"W X 38.8"H
9*	112795-67-01A	EA	WINDOW - PASSENGER HORIZ SLIDER - THERMO - 41.3" X 38.8"
10*	098647-23-02A	EA	WINDOW - PASS HORIZ SLIDER W/TRIM - TINTED- 26.1" X 59.7"
10*	112795-16-02A	EA	WINDOW - PASSENGER HORIZ SLIDER - THERMO - 26.1" X 59.8"
11*	112463-03-02A	EA	WINDOW - TIPOUT W/RETAINER RING - 33.3" X 30.2"
11*	129929-01-02A	EA	WINDOW - TORQUE - THERMO - 33.2" X 30.2"

*COMPONENT PARTS FOUND IN SERVICE PARTS LIBRARY

WINDSHIELD & WIPER GROUP

WINDSHIELD

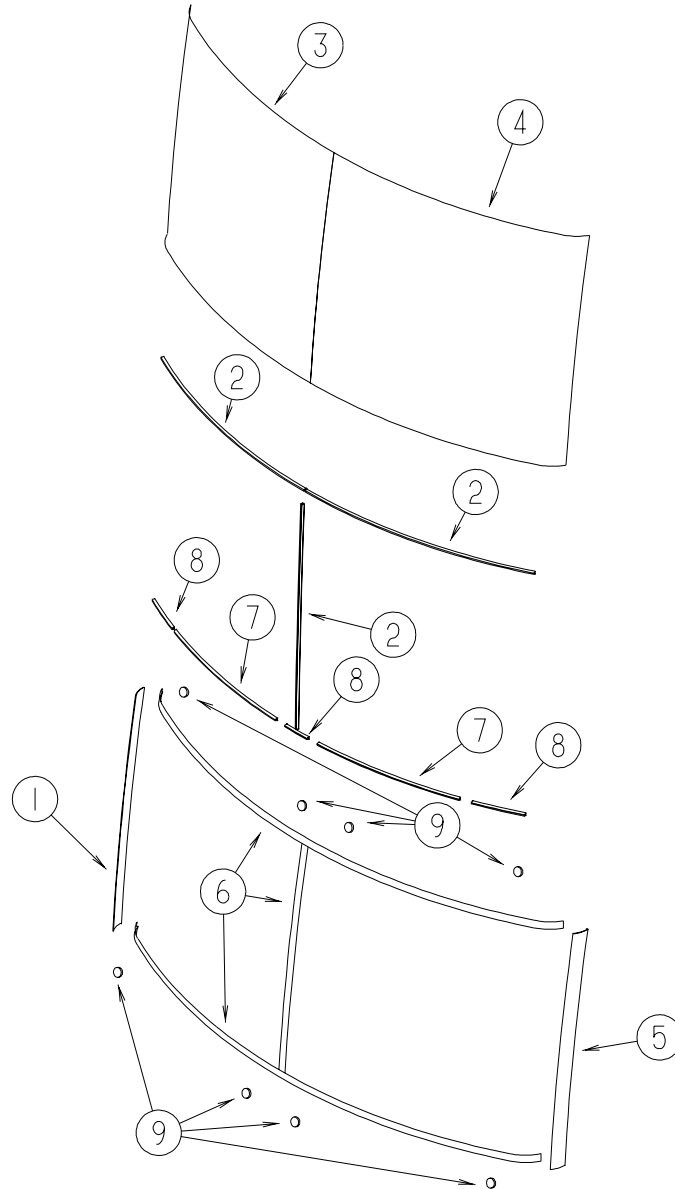

KEY	PART NUMBER	U/M	DESCRIPTION
1	129497-05-03A	EA	TRIM - WINDSHIELD - PASSENGER A-PILLAR - BRIGHT WHITE
	099418-01-000	FT	SEAL - D-SECTION/ADHESIVE BACK - .44" X .44"- BLK RUBBER
2	127862-01-000	EA	CARRIER - REVEAL - WINDSHIELD - 47.2"
3	131244-01-000	EA	WINDSHIELD - PASSENGER - 52.5" X 44.4" (CURVED)
4	131244-02-000	EA	WINDSHIELD - DRIVER - 52.5" X 44.4" (CURVED)
5	129497-06-03A	EA	TRIM - WINDSHIELD - DRIVER A-PILLAR - BRIGHT WHITE
	099418-01-000	FT	SEAL - D-SECTION/ADHESIVE BACK - .44" X .44"- BLK RUBBER
6	120533-01-000	FT	MOLDING - REVEAL - WINDSHIELD
7	117335-01-000	EA	CARRIER/REVEAL - 94.6" W/ADHESIVE BACKING
8	132375-02-000	EA	CARRIER - REVEAL/WINDSHIELD - 10"
9	081914-02-000	EA	BUMPER - RUBBER - ROUND - 5/16" DIA. X 13/64" THICK

WINDSHIELD & WIPER GROUP (CONTINUED)

WIPER

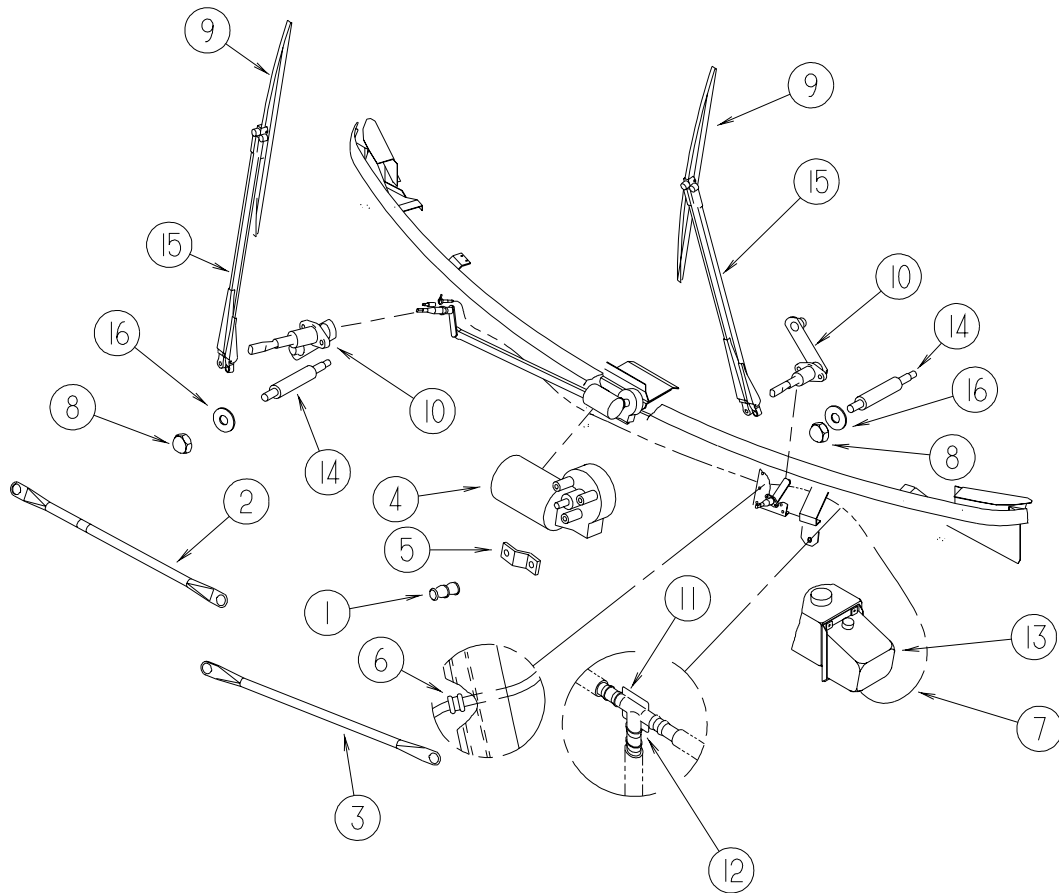

KEY	PART NUMBER	U/M	DESCRIPTION
1	067188-01-000	EA	STUD - CRANK - WIPER MOTOR
	117322-01-000	EA	SCREW - 1/4-28 UNFINISHED - 2A - TORX
2	117770-01-000	EA	LINK - CONNECTING - 24" - CLOSED GROMMET/OPEN GROMMET
3	117770-02-000	EA	LINK - CONNECTING - 24" - CLOSED GROMMET/CLOSED GROMMET
4	104346-05-000	EA	WIPER MOTOR - W/INTERNAL BREAKER - DYNAMIC PARK
5	104347-04-000	EA	ARM - DRIVE - WIPER MOTOR
6	061603-01-000	EA	GROMMET - SNAP - 3/16"ID - 3/8" HOLE - PLASTIC BLACK
7	045794-01-000	FT	HOSE - WASHER - WINDSHIELD - 5/32" ID - BLACK
8	077049-02-000	EA	NUT - ACORN - 10-32 BLACK/ANODIZED
9*	095964-01-000	EA	BLADE - WINDSHIELD WIPER - 24"
10*	096505-09-000	EA	SHAFT/PIVOT - WINDSHIELD WIPER
11	110605-01-000	EA	TEE - PLASTIC - BARBED - 1/8" X 1/8" X 3/16"
12	117765-03-000	EA	CONNECTOR - 5/32" - WINDSHIELD WASHER
13	117766-02-000	EA	RESERVOIR/PUMP - WINDSHIELD WASHER
14	117768-01-000	EA	SHAFT - ADAPTER - PANTOGRAPH ARM
15*	117769-01-000	EA	ARM - WIPER - PANTOGRAPH - 28"
16	110742-02-000	EA	GASKET - NEOPRENE - WIPER ADAPTER SHAFT - .5" ID X .9" OD

*COMPONENT PARTS FOUND IN SERVICE PARTS LIBRARY