

2000 WF324V

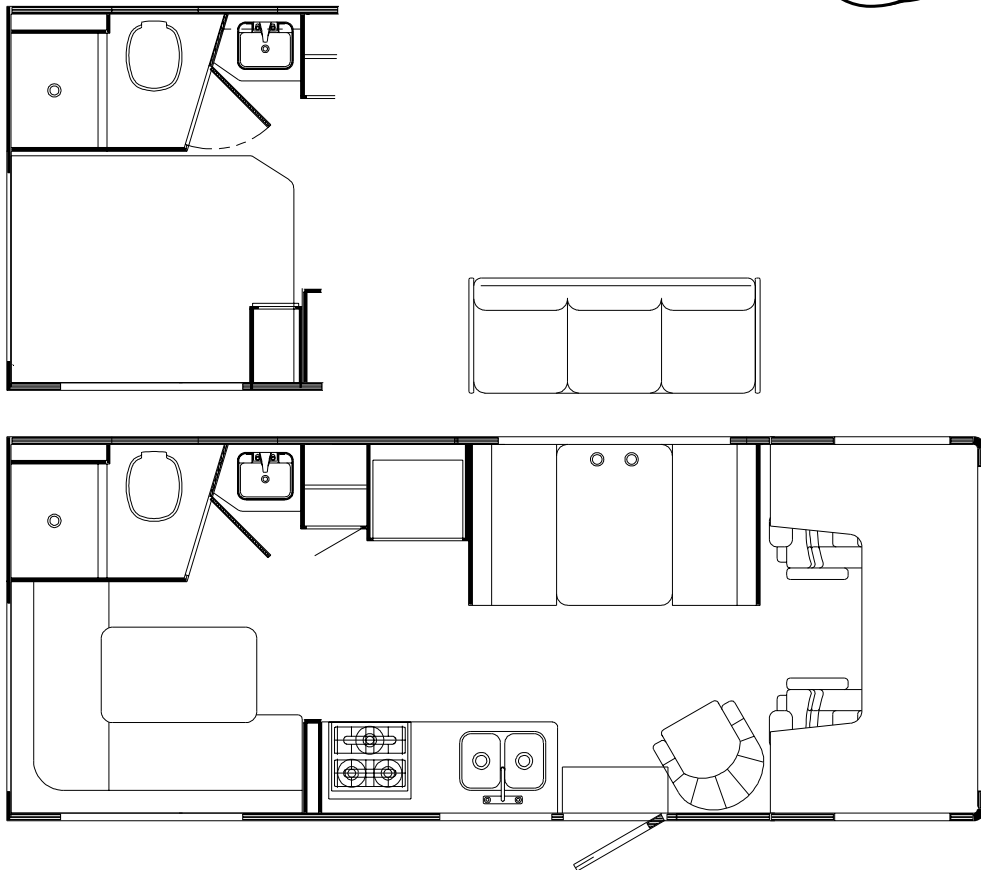
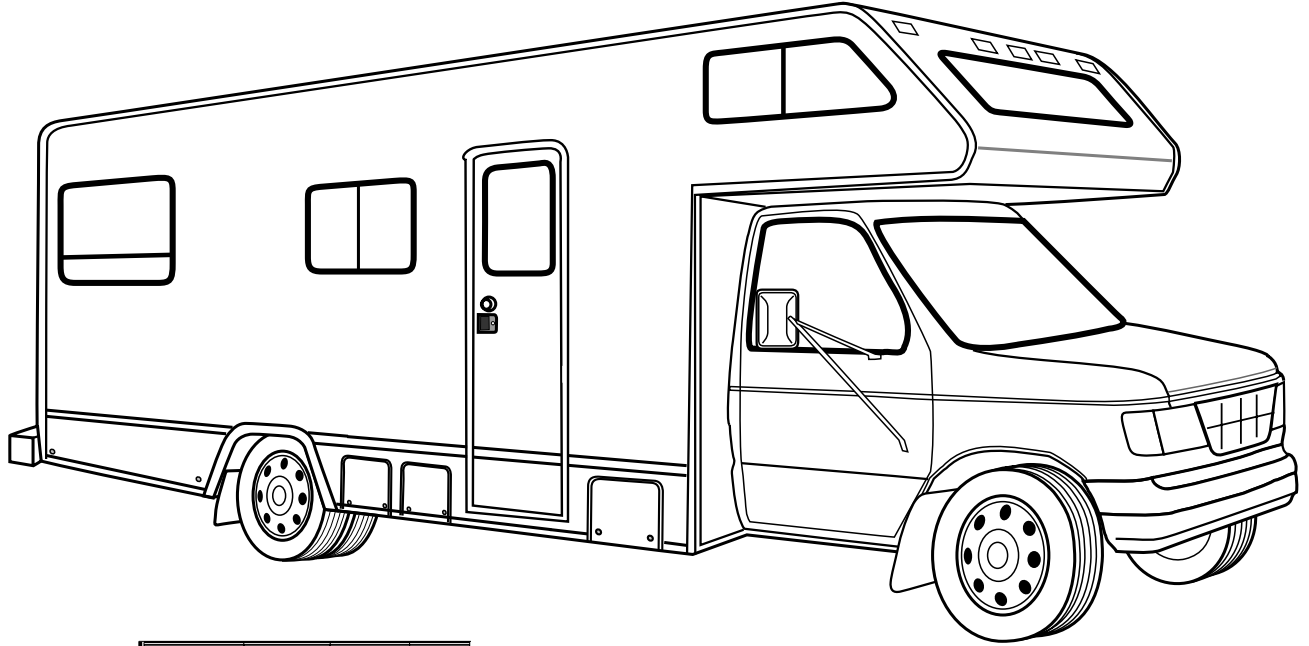

FLOORPLAN

**2000
WF324V**

**MINNIE
300 SERIES**

WATERFORD OAK

**L01 MEADOWBROOK (TEAL)
L02 BLUEBONNET (BLUE)
L03 ALMOND CREAM (BEIGE)**

CONTENTS

FLOORPLAN	2
ACCESSORIES GROUP	6
OPERATORS MANUAL	6
APPLIANCE GROUP	7
APPLIANCES	7
AUDIO VIDEO GROUP	8
RADIO SYSTEM	8
TV & VCR	8
EXTERIOR ENTERTAINMENT	8
BATH GROUP	9
CABINETS	9
SHOWER	10
BEDROOM GROUP	11
QUEEN CABINETS	11
CHASSIS GROUP	12
FRAME	12
EXHAUST	13
HITCH, REAR BUMPER & SPARE TIRE	15
FUEL FILL	16
WHEEL, TIRE, COVERS & LINERS	17
CURTAIN & CUSHION GROUP	18
NOTICE	18
CUSHION LAYOUT	19
BUCKET SEATS	21
LOUNGE CHAIR	23
WINDOW TREATMENT	24
HARDWARE	26
ACCESSORIES	28
FABRICS	29
DINETTE GROUP	30
CABINETS	30
TABLE	32
DRIVERS COMPARTMENT GROUP	33
INSTRUMENT PANEL	33
FRONT INTERIOR	34
CABINETS	36
ELECTRICAL GROUP	37
LIGHTS	37
CIRCUIT BREAKERS & FUSES	39
CONVERTER, INVERTER & LOAD CENTERS	39
RECEPTACLES	40
SWITCHES	42
BOXES & CORDS	44
WIRE ASSEMBLIES	44
CONNECTORS & CONDUIT	44
BOOTS, SOLENOIDS, RELAYS & MISCELLANEOUS	45

CONTENTS (CONTINUED)

EXTERIOR BODY GROUP	46
GRAPHICS & PAINT	46
PANELS	48
LADDER	50
RUNNING BOARDS	50
MIRRORS	50
BODY PANEL COMPONENTS	50
AWNINGS	50
EXTERIOR DOORS & COMPARTMENTS GROUP	51
DOOR & COMPARTMENT LAYOUT	51
COMPARTMENT DOOR COMPONENTS	52
ENTRY DOOR	55
SCREEN DOOR	57
LATCH - ENTRY DOOR	58
GALLEY GROUP	59
CABINETS	59
GENERATOR GROUP	60
GAS	60
HEATING & A/C GROUP	61
FURNACE	61
ROOF	61
INTERIOR FINISH GROUP	62
MOLDINGS & TRIMS	62
PANELING, LAMINATES, BATT & EDGE BAND	66
ACCESSORIES	66
FLOOR COVERINGS	66
HARDWARE	67
LABELS GROUP	73
LP GROUP	94
LP SYSTEM	94
LOUNGE GROUP	95
CABINETS	95
TABLE	98
SEALANTS & FASTENERS GROUP	99
SEALANTS & ADHESIVES	99
BOLTS, NUTS AND WASHERS	100
SCREWS	102
CLAMPS, CLIPS, GROMMETS, RIVETS & PLUGS	106
MISCELLANEOUS FASTENERS	108
WATER & SEWAGE GROUP	109
DRAINAGE SYSTEM	109
WATER SYSTEM	111
WINDOW & VENTS GROUP	117
WINDOW & VENT LAYOUT	117

ACCESSORIES GROUP
OPERATORS MANUAL

KEY	PART NUMBER	U/M	DESCRIPTION
	132000-03-000	EA	MANUAL/OWNER - MINNIE - 2000
	129079-01-01A	EA	CASE - VINYL/BLACK-EXPANDABLE ACCORDION SIDES-7"WX9"HX14"L

**APPLIANCE GROUP
APPLIANCES**

KEY	PART NUMBER	U/M	DESCRIPTION
	128527-06-000	EA	OVEN - MICROWAVE W/TRIM KIT- 1 CU.FT.- NON CONVECTION
	128642-03-000	EA	TRIM KIT W/VENT- MICROWAVE .9 CU.FT. - SAMSUNG - 2.1" HIGH
	098916-26-02B	EA	BRACE - MICROWAVE CABINET - LEFT HAND
	098916-27-02B	EA	BRACE - MICROWAVE CABINET - RIGHT HAND
	094750-10-000	EA	BRACKET - MICROWAVE - 89 DEGREE
*	102765-04-01A	EA	PANEL - MONITOR - 2 TANK/WATER HEATER - ADJUSTABLE
*	112881-02-02A	EA	RANGE - 16" - 3 BURNER - ALMOND/BLACK TEXTURED DOOR FROM: 00-00-00 THRU: 01-23-00
*	112881-02-04A	EA	RANGE - 16" - 3 BURNER - FRONT HI-OUTPUT BURNER - BISQUE FROM: 01-24-00 THRU: 99-99-99
	105458-03-000	EA	BRACKET - STOVE TIEDOWN - RIGHT HAND
	105458-04-000	EA	BRACKET - STOVE TIEDOWN - LEFT HAND
*	121568-04-01A	EA	REFRIGERATOR - SMALL DOUBLE DOOR/LEFT HAND - 2-WAY - BLACK
	065225-04-000	EA	PLATE - TIEDOWN/REFRIGERATOR
	093646-01-000	EA	BRACKET - TIEDOWN/REFRIGERATOR - RIGHT HAND
	093646-02-000	EA	BRACKET - TIEDOWN/REFRIGERATOR - LEFT HAND
	090329-01-000	FT	SEAL/T - REFRIGERATOR CABINET
	054450-01-000	EA	LEVEL - REFRIGERATOR
	116751-01-01A	EA	TRAY - REFRIGERATOR
*	100258-16-03A	EA	HOOD - RANGE - W/O MONITOR PANEL - W/O HR METER & SWITCH
*	100258-17-03A	EA	HOOD - RANGE - W/O MONITOR PANEL - W/O HOUR METER & SWITCH
*	100258-10-01A	EA	GAUGE - HOUR METER W/SWITCH - SCREW ON STYLE
*	100258-18-02A	EA	HOOD - RANGE - W/O MONITOR PANEL - W/HOUR METER & SWITCH
*	100258-10-01A	EA	GAUGE - HOUR METER W/SWITCH - SCREW ON STYLE

***COMPONENT PARTS FOUND IN SERVICE PARTS LIBRARY**

**AUDIO VIDEO GROUP
RADIO SYSTEM**

KEY	PART NUMBER	U/M	DESCRIPTION
	090944-01-000	EA	ANTENNA - RADIO - 16" RUBBER
	108847-01-000	EA	BRACKET - ANTENNA GROUND
	109889-05-000	EA	EXTENDER - ANTENNA SHAFT - 3"
	077069-02-000	EA	CABLE - ANTENNA/EXTENSION - RADIO - 96"
	108137-01-000	EA	PLUG - ANTENNA
	110469-01-000	EA	SPEAKER - 4" X 6" OVAL - COAXIAL
	110470-01-01A	EA	GRILLE - 4" X 6" OVAL - BLACK
	110465-01-000	EA	SPEAKER KIT,4 5X7 SPEAKERS - FORD F2UF-18814-CD
	111177-01-01A	EA	GRILLE - SPEAKER - 6.6" X 8.9" - HOUSING 5" X 7" SPEAKER

TV & VCR

KEY	PART NUMBER	U/M	DESCRIPTION
*	086231-10-000	EA	TV-COLOR 13" DC AUDIOVOX - AUDIOVOX AVT-1498
*	094487-05-000	EA	VIDEO CASSETTE PLAYER - VERTIC - AVP-7000VF
	082136-01-000	EA	NUT - HEX JAM - 3/8-32
	086777-02-000	EA	WALLPLATE - TV CABLE - W/ANTENNA SWITCH - BROWN
	086756-01-000	EA	SPLITTER - TV - 2 WAY
	082134-01-000	EA	ADAPTER - TV - CABLE TO CABLE
*	076319-23-000	EA	ANTENNA - TV ROOF MOUNT - 44.5" MAST
*	076319-25-000	EA	KIT - HARDWARE INTERIOR
	076319-26-000	EA	ANTENNA - TV - ROOF WEDGE
	076319-03-000	FT	CABLE - COAXIAL - 75 OHM
	082134-01-000	EA	ADAPTER - TV - CABLE TO CABLE
	076319-12-000	EA	CONNECTOR - COAXIAL - ONE PIECE
	082136-01-000	EA	NUT - HEX JAM - 3/8-32
	076319-09-000	EA	WALLPLATE - CABLE RECEPTACLE - TV - SINGLE - BROWN
	086777-02-000	EA	WALLPLATE - TV CABLE - W/ANTENNA SWITCH - BROWN

***COMPONENT PARTS FOUND IN SERVICE PARTS LIBRARY**

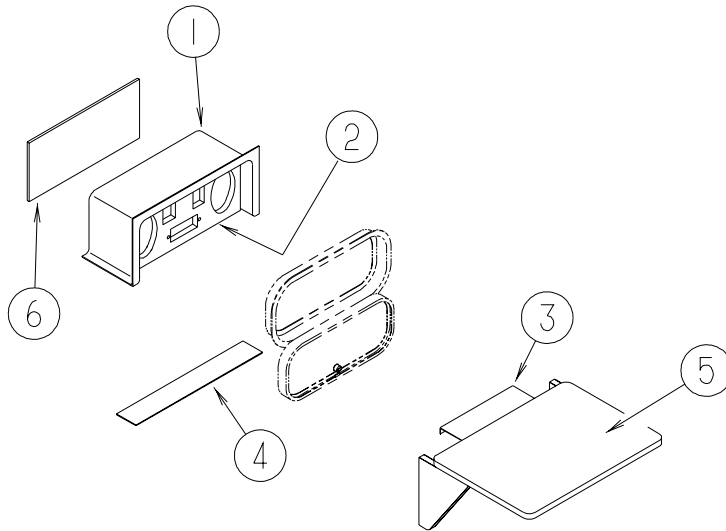

EXTERIOR ENTERTAINMENT

KEY	PART NUMBER	U/M	DESCRIPTION
1	124696-01-01A	EA	BOX - ENTERTAINMENT CENTER/EXTERIOR
2	125322-02-000	EA	RADIO - AM/FM STEREO - CASSETTE - AUDIOVOX - MS-306
2	127409-02-J01	EA	PLATE - RADIO MOUNTING
			FROM: 00-00-00 THRU: 06-13-99
2	127409-02-L15	EA	PLATE - RADIO MOUNTING
			FROM: 06-14-99 THRU: 99-99-99
3	105377-01-04A	EA	BRACKET - TABLE HANGER - BRIGHT WHITE
4	104898-01-02A	EA	PLATE - PLASTIC BOTTOM - BRIGHT WHITE
5	105230-01-J01	EA	SHELF - EXTERIOR ENTERTAINMENT CENTER - W/BRKT/HINGE/SUPT
6	104898-02-02A	EA	PLATE - PLASTIC BACK - BRIGHT WHITE

BATH GROUP CABINETS

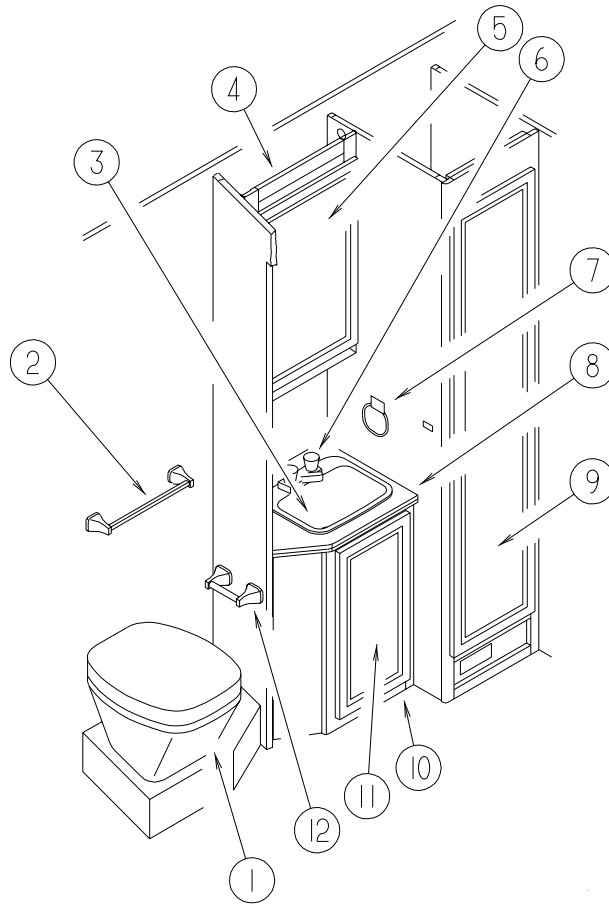

KEY	PART NUMBER	U/M DESCRIPTION
1		EA TOILET - SEE DRAINAGE SYSTEMS GROUP
2	075453-03-000	EA POST - TOWEL BAR - BRASS - 2 PER PACK
2	075453-04-000	EA ROD - TOWEL BAR - 18" W/O END BRACKETS - BRASS
3		EA SINK - SEE DRAINAGE SYSTEMS GROUP
4	116863-01-J01	EA CABINET - MEDICINE - W/O DOORS/HARDWARE
	116863-13-G01	EA SHELF - W/PLASTIC EDGE TRIM
5	115237-04-L01	EA DOOR - MIRRORED - BATH - W/O HARDWARE
6		EA FAUCET- SEE WATER SYSTEMS GROUP
7	075454-02-000	EA RING - TOWEL - W/MOUNTING HARDWARE - BRASS
8	123296-15-L01	EA COUNTERTOP - LAVATORY CABINET (L01, L03)
8	123296-15-L02	EA COUNTERTOP - LAVATORY CABINET (L02)
9	132006-04-L01	EA DOOR - MIRROR/MITERED RAIL - 15.5" X 45.4" - W/O HDW
10	123296-04-L01	EA CABINET - LAVATORY - W/O COUNTERTOP - W/O DOORS/DRAWERS/HDW (L01, L03)
10	123296-04-L02	EA CABINET - LAVATORY - W/O COUNTERTOP - W/O DOORS/DRAWERS/HDW (L02)
11	131995-P5-L01	EA DOOR - RAIL/SOLID PANEL - 13.4" X 21.8" - W/O HARDWARE
12	075452-02-000	EA HOLDER - TOILET TISSUE - BRASS
	131933-01-L01	EA DOOR - BATH - W/O HARDWARE
	100357-01-000	EA ROD - F/TOWEL BAR - BRASS
	102089-13-G09	EA RAIL END - RIGHT HAND/TOWEL RACK - 26" - WATERFORD OAK FROM: 00-00-00 THRU: 08-19-99
	102089-14-G09	EA RAIL END - LEFT HAND/TOWEL RACK - 26" - WATERFORD OAK FROM: 00-00-00 THRU: 08-19-99
	134509-01-11A	EA RAIL END - RH/LH - TOWEL RACK - 26" - WATERFORD OAK FROM: 08-20-99 THRU: 99-99-99

BATH GROUP (CONTINUED)

SHOWER

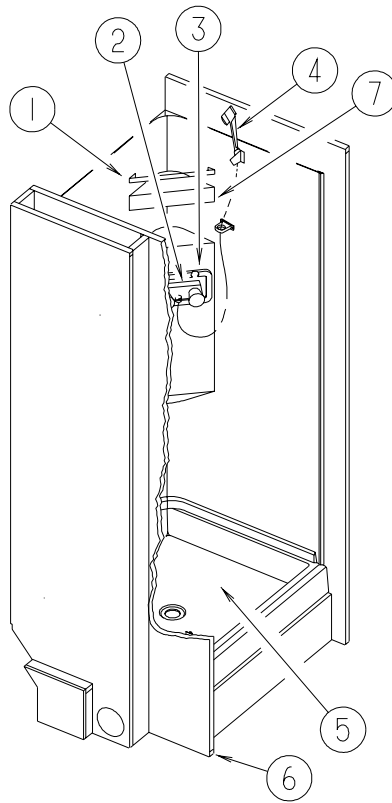

KEY	PART NUMBER	U/M	DESCRIPTION
1	113714-02-02A	EA	RETAINER - SHELF/SHOWER - SOFT WHITE
2		EA	FAUCET SHOWER - SEE WATER SYSTEMS GROUP
3		EA	PANEL - FAUCET SHOWER - SOFT WHITE- SEE WATER SYSTEMS GROUP
4		EA	SHOWERHEAD - SEE WATER SYSTEMS GROUP
5	M02673-05-L01	EA	SHOWER PAN - W/STRAINER - 29.8" X 22.7" X 5.7"
			FROM: 00-00-00 THRU: 09-19-99
5	M02673-11-L01	EA	SHOWER PAN - W/STRAINER
			FROM: 09-20-99 THRU: 99-99-99
6	105629-01-02A	EA	SURROUND - SHOWER - SOFT WHITE
7	105707-01-02A	EA	CADDY - SHOWER - SOFT WHITE
*	117431-01-01A	EA	DOOR - SHOWER - FABRIC PLEATED - 29.6" X 63.0"
			FROM: 00-00-00 THRU: 03-12-00
*	135615-01-01A	EA	DOOR - SHOWER/FOLDING - 29.7" X 62.9" - WHITE
			FROM: 03-13-00 THRU: 99-99-99

***COMPONENT PARTS FOUND IN SERVICE PARTS LIBRARY**

**BEDROOM GROUP
QUEEN CABINETS**

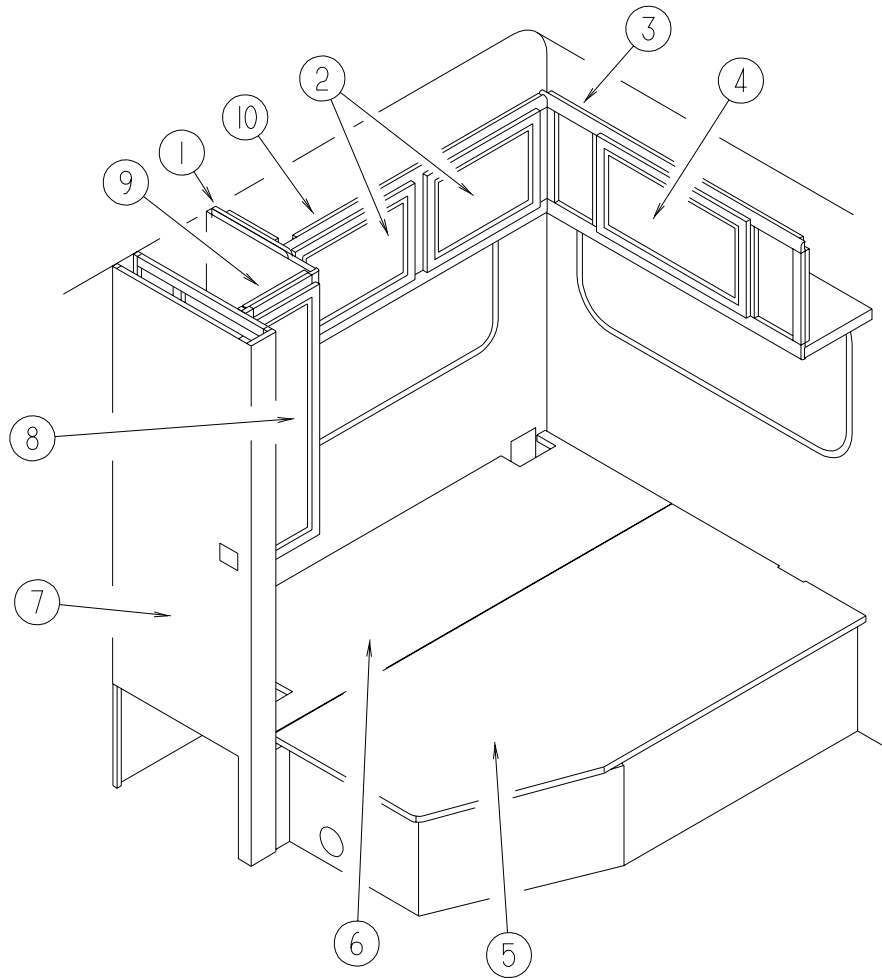

KEY	PART NUMBER	U/M	DESCRIPTION
1	109908-79-K01	EA	END CAP - OVERHEAD CABINET
2	132141-08-L01	EA	DOOR - RAIL/VENEER - 15.7" X 20.4" - W/O HARDWARE
3	127484-02-K01	EA	CABINET - OVERHEAD/REAR - W/O DOORS/HARDWARE
4	132141-14-L01	EA	DOOR - RAIL/VENEER - 15.7" X 27.9" - W/O HARDWARE
5	M07448-06-J03	EA	TOP - QUEEN BED - W/O HARDWARE
6	M07448-05-000	EA	TOP - QUEEN BED - W/O HARDWARE
7	132762-01-L01	EA	CABINET - PIPE COVER
7	132762-01-L02	EA	CABINET - PIPE COVER
7	132762-01-L03	EA	CABINET - PIPE COVER
8	132141-47-L01	EA	DOOR - RAIL/VENEER - 9.9" X 33.5" - W/O HARDWARE
9	P32374-01-L01	EA	CABINET - SHIRT CLOSET/RIGHT HAND - W/O DOORS/HARDWARE
10	132462-01-L01	EA	CABINET - OVERHEAD/REAR - W/O DOORS/HARDWARE

CHASSIS GROUP FRAME

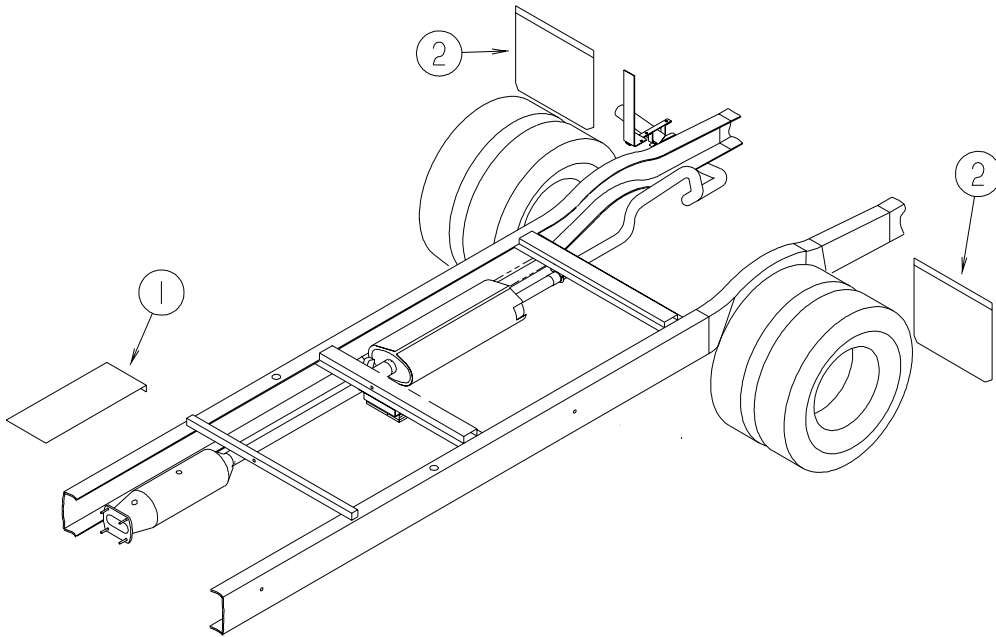

FORD

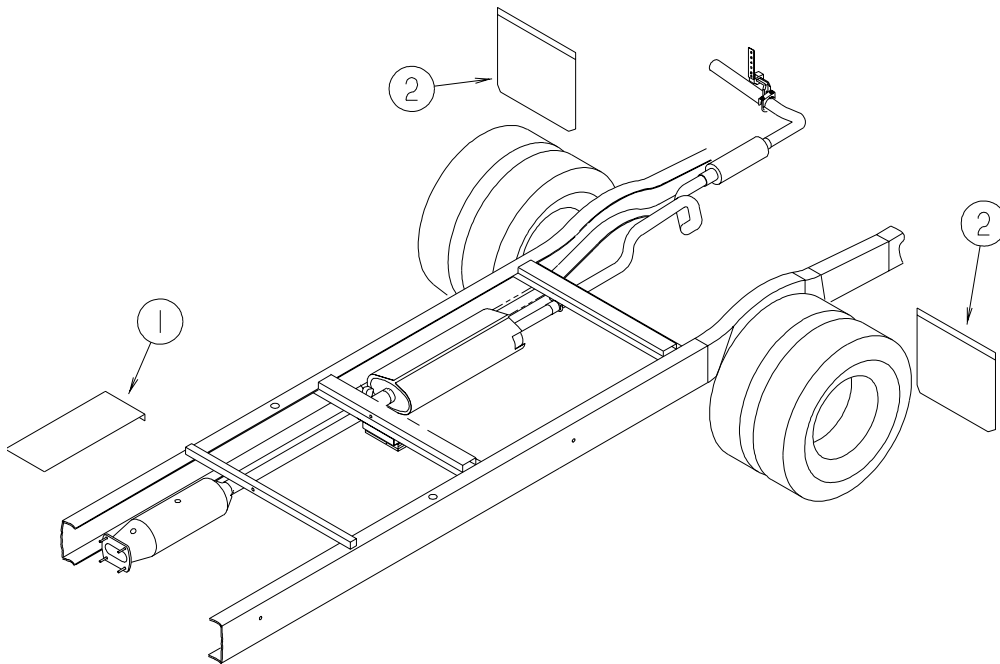

CHEVY

KEY	PART NUMBER	U/M DESCRIPTION
1	091182-09-000	EA SHIELD - HEAT
2	045731-05-000	EA GUARD - ROCK

CHASSIS GROUP (CONTINUED)
EXHAUST

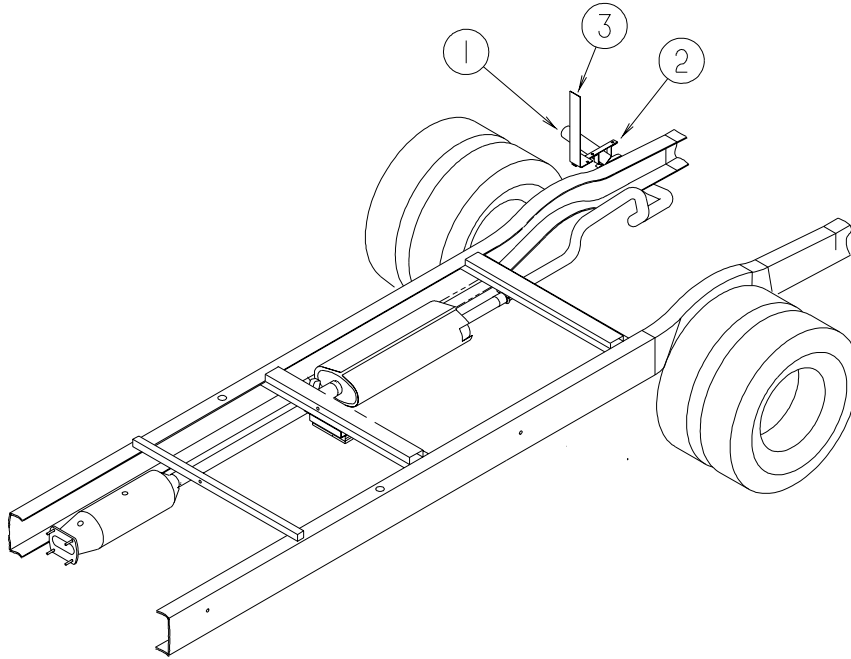

FORD - GAS

KEY	PART NUMBER	U/M	DESCRIPTION
1		EA	EXTENSION - TAIL PIPE - CHASSIS SUPPLIED
	016379-02-000	EA	STRAP - HANGER EXTENSION - 2" X 1" - STEEL
			FROM: 00-00-00 THRU: 02-14-00
2	007125-08-000	EA	CLAMP - MUFFLER - 3" DIAMETER
3	007131-01-000	EA	HANGER - TAILPIPE - 6 SLOTS

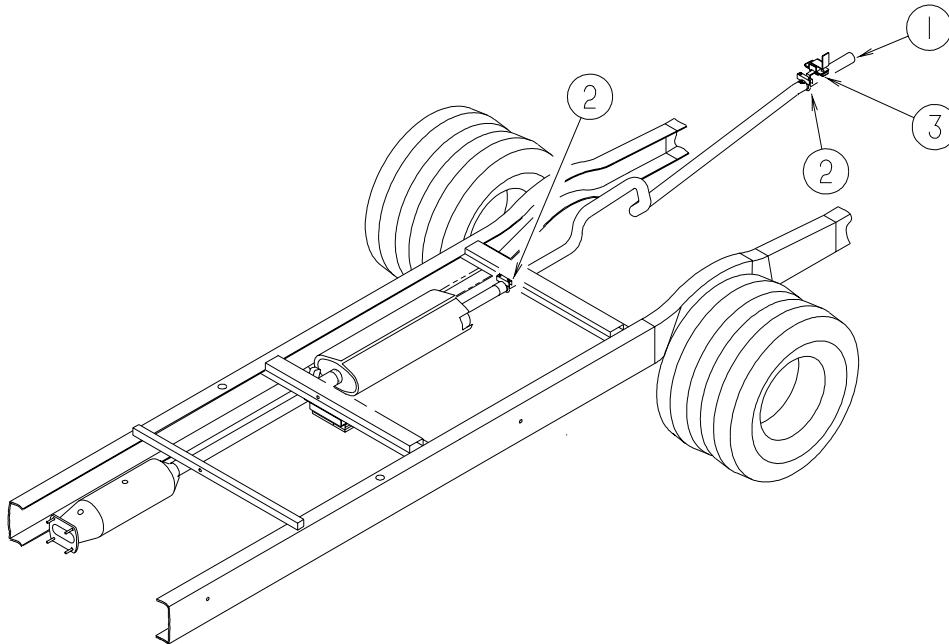

FORD - DIESEL

KEY	PART NUMBER	U/M	DESCRIPTION
1	117832-01-000	EA	PIPE - EXHAUST - TAIL
2	094918-02-000	EA	CLAMP - EXHAUST - 3.5"
3	117380-01-02B	EA	HANGER - TAILPIPE - E-COATED
	096054-04-000	EA	SUPPORT - EXHAUST PIPE
	095190-01-000	EA	HANGER - EXHAUST - 4" X 1.4"

CHASSIS GROUP (CONTINUED)
EXHAUST (CONTINUED)

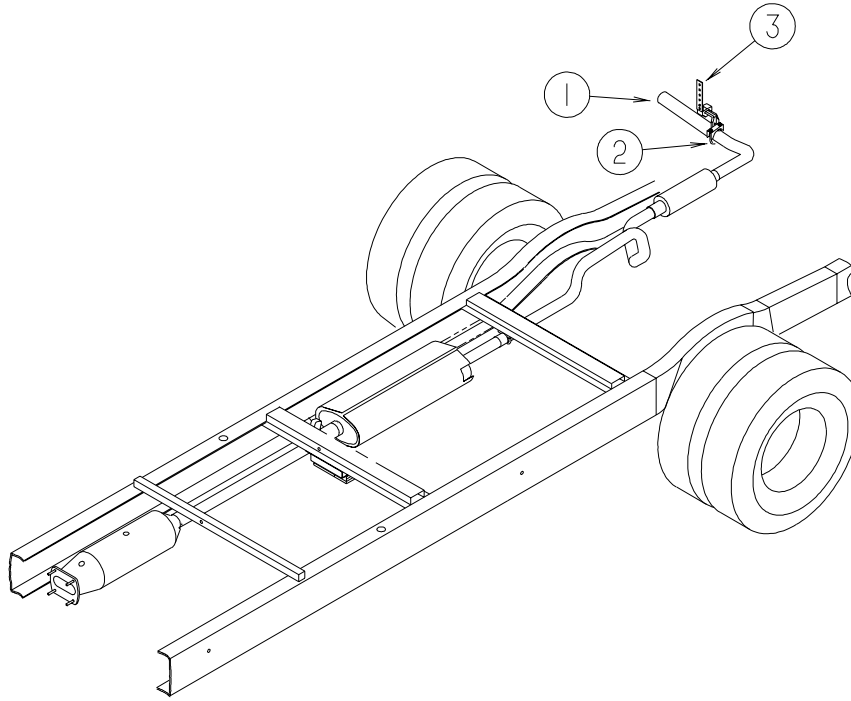

CHEVY

KEY	PART NUMBER	U/M DESCRIPTION
1	124570-02-000	EA PIPE - EXHAUST - TAIL
2	007125-07-000	EA CLAMP - MUFFLER - 2.5" DIAMETER
3	007131-01-000	EA HANGER - TAILPIPE - 6 SLOTS

CHASSIS GROUP (CONTINUED)
HITCH, REAR BUMPER & SPARE TIRE

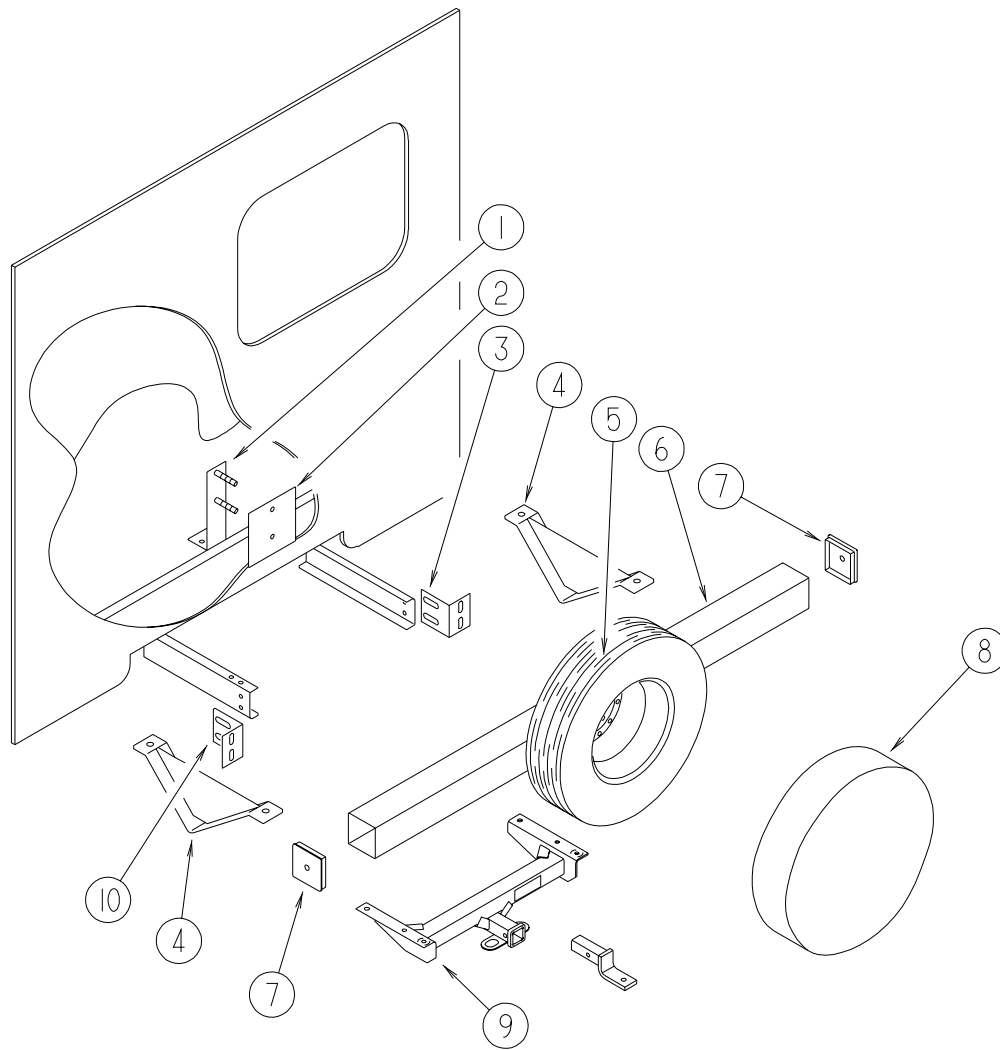

KEY	PART NUMBER	U/M	DESCRIPTION
1	105209-06-C52	EA	BRACKET - SPARE TIRE - FORD
1	105209-04-C52	EA	BRACKET - SPARE TIRE - CHEVY
2	105208-01-000	EA	PLATE - SPARE TIRE
3	104420-01-000	EA	SUPPORT/ANGLE - REAR BUMPER - RIGHT HAND
4	083376-01-000	EA	PLATE/SKID - 13.2" X 6" X 2" STEEL
5	070917-06-000	EA	TIRE - LT225/75R16E - R4S M/S - FIRESTONE
	051377-04-000	EA	VALVE STEM - .5" X 2"
5	106715-01-000	EA	TIRE - LT 225/75 R16 - LRD 550 AS - CHEVY
	051377-03-000	EA	VALVE STEM
6	103422-05-02A	EA	BUMPER - REAR - SQUARE ALUMINUM - 97.3" - BRIGHT WHITE
7	039779-01-000	EA	CAP - BUMPER - RUBBER - 4" X 4" - BLACK
8	073322-09-L01	EA	COVER - TIRE - 30"
	073322-50-000	EA	COVER - UNIVERSAL LINER
9	130339-04-000	EA	HITCH RECEIVER - BOLT ON CLASS II
10	104420-02-000	EA	SUPPORT/ANGLE - REAR BUMPER - LEFT HAND
	113589-01-000	EA	CONNECTOR - PLUG - TRAILER
	113589-02-000	EA	CONNECTOR - SOCKET - TRAILER

CHASSIS GROUP (CONTINUED)
FUEL FILL

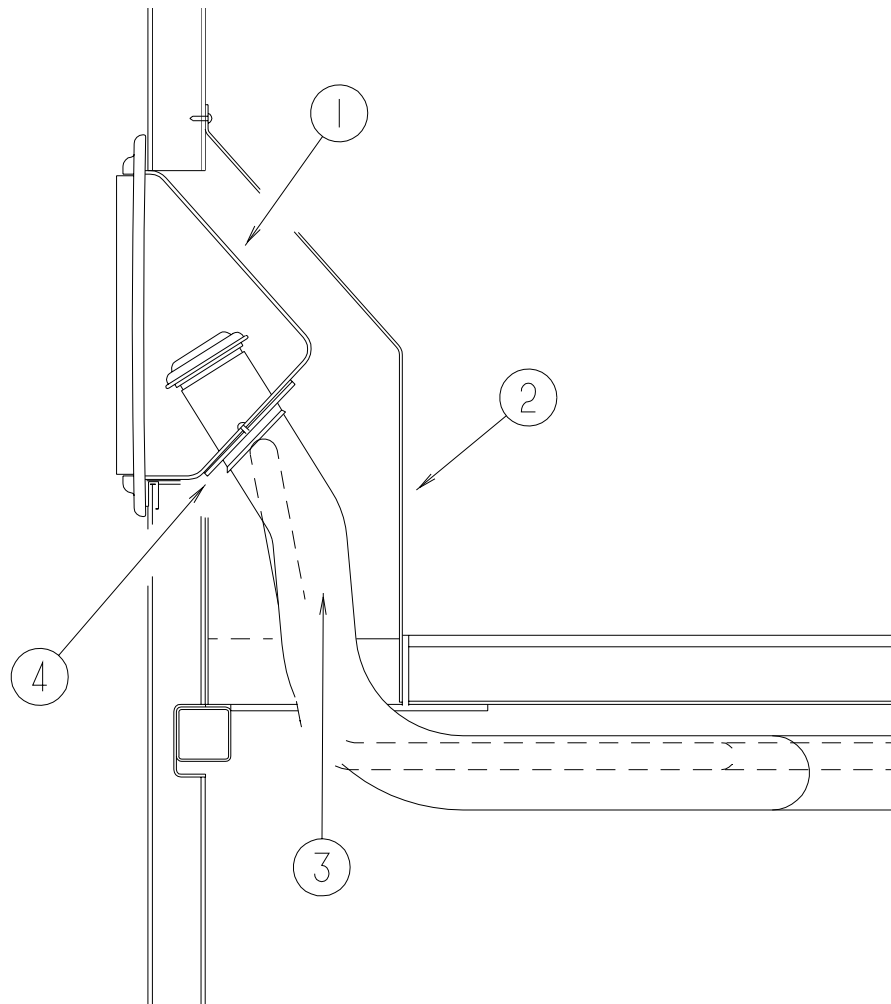

KEY	PART NUMBER	U/M	DESCRIPTION
1	095854-01-04A	EA	SHROUD - FUEL FILL - RADIUS - BRIGHT WHITE
1	127291-01-01A	EA	SHROUD - FUEL FILL - BRIGHT WHITE
2	078040-05-000	EA	SHROUD - FUEL FILL - UPPER - RECTANGULAR
3	124995-02-000	EA	NECK - FUEL FILL - UNLEADED - FORD
3	116043-02-000	EA	NECK - FILLER - FUEL FILL
3	128312-03-000	EA	NECK - FUEL FILL - UNLEADED - CHEVY
4	078200-01-000	EA	GASKET - FUEL FILL - 3.5"OD X 2"ID
	128139-03-000	FT	HOSE - FUEL - LOW PERMEABILITY - 1/4" DIAMETER
	088258-02-000	EA	CLIP-RETAINING,FUEL LINE SGL - MC-90
	062401-05-000	EA	CLAMP - HOSE - WORMGEAR - 2" - 3" ID
	084884-01-000	EA	PLUG - BRASS - 3/8"

CHASSIS GROUP (CONTINUED)

WHEEL, TIRE, COVERS & LINERS

KEY	PART NUMBER	U/M	DESCRIPTION
	083617-04-000	EA	WHEEL - STEEL - 6" X 16" - FORD
	070917-06-000	EA	TIRE - LT225/75R16E - R4S M/S - FIRESTONE
	051377-04-000	EA	VALVE STEM - .5" X 2"
	089359-03-000	EA	WHEEL - STEEL - 6" X 16" - 8 HOLE - PRIMED - #28623
	106715-01-000	EA	TIRE - LT 225/75 R16 - LRD 550 AS - CHEVY
	051377-03-000	EA	VALVE STEM
*	109443-05-000	EA	WHEEL COVER - 4/SET - 16" STAINLESS STEEL
*	110435-13-000	EA	LINER - WHEEL - SET OF 4 - 16" (8 HOLE)
	095012-05-000	EA	EXTENSION - VALVE STEM - LIVE - 5"
	095012-06-000	EA	STABILIZER - VALVE EXTENSION - LIVE - 2"
*	091209-05-000	EA	LINER - WHEEL - SET OF 4 - 16" - STAINLESS STEEL
	095012-05-000	EA	EXTENSION - VALVE STEM - LIVE - 5"
	095012-06-000	EA	STABILIZER - VALVE EXTENSION - LIVE - 2"
	112358-01-000	EA	WRENCH - LUG - 7/8" - L-SHAPE

***COMPONENT PARTS FOUND IN SERVICE PARTS LIBRARY**

CURTAIN & CUSHION GROUP NOTICE

IN ORDER TO ASSIST OUR PARTS SALES DEPT. IN PROVIDING INTERIOR SOFTWARE ITEMS, PLEASE INCLUDE THE SERIAL NUMBER AND THE COLOR CODE NUMBER FROM THE VEHICLE CERTIFICATION LABEL WHEN ORDERING. THIS LABEL IS LOCATED ON THE LEFT SIDEWALL AT THE END OF THE DASH (A-BODY), OR ON THE DRIVER'S DOOR LATCH PLATE (C-BODY). AN EXAMPLE OF A COLOR CODE NUMBER IS B07, WHICH DESIGNATES AN OVERALL COLOR SCHEME OF A PARTICULAR UNIT. THE COLOR LISTED AFTER THE ITEM DESCRIPTION ON THE MICROFICHE, INDICATES THE OVERALL UNIT COLOR. ORDER THE ITEM YOU DESIRE ACCORDING TO UNIT COLOR CODE. IF ALL COLORS USE THE SAME ITEM NO COLOR CODE WILL BE NOTED.

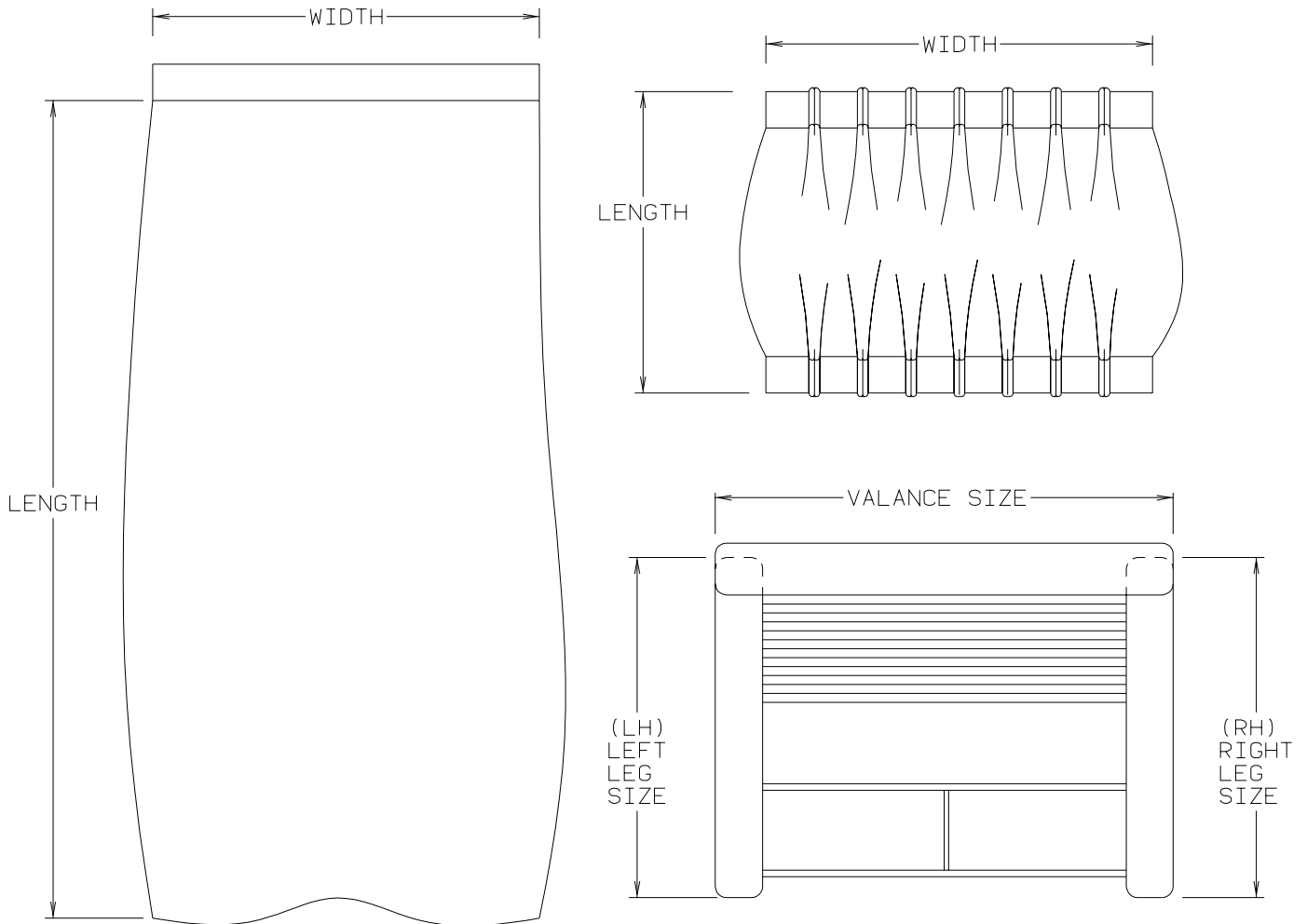

NOTE: USE THIS ILLUSTRATION WHEN DETERMINING LENGTH AND WIDTH MEASUREMENTS FOR CURTAINS. YOU WILL NOTE THE WIDTH MEASUREMENT IS TAKEN ON THE TOP OF THE CURTAIN WITH THE CURTAIN FULLY EXTENDED. THE LENGTH MEASUREMENT IS TAKEN FROM TOP TO BOTTOM. LEFT AND RIGHT WINDOW LEGS ARE DETERMINED WHEN FACING THE WINDOW.

CURTAIN & CUSHION GROUP (CONTINUED)
CUSHION LAYOUT

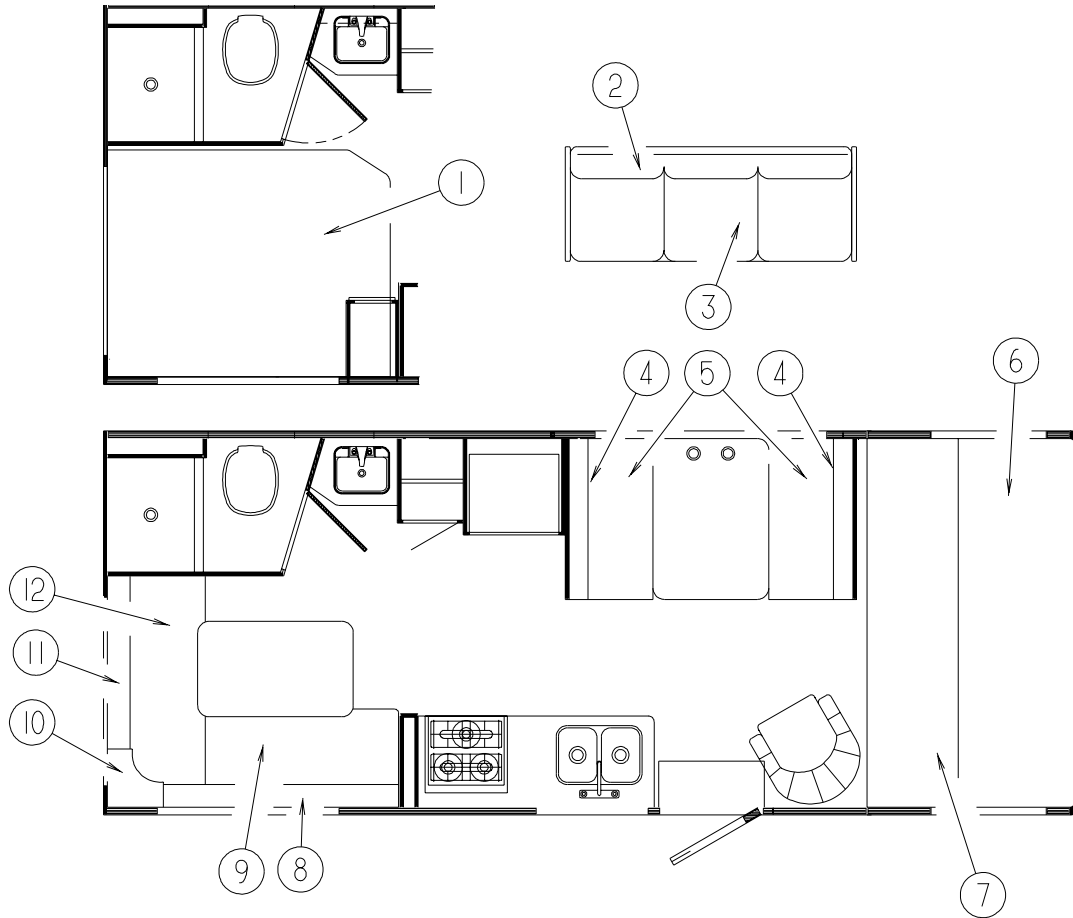

KEY	PART NUMBER	U/M	DESCRIPTION
1	123471-08-L01	EA	BEDSPREAD/THROW - 60" X 75"
1	123471-08-L02	EA	BEDSPREAD/THROW - 60" X 75"
1	123471-08-L03	EA	BEDSPREAD/THROW - 60" X 75"
1	104176-04-L01	EA	PILLOW SHAM - 30"
1	104176-04-L02	EA	PILLOW SHAM - 30"
1	104176-04-L03	EA	PILLOW SHAM - 30"
	101123-35-000	EA	MATTRESS - FOAM W/1 CUT CORNER - 60" X 75" X 6.5"
2	129688-05-L15	EA	SOFA - BACK ONLY - 74" (L01)
2	129688-05-L16	EA	SOFA - BACK ONLY - 74" (L02)
2	129688-05-L17	EA	SOFA - BACK ONLY - 74" (L03)
	P29688-05-L15	EA	COVER - BACK - 74" (L01)
	P29688-05-L16	EA	COVER - BACK - 74" (L02)
	P29688-05-L17	EA	COVER - BACK - 74" (L03)
3	129688-06-L15	EA	SOFA - SEAT ONLY - 74" (L01)
3	129688-06-L16	EA	SOFA - SEAT ONLY - 74" (L02)
3	129688-06-L17	EA	SOFA - SEAT ONLY - 74" (L03)
	P29688-06-L15	EA	COVER - SEAT - 74" (L01)
	P29688-06-L16	EA	COVER - SEAT - 74" (L02)
	P29688-06-L17	EA	COVER - SEAT - 74" (L03)
	113990-09-000	EA	LOCK - BRACKET - MALE FLEXSTEEL
	122556-04-01A	EA	LOCK - JACK KNIFE SEAT
	116104-03-02B	EA	BRACKET - ZEE W/HOLES - 5.9"
	116104-04-02B	EA	BRACKET - ZEE W/HOLES - 3.2"
4	111897-14-L01	EA	CUSHION - BACK - 13.5" X 42" X 5"
4	111897-14-L02	EA	CUSHION - BACK - 13.5" X 42" X 5"
4	111897-14-L03	EA	CUSHION - BACK - 13.5" X 42" X 5"
	P11897-14-L01	EA	COVER - BACK - 13.5" X 42" X 5"
	P11897-14-L02	EA	COVER - BACK - 13.5" X 42" X 5"
	P11897-14-L03	EA	COVER - BACK - 13.5" X 42" X 5"

CURTAIN & CUSHION GROUP (CONTINUED)
CUSHION LAYOUT (CONTINUED)

KEY	PART NUMBER	U/M	DESCRIPTION
5	105603-15-L01	EA	CUSHION - SEAT - 23" X 42" X 5"
5	105603-15-L02	EA	CUSHION - SEAT - 23" X 42" X 5"
5	105603-15-L03	EA	CUSHION - SEAT - 23" X 42" X 5"
	P05603-15-L01	EA	COVER - SEAT - 23" X 42" X 5"
	P05603-15-L02	EA	COVER - SEAT - 23" X 42" X 5"
	P05603-15-L03	EA	COVER - SEAT - 23" X 42" X 5"
6	105573-09-K03	EA	CUSHION - OVERHEAD BUNK/FRONT - 32.5" X 80" X 5" (L01)
6	105573-09-J03	EA	CUSHION - OVERHEAD BUNK/FRONT - 32.5" X 80" X 5" (L02)
6	105573-09-L03	EA	CUSHION - OVERHEAD BUNK/FRONT - 32.5" X 80" X 5" (L03)
	P05573-09-K03	EA	COVER - CUSHION/OVERHEAD BUNK/FRONT - 32.5" X 80" X 5" (L01)
	P05573-09-J03	EA	COVER - CUSHION/OVERHEAD BUNK/FRONT - 32.5" X 80" X 5" (L02)
	P05573-09-L03	EA	COVER - CUSHION/OVERHEAD BUNK/FRONT - 32.5" X 80" X 5" (L03)
7	105573-10-L01	EA	CUSHION - OVERHEAD BUNK/REAR - 27" X 23" X 80" X 5"
7	105573-10-L02	EA	CUSHION - OVERHEAD BUNK/REAR - 27" X 23" X 80" X 5"
7	105573-10-L03	EA	CUSHION - OVERHEAD BUNK/REAR - 27" X 23" X 80" X 5"
	P05573-10-L01	EA	COVER - CUSHION/OVERHEAD BUNK/REAR - 27" X 23" X 80" X 5"
	P05573-10-L02	EA	COVER - CUSHION/OVERHEAD BUNK/REAR - 27" X 23" X 80" X 5"
	P05573-10-L03	EA	COVER - CUSHION/OVERHEAD BUNK/REAR - 27" X 23" X 80" X 5"
	079145-08-000	EA	CUSHION - BUNK - 25" X 74" X 3.5"
	M79145-08-000	EA	COVER - CUSHION/BUNK - 25" X 74" X 3.5"
8	127742-02-L01	EA	CUSHION - BACK - 48" X 14" X 5"
8	127742-02-L02	EA	CUSHION - BACK - 48" X 14" X 5"
8	127742-02-L03	EA	CUSHION - BACK - 48" X 14" X 5"
	P27742-02-L01	EA	COVER - BACK - 48" X 14" X 5"
	P27742-02-L02	EA	COVER - BACK - 48" X 14" X 5"
	P27742-02-L03	EA	COVER - BACK - 48" X 14" X 5"
9	127742-01-L01	EA	CUSHION - SEAT - 31.25" X 48" X 4.75"
9	127742-01-L02	EA	CUSHION - SEAT - 31.25" X 48" X 4.75"
9	127742-01-L03	EA	CUSHION - SEAT - 31.25" X 48" X 4.75"
	P27742-01-L01	EA	COVER - SEAT - 31.25" X 48" X 4.75"
	P27742-01-L02	EA	COVER - SEAT - 31.25" X 48" X 4.75"
	P27742-01-L03	EA	COVER - SEAT - 31.25" X 48" X 4.75"
	127553-01-J03	EA	LEG - DINETTE CUSHION
	110550-01-000	EA	CAP - TUBE .9" SQUARE
9	127742-06-L01	EA	CUSHION - SEAT - 31.25" X 48" X 4.75" - CANADIAN
9	127742-06-L02	EA	CUSHION - SEAT - 31.25" X 48" X 4.75" - CANADIAN
9	127742-06-L03	EA	CUSHION - SEAT - 31.25" X 48" X 4.75" - CANADIAN
	P27742-06-L01	EA	COVER - SEAT - 31.25" X 48" X 4.75" - CANADIAN
	P27742-06-L02	EA	COVER - SEAT - 31.25" X 48" X 4.75" - CANADIAN
	P27742-06-L03	EA	COVER - SEAT - 31.25" X 48" X 4.75" - CANADIAN
10	127742-05-L01	EA	CUSHION - CORNER - BOLSTER
10	127742-05-L02	EA	CUSHION - CORNER - BOLSTER
10	127742-05-L03	EA	CUSHION - CORNER - BOLSTER
	P27742-05-L01	EA	COVER - CORNER - BOLSTER
	P27742-05-L02	EA	COVER - CORNER - BOLSTER
	P27742-05-L03	EA	COVER - CORNER - BOLSTER
11	127742-04-L01	EA	CUSHION - BACK - 27.5" X 14" X 7"
11	127742-04-L02	EA	CUSHION - BACK - 27.5" X 14" X 7"
11	127742-04-L03	EA	CUSHION - BACK - 27.5" X 14" X 7"
	P27742-04-L01	EA	COVER - BACK - 27.5" X 14" X 7"
	P27742-04-L02	EA	COVER - BACK - 27.5" X 14" X 7"
	P27742-04-L03	EA	COVER - BACK - 27.5" X 14" X 7"
12	127742-03-L01	EA	CUSHION - SEAT - 27" X 60" X 5"
12	127742-03-L02	EA	CUSHION - SEAT - 27" X 60" X 5"
12	127742-03-L03	EA	CUSHION - SEAT - 27" X 60" X 5"
	P27742-03-L01	EA	COVER - SEAT - 27" X 60" X 5"
	P27742-03-L02	EA	COVER - SEAT - 27" X 60" X 5"
	P27742-03-L03	EA	COVER - SEAT - 27" X 60" X 5"

CURTAIN & CUSHION GROUP (CONTINUED)
BUCKET SEATS

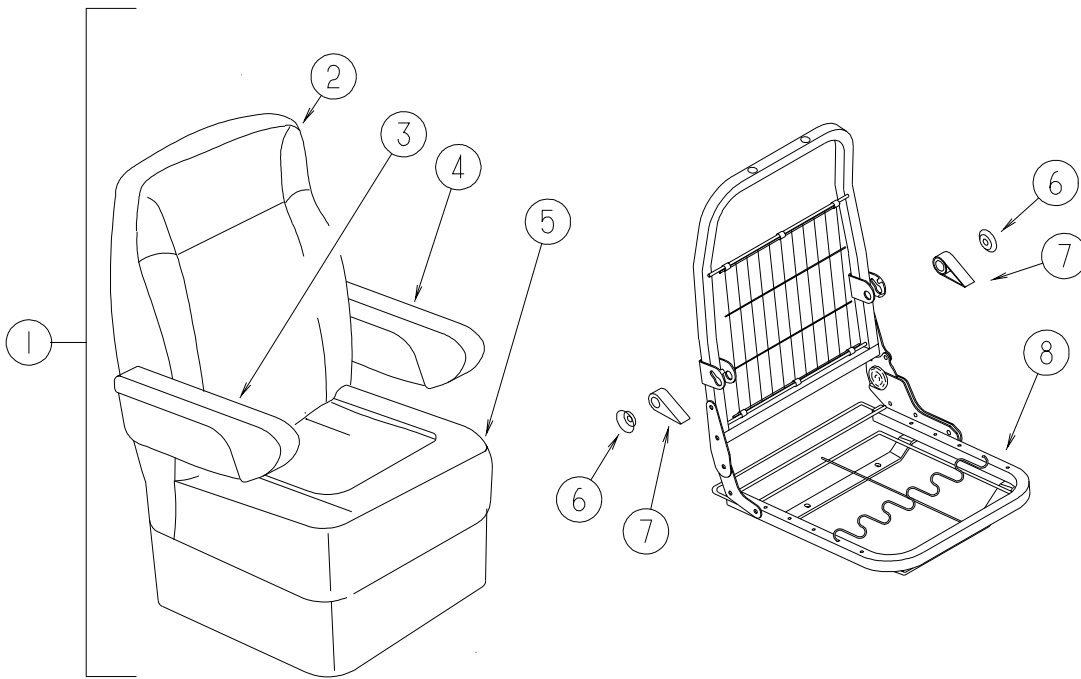

FORD

KEY	PART NUMBER	U/M	DESCRIPTION
1	132263-01-L01	EA	SEAT - DRIVER
1	132263-01-L02	EA	SEAT - DRIVER
1	132263-01-L03	EA	SEAT - DRIVER
1	132263-02-L01	EA	SEAT - PASSENGER
1	132263-02-L02	EA	SEAT - PASSENGER
1	132263-02-L03	EA	SEAT - PASSENGER
2	M05962-88-L01	EA	COVER - BACK
2	M05962-88-L02	EA	COVER - BACK
2	M05962-88-L03	EA	COVER - BACK
3	129666-07-L01	EA	ARMREST - RIGHT HAND
3	129666-07-L02	EA	ARMREST - RIGHT HAND
3	129666-07-L03	EA	ARMREST - RIGHT HAND
	P29666-07-L01	EA	COVER - ARMREST/RIGHT HAND
	P29666-07-L02	EA	COVER - ARMREST/RIGHT HAND
	P29666-07-L03	EA	COVER - ARMREST/RIGHT HAND
4	129666-08-L01	EA	ARMREST - LEFT HAND
4	129666-08-L02	EA	ARMREST - LEFT HAND
4	129666-08-L03	EA	ARMREST - LEFT HAND
	P29666-08-L01	EA	COVER - ARMREST/LEFT HAND
	P29666-08-L02	EA	COVER - ARMREST/LEFT HAND
	P29666-08-L03	EA	COVER - ARMREST/LEFT HAND
5	M05962-89-L01	EA	COVER - SEAT
5	M05962-89-L02	EA	COVER - SEAT
5	M05962-89-L03	EA	COVER - SEAT
6	130802-03-000	EA	SCREW F/LEVER
7	130802-01-000	EA	LEVER - LEFT HAND
7	130802-02-000	EA	LEVER - RIGHT HAND
8	132875-02-000	EA	FRAME - LEFT HAND CHAIR/TALL BACK
8	132875-01-000	EA	FRAME - RIGHT HAND CHAIR/TALL BACK
	007221-01-000	EA	SPACER - SEAT/ADJUSTER

CURTAIN & CUSHION GROUP (CONTINUED)
BUCKET SEATS (CONTINUED)

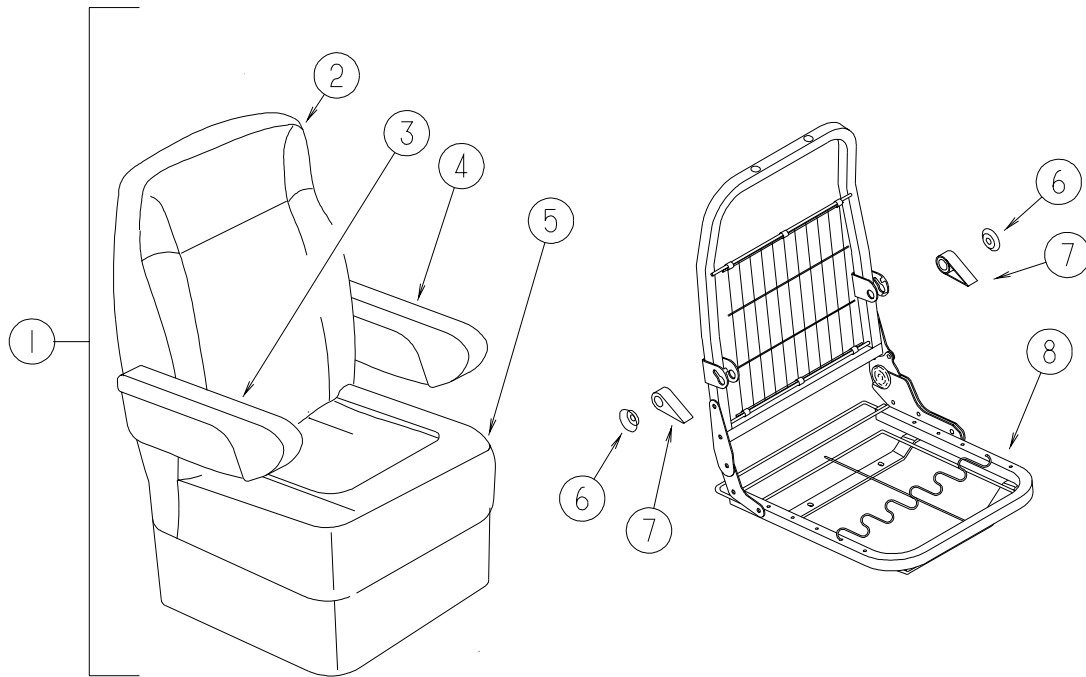

CHEVY

KEY	PART NUMBER	U/M	DESCRIPTION
1	132263-03-L01	EA	SEAT - DRIVER - W/SKIRT
1	132263-03-L02	EA	SEAT - DRIVER - W/SKIRT
1	132263-03-L03	EA	SEAT - DRIVER - W/SKIRT
1	132263-04-L01	EA	SEAT - PASSENGER - W/SKIRT
1	132263-04-L02	EA	SEAT - PASSENGER - W/SKIRT
1	132263-04-L03	EA	SEAT - PASSENGER - W/SKIRT
2	M05962-88-L01	EA	COVER - BACK
2	M05962-88-L02	EA	COVER - BACK
2	M05962-88-L03	EA	COVER - BACK
3	129666-07-L01	EA	ARMREST - RIGHT HAND
3	129666-07-L02	EA	ARMREST - RIGHT HAND
3	129666-07-L03	EA	ARMREST - RIGHT HAND
	P29666-07-L01	EA	COVER - ARMREST/RIGHT HAND
	P29666-07-L02	EA	COVER - ARMREST/RIGHT HAND
	P29666-07-L03	EA	COVER - ARMREST/RIGHT HAND
4	129666-08-L01	EA	ARMREST - LEFT HAND
4	129666-08-L02	EA	ARMREST - LEFT HAND
4	129666-08-L03	EA	ARMREST - LEFT HAND
	P29666-08-L01	EA	COVER - ARMREST/LEFT HAND
	P29666-08-L02	EA	COVER - ARMREST/LEFT HAND
	P29666-08-L03	EA	COVER - ARMREST/LEFT HAND
5	M05962-89-L01	EA	COVER - SEAT
5	M05962-89-L02	EA	COVER - SEAT
5	M05962-89-L03	EA	COVER - SEAT
6	130802-03-000	EA	SCREW F/LEVER
7	130802-01-000	EA	LEVER - LEFT HAND
7	130802-02-000	EA	LEVER - RIGHT HAND
8	132875-02-000	EA	FRAME - LEFT HAND CHAIR/TALL BACK
8	132875-01-000	EA	FRAME - RIGHT HAND CHAIR/TALL BACK
	007221-01-000	EA	SPACER - SEAT/ADJUSTER

CURTAIN & CUSHION GROUP (CONTINUED)
LOUNGE CHAIR

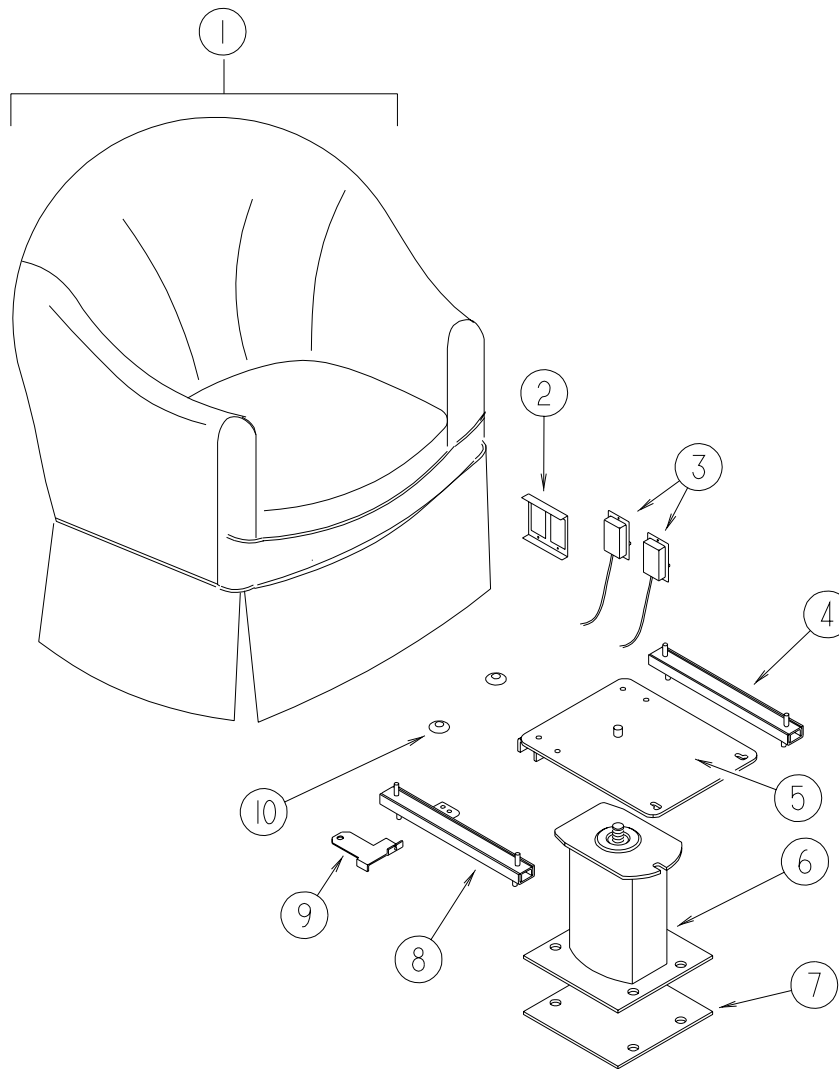

KEY	PART NUMBER	U/M	DESCRIPTION
1	115470-01-K03	EA	CHAIR - SWIVEL (L01)
1	115470-01-GB1	EA	CHAIR - SWIVEL (L02)
1	115470-01-L03	EA	CHAIR - SWIVEL (L03)
	P15470-01-K03	EA	COVER - CHAIR (L01)
	P15470-01-GB1	EA	COVER - CHAIR (L02)
	P15470-01-L03	EA	COVER - CHAIR (L03)
2	127159-02-02B	EA	BRACKET - SEAT RELEASE - DUAL REMOTE
3	108049-04-000	EA	CABLE - W/MINI LEVER ACTION SWITCH - 28" SHEATH/30" CABLE
	108049-02-000	EA	CLIP - CABLE/PEDESTAL
	010495-01-000	EA	CLAMP - CABLE - 9/16"
4	119952-01-000	EA	SLIDE/SEAT - HEAVY DUTY NON LOCKING
5	107921-08-000	EA	PLATE - TOP PEDESTAL - W/O SEAT BELT BAR
	107921-06-000	EA	BEARING KIT - PEDESTAL
6	107921-01-000	EA	PEDESTAL/FLOOR MOUNTED - W/9.75" EXTENSION
7	108445-02-000	EA	PLATE/FLOOR MOUNTED - PEDESTAL SEAT
8	119952-03-000	EA	SLIDE/SEAT - HEAVY DUTY LOCKING - 2 STUDS
9	117125-01-02B	EA	BRACKET - CABLE MOUNT - ADJUSTER W/LOCK
10	007221-01-000	EA	SPACER - SEAT/ADJUSTER

CURTAIN & CUSHION GROUP (CONTINUED)
WINDOW TREATMENT

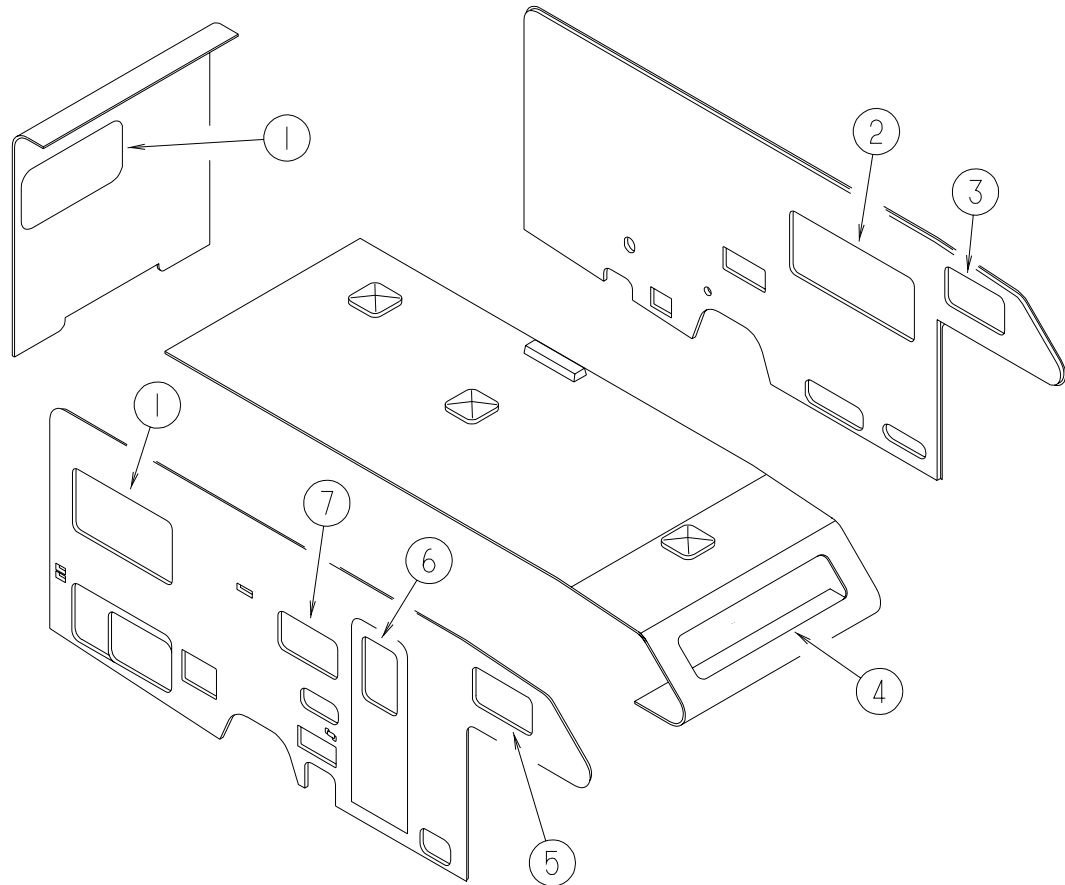

KEY	PART NUMBER	U/M	DESCRIPTION
1	P32339-01-L15	EA	COVER - VALANCE - 100" (L01) - QUEEN BED
1	P32339-01-L16	EA	COVER - VALANCE - 100" (L02) - QUEEN BED
1	P32339-01-L17	EA	COVER - VALANCE - 100" (L03) - QUEEN BED
1	132268-10-L01	EA	VALANCE - SIMPLICITY - 53" - REAR DINETTE
1	132268-10-L02	EA	VALANCE - SIMPLICITY - 53" - REAR DINETTE
1	132268-10-L03	EA	VALANCE - SIMPLICITY - 53" - REAR DINETTE
1	109802-55-J32	EA	BLIND - PLEATED - 49" X 27"
1	109802-55-L02	EA	BLIND - PLEATED - 49" X 27"
1	109802-55-L03	EA	BLIND - PLEATED - 49" X 27"
1	111910-62-L01	EA	BLIND - DAY/NIGHTER - 49" X 27"
1	111910-62-L02	EA	BLIND - DAY/NIGHTER - 49" X 27"
1	111910-62-L03	EA	BLIND - DAY/NIGHTER - 49" X 27"
1	127017-61-L15	EA	LEG - RIGHT - 25" (L01) - QUEEN BED
1	127017-61-L16	EA	LEG - RIGHT - 25" (L02) - QUEEN BED
1	127017-61-L17	EA	LEG - RIGHT - 25" (L03) - QUEEN BED
1	127017-62-L15	EA	LEG - LEFT - 25" (L01) - QUEEN BED
1	127017-62-L16	EA	LEG - LEFT - 25" (L02) - QUEEN BED
1	127017-62-L17	EA	LEG - LEFT - 25" (L03) - QUEEN BED
1	127017-59-L15	EA	LEG - RIGHT - 25" (L01) - REAR DINETTE
1	127017-59-L16	EA	LEG - RIGHT - 25" (L02) - REAR DINETTE
1	127017-59-L17	EA	LEG - RIGHT - 25" (L03) - REAR DINETTE
1	127017-60-L15	EA	LEG - LEFT - 25" (L01) - REAR DINETTE
1	127017-60-L16	EA	LEG - LEFT - 25" (L02) - REAR DINETTE
1	127017-60-L17	EA	LEG - LEFT - 25" (L03) - REAR DINETTE
2	132268-01-L01	EA	VALANCE - SIMPLICITY - 64.5"
2	132268-01-L02	EA	VALANCE - SIMPLICITY - 64.5"
2	132268-01-L03	EA	VALANCE - SIMPLICITY - 64.5"
2	109802-58-J32	EA	BLIND - PLEATED - 61" X 28.5" (L01)
2	109802-58-L02	EA	BLIND - PLEATED - 61" X 28.5" (L02)
2	109802-58-L03	EA	BLIND - PLEATED - 61" X 28.5" (L03)

CURTAIN & CUSHION GROUP (CONTINUED)
WINDOW TREATMENT (CONTINUED)

KEY	PART NUMBER	U/M	DESCRIPTION
2	111910-57-L01	EA	BLIND - DAY/NIGHTER - 61" X 28.5"
2	111910-57-L02	EA	BLIND - DAY/NIGHTER - 61" X 28.5"
2	111910-57-L03	EA	BLIND - DAY/NIGHTER - 61" X 28.5"
2	127017-59-L15	EA	LEG - RIGHT - 25" (L01)
2	127017-59-L16	EA	LEG - RIGHT - 25" (L02)
2	127017-59-L17	EA	LEG - RIGHT - 25" (L03)
2	127017-60-L15	EA	LEG - LEFT - 25" (L01)
2	127017-60-L16	EA	LEG - LEFT - 25" (L02)
2	127017-60-L17	EA	LEG - LEFT - 25" (L03)
3	101034-64-L01	EA	CURTAIN - LEFT HAND - 19.5" X 31"
3	101034-64-L02	EA	CURTAIN - LEFT HAND - 19.5" X 31"
3	101034-64-L03	EA	CURTAIN - LEFT HAND - 19.5" X 31"
4	101034-62-L01	EA	CURTAIN - LEFT HAND - 21" X 56"
4	101034-62-L02	EA	CURTAIN - LEFT HAND - 21" X 56"
4	101034-62-L03	EA	CURTAIN - LEFT HAND - 21" X 56"
4	101034-61-L01	EA	CURTAIN - RIGHT HAND - 21" X 56"
4	101034-61-L02	EA	CURTAIN - RIGHT HAND - 21" X 56"
4	101034-61-L03	EA	CURTAIN - RIGHT HAND - 21" X 56"
5	101034-63-L01	EA	CURTAIN - RIGHT HAND - 19.5" X 31"
5	101034-63-L02	EA	CURTAIN - RIGHT HAND - 19.5" X 31"
5	101034-63-L03	EA	CURTAIN - RIGHT HAND - 19.5" X 31"
6	132268-02-L01	EA	VALANCE - SIMPLICITY - 29"
6	132268-02-L02	EA	VALANCE - SIMPLICITY - 29"
6	132268-02-L03	EA	VALANCE - SIMPLICITY - 29"
6	084755-57-E07	EA	SHADE - PULL - 27.25"
7	109041-44-02A	EA	BLIND - MINI - 30.5" X 18"
	101668-53-L01	EA	CURTAIN - TAPE TOP - 70" X 60"
	101668-53-L02	EA	CURTAIN - TAPE TOP - 70" X 60"
	101668-53-L03	EA	CURTAIN - TAPE TOP - 70" X 60"
	073260-65-K03	EA	TIEBACK - 4" X 15" (L01)
	073260-65-J03	EA	TIEBACK - 4" X 15" (L02)
	073260-65-L03	EA	TIEBACK - 4" X 15" (L03)
	101668-58-K03	EA	CURTAIN - 70" X 60" - TAPE TOP (L01)
	101668-58-K02	EA	CURTAIN - 70" X 60" - TAPE TOP (L02)
	101668-58-L03	EA	CURTAIN - 70" X 60" - TAPE TOP (L03)
	073260-65-K03	EA	TIEBACK - 4" X 15" (L01)
	073260-65-J03	EA	TIEBACK - 4" X 15" (L02)
	073260-65-L03	EA	TIEBACK - 4" X 15" (L03)
	076892-23-K03	EA	CURTAIN - CAB PRIVACY - 44" X 80" (L01)
	076892-23-J03	EA	CURTAIN - CAB PRIVACY - 44" X 80" (L02)
	076892-23-L03	EA	CURTAIN - CAB PRIVACY - 44" X 80" (L03)
	101668-39-G02	EA	CURTAIN - RIGHT HAND - 35" X 50" (L01)
	101668-39-L02	EA	CURTAIN - RIGHT HAND - 35" X 50" (L02)
	101668-39-L03	EA	CURTAIN - RIGHT HAND - 35" X 50" (L03)
	101668-40-G02	EA	CURTAIN - LEFT HAND - 35" X 50" (L01)
	101668-40-L02	EA	CURTAIN - LEFT HAND - 35" X 50" (L02)
	101668-40-L03	EA	CURTAIN - LEFT HAND - 35" X 50" (L03)
	073260-23-G02	EA	TIEBACK - 3" X 18" (L01)
	073260-23-F15	EA	TIEBACK - 3" X 18" (L02)
	073260-23-L03	EA	TIEBACK - 3" X 18" (L03)

CURTAIN & CUSHION GROUP (CONTINUED)
HARDWARE

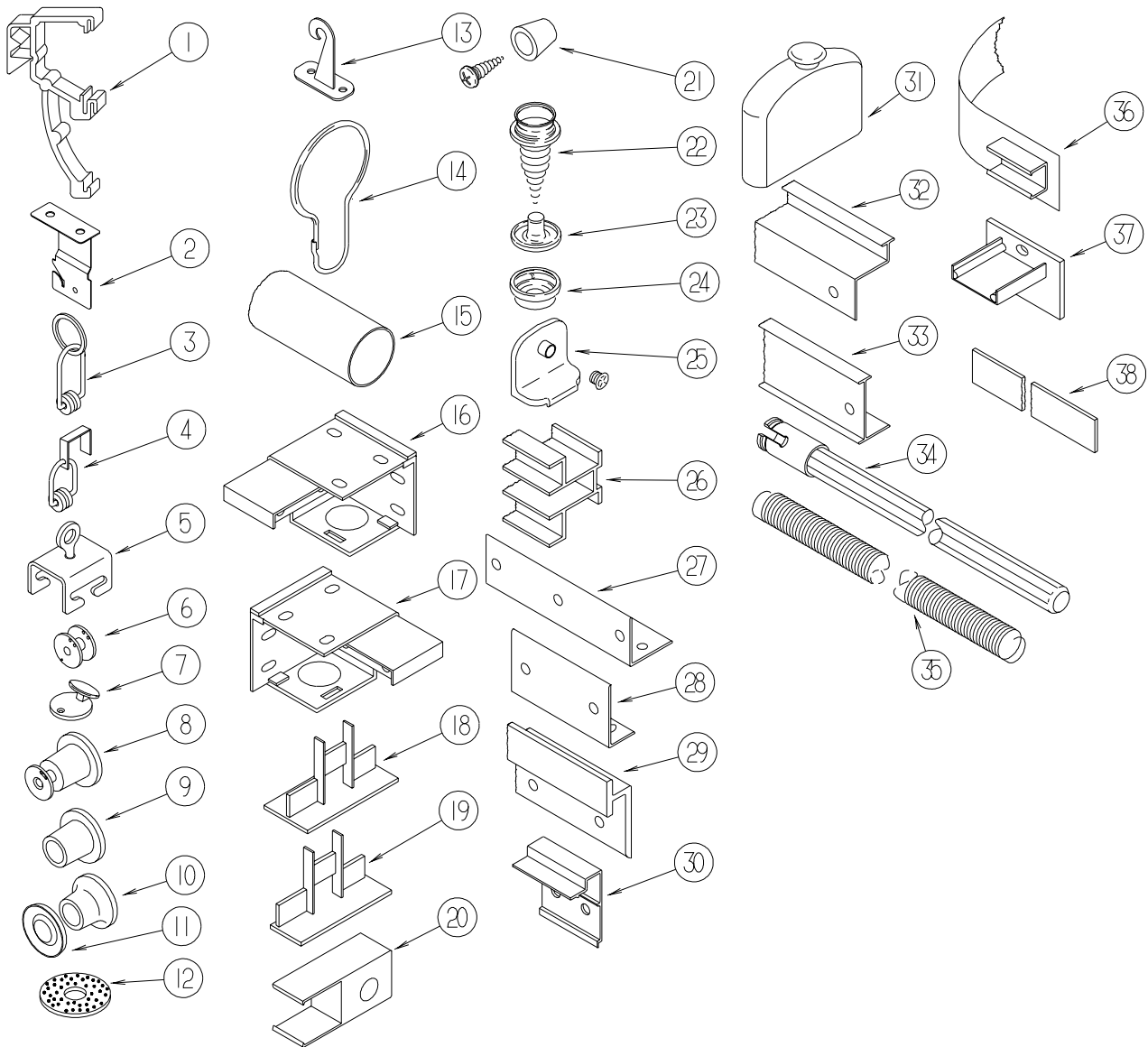

BLIND PARTS ARE COLOR COORDINATED TO MATCH THE COLOR OF THE BLINDS
HAMPTON TAN COLOR IS USED BY THE ULTIMATE FREEDOM & ADVANTAGE
TITANIUM IS USED BY ALL ITASCAS
ANTELOPE IS USED BY ALL WINNEBAGOS

KEY	PART NUMBER	U/M	DESCRIPTION
1	109353-04-000	EA	CLIP - VALANCE SLAT MOUNTING - CLEAR PLASTIC
2	084434-01-000	EA	BRACKET - MOUNTING - ROLLER SHADE - 1 3/8"
	096843-01-000	EA	SPRING - REWIND/ROLLER SHADE
	086276-01-000	EA	TAPE - DOUBLE SIDED - 1/2"
3	009701-01-000	EA	CARRIER - CURTAIN - L ROD
4	093487-91-000	EA	ROLLER/CLIP
5	009702-01-000	EA	END STOP - CURTAIN CARRIER - L ROD
6	097592-01-000	EA	SPOOL - CORD - ELEVATED BLIND HOLDUP - SMALL - CLEAR
7	102555-03-000	EA	CLEAT - BLIND CORD - MILKY WHITE PLASTIC
8	097592-02-000	EA	SPOOL - CORD - ELEVATED BLIND HOLDUP - LARGE - CLEAR
8	093475-01-701	EA	CAP-END, WITH INVERTED STUD
9	094896-02-000	EA	GROMMET - CORD/PLEATED BLIND - NYLON - GRAY
10	046867-03-000	EA	GROMMET - HANDY BUTTON #3
11	046867-02-000	EA	WASHER - HANDY BUTTON #3
12	103242-01-000	EA	VELCRO HOOK - BEIGE 7/8" ROUND W/CENTER HOLE
12	103242-02-000	EA	VELCRO HOOK - BLACK 7/8" ROUND W/CENTER HOLE
13	109441-03-000	EA	HOLD DOWN - BLIND (CLOUDY)
	109441-02-000	EA	HOLD DOWN - SPACER
14	009136-02-000	EA	HANGER - RING - PIN TYPE - CURTAIN - BRASS

CURTAIN & CUSHION GROUP (CONTINUED)
HARDWARE (CONTINUED)

KEY	PART NUMBER	U/M	DESCRIPTION
15	102075-01-02A	EA	ROD - SHOWER CURTAIN - 1" OD X 30.9" - SOFT WHITE
15	102075-06-02A	EA	ROD - SHOWER CURTAIN - 1" OD X 33.5" - SOFT WHITE
15	102075-09-01A	EA	ROD - SHOWER CURTAIN - 1" OD X 29.5" - OFF WHITE
15	102075-09-02A	EA	ROD - SHOWER CURTAIN - 1" OD X 46.3" - SOFT WHITE
15	102075-10-02A	EA	ROD - SHOWER CURTAIN - 1" OD X 46.3" - SOFT WHITE
15	102075-16-02A	EA	ROD - SHOWER CURTAIN - 1" OD X 34.2" - SOFT WHITE
15	102075-17-02A	EA	ROD - SHOWER CURTAIN - 1" OD X 39.3" - SOFT WHITE
15	102075-18-02A	EA	ROD - SHOWER CURTAIN - 1" OD X 38.9" - SOFT WHITE
15	102075-19-02A	EA	ROD - SHOWER CURTAIN - 1" OD X 39.3" - SOFT WHITE
16	083170-01-000	EA	BRACKET - BLIND - LEFT SIDE WHEN FACING WINDOW
17	083170-02-000	EA	BRACKET - BLIND - RIGHT SIDE WHEN FACING WINDOW
18	094907-04-000	EA	END CAP - BOTTOM/PLEATED BLIND (RH & LH)
19	094907-02-000	EA	END CAP - TOP/PLEATED BLIND - PLASTIC - GRAY
20	101033-02-000	EA	END CAP - TRACK/CLEAR
21	097564-03-000	EA	HANDLE - KNOB - E-Z LIFT SHADE - TAN
21	097564-05-000	EA	HANDLE - KNOB - E-Z LIFT SHADE - TEAL
21	097564-06-000	EA	HANDLE - KNOB - E-Z LIFT SHADE - ALABASTER
21	097564-07-000	EA	HANDLE - KNOB - E-Z LIFT SHADE - SILVER
21	000G68-06-12J	EA	SCREW 6-18X.75 POH BRASS
22	029130-01-000	EA	SCREW - SNAP SOCKET - #8 PH X 5/8"
22	029130-03-000	EA	SCREW - SNAP SOCKET - #8 PH X 1"
23	029155-01-000	EA	CAP - SNAP - 5/32" OUTSIDE DIAMETER OF PIN
24	029156-01-000	EA	SOCKET - SNAP - 9/16" O.D.
24	029156-02-000	EA	SOCKET - SNAP - 27/64" O.D.
25	106544-01-000	EA	PULL - SHADE/BRASS
	106544-01-001	EA	SCREW - SHADE/BRASS
26	101033-08-000	EA	TRACK - WALL - 75"
26	101033-09-000	EA	TRACK - WALL - 32"
27	105648-01-02A	EA	BRACE - VALANCE - OFF/WHITE - 14"
27	075943-10-000	EA	BRACE - VALANCE - 20"
28	083125-07-000	EA	BRACE - WINDOW MOUNT - 2.5" - OFF WHITE
28	083125-08-000	EA	BRACE - WINDOW MOUNT - 3/4 - OFF WHITE
29	127254-03-02A	EA	TRACK - CURTAIN/RIGHT HAND - ANTELOPE - F & G SERIES
29	127254-03-03A	EA	TRACK - CURTAIN/RIGHT HAND - TITANIUM - F & G SERIES
29	133236-01-02A	EA	TRACK - CURTAIN/RIGHT HAND - TITANIUM - P SERIES
29	133236-01-01A	EA	TRACK - CURTAIN/RIGHT HAND - ANTELOPE - P SERIES
29	127254-04-02A	EA	TRACK - CURTAIN/LEFT HAND - ANTELOPE - F & G SERIES
29	127254-04-03A	EA	TRACK - CURTAIN/LEFT HAND - TITANIUM - F & G SERIES
29	133235-01-02A	EA	TRACK - CURTAIN/LEFT HAND - ANTELOPE - P SERIES
29	133235-01-01A	EA	TRACK - CURTAIN/LEFT HAND - ANTELOPE - P SERIES
30	076827-02-000	EA	BRACKET - LEG - 2.9" X 1.8" - TRIANGLE
31	093475-01-701	EA	CAP-END, WITH INVERTED STUD
32	105450-14-01A	EA	TRACK - CURTAIN - 90" - OFF WHITE
33	009700-04-002	EA	TRACK - CURTAIN - L SHAPED - 15.5' - OFF WHITE
33	118896-05-02A	EA	TRACK - CURTAIN - RIGHT HAND - HAMPTON TAN - Q-SERIES
33	118897-04-02A	EA	TRACK - CURTAIN - RIGHT HAND - HAMPTON TAN - Q-SERIES
33	126456-01-03A	EA	TRACK - CURTAIN - RIGHT HAND - TITANIUM - L-SERIES
33	126456-02-03A	EA	TRACK - CURTAIN - LEFT HAND - TITANIUM - L-SERIES
33	126456-03-02A	EA	TRACK - CURTAIN - RIGHT HAND - ANTELOPE - L-SERIES
33	126456-04-02A	EA	TRACK - CURTAIN - LEFT HAND - ANTELOPE - L-SERIES
34	093487-90-000	EA	WAND - 30" - FRONT WRAP AROUND
35	097591-01-000	EA	SPRING - EXTENSION/PLEATED BLIND
36	101031-01-000	YD	TAPE - GLIDE/CURTAIN - 4.25" SPACING
37	094907-06-000	EA	HARDWARE - END CAP - E-Z LIFT - TOP
38	089275-01-000	FT	STRIP - 3/4" X 96" - CLEAR POLYETHYLENE
	094908-03-000	FT	HARDWARE - SEMI-RIDGED PVC - EZ LIFT
	094908-04-000	FT	STRAP - FLAT POLY VINYL
	095567-01-000	EA	TACK - STRIP - .5" X 625' ROLL
	097593-02-000	FT	CORD - BLIND - PLEATED - GRAY
	097593-06-000	FT	CORD - BLIND - PLEATED - PEWTER
	097593-07-000	FT	CORD - BLIND - PLEATED - PALE JADE
	097593-10-000	FT	CORD - BLIND - PLEATED - VANILLA

CURTAIN & CUSHION GROUP (CONTINUED)

ACCESSORIES

KEY	PART NUMBER	U/M	DESCRIPTION
	007021-01-000	EA	SEAT BELT - 2" X 90" - BLACK
	057759-01-000	EA	WASHER BRACKET - SEAT BELT - 4" DIAMETER
	053552-02-K01	EA	HANDLE - ASSIST - INTERIOR/ENTRY DOOR - VINYL/OFF WHITE
	069178-02-000	EA	BRACKET - MOUNTING/ASSIST HANDLE - GRAY
	000C16-07-16B	EA	BOLT - CARRIAGE - ASSIST HANDLE - 7/16" - 14 X 1"
	000D20-07-00B	EA	NUT - ACORN - ASSIST HANDLE - 7/16 - 14
	057534-06-000	EA	TIEBACK/TIEDOWN - VINYL - 6" BEIGE

CURTAIN & CUSHION GROUP (CONTINUED)
FABRICS

Color Codes	L01	L02	L03
	MEADOWBROOK	BLUEBONNET	ALMOND CREAM
BUCKET SEATS	108446-C5-000	108446-F7-000	108446-S6-000
DINETTE CUSHIONS	126883-03-000	126883-48-000	126883-47-000
DINETTE PADS	108446-C5-000	108446-F7-000	108446-S6-000
SOFA	126883-03-000	126883-48-000	126883-47-000
SWIVEL CHAIR	108446-S7-000	108446-F4-000	126883-53-000
LOUNGE/DINETTE VALANCE/LEG	126883-03-000	126883-48-000	126883-47-000
LOUNGE/DINETTE OVERLAYS	108446-C5-000	108446-F7-000	108446-S6-000
BEDROOM VALANCE	105745-L1-000	105745-M4-000	105745-M2-000
BEDROOM OVERLAYS/LEG	105745-45-000	105745-64-000	105745-M3-000
BEDSPREAD	105745-L1-000	105745-M4-000	105745-M2-000
PILLOW SHAMS	105745-L1-000 105745-45-000	105745-M4-000 105745-64-000	105745-M2-000 105745-M3-000
ENTRANCE DOOR VALANCE/OVERLAY	126883-03-000 108446-C5-000	126883-48-000 108446-F7-000	126883-47-000 108446-S6-000
BUNK CUSHIONS	108446-S7-000	108446-F4-000	126883-53-000
DIVIDER CURTAIN	105745-45-000	105745-64-000	105745-M3-000
WRAP AROUND	105745-45-000	105745-64-000	105745-M3-000
BUNK CURTAINS	105745-L1-000	105745-M4-000	105745-M2-000
BUNK/PRIVACY CURTAINS	105745-45-000	105745-64-000	105745-M3-000
DRAPERY LINING	087272-03-000	087272-03-000	087272-03-000
TIRE COVER	103907-05-000	103907-05-000	103907-05-000
HEADLINER	103907-01-06A	103907-01-06A	103907-01-06A
VINYL	113979-01-01A	113979-01-01A	113979-01-01A
CEILING	113979-09-01A	113979-09-01A	113979-09-01A

NOTE: FABRIC LISTED FIRST IN A BLOCK, IS THE LARGEST QUANTITY OF FABRIC USED

DINETTE GROUP CABINETS

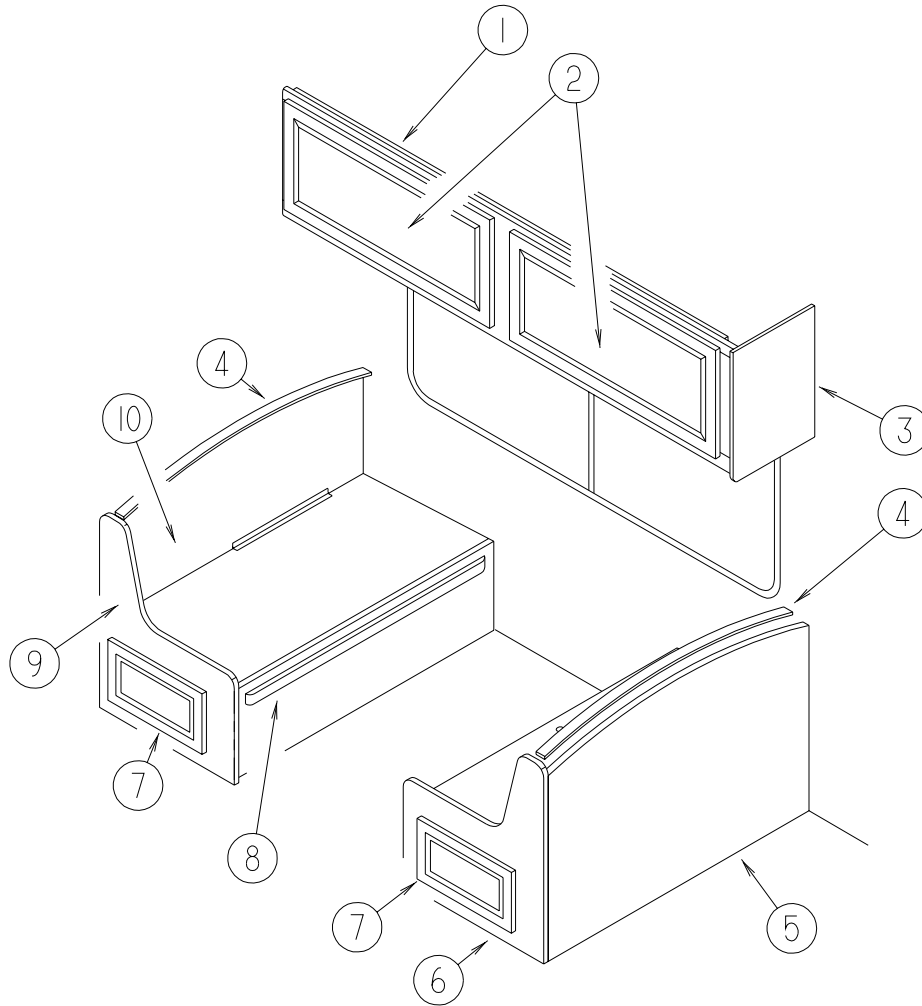

KEY	PART NUMBER	U/M	DESCRIPTION
1	131926-02-L01	EA	CABINET - OVERHEAD - W/O DOORS/HARDWARE
2	132141-14-L01	EA	DOOR - RAIL/VENEER - 15.7" X 27.9" - W/O HARDWARE
3	109908-82-K04	EA	END CAP - OVERHEAD CABINET
4	111338-11-K03	EA	PAD - DINETTE SEATBACK (L01)
4	111338-11-J03	EA	PAD - DINETTE SEATBACK (L02)
4	111338-11-K06	EA	PAD - DINETTE SEATBACK (L03)
5	M08123-16-J01	EA	CABINET - SEATBACK - RIGHT HAND
6	M08122-17-J01	EA	CABINET - SEATBASE - RIGHT HAND - W/O DOOR/DRAWER/HDW
7	131995-G4-L01	EA	DOOR - RAIL/SOLID PANEL - 10" X 19.1" - W/O HARDWARE
8	081295-01-G01	EA	SUPPORT - BED/DINETTE - 28" LONG
9	M08122-25-J03	EA	CABINET - SEATBASE - LEFT HAND - W/O DOOR/DRAWER/HDW
10	M08123-23-J03	EA	CABINET - SEATBACK - LEFT HAND

DINETTE GROUP (CONTINUED)
CABINETS (CONTINUED)

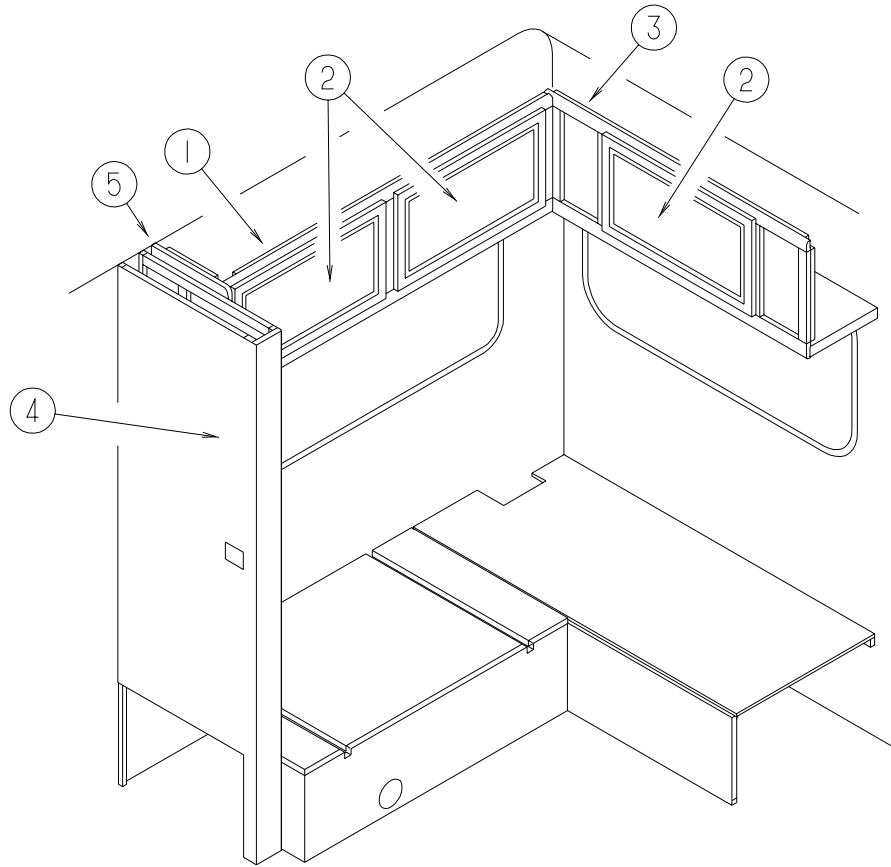

KEY	PART NUMBER	U/M	DESCRIPTION
1	122609-03-K01	EA	CABINET - OVERHEAD/REAR - W/O DOORS/HARDWARE
2	132141-14-L01	EA	DOOR - RAIL/VENEER - 15.7" X 27.9" - W/O HARDWARE
3	127484-02-K01	EA	CABINET - OVERHEAD/REAR - W/O DOORS/HARDWARE
4	132762-01-L01	EA	CABINET - PIPE COVER
4	132762-01-L02	EA	CABINET - PIPE COVER
4	132762-01-L03	EA	CABINET - PIPE COVER
5	109908-81-K04	EA	END CAP - OVERHEAD CABINET

**DINETTE GROUP (CONTINUED)
TABLE**

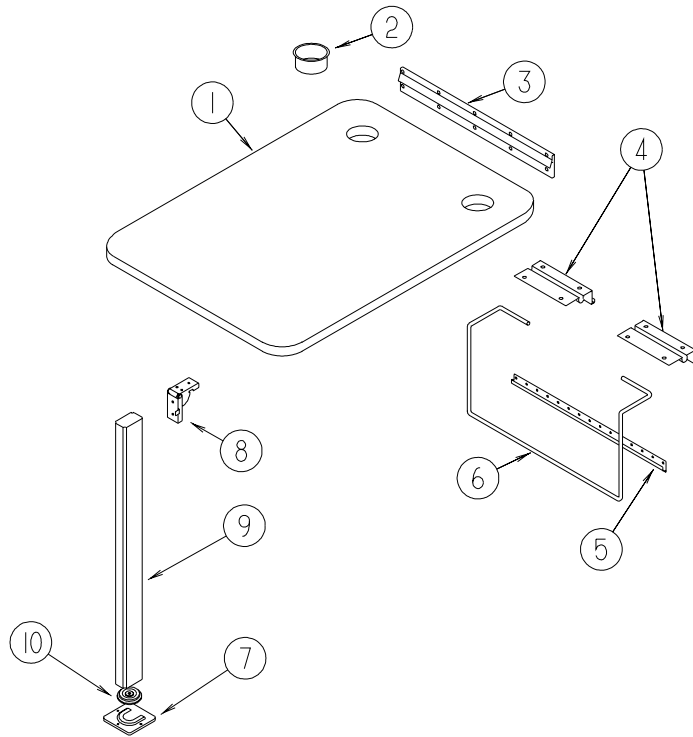

KEY	PART NUMBER	U/M	DESCRIPTION
1	132034-01-L01	EA	TABLE TOP ONLY (L01, L03)
1	132034-01-L02	EA	TABLE TOP ONLY (L02)
2	064781-06-000	EA	HOLDER/CUP - TWO STEP - OFF WHITE
3	053200-13-000	EA	SUPPORT - TABLE - 18.5"
4	088410-02-000	EA	BRACKET - LIFT - TABLE MOUNTED
5	024281-15-000	EA	BRACKET/TABLE - LIFT ROD/LOWER WALL MOUNTED - 17.1"
6	024275-13-000	EA	ROD - TABLE LIFT - OFF/WHITE
7	049493-12-000	EA	CATCH - TABLE LEG/FLOOR MOUNTED - OFF WHITE
8	093550-01-000	EA	BRACKET - HINGE - MOUNTS TO LEG & TABLE TOP - 1.7" X 2.6"
9	092707-04-05A	EA	LEG - TABLE - W/O HARDWARE - 27" - WATERFORD OAK
10	092593-01-05A	EA	CATCH - TABLE LEG - OFF/WHITE

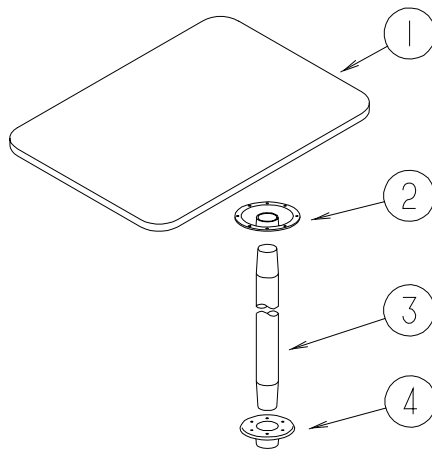

KEY	PART NUMBER	U/M	DESCRIPTION
1	130969-01-K03	EA	TABLE TOP ONLY - PEDESTAL TYPE (L01, L03)
1	130969-01-K05	EA	TABLE TOP ONLY - PEDESTAL TYPE (L02)
2	009040-03-000	EA	BASE - TABLE/RAISED - TABLE MOUNTED
3	009040-02-000	EA	PEDESTAL TABLE LEG - 27.5" X 2.25" DIAMETER
4	041194-01-000	EA	BASE - TABLE/FLUSH - FLOOR MOUNTED

**DRIVERS COMPARTMENT GROUP
INSTRUMENT PANEL**

FORD

KEY	PART NUMBER	U/M	DESCRIPTION
	094795-09-000	EA	CLUSTER - INSTRUMENT PANEL - KILOMETERS - GAS/DIESEL-FORD
	111414-01-000	EA	RECEPTACLE - 12V - W/O BIMETAL
	100138-01-000	EA	MODULE - DAYTIME/RUNNING LIGHT
	108357-09-000	EA	SWITCH - ROCKER SPDT - ON/NONE/MOM - 3 TERMINAL - AUX START
	108356-07-01A	EA	COVER/ACTUATOR SWITCH - 2 ROWS DIMPLES - AUX START - BLACK
	081994-07-000	EA	PLATE - SWITCH - AUX. START

CHEVY

KEY	PART NUMBER	U/M	DESCRIPTION
	094797-13-000	EA	CLUSTER - INSTRUMENT PANEL - KILOMETERS/MILES
	111414-01-000	EA	RECEPTACLE - 12V - W/O BIMETAL
	100138-01-000	EA	MODULE - DAYTIME/RUNNING LIGHT
	108357-09-000	EA	SWITCH - ROCKER SPDT - ON/NONE/MOM - 3 TERMINAL - AUX START
	108356-07-01A	EA	COVER/ACTUATOR SWITCH - 2 ROWS DIMPLES - AUX START - BLACK
	081994-07-000	EA	PLATE - SWITCH - AUX. START

DRIVERS COMPARTMENT GROUP (CONTINUED)
FRONT INTERIOR

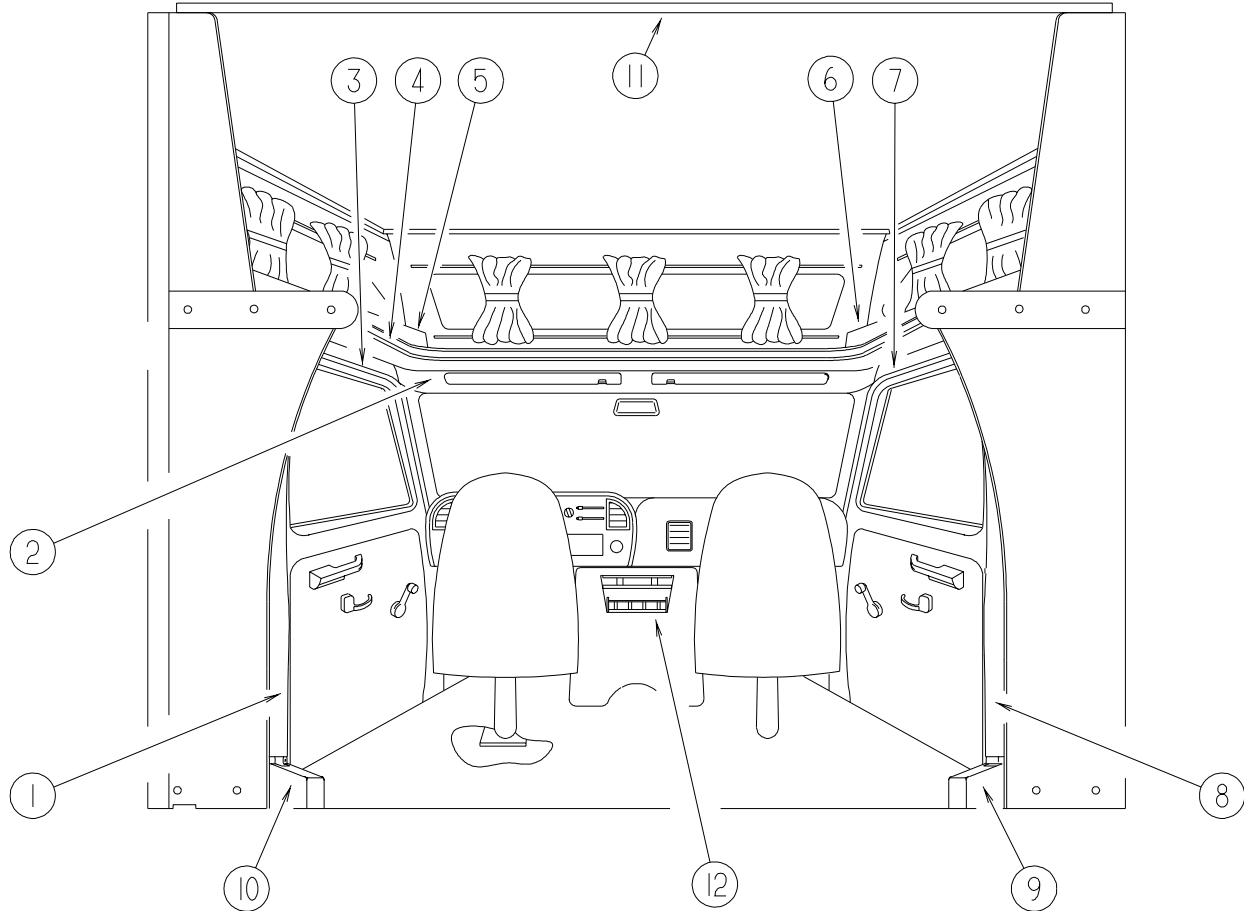

FORD

KEY	PART NUMBER	U/M	DESCRIPTION
1	125031-02-H04	EA	TRIM - CAB - B-PILLAR - DRIVER SIDE
2	106448-01-H04	EA	HEADLINER - W/VINYL
3	106447-04-H04	EA	TRIM - CAB DOOR - UPPER/LEFT HAND
4	119520-01-01A	FT	MOLDING-T - 1" - W/EDGE LIPS (OFF/WHITE-CREAM)
5	109894-01-L01	EA	CABINET - HAMPER - DRIVER/FRONT
5	109894-01-L02	EA	CABINET - HAMPER - DRIVER/FRONT
5	109894-01-L03	EA	CABINET - HAMPER - DRIVER/FRONT
6	109894-03-L01	EA	CABINET - HAMPER - PASSENGER/FRONT
6	109894-03-L02	EA	CABINET - HAMPER - PASSENGER/FRONT
6	109894-03-L03	EA	CABINET - HAMPER - PASSENGER/FRONT
7	106447-03-H04	EA	TRIM - CAB DOOR - UPPER/RIGHT HAND
8	125031-01-H04	EA	TRIM - CAB - B-PILLAR - PASSENGER SIDE
9	106431-01-02A	EA	COVER - SEATBELT RECOIL - PASSENGER SIDE - VW GRAY
10	106431-02-02A	EA	COVER - SEATBELT RECOIL - DRIVER SIDE - VW GRAY
11	131666-02-01A	EA	TRIM - FRONT ROOF SECTION
11	082111-02-000	EA	COVER-ROOF BREAK,OFF WHT
12	125291-02-01A	EA	TRAY/BEVERAGE - F/DELUXE MOTOR COVER -1999 CHASSIS
12	134093-01-01A	EA	CONSOLE-FORD,MODIFIED - 2000 CHASSIS
	133834-01-01A	EA	TRAY - BEVERAGE - 2 HOLE/INSERT MOTOR COVER - WATERFORD
	133831-01-01A	EA	HOLDER - CUP W/THREE CENTERLINE RUBBER FINGERS
	125780-01-000	EA	MAT - FLOOR - FRONT/PASSENGER - "W" - FORD
	125780-02-000	EA	MAT - FLOOR - FRONT/DRIVER - "W" - FORD

DRIVERS COMPARTMENT GROUP (CONTINUED)
FRONT INTERIOR (CONTINUED)

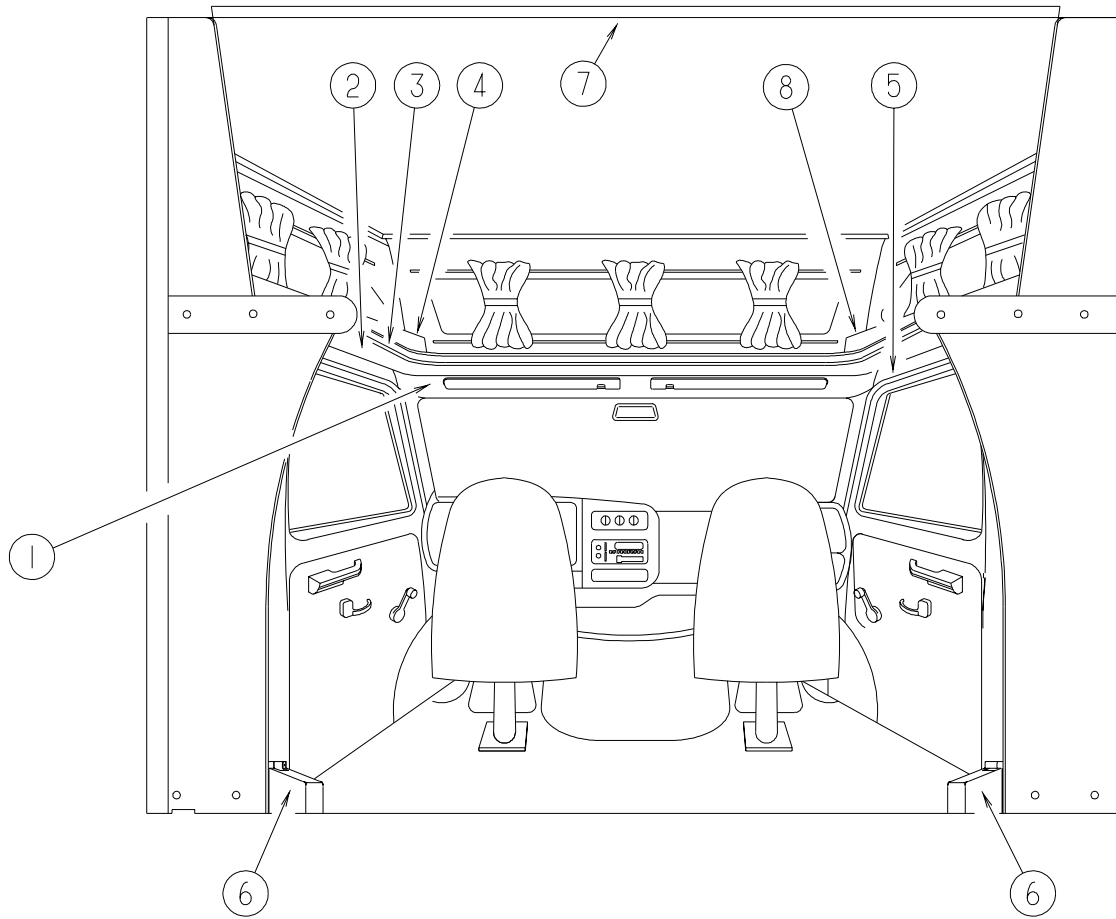

CHEVY

KEY	PART NUMBER	U/M DESCRIPTION
1	124818-01-H04	EA HEADLINER - W/VINYL
2	124819-01-H04	EA TRIM - CAB DOOR - UPPER/LEFT HAND
3	119520-01-01A	FT MOLDING-T - 1" - W/EDGE LIPS (OFF/WHITE-CREAM)
4	109894-01-L01	EA CABINET - HAMPER - DRIVER/FRONT
4	109894-01-L02	EA CABINET - HAMPER - DRIVER/FRONT
4	109894-01-L03	EA CABINET - HAMPER - DRIVER/FRONT
5	124817-01-H04	EA TRIM - CAB DOOR - UPPER/RIGHT HAND
6	076302-03-000	EA SEAT BELT - DRIVER/PASSENGER
	087932-03-000	EA BRACKET - SHOULDER HARNESS - LEFT HAND
	087932-04-000	EA BRACKET - SHOULDER HARNESS - RIGHT HAND
7	082111-02-000	EA COVER-ROOF BREAK,OFF WHT
7	131666-01-01A	EA TRIM - FRONT ROOF SECTION
8	109894-03-L01	EA CABINET - HAMPER - PASSENGER/FRONT
8	109894-03-L02	EA CABINET - HAMPER - PASSENGER/FRONT
8	109894-03-L03	EA CABINET - HAMPER - PASSENGER/FRONT
	124182-01-01A	EA MAT - PASSENGER FRONT - CHEVY
	124182-02-01A	EA MAT - DRIVER FRONT - CHEVY

DRIVERS COMPARTMENT GROUP (CONTINUED)
CABINETS

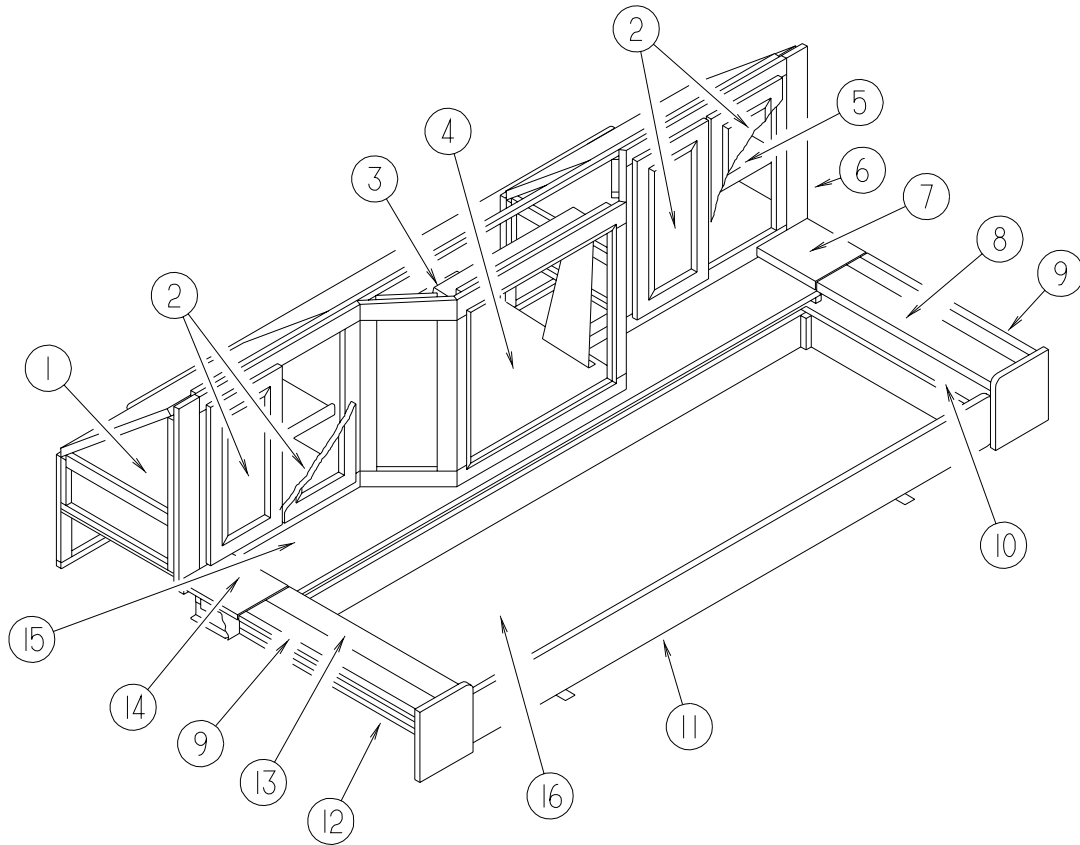

KEY	PART NUMBER	U/M	DESCRIPTION
1	133221-02-L07	EA	CABINET - ENTERTAINMENT CENTER/SHELF - W/O HARDWARE
	113156-11-G04	EA	SHELF - ENTERTAINMENT CENTER - W/MOLDING
2	132141-A1-L04	EA	DOOR - RAIL/VENEER - 10.8" X 21.8" - W/O HARDWARE
3	110790-03-000	EA	BRACKET - TIEDOWN/TV
	106699-01-01A	EA	BRACKET - OVERHEAD CABINET/TV
	122790-02-02B	EA	BRACKET - VCP - E-COATED
4	111356-02-J01	EA	SHELF - TV - W/TIEDOWN BRACKET
5	133221-01-L07	EA	CABINET - ENTERTAINMENT CENTER/SHELF - W/O HARDWARE
	133221-11-L07	EA	SHELF - W/MOLDING
6	133222-01-L01	EA	CABINET - ENTERTAINMENT CENTER FACE - W/O HARDWARE
7	113155-11-L01	EA	COUNTERTOP - ENTERTAINMENT CENTER STORAGE (L01, L03)
7	113155-11-L02	EA	COUNTERTOP - ENTERTAINMENT CENTER STORAGE (L02)
8	113155-12-L01	EA	COUNTERTOP - ENTERTAINMENT CENTER STORAGE (L01, L03)
8	113155-12-L02	EA	COUNTERTOP - ENTERTAINMENT CENTER STORAGE (L02)
9	113155-21-K08	EA	COUNTERTOP - ENTERTAINMENT CENTER STORAGE (L01, L03)
9	113155-21-K02	EA	COUNTERTOP - ENTERTAINMENT CENTER STORAGE (L02)
10	113155-01-L01	EA	CABINET/STORAGE - RIGHT END - W/FLIP UP COUNTERTOP (L01, L03)
10	113155-01-L02	EA	CABINET/STORAGE - RIGHT END - W/FLIP UP COUNTERTOP (L02)
11	100847-11-J02	EA	FACE - DRAWER VINYL COVERED - 5.5" X 76.7"
12	113155-02-L01	EA	CABINET/STORAGE - LEFT END - W/FLIP UP COUNTERTOP (L01, L03)
12	113155-02-L02	EA	CABINET/STORAGE - LEFT END - W/FLIP UP COUNTERTOP (L02)
13	113155-18-L01	EA	COUNTERTOP - ENTERTAINMENT CENTER STORAGE (L01, L03)
13	113155-18-L02	EA	COUNTERTOP - ENTERTAINMENT CENTER STORAGE (L02)
14	113155-19-L01	EA	COUNTERTOP - ENTERTAINMENT CENTER STORAGE (L01, L03)
14	113155-19-L02	EA	COUNTERTOP - ENTERTAINMENT CENTER STORAGE (L02)
15	133222-12-L01	EA	SHELF
16	100847-01-L01	EA	DRAWER - ENTERTAINMENT CENTER - W/O HARDWARE

ELECTRICAL GROUP LIGHTS

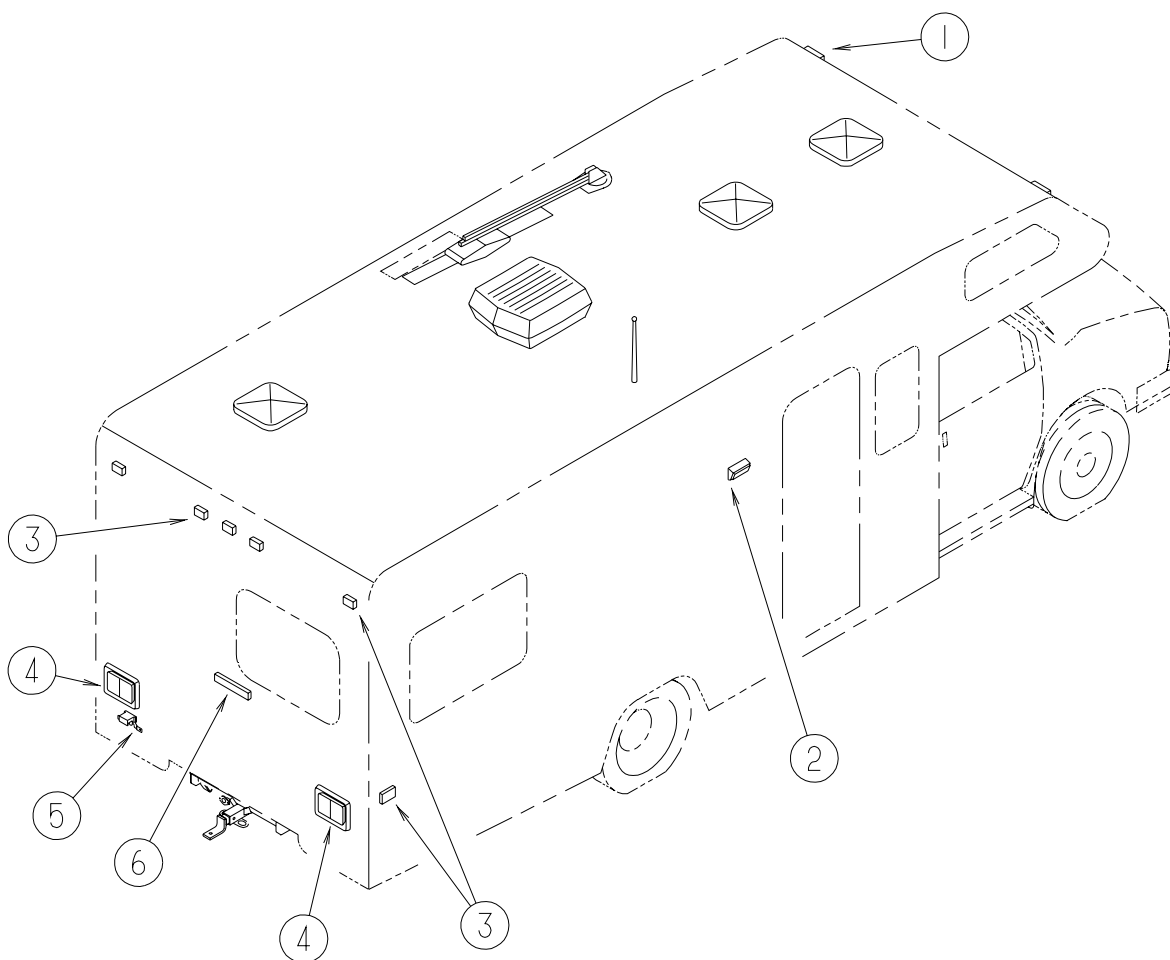

KEY	PART NUMBER	U/M	DESCRIPTION
1	111102-02-000	EA	LENS - AMBER - MARKER LAMP
	111102-01-000	EA	BASE - MARKER LAMP
	036196-01-000	EA	BULB - 12V - #194 - .27 AMP - BAYONETTE
2*	097917-01-06A	EA	LIGHT - PORCH - BRIGHT WHITE
	008215-01-000	EA	BULB - 12 VOLT - #1003 - .94 AMP
2	008089-02-000	EA	LIGHT - PORCH - RECESSED - CANADIAN
	008214-01-000	EA	BULB - 12 VOLT - #67 - .59 AMP
3	111102-03-000	EA	LENS - RED - MARKER LAMP
	111102-01-000	EA	BASE - MARKER LAMP
	036196-01-000	EA	BULB - 12V - #194 - .27 AMP - BAYONETTE
4	103355-02-01A	EA	POD - TAIL LIGHT - BRIGHT WHITE
*	081638-01-000	EA	TAILLIGHT/DOUBLE W/BLACK TRIM - DRIVER/PASSENGER SIDE
	037934-01-000	EA	BULB - 12V - #1156 - 2.1 AMP CLEAR GLASS
	037935-01-000	EA	BULB - 12V - #1157 OR #2057 - 2.1 AMP - CLEAR GLASS
5	066432-02-000	EA	LIGHT - LICENSE - BLACK
	066432-03-000	EA	BRACKET - LICENSE PLATE
6	121950-01-000	EA	LIGHT - BRAKE - CENTER MOUNT

***COMPONENT PARTS FOUND IN SERVICE PARTS LIBRARY**

ELECTRICAL GROUP (CONTINUED)
LIGHTS (CONTINUED)

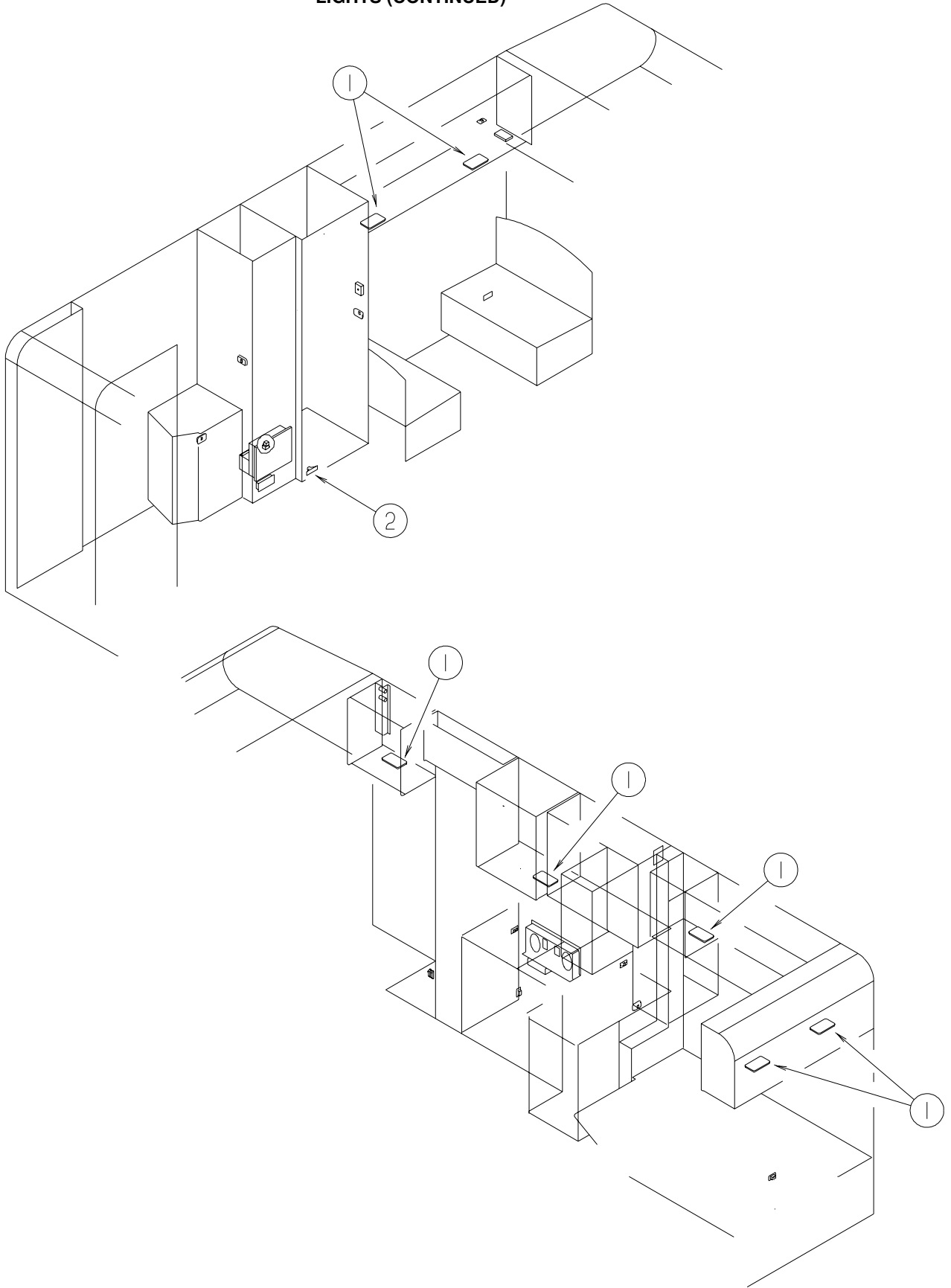

KEY	PART NUMBER	U/M	DESCRIPTION
1*	098024-05-02A	EA	LIGHT - DOME - 1 BULB - SKYLITE/OPTI CLEAR
	008218-01-000	EA	BULB - 12 VOLT - #1141 - 1.44 AMP
2	061424-01-000	EA	LIGHT - AISLE - 12 VOLT - RECTANGULAR

***COMPONENT PARTS FOUND IN SERVICE PARTS LIBRARY**

ELECTRICAL GROUP (CONTINUED)
LIGHTS (CONTINUED)

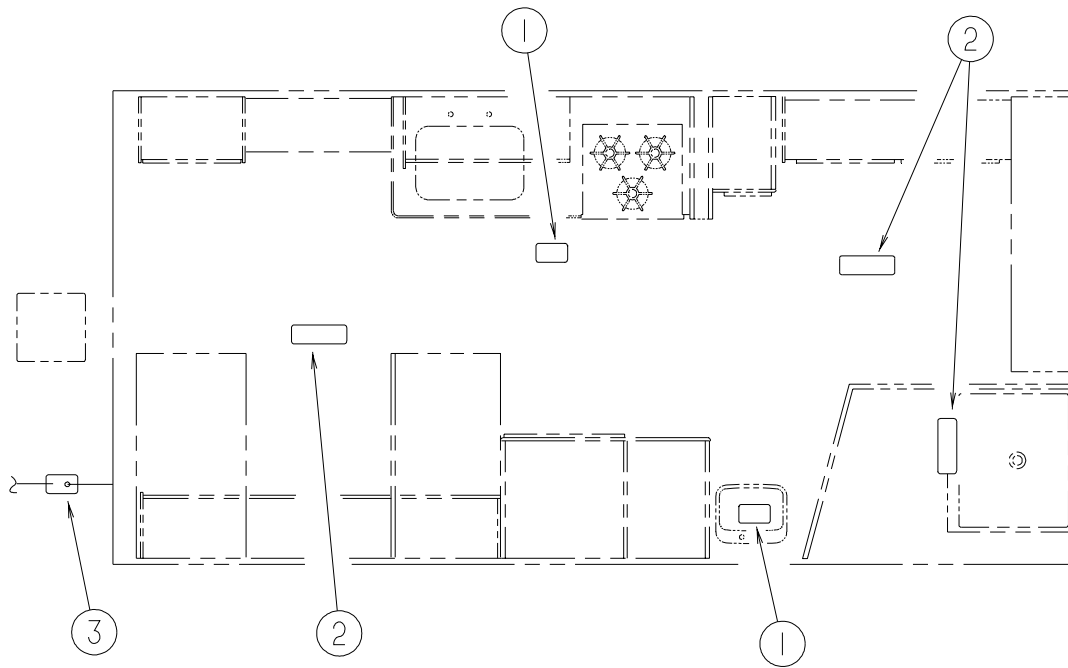

KEY	PART NUMBER	U/M	DESCRIPTION
1	098024-07-02A	EA	LIGHT - DOME W/O SWITCH - 1 BULB
2	098024-08-02A	EA	LIGHT - DOME W/O SWITCH - 2 BULB
3*	098024-05-02A	EA	LIGHT - DOME - 1 BULB - SKYLITE/OPTI CLEAR
	008218-01-000	EA	BULB - 12 VOLT - #1141 - 1.44 AMP

***COMPONENT PARTS FOUND IN SERVICE PARTS LIBRARY**

CIRCUIT BREAKERS & FUSES

KEY	PART NUMBER	U/M	DESCRIPTION
	008235-01-000	EA	FUSE - 15 AMP/12VOLT - AUTOMOTIVE
	062901-02-000	EA	FUSE - 5 AMP - AUTOMOTIVE
	062901-05-000	EA	FUSE - 15 AMP - AUTOMOTIVE
	083209-02-000	EA	CIRCUIT BREAKER - 15/15 AMP - 120 VOLT
	083209-03-000	EA	CIRCUIT BREAKER - 15/20 AMP - 120 VOLT
	083209-06-000	EA	CIRCUIT BREAKER - 30/15 AMP - 120 VOLT
	093654-01-000	EA	CIRCUIT BREAKER - 6 AMP - 12 VOLT
	093654-03-000	EA	CIRCUIT BREAKER - 20 AMP - 12 VOLT
	093654-11-000	EA	COVER - RESET BUTTON
	093655-01-000	EA	CIRCUIT BREAKER - 25 AMP - 12 VOLT
	093655-02-000	EA	CIRCUIT BREAKER - 30 AMP - 12 VOLT
	100341-01-000	EA	FUSE HOLDER - IN LINE TYPE

CONVERTER, INVERTER & LOAD CENTERS

KEY	PART NUMBER	U/M	DESCRIPTION
	083208-01-000	EA	CONTROL CENTER - 32 AMP - 120V/12V - W/O BREAKERS
	083208-06-000	EA	CONTROL CENTER - 45 AMP - 120V/12V - W/O BREAKERS
	099048-03-000	EA	INVERTER - 130 WATT

ELECTRICAL GROUP (CONTINUED)
RECEPTACLES

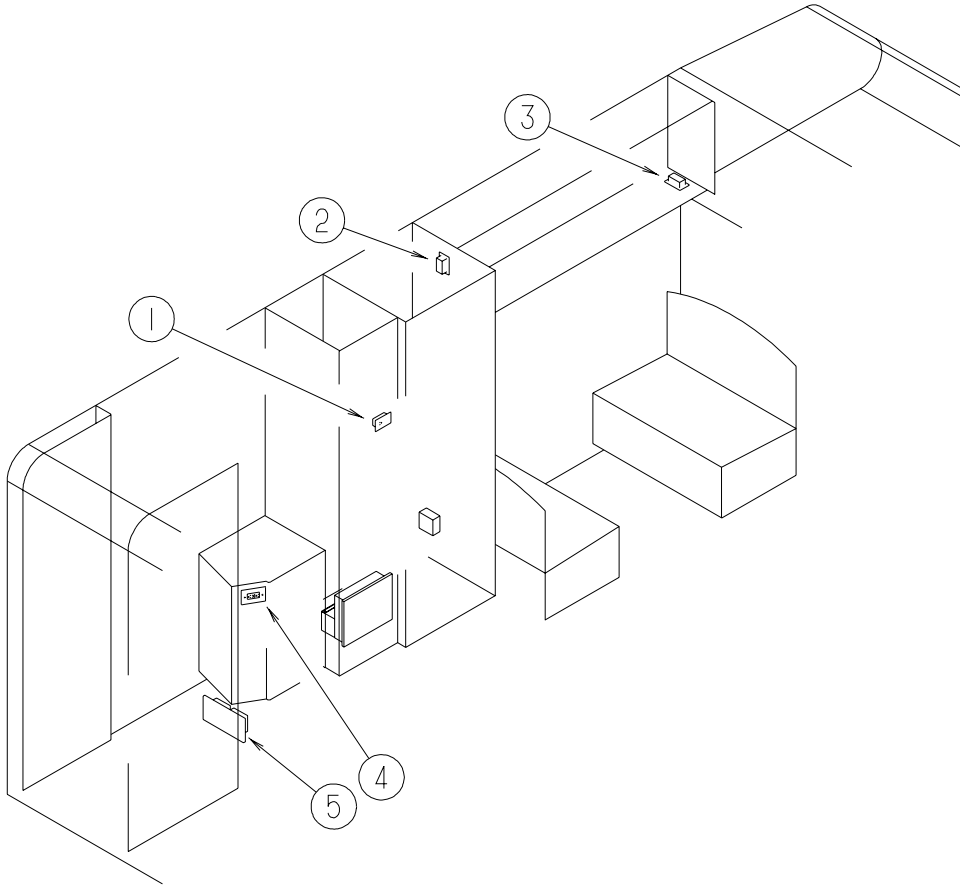

KEY	PART NUMBER	U/M	DESCRIPTION
1	058707-01-000	EA	RECEPTACLE - ELECTRIC - SINGLE - BROWN
2	058707-02-000	EA	RECEPTACLE - BLANK - JUNCTION BOX
3	058708-02-000	EA	RECEPTACLE - ELECTRIC - DOUBLE - IVORY
4	084076-02-000	EA	RECEPTACLE - GFI - 15 AMP/125 VOLT - BROWN - W/COVER
5	024924-02-000	EA	RECEPTACLE - POWER CORD - W/PARTIAL PLATE

ELECTRICAL GROUP (CONTINUED)
RECEPTACLES (CONTINUED)

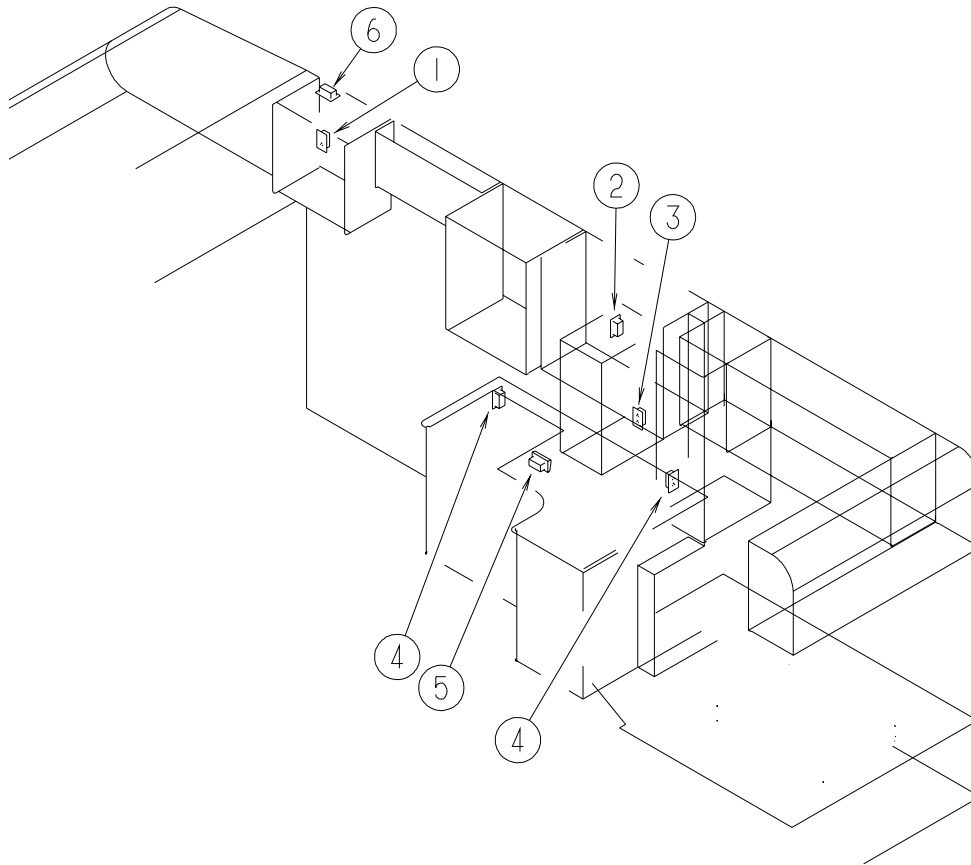

KEY	PART NUMBER	U/M	DESCRIPTION
1	058708-01-000	EA	RECEPTACLE - ELECTRIC - DOUBLE - BROWN
2	058708-05-000	EA	RECEPTACLE - ELECTRIC - SINGLE - BROWN
3	058708-01-000	EA	RECEPTACLE - ELECTRIC - DOUBLE - BROWN
	133713-01-01A	EA	SPACER - RECEPTACLE - WATERFORD OAK
4	058708-02-000	EA	RECEPTACLE - ELECTRIC - DOUBLE - IVORY
5	131826-01-01A	EA	RECEPTACLE - EXTERIOR - W/COVER/GASKET - WHITE
6	111414-01-000	EA	RECEPTACLE - 12V - W/O BIMETAL

ELECTRICAL GROUP (CONTINUED)

SWITCHES

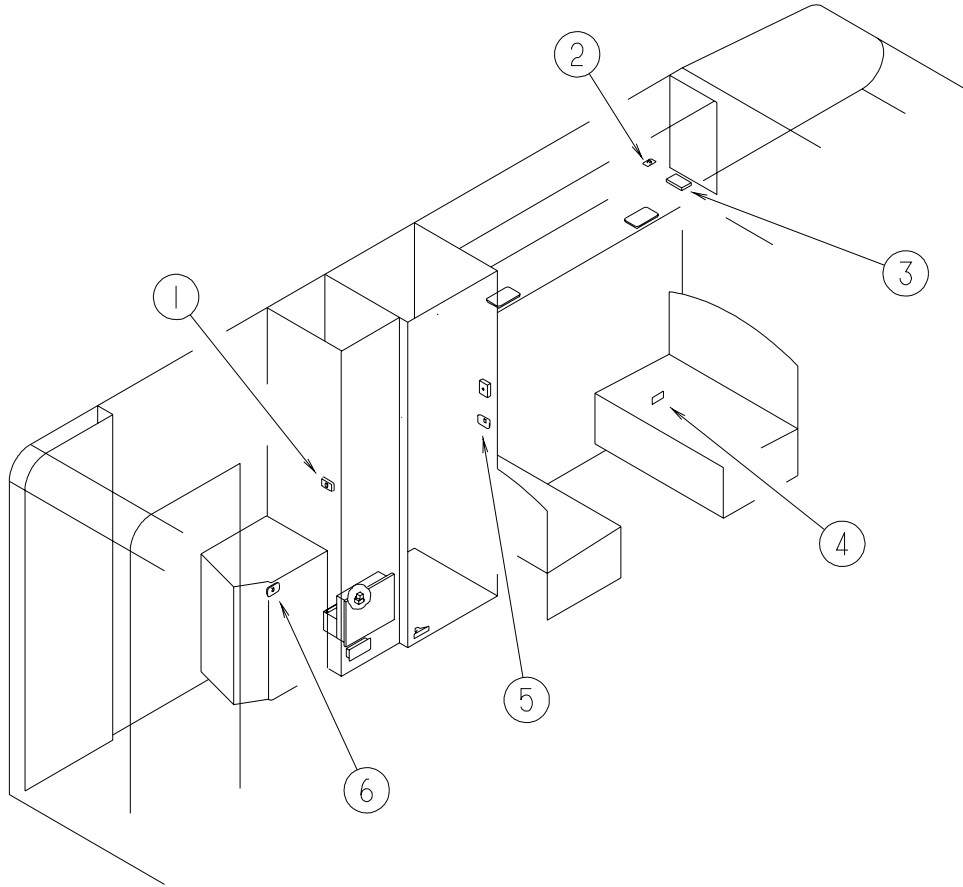

KEY	PART NUMBER	U/M	DESCRIPTION
1	132180-01-01A	EA	SWITCH - PADDLE - SPST - ON/OFF - BLACK
1	132180-02-01A	EA	SWITCH - PADDLE - SPDT - ON/OFF - BLACK
1	098351-02-01A	EA	PLATE/SWITCH - 2 GANG - POLISHED BRASS - W/O LABEL
1	095188-01-01A	EA	SPACER - SWITCH - 2.3" X 3.4" - PLASTIC - DARK BROWN
2	132180-02-01A	EA	SWITCH - PADDLE - SPDT - ON/OFF - BLACK
2	098351-01-01A	EA	PLATE/SWITCH - 1 GANG - POLISHED BRASS - W/O LABEL
2	132180-01-01A	EA	SWITCH - PADDLE - SPST - ON/OFF - BLACK
2	132180-02-01A	EA	SWITCH - PADDLE - SPDT - ON/OFF - BLACK
2	098351-15-01A	EA	PLATE/SWITCH - 2 GANG - POLISHED BRASS - COURTESY LAMP/TV
3	086777-02-000	EA	WALLPLATE - TV CABLE - W/ANTENNA SWITCH - BROWN
3	086777-06-000	EA	WALLPLATE - TV CABLE - ANTENNA BOOSTER/1 OUTPUT - BROWN
4	084077-03-000	EA	COVER/BLANK - ROOF A/C 5.2" X 3.5" - IVORY
5	132180-01-01A	EA	SWITCH - PADDLE - SPST - ON/OFF - BLACK
5	098351-01-01A	EA	PLATE/SWITCH - 1 GANG - POLISHED BRASS - W/O LABEL
5	095188-01-01A	EA	SPACER - SWITCH - 2.3" X 3.4" - PLASTIC - DARK BROWN
6	132180-01-01A	EA	SWITCH - PADDLE - SPST - ON/OFF - BLACK
6	098351-01-01A	EA	PLATE/SWITCH - 1 GANG - POLISHED BRASS - W/O LABEL
6	095188-01-01A	EA	SPACER - SWITCH - 2.3" X 3.4" - PLASTIC - DARK BROWN

ELECTRICAL GROUP (CONTINUED)
SWITCHES (CONTINUED)

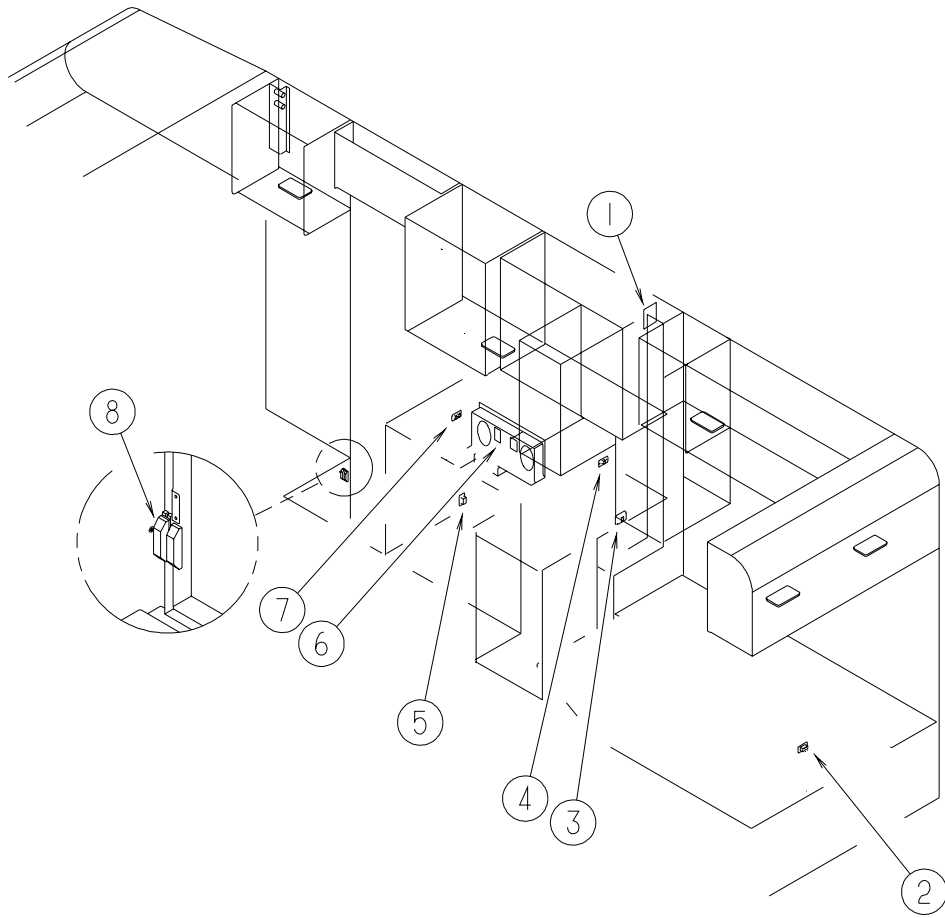

KEY	PART NUMBER	U/M	DESCRIPTION
1	084077-03-000	EA	COVER/BLANK - ROOF A/C 5.2" X 3.5" - IVORY
2	108357-08-000	EA	SWITCH - ROCKER DPDT - ON/NONE/ON - 6 TERMINAL
2	081994-02-000	EA	PLATE - SWITCH - EXTERIOR SHOWER
2	108356-02-01A	EA	COVER/ACTUATOR SWITCH - 2 ROWS DIMPLES- CONTURA II - BLACK
3	132180-01-01A	EA	SWITCH - PADDLE - SPST - ON/OFF - BLACK
3	098351-01-01A	EA	PLATE/SWITCH - 1 GANG - POLISHED BRASS - W/O LABEL
4	079364-08-000	EA	SWITCH - ON/OFF LIGHTED - GREEN
4	098351-01-01A	EA	PLATE/SWITCH - 1 GANG - POLISHED BRASS - W/O LABEL
5	108357-06-000	EA	SWITCH - ROCKER DPDT - MOM/OFF/MOM - 6 TERMINAL
5	098351-07-01A	EA	PLATE/SWITCH - 1 GANG - POLISHED BRASS - GENERATOR
5	108356-11-01A	EA	COVER/ACTUATOR SWITCH - 3 GROOVES - AUX BATT - BLACK
6	076319-09-000	EA	WALLPLATE - CABLE RECEPTACLE - TV - SINGLE - BROWN
7	132180-01-01A	EA	SWITCH - PADDLE - SPST - ON/OFF - BLACK
7	098351-06-01A	EA	PLATE/SWITCH - 2 GANG - POLISHED BRASS - PORCH/CEILING
7	098351-05-01A	EA	PLATE/SWITCH - 3 GANG - POLISHED BRASS-PORCH/CEILING/STEP
8	116995-02-000	EA	SWITCH/MAGNET - ELECTRIC STEP - BLACK/WHITE-CLOSED CIRCUIT

ELECTRICAL GROUP (CONTINUED)

BOXES & CORDS

KEY	PART NUMBER	U/M	DESCRIPTION
	008054-01-000	EA	CORD - POWER - 10/3 WIRE - 30 AMP - 25'
	008289-01-000	EA	BOX - ELECTRIC/STEEL - 1/2" & 3/4" KNOCKOUTS - 4" X 4"
	008289-02-000	EA	BOX - ELECTRIC/STEEL - 1/2" & 3/4" KNOCKOUTS - 4" X 4"-CAN
	008294-01-000	EA	COVER - ELECTRICAL BOX - BLANK/STEEL - 4" X 4" - GRAY
	008294-02-000	EA	COVER - ELECTRICAL BOX - BLANK STEEL - 4" X 4" - CANADIAN
	069238-01-000	EA	COVER - ELECTRICAL BOX - W/HOLE - 4" X 4" - GRAY
	091910-01-000	EA	BOX - ELECTRIC - 3.8" X 3.5" X 1.8" - PLASTIC
	091910-02-000	EA	BOX - ELECTRIC - 2.2" X 3.5" X 1.8" - PLASTIC
	107165-01-01A	EA	BOX - CIRCUIT BREAKER - 14.6" X 4" - PLASTIC

WIRE ASSEMBLIES

KEY	PART NUMBER	U/M	DESCRIPTION
	090986-02-000	EA	WIRE ASSEMBLY - ELECTRIC STEP
	096449-01-000	EA	WIRE ASSEMBLY - WATER TANK TO MONITOR PANEL
	106851-01-000	EA	WIRE ASSEMBLY - RUNNING LIGHTS - FUSE
	120233-05-000	EA	WIRE ASSEMBLY - 30" CONNECTS TO WALLPLATE DISPLAY
	125853-01-000	EA	WIRE ASSEMBLY - ENTERTAINMENT CENTER
	134550-01-000	EA	WIRE ASSEMBLY - HEATER/RELAY

CONNECTORS & CONDUIT

KEY	PART NUMBER	U/M	DESCRIPTION
	007956-05-000	EA	INSULATOR - SHRINK - .25 ID X 1.50
	008313-01-000	EA	CONNECTOR - WIRE NUT - INSULATED - YELLOW
	008314-01-000	EA	CONNECTOR - WIRE NUT - INSULATED - GRAY
	008326-01-000	EA	TERMINAL - RING - 16/14 WIRE - 3/8" STUD
	008328-01-000	EA	TERMINAL - RING - 12/10 WIRE - #10 STUD FIT
	008331-01-000	EA	TERMINAL - RING - TONGUE - #4 WIRE - 3/8" STUD - COPPER
	008348-01-000	EA	TERMINAL - RING - 3/8" STUD 2 GA. WIRE
	008355-01-000	EA	CONNECTOR - CABLE CLAMPING - 3/4"
	008356-01-000	EA	CONNECTOR - PLASTIC - 3/8" AVG
	008356-02-000	EA	CONNECTOR - PLASTIC - 21/32
	008394-01-000	FT	CONDUIT - FLEXIBLE - 1/2"
	035416-04-000	EA	TERMINAL - RING - #10 STUD FIT - INSULATED BARREL #16/14
	041480-01-000	EA	CONNECTOR - STRAIGHT - 1/2" FLEX CONDUIT
	041953-01-000	FT	CONDUIT - CONVOLUTE SLIT - .5" ID - POLYETHYLENE
	041953-03-000	FT	CONDUIT - CONVOLUTE SLIT - 1" ID (CLOTHES ROD COVER)
	041953-05-000	FT	CONDUIT - CONVOLUTE SOLID - .62" ID - POLYETHYLENE
	041953-06-000	FT	CONDUIT - CONVOLUTE SLIT - .375" ID - POLYETHYLENE
	041953-07-000	FT	CONDUIT - CONVOLUTE SLIT - .25" ID - POLYETHYLENE
	041953-08-000	FT	CONDUIT - CONVOLUTE SLIT - 1.50" ID - POLYETHYLENE
	041953-09-000	FT	CONDUIT - CONVOLUTE SLIT - .50" ID - NYLON
	041953-10-000	FT	CONDUIT - CONVOLUTE SLIT - .75" ID - NYLON
	041953-11-000	FT	CONDUIT - CONVOLUTE SLIT - 1.06" ID - NYLON
	041953-13-000	FT	CONDUIT - CONVOLUTE SLIT - 1.25
	047443-01-000	EA	TERMINAL - .250 RECEPTACLE FIT - INSULATED - 16/14 AWG
	047443-02-000	EA	TERMINAL - .250 RECEPTACLE FIT - INSULATED - 12/10 AWG
	058028-01-000	EA	CONNECTOR - ELECTRICAL PIGTAIL - NYLON - CLEAR
	077479-01-000	EA	BOOT - BATTERY TERMINAL - DOUBLE CABLE
	077479-02-000	EA	BOOT - BATTERY TERMINAL - SINGLE CABLE
	080015-02-000	EA	RECEPTACLE - FLAG - .185 - 16/14 GAUGE
	080015-03-000	EA	RECEPTACLE - FLAG - .250 - 14/16 GAUGE
	087225-02-000	FT	SLEEVING - 5/8" - TYPE H
	087949-01-000	EA	BUSS BAR - 2 POSITION - .6" X 1.5"
	088473-01-000	EA	HOUSING - PIN - 12 CAVITY (3 ROWS OF 4)
	088473-03-000	EA	HOUSING - PIN - 9 CAVITY (3 ROWS OF 3)
	088473-08-000	EA	HOUSING - PIN - 4 CAVITY - IN-LINE
	088473-09-000	EA	HOUSING - PIN - 3 CAVITY - IN-LINE
	088473-10-000	EA	HOUSING - PIN - 2 CAVITY - IN LINE
	088474-01-000	EA	HOUSING - SOCKET - 12 CAVITY
	088474-03-000	EA	HOUSING - SOCKET - 9 CAVITY

ELECTRICAL GROUP (CONTINUED)
CONNECTORS & CONDUIT (CONTINUED)

KEY	PART NUMBER	U/M	DESCRIPTION
	088474-07-000	EA	HOUSING - SOCKET - 5 CAVITY
	088474-08-000	EA	HOUSING - SOCKET - 4 CAVITY
	088474-09-000	EA	HOUSING - SOCKET - 3 CAVITY
	088474-10-000	EA	HOUSING - SOCKET - 2 CAVITY
	088475-01-000	EA	PIN - CONNECTOR - 14-20 AWG
	088475-02-000	EA	PIN - CONNECTOR - 10-12 AWG
	088476-01-000	EA	TERMINAL - ELECTRICAL
	088476-02-000	EA	SOCKET - CONNECTOR - 12-10 GA - PRE-TIN
	098261-02-000	EA	SOCKET - CONNECTOR - WEATHERPACK - 14-18 AWG
	098262-01-000	EA	SEAL - CONNECTOR - WEATHERPACK
	098265-02-000	EA	PIN - CONNECTOR - WEATHERPACK
	101751-02-000	EA	HOUSING - 1 PIN - WEATHERPACK
	102777-02-000	EA	TERMINAL - RING - #6 STUD - 10 AWG
	112823-01-000	EA	SPLICE - REDUCER - 16-14 TO 18-22
	119223-01-000	EA	HOUSING - 6 POSITION - MALE - WEATHERPACK
	125323-02-000	EA	HOUSING - 8 POSITION - MALE
	125323-03-000	EA	LOCK - SECONDARY 8 POSITION
	125324-01-000	EA	TERMINAL - MALE - METRI-PACK - 150
	125325-01-000	EA	SEAL - CAVITY

BOOTS, SOLENOIDS, RELAYS & MISCELLANEOUS

KEY	PART NUMBER	U/M	DESCRIPTION
	008188-01-000	EA	SOLENOID - 3 POST - BATTERY CHANGE OVER
	063910-01-000	EA	HOUSING - RELAY
	063912-02-000	EA	RELAY - CANISTER - SPDT
	086273-01-000	EA	RELAY - BATTERY DISCONNECT

**EXTERIOR BODY GROUP
GRAPHICS & PAINT**

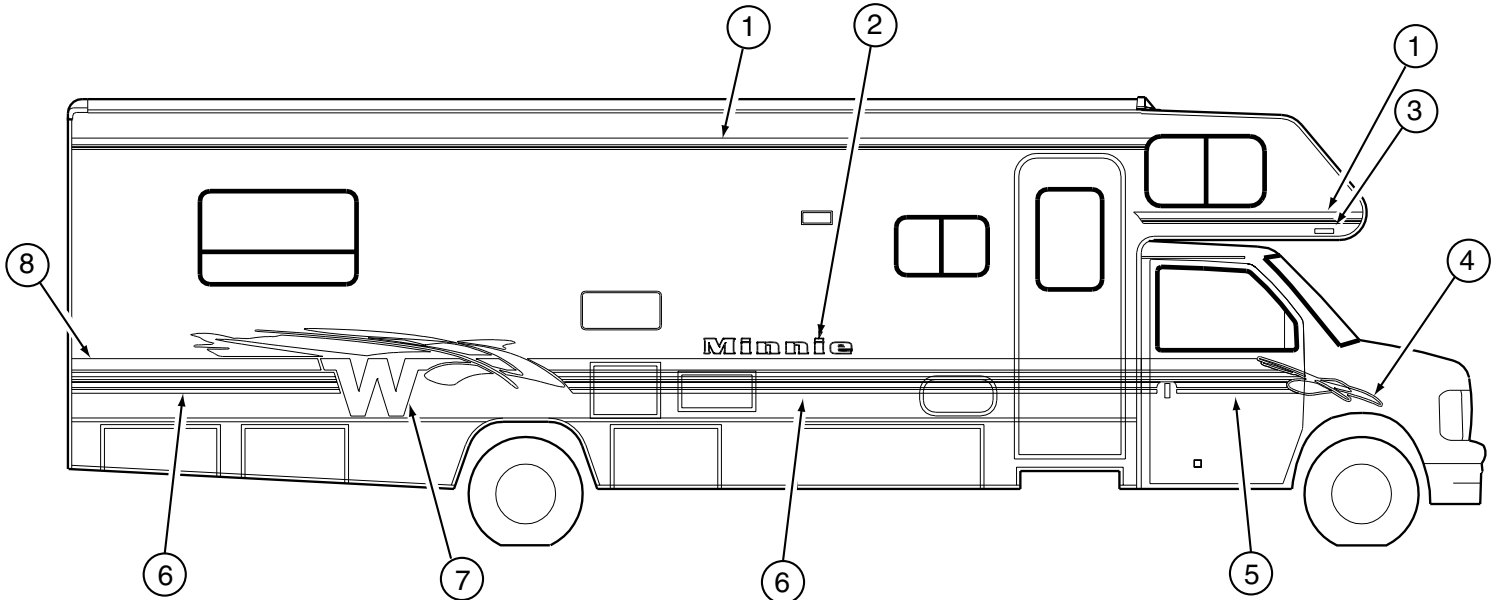

KEY	PART NUMBER	U/M	DESCRIPTION
1	094443-63-01A	FT	FILM - MULTISTRIPE - 3"
2	132089-01-01A	EA	DECAL - LOGO - MINNIE
3	132664-01-01A	EA	DECAL - LOGO/DOMED - WINNEBAGO
4	132091-01-01A	EA	DECAL - SPLASH/DOOR/PASSENGER
4	132091-02-01A	EA	DECAL - SPLASH/DOOR/DRIVER
5	132092-01-01A	EA	DECAL - CAB DOOR/PASSENGER
5	132092-02-01A	EA	DECAL - CAB DOOR/DRIVER
6	094443-64-01A	FT	FILM - MULTISTRIPE - 3.6"
			FROM: 00-00-00 THRU: 09-19-99
6	094445-09-01A	FT	FILM - MULTISTRIPE - 9"
			FROM: 09-20-99 THRU: 99-99-99
7	132090-01-01A	EA	DECAL - "W" W/SPLASH - PASSENGER
7	132090-02-01A	EA	DECAL - "W" W/SPLASH - DRIVER
8	105781-72-01A	FT	FILM - MULTISTRIPE - 4.7"
			FROM: 00-00-00 THRU: 09-19-99
	116424-01-000	EA	PROTECTOR - LATCH - WATER HEATER
	041561-03-000	EA	PAINT - 16 OUNCE SPRAY - OFF WHITE
	099399-23-701	EA	PAINT - BRT/WHT .3 OZ PEN RAABE
	099399-23-700	EA	PAINT-SPRAY-BRT WHITE ENAMEL

EXTERIOR BODY GROUP (CONTINUED)
GRAPHICS & PAINT (CONTINUED)

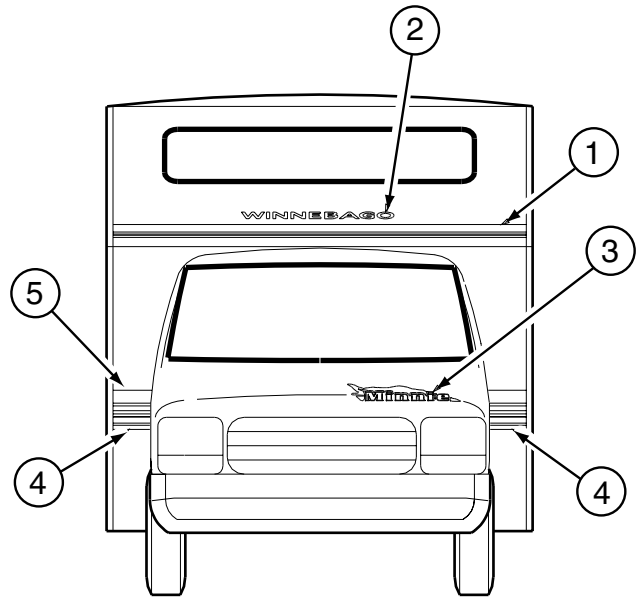
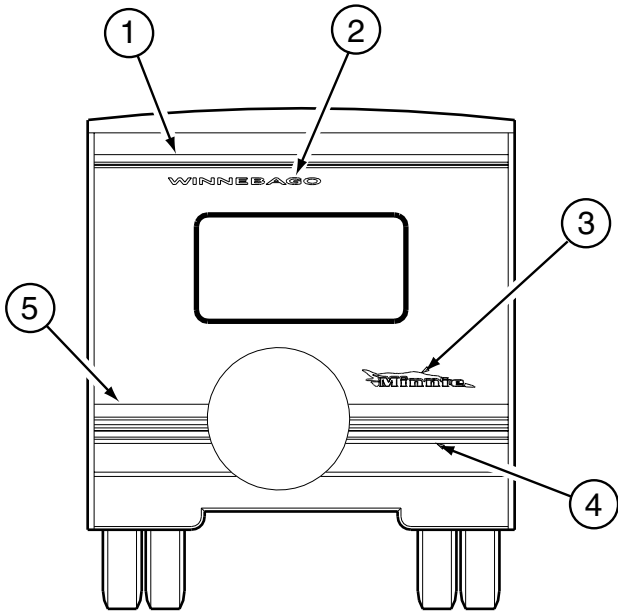

KEY PART NUMBER U/M DESCRIPTION

1	094443-63-01A	FT FILM - MULTISTRIPE - 3"
2	120702-03-13A	EA DECAL - WINNEBAGO - 35.4"
3	132095-01-01A	EA DECAL - MINNIE W/SPLASH
4	094443-64-01A	FT FILM - MULTISTRIPE - 3.6"

4	094445-09-01A	FT FILM - MULTISTRIPE - 9"
5	105781-72-01A	FT FILM - MULTISTRIPE - 4.7"

FROM: 00-00-00 THRU: 09-19-99

FROM: 09-20-99 THRU: 99-99-99

FROM: 00-00-00 THRU: 09-19-99

041561-03-000	EA PAINT - 16 OUNCE SPRAY - OFF WHITE
BRIGHT WHITE	DUPONT B8951U
FUCHSIA ICE METALLIC	DUPONT RM011
SURF BLUE METALLIC	DUPONT LM137
NEON BLUE METALLIC	DUPONT MM003
LIGHT MARINE BLUE METALLIC	DUPONT GM046

EXTERIOR BODY GROUP (CONTINUED) PANELS

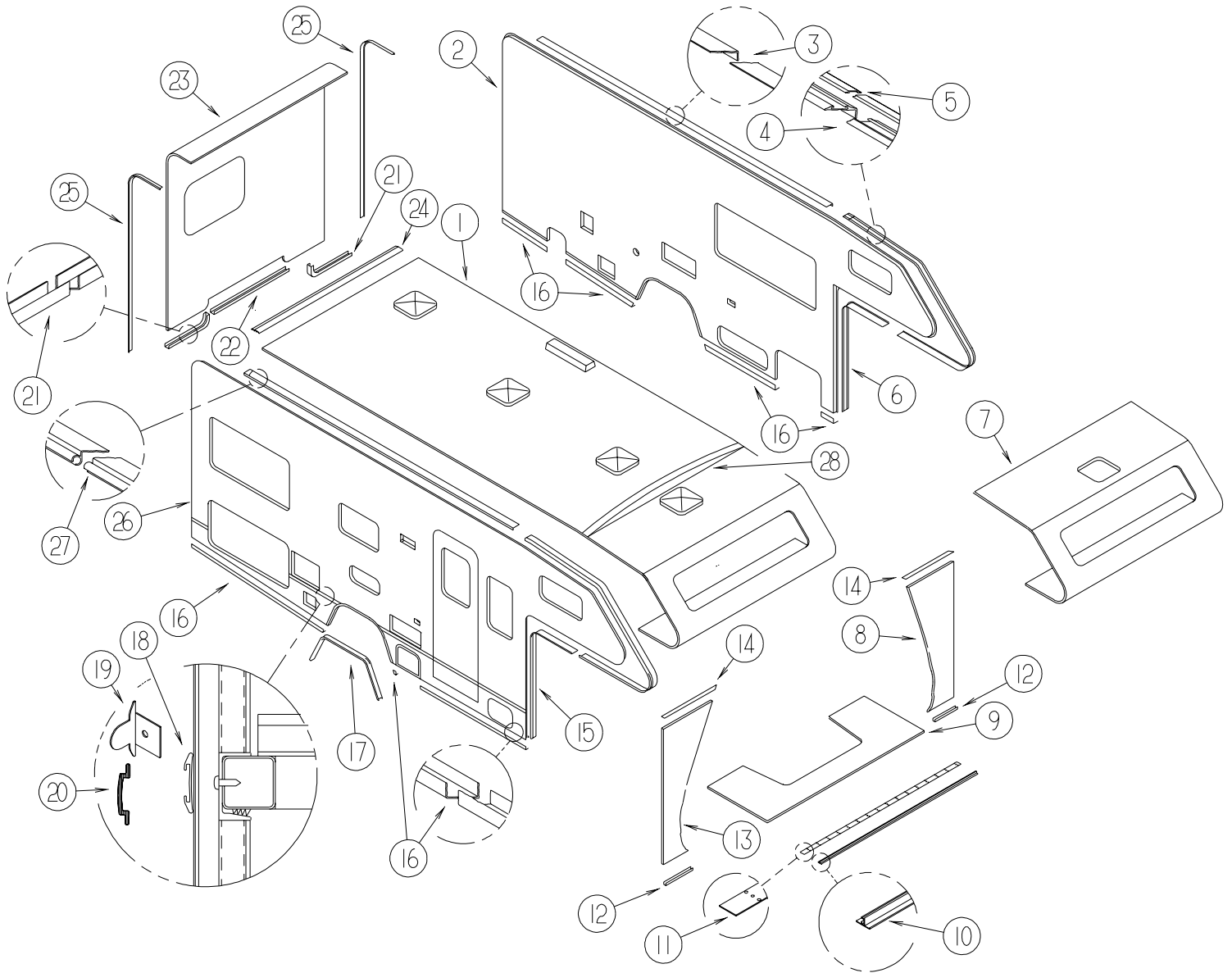

KEY	PART NUMBER	U/M	DESCRIPTION
1	132495-01-L01	EA	ROOF - REAR - W/O LIGHTS/VENTS - W/WIRING
2	P32114-01-L01	EA	SIDEWALL - DRIVER - W/O WINDOWS/TRIMS
2	P32114-01-L02	EA	SIDEWALL - DRIVER - W/O WINDOWS/TRIMS
2	P32114-01-L03	EA	SIDEWALL - DRIVER - W/O WINDOWS/TRIMS
3	131979-04-01A	EA	RAIL - AWNING - 144" - BRIGHT WHITE
4	096854-07-02A	EA	TRIM - CONTOUR - 144" - BRIGHT WHITE
5	105312-01-07A	FT	INSERT - VINYL FEATURE STRIP - BRIGHT WHITE
6	104479-06-02A	EA	TRIM - CONTOUR/FRONT - BRIGHT WHITE - LEFT HAND
7	P32079-02-L01	EA	ROOF - FRONT W/BASES - W/O LIGHTS/VENTS - W/WIRING
8	125088-06-J01	EA	WINGWALL
9	P25129-01-J01	EA	SLEEPERBOARD
10	100086-04-01A	EA	TRIM - SLEEPERBOARD/ROOF - 2" X 96.6"
11	100085-05-01A	EA	TRIM - STRAP - SLEEPERBOARD
12	002365-03-006	EA	U-CHANNEL - EXTRUDED - 1" X 192" - BRIGHT WHITE
13	125088-05-J01	EA	WINGWALL
14	022992-14-000	FT	MOLDING - REVERSE COVE - BRIGHT WHITE
15	104479-05-02A	EA	TRIM - CONTOUR/FRONT - BRIGHT WHITE - RIGHT HAND
16	108039-21-01A	EA	TRIM - SIDEWALL - 29.2" - BRIGHT WHITE
17	124517-04-01A	EA	TRIM - WHEELWELL/REAR - RIGHT/LEFT HAND - BRIGHT WHITE

EXTERIOR BODY GROUP (CONTINUED)
PANELS (CONTINUED)

KEY	PART NUMBER	U/M	DESCRIPTION
18	108688-01-03A	EA	STRIP - FEATURE - 15'
19	108651-01-01A	EA	END CAP - FEATURE STRIP
20	105312-01-07A	FT	INSERT - VINYL FEATURE STRIP - BRIGHT WHITE
21	103334-03-02A	EA	TRIM - BACKWALL - LOWER - DRIVER/PASS - 25.6" - BRT/WHT
22	103335-02-02A	EA	TRIM - BACKWALL - LOWER/CENTER - 46.3" - BRIGHT WHITE
23	P32494-01-L01	EA	BACKWALL - W/O WINDOW/TRIM
23	P32494-01-L02	EA	BACKWALL - W/O WINDOW/TRIM
23	P32494-01-L03	EA	BACKWALL - W/O WINDOW/TRIM
24	134167-01-01A	EA	CAP - ROOF - REAR - 1 PIECE - BRIGHT WHITE
	118383-01-04A	EA	RETAINER/RECESSED - F/.22" SCREW - BRIGHT WHITE
	118383-04-04A	EA	CAP - F/RECESSED RETAINER - BRIGHT WHITE
25	096854-07-02A	EA	TRIM - CONTOUR - 144" - BRIGHT WHITE
	105312-01-07A	FT	INSERT - VINYL FEATURE STRIP - BRIGHT WHITE
26	P32113-01-L01	EA	SIDEWALL - PASSENGER - W/O WINDOWS/TRIMS
26	P32113-01-L02	EA	SIDEWALL - PASSENGER - W/O WINDOWS/TRIMS
26	P32113-01-L03	EA	SIDEWALL - PASSENGER - W/O WINDOWS/TRIMS
	009126-03-000	EA	HANDLE - ASSIST - BLACK TEXTURED
27	131979-05-01A	EA	RAIL - AWNING - 144" W/NOTCHED END - BRIGHT WHITE
28	132075-02-L01	EA	CAP - TRANSITION/FRONT
	132076-01-02B	EA	BRACKET - TRANSITION/FRONT - E-COATED

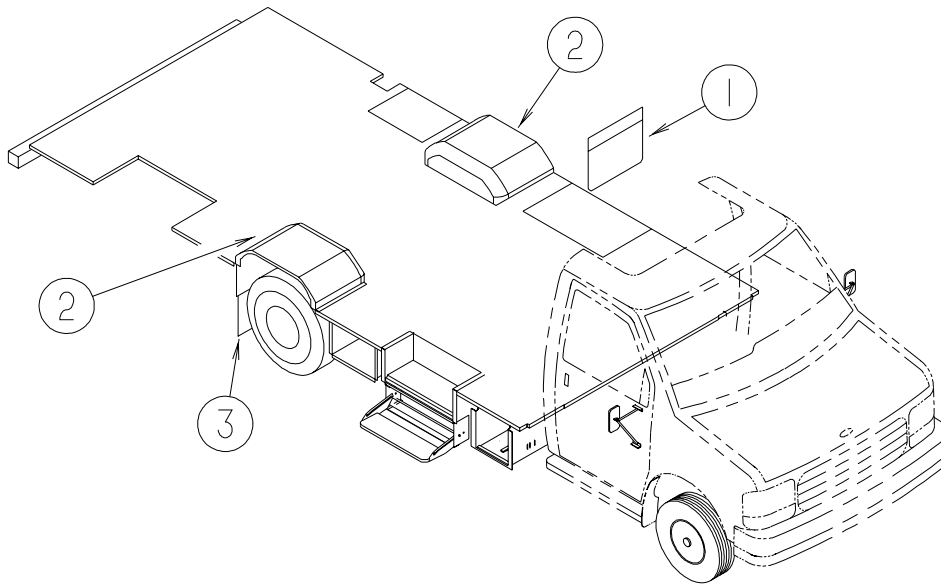

KEY	PART NUMBER	U/M	DESCRIPTION
1	111848-01-02B	EA	SHIELD - HEAT - EXHAUST
2	125621-01-000	EA	WHEELWELL
3	017516-01-000	EA	MUD FLAP - 14" X 18" - W/O MOUNTING HOLES - BLACK

EXTERIOR BODY GROUP (CONTINUED)

LADDER

KEY	PART NUMBER	U/M	DESCRIPTION
	129639-03-01A	EA	LADDER - BRUSHED ALUMINUM

RUNNING BOARDS

KEY	PART NUMBER	U/M	DESCRIPTION
*	072884-27-000	EA	RUNNING BOARD SET - 39" - FORD - ALUMINUM
*	072884-28-000	EA	RUNNING BOARD SET - ALUMINUM - CHEVY CHASSIS

*COMPONENT PARTS FOUND IN SERVICE PARTS LIBRARY

MIRRORS

KEY	PART NUMBER	U/M	DESCRIPTION
*	133908-01-01A	EA	MIRROR/PASSENGER - 102" W/B FORD - BLACK
*	133908-02-01A	EA	MIRROR/DRIVER - 102" W/B FORD - BLACK
*	133908-05-01A	EA	MIRROR/PASSENGER - 102" - BLACK
*	133908-06-01A	EA	MIRROR/DRIVER - 102" - BLACK

*COMPONENT PARTS FOUND IN SERVICE PARTS LIBRARY

BODY PANEL COMPONENTS

KEY	PART NUMBER	U/M	DESCRIPTION
	002726-01-001	EA	GARNISH - U-CHANNEL - 1.38" X 19' - SERRATED
	002754-01-001	EA	ANGLE - EXTRUDED - .75" X .75" X 16' - MILL ALUMINUM
	002766-01-001	EA	ANGLE - EXTRUDED - 1" X 1.5" X 17'
	076054-AC-000	EA	FIBERGLASS SHEET - 20" X 99.8" - OFF WHITE
	076054-N4-000	EA	FIBERGLASS SHEET - 102" X 261.8" - BRIGHT WHITE
	076054-P9-000	EA	FIBERGLASS SHEET - 37.4" X 99.3" - BRIGHT WHITE
	076054-U8-000	EA	FIBERGLASS SHEET - 100" X 105" - BRIGHT WHITE
	077517-62-000	EA	FIBERGLASS SHEET - 48" X 96" - BRIGHT WHITE
	089297-01-000	SF	PLYWOOD - LUAN - OVERLAY GRADE - 48" X 96"
	089297-02-000	SF	PLYWOOD - LUAN - OVERLAY GRADE - 48" X 108"
	100619-01-000	BF	FOAM - EXPANDED POLYSTYRENE - 1.34" X 48" X 96"
	100619-04-000	BF	FOAM - EXPANDED POLYSTYRENE - .5" X 48" X 96"
	100619-05-000	BF	FOAM - EXPANDED POLYSTYRENE - .75" X 48" X 96"-1.5 DENSITY
	100619-11-000	BF	FOAM - EXPANDED POLYSTYRENE - 2" X 48" X 96"
	100619-16-000	BF	FOAM - EXPANDED POLYSTYRENE - .75" X 48" X 96"-2.0 DENSITY

AWNINGS

KEY	PART NUMBER	U/M	DESCRIPTION
*	113874-01-02A	EA	HARDWARE KIT - AWNING - W/O STANDOFF BRACKET-BRIGHT WHITE
	113874-03-11A	EA	AWNING - 11.5' AMETHYST VINYL - BRT/WHT VINYL WRAP
	113874-10-01A	EA	SPACER - AWNING - LOWER BRACKET
	111038-01-01A	EA	SPACER - AWNING - LOWER
	127647-01-01A	EA	ROD/AWNING GUARD - ENTRY DOOR
	130320-01-02A	EA	BRACKET - AWNING - F/A&E INSTALLATION - BRIGHT WHITE

*COMPONENT PARTS FOUND IN SERVICE PARTS LIBRARY

EXTERIOR DOORS & COMPARTMENTS GROUP
DOOR & COMPARTMENT LAYOUT

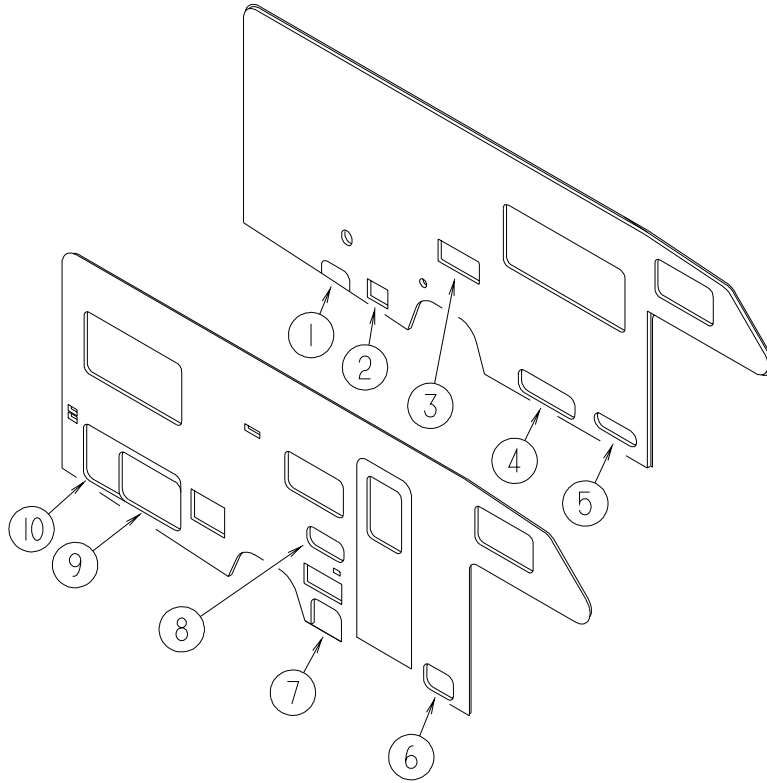

KEY	PART NUMBER	U/M	DESCRIPTION
1	127278-01-J01	EA	VALANCE/DOOR - W/O HARDWARE - DRIVER - 7.4" X 13.1" X 6.3"
2	088794-06-000	EA	DOOR - POWER CORD W/HATCH - BRIGHT WHITE - 9.2" X 11"
3*	084103-08-000	EA	DOOR - VENT - REFRIGERATOR - W/O JAMB - BRIGHT WHITE
	084104-08-000	EA	JAMB - VENT DOOR/REFRIGERATOR - BRIGHT WHITE
4	126946-05-J01	EA	DOOR/STORAGE - W/O HARDWARE - 27.5" X 9.3"
5	126945-02-J01	EA	DOOR/STORAGE - W/O HARDWARE - 18" X 8.3"
6	126945-07-J01	EA	DOOR/STORAGE - W/O HARDWARE - 14.4" X 10"
7	127405-01-J01	EA	VALANCE/DOOR - W/O HARDWARE - 14.5" X 11.8"
	089329-02-000	EA	CLIP - SPRING
	101667-03-000	EA	PROP - ROD
8	126945-01-J22	EA	DOOR/STORAGE - W/O HARDWARE - 18" X 8.3"
9	126946-08-L01	EA	DOOR/STORAGE - W/O HARDWARE - 30.1" X 20.4"
10	126946-07-J01	EA	DOOR/STORAGE - W/O HARDWARE - 47.5" X 23.3"

***COMPONENT PARTS FOUND IN SERVICE PARTS LIBRARY**

EXTERIOR DOORS & COMPARTMENTS GROUP (CONTINUED)
DOOR & COMPARTMENT LAYOUT (CONTINUED)

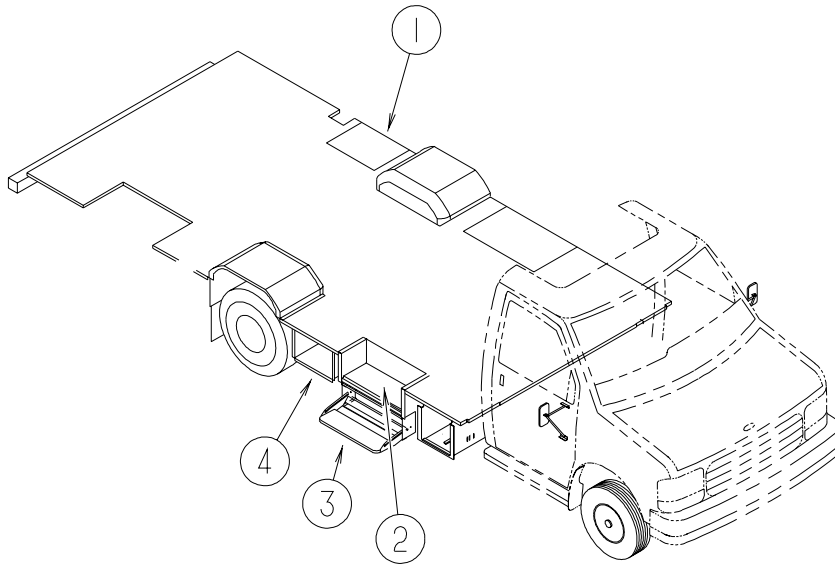

KEY	PART NUMBER	U/M	DESCRIPTION
1	101868-08-000	EA	COMPARTMENT - POWER CORD
2	122755-05-01A	EA	FLOORING/RUBBER - ENTRANCE DOOR - 11.2" X 27"
3*	094708-03-01A	EA	STEP - ELECTRIC - SINGLE - BLACK CONTROL BOX - KWIKEE
	076241-19-000	EA	SUPPORT - STEP
3	077848-02-000	EA	STEP - PULLOUT
	076241-14-000	EA	SUPPORT - STEP
	091176-01-000	EA	SUPPORT - BASE - ENTRANCE STEP
	102569-04-000	EA	MAT - ANTI SLIP
4	105203-04-000	EA	COMPARTMENT - BATTERY
	084993-01-000	EA	STRAP - BATTERY - 43.2" LONG
	084993-02-000	EA	STRAP - BATTERY - 55" LONG

***COMPONENT PARTS FOUND IN SERVICE PARTS LIBRARY**

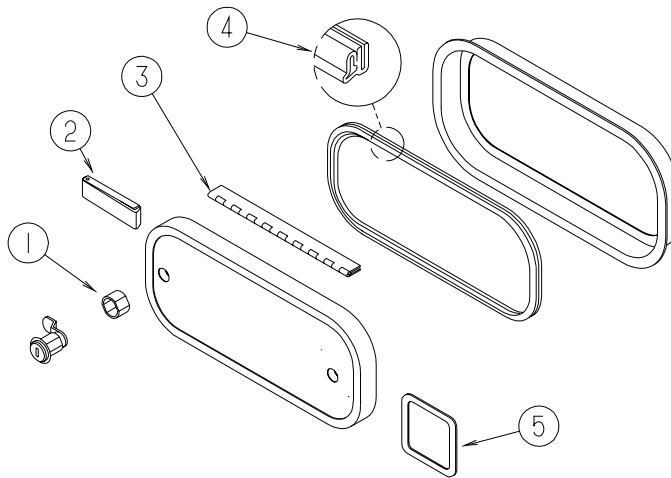

COMPARTMENT DOOR COMPONENTS

KEY	PART NUMBER	U/M	DESCRIPTION
1	107997-51-003	EA	SPACER - DOOR LOCK .79" DEEP
	107997-51-002	EA	EXTRUDED - SPACER - 16'
2	102768-01-000	EA	HOLDER - COMPARTMENT/ENTRY DOOR - METAL - MILL FINISH
3	081801-V3-000	EA	HINGE - ALUMINUM - 2" X 96" - BRIGHT WHITE
4	064075-07-000	FT	SEAL - BULB - W/WIRED U CHANNEL - .3" X .5" CHANNEL-BLACK
4	106850-02-000	FT	SEAL-E - SPONGE RUBBER - .43" X .75"
5	098338-01-000	EA	GASKET - LOCK POCKET
	098408-01-000	FT	SEAL - SPONGE RUBBER - CLOSED CELL
	096217-55-006	EA	U CHANNEL - 210"
	126694-55-001	EA	EXTRUSION - U-CHANNEL/HINGED - 191.7" - BRIGHT WHITE
	112160-02-000	FT	SEAL - D SECTION - .2 X .3" - FOAM RUBBER

EXTERIOR DOORS & COMPARTMENTS GROUP (CONTINUED)
COMPARTMENT DOOR COMPONENTS (CONTINUED)

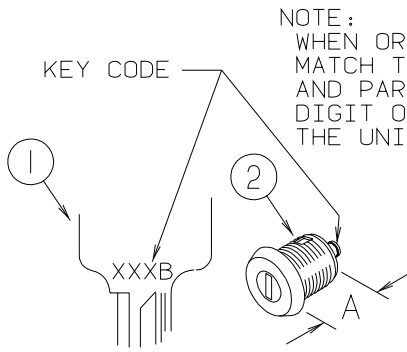

NOTE:
 WHEN ORDERING THE LOCK CASE, THE KEY CODE MUST MATCH THE LAST DIGIT OF THE UNIT'S SERIAL NUMBER AND PART NUMBER; WHEN ORDERING THE KEYS, THE THIRD DIGIT OF THE KEY CODE MUST MATCH THE LAST DIGIT OF THE UNIT'S SERIAL NUMBER AND PART NUMBER.

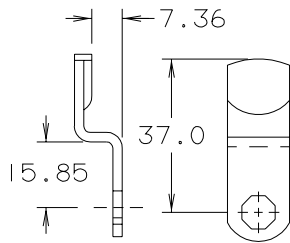

110506-66-000

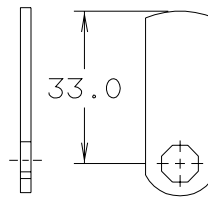

110506-70-000

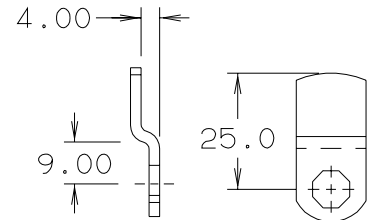

110506-76-000

KEY	PART NUMBER	U/M	DESCRIPTION	
1*	110506-59-000	EA	KEYS - SET OF TWO	596720
2	110506-52-000	EA	CASE/CYLINDER - LOCKING - W/O CAM/KEY - .65"	702370
2	110506-54-000	EA	CASE/CYLINDER - LOCKING - W/O CAM/KEY - 1.25"	703170
1*	110506-59-001	EA	KEYS - SET OF TWO	596721
2	110506-52-001	EA	CASE/CYLINDER - LOCKING - W/O CAM/KEY - .65"	702371
2	110506-54-001	EA	CASE/CYLINDER - LOCKING - W/O CAM/KEY - 1.25"	703171
1*	110506-59-002	EA	KEYS - SET OF TWO	596722
2	110506-52-002	EA	CASE/CYLINDER - LOCKING - W/O CAM/KEY - .65"	702372
2	110506-54-002	EA	CASE/CYLINDER - LOCKING - W/O CAM/KEY - 1.25"	703172
1*	110506-59-003	EA	KEYS - SET OF TWO	596723
2	110506-52-003	EA	CASE/CYLINDER - LOCKING - W/O CAM/KEY - .65"	702373
2	110506-54-003	EA	CASE/CYLINDER - LOCKING - W/O CAM/KEY - 1.25"	703173
1*	110506-59-004	EA	KEYS - SET OF TWO	596724
2	110506-52-004	EA	CASE/CYLINDER - LOCKING - W/O CAM/KEY - .65"	702374
2	110506-54-004	EA	CASE/CYLINDER - LOCKING - W/O CAM/KEY - 1.25"	703174
1*	110506-59-005	EA	KEYS - SET OF TWO	596725
2	110506-52-005	EA	CASE/CYLINDER - LOCKING - W/O CAM/KEY - .65"	702375
2	110506-54-005	EA	CASE/CYLINDER - LOCKING - W/O CAM/KEY - 1.25"	703175
1*	110506-59-006	EA	KEYS - SET OF TWO	596726
2	110506-52-006	EA	CASE/CYLINDER - LOCKING - W/O CAM/KEY - .65"	702376
2	110506-54-006	EA	CASE/CYLINDER - LOCKING - W/O CAM/KEY - 1.25"	703176

***COMPONENT PARTS FOUND IN SERVICE PARTS LIBRARY**

EXTERIOR DOORS & COMPARTMENTS GROUP (CONTINUED)

COMPARTMENT DOOR COMPONENTS (CONTINUED)

KEY	PART NUMBER	U/M	DESCRIPTION	
1*	110506-59-007	EA	KEYS - SET OF TWO	596727
2	110506-52-007	EA	CASE/CYLINDER - LOCKING - W/O CAM/KEY - .65"	702377
2	110506-54-007	EA	CASE/CYLINDER - LOCKING - W/O CAM/KEY - 1.25"	703177
1*	110506-59-008	EA	KEYS - SET OF TWO	596728
2	110506-52-008	EA	CASE/CYLINDER - LOCKING - W/O CAM/KEY - .65"	702378
2	110506-54-008	EA	CASE/CYLINDER - LOCKING - W/O CAM/KEY - 1.25"	703178
1*	110506-59-009	EA	KEYS - SET OF TWO	596729
2	110506-52-009	EA	CASE/CYLINDER - LOCKING - W/O CAM/KEY - .65"	702379
2	110506-54-009	EA	CASE/CYLINDER - LOCKING - W/O CAM/KEY - 1.25"	703179
		EA	HARDWARE KIT	
	110506-55-000	EA	CASE/CYLINDER - TWIST LOCK - W/O CAM - 1.25"	597312AA1
	110506-66-000	EA	CAM - LATCHING - DOG LEGGED 1.5" LONG	
	110506-70-000	EA	CAM - LATCHING - STRAIGHT 1.3" LONG	
	110506-76-000	EA	CAM - LOCK	
*		EA	KEY BLANK (GOLD)	

*COMPONENT PARTS FOUND IN SERVICE PARTS LIBRARY

EXTERIOR DOORS & COMPARTMENTS GROUP (CONTINUED)
ENTRY DOOR

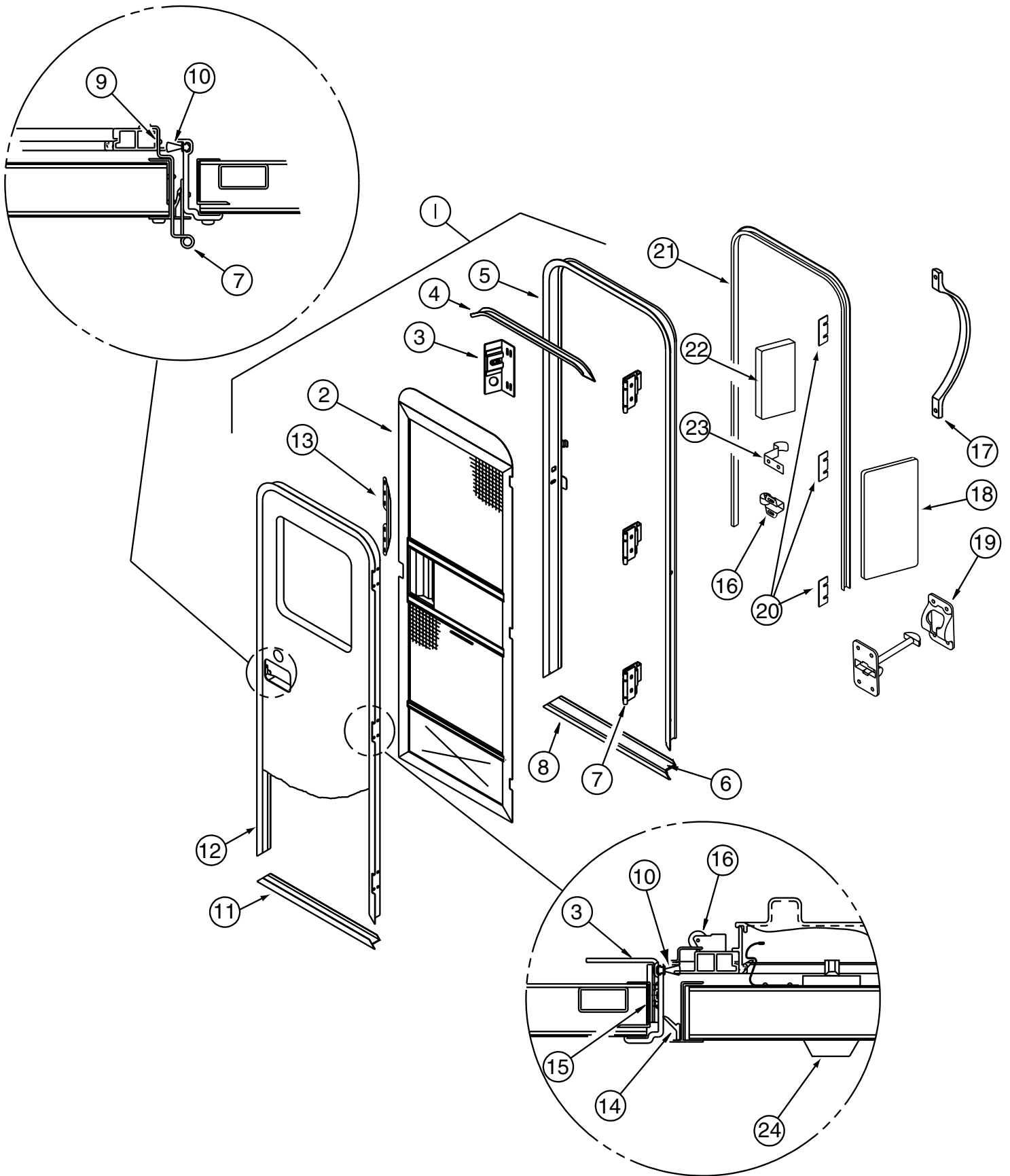

EXTERIOR DOORS & COMPARTMENTS GROUP (CONTINUED)

ENTRY DOOR (CONTINUED)

KEY	PART NUMBER	U/M	DESCRIPTION
1	115108-01-K03	EA	DOOR - ENTRY - W/SCREEN DOOR - W/O WINDOW (L01)
1	115108-01-L02	EA	DOOR - ENTRY - W/SCREEN DOOR - W/O WINDOW (L02)
1	115108-01-L03	EA	DOOR - ENTRY - W/SCREEN DOOR - W/O WINDOW (L03)
1	115108-05-K03	EA	DOOR - ENTRY - W/SCREEN DOOR - W/O WINDOW - ELECTRIC STEP (L01)
1	115108-05-L02	EA	DOOR - ENTRY - W/SCREEN DOOR - W/O WINDOW - ELECTRIC STEP (L02)
1	115108-05-L03	EA	DOOR - ENTRY - W/SCREEN DOOR - W/O WINDOW - ELECTRIC STEP (L03)
2	121899-03-GB1	EA	DOOR - SCREEN - W/O HARDWARE
3	041546-07-000	EA	BRACKET - DOOR ANGLE - OFF WHITE
4	044582-44-000	EA	CAP - DRIP - JAMB - BRIGHT WHITE
5	121898-03-01A	EA	JAMB - ENTRY DOOR
5	121898-04-01A	EA	JAMB - ENTRY DOOR - BRIGHT WHITE - ELECTRIC STEP
6	038327-01-000	EA	TAPE - ANTI SLIP - 2" X 60'
7	106719-01-05A	EA	HINGE - ENTRY DOOR - BRIGHT WHITE
	116111-02-01A	EA	SCREW - TAPTITE - 1/4-20 X 3/8 PPH - ZINC
8	051049-01-000	EA	JAMB - BOTTOM - ENTRY DOOR - 25.9" - UNPAINTED
9	100128-02-000	FT	SEAL - FOAM - ADHESIVE BACK - .37" WIDE X .37" THICK
10	118929-01-01A	FT	SEAL - PILE - PUSH ON
11	121893-01-01A	EA	FRAME - ENTRY DOOR/BOTTOM - BRIGHT WHITE
12	121894-07-01A	EA	FRAME - ENTRY DOOR - BRIGHT WHITE
13	098173-01-04A	EA	STIFFENER - ENTRY DOOR - SUPPORTS LATCH/STRIKE - UNPAINTED
	122241-01-01A	EA	BUMPER - FOAM RUBBER W/ADH BACK - .5" X .5" X .25" - BLACK
14	075671-04-000	FT	SEAL - SPONGE - LAZY T - W/ADHESIVE STRIP - .5" WIDE
15	104692-01-000	FT	SEAL - FOAM/ADHESIVE BACK - .75"THICK X .75"WIDE X 25'
16	109403-01-000	EA	CATCH - SINGLE ROLLER - SCREEN DOOR
17	009126-03-000	EA	HANDLE - ASSIST - BLACK TEXTURED
18	076725-02-000	EA	COVER - HINGE - ENTRY DOOR - 6" X 3.2" - OFF WHITE
19	104099-01-04A	EA	CATCH - DOOR HOLDER - STRIKE - BRIGHT WHITE
19	104099-02-04A	EA	CATCH - DOOR HOLDER - RETAINER - BRIGHT WHITE
20	102248-01-000	EA	SHIM - DOOR
21	115222-04-01A	EA	GARNISH - ENTRY DOOR - RADIUS
22	077461-03-000	EA	COVER - STRIKE - ENTRY DOOR - 6.5" X 2.5" - WHITE PLASTIC
23	100412-01-000	EA	CATCH - SCREEN DOOR
24*	101145-01-06A	EA	DEADBOLT - ENTRY DOOR W/O SECURITY BOLT W/2 KEYS - BLACK

*COMPONENT PARTS FOUND IN SERVICE PARTS LIBRARY

EXTERIOR DOORS & COMPARTMENTS GROUP (CONTINUED)
SCREEN DOOR

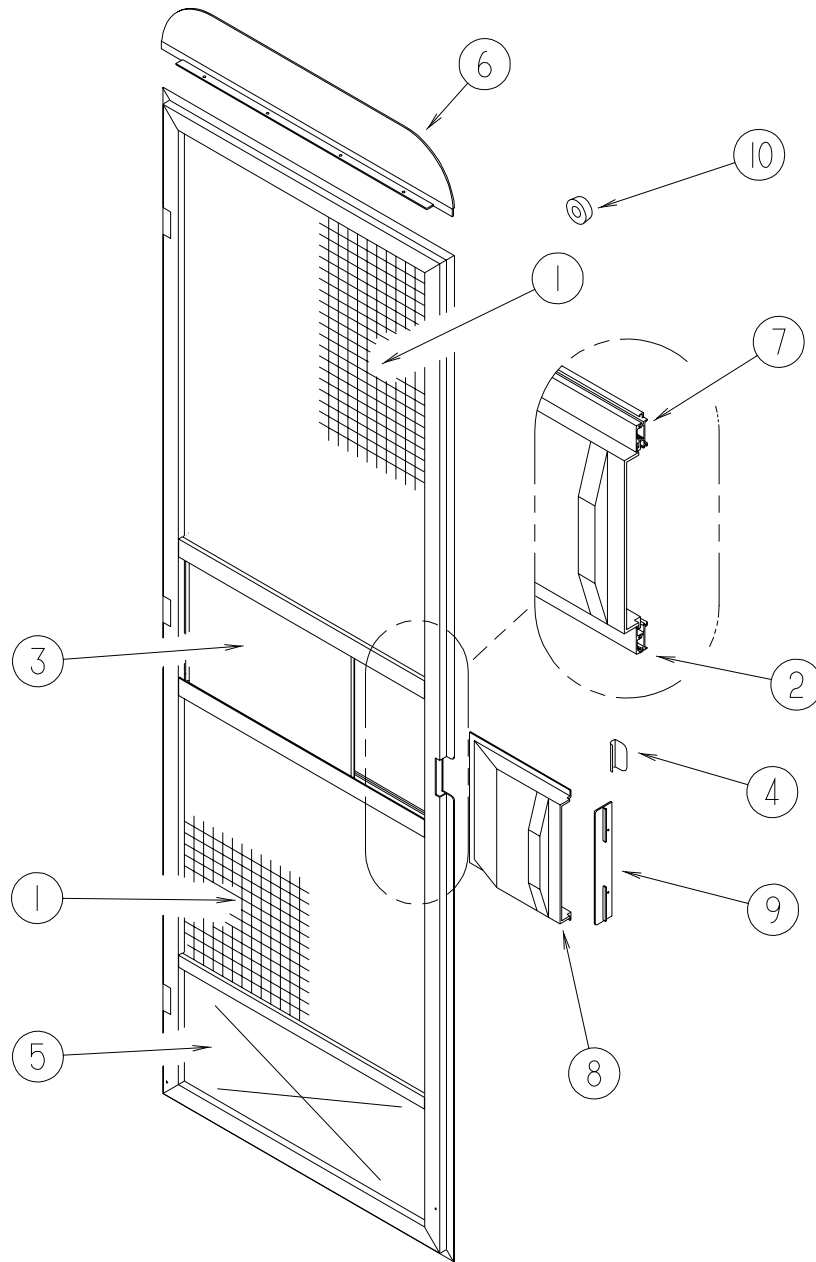

KEY	PART NUMBER	U/M	DESCRIPTION
	121899-03-GB1	EA	DOOR - SCREEN - W/O HARDWARE
1	002293-02-000	SF	SCREENING - WINDOW/DOOR - 26" - CHARCOAL
2	002294-01-000	FT	SPLINE - SCREENING - .135" X .138"
3	016454-01-000	EA	INSERT - CENTER - LEATHER GRAIN ALUMINUM - UNPAINTED
	001014-01-013	EA	INSERT - CENTER - 10.25" X 16.31" - UNPAINTED
4	050712-06-000	EA	HANDLE - SCREEN DOOR - BRIGHT WHITE
5	078552-03-000	EA	KICK PANEL - SCREEN DOOR - LOWER INSERT - UNPAINTED
6	078595-01-000	EA	TOP PLATE - SCREEN DOOR - CURVED TOP - 4.7" X 25.35"
7	078777-08-000	FT	CHANNEL - SLIDER
8	079086-03-000	EA	SLIDER - SCREEN DOOR - BRIGHT WHITE
9	079087-03-000	EA	STRIKE - SLIDER - SCREEN DOOR - BRIGHT WHITE
10	120863-06-000	EA	BUMPER - RUBBER - 3/4" X 3/8"

EXTERIOR DOORS & COMPARTMENTS GROUP (CONTINUED)

LATCH - ENTRY DOOR

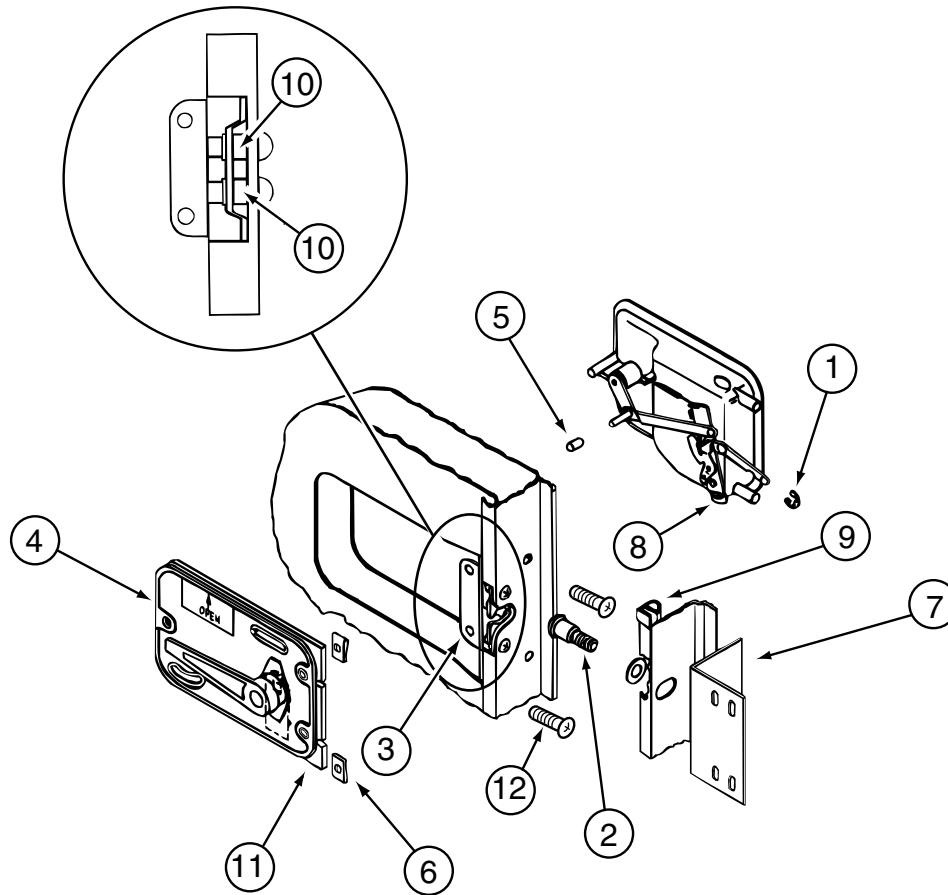

KEY	PART NUMBER	U/M	DESCRIPTION
1	036618-02-000	EA	E-RING - EXTERNAL - 3/16" SHAFT DIAMETER - LYNOR DOOR LOCK
2	039539-01-000	EA	STRIKE - LOCK - ENTRY DOOR - ROUND W/THREADED WASHER
	039715-01-000	EA	NUT-SERT - 1/4" DIAMETER - 20 THREADS
3	039540-01-000	EA	LATCH MECHANISM - HOOK - ENTRY DOOR - INTERIOR
4	039979-06-000	EA	COVER - LATCH PLATE - RIGHT HAND - BLACK TEXTURED
5	039984-01-000	EA	CAP - ROUND - VINYL - .28" ID X .62" - BLACK
6	040921-01-000	EA	NUT-SPEED-U TYPE 10-24 BLACK
7	041546-07-000	EA	BRACKET - DOOR ANGLE - OFF WHITE
8*	045017-13-000	EA	LATCH - ENTRY DOOR - BLACK TEXTURED
	045017-11-701	EA	KEY - BLANK (F1 SERIES) "K-104" - DOOR LOCK (TM 200 - 250)
	045017-11-703	EA	CYLINDER-LOCK ASM. W/KEYS 81266-09
9	064075-07-000	FT	SEAL - BULB - W/WIRED U CHANNEL - .3" X .5" CHANNEL - BLK
10	086285-05-000	EA	SPACER - NYLON - .7" X .56"
11	096810-01-01A	EA	PLATE - LATCH - ENTRY DOOR - BLACK
12	000G54-04-20B	EA	SCREW - 1/4-20 X 1 1/4 PTH TYP 23

*COMPONENT PARTS FOUND IN SERVICE PARTS LIBRARY

GALLEY GROUP CABINETS

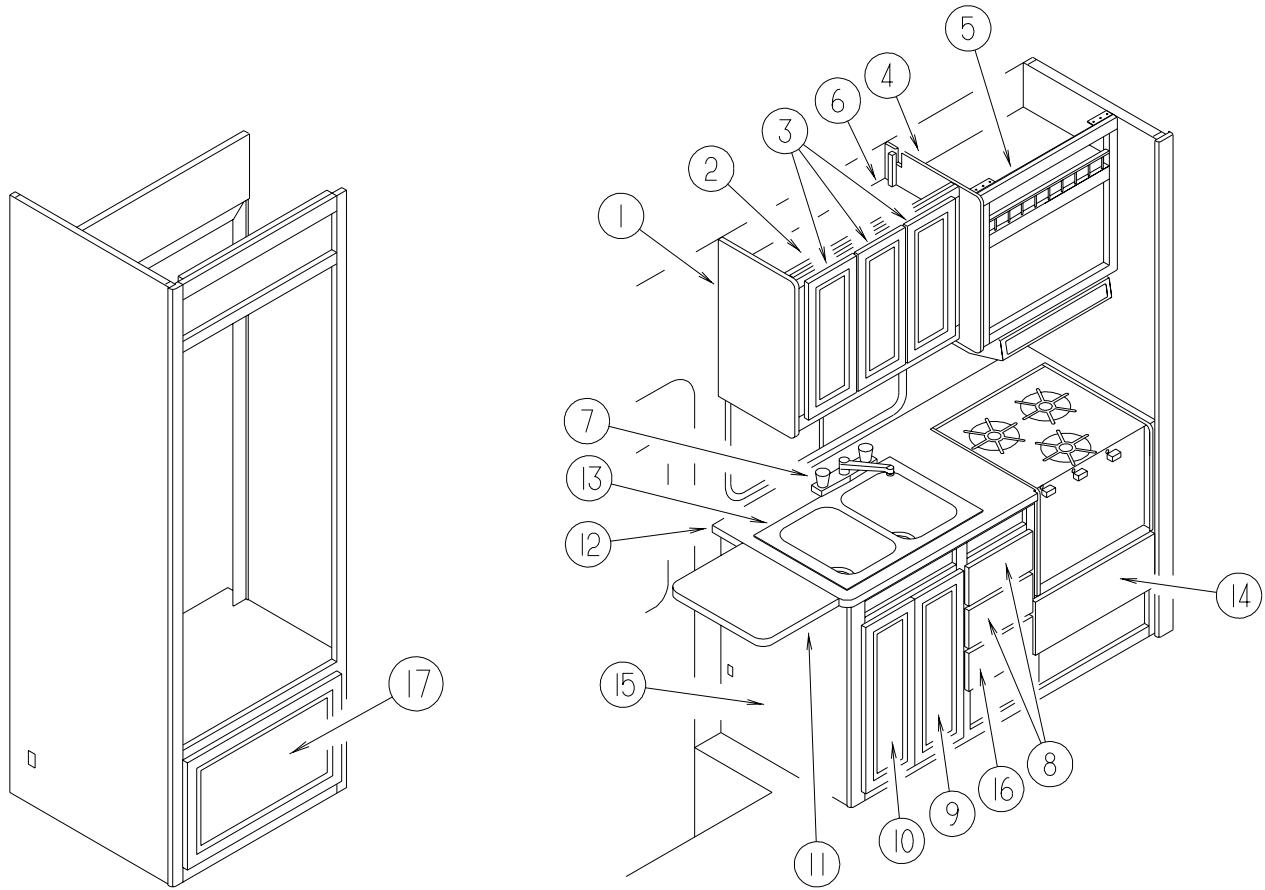

KEY	PART NUMBER	U/M	DESCRIPTION
1	109908-86-K01	EA	END CAP - OVERHEAD CABINET
			FROM: 00-00-00 THRU: 09-15-99
1	109908-B0-L01	EA	END CAP - OVERHEAD CABINET
			FROM: 09-16-99 THRU: 99-99-99
2	127482-02-K01	EA	CABINET - OVERHEAD/GALLEY - W/O DOORS/HARDWARE
			FROM: 00-00-00 THRU: 09-15-99
2	134517-01-L01	EA	CABINET - OVERHEAD/GALLEY - W/O DOORS/HARDWARE
			FROM: 09-16-99 THRU: 99-99-99
3	132141-29-L01	EA	DOOR - RAIL/VENEER - 10" X 25.1" - W/O HARDWARE
4	109908-93-K01	EA	END CAP - OVERHEAD CABINET
5	133857-02-L01	EA	CABINET - MICROWAVE - W/O DOORS/HARDWARE
6	127482-11-J03	EA	SHELF - W/PLASTIC EDGE MOLDING
			FROM: 00-00-00 THRU: 09-15-99
6	134517-12-L01	EA	SHELF - W/EDGE MOLDING
			FROM: 09-16-99 THRU: 99-99-99
7		EA	FAUCET - SEE WATER SYSTEMS GROUP
8	M09316-08-L01	EA	DRAWER - OGEE EDGE - 9.9"W X 17.7"D - W/O SLIDES/HARDWARE
9	131995-R0-L01	EA	DOOR - RAIL/SOLID PANEL - 11.4" X 16.1" - W/O HARDWARE
10	131995-P9-L01	EA	DOOR - RAIL/SOLID PANEL - 11.4" X 16.1" - W/O HARDWARE
11	129503-01-K03	EA	EXTENSION - GALLEY - W/O HARDWARE (L01, L03)
11	129503-01-K02	EA	EXTENSION - GALLEY - W/O HARDWARE (L02)
12	127448-14-K03	EA	COUNTERTOP - GALLEY (L01, L03)
12	127448-14-K02	EA	COUNTERTOP - GALLEY (L02)
13	103610-03-L01	EA	COVER - SINK - 15.2" X 11" - LAMINATED BOTH SIDES (L01, L03)
13	103610-03-L02	EA	COVER - SINK - 15.2" X 11" - LAMINATED BOTH SIDES (L02)
14	M09316-09-L01	EA	DRAWER - OGEE EDGE - 19.8"W X 11.8"D - W/O SLIDES/HARDWARE
15	M09361-03-L01	EA	CABINET - GALLEY - W/O COUNTERTOP/DOORS/DRAWERS/HARDWARE
16	M09316-10-L01	EA	DRAWER - OGEE EDGE - 9.9"W X 13.8"D - W/O SLIDES/HARDWARE
17	131995-N0-L01	EA	DOOR - RAIL/SOLID PANEL - 10" X 25.2" - W/O HARDWARE

GENERATOR GROUP GAS

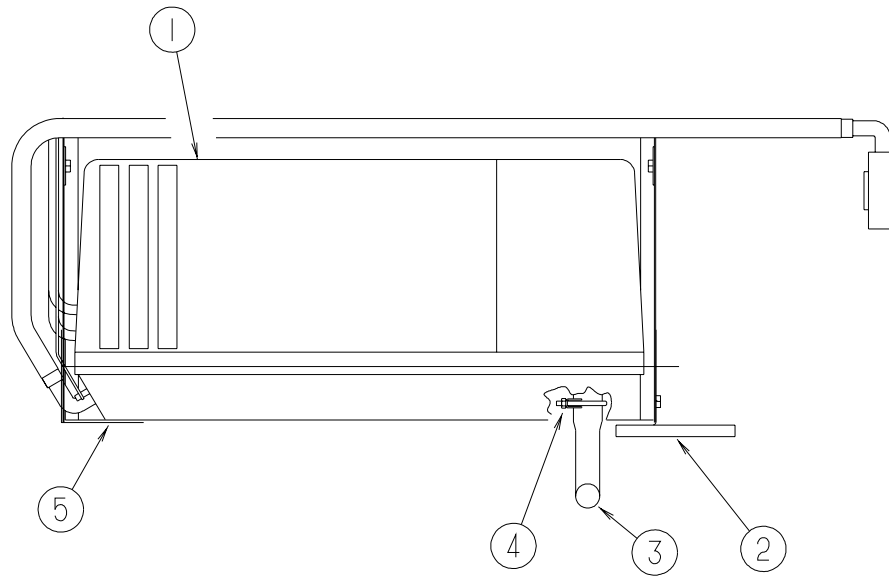

KEY	PART NUMBER	U/M	DESCRIPTION
1	109982-03-000	EA	GENERATOR - 4.0 MICROLITE
2	114071-02-02B	EA	SUPPORT - GENERATOR - RIGHT
3	105958-08-000	EA	PIPE - GENERATOR EXHAUST - 1.5" OD X 3.1" X 19.7"
4	007125-03-000	EA	CLAMP - MUFFLER - 1.5" DIAMETER
5	114070-02-02B	EA	SUPPORT - GENERATOR - LEFT
	007067-01-000	SF	INSULATION - FIBERGLASS - 1" THICK X 4'-INCREMENTS 4 SF
	007125-04-000	EA	CLAMP - MUFFLER - 1.12" DIAMETER

HEATING & A/C GROUP FURNACE

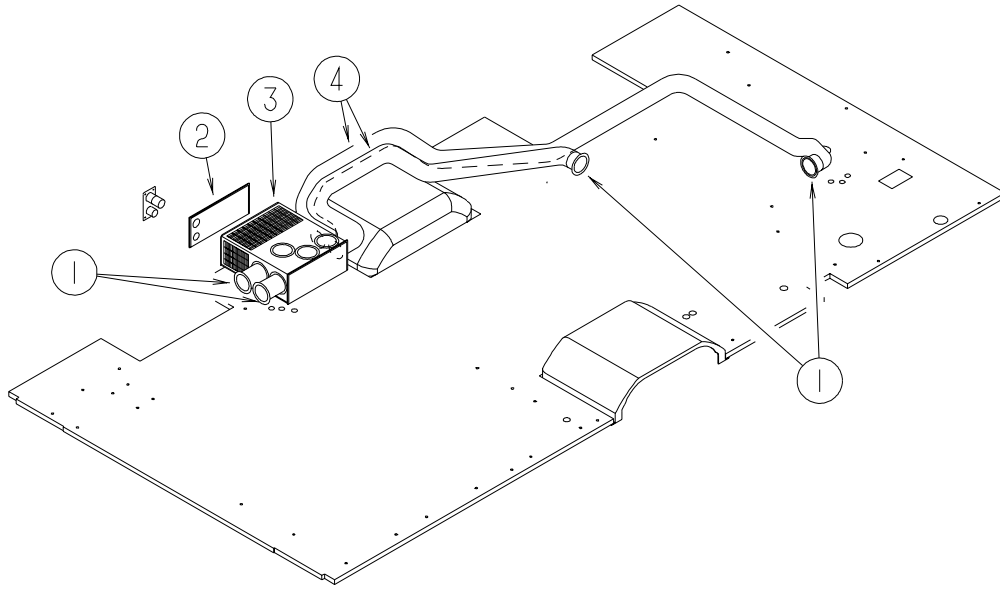

KEY	PART NUMBER	U/M	DESCRIPTION
1	056464-10-000	EA	REGISTER W/O DAMPER - 4" DIAMETER - PLASTIC - BEIGE
2	098668-23-000	EA	DOOR - ACCESS - FURNACE - BRIGHT WHITE
3*	098668-19-000	EA	FURNACE - 25000 BTU
	115764-01-01A	EA	THERMOSTAT - FURNACE
4	009198-01-000	FT	DUCT - HEAT - FLEXIBLE - 4" ID X 25'
	069636-02-000	EA	CONNECTOR - DUCT - 4" ID
	009200-01-000	EA	TAPE - FURNACE - 1 1/2"

***COMPONENT PARTS FOUND IN SERVICE PARTS LIBRARY**

ROOF

KEY	PART NUMBER	U/M	DESCRIPTION
*	131185-01-01A	EA	A/C ROOF - 13,500 BTU - WHITE
	131184-03-01A	EA	CEILING ASSEMBLY - A/C DUCTED - C-BODY - WHITE
	120134-01-02A	EA	REGISTER - W/DAMPER - 4" PIPE/7" O.D. FACE - WHITE
	117238-01-01A	EA	THERMOSTAT - A/C - FURNACE

***COMPONENT PARTS FOUND IN SERVICE PARTS LIBRARY**

INTERIOR FINISH GROUP

MOLDINGS & TRIMS

WATERFORD OAK

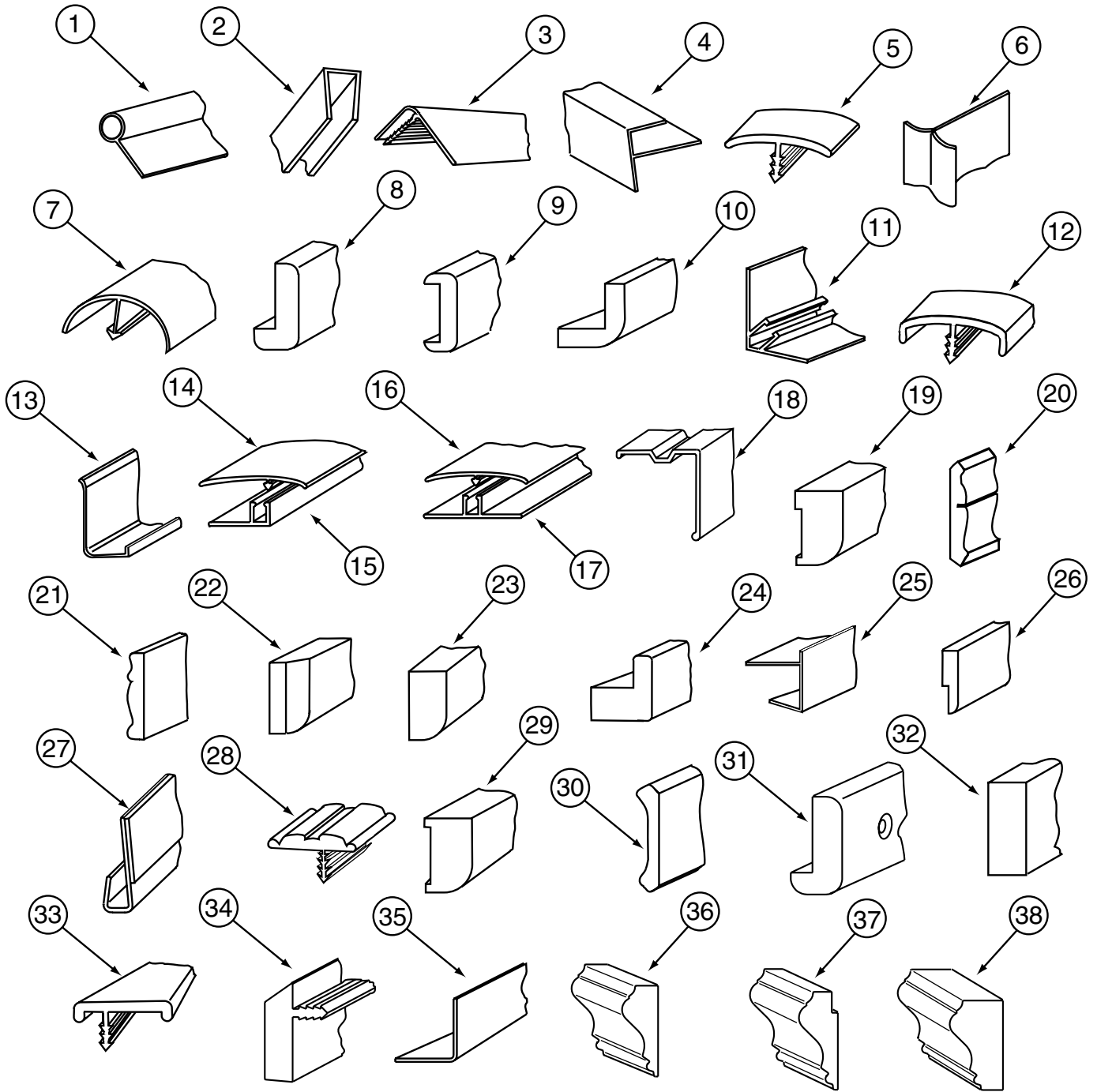

KEY	PART NUMBER	U/M DESCRIPTION
1	009767-12-000	FT WELTING - ANTIQUE WHITE
1	009767-14-000	FT WELTING - CHERRY
1	009767-15-000	FT WELTING - WATERFORD OAK
1	009767-16-000	FT WELTING - REBER BIRCH
2	009778-16-000	FT U-CHANNEL - 1" - PICKLED ASH
2	009778-18-000	FT U-CHANNEL - 1" - CHERRY WOOD/CHERRY STAIN
2	009778-21-000	FT U-CHANNEL - 1" - WATERFORD OAK
2	009778-25-000	FT U-CHANNEL - 1" - BEIGE ILLUSION
2	009778-27-000	FT U-CHANNEL - 1" - WASHED MAPLE
2	009778-31-000	FT U-CHANNEL - 1" - GRADY BROWN
2	070504-03-000	FT U-CHANNEL - PLASTIC - .9" X 96" - GRADY BROWN
2	070504-18-000	FT U-CHANNEL - PLASTIC - .13" X 84" - IVORY
2	070504-30-000	FT U-CHANNEL - PLASTIC - .13" X 84" - CHERRY

INTERIOR FINISH GROUP (CONTINUED)
MOLDINGS & TRIMS (CONTINUED)

KEY	PART NUMBER	U/M	DESCRIPTION
2	070504-31-000	FT	U-CHANNEL - PLASTIC - .9" X 84" - CHERRY
2	070504-36-000	FT	U-CHANNEL - PLASTIC - .13" X 72" - WATERFORD OAK
2	070504-37-000	FT	U-CHANNEL - PLASTIC - .9" X 84" - WATERFORD OAK
2	070504-42-000	FT	U-CHANNEL - PLASTIC - .13" X 84" - BEIGE ILLUSION
2	070504-50-000	FT	U-CHANNEL - PLASTIC - .13" X 84" - WASHED MAPLE
2	070504-51-000	FT	U-CHANNEL - PLASTIC - .9" X 96" - WASHED MAPLE
2	070504-54-000	FT	U-CHANNEL - PLASTIC - .9" X 96" - VILLAGE OAK
3	009809-27-000	EA	MOLDING - CORNER - OUTSIDE - 1" X 84" - CHERRY-CHERRY
3	009809-28-000	EA	MOLDING - CORNER - OUTSIDE - 1" X 84" - WATERFORD OAK
3	009809-30-000	EA	MOLDING - CORNER - OUTSIDE - 1" X 84" - BEIGE ILLUSION
3	009809-31-000	EA	MOLDING - CORNER - OUTSIDE - 1" X 84" - WASHED MAPLE
3	009809-32-000	EA	MOLDING - CORNER - OUTSIDE - 1" X 84" - PORTSMOUTH OAK
4	009812-24-000	EA	MOLDING - CORNER - 1/2" W/1/4"CHAN X 108" - IVORY PLASTIC
4	009812-26-000	EA	MOLDING - CORNER - 1/2" W/1/4" CHAN X 84" - CHERRY
4	009812-27-000	EA	MOLDING - CORNER - 1/2" W/1/4" CHAN X 84" - PICKLED ASH
4	009812-29-000	EA	MOLDING - CORNER - 1/2" W/1/4" CHAN X 84" - WATERFORD OAK
4	009812-31-000	EA	MOLDING - CORNER - 1/2" W/1/4" CHAN X 84" - BEIGE ILLUSION
4	009812-33-000	EA	MOLDING - CORNER - 1/2" W/1/4" CHAN X 84" - WASHED MAPLE
4	009812-34-000	EA	MOLDING - CORNER - 1/2" W/1/4" CHAN X 84" - VW LIGHT GRAY
4	009812-35-000	EA	MOLDING - CORNER - 1/2" W/1/4" CHAN X 84" - PORTSMOUTH OAK
5	009815-09-000	FT	MOLDING-T - W/EDGE LIP - 3/4" FACE - IVORY
5	105709-02-000	FT	MOLDING-T - W/EDGE LIP - 3/4" FACE - BEIGE ILLUSION
6	022992-11-000	FT	MOLDING - REVERSE COVE - T-SHAPED - IVORY
6	022992-14-000	FT	MOLDING - REVERSE COVE - T-SHAPED - BRIGHT WHITE
6	022992-15-000	FT	MOLDING - REVERSE COVE - T-SHAPED - VW GRAY
7	042357-18-000	EA	MOLDING - CORNER - RADIUS/PLASTIC - PICKLED ASH
7	042357-19-000	EA	MOLDING - CORNER - RADIUS/PLASTIC - CHERRY
7	042357-20-000	EA	MOLDING - CORNER - RADIUS/PLASTIC - WATERFORD OAK
7	042357-25-000	EA	MOLDING - CORNER - RADIUS/PLASTIC - WASHED MAPLE
7	042357-26-000	EA	MOLDING - CORNER - RADIUS/PLASTIC - PORTSMOUTH OAK
8	077840-01-E41	EA	MOLDING - WALL CAP - 8' - SALEM CHERRY
8	077840-01-G01	EA	MOLDING - WALL CAP - 8' - WATERFORD OAK
8	077840-01-J70	EA	MOLDING - WALL CAP - 8' - WASHED MAPLE
9	078323-06-G15	EA	MOLDING - CAP/WALL - 79.6" - WATERFORD OAK
10	080176-08-000	EA	CAP - CORNER - RADIUS MOLDING - PLASTIC - WASHED MAPLE
11	081521-02-007	EA	MOUNT - METAL MOLDING - F/RADIUS CORNER MOLDING - 151.5"
12	083620-09-000	FT	MOLDING-T - W/EDGE LIP - 7/8" FACE - MODERN IVORY
12	083620-11-000	FT	MOLDING-T - W/EDGE LIP - 7/8" FACE - CHERRY
12	083620-12-000	FT	MOLDING-T - W/EDGE LIP - 7/8" FACE - WATERFORD OAK
12	083620-15-000	FT	MOLDING-T - W/EDGE LIP - 7/8" FACE - BEIGE ILLUSION
12	083620-19-000	FT	MOLDING-T - W/EDGE LIP - 7/8" FACE - WASHED MAPLE
13	085746-04-000	FT	TRIM-J - CARPET 1.2" X .5" ANGLE - 10' LONG - OFF WHITE
14	086229-12-000	EA	BATTEN - 1.5" OFFSET X 96.8" - MODERN IVORY
15	086229-11-000	EA	RETAINER - OFFSET - 97.01"
16	086229-15-000	EA	BATTEN - 1" X 96" - MODERN IVORY
16	086229-19-000	EA	BATTEN - 1" X 98.3" - OFF WHITE
16	086229-20-000	EA	BATTEN - 1" X 96" - BEIGE
17	086229-01-000	EA	RETAINER - BATTEN - .75" X 92.1" - ANY COLOR
17	086229-14-000	EA	RETAINER - BATTEN - .75" X 98.3" - ANY COLOR
18	093873-01-01A	EA	TRIM - CARPET - L-ANGLE 1.1" X 1.3" X 12' - GRAY VINYL
19	126204-D2-134	EA	MOLDING - VINYL WRAPPED - .7" X 1.6" X 84" - WASHED MAPLE
19	126204-F2-134	EA	MOLDING - VINYL WRAPPED - .7" X 2.5" X 84" - WASHED MAPLE
19	126204-F2-438	EA	MOLDING - VINYL WRAPPED - .7" X 2.6" X 96" - WASHED MAPLE
20	111136-D2-134	EA	MOLDING - VINYL WRAPPED - .7" X 1.6" X 7' - CHERRY
20	111136-F2-134	EA	MOLDING - VINYL WRAPPED - .7" X 2.6" X 84" - CHERRY
20	111136-F2-438	EA	MOLDING - VINYL WRAPPED - .7" X 2.5" X 8' - CHERRY
21	100182-01-G15	EA	TRIM - RAIL - WATERFORD OAK
22	100659-27-G15	EA	MOLDING - TRIM - WATERFORD OAK

INTERIOR FINISH GROUP (CONTINUED)
MOLDINGS & TRIMS (CONTINUED)

WATERFORD OAK

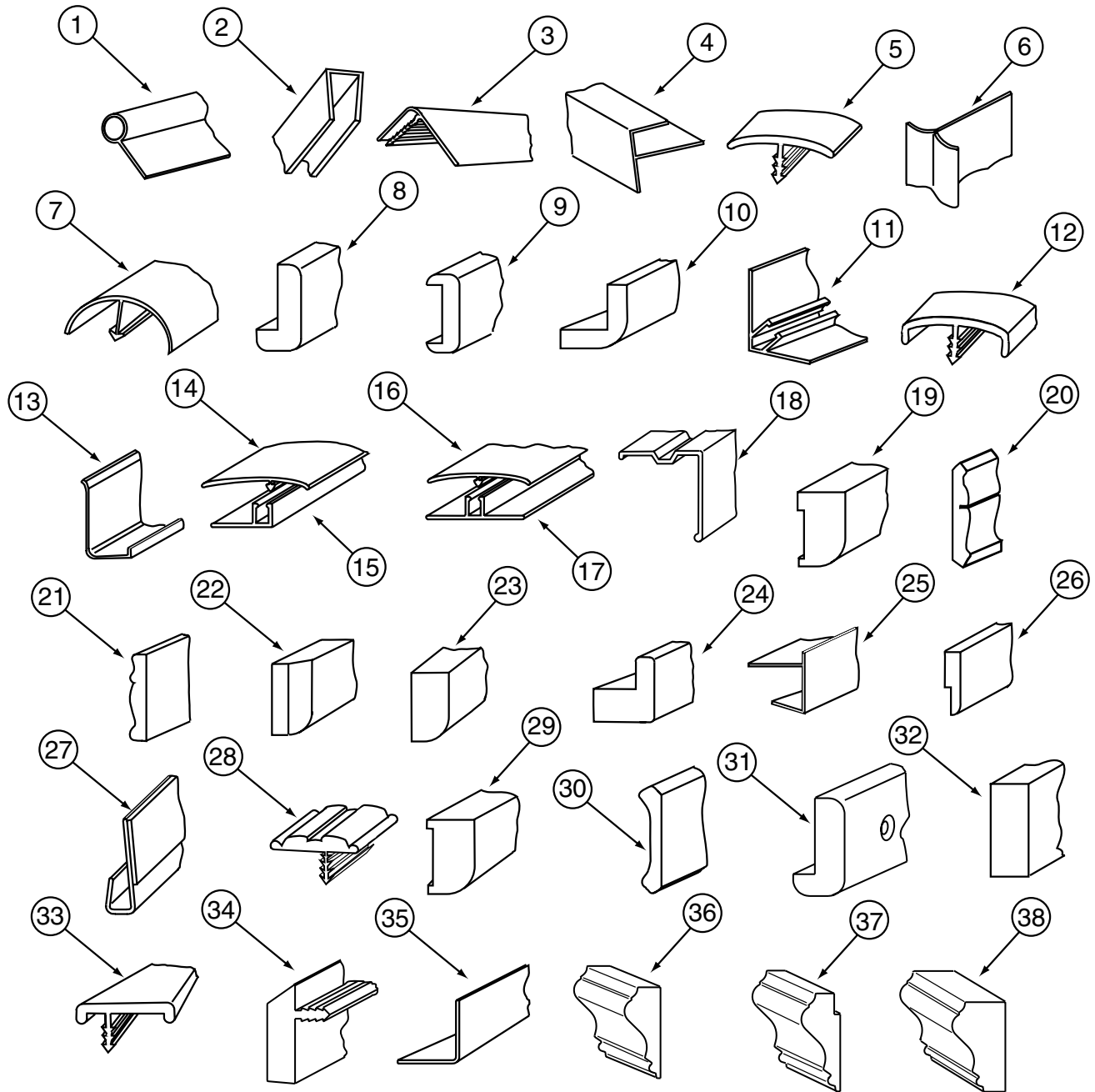

KEY	PART NUMBER	U/M	DESCRIPTION
23	100818-01-03A	EA	MOLDING - VINYL WRAPPED - 1.6" X .4" X 84" - PICKLED ASH
23	100818-01-04A	EA	MOLDING - VINYL WRAPPED - 1.6" X .4" X 84" - WATERFORD OAK
23	100818-01-05A	EA	MOLDING - VINYL WRAPPED - 1.6" X .4" X 84" - CHERRY CHERRY
23	100818-01-08A	EA	MOLDING - VINYL WRAPPED - 1.6" X .4" X 84" - WASHED MAPLE
23	100818-01-09A	EA	MOLDING - VINYL WRAPPED - 1.6" X .4" X 84" - PORTSMOUTH OAK
24	100819-01-03A	EA	MOLDING - VINYL WRAPPED - L-SHAPED - 1.5"X1.5"X84" - PICKLED ASH
24	100819-01-04A	EA	MOLDING - VINYL WRAPPED - L-SHAPED - 1.5"X1.5"X84" - CHERRY
24	100819-01-05A	EA	MOLDING - VINYL WRAPPED - L-SHAPED - 1.5"X1.5"X84" - OAK
24	100819-01-08A	EA	MOLDING - VINYL WRAPPED - L-SHAPED - 1.5"X1.5"X84" - WASHED MAPLE
24	100819-01-09A	EA	MOLDING - VINYL WRAPPED - L-SHAPED - 1.5"X1.5"X84" - PORTSMOUTH OAK
25	103186-01-04A	FT	MOLDING - PLASTIC 3/8" U-CHANNEL W/3/4" FACE - CHERRY
25	103186-01-03A	FT	MOLDING - PLASTIC 3/8" U-CHANNEL W/3/4" FACE - PICKLED ASH
25	103186-01-05A	FT	MOLDING - PLASTIC 3/8" U-CHANNEL W/3/4" FACE - WATERFORD OAK
25	103186-01-08A	FT	MOLDING - PLASTIC 3/8" U-CHANNEL W/3/4" FACE - WASHED MAPLE

INTERIOR FINISH GROUP (CONTINUED)

MOLDINGS & TRIMS (CONTINUED)

KEY	PART NUMBER	U/M	DESCRIPTION
25	103186-01-07A	FT	MOLDING - PLASTIC 3/8" U-CHANNEL W/3/4" FACE - BEIGE ILLUSION
25	103186-01-09A	FT	MOLDING - PLASTIC 3/8" U-CHANNEL W/3/4" FACE - PORTSMOUTH OAK
25	103186-02-03A	FT	MOLDING - PLASTIC - 1" U-CHANNEL 1 3/8" FACE - PICKLED ASH
25	103186-02-04A	FT	MOLDING - PLASTIC - 1" U-CHANNEL 1 3/8" FACE - CHERRY
25	103186-02-05A	FT	MOLDING - PLASTIC - 1" U-CHANNEL 1 3/8" FACE - WATERFORD OAK
25	103186-02-07A	FT	MOLDING - PLASTIC - 1" U-CHANNEL 1 3/8" FACE - BEIGE ILLUSION
25	103186-02-08A	FT	MOLDING - PLASTIC - 1" U-CHANNEL 1 3/8" FACE - WASHED MAPLE
25	103186-02-09A	FT	MOLDING - PLASTIC - 1" U-CHANNEL 1 3/8" FACE - PORTSMOUTH OAK
26	105004-01-03A	EA	MOLDING - VINYL WRAPPED - 1" X 96" - SALEM CHERRY
26	105004-01-04A	EA	MOLDING - VINYL WRAPPED - 1" X 96" - PICKLED ASH
26	105004-01-05A	EA	MOLDING - VINYL WRAPPED - 1" X 96" - WATERFORD OAK
26	105004-01-08A	EA	MOLDING - VINYL WRAPPED - 1" X 96" - WASHED MAPLE
26	105004-01-09A	EA	MOLDING - VINYL WRAPPED - 1" X 96" - PORTSMOUTH OAK
27	109332-02-03A	FT	TRIM-J - W/O ADHESIVE - SALEM CHERRY
27	109332-02-05A	FT	TRIM-J - W/O ADHESIVE - WASHED MAPLE
27	109332-02-06A	EA	TRIM-J - W/O ADHESIVE - PORTSMOUTH OAK
28	109736-02-01A	FT	MOLDING-T/OFFSET - W/EDGE LIP - 1" FACE - NATURAL OAK
29	117268-D2-134	EA	MOLDING - VINYL WRAPPED - .7" X 1.6" X 84" - WATERFORD OAK
29	117268-F2-134	EA	MOLDING - VINYL WRAPPED - .7" X 2.7" X 84" - WATERFORD OAK
29	117268-F2-438	EA	MOLDING - VINYL WRAPPED - .7" X 2.6" X 96" - WATERFORD OAK
30	113794-01-03A	FT	MOLDING - CROWN - 3.45" - MAPLE
30	113794-02-03A	FT	MOLDING - CROWN - 1.8" - MAPLE
31	116280-02-GV0	EA	MOLDING - CAP - PICKLED ASH
31	116280-02-GV1	EA	MOLDING - CAP - SALEM CHERRY
31	116280-02-J70	EA	MOLDING - CAP - WASHED MAPLE
31	116280-02-L95	EA	MOLDING - CAP - WATERFORD OAK
32	111134-F2-438	EA	LUMBER - VINYL WRAPPED - .7" X 2.5" X 96" - CHERRY
32	117267-D2-438	EA	LUMBER - VINYL WRAPPED - .7" X 1.5" X 96" - WATERFORD OAK
32	117267-E2-438	EA	LUMBER - VINYL WRAPPED - .7" X 2" X 96" - WATERFORD OAK
32	117267-F2-438	EA	LUMBER - VINYL WRAPPED - .7" X 2.5" X 96" - WATERFORD OAK
32	117267-J2-438	EA	LUMBER - VINYL WRAPPED - .7" X 5.5" X 96" - WATERFORD OAK
32	117267-R2-438	EA	LUMBER - VINYL WRAPPED - .7" X 3" X 96" - WATERFORD OAK
32	126205-D2-438	EA	LUMBER - VINYL WRAPPED - .7" X 1.5" X 96" - WASHED MAPLE
32	126205-E2-438	EA	LUMBER - VINYL WRAPPED - .7" X 2" X 96" - WASHED MAPLE
32	126205-F2-438	EA	LUMBER - VINYL WRAPPED - .7" X 2.5" X 96" - WASHED MAPLE
32	126205-G2-438	EA	LUMBER - STAINED - .7" X 3" X 96" - WASHED MAPLE
32	126205-J2-438	EA	LUMBER - VINYL WRAPPED - .7" X 5.5" X 96" - WASHED MAPLE
32	126205-R2-438	EA	LUMBER - VINYL WRAPPED - .7" X 3" X 96" - WASHED MAPLE
33	119520-01-01A	FT	MOLDING-T/OFFSET - W/EDGE LIP - 1"FACE - OFF WHITE
34	130247-01-01A	FT	MOLDING-T/OFF SET - 1.3" FACE - WATERFORD OAK
34	130247-01-02A	FT	MOLDING-T/OFF SET - 1.3" FACE - WASHED MAPLE
34	130247-01-03A	FT	MOLDING-T/OFF SET - 1.3" FACE - SALEM CHERRY
34	130247-01-04A	FT	MOLDING-T/OFF SET - 1.3" FACE - PORTSMOUTH OAK
35	130262-01-000	EA	PROTECTOR - CORNER SAVER - .7" X .7" X 5.9"
36	131923-01-01A	FT	MOLDING - CROWN - ASH
36	131923-01-02A	FT	MOLDING - CROWN - CHERRY
36	131923-01-03A	FT	MOLDING - CROWN - HARD WHITE MAPLE
37	131923-02-01A	FT	MOLDING - PICTURE - ASH
37	131923-02-02A	FT	MOLDING - PICTURE - CHERRY
37	131923-02-03A	FT	MOLDING - PICTURE - HARD WHITE MAPLE
38	131923-03-01A	FT	MOLDING - CROWN - DIVIDER - ASH
38	131923-03-02A	FT	MOLDING - CROWN - DIVIDER - CHERRY
38	131923-03-03A	FT	MOLDING - CROWN - DIVIDER - HARD WHITE MAPLE
	104676-02-02A	FT	MOLDING-T - W/EDGE LIP - 11/16" FACE - PICKLED ASH
	104676-02-03A	FT	MOLDING-T - W/EDGE LIP - 11/16" FACE - CHERRY-CHERRY
	104676-02-04A	FT	MOLDING-T - W/EDGE LIP - 11/16" FACE - WATERFORD OAK
	104676-02-06A	FT	MOLDING-T - W/EDGE LIP - 11/16" FACE - WASHED MAPLE
	104676-02-08A	FT	MOLDING-T - W/EDGE LIP - 11/16" FACE - PORTSMOUTH OAK

INTERIOR FINISH GROUP (CONTINUED)
PANELING, LAMINATES, BATT & EDGE BAND

KEY	PART NUMBER	U/M	DESCRIPTION
	088272-H8-000	SF	PANELING - UPBEAT/TWILIGHT - 4' X 7' (L01)
	088263-G0-000	EA	BATT STRIP - DECORATIVE - UPBEAT/TWILIGHT - 8' (L01)
	085284-F8-000	FT	BATT TAPE - ADHESIVE BACKED - DECORATIVE - UPBEAT/TWILIGHT (L01)
	088272-J7-000	SF	PANELING - COSMOS/SKY - 4' X 7' (L02)
	088263-G7-000	EA	BATT STRIP - DECORATIVE - COSMOS/SKY - 8' LONG (L02)
	085284-G6-000	FT	BATT TAPE - ADHESIVE BACKED - DECORATIVE - COSMOS/SKY (L02)
	088272-J3-000	SF	PANELING - PHOENIX/NEUTRAL - 4' X 7' (L03)
	088263-G3-000	EA	BATT STRIP - DECORATIVE - PHOENIX/NEUTRAL - 8' LONG (L03)
	085284-G2-000	FT	BATT TAPE - ADHESIVE BACKED - DECORATIVE - PHOENIX/NEUTRAL (L03)
	074497-28-000	SF	PANELING - WATERFORD OAK - 4' X 8'
	085284-B5-000	FT	BATT TAPE - ADHESIVE BACKED - WOODGRAINED-WATERFORD OAK
	069733-83-000	EA	BATT STRIP - WOODGRAINED/WATERFORD OAK - 8'
	088272-H9-000	SF	PANELING - PEBBLE EMBOSSED - WHITE (WET BATH)
	085284-F9-000	FT	BATT TAPE - ADHESIVE BACKED - PEBBLE EMBOSSED (WET BATH)
	088263-G1-000	EA	BATT STRIP - DECORATIVE - PEBBLE EMBOSSED - 8' LONG (WET BATH)
	074497-41-000	SF	PANELING - IMPACT PEARL/CEILING - 4' X 9'
	085284-F6-000	FT	BATT TAPE - ADHESIVE BACKED-IMPACT PEARL-W/FLEECE EMBOSSED
	088263-F9-000	EA	BATT STRIP - CEILING - IMPACT PEARL - 9'
	074497-40-000	SF	PANELING - CEILING - IMPACT PEARL - EMBOSSED - 4' X 8'
	085284-F6-000	FT	BATT TAPE - ADHESIVE BACKED-IMPACT PEARL-W/FLEECE EMBOSSED
	088263-F9-000	EA	BATT STRIP - CEILING - IMPACT PEARL - 9'
	088272-G1-000	SF	PANELING - PEBBLE EMBOSSED - ANTIQUE WHITE - 4' X 7'
	085284-D6-000	FT	BATT TAPE - ADHESIVE BACKED - DECORATIVE-EMBOSSED ANTIQUE
	088263-E3-000	EA	BATT STRIP - DECORATIVE - PEBBLE EMBOSSED/ANTIQUÉ - 8'
	074498-81-000	SF	LAMINATE - PLASTIC - ALMOND JAGUARD - 5' X 8' (L01, L03)
	074498-80-000	SF	LAMINATE - PLASTIC - WHITE TUNDRA - 5' X 8' (L02)
	074498-77-000	SF	LAMINATE - PLASTIC - ART CABIN (WATERFORD OAK) - 4' X 8'
	000846-01-000	SF	PLYWOOD - 5/16" X 48" X 96" - CD GRADE
	000846-02-000	SF	PLYWOOD/UNDERLAYMENT - 5/16" X 48" X 96"
	126339-01-000	SF	BOARD - WHEAT - 60" X 72"
	057882-04-700	EA	TAMBOUR - 48" X 48" SHEET - UNFINISHED
	000885-76-000	SF	PARTICLE BOARD-3/8" X 48" X 96"-WATERFORD OAK-VINYL 1 SIDE
	000885-77-000	SF	PARTICLE BOARD-3/8" X 48" X 96"-WATERFORD OAK-VINYL 2 SIDE
	000885-78-000	SF	PARTICLE BOARD-1/2" X 48" X 96"-WATERFORD OAK-VINYL 2 SIDE
	000885-79-000	SF	PARTICLE BOARD-3/4" X 48" X 96"-WATERFORD OAK-VINYL 2 SIDE
	076325-40-000	FT	MOLDING - EDGE BAND - .93" X .024" - ALMOND
	076325-39-000	FT	MOLDING - EDGE BAND - 1 5/16" X .030" - ALMOND
	076325-67-000	FT	MOLDING - EDGE BAND - .93" X .024" - WATERFORD OAK
	076325-68-000	FT	MOLDING - EDGE BAND - 1 5/16" X .038" - WATERFORD OAK

ACCESSORIES

KEY	PART NUMBER	U/M	DESCRIPTION
	072852-01-000	EA	DETECTOR - SMOKE - W/9 VOLT BATTERY - US
	072852-02-000	EA	DETECTOR - SMOKE - W/9 VOLT BATTERY - CANADIAN
	125136-01-000	EA	CO DETECTOR - GAS - ROUND W/2 SCREWS - 9 VOLT
	094499-03-000	EA	EXTINGUISHER/FIRE - DRY - 10BC - W/GAUGE - W/O BRACKET
	094499-04-000	EA	BRACKET - FIRE EXTINGUISHER
	094499-02-000	EA	EXTINGUISHER/FIRE - DRY - 1A10BC - CANADIAN
	094499-01-700	EA	BRACKET MTG. W/PLAS. STRAP

FLOOR COVERINGS

	096060-A2-000	SY	CARPET - NEW MEADOW - INCREMENTS OF 4 SY (L01)
	096060-E7-000	SY	CARPET - PEWTER BLUE - INCREMENTS OF 4 SY (L02)
	096060-E8-000	SY	CARPET - ALMOND - INCREMENTS OF 4 SY (L03)
	093486-01-000	SY	CARPET - COMPARTMENT - 72" WIDE - DARK GRAY
	042720-25-000	SY	VINYL - FLOOR COVERING - 14' WIDE - MODULATION
	091261-01-000	FT	SLIPNOT - ANTISLIP - 1'WIDE
	096764-02-000	FT	SLIPNOT - ANTISLIP - 1'WIDE (100' ROLLS)

INTERIOR FINISH GROUP (CONTINUED)

HARDWARE

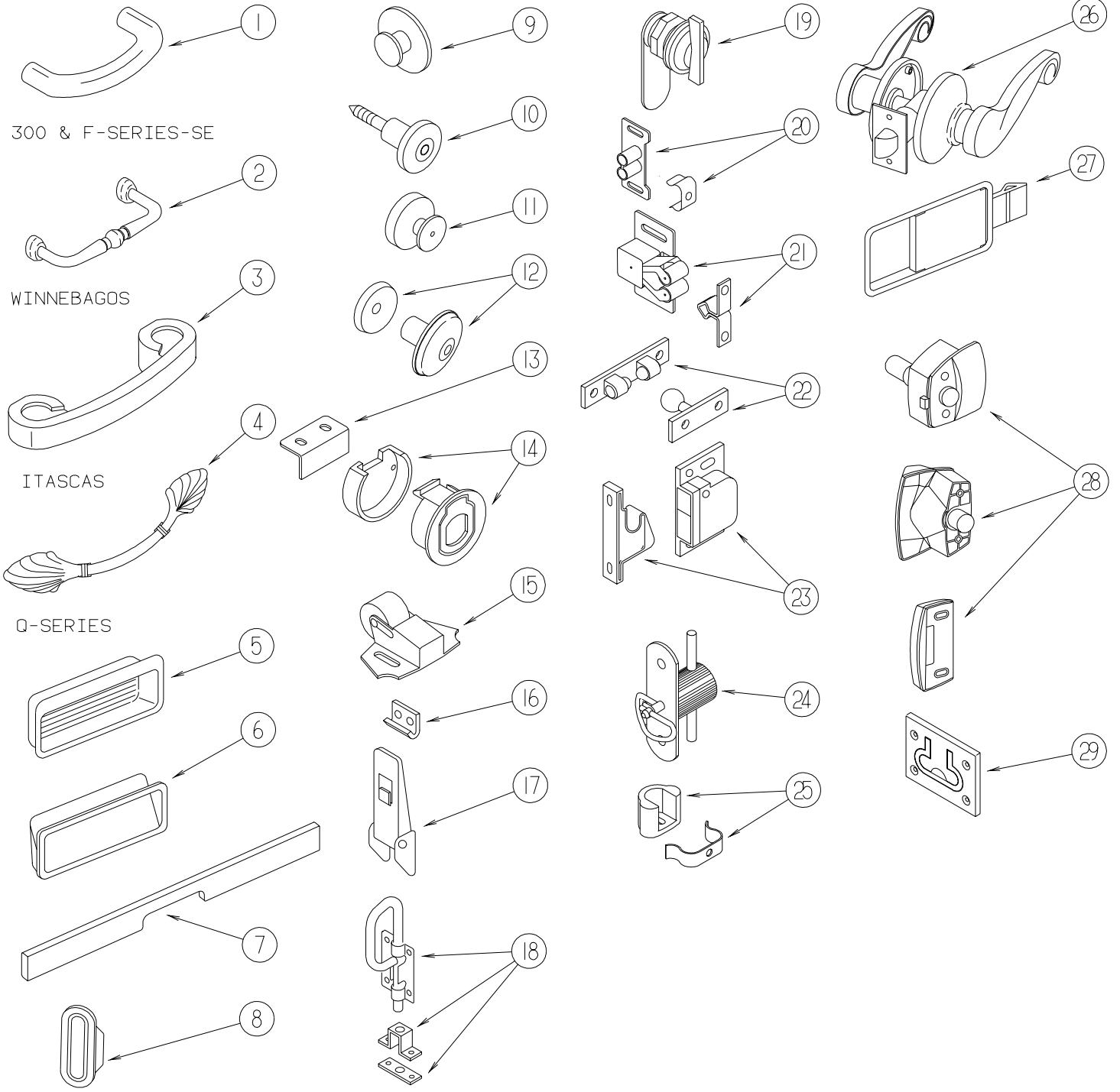

INTERIOR FINISH GROUP (CONTINUED)

HARDWARE (CONTINUED)

KEY	PART NUMBER	U/M	DESCRIPTION
1	131964-01-01A	EA	PULL - CABINET - POLISHED BRASS
2	131963-01-01A	EA	PULL - CABINET - POLISHED BRASS
3	131962-01-01A	EA	PULL - CABINET - POLISHED BRASS
4	117923-01-01A	EA	PULL - CABINET - BURNISHED BRASS - 5.5"
4	131965-01-01A	EA	PULL - CABINET - BURNISHED BRASS - 6.3"
5	124311-01-01A	EA	HANDLE - RECESSED - BRASS
6	115994-01-01A	EA	HANDLE - POCKET
7	126866-01-L81	EA	HANDLE - TAMBOUR DOOR - 18.6" - PORTSMOUTH OAK
7	126866-04-KQ0	EA	HANDLE - TAMBOUR DOOR - 14.7" - WASHED MAPLE
7	126866-04-KQ1	EA	HANDLE - TAMBOUR DOOR - 14.7" - CHERRY
7	126866-04-L95	EA	HANDLE - TAMBOUR DOOR - 14.7" - WATERFORD OAK
7	126866-05-K07	EA	HANDLE - TAMBOUR DOOR - 11.5" - WATERFORD OAK
7	126866-05-K09	EA	HANDLE - TAMBOUR DOOR - 11.5" - WASHED MAPLE
8	098410-01-01A	EA	PULL - FINGER - OVAL - BRASS
9	125221-01-01A	EA	PULL - MIRROR - W/ROUND HANDLE
10	113800-01-000	EA	KNOB - CABINET - BRASS
11	133313-01-01A	EA	PULL - DRAWER KNOB - BURNISHED BRASS
11	133313-01-02A	EA	PULL - DRAWER KNOB - BRIGHT BRASS
12	117978-01-01A	EA	KNOB - DOOR - BRIGHT BRASS
13	113375-02-01A	EA	STRIKE - DOOR - CHROME
14	113375-05-01A	EA	LATCH - SLAM - BACK - .8" THICK
14	113375-06-01A	EA	LATCH - SLAM - FACE - .7" THICK
15	109403-01-000	EA	CATCH - SINGLE ROLLER - SCREEN DOOR
16	116975-02-01A	EA	KEEPER/STRIKE - BLACK - NEW STYLE
17	116975-01-01A	EA	LATCH - W/O STRIKE - BLACK - NEW STYLE
18	103256-01-000	EA	LATCH - SLIDE
19	100710-01-01A	EA	LOCK - GLASS DOOR/TWIST TYPE - BRASS
20	009021-01-000	EA	CATCH - GRILLE - NYLON
20	009021-02-000	EA	STRIKE - SPRING STEEL
21	093586-04-000	EA	STRIKE - SPRING STEEL - 1.14"
21	093586-05-000	EA	STRIKE - SPRING STEEL - .943"
21	093586-03-000	EA	CATCH - SPRING ROLLER - .377"
21	093586-06-000	EA	CATCH - SPRING - ROLLER - .236"
22	084451-01-000	EA	CATCH - BRASS
23	117095-01-01A	EA	LATCH - DOOR - GRABBER W/KEEPER - PLASTIC - BLACK
23	117095-02-01A	EA	LATCH - DOOR - GRABBER W/KEEPER - PLASTIC - BLACK
24	098196-01-000	EA	LATCH - 1/4 TURN - T-BAR
25	129703-01-01A	EA	LATCH ASSEMBLY
26	111155-03-01A	EA	LOCK - PRIVACY/LOCKING - POLISHED BRASS/PLAIN HANDLE
26	111155-05-01A	EA	LOCK - PRIVACY/LOCKING - S SHAPED - POLISHED BRASS
27	127349-01-01A	EA	LATCH - PADDLE
28	058335-03-000	EA	LATCH W/O LOCK - BATHROOM DOOR BLACK
29	072871-01-000	EA	PULL - FLUSH - CHROME

INTERIOR FINISH GROUP (CONTINUED)
HARDWARE (CONTINUED)

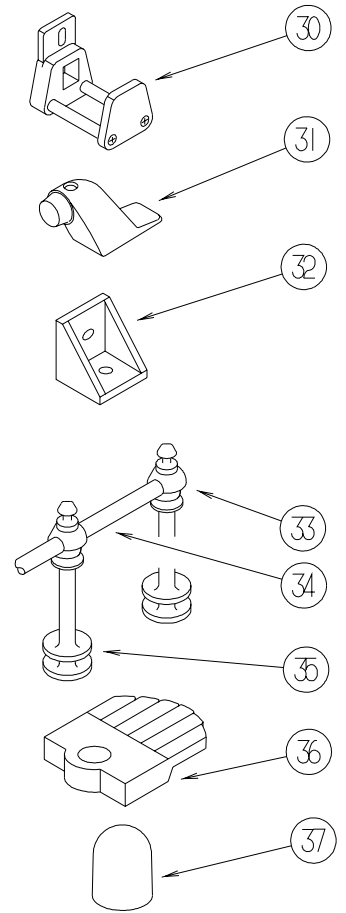
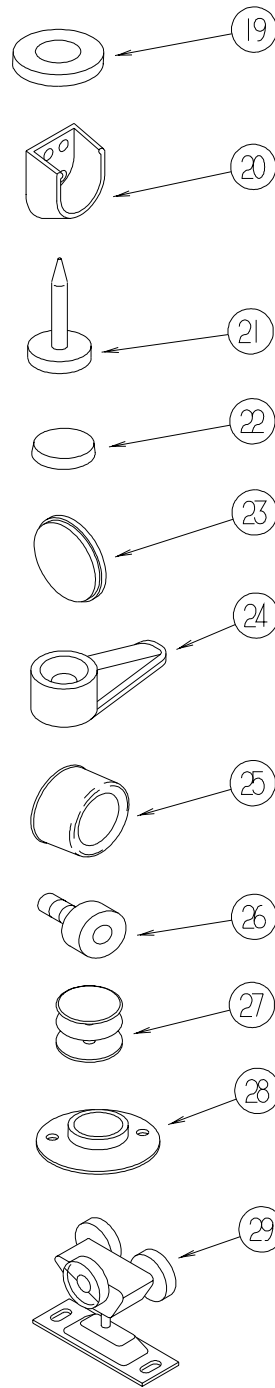
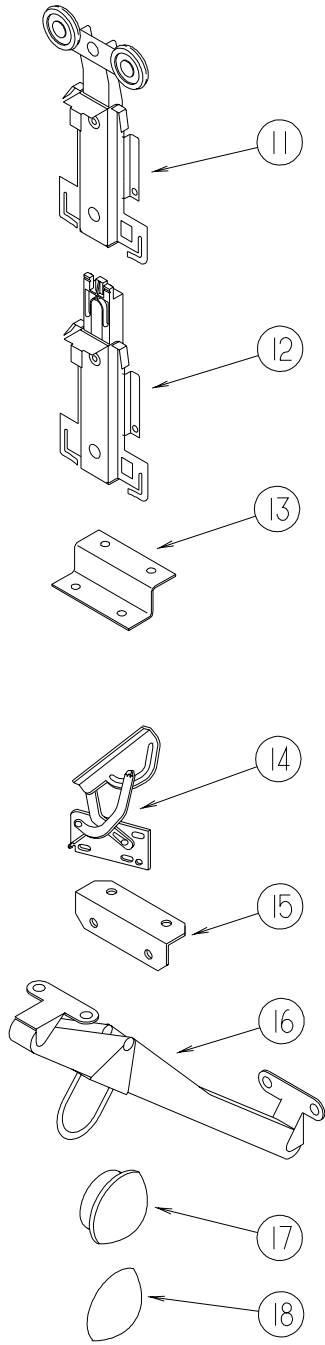
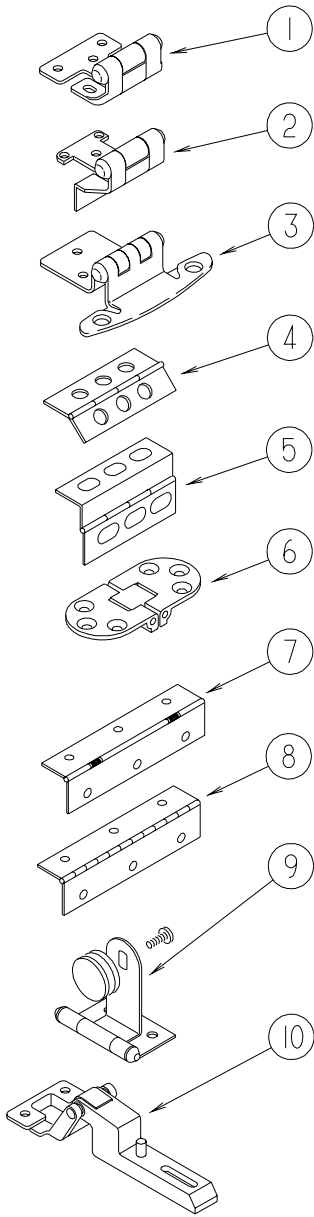

INTERIOR FINISH GROUP (CONTINUED)**HARDWARE (CONTINUED)**

KEY	PART NUMBER	U/M	DESCRIPTION
1	113676-01-01A	EA	HINGE - OVERLAY - VARIABLE
2	113677-01-01A	EA	HINGE - SELF CLOSING
3	108138-03-000	EA	HINGE - BRIGHT BRASS
	000G13-06-08G	EA	SCREW - 6-20 X .50 PFH - ANTIQUE BRASS
4	009059-01-000	EA	HINGE - DOOR - 2" X 1.4" - BRASS
4	009059-02-000	EA	HINGE - DOOR - 2" X 2.7" - BRASS
4	041389-18-000	EA	HINGE - PIANO - 1 1/2" X 19" - OFF WHITE
4	041389-35-000	EA	HINGE - PIANO - OFF WHITE - 31"
5	118802-01-02A	EA	HINGE - DOOR - CABINET - HAMPTON TAN
6	111535-01-000	EA	HINGE - TABLE/FOLDING
7	102920-01-01A	EA	HINGE/SPRING LOADED - BRASS
8	084413-01-000	EA	HINGE/CONTINUOUS - ALUMINUM 1" X 72" - W/HOLES
8	110496-01-01A	EA	HINGE - BRASS
9	100711-01-01A	EA	HINGE - GLASS DOOR
10	114443-01-01A	EA	HINGE - CABINET DOOR
11	107390-02-000	EA	CORNER HANGER (DOUBLE ROLLER W/BRACKET) (SOLD AS 1 EACH)
12	107391-01-000	EA	GUIDE - BOTTOM - BY-PASS (4 USED PER DOOR)
13	101926-01-02A	EA	BRACKET - ZEE - BLACK
14	108126-01-000	EA	TRAY HINGE SET (QTY. 2 PER SET)
15	016604-01-000	EA	BRACE - CABINET - ANGLE - 2.5" - UNPAINTED METAL
15	016604-05-000	EA	BRACE - CABINET - ANGLE - 2.5" - OFF WHITE METAL
16	104181-01-01A	EA	SUPPORT - LEAF 5.3" EXTENDS TO 7.5" - SAFETY RING - METAL
17	074045-01-000	EA	PLUG - OAK - 1/2" DIAMETER - COLONIAL WOOD
17	074045-08-000	EA	PLUG - OAK - 1/2" DIAMETER - SALEM CHERRY
17	042356-01-000	EA	PLUG - BUTTON - MAHOGANY - 3/8" DIAMETER - WOOD
18	057671-01-000	EA	COVER - SCREW - OFF WHITE - #8
18	057671-11-000	EA	COVER - SCREW - HAMPTON TAN - #8
18	057671-13-000	EA	COVER - SCREW - DARK GRAY - #8
18	057671-15-000	EA	COVER - SCREW - BRIGHT WHITE
18	057671-16-000	EA	COVER - SCREW - SOFT WHITE
19	100707-01-000	EA	SPACER - GLASS DOOR - .8" DIA - .3" HOLE - PLASTIC
20	113236-01-01A	EA	BRACKET - CLOTHES - ROD
21	102194-01-000	EA	GUIDE - PLASTIC
22	004354-01-000	EA	BUMPER - RUBBER - .5" DIA - BROWN
23	120760-01-000	EA	BUMPER - RUBBER - CLEAR
24	083204-03-000	EA	BUTTON - RETAINING MIRROR 5/16" TIP
25	069726-02-000	EA	BUMPER - .88" OD X .40" THICK - BLACK
26	079921-01-000	EA	ROLLER - NYLON - W/STEEL SHAFT - BARBED
27	081114-02-000	EA	CAP - INSERT - ROUND 1" DIAMETER - WHITE
28	009112-01-000	EA	FLANGE - PLASTIC - 1" CLOTHES ROD - OFF WHITE
29	103874-01-000	EA	HANGER - SLIDING DOOR
30	064467-01-000	EA	GUIDE - POCKET - SLIDING DOOR - WALL MOUNTED
31	103257-01-000	EA	STOP - DOOR
32	065740-01-000	EA	BRACE - CABINET/CORNER - PLASTIC
33	084070-03-000	EA	POST - END - 2.4" - BRASS
34	084071-05-000	EA	ROD - BRASS - 15"
34	084071-08-000	EA	ROD - BRASS - 9.3"
34	084071-12-000	EA	ROD - BRASS - 4.1"
34	084071-19-000	EA	ROD - BRASS - 7.1"
34	084071-20-000	EA	ROD - BRASS - 9.8"
34	084071-22-000	EA	ROD - BRASS - 15.3"
34	084071-23-000	EA	ROD - BRASS - 13.12"
34	084071-24-000	EA	ROD - BRASS - 3.8"
34	084071-27-000	EA	ROD - BRASS - 2.7"
34	084071-28-000	EA	ROD - BRASS - 6"
34	084071-30-000	EA	ROD - BRASS - 11.6"
34	084071-31-000	EA	ROD - BRASS - 14.08"
34	084071-32-000	EA	ROD - BRASS - 13.6"
35	084070-01-000	EA	POST - CENTER - 2.4" - BRASS
36	009089-01-000	EA	CLIP - MIRROR
37	039984-01-000	EA	CAP - ROUND - VINYL - .28" ID X .62" - BLACK

INTERIOR FINISH GROUP (CONTINUED)
HARDWARE (CONTINUED)

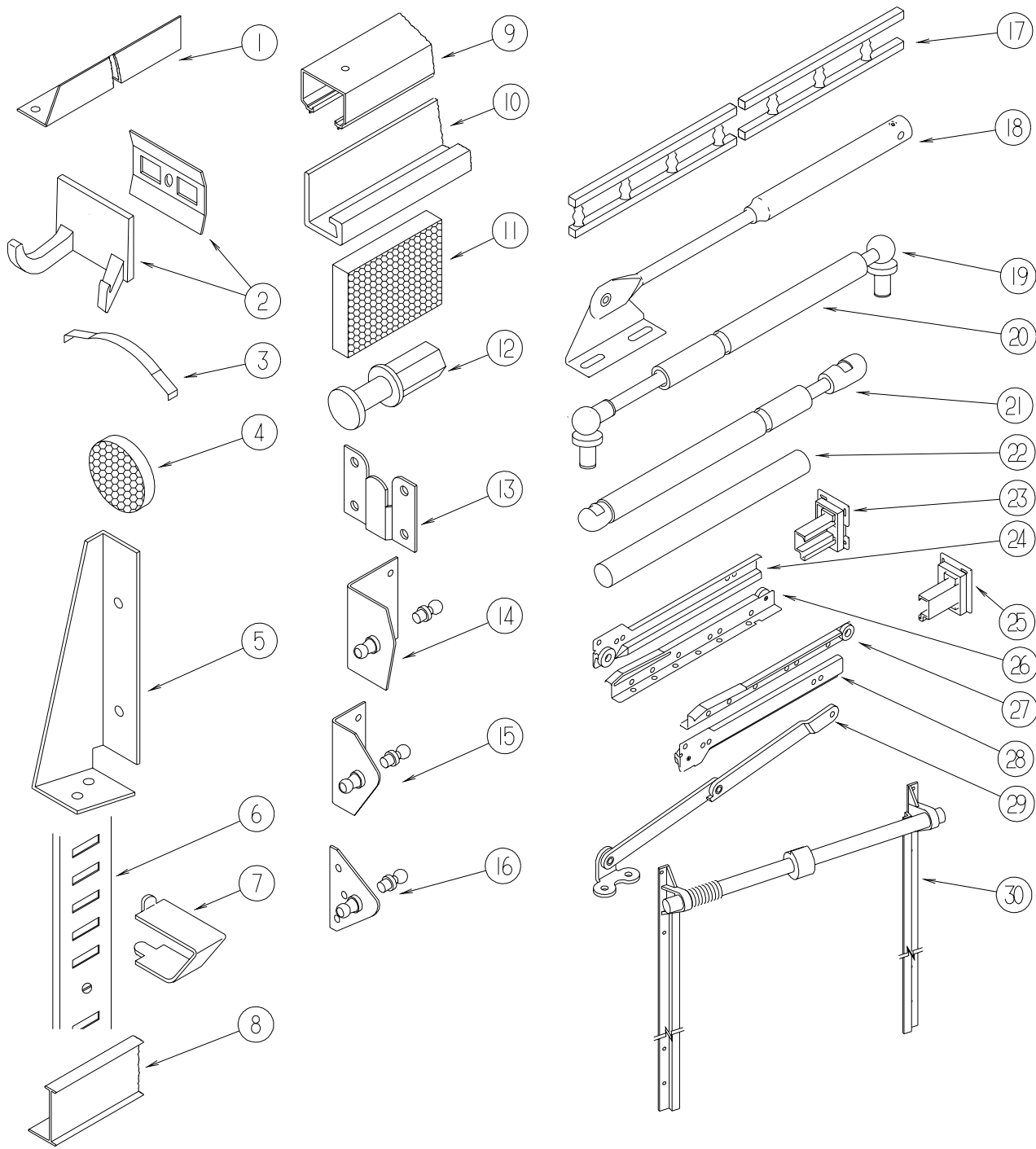

KEY	PART NUMBER	U/M	DESCRIPTION
1	114693-01-01A	EA	SUPPORT - BLACK - RIGHT HAND
1	114693-02-01A	EA	SUPPORT - BLACK - LEFT HAND
2	104174-01-000	EA	HOOK - ROBE - DOUBLE
3	115541-01-000	EA	SPRING - DOOR - SLIDING
4	122717-01-01A	EA	PAD - NON SKID - 4" DIAMETER ROUND
4	122717-04-01A	EA	PAD - NON SKID - 3" DIA. ROUND
5	076827-02-000	EA	BRACKET - 2.9" X 1.8" - TRIANGLE
6	098980-01-000	EA	PILASTER - ADJUSTABLE SHELF - 18"
6	098980-02-000	EA	PILASTER - ADJUSTABLE SHELF - 12"
6	098980-03-000	EA	PILASTER - ADJUSTABLE SHELF - 9"
6	098980-04-000	EA	PILASTER - ADJUSTABLE SHELF - 48"
6	098980-05-000	EA	PILASTER - ADJUSTABLE SHELF - 15"
6	098980-06-000	EA	PILASTER - ADJUSTABLE SHELF - 24"

INTERIOR FINISH GROUP (CONTINUED)
HARDWARE (CONTINUED)

KEY	PART NUMBER	U/M	DESCRIPTION
7	098979-01-000	EA	CLIP - ADJUSTABLE SHELF
8	094856-10-01A	EA	TRACK - FOLDING DOOR - OFF WHITE
9	103868-09-01A	EA	TRACK - SLIDING DOOR - 64.3" - OFF WHITE
9	103868-15-01A	EA	TRACK - SLIDING DOOR - 76" - OFF WHITE
10	118933-01-01A	EA	SUPPORT - HINGE LOCK
11	122717-06-01A	FT	PAD - NON-SKID - PSA - 5"W
	122717-08-01A	EA	PAD - NON-SKID - PSA - 7.2"W
12	092652-01-000	EA	GUIDE WHEEL/DOOR - TOP MOUNT
13	130120-01-01A	EA	BRACKET - MOUNTING/MIRROR
14	126263-05-02B	EA	BRACKET - GAS SPRING W/BALL STUD - E-COATED
14	126263-06-02B	EA	BRACKET - GAS SPRING W/BALL STUD - E-COATED
15	126263-10-02B	EA	BRACKET - GAS SPRING - 90 DEGREE SMALL
15	126263-13-02B	EA	BRACKET - GAS SPRING W/BALL STUD - E-COATED
16	126263-08-02B	EA	BRACKET - GAS SPRING W/BALL STUD - E-COATED
17	075249-01-000	EA	RAILING - OAK - 72" UNFINISHED
17	111775-01-03A	EA	RAIL - DECORATIVE/PLASTIC SPINDLES - 71.9" - SALEM CHERRY
17	111775-01-04A	EA	RAIL - DECORATIVE/PLASTIC SPINDLES - 71.9" - WATERFORD OAK
17	111775-01-06A	EA	RAIL - DECORATIVE/PLASTIC SPINDLES - 71.9" - WASHED MAPLE
17	111775-01-07A	EA	RAIL - DECORATIVE/PLASTIC SPINDLES - 71.9" - PORTSMOUTH OAK
18	074493-02-000	EA	SUPPORT - PISTON SPRING - CABINET DOOR - 26 LBS
19	057460-02-000	EA	STUD BALL - GAS SPRING - .39" - 5/16"-18
20	057460-04-000	EA	SPRING - GAS - BALL STUD STYLE - 120 PI - "SPD6209"
21	107796-06-000	EA	SPRING/GAS - 12" COMPRESSED/20" EXTENDED - 120LB.
21	107796-08-000	EA	SPRING/GAS - 11" COMPRESSED/17" EXTENDED - 60 LB
21	107796-15-000	EA	SPRING/GAS - 24" COMPRESSED/40" EXTENDED - 15 LB.
21	107796-16-000	EA	SPRING/GAS - 6.4" COMPRESSED/9.6" EXTENDED - 65 LB.
21	107796-26-000	EA	SPRING/GAS - 12" COMPRESSED/20" EXTENDED - 90 LB.
22	042438-02-000	EA	DOWEL - WOOD - 2" X 2"
22	042438-01-000	EA	DOWEL - WOOD - CLOTHES ROD - 1" DIAMETER X 4'
23	128811-01-01A	EA	BACKSOCKET - ADJUSTABLE - LEFT
24	128810-01-01A	EA	SLIDE - DRAWER - 12" - LEFT CABINET
24	128810-05-01A	EA	SLIDE - DRAWER - 14" - LEFT CABINET
24	128810-09-01A	EA	SLIDE - DRAWER - 16" - LEFT CABINET
24	128810-13-01A	EA	SLIDE - DRAWER - 18" - LEFT CABINET
24	128810-17-01A	EA	SLIDE - DRAWER - 20" - LEFT CABINET
24	128810-21-01A	EA	SLIDE - DRAWER - 22" - LEFT CABINET
24	128810-25-01A	EA	SLIDE - DRAWER - 24" - LEFT CABINET
25	128811-02-01A	EA	BACKSOCKET - ADJUSTABLE RIGHT
26	128810-03-01A	EA	SLIDE - DRAWER - 12" - LEFT DRAWER
26	128810-07-01A	EA	SLIDE - DRAWER - 14" - LEFT DRAWER
26	128810-11-01A	EA	SLIDE - DRAWER - 16" - LEFT DRAWER
26	128810-15-01A	EA	SLIDE - DRAWER - 18" - LEFT DRAWER
26	128810-19-01A	EA	SLIDE - DRAWER - 20" - LEFT DRAWER
26	128810-23-01A	EA	SLIDE - DRAWER - 22" - LEFT DRAWER
26	128810-27-01A	EA	SLIDE - DRAWER - 24" - LEFT DRAWER
27	128810-04-01A	EA	SLIDE - DRAWER - 12" - RIGHT DRAWER
27	128810-08-01A	EA	SLIDE - DRAWER - 14" - RIGHT DRAWER
27	128810-12-01A	EA	SLIDE - DRAWER - 16" - RIGHT DRAWER
27	128810-16-01A	EA	SLIDE - DRAWER - 18" - RIGHT DRAWER
27	128810-20-01A	EA	SLIDE - DRAWER - 20" - RIGHT DRAWER
27	128810-24-01A	EA	SLIDE - DRAWER - 22" - RIGHT DRAWER
27	128810-28-01A	EA	SLIDE - DRAWER - 24" - RIGHT DRAWER
28	128810-02-01A	EA	SLIDE - DRAWER - 12" - RIGHT CABINET
28	128810-06-01A	EA	SLIDE - DRAWER - 14" - RIGHT CABINET
28	128810-10-01A	EA	SLIDE - DRAWER - 16" - RIGHT CABINET
28	128810-14-01A	EA	SLIDE - DRAWER - 18" - RIGHT CABINET
28	128810-18-01A	EA	SLIDE - DRAWER - 20" - RIGHT CABINET
28	128810-22-01A	EA	SLIDE - DRAWER - 22" - RIGHT CABINET
28	128810-26-01A	EA	SLIDE - DRAWER - 24" - RIGHT CABINET
29	084412-01-000	EA	SUPPORT/HINGE KIT (LEFT & RIGHT HINGES)
30	130787-01-000	EA	TRACK - TAMBOUR DOOR/SPRING - 15.9"
30	130787-02-000	EA	TRACK - TAMBOUR DOOR/SPRING - 24"
30	130787-03-000	EA	TRACK - TAMBOUR DOOR/SPRING - 30"

LABELS GROUP

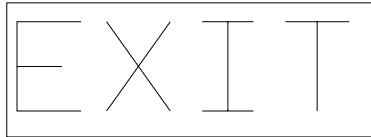

KEY PART NUMBER U/M DESCRIPTION
039290-01-000 EA LABEL - WARNING - EXIT

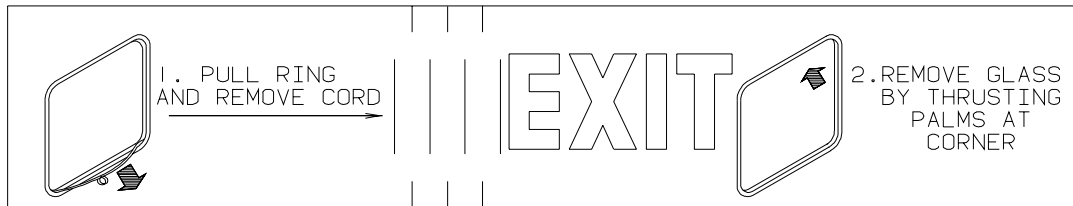

KEY PART NUMBER U/M DESCRIPTION
107571-01-000 EA LABEL - EXIT/ESCAPE WINDOW

FOR AWNING INSTALLATION
CONTACT YOUR MOTORHOME
DEALERSHIP

KEY PART NUMBER U/M DESCRIPTION
099509-01-000 EA LABEL - AWNING INSTALLATION

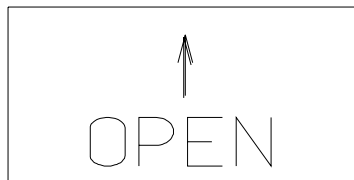

KEY PART NUMBER U/M DESCRIPTION
040944-01-000 EA LABEL - ENTRANCE DOOR - "OPEN"

WARNING
MUST BE STOWED
IN LATCHED POSITION
WHILE VEHICLE IS IN MOTION

KEY PART NUMBER U/M DESCRIPTION
079966-01-000 EA LABEL - WARNING - STOWED - MOTION

WARNING DISCONNECT BATTERIES BEFORE
CONNECTING EXTERNAL CHARGING EQUIPMENT.

KEY PART NUMBER U/M DESCRIPTION
065748-01-000 EA LABEL - CAUTION - BATTERY CHARGING

AVERTISSEMENT : DEBRANCHER LES BATTERIES AVANT
DE BRANCHER TOUT EQUIPEMENT DE CHARGE EXTERIEUR.

KEY PART NUMBER U/M DESCRIPTION
065748-02-000 EA LABEL - WARNING - BATTERY/FRENCH - CANADIAN

LABELS GROUP (CONTINUED)

WASTE WATER

KEY PART NUMBER U/M DESCRIPTION
006188-01-000 EA LABEL - WASTE WATER

SEWAGE

KEY PART NUMBER U/M DESCRIPTION
006187-01-000 EA LABEL - SEWAGE

IF YOU SMELL GAS

1. EXTINGUISH ANY OPEN FLAME, PILOT LIGHTS AND ALL SMOKING MATERIALS.
2. DO NOT TOUCH ELECTRICAL SWITCHES.
3. SHUT OFF THE GAS SUPPLY AT THE TANK VALVE(S) OR GAS SUPPLY CONNECTION.
4. OPEN DOORS AND OTHER VENTILATING OPENINGS.
5. LEAVE THE AREA UNTIL ODOR CLEARS.
6. HAVE THE GAS SYSTEM CHECKED AND LEAKAGE SOURCE CORRECTED BEFORE USING AGAIN.

KEY PART NUMBER U/M DESCRIPTION
073998-01-000 EA LABEL - LPG ODOR WARNING

WARNING: TEST SMOKE DETECTOR OPERATION AFTER VEHICLE HAS BEEN IN STORAGE, BEFORE EACH TRIP AND AT LEAST ONCE PER WEEK DURING USE.

KEY PART NUMBER U/M DESCRIPTION
077956-01-000 EA LABEL - WARNING - SMOKE DETECTOR

CAUTION	TO HELP AVOID PERSONAL INJURY DURING REMOVAL OF FUEL FILLER CAP, SLOWLY LOOSEN CAP 1/2 TURN TO ALLOW ANY FUEL PRESSURE TO BE RELIEVED BEFORE TURNING CAP FURTHER.
FUEL SPRAY MAY CAUSE PERSONAL INJURY	STOP ADDING FUEL AFTER FIRST SHUTOFF BY AUTOMATIC NOZZLE WHEN TANK IS NEARLY FULL. DO NOT OVERFILL FUEL TANK. SEE OWNERS MANUAL FOR ADDITIONAL INFORMATION. PRINTED IN U.S.A. WLC PT NO 15611763

KEY PART NUMBER U/M DESCRIPTION
087207-05-000 EA LABEL - FUEL CAP REMOVAL

UNLEADED FUEL ONLY

KEY PART NUMBER U/M DESCRIPTION
062043-01-000 EA LABEL - FUEL - UNLEADED

UNLEADED
FUEL ONLY

KEY PART NUMBER U/M DESCRIPTION
098641-01-000 EA LABEL-FUEL - UNLEADED - DASH

LABELS GROUP (CONTINUED)

LP-GAS SYSTEM
THIS GAS PIPING SYSTEM IS
DESIGNED FOR USE OF
LIQUIFIED PETROLEUM GAS
ONLY. DO NOT CONNECT
NATURAL GAS TO THIS
SYSTEM.
SECURE CAP INLET(S) WHEN NOT
CONNECTED FOR USE. AFTER TURNING
ON GAS, EXCEPT AFTER NORMAL
CONTAINER REPLACEMENT, TEST GAS
PIPING AND CONNECTIONS TO
APPLIANCES FOR LEAKAGE WITH SOAPY
WATER OR BUBBLE SOLUTION. DO NOT
USE PRODUCTS THAT CONTAIN AMMONIA
OR CLORINE. 124520

KEY	PART NUMBER	U/M	DESCRIPTION
	124520-01-01A	EA	LABEL - LP GAS ONLY - BLACK ON CLEAR
	124520-01-02A	EA	LABEL - LP GAS ONLY - WHITE ON CLEAR

WARNING

THIS SYSTEM IS DESIGNED FOR USE WITH PROPANE ONLY
DO NOT CONNECT NATURAL GAS TO THIS SYSTEM

BEFORE TURNING ON PROPANE:

- (A) BE CERTAIN APPLIANCES ARE CERTIFIED FOR PROPANE AND ARE EQUIPPED WITH CORRECT BURNING ORIFICES.
- (B) MAKE CERTAIN ALL PROPANE CONNECTIONS ARE TIGHT BY TESTING WITH SOAPY WATER. ALL APPLIANCE VALVES ARE TURNED OFF, AND ANY UNCONNECTED OUTLETS ARE CAPPED.

AFTER TURNING ON PROPANE:

- (A) LIGHT ALL PILOT LIGHTS
- (B) ALL CONNECTIONS, INCLUDING THOSE AT THE APPLIANCES, REGULATORS AND CYLINDERS SHOULD BE LEAK-TESTED PERIODICALLY WITH SOAPY WATER BY THE OCCUPANT. NEVER USE A LIGHTED MATCH OR OTHER FLAME WHEN CHECKING FOR LEAKS.
- (C) DO NOT LEAVE SYSTEM TURNED ON OF CONTAINERS CONNECTED UNTIL THE SYSTEM HAS BEEN PROVEN TO BE FREE OF LEAKS.
- (D) COOKING APPLIANCES SHOULD NOT BE USED FOR SPACE HEATING.
- (E) WHEN THE CONTAINERS ARE DISCONNECTED THE PROPANE SUPPLY LINE SHOULD BE CAPPED OR PLUGGED.

AVERTISSEMENT

CETTE INSTALLATION EST CONÇUE POUR LE PROPANE SEULEMENT
NE PAS L'ALIMENTER EN GAZ NATUREL

AVANT LA MISE EN SERVICE:

- (A) S'ASSURER QUE LES APPAREILS SONT CERTIFIÉS POUR LE PROPANE ET MUNIS D'ORIFICES DE BRÛLEUR APPROPRIÉS.
- (B) VÉRIFIER L'ÉTANCHÉITÉ DE TOUTS LES RACCORDEMENTS AU PROPANE, LA PÉREMPTURE DE TOUTS LES ROBINETS D'APPAREILS ET L'OBTURATION DE TOUTES LES SORTIES NON RACCORDEES.

APRES LA MISE EN SERVICE:

- (A) ALLUMER TOUTES LES VÉILLEUSES.
- (B) L'OCCUPANT DOIT ÉPROUVER PÉRIODIQUEMENT L'ÉTANCHÉITÉ DE TOUTS LES RACCORDEMENTS Y COMPRIS CEUX AUX APPAREILS, AUX DÉTENEURS ET AUX BOUTEILLES, EN Y APPLIQUANT DE L'EAU SAVONNEUSE. NE JAMAIS SE SERVIR D'UNE ALLUMETTE OU AUTRE POUR LA DÉTECTION DES FUITES.
- (C) NE PAS LAISSER L'ALIMENTATION OUVERTE NI LES RÉCIPIENTS RACCORDES AVANT D'AVOIR COMPLÉTÉ L'ÉPREUVE D'ÉTANCHÉITÉ AU PROPANE DE L'INSTALLATION.
- (D) LES APPAREILS DE CUISSON NE DOIVENT PAS ÊTRE UTILISÉS POUR LE CHAUFFAGE DES LOCAUX.
- (E) LORSQUE LES RÉCIPIENTS SONT DÉCONNECTÉS, L'ALIMENTATION DE PROPANE DOIT ÊTRE OBTURÉE OU SCELLÉE.

KEY	PART NUMBER	U/M	DESCRIPTION
	023769-01-000	EA	LABEL - WARNING - LPG - CANADIAN

THIS CONNECTION IS FOR
110-125 VOLT AC, 60HZ(CYCLES)
30 AMP. MAX SERVICE.

○ ○

DO NOT CONNECT TO
HIGHER VOLTAGE

KEY	PART NUMBER	U/M	DESCRIPTION
	125306-01-01A	EA	LABEL - ELECTRICAL ENTRANCE - 110VOLT 30AMP
	125306-03-01A	EA	LABEL - ELECTRICAL ENTRANCE - 100 VOLT 30 AMP

THIS CONNECTION IS FOR
(B) VOLT AC, 3-POLE, 4 WIRE
60 HZ(CYCLES), (A) AMPERE SUPPLY

DO NOT CONNECT TO
HIGHER VOLTAGE

KEY	PART NUMBER	U/M	DESCRIPTION
	125306-04-01A	EA	LABEL - ELECTRICAL ENTRANCE - 120 VOLT - 240 AMP

LABELS GROUP (CONTINUED)

THIS CONNECTION IS FOR
(B) VOLT AC,50 HZ(CYCLES)
(A) AMPERE SUPPLY

DO NOT CONNECT TO
HIGHER VOLTAGE

KEY PART NUMBER U/M DESCRIPTION
125306-05-01A EA LABEL - ELECTRICAL ENTRANCE - 220 VOLT 25 AMP

WARNING

IT IS NOT SAFE TO USE COOKING
APPLIANCES FOR COMFORT HEATING

COOKING APPLIANCES NEED FRESH AIR FOR SAFE OPERATION
BEFORE OPERATION:

1. OPEN OVERHEAD VENT OR TURN ON EXHAUST FAN AND;
2. OPEN WINDOW.

KEY PART NUMBER U/M DESCRIPTION
050225-01-000 EA LABEL - WARNING - STOVE VENT - US

"TO ENSURE A SUPPLY OF FRESH AIR TO
OCCUPANTS, OPEN VENTILATORS WHEN
FUEL BURNING RANGE, FUEL BURNING
CARRY-ON APPLIANCES AND/OR FUEL-
BURNING LIGHTS ARE IN OPERATION."

"COOKING APPLIANCES SHOULD NOT BE
USED FOR SPACE HEATING PURPOSES"

DE MANIERE A ASSURE UNE ALIMENTATION
EN AIR FRAIS AUX OCCUPANTS,OUVRIR
LES VENTILATEURS LORSQUE LA CUISINIERE,
LES APPAREILS DE CHAUFFAGE PORTABLES
ET/OU LES LAMPES DE COMBUSTION
D'HUILE SONT EN FONCTIONNEMENT.

LES APPAREILS DE CUSSON NE DOIVENT
PAS SERVIR AU CHAUFFAGES DES LOCAUX.

KEY PART NUMBER U/M DESCRIPTION
050222-01-000 EA LABEL - STOVE VENT - CANADIAN

WARNING

THIS VEHICLE, LIKE OTHER
VEHICLES, MAY CONTAIN SMALL
AMOUNTS OF ONE OR MORE
SUBSTANCES WHICH ARE LISTED
BY THE STATE OF CALIFORNIA
FOR CAUSING CANCER OR
REPRODUCTIVE TOXICITY.

KEY PART NUMBER U/M DESCRIPTION
099689-01-000 EA LABEL - WARNING - CANCER/TOXICITY

WATER HEATER
BY-PASS

NORMAL
OPERATION

KEY PART NUMBER U/M DESCRIPTION
133424-01-01A EA LABEL - BYPASS - WATER HEATER

REMOVE PRIMARY TIRE HANGER BEFORE USING
SPARE TIRE HOIST-SEE OWNERS MANUAL - PERSONAL
INJURY MAY RESULT IF NOT FOLLOWED

KEY PART NUMBER U/M DESCRIPTION
126024-01-01A EA LABEL - TIRE HANGER REMOVAL

DO NOT USE HITCH BEFORE
READING OWNERS MANUAL REGARDING
VEHICLE LOADING AND TOWING

KEY PART NUMBER U/M DESCRIPTION
111104-01-000 EA LABEL - HITCH - READ MANUAL - WHITE
111104-02-000 EA LABEL - HITCH - READ MANUAL - BLACK

LABELS GROUP (CONTINUED)

CAUTION

THIS MOTOR HOME HAS BEEN DESIGNED, MANUFACTURED AND TESTED WITH CONCERN FOR THE PROTECTION OF IT'S OCCUPANTS. WE RECOMMEND YOU PERFORM THE FOLLOWING INSPECTIONS FOR YOUR SAFETY AND THE SAFETY OF YOUR PASSENGERS BEFORE STARTING YOUR VEHICLE.

1. LP GAS SYSTEM- TURN OFF AT TANK FOR TRAVELING. TEST FOR LEAKS UPON ARRIVAL AT DESTINATION. BEFORE LIGHTING PILOTS.
2. WHEELS- INSPECT FOR DAMAGE AND CHECK LUG NUTS FOR TIGHTNESS.
3. TIRES- INSPECT FOR WEAR AND DAMAGE AND CHECK FOR RECOMMENDED AIR PRESSURE.
4. LIGHTING- TEST FOR PROPER OPERATION OF ALL INTERIOR AND EXTERIOR LIGHTS INCLUDING DASH LIGHTS, HEADLIGHTS, TAIL LIGHTS, BRAKE LIGHTS, CLEARANCE LIGHTS AND TURN SIGNALS.
5. EXITS- INSPECT RELEASE MECHANISM ON EMERGENCY EXIT WINDOW, TEST BOTH LOCKS ON MAIN ENTRANCE DOOR FOR EASE OF OPERATION AND INSTRUCT PASSENGERS HOW TO USE BOTH MEANS OF EXIT.
6. SEAT BELTS- DIRECT PASSENGERS TO DESIGNATED SEATS AND REQUIRE USE OF SEAT BELTS.
7. APPLIANCES- TURN OFF AND LATCH OR LOCK DOORS WHERE PROVIDED.
8. LOOSE PARCELS- STORE SECURELY.
9. UTILITY SUPPLY LINES- DISCONNECT ALL ELECTRIC, SEWER AND WATER LINES AND SECURE PROPERLY.
10. ENTRANCE DOOR STEP- PLACE IN RETRACTED POSITION FOR TRAVELING.

READ YOUR MOTOR HOME AND CHASSIS OWNER'S
MANUAL FOR FURTHER PRECAUTIONS

KEY PART NUMBER **U/M DESCRIPTION**
056259-01-000 EA LABEL - SAFETY CHECK LIST

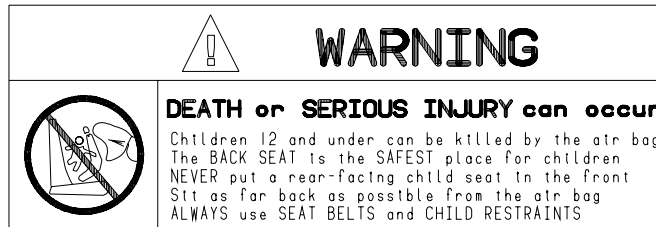

KEY PART NUMBER **U/M DESCRIPTION**
126611-01-000 EA LABEL - AIR BAG - VISOR

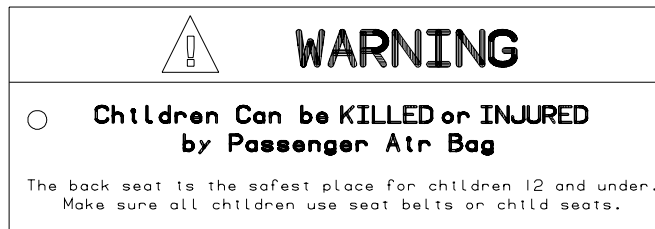

KEY PART NUMBER **U/M DESCRIPTION**
126612-01-000 EA LABEL - HANG TAG - AIR BAG - DASH

<p>AIR CONDITIONING CIRCUIT. THIS CONNECTION IS FOR AIR CONDITIONERS RATED 110- 125 VOLT AC, 60 HZ, 16 AMPERES MAXIMUM. DO NOT EXCEED CIRCUIT RATING.</p>

KEY PART NUMBER **U/M DESCRIPTION**
091243-01-000 EA LABEL - A/C COVER "AIR CONDITIONING CIRCUIT ETC."

<p>WARNING: CONTAINS "CFC" A SUBSTANCE WHICH HARMS PUBLIC HEALTH AND ENVIRONMENT BY DESTROYING OZONE IN THE UPPER ATMOSPHERE.</p>

KEY PART NUMBER **U/M DESCRIPTION**
111802-01-000 EA LABEL - CFC WARNING

LABELS GROUP (CONTINUED)

CAUTION

DO NOT LATCH DOOR IN OPEN POSITION
IF WATER HEATER CONTROL IS IN THE ON
POSITION. WATER HEATER EXHAUST MAY
DAMAGE OUTER SURFACE OF DOOR.

KEY	PART NUMBER	U/M DESCRIPTION
	113402-01-000	EA LABEL - CAUTION - WATER HEATER EXHAUST
	113402-02-000	EA LABEL - CAUTION - FURNACE EXHAUST

WARNING!

UNDERSTAND OPERATOR'S MANUAL BEFORE USING.
KEEP PEOPLE AND OBSTRUCTIONS CLEAR OF
SLIDEOUT ROOM WHEN OPERATING TO AVOID
INJURY AND/OR PROPERTY DAMAGE.

KEY	PART NUMBER	U/M DESCRIPTION
	116549-01-000	EA LABEL - WARNING - SLIDEOUT

MISE EN GARDE

POUR VOTRE SECURITE PERSONNELLE RANGEZ,
TOUT OBJET DE FAÇON SECURITAIRE LORSQUE
LE VEHICULE EST EN MOUVEMENT.

CAUTION

FOR YOUR PERSONAL SAFETY, SECURELY STOW
OBJECTS AWAY WHILE VEHICLE IS IN MOTION

KEY	PART NUMBER	U/M DESCRIPTION
	131341-02-000	EA LABEL - STOW OBJECTS - CANADIAN

DIESEL FUEL ONLY

KEY	PART NUMBER	U/M DESCRIPTION
	068383-01-000	EA LABEL - DIESEL FUEL

LABELS GROUP (CONTINUED)

WARNING

ALL PILOT LIGHTS, APPLIANCES AND THIER
IGNITORS (SEE OPERATING INSTRUCTIONS) SHALL
BE TURNED OFF DURING REFUELING OF MOTOR
FUEL TANKS AND/OR LP GAS CONTAINERS

KEY	PART NUMBER	U/M DESCRIPTION
	124519-01-01A	EA LABEL - WARNING/REFUELING - BLACK ON CLEAR
	124519-01-02A	EA LABEL - WARNING/REFUELING - WHITE ON CLEAR

WARNING:

ALL PILOT LIGHTS AND APPLIANCES SHALL BE TURNED
OFF DURING REFUELING OF MOTOR FUEL TANKS AND/
OR PROPANE CONTAINERS.

AVERTISSEMENT :

FERMER TOUTES LES VEILLEUSES AINSI QUE TOUS LES
APPAREILS LORSQU'ON FAIT LE PLEIN DES RESERVOIRS
À CARBURANT OU À PROPANE.

124519-02

KEY	PART NUMBER	U/M DESCRIPTION
	124519-02-01A	EA LABEL - WARNING/REFUELING - BLACK ON CLEAR - CSA
	124519-02-02A	EA LABEL - WARNING/REFUELING - WHITE ON CLEAR - CSA

ENTRANCE DOOR PROP ROD

THIS ROD IS DESIGNED TO PROP THE
ENTRANCE DOOR OPEN WHEN THE PATIO
AWNING ARM IS ATTACHED TO THE
SIDEWALL AND THE AWNING IS EX-
TENDED.
HOOK ONE END OF ROD INTO LOOP ON
DOOR AND OTHER END INTO LOOP ON THE
SIDEWALL AS SHOWN.

(THIS LABEL TO BE REMOVED BY RETAIL OWNER ONLY)

KEY	PART NUMBER	U/M DESCRIPTION
	128658-01-000	EA LABEL - PROP ROD - ENTRY DOOR

INPUT

KEY	PART NUMBER	U/M DESCRIPTION
	087236-01-000	EA LABEL - CABLE - INPUT

OUTLET

KEY	PART NUMBER	U/M DESCRIPTION
	087236-02-000	EA LABEL - TV OUTLET

DTS' ISI CE SIEGE N'EST PAS
DESTINE A ETRE OCCUPE LORSQUE
LE VEHICULE EST EN MOUVEMENT

THIS SEAT IS NOT INTENDED
FOR OCCUPANCY WHILE
VEHICLE IS IN MOTION

KEY	PART NUMBER	U/M DESCRIPTION
	006064-01-000	EA LABEL - SEAT W/O SEATBELT
	006064-02-000	EA LABEL - SEAT W/O SEATBELT - CSA

LABELS GROUP (CONTINUED)

CAUTION:
OPEN A WINDOW OR VENT WHILE
OPERATING DRYER. IT IS DANGEROUS
TO CREATE A NEGATIVE AIR PRESSURE
INSIDE A VEHICLE CONTAINING
FUEL-BURNING APPLIANCES

KEY PART NUMBER U/M DESCRIPTION
130670-01-01A EA LABEL - CAUTION DRYER VENTING - BLACK ON CLEAR

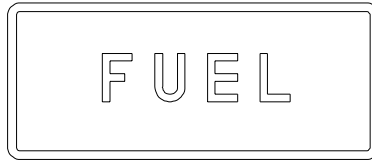

KEY PART NUMBER U/M DESCRIPTION
061417-01-000 EA LABEL - FUEL - ON FUEL FILL DOOR

INSERT RETAINER PINS IN
SLIDE MECHANISM AFTER
RETURNING GENERATOR TO
STORED POSITION.
IF RETAINER PINS ARE NOT
INSERTED, THE GENERATOR
WILL EXTEND WHICH MAY
CAUSE PERSONAL INJURY.

KEY PART NUMBER U/M DESCRIPTION
116273-01-000 EA LABEL - WARNING - GENERATOR

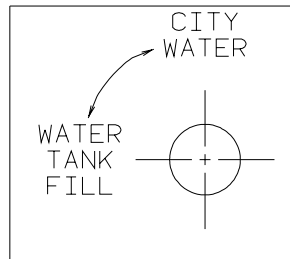

KEY PART NUMBER U/M DESCRIPTION
117629-02-000 EA LABEL - WATER PUMP/FILL-BLK LETTERS/CLEAR BACKGROUND-.24"
117629-03-000 EA LABEL - WATER PUMP/FILL-BLK LETTERS/CLEAR BACKGROUND-.31"

KEEP THE SERVICE INLET ACCESS
IN THE CLOSED POSITION WHEN
UTILITY CONNECTIONS ARE NOT IN USE

KEY PART NUMBER U/M DESCRIPTION
123562-01-000 EA LABEL - SERVICE/UTILITY ACCESS

CITY WATER FILL

KEY PART NUMBER U/M DESCRIPTION
126249-02-000 EA LABEL - CITY WATER FILL-BLK LETTER/CLEAR BACKGROUND-.24"H
126249-03-000 EA LABEL - CITY WATER FILL-BLK LETTER/CLEAR BACKGROUND-.31"H

LABELS GROUP (CONTINUED)

WARNING

ROOF SURFACE MAY BE SLIPPERY
ESPECIALLY WHERE MOISTURE IS PRESENT
SLIPPING MAY RESULT IN PERSONAL INJURY.

128218-01

KEY PART NUMBER U/M DESCRIPTION
128218-01-01A EA LABEL - WARNING - SLIPPERY ROOF

WASTE TANK FLUSH

KEY PART NUMBER U/M DESCRIPTION
130168-01-000 EA LABEL - WASTE TANK FLUSH

**LIGHTS WATER
PUMP**

KEY PART NUMBER U/M DESCRIPTION
130170-01-000 EA LABEL - SWITCH PANEL - BLK/CLEAR BACKGROUND-1.8"H X 5.9"L
117628-02-000 EA LABEL - SWITCH - WATER PUMP/LIGHTS-WHITE/CLEAR BACKGROUND

**PUSH TO
RELEASE
GENERATOR
SLIDE ASM**

KEY PART NUMBER U/M DESCRIPTION
131779-01-01A EA LABEL - GENERATOR

**MONITOR WATER
PANEL PUMP
LIGHT**

KEY PART NUMBER U/M DESCRIPTION
130170-02-000 EA LABEL - SWITCH PANEL - BLK/CLEAR BACKGROUND-1.4H X 3.9"L

WARNING

ALL LP GAS IS CONTAINED UNDER PRES-
SURE. DUE TO THE DANGEROUS POTENTIAL
OF ANY COMPRESSED GAS, IT IS MANDA-
TORY THAT THE FOLLOWING REQUIREMENTS
FOR THE USE OF THIS TANK BE FOLLOWED:
TANKS ARE TO BE INSTALLED, FUELED AND
MAINTAINED IN ACCORDANCE WITH STATE
AND LOCAL CODE, RULES, REGULATIONS OR
LAWS AND IN ACCORDANCE WITH NFPA
PAMPHLET 58, DIVISION IV.

KEY PART NUMBER U/M DESCRIPTION
116112-01-000 EA LABEL - SWITCH PANEL - BLK/CLEAR BACKGROUND-1.8"H X 5.9"L

LABELS GROUP (CONTINUED)

TOW VEHICLE RATING MAY BE LESS THAN HITCH RATING.
 MAXIMUM VERTICAL HITCH LOAD: 350 LBS
 DO NOT EXCEED REAR AXLE RATING.
 SEE OWNER'S MANUAL FOR ADDITIONAL INFORMATION.

KEY	PART NUMBER	U/M DESCRIPTION
	129669-01-01A	EA LABEL - HITCH/VEHICLE RATE - 350 - WHITE ON CLEAR
	129669-01-02A	EA LABEL - HITCH/VEHICLE RATE - 350 - BLACK ON CLEAR
	129669-02-01A	EA LABEL - HITCH/VEHICLE RATE - 500 - WHITE ON CLEAR
	129669-02-02A	EA LABEL - HITCH/VEHICLE RATE - 500 - BLACK ON CLEAR

THIS CHAIR IS NOT INTENDED FOR OCCUPANCY WHEN VEHICLE IS IN MOTION AND MUST BE RETURNED TO STOWED POSITION

KEY	PART NUMBER	U/M DESCRIPTION
	102267-01-000	EA LABEL - NO OCCUPANCY - US

DTS ISICE SIEGE N/EST PAS DESTINE A ETRE OCCUPE LORSQUE LE VEHICULE EST EN MOUVEMENT ET IL FAUT QUE LE RANGER

THIS CHAIR IS NOT INTENDED FOR OCCUPANCY WHEN VEHICLE IS IN MOTION AND MUST BE RETURNED TO STOWED POSITION

KEY	PART NUMBER	U/M DESCRIPTION
	102267-02-000	EA LABEL - NO OCCUPANCY - CSA

EXTERIOR SHOWER

KEY	PART NUMBER	U/M DESCRIPTION
	126249-03-000	EA LABEL - EXTERIOR SHOWER

W
A
T
E
R

H
E
A
T
E
R

ON
|
OFF

KEY	PART NUMBER	U/M DESCRIPTION
	083588-01-000	EA LABEL - ON/OFF - WATER HEATER

E
N
G
I
N
E

H
E
A
T
E
R

ON
|
OFF

KEY	PART NUMBER	U/M DESCRIPTION
	083588-02-000	EA LABEL - ON/OFF -ENGINE HEATER

LABELS GROUP (CONTINUED)

NOTE: TUNE ANTENNA
PER MANUFACTURER'S
DIRECTIONS. FAILURE TO
COMPLY COULD RESULT IN
DAMAGE TO CB.

CB POWER PROVISION

RED +12 V
BLACK GROUND
COAX ANTENNA
(SEE REVERSE ALSO)

KEY PART NUMBER U/M DESCRIPTION
104678-01-000 EA LABEL - CB PREP

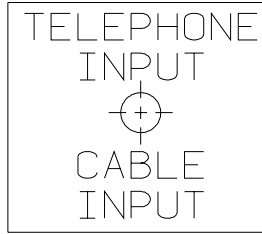

KEY PART NUMBER U/M DESCRIPTION
114886-02-000 EA LABEL - PHONE & CABLE INPUT - WHITE/CLEAR BACKGROUND
114866-03-000 EA LABEL - PHONE & CABLE INPUT - BLACK/CLEAR BACKGROUND

WARNING
DO NOT USE ETHER
OR STARTING FLUID

INTAKE MANIFOLD FLAME HEATER
STARTING AID HAS OPEN FLAME.
ETHER MAY CAUSE EXPLOSION
AND SEVERE INJURY.

KEY PART NUMBER U/M DESCRIPTION
116756-01-000 EA LABEL - WARNING - ETHER/STARTING

GRAY HOLDING TANK

KEY PART NUMBER U/M DESCRIPTION
126247-01-000 EA LABEL - GRAY HOLDING TANK-WHITE LETTERS/CLEAR BACKGROUND
126247-05-000 EA LABEL - GRAY HOLDING TANK-BLACK LETTERS/CLEAR BACKGROUND

BLACK HOLDING TANK

KEY PART NUMBER U/M DESCRIPTION
126247-02-000 EA LABEL - BLACK HOLDING TANK-WHITE LETTERS/BLACK BACKGROUND
126247-06-000 EA LABEL - BLACK HOLDING TANK-BLACK LETTERS/CLEAR BACKGROUND

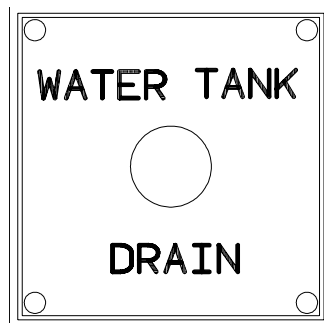

KEY PART NUMBER U/M DESCRIPTION
127170-01-000 EA LABEL - WATER TANK DRAIN

LABELS GROUP (CONTINUED)

WARNING

POTABLE WATER ONLY
 SANITIZE, FLUSH, AND
 DRAIN BEFORE USING.
 SEE INSTRUCTION MANUAL

KEY PART NUMBER U/M DESCRIPTION
 128725-01-01A EA LABEL - POTABLE WATER ONLY

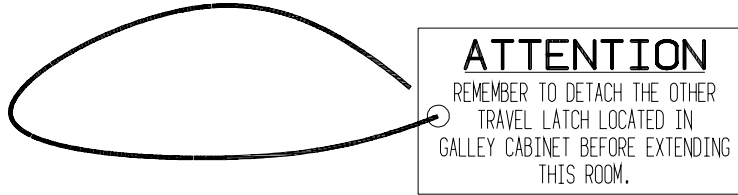

ATTENTION

REMEMBER TO DETACH THE OTHER
 TRAVEL LATCH LOCATED IN
 GALLEY CABINET BEFORE EXTENDING
 THIS ROOM.

KEY PART NUMBER U/M DESCRIPTION
 129033-01-000 EA LABEL - HANG TAG - TRAVEL LATCH - 1.5" X3"

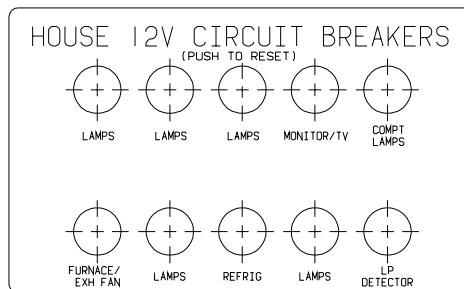

KEY PART NUMBER U/M DESCRIPTION
 092547-06-000 EA CIRCUIT BREAKER

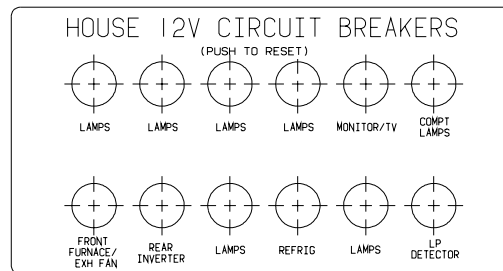

KEY PART NUMBER U/M DESCRIPTION
 092547-09-000 EA CIRCUIT BREAKER

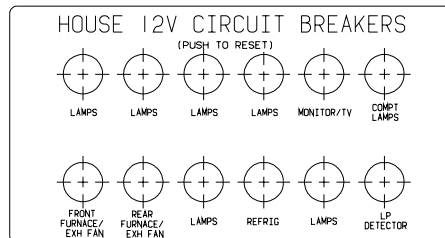

KEY PART NUMBER U/M DESCRIPTION
 092547-07-000 EA CIRCUIT BREAKER

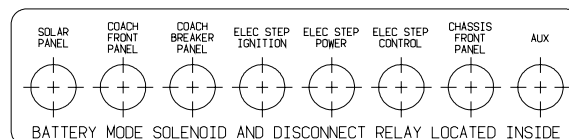

KEY PART NUMBER U/M DESCRIPTION
 093236-13-000 EA CIRCUIT BREAKER

LABELS GROUP (CONTINUED)

SLIDEOUT DRIVE	INVERTER	ELECTRIC STEP CONTROL POWER	ELECTRIC STEP BATTERY POWER	ELECTRIC STEP IGNITION POWER	COACH BREAKER PANEL	BATTERY MODE SWITCH
-------------------	----------	--------------------------------------	--------------------------------------	---------------------------------------	---------------------------	---------------------------

KEY PART NUMBER U/M DESCRIPTION
 093236-15-000 EA LABEL - CIRCUIT BREAKER

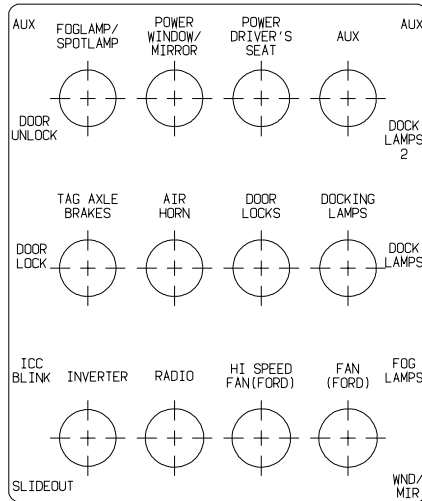

KEY PART NUMBER U/M DESCRIPTION
 093236-16-000 EA LABEL - CIRCUIT BREAKER

BATTERY MODE SWITCH	COACH BREAKER PANEL	ELECTRIC STEP IGNITION POWER	ELECTRIC STEP BATTERY POWER	ELECTRIC STEP CONTROL POWER	INVERTER	SLIDEOUT POWER
---------------------------	---------------------------	---------------------------------------	--------------------------------------	--------------------------------------	----------	-------------------

KEY PART NUMBER U/M DESCRIPTION
 093236-18-000 EA LABEL - CIRCUIT BREAKER

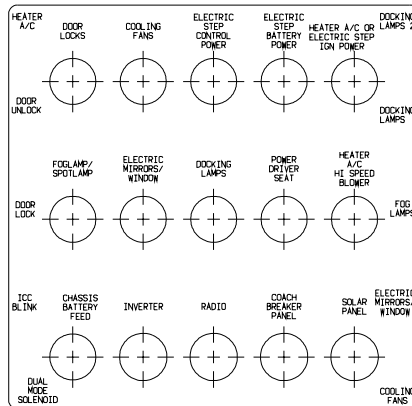

KEY PART NUMBER U/M DESCRIPTION
 093236-19-000 EA LABEL - CIRCUIT BREAKER



KEY PART NUMBER U/M DESCRIPTION
 093237-10-000 EA LABEL - CIRCUIT BREAKER - FRONT COOLING FANS

LABELS GROUP (CONTINUED)

SUB - MAIN	DISH WASHER	RECEPS	RECEPS	RECEPS	MICROWAVE
		1	2	3	

KEY PART NUMBER U/M DESCRIPTION
 095721-20-000 EA LABEL - CONTROL CENTER W/INVERTER

SUB - MAIN	APPLIANCE	APPLIANCE	RECEPS	RECEPS	MICROWAVE
	1	2	1	2	

KEY PART NUMBER U/M DESCRIPTION
 095721-21-000 EA LABEL - CONTROL CENTER W/INVERTER

A / C	MAIN	MAIN	A / C	INVERTER /	CHARGER	REFFRIG / VACUUM	WASHER / DRYER	WATER	HEATER		
CIRCUIT			CIRCUIT								
1			2								

KEY PART NUMBER U/M DESCRIPTION
 095721-22-000 EA LABEL - CONTROL CENTER 50 AMP

SUB - MAIN	APPLIANCE	APPLIANCE	RECEPS	RECEPS	MICROWAVE
	1	2	1	1	

KEY PART NUMBER U/M DESCRIPTION
 095721-25-000 EA LABEL - CONTROL CENTER 30 AMP

LABELS GROUP (CONTINUED)

A / C C I R C U I T 1	M A I N	R E F F R I G / C O N V	M I C R O W A V E	R E C P S 1	R E C P S 2	A P P L I A N C E 2		
-----------------------------	---------	-------------------------	-------------------	----------------	----------------	----------------------------	--	--

KEY PART NUMBER U/M DESCRIPTION
 095721-26-000 EA LABEL - CONTROL CENTER 30 AMP - CANADIAN

A / C C I R C U I T 1	M A I N	A / C C I R C U I T 2	R E F F R I G / C O N V	M I C R O W A V E	R E C P S 1	R E C P S 2	R E C P S 3		
-----------------------------	---------	-----------------------------	-------------------------	-------------------	----------------	----------------	----------------	--	--

KEY PART NUMBER U/M DESCRIPTION
 095721-27-000 EA LABEL - CONTROL CENTER 30 AMP

A / C C I R C U I T 1	M A I N	A / C C I R C U I T 2	R E F F R I G / C O N V	M I C R O W A V E	R E C P S 1	R E C P S 2	A P P L I A N C E		
-----------------------------	---------	-----------------------------	-------------------------	-------------------	----------------	----------------	-------------------	--	--

KEY PART NUMBER U/M DESCRIPTION
 095721-28-000 EA LABEL - CONTROL CENTER 30 AMP - CANADIAN

A / C C I R C U I T 1	M A I N	M A I N	A / C C I R C U I T 2	R E F F R I G / C O N V	M I C R O W A V E	R E C P S 1	R E C P S 2	R E C P S 3	W A S H E R / D R Y E R	
-----------------------------	---------	---------	-----------------------------	-------------------------	-------------------	----------------	----------------	----------------	-------------------------	--

KEY PART NUMBER U/M DESCRIPTION
 095721-29-000 EA LABEL - CONTROL CENTER 50 AMP

LABELS GROUP (CONTINUED)

A / C CIRCUIT 1	M A I N	M A I N	A / C CIRCUIT 2	R E F R I G / C O N V	M I C R O W A V E	R E C P S 1	R E C P S 2	R E C P S 3	A P P L I A N C E 1	A P P L I A N C E 2	W A S H E R D R Y E R
-----------------------	------------------	------------------	-----------------------	---	---	--------------------------------	--------------------------------	--------------------------------	--	--	---

KEY PART NUMBER U/M DESCRIPTION
 095721-30-000 EA LABEL - CONTROL CENTER 50 AMP- CANADIAN

A / C CIRCUIT 1	M A I N	A / C CIRCUIT 2	R E F R I G / C O N V	M I C R O W A V E	R E C P S 1	R E C P S 2	R E C P S 3	W A S H E R / D R Y E R	W A T E R H E A T E R	
-----------------------	------------------	-----------------------	---	---	--------------------------------	--------------------------------	--------------------------------	--	---	--

KEY PART NUMBER U/M DESCRIPTION
 095721-31-000 EA LABEL - CONTROL CENTER 30 AMP - U.S.

A / C CIRCUIT 1	M A I N	M A I N	A / C CIRCUIT 2	R E F R I G / C O N V	M I C R O W A V E	R E C P S 1	R E C P S 2	R E C P S 3	W A S H E R / D R Y E R	W A T E R H E A T E R
-----------------------	------------------	------------------	-----------------------	---	---	--------------------------------	--------------------------------	--------------------------------	--	---

KEY PART NUMBER U/M DESCRIPTION
 095721-33-000 EA LABEL - CONTROL CENTER 50 AMP - U.S.

A / C CIRCUIT 1	M A I N	M A I N	A / C CIRCUIT 2	I N V E R T E R / C H A R G E R	R E F R I G E R A T O R	W A S H E R / D R Y E R	W A T E R H E A T E R	
-----------------------	------------------	------------------	-----------------------	--	--	--	---	--

KEY PART NUMBER U/M DESCRIPTION
 095721-34-000 EA LABEL - CONTROL CENTER 50 AMP

LABELS GROUP (CONTINUED)

A / C C I R C U I T 1	M A I N	A / C C I R C U I T 2	R E F F R I G / C O N V	M I C R O W A V E	R E C P S 1	R E C P S 2	R E C P S 3	A P P L I A N C E	W A S H E R / D R Y E R	W A T E R H E A T E R
-----------------------------	---------	-----------------------------	-------------------------	-------------------	----------------	----------------	----------------	-------------------	-------------------------	--------------------------

KEY PART NUMBER U/M DESCRIPTION
 095721-35-000 EA LABEL - CONTROL CENTER 30 AMP - CSA

A / C C I R C U I T 1	M A I N	M A I N	A / C C I R C U I T 2	R E F F R I G / C O N V	M I C R O W A V E	R E C P S 1	R E C P S 2	A P P L I A N C E 1	A P P L I A N C E 2	W A S H E R / D R Y E R	W A T E R H E A T E R
-----------------------------	---------	---------	-----------------------------	-------------------------	-------------------	----------------	----------------	------------------------	------------------------	-------------------------	--------------------------

KEY PART NUMBER U/M DESCRIPTION
 095721-36-000 EA LABEL - CONTROL CENTER 50 AMP - CSA

M A I N	M I C R O W A V E	G F I / R E C E P S	R E F E R / C O N V	W A T E R H T R	A / C
---------	-------------------	---------------------	---------------------	--------------------	-------

KEY PART NUMBER U/M DESCRIPTION
 095721-38-000 EA LABEL - CONTROL CENTER 30 AMP - U.S.

LABELS GROUP (CONTINUED)



KEY PART NUMBER U/M DESCRIPTION
 095721-39-000 EA LABEL - CONTROL CENTER 30 AMP- CANADIAN

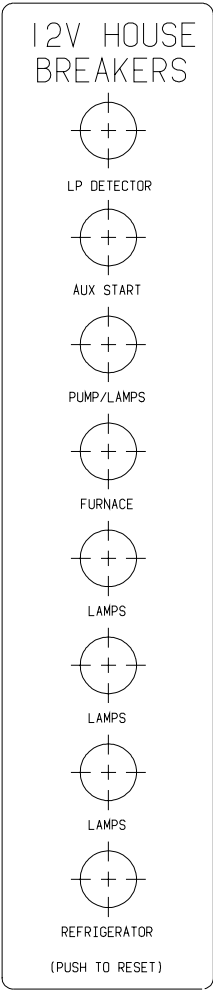

KEY PART NUMBER U/M DESCRIPTION
 092547-08-000 EA LABEL - CIRCUIT BREAKER

LABELS GROUP (CONTINUED)

BATTERY MODE SWITCH	COACH BREAKER PANEL	ELECTRIC STEP IGNITION POWER	ELECTRIC STEP BATTERY POWER	ELECTRIC STEP CONTROL POWER	INVERTER
---------------------------	---------------------------	---------------------------------------	--------------------------------------	--------------------------------------	----------

KEY PART NUMBER U/M DESCRIPTION
 093236-08-000 EA LABEL - CIRCUIT BREAKER

FRONT TIRE PRESSURE AT UNLOADED VEHICLE WEIGHT: 75 PSI
 REAR TIRE PRESSURE AT UNLOADED VEHICLE WEIGHT: 75 PSI
 FOR LOADED VEHICLE, WEIGH UNIT AND REFER TO TABLE:

TIRE PRESSURE	75	80	85	90	95	100		
FRONT LOAD-LBS	7185	7630	8070	8555	9085	9350*		
REAR LOAD-LBS	13580	14375	15255	15500*				

TIRE: MICHELIN XRV 235/80R22.5, LOAD RANGE F *GAWR = 9350
**GAWR = 15500

FOR BEST PERFORMANCE, MATCH TIRE PRESSURE TO YOUR AXLE LOAD

KEY PART NUMBER U/M DESCRIPTION
 131775-03-01A EA LABEL - TIRE PRESSURE - BROWN/BLACK

DO NOT FILL
 LP-GAS CONTAINER(S)
 TO MORE THAN 80%
 OF CAPACITY.

KEY PART NUMBER U/M DESCRIPTION
 079965-01-000 EA LABEL - LPG - 80% CAPACITY

LABELS GROUP (CONTINUED)



KEY	PART NUMBER	U/M DESCRIPTION
	111537-06-000	EA LABEL - AMPLIFIER POWER

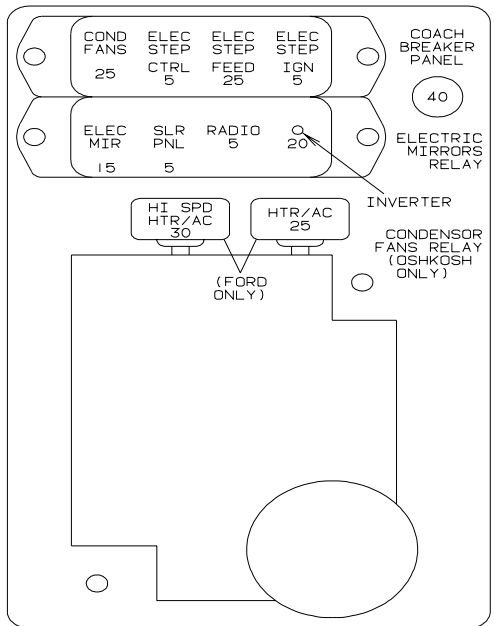

KEY	PART NUMBER	U/M DESCRIPTION
	111537-07-000	EA LABEL - FUSES

LABELS GROUP (CONTINUED)

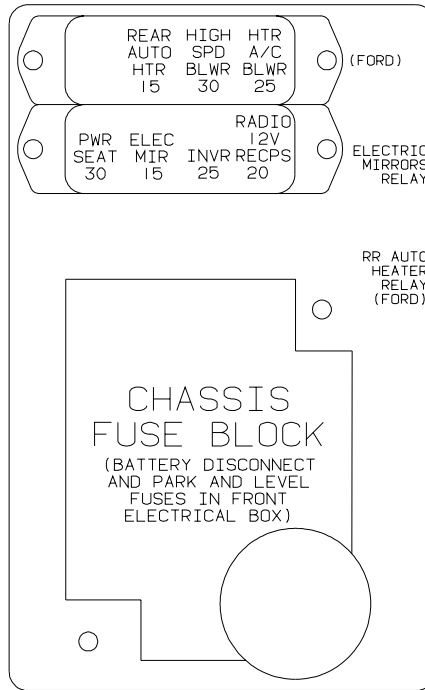

KEY PART NUMBER U/M DESCRIPTION
 111537-08-000 EA LABEL - FUSES



KEY PART NUMBER U/M DESCRIPTION
 098379-01-000 EA LABEL - CIRCUIT BREAKER - FRONT BOX

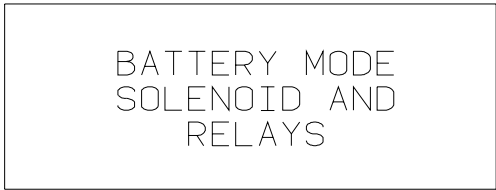

KEY PART NUMBER U/M DESCRIPTION
 098379-04-000 EA LABEL - ELECTRICAL BOX - SIDE

LP GROUP
LP SYSTEM

KEY	PART NUMBER	U/M	DESCRIPTION
*	080450-01-000	EA	TANK-LP - 42 LB - 13" DIAMETER X 24" LONG
	045703-01-000	EA	HOSE - LP - 3/8"ID X 24" - 3/8"MPT X 1/2"F SWIVEL - U.S.
	045703-02-000	EA	HOSE - LP - 3/8"ID X 24" - 3/8"MPT X 1/2"F SWIVEL - CANADA
	045703-09-000	EA	HOSE - LP - 3/8"ID X 24" - 3/8"ID F SWIVEL X 3/8"ID F SWIV
	105658-01-000	EA	COMPARTMENT - LP REGULATOR
	106150-01-000	EA	REGULATOR - TWO STAGE -W/90 DEGREE ELBOW & 3/8" FPT OUTLET
	106150-02-000	EA	REGULATOR - TWO STAGE - 1/4" FPT INLET/3/8" FPT OUTLET
	040440-02-000	EA	TRANSMITTER - DIAL - 0-90 OHM -2 TERMINAL (POWER & GROUND)
	010329-01-000	EA	ADAPTER - BRASS - 1/2"F X 1/2"MPT
	010323-01-000	EA	ADAPTER - BRASS - 3/8"F X 1/2"MPT
	010326-01-000	EA	ADAPTER - FLARE - W/CONE GASKET - 3/8"F X 1/2"F
	065318-02-000	EA	ELBOW - 90 DEGREE - 3/8" MPT TO 3/8" FPT
	010265-01-000	EA	ELBOW - BRASS - 90 DEGREE - 3/8"F X 1/2"FPT
	010377-02-000	EA	NUT - BRASS - 3/8" FLARE - FORGED
	010380-02-000	EA	NUT - BRASS - 1/2" FLARE - FORGED
	103613-03-000	EA	DETECTOR - LP GAS - W/O SHUT-OFF VALVE

***COMPONENT PARTS FOUND IN SERVICE PARTS LIBRARY**

LOUNGE GROUP CABINETS

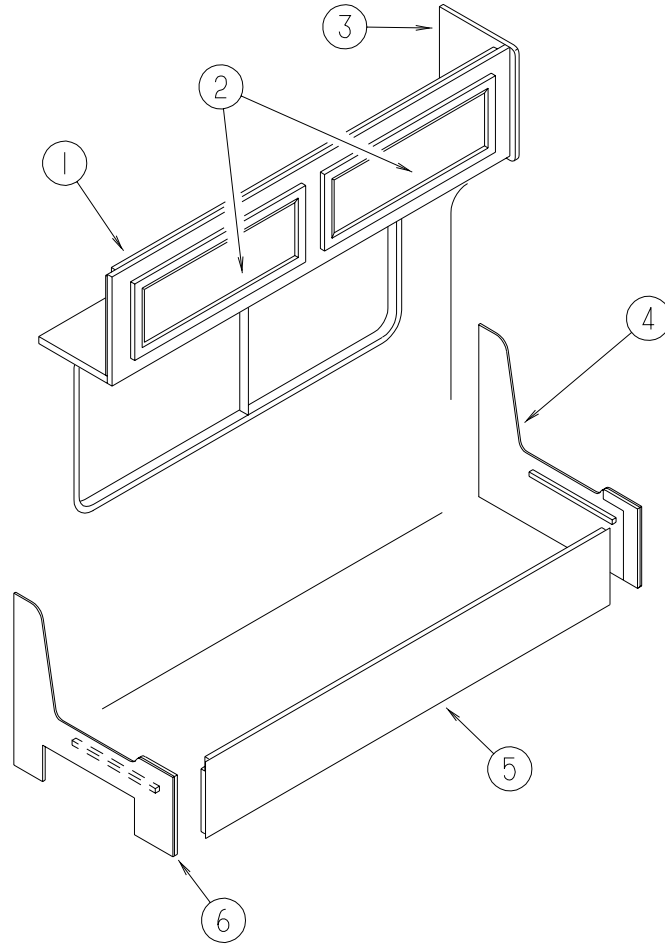

KEY	PART NUMBER	U/M	DESCRIPTION
1	131926-02-L01	EA	CABINET - OVERHEAD - W/O DOORS/HARDWARE
2	132141-14-L01	EA	DOOR - RAIL/VENEER - 15.7" X 27.9" - W/O HARDWARE
3	109908-82-K04	EA	END CAP - OVERHEAD CABINET
4	134282-02-L01	EA	PANEL - LEFT END/SHORT - SOFA/BED - FABRIC COVERED
4	134282-02-L02	EA	PANEL - LEFT END/SHORT - SOFA/BED - FABRIC COVERED
4	134282-02-L03	EA	PANEL - LEFT END/SHORT - SOFA/BED - FABRIC COVERED
5	120992-07-K18	EA	PANEL - FRONT KICK - SOFA/BED - FABRIC COVERED (L01)
5	120992-07-L02	EA	PANEL - FRONT KICK - SOFA/BED - FABRIC COVERED (L02)
5	120992-07-L03	EA	PANEL - FRONT KICK - SOFA/BED - FABRIC COVERED (L03)
	121906-01-02B	EA	BRACKET - KICKBOARD - E-COATED
6	134282-03-L01	EA	PANEL - RIGHT END/SHORT W/CUTOUT - SOFA/BED - FABRIC CVRD
6	134282-03-L02	EA	PANEL - RIGHT END/SHORT W/CUTOUT - SOFA/BED - FABRIC CVRD
6	134282-03-L03	EA	PANEL - RIGHT END/SHORT W/CUTOUT - SOFA/BED - FABRIC CVRD
	082525-01-000	EA	BRACE - COUCH - FLOOR MOUNT - ANGLE 3" LONG
	P29778-02-01A	EA	LINER - STEP - BRIGHT WHITE W/TAPE
	129778-02-01A	EA	LINER - STEP - BRIGHT WHITE

LOUNGE GROUP (CONTINUED)
CABINETS (CONTINUED)

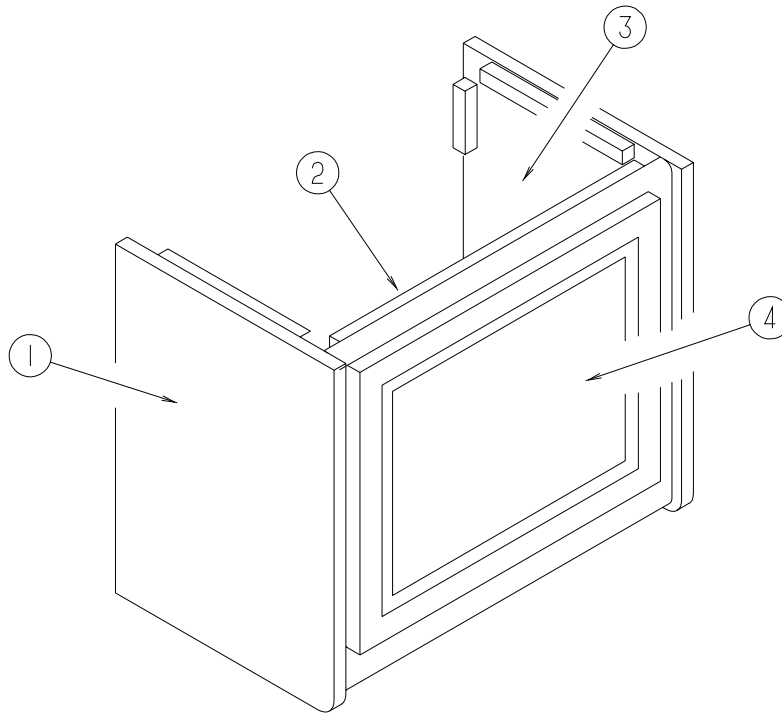

KEY	PART NUMBER	U/M	DESCRIPTION
1	109908-81-K04	EA	END CAP - OVERHEAD CABINET
2	124390-03-K01	EA	CABINET - OVERHEAD/FRONT/RIGHT HAND - W/O DOORS/HARDWARE
3	109908-82-K04	EA	END CAP - OVERHEAD CABINET
4	132141-08-L01	EA	DOOR - RAIL/VENEER - 15.7" X 20.4" - W/O HARDWARE

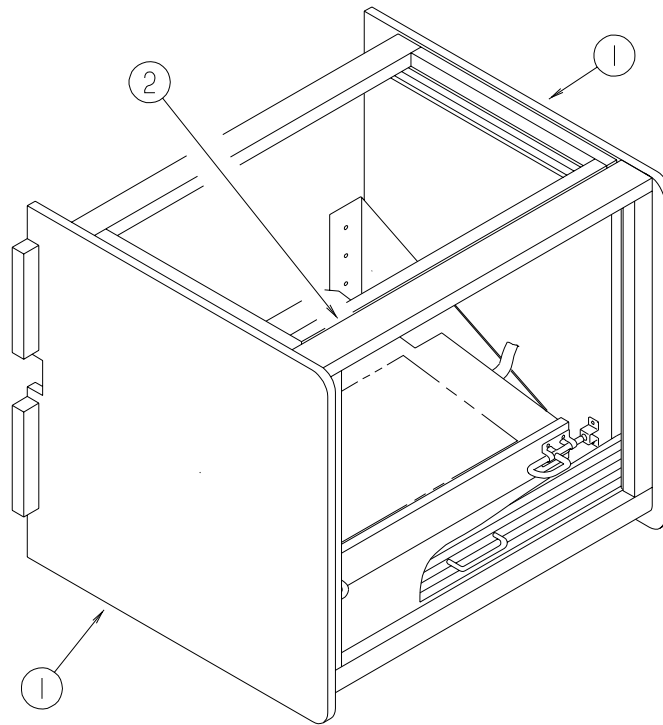

KEY	PART NUMBER	U/M	DESCRIPTION
1	109908-98-J01	EA	END CAP - OVERHEAD CABINET
2	M08163-09-K01	EA	CABINET - TV/VCP - W/O SHELF/SLIDES/SWIVEL- W/TAMBOUR DOOR
2	M08163-10-K01	EA	CABINET - TV/VCP - W/SHELF/SLIDES/SWIVEL/TAMBOUR DOOR

LOUNGE GROUP (CONTINUED)
CABINETS (CONTINUED)

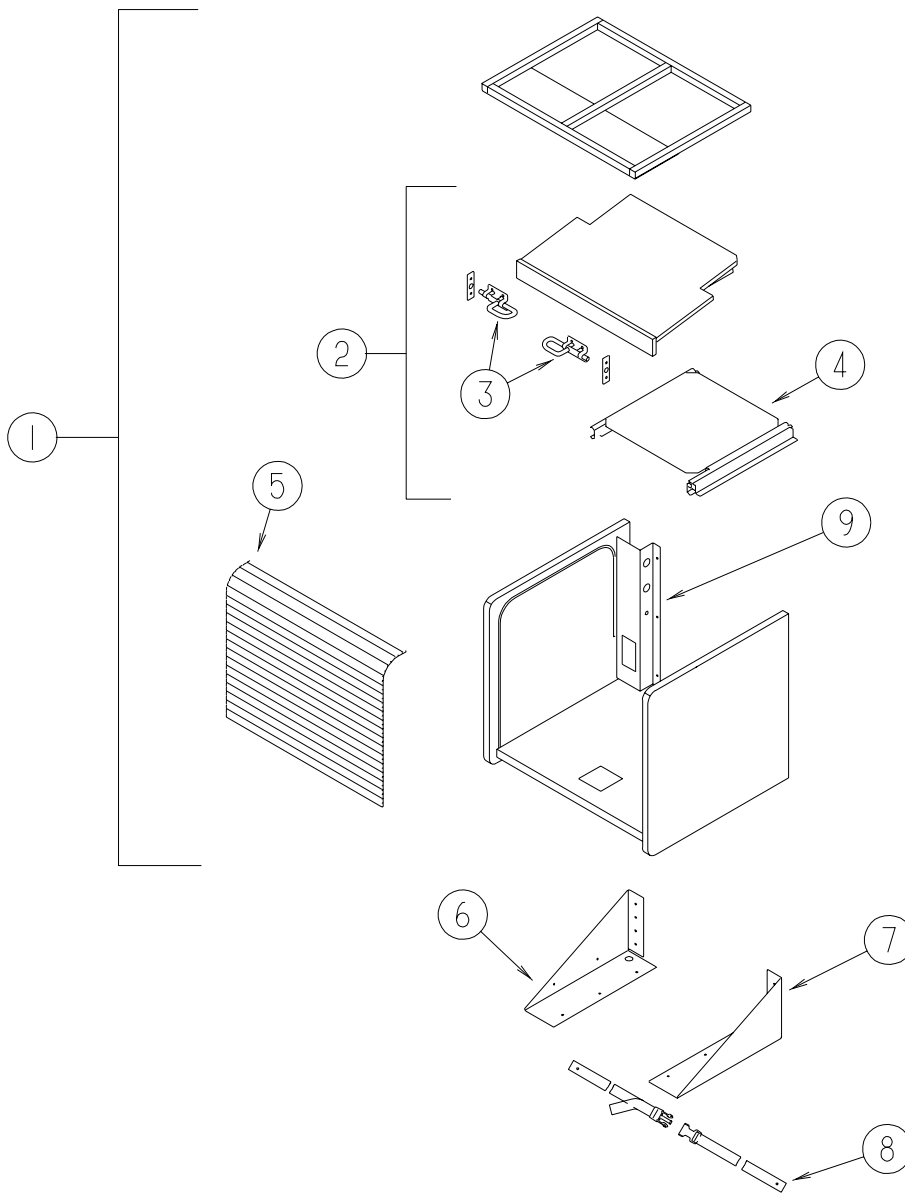

KEY	PART NUMBER	U/M	DESCRIPTION
1	M08163-09-K01	EA	CABINET - TV/VCP - W/O SHELF/SLIDES/SWIVEL- W/TAMBOUR DOOR
1	M08163-10-K01	EA	CABINET - TV/VCP - W/SHELF/SLIDES/SWIVEL/TAMBOUR DOOR
2	125722-13-J01	EA	SHELF - W/SLIDE & SWIVEL
3	103256-01-000	EA	LATCH - SLIDE
4	116773-02-000	EA	SWIVEL/SLIDES - F/TV SHELF
5	057882-04-700	EA	TAMBOUR - 48" X 48" SHEET - UNFINISHED
6	122298-03-02B	EA	BRACKET - TV/VCR W/ANGLE - LEFT HAND - E-COATED
7	122298-02-02B	EA	BRACKET - TV/VCR W/ANGLE - RIGHT HAND - E-COATED
8	099717-04-000	EA	STRAP - TIE DOWN W/21.3" FEMALE STRAP & 27.2" MALE STRAP
9	122469-02-02B	EA	BRACKET - ZEE - W/CUTOUT - E-COATED
9	122469-01-02B	EA	BRACKET - ZEE

LOUNGE GROUP (CONTINUED)
TABLE

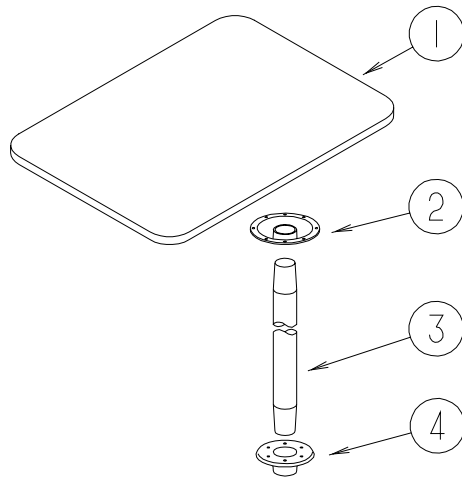

KEY	PART NUMBER	U/M	DESCRIPTION
1	130969-02-K03	EA	TABLE TOP ONLY - PEDESTAL TYPE (L01, L03)
1	130969-02-K02	EA	TABLE TOP ONLY - PEDESTAL TYPE (L02)
2	009040-03-000	EA	BASE - TABLE/RAISED - TABLE MOUNTED
3	009040-02-000	EA	PEDESTAL TABLE LEG - 27.5" X 2.25" DIAMETER
4	041194-01-000	EA	BASE - TABLE/FLUSH - FLOOR MOUNTED

SEALANTS & FASTENERS GROUP

SEALANTS & ADHESIVES

KEY	PART NUMBER	U/M	DESCRIPTION
	069640-01-000	FT	SEALER - RIBBON - 1/4" DIAMETER X 30' - BLACK
	069640-02-000	FT	SEALER - TAPE - .13"THICK X .5"WIDE X 60' - GRAY
	069640-03-000	FT	SEALER - TAPE - .13"THICK X .75"WIDE X 60' - BLACK
	069640-07-000	FT	SEALER - TAPE - .09"THICK X 2"WIDE X 45' - GRAY
	069640-09-000	FT	SEALER - TAPE - .032"THICK X 2.50"WIDE X 80' - GRAY
	069640-10-000	FT	SEALER - TAPE - .03"THICK X 1.50"WIDE X 90' - GRAY
	069640-11-000	FT	SEALER - TAPE - .19"THICK X .38"WIDE X 40' - BLACK
	069640-13-000	FT	SEALER - TAPE - .03"THICK X 2"WIDE X 45' - BLACK
	069640-14-000	FT	SEALER - TAPE - .06"THICK X 1"WIDE X 100' - GRAY
	069640-15-000	FT	SEALER - TAPE - .06"THICK X .38"WIDE X 100' - GRAY
	069640-17-000	FT	SEALER - TAPE - .03"THICK X 1"WIDE X 90' - GRAY
	069640-18-000	FT	SEALER - TAPE - .50"THICK X 1/8"WIDE X 60' - BRIGHT WHITE
	069640-19-000	FT	SEALER - TAPE - .75"THICK X 1/8"WIDE X 60'- BRIGHT WHITE
	069640-20-000	FT	SEALER - TAPE - .50" THICK X 1/8" WIDE X 60'-BRIGHT WHITE
	069640-21-000	FT	SEALER - TAPE - .50" THICK X 1/16" WIDE X 100'-BRIGHT WHT
	069640-22-000	FT	SEALER - TAPE - .25" THICK X 1/32" WIDE X 100'- BRIGHT WHT
	069640-23-000	FT	SEALER - TAPE - 1/16" THICK X .75" WIDE X 100'- BRIGHT WHT
	069640-25-000	FT	SEALER - TAPE - 1/16" X 3 1/2"
	072889-01-000	EA	SEALANT - URETHANE - BLACK - TUBE
	072889-07-000	EA	SEALANT - URETHANE - BLACK - TUBE
	072889-09-000	EA	SEALANT - URETHANE - BLACK - TUBE
	072889-10-000	EA	SEALANT - URETHANE - BRIGHT WHITE - TUBE
	072889-11-000	EA	SEALANT - URETHANE - GRAY - TUBE
	072889-13-000	EA	SEALANT - URETHANE - VW WHITE - TUBE
	072889-14-000	EA	SEALANT - URETHANE - SABLE - TUBE
	072889-16-000	EA	SEALANT - URETHANE - BLACK - TUBE
	072889-17-000	EA	SEALANT - URETHANE - BLACK - TUBE
	116767-01-01A	EA	SEALANT - WATERBASE - CLEAR
	053766-02-000	EA	BEDDING COMPOUND - TUBE - WHITE
	053766-06-000	EA	BEDDING COMPOUND - TUBE - CLEAR
	053766-08-000	EA	BEDDING COMPOUND - TUBE - GRAY
	131264-01-02A	EA	SILICONE - W/O NOZZLE - CLEAR
	131264-01-01A	EA	SILICONE - W/O NOZZLE - BLACK
	131264-01-08A	EA	SILICONE - W/O NOZZLE - BUFF
	131264-02-01A	EA	SILICONE - W/O NOZZLE - VW GRAY - BATH ONLY
	131264-03-01A	EA	SILICONE - SELF LEVELING - W/O NOZZLE - BRIGHT WHITE
	108716-01-000	EA	SILICONE - TUBE - OFF WHITE/SELF LEVELING - W/O NOZZLE
	108716-02-000	EA	SILICONE - TUBE - BUFF/SELF LEVELING - W/O NOZZLE
	102352-01-000	EA	SEALER - PUMPABLE - TUBE - BLACK
	102352-02-000	EA	SEALER - PUMPABLE - TUBE - CLEAR
	094401-01-000	EA	SEALER - BODY SEAM
	067788-01-000	EA	ADHESIVE - SPRAY - 3M - 19.5 AEROSOL CAN
	081377-01-700	EA	ADHESIVE-CYANOACRYLATE 10 GM
	099039-01-000	EA	ADHESIVE-WEATHERSTRIP, 8 OZ. - SILAPRENE M6581
	900390-01-000	EA	TIP - 2 1/2" X 1/8" ORIFICE
	900390-03-000	EA	NOZZLE - SILICONE TUBE
	900390-04-000	EA	NOZZLE - SILICONE TUBE
	112902-01-000	EA	NOZZLE - ELEMENT - 3/8 X 24
	112902-02-000	EA	NOZZLE - BELL - 3/8 X 24
	112902-03-000	EA	NOZZLE - ELEMENT - 1/4 X 6
	076322-01-000	FT	TAPE - DOUBLE COATED/ADHESIVE BACK - .025"THK X .75"W X 18'
	076322-02-000	FT	TAPE - DOUBLE COATED/ADHESIVE BACK - .045"THK X 1"W X 9'
	076322-03-000	FT	TAPE - DOUBLE COATED/ADHESIVE BACK - .045"THK X .50"W X 9'
	076322-05-000	FT	TAPE - DOUBLE COATED/ADHESIVE BACK - .045"THK X .75"W X 9'
	076322-06-000	FT	TAPE - DOUBLE COATED/ADHESIVE BACK - .045"THK X 1"W X 9'
	076322-07-000	FT	TAPE - DOUBLE COATED/ADHESIVE BACK - .045"THK X .50"W X 9'
	076322-11-000	FT	TAPE - DOUBLE COATED/ADHESIVE BACK - .020"THK X 1"W X 9'
	076322-12-000	FT	TAPE - DOUBLE COATED/ADHESIVE BACK - .045"THK X .75"W X 9'
	123816-01-000	FT	TAPE - DOUBLE SIDED - 1"
	123816-02-000	FT	TAPE - DOUBLE SIDED - 1/2" X 1 1/3" - THICK
	123816-03-000	FT	TAPE - DOUBLE SIDED - 1/2" X 3/4" - THICK
	123816-04-000	FT	TAPE - DOUBLE SIDED - 6"

SEALANTS & FASTENERS GROUP (CONTINUED)

SEALANTS & ADHESIVES (CONTINUED)

KEY	PART NUMBER	U/M	DESCRIPTION
	063642-01-000	FT	TAPE - ADHESIVE - .4" X 1.5" X 180'
	123244-01-000	FT	TAPE - DOUBLE SIDED/FOAM - 5/64" THICK X 3/4" WIDE
	123244-02-000	FT	TAPE - DOUBLE SIDED/FOAM - 5/64" THICK X 1/2" WIDE X 108'
	088479-01-000	EA	TAPE - ALUMINUM - 3"
	103202-02-000	FT	TAPE - FOAM/ADHESIVE ONE SIDE - 1/16" X 200'
	110274-01-000	FT	TAPE - DOUBLE SIDED/FOAM - .45" X 1" X 216' - BLACK
	115933-01-000	FT	TAPE - 1/64" X 3/8" X 100'
	123816-04-000	FT	TAPE - DOUBLE SIDED - 6" X 750'
	002707-02-000	FT	TAPE - SEALER - 5/16" X 1/2" - INCREMENTS OF 50 FT
	091255-02-000	FT	SEAL - ADHESIVE BACKED/FOAM - 3/64" THICK X 3/16"W X 1000'
	091255-03-000	FT	SEAL - ADHESIVE BACKED/FOAM - 1/4" THICK X 1/4"W X 1000'
	099069-01-000	FT	SEAL - RUBBER - CLOSED SPONGE - .5" WIDE X .12" THICK -BLK
	104692-01-000	FT	SEAL - ADHESIVE BACKED FOAM - 3/4" THICK X 3/4" WIDE X 25'
	104692-03-000	FT	SEAL - ADHESIVE BACKED FOAM - 1" THICK X 1 3/4" WIDE X 15'
	108353-03-000	FT	SEAL - FOAM - .19" X .25"
	112864-01-000	FT	SEAL - FOAM/BUTYL COVERED - 3/8" X 35'
	106206-01-000	EA	SEALER - PUMPABLE - TUBE - BLACK - MANUS
	120074-02-01A	EA	SILICONE - W/O NOZZLE - LOW ODOR - OFF WHITE
	120074-02-02A	EA	SEALANT - W/O NOZZLE - SOFT WHITE
	107828-01-000	EA	SEALANT - SB - 190 EVERSEAL
	112864-02-000	FT	FOAM - BUTYL COVERED 5/16" X 44'
	087211-01-000	GL	PROMOTER - ADHESIVE - GALLON
	004006-05-700	EA	ADHESIVE - 5 GALLON - NATIONAL STARCH
	004020-01-000	QT	ADHESIVE - ABS CEMENT - QUART
	112901-02-000	EA	ADHESIVE - PLEXUS - MA330 - 50ML - GRAY
	131384-01-000	EA	ADHESIVE - JETWELD
	113366-01-000	EA	ADHESIVE - INSTANT - 1 OZ
	062917-03-000	EA	ADHESIVE - LOCTITE 242
	004001-02-000	EA	GUN - PLEXUS ADHESIVE - W/O NOZZLE
	004001-03-000	EA	MIXER NOZZLE (EPX)
	004001-03-001	EA	EPOXY MIXER NOZZLE 12"
	004001-03-002	EA	TUBE/MIXER - GRACO EPOXY
	004001-04-000	EA	PLUNGER ACCESSORY (EPX)
	004001-05-000	EA	ADHESIVE - SCOTCH-WELD - 3M DP100 - CLEAR - 50ML
	099952-01-000	FT	CORE - SEAL - BULB SUPPORT

BOLTS, NUTS AND WASHERS

KEY	PART NUMBER	U/M	DESCRIPTION
	000C12-04-12A	EA	BOLT - HEX - 1/4-20 X .75 - PLAIN 5
	000C12-05-16B	EA	BOLT - HEX - 5/16-18 X 1 - GRADE #5 - ZINC
	000C12-05-12B	EA	BOLT - HEX - 5/16-18 X 3/4 - ZINC 5
	000C12-06-16B	EA	BOLT - HEX - 3/8-16 X 1 - GRADE #5 - ZINC
	000C12-06-20B	EA	BOLT - HEX - 3/8 - 16 X 1 1/4 - ZINC #5
	000C12-06-44B	EA	BOLT - HEX - 3/8-16 X 2 3/4 - ZINC 5
	000C12-07-20B	EA	BOLT - HEX - 7/16-14 X 1 1/4 - ZINC 5
	000C12-08-24B	EA	BOLT - HEX - 1/2-13 X 1.5 - GRADE #3 - ZINC
	000C12-08-28B	EA	BOLT - HEX - 1/2-13 X 1.8" - GRADE #5 - ZIN
	000C12-08-16B	EA	BOLT - HEX - 1/2-13 X 1" - GRADE #5 - ZINC
	OMC04K-06-016	EA	BOLT - HEX - M06 X 1 X 016
	OMC05K-08-055	EA	BOLT - HEX M.3 X 1.25 X 2.2
	OMC13K-14-070	EA	BOLT - HEX M14 X 2.00 X 2.75
	OMC31K-08-020	EA	BOLT - HEX - SERRATED FLANGE - M8 X 020
	OMC32K-10-030	EA	BOLT - HEX - SERRATED FLANGE - M10 X 1.50

SEALANTS & FASTENERS GROUP (CONTINUED)**BOLTS, NUTS AND WASHERS (CONTINUED)**

KEY	PART NUMBER	U/M	DESCRIPTION
	0MC53K-12-050	EA	BOLT - HEX - M12 X 1.75 X 050
	000C12-04-40B	EA	BOLT - HEX - 1/4-20 X 2 1/2 - GRADE 5 ZINC
	000C12-05-64B	EA	BOLT - HEX - 5/16-18 X 4
	000C12-06-24B	EA	BOLT - HEX - 38-16 X 1 1/2 - ZINC #5
	000C12-10-24B	EA	BOLT - HEX - 5/8-11 X 1.5" - GRADE #5 - ZINC
	000C13-07-40B	EA	BOLT - HEX - 7/16-20 X 2.5" - GRADE #5 - ZINC
	000C13-07-48B	EA	BOLT - HEX - 7/16-20 X 3" - GRADE #5 - ZINC
	000C13-08-40B	EA	BOLT - HEX - 1/2-20 X 2 1/2 - GRADE #5 - ZINC
	000C13-08-28B	EA	BOLT - HEX - 1/2-20 X 1 3/4 - GRADE #5 - ZINC
	000C14-07-28B	EA	BOLT - HEX - 7/16-14 X 1.75 - GRADE 8 ZINC
	000C14-07-20B	EA	BOLT - HEX - 7/16-14 X 1.25 - GRADE 8 ZINC
	000C14-10-24K	EA	BOLT - HEX 0 5/8-11 X 1.50 - GRADE #8 - ZINC
	000C14-10-32K	EA	BOLT - HEX - 5/8"-11 X 2 - GRADE #8 - ZINC
	000C18-05-40A	EA	BOLT - ELEVATOR - 5/16-18 X 2.50 - PL
	000C18-06-48B	EA	BOLT - ELEVATOR - 3/8-16 X 3 - GRADE 5 - ZINC
	000C18-06-56A	EA	BOLT - ELEVATOR - 3/8-16 X 3 1/2 - GRADE 5
	000C26-04-18B	EA	BOLT - HEX - SERRATED FLANGE - 1/4-20 X 1 1/8 - ZINC
	000C26-04-14B	EA	BOLT - HEX - SERRATED FLANGE - 1/4-20 X 7/8 - ZINC
	000C26-04-10B	EA	BOLT - HEX - SERRATED FLANGE - 1/4-20 X 5/8 - ZINC
	000C26-05-16B	EA	BOLT - HEX - SERRATED FLANGE - 5/16-18 X 1 - ZINC
	000C26-05-20B	EA	BOLT - HEX - SERRATED FLANGE - 5/16-18 X 1 1/4 - ZINC
	000C26-05-12B	EA	BOLT - HEX - SERRATED FLANGE - 5/16-18 X 3/4 - ZINC
	000C26-05-16B	EA	BOLT - HEX - SERRATED FLANGE - 5/16-18 X 1 - ZINC
	000C26-05-129	EA	BOLT - HEX - SERRATED FLANGE - 5/16-18 X 3/4
	000C26-05-249	EA	BOLT - HEX - SERRATED FLANGE 5/16-18 X 1.5"
	000C26-06-16B	EA	BOLT - HEX - SERRATED FLANGE - 3/8-16 X 1 - ZINC
	000C26-06-28B	EA	BOLT - HEX - SERRATED FLANGE - 3/8-16 X 1 3/4 - ZINC
	000C26-06-40B	EA	BOLT - HEX - SERRATED FLANGE - 3/8-16 X 1 3/4 - ZINC
	000C26-06-12B	EA	BOLT - HEX - SERRATED FLANGE - 3/8-16 X 3/4 - ZINC
	000C26-06-20B	EA	BOLT-HEX, SER FLG 3/8 - 16 X 1 1/4 - ZN
	000C26-08-24B	EA	BOLT - HEX - SERRATED FLANGE - 1/2-13 X 1 1/2 - ZINC
	000C27-04-40B	EA	BOLT - CARRIAGE 1/4-20 X 2.50 - ZINC
	000C27-08-64B	EA	BOLT - CARRIAGE - 1/2-13 X 4. - GRS
	106166-01-000	EA	BOLT/COLLARED HANGER - 8-32 X 1"
	000G45-04-24B	EA	BOLT - LAG - 1/4-9 X 1 1/2 - ZINC
	000G45-04-24F	EA	BOLT - LAG - 1/4" #9 X 1 1/2SS
	000G45-05-16B	EA	BOLT - LAG - 5/16-9 X 1 - ZINC
	106956-03-000	EA	BOLT - HEX TAP - 1/2-12NC X 3 - GRADE 5 - FULL THREAD/ZINC
	051387-06-000	EA	BOLT - CARRIAGE W/O HOLE - 5/16-18 X 9.5 - ZINC
	091274-03-000	EA	BOLT-J - 3/8-16 X 12.0
	106956-08-000	EA	BOLT - HEX TAP - 1/2-13NC X 4 - GRADE 5 - FULL THREAD/ZINC
	087718-01-000	EA	MONOBOLT - STEEL - 3/16 DIAMETER
	102333-02-01A	EA	BOLT - CARRIAGE - 1/4-20
	103020-02-000	EA	BOLT-U - #8-32 - GRADE 5 ZINC
	107393-02-000	EA	BOLT - SHOULDER - 3/8" SOCKETHEAD
	113985-02-000	EA	BOLT - FLANGE - M10-1.5 X 30CL10.9
	114259-05-000	EA	BOLT-7/16-20X1.25 W/WASHER
	0MD16K-10-000	EA	NUT - HEX PREV TORQUE M10 X 1.50 CLASS 8
	0MD39K-12-000	EA	NUT - HEX W/NYLON LOCK - M12 X 1.75
	000D24-10-00B	EA	NUT - HEX - SELF LOCKING - 10-32 ZINC
	000D29-05-00B	EA	NUT - HEX - LOCKING W/SERRATED FLANGE-NYLON WASHER INSERT
	000D29-09-00B	EA	NUT - HEX - SELF LOCKING - 9/16-12 - ZINC
	000D29-06-00B	EA	NUT - HEX - W/NYLON LOCK - 3/8-16 - ZINC
	000D30-07-00B	EA	NUT-HEX LOCK,NYLON 7/16X20
	000D34-04-00B	EA	NUT - HEX - LOCKING - 1/4-20 ZINC
	000D34-06-00B	EA	NUT - HEX - LOCKING - 3/8-16 GRADE C - ZINC
	000D39-04-00B	EA	NUT - HEX - LOCKING W/SERRATED FLANGE - 1/4-20 - ZINC
	000D39-05-00B	EA	NUT - HEX - LOCKING W/SERRATED FLANGE - 5/16-18 - ZINC
	000D39-06-00B	EA	NUT - HEX - LOCKING W/SERRATED FLANGE - 3/8-18 - ZINC
	000D39-07-00B	EA	NUT - HEX - LOCKING W/SERRATED FLANGE - 7/16-14 - ZINC
	000D39-08-00B	EA	NUT - HEX - LOCKING W/SERRATED FLANGE - 1/2-13 - ZINC

SEALANTS & FASTENERS GROUP (CONTINUED)

BOLTS, NUTS AND WASHERS (CONTINUED)

KEY	PART NUMBER	U/M	DESCRIPTION
	000D44-04-00B	EA	NUT - HEX - LOCKING W/SERRATED FLANGE - 1/4-28 - ZINC
	000D44-07-00B	EA	NUT - HEX - LOCKING W/SERRATED FLANGE - 7/16-20 - ZINC
	000D44-08-00B	EA	NUT - HEX - SERRATED FLANGE - 1/2-20 - GRADE #5 - ZINC
	000D46-04-00A	EA	NUT - HEX - WELD - 1/4-20 - PLAIN
	000D58-06-00A	EA	NUT - HEX - WELD 3/8-16 - PLAIN
	000D65-08-00B	EA	NUT - HEX - LOCKING W/SERRATED FLANGE - 8-32 - ZINC
	000D67-10-00B	EA	NUT - HEX - LOCK - 5/8-11 - ZINC
	000D73-07-00C	EA	NUT - HEX FLANGE - 7/16-14 - GRADE 6
	000D73-08-00C	EA	NUT - HEX FLANGE - 1/2-13
	000D76-06-00B	EA	NUT - HEX FLANGE - 3/8-16
	044364-02-000	EA	NUT - SPEED - FLAT - ROUND
	063253-07-000	EA	NUT - J - #8A - .120 - .130 PNL THK
	087234-01-000	EA	NUT - JACK - 1/4 X 20 THD - MOLLY MOUNTS LICENSE PLATES USING BOLT #000G500412B
	040921-01-000	EA	NUT - SPEED - U TYPE - #10-24 - BLACK
	104369-01-000	EA	NUT - HEX - HEAVY - 5/8-11 UNC
	000D29-04-00B	EA	NUT - HEX - SELF LOCKING - 1/4 X 20 - ZINC
	005081-01-000	EA	NUT - SPEED - C-TYPE - #8 SCREW
	040921-04-000	EA	NUT - SPEED - U TYPE - #8-.59" LENGTH X .44" WIDTH
	040921-09-000	EA	NUT - SPEED - U TYPE - #8
	044364-01-000	EA	NUT - SPEED - FLAT - RECTANGULAR - SELF LOCKING/ONE PIECE
	083163-06-000	EA	PUSHNUT - FLAT TYPE 3/8 STUD - FORD ONLY
	0ME06K-14-280	EA	WASHER - FLAT - 14 ID X 28.00 OD
	000E11-07-00B	EA	WASHER - LOCKING - 7/16 MED SPLIT - ZINC
	000E11-08-00B	EA	WASHER - LOCKING - 1/2 MED SPLIT - ZINC
	000E13-14-00B	EA	WASHER - FLAT - 1/4 WIDE - ZINC
	000E13-17-00B	EA	WASHER - FLAT - 3/8 AR - ZINC
	000E13-18-00B	EA	WASHER - FLAT - 3/8 WIDE - ZINC
	000E13-20-00B	EA	WASHER - FLAT - 7/16 WIDE - ZINC
	000E13-21-00B	EA	WASHER - FLAT - 1/2 NARROW - ZINC
	000E13-22-00B	EA	WASHER - FLAT - 1/2 WIDE - ZINC
	000E13-26-00B	EA	WASHER - FLAT - 5/8 WIDE - ZINC
	000E14-10-00B	EA	WASHER - LOCKING - #10 EXTERNAL TOOTH - ZINC
	000E16-10-00B	EA	WASHER - HARDENED - 5/8 - FLAT - ZINC
	058716-02-000	EA	WASHER - FLAT NYLON
	077071-01-000	EA	WASHER - FENDER - 3/16"ID X 1" OD
	107397-01-000	EA	WASHER - FENDER - .25" ID X 1" OD
	041322-01-000	EA	WASHER - FLANGE - 15/32 ID X 2 3/8 OD - F/SEAT BELT MTG
	044533-01-000	EA	WASHER - PLASTIC - 1 3/8" OD - FOR BUTTONS
	046867-05-000	EA	WASHER - #0
	058716-03-000	EA	WASHER - FLAT/NYLON - .500 X 1.25 X .060
	088787-12-000	EA	STUD - WELD - 1/4 - 20 X 1.0 LG - MN
	108067-03-000	EA	STUD - WELD - 1/4 - 20 X 1/2 CD
	102540-02-000	EA	SEAL - SCREW
	106648-01-000	EA	CAP - STUD - .120 TO .130 DIAMETER

SCREWS

KEY	PART NUMBER	U/M	DESCRIPTION
	0G1108-12-170	EA	SCREW - 8-18 X .75 PPH - BRIGHT WHITE
	0G1106-08-240	EA	SCREW - 6-20 X 1/2 PPH - VW LIGHT GRAY
	0G1108-12-140	EA	SCREW - 8-18 X .75 PPH
	0G1108-12-240	EA	SCREW - 8-18 X .75 PPH - VW LIGHT GRAY
	0G1208-12-170	EA	SCREW - 8-18 X .75 POH - BRIGHT WHITE
	0G3908-08-160	EA	SCREW - SF/DR-8-18X1/2 PPH
	0G3908-08-170	EA	SCREW - SF/DR - 8-18 X .50 PPH - BRIGHT WHITE
	0G3908-08-240	EA	SCREW - SF/DR - 8-18 X 1/2 PPH - VW LIGHT GRAY
	0G3908-12-250	EA	SCREW - SF/DR - 8-18 X .75 PPH - DARK GRAY
	0G3908-16-170	EA	SCREW - SF/DR - 8-18 X 1.00 PPH - BRIGHT WHITE
	0G3908-20-170	EA	SCREW - SF/DR - 8-18 X 1.25 PPH - BRIGHT WHITE
	0G3908-24-170	EA	SCREW - SF/DR - 8-18 X 1.50 PPH - BRIGHT WHITE
	0G3910-10-160	EA	SCREW - SF/DR - 10-16 X .62 PPH

SEALANTS & FASTENERS GROUP (CONTINUED)**SCREWS (CONTINUED)**

KEY	PART NUMBER	U/M	DESCRIPTION
	0G3910-10-240	EA	SCREW - SF/DR - 10-16 X .62 PPH - VW LIGHT GRAY
	0G5508-12-110	EA	SCREW - SF/DR-8-18 X .75 PWH
	0G3910-12-260	EA	SCREW - SF/DR - 10-16 X .75 PPH - ALLANTE ANTELOPE
	0G3910-12-170	EA	SCREW - SF/DR - 10-16 X .75 PPH - BRIGHT WHITE
	0G5508-12-170	EA	SCREW - SF/DR - 8-18 X .75 PWH - BRIGHT WHITE
	0G5508-12-270	EA	SCREW - SF/DR - 8-18 X .75 PWH - TITANIUM
	0G5508-12-260	EA	SCREW - SF/DR - 8-18 X .75 PWH - ALLANTE ANTELOPE
	0G5508-16-250	EA	SCREW - SF/DR - 8-18 X 1.00 PWH - VW DARK GRAY
	0G6008-16-170	EA	SCREW - SF/DR - 8-18 X 1.00 POH - BRIGHT WHITE
	0G5508-16-260	EA	SCREW - SF/DR - 8-18 X 1.00 PWH ZINC - INTERIOR ANTELOPE
	0G5508-16-270	EA	SCREW - SF/DR - 8-18 X 1.00 PWH ZINC - INTERIOR TITANIUM
	0G6710-08-130	EA	SCREW - 10-12 X .50 PPH TAUPE
	0G6710-08-170	EA	SCREW - 10-12 X 1/2 PPH - BRIGHT WHITE
	0G6710-08-240	EA	SCREW - 10-12 X .50 PPH TAUPE - VW LIGHT GRAY
	0G6710-12-170	EA	SCREW - 10-12 X .75 PPH - BRIGHT WHITE
	0G6710-16-230	EA	SCREW - 10-12 X 1 PPH - BEIGE
	000G11-05-08B	EA	SCREW - 5-20 X .50 PPH - ZINC
	000G11-06-06B	EA	SCREW - 6-20 X 3/8 PPH - ZINC
	000G11-06-10B	EA	SCREW - 6-20 X 5/8 PPH - ZINC
	000G11-06-12B	EA	SCREW - 6-20 X 3/4" PPH - ZINC
	000G11-06-10J	EA	SCREW - 6-20 X 5/8 PPH - BRASS
	000G11-06-A4B	EA	SCREW - 6-20 X 1.5 PPH ZINC
	000G11-06-08B	EA	SCREW - 6-20 X 1/2 PPH - ZINC
	000G11-07-08B	EA	SCREW - 7-19 X 1/2 PPH - ZINC
	000G11-07-08T	EA	SCREW - 7-19 X 1/2 PPH - BLACK
	000G11-08-06B	EA	SCREW - 8-18 X 3/8 PPH - ZINC
	000G11-08-06J	EA	SCREW - 8-18 X 3/8 PPH BRASS
	000G11-08-12B	EA	SCREW - 8-18 X 3/4 PPH - ZINC
	000G11-08-12S	EA	SCREW - 8-18 X 3/4 PPH - OFF WHITE
	000G11-08-08T	EA	SCREW - 8-18 X 1/2 PPH - FLUOROCARBON COATING
	000G11-08-08B	EA	SCREW - 8-18 X 1/2 PPH - ZINC
	000G11-08-20B	EA	SCREW - 8-18 X 1 1/4 PPH - ZINC
	000G11-08-16S	EA	SCREW - 8-18 X 1 PPH - OFF WHITE
	000G11-08-16B	EA	SCREW - 8-18 X 1 PPH - ZINC
	000G11-08-12P	EA	SCREW - 8-18 X 3/4 PPH - DARK BROWN
	000G11-08-12D	EA	SCREW - 8-18 X 3/4 PPH - BLACK PHOSPHATE
	000G11-08-12T	EA	SCREW - 8-18 X 3/4 PPH - BLACK MAGNESIUM
	000G11-10-12S	EA	SCREW - 10-16 X 3/4 PPH - OFF WHITE
	000G11-10-12D	EA	SCREW - 10-16 X 3/4 PPH - BLACK
	000G11-10-16B	EA	SCREW - 10-16 X 1 PPH - ZINC
	000G11-10-40B	EA	SCREW - 10-16 X 2 1/2 PPH CAD - 34927-01-000
	000G12-06-08T	EA	SCREW - 6-20 X 1/2 POH - BLACK
	000G12-08-12S	EA	SCREW - 8-18 X 3/4 POH - OFF WHITE
	000G13-05-10B	EA	SCREW - 5-12 X 5/8 PFH - ZINC
	000G13-06-16S	EA	SCREW - 6-20 X 1.00 PFH - OFF WHITE
	000G13-06-10G	EA	SCREW - 6-20 X 5/8 PFH - ANTIQUE BRASS
	000G13-06-08B	EA	SCREW - 6-20 X 1/2 PFH - ZINC
	000G13-06-08G	EA	SCREW - 6-20 X .50 PFH - ANTIQUE BRASS
	000G13-06-24J	EA	SCREW - 6-20 X 1 1/2 PFH - BRASS
	000G13-06-10J	EA	SCREW - 6-20 X .62 PFH - BRASS
	000G13-06-16E	EA	SCREW - 6-20 X 1.00 PFH - CHROME
	000G13-06-16J	EA	SCREW - 6-20 X 1 PFH - BRASS
	000G13-06-06I	EA	SCREW - 6-20 X 3/8 PFH BLACK ZINC
	000G13-06-06B	EA	SCREW - 6-20 X 3/8 PFH ZINC
	000G13-07-12B	EA	SCREW - 7-19 X 3/4 PFH - ZINC
	000G13-07-10H	EA	SCREW - 7-19 X 5/8 PFH - BLACK
	000G13-07-089	EA	SCREW - 7-19 X 1.2 PPH - SILVER
	000G13-08-10B	EA	SCREW - 8-18 X 5/8 PFH - ZINC
	000G13-08-16B	EA	SCREW - 8-18 X 1 PFH - ZINC
	000G13-08-109	EA	SCREW - 8-18 X 5/8 PFH
	000G16-04-24B	EA	SCREW - MACHINE - 1/4-20 X 1 1/2 PPH
	000G18-08-22B	EA	SCREW - MACHINE - 8-32 X 1 3/8 PPH - ZINC

SEALANTS & FASTENERS GROUP (CONTINUED)**SCREWS (CONTINUED)**

KEY	PART NUMBER	U/M	DESCRIPTION
	000G18-08-20B	EA	SCREW - MACHINE - 8-32 X 1 1/4 PPH - ZINC
	000G18-08-24B	EA	SCREW - MACH-8-32X1 1/2PPH ZN
	000G13-08-24B	EA	SCREW - #8, 18X1 1/2 PFH ZN
	000G19-10-10B	EA	SCREW - MACHINE - 10-32 X 5/8 - PPH - ZINC
	000G19-10-20B	EA	SCREW - MACHINE - 10-32 X 1 1/2 PPH - ZINC
	000G19-10-12F	EA	SCREW - MACHINE - 10-32 X 3/4 PPH - STAINLESS STEEL
	000G19-10-08B	EA	SCREW - MACHINE - 10-32 X 1/2 PPH - ZINC
	000G32-10-06B	EA	SCREW - 10-32 X 3/8 PPH - ZINC
	000G13-10-16I	EA	SCREW - 10-16X1.00 PFH,BLK
	000G34-05-12B	EA	SCREW - HEX HEAD TAPPING - 5/16 X 3/4 LONG
	000G37-08-12B	EA	SCREW - 8-18 X 3/4 PPH
	000G37-08-089	EA	SCREW - 8 X 18 X 1/2 PPH - FLUOROCARBON SILVER
	000G36-10-12T	EA	SCREW - 10-24X 3/4 PFH TYPE 23 - BLACK
	000G38-04-16D	EA	SCREW - MACHINE - 1/4-20 X 1 PFN - BLACK
	000G39-06-10T	EA	SCREW - SF/DR - 6-20 X 5/8 PPH - BLACK
	000G39-06-16T	EA	SCREW - SF/DR - 6-20 X 1 PPH - BLACK
	000G39-06-08B	EA	SCREW - SF/DR - 6-18 X 1/2 - ZINC
	000G39-08-16S	EA	SCREW - SF/DR - 8-18 X 1 PPH - OFF WHITE
	000G39-08-32B	EA	SCREW - SF/DR - 8-18 X 2 PPH - ZINC
	000G39-08-24B	EA	SCREW - SF/DR - 8-18 X 1 1/2 PPH - ZINC
	000G39-08-24S	EA	SCREW - SF/DR - 8-18 X 1 1/2 - OFF WHITE
	000G39-08-24T	EA	SCREW - SF/DR - 8-18 X 1.50 PPH - BLACK
	000G39-08-16T	EA	SCREW - SF/DR - 6-20 X 1 PPH - BLACK
	000G39-08-16B	EA	SCREW - SF/DR - 8-18 X 1 PPH - ZINC
	000G39-08-12B	EA	SCREW - SF/DR - 8-18 X 3/4 PPH - ZINC
	000G39-08-12T	EA	SCREW - SF/DR - 8-18 X 3/4 PPH - BLACK
	000G39-08-08T	EA	SCREW - SF/DR - 8-18 X 1/2 PPH - BLACK
	000G39-08-08S	EA	SCREW - SF/DR - 8-18 X 1/2 PPH - OFF WHITE
	000G39-08-08B	EA	SCREW - SF/DR - 8-18 X 1/2 PPH - ZINC
	000G39-08-06B	EA	SCREW - SF/DR - 8-18 X 3/8 PPH - ZINC
	000G39-10-10B	EA	SCREW - SF/DR - 10-16 X 5/8 - ZINC
	000G39-10-12P	EA	SCREW - SF/DR, 10-16 X .75 PPH - DARK BROWN
	000G39-10-088	EA	SCREW - SF/DR - 10-16 X 1/2 PPH - FLEX FLUOROCARBON
	000G39-10-08B	EA	SCREW - SF/DR - 10-16 X 1/2 PPH - ZINC
	000G39-10-40D	EA	SCREW - SF/DR - 10-16 X 2 1/2 PPH - BLACK
	000G39-10-32B	EA	SCREW - SF/DR - 10-16 X 2 - PPH - ZINC
	000G39-10-209	EA	SCREW - SF/DR - 10-16 X 1 1/4 PPH - FLUOROCARBON SILVER
	000G39-10-20T	EA	SCREW - SF/DR - 10-16 X 1.25 PPH
	000G39-10-20B	EA	SCREW - SF/DR - 10-16 X 1 1/4 PPH - ZINC
	000G39-10-12T	EA	SCREW - SELF TAPPING 10-16 X 3/4"
	000G39-10-12D	EA	SCREW - SF/DR - 10-16 X 3/4 PPH - BLACK
	000G39-10-12B	EA	SCREW - SF/DR - 10-16 X 3/4 PPH - ZINC
	000G39-10-10T	EA	SCREW - SF/DR - 10-16 X .625 - BLACK
	000G39-10-129	EA	SCREW - SF/DR - 10-16 X 3/4 PPH - FLUOROCARBON SILVER
	000G39-10-48B	EA	SCREW - SF/DR - 10-16 X 3 - PPH - ZINC
	000G39-10-48T	EA	SCREW - SF/DR - 10-16 X 3.00 PPH - BLACK
	000G39-10-24B	EA	SCREW - SF/DR - 10-16 X 1.50 PPH - ZINC
	000G39-10-32I	EA	SCREW - SELF TAPPING - 10-16 X 2" PPH - BLACK
	000G39-12-12E	EA	SCREW - SF/DR - 12-14 X 3/4 PPH - CHROME
	000G42-04-16B	EA	SCREW - SF/DR - 1/4-14 X 1 HWH - ZINC
	000G42-04-12B	EA	SCREW - SF/DR - 1/4-14 X 3/4 HWH - ZINC
	000G42-04-24B	EA	SCREW - SF/DR 1/4-14X1 1/2 ZN
	000G46-08-24T	EA	SCREW - MACHINE - 8-32 X 1 1/2 PFH - BLACK
	000G46-08-28T	EA	SCREW - MACHINE - 8-32 X 1 3/4 PHILLIPS FLAT HEAD - BLACK
	000G50-04-12B	EA	SCREW - MACHINE - 1/4-20 X 3/4 PPH - ZINC
	000G50-04-06B	EA	SCREW - MACHINE - 1/4-20 X 38 PTH - ZINC
	000G50-04-08B	EA	SCREW - MACHINE - 1/4-20 X 1/2 PTH - ZIN
	000G51-08-08B	EA	SCREW - 8-18 X 1/2 PTH - ZINC
	000G51-06-12B	EA	SCREW - 6-20 X 3/4 PTH - ZINC
	000G52-08-18B	EA	SCREW - MACHINE - 8-32 X 1 1/8 PTH - ZINC
	000G54-04-20B	EA	SCREW - 1/4-20 X 1.25 PTH - TYPE 23 - ZINC PLATED

SEALANTS & FASTENERS GROUP (CONTINUED)**SCREWS (CONTINUED)**

KEY	PART NUMBER	U/M	DESCRIPTION
	000G55-08-125	EA	SCREW - SF/DR - 8-18 X 3/4 PWH - WILLOW
	000G55-08-12S	EA	SCREW - SF/DR - 8-18 X 3/4 PWH - OFF WHITE
	000G55-08-124	EA	SCREW - SF/DR-8-18X.75 PWH - ASH GRAY
	000G55-08-165	EA	SCREW - SF/DR-8-18X1.00 PWH - WILLOW
	000G56-12-48B	EA	SCREW - WOOD - 12-11 X 3 POH - SPECIAL HARDENED
	000G57-05-16J	EA	SCREW - 5-20 X 1 PFH - BRASS
	000G57-14-64B	EA	SCREW - 14-10 X 4 PFH ZINC
	000G57-14-72B	EA	SCREW - 14-10-X4-1/2 PFH ZN
	000G60-08-22B	EA	SCREW - SF/DR, 8 - 18 X 1.38 POH - ZN
	000G60-10-28T	EA	SCREW - SF/DR - 10-16 X 1 3/4 - BLACK
	000G60-10-20I	EA	SCREW - SF/DR - 10-16 X 1.25 POH - BLACK
	000G60-10-20B	EA	SCREW - SF/DR - 10-16 X 1 1/4 POH - ZINC
	000G60-10-209	EA	SCREW - SF/DR - 10-16 X 1.25 POH - SILVER STALGAARD
	000G62-10-24I	EA	SCREW - SF/DR - 10-16 X 1/5 PFH - BLACK ZINC
	000G67-08-32B	EA	SCREW - 8-15 X 2 PPH - ZINC
	000G67-10-08S	EA	SCREW - 10-12 X 1/2 PPH - OFF WHITE
	000G67-10-08R	EA	SCREW - 10-12 X 1/2 PPH - BEIGE - TYPE A
	000G67-10-08B	EA	SCREW - 10-12 X 1/2 PPH - ZINC
	000G67-10-16B	EA	SCREW - 10-12 X 1 PPH - ZINC
	000G67-10-120	EA	SCREW - 10-12 X 3/4 PPH - TAN
	000G67-10-12B	EA	SCREW - 10-12 X 3/4 PPH - ZINC
	000G67-10-12R	EA	SCREW - 10-12 X .75 PPH - BEIGE
	000G67-10-12P	EA	SCREW - 10-12 X 3/4 PPH - DARK BROWN
	000G67-10-10S	EA	SCREW - 10-12 X 5/8 PPH - OFF WHITE
	000G67-10-10P	EA	SCREW - 10-12X.62 PPH - DARK BROWN
	000G67-10-10D	EA	SCREW - 10-12 X 5/8 PPH - BLACK - TYPE A
	000G67-10-10T	EA	SCREW - 10-12 X 5/8 PPH BLACK
	000G67-10-10B	EA	SCREW - 10-12 X 5/8 PPH - ZINC - TYPE A
	000G67-10-20D	EA	SCREW - 10-12 X 1.25 PPH - BLACK
	000G67-10-36T	EA	SCREW - 10-12 X 2 1/4 - PPH - BLACK
	000G67-10-32B	EA	SCREW - 10-12 X 2 1/4 - PPH - BLACK
	000G67-10-24B	EA	SCREW - 10-12 X 1.50 PPH - ZINC
	000G67-10-24S	EA	SCREW - 10-12X1.5PPH OFF WHITE
	000G67-10-125	EA	SCREW - 10-12 X .75 PPH WILLOW
	000G67-10-28B	EA	SCREW - 10-12 X 1.75 PPH - ZINC
	000G67-10-48B	EA	SCREW - 10-12 X 3 PPH - ZINC
	000G68-06-12B	EA	SCREW - 6-18 X .75 POH - ZINC & CLEAR
	000G68-06-12J	EA	SCREW - 6-18X.75 POH BRASS
	000G68-06-10G	EA	SCREW - 6-18 X 5/8 POH - ANTIQUE BRASS
	000G68-10-20I	EA	SCREW - 10-12 X 1 1/4 POH - BLACK
	000G68-10-36T	EA	SCREW - 10-12 X 2.25 POH BLACK
	049465-01-000	EA	SCREW - 10-16 PTH W/WASHER - DARK BROWN
	049465-13-000	EA	SCREW - 10-16X1 PTH W/WASHER - ASH GRAY
	049465-17-000	EA	SCREW - 10-16 X 1 POH W/WASHER - BRIGHT WHITE
	049465-22-000	EA	SCREW - 10-16 X 1 1/2 POH W/WASHER - SABLE
	054434-02-000	EA	SCREW - SF/DR - 10-16 X 2 - ZINC
	054434-03-000	EA	SCREW - SF/DR - 10-16 X 2 - PWH - ZINC - W/O WINGS
	057671-01-000	EA	COVER - SCREW - OFF WHITE - #8
	057671-11-000	EA	COVER - SCREW - HAMPTON TAN - #8
	057671-15-000	EA	COVER - SCREW - BRIGHT WHITE
	057671-16-000	EA	COVER - SCREW - SOFT WHITE
	057671-17-000	EA	COVER - SCREW - VW LT GRAY #8
	075908-01-000	EA	SCREW - MACHINE - 10-32 X .56 PTH - EXTERNAL TOOTH - ZINC
	076790-01-000	EA	SCREW - 6-20 X 1 1/4 PPH - BLACK
	076790-03-000	EA	SCREW - 6-20 X 1 PPH - BLACK
	076790-05-000	EA	SCREW - 6-20 X 1/2 PPH BLACK - THREADCUTTING - WOOD
	083554-01-000	EA	SCREW - DRYWALL - 8 X 1.25
	083554-04-000	EA	SCREW - DRYWALL - 8 X 2.50
	086256-01-000	EA	SCREW - SF/DR - 8 X 3/4 HWH
	087721-01-000	EA	SCREW - FLAT HEAD - TAPPING - 1/4" X 1 1/4" LONG - ZINC
	097974-01-000	EA	SCREW - PARTICLE BOARD - 7-9 X 3/4 PPH
	090033-02-000	EA	SCREW - 1/4-20 X 5/8 - ROUND WASHER HEAD - OFF/WHITE

SEALANTS & FASTENERS GROUP (CONTINUED)

SCREWS (CONTINUED)

KEY	PART NUMBER	U/M	DESCRIPTION
	101618-01-000	EA	SCREW - 1/4-20 X 3/4 HEX - TAPPING - STALGARD TYPE F
	101289-01-01A	EA	SCREW - MACHINE - 8-32 X 3.75 POH - BRASS -F/EXTENDED KNOB
	105126-01-000	EA	SCREW - MACHINE - 8-32 X 1 PPH TAPTIT
	110460-05-02A	EA	SCREW - MACHINE - 10-24 X 2.5 PFH - WHITE
	112782-08-01A	EA	SCREW - MOUNTING/PLATE - ZINC
	113563-01-01A	EA	SCREW - 8 X .62 LONG SHOULDER/WASHER HEAD
	117478-01-04A	EA	SCREW - 8-18 X .75 PPH W/WASHER - VW LIGHT GRAY
	126458-01-01A	EA	SCREW - 8-18 X .50 PRWH BLACK
	134126-01-01A	EA	SCREW/NAIL - HEX HEAD - 3/4"

CLAMPS, CLIPS, GROMMETS, RIVETS & PLUGS

KEY	PART NUMBER	U/M	DESCRIPTION
	010495-01-000	EA	CLAMP - CABLE - 9/16"
	010495-02-000	EA	CLAMP - CABLE - 3/8
	010495-04-000	EA	CLAMP - CABLE - 11/16" - WHITE
	010495-05-000	EA	CLAMP - CABLE - 1/2
	010497-01-000	EA	CLAMP - CLOSED - 5/8" ID
	010497-03-000	EA	CLAMP - CLOSED - 1" ID - CUSHIONED
	010497-04-000	EA	CLAMP - CLOSED - 1.62" ID
	010497-05-000	EA	CLAMP - CLOSED - 1/2 ID
	010497-06-000	EA	CLAMP - CLOSED - 11/16" ID
	010497-07-000	EA	CLAMP - CLOSED - 3/8" ID
	010497-08-000	EA	CLAMP - CLOSED - .125" ID
	062401-01-000	EA	CLAMP - HOSE - WORMGEAR - .25" - 1"
	062401-02-000	EA	CLAMP - HOSE - WORMGEAR - 1.56" - 2.5"
	062401-03-000	EA	CLAMP - HOSE - WORMGEAR - .22" - 1"
	062401-04-000	EA	CLAMP - HOSE - WORMGEAR - .69" - 1.25"
	062401-05-000	EA	CLAMP - HOSE - WORMGEAR - 2" TO 3" ID
	062401-06-000	EA	CLAMP - HOSE - WORMGEAR - .22" - .62" ID
	062401-07-000	EA	CLAMP - HOSE - WORMGEAR - 5"-7"
	062401-08-000	EA	CLAMP - HOSE - WORMGEAR 4.06" - 5.0"
	062401-09-000	EA	CLAMP - HOSE - WORMGEAR - 2.8" - 3.75"
	062401-11-000	EA	CLAMP - HOSE - WORMGEAR - 3.50" - 4.50"
	062401-12-000	EA	CLAMP - HOSE - WORMGEAR - .79" X 1.26"
	083610-01-000	EA	CLAMP - WIRE - DUAL - UNEQUAL DIAMETERS - 3/4" & 1 1/4"
	083610-02-000	EA	CLAMP - WIRE - DUAL - UNEQUAL DIAMETERS - 3/4" & 2"
	083610-03-000	EA	CLAMP - DUAL WIRE
	083609-01-000	EA	CLAMP - WIRE - DUAL - EQUAL DIAMETERS - 5/8"
	007161-01-000	EA	CLAMP - HOSE - SPRING TYPE - 1/2"
	010499-01-000	EA	CLAMP - CLOSED - 3/8" ID
	075148-02-000	EA	CLAMP - GROUNDING - BRONZE SCREWS
	008386-01-000	EA	GROMMET - SNAP - 3/8"
	023942-01-000	EA	GROMMET - RUBBER - 2" OD
	071015-07-000	EA	GROMMET - RUBBER - 1"ID X 2.25" OD W/.06" GROOVE - BLACK
	071015-11-000	EA	GROMMET - 1.00 ID - FITS .12 MATERIAL
	071015-13-000	EA	GROMMET - RUBBER - .62" ID X 1" OD W/.09" GROOVE - BLACK
	071015-19-000	EA	GROMMET - .38 ID - FITS .06 MATERIAL
	071015-21-000	EA	GROMMET - RUBBER - 1/2 ID X 1.06 OD - W/.19 GROOVE - BLACK
	071015-22-000	EA	GROMMET - RUBBER - .62"ID X 1.12"OD W/.19" GROOVE - BLACK
	071015-26-000	EA	GROMMET - RUBBER - 1.5" ID X 2.1" OD W/.06" GROOVE-BLACK
	071015-29-000	EA	GROMMET - RUBBER - .3" ID X 1.3"OD W/.12" GROOVE - BLACK
	071015-30-000	EA	GROMMET - RUBBER - .31" ID X .81" OD W/.12" GROOVE - BLK
	071015-32-000	EA	GROMMET - RUBBER - .75" ID X 1.375" OD W/.187" GROOVE-BLK
	071015-33-000	EA	GROMMET - RUBBER - .875" ID X 1.625" OD W/.187" GROOVE - BLK
	071015-35-000	EA	GROMMET - 1.25 ID,FITS .187MAT
	071015-37-000	EA	GROMMET - .81 ID FITS .56 MTL
	071015-39-000	EA	GROMMET - .75 ID FITS .06 MTL
	088756-01-000	EA	GROMMET - WEB - 1 1/8 " I.D.
	114208-01-000	EA	GROMMET - EDGE LINER - FITS 1 3/4"
	114208-02-000	EA	GROMMET - EDGE LINER - FITS .625
	114208-03-000	EA	GROMMET - EDGE LINER - FITS 2.50"

SEALANTS & FASTENERS GROUP (CONTINUED)**CLAMPS, CLIPS, GROMMETS, RIVETS & PLUGS (CONTINUED)**

KEY	PART NUMBER	U/M	DESCRIPTION
	114208-04-000	EA	GROMMET - EDGE LINER - FITS 1.00"
	114208-05-000	EA	GROMMET - EDGE LINER - FITS 2"
	016188-03-000	EA	GROMMET - L/P LINE - 3/8" HOLE X 2 1/2" LONG - RUBBER
	016188-04-000	EA	GROMMET - GAS LINE - 1/2" HOLE X 2 1/2" LONG - RUBBER
	016188-05-000	EA	GROMMET - L/P LINE - 3/8" HOLE X 1 1/4" LONG - RUBBER
	008380-01-000	EA	GROMMET - RUBBER - 5/8" HOLE X 1 1/2" DIAMETER - BLACK
	008384-01-000	EA	GROMMET - SNAP - 3/4 DIAMETER - NYLON
	077953-01-000	EA	GROMMET - EDGE LINER - FITS 1"
	099637-01-000	EA	GROMMET - RUBBER - .37" X .94" DIAMETER - BLACK
	046867-05-000	EA	GROMMET - #0
	000F10-04-16B	EA	PIN - COTTER - 1/8" X 1" - ZINC
	000F10-06-32B	EA	PIN - COTTER - 3/16" X 2" - ZINC
	000H14-04-08R	EA	RIVET - MANDREL BLIND - 4/32 ALUMINUM
	000H14-06-03R	EA	RIVET - MANDREL BLIND - 3/16 - CHERRY
	000H15-06-02R	EA	RIVET - POP - STEEL - 3/16 X .063-.125
	000H16-06-10R	EA	RIVET - POP ALUMINUM - 3/16 X .501-.625
	000H14-04-04A	EA	RIVET - MANDREL BLIND - 1/8 X .400
	000H16-04-06R	EA	RIVET - POP ALUMINUM - 1/8 X .313 - .375
	000H14-06-14R	EA	RIVET - MANDREL BLIND - 3/16 - CHERRY
	118626-01-01A	EA	RIVET - POP - ALUMINUM 3/16 X .08-.375
	118626-02-01A	EA	RIVET - POP - ALUMINUM - 3/16 X .500-.750
	069529-02-000	EA	RIVET-T - POP - 1/4 X .093 - .156
	120560-01-01A	EA	RIVET - PLASTIC - 3/16 DIAMETER
	061420-01-000	EA	PLUG/PLASTIC - 1.75" DIAMETER - BROWN
	061420-03-000	EA	PLUG/PLASTIC - 3.00" DIAMETER
	061420-04-000	EA	PLUG/PLASTIC - 1.25" DIAMETER
	061420-05-000	EA	PLUG/PLASTIC - 1.8" DIAMETER
	061420-07-000	EA	PLUG/PLASTIC - 1.8" DIAMETER
	061420-08-000	EA	PLUG/PLASTIC - 2.5" DIAMETER
	061420-09-000	EA	PLUG/PLASTIC - 1.00" - DIAMETER
	061420-10-000	EA	PLUG/PLASTIC - 1.50" DIAMETER - BLACK
	061420-11-000	EA	PLUG/PLASTIC - .50" DIAMETER
	061420-12-000	EA	PLUG/PLASTIC - 1.50" DIAMETER - RED
	061420-14-000	EA	PLUG/PLASTIC - .034" DIAMETER
	061420-15-000	EA	PLUG/PLASTIC - 2" DIAMETER - BLACK
	061420-16-000	EA	PLUG/PLASTIC - 2 1/8" DIAMETER
	081211-03-000	EA	PLUG/PLASTIC - .50 DIAMETER - BLACK
	081211-04-000	EA	PLUG/PLASTIC - .46 DIAMETER - BLACK
	081211-05-000	EA	PLUG/PLASTIC - .188 DIAMETER - NATURAL
	034141-02-000	EA	PLUG/HOLE - 3/8" NYLON/BLACK
	115361-01-01A	EA	PLUG/PLASTIC - 1/2" DIAMETER
	075312-02-000	EA	CLIP - U - .75 LONG X .50 WIDE- F/1/8"-3/16" THICK MATERIAL
	077955-01-000	EA	CLIP - J - VINYL COATED - 3/8"
	080211-03-000	EA	CLIP - X-MAS TREE W/PANEL RETAINING HEAD - 3/4" SHANK
	094362-02-000	EA	CLIP - X-MAS TREE - BINDER HEAD - .9" LONG
	119392-01-000	EA	CLIP - U TYPE - OFFSET LEG
	129962-01-01A	EA	CLIP - U-TYPE - BLACK
	091952-01-000	EA	CLIP - GRIPPER - 1"
	091952-02-000	EA	CLIP - GRIPPER - 3/4"
	080734-02-000	EA	CLIP - WIRE NYLON
	056134-01-000	EA	HOLDER - RING - 3.6" DIAMETER - METAL
	056134-02-000	EA	HOLDER - RING - 1.8" DIAMETER - METAL

SEALANTS & FASTENERS GROUP (CONTINUED)

MISCELLANEOUS FASTENERS

KEY	PART NUMBER	U/M	DESCRIPTION
	008343-01-000	EA	TIE - WIRE - 6"
	008343-02-000	EA	TIE - WIRE - 14"
	008343-03-000	EA	TIE - WIRE - 7 1/2" - BLACK
	029096-03-000	YD	VELCRO TAPE - HOOK - 1" WIDE - BLACK
	029096-04-000	YD	TAPE - HOOK - VELCRO - 1" WIDE - BLACK
	029094-04-000	YD	VELCRO TAPE - LOOP - 1" WIDE - BLACK
	029094-06-000	YD	VELCRO TAPE - LOOP - 2" WIDE - BLACK
	048394-02-000	YD	VELCRO TAPE - HOOK - ADHESIVE BACK - .75" WIDE - BEIGE
	085774-01-000	FT	FASTENER - DUAL LOCK - 1" WIDE - ADHESIVE BACK - BLACK
	085774-02-000	FT	FASTENER - DUAL HOOK - 1" WIDE - ADHESIVE BACK - BLACK
	085774-03-000	FT	FASTENER - DUAL HOOK - 1/2" WIDE - ADHESIVE BACK - BLACK
	085774-04-000	FT	FASTENER - DUAL HOOK - 1/2" WIDE - ADHESIVE BACK - BLACK
	088792-02-000	YD	VELCRO TAPE - LOOP - 3/4" - ADHESIVE BACKED - BEIGE
	088792-04-000	YD	VELCRO TAPE - LOOP - 5/8" - NON-ADHESIVE BACK - WHITE
	088792-05-000	YD	VELCRO TAPE - LOOP - 5/8" - NON-ADHESIVE BACKED - WHITE
	088792-06-000	YD	VELCRO TAPE - LOOP - 3/4" - NON-ADHESIVE BACKED - BUFF
	108046-01-000	EA	CABLE TIE - SCREW MOUNT 8"
	108046-02-000	EA	CABLE TIE - SCREW MOUNT 15"
	110943-01-000	FT	FELTSTRIP - 3/8" - ADHESIVE BACK
	110943-02-000	FT	FELTSTRIP - 3/8" - ADHESIVE BACK - WHITE
	099856-11-000	EA	STRAP - TIEDOWN - 78.6"
	086285-01-000	EA	SPACER - NYLON - .5" OD X .257" ID

WATER & SEWAGE GROUP DRAINAGE SYSTEM

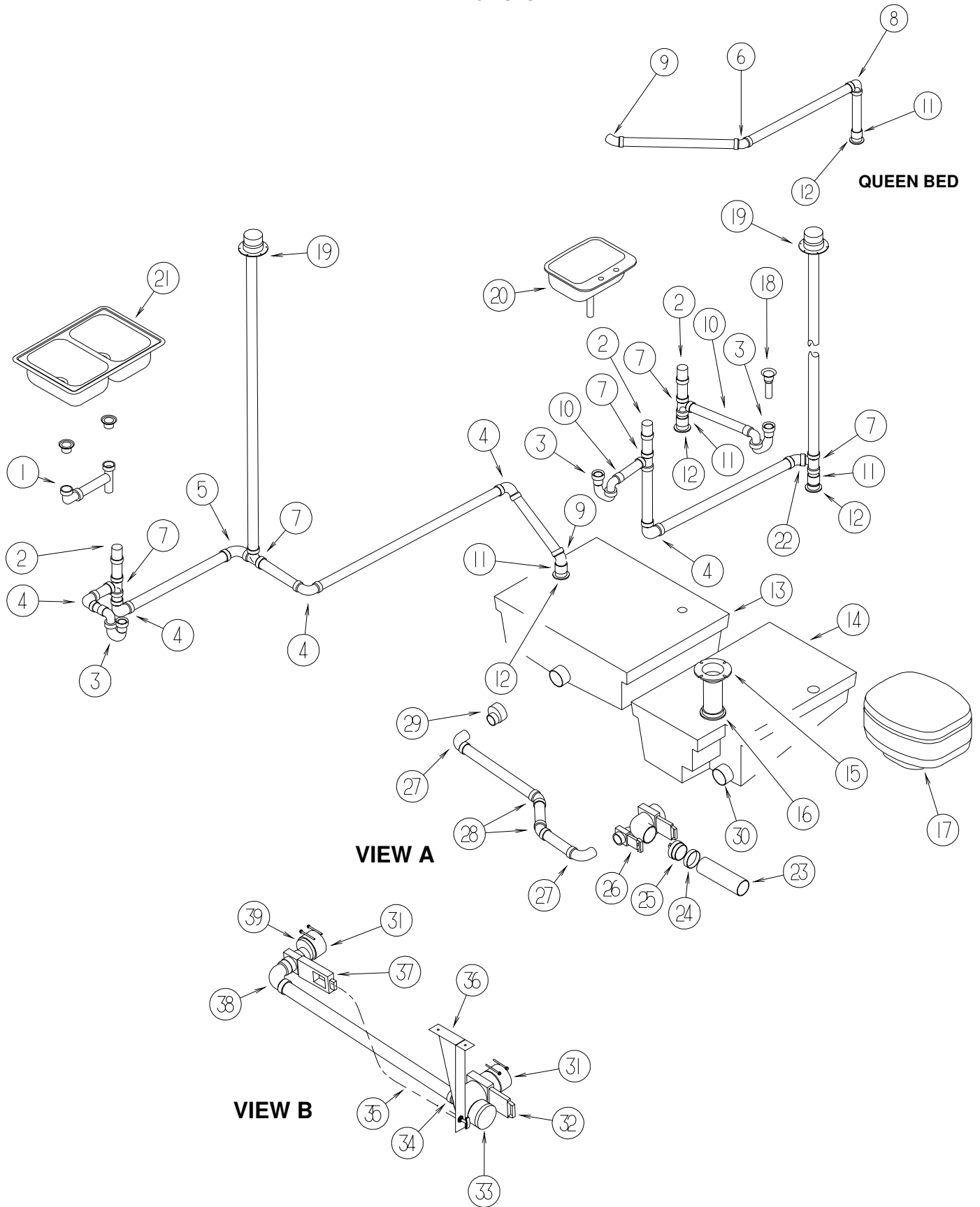

WATER & SEWAGE GROUP (CONTINUED)
DRAINAGE SYSTEM (CONTINUED)

KEY	PART NUMBER	U/M	DESCRIPTION
1	011091-02-000	EA	WASTE - CONTINUOUS - DOUBLE SINK
2	079968-01-000	EA	VENT - MECHANICAL/TRAP ARM - ANTI-SIPHON-2" X 7.3" PLASTIC
3	107538-01-000	EA	P TRAP - PLASTIC - 1 1/4" W/EXTENSION ARM
3	011071-01-000	EA	P-TRAP - PLASTIC - 1 1/2" - CSA
4	010008-01-000	EA	ELBOW - 90 DEGREE - 1 1/2" HUB X HUB - PLASTIC
5	033761-01-000	EA	ELBOW - TURN - 90 DEGREE 1 1/2" HUB X 1 1/2" SPIGOT
6	010006-01-000	EA	ELBOW - 45 DEGREE - 1 1/2" HUB X HUB - PLASTIC
7	010071-01-000	EA	TEE - SANITARY - 1 1/2" HUB X HUB X HUB - PLASTIC
8	034250-01-000	EA	ELBOW - 90 DEGREE - LONG TURN - 1 1/2" HUB X HUB - ABS
9	010051-01-000	EA	ELBOW - 45 DEGREE - 1 1/2" SPIGOT & HUB - PLASTIC
10	109571-01-000	EA	ADAPTER - P TRAP - 1 1/2"P X 1 1/4"MPT
11	010115-01-000	EA	COUPLING - 1 1/2" HUB X HUB - PLASTIC
12	061607-01-000	EA	GROMMET - HOLDING TANK - 1 1/2" NPS
13	074861-01-000	EA	TANK - HOLDING - W/O GROMMETS - 35 GALLON - 35"X 11"X 27"
14	074870-01-000	EA	TANK - HOLDING - W/O GROMMETS - 30 GALLON-36.5"X13.3"X23"
15	116644-01-000	EA	FLANGE/CLOSET - 4 BOLT X 3" FEMALE
16	061607-02-000	EA	GROMMET - HOLDING TANK - 3" NPS
17*	067487-03-000	EA	TOILET - LOW - HANDFLUSH - SOFT WHITE
18	066440-01-000	EA	STRAINER - SHOWER DRAIN - W/RUBBER WASHER
	127440-02-01A	EA	WASHER - RUBBER - 1.8" X .1"
	130403-01-000	EA	NUT - SLIP - W/WINGS 1 1/2"
19	083558-03-000	EA	VENT - PLUMBING - ROOF PIPE COVERED - OFF WHITE
20	096927-01-02A	EA	SINK - LAVATORY - RECTANGLE - SOFT WHITE
21	104113-01-000	EA	SINK - DOUBLE - STAINLESS STEEL
	092303-01-000	EA	STRAINER - SINK
22	010051-01-000	EA	ELBOW - 45 DEGREE - 1 1/2" SPIGOT & HUB - PLASTIC
22	034250-01-000	EA	ELBOW - 90 DEGREE - LONG TURN - 1 1/2" HUB X HUB - ABS

***COMPONENT PARTS FOUND IN SERVICE PARTS LIBRARY**

VIEW A - W/O HOLDING TANK HEATING PADS - FROM: 00-00-00 THRU: 08-30-99

KEY	PART NUMBER	U/M	DESCRIPTION
23	010201-01-000	EA	HOSE - SEWER - 3" ID X 8'
24	062401-05-000	EA	CLAMP - HOSE - WORMGEAR - 2" - 3" ID
25	062416-01-000	EA	ADAPTER - SEWER HOSE TO 3" PIPE
26*	070916-01-000	EA	VALVE - DUAL DUMP - W/CAP - 3" X 1 1/2"
27	033761-01-000	EA	ELBOW - TURN - 90 DEGREE 1 1/2" HUB X 1 1/2" SPIGOT
28	010006-01-000	EA	ELBOW - 45 DEGREE - 1 1/2" HUB X HUB - PLASTIC
29	062422-01-000	EA	ADAPTER - OFFSET REDUCER - 3" X 1 1/2" - PLASTIC
30	078406-01-000	EA	COUPLER - RUBBER - W/CLAMPS - 3" X 3"

***COMPONENT PARTS FOUND IN SERVICE PARTS LIBRARY**

VIEW B - W/HOLDING TANK HEATING PADS - FROM: 08-31-99 THRU: 99-99-99

KEY	PART NUMBER	U/M	DESCRIPTION
31	078406-01-000	EA	COUPLER - RUBBER - W/CLAMPS - 3" X 3"
32	072346-01-000	EA	VALVE ASM - 3" SLIP X 3" BAYONET W/CAP X 2" SOCKET-ABS
33	109450-01-000	EA	ADAPTER - SEWER HOSE - PLASTIC
34	010123-01-000	EA	BUSHING - 2" X 1 1/2" HUB - PLASTIC
35	062421-05-000	EA	CABLE - DUMP VALVE W/HANDLE - 48"
36	076827-02-000	EA	BRACKET - 2.9" X 1.8" - TRIANGLE
37	062421-03-000	EA	VALVE - DUMP - 1 1/2" HUB X 1 1/2" HUB - REMOTE
38	010008-01-000	EA	ELBOW - 90 DEGREE - 1 1/2" HUB X HUB - PLASTIC
39	062422-01-000	EA	ADAPTER - OFFSET REDUCER - 3" X 1 1/2" - PLASTIC
	133972-01-000	EA	PAD - HEATER - HOLDING TANK - 40 GALLON
	079364-08-000	EA	SWITCH - ON/OFF LIGHTED - GREEN

WATER & SEWAGE GROUP (CONTINUED)
WATER SYSTEM

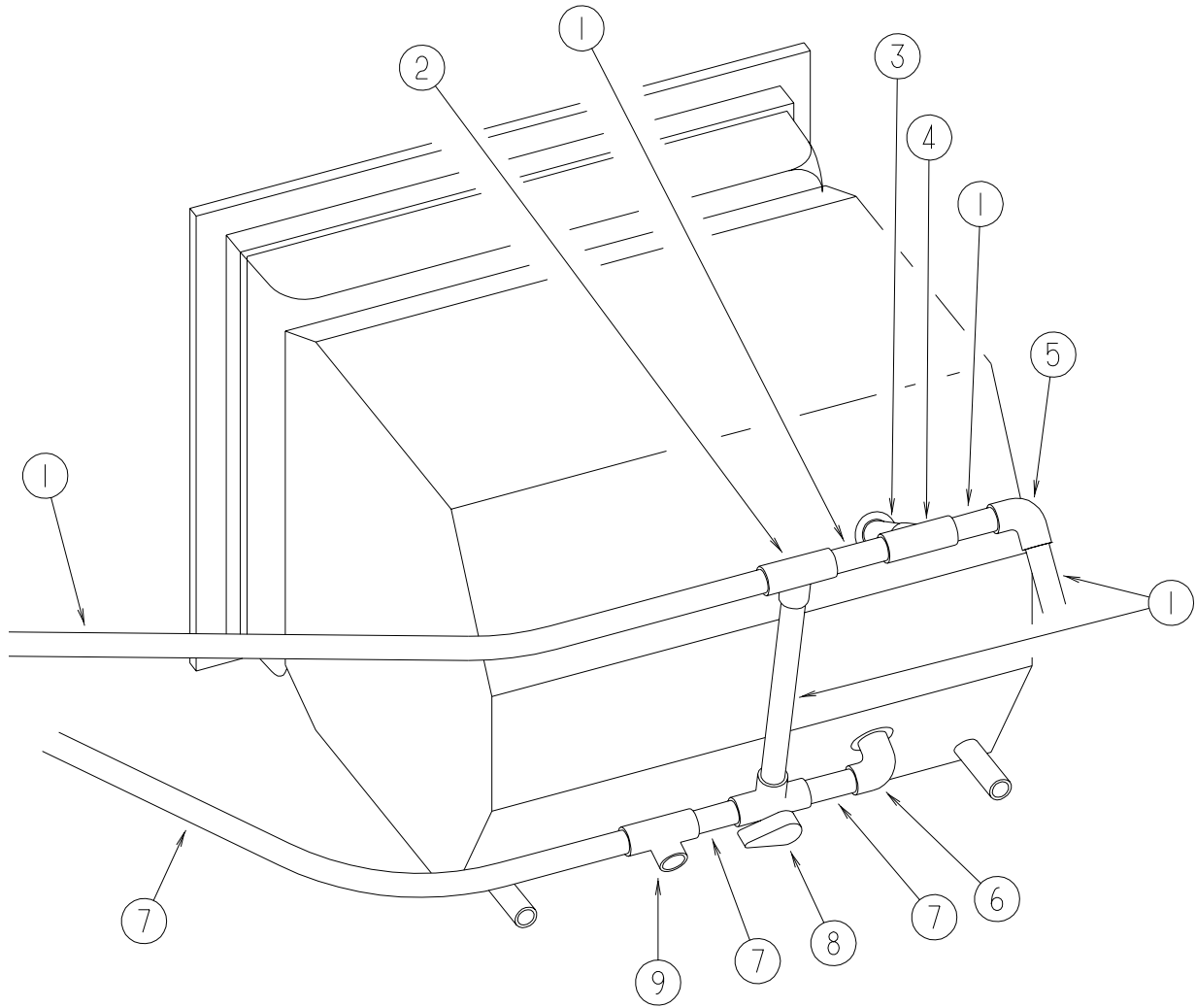

WATER HEATER BYPASS

KEY	PART NUMBER	U/M	DESCRIPTION
1	124188-02-000	FT	TUBING - PEX - 1/2" ID X 20' - RED(HOT)
2	114428-01-000	EA	TEE - 1/2"P X 1/2"P X 1/2"P
3	110438-02-000	EA	VALVE - CHECK - BRASS - 1/2 MPT X 1/2 MPT
4	114428-01-000	EA	TEE - 1/2"P X 1/2"P X 1/2"P
5	114429-01-000	EA	ELBOW - 1/2"P X 1/2"P
6	114429-02-000	EA	ELBOW - 1/2"P X 1/2"MPT
7	124188-01-000	FT	TUBING - PEX - 1/2" ID X 20' - BLUE(COLD)
8	114431-02-000	EA	VALVE - WATER BYPASS - 1/2"P - THREE WAY (WATER HEATER)
9	114428-03-000	EA	TEE - 1/2"P X 1/2"P X 1/2"MPT

WATER & SEWAGE GROUP (CONTINUED)
WATER SYSTEM (CONTINUED)

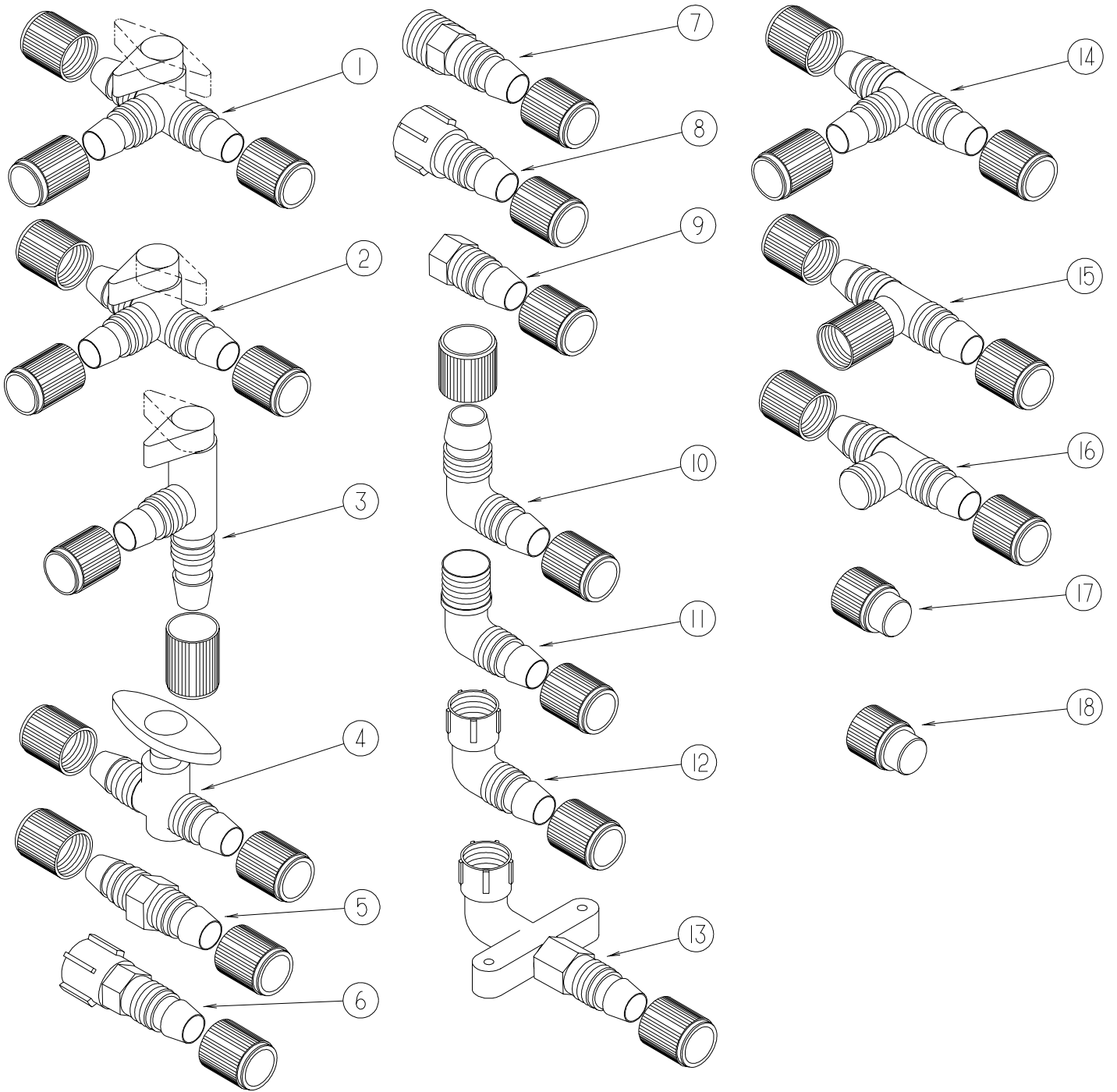

FITTINGS

WATER & SEWAGE GROUP (CONTINUED)

WATER SYSTEM (CONTINUED)

FITTINGS (CONTINUED)

KEY	PART NUMBER	U/M	DESCRIPTION
1	114431-01-000	EA	VALVE - 180 DEGREE/CENTER DRAIN - 1/2"P - THREE WAY
2	114431-02-000	EA	VALVE - WATER BYPASS - 1/2"P - THREE WAY (WATER HEATER)
3	114431-03-000	EA	VALVE - 90 DEGREE DRAIN - 1/2"P
4	114431-04-000	EA	VALVE - "INLINE SHUT-OFF" - 1/2"P
5	114430-01-000	EA	ADAPTER - 1/2"P X 1/2"P
6	114430-02-000	EA	ADAPTER - SWIVEL - 1/2"P X 1/2"FPT
7	114430-03-000	EA	ADAPTER - 1/2"P X 1/2"MPT
8	114427-02-000	EA	PLUG - W/COMP NUT - 1/2" PLASTIC PIPE/1/2" FLAIR-IT
9	114430-06-000	EA	ADAPTER - 1/2"P X 3/8"FPT
10	114429-01-000	EA	ELBOW - 1/2"P X 1/2"P
11	114429-02-000	EA	ELBOW - 1/2"P X 1/2"MPT
11	114429-04-000	EA	ELBOW - 1/2"P X 3/8"MPT
11	114429-05-000	EA	ELBOW - 1/2"P X 3/4"MPT
12	114429-03-000	EA	ELBOW - SWIVEL - 1/2"P X 1/2"FPT
12	114429-06-000	EA	ELBOW - SWIVEL - 1/2"P X 3/4"FPT
12	114429-08-000	EA	ELBOW - SWIVEL - 1/2"MPT X 1/2"FPT SWIVEL
13	114429-07-000	EA	ELBOW - 1/2"P X 1/2"FPT
14	114428-01-000	EA	TEE - 1/2"P X 1/2"P X 1/2"P
15	114428-02-000	EA	TEE - SWIVEL - 1/2"P X 1/2"P X 1/2"FPT
16	114428-03-000	EA	TEE - 1/2"P X 1/2"P X 1/2"MPT
17	113697-01-000	EA	CAP - 3/8 FTG
18	114427-01-000	EA	CAP - 1/2" - FOR CAPPING FLAIR-IT MALE FITTINGS

WATER & SEWAGE GROUP (CONTINUED)
WATER SYSTEM (CONTINUED)

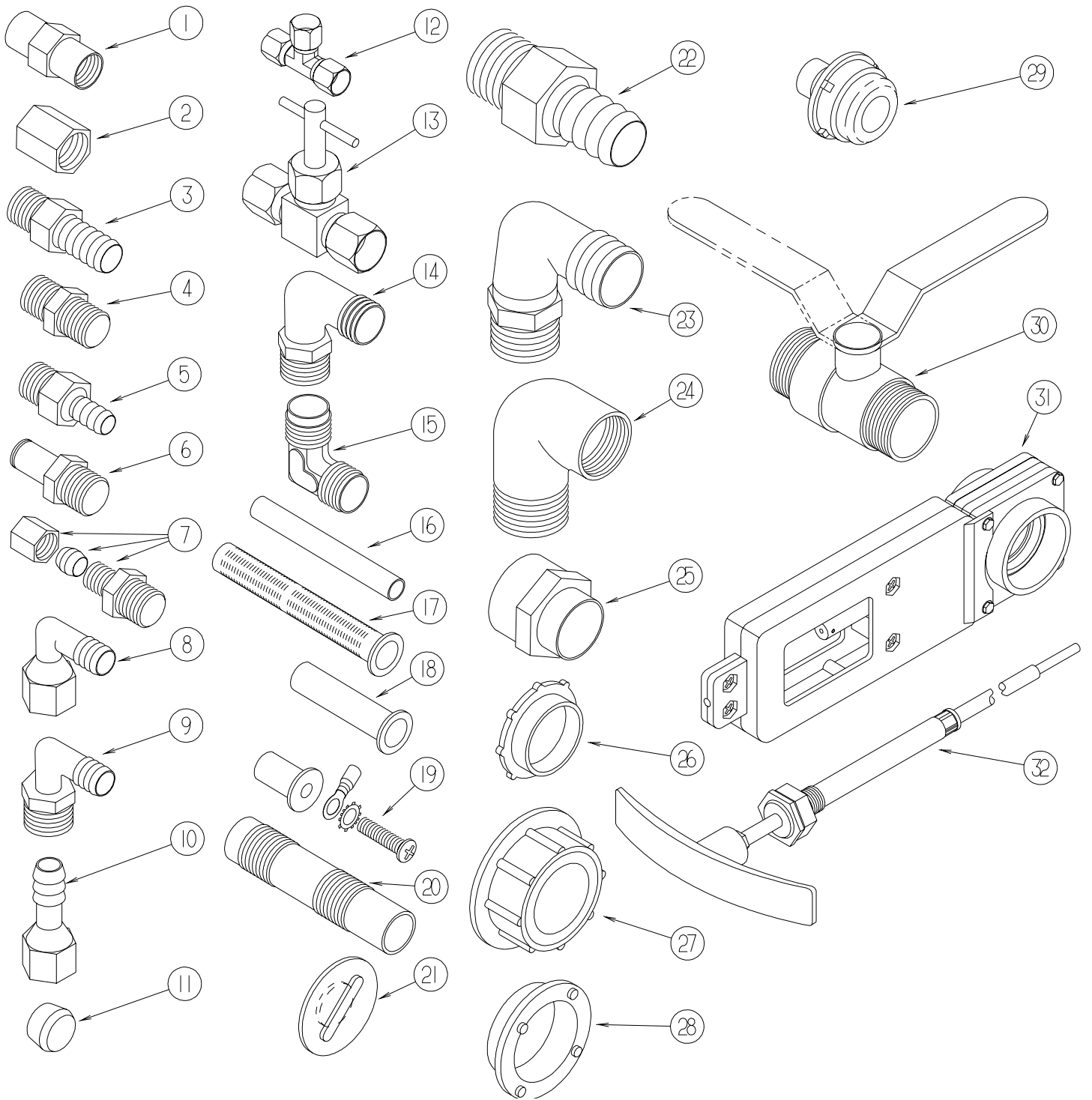

FITTINGS (CONTINUED)

WATER & SEWAGE GROUP (CONTINUED)**WATER SYSTEM (CONTINUED)****FITTINGS (CONTINUED)**

KEY	PART NUMBER	U/M	DESCRIPTION
1	132148-01-000	EA	CONNECTOR - 1/2" X 1/2" MPT - BRASS
2	101814-01-000	EA	COUPLING - FEMALE - 1/2" X 1/2" FPT - GRAY
3	118809-02-000	EA	ADAPTER - 1/2" MPT X 1/2" BARB - PLASTIC
4	110438-02-000	EA	VALVE - CHECK - BRASS - 1/2 MPT X 1/2 MPT
5	010224-01-000	EA	ADAPTER - HOSE TO PIPE - 3/8 MPT X 3/8 BARB - PLASTIC
6	090338-03-000	EA	FITTING - HOSE - .75"ID - 2" LENGTH - BRASS
7	103798-01-000	EA	CONNECTOR - 1/4 OD X 3/8 MPT
8	123150-01-000	EA	ELBOW - 1/2 FPT X 1/2 BARB - SWIVEL
9	035539-01-000	EA	ELBOW - PLASTIC - 3/8 MPT X 3/8 BARB
10	123152-01-000	EA	ADAPTER - 1/2 FPT X 1/2 BARB - SWIVEL
11	111888-01-000	EA	FERRULE - PLASTIC - .250 ID X .375 OD
12	118423-01-000	EA	FITTING - BRASS-TEE - 1/4C X 1/4C X 1/4C
13	120868-01-000	EA	VALVE - NEEDLE - 1/4" COMPRESSION X 1/4" COMPRESSION
14	111223-02-000	EA	ELBOW - PLASTIC - 1/2MPT X 3/8 BARB
14	111223-03-000	EA	ELBOW - 3/4" MPT X 1/2" BARB - PLASTIC
14	111223-04-000	EA	ELBOW - 1/2" MPT X 1/2" BARB - PLASTIC
15	039808-03-000	EA	ELBOW - 1/2" MPT X 1/2" MPT - PLASTIC
16	124188-01-000	FT	TUBING - PEX - 1/2" ID X 20' - BLUE(COLD)
16	124188-02-000	FT	TUBING - PEX - 1/2" ID X 20' - RED(HOT)
16	112176-01-000	FT	TUBING - VINYL - REINFORCED - 1/2" ID
16	074462-02-000	FT	TUBING - VINYL - 3/8 ID X 20' - CLEAR
16	039800-04-000	FT	TUBING - POLYBUTYL - 1/4"OD
17	077954-02-000	EA	FILTER - WATER TANK - W/SCREEN IN TANK
18	111888-02-000	EA	INSERT - BRASS - 1/4 COMP
19	039861-01-000	EA	SENDING UNIT - W/SCREW - WASHER - WELL NUT/TERMINAL RING
20	079381-01-000	FT	TUBING - RIBBED FLEXIBLE - WATER FILL - 1.4" I.D.
21	049032-01-000	EA	PATCH - SPINWELD - 3/8" - PLASTIC
22	044927-01-000	EA	ADAPTER - HOSE TO PIPE-1 1/4 MPTX1 1/4 BARB-BLACK PLASTIC
23	010219-01-000	EA	ELBOW - 1 1/4 MPT X 1 1/4 BARB - WATER FILL - PLASTIC
24	132484-01-000	EA	ELBOW - PLASTIC - 90 DEGREE - 1MPT X 1FPT
25	133835-01-000	EA	ADAPTER - REDUCING - 1 1/2" X 1 1/4"
26	120069-01-000	EA	PLUG - 3" - POLYETHYLENE MPT
27	042989-03-000	EA	FITTING - SPINWELD - 1 1/4"NPT - PLASTIC
27	042989-04-000	EA	FITTING - SPINWELD - 3/8"FPT - PLASTIC
27	042989-05-000	EA	FITTING - SPINWELD - 1/2"FPT - PLASTIC
27	042989-07-000	EA	FITTING - SPINWELD - 1 1/2"FPT - PLASTIC
27	042989-08-000	EA	FITTING - SPINWELD - 1"FPT - PLASTIC
28	120070-01-000	EA	FITTING - SPINWELD - PLASTIC 3" FPT
29	114966-01-000	EA	FILTER - IN LINE - TWIST ON - 1/2"
30	132483-01-000	EA	VALVE - BALL - 1" - THREADED ENDS
31	062421-03-000	EA	VALVE - DUMP - 1 1/2" HUB X 1 1/2" HUB - REMOTE
32	062421-04-000	EA	CABLE - DUMP VALVE W/HANDLE - 36"
32	062421-05-000	EA	CABLE - DUMP VALVE W/HANDLE - 48"
32	062421-06-000	EA	CABLE - DUMP VALVE W/HANDLE - 144"

WATER & SEWAGE GROUP (CONTINUED)
WATER SYSTEM (CONTINUED)

KEY	PART NUMBER	U/M	DESCRIPTION
	127281-03-000	EA	TANK - WATER - 40 GALLON - W/FITTINGS - REAR DINETTE
	127281-01-000	EA	TANK - WATER - 40 GALLON - W/O FITTINGS - REAR DINETTE
	122778-01-000	EA	TANK - WATER - 40 GALLON - W/O FITTINGS - QUEEN BED
	122778-04-000	EA	TANK - WATER - 40 GALLON - W/FITTINGS - QUEEN BED
*	051391-03-000	EA	WATER HEATER G6A-8E ELECTRONIC IGNITION
	097967-01-000	EA	SWITCH - WATER HEATER - REMOTE W/LIGHT
	052009-06-000	EA	DOOR - WATER HEATER - BRIGHT WHITE - 18" X 14.6"
*	098607-01-000	EA	PUMP - WATER - W/.5" MPT FITTING - FLOW 2.8 GPM
	075241-04-000	EA	FAUCET/SHOWER - BRASS
	075606-03-000	EA	PANEL - FAUCET SHOWER - SOFT WHITE
	075240-05-000	EA	FAUCET - LAVATORY - BRASS
	091253-01-000	EA	GASKET - FAUCET - LAVATORY/GALLEY
	104114-02-01A	EA	FAUCET - GALLEY - SINGLE CONTROL
	081240-20-000	EA	WATER FILL W/DOOR - W/O LOCK - BRIGHT WHITE

***COMPONENT PARTS FOUND IN SERVICE PARTS LIBRARY**

SERVICE CENTER

KEY	PART NUMBER	U/M	DESCRIPTION
	075241-06-000	EA	FAUCET/SHOWER - BRIGHT WHITE - 1/2"MPT X 1.9" INLET PIPES
	131383-01-02A	EA	SHOWER HEAD - W/60" HOSE & BRACKET - WHITE
	131383-02-02A	EA	SHOWER HEAD - W/60" HOSE & BRACKET - WHITE - CSA
	131383-03-02A	EA	BRACKET - SHOWER HEAD - WHITE
	091952-02-000	EA	CLIP - GRIPPER - 3/4"
	081994-02-000	EA	PLATE - SWITCH - EXTERIOR SHOWER
	108356-02-01A	EA	COVER/ACTUATOR SWITCH - 2 ROWS DIMPLES- CONTURA II - BLACK
	108357-08-000	EA	SWITCH - ROCKER DPDT - ON/NONE/ON - 6 TERMINAL
	114293-01-02A	EA	PAN - DRIP - EXTERIOR - BRIGHT WHITE
	114428-01-000	EA	TEE - 1/2"P X 1/2"P X 1/2"P
	114429-08-000	EA	ELBOW - SWIVEL - 1/2"MPT X 1/2"FPT
	124188-01-000	FT	TUBING - PEX - 1/2" ID X 20' - BLUE(COLD)
	124188-02-000	FT	TUBING - PEX - 1/2" ID X 20' - RED(HOT)

WINDOW & VENTS GROUP

WINDOW & VENT LAYOUT

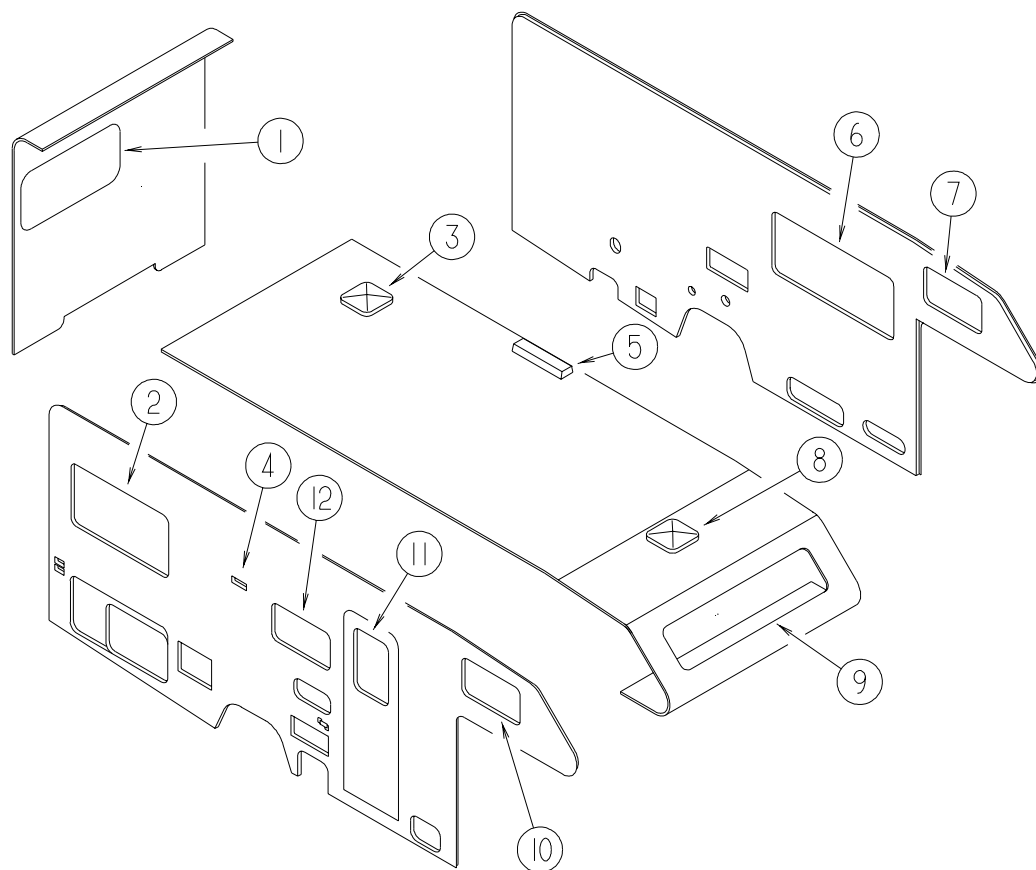

KEY	PART NUMBER	U/M	DESCRIPTION
1	078528-07-F15	EA	WINDOW - ESCAPE W/O INSIDE TRIM - CLEAR - 24.5" X 48.5"
	002282-09-000	EA	WEATHERSTRIP - WINDOW - .125" X 130.5" - BLACK
	002285-01-000	FT	FILLER - WEATHERSTRIP - RUBBER - BLACK
	076337-13-000	EA	GLASS - EGRESS - 45.5" X 21.5"
	074816-16-000	EA	FRAME - WINDOW - INSIDE ESCAPE - BLACK
1	113502-01-02A	EA	WINDOW - REAR/CENTER ESCAPE - THERMO - 24.8" X 48.7"
2*	098647-38-02A	EA	WINDOW - PASS HORIZ SLIDER W/TRIM - TINTED - 30.5" X 57.5"
2*	112795-22-02A	EA	WINDOW - PASSENGER HORIZ SLIDER - THERMO - 26.1" X 47.8"
3*	122882-02-01A	EA	VENT - ROOF - W/FAN - W/O INSIDE GARNISH - UL
	009440-01-000	EA	GEAR/ARM - LIFT - ROOF VENT COVER
	048648-01-000	EA	MOTOR - ROOF VENT - 1/8 SHAFT - 12VOLT
	048649-01-000	EA	FAN BLADE - ROOF VENT - 6 BLADES - 6"
	122882-07-01A	EA	GARNISH - ROOF VENT - 2.5" TO 4"
3*	122882-03-01A	EA	VENT - ROOF - W/FAN - W/O INSIDE GARNISH - CSA
	009440-01-000	EA	GEAR/ARM - LIFT - ROOF VENT COVER
	048648-01-000	EA	MOTOR - ROOF VENT - 1/8 SHAFT - 12VOLT
	048649-01-000	EA	FAN BLADE - ROOF VENT - 6 BLADES - 6"
	122882-07-01A	EA	GARNISH - ROOF VENT - 2.5" TO 4"
4	084878-09-000	EA	VENT - EXHAUST/RANGE HOOD - OFF WHITE
	084616-07-000	EA	SHROUD - EXHAUST VENT/RANGE HOOD - BRIGHT WHITE
5	084073-07-000	EA	VENT - ROOF/REFRIGERATOR - BRIGHT WHITE - NORCOLD
	084073-04-000	EA	BASE - ROOF VENT/REFRIGERATOR - BLACK - NORCOLD
6*	098647-28-02A	EA	WINDOW - DRIVER HORIZ SLIDER W/TRIM-CLEAR- 26.1" X 59.7"
6*	112795-15-02A	EA	WINDOW - DRIVER HORIZONTAL SLIDER - THERMO - 26.4 X 60"
7*	098647-32-02A	EA	WINDOW - DRIVER HORIZ SLIDER W/TRIM - CLEAR - 15.7"X 28.5"
7*	112795-20-02A	EA	WINDOW - DRIVER HORIZONTAL SLIDER - THERMO - 15" X 28.7"

*COMPONENT PARTS FOUND IN SERVICE PARTS LIBRARY

WINDOW & VENTS GROUP (CONTINUED)

WINDOW & VENT LAYOUT (CONTINUED)

KEY	PART NUMBER	U/M	DESCRIPTION
8*	122882-01-01A	EA	VENT - ROOF - NONPOWERED - W/O INSIDE GARNISH
	009440-01-000	EA	GEAR/ARM - LIFT - ROOF VENT COVER
	122882-06-01A	EA	GARNISH - ROOF VENT - 1" TO 2.5"
9	103313-03-F15	EA	WINDOW - PICTURE - 16.3" X 71.1" (INSIDE FRAME #117054)
	002181-29-000	EA	GLASS - PICTURE WINDOW - 71"W X 16.2"H - TINTED
	099154-01-000	FT	CHANNEL - GLAZING - STATIONARY GLASS - .62" X .45" - BLK
	117054-01-02A	EA	RETAINER - TRIM - BLACK
9*	115630-01-02A	EA	WINDOW - STATIONARY/THERMOPANE- BLACK I/S TRIM-17.2" X 72"
10*	112795-19-02A	EA	WINDOW - PASSENGER HORIZ SLIDER - THERMO - 15.7" X 28.5"
10*	098647-31-02A	EA	WINDOW - PASS HORIZ SLIDER W/TRIM - CLEAR - 15.7" X 28.5"
11	117053-04-FB1	EA	WINDOW - PICTURE - CLEAR - 17" X 26.4" - W/O RETAINER
	002181-27-000	EA	GLASS - PICTURE WINDOW - 25.8"W X 16.4"H - CLEAR
	087561-01-000	FT	SEAL - GLASS - EXTERIOR - .5" WIDE - VINYL BLACK
	117054-02-02A	EA	RETAINER - TRIM - BRIGHT WHITE
11*	113733-01-01A	EA	WINDOW - STATIONARY THERMOPANE - 17"W X 26.4"H
12*	112795-19-02A	EA	WINDOW - PASSENGER HORIZ SLIDER - THERMO - 15.7" X 28.5"
12*	098647-31-02A	EA	WINDOW - PASS HORIZ SLIDER W/TRIM - CLEAR - 15.7" X 28.5"

*COMPONENT PARTS FOUND IN SERVICE PARTS LIBRARY