

# 2000 IC327P

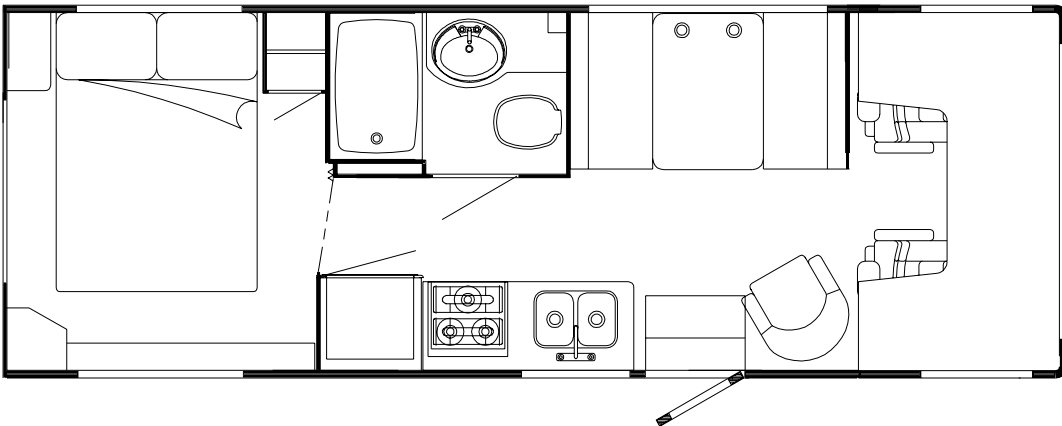
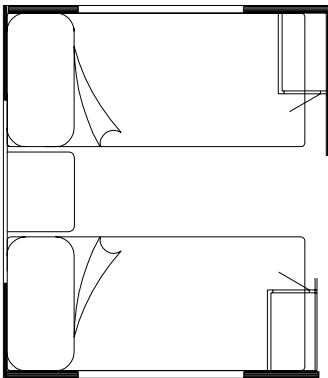
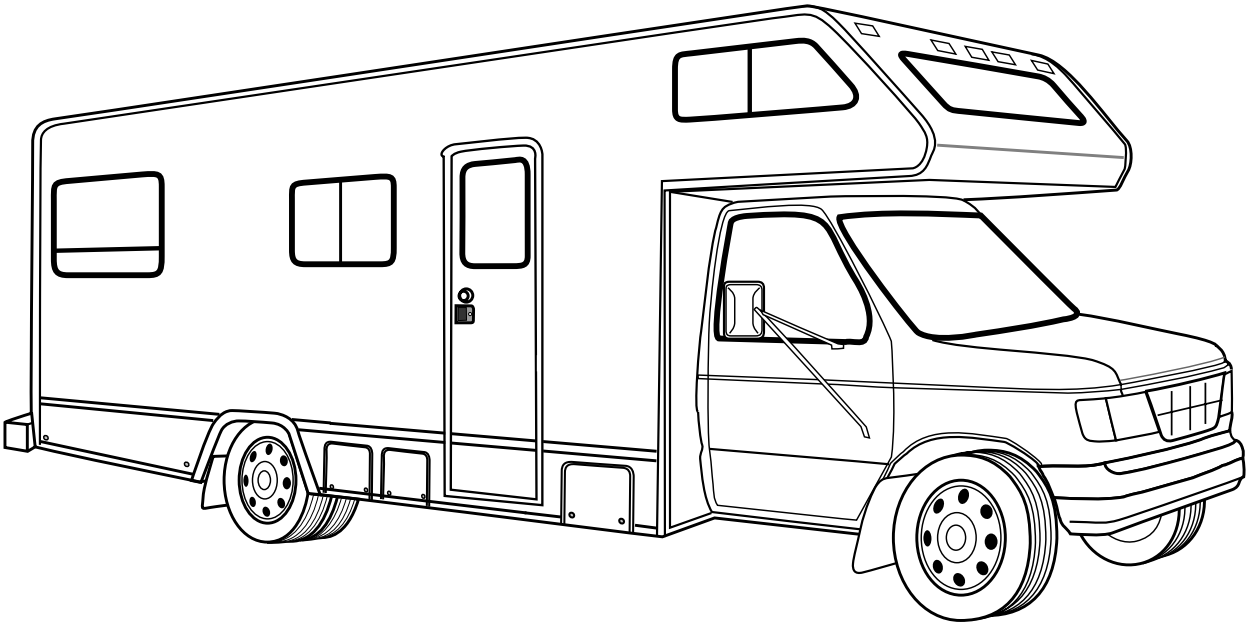

FLOORPLAN

**2000**  
**IC327P**

**SPIRIT**  
**300 SERIES**

**WATERFORD OAK**

**L04 MEADOWBROOK (TEAL)**

**L05 BLUEBONNET (BLUE)**

**L06 RIVERWALK (TAUPE)**

# CONTENTS

<b>FLOORPLAN</b> .....	<b>2</b>
<b>ACCESSORIES GROUP</b> .....	<b>6</b>
OPERATORS MANUAL .....	6
<b>APPLIANCE GROUP</b> .....	<b>7</b>
APPLIANCES .....	7
<b>AUDIO VIDEO GROUP</b> .....	<b>8</b>
RADIO SYSTEM .....	8
TV & VCR .....	8
EXTERIOR ENTERTAINMENT .....	8
<b>BATH GROUP</b> .....	<b>9</b>
CABINETS .....	9
SHOWER .....	10
<b>BEDROOM GROUP</b> .....	<b>11</b>
TWIN CABINETS .....	11
DOUBLE BED CABINETS .....	12
RADIO & TV CABINETS .....	14
<b>CHASSIS GROUP</b> .....	<b>15</b>
FRAME .....	15
DRIVETRAIN .....	15
EXHAUST .....	16
HITCH .....	17
REAR BUMPER .....	17
FUEL FILL .....	18
SPARE TIRE INSTALLATION .....	19
WHEEL, TIRE, COVERS & LINERS .....	19
<b>CURTAIN &amp; CUSHION GROUP</b> .....	<b>20</b>
NOTICE .....	20
CUSHION LAYOUT .....	21
BUCKET SEATS .....	22
LOUNGE CHAIR .....	24
WINDOW TREATMENT .....	25
HARDWARE .....	27
ACCESSORIES .....	29
FABRICS .....	30
<b>DINETTE GROUP</b> .....	<b>31</b>
CABINETS .....	31
TABLE .....	32
<b>DRIVERS COMPARTMENT GROUP</b> .....	<b>33</b>
INSTRUMENT PANEL .....	33
FRONT INTERIOR .....	34
CABINETS .....	36
<b>ELECTRICAL GROUP</b> .....	<b>37</b>
LIGHTS .....	37
CIRCUIT BREAKERS & FUSES .....	40
CONVERTER, INVERTER, LOAD CENTERS .....	40
RECEPTACLES .....	41
SWITCHES .....	43
BOXES & CORDS .....	45
WIRE ASSEMBLIES .....	45
CONNECTORS & CONDUIT .....	45
BOOTS, SOLENOIDS, RELAYS & MISCELLANEOUS .....	46

# CONTENTS (CONTINUED)

<b>EXTERIOR BODY GROUP</b> .....	<b>47</b>
GRAPHICS & PAINT .....	47
PANELS .....	49
TRIMS .....	51
LADDER .....	52
RUNNING BOARDS .....	52
MIRRORS .....	52
BODY PANEL COMPONENTS .....	52
AWNINGS .....	52
<b>EXTERIOR DOORS &amp; COMPARTMENTS GROUP</b> .....	<b>53</b>
DOOR & COMPARTMENT LAYOUT .....	53
COMPARTMENT DOOR COMPONENTS .....	54
ENTRY DOOR .....	57
SCREEN DOOR .....	59
LATCH - ENTRY DOOR .....	60
<b>GALLEY GROUP</b> .....	<b>61</b>
CABINETS .....	61
<b>GENERATOR GROUP</b> .....	<b>62</b>
GAS .....	62
LPG .....	62
<b>HEATING &amp; A/C GROUP</b> .....	<b>63</b>
FURNACE .....	63
ROOF .....	63
<b>INTERIOR FINISH GROUP</b> .....	<b>64</b>
MOLDINGS & TRIMS .....	64
PANELING, LAMINATES, BATT & EDGE BAND .....	68
ACCESSORIES .....	68
FLOOR COVERINGS .....	68
HARDWARE .....	69
<b>LABELS GROUP</b> .....	<b>75</b>
<b>LP GROUP</b> .....	<b>96</b>
LP SYSTEM .....	96
<b>LOUNGE GROUP</b> .....	<b>97</b>
CABINETS .....	97
<b>SEALANTS &amp; FASTENERS GROUP</b> .....	<b>99</b>
SEALANTS & ADHESIVES .....	99
BOLTS, NUTS AND WASHERS .....	100
SCREWS .....	102
CLAMPS, CLIPS, GROMMETS, RIVETS & PLUGS .....	106
MISCELLANEOUS FASTENERS .....	107
<b>WATER &amp; SEWAGE GROUP</b> .....	<b>108</b>
DRAINAGE SYSTEM .....	108
WATER SYSTEM .....	110
<b>WINDOW &amp; VENTS GROUP</b> .....	<b>116</b>
WINDOW & VENT LAYOUT .....	116

**ACCESSORIES GROUP**  
**OPERATORS MANUAL**

<b>KEY</b>	<b>PART NUMBER</b>	<b>U/M</b>	<b>DESCRIPTION</b>
	132000-03-000	EA	MANUAL/OWNER - MINNIE - 2000
	129079-01-01A	EA	CASE - VINYL/BLACK-EXPANDABLE ACCORDION SIDES-7"WX9"HX14"L

**APPLIANCE GROUP  
APPLIANCES**

<b>KEY</b>	<b>PART NUMBER</b>	<b>U/M</b>	<b>DESCRIPTION</b>
*	100258-16-03A	EA	HOOD - RANGE - W/O MONITOR PANEL - W/O HR METER & SWITCH
*	100258-17-03A	EA	HOOD - RANGE - W/O MONITOR PANEL - W/O HOUR METER & SWITCH
*	100258-10-01A	EA	GAUGE - HOUR METER W/SWITCH - MECHANICAL - SCREW ON STYLE
*	100258-18-02A	EA	HOOD - RANGE - W/O MONITOR PANEL - W/HOUR METER & SWITCH
*	100258-10-01A	EA	GAUGE - HOUR METER W/SWITCH - MECHANICAL - SCREW ON STYLE
	128527-06-000	EA	OVEN - MICROWAVE W/TRIM KIT- 1 CU.FT.- NON CONVECTION
	128642-03-000	EA	TRIM KIT W/VENT- MICROWAVE .9 CU.FT. - SAMSUNG - 2.1" HIGH
	098916-24-02B	EA	BRACE - MICROWAVE CABINET - LEFT HAND
	098916-25-02B	EA	BRACE - MICROWAVE CABINET - RIGHT HAND
	094750-10-000	EA	BRACKET - MICROWAVE - 89 DEGREE
*	121568-03-01A	EA	REFRIGERATOR - SMALL DBL DOOR/BLK-52.8"HX23.5"WX24"D-2-WAY
	065225-04-000	EA	PLATE - TIEDOWN/REFRIGERATOR
	093646-01-000	EA	BRACKET - TIEDOWN/REFRIGERATOR - RIGHT HAND
	093646-02-000	EA	BRACKET - TIEDOWN/REFRIGERATOR - LEFT HAND
	054450-01-000	EA	LEVEL - REFRIGERATOR
	116751-05-01A	EA	TRAY - REFRIGERATOR - BLACK
*	102765-04-01A	EA	PANEL - MONITOR - 2 TANK/WATER HEATER - ADJUSTABLE
*	112881-02-04A	EA	RANGE - 16" - 3 BURNER - FRONT HI-OUTPUT BURNER - BISQUE FROM: 00-00-00 THRU: 03-06-00
*	112881-02-02A	EA	RANGE - 16" - 3 BURNER - ALMOND/BLACK TEXTURED DOOR FROM: 03-07-00 THRU: 99-99-99
	105458-03-000	EA	BRACKET - STOVE TIEDOWN - RIGHT HAND
	105458-04-000	EA	BRACKET - STOVE TIEDOWN - LEFT HAND

**\*COMPONENT PARTS FOUND IN SERVICE PARTS LIBRARY**

## AUDIO VIDEO GROUP RADIO SYSTEM

KEY	PART NUMBER	U/M	DESCRIPTION
	090944-01-000	EA	ANTENNA - RADIO - 16" RUBBER
	108847-01-000	EA	BRACKET - ANTENNA GROUND
	109889-02-000	EA	EXTENDER - ANTENNA SHAFT - 2.1"
	077069-02-000	EA	CABLE - ANTENNA/EXTENSION - RADIO - 96"
	108137-01-000	EA	PLUG - ANTENNA
	110465-01-000	EA	SPEAKER KIT,4 5X7 SPEAKERS - FORD F2UF-18814-CD
	110470-01-01A	EA	GRILLE - 4" X 6" OVAL - BLACK
	110469-01-000	EA	SPEAKER - 4" X 6" OVAL - COAXIAL
	111177-01-01A	EA	GRILLE - SPEAKER - 6.6" X 8.9" - HOUSING 5" X 7" SPEAKER

### TV & VCR

KEY	PART NUMBER	U/M	DESCRIPTION
*	126696-03-000	EA	TV - 19" COLOR W/1/8" JACK - UL/CSA
*	126697-03-000	EA	VCR - VHS - CABLE READY - REMOTE - GE V62051
	086757-04-000	EA	CONTROL CENTER - SWITCH - VCR/TV - 5 INPUTS
	086756-01-000	EA	SPLITTER - TV - 2 WAY
	082134-01-000	EA	ADAPTER - TV - CABLE TO CABLE
	082136-01-000	EA	NUT - HEX JAM - 3/8-32
	086777-02-000	EA	WALLPLATE - TV CABLE - W/ANTENNA SWITCH - BROWN
	086777-06-000	EA	WALLPLATE - TV CABLE - ANTENNA BOOSTER/1 OUTPUT - BROWN
*	076319-23-000	EA	ANTENNA - TV ROOF MOUNT - 44.5" MAST
*	076319-25-000	EA	KIT - HARDWARE INTERIOR
	076319-26-000	EA	ANTENNA - TV - ROOF WEDGE
	076319-06-000	EA	ADAPTER - CABLE ROOF PLATE
	076319-08-000	EA	WALLPLATE - CABLE RECEPTACLE - TV - SINGLE - IVORY
	076319-03-000	FT	CABLE - COAXIAL - 75 OHM
	076319-12-000	EA	CONNECTOR - COAXIAL - ONE PIECE

\*COMPONENT PARTS FOUND IN SERVICE PARTS LIBRARY

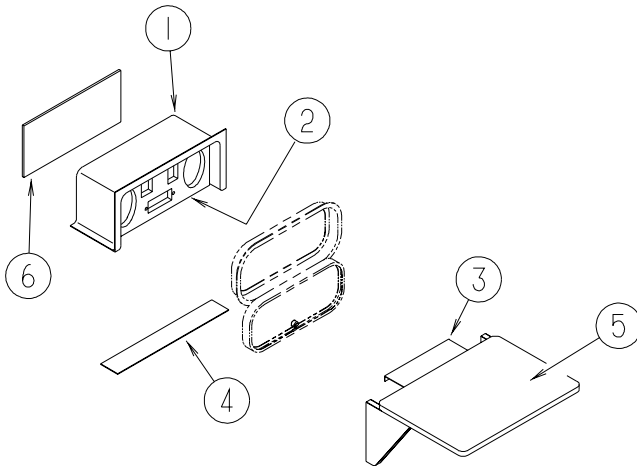

### EXTERIOR ENTERTAINMENT

KEY	PART NUMBER	U/M	DESCRIPTION
1	124696-01-01A	EA	BOX - ENTERTAINMENT CENTER/EXTERIOR
2	125322-02-000	EA	RADIO - AM/FM STEREO - CASSETTE - AUDIOVOX - MS-306
2	127409-02-L15	EA	PLATE - RADIO MOUNTING
3	105377-01-04A	EA	BRACKET - TABLE HANGER - BRIGHT WHITE
4	104898-01-02A	EA	PLATE - PLASTIC BOTTOM - BRIGHT WHITE
5	105230-01-J01	EA	SHELF - EXTERIOR ENTERTAINMENT CENTER - W/BRKT/HINGE/SUPT
6	104898-02-02A	EA	PLATE - PLASTIC BACK - BRIGHT WHITE

## BATH GROUP CABINETS

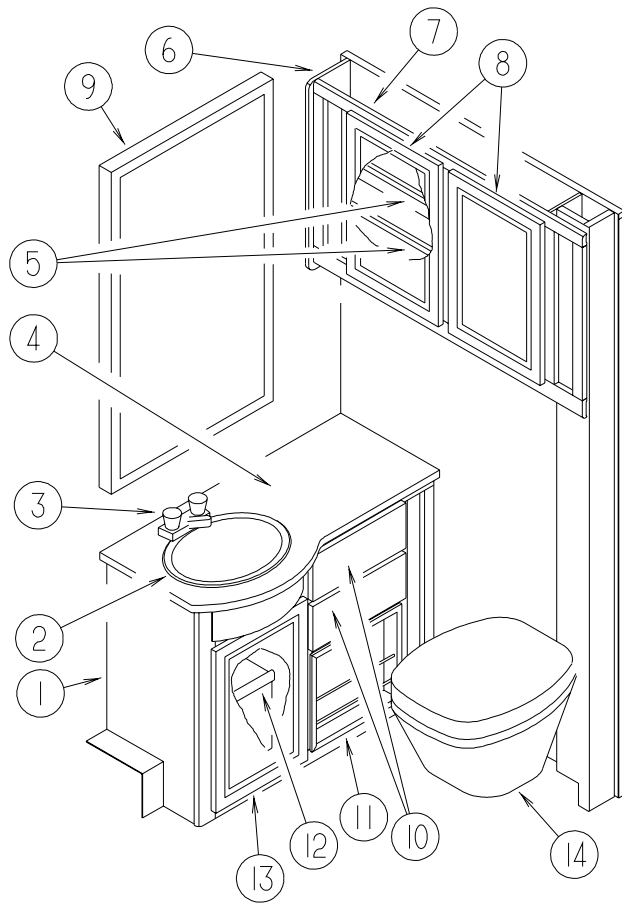

KEY	PART NUMBER	U/M	DESCRIPTION
1	P33811-01-L01	EA	CABINET - LAVATORY - W/O COUNTERTOP/DOORS/DRAWERS/HDW
2		EA	SINK - SEE DRAINAGE SYSTEMS GROUP
3		EA	FAUCET - SEE WATER SYSTEMS GROUP
4	133132-05-L01	EA	COUNTERTOP - LAVATORY - LAMINATED (L04)
4	133132-05-L02	EA	COUNTERTOP - LAVATORY - LAMINATED (L05)
4	133132-05-L06	EA	COUNTERTOP - LAVATORY - LAMINATED (L06)
5	133806-11-L01	EA	SHELF - W/PLASTIC EDGE MOLDING
6	109908-95-K04	EA	END CAP - OVERHEAD CABINET
7	133806-01-L01	EA	CABINET - MEDICINE - W/O DOORS/HARDWARE
8	132141-02-L15	EA	DOOR - RAIL/VENEER - 14.3" X 21.8" - W/O HARDWARE
9	058331-85-000	EA	MIRROR - SAFETY GLASS - 20.8" X 35.4"
10	M09316-47-L15	EA	DRAWER - OGEE EDGE - 12.4"W X 11.8"D - W/O SLIDES/HARDWARE
11	131096-02-K16	EA	WALL POCKET - MAGAZINE RACK
12	133811-11-L01	EA	SHELF - W/EDGE MOLDING
13	131995-P0-L01	EA	DOOR - RAIL/SOLID PANEL - 14.3" X 21.8" - W/O HARDWARE
14		EA	TOILET - SEE DRAINAGE SYSTEMS GROUP
	075452-02-000	EA	HOLDER - TOILET TISSUE - BRASS
	075454-02-000	EA	RING - TOWEL - W/MOUNTING HARDWARE - BRASS
	075453-03-000	EA	BRACKET - TOWEL BAR - BRASS - 2 PER PACK
	075453-04-000	EA	ROD - F/TOWEL BAR - 18" BRASS - W/O END BRACKETS
	131933-03-L15	EA	DOOR - BATH - W/O HARDWARE
	100357-01-000	EA	ROD - F/TOWEL BAR - BRASS
	134509-01-11A	EA	RAIL END - RH/LH - TOWEL RACK - 26" - WATERFORD OAK
*	131595-01-01A	EA	DOOR - FOLDING - 37" X 75" - W/4 CEILING MOUNTED BRACKETS

**\*COMPONENT PARTS FOUND IN SERVICE PARTS LIBRARY**



**BATH GROUP (CONTINUED)**  
**SHOWER**

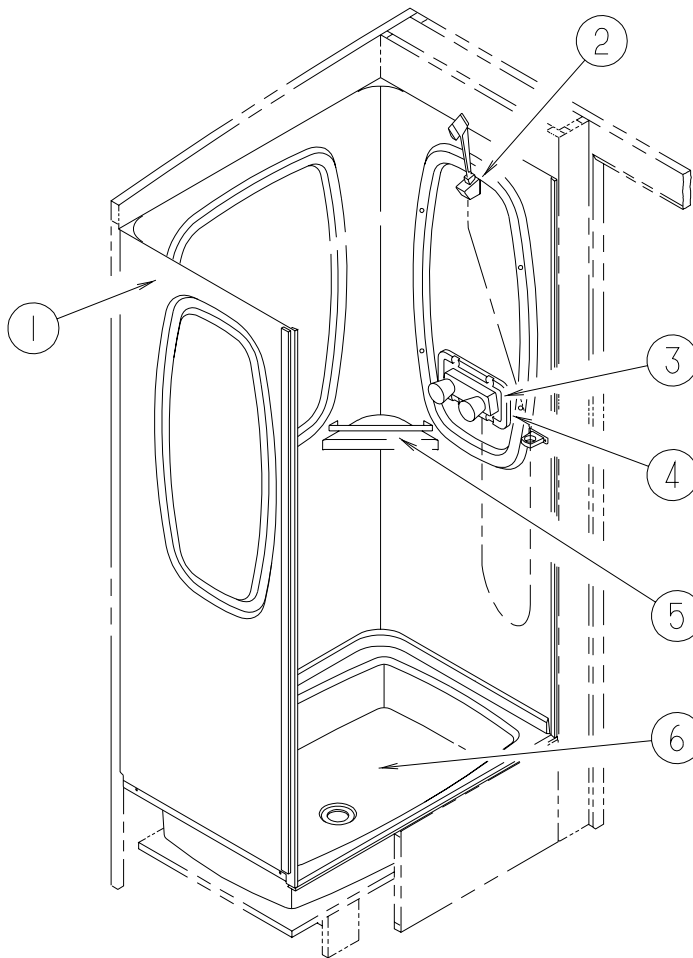

<b>KEY</b>	<b>PART NUMBER</b>	<b>U/M</b>	<b>DESCRIPTION</b>	
1	115612-03-02A	EA	SHOWER SURROUND - SOFT WHITE	
2		EA	SHOWERHEAD - SEE WATER SYSTEMS GROUP	
3		EA	FAUCET - SEE WATER SYSTEMS GROUP	
4		EA	PANEL - SEE WATER SYSTEMS GROUP	
5	113714-04-02A	EA	RETAINER - SHELF - SHOWER - SOFT WHITE	
6	M02630-28-L22	EA	SHOWER PAN - W/STRAINER	
*	117431-03-01A	EA	DOOR - SHOWER PLEATED FABRIC	
				FROM: 00-00-00 THRU: 04-09-00
	135615-03-01A	EA	DOOR - SHOWER/FOLDING - 39.3" X 58.9" - WHITE	
				FROM: 04-10-00 THRU: 99-99-99

**\*COMPONENT PARTS FOUND IN SERVICE PARTS LIBRARY**

## BEDROOM GROUP TWIN CABINETS

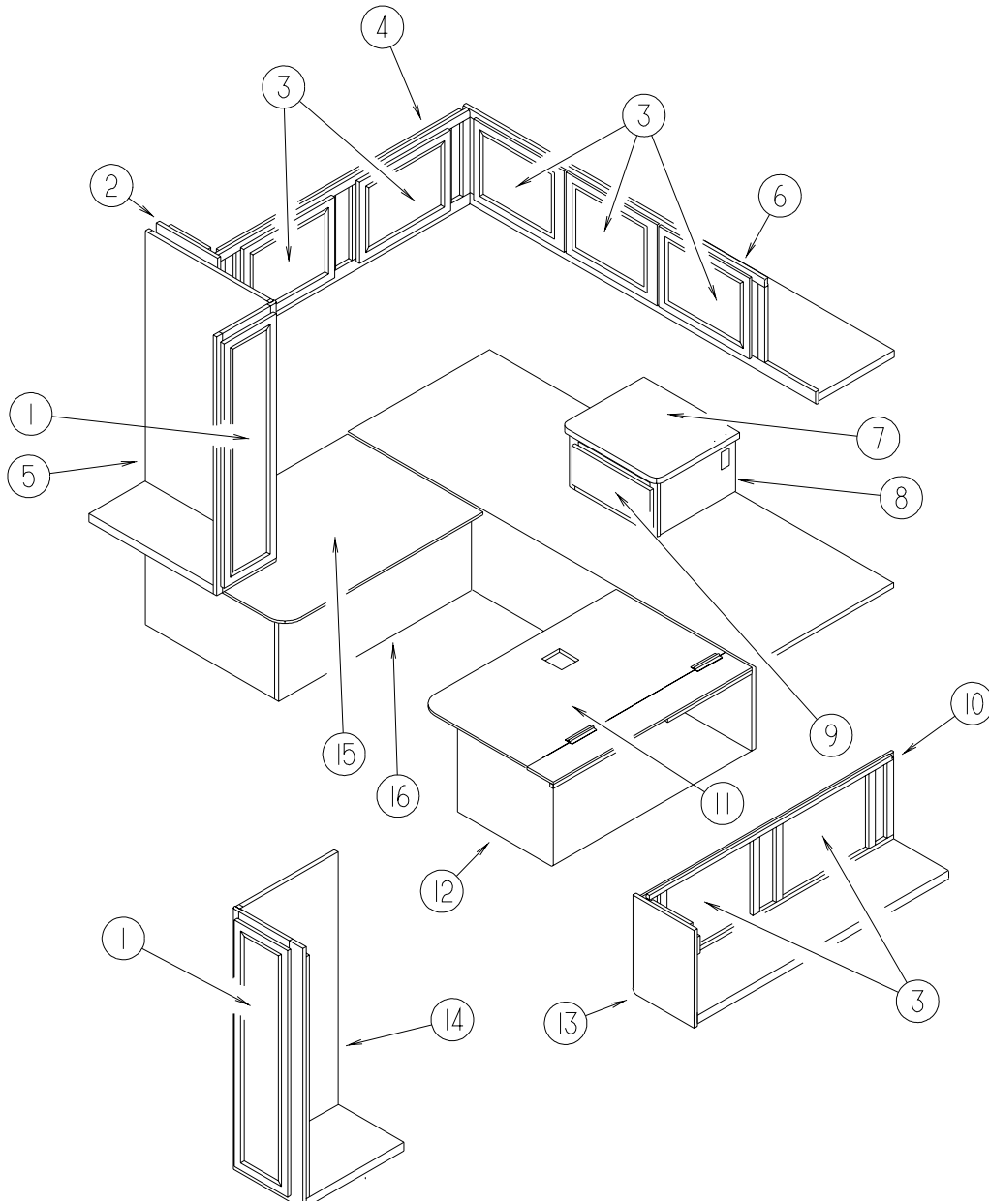

KEY	PART NUMBER	U/M	DESCRIPTION
1	132141-23-L15	EA	DOOR - RAIL/VENEER - 12" X 39.9" - W/O HARDWARE
2	109908-79-K01	EA	END CAP - OVERHEAD CABINET
3	132141-08-L01	EA	DOOR - RAIL/VENEER - 15.7" X 20.4" - W/O HARDWARE
4	132462-02-L01	EA	CABINET - OVERHEAD/FRONT
5	133809-01-L01	EA	CABINET - SHIRT CLOSET/RIGHT HAND - W/O DOORS/HARDWARE
6	132965-01-L01	EA	CABINET - OVERHEAD/REAR TWIN - W/O DOORS/HARDWARE
7	133131-22-L01	EA	COUNTERTOP - LAMINATED (L04)
7	133131-22-L02	EA	COUNTERTOP - LAMINATED (L05)
7	133131-22-L06	EA	COUNTERTOP - LAMINATED (L06)
8	131148-04-L01	EA	CABINET - NIGHTSTAND - W/O COUNTERTOP/DOOR/DRAWER/HARDWARE (L04)
8	131148-04-L05	EA	CABINET - NIGHTSTAND - W/O COUNTERTOP/DOOR/DRAWER/HARDWARE (L05)
8	131148-04-L06	EA	CABINET - NIGHTSTAND - W/O COUNTERTOP/DOOR/DRAWER/HARDWARE (L06)
9	M09316-72-L15	EA	DRAWER - OGEE EDGE - 13.5"W X 19.6"D - W/O SLIDES/HARDWARE
10	132462-03-L01	EA	CABINET - OVERHEAD/REAR
11	M06960-16-L01	EA	CABINET/TOP - TWIN BED/LEFT HAND - W/O HARDWARE
12	P31261-09-L01	EA	CABINET/BASE - TWIN BED/LEFT HAND - W/O DOOR/DRAWER/HDW
13	109908-80-K04	EA	END CAP - OVERHEAD CABINET
14	128886-01-L01	EA	CABINET - SHIRT CLOSET/LEFT HAND - W/O DOORS/HARDWARE
15	M06960-17-L01	EA	CABINET/TOP - TWIN BED/RIGHT HAND - W/O HARDWARE
16	P31261-08-L01	EA	CABINET/BASE - TWIN BED/RIGHT HAND - W/O DOOR/DRAWER/HDW

**BEDROOM GROUP (CONTINUED)**  
**DOUBLE BED CABINETS**

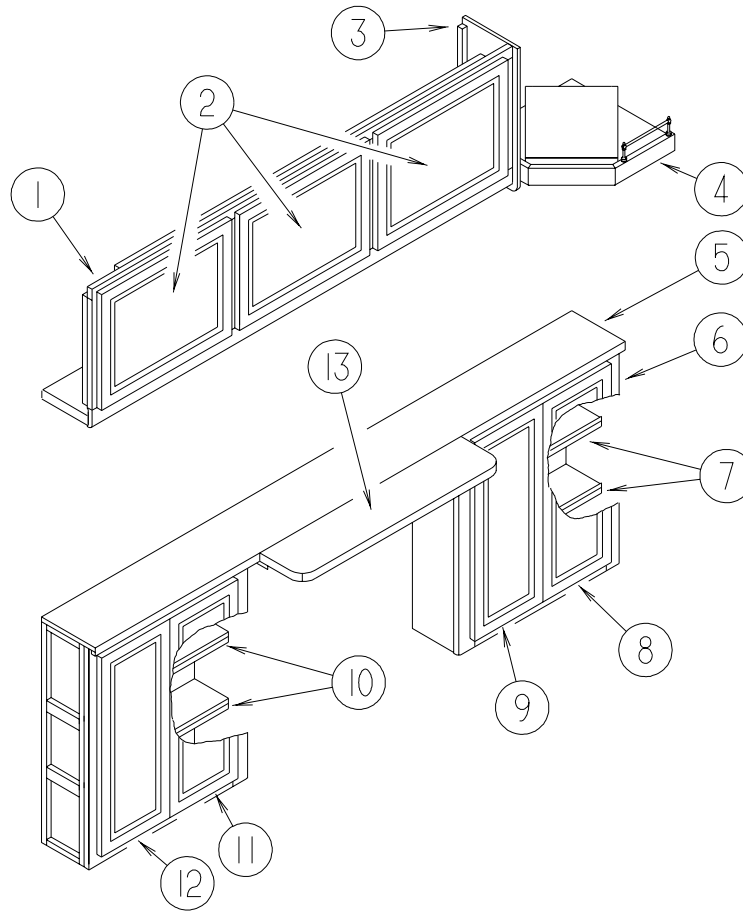

KEY	PART NUMBER	U/M	DESCRIPTION
1	128092-03-K04	EA	CABINET - OVERHEAD/REAR/RIGHT HAND - W/O DOORS/HARDWARE
2	132141-08-L01	EA	DOOR - RAIL/VENEER - 15.7" X 20.4" - W/O HARDWARE
3	109908-99-K04	EA	END CAP - OVERHEAD CABINET
4	116553-03-L04	EA	CABINET - TV SHELF - W/BRASS RODS/POST ENDS
5	133131-47-L04	EA	COUNTERTOP - LAMINATED
5	133131-47-L05	EA	COUNTERTOP - LAMINATED
5	133131-47-L06	EA	COUNTERTOP - LAMINATED
6	128037-02-L04	EA	CABINET - VANITY - W/O COUNTERTOP/DOOR/DRAWER/HARDWARE
6	128037-02-L05	EA	CABINET - VANITY - W/O COUNTERTOP/DOOR/DRAWER/HARDWARE
6	128037-02-L06	EA	CABINET - VANITY - W/O COUNTERTOP/DOOR/DRAWER/HARDWARE
7	128037-11-J03	EA	SHELF - W/PLASTIC EDGE TRIM
8	131995-P2-L01	EA	DOOR - RAIL/SOLID PANEL - 10.8" X 27.9" - W/O HARDWARE
9	131995-P1-L01	EA	DOOR - RAIL/SOLID PANEL - 10.8" X 27.9" - W/O HARDWARE
10	128037-11-J03	EA	SHELF - W/PLASTIC EDGE TRIM
11	131995-P2-L01	EA	DOOR - RAIL/SOLID PANEL - 10.8" X 27.9" - W/O HARDWARE
12	131995-P1-L01	EA	DOOR - RAIL/SOLID PANEL - 10.8" X 27.9" - W/O HARDWARE
13	133131-49-L04	EA	COUNTERTOP - LAMINATED
13	133131-49-L05	EA	COUNTERTOP - LAMINATED
13	133131-49-L06	EA	COUNTERTOP - LAMINATED

**BEDROOM GROUP (CONTINUED)**  
**DOUBLE BED CABINETS (CONTINUED)**

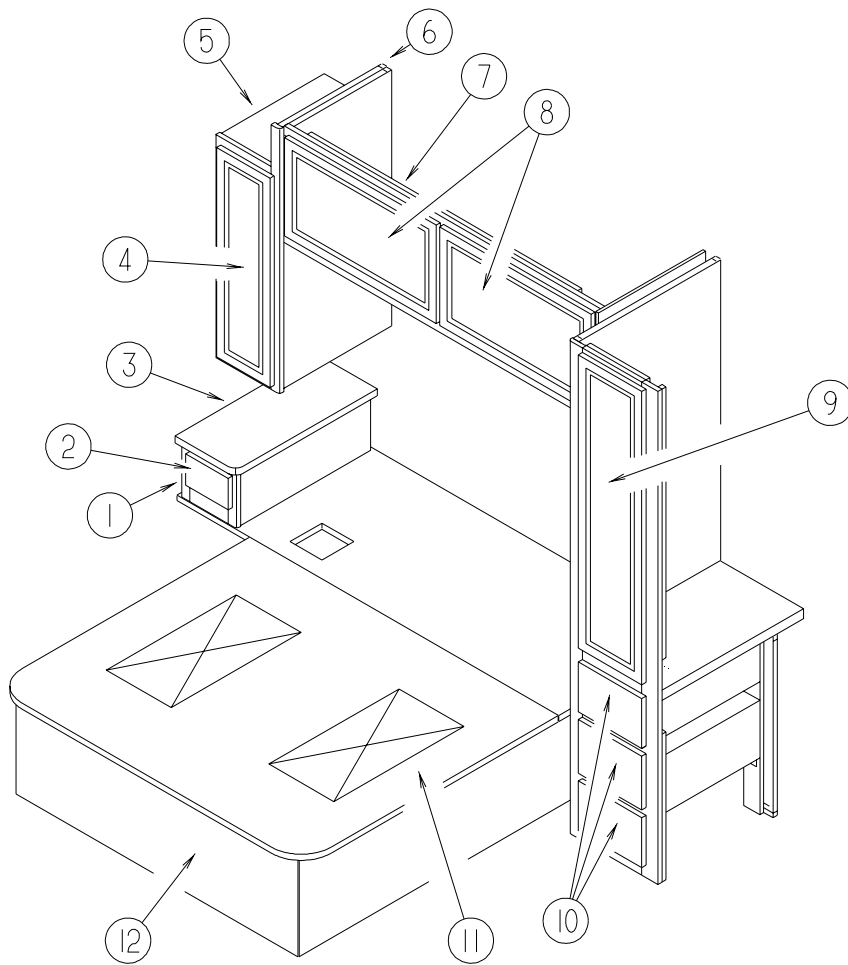

KEY	PART NUMBER	U/M	DESCRIPTION
1	P28582-02-L04	EA	CABINET - NIGHTSTAND - W/O COUNTERTOP/DOOR/DRAWER/HARDWARE
1	P28582-02-L05	EA	CABINET - NIGHTSTAND - W/O COUNTERTOP/DOOR/DRAWER/HARDWARE
1	P28582-02-L06	EA	CABINET - NIGHTSTAND - W/O COUNTERTOP/DOOR/DRAWER/HARDWARE
2	M09316-45-L04	EA	DRAWER - OGEE EDGE - 6"W X 19.7"D - W/O SLIDES/HARDWARE
3	133131-43-L04	EA	COUNTERTOP - LAMINATED
3	133131-43-L05	EA	COUNTERTOP - LAMINATED
3	133131-43-L06	EA	COUNTERTOP - LAMINATED
4	132141-47-L01	EA	DOOR - RAIL/VENEER - 9.9" X 33.5" - W/O HARDWARE
5	P32374-01-L01	EA	CABINET - SHIRT CLOSET/RIGHT HAND - W/O DOORS/HARDWARE
6	109908-A8-L01	EA	END CAP - OVERHEAD CABINET
7	133807-01-L01	EA	CABINET - OVERHEAD/REAR/LEFT HAND - W/O DOORS/HARDWARE
8	132141-08-L01	EA	DOOR - RAIL/VENEER - 15.7" X 20.4" - W/O HARDWARE
9	132006-04-L01	EA	DOOR - MIRROR/MITERED RAIL - 15.5" X 45.4" - W/O HDW
10	M09316-E4-L01	EA	DRAWER - OGEE EDGE - 13.4"W X 17.6"D - W/O SLIDES/HARDWARE
11	M07500-05-000	EA	CABINET/TOP - DOUBLE BED - W/O HARDWARE
12	P28781-01-J03	EA	CABINET/BASE - DOUBLE BED - W/O DOOR/DRAWER/HARDWARE

**BEDROOM GROUP (CONTINUED)**  
**RADIO & TV CABINETS**

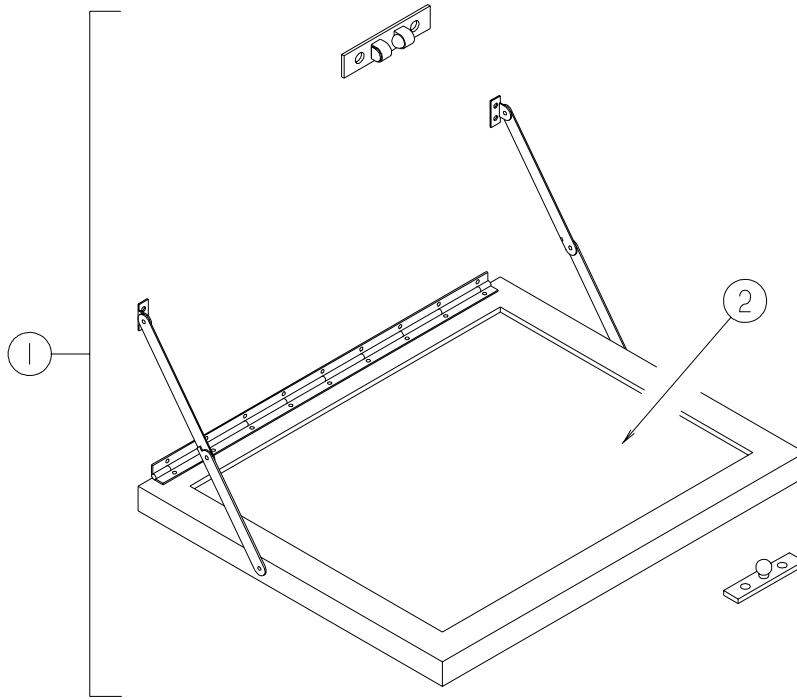

KEY	PART NUMBER	U/M	DESCRIPTION
1	084357-02-H13	EA	TV STAND
2	084356-08-000	EA	INSERT - TV STAND - W/SUPPORT HINGES - OFF WHITE

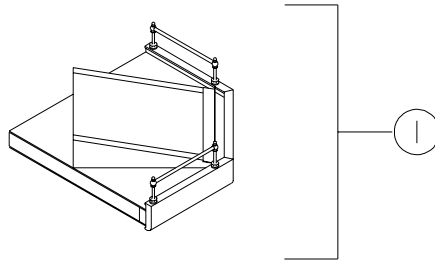

KEY	PART NUMBER	U/M	DESCRIPTION
1	116553-03-L04	EA	CABINET - TV SHELF - W/BRASS RODS/POST ENDS

## CHASSIS GROUP FRAME

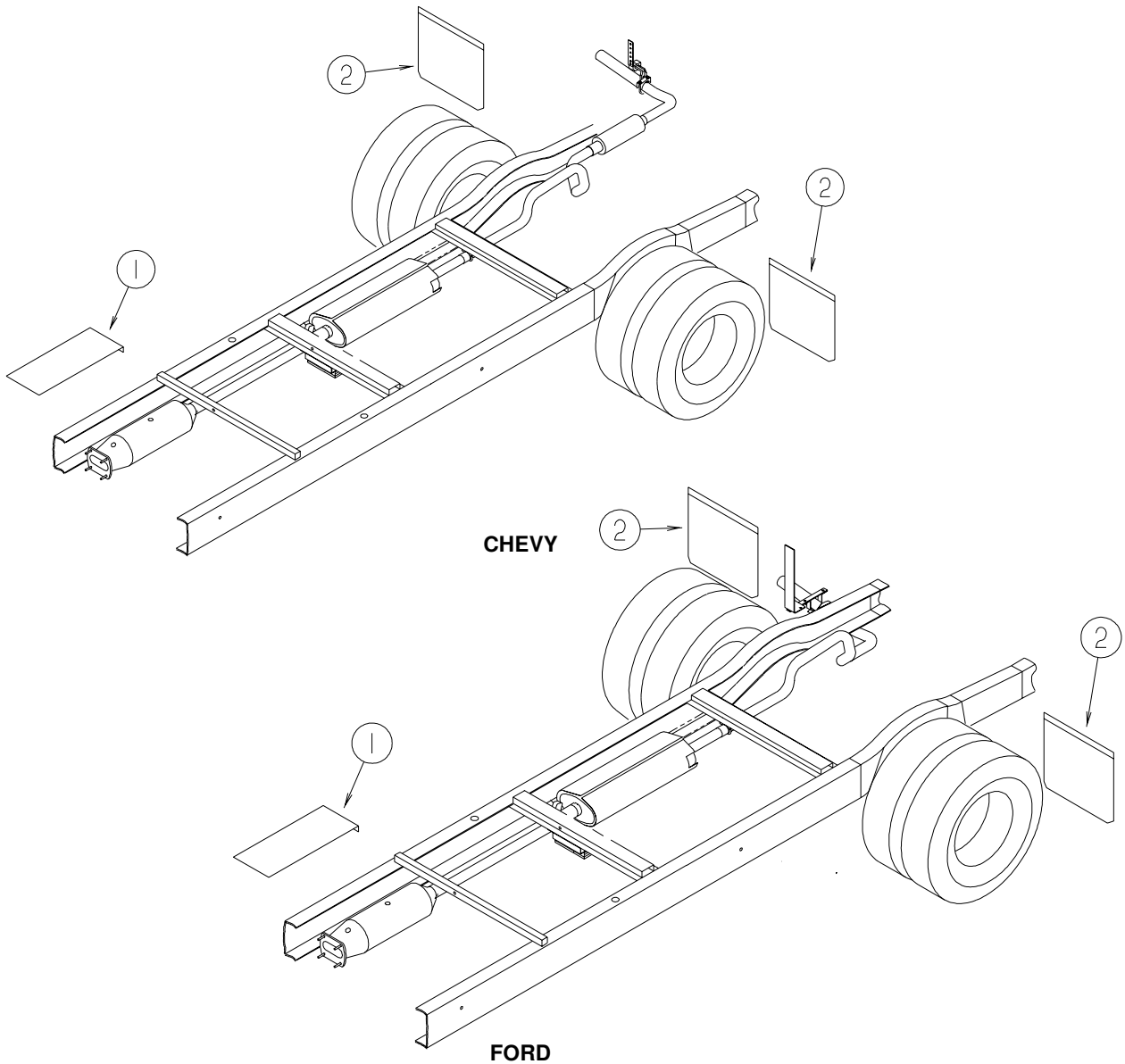

KEY	PART NUMBER	U/M	DESCRIPTION
1	091182-07-000	EA	SHIELD - HEAT
2	045731-06-000	EA	GUARD - ROCK

## DRIVETRAIN

KEY	PART NUMBER	U/M	DESCRIPTION
	P27348-01-000	EA	DRIVESHAFT - SLIP YOKE/MALE SPLINE - 159" WHEELBASE - CHEVY
	P27348-02-000	EA	DRIVESHAFT - SLIP YOKE/YOKE - 159" WHEELBASE - CHEVY
	074833-01-000	EA	SPACER - BEARING - DRIVESHAFT - 2" X 8" X .5" THICK
	085771-03-000	EA	NUT - HEX - FLARE TORQUE - GRADE G - DRIVESHAFT
	088498-01-000	EA	UNION - INVERTED FLARE - BRASS - 3/16
	088498-02-000	EA	UNION - INVERTED FLARE - BRASS - 1/4
	103653-23-000	EA	BOLT - U-JOINT - 5/16-24 X .75
	103653-24-000	EA	STRAP - U-JOINT
	000C13-07-40B	EA	BOLT - HEX - 7/16-20 X 2.5" - GRADE #5 - ZINC
	131694-02-000	EA	DRIVESHAFT ASSEMBLY - BALANCED PAIR - 188" WHEEL BASE - FORD
	074833-01-000	EA	SPACER - BEARING - DRIVESHAFT - 2" X 8" X .5" THICK
	000C13-07-40B	EA	BOLT - HEX - 7/16-20 X 2.5" - GRADE #5 - ZINC
	000E13-18-00B	EA	WASHER - FLAT - 3/8 WIDE - ZINC
	085771-03-000	EA	NUT - HEX - FLARE TORQUE - GRADE G - DRIVESHAFT

**CHASSIS GROUP (CONTINUED)**  
**EXHAUST**

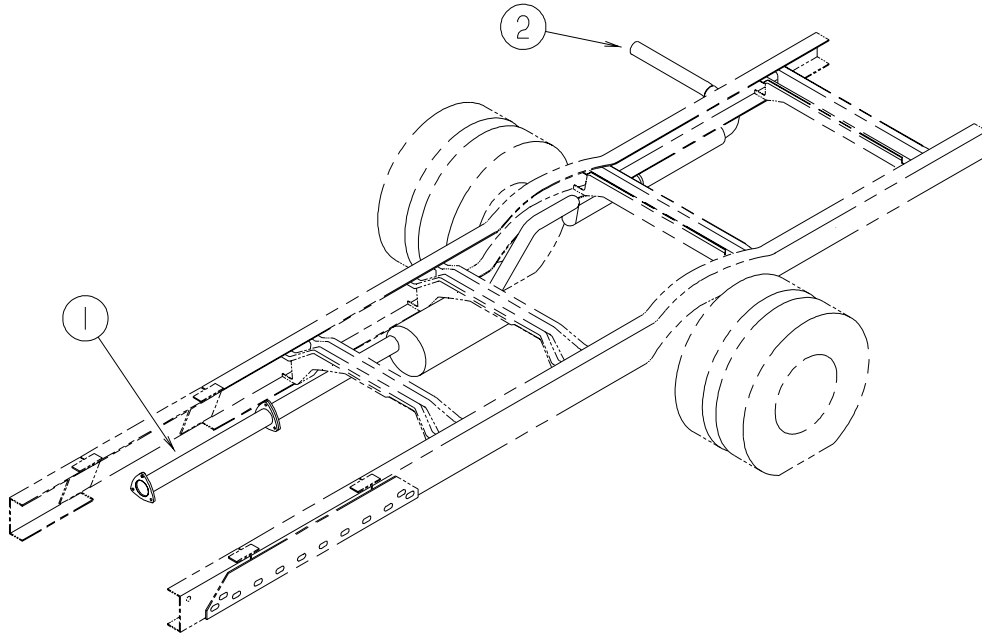

**CHEVY**

KEY	PART NUMBER	U/M	DESCRIPTION
1	124477-01-000	EA	PIPE - EXHAUST
	124610-01-000	EA	GASKET - EXHAUST
	000D39-07-00B	EA	NUT - HEX - LOCKING W/SERRATED FLANGE - 7/16-14 - ZINC
	000C12-07-20B	EA	BOLT - HEX - 7/16-14 X 1 1/4 - ZINC 5
2	124570-02-000	EA	PIPE - EXHAUST - TAIL
	094918-06-000	EA	CLAMP - EXHAUST - 3" - HEAVY DUTY

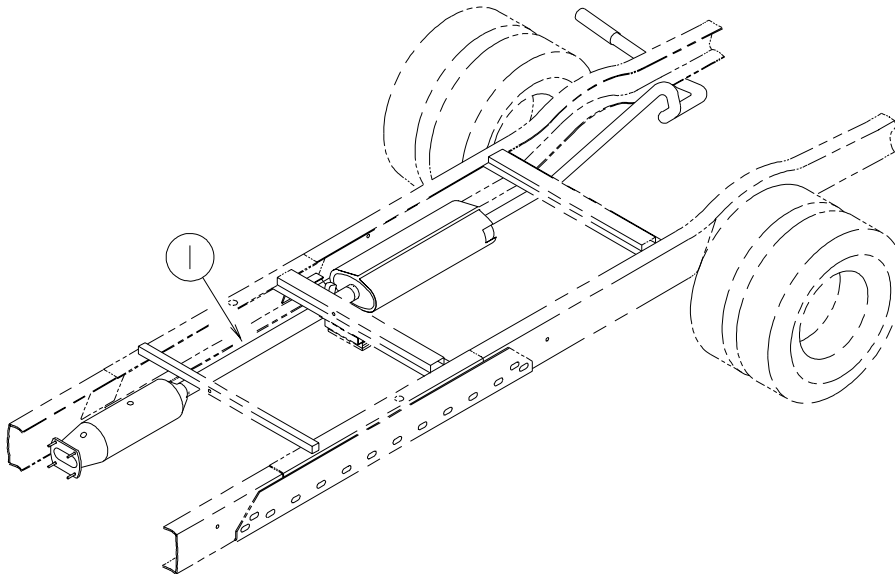

**FORD**

KEY	PART NUMBER	U/M	DESCRIPTION
1	111478-01-000	EA	EXHAUST PIPE - DOUBLE WALL STAINLESS STEEL - 32" - GAS
	094918-06-000	EA	CLAMP - EXHAUST - 3" - HEAVY DUTY
1	098762-14-000	EA	PIPE - EXHAUST - STRAIGHT - 3.5" - DIESEL
	094918-02-000	EA	CLAMP - EXHAUST - 3.5"

## CHASSIS GROUP (CONTINUED)

### HITCH

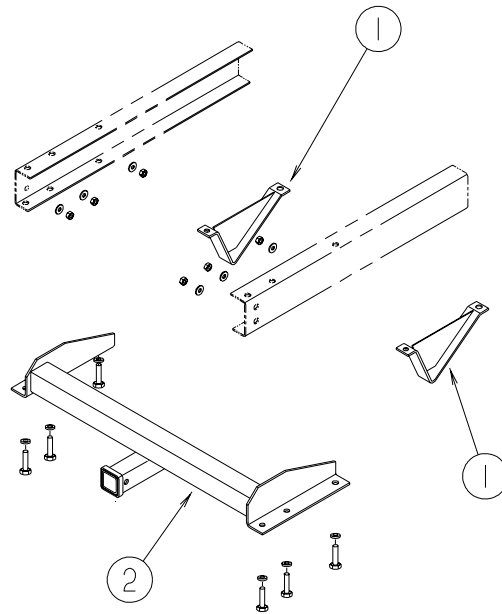

KEY	PART NUMBER	U/M	DESCRIPTION
1	083376-01-000	EA	PLATE/SKID - 13.2" X 6" X 2" STEEL
2	130339-04-000	EA	HITCH RECEIVER - BOLT ON CLASS II
	034513-01-000	EA	PIN - HITCH - 3/16" WIRE
	113589-01-000	EA	CONNECTOR - SOCKET - TRAILER
	113589-02-000	EA	CONNECTOR - PLUG - TRAILER

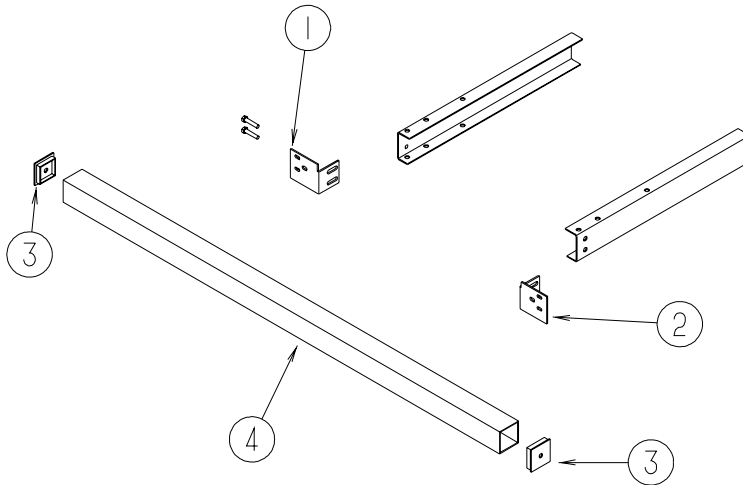

### REAR BUMPER

KEY	PART NUMBER	U/M	DESCRIPTION
1	104420-02-000	EA	SUPPORT/ANGLE - REAR BUMPER - LEFT HAND
2	104420-01-000	EA	SUPPORT/ANGLE - REAR BUMPER - RIGHT HAND
3	039779-01-000	EA	CAP - BUMPER - RUBBER - 4" X 4" - BLACK
4	103422-05-02A	EA	BUMPER - REAR - SQUARE ALUMINUM - 97.3" - BRIGHT WHITE



## CHASSIS GROUP (CONTINUED)

### FUEL FILL

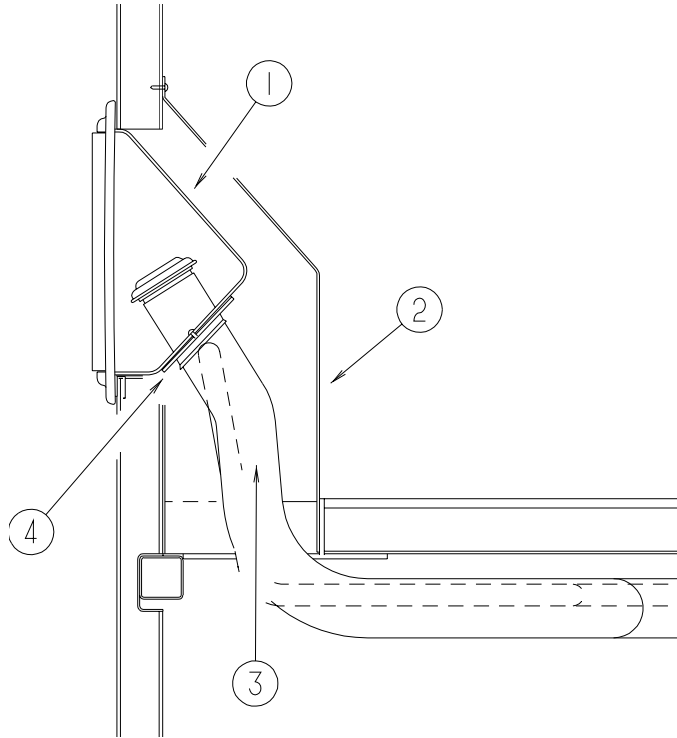

KEY	PART NUMBER	U/M	DESCRIPTION
1	127291-01-01A	EA	SHROUD - FUEL FILL - BRIGHT WHITE - CHEVY
1	127291-02-01A	EA	SHROUD - FUEL FILL - BRIGHT WHITE - FORD
2	078040-09-000	EA	SHROUD - FUEL FILL - UPPER - RECTANGULAR
3	128331-01-000	EA	NECK - FUEL FILL - UNLEADED - CHEVY
3	108603-02-000	EA	NECK - FILLER - FUEL FILL - DIESEL
4	078200-01-000	EA	GASKET - FUEL FILL - 3.5"OD X 2"ID
	129505-02-000	EA	TUBE - STEEL - 5/8" X 13.5"

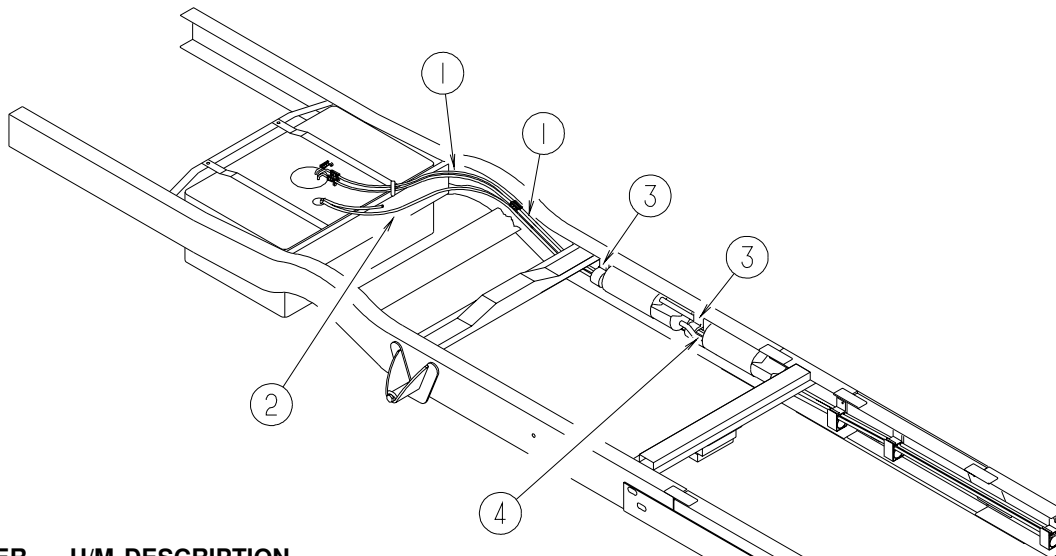

KEY	PART NUMBER	U/M	DESCRIPTION
1	106389-10-000	EA	FUEL LINE - FORD - 3/8 HP - FORD
1	125055-01-000	EA	PIPE - FUEL/GAS - CHEVY
2	125187-01-000	FT	HOSE - FUEL - LOW PERMEABILITY - 11.1 ID - FORD
3	010497-04-000	EA	CLAMP - CLOSED - 1.62" ID
4	125187-02-000	FT	HOSE - FUEL - LOW PERMEABILITY - 12.71 ID - FORD
	084884-01-000	EA	PLUG - BRASS - 3/8"
	128139-03-000	FT	HOSE - FUEL - LOW PERMEABILITY - 1/4" DIAMETER
	088258-02-000	EA	CLIP - RETAINING - FUEL LINE SINGLE
	099069-01-000	FT	SEAL - RUBBER - CLOSED SPONGE - .5" WIDE X .12" THICK -BLK

**CHASSIS GROUP (CONTINUED)**  
**SPARE TIRE INSTALLATION**

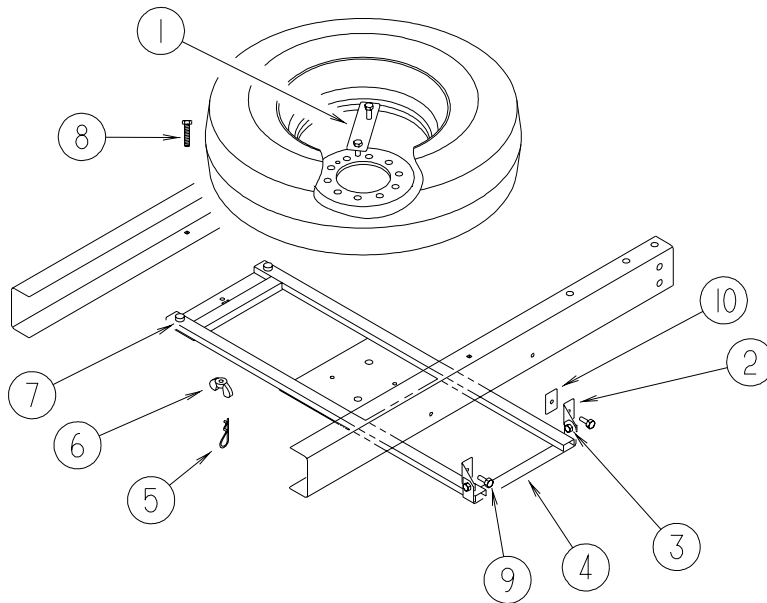

KEY	PART NUMBER	U/M	DESCRIPTION
1	116338-02-02B	EA	BRACKET/CLAMP - SPARE TIRE - E-COATED
		EA	NUT - HEX - SELF LOCKING - 9/16-12 - ZINC - SEE SEALANTS & FASTENERS GROUP
2	116349-01-02B	EA	BRACKET/HINGE - SPARE TIRE - E-COATED
3		EA	BOLT - HEX - SERRATED FLANGE - 3/8-16 X 3/4 - ZINC - SEE SEALANTS & FASTENERS GROUP
		EA	NUT - HEX - LOCKING - 3/8-16 GRADE C ZINC - SEE SEALANTS & FASTENERS GROUP
		EA	WASHER - FLAT - 3/8" AR - ZINC - SEE SEALANTS & FASTENERS GROUP
4	116348-01-02B	EA	CRADLE - SPARE TIRE - E-COATED
5	034513-01-000	EA	PIN - HITCH - 3/16" WIRE
6	064081-03-000	EA	NUT - WING 3/8-16 - W/WELD NUT
7	069726-02-000	EA	BUMPER - .88 DIAMETER - 40 - BLACK
8		EA	BOLT - ELEVATOR - 3/8-16 X 3 1/2 - GRADE 5 - SEE SEALANTS & FASTENERS GROUP
9		EA	BOLT - HEX - SERRATED FLANGE - 3/8-16 X 3/4 - ZINC - SEE SEALANTS & FASTENERS GROUP
		EA	NUT - HEX - LOCKING W/SERRATED FLANGE - 3/8-18 - ZINC - SEE SEALANTS & FASTENERS GROUP
10	070579-08-000	EA	PLATE ASM-ANCHOR

**SUSPENSION - FROM: 00-00-00 THRU: 02-01-2000**

KEY	PART NUMBER	U/M	DESCRIPTION
*	106067-03-000	EA	AIRSPRING - 4" DIA.TWIN BAG - '92 & NEWER FORD E350 C-BODY
	109236-01-000	EA	PLATE - VALVE - AIR SPRING
	107938-07-000	EA	BRACKET - PUMP

**\*COMPONENT PARTS FOUND IN SERVICE PARTS LIBRARY**

**SUSPENSION - FROM: 02-02-2000 THRU: 99-99-99**

KEY	PART NUMBER	U/M	DESCRIPTION
*	135674-01-000	EA	AIRSPRING - AIR BAG KIT - FORD 450 SUPER DUTY CHASSIS

**\*COMPONENT PARTS FOUND IN SERVICE PARTS LIBRARY**

**WHEEL, TIRE, COVERS & LINERS**

KEY	PART NUMBER	U/M	DESCRIPTION
	083617-04-000	EA	WHEEL - STEEL - 6" X 16" - FORD
	070917-06-000	EA	TIRE - LT225/75R16E - R4S M/S - FIRESTONE
	051377-04-000	EA	VALVE SYSTEM - .5" X 2"
	089359-03-000	EA	WHEEL - STEEL - 6" X 16" - 8 HOLE - PRIMED - #28623 - CHEVY
	106715-01-000	EA	TIRE - LT 225/75 R16 - LRD 550 AS - CHEVY
	051377-03-000	EA	VALVE SYSTEM
*	109443-05-000	EA	WHEEL COVER - 4/SET - 16" STAINLESS STEEL
*	110435-13-000	EA	LINER - WHEEL - SET OF 4 - 16" (8 HOLE) - FORD
	095012-05-000	EA	EXTENSION - VALVE SYSTEM - LIVE - 5"
	095012-06-000	EA	STABILIZER - VALVE EXTENSION - LIVE - 2"
*	091209-05-000	EA	LINER - WHEEL - SET OF 4 - 16" - STAINLESS STEEL - CHEVY
	095012-05-000	EA	EXTENSION - VALVE SYSTEM - LIVE - 5"
	095012-06-000	EA	STABILIZER - VALVE EXTENSION - LIVE - 2"
	112358-01-000	EA	WRENCH - LUG - 7/8" - L-SHAPE

**\*COMPONENT PARTS FOUND IN SERVICE PARTS LIBRARY**

## CURTAIN & CUSHION GROUP

### NOTICE

IN ORDER TO ASSIST OUR PARTS SALES DEPT. IN PROVIDING INTERIOR SOFTWARE ITEMS, PLEASE INCLUDE THE SERIAL NUMBER AND THE COLOR CODE NUMBER FROM THE VEHICLE CERTIFICATION LABEL WHEN ORDERING. THIS LABEL IS LOCATED ON THE LEFT SIDEWALL AT THE END OF THE DASH (A-BODY), OR ON THE DRIVER'S DOOR LATCH PLATE (C-BODY). AN EXAMPLE OF A COLOR CODE NUMBER IS B07, WHICH DESIGNATES AN OVERALL COLOR SCHEME OF A PARTICULAR UNIT. THE COLOR LISTED AFTER THE ITEM DESCRIPTION ON THE MICROFICHE, INDICATES THE OVERALL UNIT COLOR. ORDER THE ITEM YOU DESIRE ACCORDING TO UNIT COLOR CODE. IF ALL COLORS USE THE SAME ITEM NO COLOR CODE WILL BE NOTED.

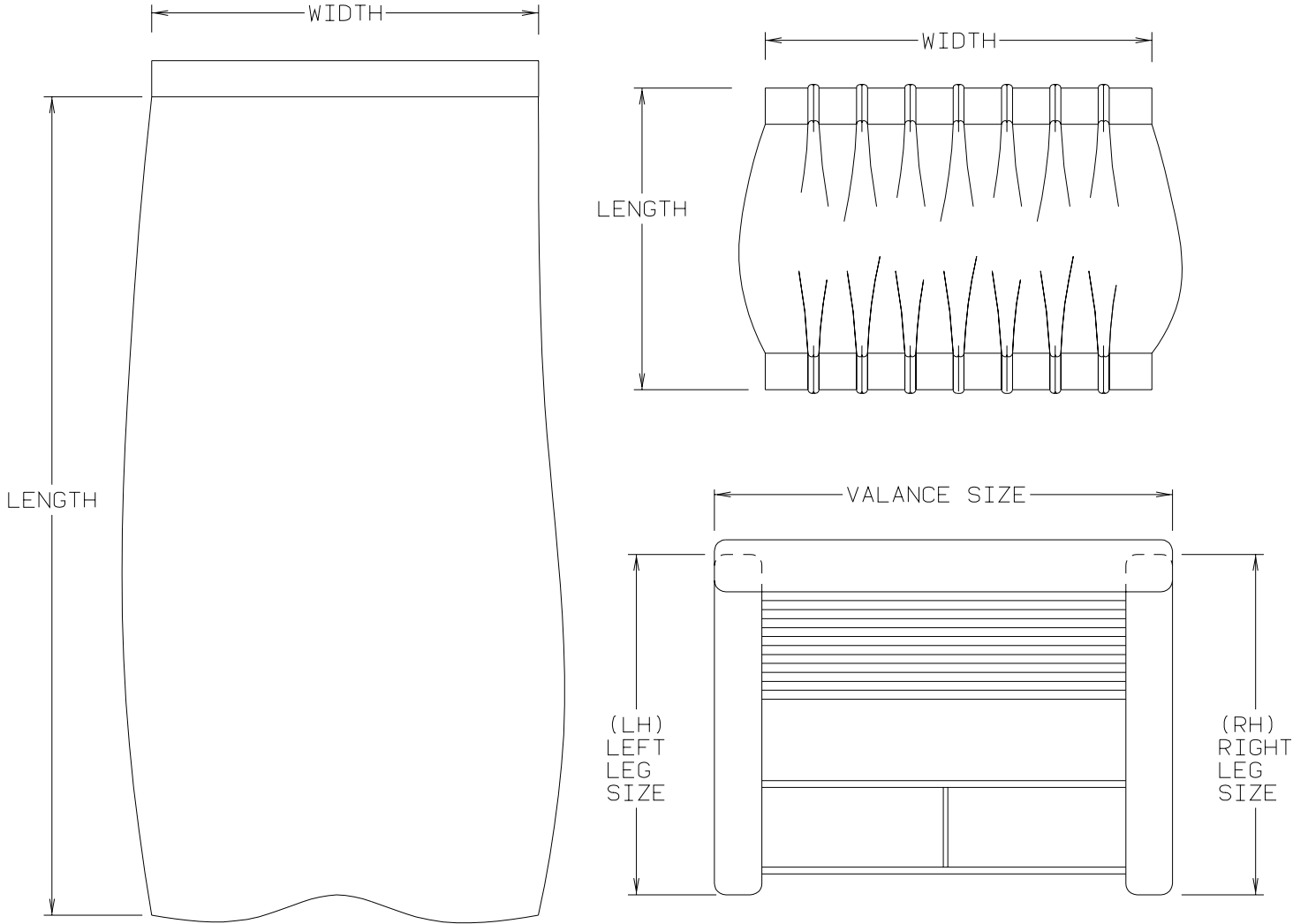

NOTE: USE THIS ILLUSTRATION WHEN DETERMINING LENGTH AND WIDTH MEASUREMENTS FOR CURTAINS. YOU WILL NOTE THE WIDTH MEASUREMENT IS TAKEN ON THE TOP OF THE CURTAIN WITH THE CURTAIN FULLY EXTENDED. THE LENGTH MEASUREMENT IS TAKEN FROM TOP TO BOTTOM. LEFT AND RIGHT WINDOW LEGS ARE DETERMINED WHEN FACING THE WINDOW.

## CURTAIN & CUSHION GROUP (CONTINUED)

### CUSHION LAYOUT

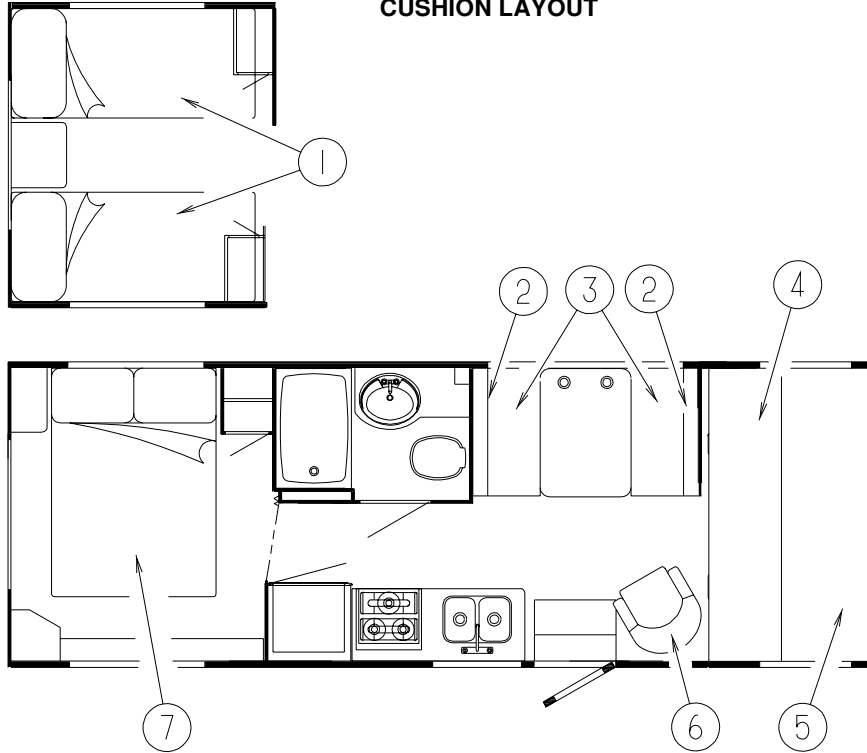

KEY	PART NUMBER	U/M	DESCRIPTION
1	123471-09-L01	EA	BEDSPREAD/THROW - 36" X 80" (L04)
1	123471-09-L02	EA	BEDSPREAD/THROW - 36" X 80" (L05)
1	123471-09-K48	EA	BEDSPREAD/THROW - 36" X 80" (L06)
	104176-04-L01	EA	PILLOW SHAM - 30" (L04)
	104176-04-L02	EA	PILLOW SHAM - 30" (L05)
	104176-04-K06	EA	PILLOW SHAM - 30" (L06)
	101123-29-000	EA	MATTRESS - FOAM - 35" X 74"
2	111897-14-L01	EA	CUSHION - BACK - 13.5" X 42" X 5" (L04)
2	111897-14-L02	EA	CUSHION - BACK - 13.5" X 42" X 5" (L05)
2	111897-14-L06	EA	CUSHION - BACK - 13.5" X 42" X 5" (L06)
	P11897-14-L01	EA	COVER - BACK - 13.5" X 42" X 5" (L04)
	P11897-14-L02	EA	COVER - BACK - 13.5" X 42" X 5" (L05)
	P11897-14-L06	EA	COVER - BACK - 13.5" X 42" X 5" (L06)
3	105603-15-L01	EA	CUSHION - SEAT - 23" X 42" X 5" (L04)
3	105603-15-L02	EA	CUSHION - SEAT - 23" X 42" X 5" (L05)
3	105603-15-L06	EA	CUSHION - SEAT - 23" X 42" X 5" (L06)
	P05603-15-L01	EA	COVER - SEAT - 23" X 42" X 5" (L04)
	P05603-15-L02	EA	COVER - SEAT - 23" X 42" X 5" (L05)
	P05603-15-L06	EA	COVER - SEAT - 23" X 42" X 5" (L06)
4	105573-10-L04	EA	CUSHION - OVERHEAD BUNK/REAR - 27" X 23" X 80" X 5"
4	105573-10-L05	EA	CUSHION - OVERHEAD BUNK/REAR - 27" X 23" X 80" X 5"
4	105573-10-L06	EA	CUSHION - OVERHEAD BUNK/REAR - 27" X 23" X 80" X 5"
	P05573-10-L04	EA	COVER - CUSHION/OVERHEAD BUNK/REAR - 27" X 23" X 80" X 5"
	P05573-10-L05	EA	COVER - CUSHION/OVERHEAD BUNK/REAR - 27" X 23" X 80" X 5"
	P05573-10-L06	EA	COVER - CUSHION/OVERHEAD BUNK/REAR - 27" X 23" X 80" X 5"
5	105573-09-K03	EA	CUSHION - OVERHEAD BUNK/FRONT - 32.5" X 80" X 5" (L04)
5	105573-09-J03	EA	CUSHION - OVERHEAD BUNK/FRONT - 32.5" X 80" X 5" (L05)
5	105573-09-L03	EA	CUSHION - OVERHEAD BUNK/FRONT - 32.5" X 80" X 5" (L06)
	P05573-09-K03	EA	COVER - CUSHION/OVERHEAD BUNK/FRONT - 32.5" X 80" X 5" (L04)
	P05573-09-J03	EA	COVER - CUSHION/OVERHEAD BUNK/FRONT - 32.5" X 80" X 5" (L05)
	P05573-09-L03	EA	COVER - CUSHION/OVERHEAD BUNK/FRONT - 32.5" X 80" X 5" (L06)
	079145-08-000	EA	CUSHION - BUNK - 25" X 74" X 3.5"
	M79145-08-000	EA	COVER - CUSHION/BUNK - 25" X 74" X 3.5"
6	115470-01-K03	EA	CHAIR - SWIVEL (L04)
6	115470-01-GB1	EA	CHAIR - SWIVEL (L05)
6	115470-01-L03	EA	CHAIR - SWIVEL (L06)
	P15470-01-K03	EA	COVER - CHAIR (L04)
	P15470-01-GB1	EA	COVER - CHAIR (L05)
	P15470-01-L03	EA	COVER - CHAIR (L06)

## CURTAIN & CUSHION GROUP (CONTINUED)

### CUSHION LAYOUT (CONTINUED)

KEY	PART NUMBER	U/M	DESCRIPTION
7	123471-22-L01	EA	BEDSPREAD/THROW - 54" X 75" (L04)
7	123471-22-L02	EA	BEDSPREAD/THROW - 54" X 75" (L05)
7	123471-22-K06	EA	BEDSPREAD/THROW - 54" X 75" (L06)
	104176-04-L01	EA	PILLOW SHAM - 30" (L04)
	104176-04-L02	EA	PILLOW SHAM - 30" (L05)
	104176-04-K06	EA	PILLOW SHAM - 30" (L06)
	123015-05-000	EA	MATTRESS - INNERSPRING - 54" X 74.5"

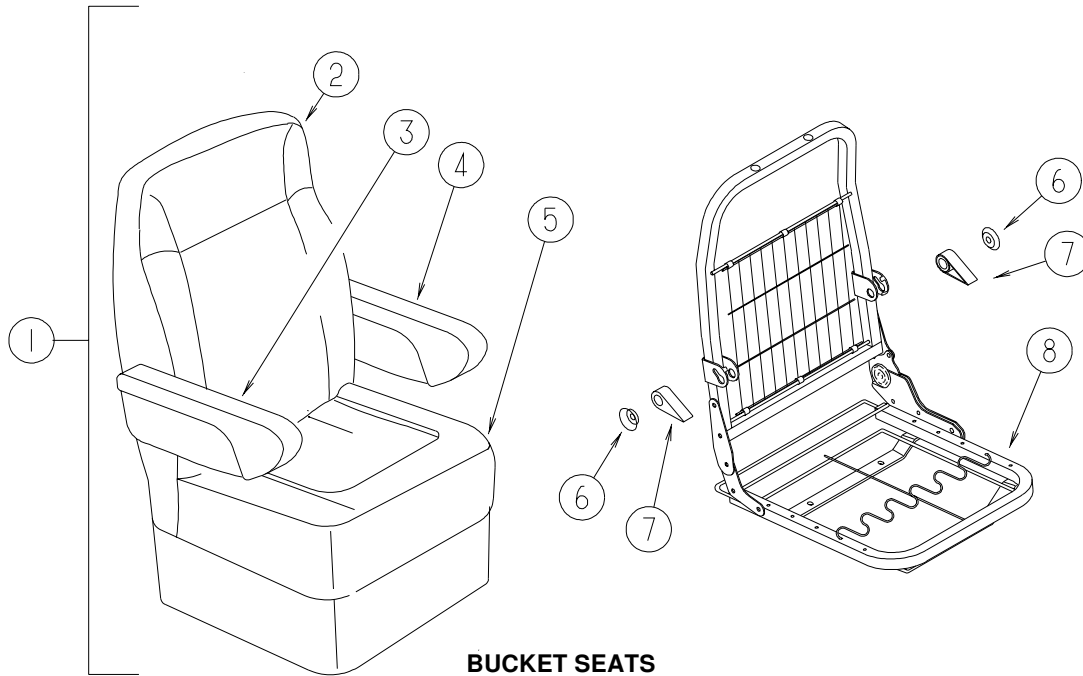

**BUCKET SEATS**

**CHEVY**

KEY	PART NUMBER	U/M	DESCRIPTION
1	132263-03-L01	EA	SEAT - DRIVER - W/SKIRT (L04)
1	132263-03-L02	EA	SEAT - DRIVER - W/SKIRT (L05)
1	132263-03-L06	EA	SEAT - DRIVER - W/SKIRT (L06)
1	132263-04-L01	EA	SEAT - PASSENGER - W/SKIRT (L04)
1	132263-04-L02	EA	SEAT - PASSENGER - W/SKIRT (L05)
1	132263-04-L06	EA	SEAT - PASSENGER - W/SKIRT (L06)
2	M05962-88-L01	EA	COVER - BACK (L04)
2	M05962-88-L02	EA	COVER - BACK (L05)
2	M05962-88-L03	EA	COVER - BACK (L06)
3	129666-07-L01	EA	ARMREST - RIGHT HAND (L04)
3	129666-07-L02	EA	ARMREST - RIGHT HAND (L05)
3	129666-07-L06	EA	ARMREST - RIGHT HAND (L06)
	P29666-07-L01	EA	COVER - ARMREST/RIGHT HAND (L04)
	P29666-07-L02	EA	COVER - ARMREST/RIGHT HAND (L05)
	P29666-07-L06	EA	COVER - ARMREST/RIGHT HAND (L06)
4	129666-08-L01	EA	ARMREST - LEFT HAND (L04)
4	129666-08-L02	EA	ARMREST - LEFT HAND (L05)
4	129666-08-L06	EA	ARMREST - LEFT HAND (L06)
	P29666-08-L01	EA	COVER - ARMREST/LEFT HAND (L04)
	P29666-08-L02	EA	COVER - ARMREST/LEFT HAND (L05)
	P29666-08-L06	EA	COVER - ARMREST/LEFT HAND (L06)
5	M05962-89-L01	EA	COVER - SEAT (L04)
5	M05962-89-L02	EA	COVER - SEAT (L05)
5	M05962-89-L03	EA	COVER - SEAT (L06)
6	130802-03-000	EA	SCREW F/LEVER
7	130802-01-000	EA	LEVER - LEFT HAND
7	130802-02-000	EA	LEVER - RIGHT HAND
8	132875-02-000	EA	FRAME - LEFT HAND CHAIR/TALL BACK
8	132875-01-000	EA	FRAME - RIGHT HAND CHAIR/TALL BACK
	007221-01-000	EA	SPACER - SEAT/ADJUSTER

**CURTAIN & CUSHION GROUP (CONTINUED)**  
**BUCKET SEATS (CONTINUED)**

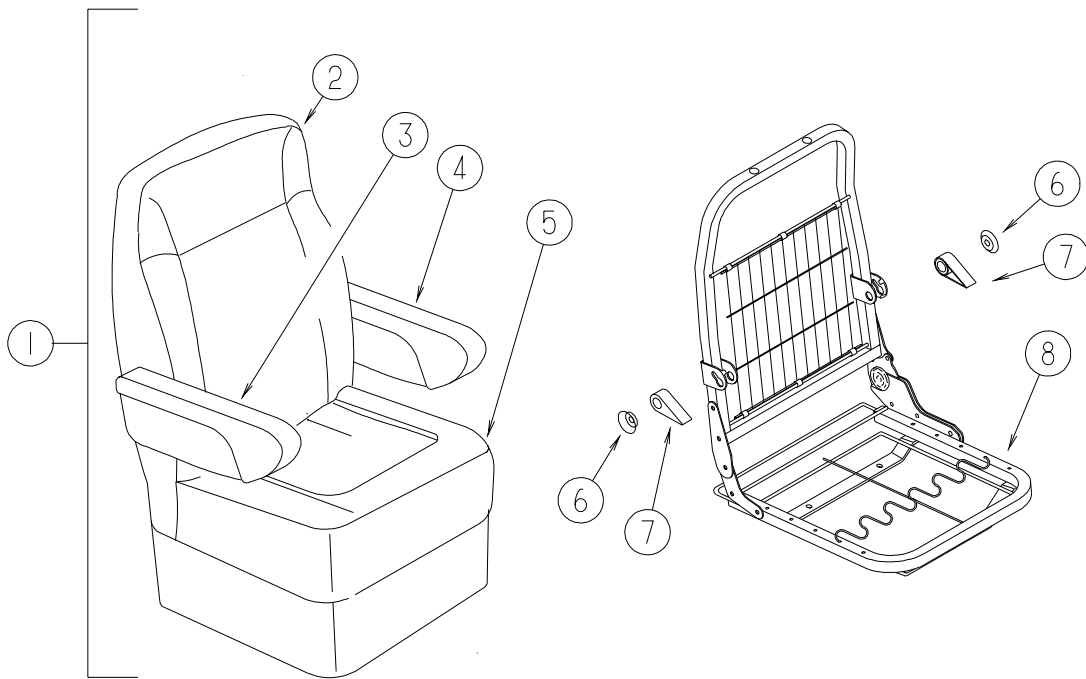

**FORD**

KEY	PART NUMBER	U/M	DESCRIPTION
1	132263-01-L01	EA	SEAT - DRIVER (L04)
1	132263-01-L02	EA	SEAT - DRIVER (L05)
1	132263-01-L06	EA	SEAT - DRIVER (L06)
1	132263-02-L01	EA	SEAT - PASSENGER (L04)
1	132263-02-L02	EA	SEAT - PASSENGER (L05)
1	132263-02-L06	EA	SEAT - PASSENGER (L06)
2	M05962-88-L01	EA	COVER - BACK (L04)
2	M05962-88-L02	EA	COVER - BACK (L05)
2	M05962-88-L03	EA	COVER - BACK (L06)
3	129666-07-L01	EA	ARMREST - RIGHT HAND (L04)
3	129666-07-L02	EA	ARMREST - RIGHT HAND (L05)
3	129666-07-L06	EA	ARMREST - RIGHT HAND (L06)
	P29666-07-L01	EA	COVER - ARMREST/RIGHT HAND (L04)
	P29666-07-L02	EA	COVER - ARMREST/RIGHT HAND (L05)
	P29666-07-L06	EA	COVER - ARMREST/RIGHT HAND (L06)
4	129666-08-L01	EA	ARMREST - LEFT HAND (L04)
4	129666-08-L02	EA	ARMREST - LEFT HAND (L05)
4	129666-08-L06	EA	ARMREST - LEFT HAND (L06)
	P29666-08-L01	EA	COVER - ARMREST/LEFT HAND (L04)
	P29666-08-L02	EA	COVER - ARMREST/LEFT HAND (L05)
	P29666-08-L06	EA	COVER - ARMREST/LEFT HAND (L06)
5	M05962-89-L01	EA	COVER - SEAT (L04)
5	M05962-89-L02	EA	COVER - SEAT (L05)
5	M05962-89-L03	EA	COVER - SEAT (L06)
6	130802-03-000	EA	SCREW F/LEVER
7	130802-01-000	EA	LEVER - LEFT HAND
7	130802-02-000	EA	LEVER - RIGHT HAND
8	132875-02-000	EA	FRAME - LEFT HAND CHAIR/TALL BACK
8	132875-01-000	EA	FRAME - RIGHT HAND CHAIR/TALL BACK
	007221-01-000	EA	SPACER - SEAT/ADJUSTER

**CURTAIN & CUSHION GROUP (CONTINUED)**  
**LOUNGE CHAIR**

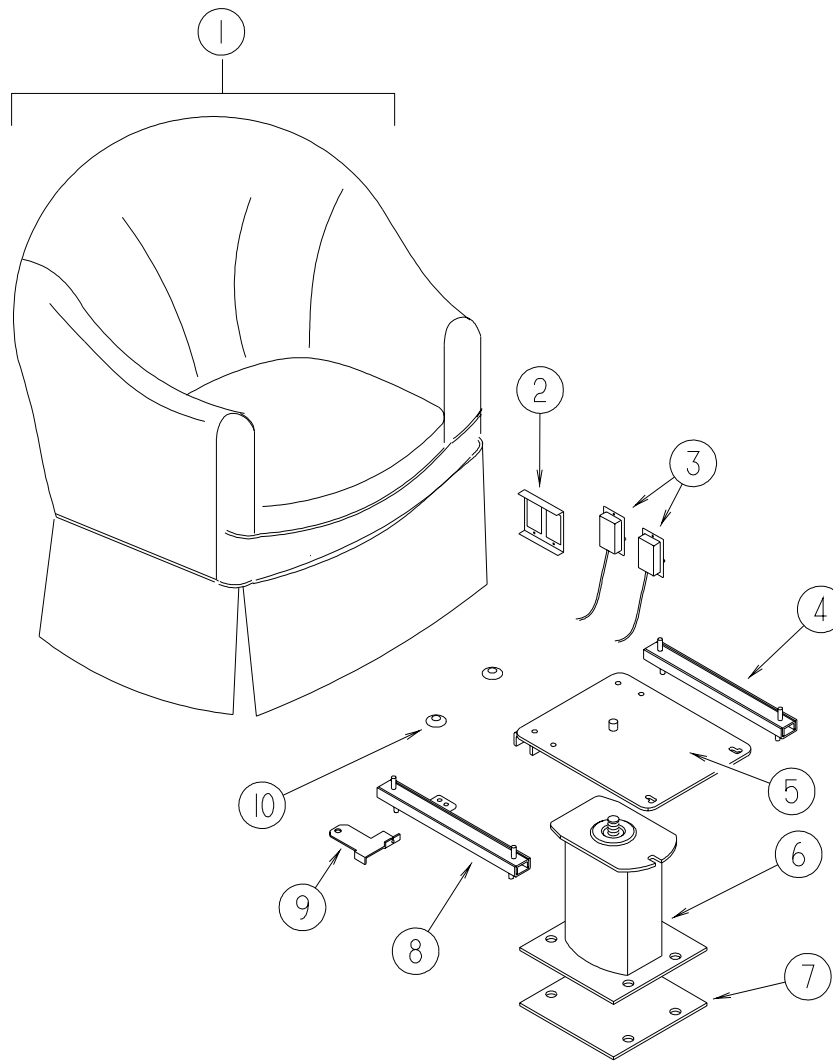

KEY	PART NUMBER	U/M	DESCRIPTION
1	115470-01-K03	EA	CHAIR - SWIVEL (L04)
1	115470-01-GB1	EA	CHAIR - SWIVEL (L05)
1	115470-01-L03	EA	CHAIR - SWIVEL (L06)
	P15470-01-K03	EA	COVER - CHAIR (L04)
	P15470-01-GB1	EA	COVER - CHAIR (L05)
	P15470-01-L03	EA	COVER - CHAIR (L06)
2	127159-02-02B	EA	BRACKET - SEAT RELEASE - DUAL REMOTE
3	108049-04-000	EA	CABLE - W/MINI LEVER ACTION SWITCH - 28" SHEATH/30" CABLE
	108049-02-000	EA	CLIP - CABLE/PEDESTAL
	010495-01-000	EA	CLAMP - CABLE - 9/16"
4	119952-01-000	EA	SLIDE/SEAT - HEAVY DUTY NON LOCKING
5	107921-08-000	EA	PLATE - TOP PEDESTAL - W/O SEAT BELT BAR
	107921-06-000	EA	BEARING KIT - PEDESTAL
6	107921-01-000	EA	PEDESTAL/FLOOR MOUNTED - W/9.75" EXTENSION
7	108445-02-000	EA	PLATE/FLOOR MOUNTED - PEDESTAL SEAT
8	119952-03-000	EA	SLIDE/SEAT - HEAVY DUTY LOCKING - 2 STUDS
9	117125-01-02B	EA	BRACKET - CABLE MOUNT - ADJUSTER W/LOCK
10	007221-01-000	EA	SPACER - SEAT/ADJUSTER

**CURTAIN & CUSHION GROUP (CONTINUED)**  
**WINDOW TREATMENT**

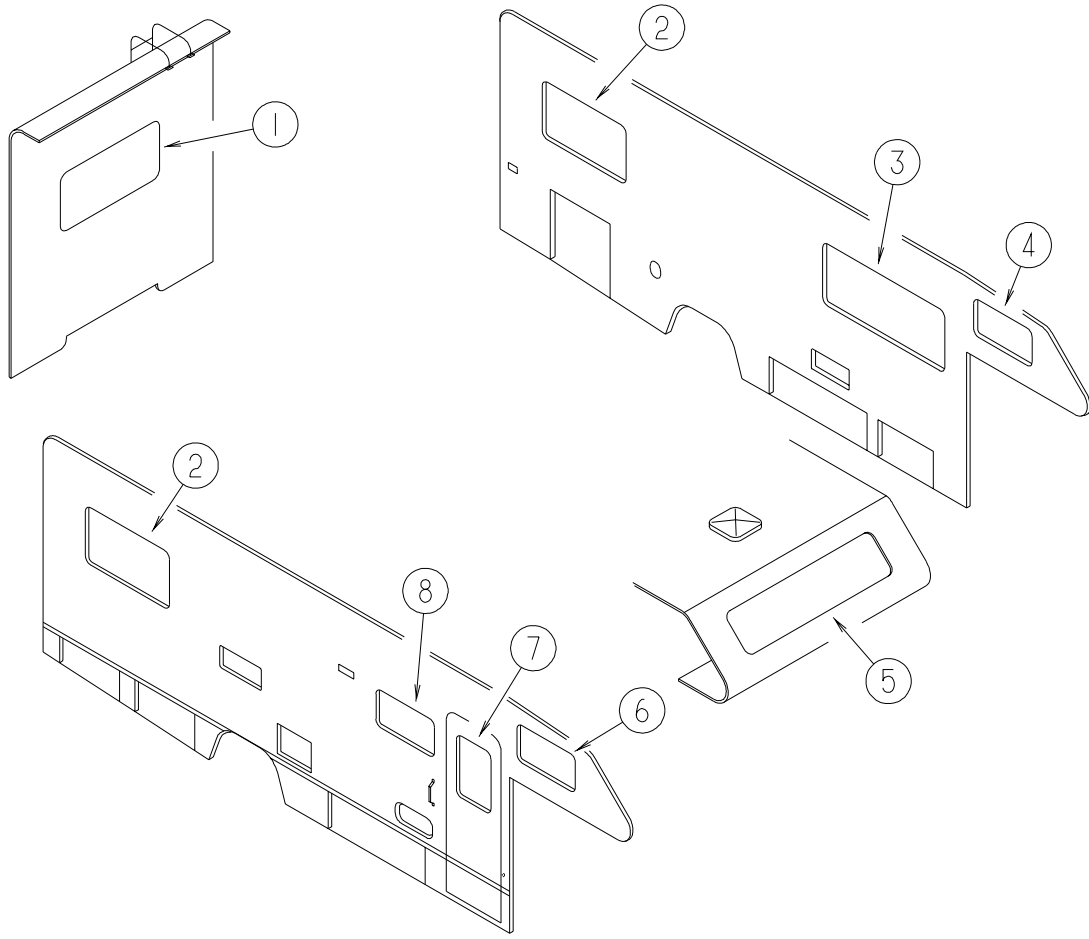

KEY	PART NUMBER	U/M	DESCRIPTION
1	P32689-01-L18	EA	COVER - VALANCE - 72" (L04)
1	P32689-01-L19	EA	COVER - VALANCE - 72" (L05)
1	P32689-01-L20	EA	COVER - VALANCE - 72" (L06)
1	111910-62-L04	EA	BLIND - DAY/NIGHTER - 49" X 27"
1	111910-62-L05	EA	BLIND - DAY/NIGHTER - 49" X 27"
1	111910-62-L06	EA	BLIND - DAY/NIGHTER - 49" X 27"
1	109041-54-03A	EA	BLIND - MINI - 49" X 27" - RENTAL
1	127017-65-L18	EA	LEG - RIGHT - 25" (L04)
1	127017-65-L19	EA	LEG - RIGHT - 25" (L05)
1	127017-65-L20	EA	LEG - RIGHT - 25" (L06)
1	127017-66-L18	EA	LEG - LEFT - 25" (L04)
1	127017-66-L19	EA	LEG - LEFT - 25" (L05)
1	127017-66-L20	EA	LEG - LEFT - 25" (L06)
2	P32689-03-L04	EA	COVER - VALANCE - 65"
2	P32689-03-L05	EA	COVER - VALANCE - 65"
2	P32689-03-L06	EA	COVER - VALANCE - 65"
2	111910-53-L04	EA	BLIND - DAY/NIGHTER - 42" X 28.5"
2	111910-53-L05	EA	BLIND - DAY/NIGHTER - 42" X 28.5"
2	111910-53-L06	EA	BLIND - DAY/NIGHTER - 42" X 28.5"
2	109041-33-03A	EA	BLIND - MINI - 42" X 28" - ALABASTER PEARL - RENTAL
2	127017-65-L18	EA	LEG - RIGHT - 25" (L04)
2	127017-65-L19	EA	LEG - RIGHT - 25" (L05)
2	127017-65-L20	EA	LEG - RIGHT - 25" (L06)
2	127017-66-L18	EA	LEG - LEFT - 25" (L04)
2	127017-66-L19	EA	LEG - LEFT - 25" (L05)
2	127017-66-L20	EA	LEG - LEFT - 25" (L06)



**CURTAIN & CUSHION GROUP (CONTINUED)**  
**WINDOW TREATMENT (CONTINUED)**

<b>KEY</b>	<b>PART NUMBER</b>	<b>U/M</b>	<b>DESCRIPTION</b>
3	132349-01-L18	EA	VALANCE - BUTTON WRAP - 64.5" (L04)
3	132349-01-L05	EA	VALANCE - BUTTON WRAP - 64.5" (L05)
3	132349-01-L20	EA	VALANCE - BUTTON WRAP - 64.5" (L06)
3	111910-57-L04	EA	BLIND - DAY/NIGHTER - 61" X 28.5"
3	111910-57-L05	EA	BLIND - DAY/NIGHTER - 61" X 28.5"
3	111910-57-L06	EA	BLIND - DAY/NIGHTER - 61" X 28.5"
3	109041-53-03A	EA	BLIND - MINI - 61" X 28.5" - RENTAL
3	127017-59-L15	EA	LEG - RIGHT - 25" (L04)
3	127017-59-L16	EA	LEG - RIGHT - 25" (L05)
3	127017-59-L06	EA	LEG - RIGHT - 25" (L06)
3	127017-60-L15	EA	LEG - LEFT - 25" (L04)
3	127017-60-L16	EA	LEG - LEFT - 25" (L05)
3	127017-60-L06	EA	LEG - LEFT - 25" (L06)
4	101034-64-L01	EA	CURTAIN - LEFT HAND - 19.5" X 31" (L04)
4	101034-64-L02	EA	CURTAIN - LEFT HAND - 19.5" X 31" (L05)
4	101034-64-L06	EA	CURTAIN - LEFT HAND - 19.5" X 31" (L06)
5	101034-61-L01	EA	CURTAIN - RIGHT HAND - 21" X 56" (L04)
5	101034-61-L02	EA	CURTAIN - RIGHT HAND - 21" X 56" (L05)
5	101034-61-L06	EA	CURTAIN - RIGHT HAND - 21" X 56" (L06)
5	101034-62-L01	EA	CURTAIN - LEFT HAND - 21" X 56" (L04)
5	101034-62-L02	EA	CURTAIN - LEFT HAND - 21" X 56" (L05)
5	101034-62-L06	EA	CURTAIN - LEFT HAND - 21" X 56" (L06)
6	101034-63-L01	EA	CURTAIN - RIGHT HAND - 19.5" X 31" (L04)
6	101034-63-L02	EA	CURTAIN - RIGHT HAND - 19.5" X 31" (L05)
6	101034-63-L06	EA	CURTAIN - RIGHT HAND - 19.5" X 31" (L06)
7	132349-02-L01	EA	VALANCE - BUTTON WRAP - 29" (L04)
7	132349-02-L05	EA	VALANCE - BUTTON WRAP - 29" (L05)
7	132349-02-L06	EA	VALANCE - BUTTON WRAP - 29" (L06)
7	084755-57-E07	EA	SHADE - PULL - 27.25"
8	109041-57-02A	EA	BLIND - MINI - 26" X 17"
8	109041-57-04A	EA	BLIND-MINI,26X17" - RENTAL
	076892-23-K03	EA	CURTAIN - CAB PRIVACY - 44" X 80" (L04)
	076892-23-J03	EA	CURTAIN - CAB PRIVACY - 44" X 80" (L05)
	076892-23-J04	EA	CURTAIN - CAB PRIVACY - 44" X 80" (L06)
	101668-39-G02	EA	CURTAIN - RIGHT HAND - 35" X 50" (L04)
	101668-39-J03	EA	CURTAIN - RIGHT HAND - 35" X 50" (L05)
	101668-39-J04	EA	CURTAIN - RIGHT HAND - 35" X 50" (L06)
	101668-40-G02	EA	CURTAIN - LEFT HAND - 35" X 50" (L04)
	101668-40-J03	EA	CURTAIN - LEFT HAND - 35" X 50" (L05)
	101668-40-J04	EA	CURTAIN - LEFT HAND - 35" X 50" (L06)
	073260-23-G02	EA	TIEBACK - 3" X 18" (L04)
	073260-23-F15	EA	TIEBACK - 3" X 18" (L05)
	073260-23-J04	EA	TIEBACK - 3" X 18" (L06)

# CURTAIN & CUSHION GROUP (CONTINUED)

## HARDWARE

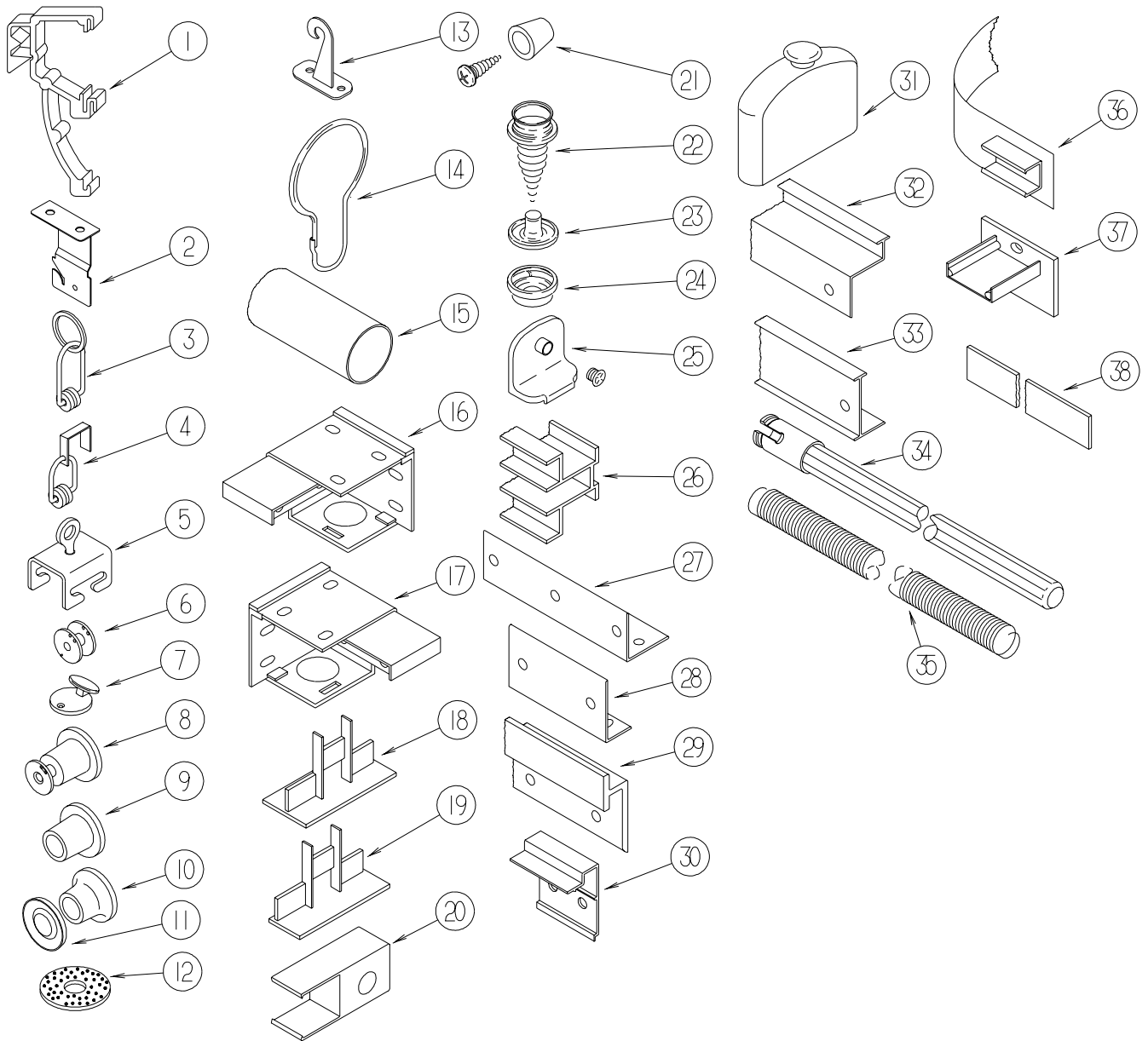

KEY	PART NUMBER	U/M	DESCRIPTION
1	109353-04-000	EA	CLIP - VALANCE SLAT MOUNTING - CLEAR PLASTIC
2	084434-01-000	EA	BRACKET - MOUNTING - ROLLER SHADE - 1 3/8"
	096843-01-000	EA	SPRING - REWIND/ROLLER SHADE
	086276-01-000	EA	TAPE - DOUBLE SIDED - 1/2"
3	009701-01-000	EA	CARRIER - CURTAIN - L ROD
4	093487-91-000	EA	ROLLER/CLIP
5	009702-01-000	EA	END STOP - CURTAIN CARRIER - L ROD
6	097592-01-000	EA	SPOOL - CORD - ELEVATED BLIND HOLDUP - SMALL - CLEAR
7	102555-03-000	EA	CLEAT - BLIND CORD - MILKX WHITE PLASTIC
8	097592-02-000	EA	SPOOL - CORD - ELEVATED BLIND HOLDUP - LARGE - CLEAR
9	094896-02-000	EA	GROMMET - CORD/PLEATED BLIND - NYLON - GRAY
10	046867-03-000	EA	GROMMET - HANDY BUTTON #3
11	046867-02-000	EA	WASHER - HANDY BUTTON #3
12	103242-01-000	EA	VELCRO HOOK - BEIGE 7/8" ROUND W/CENTER HOLE
13	109441-03-000	EA	HOLD DOWN - BLIND (CLOUDX)
	109441-02-000	EA	HOLD DOWN - SPACER
14	009136-02-000	EA	HANGER - RING - PIN TYPE - CURTAIN - BRASS
15	102075-01-02A	EA	ROD - SHOWER CURTAIN - 1" OD X 30.9" - SOFT WHITE
15	102075-06-02A	EA	ROD - SHOWER CURTAIN - 1" OD X 33.5" - SOFT WHITE
15	102075-09-01A	EA	ROD - SHOWER CURTAIN - 1" OD X 29.5" - OFF WHITE
15	102075-09-02A	EA	ROD - SHOWER CURTAIN - 1" OD X 46.3" - SOFT WHITE

**CURTAIN & CUSHION GROUP (CONTINUED)**  
**HARDWARE (CONTINUED)**

<b>KEY</b>	<b>PART NUMBER</b>	<b>U/M</b>	<b>DESCRIPTION</b>
15	102075-10-02A	EA	ROD - SHOWER CURTAIN - 1" OD X 46.3" - SOFT WHITE
15	102075-16-02A	EA	ROD - SHOWER CURTAIN - 1" OD X 34.2" - SOFT WHITE
15	102075-17-02A	EA	ROD - SHOWER CURTAIN - 1" OD X 39.3" - SOFT WHITE
15	102075-18-02A	EA	ROD - SHOWER CURTAIN - 1" OD X 38.9" - SOFT WHITE
15	102075-19-02A	EA	ROD - SHOWER CURTAIN - 1" OD X 39.3" - SOFT WHITE
16	083170-01-000	EA	BRACKET - BLIND - LEFT SIDE WHEN FACING WINDOW
17	083170-02-000	EA	BRACKET - BLIND - RIGHT SIDE WHEN FACING WINDOW
18	094907-04-000	EA	END CAP - BOTTOM/PLEATED BLIND (RH & LH)
19	094907-02-000	EA	END CAP - TOP/PLEATED BLIND - PLASTIC - GRAY
20	101033-02-000	EA	END CAP - TRACK/CLEAR
21	097564-03-000	EA	HANDLE - KNOB - E-Z LIFT SHADE - TAN
21	097564-05-000	EA	HANDLE - KNOB - E-Z LIFT SHADE - TEAL
21	097564-06-000	EA	HANDLE - KNOB - E-Z LIFT SHADE - ALABASTER
21	097564-07-000	EA	HANDLE - KNOB - E-Z LIFT SHADE - SILVER
21	000G68-06-12J	EA	SCREW 6-18X.75 POH BRASS
22	029130-01-000	EA	SCREW - SNAP SOCKET - #8 PH X 5/8"
22	029130-03-000	EA	SCREW - SNAP SOCKET - #8 PH X 1"
23	029155-01-000	EA	CAP - SNAP - 5/32" OUTSIDE DIAMETER OF PIN
24	029156-01-000	EA	SOCKET - SNAP - 9/16" O.D.
24	029156-02-000	EA	SOCKET - SNAP - 27/64" O.D.
25	106544-01-000	EA	PULL - SHADE/BRASS
	106544-01-001	EA	SCREW - SHADE/BRASS
26	101033-08-000	EA	TRACK - WALL - 75"
26	101033-09-000	EA	TRACK - WALL - 32"
27	105648-01-02A	EA	BRACE - VALANCE - OFF/WHITE - 14"
27	075943-10-000	EA	BRACE - VALANCE - 20"
28	083125-07-000	EA	BRACE - WINDOW MOUNT - 2.5" - OFF WHITE
28	083125-08-000	EA	BRACE - WINDOW MOUNT - 3/4 - OFF WHITE
29	127254-03-02A	EA	TRACK - CURTAIN/RIGHT HAND - ANTELOPE - F & G SERIES
29	127254-03-03A	EA	TRACK - CURTAIN/RIGHT HAND - TITANIUM - F & G SERIES
29	133236-01-02A	EA	TRACK - CURTAIN/RIGHT HAND - TITANIUM - P SERIES
29	133236-01-01A	EA	TRACK - CURTAIN/RIGHT HAND - ANTELOPE - P SERIES
29	127254-04-02A	EA	TRACK - CURTAIN/LEFT HAND - ANTELOPE - F & G SERIES
29	127254-04-03A	EA	TRACK - CURTAIN/LEFT HAND - TITANIUM - F & G SERIES
29	133235-01-02A	EA	TRACK - CURTAIN/LEFT HAND - ANTELOPE - P SERIES
29	133235-01-01A	EA	TRACK - CURTAIN/LEFT HAND - ANTELOPE - P SERIES
30	076827-02-000	EA	BRACKET - LEG - 2.9" X 1.8" - TRIANGLE
31	093475-01-701	EA	CAP-END, WITH INVERTED STUD
32	105450-14-01A	EA	TRACK - CURTAIN - 90" - OFF WHITE
33	009700-04-002	EA	TRACK - CURTAIN - L SHAPED - 15.5' - OFF WHITE
33	009700-04-002	EA	TRACK - CURTAIN - L SHAPED - 15.5' - OFF WHITE
33	118896-05-02A	EA	TRACK - CURTAIN - RIGHT HAND - HAMPTON TAN - Q-SERIES
33	118897-04-02A	EA	TRACK - CURTAIN - RIGHT HAND - HAMPTON TAN - Q-SERIES
33	126456-01-03A	EA	TRACK - CURTAIN - RIGHT HAND - TITANIUM - L-SERIES
33	126456-02-03A	EA	TRACK - CURTAIN - LEFT HAND - TITANIUM - L-SERIES
33	126456-03-02A	EA	TRACK - CURTAIN - RIGHT HAND - ANTELOPE - L-SERIES
33	126456-04-02A	EA	TRACK - CURTAIN - LEFT HAND - ANTELOPE - L-SERIES
34	093487-90-000	EA	WAND - 30" - FRONT WRAP AROUND
35	097591-01-000	EA	SPRING - EXTENSION/PLEATED BLIND
36	101031-01-000	YD	TAPE - GLIDE/CURTAIN - 4.25" SPACING
37	094907-06-000	EA	HARDWARE - END CAP - E-Z LIFT - TOP
38	089275-01-000	FT	STRIP - 3/4" X 96" - CLEAR POLYETHYLENE
	094908-03-000	FT	HARDWARE - SEMI-RIDGED PVC - EZ LIFT
	094908-04-000	FT	STRAP - FLAT POLY VINYL
	095567-01-000	EA	TACK - STRIP - .5" X 625' ROLL
	097593-02-000	FT	CORD - BLIND - PLEATED - GRAY
	097593-06-000	FT	CORD - BLIND - PLEATED - PEWTER
	097593-07-000	FT	CORD - BLIND - PLEATED - PALE JADE
	097593-10-000	FT	CORD - BLIND - PLEATED - VANILLA

**CURTAIN & CUSHION GROUP (CONTINUED)**  
**ACCESSORIES**

<b>KEY</b>	<b>PART NUMBER</b>	<b>U/M</b>	<b>DESCRIPTION</b>
	007021-01-000	EA	SEAT BELT - 2" X 90" - BLACK
	057759-01-000	EA	WASHER - FLAT F/SEAT BELT - 4" DIAMETER
	000C16-07-16B	EA	BOLT - CARRIAGE - ASSIST HANDLE - 7/16-14 X 1
	000D20-07-00B	EA	NUT - ACORN - ASSIST HANDLE - 7/16 - 14
	053552-02-K01	EA	HANDLE - ASSIST - INTERIOR/ENTRY DOOR - VINYL/OFF WHITE
	057534-03-000	EA	TIEBACK - CLEAR PLASTIC - 7.5"
	069178-03-000	EA	BRACKET - MOUNTING/ASSIST HANDLE - ANY COLOR
	118337-04-L18	EA	BUTTON - #60 - FABRIC COVERED (L04)
	118337-04-L19	EA	BUTTON - #60 - FABRIC COVERED (L05)
	118337-04-L06	EA	BUTTON - #60 - FABRIC COVERED (L06)
	127960-01-01A	EA	RETAINER - 3/8" - STAINLESS STEEL
	074494-02-000	EA	BUTTON - RETAINING PIVOT - #60
	074494-03-000	EA	BUTTON - SERRATED PIVOT - W/3/8 TACK

**CURTAIN & CUSHION GROUP (CONTINUED)**  
**FABRICS**

Color Codes	L04	L05	L06
	MEADOWBROOK	BLUEBONNET	RIVERWALK
BUCKET SEATS	108446-C5-000	108446-F7-000	108446-S6-000
DINETTE CUSHIONS	126883-03-000	126883-48-000	126883-04-000
DINETTE PADS	108446-C5-000	108446-F7-000	108446-S6-000
SOFA	126883-03-000	126883-48-000	126883-04-000
SWIVEL CHAIR	108446-S7-000	108446-F4-000	126883-53-000
LOUNGE/DINETTE VALANCE/LEG	126883-03-000	126883-48-000	126883-04-000
LOUNGE/DINETTE OVERLAYS	108446-C5-000	108446-F7-000	108446-S6-000
BEDROOM VALANCE/LEG	105745-L1-000	105745-M4-000	105745-G6-000
BEDROOM UNDERLAYS	105745-45-000	105745-64-000	105745-B5-000
BEDSPREAD	105745-L1-000	105745-M4-000	105745-G6-000
PILLOW SHAMS	105745-L1-000 105745-45-000	105745-M4-000 105745-64-000	105745-G6-000 105745-B5-000
ENTRANCE DOOR VALANCE	108446-C5-000	108446-F7-000	108446-S6-000
BUNK CUSHIONS	108446-S7-000	108446-F4-000	126883-53-000
DIVIDER CURTAIN	105745-45-000 105745-L1-000	105745-64-000 105745-M4-000	105745-B5-000 105745-G6-000
WRAP AROUND	105745-45-000	105745-64-000	105745-B5-000
BUNK CURTAINS	105745-G2-000	105745-65-000	105745-G6-000
BUNK/PRIVACY CURTAINS	105745-45-000	105745-64-000	105745-B5-000
DRAPERY LINING	087272-03-000	087272-03-000	087272-03-000
TIRE COVER	103907-05-000	103907-05-000	103907-05-000
HEADLINER	103907-01-06A	103907-01-06A	103907-01-06A
CEILING	113979-09-01A	113979-09-01A	113979-09-01A
VINYL	103907-01-01A	103907-01-01A	103907-01-01A

**NOTE: FABRIC LISTED FIRST IN A BLOCK, IS THE LARGEST AMOUNT USED**

## DINETTE GROUP CABINETS

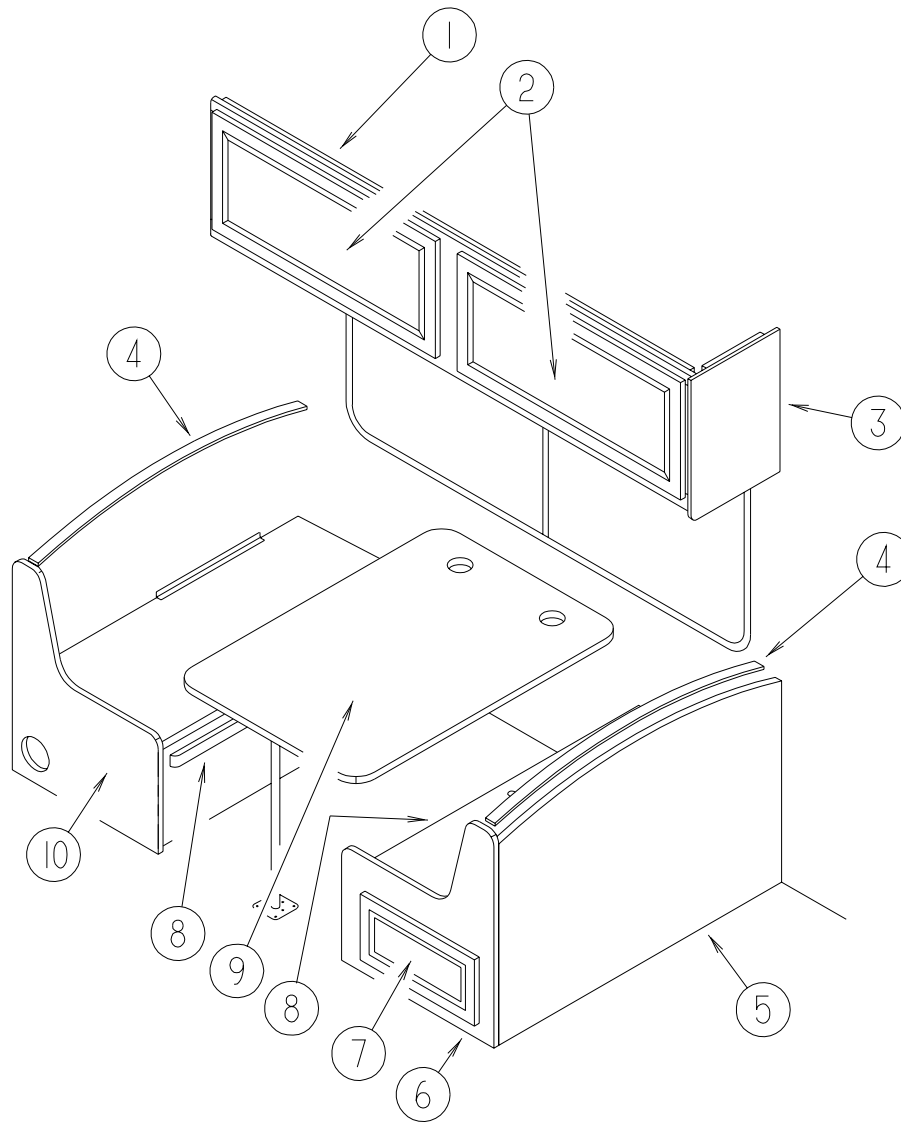

KEY	PART NUMBER	U/M	DESCRIPTION
1	131926-02-L01	EA	CABINET - OVERHEAD - W/O DOORS/HARDWARE
2	132141-14-L01	EA	DOOR - RAIL/VENEER - 15.7" X 27.9" - W/O HARDWARE
3	109908-80-K04	EA	END CAP - OVERHEAD CABINET
4	111338-11-K03	EA	PAD - DINETTE SEATBACK (L04)
4	111338-11-J03	EA	PAD - DINETTE SEATBACK (L05)
4	111338-11-K06	EA	PAD - DINETTE SEATBACK (L06)
5	M08123-16-J01	EA	CABINET - SEATBACK - RIGHT HAND
6	M08122-17-J01	EA	CABINET - SEATBASE - RIGHT HAND - W/O DOOR/DRAWER/HDW
7	131995-G4-L01	EA	DOOR - RAIL/SOLID PANEL - 10" X 19.1" - W/O HARDWARE
8	081295-01-G01	EA	SUPPORT - BED/DINETTE - 28" LONG
9	132034-01-L01	EA	TABLE TOP ONLY (L04)
9	132034-01-L02	EA	TABLE TOP ONLY (L05)
9	132034-01-L06	EA	TABLE TOP ONLY (L06)
10	M08122-24-J01	EA	CABINET - SEATBASE - LEFT HAND - W/O DOOR/DRAWER/HDW

**DINETTE GROUP (CONTINUED)**  
**TABLE**

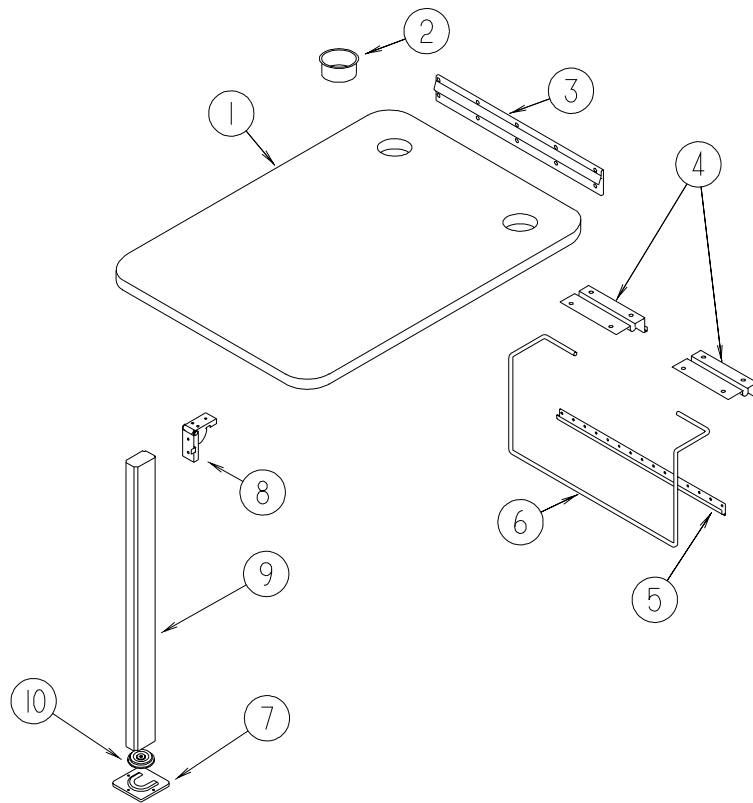

KEY	PART NUMBER	U/M	DESCRIPTION
1	132034-01-L01	EA	TABLE TOP ONLY (L04)
1	132034-01-L02	EA	TABLE TOP ONLY (L05)
1	132034-01-L06	EA	TABLE TOP ONLY (L06)
2	064781-06-000	EA	HOLDER/CUP - TWO STEP - OFF WHITE
3	053200-13-000	EA	SUPPORT - TABLE - 18.5"
4	088410-02-000	EA	BRACKET - LIFT - TABLE MOUNTED
5	024281-15-000	EA	BRACKET/TABLE - LIFT ROD/LOWER WALL MOUNTED - 17.1"
6	024275-13-000	EA	ROD - TABLE LIFT - OFF/WHITE
7	049493-12-000	EA	CATCH - TABLE LEG/FLOOR MOUNTED - OFF WHITE
8	093550-01-000	EA	BRACKET - HINGE - MOUNTS TO LEG & TABLE TOP - 1.7" X 2.6"
9	092707-04-05A	EA	LEG - TABLE - W/O HARDWARE - 27" - WATERFORD OAK
10	092593-01-05A	EA	CATCH - TABLE LEG - OFF/WHITE

**DRIVERS COMPARTMENT GROUP  
INSTRUMENT PANEL**

**CHEVY**

<b>KEY</b>	<b>PART NUMBER</b>	<b>U/M</b>	<b>DESCRIPTION</b>
	094797-13-000	EA	CLUSTER - INSTRUMENT PANEL - KILOMETERS/MILES
	111414-01-000	EA	RECEPTACLE - 12V - W/O BIMETAL
	100138-01-000	EA	MODULE - DAYTIME/RUNNING LIGHT
	108357-09-000	EA	SWITCH - ROCKER SPDT - ON/NONE/MOM - 3 TERMINAL - AUX START
	108356-07-01A	EA	COVER/ACTUATOR SWITCH - 2 ROWS DIMPLES - AUX START - BLACK
	081994-07-000	EA	PLATE - SWITCH - AUX. START

**FORD**

<b>KEY</b>	<b>PART NUMBER</b>	<b>U/M</b>	<b>DESCRIPTION</b>
	094795-09-000	EA	CLUSTER - INSTRUMENT PANEL - KILOMETERS - GAS/DIESEL-FORD
	111414-01-000	EA	RECEPTACLE - 12V - W/O BIMETAL
	100138-01-000	EA	MODULE - DAYTIME/RUNNING LIGHT
	108357-09-000	EA	SWITCH - ROCKER SPDT - ON/NONE/MOM - 3 TERMINAL - AUX START
	108356-07-01A	EA	COVER/ACTUATOR SWITCH - 2 ROWS DIMPLES - AUX START - BLACK
	081994-07-000	EA	PLATE - SWITCH - AUX. START



**DRIVERS COMPARTMENT GROUP (CONTINUED)**  
**FRONT INTERIOR**

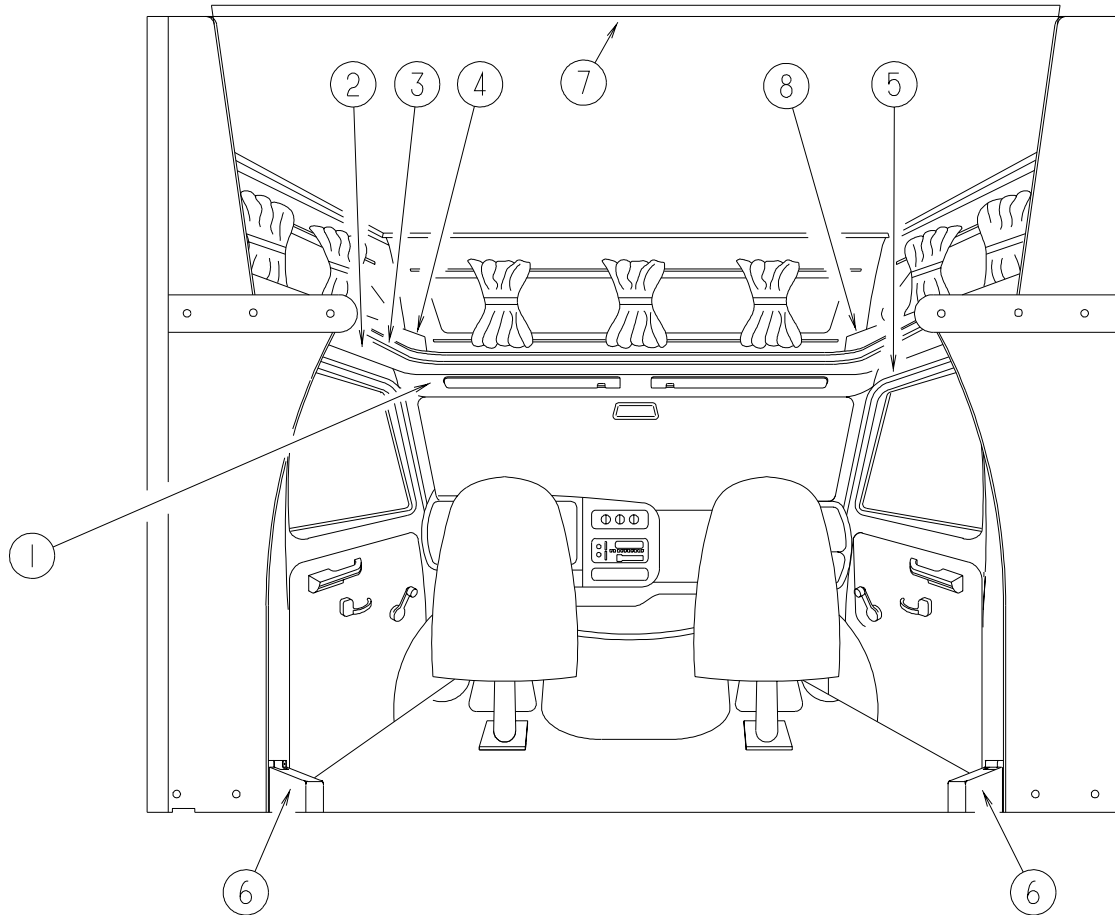

**CHEVY**

KEY	PART NUMBER	U/M	DESCRIPTION
1	124818-01-H04	EA	HEADLINER - W/VINYL
2	124819-01-H04	EA	TRIM - CAB DOOR - UPPER/LEFT HAND
3	119520-01-01A	FT	MOLDING-T - 1" - W/EDGE LIPS (OFF/WHITE-CREAM)
4	109894-01-L01	EA	CABINET - HAMPER - DRIVER/FRONT (L04)
4	109894-01-L02	EA	CABINET - HAMPER - DRIVER/FRONT (L05)
4	109894-01-L06	EA	CABINET - HAMPER - DRIVER/FRONT (L06)
5	124817-01-H04	EA	TRIM - CAB DOOR - UPPER/RIGHT HAND
6	076302-03-000	EA	SEAT BELT - DRIVER/PASSENGER
	087932-03-000	EA	BRACKET - SHOULDER HARNESS - LEFT HAND
	087932-04-000	EA	BRACKET - SHOULDER HARNESS - RIGHT HAND
7	082111-02-000	EA	COVER - ROOF BREAK - OFF WHITE
7	131666-01-01A	EA	TRIM - FRONT ROOF SECTION
8	109894-03-L01	EA	CABINET - HAMPER - PASSENGER/FRONT (L04)
8	109894-03-L02	EA	CABINET - HAMPER - PASSENGER/FRONT (L05)
8	109894-03-L06	EA	CABINET - HAMPER - PASSENGER/FRONT (L06)
	124182-03-01A	EA	MAT - PASSENGER - ITASCA/CHEVY
	124182-04-01A	EA	MAT - DRIVER - ITASCA/CHEVY

**DRIVERS COMPARTMENT GROUP (CONTINUED)**  
**FRONT INTERIOR (CONTINUED)**

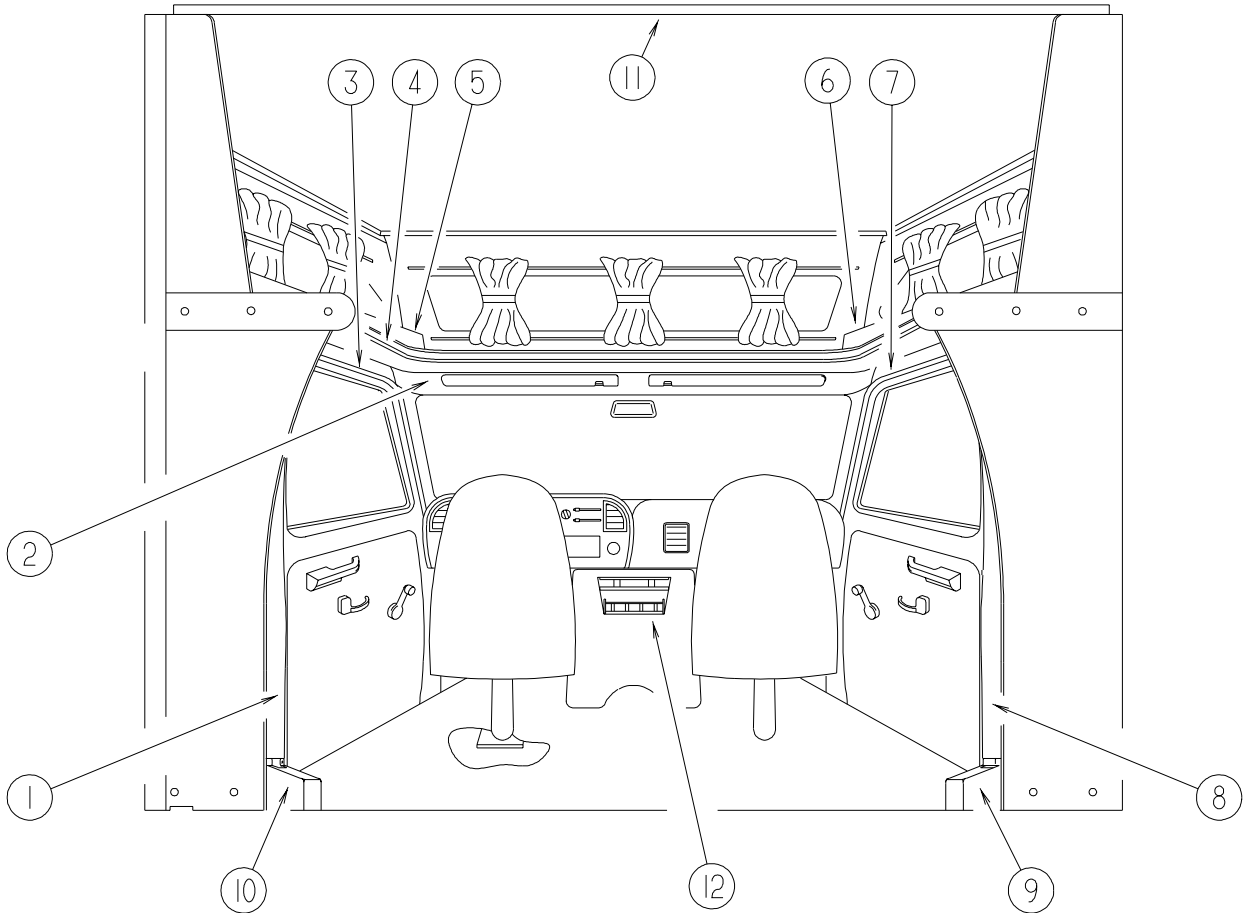

**FORD**

KEY	PART NUMBER	U/M	DESCRIPTION
1	125031-02-H04	EA	TRIM - CAB - B-PILLAR - DRIVER SIDE
2	106448-01-H04	EA	HEADLINER - W/VINYL
3	106447-04-H04	EA	TRIM - CAB DOOR - UPPER/LEFT HAND
4	119520-01-01A	FT	MOLDING-T - 1" - W/EDGE LIPS (OFF/WHITE-CREAM)
5	109894-01-L01	EA	CABINET - HAMPER - DRIVER/Front (L04)
5	109894-01-L02	EA	CABINET - HAMPER - DRIVER/Front (L05)
5	109894-01-L06	EA	CABINET - HAMPER - DRIVER/Front (L06)
6	109894-03-L01	EA	CABINET - HAMPER - PASSENGER/Front (L04)
6	109894-03-L02	EA	CABINET - HAMPER - PASSENGER/Front (L05)
6	109894-03-L06	EA	CABINET - HAMPER - PASSENGER/Front (L06)
7	106447-03-H04	EA	TRIM - CAB DOOR - UPPER/RIGHT HAND
8	125031-01-H04	EA	TRIM - CAB - B-PILLAR - PASSENGER SIDE
9	106431-01-02A	EA	COVER - SEATBELT RECOIL - PASSENGER SIDE - VW GRAY
10	106431-02-02A	EA	COVER - SEATBELT RECOIL - DRIVER SIDE - VW GRAY
11	131666-02-01A	EA	TRIM - FRONT ROOF SECTION
11	082111-02-000	EA	COVER - ROOF BREAK - OFF WHITE
12	125291-02-01A	EA	TRAY/BEVERAGE - F/DELUXE MOTOR COVER - 19999 CHASSIS
12	134093-01-01A	EA	CONSOLE-FORD,MODIFIED - 2000 CHASSIS
	133834-01-01A	EA	TRAY - BEVERAGE - 2 HOLE/INSERT MOTOR COVER - WATERFORD
	133831-01-01A	EA	HOLDER - CUP W/THREE CENTERLINE RUBBER FINGERS
	125780-03-000	EA	MAT - FLOOR - FRONT PASSENGER - "1" - FORD
	125780-04-000	EA	MAT - FLOOR - FRONT DRIVER - "1" - FORD

# DRIVERS COMPARTMENT GROUP (CONTINUED)

## CABINETS

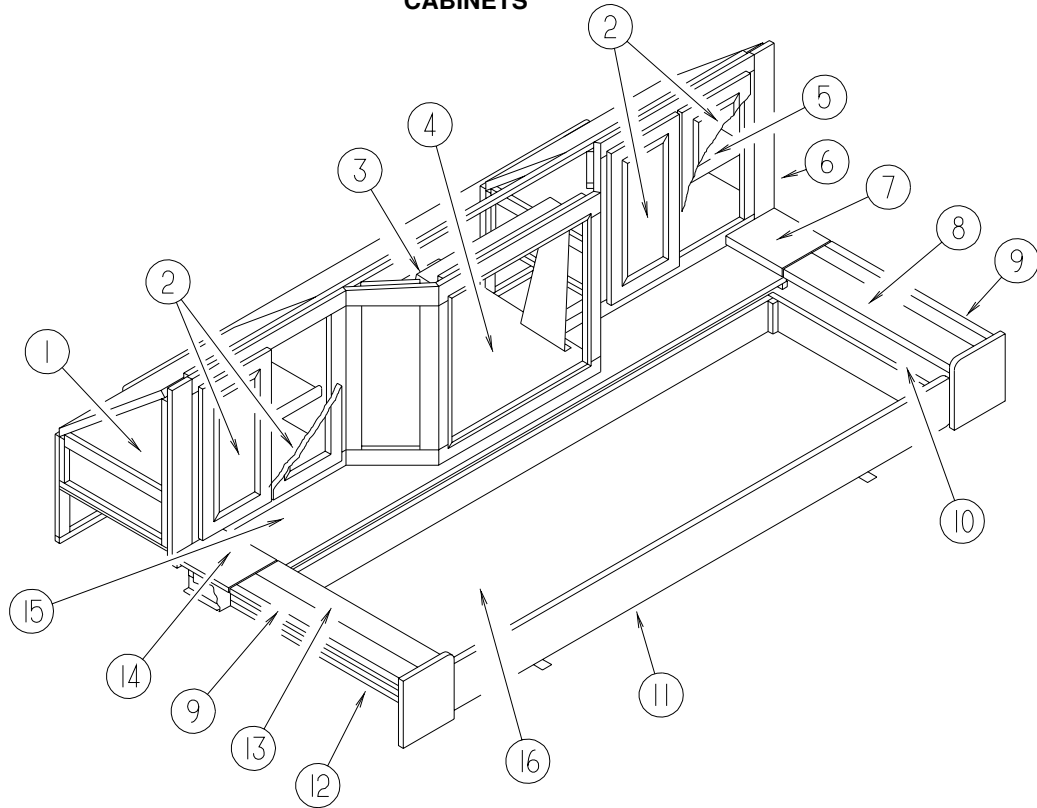

KEY	PART NUMBER	U/M	DESCRIPTION
1	133221-02-L07	EA	CABINET - ENTERTAINMENT CENTER/SHELF - W/O HARDWARE
	113156-11-G04	EA	SHELF - ENTERTAINMENT CENTER - W/MOLDING
2	132141-A1-L04	EA	DOOR - RAIL/VENEER - 10.8" X 21.8" - W/O HARDWARE
3	110790-03-000	EA	BRACKET - TIEDOWN/TV
	106699-01-01A	EA	BRACKET - OVERHEAD CABINET/TV
	122790-02-02B	EA	BRACKET - VCP - E-COATED
4	111356-02-J01	EA	SHELF - TV - W/TIEDOWN BRACKET
5	133221-01-L07	EA	CABINET - ENTERTAINMENT CENTER/SHELF - W/O HARDWARE
	133221-11-L07	EA	SHELF - W/MOLDING
6	133222-01-L01	EA	CABINET - ENTERTAINMENT CENTER FACE - W/O HARDWARE
7	113155-11-L01	EA	COUNTERTOP - ENTERTAINMENT CENTER STORAGE (L04)
7	113155-11-L02	EA	COUNTERTOP - ENTERTAINMENT CENTER STORAGE (L05)
7	113155-11-F09	EA	COUNTERTOP - ENTERTAINMENT CENTER STORAGE (L06)
8	113155-12-L01	EA	COUNTERTOP - ENTERTAINMENT CENTER STORAGE (L04)
8	113155-12-L02	EA	COUNTERTOP - ENTERTAINMENT CENTER STORAGE (L05)
8	113155-12-G07	EA	COUNTERTOP - ENTERTAINMENT CENTER STORAGE (L06)
9	113155-21-K08	EA	COUNTERTOP - ENTERTAINMENT CENTER STORAGE (L04)
9	113155-21-K02	EA	COUNTERTOP - ENTERTAINMENT CENTER STORAGE (L05)
9	113155-21-F09	EA	COUNTERTOP - ENTERTAINMENT CENTER STORAGE (L06)
10	113155-01-L01	EA	CABINET/STORAGE - RIGHT END - W/FLIP UP COUNTERTOP (L04)
10	113155-01-L02	EA	CABINET/STORAGE - RIGHT END - W/FLIP UP COUNTERTOP (L05)
10	113155-01-H07	EA	CABINET/STORAGE - RIGHT END - W/FLIP UP COUNTERTOP (L06)
11	100847-11-J02	EA	FACE - DRAWER VINYL COVERED - 5.5" X 76.7"
12	113155-02-L01	EA	CABINET/STORAGE - LEFT END - W/FLIP UP COUNTERTOP (L04)
12	113155-02-L02	EA	CABINET/STORAGE - LEFT END - W/FLIP UP COUNTERTOP (L05)
12	113155-02-G25	EA	CABINET/STORAGE - LEFT END - W/FLIP UP COUNTERTOP (L06)
13	113155-18-L01	EA	COUNTERTOP - ENTERTAINMENT CENTER STORAGE (L04)
13	113155-18-L02	EA	COUNTERTOP - ENTERTAINMENT CENTER STORAGE (L05)
13	113155-18-G07	EA	COUNTERTOP - ENTERTAINMENT CENTER STORAGE (L06)
14	113155-19-L01	EA	COUNTERTOP - ENTERTAINMENT CENTER STORAGE (L04)
14	113155-19-L02	EA	COUNTERTOP - ENTERTAINMENT CENTER STORAGE (L05)
14	113155-19-F09	EA	COUNTERTOP - ENTERTAINMENT CENTER STORAGE (L06)
15	133222-12-L01	EA	SHELF - OVERHEAD - W/T-MOLDING
16	100847-01-L01	EA	DRAWER - ENTERTAINMENT CENTER - W/O HARDWARE (L04)
16	100847-01-L02	EA	DRAWER - ENTERTAINMENT CENTER - W/O HARDWARE (L05)
16	100847-01-L06	EA	DRAWER - ENTERTAINMENT CENTER - W/O HARDWARE (L06)

## ELECTRICAL GROUP LIGHTS

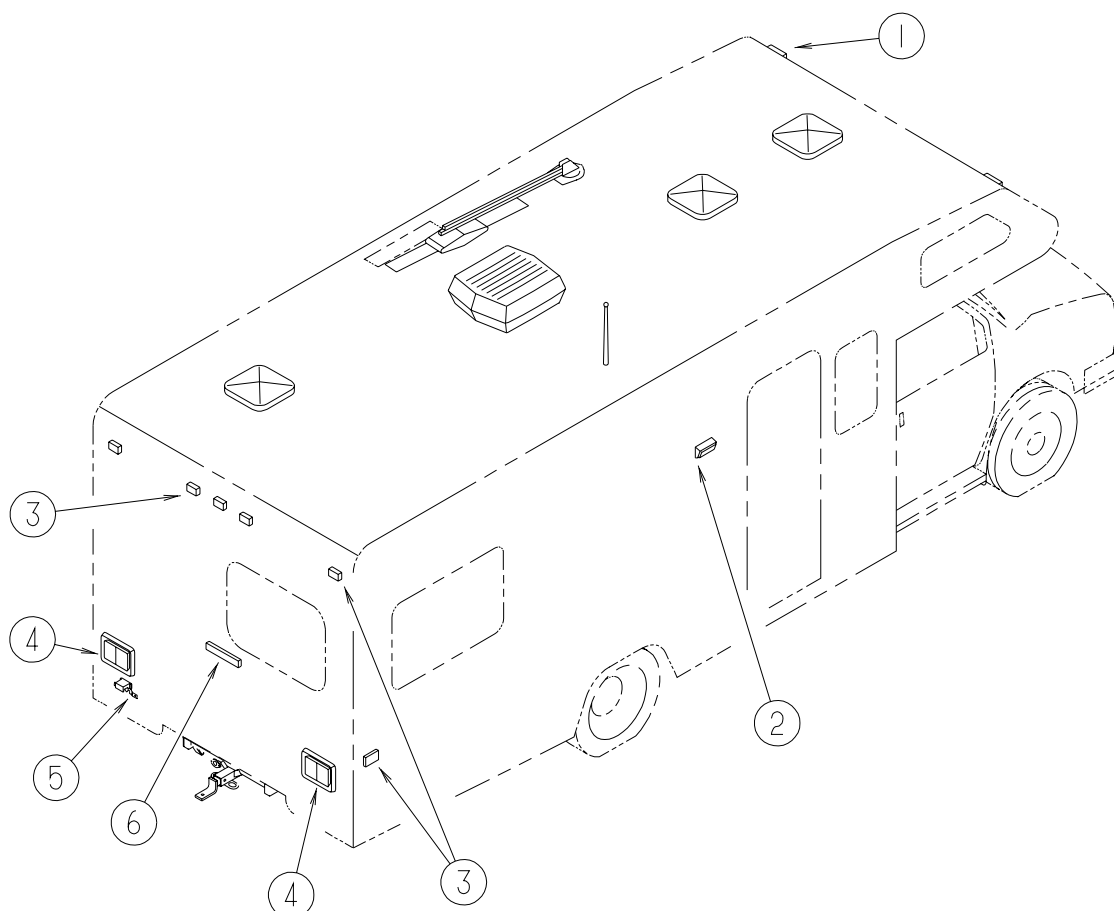

KEY	PART NUMBER	U/M	DESCRIPTION
1	111102-02-000	EA	LENS - AMBER - MARKER LAMP
	111102-01-000	EA	BASE - MARKER LAMP
	036196-01-000	EA	BULB - 12V - #194 - .27 AMP - BAYONETTE
2*	097917-01-06A	EA	LIGHT - PORCH - BRIGHT WHITE
	008215-01-000	EA	BULB - 12 VOLT - #1003 - .94 AMP
2*	008089-02-000	EA	LIGHT - PORCH - RECESSED - CANADIAN
	008214-01-000	EA	BULB - 12 VOLT - #67 - .59 AMP
	111102-03-000	EA	LENS - RED - MARKER LAMP
3	111102-01-000	EA	BASE - MARKER LAMP
	036196-01-000	EA	BULB - 12V - #194 - .27 AMP - BAYONETTE
	103355-02-01A	EA	POD - TAIL LIGHT - BRIGHT WHITE
*	081638-01-000	EA	TAILLIGHT/DOUBLE W/BLACK TRIM - DRIVER/PASSENGER SIDE
	037934-01-000	EA	BULB - 12V - #1156 - 2.1 AMP CLEAR GLASS
	037935-01-000	EA	BULB - 12V - #1157 OR #2057 - 2.1 AMP - CLEAR GLASS
5	066432-02-000	EA	LIGHT - LICENSE - BLACK
	066432-03-000	EA	BRACKET - LICENSE PLATE
6	121950-01-000	EA	LIGHT - BRAKE - CENTER MOUNT

**\*COMPONENT PARTS FOUND IN SERVICE PARTS LIBRARY**

**ELECTRICAL GROUP (CONTINUED)**  
**LIGHTS (CONTINUED)**

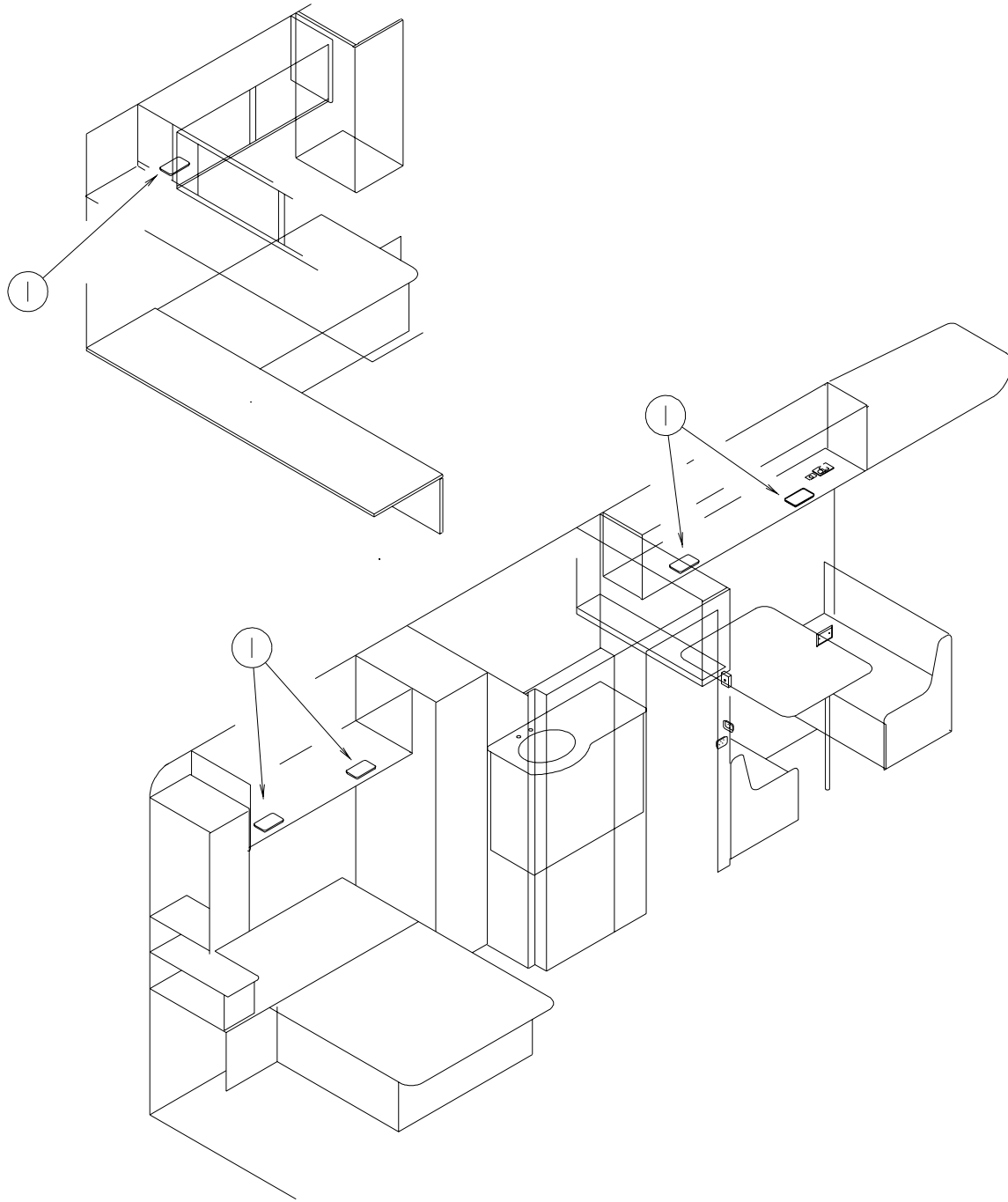

KEY	PART NUMBER	U/M	DESCRIPTION
1*	098024-05-02A	EA	LIGHT - DOME - 1 BULB - SKYLITE/OPTI CLEAR
	008218-01-000	EA	BULB - 12 VOLT - #1141 - 1.44 AMP

**\*COMPONENT PARTS FOUND IN SERVICE PARTS LIBRARY**

**ELECTRICAL GROUP (CONTINUED)**  
**LIGHTS (CONTINUED)**

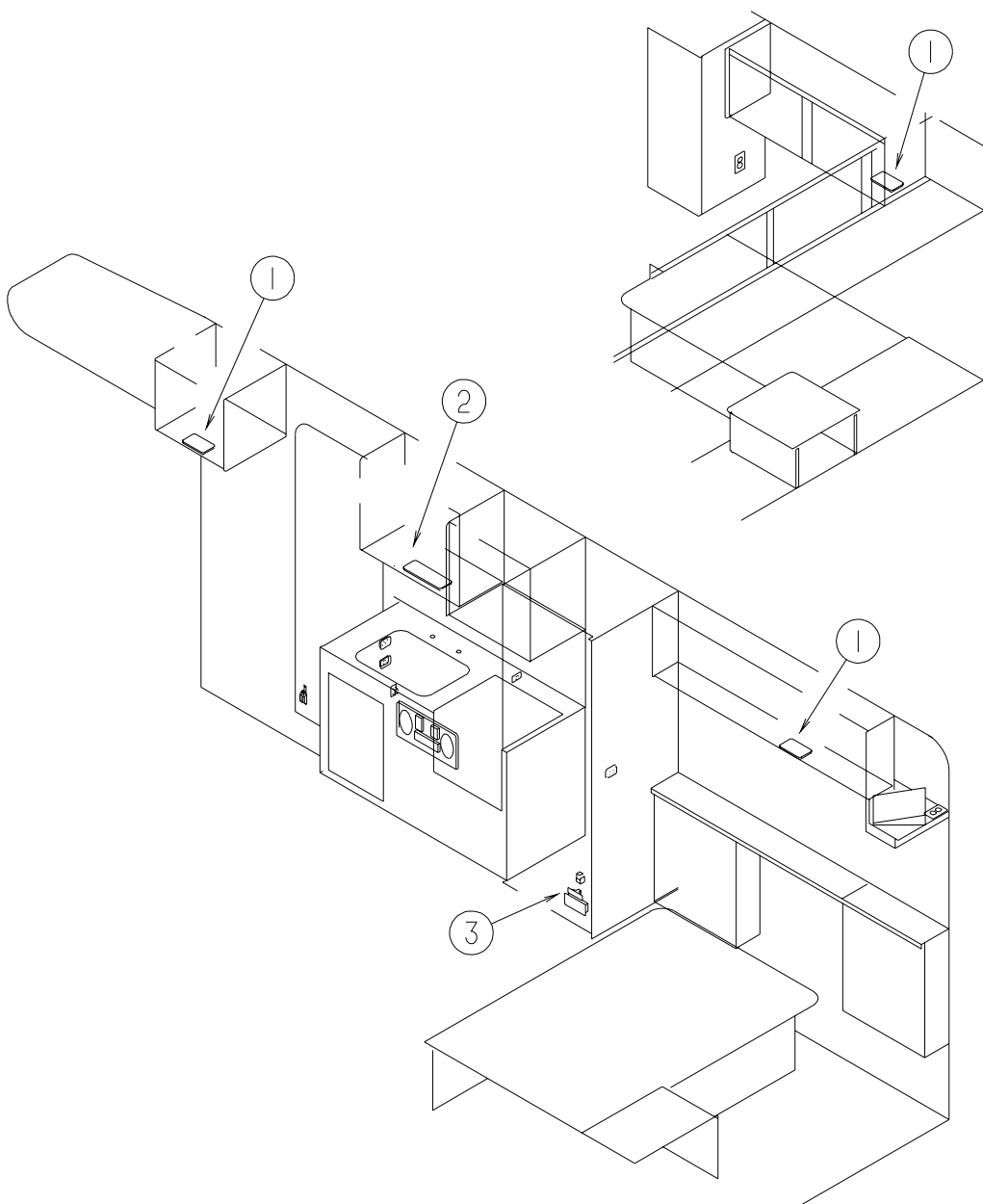

KEY	PART NUMBER	U/M	DESCRIPTION
1*	098024-05-02A	EA	LIGHT - DOME - 1 BULB - SKYLITE/OPTI CLEAR
	008218-01-000	EA	BULB - 12 VOLT - #1141 - 1.44 AMP
2*	098024-06-02A	EA	LIGHT - DOME - 2 BULB - SKYLITE/OPTI CLEAR
	008218-01-000	EA	BULB - 12 VOLT - #1141 - 1.44 AMP
3	061424-01-000	EA	LIGHT - AISLE - 12 VOLT - RECTANGULAR
	008103-01-000	EA	BULB - DASH/AISLE LIGHT - #53 - 12 VOLT - .12 AMP

**\*COMPONENT PARTS FOUND IN SERVICE PARTS LIBRARYRARY**

**ELECTRICAL GROUP (CONTINUED)**  
**LIGHTS (CONTINUED)**

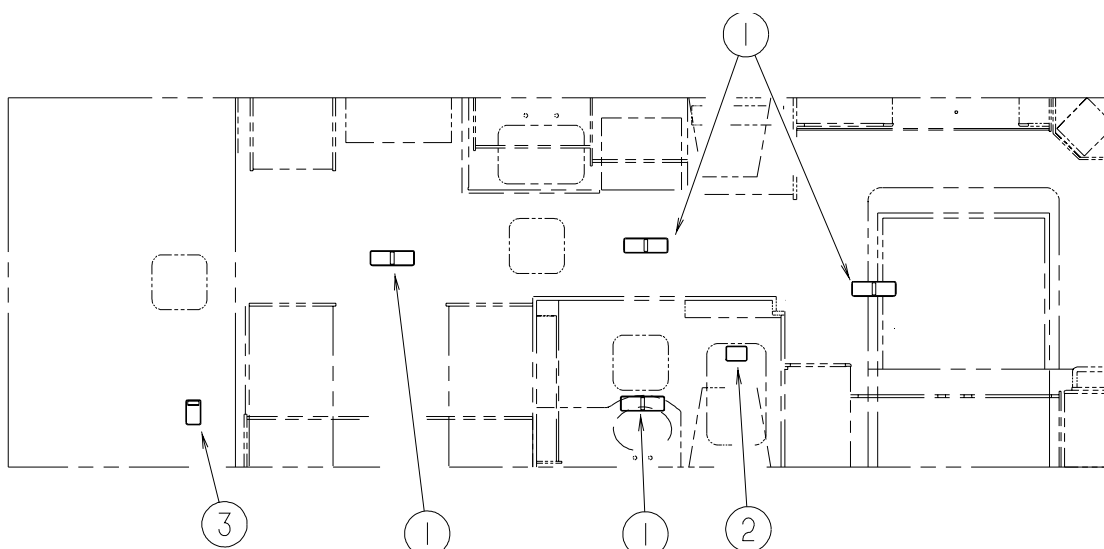

KEY	PART NUMBER	U/M	DESCRIPTION
1	098024-08-02A	EA	LIGHT - DOME W/O SWITCH - 2 BULB FROM: 00-00-00 THRU: 03-05-00
	098024-09-02A	EA	LIGHT - DOME - 1 LENS/2 BULB FIXTURE - NO SWITCH FROM: 03-06-00 THRU: 99-99-99
2*	121935-01-01A	EA	LIGHT - DOME - SHOWER
3*	098024-05-02A	EA	LIGHT - DOME - 1 BULB - SKYLITE/OPTI CLEAR
	008218-01-000	EA	BULB - 12 VOLT - #1141 - 1.44 AMP

\*COMPONENT PARTS FOUND IN SERVICE PARTS LIBRARY

**CIRCUIT BREAKERS & FUSES**

KEY	PART NUMBER	U/M	DESCRIPTION
	008235-01-000	EA	FUSE - 15 AMP/12VOLT - AUTOMOTIVE
	062901-02-000	EA	FUSE - 5 AMP - AUTOMOTIVE
	062901-05-000	EA	FUSE - 15 AMP - AUTOMOTIVE
	083209-02-000	EA	CIRCUIT BREAKER - 15/15 AMP - 120 VOLT
	083209-03-000	EA	CIRCUIT BREAKER - 15/20 AMP - 120 VOLT
	083209-04-000	EA	CIRCUIT BREAKER - 30 AMP - 120 VOLT
	083209-06-000	EA	CIRCUIT BREAKER - 30/15 AMP - 120 VOLT
	093654-01-000	EA	CIRCUIT BREAKER - 6 AMP - 12 VOLT
	093654-03-000	EA	CIRCUIT BREAKER - 20 AMP - 12 VOLT
	093655-01-000	EA	CIRCUIT BREAKER - 25 AMP - 12 VOLT
	093655-02-000	EA	CIRCUIT BREAKER - 30 AMP - 12 VOLT
	100341-01-000	EA	FUSE HOLDER - IN LINE TYPE

**CONVERTER, INVERTER, LOAD CENTERS**

KEY	PART NUMBER	U/M	DESCRIPTION
	083208-02-000	EA	CONTROL CENTER - 45 AMP/120V/12V - W/O BREAKERS/LINEAR
	083208-06-000	EA	CONTROL CENTER - 45 AMP/120V/12V - W/O BREAKERS/ELECTRONIC
	099048-03-000	EA	INVERTER - 130 WATT
	113132-01-000	EA	LOAD CENTER - 120/240 VOLT - 60 AMP

**ELECTRICAL GROUP (CONTINUED)**  
**RECEPTACLES**

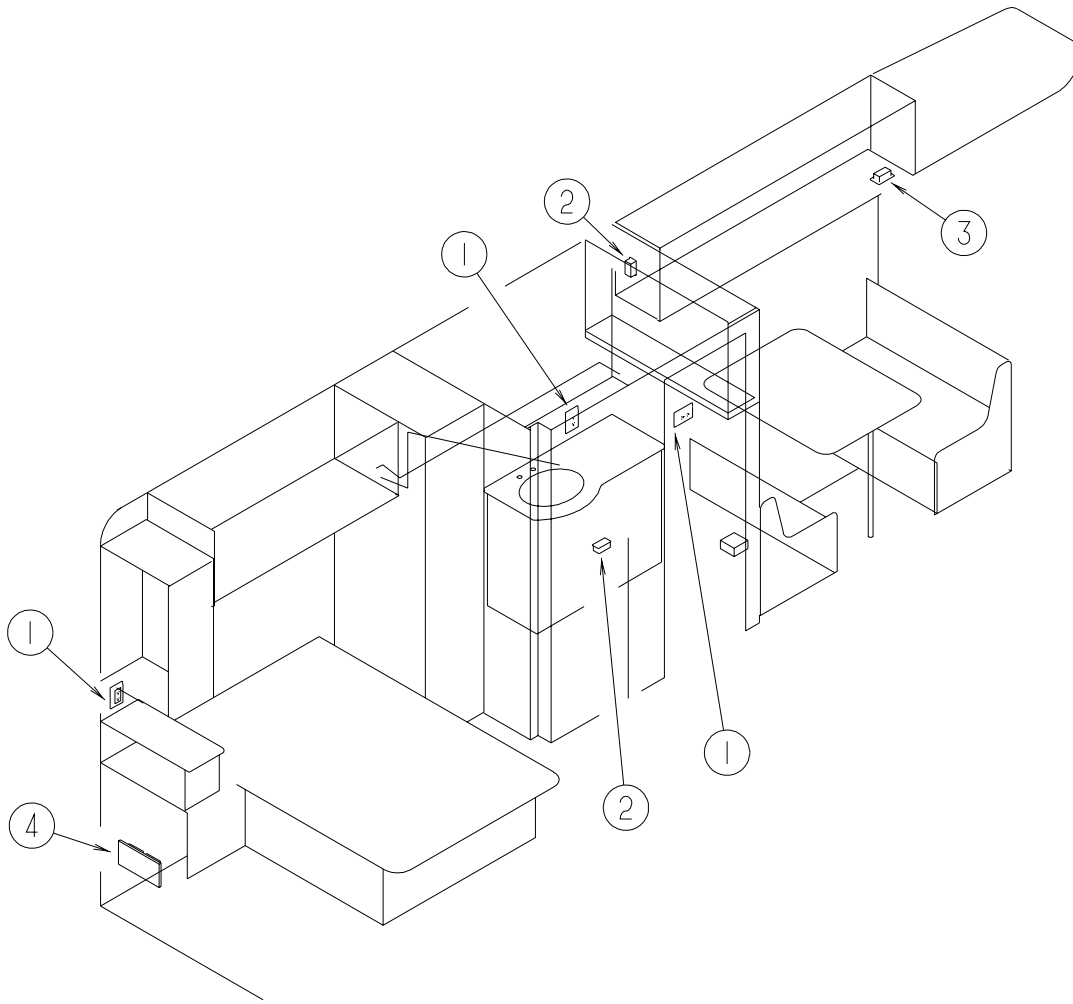

<b>KEY</b>	<b>PART NUMBER</b>	<b>U/M</b>	<b>DESCRIPTION</b>
1	058708-02-000	EA	RECEPTACLE - ELECTRIC - DOUBLE - IVORY
2	058707-02-000	EA	RECEPTACLE - BLANK - JUNCTION BOX
3	058708-01-000	EA	RECEPTACLE - ELECTRIC - DOUBLE - BROWN
4	024924-02-000	EA	RECEPTACLE - POWER CORD - W/PARTIAL PLATE



**ELECTRICAL GROUP (CONTINUED)**  
**RECEPTACLES (CONTINUED)**

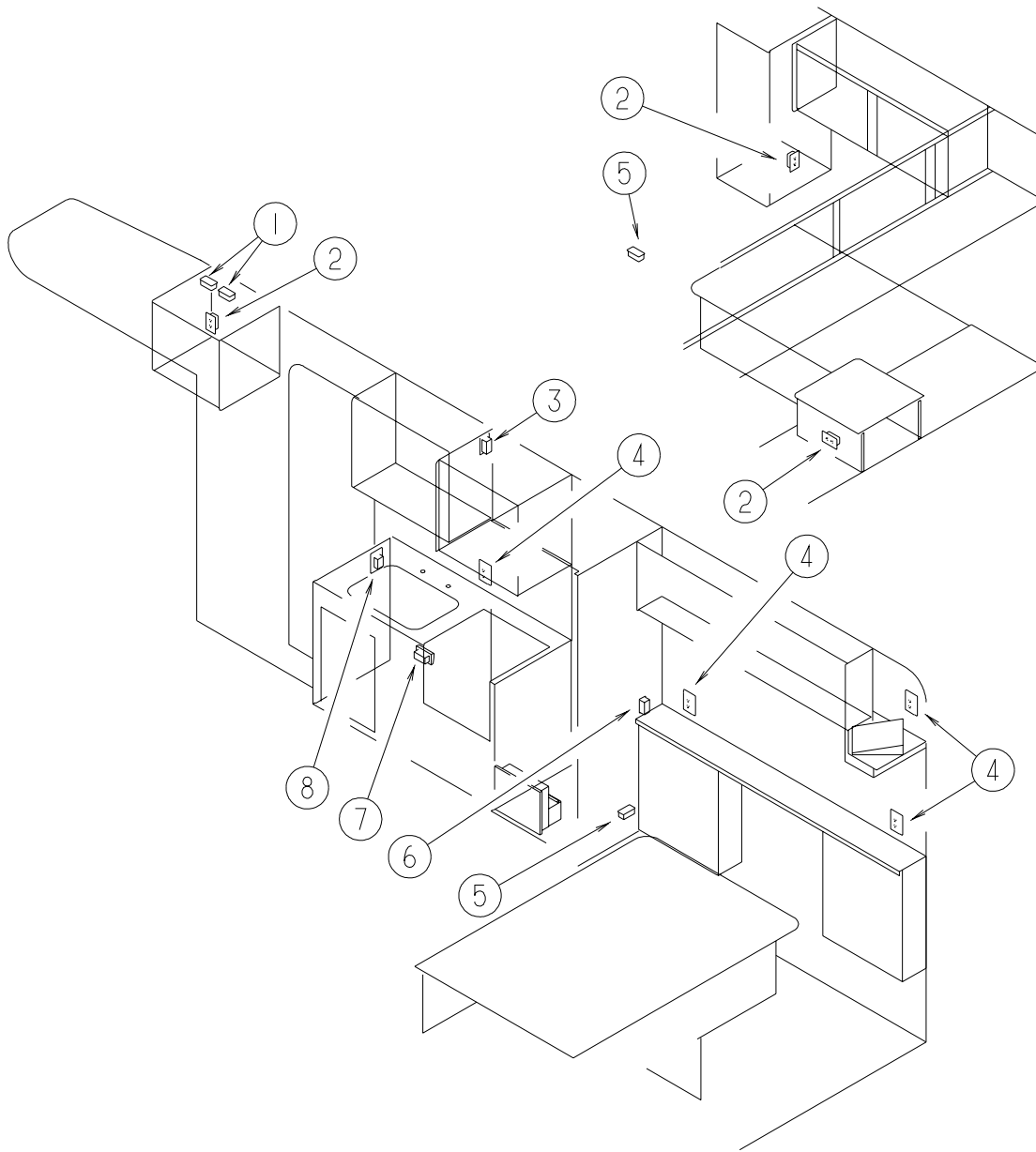

KEY	PART NUMBER	U/M	DESCRIPTION
1	111414-01-000	EA	RECEPTACLE - 12V - W/O BIMETAL
2	058708-01-000	EA	RECEPTACLE - ELECTRIC - DOUBLE - BROWN
3	058708-05-000	EA	RECEPTACLE - ELECTRIC - SINGLE - BROWN
4	058708-02-000	EA	RECEPTACLE - ELECTRIC - DOUBLE - IVORY
5	058707-02-000	EA	RECEPTACLE - BLANK - JUNCTION BOX
6	058707-01-000	EA	RECEPTACLE - ELECTRIC - SINGLE - BROWN
7	131826-01-01A	EA	RECEPTACLE - EXTERIOR - W/COVER/GASKET - WHITE
8	084076-02-000	EA	RECEPTACLE - GFI - 15 AMP/125 VOLT - BROWN - W/COVER
8	084077-02-000	EA	PLATE - COVER - RECEPTACLE - GFI - BROWN

## ELECTRICAL GROUP (CONTINUED) SWITCHES

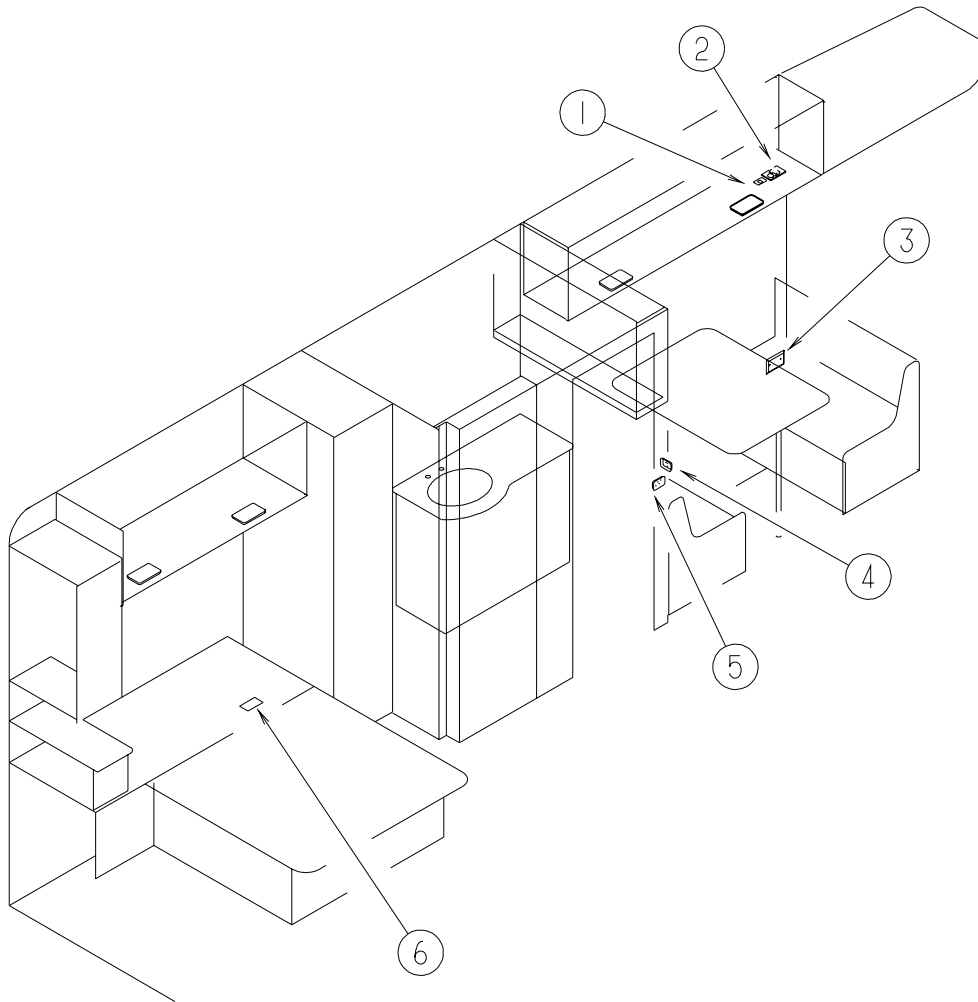

KEY	PART NUMBER	U/M	DESCRIPTION
1	132180-02-01A	EA	SWITCH - PADDLE - SPDT - ON/OFF - BLACK
1	098351-01-01A	EA	PLATE/SWITCH - 1 GANG - POLISHED BRASS - W/O LABEL
1	132180-01-01A	EA	SWITCH - PADDLE - SPST - ON/OFF - BLACK - W/OVERHEAD TV
1	132180-02-01A	EA	SWITCH - PADDLE - SPDT - ON/OFF - BLACK - W/OVERHEAD TV
1	098351-01-01A	EA	PLATE/SWITCH - 1 GANG - POLISHED BRASS - W/O LABEL - W/OVERHEAD TV
2	086777-02-000	EA	WALLPLATE - TV CABLE - W/ANTENNA SWITCH - BROWN
2	086777-06-000	EA	WALLPLATE - TV CABLE - ANTENNA BOOSTER/1 OUTPUT - BROWN
3	084077-03-000	EA	COVER/BLANK - ROOF A/C 5.2" X 3.5" - IVORY
4	132180-01-01A	EA	SWITCH - PADDLE - SPST - ON/OFF - BLACK
4	098351-01-01A	EA	PLATE/SWITCH - 1 GANG - POLISHED BRASS - W/O LABEL
4	095188-01-01A	EA	SPACER - SWITCH - 2.3" X 3.4" - PLASTIC - DARK BROWN
5	132180-01-01A	EA	SWITCH - PADDLE - SPST - ON/OFF - BLACK
5	098351-02-01A	EA	PLATE/SWITCH - 2 GANG - POLISHED BRASS - W/O LABEL
5	095188-01-01A	EA	SPACER - SWITCH - 2.3" X 3.4" - PLASTIC - DARK BROWN
6	108357-08-000	EA	SWITCH - ROCKER DPDT - ON/NONE/ON - 6 TERMINAL
6	108356-02-01A	EA	COVER/ACTUATOR SWITCH - 2 ROWS DIMPLES- CONTURA II - BLACK

**ELECTRICAL GROUP (CONTINUED)**  
**SWITCHES (CONTINUED)**

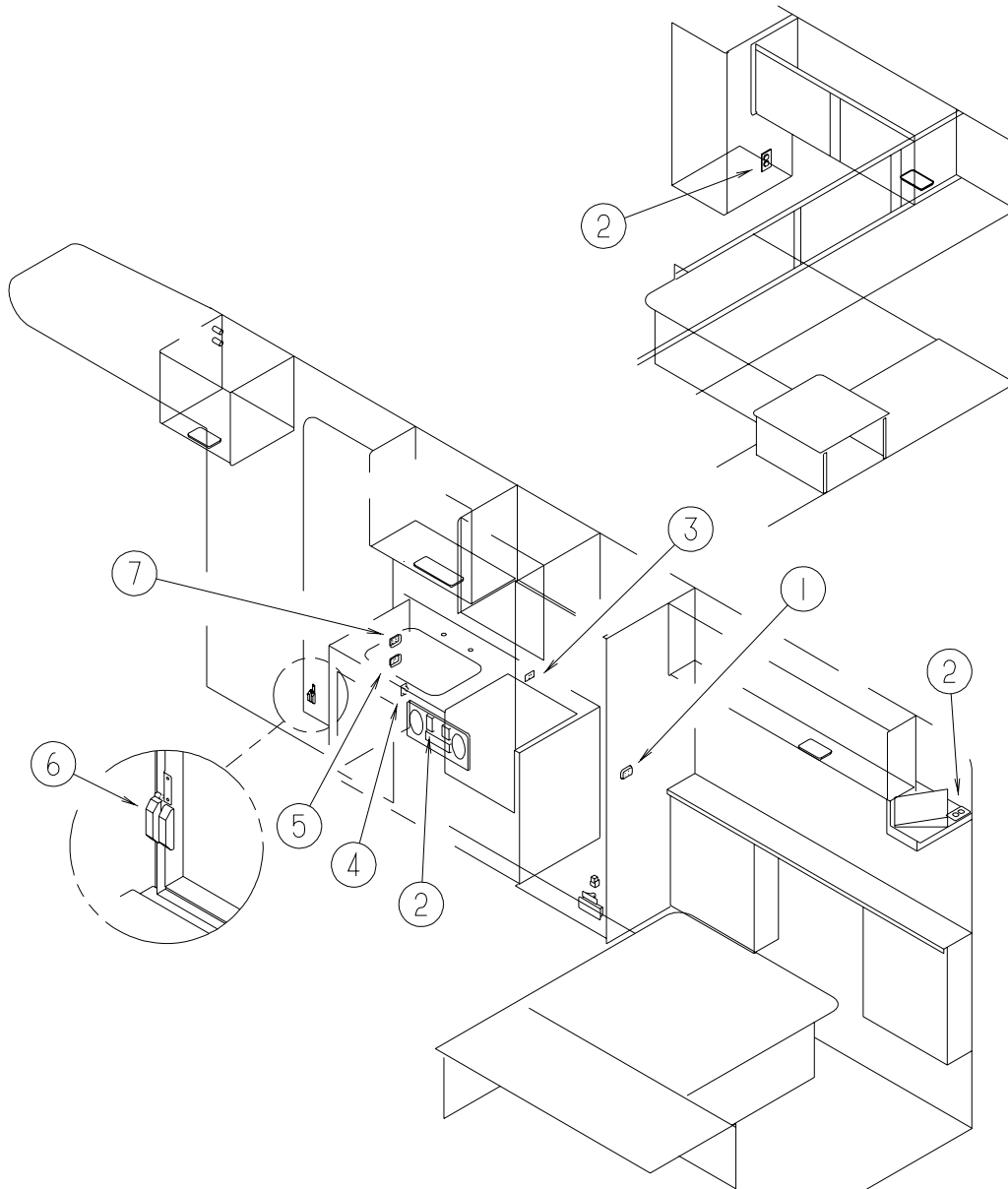

KEY	PART NUMBER	U/M	DESCRIPTION
1	132180-01-01A	EA	SWITCH - PADDLE - SPST - ON/OFF - BLACK
1	132180-02-01A	EA	SWITCH - PADDLE - SPDT - ON/OFF - BLACK
1	098351-02-01A	EA	PLATE/SWITCH - 2 GANG - POLISHED BRASS - W/O LABEL
1	095188-01-01A	EA	SPACER - SWITCH - 2.3" X 3.4" - PLASTIC - DARK BROWN
2	076319-09-000	EA	WALLPLATE - CABLE RECEPTACLE - TV - SINGLE - BROWN
3	076319-09-000	EA	WALLPLATE - CABLE RECEPTACLE - TV - SINGLE - BROWN
4	079364-08-000	EA	SWITCH - ON/OFF LIGHTED - GREEN
4	098351-01-01A	EA	PLATE/SWITCH - 1 GANG - POLISHED BRASS - W/O LABEL
4	095188-01-01A	EA	SPACER - SWITCH - 2.3" X 3.4" - PLASTIC - DARK BROWN
5	132180-02-01A	EA	SWITCH - PADDLE - SPDT - ON/OFF - BLACK
5	098351-02-01A	EA	PLATE/SWITCH - 2 GANG - POLISHED BRASS - W/O LABEL
6	116995-02-000	EA	SWITCH/MAGNET - ELECTRIC STEP - BLACK/WHITE-CLOSED CIRCUIT
7	132180-01-01A	EA	SWITCH - PADDLE - SPST - ON/OFF - BLACK
7	098351-02-01A	EA	PLATE/SWITCH - 2 GANG - POLISHED BRASS - W/O LABEL

## ELECTRICAL GROUP (CONTINUED)

### BOXES & CORDS

KEY	PART NUMBER	U/M	DESCRIPTION
	008054-01-000	EA	CORD - POWER - 10/3 WIRE - 30 AMP - 25'
	008289-01-000	EA	BOX - ELECTRIC/STEEL - 1/2" & 3/4" KNOCKOUTS - 4" X 4"
	008289-02-000	EA	BOX - ELECTRIC/STEEL - 1/2" & 3/4" KNOCKOUTS - 4" X 4"-CAN
	008294-01-000	EA	COVER - ELECTRICAL BOX - BLANK/STEEL - 4" X 4" - GRAY
	008294-02-000	EA	COVER - ELECTRICAL BOX - BLANK STEEL - 4" X 4" - CANADIAN
	069238-01-000	EA	COVER - ELECTRICAL BOX - W/HOLE - 4" X 4" - GRAY
	091910-01-000	EA	BOX - ELECTRIC - 3.8" X 3.5" X 1.8" - PLASTIC
	091910-02-000	EA	BOX - ELECTRIC - 2.2" X 3.5" X 1.8" - PLASTIC
	107165-01-01A	EA	BOX - CIRCUIT BREAKER - 14.6" X 4" - PLASTIC

### WIRE ASSEMBLIES

KEY	PART NUMBER	U/M	DESCRIPTION
	073328-B4-000	EA	CABLE ASSEMBLY - BATTERY - W/TERMINALS
	096449-01-000	EA	WIRE ASSEMBLY - WATER TANK TO MONITOR PANEL
	106851-01-000	EA	WIRE ASSEMBLY - RUNNING LIGHTS - FUSE
	116894-01-000	EA	WIRE ASSEMBLY - SPEED SENSOR EXTENDED
	125853-01-000	EA	WIRE ASSEMBLY - ENTERTAINMENT CENTER
	134550-01-000	EA	WIRE ASSEMBLY - HEATER/RELAY
	134551-04-000	EA	WIRE ASSEMBLY - HEATER/TANKS

### CONNECTORS & CONDUIT

KEY	PART NUMBER	U/M	DESCRIPTION
	008313-01-000	EA	CONNECTOR - WIRE NUT - INSULATED - YELLOW
	008314-01-000	EA	CONNECTOR - WIRE NUT - INSULATED - GRAY
	008326-01-000	EA	TERMINAL - RING - 16/14 WIRE - 3/8" STUD
	008328-01-000	EA	TERMINAL - RING - 12/10 WIRE - #10 STUD FIT
	008331-01-000	EA	TERMINAL - RING - TONGUE - #4 WIRE - 3/8" STUD - COPPER
	008348-01-000	EA	TERMINAL - RING - 3/8" STUD 2 GA. WIRE
	008355-01-000	EA	CONNECTOR - CABLE CLAMPING - 3/4"
	008356-01-000	EA	CONNECTOR - PLASTIC - 3/8" AVG
	008356-02-000	EA	CONNECTOR - PLASTIC - 21/32
	035416-04-000	EA	TERMINAL - RING - #10 STUD FIT - INSULATED BARREL #16/14
	041480-01-000	EA	CONNECTOR - STRAIGHT - 1/2" FLEX CONDUIT
	041953-01-000	FT	CONDUIT - CONVOLUTE SLIT - .5" ID - POLYETHYLENE
	041953-03-000	FT	CONDUIT - CONVOLUTE SLIT - 1" ID (CLOTHES ROD COVER)
	041953-06-000	FT	CONDUIT - CONVOLUTE SLIT - .375" ID - POLYETHYLENE
	041953-07-000	FT	CONDUIT - CONVOLUTE SLIT - .25" ID - POLYETHYLENE
	041953-08-000	FT	CONDUIT - CONVOLUTE SLIT - 1.50" ID - POLYETHYLENE
	041953-09-000	FT	CONDUIT - CONVOLUTE SLIT - .50" ID - NYLON
	041953-10-000	FT	CONDUIT - CONVOLUTE SLIT - .75" ID - NYLON
	041953-11-000	FT	CONDUIT - CONVOLUTE SLIT - 1.06" ID - NYLON
	041953-12-000	FT	CONDUIT - CONVOLUTE SOLID - 1.1" ID - NYLON
	041953-13-000	FT	CONDUIT - CONVOLUTE SLIT - 1.25
	047443-01-000	EA	TERMINAL - .250 RECEPTACLE FIT - INSULATED - 16/14 AWG
	058028-01-000	EA	CONNECTOR - ELECTRICAL PIGTAIL - NYLON - CLEAR
	077479-01-000	EA	BOOT - BATTERY TERMINAL - DOUBLE CABLE
	077479-02-000	EA	BOOT - BATTERY TERMINAL - SINGLE CABLE
	080015-02-000	EA	RECEPTACLE - FLAG - .185 - 16/14 GAUGE
	080015-03-000	EA	RECEPTACLE - FLAG - .250 - 14/16 GAUGE
	087225-01-000	FT	SLEEVING - 1/2" - TYPE H
	087225-02-000	FT	SLEEVING - 5/8" - TYPE H
	087949-01-000	EA	BUSS BAR - 2 POSITION - .6" X 1.5"
	088473-01-000	EA	HOUSING - PIN - 12 CAVITY (3 ROWS OF 4)
	088473-02-000	EA	HOUSING - PIN - 15 CAVITY (3 ROWS OF 5)
	088473-03-000	EA	HOUSING - PIN - 9 CAVITY (3 ROWS OF 3)
	007956-05-000	EA	INSULATOR - SHRINK - .25 ID X 1.50
	088473-06-000	EA	HOUSING - PIN - 6 CAVITY (2 ROWS OF 3)
	088473-08-000	EA	HOUSING - PIN - 4 CAVITY - IN-LINE
	088473-09-000	EA	HOUSING - PIN - 3 CAVITY - IN-LINE
	088473-10-000	EA	HOUSING - PIN - 2 CAVITY - IN LINE
	088474-01-000	EA	HOUSING - SOCKET - 12 CAVITY

**ELECTRICAL GROUP (CONTINUED)**  
**CONNECTORS & CONDUIT (CONTINUED)**

<b>KEY</b>	<b>PART NUMBER</b>	<b>U/M</b>	<b>DESCRIPTION</b>
	088474-02-000	EA	HOUSING - SOCKET - 15 CAVITY
	088474-03-000	EA	HOUSING - SOCKET - 9 CAVITY
	088474-06-000	EA	HOUSING - SOCKET - 6 CAVITY
	088474-07-000	EA	HOUSING - SOCKET - 5 CAVITY
	088474-08-000	EA	HOUSING - SOCKET - 4 CAVITY
	088474-09-000	EA	HOUSING - SOCKET - 3 CAVITY
	088474-10-000	EA	HOUSING - SOCKET - 2 CAVITY
	088475-01-000	EA	PIN - CONNECTOR - 14-20 AWG
	088475-02-000	EA	PIN - CONNECTOR - 10-12 AWG
	088476-01-000	EA	TERMINAL - ELECTRICAL
	088476-02-000	EA	SOCKET - CONNECTOR - 12-10 GA - PRE-TIN
	098261-02-000	EA	SOCKET - CONNECTOR - WEATHERPACK - 14-18 AWG
	098262-01-000	EA	SEAL - CONNECTOR - WEATHERPACK
	098265-02-000	EA	PIN - CONNECTOR - WEATHERPACK
	101751-02-000	EA	HOUSING - 1 PIN - WEATHERPACK
	102777-02-000	EA	TERMINAL - RING - #6 STUD - 10 AWG
	112823-01-000	EA	SPLICE - REDUCER - 16-14 TO 18-22
	119223-01-000	EA	HOUSING - 6 POSITION - MALE - WEATHERPACK
	125323-02-000	EA	HOUSING - 8 POSITION - MALE
	125323-03-000	EA	LOCK - SECONDARY 8 POSITION
	125324-01-000	EA	TERMINAL - MALE - METRI-PACK - 150
	125325-01-000	EA	SEAL - CAVITY

**BOOTS, SOLENOIDS, RELAYS & MISCELLANEOUS**

<b>KEY</b>	<b>PART NUMBER</b>	<b>U/M</b>	<b>DESCRIPTION</b>
	008188-01-000	EA	SOLENOID - 3 POST - BATTERY CHANGE OVER
	063910-01-000	EA	HOUSING - RELAY
	063912-02-000	EA	RELAY - CANISTER - SPDT
	065450-05-000	EA	TIEDOWN - BATTERY - 8.4" TUBE
	086233-01-000	EA	STUD - ISOLATED - 3/8" X 7/8" LONG
	086273-01-000	EA	RELAY - BATTERY DISCONNECT

**EXTERIOR BODY GROUP  
GRAPHICS & PAINT**

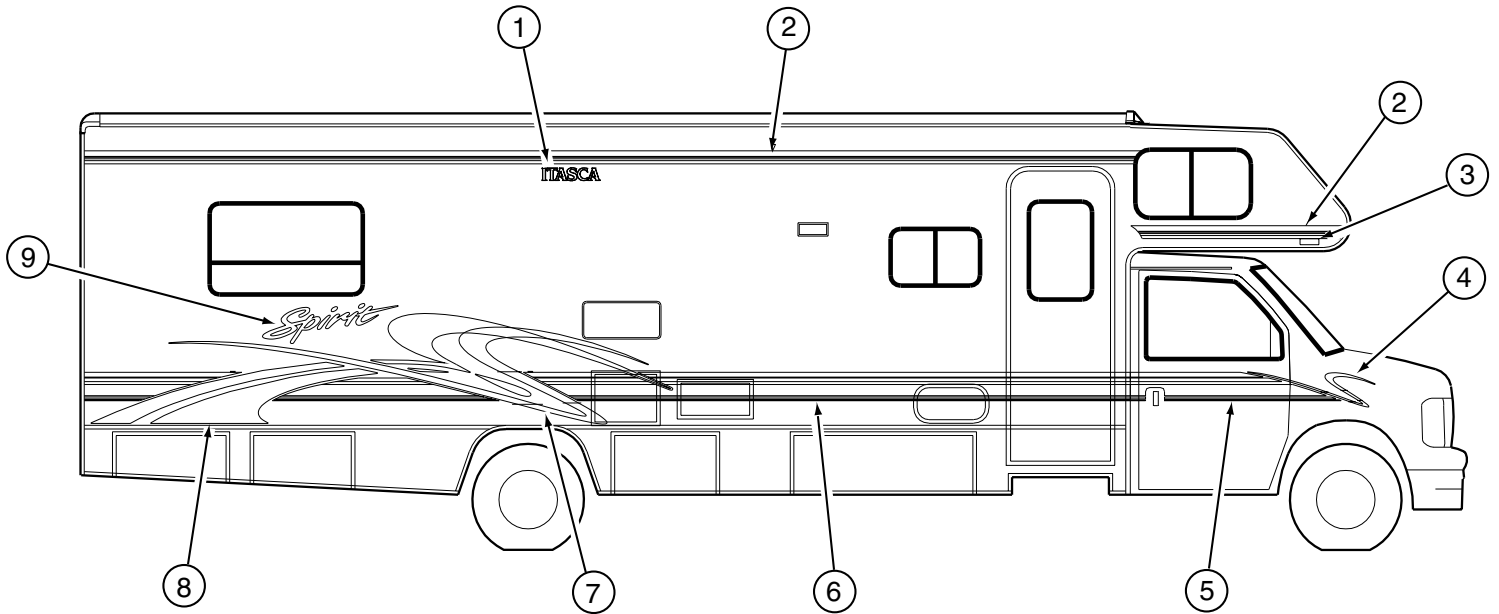

KEY	PART NUMBER	U/M	DESCRIPTION
1	124811-01-04A	EA	DECAL - LOGO - ITASCA
2	094443-65-01A	FT	FILM - MULTISTRIPE - 3.4"
3	132664-01-01A	EA	DECAL - LOGO/DOMED - WINNEBAGO - CHROME/BLACK
4	132256-01-01A	EA	DECAL - SQUIGGLE - RIGHT HAND
4	132256-02-01A	EA	DECAL - SQUIGGLE - LEFT HAND
5	132255-01-01A	EA	DECAL - CAB DOOR/PASSENGER
5	132255-02-01A	EA	DECAL - CAB DOOR/DRIVER
6	094445-08-01A	FT	FILM - MULTISTRIPE - 7.6"
7	132253-01-01A	EA	DECAL - SWEEP - #1/PASSENGER
7	132253-02-01A	EA	DECAL - SWEEP - #1/DRIVER
8	132254-01-01A	EA	DECAL - SWEEP - #2/PASSENGER
8	132254-02-01A	EA	DECAL - SWEEP - #2/DRIVER
9	115130-02-05A	EA	DECAL - LOGO - SPIRIT
	116424-01-000	EA	PROTECTOR - LATCH - WATER HEATER

**EXTERIOR BODY GROUP (CONTINUED)**  
**GRAPHICS & PAINT (CONTINUED)**

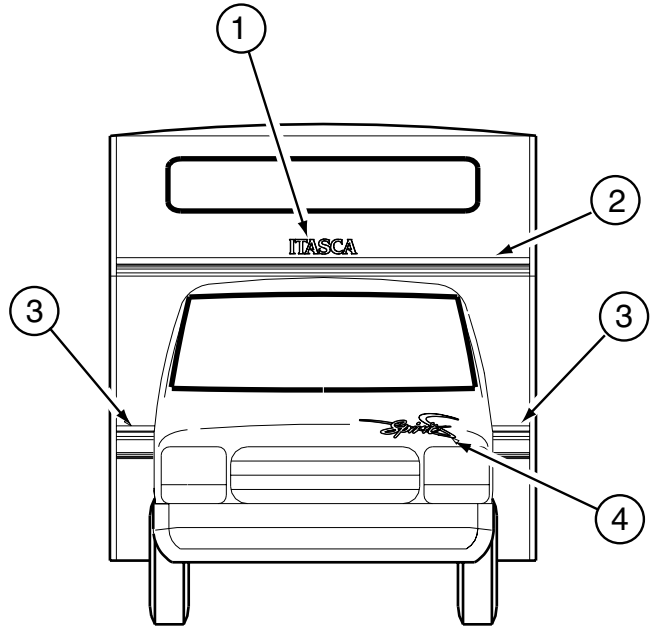
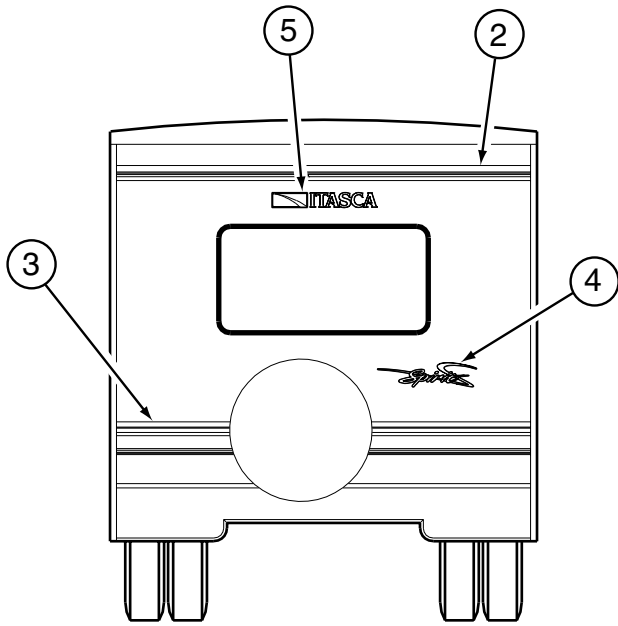

KEY	PART NUMBER	U/M	DESCRIPTION	
1	124811-01-04A	EA	DECAL - LOGO - ITASCA	
2	094443-65-01A	FT	FILM - MULTISTRIPE - 3.4"	
3	094445-08-01A	FT	FILM - MULTISTRIPE - 7.6"	
4	132257-01-01A	EA	DECAL - SPIRIT - W/SQUIGGLE	
5	124806-01-09A	EA	DECAL - LOGO - ITASCA W/ICON	
	041561-03-000	EA	PAINT - 16 OUNCE SPRAY - OFF WHITE	
	COOL BLUE METALLIC			DUPONT #G9851
	DARK TEAL METALLIC			DUPONT #K9470
	CHAMPAGNE METALLIC			DUPONT #F2997
	DARK ROSE METALLIC			DUPONT #RM018
	BRIGHT WHITE			DUPONT #B8951U

## EXTERIOR BODY GROUP (CONTINUED) PANELS

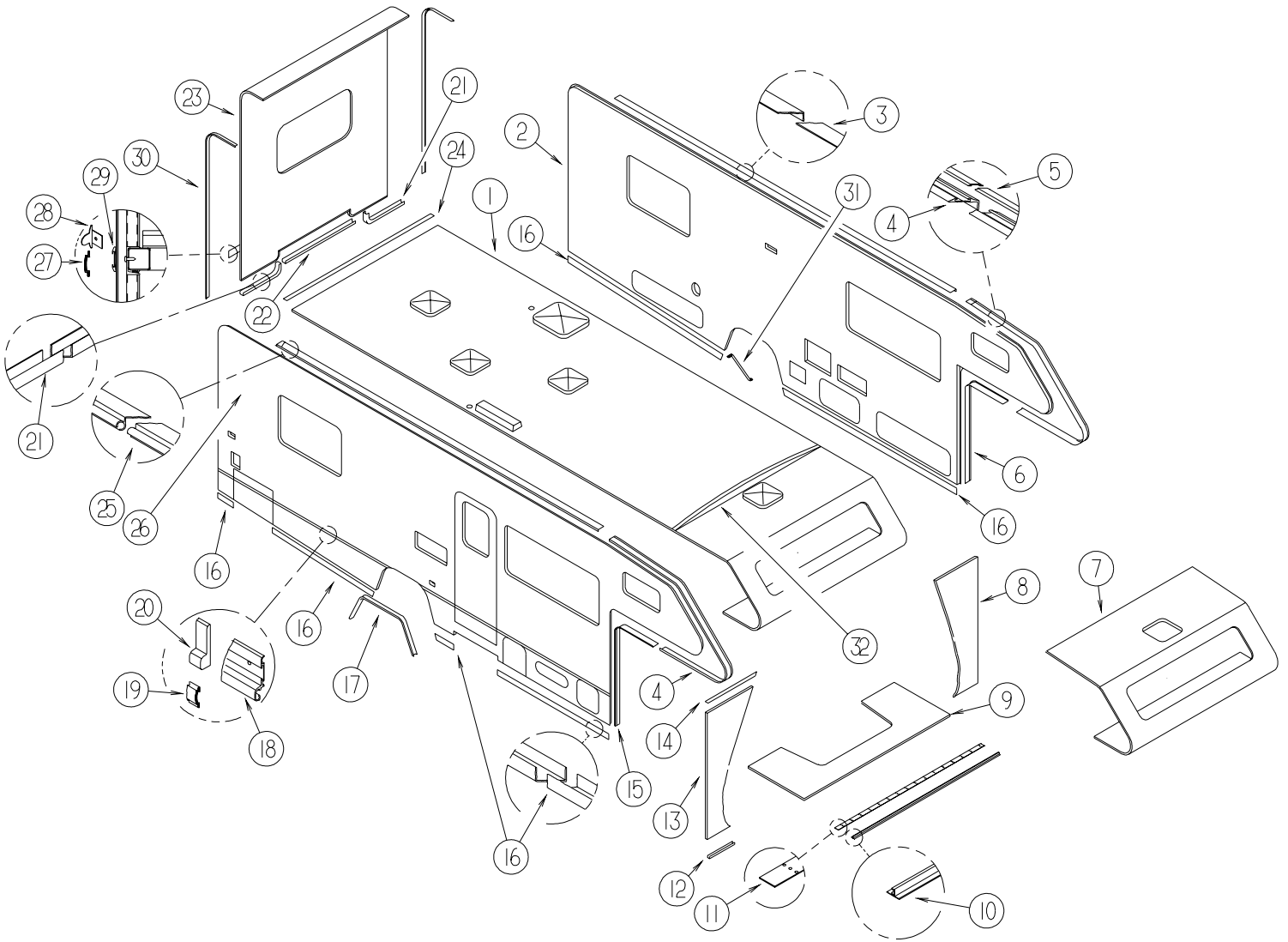

KEY	PART NUMBER	U/M	DESCRIPTION
1	P32079-02-L01	EA	ROOF - FRONT W/BASES - W/O LIGHTS/VENTS - W/WIRING
2	P33724-01-L01	EA	SIDEWALL - DRIVER - W/O WINDOWS/TRIMS (L04)
2	P33724-01-L02	EA	SIDEWALL - DRIVER - W/O WINDOWS/TRIMS (L05)
2	P33724-01-L06	EA	SIDEWALL - DRIVER - W/O WINDOWS/TRIMS (L06)
3	131979-06-01A	EA	RAIL - AWNING - 144" W/NOTCHED END - BRIGHT WHITE
	108651-01-01A	EA	CAP - FEATURE STRIP
4	096854-07-02A	EA	TRIM - CONTOUR - 144" - BRIGHT WHITE
5	105312-01-07A	FT	INSERT - VINYL FEATURE STRIP - BRIGHT WHITE
6	104479-06-02A	EA	TRIM - CONTOUR/FRONT - BRIGHT WHITE - LEFT HAND
7	P32079-01-L01	EA	ROOF - FRONT SECTION ONLY - W/WIRING
8	125088-04-J01	EA	WINGWALL - LEFT HAND
9	P25129-01-J01	EA	SLEEPERBOARD
10	100086-04-01A	EA	TRIM - SLEEPERBOARD/ROOF - 2" X 96.6"
11	100085-05-01A	EA	TRIM - STRAP - SLEEPERBOARD
12	002365-03-006	EA	U-CHANNEL - EXTRUDED - 1" X 192" - BRIGHT WHITE
13	125088-03-J01	EA	WINGWALL - RIGHT HAND
14	022992-14-000	FT	MOLDING - REVERSE COVE - BRIGHT WHITE
15	104479-05-02A	EA	TRIM - CONTOUR/FRONT - BRIGHT WHITE - RIGHT HAND
16	128426-06-01A	EA	TRIM - ROCKER - NOTCHED - 82.8" - BRIGHT WHITE
16	128426-07-01A	EA	TRIM - ROCKER - NOTCHED - 111.3" - BRIGHT WHITE
16	128426-08-01A	EA	TRIM - ROCKER - NOTCHED - 82.8" - BRIGHT WHITE
	127820-33-01A	EA	TRIM - SIDEWALL LOWER - 76.2" - BRIGHT WHITE
17	127848-01-01A	EA	TRIM - WHEELWELL - UNIVERSAL - BRIGHT WHITE
18	128129-04-01A	EA	STRIP - FEATURE - HINGE - BRIGHT WHITE



**EXTERIOR BODY GROUP (CONTINUED)**  
**PANELS (CONTINUED)**

KEY	PART NUMBER	U/M	DESCRIPTION
19	096854-07-02A	EA	TRIM - CONTOUR - 144" - BRIGHT WHITE
20	127910-01-01A	EA	CAP - TRIM/SIDEWALL - RIGHT HAND - BRIGHT WHITE
20	127910-02-01A	EA	CAP - TRIM/SIDEWALL - LEFT HAND - BRIGHT WHITE
21	103334-03-02A	EA	TRIM - LOWER BACKWALL - DRIVER/PASS - 25.6" - BRT/WHITE
22	103335-02-02A	EA	TRIM - BACKWALL - LOWER/CENTER - 46.3" - BRIGHT WHITE
23	M08778-16-L01	EA	BACKWALL - W/O WINDOW/TRIM - F/DOUBLE BED (L04)
23	M08778-16-L02	EA	BACKWALL - W/O WINDOW/TRIM - F/DOUBLE BED (L05)
23	M08778-16-L06	EA	BACKWALL - W/O WINDOW/TRIM - F/DOUBLE BED (L06)
23	M08778-17-L01	EA	BACKWALL - W/O WINDOW/TRIM - F/TWIN BED (L04)
23	M08778-17-L02	EA	BACKWALL - W/O WINDOW/TRIM - F/TWIN BED (L05)
23	M08778-17-L06	EA	BACKWALL - W/O WINDOW/TRIM - F/TWIN BED (L06)
24	134167-01-01A	EA	CAP - ROOF - REAR - 1 PIECE - BRIGHT WHITE
	118383-01-04A	EA	RETAINER/RECESSED - F/.22" SCREW - BRIGHT WHITE
	118383-04-04A	EA	CAP - F/RECESSED RETAINER - BRIGHT WHITE
25	131979-04-01A	EA	RAIL - AWNING - 144" - BRIGHT WHITE
25	131979-05-01A	EA	RAIL - AWNING - 144" W/NOTCHED END - BRIGHT WHITE
26	P33723-01-L01	EA	SIDEWALL - PASSENGER - W/O WINDOWS/TRIMS (L04)
26	P33723-01-L02	EA	SIDEWALL - PASSENGER - W/O WINDOWS/TRIMS (L05)
26	P33723-01-L06	EA	SIDEWALL - PASSENGER - W/O WINDOWS/TRIMS (L06)
	009126-03-000	EA	HANDLE - ASSIST - BLACK TEXTURED
27	105312-01-07A	FT	INSERT - VINYL FEATURE STRIP - BRIGHT WHITE
28	108651-01-01A	EA	END CAP - FEATURE STRIP
29	108688-01-03A	EA	STRIP - FEATURE - 15'
30	096854-09-01A	EA	TRIM - CONTOUR - 93.1" - BRIGHT WHITE
31	069362-06-000	EA	TUBE/SUPPORT - FLOOR TO VALANCE PANEL - 17"
32	132075-02-L01	EA	CAP - TRANSITION/FRONT
	132076-01-02B	EA	BRACKET - TRANSITION/FRONT - E-COATED

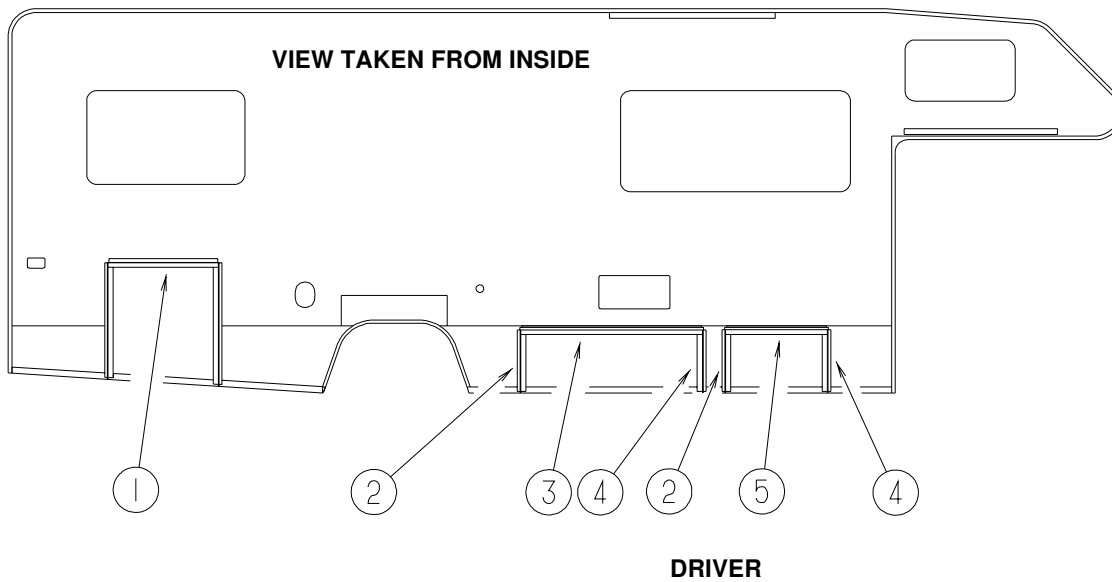

KEY	PART NUMBER	U/M	DESCRIPTION
1	129413-01-J01	EA	JAMB - DOOR
2	128425-01-01A	EA	JAMB - DOOR/STORAGE - RIGHT HAND - BRIGHT WHITE - 16"
3	128427-01-01A	EA	JAMB - DOOR/STORAGE - TOP - 48" - BRIGHT WHITE
4	128425-02-01A	EA	JAMB - DOOR/STORAGE - LEFT HAND - BRIGHT WHITE - 16"
5	128427-02-01A	EA	JAMB - DOOR/STORAGE - TOP - 27.1" - BRIGHT WHITE

## EXTERIOR BODY GROUP (CONTINUED)

### TRIMS

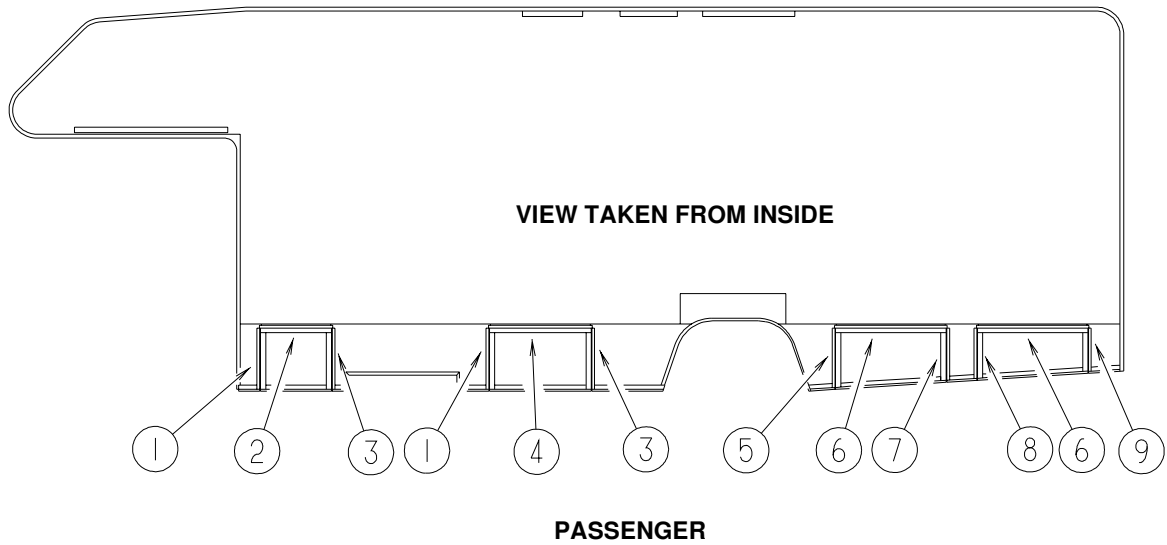

KEY	PART NUMBER	U/M DESCRIPTION
1	128425-01-01A	EA JAMB - DOOR/STORAGE - RIGHT HAND - BRIGHT WHITE - 16"
2	128425-06-01A	EA JAMB - DOOR/STORAGE - LEFT HAND - BRIGHT WHITE - 11.3"
3	128425-02-01A	EA JAMB - DOOR/STORAGE - LEFT HAND - BRIGHT WHITE - 16"
4	128427-02-01A	EA JAMB - DOOR/STORAGE - TOP - 27.1" - BRIGHT WHITE
5	128425-13-01A	EA JAMB - DOOR/STORAGE - RIGHT HAND - BRIGHT WHITE - 15.6"
6	128427-04-01A	EA JAMB - DOOR/STORAGE - TOP - 29.4" - BRIGHT WHITE
7	128425-14-01A	EA JAMB - DOOR/STORAGE - LEFT HAND - BRIGHT WHITE - 13.7"
8	128425-15-01A	EA JAMB - DOOR/STORAGE - RIGHT HAND - BRIGHT WHITE - 13.3"
9	128427-06-01A	EA JAMB - DOOR/STORAGE - TOP - 37" - BRIGHT WHITE

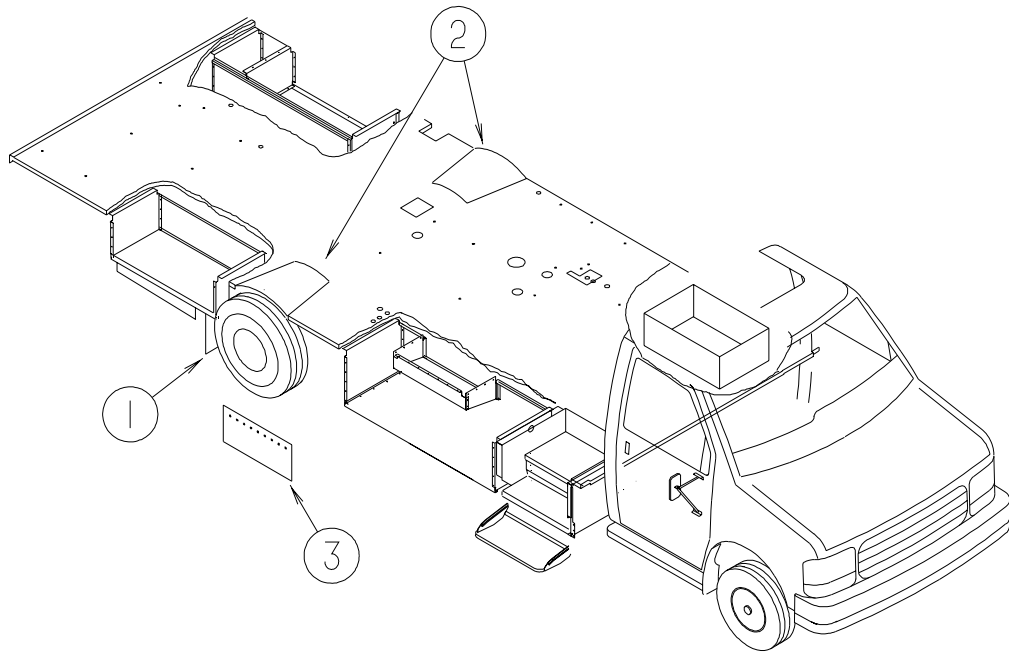

KEY	PART NUMBER	U/M DESCRIPTION
1	017516-01-000	EA MUD FLAP - 14" X 18" - W/O MOUNTING HOLES - BLACK
2	112435-03-000	EA WHEELWELL
5	121948-02-000	EA SHIELD-SIGHT

## EXTERIOR BODY GROUP (CONTINUED)

### LADDER

KEY	PART NUMBER	U/M	DESCRIPTION
	129639-02-01A	EA	LADDER - BRUSHED ALUMINUM

### RUNNING BOARDS

KEY	PART NUMBER	U/M	DESCRIPTION
*	072884-27-000	EA	RUNNING BOARD SET - 39" - FORD - ALUMINUM
*	072884-28-000	EA	RUNNING BOARD SET - ALUMINUM - CHEVY CHASSIS

**\*COMPONENT PARTS FOUND IN SERVICE PARTS LIBRARY**

### MIRRORS

KEY	PART NUMBER	U/M	DESCRIPTION
*	133908-01-01A	EA	MIRROR/PASSENGER - 102" W/B FORD - BLACK
*	133908-02-01A	EA	MIRROR/DRIVER - 102" W/B FORD - BLACK
*	133908-05-01A	EA	MIRROR/PASSENGER - 102" - BLACK
*	133908-06-01A	EA	MIRROR/DRIVER - 102" - BLACK

**\*COMPONENT PARTS FOUND IN SERVICE PARTS LIBRARY**

### BODY PANEL COMPONENTS

KEY	PART NUMBER	U/M	DESCRIPTION
	002726-01-001	EA	GARNISH - U-CHANNEL - 1.38" X 19' - SERRATED
	002766-01-001	EA	ANGLE - EXTRUDED - 1" X 1.5" X 17'
	068716-01-001	EA	BRACE - 90 DEGREE - L-ANGLE - 16'
	076054-AC-000	EA	FIBERGLASS SHEET - 20" X 99.8" - OFF WHITE
	076054-P9-000	EA	FIBERGLASS SHEET - 37.4" X 99.3" - BRIGHT WHITE
	076054-U8-000	EA	FIBERGLASS SHEET - 100" X 105" - BRIGHT WHITE
	076054-X2-000	EA	FIBERGLASS SHEET - 102" X 320.9" - BRIGHT WHITE
	077517-62-000	EA	FIBERGLASS SHEET - 48" X 96" - BRIGHT WHITE
	089297-01-000	SF	PLYWOOD - LUAN - OVERLAY GRADE - 4' X 8'
	089297-02-000	SF	PLYWOOD - LUAN - OVERLAY GRADE - 4' X 9'
	100619-01-000	BF	FOAM - EXPANDED POLYSTYRENE - 1.34" X 48" X 96"
	100619-04-000	BF	FOAM - EXPANDED POLYSTYRENE - .5" X 48" X 96"
	100619-05-000	BF	FOAM - EXPANDED POLYSTYRENE - .75" X 48" X 96"-1.5 DENSITY
	100619-11-000	BF	FOAM - EXPANDED POLYSTYRENE - 2" X 48" X 96"

### AWNINGS

KEY	PART NUMBER	U/M	DESCRIPTION
	113874-04-11A	EA	AWNING - 13' AMETHYST VINYL - BRT/WHT VINYL WRAP
*	113874-01-02A	EA	HARDWARE KIT - AWNING - W/O STANDOFF BRACKET-BRIGHT WHITE
	127647-01-01A	EA	ROD/AWNING GUARD - ENTRY DOOR
	130320-01-02A	EA	BRACKET - AWNING - F/A&E INSTALLATION - BRIGHT WHITE
	111038-01-01A	EA	SPACER - AWNING - LOWER

**\*COMPONENT PARTS FOUND IN SERVICE PARTS LIBRARY**

**EXTERIOR DOORS & COMPARTMENTS GROUP**  
**DOOR & COMPARTMENT LAYOUT**

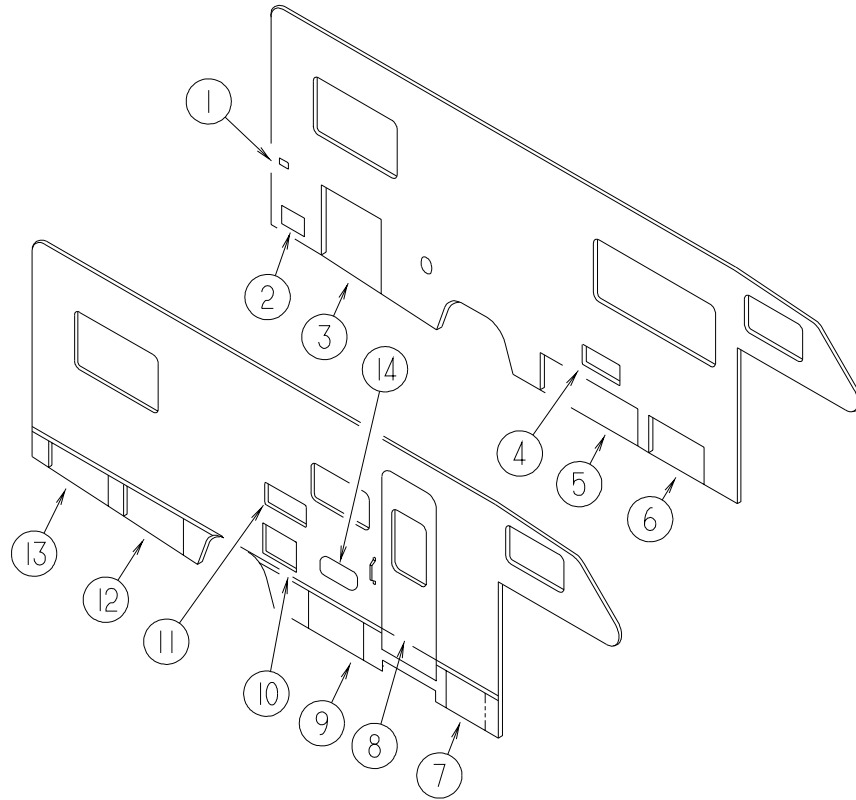

KEY	PART NUMBER	U/M	DESCRIPTION
1		EA	DOOR - WATERFILL - SEE WATER SYSTEMS GROUP
2	088794-06-000	EA	DOOR - POWER CORD W/HATCH - BRIGHT WHITE - 9.2" X 11"
3	127826-05-J01	EA	VALANCE/DOOR - PASSENGER W/O HDW - 31.1" X 27.9" X 29.4"
4		EA	DOOR - FURNACE - SEE HEATING SYSTEM GROUP
5	127795-01-J01	EA	VALANCE/DOOR - W/O HARDWARE - 46.4"W X 15.3"H
	089329-02-000	EA	CLIP - SPRING
	101667-02-000	EA	ROD - PROP - 21.97"
6	127795-02-J01	EA	VALANCE/DOOR - W/O HARDWARE - 25.6"W X 15.3"H
7	127795-03-J01	EA	VALANCE/DOOR - W/O HARDWARE - 17.6"W X 15.3"H
8	115108-01-K03	EA	DOOR - ENTRY - W/SCREEN DOOR - W/O WINDOW (L04)
8	115108-01-L02	EA	DOOR - ENTRY - W/SCREEN DOOR - W/O WINDOW (L05)
8	115108-01-L06	EA	DOOR - ENTRY - W/SCREEN DOOR - W/O WINDOW (L06)
8	115108-05-K03	EA	DOOR - ENTRY - W/SCREEN DOOR - W/O WINDOW - ELECTRIC STEP (L04)
8	115108-05-L02	EA	DOOR - ENTRY - W/SCREEN DOOR - W/O WINDOW - ELECTRIC STEP (L05)
8	115108-05-L06	EA	DOOR - ENTRY - W/SCREEN DOOR - W/O WINDOW - ELECTRIC STEP (L06)
9	127795-02-J01	EA	VALANCE/DOOR - W/O HARDWARE - 25.6"W X 15.3"H
10		EA	DOOR - WATER HEATER - SEE WATER SYSTEMS GROUP
11*	084103-08-000	EA	DOOR - VENT - REFRIGERATOR - W/O JAMB - BRIGHT WHITE
	084104-08-000	EA	JAMB - VENT DOOR/REFRIGERATOR - BRIGHT WHITE
	129413-01-J01	EA	JAMB - DOOR
12	127826-06-J01	EA	VALANCE/DOOR - PASSENGER W/O HDW - 14.9" X 27.8" X 13.4"
	089329-02-000	EA	CLIP - SPRING
	101667-02-000	EA	ROD - PROP - 21.97"
13	127826-07-J01	EA	VALANCE/DOOR - PASSENGER W/O HDW - 12.6" X 27.8" X 10.8"
14	126945-01-J22	EA	DOOR/STORAGE - W/O HARDWARE - 18" X 8.3"

**\*COMPONENT PARTS FOUND IN SERVICE PARTS LIBRARY**

**EXTERIOR DOORS & COMPARTMENTS GROUP (CONTINUED)**  
**DOOR & COMPARTMENT LAYOUT (CONTINUED)**

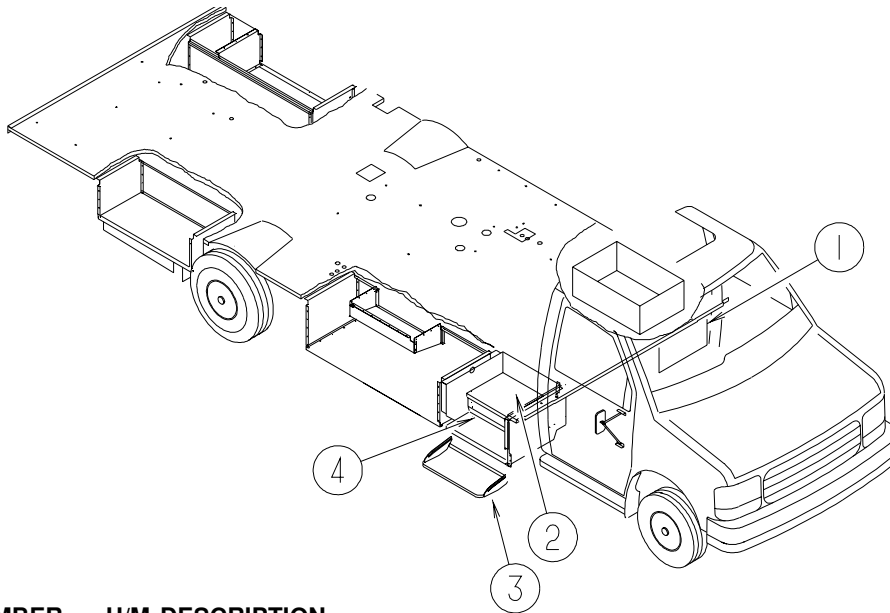

KEY	PART NUMBER	U/M	DESCRIPTION
1	017516-01-000	EA	MUD FLAP - 14" X 18" - W/O MOUNTING HOLES - BLACK
2	P14437-02-000	EA	CABINET - LID ENTRANCE DOOR - W/O CARPET
	101222-01-02A	EA	BRACKET - CATCH - LID - OFF WHITE
	064075-07-000	FT	SEAL - BULB - W/WIRED U CHANNEL - .3" X .5" CHANNEL-BLACK
	084993-01-000	EA	STRAP - BATTERY - 43.2" LONG
3	077848-05-000	EA	STEP - PULLOUT
	091176-01-000	EA	SUPPORT - BASE - ENTRANCE STEP
	077441-06-000	EA	BRACKET - STEP
	102569-04-000	EA	MAT - ANTI SLIP
3*	094708-03-01A	EA	STEP - ELECTRIC - SINGLE - BLACK CONTROL BOX - KWIKEE
4	122755-03-01A	EA	FLOORING/RUBBER - ENTRANCE DOOR - 17.7" X 26.4"
	122755-05-01A	EA	FLOORING/RUBBER - ENTRANCE DOOR - 11.2" X 27"
4	133114-03-01A	EA	TREAD - RUBBER STEP - 27.1" - TAUPE
	133114-03-02A	EA	TREAD - RUBBER STEP - 27.1" - BLUE

\*COMPONENT PARTS FOUND IN SERVICE PARTS LIBRARY

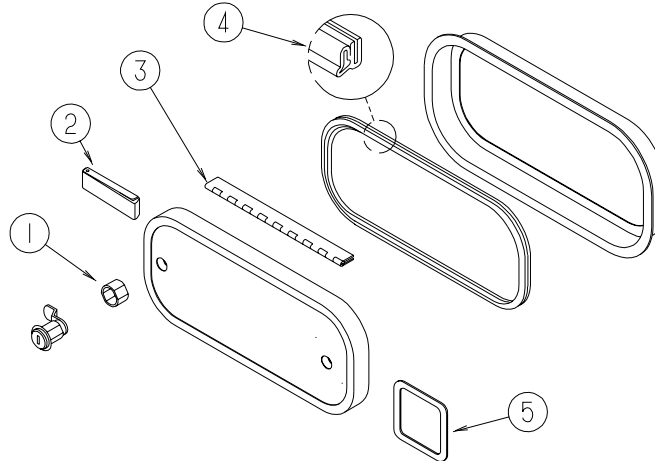

**COMPARTMENT DOOR COMPONENTS**

KEY	PART NUMBER	U/M	DESCRIPTION
1	107997-51-003	EA	SPACER - DOOR LOCK .79" DEEP
2	102768-01-000	EA	HOLDER - COMPARTMENT/ENTRY DOOR - METAL - MILL FINISH
3	081801-V3-000	EA	HINGE - ALUMINUM - 2" X 96" - BRIGHT WHITE
4	106850-02-000	FT	SEAL-E - SPONGE RUBBER - .43" X .75"
5	098338-01-000	EA	GASKET - LOCK POCKET
	098408-01-000	FT	SEAL - SPONGE RUBBER - CLOSED CELL
	096217-55-006	EA	U CHANNEL - 210"
	122612-55-008	EA	U-CHANNEL/EXTRUSION - 144" - BRIGHT WHITE
	112160-02-000	FT	SEAL - D SECTION - .2 X .3" - FOAM RUBBER

**EXTERIOR DOORS & COMPARTMENTS GROUP (CONTINUED)**  
**COMPARTMENT DOOR COMPONENTS (CONTINUED)**

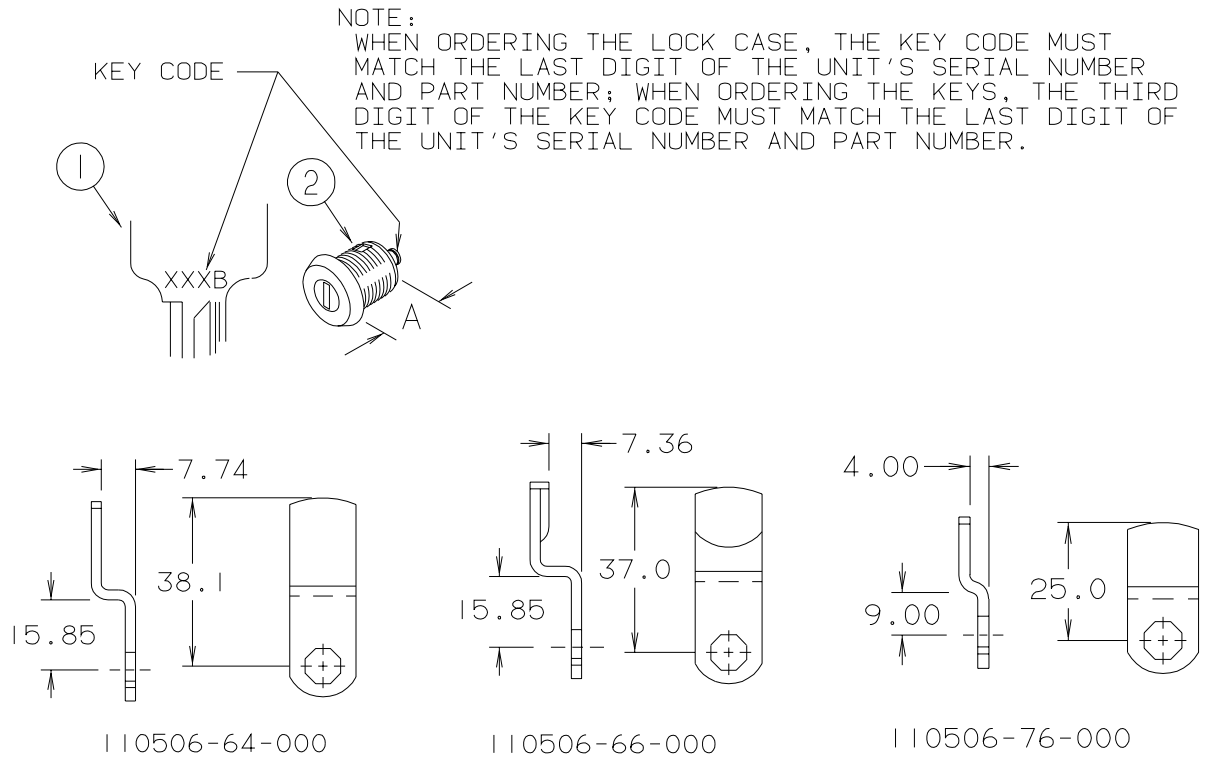

KEY	PART NUMBER	U/M	DESCRIPTION	
1*	110506-59-000	EA	KEYS - SET OF TWO	596720
2	110506-52-000	EA	CASE/CYLINDER - LOCKING - W/O CAM/KEY - .65" - 702370	
2	110506-54-000	EA	CASE/CYLINDER - LOCKING - W/O CAM/KEY - 1.25" - 703170	
1*	110506-59-001	EA	KEYS - SET OF TWO	596721
2	110506-52-001	EA	CASE/CYLINDER - LOCKING - W/O CAM/KEY - .65" - 702371	
2	110506-54-001	EA	CASE/CYLINDER - LOCKING - W/O CAM/KEY - 1.25" - 703171	
1*	110506-59-002	EA	KEYS - SET OF TWO	596722
2	110506-52-002	EA	CASE/CYLINDER - LOCKING - W/O CAM/KEY - .65" - 702372	
2	110506-54-002	EA	CASE/CYLINDER - LOCKING - W/O CAM/KEY - 1.25" - 703172	
1*	110506-59-003	EA	KEYS - SET OF TWO	596723
2	110506-52-003	EA	CASE/CYLINDER - LOCKING - W/O CAM/KEY - .65" - 702373	
2	110506-54-003	EA	CASE/CYLINDER - LOCKING - W/O CAM/KEY - 1.25" - 703173	
1*	110506-59-004	EA	KEYS - SET OF TWO	596724
2	110506-52-004	EA	CASE/CYLINDER - LOCKING - W/O CAM/KEY - .65" - 702374	
2	110506-54-004	EA	CASE/CYLINDER - LOCKING - W/O CAM/KEY - 1.25" - 703174	
1*	110506-59-005	EA	KEYS - SET OF TWO	596725
2	110506-52-005	EA	CASE/CYLINDER - LOCKING - W/O CAM/KEY - .65" - 702375	
2	110506-54-005	EA	CASE/CYLINDER - LOCKING - W/O CAM/KEY - 1.25" - 703175	
1*	110506-59-006	EA	KEYS - SET OF TWO	596726
2	110506-52-006	EA	CASE/CYLINDER - LOCKING - W/O CAM/KEY - .65" - 702376	
2	110506-54-006	EA	CASE/CYLINDER - LOCKING - W/O CAM/KEY - 1.25" - 703176	

**\*COMPONENT PARTS FOUND IN SERVICE PARTS LIBRARY**

**EXTERIOR DOORS & COMPARTMENTS GROUP (CONTINUED)**  
**COMPARTMENT DOOR COMPONENTS (CONTINUED)**

<b>KEY</b>	<b>PART NUMBER</b>	<b>U/M</b>	<b>DESCRIPTION</b>	
1*	110506-59-007	EA	KEYS - SET OF TWO	596727
2	110506-52-007	EA	CASE/CYLINDER - LOCKING - W/O CAM/KEY - .65" - 702377	
2	110506-54-007	EA	CASE/CYLINDER - LOCKING - W/O CAM/KEY - 1.25" - 703177	
1*	110506-59-008	EA	KEYS - SET OF TWO	596728
2	110506-52-008	EA	CASE/CYLINDER - LOCKING - W/O CAM/KEY - .65" - 702378	
2	110506-54-008	EA	CASE/CYLINDER - LOCKING - W/O CAM/KEY - 1.25" - 703178	
1*	110506-59-009	EA	KEYS - SET OF TWO	596729
2	110506-52-009	EA	CASE/CYLINDER - LOCKING - W/O CAM/KEY - .65" - 702379	
2	110506-54-009	EA	CASE/CYLINDER - LOCKING - W/O CAM/KEY - 1.25" - 703179	
	110506-55-000	EA	CASE/CYLINDER - TWIST LOCK - W/O CAM - 1.25"	597312AA1
	110506-64-000	EA	CAM - LATCHING - DOG LEGGED 1.8" LONG	
	110506-66-000	EA	CAM - LATCHING - DOG LEGGED 1.5" LONG	
	110506-76-000	EA	CAM - LOCK	

**\*COMPONENT PARTS FOUND IN SERVICE PARTS LIBRARY**

EXTERIOR DOORS & COMPARTMENTS GROUP (CONTINUED)  
ENTRY DOOR

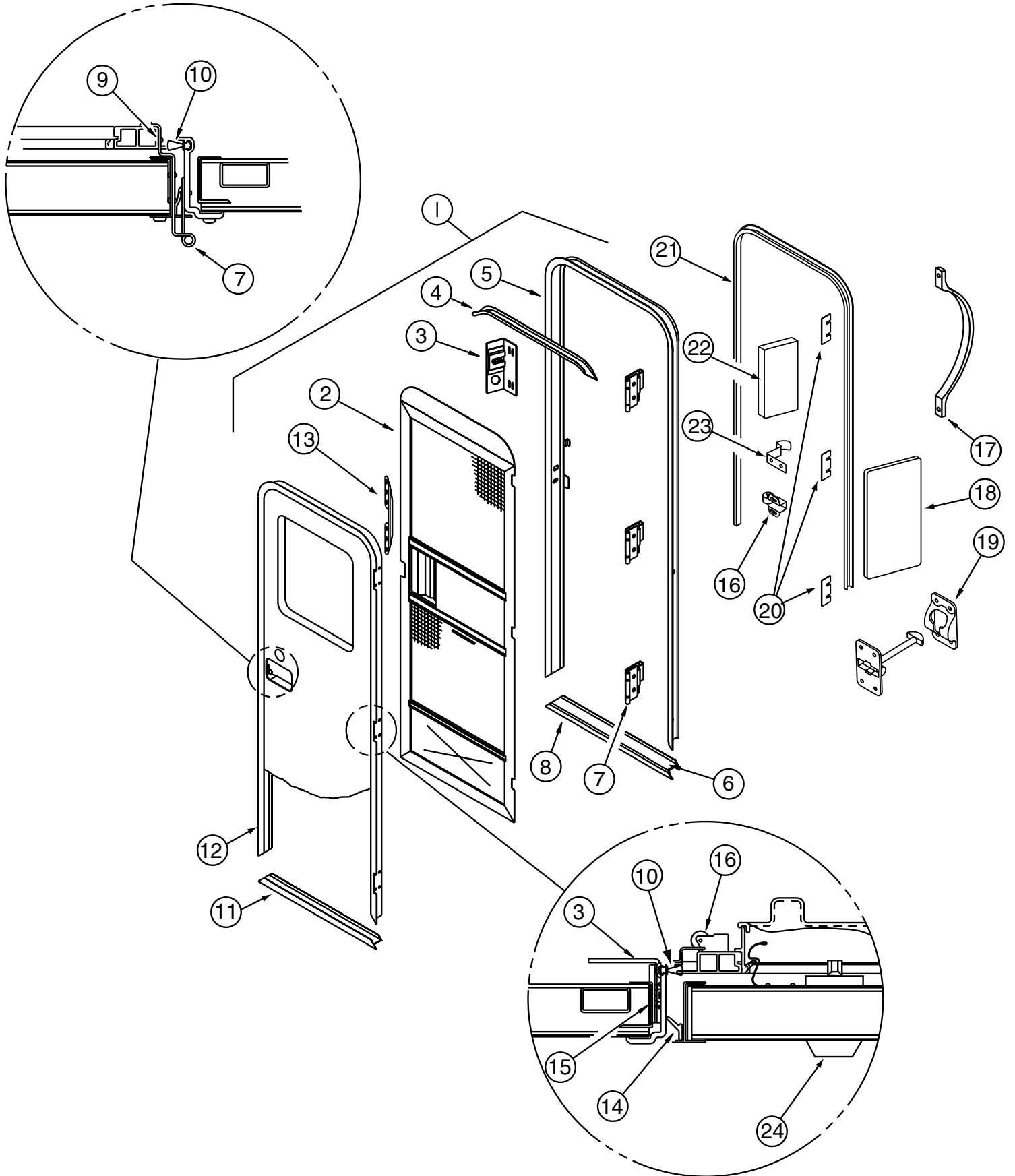



## EXTERIOR DOORS & COMPARTMENTS GROUP (CONTINUED)

### ENTRY DOOR (CONTINUED)

KEY	PART NUMBER	U/M	DESCRIPTION
1	115108-01-K03	EA	DOOR - ENTRY - W/SCREEN DOOR - W/O WINDOW (L04)
1	115108-01-L02	EA	DOOR - ENTRY - W/SCREEN DOOR - W/O WINDOW (L05)
1	115108-01-L06	EA	DOOR - ENTRY - W/SCREEN DOOR - W/O WINDOW (L06)
1	115108-05-K03	EA	DOOR - ENTRY - W/SCREEN DOOR - W/O WINDOW - ELECTRIC STEP (L04)
1	115108-05-L02	EA	DOOR - ENTRY - W/SCREEN DOOR - W/O WINDOW - ELECTRIC STEP (L05)
1	115108-05-L06	EA	DOOR - ENTRY - W/SCREEN DOOR - W/O WINDOW - ELECTRIC STEP (L06)
2	121899-03-GB1	EA	DOOR - SCREEN - W/O HARDWARE
3	041546-07-000	EA	BRACKET - DOOR ANGLE - OFF WHITE
4	044582-44-000	EA	CAP - DRIP - JAMB - BRIGHT WHITE
5	121898-03-01A	EA	JAMB - ENTRY DOOR
5	121898-04-01A	EA	JAMB - ENTRY DOOR - BRIGHT WHITE - ELECTRIC STEP
6	038327-01-000	EA	TAPE - ANTI SLIP - 2" X 60'
7	106719-01-05A	EA	HINGE - ENTRY DOOR - BRIGHT WHITE
	116111-02-01A	EA	SCREW - TAPTITE - 1/4-20 X 3/8 PPH - ZINC
8	051049-01-000	EA	JAMB - BOTTOM - ENTRY DOOR - 25.9" - UNPAINTED
9	100128-02-000	EA	SEAL - FOAM - ADHESIVE BACK - .37" WIDE X .37" THICK
10	118929-01-01A	FT	SEAL - PILE - PUSH ON
11	121893-01-01A	EA	FRAME - ENTRY DOOR/BOTTOM - BRIGHT WHITE
12	121894-07-01A	EA	FRAME - ENTRY DOOR - BRIGHT WHITE
13	098173-01-04A	EA	STIFFENER - ENTRY DOOR - SUPPORTS LATCH/STRIKE - UNPAINTED
	122241-01-01A	EA	BUMPER - FOAM RUBBER W/ADH BACK - .5" X .5" X .25" - BLACK
14	075671-04-000	FT	SEAL - SPONGE - LAZX T - W/ADHESIVE STRIP - .5" WIDE
15	104692-01-000	FT	SEAL - FOAM/ADHESIVE BACK - .75"THICK X .75"WIDE X 25'
16	109403-01-000	EA	CATCH - SINGLE ROLLER - SCREEN DOOR
17	009126-03-000	EA	HANDLE - ASSIST - BLACK TEXTURED
18	076725-02-000	EA	COVER - HINGE - ENTRY DOOR - 6" X 3.2" - OFF WHITE
19	104099-01-04A	EA	CATCH - DOOR HOLDER - STRIKE - BRIGHT WHITE
19	104099-02-04A	EA	CATCH - DOOR HOLDER - RETAINER - BRIGHT WHITE
20	102248-01-000	EA	SHIM - DOOR
21	115222-04-01A	EA	GARNISH - ENTRY DOOR - RADIUS
22	077461-03-000	EA	COVER - STRIKE - ENTRY DOOR - 6.5" X 2.5" - WHITE PLASTIC
23	100412-01-000	EA	CATCH - SCREEN DOOR
24*	101145-01-06A	EA	DEADBOLT - ENTRY DOOR W/O SECURITY BOLT W/2 KEYS - BLACK

\*COMPONENT PARTS FOUND IN SERVICE PARTS LIBRARY

# EXTERIOR DOORS & COMPARTMENTS GROUP (CONTINUED)

## SCREEN DOOR

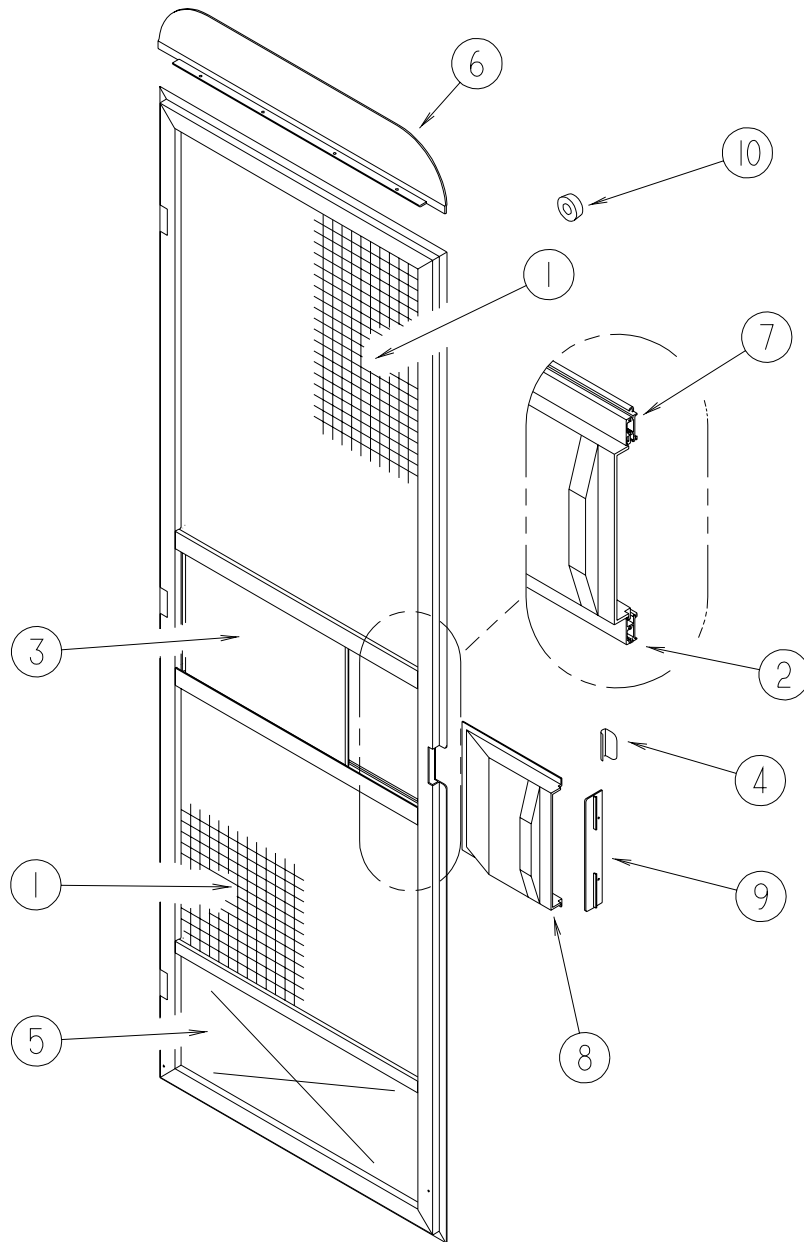

KEY	PART NUMBER	U/M	DESCRIPTION
	121899-03-GB1	EA	DOOR - SCREEN - W/O HARDWARE
1	002293-02-000	SF	SCREENING - WINDOW/DOOR - 26" - CHARCOAL
2	002294-01-000	FT	SPLINE - SCREENING - .135" X .138"
3	016454-01-000	EA	INSERT - CENTER - LEATHER GRAIN ALUMINUM - UNPAINTED
	001014-01-013	EA	INSERT - CENTER - 10.25" X 16.31" - UNPAINTED
4	050712-06-000	EA	HANDLE - SCREEN DOOR - BRIGHT WHITE
5	078552-03-000	EA	KICK PANEL - SCREEN DOOR - LOWER INSERT - UNPAINTED
6	078595-01-000	EA	TOP PLATE - SCREEN DOOR - CURVED TOP - 4.7" X 25.35"
7	078777-08-000	FT	CHANNEL - SLIDER
8	079086-03-000	EA	SLIDER - SCREEN DOOR - BRIGHT WHITE
9	079087-03-000	EA	STRIKE - SLIDER - SCREEN DOOR - BRIGHT WHITE
10	120863-06-000	EA	BUMPER - RUBBER - 3/4" X 3/8"

## EXTERIOR DOORS & COMPARTMENTS GROUP (CONTINUED)

### LATCH - ENTRY DOOR

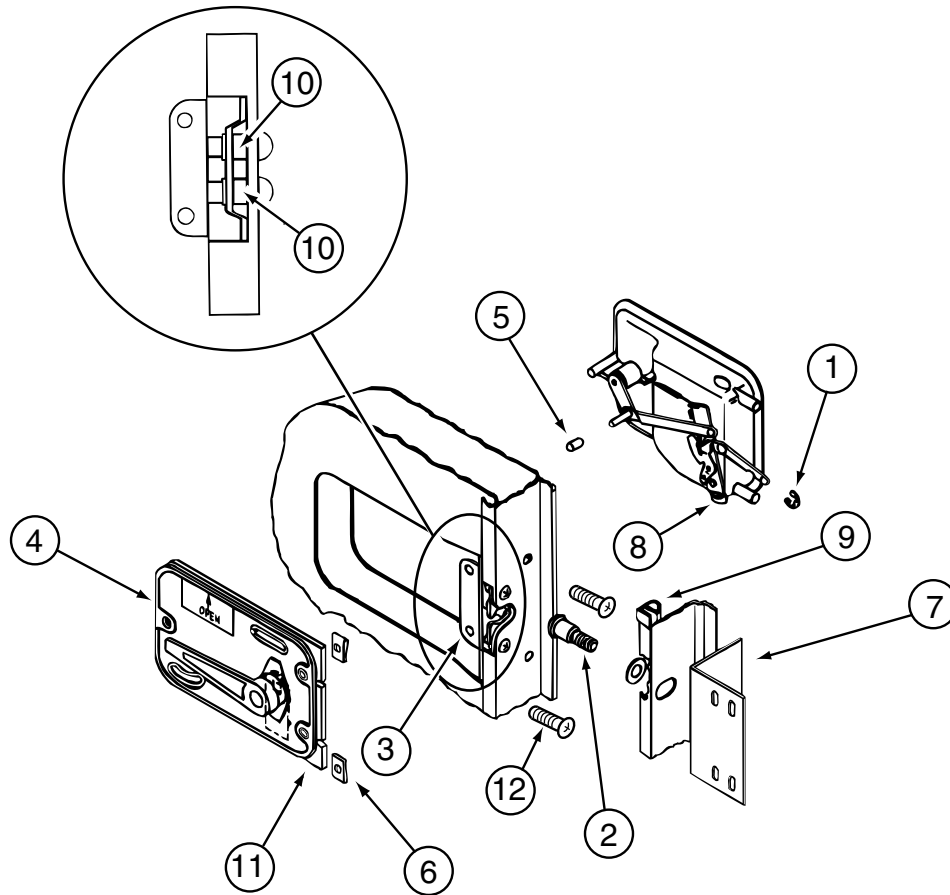

KEY	PART NUMBER	U/M	DESCRIPTION
1	036618-02-000	EA	E-RING - EXTERNAL - 3/16" SHAFT DIAMETER - LYNOR DOOR LOCK
2	039539-01-000	EA	STRIKE - LOCK - ENTRY DOOR - ROUND W/THREADED WASHER
	039715-01-000	EA	NUT-SERT - 1/4" DIAMETER - 20 THREADS
3	039540-01-000	EA	LATCH MECHANISM - HOOK - ENTRY DOOR - INTERIOR
4	039979-06-000	EA	COVER - LATCH PLATE - RIGHT HAND - BLACK TEXTURED
5	039984-01-000	EA	CAP - ROUND - VINYL - .28" ID X .62" - BLACK
6	040921-01-000	EA	NUT-SPEED-U TYPE 10-24 BLACK
7	041546-07-000	EA	BRACKET - DOOR ANGLE - OFF WHITE
8*	045017-13-000	EA	LATCH - ENTRY DOOR - BLACK TEXTURED
9	064075-07-000	FT	SEAL - BULB - W/WIRED U CHANNEL - .3" X .5" CHANNEL-BLACK
10	086285-05-000	EA	SPACER - NYLON - .7" X .56"
11	096810-01-01A	EA	PLATE - LATCH - ENTRY DOOR - BLACK
12	000G54-04-20B	EA	SCREW - 1/4-20 X 1 1/4 PTH TXP 23
	130444-01-01A	EA	CAP - KEY IDENTIFIER - GRAY

**\*COMPONENT PARTS FOUND IN SERVICE PARTS LIBRARY**

## GALLEY GROUP CABINETS

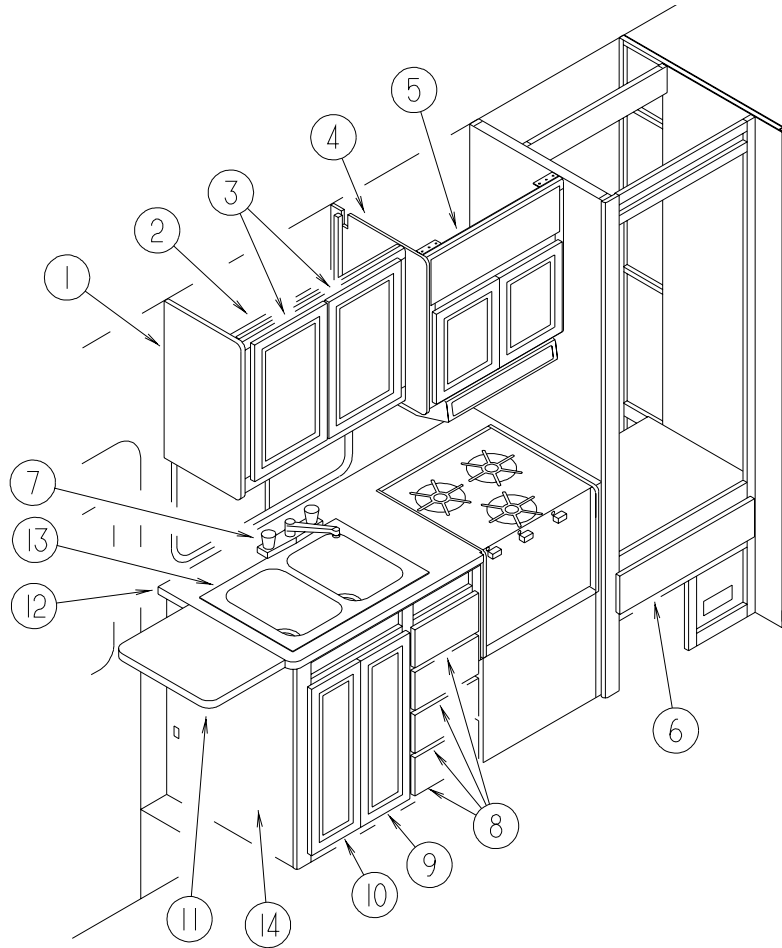

KEY	PART NUMBER	U/M	DESCRIPTION
1	109908-83-K04	EA	END CAP - OVERHEAD CABINET
2	124210-02-K04	EA	CABINET - OVERHEAD/GALLEY - W/O DOORS/HARDWARE
	124210-11-H04	EA	SHELF - W/PLASTIC EDGE TRIM
3	132141-44-L01	EA	DOOR - RAIL/VENEER - 13.4" X 21.8" - W/O HARDWARE
4	109908-52-H04	EA	END CAP - OVERHEAD CABINET
5	128618-04-K01	EA	CABINET - MICROWAVE - W/O DOORS/HARDWARE
6	M09316-33-L01	EA	DRAWER - OGEE EDGE - 22.5"W X 13.9"D - W/O SLIDES/HARDWARE
7		EA	FAUCET - SEE WATER SYSTEMS GROUP
8	M09316-08-L01	EA	DRAWER - OGEE EDGE - 9.9"W X 17.7"D - W/O SLIDES/HARDWARE
9	131995-S4-L15	EA	DOOR - RAIL/SOLID PANEL - 9" X 26.5" - W/O HARDWARE
10	131995-S3-L15	EA	DOOR - RAIL/SOLID PANEL - 9" X 26.5" - W/O HARDWARE
11	129503-01-K03	EA	EXTENSION - GALLEY - W/O HARDWARE (L04)
11	129503-01-K02	EA	EXTENSION - GALLEY - W/O HARDWARE (L05)
11	129503-01-K06	EA	EXTENSION - GALLEY - W/O HARDWARE (L06)
12	132601-64-L01	EA	COUNTERTOP - GALLEY CABINET - LAMINATED (L04)
12	132601-64-L02	EA	COUNTERTOP - GALLEY CABINET - LAMINATED (L05)
12	132601-64-L06	EA	COUNTERTOP - GALLEY CABINET - LAMINATED (L06)
13		EA	SINK - SEE DRAINAGE SYSTEMS GROUP
14	M09404-04-L01	EA	CABINET - GALLEY - W/O COUNTERTOP - W/O DOORS/DRAWERS/HW
	130379-11-K04	EA	SHELF - W/PLASTIC EDGE MOLDING
	103610-03-L01	EA	COVER - SINK - 15.2" X 11" - LAMINATED BOTH SIDES (L04)
	103610-03-L16	EA	COVER - SINK - 15.2" X 11" - LAMINATED BOTH SIDES (L05)
	103610-03-L06	EA	COVER - SINK - 15.2" X 11" - LAMINATED BOTH SIDES (L06)

## GENERATOR GROUP GAS

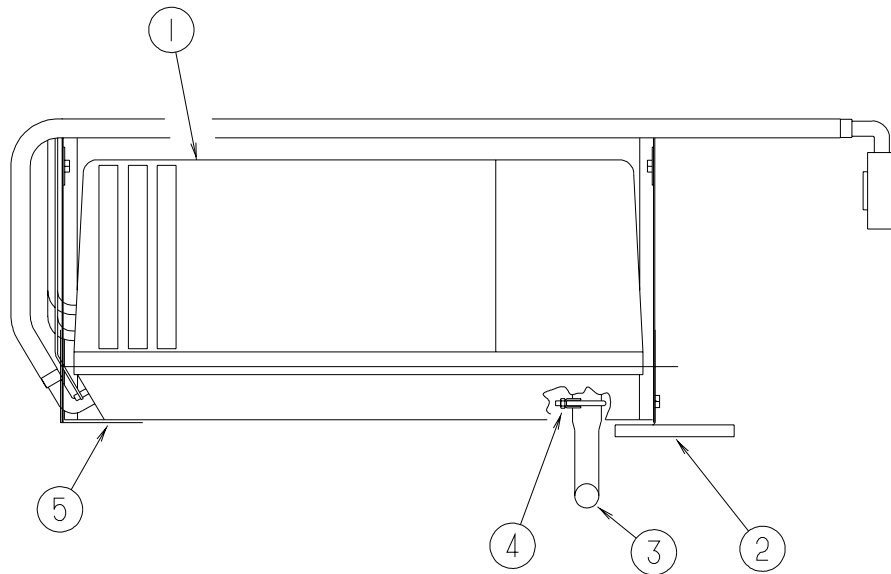

KEY	PART NUMBER	U/M	DESCRIPTION
1	109982-03-000	EA	GENERATOR - 4.0 MICROLITE

## LPG

KEY	PART NUMBER	U/M	DESCRIPTION
1	109982-04-000	EA	GENERATOR - 3.6 MICROLITE

## GENERATOR INSTALLATION

KEY	PART NUMBER	U/M	DESCRIPTION
2	114070-02-02B	EA	SUPPORT - GENERATOR - LEFT
3	105958-09-000	EA	PIPE - GENERATOR EXHAUST - 1.3" OD X 5.9" X 22"
4	007125-03-000	EA	CLAMP - MUFFLER - 1.5" DIAMETER
5	114071-02-02B	EA	SUPPORT - GENERATOR - RIGHT
	007067-01-000	SF	INSULATION - FIBERGLASS - 1" THICK X 4'-INCREMENTS 4 SF

## HEATING & A/C GROUP FURNACE

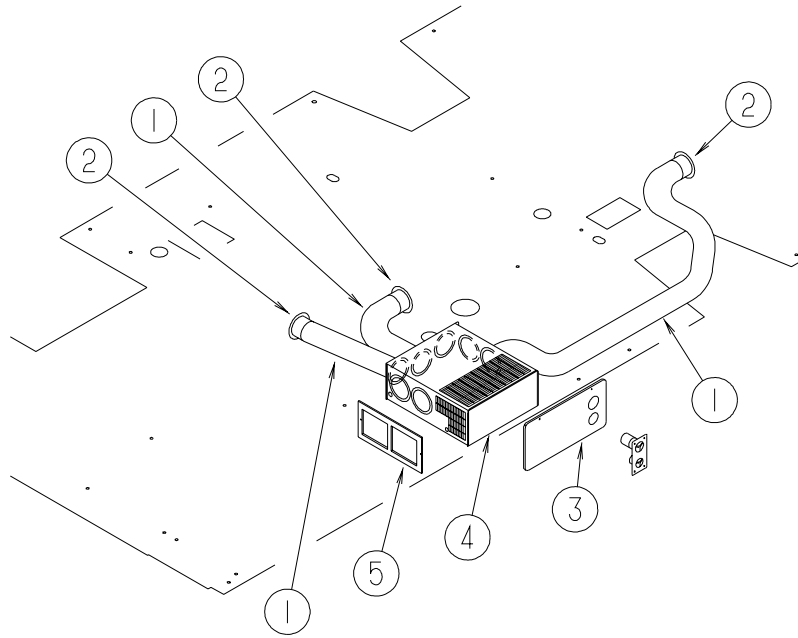

KEY	PART NUMBER	U/M	DESCRIPTION
1	009198-01-000	FT	DUCT - HEAT - FLEXIBLE - 4" ID X 25'
2	056464-10-000	EA	REGISTER W/O DAMPER - 4" DIAMETER - PLASTIC - BEIGE
3	098668-23-000	EA	DOOR - ACCESS - FURNACE - BRIGHT WHITE
4*	098668-20-000	EA	FURNACE - 30,000 BTU
5	093614-01-02A	EA	GRILLE - RETURN AIR - 15.6" X 7.6" - BEIGE
	069636-02-000	EA	CONNECTOR - DUCT - 4" ID
	009200-01-000	EA	TAPE - FURNACE - 1 1/2"

**\*COMPONENT PARTS FOUND IN SERVICE PARTS LIBRARY**

## ROOF

KEY	PART NUMBER	U/M	DESCRIPTION
*	131185-01-01A	EA	A/C ROOF - 13,500 BTU - WHITE
	131184-03-01A	EA	CEILING ASSEMBLY - A/C DUCTED - C-BODY - WHITE
	084077-03-000	EA	COVER/BLANK - ROOF A/C 5.2" X 3.5" - IVORY
	120134-01-02A	EA	REGISTER - W/DAMPER - 4" PIPE/7" O.D. FACE - WHITE
	117238-01-01A	EA	THERMOSTAT - A/C - FURNACE

**\*COMPONENT PARTS FOUND IN SERVICE PARTS LIBRARY**

**INTERIOR FINISH GROUP  
MOLDINGS & TRIMS  
WATERFORD OAK**

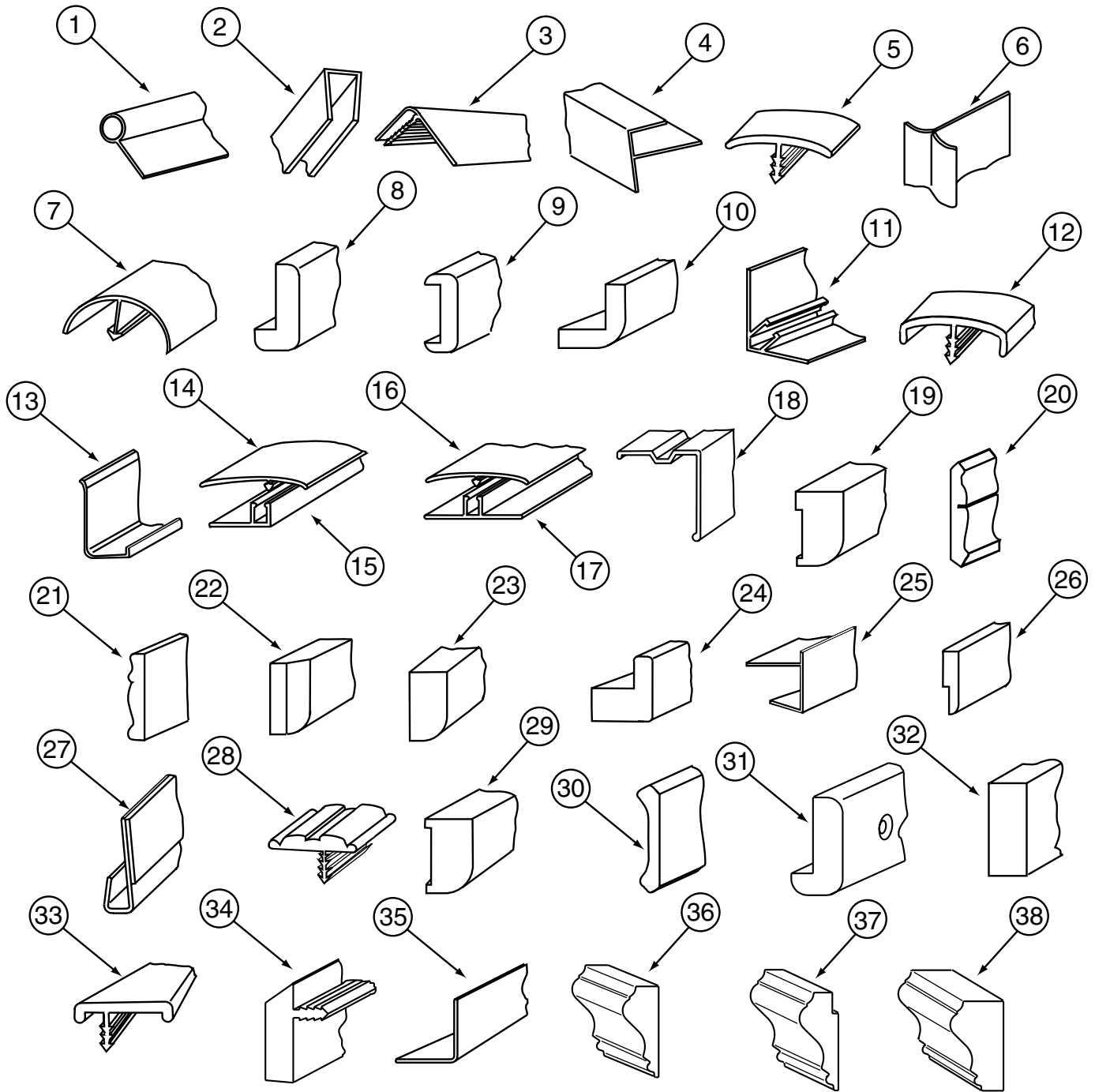

KEY	PART NUMBER	U/M	DESCRIPTION
1	009767-12-000	FT	WELTING - ANTIQUE WHITE
1	009767-14-000	FT	WELTING - CHERRY
1	009767-15-000	FT	WELTING - WATERFORD OAK
1	009767-16-000	FT	WELTING - REBER BIRCH
2	009778-16-000	FT	U-CHANNEL - 1" - PICKLED ASH
2	009778-18-000	FT	U-CHANNEL - 1" - CHERRY WOOD/CHERRY STAIN
2	009778-21-000	FT	U-CHANNEL - 1" - WATERFORD OAK
2	009778-25-000	FT	U-CHANNEL - 1" - BEIGE ILLUSION
2	009778-27-000	FT	U-CHANNEL - 1" - WASHED MAPLE
2	009778-31-000	FT	U-CHANNEL - 1" - GRADY BROWN
2	070504-03-000	FT	U-CHANNEL - PLASTIC - .9" X 96" - GRADY BROWN
2	070504-18-000	FT	U-CHANNEL - PLASTIC - .13" X 84" - IVORY
2	070504-30-000	FT	U-CHANNEL - PLASTIC - .13" X 84" - CHERRY

## INTERIOR FINISH GROUP (CONTINUED)

### MOLDINGS & TRIMS (CONTINUED)

KEY	PART NUMBER	U/M	DESCRIPTION
2	070504-31-000	FT	U-CHANNEL - PLASTIC - .9" X 84" - CHERRY
2	070504-36-000	FT	U-CHANNEL - PLASTIC - .13" X 72" - WATERFORD OAK
2	070504-37-000	FT	U-CHANNEL - PLASTIC - .9" X 84" - WATERFORD OAK
2	070504-42-000	FT	U-CHANNEL - PLASTIC - .13" X 84" - BEIGE ILLUSION
2	070504-50-000	FT	U-CHANNEL - PLASTIC - .13" X 84" - WASHED MAPLE
2	070504-51-000	FT	U-CHANNEL - PLASTIC - .9" X 96" - WASHED MAPLE
2	070504-54-000	FT	U-CHANNEL - PLASTIC - .9" X 96" - VILLAGE OAK
3	009809-27-000	EA	MOLDING - CORNER - OUTSIDE - 1" X 84" - CHERRY-CHERRY
3	009809-28-000	EA	MOLDING - CORNER - OUTSIDE - 1" X 84" - WATERFORD OAK
3	009809-30-000	EA	MOLDING - CORNER - OUTSIDE - 1" X 84" - BEIGE ILLUSION
3	009809-31-000	EA	MOLDING - CORNER - OUTSIDE - 1" X 84" - WASHED MAPLE
3	009809-32-000	EA	MOLDING - CORNER - OUTSIDE - 1" X 84" - PORTSMOUTH OAK
4	009812-24-000	EA	MOLDING - CORNER - 1/2" W/1/4" CHAN X 108" - IVORY PLASTIC
4	009812-26-000	EA	MOLDING - CORNER - 1/2" W/1/4" CHAN X 84" - CHERRY
4	009812-27-000	EA	MOLDING - CORNER - 1/2" W/1/4" CHAN X 84" - PICKLED ASH
4	009812-29-000	EA	MOLDING - CORNER - 1/2" W/1/4" CHAN X 84" - WATERFORD OAK
4	009812-31-000	EA	MOLDING - CORNER - 1/2" W/1/4" CHAN X 84" - BEIGE ILLUSION
4	009812-33-000	EA	MOLDING - CORNER - 1/2" W/1/4" CHAN X 84" - WASHED MAPLE
4	009812-34-000	EA	MOLDING - CORNER - 1/2" W/1/4" CHAN X 84" - VW LIGHT GRAY
4	009812-35-000	EA	MOLDING - CORNER - 1/2" W/1/4" CHAN X 84" - PORTSMOUTH OAK
5	009815-09-000	FT	MOLDING-T - W/EDGE LIP - 3/4" FACE - IVORY
5	105709-02-000	FT	MOLDING-T - W/EDGE LIP - 3/4" FACE - BEIGE ILLUSION
6	022992-11-000	FT	MOLDING - REVERSE COVE - T-SHAPED - IVORY
6	022992-14-000	FT	MOLDING - REVERSE COVE - T-SHAPED - BRIGHT WHITE
6	022992-15-000	FT	MOLDING - REVERSE COVE - T-SHAPED - VW GRAY
7	042357-18-000	EA	MOLDING - CORNER - RADIUS/PLASTIC - PICKLED ASH
7	042357-19-000	EA	MOLDING - CORNER - RADIUS/PLASTIC - CHERRY
7	042357-20-000	EA	MOLDING - CORNER - RADIUS/PLASTIC - WATERFORD OAK
7	042357-25-000	EA	MOLDING - CORNER - RADIUS/PLASTIC - WASHED MAPLE
7	042357-26-000	EA	MOLDING - CORNER - RADIUS/PLASTIC - PORTSMOUTH OAK
8	077840-01-E41	EA	MOLDING - WALL CAP - 8' - SALEM CHERRY
8	077840-01-G01	EA	MOLDING - WALL CAP - 8' - WATERFORD OAK
8	077840-01-J70	EA	MOLDING - WALL CAP - 8' - WASHED MAPLE
9	078323-06-G15	EA	MOLDING - CAP/WALL - 79.6" - WATERFORD OAK
10	080176-08-000	EA	CAP - CORNER - RADIUS MOLDING - PLASTIC - WASHED MAPLE
11	081521-02-007	EA	MOUNT - METAL MOLDING - F/RADIUS CORNER MOLDING - 151.5"
12	083620-09-000	FT	MOLDING-T - W/EDGE LIP - 7/8" FACE - MODERN IVORY
12	083620-11-000	FT	MOLDING-T - W/EDGE LIP - 7/8" FACE - CHERRY
12	083620-12-000	FT	MOLDING-T - W/EDGE LIP - 7/8" FACE - WATERFORD OAK
12	083620-15-000	FT	MOLDING-T - W/EDGE LIP - 7/8" FACE - BEIGE ILLUSION
12	083620-19-000	FT	MOLDING-T - W/EDGE LIP - 7/8" FACE - WASHED MAPLE
12	104676-02-02A	FT	MOLDING-T - W/EDGE LIP - 11/16" FACE - PICKLED ASH
13	085746-04-000	FT	TRIM-J - CARPET 1.2" X .5" ANGLE - 10' LONG - OFF WHITE
14	086229-12-000	EA	BATTEN - 1.5" OFFSET X 96.8" - MODERN IVORY
15	086229-11-000	EA	RETAINER - OFFSET - 97.01"
16	086229-15-000	EA	BATTEN - 1" X 96" - MODERN IVORY
16	086229-19-000	EA	BATTEN - 1" X 98.3" - OFF WHITE
16	086229-20-000	EA	BATTEN - 1" X 96" - BEIGE
17	086229-01-000	EA	RETAINER - BATTEN - .75" X 92.1" - ANY COLOR
17	086229-14-000	EA	RETAINER - BATTEN - .75" X 98.3" - ANY COLOR
18	093873-01-01A	EA	TRIM - CARPET - L-ANGLE 1.1" X 1.3" X 12' - GRAY VINYL
19	126204-D2-134	EA	MOLDING - VINYL WRAPPED - .7" X 1.6" X 84" - WASHED MAPLE
19	126204-F2-134	EA	MOLDING - VINYL WRAPPED - .7" X 2.5" X 84" - WASHED MAPLE
19	126204-F2-438	EA	MOLDING - VINYL WRAPPED - .7" X 2.6" X 96" - WASHED MAPLE
20	111136-D2-134	EA	MOLDING - VINYL WRAPPED - .7" X 1.6" X 7' - CHERRY
20	111136-F2-134	EA	MOLDING - VINYL WRAPPED - .7" X 2.6" X 84" - CHERRY
20	111136-F2-438	EA	MOLDING - VINYL WRAPPED - .7" X 2.5" X 8' - CHERRY
21	100182-01-G15	EA	TRIM - RAIL - WATERFORD OAK
22	100659-27-G15	EA	MOLDING - TRIM - WATERFORD OAK



**INTERIOR FINISH GROUP (CONTINUED)**  
**MOLDINGS & TRIMS (CONTINUED)**  
**WATERFORD OAK**

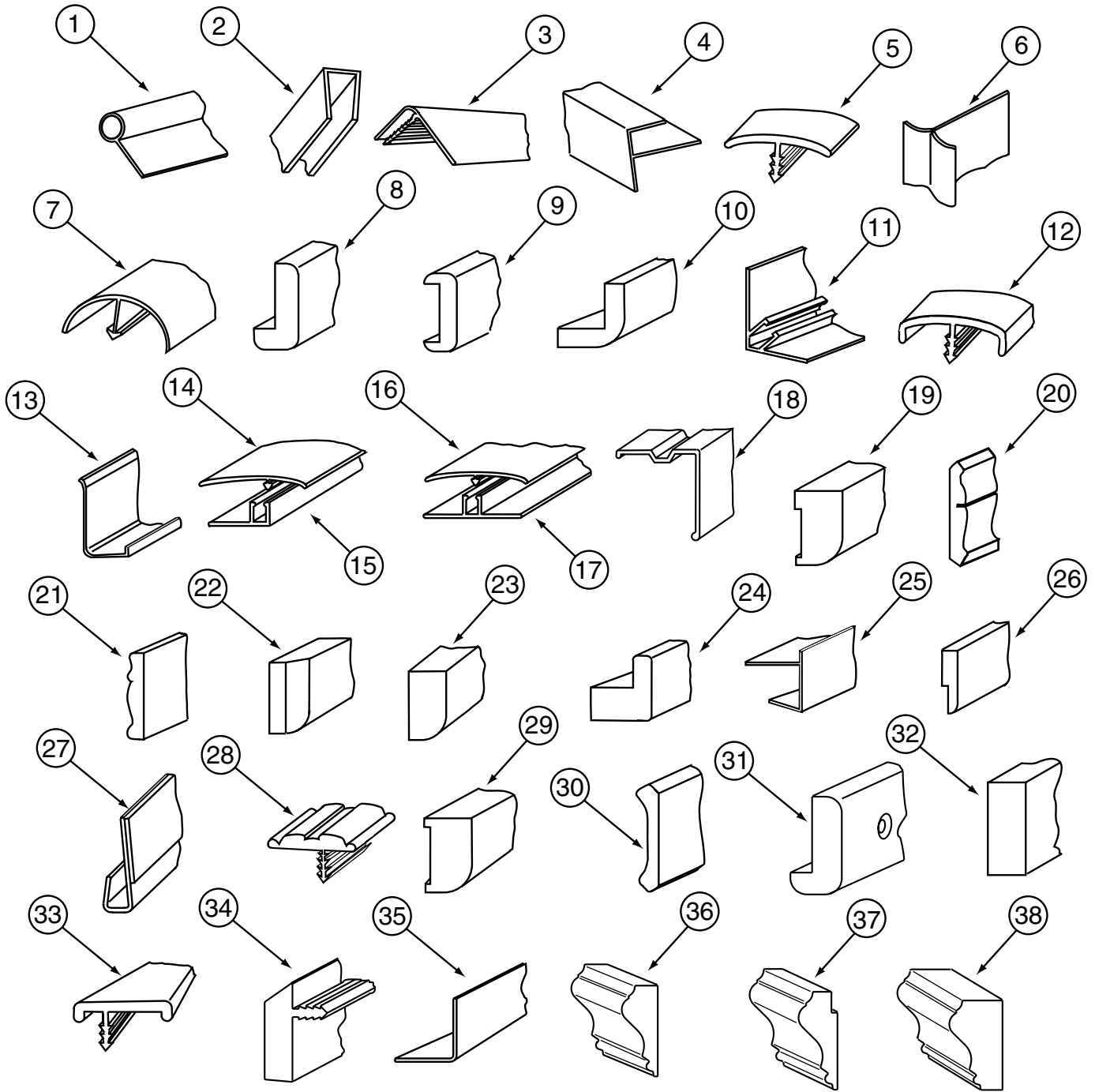

KEY	PART NUMBER	U/M	DESCRIPTION
23	100818-01-03A	EA	MOLDING - VINYL WRAPPED - 1.6" X .4" X 84" - PICKLED ASH
23	100818-01-04A	EA	MOLDING - VINYL WRAPPED - 1.6" X .4" X 84" - WATERFORD OAK
23	100818-01-05A	EA	MOLDING - VINYL WRAPPED - 1.6" X .4" X 84" - CHERRY CHERRY
23	100818-01-08A	EA	MOLDING - VINYL WRAPPED - 1.6" X .4" X 84" - WASHED MAPLE
23	100818-01-09A	EA	MOLDING - VINYL WRAPPED - 1.6" X .4" X 84" - PORTSMOUTH OAK
24	100819-01-03A	EA	MOLDING - VINYL WRAPPED - L-SHAPED - 1.5"X1.5"X84" - PICKLED ASH
24	100819-01-04A	EA	MOLDING - VINYL WRAPPED - L-SHAPED - 1.5"X1.5"X84" - CHERRY
24	100819-01-05A	EA	MOLDING - VINYL WRAPPED - L-SHAPED - 1.5"X1.5"X84" - OAK
24	100819-01-08A	EA	MOLDING - VINYL WRAPPED - L-SHAPED - 1.5"X1.5"X84" - WASHED MAPLE
24	100819-01-09A	EA	MOLDING - VINYL WRAPPED - L-SHAPED - 1.5"X1.5"X84" - PORTSMOUTH OAK
25	103186-01-04A	FT	MOLDING - PLASTIC 3/8" U-CHANNEL W/3/4" FACE - CHERRY
25	103186-01-03A	FT	MOLDING - PLASTIC 3/8" U-CHANNEL W/3/4" FACE - PICKLED ASH
25	103186-01-05A	FT	MOLDING - PLASTIC 3/8" U-CHANNEL W/3/4" FACE - WATERFORD OAK
25	103186-01-08A	FT	MOLDING - PLASTIC 3/8" U-CHANNEL W/3/4" FACE - WASHED MAPLE
25	103186-01-07A	FT	MOLDING - PLASTIC 3/8" U-CHANNEL W/3/4" FACE - BEIGE ILLUSION

**INTERIOR FINISH GROUP (CONTINUED)****MOLDINGS & TRIMS (CONTINUED)****WATERFORD OAK**

<b>KEY</b>	<b>PART NUMBER</b>	<b>U/M</b>	<b>DESCRIPTION</b>
25	103186-01-09A	FT	MOLDING - PLASTIC 3/8" U-CHANNEL W/3/4" FACE - PORTSMOUTH OAK
25	103186-02-03A	FT	MOLDING - PLASTIC - 1" U-CHANNEL 1 3/8" FACE - PICKLED ASH
25	103186-02-04A	FT	MOLDING - PLASTIC - 1" U-CHANNEL 1 3/8" FACE - CHERRY
25	103186-02-05A	FT	MOLDING - PLASTIC - 1" U-CHANNEL 1 3/8" FACE - WATERFORD OAK
25	103186-02-07A	FT	MOLDING - PLASTIC - 1" U-CHANNEL 1 3/8" FACE - BEIGE ILLUSION
25	103186-02-08A	FT	MOLDING - PLASTIC - 1" U-CHANNEL 1 3/8" FACE - WASHED MAPLE
25	103186-02-09A	FT	MOLDING - PLASTIC - 1" U-CHANNEL 1 3/8" FACE - PORTSMOUTH OAK
26	105004-01-03A	EA	MOLDING - VINYL WRAPPED - 1" X 96" - SALEM CHERRY
26	105004-01-04A	EA	MOLDING - VINYL WRAPPED - 1" X 96" - PICKLED ASH
26	105004-01-05A	EA	MOLDING - VINYL WRAPPED - 1" X 96" - WATERFORD OAK
26	105004-01-08A	EA	MOLDING - VINYL WRAPPED - 1" X 96" - WASHED MAPLE
26	105004-01-09A	EA	MOLDING - VINYL WRAPPED - 1" X 96" - PORTSMOUTH OAK
27	109332-02-03A	FT	TRIM-J - W/O ADHESIVE - SALEM CHERRY
27	109332-02-05A	FT	TRIM-J - W/O ADHESIVE - WASHED MAPLE
27	109332-02-06A	EA	TRIM-J - W/O ADHESIVE - PORTSMOUTH OAK
28	109736-02-01A	FT	MOLDING-T/OFFSET - W/EDGE LIP - 1" FACE - NATURAL OAK
29	117268-D2-134	EA	MOLDING - VINYL WRAPPED - .7" X 1.6" X 84" - WATERFORD OAK
29	117268-F2-134	EA	MOLDING - VINYL WRAPPED - .7" X 2.7" X 84" - WATERFORD OAK
29	117268-F2-438	EA	MOLDING - VINYL WRAPPED - .7" X 2.6" X 96" - WATERFORD OAK
30	113794-01-03A	FT	MOLDING - CROWN - 3.45" - MAPLE
30	113794-02-03A	FT	MOLDING - CROWN - 1.8" - MAPLE
31	116280-02-GV0	EA	MOLDING - CAP - PICKLED ASH
31	116280-02-GV1	EA	MOLDING - CAP - SALEM CHERRY
31	116280-02-J70	EA	MOLDING - CAP - WASHED MAPLE
31	116280-02-L95	EA	MOLDING - CAP - WATERFORD OAK
32	111134-F2-438	EA	LUMBER - VINYL WRAPPED - .7" X 2.5" X 96" - CHERRY
32	117267-D2-438	EA	LUMBER - VINYL WRAPPED - .7" X 1.5" X 96" - WATERFORD OAK
32	117267-E2-438	EA	LUMBER - VINYL WRAPPED - .7" X 2" X 96" - WATERFORD OAK
32	117267-F2-438	EA	LUMBER - VINYL WRAPPED - .7" X 2.5" X 96" - WATERFORD OAK
32	117267-J2-438	EA	LUMBER - VINYL WRAPPED - .7" X 5.5" X 96" - WATERFORD OAK
32	117267-R2-438	EA	LUMBER - VINYL WRAPPED - .7" X 3" X 96" - WATERFORD OAK
32	126205-D2-438	EA	LUMBER - VINYL WRAPPED - .7" X 1.5" X 96" - WASHED MAPLE
32	126205-E2-438	EA	LUMBER - VINYL WRAPPED - .7" X 2" X 96" - WASHED MAPLE
32	126205-F2-438	EA	LUMBER - VINYL WRAPPED - .7" X 2.5" X 96" - WASHED MAPLE
32	126205-G2-438	EA	LUMBER - STAINED - .7" X 3" X 96" - WASHED MAPLE
32	126205-J2-438	EA	LUMBER - VINYL WRAPPED - .7" X 5.5" X 96" - WASHED MAPLE
32	126205-R2-438	EA	LUMBER - VINYL WRAPPED - .7" X 3" X 96" - WASHED MAPLE
33	119520-01-01A	FT	MOLDING-T/OFFSET - W/EDGE LIP - 1"FACE - OFF WHITE
34	130247-01-01A	FT	MOLDING-T/OFF SET - 1.3" FACE - WATERFORD OAK
34	130247-01-02A	FT	MOLDING-T/OFF SET - 1.3" FACE - WASHED MAPLE
34	130247-01-03A	FT	MOLDING-T/OFF SET - 1.3" FACE - SALEM CHERRY
34	130247-01-04A	FT	MOLDING-T/OFF SET - 1.3" FACE - PORTSMOUTH OAK
35	130262-01-000	EA	PROTECTOR - CORNER SAVER - .7" X .7" X 5.9"
36	131923-01-01A	FT	MOLDING - CROWN - ASH
36	131923-01-02A	FT	MOLDING - CROWN - CHERRY
36	131923-01-03A	FT	MOLDING - CROWN - HARD WHITE MAPLE
37	131923-02-01A	FT	MOLDING - PICTURE - ASH
37	131923-02-02A	FT	MOLDING - PICTURE - CHERRY
37	131923-02-03A	FT	MOLDING - PICTURE - HARD WHITE MAPLE
38	131923-03-01A	FT	MOLDING - CROWN - DIVIDER - ASH
38	131923-03-02A	FT	MOLDING - CROWN - DIVIDER - CHERRY
38	131923-03-03A	FT	MOLDING - CROWN - DIVIDER - HARD WHITE MAPLE
	104676-02-03A	FT	MOLDING-T - W/EDGE LIP - 11/16" FACE - CHERRY-CHERRY
	104676-02-04A	FT	MOLDING-T - W/EDGE LIP - 11/16" FACE - WATERFORD OAK
	104676-02-06A	FT	MOLDING-T - W/EDGE LIP - 11/16" FACE - WASHED MAPLE
	104676-02-08A	FT	MOLDING-T - W/EDGE LIP - 11/16" FACE - PORTSMOUTH OAK

**INTERIOR FINISH GROUP (CONTINUED)**  
**PANELING, LAMINATES, BATT & EDGE BAND**

KEY	PART NUMBER	U/M	DESCRIPTION
	088272-H8-000	SF	PANELING - UPBEAT/TWILIGHT - 4' X 7' (L04)
	088263-G0-000	EA	BATT STRIP - DECORATIVE - UPBEAT/TWILIGHT - 8' (L04)
	085284-F8-000	FT	BATT TAPE - ADHESIVE BACKED - DECORATIVE - UPBEAT/TWILIGHT (L04)
	088272-J7-000	SF	PANELING - COSMOS/SKY - 4' X 7' (L05)
	088263-G7-000	EA	BATT STRIP - DECORATIVE - COSMOS/SKY - 8' LONG (L05)
	085284-G6-000	FT	BATT TAPE - ADHESIVE BACKED - DECORATIVE - COSMOS/SKY (L05)
	088272-J8-000	SF	PANELING - DURNHAM/MULTI - 4' X 8' (L06)
	088263-G8-000	EA	BATT STRIP - DECORATIVE - DURNHAM MULTI - 7' (L06)
	085284-G7-000	FT	BATT TAPE - ADHESIVE BACKED - DURNHAM MULTI (L06)
	074497-41-000	SF	PANELING - CEILING/IMPACT PEARL - 4' X 9'
	088263-F9-000	EA	BATT STRIP - CEILING - IMPACT PEARL - 9'
	085284-F6-000	FT	BATT TAPE - ADHESIVE BACKED-IMPACT PEARL-W/FLEECE EMBOSSED
	088272-H9-000	SF	PANELING - PEBBLE EMBOSSED - WHITE
	088263-G1-000	EA	BATT STRIP - DECORATIVE - PEBBLE EMBOSSED - 8' LONG (WET BATH)
	085284-F9-000	FT	BATT TAPE - ADHESIVE BACKED - PEBBLE EMBOSSED (WET BATH)
	074497-28-000	SF	PANELING - WATERFORD OAK - 4' X 8'
	069733-83-000	EA	BATT STRIP - WOODGRAINED/WATERFORD OAK - 8'
	085284-B5-000	FT	BATT TAPE - ADHESIVE BACKED - WOODGRAINED-WATERFORD OAK
	074498-81-000	SF	LAMINATE - PLASTIC - ALMOND JAGUARD - 5' X 8' (L04)
	074498-80-000	SF	LAMINATE - PLASTIC - WHITE TUNDRA - 5' X 8' (L05)
	074498-71-000	SF	LAMINATE - PLASTIC - NEUTRAL SANTOS - 5' X 8' (L06)
	074498-77-000	SF	LAMINATE - PLASTIC - ART CABIN (WATERFORD OAK) - 4' X 8'
	000846-01-000	SF	PLYWOOD - 5/16" X 48" X 96" - CD GRADE
	126339-01-000	SF	BOARD - WHEAT - 60" X 72"
	057882-04-700	EA	TAMBOUR - 48" X 48" SHEET - UNFINISHED
	000885-76-000	SF	PARTICLE BOARD-3/8" X 48" X 96"-WATERFORD OAK-VINYL 1 SIDE
	000885-77-000	SF	PARTICLE BOARD-3/8" X 48" X 96"-WATERFORD OAK-VINYL 2 SIDE
	000885-78-000	SF	PARTICLE BOARD-1/2" X 48" X 96"-WATERFORD OAK-VINYL 2 SIDE
	000885-79-000	SF	PARTICLE BOARD-3/4" X 48" X 96"-WATERFORD OAK-VINYL 2 SIDE
	076325-40-000	SF	MOLDING - EDGE BAND - .93" X .024" - ALMOND - SINK COVERS
	076325-39-000	SF	MOLDING - EDGE BAND - 1 5/16" X .030" - ALMOND - RANGE AREA
	076325-68-000	SF	MOLDING - EDGE BAND - 1 5/16" X .038" - WATERFORD OAK

**ACCESSORIES**

KEY	PART NUMBER	U/M	DESCRIPTION
	072852-01-000	EA	DETECTOR - SMOKE - W/9 VOLT BATTERY - US
	072852-02-000	EA	DETECTOR - SMOKE - W/9 VOLT BATTERY - CANADIAN
	125136-01-000	EA	CO DETECTOR - GAS - ROUND W/2 SCREWS - 9 VOLT
	094499-03-000	EA	EXTINGUISHER/FIRE - DRY - 10BC - W/GAUGE - W/O BRACKET
	094499-04-000	EA	BRACKET - FIRE EXTINGUISHER
	094499-02-000	EA	EXTINGUISHER/FIRE - DRY - 1A10BC - CANADIAN
	094499-01-700	EA	BRACKET MTG. W/PLAS. STRAP
	091261-01-000	FT	SLIPNOT - ANTISLIP - 1' WIDE
	096764-02-000	FT	SLIPNOT - ANTISLIP - 1' WIDE (100' ROLLS)

**FLOOR COVERINGS**

KEY	PART NUMBER	U/M	DESCRIPTION
	096060-A2-000	SY	CARPET - NEW MEADOW - INCREMENTS OF 4 SY (L04)
	096060-E7-000	SY	CARPET - PEWTER BLUE - INCREMENTS OF 4 SY (L05)
	096060-99-000	SY	CARPET - PARCHMENT - INCREMENTS OF 4 SY (L06)
	093486-01-000	SY	CARPET - COMPARTMENT - 72" WIDE - DARK GRAY
	042720-25-000	SY	VINYL - FLOOR COVERING - 14' WIDE - MODULATION

## INTERIOR FINISH GROUP (CONTINUED) HARDWARE

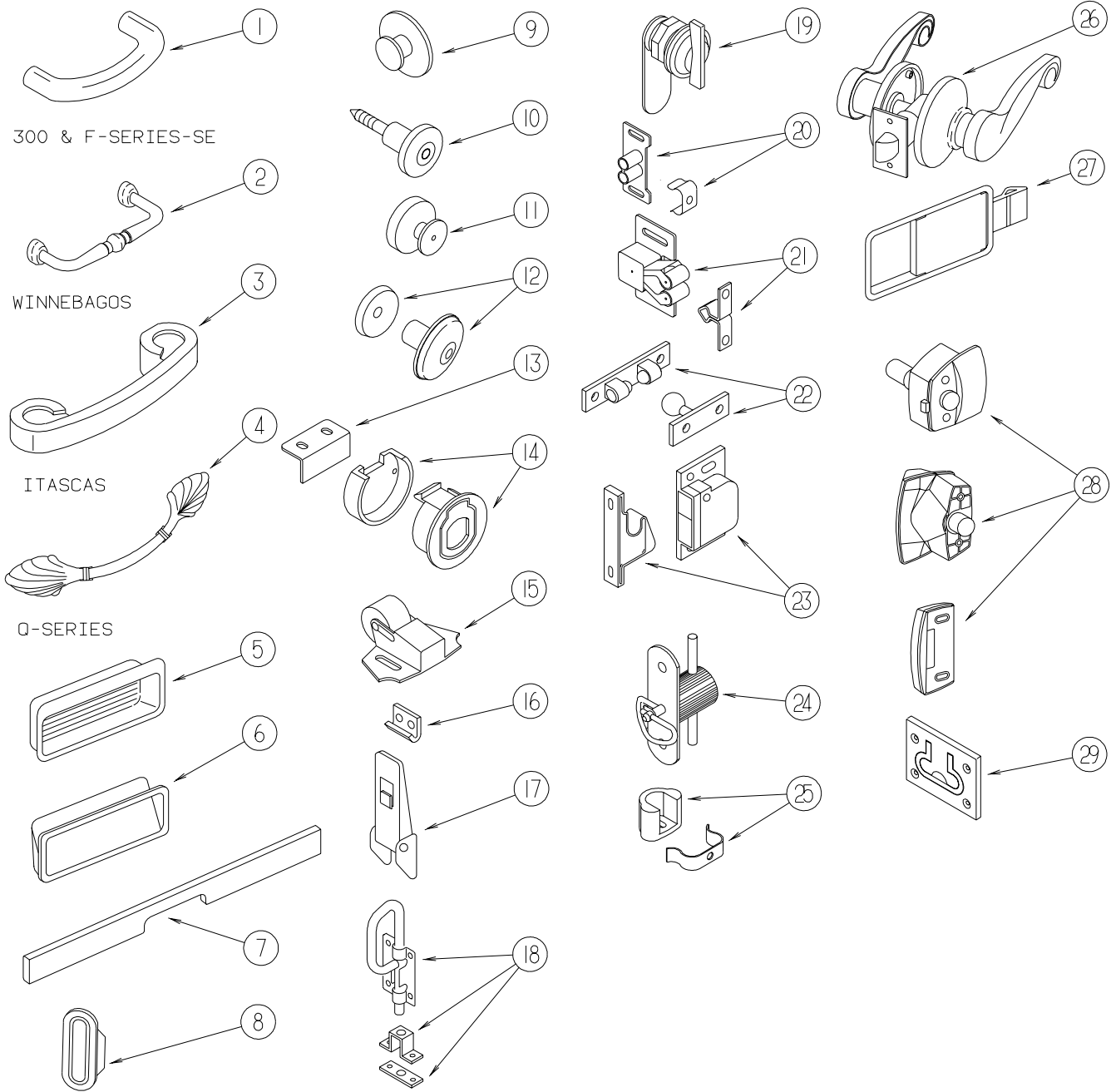

KEY	PART NUMBER	U/M	DESCRIPTION
1	131964-01-01A	EA	PULL - CABINET - POLISHED BRASS
2	131963-01-01A	EA	PULL - CABINET - POLISHED BRASS
3	131962-01-01A	EA	PULL - CABINET - POLISHED BRASS
4	117923-01-01A	EA	PULL - CABINET - BURNISHED BRASS - 5.5"
4	131965-01-01A	EA	PULL - CABINET - BURNISHED BRASS - 6.3"
5	124311-01-01A	EA	HANDLE - RECESSED - BRASS
6	115994-01-01A	EA	HANDLE - POCKET
7	126866-01-L81	EA	HANDLE - TAMBOUR DOOR - 18.6" - PORTSMOUTH OAK
7	126866-04-KQ0	EA	HANDLE - TAMBOUR DOOR - 14.7" - WASHED MAPLE
7	126866-04-KQ1	EA	HANDLE - TAMBOUR DOOR - 14.7" - CHERRY
7	126866-04-L95	EA	HANDLE - TAMBOUR DOOR - 14.7" - WATERFORD OAK
7	126866-05-K07	EA	HANDLE - TAMBOUR DOOR - 11.5" - WATERFORD OAK

**INTERIOR FINISH GROUP (CONTINUED)**  
**HARDWARE (CONTINUED)**

<b>KEY</b>	<b>PART NUMBER</b>	<b>U/M</b>	<b>DESCRIPTION</b>
7	126866-05-K09	EA	HANDLE - TAMBOUR DOOR - 11.5" - WASHED MAPLE
8	098410-01-01A	EA	PULL - FINGER - OVAL - BRASS
9	125221-01-01A	EA	PULL - MIRROR - W/ROUND HANDLE
10	113800-01-000	EA	KNOB - CABINET - BRASS
11	133313-01-01A	EA	PULL - DRAWER KNOB - BURNISHED BRASS
11	133313-01-02A	EA	PULL - DRAWER KNOB - BRIGHT BRASS
12	117978-01-01A	EA	KNOB - DOOR - BRIGHT BRASS
13	113375-02-01A	EA	STRIKE - DOOR - CHROME
14	113375-05-01A	EA	LATCH - SLAM - BACK - .8" THICK
14	113375-06-01A	EA	LATCH - SLAM - FACE - .7" THICK
15	109403-01-000	EA	CATCH - SINGLE ROLLER - SCREEN DOOR
16	116975-02-01A	EA	KEEPER/STRIKE - BLACK - NEW STYLE
17	116975-01-01A	EA	LATCH - W/O STRIKE - BLACK - NEW STYLE
18	103256-01-000	EA	LATCH - SLIDE
19	100710-01-01A	EA	LOCK - GLASS DOOR/TWIST TYPE - BRASS
20	009021-01-000	EA	CATCH - GRILLE - NYLON
20	009021-02-000	EA	STRIKE - SPRING STEEL
21	093586-04-000	EA	STRIKE - SPRING STEEL - 1.14"
21	093586-05-000	EA	STRIKE - SPRING STEEL - .943"
21	093586-03-000	EA	CATCH - SPRING ROLLER - .377"
21	093586-06-000	EA	CATCH - SPRING - ROLLER - .236"
22	084451-01-000	EA	CATCH - BRASS
23	117095-01-01A	EA	LATCH - DOOR - GRABBER W/KEEPER - PLASTIC - BLACK
23	117095-02-01A	EA	LATCH - DOOR - GRABBER W/KEEPER - PLASTIC - BLACK
24	098196-01-000	EA	LATCH - 1/4 TURN - T-BAR
25	129703-01-01A	EA	LATCH ASSEMBLY
26	111155-03-01A	EA	LOCK - PRIVACY/LOCKING - POLISHED BRASS/PLAIN HANDLE
26	111155-05-01A	EA	LOCK - PRIVACY/LOCKING - S SHAPED - POLISHED BRASS
27	127349-01-01A	EA	LATCH - PADDLE
28	058335-03-000	EA	LATCH W/O LOCK - BATHROOM DOOR BLACK
29	072871-01-000	EA	PULL - FLUSH - CHROME

**INTERIOR FINISH GROUP (CONTINUED)**  
**HARDWARE (CONTINUED)**

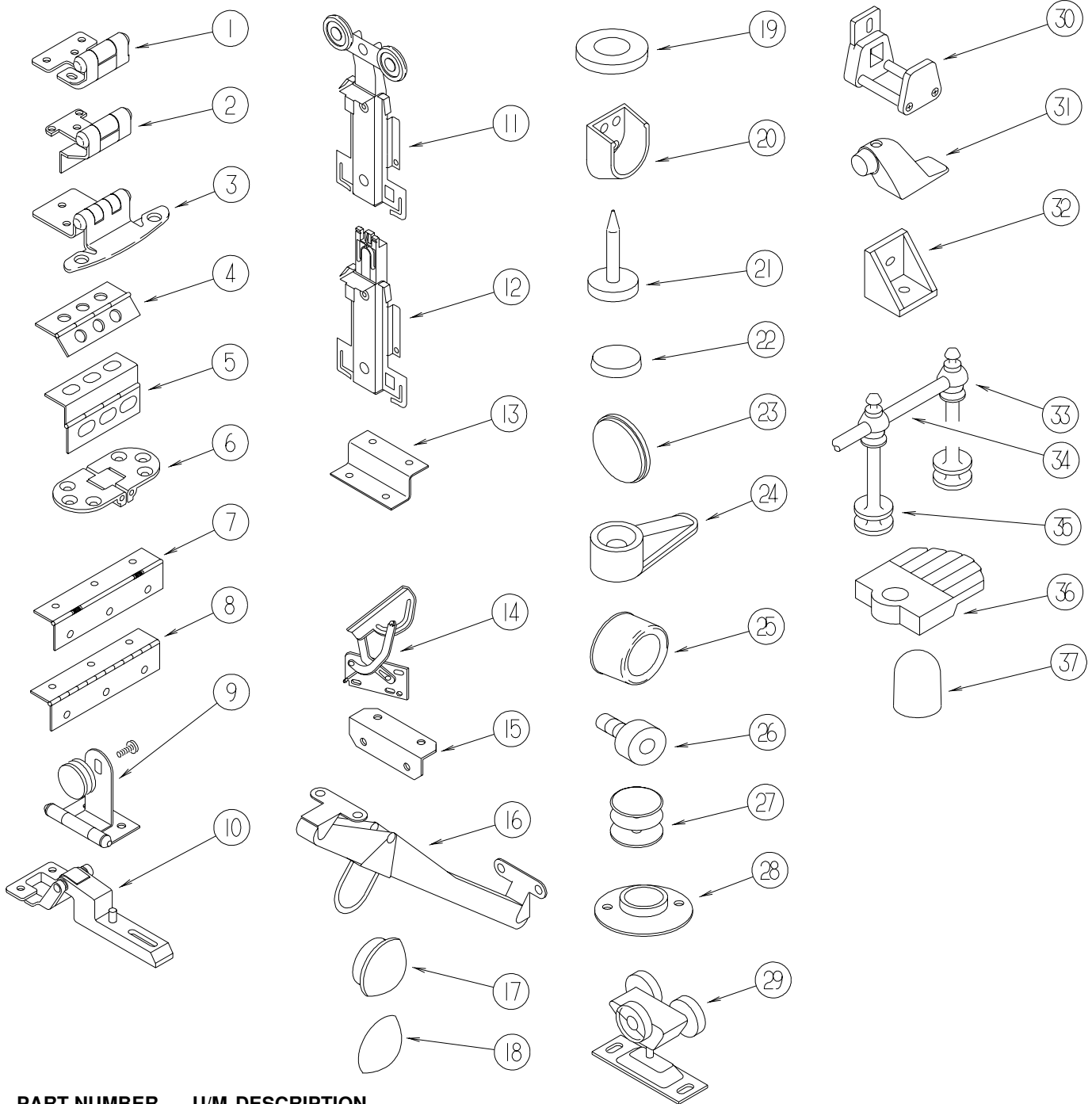

KEY	PART NUMBER	U/M	DESCRIPTION
1	113676-01-01A	EA	HINGE - OVERLAY - VARIABLE
2	113677-01-01A	EA	HINGE - SELF CLOSING
3	108138-03-000	EA	HINGE - BRIGHT BRASS
	000G13-06-08G	EA	SCREW - 6-20 X .50 PFH - ANTIQUE BRASS
4	009059-01-000	EA	HINGE - DOOR - 2" X 1.4" - BRASS
4	009059-02-000	EA	HINGE - DOOR - 2" X 2.7" - BRASS
4	041389-18-000	EA	HINGE - PIANO - 1 1/2" X 19" - OFF WHITE
4	041389-35-000	EA	HINGE - PIANO - OFF WHITE - 31"
5	118802-01-02A	EA	HINGE - DOOR - CABINET - HAMPTON TAN
6	111535-01-000	EA	HINGE - TABLE/FOLDING
7	102920-01-01A	EA	HINGE/SPRING LOADED - BRASS
8	084413-01-000	EA	HINGE/CONTINUOUS - ALUMINUM 1" X 72" - W/HOLES
8	110496-01-01A	EA	HINGE - BRASS

**INTERIOR FINISH GROUP (CONTINUED)**  
**HARDWARE (CONTINUED)**

KEY	PART NUMBER	U/M	DESCRIPTION
9	100711-01-01A	EA	HINGE - GLASS DOOR
10	114443-01-01A	EA	HINGE - CABINET DOOR
11	107390-02-000	EA	CORNER HANGER (DOUBLE ROLLER W/BRACKET) (SOLD AS 1 EACH)
12	107391-01-000	EA	TGUIDE - BOTTOM - BY-PASS (4 USED PER DOOR)
13	101926-01-02A	EA	BRACKET - ZEE - BLACK
14	108126-01-000	EA	TRAY HINGE SET (QTY. 2 PER SET)
15	016604-01-000	EA	BRACE - CABINET - ANGLE - 2.5" - UNPAINTED METAL
15	016604-05-000	EA	BRACE - CABINET - ANGLE - 2.5" - OFF WHITE METAL
16	104181-01-01A	EA	SUPPORT - LEAF 5.3" EXTENDS TO 7.5" - SAFETY RING - METAL
17	074045-01-000	EA	PLUG - OAK - 1/2" DIAMETER
17	074045-08-000	EA	PLUG - OAK - 1/2" DIAMETER - SALEM CHERRY
17	042356-01-000	EA	PLUG - BUTTON - MAHOGANY - 3/8" DIAMETER - WOOD
18	057671-01-000	EA	COVER - SCREW - OFF WHITE - #8
18	057671-11-000	EA	COVER - SCREW - HAMPTON TAN - #8
18	057671-13-000	EA	COVER - SCREW - DARK GRAY - #8
18	057671-15-000	EA	COVER - SCREW - BRIGHT WHITE
18	057671-16-000	EA	COVER - SCREW - SOFT WHITE
19	100707-01-000	EA	SPACER - GLASS DOOR - .8" DIA - .3" HOLE - PLASTIC
20	113236-01-01A	EA	BRACKET - CLOTHES - ROD
21	102194-01-000	EA	GUIDE - PLASTIC
22	004354-01-000	EA	BUMPER - RUBBER - .5" DIA - BROWN
23	120760-01-000	EA	BUMPER - RUBBER - CLEAR
24	083204-03-000	EA	BUTTON - RETAINING MIRROR 5/16" TIP
25	069726-02-000	EA	BUMPER - .88" OD X .40" THICK - BLACK
26	079921-01-000	EA	ROLLER - NYLON - W/STEEL SHAFT - BARBED
27	081114-02-000	EA	CAP - INSERT - ROUND 1" DIAMETER - WHITE
28	009112-01-000	EA	FLANGE - PLASTIC - 1" CLOTHES ROD - OFF WHITE
29	103874-01-000	EA	HANGER - SLIDING DOOR
30	064467-01-000	EA	GUIDE - POCKET - SLIDING DOOR - WALL MOUNTED
31	103257-01-000	EA	STOP - DOOR
32	065740-01-000	EA	BRACE - CABINET/CORNER - PLASTIC
33	084070-03-000	EA	POST - END - 2.4" - BRASS
34	084071-05-000	EA	ROD - BRASS - 15"
34	084071-08-000	EA	ROD - BRASS - 9.3"
34	084071-12-000	EA	ROD - BRASS - 4.1"
34	084071-19-000	EA	ROD - BRASS - 7.1"
34	084071-20-000	EA	ROD - BRASS - 9.8"
34	084071-22-000	EA	ROD - BRASS - 15.3"
34	084071-23-000	EA	ROD - BRASS - 13.12"
34	084071-24-000	EA	ROD - BRASS - 3.8"
34	084071-27-000	EA	ROD - BRASS - 2.7"
34	084071-28-000	EA	ROD - BRASS - 6"
34	084071-30-000	EA	ROD - BRASS - 11.6"
34	084071-31-000	EA	ROD - BRASS - 14.08"
34	084071-32-000	EA	ROD - BRASS - 13.6"
35	084070-01-000	EA	POST - CENTER - 2.4" - BRASS
36	009089-01-000	EA	CLIP - MIRROR
37	039984-01-000	EA	CAP - ROUND - VINYL - .28" ID X .62" - BLACK

**INTERIOR FINISH GROUP (CONTINUED)**  
**HARDWARE (CONTINUED)**

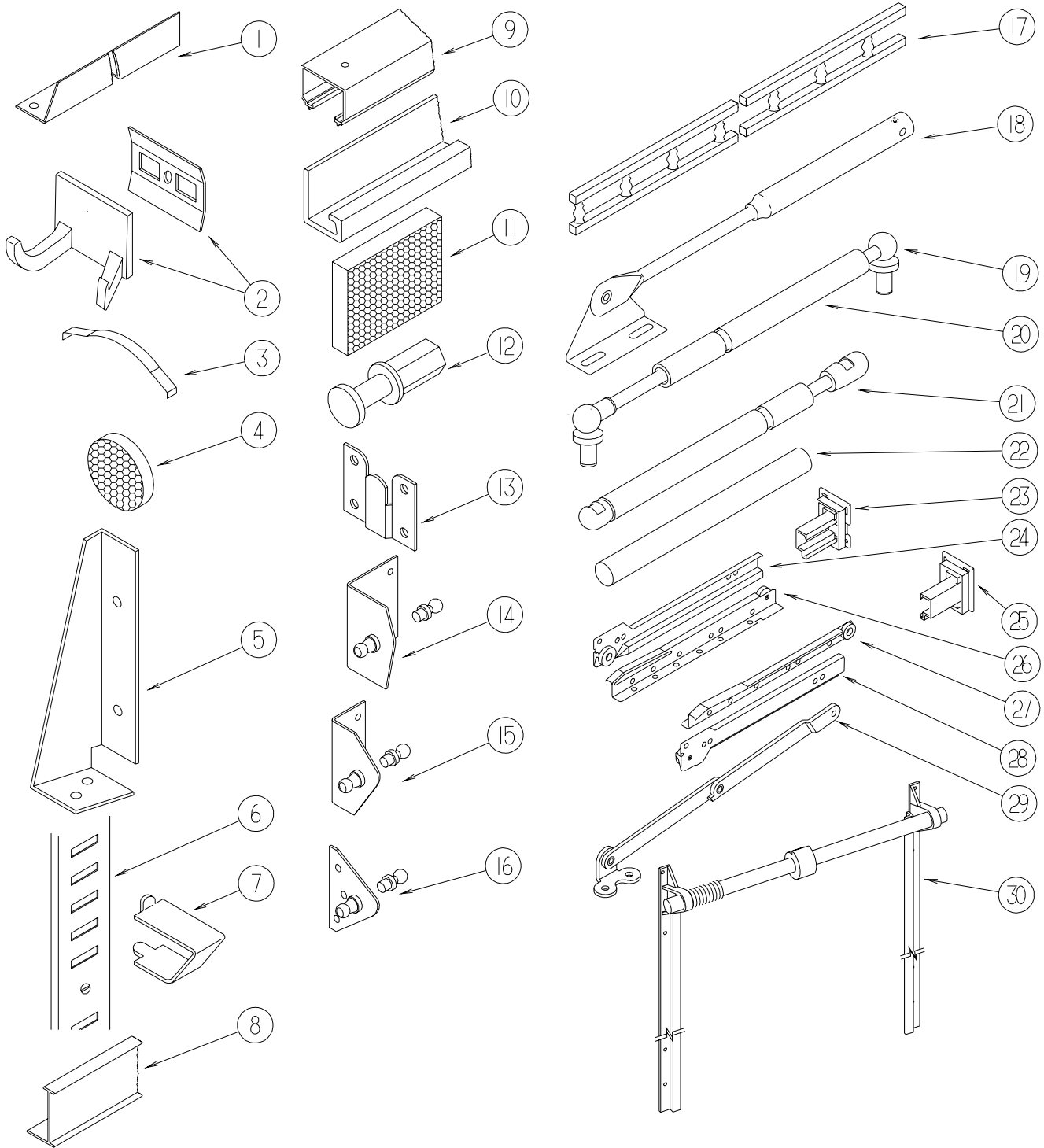

KEY	PART NUMBER	U/M DESCRIPTION
1	114693-01-01A	EA SUPPORT - BLACK - RIGHT HAND
1	114693-02-01A	EA SUPPORT - BLACK - LEFT HAND
2	104174-01-000	EA HOOK - ROBE - DOUBLE
3	115541-01-000	EA SPRING - DOOR - SLIDING
4	122717-01-01A	EA PAD - NON SKID - 4" DIAMETER ROUND
4	122717-04-01A	EA PAD - NON SKID - 3" DIA. ROUND
5	076827-02-000	EA BRACKET - 2.9" X 1.8" - TRIANGLE
6	098980-01-000	EA PILASTER - ADJUSTABLE SHELF - 18"
6	098980-02-000	EA PILASTER - ADJUSTABLE SHELF - 12"
6	098980-03-000	EA PILASTER - ADJUSTABLE SHELF - 9"
6	098980-04-000	EA PILASTER - ADJUSTABLE SHELF - 48"
6	098980-05-000	EA PILASTER - ADJUSTABLE SHELF - 15"



**INTERIOR FINISH GROUP (CONTINUED)**  
**HARDWARE (CONTINUED)**

<b>KEY</b>	<b>PART NUMBER</b>	<b>U/M</b>	<b>DESCRIPTION</b>
6	098980-04-000	EA	PILASTER - ADJUSTABLE SHELF - 48"
6	098980-05-000	EA	PILASTER - ADJUSTABLE SHELF - 15"
6	098980-06-000	EA	PILASTER - ADJUSTABLE SHELF - 24"
7	098979-01-000	EA	CLIP - ADJUSTABLE SHELF
8	094856-10-01A	EA	TRACK - FOLDING DOOR - OFF WHITE
9	103868-09-01A	EA	TRACK - SLIDING DOOR - 64.3" - OFF WHITE
9	103868-15-01A	EA	TRACK - SLIDING DOOR - 76" - OFF WHITE
10	118933-01-01A	EA	SUPPORT - HINGE LOCK
11	122717-06-01A	FT	PAD - NON-SKID - PSA - 5"W
	122717-08-01A	EA	PAD - NON-SKID - PSA - 7.2"W
12	092652-01-000	EA	GUIDE WHEEL/DOOR - TOP MOUNT
13	130120-01-01A	EA	BRACKET - MOUNTING/MIRROR
14	126263-05-02B	EA	BRACKET - GAS SPRING W/BALL STUD - E-COATED
14	126263-06-02B	EA	BRACKET - GAS SPRING W/BALL STUD - E-COATED
15	126263-10-02B	EA	BRACKET - GAS SPRING - 90 DEGREE SMALL
15	126263-13-02B	EA	BRACKET - GAS SPRING W/BALL STUD - E-COATED
16	126263-08-02B	EA	BRACKET - GAS SPRING W/BALL STUD - E-COATED
17	075249-01-000	EA	RAILING - OAK - 72" UNFINISHED
18	074493-02-000	EA	SUPPORT - PISTON SPRING - CABINET DOOR - 26 LBS
19	057460-02-000	EA	STUD BALL - GAS SPRING - .39" - 5/16"-18
20	057460-04-000	EA	SPRING - GAS - BALL STUD STYLE - 120 PI - "SPD6209"
21	107796-06-000	EA	SPRING/GAS - 12" COMPRESSED/20" EXTENDED - 120LB.
21	107796-08-000	EA	SPRING/GAS - 11" COMPRESSED/17" EXTENDED - 60 LB.
21	107796-15-000	EA	SPRING/GAS - 24" COMPRESSED/40" EXTENDED - 15 LB.
21	107796-16-000	EA	SPRING/GAS - 6.4" COMPRESSED/9.6" EXTENDED - 65 LB.
21	107796-26-000	EA	SPRING/GAS - 12" COMPRESSED/20" EXTENDED - 90 LB.
22	042438-02-000	EA	DOWEL - WOOD - 2" X 2"
22	042438-01-000	EA	DOWEL - WOOD - CLOTHES ROD - 1" DIAMETER X 4'
23	128811-01-01A	EA	BACKSOCKET - ADJUSTABLE - LEFT
24	128810-01-01A	EA	SLIDE - DRAWER - 12" - LEFT CABINET
24	128810-05-01A	EA	SLIDE - DRAWER - 14" - LEFT CABINET
24	128810-09-01A	EA	SLIDE - DRAWER - 16" - LEFT CABINET
24	128810-13-01A	EA	SLIDE - DRAWER - 18" - LEFT CABINET
24	128810-17-01A	EA	SLIDE - DRAWER - 20" - LEFT CABINET
24	128810-21-01A	EA	SLIDE - DRAWER - 22" - LEFT CABINET
24	128810-25-01A	EA	SLIDE - DRAWER - 24" - LEFT CABINET
25	128811-02-01A	EA	BACKSOCKET - ADJUSTABLE RIGHT
26	128810-03-01A	EA	SLIDE - DRAWER - 12" - LEFT DRAWER
26	128810-07-01A	EA	SLIDE - DRAWER - 14" - LEFT DRAWER
26	128810-11-01A	EA	SLIDE - DRAWER - 16" - LEFT DRAWER
26	128810-15-01A	EA	SLIDE - DRAWER - 18" - LEFT DRAWER
26	128810-19-01A	EA	SLIDE - DRAWER - 20" - LEFT DRAWER
26	128810-23-01A	EA	SLIDE - DRAWER - 22" - LEFT DRAWER
26	128810-27-01A	EA	SLIDE - DRAWER - 24" - LEFT DRAWER
27	128810-04-01A	EA	SLIDE - DRAWER - 12" - RIGHT DRAWER
27	128810-08-01A	EA	SLIDE - DRAWER - 14" - RIGHT DRAWER
27	128810-12-01A	EA	SLIDE - DRAWER - 16" - RIGHT DRAWER
27	128810-16-01A	EA	SLIDE - DRAWER - 18" - RIGHT DRAWER
27	128810-20-01A	EA	SLIDE - DRAWER - 20" - RIGHT DRAWER
27	128810-24-01A	EA	SLIDE - DRAWER - 22" - RIGHT DRAWER
27	128810-28-01A	EA	SLIDE - DRAWER - 24" - RIGHT DRAWER
28	128810-02-01A	EA	SLIDE - DRAWER - 12" - RIGHT CABINET
28	128810-06-01A	EA	SLIDE - DRAWER - 14" - RIGHT CABINET
28	128810-10-01A	EA	SLIDE - DRAWER - 16" - RIGHT CABINET
28	128810-14-01A	EA	SLIDE - DRAWER - 18" - RIGHT CABINET
28	128810-18-01A	EA	SLIDE - DRAWER - 20" - RIGHT CABINET
28	128810-22-01A	EA	SLIDE - DRAWER - 22" - RIGHT CABINET
28	128810-26-01A	EA	SLIDE - DRAWER - 24" - RIGHT CABINET
29	084412-01-000	EA	SUPPORT/HINGE KIT (LEFT & RIGHT HINGES)
30	130787-01-000	EA	TRACK - TAMBOUR DOOR/SPRING - 15.9"
30	130787-02-000	EA	TRACK - TAMBOUR DOOR/SPRING - 24"
30	130787-03-000	EA	TRACK - TAMBOUR DOOR/SPRING - 30"

## LABELS GROUP

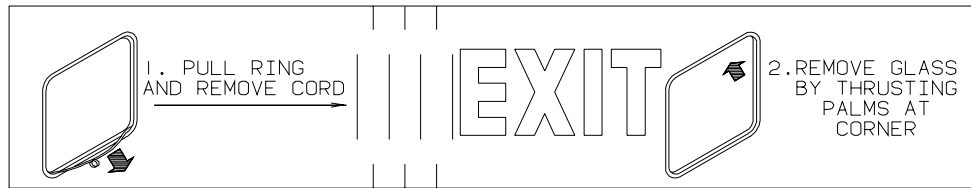

**KEY PART NUMBER U/M DESCRIPTION**  
107571-01-000 EA LABEL - EXIT/ESCAPE WINDOW

FOR AWNING INSTALLATION  
CONTACT YOUR MOTORHOME  
DEALERSHIP

**KEY PART NUMBER U/M DESCRIPTION**  
099509-01-000 EA LABEL - AWNING INSTALLATION

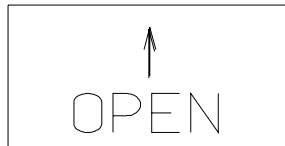

**KEY PART NUMBER U/M DESCRIPTION**  
040944-01-000 EA LABEL - ENTRANCE DOOR - "OPEN"

WARNING  
MUST BE STOWED  
IN LATCHED POSITION  
WHILE VEHICLE IS IN MOTION

**KEY PART NUMBER U/M DESCRIPTION**  
079966-01-000 EA LABEL - WARNING - STOWED - MOTION

**WARNING** DISCONNECT BATTERIES BEFORE  
CONNECTING EXTERNAL CHARGING EQUIPMENT.

**KEY PART NUMBER U/M DESCRIPTION**  
065748-01-000 EA LABEL - CAUTION - BATTERY CHARGING

AVERTISSEMENT : DEBRANCHER LES BATTERIES AVANT  
DE BRANCHER TOUT EQUIPEMENT DE CHARGE EXTERIEUR.

**KEY PART NUMBER U/M DESCRIPTION**  
065748-02-000 EA LABEL - WARNING - BATTERY/FRENCH - CANADIAN

## LABELS GROUP (CONTINUED)

WASTE WATER

**KEY PART NUMBER U/M DESCRIPTION**  
006188-01-000 EA LABEL - WASTE WATER

SEWAGE

**KEY PART NUMBER U/M DESCRIPTION**  
006187-01-000 EA LABEL - SEWAGE

### IF YOU SMELL GAS

1. EXTINGUISH ANY OPEN FLAME, PILOT LIGHTS AND ALL SMOKING MATERIALS.
2. DO NOT TOUCH ELECTRICAL SWITCHES.
3. SHUT OFF THE GAS SUPPLY AT THE TANK VALVE(S) OR GAS SUPPLY CONNECTION.
4. OPEN DOORS AND OTHER VENTILATING OPENINGS.
5. LEAVE THE AREA UNTIL ODOR CLEARS.
6. HAVE THE GAS SYSTEM CHECKED AND LEAKAGE SOURCE CORRECTED BEFORE USING AGAIN.

**KEY PART NUMBER U/M DESCRIPTION**  
073998-01-000 EA LABEL - LPG ODOR WARNING

WARNING: TEST SMOKE DETECTOR OPERATION AFTER VEHICLE HAS BEEN IN STORAGE, BEFORE EACH TRIP AND AT LEAST ONCE PER WEEK DURING USE.

**KEY PART NUMBER U/M DESCRIPTION**  
077956-01-000 EA LABEL - WARNING - SMOKE DETECTOR

CAUTION	TO HELP AVOID PERSONAL INJURY DURING REMOVAL OF FUEL FILLER CAP, SLOWLY LOOSEN CAP 1/2 TURN TO ALLOW ANY FUEL PRESSURE TO BE RELIEVED BEFORE TURNING CAP FURTHER.
FUEL SPRAY MAY CAUSE PERSONAL INJURY	STOP ADDING FUEL AFTER FIRST SHUTOFF BY AUTOMATIC NOZZLE WHEN TANK IS NEARLY FULL. DO NOT OVERFILL FUEL TANK. SEE OWNERS MANUAL FOR ADDITIONAL INFORMATION. PRINTED IN U.S.A. <span style="float: right;">WLC PT NO 15611763</span>

**KEY PART NUMBER U/M DESCRIPTION**  
087207-05-000 EA LABEL - FUEL CAP REMOVAL

UNLEADED FUEL ONLY

**KEY PART NUMBER U/M DESCRIPTION**  
062043-01-000 EA LABEL - FUEL - UNLEADED

UNLEADED  
FUEL ONLY

**KEY PART NUMBER U/M DESCRIPTION**  
098641-01-000 EA LABEL-FUEL - UNLEADED - DASH

## LABELS GROUP (CONTINUED)

LP-GAS SYSTEM  
THIS GAS PIPING SYSTEM IS  
DESIGNED FOR USE OF  
LIQUIFIED PETROLEUM GAS  
ONLY. DO NOT CONNECT  
NATURAL GAS TO THIS  
SYSTEM.  
SECURE CAP INLET(S) WHEN NOT  
CONNECTED FOR USE. AFTER TURNING  
ON GAS, EXCEPT AFTER NORMAL  
CONTAINER REPLACEMENT, TEST GAS  
PIPING AND CONNECTIONS TO  
APPLIANCES FOR LEAKAGE WITH SOAPY  
WATER OR BUBBLE SOLUTION. DO NOT  
USE PRODUCTS THAT CONTAIN AMMONIA  
OR CLORINE. 124520

KEY	PART NUMBER	U/M DESCRIPTION
	124520-01-01A	EA LABEL - LP GAS ONLY - BLACK ON CLEAR
	124520-01-02A	EA LABEL - LP GAS ONLY - WHITE ON CLEAR

WARNING

THIS SYSTEM IS DESIGNED FOR USE WITH PROPANE ONLY  
DO NOT CONNECT NATURAL GAS TO THIS SYSTEM

BEFORE TURNING ON PROPANE:

- (A) BE CERTAIN APPLIANCES ARE CERTIFIED FOR PROPANE AND ARE EQUIPPED WITH CORRECT BURNING ORIFICES.
- (B) MAKE CERTAIN ALL PROPANE CONNECTIONS ARE TIGHT BY TESTING WITH SOAPY WATER. ALL PROPANE VALVES ARE TURNED OFF, AND ANY UNCONNECTED OUTLETS ARE CAPPED.

AFTER TURNING ON PROPANE:

- (A) LIGHT ALL PILOT LIGHTS.
- (B) (B) ALL CONNECTIONS, INCLUDING THOSE AT THE APPLIANCES, REGULATORS AND CYLINDERS SHOULD BE LEAK-TESTED PERIODICALLY WITH SOAPY WATER BY THE OCCUPANT. NEVER USE A LIGHTED MATCH OR OTHER FLAME WHEN CHECKING FOR LEAKS.
- (C) DO NOT LEAVE SYSTEM TURNED ON IF CONTAINERS CONNECTED UNTIL THE SYSTEM HAS BEEN PROVEN TO BE FREE OF LEAKS.
- (D) COOKING APPLIANCES SHOULD NOT BE USED FOR SPACE HEATING.
- (E) WHEN THE CONTAINERS ARE DISCONNECTED THE PROPANE SUPPLY LINE SHOULD BE CAPPED OR PLUGGED.

AVERTISSEMENT

CETTE INSTALLATION EST CONÇUE POUR LE PROPANE SEULEMENT  
NE PAS L'ALIMENTER EN GAZ NATUREL

AVANT LA MISE EN SERVICE:

- (A) S'ASSURER QUE LES APPAREILS SONT CERTIFIÉS POUR LE PROPANE ET MUNIS D'ORIFICES DE BRÛLEUR APPROPRIÉS.
- (B) VÉRIFIER L'ÉTANCHEITÉ DE TOUTS LES RACCORDEMENTS AU PROPANE, LA FERMETURE DE TOUTS LES ROBINETS D'APPAREILS ET L'OBSTRUCTION DE TOUTES LES SORTIES NON RACCORDEES.

APRES LA MISE EN SERVICE:

- (A) ALLUMER TOUTES LES VEILLEUSES.
- (B) L'OCCUPANT DOIT ÉPROUVER PÉRIODIQUEMENT L'ÉTANCHEITÉ DE TOUTS LES RACCORDEMENTS Y COMPRIS CEUX AUX APPAREILS, AUX DÉTENEURS ET AUX ROUETTES, EN Y APPLIQUANT DE L'EAU SAVONNEUSE NE JAMAIS SE SERVIR D'UNE ALLUMETTE OU AUTRE POUR LA DÉTECTION DES FUITES.
- (C) NE PAS LAISSER L'ALIMENTATION OUVERTE NI LES RÉCIPIENTS RACCORDES AVANT D'AVOIR COMPLÈTE L'ÉPREUVE D'ÉTANCHEITÉ AU PROPANE DE L'INSTALLATION.
- (D) LES APPAREILS DE CUISSON NE DOIVENT PAS ÊTRE UTILISÉS POUR LE CHAUFFAGE DES LOCAUX.
- (E) LORSQUE LES RÉCIPIENTS SONT DÉCONNECTÉS, L'ALIMENTATION DE PROPANE DOIT ÊTRE OBTURÉE OU SCELLÉE.

KEY	PART NUMBER	U/M DESCRIPTION
	023769-01-000	EA LABEL - WARNING - LPG - CANADIAN

THIS CONNECTION IS FOR  
110-125 VOLT AC, 60HZ(CYCLES)  
30 AMP. MAX SERVICE.

DO NOT CONNECT TO  
HIGHER VOLTAGE

KEY	PART NUMBER	U/M DESCRIPTION
	125306-01-01A	EA LABEL - ELECTRICAL ENTRANCE - 110VOLT 30AMP
	125306-03-01A	EA LABEL - ELECTRICAL ENTRANCE - 100 VOLT 30 AMP

THIS CONNECTION IS FOR  
(B) VOLT AC, 3-POLE, 4 WIRE  
60 HZ(CYCLES), (A) AMPERE SUPPLY

DO NOT CONNECT TO  
HIGHER VOLTAGE

KEY	PART NUMBER	U/M DESCRIPTION
	125306-04-01A	EA LABEL - ELECTRICAL ENTRANCE - 120 VOLT - 240 AMP

## LABELS GROUP (CONTINUED)

THIS CONNECTION IS FOR  
(B) VOLT AC,50 HZ(CYCLES)  
(A) AMPERE SUPPLY  
  
DO NOT CONNECT TO  
HIGHER VOLTAGE

**KEY PART NUMBER U/M DESCRIPTION**  
125306-05-01A EA LABEL - ELECTRICAL ENTRANCE - 220 VOLT 25 AMP

**WARNING**  
IT IS NOT SAFE TO USE COOKING  
APPLIANCES FOR COMFORT HEATING  
COOKING APPLIANCES NEED FRESH AIR FOR SAFE OPERATION  
BEFORE OPERATION:  
1. OPEN OVERHEAD VENT OR TURN ON EXHAUST FAN AND;  
2. OPEN WINDOW.

**KEY PART NUMBER U/M DESCRIPTION**  
050225-01-000 EA LABEL - WARNING - STOVE VENT - US

"TO ENSURE A SUPPLY OF FRESH AIR TO  
OCCUPANTS, OPEN VENTILATORS WHEN  
FUEL BURNING RANGE, FUEL BURNING  
CARRY-ON APPLIANCES AND/OR FUEL-  
BURNING LIGHTS ARE IN OPERATION."  
"COOKING APPLIANCES SHOULD NOT BE  
USED FOR SPACE HEATING PURPOSES"

DE MANIERE A ASSURE UNE ALIMENTATION  
EN AIR FRAIS AUX OCCUPANTS,OUVRIR  
LES VENTILATEURS LORSQUE LA CUISINIERE,  
LES APPAREILS DE CHAUFFAGE PORTABLES  
ET/OU LES LAMPES DE COMBUSTION  
D'HUILE SONT EN FONCTIONNEMENT.  
LES APPAREILS DE CUSSON NE DOIVENT  
PAS SERVIR AU CHAUFFAGES DES LOCAUX.

**KEY PART NUMBER U/M DESCRIPTION**  
050222-01-000 EA LABEL - STOVE VENT - CANADIAN

**WARNING**  
THIS VEHICLE, LIKE OTHER  
VEHICLES, MAY CONTAIN SMALL  
AMOUNTS OF ONE OR MORE  
SUBSTANCES WHICH ARE LISTED  
BY THE STATE OF CALIFORNIA  
FOR CAUSING CANCER OR  
REPRODUCTIVE TOXICITY.

**KEY PART NUMBER U/M DESCRIPTION**  
099689-01-000 EA LABEL - WARNING - CANCER/TOXICITX

**WATER HEATER BY-PASS      NORMAL OPERATION**

**KEY PART NUMBER U/M DESCRIPTION**  
133424-01-01A EA LABEL - BXPASS - WATER HEATER

REMOVE PRIMARY TIRE HANGER BEFORE USING  
SPARE TIRE HOIST-SEE OWNERS MANUAL - PERSONAL  
INJURY MAY RESULT IF NOT FOLLOWED

**KEY PART NUMBER U/M DESCRIPTION**  
126024-01-01A EA LABEL - TIRE HANGER REMOVAL

DO NOT USE HITCH BEFORE  
READING OWNERS MANUAL REGARDING  
VEHICLE LOADING AND TOWING

**KEY PART NUMBER U/M DESCRIPTION**  
111104-01-000 EA LABEL - HITCH - READ MANUAL - WHITE  
111104-02-000 EA LABEL - HITCH - READ MANUAL - BLACK

## LABELS GROUP (CONTINUED)

CAUTION

THIS MOTOR HOME HAS BEEN DESIGNED, MANUFACTURED AND TESTED WITH CONCERN FOR THE PROTECTION OF IT'S OCCUPANTS. WE RECOMMEND YOU PERFORM THE FOLLOWING INSPECTIONS FOR YOUR SAFETY AND THE SAFETY OF YOUR PASSENGERS BEFORE STARTING YOUR VEHICLE.

1. LP GAS SYSTEM- TURN OFF AT TANK FOR TRAVELING. TEST FOR LEAKS UPON ARRIVAL AT DESTINATION. BEFORE LIGHTING PILOTS.
2. WHEELS- INSPECT FOR DAMAGE AND CHECK LUG NUTS FOR TIGHTNESS.
3. TIRES- INSPECT FOR WEAR AND DAMAGE AND CHECK FOR RECOMMENDED AIR PRESSURE.
4. LIGHTING- TEST FOR PROPER OPERATION OF ALL INTERIOR AND EXTERIOR LIGHTS INCLUDING DASH LIGHTS, HEADLIGHTS, TAIL LIGHTS, BRAKE LIGHTS, CLEARANCE LIGHTS AND TURN SIGNALS.
5. EXITS- INSPECT RELEASE MECHANISM ON EMERGENCY EXIT WINDOW. TEST BOTH LOCKS ON MAIN ENTRANCE DOOR FOR EASE OF OPERATION AND INSTRUCT PASSENGERS HOW TO USE BOTH MEANS OF EXIT.
6. SEAT BELTS- DIRECT PASSENGERS TO DESIGNATED SEATS AND REQUIRE USE OF SEAT BELTS.
7. APPLIANCES- TURN OFF AND LATCH OR LOCK DOORS WHERE PROVIDED.
8. LOOSE PARCELS- STORE SECURELY.
9. UTILITY SUPPLY LINES- DISCONNECT ALL ELECTRIC, SEWER AND WATER LINES AND SECURE PROPERLY.
10. ENTRANCE DOOR STEP- PLACE IN RETRACTED POSITION FOR TRAVELING.

READ YOUR MOTOR HOME AND CHASSIS OWNER'S  
MANUAL FOR FURTHER PRECAUTIONS

**KEY PART NUMBER**    **U/M DESCRIPTION**  
056259-01-000    EA LABEL - SAFETY CHECK LIST

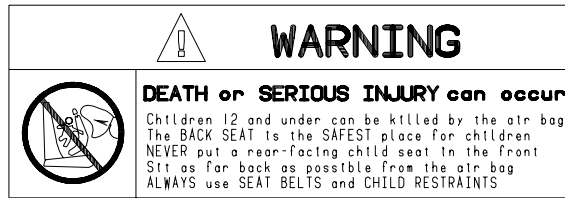

**KEY PART NUMBER**    **U/M DESCRIPTION**  
126611-01-000    EA LABEL - AIR BAG - VISOR

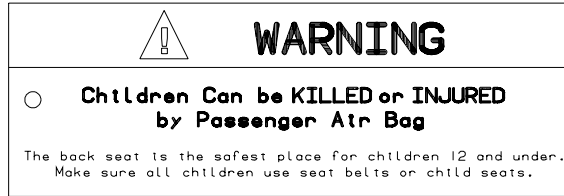

**KEY PART NUMBER**    **U/M DESCRIPTION**  
126612-01-000    EA LABEL - HANG TAG - AIR BAG - DASH

AIR CONDITIONING CIRCUIT.  
THIS CONNECTION IS FOR  
AIR CONDITIONERS RATED 110-  
125 VOLT AC, 60 HZ, 16  
AMPERES MAXIMUM. DO NOT  
EXCEED CIRCUIT RATING.

**KEY PART NUMBER**    **U/M DESCRIPTION**  
091243-01-000    EA LABEL - A/C COVER "AIR CONDITIONING CIRCUIT ETC."

WARNING: CONTAINS "CFC" A SUBSTANCE WHICH HARMS  
PUBLIC HEALTH AND ENVIRONMENT BY DESTROYING  
OZONE IN THE UPPER ATMOSPHERE.

**KEY PART NUMBER**    **U/M DESCRIPTION**  
111802-01-000    EA LABEL - CFC WARNING

## LABELS GROUP (CONTINUED)

### CAUTION

DO NOT LATCH DOOR IN OPEN POSITION  
IF WATER HEATER CONTROL IS IN THE ON  
POSITION. WATER HEATER EXHAUST MAY  
DAMAGE OUTER SURFACE OF DOOR.

KEY	PART NUMBER	U/M DESCRIPTION
	113402-01-000	EA LABEL - CAUTION - WATER HEATER EXHAUST
	113402-02-000	EA LABEL - CAUTION - FURNACE EXHAUST

### WARNING!

UNDERSTAND OPERATOR'S MANUAL BEFORE USING.  
KEEP PEOPLE AND OBSTRUCTIONS CLEAR OF  
SLIDEOUT ROOM WHEN OPERATING TO AVOID  
INJURY AND/OR PROPERTY DAMAGE.

KEY	PART NUMBER	U/M DESCRIPTION
	116549-01-000	EA LABEL - WARNING - SLIDEOUT

### WARNING

MUST BE STOWED  
IN LATCHED POSITION  
WHILE VEHICLE IS IN MOTION

KEY	PART NUMBER	U/M DESCRIPTION
	079966-01-000	EA LABEL - WARNING - STOWED - MOTION
	131341-01-000	EA LABEL - STOW OBJECTS - US

### DIESEL FUEL ONLY

KEY	PART NUMBER	U/M DESCRIPTION
	068383-01-000	EA LABEL - DIESEL FUEL

## LABELS GROUP (CONTINUED)

### WARNING

ALL PILOT LIGHTS, APPLIANCES AND THEIR IGNITORS (SEE OPERATING INSTRUCTIONS) SHALL BE TURNED OFF DURING REFUELING OF MOTOR FUEL TANKS AND/OR LP GAS CONTAINERS

KEY	PART NUMBER	U/M	DESCRIPTION
	124519-01-01A	EA	LABEL - WARNING/REFUELING - BLACK ON CLEAR
	124519-01-02A	EA	LABEL - WARNING/REFUELING - WHITE ON CLEAR

### WARNING:

ALL PILOT LIGHTS AND APPLIANCES SHALL BE TURNED OFF DURING REFUELING OF MOTOR FUEL TANKS AND/OR PROPANE CONTAINERS.

### AVERTISSEMENT :

FERMER TOUTES LES VEILLEUSES AINSI QUE TOUS LES APPAREILS LORSQU'ON FAIT LE PLEIN DES RESERVOIRS A CARBURANT OU A PROPANE.

124519-02

KEY	PART NUMBER	U/M	DESCRIPTION
	124519-02-01A	EA	LABEL - WARNING/REFUELING - BLACK ON CLEAR - CSA
	124519-02-02A	EA	LABEL - WARNING/REFUELING - WHITE ON CLEAR - CSA

### ENTRANCE DOOR PROP ROD

THIS ROD IS DESIGNED TO PROP THE ENTRANCE DOOR OPEN WHEN THE PATIO AWNING ARM IS ATTACHED TO THE SIDEWALL AND THE AWNING IS EXTENDED.  
HOOK ONE END OF ROD INTO LOOP ON DOOR AND OTHER END INTO LOOP ON THE SIDEWALL AS SHOWN.

(THIS LABEL TO BE REMOVED BY RETAIL OWNER ONLY)

KEY	PART NUMBER	U/M	DESCRIPTION
	128658-01-000	EA	LABEL - PROP ROD - ENTRY DOOR

INPUT

KEY	PART NUMBER	U/M	DESCRIPTION
	087236-01-000	EA	LABEL - CABLE - INPUT

OUTLET

KEY	PART NUMBER	U/M	DESCRIPTION
	087236-02-000	EA	LABEL - TV OUTLET

DTS' ISI CE SIEGE N'EST PAS DESTINE A ETRE OCCUPE LORSQUE LE VEHICULE EST EN MOUVEMENT

THIS SEAT IS NOT INTENDED FOR OCCUPANCY WHILE VEHICLE IS IN MOTION

KEY	PART NUMBER	U/M	DESCRIPTION
	006064-01-000	EA	LABEL - SEAT W/O SEATBELT
	006064-02-000	EA	LABEL - SEAT W/O SEATBELT - CSA



## LABELS GROUP (CONTINUED)

CAUTION:  
OPEN A WINDOW OR VENT WHILE  
OPERATING DRYER. IT IS DANGEROUS  
TO CREATE A NEGATIVE AIR PRESSURE  
INSIDE A VEHICLE CONTAINING  
FUEL-BURNING APPLIANCES

**KEY PART NUMBER U/M DESCRIPTION**  
130670-01-01A EA LABEL - CAUTION DRXER VENTING - BLACK ON CLEAR



**KEY PART NUMBER U/M DESCRIPTION**  
061417-01-000 EA LABEL - FUEL - ON FUEL FILL DOOR

INSERT RETAINER PINS IN  
SLIDE MECHANISM AFTER  
RETURNING GENERATOR TO  
STORED POSITION.  
IF RETAINER PINS ARE NOT  
INSERTED, THE GENERATOR  
WILL EXTEND WHICH MAY  
CAUSE PERSONAL INJURY.

**KEY PART NUMBER U/M DESCRIPTION**  
116273-01-000 EA LABEL - WARNING - GENERATOR

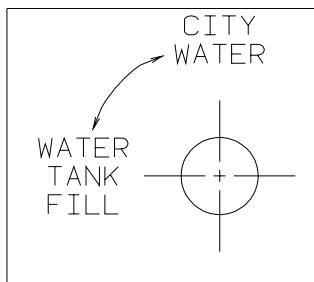

**KEY PART NUMBER U/M DESCRIPTION**  
117629-02-000 EA LABEL - WATER PUMP/FILL-BLK LETTERS/CLEAR BACKGROUND-.24"  
117629-03-000 EA LABEL - WATER PUMP/FILL-BLK LETTERS/CLEAR BACKGROUND-.31"

KEEP THE SERVICE INLET ACCESS  
IN THE CLOSED POSITION WHEN  
UTILITY CONNECTIONS ARE NOT IN USE

**KEY PART NUMBER U/M DESCRIPTION**  
123562-01-000 EA LABEL - SERVICE/UTILITY ACCESS

CITY WATER FILL

**KEY PART NUMBER U/M DESCRIPTION**  
126249-02-000 EA LABEL - CITY WATER FILL-BLK LETTER/CLEAR BACKGROUND-.24"H  
126249-03-000 EA LABEL - CITY WATER FILL-BLK LETTER/CLEAR BACKGROUND-.31"H

## LABELS GROUP (CONTINUED)

### WARNING

ROOF SURFACE MAY BE SLIPPERY  
ESPECIALLY WHERE MOISTURE IS PRESENT  
SLIPPING MAY RESULT IN PERSONAL INJURY.

128218-01

KEY	PART NUMBER	U/M	DESCRIPTION
	128218-01-01A	EA	LABEL - WARNING - SLIPPERY ROOF

WASTE TANK FLUSH

KEY	PART NUMBER	U/M	DESCRIPTION
	130168-01-000	EA	LABEL - WASTE TANK FLUSH

LIGHTS WATER  
PUMP

KEY	PART NUMBER	U/M	DESCRIPTION
	130170-01-000	EA	LABEL - SWITCH PANEL - BLK/CLEAR BACKGROUND-1.8"H X 5.9"L
	117628-02-000	EA	LABEL - SWITCH - WATER PUMP/LIGHTS-WHITE/CLEAR BACKGROUND

PUSH TO  
RELEASE  
GENERATOR  
SLIDE ASM

KEY	PART NUMBER	U/M	DESCRIPTION
	131779-01-01A	EA	LABEL - GENERATOR

MONITOR WATER  
PANEL PUMP  
LIGHT

KEY	PART NUMBER	U/M	DESCRIPTION
	130170-02-000	EA	LABEL - SWITCH PANEL - BLK/CLEAR BACKGROUND-1.4H X 3.9"L

### WARNING

ALL LP GAS IS CONTAINED UNDER PRES-  
SURE. DUE TO THE DANGEROUS POTENTIAL  
OF ANY COMPRESSED GAS, IT IS MANDA-  
TORY THAT THE FOLLOWING REQUIREMENTS  
FOR THE USE OF THIS TANK BE FOLLOWED:  
TANKS ARE TO BE INSTALLED, FUELED AND  
MAINTAINED IN ACCORDANCE WITH STATE  
AND LOCAL CODE, RULES, REGULATIONS OR  
LAWS AND IN ACCORDANCE WITH NFPA  
PAMPHLET 58, DIVISION IV.

KEY	PART NUMBER	U/M	DESCRIPTION
	116112-01-000	EA	LABEL - SWITCH PANEL - BLK/CLEAR BACKGROUND-1.8"H X 5.9"L

## LABELS GROUP (CONTINUED)

TOW VEHICLE RATING MAY BE LESS THAN HITCH RATING.  
 MAXIMUM VERTICAL HITCH LOAD: 350 LBS  
 DO NOT EXCEED REAR AXLE RATING.  
 SEE OWNER'S MANUAL FOR ADDITIONAL INFORMATION.

KEY	PART NUMBER	U/M DESCRIPTION
	129669-01-01A	EA LABEL - HITCH/VEHICLE RATE - 350 - WHITE ON CLEAR
	129669-01-02A	EA LABEL - HITCH/VEHICLE RATE - 350 - BLACK ON CLEAR
	129669-02-01A	EA LABEL - HITCH/VEHICLE RATE - 500 - WHITE ON CLEAR
	129669-02-02A	EA LABEL - HITCH/VEHICLE RATE - 500 - BLACK ON CLEAR

THIS CHAIR IS NOT INTENDED FOR OCCUPANCY WHEN VEHICLE IS IN MOTION AND MUST BE RETURNED TO STOWED POSITION

KEY	PART NUMBER	U/M DESCRIPTION
	102267-01-000	EA LABEL - NO OCCUPANCY - US

DTS ISICE SIEGE N/EST PAS DESTINE A ETRE OCCUPE LORSQUE LE VEHICULE EST EN MOUVEMENT ET IL FAUT QUE LE RANGER	THIS CHAIR IS NOT INTENDED FOR OCCUPANCY WHEN VEHICLE IS IN MOTION AND MUST BE RETURNED TO STOWED POSITION
--	---

KEY	PART NUMBER	U/M DESCRIPTION
	102267-02-000	EA LABEL - NO OCCUPANCY - CSA

EXTERIOR SHOWER

KEY	PART NUMBER	U/M DESCRIPTION
	126249-03-000	EA LABEL - EXTERIOR SHOWER

W  
A  
T  
E  
R      O  
N  
  
H  
E  
A  
T  
E  
R      O  
F  
F

KEY	PART NUMBER	U/M DESCRIPTION
	083588-01-000	EA LABEL - ON/OFF - WATER HEATER

E  
N  
G  
I  
N  
E      O  
N  
  
H  
E  
A  
T  
E  
R      O  
F  
F

KEY	PART NUMBER	U/M DESCRIPTION
	083588-02-000	EA LABEL - ON/OFF -ENGINE HEATER

## LABELS GROUP (CONTINUED)

<p>NOTE: TUNE ANTENNA PER MANUFACTURER'S DIRECTIONS. FAILURE TO COMPLY COULD RESULT IN DAMAGE TO CB.</p>	<p>CB POWER PROVISION</p> <p>RED +12 V BLACK GROUND COAX ANTENNA (SEE REVERSE ALSO)</p>
--	---

<b>KEY</b>	<b>PART NUMBER</b>	<b>U/M</b>	<b>DESCRIPTION</b>
	104678-01-000	EA	LABEL - CB PREP

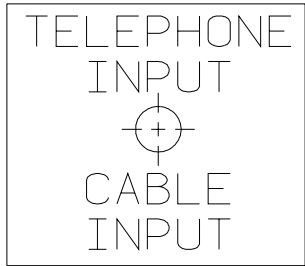

<b>KEY</b>	<b>PART NUMBER</b>	<b>U/M</b>	<b>DESCRIPTION</b>
	114886-02-000	EA	LABEL - PHONE & CABLE INPUT - WHITE/CLEAR BACKGROUND
	114886-03-000	EA	LABEL - PHONE & CABLE INPUT - BLACK/CLEAR BACKGROUND

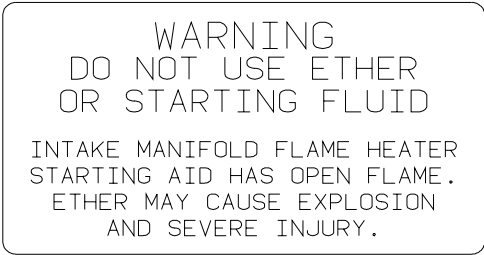

<b>KEY</b>	<b>PART NUMBER</b>	<b>U/M</b>	<b>DESCRIPTION</b>
	116756-01-000	EA	LABEL - WARNING - ETHER/STARTING



<b>KEY</b>	<b>PART NUMBER</b>	<b>U/M</b>	<b>DESCRIPTION</b>
	126247-01-000	EA	LABEL - GRAY HOLDING TANK-WHITE LETTERS/CLEAR BACKGROUND
	126247-05-000	EA	LABEL - GRAY HOLDING TANK-BLACK LETTERS/CLEAR BACKGROUND



<b>KEY</b>	<b>PART NUMBER</b>	<b>U/M</b>	<b>DESCRIPTION</b>
	126247-02-000	EA	LABEL - BLACK HOLDING TANK-WHITE LETTERS/BLACK BACKGROUND
	126247-06-000	EA	LABEL - BLACK HOLDING TANK-BLACK LETTERS/CLEAR BACKGROUND

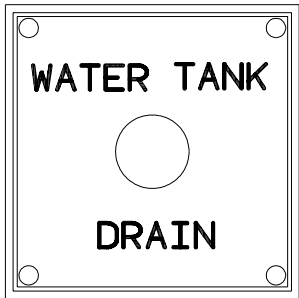

<b>KEY</b>	<b>PART NUMBER</b>	<b>U/M</b>	<b>DESCRIPTION</b>
	127170-01-000	EA	LABEL - WATER TANK DRAIN

## LABELS GROUP (CONTINUED)

### WARNING

POTABLE WATER ONLY  
SANITIZE, FLUSH, AND  
DRAIN BEFORE USING.  
SEE INSTRUCTION MANUAL

**KEY PART NUMBER**      **U/M DESCRIPTION**  
128725-01-000      EA LABEL - POTABLE WATER ONLY

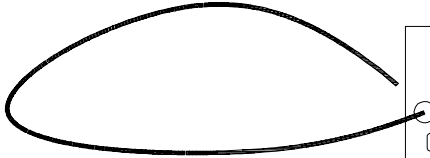

### ATTENTION

REMEMBER TO DETACH THE OTHER  
TRAVEL LATCH LOCATED IN  
GALLEY CABINET BEFORE EXTENDING  
THIS ROOM.

**KEY PART NUMBER**      **U/M DESCRIPTION**  
129033-01-000      EA LABEL - HANG TAG - TRAVEL LATCH - 1.5" X3"

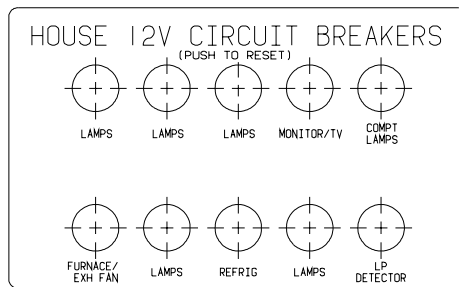

**KEY PART NUMBER**      **U/M DESCRIPTION**  
092547-06-000      EA CIRCUIT BREAKER

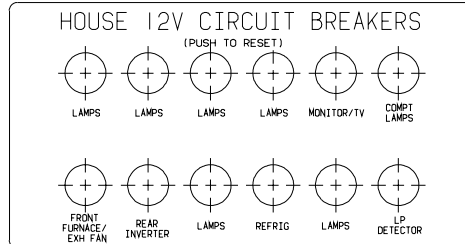

**KEY PART NUMBER**      **U/M DESCRIPTION**  
092547-09-000      EA CIRCUIT BREAKER

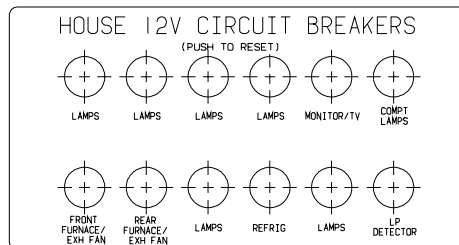

**KEY PART NUMBER**      **U/M DESCRIPTION**  
092547-07-000      EA CIRCUIT BREAKER

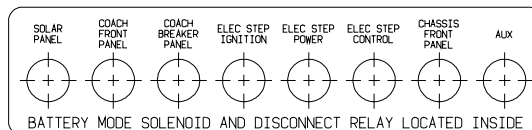

**KEY PART NUMBER**      **U/M DESCRIPTION**  
093236-13-000      EA CIRCUIT BREAKER

## LABELS GROUP (CONTINUED)

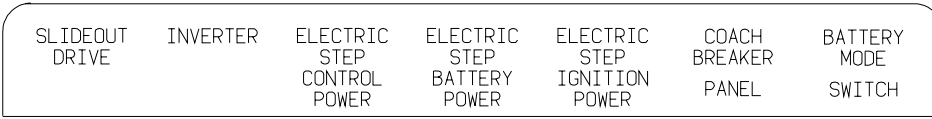

**KEY PART NUMBER U/M DESCRIPTION**  
 093236-15-000 EA LABEL - CIRCUIT BREAKER

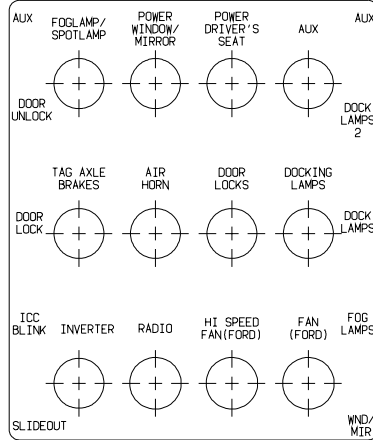

**KEY PART NUMBER U/M DESCRIPTION**  
 093236-16-000 EA LABEL - CIRCUIT BREAKER



**KEY PART NUMBER U/M DESCRIPTION**  
 093236-18-000 EA LABEL - CIRCUIT BREAKER

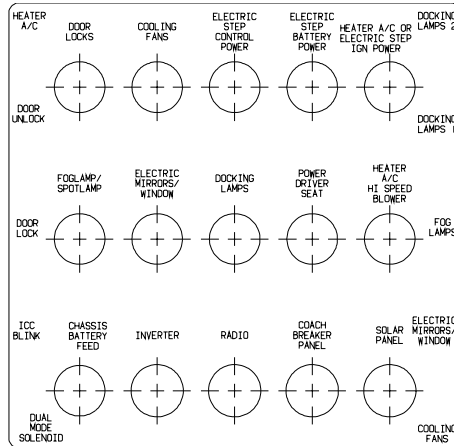

**KEY PART NUMBER U/M DESCRIPTION**  
 093236-19-000 EA LABEL - CIRCUIT BREAKER



**KEY PART NUMBER U/M DESCRIPTION**  
 093237-10-000 EA LABEL - CIRCUIT BREAKER - FRONT COOLING FANS

## LABELS GROUP (CONTINUED)

SUB - MAIN	DISH WASHER	RECEPS 1	RECEPS 2	RECEPS 3	MICROWAVE
------------	-------------	-------------	-------------	-------------	-----------

**KEY PART NUMBER U/M DESCRIPTION**  
 095721-20-000 EA LABEL - CONTROL CENTER W/INVERTER

SUB - MAIN	APPLIANCE 1	APPLIANCE 2	RECEPS 1	RECEPS 2	MICROWAVE
------------	----------------	----------------	-------------	-------------	-----------

**KEY PART NUMBER U/M DESCRIPTION**  
 095721-21-000 EA LABEL - CONTROL CENTER W/INVERTER

A / C CIRCUIT 1	MAIN	MAIN	A / C CIRCUIT 2	INVERTER / CHARGER	REFRIG / VACUUM	WASHER / DRYER	WATER HEATER		
-----------------------	------	------	-----------------------	-----------------------	-----------------	----------------	-----------------	--	--

**KEY PART NUMBER U/M DESCRIPTION**  
 095721-22-000 EA LABEL - CONTROL CENTER 50 AMP

SUB - MAIN	APPLIANCE 1	APPLIANCE 2	RECEPS 1	RECEPS 1	MICROWAVE
------------	----------------	----------------	-------------	-------------	-----------

**KEY PART NUMBER U/M DESCRIPTION**  
 095721-25-000 EA LABEL - CONTROL CENTER 30 AMP

## LABELS GROUP (CONTINUED)

A / C CIRCUIT 1	M A I N	R E F R I G / C O N V	M I C R O W A V E	R E C P S  1	R E C P S  2	A P P L I A N C E  2		
-----------------------	------------------	---	---	--------------------------------	--------------------------------	--	--	--

**KEY PART NUMBER U/M DESCRIPTION**  
 095721-26-000 EA LABEL - CONTROL CENTER 30 AMP - CANADIAN

A / C CIRCUIT 1	M A I N	A / C CIRCUIT 2	R E F R I G / C O N V	M I C R O W A V E	R E C P S  1	R E C P S  2	R E C P S  3		
-----------------------	------------------	-----------------------	---	---	--------------------------------	--------------------------------	--------------------------------	--	--

**KEY PART NUMBER U/M DESCRIPTION**  
 095721-27-000 EA LABEL - CONTROL CENTER 30 AMP

A / C CIRCUIT 1	M A I N	A / C CIRCUIT 2	R E F R I G / C O N V	M I C R O W A V E	R E C P S  1	R E C P S  2	A P P L I A N C E		
-----------------------	------------------	-----------------------	---	---	--------------------------------	--------------------------------	---	--	--

**KEY PART NUMBER U/M DESCRIPTION**  
 095721-28-000 EA LABEL - CONTROL CENTER 30 AMP - CANADIAN

A / C CIRCUIT 1	M A I N	M A I N	A / C CIRCUIT 2	R E F R I G / C O N V	M I C R O W A V E	R E C P S  1	R E C P S  2	R E C P S  3	W A S H E R / D R Y E R	
-----------------------	------------------	------------------	-----------------------	---	---	--------------------------------	--------------------------------	--------------------------------	--	--

**KEY PART NUMBER U/M DESCRIPTION**  
 095721-29-000 EA LABEL - CONTROL CENTER 50 AMP



## LABELS GROUP (CONTINUED)

A / C	C I R C U I T	1	M A I N	M A I N	A / C	C I R C U I T	2	R E F F R I G / C O N V	M I C R O W A V E	R E C P S	1	R E C P S	2	R E C P S	3	A P P L I A N C E	1	A P P L I A N C E	2	W A S H E R	D R Y E R
-------	---------------	---	---------	---------	-------	---------------	---	-------------------------	-------------------	-----------	---	-----------	---	-----------	---	-------------------	---	-------------------	---	-------------	-----------

**KEY PART NUMBER U/M DESCRIPTION**  
 095721-30-000 EA LABEL - CONTROL CENTER 50 AMP- CANADIAN

A / C	C I R C U I T	1	M A I N	A / C	C I R C U I T	2	R E F F R I G / C O N V	M I C R O W A V E	R E C P S	1	R E C P S	2	R E C P S	3	W A S H E R / D R Y E R	W A T E R	H E A T E R		
-------	---------------	---	---------	-------	---------------	---	-------------------------	-------------------	-----------	---	-----------	---	-----------	---	-------------------------	-----------	-------------	--	--

**KEY PART NUMBER U/M DESCRIPTION**  
 095721-31-000 EA LABEL - CONTROL CENTER 30 AMP - U.S.

A / C	C I R C U I T	1	M A I N	M A I N	A / C	C I R C U I T	2	R E F F R I G / C O N V	M I C R O W A V E	R E C P S	1	R E C P S	2	R E C P S	3	W A S H E R / D R Y E R	W A T E R	H E A T E R
-------	---------------	---	---------	---------	-------	---------------	---	-------------------------	-------------------	-----------	---	-----------	---	-----------	---	-------------------------	-----------	-------------

**KEY PART NUMBER U/M DESCRIPTION**  
 095721-33-000 EA LABEL - CONTROL CENTER 50 AMP - U.S.

A / C	C I R C U I T	1	M A I N	M A I N	A / C	C I R C U I T	2	I N V E R T E R /	C H A R G E E R	R E F F R I G E R A T O R	W A S H E R / D R Y E R	W A T E R	H E A T E R		
-------	---------------	---	---------	---------	-------	---------------	---	-------------------	-----------------	---------------------------	-------------------------	-----------	-------------	--	--

**KEY PART NUMBER U/M DESCRIPTION**  
 095721-34-000 EA LABEL - CONTROL CENTER 50 AMP

## LABELS GROUP (CONTINUED)

A / C C I R C U I T 1	M A I N	A / C C I R C U I T 2	R E F F R I G / C O N V	M I C R O W A V E	R E C P S 1	R E C P S 2	R E C P S 3	A P P L I A N C E	W A S H E R / D R Y E R	W A T E R H E A T E R
-----------------------------	---------	-----------------------------	-------------------------	-------------------	----------------	----------------	----------------	-------------------	-------------------------	--------------------------

**KEY PART NUMBER U/M DESCRIPTION**  
 095721-35-000 EA LABEL - CONTROL CENTER 30 AMP - CSA

A / C C I R C U I T 1	M A I N	M A I N	A / C C I R C U I T 2	R E F F R I G / C O N V	M I C R O W A V E	R E C P S 1	R E C P S 2	A P P L I A N C E 1	A P P L I A N C E 2	W A S H E R / D R Y E R	W A T E R H E A T E R
-----------------------------	---------	---------	-----------------------------	-------------------------	-------------------	----------------	----------------	------------------------	------------------------	-------------------------	--------------------------

**KEY PART NUMBER U/M DESCRIPTION**  
 095721-36-000 EA LABEL - CONTROL CENTER 50 AMP - CSA

M A I N	M I C R O W A V E	G F I / R E C E P S	R E F E R / C O N V	W A T E R H T R	A / C
---------	-------------------	---------------------	---------------------	--------------------	-------

**KEY PART NUMBER U/M DESCRIPTION**  
 095721-38-000 EA LABEL - CONTROL CENTER 30 AMP - U.S.

**LABELS GROUP (CONTINUED)**

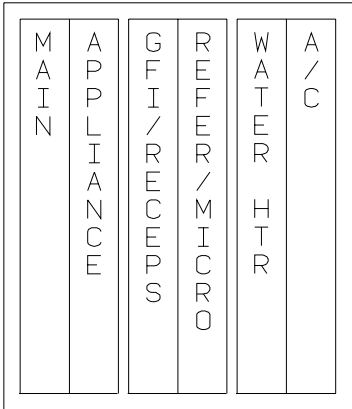

**KEY PART NUMBER U/M DESCRIPTION**  
 095721-39-000 EA LABEL - CONTROL CENTER 30 AMP - CANADIAN

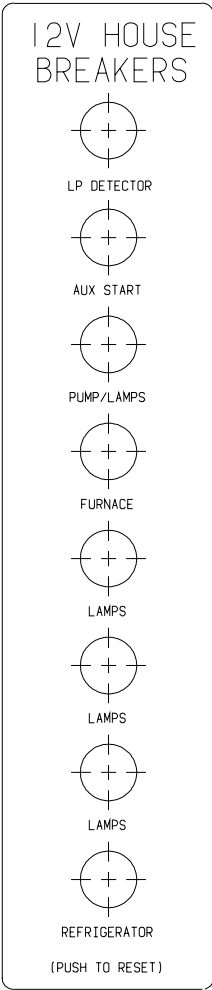

**KEY PART NUMBER U/M DESCRIPTION**  
 092547-08-000 EA LABEL - CIRCUIT BREAKER

## LABELS GROUP (CONTINUED)

BATTERY MODE SWITCH	COACH BREAKER PANEL	ELECTRIC STEP IGNITION POWER	ELECTRIC STEP BATTERY POWER	ELECTRIC STEP CONTROL POWER	INVERTER
---------------------------	---------------------------	---------------------------------------	--------------------------------------	--------------------------------------	----------

**KEY PART NUMBER U/M DESCRIPTION**  
 093236-08-000 EA LABEL - CIRCUIT BREAKER

FRONT TIRE PRESSURE AT UNLOADED VEHICLE WEIGHT: 75 PSI  
 REAR TIRE PRESSURE AT UNLOADED VEHICLE WEIGHT: 75 PSI  
 FOR LOADED VEHICLE, WEIGH UNIT AND REFER TO TABLE:

TIRE PRESSURE	75	80	85	90	95	100		
FRONT LOAD-LBS	7185	7630	8070	8555	9085	9350*		
REAR LOAD-LBS	13580	14375	15255	15500*				

\*GAWR = 9350  
 \*\*GAWR = 15500

TIRE: MICHELIN XRV 235/80R22.5, LOAD RANGE F

FOR BEST PERFORMANCE, MATCH TIRE PRESSURE TO YOUR AXLE LOAD

**KEY PART NUMBER U/M DESCRIPTION**  
 131775-03-01A EA LABEL - TIRE PRESSURE - BROWN/BLACK

DO NOT FILL  
 LP-GAS CONTAINER(S)  
 TO MORE THAN 80%  
 OF CAPACITY.

**KEY PART NUMBER U/M DESCRIPTION**  
 079965-01-000 EA LABEL - LPG - 80% CAPACITX

**LABELS GROUP (CONTINUED)**

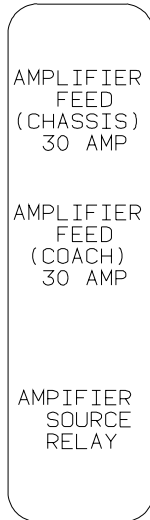

KEY	PART NUMBER	U/M	DESCRIPTION
	111537-06-000	EA	LABEL - AMPLIFIER POWER

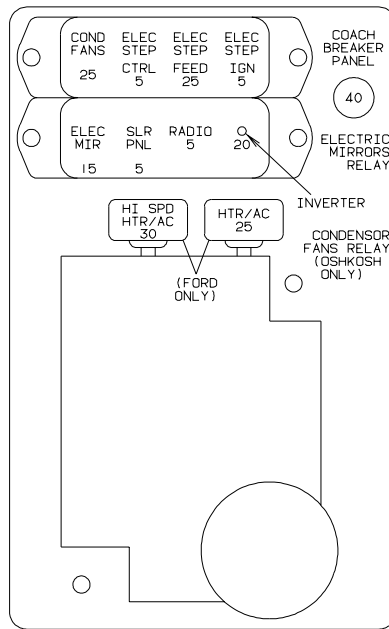

KEY	PART NUMBER	U/M	DESCRIPTION
	111537-07-000	EA	LABEL - FUSES

## LABELS GROUP (CONTINUED)

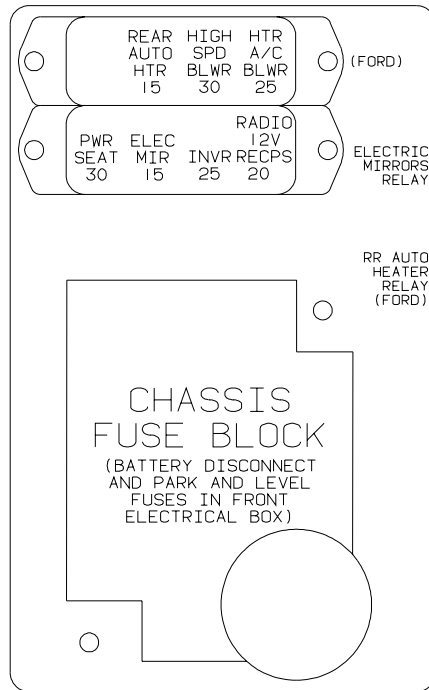

KEY	PART NUMBER	U/M DESCRIPTION
	111537-08-000	EA LABEL - FUSES

AUTOMOTIVE AND COACH  
CIRCUIT BREAKERS

KEY	PART NUMBER	U/M DESCRIPTION
	098379-01-000	EA LABEL - CIRCUIT BREAKER - FRONT BOX

BATTERY MODE  
SOLENOID AND  
RELAYS

KEY	PART NUMBER	U/M DESCRIPTION
	098379-04-000	EA LABEL - ELECTRICAL BOX - SIDE

<p style="text-align: center;">MISE EN GARDE</p> <p style="font-size: small;">POUR VOTRE SECURITE PERSONNELLE RANGEZ, TOUT OBJET DE FAÇON SECURITAIRE LORSQUE LE VEHICULE EST EN MOUVEMENT.</p>	<p style="text-align: center;">CAUTION</p> <p style="font-size: small;">FOR YOUR PERSONAL SAFETY, SECURELY STOW OBJECTS AWAY WHILE VEHICLE IS IN MOTION</p>
---	---

KEY	PART NUMBER	U/M DESCRIPTION
	131341-01-000	EA LABEL - STOW OBJECTS - US
	131341-02-000	EA LABEL - STOW OBJECTS - CSA

## LP GROUP

### LP SYSTEM

KEY	PART NUMBER	U/M	DESCRIPTION
	045703-11-000	EA	HOSE - LP - 3/8"ID X 36" - 3/8"MPT X 3/8"F SWIVEL - UL/CSA
	105658-01-000	EA	COMPARTMENT - LP REGULATOR
	106150-01-000	EA	REGULATOR - TWO STAGE -W/90 DEGREE ELBOW & 3/8" FPT OUTLET
	106150-02-000	EA	REGULATOR - TWO STAGE - 1/4" FPT INLET/3/8" FPT OUTLET
	040440-02-000	EA	TRANSMITTER - DIAL - 0-90 OHM -2 TERMINAL (POWER & GROUND)
*	080450-01-000	EA	TANK-LP - 42 LB - 13" DIAMETER X 24" LONG
	010377-02-000	EA	NUT - BRASS - 3/8" FLARE - FORGED
	010380-02-000	EA	NUT - BRASS - 1/2" FLARE - FORGED
	010265-01-000	EA	ELBOW - BRASS - 90 DEGREE - 3/8"F X 1/2"FPT
	065318-02-000	EA	ELBOW - 90 DEGREE - 3/8" MPT TO 3/8" FPT
	010323-01-000	EA	ADAPTER - BRASS - 3/8"F X 1/2"MPT
	103613-03-000	EA	DETECTOR - LP GAS - W/O SHUT-OFF VALVE

**\*COMPONENT PARTS FOUND IN SERVICE PARTS LIBRARY**

## LOUNGE GROUP CABINETS

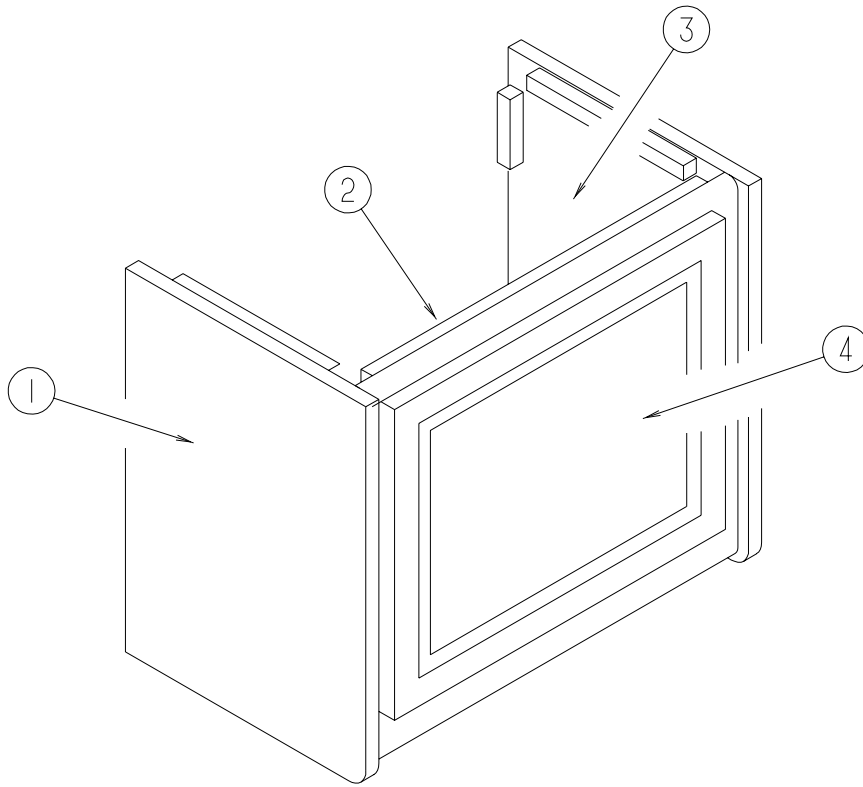

KEY	PART NUMBER	U/M	DESCRIPTION
1	109908-81-K04	EA	END CAP - OVERHEAD CABINET
2	124390-04-K04	EA	CABINET - OVERHEAD/FRONT/RIGHT HAND - W/O DOORS/HARDWARE
3	109908-82-K04	EA	END CAP - OVERHEAD CABINET
4	132141-08-L01	EA	DOOR - RAIL/VENEER - 15.7" X 20.4" - W/O HARDWARE

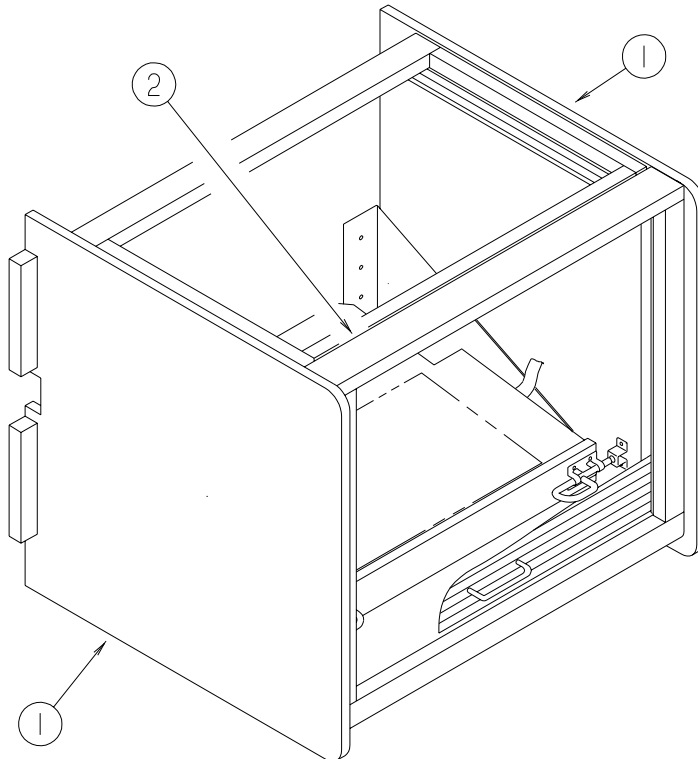

KEY	PART NUMBER	U/M	DESCRIPTION
1	109908-98-J01	EA	END CAP - OVERHEAD CABINET
2	M08163-09-K01	EA	CABINET - TV/VCP - W/O SHELF/SLIDES/SWIVEL- W/TAMBOUR DOOR
2	M08163-10-K01	EA	CABINET - TV/VCP - W/SHELF/SLIDES/SWIVEL/TAMBOUR DOOR



**LOUNGE GROUP (CONTINUED)**  
**CABINETS (CONTINUED)**

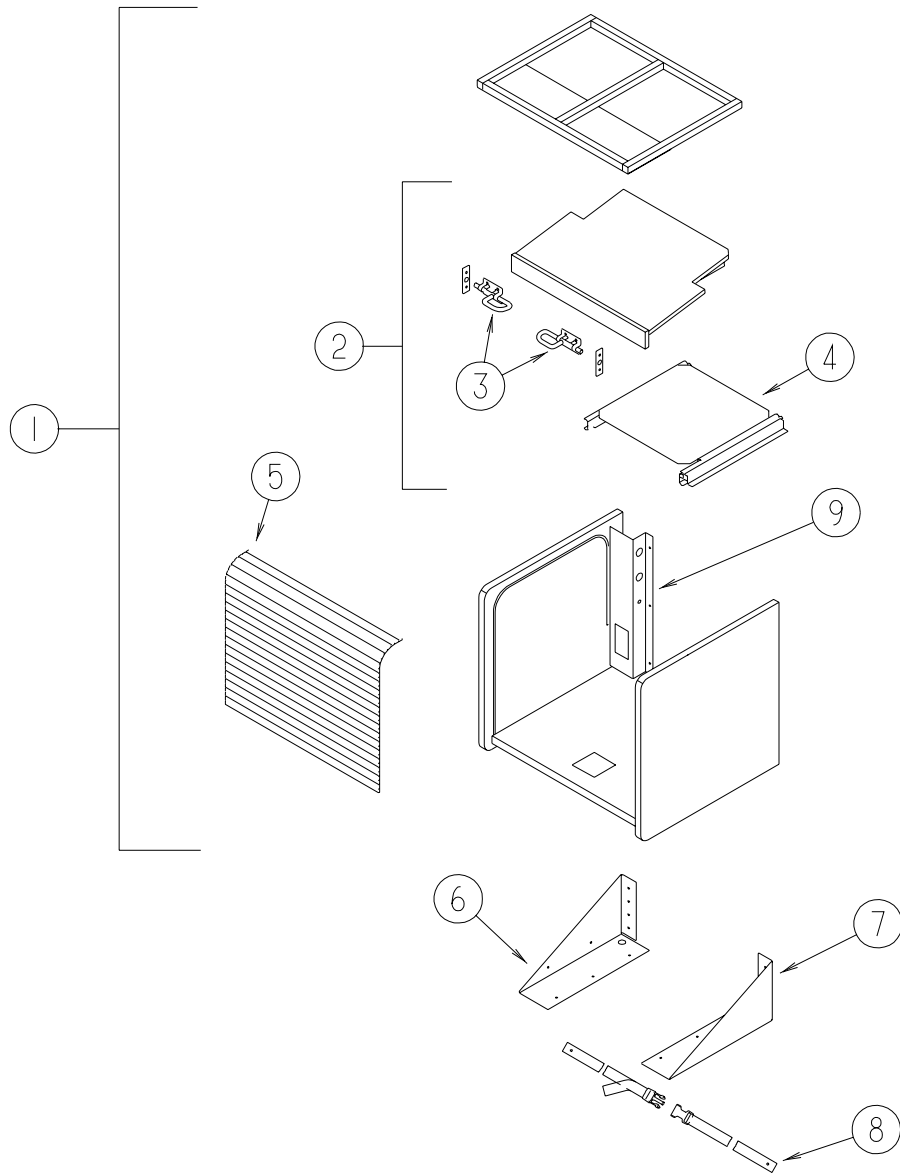

KEY	PART NUMBER	U/M	DESCRIPTION
1	M08163-09-K01	EA	CABINET - TV/VCP - W/O SHELF/SLIDES/SWIVEL- W/TAMBOUR DOOR
1	M08163-10-K01	EA	CABINET - TV/VCP - W/SHELF/SLIDES/SWIVEL/TAMBOUR DOOR
2	125722-13-J01	EA	SHELF - W/SLIDE & SWIVEL
3	103256-01-000	EA	LATCH - SLIDE
4	116773-02-000	EA	SWIVEL/SLIDES - F/TV SHELF
5	057882-04-700	EA	TAMBOUR - 48" X 48" SHEET - UNFINISHED
6	122298-03-02B	EA	BRACKET - TV/VCR W/ANGLE - LEFT HAND - E-COATED
7	122298-02-02B	EA	BRACKET - TV/VCR W/ANGLE - RIGHT HAND - E-COATED
8	099717-04-000	EA	STRAP - TIE DOWN W/21.3" FEMALE STRAP & 27.2" MALE STRAP
9	122469-02-02B	EA	BRACKET - ZEE - W/CUTOUT - E-COATED
9	122469-01-02B	EA	BRACKET - ZEE

**SEALANTS & FASTENERS GROUP**  
**SEALANTS & ADHESIVES**

KEY	PART NUMBER	U/M	DESCRIPTION
	069640-01-000	FT	SEALER - RIBBON - 1/4" DIAMETER X 30' - BLACK
	069640-02-000	FT	SEALER - TAPE - .13"THICK X .5"WIDE X 60' - GRAY
	069640-03-000	FT	SEALER - TAPE - .13"THICK X .75"WIDE X 60' - BLACK
	069640-07-000	FT	SEALER - TAPE - .09" THICK X 2" WIDE X 45' - GRAY
	069640-09-000	FT	SEALER - TAPE - .03" THICK X 2.50"WIDE X 80' - GRAY
	069640-10-000	FT	SEALER - TAPE - .03" THICK X 1.50" WIDE X 90' - GRAY
	069640-11-000	FT	SEALER - TAPE - .19" THICK X .38" WIDE X 40' - BLACK
	069640-13-000	FT	SEALER - TAPE - .03"THICK X 2"WIDE X 45' - BLACK
	069640-14-000	FT	SEALER - TAPE - .06" THICK X 1" WIDE X 100' - GRAY
	069640-15-000	FT	SEALER - TAPE - .06"THICK X .38"WIDE X 100' - GRAY
	069640-17-000	FT	SEALER - TAPE - .03" THICK X 1" WIDE X 90' - GRAY
	069640-18-000	FT	SEALER - TAPE - .50" THICK X .13" WIDE X 60' - BRT WHITE
	069640-19-000	FT	SEALER - TAPE - .75" THICK X .13" WIDE X 60' - BRT WHITE
	069640-20-000	FT	SEALER - TAPE - .50" THICK X 1/8" WIDE X 60' - BLACK
	069640-21-000	FT	SEALER - TAPE - .50" THICK X 1/16" WIDE X 100'-BRIGHT WHT
	069640-22-000	FT	SEALER - TAPE - .25" THICK X 1/32" WIDE X 100'- BRIGHT WHT
	069640-23-000	FT	SEALER - TAPE - 1/16" THICK X 3/4" WIDE X 100'-BRIGHT WHT
	069640-25-000	FT	SEALER - TAPE - .06" THICK X 3.5" WIDE X 50' - GRAY
	072889-01-000	EA	SEALANT - URETHANE - BLACK - TUBE
	072889-10-000	EA	SEALANT - URETHANE - BRIGHT WHITE - TUBE
	072889-11-000	EA	SEALANT - URETHANE - GRAY - TUBE
	072889-13-000	EA	SEALANT - URETHANE - VW WHITE - TUBE
	072889-14-000	EA	SEALANT - URETHANE - SABLE - TUBE
	116767-01-01A	EA	SEALANT - WATERBASE - CLEAR
	053766-02-000	EA	BEDDING COMPOUND - TUBE - WHITE
	053766-06-000	EA	BEDDING COMPOUND - TUBE - CLEAR
	034552-15-000	EA	SILICONE - TUBE - W/O NOZZLE - BRIGHT WHITE
	131264-01-01A	EA	SILICONE - W/O NOZZLE - BLACK
	131264-01-02A	EA	SILICONE - W/O NOZZLE - CLEAR
	131264-01-08A	EA	SILICONE - W/O NOZZLE - BUFF
	131264-02-01A	EA	SILICONE - W/O NOZZLE - VW GRAY - BATH ONLY
	131264-03-01A	EA	SILICONE - W/O NOZZLE - SELF LEVELING - BRIGHT WHITE
	108716-01-000	EA	SILICONE - W/O NOZZLE - OFF WHITE - SELF LEVELING
	108716-02-000	EA	SILICONE - W/O NOZZLE - BUFF - SELF LEVELING
	102352-01-000	EA	SEALER - PUMPABLE - TUBE - BLACK
	102352-02-000	EA	SEALER - PUMPABLE - TUBE - CLEAR
	094401-01-000	EA	SEALER - BODY SEAM - FLEXICLEAR
	094401-03-000	EA	SEALER - BODY SEAM - BLACK
	094401-04-000	EA	SEALER - BODY SEAM - CLEAR
	067788-01-000	EA	ADHESIVE - SPRAY - 3M - 19.5 OZ AEROSOL CAN
	900390-01-000	EA	NOZZLE - SILICONE TUBE - 2.5" LONG
	900390-03-000	EA	NOZZLE - SILICONE TUBE - 4.3" LONG
	112902-01-000	EA	NOZZLE - ELEMENT - 3/8 X 24
	112902-02-000	EA	NOZZLE-BELL 3/8X24
	112902-03-000	EA	MIXER NOZZLE - F/GUN #00400102000 - SCOTCH-WELD & PLEXUS
	076322-01-000	FT	TAPE-DOUBLE COATED/ADHESIVE BK-.03"THK X .8"W X 216'- WHT
	076322-02-000	FT	TAPE-DOUBLE COATED/ADHESIVE BK-.05"THK X 1"W X 108' - WHT
	076322-03-000	FT	TAPE-DOUBLE COATED/ADHESIVE BK-.05"THK X .5"W X 108' - WHT
	076322-05-000	FT	TAPE-DOUBLE COATED/ADHESIVE BK-.05"THK X .8"W X 108' - WHT
	076322-06-000	FT	TAPE - DOUBLE COATED/ADHESIVE BK-.05"THK X 1"W - BLK
	076322-07-000	FT	TAPE-DOUBLE COATED/ADHESIVE BK-.05"THK X .5"W X 200' - BLK
	076322-11-000	FT	TAPE-DOUBLE COATED/ADHESIVE BK-.02"THK X 1"W X 216' - CLR
	076322-12-000	FT	TAPE-DOUBLE COATED/ADHESIVE BK-.05"THK X .8"W X 108' - CLR
	123816-01-000	FT	TAPE - DOUBLE SIDED - 1" X 100'
	123816-02-000	FT	TAPE - DOUBLE SIDED - 1/2" X 1 1/3" X 100'
	123816-03-000	FT	TAPE - DOUBLE SIDED - 1/2" X 3/4" X 100'
	123816-04-000	FT	TAPE - DOUBLE SIDED - 6" X 750'
	120534-01-01A	EA	TAPE - SCOTCH - 3M - 1/2" FINE LINE

## SEALANTS & FASTENERS GROUP (CONTINUED)

### SEALANTS & ADHESIVES (CONTINUED)

KEY	PART NUMBER	U/M	DESCRIPTION
	063642-01-000	FT	TAPE - ADHESIVE - .4" X 1.5" X 180'
	123244-01-000	FT	TAPE - DOUBLE SIDED/FOAM - 5/64" THICK X 3/4" WIDE
	123244-02-000	FT	TAPE - DOUBLE SIDED/FOAM - 5/64" THICK X 1/2" WIDE X 108'
	088479-01-000	EA	TAPE - ALUMINUM - 3"
	103202-02-000	FT	TAPE - FOAM/ADHESIVE ONE SIDE - 1/16" X 200'
	110274-01-000	FT	TAPE - DOUBLE SIDED/FOAM - .45" X 1" X 216' - BLACK
	115933-01-000	FT	TAPE - 1/64" X 3/8" X 100'
	123816-04-000	FT	TAPE - DOUBLE SIDED - 6" X 750'
	002707-02-000	FT	TAPE - SEALER - 5/16" X 1/2" - INCREMENTS OF 50 FT
	091255-02-000	FT	SEAL - ADHESIVE BACKED/FOAM - 3/64" THICK X 3/16"W X 1000'
	091255-03-000	FT	SEAL - ADHESIVE BACKED/FOAM - 1/4" THICK X 1/4"W X 1000'
	099069-01-000	FT	SEAL - RUBBER - CLOSED SPONGE - .5" WIDE X .12" THICK -BLK
	104692-01-000	FT	SEAL - ADHESIVE BACKED FOAM - 3/4" THICK X 3/4" WIDE X 25'
	104692-03-000	FT	SEAL - ADHESIVE BACKED FOAM - 1" THICK X 1 3/4" WIDE X 15'
	108353-03-000	FT	SEAL - FOAM - .19" X .25"
	112864-01-000	FT	SEAL - FOAM/BUTYL COVERED - 3/8" X 35'
	106206-01-000	EA	SEALER - PUMPABLE - TUBE - BLACK - MANUS
	120074-02-01A	EA	SILICONE - W/O NOZZLE - LOW ODOR - OFF WHITE
	120074-02-02A	EA	SEALANT - W/O NOZZLE - SOFT WHITE
	107828-01-000	EA	SEALANT - SB - 190 EVERSEAL
	112864-02-000	FT	FOAM - BUTYL COVERED 5/16" X 44'
	087211-01-000	GL	PROMOTER - ADHESIVE - GALLON
	004006-05-700	EA	ADHESIVE - 5 GALLON - NATIONAL STARCH
	004020-01-000	QT	ADHESIVE - ABS CEMENT - QUART
	112901-02-000	EA	ADHESIVE - PLEXUS - MA330 - 50ML - GRAY
	131384-01-000	EA	ADHESIVE - JETWELD
	113366-01-000	EA	ADHESIVE - INSTANT - 1 OZ
	062917-03-000	EA	ADHESIVE - LOCTITE 242
	004001-02-000	EA	GUN - PLEXUS ADHESIVE - W/O NOZZLE
	004001-03-000	EA	MIXER NOZZLE (EPX)
	004001-03-001	EA	EPOXY MIXER NOZZLE 12"
	004001-03-002	EA	TUBE/MIXER - GRACO EPOXY
	004001-04-000	EA	PLUNGER ACCESSORY (EPX)
	004001-05-000	EA	ADHESIVE - SCOTCH-WELD - 3M DP100 - CLEAR - 50ML
	099952-01-000	FT	CORE - SEAL - BULB SUPPORT

### BOLTS, NUTS AND WASHERS

KEY	PART NUMBER	U/M	DESCRIPTION
	000C12-04-12A	EA	BOLT - HEX - 1/4-20 X .75 - PLAIN 5
	000C12-05-16B	EA	BOLT - HEX - 5/16-18 X 1 - GRADE #5 - ZINC
	000C12-05-12B	EA	BOLT - HEX - 5/16-18 X 3/4 - ZINC 5
	000C12-06-16B	EA	BOLT - HEX - 3/8-16 X 1 - GRADE #5 - ZINC
	000C12-06-20B	EA	BOLT - HEX - 3/8 - 16 X 1 1/4 - ZINC #5
	000C12-06-44B	EA	BOLT - HEX - 3/8-16 X 2 3/4 - ZINC 5
	000C12-07-20B	EA	BOLT - HEX - 7/16-14 X 1 1/4 - ZINC 5
	000C12-08-24B	EA	BOLT - HEX - 1/2-13 X 1.5 - GRADE #3 - ZINC
	000C12-08-28B	EA	BOLT - HEX - 1/2-13 X 1.8" - GRADE #5 - ZINC
	000C12-08-16B	EA	BOLT - HEX - 1/2-13 X 1" - GRADE #5 - ZINC
	OMC04K-06-016	EA	BOLT - HEX - M06 X 1 X 016
	OMC05K-08-055	EA	BOLT - HEX - M.3 X 1.25 X 2.2
	OMC13K-14-070	EA	BOLT - HEX - M14 X 2.00 X 2.75
	OMC31K-08-020	EA	BOLT - HEX - SERRATED FLANGE - M8 X 020
	OMC32K-10-030	EA	BOLT - HEX - SERRATED FLANGE - M10 X 1.50
	OMC53K-12-050	EA	BOLT - HEX - M12 X 1.75 X 050
	000C12-04-40B	EA	BOLT - HEX - 1/4-20 X 2 1/2 - GRADE 5 - ZINC
	000C12-05-64B	EA	BOLT - HEX - 5/16-18 X 4
	000C12-06-24B	EA	BOLT - HEX - 38-16 X 1 1/2 - ZINC #5
	000C12-10-24B	EA	BOLT - HEX - 5/8-11 X 1.5" - GRADE #5 - ZINC

**SEALANTS & FASTENERS GROUP (CONTINUED)****BOLTS, NUTS AND WASHERS (CONTINUED)**

<b>KEY</b>	<b>PART NUMBER</b>	<b>U/M</b>	<b>DESCRIPTION</b>
	000C13-07-40B	EA	BOLT - HEX - 7/16-20 X 2.5" - GRADE #5 - ZINC
	000C13-07-48B	EA	BOLT - HEX - 7/16-20 X 3" - GRADE #5 - ZINC
	000C13-08-40B	EA	BOLT - HEX - 1/2-20 X 2 1/2 - GRADE #5 - ZINC
	000C13-08-28B	EA	BOLT - HEX - 1/2-20 X 1 3/4 - GRADE #5 - ZINC
	000C14-07-28B	EA	BOLT - HEX - 7/16-14 X 1.75 - GRADE 8 ZINC
	000C14-07-20B	EA	BOLT - HEX - 7/16-14 X 1.25 - GRADE 8 ZINC
	000C14-10-24K	EA	BOLT - HEX - 5/8-11 X 1.50 - GRADE #8 - ZINC
	000C14-10-32K	EA	BOLT - HEX - 5/8"-11 X 2 - GRADE #8 - ZINC
	000C18-05-40A	EA	BOLT - ELEVATOR - 5/16-18 X 2.50 - PL
	000C18-06-48B	EA	BOLT - ELEVATOR - 3/8-16 X 3 - GRADE 5 - ZINC
	000C18-06-56A	EA	BOLT - ELEVATOR - 3/8-16 X 3 1/2 - GRADE 5
	000C26-04-18B	EA	BOLT - HEX - SERRATED FLANGE - 1/4-20 X 1 1/8 - ZINC
	000C26-04-14B	EA	BOLT - HEX - SERRATED FLANGE - 1/4-20 X 7/8 - ZINC
	000C26-04-10B	EA	BOLT - HEX - SERRATED FLANGE - 1/4-20 X 5/8 - ZINC
	000C26-05-16B	EA	BOLT - HEX - SERRATED FLANGE - 5/16-18 X 1 - ZINC
	000C26-05-20B	EA	BOLT - HEX - SERRATED FLANGE - 5/16-18 X 1 1/4 - ZINC
	000C26-05-12B	EA	BOLT - HEX - SERRATED FLANGE - 5/16-18 X 3/4 - ZINC
	000C26-05-129	EA	BOLT - HEX - SERRATED FLANGE - 5/16-18 X 3/4
	000C26-05-249	EA	BOLT - HEX - SERRATED FLANGE - 5/16-18 X 1.5"
	000C26-06-16B	EA	BOLT - HEX - SERRATED FLANGE - 3/8-16 X 1 - ZINC
	000C26-06-28B	EA	BOLT - HEX - SERRATED FLANGE - 3/8-16 X 1 3/4 - ZINC
	000C26-06-40B	EA	BOLT - HEX - SERRATED FLANGE - 3/8-16 X 1 3/4 - ZINC
	000C26-06-12B	EA	BOLT - HEX - SERRATED FLANGE - 3/8-16 X 3/4 - ZINC
	000C26-06-20B	EA	BOLT - HEX - SERRATED FLANGE - 3/8 - 16 X 1 1/4 - ZINC
	000C26-08-24B	EA	BOLT - HEX - SERRATED FLANGE - 1/2-13 X 1 1/2 - ZINC
	000C27-04-40B	EA	BOLT - CARRIAGE 1/4-20 X 2.50 - ZINC
	000C27-08-64B	EA	BOLT - CARRIAGE - 1/2-13 X 4. - GRS
	106166-01-000	EA	BOLT - COLLARED HANGER - 8-32 X 1"
	000G45-04-24B	EA	BOLT - LAG - 1/4-9 X 1 1/2 - ZINC
	000G45-04-24F	EA	BOLT - LAG - 1/4" #9 X 1 1/2SS
	000G45-05-16B	EA	BOLT - LAG - 5/16-9 X 1 - ZINC
	106956-03-000	EA	BOLT - HEX TAP - 1/2-12NC X 3 - GRADE 5 - FULL THREAD/ZINC
	051387-06-000	EA	BOLT - CARRIAGE W/O HOLE - 5/16-18 X 9.5 - ZINC
	091274-03-000	EA	BOLT-J - 3/8-16 X 12.0
	106956-08-000	EA	BOLT - HEX TAP - 1/2-13NC X 4 - GRADE 5 - FULL THREAD/ZINC
	087718-01-000	EA	MONOBOLT - STEEL - 3/16 DIAMETER
	102333-02-01A	EA	BOLT - CARRIAGE - 1/4-20
	103020-02-000	EA	BOLT-U - #8-32 - GRADE 5 ZINC
	107393-02-000	EA	BOLT - SHOULDER - 3/8" SOCKETHEAD
	113985-02-000	EA	BOLT - FLANGE - M10-1.5 X 30CL10.9
	114259-05-000	EA	BOLT - 7/16-20 X 1.25 W/WASHER
	0MD16K-10-000	EA	NUT - HEX - PREV TORQUE M10 X 1.50 CLASS 8
	0MD39K-12-000	EA	NUT - HEX - W/NYLON LOCK - M12 X 1.75
	000D24-10-00B	EA	NUT - HEX - SELF LOCKING - 10-32 - ZINC
	000D29-05-00B	EA	NUT - HEX - LOCKING W/SERRATED FLANGE - NYLON WASHER INSERT
	000D29-09-00B	EA	NUT - HEX - SELF LOCKING - 9/16-12 - ZINC
	000D29-06-00B	EA	NUT - HEX - W/NYLON LOCK - 3/8-16 - ZINC
	000D30-07-00B	EA	NUT - HEX - LOCK - NYLON 7/16 X 20
	000D34-04-00B	EA	NUT - HEX - LOCKING - 1/4-20 ZINC
	000D34-06-00B	EA	NUT - HEX - LOCKING - 3/8-16 GRADE C - ZINC
	000D39-04-00B	EA	NUT - HEX - LOCKING W/SERRATED FLANGE - 1/4-20 - ZINC
	000D39-05-00B	EA	NUT - HEX - LOCKING W/SERRATED FLANGE - 5/16-18 - ZINC
	000D39-06-00B	EA	NUT - HEX - LOCKING W/SERRATED FLANGE - 3/8-18 - ZINC
	000D39-07-00B	EA	NUT - HEX - LOCKING W/SERRATED FLANGE - 7/16-14 - ZINC
	000D39-08-00B	EA	NUT - HEX - LOCKING W/SERRATED FLANGE - 1/2-13 - ZINC
	000D44-04-00B	EA	NUT - HEX - LOCKING W/SERRATED FLANGE - 1/4-28 - ZINC
	000D44-07-00B	EA	NUT - HEX - LOCKING W/SERRATED FLANGE - 7/16-20 - ZINC
	000D44-08-00B	EA	NUT - HEX - SERRATED FLANGE - 1/2-20 - GRADE #5 - ZINC
	000D46-04-00A	EA	NUT - HEX - WELD - 1/4-20 - PLAIN
	000D58-06-00A	EA	NUT - HEX - WELD 3/8-16 - PLAIN
	000D65-08-00B	EA	NUT - HEX - LOCKING W/SERRATED FLANGE - 8-32 - ZINC
	000D67-10-00B	EA	NUT - HEX - LOCK - 5/8-11 - ZINC

## SEALANTS & FASTENERS GROUP (CONTINUED)

### BOLTS, NUTS AND WASHERS (CONTINUED)

KEY	PART NUMBER	U/M	DESCRIPTION
	000D73-07-00C	EA	NUT - HEX - FLANGE - 7/16-14 - GRADE 6
	000D73-08-00C	EA	NUT - HEX - FLANGE - 1/2-13
	000D76-06-00B	EA	NUT - HEX - FLANGE - 3/8-16
	044364-02-000	EA	NUT - SPEED - FLAT - ROUND
	063253-07-000	EA	NUT - J - #8A - .120 - .130 PNL THK
	087234-01-000	EA	NUT - JACK - 1/4 X 20 THD - MOLLX
	040921-01-000	EA	NUT - SPEED - U TYPE - #10-24 - BLACK
	104369-01-000	EA	NUT - HEX - HEAVY - 5/8-11 UNC
	000D29-04-00B	EA	NUT - HEX - SELF LOCKING - 1/4 X 20 - ZINC
	005081-01-000	EA	NUT - SPEED - C TYPE - #8 SCREW
	040921-04-000	EA	NUT - SPEED - U TYPE - #8-.59" LENGTH X .44" WIDTH
	040921-09-000	EA	NUT - SPEED - U TYPE - #8
	044364-01-000	EA	NUT - SPEED - FLAT - RECTANGULAR - SELF LOCKING/ONE PIECE
	083163-06-000	EA	PUSHNUT - FLAT TYPE 3/8 STUD - FORD ONLY
	0ME06K-14-280	EA	WASHER - FLAT - 14 ID X 28.00 OD
	000E11-07-00B	EA	WASHER - LOCKING - 7/16 MED SPLIT - ZINC
	000E11-08-00B	EA	WASHER - LOCKING - 1/2 MED SPLIT - ZINC
	000E13-14-00B	EA	WASHER - FLAT - 1/4 WIDE - ZINC
	000E13-17-00B	EA	WASHER - FLAT - 3/8 AR - ZINC
	000E13-18-00B	EA	WASHER - FLAT - 3/8 WIDE - ZINC
	000E13-20-00B	EA	WASHER - FLAT - 7/16 WIDE - ZINC
	000E13-21-00B	EA	WASHER - FLAT - 1/2 NARROW - ZINC
	000E13-22-00B	EA	WASHER - FLAT - 1/2 WIDE - ZINC
	000E13-26-00B	EA	WASHER - FLAT - 5/8 WIDE - ZINC
	000E14-10-00B	EA	WASHER - LOCKING - #10 EXTERNAL TOOTH - ZINC
	000E16-10-00B	EA	WASHER - HARDENED - 5/8 - FLAT - ZINC
	058716-02-000	EA	WASHER - FLAT NYLON
	077071-01-000	EA	WASHER - FENDER - 3/16" ID X 1" OD
	107397-01-000	EA	WASHER - FENDER - .25" ID X 1" OD
	041322-01-000	EA	WASHER - FLANGE - 15/32 ID X 2 3/8 OD - F/SEAT BELT MTG
	044533-01-000	EA	WASHER - PLASTIC - 1 3/8" OD - FOR BUTTONS
	046867-05-000	EA	WASHER - #0
	058716-03-000	EA	WASHER - FLAT/NYLON - .500 X 1.25 X .060
	088787-12-000	EA	STUD - WELD - 1/4 - 20 X 1.0 LG - MN
	108067-03-000	EA	STUD - WELD - 1/4 - 20 X 1/2 CD
	102540-02-000	EA	SEAL - SCREW
	106648-01-000	EA	CAP - STUD - .120 TO .130 DIAMETER

### SCREWS

KEY	PART NUMBER	U/M	DESCRIPTION
	0G1108-12-170	EA	SCREW - 8-18 X .75 PPH - BRIGHT WHITE
	0G1106-08-240	EA	SCREW - 6-20 X 1/2 PPH - VW LIGHT GRAY
	0G1108-12-140	EA	SCREW - 8-18 X .75 PPH - CAMBRIDGE BISQUE
	0G1108-12-240	EA	SCREW - 8-18 X .75 PPH - VW LIGHT GRAY
	0G1208-12-170	EA	SCREW - 8-18 X .75 POH - BRIGHT WHITE
	0G3908-08-160	EA	SCREW - SF/DR - 8-18X1/2 PPH
	0G3908-08-170	EA	SCREW - SF/DR - 8-18 X .50 PPH - BRIGHT WHITE
	0G3908-08-240	EA	SCREW - SF/DR - 8-18 X 1/2 PPH - VW LIGHT GRAY
	0G3908-12-250	EA	SCREW - SF/DR - 8-18 X .75 PPH - DARK GRAY
	0G3908-16-170	EA	SCREW - SF/DR - 8-18 X 1.00 PPH - BRIGHT WHITE
	0G3908-20-170	EA	SCREW - SF/DR - 8-18 X 1.25 PPH - BRIGHT WHITE
	0G3908-24-170	EA	SCREW - SF/DR - 8-18 X 1.50 PPH - BRIGHT WHITE
	0G3910-10-160	EA	SCREW - SF/DR - 10-16 X .62 PPH
	0G3910-10-240	EA	SCREW - SF/DR - 10-16 X .62 PPH - VW LIGHT GRAY
	0G5508-12-110	EA	SCREW - SF/DR - 8-18 X .75 PWH
	0G3910-12-260	EA	SCREW - SF/DR - 10-16 X .75 PPH - ALLANTE ANTELOPE
	0G3910-12-170	EA	SCREW - SF/DR - 10-16 X .75 PPH - BRIGHT WHITE
	0G5508-12-170	EA	SCREW - SF/DR - 8-18 X .75 PWH - BRIGHT WHITE
	0G5508-12-270	EA	SCREW - SF/DR - 8-18 X .75 PWH - TITANIUM
	0G5508-12-260	EA	SCREW - SF/DR - 8-18 X .75 PWH - ALLANTE ANTELOPE
	0G5508-16-250	EA	SCREW - SF/DR - 8-18 X 1.00 PWH - VW DARK GRAY
	0G6008-16-170	EA	SCREW - SF/DR - 8-18 X 1.00 POH - BRIGHT WHITE

**SEALANTS & FASTENERS GROUP (CONTINUED)****SCREWS (CONTINUED)**

<b>KEY</b>	<b>PART NUMBER</b>	<b>U/M</b>	<b>DESCRIPTION</b>
	0G5508-16-260	EA	SCREW - SF/DR - 8-18 X 1.00 PWH ZINC - INTERIOR ANTELOPE
	0G5508-16-270	EA	SCREW - SF/DR - 8-18 X 1.00 PWH ZINC - INTERIOR TITANIUM
	0G6710-08-130	EA	SCREW - 10-12 X .50 PPH TAUPE
	0G6710-08-170	EA	SCREW - 10-12 X 1/2 PPH - BRIGHT WHITE
	0G6710-08-240	EA	SCREW - 10-12 X .50 PPH TAUPE - VW LIGHT GRAY
	0G6710-12-170	EA	SCREW - 10-12 X .75 PPH - BRIGHT WHITE
	0G6710-16-230	EA	SCREW - 10-12 X 1 PPH - BEIGE
	000G11-05-08B	EA	SCREW - 5-20 X .50 PPH - ZINC
	000G11-06-06B	EA	SCREW - 6-20 X 3/8 PPH - ZINC
	000G11-06-10B	EA	SCREW - 6-20 X 5/8 PPH - ZINC
	000G11-06-12B	EA	SCREW - 6-20 X 3/4" PPH - ZINC
	000G11-06-10J	EA	SCREW - 6-20 X 5/8 PPH - BRASS
	000G11-06-A4B	EA	SCREW - 6-20 X 1.5 PPH ZINC
	000G11-06-08B	EA	SCREW - 6-20 X 1/2 PPH - ZINC
	000G11-07-08B	EA	SCREW - 7-19 X 1/2 PPH - ZINC
	000G11-07-08T	EA	SCREW - 7-19 X 1/2 PPH - BLACK
	000G11-08-06B	EA	SCREW - 8-18 X 3/8 PPH - ZINC
	000G11-08-06J	EA	SCREW - 8-18 X 3/8 PPH BRASS
	000G11-08-12B	EA	SCREW - 8-18 X 3/4 PPH - ZINC
	000G11-08-12S	EA	SCREW - 8-18 X 3/4 PPH - OFF WHITE
	000G11-08-08T	EA	SCREW - 8-18 X 1/2 PPH - FLUOROCARBON COATING
	000G11-08-08B	EA	SCREW - 8-18 X 1/2 PPH - ZINC
	000G11-08-20B	EA	SCREW - 8-18 X 1 1/4 PPH - ZINC
	000G11-08-16S	EA	SCREW - 8-18 X 1 PPH - OFF WHITE
	000G11-08-16B	EA	SCREW - 8-18 X 1 PPH - ZINC
	000G11-08-12P	EA	SCREW - 8-18 X 3/4 PPH - DARK BROWN
	000G11-08-12D	EA	SCREW - 8-18 X 3/4 PPH - BLACK
	000G11-08-12T	EA	SCREW - 8-18 X 3/4 PPH - BLACK
	000G11-10-12S	EA	SCREW - 10-16 X 3/4 PPH - OFF WHITE
	000G11-10-12D	EA	SCREW - 10-16 X 3/4 PPH - BLACK
	000G11-10-16B	EA	SCREW - 10-16 X 1 PPH - ZINC
	000G11-10-40B	EA	SCREW - 10-16 X 2 1/2 PPH CAD - 34927-01-000
	000G12-06-08T	EA	SCREW - 6-20 X 1/2 POH - BLACK
	000G12-08-12S	EA	SCREW - 8-18 X 3/4 POH - OFF WHITE
	000G13-05-10B	EA	SCREW - 5-12 X 5/8 PFH - ZINC
	000G13-06-16S	EA	SCREW - 6-20 X 1.00 PFH - OFF WHITE
	000G13-06-10G	EA	SCREW - 6-20 X 5/8 PFH - ANTIQUE BRASS
	000G13-06-08B	EA	SCREW - 6-20 X 1/2 PFH - ZINC
	000G13-06-08G	EA	SCREW - 6-20 X .50 PFH - ANTIQUE BRASS
	000G13-06-24J	EA	SCREW - 6-20 X 1 1/2 PFH - BRASS
	000G13-06-10J	EA	SCREW - 6-20 X .62 PFH - BRASS
	000G13-06-16E	EA	SCREW - 6-20 X 1.00 PFH - CHROME
	000G13-06-16J	EA	SCREW - 6-20 X 1 PFH - BRASS
	000G13-06-06I	EA	SCREW - 6-20 X 3/8 PFH - BLACK ZINC
	000G13-06-06B	EA	SCREW - 6-20 X 3/8 PFH ZINC
	000G13-07-12B	EA	SCREW - 7-19 X 3/4 PFH - ZINC
	000G13-07-10H	EA	SCREW - 7-19 X 5/8 PFH - BLACK
	000G13-07-089	EA	SCREW - 7-19 X 1.2 PPH - SILVER
	000G13-08-10B	EA	SCREW - 8-18 X 5/8 PFH - ZINC
	000G13-08-16B	EA	SCREW - 8-18 X 1 PFH - ZINC
	000G13-08-109	EA	SCREW - 8-18 X 5/8 PFH
	000G16-04-24B	EA	SCREW - MACHINE - 1/4-20 X 1 1/2 PPH
	000G18-08-22B	EA	SCREW - MACHINE - 8-32 X 1 3/8 PPH - ZINC
	000G18-08-20B	EA	SCREW - MACHINE - 8-32 X 1 1/4 PPH - ZINC
	000G18-08-24B	EA	SCREW - MACHINE - 8-32X1 1/2PPH - ZINC
	000G13-08-24B	EA	SCREW - #8, 18X1 1/2 PFH - ZINC
	000G19-10-10B	EA	SCREW - MACHINE - 10-32 X 5/8 - PPH - ZINC
	000G19-10-20B	EA	SCREW - MACHINE - 10-32 X 1 1/2 PPH - ZINC
	000G19-10-12F	EA	SCREW - MACHINE - 10-32 X 3/4 PPH - STAINLESS STEEL
	000G19-10-08B	EA	SCREW - MACHINE - 10-32 X 1/2 PPH - ZINC
	000G32-10-06B	EA	SCREW - 10-32 X 3/8 PPH - ZINC
	000G13-10-16I	EA	SCREW - 10-16 X 1.00 PFH - BLACK

**SEALANTS & FASTENERS GROUP (CONTINUED)****SCREWS (CONTINUED)**

<b>KEY</b>	<b>PART NUMBER</b>	<b>U/M</b>	<b>DESCRIPTION</b>
	000G34-05-12B	EA	SCREW - HEX HEAD TAPPING - 5/16 X 3/4 LONG
	000G37-08-12B	EA	SCREW - 8-18 X 3/4 PPH
	000G37-08-089	EA	SCREW - 8 X 18 X 1/2 PPH - FLUOROCARBON SILVER
	000G36-10-12T	EA	SCREW - 10-24 X 3/4 PFH TYPE 23 - BLACK
	000G38-04-16D	EA	SCREW - MACHINE - 1/4-20 X 1 PFN - BLACK
	000G39-06-10T	EA	SCREW - SF/DR - 6-20 X 5/8 PPH - BLACK
	000G39-06-16T	EA	SCREW - SF/DR - 6-20 X 1 PPH - BLACK
	000G39-06-08B	EA	SCREW - SF/DR - 6-18 X 1/2 - ZINC
	000G39-08-16S	EA	SCREW - SF/DR - 8-18 X 1 PPH - OFF WHITE
	000G39-08-32B	EA	SCREW - SF/DR - 8-18 X 2 PPH - ZINC
	000G39-08-24B	EA	SCREW - SF/DR - 8-18 X 1 1/2 PPH - ZINC
	000G39-08-24S	EA	SCREW - SF/DR - 8-18 X 1 1/2 - OFF WHITE
	000G39-08-24T	EA	SCREW - SF/DR - 8-18 X 1.50 PPH - BLACK
	000G39-08-16T	EA	SCREW - SF/DR - 6-20 X 1 PPH - BLACK
	000G39-08-16B	EA	SCREW - SF/DR - 8-18 X 1 PPH - ZINC
	000G39-08-12B	EA	SCREW - SF/DR - 8-18 X 3/4 PPH - ZINC
	000G39-08-12T	EA	SCREW - SF/DR - 8-18 X 3/4 PPH - BLACK
	000G39-08-08T	EA	SCREW - SF/DR - 8-18 X 1/2 PPH - BLACK
	000G39-08-08S	EA	SCREW - SF/DR - 8-18 X 1/2 PPH - OFF WHITE
	000G39-08-08B	EA	SCREW - SF/DR - 8-18 X 1/2 PPH - ZINC
	000G39-08-06B	EA	SCREW - SF/DR - 8-18 X 3/8 PPH - ZINC
	000G39-10-10B	EA	SCREW - SF/DR - 10-16 X 5/8 - ZINC
	000G39-10-12P	EA	SCREW - SF/DR - 10-16 X .75 PPH - DARK BROWN
	000G39-10-088	EA	SCREW - SF/DR - 10-16 X 1/2 PPH - FLEX FLUOROCARBON
	000G39-10-08B	EA	SCREW - SF/DR - 10-16 X 1/2 PPH - ZINC
	000G39-10-40D	EA	SCREW - SF/DR - 10-16 X 2 1/2 PPH - BLACK
	000G39-10-32B	EA	SCREW - SF/DR - 10-16 X 2 - PPH - ZINC
	000G39-10-209	EA	SCREW - SF/DR - 10-16 X 1 1/4 PPH - FLUOROCARBON SILVER
	000G39-10-20T	EA	SCREW - SF/DR - 10-16 X 1.25 PPH
	000G39-10-20B	EA	SCREW - SF/DR - 10-16 X 1 1/4 PPH - ZINC
	000G39-10-12T	EA	SCREW - SELF TAPPING - 10-16 X 3/4"
	000G39-10-12D	EA	SCREW - SF/DR - 10-16 X 3/4 PPH - BLACK
	000G39-10-12B	EA	SCREW - SF/DR - 10-16 X 3/4 PPH - ZINC
	000G39-10-10T	EA	SCREW - SF/DR - 10-16 X .625 - BLACK
	000G39-10-129	EA	SCREW - SF/DR - 10-16 X 3/4 PPH - FLUOROCARBON SILVER
	000G39-10-48B	EA	SCREW - SF/DR - 10-16 X 3 - PPH - ZINC
	000G39-10-48T	EA	SCREW - SF/DR - 10-16 X 3.00 PPH - BLACK
	000G39-10-24B	EA	SCREW - SF/DR - 10-16 X 1.50 PPH - ZINC
	000G39-10-32I	EA	SCREW - SELF TAPPING - 10-16 X 2" PPH - BLACK
	000G39-12-12E	EA	SCREW - SF/DR - 12-14 X 3/4 PPH - CHROME
	000G42-04-16B	EA	SCREW - SF/DR - 1/4-14 X 1 HWH - ZINC
	000G42-04-12B	EA	SCREW - SF/DR - 1/4-14 X 3/4 HWH - ZINC
	000G42-04-24B	EA	SCREW - SF/DR 1/4-14X1 1/2 - ZINC
	000G46-08-24T	EA	SCREW - MACHINE - 8-32 X 1 1/2 PFH - BLACK
	000G46-08-28T	EA	SCREW - MACHINE - 8-32 X 1 3/4 PHILLIPS FLAT HEAD - BLACK
	000G50-04-12B	EA	SCREW - MACHINE - 1/4-20 X 3/4 PPH - ZINC
	000G50-04-06B	EA	SCREW - MACHINE - 1/4-20 X 38 PTH - ZINC
	000G50-04-08B	EA	SCREW - MACHINE - 1/4-20 X 1/2 PTH - ZIN
	000G51-08-08B	EA	SCREW - 8-18 X 1/2 PTH - ZINC
	000G51-06-12B	EA	SCREW - 6-20 X 3/4 PTH - ZINC
	000G52-08-18B	EA	SCREW - MACHINE - 8-32 X 1 1/8 PTH - ZINC
	000G54-04-20B	EA	SCREW - 1/4-20 X 1.25 PTH - TYPE 23 - ZINC PLATED
	000G55-08-125	EA	SCREW - SF/DR - 8-18 X 3/4 PWH - WILLOW
	000G55-08-12S	EA	SCREW - SF/DR - 8-18 X 3/4 PWH - OFF WHITE
	000G55-08-124	EA	SCREW - SF/DR - 8-18 X .75 PWH - ASH GRAY
	000G55-08-165	EA	SCREW - SF/DR - 8-18 X 1.00 PWH - WILLOW
	000G56-12-48B	EA	SCREW - WOOD - 12-11 X 3 POH - SPECIAL HARDENED
	000G57-05-16J	EA	SCREW - 5-20 X 1 PFH - BRASS
	000G57-14-64B	EA	SCREW - 14-10 X 4 PFH - ZINC
	000G57-14-72B	EA	SCREW - 14-10 X 4-1/2 PFH - ZINC
	000G60-08-22B	EA	SCREW - SF/DR - 8-18 X 1.38 POH - ZINC
	000G60-10-28T	EA	SCREW - SF/DR - 10-16 X 1 3/4 - BLACK

**SEALANTS & FASTENERS GROUP (CONTINUED)**  
**SCREWS (CONTINUED)**

<b>KEY</b>	<b>PART NUMBER</b>	<b>U/M</b>	<b>DESCRIPTION</b>
	000G60-10-20I	EA	SCREW - SF/DR - 10-16 X 1.25 POH - BLACK
	000G60-10-20B	EA	SCREW - SF/DR - 10-16 X 1 1/4 POH - ZINC
	000G60-10-209	EA	SCREW - SF/DR - 10-16 X 1.25 POH - SILVER STALGAARD
	000G62-10-24I	EA	SCREW - SF/DR - 10-16 X 1/5 PFH - BLACK - ZINC
	000G67-08-32B	EA	SCREW - 8-15 X 2 PPH - ZINC
	000G67-10-08S	EA	SCREW - 10-12 X 1/2 PPH - OFF WHITE
	000G67-10-08R	EA	SCREW - 10-12 X 1/2 PPH - BEIGE - TYPE A
	000G67-10-08B	EA	SCREW - 10-12 X 1/2 PPH - ZINC
	000G67-10-16B	EA	SCREW - 10-12 X 1 PPH - ZINC
	000G67-10-120	EA	SCREW - 10-12 X 3/4 PPH - TAN
	000G67-10-12B	EA	SCREW - 10-12 X 3/4 PPH - ZINC
	000G67-10-12R	EA	SCREW - 10-12 X .75 PPH - BEIGE
	000G67-10-12P	EA	SCREW - 10-12 X 3/4 PPH - DARK BROWN
	000G67-10-10S	EA	SCREW - 10-12 X 5/8 PPH - OFF WHITE
	000G67-10-10P	EA	SCREW - 10-12 X .62 PPH - DARK BROWN
	000G67-10-10D	EA	SCREW - 10-12 X 5/8 PPH - BLACK - TYPE A
	000G67-10-10T	EA	SCREW - 10-12 X 5/8 PPH - BLACK
	000G67-10-10B	EA	SCREW - 10-12 X 5/8 PPH - ZINC - TYPE A
	000G67-10-20D	EA	SCREW - 10-12 X 1.25 PPH - BLACK
	000G67-10-36T	EA	SCREW - 10-12 X 2 1/4 PPH - BLACK
	000G67-10-32B	EA	SCREW - 10-12 X 2 1/4 PPH - BLACK
	000G67-10-24B	EA	SCREW - 10-12 X 1.50 PPH - ZINC
	000G67-10-24S	EA	SCREW - 10-12 X 1.5 PPH - OFF WHITE
	000G67-10-125	EA	SCREW - 10-12 X .75 PPH - WILLOW
	000G67-10-28B	EA	SCREW - 10-12 X 1.75 PPH - ZINC
	000G67-10-48B	EA	SCREW - 10-12 X 3 PPH - ZINC
	000G68-06-12B	EA	SCREW - 6-18 X .75 POH - ZINC & CLEAR
	000G68-06-12J	EA	SCREW - 6-18 X .75 POH BRASS
	000G68-06-10G	EA	SCREW - 6-18 X 5/8 POH - ANTIQUE BRASS
	000G68-10-20I	EA	SCREW - 10-12 X 1 1/4 POH - BLACK
	000G68-10-36T	EA	SCREW - 10-12 X 2.25 POH BLACK
	049465-01-000	EA	SCREW - 10-16 PTH W/WASHER - DARK BROWN
	049465-13-000	EA	SCREW - 10-16 X 1 PTH W/WASHER - ASH GRAY
	049465-17-000	EA	SCREW - 10-16 X 1 POH W/WASHER - BRIGHT WHITE
	049465-22-000	EA	SCREW - 10-16 X 1 1/2 POH W/WASHER - SABLE
	054434-02-000	EA	SCREW - SF/DR - 10-16 X 2 - ZINC
	054434-03-000	EA	SCREW - SF/DR - 10-16 X 2 - PWH - ZINC - W/O WINGS
	057671-01-000	EA	COVER - SCREW - OFF WHITE - #8
	057671-11-000	EA	COVER - SCREW - HAMPTON TAN - #8
	057671-15-000	EA	COVER - SCREW - BRIGHT WHITE
	057671-16-000	EA	COVER - SCREW - SOFT WHITE
	057671-17-000	EA	COVER - SCREW - VW LT GRAY #8
	075908-01-000	EA	SCREW - MACHINE - 10-32 X .56 PTH - EXTERNAL TOOTH - ZINC
	076790-01-000	EA	SCREW - 6-20 X 1 1/4 PPH - BLACK
	076790-03-000	EA	SCREW - 6-20 X 1 PPH - BLACK
	076790-05-000	EA	SCREW - 6-20 X 1/2 PPH - BLACK - THREADCUTTING - WOOD
	083554-01-000	EA	SCREW - DRXWALL - 8 X 1.25
	083554-04-000	EA	SCREW - DRXWALL - 8 X 2.50
	086256-01-000	EA	SCREW - SF/DR - 8 X 3/4 HWH
	087721-01-000	EA	SCREW - FLAT HEAD - TAPPING - 1/4" X 1 1/4" LONG - ZINC
	097974-01-000	EA	SCREW - PARTICLE BOARD - 7-9 X 3/4 PPH
	090033-02-000	EA	SCREW - 1/4-20 X 5/8 - ROUND WASHER HEAD - OFF/WHITE
	101618-01-000	EA	SCREW - 1/4-20 X 3/4 HEX - TAPPING - STALGARD TYPE F
	101289-01-01A	EA	SCREW - MACHINE - 8-32 X 3.75 POH - BRASS -F/EXTENDED KNOB
	105126-01-000	EA	SCREW - MACHINE - 8-32 X 1 PPH TAPTIT
	110460-05-02A	EA	SCREW - MACHINE - 10-24 X 2.5 PFH - WHITE
	112782-08-01A	EA	SCREW - MOUNTING/PLATE - ZINC
	113563-01-01A	EA	SCREW - 8 X .62 LONG SHOULDER/WASHER HEAD
	117478-01-04A	EA	SCREW - 8-18 X .75 PPH W/WASHER - VW LIGHT GRAY
	126458-01-01A	EA	SCREW - 8-18 X .50 PRWH - BLACK
	134126-01-01A	EA	SCREW/NAIL - HEX HEAD - 3/4"



## SEALANTS & FASTENERS GROUP (CONTINUED)

### CLAMPS, CLIPS, GROMMETS, RIVETS & PLUGS

KEY	PART NUMBER	U/M	DESCRIPTION
	010495-01-000	EA	CLAMP - CABLE - 9/16"
	010495-02-000	EA	CLAMP - CABLE - 3/8"
	010495-04-000	EA	CLAMP - CABLE - 11/16" - WHITE
	010495-05-000	EA	CLAMP - CABLE - 1/2"
	010497-01-000	EA	CLAMP - CLOSED - 5/8" ID
	010497-03-000	EA	CLAMP - CLOSED - 1" ID - CUSHIONED
	010497-04-000	EA	CLAMP - CLOSED - 1.62" ID
	010497-05-000	EA	CLAMP - CLOSED - 1/2" ID
	010497-06-000	EA	CLAMP - CLOSED - 11/16" ID
	010497-07-000	EA	CLAMP - CLOSED - 3/8" ID
	010497-08-000	EA	CLAMP - CLOSED - .125" ID
	062401-01-000	EA	CLAMP - HOSE - WORMGEAR - .25" - 1"
	062401-02-000	EA	CLAMP - HOSE - WORMGEAR - 1.56" - 2.5"
	062401-03-000	EA	CLAMP - HOSE - WORMGEAR - .22" - 1"
	062401-04-000	EA	CLAMP - HOSE - WORMGEAR - .69" - 1.25"
	062401-05-000	EA	CLAMP - HOSE - WORMGEAR - 2" TO 3" ID
	062401-06-000	EA	CLAMP - HOSE - WORMGEAR - .22" - .62" ID
	062401-07-000	EA	CLAMP - HOSE - WORMGEAR - 5" - 7"
	062401-08-000	EA	CLAMP - HOSE - WORMGEAR - 4.06" - 5.0"
	062401-09-000	EA	CLAMP - HOSE - WORMGEAR - 2.8" - 3.75"
	062401-11-000	EA	CLAMP - HOSE - WORMGEAR - 3.50" - 4.50"
	062401-12-000	EA	CLAMP - HOSE - WORMGEAR - .79" X 1.26"
	083610-01-000	EA	CLAMP - WIRE - DUAL - UNEQUAL DIAMETERS - 3/4" & 1 1/4"
	083610-02-000	EA	CLAMP - WIRE - DUAL - UNEQUAL DIAMETERS - 3/4" & 2"
	083610-03-000	EA	CLAMP - DUAL WIRE
	083609-01-000	EA	CLAMP - WIRE - DUAL - EQUAL DIAMETERS - 5/8"
	007161-01-000	EA	CLAMP - HOSE - SPRING TYPE - 1/2"
	010499-01-000	EA	CLAMP - CLOSED - 3/8" ID
	075148-02-000	EA	CLAMP - GROUNDING - BRONZE SCREWS
	008386-01-000	EA	GROMMET - SNAP - 3/8"
	023942-01-000	EA	GROMMET - RUBBER - 2" OD
	071015-07-000	EA	GROMMET - RUBBER - 1" ID X 2.25" OD W/.06" GROOVE - BLACK
	071015-11-000	EA	GROMMET - 1.00" ID - FITS .12" MATERIAL
	071015-13-000	EA	GROMMET - RUBBER - .62" ID X 1" OD W/.09" GROOVE - BLACK
	071015-19-000	EA	GROMMET - .38" ID - FITS .06" MATERIAL
	071015-21-000	EA	GROMMET - RUBBER - 1/2" ID X 1.06" OD - W/.19" GROOVE - BLACK
	071015-22-000	EA	GROMMET - RUBBER - .62" ID X 1.12" OD W/.19" GROOVE - BLACK
	071015-26-000	EA	GROMMET - RUBBER - 1.5" ID X 2.1" OD W/.06" GROOVE-BLACK
	071015-29-000	EA	GROMMET - RUBBER - .3" ID X 1.3" OD W/.12" GROOVE - BLACK
	071015-30-000	EA	GROMMET - RUBBER - .31" ID X .81" OD W/.12" GROOVE - BLACK
	071015-32-000	EA	GROMMET - RUBBER - .75" ID X 1.375" OD W/.187" GROOVE - BLACK
	071015-33-000	EA	GROMMET - RUBBER - .875" ID X 1.625" OD W/.187" GROOVE - BLACK
	071015-35-000	EA	GROMMET - 1.25" ID - FITS .187" MATERIAL
	071015-37-000	EA	GROMMET - .81" ID FITS .56" MATERIAL
	071015-39-000	EA	GROMMET - .75" ID FITS .06" MATERIAL
	088756-01-000	EA	GROMMET - WEB - 1 1/8" I.D.
	114208-01-000	EA	GROMMET - EDGE LINER - FITS 1 3/4"
	114208-02-000	EA	GROMMET - EDGE LINER - FITS .625"
	114208-03-000	EA	GROMMET - EDGE LINER - FITS 2.50"
	114208-04-000	EA	GROMMET - EDGE LINER - FITS 1.00"
	114208-05-000	EA	GROMMET - EDGE LINER - FITS 2"
	016188-03-000	EA	GROMMET - L/P LINE - 3/8" HOLE X 2 1/2" LONG - RUBBER
	016188-04-000	EA	GROMMET - GAS LINE - 1/2" HOLE X 2 1/2" LONG - RUBBER
	016188-05-000	EA	GROMMET - L/P LINE - 3/8" HOLE X 1 1/4" LONG - RUBBER
	008380-01-000	EA	GROMMET - RUBBER - 5/8" HOLE X 1 1/2" DIAMETER - BLACK
	008384-01-000	EA	GROMMET - SNAP - 3/4" DIAMETER - NYLON
	077953-01-000	EA	GROMMET - EDGE LINER - FITS 1"
	099637-01-000	EA	GROMMET - RUBBER - .37" X .94" DIAMETER - BLACK
	046867-05-000	EA	GROMMET - #0
	000F10-04-16B	EA	PIN - COTTER - 1/8" X 1" - ZINC
	000F10-06-32B	EA	PIN - COTTER - 3/16" X 2" - ZINC
	000H14-04-08R	EA	RIVET - MANDREL BLIND - 4/32 - ALUMINUM

## SEALANTS & FASTENERS GROUP (CONTINUED)

### CLAMPS, CLIPS, GROMMETS, RIVETS & PLUGS (CONTINUED)

KEY	PART NUMBER	U/M	DESCRIPTION
	000H14-06-03R	EA	RIVET - MANDREL BLIND - 3/16 - CHERRY
	000H15-06-02R	EA	RIVET - POP - STEEL - 3/16 X .063 -.125
	000H16-06-10R	EA	RIVET - POP - ALUMINUM - 3/16 X .501 -.625
	000H14-04-04A	EA	RIVET - MANDREL BLIND - 1/8 X .400
	000H16-04-06R	EA	RIVET - POP - ALUMINUM - 1/8 X .313 -.375
	000H14-06-14R	EA	RIVET - MANDREL BLIND - 3/16 - CHERRY
	118626-01-01A	EA	RIVET - POP - ALUMINUM 3/16 X .08-.375
	118626-02-01A	EA	RIVET - POP - ALUMINUM - 3/16 X .500-.750
	069529-02-000	EA	RIVET-T - POP - 1/4 X .093 -.156
	120560-01-01A	EA	RIVET - PLASTIC - 3/16 DIAMETER
	061420-01-000	EA	PLUG/PLASTIC - 1.75" DIAMETER - BROWN
	061420-03-000	EA	PLUG/PLASTIC - 3.00" DIAMETER
	061420-04-000	EA	PLUG/PLASTIC - 1.25" DIAMETER
	061420-05-000	EA	PLUG/PLASTIC - 1.8" DIAMETER
	061420-07-000	EA	PLUG/PLASTIC - 1.8" DIAMETER
	061420-08-000	EA	PLUG/PLASTIC - 2.5" DIAMETER
	061420-09-000	EA	PLUG/PLASTIC - 1.00" DIAMETER
	061420-10-000	EA	PLUG/PLASTIC - 1.50" DIAMETER - BLACK
	061420-11-000	EA	PLUG/PLASTIC - .50" DIAMETER
	061420-12-000	EA	PLUG/PLASTIC - 1.50" DIAMETER - RED
	061420-14-000	EA	PLUG/PLASTIC - .034" DIAMETER
	061420-15-000	EA	PLUG/PLASTIC - 2" DIAMETER - BLACK
	061420-16-000	EA	PLUG/PLASTIC - 2 1/8" DIAMETER
	081211-03-000	EA	PLUG/PLASTIC - .50" DIAMETER - BLACK
	081211-04-000	EA	PLUG/PLASTIC - .46" DIAMETER - BLACK
	081211-05-000	EA	PLUG/PLASTIC - .188" DIAMETER - NATURAL
	034141-02-000	EA	PLUG/HOLE - 3/8" NYLON/BLACK
	115361-01-01A	EA	PLUG/PLASTIC - 1/2" DIAMETER
	075312-02-000	EA	CLIP-U - .75 LONG X .50 WIDE- F/1/8"-3/16" THICK MATERIAL
	077955-01-000	EA	CLIP-J - VINYL COATED - 3/8"
	080211-03-000	EA	CLIP - X-MAS TREE W/PANEL RETAINING HEAD - 3/4" SHANK
	094362-02-000	EA	CLIP - X-MAS TREE - BINDER HEAD - .9" LONG
	119392-01-000	EA	CLIP - U TYPE - OFFSET LEG
	129962-01-01A	EA	CLIP - U-TYPE - BLACK
	091952-01-000	EA	CLIP - GRIPPER - 1"
	091952-02-000	EA	CLIP - GRIPPER - 3/4"
	080734-02-000	EA	CLIP - WIRE NYLON
	056134-01-000	EA	HOLDER - RING - 3.6" DIAMETER - METAL
	056134-02-000	EA	HOLDER - RING - 1.8" DIAMETER - METAL

### MISCELLANEOUS FASTENERS

KEY	PART NUMBER	U/M	DESCRIPTION
	008343-01-000	EA	TIE - WIRE - 6"
	008343-02-000	EA	TIE - WIRE - 14"
	008343-03-000	EA	TIE - WIRE - 7 1/2" - BLACK
	029096-03-000	YD	VELCRO TAPE - HOOK - 1" WIDE - BLACK
	029096-04-000	YD	TAPE - HOOK - VELCRO - 1" WIDE - BLACK
	029094-04-000	YD	VELCRO TAPE - LOOP - 1" WIDE - BLACK
	029094-06-000	YD	VELCRO TAPE - LOOP - 2" WIDE - BLACK
	048394-02-000	YD	VELCRO TAPE - HOOK - ADHESIVE BACK - .75" WIDE - BEIGE
	085774-01-000	FT	FASTENER - DUAL LOCK - 1" WIDE - ADHESIVE BACK - BLACK
	085774-02-000	FT	FASTENER - DUAL HOOK - 1" WIDE - ADHESIVE BACK - BLACK
	085774-03-000	FT	FASTENER - DUAL HOOK - 1/2" WIDE - ADHESIVE BACK - BLACK
	085774-04-000	FT	FASTENER - DUAL HOOK - 1/2" WIDE - ADHESIVE BACK - BLACK
	088792-02-000	YD	VELCRO TAPE - LOOP - 3/4" - ADHESIVE BACKED - BEIGE
	088792-04-000	YD	VELCRO TAPE - LOOP - 5/8" - NON-ADHESIVE BACK - WHITE
	088792-05-000	YD	VELCRO TAPE - LOOP - 5/8" - NON-ADHESIVE BACKED - WHITE
	088792-06-000	YD	VELCRO TAPE - LOOP - 3/4" - NON-ADHESIVE BACKED - BUFF
	108046-01-000	EA	CABLE TIE - SCREW MOUNT 8"
	108046-02-000	EA	CABLE TIE - SCREW MOUNT 15"
	110943-01-000	FT	FELTSTRIP - 3/8" - ADHESIVE BACK
	110943-02-000	FT	FELTSTRIP - 3/8" - ADHESIVE BACK - WHITE
	099856-11-000	EA	STRAP - TIEDOWN - 78.6"
	086285-01-000	EA	SPACER - NYLON - .5" OD X .257" ID

# WATER & SEWAGE GROUP DRAINAGE SYSTEM

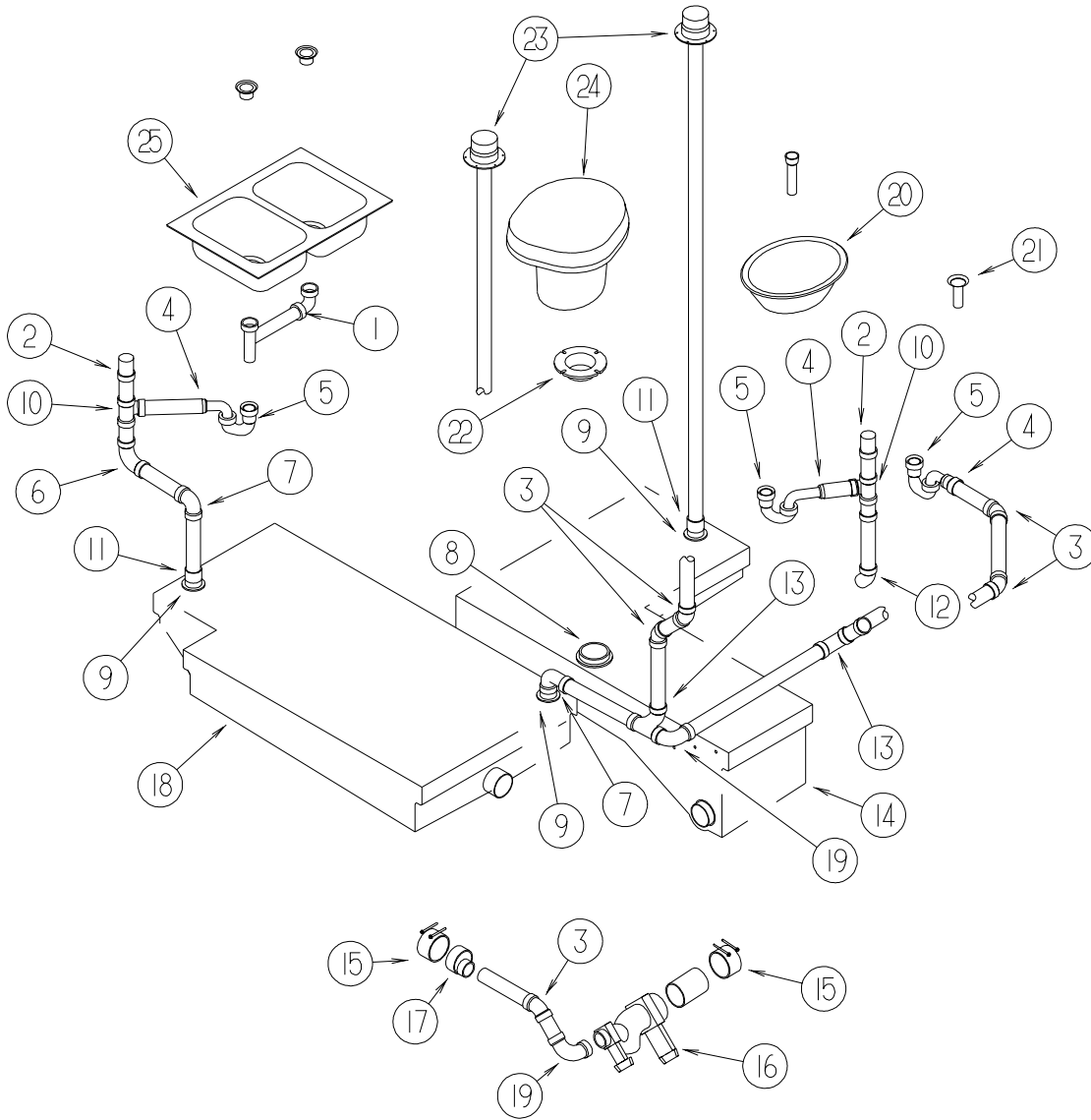

**WATER & SEWAGE GROUP (CONTINUED)**  
**DRAINAGE SYSTEM (CONTINUED)**

KEY	PART NUMBER	U/M	DESCRIPTION
1	011091-02-000	EA	WASTE - CONTINUOUS - DOUBLE SINK
2	079968-01-000	EA	VENT - MECHANICAL/TRAP ARM - ANTI-SIPHON-2" X 7.3" PLASTIC
3	010006-01-000	EA	ELBOW - 45 DEGREE - 1 1/2" HUB X HUB - PLASTIC
4	109571-01-000	EA	ADAPTER - P TRAP - 1 1/2"P X 1 1/4"MPT
5	107538-01-000	EA	P TRAP - PLASTIC - 1 1/4" W/EXTENSION ARM
5	011071-01-000	EA	P-TRAP - PLASTIC - 1 1/2" - CSA
6	010008-01-000	EA	ELBOW - 90 DEGREE - 1 1/2" HUB X HUB - PLASTIC
7	034250-01-000	EA	ELBOW - 90 DEGREE - LONG TURN - 1 1/2" HUB X HUB - ABS
8	061607-02-000	EA	GROMMET - HOLDING TANK - 3" NPS
9	061607-01-000	EA	GROMMET - HOLDING TANK - 1 1/2" NPS
10	010071-01-000	EA	TEE - SANITARY - 1 1/2" HUB X HUB X HUB - PLASTIC
11	010115-01-000	EA	COUPLING - 1 1/2" HUB X HUB - PLASTIC
12	010051-01-000	EA	ELBOW - 45 DEGREE - 1 1/2" SPIGOT & HUB - PLASTIC
13	031365-01-000	EA	TEE - PLASTIC - 3" X 3" X 1 1/2" EXTRA LONG TURN
14	128597-01-700	EA	TANK - HOLDING - 36 GALLON W/3" OUTLET NIPPLE
	010129-03-000	EA	NIPPLE - PLASTIC - 3" X 3" TOE
15	078406-01-000	EA	COUPLER - RUBBER - W/CLAMPS - 3" X 3"
16*	070916-01-000	EA	VALVE - DUAL DUMP - W/CAP - 3" X 1 1/2"
	010201-01-000	EA	HOSE - SEWER - 3" ID X 8'
*	062415-01-000	EA	CAP - SEWER - 3" DIAMETER
	062416-01-000	EA	ADAPTER - SEWER HOSE TO 3" PIPE
17	062422-01-000	EA	ADAPTER - OFFSET REDUCER - 3" X 1 1/2" - PLASTIC
18	128535-01-000	EA	TANK - HOLDING - 30 GALLON
19	033761-01-000	EA	ELBOW - TURN - 90 DEGREE 1 1/2" HUB X 1 1/2" SPIGOT
20	089366-03-000	EA	SINK - OVAL - SOFT WHITE PLASTIC
21	011069-02-000	EA	TAILPIECE - TUB/SHOWER - 1 1/2" X 1 1/4" X 4" - BRASS
	066729-01-000	EA	STRAINER - TUB/SHOWER W/PLUG - CHROME
	130403-01-000	EA	NUT - SLIP - W/WINGS 1 1/2"
22	116644-01-000	EA	FLANGE/CLOSET - 4 BOLT X 3" FEMALE
23	083558-03-000	EA	VENT - PLUMBING - ROOF PIPE COVERED - OFF WHITE
24	131932-01-02A	EA	TOILET - AQUA MAGIC 4 - HIGH - HAND FLUSH - SOFT WHITE
	131786-02-01A	EA	SPACER - TOILET - SOFT WHITE
25	104113-01-000	EA	SINK - DOUBLE - STAINLESS STEEL
	106116-01-01A	EA	STRAINER/PLASTIC - STOPPER/TAILPIECE/GASKET & NUT-LAVATORY
			FROM: 00-00-00 THRU: 08-01-99
	092303-01-000	EA	STRAINER - SINK
			FROM: 08-02-99 THRU: 99-99-99
	133972-01-000	EA	PAD - HEATER - HOLDING TANK - 40 GALLON
	133972-03-000	EA	PAD-HEATER ELBOW 1.50D - ULTRA-HEAT EH-158

**\*COMPONENT PARTS FOUND IN SERVICE PARTS LIBRARY**

**WATER & SEWAGE GROUP (CONTINUED)**  
**WATER SYSTEM**

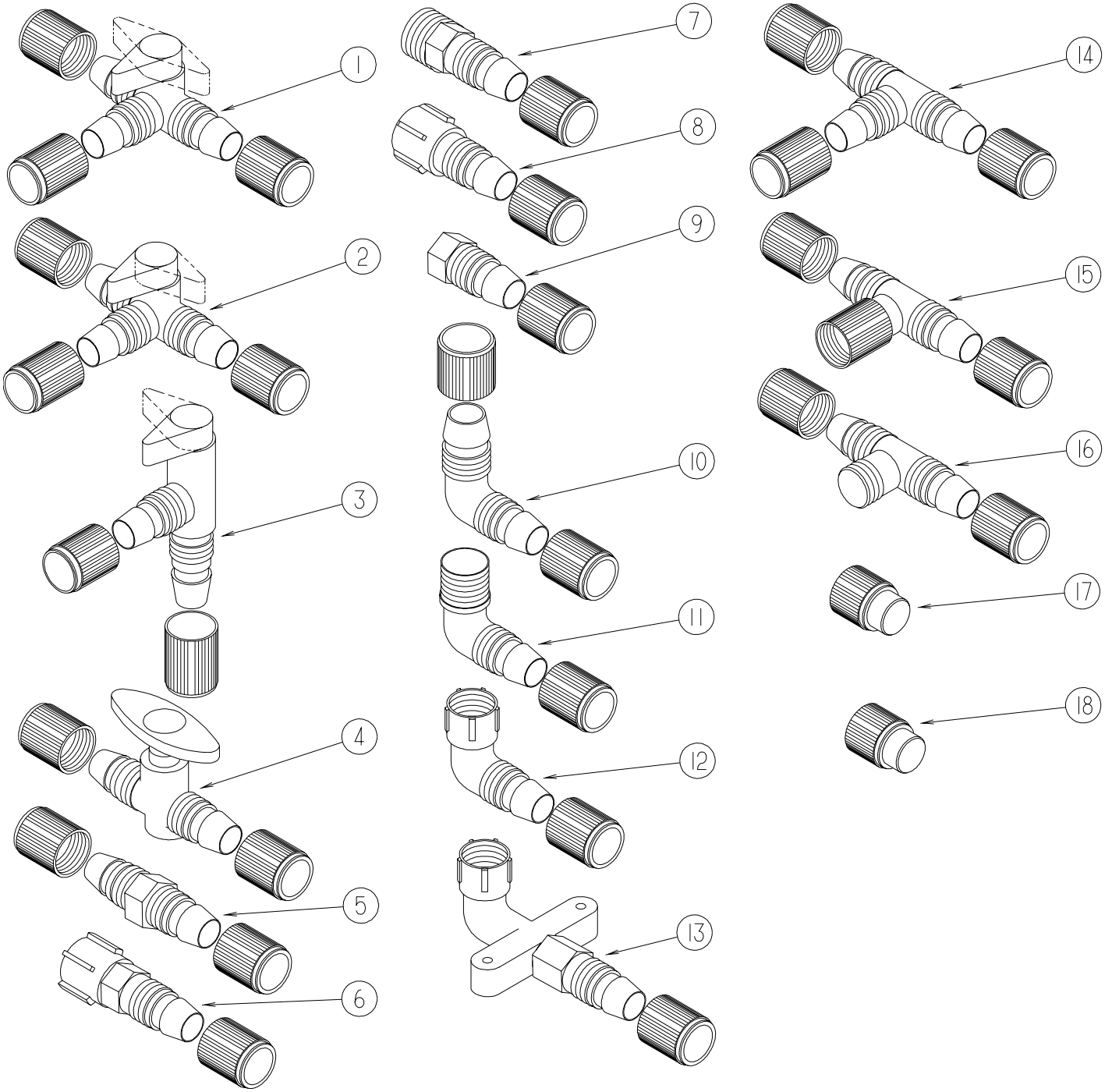

**FITTINGS**

**WATER & SEWAGE GROUP (CONTINUED)**  
**WATER SYSTEM (CONTINUED)**

**FITTINGS (CONTINUED)**

<b>KEY</b>	<b>PART NUMBER</b>	<b>U/M</b>	<b>DESCRIPTION</b>
1	114431-01-000	EA	VALVE - 180 DEGREE/CENTER DRAIN - 1/2"P - THREE WAY
2	114431-02-000	EA	VALVE - WATER BXPASS - 1/2"P - THREE WAY (WATER HEATER)
3	114431-03-000	EA	VALVE - 90 DEGREE DRAIN - 1/2"P
4	114431-04-000	EA	VALVE - "INLINE SHUT-OFF" - 1/2"P
5	114430-01-000	EA	ADAPTER - 1/2"P X 1/2"P
6	114430-02-000	EA	ADAPTER - SWIVEL - 1/2"P X 1/2"FPT
7	114430-03-000	EA	ADAPTER - 1/2"P X 1/2"MPT
8	114427-02-000	EA	PLUG - W/COMP NUT - 1/2" PLASTIC PIPE/1/2" FLAIR-IT
9	114430-06-000	EA	ADAPTER - 1/2"P X 3/8"FPT
10	114429-01-000	EA	ELBOW - 1/2"P X 1/2"P
11	114429-02-000	EA	ELBOW - 1/2"P X 1/2"MPT
11	114429-04-000	EA	ELBOW - 1/2"P X 3/8"MPT
11	114429-05-000	EA	ELBOW - 1/2"P X 3/4"MPT
12	114429-03-000	EA	ELBOW - SWIVEL - 1/2"P X 1/2"FPT
12	114429-06-000	EA	ELBOW - SWIVEL - 1/2"P X 3/4"FPT
12	114429-08-000	EA	ELBOW - SWIVEL - 1/2"MPT X 1/2"FPT SWIVEL
13	114429-07-000	EA	ELBOW - 1/2"P X 1/2"FPT
14	114428-01-000	EA	TEE - 1/2"P X 1/2"P X 1/2"P
15	114428-02-000	EA	TEE - SWIVEL - 1/2"P X 1/2"P X 1/2"FPT
16	114428-03-000	EA	TEE - 1/2"P X 1/2"P X 1/2"MPT
17	113697-01-000	EA	CAP - 3/8 FTG
18	114427-01-000	EA	CAP - 1/2" - FOR CAPPING FLAIR-IT MALE FITTINGS

**WATER & SEWAGE GROUP (CONTINUED)**  
**WATER SYSTEM (CONTINUED)**

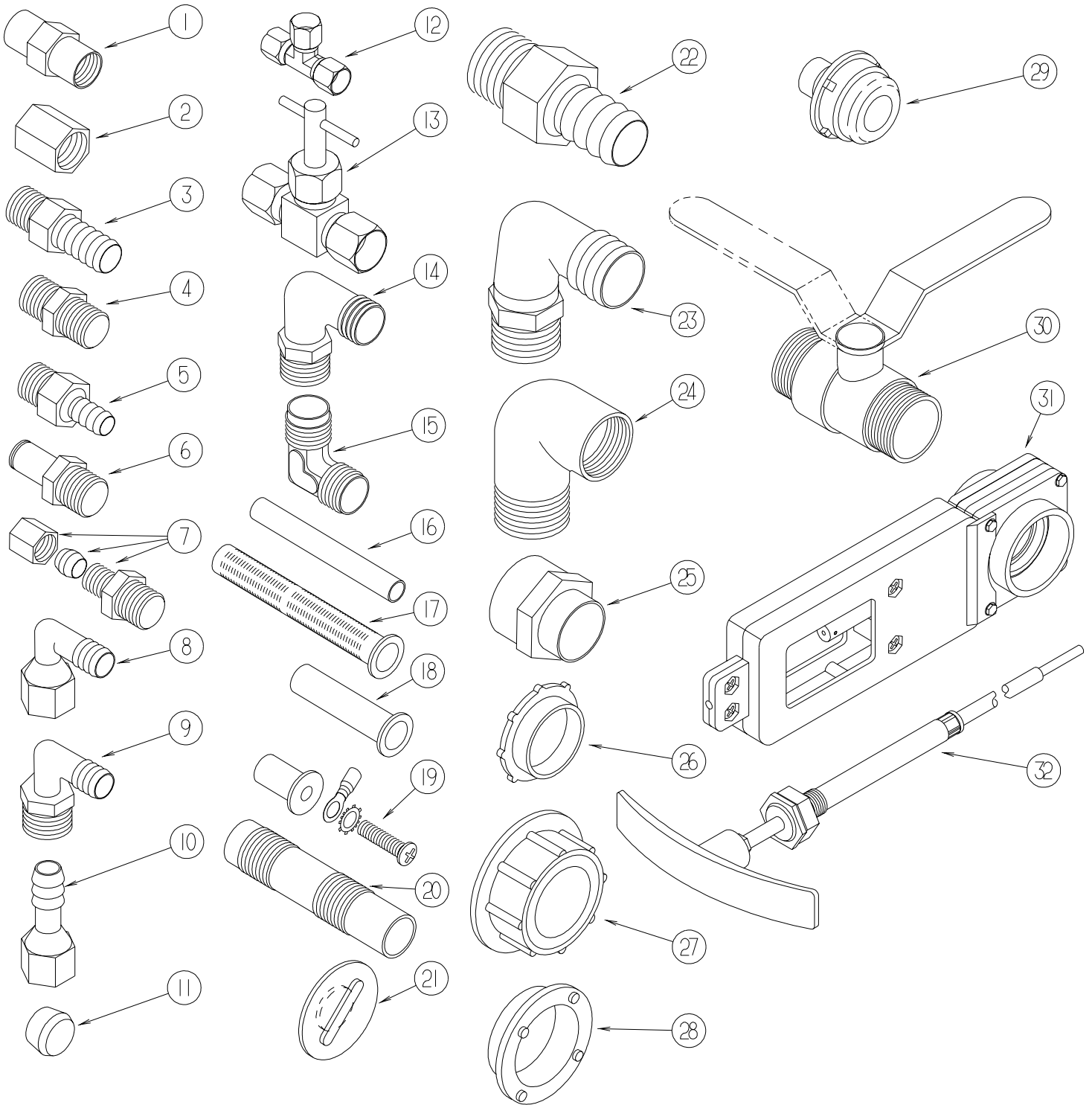

**FITTINGS (CONTINUED)**

# WATER & SEWAGE GROUP (CONTINUED)

## WATER SYSTEM (CONTINUED)

### FITTINGS (CONTINUED)

KEY	PART NUMBER	U/M	DESCRIPTION
1	132148-01-000	EA	CONNECTOR - 1/2" X 1/2" MPT - BRASS
2	101814-01-000	EA	COUPLING - FEMALE - 1/2" X 1/2" FPT - GRAY
3	118809-02-000	EA	ADAPTER - 1/2" MPT X 1/2" BARB - PLASTIC
4	110438-02-000	EA	VALVE - CHECK - BRASS - 1/2 MPT X 1/2 MPT
5	010224-01-000	EA	ADAPTER - HOSE TO PIPE - 3/8 MPT X 3/8 BARB - PLASTIC
6	090338-03-000	EA	FITTING - HOSE - .75"ID - 2" LENGTH - BRASS
7	103798-01-000	EA	CONNECTOR - 1/4 OD X 3/8 MPT
8	123150-01-000	EA	ELBOW - 1/2 FPT X 1/2 BARB - SWIVEL
9	035539-01-000	EA	ELBOW - PLASTIC - 3/8 MPT X 3/8 BARB
10	123152-01-000	EA	ADAPTER - 1/2 FPT X 1/2 BARB - SWIVEL
11	111888-01-000	EA	FERRULE - PLASTIC - .250 ID X .375 OD
12	118423-01-000	EA	FITTING - BRASS-TEE - 1/4C X 1/4C X 1/4C
13	120868-01-000	EA	VALVE - NEEDLE - 1/4" COMPRESSION X 1/4" COMPRESSION
14	111223-02-000	EA	ELBOW - PLASTIC - 1/2MPT X 3/8 BARB
14	111223-03-000	EA	ELBOW - 3/4" MPT X 1/2" BARB - PLASTIC
14	111223-04-000	EA	ELBOW - 1/2" MPT X 1/2" BARB - PLASTIC
15	039808-03-000	EA	ELBOW - 1/2" MPT X 1/2" MPT - PLASTIC
16	124188-01-000	FT	TUBING - PEX - 1/2" ID X 20' - BLUE(COLD)
16	124188-02-000	FT	TUBING - PEX - 1/2" ID X 20' - RED(HOT)
16	112176-01-000	FT	TUBING - VINYL - REINFORCED - 1/2" ID
16	074462-02-000	FT	TUBING - VINYL - 3/8 ID X 20' - CLEAR
16	039800-04-000	FT	TUBING - POLYBUTYL - 1/4"OD
17	077954-02-000	EA	FILTER - WATER TANK - W/SCREEN IN TANK
18	111888-02-000	EA	INSERT - BRASS - 1/4 COMP
19	039861-01-000	EA	SENDING UNIT - W/SCREW - WASHER - WELL NUT/TERMINAL RING
20	079381-01-000	FT	TUBING - RIBBED FLEXIBLE - WATER FILL - 1.4" I.D.
21	049032-01-000	EA	PATCH - SPINWELD - 3/8" - PLASTIC
22	044927-01-000	EA	ADAPTER - HOSE TO PIPE-1 1/4 MPTX1 1/4 BARB-BLACK PLASTIC
23	010219-01-000	EA	ELBOW - 1 1/4 MPT X 1 1/4 BARB - WATER FILL - PLASTIC
24	132484-01-000	EA	ELBOW - PLASTIC - 90 DEGREE - 1MPT X 1FPT
25	133835-01-000	EA	ADAPTER - REDUCING - 1 1/2" X 1 1/4"
26	120069-01-000	EA	PLUG - 3" - POLYETHYLENE MPT
27	042989-03-000	EA	FITTING - SPINWELD - 1 1/4"NPT - PLASTIC
27	042989-04-000	EA	FITTING - SPINWELD - 3/8"FPT - PLASTIC
27	042989-05-000	EA	FITTING - SPINWELD - 1/2"FPT - PLASTIC
27	042989-07-000	EA	FITTING - SPINWELD - 1 1/2"FPT - PLASTIC
27	042989-08-000	EA	FITTING - SPINWELD - 1"FPT - PLASTIC
28	120070-01-000	EA	FITTING - SPINWELD - PLASTIC 3" FPT
29	114966-01-000	EA	FILTER - IN LINE - TWIST ON - 1/2"
30	132483-01-000	EA	VALVE - BALL - 1" - THREADED ENDS
31	062421-03-000	EA	VALVE - DUMP - 1 1/2" HUB X 1 1/2" HUB - REMOTE
32	062421-04-000	EA	CABLE - DUMP VALVE W/HANDLE - 36"
32	062421-05-000	EA	CABLE - DUMP VALVE W/HANDLE - 48"
32	062421-06-000	EA	CABLE - DUMP VALVE W/HANDLE - 144"



**WATER & SEWAGE GROUP (CONTINUED)**  
**WATER SYSTEM (CONTINUED)**

<b>KEY</b>	<b>PART NUMBER</b>	<b>U/M</b>	<b>DESCRIPTION</b>
	077908-10-000	EA	TANK - WATER - W/SPINWELD FITTINGS - 33 GALLON - DOUBLE BED
	077908-01-000	EA	TANK - WATER - W/O FTGS - 33 GAL - 36" X 22.6" X 10.5" - DOUBLE BED
	117217-14-000	EA	TANK - WATER - W/SPINWELD FITTINGS - 30 GALLON - TWIN BED
	117217-01-000	EA	TANK - FRESH WATER - 30 GALLON - W/O FITTINGS - TWIN BED
	081240-20-000	EA	WATER FILL W/DOOR - W/O LOCK - BRIGHT WHITE
	131383-01-02A	EA	SHOWER HEAD - W/60" HOSE & BRACKET - WHITE
	131383-02-02A	EA	SHOWER HEAD - W/60" HOSE & BRACKET - WHITE - CSA
*	051391-03-000	EA	WATER HEATER G6A-8E ELECTRONIC IGNITION
	097967-01-000	EA	SWITCH - WATER HEATER - REMOTE W/LIGHT
	052009-06-000	EA	DOOR - WATER HEATER - BRIGHT WHITE - 18" X 14.6"
*	098607-01-000	EA	PUMP - WATER - W/.5" MPT FITTING - FLOW 2.8 GPM
	075241-06-000	EA	FAUCET/SHOWER - BRIGHT WHITE - 1/2"MPT X 1.9" INLET PIPES
	075606-03-000	EA	PANEL - FAUCET SHOWER - SOFT WHITE
	075242-03-000	EA	FAUCET - TUB/SHOWER - BRASS
	075240-05-000	EA	FAUCET - LAVATORY - BRASS
	104114-02-01A	EA	FAUCET - GALLEY - SINGLE CONTROL

**\*COMPONENT PARTS FOUND IN SERVICE PARTS LIBRARY**

**SERVICE CENTER**

<b>KEY</b>	<b>PART NUMBER</b>	<b>U/M</b>	<b>DESCRIPTION</b>
	131383-01-02A	EA	SHOWER HEAD - W/60" HOSE & BRACKET - WHITE
	131383-02-02A	EA	SHOWER HEAD - W/60" HOSE & BRACKET - WHITE - CSA
	075241-06-000	EA	FAUCET/SHOWER - BRIGHT WHITE - 1/2"MPT X 1.9" INLET PIPES
	131383-03-02A	EA	BRACKET - SHOWER HEAD - WHITE
	114293-01-02A	EA	PAN - DRIP - EXTERIOR - BRIGHT WHITE

**WATER & SEWAGE GROUP (CONTINUED)**  
**WATER SYSTEM (CONTINUED)**

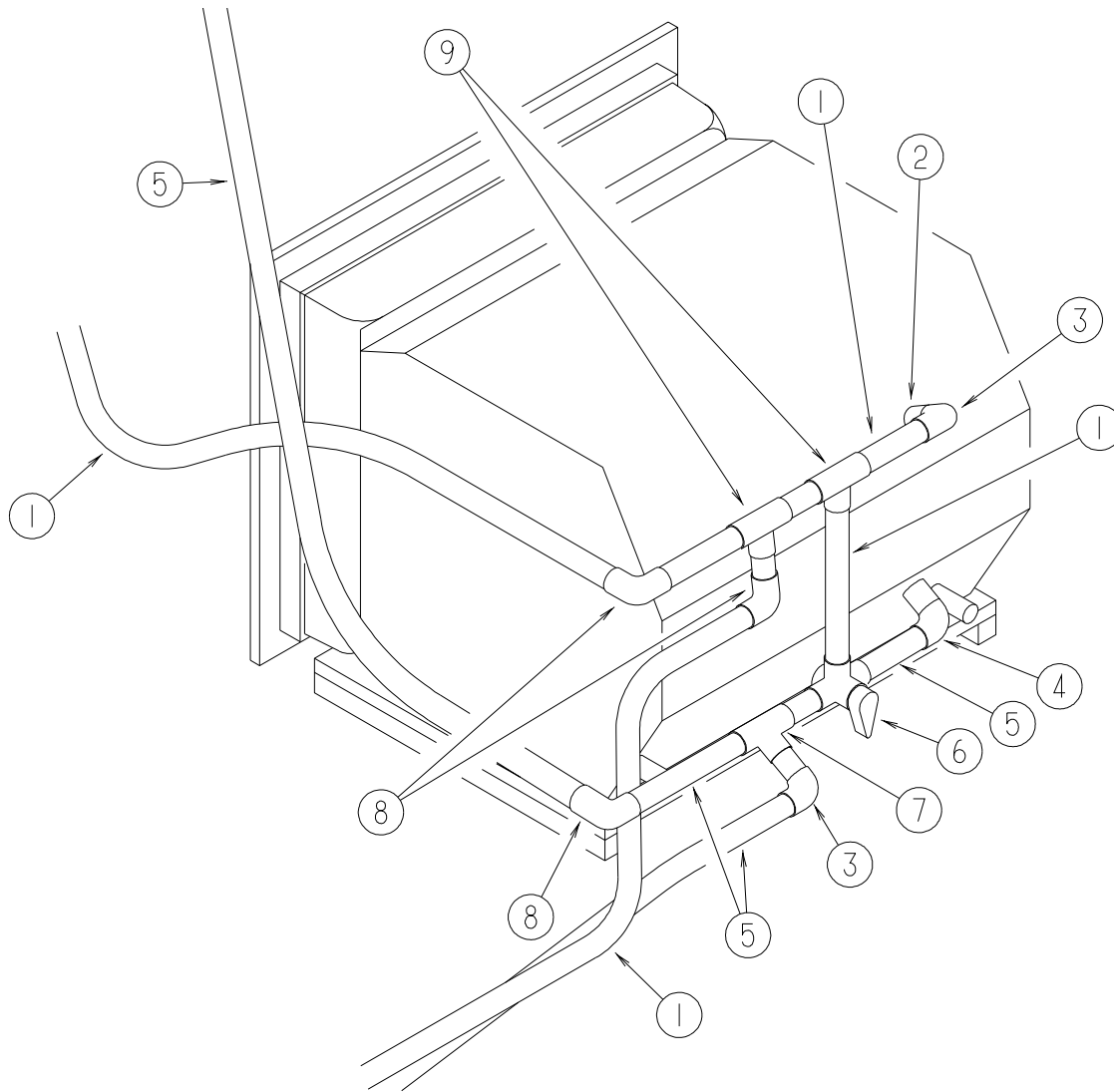

**WATER HEATER BX-PASS SYSTEM**

KEY	PART NUMBER	U/M	DESCRIPTION
1	124188-02-000	FT	TUBING - PEX - 1/2" ID X 20' - RED(HOT)
2	110438-02-000	EA	VALVE - CHECK - BRASS - 1/2 MPT X 1/2 MPT
3	114429-08-000	EA	ELBOW - SWIVEL - 1/2"MPT X 1/2"FPT SWIVEL
4	114429-02-000	EA	ELBOW - 1/2"P X 1/2"MPT
5	124188-01-000	FT	TUBING - PEX - 1/2" ID X 20' - BLUE(COLD)
6	114431-02-000	EA	VALVE - WATER BXPASS - 1/2"P - THREE WAY (WATER HEATER)
7	114428-02-000	EA	TEE - SWIVEL - 1/2"P X 1/2"P X 1/2"FPT
8	114429-01-000	EA	ELBOW - 1/2"P X 1/2"P
9	114428-01-000	EA	TEE - 1/2"P X 1/2"P X 1/2"P

**WINDOW & VENTS GROUP**  
**WINDOW & VENT LAYOUT**

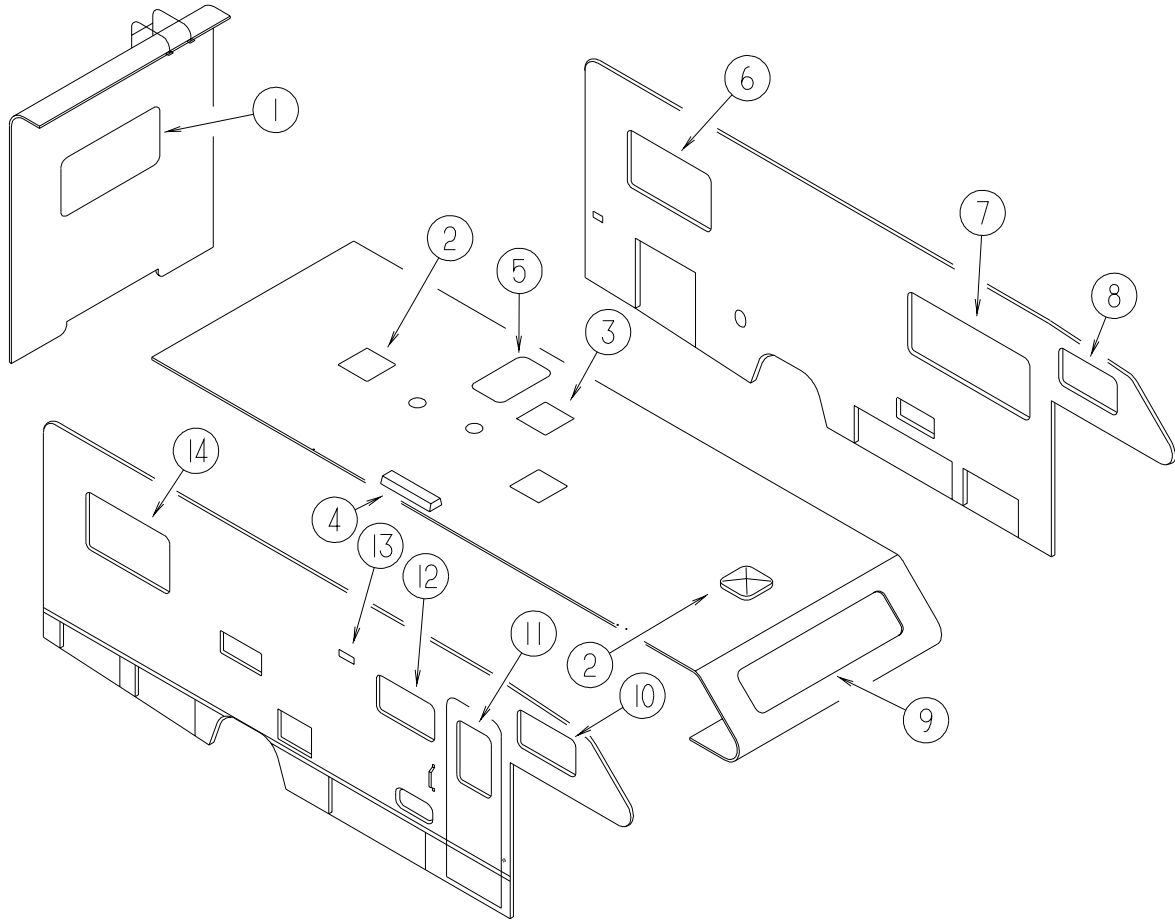

## WINDOW & VENTS GROUP (CONTINUED)

### WINDOW & VENT LAYOUT (CONTINUED)

KEY	PART NUMBER	U/M	DESCRIPTION
1	078528-07-F15	EA	WINDOW - ESCAPE W/O INSIDE TRIM - CLEAR - 24.5" X 48.5"
	074816-16-000	EA	FRAME - WINDOW - INSIDE ESCAPE - BLACK
	002282-09-000	EA	WEATHERSTRIP - WINDOW - .125" X 130.5" - BLACK
	002285-01-000	FT	FILLER - WEATHERSTRIP - RUBBER - BLACK
	076337-13-000	EA	GLASS - EGRESS - 45.5" X 21.5"
1	113502-01-02A	EA	WINDOW - REAR/CENTER ESCAPE - THERMO - 24.8" X 48.7"
2*	122882-01-01A	EA	VENT - ROOF - NON-POWERED - W/O INSIDE GARNISH
	009440-01-000	EA	GEAR/ARM - LIFT - ROOF VENT COVER
	122882-06-01A	EA	GARNISH - ROOF VENT - 1" TO 2.5"
	122882-07-01A	EA	GARNISH - ROOF VENT - 2.5" TO 4"
3*	122882-02-01A	EA	VENT - ROOF - W/FAN - W/O INSIDE GARNISH - UL
	009440-01-000	EA	GEAR/ARM - LIFT - ROOF VENT COVER
	048648-01-000	EA	MOTOR - ROOF VENT - 1/8 SHAFT - 12VOLT
	048649-01-000	EA	FAN BLADE - ROOF VENT - 6 BLADES - 6"
3*	122882-03-01A	EA	VENT - ROOF - W/FAN - W/O INSIDE GARNISH - CSA
	009440-01-000	EA	GEAR/ARM - LIFT - ROOF VENT COVER
	048648-01-000	EA	MOTOR - ROOF VENT - 1/8 SHAFT - 12VOLT
	048649-01-000	EA	FAN BLADE - ROOF VENT - 6 BLADES - 6"
	122882-07-01A	EA	GARNISH - ROOF VENT - 2.5" TO 4"
4	084073-07-000	EA	VENT - ROOF/REFRIGERATOR - BRIGHT WHITE - NORCOLD
	084073-04-000	EA	BASE - ROOF VENT/REFRIGERATOR - BLACK - NORCOLD
5	122192-01-02A	EA	PANEL - SKYLITE - OUTER - 16.4" X 27.8"
	122193-01-02A	EA	PANEL - SKYLITE - INNER
6*	098647-30-02A	EA	WINDOW - DRIVER HORIZ SLIDER W/TRIM - CLEAR - 24.2" X 41"
6*	129929-06-02A	EA	WINDOW - TORQUE - THERMO - 24.4" X 41.2"
7*	098647-28-02A	EA	WINDOW - DRIVER HORIZ SLIDER W/TRIM-CLEAR- 26.1" X 59.7"
7*	112795-15-02A	EA	WINDOW - DRIVER HORIZONTAL SLIDER - THERMO - 26.4 X 60"
8*	098647-32-02A	EA	WINDOW - DRIVER HORIZ SLIDER W/TRIM - CLEAR - 15.7"X 28.5"
8*	112795-20-02A	EA	WINDOW - DRIVER HORIZONTAL SLIDER - THERMO - 15" X 28.7"
9	103313-03-F15	EA	WINDOW - PICTURE - 16.3" X 71.1" (INSIDE FRAME #117054)
	002181-29-000	EA	GLASS - PICTURE WINDOW - 71"W X 16.2"H - TINTED
	099154-01-000	FT	CHANNEL - GLAZING - STATIONARY GLASS - .62" X .45" - BLK
	117054-01-02A	EA	RETAINER - TRIM - BLACK
9*	115630-01-02A	EA	WINDOW - STATIONARY/THERMOPANE- BLACK I/S TRIM-17.2" X 72"
10*	098647-31-02A	EA	WINDOW - PASS HORIZ SLIDER W/TRIM - CLEAR - 15.7" X 28.5"
10*	112795-19-02A	EA	WINDOW - PASSENGER HORIZ SLIDER - THERMO - 15.7" X 28.5"
11	117053-04-FB1	EA	WINDOW - PICTURE - CLEAR - 17" X 26.4" - W/O RETAINER
	002181-27-000	EA	GLASS - PICTURE WINDOW - 25.8"W X 16.4"H - CLEAR
	087561-01-000	FT	SEAL - GLASS - EXTERIOR - .5" WIDE - VINYL BLACK
	117054-02-02A	EA	RETAINER - TRIM - BRIGHT WHITE
11*	113733-01-01A	EA	WINDOW - STATIONARY THERMOPANE - 17"W X 26.4"H
12*	098647-49-02A	EA	WINDOW - PASS HORIZ SLIDER W/TRIM - TINTED-15" X 23.7"
12*	112795-61-02A	EA	WINDOW - PASSENGER HORIZ SLIDER - THERMO - 15.2" X 24"
13	084878-09-000	EA	VENT - EXHAUST/RANGE HOOD - OFF WHITE
	084616-07-000	EA	SHROUD - EXHAUST VENT/RANGE HOOD - BRIGHT WHITE
14*	098647-29-02A	EA	WINDOW - PASS HORIZ SLIDER W/TRIM - CLEAR - 24.2" X 41"
14*	129929-06-02A	EA	WINDOW - TORQUE - THERMO - 24.4" X 41.2"

\*COMPONENT PARTS FOUND IN SERVICE PARTS LIBRARY