

1999
WCF35C

K20
MINK (TAUPE)
K21
ASPEN (GREEN)
K22
PRISM (BLUE)
K23
SEASPRAY (TEAL)

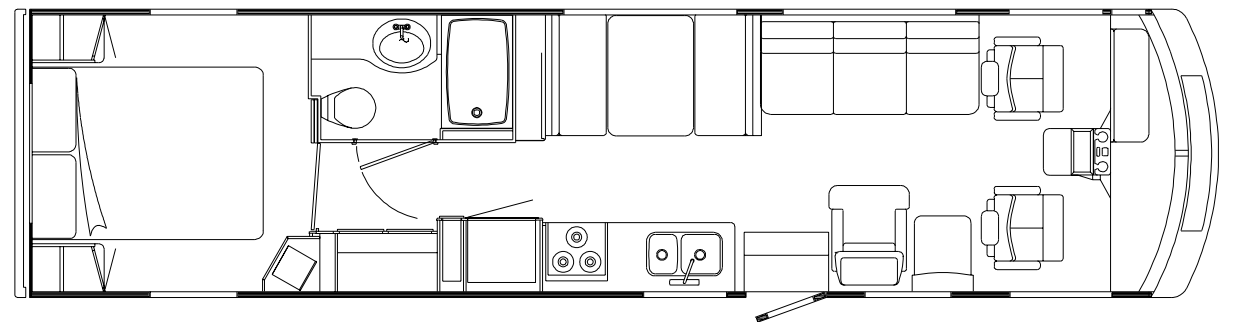
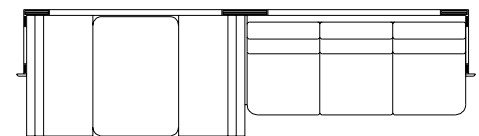
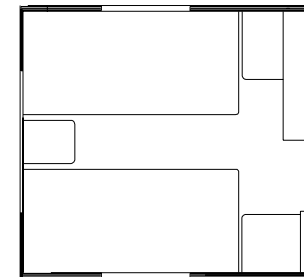
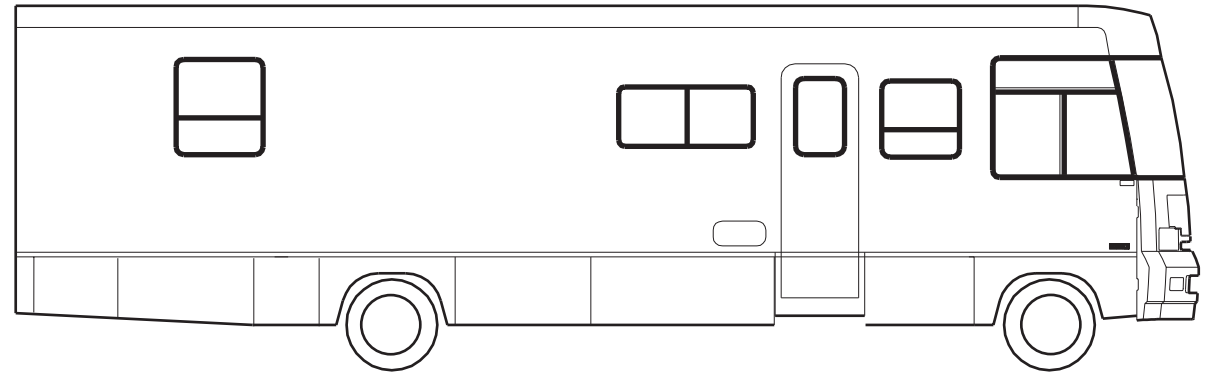

**ACCESSORIES GROUP
OPERATOR MANUAL**

KEY	PART NUMBER	U/M DESCRIPTION
	054185-K3-000	EA MANUAL - OPERATOR 99 BRAVE
	129079-01-01A	EA CASE - VINYL/BLACK-EXPANDABLE ACCORDION SIDES-7"WX9"HX14"L
	128992-01-000	DW TOP LEVEL-F, 1999

**AUDIO VIDEO GROUP
PATIO ENTERTAINMENT CENTER**

KEY	PART NUMBER	U/M DESCRIPTION
	076319-09-000	EA WALLPLATE - CABLE RECEPTACLE - TV - SINGLE - BROWN
	108847-01-000	EA BRACKET - ANTENNA GROUND
	109889-04-000	EA EXTENDER - ANTENNA SHAFT - 3"
	110469-01-000	EA SPEAKER - 4" X 6" OVAL - COAXIAL
	110470-01-01A	EA GRILLE - 4" X 6" OVAL - BLACK
	125322-02-000	EA RADIO - AM/FM STEREO - CASSETTE - AUDIOVOX - MS-306

RADIO SYSTEM & ANTENNA

KEY	PART NUMBER	U/M DESCRIPTION	VENDOR NO.
	127516-03-000	EA RADIO - AM/FM STEREO - CD PLAYER - PANASONIC - CQ-DP930	
	127516-03-700	EA FACE - REMOVABLE	YEP0FX3300
	110267-04-000	EA RADIO - AM/FM STEREO/CD COMPATIBLE - AUDIOVOX - IM 500	
	127264-03-000	EA RADIO - AM/FM STEREO/CASSETTE - EUROPEAN	
	077069-02-000	EA CABLE - ANTENNA/EXTENSION - RADIO - 96"	
	090944-01-000	EA ANTENNA - RADIO - 16" RUBBER	
	115916-01-01B	EA BRACKET - ANTENNA MOUNT	
	110469-01-000	EA SPEAKER - 4" X 6" OVAL - COAXIAL	
	110470-01-01A	EA GRILLE - 4" X 6" OVAL - BLACK	
	094097-01-000	EA SPEAKER - RADIO/TV - W/O GRILLE - 5.25" DIAMETER	

TV, VCR & COMPONENTS

KEY	PART NUMBER	U/M DESCRIPTION	VENDOR NO.
	126696-02-000	EA TV - 19" COLOR W/1/8" JACK - UL/CSA - GE19GT319M	FROM: 00-00-00 THRU: 06-09-99 226725/228006
	126696-01-700	EA REMOTE	
	126696-03-000	EA TV - 19" - 7/8" JACK - UL/CSA	FROM: 06-10-99 THRU: 99-99-99
	126697-02-000	EA VCR-VHS - CABLE READY - W/REMOTE - GE VG2042	FROM: 00-00-00 THRU: 04-04-99
	126697-02-700	EA REMOTE	238513
	126697-03-000	EA VCR-VHS - CABLE READY - REMOTE - GE V62051	FROM: 04-05-99 THRU: 99-99-99
	086757-03-000	EA CONTROL CENTER - SWITCH - VCR/TV	FROM: 00-00-00 THRU: 11-08-98
	086757-04-000	EA CONTROL CENTER - SWITCH - VCR/TV - 5 INPUTS	FROM: 11-09-98 THRU: 99-99-99
	086777-06-000	EA WALLPLATE - TV CABLE - ANTENNA BOOSTER/1 OUTPUT - BROWN	
	093214-01-02A	EA GRILLE - SPEAKER - 4" BROWN	
	098819-01-000	EA SPEAKER - 4" - 2 WATT - 8 OHM	
	076319-08-000	EA WALLPLATE - CABLE RECEPTACLE - TV - SINGLE - IVORY	
	086777-02-000	EA WALLPLATE - TV CABLE - W/ANTENNA SWITCH - BROWN	
	093901-03-000	EA PLATE - TV COAX - EXTERIOR - 1.8" X 2.5"	
	076319-03-000	FT CABLE - COAXIAL - 75 OHM	
	076319-12-000	EA CONNECTOR - COAXIAL - ONE PIECE	
	082134-01-000	EA ADAPTER - TV - CABLE TO CABLE	
	086756-01-000	EA SPLITTER - TV - 2 WAY	
	082136-01-000	EA NUT - HEX JAM - 3/8-32	

REAR MONITOR SYSTEM

KEY	PART NUMBER	U/M DESCRIPTION
	126838-01-000	EA MONITOR/CAMERA - REAR VIEW 7"
	126838-01-700	EA MONITOR - 7" VIDEOMAN
	126838-01-701	EA CAMERA VIDEOMAN
	126838-03-000	EA CABLE - MONITOR/CAMERA
	108885-02-000	EA WIRE - REAR MONITOR(W/3 PIN HOUSING F/FUSE BLOCK) CHEVY
	127053-01-000	EA WIRE ASSEMBLY - REAR MONITOR/UPPER

WINEGARD TV ANTENNA

KEY	PART NUMBER	U/M DESCRIPTION
*	076319-23-000	EA ANTENNA - TV ROOF MOUNT - 44.5" MAST
*	076319-25-000	EA KIT - HARDWARE INTERIOR

***COMPONENT PARTS FOUND IN SERVICE PARTS LIBRARY**

BATH GROUP

BATHROOM CABINETS & SHOWER COMPONENTS

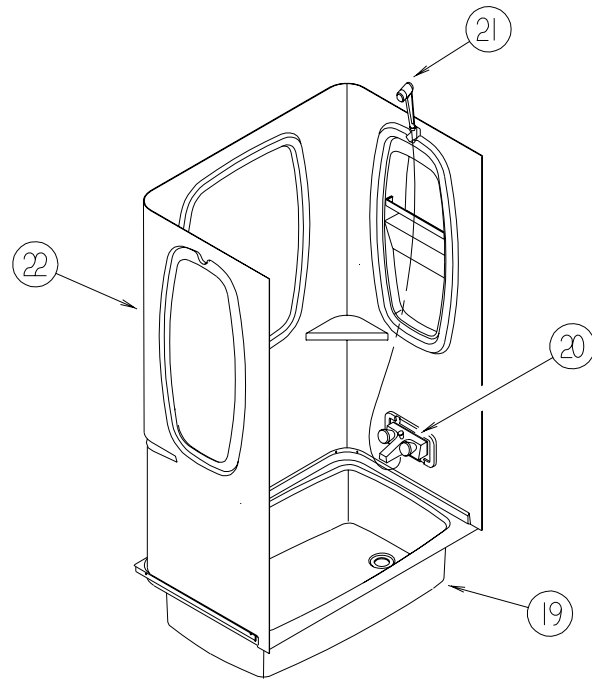
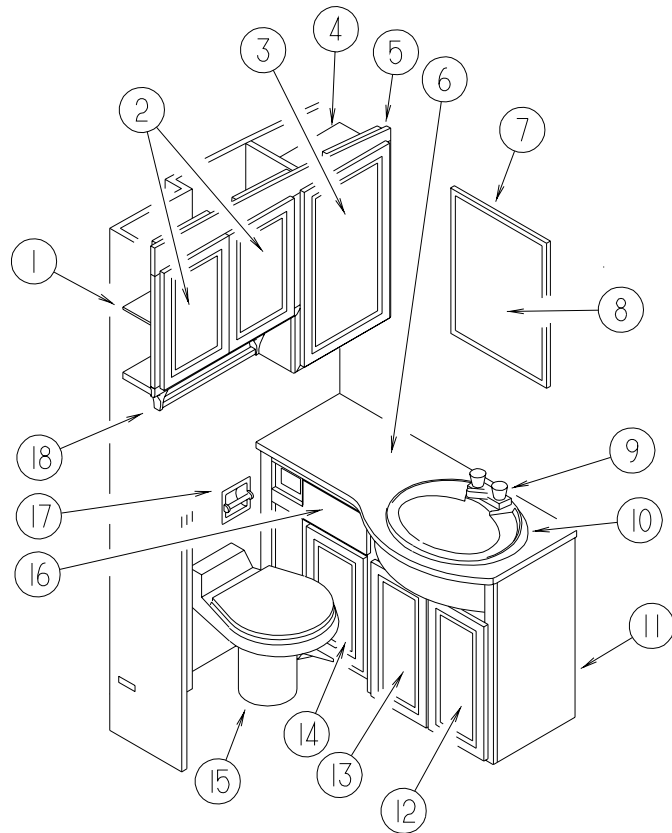

KEY	PART NUMBER	U/M DESCRIPTION	VENDOR NO.
6	126309-16-J24	EA COUNTERTOP - LAVATORY (K20)	
6	126309-16-J26	EA COUNTERTOP - LAVATORY (K21,K23)	
6	126309-16-J22	EA COUNTERTOP - LAVATORY (K22)	
7	105004-01-05A	EA MOLDING - VINYL WRAPPED - 1" X 96" - WATERFORD OAK	
8	058331-51-000	EA MIRROR - SAFETY GLASS - 25.9" X 40"	
9	075240-06-000	EA FAUCET - LAVATORY/BONE	
	091253-01-000	EA GASKET - FAUCET - LAVATORY/GALLEY	
10	105921-01-01A	EA SINK - LAVATORY - LARGE/OVAL - 17" X 20" PLASTIC/OFF WHITE	
	106116-01-01A	EA STRAINER/PLASTIC - STOPPER/TAILPIECE/GASKET & NUT-LAVATORY	
	105218-01-01A	EA SPACER - FAUCET/LAVATORY SINK - 2" X 5.9" - ABS PLASTIC	
11	126309-01-J24	EA CABINET - LAVATORY - W/COUNTERTOP - W/O DOORS/DRAWERS/HDW (K20)	
11	126309-01-J26	EA CABINET - LAVATORY - W/COUNTERTOP - W/O DOORS/DRAWERS/HDW (K21,K23)	
11	126309-01-J22	EA CABINET - LAVATORY - W/COUNTERTOP - W/O DOORS/DRAWERS/HDW (K22)	
	126309-12-J22	EA SHELF - W/PLASTIC EDGE TRIM	
12	131995-T6-K20	EA DOOR - SOLID PANEL - 10.2" X 21.4" - W/O HARDWARE	
13	131995-T5-K20	EA DOOR - SOLID PANEL - 10.2" X 21.4" - W/O HARDWARE	
14	125162-10-K20	EA CABINET - HAMPER	
14	131995-U1-K20	EA DOOR - SOLID PANEL - 21.8" X 11" - W/O HARDWARE	
15*	063740-01-000	EA TOILET - HIGH/HAND FLUSH	
		FROM: 00-00-00 THRU: 01-03-99	
	063740-01-700	EA LEVER-WATER	12514 THETFORD
	063740-01-701	EA LEVER-FLUSH	12515 THETFORD
	063740-01-706	EA BOLT PACKAGE-FLOOR FLANGE	12524 THETFORD
	063740-01-714	EA VALVE ASM (VALVE-BALL SEAL)	13168
	063740-01-717	EA TUBE-FLUSH	12509
	063740-01-720	EA LEVER KIT, WAT-FLUSH-BEARING	24629
	063740-01-721	EA BLADE ONLY	1248232
	063740-02-700	EA SEAT & COVER, PARCHMENT	2464157
15*	131932-01-01A	EA TOILET - AQUA MAGIC 4 - HIGH - HAND FLUSH - IVORY	
		FROM: 01-04-99 THRU: 99-99-99	
	063740-01-700	EA LEVER-WATER	12514 THETFORD
	063740-01-701	EA LEVER-FLUSH	12515 THETFORD
	063740-01-706	EA BOLT PACKAGE-FLOOR FLANGE	12524 THETFORD
	063740-01-714	EA VALVE ASM (VALVE-BALL SEAL)	13168
	063740-01-717	EA TUBE-FLUSH	12509
	063740-01-720	EA LEVER KIT, WAT-FLUSH-BEARING	24629
	063740-01-721	EA BLADE ONLY	1248232
	063740-02-700	EA SEAT & COVER, PARCHMENT	2464157
16	M05971-CM-K59	EA DRAWER - OGEE EDGE - 9.4"W X 11.8"D - W/O SLIDES/HARDWARE	
17	075452-02-000	EA HOLDER - TOILET TISSUE - BRASS	
18	075453-02-000	EA BAR - TOWEL - 18" BRASS	
19	M02630-27-F11	EA SHOWER PAN - W/STRAINER/TAILPIECE	
20	075242-04-000	EA FAUCET - TUB/SHOWER - BONE	
	075606-01-000	EA PANEL - PLASTIC - FAUCET BACK - 5" X 9"	
21	131383-01-01A	EA SHOWER HEAD - W/HOSE & BRACKET - 60" - IVORY	
21	131383-02-01A	EA SHOWER HEAD - W/HOSE & BRACKET - 60" - CSA- IVORY	
	103092-01-700	EA BRACKET-F/SHOWER HEAD, CLEAR	2328028
	011048-03-700	EA BRACKET - SHOWER HEAD/IVORY	2328029-I
	103092-01-702	EA SEALS-SPRAY HEAD	24466
22	115612-04-01A	EA SURROUND - SHOWER - OFF WHITE	
	113714-02-01A	EA RETAINER - SHELF - SHOWER - OFF WHITE	
		FROM: 00-00-00 THRU: 10-11-98	
	113714-04-01A	EA RETAINER - SHELF - SHOWER - OFF WHITE	
		FROM: 10-12-98 THRU: 99-99-99	

KEY	PART NUMBER	U/M DESCRIPTION
1	127987-14-J37	EA SHELF - W/PLASTIC EDGE TRIM
2	132141-A4-K20	EA DOOR - RAIL/VENEER - 12" X 18.7" - W/O HARDWARE
3	132141-14-K20	EA DOOR - RAIL/VENEER - 15.7" X 27.9" - W/O HARDWARE
4	127987-15-J37	EA SHELF - W/PLASTIC EDGE TRIM
5	127987-01-J37	EA CABINET - MEDICINE - W/O DOORS/HARDWARE
	076767-04-000	EA CABLE - SUPPORT - 5.9" STAINLESS STEEL

KEY	PART NUMBER	U/M DESCRIPTION
	114496-01-02A	EA PANEL - SKYLIGHT - OUTER - 22" X 37"
	122191-01-02A	EA PANEL - SKYLIGHT - INNER W/LIGHT CUTOUT - 20.7" X 35.4"

*COMPONENT PARTS FOUND IN SERVICE PARTS LIBRARY

SHOWER SKYLIGHT

BATH GROUP (CONTINUED)

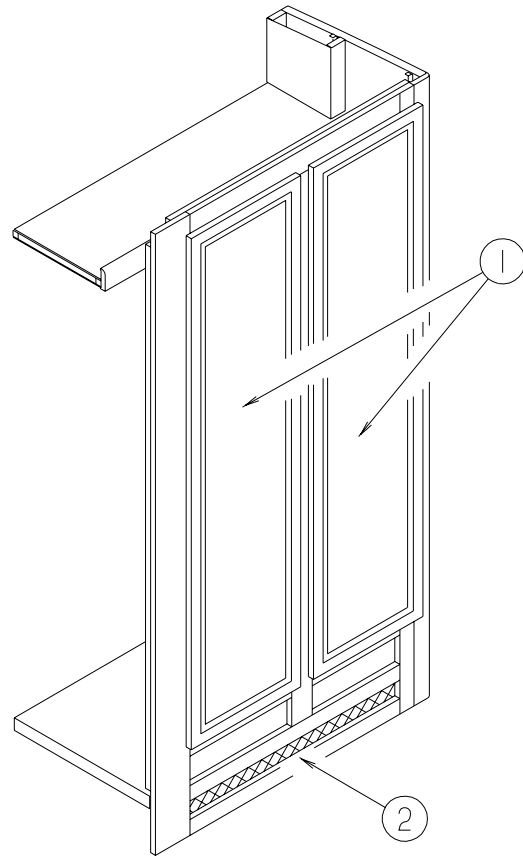

WARDROBE CABINET

KEY	PART NUMBER	U/M	DESCRIPTION
1	132006-03-K28	EA	DOOR - MIRROR/MITERED RAIL - 16.1" X 65.2" - W/O HARDWARE
2	104314-10-01A	EA	MESH-GRILLE BLACK

BATH GROUP (CONTINUED)

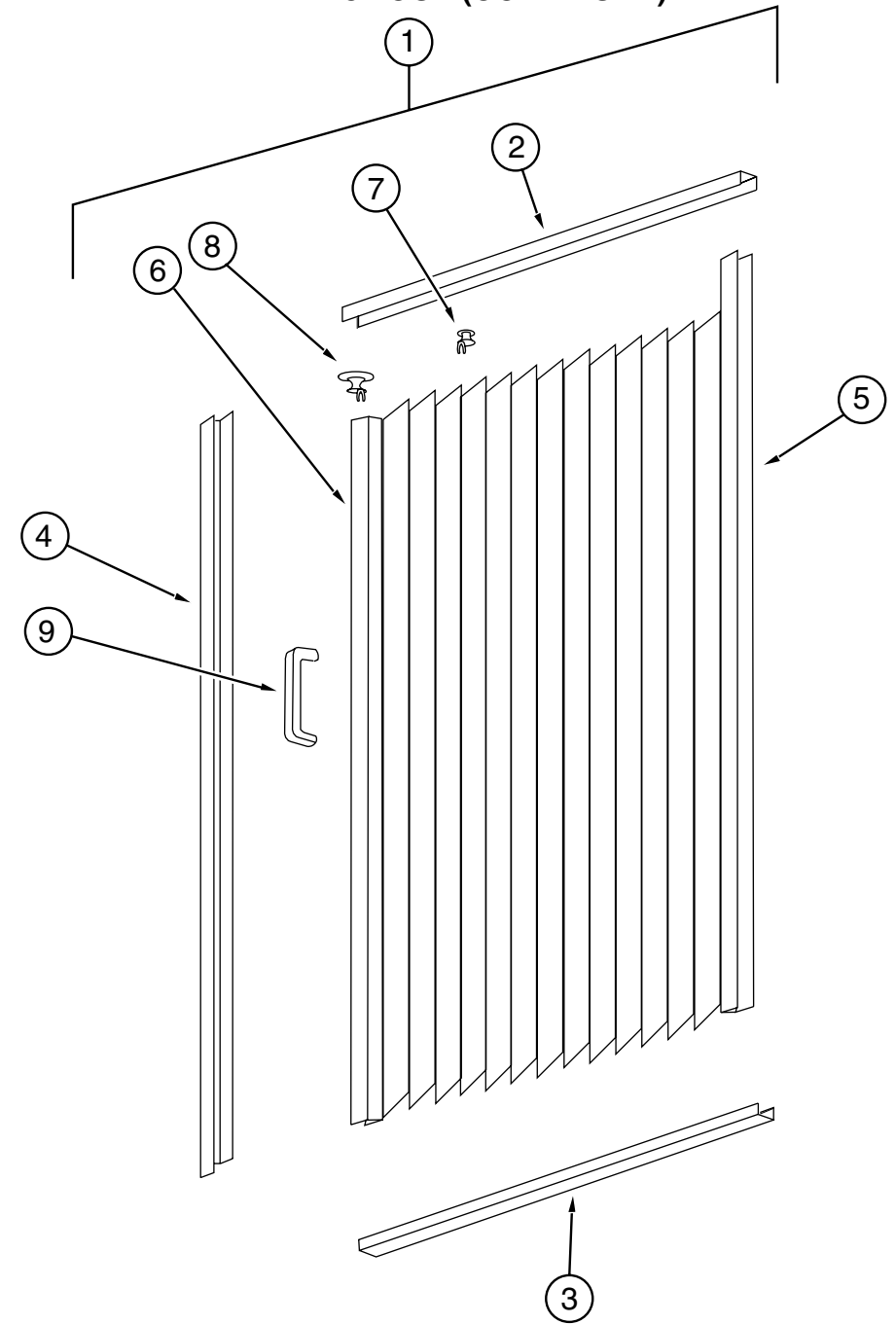

SHOWER DOOR COMPONENTS

KEY	PART NUMBER	U/M	DESCRIPTION
1	117431-03-01A	EA	DOOR - SHOWER PLEATED FABRIC
2	117431-01-700	EA	TRACK-TOP, ALUM.IVORY INSERT 48"
3	117431-01-701	EA	TRACK-BOTTOM, 48"
4	117431-01-702	EA	RAIL-SIDE, 67"
5	117431-01-703	EA	RAIL-STATIONARY, 67"
6	117431-01-704	EA	RAIL-LEAD, 67" - W/LATCH
7	117431-01-705	EA	GLIDE-IVORY, TRAVELER
8	117431-01-706	EA	GLIDE-IVORY LEAD, TRAVELER
9	117431-01-708	EA	HANDLE - W/SCREWS
	117431-01-707	EA	CATCH - BATH DOOR
	117431-03-700	EA	STRAP-VINYL SHOWER

BATH GROUP (CONTINUED)

BATH DOOR (FROM: 00-00-00 THRU: 11-08-98)

KEY	PART NUMBER	U/M	DESCRIPTION
	121449-12-G04	EA	RACK - TOWEL - BATH DOOR
	100357-01-000	EA	ROD - F/TOWEL BAR - BRASS
	121449-33-J22	EA	DOOR - BATH - W/TOWEL RACK
	111155-01-01A	EA	LOCK - PRIVACY/LOCKING - POLISHED BRASS
	009059-02-000	EA	HINGE - DOOR - 2" X 2.7" - BRASS

BATH DOOR (FROM: 11-09-98 THRU: 02-09-99)

KEY	PART NUMBER	U/M	DESCRIPTION
	128967-51-J01	EA	RACK - TOWEL/BATH DOOR
	128967-52-J01	EA	MOLDING - VINYL WRAPPED
	128967-53-J01	EA	MOLDING - VINYL WRAPPED
	100357-01-000	EA	ROD - F/TOWEL BAR - BRASS
	128967-18-K66	EA	DOOR - BATH - W/TOWEL RACK
	111155-01-01A	EA	LOCK - PRIVACY/LOCKING - POLISHED BRASS FROM: 11-09-98 THRU: 01-03-99
	111155-03-01A	EA	LOCK - PRIVACY/LOCKING - POLISHED BRASS FROM: 01-04-99 THRU: 99-99-99
	102920-01-01A	EA	HINGE/SPRING LOADED - BRASS
	110496-01-01A	EA	HINGE - BRASS

BATH DOOR (FROM: 02-10-99 THRU: 99-99-99)

KEY	PART NUMBER	U/M	DESCRIPTION
	121449-12-G04	EA	RACK - TOWEL - BATH DOOR
	100357-01-000	EA	ROD - F/TOWEL BAR - BRASS
	121449-33-J22	EA	DOOR - BATH - W/TOWEL RACK
	111155-03-01A	EA	LOCK - PRIVACY/LOCKING - POLISHED BRASS
	009059-02-000	EA	HINGE - DOOR - 2" X 2.7" - BRASS

BATH GROUP (CONTINUED)

BATHROOM/BEDROOM PRIVACY DOOR & COMPONENTS

KEY	PART NUMBER	U/M	DESCRIPTION	VENDOR NO.
	042488-10-000	EA	DOOR - FOLDING - OFF WHITE FABRIC - 37" X 75"	
				FROM: 00-00-00 THRU: 12-27-98
	042488-10-700	EA	LEADRAIL-PREPUNCHED F/HANDLE	DW2100
				FROM: 00-00-00 THRU: 12-27-98
	080224-01-703	EA	HANDLE W/LATCH-CATCH, ALMOND	DE03505
				FROM: 00-00-00 THRU: 12-27-98
	080224-01-705	EA	LATCH & CATCH ASM., ALMOND	DE25010 & DE25020
				FROM: 00-00-00 THRU: 12-27-98
	094856-06-02A	EA	TRACK - FOLDING DOOR - 37.6"	
				FROM: 00-00-00 THRU: 12-27-98
	009700-04-002	EA	TRACK/CURTAIN - L SHAPED - 15.5' - OFF WHITE	
				FROM: 00-00-00 THRU: 12-27-98
	009702-01-000	EA	END STOP - CURTAIN CARRIER - L ROD	
				FROM: 00-00-00 THRU: 12-27-98
	131595-01-01A	EA	DOOR - FOLDING - 37" X 75" - W/4 CEILING MOUNTED BRACKETS	
				FROM: 12-28-98 THRU: 01-31-99
	131595-01-700	EA	END STOP ONLY-FABRIC DOOR	
				FROM: 12-28-98 THRU: 01-31-99
	131595-01-701	EA	BRACKET/MOUNTING-FABRIC DOOR	
				FROM: 12-28-98 THRU: 01-31-99
	131595-01-702	EA	TRACK/STRAIGHT-37"FABRIC DR	
				FROM: 12-28-98 THRU: 01-31-99
	042488-10-000	EA	DOOR - FOLDING - OFF WHITE FABRIC - 37" X 75"	
				FROM: 02-01-99 THRU: 03-07-99
	042488-10-700	EA	LEADRAIL-PREPUNCHED F/HANDLE	DW2100
				FROM: 02-01-99 THRU: 03-07-99
	080224-01-703	EA	HANDLE W/LATCH-CATCH, ALMOND	DE03505
				FROM: 02-01-99 THRU: 03-07-99
	080224-01-705	EA	LATCH & CATCH ASM., ALMOND	DE25010 & DE25020
				FROM: 02-01-99 THRU: 03-07-99
	094856-06-02A	EA	TRACK - FOLDING DOOR - 37.6"	
				FROM: 02-01-99 THRU: 03-07-99
	009700-04-002	EA	TRACK/CURTAIN - L SHAPED - 15.5' - OFF WHITE	
				FROM: 02-01-99 THRU: 03-07-99
	009702-01-000	EA	END STOP - CURTAIN CARRIER - L ROD	
				FROM: 02-01-99 THRU: 03-07-99
	131595-01-01A	EA	DOOR - FOLDING - 37" X 75" - W/4 CEILING MOUNTED BRACKETS	
				FROM: 03-08-99 THRU: 99-99-99
	131595-01-700	EA	END STOP ONLY-FABRIC DOOR	
				FROM: 03-08-99 THRU: 99-99-99
	131595-01-701	EA	BRACKET/MOUNTING-FABRIC DOOR	
				FROM: 03-08-99 THRU: 99-99-99
	131595-01-702	EA	TRACK/STRAIGHT-37"FABRIC DR	
				FROM: 03-08-99 THRU: 99-99-99

BEDROOM GROUP

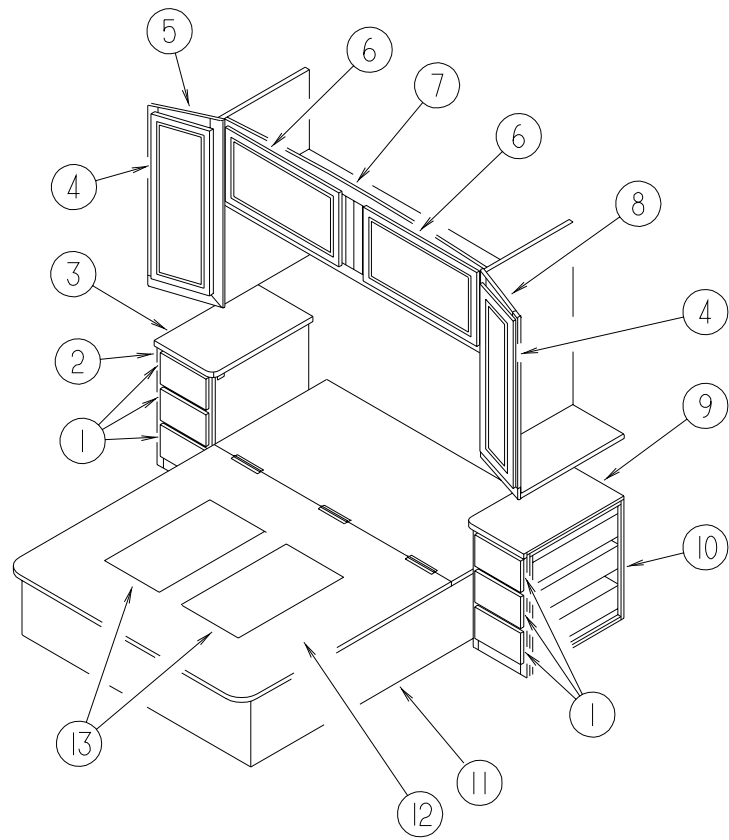

QUEEN BEDROOM CABINETRY

KEY	PART NUMBER	U/M	DESCRIPTION
1	M09316-14-K20	EA	DRAWER - OGEE EDGE - 10.7"W X 19.7"D - W/O SLIDES/HARDWARE
2	129251-07-K20	EA	CABINET - NIGHTSTAND/RH - W/COUNTERTOP - W/O DRS/DWRS/HDW (K20)
2	129251-07-K68	EA	CABINET - NIGHTSTAND/RH - W/COUNTERTOP - W/O DRS/DWRS/HDW (K21,K23)
2	129251-07-K22	EA	CABINET - NIGHTSTAND/RH - W/COUNTERTOP - W/O DRS/DWRS/HDW (K22)
3	129251-19-K20	EA	COUNTERTOP - NIGHTSTAND (K20)
3	129251-19-K28	EA	COUNTERTOP - NIGHTSTAND (K21,K23)
3	129251-19-K22	EA	COUNTERTOP - NIGHTSTAND (K22)
4	132141-71-K20	EA	DOOR - VENEER - 14.3" X 36.4" - W/O HARDWARE
5	126003-01-J20	EA	CABINET - SHIRT CLOSET/RIGHT HAND - W/O DOORS/HARDWARE
	009112-01-000	EA	FLANGE - PLASTIC - 1" CLOTHES ROD - OFF WHITE
	042438-01-000	EA	DOWEL - WOOD - CLOTHES ROD - 1" DIAMETER X 4'
6	132141-14-K20	EA	DOOR - VENEER - 15.7" X 27.9" - W/O HARDWARE
7	106523-01-G09	EA	CABINET - OVERHEAD/REAR - W/O DOORS/HARDWARE
8	126003-02-J20	EA	CABINET - SHIRT CLOSET/LEFT HAND - W/O DOORS/HARDWARE
	009112-01-000	EA	FLANGE - PLASTIC - 1" CLOTHES ROD - OFF WHITE
	042438-01-000	EA	DOWEL - WOOD - CLOTHES ROD - 1" DIAMETER X 4'
9	129251-20-K20	EA	COUNTERTOP - NIGHTSTAND (K20)
9	129251-20-K28	EA	COUNTERTOP - NIGHTSTAND (K21,K23)
9	129251-20-K22	EA	COUNTERTOP - NIGHTSTAND (K22)
10	129251-08-K20	EA	CABINET - NIGHTSTAND/LH - W/COUNTERTOP - W/O DRS/DWRS/HDW (K20)
10	129251-08-K68	EA	CABINET - NIGHTSTAND/LH - W/COUNTERTOP - W/O DRS/DWRS/HDW (K21,K23)
10	129251-08-K22	EA	CABINET - NIGHTSTAND/LH - W/COUNTERTOP - W/O DRS/DWRS/HDW (K22)
11	P26437-03-J22	EA	CABINET - BASE/QUEEN BED - W/O DOORS/DRAWERS/HARDWARE
12	M07571-03-J22	EA	TOP - QUEEN BED - W/O HARDWARE
	041389-25-000	EA	HINGE - PIANO - 1 1/2" X 55"
13	096764-02-000	FT	SLIPNOT - ANTISLIP - 1" WIDE (100' ROLLS)
	107796-06-000	EA	SPRING/GAS - 12" COMPRESSED/20" EXTENDED - 120 LB.
	126259-01-000	EA	STUD - BALL - GAS SHOCK MOUNTING
	126263-06-02B	EA	BRACKET - GAS SPRING - E-COATED
	126263-08-02B	EA	BRACKET - GAS SPRING - E-COATED
	097872-04-000	EA	DOWEL - WOOD - 1" DIAMETER X 1.38" LONG

BEDROOM GROUP (CONTINUED)

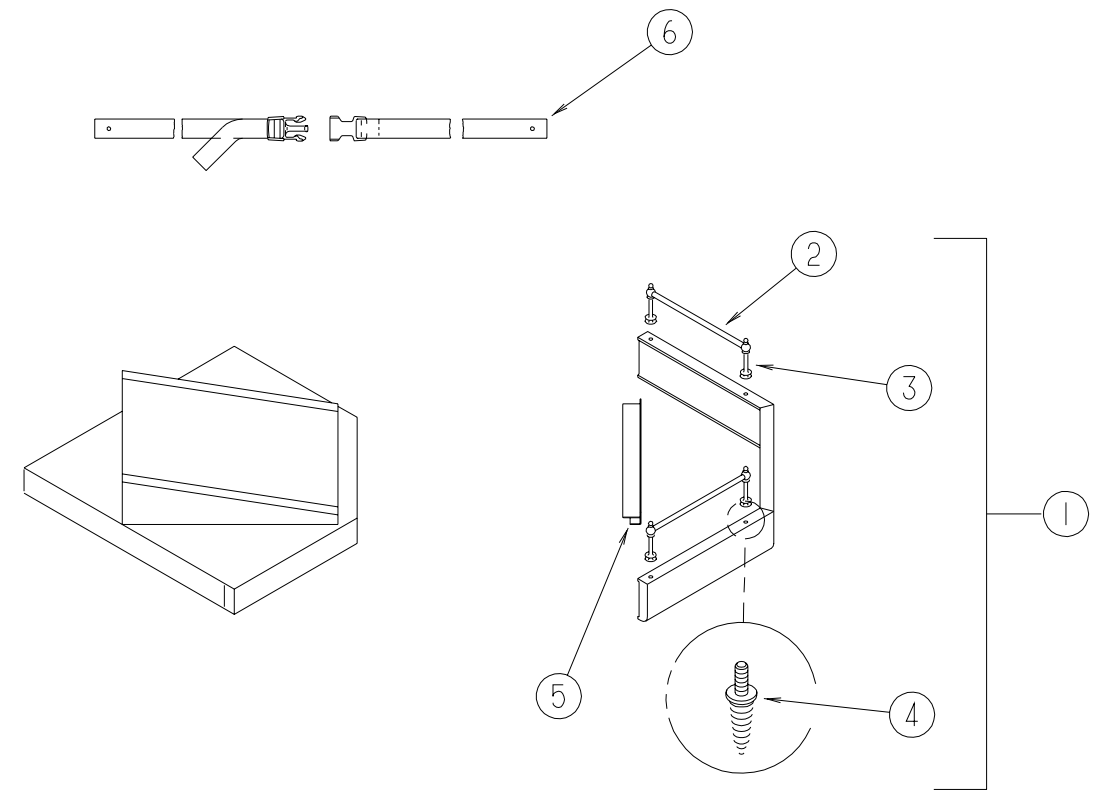

TV SHELF

KEY	PART NUMBER	U/M	DESCRIPTION
1	127376-01-J20	EA	CABINET - TV SHELF - RIGHT HAND
2	084071-19-000	EA	ROD - BRASS - 7.1"
2	084071-27-000	EA	ROD - BRASS - 2.7"
3	084070-03-000	EA	POST - END - 2.4" - SHINY BRASS
4	106166-01-000	EA	BOLT/COLLARED HANGER - 8-32 X 1"
5	103186-01-05A	FT	MOLDING - PLASTIC - 3/8" U-CHANNEL 3/4" FACE-WATERFORD OAK
6	099717-02-000	EA	STRAP - TIE DOWN W/29.9" FEMALE STRAP & 14.2" MALE STRAP

BEDROOM GROUP (CONTINUED)

TWIN BEDROOM CABINETS

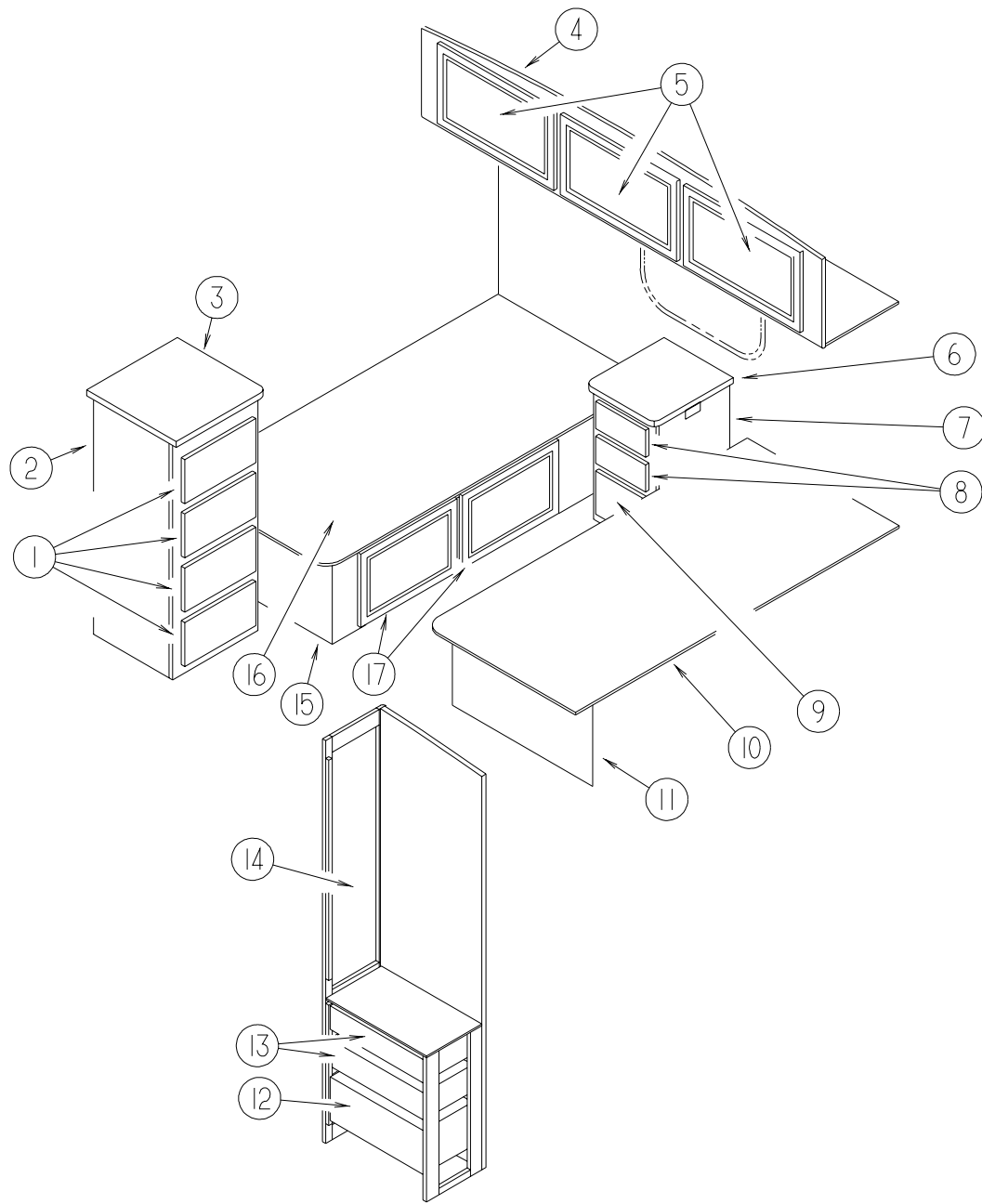

KEY	PART NUMBER	U/M	DESCRIPTION
1	M05971-C3-K20	EA	DRAWER - OGEE EDGE - 12.1"W X 17.7"D - W/O SLIDES/HARDWARE
2	128349-01-J37	EA	DRESSER - W/COUNTERTOP - W/O DRAWERS/HDW - F/RH TWIN BED (K20)
2	128349-01-J38	EA	DRESSER - W/COUNTERTOP - W/O DRAWERS/HDW - F/RH TWIN BED (K21,K23)
2	128349-01-J97	EA	DRESSER - W/COUNTERTOP - W/O DRAWERS/HDW - F/RH TWIN BED (K22)
3	128349-11-J37	EA	COUNTERTOP - DRESSER (K20)
3	128349-11-J38	EA	COUNTERTOP - DRESSER (K21,K23)
3	128349-11-J97	EA	COUNTERTOP - DRESSER (K22)
4	116187-01-K20	EA	CABINET - OVERHEAD/REAR - W/O DOORS/HARDWARE - F/TWIN BED
5	132141-14-K20	EA	DOOR - RAIL/VENEER - 15.7" X 27.9" - W/O HARDWARE
6	104507-11-J24	EA	COUNTERTOP - NIGHTSTAND (K20)
6	104507-11-F12	EA	COUNTERTOP - NIGHTSTAND (K21,K23)
6	104507-11-H37	EA	COUNTERTOP - NIGHTSTAND (K22)
7	104507-01-K47	EA	CABINET/NIGHTSTAND - W/COUNTERTOP - W/O DOORS/DRAWERS/HDW (K20)
7	104507-01-K28	EA	CABINET - NIGHTSTAND/TWN BD - W/CTRTOP-W/O DOORS/DRWRS/HDW (K21,K23)
7	104507-01-K22	EA	CABINET - NIGHTSTAND/TWN BD - W/CTRTOP-W/O DOORS/DWRS/HDW (K22)
8	M05971-65-K28	EA	DRAWER - OGEE EDGE - 12.2"W X 11.8"D - W/O SLIDES/HARDWARE
9	M05971-73-K28	EA	DRAWER - OGEE EDGE - 12.2"W X 11.8"D - W/O SLIDES/HARDWARE
10	M08754-01-000	EA	TOP - TWIN BED/LEFT HAND - W/O HARDWARE
11	P26435-02-K28	EA	CABINET - BASE/TWIN BED - LEFT HAND - W/O DOORS/DRWS/HDW
12	M05971-W5-K28	EA	DRAWER - OGEE EDGE - 9.6"W X 21.6"D - W/O SLIDES/HARDWARE
13	M05971-58-K20	EA	DRAWER - OGEE EDGE - 9.6"W X 21.6"D - W/O SLIDES/HARDWARE
	009112-01-000	EA	FLANGE - 1" ROD, CLOTHES - PLASTIC - OFF WHITE
	042438-01-000	EA	DOWEL - WOOD - CLOTHES ROD - 1" DIAMETER X 4'
14	132141-17-K20	EA	DOOR - RAIL/VENEER - 12" X 48" - W/O HARDWARE
15	P26436-01-J22	EA	CABINET - BASE/TWIN BED - RIGHT HAND - W/O DOORS/DWRS/HDW
16	M08754-02-000	EA	TOP - TWIN BED/RIGHT HAND - W/O HARDWARE
17	131995-S8-K20	EA	DOOR - SOLID PANEL - 12" X 21.8" - W/O HARDWARE
	096764-02-000	FT	SLIPNOT - ANTISLIP - 1'WIDE (100' ROLLS)

CHASSIS GROUP

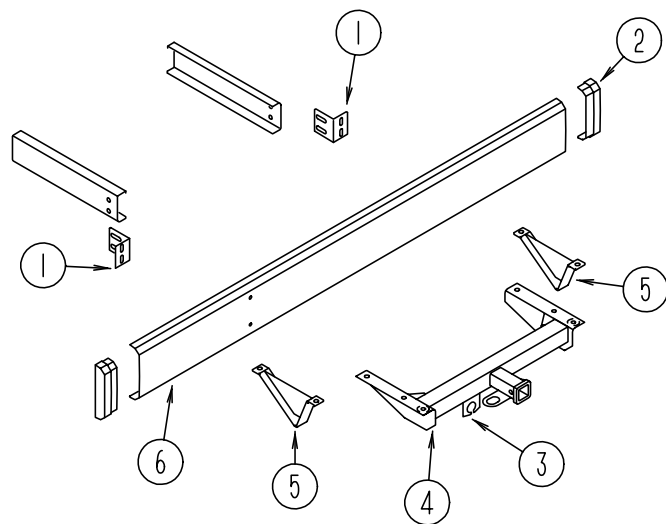

REAR BUMPER, TRAILER HITCH & COMPONENTS

KEY	PART NUMBER	U/M DESCRIPTION
1	104418-07-000	EA ANGLE - BUMPER - REAR SUPPORT
2	103228-01-06A	EA END CAP - REAR BUMPER - DRIVER/PASSENGER
3	113588-02-01B	EA BRACKET - CONNECTOR - TRAILER W/O LIP
4	130339-02-000	EA HITCH RECEIVER - BOLT ON CLASS III
5	111742-01-000	EA PLATE - SKID
6	103099-10-02A	EA BUMPER - REAR - BRIGHT WHITE
	113589-01-000	EA CONNECTOR - PLUG - TRAILER
	113589-02-000	EA CONNECTOR - SOCKET - TRAILER

CHASSIS GROUP (CONTINUED)

19.5" CHEVY STAINLESS STEEL WHEEL LINERS

KEY	PART NUMBER	U/M DESCRIPTION	VENDOR NO.
	110435-10-000	EA LINER - WHEEL - SET/4 - 19.5"	
	110435-01-711	EA DECAL-CENTER CAP, 2" 2" DECAL	
	110435-10-700	EA LINER - WHEEL - FRONT - 1 PC	V195P7-FWC
	110435-10-701	EA LINER - WHEEL - REAR - 1 PC.	V195P7-RWC
	110435-10-702	EA JAMB NUT & LUG NUT COVER COMBINATION 2 USED PER WHEEL	V195P7-EJN
	110435-10-703	EA STUD - PLASTIC F/NON-FUNCTION NUT COVERS ALSO ORDER #11043510704 PLASTIC NUT W/NUT COVER 2 USED PER EACH FRONT WHEEL	V195P7-PST
	110435-10-704	EA NUT - PLASTIC W/STAINLESS STEEL NUT COVER ALSO ORDER #11043510703 PLASTIC STUD 2 USED PER EACH FRONT WHEEL	V195P7-PJN
	110435-10-705	EA TOOL - INSTALLATION	V195P7-TOL

19.5" FORD STAINLESS STEEL WHEEL LINERS - 19.5" X 6.75" WHEEL

KEY	PART NUMBER	U/M DESCRIPTION	VENDOR NO.
	110435-15-000	EA LINER - WHEEL SET/4 - 19.5"	
	110435-04-705	EA DECAL-CTR HUB 2 3/4" DIAMOND 2 3/4" DECAL DIAMOND	
	110435-10-705	EA TOOL - INSTALLATION	V195P7-TOL
	110435-15-700	EA LINER - WHEEL - FRONT	V195F9-FWC
	110435-15-701	EA LINER - WHEEL - REAR	V195F9-RWC
	110435-15-702	EA COVER LUG NUT/JAMB NUT - 14M	V195F9-EJN

19.5" FORD WHEEL COVERS

KEY	PART NUMBER	U/M DESCRIPTION	VENDOR NO.
	109443-07-000	EA WHEEL COVER - 4/SET - 19.5"	
	098532-01-700	EA COVER-LUG NUT (CHROME) NOTE:THE VENDOR DOES NOT RECOMMEND THIS PART TO BE REPLACED DUE TO POSSIBLE DAMAGE TO THE LINER	SHAU-LNC
	109443-01-703	EA CAP-CENTER, HUB - DICOR	SHAU95-CAP
	109443-07-700	EA COVER/WHEEL-FRONT/REAR 8 LUG	SHAF95-COV
	109443-07-701	EA BRACKET SET - FRONT	SHAF95-FBS
	109443-07-702	EA BRACKET SET - REAR	SHAF95-RBS

19.5" CHEVY WHEEL COVERS

KEY	PART NUMBER	U/M DESCRIPTION	VENDOR NO.
	109443-06-000	EA WHEEL COVER - 4/SET - 19.5"	
	109443-01-700	EA COVER-WHEEL 19.5 FRT/RR EA=1	SHAG95
	109443-01-701	EA BRACKET-RETENTION FRONT	SHAG95-FBS
	109443-01-703	EA CAP-CENTER, HUB - DICOR	SHAU95-CAP
	109443-01-704	EA CLIP-RETAINER	V160GM-PNT
	109443-06-701	EA BRACKET-RETENTION REAR	SHG795-RBS

CHASSIS GROUP (CONTINUED)

STORAGE COMPARTMENTS, SEAL/PLANES, & WHEELWELLS

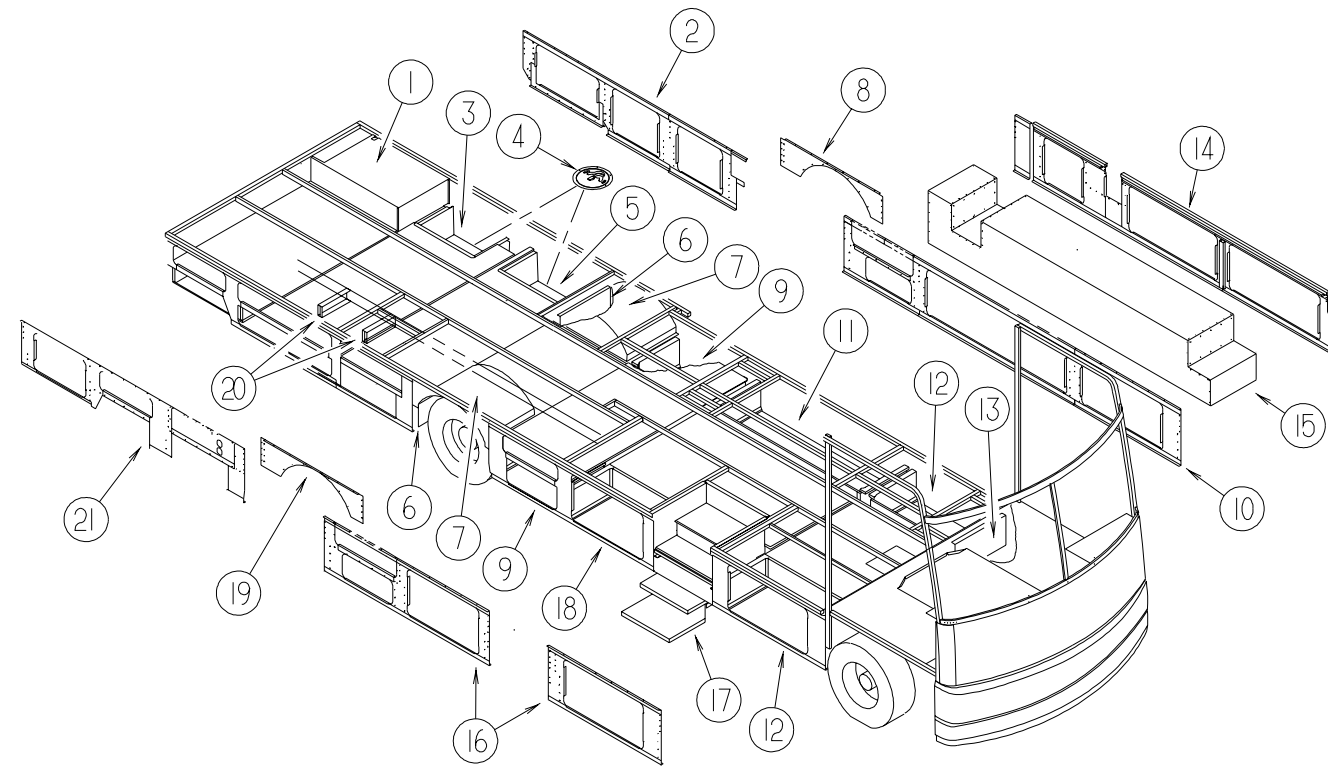

KEY	PART NUMBER	U/M	DESCRIPTION	KEY	PART NUMBER	U/M	DESCRIPTION	VENDOR NO.
1	127008-02-02B	EA	TRAY - GENERATOR - 16.2" X 20.8" X 6.9" - W/ANGLE & NUTS	17*	094707-03-01A	EA	STEP - ELECTRIC DOUBLE - W/BLACK CONTROL BOX	FROM: 01-15-99 THRU: 99-99-99
	104644-01-000	EA	ANGLE - FORMED - GENERATOR		088733-01-700	EA	BULB	9004
2	130522-19-02B	EA	PANEL - SEAL/PLANE - E-COATED		088746-01-705	EA	LIGHT-UNDER STEP	9004
3	M08627-06-K28	EA	COMPARTMENT - ELECTRIC/DRAINAGE - W/HATCH		094707-01-702	EA	FRAME W/DBL STEP,3200 SERIES	908032
4	M08628-01-H17	EA	HATCH W/FOAM INSERT		094707-02-700	EA	MOTOR ASM.,W/BEARINGS & PINS	909520
	121175-02-01A	EA	LATCH - SWELL		094707-02-701	EA	LINKAGE ASM. W/BEARINGS-PINS	909534
5	M08627-01-H17	EA	COMPARTMENT - ELECTRIC/DRAINAGE - W/HATCH		094707-02-702	EA	GEAR KIT(GEAR-BEARING-PINS)	909525
6	020167-08-000	EA	DIRT GUARD - STEEL - 13.6" LONG		094707-02-703	EA	BEARING & PINS	909530
6	017516-01-000	EA	MUD FLAP - 14" X 18" - BLACK		094707-02-704	EA	CONNECTOR-MOTOR ASM.W/PLATES	909537
7	055374-01-000	EA	WHEELWELL - PLASTIC		094707-02-706	EA	GEAR BOX ASM. W/O MOTOR	9524
8	126943-05-02B	EA	PANEL-SEAL PLANE,WHEELWELL - FORD		094707-02-707	EA	TREAD - NON-SKID - BLACK	909333
8	126943-04-02B	EA	PANEL-SEAL PLANE,WHEELWELL - CHEVY		094707-02-708	EA	TREAD - NON-SKID - YELLOW	909331
9	126386-31-K32	EA	COMPARTMENT - LUGGAGE		094707-03-700	EA	KIT CONTROL/SWITCH-RETROFIT	909506005
10	130522-18-02B	EA	PANEL - SEAL/PLANE - E-COATED - W/O SLIDEOUT OPTION		094707-03-701	EA	PLUG - 4-WAY - PACKARD	909306
11	126386-12-J22	EA	COMPARTMENT - LUGGAGE		116995-02-000	EA	SWITCH/MAGNET - ELECTRIC STEP - BLACK/WHITE-CLOSED CIRCUIT	FROM: 01-15-99 THRU: 99-99-99
12	126386-09-J22	EA	COMPARTMENT - LUGGAGE		065450-05-000	EA	TIEDOWN - BATTERY - 8.4" TUBE	
13	020167-03-000	EA	DIRT GUARD - STEEL - 11" LONG	18	126386-10-J22	EA	COMPARTMENT - LUGGAGE	
14	126423-17-02B	EA	SEAL - PLANE - E-COATED - W/SLIDEOUT OPTION	19	126943-06-02B	EA	PANEL-SEAL PLANE,WHEELWELL - FORD	
15	126390-06-000	EA	COMPARTMENT ASM-SLIDEOUT	19	126943-07-02B	EA	PANEL-SEAL PLANE,WHEELWELL - CHEVY	
16	130522-20-02B	EA	PANEL - SEAL/PLANE - E-COATED	20	120867-01-02B	EA	MOUNT - LP TANK	
17*	094707-01-01A	EA	STEP - DOUBLE - ELECTRIC - KWIKEE	21	130522-21-02B	EA	PANEL - SEAL/PLANE - E-COATED	
	116995-01-000	EA	SWITCH/MAGNET - ELECTRIC STEP - WHITE/WHITE - OPEN CIRCUIT		061420-01-000	EA	PLUG/PLASTIC - 1.75" DIAMETER - BROWN	
			FROM: 00-00-00 THRU: 01-14-99		119845-01-01A	EA	PLUG - PLASTIC - BLACK - 1 1/2" SQUARE	
			FROM: 00-00-00 THRU: 01-14-99		117154-07-02B	EA	MOUNT - FRAME RAIL/FLOOR	
					104803-01-000	EA	ANGLE - FORMED W/SLOTS	
					084852-51-003	EA	EXTRUDED - ANGLE - 1.25" X .75" X 15'	

*COMPONENT PARTS FOUND IN SERVICE PARTS LIBRARY

CHASSIS GROUP (CONTINUED)

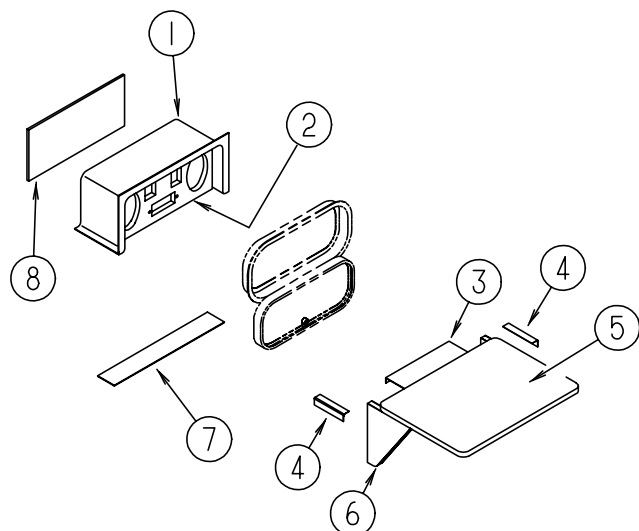

PATIO ENTERTAINMENT CENTER

KEY	PART NUMBER	U/M	DESCRIPTION
1	124696-01-01A	EA	BOX - ENTERTAINMENT CENTER/EXTERIOR
2	127409-02-K04	EA	PLATE - RADIO MOUNTING
			FROM: 00-00-00 THRU: 06-13-99
2	127409-02-L15	EA	PLATE - RADIO MOUNTING
			FROM: 06-14-99 THRU: 99-99-99
3	105377-01-04A	EA	BRACKET - TABLE HANGER - BRIGHT WHITE
4	105376-01-03A	EA	HINGE - CONTINUOUS - 2" X 5.5" - BRIGHT WHITE
5	105230-11-J01	EA	SHELF - EXTERIOR ENTERTAINMENT CENTER - W/O HARDWARE
6	105230-12-J01	EA	SUPPORT - EXTERIOR SHELF
7	104898-01-02A	EA	PLATE - PLASTIC BOTTOM - BRIGHT WHITE
8	104898-02-02A	EA	PLATE - PLASTIC BACK - BRIGHT WHITE

CHASSIS GROUP (CONTINUED)

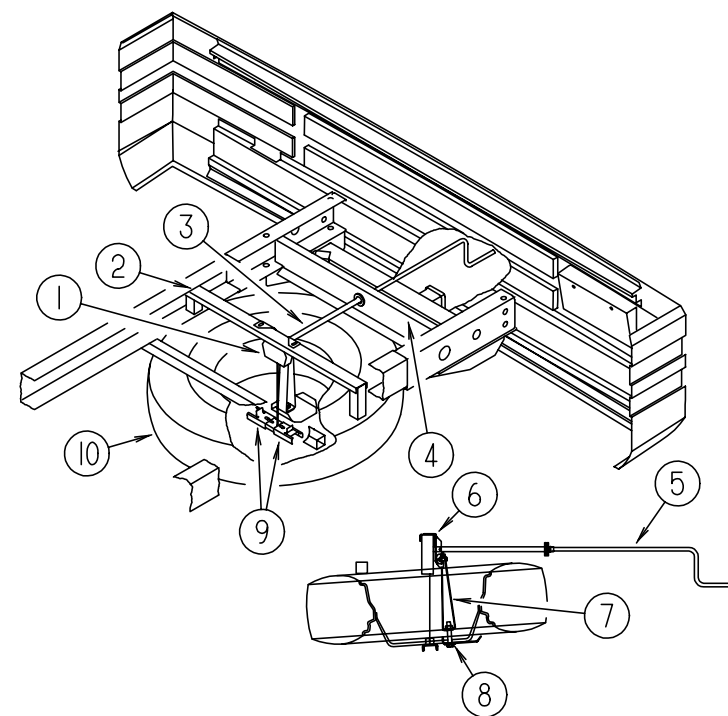

TIRE HOIST

KEY	PART NUMBER	U/M	DESCRIPTION
1	093267-03-000	EA	HOIST - SPARE TIRE - 100 LB
2	093362-06-000	EA	CHANNEL - TIRE HOIST
3	093375-06-000	EA	EXTENSION - TIRE HOIST
4	129006-01-02B	EA	SUPPORT/FRAME - TIRE CARRIER HANDLE - FORD
4	129006-02-02B	EA	SUPPORT/FRAME - TIRE CARRIER HANDLE - CHEVY
5	093376-02-000	EA	HANDLE - CRANK - TIRE HOIST
	114376-01-000	EA	PIN - DRIVE - .156 X .750 - TYPE E - TIRE HOIST
6	124751-01-02B	EA	HANGER - SPARE TIRE - E-COATED
7	129086-01-02B	EA	SUPPORT - SPARE TIRE
8	129085-01-02B	EA	PLATE - SUPPORT - SPARE TIRE
9	105499-01-000	EA	BRACKET - TIRE HOIST
10	102340-04-000	EA	TIRE - 245/70R X 19.5F - GOODYEAR - FORD - 19.5" X 6.75" WHEEL
10	091673-01-000	EA	TIRE - 225/70 R19.5 LRF - MICHELIN XZA - CHEVY
10	051377-01-000	EA	VALVE STEM - CHEVY
10	118814-04-700	EA	WHEEL/TAKE OFF (19.5X6.75RW) 8 BOLT ACCURIDE F53 - FORD
10	064963-01-000	EA	WHEEL - STEEL - 19.5" X 6" - GM 14005758 - CHEVY
	077030-02-000	EA	EXTENSION - VALVE STEM - 1.25" - CHEVY WHEEL LINERS
	077030-05-000	EA	EXTENSION - VALVE STEM - 95 DEGREE - FORD WHEEL LINERS
			FROM: 00-00-00 THRU: 11-23-98
	077030-04-000	EA	EXTENSION - VALVE STEM - .75" - FORD WHEEL LINERS
			FROM: 11-24-98 THRU: 99-99-99
	077030-06-000	EA	EXTENSION - VALVE STEM - 45 DEGREE - FORD WHEEL LINERS
	095012-10-000	EA	EXTENSION - VALVE STEM - 8.5" - FORD WHEEL LINERS
			FROM: 00-00-00 THRU: 11-23-98
	095012-09-000	EA	EXTENSION - VALVE STEM - 7.7" - FORD WHEEL LINERS
			FROM: 11-24-98 THRU: 99-99-99
	095012-07-000	EA	STABILIZER - VALVE EXTENSION - FORD WHEEL LINERS

CHASSIS GROUP (CONTINUED)

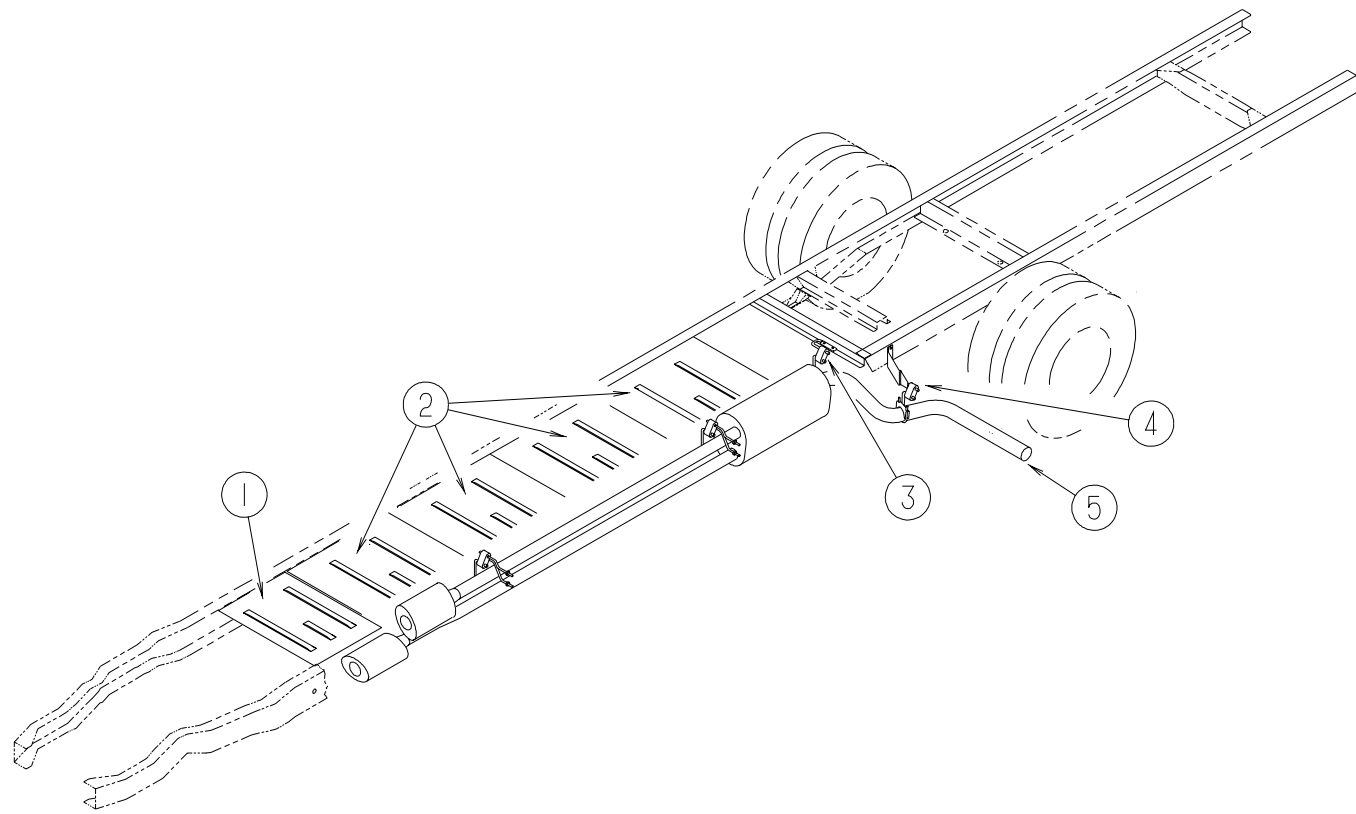

CHEVY EXHAUST SYSTEM

KEY	PART NUMBER	U/M	DESCRIPTION
1	101544-01-000	EA	SHIELD - HEAT/EXHAUST - 19.7" X 29.1"
2	101544-02-000	EA	SHIELD - HEAT/EXHAUST - 30" X 29.1"
3	122392-01-02B	EA	HANGER - TAILPIPE
4	122392-03-02B	EA	HANGER - TAILPIPE - REAR
5	122529-02-000	EA	PIPE - EXHAUST
	094918-01-000	EA	CLAMP - EXHAUST - 3" - GUILLOTINE STYLE

CHASSIS GROUP (CONTINUED)

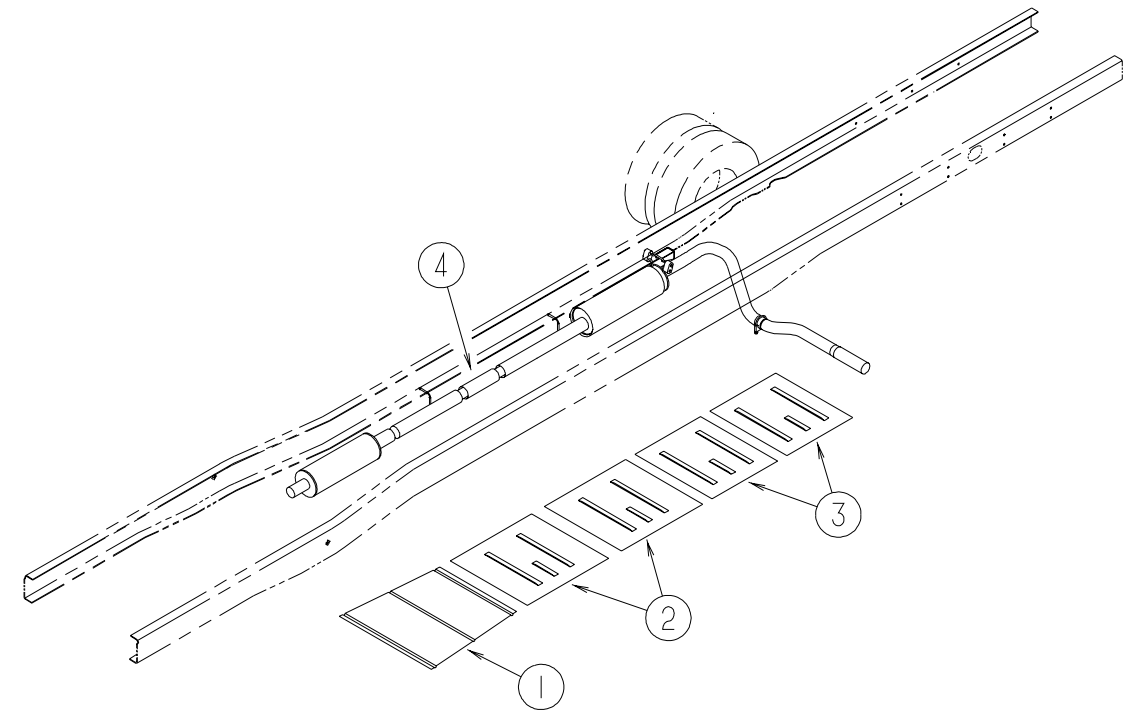

FORD EXHAUST SYSTEM

KEY	PART NUMBER	U/M	DESCRIPTION
1	128756-01-02B	EA	SHIELD - HEAT EXHAUST - E-COATED
2	101544-06-000	EA	SHIELD - HEAT/EXHAUST - 33.9" X 29.1"
3	101544-10-000	EA	SHIELD - HEAT/EXHAUST - 19.7" X 29.1" - FORD
4	112012-03-000	EA	PIPE - EXHAUST - 3" DIAMETER - FORD CHASSIS

CHASSIS GROUP (CONTINUED)

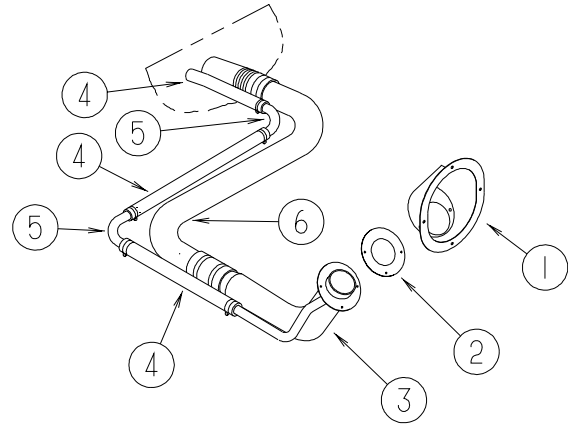

CHEVY FUEL SYSTEM

KEY	PART NUMBER	U/M DESCRIPTION
1	127291-01-01A	EA SHROUD - FUEL FILL - BRIGHT WHITE
2	078200-01-000	EA GASKET - FUEL FILL - 3.5"OD X 2"ID
3	127301-03-000	EA NECK - FUEL FILL
4	128139-02-000	FT HOSE - FUEL - LOW PERMEABILITY - 5/8" DIAMETER
5	098806-01-000	EA PIPE - FILL VENT - 90 DEGREE BEND - .635 OD - STEEL
6	124327-05-000	EA TUBE - FUEL INLET
	084884-01-000	EA PLUG - BRASS - 3/8"
	098758-01-000	EA FUEL LINE - RETURN - 5/16" STEEL X 14" LONG W/14MM NUTS FROM: 00-00-00 THRU: 01-19-99
	098758-05-000	EA FUEL LINE - RETURN - 5/16" STEEL X 30" LONG W/14MM NUTS FROM: 01-20-99 THRU: 05-30-99
	098758-01-000	EA FUEL LINE - RETURN - 5/16" STEEL X 14" LONG W/14MM NUTS FROM: 05-31-99 THRU: 99-99-99
	098759-01-000	EA FUEL LINE - SUPPLY - 3/8" STEEL X 14" LONG W/16MM NUTS FROM: 00-00-00 THRU: 01-19-99
	098759-05-000	EA FUEL LINE - SUPPLY - 3/8" STEEL X 30" LONG W/16MM NUTS FROM: 01-20-99 THRU: 05-30-99
	098759-01-000	EA FUEL LINE - SUPPLY - 3/8" STEEL X 14" LONG W/16MM NUTS FROM: 05-31-99 THRU: 99-99-99
	098779-01-000	EA COUPLER - FUEL LINE - 1.2" LONG X 14MM THREAD
	098779-02-000	EA COUPLER - FUEL LINE - 1.2" LONG X 16MM THREAD
	127392-02-000	EA HOSE - EVAPORATOR TO EMISSIONS CANISTER FROM: 00-00-00 THRU: 01-19-99
	024138-01-000	FT HOSE - FUEL - 5/16" ID FROM: 01-20-99 THRU: 05-30-99
	127392-02-000	EA HOSE - EVAPORATOR TO EMISSIONS CANISTER FROM: 05-31-99 THRU: 99-99-99
	007063-01-000	FT HOSE - FUEL - 1/4"ID X 1/2"OD FROM: 00-00-00 THRU: 01-25-99
	128139-03-000	FT HOSE - FUEL - LOW PERMEABILITY - 1/4" DIAMETER FROM: 01-26-99 THRU: 99-99-99
	068382-06-000	EA BUSHING - BRASS - 3/8"MPT X 1/8"FPT
	114254-01-000	EA ADAPTER - 1/4 BARB X 1/8 MPT
	044317-01-000	FT HOSE - FUEL - 3/8" ID

CHASSIS GROUP (CONTINUED)

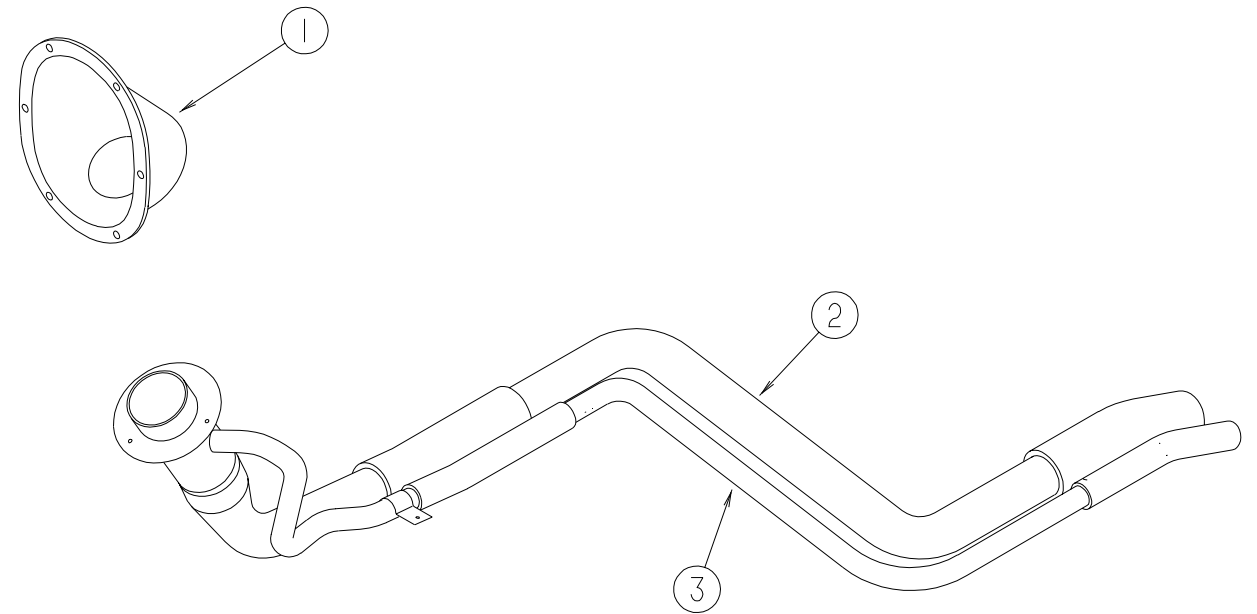

FORD FUEL SYSTEM

KEY	PART NUMBER	U/M DESCRIPTION
1	127291-02-01A	EA SHROUD - FUEL FILL - BRIGHT WHITE
2	129321-04-000	EA TUBE - FUEL INLET FROM: 00-00-00 THRU: 09-07-98
2	129321-10-000	EA TUBE - FUEL INLET FROM: 09-08-98 THRU: 99-99-99
3	129320-04-000	EA PIPE - VENT - FILL FROM: 00-00-00 THRU: 09-07-98
3	129320-10-000	EA PIPE - VENT FILL FROM: 09-08-98 THRU: 99-99-99
	007063-01-000	FT HOSE - FUEL - 1/4"ID X 1/2"OD FROM: 00-00-00 THRU: 01-25-99
	128139-03-000	FT HOSE - FUEL - LOW PERMEABILITY - 1/4" DIAMETER FROM: 01-26-99 THRU: 99-99-99
	084884-01-000	EA PLUG - BRASS - 3/8"
	129494-03-000	EA FUEL LINE - 5/16" X 21.2" - FORD CHASSIS
	129505-03-000	EA TUBE - STEEL - 5/8" X 19.5"
	128139-02-000	FT HOSE - FUEL - LOW PERMEABILITY - 5/8" DIAMETER
	092889-32-000	EA FUEL LINE - SUPPLY - GENERATOR - 1/4" X 90.9" - STEEL

CHASSIS GROUP (CONTINUED)

FORD DRIVESHAFT SPACER & BRAKE LINE UNIONS

KEY	PART NUMBER	U/M	DESCRIPTION
	074833-01-000	EA	SPACER - BEARING - DRIVESHAFT - 2" X 8" X .5" THICK
	074833-04-000	EA	SPACER - BEARING - DRIVESHAFT - 8" X 2" STEEL
	085771-03-000	EA	NUT - HEX - FLARE TORQUE - GRADE G - DRIVESHAFT
	115043-03-000	EA	BUSHING - DRIVESHAFT
	129580-02-000	EA	DRIVESHAFT - BALANCED - 99 F53 - 242" - 20,500 GVW
	075302-36-000	EA	DRIVESHAFT-BALANCED - FORD F53 - 208"/228" 18,000 GVW
	088498-01-000	EA	UNION - INVERTED FLARE - BRASS - 3/16 BRAKE LINE
	075466-01-000	EA	UNION - INVERTED FLAIR - 1/4" BRAKE LINE UNION WHEN CHASSIS IS STRETCHED

CHEVY DRIVESHAFT, SPACER & BRAKE LINE UNIONS

KEY	PART NUMBER	U/M	DESCRIPTION
	075466-01-000	EA	UNION - INVERTED FLAIR - 1/4" BRAKE LINE UNION WHEN CHASSIS IS STRETCHED
	088498-01-000	EA	UNION - INVERTED FLARE - BRASS - 3/16 BRAKE LINE
	074833-04-000	EA	SPACER - BEARING - DRIVESHAFT - 8" X 2" STEEL
	088498-02-000	EA	UNION - INVERTED FLARE - BRASS - 1/4
	075302-16-000	EA	DRIVESHAFT ASSEMBLY - YOKE/YOKE/BEARING - 46.72"
	083415-01-000	EA	SHIELD - HEAT - DRIVESHAFT BEARING - 4" X 5.5" - STEEL

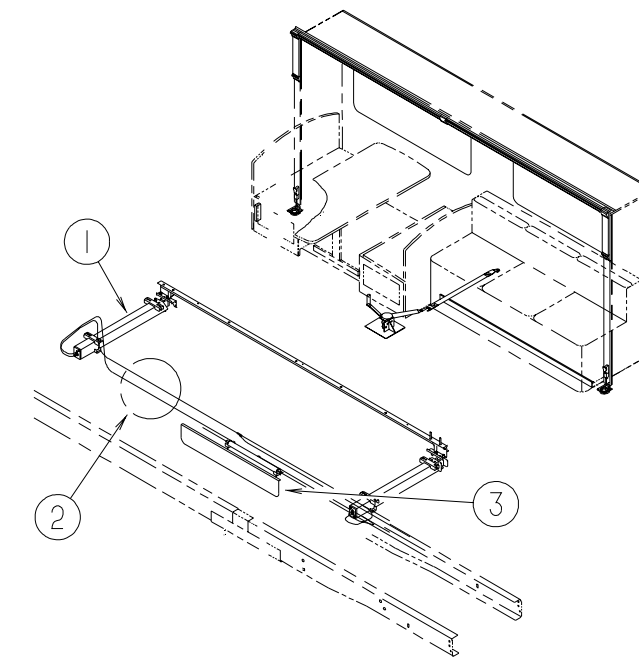

HWH HYDRAULIC SLIDEOUT SYSTEM & HEATSHIELD

KEY	PART NUMBER	U/M	DESCRIPTION	VENDOR NO.
1	125687-01-000	EA	SLIDEOUT - HYDRAULIC	
	125687-01-700	EA	CYLINDER (RAM - 2 USED PER SLIDE)	RAP90512
	125687-01-701	EA	HOSE - HYDRAULIC - 120"	AP13772
2	125687-01-702	EA	CYLINDER - SYNCHRONIZING	RAP90471
	100536-42-000	EA	HOSE KIT - PUMP TO SLIDE-OUT VALVE	
	100536-42-700	EA	HOSE - HYDRAULIC - 168"	RAP6115
	100536-42-701	EA	HOSE - HYDRAULIC - 175"	RAP90350
3	053322-10-000	EA	SHIELD - HEAT - EXHAUST - 48" X 7.5" - STEEL	

CHASSIS GROUP (CONTINUED)

HWH LEVELING SYSTEM - W/SLIDEOUT OPTION - CHEVY

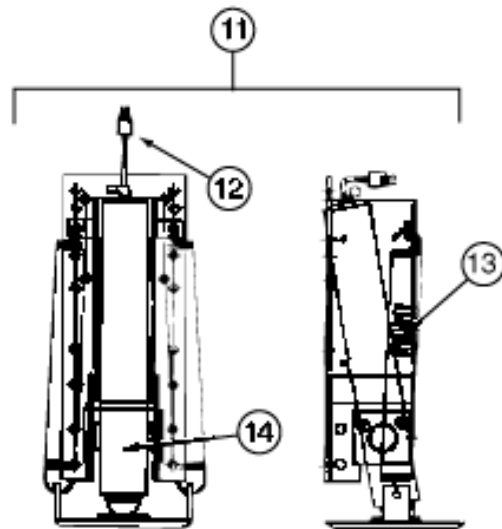
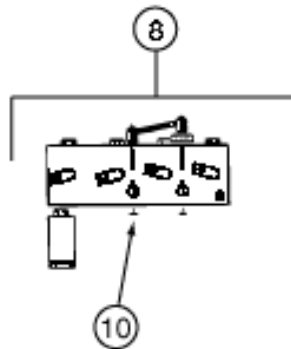
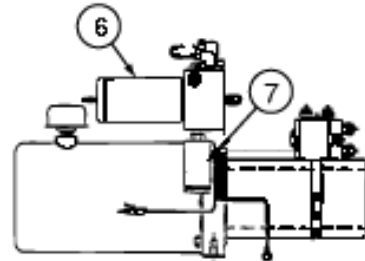
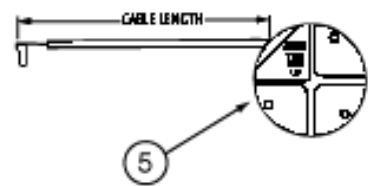
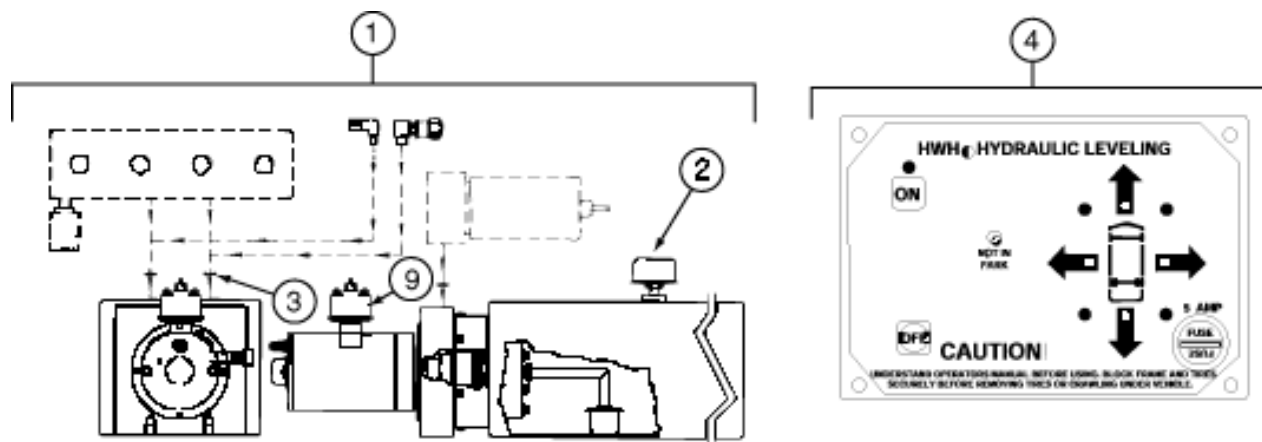

KEY	PART NUMBER	U/M DESCRIPTION	VENDOR NO.
	131306-01-000	EA LEVELING SYSTEM - F/SLIDEOUT ROOM W/OUT JACKS DOWN SYSTEM	
1	100532-01-713	EA PUMP-RESERVOIR ASM.-MONARCH	RAP90014
2	100532-03-715	EA CAP-BREATHER W/DIPSTICK	RAP7876
3	100532-03-723	EA O-RING/SEAL KIT	RAP9171
4	100532-08-703	EA PANEL ASM.-200 BI-AXIS SYS.	RAP9755
5	100532-12-703	EA SENSING UNIT BI-AXIS-27'	RAP6800
6	100532-09-704	EA VALVE-PRESSURE SOLENOID	RAP0642
7	100532-31-701	EA CHECK VALVE & KIT	RAP10021
8	100532-16-701	EA MANIFOLD ASM. F/SLIDE OUT	RAP1716
9	100532-09-710	EA SOLENOID-INTERMITTENT DUTY	RAP0533
10	100532-31-702	EA O-RING/SEAL KIT - MANIFOLD	RAP90127
11	100532-18-700	EA JACK - 9K STRAIGHT ACTING	RAP90177
12	100532-12-706	EA SWITCH - WARNING/MAGNETIC	RAP1008 / RAP90496
13	100532-12-707	EA SPRING KIT	R3847
14	100532-32-702	EA CYLINDER ONLY F/9000 LB JACK	RAP1927
	100532-03-722	EA O-RING KIT	R7430
	100532-08-702	EA VALVE,BI-AXIS	RAP9589
	100532-32-703	EA BUZZER - JACK WARNING	RAP90403
	100532-45-700	EA CYLINDER W/O FOOT - 6K X 13"	RAP90490
	100532-47-701	EA VALVE - BI-AXIS - W/O LEVERS	RAP0367
	117183-01-02B	EA COVER - SENSOR - LEVELING	
	117837-02-01B	EA SUPPORT-LEVELING,CNTRL,MILL	
	123264-01-000	EA TEE - UNION - 1/4" X 1/4" X 1/4"	

FROM: 00-00-00 THRU: 02-08-99

	120916-01-02B	EA BRACKET - PUMP - LEVELING SYSTEM	
	121177-01-02B	EA BRACKET - PASS REAR LEVEL JACK (STRAIGHT)/SLIDEOUT RM SYST PASSENGER SIDE BRACKET USED WITH STRAIGHT ACTING JACKS AND SLIDE-OUT ROOM	
	121177-02-02B	EA BRACKET - DRVR REAR LEVEL JACK (STRAIGHT)/SLIDEOUT RM SYST DRIVERS REAR STRAIGHT ACTING JACK BRACKET USED WITH THE SLIDE-OUT ROOM	
	121651-01-02B	EA CROSSMEMBER - REAR JACK MOUNTING	

HOSE KIT - LEVELING SYSTEM/JACKS

KEY	PART NUMBER	U/M DESCRIPTION	VENDOR NO.
	100536-10-000	EA HOSE KIT - LEVELING SYSTEM/JACKS	
	100536-09-700	EA HOSE-HYDRAULIC-324"	AP2464
	100536-09-701	EA HOSE-HYDRAULIC-60"	RAP4073
	100536-09-702	EA HOSE-HYDRAULIC-354"	RAP4311
	100536-10-700	EA HOSE-HYDRAULIC-84"	RAP1412
	100536-10-701	EA HOSE-HYDRAULIC-116"	RAP90349

CHASSIS GROUP (CONTINUED)

HWH LEVELING SYSTEM - W/SLIDEOUT OPTION - FORD

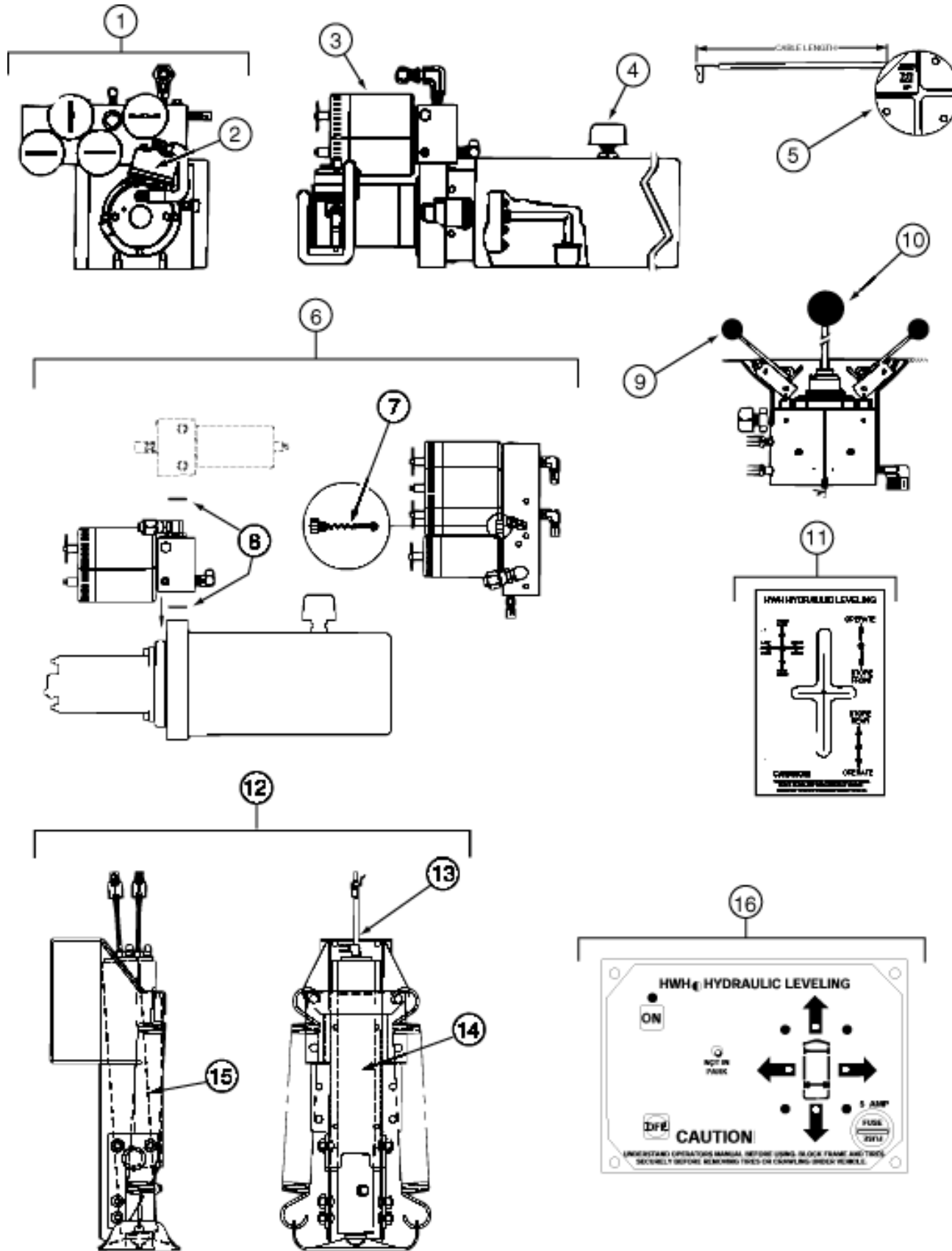

KEY	PART NUMBER	U/M DESCRIPTION	VENDOR NO.
	131306-02-000	EA LEVELING SYSTEM - OPERATES SLIDEOUT ROOM W/OUT JACKS DOWN	
1	100532-16-701	EA MANIFOLD ASM. F/SLIDE OUT	RAP1716
2	100532-09-710	EA SOLENOID-INTERMITTENT DUTY	RAP0533
3	100532-09-704	EA VALVE-PRESSURE SOLENOID	RAP0642
4	100532-03-715	EA CAP-BREATHER W/DIPSTICK	RAP7876
5	100532-12-703	EA SENSING UJNT BI-AXIS-27'	RAP6800
6	100532-01-713	EA PUMP-RESERVOIR ASM.-MONARCH	RAP90014
7	100532-31-701	EA CHECK VALVE & KIT	RAP10021
8	100532-31-702	EA O-RING/SEAL KIT - MANIFOLD	RAP90127
9	100532-08-705	EA KNOB-3/4" BLACK, SET OF FOUR	RAP1379
10	100532-08-706	EA KNOB-1 3/16" BLACK	RAP9734
11	100532-08-707	EA BEZEL W/GASKET, F/SYSTEM 200	RAP9592
12	100532-51-700	EA JACK - 6K STRAIGHT ACTING	RAP90502
13	100532-12-706	EA SWITCH - WARNING/MAGNETIC	RAP1008 / RAP90496
14	100532-53-700	EA CYLINDER ASM. - 9K	RAP90491
15	100532-12-707	EA SPRING KIT	R3847
16	100532-08-703	EA PANEL ASM.-200 BI-AXIS SYS.	RAP9755
	100532-03-722	EA O-RING KIT	R7430
	100532-03-723	EA O-RING/SEAL KIT	RAP9171
	100532-08-702	EA VALVE, BI-AXIS	RAP9589
	100532-32-703	EA BUZZER - JACK WARNING	RAP90403
	100532-45-700	EA CYLINDER W/O FOOT - 6K X 13"	RAP90490
	100532-47-701	EA VALVE - BI-AXIS - W/O LEVERS	RAP0367
	123264-01-000	EA TEE - UNION - 1/4" X 1/4" X 1/4"	
	117183-01-02B	EA COVER - SENSOR - LEVELING	FROM: 00-00-00 THRU: 02-08-99
	117837-02-01B	EA SUPPORT-LEVELING,CNTRL,MILL	FROM: 01-18-99 THRU: 99-99-99

HOSE KIT - LEVELING SYSTEM/JACKS

KEY	PART NUMBER	U/M DESCRIPTION	VENDOR NO.
	100536-10-000	EA HOSE KIT - LEVELING SYSTEM/JACKS	
	100536-09-700	EA HOSE-HYDRAULIC-324"	AP2464
	100536-09-701	EA HOSE-HYDRAULIC-60"	RAP4073
	100536-09-702	EA HOSE-HYDRAULIC-354"	RAP4311
	100536-10-700	EA HOSE-HYDRAULIC-84"	RAP1412
	100536-10-701	EA HOSE-HYDRAULIC-116"	RAP90349

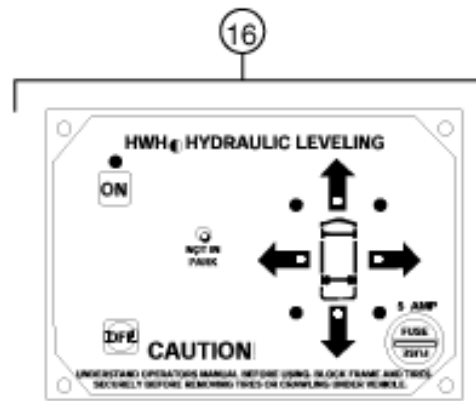

CHASSIS GROUP (CONTINUED)

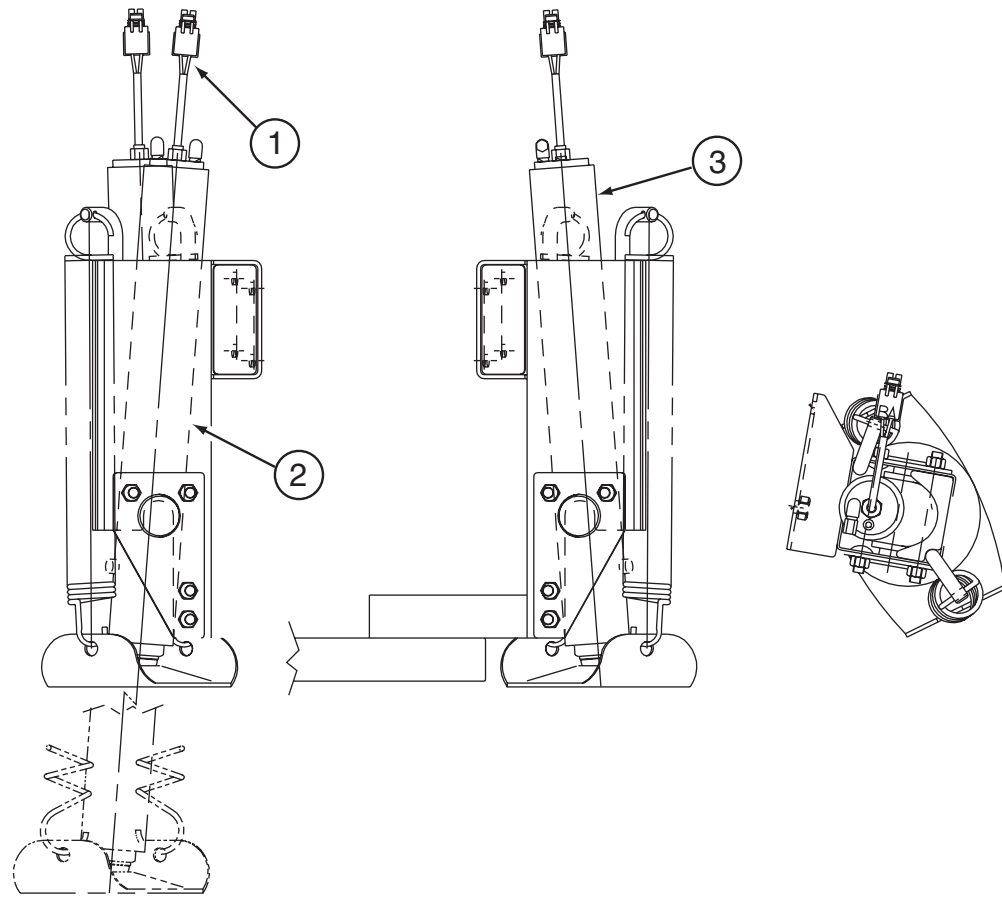

HWH LEVELING SYSTEM FRONT JACKS - W/SLIDEOUT OPTION - CHEVY

KEY	PART NUMBER	U/M	DESCRIPTION	VENDOR NO.
	128285-01-000	EA	JACK/CROSSMEMBER ASSEMBLY - FRONT - CHEVY THIS ASSEMBLY CONSISTS OF 2 FRONT JACKS AND A CROSSMEMBER	
1	100532-12-706	EA	SWITCH - WARNING/MAGNETIC	RAP1008 / RAP90496
2	100532-12-707	EA	SPRING KIT	R3847
3	100532-45-700	EA	CYLINDER W/O FOOT - 6K X 13"	RAP90490

CHASSIS GROUP (CONTINUED)

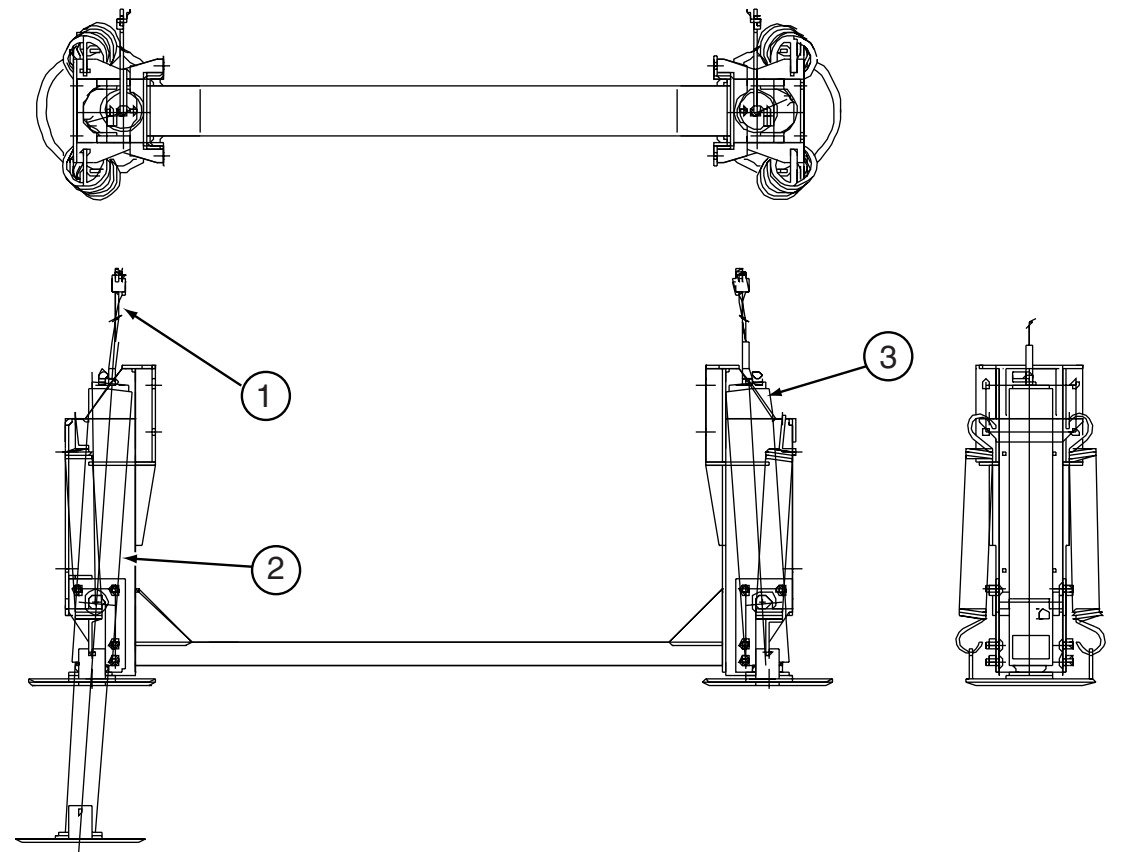

HWH LEVELING SYSTEM REAR JACKS - W/SLIDEOUT OPTION - FORD

KEY	PART NUMBER	U/M	DESCRIPTION	VENDOR NO.
	128571-03-000	EA	JACK ASSEMBLY - REAR LEVELING - W/CROSSMEMBER - MANUAL	
1	100532-12-706	EA	SWITCH - WARNING/MAGNETIC	RAP1008 / RAP90496
2	100532-12-707	EA	SPRING KIT	R3847
3	100532-53-700	EA	CYLINDER ASM. - 9K	RAP90491

CHASSIS GROUP (CONTINUED)

SHOCKS & STABILIZER KIT - FRONT (FROM: 00-00-00 THRU: 04-04-99)

KEY	PART NUMBER	U/M	DESCRIPTION	VENDOR NO.
	122756-02-000	EA	SHOCK AND STABILIZER (BLUE BOOT) KIT - FRONT END P30 CHASS NOTE: ORDER 70139029000, FOR AFTER MARKET INSTALLATION	
	122756-02-700	EA	BRACKET ASM - DRIVER SIDE	T818L
	122756-02-701	EA	BRACKET ASM - PASSENGER SIDE	T818R
	122756-02-704	EA	BOLT PACKAGE -BOLTS/NUTS ETC	T818B
	122756-02-705	EA	SHOCK	T818SH
	122756-02-706	EA	STUD - SHOCK MOUNTING	T818S
	122756-02-707	EA	DAMPNER - STEERING	T818SD
	122756-02-708	EA	BOOT - DAMPNER	T818SDB
	122756-02-709	EA	BUSHING PKG-STEERING DAMPNER	T818SDBSH
	122756-02-710	EA	BOLT PKG - STEERING DAMPNER	T818SBS

SHOCKS & STABILIZER KIT - FRONT (FROM: 04-05-99 THRU: 99-99-99)

KEY	PART NUMBER	U/M	DESCRIPTION	VENDOR NO.
	122756-03-000	EA	SHOCK & STABILIZER KIT (YELLOW SHOCK) - CHEVY	
	122756-02-706	EA	STUD - SHOCK MOUNTING	T818S
	122756-02-707	EA	DAMPNER - STEERING	T818SD
	122756-02-708	EA	BOOT - DAMPNER	T818SDB
	122756-02-709	EA	BUSHING PKG-STEERING DAMPNER	T818SDBSH
	122756-02-710	EA	BOLT PKG - STEERING DAMPNER	T818SBS
	122756-03-700	EA	BRACKET ASM-DRIVER SIDE	T818L-3
	122756-03-701	EA	BRACKET ASM-PASSENGER SIDE	T818R-3
	122756-03-702	EA	SHOCK	557003

LUG WRENCH & LEVERAGE BAR

KEY	PART NUMBER	U/M	DESCRIPTION
	080208-02-000	EA	BAR - LEVERAGE - LUG WRENCH - CHEVY/OSHKOSH
	080208-06-000	EA	LUG WRENCH - 1" X 1.06" W/DEEP SOCKET ENDS

CHASSIS MISCELLANEOUS

KEY	PART NUMBER	U/M	DESCRIPTION
	008042-01-000	FT	TUBING - VINYL - .65" ID
	008401-01-000	EA	STRAP - CONDUIT - 3/4" - 1 HOLE - GALVANIZED STEEL
	088498-02-000	EA	UNION - INVERTED FLARE - BRASS - 1/4
	053322-07-000	EA	SHIELD - HEAT - EXHAUST
	113007-01-000	EA	PIN - SPRING - .375 X 3"

CURTAIN & CUSHION GROUP

NOTICE

IN ORDER TO ASSIST OUR PARTS SALES DEPT. IN PROVIDING INTERIOR SOFTGOODS ITEMS, PLEASE INCLUDE THE SERIAL NUMBER AND THE COLOR CODE NUMBER FROM THE VEHICLE CERTIFICATION LABEL WHEN ORDERING. THIS LABEL IS LOCATED ON THE LEFT SIDEWALL AT THE END OF THE DASH (A-BODY),OR ON THE DRIVER'S DOOR LATCH PLATE (C-BODY).

AN EXAMPLE OF A COLOR CODE NUMBER IS B07, WHICH DESIGNATES AN OVERALL COLOR SCHEME OF A PARTICULAR UNIT. THE COLOR LISTED AFTER THE ITEM DESCRIPTION ON THE MICROFICHE, INDICATES THE OVERALL UNIT COLOR. ORDER THE ITEM YOU DESIRE ACCORDING TO UNIT COLOR CODE.

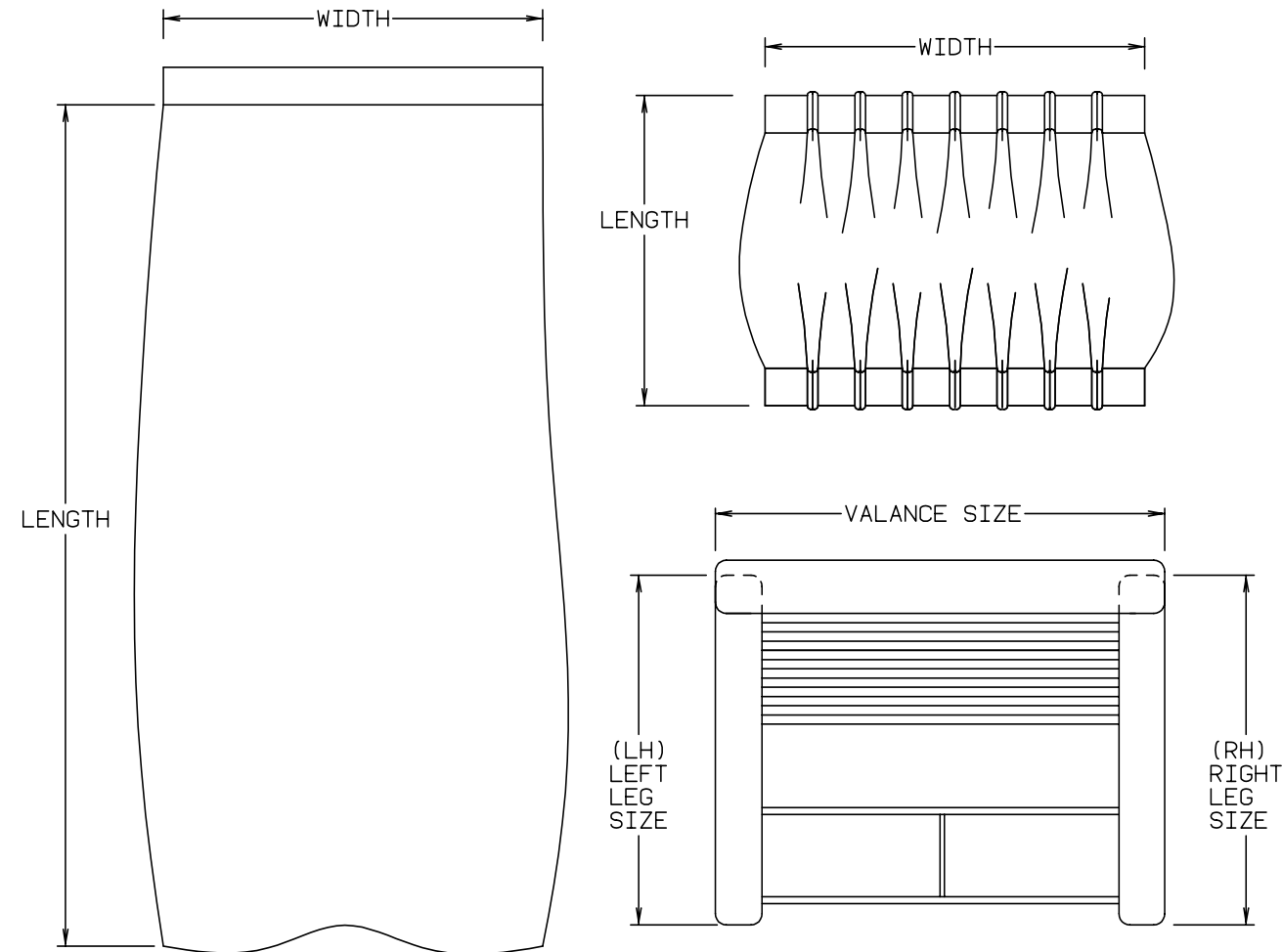

NOTE: USE THIS ILLUSTRATION WHEN DETERMINING LENGTH AND WIDTH MEASUREMENTS FOR CURTAINS. YOU WILL NOTE THE WIDTH MEASUREMENT IS TAKEN ON THE TOP OF THE CURTAIN WITH THE CURTAIN FULLY EXTENDED. THE LENGTH MEASUREMENT IS TAKEN FROM TOP TO BOTTOM. LEFT AND RIGHT WINDOW LEGS ARE DETERMINED WHEN FACING THE WINDOW.

CURTAIN & CUSHION GROUP (CONTINUED)

CURTAIN, BLIND HARDWARE & TRACKS

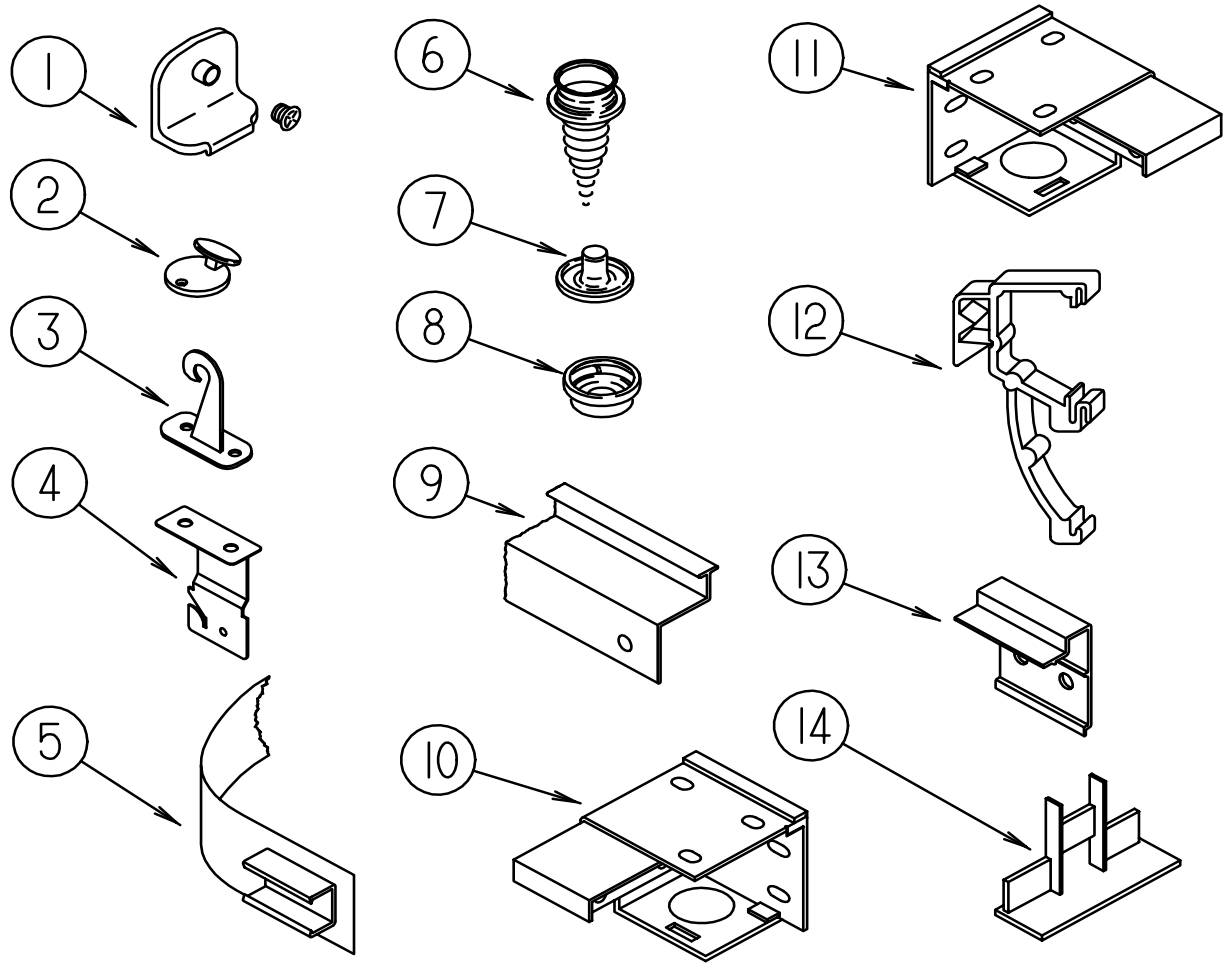

KEY	PART NUMBER	U/M	DESCRIPTION
1	106544-01-000	EA	PULL - SHADE/BRASS
1	106544-01-001	EA	SCREW - SHADE/BRASS
2	102555-03-000	EA	CLEAT - BLIND CORD - MILKY WHITE PLASTIC
3	109441-03-000	EA	HOLD DOWN - BLIND (CLOUDY)
	109441-02-000	EA	HOLD DOWN-SPACER
4	084434-01-000	EA	BRACKET - MOUNTING - ROLLER SHADE - 1 3/8"
	096843-01-000	EA	SPRING - REWIND/ROLLER SHADE
	086276-01-000	EA	TAPE - DOUBLE SIDED - 1/2"
5	101031-01-000	YD	TAPE - GLIDE/CURTAIN - 4.25" SPACING
6	029130-01-000	EA	SCREW - SNAP SOCKET - #8 PH X 5/8"
6	029130-03-000	EA	SCREW - SNAP SOCKET - #8 PH X 1"
7	029155-01-000	EA	CAP - SNAP - 5/32" OUTSIDE DIAMETER OF PIN
8	029156-01-000	EA	SOCKET - SNAP - 9/16" O.D.
9	127254-03-02A	EA	TRACK - CURTAIN/RIGHT HAND - ANTELOPE
			FROM: 00-00-00 THRU: 10-11-98
9	127254-14-02A	EA	TRACK - CURTAIN/RIGHT HAND - ANTELOPE
			FROM: 10-12-98 THRU: 99-99-99
9	127254-08-02A	EA	TRACK - CURTAIN/LEFT HAND - ANTELOPE
10	083170-01-000	EA	BRACKET - BLIND - LEFT SIDE WHEN FACING WINDOW
11	083170-02-000	EA	BRACKET - BLIND - RIGHT SIDE WHEN FACING WINDOW
12	109353-04-000	EA	CLIP - VALANCE SLAT MOUNTING - CLEAR PLASTIC
13	097565-01-000	EA	BRACKET - MOUNTING/PLEATED BLIND
14	094907-02-000	EA	END CAP - TOP/PLEATED BLIND - PLASTIC - GRAY
	097592-02-000	EA	SPOOL - CORD - ELEVATED BLIND HOLDUP - LARGE - CLEAR
	046867-02-000	EA	WASHER - HANDY BUTTON #3
	046867-03-000	EA	GROMMET - HANDY BUTTON #3
	056003-01-000	EA	BRACKET - DRAPERY RETAINING - FRONT - METAL
	056003-02-000	EA	BRACKET - DRAPERY RETAINING - REAR - METAL
	083125-07-000	EA	BRACE - COUCH - 2.5" - OFF WHITE
			USED TO SUPPORT DINETTE PADS & CURTAIN LEGS
	083125-08-000	EA	BRACE - WINDOW MOUNT - 3/4 - OFF WHITE
	068716-01-001	EA	BRACE - 90 DEGREE L-ANGLE - 16'
	075943-06-000	EA	BRACE-L-SHAPED - 8" LONG - ALUMINUM - BEIGE
	094896-02-000	EA	GROMMET - CORD/PLEATED BLIND - NYLON - GRAY
	094907-04-000	EA	END CAP - BOTTOM/PLEATED BLIND (RH & LH)
	097564-03-000	EA	HANDLE - KNOB - E-Z LIFT SHADE - TAN (K20,K21)
	097564-04-000	EA	HANDLE - KNOB - E-Z LIFT SHADE - NAVY (K22)
	097564-05-000	EA	HANDLE - KNOB - E-Z LIFT SHADE - TEAL (K23)
	097591-01-000	EA	SPRING - EXTENSION/PLEATED BLIND
	097593-02-000	FT	CORD - BLIND - PLEATED - GRAY (K20,K21)
	097593-06-000	FT	CORD - BLIND - PLEATED - PEWTER (K22)
	097593-07-000	FT	CORD - BLIND - PLEATED - PALE JADE (K23)
	095567-01-000	EA	TACK - STRIP - .5" X 625' ROLL
	105648-01-02A	EA	BRACE - VALANCE - OFF/WHITE - 14"

CURTAIN & CUSHION GROUP (CONTINUED)

WINDOW TREATMENT

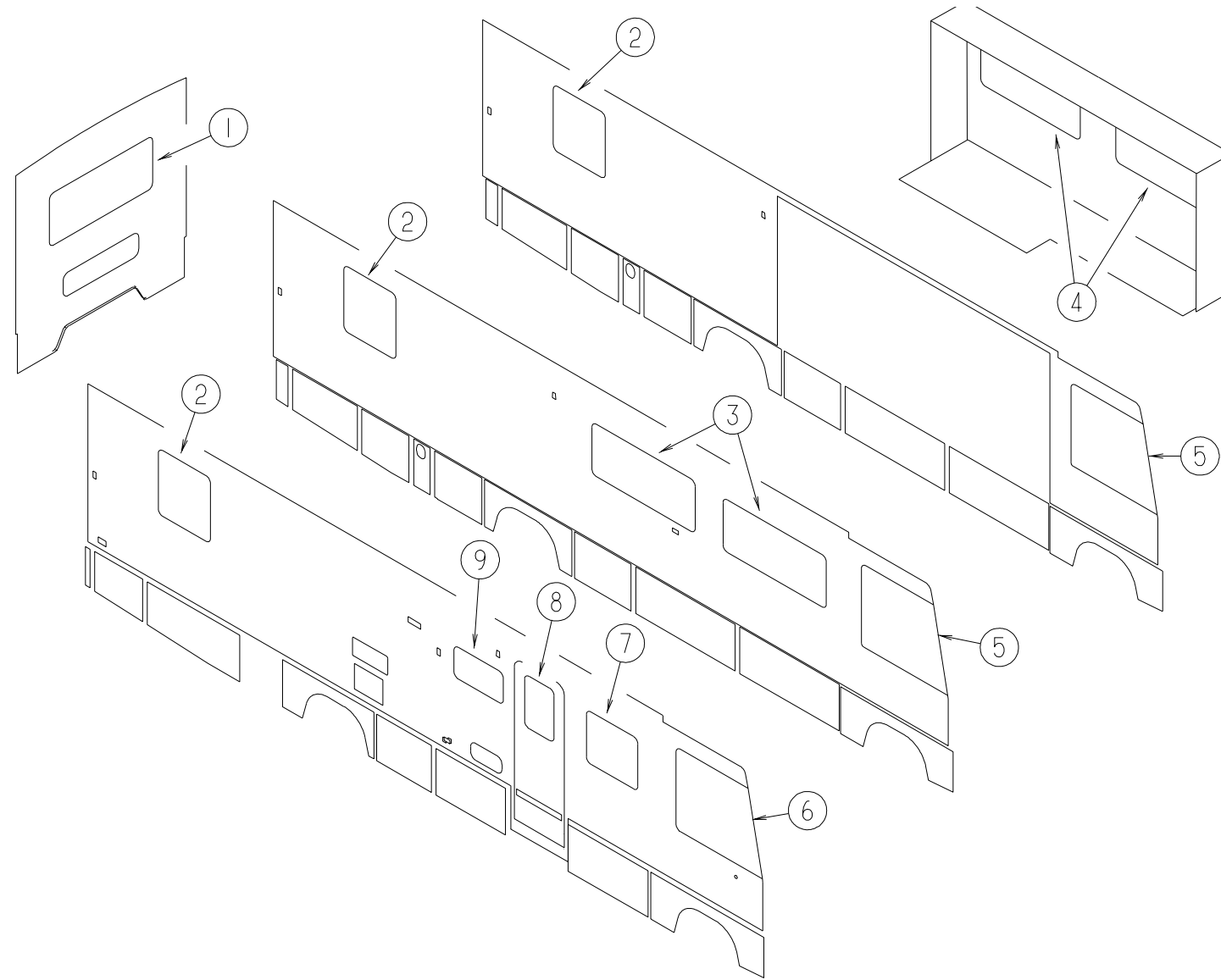

KEY	PART NUMBER	U/M	DESCRIPTION
1	127019-01-K20	EA	VALANCE - SARAH - 53"
1	127019-01-K21	EA	VALANCE - SARAH - 53"
1	127019-01-K22	EA	VALANCE - SARAH - 53"
1	127019-01-K23	EA	VALANCE - SARAH - 53"
1	127017-07-J06	EA	LEG - RIGHT - 25" (K20)
1	127017-07-K21	EA	LEG - RIGHT - 25" (K21)
1	127017-07-J30	EA	LEG - RIGHT - 25" (K22)
1	127017-07-K23	EA	LEG - RIGHT - 25" (K23)
1	127017-08-J06	EA	LEG - LEFT - 25" (K20)
1	127017-08-K21	EA	LEG - LEFT - 25" (K21)
1	127017-08-J30	EA	LEG - LEFT - 25" (K22)
1	127017-08-K23	EA	LEG - LEFT - 25" (K23)
1	111910-62-K58	EA	BLIND - DAY/NIGHTER - 49" X 27" (K20,K21)
1	111910-62-K22	EA	BLIND - DAY/NIGHTER - 49" X 27" (K22)
1	111910-62-K23	EA	BLIND - DAY/NIGHTER - 49" X 27" (K23)
2	127019-02-K20	EA	VALANCE - SARAH - 34"
2	127019-02-K21	EA	VALANCE - SARAH - 34"
2	127019-02-K22	EA	VALANCE - SARAH - 34"
2	127019-02-K23	EA	VALANCE - SARAH - 34"
2	127017-09-J24	EA	LEG - RIGHT - 34" (K20)
2	127017-09-K21	EA	LEG - RIGHT - 34" (K21)
2	127017-09-J30	EA	LEG - RIGHT - 34" (K22)
2	127017-09-K23	EA	LEG - RIGHT - 34" (K23)

KEY	PART NUMBER	U/M	DESCRIPTION
2	127017-10-J24	EA	LEG - LEFT - 34" (K20)
2	127017-10-K21	EA	LEG - LEFT - 34" (K21)
2	127017-10-J30	EA	LEG - LEFT - 34" (K22)
2	127017-10-K23	EA	LEG - LEFT - 34" (K23)
2	111910-58-K58	EA	BLIND - DAY/NIGHTER - 31" X 37" (K20,K21)
2	111910-58-K22	EA	BLIND - DAY/NIGHTER - 31" X 37" (K22)
2	111910-58-K23	EA	BLIND - DAY/NIGHTER - 31" X 37" (K23)
3	119136-43-K20	EA	VALANCE - STANWICK - 64.5"
3	119136-43-K21	EA	VALANCE - STANWICK - 64.5"
3	119136-43-K22	EA	VALANCE - STANWICK - 64.5"
3	119136-43-K23	EA	VALANCE - STANWICK - 64.5"
3	127017-11-J06	EA	LEG - RIGHT - 25" (K20)
3	127017-11-K21	EA	LEG - RIGHT - 25" (K21)
3	127017-11-K22	EA	LEG - RIGHT - 25" (K22)
3	127017-11-K23	EA	LEG - RIGHT - 25" (K23)
3	127017-12-J06	EA	LEG - LEFT - 25" (K20)
3	127017-12-K21	EA	LEG - LEFT - 25" (K21)
3	127017-12-K22	EA	LEG - LEFT - 25" (K22)
3	127017-12-K23	EA	LEG - LEFT - 25" (K23)
3	111910-57-K58	EA	BLIND - DAY/NIGHTER - 61" X 28.5" (K20,K21)
3	111910-57-K22	EA	BLIND - DAY/NIGHTER - 61" X 28.5" (K22)
3	111910-57-K23	EA	BLIND - DAY/NIGHTER - 61" X 28.5" (K23)

CURTAIN & CUSHION GROUP (CONTINUED)

WINDOW TREATMENT (CONTINUED)

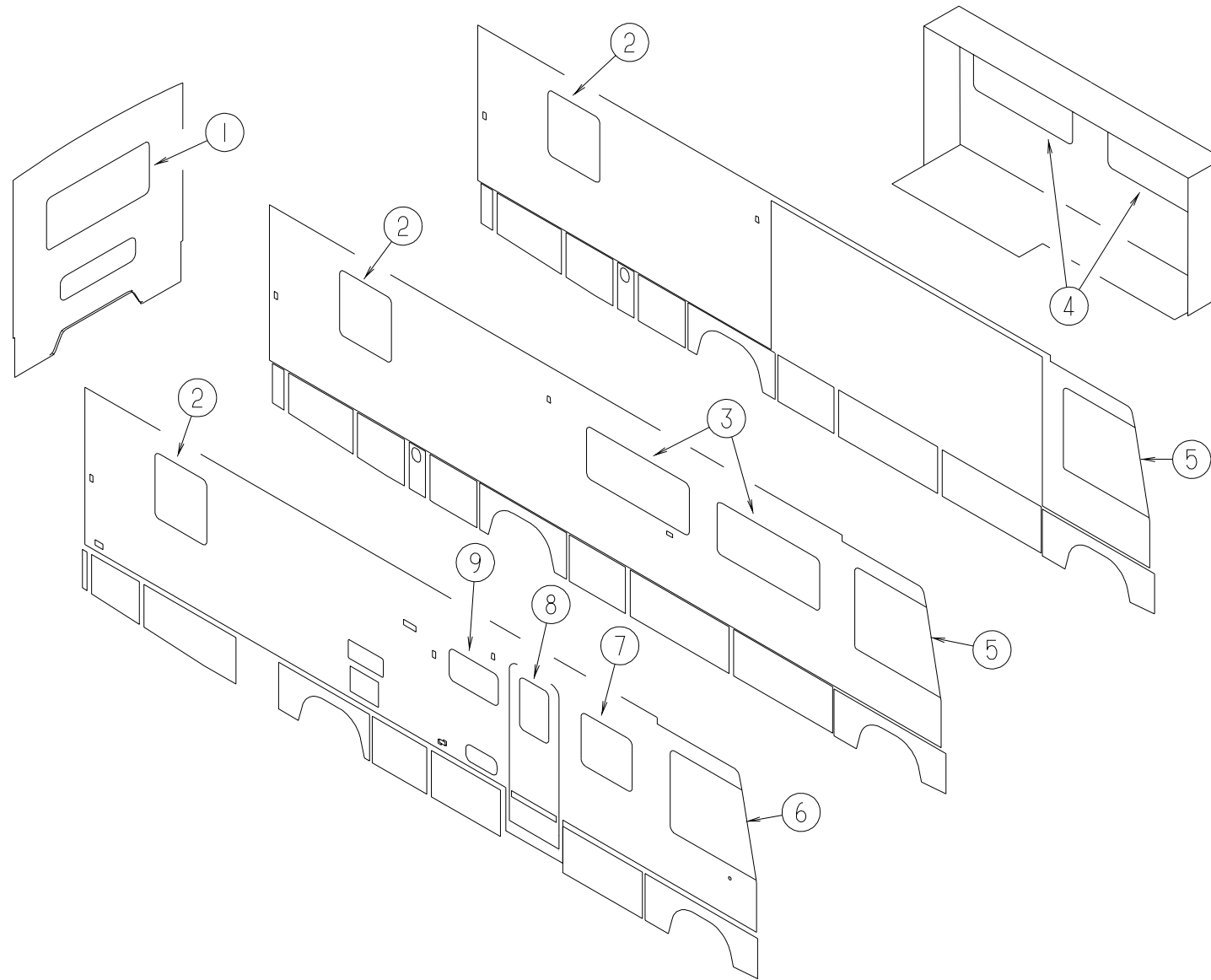

KEY	PART NUMBER	U/M	DESCRIPTION
4	119136-49-K20	EA	VALANCE - STANWICK - 62.5"
4	119136-49-K21	EA	VALANCE - STANWICK - 62.5"
4	119136-49-K22	EA	VALANCE - STANWICK - 62.5"
4	119136-49-K23	EA	VALANCE - STANWICK - 62.5"
4	127017-43-K20	EA	LEG - RIGHT - 23.5" (K20)
4	127017-43-K21	EA	LEG - RIGHT - 23.5" (K21)
4	127017-43-K22	EA	LEG - RIGHT - 23.5" (K22)
4	127017-43-K32	EA	LEG - RIGHT - 23.5" (K23)
4	127017-44-K20	EA	LEG - LEFT - 23.5" (K20)
4	127017-44-K21	EA	LEG - LEFT - 23.5" (K21)
4	127017-44-K22	EA	LEG - LEFT - 23.5" (K22)
4	127017-44-K32	EA	LEG - LEFT - 23.5" (K23)
4	111910-55-K28	EA	BLIND - DAY/NIGHTER - 59" X 26.5" (K20,K21)
4	111910-55-K22	EA	BLIND - DAY/NIGHTER - 59" X 26.5" (K22)
4	111910-55-K23	EA	BLIND - DAY/NIGHTER - 59" X 26.5" (K23)
5	101668-68-J38	EA	CURTAIN - LEFT HAND - 42" X 106"
6	101668-67-J38	EA	CURTAIN - RIGHT HAND - 42" X 106"
	073260-42-D10	EA	TIEBACK - 6" X 18"
7	119136-44-K20	EA	VALANCE - STANWICK - 31.5"
7	119136-44-K21	EA	VALANCE - STANWICK - 31.5"
7	119136-44-K22	EA	VALANCE - STANWICK - 31.5"
7	119136-44-K23	EA	VALANCE - STANWICK - 31.5"

KEY	PART NUMBER	U/M	DESCRIPTION
7	127017-11-J06	EA	LEG - RIGHT - 25" (K20)
7	127017-11-K21	EA	LEG - RIGHT - 25" (K21)
7	127017-11-K22	EA	LEG - RIGHT - 25" (K22)
7	127017-11-K23	EA	LEG - RIGHT - 25" (K23)
7	127017-12-J06	EA	LEG - LEFT - 25" (K20)
7	127017-12-K21	EA	LEG - LEFT - 25" (K21)
7	127017-12-K22	EA	LEG - LEFT - 25" (K22)
7	127017-12-K23	EA	LEG - LEFT - 25" (K23)
7	111910-59-K66	EA	BLIND - DAY/NIGHTER - 31" X 28.5" (K20,K21)
7	111910-59-J30	EA	BLIND - DAY/NIGHTER - 31" X 28.5" (K22)
7	111910-59-K32	EA	BLIND - DAY/NIGHTER - 31" X 28.5" (K23)
8	119136-48-K20	EA	VALANCE - STANWICK - 15" X 36"
8	119136-48-K21	EA	VALANCE - STANWICK - 35"
8	119136-48-K22	EA	VALANCE - STANWICK - 35"
8	119136-48-K23	EA	VALANCE - STANWICK - 35"
8	120820-43-K20	EA	VALANCE - 36" - W/CLOCK CUTOUT
8	120820-43-K21	EA	VALANCE - 36" - W/CLOCK CUTOUT
8	120820-43-K22	EA	VALANCE - 36" - W/CLOCK CUTOUT
8	120820-43-K23	EA	VALANCE - 36" - W/CLOCK CUTOUT
8	084755-57-E07	EA	SHADE - PULL - 27.25"
9	109041-58-02A	EA	BLIND - MINI - 30.5" X 17" (K20,K21)
9	109041-58-01A	EA	BLIND - MINI - 30.5" X 17" (K22,K23)

CURTAIN & CUSHION GROUP (CONTINUED)

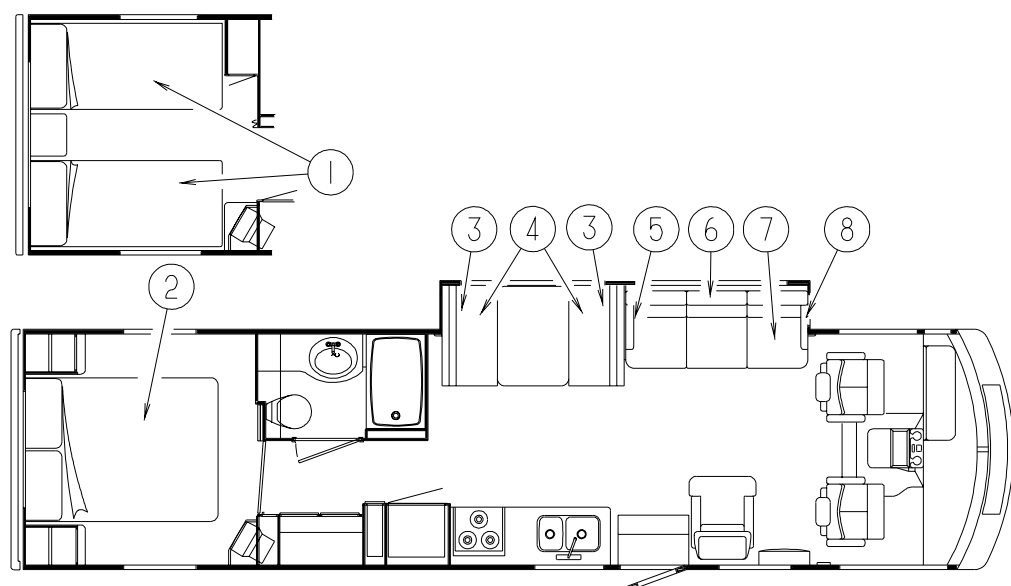

DINETTE CUSHIONS

KEY	PART NUMBER	U/M DESCRIPTION
3	111897-05-J06	EA CUSHION - BACK - 13.5" X 42" X 5" (K20)
3	111897-05-K21	EA CUSHION - BACK - 13.5" X 42" X 5" (K21)
3	111897-05-K22	EA CUSHION - BACK - 13.5" X 42" X 5" (K22)
3	111897-05-K23	EA CUSHION - BACK - 13.5" X 42" X 5" (K23)
	P11897-05-J06	EA COVER - BACK - 13.5" X 42" X 5" (K20)
	P11897-05-K21	EA COVER - BACK - 13.5" X 42" X 5" (K21)
	P11897-05-K22	EA COVER - BACK - 13.5" X 42" X 5" (K22)
	P11897-05-K23	EA COVER - BACK - 13.5" X 42" X 5" (K23)
4	105603-15-J06	EA CUSHION - SEAT - 23" X 42" X 5" (K20)
4	105603-15-K21	EA CUSHION - SEAT - 23" X 42" X 5" (K21)
4	105603-15-K22	EA CUSHION - SEAT - 23" X 42" X 5" (K22)
4	105603-15-K23	EA CUSHION - SEAT - 23" X 42" X 5" (K23)
	P05603-15-J06	EA COVER - SEAT - 23" X 42" X 5" (K20)
	P05603-15-K21	EA COVER - SEAT - 23" X 42" X 5" (K21)
	P05603-15-K22	EA COVER - SEAT - 23" X 42" X 5" (K22)
	P05603-15-K23	EA COVER - SEAT - 23" X 42" X 5" (K23)

SOFA/BED

KEY	PART NUMBER	U/M DESCRIPTION
5	130718-01-K20	EA ARMREST - REMOVABLE/RIGHT HAND
5	130718-01-K21	EA ARMREST - REMOVABLE RIGHT HAND
5	130718-01-K22	EA ARMREST - REMOVABLE RIGHT HAND
5	130718-01-K23	EA ARMREST - REMOVABLE RIGHT HAND
	P30718-01-K20	EA COVER - ARMREST - REMOVABLE/RIGHT HAND
	P30718-01-K21	EA COVER - ARMREST - REMOVABLE/RIGHT HAND
	P30718-01-K22	EA COVER - ARMREST - REMOVABLE/RIGHT HAND
	P30718-01-K23	EA COVER - ARMREST - REMOVABLE/RIGHT HAND
	127335-08-000	EA BRACKET - REMOVABLE ARM/COUCH
	127335-09-000	EA BRACKET - REMOVABLE ARM/CUSHION
6	130573-01-K20	EA BED - BACK - 74"
6	130573-01-K21	EA BED - BACK - 74"
6	130573-01-K22	EA BED - BACK - 74"
6	130573-01-K23	EA BED - BACK - 74"
	P30573-01-K20	EA COVER - BACK - SOFA/BED - 74"
	P30573-01-K21	EA COVER - BACK - SOFA/BED - 74"
	P30573-01-K22	EA COVER - BACK - SOFA/BED - 74"
	P30573-01-K23	EA COVER - BACK - SOFA/BED - 74"
7	130573-02-K20	EA BED - SEAT - 74"
7	130573-02-K21	EA BED - SEAT - 74"
7	130573-02-K22	EA BED - SEAT - 74"
7	130573-02-K23	EA BED - SEAT - 74"
	P30573-02-K20	EA COVER - SEAT - SOFA/BED - 74"
	P30573-02-K21	EA COVER - SEAT - SOFA/BED - 74"
	P30573-02-K22	EA COVER - SEAT - SOFA/BED - 74"
	P30573-02-K23	EA COVER - SEAT - SOFA/BED - 74"
8	130718-02-K20	EA ARMREST - REMOVABLE/LEFT HAND
8	130718-02-K21	EA ARMREST - REMOVABLE/LEFT HAND
8	130718-02-K22	EA ARMREST - REMOVABLE/LEFT HAND
8	130718-02-K23	EA ARMREST - REMOVABLE/LEFT HAND
	P30718-02-K20	EA COVER - ARMREST - REMOVABLE/LEFT HAND
	P30718-02-K21	EA COVER - ARMREST - REMOVABLE/LEFT HAND
	P30718-02-K22	EA COVER - ARMREST - REMOVABLE/LEFT HAND
	P30718-02-K23	EA COVER - ARMREST - REMOVABLE/LEFT HAND
	127335-08-000	EA BRACKET - REMOVABLE ARM/COUCH
	127335-09-000	EA BRACKET - REMOVABLE ARM/CUSHION
	111637-22-K20	EA PILLOW - 14"
	111637-22-K21	EA PILLOW - 14"
	111637-22-K22	EA PILLOW - 14"
	111637-22-K23	EA PILLOW - 14"

TWIN MATTRESS & BEDSPREAD

KEY	PART NUMBER	U/M DESCRIPTION
1	123015-04-000	EA MATTRESS - INNERSPRING - 36" X 79.5"
1	123471-09-J06	EA BEDSPREAD/THROW - 36" X 80" (K20)
1	123471-09-J36	EA BEDSPREAD/THROW - 36" X 80" (K21)
1	123471-09-K22	EA BEDSPREAD/THROW - 36" X 80" (K22)
1	123471-09-K23	EA BEDSPREAD/THROW - 36" X 80" (K23)
	111863-13-K20	EA PILLOW SHAM - 22" X 37"
	111863-13-K21	EA PILLOW SHAM - 22" X 37"
	111863-13-K22	EA PILLOW SHAM - 22" X 37"
	111863-13-K23	EA PILLOW SHAM - 22" X 37"
	103669-24-K20	EA PILLOW - 14" X 14"
	103669-24-K21	EA PILLOW - 14" X 14"
	103669-24-K22	EA PILLOW - 14" X 14"
	103669-24-K23	EA PILLOW - 14" X 14"

QUEEN MATTRESS & BEDSPREAD

KEY	PART NUMBER	U/M DESCRIPTION
2	123015-07-000	EA MATTRESS - INNERSPRING - 60" X 79.5"
2	123471-23-K20	EA BEDSPREAD/THROW - 60" X 80" (K20)
2	123471-23-J01	EA BEDSPREAD/THROW - 60" X 80" (K21)
2	123471-23-K22	EA BEDSPREAD/THROW - 60" X 80" (K22)
2	123471-23-K23	EA BEDSPREAD/THROW - 60" X 80" (K23)
	111863-12-K20	EA PILLOW SHAM - 20" X 33"
	111863-12-K21	EA PILLOW SHAM - 20" X 33"
	111863-12-K22	EA PILLOW SHAM - 20" X 33"
	111863-12-K23	EA PILLOW SHAM - 20" X 33"
	103669-24-K20	EA PILLOW - 14" X 14"
	103669-24-K21	EA PILLOW - 14" X 14"
	103669-24-K22	EA PILLOW - 14" X 14"
	103669-24-K23	EA PILLOW - 14" X 14"

NOTE: COUCH FRONT AND SIDE PANELS ARE FOUND IN THE LOUNGE GROUP

CURTAIN & CUSHION GROUP (CONTINUED)

LOUNGE SWIVEL CHAIR

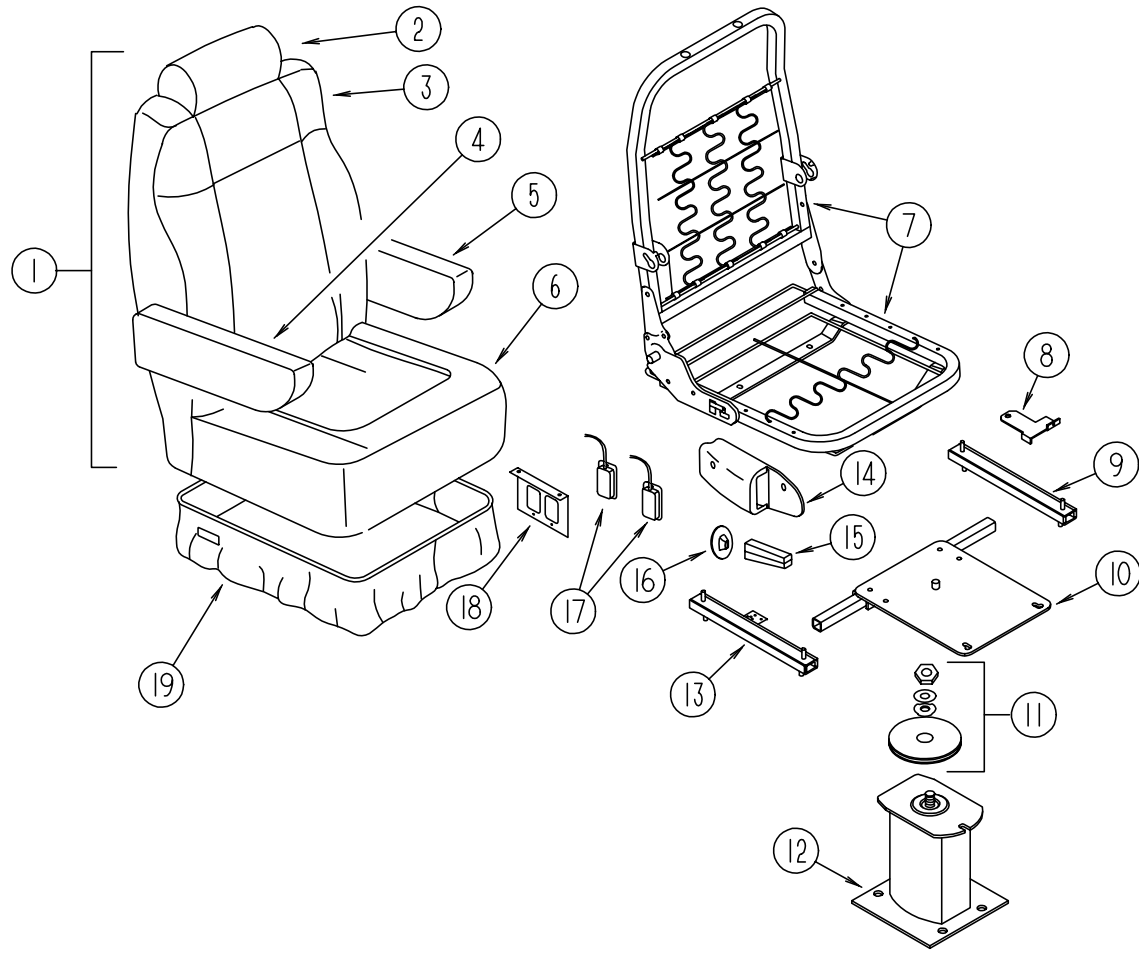

KEY	PART NUMBER	U/M	DESCRIPTION
1	127540-12-K20	EA	SEAT - BUCKET - MANUAL RECLINE - WIDE
1	127540-12-K21	EA	SEAT - BUCKET - MANUAL RECLINE - WIDE
1	127540-12-K22	EA	SEAT - BUCKET - MANUAL RECLINE - WIDE
1	127540-12-K23	EA	SEAT - BUCKET - MANUAL RECLINE - WIDE
2	127601-02-K20	EA	HEADREST (K20)
2	127601-02-K21	EA	HEADREST (K21)
2	127601-02-K22	EA	HEADREST (K22)
2	127601-02-K18	EA	HEADREST (K23)
	P27601-02-K48	EA	COVER - HEADREST (K20)
	P27601-02-K21	EA	COVER - HEADREST (K21)
	P27601-02-K22	EA	COVER - HEADREST (K22)
	P27601-02-K18	EA	COVER - HEADREST (K23)
3	M05962-67-K20	EA	COVER - BACK
3	M05962-67-K21	EA	COVER - BACK
3	M05962-67-K22	EA	COVER - BACK
3	M05962-67-K23	EA	COVER - BACK
4	122780-01-K06	EA	ARMREST - RIGHT HAND (K20)
4	122780-01-H30	EA	ARMREST - RIGHT HAND (K21)
4	122780-01-K22	EA	ARMREST - RIGHT HAND (K22)
4	122780-01-H02	EA	ARMREST - RIGHT HAND (K23)
	P22780-01-K06	EA	COVER - ARMREST - RIGHT HAND (K20)
	P22780-01-H30	EA	COVER - ARMREST - RIGHT HAND (K21)
	P22780-01-K22	EA	COVER - ARMREST - RIGHT HAND (K22)
	P22780-01-H02	EA	COVER - ARMREST - RIGHT HAND (K23)
	115617-03-000	EA	ARMREST - W/O COVER - RIGHT HAND
5	122780-02-J06	EA	ARMREST - LEFT HAND (K20)
5	122780-02-J26	EA	ARMREST - LEFT HAND (K21)
5	122780-02-K22	EA	ARMREST - LEFT HAND (K22)
5	122780-02-H02	EA	ARMREST - LEFT HAND (K23)
	P22780-02-J06	EA	COVER - ARMREST - LEFT HAND (K20)
	P22780-02-J26	EA	COVER - ARMREST - LEFT HAND (K21)
	P22780-02-K22	EA	COVER - ARMREST - LEFT HAND (K22)
	P22780-02-H02	EA	COVER - ARMREST - LEFT HAND (K23)
	115617-04-000	EA	ARMREST - W/O COVER - LEFT HAND
6	M05962-68-K20	EA	COVER - SEAT
6	M05962-68-K21	EA	COVER - SEAT
6	M05962-68-K22	EA	COVER - SEAT
6	M05962-68-K23	EA	COVER - SEAT
7	122695-01-01B	EA	FRAME - SEAT/BACK
8	117125-01-02B	EA	BRACKET - CABLE MOUNT - ADJUSTER W/LOCK
9	119952-02-000	EA	SLIDE/SEAT - HEAVY DUTY NON LOCKING
	119952-07-000	EA	WIRE - LATCH RELEASE/ROTARY
10	107921-05-000	EA	PLATE - TOP - W/SEAT BELT BAR
11	107921-06-000	EA	BEARING KIT - PEDESTAL
12	107921-01-000	EA	PEDESTAL/FLOOR MOUNTED - W/9.75" EXTENSION
13	119952-04-000	EA	SLIDE/SEAT - HEAVY DUTY LOCKING - 4 STUDS
14	080730-09-000	EA	SHIELD - RECLINER HANDLE
15	080730-08-000	EA	HANDLE - RECLINER
16	080730-11-000	EA	SHIELD - RUBBER BOOT
17	108049-04-000	EA	CABLE - W/SWITCHES - W/26" MINI LEVER ACTION
	108049-02-000	EA	CLIP - CABLE/PEDESTAL
18	127159-02-02B	EA	BRACKET - SEAT RELEASE - DUAL REMOTE
19	071126-66-K48	EA	SKIRT - BUCKET/LARGE (K20)
19	071126-66-J45	EA	SKIRT - BUCKET/LARGE (K21)
19	071126-66-K22	EA	SKIRT - BUCKET/LARGE (K22)
19	071126-66-K18	EA	SKIRT - BUCKET/LARGE (K23)
	108445-02-000	EA	PLATE/FLOOR MOUNTED - PEDESTAL SEAT

CURTAIN & CUSHION GROUP (CONTINUED)

BUCKET SEAT W/O LUMBAR

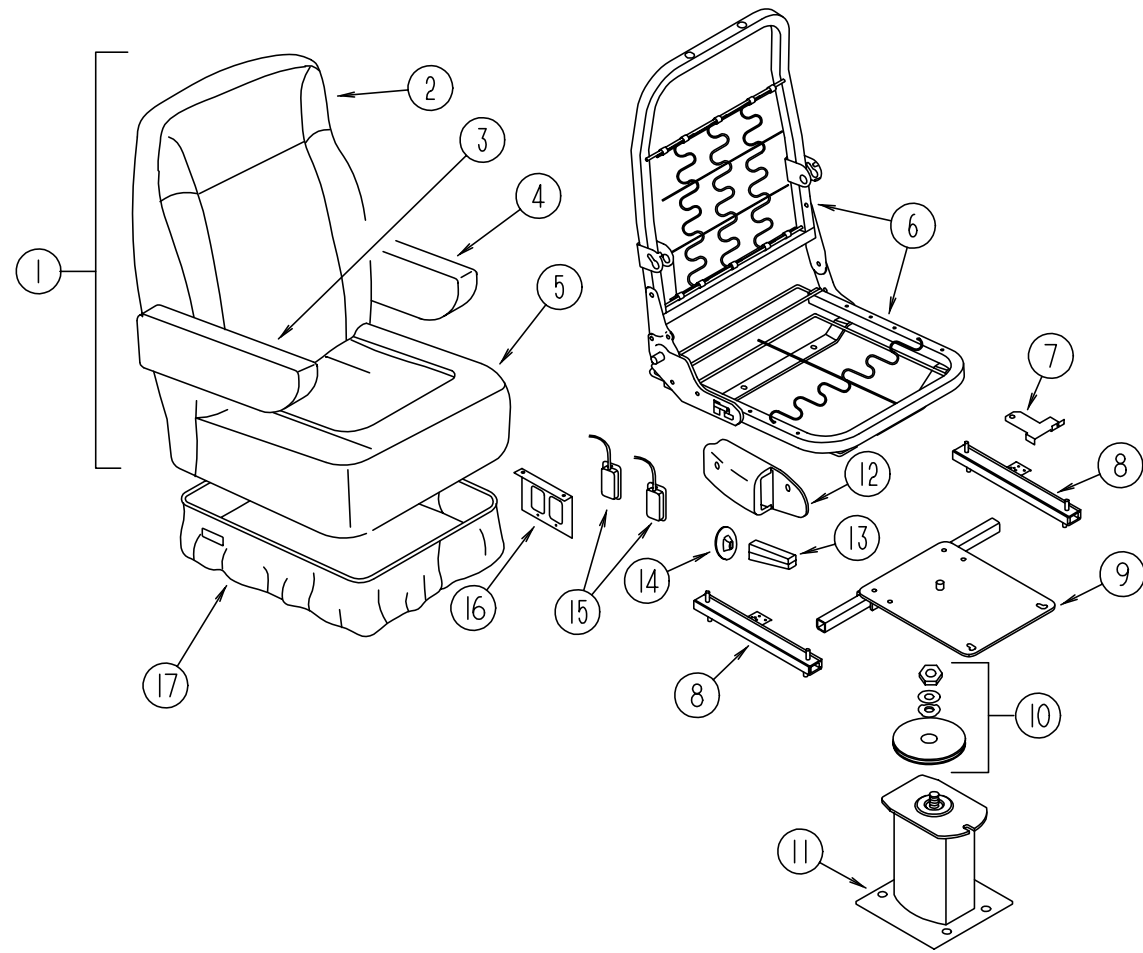

KEY	PART NUMBER	U/M	DESCRIPTION
1	129664-01-K20	EA	SEAT - BUCKET - WIDE/MANUAL RECLINE
1	129664-01-K21	EA	SEAT - BUCKET - WIDE/MANUAL RECLINE
1	129664-01-K22	EA	SEAT - BUCKET - WIDE/MANUAL RECLINE
1	129664-01-K23	EA	SEAT - BUCKET - WIDE/MANUAL RECLINE
2	M05962-80-K20	EA	COVER - BACK
2	M05962-80-K21	EA	COVER - BACK
2	M05962-80-K22	EA	COVER - BACK
2	M05962-80-K23	EA	COVER - BACK
3	129666-01-K48	EA	ARMREST - RIGHT HAND (K20)
3	129666-01-K21	EA	ARMREST - RIGHT HAND (K21)
3	129666-01-K22	EA	ARMREST - RIGHT HAND (K22)
3	129666-01-K18	EA	ARMREST - RIGHT HAND (K23)
	P29666-01-K48	EA	COVER - ARMREST - RIGHT HAND (K20)
	P29666-01-K21	EA	COVER - ARMREST - RIGHT HAND (K21)
	P29666-01-K22	EA	COVER - ARMREST - RIGHT HAND (K22)
	P29666-01-K18	EA	COVER - ARMREST - RIGHT HAND (K23)
4	129666-02-K48	EA	ARMREST - LEFT HAND (K20)
4	129666-02-K21	EA	ARMREST - LEFT HAND (K21)
4	129666-02-K22	EA	ARMREST - LEFT HAND (K22)
4	129666-02-K18	EA	ARMREST - LEFT HAND (K23)
	P29666-02-K48	EA	COVER - ARMREST - LEFT HAND (K20)
	P29666-02-K21	EA	COVER - ARMREST - LEFT HAND (K21)
	P29666-02-K22	EA	COVER - ARMREST - LEFT HAND (K22)
	P29666-02-K18	EA	COVER - ARMREST - LEFT HAND (K23)
5	M05962-81-K20	EA	COVER - SEAT
5	M05962-81-K21	EA	COVER - SEAT
5	M05962-81-K22	EA	COVER - SEAT
5	M05962-81-K23	EA	COVER - SEAT
6	122695-04-01B	EA	FRAME - SEAT/HIGH BACK
7	117125-01-02B	EA	BRACKET - CABLE MOUNT - ADJUSTER W/LOCK
8	119952-04-000	EA	SLIDE/SEAT - HEAVY DUTY LOCKING - 4 STUDS
	119952-07-000	EA	WIRE - LATCH RELEASE/ROTARY
9	107921-05-000	EA	PLATE - TOP - W/SEAT BELT BAR
10	107921-06-000	EA	BEARING KIT - PEDESTAL
11	107921-01-000	EA	PEDESTAL/FLOOR MOUNTED - W/9.75" EXTENSION
12	080730-09-000	EA	SHIELD - RECLINER HANDLE
13	080730-08-000	EA	HANDLE - RECLINER
14	080730-11-000	EA	SHIELD - RUBBER BOOT
15	108049-04-000	EA	CABLE - W/SWITCHES - W/26" MINI LEVER ACTION
	108049-02-000	EA	CLIP - CABLE/PEDESTAL
16	127159-02-02B	EA	BRACKET - SEAT RELEASE - REMOTE
17	071126-68-K48	EA	SKIRT - WIDE - 10.5" OPEN CORNER (STANDARD & 6-WAY POWER) (K20)
17	071126-68-K21	EA	SKIRT - WIDE - 10.5" OPEN CORNER (STANDARD & 6-WAY POWER) (K21)
17	071126-68-K22	EA	SKIRT - WIDE - 10.5" OPEN CORNER (STANDARD & 6-WAY POWER) (K22)
17	071126-68-K18	EA	SKIRT - WIDE - 10.5" OPEN CORNER (STANDARD & 6-WAY POWER) (K23)

CURTAIN & CUSHION GROUP (CONTINUED)

BUTTON, TRIM, ASSIST HANDLE & SEAT BELT

KEY	PART NUMBER	U/M	DESCRIPTION
	070578-02-B10	EA	BUTTON - SCREW - STUD - #30 VINYL
	079349-04-J06	YD	WELT - NARROW (K20)
	079349-04-H17	YD	WELT - NARROW (K21)
	079349-04-K22	YD	WELT - NARROW (K22)
	079349-04-GC1	YD	WELT - NARROW (K23)
	007021-01-000	EA	SEAT BELT - 2" X 90" - BLACK
	056271-01-000	EA	SEAT BELT - 2" X 102" - BLACK
	057759-01-000	EA	WASHER - FLAT F/SEAT BELT - 4" DIAMETER
	069178-02-000	EA	BRACKET - MOUNTING/ASSIST HANDLE - GRAY
	000C16-07-16B	EA	BOLT - CARRIAGE - ASSIST HANDLE - 7/16" - 14 X 1"
	000D20-07-00B	EA	NUT - ACORN - ASSIST HANDLE - 7/16 - 14
	053552-02-K01	EA	HANDLE - ASSIST - INTERIOR/ENTRY DOOR - VINYL/OFF WHITE

CURTAIN & CUSHION GROUP (CONTINUED)

BRAVE FABRIC				
COLOR CODES	K20	K21	K22	K23
	MINK (TAUPE)	ASPEN (GREEN)	PRISM (BLUE)	SEASPRAY (TEAL)
CEILING MATERIAL FROM: 00-00-00 THRU: 02-07-99	113979-01-01A	113979-01-01A	113979-01-01A	113979-01-01A
CEILING MATERIAL FROM: 02-08-99 THRU: 99-99-99	113979-09-01A	113979-09-01A	113979-09-01A	113979-09-01A
MADRID VINYL	103907-01-01A	103907-01-01A	103907-01-01A	103907-01-01A
ALLANTE ANTELOPE VINYL	103907-01-07A 103907-02-07A 103907-03-07A	103907-01-07A 103907-02-07A 103907-03-07A	103907-01-07A 103907-02-07A 103907-03-07A	103907-01-07A 103907-02-07A 103907-03-07A
DRAPERY LINING	087272-03-000	087272-03-000	087272-03-000	087272-03-000
BUCKET SEATS	108446-T4-000 108446-S6-000	126883-22-000 108446-G0-000	126883-28-000 096008-85-000	126883-11-000 108446-C5-000
DINETTE	108446-S3-000	126883-21-000	126883-25-000	126883-27-000
DINETTE PADS	108446-T4-000	126883-22-000	126883-28-000	126883-11-000
SOFA	108446-S3-000	126883-21-000	126883-25-000	126883-27-000
SOFA PILLOWS	108446-S6-000	108446-G0-000	096008-85-000	108446-C5-000
SWIVEL CHAIR	108446-T4-000 108446-S6-000	126883-22-000 108446-G0-000	126883-28-000 096008-85-000	126883-11-000 108446-C5-000
LOUNGE WINDOWS	108446-S3-000 108446-T4-000	126883-21-000 126883-22-000	126883-25-000 126883-28-000	126883-27-000 126883-11-000
BEDROOM WINDOWS	105745-G5-000 105745-B5-000	105745-G1-000 105745-E7-000	105745-E9-000 105745-E3-000	105745-K9-000 105745-E7-000
BEDSPREAD	105745-G5-000	105745-G1-000	105745-E9-000	105745-K9-000
PILLOW SHAMS	105745-G5-000 105745-B5-000	105745-G1-000 105745-E7-000	105745-E9-000 105745-E3-000	105745-K9-000 105745-E7-000
BEDROOM PILLOWS	105745-G5-000 105745-B5-000	105745-G1-000 105745-E7-000	105745-E9-000 105745-E3-000	105745-K9-000 105745-E7-000
FRONT WRAP AROUND	072333-82-000	072333-82-000	072333-82-000	072333-82-000
LOUNGE CABINET INSERTS	108446-T4-000	126883-22-000	126883-28-000	126883-11-000
BEDROOM CABINET INSERTS	105745-B5-000	105745-E7-000	105745-E3-000	105745-E7-000
MAP POCKETS	108446-S6-000	108446-G0-000	096008-85-000	108446-C5-000

NOTE: FABRIC LISTED FIRST, IN A BLOCK, IS THE LARGEST QUANTITY OF FABRIC USED.

DINETTE GROUP

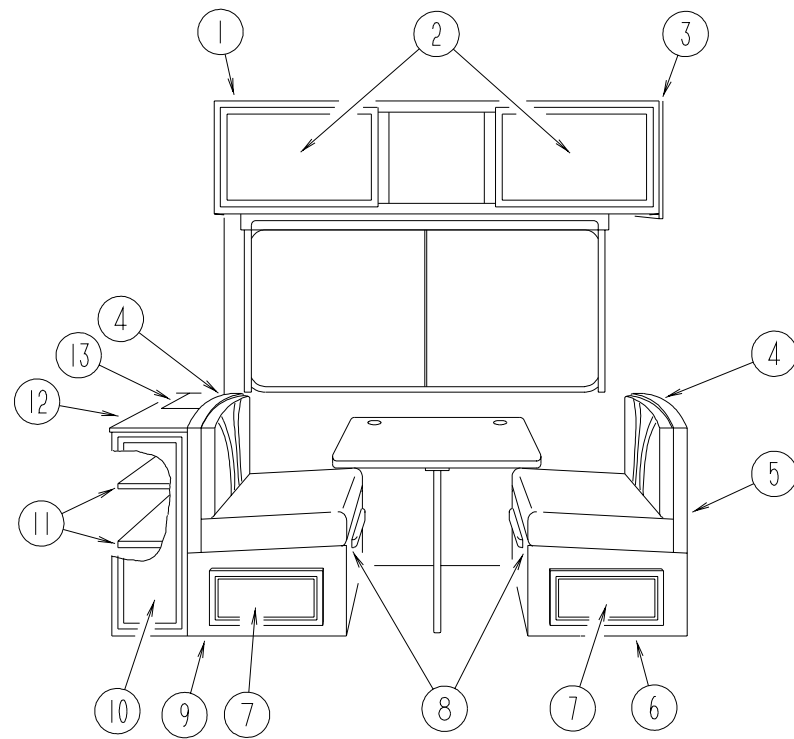

DINETTE GROUP (CONTINUED)

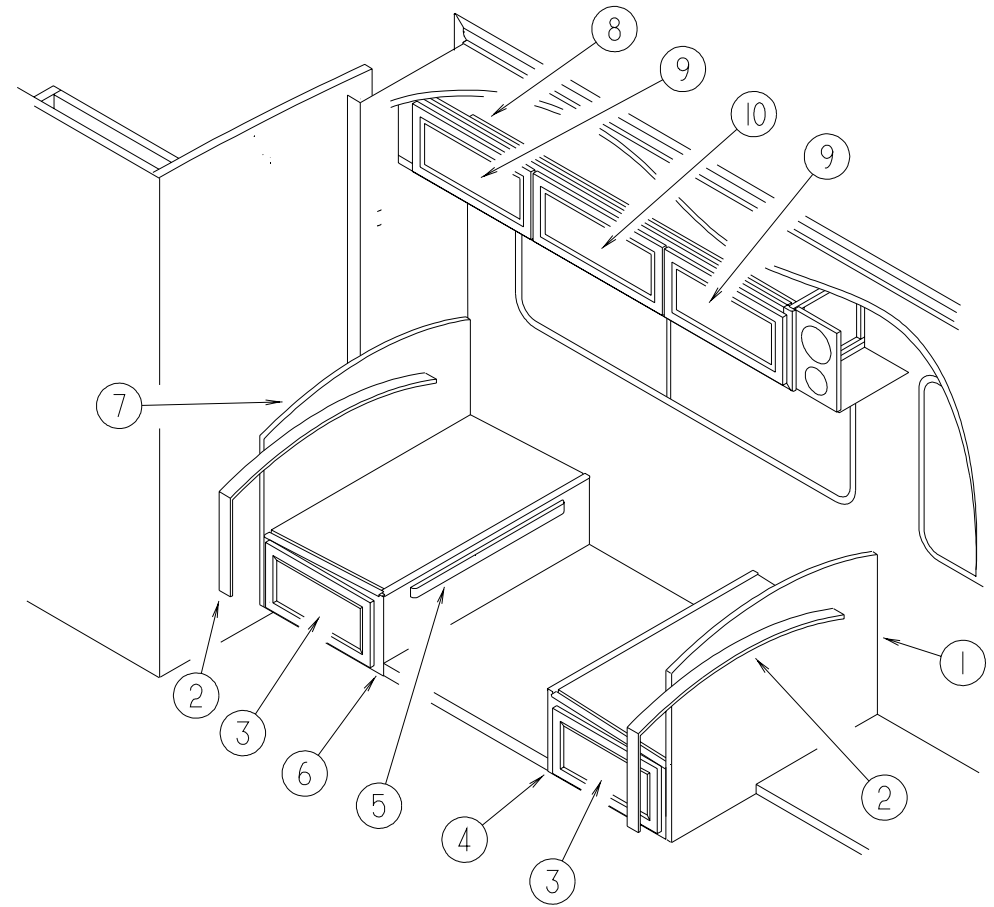

DINETTE CABINETRY

KEY	PART NUMBER	U/M DESCRIPTION
1	131166-01-K20	EA CABINET - OVERHEAD/LEFT HAND - W/O DOORS/HARDWARE
1	131166-01-K21	EA CABINET - OVERHEAD/LEFT HAND - W/O DOORS/HARDWARE
1	131166-01-K22	EA CABINET - OVERHEAD/LEFT HAND - W/O DOORS/HARDWARE
1	131166-01-K23	EA CABINET - OVERHEAD/LEFT HAND - W/O DOORS/HARDWARE
2	132141-80-K20	EA DOOR - RAIL/VENEER - 14.3" X 33.4" - W/O HARDWARE
3	103128-31-J37	EA END CAP - OVERHEAD CABINET - RIGHT HAND
4	104787-08-K20	EA PAD - DINETTE SEATBACK
4	104787-08-K21	EA PAD - DINETTE SEATBACK
4	104787-08-K22	EA PAD - DINETTE SEATBACK
4	104787-08-K23	EA PAD - DINETTE SEATBACK
5	M08752-10-J37	EA CABINET - SEATBACK - RIGHT HAND
6	M08753-10-J37	EA CABINET - SEATBASE - RIGHT HAND - W/O DOOR/DRAWER/HARDWARE
7	131995-G4-K01	EA DOOR - SOLID PANEL - 10" X 19.1" - W/O HARDWARE
8	081295-01-G01	EA SUPPORT - BED/DINETTE - 28" LONG
9	M08753-12-J37	EA CABINET - SEATBASE - LEFT HAND - W/O DOOR/DRAWER/HARDWARE
10	131995-04-K20	EA DOOR - SOLID PANEL - 9" X 26.5" - W/O HARDWARE
11	128147-14-J37	EA SHELF - W/PLASTIC EDGE TRIM
12	128147-15-J37	EA COUNTERTOP - STORAGE/DINETTE (K20)
12	128147-15-J38	EA COUNTERTOP - STORAGE/DINETTE (K21,K23)
12	128147-15-J97	EA COUNTERTOP - STORAGE/DINETTE (K22)
13	128147-16-J37	EA COUNTERTOP - STORAGE/DINETTE (K20)
13	128147-16-J38	EA COUNTERTOP - STORAGE/DINETTE (K21,K23)
13	128147-16-J97	EA COUNTERTOP - STORAGE/DINETTE (K22)
	122021-01-02A	EA ANGLE - W/HOLES - 8.6" LONG - OFF WHITE
	122021-03-01A	EA ANGLE - W/HOLES - 23.5" LONG - OFF WHITE
	122021-02-02A	EA ANGLE - W/HOLES - 13.7" LONG - OFF WHITE

DINETTE CABINETRY - SLIDEOUT OPTION

KEY	PART NUMBER	U/M DESCRIPTION
1	M08755-03-K20	EA CABINET - SEATBACK - RIGHT HAND
2	104787-08-K20	EA PAD - DINETTE SEATBACK
2	104787-08-K21	EA PAD - DINETTE SEATBACK
2	104787-08-K22	EA PAD - DINETTE SEATBACK
2	104787-08-K23	EA PAD - DINETTE SEATBACK
3	131995-G4-K01	EA DOOR - SOLID PANEL - 10" X 19.1" - W/O HARDWARE
4	M08756-03-J37	EA CABINET - SEATBASE - RIGHT HAND - W/O DOOR/DRAWER/HARDWARE
5	081295-01-G01	EA SUPPORT - BED/DINETTE - 28" LONG
6	M08756-04-J37	EA CABINET - SEATBASE - LEFT HAND - W/O DOOR/DRAWER/HARDWARE
7	M08755-02-J22	EA CABINET - SEATBACK - LEFT HAND
8	126310-01-J22	EA CABINET - OVERHEAD/DINETTE - W/O DOORS/HARDWARE
9	132141-A1-K20	EA DOOR - RAIL/VENEER - 10.8" X 21.8" - W/O HARDWARE
10	132141-38-K20	EA DOOR - RAIL/VENEER - 10.8" X 23.8" - W/O HARDWARE
	122021-01-02A	EA ANGLE - W/HOLES - 8.6" LONG - OFF WHITE
	122021-03-01A	EA ANGLE - W/HOLES - 23.5" LONG - OFF WHITE
	122021-02-02A	EA ANGLE - W/HOLES - 13.7" LONG - OFF WHITE

DINETTE GROUP (CONTINUED)

DINETTE SLIDEOUT OPTION TRIMS & HARDWARE

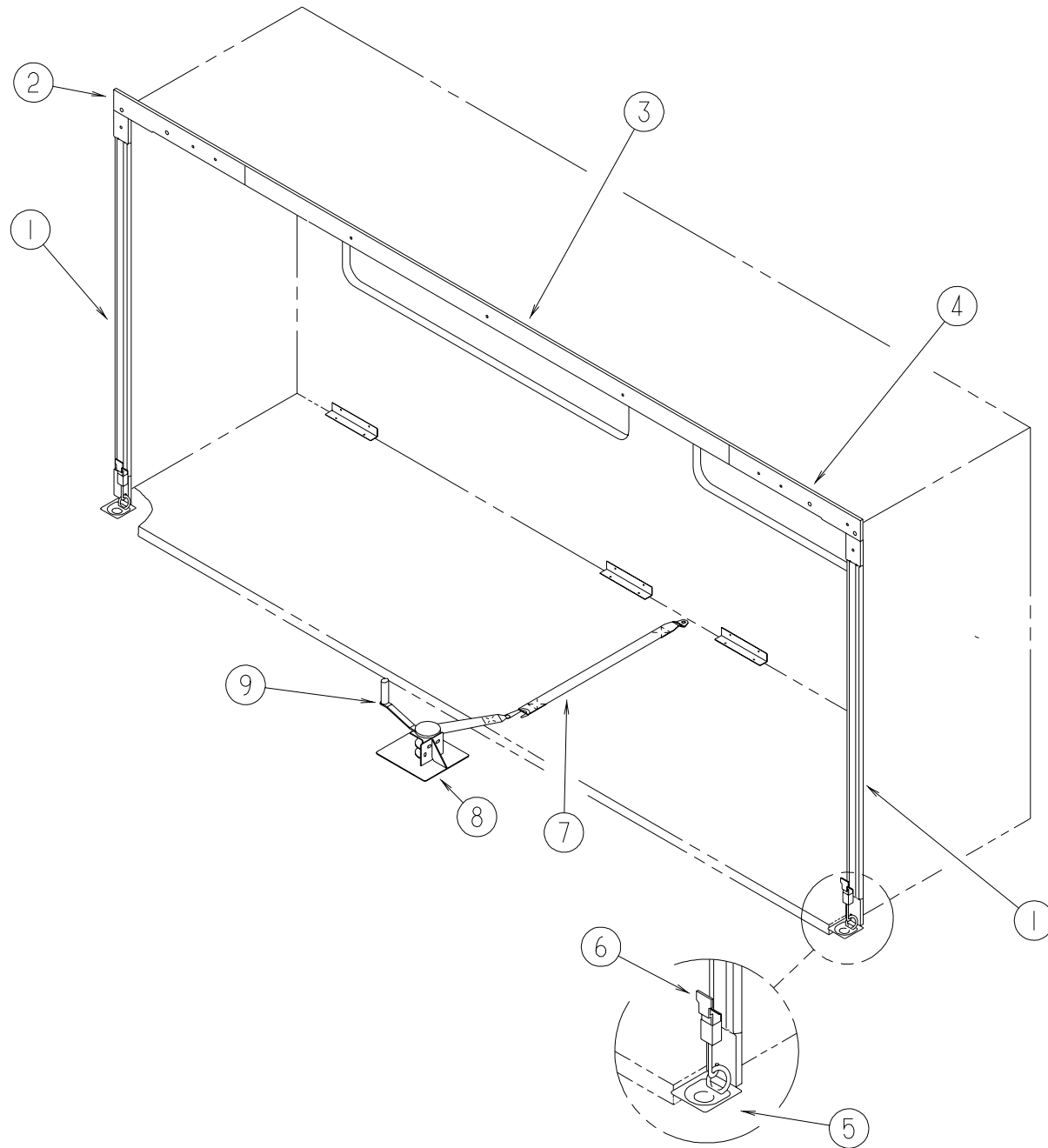

KEY	PART NUMBER	U/M	DESCRIPTION
1	116951-01-G35	EA	MOLDING - WOOD - 3" X 70.5"
2	116968-01-G35	EA	TRIM - END/LEFT HAND - WOOD - 3.8" X 19.1"
3	116967-01-G35	EA	TRIM - CENTER - WOOD - 3.8" X 120"
4	116968-02-G35	EA	TRIM - END/RIGHT HAND - WOOD - 3.8" X 19.1"
5	116736-01-01A	EA	TIEDOWN - DROP/D - ZINC
6	116737-01-01A	EA	LATCH - DRAW - ADJUSTABLE - ZINC
7	116101-02-F31	EA	STRAP - WINCH - 34" CENTER BRACKET/STRAP END
8	116082-03-02B	EA	BRACKET - WINCH
9	115767-02-000	EA	WINCH - SLIDEOUT

DINETTE GROUP (CONTINUED)

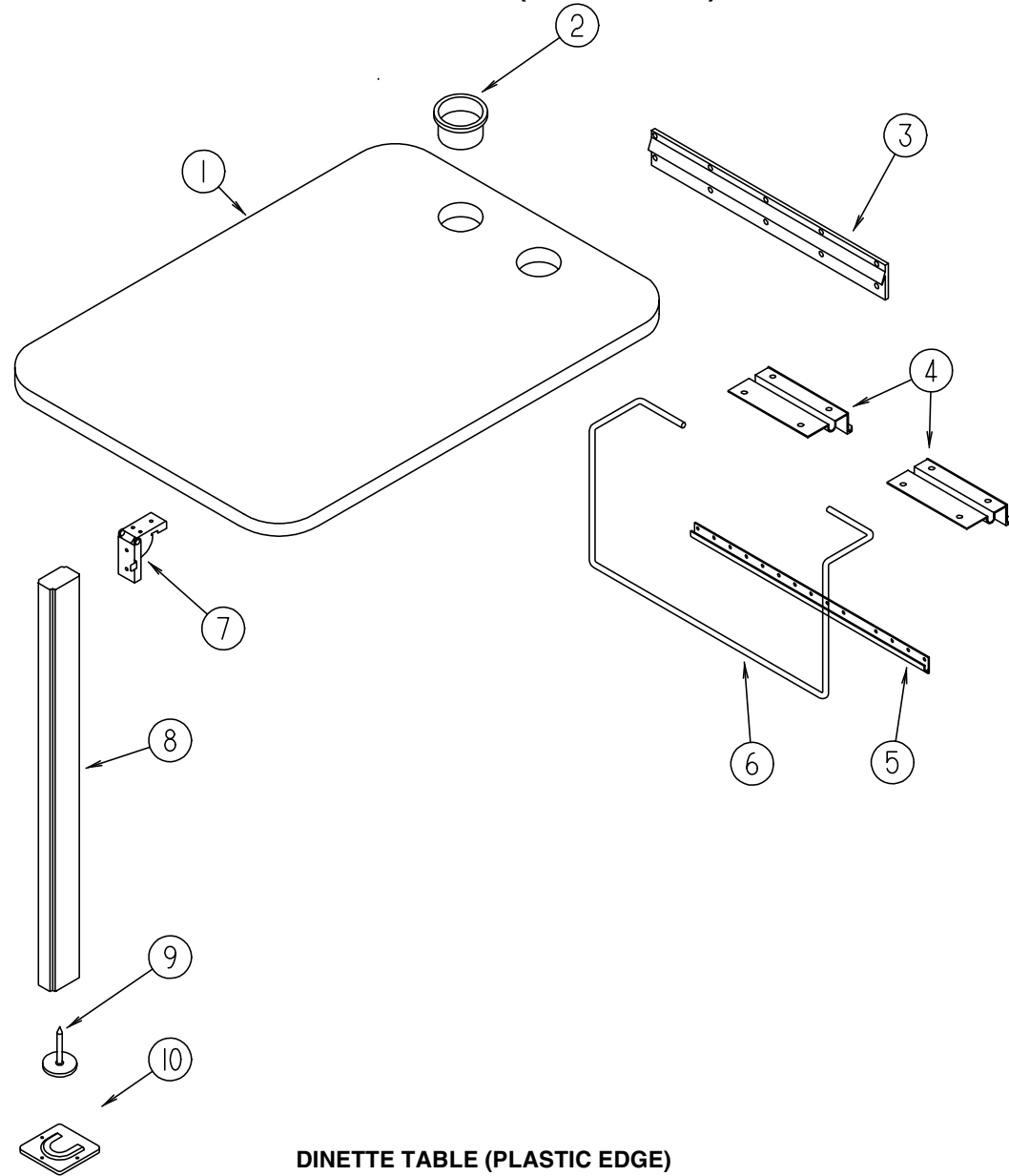

DINETTE TABLE (PLASTIC EDGE)

KEY	PART NUMBER	U/M	DESCRIPTION
1	081322-20-K17	EA	TABLE TOP ONLY (K20)
1	081322-20-J38	EA	TABLE TOP ONLY (K21,K23)
1	081322-20-J97	EA	TABLE TOP ONLY (K22)
1	081322-23-K17	EA	TABLE TOP ONLY (K20)
1	081322-23-K21	EA	TABLE TOP ONLY (K21,K23)
1	081322-23-K22	EA	TABLE TOP ONLY (K22)
2	064781-06-000	EA	HOLDER - CUP - TWO STEP - OFF WHITE
3	053200-12-000	EA	BRACKET - TABLE SUPPORT - UPPER/WALL MOUNTED - 23.50"
4	088410-02-000	EA	BRACKET - LIFT - TABLE MOUNTED
5	024281-14-000	EA	BRACKET/TABLE - LIFT ROD/LOWER WALL MOUNTED - 22.12"
6	024275-12-000	EA	ROD - TABLE LIFT
7	093550-01-000	EA	BRACKET - HINGE - MOUNTS TO LEG & TABLE TOP - 1.7" X 2.6"
8	092707-04-05A	EA	LEG - TABLE - W/O HARDWARE - 27" - WATERFORD OAK
9	092593-01-05A	EA	CATCH - TABLE LEG - OFF/WHITE
10	049493-12-000	EA	CATCH - TABLE LEG/FLOOR MOUNTED - OFF WHITE
10	049493-11-700	EA	CATCH - TABLE LEG/FLOOR MOUNTED - E COATED

DINETTE GROUP (CONTINUED)

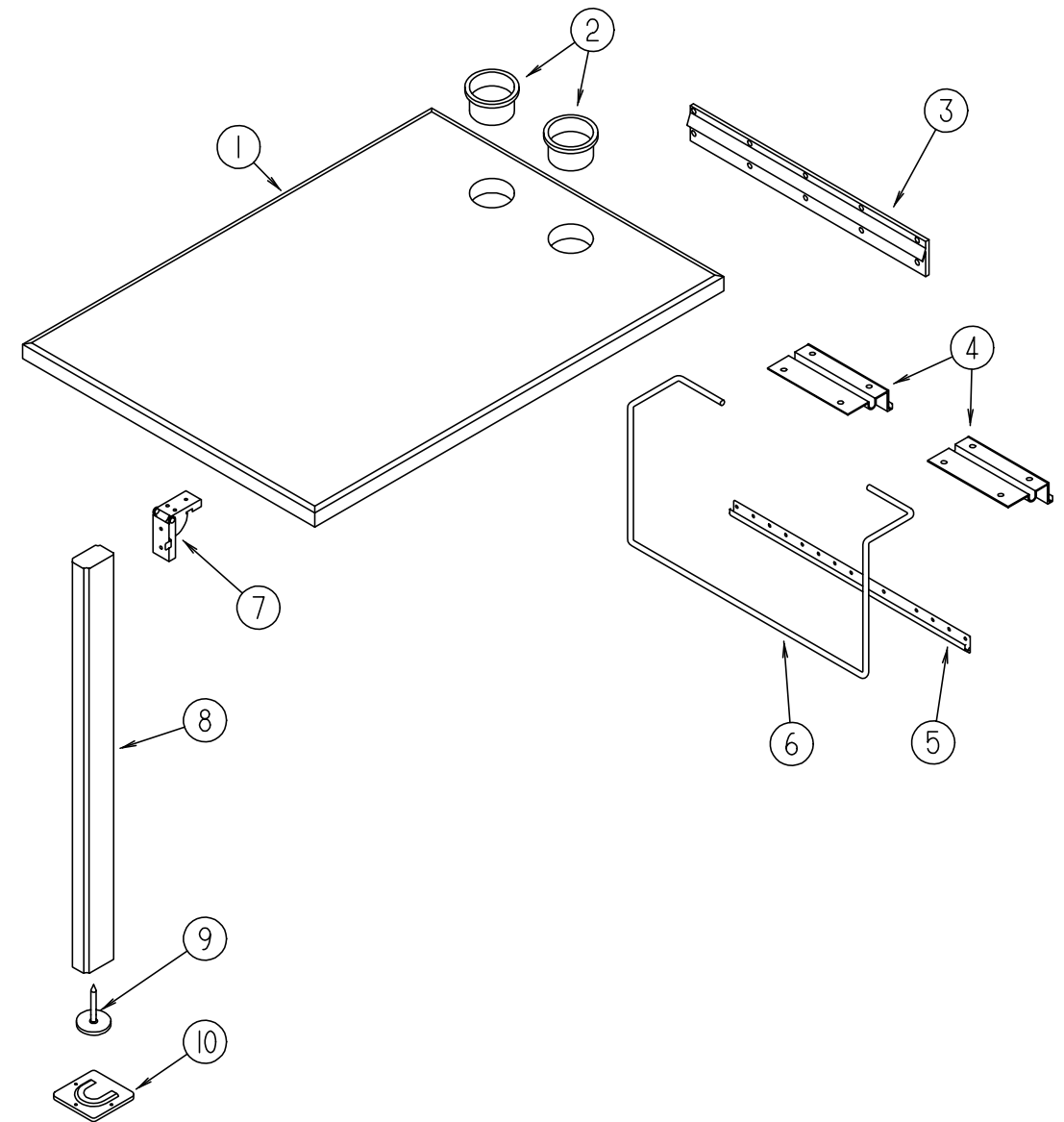

DINETTE TABLE (WOOD EDGE)

KEY	PART NUMBER	U/M	DESCRIPTION
1	088913-08-K47	EA	TABLE - DINETTE - W/O HARDWARE (K20)
1	088913-08-J20	EA	TABLE - DINETTE - W/O HARDWARE (K21,K23)
1	088913-08-J51	EA	TABLE - DINETTE - W/O HARDWARE (K22)
2	064781-06-000	EA	HOLDER - CUP - TWO STEP - OFF WHITE
3	053200-12-000	EA	BRACKET - TABLE SUPPORT - UPPER/WALL MOUNTED - 23.50"
4	088410-02-000	EA	BRACKET - LIFT - TABLE MOUNTED
5	024281-14-000	EA	BRACKET/TABLE - LIFT ROD/LOWER WALL MOUNTED - 22.12"
6	024275-12-000	EA	ROD - TABLE LIFT
7	093550-01-000	EA	BRACKET - HINGE - MOUNTS TO LEG & TABLE TOP - 1.7" X 2.6"
8	092707-04-05A	EA	LEG - TABLE - W/O HARDWARE - 27" - WATERFORD OAK
9	092593-01-05A	EA	CATCH - TABLE LEG - OFF/WHITE
10	049493-12-000	EA	CATCH - TABLE LEG/FLOOR MOUNTED - OFF WHITE
10	049493-11-700	EA	CATCH - TABLE LEG/FLOOR MOUNTED - E COATED

DRIVERS COMPARTMENT GROUP

DRIVERS COMPARTMENT - UPPER

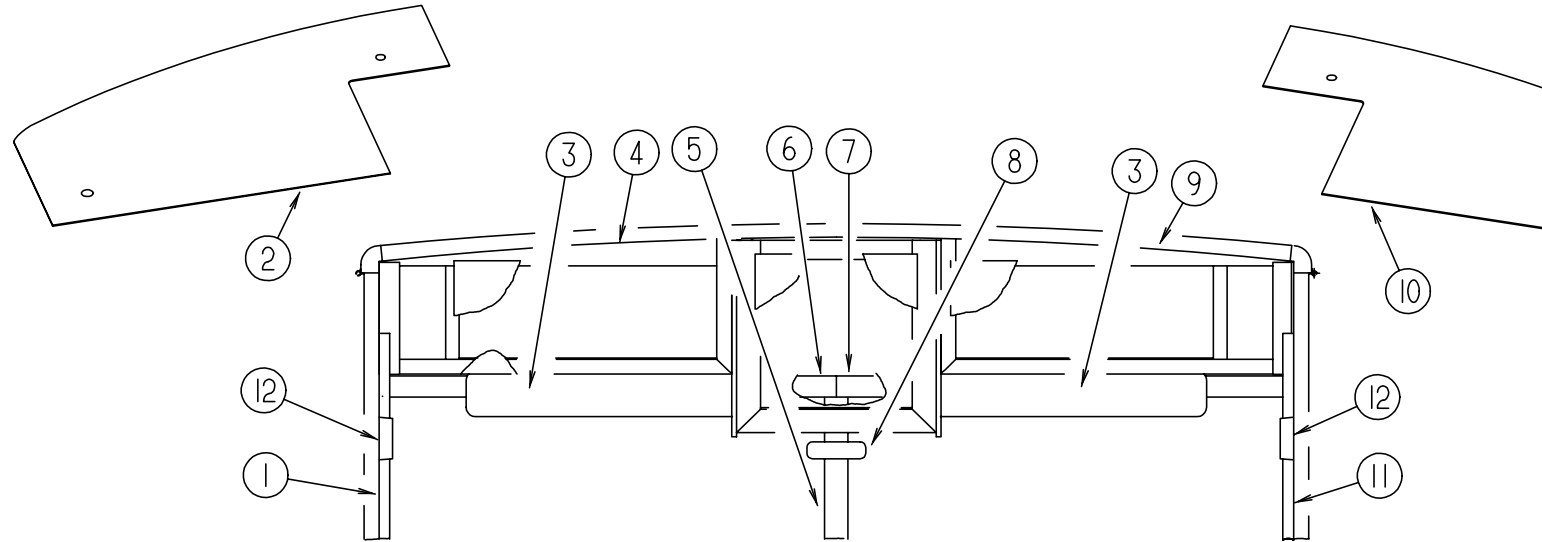

KEY	PART NUMBER	U/M	DESCRIPTION
1	125508-02-01A	EA	TRIM - A-PILLAR - INTERIOR - ANTELOPE
2	126440-04-J15	EA	PANEL - OVERHEAD/FRONT - BOTTOM/LEFT HAND
3	123298-02-04A	EA	SUNVISOR - 10.5" X 28.5"
4	126457-02-J20	EA	PANEL - CLOSEOUT - OVERHEAD FRONT - UPPER/LOWER LEFT HAND
5	118452-04-01A	EA	TRIM - WINDSHIELD - CENTER - ANTELOPE
6	118453-04-01A	EA	TRIM - WINDSHIELD - INNER/TOP/DRIVER
7	118453-03-01A	EA	TRIM - WINDSHIELD - INNER/TOP/PASSENGER
8	040714-01-000	EA	MIRROR - REAR VIEW/ARM MOUNT & SET SCREW
	067490-01-000	EA	BUTTON - MIRROR/REAR VIEW
9	126457-01-J20	EA	PANEL - CLOSEOUT - OVERHEAD FRONT - UPPER/LOWER RIGHT HAND
10	126440-03-J15	EA	PANEL - OVERHEAD/FRONT - BOTTOM/RIGHT HAND
11	125508-01-01A	EA	TRIM - A-PILLAR - INTERIOR - ANTELOPE
12	103961-03-01A	EA	COVER - BRACKET - SEATBELT/OFF WHITE

DRIVERS COMPARTMENT GROUP (CONTINUED)

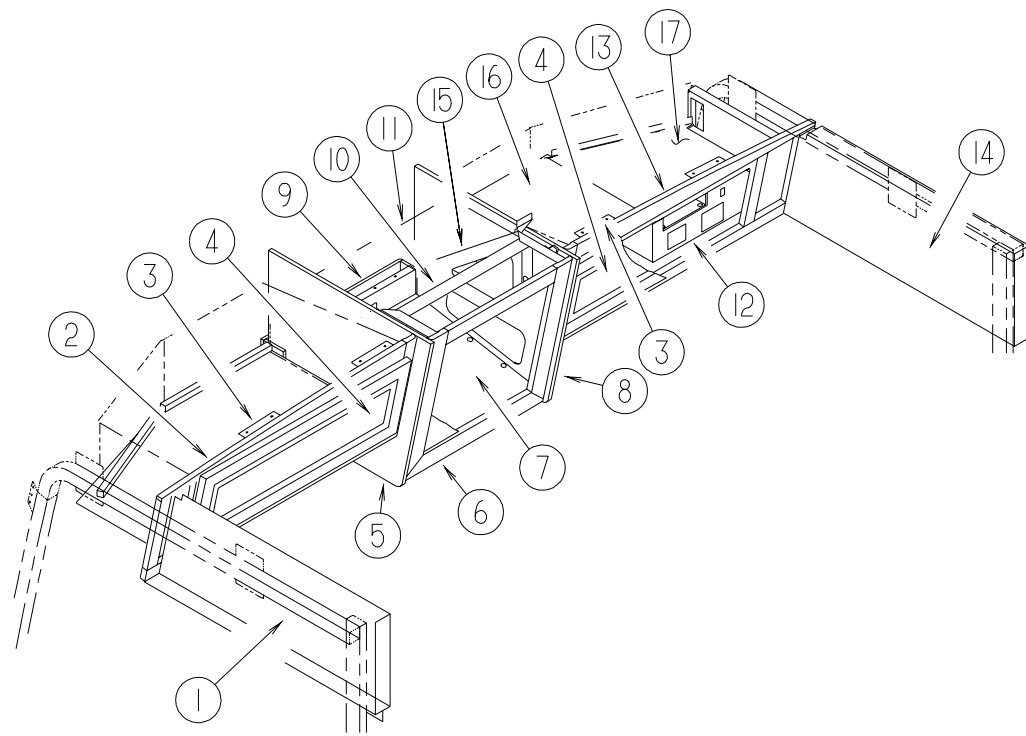

INTERIOR STORAGE AND TV CABINETS

KEY	PART NUMBER	U/M	DESCRIPTION
1	126765-06-K20	EA	PANEL - OVERHEAD/DRIVER
2	126877-02-J15	EA	CABINET - OVERHEAD/FRONT - LEFT HAND - W/O DOORS/HARDWARE
3	106699-01-01A	EA	BRACKET - OVERHEAD CABINET/TV
4	M09332-07-K16	EA	DOOR - RAISED MEMBRANE/OGEE EDGE - 10.8" X 27.9" - W/O HDW
5	103128-25-J15	EA	END CAP - OVERHEAD CABINET - LEFT HAND
6	126718-01-J15	EA	FRAME/FACE - TV CABINET - W/O DOOR/HARDWARE
6	116791-02-J15	EA	FRAME/FACE - TV CABINET - F/TV
	091261-01-000	FT	SLIPNOT - ANTISLIP - 1' WIDE
7	100708-16-000	EA	DOOR - GLASS - CABINET - 15.5" X 15.7" - W/O HARDWARE
8	103128-26-J15	EA	END CAP - OVERHEAD CABINET - RIGHT HAND
9	126801-01-J15	EA	CABINET BOTTOM - VINYL COVERED
10	114706-04-02B	EA	SUPPORT - SHELF/TV
11	126854-01-J20	EA	PANEL - HEADLINER/TV/TOP
12	126601-01-J20	EA	PANEL/SHELF - VINYL COVERED - W/ANTENNA CUTOUT
			FROM: 00-00-00 THRU: 11-08-98
12	131807-01-K28	EA	PANEL/SHELF - VINYL COVERED - W/ANTENNA CUTOUT
			FROM: 11-09-98 THRU: 99-99-99
12	126601-03-J20	EA	PANEL/SHELF - VINYL COVERED - W/NOTCH/ANTENNA CUTOUT
			FROM: 00-00-00 THRU: 11-08-98
12	131807-02-K28	EA	PANEL/SHELF - VINYL COVERED - W/NOTCH/ANTENNA CUTOUT
			FROM: 11-09-98 THRU: 99-99-99
12	126601-07-J20	EA	PANEL/SHELF - VINYL COVERED-NOTCH/INVERTER/ANTENNA CUTOUT
			FROM: 00-00-00 THRU: 11-08-98
12	131807-03-K28	EA	PANEL/SHELF - VINYL COVERED - W/NOTCH/ANTENNA CUTOUT
			FROM: 11-09-98 THRU: 99-99-99
13	126877-01-J15	EA	CABINET - OVERHEAD/FRONT - RIGHT HAND - W/O DOORS/HARDWARE
14	126765-05-K20	EA	PANEL - OVERHEAD/PASSENGER
15	126081-03-02B	EA	BRACKET/SUPPORT - TV - 10 DEGREE - E-COATED
	126081-04-02B	EA	BRACKET/SUPPORT - TV - 10 DEGREE - E-COATED
16	127637-01-02B	EA	SHELF - OVERHEAD/FRONT/LEFT HAND - E-COATED
17	126275-01-02B	EA	SHELF - OVERHEAD/FRONT - E-COATED
			FROM: 00-00-00 THRU: 11-08-98
17	126275-03-02B	EA	SHELF - OVERHEAD/FRONT - E-COATED
			FROM: 11-09-98 THRU: 99-99-99

DRIVERS COMPARTMENT GROUP (CONTINUED)

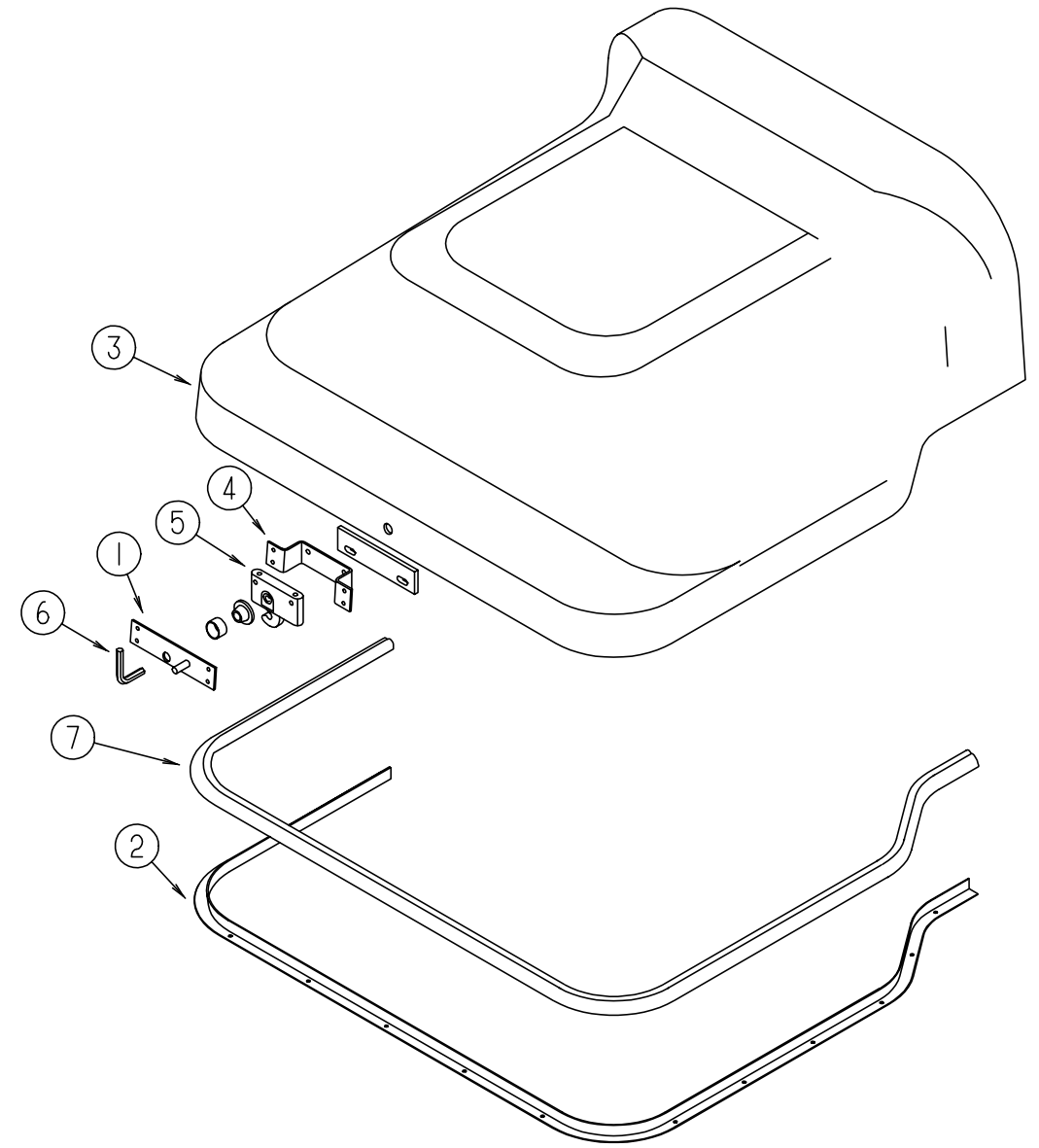

MOTOR COVER

KEY	PART NUMBER	U/M	DESCRIPTION
1	115852-01-02B	EA	STRIKE - LATCH - MOTOR COVER - E-COATED
2	115860-01-01A	EA	TRIM - MOTOR COVER - CHEVY
2	115860-03-01A	EA	TRIM - MOTOR COVER - FORD
3	115840-02-01A	EA	COVER - MOTOR - W/O CARPET - CHEVY
3	115840-03-01A	EA	COVER - MOTOR - W/O CARPET - FORD
4	115850-03-02B	EA	RETAINER - LATCH - MOTOR COVER - RIGHT HAND - E-COATED
5	116581-01-000	EA	LATCH - MOTOR COVER
6	116833-01-02B	EA	WRENCH - HEX MOTOR COVER - E-COATED
7	039623-01-000	FT	SEAL - MOTOR COVER - RUBBER BULB TYPE

DRIVERS COMPARTMENT GROUP (CONTINUED)

DRIVERS COMPARTMENT - LOWER

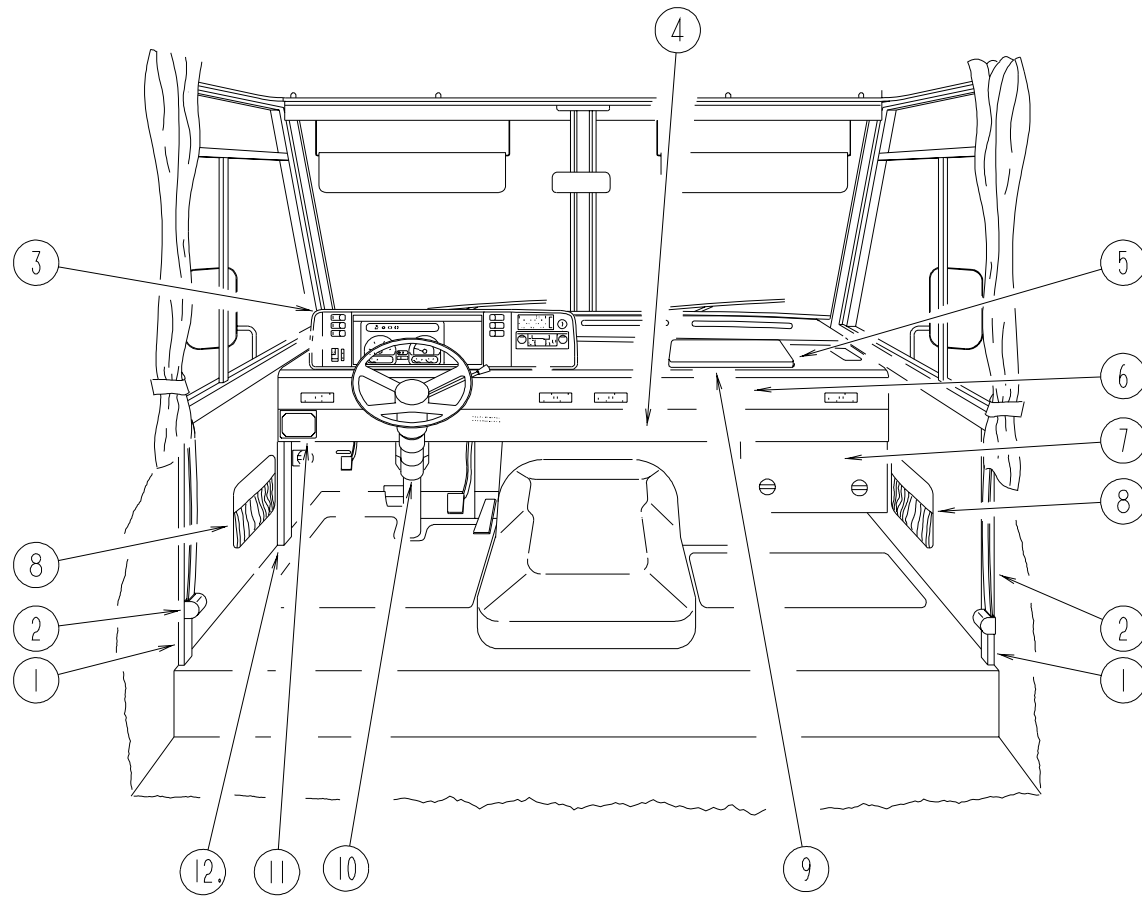

KEY	PART NUMBER	U/M DESCRIPTION	VENDOR NO.
1	024700-51-000	EA COVER - ROLL BAR - 88" - OFF WHITE	
2	091990-04-01A	EA SEAT BELT/SHOULDER HARNESS - DRIVERS/PASSENGER - BLACK	
	091990-01-701	EA EXTENDER - 9" W/POINTED LATCHING TONGUE	I-1331-02
	091990-05-700	EA SLEEVE/BUCKLE COVER-PLASTIC	209S-2
	091990-05-701	EA CAP/COVER - BOLT HOLE COVER	209SC-02
	091990-05-702	EA SLEEVE/RETRACTABLE COVER	309C-02
	109146-01-000	EA BOLT - SHOULDER/SEAT BELT	
3	125677-02-J20	EA POD - INSTRUMENT PANEL - ANTELOPE - FORD	
		FROM: 00-00-00 THRU: 02-03-99	
3	125677-04-K28	EA POD - INSTRUMENT PANEL - ANTELOPE - FORD	
		FROM: 02-04-99 THRU: 99-99-99	
3	125677-02-J20	EA POD - INSTRUMENT PANEL - ANTELOPE - CHEVY	
4	114620-12-02A	EA TRIM - LOWER DASH - GM - 96" - ANTELOPE	
4	114620-01-04A	EA TRIM - LOWER DASH - GM - 96" - ANTELOPE - HEATED MIRRORS OPTION	
4	111528-04-04A	EA TRIM - LOWER DASH - DRIVER - FD - ANTELOPE	
4	111528-03-05A	EA TRIM - LOWER DASH - PASSENGER - FD - ANTELOPE - HEATED MIRRORS OPTION	
4	111528-08-02A	EA TRIM - LOWER DASH - PASSENGER - FD - ANTELOPE	
5	P30276-02-000	EA DASH - W/O VINYL - FORD	
		FROM: 00-00-00 THRU: 03-07-99	
5	P30276-10-000	EA DASH - W/O VINYL - FORD	
		FROM: 03-08-99 THRU: 99-99-99	
5	P30276-06-000	EA DASH - W/O VINYL - CHEVY	
	118101-06-02B	EA PANEL - DASH TOP - E-COATED	
	106569-11-01A	EA VINYL - LAMINATE - ALLANTE ANTELOPE - 1/4" X 21" X 100"	
	113452-01-000	FT SEAL/TRIM - FRONT - VINYL W/WIRE CARRIER	
	110530-01-000	FT SEAL - SPONGE - .31" X .62"	
6	126340-01-01A	EA DECAL - LOGO - BRAVE	
7	095757-05-G16	EA COVER - HEATER (K20)	
7	095757-05-J31	EA COVER - HEATER (K21)	
7	095757-05-J51	EA COVER - HEATER (K22)	
7	095757-05-J17	EA COVER - HEATER (K23)	
8	086120-01-J24	EA PAD - MAP POCKET - 12" X 16" (K20)	
8	086120-01-J61	EA PAD - MAP POCKET - 12" X 16" (K21)	
8	086120-01-F05	EA PAD - MAP POCKET - 12" X 16" (K22)	
8	086120-01-G30	EA PAD - MAP POCKET - 12" X 16" (K23)	
9	127692-01-J20	EA TABLE - DASH	
	127597-01-000	EA SLIDE - WORK STATION - DASH	
10	103498-09-000	EA BOOT - STEERING COLUMN - W/1/2 CIRCLE - CHEVY	
	130111-01-01A	EA COVER - STEERING COLUMN - UPPER - BLACK - FORD	
		FROM: 00-00-00 THRU: 03-07-99	
	131804-01-01A	EA COVER - STEERING COLUMN - UPPER - BLACK - FORD	
		FROM: 03-08-99 THRU: 99-99-99	
	125795-01-01A	EA COVER - STEERING COLUMN - LOWER - FORD	
		FROM: 03-08-99 THRU: 99-99-99	
	125655-03-01A	EA TRIM - STEERING COLUMN - RIGHT HAND/FORD	
		FROM: 00-00-00 THRU: 03-07-99	
	125655-04-01A	EA TRIM - STEERING COLUMN - LEFT HAND/FORD	
		FROM: 00-00-00 THRU: 03-07-99	
11	116220-01-000	EA APPLIQUE - SWITCH/SLIDEOUT	
11	108357-07-000	EA SWITCH - ROCKER SPDT - MOM/OFF/MOM - 3 TERMINAL	
11	108356-02-01A	EA COVER/ACTUATOR SWITCH - 2 ROWS DIMPLES- CONTURA II - BLACK	
11	112236-02-J22	EA BEZEL - F/SLIDEOUT ROOM CONTROL	
11	081994-09-000	EA PLATE - SWITCH - F/SLIDEOUT	
12	127901-01-01A	EA PANEL - TOEKICK/LEFT HAND - ANTELOPE	

DRIVERS COMPARTMENT GROUP (CONTINUED)

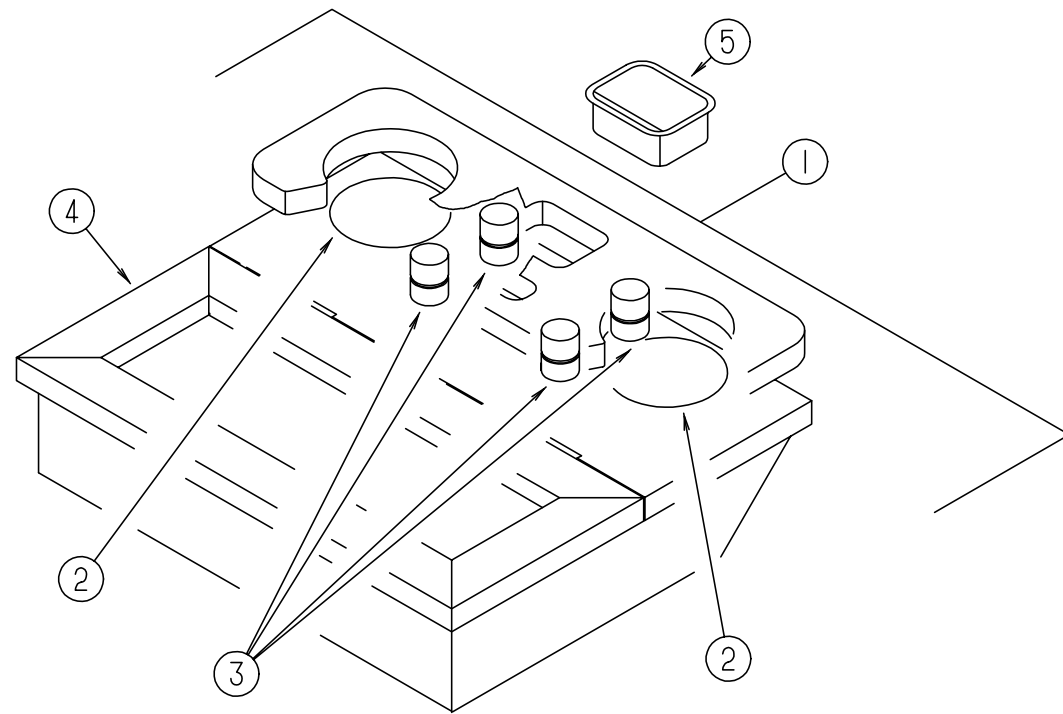

BEVERAGE TRAY (WOOD)

KEY	PART NUMBER	U/M	DESCRIPTION
1	111618-01-H17	EA	TRAY - BEVERAGE W/COMPARTMENT - W/O CUPHOLDERS
2	122717-01-01A	EA	PAD - NON SKID - 4" DIAMETER ROUND
3	097872-08-000	EA	DOWEL - WOOD - 1" DIAMETER X 1.38" LONG - WATERFORD OAK
3	097872-04-000	EA	DOWEL - WOOD - 1" DIAMETER X 1.38" LONG - UNFINISHED
4	111618-13-GB1	EA	LID - BEVERAGE TRAY COMPARTMENT
5	046886-03-000	EA	ASHTRAY - CHROME W/COVER

DRIVERS COMPARTMENT GROUP (CONTINUED)

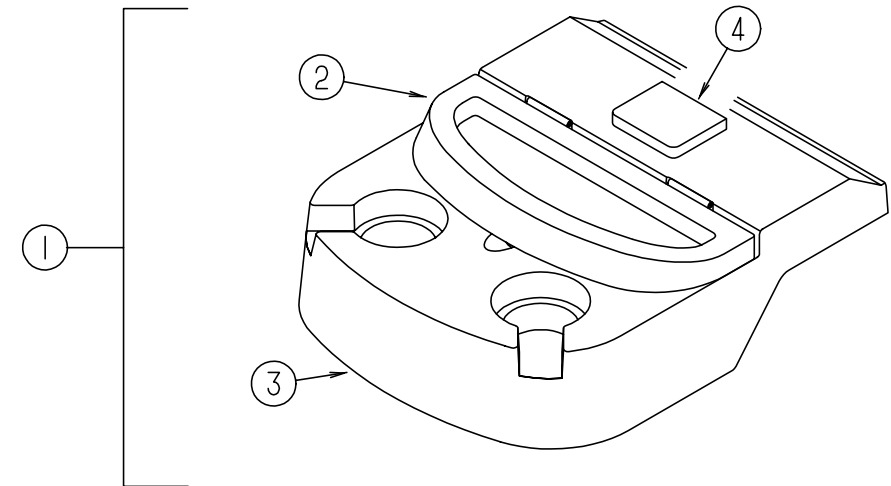

BEVERAGE TRAY (PLASTIC)

KEY	PART NUMBER	U/M	DESCRIPTION
1	126008-02-J30	EA	TRAY - BEVERAGE - W/DOOR
2	128113-01-J30	EA	LID - BEVERAGE TRAY
3	128114-01-01A	EA	TRAY - BEVERAGE - ANTELOPE
4	118719-01-01A	EA	ASHTRAY - TOP MOUNT - BLACK PLASTIC
	126010-01-01A	EA	SPACER - BEVERAGE TRAY
	122772-02-02B	EA	BRACKET - MOUNTING - BEVERAGE TRAY

DRIVERS COMPARTMENT GROUP (CONTINUED)

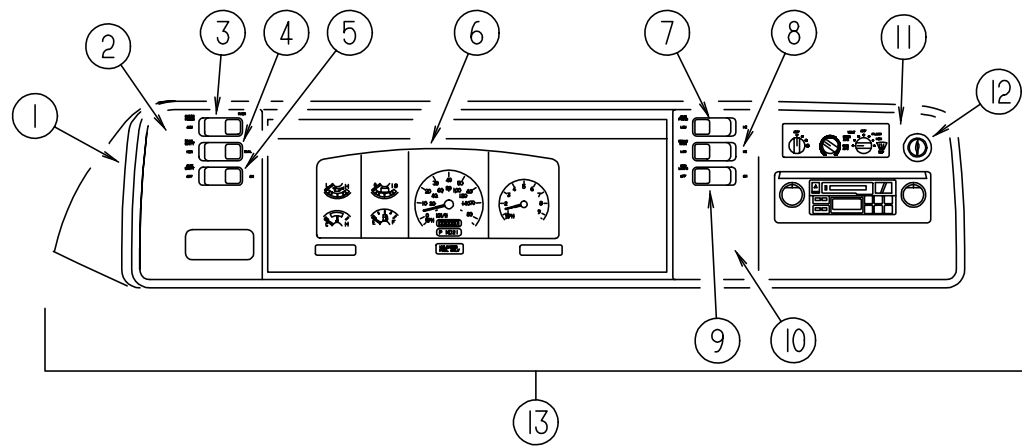

DASH, GAUGES & SWITCHES - FORD (FROM: 00-00-00 THRU: 03-14-99)

KEY	PART NUMBER	U/M	DESCRIPTION
1	103662-12-01A	EA	BEZEL - INSTRUMENT PANEL - 99 HEAVY DUTY FORD FROM: 00-00-00 THRU: 03-07-99
1	103662-14-01A	EA	BEZEL - INSTRUMENT PANEL - 99 FORD FROM: 03-08-99 THRU: 99-99-99
2	104056-39-01A	EA	APPLIQUE - BEZEL - DRIVER - BLACK
3	108356-02-01A	EA	COVER/ACTUATOR SWITCH - 2 ROWS DIMPLES- CONTURA II - BLACK
3	108357-05-000	EA	SWITCH - ROCKER SPDT - ON/NONE/ON - 3 TERMINAL - RADIO POWER W/O CD
3	108357-08-000	EA	SWITCH - ROCKER DPDT - ON/NONE/ON - 6 TERMINAL - RADIO POWER W/CD
4	108356-02-01A	EA	COVER/ACTUATOR SWITCH - 2 ROWS DIMPLES- CONTURA II - BLACK
4	108357-09-000	EA	SWITCH - ROCKER SPDT - ON/NONE/MOM - 3 TERMINAL - AUXILIARY START
5	108356-02-01A	EA	COVER/ACTUATOR SWITCH - 2 ROWS DIMPLES- CONTURA II - BLACK
5	108357-06-000	EA	SWITCH - ROCKER DPDT - MOM/OFF/MOM - 6 TERMINAL - AUXILIARY BATTERY
6	N/A	EA	CLUSTER - INSTRUMENT PANEL
7	108356-04-01A	EA	COVER/ACTUATOR SWITCH - 2 ROWS DIMPLES W/LENS-CONTURA-BLK
7	108357-10-000	EA	SWITCH - ROCKER SPDT - W/LIGHT - MOM/NONE/MOM - 5 TERMINAL - GEN
7	096241-03-000	EA	SWITCH - BLANK - BLACK
8	108356-02-01A	EA	COVER/ACTUATOR SWITCH - 2 ROWS DIMPLES- CONTURA II - BLACK
8	108357-03-000	EA	SWITCH - ROCKER SPDT - ON/OFF/ON - 3 TERMINAL - REAR HEATER
8	096241-03-000	EA	SWITCH - BLANK - BLACK
9	096241-03-000	EA	SWITCH - BLANK - BLACK
10	104056-21-01A	EA	APPLIQUE - BEZEL - PASSENGER - BLACK
11	104056-06-01A	EA	APPLIQUE - BEZEL - PASSENGER - BLACK
12	089294-01-000	EA	LIGHTER - CIGARETTE - W/SOCKET & WIRE
13	125677-02-J20	EA	POD - INSTRUMENT PANEL - ANTELOPE FROM: 00-00-00 THRU: 03-07-99
13	125677-04-K28	EA	POD - INSTRUMENT PANEL - ANTELOPE FROM: 03-08-99 THRU: 99-99-99
	077031-01-000	EA	FILM - BLACK - 1" X 1.75"
	077031-03-000	EA	FILM - WHITE - .75" X 1"
	049176-01-000	EA	HEDLOCK II - 3/4 DIAMETER SCREW MOUNT
	103603-01-000	EA	BULB - 12 VOLT - #74 - .12A WEDGE - GE 22-25 USED IN DASH
	129644-01-000	EA	CABLE/INDICATOR - TRANSMISSION - 46.7" EYE/EYE FROM: 00-00-00 THRU: 11-24-98

DRIVERS COMPARTMENT GROUP (CONTINUED)

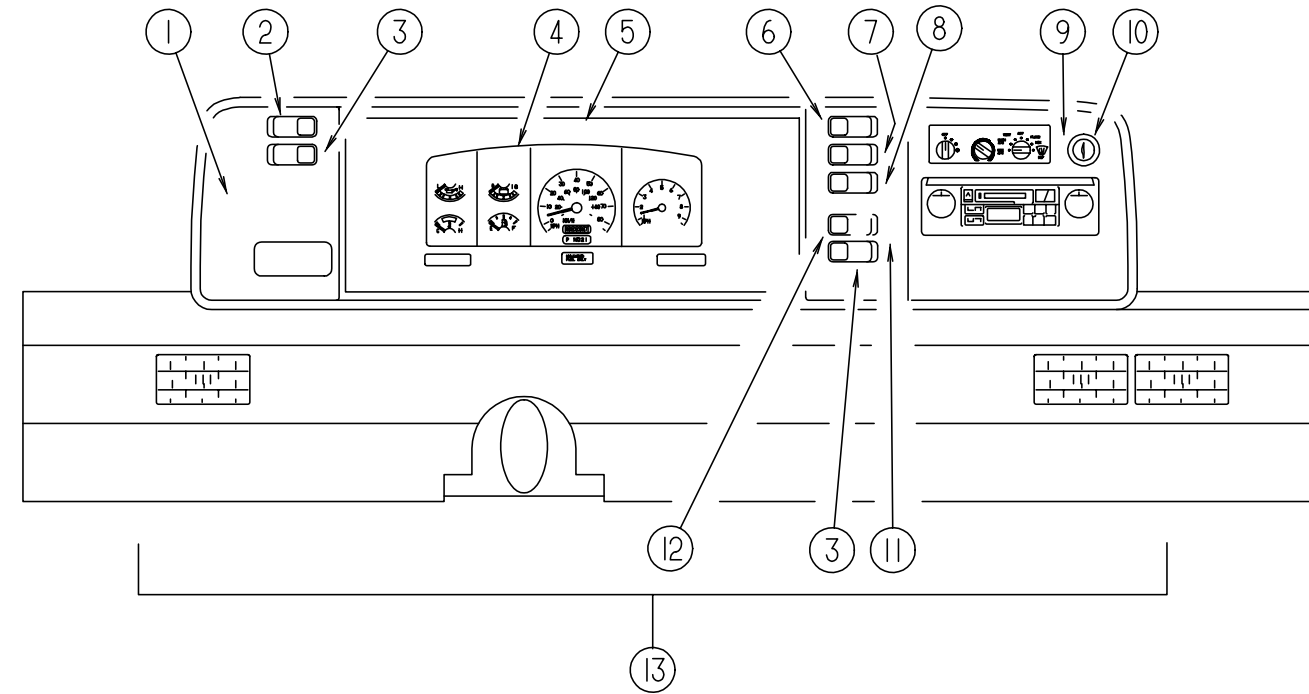

DASH, GAUGES & SWITCHES - FORD (FROM: 03-15-99 THRU: 99-99-99)

KEY	PART NUMBER	U/M	DESCRIPTION
1	104056-45-01A	EA	APPLIQUE - BEZEL - DRIVER - BLACK
2	108356-02-01A	EA	COVER/ACTUATOR SWITCH - 2 ROWS DIMPLES- CONTURA II - BLACK
2	108357-09-000	EA	SWITCH - ROCKER SPDT - ON/NONE/MOM - 3 TERMINAL - AUXILIARY START
3	096241-03-000	EA	SWITCH - BLANK - BLACK
4	N/A	EA	CLUSTER - INSTRUMENT PANEL
5	103662-14-01A	EA	BEZEL - INSTRUMENT PANEL - 99 FORD
6	108356-02-01A	EA	COVER/ACTUATOR SWITCH - 2 ROWS DIMPLES- CONTURA II - BLACK
6	108357-05-000	EA	SWITCH - ROCKER SPDT - ON/NONE/ON - 3 TERMINAL - RADIO POWER W/O CD
6	108357-08-000	EA	SWITCH - ROCKER DPDT - ON/NONE/ON - 6 TERMINAL - RADIO POWER W/CD
7	108356-04-01A	EA	COVER/ACTUATOR SWITCH - 2 ROWS DIMPLES W/LENS-CONTURA-BLK
7	108357-10-000	EA	SWITCH - ROCKER SPDT - W/LIGHT - MOM/NONE/MOM - 5 TERMINAL - GEN
7	096241-03-000	EA	SWITCH - BLANK - BLACK
8	108356-02-01A	EA	COVER/ACTUATOR SWITCH - 2 ROWS DIMPLES- CONTURA II - BLACK
8	108357-03-000	EA	SWITCH - ROCKER SPDT - ON/OFF/ON - 3 TERMINAL - REAR HEATER
8	096241-03-000	EA	SWITCH - BLANK - BLACK
9	104056-06-01A	EA	APPLIQUE - BEZEL - PASSENGER - BLACK
10	089294-01-000	EA	LIGHTER - CIGARETTE - W/SOCKET & WIRE
11	104056-43-01A	EA	APPLIQUE - BEZEL - PASSENGER - BLACK
12	108356-02-01A	EA	COVER/ACTUATOR SWITCH - 2 ROWS DIMPLES- CONTURA II - BLACK
12	108357-06-000	EA	SWITCH - ROCKER DPDT - MOM/OFF/MOM - 6 TERMINAL - AUXILIARY BATTERY
13	125677-04-K28	EA	POD - INSTRUMENT PANEL - ANTELOPE
	077031-01-000	EA	FILM - BLACK - 1" X 1.75"
	077031-03-000	EA	FILM - WHITE - .75" X 1"
	049176-01-000	EA	HEDLOCK II - 3/4 DIAMETER SCREW MOUNT
	103603-01-000	EA	BULB - 12 VOLT - #74 - .12A WEDGE - GE 22-25 USED IN DASH

DRIVERS COMPARTMENT GROUP (CONTINUED)

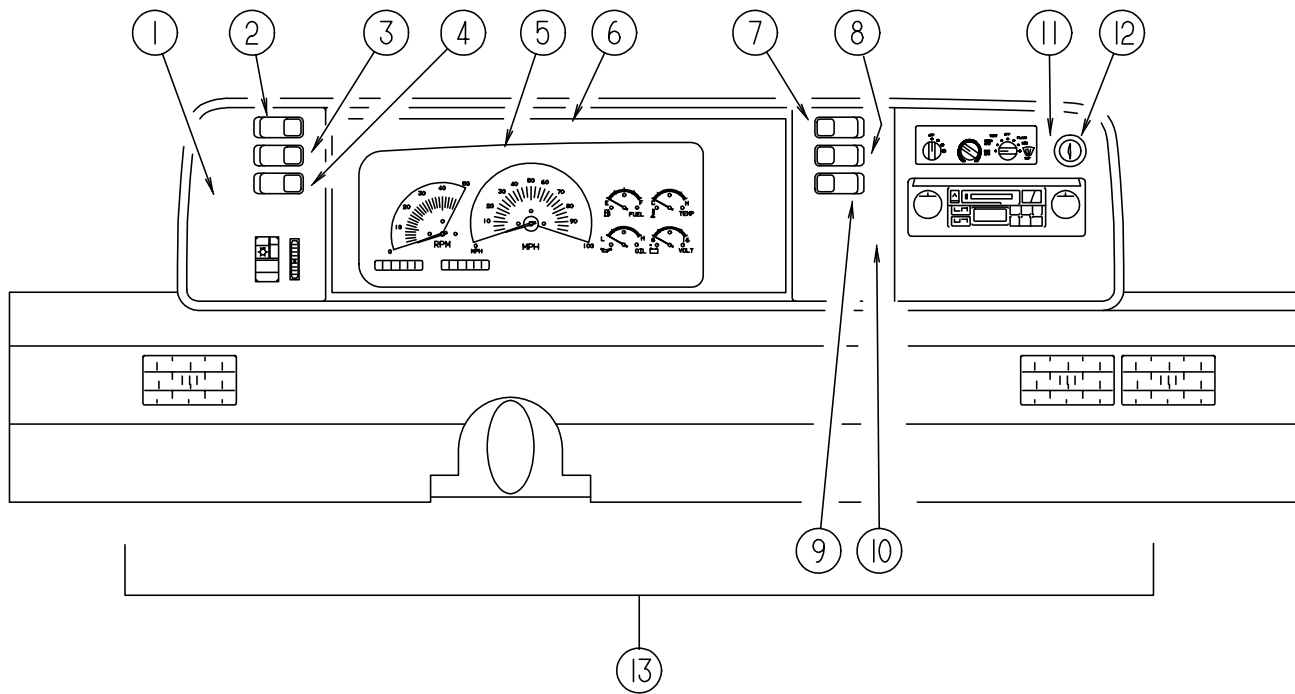

DASH, GAUGES & SWITCHES - CHEVY (FROM: 00-00-00 THRU: 03-14-99)

KEY	PART NUMBER	U/M	DESCRIPTION
1	104056-37-01A	EA	APPLIQUE - BEZEL - DRIVER - BLACK
2	108356-02-01A	EA	COVER/ACTUATOR SWITCH - 2 ROWS DIMPLES- CONTURA II - BLACK
2	108357-05-000	EA	SWITCH - ROCKER SPDT - ON/NONE/ON - 3 TERMINAL - RADIO POWER W/O CD
2	108357-08-000	EA	SWITCH - ROCKER DPDT - ON/NONE/ON - 6 TERMINAL - RADIO POWER W/CD
3	108356-02-01A	EA	COVER/ACTUATOR SWITCH - 2 ROWS DIMPLES- CONTURA II - BLACK
3	108357-09-000	EA	SWITCH - ROCKER SPDT - ON/NONE/MOM - 3 TERMINAL - AUXILIARY START
4	108356-02-01A	EA	COVER/ACTUATOR SWITCH - 2 ROWS DIMPLES- CONTURA II - BLACK
4	108357-06-000	EA	SWITCH - ROCKER DPDT - MOM/OFF/MOM - 6 TERMINAL - AUXILIARY BATTERY
5	N/A	EA	CLUSTER - INSTRUMENT PANEL - K/M - GAS - CANADIAN
6	103662-08-01A	EA	BEZEL - INSTRUMENT PANEL
7	108356-04-01A	EA	COVER/ACTUATOR SWITCH - 2 ROWS DIMPLES W/LENS-CONTURA-BLK
7	108357-10-000	EA	SWITCH - ROCKER SPDT - W/LIGHT - MOM/NONE/MOM - 5 TERMINAL - GEN
7	096241-03-000	EA	SWITCH - BLANK - BLACK
8	108356-02-01A	EA	COVER/ACTUATOR SWITCH - 2 ROWS DIMPLES- CONTURA II - BLACK
8	108357-03-000	EA	SWITCH - ROCKER SPDT - ON/OFF/ON - 3 TERMINAL - REAR HEATER
8	096241-03-000	EA	SWITCH - BLANK - BLACK
9	096241-03-000	EA	SWITCH - BLANK - BLACK
10	104056-21-01A	EA	APPLIQUE - BEZEL - PASSENGER - BLACK
11	104056-06-01A	EA	APPLIQUE - BEZEL - PASSENGER - BLACK
12	089294-01-000	EA	LIGHTER - CIGARETTE - W/SOCKET & WIRE
13	125677-02-J20	EA	POD - INSTRUMENT PANEL - ANTELOPE
	103603-01-000	EA	BULB - 12 VOLT - #74 - .12A WEDGE - GE 22-25 USED IN DASH
	077031-01-000	EA	FILM - BLACK - 1" X 1.75"
	077031-03-000	EA	FILM - WHITE - .75" X 1"
	049176-01-000	EA	HEDLOCK II - 3/4 DIAMETER SCREW MOUNT

DRIVERS COMPARTMENT GROUP (CONTINUED)

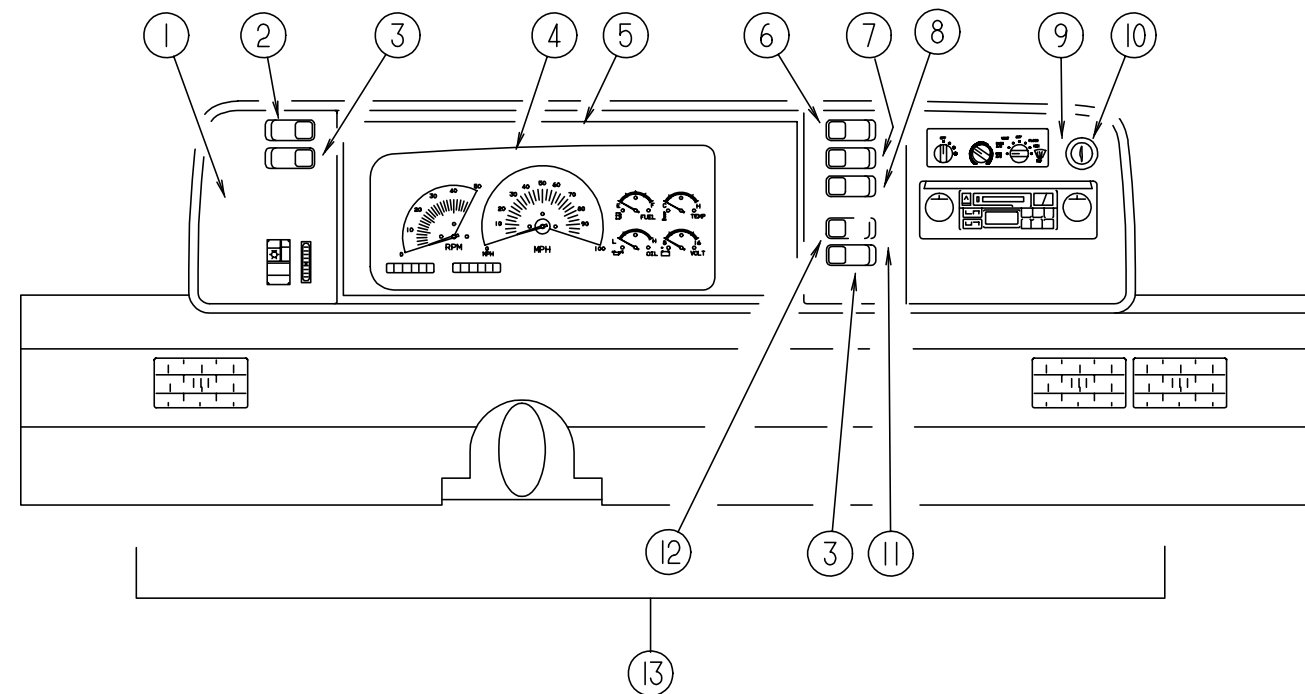

DASH, GAUGES & SWITCHES - CHEVY (FROM: 03-15-99 THRU: 99-99-99)

KEY	PART NUMBER	U/M	DESCRIPTION
1	104056-44-01A	EA	APPLIQUE - BEZEL - DRIVER - BLACK
2	108356-02-01A	EA	COVER/ACTUATOR SWITCH - 2 ROWS DIMPLES- CONTURA II - BLACK
2	108357-09-000	EA	SWITCH - ROCKER SPDT - ON/NONE/MOM - 3 TERMINAL - AUXILIARY START
3	096241-03-000	EA	SWITCH - BLANK - BLACK
4	N/A	EA	CLUSTER - INSTRUMENT PANEL - K/M - GAS - CANADIAN
5	103662-08-01A	EA	BEZEL - INSTRUMENT PANEL
6	108356-02-01A	EA	COVER/ACTUATOR SWITCH - 2 ROWS DIMPLES- CONTURA II - BLACK
6	108357-05-000	EA	SWITCH - ROCKER SPDT - ON/NONE/ON - 3 TERMINAL - RADIO POWER W/O CD
6	108357-08-000	EA	SWITCH - ROCKER DPDT - ON/NONE/ON - 6 TERMINAL - RADIO POWER W/CD
7	108356-04-01A	EA	COVER/ACTUATOR SWITCH - 2 ROWS DIMPLES W/LENS-CONTURA-BLK
7	108357-10-000	EA	SWITCH - ROCKER SPDT - W/LIGHT - MOM/NONE/MOM - 5 TERMINAL - GEN
7	096241-03-000	EA	SWITCH - BLANK - BLACK
8	108356-02-01A	EA	COVER/ACTUATOR SWITCH - 2 ROWS DIMPLES- CONTURA II - BLACK
8	108357-03-000	EA	SWITCH - ROCKER SPDT - ON/OFF/ON - 3 TERMINAL - REAR HEATER
8	096241-03-000	EA	SWITCH - BLANK - BLACK
9	104056-06-01A	EA	APPLIQUE - BEZEL - PASSENGER - BLACK
10	089294-01-000	EA	LIGHTER - CIGARETTE - W/SOCKET & WIRE
11	104056-43-01A	EA	APPLIQUE - BEZEL - PASSENGER - BLACK
12	108356-02-01A	EA	COVER/ACTUATOR SWITCH - 2 ROWS DIMPLES- CONTURA II - BLACK
12	108357-06-000	EA	SWITCH - ROCKER DPDT - MOM/OFF/MOM - 6 TERMINAL - AUXILIARY BATTERY
13	125677-02-J20	EA	POD - INSTRUMENT PANEL - ANTELOPE
	103603-01-000	EA	BULB - 12 VOLT - #74 - .12A WEDGE - GE 22-25 USED IN DASH
	077031-01-000	EA	FILM - BLACK - 1" X 1.75"
	077031-03-000	EA	FILM - WHITE - .75" X 1"
	049176-01-000	EA	HEDLOCK II - 3/4 DIAMETER SCREW MOUNT

ELECTRICAL GROUP

EXTERIOR LIGHTS

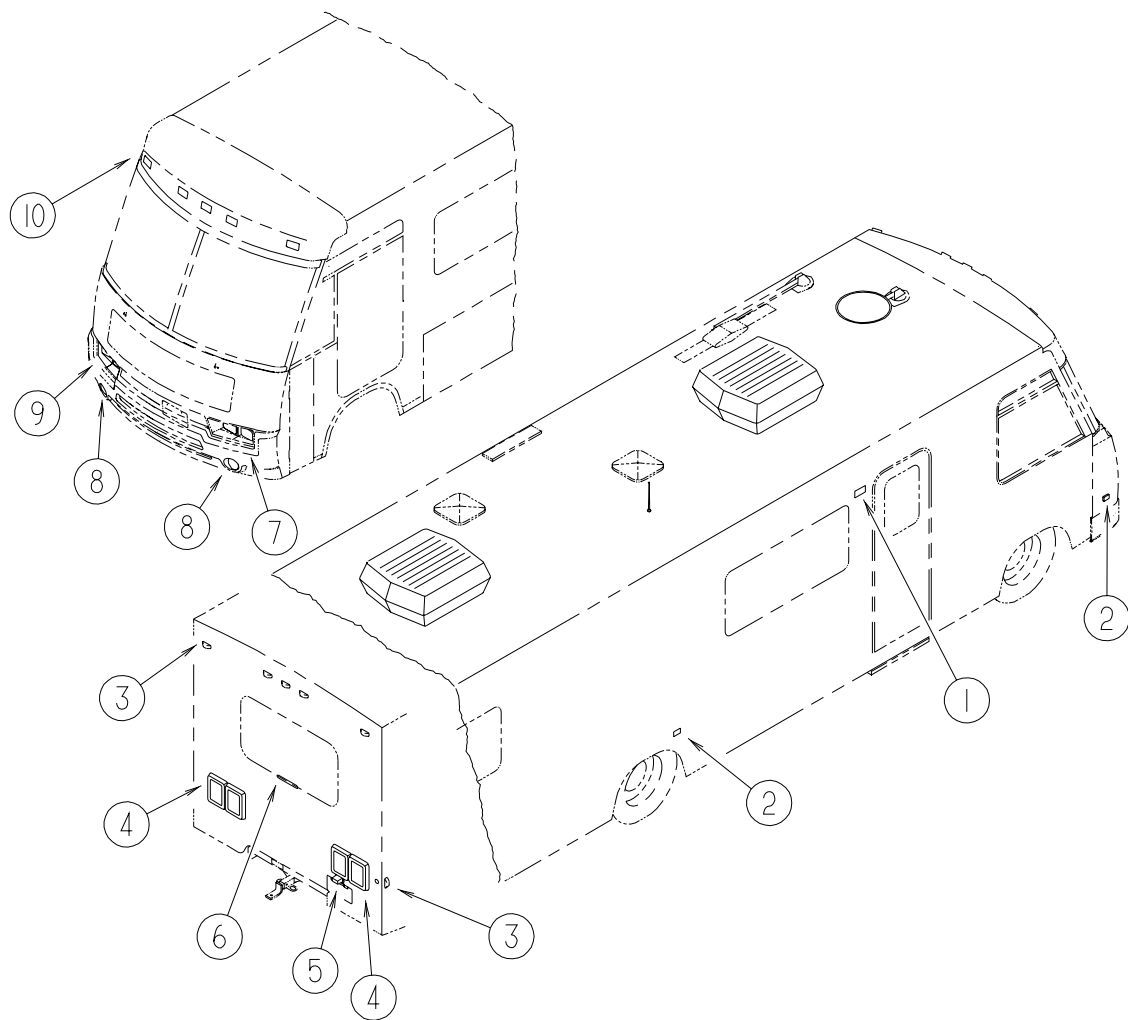

KEY	PART NUMBER	U/M DESCRIPTION	VENDOR NO.
1	097917-01-06A	EA LIGHT - PORCH - BRIGHT WHITE	
	008215-01-000	EA BULB - 12 VOLT - #1003 - .94 AMP	
	097917-01-700	EA LENS-LIGHT, CLEAR	30-78-021
1	008089-02-000	EA LIGHT - PORCH - RECESSED - CANADIAN	
	008089-01-700	EA LENS-LIGHT, RECESSED, PORCH DECO	
	008214-01-000	EA BULB - 12 VOLT - #67 - .59 AMP	
2	111102-01-000	EA BASE - LAMP MARKER	
2	111102-02-000	EA LENS - AMBER - MARKER LAMP	
	036196-01-000	EA BULB - 12V - #194 - .27 AMP - BAYONETTE	
3	111102-01-000	EA BASE - LAMP MARKER	
3	111102-03-000	EA LENS - RED - MARKER LAMP	
	036196-01-000	EA BULB - 12V - #194 - .27 AMP - BAYONETTE	
4	081638-01-000	EA TAILLIGHT/DOUBLE W/BLACK TRIM - DRIVER/PASSENGER SIDE	
	037934-01-000	EA BULB - 12V - #1156 - 2.1 AMP CLEAR GLASS BACK UP & TURN SIGNAL BULB	
	037935-01-000	EA BULB - 12V - #1157 OR #2057 - 2.1 AMP - CLEAR GLASS BRAKE LIGHT BULB	
	081638-01-700	EA LENS-TAILLIGHT, RED	30-84-010
	081638-01-701	EA LENS-TAILLIGHT, W/BACKUP	30-84-700
	103355-01-05A	EA POD - TAIL LIGHT - BRIGHT WHITE	
		FROM: 00-00-00 THRU: 11-22-98	
	103355-02-01A	EA POD - TAIL LIGHT - BRIGHT WHITE	
		FROM: 11-23-98 THRU: 99-99-99	
5	066432-02-000	EA LIGHT - LICENSE - BLACK	
5	066432-03-000	EA BRACKET - LICENSE PLATE	
6	121950-01-000	EA LIGHT - BRAKE - CENTER MOUNT	
7	049186-04-000	EA HEADLAMP - DRIVER - HIGH/LOW - HALOGEN	
7	049188-04-000	EA HEADLAMP - DRIVER - HIGH BEAM - HALOGEN	
7	049359-01-000	EA SPRING - RETAINER - HEADLAMP - GM #496096	
7	110750-01-000	EA SCREW - HEADLAMP ADJUSTING	
8	084901-01-000	EA LAMP - PARK/TURN - GM #916558 (BULB #2057)	
9	049185-04-000	EA HEADLAMP - PASSENGER - HIGH/LOW - HALOGEN	
9	049187-04-000	EA HEADLAMP - PASSENGER - HIGH BEAM - HALOGEN	
9	049359-01-000	EA SPRING - RETAINER - HEADLAMP - GM #496096	
9	110750-01-000	EA SCREW - HEADLAMP ADJUSTING	
10	102520-01-000	EA LIGHT - CLEARANCE - W/O SOCKET/HOUSING - AMBER	
10	067789-02-000	EA SOCKET - LAMP	
10	036196-01-000	EA BULB - 12V - #194 - .27 AMP - BAYONETTE	
10	102541-01-000	EA GASKET - CLEARANCE LIGHT	

ELECTRICAL GROUP (CONTINUED)

LIGHTS, SWITCHES, & RECEPTACLES PASSENGERS SIDE

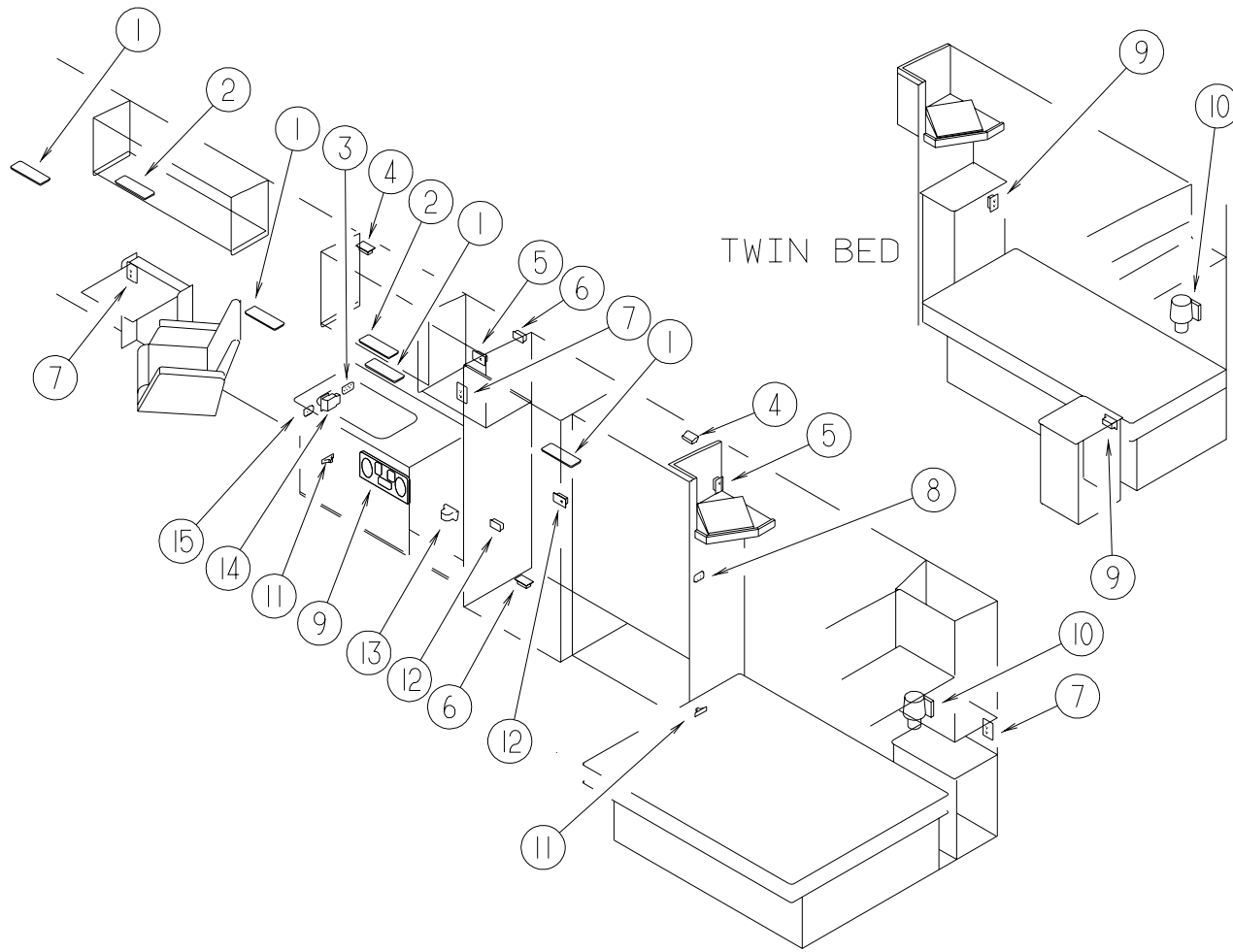

KEY	PART NUMBER	U/M	DESCRIPTION	VENDOR NO.
1	098024-03-02A	EA	LIGHT - DOME - 2 BULB - WHITE	
	008218-01-000	EA	BULB - 12 VOLT - #1141 - 1.44 AMP	
2	098024-01-700	EA	LENS-LIGHT	807877
	098024-06-02A	EA	LIGHT - DOME - 2 BULB - SKYLITE	
	008218-01-000	EA	BULB - 12 VOLT - #1141 - 1.44 AMP	
3	098024-01-701	EA	LENS - OPTI CLEAR - SKYLITE	809902
	095188-02-01A	EA	SPACER - SWITCH - 2.3" X 4.1" - PLASTIC - DARK BROWN	
3	098351-05-01A	EA	PLATE/SWITCH - 3 GANG - POLISHED BRASS-PORCH/CEILING/STEP	
	079364-01-000	EA	SWITCH - ON/OFF ROCKER - 2 TERMINAL - BROWN - PORCH/CEILING/STEP	
4	091927-01-000	EA	COVER - RECEPTACLE - DOUBLE - IVORY - W/O ROOF A/C OPTION	
5	058708-05-000	EA	RECEPTACLE - ELECTRIC - SINGLE - BROWN - MICROWAVE	
6	058707-02-000	EA	RECEPTACLE - BLANK - JUNCTION BOX	
7	058708-02-000	EA	RECEPTACLE - ELECTRIC - DOUBLE - IVORY	
7	102568-01-GB1	EA	SPACER - RECEPTACLE - BETWEEN SIDEWALL & PLATE - WOOD	
	098351-02-01A	EA	PLATE/SWITCH - 2 GANG - POLISHED BRASS - W/O LABEL	
8	079364-01-000	EA	SWITCH - ON/OFF ROCKER - 2 TERMINAL - BROWN - BEDROOM LIGHT	
8	079364-03-000	EA	SWITCH - ON/OFF ROCKER - 3 TERMINAL - BROWN - COURTESY LIGHT	
8	095188-01-01A	EA	SPACER - SWITCH - 2.3" X 3.4" - PLASTIC - DARK BROWN	
9	058708-01-000	EA	RECEPTACLE - ELECTRIC - DOUBLE - BROWN	
10	119257-03-01A	EA	SHADE - LAMP - LINEN	
10	119258-02-01A	EA	LAMP - WALL	
	119258-01-700	EA	FINIAL (PYRAMID)	12-0322
10	067479-01-000	EA	BULB - 12 VOLT - #1076 - 1.80 AMP	
11	061424-01-000	EA	LIGHT - AISLE - 12 VOLT - RECTANGULAR	
	008103-01-000	EA	BULB - DASH/AISLE LIGHT - #53 - 12 VOLT - .12 AMP	
12	058707-01-000	EA	RECEPTACLE - ELECTRIC - SINGLE - BROWN - REFRIGERATOR OR CONVERTER	
13	112822-01-01A	EA	RECEPTACLE - DUPLEX - IVORY	
13	112824-01-03A	EA	COVER - EXTERIOR DUPLEX RECEPTACLE - WHITE PLASTIC	FROM: 00-00-00 THRU: 11-15-98
				FROM: 00-00-00 THRU: 11-15-98
13	131826-01-01A	EA	RECEPTACLE - EXTERIOR - W/COVER/GASKET - WHITE	FROM: 11-16-98 THRU: 99-99-99
14	084076-02-000	EA	RECEPTACLE - GFI - 15 AMP/125 VOLT - BROWN	
15	095188-01-01A	EA	SPACER - SWITCH - 2.3" X 3.4" - PLASTIC - DARK BROWN	
	079364-03-000	EA	SWITCH - ON/OFF ROCKER - 3 TERMINAL - BROWN - COURTESY LIGHT	
15	098351-01-01A	EA	PLATE/SWITCH - 1 GANG - POLISHED BRASS - W/O LABEL	
	086280-01-000	EA	LIGHT - SURFACE MOUNT - 12 VOLT - EXTERIOR STORAGE COMPARTMENTS	ARP1089
	086280-01-700	EA	BULB,12V	
	098024-01-03A	EA	LIGHT - DOME - 1 BULB - WHITE - EXTERIOR STORAGE COMPARTMENTS	
	008218-01-000	EA	BULB - 12 VOLT - #1141 - 1.44 AMP	
	098024-01-700	EA	LENS-LIGHT	807877

ELECTRICAL GROUP (CONTINUED)

LIGHTS, SWITCHES, & RECEPTACLES DRIVERS SIDE

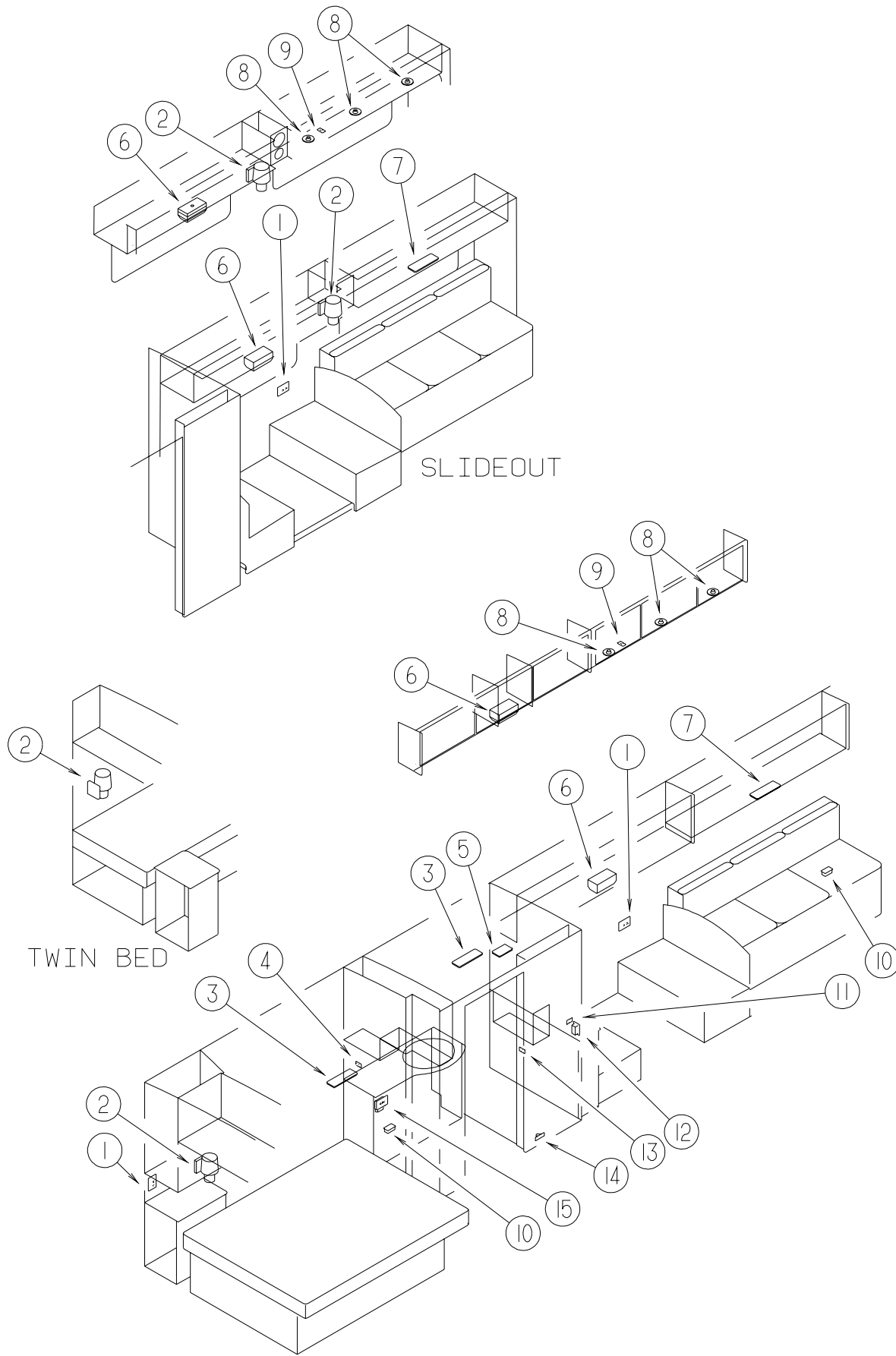

KEY	PART NUMBER	U/M	DESCRIPTION	VENDOR NO.
1	058708-02-000	EA	RECEPTACLE - ELECTRIC - DOUBLE - IVORY	
1	102568-01-GB1	EA	SPACER - RECEPTACLE - BETWEEN SIDEWALL & PLATE - WOOD	
2	119257-03-01A	EA	SHADE - LAMP - LINEN	
2	119258-02-01A	EA	LAMP - WALL	
	119258-01-700	EA	FINIAL (PYRAMID)	12-0322
2	067479-01-000	EA	BULB - 12 VOLT - #1076 - 1.80 AMP	
3	098024-03-02A	EA	LIGHT - DOME - 2 BULB - WHITE	
	008218-01-000	EA	BULB - 12 VOLT - #1141 - 1.44 AMP	
	098024-01-700	EA	LENS-LIGHT	807877
4	098351-01-01A	EA	PLATE/SWITCH - 1 GANG - POLISHED BRASS - W/O LABEL	
4	079364-03-000	EA	SWITCH - ON/OFF ROCKER - 3 TERMINAL - BROWN - WATER PUMP	
5	121935-01-01A	EA	LIGHT - DOME - SHOWER	
6	093575-06-01A	EA	LIGHT - CEILING - FLUTED	
	008218-01-000	EA	BULB - 12 VOLT - #1141 - 1.44 AMP	
	093575-06-700	EA	GLOBE	9048
7	098024-06-02A	EA	LIGHT - DOME - 2 BULB - SKYLITE	
	008218-01-000	EA	BULB - 12 VOLT - #1141 - 1.44 AMP	
	098024-01-701	EA	LENS - OPTI CLEAR - SKYLITE	809902
8	123775-01-01A	EA	LIGHT - HALOGEN - ROUND - COMFORT AND CONVENIENCE PACKAGE	
	123775-01-700	EA	BULB - 10 WATT - HALOGEN	71-JC10
	123775-01-701	EA	BEZEL/LENS - RECESSED LIGHT	
9	098351-01-01A	EA	PLATE/SWITCH - 1 GANG - POLISHED BRASS - W/O LABEL	
			COMFORT AND CONVENIENCE PACKAGE	
9	079364-01-000	EA	SWITCH - ON/OFF ROCKER - 2 TERMINAL - BROWN	
			COMFORT AND CONVENIENCE PACKAGE	
10	058707-02-000	EA	RECEPTACLE - BLANK - JUNCTION BOX	
11	079364-01-000	EA	SWITCH - ON/OFF ROCKER - 2 TERMINAL - BROWN - DINETTE LIGHT	
11	098351-01-01A	EA	PLATE/SWITCH - 1 GANG - POLISHED BRASS - W/O LABEL	
12	058708-01-000	EA	RECEPTACLE - ELECTRIC - DOUBLE - BROWN	
12	058708-02-000	EA	RECEPTACLE - ELECTRIC - DOUBLE - IVORY	
13	079364-01-000	EA	SWITCH - ON/OFF ROCKER - 2 TERMINAL - BROWN - BATH OR SHOWER LIGHT	
13	098351-02-01A	EA	PLATE/SWITCH - 2 GANG - POLISHED BRASS - W/O LABEL	
14	061424-01-000	EA	LIGHT - AISLE - 12 VOLT - RECTANGULAR	
	008103-01-000	EA	BULB - DASH/AISLE LIGHT - #53 - 12 VOLT - .12 AMP	
15	084076-02-000	EA	RECEPTACLE - GFI - 15 AMP/125 VOLT - BROWN	
	086280-01-000	EA	LIGHT - SURFACE MOUNT - 12 VOLT - EXTERIOR STORAGE COMPARTMENTS	ARP1089
	086280-01-700	EA	BULB, 12V	
	098024-01-03A	EA	LIGHT - DOME - 1 BULB - WHITE - EXTERIOR STORAGE COMPARTMENTS	
	008218-01-000	EA	BULB - 12 VOLT - #1141 - 1.44 AMP	
	098024-01-700	EA	LENS-LIGHT	807877

ELECTRICAL GROUP (CONTINUED)**FUSES & FUSE HOUSINGS**

KEY	PART NUMBER	U/M	DESCRIPTION
	062901-02-000	EA	FUSE - 05 AMPS - AUTOMOTIVE
	062901-05-000	EA	FUSE - 15 AMPS - AUTOMOTIVE
	062901-06-000	EA	FUSE - 20 AMPS - AUTOMOTIVE
	062901-07-000	EA	FUSE - 25 AMPS - AUTOMOTIVE
	062901-08-000	EA	FUSE - 30 AMPS - AUTOMOTIVE
	062037-01-000	EA	HOUSING - AUTO FUSE - NATURAL
	062037-02-000	EA	HOUSING - AUTO FUSE - GREEN
	062037-03-000	EA	HOUSING - AUTO FUSE - BLACK
	062037-04-000	EA	HOUSING - AUTO FUSE - BLUE
	062037-05-000	EA	HOUSING - AUTO FUSE - GRAY
	062037-06-000	EA	HOUSING - AUTO FUSE - BROWN
	062037-07-000	EA	HOUSING - AUTO FUSE - RED
	106656-01-000	EA	FUSE BLOCK - 4 CAVITY - AUTOFUSE
	108669-01-000	EA	HOUSING - AUTO FUSE HOLDER

CIRCUIT BREAKERS

KEY	PART NUMBER	U/M	DESCRIPTION
	083209-01-000	EA	CIRCUIT BREAKER - 15 AMP - 120 VOLT - CANADIAN
	083209-02-000	EA	CIRCUIT BREAKER - 15/15 AMP - 120 VOLT
	083209-03-000	EA	CIRCUIT BREAKER - 15/20 AMP - 120 VOLT
	083209-04-000	EA	CIRCUIT BREAKER - 30 AMP - 120 VOLT
	083209-06-000	EA	CIRCUIT BREAKER - 30/15 AMP - 120 VOLT
	083209-07-000	EA	CIRCUIT BREAKER - 20/20 AMP - 120 VOLT
	083209-10-000	EA	CIRCUIT BREAKER - 20/30 AMP - 120 VOLT
	083209-11-000	EA	CIRCUIT BREAKER - 20/15 AMP - 120 VOLT
	093654-01-000	EA	CIRCUIT BREAKER - 6 AMP - 12 VOLT
	093654-02-000	EA	CIRCUIT BREAKER - 15 AMP - 12 VOLT
	093655-03-000	EA	CIRCUIT BREAKER - 40 AMP - 12 VOLT
	093674-01-000	EA	PLATE - CIRCUIT BREAKER - HOUSE - 8.4" X 4.1" - STEEL
	097611-01-000	EA	CIRCUIT BREAKER - 10 AMP - 12 VOLT

TERMINALS

KEY	PART NUMBER	U/M	DESCRIPTION
	008326-01-000	EA	TERMINAL - RING - 16/14 WIRE - 3/8" STUD
	008328-01-000	EA	TERMINAL - RING - 12/10 WIRE - #10 STUD FIT
	008331-01-000	EA	TERMINAL - RING - TONGUE - #4 WIRE - 3/8" STUD - COPPER
	008348-01-000	EA	TERMINAL - RING - 3/8" STUD 2 GA. WIRE
	035416-04-000	EA	TERMINAL - RING - #10 STUD FIT - INSULATED BARREL #16/14
	047443-01-000	EA	TERMINAL - .250 RECEPTACLE FIT - INSULATED - 16/14 AWG
	047443-02-000	EA	TERMINAL - .250 RECEPTACLE FIT - INSULATED - 12/10 AWG
	062036-01-000	EA	TERMINAL - PACK - CON - 12/10 AWG
	062036-02-000	EA	TERMINAL - PACK - CON - 16/14 AWG
	088267-01-000	EA	TERMINAL - FEMALE - 1/4
	088476-01-000	EA	TERMINAL - ELECTRICAL
	098260-01-000	EA	TERMINAL - MALE - 56 SERIES
	104100-03-000	EA	TERMINAL - 75 AMP
	106007-01-000	EA	TERMINAL - FEMALE - 14-16 AWG
	106655-01-000	EA	TERMINAL - FUSE BLOCK - 14-16 AWG
	106655-02-000	EA	TERMINAL - FUSE BLOCK - 10-12 AWG
	113135-01-000	EA	TERMINAL - FEMALE - M/P - 14-16 - F/SEALED TERMINAL
	113306-01-000	EA	TERMINAL - FEMALE - M/P - 14-16 - F/NON-SEALED TERMINAL
	113307-01-000	EA	TERMINAL - FEMALE - M/P - 16-20
	125324-01-000	EA	TERMINAL - MALE - METRI-PACK - 150

ELECTRICAL GROUP (CONTINUED)**ELECTRIC BOXES & COVERS**

KEY	PART NUMBER	U/M	DESCRIPTION
	008289-01-000	EA	BOX - ELECTRIC/STEEL - 1/2" & 3/4" KNOCKOUTS - 4" X 4"
	008289-02-000	EA	BOX - ELECTRIC/STEEL - 1/2" & 3/4" KNOCKOUTS - 4" X 4"-CAN
	008294-01-000	EA	COVER - ELECTRICAL BOX - BLANK/STEEL - 4" X 4" - GRAY
	008294-02-000	EA	COVER - ELECTRICAL BOX - BLANK STEEL - 4" X 4" - CANADIAN
	069238-01-000	EA	COVER - ELECTRICAL BOX - W/HOLE - 4" X 4" - GRAY USED WITH 30 AMP RECEPTACLE
	074890-01-000	EA	BOX - EXTENSION/STEEL - OPEN SIDES - 4" X 4" X 1 1/2"
	074897-01-000	EA	COVER - ELECTRICAL BOX W/HOLES - 4" X 4"
	091910-01-000	EA	BOX - ELECTRIC - 3.8" X 3.5" X 1.8" - PLASTIC
	091910-02-000	EA	BOX - ELECTRIC - 2.2" X 3.5" X 1.8" - PLASTIC
	111509-01-000	EA	BOX - ELECTRICAL - E-COATED
	111510-01-000	EA	DDOOR/ACCESS PANEL - ELECTRICAL BOX - 8.1" X 11.7"

HOUSINGS, PINS & SOCKETS

KEY	PART NUMBER	U/M	DESCRIPTION
	088473-01-000	EA	HOUSING - PIN - 12 CAVITY (3 ROWS OF 4)
	088473-02-000	EA	HOUSING - PIN - 15 CAVITY (3 ROWS OF 5)
	088473-03-000	EA	HOUSING - PIN - 9 CAVITY (3 ROWS OF 3)
	088473-04-000	EA	HOUSING - PIN - 8 CAVITY IN-LINE
	088473-06-000	EA	HOUSING - PIN - 6 CAVITY (2 ROWS OF 3)
	088473-08-000	EA	HOUSING - PIN - 4 CAVITY - IN-LINE
	088473-09-000	EA	HOUSING - PIN - 3 CAVITY - IN-LINE
	088473-10-000	EA	HOUSING - PIN - 2 CAVITY - IN LINE
	098264-01-000	EA	HOUSING - 2 PIN - WEATHERPACK - MALE W/FEMALE PINS
	088474-01-000	EA	HOUSING - SOCKET - 12 CAVITY
	088474-02-000	EA	HOUSING - SOCKET - 15 CAVITY
	088474-03-000	EA	HOUSING - SOCKET - 9 CAVITY
	088474-04-000	EA	HOUSING - SOCKET - 8 CAVITY
	088474-06-000	EA	HOUSING - SOCKET - 6 CAVITY
	088474-07-000	EA	HOUSING - SOCKET - 5 CAVITY
	088474-08-000	EA	HOUSING - SOCKET - 4 CAVITY
	088474-09-000	EA	HOUSING - ELECTRICAL - 3 TERMINAL
	088474-10-000	EA	HOUSING - SOCKET - 2 CAVITY
	088475-01-000	EA	PIN - CONNECTOR - 14-20 AWG
	088475-02-000	EA	PIN - CONNECTOR - 10 - 12 AWG
	088476-02-000	EA	SOCKET - CONNECTOR - 12-10 GA - PRE-TIN
	098261-02-000	EA	SOCKET - CONNECTOR - WEATHERPACK - 14-18 AWG
	101571-01-000	EA	HOUSING - 2 POSITION - MALE
	103608-01-000	EA	SOCKET - WEDGE BASE W/LEADS
	104100-01-000	EA	HOUSING - 1 POSITION - 75 AMPS
	106006-01-000	EA	HOUSING - 1 POSITION - FEMALE
	110178-01-000	EA	HOUSING - WIPER MOTOR
	113131-01-000	EA	HOUSING - 3 PIN
	113468-01-000	EA	HOUSING - 2 POSITION - FEMALE USED ON WIPER/WASHER WIRE ASM
	115556-01-000	EA	HOUSING - 3 POSITION - FEMALE
	115556-02-000	EA	HOUSING - 2 POSITION - FEMALE
	119248-02-000	EA	HOUSING - 7 POSITION - FEMALE
	125323-02-000	EA	HOUSING - 8 POSITION - MALE
	108355-01-000	EA	HOUSING - SWITCH
	007954-01-000	EA	RECEPTACLE - HOUSING - 6 POSITION
	080015-02-000	EA	RECEPTACLE - FLAG - .185 - 16/14 GAUGE

ELECTRICAL GROUP (CONTINUED)**CONNECTORS**

KEY	PART NUMBER	U/M	DESCRIPTION
	008311-01-000	EA	CONNECTOR - WIRE NUT - INSULATED - RED
	008312-01-000	EA	CONNECTOR - WIRE NUT - INSULATED - BLUE
	008313-01-000	EA	CONNECTOR - WIRE NUT - INSULATED - YELLOW
	008314-01-000	EA	CONNECTOR - WIRE NUT - INSULATED - GRAY
	008355-01-000	EA	CONNECTOR - CABLE CLAMPING - 3/4"
	008356-01-000	EA	CONNECTOR - PLASTIC - 3/8" AVG
	008356-02-000	EA	CONNECTOR - PLASTIC - 21/32
	008398-01-000	EA	CONNECTOR - 1/2" X 90 DEGREE - FLEX CONDUIT - UL & CSA
	041480-01-000	EA	CONNECTOR - STRAIGHT - 1/2" FLEX CONDUIT
	058028-01-000	EA	CONNECTOR - ELECTRICAL PIGTAIL - NYLON - CLEAR
	098262-01-000	EA	SEAL - CONNECTOR - WEATHERPACK
	112823-01-000	EA	SPLICE - REDUCER - 16-14 TO 18-22

POWER CORDS & POWER CORD RECEPTACLE

KEY	PART NUMBER	U/M	DESCRIPTION
	008052-01-000	EA	CORD - POWER - 10/3 WIRE - 30 AMP - 25' - CANADIAN
	008054-01-000	EA	CORD - POWER - 10/3 WIRE - 30 AMP - 25'
	024924-02-000	EA	RECEPTACLE - POWER CORD - W/PARTIAL PLATE

WIRE ASSEMBLIES

KEY	PART NUMBER	U/M	DESCRIPTION
	073328-B4-000	EA	CABLE ASSEMBLY - BATTERY - W/TERMINALS
	081059-02-000	EA	WIRE ASSEMBLY - 9PIN - F/RADIO
	090986-01-000	EA	WIRE ASSEMBLY - ELECTRIC STEP
			FROM: 00-00-00 THRU: 02-07-99
	090986-02-000	EA	WIRE ASSEMBLY - ELECTRIC STEP
			FROM: 02-08-99 THRU: 99-99-99
	096449-01-000	EA	WIRE ASSEMBLY - WATER TANK TO MONITOR PANEL
	100677-01-000	EA	WIRE ASSEMBLY - RADIO
	108303-01-000	EA	WIRE ASSEMBLY - REAR AUTO HEATER
			FROM: 00-00-00 THRU: 03-14-99
	110256-01-000	EA	WIRE ASSEMBLY - INSTRUMENT PANEL - GENERATOR
			FROM: 00-00-00 THRU: 03-14-99
	111915-03-000	EA	WIRE ASSEMBLY - DAYTIME RUNNING LAMPS - FUSED - FORD
			FROM: 00-00-00 THRU: 03-01-98
	126392-01-000	EA	WIRE ASSEMBLY - REMOTE MIRRORS
			FROM: 00-00-00 THRU: 03-14-99
	129436-02-000	EA	WIRE ASSEMBLY - INSTRUMENT PANEL/POWER MIRROR
			FROM: 03-15-99 THRU: 04-13-99
	129436-03-000	EA	WIRE - INSTRUMENT PANEL - F/POWER MIRROR
			FROM: 04-14-99 THRU: 99-99-99
	111915-01-000	EA	WIRE ASSEMBLY - DAYTIME RUNNING LAMPS - FUSED - GM
	113134-03-000	EA	WIRE ASSEMBLY - WIPER/WASHER
	120233-05-000	EA	WIRE - 30" W/DIGITAL SENSOR CONNECTOR/STRIPED LEAD
	125578-02-000	EA	WIRE ASSEMBLY - INSTRUMENT PANEL - RIGHT HAND
	125853-01-000	EA	WIRE ASSEMBLY - ENTERTAINMENT CENTER
	127002-03-000	EA	WIRE ASSEMBLY - ENERGY MANAGEMENT SYSTEM
	127053-01-000	EA	WIRE ASSEMBLY - REAR MONITOR/UPPER

ELECTRICAL GROUP (CONTINUED)**INVERTER, LOAD CENTER, CONVERTER & ENERGY MANAGEMENT SYSTEM PANEL**

KEY	PART NUMBER	U/M	DESCRIPTION
	099048-03-000	EA	INVERTER - 130 WATT
	108915-02-000	EA	LOAD CENTER - 120/240 VOLT - 100 AMP
			FROM: 00-00-00 THRU: 04-04-99
	108915-03-000	EA	LOAD CENTER - 120/240 - 100 AMP
			FROM: 04-05-99 THRU: 99-99-99
	113132-01-000	EA	LOAD CENTER - 120/240 VOLT - 60 AMP
	123058-02-000	EA	CONVERTER - 45 AMP - ELECTRONIC - 4 1/8"H X 7"W X 12 3/8"L
	127002-01-000	EA	MODULE/CIRCUIT BOARD - ENERGY MANAGEMENT SYSTEM CONTROL
	127002-02-000	EA	PANEL/MONITOR - ENERGY MANAGEMENT SYSTEM

CONDUIT

KEY	PART NUMBER	U/M	DESCRIPTION
	008394-01-000	FT	CONDUIT - FLEXIBLE - 1/2"
	041953-01-000	FT	CONDUIT - CONVOLUTE SLIT - .5" ID - POLYETHYLENE
	041953-03-000	FT	CONDUIT - CONVOLUTE SLIT - 1" ID (CLOTHES ROD COVER)
	041953-05-000	FT	CONDUIT - CONVOLUTE SOLID - .62" ID - POLYETHYLENE
	041953-06-000	FT	CONDUIT - CONVOLUTE SLIT - .375" ID - POLYETHYLENE
	041953-07-000	FT	CONDUIT - CONVOLUTE SLIT - .25" ID - POLYETHYLENE
	041953-08-000	FT	CONDUIT - CONVOLUTE SLIT - 1.50" ID - POLYETHYLENE
	041953-09-000	FT	CONDUIT - CONVOLUTE SLIT - .50" ID - NYLON
	041953-10-000	FT	CONDUIT - CONVOLUTE SLIT - .75" ID - NYLON
	041953-11-000	FT	CONDUIT - CONVOLUTE SLIT - 1.06" ID - NYLON
	041953-12-000	FT	CONDUIT - CONVOLUTE SOLID - 1.1" ID - NYLON

MISCELLANEOUS ELECTRICAL COMPONENTS

KEY	PART NUMBER	U/M	DESCRIPTION
	007093-01-000	EA	SIGNAL FLASHER
	007956-05-000	EA	INSULATOR - SHRINK - .25 ID X 1.50
	008188-01-000	EA	SOLENOID - 3 POST - BATTERY CHANGE OVER
	054250-04-000	EA	COVER/ANGLED - W/O HOLE 3.6" X 4.5" - PLASTIC
			ELECTRICAL PLATE SUPPORT
	063910-01-000	EA	HOUSING - RELAY
	063912-02-000	EA	RELAY - CANISTER - SPDT
	086233-01-000	EA	STUD - ISOLATED - 3/8" X 7/8" LONG
	086273-01-000	EA	RELAY - BATTERY DISCONNECT
	092786-02-000	EA	BUSS BAR - 3.3" LONG
	092786-03-000	EA	BUSS BAR - 6.9" LONG
	103987-02-000	EA	SEAL - SOLENOID ACCESS
	125323-03-000	EA	LOCK - SECONDARY 8 POSITION
	125325-01-000	EA	SEAL - CAVITY
	087225-01-000	FT	SLEEVING - 1/2" - TYPE H
	087225-02-000	FT	SLEEVING - 5/8" - TYPE H
	077479-01-000	EA	BOOT - BATTERY TERMINAL - DOUBLE CABLE
	077479-02-000	EA	BOOT - BATTERY TERMINAL - SINGLE CABLE
	128961-01-02B	EA	HANGER - POWER CORD - E-COATED
	072368-02-000	EA	TRIM - VINYL - EDGE - BLACK
			FROM: 00-00-00 THRU: 08-27-98
	126591-01-02B	EA	CARRIER - WIRE -SLIDEOUT

EXTERIOR BODY GROUP

EXTERIOR BODY PANELS AND TRIM

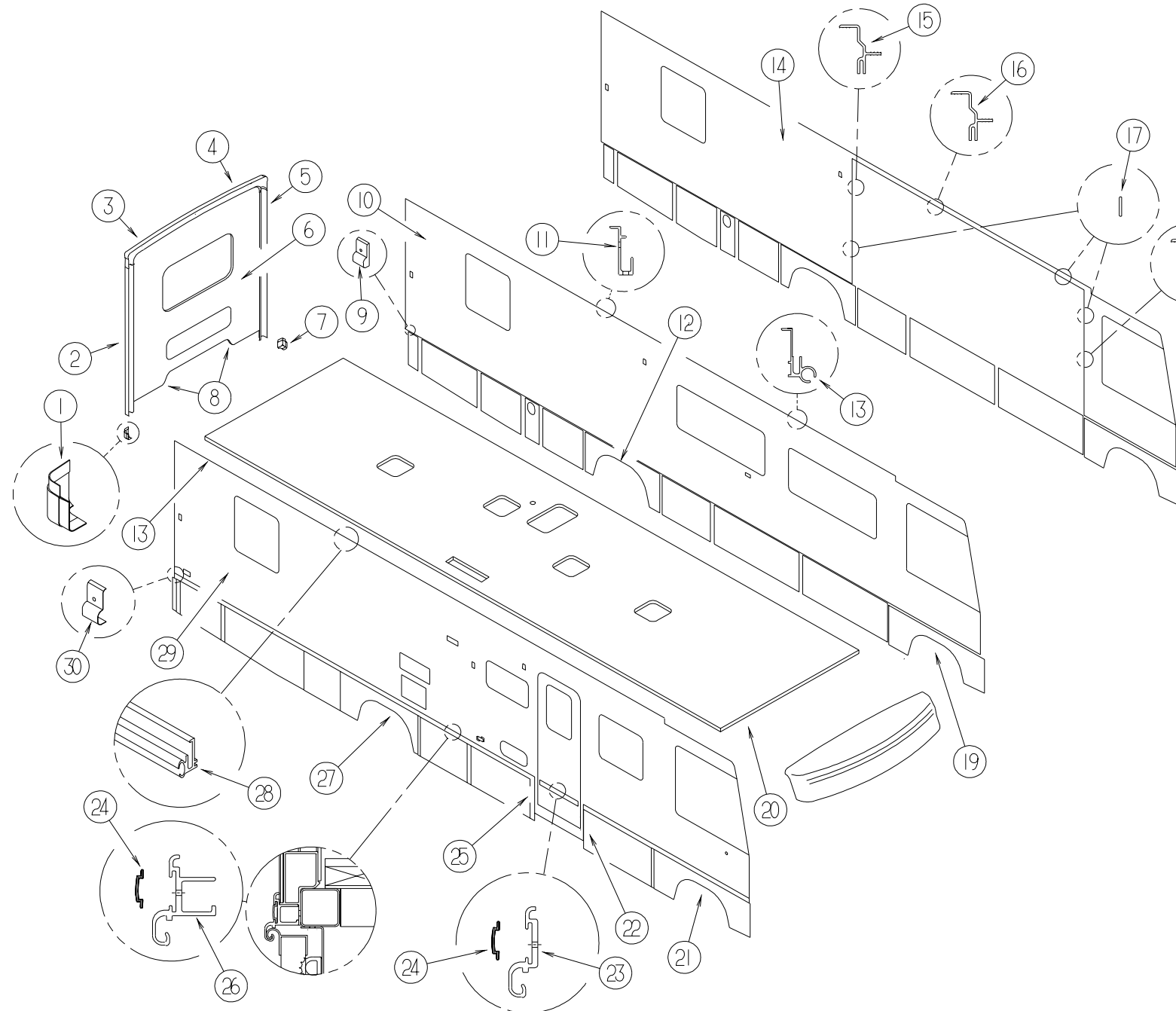

KEY	PART NUMBER	U/M	DESCRIPTION
1	119212-01-01A	EA	END CAP - LOWER BACKWALL TRIM - PASSENGER - BLACK
2	114874-03-12B	EA	TRIM - BACKWALL/PASSENGER SIDE - BRIGHT/WHITE
2	120548-01-02A	EA	TRIM-J - BACKWALL/PASSENGER - 98.3" - NOTCHED - BRIGHT WHT
3	114872-02-02A	EA	TRIM - BACKWALL/TOP - PASSENGER SIDE - BRIGHT WHITE
4	114873-02-02A	EA	TRIM - BACKWALL/TOP - DRIVER SIDE - BRIGHT WHITE
5	114874-04-12B	EA	TRIM - BACKWALL/DRIVER SIDE - BRIGHT/WHITE
5	120548-02-02A	EA	TRIM-J - BACKWALL/DRIVER - 98.3" - NOTCHED - BRIGHT WHITE
6	130352-01-K20	EA	BACKWALL - W/O WINDOW/TRIM (K20)
6	130352-01-K21	EA	BACKWALL - W/O WINDOW/TRIM (K21,K23)
6	130352-01-K22	EA	BACKWALL - W/O WINDOW/TRIM (K22)
	114248-02-01A	EA	ANGLE - PLASTIC - 96.6"
7	119212-02-01A	EA	END CAP - LOWER BACKWALL TRIM - DRIVER - BLACK
8	050406-25-000	EA	TRIM - BACKWALL/LOWER - DRIVER/PASSENGER
9	127845-05-01A	EA	CAP - SIDEWALL TRIM - RIGHT HAND - 2.1" - BRIGHT WHITE
10	130331-03-K20	EA	SIDEWALL - DRIVER - W/O WINDOWS/TRIMS (K20)
10	130331-03-K21	EA	SIDEWALL - DRIVER - W/O WINDOWS/TRIMS (K21,K23)
10	130331-03-K22	EA	SIDEWALL - DRIVER - W/O WINDOWS/TRIMS (K22)

KEY	PART NUMBER	U/M	DESCRIPTION
11	120091-01-02A	EA	TRIM - ROOF
			FROM: 00-00-00 THRU: 10-25-98
12	129421-09-K89	EA	PANEL/WHEEL LIP - REAR - FORD
12	129421-10-K89	EA	PANEL/WHEEL LIP - REAR - CHEVY
13	131483-01-01A	EA	RAIL - AWNING - BRIGHT WHITE
			FROM: 10-26-98 THRU: 99-99-99
14	130045-03-K20	EA	SIDEWALL - DRIVER - W/O WINDOWS/TRIMS - SLIDEOUT OPTION (K20)
14	130045-03-K21	EA	SIDEWALL - DRIVER - W/O WINDOWS/TRIMS - SLIDEOUT OPTION (K21,K23)
14	130045-03-K22	EA	SIDEWALL - DRIVER - W/O WINDOWS/TRIMS - SLIDEOUT OPTION (K22)
15	115863-18-01A	EA	TRIM - SIDEWALL/SLIDEOUT - RIGHT HAND - 76.1" - BRT WHT
16	115863-03-03A	EA	TRIM - SIDEWALL/SLIDEOUT - TOP - 159.4" - BRT WHT
17	115886-01-03A	EA	RETAINER - SIDEWALL - BRIGHT WHITE - 159.4"
18	115863-17-01A	EA	TRIM - SIDEWALL/SLIDEOUT - LEFT HAND - 76.1" - BRT WHT
19	129422-07-K28	EA	PANEL/WHEEL LIP - FRONT/DRIVER
			FROM: 00-00-00 THRU: 09-13-98
19	129422-07-K20	EA	PANEL/WHEEL LIP - FRONT/DRIVER
			FROM: 09-14-98 THRU: 99-99-99

EXTERIOR BODY GROUP (CONTINUED)

EXTERIOR BODY PANELS AND TRIM (CONTINUED)

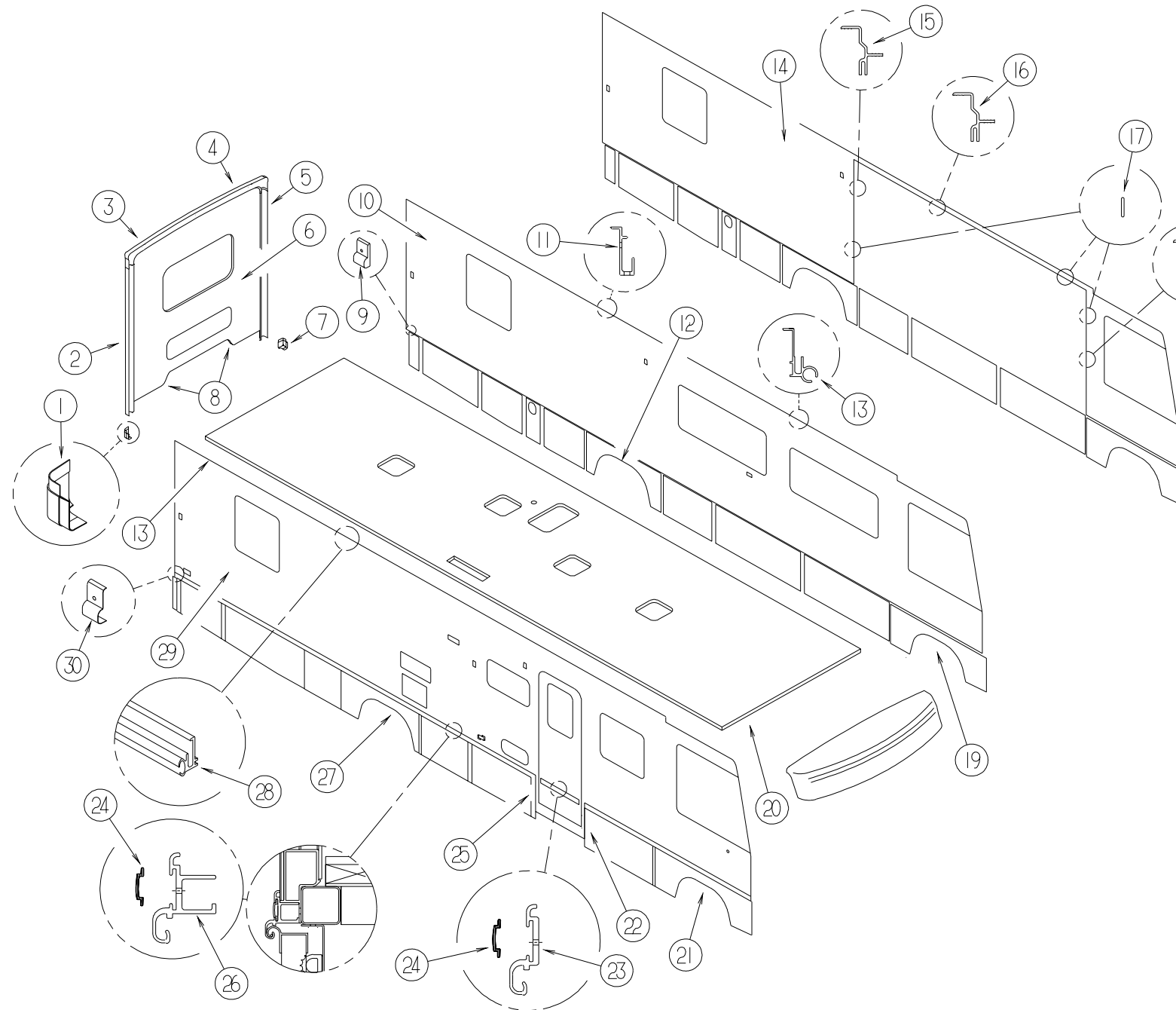

KEY	PART NUMBER	U/M DESCRIPTION
20	130632-03-K20	EA ROOF - W/O LIGHTS/VENTS - W/WIRING
21	129422-13-K28	EA PANEL/WHEEL LIP - FRONT/PASSENGER
		FROM: 00-00-00 THRU: 09-13-98
21	129422-13-K89	EA PANEL/WHEEL LIP - FRONT/PASSENGER
		FROM: 09-14-98 THRU: 99-99-99
22	124501-31-01A	EA TRIM - SIDEWALL - NOTCHED - RIGHT SIDE - BRIGHT WHITE
23	126903-01-01A	EA TRIM - SIDEWALL - 60.9" - BRIGHT WHITE
24	105312-01-07A	FT INSERT - VINYL FEATURE STRIP - BRIGHT WHITE
25	124501-30-01A	EA TRIM - SIDEWALL - NOTCHED - LEFT SIDE - BRIGHT WHITE
26	126901-21-01A	EA TRIM - SIDEWALL - 195" - BRIGHT WHITE
27	129421-11-K89	EA PANEL/WHEEL LIP - REAR - FORD
27	129421-12-K89	EA PANEL/WHEEL LIP - REAR - CHEVY
28	120092-01-02A	EA RAIL - AWNING - BRIGHT WHITE
		FROM: 00-00-00 THRU: 10-25-98
29	130148-03-K20	EA SIDEWALL - PASSENGER - W/O WINDOWS/TRIMS (K20)
29	130148-03-K21	EA SIDEWALL - PASSENGER - W/O WINDOWS/TRIMS (K21,K23)
29	130148-03-K22	EA SIDEWALL - PASSENGER - W/O WINDOWS/TRIMS (K22)

KEY	PART NUMBER	U/M DESCRIPTION
30	127845-06-01A	EA CAP - SIDEWALL TRIM - LEFT HAND - 2.1" - BRIGHT WHITE
	002726-01-001	EA GARNISH - U-CHANNEL - 1.38" X 19" - SERRATED
	002766-01-001	EA ANGLE - EXTRUDED - 1" X 1.5" X 17'
	068716-01-001	EA BRACE - 90 DEGREE L-ANGLE - 16'
	069726-02-000	EA BUMPER - .88" OD X .40" THICK - BLACK
	119568-01-01A	EA STANDOFF - VALANCE PANEL - BLACK
	120524-01-02B	EA U-CHANNEL/STEEL - 1.78" X 79.1" - E-COATED
	121117-01-12B	EA ANGLE - W/O SLOTS - 3.7" X 2" - BRIGHT WHITE
	128251-01-02B	EA SUPPORT - VALANCE - E-COATED
		FROM: 00-00-00 THRU: 09-04-98
	129854-03-01A	EA SUPPORT - WHEEL LIP - 7.9" - MILL
	129854-11-01A	EA SUPPORT - WHEEL LIP - 53.8" - MILL
	107865-01-000	EA ROD - SUPPORT - VALANCE PANEL - 14.3"
	107865-07-000	EA ROD - SUPPORT - VALANCE PANEL - 14.3"
	118383-01-04A	EA RETAINER - SCREW - .22" SCREW RECESS - BRIGHT WHITE
	118383-04-04A	EA CAP - RETAINER/SCREW

EXTERIOR BODY GROUP (CONTINUED)

EXTERIOR SLIDEOUT HARDWARE

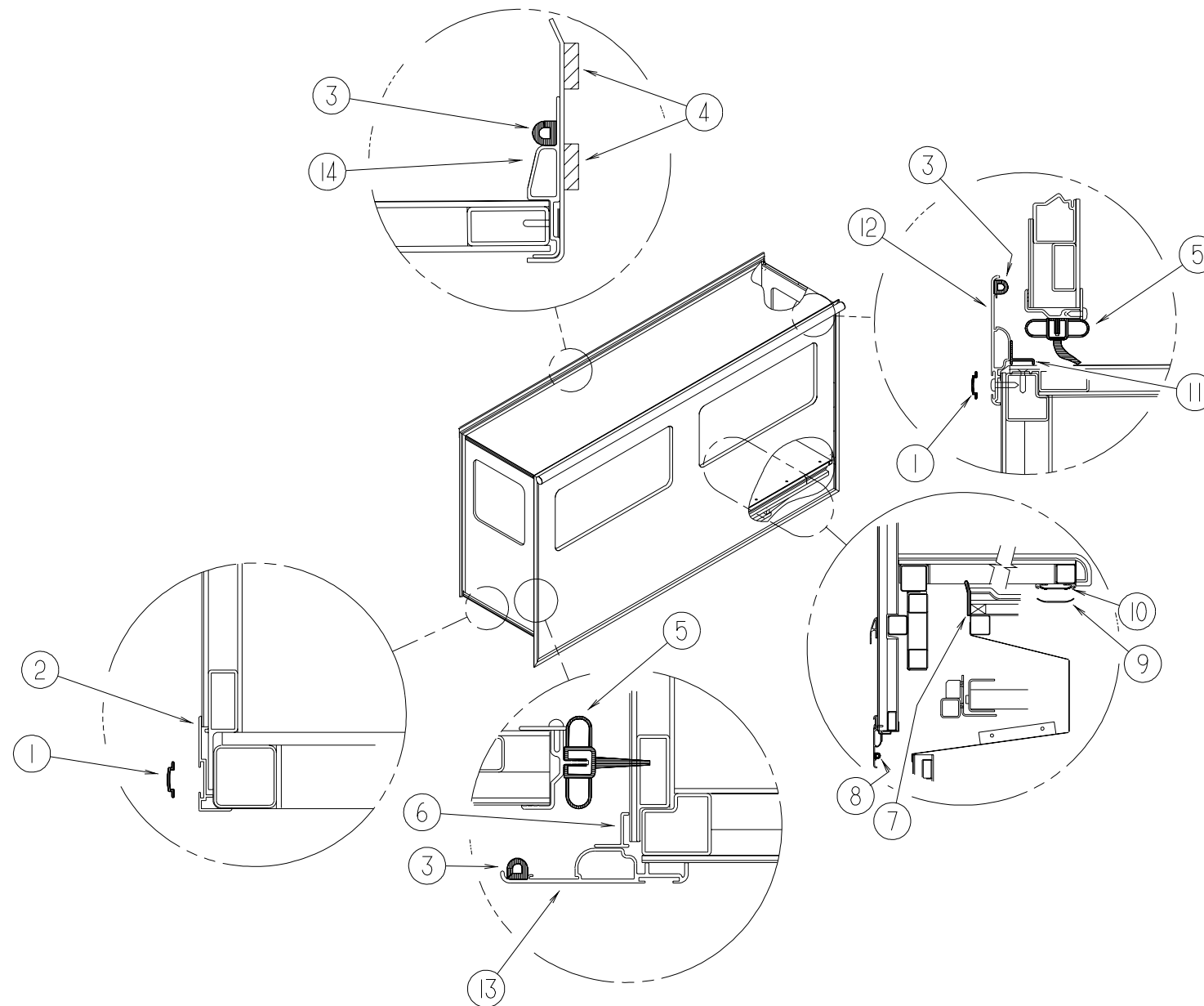

KEY	PART NUMBER	U/M	DESCRIPTION
1	105312-01-07A	FT	INSERT - VINYL FEATURE STRIP - BRIGHT WHITE
2	108688-01-03A	EA	STRIP - FEATURE - 15'
3	112091-01-000	FT	D-SEAL - NEOPRENE - TRUNK - HEAT ACTIVE ADHESIVE
4	100128-02-000	FT	SEAL - FOAM/ADHESIVE BACK - .37" WIDE X .37" THICK
5	115076-01-000	FT	SEAL - SLIDEOUT
6	116933-15-01A	EA	TRIM - SEAL/FLOOR EDGE - 166.7" - BRIGHT WHITE
7	115075-02-000	FT	SEAL - WIPE - .25" X 3.15"
8	089275-02-000	FT	STRIP - 3/4" X 84" BLACK POLYETHELENE
8	121283-01-000	FT	SEAL - P SHAPED
9	115661-01-000	FT	POLYETHYLENE - HIGH DENSITY - 1/16" X 3'
10	115325-03-02A	EA	RAIL - FLOOR/SLIDEOUT ROOM - BLACK - 64.5" LONG
10	115325-06-02A	EA	RAIL - FLOOR/SLIDEOUT ROOM - BLACK - 19.6" LONG
11	116933-15-01A	EA	TRIM - SEAL/FLOOR EDGE - 166.7" - BRIGHT WHITE
12	119992-12-01A	EA	TRIM - SEAL - W/MITERED ENDS - BRIGHT WHITE
13	119992-11-01A	EA	TRIM - SEAL - W/MITERED ENDS - BRIGHT WHITE
14	117004-03-01A	EA	TRIM - SEAL/INNER VERTICAL-W/MITERED ENDS-158" - OFF WHITE
	117004-01-01A	EA	TRIM - SEAL/INNER VERTICAL-W/MITERED ENDS-73.5"-OFF WHITE (FORWARD)
	117004-02-01A	EA	TRIM-SEAL/INNER HORIZONTAL W/MITERED ENDS-73.5"-OFF WHITE (REARWARD)

EXTERIOR BODY GROUP (CONTINUED)

EXTERIOR SLIDEOUT PANELS & TRIMS

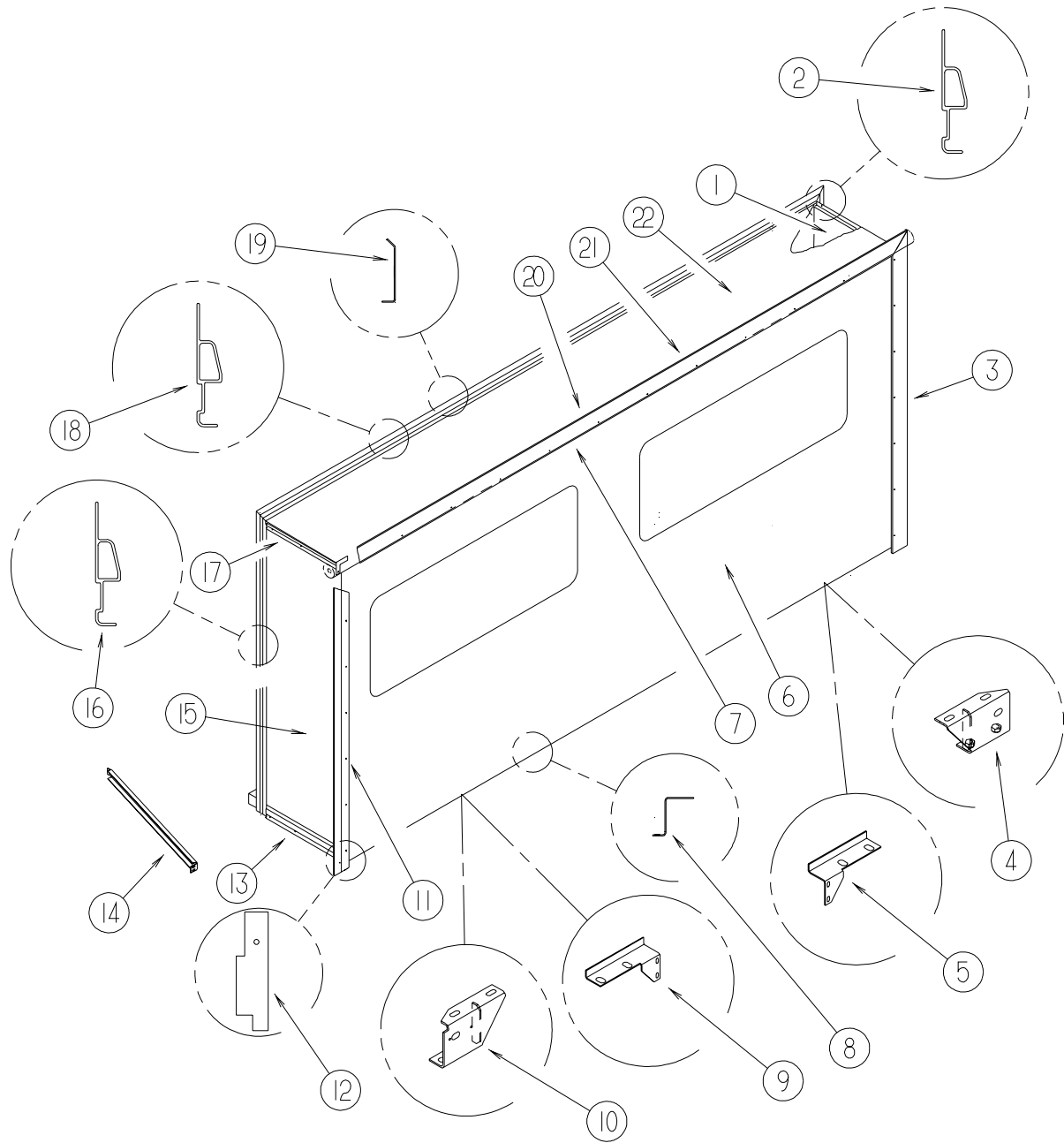

KEY	PART NUMBER	U/M	DESCRIPTION
1	126570-01-J24	EA	PANEL - SLIDEOUT - REAR (K20)
1	126570-01-K32	EA	PANEL - SLIDEOUT - REAR (K21,K23)
1	126570-01-J97	EA	PANEL - SLIDEOUT - REAR (K22)
2	117004-02-01A	EA	TRIM - SEAL/INNER HORIZONTAL W/MITERED ENDS-73.5"-OFF WHITE
3	119992-12-01A	EA	TRIM - SEAL - W/MITERED ENDS - BRIGHT WHITE
3	105312-01-07A	FT	INSERT - VINYL FEATURE STRIP - BRIGHT WHITE
3	116933-15-01A	EA	TRIM - SEAL/FLOOR EDGE - 166.7" - BRIGHT WHITE
4	127030-02-02B	EA	BRACKET - INNER FRONT/SLIDEOUT - E-COATED
5	128386-01-02B	EA	BRACKET - SLIDEOUT/COMPARTMENT - E-COATED
6	119783-18-K28	EA	PANEL - SLIDEOUT/OUTER (K20)
6	119783-18-K32	EA	PANEL - SLIDEOUT/OUTER (K21,K23)
6	119783-18-K22	EA	PANEL - SLIDEOUT/OUTER (K22)
7	122977-06-01A	EA	AWNING - SLIDEOUT - W/COVER - 160.24"
8	128621-03-01A	EA	ZEE-SLIDEOUT,W/HOLES,MILL
9	125888-02-02B	EA	BRACKET - SLIDEOUT COMPARTMENT - E-COATED - LEFT HAND
10	127030-01-02B	EA	BRACKET - INNER REAR/SLIDEOUT - E-COATED
11	119992-11-01A	EA	TRIM - SEAL - W/MITERED ENDS - BRIGHT WHITE
11	105312-01-07A	FT	INSERT - VINYL FEATURE STRIP - BRIGHT WHITE
11	116933-15-01A	EA	TRIM - SEAL/FLOOR EDGE - 166.7" - BRIGHT WHITE
12	126546-01-02A	EA	COVER - END/SIDEWALL SLIDEOUT - BRIGHT WHITE
13	125051-01-01A	EA	STRIP - FEATURE - LOWER - BRIGHT WHITE
13	105312-01-07A	FT	INSERT - VINYL FEATURE STRIP - BRIGHT WHITE
14	126497-01-02B	EA	SUPPORT - VALANCE
15	126569-01-J24	EA	PANEL - SLIDEOUT - FRONT (K20)
15	126569-01-K32	EA	PANEL - SLIDEOUT - FRONT (K21,K23)
15	126569-01-J97	EA	PANEL - SLIDEOUT - FRONT (K22)
16	117004-01-01A	EA	TRIM - SEAL/INNER VERTICAL-W/MITERED ENDS-73.5"-OFF WHITE
17	108688-01-03A	EA	STRIP - FEATURE - 15'
17	105312-01-07A	FT	INSERT - VINYL FEATURE STRIP - BRIGHT WHITE
18	117004-03-01A	EA	TRIM - SEAL/INNER VERTICAL-W/MITERED ENDS-158" - OFF WHITE
19	125466-01-01A	EA	SUPPORT - ROOF/INTERIOR - OFF WHITE
20	119992-01-02A	EA	TRIM - SEAL - W/MITERED ENDS - BRIGHT WHITE
20	105312-01-07A	FT	INSERT - VINYL FEATURE STRIP - BRIGHT WHITE
20	116933-15-01A	EA	TRIM - SEAL/FLOOR EDGE - 166.7" - BRIGHT WHITE
21	117058-01-01A	FT	TAPE - LOOP - 3/4" WIDE - ADHESIVE BACKED
22	126571-01-K20	EA	ROOF - F/SLIDEOUT - W/O LIGHTS/VENTS - W/WIRING

EXTERIOR BODY GROUP (CONTINUED)

FRONT END COMPONENTS

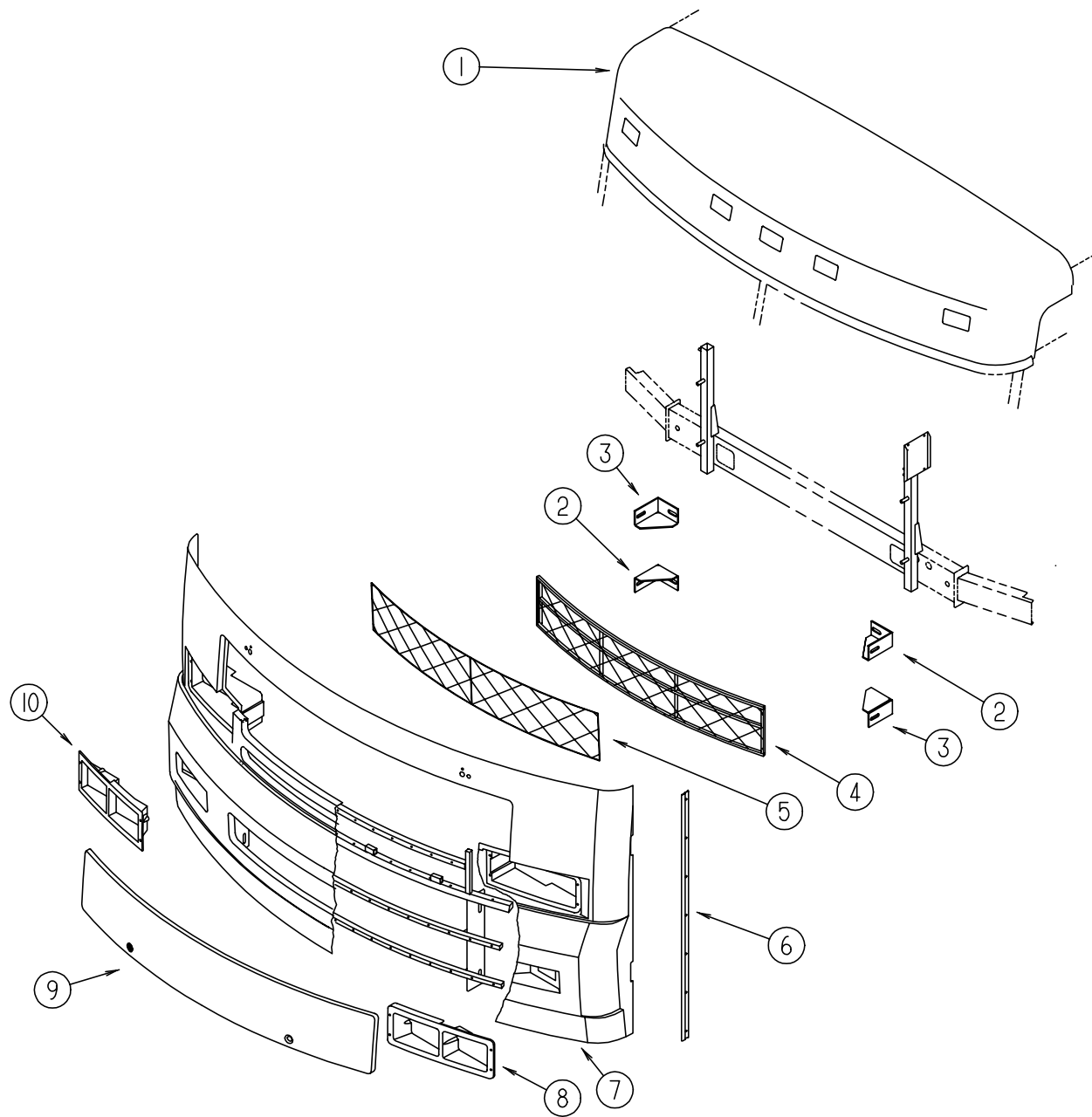

KEY	PART NUMBER	U/M	DESCRIPTION
1	125052-02-J20	EA	CAP - ROOF - W/O LIGHTS/WIRING
	118383-01-04A	EA	RETAINER - SCREW
	118383-04-04A	EA	CAP - RETAINER/SCREW
2	128455-04-02B	EA	BRACKET - BUMPER - LEFT HAND UPPER/RIGHT HAND LOWER
	128455-03-02B	EA	BRACKET - BUMPER - RIGHT HAND UPPER/LEFT HAND LOWER
4	126953-01-J15	EA	GRILLE - W/O MESH
5	115924-15-02A	EA	WIRE MESH - F/GRILLE - FLAT BLACK
6	123680-05-01A	EA	TRIM - FIBERGLASS PANEL - BRIGHT WHITE
7	126229-04-J20	EA	PANEL - FRONT/LOWER - W/O NOTCH - BRIGHT WHITE
	125846-02-J20	EA	SUPPORT - WIPER
	110782-01-000	EA	ANGLE - SUPPORT - HEADLAMP
	007157-05-000	EA	NUT - WELL
8	126230-02-01A	EA	BEZEL - HEADLAMP - LEFT HAND
	110690-02-D18	EA	PLATE - HEADLAMP - QUAD/LEFT HAND
	126956-01-J15	EA	HOOD - FRONT
10	126230-01-01A	EA	BEZEL - HEADLAMP - RIGHT HAND
	110690-01-D18	EA	PLATE - HEADLAMP - QUAD/RIGHT HAND

EXTERIOR BODY GROUP (CONTINUED)

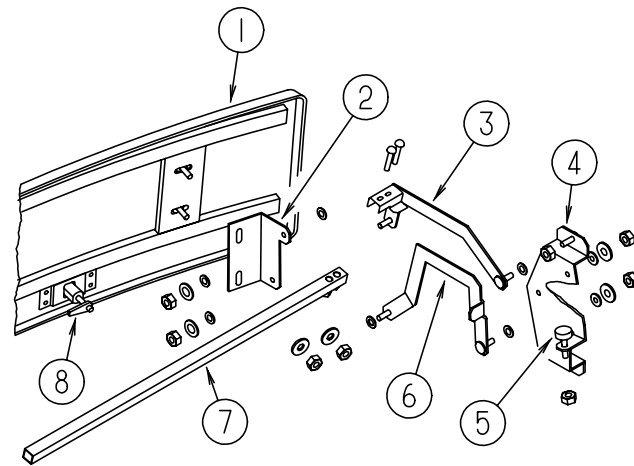

HOOD & COMPONENTS

KEY	PART NUMBER	U/M DESCRIPTION
1	126956-01-J15	EA HOOD - FRONT
	106730-10-000	EA PLATE - STUD - F/HOOD
2	126911-01-02B	EA ANGLE - HOOD HINGE - PASSENGER - E-COATED
	126911-02-02B	EA ANGLE - HOOD HINGE - DRIVER - E-COATED
3	125798-03-02B	EA LINK - HOOD HINGE - UPPER PASSENGER
	125798-04-02B	EA LINK - HOOD HINGE - UPPER DRIVER
4	126867-01-02B	EA BRACKET - LINK - HOOD HINGE - PASSENGER - E-COATED
	126867-03-02B	EA BRACKET - LINK - HOOD HINGE - DRIVER - E-COATED
5	058786-01-000	EA BOLT - ADJUSTING HOOD - W/BLACK PAD
6	125778-07-02B	EA LINK - HOOD HINGE - LOWER PASSENGER - E-COATED
	125778-08-02B	EA LINK - HOOD HINGE - LOWER DRIVER - E-COATED
7	126913-02-02B	EA TUBE - TIMING - HOOD HINGE W/WELD NUT - 53.7" - E-COATED
8	102330-02-000	EA LATCH - VISE ACTION/KEY OPERATED
	102330-04-000	EA PAWL - LATCH - STRAIGHT - 1.96"
	102328-01-000	EA KEY - BARREL - NICKEL PLATED
	126352-04-02B	EA LATCH - HOOD - E-COATED

EXTERIOR BODY GROUP (CONTINUED)

FIBERGLASS, STYROFOAM, ALUMINUM, & INSULATION

KEY	PART NUMBER	U/M DESCRIPTION
	076054-U8-000	EA FIBERGLASS SHEET - 100" X 105" - BRIGHT WHITE
	076054-X8-000	EA FIBERGLASS SHEET - 79.1" X 407.2" - BRIGHT WHITE
	076054-X9-000	EA FIBERGLASS SHEET - 22.1" X 70.6" - BRIGHT WHITE
	076054-W6-000	EA FIBERGLASS SHEET - 79" X 367" - BRIGHT WHITE
	077517-62-000	EA FIBERGLASS SHEET/SIDEWALL - 48" X 96" - BRIGHT WHITE
	108535-05-702	EA FRP FLAT 108" X 396" BRT WHT PARTS DEPT
	100619-01-000	BF FOAM - EXPANDED POLYSTYRENE - 1.34" X 48" X 96"
	100619-02-000	BF FOAM - EXPANDED POLYSTYRENE - 1.5" X 48" X 96"
	100619-04-000	BF FOAM - EXPANDED POLYSTYRENE - .5" X 48" X 96"
	100619-05-000	BF FOAM - EXPANDED POLYSTYRENE - .75" X 48" X 96"-1.5 DENSITY
	100619-10-000	BF FOAM - EXPANDED POLYSTYRENE - 1.5" X 48" X 96"
	100619-11-000	BF FOAM - EXPANDED POLYSTYRENE - 2" X 48" X 96"
	100619-13-000	BF FOAM - EXPANDED POLYSTYRENE - .34" X 34.65" X 96"
	100619-16-000	BF FOAM - EXPANDED POLYSTYRENE - .75" X 48" X 96"-2.0 DENSITY
	100619-22-000	BF FOAM - EXPANDED POLYSTYRENE - 48" X 120" X 1.34"
	116942-03-700	EA ALUM-.019 X 40.5" X 156" PART (ROOF - FLOOR)
	105077-08-000	EA FOAM - PLUG - ROOF CAP
	120107-01-000	EA FOAM - COVE - ROOF - 2.8" X 96" LONG
	120107-02-000	EA FOAM - PLUG - ROOF TUBE - 2.2" X 2.9" X 1.8" LONG
	120107-03-000	EA FOAM - PLUG - SIDEWALL TUBE - 1.2" X 2.1" X 1.8" LONG

A & E AWNING & HARDWARE

KEY	PART NUMBER	U/M DESCRIPTION
	113874-08-11A	EA AWNING - W/O HARDWARE - 19' (AMETHYST GREEN) VINYL
*	113874-01-02A	EA HARDWARE KIT - AWNING - W/O STANDOFF BRACKET-BRIGHT WHITE
	113874-11-01A	EA SCREW/LAG - AWNING - 1/4" X 1" STAINLESS STEEL USED TO MOUNT LOWER ARM BRACKET TO WALL
	113874-12-01A	EA SCREW/LAG - AWNING - 1/4" X 2 3/4" STAINLESS STEEL USED TO MOUNT UPPER ARM BRACKET TO WALL
	130320-01-02A	EA BRACKET - AWNING - F/A&E INSTALLATION - BRIGHT WHITE

*COMPONENT PARTS FOUND IN SERVICE PARTS LIBRARY

EXTERIOR BODY GROUP (CONTINUED)

MISCELLANEOUS FRONT END COMPONENTS

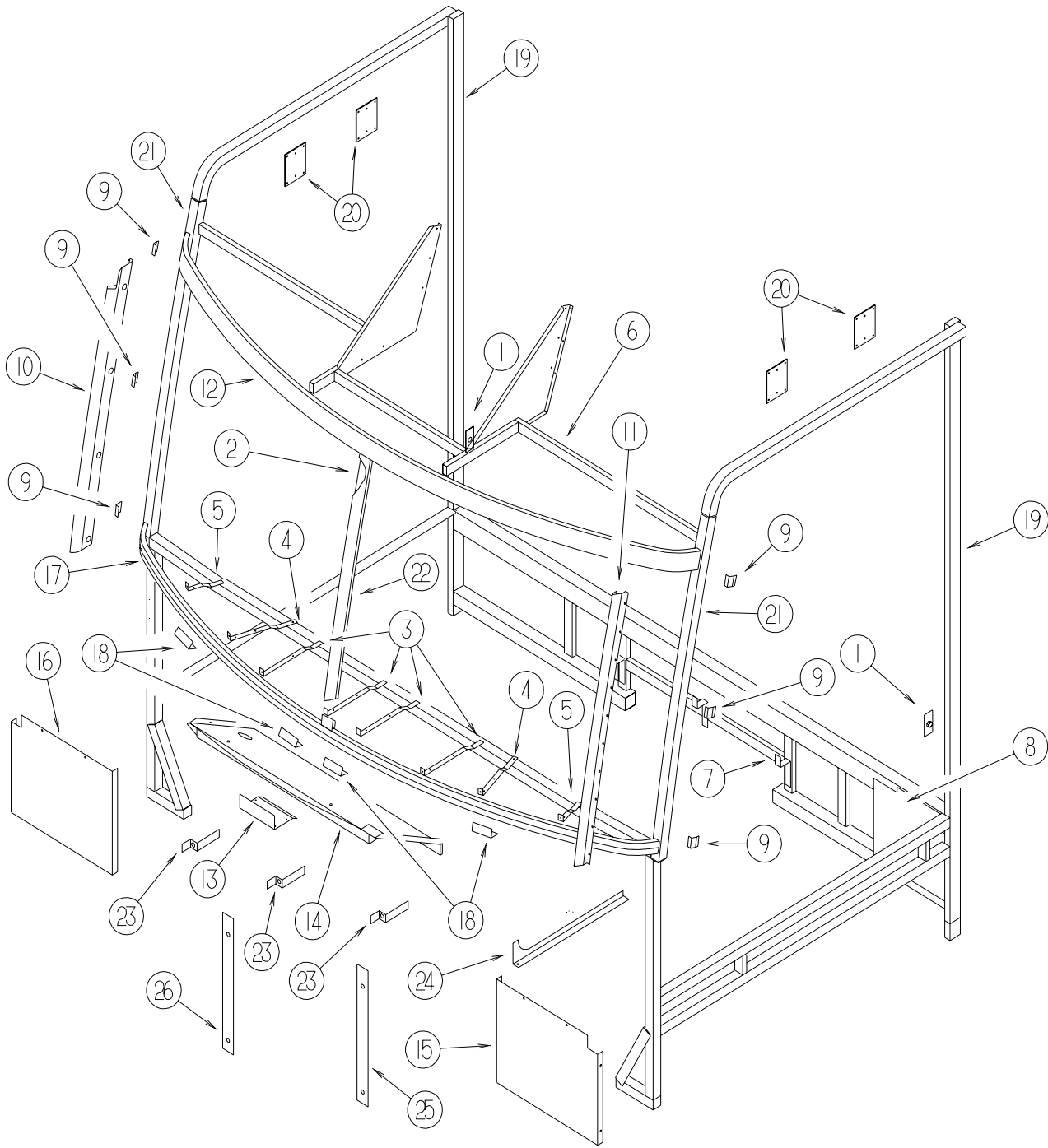

KEY	PART NUMBER	U/M	DESCRIPTION
1	070579-06-000	EA	PLATE - ANCHOR - W/7/16" WELD NUT - 1.5" X 3.3"
1	070579-07-000	EA	PLATE - ANCHOR - W/O WELD NUT - 1.5" X 3.3"
2	078249-17-000	EA	TUBE - SWEPT - CAB FRAME
3	104797-03-000	EA	BRACKET-DEFROSTER
4	104797-04-000	EA	BRACKET-DEFROSTER
5	104797-05-000	EA	BRACKET-DEFROSTER
6	124764-51-01B	EA	HEADER - F/TV - MILL
	124904-03-01B	EA	HEADER - WINDSHIELD - CENTER
7	117287-01-01B	EA	BRACKET - MOUNT - CABLE
8	118592-01-01B	EA	SHIELD - SPLASH
9	120363-01-01B	EA	BRACKET - WINDSHIELD
10	121269-05-01B	EA	FRAME - WINDSHIELD - A-PILLAR - MILL
11	121269-06-01B	EA	FRAME - WINDSHIELD - A-PILLAR - MILL
12	124975-01-01B	EA	SUPPORT-WINDSHIELD,UPPER,MLL
13	125836-02-01B	EA	ZEE-WIPER MOTOR,MILL
14	125837-02-01B	EA	BRACE-WIPER MOTOR,MILL
15	104147-14-000	EA	SHIELD/SPLASH - HEADLIGHT
16	121962-02-02B	EA	SHIELD/SPLASH - HEADLIGHT - E-COATED
17	124974-01-01B	EA	SUPPORT-WINDSHIELD,LOWER,MLL
18	076364-57-000	EA	ANGLE - FORMED
19	127874-01-01B	EA	TUBE-B PILLAR,MILL
20	104409-01-000	EA	PLATE-MOUNT,SIDEWALL
21	117273-01-01A	EA	TUBE - SUPPORT - A-PILLAR
22	120840-07-01B	EA	STRAP-W/HOLES,MILL
23	117287-01-01B	EA	BRACKET - MOUNT - CABLE
	129385-01-02B	EA	BRACKET - SEAL TRANSITION - E-COATED
			FROM: 00-00-00 THRU: 05-01-99
24	131859-01-02B	EA	BRACKET - SEAL - TRANSITION/LEFT HAND - E-COATED
			FROM: 05-02-99 THRU: 99-99-99
	131860-01-02B	EA	BRACKET - SEAL - TRANSITION/LEFT HAND - E-COATED
			FROM: 05-02-99 THRU: 99-99-99
25	119892-12-02B	EA	SUPPORT ASM-FRONT,GM,LH,E-CT
25	119892-14-02B	EA	SUPPORT ASM-FRT,FORD,LH,E-CT
26	119892-17-02B	EA	SUPPORT ASM-FRONT,GM,RH,E-CT
26	119892-13-02B	EA	SUPPORT ASM-FRT,FORD,RH,E-CT
	128419-03-01A	EA	BRACKET - ROD SUPPORT
			FROM: 00-00-00 THRU: 11-03-98
	113452-01-000	FT	SEAL/TRIM - FRONT - VINYL W/WIRE CARRIER
	130885-14-877	FT	STEEL - TUBE - 16 GAUGE 1.5" X 1.5"

EXTERIOR BODY GROUP (CONTINUED)

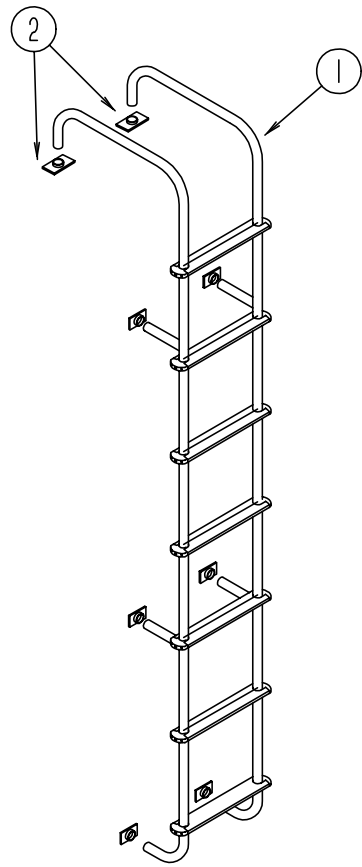

LADDER

KEY	PART NUMBER	U/M DESCRIPTION
1	129639-02-01A	EA LADDER - BRUSHED ALUMINUM
2	131256-01-01A	EA PLATE - LADDER
	129375-01-000	EA SEAL/FOAM - LADDER BRACKET
	038327-01-000	EA TAPE - ANTI-SLIP - 2" X 60'

EXTERIOR BODY GROUP (CONTINUED)

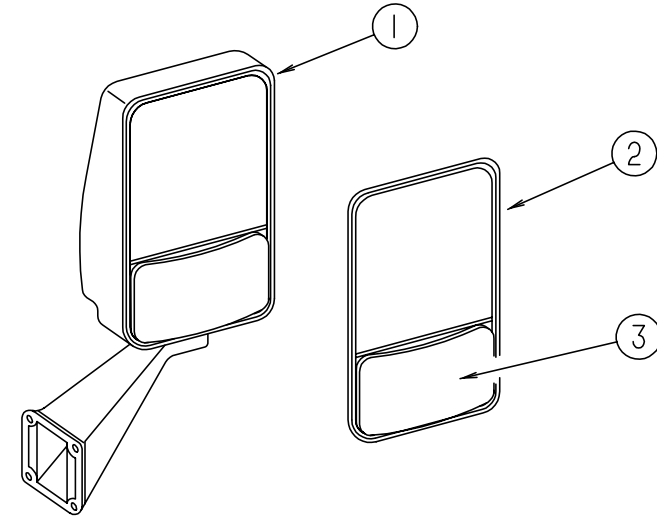

VELVAC HEATED EXTERIOR MIRRORS

KEY	PART NUMBER	U/M DESCRIPTION	VENDOR NO.
1	106015-12-01A	EA MIRROR - EXTERIOR REMOTE/HEAT - PASSENGER	
	119774-09-700	EA PLATE-INNER SUPT/MIRROR HEAD	709418-7RH
1	106015-13-01A	EA MIRROR - EXTERIOR REMOTE/HEAT - DRIVER	
	119774-09-701	EA PLATE INNER SUPT/MIRROR HEAD	709419-7LH
2	106015-12-700	EA MIRROR-FLAT - W/W/O HEAT	709448
3	106015-12-701	EA MIRROR-CONVEX - W/W/O HEAT	709449
	106015-12-702	EA SCREW CAP - (BAG OF 4)	748329
	087695-02-000	EA SWITCH - HEATER - EXTERIOR MIRROR	
	088246-01-000	EA SWITCH - REMOTE - EXTERIOR - SQUARE PUSH	
	087695-03-000	EA CONNECTOR - ASSEMBLY	

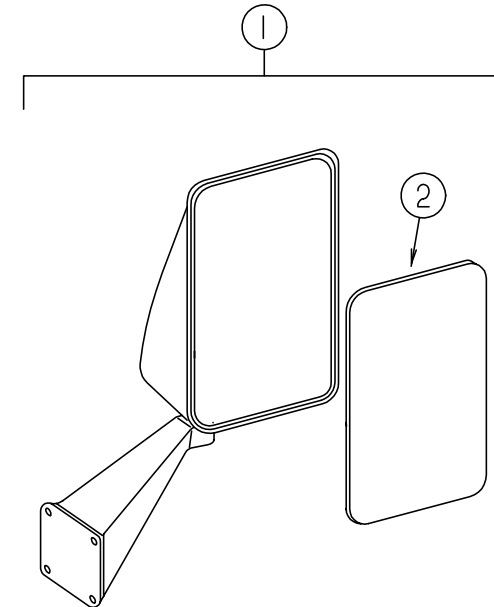

VELVAC EXTERIOR MIRRORS

KEY	PART NUMBER	U/M DESCRIPTION	VENDOR NO.
1	123297-01-01A	EA MIRROR - EXTERIOR - ADJUSTABLE GLASS - DRIVER	
1	123297-02-01A	EA MIRROR - EXTERIOR - ADJUSTABLE GLASS - PASSENGER	
2	106860-02-702	EA GLASS ONLY FLAT RH/LH STAR	702086-8

EXTERIOR BODY GROUP (CONTINUED)

DECALS, FILM STRIPES & PAINT

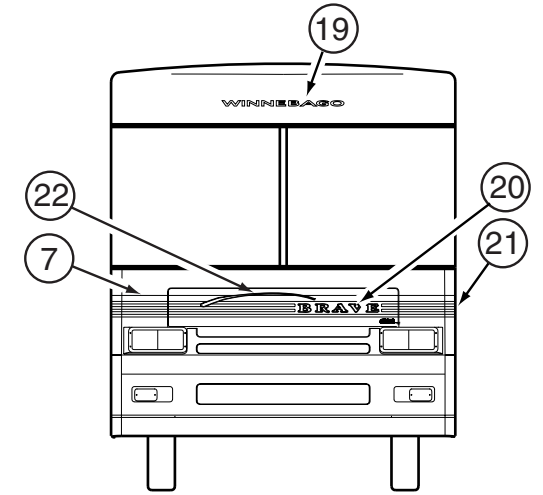
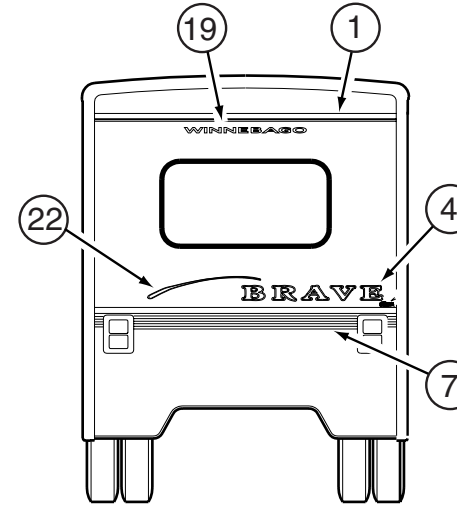
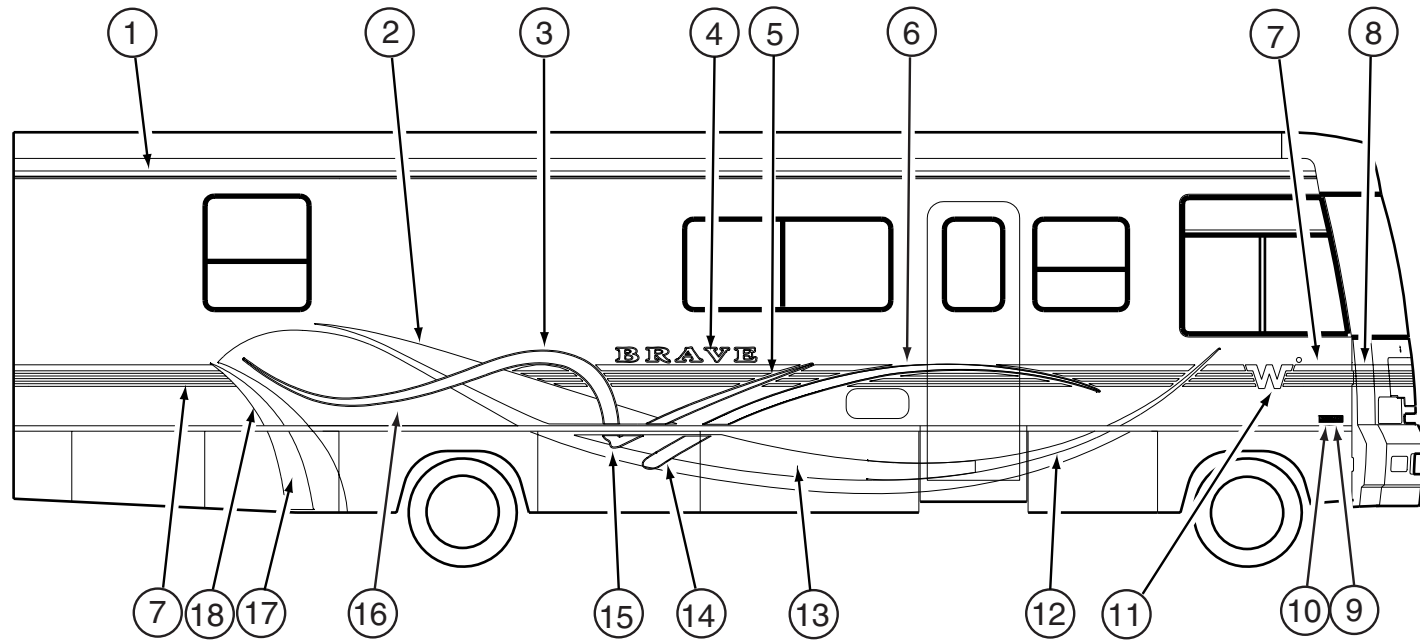

KEY	PART NUMBER	U/M	DESCRIPTION
1	105781-69-01A	FT	FILM - MULTISTRIPE - 2.3"
2	128024-01-02A	EA	DECAL - SWEEP - UPPER/RIGHT HAND
	128024-02-02A	EA	DECAL - SWEEP - UPPER/LEFT HAND
3	128027-01-02A	EA	DECAL - SLASH - #1/RIGHT HAND
	128027-02-02A	EA	DECAL - SLASH - #1/LEFT HAND
4	121437-01-04A	EA	DECAL - LOGO - BRAVE/LARGE
4	121437-01-05A	EA	DECAL - LOGO - BRAVE/LARGE - COMFORT AND CONVENIENCE PACKAGE
5	128029-01-02A	EA	DECAL - SLASH TIP - #1/RIGHT HAND
	128029-02-02A	EA	DECAL - SLASH TIP - #1/LEFT HAND
6	128031-01-02A	EA	DECAL - SLASH TIP - #2/RIGHT HAND
	128031-02-02A	EA	DECAL - SLASH TIP - #2/LEFT HAND
7	093689-25-02A	FT	FILM - MULTISTRIPE - 6.3"
8	128036-01-02A	EA	DECAL - CORNER/RIGHT HAND
9	122312-02-01A	EA	DECAL - VORTEC 7400 FUEL INJECTED
10	129922-01-01A	EA	EMBLEM - TRITON V10
11	121743-02-03A	EA	DECAL - LOGO "W"
12	128026-01-02A	EA	DECAL - SWEEP - #2/RIGHT HAND
	128026-02-02A	EA	DECAL - SWEEP - #2/LEFT HAND
13	128025-01-02A	EA	DECAL - SWEEP - #1 RIGHT HAND
	128025-02-02A	EA	DECAL - SWEEP - #1/LEFT HAND
14	128030-01-02A	EA	DECAL - SLASH END - #2/RIGHT HAND
	128030-02-02A	EA	DECAL - SLASH END - #2/LEFT HAND
15	128028-01-02A	EA	DECAL - SLASH END - #1/RIGHT HAND
	128028-02-02A	EA	DECAL - SLASH END - #1/LEFT HAND
16	128023-01-01A	EA	DECAL - PAINT - UPPER/RIGHT HAND
	128023-02-01A	EA	DECAL - PAINT - UPPER/LEFT HAND
17	128032-01-02A	EA	DECAL - SWEEP - REAR/RIGHT HAND
	128032-02-02A	EA	DECAL - SWEEP - REAR/LEFT HAND
18	128033-01-02A	EA	DECAL - SWEEP - REAR/TIP/RIGHT HAND
	128033-02-02A	EA	DECAL - SWEEP - REAR/TIP/LEFT HAND
19	120702-02-03A	EA	DECAL - LOGO, WINNEBAGO
20	121437-02-04A	EA	DECAL - LOGO - BRAVE/SMALL
20	121437-02-05A	EA	DECAL - LOGO - BRAVE/SMALL - COMFORT AND CONVENIENCE PACKAGE
21	128036-02-02A	EA	DECAL - CORNER/LEFT HAND
22	128034-01-02A	EA	DECAL - SLASH - HOOD
	041561-03-000	EA	PAINT - 16 OUNCE SPRAY - OFF WHITE
	004308-01-000	EA	PAINT - BLACK SPRAY

DUPONT COLOR CODES

BRIGHT WHITE (MAIN BODY COLOR)	#B8951
LT. SILVER METALLIC (ACCENT COLOR)	#F2573U
TEAL FIREMIST METALLIC (DECAL COLOR)	#GM016
VIOLET FIREMIST METALLIC (DECAL COLOR)	#F4572
WIN BLUE METALLIC (DECAL COLOR)	#BM351
AZTEC SILVER METALLIC(DECAL COLOR)	#F2573

GALLEY GROUP

GALLEY CABINETRY

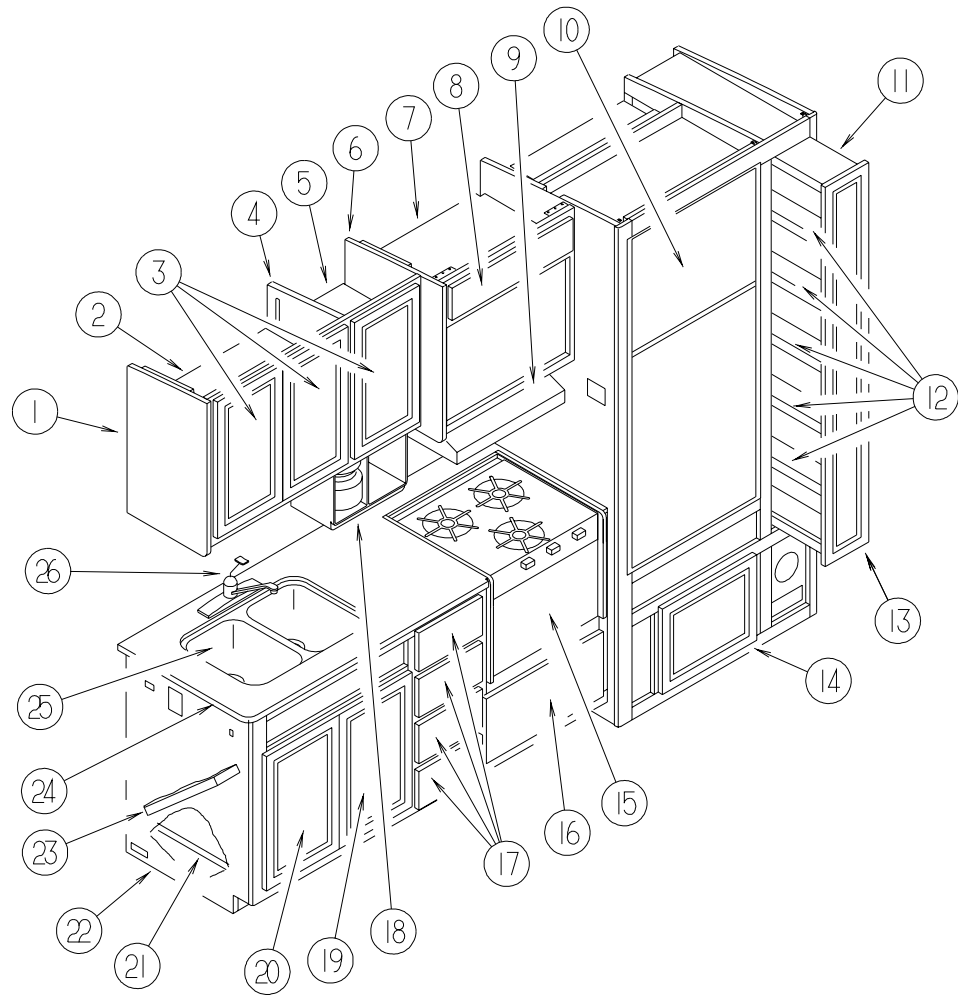

KEY	PART NUMBER	U/M DESCRIPTION	VENDOR NO.
	104137-06-714	EA BURNER ASSEMBLY, 5-SLOT	61705222
	104137-06-715	EA ELECTRODE-SPARK/SENSOR, SGL	61692222
	113737-01-702	EA PLUG 1/8" F/PRESSURE TAP	61445322
	113737-01-716	EA TAP-PRESSURE	61594422
	113737-01-750	EA TUBE-UNION	61694622
	120075-01-701	EA HINGE-TOP RH/BOTTOM LH(DOOR)	618511
	120075-01-702	EA CAP, (HINGE PLUG)	618160
	120075-01-705	EA HINGE-TOP LH/BOTTOM RH(DOOR)	618510
	120075-01-714	EA PLUG-HOLE	618170
	120075-01-720	EA TRAY-DRIP	618137
	120075-01-721	EA LOUVER-DRIP TRAY	618176
	120075-01-725	EA COVER-CRISPER	618158
	120075-01-727	EA PIN-HINGE	618145
	120075-01-729	EA TRIM-BOTTOM PIECE	618136
	120075-01-730	EA RETAINER-SHELF	618181
	120075-01-732	EA PLATE-STRIKE	618167
	120075-01-735	EA THERMISTER W/LAMP & WIRE/ASM	618548
	120075-01-738	EA COVER-POWER BOARD	618185
	120076-01-705	EA ORIFICE - JEWEL .015	618283
	121568-01-701	EA BIN - DOOR WHITE	618619
	121568-01-704	EA RAIL - DOOR LOWER	618578
	121568-01-707	EA SHELF - WIRE - SHORT	618624
	121568-01-708	EA SHELF - WIRE	618589
	121568-01-709	EA CRISPER	618571
	121568-03-700	EA RETAINER - DOOR PANEL/BLACK	619558
	121568-03-701	EA BUSHING - HINGE PIN/GRAY	619671
	121568-03-702	EA DOOR LINER - W/TRIM/BLACK	619627
	121568-03-703	EA HANDLE ASM TOP/RH-LWR/LH BLK	619865
	121568-03-704	EA TRAVEL LATCH - GRAY	619647
	121568-03-705	EA STORAGE LATCH - GRAY	619648
	121568-03-706	EA RETAINER - DOOR PANEL/BLACK	619559
	121568-03-707	EA DOOR LINER - BLACK	619629
	121568-03-708	EA HANDLE ASM - TOP/LH-LWR/RH	619866
	121568-03-709	EA TRIM - TOP/BLACK	619687
	121568-03-710	EA HINGE/CABINET-TOP/RH-LWR/LH	619335
	121568-03-711	EA TRIM - SIDE/BLACK	619801
	121568-03-712	EA SHELF - WIRE/FREEZER	620250
	121568-03-713	EA FRONT BOX/DECORATIVE-BLACK	619282
	121568-03-714	EA CONTROL ASM - 2 WAY BLACK	619350
	121568-03-715	EA HINGE/CABINET-TOP/LH-LWR/RH	619336
	121568-03-716	EA COVER - HINGE HOLES	619301
	121568-03-717	EA HOLE PLUG - WHITE	619561
	121568-03-718	EA CABINET - FOAMED - N62	619658
	121568-03-719	EA POWER - BOARD - 2-WAY	619353
	054450-01-000	EA LEVEL - REFRIGERATOR	
	065225-02-000	EA PLATE - TIEDOWN - REFRIGERATOR	
	090195-08-000	EA BAFFLE - REFRIGERATOR - LOWER	
	093369-03-000	EA STRAP - REFRIGERATOR	
	093646-01-000	EA BRACKET - TIEDOWN/REFRIGERATOR - RIGHT HAND	
	093646-02-000	EA BRACKET - TIEDOWN/REFRIGERATOR - LEFT HAND	
	116751-02-01A	EA TRAY - REFRIGERATOR - BLACK	
	116751-09-01A	EA TRAY - REFRIGERATOR - BLACK - CANADIAN	
	111222-01-02A	EA COVER - VENT - SIDE - BRIGHT WHITE - REFRIGERATOR TRAY DRAIN	
	090329-01-000	FT SEAL/T - REFRIGERATOR CABINET	

KEY	PART NUMBER	U/M DESCRIPTION	VENDOR NO.
1	081319-20-G15	EA END CAP - OVERHEAD CABINET	
2	122393-11-H17	EA SHELF/LARGE - W/PLASTIC EDGE MOLDING	
3	132141-65-K20	EA DOOR - RAIL/VENEER - 12" X 21.8" - W/O HARDWARE	
4	P22393-01-H17	EA CABINET - OVERHEAD/GALLEY - W/O DOORS/HARDWARE	
5	122393-12-H17	EA SHELF/SMALL - W/PLASTIC EDGE MOLDING	
6	081320-14-G09	EA END CAP - OVERHEAD CABINET	
7	128620-02-J15	EA CABINET - MICROWAVE - W/O DOORS/HARDWARE	
8	131995-K2-K20	EA DOOR - SOLID PANEL - 6.3" X 23.2" - W/O HARDWARE	
9*	100258-16-04A	EA HOOD - RANGE - W/O MONITOR PANEL-W/O HOUR METER/SWITCH-US	
9*	100258-17-04A	EA HOOD - RANGE - W/O MONITOR PANEL-W/O HOUR METER/SWITCH-CSA	
9*	100258-18-03A	EA HOOD - RANGE - W/O MONITOR PANEL-W/HOUR METER/SWITCH - US	
10*	121568-03-01A	EA REFRIGERATOR - SMALL DBL DOOR/BLK-52.8"HX23.5"WX24"D-2-WAY	
	084880-01-718	EA VALVE-GAS, (ASCO)	61551822
	084880-01-760	EA CLIP (THERMISTER)	61689122
	084880-03-705	EA BRACKET-LIGHT-INTERIOR	61629722
	084880-03-706	EA BULB-LAMP	61628922
	084880-03-707	EA COVER-LAMP, LENS	61627922
	088248-01-709	EA HEATER-AC (HORIZONTAL)	61562722
	104137-06-709	EA VALVE-SHUT OFF/MAN-OLD STYLE	61694922
		FROM: 00-00-00 THRU: 01-10-99	
	104137-06-734	EA VALVE-SHUT OFF/MAN-NEW STYLE	618696
		FROM: 01-11-99 THRU: 99-99-99	

*COMPONENT PARTS FOUND IN SERVICE PARTS LIBRARY

GALLEY GROUP (CONTINUED)

GALLEY CABINETRY (CONTINUED)

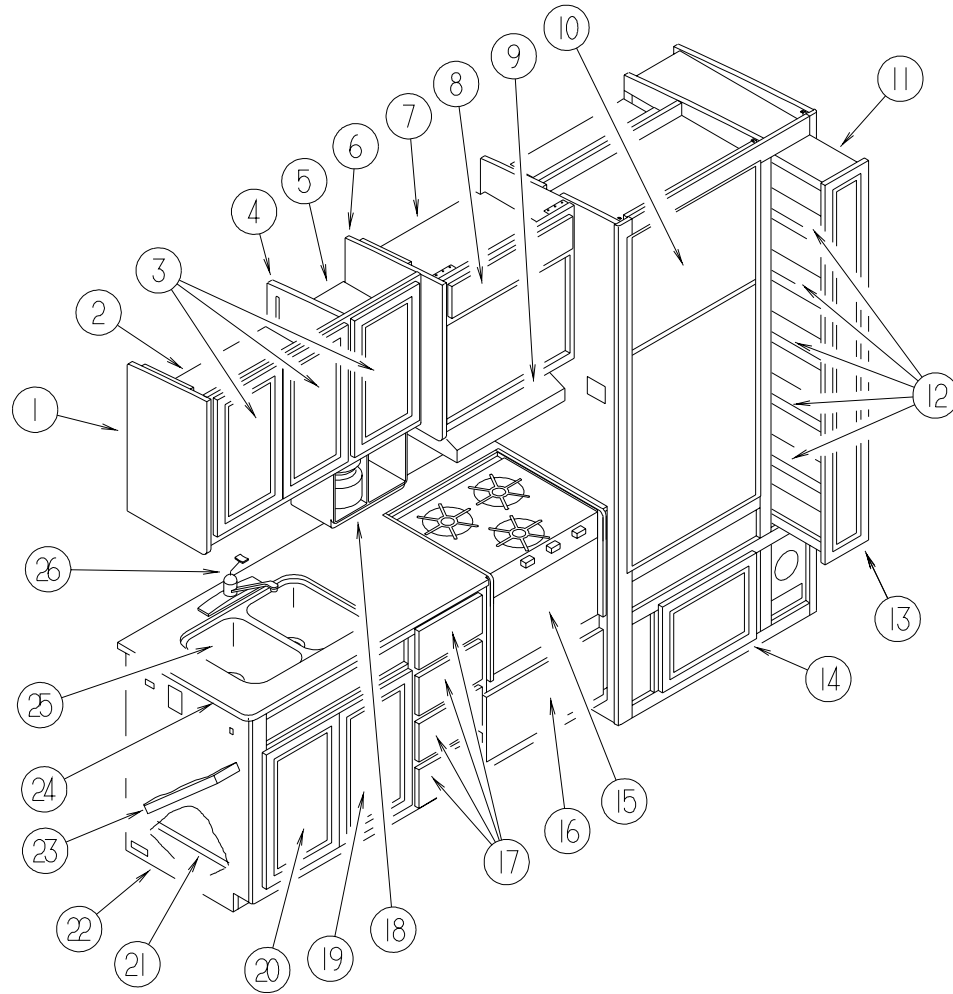

KEY	PART NUMBER	U/M DESCRIPTION	VENDOR NO.
11	122325-01-J22	EA CABINET - PANTRY/RIGHT HAND SLIDING - W/O SLIDES/HARDWARE	
	122360-02-000	EA SLIDE - PANTRY - W/O LOCK - RIGHT/LEFT HAND	
	122360-03-000	EA SLIDE - PANTRY - W/LOCK - RIGHT HAND (FACING PANEL)	
	123673-01-01A	EA KNOB - PANTRY SLIDE	
12	122325-11-H17	EA SHELF - W/PLASTIC EDGE MOLDING (PANTRY)	
13	131995-J3-K28	EA DOOR - SOLID PANEL - 8" X 60.7" - W/O HARDWARE	
14	131995-N2-K20	EA DOOR - SOLID PANEL - 13.7" X 23.2" - W/O HARDWARE	
15*	112881-02-03A	EA RANGE-16"-3 BURNER-FRONT HI-OUTPUT BURNER - BLK TOP/DOOR	
	098507-02-701	EA INSERT-BURNER, SLOTTED VENT	7214P015-60
	102020-01-701	EA HANDLE,DOOR	7701P092-60
	102020-01-709	EA BUMPER-GRATE	8007-P020-60
	102020-01-714	EA PILOT-OVEN	968-143
	102020-01-724	EA BUMPER-MAIN TOP	8003P008-60
	102022-01-708	EA REGULATOR, 1/4 & 1/2 OUT	7510P041-60
	112881-01-705	EA KNOB-TOP BURNER	7733P072-60
	126023-01-728	EA TOP - MAIN (BLACK) W/BRACE	74003323
	112881-01-717	EA BURNER, TOP REAR	7505P181-60
	112881-01-718	EA KNOB - TOP BURNER HI-OUTPUT	74001794

KEY	PART NUMBER	U/M DESCRIPTION	VENDOR NO.
	112881-01-719	EA TRIM-FLAT LH BLACK TEXTURED	74002813
	112881-01-720	EA TRIM-FLAT RH BLACK TEXTURED	74002812
	112881-01-722	EA THERMOSTAT	7515P029-60K
	112881-02-700	EA VALVE - OVEN	7501P056-60
	112881-02-701	EA CLIP - MAIN TOP (REAR)	7112P071-60
	112881-02-702	EA SPRING - OVEN DOOR	7803P051-60
	112881-02-703	EA BURNER - TOP (FRT)HGH OUTPUT	7505P142-60
	126023-01-703	EA GRATE - TOP	74003358
	126023-01-704	EA KNOB - THERMOSTAT	7731P109-60
	126023-01-705	EA PIPE - MANIFOLD	7513P161-60
	126023-01-728	EA TOP - MAIN (BLACK) W/BRACE	74003323
	126023-01-727	EA TOP - MAIN (ALMOND) W/BRACE	74003324
	126023-01-709	EA VALVE - BURNER (REAR)	74003348
	126023-01-710	EA VALVE - BURNER (FRONT)	74003349
	126023-01-715	EA PANEL - MANIFOLD	74003350
	126023-01-716	EA RACK - OVEN	74003106
	126023-01-717	EA BURNER - OVEN	74003343
	126023-01-718	EA FLUE BOX ASSEMBLY	4006W075-80
	105458-03-000	EA BRACKET - STOVE TIEDOWN - RIGHT HAND	
	105458-04-000	EA BRACKET - STOVE TIEDOWN - LEFT HAND	
16	M09316-61-K20	EA DRAWER - OGEE EDGE - 19.8"W X 11.8"D - W/O SLIDES/HARDWARE	
17	M09316-03-K30	EA DRAWER - OGEE EDGE - 9.2"W X 17.7"D - W/O SLIDES/HARDWARE	
18	126019-01-01A	EA COFFEEMAKER - OPTIMA - W/BRACKETS - BLACK & DECKER	
19	131995-T1-K20	EA DOOR - SOLID PANEL - 13.5" X 27.1" - W/O HARDWARE	
20	131995-T0-K20	EA DOOR - SOLID PANEL - 13.5" X 27.1" - W/O HARDWARE	
21	131168-11-K20	EA SHELF - W/PLASTIC EDGE TRIM	
22	131168-01-K20	EA CABINET - GALLEY - W/COUNTERTOP - W/O DOORS/DRAWERS/HDW (K20)	
22	131168-01-K21	EA CABINET - GALLEY - W/COUNTERTOP - W/O DOORS/DRAWERS/HDW (K21,K23)	
22	131168-01-K22	EA CABINET - GALLEY - W/COUNTERTOP - W/O DOORS/DRAWERS/HDW (K22)	
22	131168-02-K20	EA CABINET - GALLEY - W/COUNTERTOP - W/O DOORS/DRAWERS/HDW (K20)	
		COMFORT AND CONVENIENCE PACKAGE	
22	131168-02-K21	EA CABINET - GALLEY - W/COUNTERTOP - W/O DOORS/DRAWERS/HDW (K21,K23)	
		COMFORT AND CONVENIENCE PACKAGE	
22	131168-02-K22	EA CABINET - GALLEY - W/COUNTERTOP - W/O DOORS/DRAWERS/HDW (K22)	
		COMFORT AND CONVENIENCE PACKAGE	
23	091257-10-000	EA HANDLE - ASSIST - WATERFORD OAK	
24	131168-14-K20	EA COUNTERTOP - GALLEY CABINET (K20)	
24	131168-14-K21	EA COUNTERTOP - GALLEY CABINET (K21,K23)	
24	131168-14-K22	EA COUNTERTOP - GALLEY CABINET (K22)	
24	131168-15-K20	EA COUNTERTOP - GALLEY CABINET (K20)	
		COMFORT AND CONVENIENCE PACKAGE	
24	131168-15-K21	EA COUNTERTOP - GALLEY CABINET (K21,K23)	
		COMFORT AND CONVENIENCE PACKAGE	
24	131168-15-K22	EA COUNTERTOP - GALLEY CABINET (K22)	
		COMFORT AND CONVENIENCE PACKAGE	
25	104113-01-000	EA SINK - DOUBLE - STAINLESS STEEL	
	092303-01-000	EA STRAINER - SINK	
	103610-03-K02	EA COVER - SINK - 15.2" X 11" - LAMINATED BOTH SIDES (K20)	
	103610-03-H07	EA COVER - SINK - 15.2" X 11" - LAMINATED BOTH SIDES (K21,K23)	
	103610-03-H04	EA COVER - SINK - 15.2" X 11" - LAMINATED BOTH SIDES (K22)	
26	104114-02-01A	EA FAUCET - GALLEY - SINGLE CONTROL	
	P27942-01-000	EA CABINET - COVER - WATER FILL - W/O DOORS/HARDWARE - FORD	

*COMPONENT PARTS FOUND IN SERVICE PARTS LIBRARY

GALLEY GROUP (CONTINUED)

MICROWAVE OVEN & TRIMS, BRACKETS, AND BRACES

KEY	PART NUMBER	U/M DESCRIPTION	VENDOR NO.
	128527-02-000	EA OVEN - MICROWAVE - 1.2 CU FT - NON CONVECTION	
			FROM: 00-00-00 THRU: 02-07-99
	128527-02-700	EA TRIM RING-F/1.2 CU.FT. MICRO	MC-6471-EA
			FROM: 00-00-00 THRU: 02-07-99
	128642-02-000	EA TRIM KIT W/VENT - MICROWAVE - 1.2 CU FT - SAMSUNG	
			FROM: 00-00-00 THRU: 02-07-99
	128527-04-000	EA OVEN - MICROWAVE - 1.2 CU FT	
			FROM: 02-08-99 THRU: 99-99-99
	098916-22-02B	EA BRACE - MICROWAVE CABINET - LEFT HAND	
	098916-23-02B	EA BRACE - MICROWAVE CABINET - RIGHT HAND	
	094750-10-000	EA BRACKET - MICROWAVE - 89 DEGREE	

COFFEE MAKER

KEY	PART NUMBER	U/M DESCRIPTION	VENDOR NO.
	126019-01-01A	EA COFFEEMAKER - OPTIMA - W/BRACKETS - BLACK & DECKER	
	126019-01-700	EA GLASS CARAFE	172547-00
	126019-01-701	EA RESERVOIR- WATER	172554
	126019-01-702	EA BASKET - FILTER	172553-00
	126019-01-703	EA HARDWARE - MOUNTING	172174-00

LVS MONITOR PANEL

KEY	PART NUMBER	U/M DESCRIPTION
*	102765-04-01A	EA PANEL - MONITOR - 2 HOLDING TANKS - ADJUSTABLE

*COMPONENT PARTS FOUND IN SERVICE PARTS LIBRARY

GENERATOR GROUP

5,000 WATT ONAN EMERALD PLUS

KEY	PART NUMBER	U/M DESCRIPTION
	109303-01-000	EA GENERATOR - 5 KW - EMERALD PLUS
		WITH ONAN TRAY #403-2727
	007067-01-000	SF INSULATION - FIBERGLASS - 1" THICK X 4'-INCREMENTS 4 SF
	007125-03-000	EA CLAMP - MUFFLER - 1.5" DIAMETER
	007125-04-000	EA CLAMP - MUFFLER - 1.12" DIAMETER
	007131-01-000	EA HANGER - TAILPIPE - 6 SLOTS
	079654-05-000	EA PIPE - EXHAUST - ANGLED W/FLANGE - 2" ID
	081364-03-000	EA MUFFLER - GENERATOR - ONAN
	094059-01-000	EA SPACER - GENERATOR - ONAN

6,500 WATT ONAN EMERALD PLUS

KEY	PART NUMBER	U/M DESCRIPTION
	100975-01-000	EA GENERATOR - 6.5 KW EMERALD PLUS
		WITH ONAN TRAY #403-2218
	007067-01-000	SF INSULATION - FIBERGLASS - 1" THICK X 4'-INCREMENTS 4 SF
	007125-03-000	EA CLAMP - MUFFLER - 1.5" DIAMETER
	007125-04-000	EA CLAMP - MUFFLER - 1.12" DIAMETER
	007131-01-000	EA HANGER - TAILPIPE - 6 SLOTS
	079654-05-000	EA PIPE - EXHAUST - ANGLED W/FLANGE - 2" ID
	081364-03-000	EA MUFFLER - GENERATOR - ONAN
	094059-01-000	EA SPACER - GENERATOR - ONAN

NOTE: ADDITIONAL GENERATOR COMPONENTS ARE FOUND IN THE CHASSIS GROUP

HEATING & AIR CONDITIONING GROUP

SCS EVAPORATOR/HEATER ASSEMBLY - FORD AND 1999 CHEVY CHASSIS

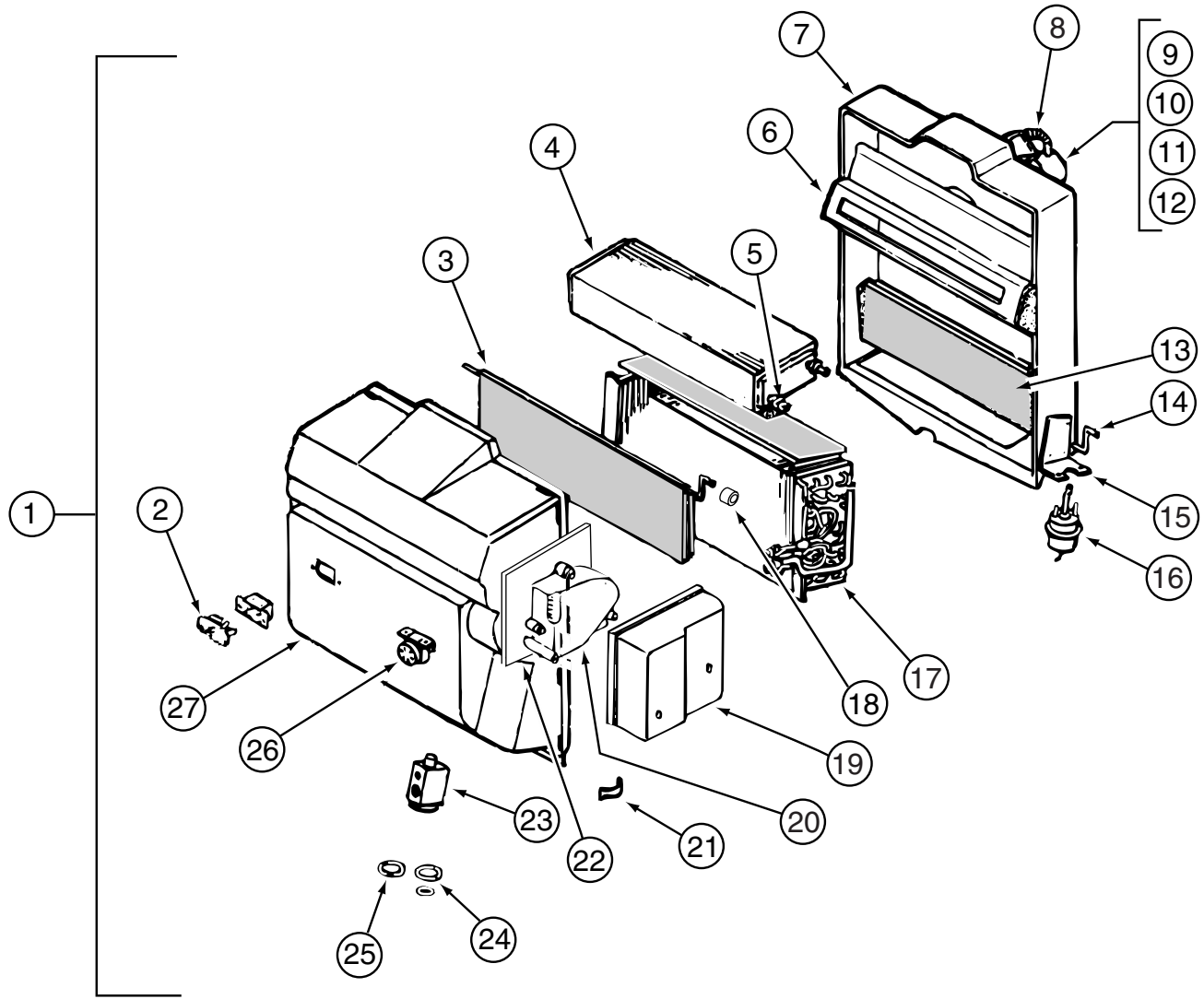

KEY	PART NUMBER	U/M DESCRIPTION	VENDOR NO.
1	103930-43-000	EA EVAPORATOR/HEATER ASSEMBLY - NON-CHARGED	
2	103930-01-710	EA RESISTOR-FUSED, A/C	035-0006
3	103930-43-700	EA DOOR - AIR BLEND	071-0568
4	103930-01-703	EA CORE-HEATER	042-0010
5	110279-01-712	EA FITTING-HEATER	050-0076
6	103930-30-707	EA DIVIDER ASM.	086-0061
7	103930-20-711	EA CASE-BACK, SUB-ASSEMBLY	062-0147
8	110279-01-703	EA HOSE-VENT F/BLOWER MOTOR	051-0034
9	103930-20-707	EA HOUSING-BLOWER	062-0145
10	103930-30-706	EA MOTOR-BLOWER PM147 W/ADAPTER	030-0109
11	103930-01-717	EA WHEEL-BLOWER, CLOCKWISE	062-0010
12	103930-20-708	EA CLIP-MOTOR SHAFT	022-0001
13	103930-20-705	EA PANEL-DOOR, RECIRCULATING	071-0213
14	103930-20-704	EA ROD-DOOR-RECIRCULATING	073-0018
15	103930-01-708	EA BRACKET-VACUUM MOTOR	070-0113
16	103930-02-708	EA MOTOR-VACUUM SERVO, A/C	030-0025
17	103930-01-704	EA COIL-EVAPORATOR	041-0017
18	103930-30-702	EA BUSHING - BLEND AIR DOOR	062-0168
19	103930-30-704	EA COVER - SERVO	062-0545
20	103930-30-703	EA MOTOR - SERVO	030-0104
21	103930-20-706	EA CLIP-RETAINER - CASE ATTACH	022-0057
22	103930-30-701	EA PLATE - MOTOR MOUNT	062-0544
23	103930-20-700	EA VALVE-EXPANSION-BLOCK, 2 TON	034-0032
24	103930-17-702	EA O'RING #10	045-0127
25	113245-01-707	EA O'RING #8	045-0126
26	103930-01-711	EA THERMOSTAT	033-0003
27	103930-30-700	EA CASE - FRONT	062-0542
	103930-02-714	EA CLAMP-CLUTCH, BARREL	022-0006
	094831-01-709	EA CLAMP-ROD 3/16"	022-0025
	113245-01-718	EA HOSE - DRAIN/1/2" X 6"	051-0002

HEATING & AIR CONDITIONING GROUP (CONTINUED)

SCS EVAPORATOR/HEATER ASSEMBLY - 1998 CHEVY CHASSIS

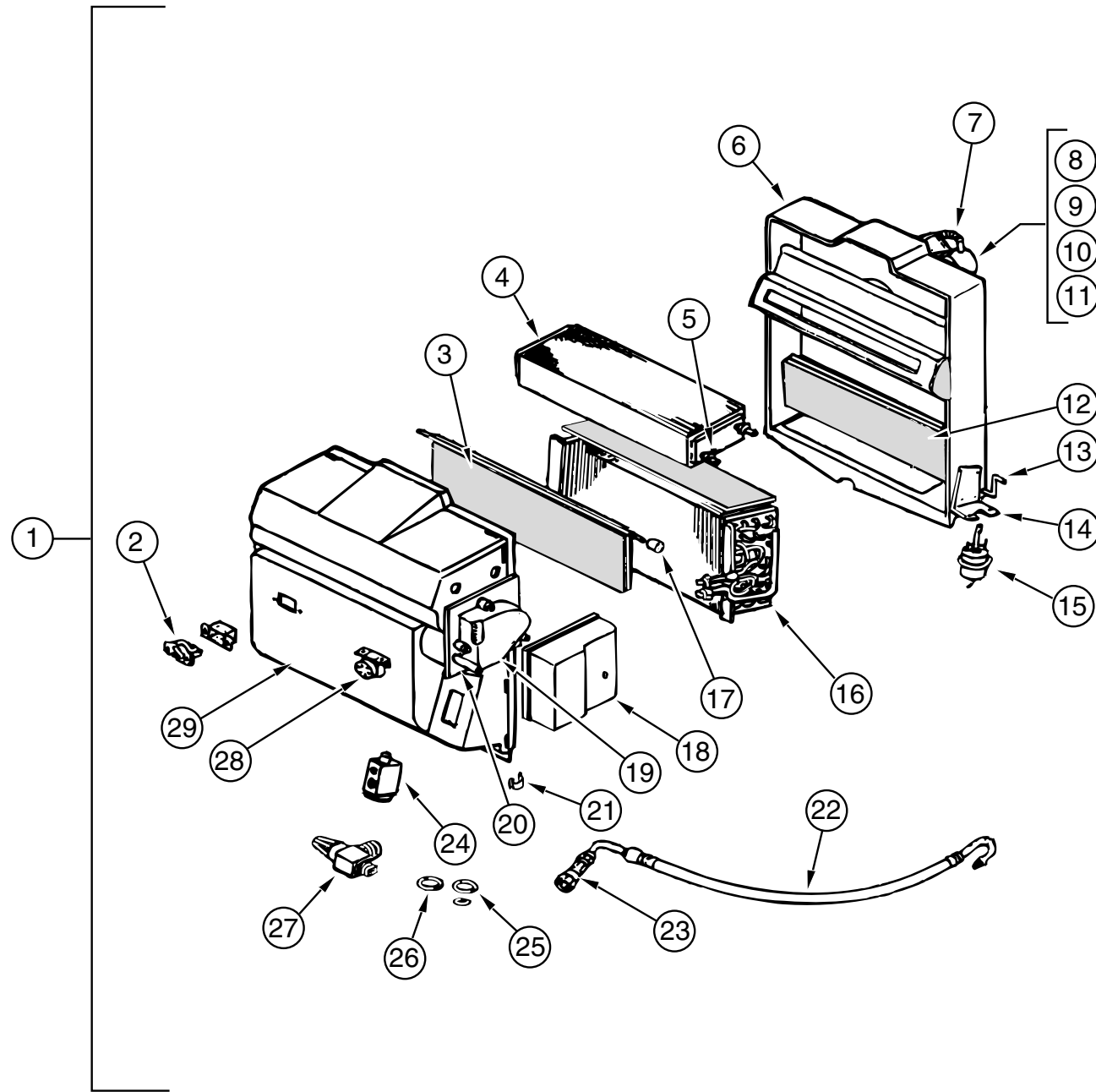

KEY	PART NUMBER	U/M DESCRIPTION	VENDOR NO.
1	103930-30-000	EA EVAPORATOR/HEATER - CHEVY - SERVO MOTOR CONTROLLED	
2	103930-01-710	EA RESISTOR-FUSED, A/C	035-0006
3	103930-30-705	EA DOOR - BLEND AIR	071-0568
4	103930-01-703	EA CORE-HEATER	042-0010
5	110279-01-712	EA FITTING-HEATER	050-0076
6	103930-20-711	EA CASE-BACK, SUB-ASSEMBLY	062-0147
7	110279-01-703	EA HOSE-VENT F/BLOWER MOTOR	051-0034
8	103930-20-707	EA HOUSING-BLOWER	062-0145
9	103930-30-706	EA MOTOR-BLOWER PM147 W/ADAPTER	030-0109
10	103930-01-717	EA WHEEL-BLOWER, CLOCKWISE	062-0010
11	103930-20-708	EA CLIP-MOTOR SHAFT	022-0001
12	103930-20-705	EA PANEL-DOOR, RECIRCULATING	071-0213
13	103930-20-704	EA ROD-DOOR-RECIRCULATING	073-0018
14	103930-01-708	EA BRACKET-VACUUM MOTOR	070-0113
15	103930-02-708	EA MOTOR-VACUUM SERVO, A/C	030-0025
16	103930-01-704	EA COIL-EVAPORATOR	041-0017
17	103930-30-702	EA BUSHING - BLEND AIR DOOR	062-0168
18	103930-30-704	EA COVER - SERVO	062-0545
19	103930-30-703	EA MOTOR - SERVO	030-0104
20	103930-30-701	EA PLATE - MOTOR MOUNT	062-0544
21	103930-20-706	EA CLIP-RETAINER - CASE ATTACH	022-0057
22	103930-25-700	EA HOSE ASM #6 EVAPORATOR/DRIER	085-0350
23	103930-12-709	EA FITTING-QUICK CONNECT	050-0120
24	103930-20-700	EA VALVE-EXPANSION-BLOCK, 2 TON	034-0032
25	103930-17-702	EA O'RING #10	045-0127
26	113245-01-707	EA O'RING #8	045-0126
27	103930-20-709	EA VALVE-SERVICE	050-0159
28	103930-01-711	EA THERMOSTAT	033-0003
29	103930-30-700	EA CASE - FRONT	062-0542

HEATING & AIR CONDITIONING GROUP (CONTINUED)

AUTOMOTIVE HEATER MISCELLANEOUS

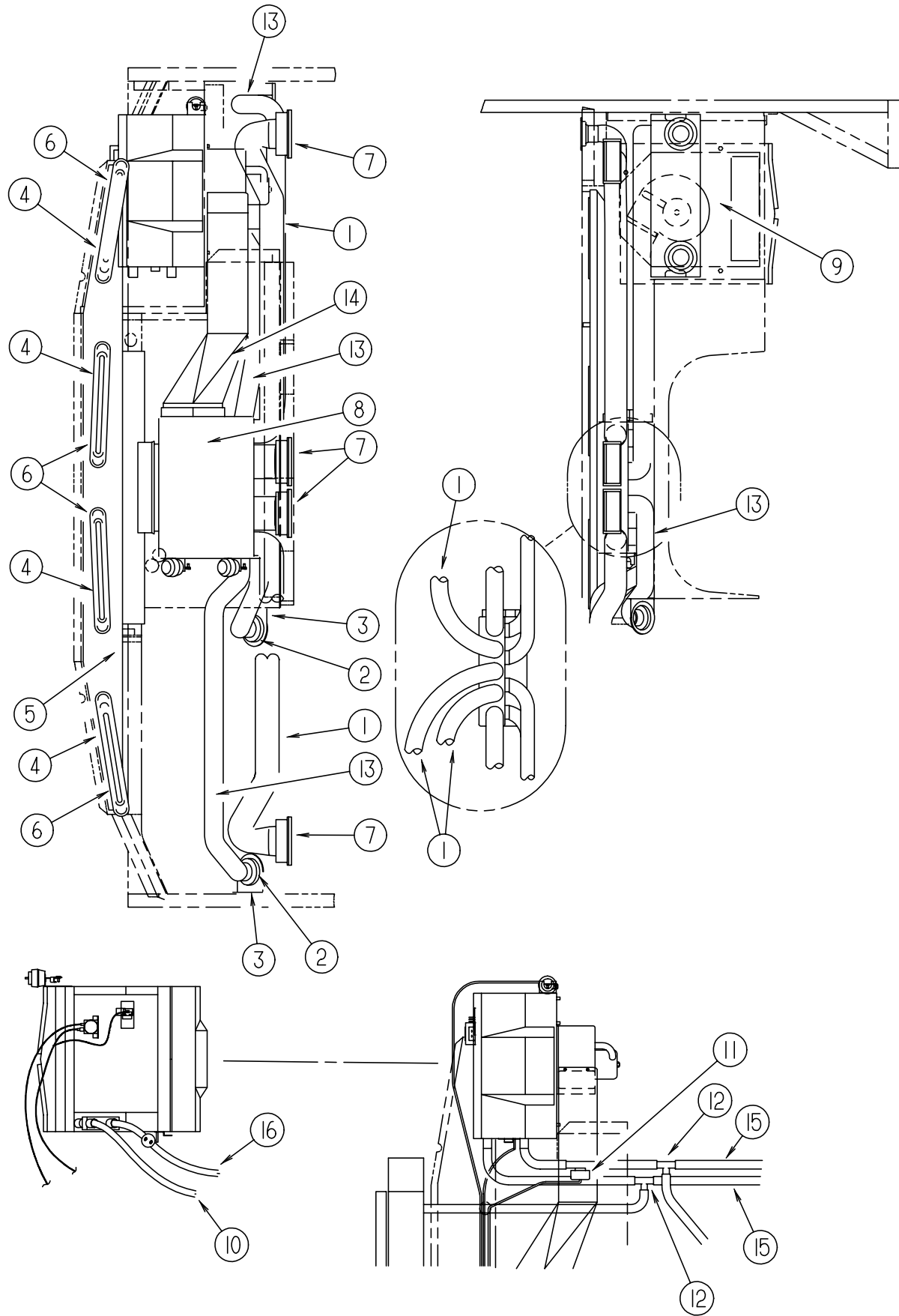

KEY	PART NUMBER	U/M DESCRIPTION	VENDOR NO.
1	007281-01-000	EA HOSE - FLEXIBLE PVC - 2.5" ID X 50'	
1	007281-01-700	FT HOSE-FLEXIBLE PVC, 2 1/2 ID	
2	024990-05-000	EA OUTLET - DEFROSTER - 4" DIAMETER W/SWIVEL DEFLECTORS	
3	056402-05-000	EA BRACKET - HEATER VENT - ROUND W/BEND - BLACK	
4	077075-01-000	EA GASKET - INSTRUMENT PANEL/DEFROSTER PLENUM - .6" X 10.2"	
5	103017-03-000	EA PLENUM - DEFROSTER	
6	103558-01-10A	EA VENT - DEFROSTER - 2" X 14.4" X 1.4" - ANTELOPE	
		FROM: 00-00-00 THRU: 11-08-98	
6	103558-04-03A	EA VENT - DEFROSTER - ANTELOPE	
		FROM: 11-09-98 THRU: 99-99-99	
7	103796-01-01A	EA LOUVER - A/C-ADJUSTABLE - 2.2" X 5.4" F/2.5" HOSE - BLACK	
8	103930-39-000	EA CONTROL/PLENUM - ROTARY	
9	103930-30-000	EA EVAPORATOR/HEATER - CHEVY - SERVO MOTOR CONTROLLED	
		1998 CHEVY CHASSIS	
9	103930-43-000	EA EVAPORATOR/HEATER ASSEMBLY - NON-CHARGED	
		FORD AND 1999 CHEVY CHASSIS	
10	103930-29-000	EA HOSE KIT - #10 F/GM L-29 & L-65 CHASSIS	
		1998 CHEVY CHASSIS	
	103930-17-702	EA O'RING #10	045-0127
	103930-29-701	EA O'RING F/LOW PRESSURE SWITCH	045-0483
10	103930-46-000	EA HOSE - EVAPORATER/COMPRESSOR - EXP. BLOCK TO COMPRESSOR	
		1999 CHEVY CHASSIS	
	103930-17-702	EA O'RING #10	045-0127
	103930-29-701	EA O'RING F/LOW PRESSURE SWITCH	045-0483
10	103930-45-000	EA HOSE - EVAPORATOR/COMPRESSOR - FORD CHASSIS	
	103930-17-702	EA O'RING #10	045-0127
11	103930-23-000	EA VALVE - WATER - 2 PORT	
12	076776-01-000	EA TEE - BEADED - 5/8" X 5/8" X 5/8"	
13	007076-01-000	EA HOSE - FLEXIBLE PVC - 2" ID - INCREMENTS OF 50'	
14	103016-03-000	EA PLENUM - TRANSITION	
15	007108-01-000	FT HOSE - HEATER - 5/8" ID - HI-TEMP - FORD	
16	103930-47-000	EA HOSE - EXPANSION VALVE - RECEIVER DRIER	
		1999 CHEVY CHASSIS	
	113245-01-710	EA O'RING, #12	045-0128
16	103930-44-000	EA HOSE - EVAPORATOR/DRYER - #6 - FORD CHASSIS	
	113245-01-710	EA O'RING, #12	045-0128
	077539-01-000	EA BRACKET - MOUNTING/DASH PANEL - L/SHAPED - 2.5"X1"X1.5"	
	103930-37-000	EA MANUAL - OWNERS - HEATER/A/C	
	7SB003-97-01A	EA SCS/FRIGETTE SERVICE MANUAL AIR CONDITIONING	

HEATING & AIR CONDITIONING GROUP (CONTINUED)

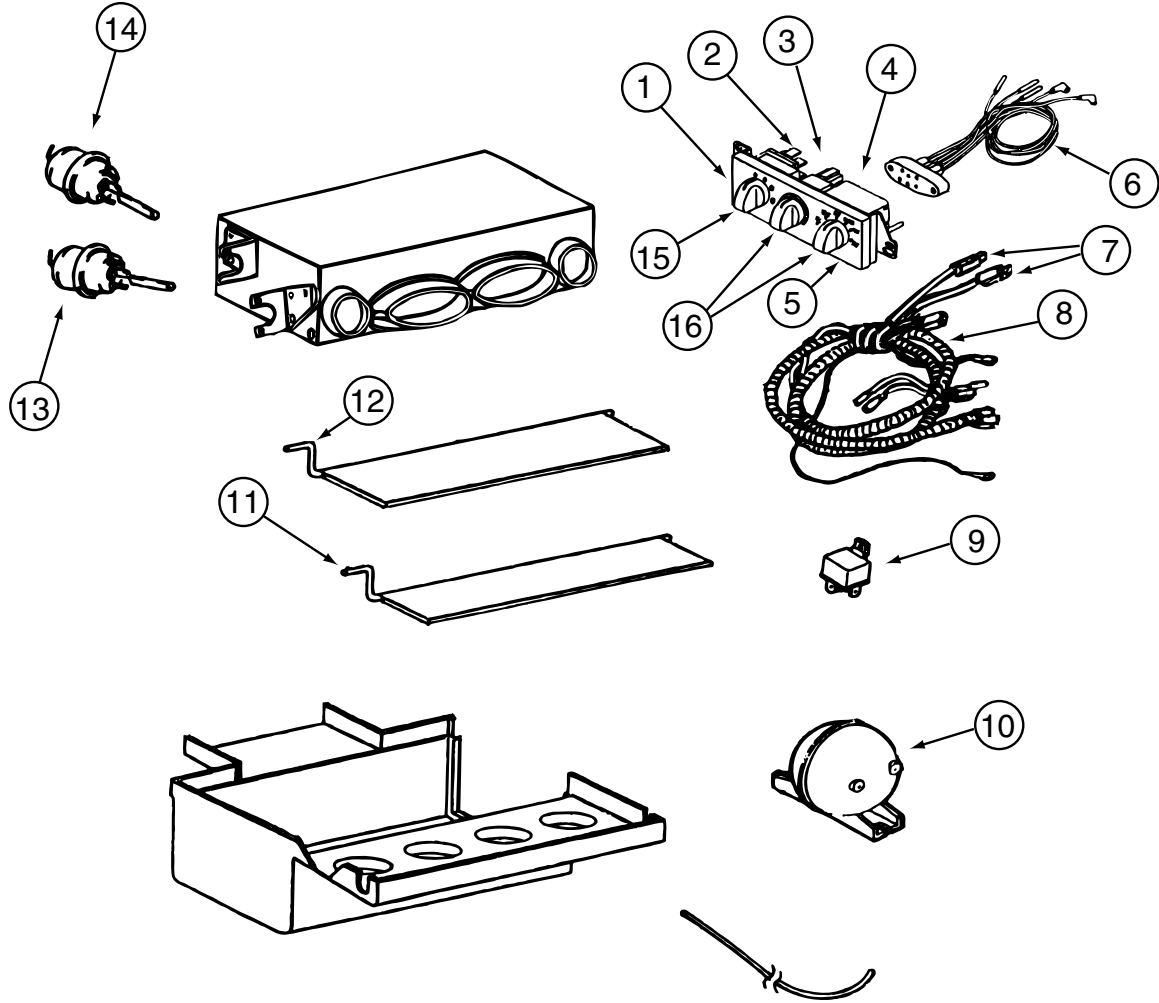

SCS CONTROL/PLENUM

KEY	PART NUMBER	U/M DESCRIPTION	VENDOR NO.
	103930-39-000	EA CONTROL/PLENUM - ROTARY	
1	103930-33-702	EA CONTROL PANEL	083-0169
2	103930-33-707	EA SWITCH - BLOWER	032-00066
3	103930-33-708	EA SWITCH - POTENTIOMETER	032-0184
4	103930-33-709	EA SWITCH - VACUUM	032-0183
5	103930-33-710	EA DECAL F/CONTROL HEAD	058-0102
6	103930-33-703	EA VACUUM HARNESS	036-0466
7	103930-33-705	EA LIGHT BULBS	035-0030
8	103930-33-711	EA WIRE HARNESS - MAIN	036-0496
9	103930-02-707	EA RELAY-BOSCH W/RESISTER	031-0001
10	103930-02-710	EA CANISTER-VACUUM	054-0002
11	103930-39-700	EA ROD - DOOR - AC/HEAT	073-067
12	103930-39-701	EA ROD - DOOR - AC/DEFROST	073-0069
13	103930-02-708	EA MOTOR-VACUUM SERVO, A/C	030-0025
14	103930-33-701	EA MOTOR - VACUUM, 3 STAGE	030-0105
15	103930-39-702	EA KNOB - BLOWER	062-0539
16	103930-39-703	EA KNOB - TEMPERATURE	062-0540
	103930-39-704	EA SPRING	022-0119

HEATING & AIR CONDITIONING GROUP (CONTINUED)

40,000 BTU SUBURBAN FURNACE, REGISTERS & WALL THERMOSTAT

KEY	PART NUMBER	U/M DESCRIPTION
*	098668-22-000	EA FURNACE - 40,000 BTU
	094600-05-01A	EA REGISTER W/O DAMPER-3.6" X 11.3" FACE/2.1" X 9.9" RO-BEIGE
	098668-14-000	EA GASKET - FIBERGLASS - .5" X 18" X 18"
	098668-16-000	EA VENT-INTAKE
	009198-01-000	FT DUCT - HEAT - FLEXIBLE - 4" ID X 25'
	009198-02-000	FT DUCT - FLEXIBLE - 2" ID X 25'
	009200-01-000	EA TAPE - FURNACE - 1 1/2"
	115764-01-01A	EA THERMOSTAT - FURNACE

***COMPONENT PARTS FOUND IN SERVICE PARTS LIBRARY**

EVANS REAR HEATER & COMPONENTS

KEY	PART NUMBER	U/M DESCRIPTION	VENDOR NO.
	084405-01-000	EA HEATER - REAR/DUCTED - W/MOTOR AID	
	084405-01-700	EA CORE-HEATER	FT200229
	084405-01-701	EA FAN BLADES	HV029931
	084405-01-702	EA MOTOR ASSEMBLY, 12 VOLT	RV010348
	009198-01-000	FT DUCT - HEAT - FLEXIBLE - 4" ID X 25'	
	056464-10-000	EA REGISTER - 4" DIAMETER - PLASTIC - W/O DAMPER - BEIGE	
	061673-01-000	EA BRACKET - MOTOR AID TUBES - 4" X 1.5" - STEEL	
		FROM: 00-00-00 THRU: 12-07-98	
	069636-02-000	EA CONNECTOR - DUCT - 4" ID	
	079059-01-000	EA HOSE - 90 DEGREE - 5/8" ID X 4" X 36"	
	079059-02-000	EA HOSE - 90 DEGREE - .61" ID X 4" X 6"	
	118761-01-000	EA REDUCER - 4"-2" - GALVANIZED	

COLEMAN ROOF A/C

KEY	PART NUMBER	U/M DESCRIPTION	VENDOR NO.
	131186-01-01A	EA A/C - ROOF MACH 1 POWERSAVER - WHITE	
	131187-01-01A	EA A/C - ROOF MACH 3 POWER SAVER - WHITE	
	131185-01-01A	EA A/C ROOF - 13,500 BTU - WHITE	

COLEMAN CEILING ASM AND THERMOSTATS

KEY	PART NUMBER	U/M DESCRIPTION	VENDOR NO.
	131184-01-01A	EA CEILING ASSEMBLY - A/C DUCTED - WHITE	

ROOF A/C SELECTOR SWITCH, COVERS, AND REGISTER

KEY	PART NUMBER	U/M DESCRIPTION
	073937-03-000	EA SWITCH - ROTARY- AC - SELECTOR - 3 DECK
	084077-03-000	EA COVER/BLANK - ROOF A/C 5.2" X 3.5" - IVORY
	121365-01-01A	EA COVER - A/C SWITCH - DUAL
	120134-01-02A	EA REGISTER - 4" TO 5" IN DIAMETER W/DAMPER

INTERIOR FINISH GROUP

MOLDINGS & TRIMS

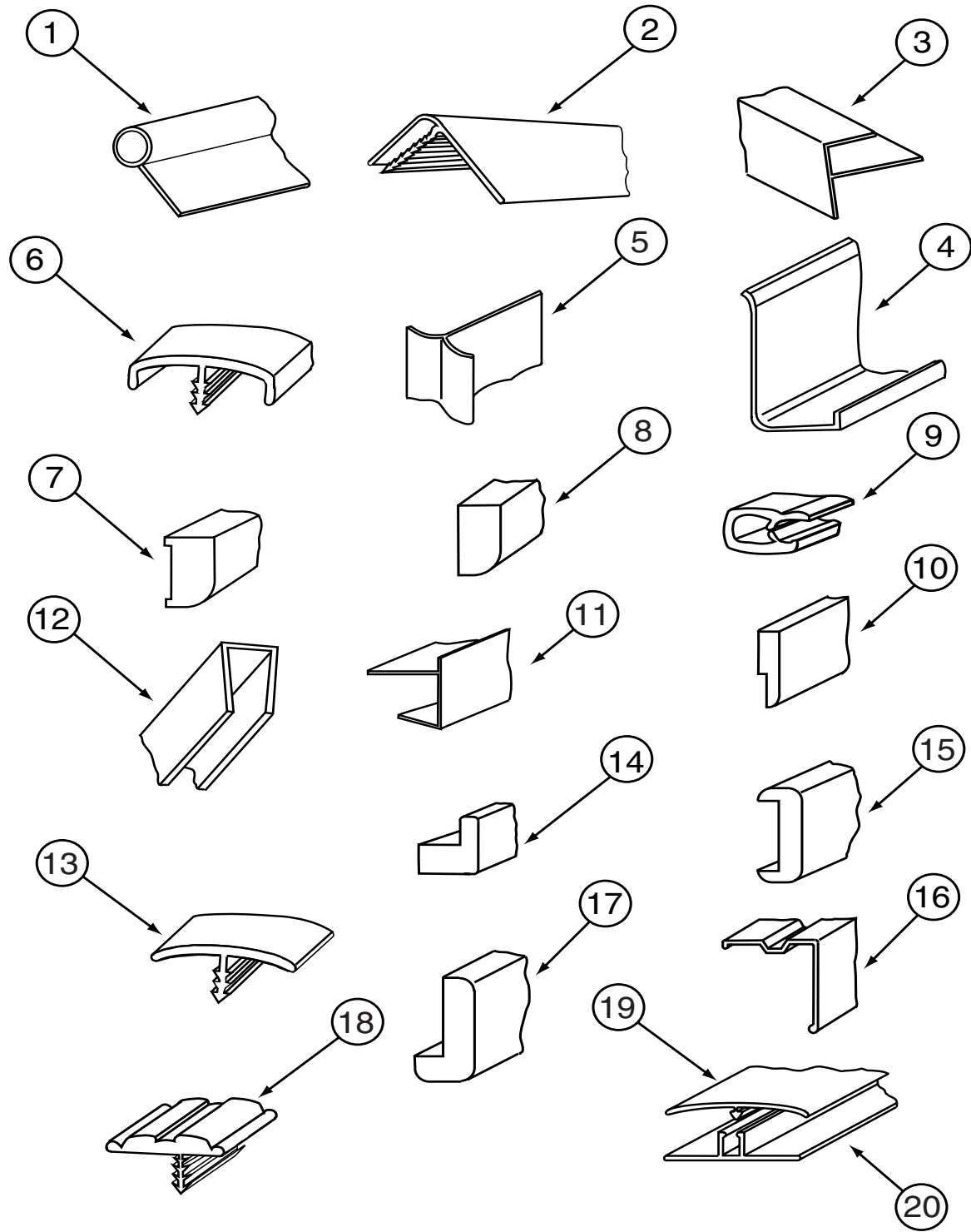

KEY	PART NUMBER	U/M DESCRIPTION
1	009767-12-000	FT WELTING - SIDEWALL/CEILING/CABINET - OFF/WHT
2	009809-23-000	EA MOLDING - CORNER - OUTSIDE - 1" X 84" - MODERN IVORY
2	009809-28-000	EA MOLDING - CORNER - OUTSIDE - 1" X 84" - WATERFORD OAK
3	009812-29-000	EA MOLDING - CORNER - 1/2" W/1/4" CHAN X 84" - WATERFORD OAK
4	085746-04-000	FT TRIM-J - CARPET 1.2" X .5" ANGLE - 12' LONG - OFF WHITE
5	022992-11-000	FT MOLDING - REVERSE COVE - T-SHAPED VINYL - IVORY
6	083620-12-000	FT MOLDING-T - END CAP EDGE - W/EDGE LIP - .75"-WATERFORD OAK
7	117268-D2-134	EA MOLDING - VINYL WRAPPED - .7" X 1.6" X 84" - WATERFORD OAK
7	117268-F2-134	EA MOLDING - VINYL WRAPPED - .7" X 2.7" X 84" - WATERFORD OAK
7	117268-F2-438	EA MOLDING - VINYL WRAPPED - .7" X 2.6" X 96" - WATERFORD OAK
8	100818-01-05A	EA MOLDING - VINYL WRAP - 1.6" X .4" X 84" - WATERFORD OAK
9	113452-01-000	FT SEAL/TRIM - FRONT - VINYL W/WIRE CARRIER
10	105004-01-05A	EA MOLDING - VINYL WRAPPED - 1" X 96" - WATERFORD OAK
11	103186-01-05A	FT MOLDING - PLASTIC - 3/8" U-CHANNEL 3/4" FACE-WATERFORD OAK
11	103186-02-05A	FT MOLDING - PLASTIC - 1" U-CHANNEL 1 3/8" FACE-WATERFORD OAK
12	009778-21-000	FT U-CHANNEL - 1" - WATERFORD OAK
12	070504-03-000	FT U-CHANNEL - PLASTIC - .9" X 96" - GRADY BROWN
12	070504-36-000	FT U-CHANNEL - PLASTIC - .13" X 72" - WATERFORD OAK
12	070504-37-000	FT U-CHANNEL - PLASTIC - .9" X 84" - WATERFORD OAK
13	105709-01-000	FT MOLDING-T - 1" - MODERN IVORY
14	100819-01-05A	EA MOLDING - VINYL WRAP - L-SHAPED - 1.5" X 1.5" X 7' - OAK
15	078323-06-G15	EA MOLDING - CAP/WALL - 79.6" - WATERFORD OAK
16	093873-01-01A	EA TRIM - CARPET - L-ANGLE 1.1" X 1.3" X 12' - GRAY VINYL
17	077840-01-G01	EA MOLDING - CAP/WALL - 8' WATERFORD OAK
18	109736-02-01A	FT T-MOLDING - 1" - NATURAL OAK
19	086229-20-000	EA BATTEN - 1" X 96" - BEIGE
20	086229-14-000	EA RETAINER - .75" X 98.43" - ANY COLOR
	072368-02-000	EA TRIM - VINYL - EDGE - BLACK
	117267-D2-438	EA LUMBER - VINYL WRAPPED - .7" X 1.5" X 96" - WATERFORD OAK
	117267-E2-438	EA LUMBER - VINYL WRAPPED - .7" X 2" X 96" - WATERFORD OAK
	117267-F2-438	EA LUMBER - VINYL WRAPPED - .7" X 2.5" X 96" - WATERFORD OAK
	117267-J2-438	EA LUMBER - VINYL WRAPPED - .7" X 5.5" X 96" - WATERFORD OAK
	117267-R2-438	EA LUMBER - VINYL WRAPPED - .7" X 3" X 96" - WATERFORD OAK

INTERIOR FINISH GROUP (CONTINUED)

BATT STRIPS

KEY	PART NUMBER	U/M	DESCRIPTION
	069733-83-000	EA	BATT STRIP - WOODGRAINED/WATERFORD OAK - 8'
	079653-28-000	EA	BATT STRIP - KERFED - WOODGRAINED/WATERFORD OAK - 8'
	088263-E3-000	EA	BATT STRIP - DECORATIVE - PEBBLE EMBOSSED/ANTIQUE-8' LONG
	088263-F2-000	EA	BATT STRIP - DECORATIVE - TUSCAN MINK - 8' LENGTHS (K20)
	088263-G0-000	EA	BATT STRIP - DECORATIVE - UPBEAT/TWILIGHT - 8' LONG (K21,K23)
	088263-E6-000	EA	BATT STRIP - DECORATIVE - MONTANA FROST - 8' (K22)
	085284-B5-000	FT	BATT TAPE - ADHESIVE BACKED - WOODGRAINED - WATERFORD OAK
	085284-D6-000	FT	BATT TAPE - ADHESIVE BACKED -DECORATIVE - EMBOSSED ANTIQUE
	085284-E7-000	FT	BATT TAPE - ADHESIVE BACKED - DECORATIVE/TUSCAN MINK (K20)
	085284-F8-000	FT	BATT TAPE - ADHESIVE BACKED - UPBEAT/TWILIGHT (K21,K23)
	085284-E0-000	FT	BATT TAPE - ADHESIVE BACKED - DECORATIVE - MONTANA FROST (K22)

PLASTIC LAMINATE & EDGE BAND

KEY	PART NUMBER	U/M	DESCRIPTION
	074498-80-000	SF	LAMINATE - PLASTIC - WHITE TUNDRA - 5' X 8' (K20)
	074498-71-000	SF	LAMINATE - PLASTIC - NEUTRAL SANTOS - 5'X 8' (K21,K23)
	074498-62-000	SF	LAMINATE - PLASTIC - GREY FINESSE - 5' X 8' (K22)
	076325-39-000	FT	MOLDING - EDGE BAND - 1 5/16" X .030" - ALMOND (K20,K21,K23)
	076325-46-000	FT	MOLDING - EDGE BAND - 1 5/16" X .030" - CLOUD (K22)
	076325-40-000	FT	MOLDING - EDGE BAND - .875" X .024" - ALMOND (K20,K21,K23)
	076325-43-000	FT	MOLDING - EDGE BAND - .875" X .024" - CLOUD (K22)
	074498-77-000	SF	LAMINATE - PLASTIC - ART CABIN - 4' X 8' (PULL OUT TABLE)
	076325-68-000	FT	MOLDING - EDGE BAND - 1 5/16" X .038" - WATERFORD OAK (PULL OUT TABLE)
	074498-40-000	SF	LAMINATE - PLASTIC - OFF WHITE - 5' X 8' (PATIO ENTERTAINMENT CENTER TABLE)
	076325-73-000	FT	MOLDING - EDGE BAND - .93" X .024" - OFF WHITE (PATIO ENTERTAINMENT CENTER TABLE)

WALLPAPER BORDER

KEY	PART NUMBER	U/M	DESCRIPTION
	122481-23-000	FT	WALLPAPER - 6.9" BORDER (K20)
	122481-16-000	FT	WALLPAPER - 6.9" BORDER (K21)
	122481-04-000	FT	WALLPAPER - 6" BORDER - TRAVIS BLUE (K22)
	122481-15-000	FT	WALLPAPER - 6.9" BORDER (K23)

INTERIOR FINISH GROUP (CONTINUED)

SMOKE DETECTOR, CO DETECTOR, FIRE EXTINGUISHER & CLOCK

KEY	PART NUMBER	U/M	DESCRIPTION	VENDOR NO.
	072852-01-000	EA	DETECTOR - SMOKE - W/9 VOLT BATTERY - US	
	072852-02-000	EA	DETECTOR - SMOKE - W/9 VOLT BATTERY - CANADIAN	
	094499-03-000	EA	EXTINGUISHER/FIRE - DRY - 10B:C - W/O BRACKET	
	094499-04-000	EA	BRACKET - FIRE EXTINGUISHER	
	094499-02-000	EA	EXTINGUISHER/FIRE - DRY - 1A10BC - CANADIAN	
	094499-01-700	EA	BRACKET MTG. W/PLAS. STRAP	294039
	118081-02-01A	EA	CLOCK - WALL - ROUND 8" - BRASS	
	125136-01-000	EA	CO DETECTOR - GAS - ROUND W/2 SCREWS - 9 VOLT	

ANTISLIP & FLOOR MATS

KEY	PART NUMBER	U/M	DESCRIPTION
	091261-01-000	FT	SLIPNOT - ANTISLIP - 1' WIDE
	105924-01-F12	EA	MAT - FLOOR - 18" X 27" (K20)
	105924-01-J69	EA	MAT - FLOOR - 18" X 27" (K21)
	105924-01-F05	EA	MAT - FLOOR - 18" X 27" (K22)
	105924-01-K32	EA	MAT - FLOOR - 18" X 27" (K23)

CARPET, VINYL, & TILE

KEY	PART NUMBER	U/M	DESCRIPTION
	093486-01-000	SY	CARPET - COMPARTMENT - 72" WIDE - DARK GRAY
	096060-99-000	SY	CARPET - PARCHMENT - INCREMENTS OF 4 SY (K20)
	096060-98-000	SY	CARPET - SILVER ASPEN - INCREMENTS OF 4 SY (K21)
	096060-97-000	SY	CARPET - LAPIS - INCREMENTS OF 4 SY (K22)
	096060-A2-000	SY	CARPET - NEW MEADOW - INCREMENTS OF 4 SY (K23)
	042720-21-000	SY	VINYL - FLOOR COVERING - 7' WIDE - MODULATION FROM: 00-00-00 THRU: 02-07-99
	042720-25-000	SY	VINYL - FLOOR COVERING - 14' WIDE - MODULATION FROM: 02-08-99 THRU: 99-99-99
	122755-02-01A	EA	FLOORING/RUBBER - ENTRANCE DOOR - 18.5" X 29.3"
	122755-04-01A	EA	FLOORING/RUBBER - ENTRANCE DOOR - 17.7" X 28.5"
	124253-01-02A	EA	VINYL - FLOOR PLANK - 3" X 12" - MAPLE

PANELING, PLYWOOD, & PARTICLE BOARD

KEY	PART NUMBER	U/M	DESCRIPTION
	074497-28-000	SF	PANELING - WATERFORD OAK - 4' X 8'
	088272-G1-000	SF	PANELING - PEBBLE EMBOSSED - ANTIQUE WHITE - 4' X 7'
	088272-H2-000	SF	PANELING - FLAGSTAFF - 48" X 84" (K20)
	088272-H8-000	SF	PANELING - UPBEAT/TWILIGHT (K21,K23)
	088272-G4-000	SF	PANELING - MONTANA FROST - 4' X 7' (K22)
	080215-10-000	SF	PANELING - 2 SIDED - WATERFORD - .2" X 4' X 8'
	000846-01-000	SF	PLYWOOD - 5/16" X 48" X 96" - CD GRADE
	000846-02-000	SF	PLYWOOD/UNDERLAYMENT - 5/16" X 48" X 96"
	089297-01-000	SF	PLYWOOD - LUAN - OVERLAY GRADE - 48" X 96"
	089297-02-000	SF	PLYWOOD - LUAN - OVERLAY GRADE - 48" X 108"
	126339-01-000	SF	BOARD - WHEAT - 60" X 72"
	000885-76-000	SF	PARTICLE BOARD-3/8" X 48" X 96"-WATERFORD OAK/VINYL 1 SIDE
	000885-77-000	SF	PARTICLE BOARD-3/8" X 48" X 96"-WATERFORD OAK/VINYL 2 SIDE
	000885-79-000	SF	PARTICLE BOARD-3/4" X 48" X 96"-WATERFORD OAK/VINYL 2 SIDE

INTERIOR FINISH GROUP (CONTINUED)

CABINET HARDWARE

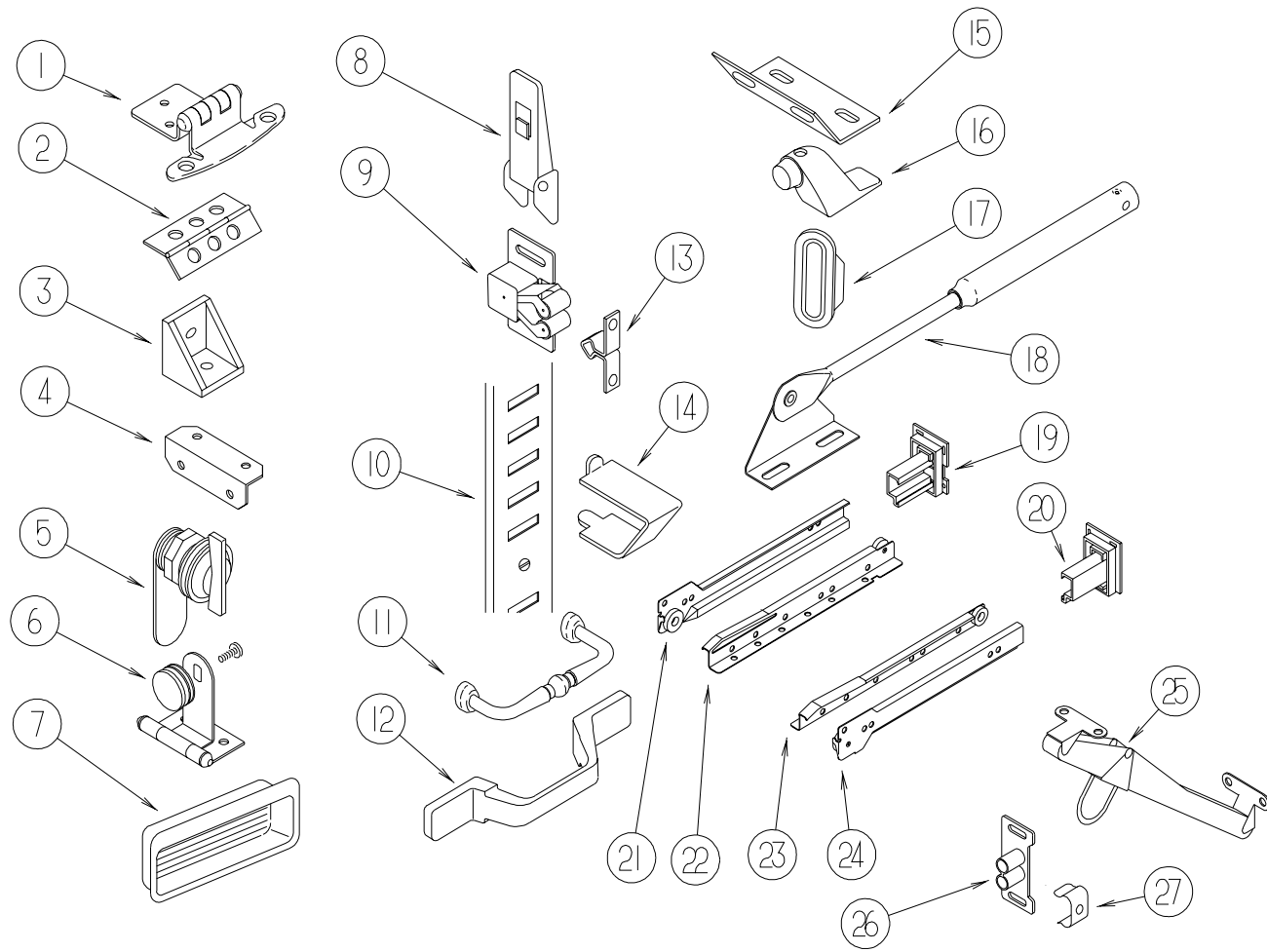

KEY	PART NUMBER	U/M	DESCRIPTION
1	108138-01-000	EA	HINGE - CABINET DOOR - BURNISHED BRASS
2	009059-01-000	EA	HINGE - DOOR - 2" X 1.4" - BRASS
3	065740-01-000	EA	BRACE - CABINET/CORNER - PLASTIC
4	016604-01-000	EA	BRACE - CABINET - ANGLE - 2.5" - UNPAINTED METAL
4	016604-05-000	EA	BRACE - CABINET - ANGLE - 2.5" - OFF WHITE METAL
5	100710-01-01A	EA	LOCK - GLASS DOOR/TWIST TYPE - BRASS
6	100711-01-01A	EA	HINGE - GLASS DOOR
7	124311-01-01A	EA	HANDLE - RECESSED - BRASS
8	116975-01-01A	EA	LATCH - W/O STRIKE - BLACK - NEW STYLE
	116975-02-01A	EA	KEEPER/STRIKE - BLACK - NEW STYLE
9	093586-06-000	EA	CATCH - SPRING ROLLER
10	098980-01-000	EA	PILASTER - ADJUSTABLE SHELF - 18" WOODGRAIN APPEARANCE
10	098980-02-000	EA	PILASTER - ADJUSTABLE SHELF - 12" WOODGRAIN APPEARANCE
10	098980-03-000	EA	PILASTER - ADJUSTABLE SHELF - 9" WOODGRAIN APPEARANCE
10	098980-04-000	EA	PILASTER - ADJUSTABLE SHELF - 48" WOODGRAIN APPEARANCE
11	131963-01-01A	EA	PULL - CABINET - POLISHED BRASS
			FROM: 04-30-99 THRU: 99-99-99
12	117801-01-01A	EA	PULL - CABINET - BRASS
			FROM: 00-00-00 THRU: 04-29-99
13	093586-05-000	EA	STRIKE - SPRING STEEL
14	098979-01-000	EA	CLIP - ADJUSTABLE SHELF
15	111866-01-02A	EA	BRACE - SEAT - ANGLE - OFF WHITE
16	103257-01-000	EA	STOP - DOOR
17	098410-01-01A	EA	PULL - FINGER - OVAL - BRASS
18	074493-02-000	EA	SUPPORT - PISTON SPRING - CABINET DOOR - 26 LBS
19	128811-01-01A	EA	BACKSOCKET - ADJUSTABLE - LEFT
20	128811-02-01A	EA	BACKSOCKET - ADJUSTABLE - RIGHT
21	128810-01-01A	EA	SLIDE - DRAWER - 12" - LEFT CABINET
21	128810-05-01A	EA	SLIDE - DRAWER - 14" - LEFT CABINET
21	128810-13-01A	EA	SLIDE - DRAWER - 18" - LEFT CABINET
21	128810-17-01A	EA	SLIDE - DRAWER - 20" - LEFT CABINET
21	128810-21-01A	EA	SLIDE - DRAWER - 22" - LEFT CABINET
22	128810-03-01A	EA	SLIDE - DRAWER - 12" - LEFT DRAWER
22	128810-07-01A	EA	SLIDE - DRAWER - 14" - LEFT DRAWER
22	128810-15-01A	EA	SLIDE - DRAWER - 18" - LEFT DRAWER
22	128810-19-01A	EA	SLIDE - DRAWER - 20" - LEFT DRAWER
22	128810-23-01A	EA	SLIDE - DRAWER - 22" - LEFT DRAWER
23	128810-04-01A	EA	SLIDE - DRAWER - 12" - RIGHT DRAWER
23	128810-08-01A	EA	SLIDE - DRAWER - 14" - RIGHT DRAWER
23	128810-16-01A	EA	SLIDE - DRAWER - 18" - RIGHT DRAWER
23	128810-20-01A	EA	SLIDE - DRAWER - 20" - RIGHT DRAWER
23	128810-24-01A	EA	SLIDE - DRAWER - 22" - RIGHT DRAWER
24	128810-02-01A	EA	SLIDE - DRAWER - 12" - RIGHT CABINET
24	128810-06-01A	EA	SLIDE - DRAWER - 14" - RIGHT CABINET
24	128810-14-01A	EA	SLIDE - DRAWER - 18" - RIGHT CABINET
24	128810-18-01A	EA	SLIDE - DRAWER - 20" - RIGHT CABINET
24	128810-22-01A	EA	SLIDE - DRAWER - 22" - RIGHT CABINET
25	104181-01-01A	EA	SUPPORT - LEAF 5.3" EXTENDS TO 7.5" - SAFETY RING - METAL
26	009021-01-000	EA	CATCH - GRILLE - NYLON
27	009021-02-000	EA	STRIKE - SPRING STEEL
	004354-01-000	EA	BUMPER - RUBBER - .5" DIA - BROWN
	023320-01-000	EA	PAD - FELT 3/8" DIAMETER

LABELS GROUP

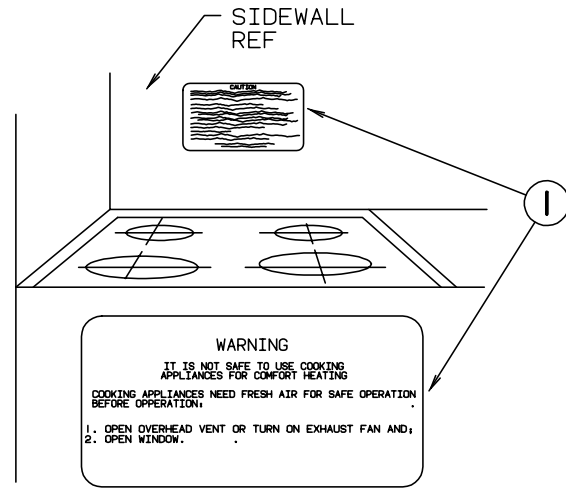

KEY	PART NUMBER	U/M DESCRIPTION
1	050225-01-000	EA LABEL - STOVE VENT - US
1	050222-01-000	EA LABEL - STOVE VENT - CANADIAN

LABELS GROUP (CONTINUED)

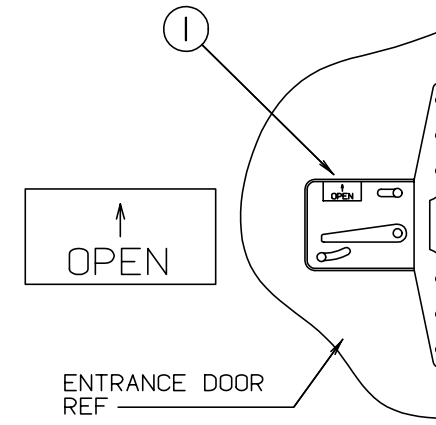

KEY	PART NUMBER	U/M DESCRIPTION
1	040944-01-000	EA LABEL - ENTRANCE DOOR - "OPEN"

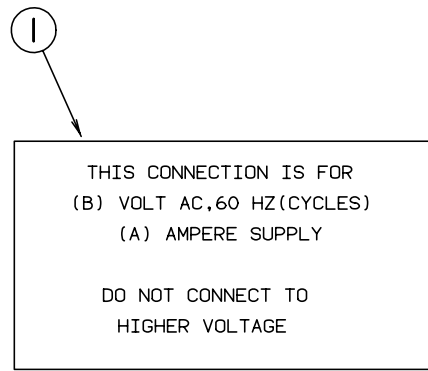

KEY	PART NUMBER	U/M DESCRIPTION
1	125306-01-01A	EA LABEL - ELECTRICAL ENTRANCE - 110 VOLT - 30 AMP

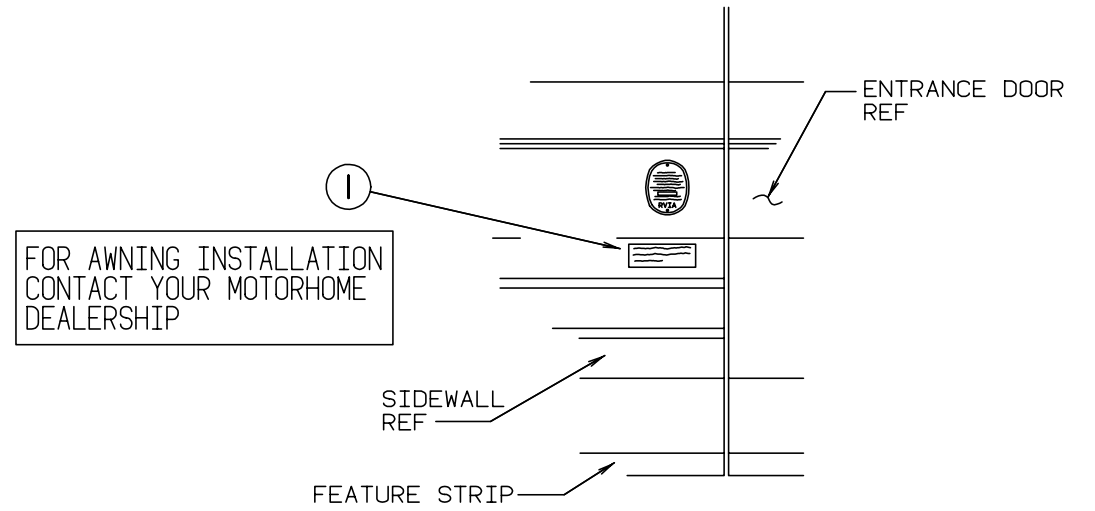

KEY	PART NUMBER	U/M DESCRIPTION
1	099509-01-000	EA LABEL - AWNING INSTALLATION

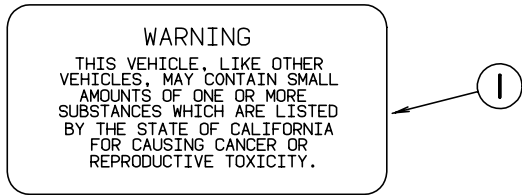

KEY	PART NUMBER	U/M DESCRIPTION
1	099689-01-000	EA LABEL - WARNING - CANCER/TOXICITY - CALIFORNIA

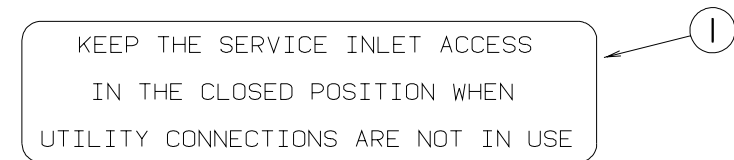

KEY	PART NUMBER	U/M DESCRIPTION
1	123562-01-000	EA LABEL - SERVICE/UTILITY ACCESS

LABELS GROUP (CONTINUED)

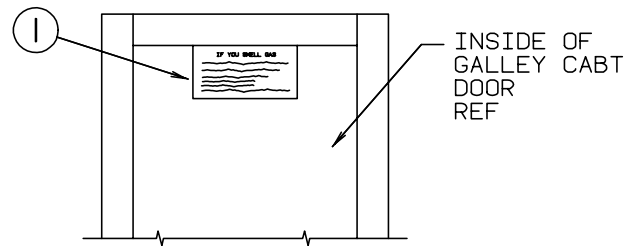

INSIDE OF
GALLEY CABT
DOOR
REF

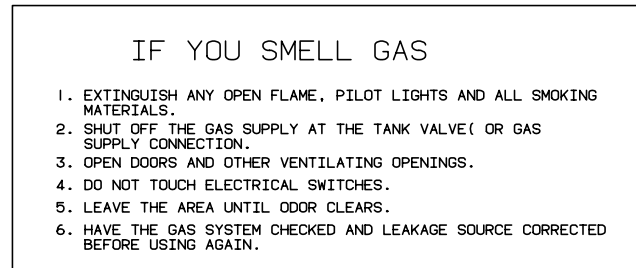

KEY	PART NUMBER	U/M DESCRIPTION
1	073998-01-000	EA LABEL - LPG ODOR WARNING

LABELS GROUP (CONTINUED)

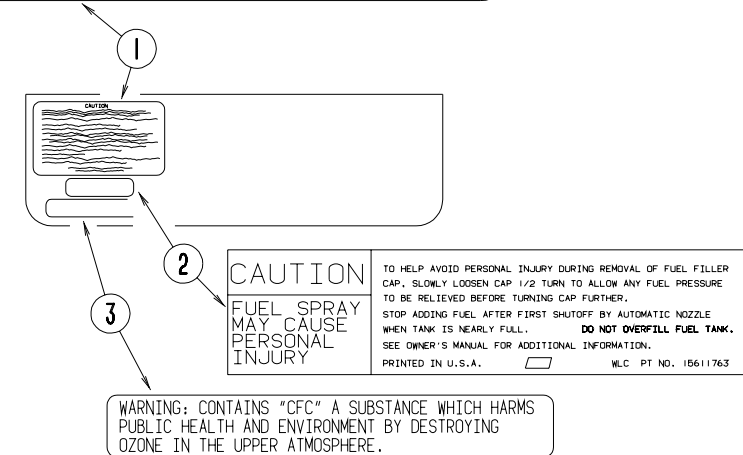
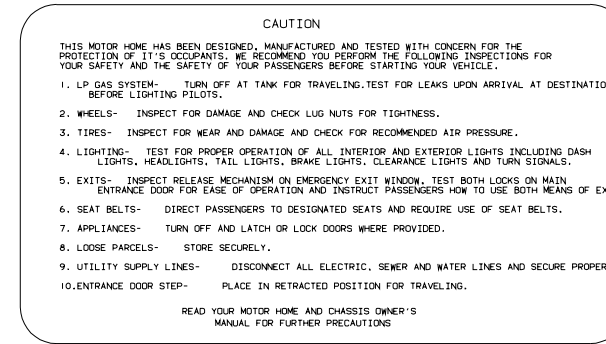

KEY	PART NUMBER	U/M DESCRIPTION
1	056259-01-000	EA LABEL - SAFETY CHECK LIST
2	087207-05-000	EA LABEL - FUEL CAP REMOVAL
3	111802-01-000	EA LABEL - CFC WARNING

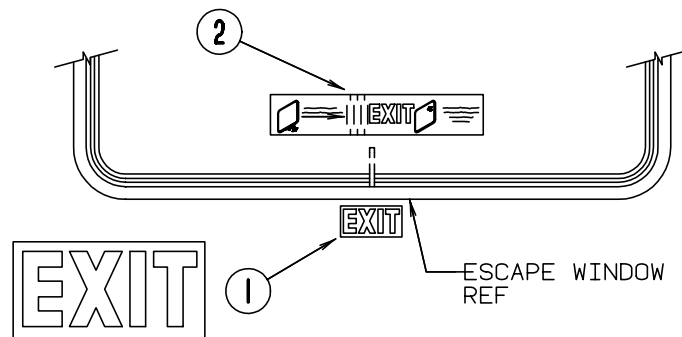

KEY	PART NUMBER	U/M DESCRIPTION
1	039290-01-000	EA LABEL - WARNING - EXIT
2	107571-01-000	EA LABEL - EXIT/ESCAPE WINDOW

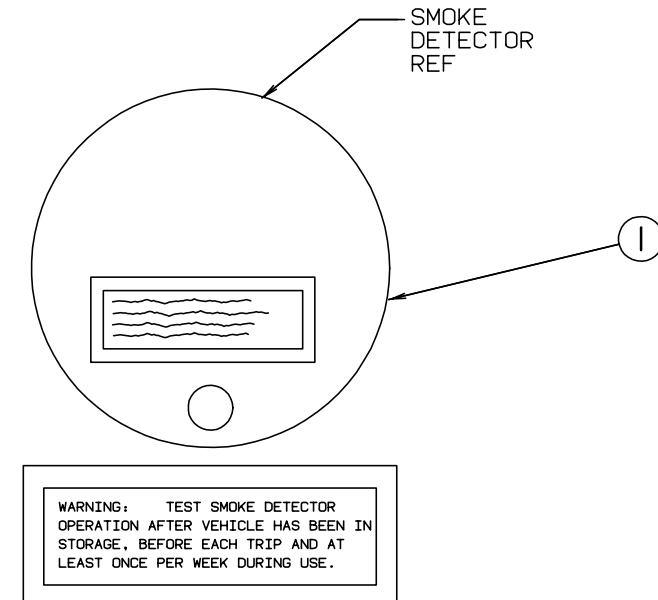

KEY	PART NUMBER	U/M DESCRIPTION
1	077956-01-000	EA LABEL - WARNING - SMOKE DETECTOR

LABELS GROUP (CONTINUED)

AIR CONDITIONING CIRCUIT.
THIS CONNECTION IS FOR
AIR CONDITIONERS RATED 110-
125 VOLT AC, 60 HZ, 16
AMPERES MAXIMUM. DO NOT
EXCEED CIRCUIT RATING.



KEY	PART NUMBER	U/M DESCRIPTION
1	091243-01-000	EA LABEL - A/C COVER "AIR CONDITIONING CIRCUIT ETC."

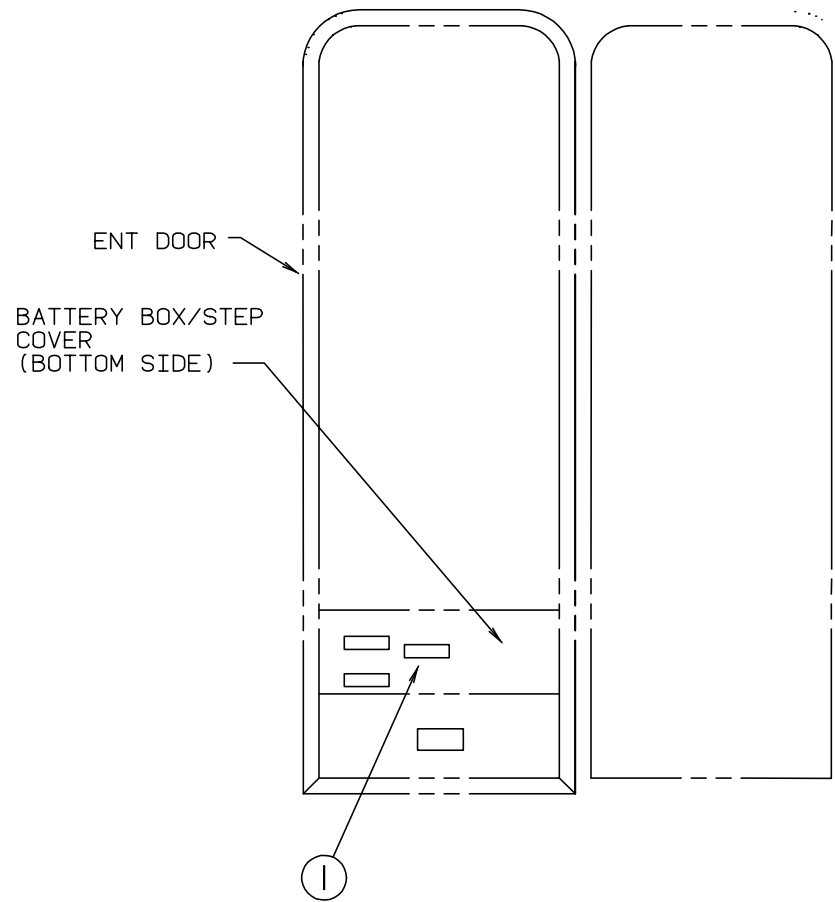

WARNING: DISCONNECT BATTERIES BEFORE
CONNECTING EXTERNAL CHARGING EQUIPMENT.

AVERTISSEMENT: DEBRANCHER LES BATTERIES AVANT
DE BRANCHER TOUT EQUIPEMENT DE CHARGE EXTERIEUR.

KEY	PART NUMBER	U/M DESCRIPTION
1	065748-01-000	EA LABEL - CAUTION - BATTERY CHARGING
1	065748-02-000	EA LABEL - WARNING - BATTERY/FRENCH

LABELS GROUP (CONTINUED)

DO NOT USE HITCH BEFORE
READING OWNERS MANUAL REGARDING
VEHICLE LOADING AND TOWING



KEY	PART NUMBER	U/M DESCRIPTION
1	111104-01-000	EA LABEL - HITCH - READ MANUAL - WHITE
1	111104-02-000	EA LABEL - HITCH - READ MANUAL - BLACK

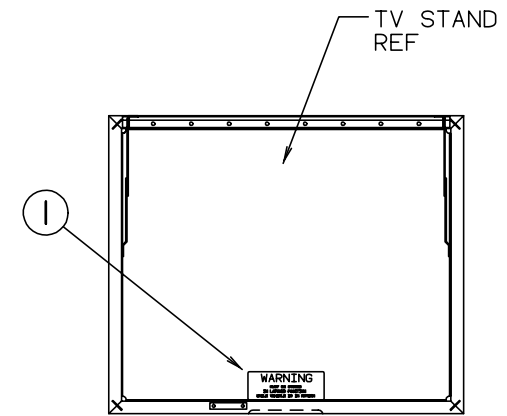

WARNING
MUST BE STOWED
IN LATCHED POSITION
WHILE VEHICLE IS IN MOTION

KEY	PART NUMBER	U/M DESCRIPTION
1	079966-01-000	EA LABEL - WARNING - STOWED - MOTION

TOW VEHICLE RATING MAY BE LESS THAN HITCH RATING.
MAXIMUM VERTICAL HITCH LOAD: A LBS
DO NOT EXCEED REAR AXLE RATING.
SEE OWNER'S MANUAL FOR ADDITIONAL INFORMATION.



KEY	PART NUMBER	U/M DESCRIPTION
1	129669-01-01A	EA LABEL - HITCH/VEHICLE RATE - 350 - WHITE ON CLEAR

LABELS GROUP (CONTINUED)

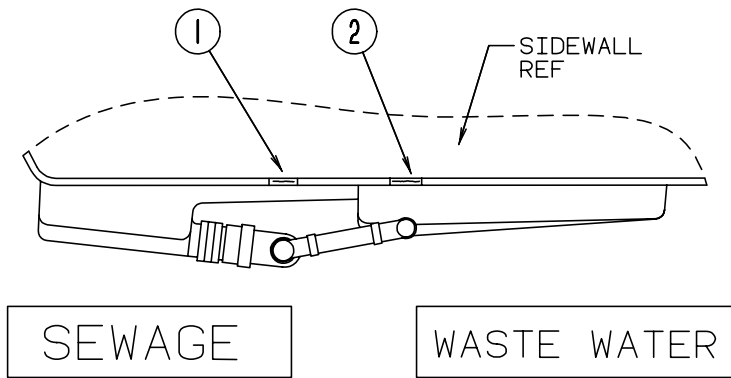

KEY	PART NUMBER	U/M DESCRIPTION
1	006187-01-000	EA LABEL - SEWAGE
2	006188-01-000	EA LABEL - WASTE WATER

WARNING
ALL PILOT LIGHTS AND APPLIANCES SHALL BE TURNED OFF DURING REFUELING OF MOTOR FUEL TANKS AND/OR PERMANENTLY MOUNTED LP-GAS CONTAINERS.

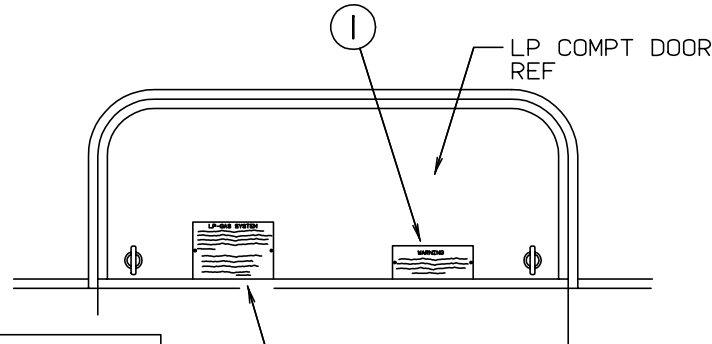

LP-GAS SYSTEM
THIS GAS PIPING SYSTEM IS DESIGNED FOR USE OF LIQUEFIED PETROLEUM GAS ONLY. DO NOT CONNECT NATURAL GAS TO THIS SYSTEM.

SECURELY CAP INLET(S) WHEN NOT CONNECTED FOR USE. AFTER TURNING ON GAS, EXCEPT AFTER NORMAL CONTAINER REPLACEMENT, TEST GAS PIPING AND CONNECTIONS TO APPLIANCE FOR LEAKAGE WITH SOAPY WATER OR BUBBLE SOLUTION. DO NOT USE PRODUCTS THAT CONTAIN AMMONIA OR CHLORINE.
P.N. 54531

KEY	PART NUMBER	U/M DESCRIPTION
1	124519-01-01A	EA LABEL - WARNING/REFUELING - BLACK ON CLEAR
1	124519-02-01A	EA LABEL - WARNING/REFUELING - CSA
2	124520-01-01A	EA LABEL - LP GAS ONLY - BLACK ON CLEAR
2	023769-01-000	EA LABEL - WARNING - LPG - CANADIAN

LABELS GROUP (CONTINUED)

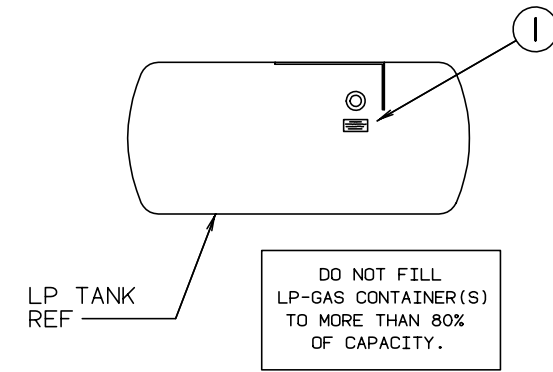

KEY	PART NUMBER	U/M DESCRIPTION
1	079965-01-000	EA LABEL - LPG - 80% CAPACITY

CAUTION
FUEL SPRAY MAY CAUSE PERSONAL INJURY

TO HELP AVOID PERSONAL INJURY DURING REMOVAL OF FUEL FILLER CAP, SLOWLY LOOSEN CAP 1/2 TURN TO ALLOW ANY FUEL PRESSURE TO BE RELIEVED BEFORE TURNING CAP FURTHER.

STOP ADDING FUEL AFTER FIRST SHUTOFF BY AUTOMATIC NOZZLE WHEN TANK IS NEARLY FULL. DO NOT OVERFILL FUEL TANK.

SEE OWNERS MANUAL FOR ADDITIONAL INFORMATION.

PRINTED IN U.S.A. MLC PT NO 15611763

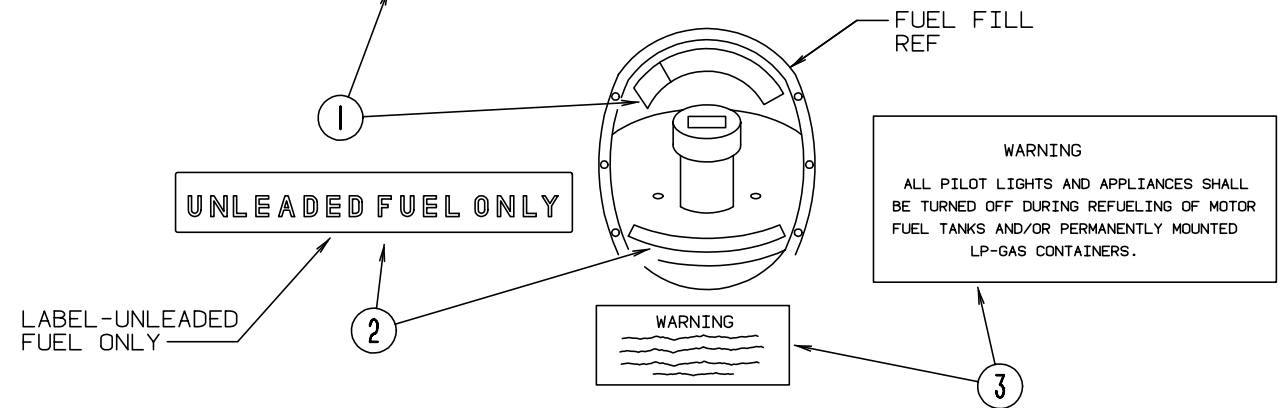

KEY	PART NUMBER	U/M DESCRIPTION
1	087207-05-000	EA LABEL - FUEL CAP REMOVAL
2	062043-01-000	EA LABEL - FUEL - UNLEADED
3	124519-01-01A	EA LABEL - WARNING/REFUELING - BLACK ON CLEAR
3	124519-02-01A	EA LABEL - WARNING/REFUELING - CSA

WARNING
ROOF SURFACE MAY BE SLIPPERY ESPECIALLY WHERE MOISTURE IS PRESENT SLIPPING MAY RESULT IN PERSONAL INJURY.

128218-01

KEY	PART NUMBER	U/M DESCRIPTION
1	128218-01-01A	EA LABEL - WARNING - SLIPPERY ROOF

LABELS GROUP (CONTINUED)

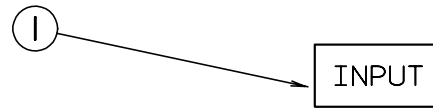

KEY PART NUMBER U/M DESCRIPTION
 1 087236-01-000 EA LABEL - CABLE - INPUT

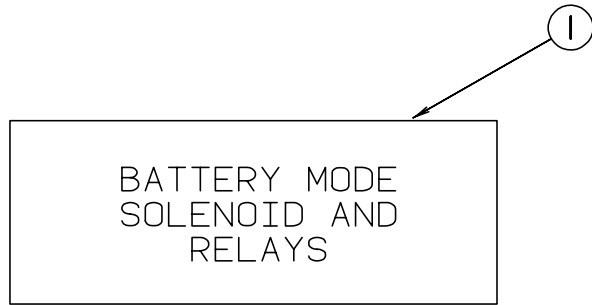

KEY PART NUMBER U/M DESCRIPTION
 1 098379-04-000 EA LABEL - ELECTRICAL BOX - SIDE

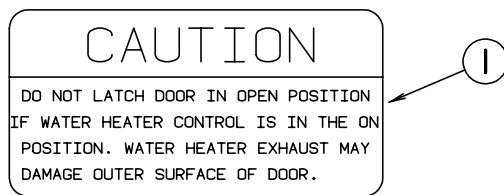

KEY PART NUMBER U/M DESCRIPTION
 1 113402-01-000 EA LABEL - CAUTION - WATER HEATER EXHAUST

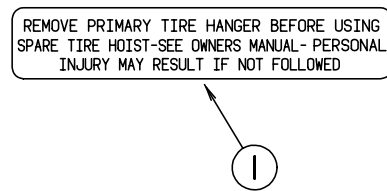

KEY PART NUMBER U/M DESCRIPTION
 1 126024-01-01A EA LABEL - TIRE HANGER REMOVAL

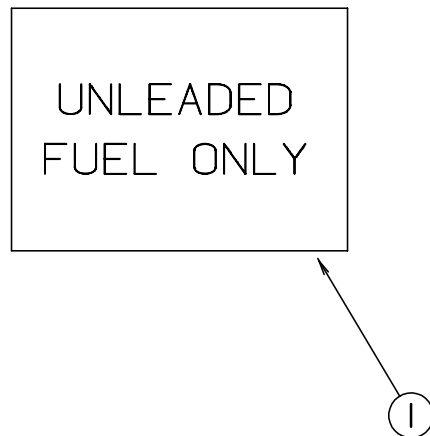

KEY PART NUMBER U/M DESCRIPTION
 1 098641-01-000 EA LABEL - FUEL - UNLEADED - DASH

LABELS GROUP (CONTINUED)

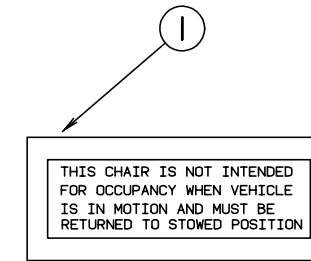

KEY PART NUMBER U/M DESCRIPTION
 1 102267-01-000 EA LABEL - NO OCCUPANCY - US
 102267-02-000 EA LABEL - NO OCCUPANCY - CSA

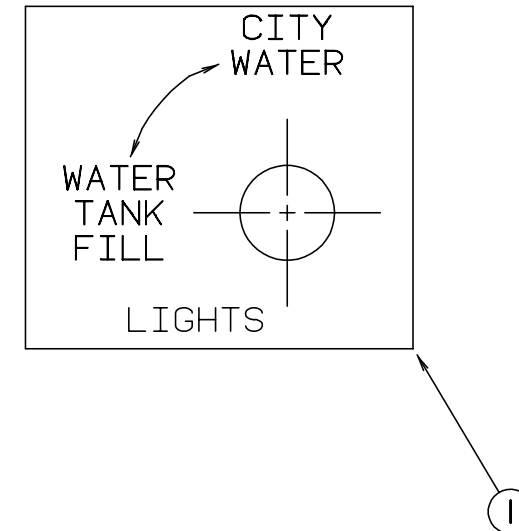

KEY PART NUMBER U/M DESCRIPTION
 1 117629-03-000 EA LABEL - WATER PUMP/FILL

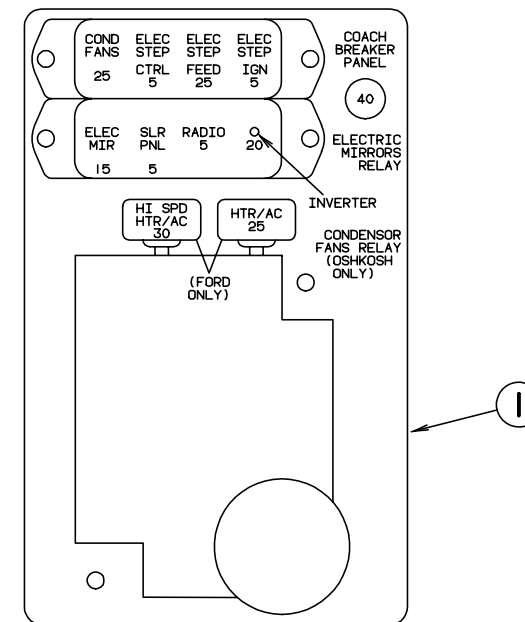

KEY PART NUMBER U/M DESCRIPTION
 1 111537-07-000 EA LABEL - FUSES

LABELS GROUP (CONTINUED)



KEY PART NUMBER U/M DESCRIPTION
 1 087236-02-000 EA LABEL - TV OUTLET

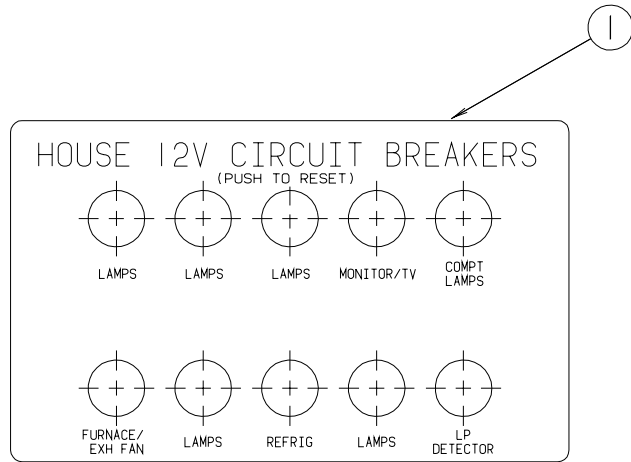

KEY PART NUMBER U/M DESCRIPTION
 1 092547-06-000 EA LABEL - CIRCUIT BREAKER

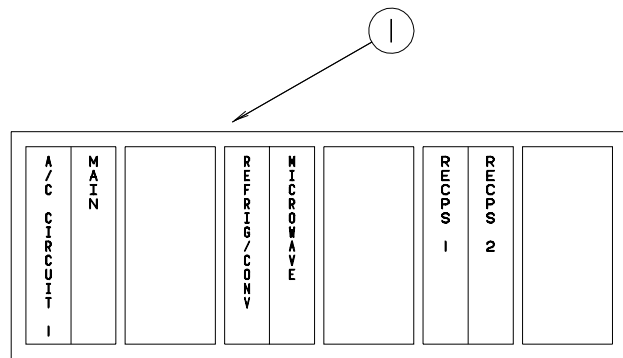

KEY PART NUMBER U/M DESCRIPTION
 1 095721-25-000 EA LABEL - CONTROL CENTER - 30 AMP

LABELS GROUP (CONTINUED)

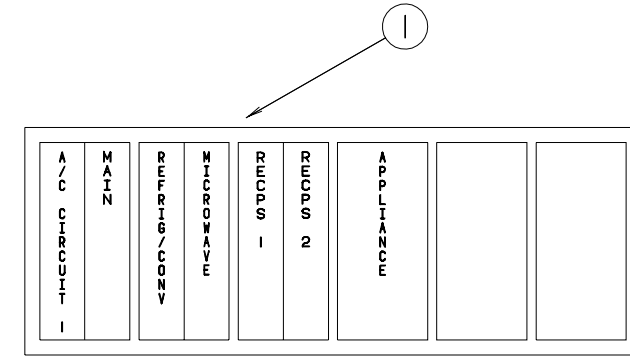

KEY PART NUMBER U/M DESCRIPTION
 1 095721-26-000 EA LABEL - CONTROL CENTER - 30 AMP - CANADIAN

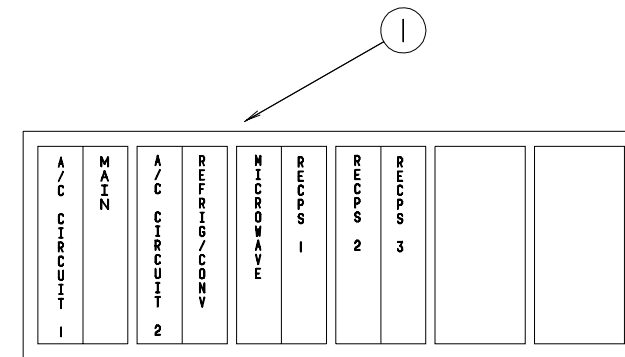

KEY PART NUMBER U/M DESCRIPTION
 1 095721-27-000 EA LABEL - CONTROL CENTER - 30 AMP

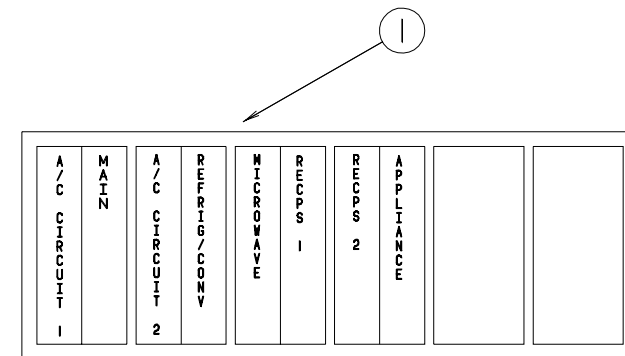

KEY PART NUMBER U/M DESCRIPTION
 1 095721-28-000 EA LABEL - CONTROL CENTER - 30 AMP - CANADIAN

LABELS GROUP (CONTINUED)

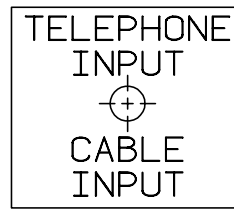

KEY	PART NUMBER	U/M DESCRIPTION
1	114866-03-000	EA LABEL - PHONE & CABLE INPUT

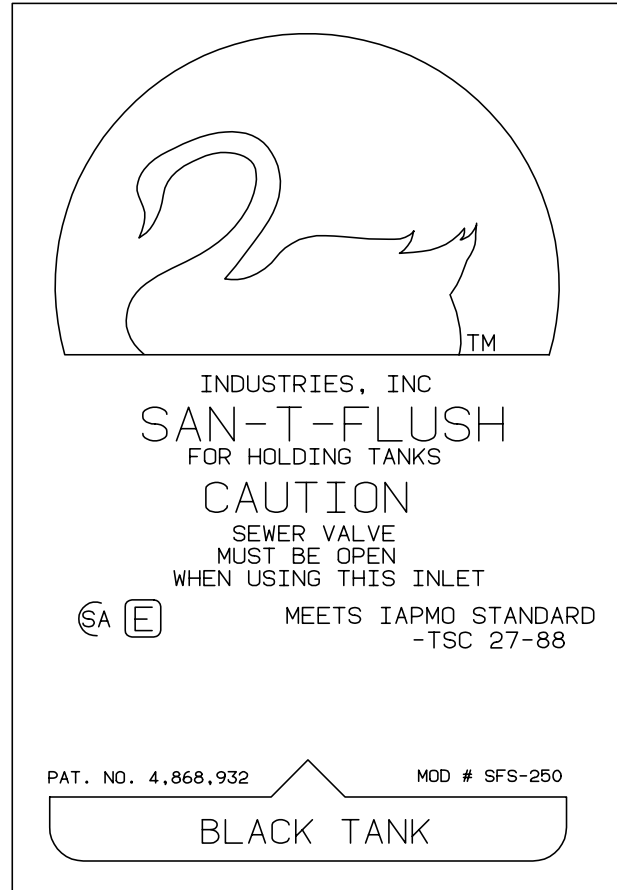

KEY	PART NUMBER	U/M DESCRIPTION
1	125697-07-000	EA LABEL - CAUTION - FLUSHING SYSTEM



KEY	PART NUMBER	U/M DESCRIPTION
1	126247-05-000	EA LABEL - GRAY HOLDING TANK

LABELS GROUP (CONTINUED)



KEY	PART NUMBER	U/M DESCRIPTION
1	126249-03-000	EA LABEL - CITY WATER FILL



KEY	PART NUMBER	U/M DESCRIPTION
1	130168-01-000	EA LABEL - WASTE TANK FLUSH



KEY	PART NUMBER	U/M DESCRIPTION
1	130170-02-000	EA LABEL-PANEL SWITCH



KEY	PART NUMBER	U/M DESCRIPTION
1	126247-06-000	EA LABEL-HOLDING TANK, BLACK



KEY	PART NUMBER	U/M DESCRIPTION
1	126248-03-000	EA LABEL - EXTERIOR SHOWER

LABELS GROUP (CONTINUED)

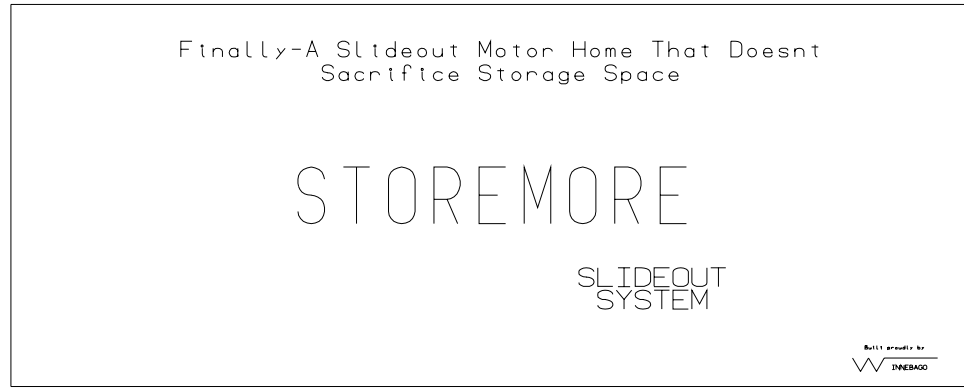

KEY	PART NUMBER	U/M DESCRIPTION
1	131274-02-000	EA STICKER - WINDOW - STATIC CLING - SLIDEOUT

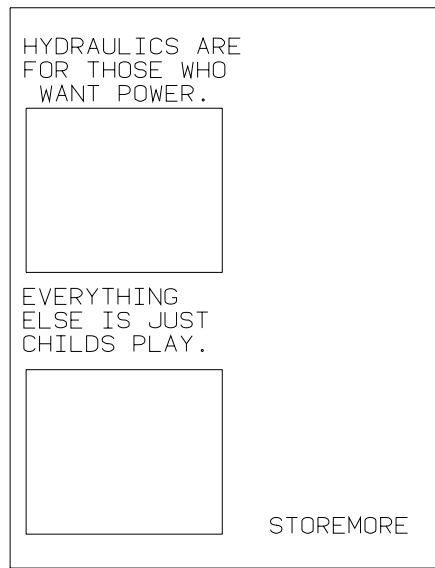

KEY	PART NUMBER	U/M DESCRIPTION
1	131274-03-000	EA STICKER - WINDOW - STATIC CLING - SLIDEOUT



KEY	PART NUMBER	U/M DESCRIPTION
1	131274-04-000	EA STICKER - WINDOW - STATIC CLING - SLIDEOUT

LP GROUP

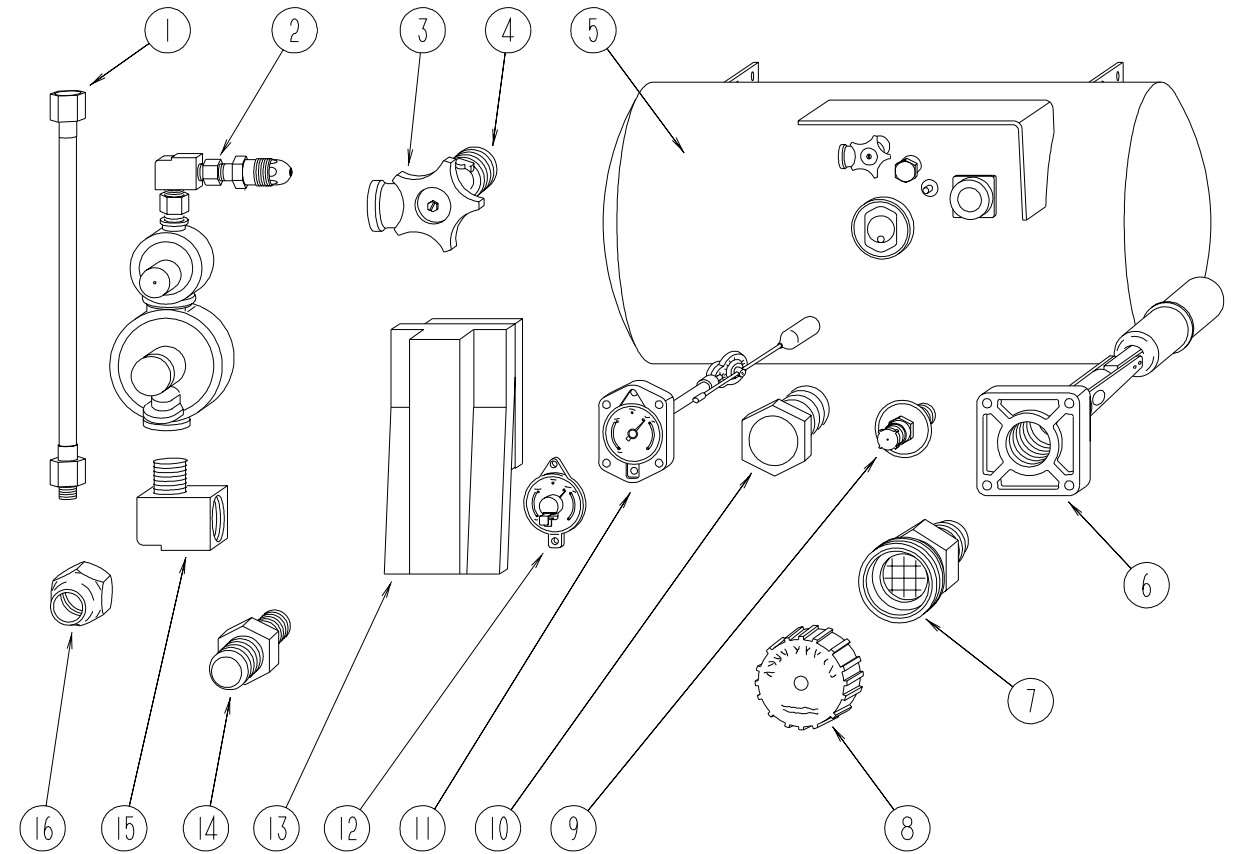

LP TANK & COMPONENTS

KEY	PART NUMBER	U/M DESCRIPTION	VENDOR NO.
1	045703-01-000	EA HOSE - LP - 3/8"ID X 24" - 3/8"MPT X 1/2"F SWIVEL - U.S.	
1	045703-02-000	EA HOSE - LP - 3/8"ID X 24" - 3/8"MPT X 1/2"F SWIVEL - CANADA	
2	106150-01-000	EA REGULATOR - TWO STAGE -W/90 DEGREE ELBOW & 3/8" FPT OUTLET	
3	040421-01-708	EA HANDWHEEL-SERVICE VALVE	G-1015-A
4	040421-01-712	EA VALVE,SERV. W/O VAPOR RELIEF	29000853
5	088253-09-000	EA TANK - LP - 100 LB - 14" DIAMETER X 47" LONG	
6	040421-01-711	EA VALVE-80% FILL W/AUTO STOP	LLL/TL3
7	040421-01-701	EA VALVE-FILL-SHORT, LP	7547B
8	040421-01-702	EA CAP-FILL VALVE, PLASTIC	G-1014-A
9	040421-01-700	EA VALVE-LIQUID LEVEL, 20%	G-1013
10	040421-01-713	EA VALVE-RELIEF 1" W/SPRING 7"	29000587
11	040421-01-707	EA FLOAT ASM.(SIGHT GAUGE) 14"	14C
12	040440-02-000	EA TRANSMITTER - DIAL - 0-90 OHM -2 TERMINAL (POWER & GROUND)	
13	105658-01-000	EA COMPARTMENT - LP REGULATOR	
14	010323-01-000	EA ADAPTER - BRASS - 3/8"F X 1/2"MPT	
14	010329-01-000	EA ADAPTER - BRASS - 1/2" F X 1/2" MPT	
15	065318-02-000	EA ELBOW - 90 DEGREE - 3/8" MPT TO 3/8" FPT	
16	010377-02-000	EA NUT - BRASS - 3/8" FLARE - FORGED	
16	010380-02-000	EA NUT - BRASS - 1/2" FLARE - FORGED	
	008042-01-000	FT TUBING - VINYL - .65" ID	
	010326-01-000	EA ADAPTER - FLARE - W/CONE GASKET - 3/8"FEMALE X 1/2"MALE	
	103613-03-000	EA DETECTOR - LP GAS - W/O SHUT-OFF VALVE	

LOUNGE GROUP

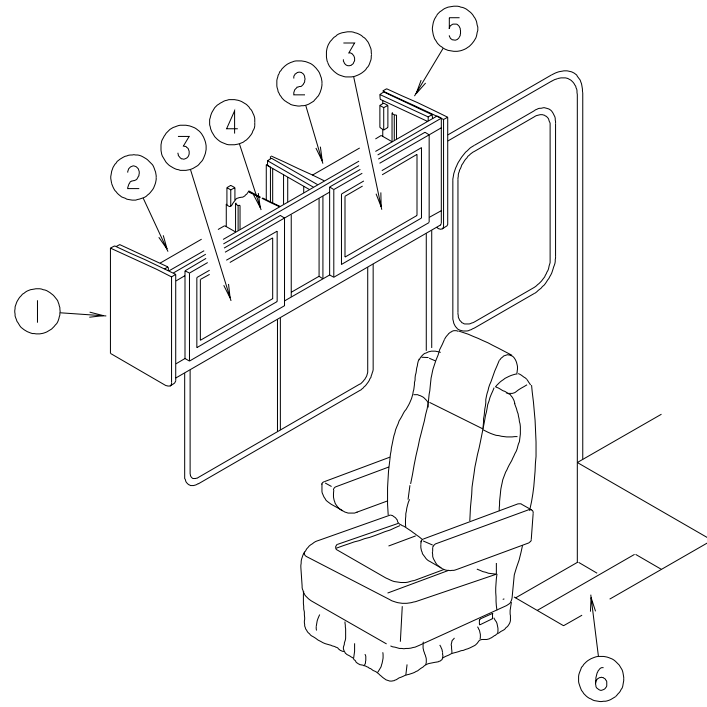

LOUNGE GROUP (CONTINUED)

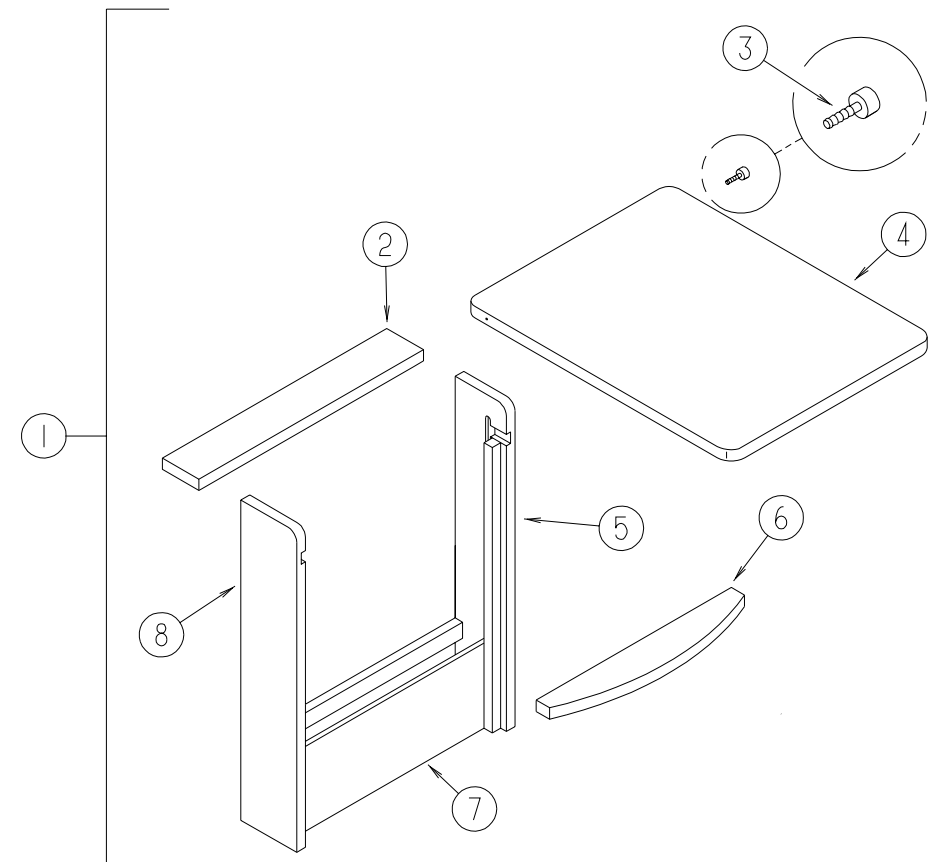

PASSENGER SIDE LOUNGE

KEY	PART NUMBER	U/M DESCRIPTION
1	103128-32-J37	EA END CAP - OVERHEAD CABINET - LEFT HAND
2	131167-11-K20	EA SHELF - W/PLASTIC EDGE TRIM
3	132141-59-K20	EA DOOR - RAIL/VENEER - 14.3" X 17.9" - W/O HARDWARE
4	131167-01-K20	EA CABINET - OVERHEAD/FRONT/RIGHT HAND - W/O DOORS/HARDWARE
4	131167-01-K21	EA CABINET - OVERHEAD/FRONT/RIGHT HAND - W/O DOORS/HARDWARE
4	131167-01-K22	EA CABINET - OVERHEAD/FRONT/RIGHT HAND - W/O DOORS/HARDWARE
4	131167-01-K23	EA CABINET - OVERHEAD/FRONT/RIGHT HAND - W/O DOORS/HARDWARE
5	103128-31-J37	EA END CAP - OVERHEAD CABINET - RIGHT HAND
6	120234-03-H13	EA LID - ENTRY STEP
	101222-01-04A	EA BRACKET - CATCH - LID - E-COATED
	116975-01-01A	EA LATCH - W/O STRIKE - BLACK - NEW STYLE
	116975-02-01A	EA KEEPER/STRIKE - BLACK - NEW STYLE
	064075-07-000	FT SEAL - BULB - W/WIRED U CHANNEL - .3" X .5" CHANNEL - BLK

PULLOUT TABLE

KEY	PART NUMBER	U/M DESCRIPTION
1	P19559-03-J22	EA CABINET - W/PULLOUT TABLE
2	119559-22-J22	EA TOP - F/CABINET/PULLOUT TABLE
3	079921-01-000	EA ROLLER - NYLON - W/STEEL SHAFT - BARBED
4	119559-25-J22	EA TABLE TOP - PULLOUT
	080736-01-000	EA PULL - RECESSED - 1.25 X 4" - OAK
5	119559-11-G35	EA CABINET/RIGHT SIDE - F/PULLOUT TABLE - 5.7" X 28.7"
6	119559-23-J22	EA SHELF - W/PLASTIC EDGE TRIM
7	119559-24-J22	EA PANEL - LOWER/FRONT
8	119559-12-G35	EA CABINET/LEFT SIDE - F/PULLOUT TABLE - 5.7" X 28.7"

LOUNGE GROUP (CONTINUED)

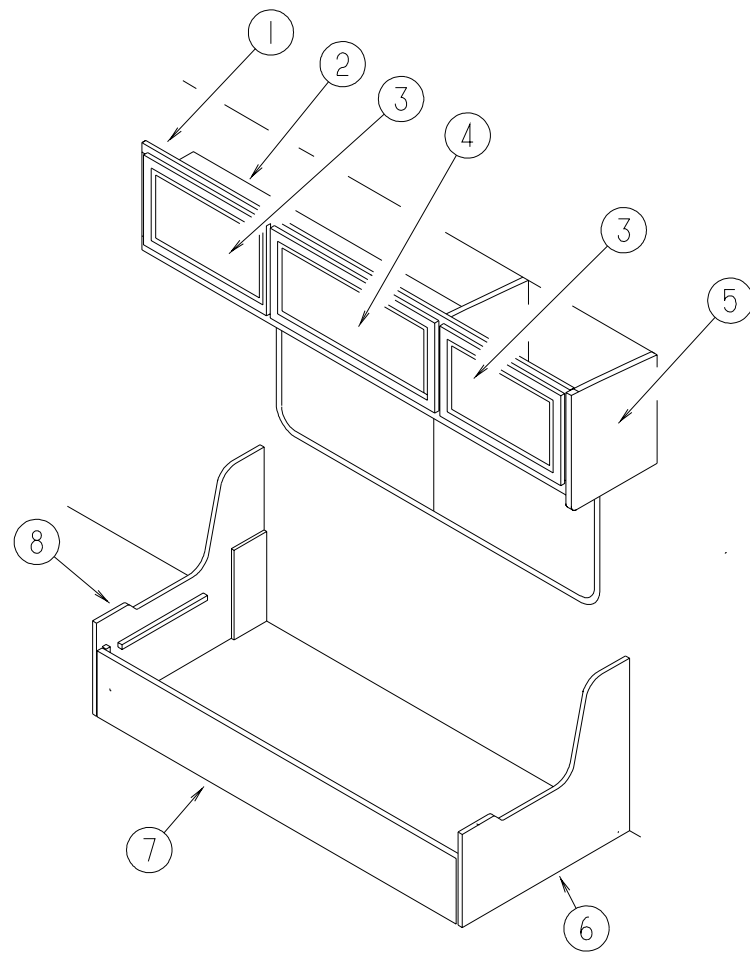

DRIVER SIDE LOUNGE

KEY	PART NUMBER	U/M	DESCRIPTION
1	127596-03-K20	EA	CABINET - OVERHEAD/FRONT/LEFT HAND - W/O DOORS/HARDWARE
1	127596-02-J37	EA	CABINET - OVERHEAD FRONT/LEFT HAND - W/O DOORS/HARDWARE COMFORT AND CONVENIENCE PACKAGE
2	127596-11-J37	EA	SHELF - W/PLASTIC EDGE TRIM
3	132141-02-K20	EA	DOOR - RAIL/VENEER - 14.3" X 21.8" - W/O HARDWARE
4	132141-56-K20	EA	DOOR - RAIL/VENEER - 14.3" X 26.7" - W/O HARDWARE
5	103128-31-J37	EA	END CAP - OVERHEAD CABINET - RIGHT HAND
6	127840-02-J24	EA	PANEL - LEFT END - SOFA/BED - FABRIC COVERED (K20)
6	127840-02-K21	EA	PANEL - LEFT END - SOFA/BED - FABRIC COVERED (K21)
6	127840-02-K22	EA	PANEL - LEFT END - SOFA/BED - FABRIC COVERED (K22)
6	127840-02-K23	EA	PANEL - LEFT END - SOFA/BED - FABRIC COVERED (K23)
7	120992-07-J24	EA	PANEL - FRONT KICK - SOFA/BED - FABRIC COVERED (K20)
7	120992-07-K21	EA	PANEL - FRONT KICK - SOFA/BED - FABRIC COVERED (K21)
7	120992-07-K22	EA	PANEL - FRONT KICK - SOFA/BED - FABRIC COVERED (K22)
7	120992-07-K23	EA	PANEL - FRONT KICK - SOFA/BED - FABRIC COVERED (K23)
	121906-01-02B	EA	BRACKET - KICKBOARD - E-COATED
8	127840-01-J24	EA	PANEL - RIGHT END - SOFA/BED - FABRIC COVERED (K20)
8	127840-01-K21	EA	PANEL - RIGHT END - SOFA/BED - FABRIC COVERED (K21)
8	127840-01-K22	EA	PANEL - RIGHT END - SOFA/BED - FABRIC COVERED (K22)
8	127840-01-K23	EA	PANEL - RIGHT END - SOFA/BED - FABRIC COVERED (K23)
	101926-01-02A	EA	BRACKET - ZEE - BLACK
	116104-03-02B	EA	BRACKET - ZEE W/HOLES - 5.9"
	127335-10-000	EA	BRACKET - CANADIAN LATCH
	127335-12-000	EA	FRAME-10" LEG

LOUNGE GROUP (CONTINUED)

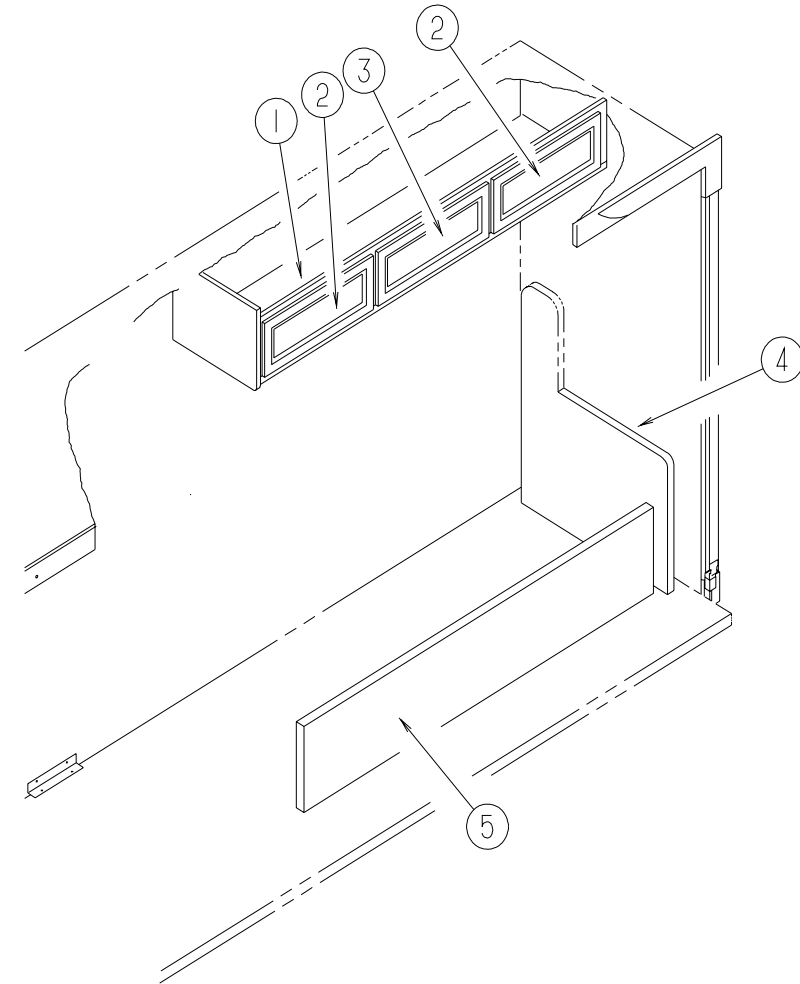

DRIVER SIDE LOUNGE - SLIDEOUT OPTION

KEY	PART NUMBER	U/M	DESCRIPTION
1	126433-01-J22	EA	CABINET - OVERHEAD/COUCH - W/O DOORS/HARDWARE
1	126433-02-J37	EA	CABINET - OVERHEAD/COUCH - W/O DOORS/HARDWARE COMFORT AND CONVENIENCE PACKAGE
2	132141-A1-K20	EA	DOOR - RAIL/VENEER - 10.8" X 21.8" - W/O HARDWARE
3	132141-38-K20	EA	DOOR - RAIL/VENEER - 10.8" X 23.8" - W/O HARDWARE
4	127840-07-J24	EA	PANEL - LEFT END - SOFA/BED - FABRIC COVERED (K20)
4	127840-07-K21	EA	PANEL - LEFT END - SOFA/BED - FABRIC COVERED (K21)
4	127840-07-K22	EA	PANEL - LEFT END - SOFA/BED - FABRIC COVERED (K22)
4	127840-07-K23	EA	PANEL - LEFT END - SOFA/BED - FABRIC COVERED (K23)
5	120992-07-J24	EA	PANEL - FRONT KICK - SOFA/BED - FABRIC COVERED (K20)
5	120992-07-K21	EA	PANEL - FRONT KICK - SOFA/BED - FABRIC COVERED (K21)
5	120992-07-K22	EA	PANEL - FRONT KICK - SOFA/BED - FABRIC COVERED (K22)
5	120992-07-K23	EA	PANEL - FRONT KICK - SOFA/BED - FABRIC COVERED (K23)
	121906-01-02B	EA	BRACKET - KICKBOARD - E-COATED
	101926-01-02A	EA	BRACKET - ZEE - BLACK
	116104-03-02B	EA	BRACKET - ZEE W/HOLES - 5.9"
	127335-10-000	EA	BRACKET - CANADIAN LATCH
	127335-07-000	EA	FRAME-8" LEG

LOUNGE GROUP (CONTINUED)

LOUNGE SLIDEOUT OPTION TRIMS & HARDWARE

KEY	PART NUMBER	U/M	DESCRIPTION
1	116951-01-G35	EA	MOLDING - WOOD - 3" X 70.5"
2	116968-01-G35	EA	TRIM - END/LEFT HAND - WOOD - 3.8" X 19.1"
3	116967-01-G35	EA	TRIM - CENTER - WOOD - 3.8" X 120"
4	116968-02-G35	EA	TRIM - END/RIGHT HAND - WOOD - 3.8" X 19.1"
5	116736-01-01A	EA	TIEDOWN - DROP/D - ZINC
6	116737-01-01A	EA	LATCH - DRAW - ADJUSTABLE - ZINC
7	116101-02-F31	EA	STRAP - WINCH - 34" CENTER BRACKET/STRAP END
8	116082-03-02B	EA	BRACKET - WINCH
9	115767-02-000	EA	WINCH - SLIDEOUT

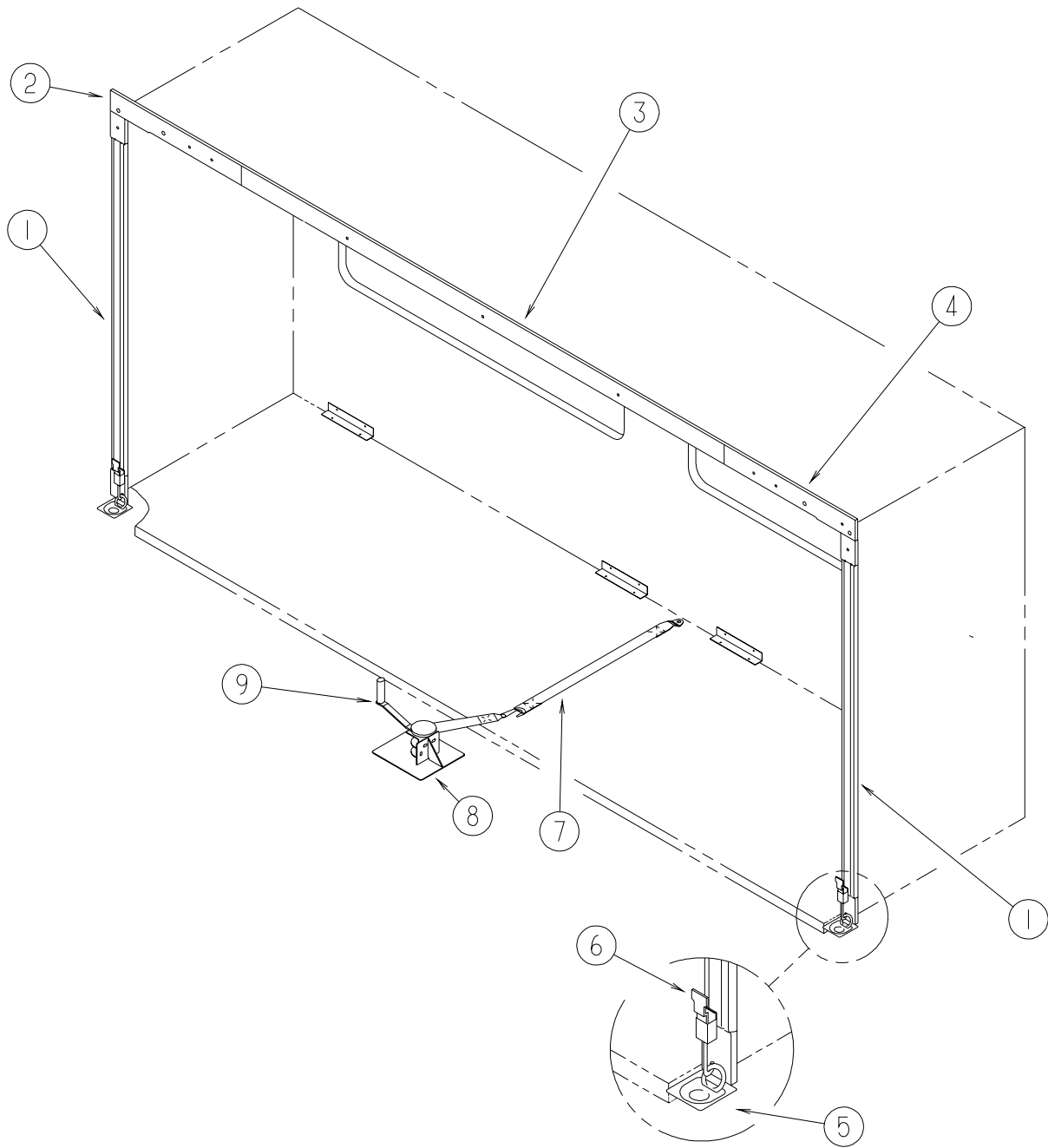

SEALANTS & FASTENERS GROUP

ADHESIVE

KEY	PART NUMBER	U/M DESCRIPTION	VENDOR NO.
	004020-01-000	QT ADHESIVE - ABS CEMENT - QUART	
	081377-01-700	EA ADHESIVE-CYANOACRYLATE 10 GM	
	087211-01-000	GL PROMOTER - ADHESIVE	
	004006-05-700	EA ADHESIVE-NAT. STARCH (5 GAL)	0802
	062917-03-000	EA ADHESIVE - LOCTITE 242	
	067788-01-000	EA ADHESIVE - SPRAY - 3M - 19.5 AEROSOL CAN	
	112901-02-000	EA ADHESIVE - PLEXUS - 50ML	
	131384-01-000	EA ADHESIVE - JET - WELD	

NUTS

KEY	PART NUMBER	U/M DESCRIPTION
	000D24-10-00B	EA NUT - HEX - SELF LOCKING - 10-32 ZINC
	000D29-05-00B	EA NUT - HEX - LOCKING W/SERRATED FLANGE-NYLON WASHER INSERT
	000D34-04-00B	EA NUT - HEX - LOCKING - 1/4-20 ZINC
	000D34-06-00B	EA NUT - HEX - LOCKING - 3/8-16 GRADE C - ZINC-PREVAILING
	000D39-04-00B	EA NUT - HEX - LOCKING W/SERRATED FLANGE - 1/4-20 - ZINC
	000D39-05-00B	EA NUT - HEX - LOCKING W/SERRATED FLANGE - 5/16-18 - ZINC
	000D39-06-00B	EA NUT - HEX - LOCKING W/SERRATED FLANGE - 3/8-18 - ZINC
	000D39-06-00D	EA NUT - HEX - LOCKING W/SERRATED FLANGE - 3/8"-16 BLACK
	000D39-07-00B	EA NUT - HEX - LOCKING W/SERRATED FLANGE - 7/16-14 - ZINC
	000D39-08-00B	EA NUT - HEX - LOCKING W/SERRATED FLANGE - 1/2-13 - ZINC
	000D44-04-00B	EA NUT - HEX - LOCKING W/SERRATED FLANGE - 1/4-28 ZINC
	000D44-07-00B	EA NUT - HEX - LOCKING W/SERRATED FLANGE - 7/16-20 - ZINC
	000D46-04-00A	EA NUT - HEX - WELD - 1/4-20 - PLAIN
	000D65-08-00B	EA NUT - HEX/SERRATED FLANGE - 8-32 ZINC
	000D73-07-00C	EA NUT - HEX FLANGE - 7/16-14 - GRADE 6
	000D76-06-00B	EA NUT - HEX FLANGE - 3/8-16
	040921-01-000	EA NUT - SPEED - U TYPE - 10-24 BLACK
	040921-03-000	EA NUT - SPEED - U TYPE - #10
	040921-04-000	EA NUT - SPEED - U TYPE - 8-.59" LENGTH X .44" WIDTH
	040921-09-000	EA NUT - SPEED - U TYPE - 8
	044364-02-000	EA NUT - SPEED - FLAT - ROUND
	083163-06-000	EA PUSHNUT - FLAT TYPE 3/8 STUD - FORD ONLY TO RETAIN THE AIR BAFFLE ON THE OIL DIPSTICK TUBE
	104369-01-000	EA NUT - HEX - HEAVY - 5/8-11 UNC

SEALANTS & FASTENERS GROUP (CONTINUED)

BOLTS

KEY	PART NUMBER	U/M DESCRIPTION
	000C12-05-16B	EA BOLT - HEX - 5/16-18 X 1 - ZINC 5
	000C12-06-16B	EA BOLT - HEX - 3/8-16 X 1 LG - ZINC 5
	000C12-08-16B	EA BOLT - HEX - 1/2-13 X 1.00 - GD5 - ZINC
	000C12-08-28B	EA BOLT - HEX - 1/2-13 X 1.8" - GRADE #5 - ZINC
	000C12-08-24B	EA BOLT - HEX - 1/2-13 X 1.5" - GRADE #3 - ZINC
	000C12-10-24B	EA BOLT - HEX - 5/8-11 X 1.50 - ZINC 5
	000C13-07-24B	EA BOLT - HEX - 7/16-20 X 1.5" - GRADE #5
	000C13-07-40B	EA BOLT - HEX - 7/16-20 X 2.5" - GRADE #5 - ZINC
	000C13-07-48B	EA BOLT - HEX - 7/16-20 X 3 - ZINC 5
	000C18-05-40A	EA BOLT - ELEVATOR - 5/16-18 X 2.50 - PL
	000C26-04-18B	EA BOLT - HEX - SERRATED FLANGE - 1/4-20 X 1 1/8 - ZINC
	000C26-04-14B	EA BOLT - HEX - SERRATED FLANGE - 1/4-20 X 7/8 - ZINC
	000C26-04-10B	EA BOLT - HEX - SERRATED FLANGE - 1/4-20 X 5/8 - ZINC
	000C26-05-16B	EA BOLT - HEX - SERRATED FLANGE - 5/16-18 X 1 - ZINC
	000C26-05-12B	EA BOLT - HEX - SERRATED FLANGE - 5/16-18 X 3/4 - ZINC
	000C26-06-16B	EA BOLT - HEX - SERRATED FLANGE - 3/8-16 X 1 - ZINC
	000C26-06-12B	EA BOLT - HEX - SERRATED FLANGE - 3/8-16 X 3/4 - ZINC
	000C26-08-24B	EA BOLT - HEX - SERRATED FLANGE - 1/2-13 X 1 1/2 ZINC
	000C27-10-32B	EA BOLT - CARRIAGE - 5/8-11 X 2
	051387-06-000	EA BOLT - CARRIAGE W/O HOLE - 5/16-18 X 9.5 - ZINC
	102333-01-06A	EA BOLT - CARRIAGE - 7/16-14 STAINLESS STEEL CAP
	106166-01-000	EA BOLT/COLLARED HANGER - 8-32 X 1"
	106956-08-000	EA BOLT - HEX TAP - 1/2-13NC X 4 - GRADE 5 - FULL THREAD/ZINC
	088787-12-000	EA STUD - WELD - 1/4 - 20 X 1.0 LG - MN
	108067-03-000	EA STUD - WELD - 1/4 - 20 X 1/2 CD

WASHERS

KEY	PART NUMBER	U/M DESCRIPTION
	000E11-07-00B	EA WASHER - LOCKING - 7/16 MED SPLIT - ZINC
	000E13-14-00B	EA WASHER - FLAT - 1/4 WIDE - ZINC
	000E13-18-00B	EA WASHER - FLAT - 3/8 WIDE - ZINC
	000E13-20-00B	EA WASHER - FLAT - 7/16 WIDE - ZINC
	000E13-22-00B	EA WASHER - FLAT - 1/2 WIDE - ZINC
	000E13-26-00B	EA WASHER - FLAT - 5/8 WIDE - ZINC
	000E14-10-00B	EA WASHER - LOCKING - #10 EXTERNAL TOOTH - ZINC
	044533-01-000	EA WASHER - PLASTIC - 1 3/8" OD - FOR BUTTONS
	058716-02-000	EA WASHER - FLAT NYLON
	107397-01-000	EA WASHER - FENDER - .25" ID X 1" OD

SEALANTS & FASTENERS GROUP (CONTINUED)

SCREWS

KEY	PART NUMBER	U/M	DESCRIPTION
	0G1108-12-170	EA	SCREW - 8-18 X .75 PPH - BRIGHT WHITE
	0G1208-12-170	EA	SCREW - 8-18 X .75 POH - BRIGHT WHITE
	0G3908-08-170	EA	SCREW - SF/DR - 8-18 X .50 PPH - BRIGHT WHITE
	0G3908-24-170	EA	SCREW - SF/DR - 8-18 X 1.50 PPH - BRIGHT WHITE
	0G3910-12-170	EA	SCREW - SF/DR - 10-16 X .75 PPH - BRIGHT WHITE
	0G5508-12-260	EA	SCREW - SF/DR - 8-18 X .75 PWH - ALLANTE ANTELOPE
	0G6710-08-170	EA	SCREW - 10-12 X 1/2 PPH - BRIGHT WHITE
	0G6710-16-230	EA	SCREW - 10-12 X 1 PPH
	000G11-05-08B	EA	SCREW - 5-20 X .50 PPH - ZINC
	000G11-06-08B	EA	SCREW - 6-20 X 1/2 PPH - ZINC
	000G11-06-06B	EA	SCREW - 6-20 X 3/8 PPH - ZINC
	000G11-06-10J	EA	SCREW - 6-20 X 5/8 PPH - BRASS
	000G11-06-10B	EA	SCREW - 6-20 X 5/8 PPH - ZINC
	000G11-07-08B	EA	SCREW - 7-19 X 1/2 PPH - ZINC
	000G11-08-06B	EA	SCREW - 8-18 X 3/8 PPH - ZINC
	000G11-08-12D	EA	SCREW - 8-18 X 3/4 PPH - BLACK
	000G11-08-12B	EA	SCREW - 8-18 X 3/4 PPH - ZINC
	000G11-08-08T	EA	SCREW - 8-18 X 1/2 PPH - FLUOROCARBON COATING
	000G11-08-08B	EA	SCREW - 8-18 X 1/2 PPH - ZINC
	000G11-08-20B	EA	SCREW - 8-18 X 1 1/4 PPH - ZINC
	000G11-08-16S	EA	SCREW - 8-18 X 1 PPH - OFF WHITE
	000G11-08-16B	EA	SCREW-8-18X1 PPH ZN
	000G11-08-12T	EA	SCREW - 8-18 X 3/4 PPH - BLACK
	000G11-08-12P	EA	SCREW - 8-18 X 3/4 PPH - DARK BROWN
	000G11-10-12S	EA	SCREW - 10-16 X 3/4 PPH - OFF WHITE
	000G11-10-12D	EA	SCREW - 10-16 X 3/4 PPH - BLACK
	000G11-10-40B	EA	SCREW - 10-16 X 2 1/2 PPH CAD - 34927-01-000
	000G11-10-24P	EA	SCREW - 10-16 X 1 1/2 PPH - DARK BROWN
	000G11-10-16B	EA	SCREW - 10-16 X 1 PPH - ZINC
	000G12-06-08T	EA	SCREW - 6-20 X 1/2 POH - BLACK
	000G13-06-08B	EA	SCREW - 6-20 X 1/2 PFH - ZINC
	000G13-06-24J	EA	SCREW - 6-20 X 1 1/2 PFH - BRASS
	000G13-06-16J	EA	SCREW - 6-20 X 1 PFH - BRASS
	000G13-06-10G	EA	SCREW - 6-20 X 5/8 PFH - ANTIQUE BRASS
	000G13-06-08G	EA	SCREW - 6-20 X .50 PFH - ANTIQUE BRASS
	000G13-07-12B	EA	SCREW - 7-19 X 3/4 PFH - ZINC
	000G18-08-22B	EA	SCREW - MACHINE - 8-32 X 1 3/8 PPH - ZINC
	000G19-10-20B	EA	SCREW - MACHINE - 10-32 X 1 1/2 PPH - ZINC
	000G19-10-12F	EA	SCREW - MACHINE - 10-32 X 3/4 PPH - STAINLESS STEEL
	000G19-10-08B	EA	SCREW - MACHINE - 10-32 X 1/2 PPH - ZINC
	000G32-10-06B	EA	SCREW - 10-32 X 3/8 PPH - ZINC
	000G37-08-089	EA	SCREW - 8 X 18 X 1/2 PPH
	000G39-06-16T	EA	SCREW - SF/DR - 6-20 X 1 PPH - BLACK
	000G39-06-10T	EA	SCREW - SF/DR - 6-20 X 5/8 PPH - BLACK
	000G39-08-16B	EA	SCREW - SF/DR - 8-18 X 1 PPH - ZINC
	000G39-08-12T	EA	SCREW - SF/DR - 8-18 X 3/4 PPH - BLACK
	000G39-08-12B	EA	SCREW - SF/DR - 8-18 X 3/4 PPH - ZINC
	000G39-08-08T	EA	SCREW - SF/DR - 8-18 X 1/2 PPH - BLACK
	000G39-08-08S	EA	SCREW - SF/DR - 8-18 X 1/2 PPH - OFF WHITE
	000G39-08-08B	EA	SCREW - SF/DR - 8-18 X 1/2 PPH - ZINC
	000G39-08-06B	EA	SCREW - SF/DR - 8-18 X 3/8 PPH - ZINC
	000G39-08-24B	EA	SCREW - SF/DR - 8-18 X 1 1/2 PPH - ZINC
	000G39-08-24T	EA	SCREW - SF/DR - 8-18 X 1.50 PPH - BLACK
	000G39-08-16T	EA	SCREW - SF/DR - 6-20 X 1 PPH - BLACK
	000G39-10-08B	EA	SCREW - SF/DR - 10-16 X 1/2 PPH - ZINC
	000G39-10-209	EA	SCREW - SF/DR - 10-16 X 1 1/4 PPH - FLUOROCARBON SILVER
	000G39-10-20B	EA	SCREW - SF/DR - 10-16 X 1 1/4 PPH - ZINC
	000G39-10-129	EA	SCREW - SF/DR - 10-16 X 3/4 PPH - FLUOROCARBON SILVER
	000G39-10-12D	EA	SCREW - SF/DR - 10-16 X 3/4 PPH - BLACK
	000G39-10-12B	EA	SCREW - SF/DR - 10-16 X 3/4 PPH - ZINC
	000G39-10-10B	EA	SCREW - SF/DR - 10-16 X 5/8 - ZINC
	000G39-10-088	EA	SCREW - SF/DR - 10-16 X 1/2 PPH - FLEX FLUOROCARBON
	000G39-10-209	EA	SCREW - SF/DR - 10-16 X 1 1/4 PPH - FLUOROCARBON SILVER

SEALANTS & FASTENERS GROUP (CONTINUED)

SCREWS (CONTINUED)

KEY	PART NUMBER	U/M	DESCRIPTION
	000G42-04-12B	EA	SCREW - SF/DR - 1/4-14 X 3/4 HWH - ZINC
	000G46-08-24T	EA	SCREW - MACHINE - 8-32 X 1 1/2 PFH - BLACK
	000G50-04-12B	EA	SCREW - MACHINE - 1/4-20 X 3/4 PPH - ZINC
	000G52-08-18B	EA	SCREW - MACHINE - 8-32 X 1 1/8 PTH - ZINC
	000G54-04-20B	EA	SCREW - 1/4-20 X 1.25 PTH - TYPE 23 - ZINC PLATED
	000G55-08-12S	EA	SCREW - SF/DR - 8-18 X 3/4 PWH - OFF WHITE
	000G56-12-48B	EA	SCREW - WOOD - 12-11 X 3 POH - SPECIAL HARDENED
	000G60-10-28T	EA	SCREW - SF/DR - 10-16 X 1 3/4 - BLACK
	000G60-10-20B	EA	SCREW - SF/DR - 10-16 X 1 1/4 POH - ZINC
	000G67-08-32B	EA	SCREW - 8-15 X 2 PPH - ZINC
	000G67-10-12P	EA	SCREW - 10-12 X 3/4 PPH - DARK BROWN
	000G67-10-12B	EA	SCREW - 10-12 X 3/4 PPH - ZINC
	000G67-10-10S	EA	SCREW - 10-12 X 5/8 PPH - OFF WHITE
	000G67-10-10D	EA	SCREW - 10-12 X 5/8 PPH - BLACK - TYPE A
	000G67-10-10B	EA	SCREW - 10-12 X 5/8 PPH - ZINC - TYPE A
	000G67-10-08S	EA	SCREW - 10-12 X 1/2 PPH - OFF WHITE
	000G67-10-08R	EA	SCREW - 10-12 X 1/2 PPH - BEIGE - TYPE A
	000G67-10-08B	EA	SCREW - 10-12 X 1/2 PPH - ZINC
	000G67-10-10P	EA	SCREW - 10-12X.62 PPH - DARK BROWN
	000G67-10-24B	EA	SCREW - 10-12 X 1.50 PPH - ZINC
	000G67-10-20D	EA	SCREW - 10-12 X 1.25 PPH - BLACK
	000G67-10-12S	EA	SCREW - 10-12 X 3/4 PPH - OFF/WHITE
	000G67-10-48B	EA	SCREW - 10-12 X 3 PPH - ZINC
	000G67-10-36T	EA	SCREW - 10-12 X 2 1/4 - PPH - BLACK
	000G67-10-32B	EA	SCREW - 10-12 X 2 PPH - ZINC
	000G67-10-120	EA	SCREW - 10-12 X 3/4 PPH - TAN
	000G68-06-12S	EA	SCREW - 6-18 X 3/4 POH
	000G68-06-10G	EA	SCREW - 6-18 X 5/8 POH - ANTIQUE BRASS
	000G68-10-20I	EA	SCREW - 10-12 X 1 1/4 POH - BLACK
	049465-01-000	EA	SCREW - 10-16 W/WASHER PTH - DARK BROWN
	049465-17-000	EA	SCREW - 10-16 X 1 POH W/WASHER - BRIGHT WHITE
	049465-22-000	EA	SCREW - 10-16 X 1 1/2 POH W/WASHER - SABLE
	054434-02-000	EA	SCREW - SF/DR - 10-16 X 2 - ZINC
	057671-01-000	EA	COVER - SCREW - #8 - PLASTIC - OFF WHITE
	057671-15-000	EA	COVER - SCREW - BRIGHT WHITE
	075908-01-000	EA	SCREW - MACHINE - 10-32 X .56 PTH - EXTERNAL TOOTH - ZINC
	076790-01-000	EA	SCREW - 6-20 X 1 1/4 PPH - BLACK
	083554-04-000	EA	SCREW - DRYWALL - 8 X 2.50
	086256-01-000	EA	SCREW - SF/DR - 8 X 3/4 HWH LONG
	097974-01-000	EA	SCREW - PARTICLE BOARD - 7-9 X 3/4 PPH
	101618-01-000	EA	SCREW - 1/4-20 X 3/4 HEX - TAPPING - STALGARD TYPE F
	113563-01-01A	EA	SCREW - 8 X .62 LONG SHOULDER/WASHER HEAD

SEALANTS & FASTENERS GROUP (CONTINUED)

TAPES

KEY	PART NUMBER	U/M DESCRIPTION
	004363-01-000	FT TAPE - ADHESIVE FOAM/1 SIDE - 3/16" X 1/2" X 50' - GRAY
	076314-02-000	FT TAPE - CARPET SEAM - HEAT-BOND - 4" WIDE
	076322-01-000	FT TAPE - DOUBLE COATED/ADHESIVE BACK - .025"THK X .75"W X18'
	076322-02-000	FT TAPE - DOUBLE COATED/ADHESIVE BACK - .045"THK X 1"W X 108'
	076322-03-000	FT TAPE - DOUBLE COATED/ADHESIVE BACK - .045"THK X .50"W X 9'
	076322-05-000	FT TAPE - DOUBLE COATED/ADHESIVE BACK - .045"THK X .75"W X 9'
	076322-07-000	FT TAPE - DOUBLE COATED/ADHESIVE BACK - .045"THK X .50"W X 9'
	088479-01-000	EA TAPE - ALUMINUM - 3"
	110274-01-000	FT TAPE - DOUBLE SIDED FOAM - .45" X 1"
	118085-02-01A	FT TAPE - FOIL - 1"
	120534-01-01A	EA TAPE - SCOTCH - 3M - 1/2" FINE LINE
	123244-01-000	FT TAPE - DOUBLE SIDED FOAM - 5/64" THICK X .75" WIDE
	123244-02-000	FT TAPE - DOUBLE SIDED FOAM - 5/64" THICK X .50" WIDE
	123816-01-000	FT TAPE - DOUBLE SIDED - 1"
	123816-02-000	FT TAPE - DOUBLE SIDED - 1/2" X 1 1/3" THICK
	123816-03-000	FT TAPE - DOUBLE SIDED - 1/2" X 3/4" - THICK
	123816-04-000	FT TAPE - DOUBLE SIDED - 6"

SEALERS

KEY	PART NUMBER	U/M DESCRIPTION
	069640-01-000	FT SEALER - RIBBON - 1/4" DIAMETER X 30' - BLACK
	069640-03-000	FT SEALER - TAPE - .13"THICK X .75"WIDE X 60' - BLACK
	069640-09-000	FT SEALER - TAPE - .032"THICK X 2.50"WIDE X 80' - GREY
	069640-11-000	FT SEALER - TAPE - .19"THICK X .38"WIDE X 40' - BLACK
	069640-15-000	FT SEALER - TAPE - .06"THICK X .38"WIDE X 80' - GRAY
	069640-18-000	FT SEALER - TAPE - .50"THICK X 1/8"WIDE X 60' - BRIGHT WHITE
	069640-19-000	FT SEALER - TAPE - .75"THICK X 1/8"WIDE X 60'- BRIGHT WHITE
	069640-23-000	FT SEALER - TAPE - 1/16" X 3/4" X 100' - BRIGHT WHITE
	900390-01-000	EA TIP - 2 1/2" X 1/8" ORIFICE
	900390-03-000	EA NOZZLE - SILICONE TUBE
	034552-15-000	EA SILICONE - TUBE - W/O NOZZLE - BRIGHT WHITE
	108716-03-000	EA SILICONE - TUBE - BRIGHT WHITE/SELF LEVELING - W/O NOZZLE FROM: 00-00-00 THRU: 09-06-98
	131264-01-01A	EA SILICONE - W/O NOZZLE - BLACK
	131264-01-02A	EA SILICONE - W/O NOZZLE - CLEAR
	131264-03-01A	EA SILICONE - SELF LEVELING - W/O NOZZLE - BRIGHT WHITE FROM: 09-07-98 THRU: 99-99-99
	053766-02-000	EA BEDDING COMPOUND - TUBE - WHITE
	072889-09-000	EA SEALANT - URETHANE - BLACK (TUBE) FROM: 00-00-00 THRU: 09-06-98
	072889-10-000	EA SEALANT - URETHANE (HV) - BRIGHT WHITE FROM: 00-00-00 THRU: 09-06-98
	072889-11-000	EA SEALANT - URETHANE - (TUBE) - GRAY
	072889-12-000	EA SEALANT - URETHANE (LV) BRIGHT WHITE FROM: 00-00-00 THRU: 09-06-98
	072889-18-000	EA SEALANT - URETHANE - BLACK (FOIL) FROM: 09-07-98 THRU: 99-99-99
	072889-19-000	EA SEALANT - URETHANE - (FOIL) - BLACK - 10 OUNCE FROM: 09-07-98 THRU: 99-99-99
	072889-20-000	EA SEALANT - URETHANE - (FOIL) - BRIGHT WHITE - 10 OUNCE FROM: 09-07-98 THRU: 99-99-99
	072889-21-000	EA SEALANT - URETHANE - (FOIL) - BRIGHT WHITE - 20 OUNCE FROM: 09-07-98 THRU: 99-99-99
	102352-01-000	EA SEALER - PUMPABLE - BLACK
	102352-02-000	EA SEALER - PUMPABLE - CLEAR
	106206-01-000	EA SEALER - PUMPABLE - MANUS 30A - BLACK
	091255-02-000	FT SEAL - ADHESIVE BACKED/FOAM - .18" THICK X 1.5" WIDE
	104692-01-000	FT SEAL - FOAM/ADHESIVE BACK - .75"THICK X .75"WIDE X 25'
	112864-01-000	FT SEAL - FOAM/BUTYL COVERED - 3/8"
	110530-01-000	FT SEAL - SPONGE - .31" X .62"
	120074-02-01A	EA SEALANT - SILICONE - OFF WHITE

SEALANTS & FASTENERS GROUP (CONTINUED)

CLAMPS

KEY	PART NUMBER	U/M DESCRIPTION
	007161-01-000	EA CLAMP - HOSE - SPRING TYPE - 1/2"
	010495-01-000	EA CLAMP - CABLE - 9/16"
	010495-02-000	EA CLAMP - CABLE - 3/8"
	010497-01-000	EA CLAMP - CLOSED - 5/8" ID
	010497-03-000	EA CLAMP - CLOSED - 1" ID - CUSHIONED
	010497-04-000	EA CLAMP - CLOSED - 1.62" ID
	062401-01-000	EA CLAMP - HOSE - WORMGEAR - .25" - 1"
	062401-02-000	EA CLAMP - HOSE - WORMGEAR - 1.56" - 2.5"
	062401-03-000	EA CLAMP - HOSE - WORMGEAR - .22" - 1"
	062401-04-000	EA CLAMP - HOSE - WORMGEAR - .69" - 1.25"
	062401-05-000	EA CLAMP - HOSE - WORMGEAR - 2" TO 3" ID
	062401-06-000	EA CLAMP - HOSE - WORMGEAR - .22" - .62" ID
	062401-11-000	EA CLAMP - HOSE - WORMGEAR - 3.50" - 4.50"
	075148-02-000	EA CLAMP - GROUNDING - BRONZE SCREWS
	083609-01-000	EA CLAMP - WIRE - DUAL - EQUAL DIAMETERS - 5/8"
	083610-01-000	EA CLAMP - WIRE - DUAL - UNEQUAL DIAMETERS - 3/4" & 1 1/4"

RIVETS, GROMMETS AND MISCELLANEOUS FASTENERS

KEY	PART NUMBER	U/M DESCRIPTION
	000F10-06-32B	EA PIN - COTTER - 3/16" X 2" - ZINC
	000H14-04-04A	EA RIVET - MANDREL BLIND - 1/8 X .400
	000H16-04-06R	EA RIVET - POP ALUMINUM - 1/8 X .313 - .375
	000H16-06-10R	EA RIVET - POP ALUMINUM - 3/16 X .501-.625
	069592-02-000	EA RIVET-T - POP - 1/4 X .093 - .156
	016188-03-000	EA GROMMET - L/P LINE - 3/8" HOLE X 2 1/2" LONG - RUBBER
	016188-04-000	EA GROMMET-GASLINE,.50,2.5 LONG
	023942-01-000	EA GROMMET - RUBBER - 2" OD
	071015-11-000	EA GROMMET - 1.00 ID - FITS .12 MATERIAL
	071015-30-000	EA GROMMET - RUBBER - .31" ID X .81" OD W/.12" GROOVE - BLK
	008343-02-000	EA TIE - WIRE - 14"
	029094-04-000	YD VELCRO TAPE - LOOP - 1" WIDE - BLACK
	029096-03-000	YD VELCRO TAPE - HOOK - 1" WIDE - BLACK
	081211-03-000	EA PLUG - PLASTIC - .50 DIAMETER - BLACK
	081211-04-000	EA PLUG - PLASTIC - .46 DIAMETER - BLACK USED IN HOUSE CIRCUIT BREAKER PANELS
	081211-05-000	EA PLUG - PLASTIC - .188 DIAMETER - NATURAL
	085774-01-000	FT FASTENER - DUAL LOCK - 1" WIDE - ADHESIVE BACK - BLACK
	085774-02-000	FT FASTENER - DUAL HOOK - 1" WIDE - ADHESIVE BACK - BLACK
	110943-02-000	FT FELTSTRIP - 3/8" - ADHESIVE BACK - WHITE
	080734-02-000	EA CLIP - WIRE NYLON
	094362-02-000	EA CLIP - XMAS TREE - BINDER HEAD - .9" LONG

WATER & SEWAGE GROUP

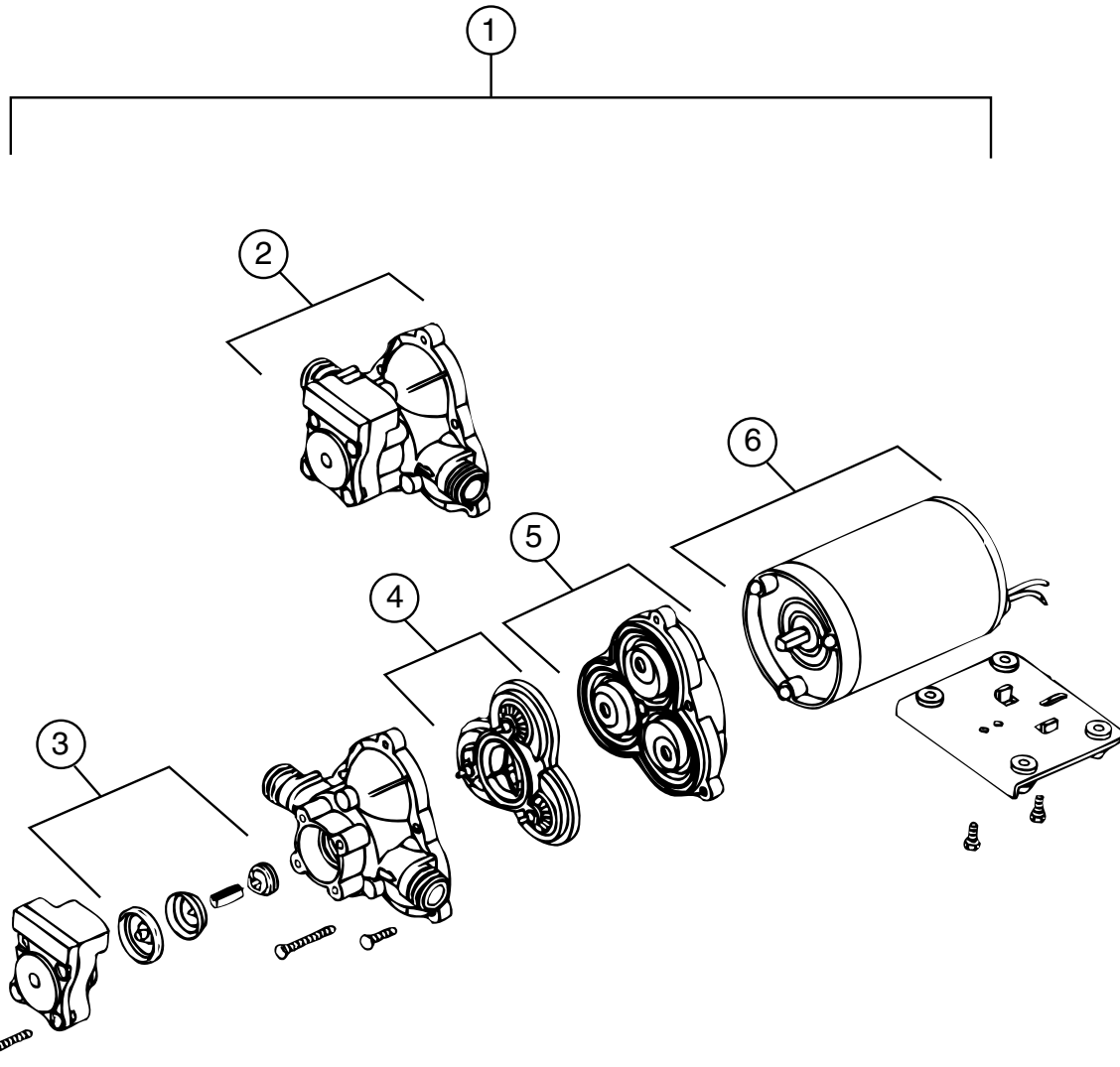

SHURFLO WATER PUMP

KEY	PART NUMBER	U/M DESCRIPTION	VENDOR NO.
1	098607-01-000	EA PUMP - WATER - W/.5" MPT FITTING - FLOW 2.8 GPM	
2	098607-01-706	EA HOUSING, W/SWITCH ONLY	94-231-20
3	098607-01-705	EA VALVE-CHECK, KIT	94-237-00
4	098607-01-703	EA VALVE KIT	94-232-00
5	098607-01-702	EA DIAPHRAGM/DRIVE ASSEMBLY KIT	94-238-04
6	098607-01-707	EA MOTOR W/BASEPLATE	11-148-04

WATER & SEWAGE GROUP (CONTINUED)

EXTERIOR SHOWER

KEY	PART NUMBER	U/M DESCRIPTION
	075241-06-000	EA FAUCET - SHOWER CONTROL - BRIGHT WHITE
	131383-01-02A	EA SHOWER HEAD - W/HOSE & BRACKET - 60" - WHITE
	131383-02-02A	EA SHOWER HEAD - W/HOSE & BRACKET - 60" - CSA - WHITE
	093527-02-000	EA BRACKET - EXTERIOR SHOWER HEAD/SQUEEGEE
		FROM: 00-00-00 THRU: 10-27-98
	131732-01-12B	EA BRACKET - SQUEEGEE - BRIGHT WHITE
		FROM: 10-28-98 THRU: 99-99-99
	108357-08-000	EA SWITCH - ROCKER DPDT - ON/NONE/ON - 6 TERMINAL - WATER PUMP
	108357-01-000	EA SWITCH - ROCKER SPST - ON/OFF - 2 TERMINAL - LIGHTS
	108356-02-01A	EA COVER/ACTUATOR SWITCH - 2 ROWS DIMPLES- CONTURA II - BLACK

WATER TANKS

KEY	PART NUMBER	U/M DESCRIPTION
	128015-03-000	EA TANK - WATER - 44 GALLON - W/FITTINGS - CHEVY & FORD 20,500# CHASSIS
	128015-04-000	EA TANK - WATER - 44 GALLON - W/FITTINGS - FORD 18,000# CHASSIS
	128015-01-000	EA TANK - WATER - 45 GALLON - W/O FITTINGS - CHEVY OR FORD CHASSIS
	118645-03-000	EA TANK - WATER - 17 GALLON - W/FITTINGS
	118645-01-000	EA TANK - WATER - 17 GALLON - W/O FITTINGS
	039861-01-000	EA SENDING UNIT - W/SCREW - WASHER - WELL NUT/TERMINAL RING
	044927-01-000	EA ADAPTER - HOSE TO PIPE-1 1/4 MPTX1 1/4 BARB-BLACK PLASTIC
	010219-01-000	EA ELBOW - 1 1/4 MPT X 1 1/4 BARB - WATER FILL - PLASTIC
	010224-01-000	EA ADAPTER - HOSE TO PIPE - 3/8 MPT X 3/8 BARB - PLASTIC
	042989-03-000	EA FITTING - SPINWELD - 1 1/4"NPT - PLASTIC
	042989-05-000	EA FITTING - SPINWELD - 1/2"FPT - PLASTIC
	049032-01-000	EA PATCH - SPINWELD - 3/8" - PLASTIC
	077954-02-000	EA FILTER - WATER TANK - W/SCREEN IN TANK
	074462-02-000	FT TUBING - VINYL - 3/8 ID X 20' - CLEAR
	079381-01-000	FT TUBING - RIBBED FLEXIBLE - WATER FILL - 1.4" X 10"
	112628-01-02A	EA BRACKET - TIEDOWN - WATER TANK - E-COATED

WATER SYSTEM

KEY	PART NUMBER	U/M DESCRIPTION
	110438-02-000	EA VALVE - CHECK - BRASS - 1/2 MPT X 1/2 MPT
	010230-06-000	EA FILL - CITY WATER - W/CHECK VALVE - MPT
	112176-01-000	FT TUBING - VINYL - REINFORCED - 1/2" ID
	113697-01-000	EA CAP - 3/8 FTG
	114428-01-000	EA TEE - 1/2"P X 1/2"P X 1/2"P
	114428-02-000	EA TEE - SWIVEL - 1/2"P X 1/2"P X 1/2"FPT
	114428-03-000	EA TEE - 1/2"P X 1/2"P X 1/2"MPT
	114429-01-000	EA ELBOW - 1/2"P X 1/2"P
	114429-02-000	EA ELBOW - 1/2"P X 1/2"MPT
	114429-03-000	EA ELBOW - SWIVEL - 1/2"P X 1/2"FPT
	114429-04-000	EA ELBOW - 1/2"P X 3/8"MPT
	114429-08-000	EA ELBOW - SWIVEL - 1/2"MPT X 1/2"FPT SWIVEL
	114430-02-000	EA ADAPTER - SWIVEL - 1/2"P X 1/2"FPT
	114430-03-000	EA ADAPTER - 1/2"P X 1/2"MPT
	114430-06-000	EA ADAPTER - 1/2"P X 3/8"FPT
	114431-01-000	EA VALVE - 180 DEGREE/CENTER DRAIN - 1/2"P - THREE WAY
	114431-02-000	EA VALVE - WATER BYPASS - 1/2"P - THREE WAY (WATER HEATER)
	114431-03-000	EA VALVE - 90 DEGREE DRAIN - 1/2"P
	123150-01-000	EA ELBOW - 1/2 FPT X 1/2 BARB - SWIVEL
	123152-01-000	EA ADAPTER - 1/2 FPT X 1/2 BARB - SWIVEL
	124184-01-000	EA SUPPORT - WATER LINE - BEND
	124188-01-000	FT TUBING - PEX - 1/2" ID X 20' - BLUE(COLD)
	124188-02-000	FT TUBING - PEX - 1/2" ID X 20' - RED(HOT)

ATWOOD WATER HEATER W/MOTOR AID (GH6-8E)

KEY	PART NUMBER	U/M DESCRIPTION
*	051393-01-000	EA WATER HEATER - GH6-8E - ELECTRONIC IGNITION W/MOTOR AID

*COMPONENT PARTS FOUND IN SERVICE PARTS LIBRARY

WATER & SEWAGE GROUP (CONTINUED)

DRAINAGE SYSTEM

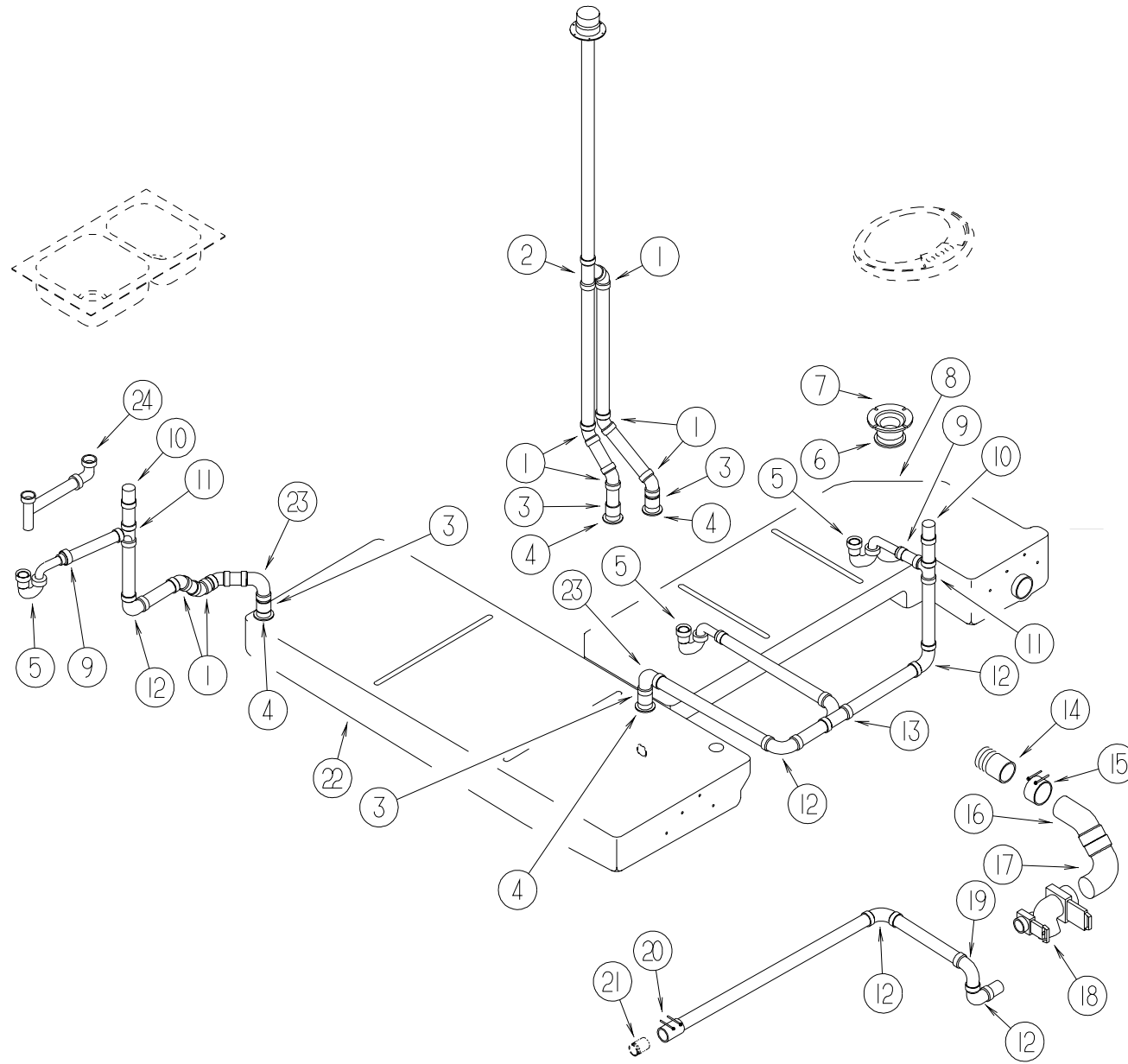

KEY	PART NUMBER	U/M	DESCRIPTION	VENDOR NO.
1	010006-01-000	EA	ELBOW - 45 DEGREE - 1 1/2" HUB X HUB - PLASTIC	
2	010073-01-000	EA	WYE - 45 DEGREE - 1 1/2" HUB X HUB X HUB - PLASTIC	
3	010115-01-000	EA	COUPLING - 1 1/2" HUB X HUB - PLASTIC	
4	061607-01-000	EA	GROMMET - HOLDING TANK - 1 1/2" NPS	
5	107538-01-000	EA	P TRAP - PLASTIC - 1 1/4" W/EXTENSION ARM	
5	011071-01-000	EA	P-TRAP - PLASTIC - 1 1/2" - CSA	
6	061607-02-000	EA	GROMMET - HOLDING TANK - 3" NPS	
7	116644-01-000	EA	FLANGE - CLOSET - 4" X 3"	
8	123055-01-700	EA	TANK-HOLDING 40 GAL-3"NIPPLE	PARTS SALES
9	039861-01-000	EA	SENDING UNIT - W/SCREW - WASHER - WELL NUT/TERMINAL RING	
9	109571-01-000	EA	ADAPTER - P TRAP - 1 1/2"P X 1 1/4"MPT - US	
10	079968-01-000	EA	VENT - MECHANICAL/TRAP ARM - ANTI-SIPHON-2" X 7.3" PLASTIC	
11	010071-01-000	EA	TEE - SANITARY - 1 1/2" HUB X HUB X HUB - PLASTIC	
12	010008-01-000	EA	ELBOW - 90 DEGREE - 1 1/2" HUB X HUB - PLASTIC	
13	031365-02-000	EA	TEE - PLASTIC - 1 1/2" EXTRA LONG TURN	
14	010129-03-000	EA	NIPPLE - PLASTIC - 3" X 3" TOE	
15	078406-01-000	EA	COUPLER - RUBBER - W/CLAMPS - 3" X 3"	
16	010061-01-000	EA	ELBOW - 45 DEGREE ST - 3" SPIGOT & HUB - PLASTIC	
17	041956-01-000	EA	ELBOW - 3" STREET - 90 DEGREE PLASTIC	
18	070916-01-000	EA	VALVE - DUAL DUMP - W/CAP - 3" X 1 1/2"	
	070916-01-700	EA	VALVE ONLY (WASTE) 3"	T1003BU
	070916-01-701	EA	VALVE ONLY (WASTE) 1 1/2"	T1001BU
	010201-01-000	EA	HOSE - SEWER - 3" ID X 8'	
	062416-01-000	EA	ADAPTER - SEWER HOSE TO 3" PIPE	
19	033761-01-000	EA	ELBOW - TURN - 90 DEGREE 1 1/2" HUB X 1 1/2" SPIGOT	
20	089355-01-000	EA	COUPLER - RUBBER - 1 1/2" X 1 1/2"	
21	102024-01-000	EA	NIPPLE - PLASTIC - 1.5" X 2.62" TOE	
22	127961-01-700	EA	TANK-HOLDING 54 GAL-1.5"ADAP	PARTS SALES
	039861-01-000	EA	SENDING UNIT - W/SCREW - WASHER - WELL NUT/TERMINAL RING	
23	034250-01-000	EA	ELBOW - 90 DEGREE - LONG TURN - 1 1/2" HUB X HUB - ABS	
24	011091-02-000	EA	WASTE - CONTINUOUS - DOUBLE SINK	
	011069-02-000	EA	TAILPIECE - TUB/SHOWER - 1 1/2" X 1 1/4" X 4" - BRASS	
	066729-01-000	EA	STRAINER - TUB/SHOWER W/PLUG - CHROME	
	127440-02-01A	EA	WASHER - RUBBER - 1.8" X .1"	
	130403-01-000	EA	NUT - SLIP - W/WINGS 1 1/2"	
	094756-02-01A	EA	BRACKET - L - 6.1" LONG X 3.9" WIDE - STEEL	

WINDOW, VENT & EXTERIOR DOOR GROUP

WINDOWS AND ROOF VENTS

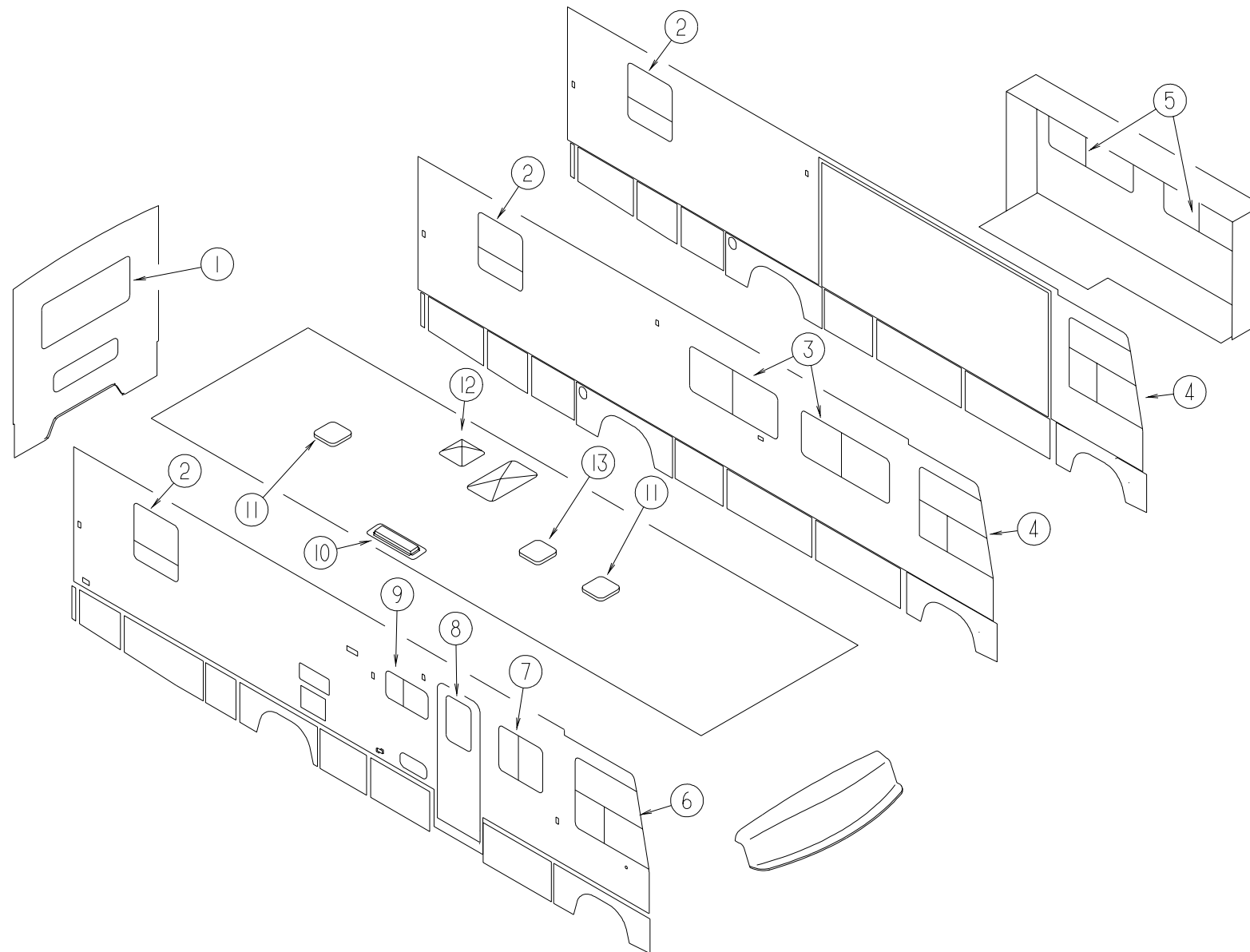

KEY	PART NUMBER	U/M	DESCRIPTION
1*	078528-06-E10	EA	WINDOW - ESCAPE - W/O RETAINER/TRIM - 48.5" X 24.5"
1*	113502-01-01A	EA	WINDOW - REAR/CENTER ESCAPE - THERMO - 24.8" X 48.7"
2*	112463-03-01A	EA	WINDOW - TIPOUT W/RETAINER TRIM - 33.3" X 30.2"
2*	112898-16-01A	EA	WINDOW - VERTICAL SLIDER - THERMO - 30.2" X 33.2"
3*	098647-22-01A	EA	WINDOW - DRIVER HORIZ SLIDER W/TRIM-TINTED - 26.1" X 59.7"
3*	112795-15-01A	EA	WINDOW - DRIVER HORIZONTAL SLIDER - THERMO - 26.4" X 60"
4*	125582-02-01A	EA	WINDOW - DRIVER CAB/3 WINDOW - 42.9"T X 42.6"H X 51.2"B
4*	125583-02-01A	EA	WINDOW - CAB DRVR-3 GLASS THERMO-42.9"T X 51.2"B X 42.6"H
5*	098647-47-01A	EA	WINDOW - DRIVER HORIZ SLIDER W/TRIM - TINTED-23.6" X 57.5"
5*	112795-54-01A	EA	WINDOW - DRIVER HORIZONTAL SLIDER - THERMO - 23.9" X 57.8"

KEY	PART NUMBER	U/M	DESCRIPTION
6*	125582-01-01A	EA	WINDOW - PASSENGER CAB/3 WINDOW - 42.9"T X 42.6"H X 51.2"B
6*	125583-01-01A	EA	WINDOW - CAB PASS-3 GLASS THERMO- 42.9"T X 51.2"B X 42.6"H
7*	098647-25-01A	EA	WINDOW - PASS HORIZ SLIDER W/TRIM - TINTED - 26.1" X 29.6"
7*	112795-18-01A	EA	WINDOW - PASSENGER HORIZ SLIDER - THERMO - 26.4" X 30"
8*	117053-02-F36	EA	WINDOW - PICTURE - 60% TINTING - 17" X 26.4"
8*	113733-01-01A	EA	WINDOW - STATIONARY THERMOPANE - 17" X 26.4"
9*	098647-33-01A	EA	WINDOW - PASS HORIZ SLIDER W/TRIM - TINTED - 15.7" X 28.5"
9*	112795-19-01A	EA	WINDOW - PASSENGER HORIZ SLIDER - THERMO - 15.7" X 28.5"
10	084073-04-000	EA	BASE - ROOF VENT/REFRIGERATOR - BLACK - NORCOLD
10	084073-07-000	EA	VENT - ROOF/REFRIGERATOR - BRIGHT WHITE - NORCOLD

*COMPONENT PARTS FOUND IN SERVICE PARTS LIBRARY

WINDOW, VENT & EXTERIOR DOOR GROUP (CONTINUED)

WINDOWS AND ROOF VENTS (CONTINUED)

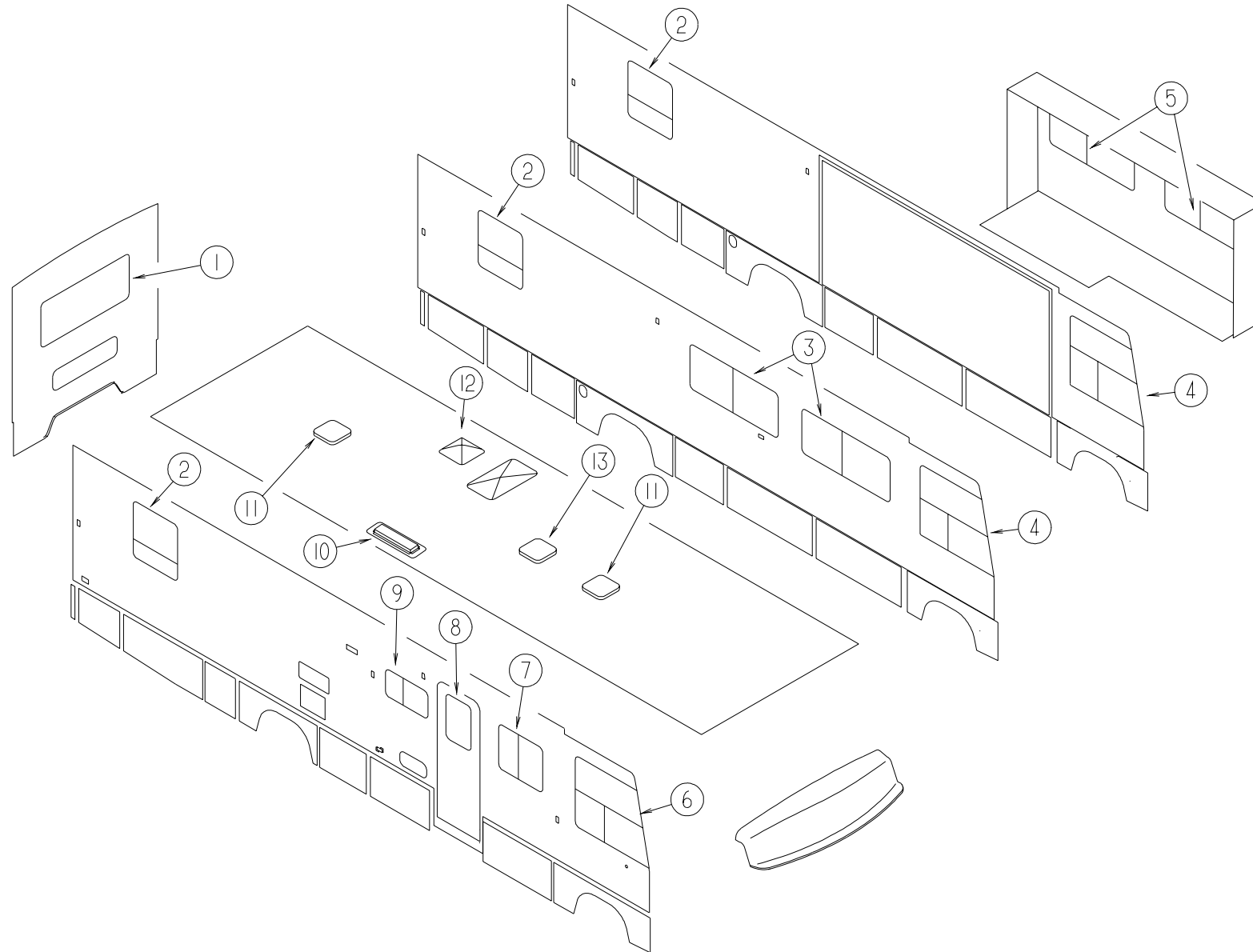

KEY	PART NUMBER	U/M	DESCRIPTION	VENDOR NO.
11*	122882-01-01A	EA	VENT - ROOF - NONPOWERED - W/O INSIDE GARNISH	
11	122882-07-01A	EA	GARNISH - ROOF VENT - 2.5" TO 4"	
12*	122882-02-01A	EA	VENT - ROOF - W/FAN - W/O INSIDE GARNISH - UL	
12*	122882-03-01A	EA	VENT - ROOF - W/FAN - W/O INSIDE GARNISH - CSA	
12	122882-07-01A	EA	GARNISH - ROOF VENT - 2.5" TO 4"	

KEY	PART NUMBER	U/M	DESCRIPTION	VENDOR NO.
13*	122882-01-01A	EA	VENT - ROOF - NONPOWERED - W/O INSIDE GARNISH	
13	122882-07-01A	EA	GARNISH - ROOF VENT - 2.5" TO 4"	
13*	123780-03-01A	EA	VENT - ROOF - 3" TO 4" - W/FAN/POWER LIFT - W/O THERMOSTAT	
	083558-03-000	EA	VENT - PLUMBING - ROOF PIPE COVERED - OFF WHITE	
	084616-07-000	EA	SHROUD - EXHAUST VENT/RANGE HOOD - BRIGHT WHITE	
	084878-09-000	EA	VENT - EXHAUST/RANGE HOOD - OFF WHITE	
	117046-01-000	EA	BUMPER - RUBBER/ROUND END - THERMOPANE WINDOW OPTION	

*COMPONENT PARTS FOUND IN SERVICE PARTS LIBRARY

WINDOW, VENT & EXTERIOR DOOR GROUP (CONTINUED)

EXTERIOR DOORS & PANELS

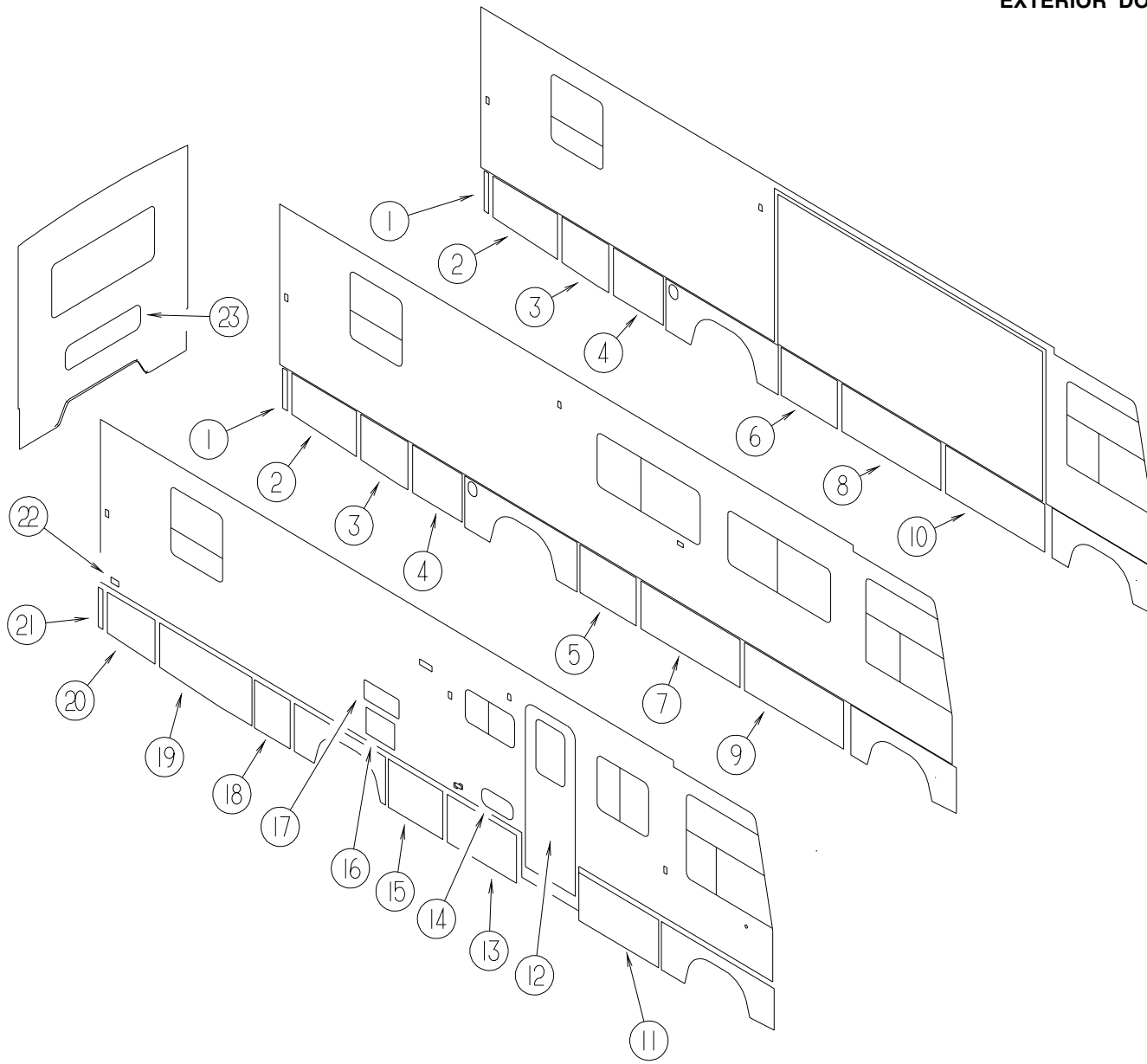

KEY	PART NUMBER	U/M DESCRIPTION	VENDOR NO.
1	126645-15-K20	EA VALANCE/PANEL - REAR DRIVER - W/O HARDWARE	
2	126647-13-J37	EA VALANCE/DOOR - DRIVER W/O LATCH - 22.7" X 39.8" X 20.7"	
3	126647-15-J37	EA VALANCE/DOOR - DRIVER W/O LATCH - 23.7" X 29.6" X 22.8"	
4	126646-34-K20	EA VALANCE/DOOR - W/O PADDLE LATCH - 31.4"W X 23.7"H	
5	126646-29-J37	EA VALANCE/DOOR - W/O PADDLE LATCH - 29.2"W X 23.7"H	
6	126646-25-J37	EA VALANCE/DOOR - W/O PADDLE LATCH - 35.1"W X 23.7"H	
7	126646-28-J37	EA VALANCE/DOOR - W/O PADDLE LATCH - 77.5"W X 23.7"H	
			FROM: 00-00-00 THRU: 09-20-98
7	122239-C7-K20	EA VALANCE/DOOR - W/O PADDLE LATCH/HINGE - 77.5"W X 23.7"H	
			FROM: 09-21-98 THRU: 99-99-99
8	126646-24-J37	EA VALANCE/DOOR - W/O PADDLE LATCH - 50"W X 23.7"H	
			FROM: 00-00-00 THRU: 09-20-98
8	122239-C5-K20	EA VALANCE/DOOR - W/O PADDLE LATCH/HINGE - 60"W X 23.7"H	
			FROM: 09-21-98 THRU: 99-99-99
9	126646-21-J37	EA VALANCE/DOOR - W/O PADDLE LATCH - 48.7"W X 23.7"H	
			FROM: 00-00-00 THRU: 09-20-98
9	122239-C8-K20	EA VALANCE/DOOR - W/O PADDLE LATCH/HINGE - 48.7"W X 34.1"H	
			FROM: 09-21-98 THRU: 99-99-99
10	126646-24-J37	EA VALANCE/DOOR - W/O PADDLE LATCH - 50"W X 23.7"H	
			FROM: 00-00-00 THRU: 09-20-98
10	122239-C5-K20	EA VALANCE/DOOR - W/O PADDLE LATCH/HINGE - 60"W X 23.7"H	
			FROM: 09-21-98 THRU: 99-99-99
11	126646-21-J37	EA VALANCE/DOOR - W/O PADDLE LATCH - 48.7"W X 23.7"H	
12	115108-10-J25	EA DOOR - ENTRY - W/SCREEN DOOR - W/O WINDOW (K20)	
12	115108-10-K21	EA DOOR - ENTRY - W/SCREEN DOOR - W/O WINDOW (K21,K23)	
12	115108-10-J30	EA DOOR - ENTRY - W/SCREEN DOOR - W/O WINDOW (K22)	
13	126646-22-J37	EA VALANCE/DOOR - W/O PADDLE LATCH - 42.5"W X 23.7"H	
14	126945-01-J22	EA DOOR/STORAGE - W/O HARDWARE - 18" X 8.3"	
15	126646-31-K20	EA VALANCE/DOOR - W/O PADDLE LATCH - 34.1"W X 23.7"H	
			FROM: 00-00-00 THRU: 08-30-98
15	126646-23-J37	EA VALANCE/DOOR - W/O PADDLE LATCH - 34.1"W X 23.7"H	
			FROM: 08-31-98 THRU: 99-99-99
16	052009-06-000	EA DOOR - WATER HEATER - BRIGHT WHITE - 18" X 14.6"	
17	084103-08-000	EA DOOR - VENT/REFRIGERATOR - W/O JAMB - BRIGHT WHITE	
	084104-01-700	EA LOCK-MALE, FASTENER	201-721-010
	084104-01-701	EA LOCK-FEMALE, FASTENER	201-802-010
17	084104-08-000	EA JAMB - VENT DOOR/REFRIGERATOR - BRIGHT WHITE	
18	122776-37-K20	EA VALANCE/PANEL - W/O HARDWARE - 33.4"W X 24"H	
19	126647-18-K20	EA VALANCE/DOOR - PASS W/O LATCH - 22.3" X 35.1" X 23.7"	
20	126647-19-K20	EA VALANCE/DOOR - PASS W/O LATCH - 20.5" X 33.4" X 22.2"	
21	126645-14-K20	EA VALANCE/PANEL - REAR DRIVER - W/O HARDWARE	
22	081240-16-000	EA DOOR - WATER FILL - W/O LOCK - 4" X 4 5/8"	
			FROM: 00-00-00 THRU: 09-12-98
22	081240-20-000	EA FILL - WATER - LOCKABLE - BRIGHT WHITE	
			FROM: 09-13-98 THRU: 99-99-99
23	126944-02-J22	EA DOOR/STORAGE - W/O HARDWARE - 43.5" X 11.7" - QUEEN BED	
	117047-01-000	EA BUMPER - RUBBER - WASHER INSERT	

WINDOW, VENT & EXTERIOR DOOR GROUP (CONTINUED)

ENTRANCE DOOR

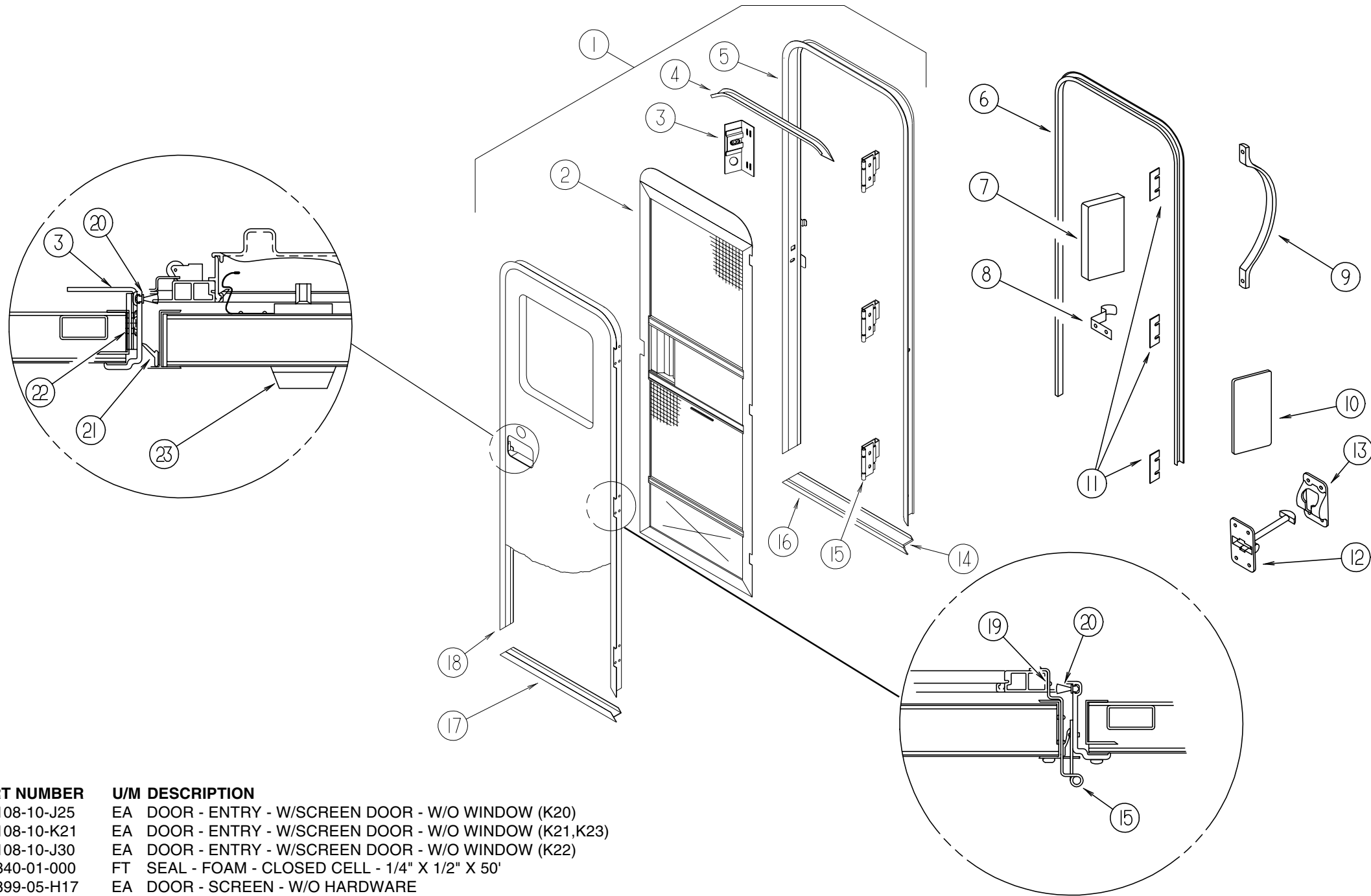

KEY	PART NUMBER	U/M	DESCRIPTION
1	115108-10-J25	EA	DOOR - ENTRY - W/SCREEN DOOR - W/O WINDOW (K20)
1	115108-10-K21	EA	DOOR - ENTRY - W/SCREEN DOOR - W/O WINDOW (K21,K23)
1	115108-10-J30	EA	DOOR - ENTRY - W/SCREEN DOOR - W/O WINDOW (K22)
	090340-01-000	FT	SEAL - FOAM - CLOSED CELL - 1/4" X 1/2" X 50'
2	121899-05-H17	EA	DOOR - SCREEN - W/O HARDWARE
3	041546-07-000	EA	BRACKET - DOOR ANGLE - OFF WHITE
4	044582-50-000	EA	CAP - DRIP JAMB MITERED
5	121898-09-01A	EA	JAMB - ENTRY DOOR - BRIGHT WHITE
6	115222-12-02A	EA	GARNISH - RADIUS - ENTRY DOOR
7	077461-03-000	EA	COVER - STRIKE - ENTRY DOOR - 6.5" X 2.5" - WHITE PLASTIC
8	100412-01-000	EA	CATCH - SCREEN DOOR
9	009126-03-000	EA	HANDLE - ASSIST - BLACK TEXTURED
10	076725-02-000	EA	COVER - HINGE - ENTRY DOOR - 6" X 3.2" - OFF WHITE
11	102248-01-000	EA	SHIM - DOOR
12	104099-01-04A	EA	CATCH - DOOR HOLDER - STRIKE - BRIGHT WHITE
13	104099-02-04A	EA	CATCH - DOOR HOLDER - RETAINER - BRIGHT WHITE
14	038327-01-000	EA	TAPE - ANTI-SLIP - 2" X 60'
15	106719-01-05A	EA	HINGE - ENTRY DOOR - BRIGHT WHITE
15	106719-01-01A	EA	HINGE - ENTRANCE DOOR - MILL
	116111-02-01A	EA	SCREW - TAPTITE - 1/4-20 X 3/8 PPH - ZINC
	039715-01-000	EA	NUT-SERT - 1/4" DIAMETER - 20 THREADS

KEY	PART NUMBER	U/M	DESCRIPTION	VENDOR NO.
16	051049-05-000	EA	JAMB/DOOR - LOWER - ENTRANCE DOOR	
17	121893-03-02A	EA	FRAME - ENTRY DOOR/LOWER - BRIGHT WHITE	
18	121894-11-01A	EA	FRAME - ENTRY DOOR - BRIGHT WHITE	
	098173-01-04A	EA	STIFFENER - ENTRY DOOR - SUPPORTS LATCH/STRIKE/UNPAINTED	
19	100128-02-000	FT	SEAL - FOAM/ADHESIVE BACK - .37" WIDE X .37" THICK	
20	118929-01-01A	FT	SEAL - PILE - PUSH ON	
21	075671-04-000	FT	SEAL - SPONGE - LAZY T - W/ADHESIVE STRIP - .5" WIDE	
22	104692-01-000	EA	SEAL - FOAM/ADHESIVE BACK - .75"THICK X .75"WIDE X 25'	
23	101145-01-06A	EA	DEADBOLT - ENTRY DOOR W/O SECURITY BOLT W/2 KEYS - BLACK	
	101147-01-000	EA	BOLT - SECURITY - 4.12"	
	095229-01-700	EA	KEY-BLANK, DEADBOLT	81205-03
	101145-01-701	EA	CYLINDER-LOCK ASM., W/KEY	81306-03

WINDOW, VENT & EXTERIOR DOOR GROUP (CONTINUED)

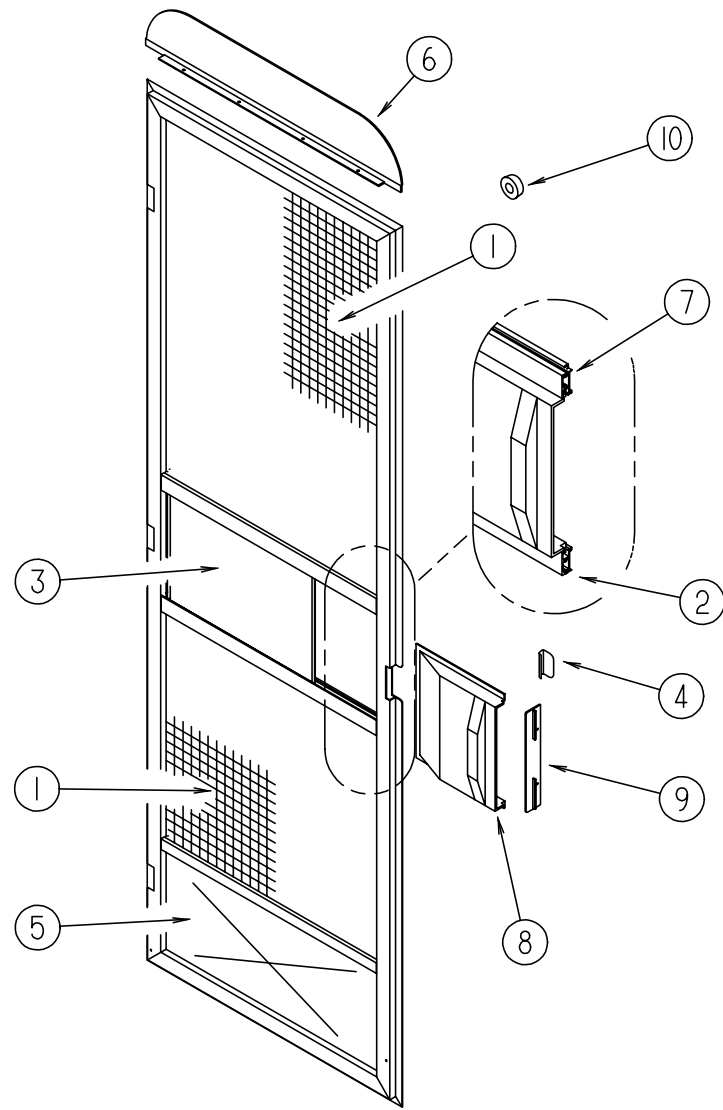

SCREEN DOOR

KEY	PART NUMBER	U/M	DESCRIPTION
	121899-05-H17	EA	DOOR - SCREEN - W/O HARDWARE
1	002293-02-000	SF	SCREENING - WINDOW/DOOR - 26" - CHARCOAL
2	002294-01-000	FT	SPLINE - SCREENING - .135" X .138"
3	016454-15-000	EA	INSERT - SCREEN DOOR - CENTER
4	050712-06-000	EA	HANDLE - SCREEN DOOR - BRIGHT WHITE
5	078552-09-000	EA	INSERT - SCREEN DOOR - LOWER
6	078595-03-000	EA	PLATE - SCREEN DOOR
7	078777-08-000	FT	CHANNEL - SLIDER
8	079086-03-000	EA	SLIDER - SCREEN DOOR - BRIGHT WHITE
9	079087-03-000	EA	STRIKE - SLIDER - SCREEN DOOR - BRIGHT WHITE
10	120863-05-000	EA	BUMPER - RUBBER - 3/4" X 3/8"
	075673-05-000	FT	SEAL - PILE - ADHESIVE BACK - BLACK

WINDOW, VENT & EXTERIOR DOOR GROUP (CONTINUED)

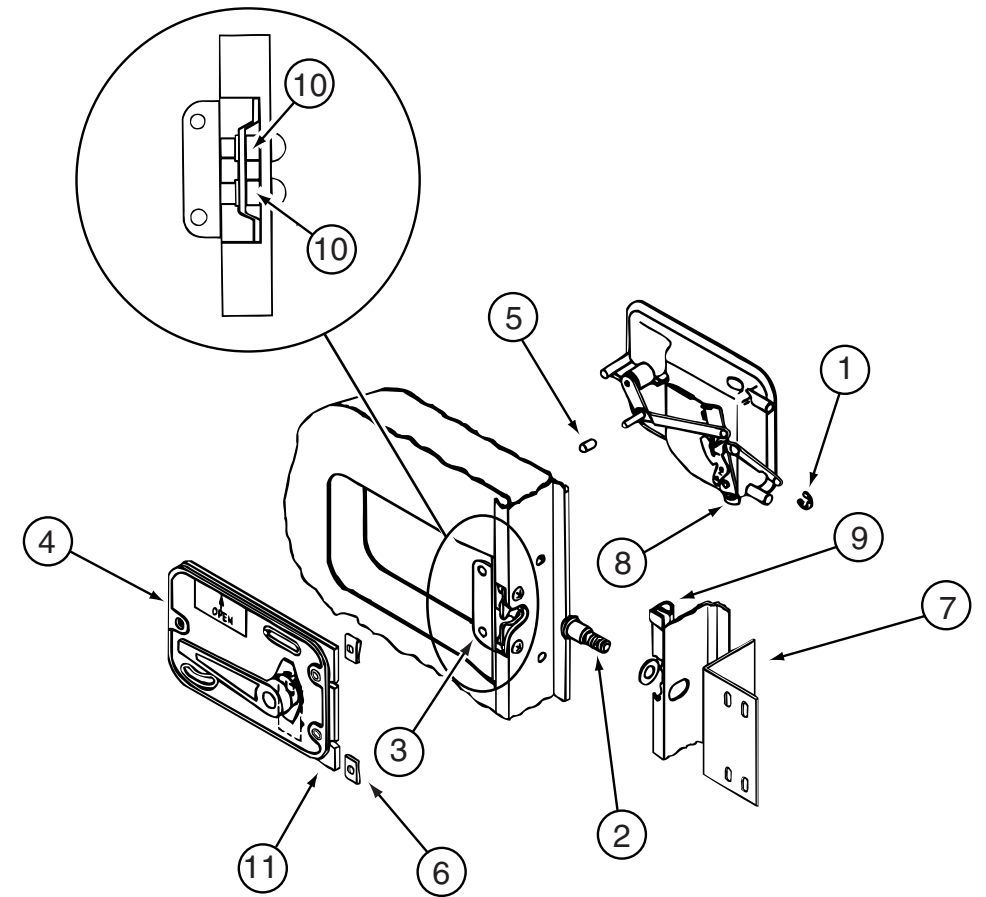

ENTRY DOOR LOCK INSTALLATION

KEY	PART NUMBER	U/M	DESCRIPTION	VENDOR NO.
1	036618-02-000	EA	E-RING - EXTERNAL - 3/16" SHAFT DIAMETER - LYNOR DOOR LOCK	
2	039539-01-000	EA	STRIKE - LOCK - ENTRY DOOR - ROUND W/THREADED WASHER	
3	039540-01-000	EA	LATCH MECHANISM - HOOK - ENTRY DOOR - INTERIOR	
4	039979-06-000	EA	COVER - LATCH PLATE - RIGHT HAND - BLACK TEXTURED	
5	039984-01-000	EA	CAP - ROUND - VINYL - .28" ID X .62" - BLACK	
6	040921-01-000	EA	NUT - SPEED - U TYPE - 10-24 BLACK	
7	041546-07-000	EA	BRACKET - DOOR ANGLE - OFF WHITE	
8	045017-13-000	EA	LATCH - ENTRY DOOR - BLACK TEXTURED	
	045017-11-703	EA	CYLINDER-LOCK ASM. W/KEYS	81266-09
	045017-11-701	EA	KEY - BLANK (F1 SERIES) "K-104" - DOOR LOCK (TM 200 - 250)	
	130444-01-01A	EA	CAP - KEY IDENTIFIER - GRAY	
9	064075-07-000	FT	SEAL - BULB - W/WIRED U CHANNEL - .3" X .5" CHANNEL - BLACK	
10	086285-05-000	EA	SPACER - NYLON - .7" X .56"	
11	096810-01-01A	EA	PLATE - LATCH - ENTRY DOOR - BLACK	

WINDOW, VENT & EXTERIOR DOOR GROUP (CONTINUED)

EXTERIOR ACCESS DOOR COMPONENTS

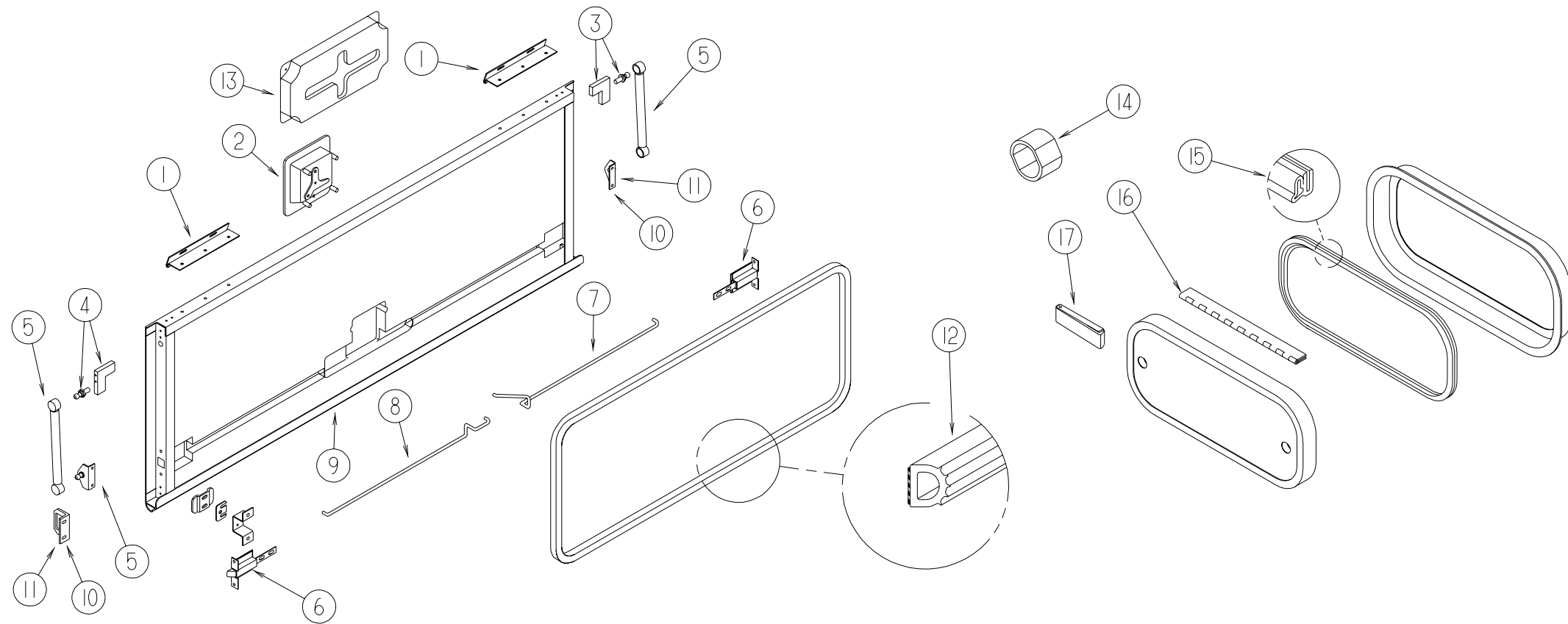

KEY	PART NUMBER	U/M	DESCRIPTION
1	131271-01-04A	EA	HINGE - VALANCE DOOR - BRIGHT WHITE
2	112949-01-03A	EA	LATCH - PADDLE W/LOCK - W/O KEY - BRIGHT WHITE
	112949-03-000	EA	KEY - TRI-MARK #TM500
2	112949-02-04A	EA	LATCH - PADDLE NON-LOCKING - BRIGHT WHITE
3	123892-10-02B	EA	CORNER STABILIZER W/BALL STUD - RIGHT HAND - E-COATED
4	123892-12-02B	EA	CORNER STABILIZER W/BALL STUD - LEFT HAND - E-COATED
5	107796-24-000	EA	SPRING/GAS - 11.3" COMPRESSED/18.5" EXTENDED - 60 LB.
			FROM: 00-00-00 THRU: 09-20-98
5	107796-20-000	EA	SPRING/GAS - 7" COMPRESSED/10" EXTENDED - 60 LB
			FROM: 09-21-98 THRU: 99-99-99
	126263-02-02B	EA	BRACKET - GAS SPRING
6	121947-01-01A	EA	BOLT - SLIDE W/PLASTIC PLUNGER
7	122269-07-000	EA	ROD - LATCH - 16.63"
7	122269-10-000	EA	ROD - LATCH - 31.03"
7	122269-12-000	EA	ROD - LATCH - 22.28"
7	122269-16-000	EA	ROD - LATCH - 8.96"
7	122269-32-000	EA	ROD - LATCH - 6.89"
7	122269-35-000	EA	ROD - LATCH - 7.09"
7	122269-36-000	EA	ROD - LATCH - 12.18"
7	122269-52-000	EA	ROD - LATCH - 13.54"
7	122269-55-000	EA	ROD - LATCH - 7.95"
7	122269-59-000	EA	ROD - LATCH - 9.84"
7	122269-66-000	EA	ROD - LATCH - 9.32"
8	122268-07-000	EA	ROD - LATCH - 16.63"
8	122268-10-000	EA	ROD - LATCH - 31.03"
8	122268-12-000	EA	ROD - LATCH - 22.28"
8	122268-16-000	EA	ROD - LATCH - 8.96"
8	122268-32-000	EA	ROD - LATCH - 6.89"
8	122268-35-000	EA	ROD - LATCH - 7.1"
8	122268-36-000	EA	ROD - LATCH - 12.18"

KEY	PART NUMBER	U/M	DESCRIPTION
8	122268-52-000	EA	ROD - LATCH - 13.54"
8	122268-55-000	EA	ROD - LATCH - 7.95"
8	122268-66-000	EA	ROD - LATCH - 9.3"
8	122268-67-000	EA	ROD - LATCH - 9.8"
9	122613-55-001	EA	ROCKER PANEL/EXTRUSION - 192" - BRIGHT WHITE
10	123783-01-01A	EA	STRIKER - DOOR - MILL
			FROM: 00-00-00 THRU: 02-01-99
11	130053-01-01A	EA	STRIKER - LUGGAGE DOOR - FLUSH - BLACK
			FROM: 02-02-99 THRU: 99-99-99
11	130053-02-01A	EA	STRIKER - LUGGAGE DOOR - OFF SET - BLACK
			FROM: 02-02-99 THRU: 99-99-99
12	107721-07-000	FT	SEAL - ACCESS DOOR
13	122277-02-01A	EA	COVER - LATCH - BLACK
14	107997-51-001	EA	SPACER - DOOR LOCK - .6" DEEP
14	107997-51-002	EA	EXTRUDED - SPACER - 16'
15	106850-02-000	FT	SEAL-E - SPONGE RUBBER - .43" X .75"
16	081801-V3-000	EA	HINGE - ALUMINUM - 2" X 96" - BRIGHT WHITE
17	102768-01-000	EA	HOLDER - COMPARTMENT/ENTRY DOOR - METAL - MILL FINISH
	098408-01-000	FT	SEAL - SPONGE RUBBER - CLOSED CELL
	099069-01-000	FT	SEAL - RUBBER - CLOSED SPONGE - .5" WIDE X .12" THICK -BLK
	123512-01-02B	EA	BRACKET - VALANCE DOOR - E-COATED
	116424-01-000	EA	PROTECTOR - LATCH - WATER HEATER
	120863-05-000	EA	BUMPER - RUBBER - 3/4" X 3/8"
	122614-55-001	EA	H-CHANNEL/EXTRUSION - 192" - BRIGHT WHITE
	122612-55-001	EA	U-CHANNEL/EXTRUSION - 192" - BRIGHT WHITE
	126694-55-001	EA	EXTRUSION - U-CHANNEL/HINGED - 191.7" - BRIGHT WHITE
	126516-01-01A	FT	TRIM - VINYL/EXTRUDED - 96"
	128298-01-12B	EA	CATCH - F/LOCK - COMPARTMENT DOORS

WINDOW, VENT & EXTERIOR DOOR GROUP (CONTINUED)

BRIGGS & STRATTON LOCKS & COMPONENTS

NOTE:
 WHEN ORDERING THE LOCK CASE, THE KEY CODE MUST MATCH THE LAST DIGIT OF THE UNIT'S SERIAL NUMBER AND PART NUMBER; WHEN ORDERING THE KEYS, THE THIRD DIGIT OF THE KEY CODE MUST MATCH THE LAST DIGIT OF THE UNIT'S SERIAL NUMBER AND PART NUMBER.

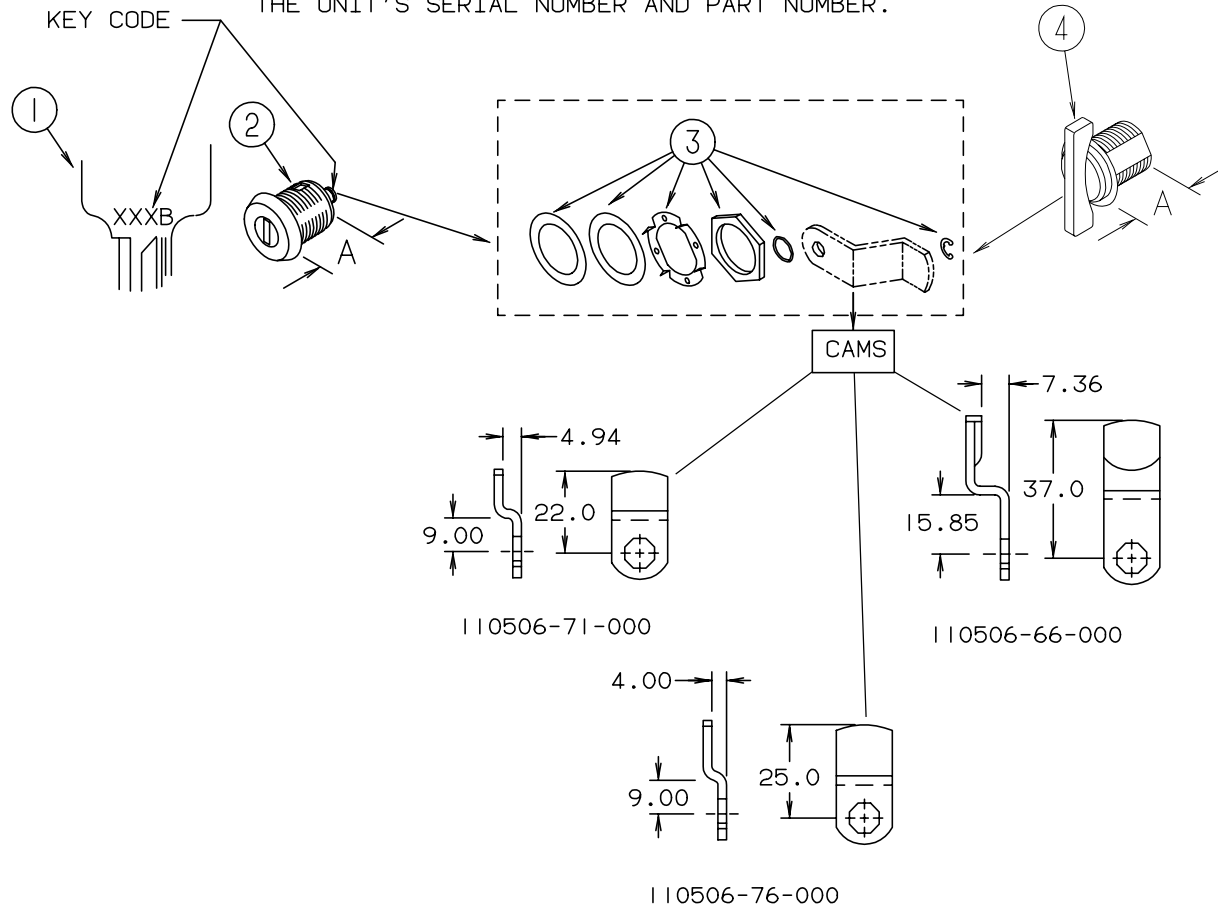

KEY	PART NUMBER	U/M	DESCRIPTION	VENDOR NO.
1	110506-59-000	EA	KEYS - SET OF TWO	596720
2	110506-52-000	EA	CASE/CYLINDER - LOCKING W/O CAM - .65"	702370
2	110506-54-000	EA	CASE/CYLINDER - LOCKING W/O CAM OR KEY - 1 1/4"	703170
1	110506-59-001	EA	KEYS - SET OF TWO	596721
2	110506-52-001	EA	CASE/CYLINDER - LOCKING W/O CAM - .65"	702371
2	110506-54-001	EA	CASE/CYLINDER - LOCKING W/O CAM OR KEY - 1 1/4"	703171
1	110506-59-002	EA	KEYS - SET OF TWO	596722
2	110506-52-002	EA	CASE/CYLINDER - LOCKING W/O CAM - .65"	702372
2	110506-54-002	EA	CASE/CYLINDER - LOCKING W/O CAM OR KEY - 1 1/4"	703172
1	110506-59-003	EA	KEYS - SET OF TWO	596723
2	110506-52-003	EA	CASE/CYLINDER - LOCKING W/O CAM - .65"	702373
2	110506-54-003	EA	CASE/CYLINDER - LOCKING W/O CAM OR KEY - 1 1/4"	703173
1	110506-59-004	EA	KEYS - SET OF TWO	596724
2	110506-52-004	EA	CASE/CYLINDER - LOCKING W/O CAM - .65"	702374
2	110506-54-004	EA	CASE/CYLINDER - LOCKING W/O CAM OR KEY - 1 1/4"	703174
1	110506-59-005	EA	KEYS - SET OF TWO	596725
2	110506-52-005	EA	CASE/CYLINDER - LOCKING W/O CAM - .65"	702375
2	110506-54-005	EA	CASE/CYLINDER - LOCKING W/O CAM OR KEY - 1 1/4"	703175
1	110506-59-006	EA	KEYS - SET OF TWO	596726
2	110506-52-006	EA	CASE/CYLINDER - LOCKING W/O CAM - .65"	702376
2	110506-54-006	EA	CASE/CYLINDER - LOCKING W/O CAM OR KEY - 1 1/4"	703176
1	110506-59-007	EA	KEYS - SET OF TWO	596727
2	110506-52-007	EA	CASE/CYLINDER - LOCKING W/O CAM - .65"	702377
2	110506-54-007	EA	CASE/CYLINDER - LOCKING W/O CAM OR KEY - 1 1/4"	703177
1	110506-59-008	EA	KEYS - SET OF TWO	596728
2	110506-52-008	EA	CASE/CYLINDER - LOCKING W/O CAM - .65"	702378
2	110506-54-008	EA	CASE/CYLINDER - LOCKING W/O CAM OR KEY - 1 1/4"	703178
1	110506-59-009	EA	KEYS - SET OF TWO	596729
2	110506-52-009	EA	CASE/CYLINDER - LOCKING W/O CAM - .65"	702379
2	110506-54-009	EA	CASE/CYLINDER - LOCKING W/O CAM OR KEY - 1 1/4"	703179
3	110506-40-700	EA	HARDWARE PACKAGE-CYLINDER/CASE	596950AAL
	110506-59-701	EA	KEY BLANK (GOLD)	596728
4	110506-55-000	EA	CASE/CYLINDER - TWIST LOCK - W/O CAM - 1.25"	597312AA1

WINDSHIELD & WIPER GROUP

WIPER & WASHER COMPONENTS

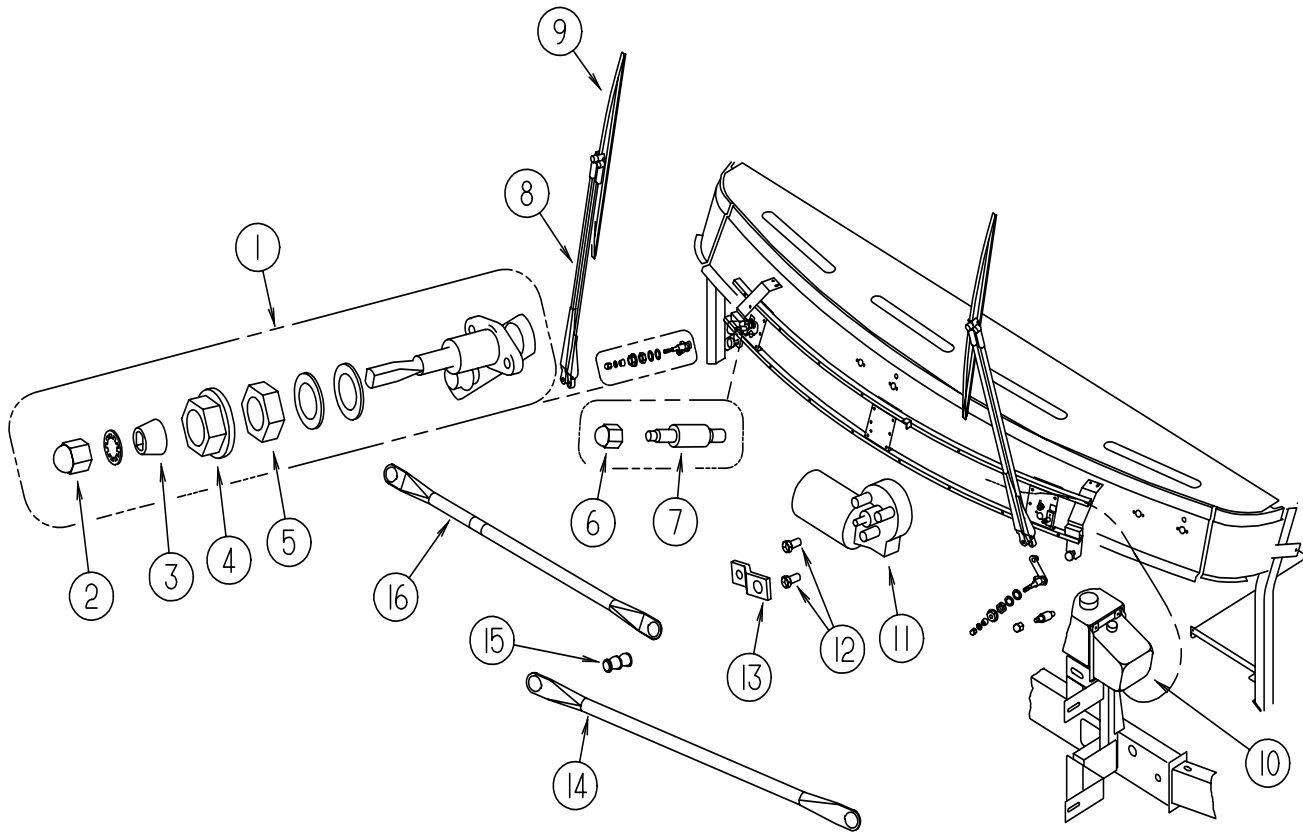

KEY	PART NUMBER	U/M	DESCRIPTION	VENDOR NO.
1	096505-09-000	EA	SHAFT/PIVOT - WINDSHIELD WIPER	
2	096505-02-703	EA	CAP-NUT(ACORN) HD W/.687 BRL	51065-40-NT27WC
3	096505-02-700	EA	DRIVER-KNURLED,(HD) BRL .687	NT721017
4	096505-02-702	EA	CAP-RUBBER (HD) BARREL .687	CP721084
5	096505-02-701	EA	NUT-HEX (HD) W/.687 BARREL	NT721021
6	077049-02-000	EA	NUT - ACORN - 10-32 BLACK/ANODIZED	
7	117768-01-000	EA	SHAFT - ADAPTER - PANTOGRAPH ARM	
8	117769-01-000	EA	ARM - WIPER - PANTOGRAPH - 28"	
	096931-01-700	FT	HOSE-WIPER	XTU-66-0001
	096931-01-701	EA	NOZZLE-HARDWARE KIT	
9	095964-01-000	EA	BLADE - WINDSHIELD WIPER - 24"	
	095964-01-700	EA	BLADE-REFILL 24" EA= 1 PAIR	12360
10	117766-02-000	EA	RESERVOIR/PUMP - WINDSHIELD WASHER	
	045794-01-000	FT	HOSE - WASHER - WINDSHIELD - 5/32" ID - BLACK	
	110605-01-000	EA	TEE - PLASTIC - BARBED - 1/8" X 1/8" X 3/16"	
	117765-03-000	EA	CONNECTOR - 5/32" - WINDSHIELD WASHER	
11	104346-05-000	EA	WIPER MOTOR - W/INTERNAL BREAKER - DYNAMIC PARK - FORD	
	125829-02-02B	EA	BRACKET - WIPER MOTOR - E-COATED	
11	104346-04-000	EA	WIPER MOTOR - "COAST TO PARK" W/BKR - W/GRN/RED/WHITE WIRE - CHEVY	
12	117322-01-000	EA	SCREW - 1/4-28 UNFINISHED - 2A - TORX	
13	104347-04-000	EA	ARM - DRIVE - WIPER MOTOR	
14	117770-01-000	EA	LINK - CONNECTING - 24" - CLOSED GROMMET/OPEN GROMMET	
15	067188-01-000	EA	STUD - CRANK - WIPER MOTOR	
16	117770-02-000	EA	LINK - CONNECTING - 24" - CLOSED GROMMET/CLOSED GROMMET	
	061603-01-000	EA	GROMMET - SNAP - 3/16"ID - 3/8" HOLE - PLASTIC BLACK	
	110742-02-000	EA	GASKET - NEOPRENE - WIPER ADAPTER SHAFT - .5" ID X .9" OD	

WINDSHIELD & WIPER GROUP (CONTINUED)

WINDSHIELD MOLDINGS & GLASS

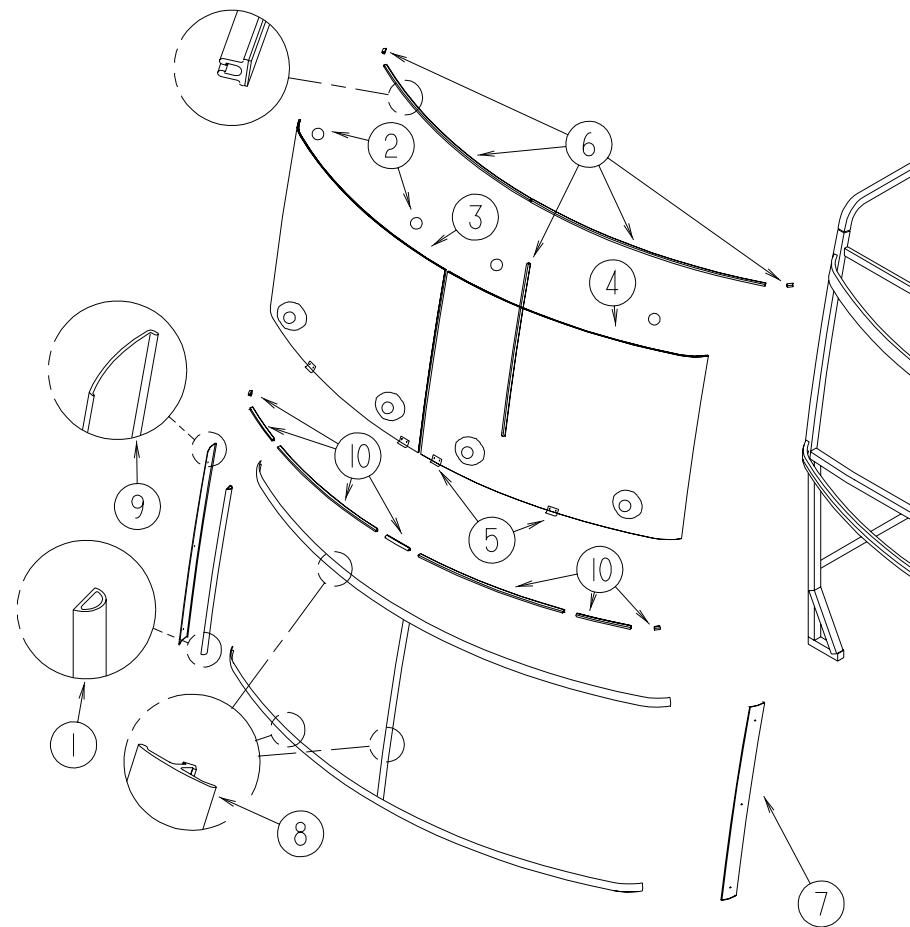

KEY	PART NUMBER	U/M	DESCRIPTION
1	099418-01-000	FT	SEAL - D-SECTION/ADHESIVE BACK - .44" X .44"- BLK RUBBER
2	081914-01-000	EA	BUMPER - RUBBER - ROUND - .43" DIAMETER
3	124328-01-000	EA	WINDSHIELD - PASSENGER - 52" X 41" (CURVED)
4	124328-02-000	EA	WINDSHIELD - DRIVERS - 52" X 41" (CURVED)
5	002328-02-000	EA	BLOCK - WINDSHIELD - .062" X .5" X .98"
6	127862-01-000	EA	CARRIER - REVEAL - WINDSHIELD - 47.2"
7	125384-02-02A	EA	TRIM - WINDSHIELD - A-PILLAR - DRIVER - BLACK
8	120533-01-000	FT	MOLDING - REVEAL - WINDSHIELD
9	125384-01-02A	EA	TRIM - WINDSHIELD - A-PILLAR - PASSENGER - BLACK
10	117335-01-000	EA	CARRIER/REVEAL - 94.6" W/ADHESIVE BACKING