

1997 ICG34WA

**H37 COZUMEL (BLUE / MULTI)
(MAPLE)**

**H47 COZUMEL (BLUE / MULTI)
(OAK)**

**H38 FOREST FLOOR (TAUPE)
(MAPLE)**

**H48 FOREST FLOOR (TAUPE)
(OAK)**

**H39 REGENCY (BLUE)
(MAPLE)**

**H49 REGENCY (BLUE)
(OAK)**

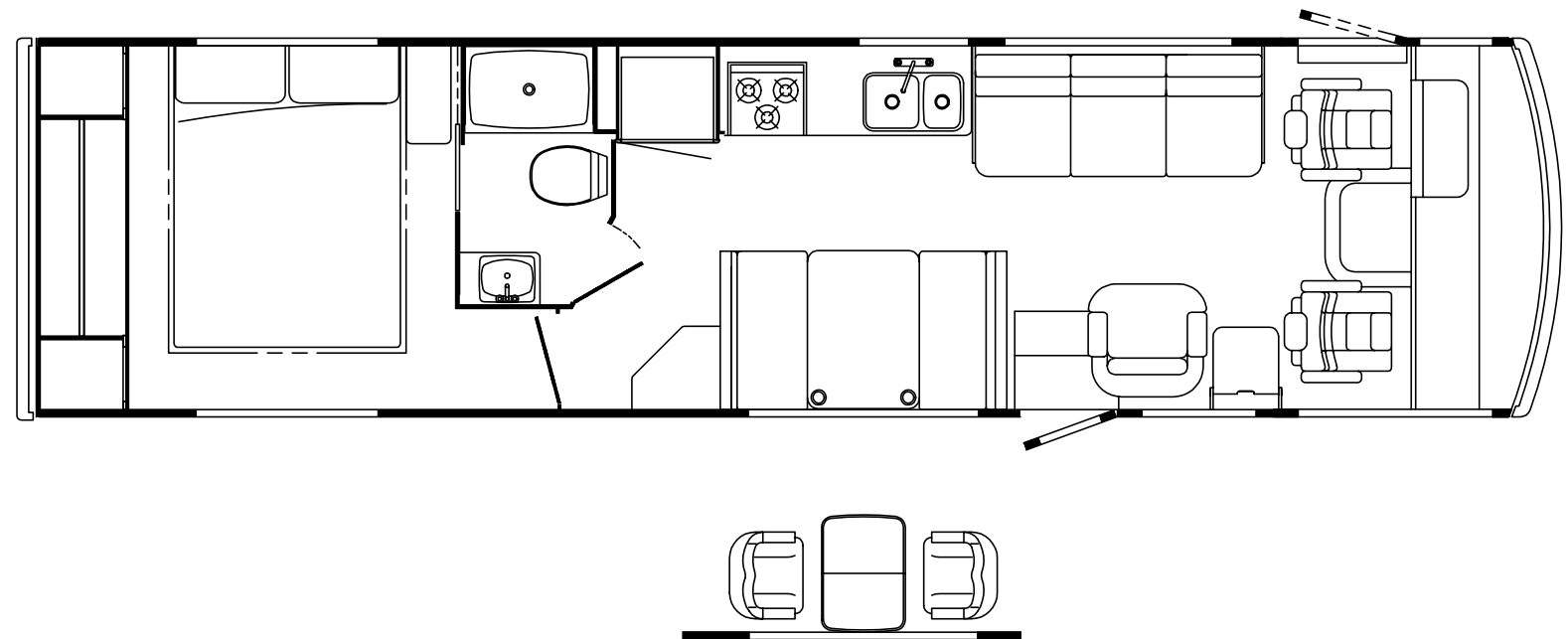
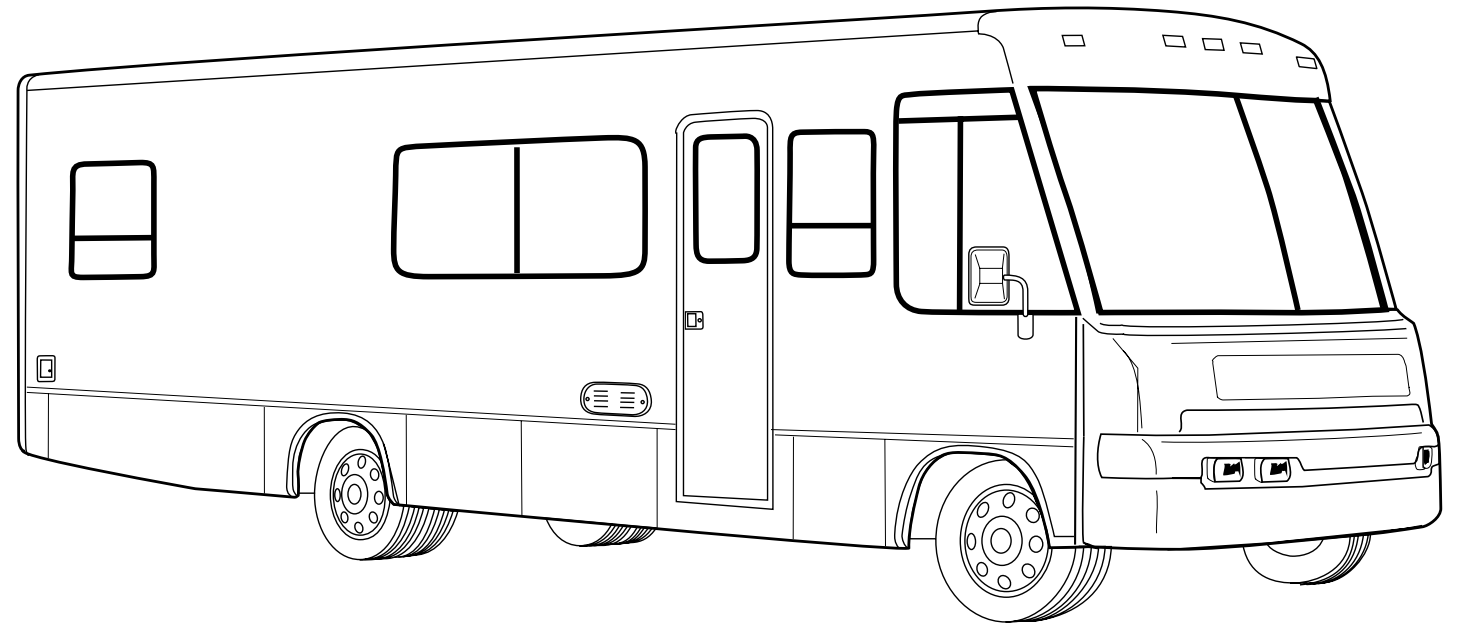

ACCESSORIES GROUP

OPERATOR MANUAL

KEY	PART NUMBER	U/M DESCRIPTION
	054185-G1-000	EA MANUAL - OPERATOR 97 SUNCRUISER
	092318-01-000	EA BINDER - 3 RING - MOTOR HOME MANUAL
	092319-01-000	EA POCKET PAGE - 3 RING BINDER - PLASTIC - (50 PER PKG)
	122567-01-000	EA TOP LEVEL-G - 1997

AUDIO VIDEO GROUP

RADIO SYSTEMS & ANTENNA

KEY	PART NUMBER	U/M DESCRIPTION
	087683-03-000	EA RADIO - AM/FM STEREO CASSETTE
	110267-04-000	EA RADIO - AM/FM STEREO - CD COMPATIBLE - AUDIOVOX
	116148-04-000	EA RADIO - AM/FM STEREO W/CD PLAYER - CLARION
	110469-01-000	EA SPEAKER - 4" X 6" OVAL - COAXIAL
	110470-01-01A	EA GRILLE - 4" X 6" OVAL - BLACK
	089340-02-000	EA GRILLE - SPEAKER - 6.5" SQUARE
	089340-03-000	EA SPACER - GRILLE - 6.5" SQUARE - TAN - MAGNADYNE G514
	094097-01-000	EA SPEAKER - RADIO/TV - W/O GRILLE - 5.25" DIA
	090944-01-000	EA ANTENNA - RADIO - 16" RUBBER
	108847-01-000	EA BRACKET - ANTENNA GROUND
	109889-04-000	EA EXTENDER - SHAFT -ANTENNA 3" - MAGNADYNE RV71EX3
	123256-01-000	EA ANTENNA - CB - W/O CABLE
	123256-02-000	EA CABLE - CB - COAX
	077069-02-000	EA CABLE - ANTENNA/EXTENSION - RADIO - 96"
	115916-01-01B	EA BRACKET - ANTENNA MOUNT

REAR MONITOR SYSTEM

KEY	PART NUMBER	U/M DESCRIPTION
	093040-08-000	EA MONITOR SYSTEM - REAR VIEW 7" - W/AUDIO JACK
	093040-09-000	EA CAMERA - REAR VIEW - W/BRACKET - SONY
	093040-04-700	EA CAMERA - W/BRACKET & WIRING - SSC-530AM REAR VIEW
	093040-05-700	EA MONITOR - 7" W/ POWER HARNESS - SSM721AMR
	093040-06-000	EA WIRE ASM - MONITOR - F/ NON PREWIRED AFTER MARKET INSTALLATION
	096717-03-000	EA WIRE - REAR MONITOR - AFTER MARKET INSTALLATION
	108885-02-000	EA WIRE - REAR MONITOR (W/3 PIN HOUSING F/FUSE BLOCK) CHEVY
	093041-01-000	EA CABLE - MONITOR/ CAMERA INTERNAL USE - 65.6'

PATIO ENTERTAINMENT CENTER

KEY	PART NUMBER	U/M DESCRIPTION
	077069-02-000	EA CABLE - ANTENNA/EXTENSION - RADIO - 96"
	087683-03-000	EA RADIO - AM/FM STEREO CASSETTE
	090944-01-000	EA ANTENNA - RADIO - 16" RUBBER
	108847-01-000	EA BRACKET - ANTENNA GROUND
	109889-04-000	EA EXTENDER - ANTENNA SHAFT - 3"
	110469-01-000	EA SPEAKER - 4" X 6" OVAL - COAXIAL
	110470-01-01A	EA GRILLE - 4" X 6" OVAL - BLACK

AUDIO VIDEO GROUP (CONTINUED)

SATELLITE ANTENNA (WINEGARD) (OLD STYLE)

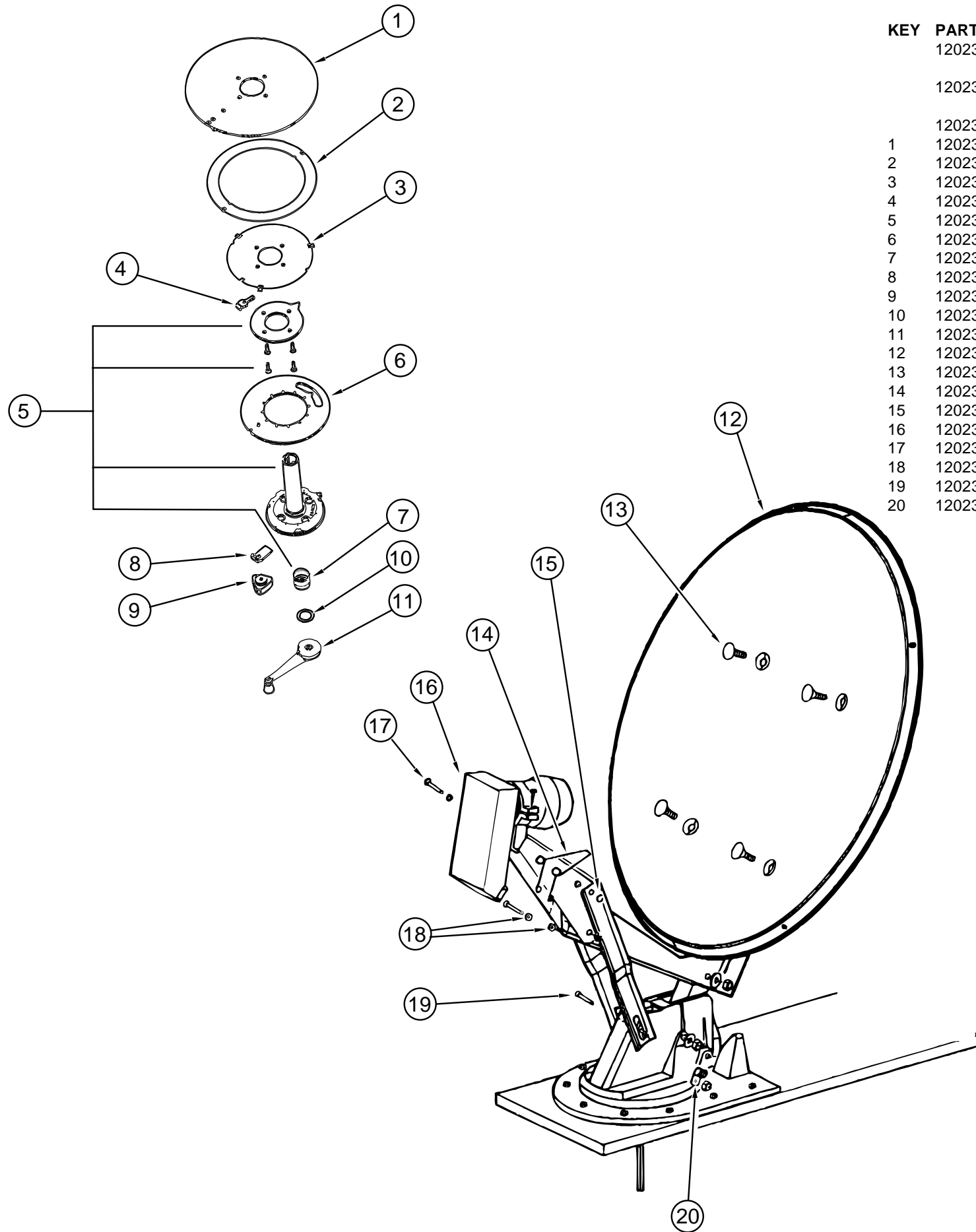

KEY	PART NUMBER	U/M	DESCRIPTION	VENDOR NO.
	120233-02-000	EA	RECEIVER - SATELLITE ONLY	
				FROM: 00-00-00 THRU: 01-26-97
	120233-02-700	EA	REMOTE	RC-0012
				FROM: 00-00-00 THRU: 01-26-97
	120233-01-000	EA	ANTENNA - SATELLITE W/O RECEIVER (DISH & HARDWARE KIT) MANUAL	
1	120233-01-700	EA	PLATE - FIXED	3750821
2	120233-01-701	EA	DIAL - DIRECTIONAL	2745056
3	120233-01-702	EA	PIVOT - DIAL - DIRECTIONAL	2745058
4	120233-01-703	EA	STOP - ROTATION	3711281
5	120233-01-704	EA	PLATE - CEILING W/DIR. HANDLE	RP-6300
6	120233-01-705	EA	PLATE - ROTATE	3750820
7	120233-01-706	EA	SPRING	RP-6822
8	120233-01-707	EA	CLAMP - ROTATE	3711280
9	120233-01-708	EA	KNOB - CLAMP	2200061
10	120233-01-709	EA	WASHER - NYLON	RP-2658
11	120233-01-710	EA	HANDLE - CRANK	RP-6795
12	120233-01-711	EA	REFLECTOR - 46CM	2745304
13	120233-01-712	EA	BOLT - FLAT HEAD	2160253
14	120233-01-713	EA	SPRING	2160820
15	120233-01-714	EA	CLIP - E	5160818
16	120233-01-715	EA	LOW NOISE BLOCK FILTER (LNBF)	2780177
17	120233-01-716	EA	PIN	2160814
18	120233-01-717	EA	BEARING - NYLON	2200726
19	120233-01-718	EA	PIN	5160817
20	120233-01-719	EA	CLAMP - CABLE	2200060

AUDIO VIDEO GROUP (CONTINUED)

SATELLITE ANTENNA (WINEGARD) (NEW STYLE)

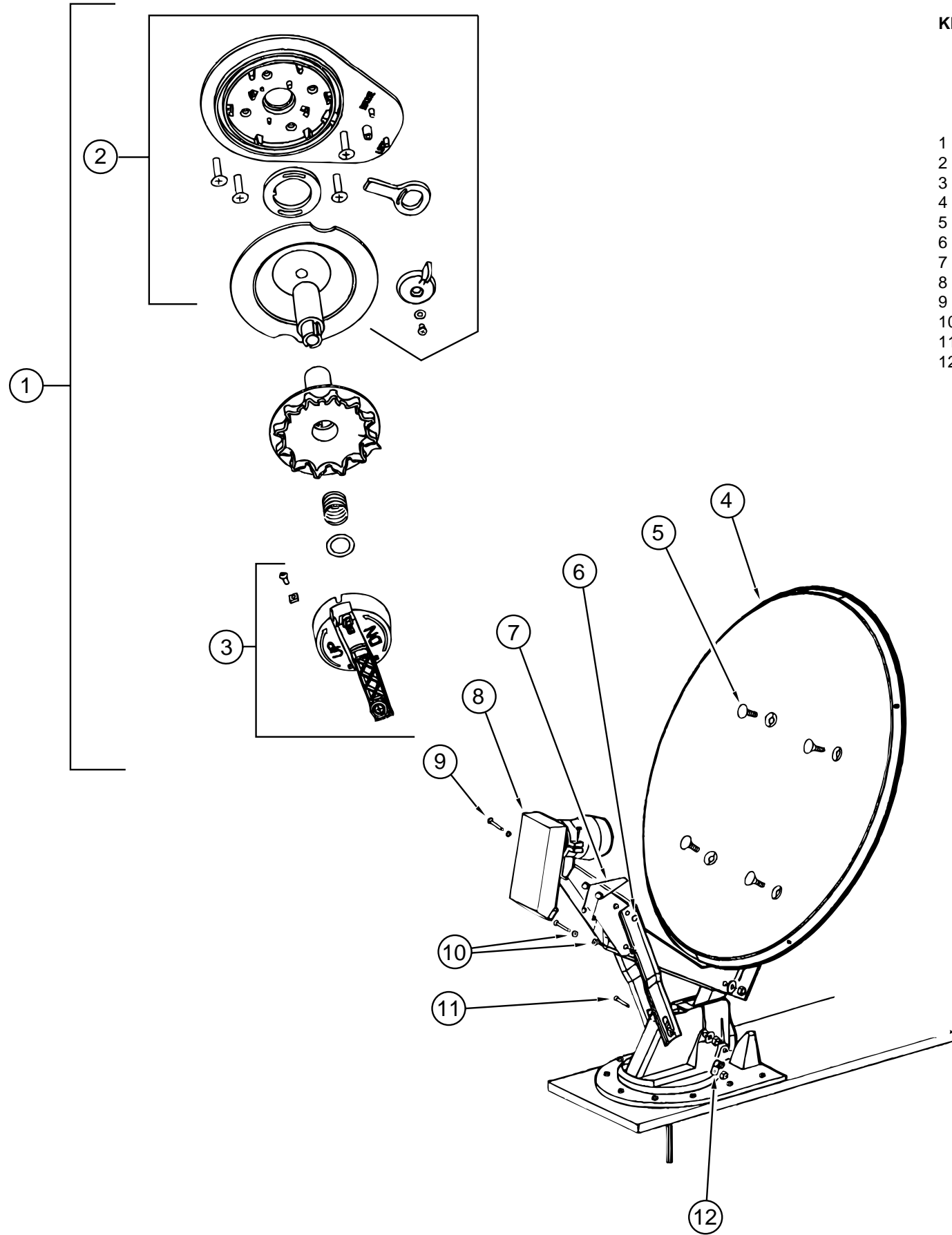

KEY	PART NUMBER	U/M	DESCRIPTION	VENDOR NO.
	120233-02-000	EA	RECEIVER - SATELLITE ONLY	
	120233-02-700	EA	REMOTE	FROM: 00-00-00 THRU: 01-26-97 RC-0012
	120233-01-000	EA	ANTENNA - SATELLITE W/O RECEIVER (DISH & HARDWARE KIT) MANUAL	FROM: 00-00-00 THRU: 01-26-97
1	120233-01-720	EA	CEILING PLATE ASM (RETRO FIT)	RP-4100
2	120233-01-722	EA	PLATE ASSEMBLY (CEILING)	2762826
3	120233-01-721	EA	CRANK HANDLE ASSEMBLY	2762825
4	120233-01-711	EA	REFLECTOR - 46 CM	2745304
5	120233-01-712	EA	BOLT - FLAT HEAD	2160253
6	120233-01-714	EA	CLIP - E	5160818
7	120233-01-713	EA	SPRING	2160820
8	120233-01-715	EA	LOW NOISE BLOCK FILTER (LNBF)	2780177
9	120233-01-716	EA	PIN	2160814
10	120233-01-717	EA	BEARING - NYLON	2200726
11	120233-01-718	EA	PIN	5160817
12	120233-01-719	EA	CLAMP - CABLE	2200060

AUDIO VIDEO GROUP (CONTINUED)

AUDIO VIDEO GROUP (CONTINUED)

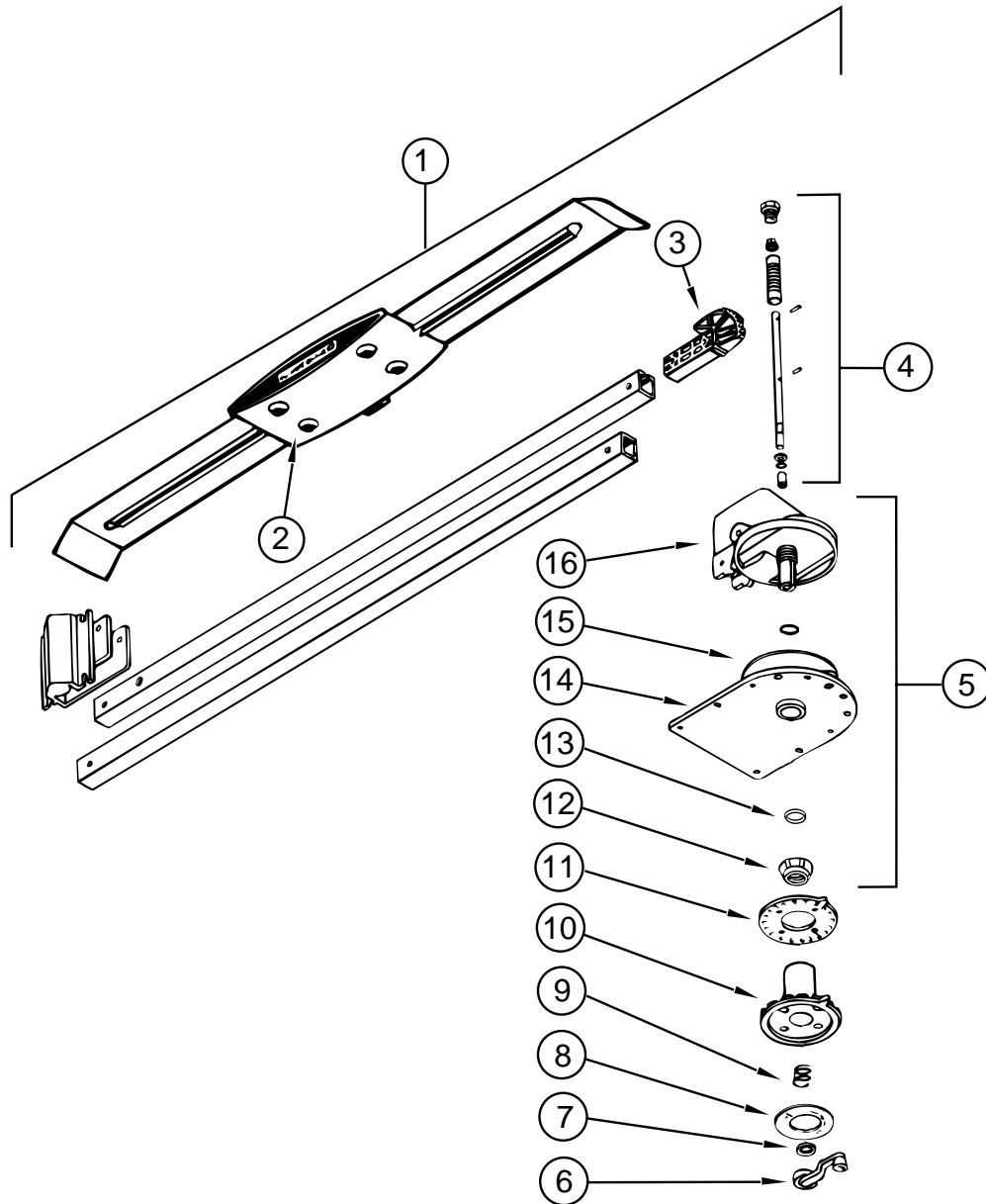

TV - VCR SYSTEMS

KEY	PART NUMBER	U/M	DESCRIPTION
	113684-02-000	EA	TV - 19" COLOR W/1/8" JACK - UL/CSA - AUDIOVOX
	113684-01-700	EA	REMOTE - 0892345
	122863-01-000	EA	TV - 13" COLOR W/SPEAKER - UL/CSA - AUDIOVOX
	122863-01-700	EA	REMOTE - 0892345
	119120-03-000	EA	VCR-VHS - CABLE READY - REMOTE - AUDIOVOX
			FROM: 02-17-97 THRU: 99-99-99
	119120-03-700	EA	REMOTE - 0994571
	119120-02-700	EA	REMOTE (AUDIOVOX AVR-1170)
	086757-03-000	EA	CONTROL CENTER - SWITCH - VCR/TV
	086777-01-000	EA	WALLPLATE - TV CABLE - W/ANTENNA SWITCH - IVORY
	086777-05-000	EA	WALLPLATE - TV CABLE - ANTENNA/1 OUTPUT - IVORY
	093214-01-02A	EA	GRILLE - SPEAKER - 4" BROWN
	098819-01-000	EA	SPEAKER - 4" - 2 WATT - 8 OHM
	082134-01-000	EA	ADAPTER - TV - CABLE TO CABLE
	086756-01-000	EA	SPLITTER - TV - 2 WAY
	114870-02-000	EA	PLUG - .14" AUDIO W/LEADS
	082136-01-000	EA	NUT - HEX JAM - 3/8 - 32

TV ANTENNA (WINEGARD)

KEY	PART NUMBER	U/M	DESCRIPTION	VENDOR NO.
1	076319-21-000	EA	ANTENNA - TV ROOF MOUNT - 3" ROOF	
2	076319-01-700	EA	HEAD - ANTENNA - AMPLIFIED	RVSA U/V
3	076319-01-701	EA	GEAR - ELEVATING - PLASTIC	2200046
4	076319-01-702	EA	SHAFT ASM - ELEVATING	RVP-400A
5	076319-01-711	EA	BASE & LIFT ASM	2762802
6	076319-01-706	EA	CRANK - ELEVATING - W/ SET SCREW - UNIVERSAL	2750897
7	076319-01-705	EA	BEARING - NYLON - 7/8"ID	3200658
8	076319-01-708	EA	CRANK COVER DECAL	5413002
9	076319-01-707	EA	SPRING - HANDLE	5160822
10	076319-01-709	EA	PLATE - DIRECTIONAL - FOR HEAD	3200621
11	076319-01-712	EA	CEILING PLATE - WINEGARD	3200608
12	076319-01-715	EA	NUT (GEAR HOUSING)	2200047
13	076319-01-704	EA	BEARING - NYLON - 1.5"OD	3200657
14	076319-01-713	EA	BASE PLATE	3100523
15	076319-01-703	EA	BEARING - NYLON - 5"OD	3200656
16	076319-01-714	EA	HOUSING - ROTATING GEAR	2200049

BATH GROUP

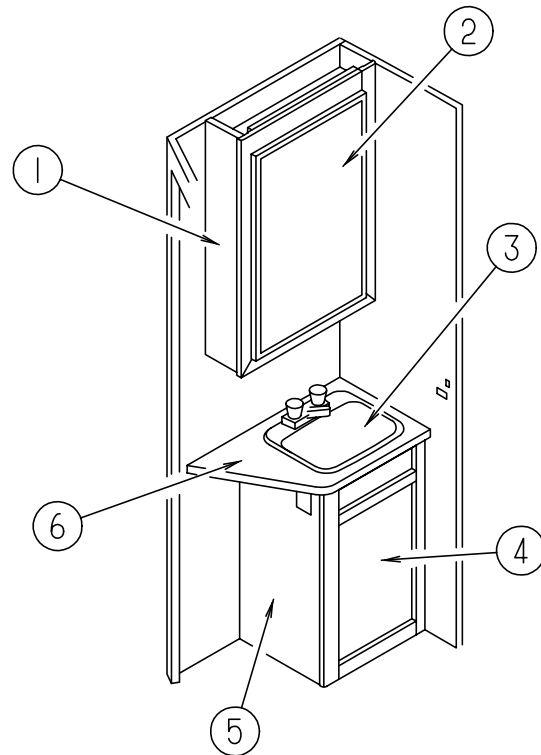

BATH GROUP (CONTINUED)

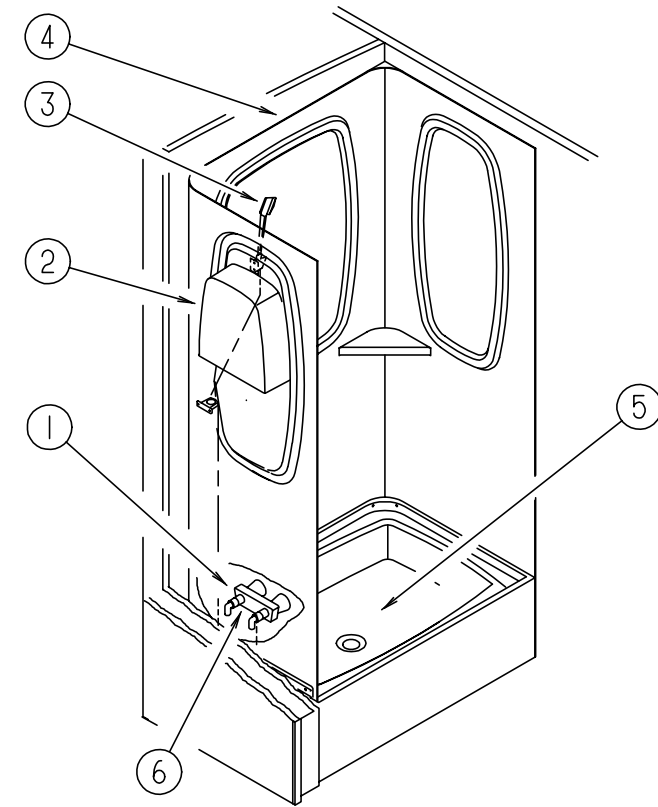

BATH CABINETS, PRIVACY DOOR & SHOWER COMPONENTS

KEY	PART NUMBER	U/M DESCRIPTION	VENDOR NO.
1	P04650-01-H37	EA CABINET - MEDICINE - W/O DOOR/HARDWARE (MAPLE)	
1	P04650-01-G15	EA CABINET - MEDICINE - W/O DOOR/HARDWARE (OAK)	
	104650-11-H37	EA SHELF - W/PLASTIC EDGE TRIM (MAPLE)	
	104650-11-G35	EA SHELF - W/PLASTIC EDGE TRIM (OAK)	
2	115237-01-H37	EA DOOR - MIRRORED/MEDICINE CABINET - 19.7" X 29.5" - W/O HDW (MAPLE)	
2	115237-01-G01	EA DOOR - MIRRORED/MEDICINE CABINET - 19.7" X 29.5" - W/O HDW (OAK)	
	093606-18-000	EA MIRROR - BEVELED PANEL - 19.7" X 29.5"	
3	096927-01-01A	EA SINK - LAVATORY - RECTANGULAR - PLASTIC/BONE	
	096927-01-700	EA SINK STOPPER	M9801
	096927-01-701	EA TAILPIECE - DRAIN - LAVATORY	M9802
	075240-06-000	EA FAUCET - LAVATORY/BONE	
	091253-01-000	EA GASKET - FAUCET - LAVATORY/GALLEY	
4	M08166-37-H37	EA DOOR - MITERED CORNER/SQUARE EDGE - 14.3" X 21.8" - W/O HDW (MAPLE)	
4	M06803-78-H17	EA DOOR - MITERED CORNER/OGEE EDGE - 14.3" X 21.8" - W/O HDW (OAK)	
5	P04634-01-H37	EA CABINET - LAVATORY - W/O DOOR/HARDWARE (H37, H39) (MAPLE)	
5	P04634-01-H38	EA CABINET - LAVATORY - W/O DOOR/HARDWARE (H38) (MAPLE)	
5	P04634-01-H47	EA CABINET - LAVATORY - W/O DOOR/HARDWARE (H47, H49) (OAK)	
5	P04634-01-H48	EA CABINET - LAVATORY - W/O DOOR/HARDWARE (H48) (OAK)	
	104634-12-H37	EA SHELF - W/PLASTIC EDGE TRIM (MAPLE)	
	104634-12-G35	EA SHELF - W/PLASTIC EDGE TRIM (OAK)	
6	104634-11-H37	EA COUNTERTOP - LAVATORY (H37, H39) (MAPLE)	
6	104634-11-F12	EA COUNTERTOP - LAVATORY (H38) (MAPLE)	
6	104634-11-H37	EA COUNTERTOP - LAVATORY (H47, H49) (OAK)	
6	104634-11-F12	EA COUNTERTOP - LAVATORY (H48) (OAK)	
	085330-06-000	EA TOILET - STANDARD CHINA W/SPRAYER - BONE	
	075452-02-000	EA HOLDER - TOILET TISSUE - BRASS	
	075454-02-000	EA RING - TOWEL - W/MOUNTING HARDWARE - BRASS	

SHOWER COMPONENTS

KEY	PART NUMBER	U/M DESCRIPTION	VENDOR NO.
1	075241-05-000	EA FAUCET/SHOWER - BONE 3/4" MPT X 1.4" LONG INLET PIPES	
2	104462-01-01A	EA CADDY - SHOWER - OFF WHITE	
3	103092-01-000	EA SHOWER HEAD - W/60" HOSE - WHITE	
	103092-01-700	EA BRACKET - F/SHOWER HEAD - CLEAR	2328028
3	103092-02-000	EA SHOWER HEAD - W/60" HOSE - CSA	
	011048-03-700	EA BRACKET - F/SHOWER HEAD	2328029-3
4	104464-01-01A	EA SURROUND - SHOWER	
5	M02630-22-C07	EA SHOWER PAN	
	066436-01-000	EA NUT - SLIP - TAILPIECE 1.5"	
	066729-01-000	EA STRAINER - TUB/SHOWER - W/PLUG	
	066436-01-000	EA NUT - SLIP - TAILPIECE 1.5"	
6	075606-01-000	EA PANEL - PLASTIC - FAUCET BACK - 5" X 9"	
	113646-01-01A	EA RETAINER - SHELF/SHOWER	

FROM: 00-00-00 THRU: 12-06-96

BATH GROUP (CONTINUED)

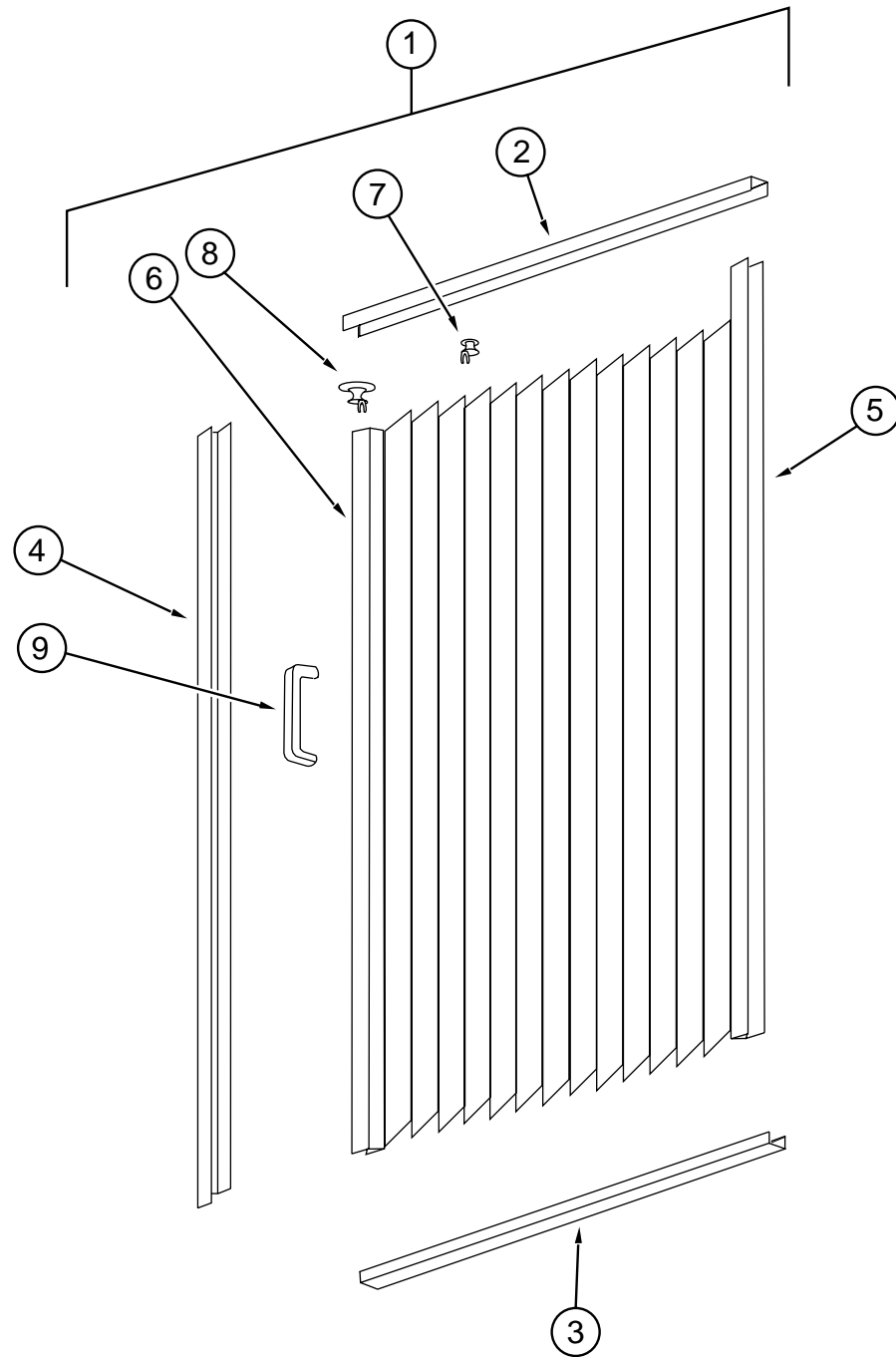

SHOWER DOOR

KEY	PART NUMBER	U/M DESCRIPTION
1	117431-02-01A	EA DOOR - SHOWER - PLEATED FABRIC
2	117431-01-700	EA TRACK - TOP - ALUM. IVORY INSERT - 48"
3	117431-01-701	EA TRACK - BOTTOM - 40 "
4	117431-01-702	EA RAIL - SIDE - 67"
5	117431-01-703	EA RAIL - STATIONARY - 67"
6	117431-01-704	EA RAIL - LEAD - 67"
7	117431-01-705	EA GLIDE - IVORY - TRAVELER
8	117431-01-706	EA GLIDE - IVORY LEAD - TRAVELER
9	117431-01-708	EA HANDLES & SCREWS
	117431-01-707	EA LATCH
	117431-02-700	EA STRAP - VINYL SHOWER

BATH GROUP (CONTINUED)

BATH DOOR - SIDE AISLE

KEY	PART NUMBER	U/M DESCRIPTION
	104014-03-H37	EA DOOR - BATH (SIDE AISLE) W/O HARDWARE (MAPLE)
	104014-03-G15	EA DOOR - BATH (SIDE AISLE) W/O HARDWARE (OAK)
	009059-02-000	EA HINGE - DOOR - 2" X 2.7" - BRASS
	102920-01-01A	EA HINGE - SPRING LOADED/BRASS
	080728-01-000	EA HANDLE - PULL - 1.3" X 4.4" - BROWN PLASTIC

BATH DOOR

KEY	PART NUMBER	U/M DESCRIPTION
	121449-22-H37	EA DOOR - BATH - W/O HARDWARE (MAPLE)
	121449-22-H17	EA DOOR - BATH - W/O HARDWARE (OAK)
	094485-03-01A	EA KNOB - BRASS
	121449-12-H37	EA RACK - TOWEL - BATH DOOR
	100357-01-000	EA ROD - F/TOWEL BAR - BRASS

BATH/BEDROOM PRIVACY DOOR

KEY	PART NUMBER	U/M DESCRIPTION
	104013-07-H37	EA DOOR - SLIDING - W/O HARDWARE (MAPLE)
	104013-07-H38	EA DOOR - SLIDING - W/O HARDWARE (MAPLE)
	104013-07-H39	EA DOOR - SLIDING - W/O HARDWARE (MAPLE)
	104013-07-H47	EA DOOR - SLIDING - W/O HARDWARE (OAK)
	104013-07-H48	EA DOOR - SLIDING - W/O HARDWARE (OAK)
	104013-07-H49	EA DOOR - SLIDING - W/O HARDWARE (OAK)
	103908-06-H37	EA HEADER - DOOR (MAPLE)
	103908-06-G15	EA HEADER - DOOR (OAK)
	103868-09-01A	EA TRACK - SLIDING DOOR - 64.3" - OFF WHITE
	092652-01-000	EA GUIDE WHEEL - DOOR - TOP MOUNT
	098410-01-01A	EA PULL - FINGER - BRASS
	103874-01-000	EA HANGER - SLIDING DOOR

BATH GROUP (CONTINUED)

TOILET (SEALAND MODEL 910 W/ SPRAYER)

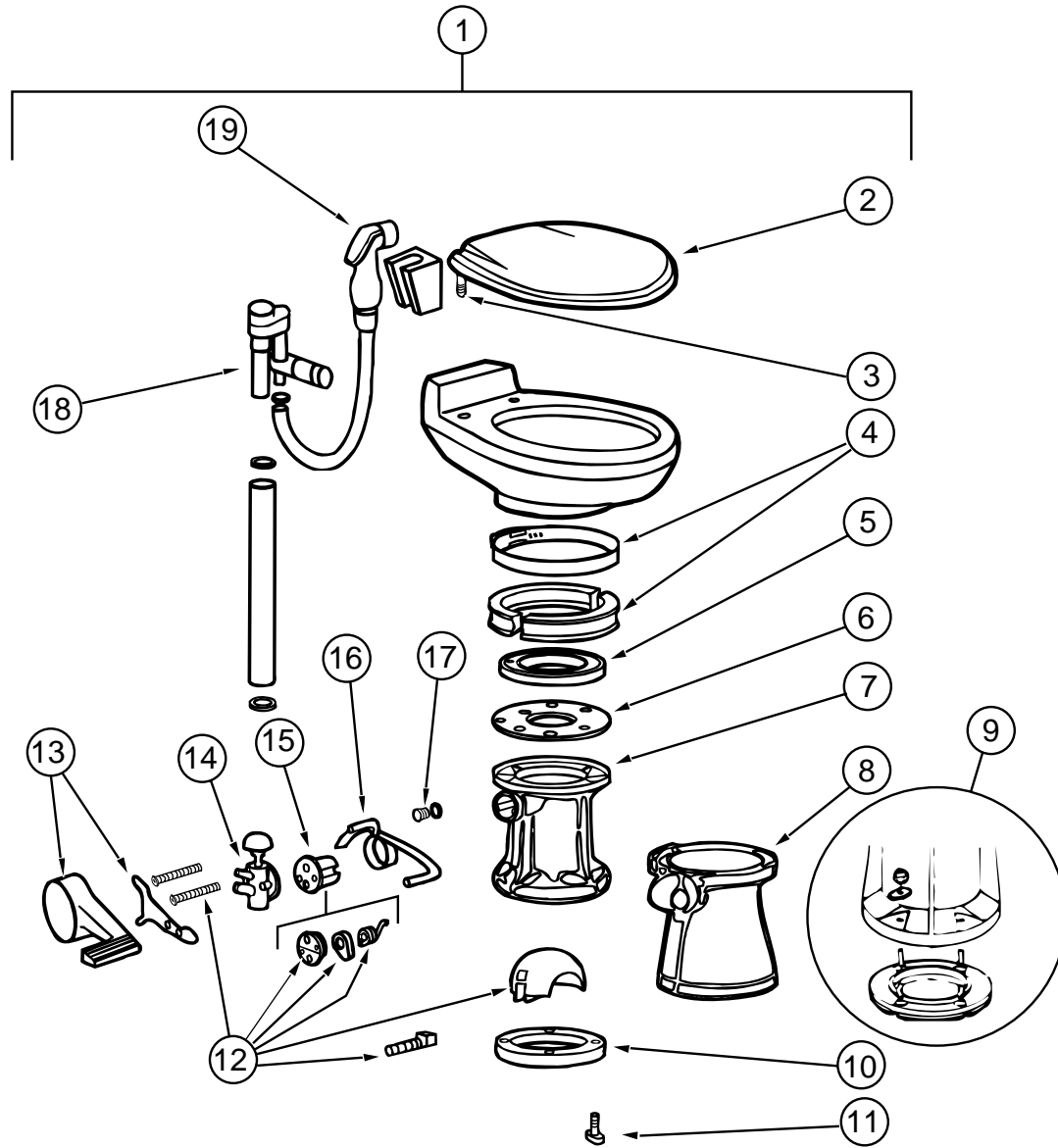

KEY	PART NUMBER	U/M	DESCRIPTION	VENDOR NO.
1	085330-06-000	EA	TOILET - CHINA - STANDARD (BONE) - 591003	
2	085330-06-700	EA	SEAT ASSEMBLY (BONE)	340591
3	085330-06-702	EA	HINGE HARDWARE (BONE) SET	342131
4	085330-01-703	EA	RING & HALF CLAMPS (BONE)	385310048
5	085330-01-704	EA	TEFLON & RUBBER SEAL KIT	385316140
6	085330-01-705	EA	SUPPORT - SEAL - PLASTIC	390346405
7	085330-02-700	EA	BASE ASM	310121
8	085330-02-702	EA	COVER - PEDESTAL - BONE 510	310112
9	085330-01-718	EA	SEAL & BASE W/ MOUNTING HARDWARE	3853100-63
10	085330-01-714	EA	SEAL - FLANGE - FLOOR	390343892
11	085330-01-717	EA	STOOL MOUNTING PACKAGE - BOLT & SEAL	3100-64
12	085330-01-706	EA	BALL - SHAFT & CARTRIDGE	385318162
13	085330-02-703	EA	COVER - PEDAL - BONE NEW STYLE	310115
14	085330-01-709	EA	VALVE - WATER	385314349
15	085330-01-707	EA	CARTRIDGE - SPRING ASM.	381236096
16	085330-06-703	EA	LEVER - FLUSH	340873
17	085330-01-710	EA	DRAIN - KIT - PLUG - CAP W/ SEAL	230384
18	085330-06-701	EA	BREAKER - VACUUM/ DIVERTER (900)	230335
19	085330-04-701	EA	HAND SPRAY - W/ HOSE (500 & 900)	340683

BEDROOM GROUP

QUEEN BEDROOM

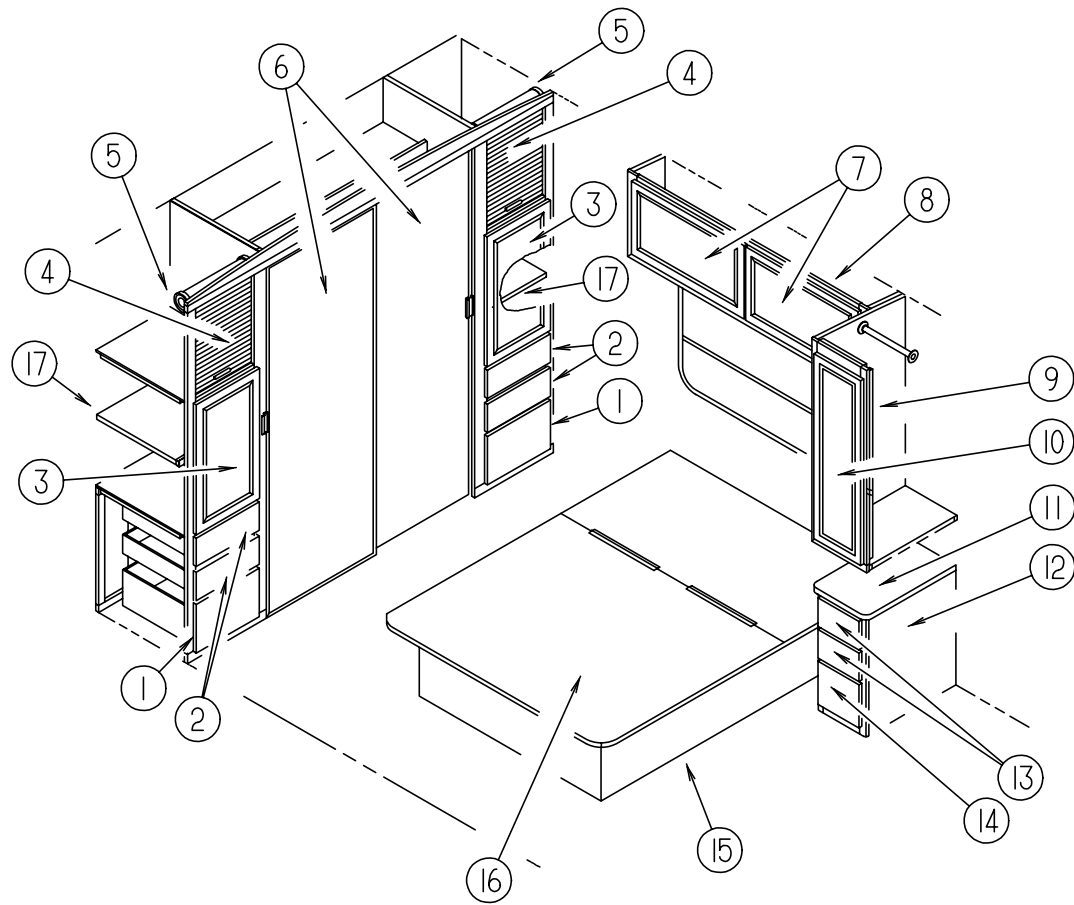

KEY	PART NUMBER	U/M DESCRIPTION
11	104639-11-H37	EA COUNTERTOP - NIGHTSTAND (H37, H39, H47, H49)
11	104639-11-F12	EA COUNTERTOP - NIGHTSTAND (H38, H48)
12	104639-01-H37	EA CABINET - NIGHTSTAND - W/O DRAWERS/HARDWARE (H37, H39) (MAPLE)
12	104639-01-H38	EA CABINET - NIGHTSTAND - W/O DRAWERS/HARDWARE (H38) (MAPLE)
12	104639-01-G36	EA CABINET - NIGHTSTAND - W/O DRAWERS/HARDWARE (H47, H49) (OAK)
12	104639-01-G15	EA CABINET - NIGHTSTAND - W/O DRAWERS/HARDWARE (H48) (OAK)
13	M08168-97-H37	EA DRAWER - SQUARE EDGE - 7.9"W X 17.7"D - W/O SLIDES/HDW (MAPLE)
13	M05971-97-H17	EA DRAWER - OGEE EDGE - 8.0"W X 17.7"D - W/O SLIDES/HARDWARE (OAK)
14	M08168-71-H37	EA DRAWER - SQUARE EDGE - 7.8"W X 17.7"D - W/O SLIDES/HDW (MAPLE)
14	M05971-71-H17	EA DRAWER - OGEE EDGE - 7.8"W X 17.7"D - W/O SLIDES/HARDWARE (OAK)
15	P15694-01-H37	EA CABINET - BASE - QUEEN BED (MAPLE)
15	P15694-01-G15	EA CABINET - BASE/QUEEN BED (OAK)
16	M05905-08-F11	EA TOP - QUEEN BED - W/O HARDWARE (MAPLE)
16	M05905-08-F11	EA TOP - QUEEN BED - W/O HARDWARE (OAK)
	089025-01-000	EA SUPPORT - SPRING TO BED - ANGLE 1.5" X 11.8"
	107796-06-000	EA SPRING/GAS - 12" COMPRESSED/20" EXTENDED - 120 LB.
	107796-07-000	EA BRACKET - SUPPORT - GAS SPRING TO BED - ANGLE(UPPER)
	091952-01-000	EA CLIP - GRIPPER - 1"
	097872-04-000	EA DOWEL - WOOD - 1" DIAMETER X 1.38" LONG
	126263-06-02B	EA BRACKET - GAS SPRING - E-COATED
	126263-08-02B	EA BRACKET - GAS SPRING - LOWER - E-COATED
17	124732-18-H37	EA SHELF - W/PLASTIC EDGE MOLDING (MAPLE)
17	124732-18-H17	EA SHELF - W/PLASTIC EDGE MOLDING (OAK)

KEY	PART NUMBER	U/M DESCRIPTION
1	M08168-CB-H37	EA DRAWER - SQUARE EDGE - 14"W X 17.7"D - W/O SLIDES/HDW (MAPLE)
1	M05971-CB-H17	EA DRAWER - OGEE EDGE - 14.3"W X 17.7"D - W/O SLIDES/HARDWARE (OAK)
2	M08168-CC-H37	EA DRAWER - SQUARE EDGE - 14"W X 17.7"D - W/O SLIDES/HDW (MAPLE)
2	M05971-CC-H17	EA DRAWER - OGEE EDGE - 14"W X 17.7"D - W/O SLIDES/HARDWARE (OAK)
3	M08166-39-H37	EA DOOR - MITERED CORNER/SQUARE EDGE - 15.7" X 28" - W/O HDW (MAPLE)
3	M06803-79-H17	EA DOOR - MITERED CORNER/OGEE EDGE - 15.7" X 27.9" - W/O HDW (OAK)
4	124732-20-H37	EA DOOR - TAMBOUR - W/O TRACK/HARDWARE (MAPLE)
4	124732-20-H17	EA DOOR - TAMBOUR - W/O TRACK/HARDWARE (OAK)
	097191-01-H56	EA HANDLE - TAMBOUR DOOR (MAPLE)
	097191-01-G15	EA HANDLE - TAMBOUR DOOR (OAK)
5	097141-02-700	EA KIT - TRACK - TAMBOUR DOOR - W/ONE RT & ONE LEFT TRACK
6	114149-06-H37	EA DOOR - MIRRORED WARDROBE
		FROM: 00-00-00 THRU: 10-07-96
6	114149-15-H17	EA DOOR - MIRRORED WARDROBE
		FROM: 10-08-96 THRU: 99-99-99
7	M08166-36-H37	EA DOOR - MITERED CORNER/SQUARE EDGE - 9" X 26.5" - W/O HDW (MAPLE)
7	M06803-G7-H17	EA DOOR - MITERED CORNER/OGEE EDGE - 9" X 27" - W/O HARDWARE (OAK)
8	123473-01-H37	EA CABINET - OVERHEAD REAR - W/O DOORS/HARDWARE (MAPLE)
8	123473-01-H17	EA CABINET - OVERHEAD REAR - W/O DOORS/HARDWARE (OAK)
9	123474-01-H37	EA CABINET - SHIRT CLOSET - W/O DOOR/HARDWARE (MAPLE)
9	123474-01-H17	EA CABINET - SHIRT CLOSET - W/O DOOR/HARDWARE (OAK)
10	M08166-23-H37	EA DOOR - MITERED CORNER/SQUARE EDGE - 12" X 40" - W/O HDW (MAPLE)
10	M06803-F3-H17	EA DOOR - MITERED CORNER/OGEE EDGE - 12" X 40" - W/O HARDWARE (OAK)

BEDROOM GROUP (CONTINUED)

WARDROBE DOOR

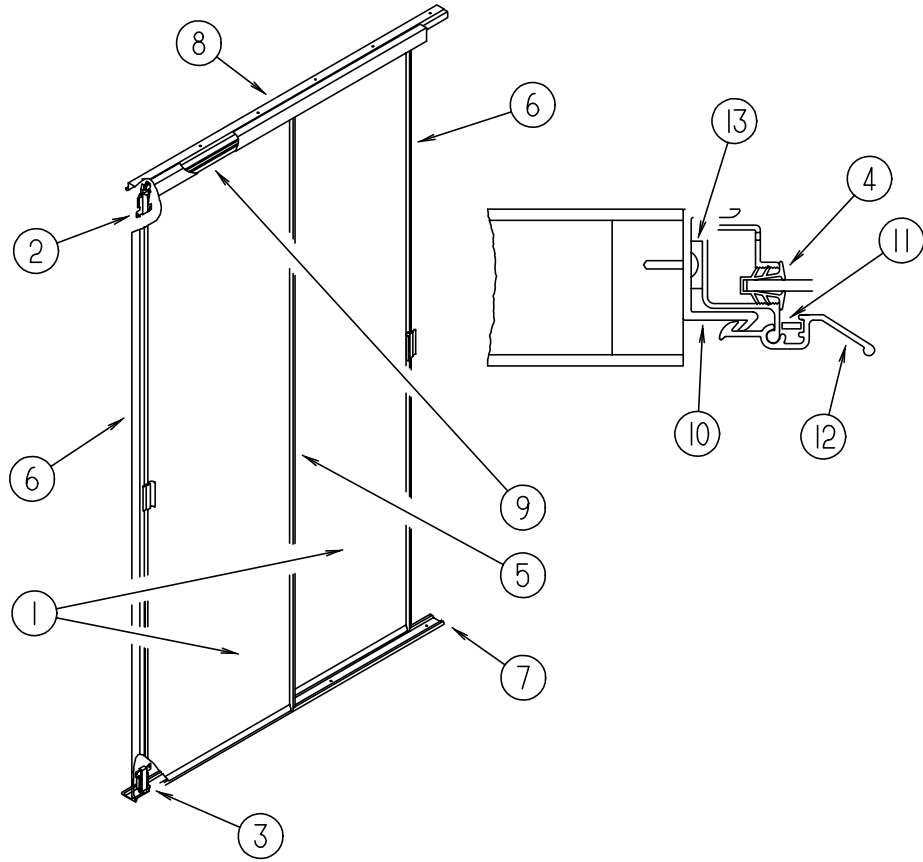

KEY	PART NUMBER	U/M	DESCRIPTION	
	114149-06-H37	EA	DOOR - MIRRORED WARDROBE	FROM: 00-00-00 THRU: 10-07-96
	114149-15-H17	EA	DOOR - MIRRORED WARDROBE	FROM: 10-08-96 THRU: 99-99-99
1	058331-D2-000	EA	MIRROR - GLASS - SAFETY	
2	107390-01-000	EA	CORNER HANGER (SINGLE ROLLER W/BRACKET) (SOLD AS 1 EACH)	
3	107391-01-000	EA	GUIDE - BOTTOM - BY-PASS (PAIR)	
4	111575-01-01A	FT	CHANNEL - GLAZING - SWING DOOR	
5	114104-06-01A	EA	STILE - DOOR - SLIDING	
6	114104-02-01A	EA	STILE - DOOR - SLIDING	
7	114105-08-01A	EA	TRACK - DOOR - SLIDING/LOWER	
8	114106-08-01A	EA	TRACK - DOOR - SLIDING/UPPER	
9	114107-07-01A	EA	RAIL - SLIDING DOOR	
10	115538-03-01A	EA	JAMB - DOOR - WARDROBE/MIRRORED	
11	115541-01-000	EA	SPRING - DOOR - SLIDING	
12	115553-01-01A	EA	LATCH - DOOR - WARDROBE/MIRRORED	
13	123655-01-000	FT	SEAL - CLOSED CELL/FOAM	

CHASSIS GROUP

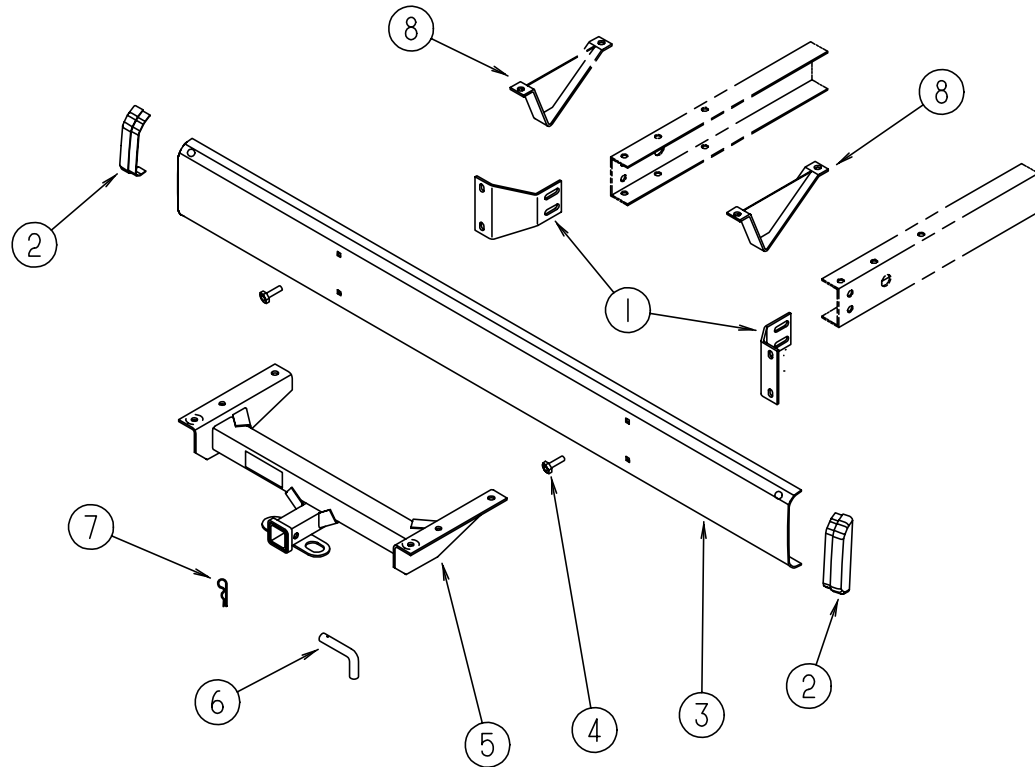

REAR BUMPER & COMPONENTS

KEY	PART NUMBER	U/M DESCRIPTION
1	104418-07-000	EA ANGLE - BUMPER REAR SUPPORT
2	103228-01-05A	EA END CAP - REAR BUMPER - DRIVER/ PASSENGER SIDE
3	103099-04-02A	EA BUMPER - REAR - BRIGHT WHITE
4	102333-01-05A	EA BOLT - 7/16"
5	107707-01-000	EA HITCH RECEIVER - BOLT-ON CLASS II
6	034512-01-000	EA PIN - LOCKING - DRAWBAR
7	034513-01-000	EA PIN - 3/16" WIRE
8	111742-01-000	EA PLATE - SKID
	113589-01-000	EA CONNECTOR - PLUG - TRAILER
	113589-02-000	EA CONNECTOR - SOCKET - TRAILER
	070579-09-000	EA PLATE - ANCHOR
	113588-02-01B	EA BRACKET - CONNECTOR TRAILER W/O LIP

CHASSIS GROUP (CONTINUED)

FORD - HWH HYDRAULIC LEVELING SYSTEM

KEY	PART NUMBER	U/M DESCRIPTION	VENDOR NO.
	100532-33-000	EA LEVELING SYSTEM - HYDRAULIC	
	100532-01-713	EA PUMP - RESERVOIR ASM. - MONARCH	RAP90014
	100532-01-714	EA SCREW KIT (LEVELING JACKS)	R1280
	100532-03-710	EA SENSING UNIT 21' MTA	RAP6798
	100532-03-715	EA CAP - BREATHER W/DIPSTICK	RAP7876
	100532-03-723	EA O-RING/SEAL KIT	RAP9171
	100532-08-702	EA VALVE - BI-AXIS	RAP9589
	100532-08-703	EA PANEL ASM. - 200 BI-AXIS SYS.	RAP9755
	100532-08-705	EA KNOB - 3/4" BLACK - SET OF FOUR	RAP1379
	100532-08-706	EA KNOB - 1 3/16" BLACK	RAP9734
	100532-08-707	EA BEZEL W/GASKET - F/SYSTEM 200	RAP9592
	100532-09-710	EA SOLENOID - INTERMITTENT DUTY	RAP0533
	100532-12-706	EA SWITCH - WARNING/MAGNETIC	RAP1008
	100532-12-707	EA SPRING KIT	R3847
	100532-16-700	EA JACK ASM. 6K - STATIONARY	RAP0468
	100532-18-700	EA JACK - 9K STRAIGHT ACTING	RAP90177
	100532-32-702	EA CYLINDER ONLY F/9000 LB JACK	RAP1927
	100536-28-000	EA HOSE KIT - LEVELING JACKS	
	100536-09-701	EA HOSE - HYDRAULIC - 60"	RAP4073
	100536-25-700	EA HOSE - HYDRAULIC - 306"	RAP4904
	100536-25-701	EA HOSE - HYDRAULIC - 312"	RAP5216
	100536-28-700	EA HOSE - HYDRAULIC - 372"	RAP4391
	117183-01-02B	EA COVER - SENSOR - LEVELING	
	121651-01-02B	EA CROSSMEMBER - REAR JACK MOUNTING	
			FROM: 12-21-96 THRU: 99-99-99
	107938-07-000	EA BRACKET - PUMP	
	121651-01-02B	EA CROSSMEMBER - REAR JACK MOUNTING	

CHEVY - HWH HYDRAULIC LEVELING SYSTEM

KEY	PART NUMBER	U/M DESCRIPTION	VENDOR NO.
	100532-32-000	EA LEVELING SYSTEM - HYDRAULIC	
			FROM: 00-00-00 THRU: 03-01-97
	100532-01-714	EA SCREW KIT (LEVELING JACKS)	R1280
	100532-32-702	EA CYLINDER ONLY F/9000 LB JACK	RAP1927
	100536-28-000	EA HOSE KIT - LEVELING JACKS	
	100536-09-701	EA HOSE - HYDRAULIC - 60"	RAP4073
	100536-25-700	EA HOSE - HYDRAULIC - 306"	RAP4904
	100536-25-701	EA HOSE - HYDRAULIC - 312"	RAP5216
	100536-28-700	EA HOSE - HYDRAULIC - 372"	RAP4391
	107938-07-000	EA BRACKET - PUMP	
	114711-01-09B	EA SHIELD - LEVELING JACK	
	117183-01-02B	EA COVER - SENSOR - LEVELING	
	120916-01-02B	EA BRACKET - PUMP - LEVELING SYSTEM	
	121177-01-02B	EA BRACKET - PASS REAR LEVEL JACK (STRAIGHT)/SLIDEOUT RM SYST	
	121177-02-02B	EA BRACKET - DRVR REAR LEVEL JACK (STRAIGHT)/SLIDEOUT RM SYST	
	121651-01-02B	EA CROSSMEMBER - REAR JACK MOUNTING	
	100533-05-000	EA BRACKETS - FRONT LEVELING JACK - CHEVY	
			FROM: 00-00-00 THRU: 12-20-96
	100534-12-000	EA BRACKETS - REAR LEVELING JACKS (KICKDOWN) - CHEV	
			FROM: 00-00-00 THRU: 12-20-96
	126135-01-02B	EA BRACKET - JACKS - FRONT	
			FROM: 12-21-96 THRU: 99-99-99
	121651-01-02B	EA CROSSMEMBER - REAR JACK MOUNTING	
			FROM: 12-21-96 THRU: 99-99-99
	107890-01-000	EA ELBOW - STEEL 90D 1/4 X 3/7D FLARE PARKER 4-C6X-S	
	122309-01-09B	EA SHIELD - LEVELING JACK - GALV	

CHASSIS GROUP (CONTINUED)

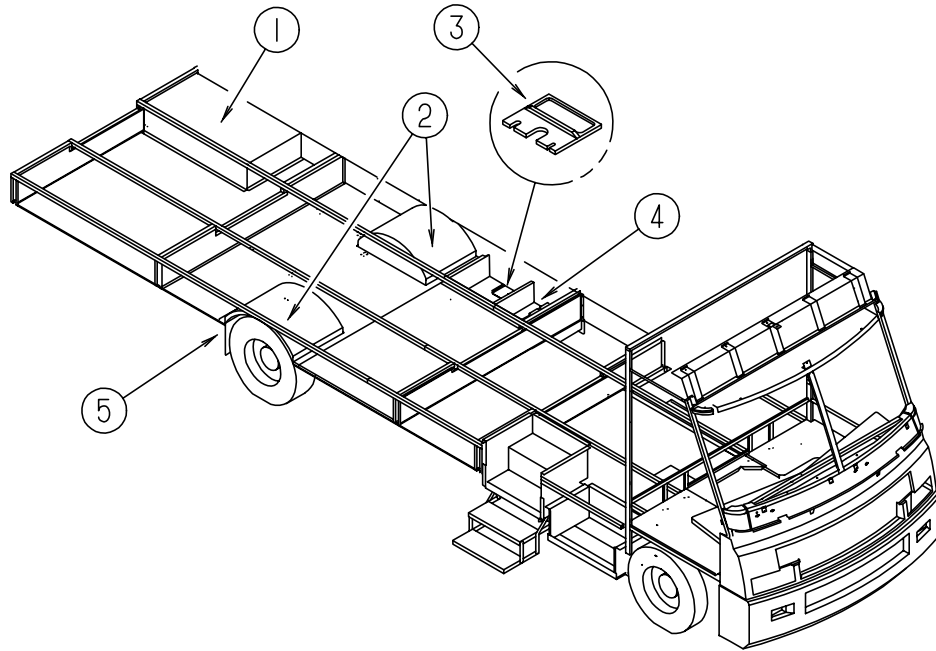

COMPARTMENTS & TRAYS

KEY	PART NUMBER	U/M	DESCRIPTION
1	094657-02-000	EA	TRAY - GENERATOR - 22.5" X 30.4" X 6.9" W/ANGLE & NUTS
2	055374-03-000	EA	WHEELWELL - PLASTIC
3	M06991-05-G38	EA	HATCH - W/FOAM
	121175-01-01A	EA	LATCH - SWELL - BLACK
4	M07452-04-G38	EA	COMPARTMENT - STORAGE - 14.4" X 48.9"
5	020167-04-000	EA	DIRT GUARD - STEEL - 14.9" LONG
			FROM: 00-00-00 THRU: 12-18-96
5	020167-08-000	EA	DIRT GUARD - STEEL - 13.6" LONG
			FROM: 12-19-96 THRU: 99-99-99
5	017516-01-000	EA	MUD FLAP - 14" X 18" - BLACK
	065450-05-000	EA	TIEDOWN - BATTERY - 8.4" TUBE
	113452-01-000	FT	SEAL/TRIM - FRONT - VINYL W/WIRE CARRIER
			FROM: 02-03-97 THRU: 99-99-99
	056748-01-000	EA	PLUG - CAP - 1.5" DIAMETER
			FROM: 00-00-00 THRU: 06-01-97
	061420-10-000	EA	PLUG/PLASTIC - 1.50" DIAMETER - BLACK
			FROM: 06-02-97 THRU: 99-99-99
	119845-01-01A	EA	PLUG - PLASTIC - BLACK
	123361-01-000	EA	DUCT - AIR INTAKE
	123362-01-000	EA	ELBOW - RUBBER - 90 DEGREE 3.5" I.D.
	119847-01-02B	EA	SHIELD - A/C COMPRESSOR
	112864-01-000	FT	SEAL - FOAM/BUTYL COVERED - 3/8"
	120867-01-02B	EA	MOUNT - LP TANK
	077298-55-003	EA	EXTRUSION - TUBE - .275"

CHASSIS GROUP (CONTINUED)

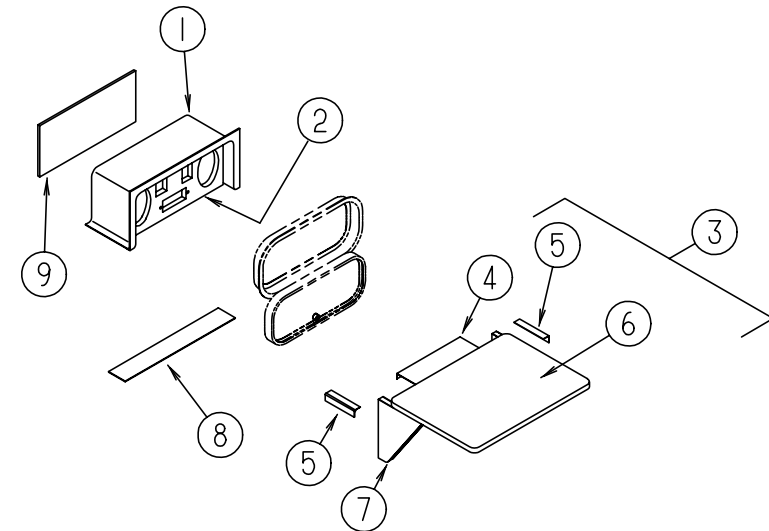

COMPARTMENT (ENTERTAINMENT CENTER)

KEY	PART NUMBER	U/M	DESCRIPTION
1	124696-01-01A	EA	BOX - ENTERTAINMENT CENTER
2	104899-01-C05	EA	PLATE - RADIO MOUNTING
3	105230-01-H33	EA	SHELF - EXTERIOR TV
4	105377-01-04A	EA	BRACKET - TABLE HANGER - BRIGHT WHITE
5	105376-01-03A	EA	HINGE - CONTINUOUS - 2" X 5.5" - BRIGHT WHITE
6	105230-11-E01	EA	SHELF - EXTERIOR ENTERTAINMENT CENTER - W/O HARDWARE
7	105230-12-F11	EA	SUPPORT
8	104898-01-02A	EA	PLATE - PLASTIC BOTTOM - BRIGHT WHITE
9	104898-02-02A	EA	PLATE - PLASTIC BACK - BRIGHT WHITE

CHASSIS GROUP (CONTINUED)

SPARE TIRE & HOIST

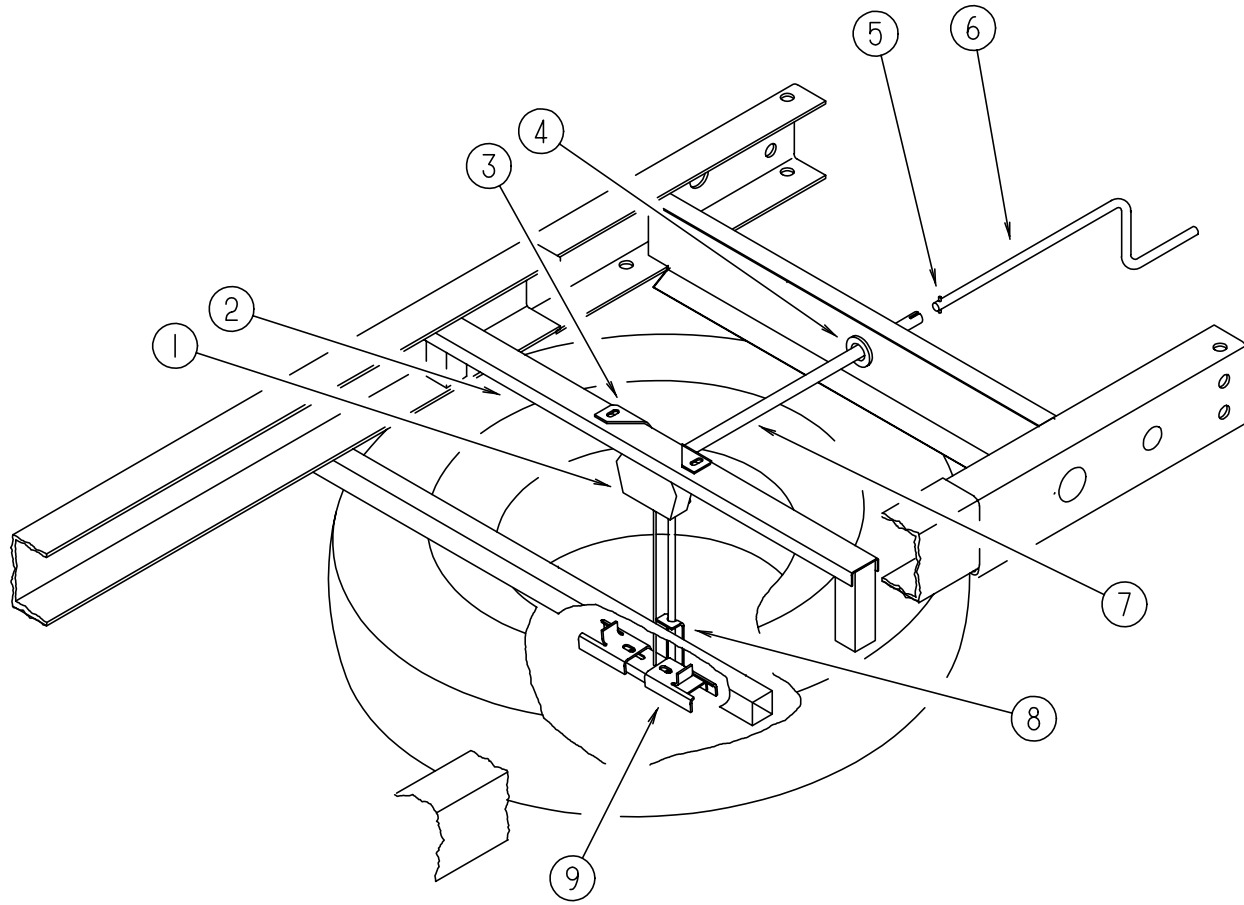

KEY	PART NUMBER	U/M	DESCRIPTION
1	093267-03-000	EA	HOIST - SPARE TIRE - 100#
2	093362-06-000	EA	CHANNEL - TIRE HOIST
3	124751-01-02B	EA	HANGER - SPARE TIRE - E-COATED
4	071015-11-000	EA	GROMMET - 1" ID
5	114376-01-000	EA	PIN - DRIVE - .156 X .750 - TYPE-E
6	093376-02-000	EA	HANDLE - CRANK - TIRE HOIST
7	093375-06-000	EA	EXTENSION - TIRE HOIST
8	124754-01-02B	EA	CATCH - SPARE TIRE
9	105499-01-000	EA	BRACKET
	077030-02-000	EA	EXTENSION - VALVE STEM - 1.25" (FORD)
	051377-05-000	EA	VALVE STEM (FORD)
	051377-01-000	EA	VALVE STEM (CHEVY)
	M00080-60-000	EA	FORD TIRE & WHEEL
	083425-05-000	EA	TIRE - MICHELIN - LT 235/85R16 - LOAD RANGE E (FORD)
	091673-01-000	EA	TIRE - 225.70 R19.5 LRF - XZA (CHEVY)
	095853-02-000	EA	WHEEL - STEEL - 16 X 6K - F2TA-1015-NA (FORD)
	064963-01-000	EA	WHEEL - STEEL - 19.5" X 6" - GM 14005758 (CHEVY)
	080208-01-000	EA	LUG WRENCH - 1.06 X 1.00 W/SHALLOW SOCKET ENDS (CHEVY)
			FROM: 00-00-00 THRU: 09-26-96
	080208-06-000	EA	LUG WRENCH - 1" X 1.06" W/DEEP SOCKET ENDS (CHEVY)
			FROM: 09-27-96 THRU: 99-99-99
	080208-02-000	EA	BAR - LEVERAGE - LUG WRENCH (CHEVY)

CHASSIS GROUP (CONTINUED)

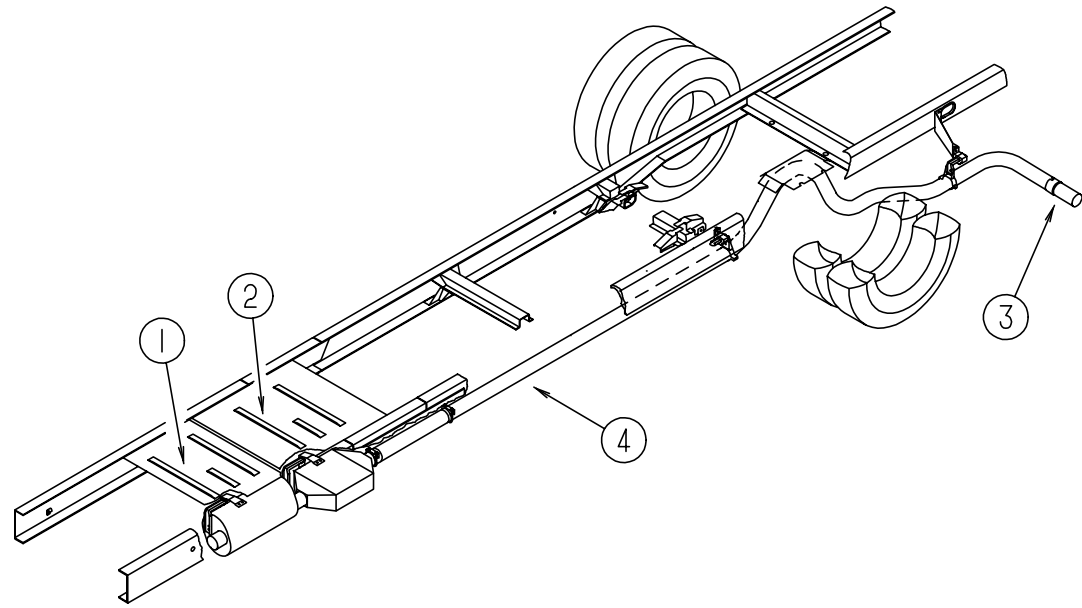

EXHAUST SYSTEM (CHEVY)

KEY	PART NUMBER	U/M	DESCRIPTION
1	101544-01-000	EA	SHIELD - HEAT - EXHAUST - 19.7" X 28.9" - STEEL
2	101544-02-000	EA	SHIELD - HEAT - EXHAUST - 30" X 28.9" - STEEL
3	098762-11-000	EA	PIPE - EXHAUST - STRAIGHT - 3"
4	098762-06-000	EA	PIPE - EXHAUST - STRAIGHT
4	094918-01-000	EA	CLAMP - EXHAUST - 3" - GUILLOTINE STYLE

CHASSIS GROUP (CONTINUED)

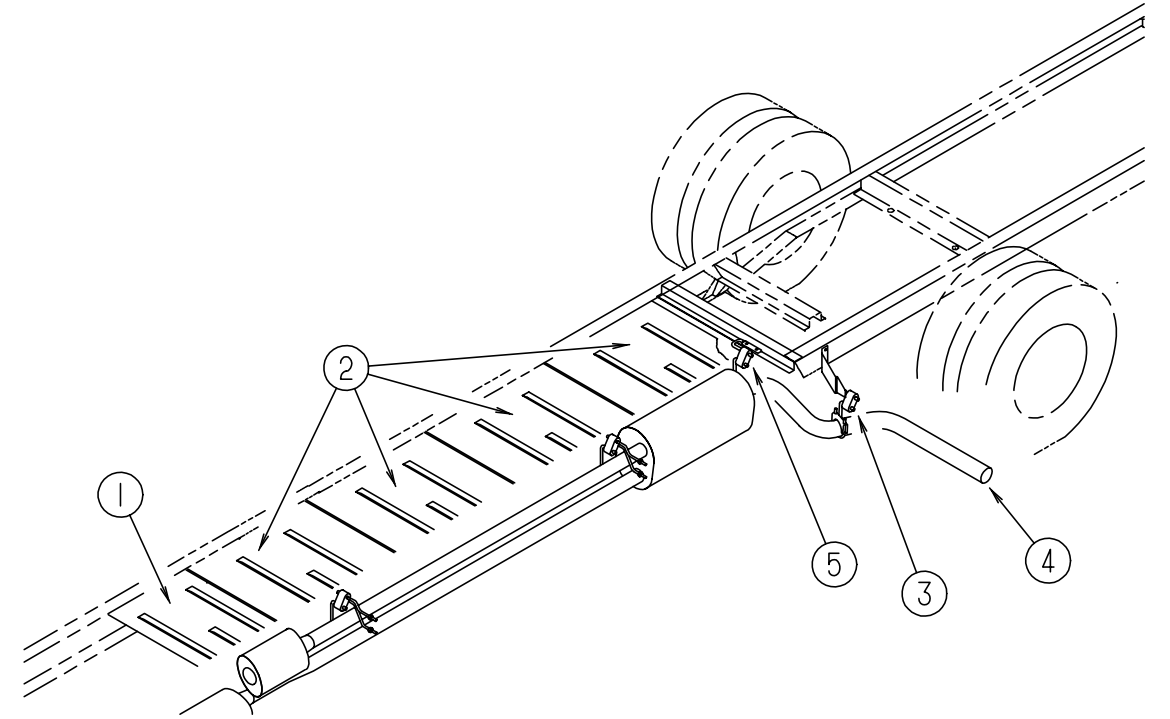

EXHAUST SYSTEM (CHEVY VORTEC)

KEY	PART NUMBER	U/M	DESCRIPTION
1	101544-01-000	EA	SHIELD - HEAT - EXHAUST - 19.7" X 28.9" - STEEL
2	101544-02-000	EA	SHIELD - HEAT - EXHAUST - 30" X 28.9" - STEEL
3	122392-03-02B	EA	HANGER - TAILPIPE - REAR
4	122529-02-000	EA	PIPE - EXHAUST
5	122392-01-02B	EA	HANGER - TAILPIPE

CHASSIS GROUP (CONTINUED)

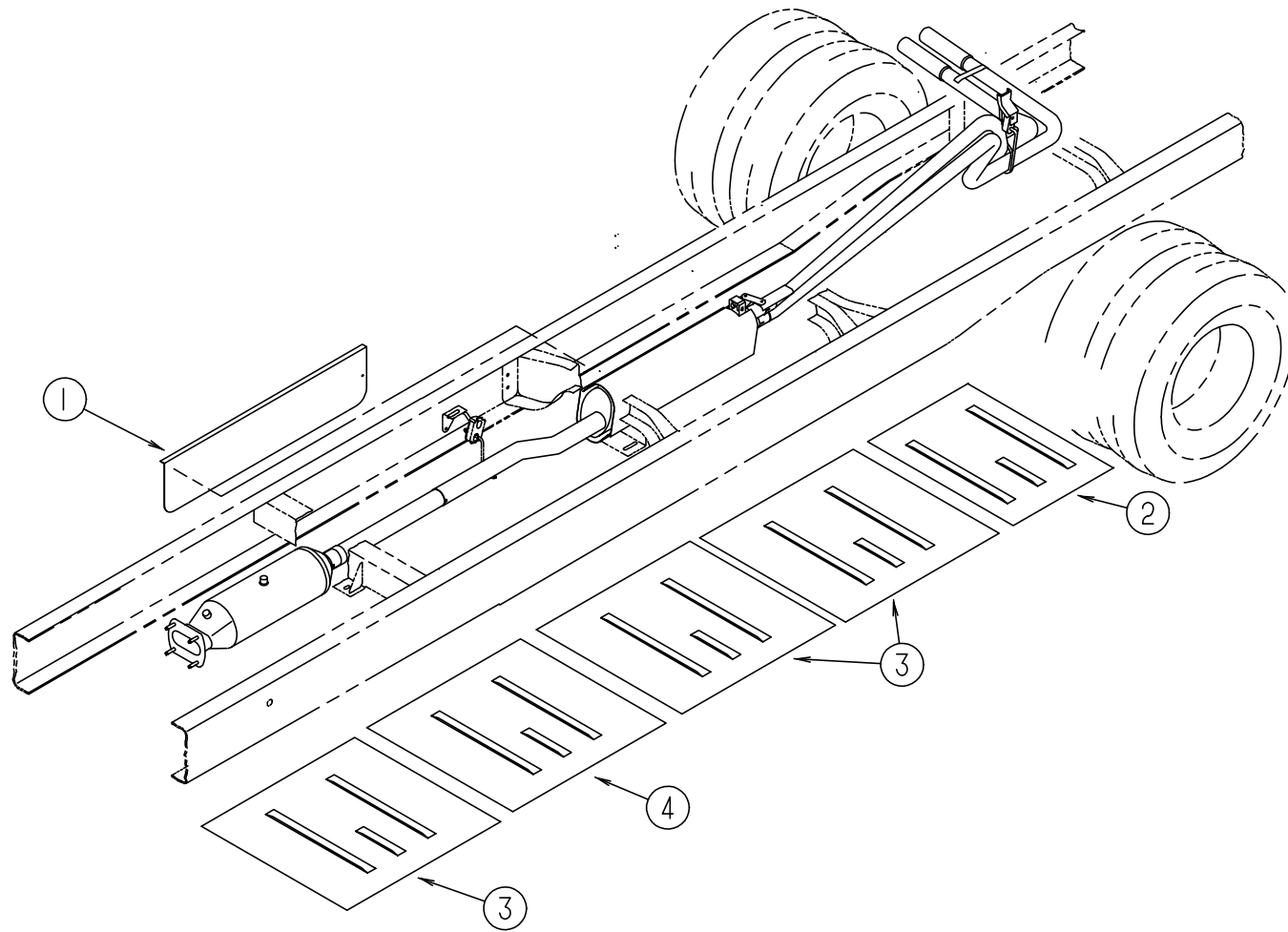

EXHAUST SYSTEM (FORD)

KEY	PART NUMBER	U/M DESCRIPTION
1	075307-03-000	EA SHIELD - HEAT - LP
2	101544-01-000	EA SHIELD - HEAT - EXHAUST - 19.7" X 28.9"
3	101544-06-000	EA SHIELD - HEAT - EXHAUST
4	101544-02-000	EA SHIELD - HEAT - EXHAUST

CHASSIS GROUP (CONTINUED)

CHEVY SHOCK ABSORBER

KEY	PART NUMBER	U/M DESCRIPTION	VENDOR NO.
	104993-02-000	EA SHOCK ABSORBER - GAS - P30 FRONT	
	N/A	EA SHOCK AND STABILIZER (BLUE BOOT) KIT - FRONT END P30 CHASSIS	
	122756-02-700	EA BRACKET ASM - DRIVERS SIDE	T818L
	122756-02-701	EA BRACKET ASM - PASSENGER SIDE	T818R
	122756-02-702	EA BRACKET ONLY - DRIVERS SIDE	T818L
	122756-02-703	EA BRACKET ONLY - PASSENGER SIDE	T818R
	122756-02-704	EA BOLT PACKAGE - BOLTS/NUTS ETC	T818R
	122756-02-705	EA SHOCK	T818SH
	122756-02-706	EA STUD - SHOCK MOUNTING	T818S
	122756-02-707	EA DAMPENER - STEERING	T818SD
	122756-02-708	EA BOOT - STEERING DAMPNER	T818SDB
	122756-02-709	EA BUSHING PKG - STEERING DAMPNER	T818SDBSH
	122756-02-710	EA BOLT PKG - STEERING DAMPNER	T818S

DRIVETRAIN

KEY	PART NUMBER	U/M DESCRIPTION
	088498-01-000	EA UNION - INVERTED FLARE - BRASS - 3/16

CHASSIS GROUP (CONTINUED)

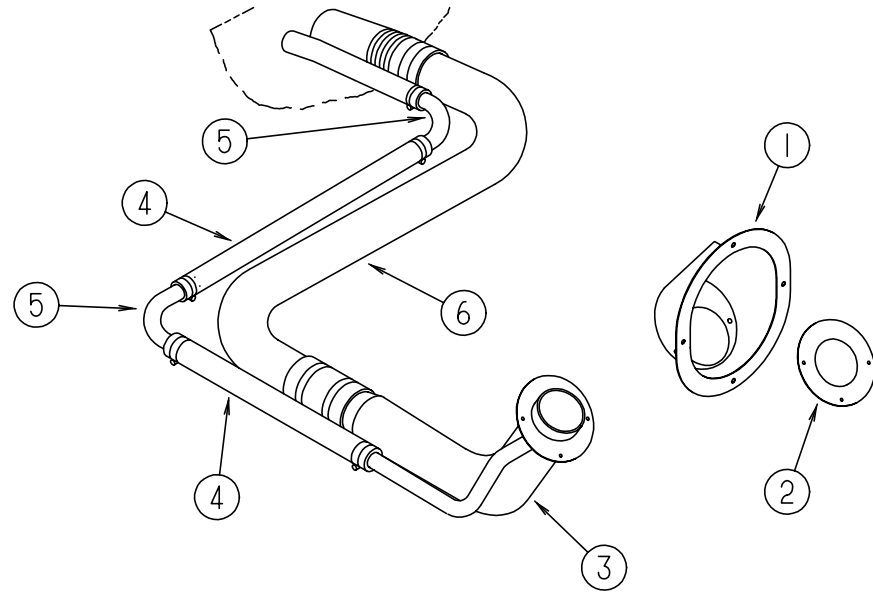

FUEL SYSTEM (FORD)

KEY	PART NUMBER	U/M	DESCRIPTION
1	095854-01-04A	EA	SHROUD - FUEL FILL - BRIGHT WHITE
2	078200-01-000	EA	GASKET - FUEL FILL - 3.5"OD X 2"ID
3	087256-07-000	EA	NECK ASM - FUEL FILL
4	066732-01-000	FT	HOSE - FUEL FILL - .62" ID
5	098806-01-000	EA	PIPE - FILL VENT - 90 DEGREE BEND - .625" OD - STEEL
6	100140-03-000	EA	TUBE - FUEL INLET
	007063-01-000	FT	HOSE - GAS 1/4"ID X 1/2"OD
	084884-01-000	EA	PLUG - BRASS - 3/8"
	007111-02-000	EA	HOSE - FUEL FILL - 2" ID - IN 3FT LENGTHS
	114254-01-000	EA	ADAPTER - 1/4 BARB X 1/8 MPT
	068382-06-000	EA	BUSHING - BRASS - 3/8 MPT X 1/8 FPT

CHASSIS GROUP (CONTINUED)

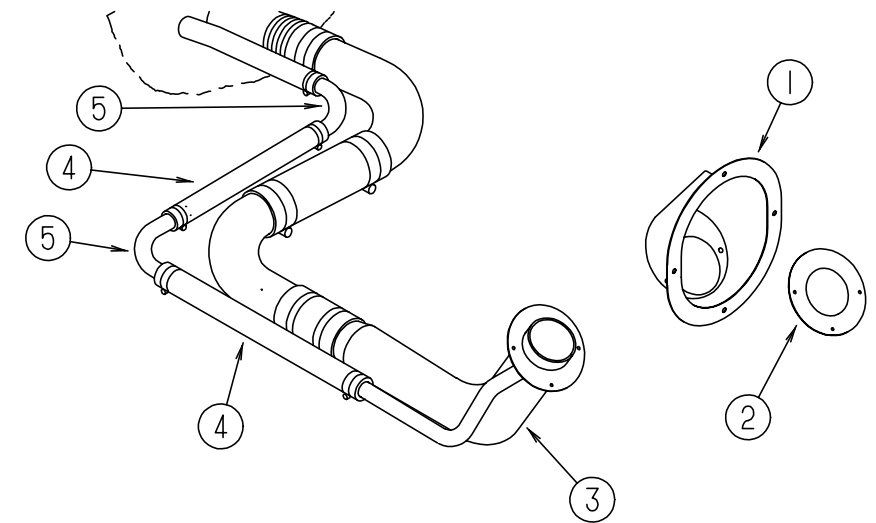

FUEL SYSTEM (CHEVY)

KEY	PART NUMBER	U/M	DESCRIPTION
1	095854-01-04A	EA	SHROUD - FUEL FILL - BRIGHT WHITE
2	078200-01-000	EA	GASKET - FUEL FILL - 3.5"OD X 2"ID
3	087256-10-000	EA	NECK ASM. - FUEL FILL
4	066732-01-000	FT	HOSE - FUEL FILL - .62" ID
5	098806-01-000	EA	PIPE - FILL VENT - 90 DEGREE BEND - .625" OD - STEEL
	098803-01-000	EA	PIPE - FUEL FILL - 90 DEGREE BEND - 13.2" - 1 3/4" OD - STEEL
	098807-01-000	EA	PIPE - FUEL FILL - 90 DEGREE BEND - 6.6" - 1 3/4" OD
	024138-01-000	FT	HOSE - FUEL - 5/16" ID
	084884-01-000	EA	PLUG - BRASS - 3/8"

CHASSIS GROUP (CONTINUED)

FORD WHEEL LINERS

KEY	PART NUMBER	U/M DESCRIPTION	VENDOR NO.
	110435-08-000	EA LINER - WHEEL SET (SET=4) 16"	
	110435-01-711	EA DECAL - CENTER CAP - 2"	2" DECAL
	110435-02-702	EA STUD EXTENDER	V160SD-STX
	110435-02-703	EA NUT (JAMB)	V160SD-JNT
	110435-02-704	EA COVER - LUG NUT	V160F0-LNC
	110435-02-705	EA TOOL F/ JAMB NUT - INSTALL.	V160FO-TOL
	110435-08-700	EA LINER - WHEEL - FRONT	V160SD-FWC
	110435-08-701	EA LINER - WHEEL - REAR	V160SD-RWC

FORD WHEEL COVERS

KEY	PART NUMBER	U/M DESCRIPTION	VENDOR NO.
	098532-01-000	EA COVER - WHEEL - FORD - 16" - SET OF 4 DICOR SH-SD-16	
	098532-01-700	EA COVER - LUG NUT (CHROME)	SHAU-LNC
	098532-01-701	EA COVER - WHEEL - FRT/REAR 1 ONLY	SH-SD

CHEVY WHEEL LINERS

KEY	PART NUMBER	U/M DESCRIPTION	VENDOR NO.
	110435-06-000	EA LINER - WHEEL SET (SET=4) 19.5" R/GM W/LONG STUDS	
		FROM: 00-00-00 THRU: 05-06-97	
	110435-01-711	EA DECAL - CENTER CAP, 2"	2" DECAL
	110435-02-703	EA NUT (JAMB)	V160SD-JNT
	110435-02-704	EA COVER - LUG NUT	V160F0-LNC
	110435-02-705	EA TOOL F/ JAMB NUT - INSTALL.	V160FO-TOL
	110435-06-700	EA LINER - WHEEL - FRONT	V195P5-FWC
	110435-06-701	EA LINER - WHEEL - REAR	V195P5-RWC
	110435-06-702	EA BRACKET - BRIDGE	V195P5-BRK
	110435-06-703	EA NUT - JAM - BRIDGE BRKT 1 1/16	V195P5-BJN
	110435-06-704	EA STUD EXTENDERS - P30	V195P5-STX
	110435-10-000	EA LINER - WHEEL - SET 4 - 19.5"	
		FROM: 05-07-97 THRU: 99-99-99	
	110435-10-700	EA LINER - WHEEL - FRONT - 1 PC	V195P7-FWC
	110435-10-701	EA LINER - WHEEL - REAR - 1 PC.	V195P7-RWC
	110435-10-702	EA JAMB NUT - ENCLOSED/LNC	V195P7-EJN
	110435-10-703	EA STUD - PLASTIC	V195P7-PST
	110435-10-704	EA JAMB NUT - PLASTIC/LNC	V195P7-PJN
	110435-10-705	EA TOOL - INSTALLATION	V195P7-TOL

CHEVY WHEEL COVERS

KEY	PART NUMBER	U/M DESCRIPTION	VENDOR NO.
	109443-01-000	EA WHEEL COVER SET - (EA = 4 WHEEL COVERS W/HARDWARE) 19.5"	
		FROM: 00-00-00 THRU: 12-20-96	
	109443-01-700	EA COVER - WHEEL 19.5 FRT/RR EA=1	SHAG95
	109443-01-701	EA BRACKET - RETENTION FRONT	SHAG95-FBS
	109443-01-702	EA BRACKET - RETENTION REAR	SHAG95-RBS
	109443-01-703	EA CAP - CENTER - HUB - DICOR	SHAU95-CAP
	109443-01-704	EA CLIP - RETAINER	V160GM-PNT
	109443-06-000	EA WHEEL - COVER - 4/SET - 19.5"	
		FROM: 12-21-96 THRU: 99-99-99	
	109443-01-700	EA COVER - WHEEL 19.5 FRT/RR EA=1	SHAG95
	109443-01-701	EA BRACKET - RETENTION FRONT	SHAG95-FBS
	109443-01-703	EA CAP - CENTER - HUB - DICOR	SHAU95-CAP
	109443-01-704	EA CLIP - RETAINER	V160GM-PNT
	109443-06-701	EA BRACKET - RETENTION REAR	SHG795-RBS

CHASSIS GROUP (CONTINUED)

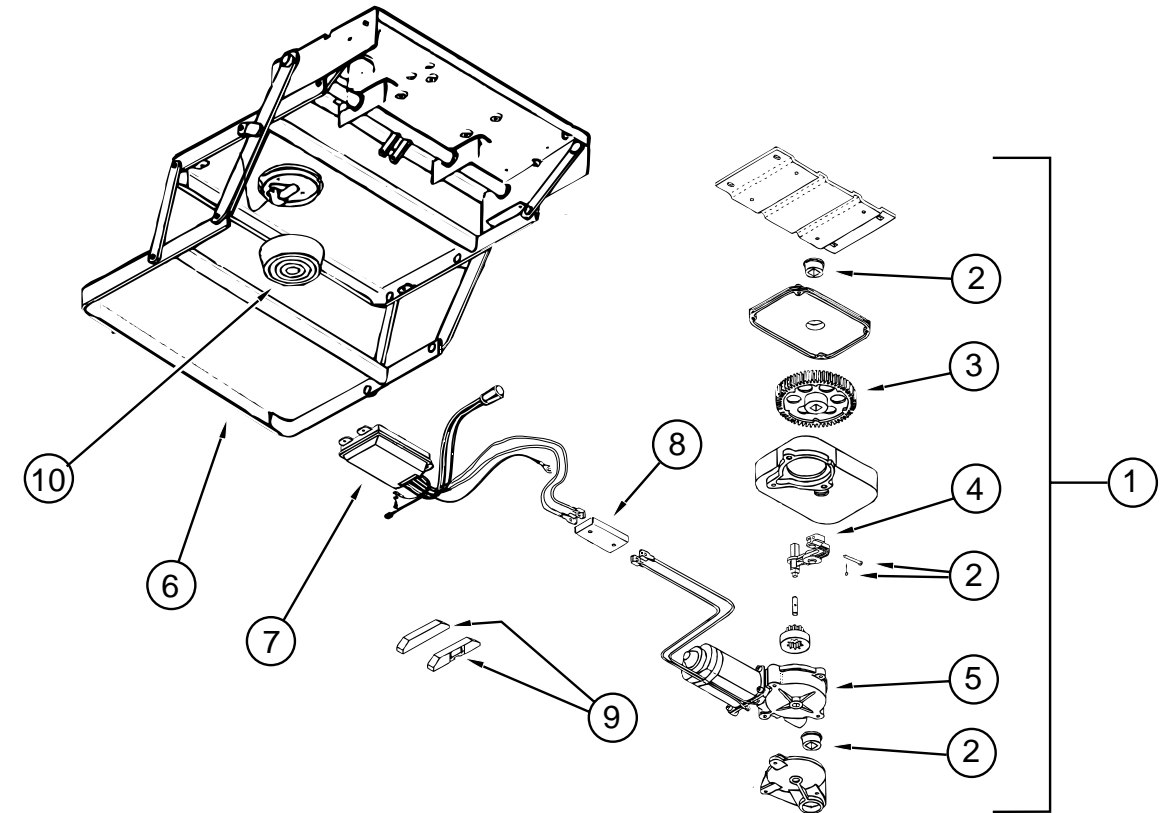

STEP ASSEMBLY (3200 SERIES)

KEY	PART NUMBER	U/M DESCRIPTION	VENDOR NO.
1	094707-01-01A	EA STEP ASSEMBLY W/O SWITCH	
2	094707-02-703	EA BEARINGS & PINS	909530
3	094707-02-702	EA GEAR KIT - W/ BEARINGS & PIN-CASE	909525
4	094707-02-701	EA LINKAGE ASSEMBLY - W/ BEARINGS & PINS	909534
5	094707-02-700	EA MOTOR ASSEMBLY - W/ BEARINGS & PINS	909520
6	094707-01-702	EA FRAME W/ DOUBLE STEP	908032
7	094707-02-705	EA CONTROL UNIT - WHITE	909513
8	094707-02-704	EA CONNECTOR - MOTOR ASSEMBLY - W/ PLATES	909537
9	116995-01-000	EA SWITCH/ MAGNET - ELECTRIC	
10	088746-01-705	EA LIGHT - UNDER STEP	9004
	088733-01-700	EA BULB	9004
	094707-02-707	EA TREAD - NON SKID - BLACK - 6"X21"	909333
	094707-02-708	EA TREAD - NON SKID - YELLOW	909331
	104452-03-000	EA SUPPORT - STEP	

FROM: 12-20-96 THRU: 99-99-99

CURTAIN & CUSHION GROUP

NOTICE

IN ORDER TO ASSIST OUR PARTS SALES DEPT. IN PROVIDING INTERIOR SOFTGOODS ITEMS, PLEASE INCLUDE THE SERIAL NUMBER AND THE COLOR CODE NUMBER FROM THE VEHICLE CERTIFICATION LABEL WHEN ORDERING. THIS LABEL IS LOCATED ON THE LEFT SIDEWALL AT THE END OF THE DASH (A-BODY), OR ON THE DRIVER'S DOOR LATCH PLATE (C-BODY).

AN EXAMPLE OF A COLOR CODE NUMBER IS B07, WHICH DESIGNATES AN OVERALL COLOR SCHEME OF A PARTICULAR UNIT. THE COLOR LISTED AFTER THE ITEM DESCRIPTION ON THE MICROFICHE, INDICATES THE OVERALL UNIT COLOR. ORDER THE ITEM YOU DESIRE ACCORDING TO UNIT COLOR CODE.

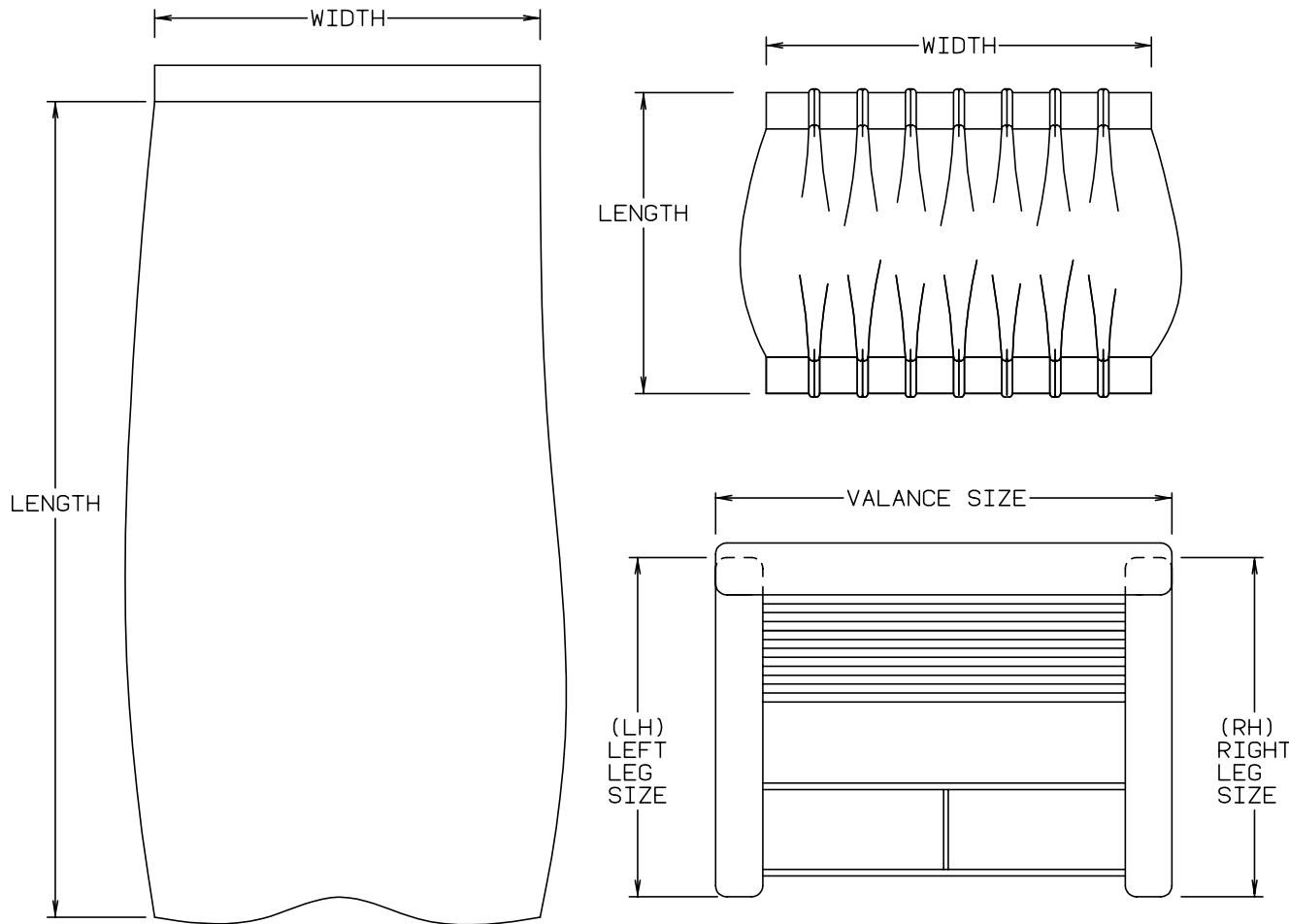

NOTE: USE THIS ILLUSTRATION WHEN DETERMINING LENGTH AND WIDTH MEASUREMENTS FOR CURTAINS. YOU WILL NOTE THE WIDTH MEASUREMENT IS TAKEN ON THE TOP OF THE CURTAIN WITH THE CURTAIN FULLY EXTENDED. THE LENGTH MEASUREMENT IS TAKEN FROM TOP TO BOTTOM. LEFT AND RIGHT WINDOW LEGS ARE DETERMINED WHEN FACING THE WINDOW.

CURTAIN & CUSHION GROUP (CONTINUED)

SUNCRUISER FABRICS			
COLOR CODES	H37, H47	H38, H48	H39, H49
MARKETING COLORS	COZUMEL (BLUE/MULT))	FOREST FLOOR (TAUPE)	REGENCY (BLUE)
MAIN	108446-L5-000	108446-L6-000	108446-L1-000
PLAIN ACCENT	108446-M6-000	108446-L7-000	108446-L2-000
PATTERN ACCENT	108446-48-000	108446-L7-000	108446-L2-000
BUCKET SEAT	108446-M6-000	108446-L7-000	108446-L2-000
DINETTE	108446-L5-000	108446-L6-000	108446-L1-000
DINETTE PAD	108446-M6-000	108446-L7-000	108446-L2-000
DINETTE SWIVEL CHAIR	108446-48-000	108446-L7-000	108446-L2-000
SOFA	108446-L5-000	108446-L6-000	108446-L1-000
SWIVEL CHAIR LOUNGE	108446-48-000	108446-L7-000	108446-L2-000
LOUNGE WINDOW VALANCE	108446-L5-000	108446-L6-000	108446-L1-000
LOUNGE WINDOW LEGS	108446-48-000	108446-L7-000	108446L2-000
BEDSPREAD MAIN	105745-E1-000	105745-E4-000	105745-D6-000
BEDSPREAD ACCENT	105745-E3-000	105745-D0-000	105745-64-000
BEDSPREAD TRIM	084415-80-000	084415-83-000	084415-78-000
BEDROOM WINDOW VALANCE	105745-E1-000	105745-E4-000	105745-D6-000
BEDROOM WINDOW LEGS	105745-E3-000	105745-D0-000	105745-64-000
LOUNGE PILLOW TRIM BRAID	108446-L5-000 084415-80-000	108446-L6-000 084415-83-000	108446-L1-000 084415-78-000
MAP POCKETS	108446-M6-000	108446-L7-000	108446-L2-000
FRONT CURTAIN WRAP AROUND	072333-85-000	072333-85-000	072333-88-000
CEILING	113979-01-99A	113979-01-99A	113979-01-99A

NOTE: THE FABRIC LISTED FIRST, IN A BLOCK, IS THE LARGEST QUANTITY OF FABRIC USED

ASSIST HANDLE & BUTTONS

KEY	PART NUMBER	U/M	DESCRIPTION
	070578-02-G35	EA	BUTTON - #30 - VINYL
	053552-02-AA8	EA	HANDLE - ASSIST - INTERIOR/ ENTRY DOOR - VINYL/ OFF WHITE
	057759-01-000	EA	WASHER BRACKET - SEAT BELT - 4" DIAMETER
	007021-01-000	EA	BELT - SEAT - 2" X 90" - BLACK
	069178-02-000	EA	BRACKET - MOUNTING ASSIST HANDLE
	000C16-07-16B	EA	BOLT - CARRIAGE - ASSIST HANDLE - 7/16" - 14 X 1"
	000D20-07-00B	EA	NUT - ACORN - ASSIST HANDLE - 7/16 - 14
	057534-03-000	EA	TIEBACK - PLASTIC - 7.50" - CLEAR

CURTAIN & CUSHION GROUP (CONTINUED)

CURTAINS & WINDOW TREATMENT

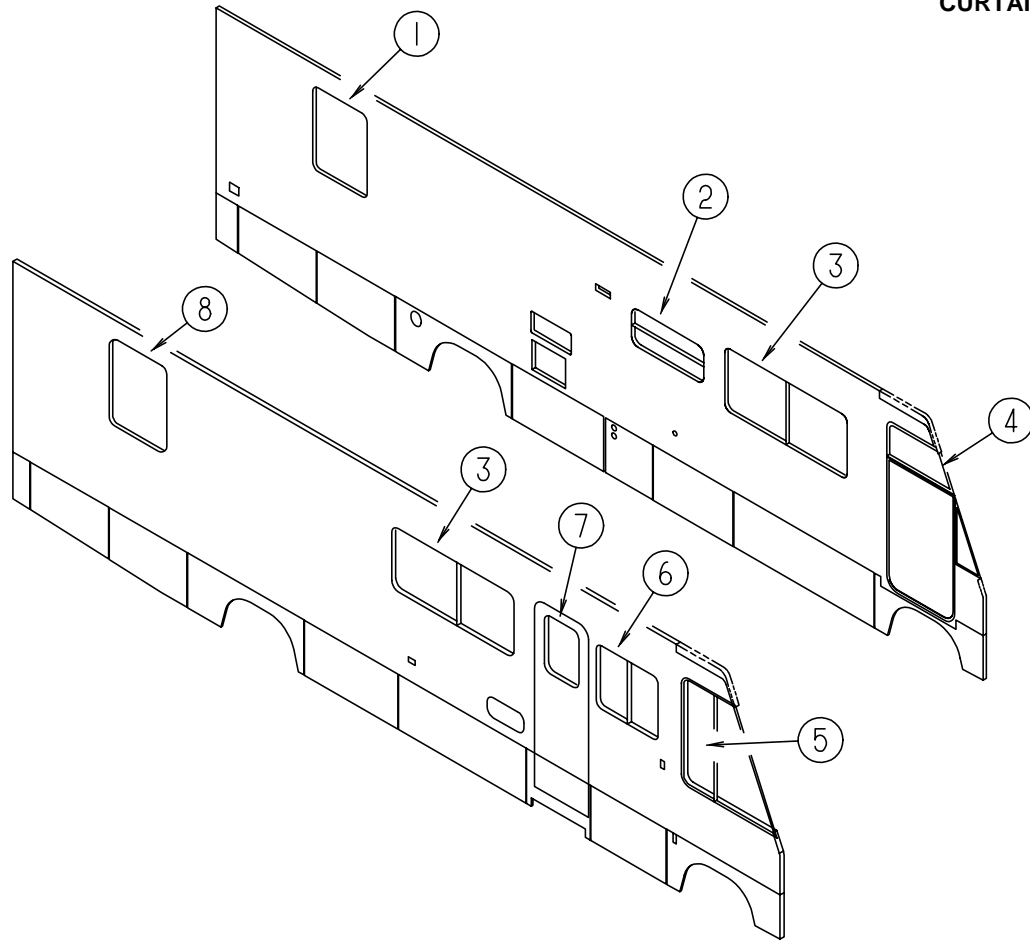

KEY	PART NUMBER	U/M DESCRIPTION
1	119299-12-H37	EA VALANCE - WHITNEY - 34" (H37, H47)
1	119138-33-H38	EA VALANCE - BELLINI - 34" (H38, H48)
1	119262-58-H39	EA VALANCE - MONACO - 34" (H39, H49)
1	111910-51-H37	EA BLIND - DAY/NIGHTER - 30" X 37" (H37, H47, H39, H49)
1	111910-51-H38	EA BLIND - DAY/NIGHTER - 30" X 37" (H38, H48)
		FROM: 00-00-00 THRU: 10-27-96
1	111910-51-HA3	EA BLIND - DAY/NIGHTER - 30" X 37" (H38, H48)
		FROM: 10-27-96 THRU: 99-99-99
1	119333-97-H37	EA LEG - RIGHT - 34" (H37, H47)
1	123910-01-H38	EA LEG - RIGHT - 34" (H38, H48)
1	119333-93-H39	EA LEG - RIGHT - 34" (H39, H49)
1	119333-98-H37	EA LEG - LEFT - 34" (H37, H47)
1	123910-02-H38	EA LEG - LEFT - 34" (H38, H48)
1	119333-94-H39	EA LEG - LEFT - 34" (H39, H49)
2	109041-44-01A	EA BLIND - MINI - 30.5" X 18" (H37, H47, H39, H49)
2	109041-44-02A	EA BLIND - MINI - 30.5" X 18" (H38, H48)
	109353-04-000	EA CLIP - VALANCE SLAT MOUNTING - CLEAR PLASTIC
3	119263-01-H37	EA VALANCE - STARBUCK - 64.5" (H37, H47)
3	119136-23-H38	EA VALANCE - STANWICK - 64.5" (H38, H48)
3	119262-39-G45	EA VALANCE - MONACO - 64.5" (H39, H49)
3	109802-38-G45	EA BLIND - PLEATED - 60" X 30" (H37, H47, H39, H49)
3	109802-38-F32	EA BLIND - PLEATED - 60" X 30" (H38, H48)
3	119333-01-H37	EA LEG - RIGHT - 25" (H37, H47)
3	119333-01-H38	EA LEG - RIGHT - 25" (H38, H48)
3	119333-01-G45	EA LEG - RIGHT - 25" (H39, H49)
3	119333-02-H37	EA LEG - LEFT - 25" (H37, H47)
3	119333-02-H38	EA LEG - LEFT - 25" (H38, H48)
3	119333-02-G45	EA LEG - LEFT - 25" (H39, H49)

KEY	PART NUMBER	U/M DESCRIPTION
4	101668-46-E91	EA CURTAIN - LEFT HAND - 48" X 95" (H37, H38, H47, H48)
4	101668-46-F87	EA CURTAIN - LEFT HAND - 48" X 95" (H39, H49)
5	101668-45-E91	EA CURTAIN - RIGHT HAND - 48" X 95" (H37, H38, H47, H48)
5	101668-45-E91	EA CURTAIN - RIGHT HAND - 48" X 95" (H39, H49)
	073260-42-C18	EA TIEBACK - 6" X 18" (H37, H38, H47, H48)
	073260-42-C17	EA TIEBACK - 6" X 18" (H39, H49)
6	119263-02-H37	EA VALANCE - STARBUCK - 34.5" (H37, H47)
6	119138-24-H38	EA VALANCE - BELLINI - 34" (H38, H48)
6	119262-42-G45	EA VALANCE - MONACO - 34.5" (H39, H49)
6	109802-39-H37	EA BLIND - PLEATED - 30" X 30" (H37, H47, H39, H49)
6	109802-39-F32	EA BLIND - PLEATED - 30" X 30" (H38, H48)
6	119333-01-H37	EA LEG - RIGHT - 25" (H37, H47)
6	119333-01-H38	EA LEG - RIGHT - 25" (H38, H48)
6	119333-01-G45	EA LEG - RIGHT - 25" (H39, H49)
6	119333-02-H37	EA LEG - LEFT - 25" (H37, H47)
6	119333-02-H38	EA LEG - LEFT - 25" (H38, H48)
6	119333-02-G45	EA LEG - LEFT - 25" (H39, H49)
7	119263-03-H37	EA VALANCE - STARBUCK - 30.35" (H37, H47)
7	119136-26-H38	EA VALANCE - FLAT STANWICK - 15" X 30.25" (H38, H48)
7	119262-41-G45	EA VALANCE - MONACO - 15" X 30.25" (H39, H49)
7	084755-57-E07	EA SHADE - PULL - 27.25"
8	119299-08-H37	EA VALANCE - WHITNEY - 34" (H37, H47)
8	119138-28-H38	EA VALANCE - BELLINI - 34" (H38, H48)
8	119262-53-H39	EA VALANCE - MONACO - 34" (H39, H49)
8	111910-51-H37	EA BLIND - DAY/NIGHTER - 30" X 37" (H37, H47, H39, H49)
8	111910-51-H38	EA BLIND - DAY/NIGHTER - 30" X 37" (H38, H48)
		FROM: 00-00-00 THRU: 10-27-96
8	111910-51-HA3	EA BLIND - DAY/NIGHTER - 30" X 37" (H38, H48)
		FROM: 10-27-96 THRU: 99-99-99
8	119333-25-H37	EA LEG - RIGHT - 34" (H37, H47)
8	119333-21-H38	EA LEG - RIGHT - 34" (H38, H48)
8	119333-91-H39	EA LEG - RIGHT - 34" (H39, H49)
8	119333-26-H37	EA LEG - LEFT - 34" (H37, H47)
8	119333-22-H38	EA LEG - LEFT - 34" (H38, H48)
8	119333-92-H39	EA LEG - LEFT - 34" (H39, H49)

CURTAIN & CUSHION GROUP (CONTINUED)

DRIVER BUCKET SEAT

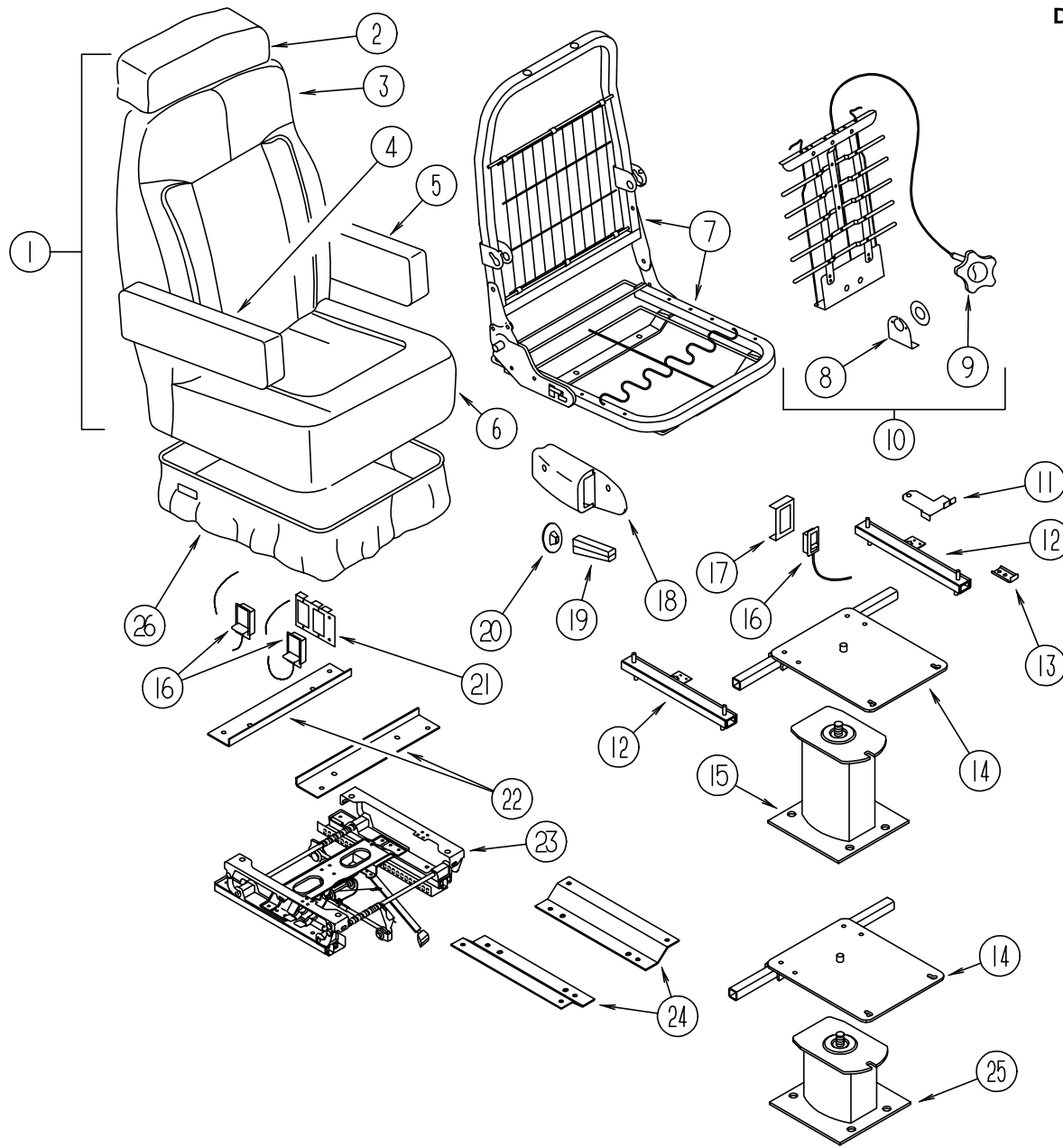

KEY	PART NUMBER	U/M	DESCRIPTION
1	122738-01-H37	EA	SEAT - BUCKET - DRIVER - W/LUMBAR/HEADREST/ARMRESTS (H37, H47)
1	122738-01-H38	EA	SEAT - BUCKET - DRIVER - W/LUMBAR/HEADREST/ARMRESTS (H38, H48)
1	122738-01-H39	EA	SEAT - BUCKET - DRIVER - W/LUMBAR/HEADREST/ARMRESTS (H39, H49)
2	119509-01-H37	EA	HEADREST - BUCKET SEAT (H37, H47)
2	119509-01-H38	EA	HEADREST - BUCKET SEAT (H38, H48)
2	119509-01-H39	EA	HEADREST - BUCKET SEAT (H39, H49)
2	P19509-01-H37	EA	COVER - HEADREST (H37, H47)
2	P19509-01-H38	EA	COVER - HEADREST (H38, H48)
2	P19509-01-H39	EA	COVER - HEADREST (H39, H49)
	113977-12-000	EA	INSERT/HEADREST - W/O LOCK
	113977-13-000	EA	INSERT/HEADREST - W/LOCK
	114791-03-000	EA	FRAME - HEADREST
3	M05962-37-H37	EA	COVER - BACK (H37, H47)
3	M05962-37-H38	EA	COVER - BACK (H38, H48)
3	M05962-37-H39	EA	COVER - BACK (H39, H49)
	089323-01-000	FT	STRIP - POLYENTHYLENE - J-CHANNEL

KEY	PART NUMBER	U/M	DESCRIPTION	VENDOR NO.
4	122780-01-H37	EA	ARMREST - RIGHT HAND (H37, H47)	
4	122780-01-H38	EA	ARMREST - RIGHT HAND (H38, H48)	
4	122780-01-H39	EA	ARMREST - RIGHT HAND (H39, H49)	
4	P22780-01-H37	EA	COVER - ARMREST - RIGHT HAND (H37, H47)	
4	P22780-01-H38	EA	COVER - ARMREST - RIGHT HAND (H38, H48)	
4	P22780-01-H39	EA	COVER - ARMREST - RIGHT HAND (H39, H49)	
4	115617-03-000	EA	ARMREST - W/O COVER - RIGHT HAND	
5	122780-02-H37	EA	ARMREST - LEFT HAND (H37, H47)	
5	122780-02-H38	EA	ARMREST - LEFT HAND (H38, H48)	
5	122780-02-H39	EA	ARMREST - LEFT HAND (H39, H49)	
5	P22780-02-H37	EA	COVER - ARMREST - LEFT HAND (H37, H47)	
5	P22780-02-H38	EA	COVER - ARMREST - LEFT HAND (H38, H48)	
5	P22780-02-H39	EA	COVER - ARMREST - LEFT HAND (H39, H49)	
5	115617-04-000	EA	ARMREST - W/O COVER - LEFT HAND	
6	M05962-38-H37	EA	COVER - SEAT (H37, H47)	
6	M05962-38-H38	EA	COVER - SEAT (H38, H48)	
6	M05962-38-H39	EA	COVER - SEAT (H39, H49)	
7	122695-01-01B	EA	FRAME - SEAT/BACK	
8	122611-01-702	EA	LUMBAR - BRACKET	157C-90
	122611-01-703	EA	LUMBAR - SCREW	210
9	122611-01-701	EA	LUMBAR - KNOB	218
10	122611-01-000	EA	LUMBAR	
11	117125-01-02B	EA	BRACKET - CABLE MOUNT - ADJUSTER W/LOCK	
12	119952-06-000	EA	SLIDE/SEAT - HEAVY DUTY LOCKING - 4 STUDS	
	119952-07-000	EA	WIRE - LATCH RELEASE/ROTARY	
13	114889-01-000	EA	STOP BAR - UNIVERSAL	
14	107921-05-000	EA	PLATE - TOP - W/SEAT BELT BAR	
	107921-06-000	EA	BEARING KIT - PEDESTAL	
15	107921-01-000	EA	PEDESTAL/FLOOR MOUNTED - W/9.75" EXTENSION	
16	108049-03-000	EA	CABLE/CONTROL 25.5" SHEATH/28.5" CABLE W/DOG LEG	
	108049-02-000	EA	CLIP - CABLE/PEDESTAL	
17	097683-03-000	EA	BRACKET - REMOTE/SIDE MOUNT - SINGLE	
18	080730-09-000	EA	SHIELD - RECLINER HANDLE	
19	080730-08-000	EA	HANDLE - RECLINER	
20	080730-11-000	EA	SHIELD - RUBBER BOOT	
21	097683-02-000	EA	BRACKET - REMOTE/SIDE MOUNT - DOUBLE	
22	116215-02-000	EA	PLATE - UPPER - 6-WAY MANUAL CONTROL	
	007221-01-000	EA	SPACER - SEAT/ADJUSTER	
23	116215-01-000	EA	PLATE - UPPER PEDESTAL - 6-WAY MANUAL - DRIVER	
24	116215-03-000	EA	PLATE - LOWER - 6-WAY MANUAL CONTROL	
25	107921-07-000	EA	PEDESTAL BASE - POWER	
26	071126-59-H37	EA	SKIRT - SINGLE - 10.5" - W/SEAT BELT SLOT (H37, H47)	
26	071126-59-H38	EA	SKIRT - SINGLE - 10.5" - W/SEAT BELT SLOT (H38, H48)	
26	071126-59-H39	EA	SKIRT - SINGLE - 10.5" - W/SEAT BELT SLOT (H39, H49)	
26	071126-61-H37	EA	SKIRT - SINGLE - 10.5" - 6-WAY MANUAL (H37, H47)	
26	071126-61-H38	EA	SKIRT - SINGLE - 10.5" - 6 WAY MANUAL (H38, H48)	
26	071126-61-H39	EA	SKIRT - SINGLE - 10.5" - 6 WAY MANUAL (H39, H49)	

CURTAIN & CUSHION GROUP (CONTINUED)

PASSENGER BUCKET SEAT

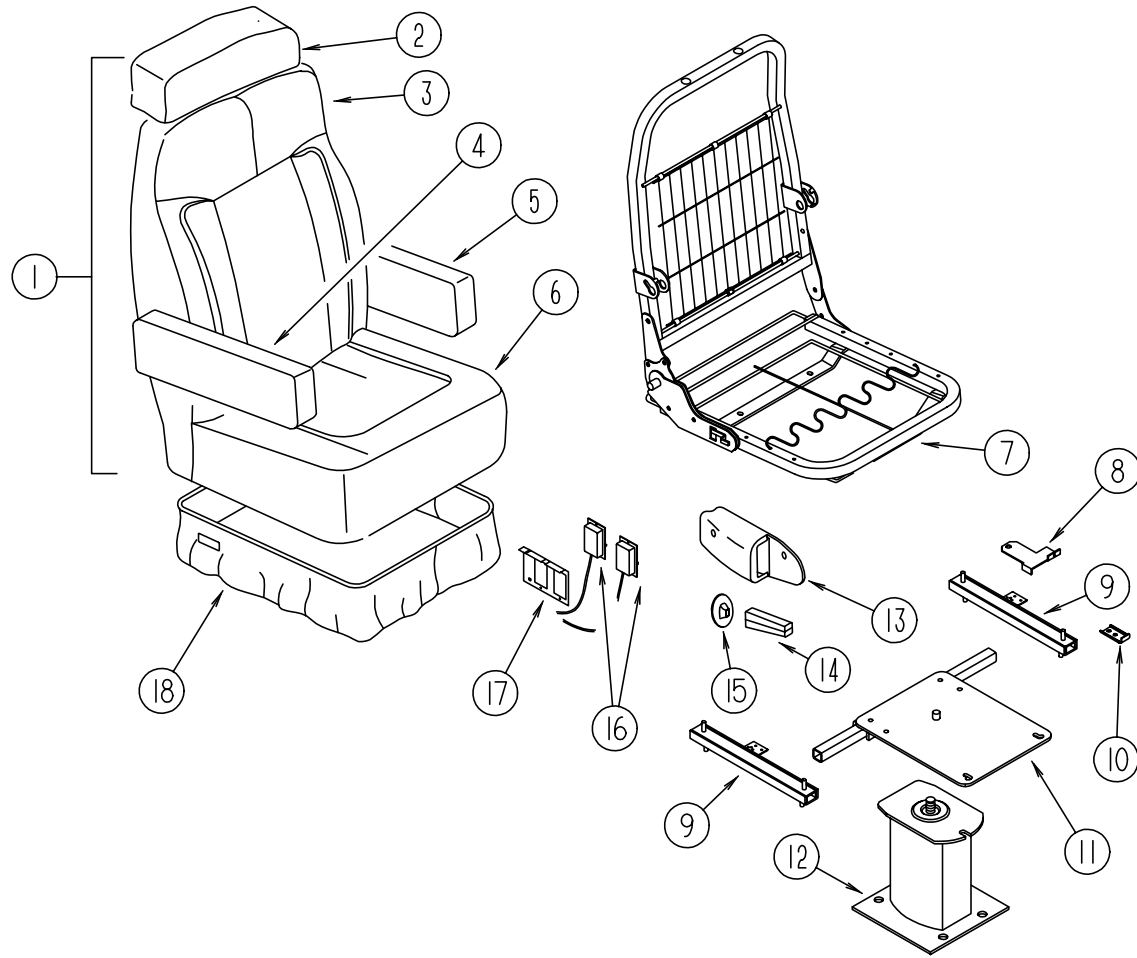

KEY	PART NUMBER	U/M	DESCRIPTION
1	122738-02-H37	EA	SEAT - BUCKET (H37, H47)
1	122738-02-H38	EA	SEAT - BUCKET (H38, H48)
1	122738-02-H39	EA	SEAT - BUCKET (H39, H49)
2	119509-01-H37	EA	HEADREST - BUCKET SEAT (H37, H47)
2	119509-01-H38	EA	HEADREST - BUCKET SEAT (H38, H48)
2	119509-01-H39	EA	HEADREST - BUCKET SEAT (H39, H49)
2	P19509-01-H37	EA	COVER - HEADREST F/ BUCKET SEAT (H37, H47)
2	P19509-01-H38	EA	COVER - HEADREST F/ BUCKET SEAT (H38, H48)
2	P19509-01-H39	EA	COVER - HEADREST F/ BUCKET SEAT (H39, H49)
	113977-12-000	EA	HEADREST INSERT - W/O LOCK
	113977-13-000	EA	HEADREST INSERT - W/ LOCK
	114791-03-000	EA	FRAME - HEADREST
3	M05962-37-H37	EA	COVER - BACK - BUCKET (H37, H47)
3	M05962-37-H38	EA	COVER - BACK - BUCKET (H38, H48)
3	M05962-37-H39	EA	COVER - BACK - BUCKET (H39, H49)
4	122780-01-H37	EA	ARMREST - RIGHT HAND (H37, H47)
4	122780-01-H38	EA	ARMREST - RIGHT HAND (H38, H48)
4	122780-01-H39	EA	ARMREST - RIGHT HAND (H39, H49)
4	P22780-01-H37	EA	COVER - ARMREST - RIGHT HAND (H37, H47)
4	P22780-01-H38	EA	COVER - ARMREST - RIGHT HAND (H38, H48)
4	P22780-01-H39	EA	COVER - ARMREST - RIGHT HAND (H39, H49)
4	115617-03-000	EA	ARMREST - W/O COVER - RIGHT
5	122780-02-H37	EA	ARMREST - LEFT HAND (H37, H47)
5	122780-02-H38	EA	ARMREST - LEFT HAND (H38, H48)
5	122780-02-H39	EA	ARMREST - LEFT HAND (H39, H49)
5	P22780-02-H37	EA	COVER - ARMREST - LEFT HAND (H37, H47)
5	P22780-02-H38	EA	COVER - ARMREST - LEFT HAND (H38, H48)
5	P22780-02-H39	EA	COVER - ARMREST - LEFT HAND (H39, H49)
5	115617-04-000	EA	ARMREST - W/O COVER - LEFT
6	M05962-38-H37	EA	COVER - SEAT - BUCKET (H37, H47)
6	M05962-38-H38	EA	COVER - SEAT - BUCKET (H38, H48)
6	M05962-38-H39	EA	COVER - SEAT - BUCKET (H39, H49)
7	122695-01-01B	EA	FRAME ASM - SEAT & BACK - WIDE - ML
8	117125-01-02B	EA	BRACKET - CABLE MOUNT - ADJUSTER W/ LOCK
9	119952-06-000	EA	SLIDE - SEAT HEAVY DUTY LOCKING - 4 STUDS
	119952-07-000	EA	WIRE - LATCH RELEASE/ ROTARY
10	114889-01-000	EA	STOP BAR - UNIVERSAL
11	107921-05-000	EA	PLATE TOP - W/ SEAT BELT BAR
	107921-06-000	EA	BEARING KIT - PEDESTAL
12	107921-01-000	EA	PEDESTAL FLOOR MOUNTED - W/9.75" EXTENSION
13	080730-09-000	EA	SHIELD - RECLINER HANDLE
14	080730-08-000	EA	HANDLE - RECLINER
15	080730-11-000	EA	SHIELD - RUBBER BOOT
16	108049-03-000	EA	CABLE - W/ CONTROL 25.5" SHEATH/ 28.5" CABLE W/ DOG LEG
	108049-02-000	EA	CLIP - CABLE/ PEDESTAL
17	097683-02-000	EA	BRACKET - REMOTE SIDE MOUNT - DOUBLE
18	071126-59-H37	EA	SKIRT - SINGLE 10.5" - W/SEAT BELT SLOT (H37, H47)
18	071126-59-H38	EA	SKIRT - SINGLE 10.5" - W/SEAT BELT SLOT (H38, H48)
18	071126-59-H39	EA	SKIRT - SINGLE 10.5" - W/SEAT BELT SLOT (H39, H49)

CURTAIN & CUSHION GROUP (CONTINUED)

SWIVEL CHAIR (RECLINER)

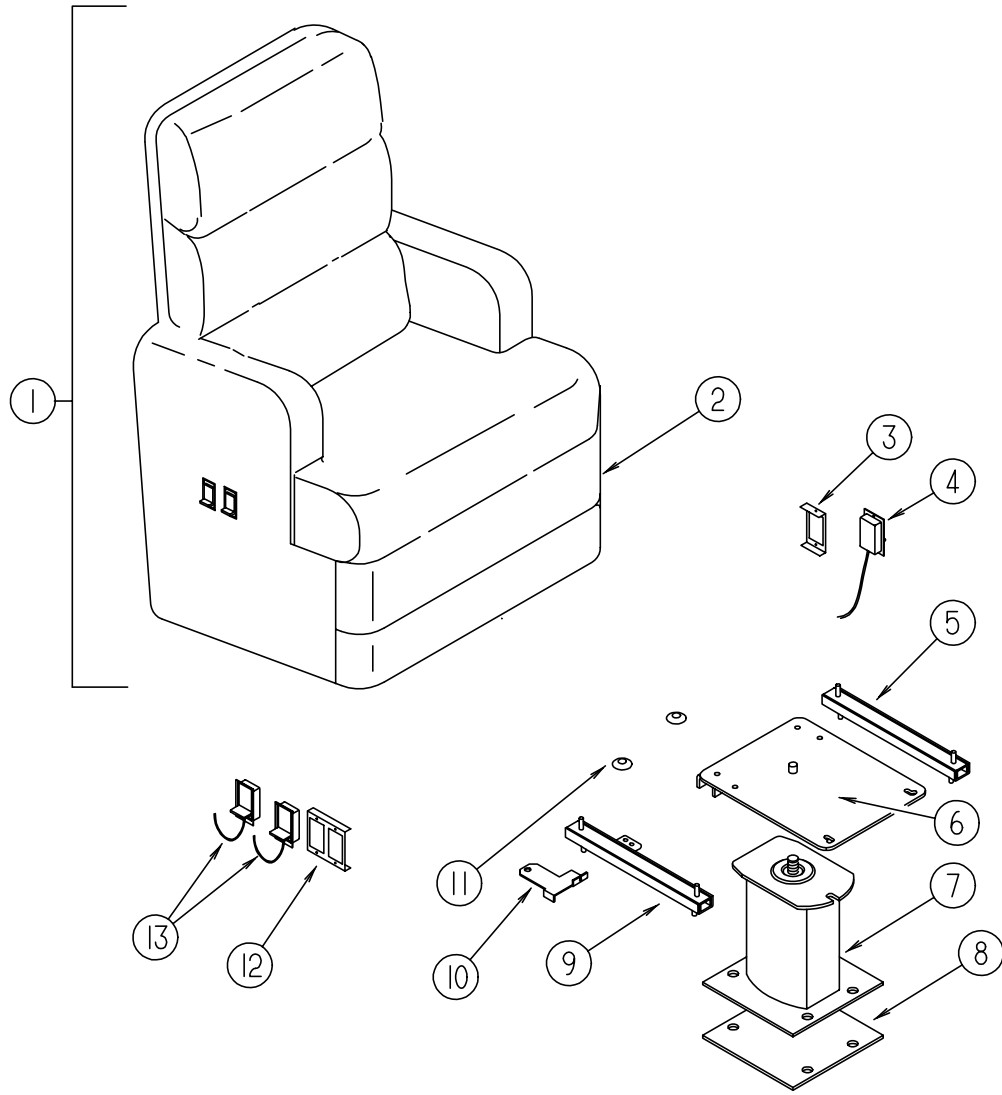

KEY	PART NUMBER	U/M	DESCRIPTION
1	118538-01-H37	EA	CHAIR - RECLINER W/SKIRT (H37, H47)
1	118538-01-H38	EA	CHAIR - RECLINER W/SKIRT (H38, H48)
1	118538-01-H39	EA	CHAIR - RECLINER W/SKIRT (H39, H49)
1	P18538-01-H37	EA	COVER - RECLINER CHAIR (H37, H47)
1	P18538-01-H38	EA	COVER - RECLINER CHAIR (H38, H48)
1	P18538-01-G45	EA	COVER - RECLINER CHAIR (H39, H49)
	P18538-27-H37	EA	COVER - ARMREST - UNIVERSAL - SWIVEL CHAIR (H37, H47)
	P18538-27-H38	EA	COVER - ARMREST - UNIVERSAL - SWIVEL CHAIR (H38, H48)
	P18538-27-H39	EA	COVER - ARMREST - UNIVERSAL - SWIVEL CHAIR (H39, H49)
2	118539-01-H37	EA	SKIRT - RECLINER CHAIR (H37, H47)
2	118539-01-H38	EA	SKIRT - RECLINER CHAIR (H38, H48)
2	118539-01-G45	EA	SKIRT - RECLINER CHAIR (H39, H49)
3	097683-03-000	EA	BRACKET - REMOTE SIDE MOUNT - SINGLE
4	089368-05-000	EA	CABLE - W/ SWITCH 25.5" SHEATH-29 3/4" CABLE W/ DOG LEG
	108049-02-000	EA	CLIP - PEDESTAL CABLE
5	119952-02-000	EA	SLIDE - SEAT - HEAVY DUTY NONLOCKING
6	107921-08-000	EA	TOP PLATE - PEDESTAL - W/O SEATBELT BAR
7	107921-01-000	EA	FLOOR MOUNTED PEDESTAL - W/9.75" EXTENSION
8	108445-02-000	EA	SUB PLATE - FLOOR MOUNTED PEDESTAL
	107921-06-000	EA	BEARING KIT - PEDESTAL
9	119952-04-000	EA	SLIDE - SEAT - HEAVY DUTY LOCKING
10	117125-01-02B	EA	BRACKET - CABLE MOUNT - ADJUSTER W/LOCK
11	007221-01-000	EA	SPACER - SEAT ADJUSTER
12	097683-02-000	EA	BRACKET - REMOTE SIDE MOUNT - DOUBLE
13	108049-03-000	EA	CABLE - W/ CONTROL 25.5" SHEATH/ 28.5" CABLE W/ DOG LEG
	108049-02-000	EA	CLIP - PEDESTAL CABLE
	057759-01-000	EA	WASHER BRACKET - SEAT BELT - 4" DIAMETER
	007021-01-000	EA	SEAT BELT - 2" X 90" - BLACK

CURTAIN & CUSHION GROUP (CONTINUED)

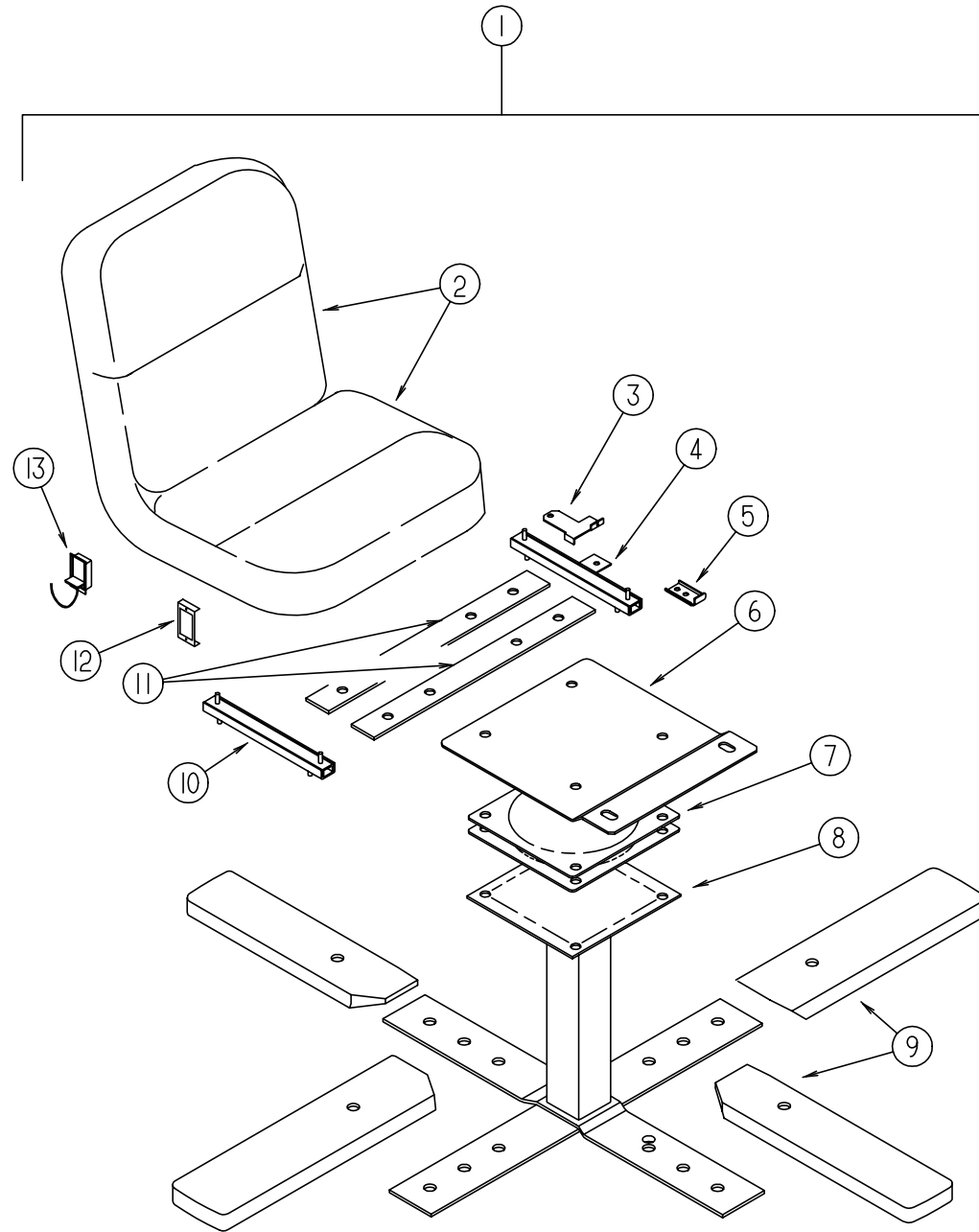

DINETTE SWIVEL CHAIR ASM (210 KC)

KEY	PART NUMBER	U/M	DESCRIPTION
1	122739-01-H37	EA	CHAIR - KITCHEN (H37, H47)
1	122739-01-H38	EA	CHAIR - KITCHEN (H38, H48)
1	122739-01-H39	EA	CHAIR - KITCHEN (H39, H49)
2	P22739-01-H37	EA	COVER - BACK & SEAT - KITCHEN CHAIR (H37, H47)
2	P22739-01-H38	EA	COVER - BACK & SEAT - KITCHEN CHAIR (H38, H48)
2	P22739-01-H39	EA	COVER - BACK & SEAT - KITCHEN CHAIR (H39, H49)
3	117125-01-02B	EA	BRACKET - CABLE MOUNT - ADJUSTER W/LOCK
4	119952-04-000	EA	SLIDE - SEAT - HEAVY DUTY LOCKING
5	114889-01-000	EA	STOP BAR - UNIVERSAL
6	119705-11-02B	EA	PLATE - SEAT
7	119105-01-000	EA	PLATE - SWIVEL - RETURN-0-MATIC
8	119705-02-03B	EA	PEDESTAL
9	116080-02-H37	EA	COVER - CHAIR LEG
10	119952-02-000	EA	SLIDE - SEAT - HEAVY DUTY NONLOCKING
11	120109-01-02B	EA	ADAPTER BRACKET - DINETTE SWIVEL CHAIR
12	097683-03-000	EA	BRACKET - REMOTE SIDE MOUNT - SINGLE
13	108049-03-000	EA	CABLE - W/ CONTROL 25.5" SHEATH/ 28.5" CABLE W/ DOG LEG
	108049-02-000	EA	CLIP - PEDESTAL CABLE

CURTAIN & CUSHION GROUP (CONTINUED)

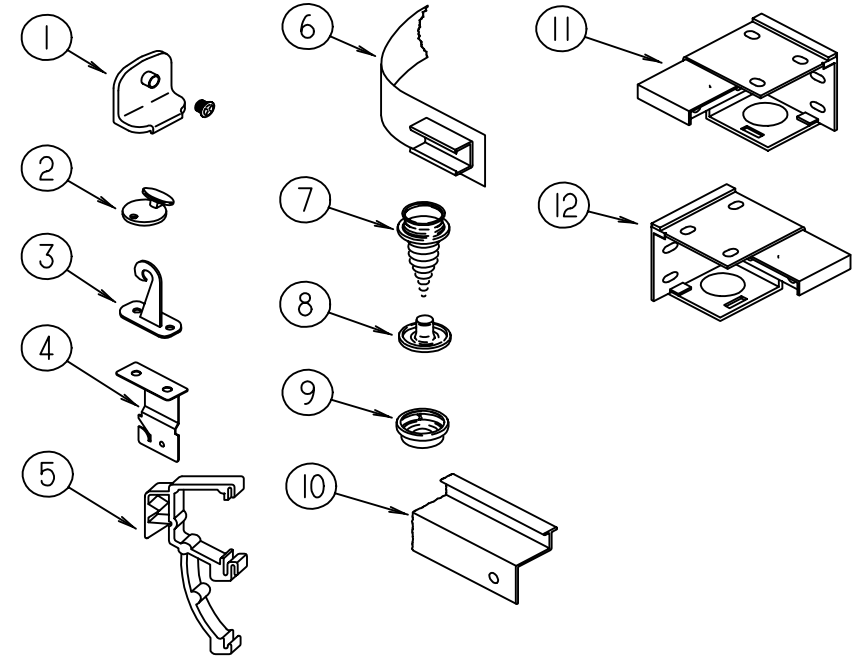

CURTAIN & BLIND HARDWARE

KEY	PART NUMBER	U/M	DESCRIPTION
1	106544-01-000	EA	PULL - SHADE/BRASS
	106544-01-001	EA	SCREW - SHADE/BRASS
2	102555-01-000	EA	CLEAT - BLIND CORD - CLEAR PLASTIC
3	109441-03-000	EA	HOLD DOWN - BLIND (CLOUDY)
4	084434-01-000	EA	BRACKET - MOUNTING - ROLLER SHADE - 1 3/8"
	096843-01-000	EA	SPRING - REWIND/ROLLER SHADE
5	109353-04-000	EA	CLIP - VALANCE SLAT MOUNTING - CLEAR PLASTIC
6	101031-01-000	YD	TAPE - GLIDE/CURTAIN - 4.25" SPACING
7	029130-01-000	EA	SCREW - SNAP SOCKET - #8 PH X 5/8"
8	029155-01-000	EA	CAP - SNAP - 5/32" O.D. OF PIN
	046867-03-000	EA	GROMMET - HANDY BUTTON #3
9	029156-01-000	EA	SOCKET - SNAP - 9/16" O.D.
10	114641-12-H37	EA	TRACK - CURTAIN - WRAPAROUND W/SPACERS - LEFT HAND
10	114641-13-H37	EA	TRACK - CURTAIN - WRAPAROUND W/SPACERS - RIGHT HAND
11	083170-02-000	EA	BRACKET - BLIND - RIGHT SIDE WHEN FACING WINDOW
12	083170-01-000	EA	BRACKET - BLIND - LEFT SIDE WHEN FACING WINDOW
	088792-02-000	YD	VELCRO TAPE - LOOP - .75" - ADHESIVE BACKED - BEIGE
	048394-02-000	YD	VELCRO TAPE - HOOK - ADHESIVE BACK - .75" WIDE - BEIGE
	086276-01-000	EA	TAPE - DOUBLE SIDED - 1/2"
	094896-02-000	EA	GROMMET - CORD/PLEATED BLIND - NYLON - GRAY
	094907-02-000	EA	END CAP - TOP/PLEATED BLIND - PLASTIC - GRAY
	094907-04-000	EA	HARDWARE - END CAP BOTTOM - PULL TYPE (RH & LH)
	097564-04-000	EA	HANDLE - KNOB - E-Z LIFT SHADE - NAVY (H37, H47, H39, H49)
	097564-03-000	EA	HANDLE - KNOB - E-Z LIFT SHADE - TAN (H38, H48)
	094907-04-701	EA	END CAP - LH BOTTOM BLIND
	000G68-06-12B	EA	SCREW - 6-18 X .75 POH
	097565-01-000	EA	BRACKET - MOUNTING/PLEATED BLIND
	097591-01-000	EA	SPRING - EXTENSION/PLEATED BLIND
	097592-01-000	EA	SPOOL - CORD - ELEVATED BLIND HOLDUP - CLEAR PLASTIC
	097593-06-000	FT	CORD - BLIND - PLEATED - PEWTER (H37, H47, H39, H49)
	097593-02-000	FT	CORD - BLIND/PLEATED - GRAY (H38, H48)
	105648-01-02A	EA	BRACE - VALANCE - OFF/WHITE - 14"

CURTAIN & CUSHION GROUP (CONTINUED)

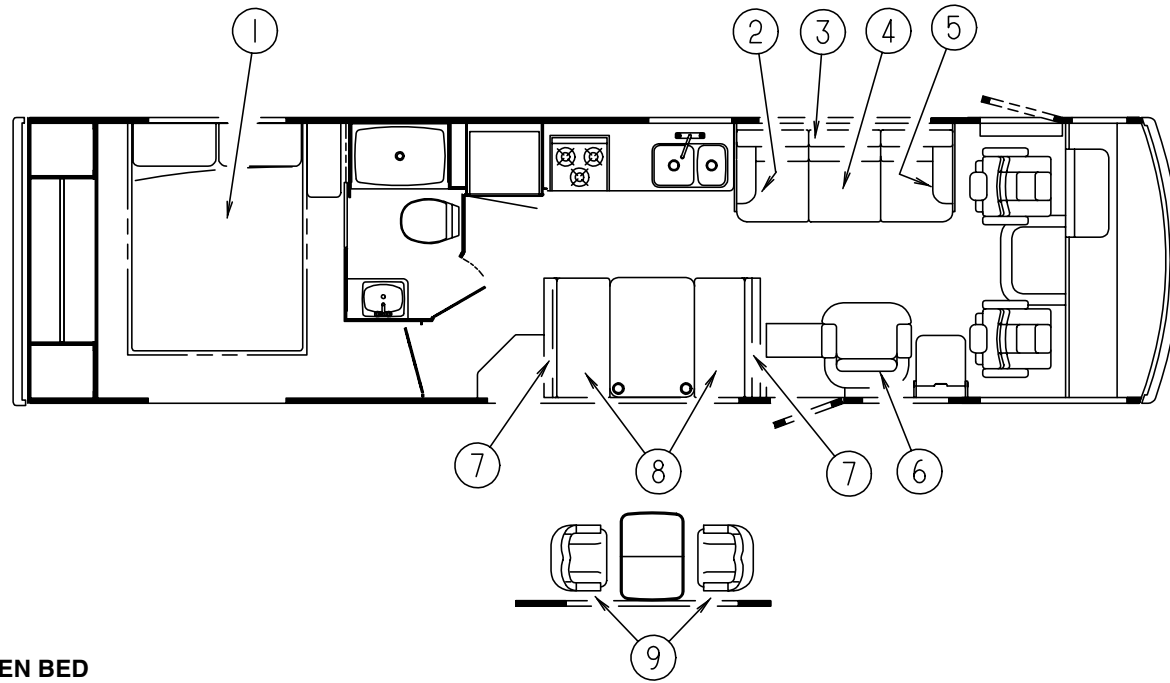

QUEEN BED

SOFA PILLOWS

KEY	PART NUMBER	U/M DESCRIPTION
1	119141-01-H37	EA BEDSPREAD/THROW - 60" X 80" (H37, H47)
1	119141-01-H38	EA BEDSPREAD/THROW - 60" X 80" (H38, H48)
1	119141-01-G45	EA BEDSPREAD/THROW - 60" X 80" (H39, H49)
1	123015-07-000	EA MATTRESS - INNERSPRING - 60" X 79.5"
	119249-01-000	EA PILLOWCASE - 20" X 33" - QUEEN
	103669-09-H37	EA PILLOW - 15" X 15" (H37, H47)
	103669-09-H38	EA PILLOW - 15" X 15" (H38, H48)
	103669-09-G45	EA PILLOW - 15" X 15" (H39, H49)
	103669-12-H39	EA PILLOW - 15" X 15" (H39, H49)

FROM: 00-00-00 THRU: 11-30-96
FROM: 12-01-96 THRU: 99-99-99

KEY	PART NUMBER	U/M DESCRIPTION
	106728-03-H37	EA PILLOW - 9" X 20" (H37, H47)
	106728-02-H38	EA PILLOW - 9" X 20" (H38, H48)
	106728-02-G45	EA PILLOW - 9" X 20" (H39, H49)

SWIVEL CHAIR (RECLINER)

KEY	PART NUMBER	U/M DESCRIPTION
6	118538-01-H37	EA CHAIR - RECLINER W/SKIRT (H37, H47)
6	118538-01-H38	EA CHAIR - RECLINER W/SKIRT (H38, H48)
6	118538-01-H39	EA CHAIR - RECLINER W/SKIRT (H39, H49)

SOFA BED

DINETTE CUSHIONS

KEY	PART NUMBER	U/M DESCRIPTION
2	111905-03-H37	EA ARMREST - RIGHT HAND - SOFA/BED (H37, H47)
2	111905-03-H38	EA ARMREST - RIGHT HAND - SOFA/BED (H38, H48)
2	111905-03-G45	EA ARMREST - RIGHT HAND - SOFA/BED (H39, H49)
2	P11905-03-H37	EA COVER - ARMREST - RIGHT HAND - SOFA/BED (H37, H47)
2	P11905-03-H38	EA COVER - ARMREST - RIGHT HAND - SOFA/BED (H38, H48)
2	P11905-03-G45	EA COVER - ARMREST - RIGHT HAND - SOFA/BED (H39, H49)
3	104655-01-H37	EA CUSHION - BACKREST - SOFA/BED (H37, H47)
3	104655-01-H38	EA CUSHION - BACKREST - SOFA/BED (H38, H48)
3	104655-01-G45	EA CUSHION - BACKREST - SOFA/BED (H39, H49)
3	P04655-01-H37	EA COVER - CUSHION/BACK - SOFA/BED (H37, H47)
3	P04655-01-H38	EA COVER - CUSHION/BACK - SOFA/BED (H38, H48)
3	P04655-01-G45	EA COVER - CUSHION/BACK - SOFA/BED (H39, H49)
4	104652-03-H37	EA SEAT - SOFA/BED - 70" (H37, H47)
4	104652-03-H38	EA SEAT - SOFA/BED - 70" (H38, H48)
4	104652-03-G45	EA SEAT - SOFA/BED - 70" (H39, H49)
4	P04652-03-H37	EA COVER - SEAT CUSHION - SOFA/BED - 70" (H37, H47)
4	P04652-03-H38	EA COVER - SEAT CUSHION - SOFA/BED - 70" (H38, H48)
4	P04652-03-G45	EA COVER - SEAT CUSHION - SOFA/BED - 70" (H39, H49)
	105433-01-000	EA FRAME - COUCH
5	111905-02-H37	EA ARMREST - LEFT HAND - SOFA/BED (H37, H47)
5	111905-02-H38	EA ARMREST - LEFT HAND - SOFA/BED (H38, H48)
5	111905-02-G45	EA ARMREST - LEFT HAND - SOFA/BED (H39, H49)
5	P11905-02-H37	EA COVER - ARMREST - LEFT HAND - SOFA/BED (H37, H47)
5	P11905-02-H38	EA COVER - ARMREST - LEFT HAND - SOFA/BED (H38, H48)
5	P11905-02-G45	EA COVER - ARMREST - LEFT HAND - SOFA/BED (H39, H49)

KEY	PART NUMBER	U/M DESCRIPTION
7	111897-05-H37	EA CUSHION - BACK - 13.5" X 42" X 5" (H37, H47)
7	111897-05-H38	EA CUSHION - BACK - 13.5" X 42" X 5" (H38, H48)
7	111897-05-H39	EA CUSHION - BACK - 13.5" X 42" X 5" (H39, H49)
7	P11897-05-H37	EA COVER - BACK - 13.5" X 42" X 5" (H37, H47)
7	P11897-05-H38	EA COVER - BACK - 13.5" X 42" X 5" (H38, H48)
7	P11897-05-H39	EA COVER - BACK - 13.5" X 42" X 5" (H39, H49)
	078155-01-000	EA STRAP - SNAP - BACK CUSHION
8	105603-15-H37	EA CUSHION - SEAT - 23" X 42" X 5" (H37, H47)
8	105603-15-H38	EA CUSHION - SEAT - 23" X 42" X 5" (H38, H48)
8	105603-15-G45	EA CUSHION - SEAT - 23" X 42" X 5" (H39, H49)
8	P05603-15-H37	EA COVER - CUSHION/SEAT - 23" X 42" X 5" (H37, H47)
8	P05603-15-H38	EA COVER - CUSHION/SEAT - 23" X 42" X 5" (H38, H48)
8	P05603-15-G45	EA COVER - CUSHION/SEAT - 23" X 42" X 5" (H39, H49)

DINETTE OPTION

KEY	PART NUMBER	U/M DESCRIPTION
9	122739-01-H37	EA CHAIR - KITCHEN (H37, H47)
9	122739-01-H38	EA CHAIR - KITCHEN (H38, H48)
9	122739-01-H39	EA CHAIR - KITCHEN (H39, H49)
	101604-01-04A	EA CHAIR - FOLDING/DINETTE - W/O FABRIC - SOLAR MAPLE
	101604-01-03A	EA CHAIR - FOLDING/DINETTE - WATERFORD OAK - W/O FABRIC

DINETTE GROUP

DINETTE & OVERHEAD CABINETRY

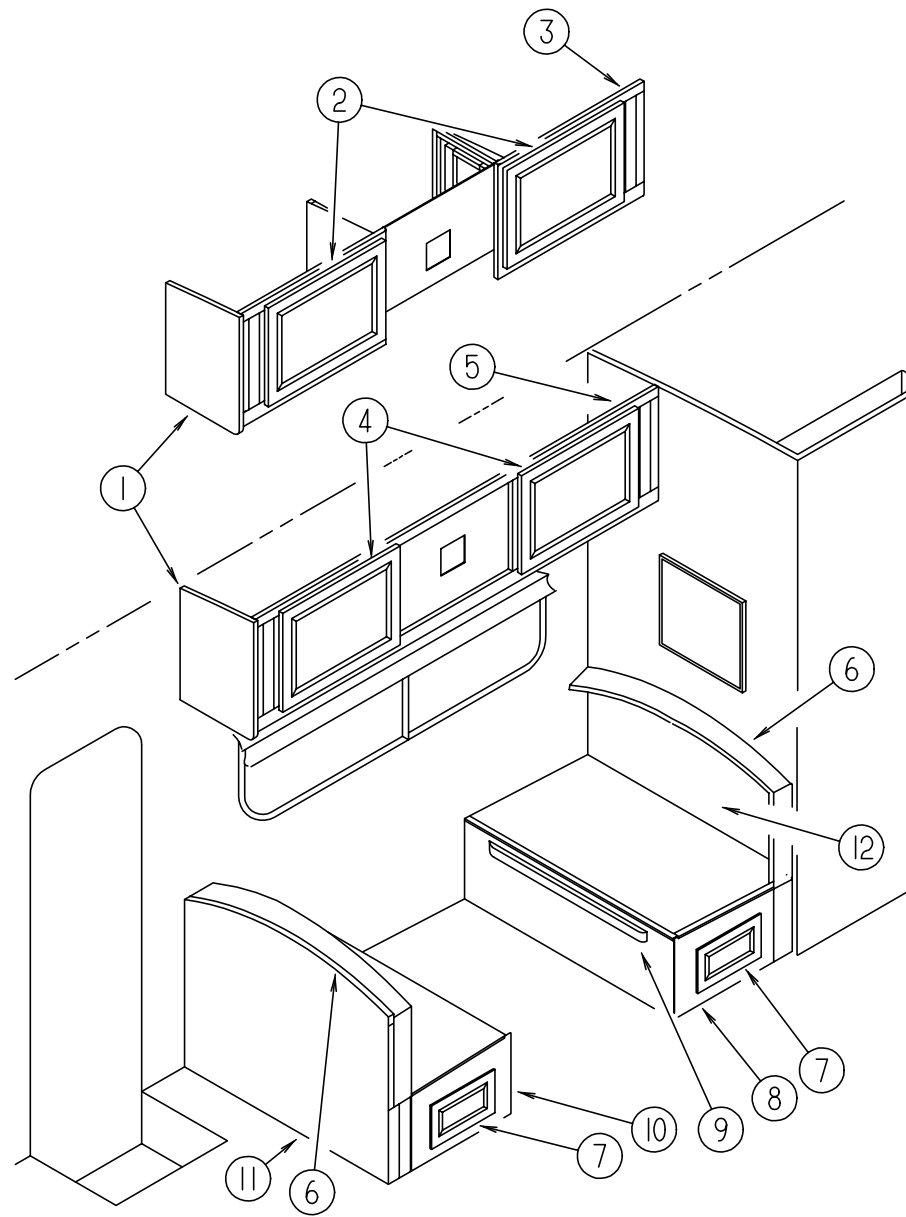

KEY	PART NUMBER	U/M	DESCRIPTION
1	103128-02-H37	EA	END CAP - OVERHEAD CABINET - LEFT HAND (MAPLE)
1	103128-02-G09	EA	END CAP - OVERHEAD CABINET - LEFT HAND (OAK)
2	M08166-24-H37	EA	DOOR - MITERED CORNER/SQUARE EDGE - 28" X 15.7" - W/O HDW (MAPLE)
2	M06803-N6-H17	EA	DOOR - MITERED CORNER/OGEE EDGE - 15.7" X 27.9" - W/O HDW (OAK)
3	117579-03-H37	EA	CABINET - OVERHEAD/DINETTE - W/O DOORS/HDW - F/COFFEEMAKER (H37) (MAPLE)
3	117579-03-H38	EA	CABINET - OVERHEAD/DINETTE - W/O DOORS/HDW - F/COFFEEMAKER (H38) (MAPLE)
3	117579-03-H39	EA	CABINET - OVERHEAD/DINETTE - W/O DOORS/HDW - F/COFFEEMAKER (H39) (MAPLE)
	117579-13-H37	EA	SHELF - W/PLASTIC EDGE TRIM (MAPLE)
3	117579-03-H47	EA	CABINET - OVERHEAD/DINETTE - W/O DOORS/HDW - F/COFFEEMAKER (H47) (OAK)
3	117579-03-H48	EA	CABINET - OVERHEAD/DINETTE - W/O DOORS/HDW - F/COFFEEMAKER (H48) (OAK)
3	117579-03-G45	EA	CABINET - OVERHEAD/DINETTE - W/O DOORS/HDW - F/COFFEEMAKER (H49) (OAK)
	117579-13-G09	EA	SHELF - W/PLASTIC EDGE TRIM (OAK)
4	M08166-13-H37	EA	DOOR - MITERED CORNER/SQUARE EDGE - 15.7" X 28" - W/O HDW (MAPLE)
4	M06803-13-H17	EA	DOOR - MIRROR/MTRD CRNR/OGEE EDGE - 15.7" X 28" - W/O HDW (OAK)
4	M06803-82-H17	EA	DOOR - MITERED CORNER/OGEE EDGE - 15.7" X 28" - W/O HDW (OAK)
5	117902-02-H37	EA	CABINET - OVERHEAD DINETTE - W/O DOORS/HARDWARE (H37) (MAPLE)
5	117902-02-H38	EA	CABINET - OVERHEAD DINETTE - W/O DOORS/HARDWARE (H38) (MAPLE)
5	117902-02-H39	EA	CABINET - OVERHEAD DINETTE - W/O DOORS/HARDWARE (H39) (MAPLE)
	117902-14-H37	EA	SHELF - W/PLASTIC EDGE TRIM (MAPLE)
5	117902-02-H47	EA	CABINET - OVERHEAD DINETTE - W/O DOORS/HARDWARE (H47) (OAK)
5	117902-02-H48	EA	CABINET - OVERHEAD DINETTE - W/O DOORS/HARDWARE (H48) (OAK)
5	117902-02-G45	EA	CABINET - OVERHEAD DINETTE - W/O DOORS/HARDWARE (H49) (OAK)
	117902-14-G09	EA	SHELF - W/PLASTIC EDGE TRIM (OAK)
6	104787-08-H37	EA	PAD - DINETTE (H37, H47)
6	104787-08-H38	EA	PAD - DINETTE (H38, H48)
6	104787-08-G45	EA	PAD - DINETTE (H39, H49)
7	M08168-81-H37	EA	DRAWER - SQUARE EDGE - 16.9"W X 21.6"D - W/O SLIDES/HDW (MAPLE)
7	M05971-35-H17	EA	DRAWER - OGEE EDGE - 17"W X 21.6"D - W/O SLIDES/HARDWARE (OAK)
8	M07515-05-H37	EA	CABINET - SEATBASE/RIGHT HAND - W/O DOORS/DRAWERS/HARDWARE (MAPLE)
8	M07515-05-G15	EA	CABINET - SEATBASE/RIGHT HAND - W/O DOORS/DRAWERS/HARDWARE (OAK)
9	081295-01-H37	EA	SUPPORT - BED/DINETTE - 28" LONG (MAPLE)
9	081295-01-G01	EA	SUPPORT - BED/DINETTE - 28" LONG (OAK)
10	M07515-04-H37	EA	CABINET - SEATBASE/LEFT HAND - W/O DOORS/DRAWERS/HARDWARE (MAPLE)
10	M07515-04-G15	EA	CABINET - SEATBASE/LEFT HAND - W/O DOORS/DRAWERS/HARDWARE (OAK)
11	M07514-04-H37	EA	CABINET - SEATBACK/LEFT HAND - W/O HARDWARE (MAPLE)
11	M07514-04-G15	EA	CABINET - SEATBACK/LEFT HAND - W/O HARDWARE (OAK)
12	M07514-05-H37	EA	CABINET - SEATBACK/RIGHT HAND - W/O HARDWARE (MAPLE)
12	M07514-05-G15	EA	CABINET - SEATBACK/RIGHT HAND - W/O HARDWARE (OAK)

DINETTE GROUP (CONTINUED)

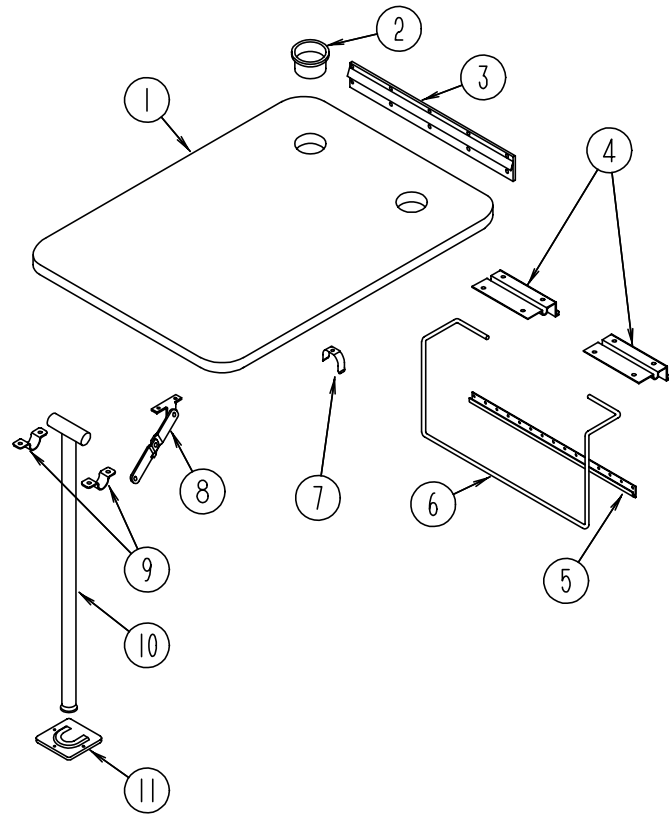

DINETTE TABLE ASM.

KEY	PART NUMBER	U/M	DESCRIPTION
1	081322-12-H37	EA	DINETTE TABLE (H37, H39, H47, H49)
1	081322-12-F09	EA	DINETTE TABLE (H38, H48)
2	064781-06-000	EA	HOLDER - CUP TWO STEP - OFF WHITE
3	053200-12-000	EA	BRACKET - TABLE SUPPORT - UPPER WALL MOUNTED 23.50"
4	088410-02-000	EA	BRACKET - LIFT - TABLE MOUNTED
5	024281-14-000	EA	BRACKET - LIFT ROD LOWER WALL MOUNTED - 22.12"
6	024275-12-000	EA	ROD - TABLE LIFT
7	024283-01-000	EA	CLIP - LEG - 1" - 1.125" OD - BLACK
8	024282-01-000	EA	BRACE - TABLE LEG - HINGED
9	064050-05-000	EA	HINGE - TABLE LEG - OFF WHITE
10	024276-23-000	EA	LEG - TABLE - METAL - OFF WHITE
11	049493-12-000	EA	CATCH - LEG FLOOR MOUNTED 2.5" X 2.7" - OFF WHITE
11	049493-11-700	EA	CATCH - LEG FLOOR MOUNTED 2.5" X 2.7" - E-COAT

DINETTE GROUP (CONTINUED)

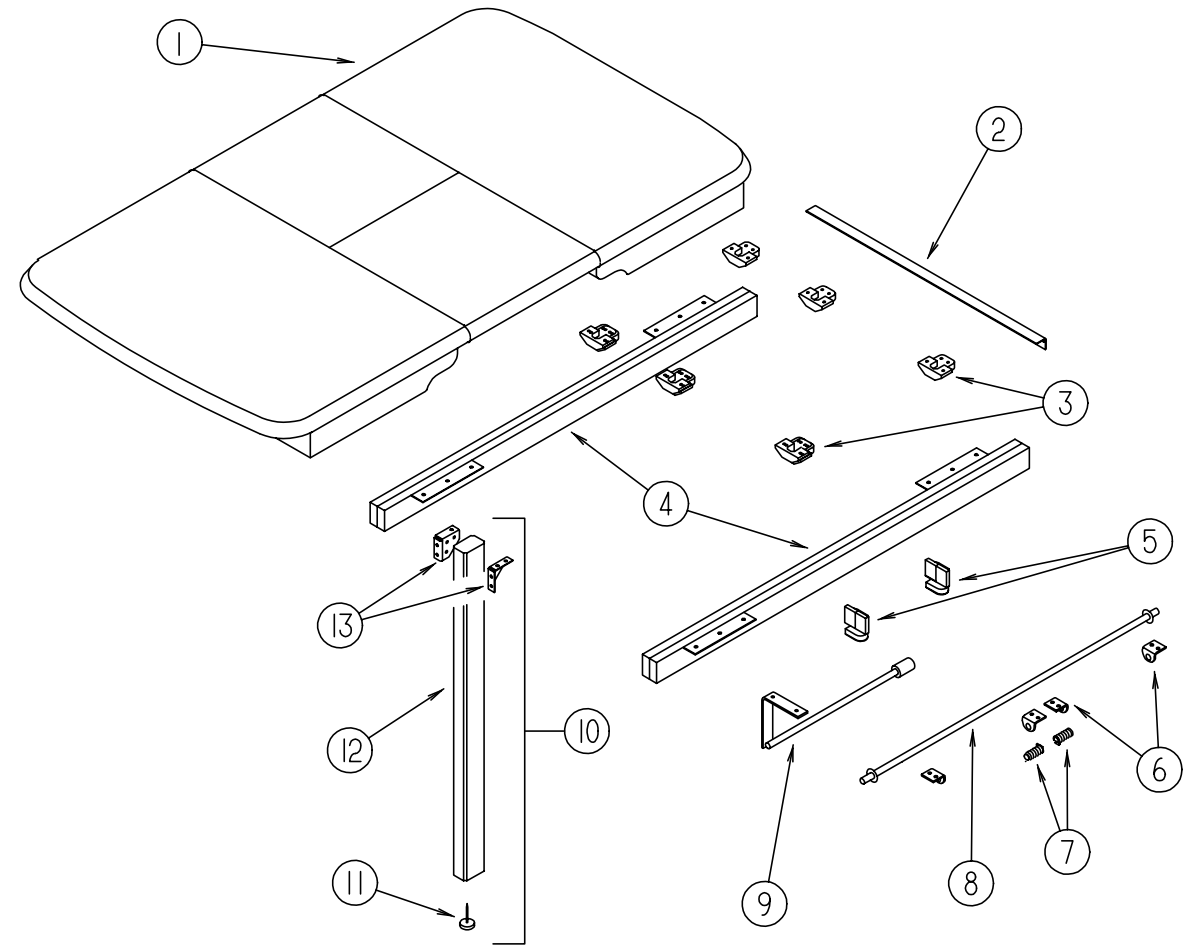

DINETTE TABLE ASM. W/ DROP LEAF

KEY	PART NUMBER	U/M	DESCRIPTION
	P18322-01-H37	EA	TABLE - PULLOUT/SELF STORING - W/O HARDWARE (MAPLE)
	P18322-01-H17	EA	TABLE - PULLOUT/SELF STORING - W/O HARDWARE (OAK)
1	118322-11-H37	EA	TABLE TOP ONLY - PULLOUT (MAPLE)
1	118322-11-H17	EA	TABLE TOP ONLY - PULLOUT (OAK)
2	041389-18-000	EA	HINGE - PIANO - 1.50X 482.6 0 O/WHITE
3	009050-02-000	EA	LEVELER - TABLE TOP - MALE END W/4 SCREWS - PLASTIC
3	009050-03-000	EA	LEVELER - TABLE TOP - FEMALE END W/2 SCREWS - PLASTIC
4	110749-01-000	EA	SLIDE - TABLE - 19 3/4" LONG
5	108663-01-000	EA	HINGE - LEAF - FOLDING
6	108874-01-000	EA	BRACKET - HINGE - TABLE LEAF
7	108664-01-000	EA	SPRING - COMPRESSION - .51" X 1.96"
8	108932-01-000	EA	ROD - PIVOT
9	108905-01-000	EA	SUPPORT - TABLE LEAF
10	092708-12-H37	EA	LEG - TABLE - W/O HARDWARE (MAPLE)
10	092708-12-G35	EA	LEG - TABLE - W/O HARDWARE (OAK)
11	102194-01-000	EA	GUIDE - PLASTIC
12	092707-07-06A	EA	MOLDING - TABLE LEG - 27.8"(MAPLE)
12	092707-07-05A	EA	MOLDING - TABLE LEG - 27.8" (OAK)
13	102810-01-04A	EA	BRACE - TABLE LEG - BLACK
	102810-01-03A	EA	BRACE - TABLE LEG - MILL

DINETTE GROUP (CONTINUED)

UPPER AND LOWER HUTCH

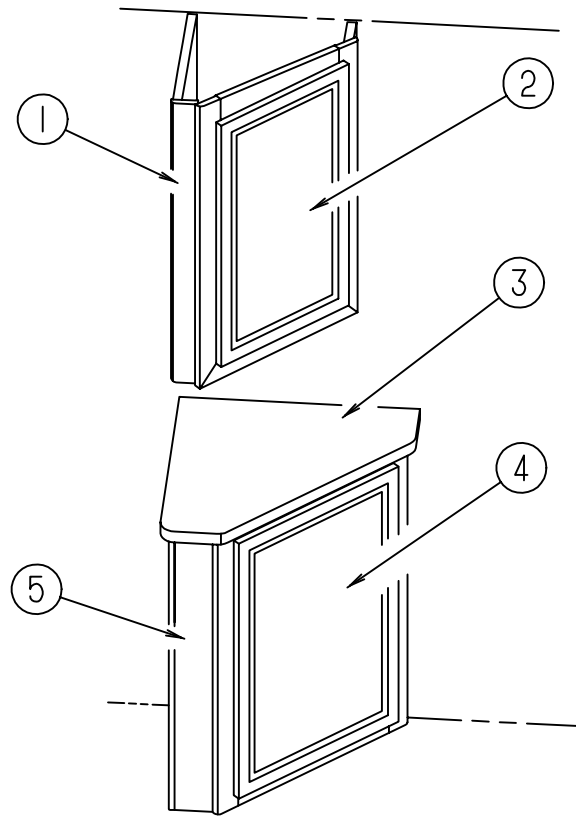

KEY	PART NUMBER	U/M DESCRIPTION
1	P15833-01-H37	EA CABINET - HUTCH/UPPER - W/O DOORS/HARDWARE (MAPLE)
1	P15833-01-G17	EA CABINET - HUTCH/UPPER - W/O DOORS/HARDWARE (OAK)
	115833-15-H37	EA SHELF - W/PLASTIC EDGE TRIM (MAPLE)
	115833-15-G15	EA SHELF - W/PLASTIC EDGE TRIM (OAK)
2	M08166-39-H37	EA DOOR - MITERED CORNER/SQUARE EDGE - 15.7" X 28" - W/O HDW (MAPLE)
2	M06803-13-H17	EA DOOR - MIRROR/MTRD CRNR/OGEE EDGE - 15.7" X 28" - W/O HDW (OAK)
3	104635-11-F12	EA COUNTERTOP - HUTCH (MAPLE)
3	104635-11-F32	EA COUNTERTOP - HUTCH (OAK)
4	M08166-35-H37	EA DOOR - MITERED CORNER/SQUARE EDGE - 29.5" X 22.6" - W/O HDW (MAPLE)
4	M06803-77-H17	EA DOOR - MITERED CORNER/OGEE EDGE - 29.5" X 22.6" - W/O HDW (OAK)
5	104635-01-H37	EA CABINET - HUTCH/LOWER - W/O DOORS/HARDWARE (H37, H39) (MAPLE)
5	104635-01-H38	EA CABINET - HUTCH/LOWER - W/O DOORS/HARDWARE (H38) (MAPLE)
	104635-12-H38	EA SHELF - W/PLASTIC EDGE TRIM (MAPLE)
5	104635-01-G36	EA CABINET - HUTCH/LOWER - W/O DOORS/HARDWARE (H47, H49) (OAK)
5	104635-01-G15	EA CABINET - HUTCH/LOWER - W/O DOORS/HARDWARE (H48) (OAK)
	104635-12-G15	EA SHELF - W/PLASTIC EDGE TRIM (OAK)

DRIVERS COMPARTMENT GROUP

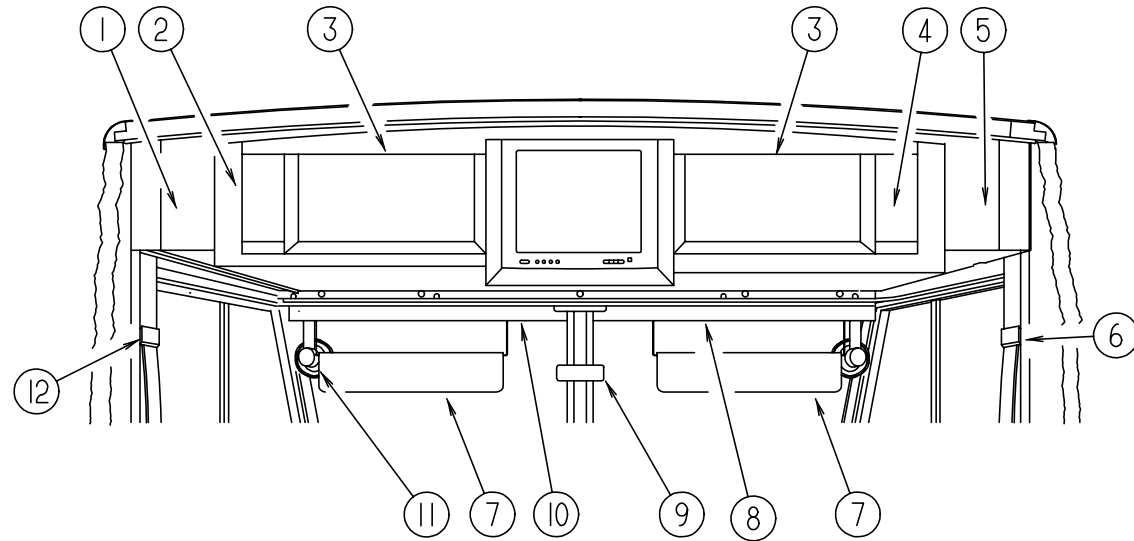

UPPER DRIVER COMPARTMENT

KEY	PART NUMBER	U/M	DESCRIPTION
1	104289-04-G35	EA	PANEL - VINYL COVERED OVERHEAD DRIVER SIDE - ANGLED
2	114612-04-H37	EA	FACE - OVERHEAD - DRIVER TV CABINET - 15.7" X 36.4" (MAPLE)
2	114612-04-H17	EA	FACE - CABINET/ DRIVERS TV OVERHEAD - 15.7" X 36.4" (OAK)
3	100708-13-000	EA	DOOR - CABINET - GLASS
	100710-01-01A	EA	LOCK ASSEMBLY - TWIST TYPE - BRASS
	100711-01-01A	EA	HINGE - GLASS DOOR
	100707-01-000	EA	SPACER - GLASS DOOR - .8" DIAMETER - .3" HOLE - PLASTIC
	101272-01-000	EA	CATCH - GLASS DOOR
	101766-01-000	EA	PIN - SUPPORT - GLASS DOOR
	108486-01-01A	EA	BRACKET - PROP ROD/OVERHEAD - BLACK
	108487-02-01A	EA	SUPPORT - PROP ROD/OVERHEAD - BLACK
4	114612-03-H37	EA	FACE - TV OVERHEAD PASSENGER -15.7 X 36.4 (MAPLE)
4	114612-03-H17	EA	FACE - CABINET/ PASSENGER TV OVERHEAD -15.7 X 36.4 (OAK)
5	104289-03-G35	EA	PAD - VINYL COVERED - OVERHEAD TV - PASSENGER
6	103961-01-01A	EA	SEAT BELT BRACKET COVER - OFF WHITE
7	123298-02-01A	EA	SUNVISOR - 10.5" X 28.5"
8	078579-21-000	EA	TRIM - WINDSHIELD - UPPER INNER PASSENGER
9	040714-01-000	EA	MIRROR - REAR VIEW/ ARM MOUNT & SET SCREW - GM # 911722
	067490-01-000	EA	BUTTON - MIRROR/ REAR VIEW
10	078579-22-000	EA	TRIM - WINDSHIELD - UPPER INNER DRIVER
11	122856-01-01A	EA	FAN - DEFROSTER - 2 SPEED - CHROME - DRIVER & PASSENGER SIDE
12	103961-02-01A	EA	COVER - BRACKET - SEATBELT/LEFT HAND-F/DRIVER DOOR OPTION

DRIVERS COMPARTMENT GROUP (CONTINUED)

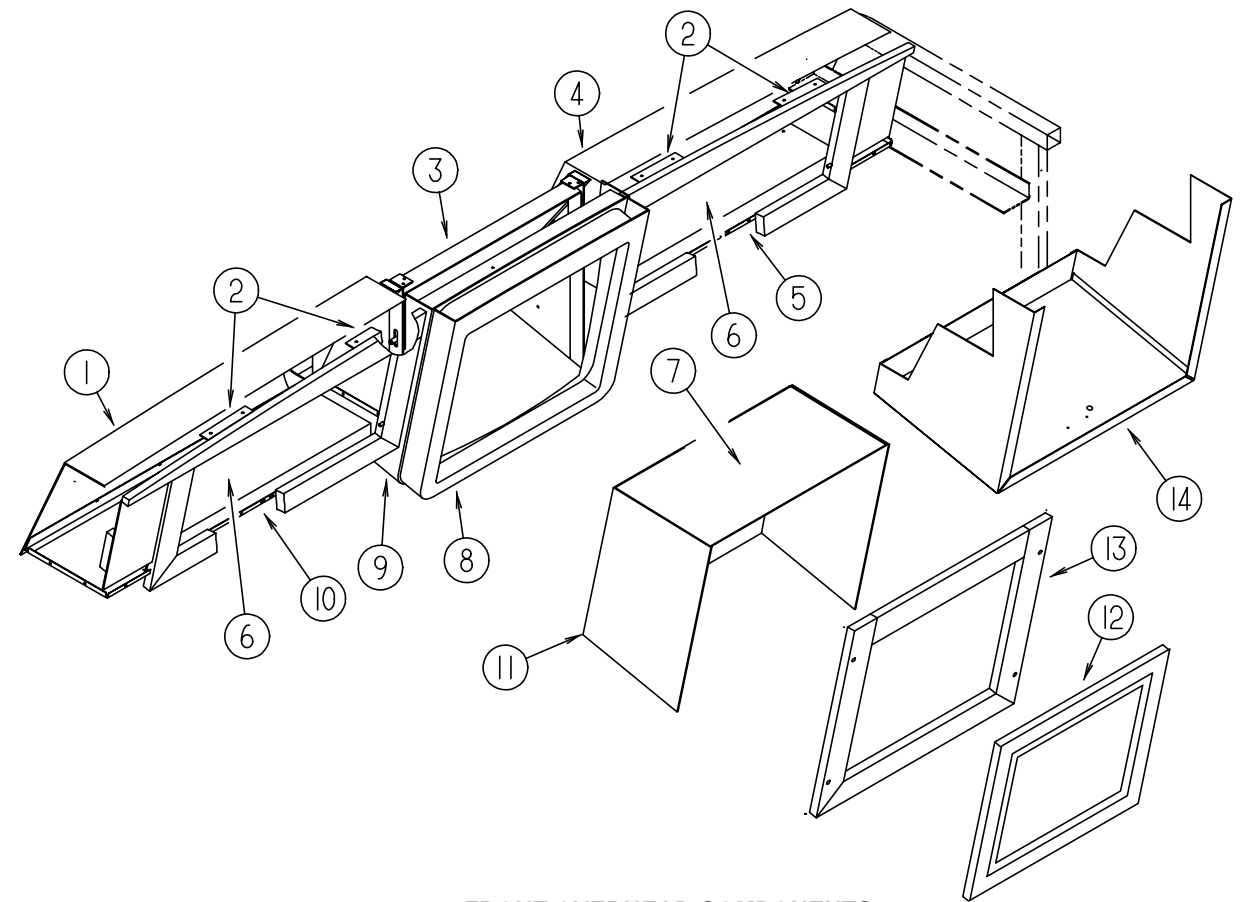

FRONT OVERHEAD COMPONENTS

KEY	PART NUMBER	U/M	DESCRIPTION
1	114661-11-G35	EA	PANEL - LINER - DRIVER OVERHEAD - W/O TV
1	114661-17-G35	EA	PANEL - LINER - DRIVER OVERHEAD - W/ TV
1	114661-23-G35	EA	PANEL - LINER - DRIVER OVERHEAD - W/ SATELLITE DISH
2	106699-01-01A	EA	BRACKET - OVERHEAD CABINET - W/ TV
3	114706-02-02B	EA	SUPPORT - SHELF - TV - E-COAT
4	114661-22-G35	EA	PANEL - LINER - PASSENGER OVERHEAD - W/O TV
4	114661-18-G35	EA	PANEL - LINER - PASSENGER OVERHEAD - W/ TV
4	114661-19-G35	EA	PANEL - LINER - PASSENGER OVERHEAD - W/ TV & VCR
4	114661-20-G35	EA	PANEL - LINER - PASSENGER OVERHEAD - W/ TV - VCR/ INVERTER
4	114661-21-G35	EA	PANEL - LINER - PASSENGER OVERHEAD - W/ TV & INVERTER
5	P03077-06-G35	EA	SHELF - BASE - PASSENGER SIDE OVERHEAD CABINET - W/O TV
5	P03077-10-G35	EA	SHELF - BASE - PASSENGER SIDE OVERHEAD CABINET - W/ TV
6	100676-02-000	EA	SHELF - OVERHEAD CABINET - VCR/ INVERTER
7	115638-01-G35	EA	PANEL - LINER - TOP - W/O TV
8	122881-01-02A	EA	INSERT - OVERHEAD FRONT TV
9	118022-04-H33	EA	COVER ASM - TV - OVERHEAD FRONT
	118836-02-G35	EA	PANEL - VINYL COVERED - BACK - SATELLITE DISH PACKAGE W/O RECEIVER
	120106-11-02B	EA	SHELF - TV
10	P03077-05-G35	EA	SHELF - BASE - OVERHEAD CABINET - DRIVER SIDE - W/O TV
10	P03077-09-G35	EA	SHELF - BASE - OVERHEAD CABINET - DRIVER SIDE - W/ TV
11	115639-01-G35	EA	PANEL - LINER - W/O TV - SIDE
12	M08166-28-H37	EA	DOOR - MITERED CORNER/ SQUARE EDGE - 16.7" X 18.1" - W/O HDW (MAPLE)
12	M06803-C1-H17	EA	DOOR - MITERED CORNER/ OGEE EDGE - 16.7" X 18.1" - W/O HDW (OAK)
13	116791-01-H37	EA	FACE FRAME - TV CABINET - 20.6" X 22.2" - W/O TV (MAPLE)
13	116791-01-H33	EA	FACE FRAME - TV CABINET - 20.6" X 22.2" - W/O TV (OAK)
14	P18192-01-G35	EA	COVER ASM. - W/O TV - WITH VINYL
	099856-01-0S00	EA	TIEDOWN - STRAP - TV - W/ BUCKLE - 53.1" X 1" - WEBBING - BLACK
	078811-09-G35	EA	PANEL - TRIM - HEADER - LOWER - BETWEEN OVERHEAD AND W/S TRIM

DRIVERS COMPARTMENT GROUP (CONTINUED)

LOWER DRIVER COMPARTMENT

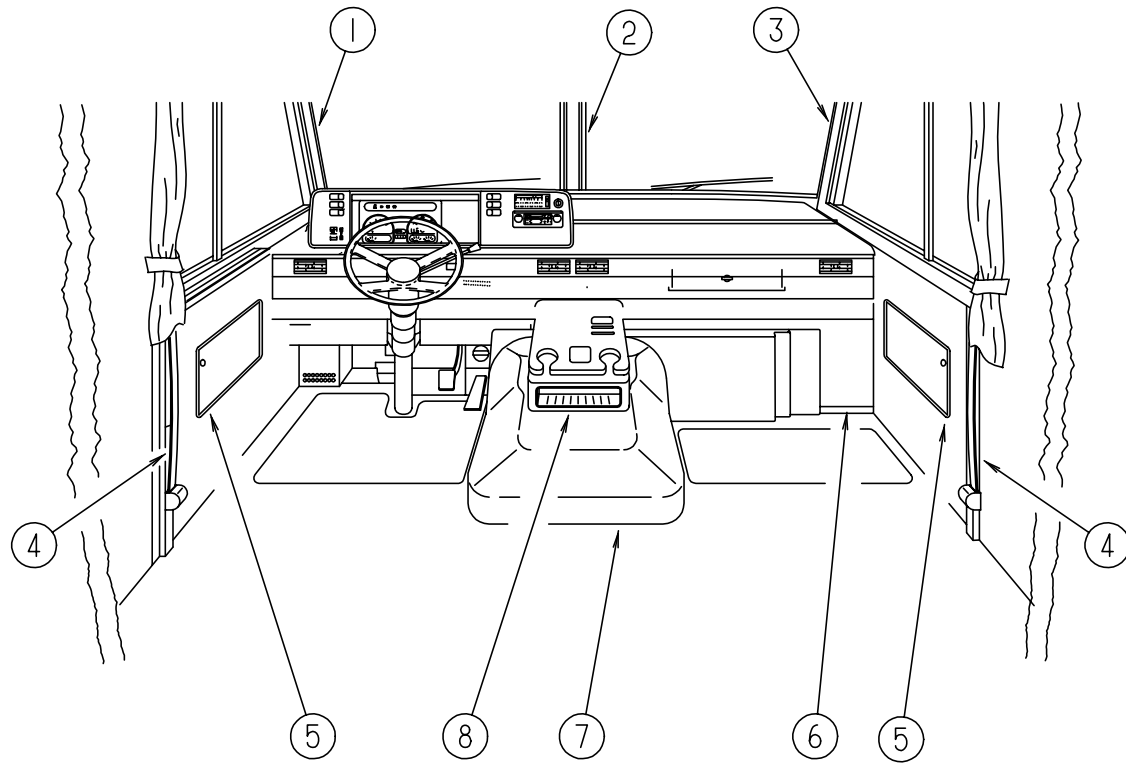

KEY	PART NUMBER	U/M	DESCRIPTION
1	103931-04-04A	EA	COVER - INTERIOR A-PILLAR - DRIVER
2	079765-13-000	EA	TRIM - WINDSHIELD CENTER
3	103931-03-04A	EA	COVER - INTERIOR A-PILLAR - PASSENGER SIDE
	024700-44-000	EA	COVER - ROLL BAR - DRIVER/ PASSENGER LOWER -53" - W/O DRIVER DOOR
	024700-46-000	EA	COVER - ROLL BAR - DRIVER/ PASSENGER UPPER - 21.20"
	024700-47-000	EA	COVER - ROLL BAR - 18.9" - W/ DRIVER DOOR - OFF WHITE
	024700-48-000	EA	COVER - ROLL BAR - 25" - W/ DRIVER DOOR - OFF WHITE
4	091990-04-01A	EA	SEAT BELT - SHOULDER HARNESS - DRIVERS/ PASSENGER - BLACK
	091990-01-701	EA	EXTENDER 9" FOR A8408 3 PT
	109146-01-000	EA	BOLT - SHOULDER/ SEAT BELT
5	086120-01-H37	EA	PAD - MAP POCKET - 12" X 16" (H37, H47)
5	086120-01-H38	EA	PAD - MAP POCKET - 12" X 16" (H38, H48)
5	086120-01-H39	EA	PAD - MAP POCKET - 12" X 16" (H39, H49)
6	095757-04-H37	EA	COVER - HEATER (H37, H47)
6	095757-04-F12	EA	COVER - HEATER (H38, H48)
6	095757-04-H39	EA	COVER - HEATER (H39, H49)
7	115840-01-01A	EA	COVER - MOTOR - W/O CARPET
7	115840-02-01A	EA	COVER - MOTOR - W/O CARPET - VORTEC OPT.
	115852-01-02B	EA	STRIKE - LATCH - MOTOR COVER - E-COATED
	115860-01-01A	EA	TRIM - MOTOR COVER
	115850-01-02B	EA	RETAINER - LATCH MOTOR COVER - E-COAT
	116581-01-000	EA	LATCH - MOTOR COVER
	116833-01-02B	EA	WRENCH - HEX MOTOR COVER - E-COATED
8	122707-01-H37	EA	TRAY - BEVERAGE (MAPLE)
			FROM: 00-00-00 THRU: 03-16-97
8	122707-01-H17	EA	TRAY - BEVERAGE (OAK)
			FROM: 00-00-00 THRU: 03-16-97
8	122707-02-H37	EA	TRAY - BEVERAGE - CHEV VORTEC OPT. (MAPLE)
			FROM: 00-00-00 THRU: 03-16-97
8	122707-02-H17	EA	TRAY - BEVERAGE - CHEV VORTEC OPT. (OAK)
			FROM: 00-00-00 THRU: 03-16-97
8	126680-01-H37	EA	TRAY ASM - BEVERAGE - W/O DRAWER OR LOUVERS (MAPLE)
			FROM: 03-17-97 THRU: 99-99-99
8	126680-01-H17	EA	TRAY ASM - BEVERAGE - W/O DRAWER OR LOUVERS (OAK)
			FROM: 03-17-97 THRU: 99-99-99
8	126680-02-H37	EA	TRAY ASM - BEVERAGE - W/O DRAWER OR LOUVERS - VORTEC ENGINE (MAPLE)
			FROM: 03-17-97 THRU: 99-99-99
8	126680-02-H17	EA	TRAY ASM - BEVERAGE - W/O DRAWER OR LOUVERS - VORTEC ENGINE (OAK)
			FROM: 03-17-97 THRU: 99-99-99
	103498-06-000	EA	BOOT - STEERING COLUMN/UNIVERSAL
			FROM: 00-00-00 THRU: 12-18-96
	103498-09-000	EA	BOOT - STEERING COLUMN - W/1/2 CIRCLE
			FROM: 12-19-96 THRU: 99-99-99
	112634-01-01A	EA	TRIM - STEERING COLUMN - RIGHT HAND - FORD
	112634-02-01A	EA	TRIM - STEERING COLUMN - LEFT HAND - FORD
	111521-03-01A	EA	COVER - STEERING COLUMN - FORD
	111521-04-01A	EA	COVER - STEERING COLUMN - FORD

DRIVERS COMPARTMENT GROUP (CONTINUED)

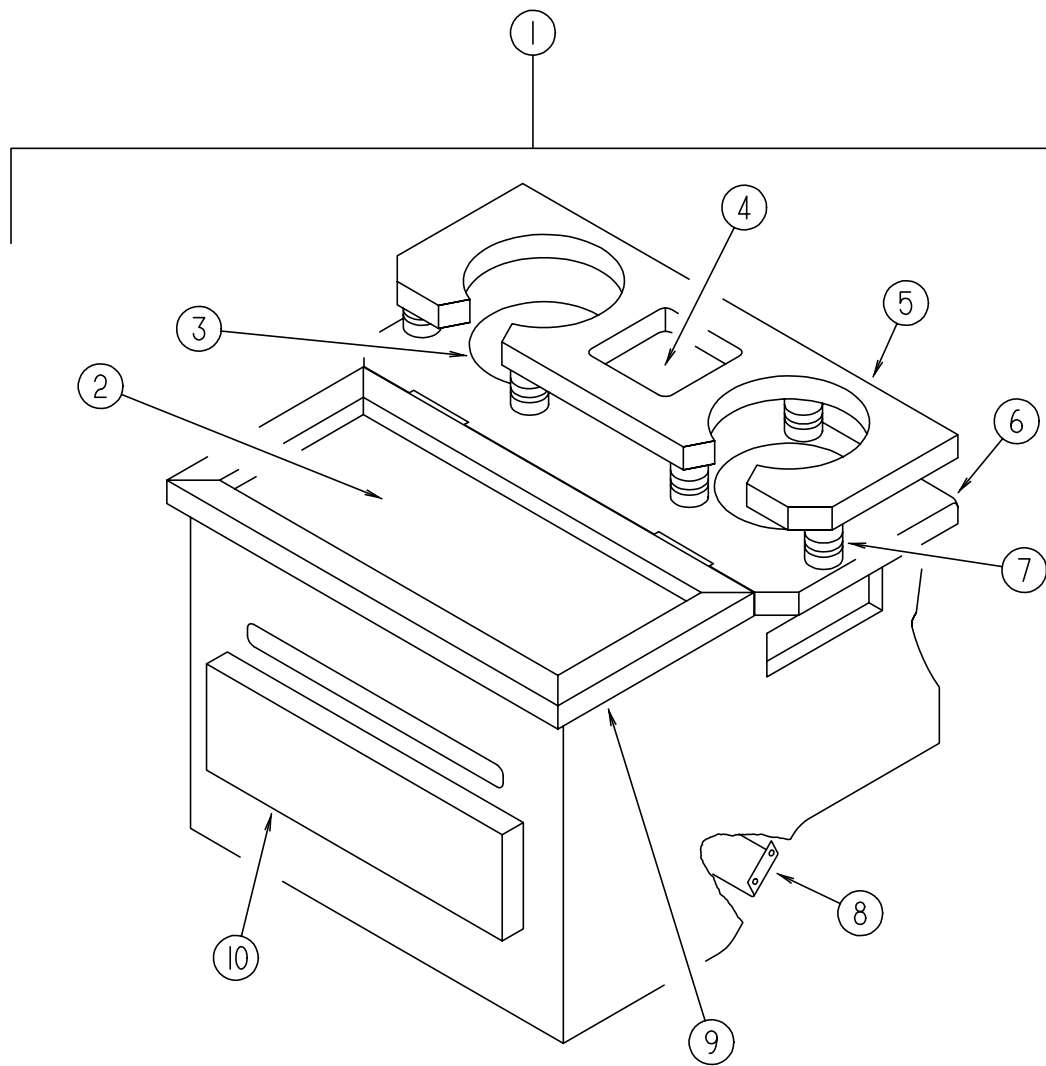

BEVERAGE TRAY, DRIVER COMPARTMENT (FROM: 00-00-00 THRU: 03-16-97)

KEY	PART NUMBER	U/M	DESCRIPTION
1	122707-01-H37	EA	TRAY - BEVERAGE - W/SHELF/CUPHOLDER - W/O DRAWER (MAPLE)
1	122707-01-H17	EA	TRAY - BEVERAGE - W/SHELF/CUPHOLDER - W/O DRAWER (OAK)
1	122707-02-H37	EA	TRAY - BEVERAGE - W/SHELF/CUPHOLDER - W/O DRAWER - VORTEC ENGINE (MAPLE)
1	122707-02-H17	EA	TRAY - BEVERAGE - W/SHELF/CUPHOLDER - W/O DRAWER - VORTEC ENGINE (OAK)
2	122717-03-01A	FT	PAD - NON SKID
3	122717-01-01A	EA	PAD - NON SKID - 4" DIA. ROUND
4	122717-02-01A	EA	PAD - NON SKID - 4" X 4"
5	122707-11-H37	EA	SHELF - CUPHOLDER - W/O PADS (MAPLE)
5	122707-11-H17	EA	SHELF - CUPHOLDER - W/O PADS (OAK)
6	122707-12-H37	EA	SHELF - CUPHOLDER - W/ PADS (MAPLE)
6	122707-12-H17	EA	SHELF - CUPHOLDER - W/ PADS (OAK)
7	097872-04-000	EA	DOWEL - WOOD - 1" DIAMETER X 1.38" LONG - UNFINISHED
8	122832-01-02B	EA	BRACKET - MOUNT - BEVERAGE TRAY - E-COAT
	122772-02-02B	EA	BRACKET - MOUNTING - BEVERAGE TRAY(MOTOR COVER)
9	122707-13-H37	EA	LID - BEVERAGE TRAY (MAPLE)
9	122707-13-H17	EA	LID - BEVERAGE TRAY (OAK)
10	M08168-AZ-H37	EA	DRAWER - SQUARE EDGE - 10.0"W X 11.8"D - W/O SLIDES/ HDW (MAPLE)
10	M05971-AZ-H17	EA	DRAWER - OGEE EDGE - 10"W X 11.8"D - W/O SLIDES/HARDWARE (OAK)
	100128-02-000	FT	SEAL - FOAM - ADHESIVE BACK - .37" W X .37" THICK

DRIVERS COMPARTMENT GROUP (CONTINUED)

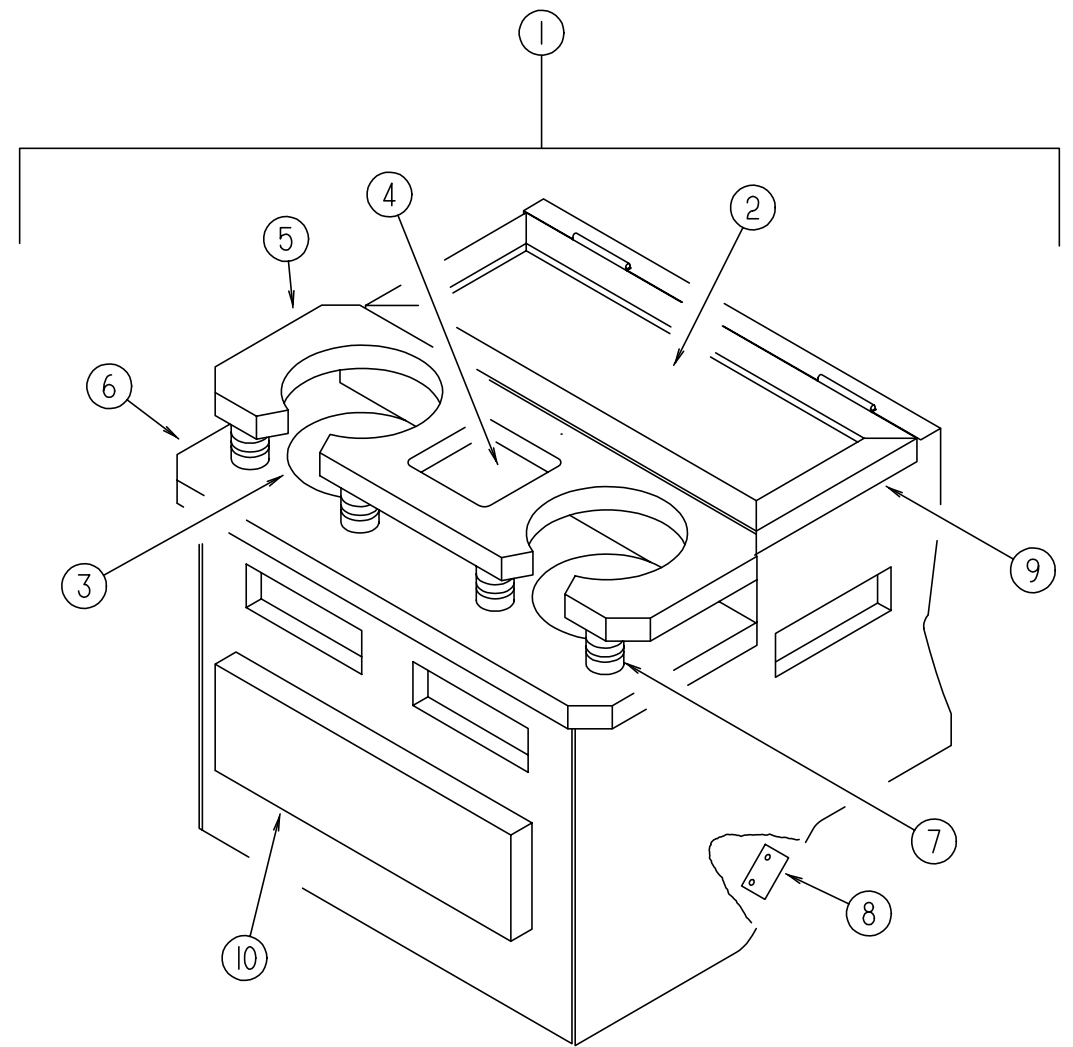

BEVERAGE TRAY, DRIVER COMPARTMENT (FROM: 03-17-97 THRU: 99-99-99)

KEY	PART NUMBER	U/M	DESCRIPTION
1	126680-01-H37	EA	TRAY - BEVERAGE - W/SHELF/CUPHOLDER - W/O DRAWER (MAPLE)
1	126680-01-H17	EA	TRAY - BEVERAGE - W/SHELF/CUPHOLDER - W/O DRAWER (OAK)
1	126680-02-H37	EA	TRAY - BEVERAGE - W/SHELF/CUPHOLDER - W/O DRAWER - VORTEC ENGINE (MAPLE)
1	126680-02-H17	EA	TRAY - BEVERAGE - W/SHELF/CUPHOLDER - W/O DRAWER - VORTEC ENGINE (OAK)
2	122717-06-01A	FT	PAD - NON-SKID
3	122717-01-01A	EA	PAD - NON SKID - 4" DIA. ROUND
4	122717-02-01A	EA	PAD - NON SKID - 4" X 4"
5	126680-15-H37	EA	SHELF - CUPHOLDER - W/ PAD (MAPLE)
5	126680-15-H17	EA	SHELF - CUPHOLDER - W/ PAD (OAK)
6	126680-14-H37	EA	SHELF - CUPHOLDER - W/O PADS (MAPLE)
6	126680-14-H17	EA	SHELF - CUPHOLDER - W/O PADS (OAK)
7	097872-04-000	EA	DOWEL-WOOD - 1" DIAMETER X 1.38" LONG - UNFINISHED
8	122832-01-02B	EA	BRACKET - MOUNT - BEVERAGE TRAY - E-COAT
	122772-02-02B	EA	BRACKET - MOUNTING - BEVERAGE TRAY(MOTOR COVER)
9	126680-16-H37	EA	LID - W/O PAD OR HARDWARE (MAPLE)
9	126680-16-H17	EA	LID - W/O PAD OR HARDWARE (OAK)
10	M08168-AZ-H37	EA	DRAWER - SQUARE EDGE - 10.0"W X 11.8"D - W/O SLIDES/ HARDWARE (MAPLE)
10	M05971-AZ-H17	EA	DRAWER - OGEE EDGE - 10"W X 11.8"D - W/O SLIDES/HARDWARE (OAK)
	100128-02-000	FT	SEAL - FOAM - ADHESIVE BACK - .37" W X .37" THICK

DRIVERS COMPARTMENT GROUP (CONTINUED)

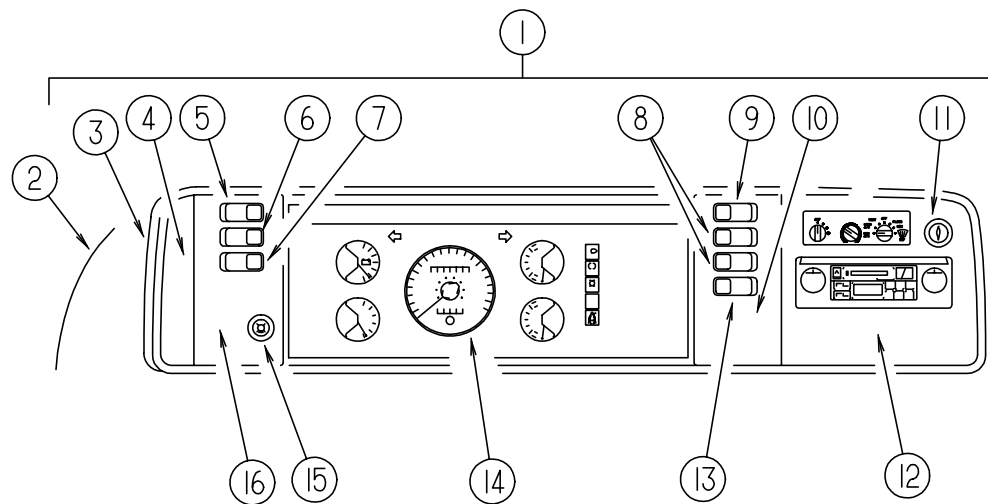

DASH, GAUGES & SWITCHES (FORD)

KEY	PART NUMBER	U/M	DESCRIPTION
1	M05946-43-H37	EA	DASH POD - FORD - W/O CLUSTER
2	111499-01-05A	EA	POD - INSTRUMENT PANEL
3	103662-04-01A	EA	BEZEL - INSTRUMENT PANEL
4	104056-01-04A	EA	APPLIQUE - BEZEL - DRIVER DRESS UP
5	108357-05-000	EA	SWITCH - ROCKER - SPDT ON/ NONE/ ON 3 TERM. CARLING - V4D1000B-0
5	108357-08-000	EA	SWITCH - ROCKER DPDT - ON/NONE/ON - 6 TERMINAL (W/CD PLAYER)
5	108356-02-01A	EA	SWITCH COVER W/ 2 DIMPLES - CARLING - CCAZC00
6	108357-09-000	EA	SWITCH - ROCKER - SPDT ON/ NONE/ MOM 3 TERM. CARLING - V5D1000B-0
6	108356-02-01A	EA	SWITCH COVER W/ 2 DIMPLES - CARLING - CCAZC00
7	108357-06-000	EA	SWITCH - ROCKER - DPDT MOM/ OFF/ MOM 6 TERM. CARLING - VLD1000B-0
7	108356-02-01A	EA	SWITCH COVER W/ 2 DIMPLES - CARLING - CCAZC00
8	108357-03-000	EA	SWITCH - ROCKER - SPDT ON/ OFF/ ON 3 TERM. CARLING - V6D1000B-0
8	108356-02-01A	EA	SWITCH COVER W/ 2 DIMPLES - CARLING - CCAZC00
9	108357-10-000	EA	SWITCH - RKR SPDT MOM/ ON LIGHTED-5 TERM (3 SWITCH/ 2 LIGHT)
9	108356-04-01A	EA	SWITCH COVER W/ DIMPLES - LIGHTED - CARLING - VVAGC00
	096241-03-000	EA	SWITCH - BLANK
	077942-01-000	EA	SWITCH - DUMMY - BLACK
10	104056-21-01A	EA	APPLIQUE - BEZEL - PASSENGER DRESS UP
10	104056-08-01A	EA	APPLIQUE - BEZEL (W/ FOG LAMPS OR EXPORT)
11	089294-01-000	EA	LIGHTER - CIGARETTE - W/O WIRES
12	104056-06-04A	EA	APPLIQUE - BEZEL - PASSENGER DRESS UP
13	108357-01-000	EA	SWITCH - ROCKER SPST - ON/OFF - 2 TERMINAL
13	108356-02-01A	EA	SWITCH COVER W/ 2 DIMPLES - CARLING - CCAZC00
14	094794-06-000	EA	CLUSTER - INSTRUMENT PANEL - KILO/FORD F53 - F5TD-10849-BB
15	096675-01-000	EA	KNOB - HEADLAMP SWITCH - W/SHAFT
	096674-01-000	EA	NUT - HEADLAMP SWITCH - BLACK
16	104056-24-01A	EA	APPLIQUE - BEZEL - DRIVER SIDE DRESS UP
	106569-07-02A	EA	VINYL - LAMINATE - 1/4" X 17" X 8.3' - QUICK SILVER
	100138-01-000	EA	MODULE - DAYTIME RUNNING LIGHT (CSA)
	077031-03-000	EA	FILM - WHITE .75" X 1"
	104354-09-03A	EA	APPLIQUE - LOWER DASH - FORD
	112236-01-G35	EA	BEZEL - LEVELING PANEL
	111528-07-03A	EA	TRIM - DASH - LOWER PASSENGER - FORD
	117306-02-G35	EA	TRIM - DASH - LOWER - FORD
	111528-04-01A	EA	TRIM - DASH - LOWER DRIVER
	P14614-02-000	EA	DASH - W/O VINYL - FORD

DRIVERS COMPARTMENT GROUP (CONTINUED)

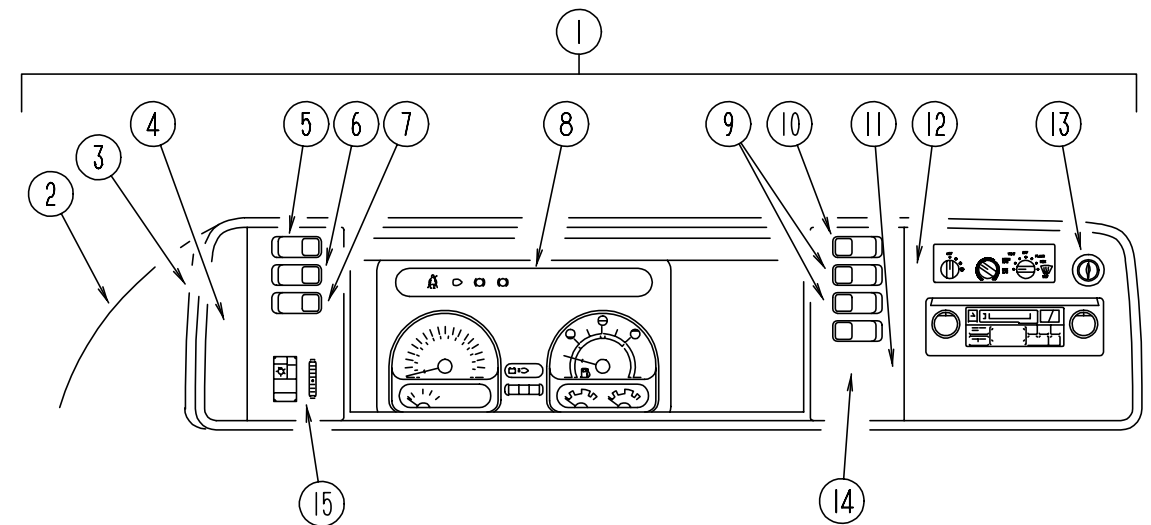

DASH, GAUGES & SWITCHES (CHEVY)

KEY	PART NUMBER	U/M	DESCRIPTION
1	M05946-42-H37	EA	DASH POD - CHEVY
2	111499-01-05A	EA	POD - INSTRUMENT PANEL
3	103662-01-01A	EA	BEZEL - INSTRUMENT PANEL
4	104056-01-04A	EA	APPLIQUE - BEZEL - DRIVER DRESS UP
5	108357-05-000	EA	SWITCH - ROCKER - SPDT ON/ NONE/ ON 3 TERM. CARLING - V4D1000B-0
5	108357-08-000	EA	SWITCH - ROCKER DPDT - ON/NONE/ON - 6 TERMINAL (W/CD PLAYER)
5	108356-02-01A	EA	SWITCH COVER W/ 2 DIMPLES - CARLING - CCAZC00
6	108357-09-000	EA	SWITCH - ROCKER - SPDT ON/ NONE/ MOM 3 TERM. CARLING - V5D1000B-0
6	108356-02-01A	EA	SWITCH COVER W/ 2 DIMPLES - CARLING - CCAZC00
7	108357-06-000	EA	SWITCH - ROCKER - DPDT MOM/ OFF/ MOM 6 TERM. CARLING - VLD1000B-0
7	108356-02-01A	EA	SWITCH COVER W/ 2 DIMPLES - CARLING - CCAZC00
8	094796-07-000	EA	CLUSTER - INSTRUMENT PANEL - KILOMETER, GAS FROM: 00-00-00 THRU: 10-27-96
8	125001-02-000	EA	CLUSTER - INSTRUMENT PANEL - KILOMETERS/MILES - CANADIAN FROM: 10-28-96 THRU: 99-99-99
9	108357-03-000	EA	SWITCH - ROCKER - SPDT ON/ OFF/ ON 3 TERM. CARLING - V6D1000B-0
9	108356-02-01A	EA	SWITCH COVER W/ 2 DIMPLES - CARLING - CCAZC00
10	108357-10-000	EA	SWITCH - RKR SPDT MOM/ ON LIGHTED-5 TERM (3 SWITCH/ 2 LIGHT)
10	108356-04-01A	EA	SWITCH COVER W/ DIMPLES - LIGHTED - CARLING - VVAGC00
	096241-03-000	EA	SWITCH - BLANK
	077942-01-000	EA	SWITCH - DUMMY - BLACK
11	104056-08-01A	EA	APPLIQUE - BEZEL
11	104056-21-01A	EA	APPLIQUE - BEZEL - PASSENGER DRESS UP
12	104056-06-04A	EA	APPLIQUE - BEZEL - PASSENGER DRESS UP
13	089294-01-000	EA	LIGHTER - CIGARETTE - W/O WIRES
14	108357-01-000	EA	SWITCH - ROCKER SPST - ON/OFF - 2 TERMINAL
14	108356-02-01A	EA	SWITCH COVER W/ 2 DIMPLES - CARLING - CCAZC00
15	104056-22-01A	EA	APPLIQUE - BEZEL - DRIVER SWITCHES
	P14614-01-000	EA	DASH - W/O VINYL - GM
	106569-07-02A	EA	VINYL - LAMINATE - 1/4" X 17" X 8.3' - QUICK SILVER
	077031-03-000	EA	FILM - WHITE .75" X 1"
	114620-05-03A	EA	TRIM - DASH - LOWER - GM
	114620-05-02A	EA	TRIM - DASH - LOWER - GM
	104354-09-03A	EA	APPLIQUE - LOWER DASH

ELECTRICAL GROUP

EXTERIOR LIGHTS

KEY	PART NUMBER	U/M	DESCRIPTION
1	111102-02-000	EA	LENS - MARKER LAMP - AMBER
1	111102-01-000	EA	LAMP - MARKER - BASE
1	036196-01-000	EA	BULB - 12 VOLT - #194 - .27 AMP - BAYONETTE
2	097917-01-06A	EA	LIGHT - PORCH - BRIGHT WHITE
2	008215-01-000	EA	BULB - 12 VOLT - #1003 - .94 AMP
2	097917-01-700	EA	LENS - LIGHT - CLEAR
2	008089-02-000	EA	LIGHT - PORCH - RECESSED - CANADIAN
2	008089-01-700	EA	LENS - LIGHT - RECESSED - PORCH - CANADIAN
2	008214-01-000	EA	BULB - 12 VOLT NO 67 - 0.59 AMP - CANADIAN
3	111102-03-000	EA	LENS - MARKER LAMP - RED
3	111102-01-000	EA	LAMP - MARKER - BASE
3	036196-01-000	EA	BULB - 12 VOLT - #194 - .27 AMP - BAYONETTE
4	115632-01-02A	EA	LIGHT - STOP/ TURN/ TAIL RED
5	115632-03-02A	EA	LIGHT - STOP/ TAIL/ BACKUP
6	066432-03-000	EA	BRACKET - LICENSE PLATE
7	066432-02-000	EA	LIGHT - LICENSE - BLACK
8	121950-01-000	EA	LIGHT - BRAKE - CENTER MOUNT
9	070907-04-000	EA	HEADLAMP - HIGH/ LOW HALOGEN
9	049359-01-000	EA	SPRING - RETAINER - HEADLAMP
9	110750-01-000	EA	SCREW - HEADLAMP ADJUSTING
	124215-01-000	EA	FOG LIGHT - RECTANGULAR/ CLEAR LENS
10	089292-01-000	EA	LIGHT - TURN - DRIVER/ PASSENGER - W/AMBER LENS
10	037935-01-000	EA	BULB - 12V - #1157 OR #2057 - 2.1 AMP - CLEAR GLASS
11	102520-01-000	EA	LIGHT - CLEARANCE - W/O SOCKET CONNECTINS - AMBER
11	036196-01-000	EA	BULB - 12 VOLT - #194 - .27 AMP - BAYONETTE
11	102541-01-000	EA	GASKET - CLEARANCE LIGHT
11	067789-02-000	EA	SOCKET - LAMP

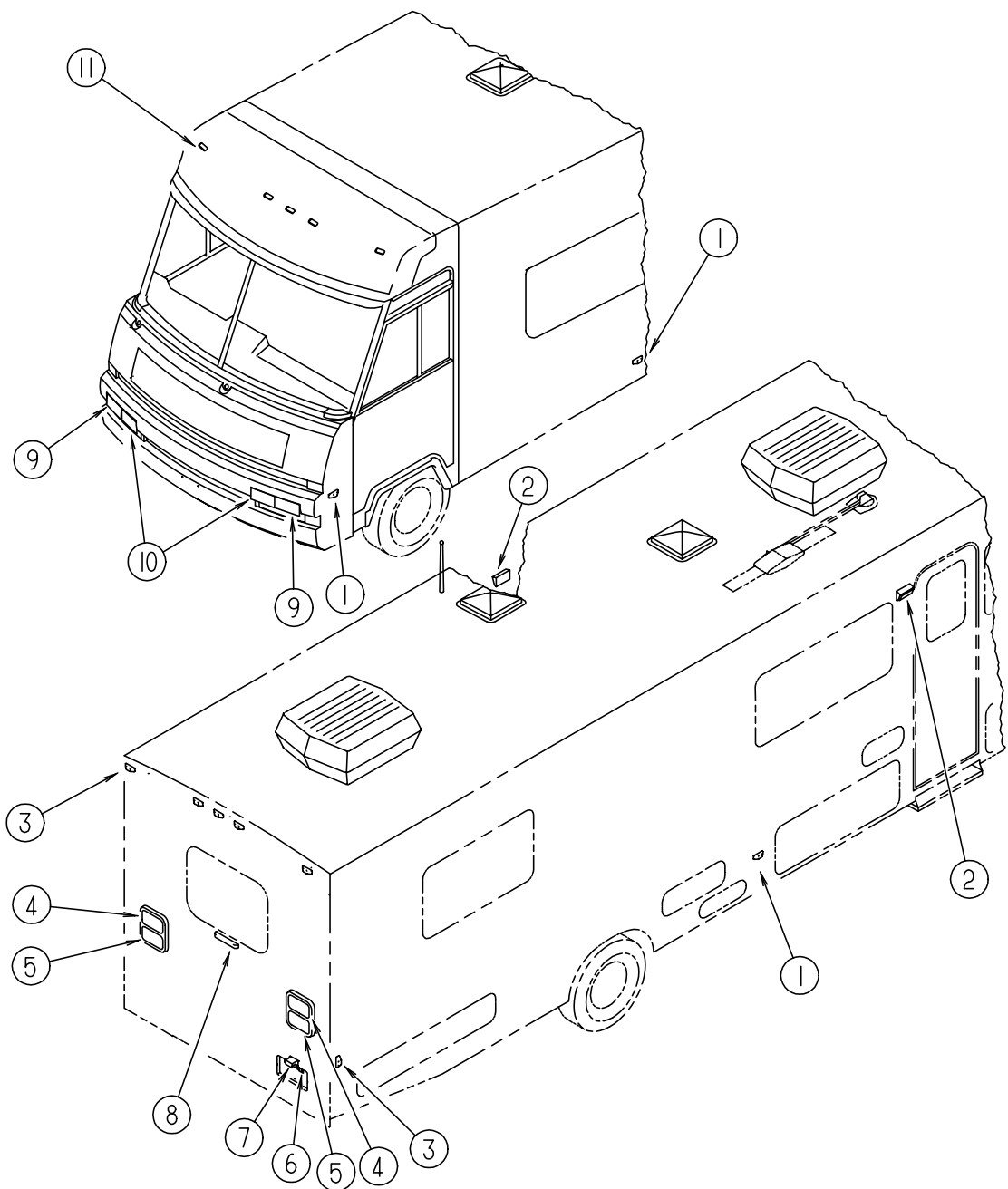

ELECTRICAL GROUP (CONTINUED)

LIGHTS, RECEPTACLES, & SWITCHES (DRIVER SIDE)

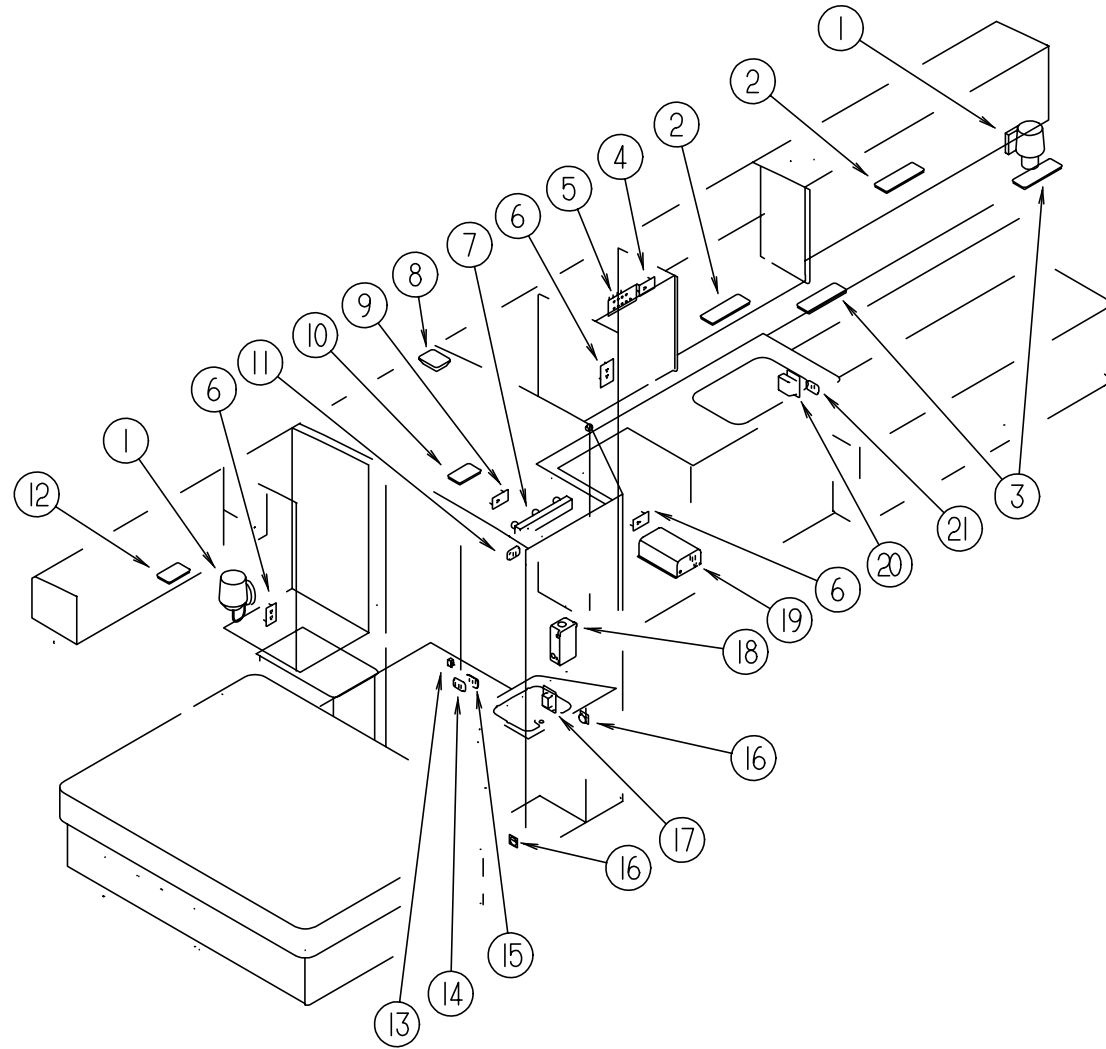

KEY	PART NUMBER	U/M	DESCRIPTION
1	065202-38-000	EA	LAMP - WALL
	067479-01-000	EA	BULB - 12 VOLT - #1076 - 1.80 AMP
2	098024-06-02A	EA	LIGHT - DOME - 2 BULB - SKYLITE
	008218-01-000	EA	BULB - DOME LIGHT - 12 VOLT - NO. 1141
	098024-01-701	EA	LENS - OPTI CLEAR - SKYLITE 809902
3	098024-03-02A	EA	LIGHT - DOME - 2 BULB - WHITE
	008218-01-000	EA	BULB - DOME LIGHT - 12 VOLT - NO. 1141
	098024-01-700	EA	LENS-LIGHT 807877
4	058707-01-000	EA	RECEPTACLE - ELECTRIC - SINGLE - BROWN
5	093674-01-000	EA	PLATE - CIRCUIT BREAKER - HOUSE - 8.4" X 4.1" - STEEL
5	081211-04-000	EA	PLUG - PLASTIC - .46" DIAMETER - BLACK
6	058708-01-000	EA	RECEPTACLE - ELECTRIC - DOUBLE - BROWN
6	058708-02-000	EA	RECEPTACLE - ELECTRIC - DOUBLE - IVORY
	102568-01-H37	EA	SPACER - RECEPTACLE - SIDEWALL
7	110235-01-01A	EA	LIGHT - MAKE UP - 3 BULB - PANLESS
	081633-01-700	EA	BULB - MAKE-UP
8	121935-01-01A	EA	LIGHT - DOME - SHOWER
9	058707-01-000	EA	RECEPTACLE - ELECTRIC - SINGLE - BROWN
10	098024-01-03A	EA	LIGHT - DOME - 1 BULB - WHITE
	008218-01-000	EA	BULB - DOME LIGHT - 12 VOLT - NO. 1141
	098024-01-700	EA	LENS-LIGHT 807877
11	079364-01-000	EA	SWITCH - ON/OFF ROCKER - 2 TERMINAL - BROWN
12	098024-05-02A	EA	LIGHT - DOME - 1 BULB - SKYLITE - WHITE
	008218-01-000	EA	BULB - DOME LIGHT - 12 VOLT - NO. 1141
	098024-01-701	EA	LENS - OPTI CLEAR - SKYLITE 809902
13	108357-08-000	EA	SWITCH - ROCKER DPDT - ON/NONE/ON - 6 TERMINAL
13	108356-02-01A	EA	COVER/ACTUATOR SWITCH - 2 ROWS DIMPLES- CONTURA II - BLACK
14	079364-01-000	EA	SWITCH - ON/OFF ROCKER - 2 TERMINAL - BROWN
15	079364-03-000	EA	SWITCH - ON/OFF ROCKER - 3 TERMINAL - BROWN
15	079364-01-000	EA	SWITCH - ON/OFF ROCKER - 2 TERMINAL - BROWN
16	108354-01-01A	EA	LIGHT - COURTESY
	108354-01-700	EA	BULB-COURTESY LIGHT 395-B
17	084076-02-000	EA	RECEPTACLE - GFI - 15 AMP - 125 VOLT - BROWN
18	109677-01-000	EA	LOAD CENTER - 120 VOLT - 40 AMP
19	123058-02-000	EA	CONVERTER - 45 AMP - ELECTRONIC - 4 1/8"H X 7"W X 12 3/8"L
20	058708-01-000	EA	RECEPTACLE - ELECTRIC - DOUBLE - BROWN
20	058708-02-000	EA	RECEPTACLE - ELECTRIC - DOUBLE - IVORY
20	058708-05-000	EA	RECEPTACLE - SINGLE - BROWN
21	079364-01-000	EA	SWITCH - ON/OFF ROCKER - 2 TERMINAL - BROWN
21	098351-01-01A	EA	PLATE - SWITCH - 1 GANG POLISHED BRASS

ELECTRICAL GROUP (CONTINUED)

LIGHTS, RECEPTACLES, & SWITCHES (PASSENGER SIDE)

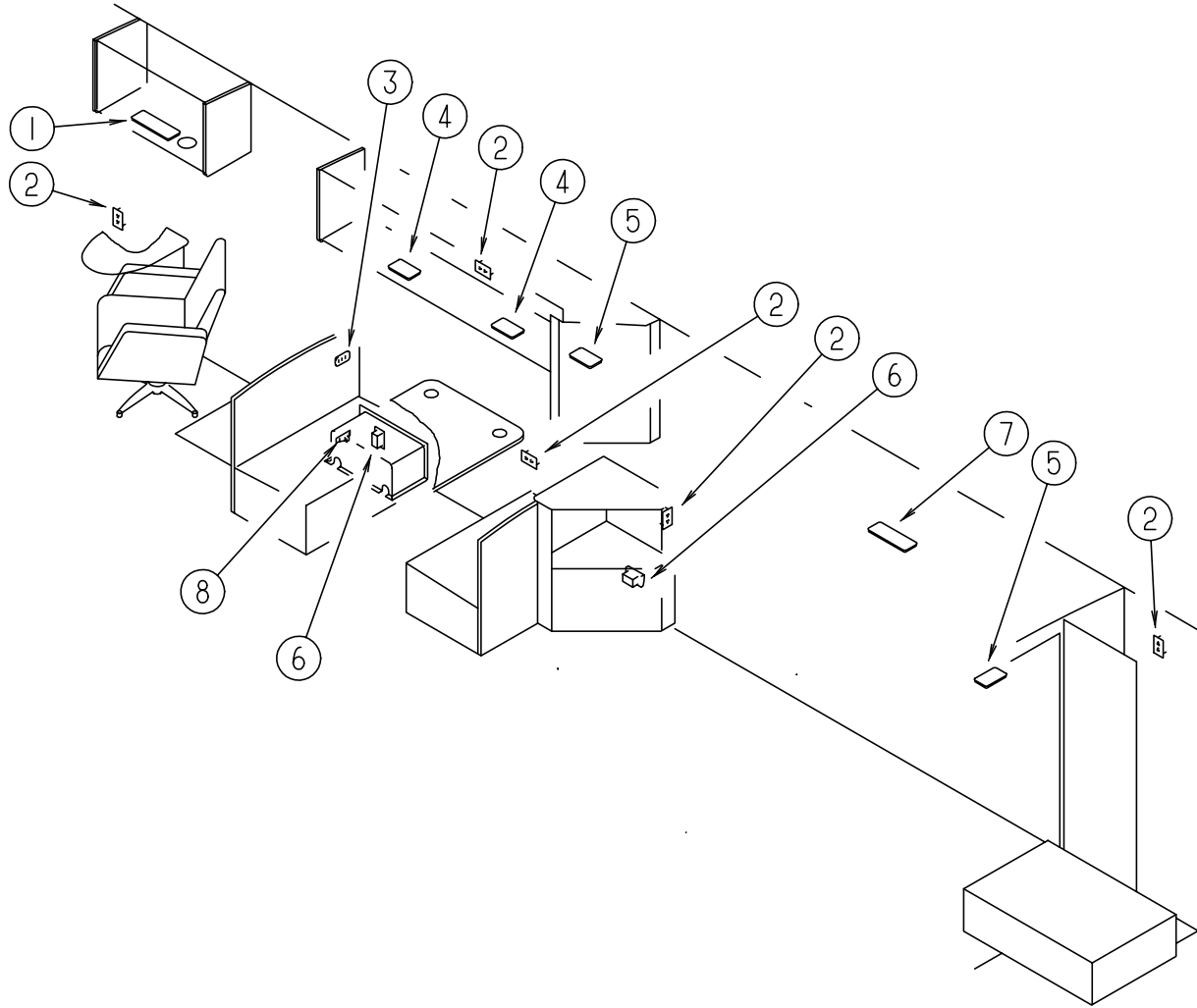

KEY	PART NUMBER	U/M	DESCRIPTION
1	098024-06-02A	EA	LIGHT - DOME - 2 BULB - SKYLITE
	008218-01-000	EA	BULB - DOME LIGHT - 12 VOLT - NO. 1141
	098024-01-701	EA	LENS - OPTI CLEAR - SKYLITE 809902
2	058708-01-000	EA	RECEPTACLE - ELECTRIC - DOUBLE - BROWN
	058708-02-000	EA	RECEPTACLE - ELECTRIC - DOUBLE - IVORY
3	079364-01-000	EA	SWITCH - ON/OFF ROCKER - 2 TERMINAL - BROWN
4	098024-05-02A	EA	LIGHT - DOME - 1 BULB - SKYLITE - WHITE
	008218-01-000	EA	BULB - DOME LIGHT - 12 VOLT - NO. 1141
	098024-01-701	EA	LENS - OPTI CLEAR - SKYLITE 809902
5	098024-01-03A	EA	LIGHT - DOME - 1 BULB - WHITE
	008218-01-000	EA	BULB - DOME LIGHT - 12 VOLT - NO. 1141
	098024-01-700	EA	LENS-LIGHT 807877
6	112822-01-01A	EA	RECEPTACLE - DUPLEX - IVORY
7	098024-03-02A	EA	LIGHT - DOME - 2 BULB - WHITE
	008218-01-000	EA	BULB - DOME LIGHT - 12 VOLT - NO. 1141
	098024-01-700	EA	LENS-LIGHT 807877
8	061424-01-000	EA	LIGHT - AISLE - 12 VOLT - RECTANGULAR
	008103-01-000	EA	BULB - DASH/AISLE LIGHT - #53 - 12 VOLT - .12 AMP

ELECTRICAL GROUP (CONTINUED)**CONVERTER & LOAD CENTER**

KEY	PART NUMBER	U/M DESCRIPTION
	083208-02-000	EA CONVERTER - POWER - 45A - 120/12V
	099048-03-000	EA INVERTER - 130 WATT
	106071-01-000	EA SWITCH - AUTOMATIC TRANSFER - 30 AMP
	106071-02-000	EA SWITCH - AUTOMATIC TRANSFER - 50 AMP
	108915-02-000	EA LOAD CENTER - 120/240 VOLT - 100 AMP
	109677-01-000	EA LOAD CENTER - 120 VOLT - 40 AMP
	123058-02-000	EA CONVERTER - 45 AMP - ELECTRONIC - 4 1/8"H X 7"W X 12 3/8"L

ELECTRICAL SWITCHES

KEY	PART NUMBER	U/M DESCRIPTION
	073626-04-000	EA COVER - ELECTRIC - 10.4' X 7.8"
	079364-01-000	EA SWITCH - ON/OFF ROCKER - 2 TERMINAL - BROWN
	079364-03-000	EA SWITCH - ON/OFF ROCKER - 3 TERMINAL - BROWN
	095188-01-01A	EA SPACER - SWITCH - 2.3" X 3.4" - PLASTIC - DARK BROWN
	098351-01-01A	EA PLATE - SWITCH - 1 GANG POLISHED BRASS
	098351-05-01A	EA PLATE - SWITCH - 3 GANG POLISHED BRASS
	108355-01-000	EA HOUSING - SWITCH
	108356-01-01A	EA COVER/ACTUATOR SWITCH - 3 GROOVES - CONTURA III - BLACK
	108356-02-01A	EA COVER/ACTUATOR SWITCH - 2 ROWS DIMPLES- CONTURA II - BLACK
	108356-04-01A	EA COVER/ACTUATOR SWITCH-2 ROWS DIMPLES W/LENS-CONTURAIIBLK
	106071-01-000	EA SWITCH - AUTOMATIC TRANSFER - MAGNETEK 30 AMP
	106071-02-000	EA AUTOMATIC TRANSFER SWITCH - 50 AMP. - MAGNETEK ATS100
	108355-01-000	EA HOUSING - SWITCH
	108356-02-01A	EA SWITCH COVER - W/ 2 DIMPLES
	108356-04-01A	EA SWITCH COVER - W/ DIMPLES - LIGHTED
	108357-01-000	EA SWITCH - ROCKER - SPST - ON/ OFF 2 TERMINAL
	108357-08-000	EA SWITCH - ROCKER DPDT ON/ NONE/ ON 6 TERMINAL
	108357-10-000	EA SWITCH - ROCKER - SPDT MOM/ OFF/ MOM - LIGHTED 5 TERMINAL

ROCKER SWITCHES (DASH)

KEY	PART NUMBER	U/M DESCRIPTION
	108357-03-000	EA SWITCH - ROCKER - SPDT ON/ OFF/ ON 3 TERM. CARLING - V6D1000B-0
	108356-02-01A	EA SWITCH COVER W/ 2 DIMPLES - CARLING - CCAZC00
	108357-05-000	EA SWITCH - ROCKER - SPDT ON/ NONE/ ON 3 TERM. CARLING - V4D1000B-0
	108356-02-01A	EA SWITCH COVER W/ 2 DIMPLES - CARLING - CCAZC00
	108357-06-000	EA SWITCH - ROCKER - DPDT MOM/ OFF/ MOM 6 TERM. CARLING - VLD1000B-0
	108356-02-01A	EA SWITCH COVER W/ 2 DIMPLES - CARLING - CCAZC00
	108357-09-000	EA SWITCH - ROCKER - SPDT ON/ NONE/ MOM 3 TERM. CARLING - V5D1000B-0
	108356-02-01A	EA SWITCH COVER W/ 2 DIMPLES - CARLING - CCAZC00
	108357-10-000	EA SWITCH - ROCKER - SPDT MOM/ ON LIGHTED-5 TERM (3 SWITCH/ 2 LIGHT)
	108356-04-01A	EA SWITCH COVER W/ DIMPLES - LIGHTED - CARLING - VVAGC00
	096241-03-000	EA SWITCH - BLANK
	077942-01-000	EA SWITCH - DUMMY - BLACK

RECEPTACLES

KEY	PART NUMBER	U/M DESCRIPTION
	024924-02-000	EA RECEPTACLE - POWER CORD - W/PARTIAL PLATE
	058707-01-000	EA RECEPTACLE - ELECTRIC - SINGLE - BROWN
	058707-02-000	EA RECEPTACLE - BLANK JUNCTION BOX
	058708-01-000	EA RECEPTACLE - ELECTRIC - DOUBLE - BROWN
	058708-02-000	EA RECEPTACLE - ELECTRIC - DOUBLE - IVORY
	058708-05-000	EA RECEPTACLE - SINGLE - BROWN
	084076-02-000	EA RECEPTACLE - GFI - 15 AMP - 125 VOLT - BROWN
	084077-02-000	EA PLATE - COVER - RECEPTACLE - GFI - BROWN
	091927-01-000	EA COVER - RECEPTACLE - DOUBLE - IVORY
	097734-01-01A	EA EXTENSION/RECEPTACLE - .7" 3.2" X 5" - IVORY
	102568-01-GB1	EA SPACER - RECEPTACLE - BETWEEN SIDEWALL & PLATE - WOOD
	112822-01-01A	EA RECEPTACLE - DUPLEX - IVORY
	112824-01-03A	EA COVER - RECEPTACLE - EXTERIOR DUPLEX
	115930-02-000	EA INLET - 50 AMP - 240 VOLT - EXTERIOR

ELECTRICAL GROUP (CONTINUED)**WIRE ASSEMBLIES**

KEY	PART NUMBER	U/M DESCRIPTION
	073328-B4-000	EA CABLE ASSEMBLY - BATTERY - W/TERMINALS
	090986-01-000	EA WIRE ASSEMBLY - ELECTRIC STEP
	096449-01-000	EA WIRE ASSEMBLY - WATER TANK TO MONITOR PANEL
	096717-03-000	EA WIRE ASSEMBLY - REAR MONITOR - AFTER MARKET INSTALLATION
	097618-01-000	EA WIRE ASSEMBLY - MONITOR PANEL- W/3 WIRES & ORANGE RESISTOR
	102636-02-000	EA WIRE ASSEMBLY - CLEARANCE LAMPS
	108303-01-000	EA WIRE ASSEMBLY - REAR AUTO HEATER
	108304-01-000	EA WIRE ASSEMBLY - INSTRUMENT PANEL - AUXILIARY FANS
	108885-02-000	EA WIRE-REAR MONITOR -(W/3 PIN HOUSING F/FUSE BLOCK) CHEVY
	110256-01-000	EA WIRE ASSEMBLY - INSTRUMENT PANEL - GENERATOR
	111915-01-000	EA WIRE ASSEMBLY - DAYTIME RUNNING LAMPS - FUSED
	111915-03-000	EA WIRE ASSEMBLY - DAYTIME RUNNING LAMPS - FUSED
	113134-03-000	EA WIRE ASSEMBLY - WIPER/WASHER
	124096-01-000	EA WIRE - INSTRUMENT PANEL - FOG LAMPS

CIRCUIT BREAKERS & FUSES

KEY	PART NUMBER	U/M DESCRIPTION
	062037-01-000	EA HOUSING - AUTO FUSE - NATURAL
	062037-02-000	EA HOUSING - AUTO FUSE - GREEN
	062037-03-000	EA HOUSING - AUTO FUSE - BLACK
	062037-04-000	EA HOUSING - AUTO FUSE - BLUE
	062037-06-000	EA HOUSING - AUTO FUSE - BROWN
	062037-07-000	EA HOUSING - AUTO FUSE - RED
	062901-02-000	EA FUSE - 05 AMPS - AUTOMOTIVE
	062901-05-000	EA FUSE - 15 AMPS - AUTOMOTIVE
	062901-06-000	EA FUSE - 20 AMPS - AUTOMOTIVE
	062901-07-000	EA FUSE - 25 AMPS - AUTOMOTIVE
	062901-08-000	EA FUSE - 30 AMPS - AUTOMOTIVE
	083209-01-000	EA CIRCUIT BREAKER - 15 AMP - 120 VOLT - CANADIAN
	083209-02-000	EA CIRCUIT BREAKER - 15/15 AMP - 120 VOLT
	083209-03-000	EA CIRCUIT BREAKER - 15/20 AMP - 120 VOLT
	083209-06-000	EA CIRCUIT BREAKER - 30/15 AMP - 120 VOLT
	093654-01-000	EA CIRCUIT BREAKER - 6 AMP - 12 VOLT
	093654-02-000	EA CIRCUIT BREAKER - 15 AMP - 12 VOLT
	093655-03-000	EA CIRCUIT BREAKER - 40 AMP - 12 VOLT
	093674-01-000	EA PLATE - CIRCUIT BREAKER - HOUSE - 8.4" X 4.1" - STEEL
	106656-01-000	EA FUSE BLOCK - 4 CAVITY - AUTOFUSE
	108669-01-000	EA HOUSING - AUTO FUSE HOLDER
	112591-01-000	EA CIRCUIT BREAKER - 16 AMP 240 VOLT
	122811-01-000	EA CIRCUIT BREAKER - 20/50/50/20

ELECTRICAL BOXES & CORDS

KEY	PART NUMBER	U/M DESCRIPTION
	008052-01-000	EA CORD - POWER - 10/3 - 30 AMP - 25' - CANADIAN
	008054-01-000	EA CORD - POWER - 10/3 - 30 AMP - 25'
	008289-01-000	EA BOX - ELECTRIC/STEEL - 1/2" & 3/4" KNOCKOUTS - 4" X 4"
	008289-02-000	EA BOX - ELECTRIC/STEEL - 1/2" & 3/4" KNOCKOUTS - 4" X 4"-CAN
	008294-01-000	EA COVER - ELECTRICAL BOX - BLANK/STEEL - 4" X 4" - GRAY
	008294-02-000	EA COVER - ELECTRICAL BOX - BLANK STEEL - 4" X 4" - CANADIAN
	069238-01-000	EA COVER - ELECTRICAL BOX - W/HOLE - 4" X 4" - GRAY
	074890-01-000	EA BOX - EXTENSION/STEEL - OPEN SIDES - 4" X 4" X 1 1/2"
	074897-01-000	EA COVER - ELECTRICAL BOX W/HOLES - 4" X 4"
	091910-01-000	EA BOX - ELECTRIC - 3.8" X 3.5" X 1.8" - PLASTIC
	091910-02-000	EA BOX - ELECTRIC - 2.2" X 3.5" X 1.7" - PLASTIC
	108934-01-000	EA CORD - POWER - 50 AMP - 4 WIRE - 36'
	111509-01-000	EA BOX - ELECTRICAL - E-COATED
	111510-01-000	EA DOOR/ACCESS PANEL - ELECTRICAL BOX
	113096-01-000	EA CORD - POWER - 50 AMP - 4 WIRE - 36' - CSA
	121470-01-000	EA CORD/EXTENSION - 6 FOOT - 16-2 WIRE

ELECTRICAL GROUP (CONTINUED)**ELECTRICAL CONNECTORS & CONDUIT**

KEY	PART NUMBER	U/M	DESCRIPTION
	007954-01-000	EA	RECEPTACLE - HOUSING - 6 POSITION
	007956-05-000	EA	INSULATOR - SHRINK - .25 ID X 1.50
	008311-01-000	EA	CONNECTOR - WIRE NUT - INSULATED - RED
	008312-01-000	EA	CONNECTOR - WIRE NUT - INSULATED - BLUE
	008313-01-000	EA	CONNECTOR - WIRE NUT - INSULATED - YELLOW
	008314-01-000	EA	CONNECTOR - WIRE NUT - INSULATED - GRAY
	008326-01-000	EA	TERMINAL - RING - 16/14 WIRE - 3/8" STUD
	008328-01-000	EA	TERMINAL - RING - 12/10 WIRE - #10 STUD FIT
	008331-01-000	EA	TERMINAL - RING - TONGUE - #4 WIRE - 3/8" STUD - COPPER
	008348-01-000	EA	TERMINAL - RING - 3/8" STUD 2 GA. WIRE
	008355-01-000	EA	CONNECTOR - CABLE CLAMPING - 3/4"
	008356-01-000	EA	CONNECTOR - PLASTIC - 3/8" AVG
	008356-02-000	EA	CONNECTOR - PLASTIC - 21/32
	008394-01-000	FT	CONDUIT - FLEXIBLE - 1/2"
	008398-01-000	EA	CONNECTOR - 1/2" X 90 DEGREE - FLEX CONDUIT - UL & CSA
	035416-04-000	EA	TERMINAL - RING - #10 STUD FIT - INSULATED BARREL #16/14
	041480-01-000	EA	CONNECTOR - STRAIGHT - 1/2' FLEX CONDUIT
	041953-01-000	FT	CONDUIT - CONVOLUTE SLIT - .5" ID
	041953-01-000	FT	CONDUIT - CONVOLUTE SLIT - .5" ID
	041953-01-000	FT	CONDUIT - CONVOLUTE SLIT - .5" ID
	041953-03-000	FT	CONDUIT - CONVOLUTE SLIT - 1" ID (CLOTHES ROD COVER)
	041953-05-000	FT	CONDUIT - CONVOLUTE SOLID - .62" ID
	041953-06-000	FT	CONDUIT - CONVOLUTE SLIT - .375" ID
	041953-07-000	FT	CONDUIT - CONVOLUTE SLIT - .25" ID
	041953-08-000	FT	CONDUIT - CONVOLUTE SLIT - 1.50" ID
	041953-09-000	FT	CONDUIT - CONVOLUTE SLIT - .50" ID
	041953-10-000	FT	CONDUIT - CONVOLUTE SLIT - .75" ID
	041953-11-000	FT	CONDUIT - CONVOLUTE SLIT - 1.06" ID
	041953-12-000	FT	CONDUIT - CONVOLUTE NON SLIT - 1.1" ID
	047443-01-000	EA	TERMINAL - .250 RECEPTACLE FIT - INSULATED - 16/14 AWG
	047443-02-000	EA	TERMINAL - .250 RECEPTACLE FIT - INSULATED - 12/10 AWG
	058028-01-000	EA	CONNECTOR - ELECTRICAL PIGTAIL - NYLON - CLEAR
	062036-01-000	EA	TERMINAL - PACK - CON - 12/10 AWG
	062036-02-000	EA	TERMINAL - PACK - CON - 16/14 AWG
	077479-01-000	EA	BOOT - BATTERY TERMINAL - DOUBLE CABLE
	077479-02-000	EA	BOOT - BATTERY TERMINAL - SINGLE CABLE
	080015-02-000	EA	RECEPTACLE - FLAG - .185 - 16/14 GAUGE
	087225-01-000	FT	SLEEVING - 1/2" - TYPE H
	087225-02-000	FT	SLEEVING - 5/8" - TYPE H
	087949-01-000	EA	BUSS BAR - 2 POSITION - .6" X 1.5"
	087949-02-000	EA	BUSS BAR - 3 POSITION - .6" X 2.4"
	088267-01-000	EA	TERMINAL - FEMALE - 1/4
	088473-01-000	EA	HOUSING - PIN - 12 CAVITY
	088473-02-000	EA	HOUSING - PIN - 15 CAVITY
	088473-03-000	EA	HOUSING - PIN - 9 CAVITY
	088473-05-000	EA	HOUSING - PIN - 6 CAVITY
	088473-06-000	EA	HOUSING - PIN - 6 CAVITY
	088473-08-000	EA	HOUSING - PIN - 4 CAVITY
	088473-09-000	EA	HOUSING - PIN - 3 CAVITY
	088473-10-000	EA	HOUSING - PIN - 2 CAVITY
	088474-01-000	EA	HOUSING - SOCKET - 12 CAVITY
	088474-02-000	EA	HOUSING - SOCKET - 15 CAVITY
	088474-03-000	EA	HOUSING - SOCKET - 9 CAVITY
	088474-06-000	EA	HOUSING - SOCKET - 6 CAVITY
	088474-07-000	EA	HOUSING - SOCKET - 5 CAVITY
	088474-08-000	EA	HOUSING - SOCKET - 4 CAVITY
	088474-09-000	EA	HOUSING - ELECTRICAL - 3 TERMINAL
	088474-10-000	EA	HOUSING - SOCKET - 2 CAVITY
	088475-01-000	EA	PIN - CONNECTOR - 14 - 20 AWG
	088475-02-000	EA	PIN - CONNECTOR - 10-12 AWG
	088476-01-000	EA	TERMINAL - ELECTRICAL

ELECTRICAL GROUP (CONTINUED)**ELECTRICAL CONNECTORS & CONDUIT (CONTINUED)**

KEY	PART NUMBER	U/M	DESCRIPTION
	088476-02-000	EA	SOCKET - CONNECTOR - 12-10 GA - PRE-TIN
	092786-03-000	EA	BUSS BAR - 6.9" LONG
	098260-01-000	EA	TERMINAL - MALE - 56 SERIES
	098261-02-000	EA	SOCKET - CONNECTOR - WEATHERPACK
	098262-01-000	EA	SEAL - CONNECTOR - WEATHERPACK
	098264-01-000	EA	HOUSING - 2 PIN - WEATHERPACK
	101571-01-000	EA	HOUSING - 2 POSITION - MALE
	103608-01-000	EA	SOCKET - WEDGE BASE W/LEADS
	103987-02-000	EA	SEAL - SOLENOID ACCESS
	104016-01-000	EA	WIRE ASSEMBLY - AUXILIARY FANS
	104100-01-000	EA	HOUSING - 1 POSITION - 75 AMPS
	104100-03-000	EA	TERMINAL - 75 AMP
	106006-01-000	EA	HOUSING - 1 POSITION - FEMALE
	106007-01-000	EA	TERMINAL - FEMALE - 14-16 AWG
	106655-01-000	EA	TERMINAL - FUSE BLOCK - 14-16 AWG
	106655-02-000	EA	TERMINAL - FUSE BLOCK - 10-12 AWG
	110178-01-000	EA	HOUSING - WIPER MOTOR
	112823-01-000	EA	SPLICE - REDUCER - 16-14 TO 18-22
	113131-01-000	EA	HOUSING - 3 PIN
	113135-01-000	EA	TERMINAL - FEMALE- M/P - 14-16
	113306-01-000	EA	TERMINAL - FEMALE - M/P - 14-16
	113307-01-000	EA	TERMINAL - FEMALE - M/P - 16-20
	113468-01-000	EA	HOUSING - 2 POSITION - FEMALE
	115556-01-000	EA	HOUSING - 3 POSITION - FEM
	115931-02-000	EA	COVER - CONNECTOR
	115932-02-000	EA	CONNECTOR - FEMALE - 50 AMP - 240 VOLT
	119248-02-000	EA	HOUSING - 7 POSITION - FEMALE
	125323-02-000	EA	HOUSING - 8 POSITION - MALE
	125324-01-000	EA	TERMINAL - MALE - METRI-PACK - 150
	125325-01-000	EA	SEAL - CAVITY

ELECTRICAL MISCELLANEOUS

KEY	PART NUMBER	U/M	DESCRIPTION
	007093-01-000	EA	SIGNAL FLASHER
	008188-01-000	EA	SOLENOID - 3 POST - BATTERY CHANGE OVER
	063910-01-000	EA	HOUSING - RELAY
	063912-02-000	EA	RELAY - CANISTER - SPDT
	083172-02-000	EA	PANEL-DI-ELECTRIC 110 28X36 - COATED BOTH SIDES
	086233-01-000	EA	STUD - ISOLATED - 3/8" X 7/8" LONG
	086273-01-000	EA	RELAY - BATTERY DISCONNECT
	115504-01-000	EA	PANEL - SOLAR 10 WATT
	115504-01-700	EA	PLUG & CABLE, 10 WATT PANEL 600-016
	115505-01-000	EA	LIGHT - MONITOR/SOLAR PANEL - RED LED INDICATOR

EXTERIOR BODY GROUP

EXTERIOR BODY PANELS & TRIM

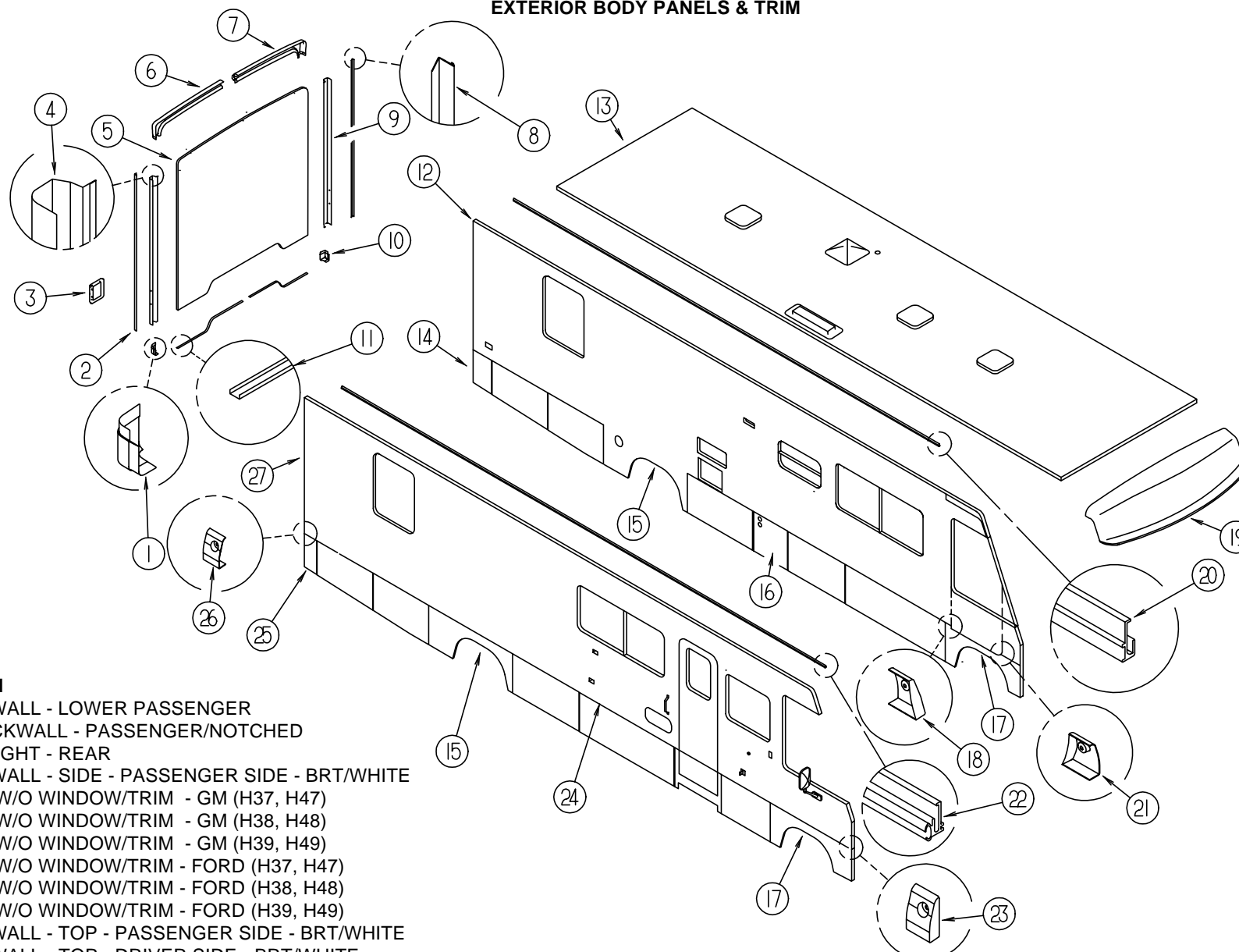

KEY	PART NUMBER	U/M DESCRIPTION
1	119212-01-01A	EA TRIM - BACKWALL - LOWER PASSENGER
2	120548-01-02A	EA TRIM - J - BACKWALL - PASSENGER/NOTCHED
3	117379-01-02A	EA TRIM - TAIL LIGHT - REAR
4	114874-03-12B	EA TRIM - BACKWALL - SIDE - PASSENGER SIDE - BRT/WHITE
5	M08003-03-H37	EA BACKWALL - W/O WINDOW/TRIM - GM (H37, H47)
5	M08003-03-H38	EA BACKWALL - W/O WINDOW/TRIM - GM (H38, H48)
5	M08003-03-H39	EA BACKWALL - W/O WINDOW/TRIM - GM (H39, H49)
5	M08003-04-H37	EA BACKWALL - W/O WINDOW/TRIM - FORD (H37, H47)
5	M08003-04-H38	EA BACKWALL - W/O WINDOW/TRIM - FORD (H38, H48)
5	M08003-04-H39	EA BACKWALL - W/O WINDOW/TRIM - FORD (H39, H49)
6	114872-02-02A	EA TRIM - BACKWALL - TOP - PASSENGER SIDE - BRT/WHITE
7	114873-02-02A	EA TRIM - BACKWALL - TOP - DRIVER SIDE - BRT/WHITE
8	120548-02-02A	EA TRIM - J - BACKWALL - DRIVER/NOTCHED
9	114874-04-12B	EA TRIM - BACKWALL - SIDE - DRIVER SIDE - BRT WHITE
10	119212-02-01A	EA TRIM - BACKWALL - LOWER DRIVER
11	050406-25-000	EA TRIM - BACKWALL - LOWER
12	M08158-07-H37	EA SIDEWALL - DRIVER - W/O WINDOWS/TRIMS/DRVR DOOR - W/WAINSCOT
12	M08158-07-H38	EA SIDEWALL - DRIVER - W/O WINDOWS/TRIMS/DRVR DOOR - W/WAINSCOT
12	M08158-07-H39	EA SIDEWALL - DRIVER - W/O WINDOWS/TRIMS/DRVR DOOR - W/WAINSCOT
12	M08158-07-H47	EA SIDEWALL - DRIVER - W/O WINDOWS/TRIMS/DRVR DOOR - W/WAINSCOT
12	M08158-07-H48	EA SIDEWALL - DRIVER - W/O WINDOWS/TRIMS/DRVR DOOR - W/WAINSCOT
12	M08158-07-H49	EA SIDEWALL - DRIVER - W/O WINDOWS/TRIMS/DRVR DOOR - W/WAINSCOT
12	M08158-08-H37	EA SIDEWALL - DRIVER - W/O WINDOWS/TRIMS - W/DRVR DOOR/WAINSCOT
12	M08158-08-H38	EA SIDEWALL - DRIVER - W/O WINDOWS/TRIMS - W/DRVR DOOR/WAINSCOT
12	M08158-08-H39	EA SIDEWALL - DRIVER - W/O WINDOWS/TRIMS - W/DRVR DOOR/WAINSCOT
12	M08158-08-H47	EA SIDEWALL - DRIVER - W/O WINDOWS/TRIMS - W/DRVR DOOR/WAINSCOT
12	M08158-08-H48	EA SIDEWALL - DRIVER - W/O WINDOWS/TRIMS - W/DRVR DOOR/WAINSCOT
12	M08158-08-H49	EA SIDEWALL - DRIVER - W/O WINDOWS/TRIMS - W/DRVR DOOR/WAINSCOT
13	P23538-01-H17	EA ROOF - W/O LIGHTS/VENTS - W/WIRING (H37,H38,H39,H47,H48,H49)
14	122732-02-H37	EA PANEL - VALANCE/REAR - W/O HARDWARE
15	122700-01-01A	EA TRIM - WHEELWELL - REAR - BRIGHT WHITE
		FROM: 00-00-00 THRU: 09-02-96
15	124517-01-01A	EA TRIM - WHEELWELL - REAR - BRIGHT WHITE
		FROM: 09-03-96 THRU: 99-99-99
16	122776-05-H37	EA PANEL - VALANCE - W/O HARDWARE

KEY	PART NUMBER	U/M DESCRIPTION
17	122699-01-01A	EA TRIM - WHEELWELL - FRONT - BRIGHT WHITE
		FROM: 00-00-00 THRU: 09-02-96
17	124518-01-01A	EA TRIM - WHEELWELL - FRONT
		FROM: 09-03-96 THRU: 99-99-99
18	124178-02-01A	EA CAP - TRIM/DRIVER DOOR (REAR)
19	115001-01-02A	EA CAP - ROOF
20	120091-02-02A	EA TRIM - ROOF
21	124178-01-01A	EA CAP - TRIM/DRIVER DOOR (FRONT)
22	120092-01-02A	EA RAIL - AWNING - BRIGHT WHITE
23	124132-01-01A	EA CAP - TRIM/SIDEWALL - RIGHT HAND - BRIGHT WHITE
24	124176-01-01A	EA TRIM - SIDEWALL - BRIGHT WHITE - 16'
24	105312-01-03A	FT INSERT - VINYL FEATURE STRIP - GRAY METALLIC
25	122732-01-H37	EA PANEL - VALANCE REAR - W/O HARDWARE
26	124132-02-01A	EA CAP - TRIM/SIDEWALL - LEFT HAND - BRIGHT WHITE
27	M08159-04-H37	EA SIDEWALL - PASSENGER - W/O WINDOWS/TRIM - W/WAINSCOTING
27	M08159-04-H38	EA SIDEWALL - PASSENGER - W/O WINDOWS/TRIM - W/WAINSCOTING
27	M08159-04-H39	EA SIDEWALL - PASSENGER - W/O WINDOWS/TRIM - W/WAINSCOTING
27	M08159-04-H47	EA SIDEWALL - PASSENGER - W/O WINDOWS/TRIM - W/WAINSCOTING
27	M08159-04-H48	EA SIDEWALL - PASSENGER - W/O WINDOWS/TRIM - W/WAINSCOTING
27	M08159-04-H49	EA SIDEWALL - PASSENGER - W/O WINDOWS/TRIM - W/WAINSCOTING

EXTERIOR BODY GROUP (CONTINUED)

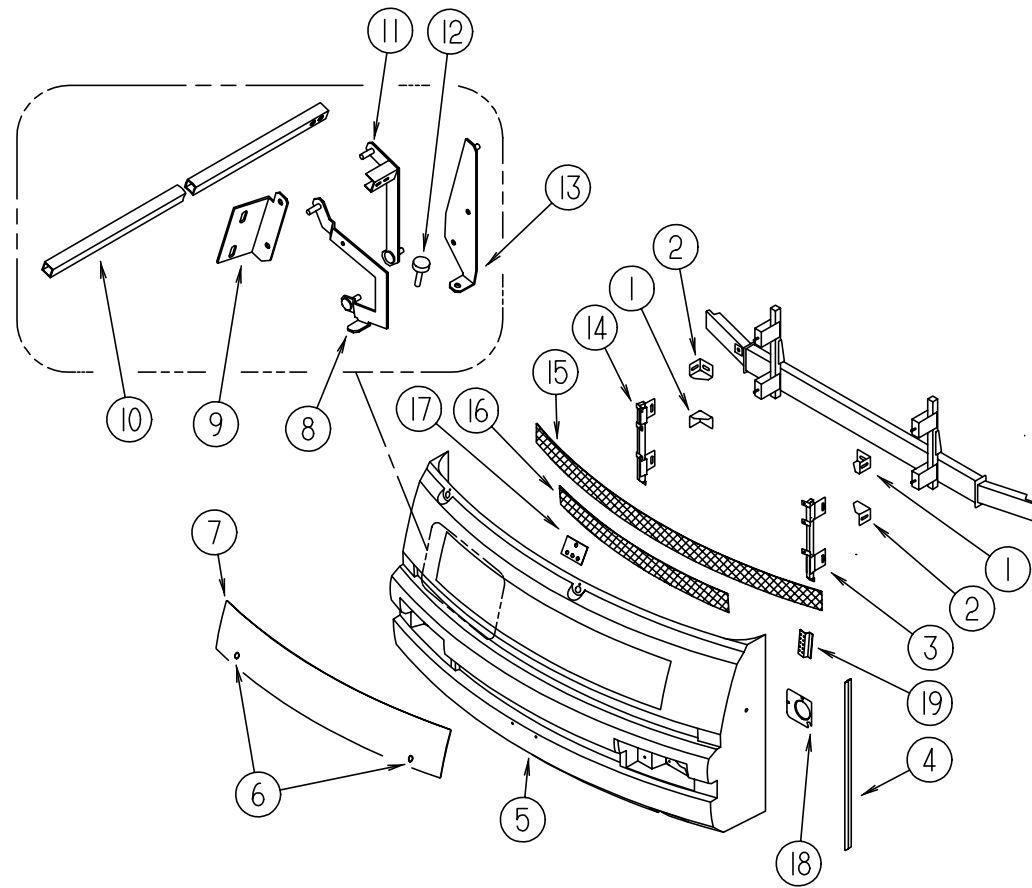

FRONT END ASM

KEY	PART NUMBER	U/M	DESCRIPTION
1	117611-04-02B	EA	BRACKET - BUMPER
2	117611-03-02B	EA	BRACKET - BUMPER
	116617-02-02B	EA	SPACER - BUMPER
3	118997-02-G35	EA	SUPPORT - GRILLE - DRIVER FRONT
4	089922-34-000	EA	TRIM - FIBERGLASS - PANEL B/W
5	118999-03-G35	EA	PANEL - LOWER FRONT
6	102330-02-000	EA	HOOD LOCK - SINGLE HOLE - VISE ACTION
	102328-01-000	EA	BARREL KEY - HOOD LOCK
7	115976-03-G35	EA	PANEL - HOOD
8	109930-11-000	EA	LINK - HINGE - HOOD/LOWER PASSENGER SIDE
	109930-12-000	EA	LINK - HINGE - HOOD/LOWER DRIVER SIDE
9	109927-03-000	EA	ANGLE - LINK - HOOD RIGHT HAND
	109927-04-000	EA	ANGLE - LINK - HOOD LEFT HAND
10	105096-10-000	EA	TUBE - HOOD HINGE TIMING W/WELDNUTS
	106748-04-000	EA	LATCH - HOOD - FRONT END
11	109929-05-000	EA	LINK - UPPER HOOD HINGE - PASSENGER SIDE
	109929-06-000	EA	LINK - UPPER HOOD HINGE - DRIVER SIDE
12	058786-01-000	EA	BOLT - ADJUSTING HOOD - W/BLACK PAD - .31" - 18X2
13	109926-15-000	EA	BRACKET - HOOD HINGE LINK - PASSENGER SIDE
	109926-16-000	EA	BRACKET - HOOD HINGE LINK - DRIVERS SIDE
14	118997-01-G35	EA	SUPPORT - GRILLE - PASSENGER FRONT
15	115924-05-02A	EA	GRILLE - WOVEN WIRE - FLAT BLACK
16	115924-11-01A	EA	GRILLE - WOVEN WIRE
17	119445-01-02B	EA	PLATE - W/ HOLES
18	115951-02-02B	EA	PLATE - HEADLAMP - DUAL/ LEFT HAND
	115951-01-02B	EA	PLATE - HEADLAMP - DUAL/ RIGHT HAND
19	113495-02-02B	EA	SUPPORT - HINGE
	070579-06-000	EA	PLATE - ANCHOR - W/ 7/16 WELD NUT - 1.5" X 3.3"
	070579-07-000	EA	PLATE - ANCHOR W/O NUT
	077001-01-000	EA	ANGLE - MOUNTING ROOF PANEL V ANGLE - 3" X 2.4" X 1.5"

EXTERIOR BODY GROUP (CONTINUED)

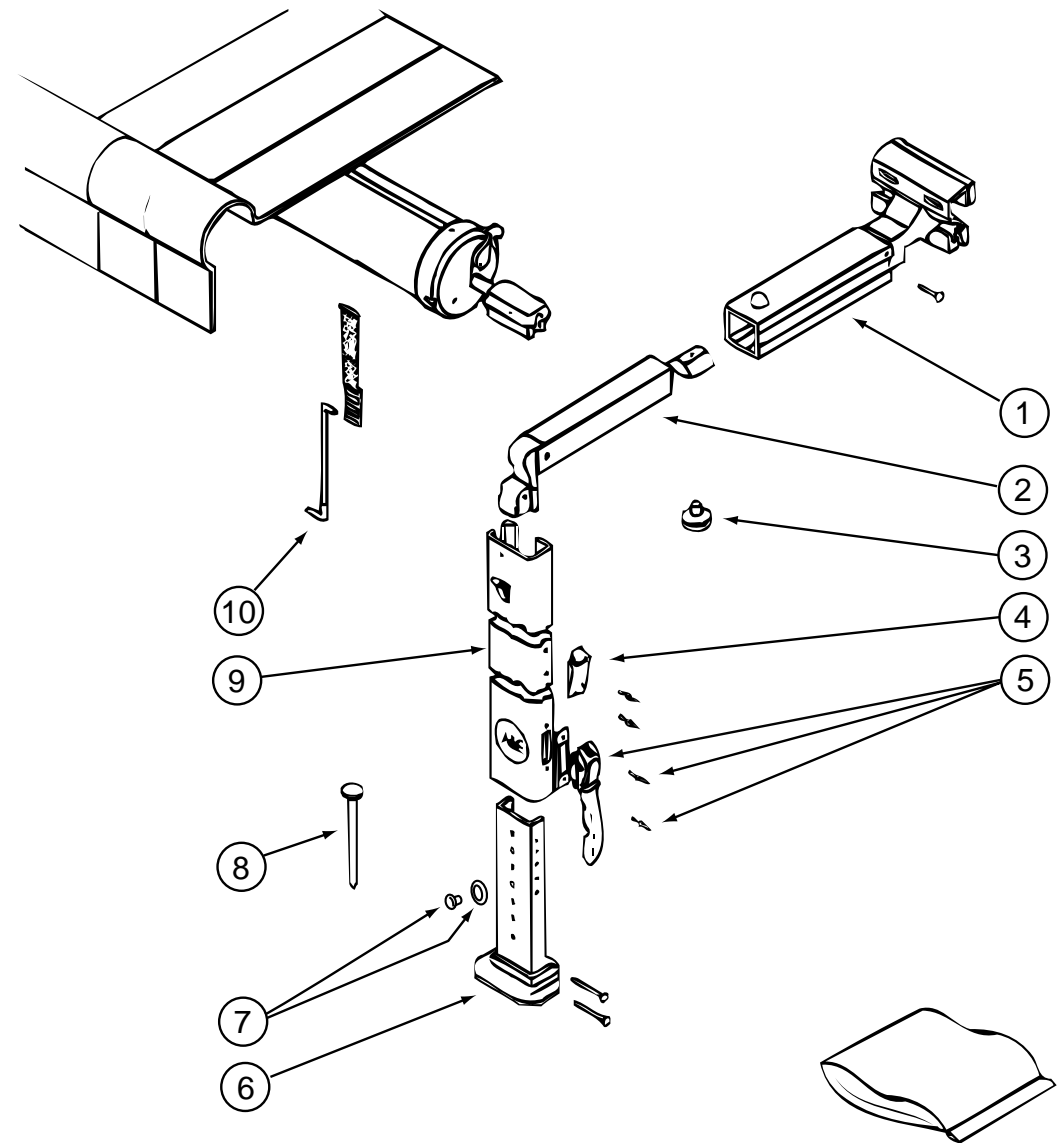

EXTERIOR AWNING

KEY	PART NUMBER	U/M	DESCRIPTION	VENDOR NO.
	113874-08-01A	EA	AWNING - W/O HDW 19' (POLAR NAVY TEAL) VINYL	
	111037-01-01A	EA	SPACER - AWNING - UPPER - BLACK	
	119496-01-02A	EA	SPACER/ZEE - AWNING	
	113874-01-02A	EA	HARDWARE KIT - AWNING - W/O STANDOFF BRACKET - BRIGHT WHT	
1	113874-01-714	EA	RAFTER - MAIN RH/LH BRT/WHT	830295.536F
2	113874-01-715	EA	RAFTER - SECONDARY BRT/WHT	830463.511F
3	113874-01-702	EA	KNOB - ADJUSTING	3105421.014
4	113874-01-706	EA	LOCK - TRAVEL	830587.001
5	113874-01-707	EA	HANDLE - LIFT W/RIVETS	830644
6	113874-01-712	EA	FOOT - PATIO	730366-001
7	113874-01-710	EA	PLUG - STOP KIT	830456
8	113874-01-709	EA	NAIL - SPIKE, 8"	113006
9	113874-01-716	EA	ARM - MAIN SUPPORT BRT/WHT	3104502.293/F
10	113874-01-703	EA	ROD - CENTER PULL W/ACCESSORY	830152.102

EXTERIOR BODY GROUP (CONTINUED)

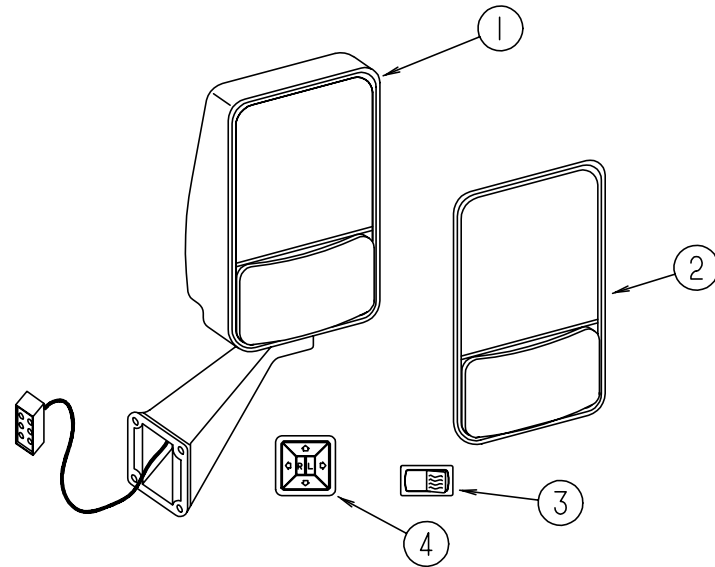

EXTERIOR MIRROR OPTION (REMOTE & HEAT) (FROM: 00-00-00 THRU: 11-05-96)

KEY	PART NUMBER	U/M DESCRIPTION
1	106015-05-01A	EA MIRROR ASM. RH W/WIRE PIGTAIL-REMOTE/HEATED - W/O SWITCH
1	106015-06-01A	EA MIRROR ASM LH W/WIRE PIGTAIL - REMOTE/HEATED - W/O SWITCH
2	086261-02-701	EA KIT - EXTERIOR. MIRROR - W/BEZEL - FLAT & CONVEX GLASS - DRIVER SIDE
2	086261-01-704	EA KIT - EXTERIOR. MIRROR - W/BEZEL - FLAT & CONVEX GLASS - PASS. SIDE
3	087695-02-000	EA SWITCH-MIRROR HEATER
4	088246-01-000	EA SWITCH-REMOTE, EXT. MIRROR - SQUARE PUSH - VELVAC 7471290
	087695-03-000	EA CONNECTOR-ASSEMBLY

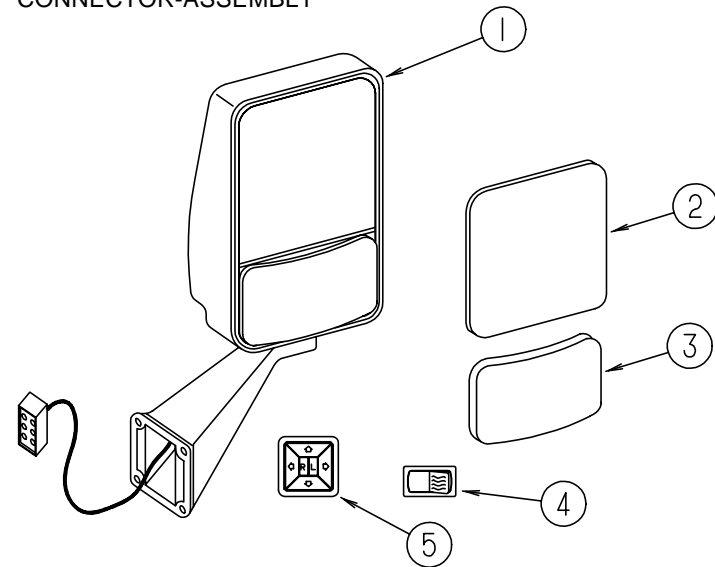

EXTERIOR MIRROR OPTION (REMOTE & HEAT) (FROM: 11-06-96 THRU: 99-99-99)

KEY	PART NUMBER	U/M DESCRIPTION
1	106015-12-01A	EA MIRROR - EXTERIOR REMOTE/HEAT - PASSENGER
1	106015-13-01A	EA MIRROR - EXTERIOR REMOTE/HEAT - DRIVER
2	106015-12-700	EA MIRROR - FLAT HEATED W/CLIP
3	106015-12-701	EA MIRROR - CONVEX HEATED W/CLIP
4	087695-02-000	EA SWITCH - HEATER - EXTERIOR MIRROR
5	088246-01-000	EA SWITCH - REMOTE - EXTERIOR - SQUARE PUSH
	087695-03-000	EA CONNECTOR - ASSEMBLY

EXTERIOR BODY GROUP (CONTINUED)

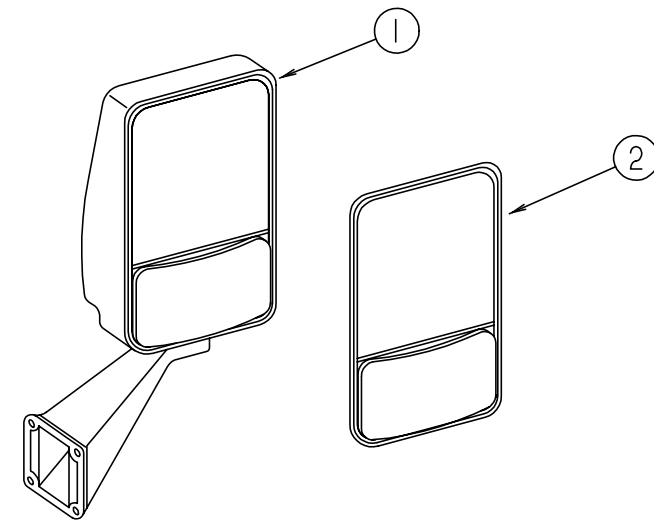

EXTERIOR MIRROR (FROM: 00-00-00 THRU: 03-02-97)

KEY	PART NUMBER	U/M DESCRIPTION
1	106015-09-01A	EA MIRROR - EXTERIOR ADJUSTABLE GLASS - PASSENGER
1	106015-10-01A	EA MIRROR - EXTERIOR ADJUSTABLE GLASS - DRIVER
2	106015-01-703	EA MIRROR KIT (BEZEL W/MIRRORS) PASSENGER SIDE
2	106015-02-702	EA MIRROR KIT (BEZEL W/MIRRORS) DRIVER SIDE

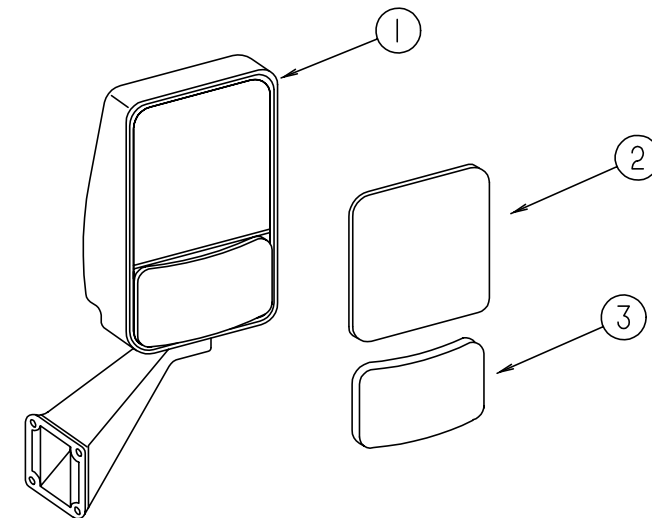

EXTERIOR MIRROR (FROM: 03-03-97 THRU: 99-99-99)

KEY	PART NUMBER	U/M DESCRIPTION
1	106015-14-01A	EA MIRROR - EXTERIOR ADJUSTABLE GLASS - PASSENGER
1	106015-15-01A	EA MIRROR - EXTERIOR ADJUSTABLE GLASS - DRIVER
2	106015-14-700	EA MIRROR - FLAT
3	106015-14-701	EA MIRROR - CONVEX

EXTERIOR BODY GROUP (CONTINUED)

DECALS, FILM STRIPES & PAINT

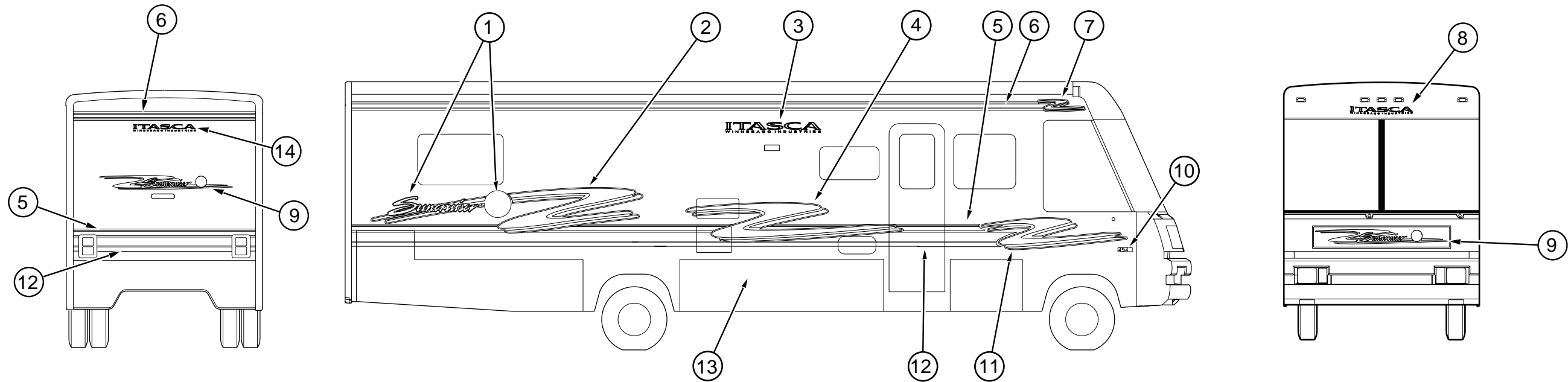

KEY	PART NUMBER	U/M	DESCRIPTION
1	122036-01-01A	EA	DECAL - TAIL - RIGHT HAND (PASSENGER)
	122036-02-01A	EA	DECAL - TAIL - LEFT HAND (DRIVERS)
2	122032-01-01A	EA	DECAL - SWOOP - #1 - RIGHT HAND (PASSENGER)
	122032-02-01A	EA	DECAL - SWOOP - #1 - LEFT HAND (DRIVERS)
3	116921-01-05A	EA	DECAL - LOGO - ITASCA - WINNEBAGO INDUSTRIES
4	122033-01-01A	EA	DECAL - SWOOP - #2 - RIGHT HAND (PASSENGER)
	122033-02-01A	EA	DECAL - SWOOP - #2 - LEFT HAND (DRIVERS)
5	105781-55-01A	FT	FILM - MULTISTRIPE - 3.12"
6	094443-45-01A	FT	FILM - MULTISTRIPE - 4.24"
7	122035-01-01A	EA	DECAL - SWOOP - #4 - RIGHT HAND (PASSENGER)
	122035-02-01A	EA	DECAL - SWOOP - #4 - LEFT HAND (DRIVERS)
8	118312-01-03A	EA	DECAL - ITASCA - WINNEBAGO INDUSTRIES - SWEEP
9	122031-01-01A	EA	DECAL - HOOD
10	122312-01-01A	EA	DECAL - VORTEC 7400
11	122034-01-01A	EA	DECAL - SWOOP - #3 - RIGHT HAND (PASSENGER)
	122034-02-01A	EA	DECAL - SWOOP/#3 - LEFT HAND (DRIVERS)
12	105781-56-01A	FT	FILM - MULTISTRIPE - 6.74"
13	N/A		PAINT - LACQUER - DELFT BLUE 1GL - DUPONT F1919L
14	116921-02-06A	EA	DECAL - LOGO - ITASCA - WINNEBAGO INDUSTRIES
	004308-01-000	EA	PAINT - BLACK SPRAY
	041561-03-000	EA	PAINT - 16 OZ SPRAY - OFF WHITE

DUPONT PAINT COLOR CODES

OFF WHITE	DUPONT L8723
BLUE	DUPONT F1919L
BRIGHT WHITE	DUPONT B8951U

EXTERIOR BODY GROUP (CONTINUED)

STYROFOAM & FIBERGLASS SHEETING

KEY	PART NUMBER	U/M DESCRIPTION
	000870-08-000	SF STYROFOAM - .75" X 48" X 96" PLANED EXPANDED BEAD BOARD
	002726-01-001	EA GARNISH - U-CHANNEL - 1.38" X 19' - SERRATED
	002766-01-001	EA ANGLE - EXTRUDED - 1" X 1.5" X 17'
	033381-17-001	FT STEEL - TUBE - 16 GAUGE 1.5" X 1.5" X 16'
	068716-01-001	EA BRACE - 90 DEGREE L-ANGLE - 16'
	076054-U4-000	EA FIBERGLASS SHEET - 101" X 104" - BRIGHT WHITE
	076054-U8-000	EA FIBERGLASS SHEET - 100" X 105" - BRIGHT WHITE
	076054-V7-000	EA FIBERGLASS SHEET - 79" X 385" - BRIGHT WHITE
	077517-62-000	EA FIBERGLASS - SHEET/SIDEWALL - 4' X 8' - BRIGHT WHITE
	089297-01-000	SF PLYWOOD - LUAN - OVERLAY GRADE - 48" X 96"
	100619-01-000	BF FOAM - EXPANDED POLYSTYRENE - 1.34" X 48" X 96"
	100619-02-000	BF FOAM - EXPANDED POLYSTYRENE - 1.5" X 48" X 96"
	100619-04-000	BF FOAM - EXPANDED POLYSTYRENE - .5" X 48" X 96"
	100619-05-000	BF FOAM - EXPANDED POLYSTYRENE - .75" X 48" X 96"
	100619-11-000	BF FOAM - EXPANDED POLYSTYRENE - 2" X 48" X 96"
	100619-13-000	BF FOAM - EXPANDED POLYSTYRENE - .34" X 34.65" X 96"
	100619-16-000	BF FOAM - EXPANDED POLYSTYRENE - .75" X 48" X 96"
	108535-05-702	EA FRP FLAT 110" X 396" BRT WHT PARTS DEPT
	108535-05-03A	SF FIBERGLASS SHEET - 110" X 500' ROLL - BRIGHT WHITE
	120107-01-000	EA FOAM - COVE - ROOF - 2.8" X 96" LONG
	120107-02-000	EA FOAM - PLUG - ROOF TUBE - 2.2" X 2.9" X 1.8" LONG
	120107-03-000	EA FOAM - PLUG - SIDEWALL TUBE - 1.2" X 2.1" X 1.8" LONG
	125838-01-001	EA ACRYLIC SHEET - .125" X 1.49" X 2"

EXTERIOR BODY HARDWARE

KEY	PART NUMBER	U/M DESCRIPTION
	002726-01-001	EA GARNISH - U-CHANNEL - 1.38" X 19' - SERRATED - MILL ALUMINUM
	055278-01-001	FT TUBING - STEEL - .75" X 1.5" X 288"
	033381-17-001	FT STEEL - TUBE 16GA 1.5 X 1.5 X 288.00 HOT FORMED ASTM A50
	044487-01-001	LB ALUMINUM - 019 X 96.00 X 300" MILL FINISH
	058267-01-000	FT CHANNEL - STEEL - W/ HOLES - SIDEWALL STIFFENER - 2" X 20'
	068716-01-001	EA BRACE - 90 DEGREE L-ANGLE - 192" - EXTRUDED ALUMINUM

EXTERIOR BODY GROUP (CONTINUED)

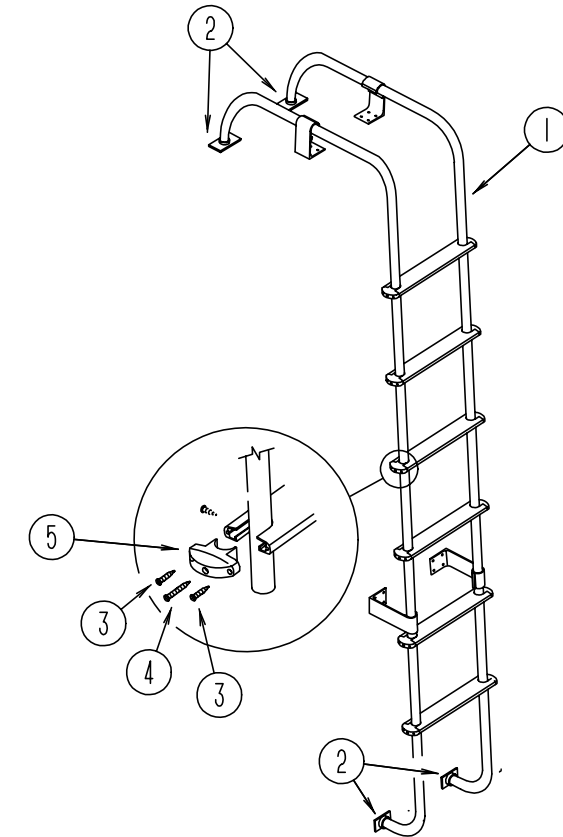

LADDER

KEY	PART NUMBER	U/M DESCRIPTION
1	102953-11-F31	EA LADDER
2	067165-01-000	EA MOUNTING BRACKET - LADDER - LOWER
3	000G39-06-10T	EA SCREW-SF/ DR - 6 - 20 X 5/8 PPH - BLACK
4	000G68-10-36T	EA SCREW - 10 - 12 X 2.25 POH BLACK
5	076980-02-000	EA END CAP - STEP - BLACK
	038327-01-000	FT TAPE - ANTI SLIP - 2" X 60FT

GALLEY GROUP

GALLEY CABINETRY & FIXTURES

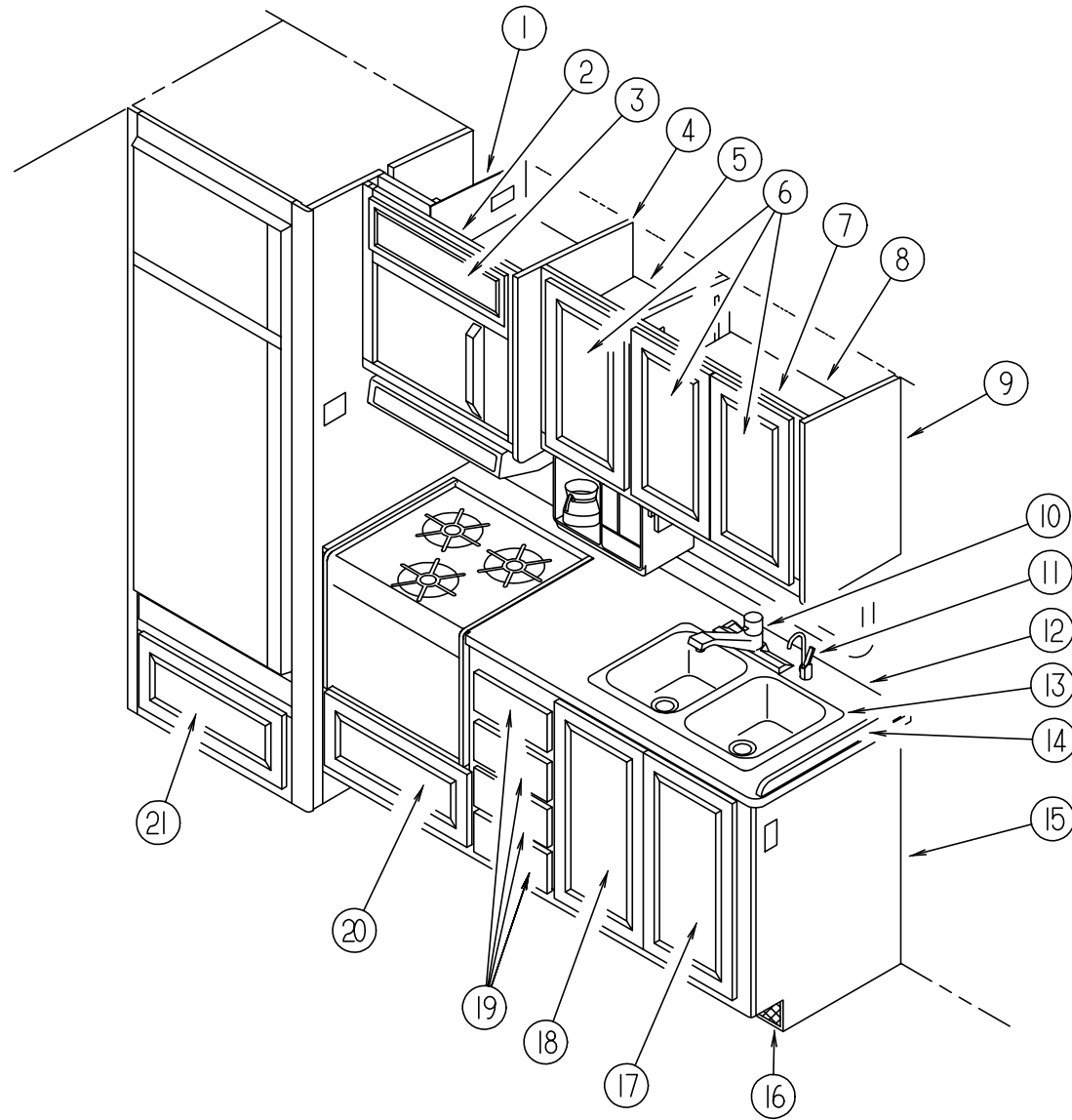

KEY	PART NUMBER	U/M DESCRIPTION
1	119280-03-H37	EA CABINET - A/C SWITCH (MAPLE)
1	119280-03-H17	EA CABINET - A/C SWITCH (OAK)
2	121328-07-H37	EA CABINET - OVERHEAD/ MICROWAVE - W/O DOORS/ HARDWARE (MAPLE) FROM: 00-00-00 THRU: 01-21-97
2	121328-07-H49	EA CABINET - OVERHEAD/ MICROWAVE - W/O DOORS/ HARDWARE (OAK) FROM: 00-00-00 THRU: 01-21-97
2	121328-05-H37	EA CABINET - OVERHEAD/ MICROWAVE - W/O DOORS/ HARDWARE (MAPLE) FROM: 01-22-97 THRU: 99-99-99
2	121328-05-H47	EA CABINET - OVERHEAD/ MICROWAVE - W/O DOORS/ HARDWARE (OAK) FROM: 01-22-97 THRU: 99-99-99
3	M08166-26-H37	EA DOOR - SQUARE EDGE - 5.1" X 22.4" - W/O HARDWARE (MAPLE)
3	M05992-J9-H17	EA DOOR - OGEE EDGE - 5.11" X 22.4" - W/O HARDWARE (OAK)
4	081320-16-H37	EA END CAP - OVERHEAD CABINET (MAPLE)
4	081320-16-G09	EA END CAP - OVERHEAD CABINET (OAK)
5	118158-12-H37	EA SHELF - W/ PLASTIC EDGE TRIM (MAPLE)
5	118158-12-H17	EA SHELF - W/ PLASTIC EDGE TRIM (OAK)
6	M08166-04-H37	EA DOOR - MITERED CORNER/SQUARE EDGE - 12" X 21.8" - W/O HDW (MAPLE)
6	M06803-29-H17	EA DOOR - MITERED CORNER/OGEE EDGE - 12" X 21.8" - W/O HDW (OAK)
7	P18158-02-H37	EA CABINET - OVERHEAD GALLEY - W/O DOORS/HARDWARE (MAPLE)
7	P18158-01-H17	EA CABINET - OVERHEAD GALLEY - W/O DOORS/HARDWARE (OAK)
8	118158-11-H37	EA SHELF - W/PLASTIC EDGE MOLDING (MAPLE)
8	118158-11-H17	EA SHELF W/PLASTIC EDGE TRIM (OAK)
9	081319-17-H37	EA END CAP - OVERHEAD (MAPLE)
9	081319-17-H17	EA END CAP - OVERHEAD CABINET (OAK)
10	104114-02-01A	EA FAUCET - SINGLE CONTROL
11	103635-01-000	EA FAUCET - SINGLE CONTROL
12	123647-11-H37	EA COUNTERTOP (H37, H39, H47, H49)
12	123647-11-H17	EA COUNTERTOP (H38, H48)
13	110654-01-000	EA SINK - STAINLESS STEEL DOUBLE BASIN (1 LG 1 SM BASIN)
	092303-01-000	EA STRAINER - SINK
14	098335-07-G05	EA RAIL - GALLEY (H37, H39, H47, H49)
14	098335-07-G07	EA RAIL - GALLEY (H38, H48)
15	123647-01-H37	EA CABINET - GALLEY - W/O DOORS/DRAWERS/HARDWARE (H37, H39)
15	123647-01-H38	EA CABINET - GALLEY - W/O DOORS/ DRAWERS/ HARDWARE (H38)
15	123647-01-H47	EA CABINET - GALLEY - W/O DOORS/ DRAWERS/ HARDWARE (H47, H49)
15	123647-01-H48	EA CABINET - GALLEY - W/O DOORS/ DRAWERS/ HARDWARE (H48)
15	123647-12-H37	EA SHELF - W/ PLASTIC EDGE TRIM (MAPLE)
15	123647-12-H17	EA SHELF - W/ PLASTIC EDGE TRIM (OAK)
16	118200-01-01A	SF MESH - PLASTIC - 1/2 INCH
	108464-04-E38	EA COVER - SINK - 15" X 15" (H37, H39, H47, H49)
	108464-04-F40	EA COVER - SINK - 15" X 15" (H38, H48)
	108464-03-E38	EA COVER - SINK - 15" X 11" (H37, H39, H47, H49)
	108464-03-F40	EA COVER - SINK - 15" X 11" (H38, H48)
	126019-01-01A	EA COFFEEMAKER - OPTIMA - W/BRACKETS - BLACK & DECKER
	103799-01-701	EA BRACKETS - WHITE PAIR
	090329-01-000	FT T-SEAL - REFRIGERATOR CABINET - .6" WIDE TOP X 2" TAIL
	054450-01-000	EA LEVEL - REFRIGERATOR
17	M08166-05-H37	EA DOOR - MITERED CORNER/SQUARE EDGE - 13.6" X 27.1" - W/O HDW (MAPLE)
17	M06803-N7-H17	EA DOOR - MITERED CORNER/OGEE EDGE - 13.6" X 27.1" - W/O HDW (OAK)
18	M08166-06-H37	EA DOOR - MITERED CORNER/SQUARE EDGE - 13.6" X 27.1" - W/O HDW (MAPLE)
18	M06803-N8-H17	EA DOOR - MITERED CORNER/OGEE EDGE - 13.6" X 27.1" - W/O HDW (OAK)
19	M08168-11-H37	EA DRAWER - W/O SLIDES/HARDWARE (MAPLE)
19	M05971-11-H17	EA DRAWER - W/O SLIDES/HARDWARE (OAK)
20	M08168-V1-H37	EA DRAWER - W/SQUARE EDGE - W/O SLIDES/HARDWARE (MAPLE)
20	M05971-V1-H17	EA DRAWER - OGEE EDGE - W/O SLIDES/HARDWARE (OAK)
21	M08166-09-H37	EA DOOR - MITERED CORNER/SQUARE EDGE - 13.8" X 23.2" - W/O HDW (MAPLE)
21	M06803-V0-H17	EA DOOR - MITERED CORNER/OGEE EDGE - 13.9" X 23" - W/O HDW (OAK)

GALLEY GROUP (CONTINUED)

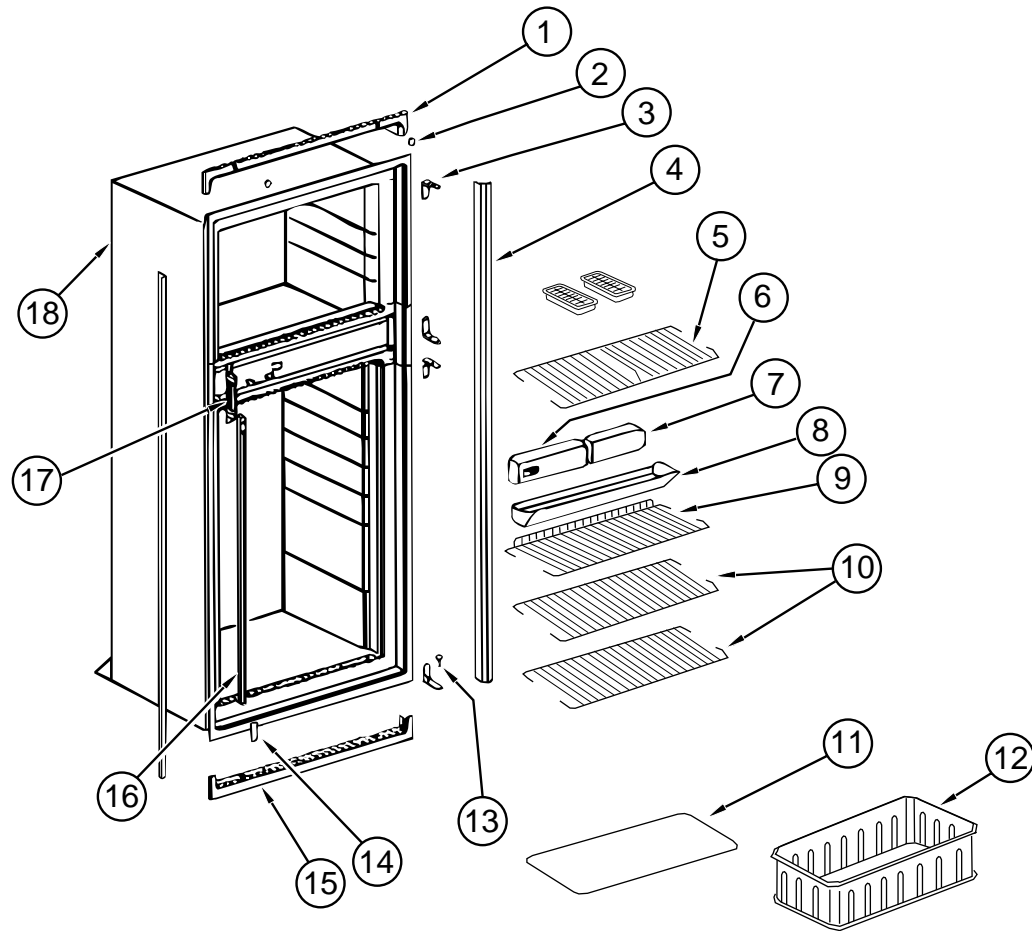

GALLEY GROUP (CONTINUED)

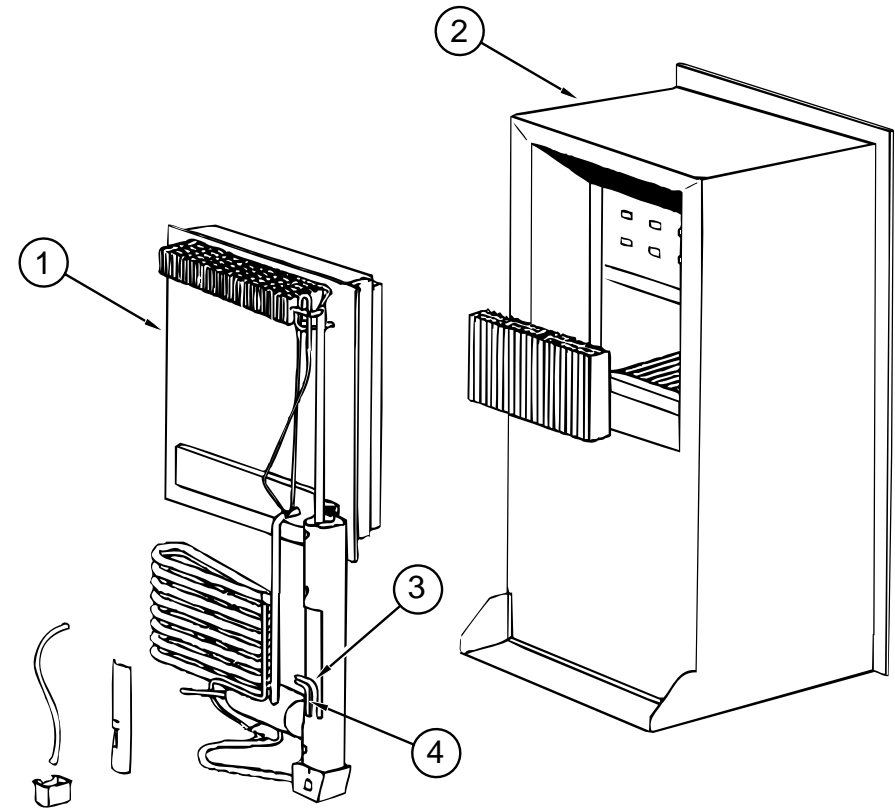

NORCOLD MODEL 9182 REFRIGERATOR CABINET ASM WITH TRAY, TIEDOWNS & LEVEL

KEY	PART NUMBER	U/M	DESCRIPTION	VENDOR NO.
	121569-02-01A	EA	REFRIGERATOR - LARGE DOUBLE DOOR - 2-WAY	
1	120075-01-713	EA	TRIM - TOP PIECE	618124
2	120075-01-714	EA	PLUG - HOLE	618170
3	120075-01-715	EA	HINGE - CABINET SIDE - PAINTED	618512
	120075-01-708	EA	BUSHING - DOOR HINGE	618144
4	120075-01-716	EA	TRIM - SIDE PIECE	618134
5	121568-01-705	EA	SHELF - WIRE - FREEZER	618620
6	121568-01-706	EA	CONTROL BOX ASSEMBLY	618588
7	120075-01-718	EA	BOX - FILLER	618112
8	120075-01-720	EA	TRAY - DRIP	618137
	120075-01-721	EA	LOUVER - DRIP TRAY	618176
9	121568-01-707	EA	SHELF - WIRE - SHORT	618624
10	121568-01-708	EA	SHELF - WIRE	618589
11	120075-01-725	EA	COVER - CRISPER	618158
12	121568-01-709	EA	CRISPER	618571
13	120075-01-727	EA	PIN - HINGE	618145
14	120075-01-728	EA	COVER - HINGE HOLE	618171
15	120075-01-729	EA	TRIM - BOTTOM PIECE	618136
16	120075-01-730	EA	RETAINER - SHELF	618181
17	120075-01-732	EA	PLATE - STRIKE	618167
18	120076-01-733	EA	CABINET - FOAMED	618265
	120075-01-731	EA	PLUG - FACADE	618184
	116751-02-01A	EA	TRAY - REFRIGERATOR - BLACK	
	054450-01-000	EA	LEVEL - REFRIGERATOR	
	065225-02-000	EA	PLATE - TIEDOWN - REFRIGERATOR	
	090195-08-000	EA	BAFFLE - REFRIGERATOR - LOWER	
	093369-03-000	EA	STRAP - REFRIGERATOR	
	093646-01-000	EA	BRACKET - TIEDOWN - REFRIGERATOR - RIGHT HAND	
	093646-02-000	EA	BRACKET - TIEDOWN - REFRIGERATOR - LEFT HAND	

NORCOLD MODEL 9182 REFRIGERATOR COOLING UNIT, CABINET, & HEATERS

KEY	PART NUMBER	U/M	DESCRIPTION	VENDOR NO.
	121569-02-01A	EA	REFRIGERATOR - LARGE DOUBLE DOOR - LEFT HAND - 2-WAY	
1	120075-01-736	EA	COOLING UNIT - SERVICE PACK	618542
2	120076-01-733	EA	CABINET - FOAMED	618265
3	088248-01-710	EA	HEATER - DC - HORIZONTAL	61562822
4	088248-01-709	EA	HEATER - AC - HORIZONTAL	61562722

GALLEY GROUP (CONTINUED)

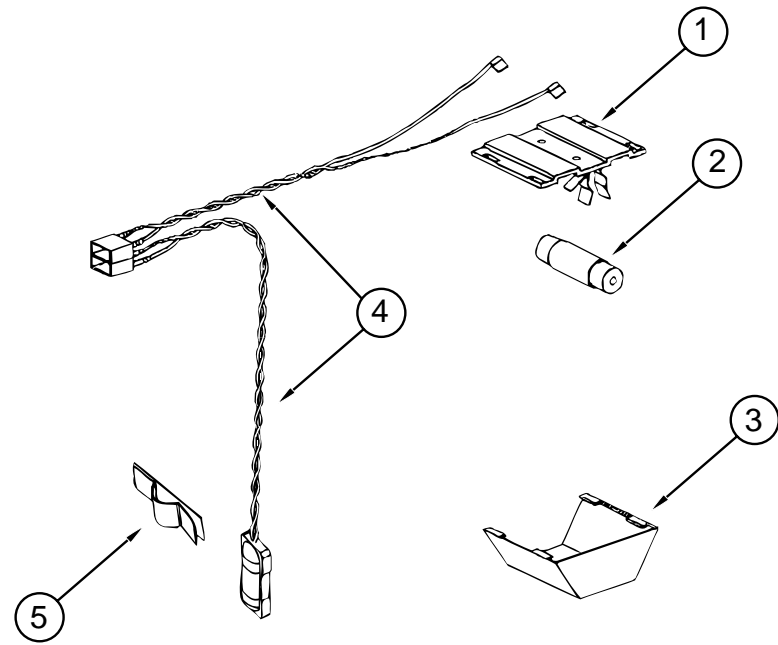

NORCOLD MODEL 9182 REFRIGERATOR LAMP ASM

KEY	PART NUMBER	U/M	DESCRIPTION	VENDOR NO.
	121569-02-01A	EA	REFRIGERATOR - LARGE DOUBLE DOOR - LEFT HAND - 2-WAY	
1	084880-03-705	EA	BRACKET - LIGHT - INTERIOR	61629722
2	084880-03-706	EA	BULB - LAMP	61628922
3	084880-03-707	EA	COVER - LAMP - LENS	61627922
4	120075-01-735	EA	WIRE ASSEMBLY - LAMP	618548
5	084880-01-760	EA	CLIP - THERMISTER	61689122

GALLEY GROUP (CONTINUED)

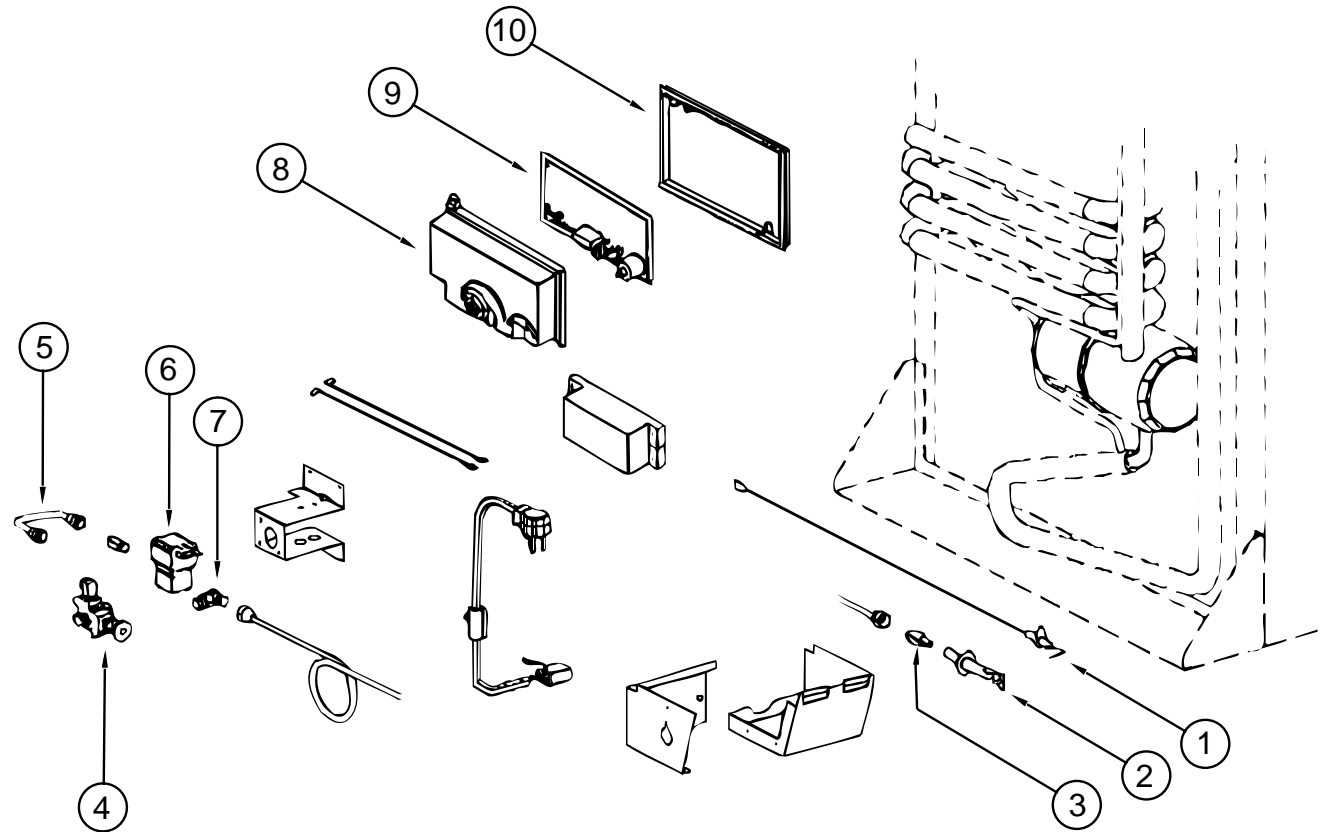

NORCOLD MODEL 9182 REFRIGERATOR BURNER & POWER BOARDS

KEY	PART NUMBER	U/M	DESCRIPTION	VENDOR NO.
	121569-02-01A	EA	REFRIGERATOR - LARGE DOUBLE DOOR - LEFT HAND - 2-WAY	
1	104137-06-715	EA	ELECTRODE - SPARK/SENSOR - SGL	61692222
2	104137-06-714	EA	BURNER ASSEMBLY - 5 SLOT	61705222
3	120075-01-737	EA	ORIFICE - JEWEL - .0155	618284
4	104137-06-709	EA	VALVE - SHUT OFF - MANUAL	61694922
5	113737-01-750	EA	TUBE - UNION	61694622
6	084880-01-718	EA	VALVE - GAS - ASCO	61551822
7	113737-01-716	EA	TAP - PRESSURE	61594422
8	120075-01-738	EA	COVER - POWER BOARD	618185
9	120075-01-739	EA	BOARD - POWER - 2-WAY	618198
9	121568-01-710	EA	BOARD - POWER - 3-WAY	618575
10	120075-01-740	EA	COVER - BASE - POWER BOARD	618186
	113737-01-702	EA	PLUG - 1/8" F/PRESSURE TAP	61445322

GALLEY GROUP (CONTINUED)

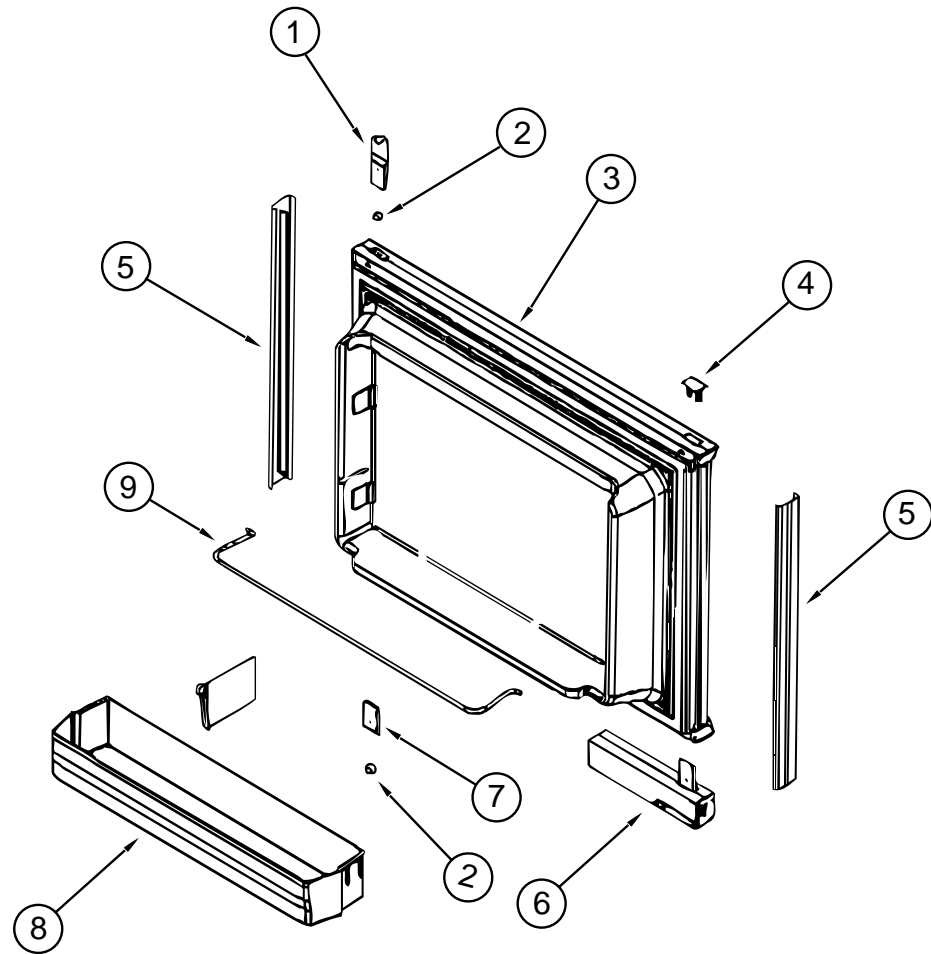

NORCOLD MODEL 9182 REFRIGERATOR UPPER DOOR

KEY	PART NUMBER	U/M DESCRIPTION	VENDOR NO.
	121569-02-01A	EA REFRIGERATOR - LARGE DOUBLE DOOR - LEFT HAND - 2-WAY	
1	120075-01-701	EA HINGE - TOP RH/BOTTOM LH - PAINTED	618511
2	120075-01-708	EA BUSHING - DOOR HINGE	618144
3	120075-01-703	EA DOOR ASSEMBLY - FOAMED - W/GASKET	618205
4	120075-01-702	EA CAP - HINGE PLUG	618160
5	120075-01-700	EA RETAINER - DOOR - DECOR PANEL	618128
6	121568-01-702	EA HANDLE ASSEMBLY - DOOR - LOWER LH/TOP RH	618230
7	120075-01-705	EA HINGE - PAINTED - TOP LH/BOTTOM RH	618510
8	121568-01-701	EA BIN - DOOR - WHITE	618619
9	121568-01-700	EA RAIL - DOOR - UPPER	618618

GALLEY GROUP (CONTINUED)

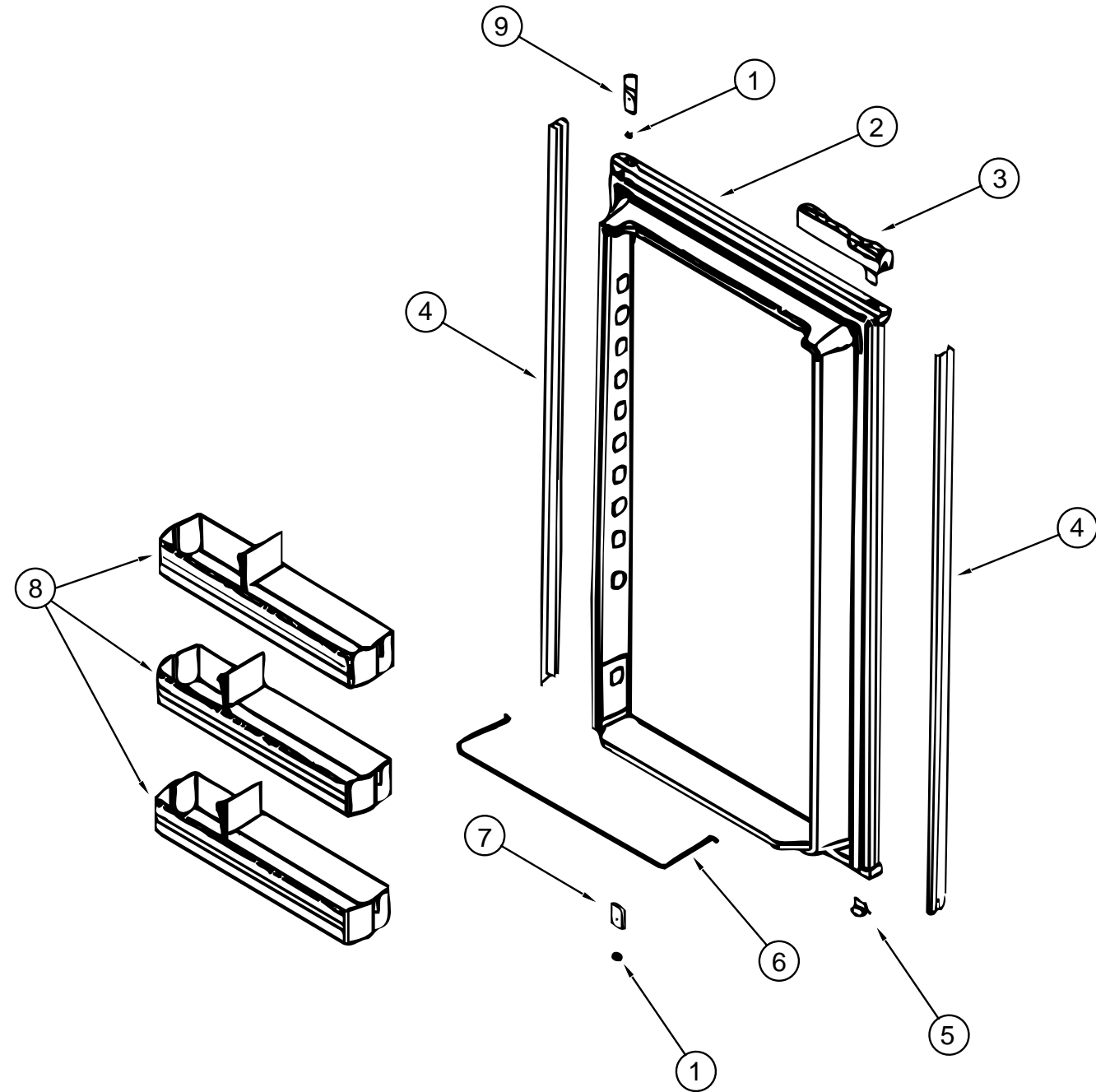

NORCOLD MODEL 9182 REFRIGERATOR LOWER DOOR

KEY	PART NUMBER	U/M DESCRIPTION	VENDOR NO.
	121569-02-01A	EA REFRIGERATOR - LARGE DOUBLE DOOR - LEFT HAND - 2-WAY	
1	120075-01-708	EA BUSHING - DOOR HINGE	618144
2	120075-01-710	EA DOOR - LOWER - FOAMED W/GASKET	618270
3	120075-01-711	EA HANDLE ASSEMBLY - UPPER RH/LOWER LH	618235
4	121568-01-703	EA RETAINER - LOWER DOOR PANEL	618129
5	120075-01-702	EA CAP - HINGE PLUG	618160
6	121568-01-704	EA RAIL - DOOR - LOWER	618578
7	120075-01-705	EA HINGE - PAINTED - TOP LH/BOTTOM RH	618510
8	121568-01-701	EA BIN - DOOR - WHITE	618619
9	120075-01-701	EA HINGE - TOP RH/BOTTOM LH - PAINTED	618511

GALLEY GROUP (CONTINUED)

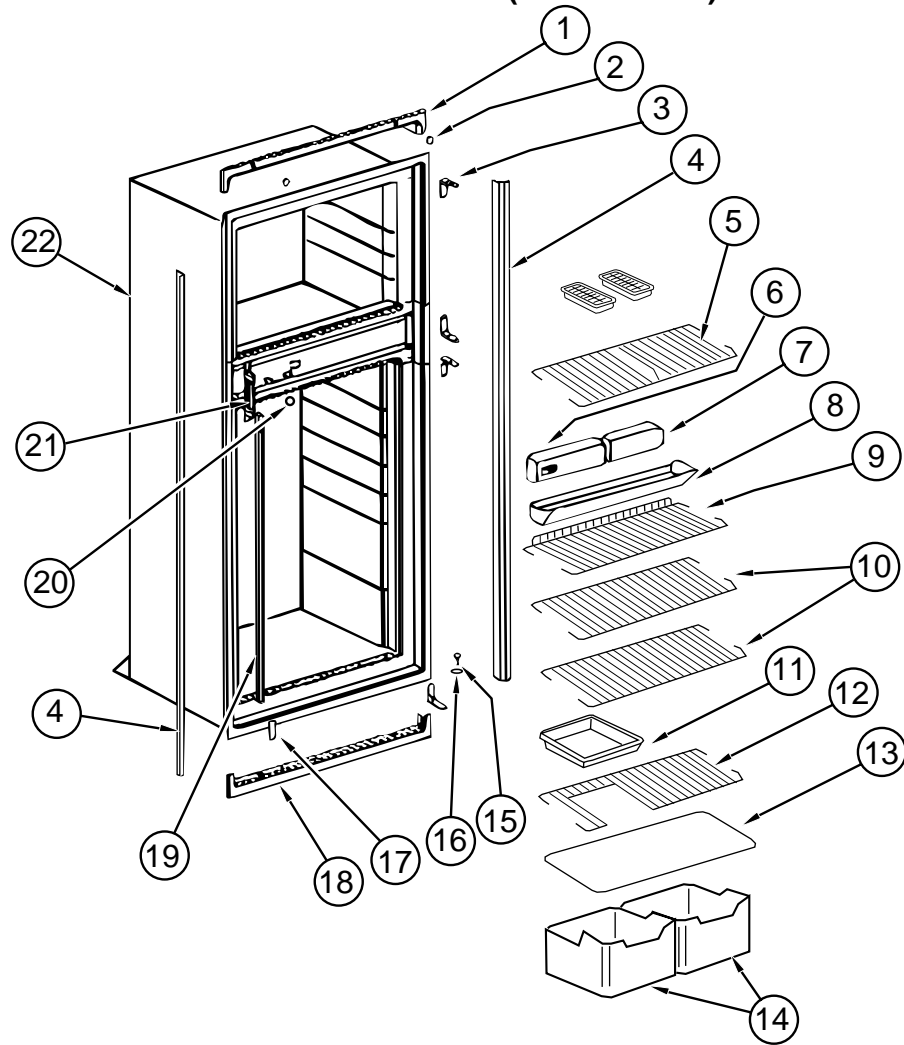

NORCOLD MODEL 982 REFRIGERATOR CABINET ASM WITH TRAY, TIEDOWNS, & LEVEL

KEY	PART NUMBER	U/M	DESCRIPTION	VENDOR NO.
	120075-04-01A	EA	REFRIGERATOR - LARGE DOUBLE DOOR - BLACK W/ICE MAKER	
1	120075-01-713	EA	TRIM - TOP PIECE	618124
2	120075-01-714	EA	PLUG - HOLE	618170
3	120075-01-715	EA	HINGE - CABINET SIDE - PAINTED	618512
4	120076-01-716	EA	TRIM - SIDE PIECE	618134
5	120075-01-717	EA	SHELF - FREEZER - WIRE	618172
6	120075-01-719	EA	OPTICAL CONTROL BOX ASSEMBLY	618245
7	120075-01-718	EA	BOX - FILLER	618112
8	120075-01-720	EA	TRAY - DRIP	618137
	120075-01-721	EA	LOUVER - DRIP TRAY	618176
9	120075-01-722	EA	SHELF - WIRE - SHORT	618239
10	120075-01-723	EA	SHELF - WIRE	618114
11	104137-06-718	EA	SHELF - TRAY - WHITE - W/CUTOUT	617756
12	120075-01-724	EA	SHELF - WIRE - W/CUTOUT	618177
13	120075-01-725	EA	COVER - CRISPER	618158
14	120075-03-704	EA	BIN - ICE CUBE	618154
15	120075-01-727	EA	PIN - HINGE	618145
16	120075-01-708	EA	BUSHING - DOOR HINGE	618144
17	120075-01-728	EA	COVER - HINGE HOLE	618171
18	120075-01-729	EA	TRIM - BOTTOM PIECE	618136
19	120075-01-730	EA	RETAINER - SHELF	618181
20	120075-01-731	EA	PLUG - FACADE	618184
21	120075-01-732	EA	PLATE - STRIKE	618167
22	120075-03-700	EA	CABINET - FOAMED	618285
	093646-01-000	EA	BRACKET - TIEDOWN/REFRIGERATOR - RIGHT HAND	
	093646-02-000	EA	BRACKET - TIEDOWN/REFRIGERATOR - LEFT HAND	
	116751-05-01A	EA	TRAY - REFRIGERATOR BLACK	
	054450-01-000	EA	LEVEL - REFRIGERATOR	
	065225-02-000	EA	PLATE - TIEDOWN - REFRIGERATOR	

GALLEY GROUP (CONTINUED)

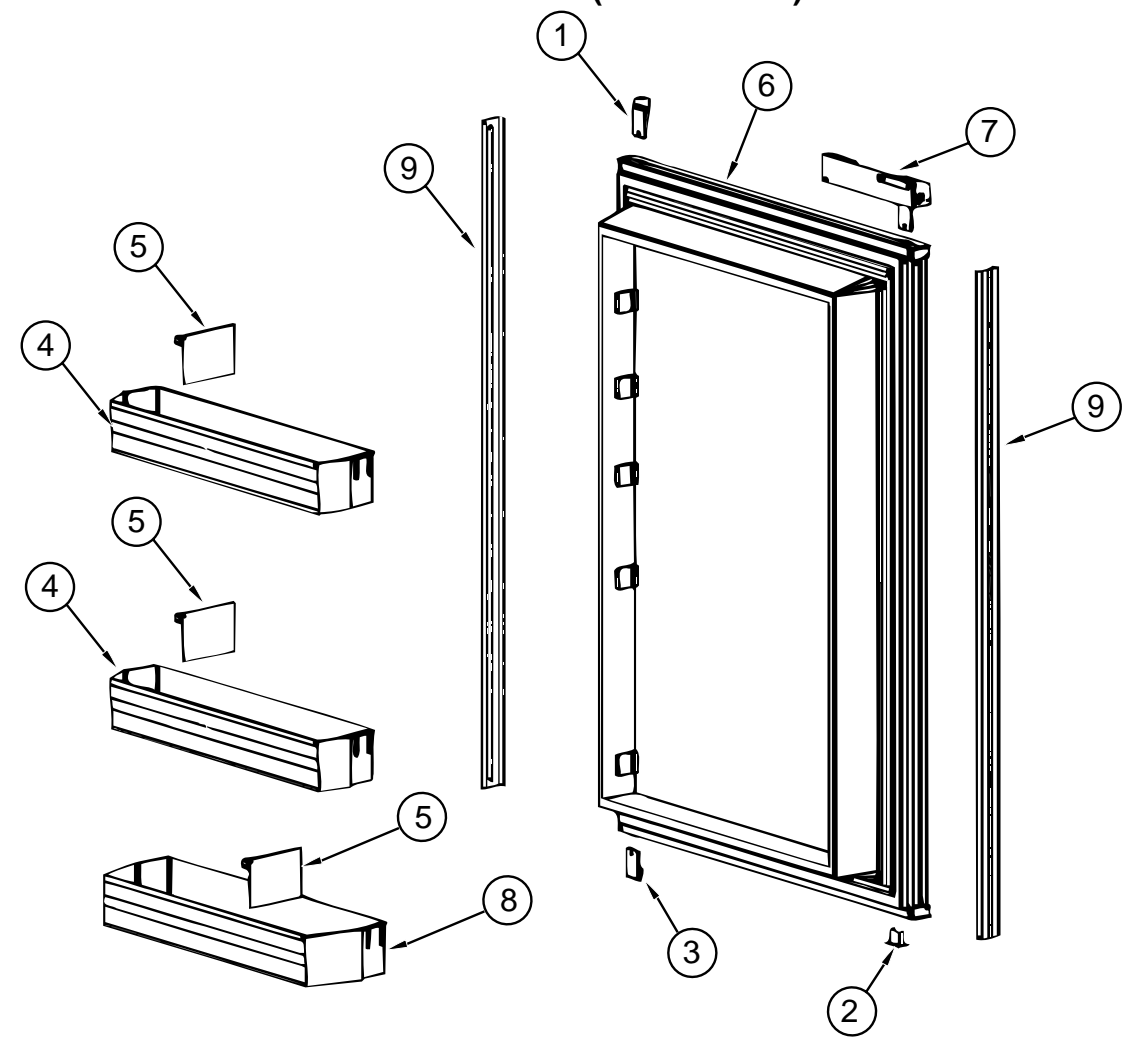

NORCOLD MODEL 982 REFRIGERATOR LOWER DOOR

KEY	PART NUMBER	U/M	DESCRIPTION	VENDOR NO.
	120075-04-01A	EA	REFRIGERATOR - LARGE DOUBLE DOOR - BLACK W/ICE MAKER	
1	120075-01-701	EA	HINGE - TOP RH/BTM LH - PAINTED	618511
2	120075-01-702	EA	CAP (HINGE PLUG)	618160
3	120075-01-705	EA	HINGE - PAINTED - TOP LH/BTM RT	618510
4	120075-01-706	EA	BIN - DOOR	618635
5	120075-01-707	EA	DIVIDER - BIN - DOOR	618637
6	120076-01-701	EA	DOOR - LOWER - FOAMED - W/GASKET	618210
7	120075-01-711	EA	HANDLE ASM - UPPER RH/LOWER LH	618235
8	120075-01-712	EA	BIN - DOOR/BOTTOM - LARGE	618634
9	121568-01-703	EA	RETAINER - PANEL LOWER DOOR	618129

GALLEY GROUP (CONTINUED)

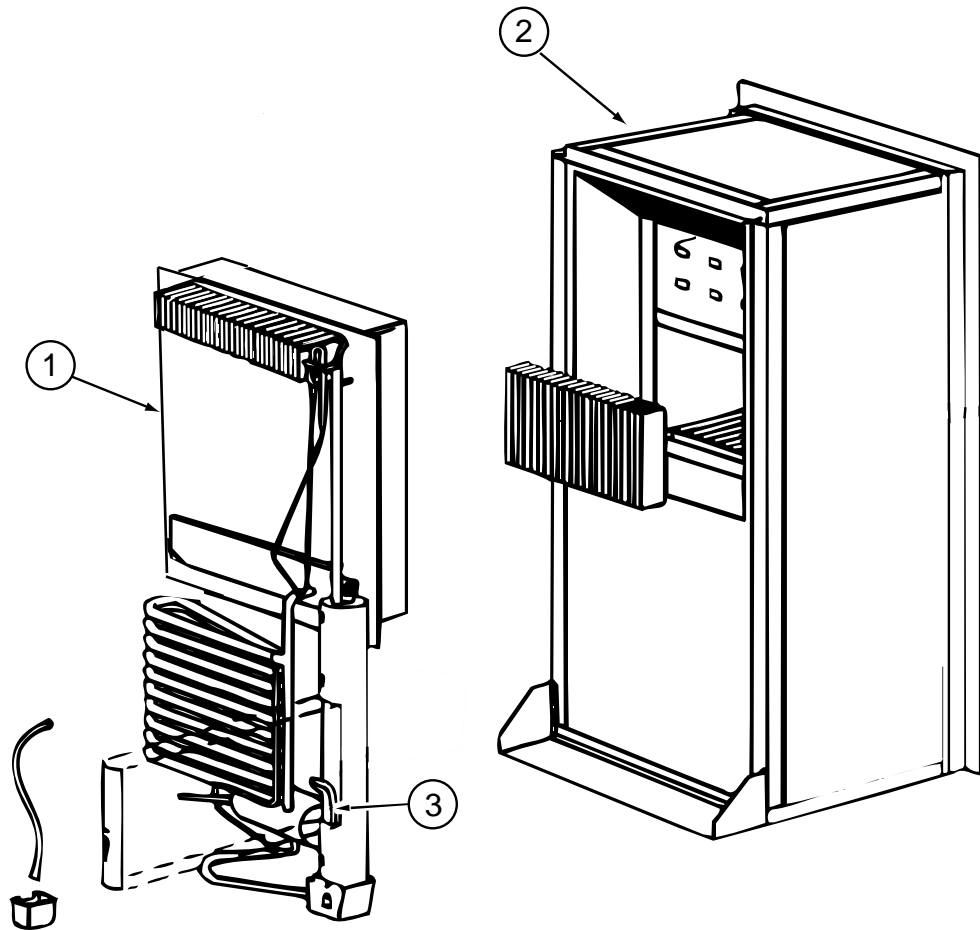

NORCOLD MODEL 982 REFRIGERATOR COOLING UNIT, CABINET, & HEATERS

KEY	PART NUMBER	U/M	DESCRIPTION	VENDOR NO.
	121569-01-01A	EA	REFRIGERATOR - LARGE DOUBLE DOOR - RIGHT HAND - 2-WAY	
1	120075-01-736	EA	COOLING UNIT - SERVICE PACK	618542
2	120075-01-733	EA	CABINET - FOAMED	618265
3	088248-01-709	EA	HEATER - AC (HORIZONTAL)	61562722

GALLEY GROUP (CONTINUED)

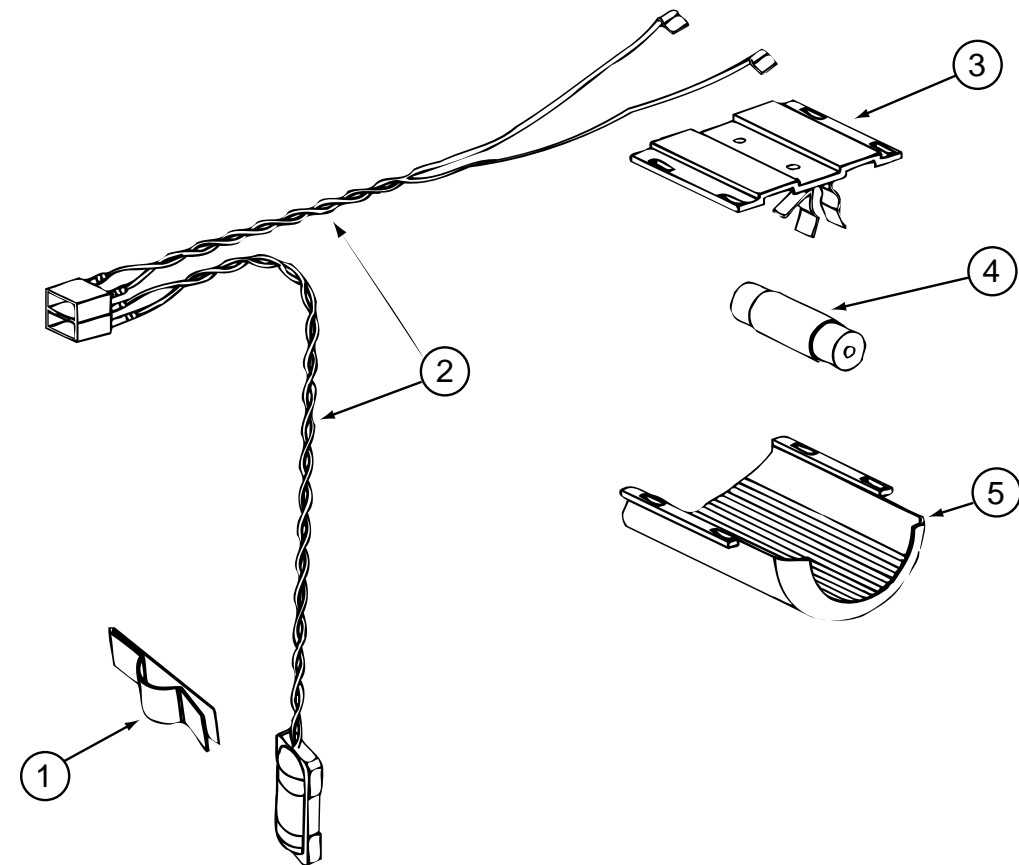

NORCOLD MODEL 982 REFRIGERATOR LAMP ASM

KEY	PART NUMBER	U/M	DESCRIPTION	VENDOR NO.
	120075-04-01A	EA	REFRIGERATOR - LARGE DOUBLE DOOR - BLACK W/ICE MAKER	
1	084880-01-760	EA	CLIP (THERMISTER)	61689122
2	120075-01-735	EA	WIRE ASM. - LAMP	618548
3	084880-03-705	EA	BRACKET - LIGHT-INTERIOR	61629722
4	084880-03-706	EA	BULB - LAMP	61628922
5	120075-01-734	EA	COVER - LENS	618190

GALLEY GROUP (CONTINUED)

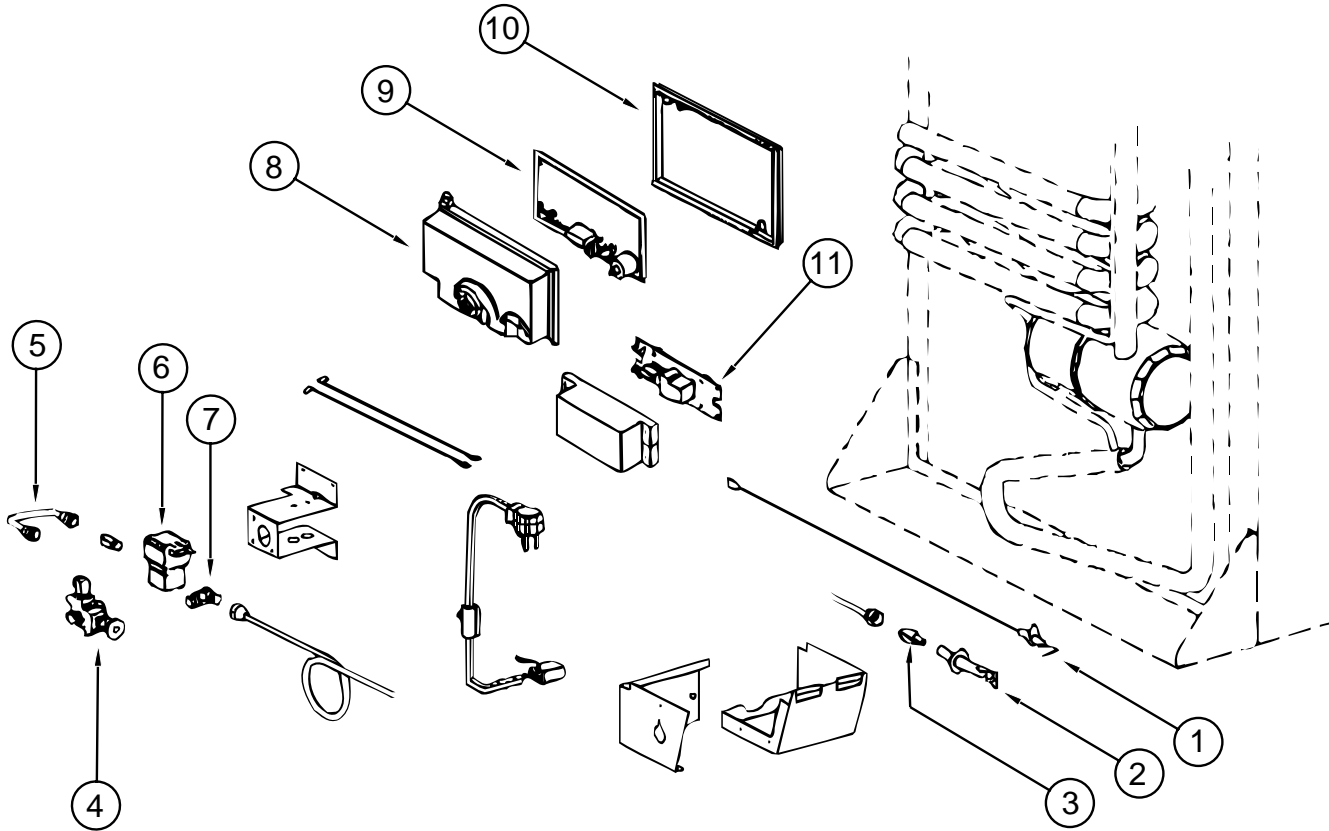

NORCOLD MODEL 982 REFRIGERATOR BURNER & POWER BOARDS

KEY	PART NUMBER	U/M	DESCRIPTION	VENDOR NO.
	120075-04-01A	EA	REFRIGERATOR - LARGE DOUBLE DOOR - BLACK W/ICE MAKER	
1	104137-06-715	EA	ELECTRODE - SPARK/SENSOR - SGL	61692222
2	104137-06-714	EA	BURNER ASSEMBLY - 5-SLOT	61705222
3	120075-01-737	EA	ORIFICE - JEWEL - .0155	618284
4	104137-06-709	EA	VALVE - SHUT OFF - MANUAL	61694922
5	113737-01-750	EA	TUBE - UNION	61694622
6	084880-01-718	EA	VALVE - GAS - (ASCO)	61551822
7	113737-01-716	EA	TAP - PRESSURE	61594422
	113737-01-702	EA	PLUG 1/8" F/PRESSURE TAP	61445322
8	120075-01-738	EA	COVER - POWER BOARD	618185
9	120075-01-739	EA	BOARD - POWER - 2-WAY	618574
10	120075-01-740	EA	COVER - BASE - POWER BOARD	618186
11	121568-01-711	EA	BOARD - MODULE - DC	618561

GALLEY GROUP (CONTINUED)

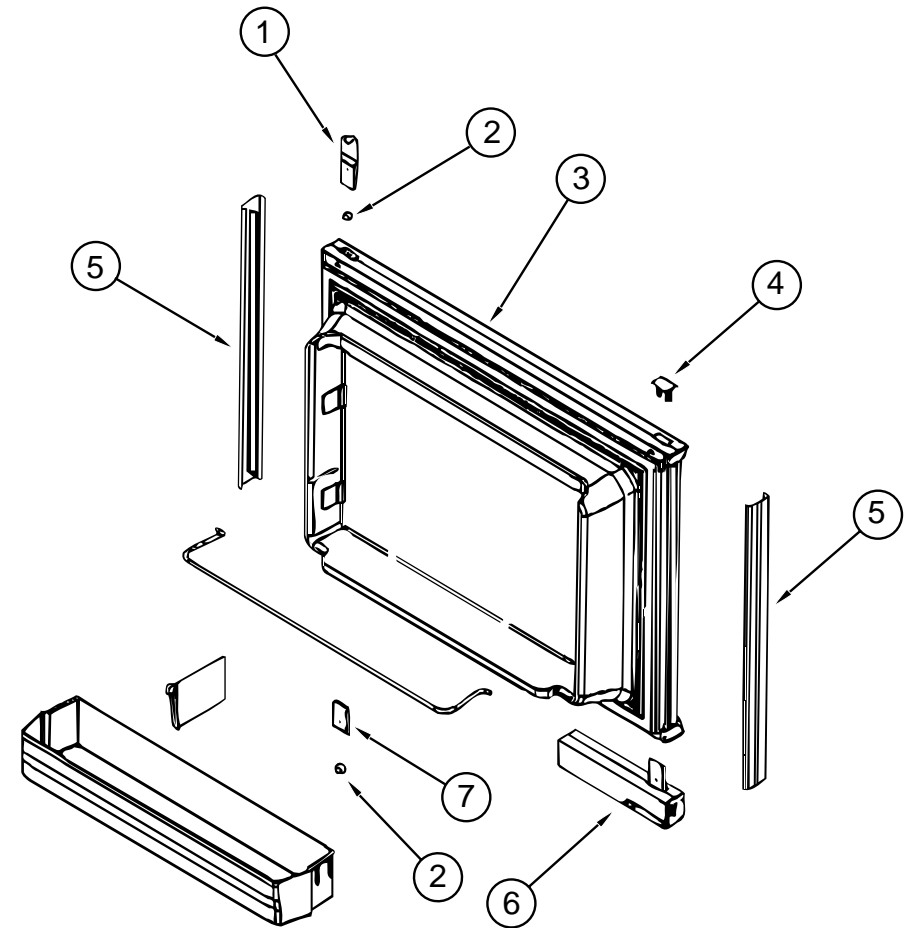

NORCOLD MODEL 982 REFRIGERATOR UPPER DOOR

KEY	PART NUMBER	U/M	DESCRIPTION	VENDOR NO.
	120075-04-01A	EA	REFRIGERATOR - LARGE DOUBLE DOOR - BLACK W/ICE MAKER	
1	120075-01-701	EA	HINGE - TOP RH/BTM LH - PAINTED	618511
2	120075-01-708	EA	BUSHING - DOOR HINGE	618144
3	120075-01-703	EA	DOOR ASM. - FOAMED - W/GASKET	618205
4	120075-01-702	EA	CAP - (HINGE PLUG)	618160
5	120075-01-700	EA	RETAINER - DOOR - DECOR PANEL	618128
6	121568-01-702	EA	DOOR HANDLE ASM LWR/LH - TOP/R	618230
7	120075-01-705	EA	HINGE - TOP LH/BTM RH - PAINTED	618510

GALLEY GROUP (CONTINUED)

ATWOOD RANGE W/ OVEN, R-2137BGP (FROM: 00-00-00 THRU: 11-26-96)

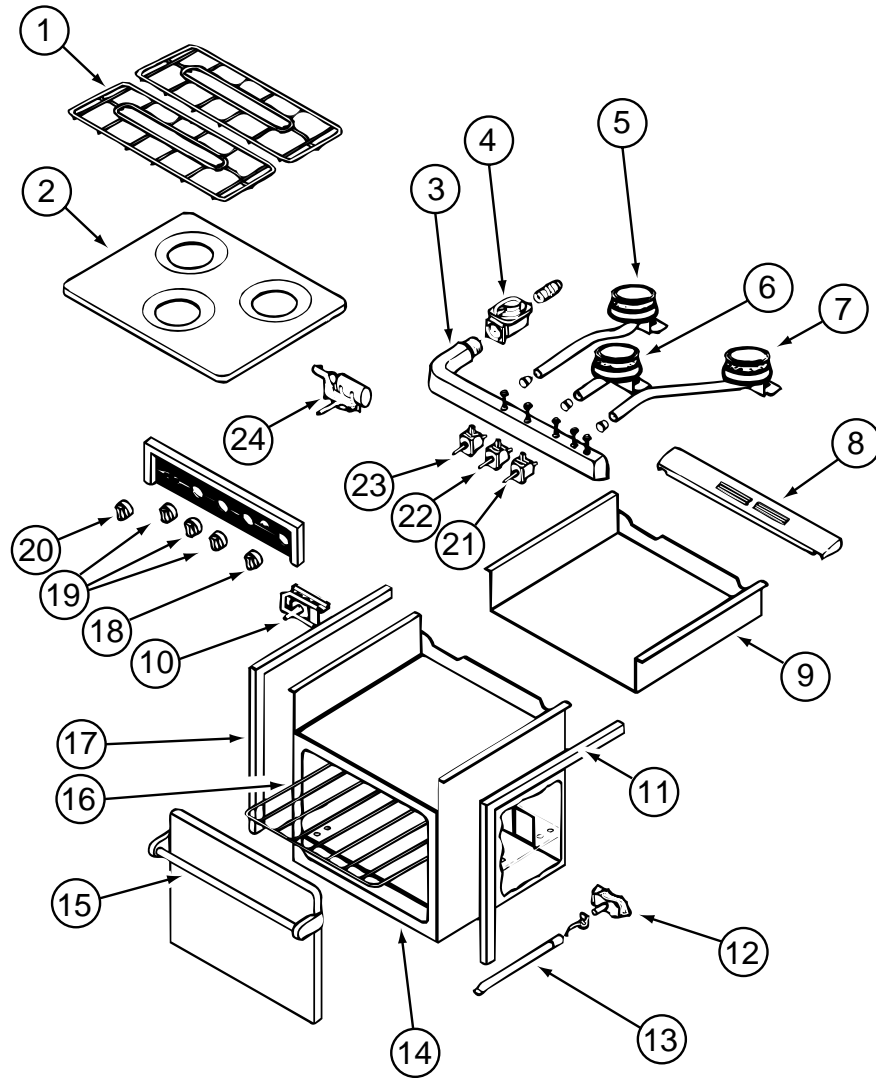

KEY	PART NUMBER	U/M	DESCRIPTION	VENDOR NO.
	121758-01-01A	EA	RANGE - W/ OVEN - BLACK - R-2137BGP	
1	121758-02-700	EA	GRATE - SINGLE	56261
	107323-01-711	EA	CUSHION - GRATE - RUBBER	53008
	121758-02-701	EA	CLIP - GRATE	56117
2	121758-01-714	EA	RANGE - TOP - ALMOND	53082
3	121758-01-709	EA	MANIFOLD 3 BURNER	51272
	121758-01-713	EA	COVER - MANIFOLD	56107
4	106689-01-704	EA	REGULATOR - EXTREME PRESSURE	51062
5	121758-01-707	EA	BURNER LEFT REAR PZO	56066
6	121758-01-708	EA	BURNER CENTER (HIGH OUTPUT)	56068
7	121758-01-706	EA	BURNER RIGHT REAR PZO	56067
8	107323-01-705	EA	TRIM - VENT	53525
9	121758-01-711	EA	BURNER BOX	51684
10	107246-01-703	EA	THERMOSTAT - ROBERT SHAW	52122
11	107323-01-703	EA	TRIM-RIGHT	53024
12	107246-01-706	EA	PILOT ASM. - ONLY (OVEN)	51065
13	107246-01-721	EA	BURNER - OVEN	52017
14	107323-01-706	EA	TRIM - BOTTOM	53526
15	107323-01-714	EA	HANDLE ASM. DESIGNER STYLE	51112
	107323-01-713	EA	GLASS - BLACK - INSERT OVEN DOOR	53426
16	107246-01-704	EA	RACK - OVEN	51069
	107246-01-708	EA	SHELF - OVEN - LOWER	51657
17	107323-01-702	EA	TRIM - LEFT	53023
18	121758-01-703	EA	KNOB THERMOSTAT	56094
19	121758-01-712	EA	KNOB - BURNER (3)	56093
20	121758-01-700	EA	KNOB (TURN STYLE) PIEZO IGN	56095
21	121758-01-710	EA	VALVE - BURNER	56086
22	121758-01-705	EA	VALVE HIGH OUTPUT	56087
23	121758-01-710	EA	VALVE - BURNER	56086
24	121758-01-701	EA	IGNITOR PIEZO (ROTARY)	56096
	121758-01-702	EA	ELECTRODE WIRE (PIEZO IGNITOR)	56097
	107246-01-707	EA	VALVE - SAFETY W/ PILOT COMP	51063

GALLEY GROUP (CONTINUED)

ATWOOD RANGE W/ OVEN, R-2138BGP (FROM: 11-27-96 THRU: 99-99-99)

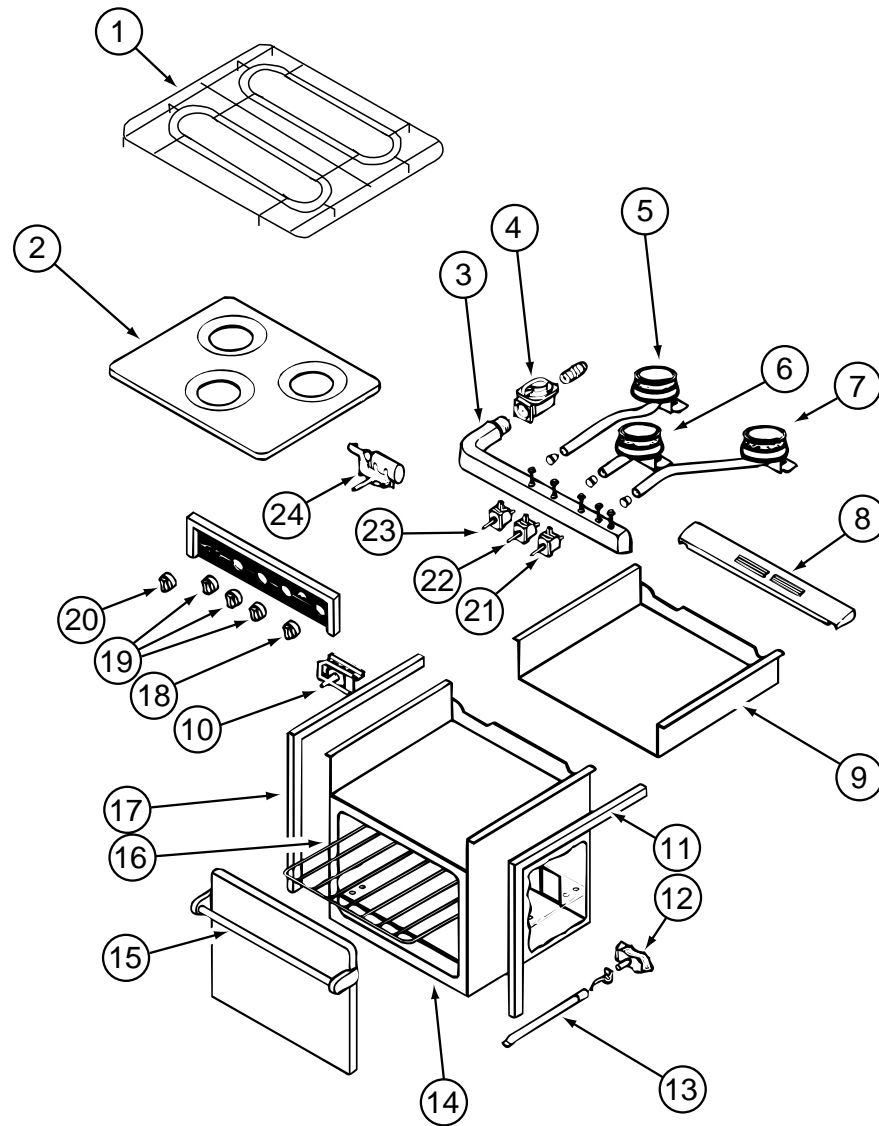

KEY	PART NUMBER	U/M	DESCRIPTION	VENDOR NO.
	121758-02-01A	EA	RANGE - W/ OVEN - BLACK - R-2138BGP	
1	121758-02-700	EA	GRATE - SINGLE	56261
	121758-02-701	EA	CLIP - GRATE	56117
2	107246-01-700	EA	TOP - MAIN - BLACK - 3-BURNER	53083
3	121758-01-709	EA	MANIFOLD 3 BURNER	51272
	121758-01-713	EA	COVER - MANIFOLD	56107
4	106689-01-704	EA	REGULATOR - EXTREME PRESSURE	51062
5	121758-01-707	EA	BURNER LEFT REAR PZO	56066
6	121758-01-708	EA	BURNER CENTER (HIGH OUTPUT)	56068
7	121758-01-706	EA	BURNER RIGHT REAR PZO	56067
8	107323-01-705	EA	TRIM - VENT	53525
9	121758-01-711	EA	BURNER BOX	51684
10	121758-02-702	EA	THERMOSTAT - (OVEN)	56119
11	107323-01-703	EA	TRIM - RIGHT	53024
12	121758-02-705	EA	PILOT ASM. - ONLY (OVEN)	56121
13	121758-02-706	EA	BURNER - OVEN	56123
14	107323-01-706	EA	TRIM - LOWER - BLACK	53526
15	107323-01-714	EA	HANDLE ASM. DESIGNER STYLE	51112
	107323-01-713	EA	GLASS - BLACK - INSERT OVEN DOOR	53426
16	107246-01-704	EA	RACK - OVEN	51069
17	107323-01-702	EA	TRIM - LEFT	53023
18	121758-02-703	EA	KNOB - OVEN - THERMOSTAT	56124
19	121758-01-712	EA	KNOB - BURNER (3)	56093
20	121758-01-700	EA	KNOB (TURN STYLE) PIEZO IGN	56095
21	121758-01-710	EA	VALVE - BURNER	56086
22	121758-01-705	EA	VALVE HIGH OUTPUT	56087
23	121758-01-710	EA	VALVE - BURNER	56086
24	121758-01-701	EA	IGNITOR PIEZO (ROTARY)	56096
	121758-02-704	EA	VALVE - SAFETY	56120

GALLEY GROUP (CONTINUED)

RANGE HOOD , W/HOUR METER, TPS-5009-SBDLG (USA)

KEY	PART NUMBER	U/M	DESCRIPTION	VENDOR NO.
1	100258-18-03A	EA	HOOD - RANGE - W/O MONITOR PANEL - W/HOUR METER & SWITCH	
2	096983-01-707	EA	FILTER - MESH	CC246
3	090973-01-700	EA	MOTOR - 12 VOLT - CSA & UL	CA508-1
4	090973-01-702	EA	BLADE - FAN	VA183-1
5	092696-02-701	EA	LENS - LAMP	CC179-2
6	092696-01-710	EA	HOLDER - LAMP	CB267-2
7	092696-01-709	EA	LAMP - 912	VA415
8	096983-01-702	EA	SWITCH - MOM/OFF/MOM/3 TERM	L0112-00
9	096983-01-700	EA	SWITCH - ON/OFF	L0108-00
10	100258-01-700	EA	LABEL - HOOD NOSE	CC428
11	100258-10-01A	EA	GAUGE - HOUR METER W/SWITCH - SCREW ON STYLE	
11	100258-10-701	EA	GAUGE - HOUR METER - CLIP ON	L0775-00

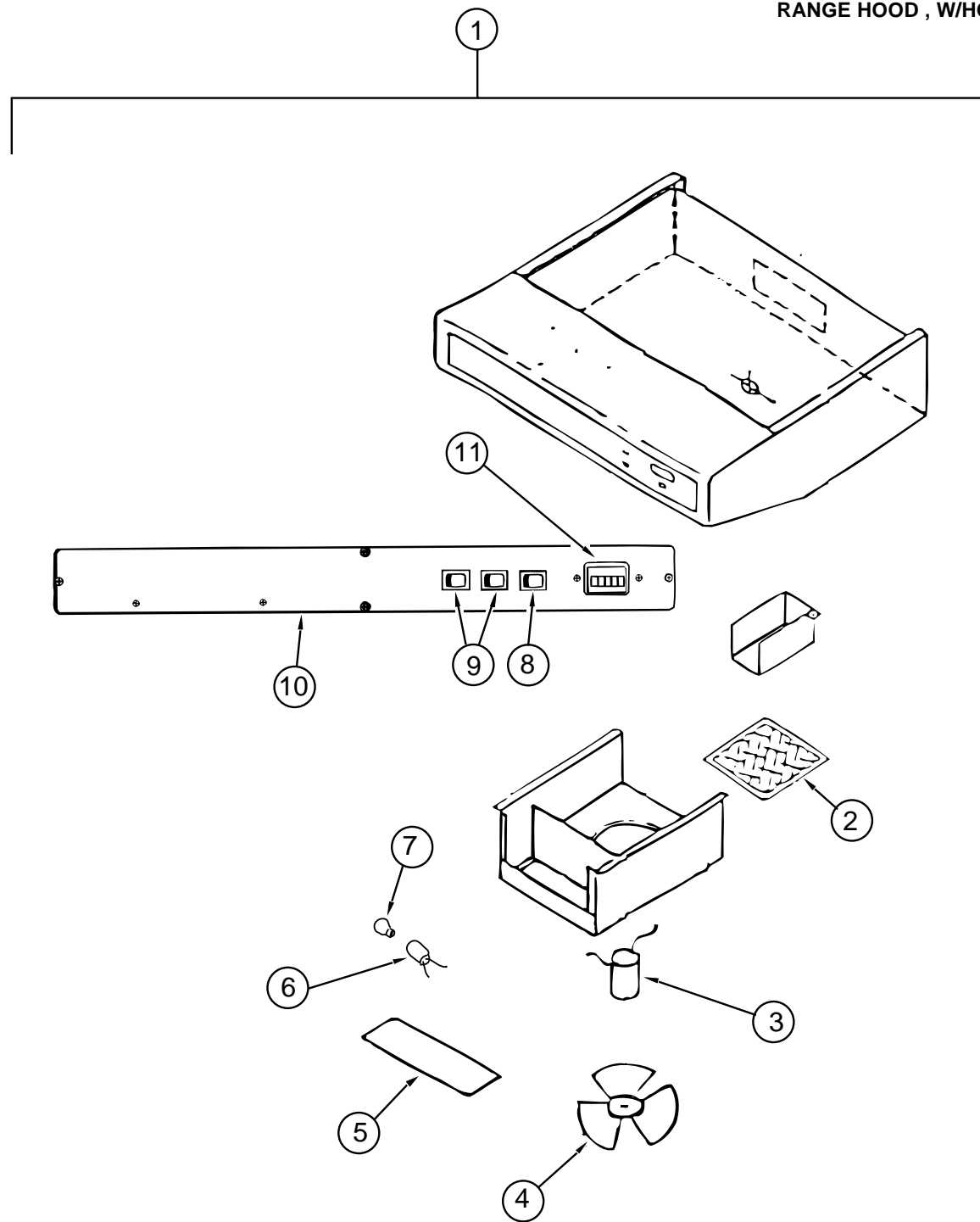

GALLEY GROUP (CONTINUED)

1

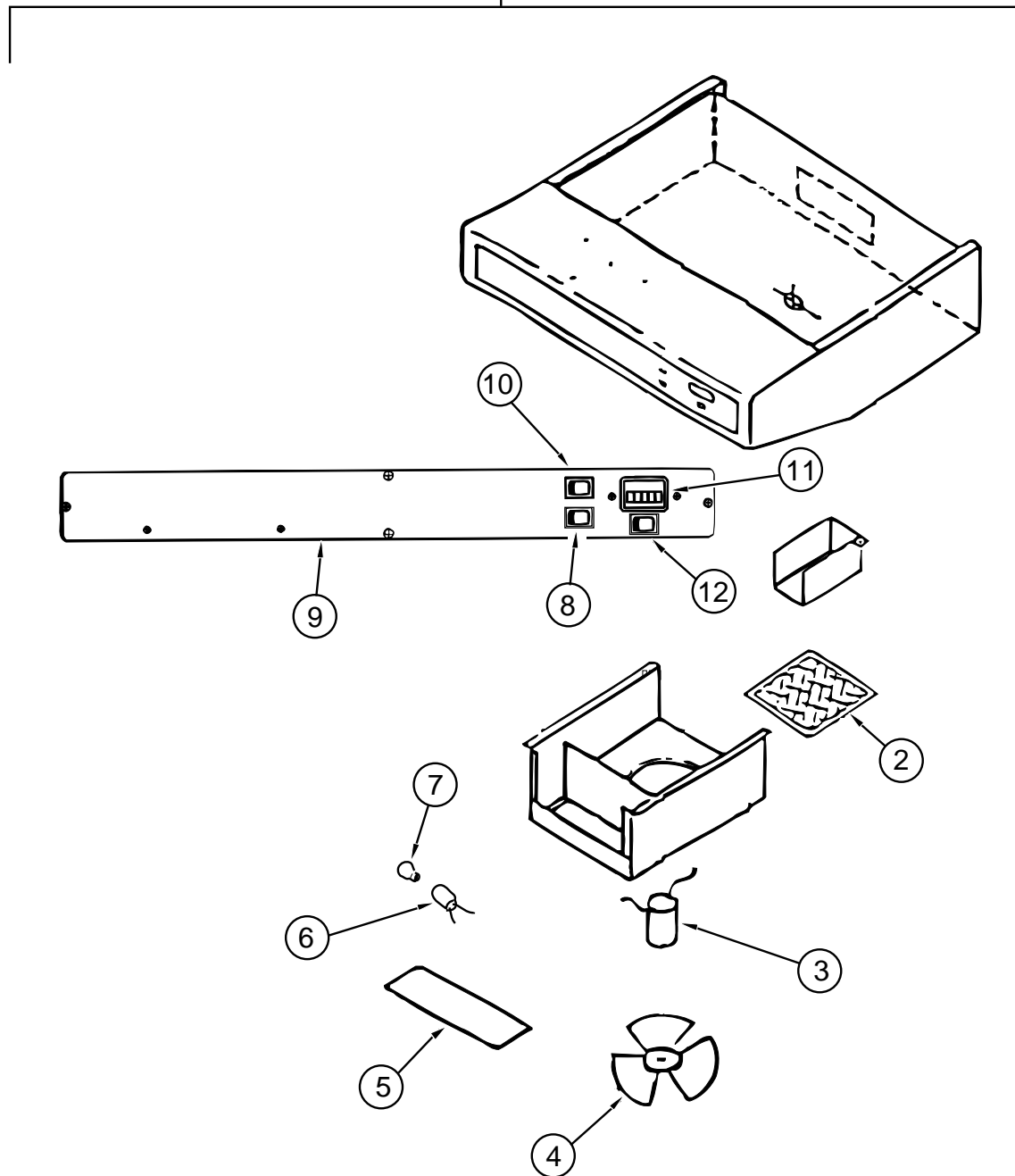

RANGE HOOD , W/O HOUR METER, TCS 5008-NBCLG (CANADIAN)

KEY	PART NUMBER	U/M	DESCRIPTION	VENDOR NO.
1	100258-17-04A	EA	HOOD - RANGE - W/O MONITOR PANEL - W/O HOUR METER & SWITCH	
2	096983-01-707	EA	FILTER - MESH	CC246
3	090973-01-700	EA	MOTOR - 12 VOLT - CSA & UL	CA508-1
4	090973-01-702	EA	BLADE - FAN	VA183-1
5	092696-02-701	EA	LENS - LAMP	CC179-2
6	092696-01-710	EA	HOLDER - LAMP	CB267-2
7	092696-01-709	EA	LAMP - 912	VA415
8	096983-01-700	EA	SWITCH - ON/OFF	L0108-00
9	100258-01-700	EA	LABEL - HOOD NOSE	CC428
10	096983-01-700	EA	SWITCH - ON/OFF	L0108-00
11	100258-10-01A	EA	GAUGE - HOUR METER W/SWITCH - SCREW ON STYLE (OPTION)	
11	100258-10-701	EA	GAUGE - HOUR METER - CLIP ON (OPTION)	L0775-00
12	096983-01-702	EA	SWITCH - MOM/OFF/MOM/3 TERM (OPTION)	L0112-00

GALLEY GROUP (CONTINUED)

1

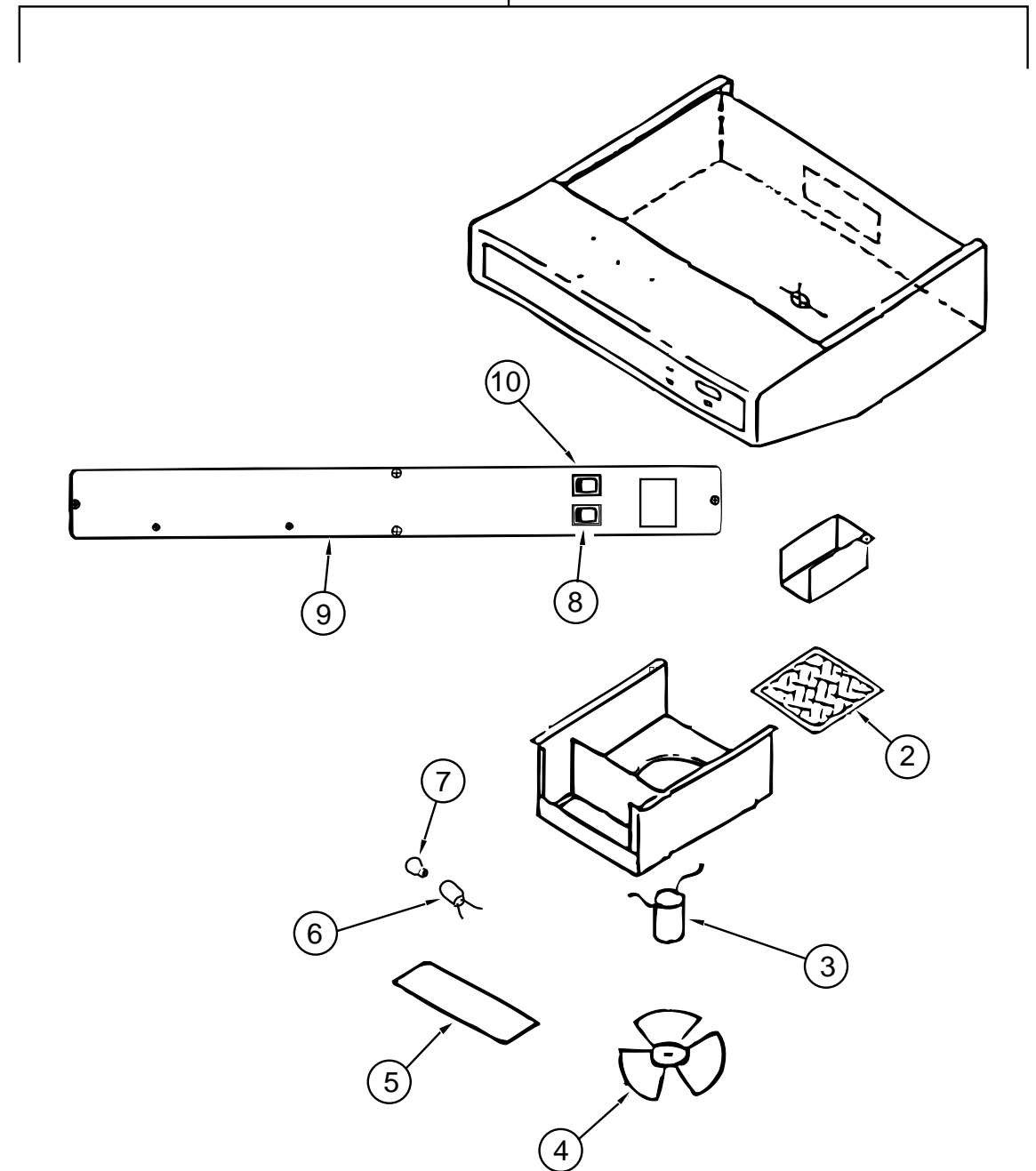

RANGE HOOD , W/O HOUR METER, TCS-5008-NBDLG (USA)

KEY	PART NUMBER	U/M	DESCRIPTION	VENDOR NO.
1	100258-16-04A	EA	HOOD - RANGE - W/O MONITOR PANEL - W/O HOUR METER & SWITCH	
2	096983-01-707	EA	FILTER-MESH	CC246
3	090973-01-700	EA	MOTOR-12 VOLT, CSA & UL	CA508-1
4	090973-01-702	EA	BLADE-FAN	VA183-1
5	092696-02-701	EA	LENS-LAMP	CC179-2
6	092696-01-710	EA	HOLDER-LAMP	CB267-2
7	092696-01-709	EA	LAMP - 912	VA415
8	096983-01-700	EA	SWITCH - ON/OFF	L0108-00
9	100258-01-700	EA	LABEL-HOOD NOSE	CC428
10	096983-01-702	EA	SWITCH - MOM/OFF/MOM/3 TERM	L0112-00

GALLEY GROUP (CONTINUED)

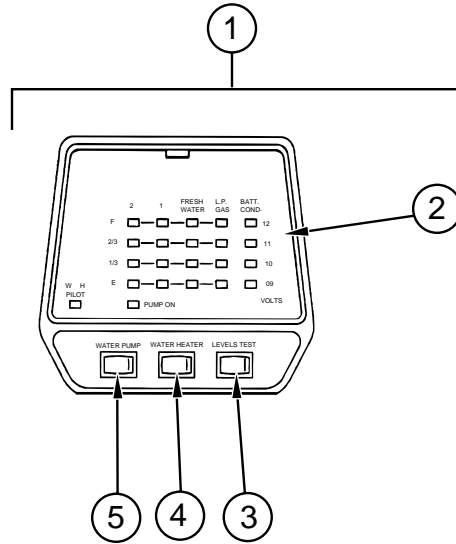

MONITOR PANEL (2 WATER TANKS & WATER HEATER)

KEY	PART NUMBER	U/M DESCRIPTION	VENDOR NO.
1	102765-04-01A	EA PANEL - MONITOR - W/ PLUG - 2 TANKS & WATER HEATER - LVS	
2	102765-04-700	EA CIRCUIT BOARD - 2 HOLDING TANKS	5076-11
3	097617-01-702	EA SWITCH (ALMOND)	107
4	097617-01-701	EA SWITCH - ON/OFF - ALMOND	106
5	102765-01-700	EA SWITCH - ON-ON - ALMOND	110-01

MAGIC CHEF MICROWAVE OVEN

KEY	PART NUMBER	U/M DESCRIPTION
	115303-02-000	EA OVEN - MICROWAVE - 1.3 CU FT
	115401-02-01A	EA TRIM - MICROWAVE
	094756-03-D18	EA BRACKET - ANGLE - W/HOLES
	098916-16-02B	EA BRACE - MICROWAVE - LEFT HAND
	098916-17-02B	EA BRACE - MICROWAVE - RIGHT HAND
	094750-07-000	EA BRACKET - MICROWAVE - 89 DEGREE

GENERATOR GROUP

ONAN GENERATOR, 3.5 KW EMERALD PLUS

KEY	PART NUMBER	U/M DESCRIPTION
	100974-04-000	EA GENERATOR - 4.0 KW EMERALD PLUS
	007125-03-000	EA CLAMP - MUFFLER - 1.5" DIAMETER
	007125-04-000	EA CLAMP - MUFFLER - 1.12" DIAMETER
	079654-05-000	EA PIPE - EXHAUST - ANGLED W/FLANGE - 2" ID
	081364-03-000	EA MUFFLER - GENERATOR - ONAN
	094059-01-000	EA SPACER - GENERATOR - ONAN
	105958-04-000	EA PIPE - EXHAUST - 1.4" INLET X 1.5" O.D. - 4.9" X 66.9"

ONAN GENERATOR, 5.0 KW EMERALD PLUS

KEY	PART NUMBER	U/M DESCRIPTION
	109303-01-000	EA GENERATOR - 5 KW - EMERALD PLUS
	007125-03-000	EA CLAMP - MUFFLER - 1.5" DIAMETER
	007125-04-000	EA CLAMP - MUFFLER - 1.12" DIAMETER
	007131-01-000	EA HANGER - TAILPIPE - 6 SLOTS
	079654-05-000	EA PIPE - EXHAUST - ANGLED W/FLANGE - 2" ID
	081364-03-000	EA MUFFLER - GENERATOR - ONAN
	094059-01-000	EA SPACER - GENERATOR - ONAN
	106602-01-000	EA PIPE - EXHAUST - GENERATOR
	106607-01-000	EA ANGLE - SUPPORT - EXHAUST
	105958-04-000	EA PIPE - EXHAUST - 1.4" INLET X 1.5" O.D. - 4.9" X 66.9"

ONAN GENERATOR, 5.0 KW EMERALD PLUS (EXPORT)

KEY	PART NUMBER	U/M DESCRIPTION
	100975-03-000	EA GENERATOR - 5. KW EMERALD PLUS
	007125-03-000	EA CLAMP - MUFFLER - 1.5" DIAMETER
	007125-04-000	EA CLAMP - MUFFLER - 1.12" DIAMETER
	007131-01-000	EA HANGER - TAILPIPE - 6 SLOTS
	079654-05-000	EA PIPE - EXHAUST - ANGLED W/FLANGE - 2" ID
	081364-03-000	EA MUFFLER - GENERATOR - ONAN
	094059-01-000	EA SPACER - GENERATOR - ONAN
	106602-01-000	EA PIPE - EXHAUST - GENERATOR
	106607-01-000	EA ANGLE - SUPPORT - EXHAUST

ONAN GENERATOR, 6.5 KW EMERALD PLUS (NHE-FA/26100G)

KEY	PART NUMBER	U/M DESCRIPTION
	100975-01-000	EA GENERATOR - 6.5 KW EMERALD PLUS
	106602-01-000	EA PIPE - EXHAUST - GENERATOR
	106607-01-000	EA ANGLE - SUPPORT - EXHAUST
	007125-03-000	EA CLAMP - MUFFLER - 1.5" DIAMETER
	007125-04-000	EA CLAMP - MUFFLER - 1.12" DIAMETER
	007131-01-000	EA HANGER - TAILPIPE - 6 SLOTS
	079654-05-000	EA PIPE - EXHAUST - ANGLED W/FLANGE - 2" ID
	081364-03-000	EA MUFFLER - GENERATOR - ONAN
	094059-01-000	EA SPACER - GENERATOR - ONAN
	105958-04-000	EA PIPE - EXHAUST - 1.4" INLET X 1.5" O.D. - 4.9" X 66.9"
	007067-01-000	SF INSULATION - FIBERGLASS - 1" THICK X 4' - INCREMENTS/4 SF

NOTE: ADDITIONAL GENERATOR COMPONENTS ARE FOUND IN THE CHASSIS GROUP

HEATING & AIR CONDITIONING GROUP

FURNACE (SUBURBAN SF-42 227)

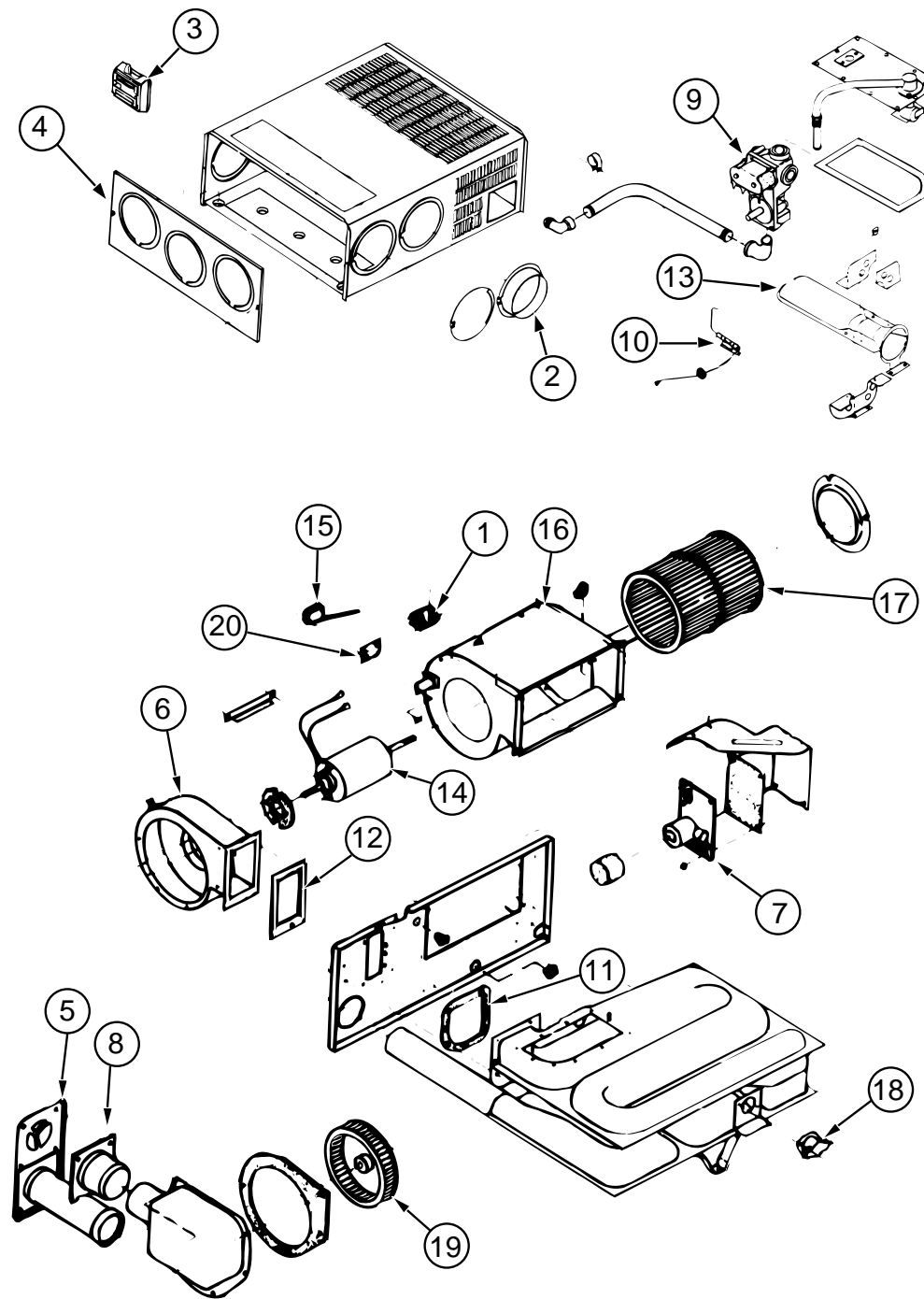

KEY	PART NUMBER	U/M	DESCRIPTION	VENDOR NO.
	098668-22-000	EA	FURNACE - 40,000 BTU	
1	074466-01-702	EA	RELAY - TIME DELAY	230625
2	075696-02-703	EA	COLLAR-DUCT	050715
3	115764-01-01A	EA	THERMOSTAT - FURNACE	
4	098668-01-700	EA	CABINET FRONT	101242
5	098668-01-707	EA	TUBE ASSEMBLY - EXHAUST W/CAP	260231
6	098668-01-708	EA	HOUSING - BLOWER - COMBUSTION	390441
7	098668-01-712	EA	BOARD - MODULE	520741
8	098668-01-713	EA	TUBE ASSEMBLY - INTAKE	051248
9	098668-01-714	EA	VALVE - GAS - SF S.N. 921401821	161070
10	098668-01-715	EA	ELECTRODE ASM. - SINGLE PROBE	232166
11	098668-01-716	EA	GASKET - FIREWALL - CHAMBER SIDE	070808
12	098668-01-717	EA	GASKET - FIREWALL - BLOWER SIDE	070809
	098668-11-700	EA	ORIFICE - MAIN BURNER - SF-42F	180216
13	098668-11-701	EA	BURNER ASSEMBLY - SF-42F	010799
14	098668-11-702	EA	MOTOR ASSEMBLY - SF-42F	232212
15	098668-11-703	EA	SWITCH - SAIL - SF-42F	232216
16	098668-11-704	EA	BLOWER ASM. - ROOM AIR SF-42F	390698
17	098668-01-711	EA	WHEEL - BLOWER - ROOM AIR	350129
18	098668-11-706	EA	SWITCH - LIMIT - SF42/SF42F	232217
19	098668-22-702	EA	WHEEL - COMBUSTION AIR	350183
20	101990-01-714	EA	GASKET - MICROSWITCH	230877
	098668-22-703	EA	GASKET	070811
	098668-14-000	EA	GASKET - FIBERGLASS - .5" X 18" X 18"	
	093614-04-02A	EA	GRILLE - RETURN AIR - 15.9" X 9.9"	
	009200-01-000	EA	TAPE - FURNACE - 1 1/2"	
	089367-02-000	EA	TEE - 4" X 2" X 4"	
	093614-03-02A	EA	GRILLE - RETURN AIR	
	094600-05-01A	EA	REGISTER - HEAT - W/O DAMPER - 11.3" - BEIGE	

HEATING & AIR CONDITIONING GROUP (CONTINUED)

HEATING & AIR CONDITIONING GROUP (CONTINUED)

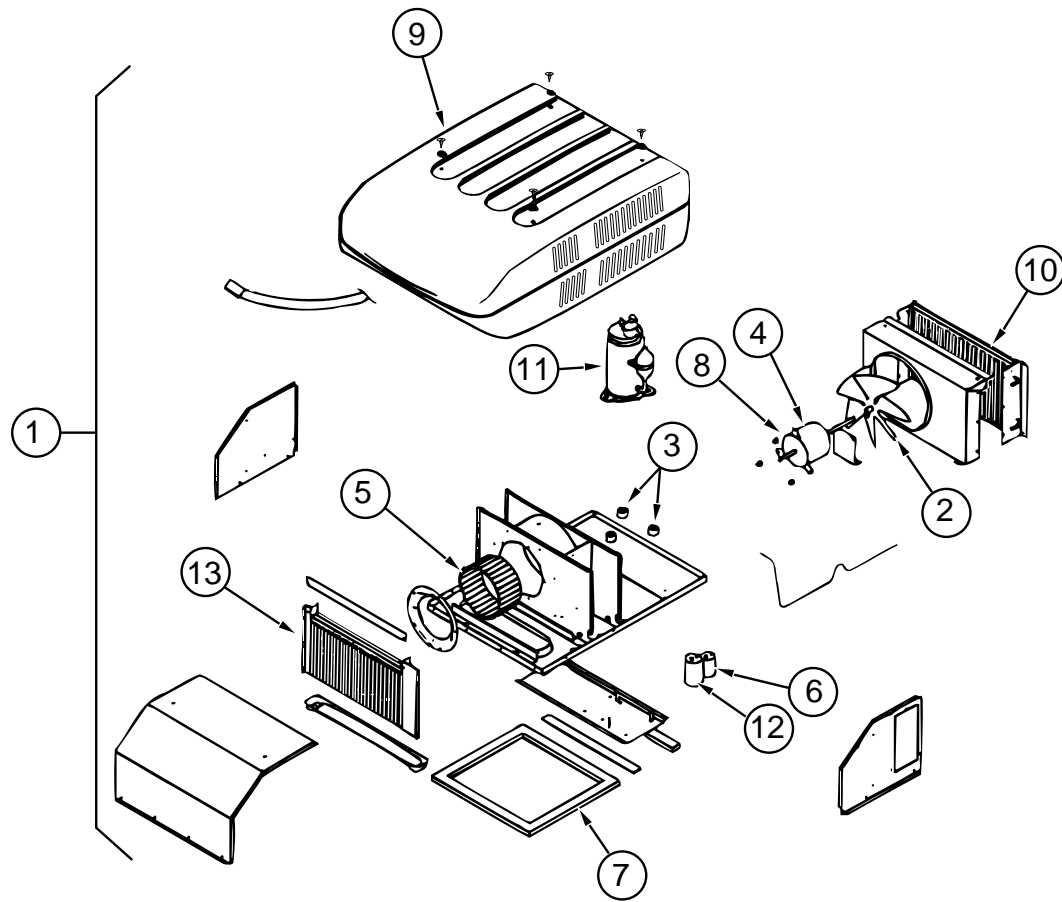

COLEMAN ROOF AIR 13,500 BTU (EXPORT)

KEY	PART NUMBER	U/M	DESCRIPTION	VENDOR NO.
1	108889-02-03A	EA	AIR CONDITIONER - 13,500 BTU/220 VOLT	
2	093763-01-712	EA	BLADE-FAN-CONDENSER	6733-3221
3	105620-01-706	EA	MOUNTING PKG.,COMP., 3 PER	6759-3081
4	108889-02-701	EA	MOTOR	1468-3059
5	108889-01-706	EA	IMPELLOR	1472-1041
6	093763-01-704	EA	CAPACITOR-FAN	1499-5461
7	108889-01-711	EA	GASKET PKG	6792-3301
8	108889-01-715	EA	MOTOR MOUNT & SHAFT SEAL KIT	6792-3361
9	108889-05-700	EA	SHROUD-BRIGHT/WHT. W/O LOGO	7333-4601
10	108889-01-703	EA	COIL-CONDENSER	1452A1301
11	108889-02-700	EA	COMPRESSOR-TECUMSEH	1450A2029
12	108889-01-707	EA	CAPACITOR-RUN,COMP-25MFD/370	1499-5661
13	108889-01-709	EA	COIL-EVAPORATOR	1452A1311
	102289-01-000	EA	SPRING - SCREW - ROOF A/C GASKET	
	108889-01-710	EA	PAD-FILLER, CONDENSER SEAL	6759A3971
	108889-01-713	EA	LINE-SUCTION, 3/8ODX032 WALL	6792-130
	108889-01-714	EA	LINE ASSEMBLY-DISCHARGE	6792-531
	105620-01-705	EA	PROTECTOR-OVERLOAD, RH & LH	6759-3791
	093306-01-701	EA	DECAL PACKAGE, LEFT & RIGHT	6798B3591
	108889-02-702	EA	CAPACITOR-START	1497-0891
	108889-02-703	EA	RELAY-START	1497-4141
	117238-02-01A	EA	THERMOSTAT - A/C ONLY	
	120134-01-02A	EA	REGISTER - 4-5 INCH DIAMETER W/DAMPER	
	073937-03-000	EA	SWITCH - ROTARY- AC - SELECTOR - 3 DECK	

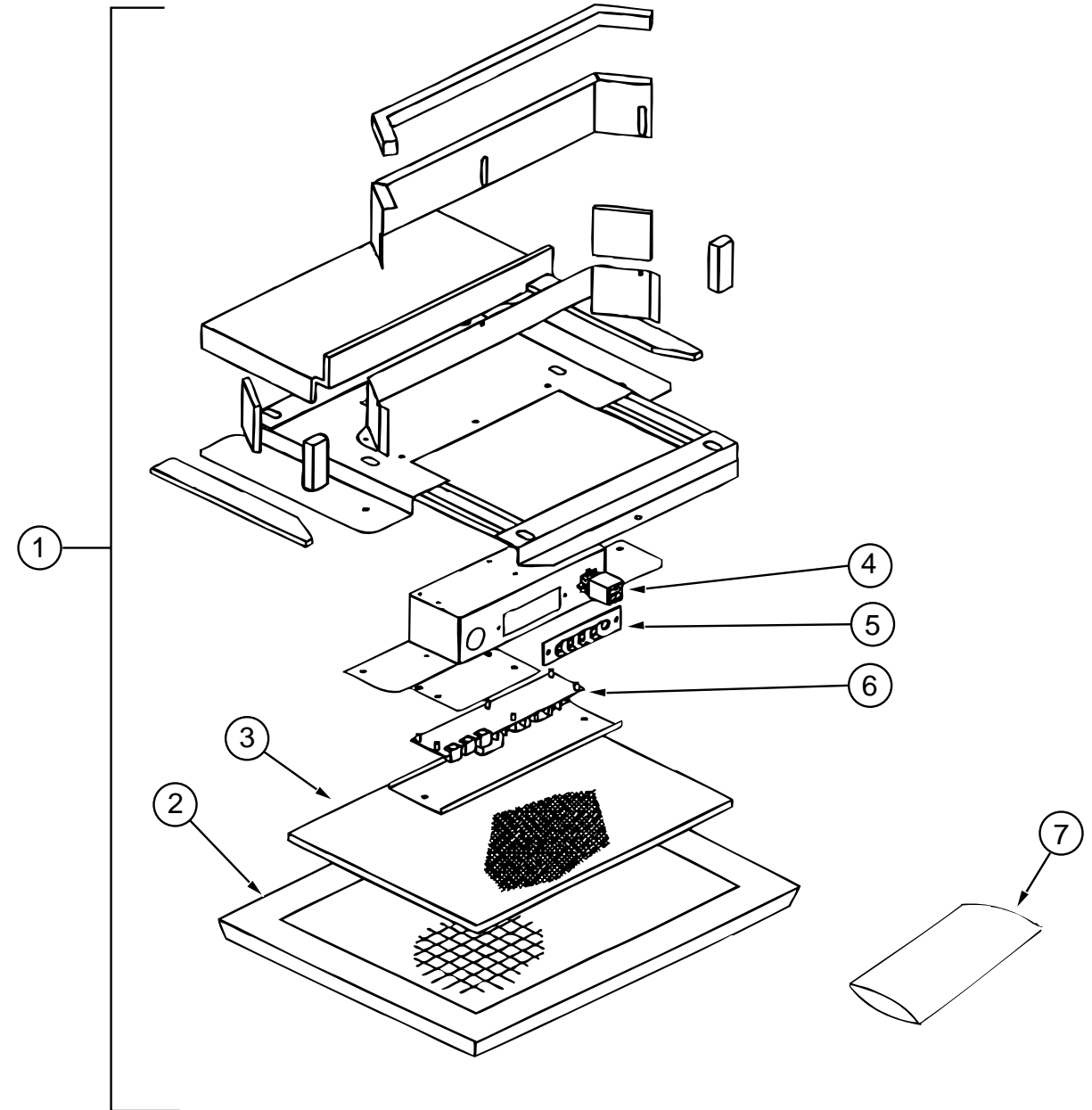

CEILING ASM-A/C DUCTED (EXPORT)

KEY	PART NUMBER	U/M	DESCRIPTION	VENDOR NO.
1	108892-01-01A	EA	CEILING ASM-A/C DUCTED-COLEMAN 7330-73	
2	108892-01-704	EA	GRILLE (PLASTIC)	6798-3041
3	108892-01-703	EA	FILTER	6798A3761
4	108892-01-700	EA	PLUG ASSEMBLY	7330-540
5	108892-01-701	EA	BOARD-TERMINAL	7330-3201
6	108892-01-702	EA	BOARD-P.C.	7330A3211
7	108892-01-705	EA	SMALL PARTS PKG	7330A6101

HEATING & AIR CONDITIONING GROUP (CONTINUED)

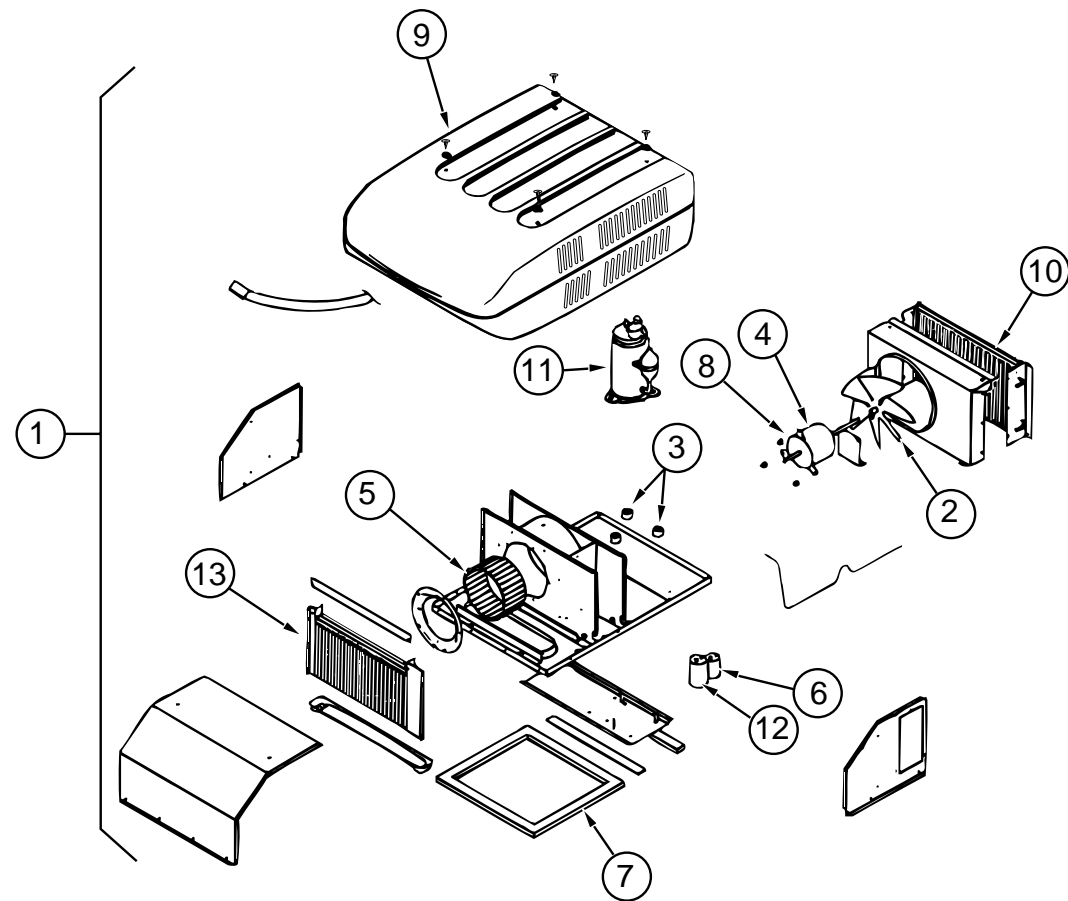

COLEMAN ROOF AIR 13,500 BTU (US, CSA)

KEY	PART NUMBER	U/M DESCRIPTION	VENDOR NO.
1	108889-01-05A	EA A/C - ROOF - 13,500 TSR	
2	093763-01-712	EA BLADE - FAN-CONDENSER	6733-3221
3	105620-01-706	EA MOUNTING PKG. - COMP. - 3 PER	6759-3081
4	108889-01-705	EA MOTOR (115, 60HZ)	1468-3049
5	108889-01-706	EA IMPELLOR	1472-1041
6	093763-01-704	EA CAPACITOR - FAN	1499-5461
7	108889-01-711	EA GASKET PKG	6792-3301
8	108889-01-715	EA MOTOR MOUNT & SHAFT SEAL KIT	6792-3361
9	108889-05-700	EA SHROUD - BRIGHT/WHT. W/O LOGO	7333-4601
10	108889-01-703	EA COIL - CONDENSER	1452A1301
11	108889-01-721	EA COMPRESSOR TSR3'S A & B'S	1450-2079
11	108889-01-722	EA COMPRESSOR TSR3 C & D ONLY	1450-2099
12	108889-01-707	EA CAPACITOR-RUN - COMP-25MFD/370	1499-5661
13	108889-01-709	EA COIL - EVAPORATOR	1452A1311
	108889-01-710	EA PAD - FILLER - CONDENSER SEAL	6759A3971
	108889-01-712	EA LINE - SUCTION - REDUCER 3/8 X 1/2	1215-2161
	108889-01-713	EA LINE - SUCTION - 3/8OD X 032 WALL	6792-130
	108889-01-714	EA LINE ASSEMBLY - DISCHARGE	6792-531
	108889-01-720	EA TUBE - CAP	6792-1351
	108889-01-704	EA OVERLOAD (MRA#98693)	6749-3541
	091225-01-709	EA RELAY - START	1497-4131
	091225-01-710	EA CAPACITOR - START	1497-0881
	093306-01-701	EA DECAL PACKAGE - LEFT & RIGHT	6798B3591
	108889-05-700	EA SHROUD - BRIGHT/WHT. W/O LOGO	7333-4601
	117238-01-01A	EA THERMOSTAT - A/C - FURNACE	
	117238-02-01A	EA THERMOSTAT - A/C ONLY	
	120134-01-02A	EA REGISTER - 4" TO 5" IN DIAMETER W/DAMPER	
	102289-01-000	EA SPRING - SCREW - ROOF A/C GASKET	
	073937-03-000	EA SWITCH - ROTARY- AC - SELECTOR - 3 DECK	

HEATING & AIR CONDITIONING GROUP (CONTINUED)

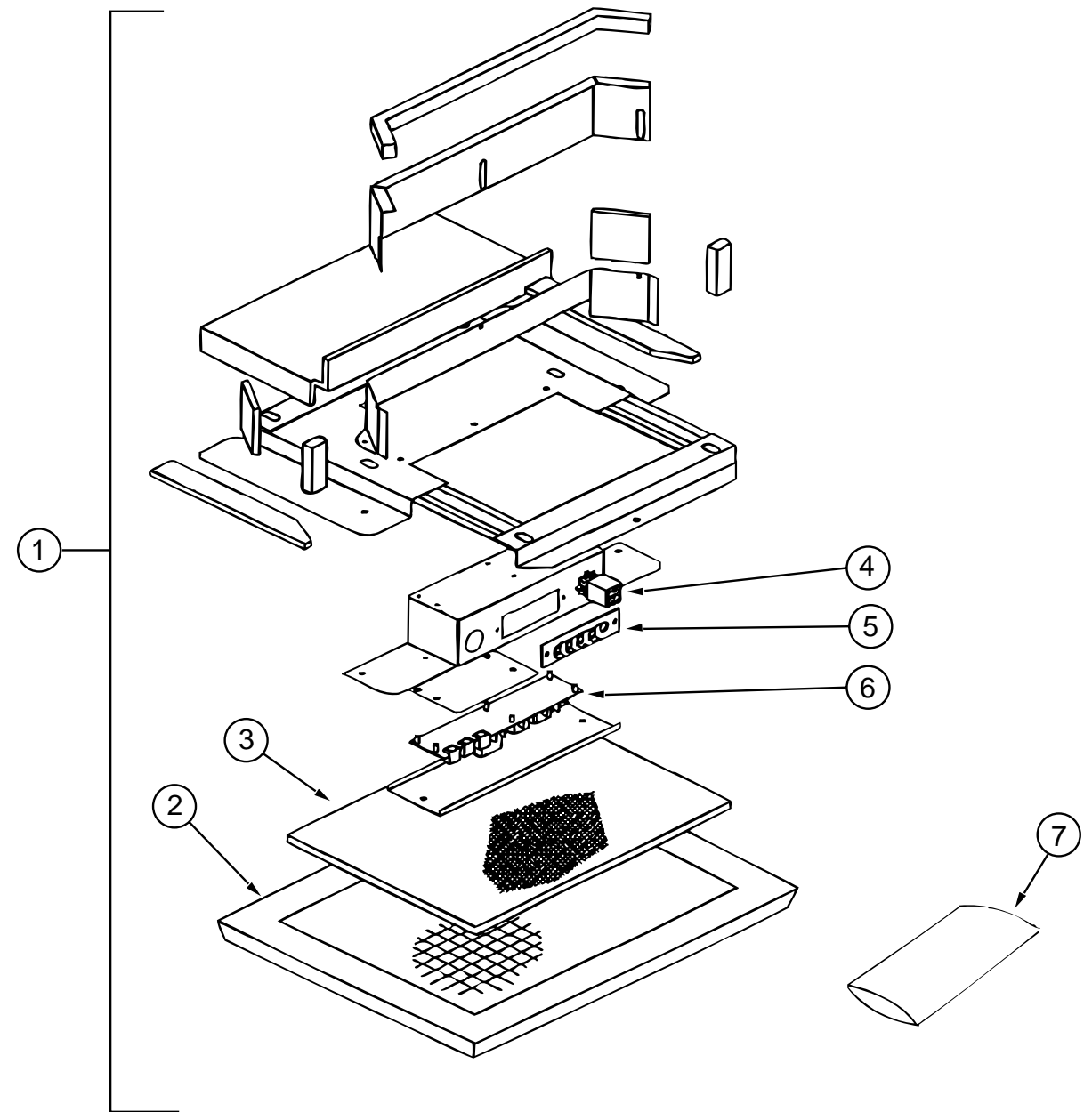

CEILING ASM-A/C DUCTED

KEY	PART NUMBER	U/M DESCRIPTION	VENDOR NO.
1	108892-01-01A	EA CEILING ASM-A/C DUCTED-COLEMAN 7330-73	
2	108892-01-704	EA GRILLE (PLASTIC)	6798-3041
3	108892-01-703	EA FILTER	6798A3761
4	108892-01-700	EA PLUG ASSEMBLY	7330-540
5	108892-01-701	EA BOARD-TERMINAL	7330-3201
6	108892-01-702	EA BOARD-P.C.	7330A3211
7	108892-01-705	EA SMALL PARTS PKG	7330A6101

HEATING & AIR CONDITIONING GROUP (CONTINUED)

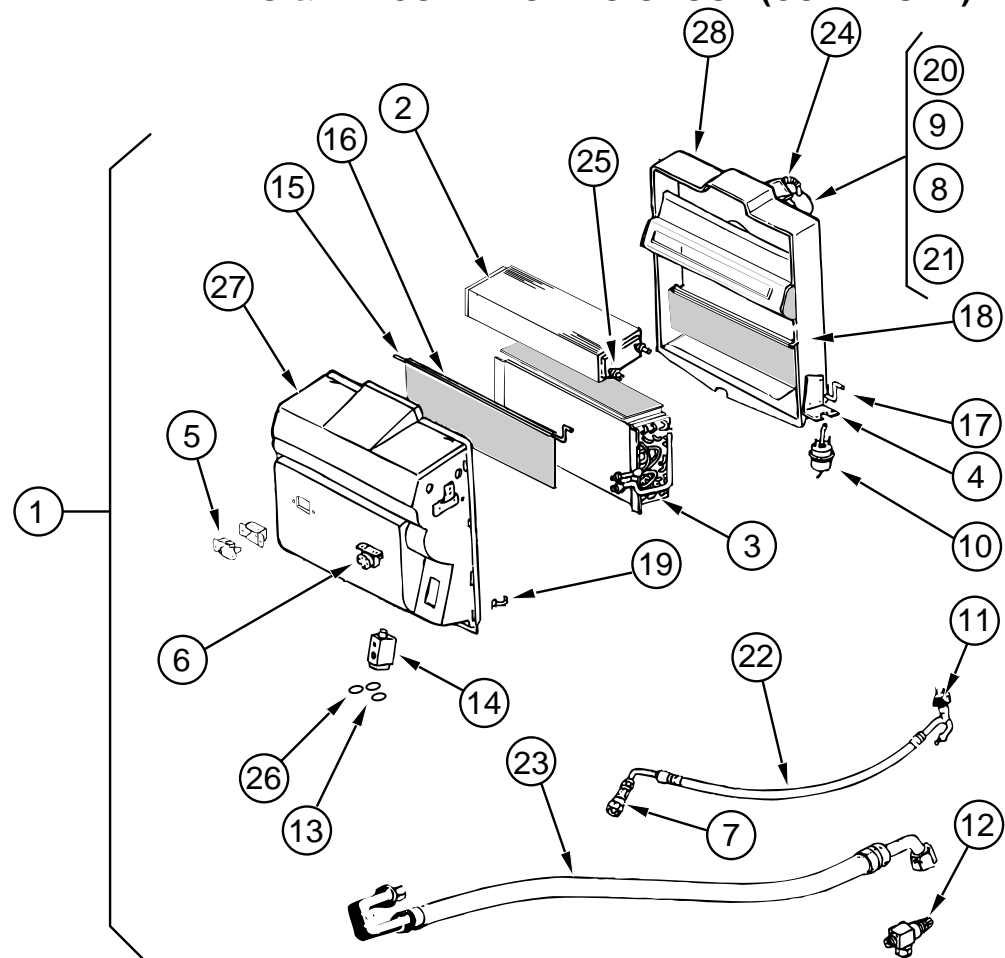

AUTOMOTIVE AIR CONDITIONING (FORD) (FROM 00-00-00 THRU: 09-01-96)

KEY	PART NUMBER	U/M	DESCRIPTION	VENDOR NO.
1	103930-21-000	EA	EVAPORATER/HEATER - FORD - R134A BLOCK	
2	103930-01-703	EA	COIL - HEATER	042-0010
3	103930-01-704	EA	COIL EVAPORATOR	041-0017
4	103930-01-708	EA	BRACKET - VACUUM MOTOR	070-0113
5	103930-01-710	EA	RESISTOR - FUSED	035-0006
6	103930-01-711	EA	THERMOSTAT	033-0003
7	103930-01-713	EA	FITTING - QUICK CONNECT - #4	050-003
8	103930-01-717	EA	WHEEL - CLOCKWISE	062-0010
9	103930-30-706	EA	MOTOR - BLOWER W/PIGTAIL HARNESS	030-0109
10	103930-02-708	EA	MOTOR - VACUUM SERVO - A/C	030-0025
11	103930-12-708	EA	SWITCH - BINARY - R-134A	032-0048
12	103930-13-702	EA	SERVICE VALVE W/O C.P.	050-152
13	103930-17-702	EA	O'RING #10	045-0127
14	103930-20-700	EA	VALVE EXPANSION BLOCK (2 TON)	034-0032
15	103930-20-702	EA	ROD F/BLEND AIR DOOR	073-0039
16	103930-20-703	EA	DOOR - BLEND AIR	071-0212
17	103930-20-704	EA	ROD - DOOR - RECIRCULATING	073-0018
18	103930-20-705	EA	DOOR PANEL - RECIRCULATING	071-0213
19	103930-20-706	EA	CLIP - RETAINER	022-0057
20	103930-20-707	EA	BLOWER HOUSING	062-0145
21	103930-20-708	EA	CLIP F/ MOTOR SHAFT	022-0001
22	103930-21-700	EA	HOSE ASM #6 EVAPORATOR/DRIER	085-0139
23	103930-21-701	EA	HOSE ASM #10 EVAPORATOR/COMP	085-0149
24	110279-01-703	EA	HOSE - VENT - MOTOR BLOWER	70510034
25	110279-01-712	EA	HEATER FITTING	
26	113245-01-707	EA	GASKET	045-0126
27	103930-20-710	EA	CASE - FRONT - SUB-ASM.	062-0146
28	103930-20-711	EA	CASE - BACK - SUB-ASM.	062-0147

HEATING & AIR CONDITIONING GROUP (CONTINUED)

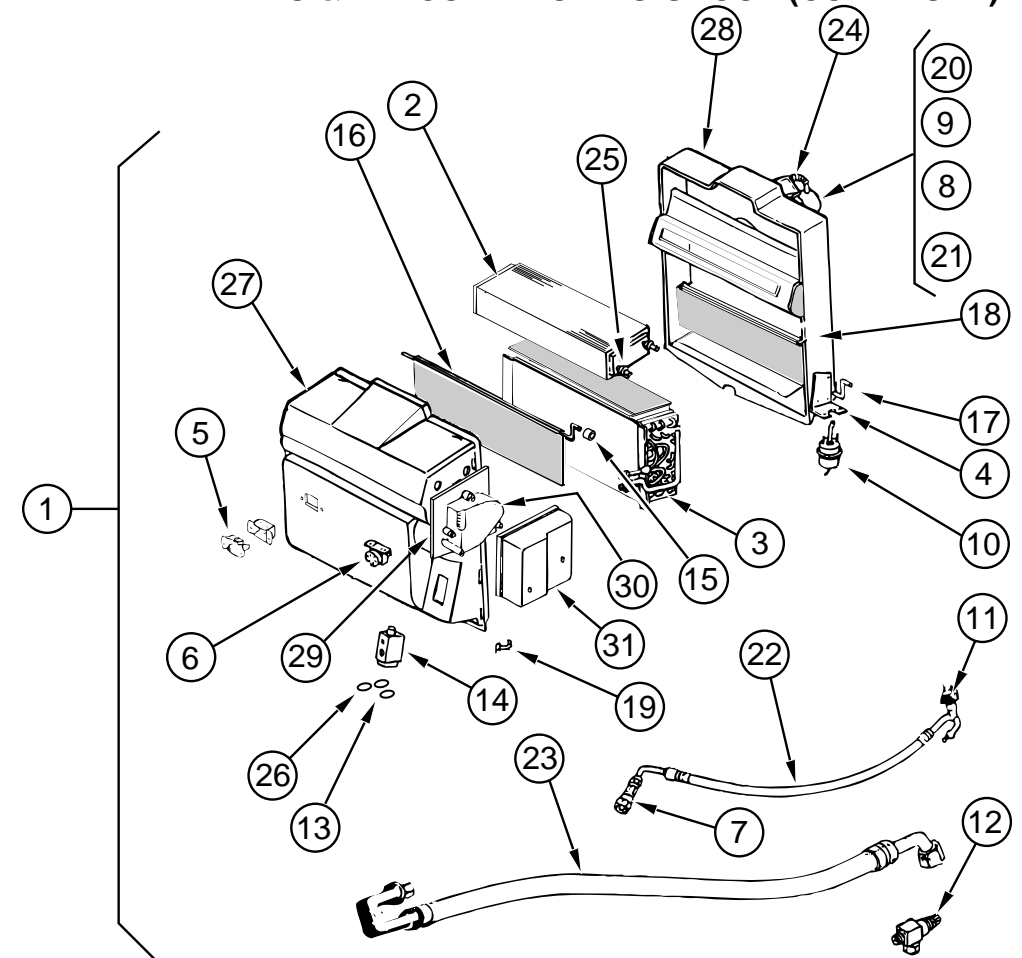

AUTOMOTIVE AIR CONDITIONING (FORD)(FROM 09-02-96 THRU: 99-99-99)

KEY	PART NUMBER	U/M	DESCRIPTION	VENDOR NO.
1	103930-31-000	EA	EVAPORATOR/HEATER - FORD - SERVO MOTOR CONTROLLED	
2	103930-01-703	EA	CORE - HEATER	042-0010
3	103930-01-704	EA	COIL - EVAPORATOR	041-0017
4	103930-01-708	EA	BRACKET - VACUUM MOTOR	070-0113
5	103930-01-710	EA	RESISTOR - FUSED - A/C	035-0006
6	103930-01-711	EA	THERMOSTAT	033-0003
7	103930-01-713	EA	FITTING - QUICK CONNECT - #4	050-0030
8	103930-01-717	EA	WHEEL - BLOWER - CLOCKWISE	062-0010
9	103930-30-706	EA	MOTOR - BLOWER - (PM147)	030-0109
10	103930-02-708	EA	MOTOR - VACUUM SERVO - A/C	030-0025
11	103930-12-708	EA	SWITCH - BINARY - HI-LOW CUTOUT	032-0048
12	103930-13-702	EA	VALVE - SERVICE - W/O COMP.	050-0152
13	103930-17-702	EA	O'RING #10	045-0127
14	103930-20-700	EA	VALVE - EXPANSION - BLOCK - 2 TON	034-0032
15	103930-30-702	EA	BUSHING - BLEND AIR DOOR	062-0168
16	103930-30-705	EA	DOOR - BLEND AIR	071-0568
17	103930-20-704	EA	ROD - DOOR - RECIRCULATING	073-0018
18	103930-20-705	EA	PANEL - DOOR - RECIRCULATING	071-0213
19	103930-20-706	EA	CLIP - RETAINER	022-0057
20	103930-20-707	EA	HOUSING - BLOWER	062-0145
21	103930-20-708	EA	CLIP - MOTOR SHAFT	022-0001
22	103930-21-700	EA	HOSE ASM. - #6 EXP. VALVE-DRIER	085-0139
23	103930-21-701	EA	HOSE ASM. - #10 - EXP. VALVE-COMP	085-0149
24	110279-01-703	EA	HOSE-VENT - BLOWER MOTOR	051-0034
25	110279-01-712	EA	FITTING - HEATER	050-0076
26	113245-01-707	EA	O'RING #8	045-0126
27	103930-30-700	EA	CASE - FRONT	062-0542
28	103930-20-711	EA	CASE - BACK - SUB-ASSEMBLY	062-0147
29	103930-30-701	EA	PLATE - MOTOR MOUNT	062-0544
30	103930-30-703	EA	MOTOR - SERVO	030-0104
31	103930-30-704	EA	COVER - SERVO	062-0545

HEATING & AIR CONDITIONING GROUP (CONTINUED)

SCS EVAPORATOR/ HEATER - CHEVY (FROM: 00-00-00 THRU: 09-01-96)

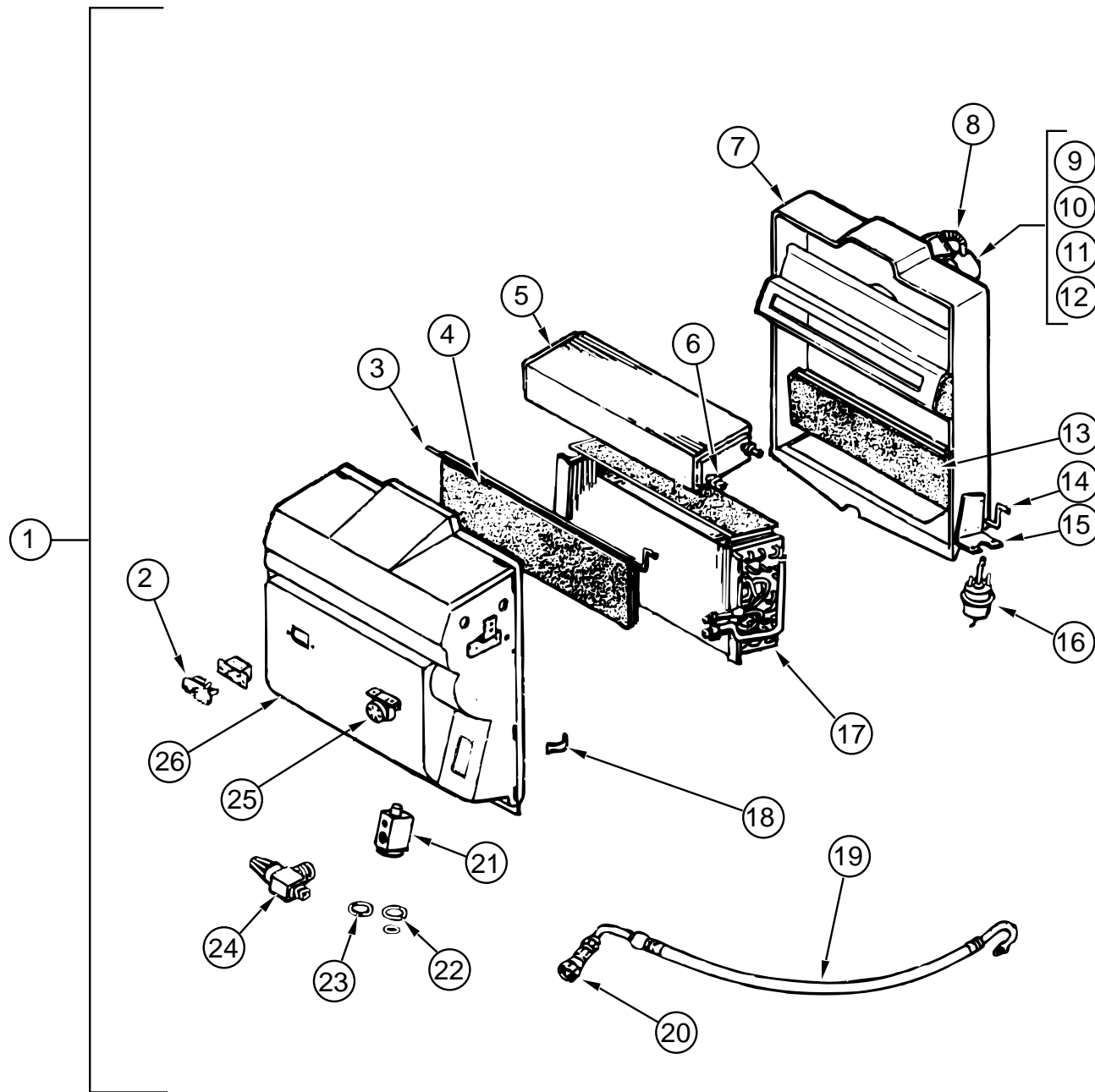

KEY	PART NUMBER	U/M	DESCRIPTION	VENDOR NO.
1	103930-25-000	EA	EVAPORATOR/ HEATER - CHEVY - "96"	
2	103930-01-710	EA	RESISTOR - FUSED - A/C	035-0006
3	103930-20-702	EA	ROD - DOOR - BLEND AIR	073-0039
4	103930-20-703	EA	DOOR - BLEND AIR	071-0212
5	103930-01-703	EA	CORE - HEATER	042-0010
6	110279-01-712	EA	FITTING - HEATER	050-0076
7	103930-20-711	EA	CASE - BACK - SUB-ASSEMBLY	062-0147
8	110279-01-703	EA	HOSE - VENT - BLOWER MOTOR	051-0034
9	103930-20-707	EA	HOUSING - BLOWER	062-0145
10	103930-30-706	EA	MOTOR - BLOWER W/PIGTAIL HARNESS	030-0109
11	103930-01-717	EA	WHEEL - BLOWER - CLOCKWISE	062-0010
12	103930-20-708	EA	CLIP - MOTOR SHAFT	022-0001
13	103930-20-705	EA	PANEL - DOOR - RECIRCULATING	071-0213
14	103930-20-704	EA	ROD - DOOR-RECIRCULATING	073-0018
15	103930-01-708	EA	BRACKET - VACUUM MOTOR	070-0113
16	103930-02-708	EA	MOTOR - VACUUM SERVO - A/C	030-0025
17	103930-01-704	EA	COIL - EVAPORATOR	041-0017
18	103930-20-706	EA	CLIP - RETAINER	022-0057
19	103930-25-700	EA	HOSE ASM. - #6 EVAP TO DRIER	085-0350
20	103930-12-709	EA	FITTING - QUICK CONNECT	050-0120
21	103930-20-700	EA	VALVE - EXPANSION-BLOCK - 2 TON	034-0032
22	103930-17-702	EA	O'RING #10	045-0127
23	113245-01-707	EA	O'RING #8	045-0126
24	103930-20-709	EA	VALVE - SERVICE	050-0159
25	103930-01-711	EA	THERMOSTAT	033-0003
26	103930-20-710	EA	CASE - FRONT - SUB-ASSEMBLY	062-0146
	103930-02-714	EA	CLAMP - CLUTCH - BARREL	022-0006

HEATING & AIR CONDITIONING GROUP (CONTINUED)

SCS EVAPORATOR/ HEATER - CHEVY (FROM: 09-02-96 THRU: 99-99-99)

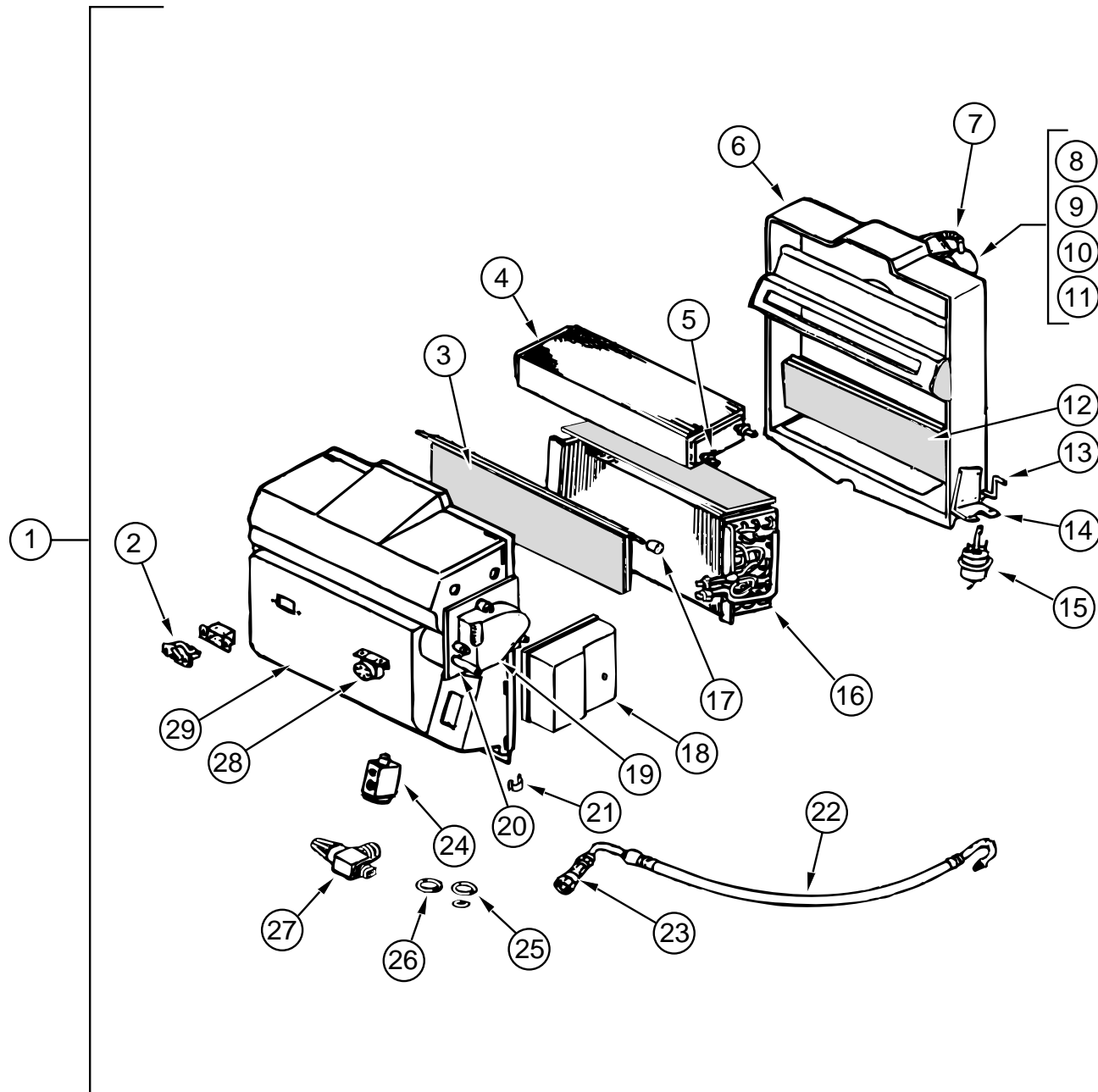

KEY	PART NUMBER	U/M	DESCRIPTION	VENDOR NO.
1	103930-30-000	EA	EVAPORATOR/HEATER - CHEVY - SERVO MOTOR CONTROLLED	
2	103930-01-710	EA	RESISTOR - FUSED - A/C	035-0006
3	103930-30-705	EA	DOOR - BLEND AIR	071-0568
4	103930-01-703	EA	CORE - HEATER	042-0010
5	110279-01-712	EA	FITTING - HEATER	050-0076
6	103930-20-711	EA	CASE - BACK	062-0147
7	110279-01-703	EA	HOSE-VENT - BLOWER MOTOR	051-0034
8	103930-20-707	EA	HOUSING - BLOWER	062-0145
9	103930-30-706	EA	MOTOR - BLOWER - (PM147)	030-0109
10	103930-01-717	EA	WHEEL - BLOWER - CLOCKWISE	062-0010
11	103930-20-708	EA	CLIP - MOTOR SHAFT	022-0001
12	103930-20-705	EA	PANEL - DOOR - RECIRCULATING	071-0213
13	103930-20-704	EA	ROD - DOOR-RECIRCULATING	073-0018
14	103930-01-708	EA	BRACKET - VACUUM MOTOR	070-0113
15	103930-02-708	EA	MOTOR - VACUUM SERVO - A/C	030-0025
16	103930-01-704	EA	COIL - EVAPORATOR	041-0017
17	103930-30-702	EA	BUSHING - BLEND AIR DOOR	062-0168
18	103930-30-704	EA	COVER - SERVO	062-0545
19	103930-30-703	EA	MOTOR - SERVO	030-0104
20	103930-30-701	EA	PLATE - MOTOR MOUNT	062-0544
21	103930-20-706	EA	CLIP - RETAINER	022-0057
22	103930-25-700	EA	HOSE ASM. - #6 EVAP TO DRIER	085-0350
23	103930-12-709	EA	FITTING - QUICK CONNECT	050-0120
24	103930-20-700	EA	VALVE - EXPANSION-BLOCK - 2 TON	034-0032
25	103930-17-702	EA	O'RING #10	045-0127
26	113245-01-707	EA	O'RING #8	045-0126
27	103930-20-709	EA	VALVE - SERVICE	050-0159
28	103930-01-711	EA	THERMOSTAT	033-0003
29	103930-30-700	EA	CASE - FRONT	062-0542

HEATING & AIR CONDITIONING GROUP (CONTINUED)

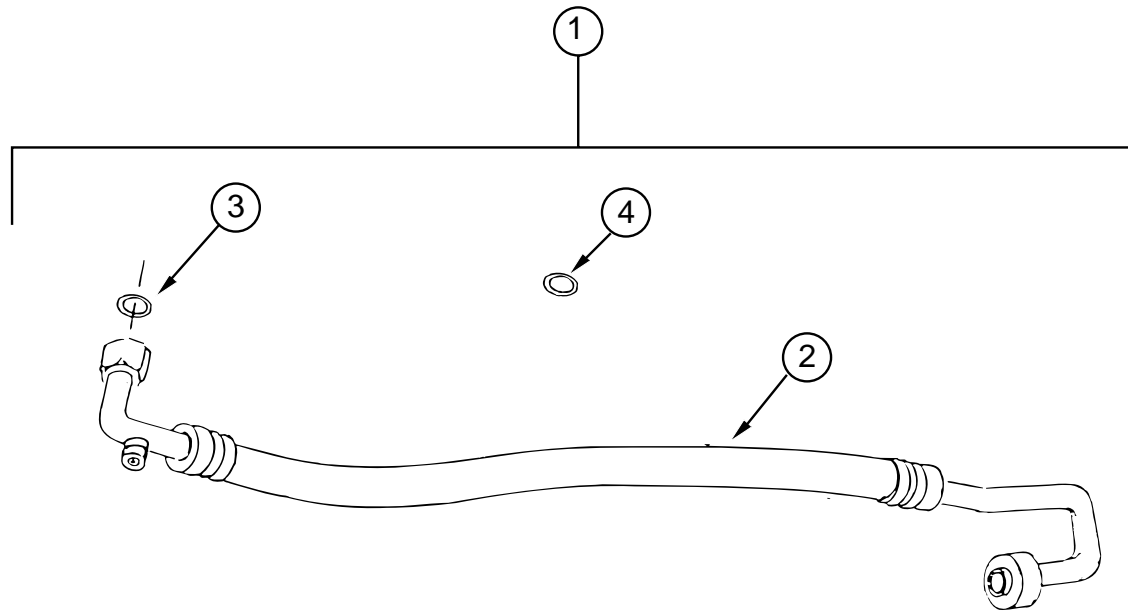

CHEVY HOSE KIT - STANDARD GAS

KEY	PART NUMBER	U/M DESCRIPTION	VENDOR NO.
1	103930-28-000	EA HOSE KIT - #10 W/GM L-19 CHASSIS	
2	103930-28-700	EA HOSE ASSM #10 W/SELTEC COMP	085-0347
3	103930-17-702	EA O'RING #10	045-0127
4	103930-29-701	EA GASKET-GMLP SW 1996	045-0483

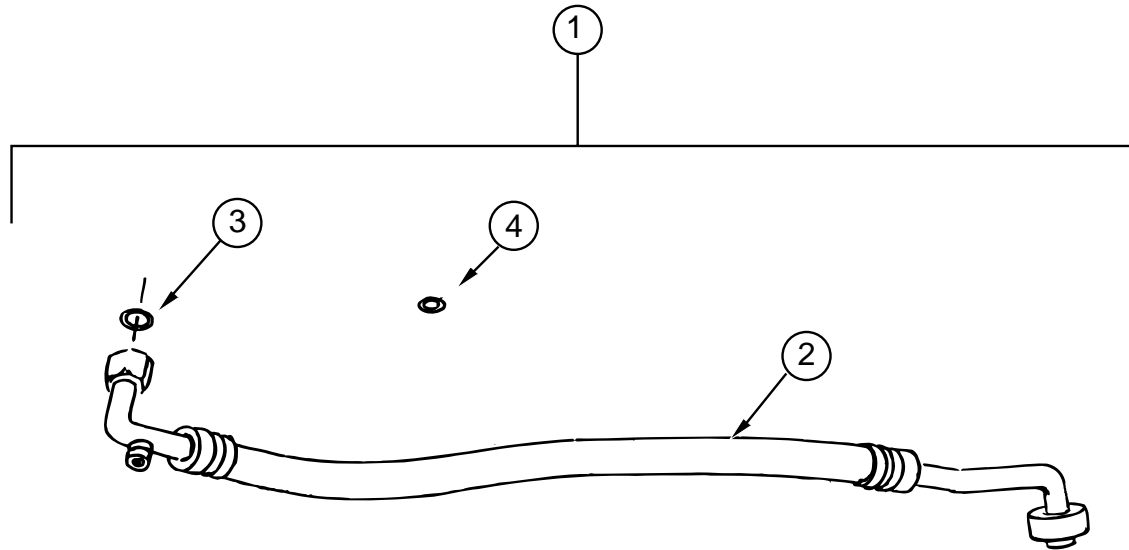

CHEVY HOSE KIT - VORTEC GAS OR DIESEL OPTION

KEY	PART NUMBER	U/M DESCRIPTION	VENDOR NO.
1	103930-29-000	EA HOSE KIT - #10 W/GM L-29 & L-65 CHASSIS	
2	103930-29-700	EA HOSE ASSM #10W/HARRISON COMP	085-0348
3	103930-17-702	EA O'RING #10	045-0127
4	103930-29-701	EA GASKET-GMLP SW 1996	045-0483

HEATING & AIR CONDITIONING GROUP (CONTINUED)

AUTOMOTIVE HEATER MISCELLANEOUS

KEY	PART NUMBER	U/M DESCRIPTION
	007281-01-000	EA HOSE - FLEXIBLE PVC - 2.5" ID X 50'
	024990-05-000	EA OUTLET - DEFROSTER - 4" DIAMETER W/SWIVEL DEFLECTORS
	056402-05-000	EA BRACKET - HEATER VENT - ROUND W/BEND - BLACK
	077075-01-000	EA GASKET - INSTRUMENT PANEL TO DEFROSTER PLENUM -.6" X 11.3"
	077075-03-000	EA GASKET - INSTRUMENT PANEL TO DEFROSTER PLENUM
	103016-01-000	EA PLENUM - TRANSITION
	103017-01-000	EA PLENUM - DEFROSTER
	103558-01-06A	EA VENT - DEFROSTER - ABS PLASTIC
	103796-01-01A	EA LOUVER - A/C
	076776-01-000	EA TEE - BEADED - 5/8" X 5/8" X 5/8"
	103930-23-000	EA VALVE - WATER - 2 PORT
	077539-01-000	EA BRACKET - MOUNTING/DASH PANEL - L/SHAPED - 2.5"X1"X1.5"
	103930-05-000	EA MANUAL - OWNER - HEATER/A/C
	103930-37-000	EA MANUAL - OWNERS - HEATER/A/C
	088238-01-000	EA COVER - SWITCH - A/C SELECTOR - FRONT TO REAR A/C
	088238-02-000	EA COVER - SWITCH - A/C SELECTOR - FRONT TO REAR A/C
	092633-02-02A	EA COVER - BLANK - ROOF A/C - 5.1" X 5.1"

FROM: 00-00-00 THRU: 02-23-97
FROM: 02-24-97 THRU: 99-99-99

AUTOMOTIVE REAR HEATER SYSTEM

KEY	PART NUMBER	U/M DESCRIPTION	VENDOR NO.
	084405-01-000	EA HEATER - REAR - DUCTED - W/MOTOR AID - EVANS	
	084405-01-700	EA CORE-HEATER	FT200229
	084405-01-701	EA FAN BLADES	HV029931
	084405-01-702	EA MOTOR ASSEMBLY, 12 VOLT	R0200180
	007076-01-000	EA HOSE - FLEXIBLE PVC - 2" ID - INCREMENTS OF 50'	
	007108-01-000	FT HOSE - HEATER - 5/8" ID - HI -TEMP - FORD	
	079059-01-000	EA HOSE - 90 DEGREE - 5/8" ID X 4" X 36"	
	061673-01-000	EA BRACKET - MOTOR AID TUBES - 4" X 1.5" - STEEL	
	009198-01-000	FT DUCT - HEAT - FLEXIBLE - 4" X 1.5" - STEEL	
	056464-10-000	EA REGISTER - 4" DIAMETER - PLASTIC - W/O DAMPENR - BEIGE	

HEATING & AIR CONDITIONING GROUP (CONTINUED)

HEATING & AIR CONDITIONING GROUP (CONTINUED)

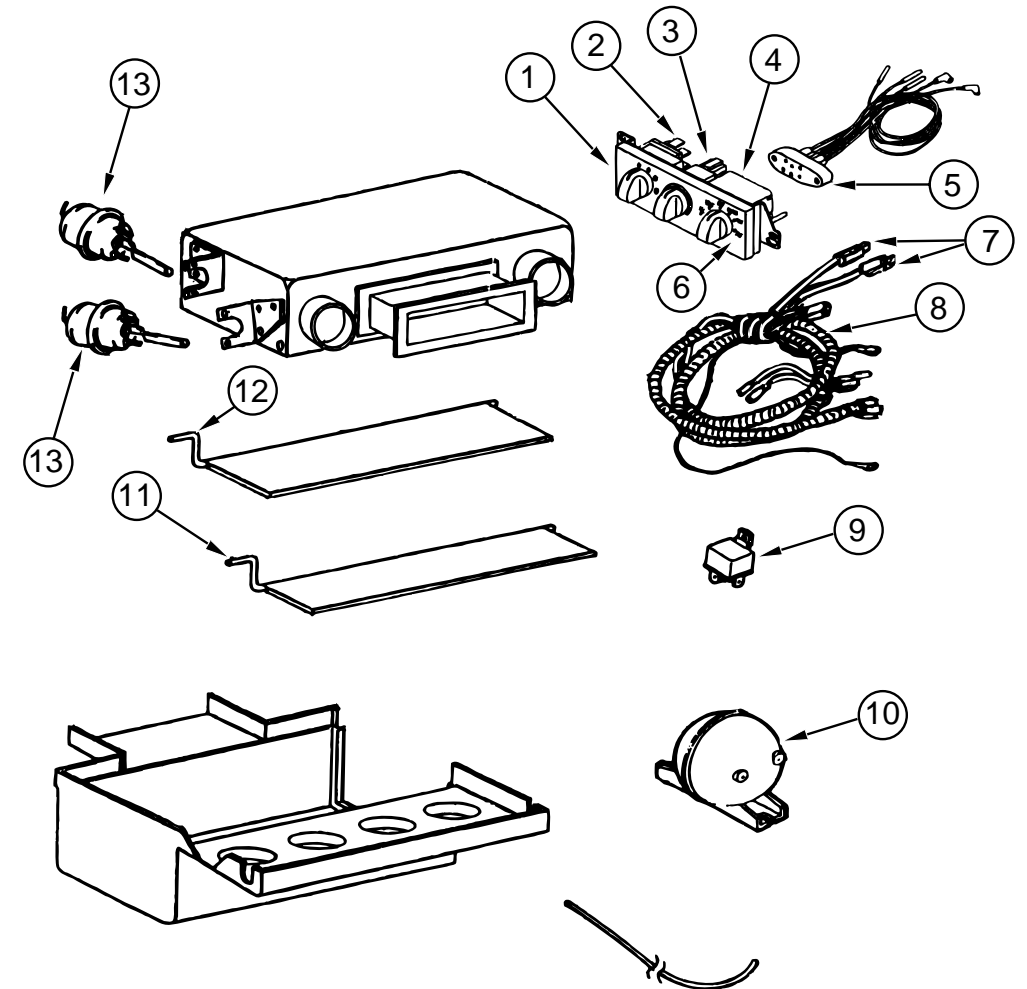
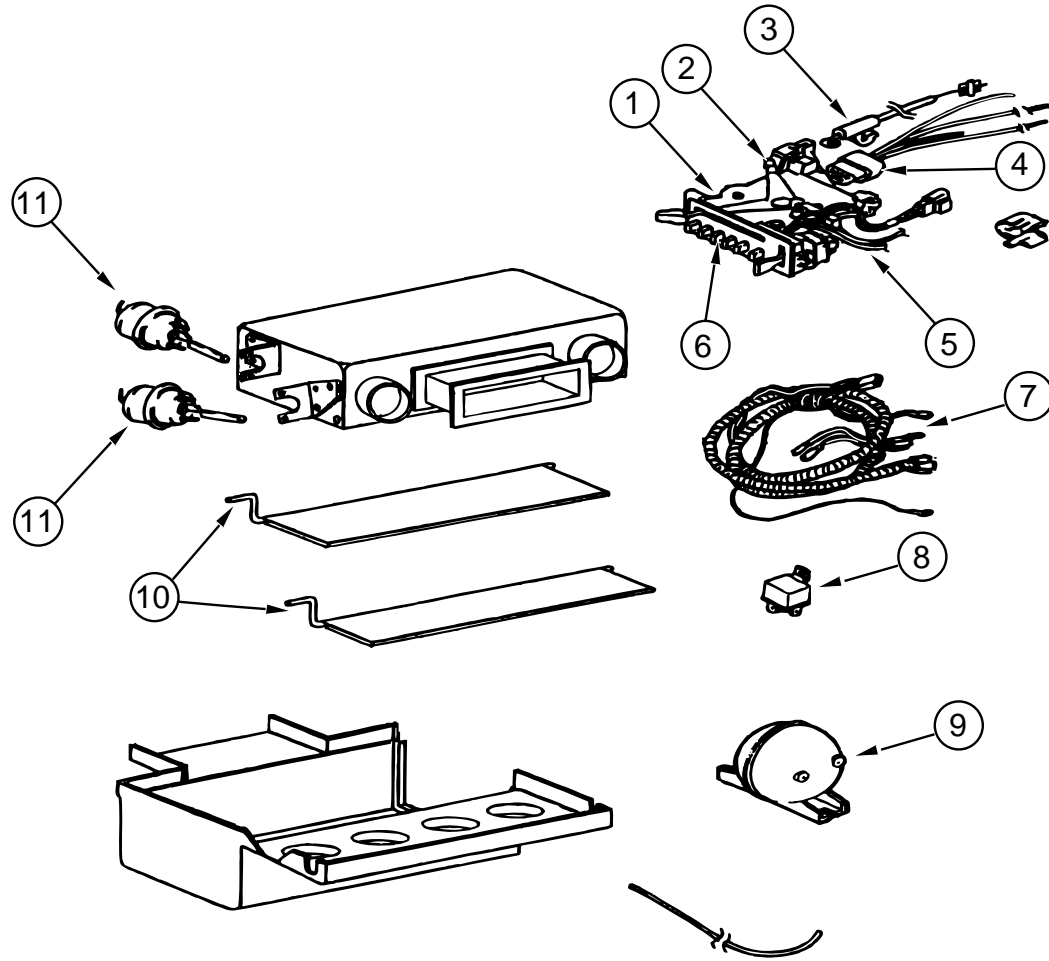

SCS CONTROL/ PLENUM (FROM 00-00-00 THRU: 09-01-96)

SCS CONTROL/ PLENUM (FROM 09-02-96 THRU: 99-99-99)

KEY	PART NUMBER	U/M	DESCRIPTION	VENDOR NO.
	103930-38-000	EA	CONTROL/ PLENUM SET	
1	103930-02-712	EA	PANEL - CONT. A/C BLACK BEZEL	032-0054
	072341-06-700	EA	SWITCH - 4 SPEED, FAN	032-0043
2	103930-02-714	EA	CLAMP-CLUTCH, BARREL	022-0006
3	103930-02-705	EA	CABLE - BOWDEN W/O LEVER 89"	074-0011
4	103930-02-704	EA	HARNESS - VACUUM CONTROL	036-0049
5	103930-02-701	EA	SWITCH - VACUUM, CONTROL HEAD	034-0015
6	103930-02-702	EA	DECAL - CONT. HEAD - (N) SERIES	058-0009
7	103930-02-703	EA	HARNESS - WIRE CONTROL	036-0048
8	103930-02-707	EA	RELAY - BOSCH W/ RESISTER	031-0001
9	103930-02-710	EA	CANISTER - VACUUM	054-0002
10	103930-33-700	EA	ROD - DOOR DEFROSTER/ AC	073-0028
11	103930-02-708	EA	MOTOR - VACUUM SERVO - A/C	030-0025
	094831-01-731	EA	ADAPTER - 2"	062-0001

KEY	PART NUMBER	U/M	DESCRIPTION	VENDOR NO.
	103930-34-000	EA	CONTROL/PLENUM - ROTARY CONTROL HEAD	
1	103930-33-702	EA	CONTROL PANEL	083-0169
2	103930-33-707	EA	SWITCH - BLOWER	032-0186
3	103930-33-708	EA	SWITCH - POTENTIOMETER	032-0184
4	103930-33-709	EA	SWITCH - VACUUM	032-0183
5	103930-33-703	EA	VACUUM HARNESS	036-0465
6	103930-33-710	EA	DECAL F/CONTROL HEAD	058-0102
7	103930-33-705	EA	LIGHT BULBS	035-0030
8	103930-33-704	EA	WIRE HARNESS W/BULBS	036-0466
			FROM: 09-02-96 THRU: 12-21-96	
8	103930-33-711	EA	WIRE HARNESS MAIN	036-0466
			FROM: 12-22-96 THRU: 99-99-99	
9	103930-02-707	EA	RELAY-BOSCH W/RESISTER	031-0001
10	103930-02-710	EA	CANISTER-VACUUM	054-0002
11	103930-33-700	EA	ROD - DOOR DEFROSTER/AC	073-0028
12	103930-33-706	EA	ROD - DOOR AC/DEFROST	073-0060
13	103930-02-708	EA	MOTOR-VACUUM SERVO, A/C	030-0025
	103930-33-701	EA	MOTOR - VACUUM, 3 STAGE	030-0105
	103930-33-712	EA	KNOB - BLOWER	062-00539
	103930-33-713	EA	KNOB	062-00540

INTERIOR FINISH GROUP

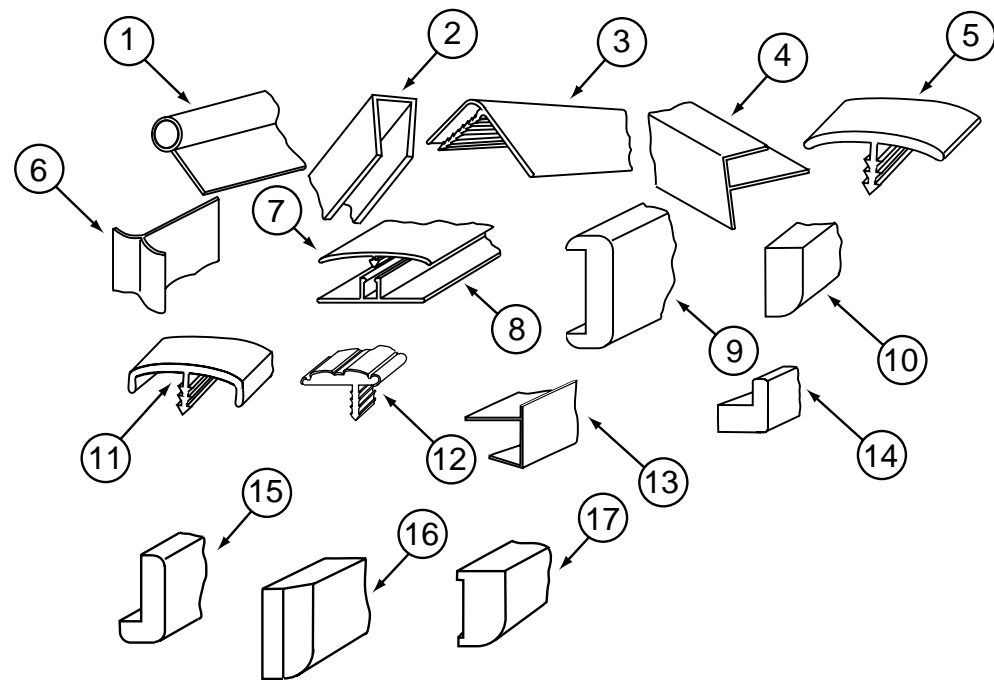

INTERIOR TRIM, BATT STRIPS & MOLDINGS (MAPLE)

KEY	PART NUMBER	U/M	DESCRIPTION
1	009767-16-000	FT	WELTING - REBER BIRCH
2	070504-40-000	FT	EXTRUSION - U-CHANNEL - 20.70" - SOLAR MAPLE
2	070504-41-000	FT	EXTRUSION - U-CHANNEL - 1.65" - SOLAR MAPLE
2	009778-24-000	FT	U-CHANNEL - 1" - SOLAR MAPLE
3	009809-23-000	EA	MOLDING - CORNER - OUTSIDE - 1" PLASTIC - IVORY
3	009809-29-000	EA	MOLDING - PLASTIC - OUTSIDE CORNER - 1" - SOLAR MAPLE
4	009812-29-000	EA	MOLDING - PLASTIC - 1/2" O/S CORNER - WATERFORD OAK
4	009812-30-000	EA	MOLDING - PLASTIC - OUTSIDE CORNER - .50" - SOLAR MAPLE
5	105709-01-000	FT	T-MOLDING - 1" MODERN IVORY
6	022992-11-000	FT	MOLDING - REVERSE COVE - T-SHAPED VINYL - IVORY
7	086229-13-000	EA	BATTEN - 1" X 96" - IVORY
7	086229-19-000	EA	BATTEN - 1" X 98.43" - OFF WHITE
7	086229-20-000	EA	BATTEN - 1" X 96" - BEIGE
8	086229-01-000	EA	RETAINER - BATTEN - .75" WIDE - 7.6'
8	086229-14-000	EA	RETAINER - 3/4" X 98.43" - ANY COLOR
9	078323-06-H37	EA	MOLDING - CAP - WALL - 6.6'
10	100818-01-06A	EA	MOLDING - VINYL WRAPPED - 1.65" X .4" X 7' - SOLAR MAPLE
11	083620-07-000	FT	T-MOLDING - END CAP EDGE - W/EDGE LIPS - .75" - THOR PECAN
11	083620-14-000	FT	T-MOLDING - W/ EDGE LIP - .75" - SOLAR MAPLE
12	109736-01-01A	FT	T-MOLDING - 1" - BRASS/BLACK
13	103186-01-06A	FT	MOLDING - EDGE - SHELF - .78" - SOLAR MAPLE
13	103186-02-06A	FT	MOLDING - SHELF - EDGE - 1.3" - PLASTIC
14	100819-01-06A	EA	MOLDING - VINYL WRAP - DOOR
15	077840-01-H37	EA	MOLDING - CAP/WALL - 8' SOLAR MAPLE
15	077840-96-H37	EA	MOLDING - CAP/WALL
16	100659-01--H37	EA	MOLDING/TRIM - VINYL FLOOR
17	122186-D2-134	EA	MOLDING - VINYL WRAPPED - .7" X 1.6" X 84" - SOLAR MAPLE
17	122186-F2-134	EA	MOLDING - VINYL WRAPPED - .7" X 2.6" X 84" - SOLAR MAPLE
	093873-01-01A	EA	TRIM - CARPET - L-ANGLE 1.1" X 1.3" X 12' - GRAY VINYL
	109736-01-06A	FT	T-MOLDING - 1" - SOLAR MAPLE
	122185-D2-438	EA	LUMBER - VINYL WRAPPED - .7" X 1.5" X 96" - SOLAR MAPLE
	122185-E2-438	EA	LUMBER - VINYL WRAPPED - .7" X 2" X 96" - SOLAR MAPLE
	122185-G2-438	EA	LUMBER - VINYL WRAPPED - .7" X 3" X 96" - SOLAR MAPLE

INTERIOR FINISH GROUP (CONTINUED)

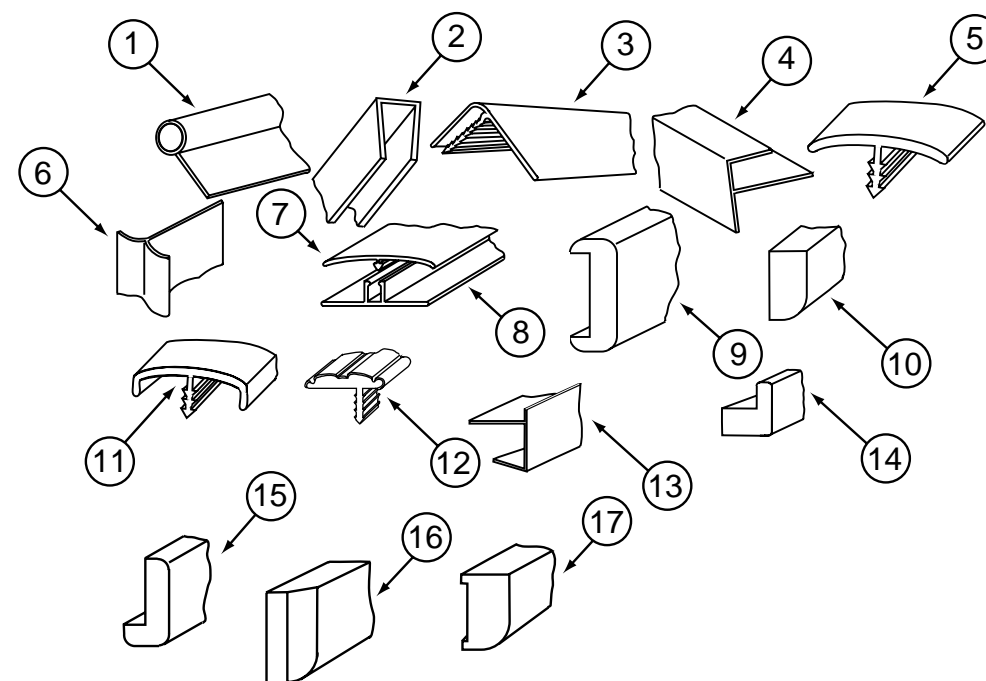

INTERIOR TRIM, BATT STRIPS & MOLDINGS (OAK)

KEY	PART NUMBER	U/M	DESCRIPTION
1	009767-12-000	FT	MOLDING - SIDEWALL TO CEILING/ CABINET - WELTING - OFF/WHT
2	009778-21-000	FT	U - CHANNEL - 1" X 7' INCREMENTS - PLASTIC
2	070504-36-000	FT	U - CHANNEL - PLASTIC - 1.65" WIDE - INCREMENTS OF 8'
2	070504-37-000	FT	U - CHANNEL - PLASTIC - .815" WIDE - INCREMENTS OF 8'
3	009809-23-000	EA	MOLDING - CORNER - OUTSIDE - 1" PLASTIC - IVORY
3	009809-28-000	EA	MOLDING - PLASTIC - OUTSIDE CORNER - 1" - WATERFORD OAK
4	009812-29-000	EA	MOLDING - PLASTIC - OUTSIDE CORNER - .50" - WATERFORD OAK
5	105709-01-000	FT	T-MOLDING - 1" MODERN IVORY
6	022992-11-000	FT	MOLDING - REVERSE COVE - T-SHAPED VINYL - IVORY
7	086229-13-000	EA	BATTEN - 1" X 96" - IVORY
7	086229-19-000	EA	BATTEN - 1" X 98.43" - OFF WHITE
7	086229-20-000	EA	BATTEN - 1" - BEIGE
8	086229-14-000	EA	RETAINER - 3/4" X 98.43" - ANY COLOR
8	086229-01-000	EA	RETAINER - BATTEN - .75" WIDE - 7.6'
9	078323-06-G15	EA	MOLDING - CAP - WALL - 6.6'
10	100818-01-05A	EA	MOLDING - VINYL WRAPPED - 1.65" X .4" X 7'
11	083620-07-000	FT	T-MOLDING - END CAP EDGE - W/EDGE LIPS - .75" - THOR PECAN
11	083620-12-000	FT	T-MOLDING - 3/4" W/EDGE LIPS - WATERFORD OAK
12	109736-01-01A	FT	T-MOLDING - 1" - BRASS/BLACK
	104676-01-01A	FT	T-MOLDING - 5/16" - RIGID GOLD
13	103186-01-05A	FT	MOLDING - SHELF EDGE - .78" PLASTIC - WATERFORD OAK
13	103186-02-05A	FT	MOLDING - PLASTIC - SHELF - WATERFORD OAK
14	100819-01-05A	EA	MOLDING - VINYL WRAP - DOOR - WATERFORD OAK
15	077840-01-G01	EA	MOLDING - CAP - WALL - 8'
16	100659-01-G09	EA	MOLDING/TRIM - VINYL FLOOR
17	117268-D2-134	EA	MOLDING - VINYL WRAPPED - .7" X 1.6" X 7' - WATERFORD
17	117268-D2-438	EA	MOLDING - VINYL WRAPPED - .7" X 1.5" X 96" - WATERFORD
17	117268-F2-134	EA	MOLDING - VINYL WRAPPED - .7" X 2.6" X 7' - WATERFORD
	093873-01-01A	EA	TRIM - CARPET - L-ANGLE 1.1" X 1.3" X 12' - GRAY VINYL
	117267-D2-438	EA	LUMBER - VINYL WRAPPED - .7" X 1 1/2" X 8' - WATERFORD OAK
	117267-E2-438	EA	LUMBER - VINYL WRAPPED .7" X 2" X 96" - WATERFORD OAK
	117267-G2-438	EA	LUMBER - VINYL WRAPPED - .7" X 3" X 96" - WATERFORD OAK

INTERIOR FINISH GROUP (CONTINUED)

CABINET HARDWARE

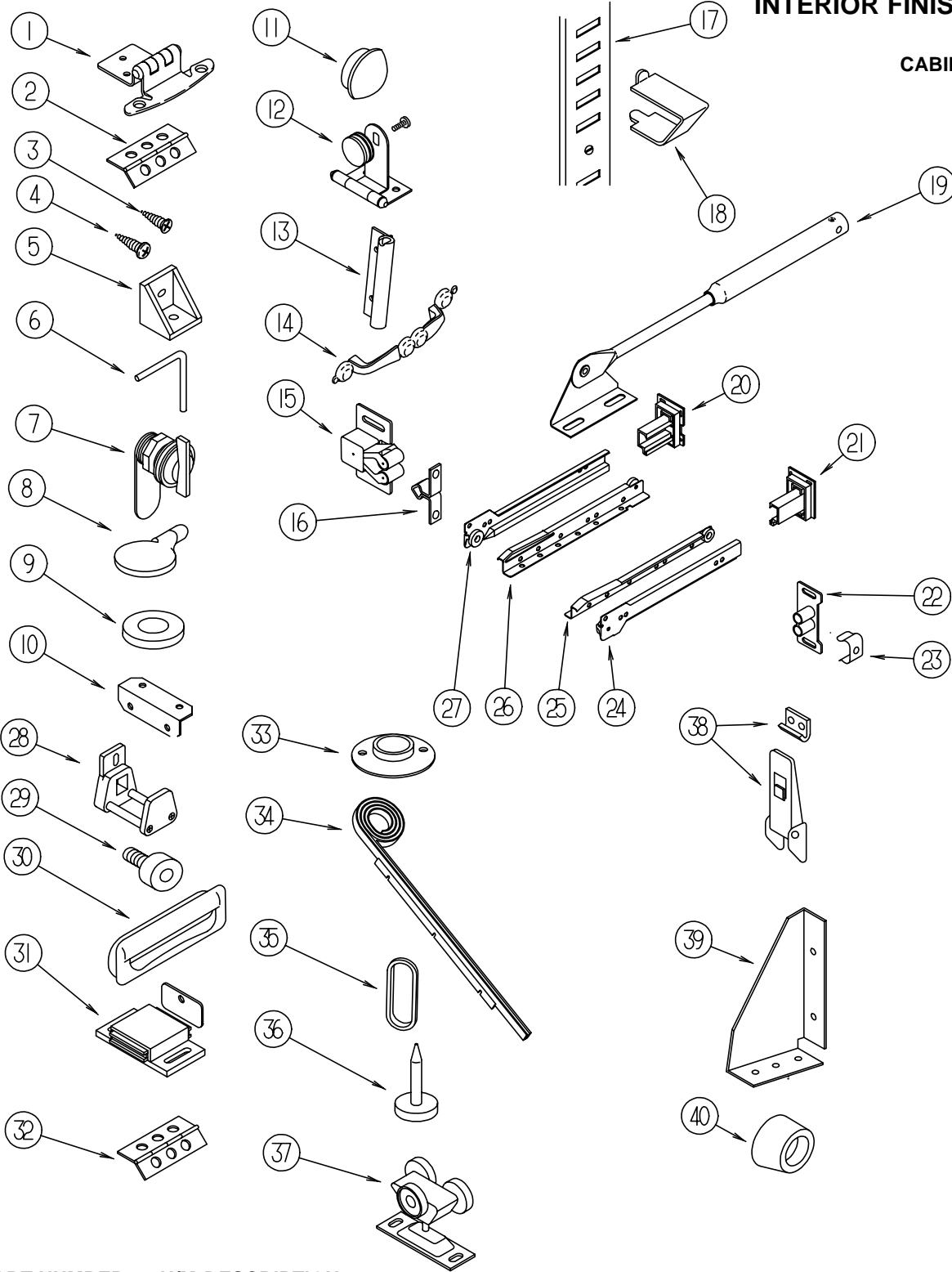

KEY	PART NUMBER	U/M	DESCRIPTION
1	108138-01-000	EA	HINGE - DOOR - CABINET - BURNISHED BRASS
2	009059-02-000	EA	HINGE - DOOR - 2" X 2.7" - BRASS
3	000G13-06-08G	EA	SCREW - 6-20 X .50 PFH - ANTIQUE BRASS
4	000G68-06-10G	EA	SCREW - 6-18 X 5/8" - PHILLIP OVAL HEAD - ANTIQUE BRASS
5	065740-01-000	EA	BRACE - CABINET CORNER - PLASTIC
6	108487-02-01A	EA	PROP ROD - OVERHEAD GLASS DOOR SUPPORT - BLACK
	039984 01 000	EA	CAP - VINYL - BLACK (PROP ROD)
7	100710-01-01A	EA	LOCK - GLASS DOOR - TWIST TYPE - BRASS
	101272-01-000	EA	CATCH - DOOR - GLASS
8	101766-01-000	EA	PIN - SUPPORT - GLASS DOOR
9	100707-01-000	EA	SPACER - DOOR - GLASS - PLASTIC
10	016604-05-000	EA	BRACE - CABINET - ANGLE - 2.5" - METAL - OFF WHITE
10	016604-01-000	EA	BRACE - CABINET - ANGLE - 2.5" - UNPAINTED METAL

KEY	PART NUMBER	U/M	DESCRIPTION
11	042356-01-000	EA	PLUG - MAHOGANY - 3/8" DIAMETER - WOOD
11	074045-10-000	EA	PLUG - OAK - 1/2" DIAMETER
12	100711-01-01A	EA	HINGE - DOOR - GLASS
13	108486-01-01A	EA	BRACKET - PROP ROD - OVHD - BLACK
14	121891-01-01A	EA	PULL - CABINET - BRASS (MAPLE)
14	121890-01-01A	EA	PULL - CABINET - BRASS (OAK)
15	093586-06-000	EA	CATCH - SPRING - ROLLER
16	093586-05-000	EA	STRIKE - SPRING STEEL
17	098980-01-000	EA	PILASTER - ADJUSTABLE SHELF - 18" LONG
17	098980-02-000	EA	PILASTER - ADJUSTABLE SHELF - 12" LONG
17	098980-03-000	EA	PILASTER - ADJUSTABLE SHELF - WOOD GRAIN
18	098979-01-000	EA	CLIP - ADJUSTABLE SHELF
19	074493-02-000	EA	SUPPORT - PISTON SPRING - CABINET DOOR
20	114045-01-000	EA	BACKSOCKET - ADJUSTABLE - LEFT
21	114045-02-000	EA	BACKSOCKET - ADJUSTABLE - RIGHT
22	009021-01-000	EA	CATCH - GRILLE - NYLON
23	009021-02-000	EA	STRIKE - SPRING STEEL
24	114031-02-000	EA	SLIDE - 12" - RIGHT SIDE/ CABINET
24	114031-14-000	EA	SLIDE - 18" - RIGHT SIDE/ CABINET
24	114031-18-000	EA	SLIDE - 20" - RIGHT SIDE/ CABINET
24	114031-22-000	EA	SLIDE - 22" - RIGHT SIDE/ CABINET
25	114031-04-000	EA	SLIDE - 12" - RIGHT SIDE/ DRAWER
25	114031-16-000	EA	SLIDE - 18" - RIGHT SIDE/ DRAWER
25	114031-20-000	EA	SLIDE - 20" - RIGHT SIDE/ DRAWER
25	114031-24-000	EA	SLIDE - 22" - RIGHT SIDE/ DRAWER
26	114031-03-000	EA	SLIDE - 12" - LEFT SIDE/ DRAWER
26	114031-15-000	EA	SLIDE - 18" - LEFT SIDE/ DRAWER
26	114031-19-000	EA	SLIDE - 20" - LEFT SIDE/ DRAWER
26	114031-23-000	EA	SLIDE - 22" - LEFT SIDE/ DRAWER
27	114031-01-000	EA	SLIDE - 12" - LEFT SIDE/ CABINET
27	114031-13-000	EA	SLIDE - 18" - LEFT SIDE/ CABINET
27	114031-17-000	EA	SLIDE - 20" - LEFT SIDE/ CABINET
27	114031-21-000	EA	SLIDE - 22" - LEFT SIDE/ CABINET
28	064467-01-000	EA	GUIDE - POCKET - SLIDING DOOR - WALL MOUNTED
29	079921-01-000	EA	ROLLER - NYLON - W/STEEL SHAFT - BARBED
30	080728-01-000	EA	HANDLE - PULL - 1.3" X 4.4" - BROWN PLASTIC
31	088254-01-000	EA	CATCH - MAGNETIC - 1.8" X .7"
32	041389-18-000	EA	HINGE - PIANO - 1.50X 482.6 0 O/WHITE
32	041389-25-000	EA	HINGE - PIANO - 1.50" X 55"
33	009112-01-000	EA	FLANGE - 1" CLOTHES ROD - OFF WHITE PLASTIC
34	097141-01-000	EA	TRACK - SPIRAL - TAMBOUR DOOR - 24"
	097141-02-700	EA	TRACK - SPIRAL KIT (1)LH & (1)RH
34	097141-02-000	EA	TRACK - SPIRAL - TAMBOUR DOOR - 24"
35	098410-01-01A	EA	PULL - FINGER - BRASS
36	102194-01-000	EA	GUIDE - PLASTIC
37	103874-01-000	EA	HANGER - SLIDING DOOR
38	116975-01-01A	EA	LATCH - W/O STRIKE - BLACK - NEW STYLE
38	116975-02-01A	EA	KEEPER/STRIKE - BLACK - NEW STYLE
39	116978-01-03B	EA	GUSSET - SLIDEOUT ROOM - OFF/WHITE
40	004354-01-000	EA	BUMPER - RUBBER - .5" DIA - BROWN
	091257-10-000	EA	HANDLE - ASSIST - WATERFORD OAK
	099682-01-01A	EA	BRACKET - MOUNTING/HAND RAIL - ROUND BASE
	P02786-04-H37	EA	HANDRAIL ONLY - W/O BRACKET (MAPLE)
	P02786-04-G15	EA	HANDRAIL ONLY - W/O BRACKET (OAK)
	M97191-01-E37	EA	HANDLE - TAMBOUR DOOR
	M97191-01-H56	EA	HANDLE - TAMBOUR DOOR
	042438-01-000	EA	DOWEL - WOOD - CLOTHES ROD - 1" DIAMETER X 4'
	042438-06-000	EA	DOWEL - WOOD - 1.5" X 26" - OAK

INTERIOR FINISH GROUP (CONTINUED)

BATT STRIPS & TAPES

KEY	PART NUMBER	U/M	DESCRIPTION
	079653-13-000	EA	BATT STRIP - TRAVERTINE WHITE
	079653-34-000	EA	BATT STRIP - KERFED - SOLAR MAPLE - 8'
	079653-29-000	EA	BATT STRIP - KERFED - FRENCH WASH - 8'
	088263-E1-000	EA	BATT STRIP - DECORATIVE - BOLERO/ AQUA FROST - 8' LONG (H37,H47)
	088263-E2-000	EA	BATT STRIP - DECORATIVE - PRIMAVERA STONE - 8' LONG (H38,H48)
	088263-B8-000	EA	BATT STRIP - DECORATIVE - METRO/ MIST - 8' LONG (H39,H49)
	085284-D4-000	FT	BATT TAPE - ADHESIVE BACKED - DECORATIVE - BOLERO/ AQUA FROST (H37,H47)
	085284-D5-000	FT	BATT TAPE - ADHESIVE BACKED - DECORATIVE - PRIMAVERA STONE (H38,H48)
	085284-B1-000	FT	BATT TAPE - ADHESIVE BACKED - DECORATIVE - METRO/ MIST (H39,H49)
	069733-84-000	EA	BATT STRIP - WOODGRAINED/ SOLAR MAPLE - 8' LONG (H37,H38,H39)
	069733-83-000	EA	BATT STRIP - WOODGRAINED/WATERFORD OAK - 8' (H47,H48,H49)
	085284-D8-000	FT	BATT TAPE - ADHESIVE BACKED - WOODGRAINED - SOLAR MAPLE (H37,H38,H39)
	085284-B5-000	FT	BATT TAPE - ADHESIVE BACKED - WOODGRAIN - WATERFORD OAK (H47,H48,H49)

FLOOR MAT & CARPET

KEY	PART NUMBER	U/M	DESCRIPTION
	075233-01-000	SY	PAD - CARPET - 3/8" X 6' ROLL
	093486-01-000	SY	CARPET - COMPARTMENT - 54" WIDE - DARK GRAY
	114129-01-02A	SF	LINER - CABINET - .02" X 48" X 96"
	096060-A8-000	SY	CARPET - BLUE LAGOON - INCREMENTS OF 4 SQ YD (H37, H47)
	096060-99-000	SY	CARPET - PARCHMENT - INCREMENTS OF 4 SQ YD (H38, H48)
	096060-96-000	SY	CARPET- JUBILATION - CRYSTAL (H39, H49)
	105924-01-F25	EA	MAT - FLOOR 18 X 27 (DRIVERS COMPARTMENT) (H37, H47)
	105924-01-F12	EA	MAT - FLOOR 18 X 27 (DRIVERS COMPARTMENT) (H38, H48)
	105924-01-H39	EA	MAT - FLOOR 18 X 27 (DRIVERS COMPARTMENT) (H39, H49)
	122755-01-01A	EA	TILE - RUBBER/ENTRANCE DOOR - 18.5" X 27.2"
	122755-03-01A	EA	TILE - RUBBER/ENTRANCE DOOR - 17.7" X 26.4"

FIRE EXTINGUISHER, DETECTORS & WALL CLOCK

KEY	PART NUMBER	U/M	DESCRIPTION
	072852-01-000	EA	DETECTOR - SMOKE - W/9 VOLT BATTERY - US
	072852-02-000	EA	DETECTOR - SMOKE - W/9/VOLT BATTERY - CANADIAN
	094499-02-000	EA	EXTINGUISHER - FIRE - DRY - 1A10BC - CANADIAN
	094499-01-000	EA	EXTINGUISHER - FIRE - DRY W/MOUNTING BRACKET - 10 B:C
	094499-01-700	EA	BRACKET MTG. W/PLAS. STRAP
	094499-01-701	EA	STRAP ONLY (METAL)
	112320-03-000	EA	DETECTOR - CO GAS - MODEL 9D-I
			FROM: 00-00-00 THRU: 10-20-96
	125136-01-000	EA	DETECTOR - CO - GAS - MODEL 9L-I
			FROM: 10-21-96 THRU: 99-99-99
	112320-04-000	EA	BATTERY/SENSOR MODULE - CO (BLACK MODULE) F/9D-I SYSTEM
			FROM: 00-00-00 THRU: 10-20-96
	118081-02-01A	EA	CLOCK - WALL - ROUND 8" - BRASS
			FROM: 06-23-97 THRU: 99-99-99

INTERIOR FINISH GROUP (CONTINUED)

PANELING & PLYWOOD

KEY	PART NUMBER	U/M	DESCRIPTION
	000846-01-000	SF	PLYWOOD - 5/16' X 4' X 8'
	000846-02-000	SF	PLYWOOD - UNDR - 5/16" X 4' X 8'
	000885-80-000	SF	PARTICLE BOARD - 3/8" X 4' X 8' - 1 SIDED (MAPLE)
	000885-81-000	SF	PARTICLE BOARD - 3/8" X 4' X 8' - 2 SIDED (MAPLE)
	000885-83-000	SF	PARTICLE BOARD - 3/4" X 4' X 8' - 2 SIDED (MAPLE)
	000885-76-000	SF	PARTICLE BOARD - 3/8" X 4' X 8' - WATERFORD OAK VINYL 1 SIDED (OAK)
	000885-77-000	SF	PARTICLE BOARD - 3/8" X 4' X 8' - WATERFORD OAK VINYL 2 SIDED (OAK)
	000885-79-000	SF	PARTICLE BOARD - 3/4" X 4' X 8' - WATERFORD OAK VINYL 2 SIDED (OAK)
	074497-35-000	SF	PANELING - SOLAR MAPLE (MAPLE)
	074497-28-000	SF	PANELING - WATERFORD OAK - 4' X 8' (OAK)
	080215-11-000	SF	PANELING - 2 SIDED - SOLAR MAPLE - 4' X 8' (MAPLE)
	080215-10-000	SF	PANELING - 2 SIDED - WATERFORD - 4' X 8' (OAK)
	088272-F8-000	SF	PANELING - BOLERO - AQUA FROST (H37, H47)
	088272-F9-000	SF	PANELING - PRIMAVERA STONE (H38, H48)
	088272-E0-000	SF	PANELING - DECORATIVE METRO/ MIST - 4' X 7' (H39, H49)
	088272-G1-000	SF	PANELING - PEBBLE EMBOSS ANTIQUE - 4' X 7' INC OF 28 SQ FT (WET BATH)
	083618-07-000	SF	PLYWOOD - MAPLE - 1 SIDE 3/16"
	126339-01-000	EA	BOARD - WHEAT - 60" X 72"

PLASTIC LAMINATE & EDGE BAND MOLDING

KEY	PART NUMBER	U/M	DESCRIPTION
	074498-67-000	SF	LAMINATE - PLASTIC - ORCHID MIST - 5' X 8' INCR OF 40 SF (EXTERIOR ENTRTNT.)
	074498-62-000	SF	LAMINATE - PLASTIC - GREY FINESSE - 5' X 8' INCR OF 40 SF (H37, H39, H47, H49)
	074498-71-000	SF	LAMINATE - PLASTIC - NEUTRAL SANTOS - 5' X 8' INC OF 40 SF (H38, H48)
	074498-79-000	SF	LAMINATE - PLASTIC - SOLAR MAPLE - 5' X 8' INC OF 40 SF (MAPLE)
	074498-77-000	SF	LAMINATE - PLASTIC ART CABIN 5' X 8' INCR OF 40 SQ FT (OAK)
	076325-43-000	FT	MOLDING - EDGE BAND - .876" X .024" - CLOUD (H37, H39,H47,H49)
	076325-40-000	FT	MOLDING - EDGE BAND - .876" X .024" - NEUTRAL (H38,H48)
	076325-46-000	FT	MOLDING - EDGE BAND - 1 5/16" X .030" - CLOUD (H37, H39,H47,H49)
	076325-39-000	FT	MOLDING - EDGE BAND - 1 5/16" X .030" - NEUTRAL (H38,H48)
	076325-34-000	FT	MOLDING - EDGE BAND - 1 5/16" X .030" - ORCHID MIST (EXTERIOR ENTRTNT.)
	076325-69-000	FT	MOLDING - EDGE BAND - .93" X .024" - SOLAR MAPLE
	076325-67-000	FT	MOLDING - EDGE BAND - .93" X .024" WATERFORD OAK

LABELS GROUP

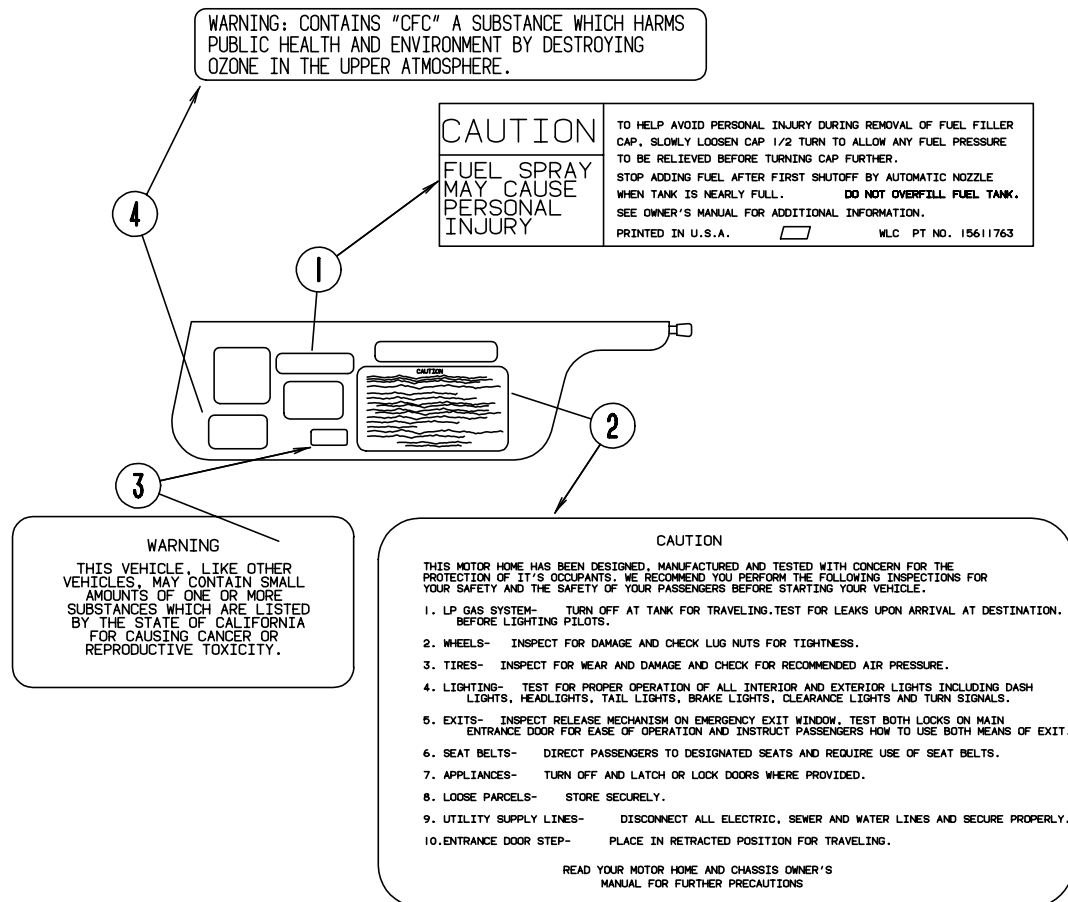

KEY	PART NUMBER	U/M DESCRIPTION
1	087207-05-000	EA LABEL - FUEL CAP REMOVAL
2	056259-01-000	EA LABEL - SAFETY CHECK LIST
3	099689-01-000	EA LABEL - WARNING - CANCER/TOXICITY
4	111802-01-000	EA LABEL - CFC WARNING

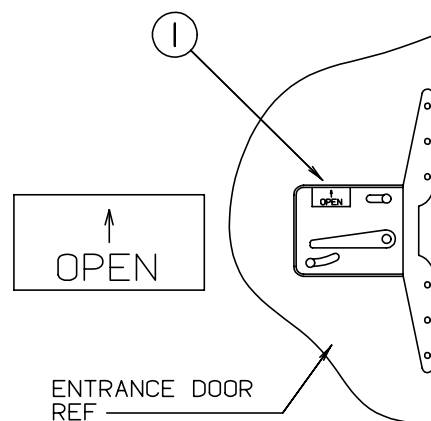

KEY	PART NUMBER	U/M DESCRIPTION
1	040944-01-000	EA LABEL - ENTRANCE DOOR - "OPEN"

LABELS GROUP (CONTINUED)

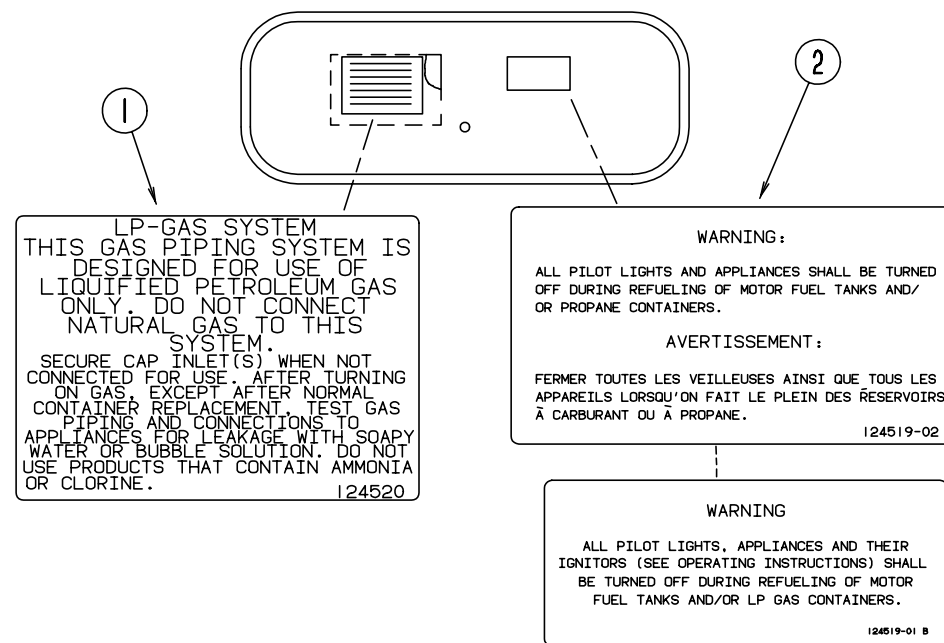

KEY	PART NUMBER	U/M DESCRIPTION	
1	124520-01-02A	EA LABEL - LP GAS ONLY	
			FROM: 09-03-96 THRU: 99-99-99
	023769-01-000	EA LABEL - WARNING - LPG - CANADIAN	
2	124519-01-02A	EA LABEL - WARNING/REFUELING	
			FROM: 09-03-96 THRU: 99-99-99
2	124519-02-02A	EA LABEL - WARNING/REFUELING - CSA	

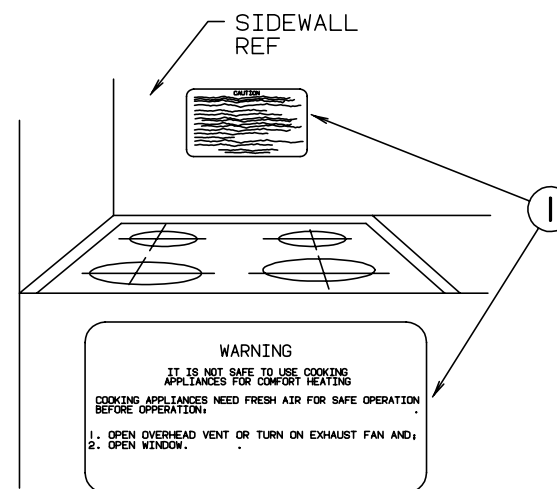

KEY	PART NUMBER	U/M DESCRIPTION
1	050225-01-000	EA LABEL - WARNING - STOVE VENT - US
1	050222-01-000	EA LABEL - STOVE VENT - CANADIAN

LABELS GROUP (CONTINUED)

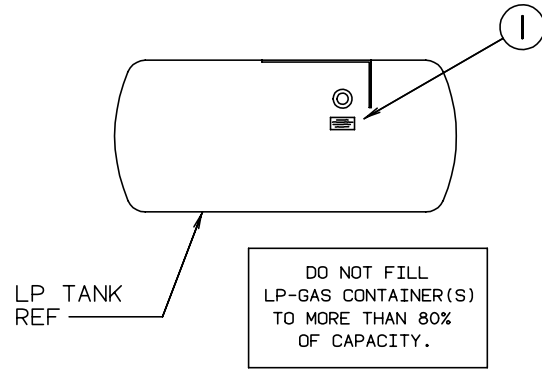

KEY	PART NUMBER	U/M DESCRIPTION
1	079965-01-000	EA LABEL - LPG - 80% CAPACITY

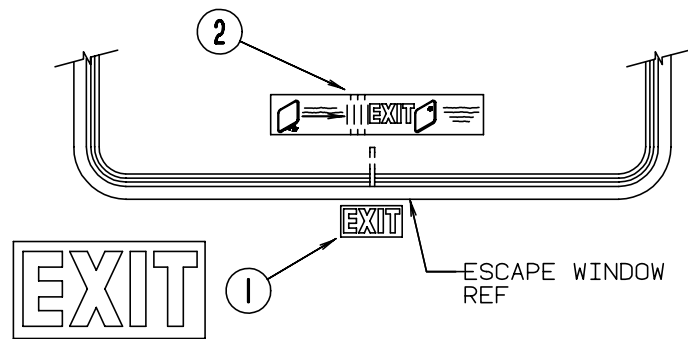

KEY	PART NUMBER	U/M DESCRIPTION
1	107571-01-000	EA LABEL - EXIT/ESCAPE WINDOW
2	039290-01-000	EA LABEL - EXIT WARNING

LABELS GROUP (CONTINUED)

CAUTION	TO HELP AVOID PERSONAL INJURY DURING REMOVAL OF FUEL FILLER CAP, SLOWLY LOOSEN CAP 1/2 TURN TO ALLOW ANY FUEL PRESSURE TO BE RELIEVED BEFORE TURNING CAP FURTHER.
FUEL SPRAY MAY CAUSE PERSONAL INJURY	STOP ADDING FUEL AFTER FIRST SHUTOFF BY AUTOMATIC NOZZLE WHEN TANK IS NEARLY FULL. DO NOT OVERFILL FUEL TANK. SEE OWNERS MANUAL FOR ADDITIONAL INFORMATION. PRINTED IN U.S.A. MLC PT NO 15611763

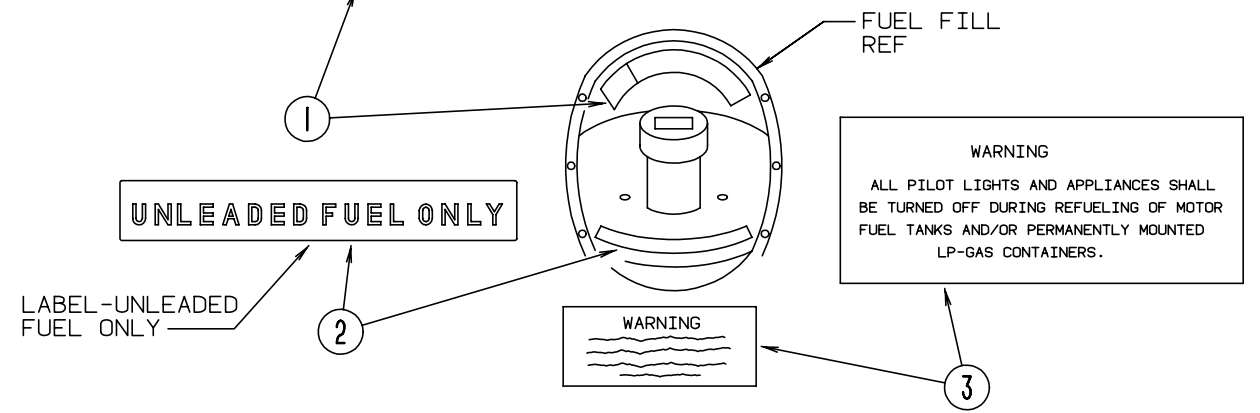

KEY	PART NUMBER	U/M DESCRIPTION	
1	087207-05-000	EA LABEL - FUEL CAP REMOVAL	
2	062043-01-000	EA LABEL - FUEL - UNLEADE	
3	006040-01-000	EA TAG - GAS REFUEL WARNING	
			FROM: 00-00-00 THRU: 09-02-96
3	124519-01-02A	EA LABEL - WARNING/REFUELING	
			FROM: 09-03-96 THRU: 99-99-99
3	124519-02-02A	EA LABEL - WARNING/REFUELING - CSA	

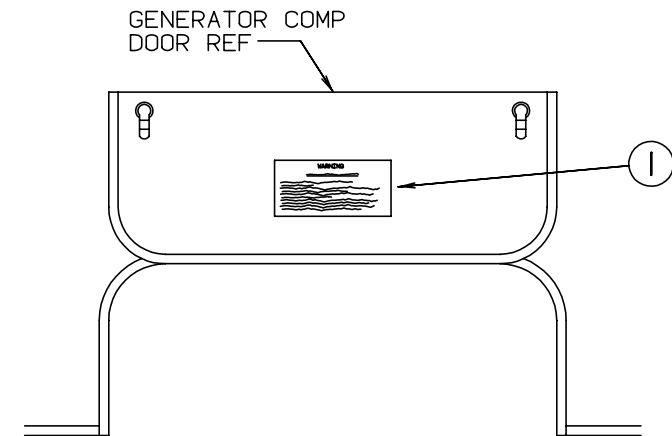

WARNING

WHEN ADDING A GENERATOR SET:

HIGH VOLTAGE-USE EXTREME CAUTION WHEN WORKING ON ELECTRICAL COMPONENTS.
HAVE ALL ELECTRICAL INSTALLATION PERFORMED BY A QUALIFIED LICENSED ELECTRICIAN-FOLLOW ALL STATE AND LOCAL CODES.
ONLY INSTALL GENERATOR SET APPROVED FOR R.V. APPLICATION. HAVE INSTALLED BY QUALIFIED TECHNICIAN.
TO AVOID HEAT BUILD-UP AND TO GUARANTEE AN ADEQUATE AIR SUPPLY TO THE GENERATOR CARBURETOR, FOLLOW INSTALLATION INSTRUCTIONS.
GENERATOR ENGINE EXHAUST GASES ARE TOXIC AND MUST NOT TERMINATE UNDER THE VEHICLE-DISCHARGE EXHAUST AWAY FROM VEHICLE.

KEY	PART NUMBER	U/M DESCRIPTION
1	077510-01-000	EA LABEL - GENERATOR PREP

LABELS GROUP (CONTINUED)

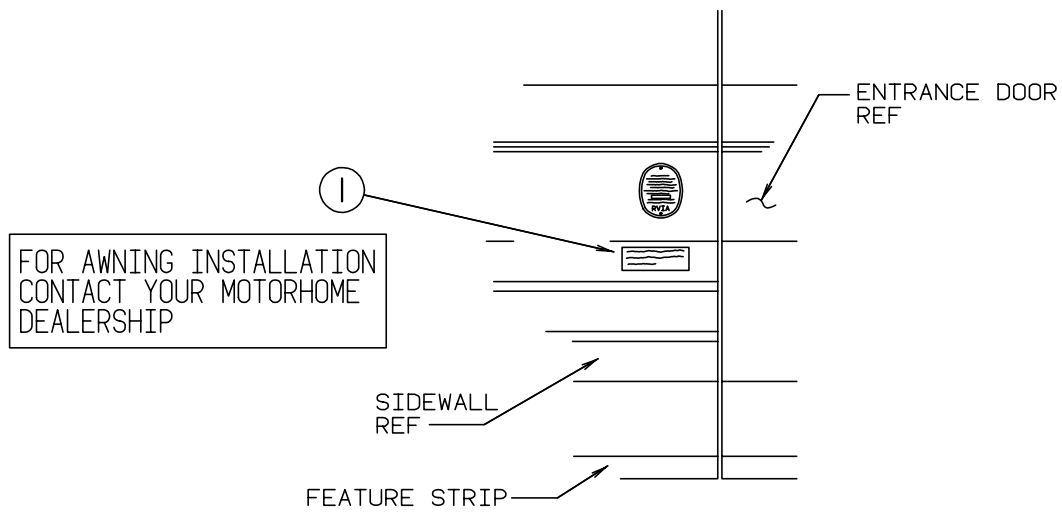

KEY	PART NUMBER	U/M DESCRIPTION
1	099509-01-000	EA LABEL - AWNING INSTALLATION

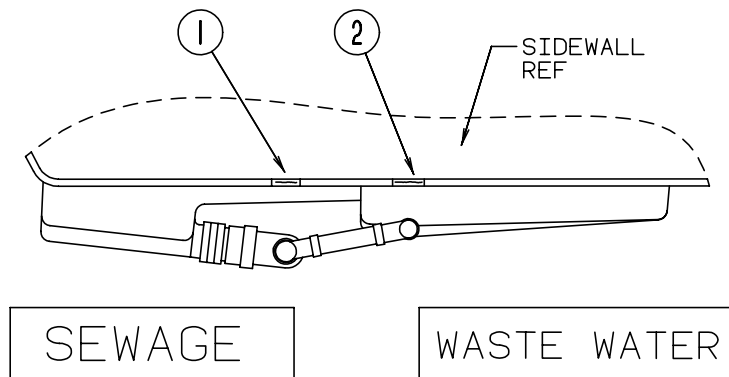

KEY	PART NUMBER	U/M DESCRIPTION
1	006187-01-000	EA LABEL - SEWAGE
2	006188-01-000	EA LABEL - WASTE WATER

LABELS GROUP (CONTINUED)

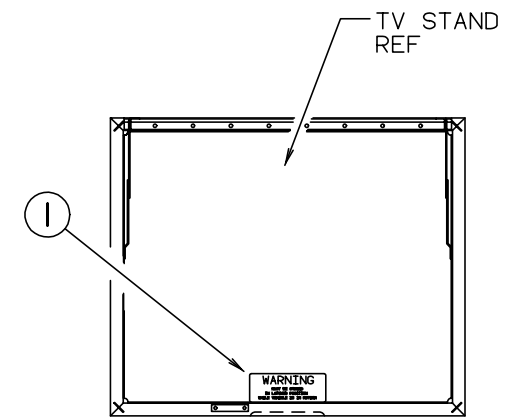

WARNING
MUST BE STOWED
IN LATCHED POSITION
WHILE VEHICLE IS IN MOTION

KEY	PART NUMBER	U/M DESCRIPTION
1	079966-01-000	EA LABEL - WARNING - STOWED - MOTION

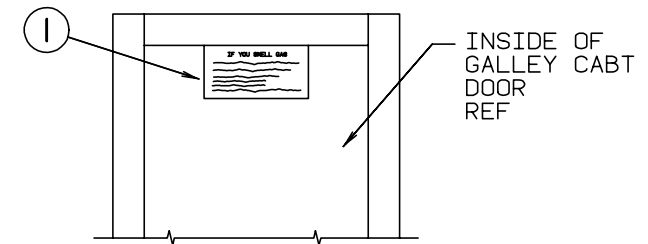

IF YOU SMELL GAS

1. EXTINGUISH ANY OPEN FLAME, PILOT LIGHTS AND ALL SMOKING MATERIALS.
2. SHUT OFF THE GAS SUPPLY AT THE TANK VALVE(OR GAS SUPPLY CONNECTION.
3. OPEN DOORS AND OTHER VENTILATING OPENINGS.
4. DO NOT TOUCH ELECTRICAL SWITCHES.
5. LEAVE THE AREA UNTIL ODOR CLEARS.
6. HAVE THE GAS SYSTEM CHECKED AND LEAKAGE SOURCE CORRECTED BEFORE USING AGAIN.

MISCELLANEOUS LABELS

KEY	PART NUMBER	U/M DESCRIPTION
1	073998-01-000	EA LABEL - LPG ODOR WARNING

LABELS GROUP (CONTINUED)

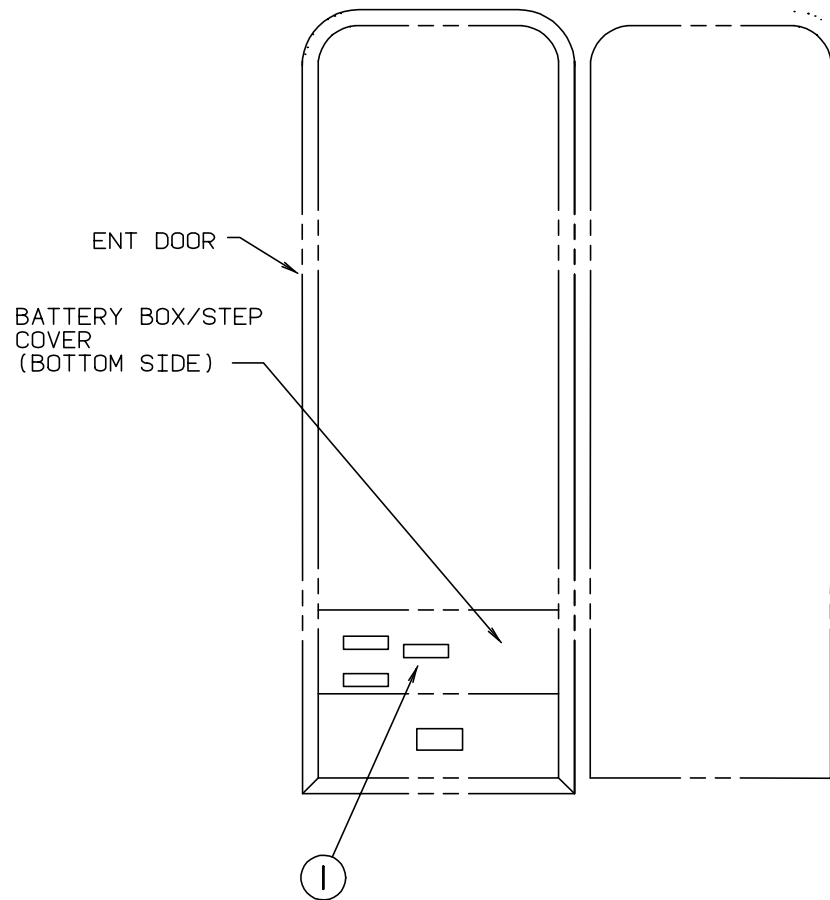

WARNING: DISCONNECT BATTERIES BEFORE CONNECTING EXTERNAL CHARGING EQUIPMENT.

AVERTISSEMENT: DEBRANCHER LES BATTERIES AVANT DE BRANCHER TOUT EQUIPEMENT DE CHARGE EXTERIEUR.

KEY	PART NUMBER	U/M DESCRIPTION
1	065748-01-000	EA LABEL - CAUTION - BATTERY CHARGING
1	065748-02-000	EA LABEL - WARNING - BATTERY/FRENCH

NOTE: TUNE ANTENNA PER MANUFACTURER'S DIRECTIONS. FAILURE TO COMPLY COULD RESULT IN DAMAGE TO CB.

CB POWER PROVISION

RED +12 V
 BLACK GROUND
 COAX ANTENNA
 (SEE REVERSE ALSO)

KEY	PART NUMBER	U/M DESCRIPTION
1	104678-01-000	EA LABEL - CB PREP

LABELS GROUP (CONTINUED)

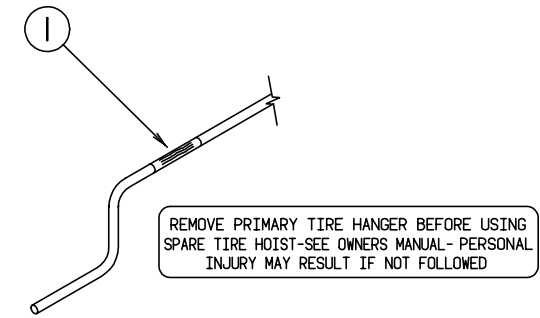

KEY	PART NUMBER	U/M DESCRIPTION
1	126024-01-01A	EA LABEL - TIRE HANGER REMOVAL

DO NOT USE HITCH BEFORE READING OWNERS MANUAL REGARDING VEHICLE LOADING AND TOWING

KEY	PART NUMBER	U/M DESCRIPTION
1	111104-01-000	EA LABEL - HITCH - READ MANUAL - WHITE

AIR CONDITIONING CIRCUIT. THIS CONNECTION IS FOR AIR CONDITIONERS RATED 110-125 VOLT AC, 60 HZ, 16 AMPERES MAXIMUM. DO NOT EXCEED CIRCUIT RATING.

KEY	PART NUMBER	U/M DESCRIPTION
1	091243-01-000	EA LABEL - A/C COVER "AIR CONDITIONING CIRCUIT ETC."

LABELS GROUP (CONTINUED)

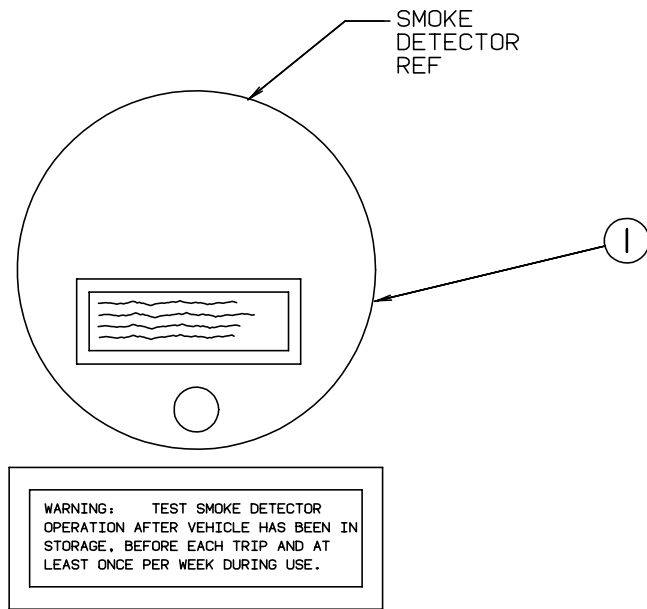

KEY	PART NUMBER	U/M DESCRIPTION
1	077956-01-000	EA LABEL - WARNING - SMOKE DETECTOR

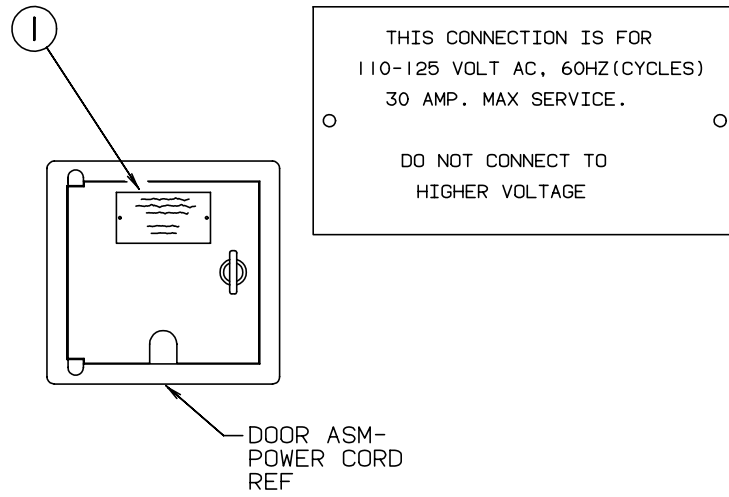

KEY	PART NUMBER	U/M DESCRIPTION
1	006062-01-000	EA LABEL - ELECTRIC - 110 VOLT CONNECTION

LABELS GROUP (CONTINUED)

MISCELLANEOUS LABELS

KEY	PART NUMBER	U/M DESCRIPTION
	092547-06-000	EA LABEL - CIRCUIT BREAKER
	094675-01-000	EA LABEL - EXTERIOR LIGHT - SERVICE
	095721-10-000	EA LABEL - CONTROL CENTER (30A) (CANADIAN)
	095721-14-000	EA LABEL - CONTROL CENTER (30A)
	095721-17-000	EA LABEL - CONTROL CENTER - 50 AMP
	095721-18-000	EA LABEL - CONTROL CENTER - 50 AMP - CSA
	098379-04-000	EA LABEL - ELECTRICAL BOX - SIDE
	098641-01-000	EA LABEL - FUEL - UNLEADED - DASH
	111537-07-000	EA LABEL - FUSES
	087236-01-000	EA LABEL - CABLE INPUT

LP GROUP

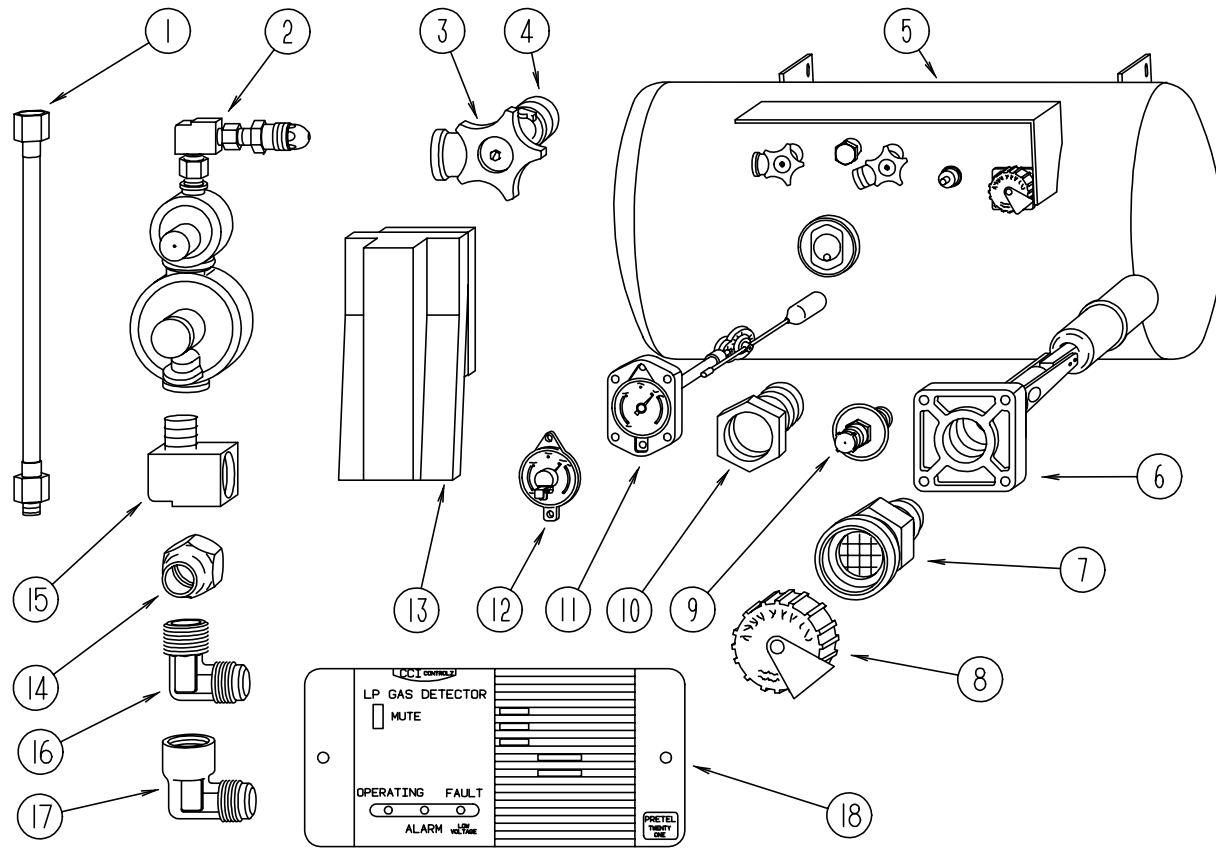

LP TANK & COMPONENTS

KEY	PART NUMBER	U/M	DESCRIPTION	VENDOR NO.
1	045703-01-000	EA	HOSE - LP - 3/8"ID X 24" - 3/8"MPT X 1/2"F SWIVEL - U.S.	
1	045703-02-000	EA	HOSE - LP - 3/8"ID X 24" - 3/8"MPT X 1/2"F SWIVEL - CANADA	
2	106150-01-000	EA	REGULATOR - TWO STAGE	
3	040421-01-708	EA	HANDWHEEL - SERVICE VALVE	G-1015-A
4	040421-01-712	EA	VALVE - SERV. W/O VAPOR RELIEF	29000853
5	088253-03-000	EA	TANK - LP - 100 LB - 16" DIAMETER X 36" LONG - SPL	
6	040421-01-711	EA	VALVE - 80% FILL W/AUTO STOP	LLL/TL3
7	040421-01-701	EA	VALVE - FILL - SHORT, LP	7547B
8	040421-01-702	EA	CAP - FILL VALVE - PLASTIC	G-1014-A
9	040421-01-700	EA	VALVE - LIQUID LEVEL - 20%	G-1013
10	040421-01-713	EA	VALVE - RELIEF 1" W/SPRING 7"	29000587
11	088253-01-700	EA	GAUGE - FLOAT ASSEMBLY - L.P.	16C
12	040440-02-000	EA	TRANSMITTER - DIAL - 0-90 OHM -2 TERMINAL (POWER & GROUND)	
13	105658-01-000	EA	COMPARTMENT - LP REGULATOR	
14	010377-02-000	EA	NUT - BRASS - 3/8" FLARE - FORGED	
14	010380-02-000	EA	NUT - BRASS - 1/2" FLARE - FORGED	
15	065318-02-000	EA	ELBOW - 90 DEGREE - 3/8" MPT TO 3/8" FPT	
16	010252-01-000	EA	ELBOW - BRASS - 90 DEGREE - 3/8"F X 1/2"MPT	
17	010265-01-000	EA	ELBOW - BRASS - 90 DEGREE - 3/8"F X 1/2"FPT	
18	103613-03-000	EA	DETECTOR - LP GAS - W/O SHUT-OFF VALVE	

LOUNGE GROUP

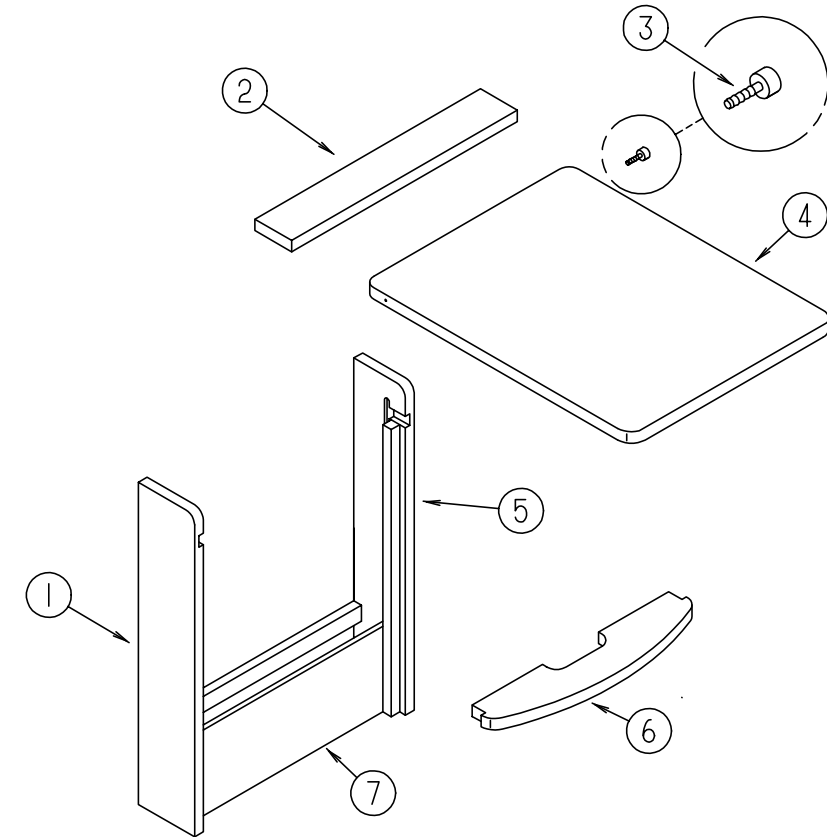

PULLOUT TABLE

KEY	PART NUMBER	U/M	DESCRIPTION
	P19559-01-H37	EA	CABINET - TABLE - W/O PULLOUT TOP (MAPLE)
	P19559-01-H47	EA	CABINET - TABLE - W/O PULLOUT TOP (OAK)
	119559-11-H37	EA	END - TABLE - RIGHT SIDE - 28.7" X 5.7" (MAPLE)
1	119559-12-H37	EA	END - TABLE - LEFT SIDE - 28.7" X 5.7" (MAPLE)
1	119559-12-G35	EA	END - TABLE - LEFT SIDE - 28.7" X 5.7" (OAK)
2	119559-13-H37	EA	TOP - SHELF F/PULLOUT TABLE (MAPLE)
2	119559-13-G35	EA	SHELF - TOP F/PULLOUT TABLE (OAK)
3	079921-01-000	EA	ROLLER - NYLON - W/STEEL SHAFT - BARBED
4	119559-17-H37	EA	TABLE TOP - PULLOUT (MAPLE)
4	119559-17-G35	EA	TABLE TOP - PULLOUT (OAK)
5	119559-11-H37	EA	END - TABLE - RIGHT SIDE - 28.7" X 5.7" (MAPLE)
5	119559-11-G35	EA	END - TABLE - RIGHT SIDE - 28.7" X 5.7" (OAK)
6	119559-14-H37	EA	SHELF - SUPPORT F/PULLOUT TABLE (MAPLE)
6	119559-14-G35	EA	SHELF - SUPPORT F/PULLOUT TABLE (OAK)
7	119559-15-H37	EA	PANEL - BOTTOM F/TABLE CABINET - 18.1" X 6.7" (MAPLE)
7	119559-15-G35	EA	PANEL - BOTTOM F/TABLE CABINET - 18.1" X 6.7" (OAK)
	080736-01-000	EA	PULL - RECESSED - 1.25 X 4" - OAK

ENTRY STEP COMPONENTS

KEY	PART NUMBER	U/M	DESCRIPTION
	120234-04-H23	EA	LID - ENTRY STEP (MAPLE)
	120234-04-H47	EA	LID - ENTRY STEP (OAK)
	122755-03-01A	EA	TILE - RUBBER/ENTRANCE DOOR - 17.7" X 26.4"
	101222-01-04A	EA	BRACKET - CATCH - LID
	116975-01-01A	EA	LATCH - W/O STRIKE - BLACK - NEW STYLE
	116975-02-01A	EA	KEEPER/STRIKE - BLACK - NEW STYLE

LOUNGE GROUP (CONTINUED)

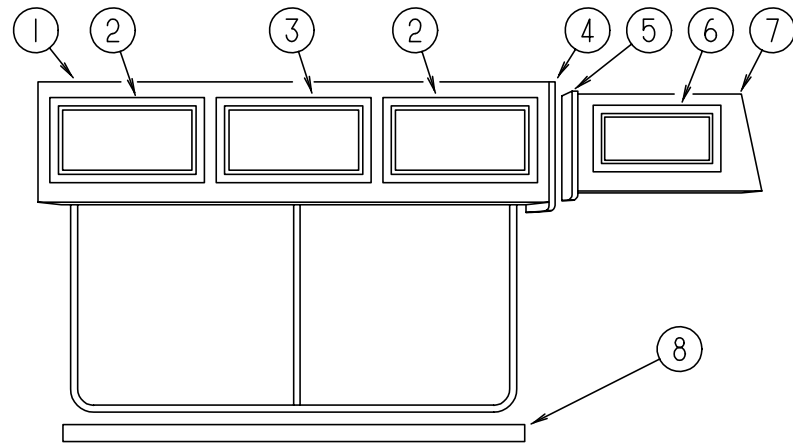

LOUNGE & FRONT OVERHEAD CABINET (DRIVER SIDE)

KEY	PART NUMBER	U/M	DESCRIPTION
1	122986-01-H17	EA	CABINET - OVERHEAD/FRONT LEFT HAND - W/O DOORS/HARDWARE (OAK)
1	122986-01-H37	EA	CABINET - OVERHEAD FRONT - LEFT HAND - W/O DOORS/HARDWARE (MAPLE)
	122986-11-H37	EA	SHELF - W/PLASTIC EDGE MOLDING (MAPLE)
	122986-11-H17	EA	SHELF - W/PLASTIC EDGE TRIM (OAK)
2	M08166-09-H37	EA	DOOR - MITERED CORNER/SQUARE EDGE - 13.8" X 23.2"- W/O HDW (MAPLE)
2	M06803-V0-H17	EA	DOOR - MITERED CORNER/OGEE EDGE - 13.9" X 23" - W/O HDW (OAK)
3	M08166-11-H37	EA	DOOR - MITERED CORNER/SQUARE EDGE - 15.7" X 20.5" - W/O HDW (MAPLE)
3	M06803-03-H17	EA	DOOR - MIRROR/MTRD CRNR/OGEE EDGE - 20.5" X 15.7" - W/O HDW (OAK)
4	103128-01-H37	EA	END CAP - OVERHEAD CABINET - RIGHT HAND (MAPLE)
4	103128-01-G09	EA	END CAP - OVERHEAD CABINET - RIGHT HAND (OAK)
5	103128-09-H37	EA	END CAP - OVERHEAD CABINET - LEFT HAND (MAPLE)
5	103128-09-G09	EA	END CAP - OVERHEAD CABINET - LEFT HAND (OAK)
6	M08166-01-H37	EA	DOOR - MITERED CORNER/SQUARE EDGE - 19.1" X 10" - W/O HDW (MAPLE)
6	M06803-04-H17	EA	DOOR - MITERED CORNER/OGEE EDGE - 10" X 19.1" - W/O HDW (OAK)
7	M06839-42-H37	EA	CABINET - OVERHEAD - W/O DOORS/HARDWARE (MAPLE)
7	M06839-42-H38	EA	CABINET - OVERHEAD - W/O DOORS/HARDWARE (MAPLE)
7	M06839-42-H39	EA	CABINET - OVERHEAD - W/O DOORS/HARDWARE (MAPLE)
7	M06839-42-H47	EA	CABINET - FRONT DR. OVERHEAD W/O DOORS/HARDWARE (OAK)
7	M06839-42-H48	EA	CABINET - FRONT DR. OVERHEAD W/O DOORS/HARDWARE (OAK)
7	M06839-42-H49	EA	CABINET - FRONT DR. OVERHEAD W/O DOORS/HARDWARE (OAK)
8	118409-01-H37	EA	CABINET - SHELF - BEHIND SOFA - W/O HARDWARE (MAPLE)
8	118409-01-G35	EA	CABINET - SHELF - BEHIND SOFA - W/O HARDWARE (OAK)

LOUNGE GROUP (CONTINUED)

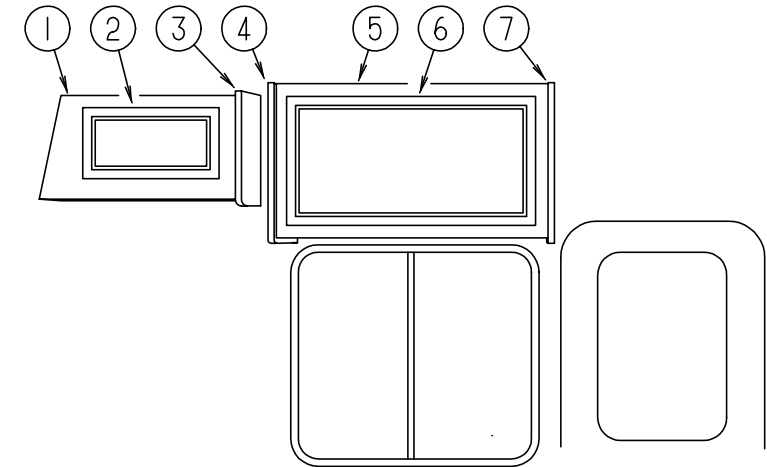

FRONT OVERHEAD CABINET (PASSENGER SIDE)

KEY	PART NUMBER	U/M	DESCRIPTION
1	M06839-41-H37	EA	CABINET - OVERHEAD/FRONT/RIGHT HAND - W/O DOORS/HARDWARE (MAPLE)
1	M06839-41-H38	EA	CABINET - OVERHEAD/FRONT/RIGHT HAND - W/O DOORS/HARDWARE (MAPLE)
1	M06839-41-H39	EA	CABINET - OVERHEAD/FRONT/RIGHT HAND - W/O DOORS/HARDWARE (MAPLE)
1	M06839-41-H47	EA	CABINET - OVERHEAD/FRONT/RIGHT HAND - W/O DOORS/HARDWARE (OAK)
1	M06839-41-H48	EA	CABINET - OVERHEAD/FRONT/RIGHT HAND - W/O DOORS/HARDWARE (OAK)
1	M06839-41-H49	EA	CABINET - OVERHEAD/FRONT/RIGHT HAND - W/O DOORS/HARDWARE (OAK)
2	M08166-01-H37	EA	DOOR - MITERED CORNER/SQUARE EDGE - 10" X 19.1" - W/O HDW (MAPLE)
2	M06803-04-H17	EA	DOOR - MITERED CORNER/OGEE EDGE - 10" X 19.1" - W/O HDW (OAK)
3	103128-08-H37	EA	END CAP - OVERHEAD CABINET - RIGHT HAND (MAPLE)
3	103128-08-G09	EA	END CAP - OVERHEAD CABINET - RIGHT HAND (OAK)
4	103128-38-H37	EA	END CAP - OVERHEAD CABINET - LEFT HAND (MAPLE)
4	103128-38-G15	EA	END CAP - OVERHEAD CABINET - LEFT HAND (OAK)
5	M06839-43-H37	EA	CABINET - OVERHEAD/RIGHT HAND - W/O DOORS/HARDWARE (MAPLE)
5	M06839-43-H47	EA	CABINET - OVERHEAD/RIGHT HAND - W/O DOORS/HARDWARE (OAK)
	104414-12-H37	EA	SHELF - W/PLASTIC EDGE MOLDING (MAPLE)
	104414-12-G35	EA	SHELF - W/PLASTIC EDGE MOLDING (OAK)
6	M08166-10-H37	EA	DOOR - MITERED CORNER/SQUARE EDGE - 29.5" X 15.5" - W/O HDW (MAPLE)
6	M06803-30-H17	EA	DOOR - MITERED CORNER/OGEE EDGE - 15.5" X 29.5" - W/O HDW (OAK)
7	103128-10-H37	EA	END CAP - OVERHEAD CABINET - RIGHT HAND (MAPLE)
7	103128-10-G15	EA	END CAP - OVERHEAD CABINET - RIGHT HAND (OAK)

SEALANTS & FASTENERS GROUP

BOLTS

KEY	PART NUMBER	U/M DESCRIPTION
	000C12-05-16B	EA BOLT - HEX - 5/16-18 X 1 - ZINC 5
	000C12-05-12B	EA BOLT - HEX - 5/16-13 X 3/4 ZINC 5
	000C12-06-16B	EA BOLT - HEX - 3/8-16 X 1 LG - ZINC 5
	000C12-08-24B	EA BOLT - HEX - 1/2-13 X 1.50 - ZINC 5
	000C12-08-16B	EA BOLT - HEX - 1/2-13 X 1.00 - GD5 - ZINC
	000C12-10-24B	EA BOLT - HEX - 5/8-11 X 1.50 - ZINC 5
	000C13-07-48B	EA BOLT - HEX - 7/16-20 X 3 - ZINC 5
	000C26-04-18B	EA BOLT - HEX - SERRATED FLANGE - 1/4-20 X 1 1/8 - ZINC
	000C26-04-10B	EA BOLT - HEX - SERRATED FLANGE - 1/4-20 X 5/8 - ZINC
	000C26-05-16B	EA BOLT - HEX - SERRATED FLANGE - 5/16-18 X 3/4 - ZINC
	000C26-05-12B	EA BOLT - HEX - SERRATED FLANGE - 5/16-18 X 3/4 - ZINC
	000C26-05-20B	EA BOLT - HEX - SERRATED FLANGE - 5/16-18 X 1 1/4 - ZINC
	000C26-06-28B	EA BOLT - HEX - SERRATED FLANGE - 3/8-16 X 1 3/4 - ZINC
	000C26-06-16B	EA BOLT - HEX - SERRATED FLANGE - 3/8-16 X 1 - ZINC
	000C26-06-12B	EA BOLT - HEX - SERRATED FLANGE - 3/8-16 X 3/4 - ZINC
	000G45-04-24B	EA BOLT - LAG - 1/4-9 X 1.50 ZINC
	051387-05-000	EA BOLT - CARRIAGE W/O HOLE - 5/16-18 X 9.5 - ZINC
	051387-06-000	EA BOLT - CARRIAGE W/O HOLE - 5/16-18 X 9.5 - ZINC
	091274-03-000	EA BOLT-J - 3/8-16 X 12.0
	102333-01-05A	EA BOLT - CARRIAGE - 7/16 - 14 STAINLESS STEEL CAP
	088787-12-000	EA STUD - WELD - 1/4 - 20 X 1.0 LG - MN
	108067-03-000	EA STUD - WELD - 1/4 - 20 X 1/2 CD

RIVETS, GROMMETS AND MISCELLANEOUS FASTENERS

KEY	PART NUMBER	U/M DESCRIPTION
	000H14-04-04A	EA RIVET - MANDREL BLIND - 1/8 X .400
	000H14-06-14R	EA RIVET - MANDREL BLIND - 3/16"
	000H15-06-02R	EA RIVET - POP - STEEL - 3/16 X .063-.125
	000H16-04-06R	EA RIVET - POP ALUMINUM - 1/8" X .313 - .375
	000H16-06-10R	EA RIVET - POP ALUMINUM - 3/16 X .501-.625
	008380-01-000	EA GROMMET - RUBBER - 5/8" HOLE X 1 1/2" DIAMETER - BLACK
	016188-05-000	EA GROMMET - L/P LINE - 3/8" HOLE X 1 1/4" LONG - RUBBER
	023942-01-000	EA GROMMET - RUBBER - 2" OD
	071015-11-000	EA GROMMET - 1.00 ID - FITS .12 MATERIAL
	071015-19-000	EA GROMMET - .38 ID - FITS .06 MATERIAL
	071015-29-000	EA GROMMET - RUBBER - 1/4 ID X 1 1/4 OD W .12 GROOVE - BLK
	071015-30-000	EA GROMMET - RUBBER - .31" ID X .81" OD W/.12" GROOVE - BLK
	088756-01-000	EA GROMMET - WEB - 1 1/8 " I.D.
	000F10-04-16B	EA PIN - COTTER - 1/8" X 1" - ZINC
	000F10-06-32B	EA PIN - COTTER - 3/16" X 2" - ZINC
	086285-01-000	EA SPACER - NYLON - .5" OD X .257" ID
	081211-04-000	EA PLUG - PLASTIC - .46" DIAMETER - BLACK
	081211-05-000	EA PLUG - PLASTIC - .188 DIAMETER - NATURAL
	115361-01-01A	EA PLUG - PLASTIC
	029094-04-000	YD VELCRO TAPE - LOOP - 1" WIDE - BLACK
	029096-03-000	YD VELCRO TAPE - HOOK - 1" WIDE - BLACK
	085774-01-000	FT FASTENER - DUAL HOOK - 1" WIDE - ADHESIVE BACK - BLACK
	085774-02-000	FT FASTENER - DUAL LOOP - 1" WIDE - ADHESIVE BACK - BLACK
	008343-01-000	EA TIE - WIRE - 6"
	008343-02-000	EA TIE - WIRE - 14"
	108046-02-000	EA CABLE TIE - SCREW MOUNT 15"
	077955-01-000	EA CLIP-J - VINYL COATED - 3/8"
	091952-01-000	EA CLIP - GRIPPER - 1"
	091952-02-000	EA CLIP - GRIPPER - 3/4"
	094362-02-000	EA CLIP - XMAS TREE - BINDER HEAD - .9" LONG
	110943-02-000	FT FELTSTRIP - 3/8" - ADHESIVE BACK - WHITE

SEALANTS & FASTENERS GROUP (CONTINUED)

WASHERS

KEY	PART NUMBER	U/M DESCRIPTION
	000E11-07-00B	EA WASHER - LOCKING - 7/16 MED SPLIT - ZINC
	000E11-08-00B	EA WASHER - LOCKING - 1/2 MED SPLIT - ZINC
	000E13-14-00B	EA WASHER - FLAT - 1/4 WIDE - ZINC
	000E13-18-00B	EA WASHER - FLAT - 3/8 WIDE - ZINC
	000E13-20-00B	EA WASHER - FLAT - 7/16 WIDE - ZINC
	000E13-22-00B	EA WASHER - FLAT - 1/2 WIDE - ZINC
	000E13-26-00B	EA WASHER - FLAT - 5/8 WIDE - ZINC
	058716-02-000	EA WASHER - FLAT NYLON
	110794-01-000	EA WASHER - FLAT - 1" ID X 1 3/4' OD

NUTS

KEY	PART NUMBER	U/M DESCRIPTION
	000D24-10-00B	EA NUT - HEX - SELF LOCKING - 10-32 ZINC
	000D29-05-00B	EA NUT - 5/16 - 18 UNC - SF/LOCKING - NYLON WASHER INSERT
	000D34-06-00B	EA NUT - HEX - LOCKING - 3/8 - 16 GRADE C - ZINC-PREVAILING T
	000D39-04-00B	EA NUT - HEX - SERRATED FLANGE/LOCKING - 1/4 - 20 - ZINC
	000D39-05-00B	EA NUT - HEX - SERRATED FLANGE/LOCKING - 5/16 - 18 - ZINC
	000D39-06-00B	EA NUT - HEX - SERRATED FLANGE/LOCKING - 3/8 - 18 - ZINC
	000D39-07-00B	EA NUT - HEX - SERRATED FLANGE/LOCKING - 7/16 - 14 - ZINC
	000D39-08-00B	EA NUT - HEX - SERRATED FLANGE - LOCKING - 1/2 - 13 - ZINC
	000D44-07-00B	EA NUT - HEX - SERRATED FLANGE - LOCKING - 7/16-20 - ZINC
	000D46-04-00A	EA NUT - HEX - WELD - 1/4 - 20 - PLAIN
	000D73-07-00C	EA NUT - HEX FLANGE - 7/16 - 14 - GRADE G
	000D76-06-00B	EA NUT - HEX FLANGE - 3/8-16
	040921-01-000	EA NUT - SPEED - U TYPE - 10-24 BLACK
	040921-04-000	EA NUT - SPEED - U TYPE - # 8 - .59" LENGTH X .44" WIDTH
	040921-09-000	EA NUT - SPEED - U TYPE - # 8
	044364-02-000	EA NUT - SPEED - FLAT - ROUND
	063253-07-000	EA NUT - J - #8A - .120 - .130 PNL THK
	087234-01-000	EA NUT - JACK - 1/4 X 20 THD - MOLLY - MOUNTS LICENSE PLATES
	083163-06-000	EA PUSHNUT - FLAT TYPE 3/8 STUD - FORD ONLY

CLAMPS

KEY	PART NUMBER	U/M DESCRIPTION
	007161-01-000	EA CLAMP - HOSE - SPRING TYPE - 1/2"
	010495-01-000	EA CLAMP - CABLE - 9/16"
	010497-01-000	EA CLAMP - CLOSED - 5/8" ID
	010497-03-000	EA CLAMP - CLOSED - 1" ID - CUSHIONED
	010499-01-000	EA CLAMP - CLOSED - 3/8" ID
	062401-01-000	EA CLAMP - HOSE - WORMGEAR - .25" - 1"
	062401-02-000	EA CLAMP - HOSE - WORMGEAR - 1.56" - 2.5"
	062401-04-000	EA CLAMP - HOSE - WORMGEAR - .69" - 1.25"
	062401-05-000	EA CLAMP - HOSE - WORMGEAR - 2" TO 3" ID
	062401-06-000	EA CLAMP - HOSE - WORMGEAR - .22" - .62" ID
	062401-11-000	EA CLAMP - HOSE - WORMGEAR - 3.50" - 4.50"
	075148-02-000	EA CLAMP - GROUNDING - BRONZE SCREWS
	083609-01-000	EA CLAMP - WIRE - DUAL - EQUAL DIAMETERS - 5/8"
	083610-01-000	EA CLAMP - WIRE - DUAL - UNEQUAL DIAMETERS - 3/4" & 1 1/4"
	083610-02-000	EA CLAMP - WIRE - DUAL - UNEQUAL DIAMETERS

SEALANTS & FASTENERS GROUP (CONTINUED)

SCREWS

KEY	PART NUMBER	U/M	DESCRIPTION
	0G3908-08-170	EA	SCREW - SF/DR - 8-18 X .50 PPH - BRIGHT WHITE
	0G3908-20-170	EA	SCREW - SF/DR - 8-18 X 1.25 PPH - BRIGHT WHITE
	000G11-05-08B	EA	SCREW - 5-20 X .50 PPH - ZINC
	000G11-06-08B	EA	SCREW - 6-20 X .50 PPH - ZINC
	000G11-06-06B	EA	SCREW - 6-20 X 3/8 PPH - ZINC
	000G11-06-10J	EA	SCREW - 6-20 X 5/8 PPH - BRASS
	000G11-07-08B	EA	SCREW - 7-19 X .50 PPH - ZINC
	000G11-08-08B	EA	SCREW - 8-18 X .50 PPH - ZINC
	000G11-08-06B	EA	SCREW - 8-18 X 3/8 PPH - ZINC
	000G11-08-20B	EA	SCREW - 8-18 X 1.25 PPH - ZINC
	000G11-08-16S	EA	SCREW - 8-18 X 1 PPH - OFF WHITE
	000G11-08-12T	EA	SCREW - 8-18 X .75 PPH - BLACK
	000G11-08-12P	EA	SCREW - 8-18 X .75 PPH - DARK BROWN
	000G11-08-12P	EA	SCREW - 8-18 X .75 PPH - DARK BROWN
	000G11-08-12D	EA	SCREW - 8-18 X .75 PPH - BLACK
	000G11-08-12B	EA	SCREW - 8-18 X .75 PPH - ZINC
	000G11-08-08T	EA	SCREW - 8-18 X 1/5 PPH - FLUOROCARBON COATING
	000G11-10-40B	EA	SCREW - 10-16 X 2 1/2 PPH CAD - 34927-01-000
	000G11-10-16B	EA	SCREW - 10-16 X 1 PPH - ZINC
	000G11-10-12S	EA	SCREW - 10-16 X .75 PPH - OFF WHITE
	000G11-10-12D	EA	SCREW - 10-16 X .75 PPH - BLACK
	000G12-06-08T	EA	SCREW - 6-20 X 1/2 POH - BLACK
	000G13-06-10G	EA	SCREW - 6-20 X 5/8 PFH - ANTIQUE BRASS
	000G13-06-08G	EA	SCREW - 6-20 X .50 PFH - ANTIQUE BRASS
	000G13-06-08B	EA	SCREW - 6-20 X .50 PFH - ZINC
	000G13-06-24J	EA	SCREW - 6-20 X 1.50 PFH - BRASS
	000G13-06-16J	EA	SCREW - 6-20 X 1 PFH - BRASS
	000G13-07-12B	EA	SCREW - 7-19 X .75 PFH - ZINC
	000G13-08-16B	EA	SCREW - 8-18 X 1 PFH - ZINC
	000G18-08-22B	EA	SCREW - MACHINE - 8-32 X 1 3/8 PPH - ZINC
	000G19-10-20B	EA	SCREW - MACHINE - 10-32 X 1.25 PPH - ZINC
	000G19-10-12F	EA	SCREW - MACHINE - 10-32 X .75 - PPH - STAINLESS STEEL
	000G19-10-08B	EA	SCREW - MACHINE - 10-32 X .50 - PPH - ZINC
	000G32-10-06B	EA	SCREW - 10-32 X 3/8 PPH - ZINC
	000G39-06-10T	EA	SCREW - SF/DR - 6-20 X 5/8 PPH - BLACK
	000G39-06-08B	EA	SCREW - SF/DR - 6-18 X .50 - ZINC
	000G39-06-16T	EA	SCREW - SF/DR - 6-20 X 1 PPH - BLACK
	000G39-06-10T	EA	SCREW - SF/DR - 6-20 X 5/8 PPH - BLACK
	000G39-08-24S	EA	SCREW - SF/DR - 8-18 X 1.50 - OFF WHITE
	000G39-08-24B	EA	SCREW - SF/DR - 8-18 X 1 1/2 PPH - ZINC
	000G39-08-16T	EA	SCREW - SF/DR - 6-20 X 1 PPH - BLACK
	000G39-08-16R	EA	SCREW - SF/DR - 8-18 X 1 PPH - BEIGE
	000G39-08-16B	EA	SCREW - SF/DR - 8-18 X 1 PPH - ZINC
	000G39-08-12T	EA	SCREW - SF/DR - 8-18 X .75 PPH - BLACK
	000G39-08-12B	EA	SCREW - SF/DR - 8-18 X .75 PPH - ZINC
	000G39-08-08S	EA	SCREW - SF/DR - 8-18 X .50 PPH - OFF WHITE
	000G39-08-08B	EA	SCREW - SF/DR - 8-18 X 1.50 PPH - ZINC
	000G39-08-06B	EA	SCREW - SF/DR - 8-18 X 3/8 PPH - ZINC
	000G39-10-08B	EA	SCREW - SF/DR - 10-16 X .50 PPH - ZINC
	000G39-10-209	EA	SCREW - SF/DR - 10-16 X 1 1/4 PPH - FLUOROCARBON SILVER
	000G39-10-20B	EA	SCREW - SF/DR - 10-16 X 1.25 PPH - ZINC
	000G39-10-129	EA	SCREW - SF/DR - 10-16 X .75 PPH - FLUOROCARBON SILVER
	000G39-10-12D	EA	SCREW - SF/DR - 10-16 X .75 PPH - BLACK
	000G39-10-12B	EA	SCREW - SF/DR - 10-16 X .75 PPH - ZINC
	000G39-10-10B	EA	SCREW - SF/DR - 10-16 X .625 - ZINC
	000G39-10-088	EA	SCREW - SF/DR - 10-16 X 1/2 PPH - FLEX FLUOROCARBON
	000G42-04-12B	EA	SCREW - SF/DR - 1/4-14 X .75 HWH - ZINC
	000G43-06-24B	EA	SCREW - MACHINE - 6-32 X 1.50 - ZINC

SEALANTS & FASTENERS GROUP (CONTINUED)

SCREWS (CONTINUED)

KEY	PART NUMBER	U/M	DESCRIPTION
	000G46-08-24T	EA	SCREW - MACHINE - 8-32 X 1.50 PFH - BLACK
	000G50-04-08B	EA	SCREW - MACHINE - 1/4-20 X .50 PTH - ZINC
	000G50-04-12B	EA	SCREW - MACHINE - 1/4-20 X .75 PPH - ZINC
	000G52-08-18B	EA	SCREW - MACHINE - 8-32 X 1 1/8 PTH - ZINC
	000G54-04-20B	EA	SCREW - 1/4-20 X 1.25 PTH - TYPE 23 - ZINC PLATED
	000G55-08-12S	EA	SCREW - SF/DR - 8-18 X .75 PWH - OFF WHITE
	000G55-08-16S	EA	SCREW - SF/DR - 8-18 X 1.00 - PWH - OFF WHITE
	000G55-08-125	EA	SCREW - SF/DR - 8-18 X 3/4 PWH - WILLOW
	000G60-10-28T	EA	SCREW - SF/DR - 10-16 X 1.75 - BLACK
	000G67-08-32B	EA	SCREW - 8-15 X 2 PPH - ZINC
	000G67-10-10D	EA	SCREW - 10-12 X 5/8 PPH - BLACK - TYPE A
	000G67-10-10B	EA	SCREW - 10-12 X 5/8 PPH - ZINC - TYPE A
	000G67-10-08B	EA	SCREW - 10-12 X .50 PPH - ZINC
	000G67-10-48B	EA	SCREW - 10-12 X 3 PPH - ZINC
	000G67-10-36T	EA	SCREW - 10-12 X 2.25 PPH - BLACK
	000G67-10-24B	EA	SCREW - 10-12 X 1.25 PPH - ZINC
	000G67-10-16B	EA	SCREW - 10-12 X 1 PPH - ZINC
	000G67-10-120	EA	SCREW - 10-12 X .75 PPH - TAN
	000G67-10-12P	EA	SCREW - 10-12 X .75 - PPH - DARK BROWN
	000G67-10-12B	EA	SCREW - 10-12 X .75 PPH - ZINC
	000G67-10-10S	EA	SCREW - 10-12 X 5/8 PPH - OFF WHITE
	000G68-06-12S	EA	SCREW - 6-18 X 3/4 POH
	000G68-06-10G	EA	SCREW - 6-18 X 5/8 POH - ANTIQUE BRASS
	049465-03-000	EA	SCREW - 10-16 X 1 POH W/WASHER - OFF WHITE
	057671-01-000	EA	COVER - SCREW - #8 - PLASTIC - OFF WHITE
	057671-12-000	EA	COVER - SCREW - #8 - QUICK SILVER
	057671-15-000	EA	COVER - SCREW - BRIGHT WHITE
	075908-01-000	EA	SCREW - MACHINE - 10-32 X .56 PTH - EXTERNAL TOOTH - ZINC
	076790-01-000	EA	SCREW - 6-20 X 1 1/4 PPH - BLACK
	083554-01-000	EA	SCREW - DRYWALL - 8 X 1.25
	083554-04-000	EA	SCREW - DRYWALL - 8 X 2.50
	086256-01-000	EA	SCREW - SF/DR - 8 X 3/4 HWH LONG
	097974-01-000	EA	SCREW - PARTICLE BOARD - 7-9 X 3/4 PPH
	101618-01-000	EA	SCREW - 1/4-20 X 3/4 HEX - TAPPING - STALGARD TYPE F

SEALANTS & FASTENERS GROUP (CONTINUED)

ADHESIVES

KEY	PART NUMBER	U/M DESCRIPTION	VENDOR NO.
	004006-05-700	EA ADHESIVE-NAT. STARCH (5 GAL)	0802
	004020-01-000	QT ADHESIVE - ABS CEMENT - QUART	
	067788-01-000	EA ADHESIVE - SPRAY - 3M - 19.5 AEROSOL CAN	
	087211-01-000	GL PROMOTER - ADHESIVE	

TAPES

KEY	PART NUMBER	U/M DESCRIPTION
	063642-01-000	FT TAPE - ADHESIVE - .4" X 1.5" X 180"
	110274-01-000	FT TAPE - DOUBLE SIDED FOAM - .45" X 1"
	120534-01-01A	EA TAPE - SCOTCH - 3M - 1/2" FINE LINE
	123816-01-000	FT TAPE - DOUBLE SIDED - 1"
	123816-02-000	FT TAPE - DOUBLE SIDED - 1/2"
	123816-03-000	FT TAPE - DOUBLE SIDED - 1/2"
	123816-04-000	FT TAPE - DOUBLE SIDED - 6"

SEALERS

KEY	PART NUMBER	U/M DESCRIPTION
	069640-01-000	FT SEALER - RIBBON - 1/4" DIAMETER X 30'
	069640-02-000	FT SEALER - TAPE - 1/8"THICK X .50"WIDE X 60'
	069640-03-000	FT SEALER - TAPE - 1/8"THICK X .75"WIDE X 60' - BLACK
	069640-07-000	FT SEALER - TAPE - 3/32"THICK X 2"WIDE X 45'
	069640-09-000	FT SEALER - TAPE - 1/32"THICK X 2.50"WIDE X 80' - GREY
	069640-11-000	FT SEALER - TAPE - 3/16"THICK X 3/8"WIDE X 40'
	069640-15-000	FT SEALER - TAPE - 1/16"THICK X 3/8"WIDE X 80' - GREY
	069640-17-000	FT SEALER - TAPE - 1/32" THICK X 1"WIDE X 90'
	069640-18-000	FT SEALER - TAPE - 1/2"THICK X 1/8"WIDE X 60' - BRT/WHITE
	072889-01-000	EA SEALANT - URETHANE - BLACK - 1/10
	072889-09-000	EA SEALANT - URETHANE - BLACK (TUBE)
	072889-10-000	EA SEALANT - URETHANE (HV) - BRIGHT WHITE
	072889-12-000	EA SEALANT - URETHANE (LV) BRIGHT WHITE
	107828-01-000	EA SEALANT - SB - 190 EVERSEAL
	120074-02-01A	EA SEALANT - SILICONE - OFF WHITE
	102352-01-000	EA SEALER - PUMPABLE - BLACK
	102352-02-000	EA SEALER - PUMPABLE - CLEAR
	106206-01-000	EA SEALER - PUMPABLE - MANUS 30A - BLACK
	900390-01-000	EA TIP - 2 1/2" X 1/8" ORIFICE
	900390-03-000	EA NOZZLE - SILICONE TUBE
	034552-02-000	EA SILICONE - TUBE - 300 ML - W/O NOZZLE - CLEAR
	039518-01-000	EA SILICONE - TUBE - 300 ML - BLACK - W/O NOZZLE
	108716-03-000	EA SILICONE - TUBE - BRIGHT WHITE/SELF LEVELING - W/O NOZZLE
	053766-02-000	EA BEDDING COMPOUND - TUBE - WHITE
	076322-05-000	FT TAPE - FOAM - DOUBLE COATED - .045" X .75" X 108'
	076322-07-000	FT TAPE - FOAM - DOUBLE COATED .045 X .50 - NORT V2000

WATER & SEWAGE GROUP

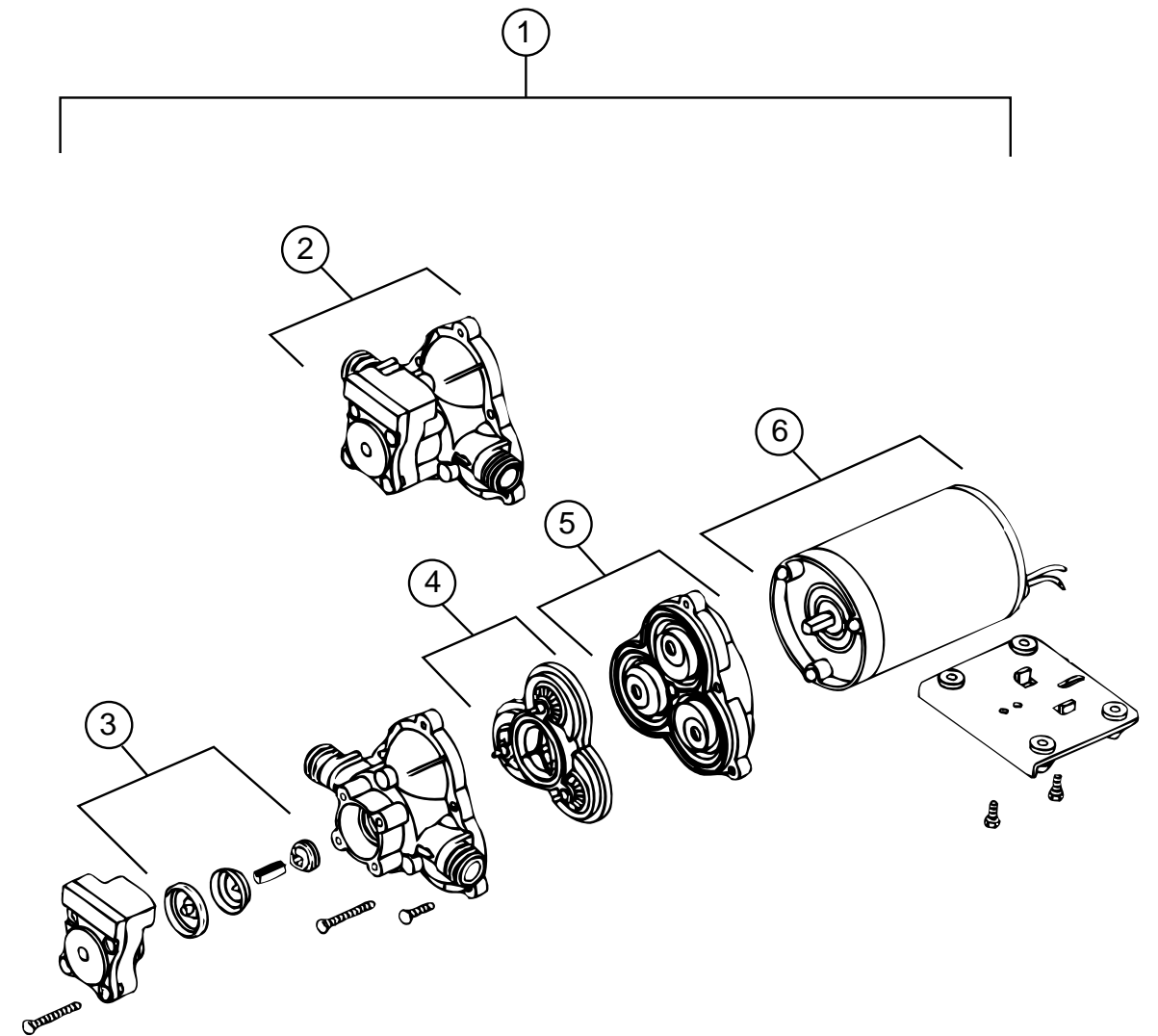

WATER PUMP (SHURFLO)

KEY	PART NUMBER	U/M DESCRIPTION	VENDOR NO.
1	098607-01-000	EA PUMP - WATER - W/.5" MPT FITTING - FLOW W.9 GPM - UL	
2	098607-01-706	EA HOUSING, W/SWITCH ONLY	94-231-20
3	098607-01-705	EA VALVE-CHECK, KIT	94-237-00
4	098607-01-703	EA VALVE KIT	94-232-00
5	098607-01-702	EA DIAPHRAGM/DRIVE ASSEMBLY KIT	94-238-04
6	098607-01-707	EA MOTOR W/BASEPLATE	11-148-04

WATER & SEWAGE GROUP (CONTINUED)

FRESH WATER TANK

KEY	PART NUMBER	U/M DESCRIPTION
	123243-01-000	EA TANK - ACCUMULATOR - 24 OZ
	117217-02-000	EA TANK - WATER - 30 GALLON - W/FITTINGS FROM: 00-00-00 THRU: 02-02-97
	117217-07-000	EA TANK - WATER - 30 GALLON - W/FITTINGS FROM: 02-03-97 THRU: 99-99-99
	117217-01-000	EA TANK - WATER - 30 GALLON - W/O FITTINGS
	116881-08-000	EA TANK - FRESH WATER - 48 GALLON W/NOTCHED CORNER - W/FITTINGS FROM: 00-00-00 THRU: 02-02-97
	116881-11-000	EA TANK - WATER - 48 GALLON - W/FITTINGS FROM: 02-03-97 THRU: 99-99-99
	116881-01-000	EA TANK - FRESH WATER - 48 GAL. W/NOTCHED CORNER W/O FITTINGS
	042989-03-000	EA FITTING - WATER TANK - SPINWELD - 1 1/4"NPT - WHITE PLASTIC
	042989-05-000	EA FITTING - WATER TANK - SPINWELD - 1/2"FPT - WHITE PLASTIC
	049032-01-000	EA PATCH - SPINWELD - 3/8" - PLASTIC
	039861-01-000	EA SENDING UNIT - W/SCREW - WASHER - WELL NUT & TERMINAL RING
	077954-02-000	EA FILTER - WATER TANK - SCREEN IN TANK

WATER SYSTEM COMPONENTS (FLAIR-IT)

KEY	PART NUMBER	U/M DESCRIPTION
	114427-01-000	EA CAP - 1/2P - 02860
	114427-02-000	EA PLUG - 1/2P - 02863
	114427-03-000	EA NUT - 1/2"Q - #6453
	114428-01-000	EA TEE - 1/2P X 1/2P X 1/2P - 02820
	114428-02-000	EA TEE - SWIVEL - 1/2P X 1/2PX1/2FPT - 02821
	114428-03-000	EA TEE - 1/2P X 1/2P X 1/2MPT - 02822
	114428-04-000	EA TEE - 1/2P X 1/2P X 1/8FPT - 02834
	114429-01-000	EA ELBOW - 1/2P X 1/2P - 02800
	114429-02-000	EA ELBOW - 1/2P X 1/2MPT - 02803
	114429-03-000	EA ELBOW - SWIVEL - 1/2P X 1/2FPT - 02816
	114429-04-000	EA ELBOW - 1/2P X 3/8MPT - 02810
	114429-05-000	EA ELBOW - 1/2P X 3/4MPT - 02812
	114429-06-000	EA ELBOW - SWIVEL - 1/2P X 3/4FPT - 02811
	114429-07-000	EA ELBOW - 1/2P X 1/2FPT DROPEAR - 02801
	114430-01-000	EA ADAPTER - 1/2P X 1/2P - 02840
	114430-02-000	EA ADAPTER - SWIVEL - 1/2P X 1/2FPT -02873
	114430-03-000	EA ADAPTER - 1/2P X 1/2MPT - 02842
	114430-04-000	EA ADAPTER - 1/2P X 3/8MPT - 02852
	114430-05-000	EA ADAPTER - 1/2P X 1/8FPT - 02871
	114430-06-000	EA ADAPTER - 1/2P X 3/8FPT - 02851
	114430-07-000	EA ADAPTER - 1/2P X 3/8P - 02853
	114430-08-000	EA ADAPTER - 1/2P X 3/4MPT - 02868
	114431-01-000	EA VALVE - LINE DRAIN 1/2P - 02914
	114431-02-000	EA VALVE - 1/2P - BYPASS - 02910
	114431-03-000	EA VALVE - 1/2P X 1/2P - 02884
	114431-04-000	EA VALVE - STOP - 1/2P X 1/2P - 02880
	114431-05-000	EA VALVE - NEEDLE - COMP 1/8MPTX1/4 - 64858
	114431-06-000	EA VALVE - 3/8P X 3/8P - 02882
	114431-07-000	EA VALVE - 3/8P THREE - WAY - 02900
	114431-08-000	EA STRAIGHT STOP VALVE3/8P X 3/8P - 02879

WATER & SEWAGE GROUP (CONTINUED)

WATER SYSTEM COMPONENTS

KEY	PART NUMBER	U/M DESCRIPTION
	701069-01-000	EA WATER PURIFICATION SYSTEM
	701069-03-700	EA CARTRIDGE - WATER FILTER - AC - EVERPURE 9601-11
	010224-01-000	EA ADAPTER - HOSE TO PIPE - 3/8" MPT X 3/8" BARB-BLK PLASTIC
	123152-01-000	EA ADAPTER - 1/2 FPT X 1/2 BARB - SWIVEL
	118809-02-000	EA ADAPTER - 1/2" MPT X 1/2" BARB - PLASTIC
	010230-05-000	EA FILL - CITY WATER - W/CHECK VALVE FROM: 00-00-00 THRU: 09-25-96
	010230-06-000	EA FILL - CITY WATER - W/CHECK VALVE - MPT FROM: 09-26-96 THRU: 99-99-99
	039800-02-000	FT TUBING - POLYBUTYL - 5/8" OD X 20' - INCR OF 20' - BLACK
	039800-04-000	FT TUBING - POLYBUTYL - 1/4" OD
	112176-01-000	FT TUBING - VINYL - REINFORCED - 1/2" ID
	074462-02-000	FT TUBING - VINYL - 3/8" ID X 20' - CLEAR
	079381-01-000	FT TUBING - SMOOTH FLEXIBLE - 1 3/8" ID X 20'
	010219-01-000	EA ELBOW - 1 1/4" MPT X 1 1/4" BARB - WATER FILL - PLASTIC
	123150-01-000	EA ELBOW - 1/2 FPT X 1/2 BARB - SWIVEL
	111888-01-000	EA FERRULE - PLASTIC - .250 ID X .375 OD
	111888-02-000	EA INSERT - BRASS - 1/4 COMP
	118423-01-000	EA FITTING - BRASS-TEE - 1/4C X 1/4C X 1/4C
	101814-01-000	EA COUPLING - FEMALE - 1/2" X 1/2" FPT - GRAY
	110438-01-000	EA VALVE - CHECK - BRASS - 1/2 MPT X 1/2 FPT FROM: 00-00-00 THRU: 02-16-97
	110438-02-000	EA VALVE - CHECK - BRASS - 1/2 MPT X 1/2 MPT FROM: 02-17-97 THRU: 99-99-99
	120868-01-000	EA VALVE - NEEDLE - 1/4" COMPRESSION X 1/4" COMPRESSION

EXTERIOR SHOWER COMPONENTS

KEY	PART NUMBER	U/M DESCRIPTION
	103092-01-000	EA SHOWER HEAD - W/ 60" HOSE (US)
	103092-02-000	EA SHOWER HEAD - W/ HOSE (CSA)
	118051-01-02B	EA BRACKET - FAUCET SUPPORT - E - COAT
	103092-01-701	EA BRACKET (FOR SHOWER HEAD) BONE
	079563-04-01A	EA FAUCET - SHOWER W/ 1/2" MPT X 1.25" LONG INLET PIPE

WATER & SEWAGE GROUP (CONTINUED)

DRAINAGE SYSTEM

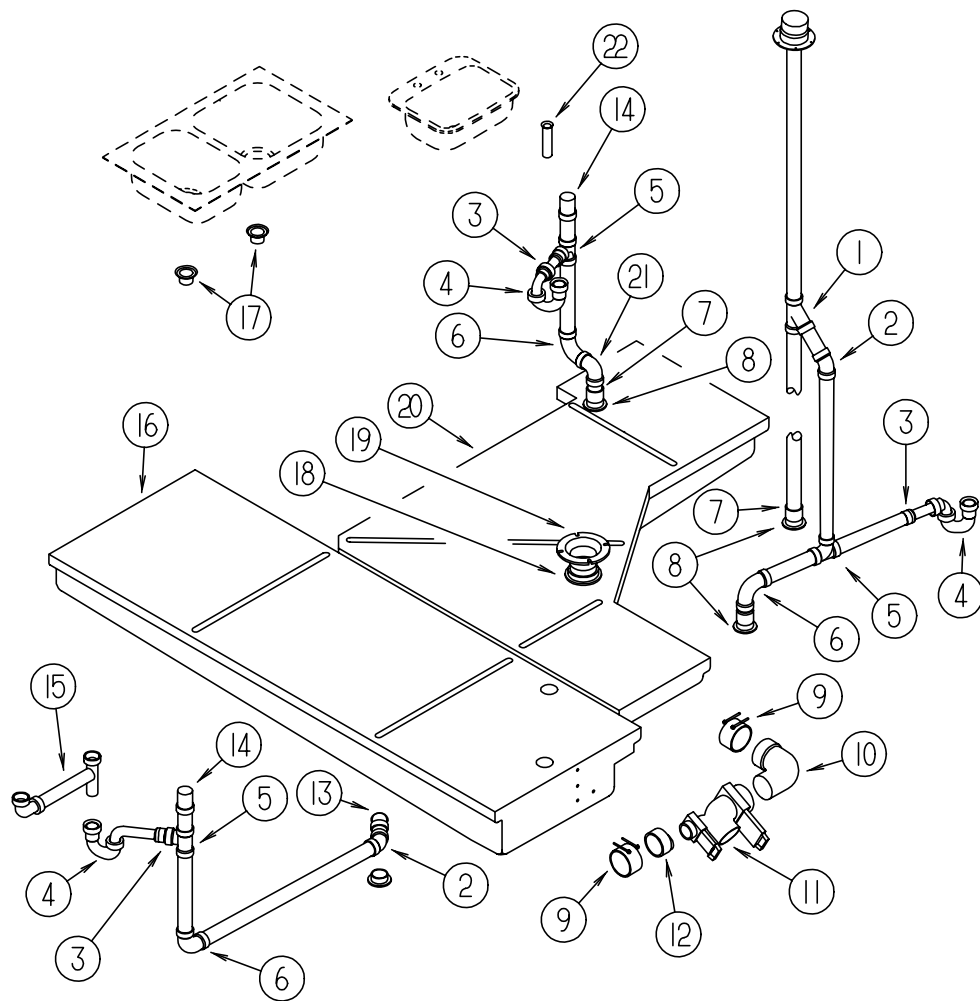

KEY	PART NUMBER	U/M DESCRIPTION	VENDOR NO.
1	010073-01-000	EA WYE - 45 DEGREE - 1 1/2" HUB X HUB X HUB - PLASTIC	
2	010006-01-000	EA ELBOW - 45 DEGREE - 1 1/2" HUB X HUB - PLASTIC	
3	109571-01-000	EA ADAPTER - P TRAP - 1 1/2" P X 1 1/4" MPT	
4	107538-01-000	EA P TRAP - PLASTIC - 1 1/4" W/EXTENSION ARM	
4	011066-02-000	EA P TRAP - 1 1/4" HUB X SLIP JOINT - W/UNION - ABS - CANADIA	
6	010008-01-000	EA ELBOW - 90 DEGREE - 1 1/2" HUB X HUB - PLASTIC	
5	010071-01-000	EA TEE - SANITARY - 1 1/2" HUB X HUB X HUB - PLASTIC	
7	010115-01-000	EA COUPLING - 1 1/2" HUB X HUB - PLASTIC	
8	061607-01-000	EA GROMMET - HOLDING TANK - 1 1/2" NPS	
9	078406-01-000	EA COUPLER - RUBBER - W/CLAMPS - 3" X 3"	
10	041956-01-000	EA ELBOW - STREET - 1/4" BARB X 90 DEGREE X 3 XLT	
11	070916-01-000	EA VALVE - DUAL DUMP - W/CAP - 3" X 1 1/2"	
	070916-01-700	EA VALVE ONLY (WASTE) 3"	T1003BU
	070916-01-701	EA VALVE ONLY (WASTE) 1 1/2"	T1001BU
12	062422-01-000	EA ADAPTER - OFFSET REDUCER - 3" X 1 1/2" - PLASTIC	
13	034250-01-000	EA ELBOW - 90 DEGREE - LONG TURN - 1 1/2" HUB X HUB - ABS	
14	079968-01-000	EA VENT - MECHANICAL/TRAP ARM - ANTI-SIPHON-2" X 7.3" PLASTIC	
15	011091-02-000	EA WASTE - CONTINUOUS - DOUBLE SINK	
16	104352-01-000	EA TANK - HOLDING - 50 GALLON (GRAY) - RECTANGULAR	
17	092303-01-000	EA STRAINER - SINK	
18	061607-02-000	EA GROMMET - HOLDING TANK - 3" NPS	
19	116644-01-000	EA FLANGE - CLOSET - 4" X 3"	
20	104350-01-000	EA TANK - HOLDING - 69 GALLON - "REVISED DESIGN"	
21	010009-01-000	EA ELBOW - 90 DEGREE - 1/4 BEND - 1 1/2" PLASTIC	
22	096927-01-701	EA TAILPIECE - DRAIN - LAVATORY	M9802
	096927-01-700	EA SINK STOPPER	M9801
	011069-02-000	EA TAILPIECE - TUB/SHOWER - 1 1/2" X 1 1/4" X 4" - BRASS	
	066440-01-000	EA STRAINER - SHOWER DRAIN - W/RUBBER WASHER	
	127440-02-01A	EA WASHER - RUBBER - 1.8" X .1"	
	010201-01-000	EA HOSE - SEWER - 3" ID X 8'	
	062416-01-000	EA ADAPTER - SEWER HOSE TO 3" PIPE	

WATER & SEWAGE GROUP (CONTINUED)

WATER HEATER W/MOTOR AID ATWOOD (GH6-8E)

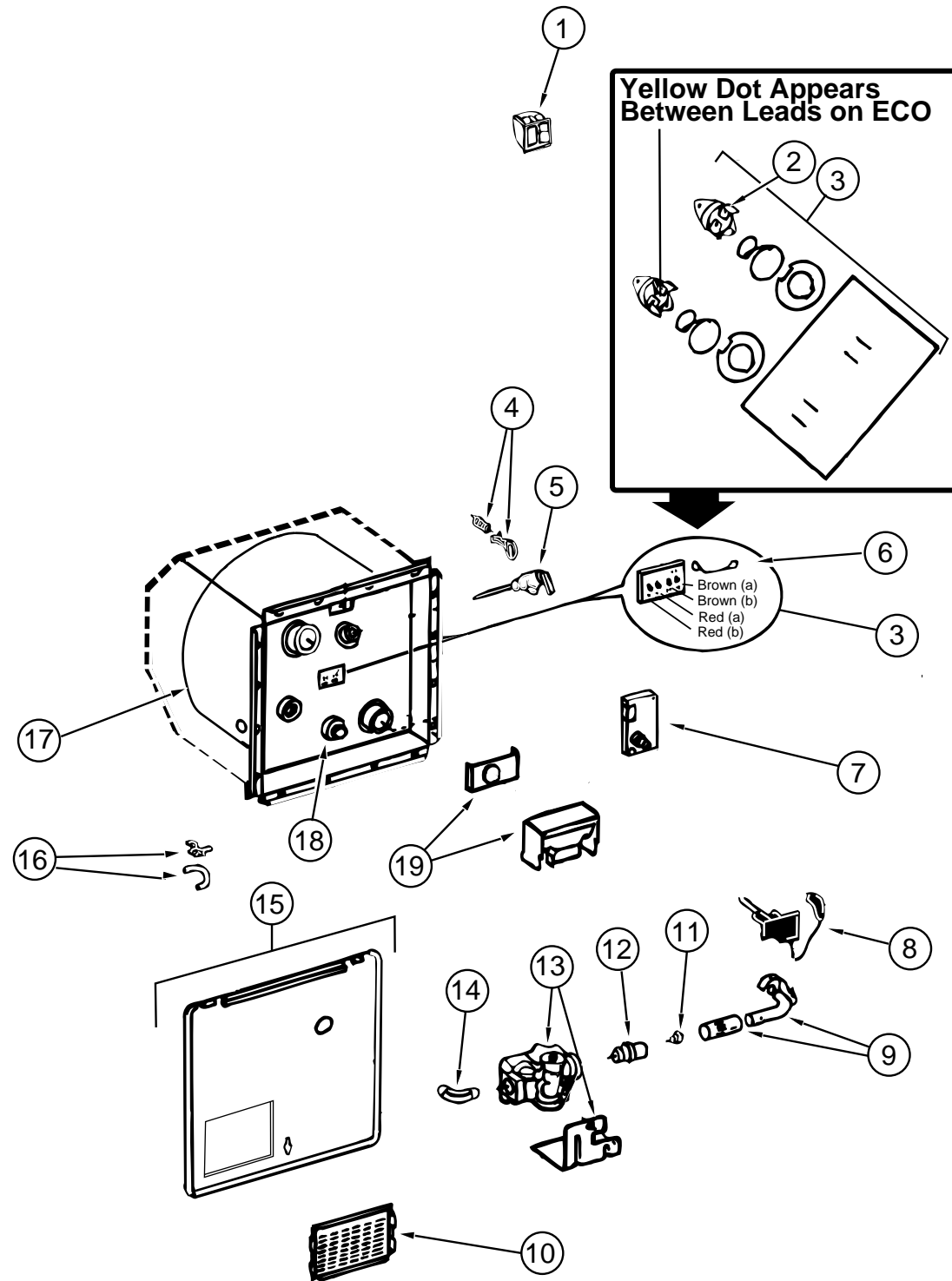

KEY	PART NUMBER	U/M	DESCRIPTION	VENDOR NO.
	051393-01-000	EA	WATER HEATER - W/ MOTOR AID - PILOTLESS IGNITION	
1	097967-01-000	EA	SWITCH - WATER HEATER - REMOTE W/LIGHT - ATWOOD	91959
2	051391-04-701	EA	THERMOSTAT 12VDC - 120 PRESET	91470
3	051393-01-721	EA	THERMOSTAT W/ ECO - 140 FRT MT	91447
4	051391-01-705	EA	FASTENER - CAMLOCK	92609
5	051391-01-704	EA	VALVE - RELIEF - 1/2" FITTING	91604
6	051393-01-723	EA	SWITCH - THERMAL - CUT OFF 2/ PKG	93866
7	051393-01-724	EA	BOARD - CIRCUIT - SPADE TERMINAL	93865
8	051393-01-725	EA	ELECTRODE - SGL SPADE CONNECT.	93868
9	051391-04-703	EA	BURNER - MAIN	91638
10	051391-01-717	EA	GRILLE - WATER HEATER DOOR	92640
11	051391-01-710	EA	ORIFICE - MAIN BURNER	92742
12	051391-03-700	EA	HOLDER - ORIFICE	91563
13	051393-01-726	EA	VALVE - SOLENOID - W/BRACKET	93870
14	051391-01-714	EA	FITTING - ELBOW 45 - 3/8F X 3/8 MPT	1044
15	052009-06-000	EA	DOOR - WATER HEATER	
16	051391-01-700	EA	HINGE KIT - (PIN & CLIP)	92568&92559
17	051391-04-704	EA	TANK - INNER (FRONT MOUNT)	91642
18	051391-01-715	EA	PLUG - DRAIN - 1 EA = 2 PER PKG	91857
19	051391-04-707	EA	KIT - EXHAUST - (FLUE & GASKET)	90960
	111129-01-711	EA	BRACKET - CORNER - SET OF FOUR	91928
	116424-01-000	EA	PROTECTOR - ROUND VINYL - WATER HEATER LATCH	

WINDOW, VENT & EXTERIOR DOOR GROUP

WINDOWS & VENTS

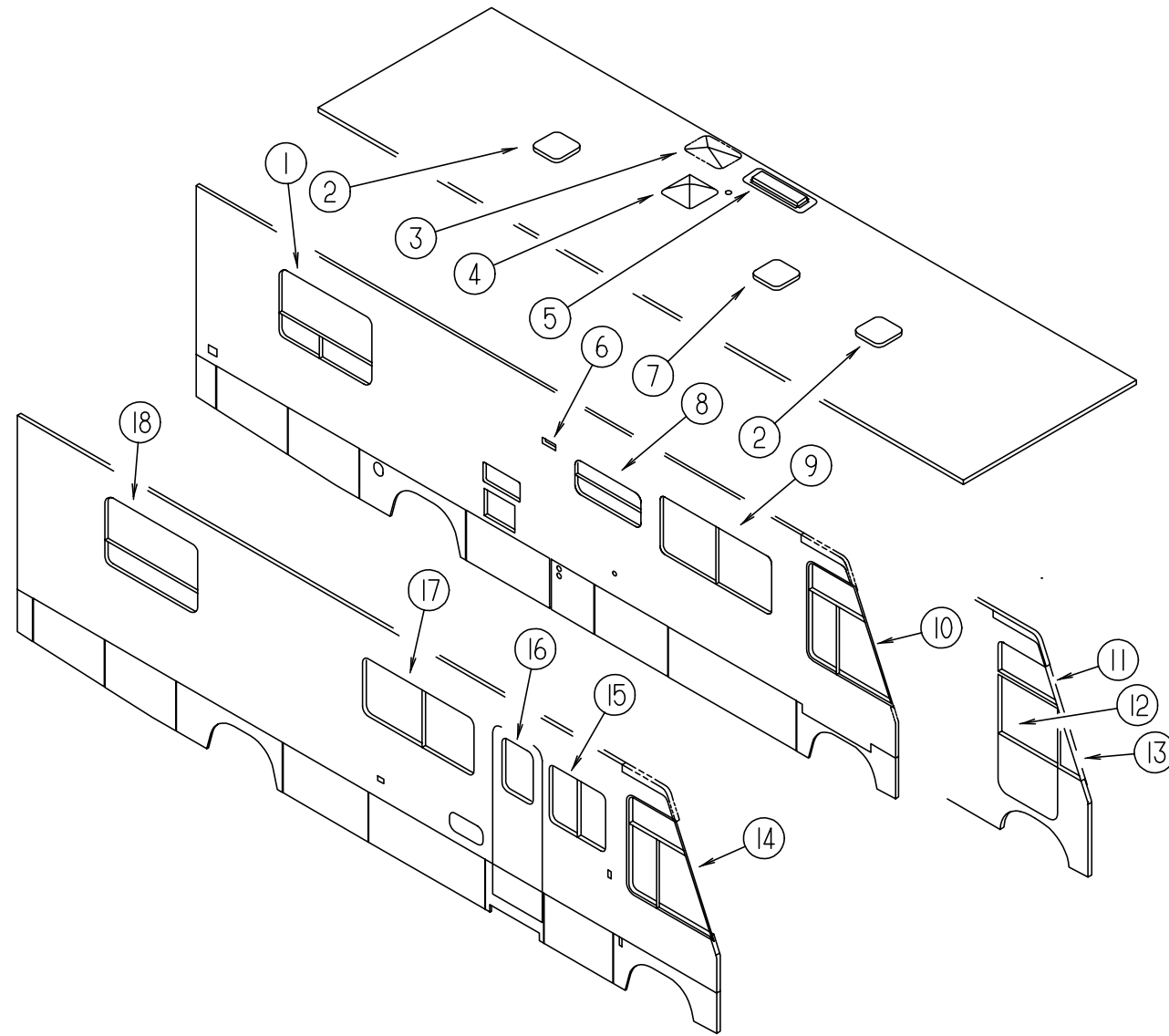

KEY	PART NUMBER	U/M DESCRIPTION
1	112463-05-01A	EA WINDOW - TIPOUT/ ESCAPE W/ RETAINER TRIM - 33.3" X 30.2"
1	112898-18-01A	EA WINDOW ASM - SLD - VERT - THERMO
2	122882-01-01A	EA VENT - ROOF - NONPOWERED - W/O INSIDE GARNISH
3	122192-01-02A	EA PANEL - SKYLITE - OUTER - 16.4" X 27.8"
3	122192-01-02A	EA PANEL - SKYLITE - OUTER - 16.4" X 27.8" FROM: 00-00-00 THRU: 02-13-97
3	122193-01-02A	EA PANEL - SKYLITE - INNER FROM: 02-14-97 THRU: 99-99-99
3	122193-01-02A	EA PANEL - SKYLITE - INNER FROM: 00-00-00 THRU: 02-13-97
3	122193-01-02A	EA PANEL - SKYLITE - INNER FROM: 02-14-97 THRU: 99-99-99
4	122882-02-01A	EA VENT - ROOF - POWERED
4	122882-03-01A	EA VENT - ROOF - POWERED CSA
5	084073-04-000	EA BASE - ROOF VENT - REFRIGERATOR
5	084073-07-000	EA VENT - ROOF - REFRIGERATOR - BRIGHT WHITE - NORCOLD
6	084616-07-000	EA SHROUD - VENT - RANGE HOOD - BRIGHT WHITE
6	084878-09-000	EA VENT - EXHAUST/RANGE HOOD - OFF WHITE
6	083558-03-000	EA VENT - PLUMBING PIPE ROOF - W/ COVER - OFF WHITE
7	123780-03-01A	EA VENT - EXHAUST - F/3" TO 4" ROOF (UL, CSA)
8	098647-34-01A	EA WINDOW - DRIVER HORIZONTAL SLIDER 15.7" X 28.5"
8	112795-20-01A	EA WINDOW - DRIVER HORIZONTAL SLIDER THERMO 16" X 28 3/4"

KEY	PART NUMBER	U/M DESCRIPTION
9	098647-22-01A	EA WINDOW - DRIVERS HORIZONTAL SLIDER 26.1" X 59.7"
9	112795-15-01A	EA WINDOW - DRIVERS HORIZONTAL SLIDER THERMO 26 3/8" X 60"
10	113501-01-01A	EA WINDOW - DRIVER CAB THERMO (3 WINDOW) 44.3" X 24.4" X 44.1"
10	103658-07-01A	EA WINDOW - DRIVER CAB 3 GLASS 25.3"T X 45.4"B X 45.2"H
11	106467-03-01A	EA WINDOW - DRIVER VISTA (ABOVE DR DOOR) 26.5"T X 35.5"B X 15.8"H
11	116000-02-01A	EA WINDOW - DRIVER VISTA - THERMO - 14.8" X 25.7" X 32.2"
12	106469-02-702	EA GLASS - STATIONARY
12	106469-01-704	EA GLASS ASM - ROLL-UP W/ BRACKET
13	106468-02-01A	EA WINDOW - DRIVER WING TRIANGULAR
13	115999-02-01A	EA WINDOW - DRIVER WING/ THERMO/ TRIANGULAR
14	103658-08-01A	EA WINDOW - PASSENGER CAB 3 GLASS 25.3"T X 45.4"B X 45.2"H
14	113501-02-01A	EA WINDOW - PASS CAB THERMO (3 WINDOW) 44.3" X 24.4" X 44.1"
15	098647-25-01A	EA WINDOW - PASSENGER HORIZONTAL SLIDER 26.1" X 59.6"
15	112795-18-01A	EA WINDOW - PASSENGER HORIZONTAL SLIDER THERMO 26 3/8" X 30"
16	117053-02-F36	EA WINDOW - PICTURE 17" X 26.4"
16	113733-01-01A	EA WINDOW - STATIONARY THERMOPANE 26.4" X 17"
17	098647-23-01A	EA WINDOW - PASSENGER HORIZONTAL SLIDER 26.1" X 59.7"
17	112795-16-01A	EA WINDOW - PASSENGER HORIZONTAL SLIDER THERMO 26 3/8" X 60"
18	112463-03-01A	EA WINDOW - TIPOUT W/ RETAINER TRIM - 33.3" X 30.2"
18	112898-16-01A	EA WINDOW ASM - SLD - VERT - THERMO

WINDOW, VENT & EXTERIOR DOOR GROUP (CONTINUED)

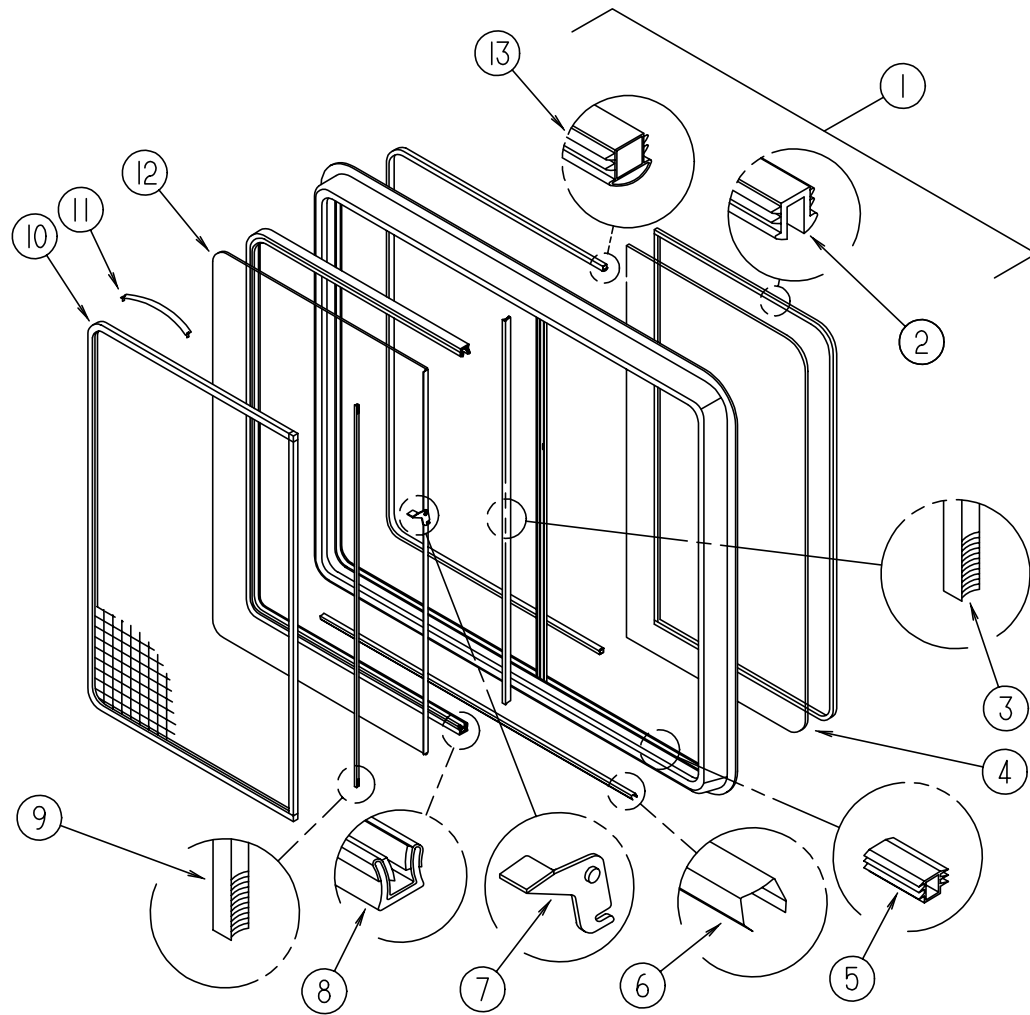

SINGLE SLIDER WINDOW (EXCEL) (PASSENGER SIDE LOUNGE)

KEY	PART NUMBER	U/M	DESCRIPTION	VENDOR NO.
	098647-25-01A	EA	WINDOW - PASSENGER HORIZONTAL SLIDER 26.1" X 59.6"	
1	098647-25-700	EA	WINDOW - SLIDER	H286-G2R
	098647-25-701	EA	RETAINER TRIM	W28666
2	098644-01-705	FT	GLAZING - STRIP	132-010231
3	098644-01-706	FT	WEATHERSTRIP - GLASS	171-010668
4	098647-25-702	EA	GLASS - STATIONARY	106-017657
5	098644-01-719	FT	STOP - SLIDER GLASS	132-014203
6	098644-01-710	FT	TRACK - SCREEN SPACER 12'	132-017135
7	098644-01-700	EA	LATCH - REPAIR KIT (BLACK)	B801-CK
8	098644-01-708	FT	CHANNEL - RUN PIERCED	122-016543
9	098644-01-711	FT	WEATHERSTRIP - SCREEN - BLACK	171-016965
10	098647-25-704	EA	SCREEN ASM - W/SEALS & CLIPS	410-019065
	098644-01-717	FT	SPLINE - SCREEN	132-004716
11	098644-01-713	EA	CLIP - SPRING - METAL	226-016966
12	098647-25-703	EA	GLASS - SLIDING - W/ SASH & LATCH	H286-G9
13	098644-01-716	FT	PLUG - FILLER	132-014470

SINGLE SLIDER WINDOW (EXCEL) (GALLEY)

KEY	PART NUMBER	U/M	DESCRIPTION	VENDOR NO.
	098647-34-01A	EA	WINDOW - DRIVERS HORIZONTAL SLIDER 15.7" X 28.5"	
1	098647-34-700	EA	WINDOW - SLIDER W/O RETAINER	H425-G2L
	098647-31-701	EA	RETAINER - TRIM	CW29-66
2	098644-01-705	FT	GLAZING - STRIP	132-010231
3	098644-01-706	FT	WEATHERSTRIP - GLASS	171-010668
4	098647-33-702	EA	GLASS - STATIONARY	106-019297
5	098644-01-719	EA	STOP - SLIDER GLASS	132-014203
6	098644-01-710	FT	TRACK - SCREEN SPACER 12'	132-017135
7	098644-01-700	EA	LATCH - REPAIR KIT (BLACK)	B801-CK
8	098644-01-708	FT	CHANNEL - RUN PIERCED	122-016543
9	098644-01-711	FT	WEATHERSTRIP - SCREEN BLACK	171-016965
10	098647-33-704	EA	SCREEN ASM - W/SEALS & CLIPS	410-019134
	098644-01-717	FT	SPLINE - SCREEN	132-004716
11	098644-01-713	EA	CLIP - SPRING - METAL	226-016966
12	098647-33-703	EA	GLASS-SLIDING W/SASH & LATCH	H425-G9
13	098644-01-716	FT	PLUG - FILLER	132-014470

SINGLE SLIDER WINDOW (EXCEL) (DRIVER SIDE LOUNGE)

KEY	PART NUMBER	U/M	DESCRIPTION	VENDOR NO.
	098647-22-01A	EA	WINDOW - DRIVERS HORIZONTAL SLIDER 26.1" X 59.7G2W66L	
1	098647-22-700	EA	WINDOW-SLIDING W/O RETAINER	H287-G2L
	098647-23-702	EA	RETAINER - TRIM	W28766
2	098644-01-705	FT	GLAZING - STRIP	132-010231
3	098644-01-706	FT	WEATHERSTRIP - GLASS	171-010668
4	098647-23-703	EA	GLASS - STATIONARY	106-017622
5	098644-01-719	FT	STOP - SLIDER GLASS	132-014203
6	098644-01-710	FT	TRACK - SCREEN SPACER 12'	132-017135
7	098644-01-700	EA	LATCH - REPAIR KIT (BLACK)	B801-CK
8	098644-01-708	FT	CHANNEL - RUN PIERCED	122-016543
9	098644-01-711	FT	WEATHERSTRIP - SCREEN BLACK	171-016965
10	098647-23-704	EA	SCREEN ASM - W/SEALS & CLIPS	410-019066
	098644-01-717	FT	SPLINE - SCREEN	132-004716
11	098644-01-713	EA	CLIP - SPRING - METAL	226-016966
11	125582-01-701	EA	CLIP - SPRING - PLASTIC	130005153
12	098647-23-700	EA	GLASS - SLIDING - W/ SASH & LATCH	H287-G9
13	098644-01-716	FT	PLUG - FILLER	132-014470

SINGLE SLIDER WINDOW (EXCEL) (PASSENGER SIDE DINETTE)

KEY	PART NUMBER	U/M	DESCRIPTION	VENDOR NO.
	098647-23-01A	EA	WINDOW - PASSENGER HORIZONTAL SLIDER 26.1" X 59.7"	
1	098647-23-701	EA	WINDOW - SLIDER W/O RETAINER	H287-G2R
	098647-23-702	EA	RETAINER - TRIM	W287-66
2	098644-01-705	FT	GLAZING - STRIP	132-010231
3	098644-01-706	FT	WEATHERSTRIP - GLASS	171-010668
4	098647-23-703	EA	GLASS - STATIONARY	106-017622
5	098644-01-719	EA	STOP - SLIDER GLASS	132-014203
6	098644-01-710	FT	TRACK - SCREEN SPACER 12'	132-017135
7	098644-01-700	EA	LATCH - REPAIR KIT (BLACK)	B801-CK
8	098644-01-708	FT	CHANNEL - RUN PIERCED	122-016543
9	098644-01-711	FT	WEATHERSTRIP - SCREEN BLACK	171-016965
10	098647-23-704	EA	SCREEN ASM - W/SEALS & CLIPS	410-019066
	098644-01-717	FT	SPLINE - SCREEN	132-004716
11	098644-01-713	EA	CLIP - SPRING - METAL	226-016966
12	098647-23-700	EA	GLASS SLIDING W/SASH & LATCH	H287-G9
13	098644-01-716	FT	PLUG - FILLER	132-014470

WINDOW, VENT & EXTERIOR DOOR GROUP (CONTINUED)

DINETTE WINDOW (THERMO INSULATED)

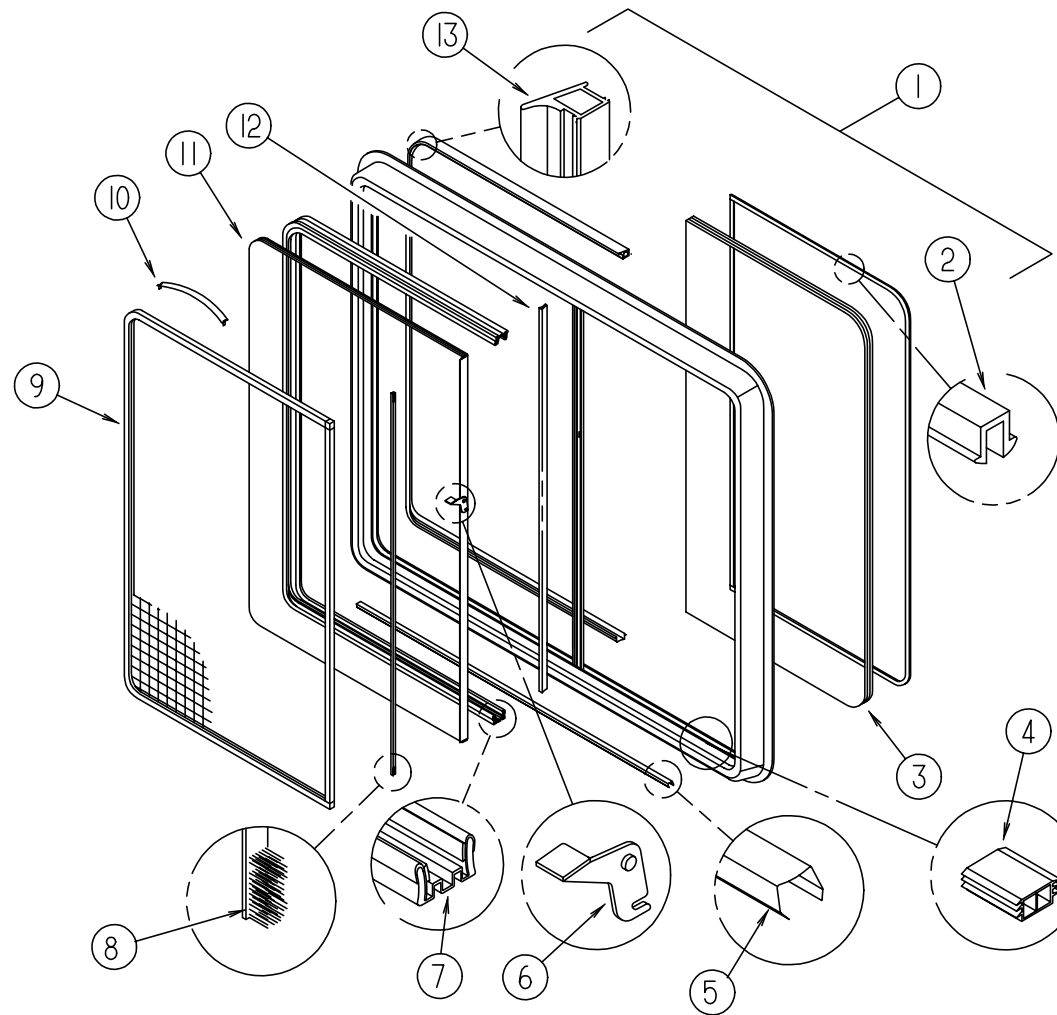

KEY	PART NUMBER	U/M	DESCRIPTION	VENDOR NO.
	112795-16-01A	EA	WINDOW-PASSENGER HORIZONTAL SLIDER THERMO 26 3/8" X 60"	
1	112795-16-700	EA	WINDOW W/O TRIM	DH287-G2R
	098647-23-702	EA	RETAINER - TRIM	W287-66
2	112795-01-705	FT	VINYL - GLAZING	132-019702
3	112795-15-701	EA	GLASS - STATIONARY	390-019045
4	112795-01-701	EA	SLIDE - STOP	132-019092
5	098644-01-710	FT	TRACK - SCREEN SPACER 12'	132-017135
6	112795-01-700	EA	LATCH ASM. - BLK. (BOLT ON)	DH287-CK
7	112795-01-703	IN	CHANNEL - RUN (INCHES)	122-018736
8	098644-01-711	FT	WEATHERSTRIP - SCREEN BLACK	171-016965
9	098647-23-704	EA	SCREEN ASM - W/ SEALS & CLIPS	410-019066
10	125582-01-701	EA	CLIP - SCREEN - PLASTIC	130005153
10	098644-01-713	EA	CLIP - SCREEN - METAL	226-016966
11	112795-15-702	EA	GLASS-SLIDING W/SASH & LATCH	DH287-G9
12	098644-01-706	FT	WEATHERSTRIP - GLASS	171-010668
13	112795-01-704	FT	PLUG FILLER (DOUBLE GLAZED)	122-018737

PASSENGER SIDE LOUNGE WINDOW (THERMO INSULATED)

KEY	PART NUMBER	U/M	DESCRIPTION	VENDOR NO.
	112795-18-01A	EA	WINDOW-PASSENGER HORIZONTAL SLIDER THERMO 26 3/8" X 30"	
1	112795-18-702	EA	WINDOW W/O TRIM	DH286-G2R
	098647-25-701	EA	RETAINER - TRIM	W286-66
2	112795-01-705	FT	VINYL - GLAZING	132-019702
3	112795-18-700	EA	GLASS - STATIONARY	390-019043
4	112795-01-701	EA	SLIDE-STOP	132-019092
5	098644-01-710	FT	TRACK - SCREEN SPACER 12'	132-017135
6	112795-01-700	EA	LATCH ASM., BLK., (BOLT ON)	DH287-CK
7	112795-01-703	IN	CHANNEL-RUN (INCHES)	122-018736
8	098644-01-711	FT	WEATHERSTRIP - SCREEN BLACK	171-016965
9	098647-25-704	EA	SCREEN ASM - W/SEALS & CLIPS	410-019065
10	125582-01-701	EA	CLIP - SCREEN - PLASTIC	130005153
10	098644-01-713	EA	CLIP - SCREEN - METAL	226-016966
11	112795-18-701	EA	GLASS-SLIDING W/SASH & LATCH	DH286-G9
12	098644-01-706	FT	WEATHERSTRIP - GLASS	171-010668
13	112795-01-704	FT	PLUG FILLER (DOUBLE GLAZED)	122-018737

DRIVER SIDE LOUNGE WINDOW (THERMO INSULATED)

KEY	PART NUMBER	U/M	DESCRIPTION	VENDOR NO.
	112795-15-01A	EA	WINDOW - DRIVERS HORIZONTAL SLIDER THERMO 26 3/8" X 60"	
1	112795-15-700	EA	WINDOW W/O TRIM	DH287-G2L
	098647-23-702	EA	RETAINER - TRIM	W287-66
2	112795-01-705	FT	VINYL - GLAZING	132-019702
3	112795-15-701	EA	GLASS - STATIONARY	390-019045
4	112795-01-701	EA	SLIDE - STOP	132-019092
5	098644-01-710	FT	TRACK - SCREEN SPACER 12'	132-017135
6	112795-01-700	EA	LATCH ASM. - BLK. (BOLT ON)	DH287-CK
7	112795-01-703	IN	CHANNEL - RUN (INCHES)	122-018736
8	098644-01-711	FT	WEATHERSTRIP - SCREEN BLACK	171-016965
9	098647-23-704	EA	SCREEN ASM - W/ SEALS & CLIPS	410-019066
10	125582-01-701	EA	CLIP - SCREEN - PLASTIC	130005153
10	098644-01-713	EA	CLIP - SCREEN - METAL	226-016966
11	112795-15-702	EA	GLASS - SLIDING W/ SASH & LATCH	DH287-G9
12	098644-01-706	FT	WEATHERSTRIP - GLASS	171-010668
13	112795-01-704	FT	PLUG FILLER (DOUBLE GLAZED)	122-018737

GALLEY WINDOW (THERMO INSULATED)

KEY	PART NUMBER	U/M	DESCRIPTION	VENDOR NO.
	112795-20-01A	EA	WINDOW-DRIVER HORIZONTAL SLIDER THERMO 16" X 28 3/4"	
1	112795-20-700	EA	WINDOW W/O TRIM	DC29-G2L
	098647-31-701	EA	RETAINER - TRIM	CW29-66
2	112795-01-705	FT	VINYL - GLAZING	132-019702
3	112795-19-701	EA	GLASS - STATIONARY	390-019134
4	112795-01-701	EA	SLIDE-STOP	132-019092
5	098644-01-710	FT	TRACK - SCREEN SPACER 12'	132-017135
6	112795-01-700	EA	LATCH ASM., BLK., (BOLT ON)	DH287-CK
7	112795-01-703	IN	CHANNEL-RUN (INCHES)	122-018736
8	098644-01-711	FT	WEATHERSTRIP - SCREEN BLACK	171-016965
9	098647-31-704	EA	SCREEN ASM - W/SEALS & CLIPS	410-019128
10	125582-01-701	EA	CLIP - SCREEN - PLASTIC	130005153
10	098644-01-713	EA	CLIP - SCREEN - METAL	226-016966
11	112795-19-702	EA	GLASS-SLIDING W/SASH & LATCH	DC29-G9
12	098644-01-706	FT	WEATHERSTRIP - GLASS	171-010668
13	112795-01-704	FT	PLUG FILLER (DOUBLE GLAZED)	122-018737

WINDOW, VENT & EXTERIOR DOOR GROUP (CONTINUED)

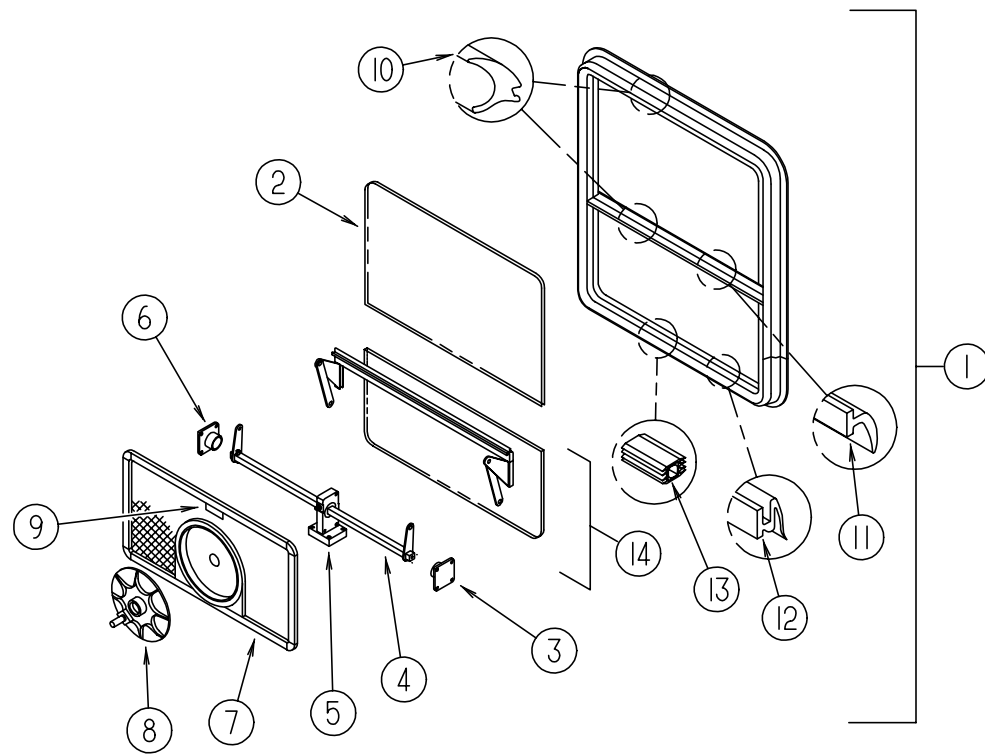

EXCEL BEDROOM TIPOUT WINDOW - DRIVER OR PASSENGER SIDE

KEY	PART NUMBER	U/M	DESCRIPTION	VENDOR NO.
1	112463-03-01A	EA	WINDOW - TIPOUT W/RETAINER TRIM - 33.3" X 30.2"	
	113500-05-705	EA	RETAINER - TRIM	CW100-59
2	112463-03-701	EA	GLASS - STATIONARY	106-025377
3	100322-01-714	EA	SUPPORT - TORQUE BAR - LH	130-015978
4	112463-03-702	EA	OPERATOR & BAR ASSEMBLY	CH10-18
5	100322-01-716	EA	SUPPORT - TORQUE BAR - CTR RAIL	130-015980
6	100322-01-715	EA	SUPPORT - TORQUE BAR - RH	130-015979
7	112463-03-703	EA	SCREEN ASM - W/SEALS & CLIPS	410-018439
8	100322-01-718	EA	HANDLE - DIAL	410-016081
9	112519-01-706	EA	CLIP - SCREEN	CH21-50
10	100322-01-703	FT	VINYL - GLAZING - BUTYL	132-010723
11	100322-01-702	EA	WEATHERSTRIP - HORIZONTAL RAIL	132-015976
12	100322-01-701	FT	SEAL - VENT	122-016071
13	098644-01-716	FT	PLUG - FILLER	132-014470
14	112463-03-700	EA	VENT ASSEMBLY	CH100-G9
	100322-01-704	FT	TAPE - BUTYL	154-016083
	100322-01-717	EA	E-RING	245-015975

WINDOW, VENT & EXTERIOR DOOR GROUP (CONTINUED)

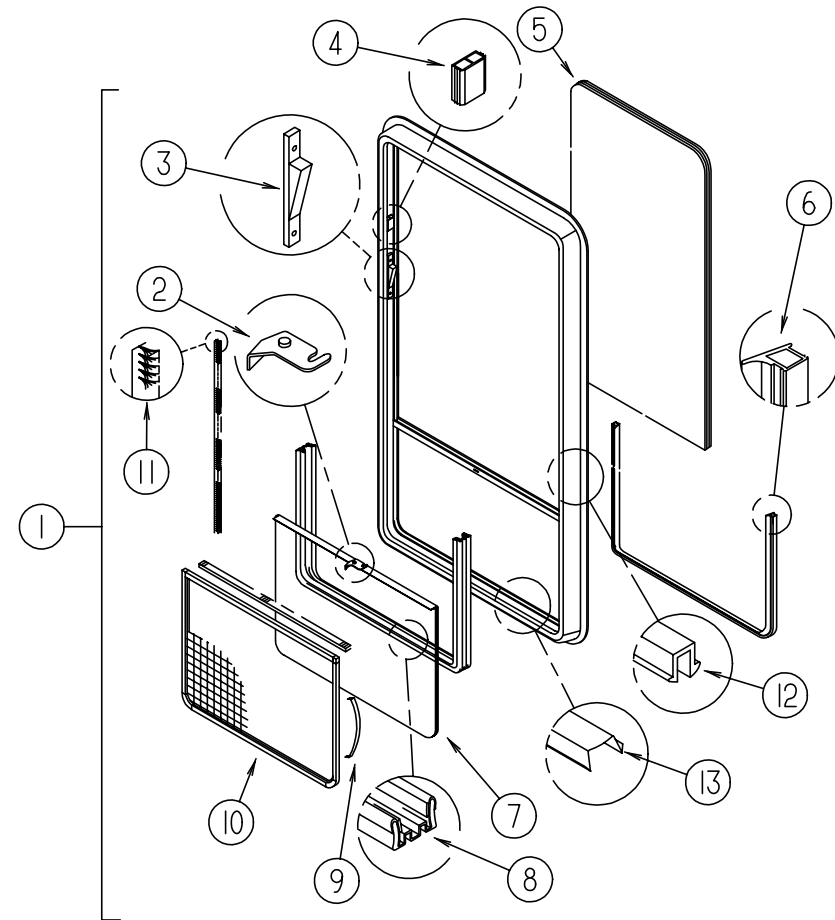

BEDROOM SIDE WINDOW, THERMO

KEY	PART NUMBER	U/M	DESCRIPTION	VENDOR NO.
1	112898-16-01A	EA	WINDOW - SLIDER/VERTICAL - THERMOPANE - 33.2" X 30.2"	
	112898-16-702	EA	RETAINER - TRIM	CW100-66
2	112795-01-700	EA	LATCH ASM., BLK., (BOLT ON)	DH287-CK
3	112898-04-703	EA	SASH LATCH KIT, RAISED	DH343-CK
4	112795-01-701	EA	SLIDE-STOP	132-019092
5	112898-16-701	EA	GLASS - STATIONARY	390-025433
6	112795-01-704	FT	PLUG FILLER (DOUBLE GLAZED)	122-018737
7	112898-16-700	EA	GLASS-SLIDING W/SASH & LATCH	DH510-G9
8	112795-01-703	IN	CHANNEL-RUN (INCHES)	122-018736
9	125582-01-701	EA	CLIP - SCREEN - PLASTIC	130005153
9	098644-01-713	EA	CLIP - SCREEN - METAL	226-016966
10	112898-05-704	EA	SCREEN ASM - W/SEALS & CLIPS	410-018862
	098644-01-717	FT	SPLINE - SCREEN	132-004716
11	098644-01-711	FT	WEATHERSTRIP - SCREEN BLACK	171-016965
12	112795-01-705	FT	VINYL - GLAZING	132-025736
13	098644-01-710	FT	TRACK - SCREEN SPACER 12'	132-017135
	098644-01-706	FT	WEATHERSTRIP - GLASS	171-010668

WINDOW, VENT & EXTERIOR DOOR GROUP (CONTINUED)

BEDROOM SIDE WINDOW (ESCAPE)

KEY	PART NUMBER	U/M DESCRIPTION	VENDOR NO.
	112463-05-01A	EA WINDOW - TIPOUT/ ESCAPE W/ RETAINER TRIM - 33.3" X 30.2"	
	098644-01-716	FT PLUG - FILLER	132-014470
	100322-01-701	FT SEAL - VENT	122-016071
	100322-01-702	EA WEATHERSTRIP - HORIZONTAL RAIL	132-015976
	100322-01-703	FT VINYL - GLAZING - BUTYL	132-010723
	100322-01-704	FT TAPE - BUTYL	154-016083
	100322-01-717	EA E-RING	245-015975
	112898-06-704	EA HANDLE - LATCH - RED - RH	182-11293
	112898-06-705	EA HANDLE - LATCH - RED - LH	182-11294
	100322-01-718	EA HANDLE - DIAL	410-016081

BEDROOM SIDE WINDOW, THERMO (ESCAPE)

KEY	PART NUMBER	U/M DESCRIPTION	VENDOR NO.
	112898-18-01A	EA WINDOW ASM - SLD - VERT - THERMO	
	098644-01-710	FT TRACK - SCREEN SPACER 12'	132-017135
	098644-01-711	FT WEATHERSTRIP - SCREEN BLACK	171-016965
	098644-01-713	EA CLIP - SPRING - METAL	226-016966
	112795-01-700	EA LATCH ASM. - BLK. - (BOLT ON)	DH287-CK
	112795-01-701	EA SLIDE - STOP	132-019092
	112795-01-703	IN CHANNEL - RUN (INCHES)	122-018736
	112795-01-704	FT PLUG FILLER (DOUBLE GLAZED)	122-018737
	112795-01-705	FT VINYL - GLAZING	132-019702

VISTA WINDOW (DRIVER SIDE)

KEY	PART NUMBER	U/M DESCRIPTION	VENDOR NO.
	106467-03-01A	EA WINDOW - DRIVER VISTA (ABOVE DR DOOR) 26.5"T X 35.5"B X 15.8"H	
	106467-03-700	EA GLASS - STATIONARY	106-018752
	106467-03-701	EA WINDOW	H388-G2L
	106467-03-702	EA RETAINER - TRIM - BLACK	H38827L
	100322-01-703	FT STRIP - GLAZING - BUTYL	132-010723

VISTA WINDOW, THERMO (DRIVER SIDE)

KEY	PART NUMBER	U/M DESCRIPTION	VENDOR NO.
	116000-02-01A	EA WINDOW - DRIVER VISTA - THERMO - 14.8" X 25.7" X 32.2"	
	116000-01-704	FT VINYL - GLAZING	132-018161
	116000-02-700	EA RETAINER - TRIM RAIL TOP/REAR	H388-41L
	116000-02-701	EA RETAINER - TRIM RAIL FRONT	H388-42L
	116000-02-702	EA RETAINER - TRIM RAIL BOTTOM	H382-43L
	116000-03-701	EA GLASS - STATIONARY	390-019551

FRONT SLANT WINDOW (DRIVER SIDE)

KEY	PART NUMBER	U/M DESCRIPTION	VENDOR NO.
	106468-02-01A	EA WINDOW - DRIVERS WING TRIANGULAR	
	100322-01-703	FT VINYL - GLAZING, BUTYL	132-010723
	106468-02-701	EA RETAINER - TRIM	H383-27L
	106468-02-702	EA GLASS - STATIONARY	106-018740

FRONT SLANT WINDOW, THERMO (DRIVER SIDE)

KEY	PART NUMBER	U/M DESCRIPTION	VENDOR NO.
	115999-02-01A	EA WINDOW - DRIVER WING/THERMO/TRIANGULAR	
	115999-01-701	EA RETAINER - TRIM	H358-27L
	115999-02-700	EA RETAINER - TRIM RAIL REAR	H383-41L
	115999-03-701	EA GLASS - STATIONARY	390-019550
	116000-01-704	FT VINYL - GLAZING	132-018161

WINDOW, VENT & EXTERIOR DOOR GROUP (CONTINUED)

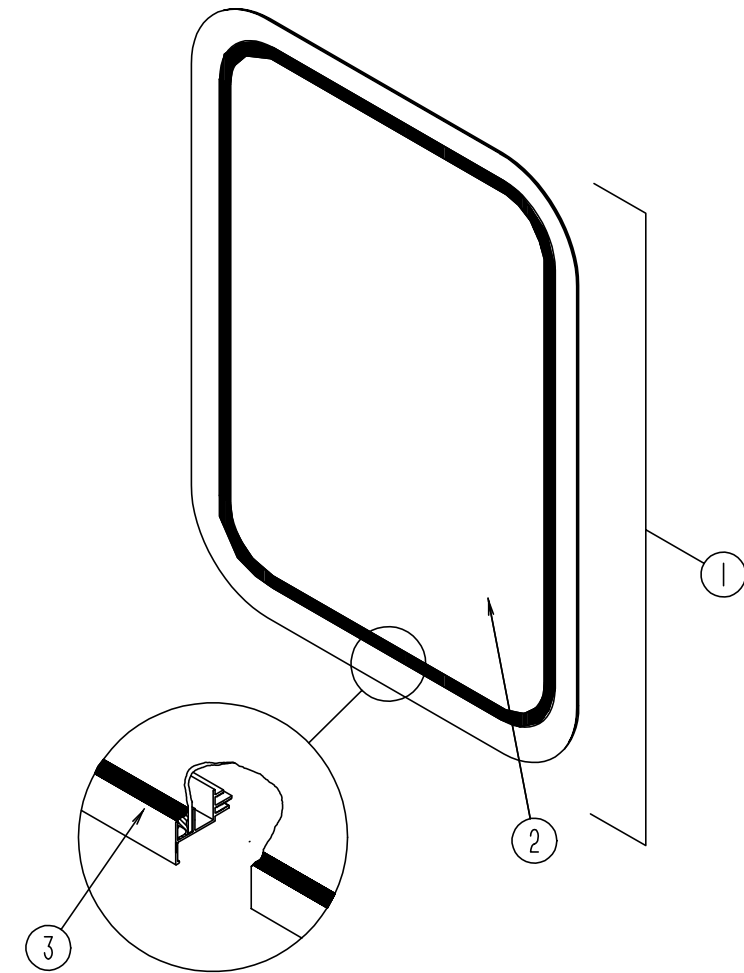

ENTRY DOOR WINDOW

KEY	PART NUMBER	U/M DESCRIPTION
1	117053-02-F36	EA WINDOW - PICTURE 17" X 26.4"
2	002181-25-000	EA GLASS - PICTURE 25.7" X 16.4"
3	087561-01-000	FT SEAL - GLASS - EXTERIOR - .5" WIDE - VINYL - BLACK
	117054-02-02A	EA RETAINER - TRIM - BRIGHT/ WHITE

ENTRY DOOR WINDOW (THERMO INSULATED)

KEY	PART NUMBER	U/M DESCRIPTION	VENDOR NO.
	113733-01-01A	EA WINDOW - STATIONARY THERMOPANE 26.4" X 17"	
	112795-01-705	FT VINYL - GLAZING	132-019702
1	113733-01-700	EA WINDOW ASM. - W/O TRIM	DH416-G2
	113733-01-701	EA RETAINER - TRIM	W41666
2	113733-01-702	EA GLASS - STATIONARY	390-019187

WINDOW, VENT & EXTERIOR DOOR GROUP (CONTINUED)

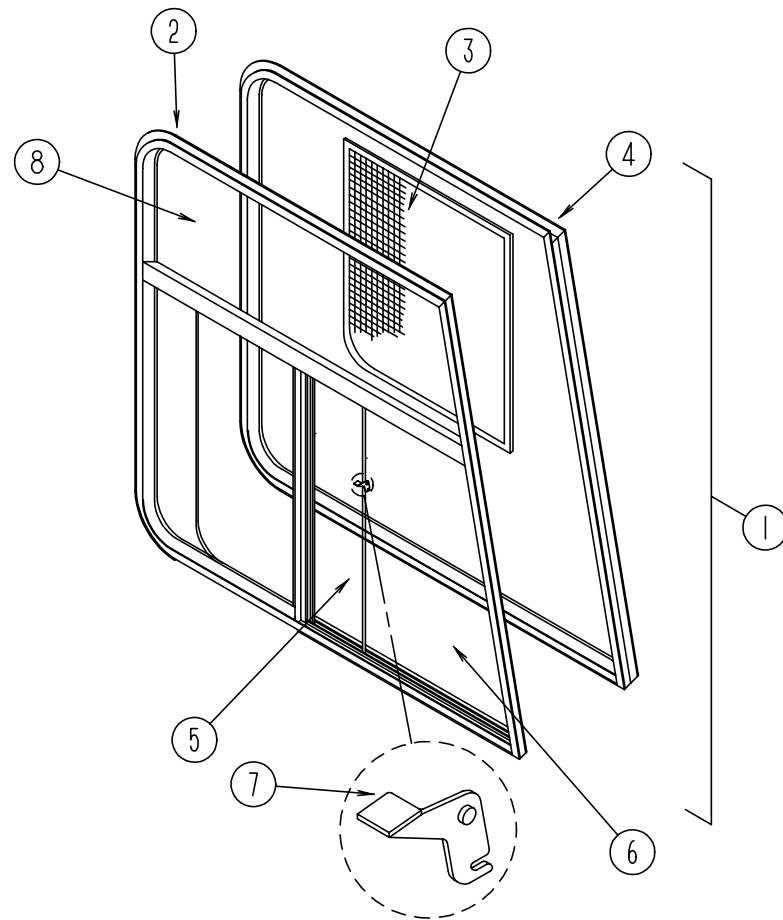

FRONT CAB WINDOWS (EXCEL)

KEY	PART NUMBER	U/M	DESCRIPTION
1	103658-07-01A	EA	WINDOW - DRIVER CAB 3 GLASS 25.3"T X 45.4"B X 45.2"H
1	103658-08-01A	EA	WINDOW - PASSENGER CAB 3 GLASS 25.3"T X 45.4"B X 45.2"H
2	103658-07-704	EA	WINDOW ASM. - W/O TRIM - DRIVER SIDE
2	103658-08-700	EA	WINDOW ASM. - W/O TRIM - PASSENGER SIDE
3	103658-01-700	EA	SCREEN ASM - W/ SEALS & CLIPS - DRIVER SIDE
3	103658-02-700	EA	SCREEN ASM - W/ SEALS & CLIPS - PASSENGER SIDE
4	103658-07-700	EA	RETAINER - TRIM - DRIVER SIDE
4	103658-08-701	EA	RETAINER - TRIM - PASSENGER SIDE
5	103658-01-703	EA	GLASS - SLIDING - W/ SASH & LATCH LH - DRIVER SIDE
5	103658-02-701	EA	GLASS - SLIDING - W/ SASH & LATCH RH - PASSENGER SIDE
6	103658-01-702	EA	GLASS - STATIONARY - BOTTOM - DRIVER SIDE
6	103658-01-702	EA	GLASS - STATIONARY - BOTTOM - PASSENGER SIDE
7	098644-01-700	EA	LATCH - REPAIR KIT (BLACK)
8	103658-07-701	EA	GLASS - STATIONARY TOP
	098644-01-706	FT	WEATHERSTRIP - GLASS
	098644-01-708	FT	CHANNEL - RUN PIERCED
	098644-01-710	FT	TRACK - SCREEN SPACER 12'
	098644-01-711	FT	WEATHERSTRIP - SCREEN BLACK
	098644-01-713	EA	CLIP - SPRING - METAL
	098644-01-716	FT	PLUG - FILLER
	098644-01-717	FT	SPLINE - SCREEN

WINDOW, VENT & EXTERIOR DOOR GROUP (CONTINUED)

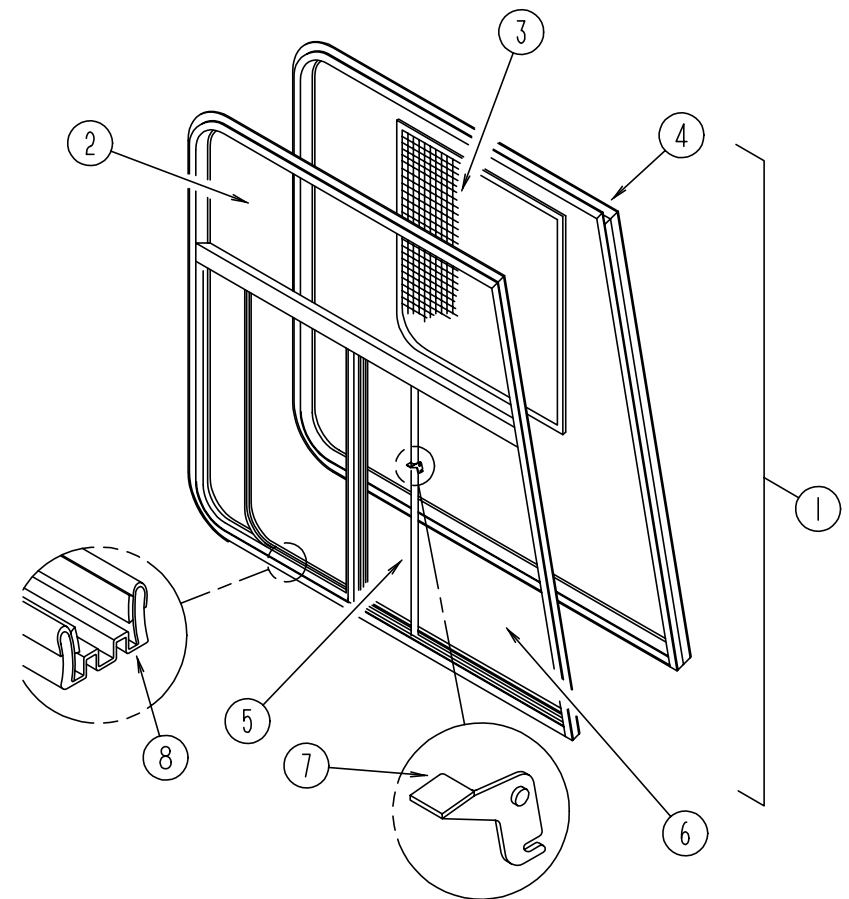

FRONT CAB THERMOPANE WINDOWS (EXCEL)

VENDOR NO.	KEY	PART NUMBER	U/M	DESCRIPTION	VENDOR NO.
	1	113501-01-01A	EA	WINDOW - DRIVER CAB THERMO (3 WINDOW) 44.3" X 24.4" X 44.1"	
	1	113501-02-01A	EA	WINDOW - PASS CAB THERMO (3 WINDOW) 44.3" X 24.4" X 44.1"	
	2	113501-01-701	EA	GLASS - STATIONARY - UPPER - DRIVER OR PASSENGER SIDE	390-019137
	3	103658-01-700	EA	SCREEN ASM - W/ SEALS & CLIPS - DRIVER SIDE	H322-03L
	3	103658-02-700	EA	SCREEN ASM - W/ SEALS & CLIPS - PASSENGER SIDE	H322-03R
		098644-01-717	FT	SPLINE - SCREEN	132-004716
		098644-01-713	EA	CLIP - SPRING - METAL	226-016966
	4	103658-05-702	EA	RETAINER - TRIM - DRIVER SIDE	H374-66 & 76L
	4	103658-10-701	EA	RETAINER - TRIM - PASSENGER SIDE	H373-66 & 76R
	5	113501-01-703	EA	GLASS-SLIDING W/ SASH & LATCH - DRIVER SIDE	DH374-A9L
	5	113501-02-702	EA	GLASS-SLIDING W/ SASH & LATCH - PASSENGER SIDE	DH374-A9R
	6	113501-01-702	EA	GLASS - STATIONARY - LOWER - DRIVER SIDE	390-019139L
	6	113501-02-701	EA	GLASS - STATIONARY - LOWER - PASSENGER SIDE	390-019138R
	7	112795-01-700	EA	LATCH ASM. - BLACK (BOLT ON)	DH287-CK
	8	112795-01-703	IN	CHANNEL - RUN (INCHES)	122-018736
		098644-01-711	FT	WEATHERSTRIP - SCREEN BLACK	171-016965
		112795-01-701	EA	SLIDE - STOP	132-019092
		112795-01-704	FT	PLUG FILLER (DOUBLE GLAZED)	122-018737
		112795-01-705	FT	VINYL - GLAZING	132-019702
		112898-04-703	EA	SASH LATCH KIT - RAISED	DH343-CK

WINDOW, VENT & EXTERIOR DOOR GROUP (CONTINUED)

POWERED ROOF VENT (FANTASTIC)

KEY	PART NUMBER	U/M DESCRIPTION	VENDOR NO.
	123780-03-01A	EA VENT - EXHAUST - F/3" TO 4" ROOF - UL-CSA	
	009440-01-000	EA GEAR/ ARM - VENT COVER - LIFT	
	084079-01-703	EA KNOB - LIFT - W/ EXT. & SCREW	1140K-00
	084079-01-704	EA BLADE - FAN	1070-00
	084079-01-705	EA MOTOR	1080-00
	084079-01-707	EA SWITCH - SAFETY	1122.05
	084079-01-709	EA SWITCH - MAIN - 3 SPEED	1031-05
	084079-01-711	EA H-MOLDING - MOTOR MOUNT	
	084079-11-700	EA MOTOR - BRKT. - FAN BLADE - KIT	4017K-09
	123780-01-700	EA COVER - VENT W/ HINGE & SLIDE	1020K-81
	123780-03-700	EA GARNISH - INT. 3"-4" BRT/ WHT	1040-81

WINDOW, VENT & EXTERIOR DOOR GROUP (CONTINUED)

NON POWERED ROOF VENT

KEY	PART NUMBER	U/M DESCRIPTION	VENDOR NO.
	122882-01-01A	EA VENT - ROOF - NONPOWERED ELIXIR V971201 WHT	
	009440-01-000	EA GEAR - ARM - ROOF VENT - 705221K38	
	064470-01-700	EA COVER - VENT - W/O (SLIDE BAR)	J7291
	064470-01-701	EA SLIDE BAR (VENT-LID)	JRP1291B
	122882-01-700	EA HANDLE - CRANK BLACK	90128
	122882-01-701	EA SCREEN	JRP-1124-B
	122882-07-01A	EA GARNISH - ROOF VENT - 2.50" TO 4.12"	

POWERED ROOF VENT

KEY	PART NUMBER	U/M DESCRIPTION	VENDOR NO.
	122882-02-01A	EA VENT - ROOF - W/ FAN - UL ELIXIR V971202 WHT	
	009440-01-000	EA GEAR/ ARM - LIFT - ROOF VENT COVER - 705221K38	
	048648-01-000	EA MOTOR - ROOF VENT - 1/8 SHAFT - 12VOLT	
	048649-01-000	EA FAN - ROOF VENT - 6 BLADES - 6"	
	064470-01-700	EA COVER - VENT - W/O (SLIDE BAR)	J7291
	064470-01-701	EA SLIDE BAR (VENT-LID)	JRP1291B
	110051-03-700	EA SWITCH - BLACK/ PUSH BUTTON	27-0164
	122882-01-700	EA HANDLE - CRANK BLACK	90128
	122882-01-701	EA SCREEN	JRP-1124-B
	122882-07-01A	EA GARNISH - ROOF VENT - 2.50" TO 4.12"	

POWERED ROOF VENT CSA

KEY	PART NUMBER	U/M DESCRIPTION	VENDOR NO.
	122882-03-01A	EA VENT - ROOF - W/FAN - CSA	
	009440-01-000	EA GEAR/ARM - LIFT - ROOF VENT COVER	
	048648-01-000	EA MOTOR - ROOF VENT - 1/8 SHAFT - 12VOLT	
	048649-01-000	EA FAN - ROOF VENT - 6 BLADES - 6"	
	064470-01-700	EA COVER-VENT, W/O (SLIDE BAR)	J7291
	064470-01-701	EA SLIDE BAR, (VENT-LID)	JRP1291B
	110051-03-700	EA SWITCH-BLACK/PUSH BUTTON	27-0164
	122882-01-700	EA HANDLE-CRANK BLACK	90128
	122882-01-701	EA SCREEN	JRP-1124-B

ROOF VENTS

KEY	PART NUMBER	U/M DESCRIPTION
	083558-03-000	EA VENT - PLUMBING - PIPE ROOF - W/COVER - OFF WHITE
	084073-04-000	EA BASE - ROOF VENT - REFRIGERATOR
	084073-07-000	EA VENT - ROOF - REFRIGERATOR - BRIGHT WHITE

SIDEWALL VENTS

KEY	PART NUMBER	U/M DESCRIPTION
	084616-07-000	EA VENT - SHROUD - RANGE HOOD - BRIGHT WHITE
	084878-09-000	EA VENT - HOOD - RANGE/SHORT - OFF WHITE

WINDOW, VENT & EXTERIOR DOOR GROUP (CONTINUED)

EXTERIOR DOORS

KEY	PART NUMBER	U/M	DESCRIPTION	VENDOR NO.
1	122391-07-H37	EA	DOOR - STORAGE - TAPERED - W/O PADDLE LATCH - 38.6"	
2	122391-05-H37	EA	DOOR - STORAGE - TAPERED - W/O PADDLE LATCH - 38.6"	
3	084103-08-000	EA	DOOR - REFRIGERATOR - VENTED - W/O JAMB	
3	084104-08-000	EA	JAMB - REFRIGERATOR DOOR	
	084104-01-700	EA	LOCK - MALE - FASTENER	201-721-010
	084104-01-701	EA	LOCK - FEMALE - FASTENER	201-802-010
4	052009-06-000	EA	DOOR - WATER HEATER - W/O LATCHES	
4	116424-01-000	EA	PROTECTOR - WATER HEATER LATCH	
5	122239-04-H37	EA	DOOR - STORAGE - W/O PADDLE LATCH - 46.3"	
6	122239-03-H37	EA	DOOR - STORAGE - W/O PADDLE LATCH - 39.7"	
7	122239-02-H37	EA	DOOR - STORAGE - W/O PADDLE LATCH - 69.6"	
8	106469-07-01A	EA	DOOR ASM. - DRIVERS - BLACK - V130-01L	
9	122239-05-H37	EA	DOOR - STORAGE - W/O PADDLE LATCH - 37.7"	
10	115108-02-H37	EA	DOOR - ENTRY - W/ SCREEN DOOR - W/O WINDOW (H37, H47)	
10	115108-02-H38	EA	DOOR - ENTRY - W/ SCREEN DOOR - W/O WINDOW (H38, H48)	
10	115108-02-GB1	EA	DOOR - ENTRY - W/ SCREEN DOOR - W/O WINDOW (H39, H49)	
11	111017-01-H23	EA	DOOR - PATIO ENTERTAINMENT CENTER - W/O LATCH - 17.8" X 8.1"	
12	122239-06-H37	EA	DOOR - STORAGE - W/O PADDLE LATCH - 63.6"	
13	122239-35-H37	EA	DOOR - STORAGE - W/O PADDLE LATCH - 46.2"	
14	122391-06-H37	EA	DOOR - STORAGE - W/O PADDLE LATCH - TAPERED - 28.6"	
15	122391-08-H37	EA	DOOR - STORAGE - TAPERED - W/O PADDLE LATCH - 38.6"	
16	081240-16-000	EA	DOOR - WATER FILL - LOCKABLE W/O LOCK - 4" X 4 5/8"	

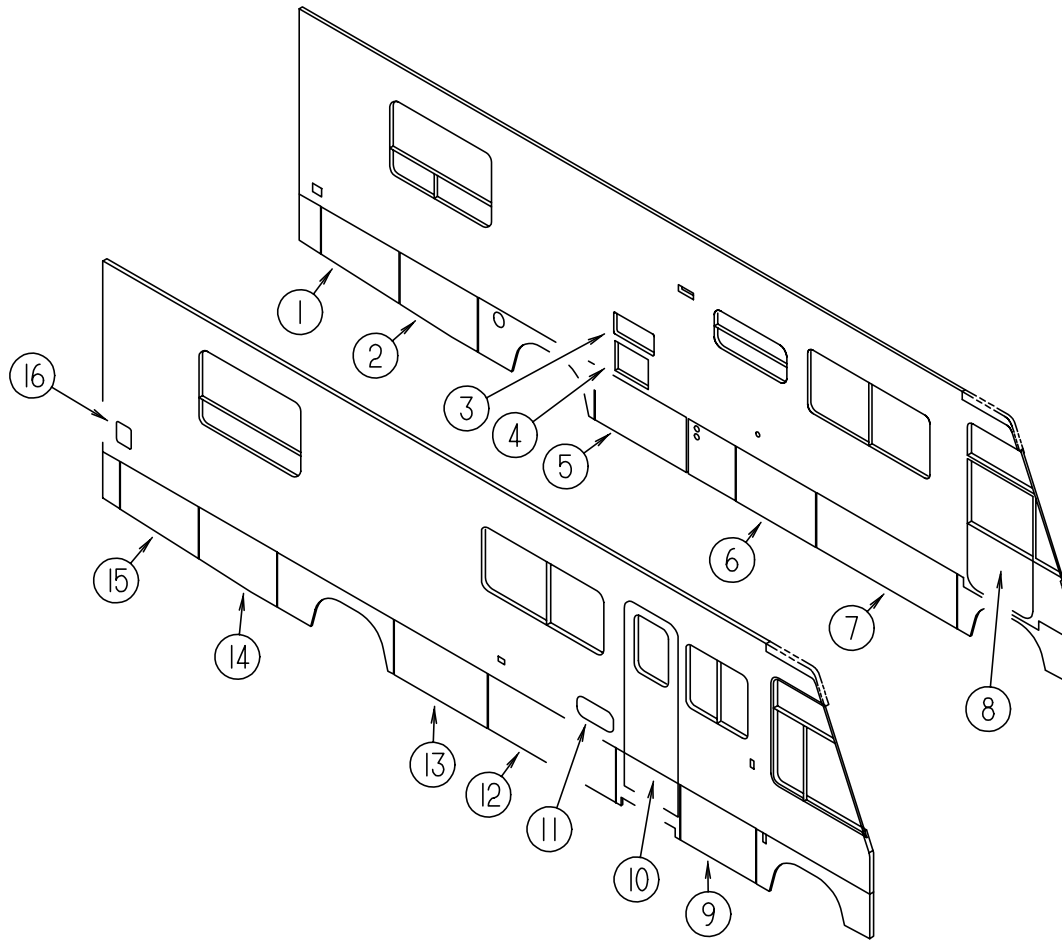

WINDOW, VENT & EXTERIOR DOOR GROUP (CONTINUED)

DRIVER DOOR (EXCEL)

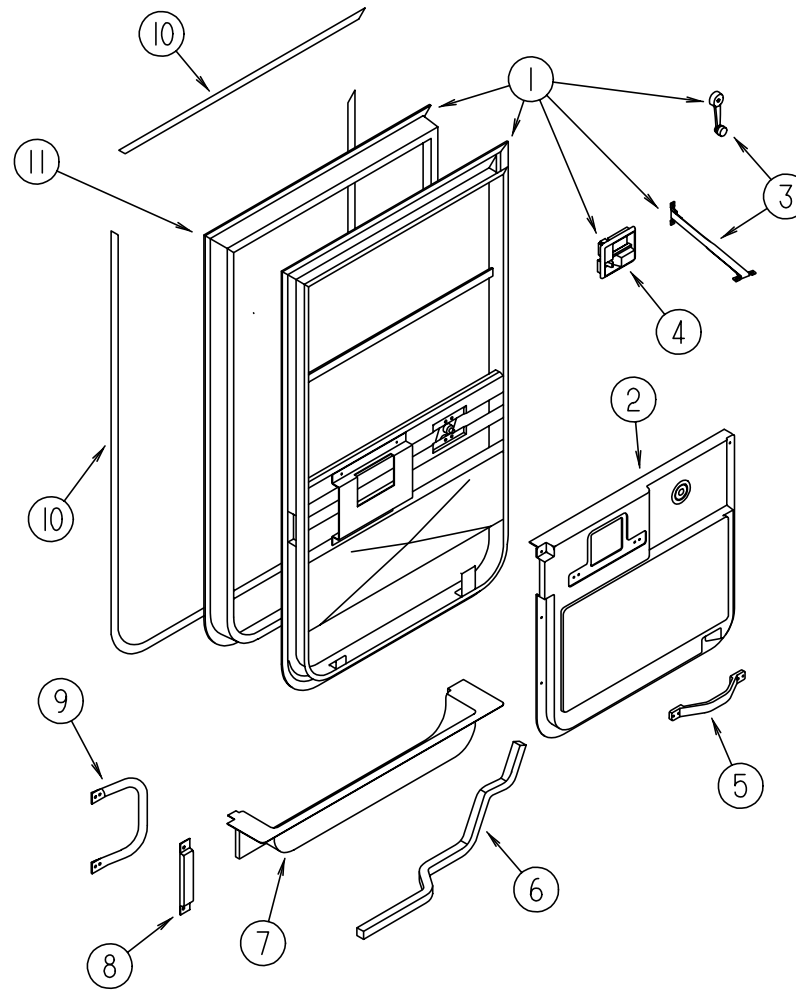

KEY	PART NUMBER	U/M	DESCRIPTION	VENDOR NO.	KEY	PART NUMBER	U/M	DESCRIPTION	VENDOR NO.
1	106469-07-01A	EA	DOOR - DRIVER - BLACK - MANUAL WINDOW		8	108654-01-01A	EA	COVER - STRIKE - DRIVER DOOR	
2	114973-01-02A	EA	PANEL - DRIVER DOOR - INNER		9	108832-01-02A	EA	HANDLE - ASSIST - DRIVER DOOR - METAL - OFF WHITE	
3	106469-02-704	EA	PARTS BAG (WINDOW HANDLE & CHECK STRAP)	V068-16	10	108833-02-01A	EA	COVER - ASSIST HANDLE	
4	106469-04-712	EA	INNER HANDLE HRDWE. L. H.	248-041148	10	109235-01-01A	FT	COVER - SCREW - MAT BLACK - 132-081046	
5	110604-01-01A	EA	HANDLE - ASSIST - DRIVERS DOOR		11	106469-07-700	EA	MOUNTING FRAME ASM.	V130-30L
6	063977-11-000	EA	STEP - DRIVER DOOR - LEFT - UNPAINTED			108129-02-02A	EA	GARNISH - DRIVERS DOOR - FRONT - BLACK	
7	107818-01-01A	EA	TRIM - STEP - DRIVERS DOOR			108107-01-02A	EA	GARNISH - DRIVERS DOOR - TOP - BLACK	
						108108-04-02A	EA	GARNISH - DRIVERS DOOR - REAR UPPER - BLACK	
						108897-02-01A	EA	GARNISH - DRIVERS DOOR - REAR LOWER - BLACK	
7	126069-03-01A	EA	TRIM - STEP - DRIVER	FROM: 00-00-00 THRU: 01-14-97		P01713-01-000	EA	SWITCH - PUSH BUTTON - IN DOOR JAMB - METAL CHROME	
				FROM: 01-15-97 THRU: 99-99-99		076725-06-000	EA	COVER - ACCESS - DOOR JAMB PUSH BUTTON - BLACK	
	102569-02-000	EA	MAT - ANTI SLIP - LOWER						

WINDOW, VENT & EXTERIOR DOOR GROUP (CONTINUED)

DRIVER DOOR (EXCEL)

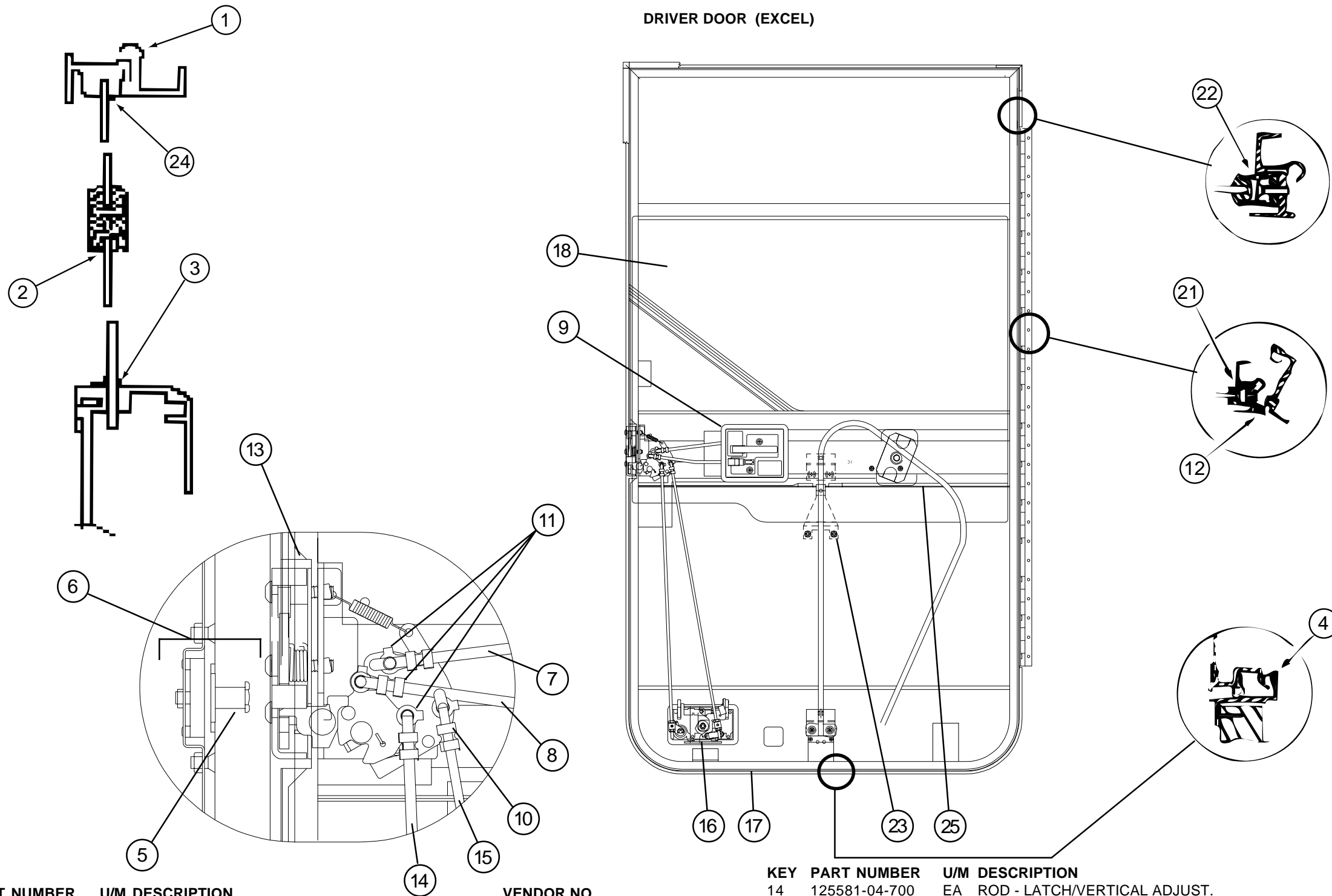

KEY	PART NUMBER	U/M	DESCRIPTION	VENDOR NO.
1	106469-01-702	EA	DOOR SEAL	122-040984
2	106469-01-705	FT	CHANNEL - RUN - SLIDING	122-010850
3	106469-01-709	FT	WEATHERSTRIP - FUZZY	171-040630
4	106469-01-723	EA	SEAL - BULB ASM. (JAMB)	171-040985
5	106469-04-703	EA	BOLT - STRIKER (W/ WASHER)	248-041152
6	106469-04-704	EA	NUT ASSEMBLY - CAGED - W/STRIKER	248-041151
7	106469-04-705	EA	LATCH ROD - HORIZONTAL	203-041139
8	106469-04-711	EA	LOCK ROD - HORIZONTAL	203-041137
9	106469-04-712	EA	HANDLE/DOOR - INNER W/HARDWARE	248-041402
10	106469-04-713	EA	ROD CLIP L.H.	248-041154
11	106469-04-714	EA	ROD CLIP R.H.	248-041153
12	106469-05-702	EA	HINGE - 42"	211-041194
13	106469-05-706	EA	LATCH - ROTARY - W/LINKAGE	248-041150

KEY	PART NUMBER	U/M	DESCRIPTION	VENDOR NO.
14	125581-04-700	EA	ROD - LATCH/VERTICAL ADJUST.	203041767
15	125581-04-701	EA	ROD - LOCK/VERTICAL ADJUST.	203-041768
16	125581-04-702	EA	PADDLE RH-W/COLLAR BLACK TEX	248-041403
17	125581-04-703	EA	FRAME - MOUNTING - BLACK	V180-35L
18	125581-04-704	EA	GLASS - ROLL-UP	106-041821
19	125581-04-705	EA	GLASS - STATIONARY	106-041547
20	125581-04-706	EA	FRAME - DOOR - SUB-ASSEMBLY	V180-94L
21	125581-04-707	EA	CHANNEL - ROLL UP GLASS	V156-60
22	125581-04-708	EA	CHANNEL - STATIONARY GLASS	V156-61
23	125581-04-709	EA	REGULATOR - MANUAL	410-08389
24	125581-04-710	EA	VINYL - GLAZING	132-041484
25	125581-04-711	EA	CHANNEL- GLASS	N135-66
	106469-04-701	EA	TUMBLER & KEYS (TRI-MARK)	248-041179
	106469-04-702	EA	KEYS (BLANK)	248-041180

WINDOW, VENT & EXTERIOR DOOR GROUP (CONTINUED)

BRIGGS & STRATTON LOCKS & COMPONENTS

NOTE:
 WHEN ORDERING THE LOCK CASE, THE KEY CODE MUST MATCH THE LAST DIGIT OF THE VEHICLE'S SERIAL NUMBER AND PART NUMBER; WHEN ORDERING THE KEYS, THE THIRD DIGIT OF THE KEY CODE MUST MATCH THE LAST DIGIT OF THE VEHICLE'S SERIAL NUMBER AND PART NUMBER

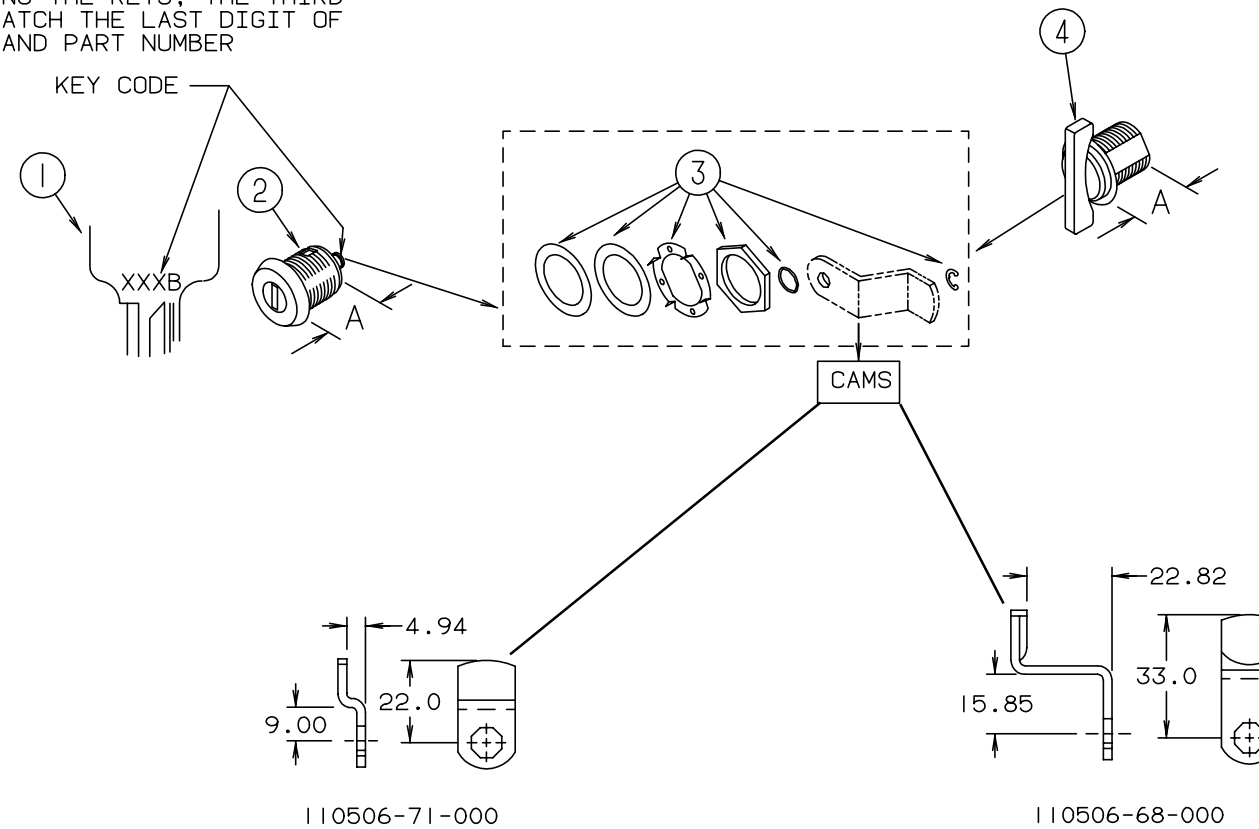

KEY	PART NUMBER	U/M	DESCRIPTION	VENDOR NO.
1	110506-59-000	EA	KEYS - SET OF TWO	596720
2	110506-52-000	EA	CASE - LOCK - A= 17 MM	702370
2	110506-53-000	EA	CASE - LOCK - A= 25 MM	702380
1	110506-59-001	EA	KEYS - SET OF TWO	596721
2	110506-52-001	EA	CASE - LOCK - A= 17 MM	702371
2	110506-53-001	EA	CASE - LOCK - A= 25 MM	702381
1	110506-59-002	EA	KEYS - SET OF TWO	596722
2	110506-52-002	EA	CASE - LOCK - A= 17 MM	702372
2	110506-53-002	EA	CASE - LOCK - A= 25 MM	702382
1	110506-59-003	EA	KEYS - SET OF TWO	596723
2	110506-52-003	EA	CASE - LOCK - A= 17 MM	702373
2	110506-53-003	EA	CASE - LOCK - A= 25 MM	702383
1	110506-59-004	EA	KEYS - SET OF TWO	596724
2	110506-52-004	EA	CASE - LOCK - A= 17 MM	702374
2	110506-53-004	EA	CASE - LOCK - A= 25 MM	702384
1	110506-59-005	EA	KEYS - SET OF TWO	596725
2	110506-52-005	EA	CASE - LOCK - A= 17 MM	702375
2	110506-53-005	EA	CASE - LOCK - A= 25 MM	702385

KEY	PART NUMBER	U/M	DESCRIPTION	VENDOR NO.
1	110506-59-006	EA	KEYS - SET OF TWO	596726
2	110506-52-006	EA	CASE - LOCK - A= 17 MM	702376
2	110506-53-006	EA	CASE - LOCK - A= 25 MM	702386
1	110506-59-007	EA	KEYS - SET OF TWO	596727
2	110506-52-007	EA	CASE - LOCK - A= 17 MM	702377
2	110506-53-007	EA	CASE - LOCK - A= 25 MM	702387
1	110506-59-008	EA	KEYS - SET OF TWO	596728
2	110506-52-008	EA	CASE - LOCK - A= 17 MM	702378
2	110506-53-008	EA	CASE - LOCK - A= 25 MM	702388
1	110506-59-009	EA	KEYS - SET OF TWO	596729
2	110506-52-009	EA	CASE - LOCK - A= 17 MM	702379
2	110506-53-009	EA	CASE - LOCK - A= 25 MM	702389
3	110506-40-700	EA	HARDWARE KIT	
4	110506-50-000	EA	CASE - TWIST LOCK - A= 17 MM	596952
4	110506-51-000	EA	CASE - TWIST LOCK - A= 25 MM	596669
	110506-40-000	EA	CLIP-E - LOCK ASM.	93981
	110506-64-000	EA	CAM - LOCK	322280
	110506-68-000	EA	CAM - LOCK	322284
	110506-71-000	EA	CAM - LOCK	322287
	110506-59-701	EA	KEY BLANK - GOLD	

WINDOW, VENT & EXTERIOR DOOR GROUP (CONTINUED)

ENTRY DOOR W/O WINDOW

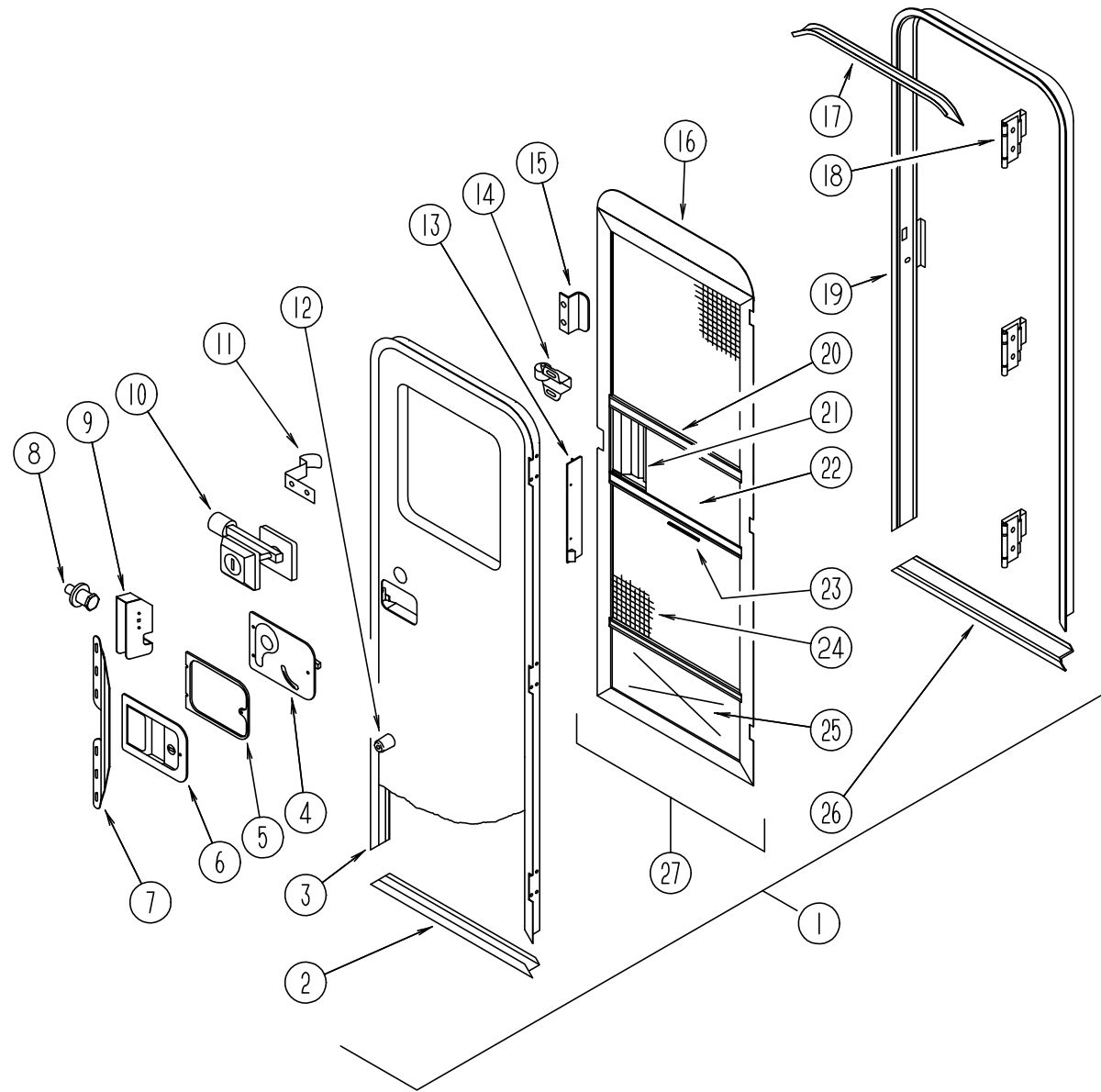

KEY	PART NUMBER	U/M	DESCRIPTION
1	115108-02-H37	EA	DOOR - ENTRY - W/SCREEN DOOR - W/O WINDOW (H37, H47)
1	115108-02-H38	EA	DOOR - ENTRY - W/SCREEN DOOR - W/O WINDOW (H38, H48)
1	115108-02-GB1	EA	DOOR - ENTRY - W/SCREEN DOOR - W/O WINDOW (H39, H49)
2	121893-01-01A	EA	FRAME - DOOR - ENTRANCE
3	121894-03-01A	EA	FRAME - DOOR - ENTRANCE B/ W
4	039979-06-000	EA	COVER - LATCH PLATE - RIGHT HAND - BLACK TEXTURED
5	096810-01-01A	EA	PLATE - LATCH - ENTRY DOOR - BLACK PLASTIC
6	045017-13-000	EA	LATCH - ENTRANCE DOOR - BLACK TEXTURED
7	098173-01-07A	EA	STIFFENER - ENTRANCE DOOR - SUPPORTS LATCH/ STRIKE AREA
7	098173-01-04A	EA	STIFFENER - ENTRY DOOR - SUPPORTS LATCH/ STRIKE AREA - UNPAINTED
8	039539-01-000	EA	STRIKE - LOCK - ENTRY DOOR - ROUND W/ THREADED WASHER
9	039540-01-000	EA	LATCH MECHANISM - HOOK - ENTRY DOOR - INTERIOR
	039715-01-000	EA	NUT-SERT - 1/4" DIAMETER - 20 THREADS (ENTRANCE DOOR HINGE)
	041546-07-000	EA	BRACKET - DOOR ANGLE - OFF WHITE
	036618-02-000	EA	E-RING - EXTERNAL - 3/16" SHAFT DIAMETER - LYNOR DOOR LOCK
	045017-11-701	EA	KEY - BLANK - F1 SERIES
	045017-11-703	EA	CYLINDER - LOCK ASM. W/ KEYS
	072893-04-000	EA	NUTSERT - 10-32 (ENTRANCE DOOR STIFFENER)
	075671-04-000	FT	SEAL - SPONGE - LAZY T SHAPE - W/ ADHESIVE STRIP - .5" WIDE
	086285-05-000	EA	SPACER - NYLON - .7" X .56"
10	101145-01-06A	EA	DEADBOLT - ENTRY DOOR - W/ 2 KEYS
	095229-01-700	EA	KEY - BLANK - DEADBOLT
	101145-01-701	EA	CYLINDER - LOCK ASM. - W/ KEY
	101147-01-000	EA	BOLT - SECURITY - 4.12" BACKSET
11	100412-01-000	EA	CATCH - SCREEN DOOR - THUMB CLIP
12	117046-01-000	EA	BUMPER - RUBBER - ROUND END
13	079087-03-000	EA	STRIKE - SLIDER - SCREEN DOOR - BRIGHT WHITE
14	109403-01-000	EA	CATCH - SCREEN DOOR ROLLER
15	050712-06-000	EA	HANDLE - SCREEN DOOR - BRIGHT WHITE
16	078595-01-000	EA	TOP PLATE - SCREEN DOOR - CURVED TOP - 4.7" X 25.35"
17	044582-44-000	EA	CAP - DRIP - ENTRY DOOR - ALUMINUM - BRIGHT WHITE
18	106719-01-05A	EA	HINGE - ENTRANCE DOOR - BRIGHT WHITE
18	106719-01-01A	EA	HINGE - ENTRANCE DOOR - MILL
	116111-02-01A	EA	SCREW - TAPTITE - 1/4-20 X 3/8 PPH - ZINC
	118929-01-01A	FT	SEAL - PILE - PUSH ON
19	121898-01-01A	EA	JAMB - DOOR - ENTRANCE
20	078777-01-000	EA	CHANNEL - SLIDE - SCREEN DOOR CENTER SLIDER COVER
21	079086-03-000	EA	SLIDER - SCREEN DOOR - BRIGHT WHITE
22	016454-01-000	EA	INSERT - CENTER - LEATHER GRAIN ALUMINUM - UNPAINTED
	001014-01-013	EA	INSERT - CENTER - 10.25" X 16.31" - UNPAINTED
23	002294-01-000	FT	SPLINE - SCREENING - .005" X .0054"
24	002293-02-000	SF	SCREENING - WINDOW/ DOOR - 26"
	075673-01-000	FT	SEAL - PILE - ADHESIVE BACK - GRAY
25	078552-03-000	EA	KICK PANEL - SCREEN DOOR - LOWER INSERT - UNPAINTED
	078595-01-000	EA	TOP PLATE - SCREEN DOOR - CURVED TOP - 4.7" X 25.35"
26	051049-01-000	EA	JAMB - BOTTOM - ENTRY DOOR - 25.9" - UNPAINTED
27	121899-01-G04	EA	DOOR - SCREEN - W/O HARDWARE
	122241-01-01A	EA	BUMPER - FOAM RUBBER - BLACK
	102248-01-000	EA	SHIM - DOOR

WINDOW, VENT & EXTERIOR DOOR GROUP (CONTINUED)

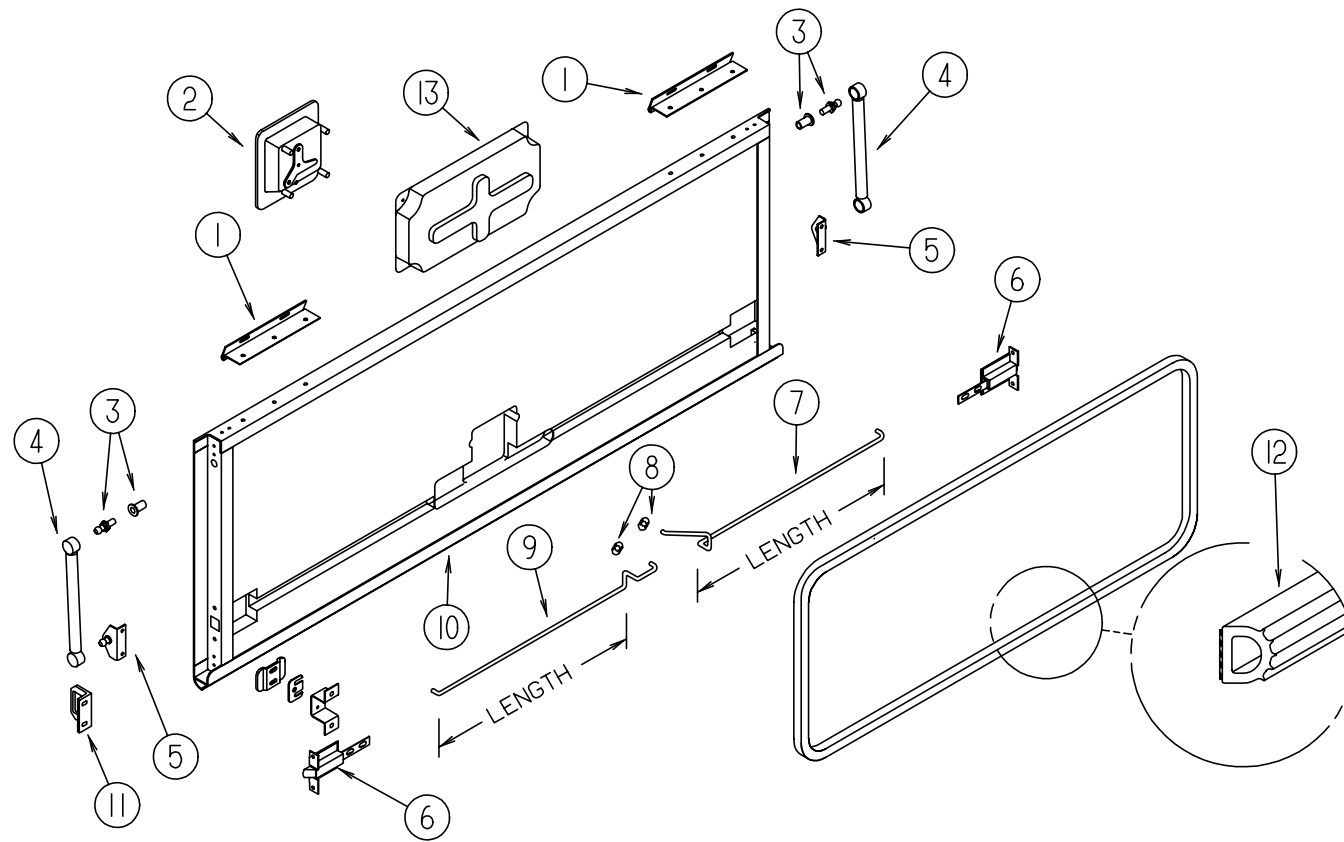

EXTERIOR DOORS

KEY	PART NUMBER	U/M	DESCRIPTION
1	121755-01-04A	EA	HINGE - 6.00 INCH
2	112949-01-04A	EA	LATCH - PADDLE W/ LOCK W/O KEY - BLACK
	112949-03-000	EA	KEY - TRI-MARK #TM500
3	057460-08-000	EA	BALL STUD - 10MM BALL - 5/16-18
4	107796-20-000	EA	SPRING - GAS - 10" LENGTH
5	107796-19-000	EA	BRACKET - GAS SPRING
6	121947-01-01A	EA	BOLT - SLIDE - LATCH - STEEL
7	122269-02-000	EA	ROD - LATCH - 27.08"
7	122269-04-000	EA	ROD - LATCH - 15.42"
7	122269-05-000	EA	ROD - LATCH - 11.09"
7	122269-17-000	EA	ROD - LATCH - 11.57"
7	122269-03-000	EA	ROD - LATCH - 12.11"
7	122269-06-000	EA	ROD - LATCH - 24.07"
8	124304-01-000	EA	CLIP - ROUND PUSH ON
9	122268-02-000	EA	ROD - LATCH - 27.08"
9	122268-04-000	EA	ROD - LATCH - 15.42"
9	122268-05-000	EA	ROD - LATCH - 11.09"
9	122268-17-000	EA	ROD - LATCH - 11.57"
9	122268-03-000	EA	ROD - LATCH - 12.11"
9	122268-06-000	EA	ROD - LATCH - 24.07"
10	122613-55-004	EA	EXTR - PANEL ROCKER - DBLU - 4877 MM
11	123783-01-01A	EA	STRIKER - DOOR - MILL
12	107721-04-000	FT	SEAL-D - ACCESS DOOR
13	122277-01-01A	EA	COVER - LATCH - BLACK

WINDOW, VENT & EXTERIOR DOOR GROUP (CONTINUED)

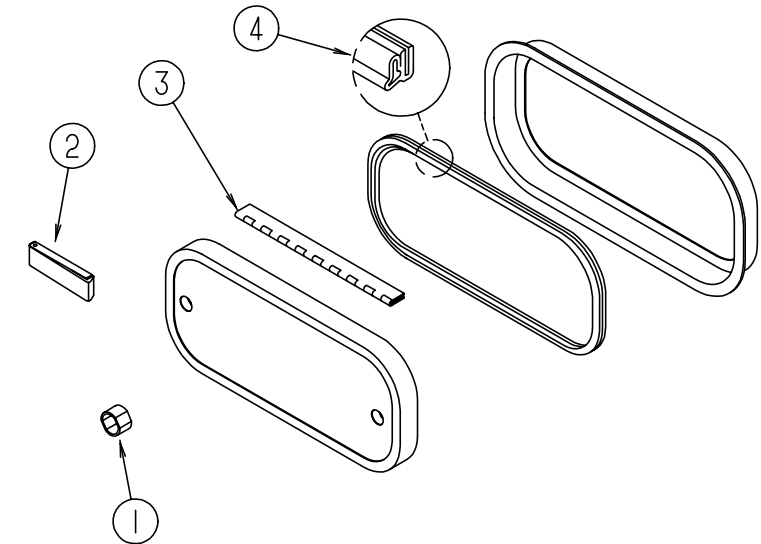

EXTERIOR DOORS

KEY	PART NUMBER	U/M	DESCRIPTION
1	107997-51-001	EA	SPACER - DOOR LOCK - .6" DEEP
2	102768-01-000	EA	HOLDER - COMPARTMENT/ ENTRY DOOR - METAL - MILL FINISH
3	081801-V3-000	EA	HINGE - ALUMINUM - 2" X 8' - BRIGHT WHITE
4	064075-07-000	FT	SEAL - BULB - W/ WIRED U CHANNEL - .3" X .5" CHANNEL - BLK

WINDSHIELD & WIPER GROUP

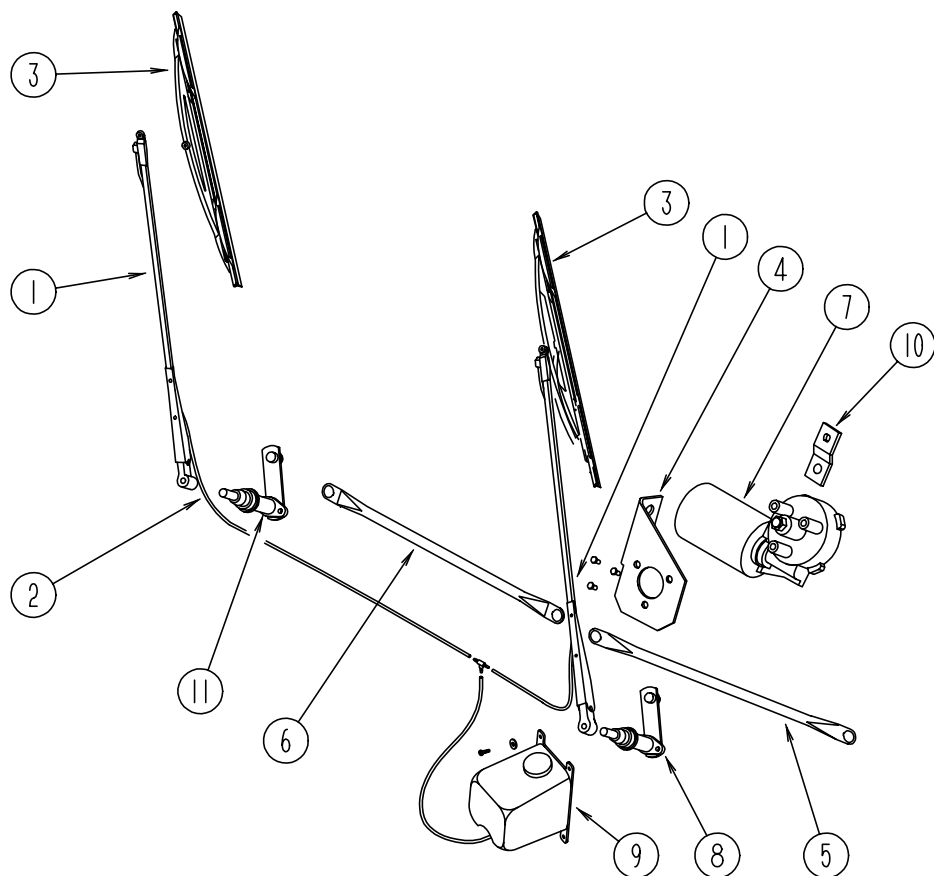

WINDSHIELD & WIPER GROUP (CONTINUED)

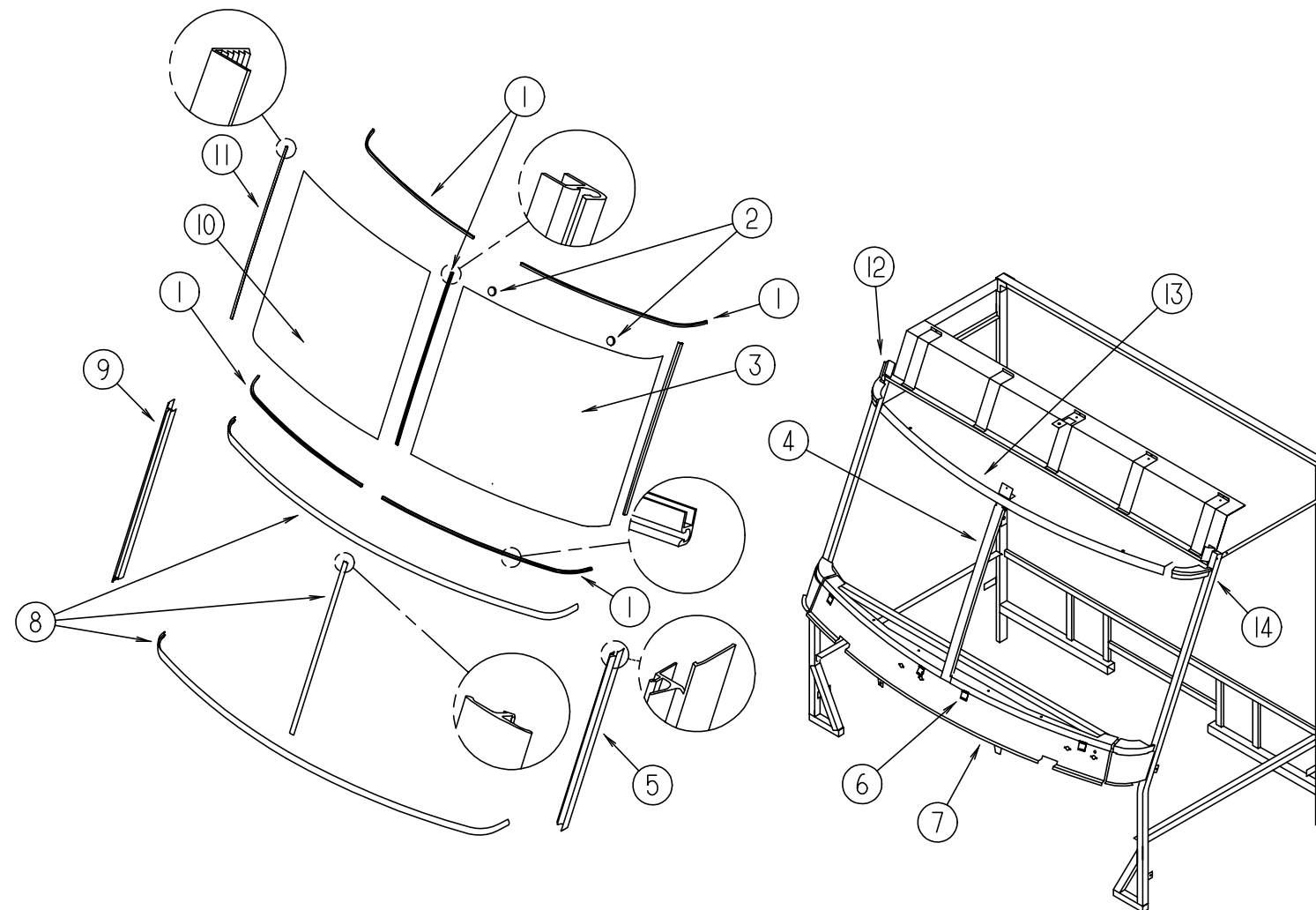

WINDSHIELD WIPER ASM

KEY	PART NUMBER	U/M	DESCRIPTION
1	103671-01-000	EA	ARM - WIPER - 24"
2	096931-01-700	FT	HOSE - WIPER
3	095964-01-000	EA	BLADE - WIPER - WINDSHIELD - 24"
4	104549-01-000	EA	BRACKET - WIPER MOTOR
5	117008-01-000	EA	LINK ASSEMBLY - WIPER CONNECTING - DRIVER SIDE
6	117008-02-000	EA	LINK ASSEMBLY - WIPER CONNECTING - PASSENGER SIDE
7	104346-05-000	EA	WIPER MOTOR W/ INTERNAL BREAKER - DYNAMIC PARK (FORD)
7	104346-04-000	EA	MOTOR - WIPER W/ INTERNAL BREAKER (CHEVY)
	117322-01-000	EA	SCREW - 1/4-28 UNF -2A - TORX
8	096505-06-000	EA	SHAFT & PIVOT ASSEMBLY - DRIVER SIDE
9	117766-02-000	EA	RESERVOIR/ PUMP - WINDSHIELD WASHER
	096931-01-701	EA	NOZZLE - HARDWARE KIT
	110605-01-000	EA	TEE - PLAS - BARBED 1/8 X 1/8 X 3/16 - BAYLOCK 3799721
	045794-01-000	FT	HOSE - WASHER - WINDSHIELD - 5/32" ID - BLACK
	117765-03-000	EA	CONNECTOR - 5/32 - WINDSHIELD WASHER
10	104347-01-000	EA	ARM - DRIVE - WIPER MOTOR - 1.54" -W/ TAPERED DRIVE HOLE
	067188-01-000	EA	STUD - CRANK - WIPER - WINDSHIELD
11	096505-05-000	EA	SHAFT & PIVOT ASM
	110742-01-000	EA	GASKET - NEOPRENE WIPER ADAPTER SHAFT - 1 3/4"OD X 1" ID
	096505-02-700	EA	DRIVER - KNURLED (HD) BRL .687 NT721017
	096505-02-701	EA	NUT - HEX (HD) W/.687 BARREL NT721021
	096505-02-702	EA	CAP - RUBBER (HD) BARREL .687 CP721084
	096505-02-703	EA	CAP - NUT(ACORN) HD W/.687 BRL 51065-40-NT27WC

WINDSHIELD MOLDINGS & GLASS

KEY	PART NUMBER	U/M	DESCRIPTION
1	110268-01-000	EA	WINDSHIELD CARRIER - 50.4"
2	081914-01-000	EA	BUMPER - RUBBER - ROUND - .43" DIAMETER - BLACK
3	114432-02-000	EA	GLASS - WINDSHIELD - DRIVER - 52.75" W X 47.5" T
4	075710-01-000	EA	FRAME - WINDSHIELD - CENTER DIVIDER - INNER
5	103107-04-01A	EA	TRIM - WINDSHIELD - DRIVER SIDE
6	104449-01-000	EA	SUPPORT - WINDSHIELD
7	077847-05-000	EA	SUPPORT - WINDSHIELD - CENTER
	077847-03-000	EA	SUPPORT - WINDSHIELD - PASSENGER SIDE END
	077847-04-000	EA	SUPPORT - WINDSHIELD - DRIVER SIDE END
8	120533-01-000	FT	MOLDING - REVEAL - WINDSHIELD
9	103107-03-01A	EA	TRIM - WINDSHIELD - PASSENGER SIDE - BLACK
10	114432-01-000	EA	GLASS - WINDSHIELD - PASSENGER - 52.75"W X 47.5" T
11	098788-06-000	EA	CHANNEL - 47.2" PVC
12	077922-03-000	EA	HEADER - WINDSHIELD END - RIGHT HAND
	114583-01-01B	EA	HEADER - WINDSHIELD - FILLER - UPPER
13	077922-06-000	EA	HEADER - WINDSHIELD - CENTER
14	077922-04-000	EA	HEADER - WINDSHIELD END - LEFT HAND
	114583-02-01B	EA	HEADER - WINDSHIELD - FILLER - UPPER
	002328-02-000	EA	BLOCK - WINDSHIELD - .062" X .5" X .98"