

**1996**

**WCG34WQ**

**G15**

**BOTANICAL (GREEN)**

**G16**

**THISTLE (TAN)**

**G17**

**COPPER CANYON**

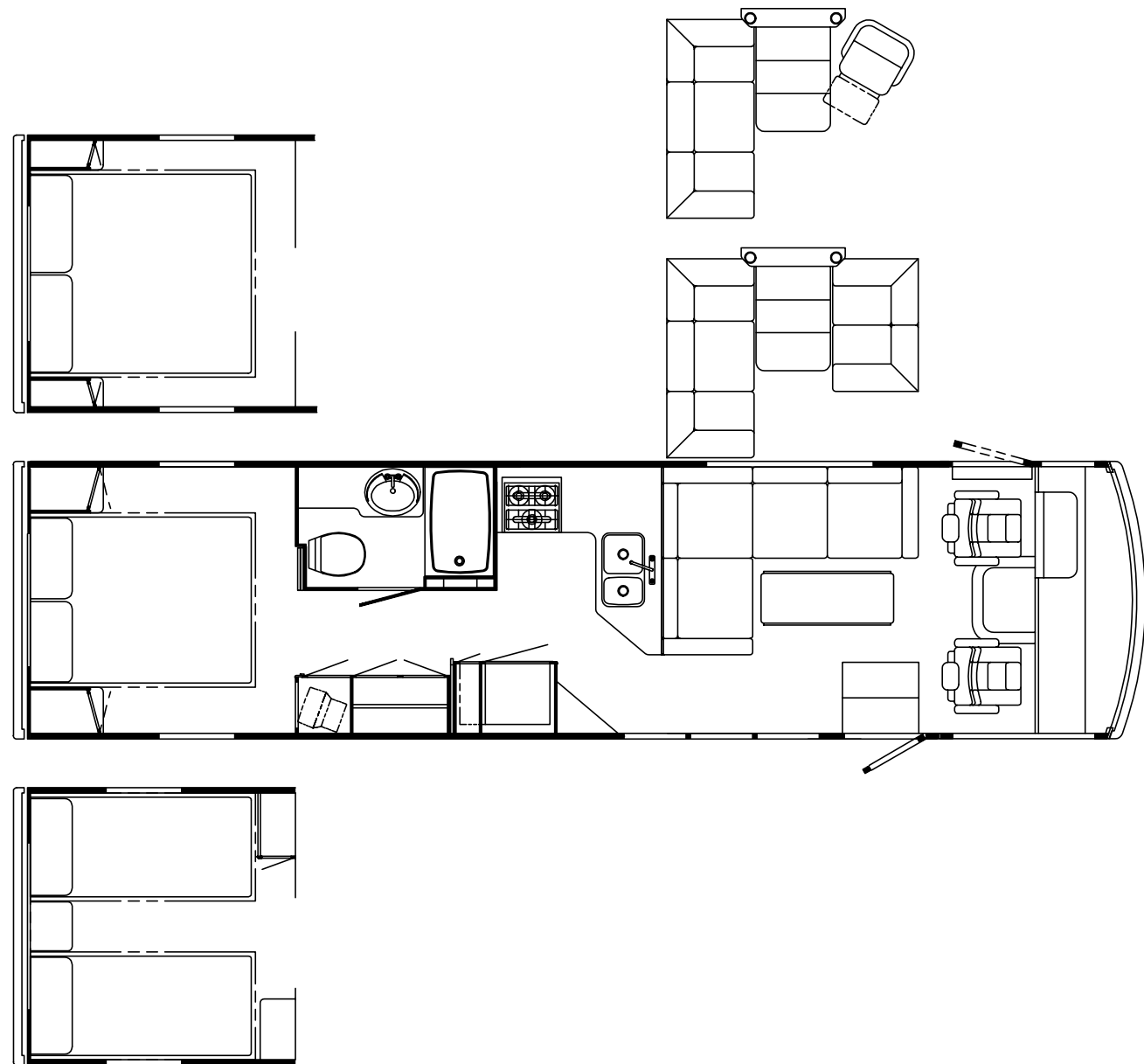
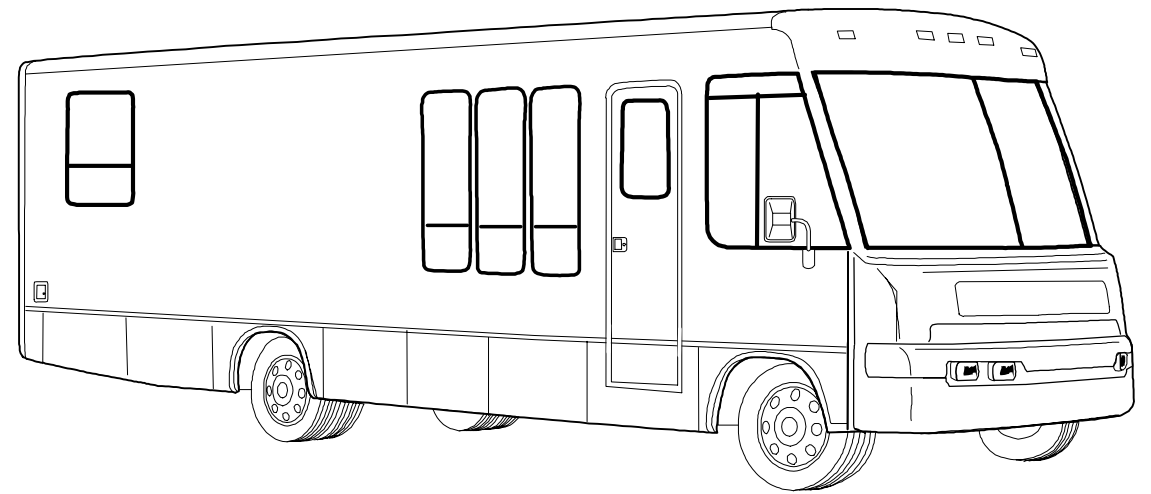

## ACCESSORIES GROUP

### OPERATOR MANUAL

KEY	PART NUMBER	U/M	DESCRIPTION
	054185-E1-000	EA	MANUAL-OPERATOR 96 ADVENTURER - G-SERIES
	092318-01-000	EA	BINDER - 3 RING - MOTOR HOME MANUAL
	092319-01-000	EA	POCKET PAGE - 3 RING BINDER - PLASTIC
	118752-01-000	EA	TOP LEVEL DRAWING NUMBER

## AUDIO VIDEO GROUP

### RADIO SYSTEMS & ANTENNA

KEY	PART NUMBER	U/M	DESCRIPTION
	087683-03-000	EA	RADIO - AM/ FM STEREO CASSETTE - AUDIOVOX RS-100
	110267-03-000	EA	RADIO - AM/ FM STEREO CD COMPATIBLE - AUDIOVOX IM-400
	116148-02-000	EA	RADIO - AM/ FM STEREO - CD PLAYER - CLARION RDB515F
	077069-02-000	EA	CABLE - ANTENNA - RADIO - EXTENSION 96" - ARA 6700667
	110469-01-000	EA	SPEAKER - OVAL - 4" X 6" - BLACK
	110470-01-01A	EA	GRILLE - SPEAKER - OVAL - 4" X 6" - BLACK
	081059-02-000	EA	WIRE ASM - 9-PIN - RADIO - AUDIOVOX 112B-1761
	105248-01-000	EA	ANTENNA - CB - ADVANCE 8604
	090944-01-000	EA	ANTENNA - RADIO - 16" RUBBER
	109889-04-000	EA	EXTENDER-SHAFT, ANTENNA 3" - MAGNADYNE RV71EX3
	108847-01-000	EA	BRACKET - ANTENNA GROUND
	115916-01-01B	EA	BRACKET - ANTENNA MOUNT
	074979-08-000	EA	SHIELD - SPEAKER - BACK - MOLDED PLASTIC - LIGHT OAK
	089340-02-000	EA	GRILLE - SPEAKER - 6.5" SQUARE
	089340-03-000	EA	SPACER - GRILLE - 6.5" SQUARE - TAN - MAGNADYNE G514
	094097-01-000	EA	SPEAKER - RADIO - W/O GRILLE - 5.25" DIA - AUDIOVOX 110C3030

### PATIO ENTERTAINMENT CENTER

KEY	PART NUMBER	U/M	DESCRIPTION
	110469-01-000	EA	SPEAKER - OVAL - 4" X 6" - BLACK
	110470-01-01A	EA	GRILLE - SPEAKER - OVAL - 4" X 6" - BLACK
	077069-02-000	EA	CABLE - ANTENNA - RADIO - EXTENSION 96" - ARA 6700667
	087683-03-000	EA	RADIO - AM/ FM STEREO W/ CASSETTE - AUDIOVOX
	090944-01-000	EA	ANTENNA - RADIO - 16" RUBBER
	108847-01-000	EA	BRACKET - ANTENNA GROUND
	109889-04-000	EA	ANTENNA - 2" SHAFT EXTENDER - MAGNADYNE RV71EX3

**AUDIO VIDEO GROUP (CONTINUED)**

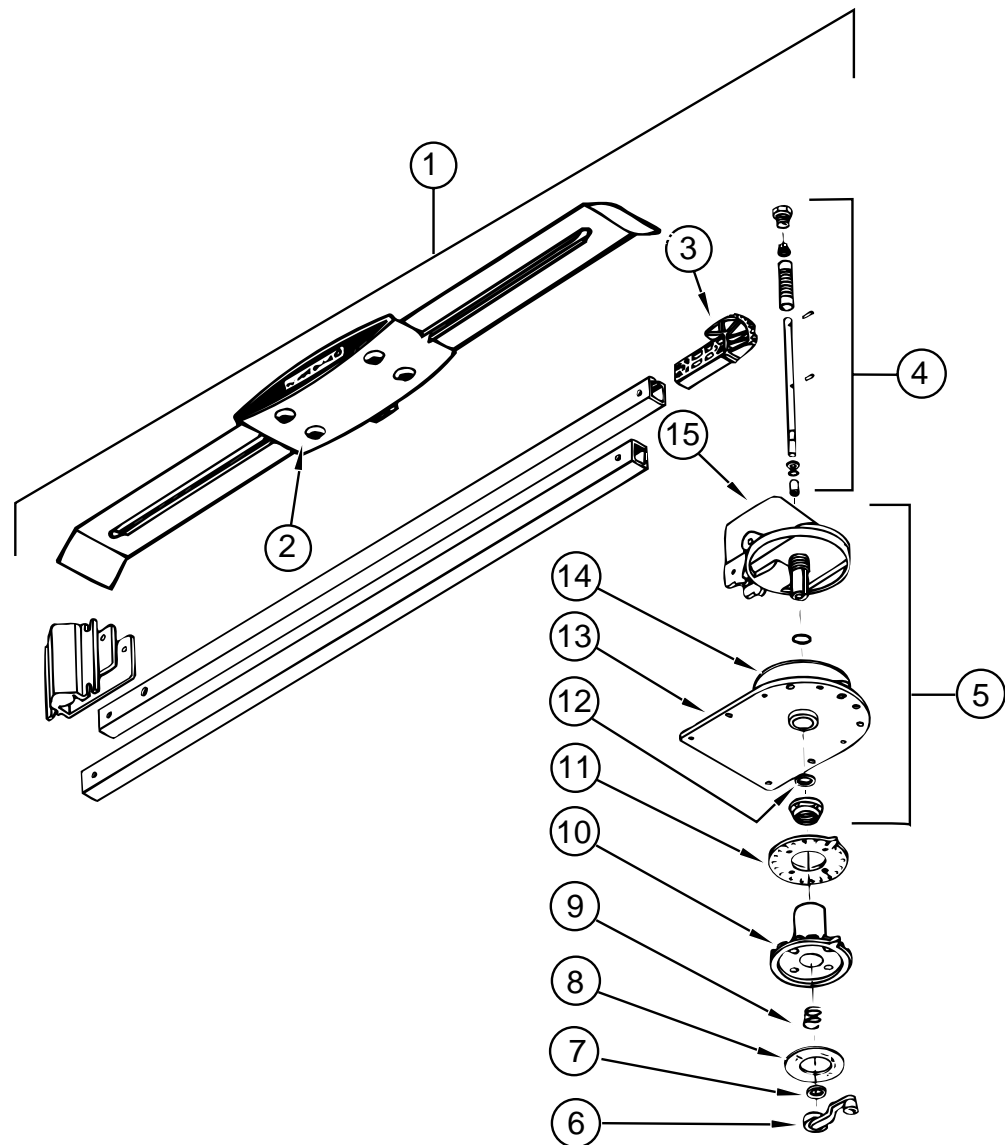

**TV ANTENNA (WINEGARD)**

KEY	PART NUMBER	U/M	DESCRIPTION	VENDOR NO.
1	076319-18-000	EA	ANTENNA - TV - ROOF MOUNT	
2	076319-01-700	EA	HEAD - ANTENNA - AMPLIFIED	RVSA U/V
3	076319-01-701	EA	GEAR - ELEVATING - PLASTIC	2200046
4	076319-01-702	EA	SHAFT ASM - ELEVATING	RVP-400A
5	076319-01-711	EA	BASE & LIFT ASM	2762802
6	076319-01-706	EA	CRANK - ELEVATING - W/ SET SCREW	5755100
7	076319-01-705	EA	BEARING - NYLON - 7/8"ID	3200658
8	076319-01-708	EA	CRANK COVER DECAL	5413002
9	076319-01-707	EA	SPRING - HANDLE	5160822
10	076319-01-709	EA	PLATE - DIRECTIONAL - FOR HEAD	3200644
11	076319-01-712	EA	CEILING PLATE	3200608
12	076319-01-704	EA	BEARING - NYLON - 1.5"OD	3200657
13	076319-01-713	EA	BASE PLATE	3100523
14	076319-01-703	EA	BEARING - NYLON - 5"OD	3200656
15	076319-01-714	EA	HOUSING - ROTATING GEAR	2200049

**AUDIO VIDEO GROUP (CONTINUED)**

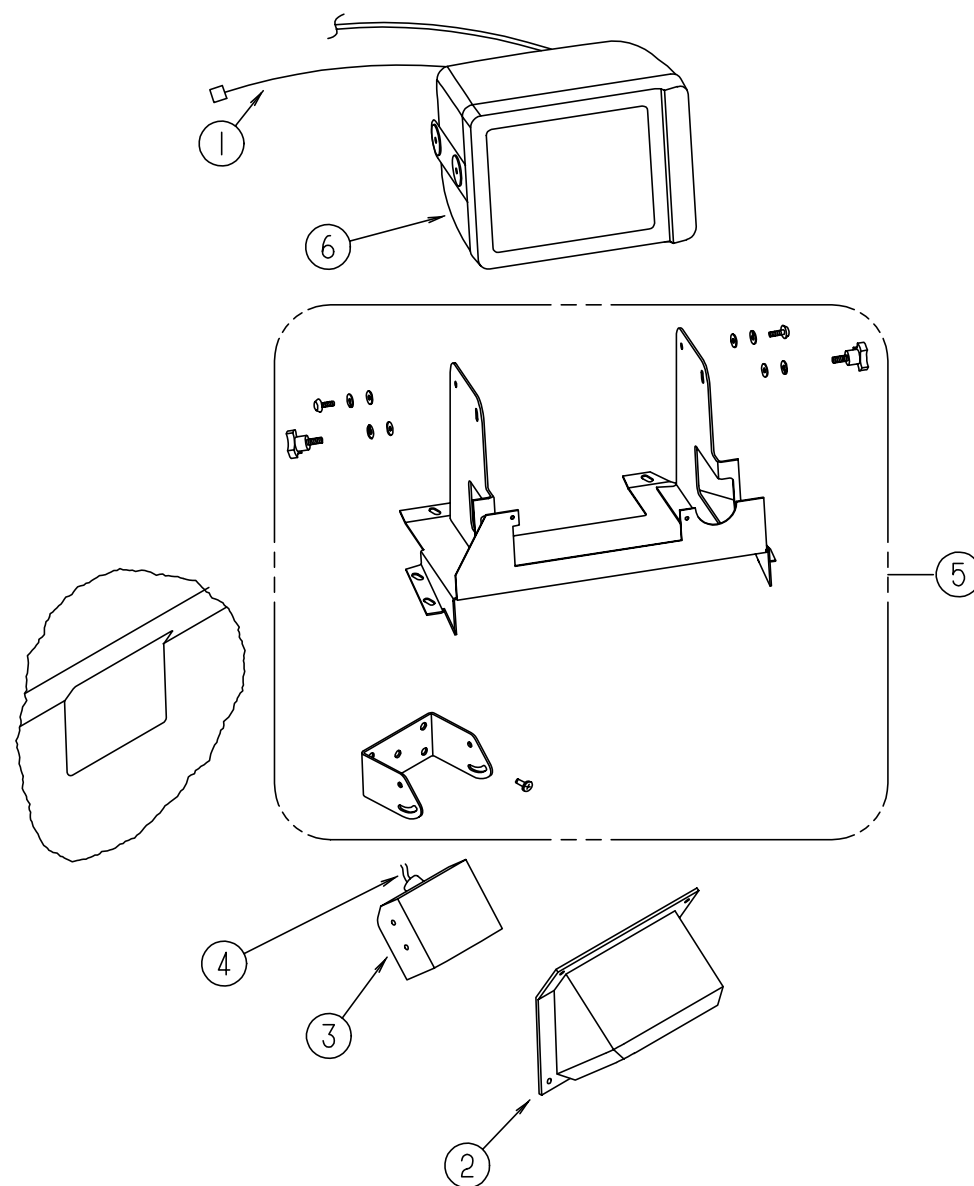

**REAR MONITOR SYSTEM**

KEY	PART NUMBER	U/M	DESCRIPTION	VENDOR NO.
1	096717-03-000	EA	WIRE ASM-REAR MONITOR, UPPER	
	093040-06-000	EA	WIRE ASM-MONITOR - SONY SM-HRN7	
2	107852-01-01A	EA	SHROUD-CAMERA, OUTER, BUFF	
	108529-01-01A	EA	SHROUD-CAMERA, INNER, BLACK	
2	093040-08-000	EA	7" REAR VIEW MONITOR SYSTEM W/AUDIO JACK	
3	093040-04-700	EA	CAMERA, W/BACKET & WIRING	SSC-530AM
4	093041-01-000	EA	CABLE-MONITOR/CAMERA, INTERNAL USE - 65.6'	
	093041-02-000	EA	CABLE-MONITOR/CAMERA, EXTERNAL USE	
5	N/A		PARTS ARE INCLUDED W/TELEVISION SYSTEM - SONY	
6	093040-05-700	EA	MONITOR-7" W/POWER HARNESS	SSM721AMR
	108885-02-000	EA	WIRE ASM-INSTRUMENT PANEL - REAR MONITOR	

# AUDIO VIDEO GROUP (CONTINUED)

## SATELLITE DISK (WINEGARD)

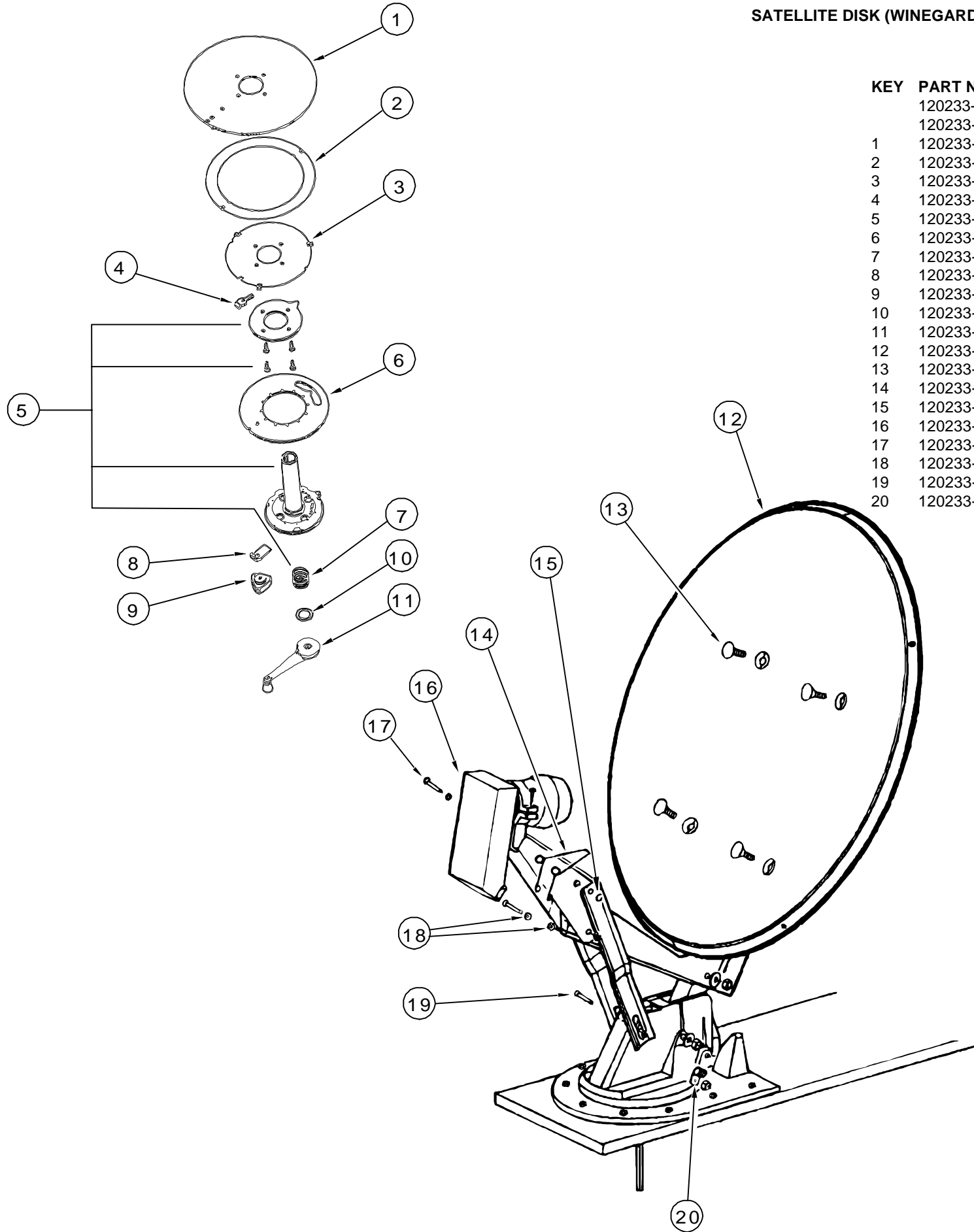

KEY	PART NUMBER	U/M	DESCRIPTION	VENDOR NO.
	120233-02-000	EA	RECEIVER-SATELLITE ONLY - RD-1046	
	120233-01-000	EA	ANTENNA-SATELLITE, W/O RECEIVER (DISH & HDWR KIT) - RD-4600	
1	120233-01-700	EA	PLATE-FIXED	3750821
2	120233-01-701	EA	DIAL-DIRECTIONAL	2745056
3	120233-01-702	EA	PIVOT-DIAL-DIRECTIONAL	2745058
4	120233-01-703	EA	STOP-ROTATION	3711281
5	120233-01-704	EA	PLATE-CEILING W/DIRECTIONAL HANDLE	RP-6300
6	120233-01-705	EA	PLATE-ROTATE	3750820
7	120233-01-706	EA	SPRING	RP-6822
8	120233-01-707	EA	CLAMP-ROTATE	3711280
9	120233-01-708	EA	KNOB-CLAMP	160822
10	120233-01-709	EA	WASHER-NYLON	RP-2658
11	120233-01-710	EA	HANDLE-CRANK	RP-6795
12	120233-01-711	EA	REFLECTOR - 46 CM	2745304
13	120233-01-712	EA	BOLT-FLAT HEAD	2160253
14	120233-01-713	EA	SPRING	2160820
15	120233-01-714	EA	CLIP-E	5160818
16	120233-01-715	EA	RCA LNB	278015
17	120233-01-716	EA	PIN	2160814
18	120233-01-717	EA	BEARING-NYLON	2200728
19	120233-01-718	EA	PIN	5160817
20	120233-01-719	EA	CLAMP-CABLE	2200060

## AUDIO VIDEO GROUP (CONTINUED)

### TV - VCR SYSTEMS

KEY	PART NUMBER	U/M DESCRIPTION	VENDOR NO.
	082134-01-000	EA ADAPTER - TV - CABLE TO CABLE - WINEGARD F-81M	
	086756-01-000	EA SPLITTER - TV - 2 WAY	
	076319-03-000	FT CABLE - COAXIAL - 75 OHM	
	076319-12-000	EA CONNECTOR - COAXIAL - ONE PIECE	
	086757-03-000	EA CONTROL CENTER - SWITCH - VCR/TV - MAGNADYNE VCS-6	
	119120-01-000	EA VCR-VHS, CABLE READY - REMOTE - AUDIOVOX AVR-1075	
	119120-02-000	EA VCR-VHS, CABLE READY - REMOTE - AUDIOVOX AVR-1170	
		FROM: 00-00-00 THRU: 12-10-95	
		FROM: 12-11-95 THRU: 99-99-99	
	119120-01-700	EA VCR-REMOTE	8874570
	113684-01-000	EA TV - 19" COLOR UL AND CSA - AUDIOVOX AVT-1975	
	113684-01-700	EA REMOTE	8822345
	092310-02-000	EA TV - COLOR - 9" - AC/ DC - MAGNAVOX (REAR TV) RD0945	
	092310-02-700	EA REMOTE - F/TV MAGNAVOX RD0945	0822334
	098819-01-000	EA SPEAKER - 2 WATT - 8 OHM - 4"	
	093214-01-02A	EA GRILL - SPEAKER, 4" BROWN	
	099717-01-000	EA TIEDOWN - TV STRAP - 38.2" LONG	
	109889-04-000	EA EXTENDER - SHAFT - ANTENNA 3" - MAGNADYNE RV71EX3	
	082136-01-000	EA JAM NUT - HEX 3/8-32 - WINEGARD	
	076319-08-000	EA WALLPLATE - CABLE RECEPTACLE - TV - SINGLE - IVORY	
	076319-09-000	EA WALLPLATE - CABLE RECEPTACLE - TV - SINGLE - BROWN	
	086777-01-000	EA WALLPLATE - TV CABLE - W/ ANTENNA SWITCH - IVORY	
	086777-05-000	EA PLATE-WALL, ANTENNA 1 OUTPUT - IVORY - WINEGARD RV-0921	
	114870-02-000	EA PLUG ASM - 3.5MM AUDIO, W/LEADS - OW DONALD 35-P8	

## BATH GROUP

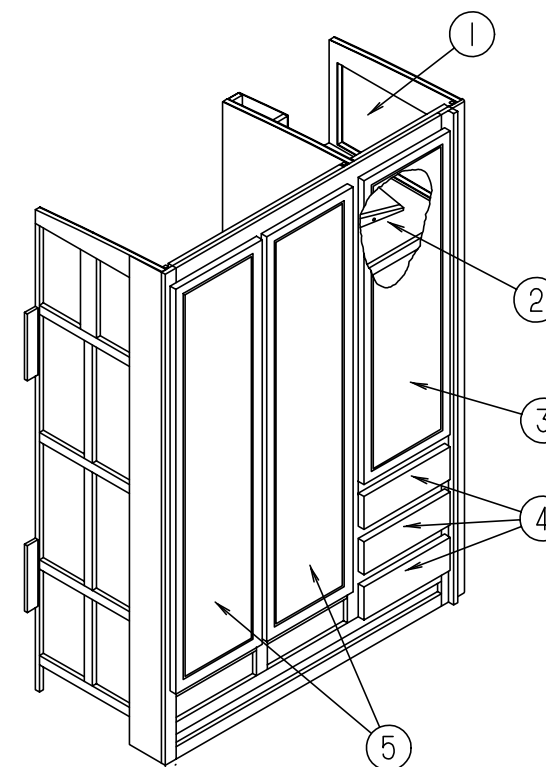

### WARDROBE CABINET

KEY	PART NUMBER	U/M DESCRIPTION
1	M06803-05-G15	EA DOOR ASM. - RAIL - W/O HARDWARE - MTRD/ OG 0365 X 0555
2	116172-12-G15	EA TV WEDGE SHELF
	099717-01-000	EA STRAP - TV TIE DOWN, W/ 24" FEMALE STRAP & 14.2" MALE STRAP
3	M06803-C6-G15	EA DOOR ASM. - RAIL - W/O HARDWARE - MTRD/ OG 0425X1220
	058331-A3-000	EA MIRROR-GLASS, SAFETY - 342 X 1137
4	M05971-L3-G15	EA DRAWER ASM.
5	M06803-11-G15	EA DOOR ASM. - RAIL - W/O HARDWARE - MTRD/ RAD 0410 X 1660
	042438-01-000	EA DOWEL - CLOTHES ROD - 1" DIAMETER - WOOD
	009112-01-000	EA FLANGE - 1" CLOTHES ROD - PLASTIC - OFF WHITE

## BATH GROUP (CONTINUED)

### BATH CABINETS, PRIVACY DOOR & SHOWER COMPONENTS

KEY	PART NUMBER	U/M	DESCRIPTION
1	M06803-G0-G15	EA	DOOR - RAIL - W/O HARDWARE - MTRD/OG 305 X 475
2	M06803-82-G15	EA	DOOR - RAIL - W/O HARDWARE - MTRD/OG 400 X 710
	076767-04-000	EA	CABLE-SUPPORT, 5.9" - STAINLESS STEEL
3	P16188-01-F11	EA	CABINET ASM - MEDICINE
4	058331-51-000	EA	MIRROR-GLASS, SAFETY - 660 X 1016
5	075454-02-000	EA	RING - TOWEL - W/ MOUNTING HARDWARE - BRASS
6	075240-06-000	EA	FAUCET - LAVATORY - BONE
	105218-01-01A	EA	SPACER-FAUCET, LAVATORY SINK - 2" X 5.6" - ABS PLASTIC O/W
7	105921-01-01A	EA	SINK-LAVATORY, LARGE OVAL - 17 X 20 - PLASTIC - O/W
	106116-01-01A	EA	STRAINER-SINK, W/STOPPER TAILPIECE GASKET & NUT - PLASTIC
8	P16196-01-G15	EA	CABINET ASM - LAVATORY - W/ COUNTERTOP ASM (G15,G16)
8	P16196-01-G17	EA	CABINET ASM - LAVATORY - W/ COUNTERTOP ASM
9	M06803-20-G15	EA	DOOR ASM - W/O HARDWARE,MTRD/OG 0255 X 0640
10	M06803-D9-G15	EA	DOOR ASM - W/O HARDWARE,MTRD/OG 0255 X 0640
11	116237-01-G15	EA	DRAWER ASM-HAMPER
12	085330-06-000	EA	TOILET - CHINA - W/ SPRAY (SEALAND)
13	075452-02-000	EA	HOLDER - TOILET TISSUE - BRASS
14	M05971-L4-G15	EA	DRAWER ASM. - W/O HARDWARE
15	116196-12-F12	EA	COUNTERTOP ASM. (G15,G16)
15	116196-12-G17	EA	COUNTERTOP ASM.
	M03866-04-F31	EA	DOOR ASM. (1 BIFOLD ONLY) W/O HARDWARE
	093170-06-02A	EA	HEADER - BIFOLD DOOR (TRACK) OFF WHITE
	117978-01-01A	EA	KNOB - DOOR - BRIGHT BRASS
	092652-01-000	EA	GUIDE WHEEL (BIFOLD DOOR) TOP MOUNT
	084451-01-000	EA	CATCH (BIFOLD DOOR) BRASS
	102920-01-01A	EA	HINGE - DOOR - SPRING LOADED - BRASS
	009059-01-000	EA	HINGE-W IN-BRASS
	009059-02-000	EA	HINGE-2 IN-BRASS
	M87868-13-G15	EA	DOOR ASM. - CABINET, BATH
	094485-03-01A	EA	KNOB - DOOR - BRASS
	100357-01-000	EA	ROD -TOWEL - BRASS W/ENDS BENT FOR BACK OF BATH DOOR
	102089-13-E07	EA	MOUNT - ROD - RIGHT SIDE - FOR TOWEL RODS - 53.5" LONG - WOOD
	102089-14-E07	EA	MOUNT - ROD - LEFT SIDE - FOR TOWEL RODS - 53.5" LONG - WOOD
	102089-02-G15	EA	RACK ASM-TOWEL
	100357-01-000	EA	ROD-TOWEL, BRASS W/ENDS BENT FOR BACK OF BATH DOOR
	104013-03-G15	EA	DOOR ASM - SLIDING (BATH / GALLEY)
	103874-01-000	EA	ROLLER HANGER - SLIDING DOOR
	103868-03-01A	EA	TRACK - DOOR - 1250 OFF WHITE
	103908-07-G15	EA	HEADER - SLIDING DOOR
	057534-01-000	EA	TIEBACK - CLEAR PLASTIC (BATH / GALLEY DOOR)
16	115612-01-01A	EA	SURROUND - SHOWER - OFF WHITE
17	103092-01-000	EA	SHOWER HEAD - W/60" HOSE (US)
17	103092-02-000	EA	SHOWER HEAD - W/HOSE (CSA)
	103092-01-701	EA	BRACKET (FOR SHOWER HEAD) BONE
	104462-02-01A	EA	CADDY - SHOWER - OFF WHITE
18	079563-04-01A	EA	FAUCET - SHOWER
	075606-01-000	EA	PANEL-FAUCET BACK, SHOWER - 5" X 9" - PLASTIC
19	M02630-27-F11	EA	SHOWER PAN ASM
	066436-01-000	EA	NUT-SLIP,1.5" TAILPIECE
	066729-01-000	EA	STRAINER-TUB,SHOWER DRAIN
	069640-01-000	FT	SEALER-RIBBON,1/4"DIA X 30'
	069735-01-000	EA	WASHER-TAILPIECE,1.5" PLASTIC
	011069-06-000	EA	TAILPIECE - 1 1/2" X 1 1/4" X 2.5" - BRASS (SHOWER PAN)
	057671-01-000	EA	COVER - SCREW - #8 - PLASTIC - OFF WHITE

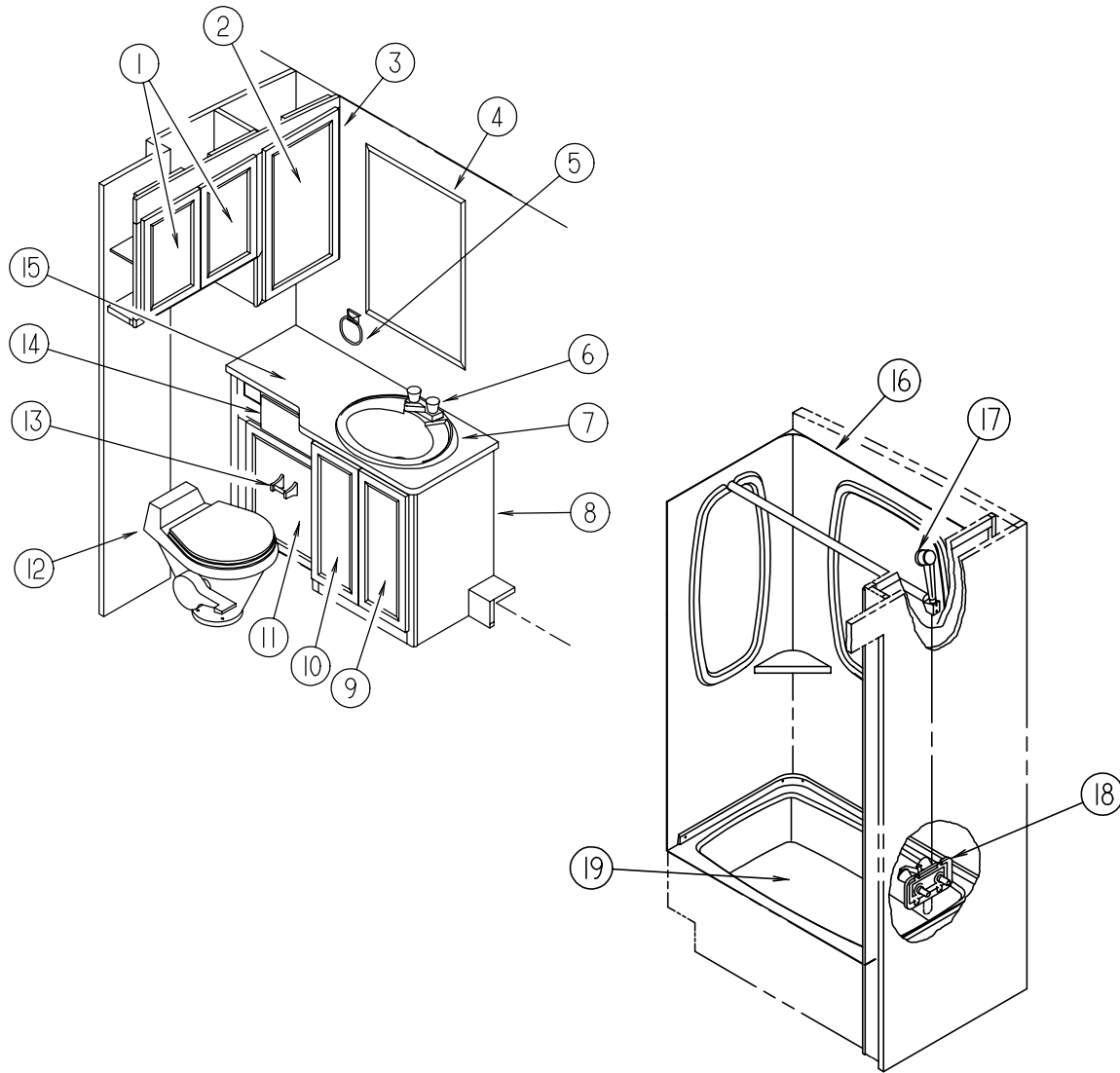

**BATH GROUP (CONTINUED)**

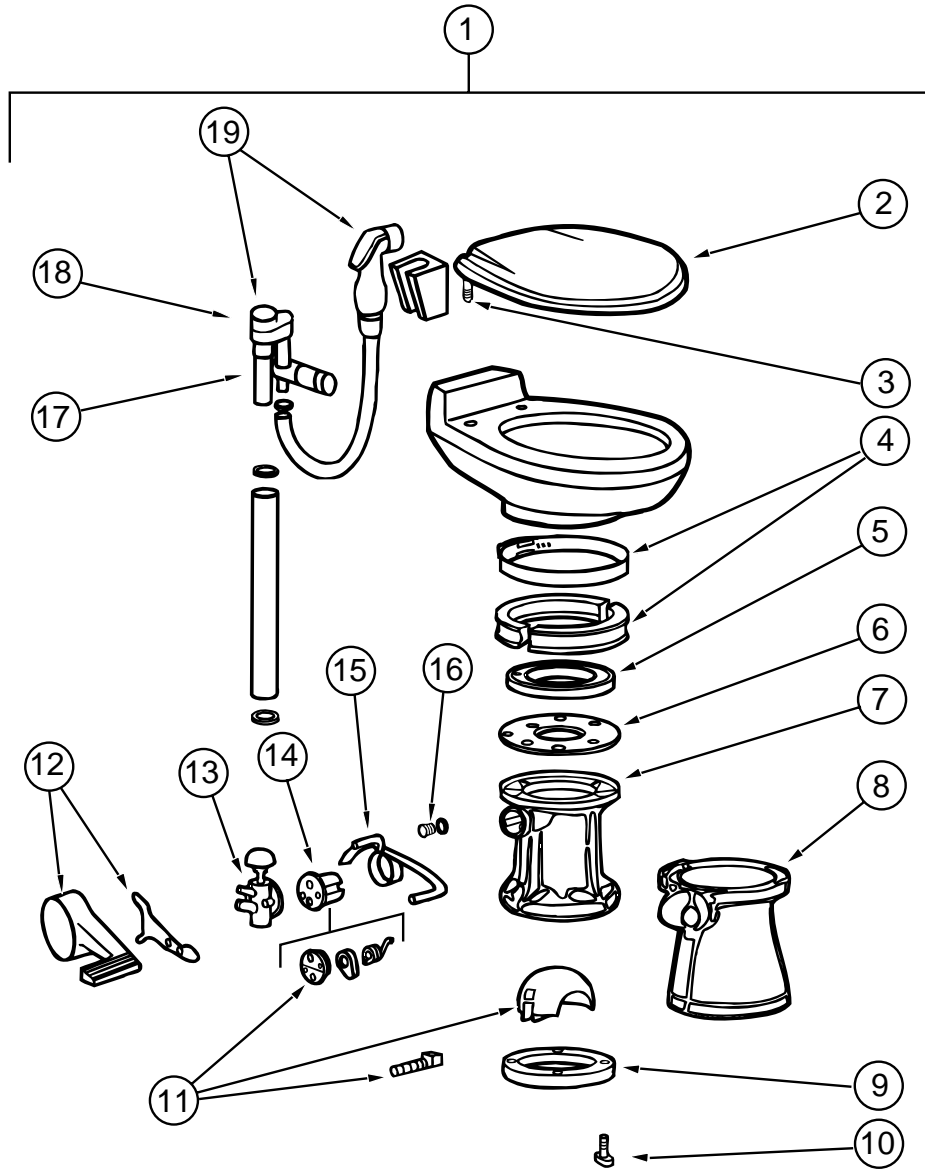

**TOILET (SEALAND)**

KEY	PART NUMBER	U/M	DESCRIPTION	VENDOR NO.
1	085330-06-000	EA	TOILET-CHINA - STANDARD (BONE) - 591003	
2	085330-06-700	EA	SEAT ASSEMBLY (BONE)	340591
3	085330-06-702	EA	HINGE HARDWARE (BONE) SET	342131
4	085330-01-703	EA	RING & HALF CLAMPS ASM (BONE)	385310048
5	085330-01-704	EA	TEFLON & RUBBER SEALS	385316140
6	085330-01-705	EA	SUPPORT - SEAL - PLASTIC	390346405
7	085330-02-700	EA	BASE ASM	310121
8	085330-02-702	EA	PEDESTAL COVER KIT (BONE)	510 - 310112
9	085330-01-714	EA	SEAL - FLANGE - FLOOR	390343892
10	085330-01-717	EA	BOLT MOUNTING PACKAGE	385310064
	085330-01-718	EA	SEAL & BOLT MOUNTING PACKAGE	385310063
11	085330-01-706	EA	BALL - SHAFT & CARTRIDGE	385318162
12	085330-02-703	EA	PEDAL COVER KIT (BONE) NEW STYLE	310115
13	085330-01-709	EA	VALVE - WATER	385314349
14	085330-01-707	EA	CARTRIDGE - SPRING	381236096
15	085330-06-703	EA	FLUSH LEVER	340873
16	085330-01-710	EA	PLUG - DRAIN - & CAP - W/ SEAL	385316142
17	085330-06-701	EA	VALVE W/ DIVERTER (VACUUM BREAKER)	230335
18	085330-06-704	EA	VACUUM BREAKER KIT	316906
19	085330-04-701	EA	HAND SPRAY W/HOSE	340683

**BATH GROUP (CONTINUED)**

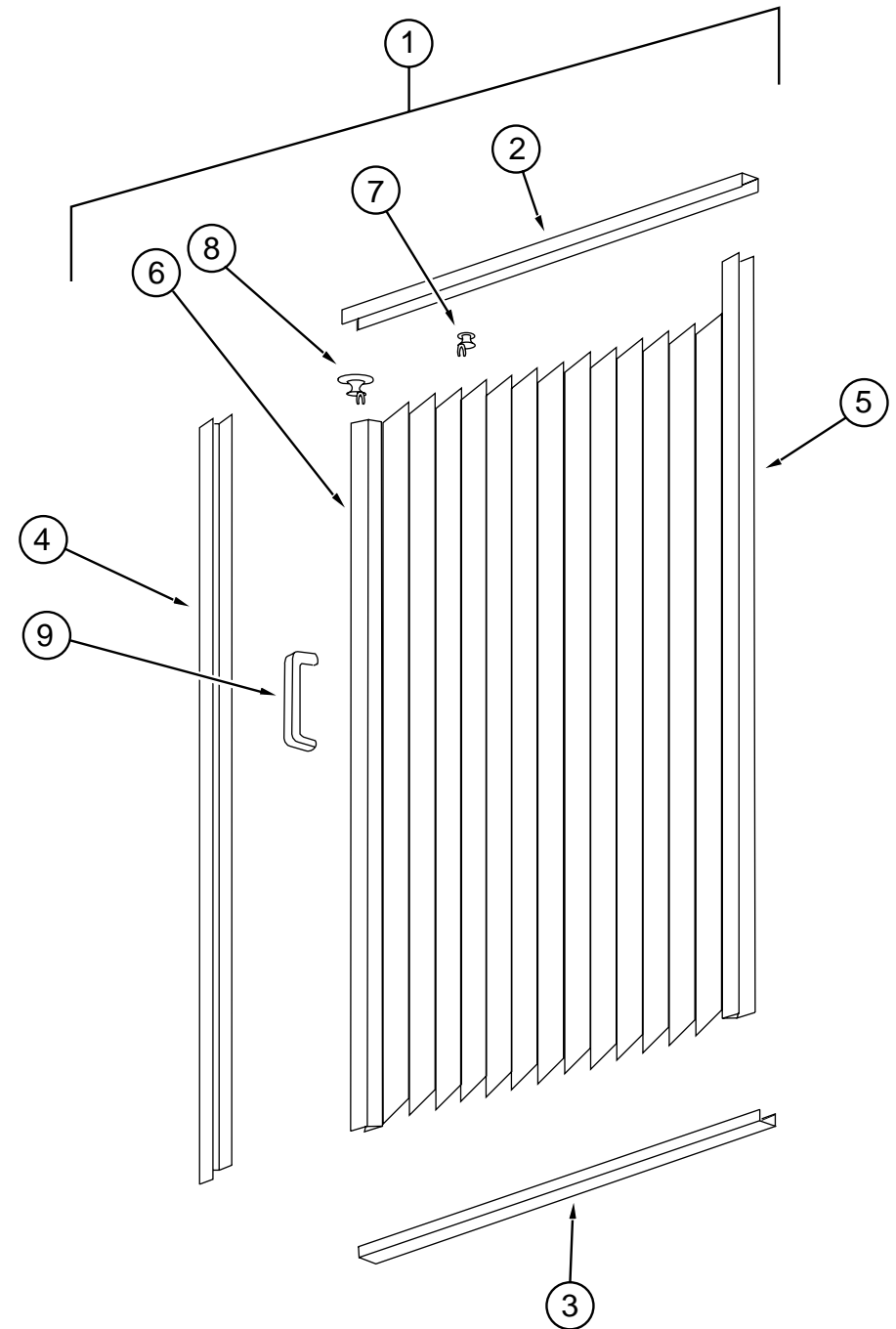

**SHOWER DOOR**

KEY	PART NUMBER	U/M	DESCRIPTION
1	117431-03-01A	EA	DOOR-SHOWER, FABRIC - PLEATED
2	117431-01-700	EA	TRACK-TOP, ALUM. IVORY INSERT - 39 3/8"
3	117431-01-701	EA	TRACK-BOTTOM, 39 3/8"
4	117431-01-702	EA	RAIL-SIDE, 63"
5	117431-01-703	EA	RAIL-STATIONARY, 63"
6	117431-01-704	EA	RAIL-LEAD, 63"
7	117431-01-705	EA	GLIDE-IVORY, TRAVELER
8	117431-01-706	EA	GLIDE-IVORY LEAD, TRAVELER
9	117431-01-708	EA	HANDLES & SCREWS
	117431-01-707	EA	LATCH
	117431-01-709	EA	STRAP-VINYL SHOWER

# BEDROOM GROUP

## TWIN BEDROOM

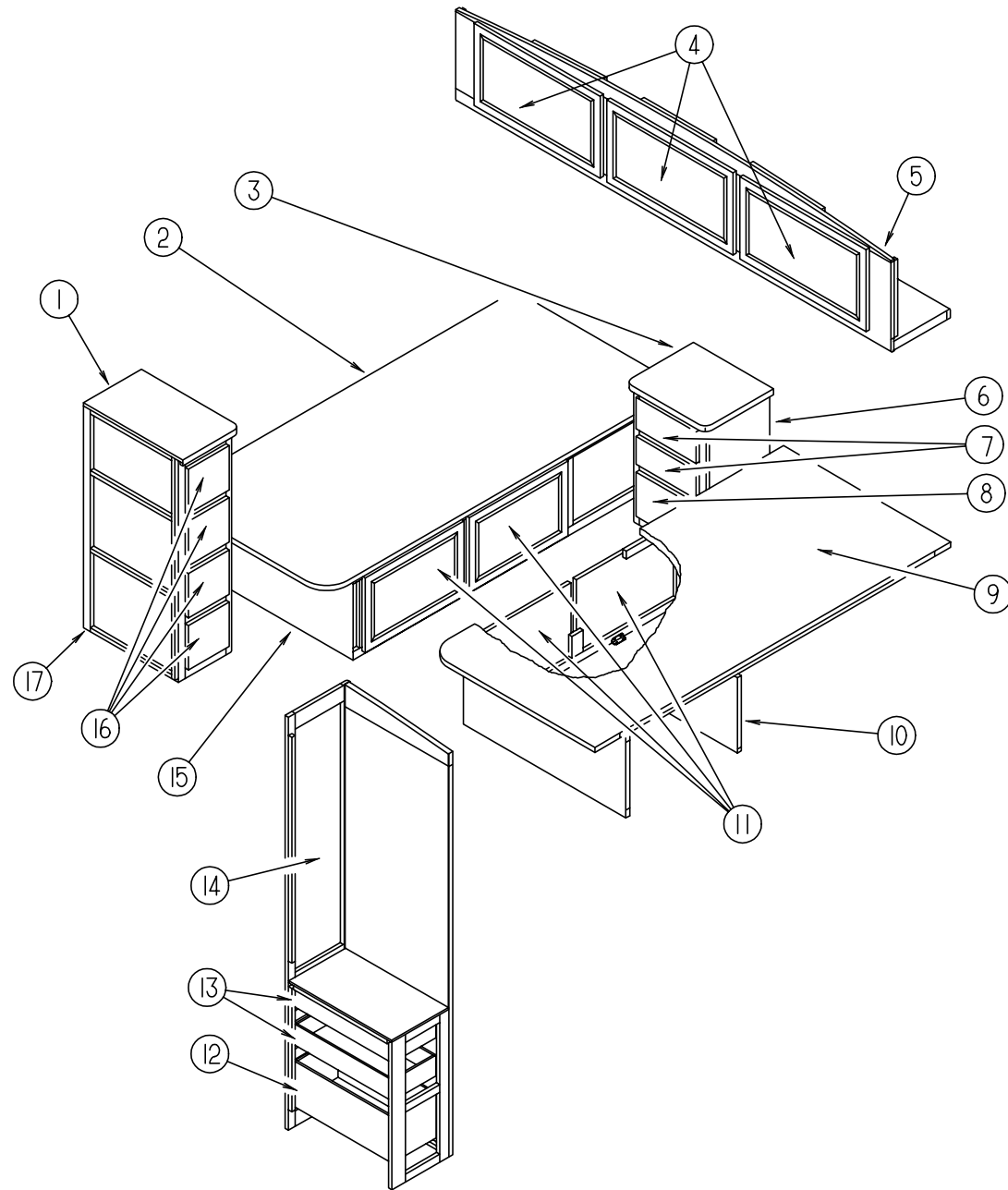

KEY	PART NUMBER	U/M	DESCRIPTION
1	116192-11-F12	EA	COUNTERTOP ASM. - WARDROBE - REAR, DRIVER (G15,G16)
1	116192-11-G17	EA	COUNTERTOP ASM. - WARDROBE - REAR, DRIVER
2	M07464-01-000	EA	CABINET ASM. - TWIN BED TOP - PASSENGER SIDE
3	104507-11-F12	EA	COUNTERTOP ASM. (G15,G16)
3	104507-11-E10	EA	COUNTERTOP ASM. (G17)
4	M06803-13-G15	EA	DOOR ASM - RAIL - W/O HARDWARE - MITERED/OGEE 0400 X 0710
4	M06803-82-G15	EA	DOOR ASM - RAIL - W/O HARDWARE - MITERED/OGEE 0400 X 0710 (EXPORT)
5	116187-01-G15	EA	CABINET ASM. - OVERHEAD - W/O DOORS & HARDWARE
6	104507-01-G15	EA	CABINET ASM - NIGHTSTAND (G15,G16)
6	104507-01-G17	EA	CABINET ASM - NIGHTSTAND
7	M05971-65-G15	EA	DRAWER ASM. - W/O HARDWARE
8	M05971-74-G15	EA	DRAWER ASM. - W/O HARDWARE
9	M07464-02-000	EA	CABINET ASM. - TWIN BED TOP - DRIVER SIDE
10	P16194-02-G15	EA	CABINET - TWIN BED BASE - DRIVER SIDE
11	M06803-68-G15	EA	DOOR ASM - W/O HARDWARE - RAD 0305 X 0555
12	M05971-L7-G15	EA	DRAWER COMPL-SLIDE OGEE
13	M05971-58-G15	EA	DRAWER COMPL-SLIDE OGEE
14	M06803-E9-G15	EA	DOOR ASM - RAIL - W/O HARDWARE - MITERED/OGEE 0305 X 1220
15	P16194-01-G15	EA	CABINET ASM. - TWIN BED BASE - PASSENGER SIDE
16	M05971-71-G15	EA	DRAWER COMPL-SLIDE OGEE
17	116192-01-G15	EA	CABINET ASM-CHEST (G15,G16)
17	116192-01-G17	EA	CABINET ASM-CHEST



## BEDROOM GROUP (CONTINUED)

### QUEEN BEDROOM

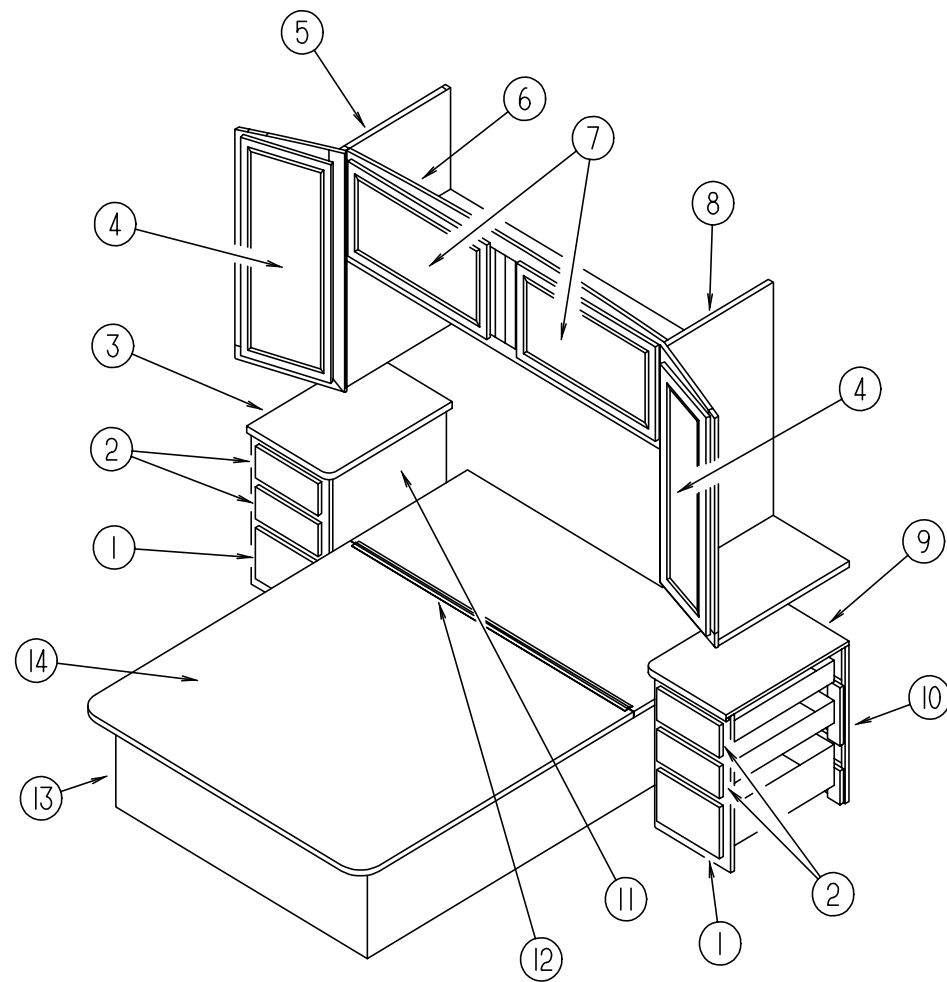

KEY	PART NUMBER	U/M	DESCRIPTION
1	M05971-L6-G15	EA	DRAWER ASM - CABINET - W/O HARDWARE
2	M05971-L5-G15	EA	DRAWER ASM - CABINET - W/O HARDWARE
3	116193-11-F12	EA	COUNTERTOP ASM. (G15,G16)
3	116193-11-G17	EA	COUNTERTOP ASM.
4	M06803-G1-G15	EA	DOOR ASM - RAIL - W/O HARDWARE - MITERED/OG 0365 X 0925
4	058331-D4-000	EA	MIRROR - CABINET DOOR
5	116142-01-G15	EA	CABINET ASM - SHIRT CLOSET (PASSENGER SIDE)
6	121273-01-G15	EA	CABINET ASM - OVERHEAD - REAR
7	M06803-82-G15	EA	DOOR ASM - W/O HARDWARE - MITERED/OG 0400 X 0710
8	116142-02-G15	EA	CABINET ASM - SHIRT CLOSET (DRIVER SIDE)
9	116193-12-F12	EA	COUNTERTOP ASM. (G15,G16)
9	116193-12-G17	EA	COUNTERTOP ASM.
10	116193-02-G15	EA	CABINET ASM. - W/ COUNTERTOP - NIGHTSTAND (G15,G16)
10	116193-02-G17	EA	CABINET ASM. - W/ COUNTERTOP - NIGHTSTAND
11	116193-01-G15	EA	CABINET ASM. - W/ COUNTERTOP - NIGHTSTAND (G15,G16)
11	116193-01-G17	EA	CABINET ASM. - W/ COUNTERTOP - NIGHTSTAND
12	041389-25-000	EA	HINGE-PIANO, 1.50 X 1397 - MILL
13	P18758-01-G15	EA	CABINET ASM. - QUEEN BED - W/O TOP
14	M07571-02-G15	EA	CABINET ASM. - QUEEN BED TOP - COMPLETE W/HINGE
	107796-06-000	EA	SPRING-GAS 20" LENGTH,120 LB
	107796-07-000	EA	BRACKET-GAS SPRING
	089025-01-000	EA	SUPPORT-SPRING, TO BED - ANGLE 1.5" X 11.8" LONG - STEEL

## BEDROOM GROUP (CONTINUED)

### KING BEDROOM

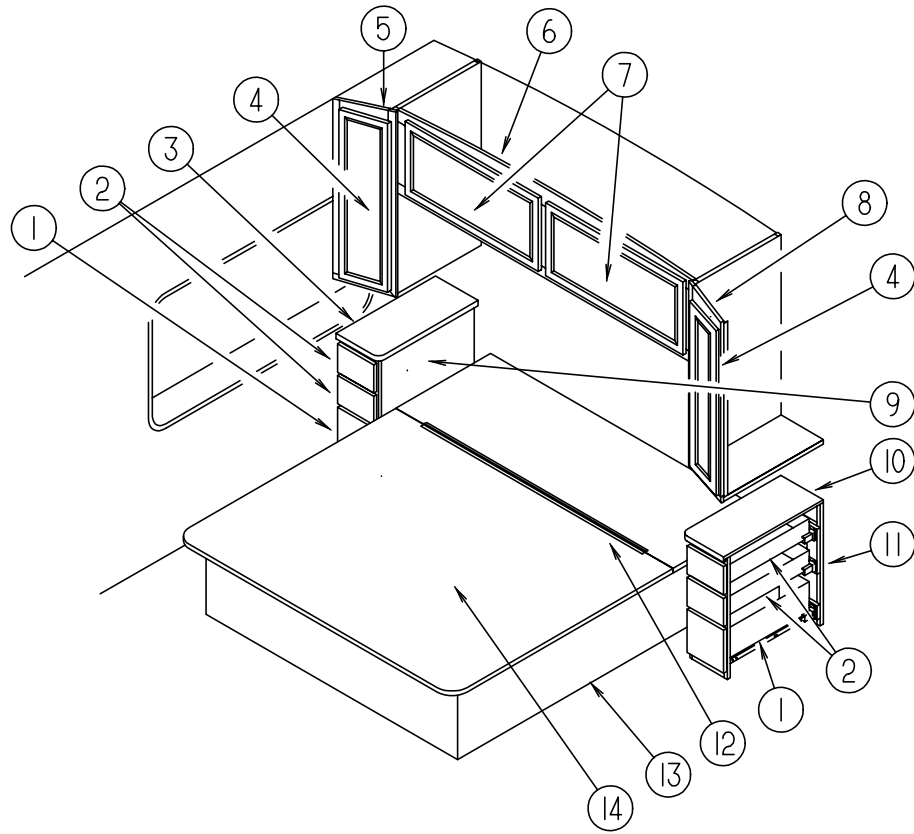

KEY	PART NUMBER	U/M	DESCRIPTION
1	M05971-W8-G15	EA	DRAWER ASM - CABINET - W/O HARDWARE
2	M05971-W9-G15	EA	DRAWER ASM - CABINET - W/O HARDWARE
3	117173-11-F12	EA	COUNTERTOP ASM. (G15,G16)
3	117173-11-G17	EA	COUNTERTOP ASM.
4	M06803-37-G15	EA	DOOR ASM - RAIL - W/O HARDWARE - 275 X 925 MM
4	058331-A7-000	EA	MIRROR - CABINET DOOR - 192 X 842 MM
5	117175-01-G15	EA	CABINET - SHIRT CLOSET - PASSENGER SIDE
6	117240-01-G15	EA	CABINET - OVERHEAD - REAR
			FROM: 00-00-00 THRU: 10-12-95
6	121272-01-G15	EA	CABINET - OVERHEAD - REAR
			FROM: 10-13-95 THRU: 99-99-99
7	M06803-L7-G15	EA	DOOR - CABINET - W/O HARDWARE - 365 X 850 MM
8	117175-02-G15	EA	CABINET - SHIRT CLOSET - DRIVER SIDE
9	117173-01-G15	EA	CABINET - NIGHTSTAND - PASSENGER SIDE (G15,G16)
9	117173-01-G17	EA	CABINET - NIGHTSTAND - PASSENGER SIDE
10	117173-12-F12	EA	COUNTERTOP - NIGHTSTAND (G15,G16)
10	117173-12-G17	EA	COUNTERTOP - NIGHTSTAND
11	117173-02-G15	EA	CABINET - NIGHTSTAND - DRIVER SIDE (G15,G16)
11	117173-02-G17	EA	CABINET - NIGHTSTAND - DRIVER SIDE
12	041389-25-000	EA	PIANO HINGE - MILL FINISH - 55"
13	P18759-01-G15	EA	CABINET ASM-BED,KING W/O TOP
14	M08093-02-G15	EA	TOP ASM-BED,KING
	091952-01-000	EA	CLIP-GRIPPER - 1."
	097872 04 000	EA	DOWEL - WOOD - 1." DIA X 1.38" LONG
	107796-05-000	EA	BRACKET - GAS SPRING - FLAT
	107796-06-000	EA	GAS SPRING - 20" LENGTH - 120 LB
	107796-07-000	EA	BRACKET - GAS SPRING

**CHASSIS GROUP (CONTINUED)**

**REAR BUMPER**

KEY	PART NUMBER	U/M	DESCRIPTION
1	104418-07-000	EA	ANGLE - SUPPORT - BUMPER REAR
2	103228-01-05A	EA	END CAP - BUMPER REAR - BLACK
3	103099-04-01A	EA	REAR BUMPER - BUFF
4	102333-01-02A	EA	BOLT - 7/16"
5	107707-01-000	EA	HITCH ASM - CLASS II
6	034512-01-000	EA	PIN
7	034513-01-000	EA	PIN - 3/16" WIRE
	113589-01-000	EA	CONNECTOR - PLUG - TRAILER
	113589-02-000	EA	CONNECTOR - SOCKET - TRAILER
	113588-02-01B	EA	BRACKET-CONNECTOR, TRAILER - MILL
	111742-01-000	EA	PLATE-SKID, STEEL

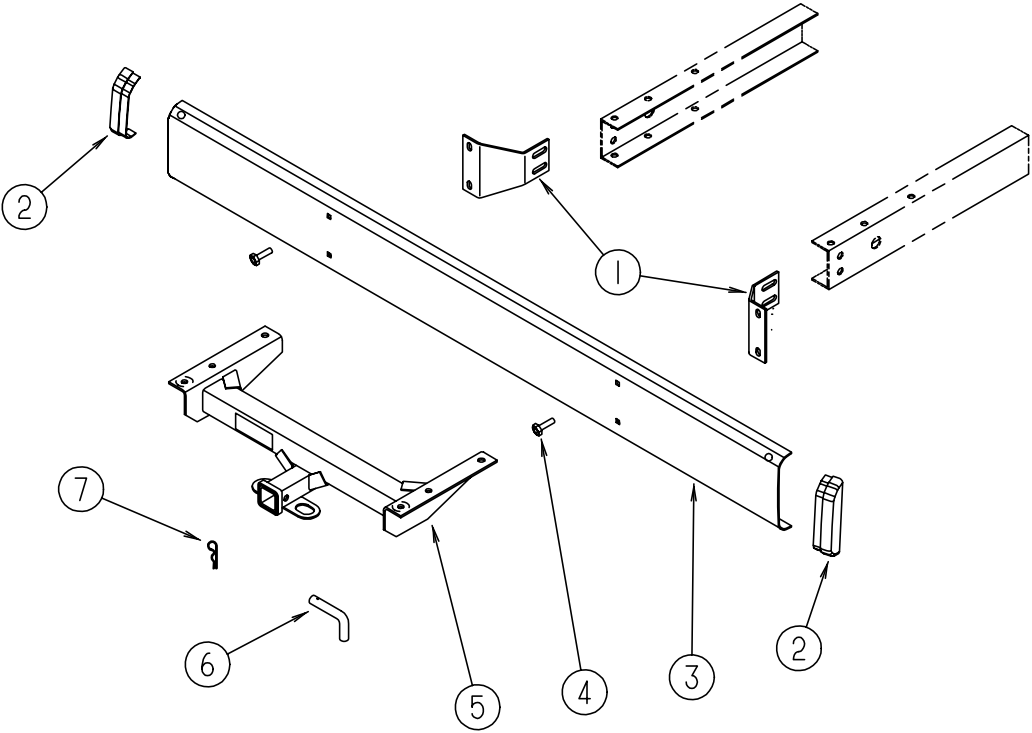

### CHASSIS GROUP (CONTINUED)

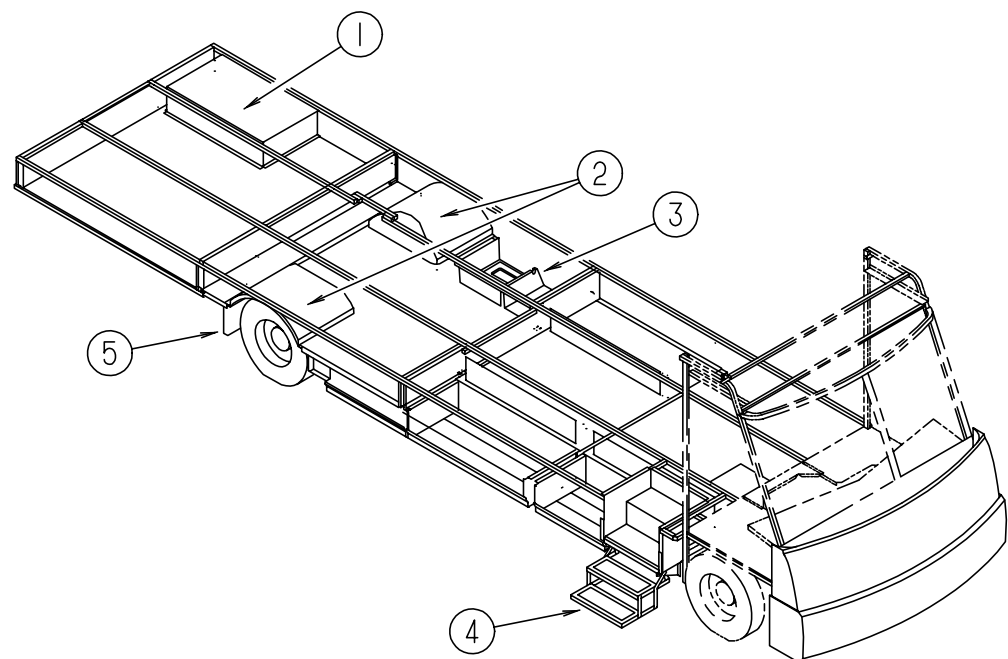

#### COMPARTMENTS & TRAYS

KEY	PART NUMBER	U/M	DESCRIPTION
1	094657-02-000	EA	TRAY-GENERATOR, 22.5" X 30.4" X 6.9" W/ANGLE & NUTS
2	055374-03-000	EA	REAR WHEELWELL - PLASTIC
3	117757-01-01A	EA	COMPARTMENT-STORAGE
3	M06991-05-G38	EA	HATCH ASM W/ FOAM
	114677-01-01A	EA	RETAINER-HATCH, COMPARTMENT MILL
			FROM: 00-00-00 THRU: 01-25-96
	121175-01-01A	EA	LATCH-SWELL, BLACK
			FROM: 01-26-96 THRU: 99-99-99
4	094707-01-01A	EA	STEP ASM-ELECTRIC,DOUBLE
5	017516-01-000	EA	FLAP - MUD - 14" X 18" - BLACK
5	020167-04-000	EA	GUARD-DIRT
	093287-07-01A	EA	NET - CARGO - 254 MM X 865 MM
	093287-09-01A	EA	NET - CARGO - 254 MM X 1510 MM
	065450-05-000	EA	TIEDOWN-BATTERY - 8.4" TUBE

### CHASSIS GROUP (CONTINUED)

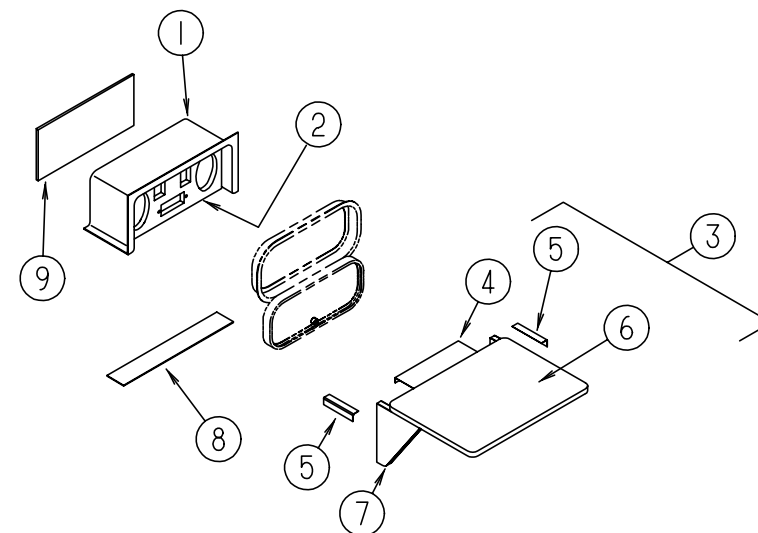

#### COMPARTMENT (ENTERTAINMENT CENTER)

KEY	PART NUMBER	U/M	DESCRIPTION
1	104897-03-01A	EA	BOX - ENTERTAINMENT CENTER - OFF WHITE
2	104899-01-C05	EA	PLATE - RADIO MOUNTING
3	105230-01-G15	EA	SHELF ASM. - EXTERIOR
4	105377-01-01A	EA	BRACKET - TABLE HANGER - OFF WHITE
5	105376-01-02A	EA	HINGE - CONTINUOUS - 2" X 140 MM - OFF WHITE
6	105230-11-G15	EA	SHELF ASM.
7	105230-12-G15	EA	SUPPORT ASM.
8	104898-01-01A	EA	PLATE - PLASTIC BOTTOM - OFF WHITE
9	104898-02-01A	EA	PLATE - PLASTIC BACK - OFF WHITE

### CHASSIS GROUP (CONTINUED)

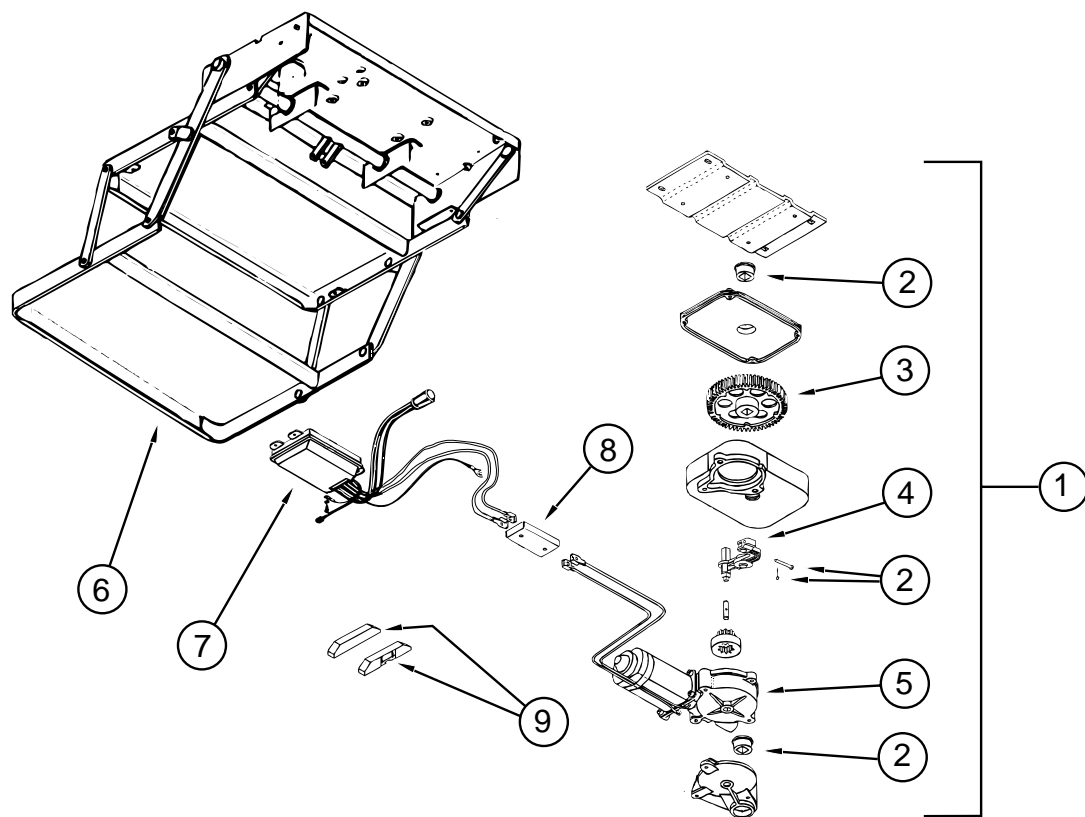

#### STEP ASSEMBLY KWIKEE (3200 SERIES)

KEY	PART NUMBER	U/M DESCRIPTION	VENDOR NO.
1	094707-01-01A	EA STEP-ENTRY DOOR, ELECTRIC - DOUBLE - 3218	
2	094707-02-703	EA BEARING & PINS	909530
3	094707-02-702	EA GEAR KIT, W/BEARINGS, PIN-CASE	909525
4	094708-02-701	EA LINKAGE ASSEMBLY	909523
5	094707-02-700	EA MOTOR ASM., W/BEARINGS & PINS	909520
6	094707-01-702	EA FRAME W/DOUBLE STEP	908032
7	094707-02-705	EA CONTROL UNIT, WHITE	909513
8	094707-02-704	EA CONNECTOR-MOTOR ASM.W/PLATES	909537
	094707-02-707	EA TREAD-NON SKID, BLACK 6" X 21"	909333
9	116995-01-000	EA SWITCH/MAGNET-STEP, ELECTRIC - 905306	

#### BRAKE LINE

KEY	PART NUMBER	U/M DESCRIPTION
	088498-01-000	EA UNION - INVERTED FLARE - BRASS - 3/16 - 3/8 - 24 THREAD - BRAKE LINE
	088497-02-000	EA NUT - INVERTED FLARE - 1/4"
	085771-03-000	EA NUT - HEX - FL. PREV. TORQUE - GRADE G DRIVE SHAFT

#### SHOCK ABSORBER (CHEVY)

KEY	PART NUMBER	U/M DESCRIPTION
	104993-01-000	EA SHOCK ABSORBER-GAS, P30 FRONT-BILSTEIN B46-1173 (SINGLE-1) FROM: 00-00-00 THRU: 01-07-96
	104993-02-000	EA SHOCK ABSORBER-GAS,P30 FRONT FROM: 01-08-96 THRU: 99-99-99

### CHASSIS GROUP (CONTINUED)

#### HYDRAULIC LEVELING SYSTEM (CHEVY,FORD)

KEY	PART NUMBER	U/M DESCRIPTION	VENDOR NO.
	100532-08-000	EA LEVELING SYSTEM - HYDRAULIC - JOYSTICK	
	100532-01-704	EA SWITCH - MERCURY F/ 6K & 9K JACK	RAP1010
	100532-01-705	EA SPRING KIT - 9K JACK	R1171
	100532-02-700	EA 6K TALL JACK ASM	RAP7164
	100532-02-701	EA SPRING KIT - 6K JACK	R6824
	100532-02-704	EA ACTIVATOR CABLE - 6K JACK	RAP7194
	100532-02-705	EA PUMP/ RESERVOIR ASM - MONARCH	RAP8178
	100532-03-710	EA SENSING UNIT 21' MTA	RAP6798
	100532-03-715	EA CAP - BREATHER	RAP7876
	100532-08-700	EA POWER UNIT ASM.	RAP0595
	100532-08-701	EA BI-AXIS CONTROL - 200 SYSTEM	RAP0612
	100532-08-702	EA VALVE - BI-AXIS	RAP9589
	100532-08-703	EA PANEL ASM. - 200 BI - AXIS SYSTEM	RAP9755
	100532-08-704	EA JACK ASM. - 9K TALL 200 SYSTEM	RAP7002
	100532-08-705	EA KNOB - 3/4" BLACK - SET OF FOUR	RAP1379
	100532-08-706	EA KNOB - 1 3/16" BLACK	RAP9734
	100532-08-707	EA BEZEL W/ GASKET - F/ SYSTEM 200	RAP9592
	100532-09-707	EA ACTUATOR ASM. - 9K - REAR JACKS	RAP0547
	100532-09-709	EA ACTUATOR ASM. - 6K - FRONT JACKS	RAP0448
	100532-09-710	EA SOLENOID - 4 POST (INTERMITENT)	RAP0533
	100533-05-000	EA BRACKETS - FRONT LEVELING JACKS (GM)	
	100533-06-000	EA BRACKETS - FRONT LEVELING JACKS (FORD)	
	100534-12-000	EA BRACKETS - REAR LEVELING JACKS (GM)	
	100534-06-000	EA BRACKETS - REAR LEVELING JACKS (FORD)	
	100536-10-000	EA HOSE KIT - AP0012	
	100536-09-700	EA HOSE - HYDRAULIC - 324"	RAP2464
	100536-09-701	EA HOSE - HYDRAULIC - 60"	RAP4073
	100536-09-702	EA HOSE - HYDRAULIC - 354"	RAP4311
	100536-10-700	EA HOSE - HYDRAULIC - 84"	RAP1412
	100536-10-701	EA HOSE - HYDRAULIC - 116"	RAP5384
	107890-01-000	EA ELBOW - STEEL 90D 1/4 X 37D FLARE PARKER 4-C6X-S	
	112236-01-E10	EA BEZEL - MONITOR - UNDER DASH - LEFT SIDE	

#### DRIVESHAFT

KEY	PART NUMBER	U/M DESCRIPTION
	074833-01-000	EA SPACER - BEARING - DRIVESHAFT - 2" X 8" X .5" THICK FROM: 00-00-00 THRU: 01-15-96
	074833-04-000	EA SPACER - BEARING - DRIVESHAFT - 8" X 2" - STEEL FROM: 00-00-00 THRU: 01-15-96
	075302-09-000	EA DRIVESHAFT ASM. - YOKE/ YOKE - 50" FROM: 00-00-00 THRU: 01-15-96
	075302-25-000	EA DRIVESHAFT ASM. - BAL.PR-20/21 FROM: 00-00-00 THRU: 01-15-96
	075302-20-000	EA DRIVESHAFT ASM. - YOKE/ BRG/ SPLINE FROM: 00-00-00 THRU: 01-15-96
	075302-21-000	EA DRIVESHAFT ASM. - SLIP - YOKE/ YOKE FROM: 00-00-00 THRU: 01-15-96
	107212-01-000	EA CROSSMEMBER ASM. - BREARING SUPPORT CHEVY 228 3 SHAFT FROM: 00-00-00 THRU: 01-15-96

## CHASSIS GROUP (CONTINUED)

### EXHAUST SYSTEM (FORD)

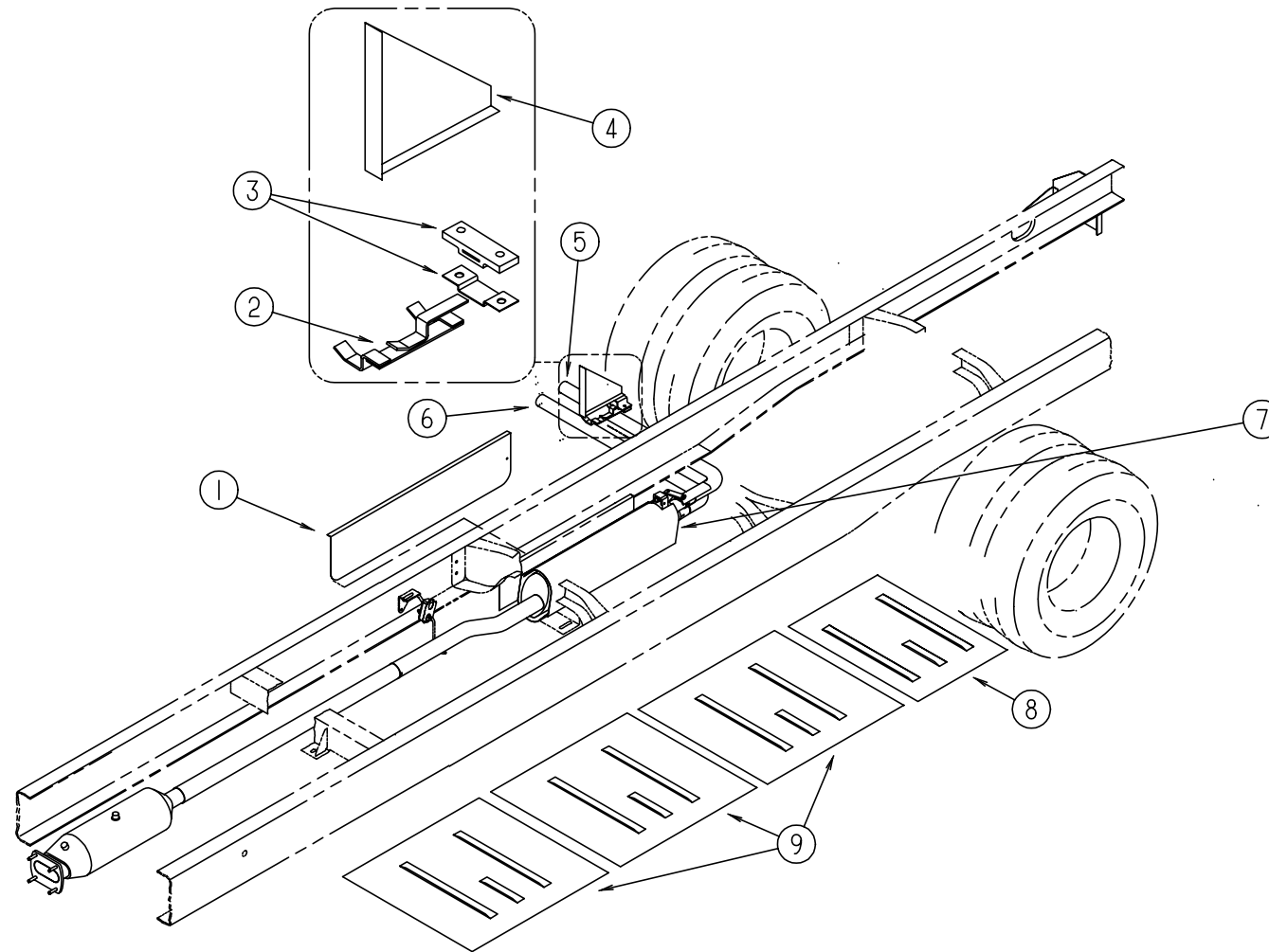

KEY	PART NUMBER	U/M	DESCRIPTION
1	075307-03-000	EA	SHIELD - HEAT - LP
2	096055-05-000	EA	SUPPORT - EXHAUST PIPE
3	095190-01-000	EA	HANGER ASM - EXHAUST
4	102117-06-000	EA	HANGER ASM - TAILPIPE
5	112166-01-000	EA	TAIL PIPE - EXHAUST
6	112165-01-000	EA	TAIL PIPE - EXHAUST
	007125-07-000	EA	CLAMP - MUFFLER - 2.50" DIAMETER
7	007125-05-000	EA	CLAMP - MUFFLER - 2" DIAMETER
8	101544-06-000	EA	SHIELD - EXHAUST
9	101544-01-000	EA	SHIELD - EXHAUST

**CHASSIS GROUP (CONTINUED)**

**EXHAUST SYSTEM (CHEVY)**

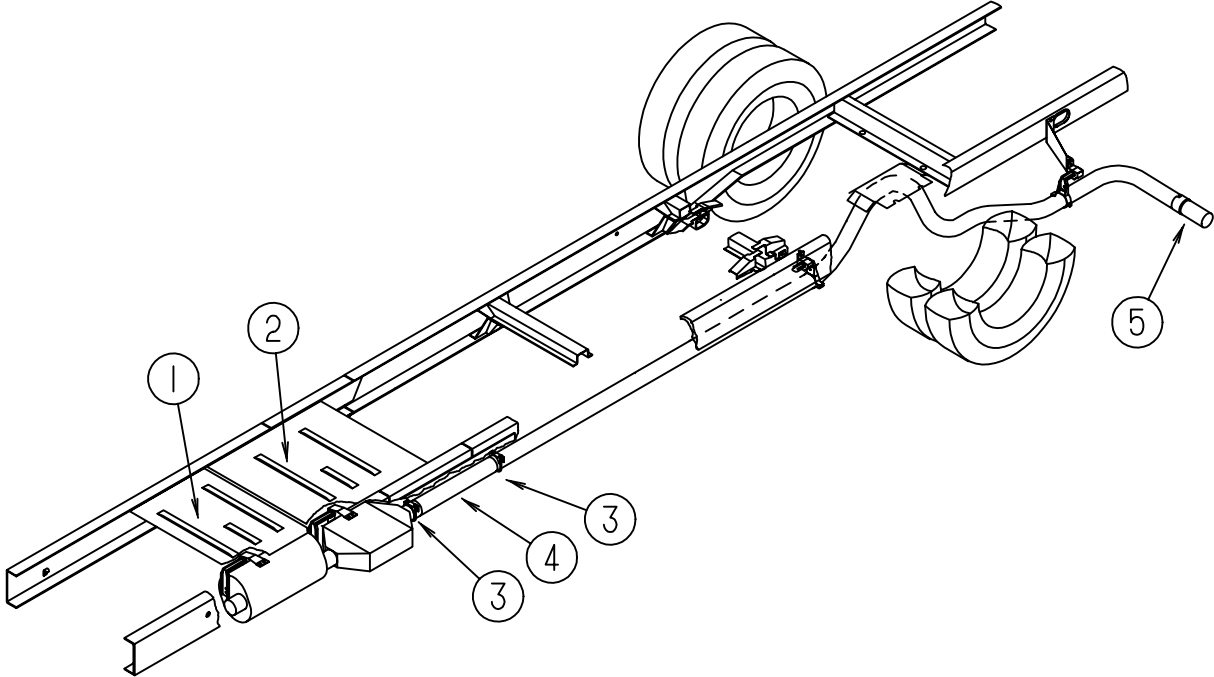

KEY	PART NUMBER	U/M	DESCRIPTION
1	101544-01-000	EA	SHIELD - HEAT - EXHAUST - 19.7" X 28.9" - STEEL
2	101544-02-000	EA	SHIELD - HEAT - EXHAUST - 30" X 28.9" - STEEL
3	094918-01-000	EA	CLAMP - EXHAUST - 3"
4	098762-06-000	EA	PIPE - EXHAUST - STRAIGHT - 3.0" X 22"
			FROM: 00-00-00 THRU: 01-15-96
5	098762-11-000	EA	PIPE - EXHAUST - STRAIGHT - 3.0"
			FROM: 00-00-00 THRU: 02-09-96

**CHASSIS GROUP (CONTINUED)**

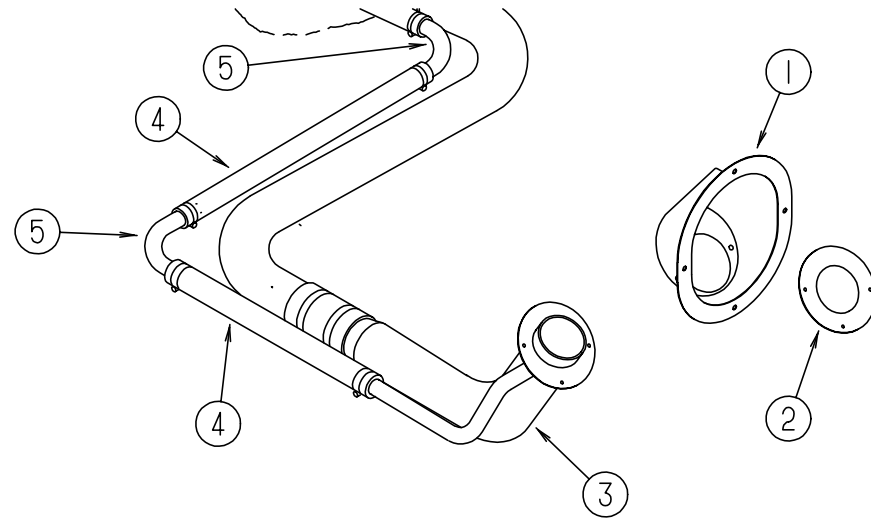

**FUEL SYSTEM (FORD)**

KEY	PART NUMBER	U/M	DESCRIPTION
1	095854-01-05A	EA	SHROUD - FUEL FILL
2	078200-01-000	EA	GASKET - FUEL FILL - 3.5"OD X 2"ID
3	087256-07-000	EA	NECK ASM - FUEL FILL
4	066732-01-000	FT	HOSE - FUEL FILL - .62" ID
5	098806-01-000	EA	PIPE - FILL VENT - 90 DEGREE BEND - .625" OD - STEEL
	007063-01-000	FT	HOSE - GAS 1/4"ID X 1/2"OD
	084884-01-000	EA	PLUG - BRASS - 3/8"
	007111-02-000	EA	HOSE - FUEL FILL - 2" ID - IN 3FT LENGTHS

**CHASSIS GROUP (CONTINUED)**

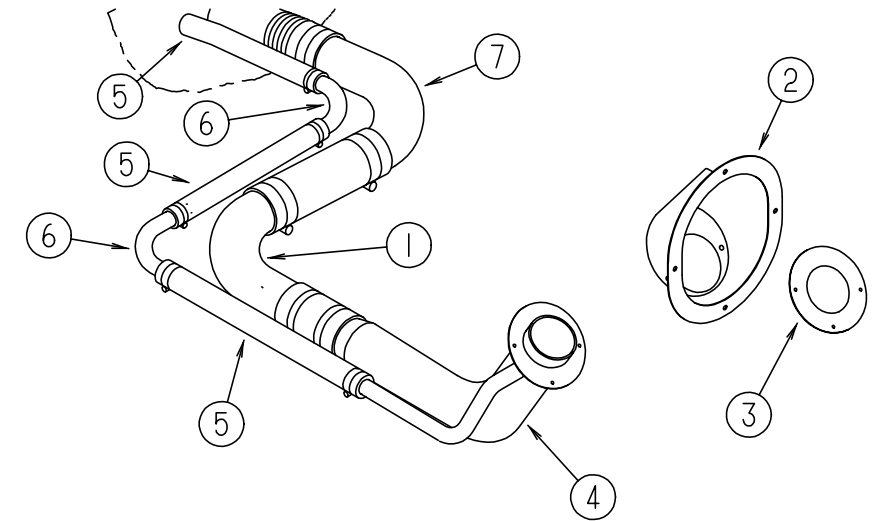

**FUEL SYSTEM (CHEVY)**

KEY	PART NUMBER	U/M	DESCRIPTION
1	098807-01-000	EA	PIPE - FUEL FILL - 90 DEGREE BEND - 6.6" - 1 3/4" OD - STEEL
2	095854-01-05A	EA	SHROUD - FUEL FILL
3	078200-01-000	EA	GASKET - FUEL FILL - 3.5"OD X 2"ID
4	087256-10-000	EA	NECK ASM. - FUEL FILL
5	066732-01-000	FT	HOSE - FUEL FILL - .62" ID
6	098806-01-000	EA	PIPE - FILL VENT - 90 DEGREE BEND - .625" OD - STEEL
7	098803-01-000	EA	PIPE-FUEL,FILL
	007063-01-000	FT	HOSE - GAS 1/4"ID X 1/2"OD



## CHASSIS GROUP (CONTINUED)

### WHEEL LINERS, KAPER (FORD)

KEY	PART NUMBER	U/M DESCRIPTION	VENDOR NO.
	091209-14-000	EA WHEEL LINER SET - F/F53 CHASSIS - 16" WHEEL (SET = 4)	
	091209-01-704	EA COVER-LUG NUT W/O FLANGE LUG NUT COVER - NO SHOULDER OR FLANGE AT BASE	36 KAPER
	091209-08-700	EA LINER-WHEEL, FRONT, W/AXLE COVER HAS 8 PRESS-IN NUT COVERS WHICH ARE N/A, AND 2 SNAP-ON NUT COVERS #09120901704	157 KAPER
	091209-08-706	EA NUT-FLAT .500, 9/16 STUD	165
	091209-14-700	EA LINER-WHEEL, (REAR)	159

### WHEEL COVERS, DICOR (FORD)

KEY	PART NUMBER	U/M DESCRIPTION	VENDOR NO.
	098532-01-000	EA COVER-WHEEL, FORD - 16" - SET OF 4 - DICOR SH-SD-16	
	098532-01-700	EA COVER-LUG NUT (CHROME)	SH-AU-LNC
	098532-01-701	EA COVER-WHEEL (FRT & REAR)	SH-SD-16

### WHEEL LINERS, KAPER (CHEVY)

KEY	PART NUMBER	U/M DESCRIPTION	VENDOR NO.
	091209-01-000	EA LINER - WHEEL - 19.5" - SST - SET OF 4 - 1954-ION	
	091209-01-700	EA LINER - WHEEL - 19.5" FRONT - 10 LUG	37N
	091209-01-701	EA LINER - WHEEL - 19.5" REAR - 10 LUG	38N
	091209-01-702	EA COVER - AXLE - 19.5" FRONT - 10 LUG	34N
	091209-01-703	EA COVER - AXLE - 19.5" REAR - 10 LUG	35N
	091209-01-704	EA COVER - LUG NUT	36

### WHEEL COVERS, DICOR (CHEVY)

KEY	PART NUMBER	U/M DESCRIPTION	VENDOR NO.
	109443-01-000	EA COVER - WHEEL - 4/ SET 19.5 W/ HARDWARE	
	109443-01-700	EA COVER - WHEEL - 19.5 - FRONT & REAR	SHAG95
	109443-01-701	EA SET - BRACKET - 1 FRONT WHEEL	SHAG95-FBS
	109443-01-702	EA SET - BRACKET - 1 REAR WHEEL	SHAG95-RBS
	109443-01-703	EA CAP - CENTER - HUB	SP-AUCAP
	109443-01-704	EA CLIP-RETAINER	V160GM-PNT

## CHASSIS GROUP (CONTINUED)

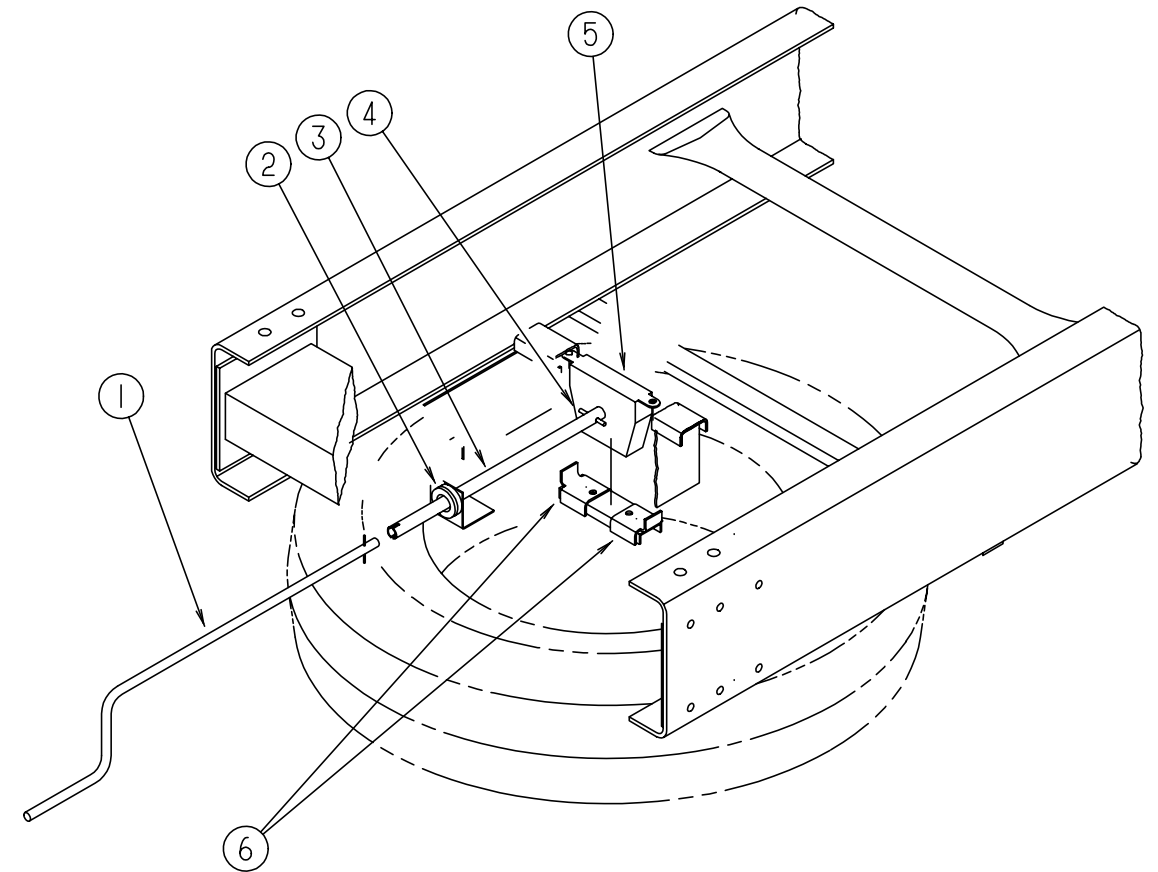

### SPARE TIRE HOIST

KEY	PART NUMBER	U/M DESCRIPTION
1	093376-02-000	EA HANDLE-CRANK, TIRE HOIST
2	071015-11-000	EA GROMMET - 1.00 ID
3	093375-06-000	EA EXTENSION-TIRE HOIST
	093362-06-000	EA CHANNEL-TIRE HOIST
4	114376-01-000	EA PIN-DRIVE, .156 X .750 - TYPE E - TIRE HOIST
5	093267-02-000	EA HOIST-SPARE TIRE
	093267-01-000	EA HOIST-SPARE TIRE - DEUER MFG6L201
6	105499-01-000	EA BRACKET-TIRE HOIST
	077030-02-000	EA EXTENSION-VALVE STEM, 1.25"
	083425-05-000	EA TIRE-MICHELIN, LT235/85R16 LRE - XPS RIB - FORD
	095853-02-000	EA WHEEL-STEEL, 16 X 6K - F2TA-1015-NA - FORD - ACCURIDE 28513-7
	051377-05-000	EA VALVE STEM ASM - EATON VS-938 F53-92
	007324-03-000	EA TIRE-MICHELIN, 8R 19.8 LRF - CHEVY
	064963-01-000	EA WHEEL-STEEL, 19.5" X 6" - GM 14005758
	051377-01-000	EA STEM-VALVE, TR 500
	080208-01-000	EA LUG WRENCH, 1.06 X 1.00
	080208-02-000	EA BAR-LEVERAGE, LUG WRENCH

## CURTAIN & CUSHION GROUP

### NOTICE

IN ORDER TO ASSIST OUR PARTS SALES DEPT. IN PROVIDING INTERIOR SOFTGOODS ITEMS, PLEASE INCLUDE THE SERIAL NUMBER AND THE COLOR CODE NUMBER FROM THE VEHICLE CERTIFICATION LABEL WHEN ORDERING. THIS LABEL IS LOCATED ON THE LEFT SIDEWALL AT THE END OF THE DASH (A-BODY), OR ON THE DRIVER'S DOOR LATCH PLATE (C-BODY).

AN EXAMPLE OF A COLOR CODE NUMBER IS B07, WHICH DESIGNATES AN OVERALL COLOR SCHEME OF A PARTICULAR UNIT. THE COLOR LISTED AFTER THE ITEM DESCRIPTION ON THE MICROFICHE, INDICATES THE OVERALL UNIT COLOR. ORDER THE ITEM YOU DESIRE ACCORDING TO UNIT COLOR CODE.

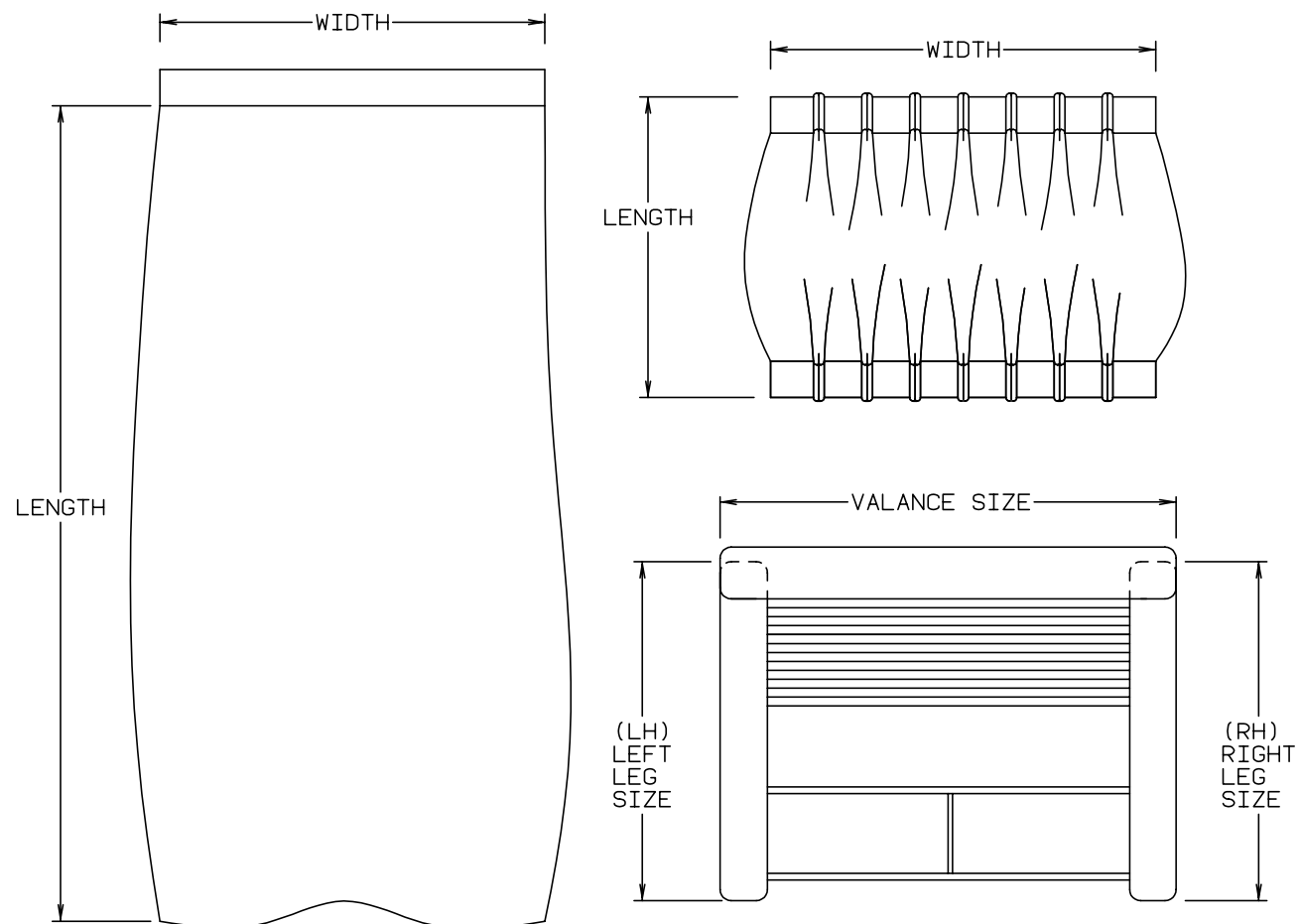

NOTE: USE THIS ILLUSTRATION WHEN DETERMINING LENGTH AND WIDTH MEASUREMENTS FOR CURTAINS. YOU WILL NOTE THE WIDTH MEASUREMENT IS TAKEN ON THE TOP OF THE CURTAIN WITH THE CURTAIN FULLY EXTENDED. THE LENGTH MEASUREMENT IS TAKEN FROM TOP TO BOTTOM. LEFT AND RIGHT WINDOW LEGS ARE DETERMINED WHEN FACING THE WINDOW.

## CURTAIN & CUSHION GROUP (CONTINUED)

ADVENTURER FABRIC				
COLOR CODES		G15	G16	G17
		<b>BOTANICAL (GREEN)</b>	<b>THISTLE (TAN)</b>	<b>COPPER CANYON</b>
<b>CEILING MATERIAL</b>	<b>FROM: 00-00-00 THRU: 01-31-96</b>	113979-04-01A	113979-04-01A	113979-04-01A
<b>CEILING MATERIAL</b>	<b>FROM: 02-01-96 THRU: 99-99-99</b>	113979-06-01A	113979-06-01A	113979-06-01A
<b>OFF WHITE VINYL</b>		103907-01-01A	103907-01-01A	103907-01-01A
<b>BEIGE VINYL</b>		079680-07-000	079680-07-000	079680-07-000
<b>MADRID WILLOW VINYL</b>		103907-01-03A	103907-01-03A	103907-01-03A
<b>DRAPERY FABRIC</b>		072333-85-000	072333-85-000	072333-85-000
<b>BUCKET SEATS</b>		108446-G0-000	108446-77-000	104233-59-000
<b>DINETTE</b>		108446-F8-000	108446-F9-000	108446-H0-000
<b>DINETTE CHAIR</b>		108446-G1-000	108446-G2-000	108446-H2-000
<b>DINETTE PAD</b>		108446-G0-000	108446-77-000	104233-59-000
<b>SOFA</b>		108446-F8-000	108446-F9-000	108446-H0-000
<b>SOFA PILLOWS</b>		108446-G1-000 084415-70-000	108446-G2-000 084415-69-000	108446-H2-000 084415-77-000
<b>SWIVEL CHAIR</b>		108446-G1-000	108446-G2-000	108446-H2-000
<b>LOUNGE WINDOWS</b>		108446-F8-000 108446-G1-000	108446-F9-000 108446-G2-000	108446-H0-000 108446-H2-000
<b>BEDROOM WINDOW</b>		105745-B2-000 105745-B0-000	105745-62-000 105745-B1-000	105745-B7-000 105745-A2-000
<b>BEDSPREAD</b>		105745-B2-000 105745-B0-000	105745-62-000 105745-B1-000	105745-B7-000 105745-A2-000
<b>PILLOW SHAMS</b>			105745-62-000 105745-B1-000	105745-B7-000 105745-A2-000
<b>BEDROOM PILLOWS</b>		105745-B2-000	105745-62-000	105745-B7-000
<b>HEADBOARD</b>		105745-B0-000 105745-B2-000	105745-B1-000 105745-62-000	105745-A2-000 105745-B7-000
<b>FRONT WRAP AROUND</b>		072333-85-000	072333-85-000	072333-85-000
<b>PLEATED BLINDS</b>		094911-30-000	094911-30-000	094911-30-000
<b>MAP POCKETS</b>		108446-G0-000	108446-77-000	104233-59-000

NOTE: FABRIC LISTED FIRST, IN A BLOCK, IS THE LARGEST QUANTITY OF FABRIC USED

# CURTAIN & CUSHION GROUP (CONTINUED)

## CURTAINS & WINDOW TREATMENT

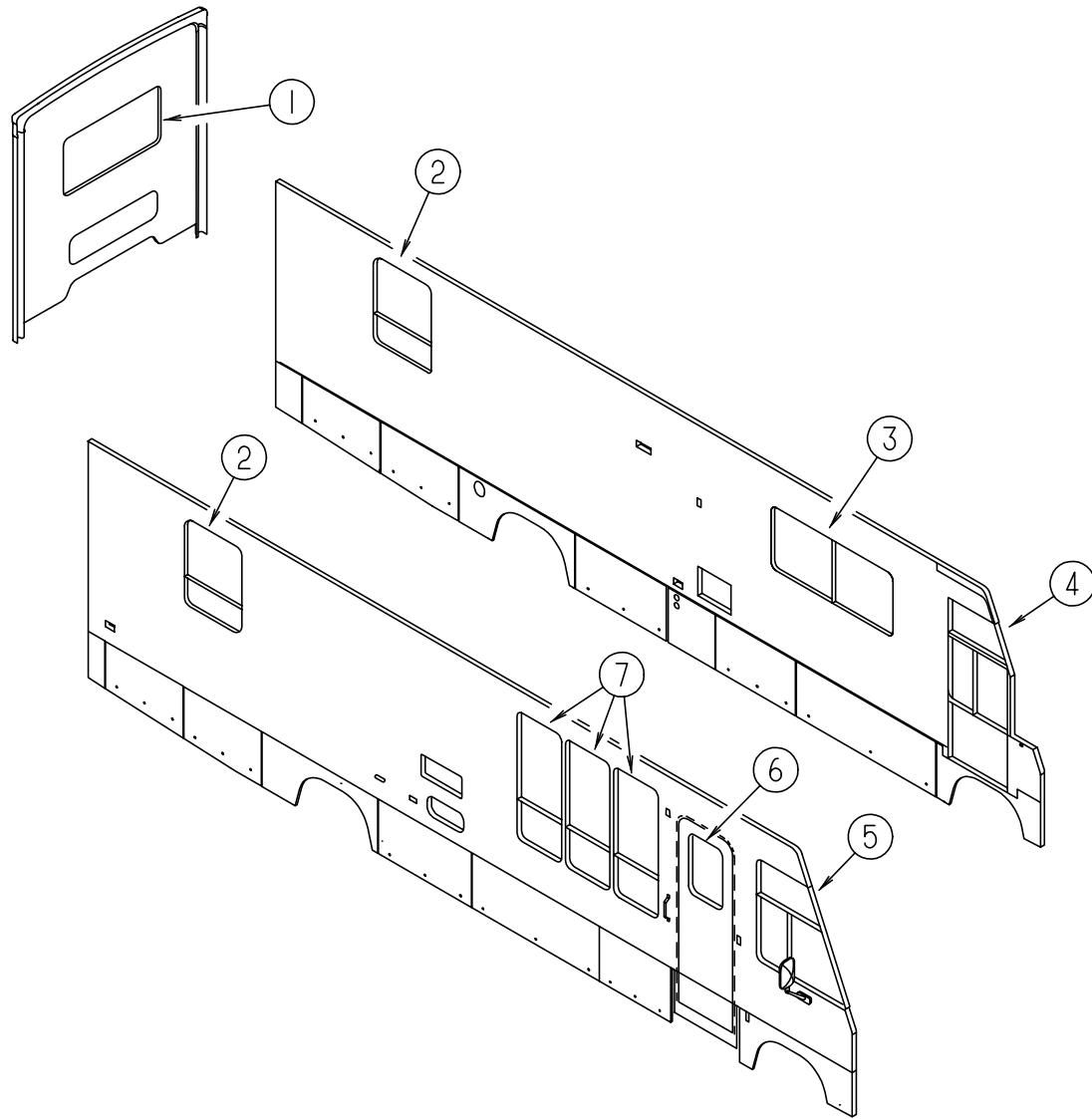

KEY	PART NUMBER	U/M	DESCRIPTION
1	119262-03-G15	EA	VALANCE ASM. - 52.5" MONACO W/BRAID
1	119299-01-G16	EA	VALANCE ASM. - 53" WHITNEY
1	119299-01-G17	EA	VALANCE ASM. - 53" WHITNEY
1	119262-24-G15	EA	VALANCE ASM. - 64.5" MONACO W/BRAID (TWIN BED OPTION)
1	119299-07-G16	EA	VALANCE ASM. - 65" WHITNEY (TWIN BED OPTION)
1	119299-07-G17	EA	VALANCE ASM. - 65" WHITNEY (TWIN BED OPTION)
1	119333-03-G15	EA	LEG-RH, 25" - PLAIN - W/O HOLE
1	119333-07-G16	EA	LEG-RH, 25" - GATHERED - W/O HOLE
1	119333-07-G17	EA	LEG-RH, 25" - GATHERED - W/O HOLE
1	119333-04-G15	EA	LEG-LH, 25" - PLAIN - W/O HOLE
1	119333-08-G16	EA	LEG-LH, 25" - GATHERED - W/O HOLE
1	119333-08-G17	EA	LEG-LH, 25" - GATHERED - W/O HOLE
1	109802-36-G15	EA	BLIND - PLEATED - 49" X 29"
1	109802-36-F12	EA	BLIND - PLEATED - 49" X 29" (G16,G17)
2	119262-04-G15	EA	VALANCE ASM. - 31" MONACO W/BRAID
2	119299-02-G16	EA	VALANCE ASM. - 32" WHITNEY
2	119299-02-G17	EA	VALANCE ASM. - 32" WHITNEY
2	119333-05-G15	EA	LEG-RH, 38" - PLAIN - W/O HOLE
2	119333-09-G16	EA	LEG-RH, 38" - GATHERED - W/O HOLE
2	119333-09-G17	EA	LEG-RH, 38" - GATHERED - W/O HOLE
2	119333-06-G15	EA	LEG-LH, 38" - PLAIN - W/O HOLE
2	119333-10-G16	EA	LEG-LH, 38" - GATHERED - W/O HOLE
2	119333-10-G17	EA	LEG-LH, 38" - GATHERED - W/O HOLE
2	109802-37-G15	EA	BLIND - PLEATED - 27.5" X 38.5"
2	109802-37-F12	EA	BLIND - PLEATED - 27.5" X 38.5" (G16,G17)
3	119262-17-G15	EA	VALANCE ASM. - 65.5" MONACO W/BRAID
3	119263-09-G16	EA	VALANCE ASM - 65.5" STARBUCK
3	119263-09-G17	EA	VALANCE ASM - 65.5" STARBUCK
3	119333-31-G15	EA	LEG-RH, 38" - PLAIN - W/O HOLE
3	119333-31-G16	EA	LEG-RH, 38" - PLAIN - W/O HOLE
3	119333-31-G17	EA	LEG-RH, 38" - PLAIN - W/O HOLE
3	119333-32-G15	EA	LEG-LH, 38" - PLAIN - W/O HOLE
3	119333-32-G16	EA	LEG-LH, 38" - PLAIN - W/O HOLE
3	119333-32-G17	EA	LEG-LH, 38" - PLAIN - W/O HOLE
3	109802-35-F12	EA	BLIND - PLEATED - 61" X 41"
3	119262-01-G15	EA	VALANCE ASM. - 64.5" MONACO W/BRAID (WINDOW EXCHANGE OPTION)
3	119263-01-G16	EA	VALANCE ASM - 64.5" STARBUCK (WINDOW EXCHANGE OPTION)
3	119263-01-G17	EA	VALANCE ASM - 64.5" STARBUCK (WINDOW EXCHANGE OPTION)
3	109802-10-G15	EA	BLIND - PLEATED - 60" X 28.5" (WINDOW EXCHANGE OPTION)
3	109802-10-G09	EA	BLIND - PLEATED - 60" X 28.5" (G16,G17) (WINDOW EXCHANGE OPTION)
4	101668-46-E91	EA	CURTAIN ASM. - 48" X 95" - DRIVER SIDE - TAPE TOP
4	073260-42-C18	EA	TIEBACK ASM. - 6" X 18"
5	101668-45-E91	EA	CURTAIN ASM. - 48" X 95" - PASSENGER SIDE - TAPE TOP
5	073260-42-C18	EA	TIEBACK ASM. - 6" X 18"
6	084755-57-E07	EA	PULL SHADE - 27.25,W/O TRIM
7	119262-16-G15	EA	VALANCE ASM. - 110.5" MONACO W/BRAID
7	119263-08-G16	EA	VALANCE ASM. - 110.5" - STARBUCK
7	119263-08-G17	EA	VALANCE ASM. - 110.5" - STARBUCK
7	119333-23-G15	EA	LEG-RH, 57" - PLAIN - W/O HOLE
7	119333-23-G16	EA	LEG-RH, 57" - PLAIN - W/O HOLE
7	119333-23-G17	EA	LEG-RH, 57" - PLAIN - W/O HOLE
7	119333-24-G15	EA	LEG-LH, 57" - PLAIN - W/O HOLE
7	119333-24-G16	EA	LEG-LH, 57" - PLAIN - W/O HOLE
7	119333-24-G17	EA	LEG-LH, 57" - PLAIN - W/O HOLE
7	109802-33-F12	EA	BLIND ASM-PLEATED - 70" X 58.5"

## CURTAIN & CUSHION GROUP (CONTINUED)

### BUCKET SEAT

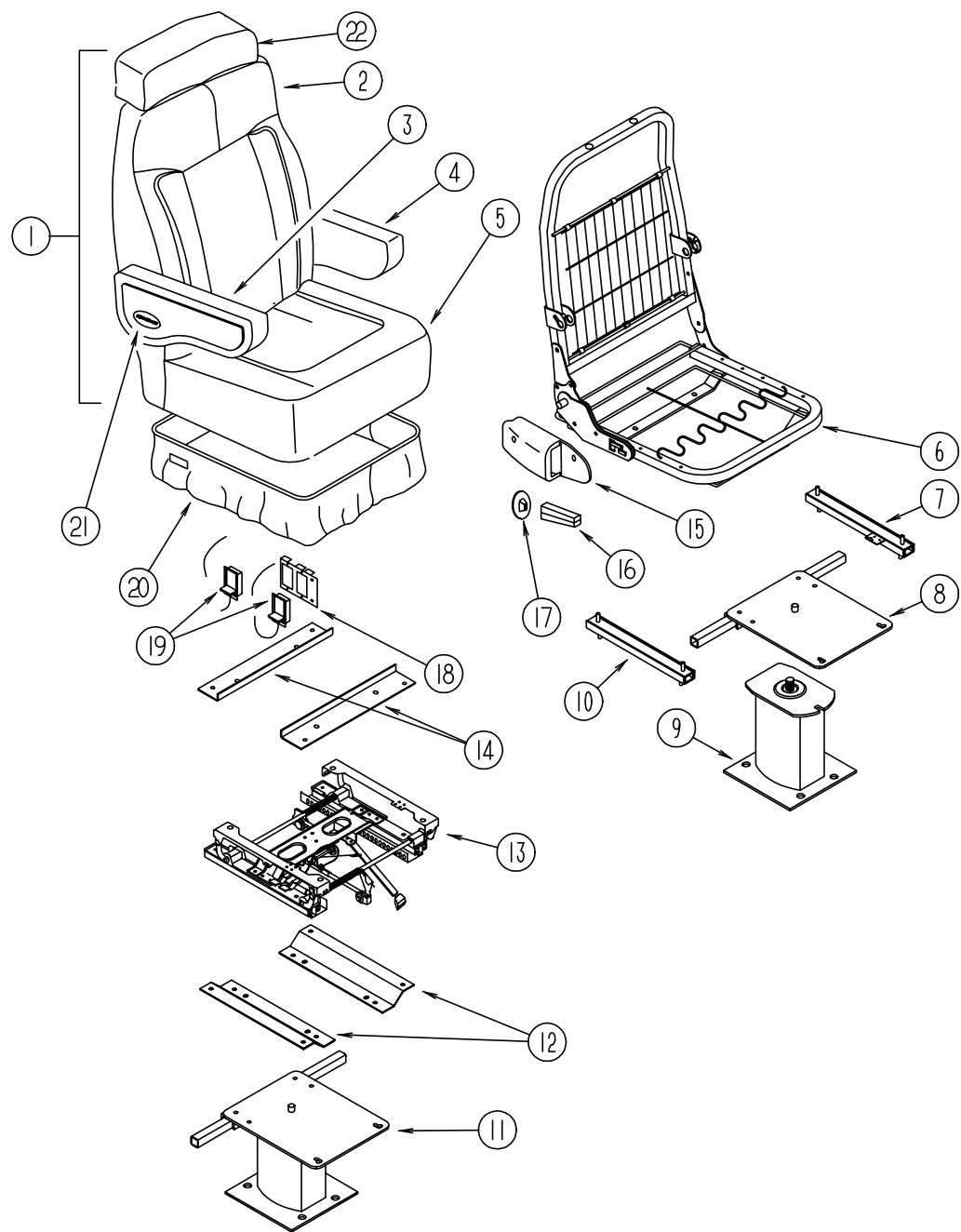

KEY	PART NUMBER	U/M	DESCRIPTION
1	115390-05-G15	EA	SEAT-NEWPORT, MANUAL RECLINER W/HEADREST
1	115390-05-G16	EA	SEAT-NEWPORT, MANUAL RECLINER W/HEADREST
1	115390-05-G17	EA	SEAT-NEWPORT, MANUAL RECLINER W/HEADREST
2	M05962-13-G15	EA	COVER - BACK - NEWPORT
2	M05962-13-G16	EA	COVER - BACK - NEWPORT
2	M05962-13-G17	EA	COVER - BACK - NEWPORT
3	114929-01-G15	EA	ARMREST ASM - RIATTA, RH
3	114929-01-G16	EA	ARMREST ASM - RIATTA, RH
3	114929-01-G17	EA	ARMREST ASM - RIATTA, RH
3	P14929-01-G15	EA	COVER - ARMREST - RIATTA, RH
3	P14929-01-G16	EA	COVER - ARMREST - RIATTA, RH
3	P14929-01-G17	EA	COVER - ARMREST - RIATTA, RH
4	114929-02-G15	EA	ARMREST ASM - RIATTA, LH
4	114929-02-G16	EA	ARMREST ASM - RIATTA, LH
4	114929-02-G17	EA	ARMREST ASM - RIATTA, LH
4	P14929-02-G15	EA	COVER - ARMREST - RIATTA, LH
4	P14929-02-G16	EA	COVER - ARMREST - RIATTA, LH
4	P14929-02-G17	EA	COVER - ARMREST - RIATTA, LH
5	M05962-14-G15	EA	COVER - SEAT - NEWPORT
5	M05962-14-G16	EA	COVER - SEAT - NEWPORT
5	M05962-14-G17	EA	COVER - SEAT - NEWPORT
6	M80906-12-000	EA	FRAME - SEAT - BACK & SPRING
7	119952-04-000	EA	SLIDE-SEAT, HD - LOCKING 4 STUDS - ATWOOD 83785
	069246-99-000	EA	SPRING - ADJUSTER - FOR REMOTE - LIGHT BLUE
	117125 01 02B	EA	BRACKET - CABLE HOLDER - STEEL
	069246-05-701	EA	CLIP - CABLE - FOR REMOTE
8	107921-05-000	EA	TOP PLATE - PEDESTAL - W/ SEATBELT BAR
9	107921-01-000	EA	PEDESTAL - FLOOR MOUNTED - W/ 9.75" EXTENSION
	107921-06-000	EA	BEARING KIT - PEDESTAL
10	119952-02-000	EA	SLIDE-SEAT, HD - NONLOCKING 4 STUDS - ATWOOD 83731
11	107921-14-000	EA	PEDESTAL ASM-SEAT 5.75 IN - MANUAL SEAT OPTION - FLEXSTEEL XP1774
12	116215-03-000	EA	PLATE-LOWER, MANUAL - 6-WAY - MANUAL SEAT OPTION - ATWOOD 83835
13	116215-01-000	EA	SEAT-MANUAL, 6-WAY - DRIVER - MANUAL SEAT OPTION - ATWOOD 83805
14	116215-02-000	EA	PLATE-UPPER, MANUAL - 6-WAY - MANUAL SEAT OPTION - ATWOOD 85118
15	080730-09-000	EA	SHIELD - RECLINER HANDLE
	080730-10-000	EA	SCREW - RECLINER HANDLE SHIELD
16	080730-08-000	EA	HANDLE - RECLINER - BLACK
17	080730-11-000	EA	SHIELD - RUBBER BOOT
18	108049-03-000	EA	26" CONTROL CABLE - 2 END W/SWITCH LEVER
	108049-02-000	EA	CLIP - CABLE
19	097683-03-000	EA	BRACKET - REMOTE - SIDE MOUNT - SINGLE
20	071126-43-G15	EA	SKIRT - SINGLE - 10.5" - W/OPEN BACK
20	071126-43-E33	EA	SKIRT - SINGLE - 10.5" - W/OPEN BACK (G16)
20	071126-43-F86	EA	SKIRT - SINGLE - 10.5" - W/OPEN BACK (G17)
20	071126-54-G15	EA	SKIRT - SINGLE - 10.5" - W/OPEN BACK - 6 WAY MANUAL CONTROL
20	071126-54-F12	EA	SKIRT - SINGLE - 10.5" - W/OPEN BACK - 6 WAY MANUAL CONTROL (G16)
20	071126-54-F04	EA	SKIRT - SINGLE - 10.5" - W/OPEN BACK - 6 WAY MANUAL CONTROL (G17)
21	111169-01-000	EA	BACK PLATE - EMBLEM
21	111169-02-000	EA	EMBLEM - "WINNEBAGO"
22	119698-01-G15	EA	HEADREST - STRATON II
22	119698-01-G16	EA	HEADREST - STRATON II
22	119698-01-G17	EA	HEADREST - STRATON II
22	P19698-01-G15	EA	COVER-HEADREST, STRATON II
22	P19698-01-G16	EA	COVER-HEADREST, STRATON II
22	P19698-01-G17	EA	COVER-HEADREST, STRATON II

# CURTAIN & CUSHION GROUP (CONTINUED)

## SWIVEL CHAIR RECLINER

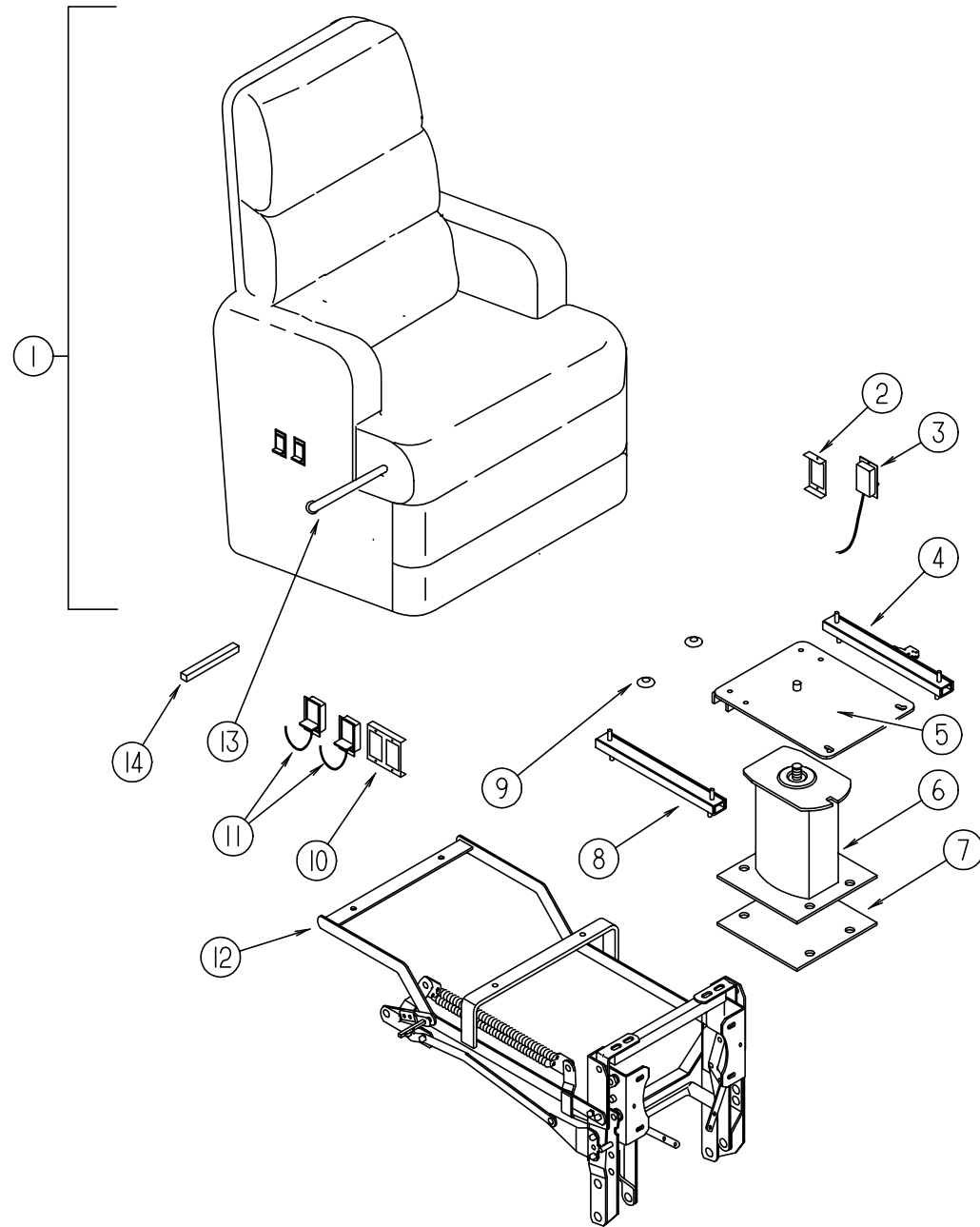

KEY	PART NUMBER	U/M	DESCRIPTION	VENDOR NO.
1	118821-01-G15	EA	SWIVEL CHAIR - RECLINER W/FOOTREST	
1	118821-01-G16	EA	SWIVEL CHAIR - RECLINER W/FOOTREST	
1	118821-01-G17	EA	SWIVEL CHAIR - RECLINER W/FOOTREST	
1	P18821-01-G15	EA	COVER ASM. - SWIVEL CHAIR - RECLINER W/FOOTREST	
1	P18821-01-G16	EA	COVER ASM. - SWIVEL CHAIR - RECLINER W/FOOTREST	
1	P18821-01-G17	EA	COVER ASM. - SWIVEL CHAIR - RECLINER W/FOOTREST	
2	097683-03-000	EA	BRACKET - REMOTE - SIDE MOUNT	
3	089368-05-000	EA	CABLE - RECLINER, W/SWITCH	
4	119952-02-000	EA	ADJUSTER SLIDE - W/ LOCKING ARM	
	108049-02-000	EA	CLIP - PEDESTAL CABLE	
5	107921-08-000	EA	TOP PLATE - PEDESTAL - W/O SEATBELT BAR	
6	107921-01-000	EA	FLOOR MOUNTED PEDESTAL - W/9.75" EXTENSION	
7	108445-02-000	EA	SUB PLATE - FLOOR MOUNTED PEDESTAL	
	107921-06-000	EA	BEARING KIT - PEDESTAL	
8	119952-02-000	EA	ADJUSTER SLIDE - W/O LOCKING ARM	
9	007221-01-000	EA	SPACER - SEAT ADJUSTER	
10	097683-02-000	EA	BRACKET - REMOTE - SIDE MOUNT	
11	089368-03-000	EA	REMOTE & CABLE - 26"	
12	119106-01-000	EA	FRAME - FOOTREST	
13	119106-01-701	EA	HANDLE	92596
14	119106-01-700	EA	TUBE - EXTENSION, RECTANGULAR	92859
	108049-02-000	EA	CLIP - PEDESTAL CABLE	
	057759-01-000	EA	WASHER BRACKET - SEAT BELT - 4" DIAMETER	
	007021-01-000	EA	SEAT BELT - 2" X 90" - BLACK	

**CURTAIN & CUSHION GROUP (CONTINUED)**

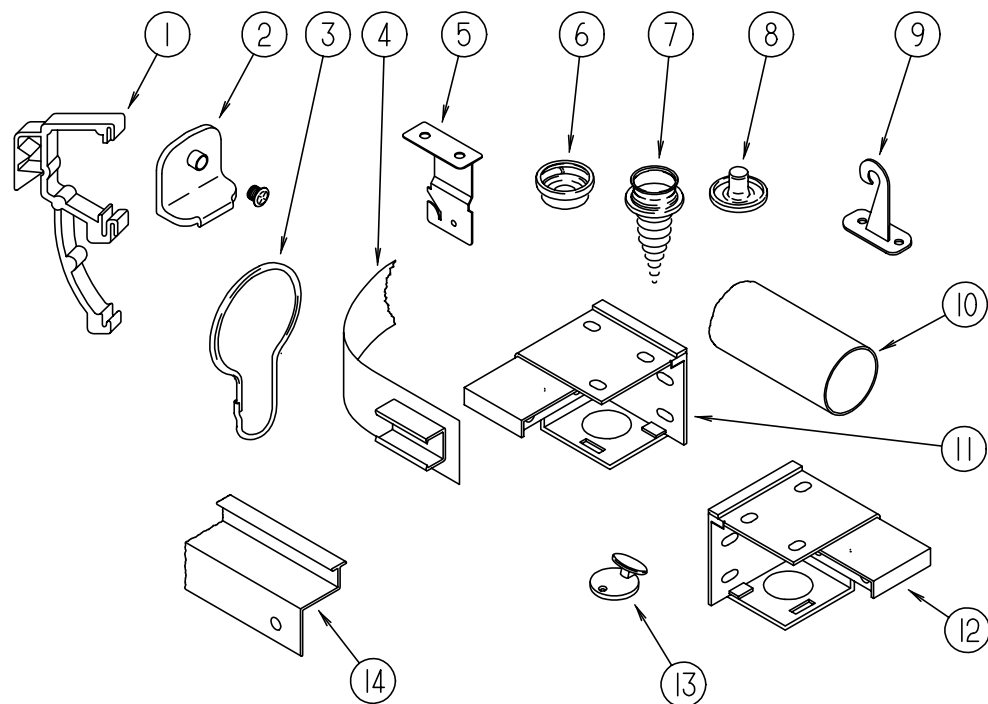

**CURTAIN & BLIND HARDWARE**

KEY	PART NUMBER	U/M DESCRIPTION
1	109353-04-000	EA CLIP - VALANCE SLAT MOUNTING - CLEAR PLASTIC - PAR
2	106544-01-000	EA SHADE PULL - BRASS
	106544-01-001	EA SCREW - SHADE PULL - BRASS
3	009136-02-000	EA HANGER - RING - PIN TYPE - CURTAIN - BRASS
4	101031-01-000	YD TAPE - GLIDE - CURTAIN - 4.25" SPACING
5	084434-01-000	EA BRACKET - MOUNTING - ROLLER SHADE - 1 3/8"
	096843-01-000	EA SPRING - REWIND - ROLLER SHADE
6	029156-01-000	EA SOCKET - SNAP - 9/16" O.D
7	029130-01-000	EA SCREW - SNAP SOCKET - 8 PH X 5/8"
8	029155-01-000	EA CAP - SNAP - 5/32" O.D. OF PIN
	046867-01-000	EA GROMMET-BRASS - 7/16" ID X 1" OD
		FROM: 00-00-00 THRU: 10-01-95
	046867-03-000	EA GROMMET-HANDY BUTTON NO 3
		FROM: 10-02-95 THRU: 99-99-99
9	109441-01-000	EA HOLD DOWN - BLIND, HOOK
10	102075-06-01A	EA SHOWER ROD
	009136-02-000	EA BRASS SHOWER RINGS
	009112-01-000	EA FLANGE - SHOWER ROD
11	083170-02-000	EA BRACKET - BLIND - LEFT SIDE
12	083170-01-000	EA BRACKET - BLIND - RIGHT SIDE
13	102555-01-000	EA CLEAT - CORD - BLIND - OFF WHITE
14	114641-07-G15	EA TRACK - WRAPAROUND CURTAIN - WILLOW (PASSENGER SIDE)
14	114641-08-G15	EA TRACK - WRAPAROUND CURTAIN - WILLOW (DRIVER SIDE)
	048394-02-000	YD VELCRO TAPE - HOOK - ADHESIVE BACK - .75" WIDE - BEIGE
	088792-02-000	YD VELCRO TAPE - LOOP - ADHESIVE BACKED - .75" WIDE - BEIGE
	068716-01-001	EA BRACKET - 90 DEGREE L-ANGLE - 192" - EXTRUDED ALUMINUM
	075943-01-000	EA BRACE - WINDOW VALANCE - 1" X 1.5" X 20" - ALUMINUM - BEIGE
	094896-02-000	EA GROMMET - CORD - PLEATED BLIND - NYLON - GRAY
	094907-02-000	EA END CAP - TOP - PLEATED BLIND - PLASTIC - GRAY
	094907-04-000	EA END CAP - BOTTOM - PULL TYPE SPECIALITY WINDOW
	097564-01-000	EA T-HANDLE - EZ LIFT SHADE
	097565-01-000	EA BRACKET - MOUNTING - PLEATED BLIND

**CURTAIN & CUSHION GROUP (CONTINUED)**

**CURTAIN & BLIND HARDWARE (CONTINUED)**

KEY	PART NUMBER	U/M DESCRIPTION
	097591-01-000	EA SPRING - EXTENSION - PLEATED BLIND
	097592-01-000	EA SPOOL - CORD - ELEVATED BLIND HOLDUP - CLEAR PLASTIC
	089916-01-000	EA MOUNT - WINDOW LEG - 23.75" LONG - ALUMINUM - BLACK
	056003-01-000	EA BRACKET - DRAPERY RETAINING - FRONT - METAL
	056003-02-000	EA BRACKET - DRAPERY RETAINING - REAR - METAL
	086276-01-000	EA TAPE - DOUBLE SIDED - 1/2"
	009702-01-000	EA END STOP-CURTAIN CARRIER, L ROD
	094896-02-000	EA GROMMET-CORD, PLEATED BLIND - NYLON - GRAY
	097593-02-000	FT CORD - BLIND - PLEATED - GRAY
	103986-01-000	FT TRIM - VALANCE - U-CHANNEL - .75" WIDE - BRASS

**TRIMS & BUTTONS**

KEY	PART NUMBER	U/M DESCRIPTION
	084415-70-000	YD TRIM-BRAID, 60261-V118 - CORD (G15)
	084415-69-000	YD TRIM-BRAID, 62027-P57 - FRINGE (G16)
	084415-77-000	YD TRIM-BRAID, 61814-N10 - CORD (G17)
	050263-01-000	YD WELT-CORD, 5/32 DIA.
	070578-02-E38	EA BUTTON - SCREW - STUD - #30 - VINYL

**ASSIST HANDLE & SEAT BELTS**

KEY	PART NUMBER	U/M DESCRIPTION
	007021-01-000	EA BELT - SEAT - 2" X 90" - BLACK
	056271-01-000	EA BELT - SEAT - 2" X 102" - BLACK
	069178-02-000	EA BRACKET - MOUNTING - ASSIST HANDLE - L ANGLE - W/HOLES
	000C16-07-16B	EA BOLT - CARRIAGE - ASSIST HANDLE - 7/16-14 X 1" - ZINC
	000D20-07-00B	EA NUT - ACORN - ASSIST HANDLE - 7/16" X 14 - ZINC
	057759-01-000	EA WASHER BRACKET-SEAT BELT, 4" DIAMETER
	053552-02-AA8	EA HANDLE - ASSIST - INTERIOR - ENTRY DOOR - VINYL - OFF WHITE
	108808-02-02A	EA HANDRAIL - STEP - ENTRANCE - OFF WHITE

## CURTAIN & CUSHION GROUP (CONTINUED)

### QUEEN BED

KEY	PART NUMBER	U/M DESCRIPTION
3	119249-01-000	EA PILLOW-CASE ASM, 20" X 33" - QUEEN (G15)
3	106727-04-G16	EA PILLOW-TOOTSIE, W/.5" WELT, QUEEN
3	106727-04-G17	EA PILLOW-TOOTSIE, W/.5" WELT, QUEEN
4	101123-06-000	EA MATTRESS - FOAM - 60" X 80"
4	P01123-06-000	EA COVER - MATTRESS
4	119141-01-G15	EA BEDSPREAD-THROW - W/ REVERSE SHAM - 60" X 80"
4	109588-20-G16	EA BEDSPREAD - 60" X 80" - FITTED GUSSET CORNER
4	109588-20-G17	EA BEDSPREAD - 60" X 80" - FITTED GUSSET CORNER

### TWIN BEDS

KEY	PART NUMBER	U/M DESCRIPTION
5	101123-21-000	EA MATTRESS - FOAM - 36" X 80"
5	P01123-21-000	EA COVER - MATTRESS
5	119141-04-G15	EA BEDSPREAD-THROW - W/ REVERSE SHAM - 36" X 80"
5	109588-19-G16	EA BEDSPREAD - 36" X 80" - FITTED GUSSET CORNER
5	109588-19-G17	EA BEDSPREAD - 36" X 80" - FITTED GUSSET CORNER
2	119249-02-000	EA PILLOW-CASE ASM, 22" X 37" (G15)
2	106727-03-G16	EA PILLOW-TOOTSIE, W/.5" WELT
2	106727-03-G17	EA PILLOW-TOOTSIE, W/.5" WELT
	111637-08-G15	EA PILLOW ASM - 16" X 16" - KNIFE EDGE W/BRAID
	111637-09-G16	EA PILLOW ASM - 16" X 16" - KNIFE EDGE W/BRAID
	111637-09-G17	EA PILLOW ASM - 16" X 16" - KNIFE EDGE W/BRAID

### RECLINER & SOFA BED

KEY	PART NUMBER	U/M DESCRIPTION
6	120286-01-000	EA SOFA ASM - 4202-62LS W/RECLINER (G15)
6	116286-03-000	EA SOFA ASM - 4143-62LS W/RECLINER (G16)
6	116286-04-000	EA SOFA ASM - 4143-62LS W/RECLINER (G17)
7	120287-01-000	EA SOFA ASM - E-Z BED, 4202-58EB (G15)
7	116285-03-000	EA SOFA ASM - E-Z BED, 4143-58EB (G16)
7	116285-04-000	EA SOFA ASM - E-Z BED, 4143-58EB (G17)
	111637-03-G15	EA PILLOW ASM - 22" X 22", KNIFE EDGE W/BRAID
	111637-03-G16	EA PILLOW ASM - 22" X 22", KNIFE EDGE W/BRAID
	111637-03-G13	EA PILLOW ASM - 22" X 22", KNIFE EDGE W/BRAID (G17)

### SOFA BED, LOVESEAT & RECLINER CHAIR

KEY	PART NUMBER	U/M DESCRIPTION
8	120288-01-000	EA SOFA ASM-4202-66 EB (G15)
8	117711-03-000	EA SOFA ASM-4143-66 EB (G16)
8	117711-04-000	EA SOFA ASM-4143-66 EB (G17)
9	120289-01-000	EA LOVE SEAT ASM-4202-44 LS (G15)
9	117712-03-000	EA LOVE SEAT ASM-4143-44 LS (G16)
9	117712-04-000	EA LOVE SEAT ASM-4143-44 LS (G17)
10	118821-01-G15	EA SWIVEL CHAIR - RECLINER
10	118821-01-G16	EA SWIVEL CHAIR - RECLINER
10	118821-01-G17	EA SWIVEL CHAIR - RECLINER

### KING BED

KEY	PART NUMBER	U/M DESCRIPTION
1	101123-25-000	EA MATTRESS - FOAM - 72" X 80" X 6.5"
1	P01123-25-000	EA COVER - MATTRESS
1	119141-03-G15	EA BEDSPREAD-THROW, W/REVERSE SHAM - 72" X 80"
1	109588-18-G16	EA BEDSPREAD - 72" X 80" - W/FITTED GUSSET CORNERS
1	109588-18-G17	EA BEDSPREAD - 72" X 80" - W/FITTED GUSSET CORNERS
2	119249-02-000	EA PILLOW-CASE ASM, 22" X 37" (G15)
2	106727-03-G16	EA PILLOW-TOOTSIE, W/.5" WELT
2	106727-03-G17	EA PILLOW-TOOTSIE, W/.5" WELT
	111637-08-G15	EA PILLOW ASM - 16" X 16" - KNIFE EDGE W/BRAID
	111637-09-G16	EA PILLOW ASM - 16" X 16" - KNIFE EDGE W/BRAID
	111637-09-G17	EA PILLOW ASM - 16" X 16" - KNIFE EDGE W/BRAID

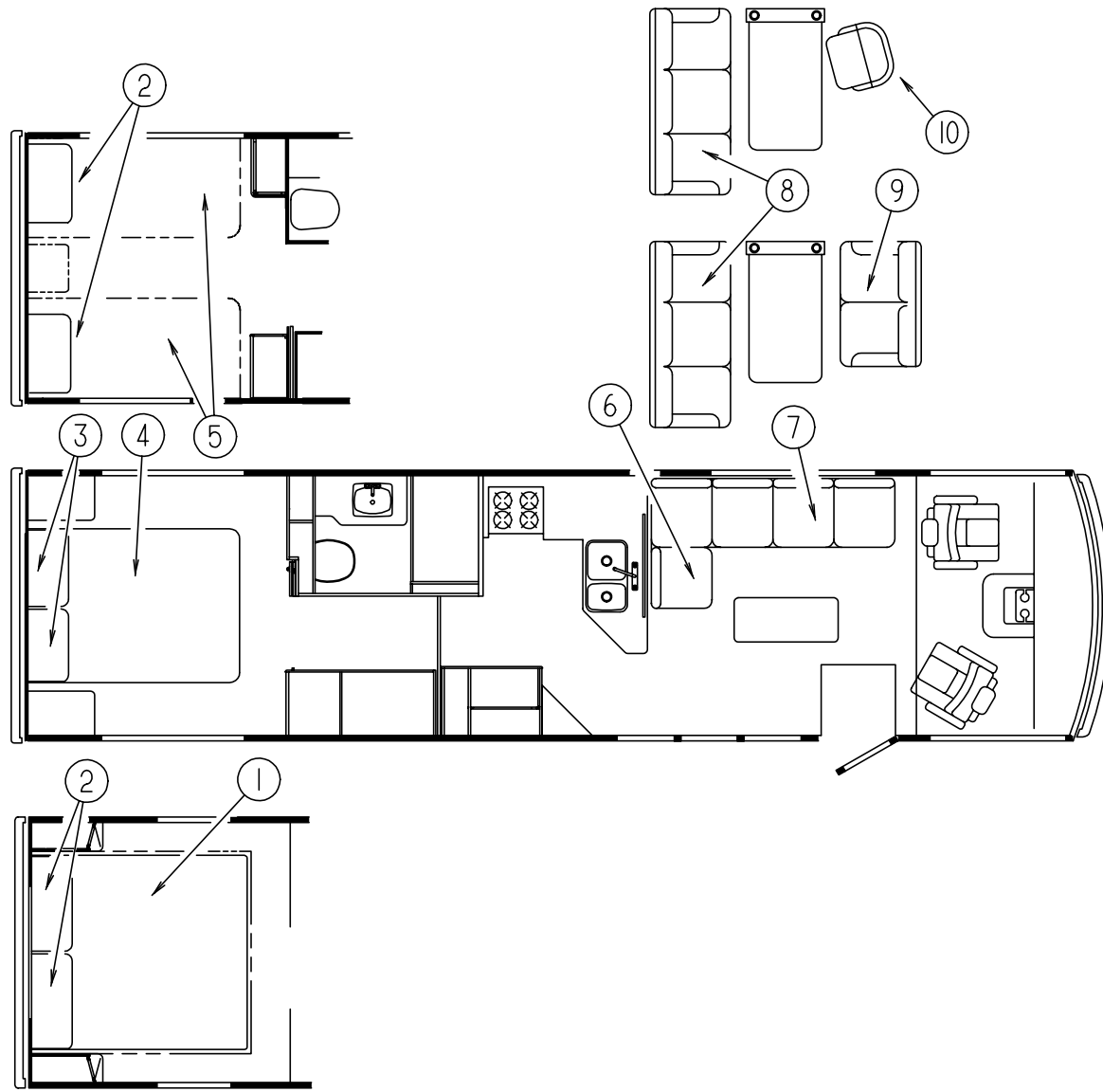

## DINETTE GROUP

### FOLDOUT TABLE

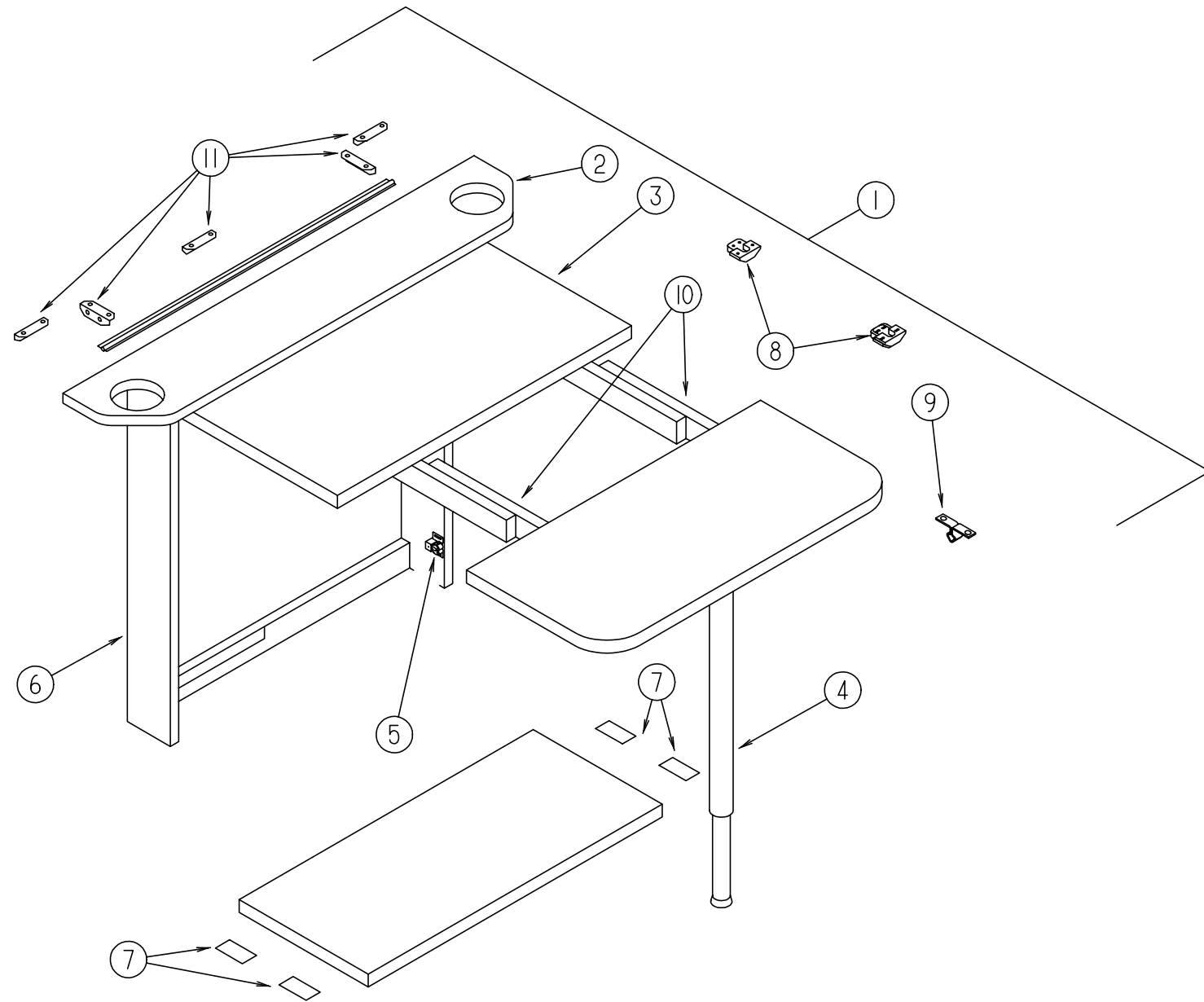

KEY	PART NUMBER	U/M	DESCRIPTION
1	117607-01-F11	EA	TABLE ASM-FOLDOUT, W/LEG
2	117607-12-G15	EA	COUNTERTOP ASM
3	117607-11-G15	EA	COUNTERTOP ASM
4	108483-01-000	EA	LEG-TABLE - ADJUST 597 TO 902
5	093586-03-000	EA	CATCH-SPRING, ROLLER
6	117607-13-G15	EA	END-TABLE
7	085774-01-000	FT	FASTENER-DUAL HOOK, 1" WIDE - ADHESIVE BACK - BLACK
8	009050-02-000	EA	LEVELER-TABLE TOP
8	009050-03-000	EA	LEVELER-TABLE TOP
9	093586-04-000	EA	STRIKE-SPRING STEEL
10	110749-01-000	EA	SLIDE-TABLE 19 3/4" LONG
11	016604-05-000	EA	BRACE-CABINET, L ANGLE - 2.5" - METAL - O/W
	113109-02-01A	EA	HINGE-TABLE, FOLD UP - O/W

### FOLDING CHAIR

KEY	PART NUMBER	U/M	DESCRIPTION
	101604-01-01A	EA	CHAIR-FOLDING, DINETTE - OAK



# DRIVERS COMPARTMENT GROUP

## UPPER & LOWER DRIVER COMPARTMENT

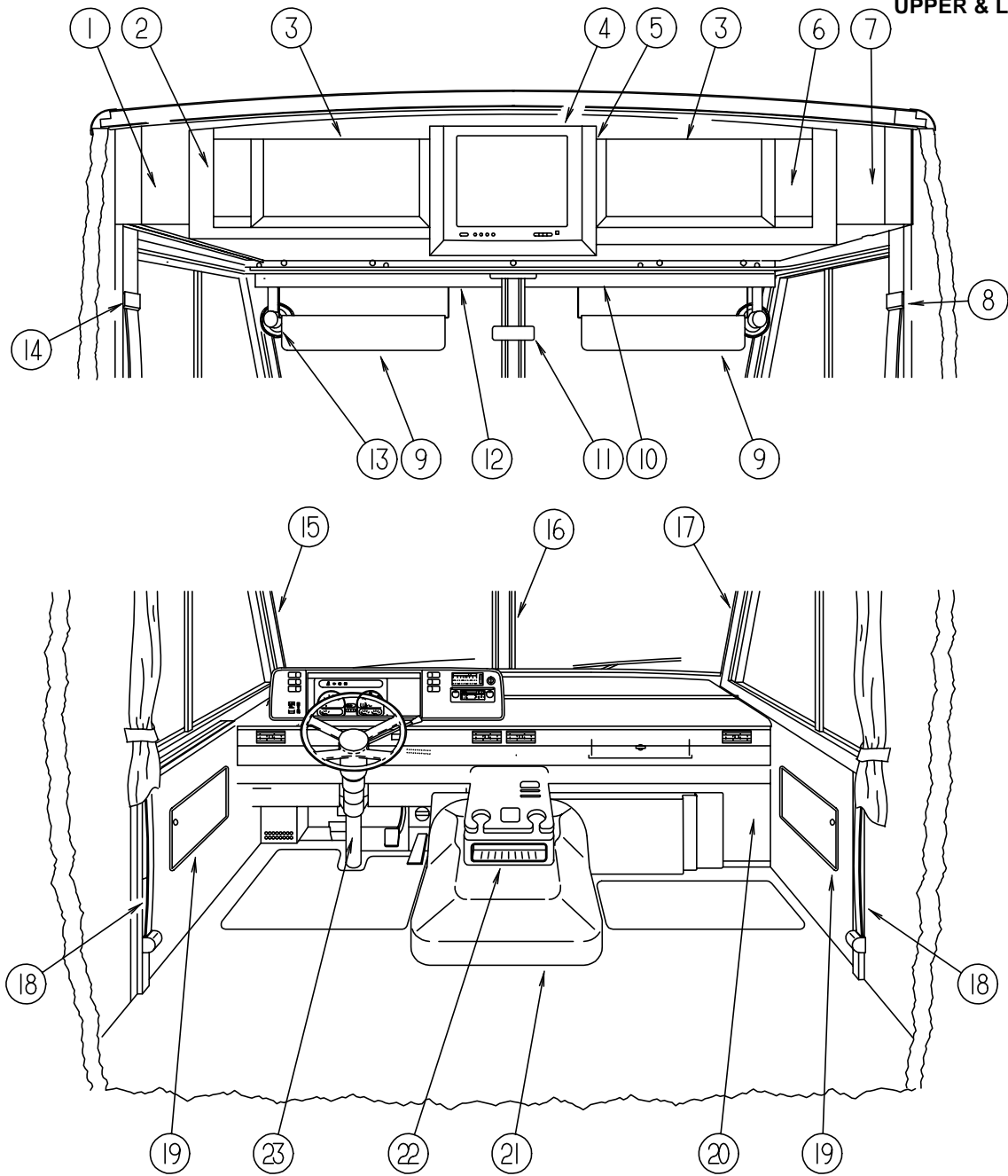

KEY	PART NUMBER	U/M DESCRIPTION
4	M06803-C1-G15	EA DOOR - CABINET - W/O TV - 425 X 460 MM
5	116791-01-F31	EA FRAME ASSEMBLY - CABINET - W/ TV
	P18192-01-G15	EA COVER ASSEMBLY - TV - WITH VINYL
	115639-01-G15	EA PANEL ASSEMBLY - LINER-W/O TV - DRIVER
6	114612-03-G15	EA FACE ASSEMBLY - CABINET - PASSENGER SIDE OVERHEAD - 15.7" X 36.4"
	106699-01-01A	EA BRACKET - OVERHEAD CABINET - OFF WHITE
	P03077-06-G15	EA SHELF - BASE - CABINET - PASSENGER OVERHEAD
	100676-02-000	EA STAND - VCR
	114661-03-E10	EA PANEL ASSEMBLY - LINER - PASSENGER OVERHEAD - W/ TV
	114661-17-G15	EA PANEL ASSEMBLY - LINER - PASSENGER OVERHEAD - W/ TV & VCR
	114661-09-F11	EA PANEL ASSEMBLY - LINER - PASSENGER OVERHEAD - W/ TV - VCR/ INVERTER
	114661-10-E10	EA PANEL ASSEMBLY - LINER - PASSENGER OVERHEAD - W/ TV & INVERTER
7	104289-03-D12	EA PANEL - SIDE - PASSENGER OVERHEAD - VINYL
8	103961-01-01A	EA COVER-BRACKET - SEATBELT - OFF WHITE
9	082286-19-F11	EA SUNVISOR ASSEMBLY
	007211-01-000	EA HINGE - SUNVISOR - 25.5" X 1.5" - METAL
	074012-01-000	EA CLIP - SUNVISOR - SQUARE - PINCH ON
	116093-01-02A	EA BRACKET - SUNVISOR - W/ ROD - RH - BLACK
	116093-02-02A	EA BRACKET - SUNVISOR - W/ ROD - LH - BLACK
10	078579-17-000	EA TRIM - WINDSHIELD - UPPER INNER - RH - WILLOW
11	040714-01-000	EA MIRROR - REAR VIEW - W/ARM MOUNT & SET SCREW
	067490-01-000	EA BUTTON - MIRROR - REAR VIEW - STANK S927H
12	078579-18-000	EA TRIM - WINDSHIELD - UPPER INNER - LH - WILLOW
13	036420-02-000	EA FAN - DEFROSTER - 2 SPEED - 6" DIAMETER
14	103961-01-01A	EA COVER - BRACKET - SEATBELT - W/O DRIVER DOOR - OFF WHITE
14	103961-02-01A	EA COVER - BRACKET - SEATBELT - W/ DRIVER DOOR - OFF WHITE
	R77030-53-447	EA WASHER - FLAT
15	103931-04-03A	EA COVER - INTERIOR - A-PILLAR - DRIVER SIDE - WILLOW
16	079765-11-000	EA TRIM - WINDSHIELD - CENTER - WILLOW
17	103931-03-03A	EA COVER - INTERIOR - A-PILLAR - PASSENGER SIDE - WILLOW
	024700-46-000	EA COVER - ROLL BAR - DRIVER & PASSENGER SIDE UPPER - OFF WHITE - 21.2"
	024700-44-000	EA COVER - ROLL BAR - DRIVER & PASSENGER SIDE LOWER - 53" (W/O DR. DOOR)
	024700-47-000	EA COVER - ROLL BAR - DRIVER SIDE LOWER - 18.9" (W/ DRIVER DOOR)
	024700-48-000	EA COVER - ROLL BAR - DRIVER SIDE CENTER - 25" (W/ DRIVER DOOR)
18	091990-04-01A	EA SEAT BELT - 3 POINT - BLACK - INTERTEK A8408
	109146-01-000	EA BOLT - SHOULDER - SEAT BELT
19	086120-10-G15	EA PAD - MAP POCKET - 12" X 16"
19	086120-10-G16	EA PAD - MAP POCKET - 12" X 16"
19	086120-10-G17	EA PAD - MAP POCKET - 12" X 16"
20	095757-05-G15	EA COVER - HEATER
20	095757-05-G16	EA COVER - HEATER
20	095757-05-G17	EA COVER - HEATER
21	115840-01-01A	EA COVER - MOTOR
	115850-01-02B	EA RETAINER ASM - MOTOR COVER LATCH
	116581-01-000	EA LATCH - MOTOR COVER
	115860-01-01A	EA TRIM - MOTOR COVER MILL
	115852-01-02B	EA STRIKE ASM. - MOTOR COVER
	116833-01-02B	EA WRENCH - HEX - MOTOR COVER
22	111618-01-GB1	EA TRAY - BEVERAGE
22	111618-13-GB1	EA LID ASM. - TRAY - BEVERAGE
	046886-03-000	EA ASHTRAY - CHROME - W/ COVER
23	103498-06-000	EA BOOT - COLUMN - UNIVERSAL
	112634-01-01A	EA TRIM - STEERING COLUMN - RH BLACK
	112634-02-01A	EA TRIM - STEERING COLUMN - LH BLACK
	111521-03-01A	EA COVER - STEERING COLUMN - BLACK

KEY	PART NUMBER	U/M DESCRIPTION
1	104289-04-G15	EA PANEL - SIDE - DRIVER - OVERHEAD - VINYL
2	114612-04-G15	EA FACE ASSEMBLY - OVERHEAD CABINET - DRIVER SIDE - W/TV
	106699-01-01A	EA BRACKET - OVERHEAD CABINET - OFF WHITE
	P03077-05-G15	EA SHELF - BASE - OVERHEAD CABINET - DRIVER
	114661-11-G15	EA PANEL ASSEMBLY - LINER - DRIVER OVERHEAD
	078811-09-F11	EA PANEL - TRIM - HEADER - LOWER - BETWEEN OVERHEAD AND W/S TRIM
3	100708-13-000	EA DOOR - CABINET - GLASS - 246 X 658 MM
	100710-01-01A	EA LOCK ASSEMBLY - TWIST TYPE - BRASS
	100711-01-01A	EA HINGE - GLASS DOOR
	100707-01-000	EA SPACER - GLASS DOOR - .8" DIAMETER - .3" HOLE - PLASTIC
	101272-01-000	EA CATCH - GLASS DOOR
	101766-01-000	EA PIN - SUPPORT - GLASS DOOR
	108487-02-01A	EA SUPPORT - PROP ROD - PASSENGER OVERHEAD - BLACK
	108486-01-01A	EA BRACKET - PROP ROD - PASSENGER OVERHEAD - BLACK

## DRIVERS COMPARTMENT GROUP (CONTINUED)

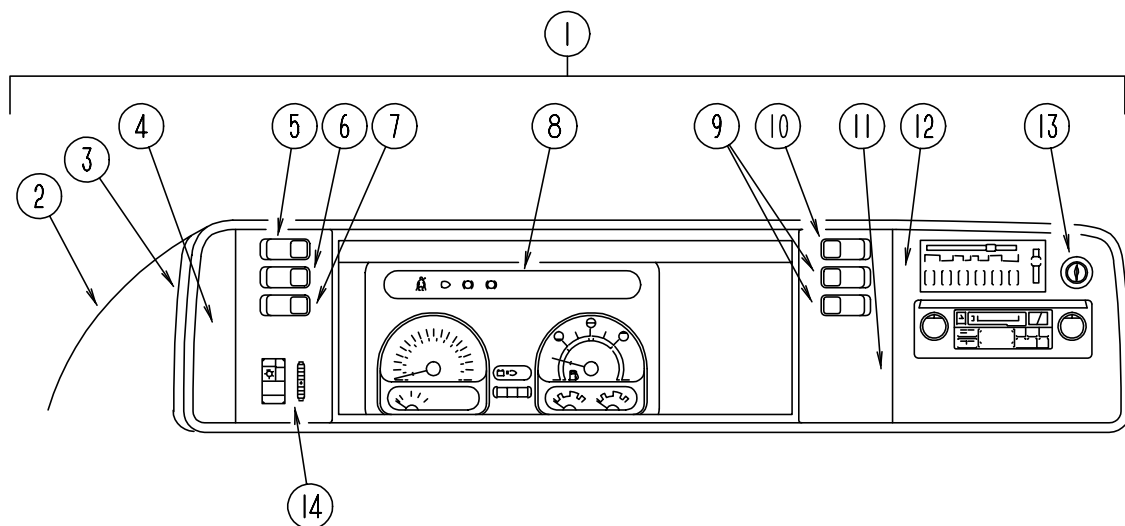

DASH, GAUGES & SWITCHES (FORD)

KEY	PART NUMBER	U/M	DESCRIPTION
1	M05946-30-G15	EA	DASH POD ASM.-FORD, W/O INSTRUMENT CLUSTER
2	111499-01-03A	EA	POD - INSTRUMENT PANEL - WILLOW
3	103662-04-01A	EA	BEZEL - INSTRUMENT PANEL
4	104056-01-02A	EA	APPLIQUE - BEZEL - LEFT - DRESS UP
5	108357-05-000	EA	SWITCH - ROCKER - SPDT ON/ NONE/ ON
5	108356-02-01A	EA	SWITCH COVER - W/ DIMPLES - CARLING VVAZC00 BLA
6	108357-09-000	EA	SWITCH - ROCKER - SPDT ON/ NONE/ MOM
6	108356-02-01A	EA	SWITCH COVER - W/ DIMPLES - CARLING VVAZC00 BLA
7	108357-06-000	EA	SWITCH - ROCKER - DPDT MOM/ OFF/ MOM
7	108356-02-01A	EA	SWITCH COVER - W/ DIMPLES - CARLING VVAZC00 BLA
8	108357-03-000	EA	SWITCH - ROCKER - SPDT ON/ OFF/ ON
8	108356-02-01A	EA	SWITCH COVER - W/ DIMPLES - CARLING VVAZC00 BLA
9	108357-10-000	EA	SWITCH - ROCKER - SPDT MOM/ OFF/ MOM
9	108356-04-01A	EA	SWITCH COVER - W/ DIMPLES & LENS - CARLING VVAGC00
	096241-03-000	EA	SWITCH - BLANK
10	104056-21-01A	EA	APPLIQUE - BEZEL - SWITCH RIGHT
11	089294-01-000	EA	LIGHTER ASM. - CIGARETTE
12	104056-06-02A	EA	APPLIQUE - BEZEL - RIGHT DRESS UP
13	096675-01-000	EA	KNOB - HEADLAMP SWITCH - W/SHAFT
	096674-01-000	EA	NUT - HEADLAMP SWITCH - BLACK
14	104056-24-01A	EA	APPLIQUE - BEZEL - SWITCH LEFT
	106569-07-01A	EA	VINYL - LAMINATE MADRID WILLOW - 1/4" X 17" X 100"
	100138-01-000	EA	MODULE - DAYTIME RUNNING LIGHT (CSA)
	077031-01-000	EA	FILM - BLACK - 1" X 1.75"
	077031-03-000	EA	FILM - WHITE .75" X 1"
	104354-08-01A	EA	APPLIQUE - LOWER DASH - FORD
	112235-01-01A	EA	BEZEL - MONITOR - LEVELING JACK - WILLOW
	111528-03-02A	EA	TRIM - DASH - LOWER - RIGHT HAND - WILLOW
	117306-02-F11	EA	TRIM ASM - DASH - LOWER,FORD
	P14614-02-F11	EA	DASH ASM - FORD - W/O VINYL
	108067-03-000	EA	STUD - WELD - 1/4-20 X 1/2 CD

## DRIVERS COMPARTMENT GROUP (CONTINUED)

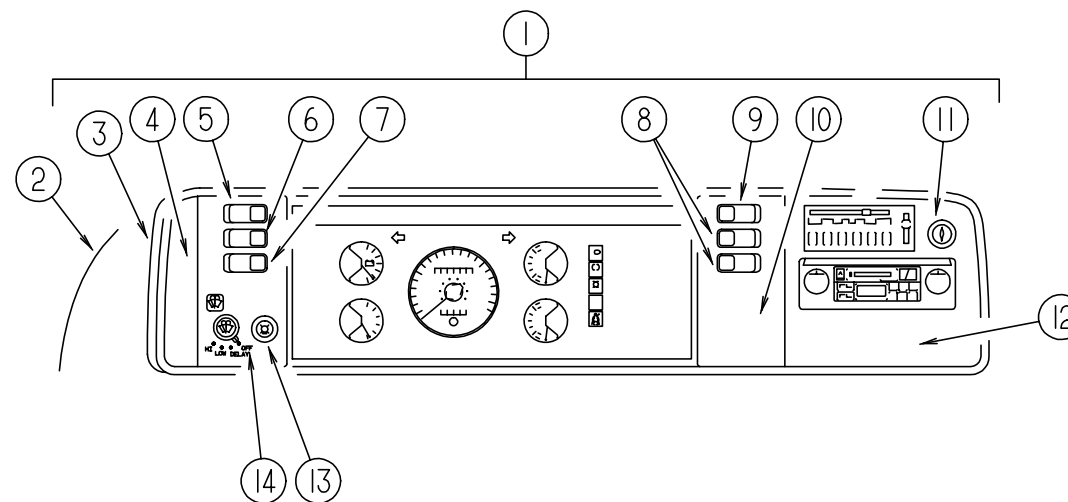

DASH, GAUGES & SWITCHES (CHEVY)

KEY	PART NUMBER	U/M	DESCRIPTION
1	M05946-29-G15	EA	DASH POD ASM.-CHEVY, W/O INSTRUMENT CLUSTER
2	111499-01-03A	EA	POD - INSTRUMENT PANEL - WILLOW
3	103662-01-01A	EA	BEZEL - INSTRUMENT PANEL
4	104056-01-02A	EA	APPLIQUE - BEZEL - LEFT - DRESS UP
5	108357-05-000	EA	SWITCH - ROCKER - SPDT ON/ NONE/ ON
5	108356-02-01A	EA	SWITCH COVER - W/ DIMPLES - CARLING VVAZC00 BLA
6	108357-09-000	EA	SWITCH - ROCKER - SPDT ON/ NONE/ MOM
6	108356-02-01A	EA	SWITCH COVER - W/ DIMPLES - CARLING VVAZC00 BLA
7	108357-06-000	EA	SWITCH - ROCKER - DPDT MOM/ OFF/ MOM
7	108356-02-01A	EA	SWITCH COVER - W/ DIMPLES - CARLING VVAZC00 BLA
8	094796-07-000	EA	CLUSTER - INSTRUMENT PANEL - KILOMETER (CSA)
9	108357-03-000	EA	SWITCH - ROCKER - SPDT ON/ OFF/ ON
9	108356-02-01A	EA	SWITCH COVER - W/ DIMPLES - CARLING VVAZC00 BLA
10	108357-10-000	EA	SWITCH - ROCKER - SPDT MOM/ OFF/ MOM
10	108356-04-01A	EA	SWITCH COVER - W/ DIMPLES & LENS - CARLING VVAGC00
	096241-03-000	EA	SWITCH - BLANK
11	104056-21-01A	EA	APPLIQUE - BEZEL - SWITCH RIGHT
12	104056-06-02A	EA	APPLIQUE - BEZEL - RIGHT DRESS UP
13	089294-01-000	EA	LIGHTER ASM. - CIGARETTE
14	104056-22-01A	EA	APPLIQUE - BEZEL - SWITCH LEFT
	P14614-01-F11	EA	DASH ASM - LOWER - W/O VINYL
	106569-07-01A	EA	VINYL - LAMINATE MADRID WILLOW - 1/4" X 17" X 100"
	077031-01-000	EA	FILM - BLACK - 1" X 1.75"
	077031-03-000	EA	FILM - WHITE .75" X 1"
	105615-01-000	FT	FILM - PROTECTIVE - CLEAR
	114620-01-01A	EA	TRIM - DASH - LOWER - WILLOW
	104354-08-01A	EA	APPLIQUE - LOWER DASH
	100138-01-000	EA	MODULE - DAYTIME RUNNING LIGHT (CSA)
	077539-01-000	EA	BRACKET - MOUNTING - DASH PANEL - L/ SHAPED
	112235-01-01A	EA	BEZEL - MONITOR - LEVELING JACK - WILLOW

# ELECTRICAL GROUP

## EXTERIOR LIGHTS

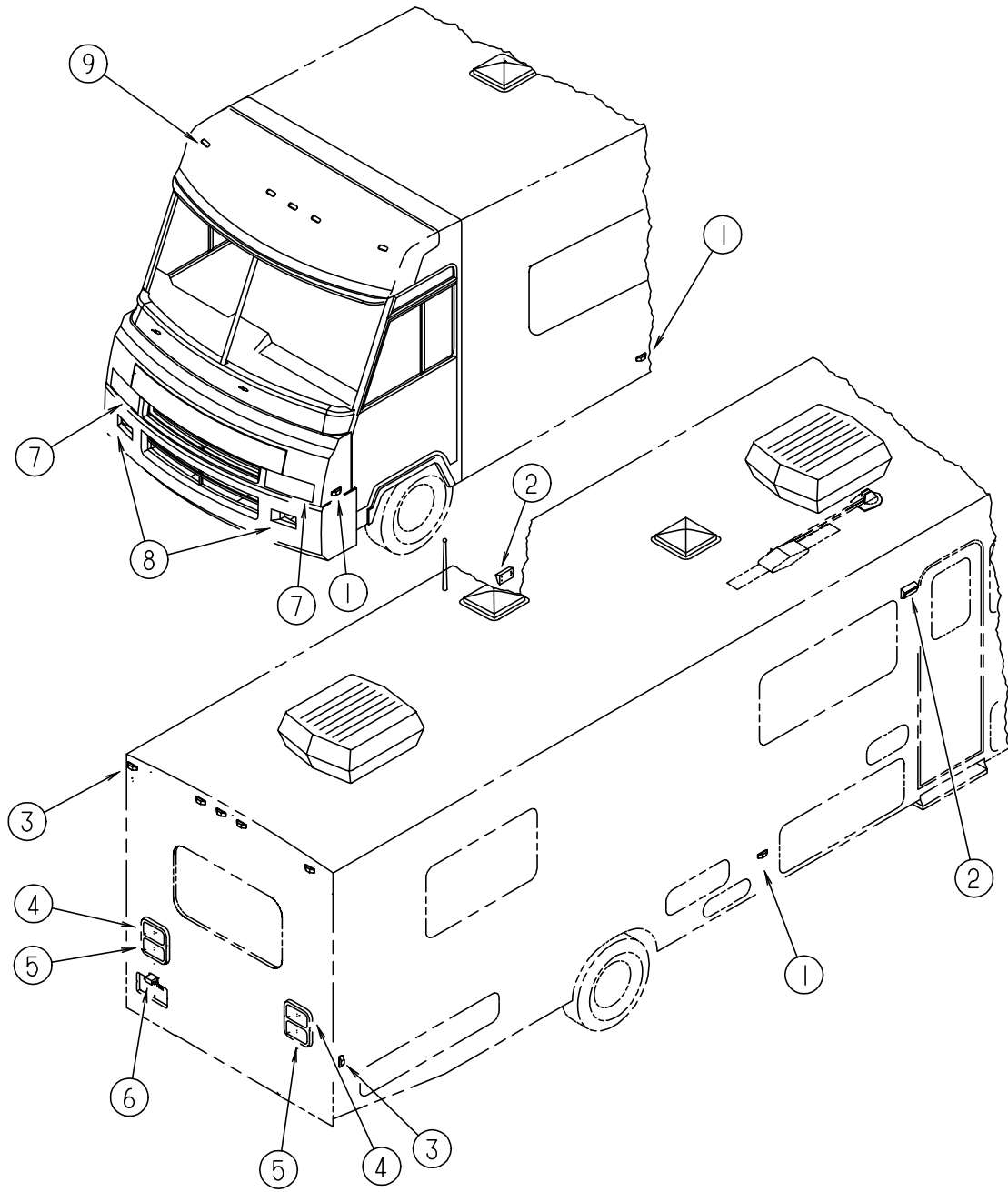

KEY	PART NUMBER	U/M DESCRIPTION
1	111102-01-000	EA LAMP - MARKER - BASE - TRIPLEX 117XAS
1	036196-01-000	EA BULB - 12V - #194 - .27 AMP - BAYONETTE
1	111102-02-000	EA LENS - MARKER LAMP - AMBER - TRIPLEX 118A
1	112823-01-000	EA SPLICE - REDUCER
2	097917-01-04A	EA LIGHT - PORCH - ENTRY DOOR - BUFF - US
2	008215-01-000	EA BULB - 12V - #1003 - .94 AMP
2	097917-01-700	EA LENS - LIGHT - PORCH
2	008089-02-000	EA LIGHT - PORCH, RECESSED - CANADIAN
2	008215-01-000	EA BULB - 12V - #1003 - .94 AMP
2	008089-01-700	EA LENS - LIGHT - PORCH - CANADIAN
3	111102-01-000	EA LAMP - MARKER - BASE - TRIPLEX 117XAS
3	036196-01-000	EA BULB - 12V - #194 - .27 AMP - BAYONETTE
3	111102-03-000	EA LENS - MARKER LAMP - RED - TRIPLEX 117R
3	112823-01-000	EA SPLICE - REDUCER
4	115632-01-02A	EA LIGHT - STOP/TURN/TAIL RED - BARGMAN 3092106
4	115632-03-02A	EA LIGHT - STOP/TAIL/BACKUP - BARGMAN 3092107
	117379-01-01A	EA TRIM - TAIL LIGHT - REAR - BUFF
5	115632-03-02A	EA LIGHT - STOP/TAIL/BACK UP - BARGMAN 3092107
6	066432-02-000	EA LIGHT - LICENSE
	066432-03-000	EA BRACKET - LICENSE PLATE - BARGMAN 30-60-030
7	070907-04-000	EA HEADLAMP ASM-HIGH/LOW HALOGEN - BLACK - KD 923-23-276
	049359-01-000	EA SPRING - RETAINER - HEADLAMP - GM 496096
	110750-01-000	EA SCREW - HEADLAMP ADJUSTING
8	089292-01-000	EA LIGHT - TURN - W/AMBER LENS
	037935-01-000	EA BULB - 12V - #1157 - 2.1AMP
9	102520-01-000	EA LIGHT - CLEARANCE - W/O SOCKET CONNECTIONS - AMBER
	102540-01-000	EA SEAL - SCREW - ROUND - RUBBER
	088474-09-000	EA HOUSING - SOCKET - 3 CAVITY - AMP 1-480701-0
	088476-01-000	EA SOCKET - CONNECTOR - BRASS - PRE-TIN
	102541-01-000	EA GASKET - CLEARANCE LIGHT
	067789-02-000	EA SOCKET - LAMP

**ELECTRICAL GROUP (CONTINUED)**  
**LIGHTS, SWITCHES & RECEPTACLES DRIVERS SIDE**

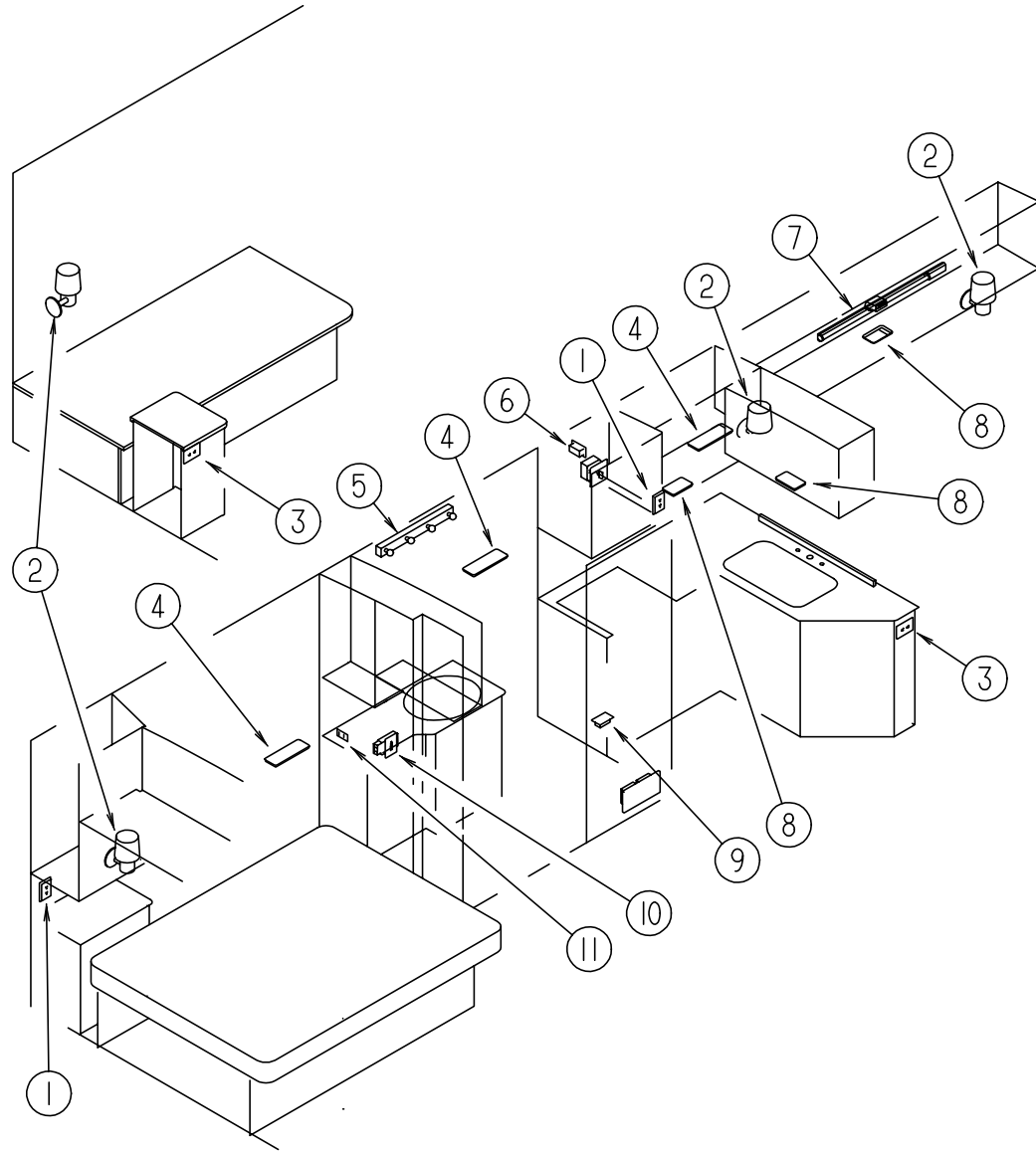

KEY	PART NUMBER	U/M	DESCRIPTION	VENDOR NO.
1	058708-02-000	EA	RECEPTACLE-ELECTRIC, DOUBLE - IVORY	
1	102568-01-GB1	EA	SPACER-RECEPTACLE, SIDEWALL	
2	065202-24-000	EA	LAMP-WALL, BRASS UL/CSA - GUSTAFSON OV-531	
2	065201-12-000	EA	SHADE-LAMP, FABRIC - WHITE SWIRL	
2	067479-01-000	EA	BULB - 12V, NUMBER 1076	
3	058708-01-000	EA	RECEPTACLE-ELECTRIC, DOUBLE - BROWN	
4	098024-03-01A	EA	LIGHT-DOME, 2 BULB - IVORY	
4	008218-01-000	EA	BULB-DOME LIGHT, 12V - NUMBER 1141	
4	098024-01-700	EA	LENS-LIGHT	807877
5	110235-02-01A	EA	LIGHT-MAKE UP, 4 BULB PANLESS - PD PD200-622 BRASS	
5	081633-01-700	EA	BULB-LIGHT, MAKE-UP	RP1041
6	058708-05-000	EA	RECEPTACLE-SINGLE, BRN - WIRECON WDR15BRS	
7	113371-03-000	EA	LIGHT-FLUORESCENT 42", STRIP - THIN-LITE 147 UL/CS	
8	098024-01-01A	EA	LIGHT-DOME, 1 BULB - US - IVORY	
8	008218-01-000	EA	BULB-DOME LIGHT, 12V - NUMBER 1141	
8	098024-01-700	EA	LENS-LIGHT	807877
9	058707-02-000	EA	RECEPTACLE-BLANK, JUNCTION - WIRECON WDJ20BR	
10	084076-02-000	EA	RECEPTACLE-GFI, 15A - 125V - BROWN	
11	079364-01-000	EA	SWITCH-ON/OFF ROCKER, 2 PRONGS - BROWN - VANITY	
11	079364-03-000	EA	SWITCH-ON/OFF ROCKER, 3 PRONGS - BROWN - PUMP	
11	098351-02-01A	EA	PLATE-SWITCH, 2 GANG - POLISHED BRASS - JENSEN	
11	095188-01-01A	EA	SPACER-SWITCH, 2.3" X 3.4" - PLASTIC - DARK BROWN	

## ELECTRICAL GROUP (CONTINUED)

### LIGHTS, SWITCHES & RECEPTACLES PASSENGER SIDE

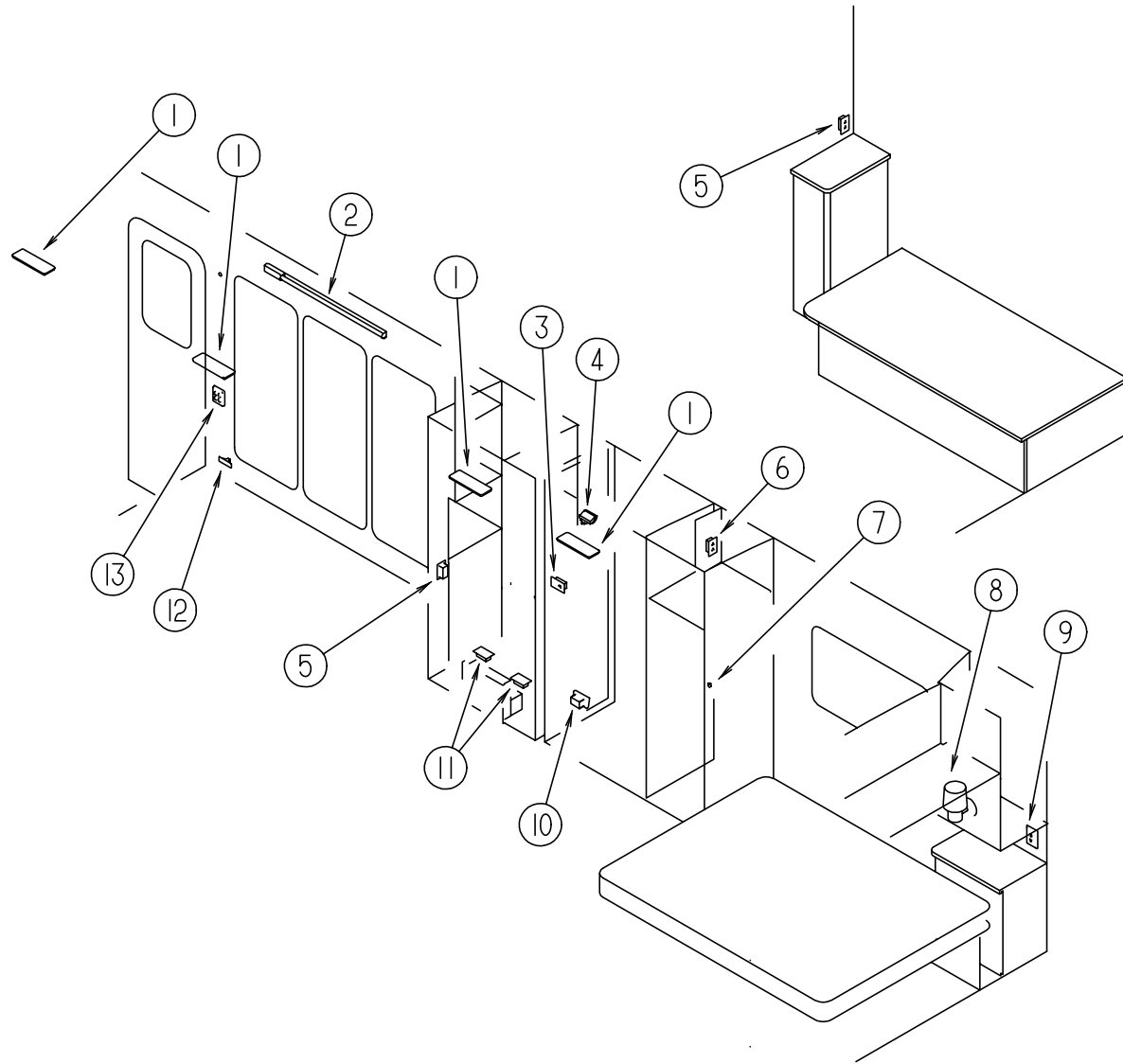

KEY	PART NUMBER	U/M	DESCRIPTION	VENDOR NO.
1	098024-03-01A	EA	LIGHT-DOME, 2 BULB - IVORY	
1	008218-01-000	EA	BULB-DOME LIGHT, 12V - NUMBER 1141	
1	098024-01-700	EA	LENS-LIGHT	807877
2	113371-03-000	EA	LIGHT-FLUORESCENT 42", STRIP - THIN-LITE 147 UL/CS	
3	058707-01-000	EA	RECEPTACLE-ELECTRIC, SINGLE - BROWN	
4	087694-01-000	EA	LIGHT-WARDROBE/CLOSET, W/SWITCH	
4	087694-01-700	EA	BULB	GE561
5	058708-01-000	EA	RECEPTACLE-ELECTRIC, DOUBLE - BROWN	
6	058708-05-000	EA	RECEPTACLE-SINGLE, BRN - WIRECON WDR15BRS	
6	076319-09-000	EA	WALLPLATE-CABLE RECEPTACLE, TV - SINGLE - BROWN	
7	079364-01-000	EA	SWITCH-ON/OFF ROCKER, 2 PRONGS - BROWN	
7	098351-01-01A	EA	PLATE-SWITCH, 1 GANG - POLISHED BRASS - JENSEN	
8	065202-24-000	EA	LAMP-WALL, BRASS UL/CSA - GUSTAFSON OV-531	
8	065201-12-000	EA	SHADE-LAMP, FABRIC - WHITE SWIRL	
8	067479-01-000	EA	BULB - 12V, NUMBER 1076	
9	058708-02-000	EA	RECEPTACLE-ELECTRIC, DOUBLE - IVORY	
9	102568-01-GB1	EA	SPACER-RECEPTACLE, SIDEWALL	
10	112822-01-01A	EA	RECEPTACLE-DUPLEX, IVORY - WIRECON WDRU15IV	
10	112824-01-02A	EA	COVER-EXTERIOR DUPLEX RECEPTACLE, O/W - P&S 3780-SC-CW	
11	058707-02-000	EA	RECEPTACLE-BLANK, JUNCTION - WIRECON WDJ20BR	
12	108354-01-01A	EA	LIGHT-COURTESY, ITC 81395-B	
12	108354-01-700	EA	BULB-COURTESY LIGHT	12842
13	079364-01-000	EA	SWITCH-ON/OFF ROCKER, 2 PRONGS - BROWN	
13	098351-11-01A	EA	PLATE-SWITCH, 4 GANG W/LABEL - JENSEN-BRASS, POLISH	
13	095188-03-01A	EA	SPACER-SWITCH, DK BRN - JENSEN A8932BN	

**ELECTRICAL GROUP (CONTINUED)**

**TERMINALS**

KEY	PART NUMBER	U/M DESCRIPTION
	008326-01-000	EA TERMINAL - RING - 16/14 WIRE - 3/8" STUD
	008328-01-000	EA TERMINAL - RING - 12/10 WIRE - #10 STUD FIT
	008331-01-000	EA TERMINAL - RING - TONGUE - #4 WIRE - 3/8" STUD - COPPER
	008348-01-000	EA TERMINAL - RING - 3/8" STUD - #2 WIRE
	035416-04-000	EA TERMINAL - RING #10 STUD FITTING - INSULATED BARREL #16/14
	047443-01-000	EA TERMINAL - .250 RECEPTACLE FITTING - INSULATED - 16/14 AWG
	062036-01-000	EA TERMINAL - PACK - CONNECTOR - 12/10 AWG - PARKARD 12033817
	062036-02-000	EA TERMINAL - PACK - CONNECTOR - 16/14 AWG - PARKARD 08917021
	088267-01-000	EA TERMINAL - FEMALE, 1/4 - PACKARD 2962573
	104100-03-000	EA TERMINAL - 75 AMP AMP 53880-4 LOOSE
	106655-01-000	EA TERMINAL - FUSE BLOCK - 14-16AWG - PARKARD 12020321
	106655-02-000	EA TERMINAL - FUSE BLOCK - 10-12AWG - PARKARD 12020400
	106007-01-000	EA TERMINAL - FEMALE, 14-16AWG - PARKARD 12015861-L
	113135-01-000	EA TERMINAL - FEMALE - METRI-PACK - 280 - 14-16 - PARKARD 12048451
	113306-01-000	EA TERMINAL - FEMALE - METRI-PACK - 480 - 14-16 - PARKARD 12048451
	113307-01-000	EA TERMINAL - FEMALE - METRI-PACK - 150 - 16-20 - PARKARD 12048074

**ELECTRICAL CONNECTORS & CONDUIT**

KEY	PART NUMBER	U/M DESCRIPTION
	041953-01-000	FT CONDUIT - CONVOLUTE - SLIT - .5"ID
	041953-03-000	FT CONDUIT - CONVOLUTE - SLIT - 1" ID (CLOTHES ROD COVER)
	041953-04-000	FT CONDUIT - CONVOLUTE - SLIT - .50"ID
	041953-05-000	FT CONDUIT - CONVOLUTE - SOLID - .62" ID
	041953-06-000	FT CONDUIT - CONVOLUTE - SLIT .375"ID
	041953-07-000	FT CONDUIT - CONVOLUTE - SLIT - .25" ID
	041953-08-000	FT CONDUIT - CONVOLUTE - SLIT - 1.50"ID
	041953-09-000	FT CONDUIT - CONVOLUTE - SLIT .50"ID
	041953-10-000	FT CONDUIT - CONVOLUTE - SLIT - .75" ID
	041953-11-000	FT CONDUIT - CONVOLUTE - SLIT - 1.06" ID
	041953-12-000	FT CONDUIT - CONVOLUTE - NON SLIT 1.1" ID
	008311-01-000	EA CONNECTOR - WIRE NUT - INSULATED - RED
	008312-01-000	EA CONNECTOR - WIRE NUT - INSULATED - BLUE
	008314-01-000	EA CONNECTOR - WIRE NUT - INSULATED - GRAY
	008355-01-000	EA CONNECTOR - CABLE CLAMPING - 3/4"
	008356-01-000	EA CONNECTOR - PLASTIC - 3/8" AVG
	008398-01-000	EA CONNECTOR - 1/2" X 90 DEGREE, FLEX CONDUIT - UL & CSA
	082741-01-000	EA CONNECTOR - BODY - 2 CONNECTOR - MALE
	058028-01-000	EA CONNECTOR - ELECTRICAL PIGTAIL - NYLON - CLEAR
	041480-01-000	EA CONNECTOR - STRAIGHT - 1/2" FLEX CONDUIT
	087695-03-000	EA CONNECTOR - ASSEMBLY - EURAMTEC RT10484802
	088475-01-000	EA PIN - CONNECTOR - 14 TO 20 AWG
	088476-01-000	EA SOCKET - CONNECTOR - BRASS - PRE - TIN
	088476-02-000	EA SOCKET - CONNECTOR - 12-10 GA - PHOS. BRZ - PRE - TIN
	098261-02-000	EA SOCKET - CONNECTOR, WEATHERPACK - PACKARD 12124580
	098262-01-000	EA SEAL - CONNECTOR, WEATHERPACK - PACKARD 12010293

**CONVERTER & LOAD CENTER**

KEY	PART NUMBER	U/M DESCRIPTION
	113132-01-000	EA LOAD CENTER - 120/ 240V - 60A - WESCO 2460SGNM
	083208-02-000	EA CONVERTER - POWER - 45A - 120V/12V - BW 6345
	099048-02-000	EA INVERTER - 100 WATT - W/EXTRA SURGE CAPACITY

**ELECTRICAL GROUP (CONTINUED)**

**ELECTRICAL HOUSINGS**

KEY	PART NUMBER	U/M DESCRIPTION
	088473-01-000	EA HOUSING-PIN, 12 CAVITY - AMP 1-480708-0
	088473-02-000	EA HOUSING-PIN, 15 CAVITY - AMP 1-480710-0
	088473-03-000	EA HOUSING-PIN, 9 CAVITY - AMP 1-480706-0
	088473-05-000	EA HOUSING-PIN, 6 CAVITY - AMP 640585-1
	088473-06-000	EA HOUSING-PIN, 6 CAVITY - AMP 1-480704-0
	088473-08-000	EA HOUSING-PIN, 4 CAVITY - AMP 1-480702-0
	088473-09-000	EA HOUSING-PIN, 3 CAVITY - AMP 1-480700-0
	088473-10-000	EA HOUSING-PIN, 2 CAVITY - AMP 1-480698-0
	088474-01-000	EA HOUSING-SOCKET, 12 CAVITY - AMP 1-480709-0
	088474-02-000	EA HOUSING-SOCKET, 12 CAVITY - AMP 1-480711-0
	088474-03-000	EA HOUSING-SOCKET, 9 CAVITY - AMP 1-480707-0
	088474-06-000	EA HOUSING-SOCKET, 6 CAVITY - AMP 1-480705-0
	088474-07-000	EA HOUSING-SOCKET, 5 CAVITY - AMP 1-480764-0
	088474-08-000	EA HOUSING-SOCKET, 4 CAVITY - AMP 1-480703-0
	088474-09-000	EA HOUSING-SOCKET, 3 CAVITY - AMP 1-480701-0
	088474-10-000	EA HOUSING-SOCKET, 2 CAVITY - AMP 1-480699-0
	098264-01-000	EA HOUSING - 2 PIN, WEATHER PACK - MALE - PACKARD 12015792
	104100-01-000	EA HOUSING - 1 POSITION, 75 AMP - AMP 53884-1
	106006-01-000	EA HOUSING - 1 POSITION, FEMALE - PACKARD 12015952
	113131-01-000	EA HOUSING - 3 PIN, METRI-PACK - FEMALE - PACKARD12020397
	113468-01-000	EA HOUSING - 2 POSITION, FEMALE - 56-SERIES - PACKARD 02965981 USED ON WIPER/WASHER WIRE ASM
	115556-01-000	EA HOUSING - 3 POSITION, FEMALE 59-SERIES - PACKARD 02965810
	115556-02-000	EA HOUSING - 2 POSITION, FEMALE 59-SERIES - PACKARD 02965809
	119248-02-000	EA HOUSING - 7 POSTION, FEMALE - PACKARD 12059472

**CIRCUIT BREAKERS & FUSES**

KEY	PART NUMBER	U/M DESCRIPTION
	097611-01-000	EA CIRCUIT BREAKER - 6AMP - ATC - BLACK
	093655-03-000	EA CIRCUIT BREAKER - 40 AMP USD 17440-4E03A2A
	083209-02-000	EA CIRCUIT BREAKER - 15/20AMP - 120V - BW H - 15/15
	083209-03-000	EA CIRCUIT BREAKER - 15/20AMP - 120V - BW - 0-15/20
	083209-04-000	EA CIRCUIT BREAKER - 30A - 120V - BW L - 30
	083209-06-000	EA CIRCUIT BREAKER - 30/15 AMP - 120V - BW D - 30/15
	083209-07-000	EA CIRCUIT BREAKER - 20/20A - 120V - BW K - 20/20
	083209-08-000	EA CIRCUIT BREAKER - BLANK - BW
	112591-01-000	EA CIRCUIT BREAKER - 16A, 240V
	062901-02-000	EA FUSE - 5 AMP - AUTOMOTIVE
	062901-05-000	EA FUSE - 15 AMPS - AUTOMOTIVE
	062901-06-000	EA FUSE - 20 AMPS - AUTOMOTIVE
	062901-07-000	EA FUSE - AUTOMOTIVE - 25 AMPS
	062901-08-000	EA FUSE - 30 AMPS - AUTOMOTIVE
	106656-01-000	EA FUSE BLOCK - 4 CAVITY AUTOFUSE
	008235-01-000	EA FUSE-AUTOMOTIVE, 12V - 15AMP
	100341-01-000	EA FUSE HOLDER-IN LINE TYPE, WESCO 8931-92020
	108669-01-000	EA HOUSING - AUTO FUSE HOLDER
	062037-01-000	EA HOUSING - AUTO FUSE - NATURAL
	062037-02-000	EA HOUSING - AUTO FUSE - GREEN
	062037-03-000	EA HOUSING - AUTO FUSE - BLACK
	062037-04-000	EA HOUSING - AUTO FUSE - BLUE
	062037-06-000	EA HOUSING - AUTO FUSE - BROWN
	062037-07-000	EA HOUSING - AUTO FUSE - RED

## ELECTRICAL GROUP (CONTINUED)

### ELECTRICAL WIRING & BOXES

KEY	PART NUMBER	U/M	DESCRIPTION
	008052-01-000	EA	CORD-POWER, 10/3 - 30 AMP - 25' - CANADIAN
	008054-01-000	EA	CORD-POWER, 10/3 - 30 AMP - 25'
	121470-01-000	EA	CORD-EXTENSION, 6'
	008289-01-000	EA	BOX-ELECTRIC, STEEL - 1/2" AND 3/4" KNOCKOUTS - 4" X 4"
	008289-02-000	EA	BOX-ELECTRICAL, 4" X 4" - 1/2" & 3/4" KNOCKOUTS - CANADIAN
	008294-01-000	EA	COVER-ELECTRICAL BOX, BLANK/STEEL - 4" X 4" - GRAY
	069238-01-000	EA	COVER-ELECTRICAL BOX, W/HOLE - 4" X 4" - GRAY USED WITH 30 AMP RECEPTACLE
	074890-01-000	EA	BOX-EXTENSION, STEEL - OPEN SIDES - 4" X 4" X 1 1/2"
	074897-01-000	EA	COVER-ELECTRIC BOX, 1 LARGE & 2 SMALL HOLES - 4" X 4"
	091910-01-000	EA	BOX-ELECTRIC, 3.75" X 3.5" X 1.75" - PLASTIC
	091910-02-000	EA	BOX-ELECTRICAL, PLASTIC - 57 X 88MM
	111509-01-000	EA	BOX ASM-ELECTRICAL, FRONT
	111510-01-000	EA	DOOR-ELECTRICAL BOX, FRONT
	073328-B4-000	EA	CABLE ASSEMBLY-BATTERY, W/TERMINALS
	090986-01-000	EA	WIRE ASM-ELECTRIC STEP, KWIKEE 9009
	096449-01-000	EA	WIRE ASSEMBLY-WATER TANK TO MONITOR PANEL
	097618-01-000	EA	WIRE ASM-MONITOR PANEL, W/3 WIRES & ORANGE RESISTOR- LVS ORANGE RESISTOR W/3 (ORANGE-GREEN-BLUE) WIRES
	100159-01-000	EA	WIRE ASM-DAYTIME RUNNING LIGHTS, W/FUSE
	102636-02-000	EA	WIRE ASM-CLEARANCE LAMPS
	103342-02-000	EA	WIRE ASM-CLEARANCE, UPPER
	103342-03-000	EA	WIRE ASM-CLEARANCE, UPPER RH
	113134-03-000	EA	WIRE ASM-WIPER/WASHER
	108303-01-000	EA	WIRE ASM-REAR AUTO HEATER
	108304-01-000	EA	WIRE ASM-IP, AUX FANS
	110256-01-000	EA	WIRE ASM-IP, GENERATOR
	111915-01-000	EA	WIRE ASM-DAY RUN LAMPS, FUSE
	111915-03-000	EA	WIRE ASM-DAY RUN LAMPS, FUSE
	119456-01-000	EA	WIRE ASM-IP, MAIN (FORD)
	119459-01-000	EA	WIRE ASM-IP, MAIN (CHEVY)
	104016-01-000	EA	WIRE ASM-AUX FANS

### DASH SWITCHES

KEY	PART NUMBER	U/M	DESCRIPTION
	077942-01-000	EA	SWITCH-DUMMY, BLACK
	079364-04-000	EA	SWITCH-ON/OFF, ROCKER - BLACK
	087695-02-000	EA	SWITCH-MIRROR HEATER - DAV 4720-12
	096241-03-000	EA	SWITCH-BLANK
	108355-01-000	EA	HOUSING-SWITCH - CARLING VCH
	108356-01-01A	EA	SWITCH COVER W/ 3 GROOVES - CARLIN VVCZC00
	108356-02-01A	EA	SWITCH COVER W/ 2 DIMPLES - CARLING CCAZC00
	108356-04-01A	EA	SWITCH COVER W/DIMPLES-LIGHTED-CARLING VVAGC00
	108357-05-000	EA	ROCKER SWITCH, SPDT ON/NONE/ON - CARLING V4D1000B-0
	108357-08-000	EA	ROCKER SWITCH, DPDT ON/NONE/ON - CARLING VDD1S00C-0
	108357-10-000	EA	ROCKER SWITCH, SPDT MOM/OFF/MOM - CARLING V8D1160B-0 (LIGHTED)

## ELECTRICAL GROUP (CONTINUED)

### ELECTRICAL COMPONENTS

KEY	PART NUMBER	U/M	DESCRIPTION	VENDOR NO.
	007956-05-000	EA	INSULATOR-SHRINK .25ID X 1.50 - BLACK	
	077479-01-000	EA	BOOT-BATTERY TERMINAL, DOUBLE CABLE	
	077479-02-000	EA	BOOT-BATTERY TERMINAL, SINGLE CABLE	
	087225-01-000	FT	SLEEVING - 1/2", TYPE H - VARFLEX	
	087225-02-000	FT	SLEEVING - 5/8", TYPE H - VARFLEX VARGLAS	
	087949-01-000	EA	BUSS BAR - 2 POSITION, .6" X 1.5" - ALUMINUM	
	087949-02-000	EA	BUSS BAR - 3 POSITION, .6" X 2.4" - ALUMINUM	
	103608-01-000	EA	SOCKET-WEDGE BASE W/LEADS - JKL 2944-6 OR EQUIV	
	103987-02-000	EA	SEAL-SOLENOID ACCESS	
	112823-01-000	EA	SPLICE-REDUCER 16-14 TO 18-22 - ETC BA-631X	
	007093-01-000	EA	FLASHER-SIGNAL, STAT	
	008188-01-000	EA	SOLENOID - 3 POST, BATTERY CHANGE OVER	
	063910-01-000	EA	HOUSING-RELAY - BOSCH 3 334 485 008	
	063912-02-000	EA	RELAY-CANISTER, SPDT - BOSCH 0332204101	
	086233-01-000	EA	STUD-ISOLATED, 3/8" X 7/8" LONG	
	086273-01-000	EA	RELAY-BATTERY DISCONNECT	
	115504-01-700	EA	PLUG & CABLE, 10 WATT PANEL	600-016

### SOLAR PANEL

KEY	PART NUMBER	U/M	DESCRIPTION	VENDOR NO.
	115505-01-000	EA	MONITOR-SOLAR CHARGER, NAGY IL-1W	
	115504-01-000	EA	PANEL-SOLAR, 10 WATT - NAGY TJN-2SW	
	115504-01-700	EA	PLUG & CABLE, 10 WATT PANEL	600-016

# EXTERIOR BODY GROUP

## EXTERIOR BODY PANELS & TRIM

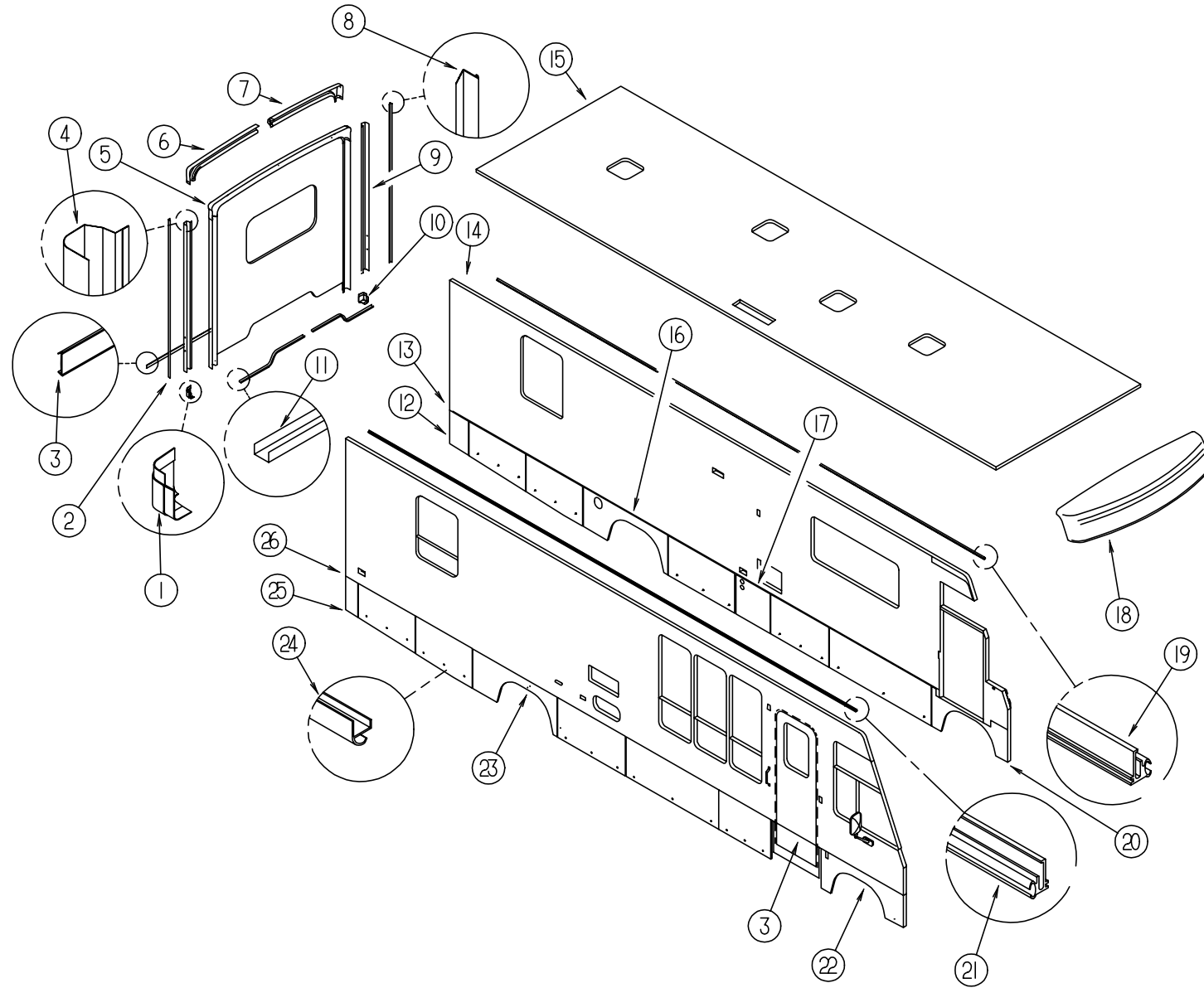

KEY	PART NUMBER	U/M DESCRIPTION
1	119212-01-01A	EA TRIM - BACKWALL - LOWER - RH - BLK
2	120548-01-01A	EA TRIM-J, RH - BACKWALL - W/NOTCH - BUFF
3	108688-01-04A	EA STRIP - FEATURE - BUFF - 4623 MM
	105312-01-06A	FT INSERT - FEATURE STRIP - PEARL FAWN
	108651-02-02A	EA END CAP - FEATURE STRIP
4	114874-03-07B	EA TRIM - BACKWALL - BUFF (PASSENGER SIDE)
5	M07576-02-G15	EA BACKWALL ASM - QUEEN BED (CHEVY)
5	M07576-02-G16	EA BACKWALL ASM - QUEEN BED (CHEVY)
5	M07576-02-G17	EA BACKWALL ASM - QUEEN BED (CHEVY)
5	M07577-02-G15	EA BACKWALL ASM - QUEEN BED (FORD)
5	M07577-02-G16	EA BACKWALL ASM - QUEEN BED (FORD)
5	M07577-02-G17	EA BACKWALL ASM - QUEEN BED (FORD)
5	M07576-03-G15	EA BACKWALL ASM - TWIN BED (CHEVY)
5	M07576-03-G16	EA BACKWALL ASM - TWIN BED (CHEVY)
5	M07576-03-G17	EA BACKWALL ASM - TWIN BED (CHEVY)

KEY	PART NUMBER	U/M DESCRIPTION
5	M07577-03-G15	EA BACKWALL ASM - TWIN BED (FORD)
5	M07577-03-G16	EA BACKWALL ASM - TWIN BED (FORD)
5	M07577-03-G17	EA BACKWALL ASM - TWIN BED (FORD)
5	M07576-01-G15	EA BACKWALL ASM - KING BED (CHEVY)
5	M07576-01-G16	EA BACKWALL ASM - KING BED (CHEVY)
5	M07576-01-G17	EA BACKWALL ASM - KING BED (CHEVY)
5	M07577-01-G15	EA BACKWALL ASM - KING BED (FORD)
5	M07577-01-G16	EA BACKWALL ASM - KING BED (FORD)
5	M07577-01-G17	EA BACKWALL ASM - KING BED (FORD)
6	114872-02-01A	EA TRIM - BACKWALL - TOP - BUFF (PASSENGER SIDE)
7	114873-02-01A	EA TRIM - BACKWALL - TOP - BUFF (DRIVER SIDE)
8	120548-02-01A	EA TRIM - J, LH - BACKWALL - W/NOTCH - BUFF
9	114874-04-07B	EA TRIM - BACKWALL - BUFF (DRIVER SIDE)
10	119212-02-01A	EA TRIM - BACKWALL, LOWER - LH - BLK
11	050406-22-000	EA TRIM - BACKWALL - LOWER LEFT OR RIGHT SIDE - BUFF



## EXTERIOR BODY GROUP (CONTINUED)

### EXTERIOR BODY PANELS & TRIM (CONTINUED)

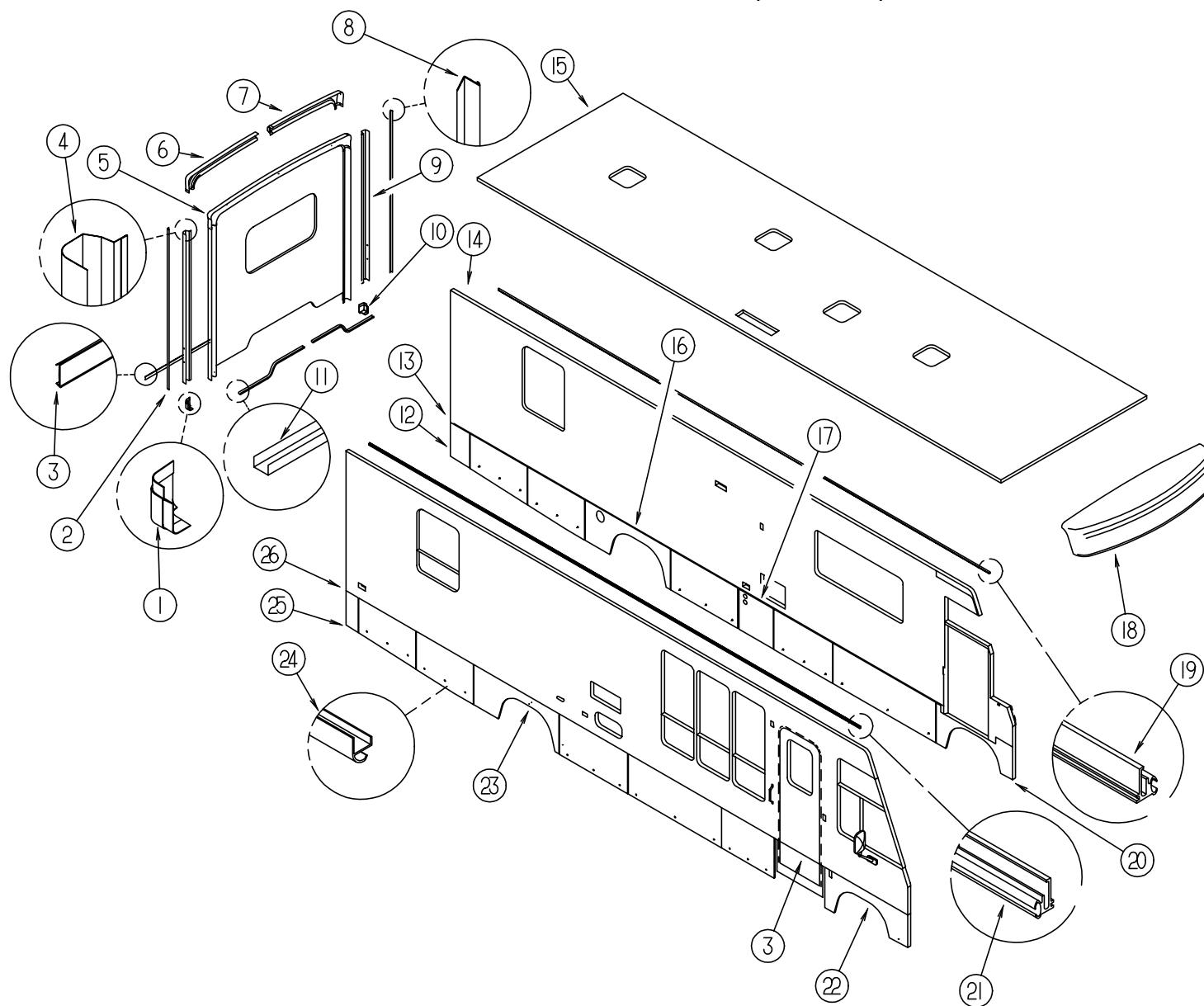

KEY	PART NUMBER	U/M DESCRIPTION
12	118657-02-G15	EA PANEL ASM - VALANCE REAR - LH
13	118785-03-01A	EA TRIM - SIDEWALL - HINGE - 4876 MM - VW GRAY
14	M08037-02-G15	EA SIDEWALL ASM (DRIVER SIDE) (W/ DRIVER DOOR)
14	M08037-02-G16	EA SIDEWALL ASM (DRIVER SIDE) (W/ DRIVER DOOR)
14	M08037-02-G17	EA SIDEWALL ASM (DRIVER SIDE) (W/ DRIVER DOOR)
14	M08037-01-G15	EA SIDEWALL ASM (DRIVER SIDE) (W/O DRIVER DOOR)
14	M08037-01-G16	EA SIDEWALL ASM (DRIVER SIDE) (W/O DRIVER DOOR)
14	M08037-01-G17	EA SIDEWALL ASM (DRIVER SIDE) (W/O DRIVER DOOR)
15	M08038-01-G15	EA ROOF ASM - QUEEN BED
15	M08038-02-G15	EA ROOF ASM - KING BED
15	M08038-03-G15	EA ROOF ASM - TWIN BED
16	118609-02-G15	EA WHEEL LIP ASM - REAR - LH
17	118658-01-G15	EA PANEL ASM - VALANCE - FURNACE
18	M05145-08-F11	EA CAP ASM - FRONT - W/O TRIM - BUFF

KEY	PART NUMBER	U/M DESCRIPTION	
19	103801-02-04A	EA TRIM - ROOF	FROM: 00-00-00 THRU: 10-08-95
19	120091-01-01A	EA TRIM - ROOF, BUFF	FROM: 10-09-95 THRU: 99-99-99
20	118528-03-G15	EA WHEEL LIP ASM-FRONT, LH	
21	103802-02-04A	EA RAIL - AWNING	FROM: 00-00-00 THRU: 10-08-95
21	120092-01-01A	EA RAIL - AWNING, BUFF	FROM: 10-09-95 THRU: 99-99-99
22	118528-04-G15	EA WHEEL LIP ASM-FRONT, RH	
23	118609-01-G15	EA WHEEL LIP ASM-REAR, RH	
24	118442-55-002	EA ROCKER PANEL - EXTRUDED 192" - ANY COLOR	
25	118657-01-G15	EA PANEL ASM-VALANCE REAR, RH	
26	P19598-01-G15	EA SIDEWALL ASM - (PASSENGER SIDE)	
26	P19598-01-G16	EA SIDEWALL ASM - (PASSENGER SIDE)	
26	P19598-01-G17	EA SIDEWALL ASM - (PASSENGER SIDE)	

**EXTERIOR BODY GROUP (CONTINUED)**

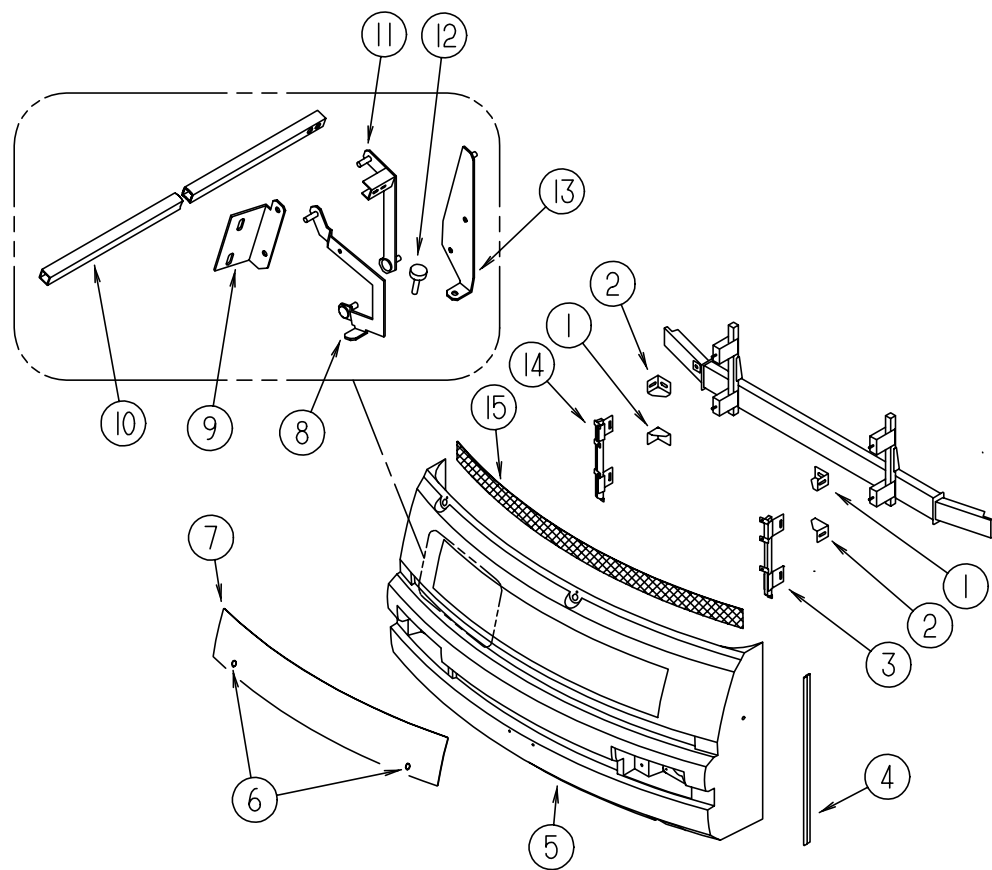

**FRONT END ASSEMBLY**

KEY	PART NUMBER	U/M DESCRIPTION
1	117611-04-02B	EA BRACKET - BUMPER
2	117611-03-02B	EA BRACKET - BUMPER
3	118997-02-000	EA SUPPORT ASM - FRONT PANEL - LH
4	089922-36-000	EA TRIM - FIBERGLASS - PANEL - BUFF
5	118999-03-G15	EA PANEL ASM - FRONT - LOWER
6	102330-02-000	EA HOOD LOCK - SINGLE HOLE - VISE ACTION
	102328-01-000	EA BARREL KEY - HOOD LOCK
7	115976-03-G15	EA PANEL ASM - HOOD - BUFF
8	109930-11-000	EA LINK - HINGE - HOOD - LOWER - RH
	109930-12-000	EA LINK - HINGE - HOOD - LOWER - LH
9	109927-03-000	EA ANGLE - LINK - HOOD - RH
	109927-04-000	EA ANGLE - LINK - HOOD - LH
10	105096-10-000	EA TUBE ASM - TIMING - HOOD HINGE
11	109929-05-000	EA LINK ASM - HINGE - HOOD - UPPER - RH
	109929-06-000	EA LINK ASM - HINGE - HOOD - UPPER - LH
12	058786-01-000	EA BOLT - ADJUSTING - HOOD - W/BLACK PAD - .31" #18 X 2"
13	109926-15-000	EA BRACKET - LINK - HINGE - HOOD - RH
	109926-16-000	EA BRACKET - LINK - HINGE - HOOD - LH
14	118997-01-000	EA SUPPORT ASM - FRONT PANEL - RH
15	115924-05-01A	EA GRILLE - WOVEN WIRE
	070579-06-000	EA PLATE - ANCHOR - W/ 7/16 WELD NUT - 1.5" X 3.3"
	077001-01-000	EA ANGLE - MOUNTING - ROOF PANEL - V ANGLE - 3" X 2.4" X 1.5"
	106746-01-000	EA PANEL - STEPWELL
	106747-01-000	EA PANEL - STEPWELL - END RH
	106747-02-000	EA PANEL - STEPWELL - END LH
	106765-01-000	EA SUPPORT - BOLT - HOOD ADJUSTING

**EXTERIOR BODY GROUP (CONTINUED)**

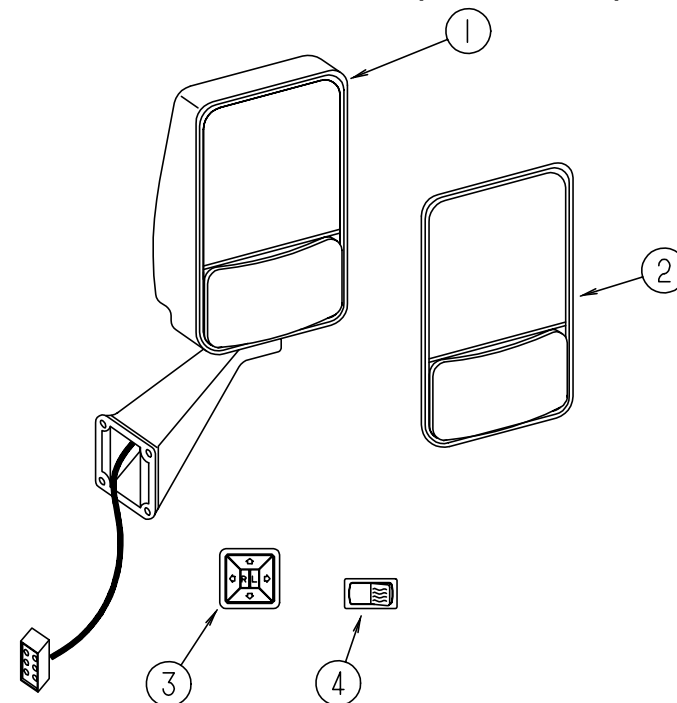

**EXTERIOR MIRROR OPTION (REMOTE & HEAT)**

KEY	PART NUMBER	U/M DESCRIPTION
1	106015-05-01A	EA MIRROR ASM - EXTERIOR REMOTE & HEAT - PASSENGER SIDE
1	106015-06-01A	EA MIRROR ASM - EXTERIOR REMOTE & HEAT - DRIVER SIDE
2	086261-02-701	EA MIRROR KIT-BEZEL, CONVEX GLASS - HEATED FLAT GLASS - DRIVER SIDE
2	086261-01-704	EA MIRROR KIT-BEZEL, CONVEX GLASS - HEATED FLAT GLASS - PASSENGER SIDE
3	088246-01-000	EA SWITCH - REMOTE - EXTERIOR MIRROR - SQUARE PUSH
4	087695-01-000	EA SWITCH - HEATER - EXTERIOR MIRROR

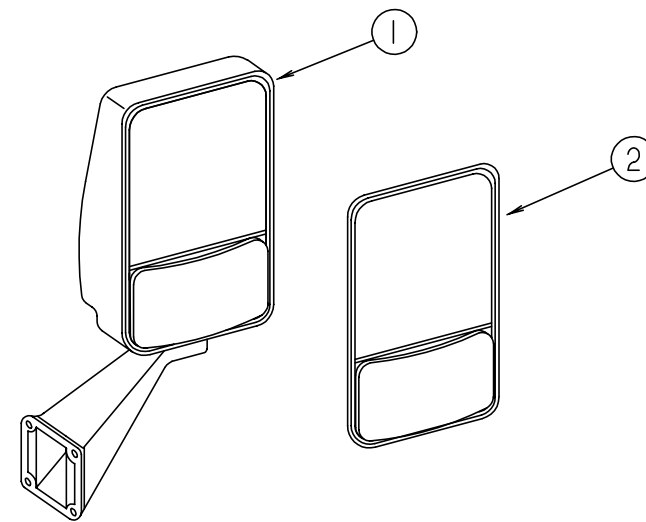

**EXTERIOR MIRROR**

KEY	PART NUMBER	U/M DESCRIPTION
1	106015-09-01A	EA MIRROR ASM - PASSENGER SIDE
1	106015-10-01A	EA MIRROR ASM - DRIVER SIDE
2	106015-01-703	EA MIRROR KIT (BEZEL W/MIRRORS) PASSENGER SIDE
2	106015-02-702	EA MIRROR KIT (BEZEL W/MIRRORS) DRIVER SIDE

## EXTERIOR BODY GROUP (CONTINUED)

### DECALS, FILM STRIPES & PAINT

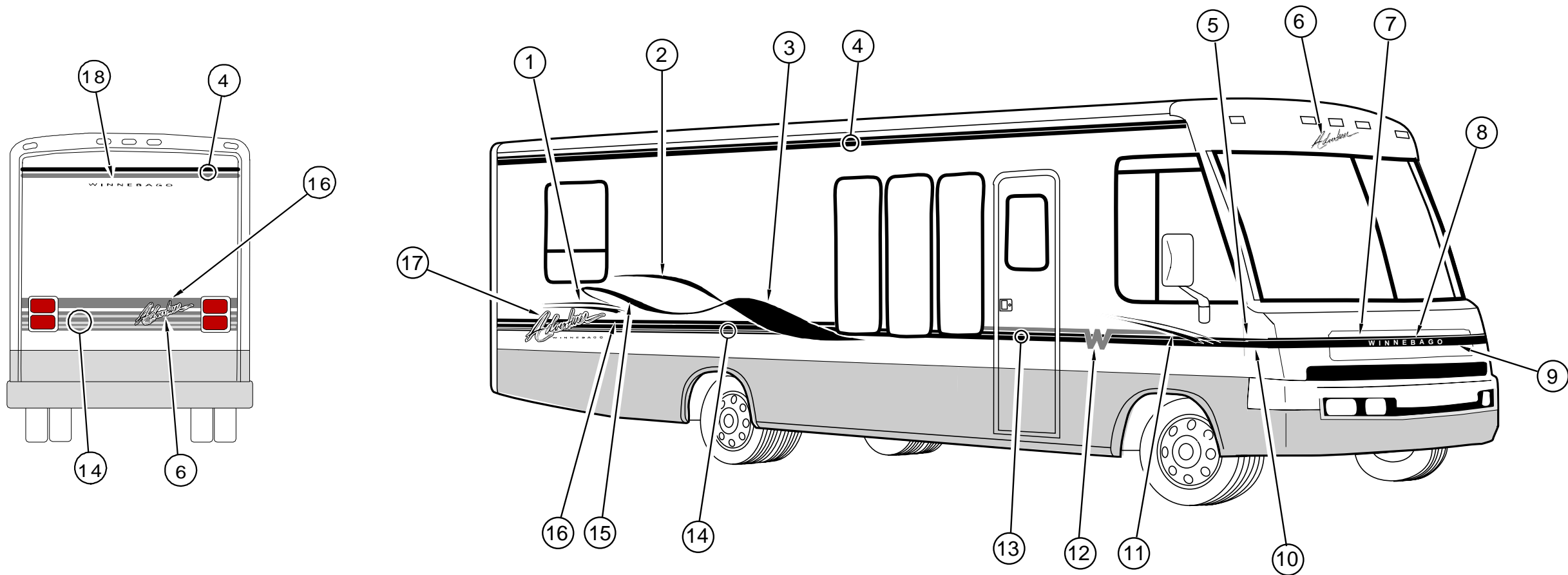

KEY	PART NUMBER	U/M	DESCRIPTION
1	117488-01-01A	EA	DECAL-RIBBON, #4 - RH - AMETHYST/LAGO BLUE
1	117488-02-01A	EA	DECAL-RIBBON, #4 - LH - AMETHYST/LAGO BLUE
2	117484-01-01A	EA	DECAL-RIBBON, #2 - RH - MED BLUE/BLACK
2	117484-02-01A	EA	DECAL-RIBBON, #2 - LH - MED BLUE/BLACK
3	117483-01-01A	EA	DECAL-RIBBON, #1 - RH - MED BLUE/AMETHYST/BLK
3	117483-02-01A	EA	DECAL-RIBBON, #1 - LH - MED BLUE/AMETHYST/BLK
4	094423-07-01A	FT	FILM-OVERLAY, MULTISTRIP 63.5MM - LAGO/AMETHYST/GOLDEN
5	117489-01-01A	EA	DECAL-CORNER, UPPER - RH - LAGO/GOLDEN/AMETHYST
5	117489-02-01A	EA	DECAL-CORNER, UPPER - LH - LAGO/GOLDEN/AMETHYST
6	117482-02-01A	EA	DECAL-ADVENTURER, SMALL - BUFF/GOLDEN/AMETHYST/SLATE
7	117491-01-01A	EA	DECAL-HOOD, UPPER - LAGO/GOLDEN/AMETHYST
8	110889-03-02A	EA	DECAL-LOGO, WINNEBAGO - BUFF
9	117492-01-01A	EA	DECAL-HOOD, LOWER - MED BLUE/GOLDEN
10	117490-01-01A	EA	DECAL-CORNER, LOWER - RH - MED BLUE/GOLDEN
10	117490-02-01A	EA	DECAL-CORNER, LOWER - LH - MED BLUE/GOLDEN
11	117481-01-01A	EA	DECAL-SLASH, RH - AMETHYST/LAGO BLUE
11	117481-02-01A	EA	DECAL-SLASH, LH - AMETHYST/LAGO BLUE
12	117480-01-01A	EA	DECAL-LOGO, W - GOLDEN
13	115335-05-01A	FT	FILM-OVERLAY, MULTISTRIP 31.8MM - MED BLUE/GOLDEN
14	117479-01-01A	FT	FILM-OVERLAY, MULTISTRIP 158.8MM - LAGO/GOLDEN/AMETHYST/AMETHYST
15	117486-01-01A	EA	DECAL-RIBBON, #3 - RH - AMETHYST/BLACK
15	117486-02-01A	EA	DECAL-RIBBON, #3 - LH - AMETHYST/BLACK
16	093681-40-06A	FT	FILM - 50.8MM X 150FT - GOLDEN
17	117482-01-01A	EA	DECAL-ADVENTURER, LARGE - BUFF/GOLDEN/AMETHYST/SLATE
18	110206-02-04A	EA	DECAL-WINNEBAGO - LAGO BLUE
	004308-01-000	EA	PAINT-SPRAY, BLACK
	099399-12-700	EA	PAINT-16OZ SPRAY - ENAMEL/BUFF

#### DUPONT PAINT COLOR CODES

BUFF	G9692
GRAPHITE METALLIC	F0901

**EXTERIOR BODY GROUP (CONTINUED)**

**STYROFOAM & FIBERGLASS SHEETING**

KEY	PART NUMBER	U/M	DESCRIPTION
	000870-08-000	SF	STYROFOAM - .75" X 48" X 96" - PLANED
	083574-03-000	SF	STYROFOAM - 3/4" X 48" X 96"
	083574-05-000	SF	STYROFOAM - 2.0" X 48" X 96"
	065747-01-000	SF	INSULATION - MICROFOAM - .5" X 72" X 112' ROLL
	076054-T5-000	EA	FIBERGLASS-SHEET, 2572 X 2647 - BUFF
	108535-03-700	EA	FRP FLAT 110" X 396" BUFF
	076054-V1-000	EA	FIBERGLASS SHEET 2008 X 8575 - BUFF
	117754-01-01A	EA	FIBERGLASS-SHEET, 328 X 2448MM - ANY COLOR
	117754-01-05A	EA	FIBERGLASS-SHEET, 328 X 2448MM - BUFF
	117754-01-02A	EA	FIBERGLASS-SHEET, 328 X 2442MM - BRIGHT WHITE
	077517-59-000	EA	FIBERGLASS SHEET - 48" X 96" - BUFF
	100619-01-000	BF	FOAM - EXPANDED POLYSTYRENE - 48" X 96" X 1.34"
	100619-04-000	BF	FOAM - EXPANDED POLYSTYRENE - EPS 48" X 96" X .5
	100619-02-000	BF	FOAM - EXPANDED POLYSTYRENE - 48" X 96" X 1.5"
	100619-05-000	BF	FOAM - EXPANDED POLYSTYRENE - 48" X 96" X .75"
	100619-11-000	BF	FOAM - EXPANDED POLYSTYRENE - 48" X 96" X 2"
	100619-13-000	BF	FOAM - EXPANDED POLYSTYRENE - 48" X 96" X .34"
	108535-03-700	EA	FIBERGLASS-FLAT 110" X 396" - BUFF - FOR ROOF SKIN
	108535-05-700	EA	FIBERGLASS-FLAT 110" X 396" - BUFF
	120107-01-000	EA	FOAM-COVE, ROOF - WISCONSIN EPS
	120107-02-000	EA	FOAM-PLUG, ROOF TUBE - WISCONSIN EPS - 45 MM X 74.3 MM
	120107-03-000	EA	FOAM-PLUG, ROOF TUBE - WISCONSIN EPS - 45MM X 54.5 MM
	058804-01-000	EA	AL - .032 X 36.00 X 064.00 1/4 HEX - PERFORATED .79 OPEN
	119389-01-01A	EA	TUBE-W/HOLE MILL - EXTR 119391

**EXTERIOR BODY HARDWARE**

KEY	PART NUMBER	U/M	DESCRIPTION
	002726-01-001	EA	GARNISH - U-CHANNEL - 1.38" X 19' - SERRATED - MILL ALUMINUM
	002754-01-001	EA	ANGLE - EXTRUDED - .75" X .75" X 18' - MILL ALUMINUM
	033381-17-001	FT	STEEL - TUBE 16GA 1.5 X 1.5 X 288.00 HOT FORMED ASTM A50
	044487-01-002	EA	ALUMINUM - .019 X 96.00 X 432"
	055278-51-259	EA	TUBING - STEEL - 12.5'
	058267-01-000	FT	CHANNEL - STEEL - W/ HOLES - SIDEWALL STIFFENER - 2" X 20'
	068716-01-001	EA	BRACE - 90 DEGREE L-ANGLE - 192" - EXTRUDED ALUMINUM
	089297-01-000	SF	PLYWOOD - LUAN - OVERLAY GRADE - 4' X 8'
	089297-02-000	SF	PLYWOOD - LUAN GRADE CC LFE 2.7 MM X 48 X 108

**EXTERIOR BODY GROUP (CONTINUED)**

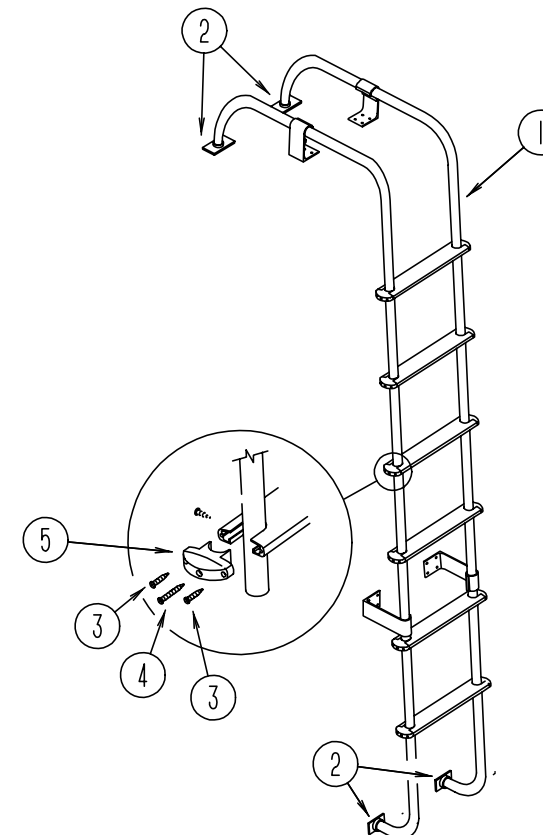

**LADDER**

KEY	PART NUMBER	U/M	DESCRIPTION
1	102953-11-F31	EA	LADDER ASM
2	067165-01-000	EA	MOUNTING BRACKET - LADDER - LOWER
3	000G39-06-10T	EA	SCREW-SF/ DR - 6 - 20 X 5/8 PPH - BLACK
4	000G68-10-36T	EA	SCREW - 10 - 12 X 2.25 POH BLACK
5	076980-02-000	EA	END CAP - STEP - BLACK
	038327-01-000	FT	TAPE - ANTI SLIP - 2" X 60FT

## EXTERIOR BODY GROUP (CONTINUED)

### EXTERIOR AWNING (FAULKNER)

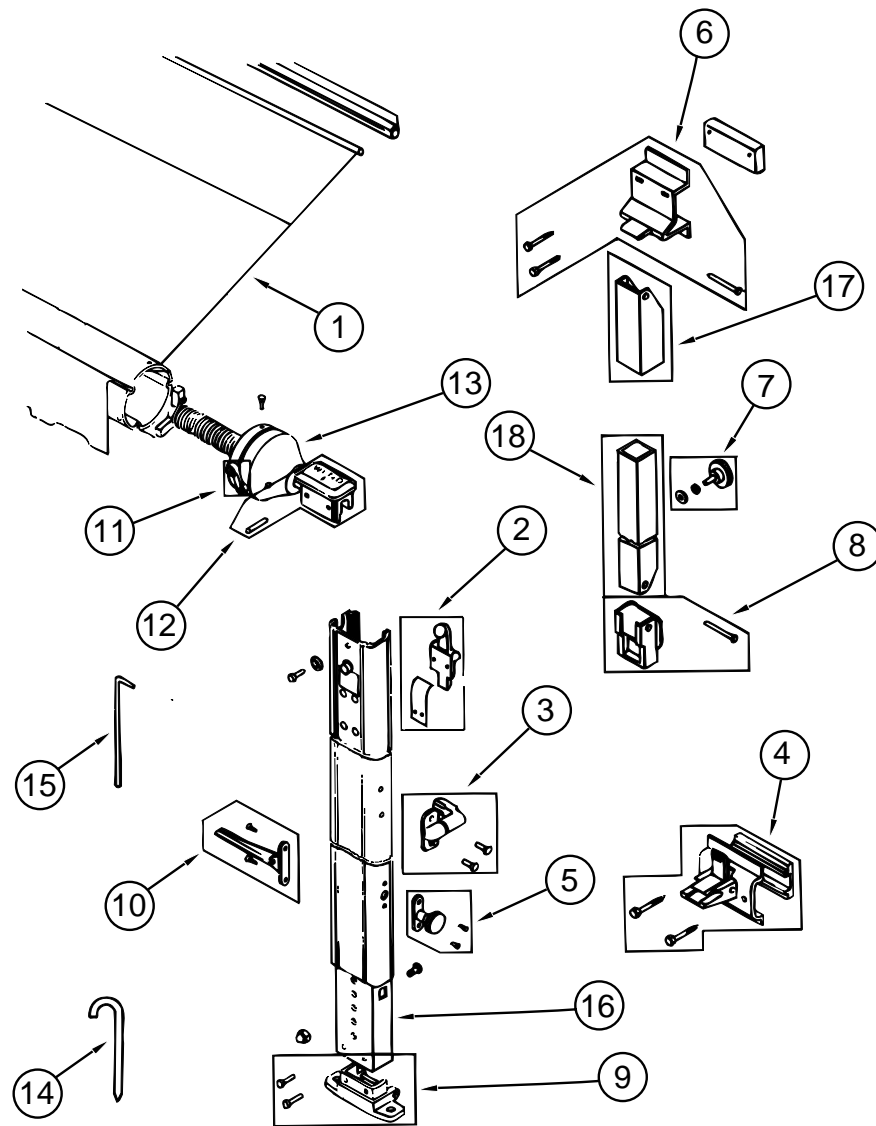

KEY	PART NUMBER	U/M	DESCRIPTION	VENDOR NO.
	110634-02-01A	EA	AWNING - HARDWARE KIT - BUFF	
1	110634-07-18A	EA	AWNING - ROLLER ASM - 19'	
2	110634-01-700	EA	RAFTER LOCKING MECHANICAL KIT	7605-0001
3	110634-01-701	EA	SAFETY & LATCH KIT	7509-0001
4	110634-01-702	EA	BOTTOM BRACKET KIT	7512-0001
	111038-01-01A	EA	SPACER - AWNING - LOWER - BLACK	
5	110634-01-703	EA	HEIGHT LOCK HANDLE KIT	7510-0001
6	110634-01-704	EA	UPPER BRACKET KIT W/BOLTS	7505-0001
	111037-01-01A	EA	SPACER - AWNING - UPPER - BLACK	
7	110634-01-705	EA	ULTRA RAFTER KNOB KIT	7522-0001
8	110634-01-706	EA	RAFTER SLIDE KIT	
9	110634-01-707	EA	GROUND BRACKET KIT	7511-0001
10	110634-01-708	EA	LIFT HANDLES W/ RIVETS	7000-0001
11	110634-01-709	EA	RATCHET HANDLE KIT	7507-0001
12	110634-01-710	EA	ARM CAP KIT	7503-0001
13	110634-01-711	EA	FRONT SPRING ASM	6598-0001
	110634-01-712	EA	REAR SPRING ASM	6599-0001
	110634-01-713	EA	REAR END CAP KIT	7504-0001
14	110634-01-714	EA	STAKE (4 PER BAG)	5208-0001
15	110634-01-715	EA	PULL DOWN WAND	7604-0001
16	110634-01-721	EA	ARM - INNER - FRONT - BUFF	5686-0001
16	110634-01-722	EA	ARM - INNER - REAR - BUFF	5687-0001
17	110634-01-723	EA	RAFTER - OUTER - BUFF	5688A0001
18	110634-01-724	EA	RAFTER - INNER - BUFF	5689A0001
	110634-12-02A	EA	SHIM-FILLER, LOWER BRACKET	

## GALLEY GROUP

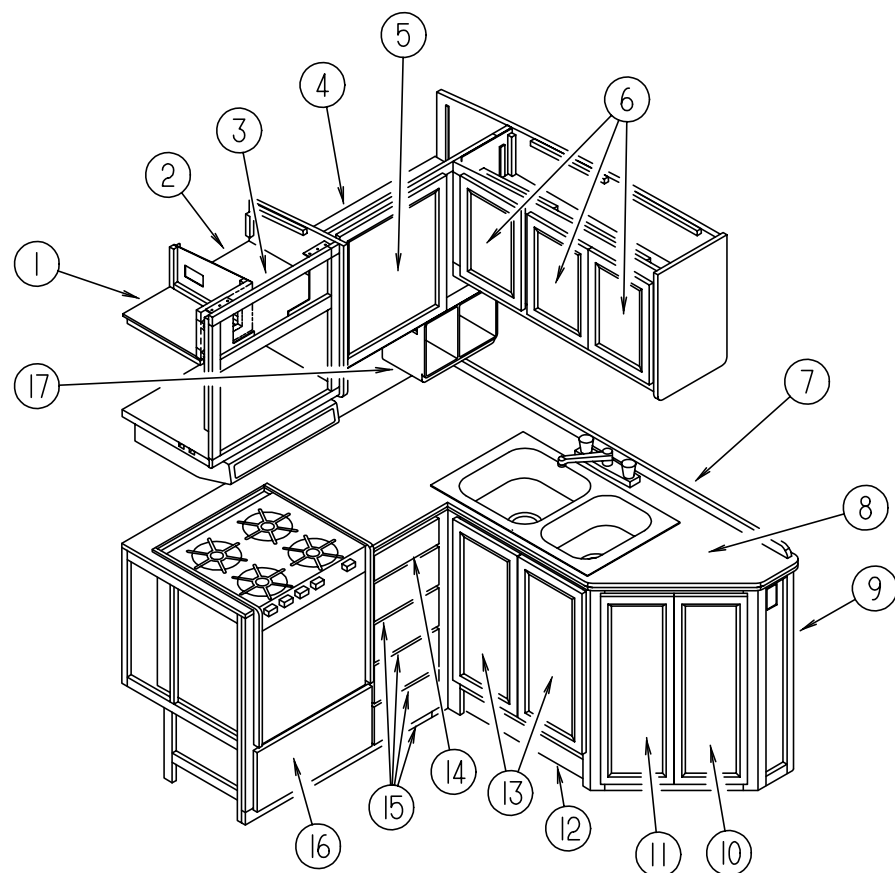

### GALLEY CABINETRY & FIXTURES

KEY	PART NUMBER	U/M	DESCRIPTION
1	116592-01-G09	EA	CABINET ASM - A/C SWITCH
2	114390-01-G15	EA	CABINET ASM - MICROWAVE OVHD
3	M05992-11-G15	EA	DOOR ASM - RAIL -MICROWAVE OVHD - W/O HARDWARE - 0180 X 0555 MM
4	M07493-01-G15	EA	CABINET ASM - GALLEY - OVERHEAD
5	M06803-F4-G15	EA	DOOR ASM - GALLEY OVERHEAD - W/O HARDWARE - 0505 X 0555
6	M06803-F5-G15	EA	DOOR ASM - GALLEY OVERHEAD - W/O HARDWARE - 0290 X 0410
7	093614-02-01A	EA	GRILL - RETURN AIR - BROWN
7	098335-10-F12	EA	RAIL - GALLEY (G15,G16)
7	098335-10-G17	EA	RAIL - GALLEY
8	116197-11-F12	EA	COUNTERTOP ASM. (G15,G16)
8	116197-11-G17	EA	COUNTERTOP ASM.
9	P16197-01-G15	EA	GALLEY CABINET ASM.
9	P16197-01-G16	EA	GALLEY CABINET ASM.
9	P16197-01-G17	EA	GALLEY CABINET ASM.
10	M06803-F6-G15	EA	DOOR ASM - GALLEY - W/O HARDWARE - 0245 X 0770
11	M06803-F7-G15	EA	DOOR ASM - GALLEY - W/O HARDWARE - 0245 X 0770
12	M06803-26-G15	EA	DOOR ASM - GALLEY - W/O HARDWARE - 0305 X 0660
13	M06803-27-G15	EA	DOOR ASM - GALLEY - W/O HARDWARE - 0305 X 0660
14	M05971-A2-G15	EA	DRAWER ASM. - W/O HARDWARE
15	M05971-11-G15	EA	DRAWER ASM. - W/O HARDWARE
16	M05971-68-G15	EA	DRAWER ASM. - W/O HARDWARE
	108464-04-F40	EA	COVER ASM - SINK (G15,G16)
	108464-04-E08	EA	COVER ASM - SINK (G17)
	110654-01-000	EA	SINK - STAINLES STEEL - DOUBLE - LARGE/SMALL BASIN
	092303-01-000	EA	STRAINER - SINK
	103243-01-000	EA	FAUCET-GALLEY,DUAL CONTROL
17	103799-01-02A	EA	COFFEE MAKER - GRAY - BLACK & DECKER - W/GLASS POT
	103799-01-700	EA	POT-CARAFE, GLASS
	103799-01-701	EA	BRACKETS, WHITE PAIR
	090329-01-000	FT	T-SEAL - REFRIGERATOR CABINET - .6" WIDE TOP X 2" TAIL

## GALLEY GROUP (CONTINUED)

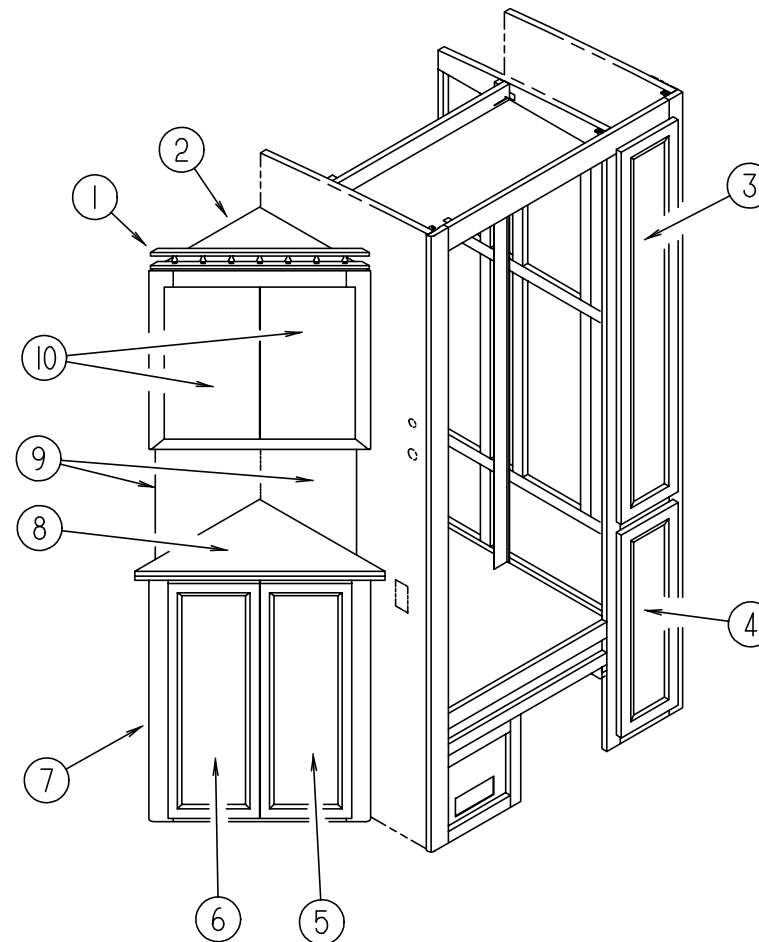

### REFRIGERATOR CABINET & HUTCH

KEY	PART NUMBER	U/M	DESCRIPTION
1	111775-09-01A	EA	RAIL ASM-DECORATIVE, 586MM
2	P16206-01-G15	EA	CABINET ASM-HUTCH, UPPER
	116206-11-G15	EA	SHELF ASM
3	M06803-C9-G15	EA	DOOR ASM - W/O HARDWARE - 0215 X 1220
4	M06803-K1-G15	EA	DOOR ASM - W/O HARDWARE - 0215 X 0485
5	M06803-F6-G15	EA	DOOR ASM - W/O HARDWARE - 0245 X 0770
6	M06803-F7-G15	EA	DOOR ASM - W/O HARDWARE - 0245 X 0770
7	P16205-01-G15	EA	CABINET ASM-HUTCH, LOWER (G15,G16)
7	P16205-01-G17	EA	CABINET ASM-HUTCH, LOWER
	116205-11-G15	EA	SHELF ASM
8	116205-12-F12	EA	COUNTERTOP (G15,G16)
8	116205-12-G17	EA	COUNTERTOP
9	058331-D3-000	EA	MIRROR-GLASS, SAFETY - 380MM X 380MM
10	M06803-F8-G15	EA	DOOR ASM - W/O HARDWARE - 0255 X 0485
10	M06803-24-G15	EA	DOOR ASM - W/O HARDWARE - W/MIRROR - 0255 X 0485

**GALLEY GROUP (CONTINUED)**

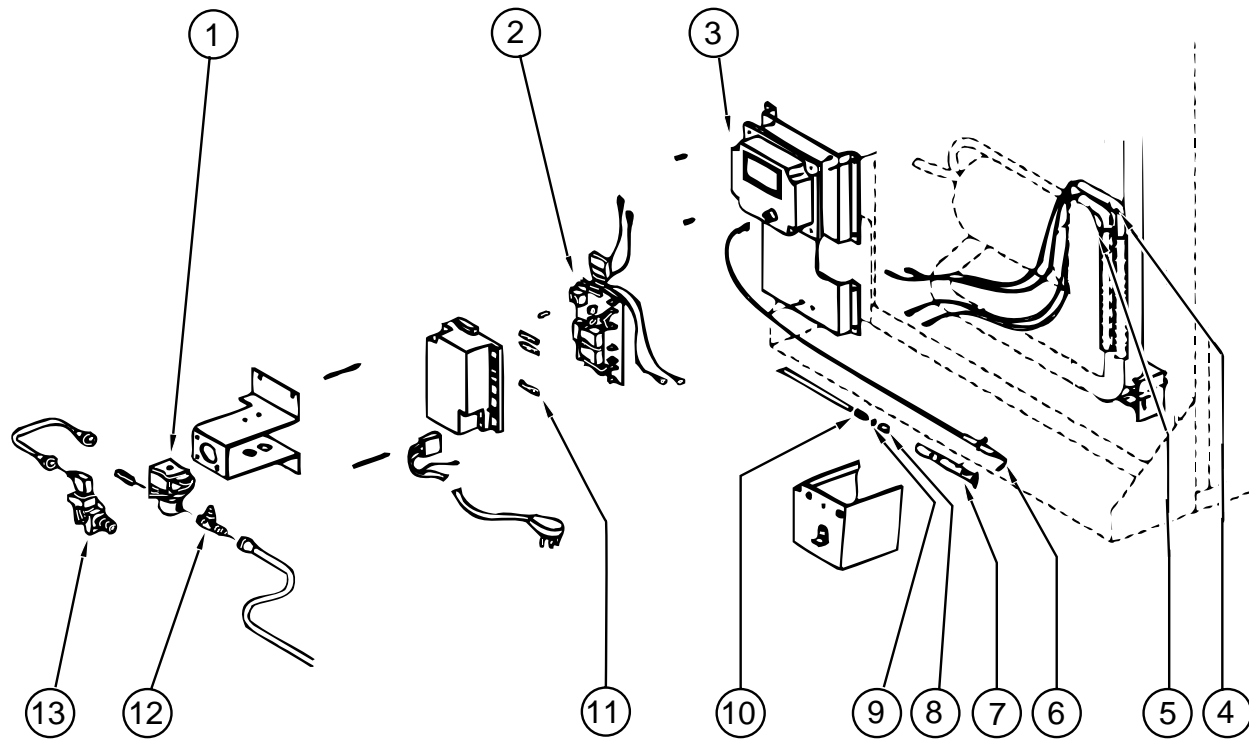

**NORCOLD 6182 REFRIGERATOR CONTROL ASM.**

KEY	PART NUMBER	U/M DESCRIPTION	VENDOR NO.
1	084880-01-718	EA VALVE-GAS	61551822
2	094039-04-702	EA POWER SUPPLY (2-WAY)	61647422
3	102621-01-702	EA IGNITION MODULE	61688922
4	088248-01-710	EA HEATER-DC, (HORIZONTAL)	61562822
5	088248-01-709	EA HEATER-AC, (HORIZONTAL)	61562722
6	104137-06-715	EA SPARK/SENSE ELECTRODE (SINGLE)	61692222
7	104137-06-714	EA BURNER ASSEMBLY (5-SLOT)	61705222
8	084880-01-705	EA ORIFICE	61452122
9	104137-06-713	EA ORIFICE GASKET	61475122
10	104137-06-712	EA FITTING-GAS TUBE CONNECTION	61692722
11	104137-06-711	EA FUSE - 5 AMP	61611622
12	104137-06-710	EA PRESSURE TAP	61594422
13	104137-06-709	EA VALVE SHUT-OFF-MANUAL ASM	61694922
	084880-03-701	EA COIL-COOLING, FOR HORIZONTAL BURNER	61687337

**GALLEY GROUP (CONTINUED)**

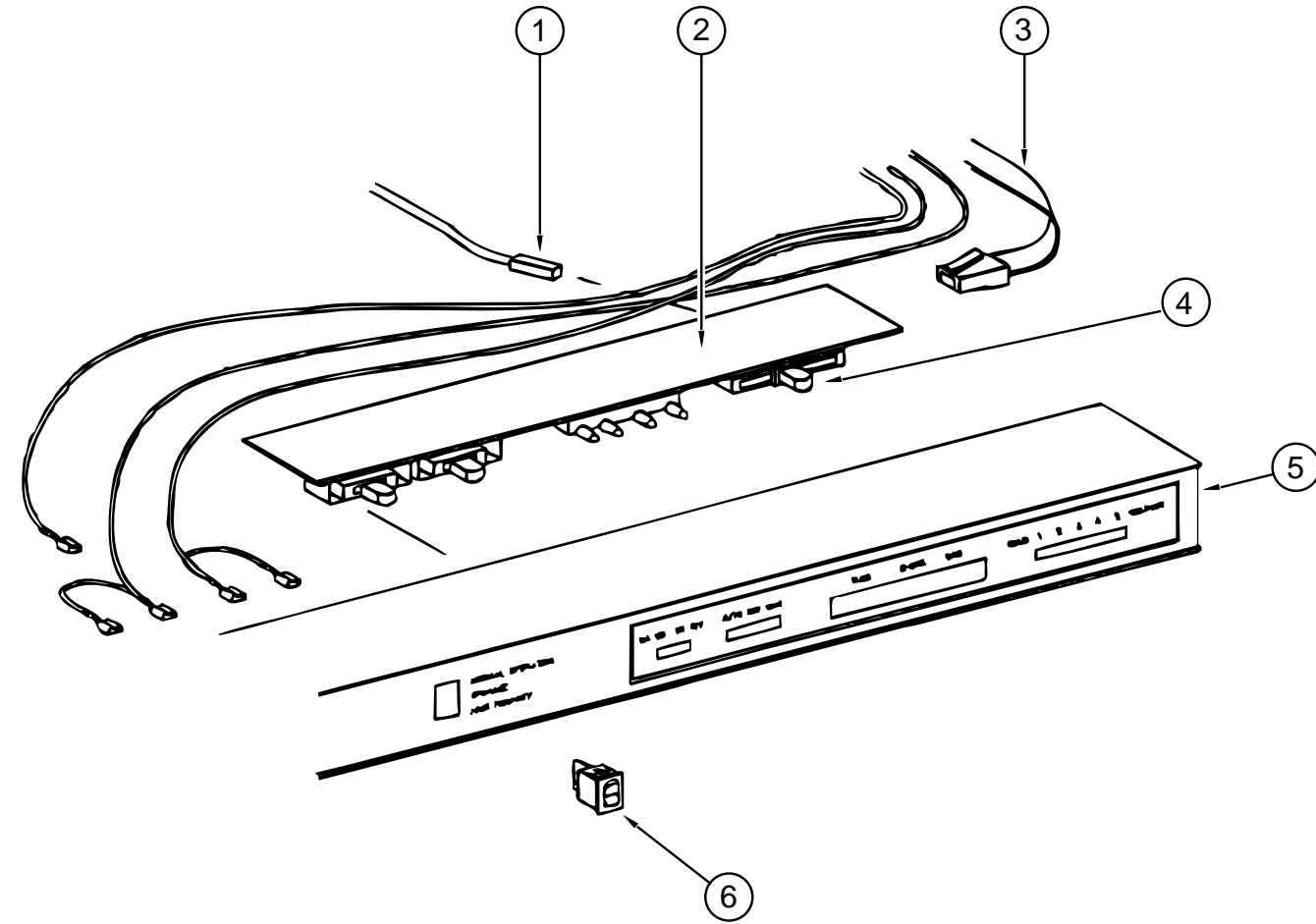

**NORCOLD 6182 REFRIGERATOR EYEBROW ASM.**

KEY	PART NUMBER	U/M DESCRIPTION	VENDOR NO.
1	084880-01-753	EA THERMISTER 78"	61693822
2	094039-04-700	EA PRINTED CIRCUIT BOARD - 2 WAY	61647322
3	084880-01-746	EA CABLE- PRINTED CIRCUIT BOARD TO POWER SUPPLY	61571522
4	102621-01-703	EA THERMOSTAT BUTTON	61587422
5	104137-06-700	EA EYEBROW SHELL (2-WAY)	61726622
6	075217-01-738	EA SWITCH-HUMIDITY	61525922

## GALLEY GROUP (CONTINUED)

NORCOLD 6182 REFRIGERATOR DOORS

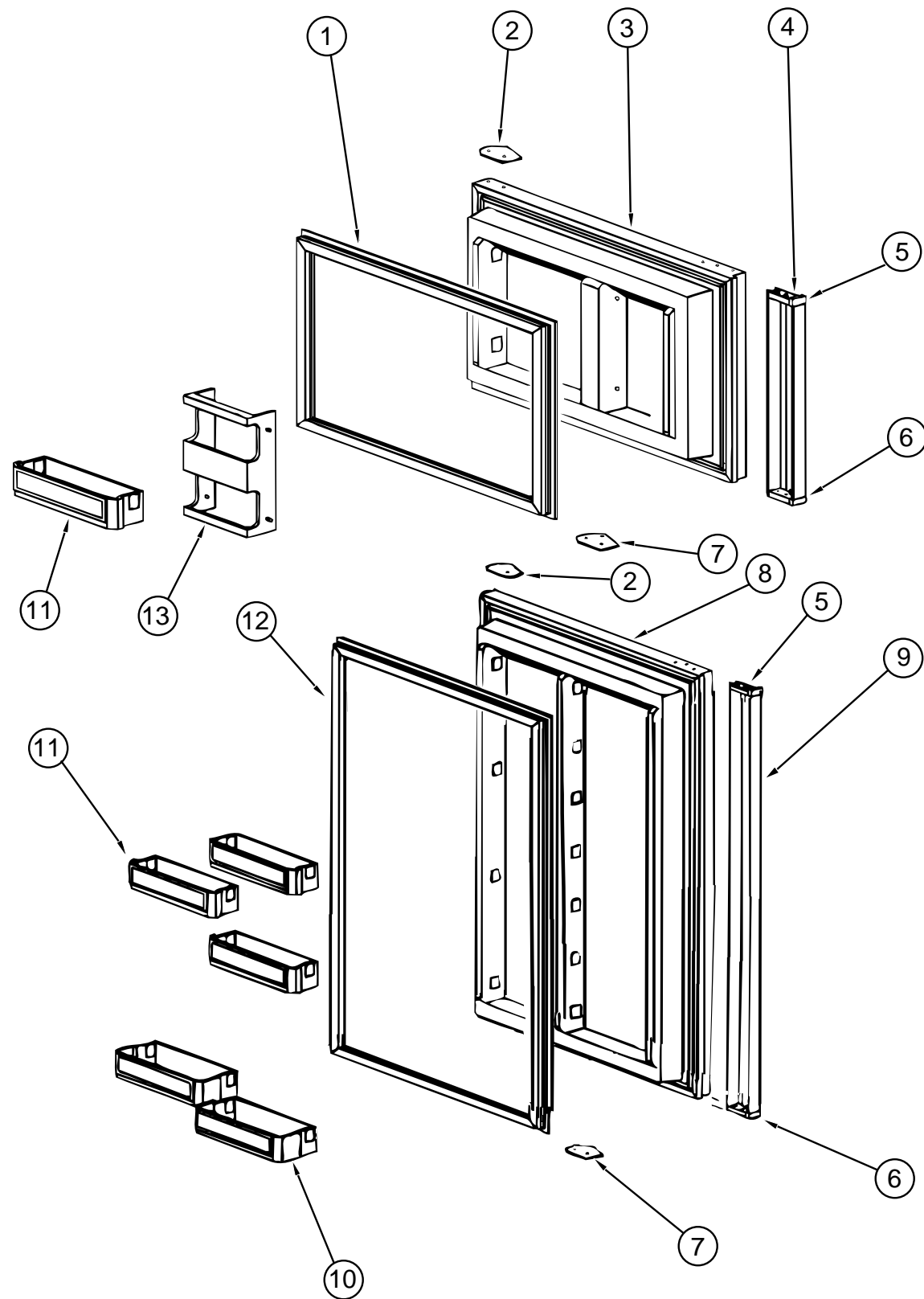

KEY	PART NUMBER	U/M	DESCRIPTION	VENDOR NO.
1	094039-01-702	EA	GASKET (GRAY) UPPER	61567830
2	094039-01-710	EA	PLATE-HINGE, BLACK	61631330
3	094039-01-706	EA	UPPER DOOR LINER (WHITE) BLACK	61581838-B
4	094039-01-708	EA	HANDLE-DOOR, UPPER - BLACK	61650038
	084880-01-720	EA	SPRING (FOR DOOR HANDLE)	61558822
5	084880-01-761	EA	CAP-END, SPRING CATCH - UPPER	61593730
6	084880-01-740	EA	CAP-END, STOP CATCH - LOWER	61593830
7	094039-01-704	EA	PLATE-HINGE, BLACK	61631430
8	094039-01-715	EA	LINER-DOOR, LOWER - BLACK/WHITE	61581738-B
9	094039-01-717	EA	HANDLE-DOOR, LOWER - BLACK	61649938
	084880-01-720	EA	SPRING (FOR DOOR HANDLE)	61558822
10	104137-06-704	EA	MILK BIN (WHITE)	61579425
11	104137-06-703	EA	BIN-DOOR SHELF (WHITE)	61564025
12	094039-01-713	EA	GASKET-LOWER, GRAY	61568030
13	104137-06-702	EA	RACK-JUICE (WHITE)	61580525



## GALLEY GROUP (CONTINUED)

NORCOLD 6182 REFRIGERATOR CABINET ASM.

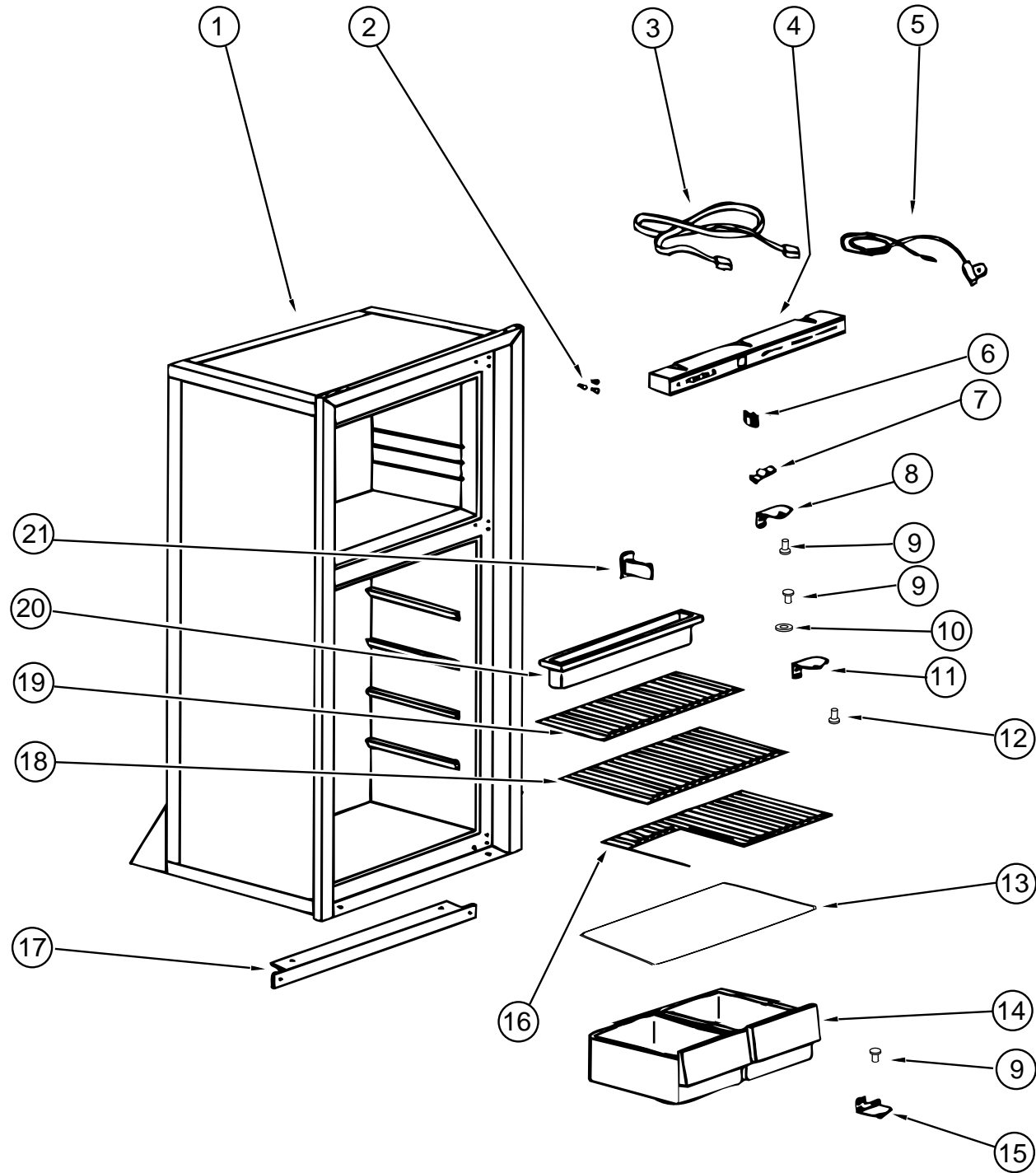

KEY	PART NUMBER	U/M	DESCRIPTION	VENDOR NO.
	104137-06-01A	EA	REFRIGERATOR LARGE DOUBLE DOOR 2-WAY - 6182 RH	
1	104137-06-708	EA	CABINET-W/BLACK TRIM, WHITE INTERIOR	61725138
2	094039-01-722	EA	HOLE PLUG (BLK) HINGE HOLES	61582030
3	084880-01-746	EA	CABLE-PRINTED CIRCUIT BOARD TO POWER SUPPLY	61571522
4	104137-06-700	EA	EYEBROW SHELL (2-WAY)	61726622
5	084880-01-753	EA	THERMISTER 78"	61697822
6	075217-01-738	EA	SWITCH-HUMIDITY	61525922
7	084880-01-760	EA	CLIP (THERMISTER)	61689122
8	094039-01-723	EA	HINGE BRACKET, TOP RH-BOTTOM LH BLK	61580838
9	094039-01-725	EA	HINGE PIN (BLACK) (MALE)	61578130
	084880-03-702	EA	HINGE PIN (BLACK) FEMALE	61580630
10	084880-01-749	EA	HINGE BUSHING	61580722
11	094039-01-728	EA	BRACKET-HINGE, CENTER BLACK	61566530
12	094039-01-730	EA	HINGE PIN SHAFT (BLK) CENTER HINGE	61566730
13	084880-01-722	EA	CRISPER COVER	61564122
14	104137-06-707	EA	CRISPER (WHITE)	61571325
15	094039-01-724	EA	BRACKET-HINGE, TOP LH - BOTTOM RH - BLK	61580938
16	094039-01-739	EA	SHELF (CUTOUT)	61646722
17	094039-01-732	EA	FRONT COVER (BLK) BOTTOM TRIM	61622130
18	094039-01-733	EA	WIRE SHELF (MIDDLE)	61563822
19	104137-06-706	EA	WIRE SHELF (TOP) W/RISER	61718222
20	094039-01-735	EA	INSIDE DRIP TRAY (WHITE)	61572830
21	084880-01-732	EA	LATCH	61578522
	094039-01-736	EA	SWITCH-LIGHT, BLACK	61581022
	104137-06-727	EA	SHELF-FREEZER, WHITE	618057
	104137-08-01A	EA	LIGHT KIT - 61771022	
	093646-01-000	EA	BRACKET-TIEDOWN, RH	
	093646-02-000	EA	BRACKET-TIEDOWN, LH	

**GALLEY GROUP (CONTINUED)**

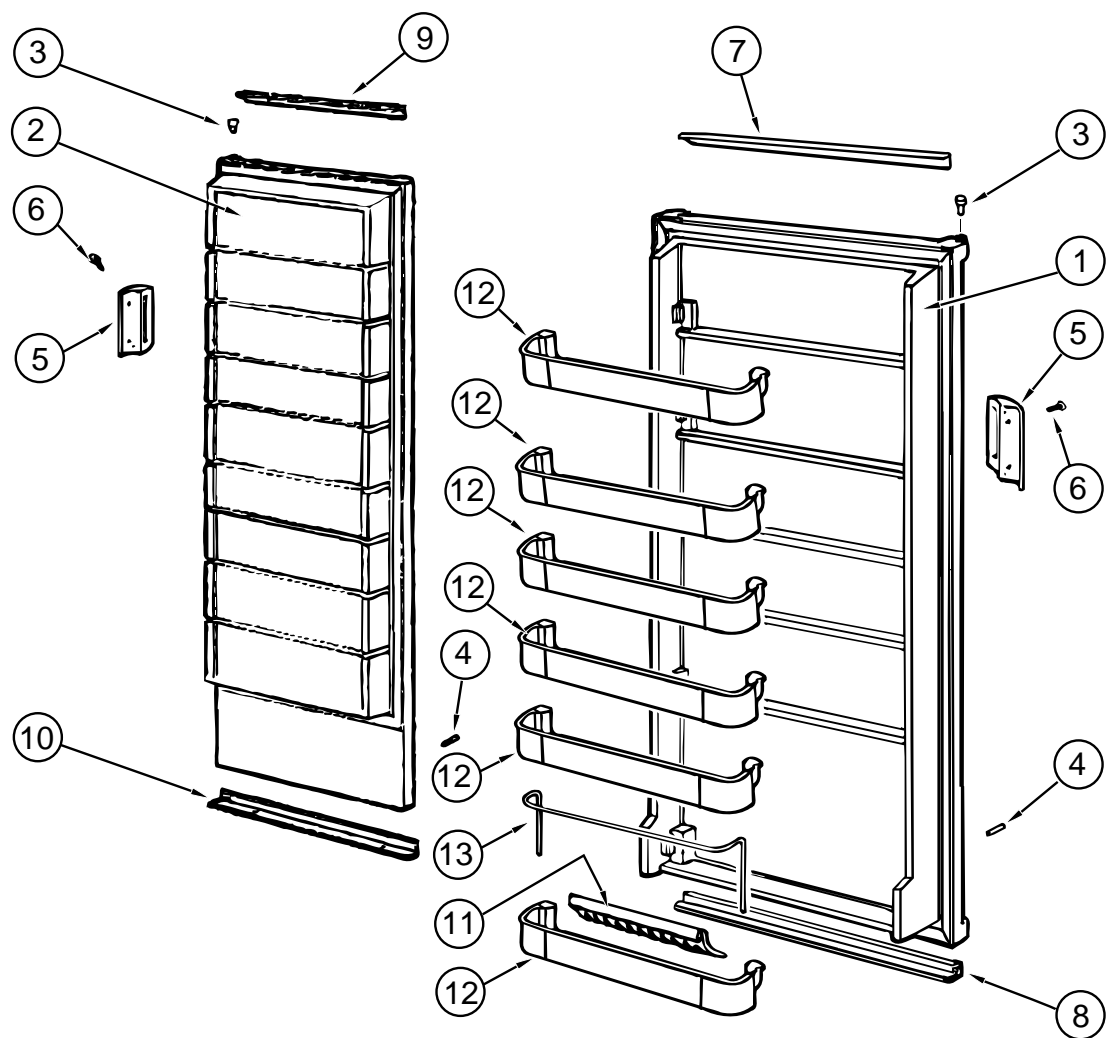

**DOMETIC RM 7732IM REFRIGERATOR DOORS**

KEY	PART NUMBER	U/M DESCRIPTION	VENDOR NO.
	118367-01-01A	EA REFRIGERATOR-SIDE BY SIDE DOOR, 2 WAY - RM 7732IM	
1	118367-01-700	EA DOOR-REFRIGERATOR	293 25 90-11/6
2	118367-01-701	EA DOOR-FREEZER	293 25 89-11/8
3	118367-01-702	EA BUSHING-HINGE,FREEZER-REFRIGERATOR	293 11 71-01/7
4	118367-01-703	EA STOP-LOWER, FREEZER-REFRIGERATOR	293 25 88-01/1
5	118367-01-704	EA HANDLE, FREEZER-REFRIGERATOR	293 27 29-01/1
6	118367-01-705	EA SCREW-HANDLE, FREEZER-REFRIGERATOR	724 13 23-61/2
7	118367-01-706	EA DECORATION-DOOR, REFRIGERATOR UPPER	293 26 42-08/1
8	118367-01-707	EA DECORATION-DOOR, REFRIGERATOR LOWER	293 26 42-03/2
9	118367-01-708	EA DECORATION-DOOR FREEZER, UPPER	293 26 42-12/3
10	118367-01-709	EA DECORATION-DOOR, FREEZER LOWER	293 26 42-02/4
11	118367-01-710	EA HOLDER-BOTTLE, DOOR, REFRIGERATOR	293 26 58-01/2.
12	118367-01-711	EA SHELF-DOOR, REFRIGERATOR	293 25 83-02/0
13	118367-01-712	EA RACK-DOOR, REFRIGERATOR	293 25 85-04/1
	065225-01-000	EA PLATE-TIEDOWN, REFRIGERATOR	
	103251-05-01A	EA INSERT-ACRYLIC BLACK, 16.81" X 55.06"	
	103251-06-01A	EA INSERT-ACRYLIC BLACK, 10.44" X 55.06"	

**GALLEY GROUP (CONTINUED)**

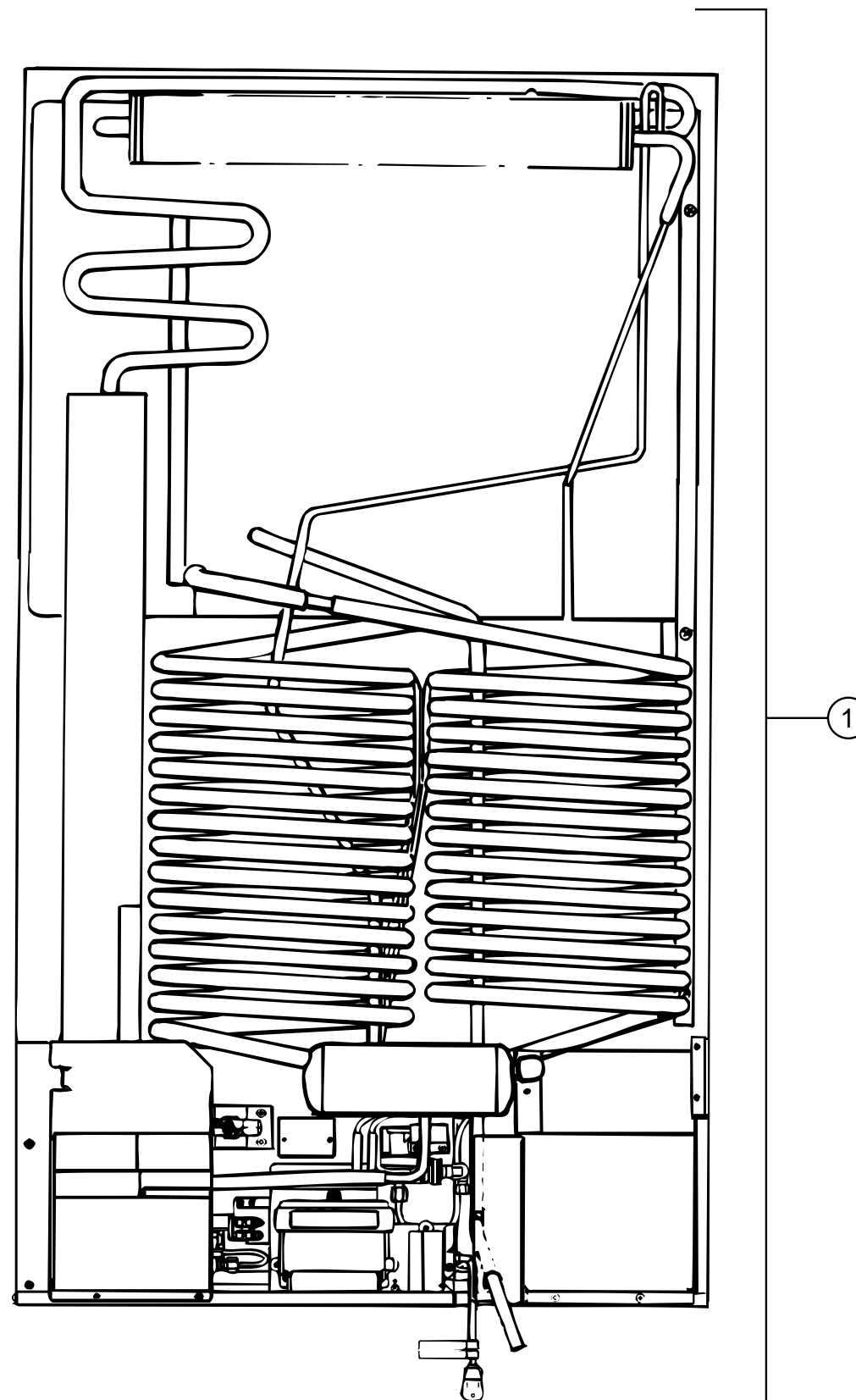

**DOMETIC RM 7732IM REFRIGERATOR COOLING COIL**

KEY	PART NUMBER	U/M DESCRIPTION	VENDOR NO.
1	118367-01-783	EA COIL-COOLING	293 49 45-09/4

## GALLEY GROUP (CONTINUED)

### DOMETIC RM 7732IM REFRIGERATOR FREEZER SHELVES & COMPONENTS

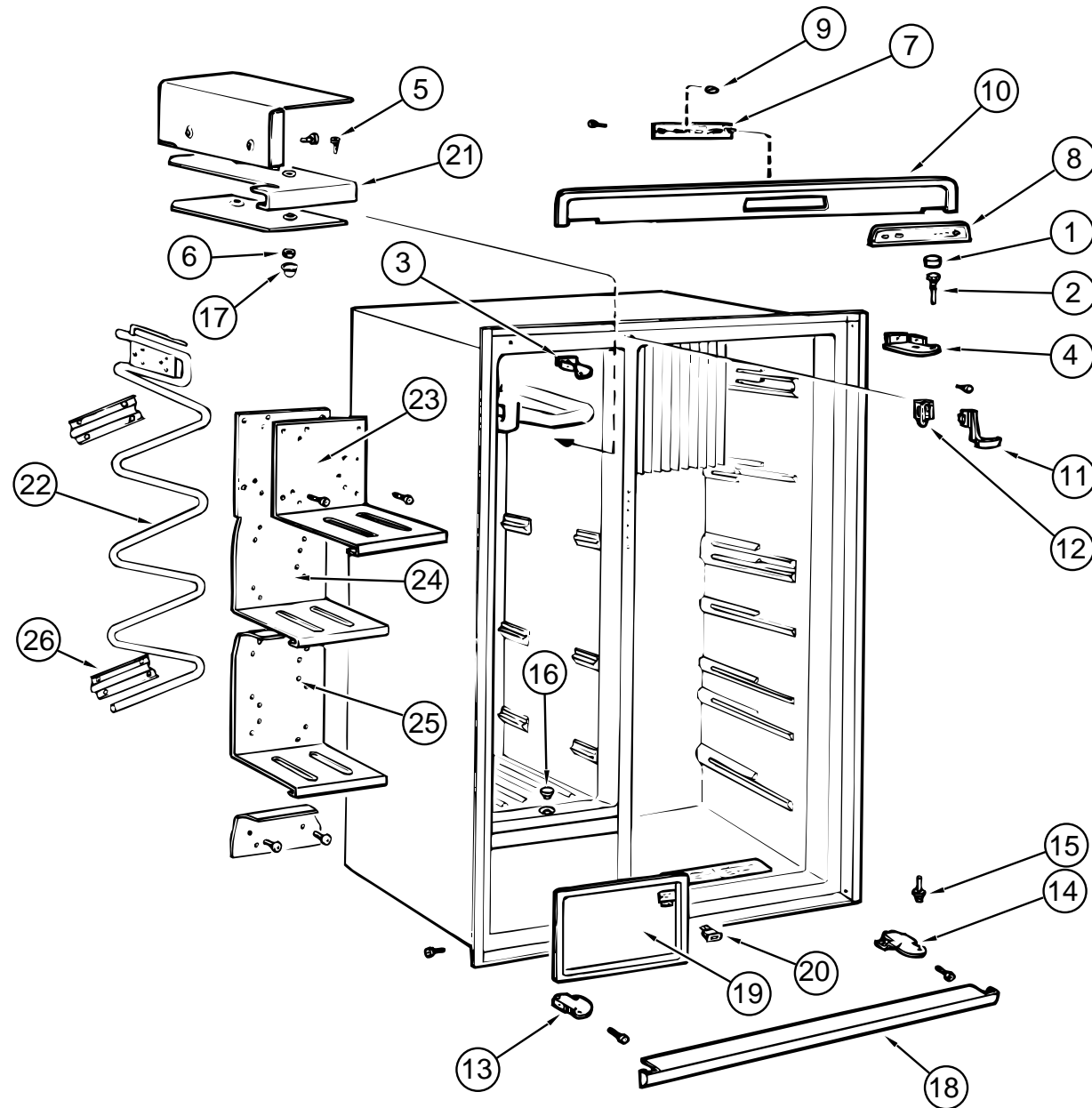

KEY	PART NUMBER	U/M DESCRIPTION	VENDOR NO.
1	118367-01-713	EA PLUG	293 27 36-01/6
2	118367-01-714	EA PIN-HINGE, UPPER	293 26 47-01/5
3	118367-01-715	EA HINGE-UPPER, LEFT (FREEZER)	293 26 46-01/7
4	118367-01-716	EA HINGE-UPPER, RIGHT (REFRIGERATOR)	293 26 46-02/5
5	118367-01-717	EA SCREW, M6S,5X20,FN	725 23 30-13/4
6	118367-01-718	EA NUT, M5, BRASS, FN	731 43 14-13/4
7	118367-01-719	EA BOARD-CIRCUIT, AES ASSY.	293 26 97-05/1
8	118367-01-720	EA DECORATION	95 50 24-53/4
9	118367-01-721	EA BUTTON	95 50 24-13/8
10	118367-01-722	EA DECORATION-FRONT	293 26 63-01/2
11	118367-01-723	EA BOW-LOCKING	293 27 45-01/7
12	118367-01-724	EA RETAINER	293 27 46-01/5
13	118367-01-725	EA HINGE-LOWER, LEFT (FREEZER)	293 26 45-01/9
14	118367-01-726	EA HINGE-LOWER, RIGHT (REFRIGERATOR)	293 26 45-02/7
15	118367-01-727	EA PIN-HINGE, LOWER	293 26 49-02/9
16	118367-01-728	EA LID-LOWER	293 17 15-01/1
17	118367-01-729	EA LID-UPPER	293 04 87-00/0
18	118367-01-730	EA STRIP-FRONT	293 26 64-01/0
19	118367-01-731	EA FLAP	293 26 55-01/8
20	118367-01-732	EA SWITCH-DOOR	293 26 80-01/6
21	118367-01-733	EA SHELF-UPPER, FREEZER	293 14 77-02/6
22	118367-01-734	EA COIL-FREEZER	293 14 74-01/5
23	118367-01-735	EA SHELF - #2, FREEZER	293 19 83-02/3
24	118367-01-736	EA SHELF - #3, FREEZER	293 19 82-02/5
25	118367-01-737	EA SHELF - #4, FREEZER	293 14 82-02/6
26	118367-01-738	EA BRACKET-SHELF, FREEZER	293 14 84-01/4

## GALLEY GROUP (CONTINUED)

### DOMETIC RM 7732IM REFRIGERATOR SHELVES & COMPONENTS

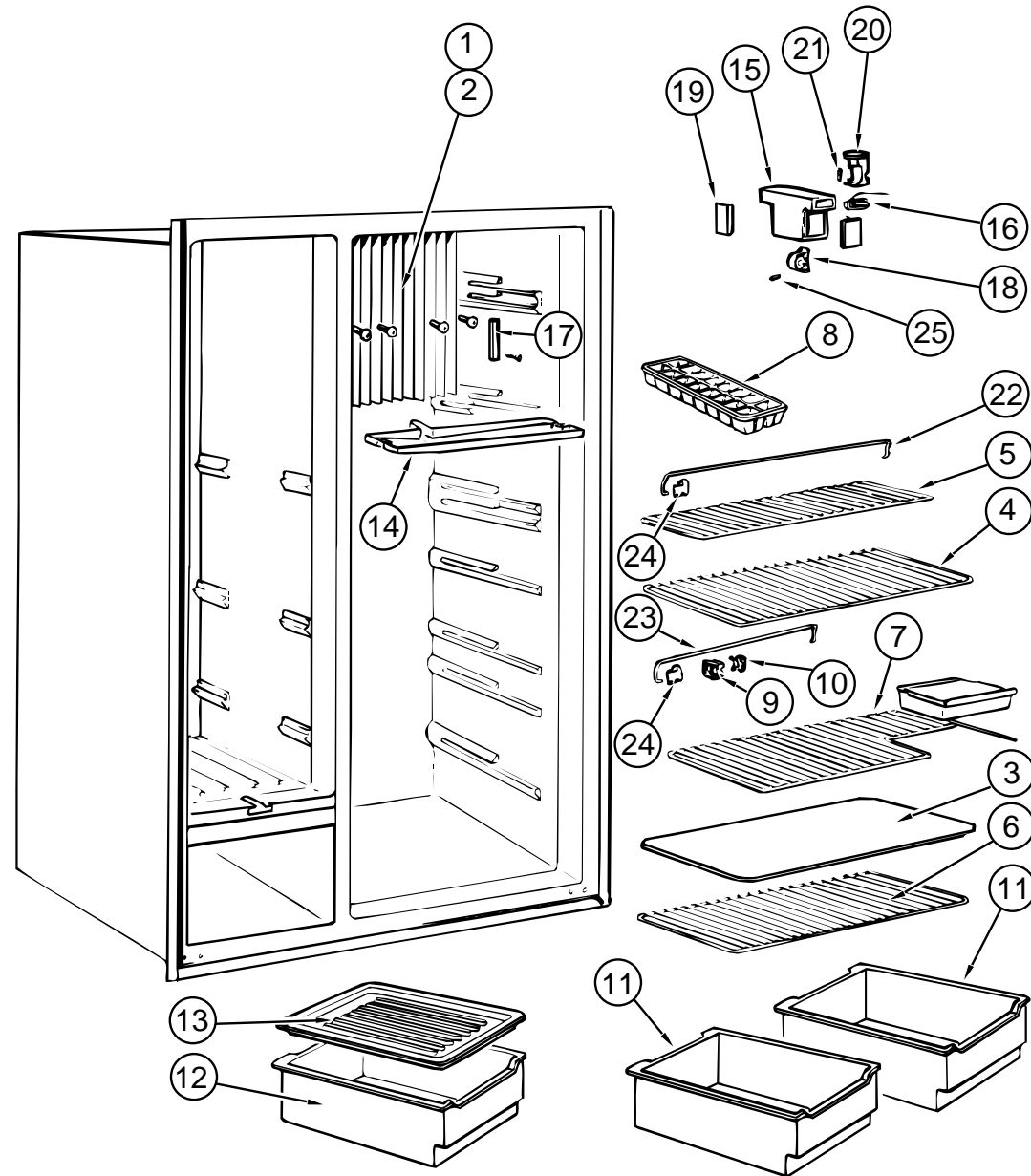

KEY	PART NUMBER	U/M	DESCRIPTION	VENDOR NO.
1	118367-01-739	EA	FLANGE-COOLING COIL, LEFT	293 16 61-02/5
2	118367-01-740	EA	FLANGE-COOLING COIL, RIGHT	293 16 61-03/3
3	118367-01-741	EA	SHELF-UPPER, (REFRIGERATOR)	293 15 41-05/2
4	118367-01-742	EA	SHELF #2, (REFRIGERATOR)	293 15 41-04/5
5	118367-01-743	EA	SHELF #3, (REFRIGERATOR)	293 15 42-02/7
6	118367-01-744	EA	SHELF #4, (REFRIGERATOR)	293 11 17-06/9
7	118367-01-745	EA	SHELF #5, (REFRIGERATOR)	293 15 41-06/0
8	118367-01-746	EA	TRAY-ICE	293 04 00-00/3
9	118367-01-747	EA	LOCK-FLAP, INNER	200 73 92-02/6
10	118367-01-748	EA	LOCK-FLAP, OUTER	200 73 93-02/4
11	118367-01-749	EA	BOX-VEGETABLE	293 14 71-03/7
12	118367-01-750	EA	BOX-VEGETABLE	293 14 71-03/7
13	118367-01-751	EA	LID-VEGETABLE	293 26 93-01/9
14	118367-01-752	EA	PAN-DRIP	293 61 63-01/3
15	118367-01-753	EA	COVER-SWITCH & LIGHT	200 40 44-09/1
16	118367-01-754	EA	SWITCH-DOOR	294 08 25 00/9
17	118367-01-755	EA	RETAINER-PROBE	293 19 76-01/9
18	118367-01-756	EA	SUPPORT-THERMOSTAT	200 40 42-00/4
19	118367-01-757	EA	CAP-END LAMP PROTECTION	200 40 43-00/2
20	118367-01-758	EA	LIGHTING	293 07 44-01/2
21	118367-01-759	EA	LAMP, 10W - 12VOLT	200 72 90-00/6
22	118367-01-760	EA	RACK-UPPER	200 73 37-15/3
23	118367-01-761	EA	RACK-LOWER	200 73 37-16/1
24	118367-01-762	EA	RETAINER-RACKS	293 06 93-04/5
25	118367-01-763	EA	PIN-LOCKING	200 12 81-01/9
	118367-01-784	EA	BUCKET-ICE	293 08 80-02
	118367-01-785	EA	CONNECTION-WATER, COMPLETE	293 09 16-02
	118367-01-786	EA	STRIP-DOOR DECORATION	293 1163-11
	118367-01-787	EA	SHELF-ICE BUCKET	293 19 23-01
	118367-01-788	EA	BLOCK-TERMINAL	293 19 63-01
	118367-01-789	EA	ICEMAKER	293 19 71-02
	118367-01-790	EA	VALVE-WATER	293 19 72-02

## GALLEY GROUP (CONTINUED)

### DOMETIC RM 7732IM REFRIGERATOR ELECTRICAL COMPONENTS

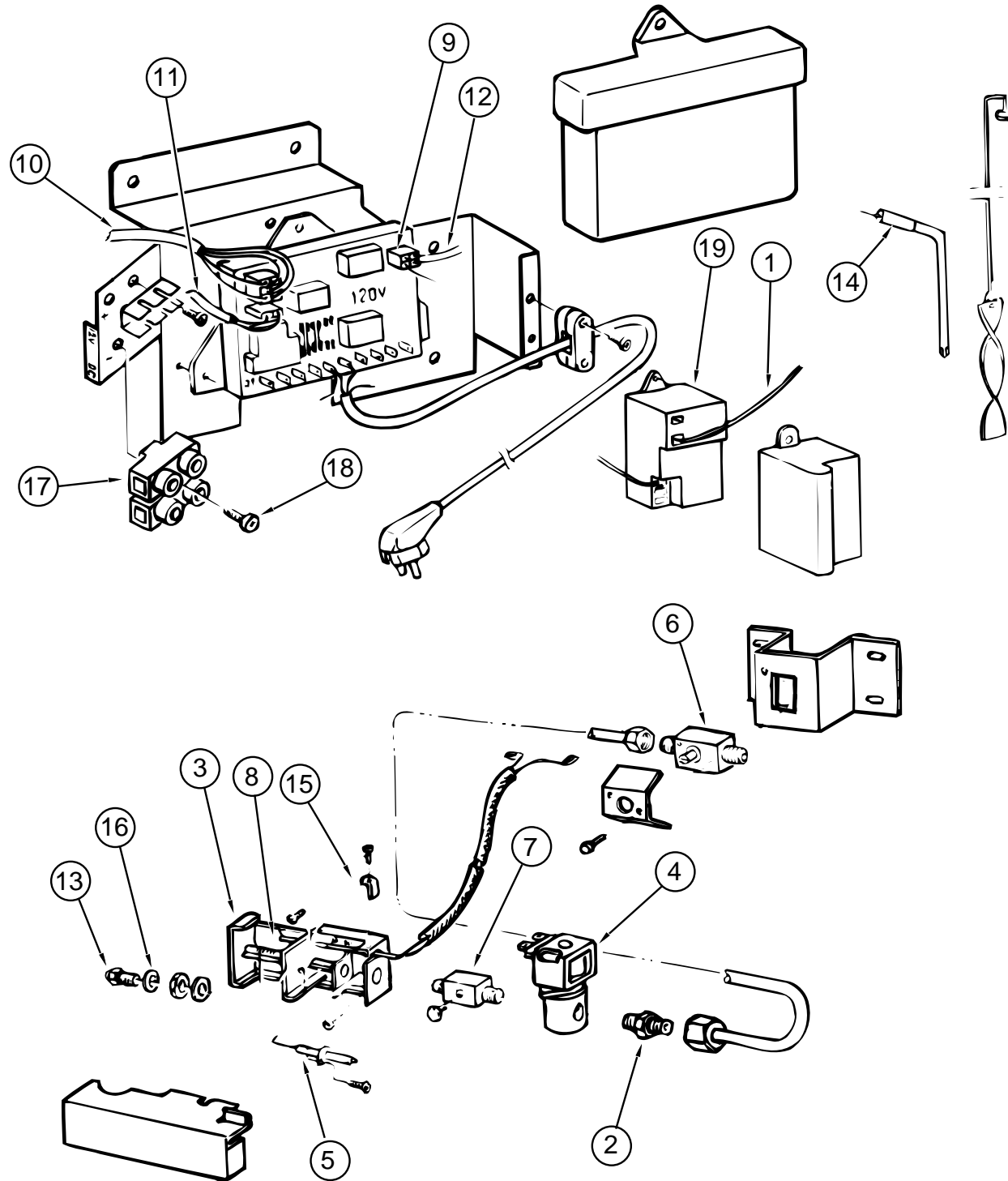

KEY	PART NUMBER	U/M	DESCRIPTION	VENDOR NO.
1	118367-01-764	EA	CONDUCTOR-ELECTRODE	200 76 68-04/5
2	118367-01-765	EA	NIPPLE	293 20 63-01/5
3	118367-01-766	EA	HOUSING-BURNER	293 21 61-01/7
4	118367-01-767	EA	VALVE-SOLENOID	294 3298-03/0
5	118367-01-768	EA	ELECTRODE	293 14 95-01/0
6	118367-01-769	EA	GAS SHUTOFF	293 26 16-01/0
7	118367-01-770	EA	NIPPLE	293 18 24-01/1
8	118367-01-771	EA	THERMOSTAT	293 18 26-01/6
9	118367-01-772	EA	BOARD-CIRCUIT, COMPLETE	293 18 42-03/9
10	118367-01-773	EA	CONDUCTOR-CIRCUIT BOARD	293 18 62-02/9
11	118367-01-774	EA	CONDUCTOR-THERMISTOR	293 18 63-02/7
12	118367-01-775	EA	CONDUCTOR-GAS VALVE	295 44 37-02/2
13	118367-01-776	EA	ORIFICE-JET, NR76	200 74 19-33/2
14	118367-01-777	EA	HEATER - 210 WATT, 120 VOLT	17 37 58-03/8
15	118367-01-778	EA	RETAINER	293 06 60-01/0
16	118367-01-779	EA	WASHER	200 74 57-00/1
17	118367-01-780	EA	BLOCK-TERMINAL	293 04 63-01/9
18	118367-01-781	EA	SCREW,RXS,B6X25,STAINLESS	729 52 87-40/8
19	118367-01-782	EA	IGNITION-SPARK	293 11 32-01/9

**GALLEY GROUP (CONTINUED)**

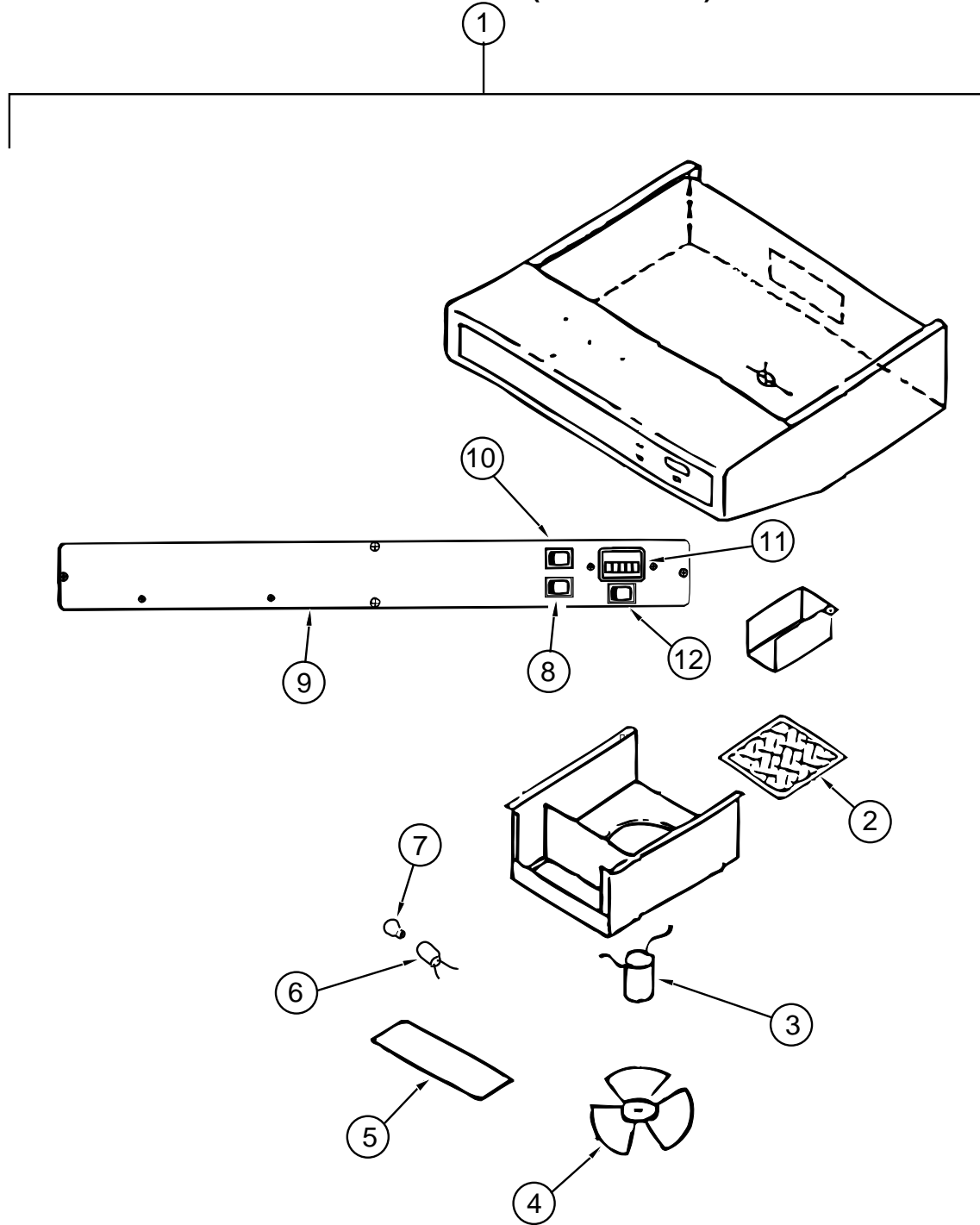

**RANGE HOOD W/O HOUR METER (CANADIAN)**

KEY	PART NUMBER	U/M DESCRIPTION	VENDOR NO.
1	100258-17-04A	EA HOOD-RANGE, W/O MONITOR PANEL - TCS-500-NBCLG	
2	096983-01-707	EA FILTER-MESH	CC246
3	090973-01-700	EA MOTOR-12 VOLT, CSA & UL	CA508-1
4	090973-01-702	EA BLADE-FAN	VA183-1
5	092696-02-701	EA LENS-LAMP	CC179-2
6	092696-01-710	EA HOLDER-LAMP	CB267-2
7	092696-01-709	EA LAMP #912	VA415
8	096983-01-700	EA SWITCH-ON/OFF	108
9	100258-01-700	EA LABEL-HOOD NOSE	CC428
10	096983-01-702	EA SWITCH-MOM/MOM	112
11	100258-10-01A	EA GAUGE-HOUR METER W/SWITCH - SCREW ON (OPTION) - 150	
11	100258-10-701	EA GAUGE-HOUR METER, CLIP ON (OPTION)	L0775-00
12	096983-01-702	EA SWITCH-MOM/MOM (OPTION)	112

**GALLEY GROUP (CONTINUED)**

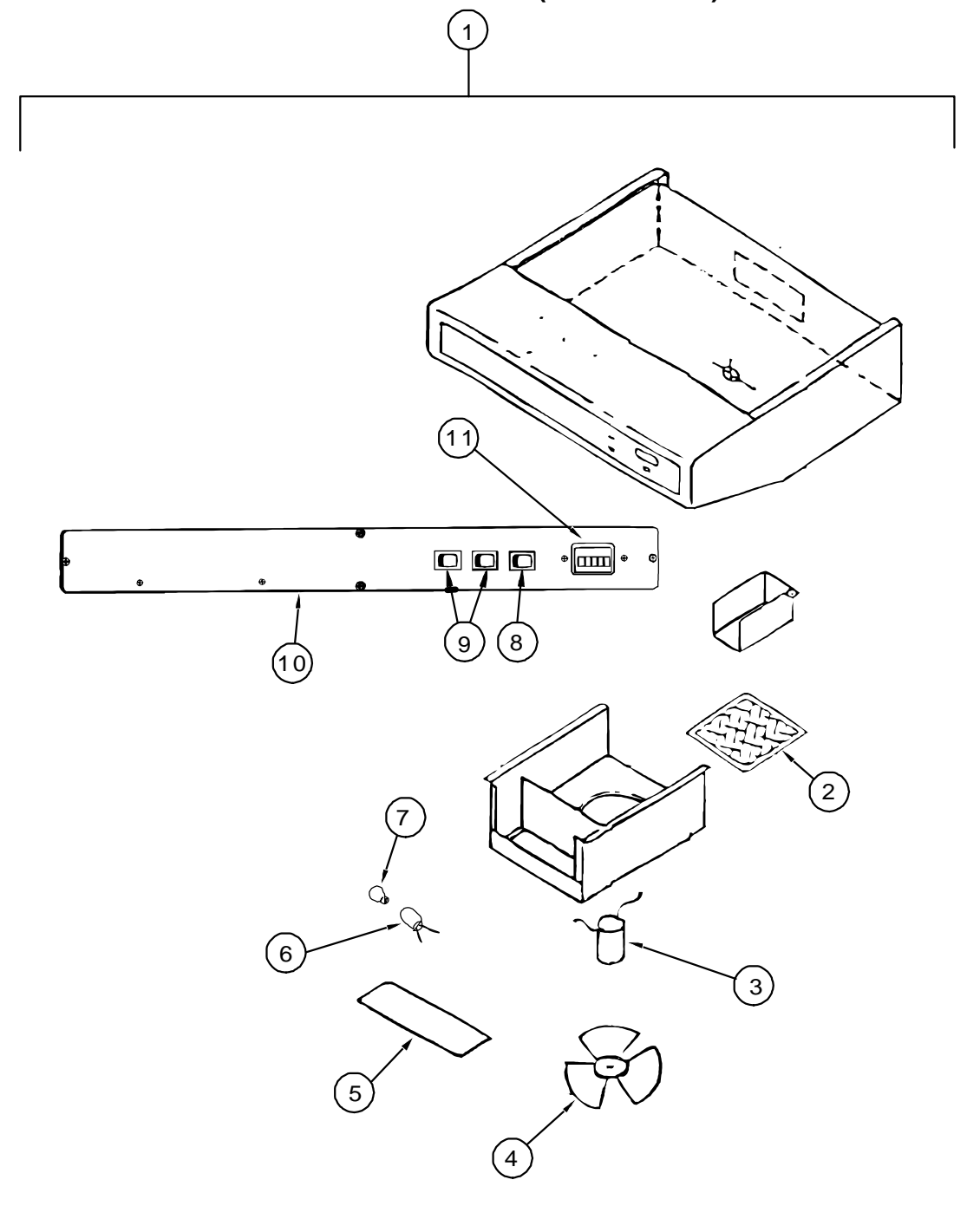

**RANGE HOOD W/HOUR METER (US)**

KEY	PART NUMBER	U/M DESCRIPTION	VENDOR NO.
1	100258-18-03A	EA HOOD-RANGE, W/O MONITOR PANEL - TP55009-SBO-LG	
2	096983-01-707	EA FILTER-MESH	CC246
3	090973-01-700	EA MOTOR-12 VOLT, CSA & UL	CA508-1
4	090973-01-702	EA BLADE-FAN	VA183-1
5	092696-02-701	EA LENS-LAMP	CC179-2
6	092696-01-710	EA HOLDER-LAMP	CB267-2
7	092696-01-709	EA LAMP #912	VA415
8	096983-01-702	EA SWITCH-MOM/MOM	112
9	096983-01-700	EA SWITCH-ON/OFF	108
10	100258-01-700	EA LABEL-HOOD NOSE	CC428
11	100258-10-01A	EA GAUGE-HOUR METER W/SWITCH - SCREW ON STYLE - 150	
11	100258-10-701	EA GAUGE-HOUR METER, CLIP ON	L0775-00

**GALLEY GROUP (CONTINUED)**

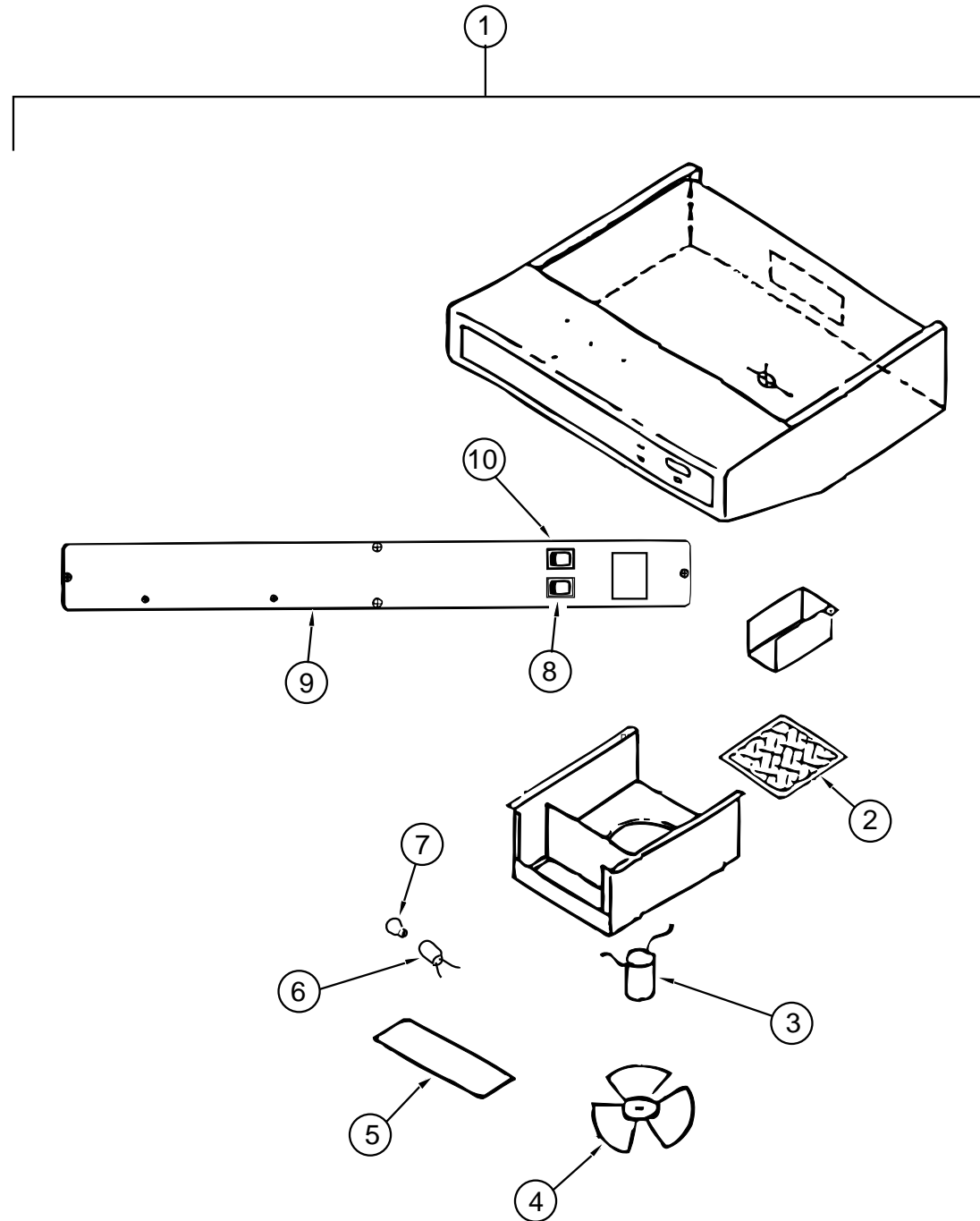

**RANGE HOOD W/O HOUR METER (US)**

KEY	PART NUMBER	U/M DESCRIPTION	VENDOR NO.
1	100258-16-04A	EA HOOD-RANGE, W/O MONITOR PANEL - TCS-5008-NBDLG	
2	096983-01-707	EA FILTER-MESH	CC246
3	090973-01-700	EA MOTOR-12 VOLT, CSA & UL	CA508-1
4	090973-01-702	EA BLADE-FAN	VA183-1
5	092696-02-701	EA LENS-LAMP	CC179-2
6	092696-01-710	EA HOLDER-LAMP	CB267-2
7	092696-01-709	EA LAMP #912	VA415
8	096983-01-700	EA SWITCH-ON/OFF	108
9	100258-01-700	EA LABEL-HOOD NOSE	CC428
10	096983-01-702	EA SWITCH-MOM/MOM	112

**GALLEY GROUP (CONTINUED)**

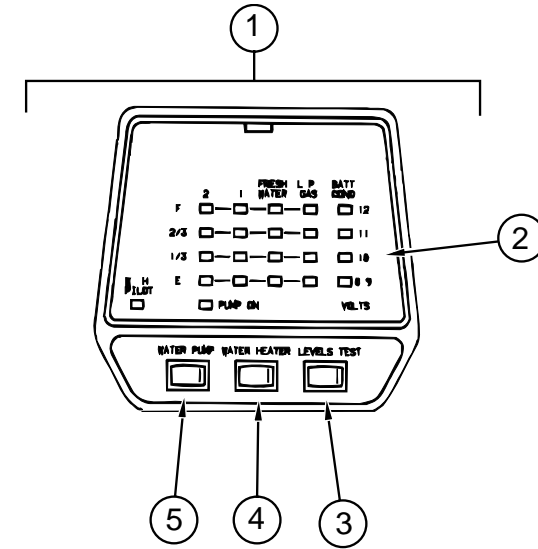

**LVS MONITOR PANEL**

KEY	PART NUMBER	U/M DESCRIPTION	VENDOR NO.
1	102765-04-01A	EA PANEL-MONITOR, W/PLUG - FOR 2 TANKS & WATER HEATER - LVS	
2	102765-04-700	EA BOARD-CIRCUIT, 2 HOLDING TANK	5076-11
3	097617-01-702	EA SWITCH (ALMOND)	107
4	097617-01-701	EA SWITCH-ON/OFF, ALMOND	106
5	102765-01-700	EA SWITCH-ON-ON, ALMOND	110-01

**MICROWAVE OVEN**

KEY	PART NUMBER	U/M DESCRIPTION
	115303-01-000	EA OVEN-MICROWAVE - MCD-DM15K-7B
	115303-01-700	EA TRIM F/VENT TOP
	115401-01-01A	EA TRIM-MICROWAVE, BLACK
	094750-07-000	EA BRACKET-MICROWAVE, 89 DEGREE - STEEL
	094756-02-01A	EA BRACKET-L, MICROWAVE - 6.1" LONG X 3.9" WIDE - STEEL - TAN
	098916-14-01A	EA BRACE-MICROWAVE
	098916-15-01A	EA BRACE-MICROWAVE

**COFFEE MAKER**

KEY	PART NUMBER	U/M DESCRIPTION	VENDOR NO.
	103799-01-02A	EA COFFEE MAKER - GRAY - BLACK & DECKER - W/GLASS POT	
	103799-01-700	EA POT-CARAFE, GLASS	679420
	103799-01-701	EA BRACKETS, WHITE PAIR	167734-06

# GALLEY GROUP (CONTINUED)

## ATWOOD RANGE W/OVEN

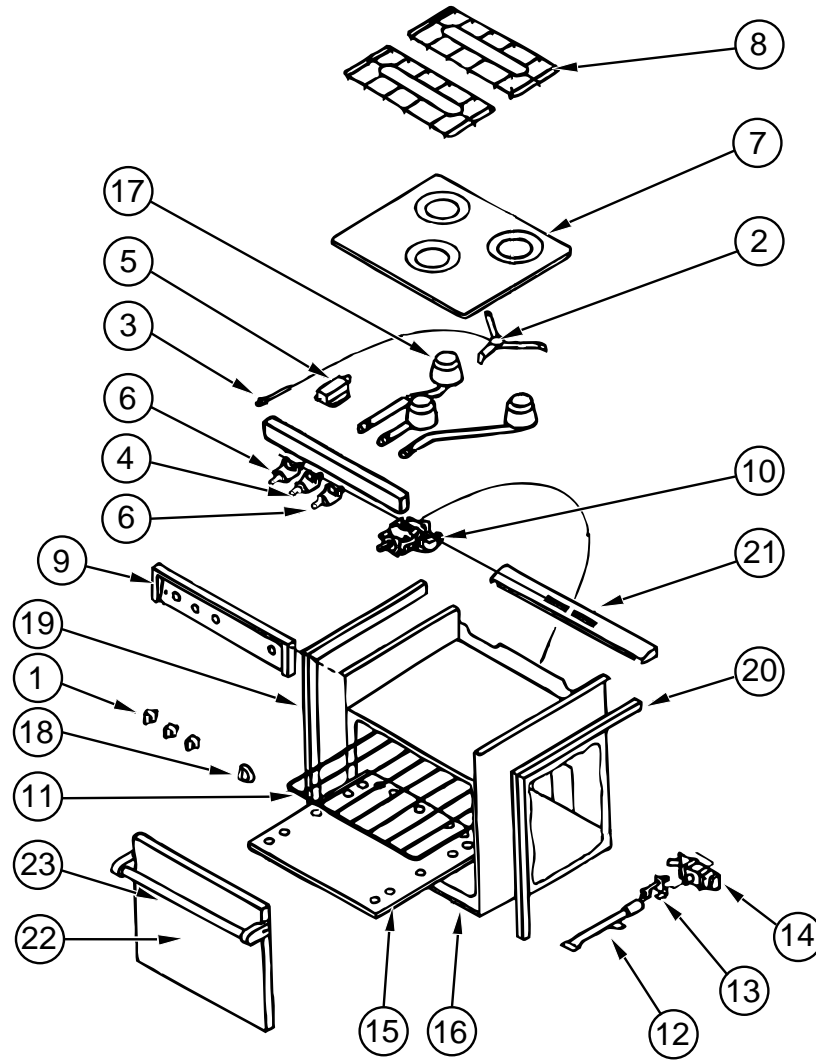

KEY	PART NUMBER	U/M	DESCRIPTION	VENDOR NO.
	107246-01-01A	EA	RANGE-W/OVEN, BLACK - R-2136BG	
			FROM: 00-00-00 THRU: 01-14-96	
1	101593-01-703	EA	BURNER KNOB	53000
2	106689-01-701	EA	SPARK-IGNITOR ASM, HIGH OUTPUT	53078
3	106689-01-702	EA	PIEZO PUSH BUTTON	52279
4	106689-01-703	EA	VALVE-BURNER, ROBERT SHAW 9000 BTU	53047
5	106689-01-704	EA	REGULATOR W/EXTREME PRESSURE	52154
6	107323-01-719	EA	VALVE-BURNER, HARPER WYMAN 5200 BTU	51138
6	106689-01-705	EA	VALVE-BURNER, ROBERT SHAW 5200 BTU	52123
7	107246-01-700	EA	RANGE TOP (BLACK)	53083
8	107246-01-701	EA	GRATE	53050
9	107246-01-702	EA	MANIFOLD COVER	53072
10	107246-01-703	EA	THERMOSTAT	52122
11	107246-01-704	EA	RACK-OVEN	51069
12	107246-01-705	EA	BURNER-OVEN	52018
13	107246-01-706	EA	PILOT ASSEMBLY-OVEN	52242
14	107246-01-707	EA	VALVE-SAFETY	51177
15	107246-01-708	EA	SHELF-OVEN, BOTTOM	51657
16	107246-01-709	EA	TRIM-BOTTOM, BLACK	53526D
17	107246-01-710	EA	BURNER (HIGH OUTPUT)	53069
18	107246-01-711	EA	KNOB, THERMOSTAT	53001
19	107323-01-702	EA	TRIM-LEFT	53023
20	107323-01-703	EA	TRIM-RIGHT	53024
21	107323-01-705	EA	TRIM VENT	53525
	107323-01-710	EA	GRATE CLIP	53301
	107323-01-711	EA	RUBBER GRATE CUSHION	53008
22	107246-01-717	EA	DOOR-OVEN ASM, BLACK GLASS LARGE	51835
22	107323-01-713	EA	BLACK GLASS INSERT-W/HOLE	53426
23	107323-01-714	EA	HANDLE FOR W/HOLE GLASS	51112
	107314-01-01A	EA	COVER-RANGE, SLOTTED BIFOLD	
	106693-01-702	EA	BUMPER-RUBBER, 1/2"	
	105458-03-000	EA	TIEDOWN BRACKET, STOVE - RH	
	105458-04-000	EA	TIEDOWN BRACKET, STOVE - LH	



# GALLEY GROUP (CONTINUED)

## ATWOOD RANGE W/OVEN

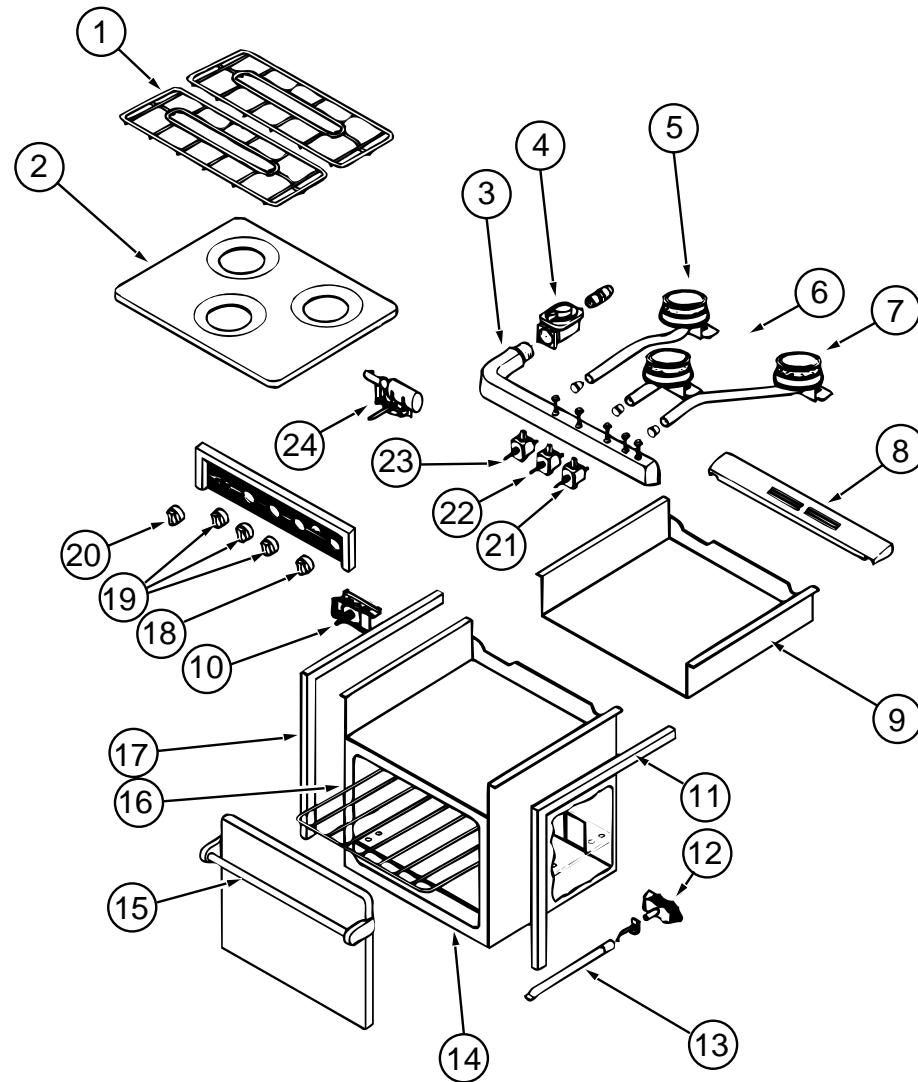

KEY	PART NUMBER	U/M	DESCRIPTION	VENDOR NO.
	121758-01-01A	EA	RANGE-W/OVEN, 21" - 3 BURNER - BLACK - R-2137BGP	
			FROM: 01-15-96 THRU: 99-99-99	
1	107246-01-701	EA	GRATE-BURNER	53050
	107323-01-711	EA	CUSHION-GRATE, RUBBER	53008
	107323-01-716	EA	CLIP-GRATE, GREEN	50005
2	121758-01-714	EA	RANGE-TOP, ALMOND	53082
3	121758-01-709	EA	MANIFOLD 3 BURNER	51272
	121758-01-713	EA	COVER-MANIFOLD	56107
4	106689-01-704	EA	REGULATOR-EXTREME PRESSURE	51062
5	121758-01-707	EA	BURNER LEFT REAR PZO	56066
6	121758-01-708	EA	BURNER CENTER (HIGH OUTPUT)	56068
7	121758-01-706	EA	BURNER RIGHT REAR PZO	56067
8	107323-01-705	EA	TRIM-VENT	53525
9	121758-01-711	EA	BURNER BOX	51684
10	107246-01-703	EA	THERMOSTAT, ROBERT SHAW	52122
11	107323-01-703	EA	TRIM-RIGHT	53024
12	107246-01-706	EA	PILOT ASM., ONLY (OVEN)	51065
13	107246-01-705	EA	BURNER-OVEN	52018
14	107246-01-709	EA	TRIM-LOWER, BLACK	53526D
15	107323-01-714	EA	HANDLE ASM. DESIGNER STYLE	51112
	107323-01-713	EA	GLASS-BLACK, INSERT OVEN DOOR	53426
16	107246-01-704	EA	RACK-OVEN	51069
	107246-01-708	EA	SHELF-OVEN, LOWER	51657
17	107323-01-702	EA	TRIM-LEFT	53023
18	121758-01-703	EA	KNOB THERMOSTAT	56094
19	121758-01-712	EA	KNOB, BURNER (3)	56093
20	121758-01-700	EA	KNOB (TURN STYLE) PIEZO IGN	56095
21	121758-01-710	EA	VALVE, BURNER	56086
22	121758-01-705	EA	VALVE HIGH OUTPUT	56087
23	121758-01-710	EA	VALVE, BURNER	56086
24	121758-01-701	EA	IGNITOR PIEZO (ROTARY)	56096
	121758-01-702	EA	ELECTRODE WIRE (PIEZO IGNITOR)	56097
	107246-01-707	EA	VALVE-SAFETY W/PILOT COMP	51063

## GENERATOR GROUP

### ONAN GENERATOR, 5.0 KW EMERALD PLUS (US, CSA)

KEY	PART NUMBER	U/M DESCRIPTION
	109303-01-000	EA GENERATOR - 5.0 KW EMERALD PLUS
	007125-03-000	EA CLAMP - MUFFLER - 1.5" DIA
	007125-04-000	EA CLAMP - MUFFLER - 1.1" DIA
	081364-03-000	EA MUFFLER
	079654-05-000	EA PIPE - EXHAUST - ANGLED - W/ FLANGE - 2" ID - ONAN# 154-2539
	106602-01-000	EA PIPE - EXHAUST - GENERATOR
	094059-01-000	EA SPACER
	068382-06-000	EA BUSHING - BRASS - 3/8 MPT X 1/8 FPT
	106607-01-000	EA ANGLE-SUPPORT, EXHAUST

### ONAN GENERATOR, 4.0 KW EMERALD PLUS (BGE-FN/29236G) (EXPORT)

KEY	PART NUMBER	U/M DESCRIPTION
	100974-04-000	EA GENERATOR - 4.0 KW EMERALD PLUS
	105958-03-000	EA PIPE - EXHAUST - GENERATOR
	007125-03-000	EA CLAMP - MUFFLER - 1.5" DIA
	007125-04-000	EA CLAMP - MUFFLER - 1.1" DIA
	079654-05-000	EA PIPE - EXHAUST - ANGLED - W/FLANGE - 2" ID - ONAN# 154-2539
	082272-01-000	EA MUFFLER
	094059-01-000	EA SPACER

### ONAN GENERATOR, 6.5 KW EMERALD PLUS (NHE-FA/26100G) (US, CSA)

KEY	PART NUMBER	U/M DESCRIPTION
	100975-01-000	EA GENERATOR - 6.5 KW EMERALD PLUS
	106602-01-000	EA PIPE - EXHAUST - GENERATOR
	007125-03-000	EA CLAMP - MUFFLER - 1.5" DIA
	007125-04-000	EA CLAMP - MUFFLER - 1.1" DIA
	079654-05-000	EA PIPE - EXHAUST - ANGLED - W/FLANGE - 2" ID - ONAN# 154-2539
	081364-03-000	EA MUFFLER
	094059-01-000	EA SPACER

### ONAN GENERATOR, 5.0 KW EMERALD PLUS (EXPORT)

KEY	PART NUMBER	U/M DESCRIPTION
	100975-03-000	EA GENERATOR - 5.0 KW EMERALD PLUS
	007125-03-000	EA CLAMP - MUFFLER - 1.5" DIA
	007125-04-000	EA CLAMP - MUFFLER - 1.1" DIA
	081364-03-000	EA MUFFLER
	079654-05-000	EA PIPE - EXHAUST - ANGLED - W/ FLANGE - 2" ID - ONAN# 154-2539
	106602-01-000	EA PIPE - EXHAUST - GENERATOR
	094059-01-000	EA SPACER
	007131-01-000	EA HANGER-TAILPIPE
	106607-01-000	EA ANGLE-SUPPORT, EXHAUST

**NOTE: GENERATOR TRAY AND COMPONENTS ARE FOUND IN THE CHASSIS GROUP**

## HEATING & AIR CONDITIONING GROUP

### REAR HEATER W/ MOTOR AID (EVANS)

KEY	PART NUMBER	U/M DESCRIPTION	VENDOR NO.
	084405-01-000	EA HEATER ASM - REAR - DUCTED - W/ MOTOR AID	
	084405-01-700	EA HEATER CORE	FT200229
	084405-01-701	EA FAN BLADES	HV029931
	084405-01-702	EA MOTOR ASM - 12 V	200146
	061673-01-000	EA BRACKET - MOTOR AID TUBES - 4" X 1.5" - STEEL	
	088753-01-000	FT TUBE - ALUMINIZED STEEL - 5/8" - 18 GAUGE	
	007076-01-000	EA HOSE - FLEXIBLE PVC - 2" ID X 50'	
	007108-01-000	FT HOSE - HEATER, 5/8" ID - HI-TEMP	
	079059-01-000	EA HOSE - 90 DEGREE - 5/8"ID X 4" X 36"	
	079059-02-000	EA HOSE - 90 DEGREE - .61"ID X 4" X 6"	
	079059-03-000	EA HOSE - 90 DEGREE - .61"ID X 4" X 18"	
	089353-01-000	EA UNION - 5/8 - TUBE TO TUBE	

# HEATING & AIR CONDITIONING GROUP (CONTINUED)

## FURNACE (SUBURBAN SF-42 2275)

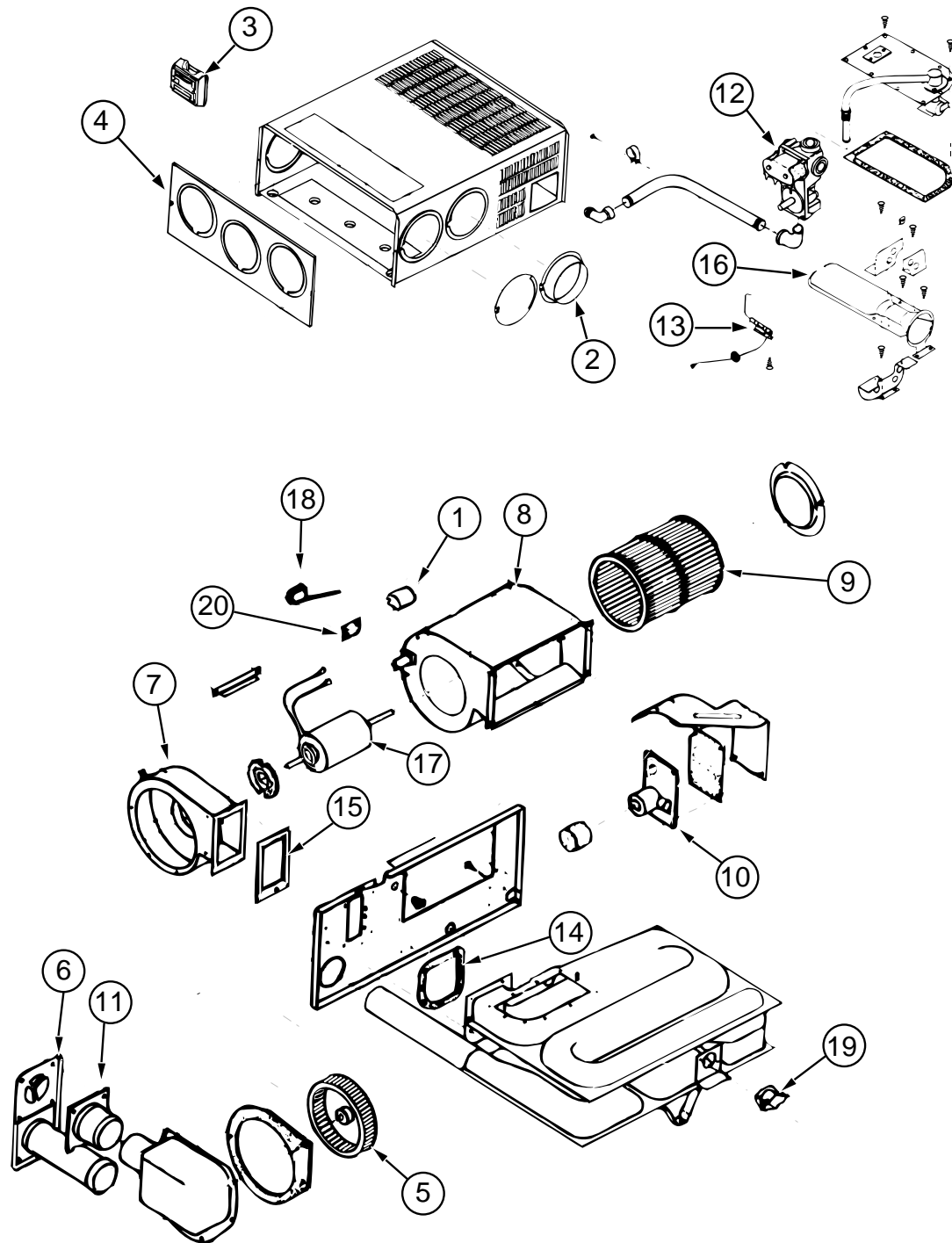

KEY	PART NUMBER	U/M	DESCRIPTION	VENDOR NO.
	098668-22-000	EA	FURNACE - 40,000 BTU - SF-30 2273	
	098668-14-000	EA	GASKET-FIBERGLASS, .5" X 18" X 18" - 070976	
	098668-11-700	EA	ORIFICE-MAIN BURNER	180216
1	074466-01-702	EA	RELAY, TIME DELAY 205 & L & 45000	230625
2	075696-02-703	EA	DUCT COLLAR	050715
3	115764-01-01A	EA	THERMOSTAT-WALL, FURNACE - 0160902	
4	098668-01-700	EA	CABINET FRONT	101242
5	098668-22-702	EA	WHEEL-AIR	350183
6	098668-01-707	EA	VENT CAP & EXHAUST TUBE ASM	260193
7	098668-01-708	EA	BLOWER ASM.(COMBUSTION AIR)	390441
8	098668-11-704	EA	BLOWER ASM (ROOM AIR)	390698
9	098668-01-711	EA	WHEEL-ROOM AIR	350129
10	098668-01-712	EA	BOARD-MODULE	520741
11	098668-01-713	EA	INTAKE VENT TUBE ASM	051044
12	098668-01-714	EA	GAS VALVE (WHITE ROGERS)	161070
13	098668-01-715	EA	ELECTRODE ASM.(SGL PROBE)	232166
14	098668-01-716	EA	GASKET FIREWALL(CHAMBER SIDE)	070808
15	098668-01-717	EA	GASKET FIREWALL(BLOWER SIDE)	070809
16	098668-11-701	EA	BURNER ASM	010799
17	098668-11-702	EA	MOTOR ASM	232212
18	098668-11-703	EA	SWITCH-SAIL, SF-42F	232216
19	098668-11-706	EA	LIMIT SWITCH	232217
20	101990-01-714	EA	MICROSWITCH GASKET	230877
	024990-05-000	EA	OUTLET-DEFROSTER, W/SWIVEL - 2" DIAMETER - BLACK	
	009198-01-000	FT	DUCT-HEAT- FLEXIBLE - 4" ID X 25 FT	
	094600-05-01A	EA	REGISTER-HEAT, W/O DAMPER	
	093614-02-02A	EA	GRILLE-RETURN AIR- FURNACE - 15.6" X 7.6" - BEIGE	
	009200-01-000	EA	TAPE-FURNACE, 1 1/2"	
	056464-09-000	EA	REGISTER-HEAT/A/C, ROUND W/DAMPER - 4" - PLASTIC - BEIGE	
	056464-10-000	EA	REGISTER-HEAT/A/C, ROUND W/O DAMPER - 4" - PLASTIC - BEIGE	
	069636-02-000	EA	CONNECTOR-DUCT, 4" ID - 050715	
	092777-01-000	EA	ADAPTER-DUCT, 4"	
	023146-01-000	EA	CLAMP-SCREW TYPE - 4"	
	093741-01-000	EA	BOX-BOOT, FLOOR REGISTER	
	093614-03-02A	EA	GRILLE-RETURN AIR	
	115764-01-01A	EA	THERMOSTAT-FURNACE, SUBURBAN 160902	

# HEATING & AIR CONDITIONING GROUP (CONTINUED)

COLEMAN ROOF AIR 13,500 BTU (US, CSA)

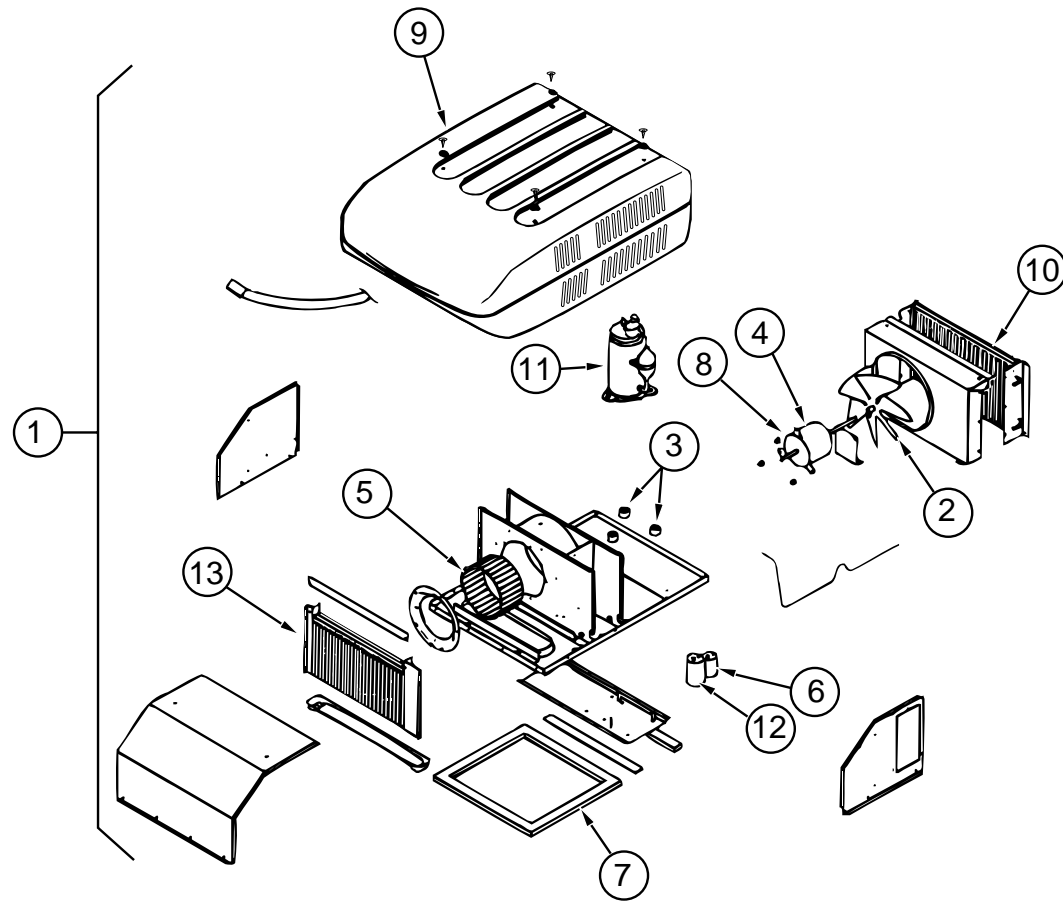

KEY	PART NUMBER	U/M DESCRIPTION	VENDOR NO.
1	108889-01-03A	EA A/C - ROOF - 13,500 TSR HO BUFF - 7333A888	
2	093763-01-712	EA FAN BLADE - CONDENSER - 6733-3221	
3	105620-01-706	EA FOOT PKG - COMPRESSOR - 3 PER PACKAGE	6759-3081
4	108889-01-705	EA MOTOR (115 - 60HZ)	1468-3049
5	108889-01-706	EA IMPELLOR	1472-1041
6	093763-01-704	EA CAPACITOR - FAN	1499-3461
7	108889-01-711	EA GASKET PACKAGE	6792-3301
8	108889-01-715	EA MOTOR MOUNT & SHAFT SEAL KIT	6792-3361
9	108889-01-702	EA SHROUD (BUFF/ BUFF) LESS LOGO	6759-6411
10	108889-01-703	EA CONDENSER COIL	1452A1301
11	105620-01-704	EA COMPRESSOR - RH & LH	1450-2009
	108889-01-704	EA OVERLOAD (MRA#98693)	6749-3541
12	108889-01-707	EA RUN CAPACITOR (COMP-25MFD/ 370)	1499-5661
13	108889-01-709	EA EVAPORATOR COIL	1452A1311
	091225-01-709	EA START RELAY	1497-4131
	091225-01-710	EA START CAPACITOR	1497-0881
	093306-01-701	EA DECAL PKG - LEFT & RIGHT	6798B3591
	108889-01-710	EA FILLER PAD - COND AIR SEAL	6759A3971
	108889-01-712	EA SUCTION LINE REDUCER (3/8 X 1/2)	1215-2161
	108889-01-713	EA SUCTION LINE (3/8 OD X .032 WALL)	6792-130
	108889-01-714	EA DISCHARGE LINE ASM.	6792-531
	108892-01-01A	EA CEILING ASM - A/C DUCTED - 7330-730 IV	
	108892-01-700	EA PLUG ASSEMBLY	7330-540
	108892-01-701	EA TERMINAL BOARD	7330-3201
	108892-01-702	EA PRINTED CIRCUIT BOARD	7330-3211
	108892-01-703	EA FILTER	6798A3761
	108892-01-704	EA GRILLE (PLASTIC)	6798-3041
	108892-01-705	EA SMALL PARTS PKG	7330A6101
	108892-01-706	EA COIL - SENSOR	7330-6111
	110403-01-F31	EA SPACER ASM - RETURN AIR -OAK	
	117238-01-01A	EA THERMOSTAT - A/C AND FURNACE - 7330-3371	
	117238-02-01A	EA THERMOSTAT - A/C ONLY - 7330-3381	
	088238-01-000	EA COVER - SWITCH - A/C SELECTOR - FRONT TO REAR A/C	
	073937-03-000	EA SWITCH - ROTARY SELECTOR - 3 DECK - A/C - CA20-USA892	
	088238-02-000	EA COVER - SWITCH - A/C SELECTOR FOR FRONT OR REAR	

# HEATING & AIR CONDITIONING GROUP (CONTINUED)

## 13,500 BTU COLEMAN ROOF A/C & CEILING ASSEMBLY - EUROPEAN

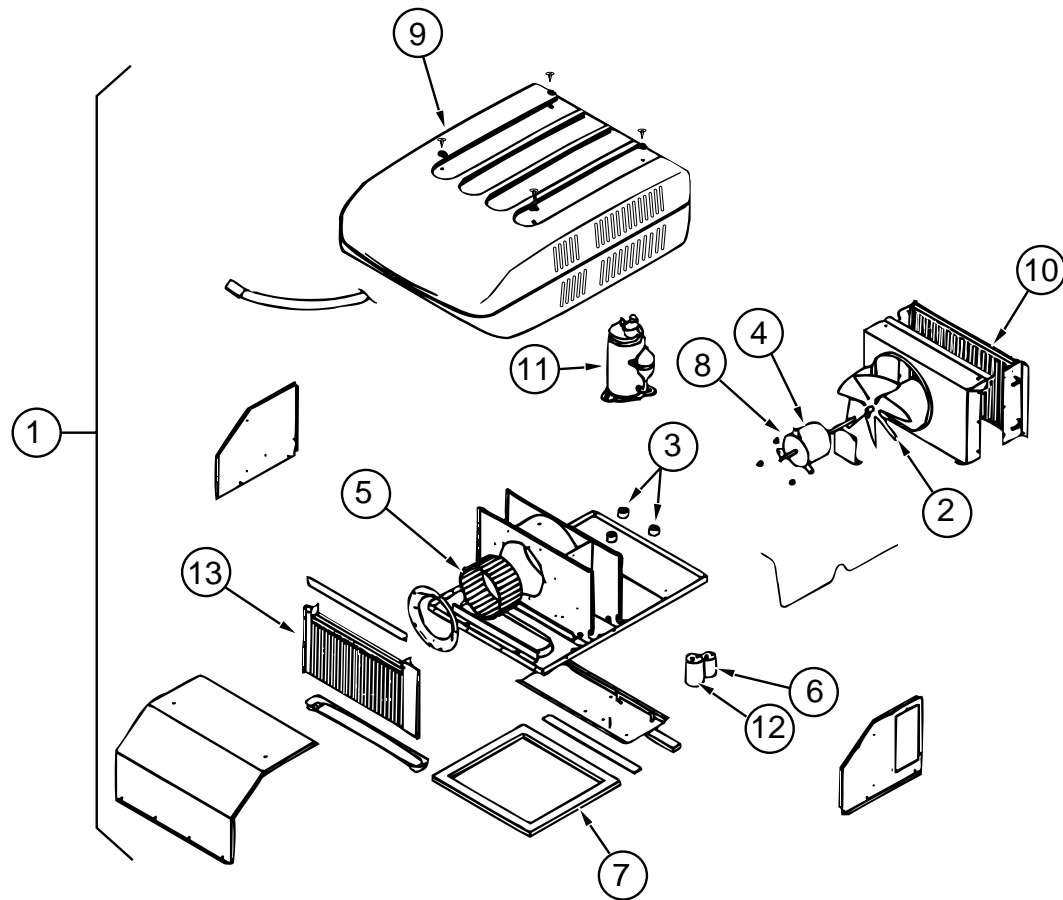

KEY	PART NUMBER	U/M	DESCRIPTION	VENDOR NO.
1	108889-02-01A	EA	A/C-ROOF, 13,500 TSR 220 IVORY - 7373-597	
2	093763-01-712	EA	FAN BLADE-CONDENSER	6733-3221
3	105620-01-706	EA	FOOT PACKAGE-COMPRESSOR, 3 PER PACKAGE	6759-3081
4	108889-02-701	EA	MOTOR - 115V, 60HZ	1468-3059
5	108889-01-706	EA	IMPELLOR	1472-1041
6	108889-01-708	EA	CAPACITOR-FAN, (7.5MFD.370U)	1499-5461
	108889-01-710	EA	FILLER PAD-COND AIR SEAL	6759A3971
7	108889-01-711	EA	GASKET PACKAGE	6792-3301
8	108889-01-715	EA	MOTOR MOUNT & SHAFT SEAL KIT	6792-3361
9	063903-01-700	EA	SHROUD	6759-4601
10	108889-01-703	EA	CONDENSER COIL	1452-1301
11	108889-02-700	EA	COMPRESSOR, TECUMSEH	1452-2029
12	108889-01-707	EA	CAPACITOR-RUN, COMPRESSOR-25MFD/370	1499-5661
	108889-02-703	EA	RELAY-START	1497-4141
13	108889-01-709	EA	EVAPORATOR COIL	1452-1311
	108889-01-714	EA	DISCHARGE LINE ASSEMBLY	6792-531
	108889-01-712	EA	REDUCER-SUCTION LINE, (3/8" X 1/2")	1215-2161
	108889-01-713	EA	SUCTION LINE, (3/8" OD X .032" WALL)	6792-130
	108889-02-702	EA	CAPACITOR-START	1497-0891
	093306-01-701	EA	DECAL PACKAGE-LEFT & RIGHT	6798B3591
	105620-01-705	EA	OVERLOAD	6759-3791
	102289-01-000	EA	SPRING-SCREW, ROOF A/C GASKET	6757-150
	108892-01-01A	EA	CEILING ASM-A/C DUCTED - 7330-730 IV	
	108892-01-700	EA	PLUG ASSEMBLY	7330-540
	108892-01-701	EA	BOARD-TERMINAL	7330-3201
	108892-01-702	EA	BOARD-PRINTED CIRCUIT	7330A3211
	108892-01-703	EA	FILTER	6798A3761
	108892-01-704	EA	GRILLE (PLASTIC)	6798-3041
	108892-01-705	EA	SMALL PARTS PKG	7330A6101

# HEATING & AIR CONDITIONING GROUP (CONTINUED)

## SCS AUTOMOTIVE AIR CONDITIONING (FORD)

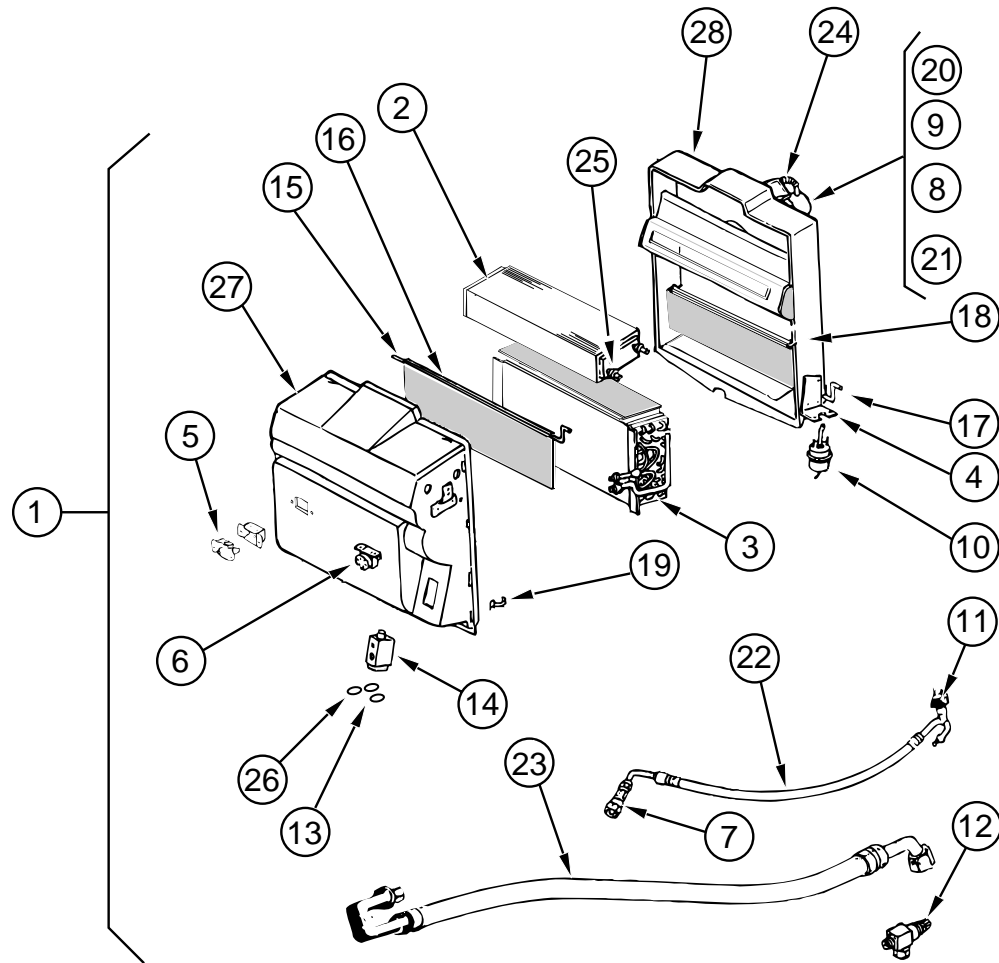

KEY	PART NUMBER	U/M	DESCRIPTION	VENDOR NO.
1	103930-21-000	EA	EVAPORATOR/ HEATER ASSEMBLY - 090-00084	
2	103930-01-703	EA	COIL - HEATER	042-0010
3	103930-01-704	EA	COIL EVAPORATOR	041-0017
4	103930-01-708	EA	BRACKET - VACUUM MOTOR	070-0113
5	103930-01-710	EA	RESISTOR - FUSED	035-0006
6	103930-01-711	EA	THERMOSTAT	033-0003
7	103930-01-713	EA	FITTING - QUICK CONNECT - #4	050-003
8	103930-01-717	EA	WHEEL - CLOCKWISE	062-0010
9	103930-01-720	EA	MOTOR	030-0004
10	103930-02-708	EA	MOTOR - VACUUM SERVO - A/C	030-0002
11	103930-12-708	EA	SWITCH - BINARY - R-134A	032-0048
12	103930-13-702	EA	SERVICE VALVE W/O C.P.	050-152
13	103930-17-702	EA	GASKET OR SAE 015 #10 33-781	045-0127
14	103930-20-700	EA	VALVE EXPANSION BLOCK (2 TON)	034-0032
15	103930-20-702	EA	ROD F/BLEND AIR DOOR	073-0039
16	103930-20-703	EA	DOOR - BLEND AIR	071-0212
17	103930-20-704	EA	ROD - DOOR - RECIRCULATING	073-0018
18	103930-20-705	EA	DOOR PANEL - RECIRCULATING	071-0213
19	103930-20-706	EA	CLIP - RETAINER	022-0057
20	103930-20-707	EA	BLOWER HOUSING	062-0145
21	103930-20-708	EA	CLIP F/ MOTOR SHAFT	022-0001
22	103930-21-700	EA	HOSE ASM. - #6	085-0139
23	103930-21-701	EA	HOSE ASM. - #10	085-0140
24	110279-01-703	EA	HOSE - VENT - MOTOR BLOWER	70510034
25	110279-01-712	EA	HEATER FITTING	
26	113245-01-707	EA	GASKET	045-0126
27	103930-20-710	EA	CASE-FRONT, SUB-ASSEMBLY	062-0146
28	103930-20-710	EA	CASE-BACK, SUB-ASSEMBLY	062-0147
	007281-01-000	EA	HOSE - FLEXIBLE PVC - 2.5"ID X 50' - ATCOFLEX - A-182-355	
	072341-06-700	EA	SWITCH - 4 SPEED - FAN	ARA 0883502
	094831-01-709	EA	CLAMPS - ROD - 3/16" - MOTIVAIR	ZGG14431
	103930-02-701	EA	VALVE - CONTROL HEAD	034-0015
	103930-02-702	EA	DECAL - CONTROL SETTING	058-0008
	103930-02-703	EA	HARNES - WIRE CONTROL	036-0048
	103930-02-704	EA	HARNES - VACUUM CONTROL	036-0049
	103930-02-705	EA	CABLE - CONTROL - BOWDEN	074-0011
	103930-02-706	EA	CLIP - CABLE - CONTROL	022-0017
	103930-02-707	EA	RELAY	031-0001
	103930-02-710	EA	CANISTER - VACUUM	054-0002
	103930-02-711	EA	VALVE - WATER	034-00114
	103930-02-712	EA	CONTROL PANEL - A/C & HEAT - BLACK FACING	
	103930-04-000	EA	CONTROL/ PLENUM SET - 093-00037	
	103930-05-000	EA	MANUAL - OWNERS - HEATER - A/C - 057-0049	
	103930-17-000	EA	HOSE KIT - #10 GM - SANDEN COMP - 093-00076	
	103930-17-700	EA	FITTING - PAD COMP. SUCTION SAN	050-0131
	103930-17-701	EA	FITTING - #10.90 W/FERRULE/1342CP	050-0132
	103930-17-703	EA	GASKET - SEAL,SANDEW COMP33-76	045-0142
	103930-17-704	EA	HOSE ASSY - #10	085-0113
	024990-05-000	EA	4" DIAMETER OUTLET - W/ SWIVEL DEFLECTORS	
	103016-01-000	EA	PLENUM - TRANSITION	
	103017-01-000	EA	PLENUM - DEFROSTER	
	103558-01-07A	EA	VENT - DEFROSTER - ABS WILLOW	
	103796-01-01A	EA	LOUVER ASM - A/C CARY PROD BLACK	
	056402-05-000	EA	BRACKET - HEATER VENT - ROUND - W/ BEND - BLACK	
	077075-01-000	EA	GASKET - INSTRUMENT PANEL TO DEFROSTER PLENUM - .6" X 11.3"	
	077075-03-000	EA	GASKET - INSTRUMENT TO DEFROSTER PLENUM - SPL	

# HEATING & AIR CONDITIONING GROUP (CONTINUED)

## SCS AUTOMOTIVE AIR CONDITIONING (CHEVY)

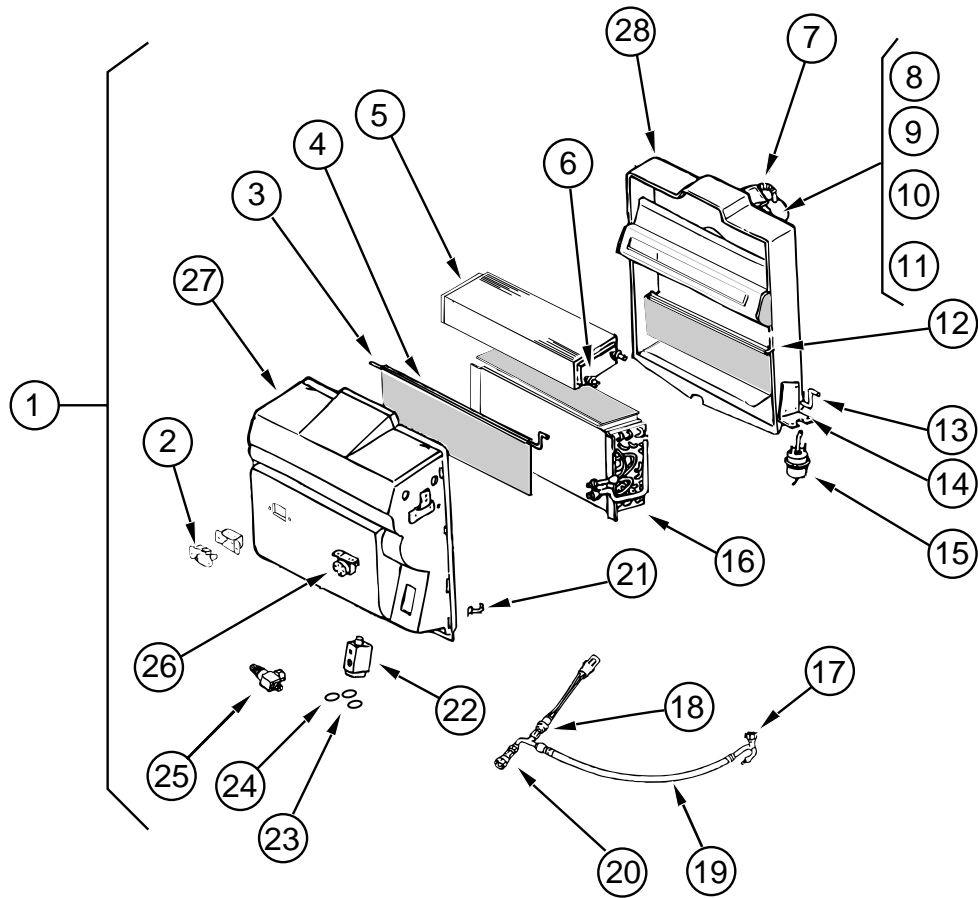

KEY	PART NUMBER	U/M DESCRIPTION	VENDOR NO.
1	103930-25-000	EA EVAPORATOR/ HEATER ASSEMBLY - 090-00296	
2	103930-01-710	EA RESISTOR - FUSED	035-0006
3	103930-20-702	EA ROD F/BLEND AIR DOOR	073-0039
4	103930-20-703	EA DOOR - BLEND AIR	071-0212
5	103930-01-703	EA COIL - HEATER	042-0010
6	110279-01-712	EA HEATER FITTING	
7	110279-01-703	EA HOSE - VENT - MOTOR BLOWER	70510034
8	103930-01-717	EA WHEEL - CLOCKWISE	062-0010
9	103930-01-720	EA MOTOR	030-0004
10	103930-20-707	EA BLOWER HOUSING	062-0145
11	103930-20-708	EA CLIP F/ MOTOR SHAFT	022-0001
12	103930-20-705	EA DOOR PANEL - RECIRCULATING	071-0213
13	103930-20-704	EA ROD - DOOR - RECIRCULATING	073-0018
14	103930-01-708	EA BRACKET - VACUUM MOTOR	070-0113
15	103930-02-708	EA MOTOR - VACUUM SERVO - A/C	030-0002
16	103930-01-704	EA COIL EVAPORATOR	041-0017
17	103930-12-708	EA SWITCH - BINARY - R-134A	032-0048
18	103930-01-716	EA SWITCH - PRESSURE - FAN	032-0036
19	103930-20-701	EA HOSE ASM. - #6 GM	085-0138
20	103930-12-709	EA FITTING - QUICK CONNECT	050-0120
21	103930-20-706	EA CLIP - RETAINER	022-0057
22	103930-20-700	EA VALVE EXPANSION BLOCK (2 TON)	034-0032
23	103930-17-702	EA GASKET OR SAE 015 #10 33-781	045-0127
24	113245-01-707	EA GASKET	045-0126
25	103930-20-709	EA SERVICE VALVE W/O C.P.	050-0159
26	103930-01-711	EA THERMOSTAT	033-0003
27	103930-20-710	EA CASE-FRONT, SUB-ASSEMBLY	062-0146
28	103930-20-710	EA CASE-BACK, SUB-ASSEMBLY	062-0147
	007281-01-000	EA HOSE - FLEXIBLE PVC - 2.5"ID X 50' - ATCOFLEX - A-182-355	
	072341-06-700	EA SWITCH - 4 SPEED - FAN	ARA 0883502
	094831-01-709	EA CLAMPS - ROD - 3/16" - MOTIVAIR	ZGG14431
	103930-02-701	EA VALVE - CONTROL HEAD	034-0015
	103930-02-702	EA DECAL - FAN SWITCH	058-0008
	103930-02-703	EA HARNESS - WIRE CONTROL	036-0048
	103930-02-704	EA HARNESS - VACUUM CONTROL	036-0049
	103930-02-705	EA CABLE - CONTROL - BOWDEN	074-0011
	103930-02-706	EA CLIP - CABLE - CONTROL	022-0017
	103930-02-707	EA RELAY	031-0001
	103930-02-710	EA CANISTER - VACUUM	054-0002
	103930-02-711	EA VALVE - WATER	034-00114
	103930-02-712	EA CONTROL PANEL - A/C & HEAT - BLACK FACING	
	103930-04-000	EA CONTROL/ PLENUM SET - 093-00037	
	103930-05-000	EA MANUAL - OWNERS - HEATER - A/C - 057-0049	
	024990-05-000	EA 4" DIAMETER OUTLET - W/ SWIVEL DEFLECTORS	
	103016-01-000	EA PLENUM - TRANSITION	
	103017-01-000	EA PLENUM - DEFROSTER	
	103558-01-07A	EA VENT - DEFROSTER - ABS WILLOW	
	103796-01-01A	EA LOUVER ASM - A/C CARY PROD BLACK	
	056402-05-000	EA BRACKET - HEATER VENT - ROUND - W/ BEND - BLACK	
	077075-01-000	EA GASKET - INSTRUMENT PANEL TO DEFROSTER PLENUM - .6" X 11.3"	
	077075-03-000	EA GASKET - INSTRUMENT TO DEFROSTER PLENUM - SPL	

# INTERIOR FINISH GROUP (CONTINUED)

## INTERIOR TRIM & MOLDINGS

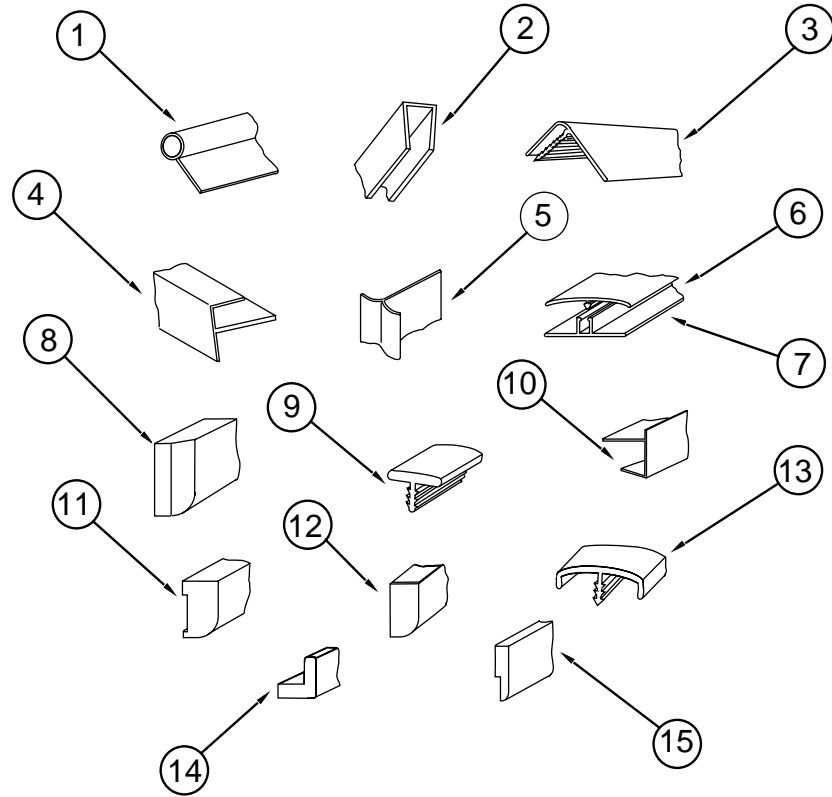

KEY	PART NUMBER	U/M	DESCRIPTION
1	009767-12-000	FT	MOLDING-SIDEWALL TO CEILING/CABINET - WELTING - OFF WHITE
1	009767-15-000	FT	WELTING-WATERFORD OAK
2	009778-12-000	FT	U CHANNEL-PLASTIC, 1" WIDE X 8' INCREMENTS - WOODGRAIN
2	009778-21-000	FT	U-CHANNEL - 1" - WATERFORD OAK
2	070504-23-000	FT	EXTRUSION-U CHANNEL, 22.56" - COUNTRY FOREST
2	070504-37-000	FT	EXTRUSION-U-CHANNEL, 20.70" - WATERFORD OAK
3	009809-23-000	EA	MOLDING-CORNER, OUTSIDE - 1" - PLASTIC - IVORY
3	009809-28-000	EA	MOLDING-PLASTIC, CORNER - 1" - WATERFORD OAK
4	009812-29-000	EA	MOLDING-PLASTIC, CORNER - O/S 1/2" - WATERFORD OAK
5	022992-11-000	FT	MOLDING-REVERSE COVE, T-SHAPED - VINYL - IVORY
6	086229-13-000	EA	BATTEN - 1" CEILING MOD IVORY
6	086229-19-000	EA	BATTEN - 1" CEILING, OFF WHITE - W&B RN323-W-129 FROM: 00-00-00 THRU: 01-31-96
6	086229-18-000	EA	BATTEN - 1" CEILING, OFF WHITE - W&B RN323-W-129 FROM: 02-01-96 THRU: 99-99-99
7	086229-14-000	EA	RETAINER - 3/4 - W&B RN 391 FROM: 00-00-00 THRU: 01-31-96
7	086229-16-000	EA	RETAINER - 3/4" - RN 391-X FROM: 02-01-96 THRU: 99-99-99
8	100659-01-E01	EA	MOLDING-TRIM, VINYL FLOOR
9	105709-01-000	FT	T-MOLDING - 1", MODERN IVORY
10	103186-01-05A	FT	MOLDING-PLASTIC, SHELF - WATERFORD OAK
10	103186-01-01A	FT	MOLDING-EDGE, SHELF - .78" WIDE - PLASTIC - RAMBLING OAK
10	103186-02-01A	FT	MOLDING-EDGE, SHELF - 1.3" WIDE - PLASTIC - RAMBLING OAK
11	100041-01-000	EA	MOLDING-VINYL WRAPPED, .7" X 1.57" X 84.02" - RAMBLING OAK
12	100818-01-05A	EA	MOLDING-VINYL WRAP, TRIM - WATERFORD OAK
13	083620-07-000	FT	MOLDING-T, END CAP EDGE - W/EDGE LIPS - .75" - THOR PECAN
13	104676-01-01A	FT	T-MOLDING, 5/16 RIGID - GOLD
14	100819-01-05A	EA	MOLDING-VINYL WRAP, DOOR - WATERFORD OAK
15	105004-01-02A	EA	MOLDING-VINYL WRAP - RAMBLING OAK
	076325-39-000	FT	MOLDING-EDGE BAND, 1527 - 1-5/16 X .030 X 600'
	076325-53-000	FT	MOLDING-EDGE BAND, 1049 NEUTRA - 1 5/16 X .030 X 600'
	076325-67-000	FT	MOLDING-EDGE BAND, WATERFORD - .93 X .024 X 600'
	076325-68-000	FT	MOLDING-EDGE BAND, WATERFORD - 1 5/16 X .038 X 600'
	100040-01-000	EA	LUMBER-VINYL WRAPPED, .71" X 1.5" X 8' - RAMBLING OAK
	100040-06-000	EA	LUMBER-VINYL WRAPPED - RAMBLING OAK
	117268-D2-134	EA	MOLDING - 018 X 040 X 2134 MM - VINYL - WRAPPED WATERFORD
	117268-F2-134	EA	MOLDING - 018 X 065 X 2134 MM - WRAPPED WATERFORD



# INTERIOR FINISH GROUP (CONTINUED)

## CABINET HARDWARE

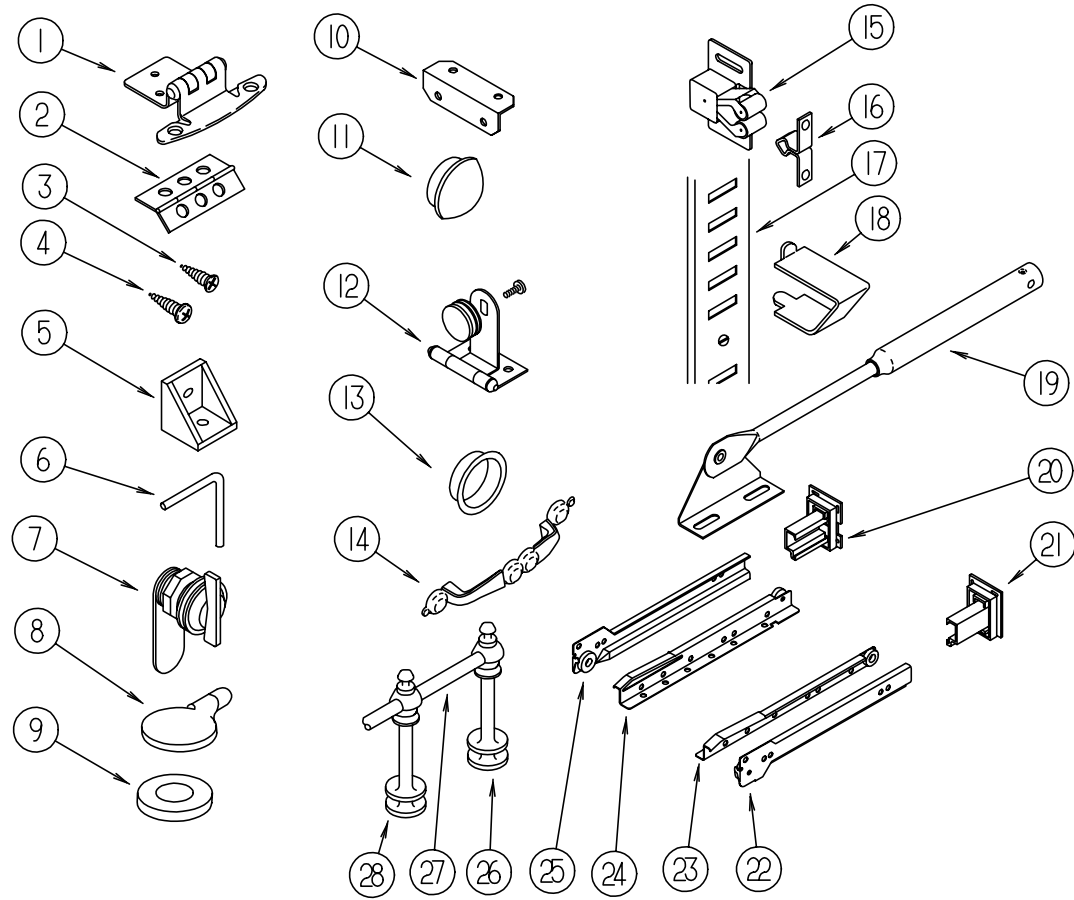

KEY	PART NUMBER	U/M	DESCRIPTION
1	108138-01-000	EA	HINGE-DOOR, CABINET - BURNISHED BRASS
2	009059-01-000	EA	HINGE-DOOR, 2" X 1.4" - BRASS
2	009059-02-000	EA	HINGE-DOOR, 2" X 2.7" - BRASS
3	000G13-06-10G	EA	SCREW - PHILLIPS - FLAT HEAD - 6-20 X 5/8" - ANTIQUE BRASS
4	000G68-06-10G	EA	SCREW - PHILLIPS - OVAL HEAD - 6-18 X 5/8" - ANTIQUE BRASS
5	065740-01-000	EA	BRACE-CABINET CORNER, PLASTIC
6	108487-02-01A	EA	SUPPORT-PROP ROD, OVHD - BLACK
	108486-01-01A	EA	BRACKET-PROP ROD, OVHD - BLACK
7	100710-01-01A	EA	LOCK-GLASS DOOR, TWIST TYPE - BRASS
	101272-01-000	EA	CATCH-DOOR, GLASS
8	101766-01-000	EA	PIN-SUPPORT, GLASS DOOR
9	100707-01-000	EA	SPACER-DOOR, GLASS - .8" DIA - .3" HOLE - PLASTIC
10	016604-01-000	EA	BRACE-CABINET, ANGLE - 2.5" - METAL - UNPAINTED
10	016604-05-000	EA	BRACE-CABINET, L ANGLE - 2.5" - METAL - OFF WHITE
11	042356-01-000	EA	PLUG-BUTTON, MAHOGANY - 3/8" DIAMETER - WOOD
12	100711-01-01A	EA	HINGE-DOOR, GLASS
13	098410-01-01A	EA	PULL-FINGER, OVAL - BRASS
14	117800-01-01A	EA	PULL-CABINET, BRASS
15	093586-06-000	EA	CATCH-SPRING, ROLLER - FASTEC C411-AC
16	093586-05-000	EA	STRIKE-SPRING STEEL, FASTEC S411-AC

KEY	PART NUMBER	U/M	DESCRIPTION
17	098980-01-000	EA	PILASTER-ADJUSTABLE SHELF, 18" LONG WOODGRAIN APPEARANCE
17	098980-02-000	EA	PILASTER-ADJUSTABLE SHELF, 12" LONG WOODGRAIN APPEARANCE
17	098980-03-000	EA	PILASTER-ADJUSTABLE SHELF WOODGRAIN APPEARANCE
17	098980-06-000	EA	PILASTER-ADJUSTABLE SHELF, 24" LONG
18	098979-01-000	EA	CLIP-ADJUSTABLE SHELF
19	074493-02-000	EA	SUPPORT-PISTON SPRING, CABINET DOOR
20	114045-01-000	EA	BACKSOCKET-ADJUSTABLE, LEFT - HOUCK 751-1 N/A ORDER KIT ACCORDING TO LENGTH OF DRAWER SLIDE 114031
21	114045-02-000	EA	BACKSOCKET-ADJUSTABLE, RIGHT - HOUCK 751-2 N/A ORDER KIT ACCORDING TO LENGTH OF DRAWER SLIDE 114031
22	114031-02-000	EA	SLIDE-DRAWER, 12" RIGHT CABT N/A ORDER #114031-01-700 SLIDE DRAWER KIT
22	114031-14-000	EA	SLIDE-DRAWER, 18" RIGHT CABINET-HOUCK 7200-RV-2 N/A ORDER #114031-13-700 SLIDE DRAWER KIT
22	114031-18-000	EA	SLIDE-DRAWER, 20" RIGHT CABT N/A ORDER #114031-17-700 SLIDE DRAWER KIT
22	114031-22-000	EA	SLIDE-DRAWER, 22" RIGHT CABT N/A ORDER #114031-21-700 SLIDE DRAWER KIT
23	114031-04-000	EA	SLIDE-DRAWER, 12" - RIGHT DRAWER - HOUCK 7200-RV-4 N/A ORDER #114031-01-700 SLIDE DRAWER KIT
23	114031-16-000	EA	SLIDE-DRAWER, 18" RIGHT DRAWER -HOUCK 7200-RV-4 N/A ORDER #114031-13-700 SLIDE DRAWER KIT
23	114031-24-000	EA	SLIDE-DRAWER, 22" RIGHT DRAWER N/A ORDER #114031-21-700 SLIDE DRAWER KIT
24	114031-03-000	EA	SLIDE-DRAWER, 12" - LEFT DRAWER - HOUCK 7200-RV-3 N/A ORDER #114031-01-700 SLIDE DRAWER KIT
24	114031-15-000	EA	SLIDE-DRAWER, 18" LEFT DRAWER - HOUCK 7200-RV-3 N/A ORDER #114031-13-700 SLIDE DRAWER KIT
24	114031-23-000	EA	SLIDE-DRAWER, 22" LEFT DRAWER N/A ORDER #114031-21-700 SLIDE DRAWER KIT
25	114031-01-000	EA	SLIDE-DRAWER, 12" LEFT CABT N/A ORDER KIT #114031-01-700 SLIDE DRAWER KIT
25	114031-13-000	EA	SLIDE-DRAWER, 18" LEFT CABINET -HOUCK 7200-RV-1 N/A ORDER #114031-13-700 SLIDE DRAWER KIT
25	114031-17-000	EA	SLIDE-DRAWER, 20" LEFT CABT N/A ORDER #114031-17-700 SLIDE DRAWER KIT
25	114031-21-000	EA	SLIDE-DRAWER, 22" LEFT CABT N/A ORDER #114031-21-700 SLIDE DRAWER KIT
26	084070-02-000	EA	POST - END - 2.4" - BRASS
27	084071-04-000	EA	ROD - 11.9" - BRASS
27	084071-15-000	EA	ROD - 8.27" - BRASS
28	084070-01-000	EA	POST - CENTER - 2.4" - BRASS
	004354-01-000	EA	BUMPER-RUBBER, .5" DIA - BROWN
	009112-01-000	EA	FLANGE-ROD, 1" - CLOTHES ROD - PLASTIC - OFF WHITE
	041389-25-000	EA	HINGE-PIANO, 1.50 X 1397.0 MILL
	042438-01-000	EA	DOWEL-WOOD, CLOTHES ROD - 1" DIAMETER X 4'
	042438-06-000	EA	DOWEL-WOOD, 1.5" X 26" - OAK
	064467-01-000	EA	GUIDE-POCKET, SLIDING DOOR - WALL MOUNTED
	076790-01-000	EA	SCREW, 6-20 X 1 1/4 PPH - BLACK
	079921-01-000	EA	ROLLER-NYLON, W/STEEL SHAFT - BARBED
	084451-01-000	EA	CATCH-TV SHELF, BRASS
	102194-01-000	EA	GUIDE-PLASTIC
	103874-01-000	EA	HANGER-SLIDING DOOR
	110643-01-000	EA	ANGLE-FORMED W/HOLES
	116975-01-01A	EA	LATCH ASM-UNDERCENTER, BLACK STRIKE #042541-05-000

## INTERIOR FINISH GROUP (CONTINUED)

### BATT STRIPS

KEY	PART NUMBER	U/M	DESCRIPTION
	088272-C8-000	EA	BATT STRIP - MAIN WALL - PAINTED DESERT (G15)
	088272-B3-000	EA	BATT STRIP - MAIN WALL - ALLURE-MEADOW (G16)
	088272-C7-000	EA	BATT STRIP - MAIN WALL - ETCHINGS-SAGE (G17)
	069733-83-000	EA	BATT STRIP - WOODGRAIN - 8' - WATERFORD OAK
	088263-78-000	EA	BATT STRIP - SHOWER - 8' - OFF WHITE
	085284-C2-000	FT	STRIP - TAPE - MAIN WALL - PAINTED DESERT (G15)
	085284-A4-000	FT	STRIP - TAPE - MAIN WALL - ALLURE-MEADOW (G16)
	085284-C1-000	FT	STRIP - TAPE - MAIN WALL - ETCHINGS-SAGE (G17)
	085284-B5-000	FT	STRIP - TAPE - WATERFORD OAK
	085284-76-000	FT	STRIP - TAPE - WET BATH - ANTIQUE WHITE
	086229-04-000	EA	BATTEN - 1" WIDE - IVORY
	086229-15-000	EA	BATTEN - CEILING - 1" - MODERN IVORY
	086229-16-000	EA	RETAINER - BATTEN - 3/4"

### PANELING & PLASTIC LAMINATE

KEY	PART NUMBER	U/M	DESCRIPTION
	088272-E9-000	SF	PANELING - MAIN WALL - PAINTED DESERT (G15)
	088272-D6-000	SF	PANELING - MAIN WALL - ALLURE-MEADOW (G16)
	088272-E8-000	SF	PANELING - MAIN WALL - ETCHINGS-SAGE (G17)
	088272-98-000	SF	PANELING - SHOWER - OFF WHITE - 4' X 7'
	074497-28-000	SF	PANELING - WOODGRAIN - 4' X 8'
	080215-10-000	SF	PANELING - 2 SIDE WATERFORD, 48" X 96"
	000885-76-000	SF	PARTICLE BOARD - 3/8" X 48" X 96" WATERFORD - OAK VINYL 1 SIDED
	000885-77-000	SF	PARTICLE BOARD - 3/8, WATERFORD OAK-VINYL 2 SIDED
	000885-79-000	SF	PARTICLE BOARD - 3/4" X 48" X 96" WATERFORD OAK-VINYL 2 SIDED
	074498-71-000	SF	LAMINATE-PLASTIC, NEUTRAL SANTOS (G15,G16)
	074498-54-000	SF	LAMINATE-PLASTIC, SAND SPECKTRUM (G17)
	074498-61-000	SF	LAMINATE-PLASTIC, NEUTRA MATR (EXTERIOR ENTERTAINMENT)
	074498-77-000	SF	LAMINATE-PLASTIC, ART CABIN (PULL OUT TABLE)
	095688-01-000	SF	VENEER - FLAT LUANA - 48" X 96"
	117267-E2-438	EA	LUMBER - 018 X 50.8 X 2438MM VINYL
	117267-G2-438	EA	LUMBER - 018 X 076 X 2438 MM VINYL

### CARPET, PADS & FLOOR MATS

KEY	PART NUMBER	U/M	DESCRIPTION
	096060-98-000	SY	CARPET - 12' ROLL - SILVER ASPEN (G15)
	096060-99-000	SY	CARPET - 12' ROLL - PARCHMENT (G16)
	096060-95-000	SY	CARPET - 12' ROLL - DOESKIN (G17)
	093486-01-000	SY	CARPET - COMPARTMENT - 54" WIDE - DARK GRAY
	075233-01-000	SY	PAD - CARPET - 3/8" X 6' ROLL
	047034-06-000	SF	PLASTIC - CARPET - 2' WIDE - CLEAR POLY
	119950-01-01A	EA	COVER-PLASTIC
	042720-12-000	SF	VINYL FLOOR - ARMSTRONG/MODULATIONS
	105924-01-F06	EA	MAT - FLOOR - DRIVERS COMPARTMENT - 18" X 27" (G15)
	105924-01-F12	EA	MAT - FLOOR - DRIVERS COMPARTMENT - 18" X 27" (G16)
	105924-01-G36	EA	MAT - FLOOR - DRIVERS COMPARTMENT - 18" X 27" (G17)

### FIRE EXTINGUISHER, DETECTORS & WALL CLOCK

KEY	PART NUMBER	U/M	DESCRIPTION
	094499-01-000	EA	EXTINGUISHER - FIRE - DRY W/ MOUNTING BRACKET - 10 BC - US
	094499-02-000	EA	EXTINGUISHER - FIRE - DRY - 1A10BC - CANADIAN
	094499-01-700	EA	BRACKET - MOUNTING - W/ PLASTIC STRAP - FIRE EXTINGUISHER
	094499-01-701	EA	STRAP ONLY (METAL)
	072852-01-000	EA	DETECTOR - SMOKE - W/ 9 VOLT BATTERY - US
	072852-02-000	EA	DETECTOR - SMOKE - W/ 9 VOLT BATTERY - CANADIAN
	112320-01-000	EA	DETECTOR - CO GAS - MODEL 9B-I - COSTAR 940000000
	112320-02-000	EA	BATTERY/ SENSOR - CO GAS - COSTAR 940001000
	112320-03-000	EA	DETECTOR-CO GAS MODEL 9D-I - COSTAR 946000001
	112320-04-000	EA	DETECTOR-CO SENSOR ASM. - COSTAR 946001001
	118081-01-01A	EA	CLOCK - WALL - ROUND 8" BRASS - LINDEN 9987

## LABELS GROUP

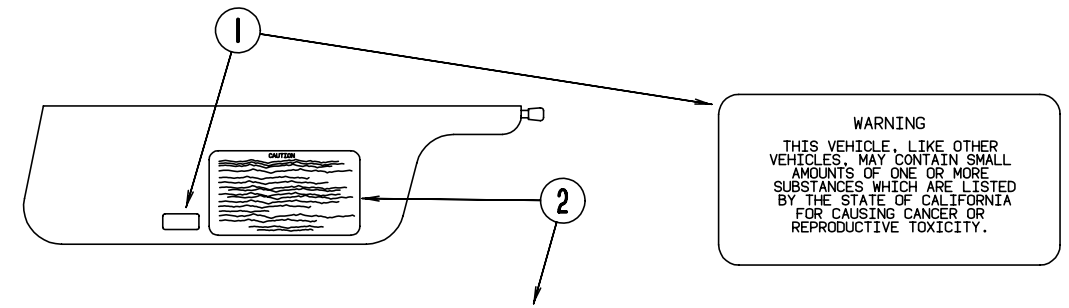

**WARNING**  
THIS VEHICLE, LIKE OTHER VEHICLES, MAY CONTAIN SMALL AMOUNTS OF ONE OR MORE SUBSTANCES WHICH ARE LISTED BY THE STATE OF CALIFORNIA FOR CAUSING CANCER OR REPRODUCTIVE TOXICITY.

### CAUTION

THIS MOTOR HOME HAS BEEN DESIGNED, MANUFACTURED AND TESTED WITH CONCERN FOR THE PROTECTION OF IT'S OCCUPANTS. WE RECOMMEND YOU PERFORM THE FOLLOWING INSPECTIONS FOR YOUR SAFETY AND THE SAFETY OF YOUR PASSENGERS BEFORE STARTING YOUR VEHICLE.

1. LP GAS SYSTEM- TURN OFF AT TANK FOR TRAVELING. TEST FOR LEAKS UPON ARRIVAL AT DESTINATION. BEFORE LIGHTING PILOTS.
2. WHEELS- INSPECT FOR DAMAGE AND CHECK LUG NUTS FOR TIGHTNESS.
3. TIRES- INSPECT FOR WEAR AND DAMAGE AND CHECK FOR RECOMMENDED AIR PRESSURE.
4. LIGHTING- TEST FOR PROPER OPERATION OF ALL INTERIOR AND EXTERIOR LIGHTS INCLUDING DASH LIGHTS, HEADLIGHTS, TAIL LIGHTS, BRAKE LIGHTS, CLEARANCE LIGHTS AND TURN SIGNALS.
5. EXITS- INSPECT RELEASE MECHANISM ON EMERGENCY EXIT WINDOW, TEST BOTH LOCKS ON MAIN ENTRANCE DOOR FOR EASE OF OPERATION AND INSTRUCT PASSENGERS HOW TO USE BOTH MEANS OF EXIT.
6. SEAT BELTS- DIRECT PASSENGERS TO DESIGNATED SEATS AND REQUIRE USE OF SEAT BELTS.
7. APPLIANCES- TURN OFF AND LATCH OR LOCK DOORS WHERE PROVIDED.
8. LOOSE PARCELS- STORE SECURELY.
9. UTILITY SUPPLY LINES- DISCONNECT ALL ELECTRIC, SEWER AND WATER LINES AND SECURE PROPERLY.
10. ENTRANCE DOOR STEP- PLACE IN RETRACTED POSITION FOR TRAVELING.

READ YOUR MOTOR HOME AND CHASSIS OWNER'S MANUAL FOR FURTHER PRECAUTIONS

KEY	PART NUMBER	U/M	DESCRIPTION
1	099689-01-000	EA	LABEL - WARNING - CANCER/TOXICITY
2	056259-01-000	EA	LABEL - SAFETY CHECK LIST

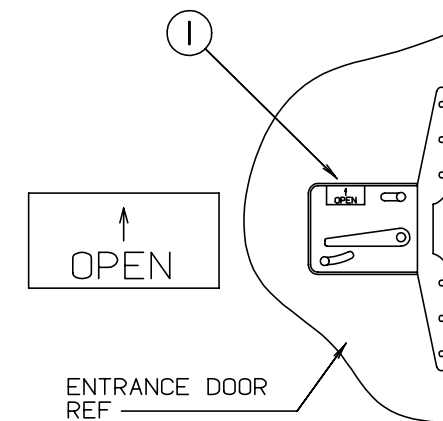

KEY	PART NUMBER	U/M	DESCRIPTION
1	040944-01-000	EA	LABEL - ENTRANCE DOOR - "OPEN"

**LABELS GROUP (CONTINUED)**

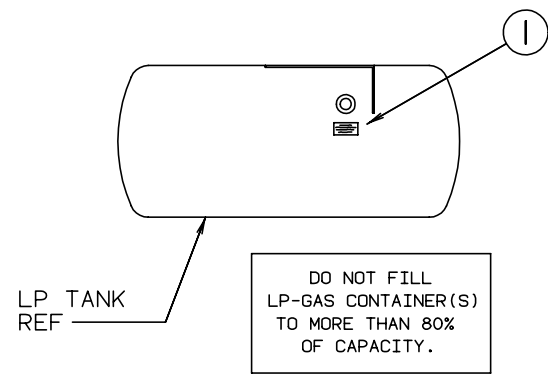

KEY	PART NUMBER	U/M DESCRIPTION
1	079965-01-000	EA LABEL - LPG - 80% CAPACITY

**LABELS GROUP (CONTINUED)**

<b>CAUTION</b>	TO HELP AVOID PERSONAL INJURY DURING REMOVAL OF FUEL FILLER CAP, SLOWLY LOOSEN CAP 1/2 TURN TO ALLOW ANY FUEL PRESSURE TO BE RELIEVED BEFORE TURNING CAP FURTHER.
<b>FUEL SPRAY MAY CAUSE PERSONAL INJURY</b>	STOP ADDING FUEL AFTER FIRST SHUTOFF BY AUTOMATIC NOZZLE WHEN TANK IS NEARLY FULL. DO NOT OVERFILL FUEL TANK. SEE OWNERS MANUAL FOR ADDITIONAL INFORMATION. PRINTED IN U.S.A. <span style="float: right;">MLC PT NO 15611763</span>

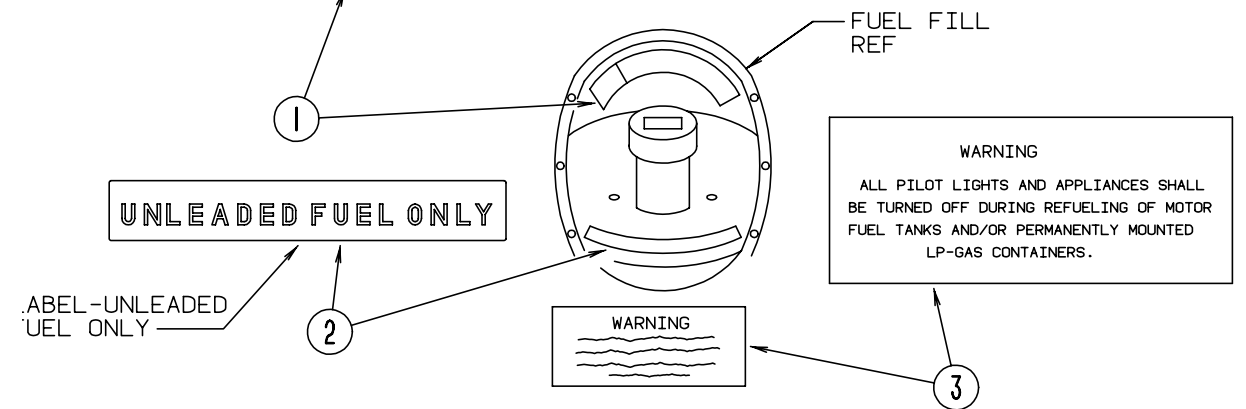

KEY	PART NUMBER	U/M DESCRIPTION
1	087207-05-000	EA LABEL - FUEL CAP REMOVAL
2	062043-01-000	EA LABEL - FUEL - UNLEADED
3	006040-01-000	EA TAG - GAS REFUELING WARNING
3	006040-02-000	EA TAG - GAS REFUELING WARNING (CANADIAN)

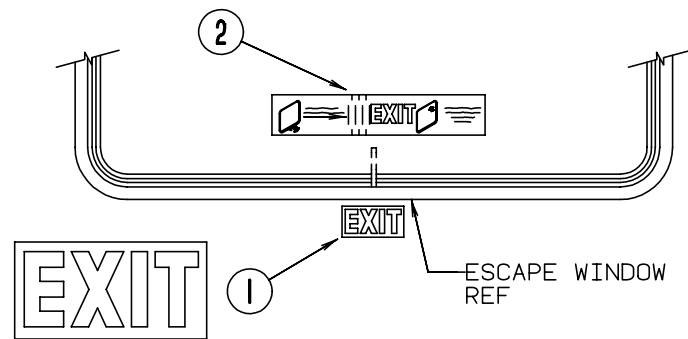
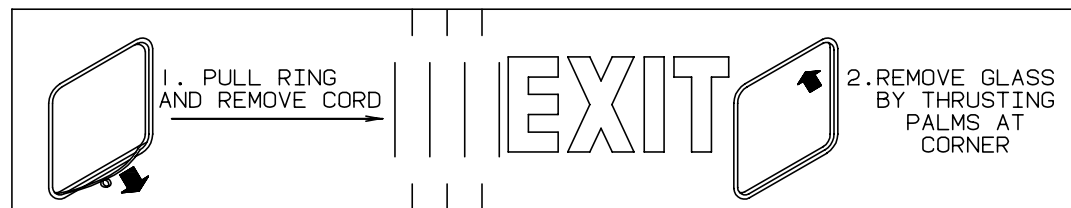

KEY	PART NUMBER	U/M DESCRIPTION
1	107571-01-000	EA LABEL - EXIT/ESCAPE WINDOW
2	039290-01-000	EA LABEL - EXIT WARNING

GENERATOR COMP  
DOOR REF

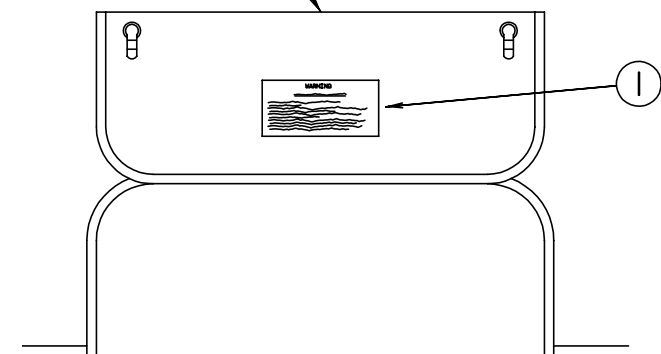

**WARNING**

WHEN ADDING A GENERATOR SET:

HIGH VOLTAGE-USE EXTREME CAUTION WHEN WORKING ON ELECTRICAL COMPONENTS.  
HAVE ALL ELECTRICAL INSTALLATION PERFORMED BY A QUALIFIED LICENSED ELECTRICIAN-FOLLOW ALL STATE AND LOCAL CODES.  
ONLY INSTALL GENERATOR SET APPROVED FOR R.V. APPLICATION. HAVE INSTALLED BY QUALIFIED TECHNICIAN.  
AVOID HEAT BUILD-UP AND TO GUARANTEE AN ADEQUATE AIR SUPPLY TO THE GENERATOR CARBURETOR, FOLLOW INSTALLATION INSTRUCTIONS.  
GENERATOR ENGINE EXHAUST GASES ARE TOXIC AND MUST NOT TERMINATE UNDER THE VEHICLE-DISCHARGE EXHAUST AWAY FROM VEHICLE.

KEY	PART NUMBER	U/M DESCRIPTION
1	077510-01-000	EA LABEL - GENERATOR PREP

**LABELS GROUP (CONTINUED)**

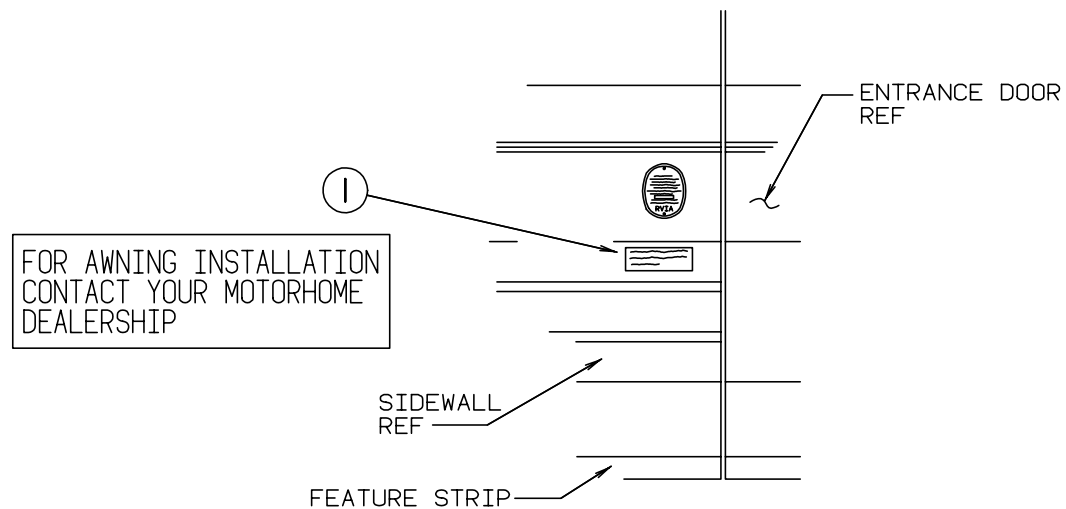

KEY	PART NUMBER	U/M DESCRIPTION
1	099509-01-000	EA LABEL - AWNING INSTALLATION

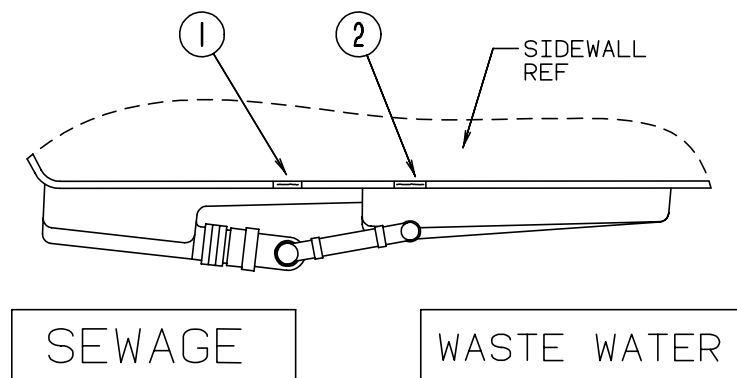

KEY	PART NUMBER	U/M DESCRIPTION
1	006187-01-000	EA LABEL - SEWAGE
2	006188-01-000	EA LABEL - WASTE WATER

**LABELS GROUP (CONTINUED)**

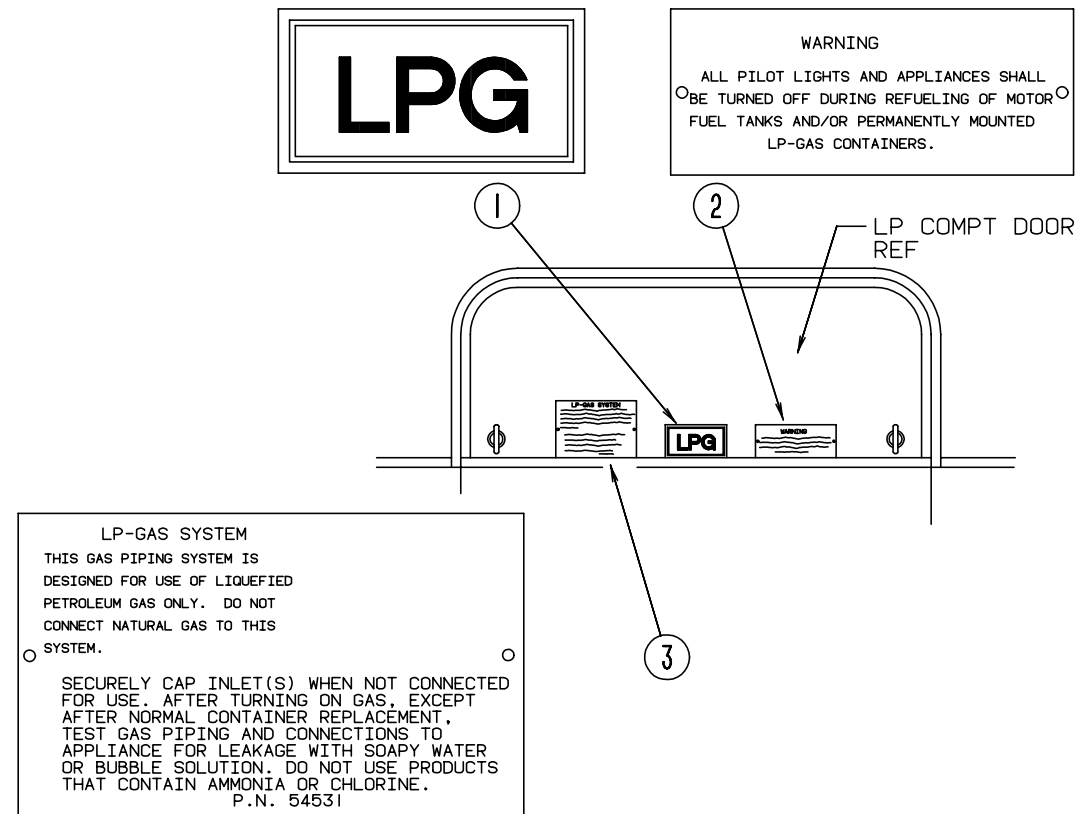

KEY	PART NUMBER	U/M DESCRIPTION
1	074559-01-000	EA DECAL - LOGO - LPG - RED - (CALIF. CODE)
2	006040-01-000	EA TAG - GAS REFUELING WARNING
2	006040-02-000	EA TAG - GAS REFUELING WARNING (CANADIAN)
3	054531-01-000	EA LABEL - LP GAS ONLY
3	023769-01-000	EA LABEL - WARNING-LPG (CANADIAN)

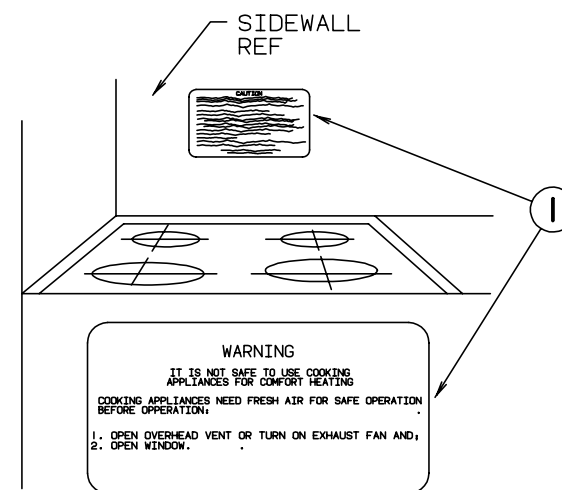

KEY	PART NUMBER	U/M DESCRIPTION
1	050225-01-000	EA LABEL - WARNING - STOVE VENT - US
1	050222-01-000	EA LABEL - WARNING - STOVE VENT - CSA

**LABELS GROUP (CONTINUED)**

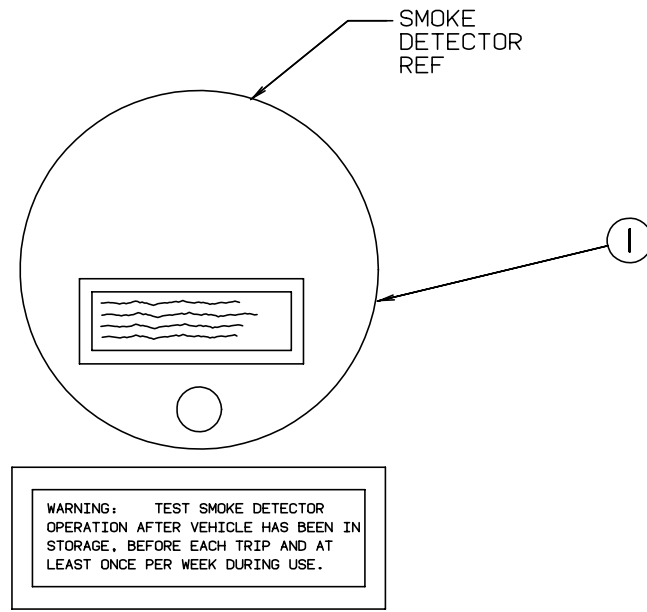

KEY	PART NUMBER	U/M DESCRIPTION
1	077956-01-000	EA LABEL - WARNING - SMOKE DETECTOR

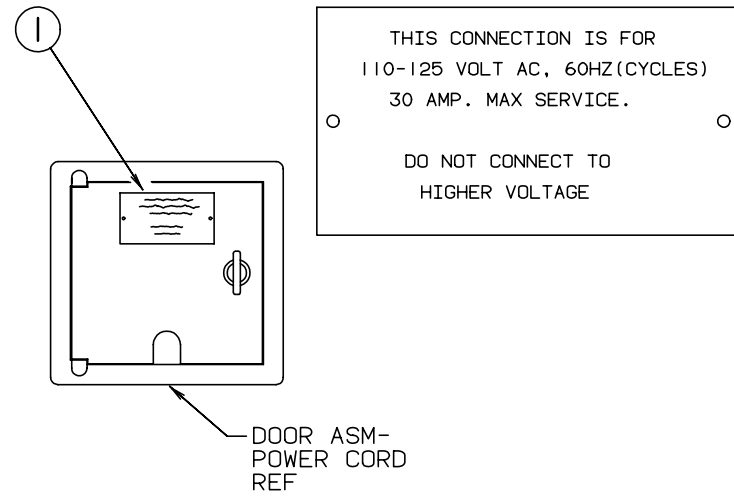

KEY	PART NUMBER	U/M DESCRIPTION
1	006062-01-000	EA TAG - ELECTRIC - 110V CONNECTION

**LABELS GROUP (CONTINUED)**

**MISCELLANEOUS LABELS**

KEY	PART NUMBER	U/M DESCRIPTION
	061606-01-000	EA LABEL - OVERLAY - VEHICLE CERTIFICATION - ADHESIVE BACKED
	073998-01-000	EA LABEL - LPG ODOR WARNING
	074983-01-000	EA LABEL - SWITCH - A/C SELECTOR FOR FRONT OR REAR
	079966-01-000	EA LABEL - WARNING - STOWED - MOTION
	091224-02-000	EA LABEL - TRAILER LIGHTING
	091243-01-000	EA LABEL - A/C COVER - "AIR CONDITIONING CIRCUIT. ETC."
	098641-01-000	EA LABEL - FUEL - UNLEADED - DASH
	104678-01-000	EA LABEL - CB PREP
	111537-07-000	EA LABEL - FUSES
	111104-01-000	EA LABEL - HITCH - READ MANUAL
	094675-01-000	EA LABEL - EXTERIOR LIGHT, SERVICE
	098379-04-000	EA LABEL - ELECTRICAL BOX, SIDE
	111802-01-000	EA LABEL - CFC WARNING

# LP GROUP

## LP TANK & COMPONENTS

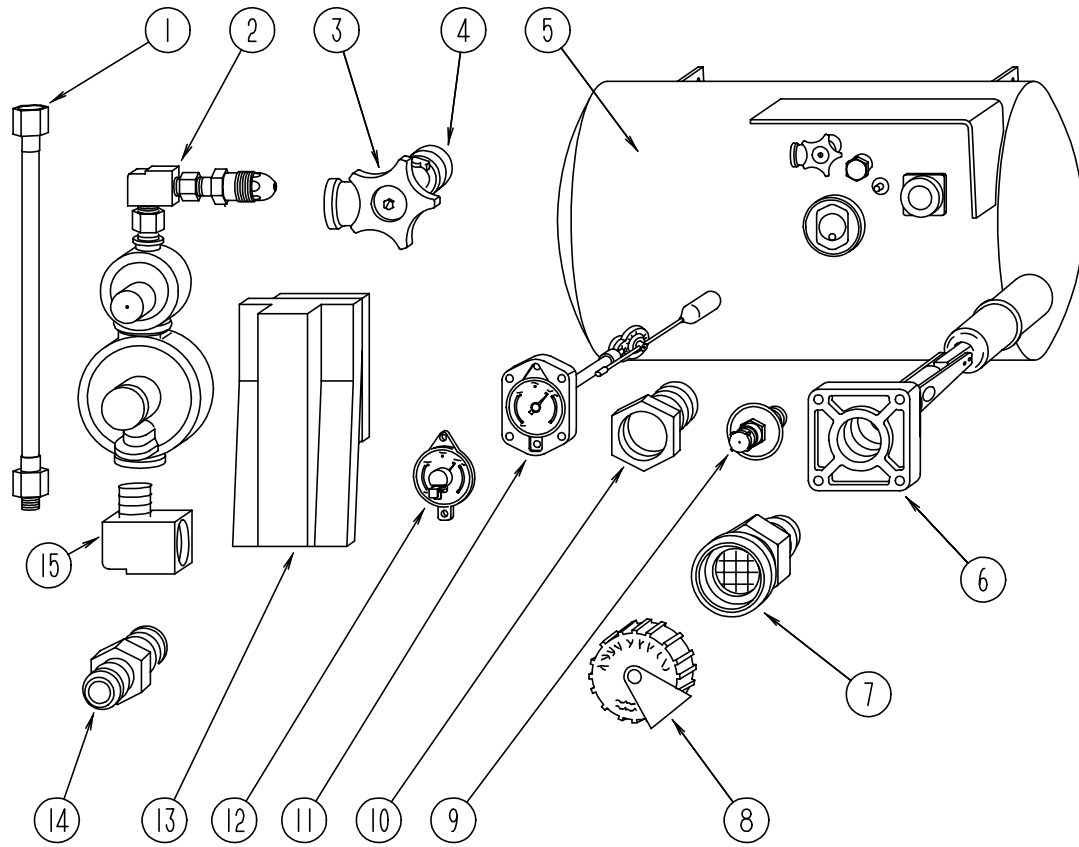

KEY	PART NUMBER	U/M DESCRIPTION	VENDOR NO.
1	045703-01-000	EA HOSE - LP - 3/8" ID X 24" - 3/8" MPT X 1/2" F SWIVEL - US	
1	045703-02-000	EA HOSE - LP - 3/8" ID X 24" - 3/8" MPT X 1/2" F SWIVEL - CANADA	
2	106150-01-000	EA REGULATOR - TWO STAGE	
3	040421-01-708	EA HANDWHEEL - VAPOR RELIEF VALVE - BRUNNER	G-1015-A
4	040421-01-712	EA VALVE - SERVICE W/HANDWHEEL	
5	088253-03-000	EA TANK - LP - 100 LB - 16"D X 36" - SPL	
6	040421-01-711	EA VALVE - 80% W/FLOAT - PLATE - BOLTS & GASKET - BRUNNER	
7	040421-01-701	EA VALVE - SHORT LP FILLER W/YELLOW CAP - BRUNNER	75478
8	040421-01-702	EA CAP - LP FILLER VALVE - PLASTIC - YELLOW - BRUNNER	G-1014-A
9	040421-01-700	EA GAUGE - LIQUID LEVEL - 20% LP - BRUNNER	G-1013
10	040421-01-713	EA PRESSURE RELIEF VALVE	
11	088253-01-700	EA L.P. FLOAT GAUGE - 4 MACHINE SCREW STYLE	
12	040440-02-000	EA TRANSMITTER - DIAL - 90 OHM	
13	105658-01-000	EA COMPARTMENT - LP REGULATOR	
14	010323-01-000	EA ADAPTER - BRASS - 3/8" F X 1/2" MPT	
14	065318-02-000	EA ELBOW - 90 DEGREE - 3/8" MPT TO 3/8" FPT	
15	010329-01-000	EA ADAPTER - BRASS - 1/2" F X 1/2" MPT	
	103613-01-000	EA DETECTOR - LP GAS	
	010252-01-000	EA ELBOW - BRASS, 90 DEGREE - 3/8" F X 1/2" MPT	
	010265-01-000	EA ELBOW - BRASS, 90 DEGREE - 3/8" F X 1/2" FPT	
	010377-02-000	EA NUT - BRASS, 3/8" FLARE - FORGED	
	010326-01-000	EA ADAPTER - FLARE, W/CONE GASKET - 3/8" F X 1/2" M	

## LOUNGE GROUP

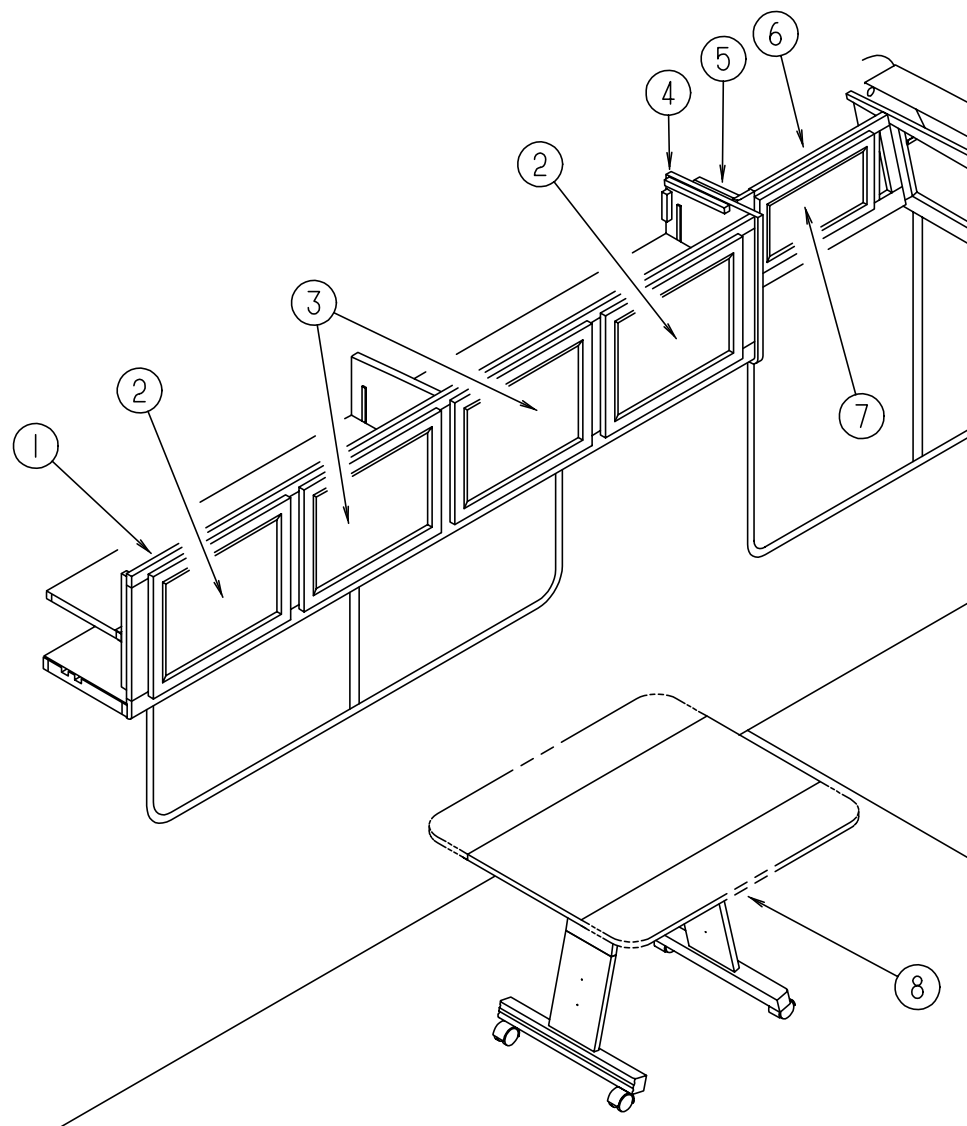

FRONT OVERHEAD CABINET (DRIVER SIDE)

KEY	PART NUMBER	U/M	DESCRIPTION
1	116191-01-G15	EA	CABINET ASM.
2	M06803-B1-G15	EA	DOOR ASM. - RAIL - W/O HARDWARE - W/O MIRROR - 400 X 520 MM
3	M06803-03-G15	EA	DOOR ASM. - RAIL - W/O HARDWARE - W/ MIRROR - 400 X 520 MM
3	M06803-B1-G15	EA	DOOR ASM. - RAIL - W/O HARDWARE - W/O MIRROR - 400 X 520 MM
4	103128-01-G09	EA	END CAP ASM. - RIGHT HAND
5	103128-09-G15	EA	END CAP ASM. (FRONT OVERHEAD)
6	M06838-02-G15	EA	CABINET ASM. - FRONT OVERHEAD - DRIVER SIDE
6	M06838-02-G16	EA	CABINET ASM. - FRONT OVERHEAD - DRIVER SIDE
6	M06838-02-G17	EA	CABINET ASM. - FRONT OVERHEAD - DRIVER SIDE
7	M06803-04-G15	EA	DOOR ASM - W/O HARDWARE - 255 X 485 MM
8	115993-01-01A	EA	TABLE - HI-LO

## LOUNGE GROUP (CONTINUED)

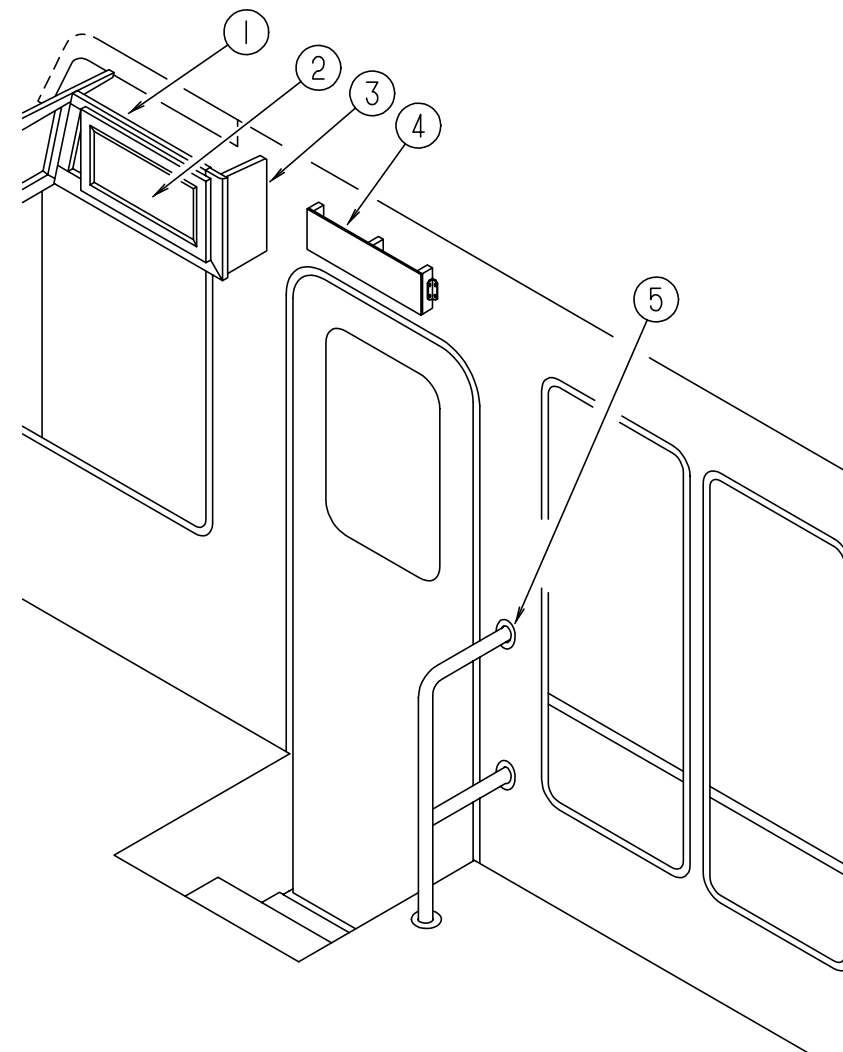

FRONT OVERHEAD CABINET (PASSENGER SIDE)

KEY	PART NUMBER	U/M	DESCRIPTION
1	M06838-01-G15	EA	CABINET ASM. - FRONT OVERHEAD - PASSENGER SIDE
1	M06838-01-G16	EA	CABINET ASM. - FRONT OVERHEAD - PASSENGER SIDE
1	M06838-01-G17	EA	CABINET ASM. - FRONT OVERHEAD - PASSENGER SIDE
2	M06803-04-G15	EA	DOOR ASM - RAIL - W/O HARDWARE - 255 X 485
3	103128-08-G15	EA	END CAP ASM. (FRONT OVERHEAD)
4	116956-01-G15	EA	CABINET ASM - SPEAKER
5	108808-02-02A	EA	HANDRAIL - STEP, ENTRANCE - O/W
	101222-01-02A	EA	BRACKET - CATCH, LID - O/W
	107941-02-03B	EA	SUPPORT - LID, ENTRANCE STEP - O/W
	107941-02-01B	EA	SUPPORT - LID, ENTRANCE STEP - MILL
	P14437-01-000	EA	CABINET ASM - LID, W/O CARPET
	116677-01-G15	EA	COVER ASM-STEP, ENTRANCE
	116681-01-01A	EA	TRIM-COVER, STEP, O/W

## SEALANTS & FASTENERS GROUP

### SEALANTS & ADHESIVE

KEY	PART NUMBER	U/M	DESCRIPTION
	034552-02-000	EA	SILICONE-TUBE, 300 ML - CLEAR - W/O NOZZLE ALSO ORDER P.N.#900390-03-000 NOZZLE SEPARATELY
	034552-12-000	EA	SILICONE-TUBE, 300 ML - BUFF - W/O NOZZLE ALSO ORDER P.N.#900390-03-000 NOZZLE SEPARATELY
	120074-01-01A	EA	SILICONE TUBE - OFF WHITE W/O NOZZLE ALSO ORDER NOZZLE #900390-03-000
	900390-01-000	EA	TIP - 2 1/2" X 1/8" ORIFICE, ELLSWORTH#TS216
	900390-03-000	EA	NOZZLES-SILICONE TUBE, CSL# D10
	053766-02-000	EA	BEDDING COMPOUND-TUBE, WHITE SCHNEE# 5522
	053766-06-000	EA	BEDDING COMPOUND-TUBE, CLEAR
	067788-01-000	EA	ADHESIVE-SPRAY, 3M 74 - 19.5 OZ AEROSOL CAN
	069640-01-000	FT	SEALER-RIBBON, 1/4" DIAMETER - INCREMENTS OF 30'
	069640-02-000	FT	SEALER-RIBBON, 1/2" X 1/8" - INCREMENTS OF 60'
	069640-03-000	FT	SEALER-RIBBON, 3/4" X 1/8" - INCREMENTS OF 60'
	069640-07-000	FT	SEALER-RIBBON, 2" X 3/32" - INCREMENTS OF 45'
	069640-09-000	FT	SEALER-RIBBON, 1/32" X 2 1/2" - INCREMENTS OF 80'
	072889-01-000	EA	SEALANT-URETHANE, BLACK - 1/10 - ESSEX 552.2
	072889-09-000	EA	SEALANT-URETHANE(TUBE) BLACK - MANUS 75AM
	076322-01-000	FT	TAPE-FOAM, DOUBLE COATED ADHESIVE BACKED - .75" X 216'
	076322-02-000	FT	TAPE-FOAM, DOUBLE COATED ADHESIVE BACKED - 1" X 108'
	076322-05-000	FT	TAPE-FOAM, DOUBLE COATED - .045" X .75" X 108'
	076322-07-000	FT	TAPE-FOAM, DOUBLE COATED - .045 X .50 - NORT V2000
	087211-01-000	GL	PROMOTER-ADHESIVE
	088479-01-000	EA	TAPE-ALUM 3" 3M
	091255-02-000	FT	SEAL-ADHESIVE BACKED FOAM, .18" THICK X 1.5" WIDE
	094401-01-000	EA	SEALER-BODY SEAM SEALER, 3M FLEXICLEAR
	102352-01-000	EA	SEALER-PUMPABLE, BLACK - COLORIMETRIC MS101
	106206-01-000	EA	SEALER-PUMPABLE - MANUS 30ABLACK
	108716-02-000	EA	SILICONE (TUBE) BUFF LEVEL - CSL 510
	110274-01-000	FT	TAPE-FOAM, DBL COATED .045 X 1.0 - NORTON V-2800
	112901-02-000	EA	ADHESIVE-PLEXUS MA 330 50ML - P33500
	118085-02-01A	FT	TAPE-FOIL, 1" X 150 FT
	063642-01-000	FT	TAPE-ADHESIVE, 10 MIL. X 1.5" WIDE X 180"
	120534-01-01A	EA	TAPE-SCOTCH 3M 1/2" FINE LINE - #471 GREEN

### BOLTS, NUTS & WASHERS

KEY	PART NUMBER	U/M	DESCRIPTION
	000C12-05-16B	EA	BOLT-HEX, 5/16-18 X 1 - ZINC 5
	000C12-05-12B	EA	BOLT-HEX, 5/16-18 X 3/4 ZN 5
	000C12-06-16B	EA	BOLT-HEX, 3/8-16 X 1LG, ZN 5
	000C12-08-24B	EA	BOLT-HEX, 1/2-13 X 1 1/2 - ZN 5
	000C12-10-24B	EA	BOLT-HEX, 5/8-11 X 1 1/2 ZN 5
	000C13-07-48B	EA	BOLT-HEX, 7/16 - 20 X 3 - ZN 5
	000C13-07-40B	EA	BOLT-HEX, 7/16 - 20 X 2 1/2 - ZN 5
	000C26-04-18B	EA	BOLT-HEX, SER FLG 1/4-20 X 1 1/8 - ZN
	000C26-04-10B	EA	BOLT-HEX, SER FLG 1/4-20 X 5/8 ZINC
	000C26-05-12B	EA	BOLT-HEX, SER FLG 5/16-18 X 3/4 - ZN
	000C26-05-20B	EA	BOLT-HEX, SER FLG 5/16 - 18 X 1 1/4 ZINC
	000C26-05-16B	EA	BOLT-HEX, SER FLG 5/16-18 X 1 - ZINC
	000C26-06-12B	EA	BOLT-HEX, SER FLG 3/8-16 X 3/4 - ZN
	000D24-10-00B	EA	NUT-HEX, SF/LK - 10-32 ZN
	000D29-05-00B	EA	NUT - 5/16 - 18 UNC, SF/LOCKING - NYLON WASHER INSERT
	000D34-06-00B	EA	NUT-HEX, LK - 3/8 - 16 GRADE C ZN - PREVAILING TORQUE
	000D39-04-00B	EA	NUT-HEX, SER FLG LK 1/4 - 20 ZN
	000D39-05-00B	EA	NUT-HEX, SER FLG LK - 5/16 - 18 ZN
	000D39-06-00B	EA	NUT-HEX, SER FLG LK - 3/8 - 16 ZN
	000D39-08-00B	EA	NUT-HEX, SER FLG LK - 1/2 - 13 ZN
	000D44-07-00B	EA	NUT-HEX, SER FLG LK - 7/16 - 20 ZN

## SEALANTS & FASTENERS GROUP (CONTINUED)

### BOLTS, NUTS & WASHERS (CONTINUED)

KEY	PART NUMBER	U/M	DESCRIPTION
	000D46-04-00A	EA	NUT-HEX, WELD, 1/4-20 - PLAIN - SHORT PILOT
	000E11-08-00B	EA	WASHER-LK - 1/2 MED SPLIT ZN
	000E13-14-00B	EA	WASHER-FL, 1/4" WIDE ZN
	000E13-18-00B	EA	WASHER-FL, 3/8 WIDE ZN
	000E13-20-00B	EA	WASHER-FL, 7/16" WIDE - ZN
	000E13-21-00B	EA	WASHER-FL - W/2 NAR ZN
	000E13-22-00B	EA	WASHER-FL, 1/2 WIDE ZN
	000G45-04-24B	EA	BOLT-LAG, 1/4 - 9 X 1 1/2 ZN
	040921-04-000	EA	NUT-SPEED, U TYPE - NO. 8 - .59" LENGTH X .44" WIDTH
	040921-09-000	EA	NUT-SPEED-U TYPE NO 8 - T'MN C9812-8A
	044364-02-000	EA	NUT-SPEED, FLAT - ROUND
	051387-05-000	EA	BOLT-CARR, 5/16 - 18 X 8.5 - ZN - W/O HOLE
	051387-06-000	EA	BOLT-CARRIAGE, W/O HOLE - 5/16-18 X 9.5 ZN
	058716-02-000	EA	WASHER-FLAT NYLON - .406 X .750 X .060
	063253-07-000	EA	NUT-J, #8A .120- .130 PNL THK
	083163-06-000	EA	PUSHNUT-FLAT TYPE 3/8 STUD - FORD ONLY TO RETAIN THE AIR BAFFLE ON THE OIL DIPSTICK TUBE
	087234-01-000	EA	NUT-JACK, 1/4 X 20THD, MOLLY - ARDEN 8-L - JN BRASS MOUNTS LICENSE PLATES
	088787-12-000	EA	STUD-WELD, 1/4-20 X 1.0 LG MN - ARDEN MN-1420-S-100
	102333-01-02A	EA	BOLT-CARRIAGE, 7/16 - 14 SST CAP O/WHT BUMPER BOLT
	108067-03-000	EA	STUD-WELD, 1/4-20 X 1/2 CD - IMAGE
	110794-01-000	EA	WASHER-FL- 1ID X 1 3/4OD - C-TECH 36T1043187

### CLAMPS, CLIPS & GROMMETS

KEY	PART NUMBER	U/M	DESCRIPTION
	000H16-06-10R	EA	RIVET-POP-AL 3/16 X .501 - .625
	008380-01-000	EA	GROMMET-RUBBER, 5/8" HOLE X 1 1/2" DIAMETER - BLACK
	010495-01-000	EA	CLAMP-CABLE, 9/16"
	010497-01-000	EA	CLAMP-CLOSED, 5/8" ID
	010497-03-000	EA	CLAMP-CLOSED, 1" ID - CUSHIONED
	010497-04-000	EA	CLAMP-CLOSED, 1.62 ID - ADEL,945-2717
	010499-01-000	EA	CLAMP-CLOSED, 3/8" ID
	016188-05-000	EA	GROMMET-L/P LINE, 3/8" HOLE X 1 1/4" LONG - RUBBER
	023942-01-000	EA	GROMMET-RUBBER, 2" OD
	062401-01-000	EA	CLAMP-HOSE, WORMGEAR .25" - 1"
	062401-02-000	EA	CLAMP-HOSE, WORMGEAR, 1.56" - 2.5"
	062401-03-000	EA	CLAMP-HOSE, WORMGEAR - .22" - 1"
			FROM: 00-00-00 THRU: 01-15-96
	062401-04-000	EA	CLAMP-HOSE, WORMGEAR .69"- 1.25"
	062401-05-000	EA	CLAMP-HOSE, WORMGEAR - 2" X 3"
	062401-06-000	EA	CLAMP-HOSE, WORMGEAR .22"-.62"
	062401-11-000	EA	CLAMP-HOSE, WORMGEAR 3.56"- 4.5"
	071015-11-000	EA	GROMMET - 1.00 ID, FITS .12 MATL - MINOR RUBBER Z-3065
	071015-29-000	EA	GROMMET-RUBBER, .25" ID X 1.25" OD W/.12" GROOVE - BLACK
	071015-30-000	EA	GROMMET-RUBBER, .31" ID X .81" OD W/.12" GROOVE - BLACK
	075148-02-000	EA	CLAMP-GROUNDING, BRONZE SCREWS
	077955-01-000	EA	CLIP-J, VINYL COATED, 3/8"
	081211-05-000	EA	PLUG-PLASTIC, .188 DIA - NATURAL
	083609-01-000	EA	CLAMP-WIRE, DUAL EQUAL - 5/8" DIAMETER
	083610-01-000	EA	CLAMP-WIRE, DUAL - UNEQUAL DIAMETERS - .75" & 1.25"
	083610-02-000	EA	CLAMP-WIRE, DUAL UNEQUAL DIA
	091952-01-000	EA	CLIP-GRIPPER, 1"
	091952-02-000	EA	CLIP-GRIPPER, 3/4"
	094362-02-000	EA	CLIP-CHRISTMAS TREE, FLAT HEAD - .5" X .95"



**SEALANTS & FASTENERS GROUP (CONTINUED)**

**SCREWS**

KEY	PART NUMBER	U/M DESCRIPTION
	000G11-05-08B	EA SCREW, 5-20 X 1/2 PPH ZN
	000G11-06-08B	EA SCREW, 6-20 X 1/2 PPH ZINC
	000G11-06-06B	EA SCREW, 6-20 X 3/8 PPH ZN
	000G11-06-10J	EA SCREW, 6-20 X 5/8 PPH - BRASS
	000G11-07-08B	EA SCREW, 7-19 X 1/2 PPH - ZN
	000G11-08-08B	EA SCREW, 8-18 X 1/2 PPH - ZN
	000G11-08-06B	EA SCREW, 8-18 X 3/8 PPH ZN
	000G11-08-20B	EA SCREW, 8-18 X 1 1/4 PPH ZN
	000G11-08-16S	EA SCREW, 8-18 X 1.00 PPH - OFF WHITE
	000G11-08-12T	EA SCREW, 8-18 X 3/4 PPH - BLACK
	000G11-08-12S	EA SCREW, 8-18 X 3/4 PPH - OFF WHITE MAY NEED TO PAINT THIS SCREW - USED AS A REPLACEMENT FOR VARIOUS COLORED SCREWS
	000G11-08-12P	EA SCREW, 8-18 X .75 PPH - DARK BROWN
	000G11-08-12D	EA SCREW, 8-18 X 3/4 PPH - BLACK
	000G11-08-12B	EA SCREW, 8-18 X 3/4 PPH ZN
	000G11-08-10B	EA SCREW, 8-18 X 5/8 PPH ZN
	000G11-08-08T	EA SCREW, 8-18 X 1/2 PPH
	000G11-10-40B	EA SCREW, 10-16 X 2 1/2 PPH CAD
	000G11-10-12D	EA SCREW, 10-16 X 3/4 PPH - BLACK
	000G12-06-08T	EA SCREW, 6-20 X .50 POH - BLACK
	000G13-05-16S	EA SCREW, 5-20 X 1 PFH OFF WHITE
	000G13-06-08G	EA SCREW, 6-20 X 1/2 PFH - ANTIQUE BRASS
	000G13-06-08B	EA SCREW, 6-20 X 1/2 PFH ZN
	000G13-06-24J	EA SCREW, 6-20 X 1.50 PFH BRASS
	000G13-06-16J	EA SCREW, 6-20 X 1.00 PFH - BRASS
	000G13-07-12B	EA SCREW, 7-19 X 3/4 PFH ZN
	000G13-08-10B	EA SCREW, 8-18 X 5/8 PFH ZN
	000G18-08-22B	EA SCREW-MACH, 8-32 X 1 3/8 PPH ZN
	000G19-10-20B	EA SCREW-MACHINE, 10-32 X 1 1/14 PPH ZINK
	000G19-10-08B	EA SCREW-MACHINE, 10-32 X 1/2 PPH ZN
	000G32-10-06B	EA SCREW, 10-32 X 3/8" - PPH - ZINC
	000G39-06-16T	EA SCREW-SF/DR, 6-20 X 1 PPH - BLACK
	000G39-06-10T	EA SCREW-SF/DR, 6-20 X 5/8 PPH - BLACK
	000G39-06-08B	EA SCREW-DR, 6-18 X 1/2 ZN
	000G39-06-10T	EA SCREW-SF/DR, 6-20 X 5/8 PPH - BLACK
	000G39-08-24B	EA SCREW-SF/DR, 8-18 X 1 1/2 PPH ZN
	000G39-08-16T	EA SCREW-SF/DR, 8-18 X 1 PPH - BLACK
	000G39-08-16R	EA SCREW-SF/DR, 8-18 X 1.00 PPH BEIGE
	000G39-08-16B	EA SCREW-SF/DR, 8-18 X 1 PPH ZN
	000G39-08-12T	EA SCREW-SF/DR, 8-18 X 3/4 PPH - BLACK
	000G39-08-06B	EA SCREW-SF/DR, 8-18 X 3/8 PPH ZN
	000G39-08-12B	EA SCREW-SF/DR, 8-18 X 3/4 PPH ZN
	000G39-08-08T	EA SCREW-SF/DR, 8-18 X .50 PPH - BLACK
	000G39-08-08S	EA SCREW-SF/DR, 8-18 X 1/2 PPH - OFF WHITE
	000G39-08-08B	EA SCREW-SF/DR, 8-18 X 1/2 PPH ZN
	000G39-10-12B	EA SCREW-SF/DR, 10-16 X .75 PPH ZN
	000G39-10-10B	EA SCREW-SF/DR, 10-16 X .625 - ZN
	000G39-10-08B	EA SCREW-SF/DR, 10-16 X .50 P&H - ZINC
	000G39-10-209	EA SCREW-SF/DR, 10-16 X 1.25 PPH - FLUOROCARBON SILVER
	000G39-10-20B	EA SCREW-SF/DR, 10-16 X 1 1/4 PPH ZN
	000G39-10-129	EA SCREW-SF/DR, 10-16 X 3/4 PPH - FLUOROCARBON SILVER
	000G39-10-12D	EA SCREW-SF/DR, 10-16 X 3/4 PPH - BLACK
	000G42-04-12B	EA SCREW-SF/DR, 1/4-14 X 3/4 HWH ZN
	000G46-08-24T	EA SCREW-MACHINE, 8-32-1.50 IN PFH - BLACK
	000G50-04-08B	EA SCREW-MACH, 1/4-20 X 1/2 PTH - 2N
	000G50-04-12B	EA SCREW-MACH, 1/4-20 X 3/4 PPH ZN
	000G52-08-18B	EA SCREW-MACH, 8-32 X 1 1/8 PTH ZN
	000G54-04-20B	EA SCREW, 1/4-20 X 1 1/4 PTH - TYPE 23 - ZINC PLATED
	000G55-08-12S	EA SCREW-SF/DR, 8-18 X .75 PWH - OFF WHITE
	000G55-08-125	EA SCREW-SF/DR, 8-18 X .75 PWH - WILLOW
	000G57-05-16J	EA SCREW, 5-20 X 1 PFH - BRASS

**SEALANTS & FASTENERS GROUP (CONTINUED)**

**SCREWS (CONTINUED)**

KEY	PART NUMBER	U/M DESCRIPTION
	000G60-10-28T	EA SCREW-SF/DR, 10-16 X 1.75 - BLACK
	000G67-08-32B	EA SCREW, 8-15 X 2 PPH ZN
	000G67-10-10B	EA SCREW, 10-12 X 5/8 PPH ZN - TYPE A
	000G67-10-08R	EA SCREW, 10-12 X 1/2 PPH - BEIGE - TYPE A
	000G67-10-08B	EA SCREW, 10-12 X 1/2 PPH ZN
	000G67-10-120	EA SCREW, 10-12 X .75" PPH - TAN
	000G67-10-12B	EA SCREW, 10-12 X 3/4" PPH - ZN
	000G67-10-10P	EA SCREW, 10-12 X .62 PPH - DARK BROWN
	000G67-10-10D	EA SCREW, 10-12 X 5/8 PPH - BLACK - TYPE A
	000G67-10-48B	EA SCREW, 10-12 X 3 PPH ZN
	000G67-10-36T	EA SCREW, 10-12 X 2.25 PPH BLACK - STALGARD
	000G68-06-10G	EA SCREW, 6-18 X 5/8 POH - ANTIQUE BRASS
	049465-01-000	EA SCREW, 10-16 W/WASHER PTH - DARK BROWN
	049465-03-000	EA SCREW, 10-16 X 1 POH W/WASHER - OFF WHITE
	057671-01-000	EA COVER-SCREW, #8 - PLASTIC - OFF WHITE
	075908-01-000	EA SCREW-MACHINE, 10-32 X .56 PTH - ZINC EXTERNAL TOOTH
	086256-01-000	EA SCREW ASM-SF/DR 8 X .75 HWH LG - PL BODY PNL MT
	097974-01-000	EA SCREW-PART BD 7-9 X .75 PPH - FHM 0543 PLAIN
	101618-01-000	EA SCREW - 1/4-20 X 3/4 HEX/TAPPING - STALGARD TYPE F
	106477-01-000	EA SCREW - 14-10 X 3.00 PFH - STEEL BRASS PLATED
	110460-04-01A	EA SCREW-MACH - 10-24 X 3.25IN PFH - ALMOND
	116111-02-01A	EA SCREW-TAPTITE - 1/4-20 X 3/8 PPH - ZINC
	117322-01-000	EA SCREW - 1/4-28 UNF-2A, TORX - U.T. 6270020 SC25WJ

**TAPES AND TIES**

KEY	PART NUMBER	U/M DESCRIPTION
	008343-01-000	EA TIE-WIRE, 6"
	008343-02-000	EA TIE-WIRE, 14"
	008343-03-000	EA TIE-WIRE, 7.5" BLACK - DENNISON 10003
	029094-04-000	YD VELCRO TAPE-LOOP, 1" WIDE - BLACK
	029096-03-000	YD VELCRO TAPE-HOOK, 1" WIDE - BLACK
	085774-01-000	FT FASTENER-DUAL HOOK, 1" WIDE - ADHESIVE BACK - BLACK
	085774-02-000	FT FASTENER-DUAL LOOP, 1" WIDE - ADHESIVE BACK - BLACK
	086285-01-000	EA SPACER-NYLON, .5" OD X .257" ID
	108046-02-000	EA CABLE TIE-SCREW MOUNT 15" - DENNISON 10035

# WATER & SEWAGE GROUP

## DRAINAGE SYSTEM

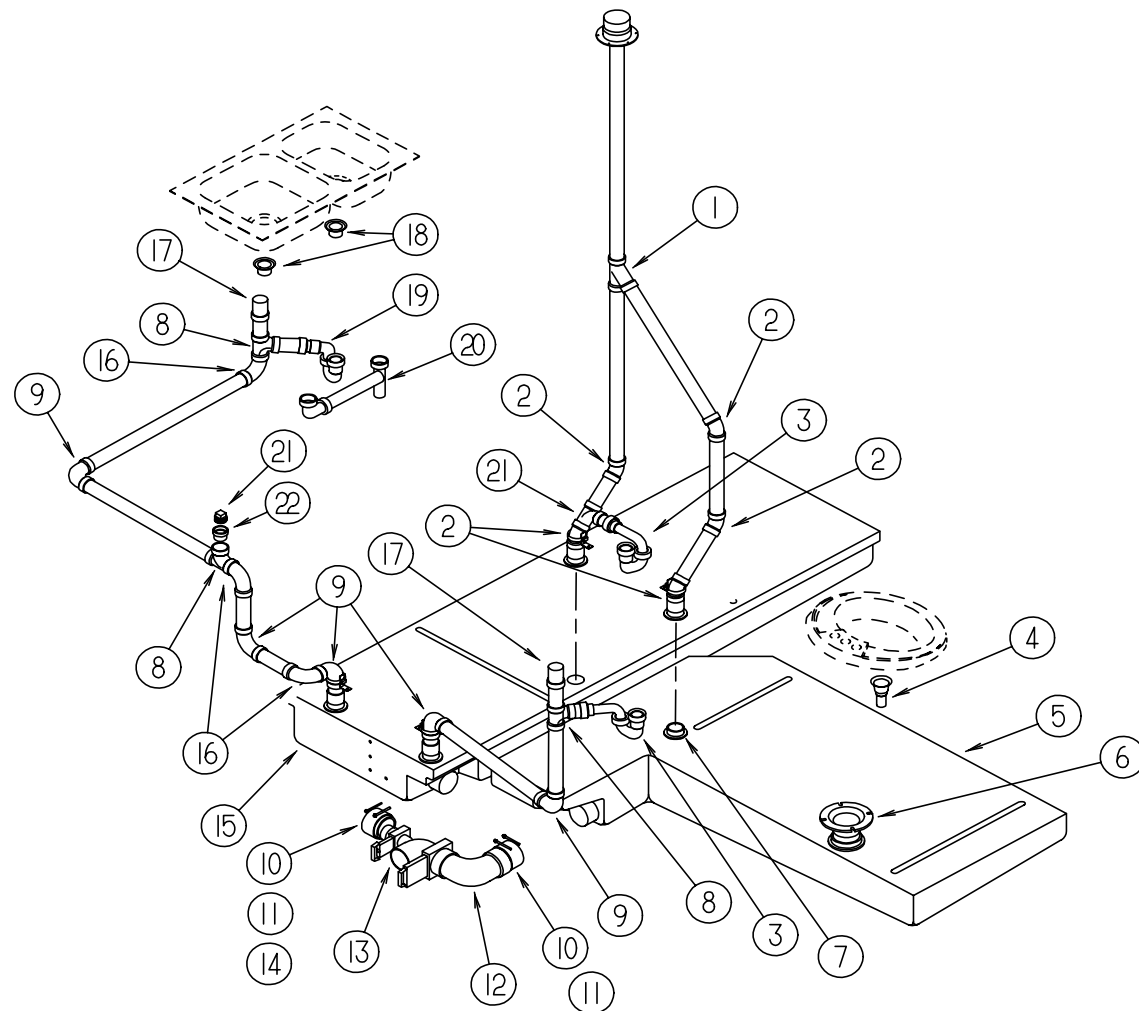

KEY	PART NUMBER	U/M	DESCRIPTION
1	010073-01-000	EA	WYE - 45 DEGREE, 1 1/2" HUB X HUB X HUB - PLASTIC - BLACK
2	010006-01-000	EA	ELBOW - 45 DEGREE, 1/8 BEND - 1 1/2" HUB X HUB - BLACK PLASTIC
3	107538-01-000	EA	P TRAP-PLASTIC 1 1/4 W/EXT ARM KEVCO P814 1-1/4"
3	011066-02-000	EA	P TRAP-PLASTIC 1 1/4 - SLOANE 3220-A - CSA
3	109571-01-000	EA	ADAPTER-P TRAP, 1 1/2" P X 1 1/4" MPT
4	011069-06-000	EA	TAILPIECE - 1 1/2 X 1/4 X 2.50
5	112789-01-000	EA	TANK-HOLDING, 46 GAL
6	061607-02-000	EA	GROMMET-HOLDING TANK, 3" NPS
6	116644-01-000	EA	FLANGE-CLOSET 4" X 3"
6	024676-02-000	EA	FLANGE-CLOSET, 4" X 3" - ABS - CANADIAN
7	061607-01-000	EA	GROMMET-HOLDING TANK, 1 1/2" NPS
8	010071-01-000	EA	TEE-SANITARY, 1 1/2" HUB X HUB X HUB - PLASTIC - BLACK
	011069-02-000	EA	TAILPIECE - LAVATORY, 1 1/2" X 1 1/4" X 4" - BRASS
9	010008-01-000	EA	ELBOW-90 DEG, 1/4 BEND - 1 1/2" HUB X HUB - BLACK PLASTIC
10	078406-01-000	EA	COUPLER-RUBBER, W/CLAMPS - 3" X 3"
11	062401-05-000	EA	CLAMP-HOSE,WORMGEAR - 2-3.00ID
12	041956-01-000	EA	ELBOW-STREET, PLASTIC - 1/4 BEND - 3" X 90 XLT
13	070916-01-000	EA	VALVE-DUAL DUMP, W/CAP - 3" X 1 1/2" - PLASTIC - BLACK
	070916-01-700	EA	VALVE ONLY, 3"
	070916-01-701	EA	VALVE ONLY, 1 1/2"
	010201-01-000	EA	HOSE-SEWER, 3" ID X 8'
	062416-01-000	EA	ADAPTER-SEWER HOSE TO 3" PIPE
14	062422-01-000	EA	ADAPTER-OFFSET REDUCER, 3" X 1 1/2" - PLASTIC - BLACK
	010115-01-000	EA	COUPLING - 1 1/2" HUB X HUB, PLASTIC
15	104352-01-000	EA	TANK-HOLDING, 50 GAL
16	033761-01-000	EA	ELBOW-TURN, 1/4 BEND X 1.5"HUB X 1.5"SPIGOT - BLK PLASTIC
17	079968-01-000	EA	VENT-MECH. TRAP ARM, ANTI-SIPHON - 2" DIA X 7.3" - PLASTIC
18	092303-01-000	EA	STRAINER-SINK
	069735-01-000	EA	WASHER-STRAINER TO TAILPIECE PLASTI, 1.5"
19	107538-01-000	EA	P TRAP-PLASTIC 1 1/4 W/EXT ARM KEVCO P814 1-1/4"
19	011071-01-000	EA	P TRAP-PLASTIC 1 1/2 CSA
19	109571-01-000	EA	ADAPTER-P TRAP, 1 1/2" P X 1 1/4" MPT
20	011091-03-000	EA	PIPE-DRAIN, W/SEALS - DOUBLE SINK - EXTENDS 9" TO 16"
20	011091-02-000	EA	WASTE-CONTINOUS DOUBLE, SINK
20	011091-02-000	EA	PIPE-DRAIN, DOUBLE SINK - BAFFLE TEE - 1 1/2"
20	011091-03-000	EA	WASTE-CONTINOUS DOUBLE SINK, CSA
	010115-01-000	EA	COUPLING - 1 1/2" HUB X HUB, PLASTIC
21	010166-01-000	EA	PLUG-THREADED, 1 1/4" DIAMETER - PLASTIC - BLACK
21	010166-02-000	EA	PLUG-PLASTIC, 1 1/4 MPT - CSA
22	010122-01-000	EA	BUSHING-REDUCER, 1 1/2 SMTH X 1 1/4 THD - PLASTIC - BLACK
22	010122-02-000	EA	BUSHING-PLASTIC, RED 1 1/25 X 1 1/4T - CSA
	010071-01-000	EA	TEE-SANITARY, 1 1/2" HUB X HUB X HUB - PLASTIC - BLACK
	061607-01-000	EA	GROMMET-HOLDING TANK, 1 1/2" NPS
	011069-04-000	EA	TAILPIECE - 1 1/2 X 1 1/4 X 8 - BRASS

## WATER & SEWAGE GROUP (CONTINUED)

### FRESH WATER TANK

KEY	PART NUMBER	U/M DESCRIPTION
	117217-01-000	EA TANK ASM - WATER - 30 GAL - W/O FITTINGS
	117217-02-000	EA TANK ASM - WATER - 30 GAL - W/ FITTINGS
	116881-01-000	EA TANK ASM - WATER - 48 GAL (W/ NOTCHED CORNER) - W/O FITTINGS
	116881-04-000	EA TANK ASM - WATER - 48 GAL (W/ NOTCHED CORNER) - W/ FITTINGS
	042989-05-000	EA FITTING - SPINWELD - PLASTIC 1/2FPT
	042989-03-000	EA FITTING - SPINWELD - PLASTIC - 1 1/4" FPT
	049032-01-000	EA PATCH - SPINWELD - 3/8" - PLASTIC
	039861-01-000	EA SENDING UNIT W/SCREW - WASHER
	091208-01-000	EA WASHER - RUBBER - .06" X .75" X .5"
	077954-02-000	EA FILTER - WATER TANK - SCREEN IN TANK

### EXTERIOR SHOWER COMPONENTS

KEY	PART NUMBER	U/M DESCRIPTION
	103092-01-000	EA SHOWER HEAD - W/60" HOSE (US)
	103092-02-000	EA SHOWER HEAD - W/HOSE (CSA)
	104044-01-000	EA BRACKET - SUPPORT - FAUCET
	103092-01-700	EA BRACKET (FOR SHOWER HEAD) CLEAR
	103092-01-701	EA BRACKET (FOR SHOWER HEAD) BONE
	075241-05-000	EA FAUCET - SHOWER - BONE

### WATER SYSTEM COMPONENTS

KEY	PART NUMBER	U/M DESCRIPTION
	701069-01-000	EA WATER PURIFICATION SYSTEM
	701069-03-700	EA CARTRIDGE - WATER FILTER - AC - EVERPURE 9601-11
	039800-04-000	FT TUBING - POLYBUTYL - 1/4" OD X 20FT
	039800-02-000	FT TUBING - POLYBUTYL - 5/8" OD X 20FT
	079381-01-000	FT TUBING-SMOOTH FLEXIBLE, 1 3/8" ID X 20'
	010219-01-000	EA ELBOW - 1 1/4" MPT X 1 1/4" BARB - WATER FILL - PLASTIC
	039798-01-000	EA TEE - 1/2" MPT X 1/2" MPT X 1/2" MPT - PLASTIC
	101814-01-000	EA COUPLING - FEMALE - 1/2" X 1/2" FPT
	M06993-02-000	EA INSULATION - WATER TANK
	010230-05-000	EA CITY WATER FILL, W/CHECK VALVE
	103798-01-000	EA CONNECTOR - 1/4"OD X 3/8"MPT
	110438-01-000	EA VALVE - CHECK - BRASS
	111888-02-000	EA INSERT-BRASS, 1/4 COMP

### WATER SYSTEM COMPONENTS (FLAIR-IT)

KEY	PART NUMBER	U/M DESCRIPTION
	114427-01-000	EA CAP - 1/2P - 02860
	114427-02-000	EA PLUG - 1/2P - 02863
	114428-01-000	EA TEE - 1/2P X 1/2P X 1/2P - 02820
	114428-02-000	EA TEE - SWIVEL - 1/2P X 1/2P X 1/2FPT - 02821
	114428-03-000	EA TEE - 1/2P X 1/2P X 1/2MPT - 02822
	114429-01-000	EA ELBOW - 1/2P X 1/2P - 02800
	114429-02-000	EA ELBOW - 1/2P X 1/2MPT - 02803
	114429-03-000	EA ELBOW - SWIVEL - 1/2P X 1/2FPT - 02816
	114429-04-000	EA ELBOW - 1/2P X 3/8MPT - 02810
	114429-05-000	EA ELBOW - 1/2P X 3/4MPT - 02812
	114429-06-000	EA ELBOW - SWIVEL - 1/2P X 3/4FPT - 02811
	114430-01-000	EA ADAPTER - 1/2P X 1/2P - 02840
	114430-02-000	EA ADAPTER - SWIVEL - 1/2P X 1/2FPT - 02873
	114430-03-000	EA ADAPTER - 1/2P X 1/2MPT - 02842
	114431-01-000	EA VALVE - LINE DRAIN 1/2P - 02914
	114431-02-000	EA VALVE - 1/2P - BYPASS - 02910
	114431-03-000	EA VALVE - 1/2P X 1/2P - 02884
	114431-04-000	EA VALVE - STOP - 1/2P X 1/2P - 02880

## WATER & SEWAGE GROUP (CONTINUED)

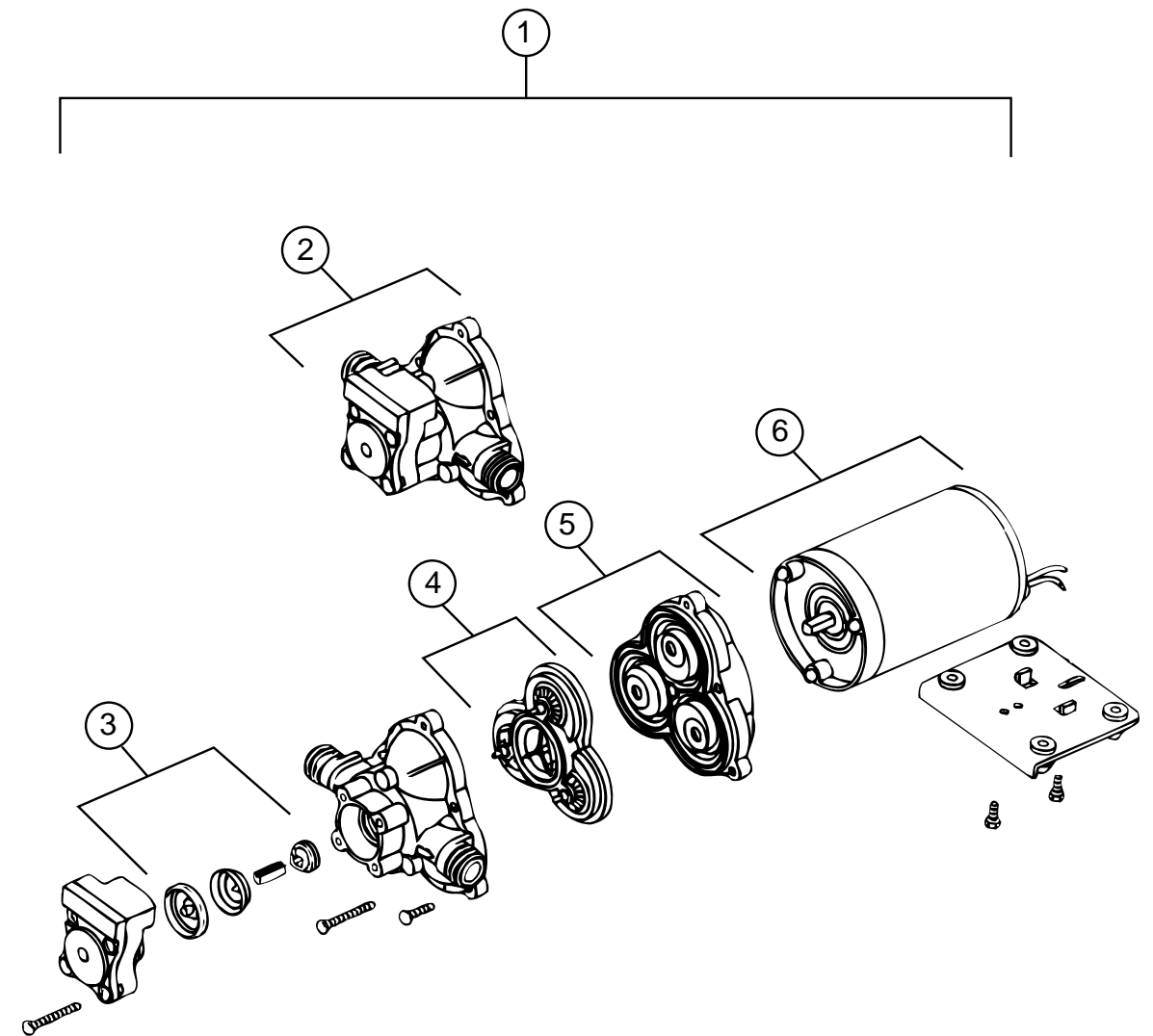

### WATER PUMP (SHURFLO)

KEY	PART NUMBER	U/M DESCRIPTION	VENDOR NO.
1	098607-01-000	EA PUMP - WATER - W/.5"MPT FITTING - FLOW 2.8 GPM - UL	
2	098607-01-706	EA UPPER HOUSING/ SWITCH KIT	94-231-20
3	098607-01-705	EA CHECK VALVE - KIT	94-237-00
4	098607-01-703	EA VALVE ASM	94-232-00
5	098607-01-702	EA DRIVE/ DIAPHRAGM - KIT	94-238-04
6	098607-01-707	EA MOTOR/ BASEPLATE REPLACEMENT	94-235-03

## WATER & SEWAGE GROUP (CONTINUED)

### WATER HEATER W/MOTOR AID ATWOOD (GH6-7E)

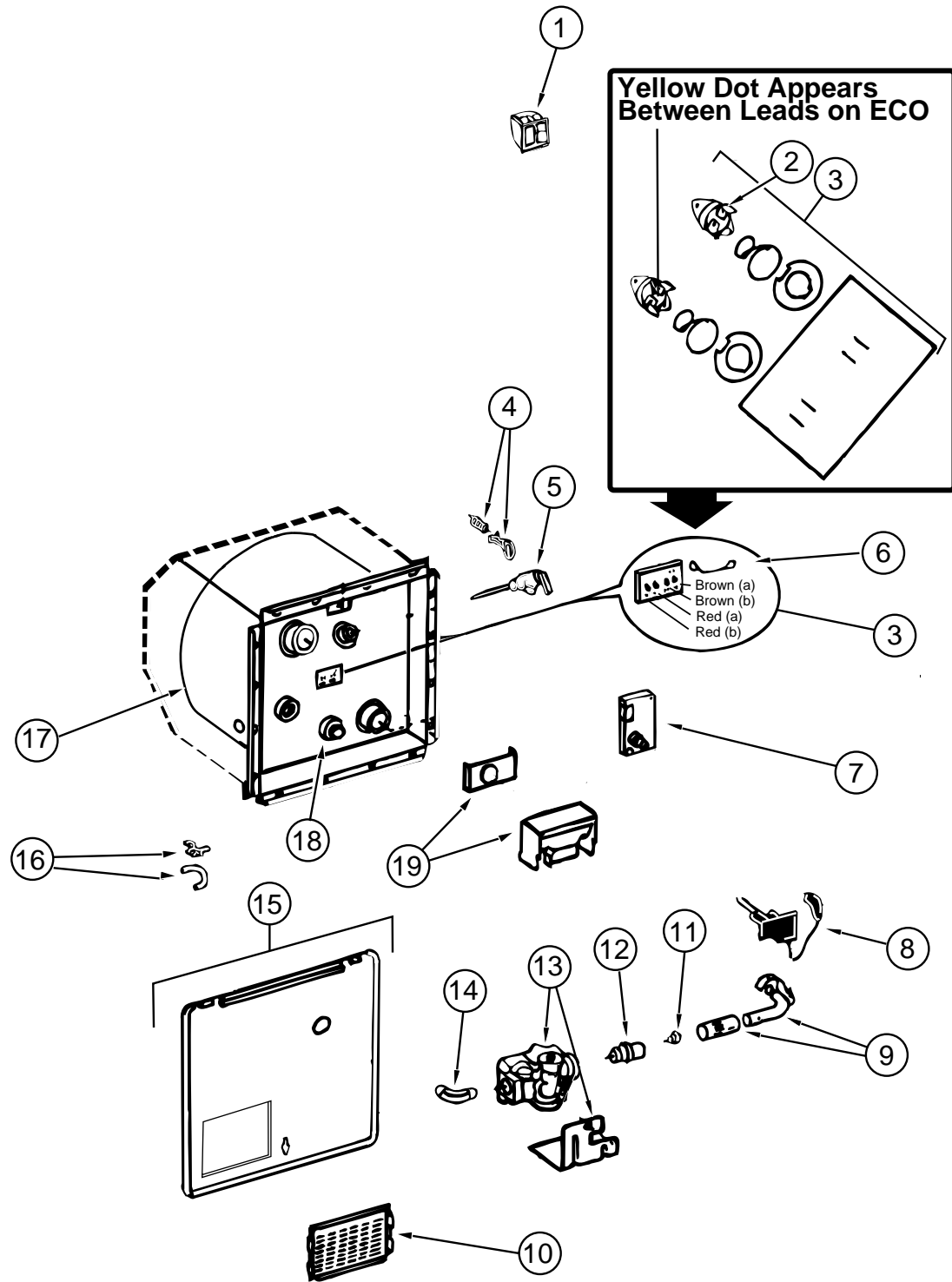

KEY	PART NUMBER	U/M DESCRIPTION	VENDOR NO.
	051393-01-000	EA WATER HEATER - W/ MOTOR AID - PILOTLESS IGNITION	
1	051393-01-701	EA SWITCH PACKAGE	91959
2	051391-04-701	EA THERMOSTAT 12 VDC-120 PRESET	91470
3	051393-01-721	EA ECO & THERMOSTAT ASM - FRONT MOUNT - 140°	91447
4	051391-01-705	EA FASTENER - CAMLOC	92609
5	051391-01-704	EA VALVE - RELIEF - 1/2" FITTING	91604
6	051393-01-723	EA SWITCH - ENERGY CUT-OFF	93866
7	051393-01-724	EA CIRCUIT BOARD - W/ SPADE TERMINAL	93867
8	051393-01-725	EA ELECTRODE - SINGLE SPADE CONNECTION	93868
9	051391-04-703	EA BURNER - MAIN	91638
10	051391-01-717	EA GRILLE	92640
11	051391-01-710	EA ORIFICE - MAIN BURNER	92742
12	051391-03-700	EA ORIFICE HOLDER	91563
13	051393-01-726	EA SOLENOID VALVE & BRACKET	93870
14	051391-01-714	EA ELBOW - 45 DEGREE - 3/8"F X 3/8"MPT	91044
15	052009-04-000	EA DOOR - WATER HEATER - BUFF	
16	051391-01-700	EA HINGE KIT - W/CLIP	92568 & 92559
17	051393-03-701	EA TANK - INNER	91642
18	051391-01-715	EA DRAIN PLUG	91857
19	051391-01-706	EA FLUE & GASKET	92787
	116424-01-000	EA PROTECTOR - ROUND VINYL - WATER HEATER LATCH	

### WATER HEATER W/MOTOR AID ATWOOD (G6A-7E)

KEY	PART NUMBER	U/M DESCRIPTION	VENDOR NO.
	051391-03-000	EA WATER HEATER - W/ ELECTRIC IGNITION	
1	051393-01-701	EA SWITCH PACKAGE	91959
2	051391-04-701	EA THERMOSTAT 12 VDC-120 PRESET	91470
3	051393-01-721	EA ECO & THERMOSTAT ASM - FRONT MOUNT - 140°	91447
4	051391-01-705	EA FASTENER - CAMLOC	92609
5	051391-01-704	EA VALVE - RELIEF - 1/2" FITTING	91604
6	051393-01-723	EA SWITCH - ENERGY CUT-OFF	93866
7	051393-01-724	EA CIRCUIT BOARD - W/ SPADE TERMINAL	93867
8	051393-01-725	EA ELECTRODE - SINGLE SPADE CONNECTION	93868
9	051391-04-703	EA BURNER - MAIN	91638
10	051391-01-717	EA GRILLE	92640
11	051391-01-710	EA ORIFICE - MAIN BURNER	92742
12	051391-03-700	EA ORIFICE HOLDER	91563
13	051393-01-726	EA SOLENOID VALVE & BRACKET	93870
14	051391-01-714	EA ELBOW - 45 DEGREE - 3/8"F X 3/8"MPT	91044
15	052009-04-000	EA DOOR - WATER HEATER - BUFF	
16	051391-01-700	EA HINGE KIT - W/CLIP	92568 & 92559
17	051391-04-706	EA TANK - INNER	91641
18	051391-01-715	EA DRAIN PLUG	91857
19	051391-01-706	EA FLUE & GASKET	92787
	116424-01-000	EA PROTECTOR - ROUND VINYL - WATER HEATER LATCH	

## WATER & SEWAGE GROUP (CONTINUED)

### WATER HEATER W/MOTOR AID ATWOOD (GH6-8E)

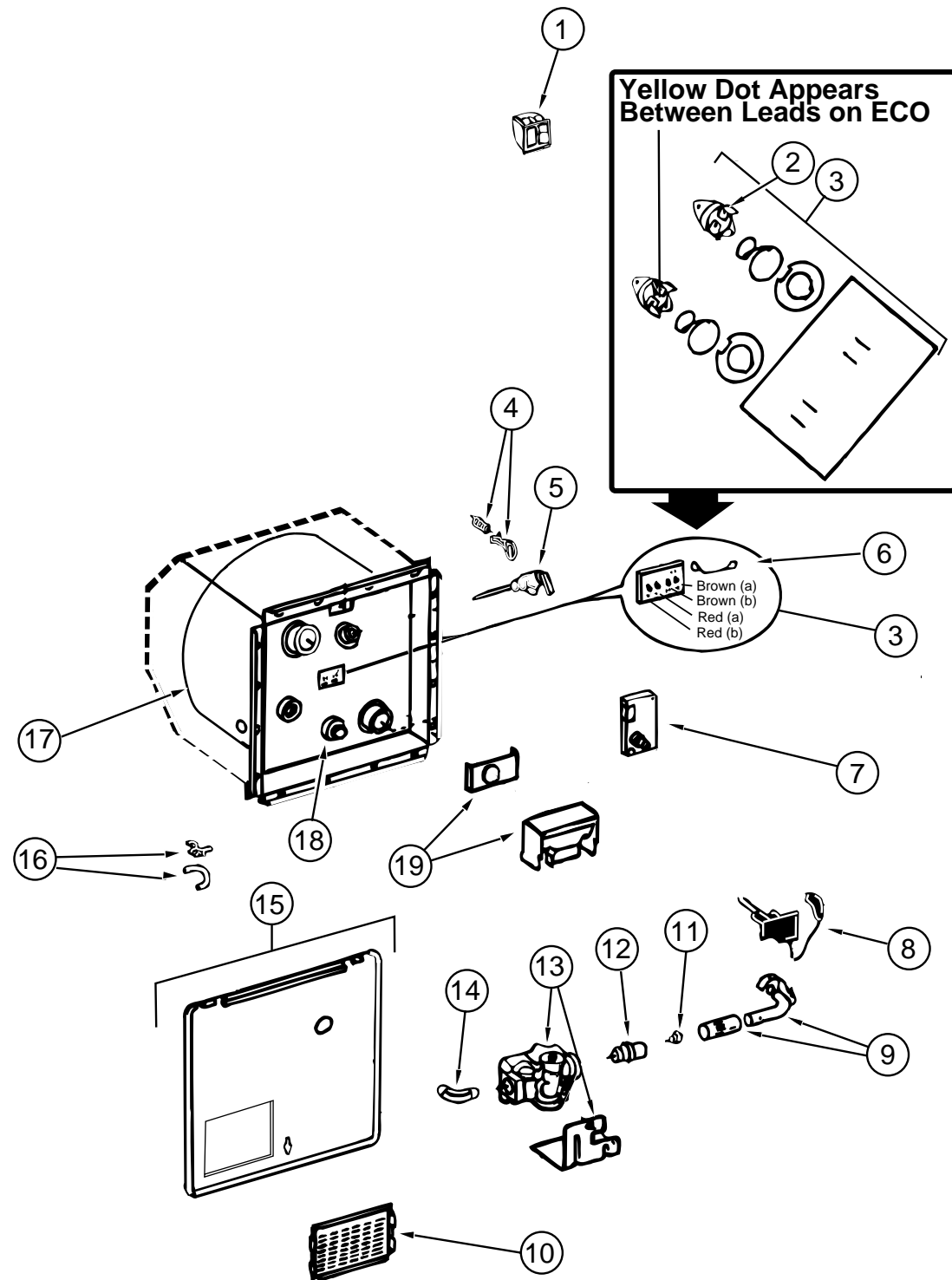

KEY	PART NUMBER	U/M	DESCRIPTION	VENDOR NO.
	051393-01-000	EA	WATER HEATER - W/ MOTOR AID - PILOTLESS IGNITION	
1	051393-01-701	EA	SWITCH PACKAGE	91959
2	051391-04-701	EA	THERMOSTAT 12 VDC-120 PRESET	91470
3	051393-01-721	EA	ECO & THERMOSTAT ASM - FRONT MOUNT - 140°	91447
4	051391-01-705	EA	FASTENER - CAMLOC	92609
5	051391-01-704	EA	VALVE - RELIEF - 1/2" FITTING	91604
6	051393-01-723	EA	SWITCH - ENERGY CUT-OFF	93866
7	051393-01-724	EA	CIRCUIT BOARD - W/ SPADE TERMINAL	93867
8	051393-01-725	EA	ELECTRODE - SINGLE SPADE CONNECTION	93868
9	051391-04-703	EA	BURNER - MAIN	91638
10	051391-01-717	EA	GRILLE	92640
11	051391-01-710	EA	ORIFICE - MAIN BURNER	92742
12	051391-03-700	EA	ORIFICE HOLDER	91563
13	051393-01-726	EA	SOLENOID VALVE & BRACKET	93870
14	051391-01-714	EA	ELBOW - 45 DEGREE - 3/8"F X 3/8"MPT	91044
15	052009-04-000	EA	DOOR - WATER HEATER - BUFF	
16	051391-01-700	EA	HINGE KIT - W/CLIP	92568 & 92559
17	051391-04-704	EA	TANK - INNER	91642
18	051391-01-715	EA	DRAIN PLUG	91857
19	051391-04-707	EA	FLUE & GASKET	90960
	111129-01-711	EA	BRACKET-CORNER, SET OF FOUR	91928
	116424-01-000	EA	PROTECTOR - ROUND VINYL - WATER HEATER LATCH	

### WATER HEATER W/MOTOR AID ATWOOD (G6A-8E)

KEY	PART NUMBER	U/M	DESCRIPTION	VENDOR NO.
	051391-03-000	EA	WATER HEATER - W/ ELECTRIC IGNITION	
1	051393-01-701	EA	SWITCH PACKAGE	91959
2	051391-04-701	EA	THERMOSTAT 12 VDC-120 PRESET	91470
3	051393-01-721	EA	ECO & THERMOSTAT ASM - FRONT MOUNT - 140°	91447
4	051391-01-705	EA	FASTENER - CAMLOC	92609
5	051391-01-704	EA	VALVE - RELIEF - 1/2" FITTING	91604
6	051393-01-723	EA	SWITCH - ENERGY CUT-OFF	93866
7	051393-01-724	EA	CIRCUIT BOARD - W/ SPADE TERMINAL	93867
8	051393-01-725	EA	ELECTRODE - SINGLE SPADE CONNECTION	93868
9	051391-04-703	EA	BURNER - MAIN	91638
10	051391-01-717	EA	GRILLE	92640
11	051391-01-710	EA	ORIFICE - MAIN BURNER	92742
12	051391-03-700	EA	ORIFICE HOLDER	91563
13	051393-01-726	EA	SOLENOID VALVE & BRACKET	93870
14	051391-01-714	EA	ELBOW - 45 DEGREE - 3/8"F X 3/8"MPT	91044
15	052009-04-000	EA	DOOR - WATER HEATER - BUFF	
16	051391-01-700	EA	HINGE KIT - W/CLIP	92568 & 92559
17	051391-04-706	EA	TANK - INNER	91641
18	051391-01-715	EA	DRAIN PLUG	91857
19	051391-04-707	EA	FLUE & GASKET	90960
	111129-01-711	EA	BRACKET-CORNER, SET OF FOUR	91928
	116424-01-000	EA	PROTECTOR - ROUND VINYL - WATER HEATER LATCH	

# WINDOW, VENT & EXTERIOR DOOR GROUP

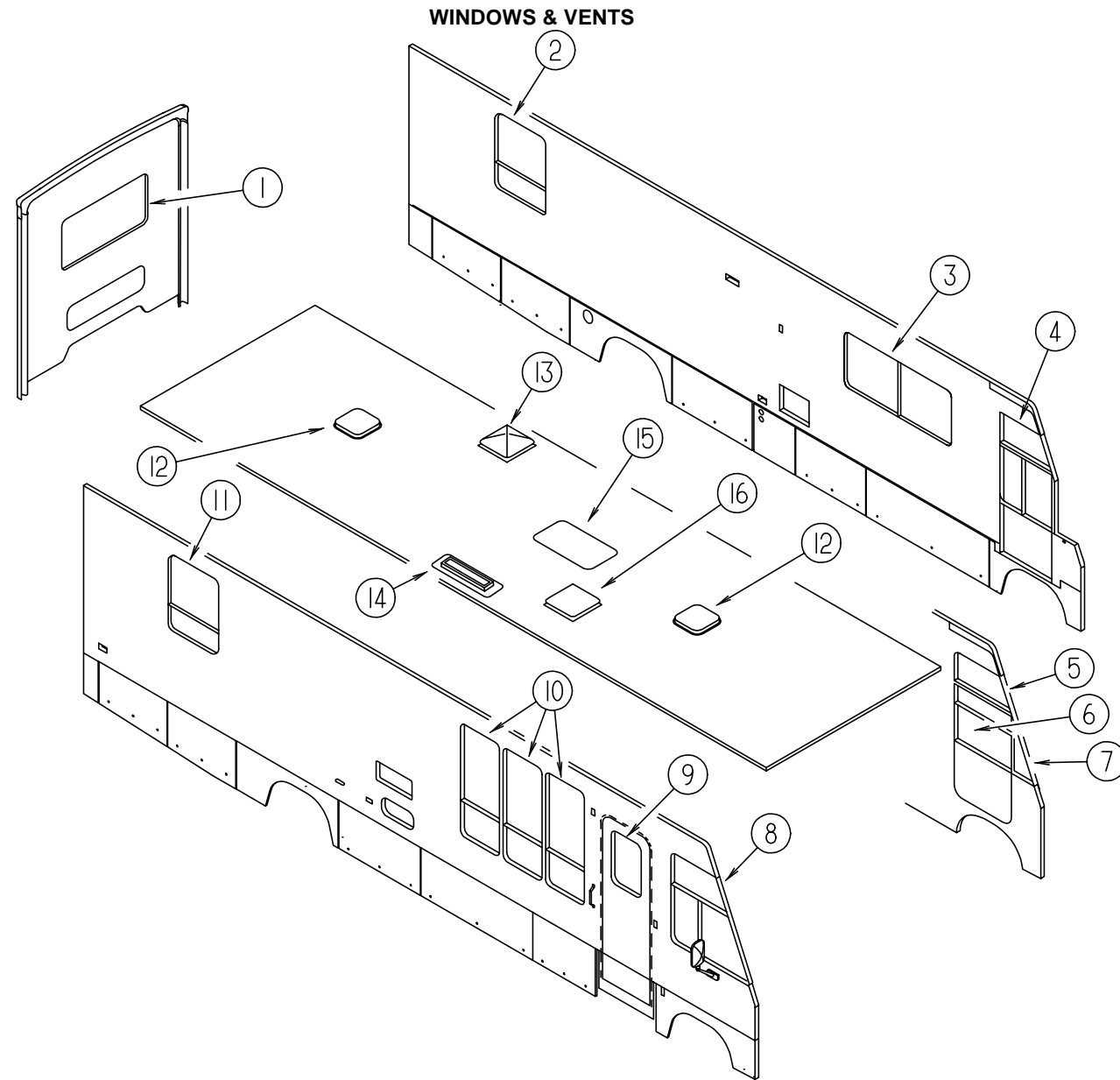

KEY	PART NUMBER	U/M	DESCRIPTION
1	078528-06-E10	EA	WINDOW ASM. - ESCAPE - 24.75" X 48.75" - W/O INSIDE FRAME - USED W/QUEEN
1	113502-01-01A	EA	WINDOW ASM. - ESCAPE - THERMOPANE - W/ INSIDE FRAME - USED W/QUEEN
1	078528-13-F11	EA	WINDOW ASM. - ESCAPE - USED W/TWIN
1	113733-07-01A	EA	WINDOW ASM. - STATIONARY - THERMOPANE - W/ INSIDE FRAME - USED W/TWIN
2	112463-01-01A	EA	WINDOW ASM. - TORQUE - USED W/QUEEN
2	112898-08-01A	EA	WINDOW ASM. - SLIDER, VERTICAL - THERMOPANE - USED W/ QUEEN
2	112463-02-01A	EA	WINDOW ASM. - TORQUE EGRESS - USED W/TWIN
2	112898-09-01A	EA	WINDOW ASM. - SLIDER, VERTICAL, THERMOPANE - USED W/ TWIN
3	098647-39-01A	EA	WINDOW ASM. - SLIDER - W/INSIDE FRAME
3	112795-37-01A	EA	WINDOW ASM. - SLIDER - THERMO - W/ INSIDE FRAME
3	098647-22-01A	EA	WINDOW ASM. - SLIDER - W/INSIDE FRAME - 26 3/8 " HIGH (WINDOW EXCHANGE OPTION)
3	112795-15-01A	EA	WINDOW ASM. - SLIDER -THERMOPANE - 26 3/8 " HIGH (WINDOW EXCHANGE OPTION)
4	113501-01-01A	EA	WINDOW ASM. - CAB - THERMOPANE INSULATED - W/ INSIDE FRAME (OPTION)
4	103658-07-01A	EA	WINDOW ASM. - CAB - DRIVER SIDE
5	116000-02-01A	EA	WINDOW ASM. - VISTA - THERMOPANE INSULATED - W/ INSIDE FRAME (OPTION)
5	106467-03-01A	EA	WINDOW ASM. - VISTA - DRIVER SIDE
6	106469-01-704	EA	WINDOW - DRIVER DOOR - ROLL-UP GLASS ASM. - W/ BRACKET
7	115999-02-01A	EA	WINDOW ASM. - FRONT SLANT - THERMO INSULATED - DRIVER SIDE (OPTION)
7	106468-02-01A	EA	WINDOW ASM. - FRONT SLANT- DRIVER SIDE

KEY	PART NUMBER	U/M	DESCRIPTION
8	103658-08-01A	EA	WINDOW ASM. - CAB - PASSENGER SIDE
8	113501-02-01A	EA	WINDOW ASM. - CAB - PASSENGER SIDE W/ INSIDE FRAME (OPTION)THERMO
9	117053-02-F36	EA	WINDOW ASM. - PICTURE ENTRANCE DOOR
9	113733-01-01A	EA	WINDOW ASM. - STATIONARY,THERMOPANE
10	098644-09-01A	EA	WINDOW ASM. - SLIDER RAISE
10	112898-11-01A	EA	WINDOW ASM. - SLIDER VERTICAL,THERMOPANE
11	112463-01-01A	EA	WINDOW ASM. - TORQUE - EXCEL CH81-G2W59 - USED W/QUEEN
11	112898-08-01A	EA	WINDOW ASM. - SLIDER, VERTICAL-THERMOPANE - USED W/ QUEEN
12	110051-02-01A	EA	VENT - ROOF - NON POWERED
13	110051-04-01A	EA	VENT - ROOF - POWERED (US)
13	110051-06-01A	EA	VENT - ROOF - POWERED (CSA)
14	118369-01-01A	EA	VENT - ROOF CAP, REFRIGERATOR - BUFF
14	118369-02-01A	EA	VENT - ROOF BASE, REFRIGERATOR - BUFF
15	114495-01-01A	EA	PANEL-SKYLITE,INNER
15	114496-01-01A	EA	PANEL-SKYLITE,OUTER
16	084079-14-000	EA	VENT - ROOF - POWERED (US)
16	084079-15-000	EA	VENT - ROOF - POWERED (CSA)
16	110051-02-01A	EA	VENT - ROOF - NON POWERED

## WINDOW, VENT & EXTERIOR DOOR GROUP (CONTINUED)

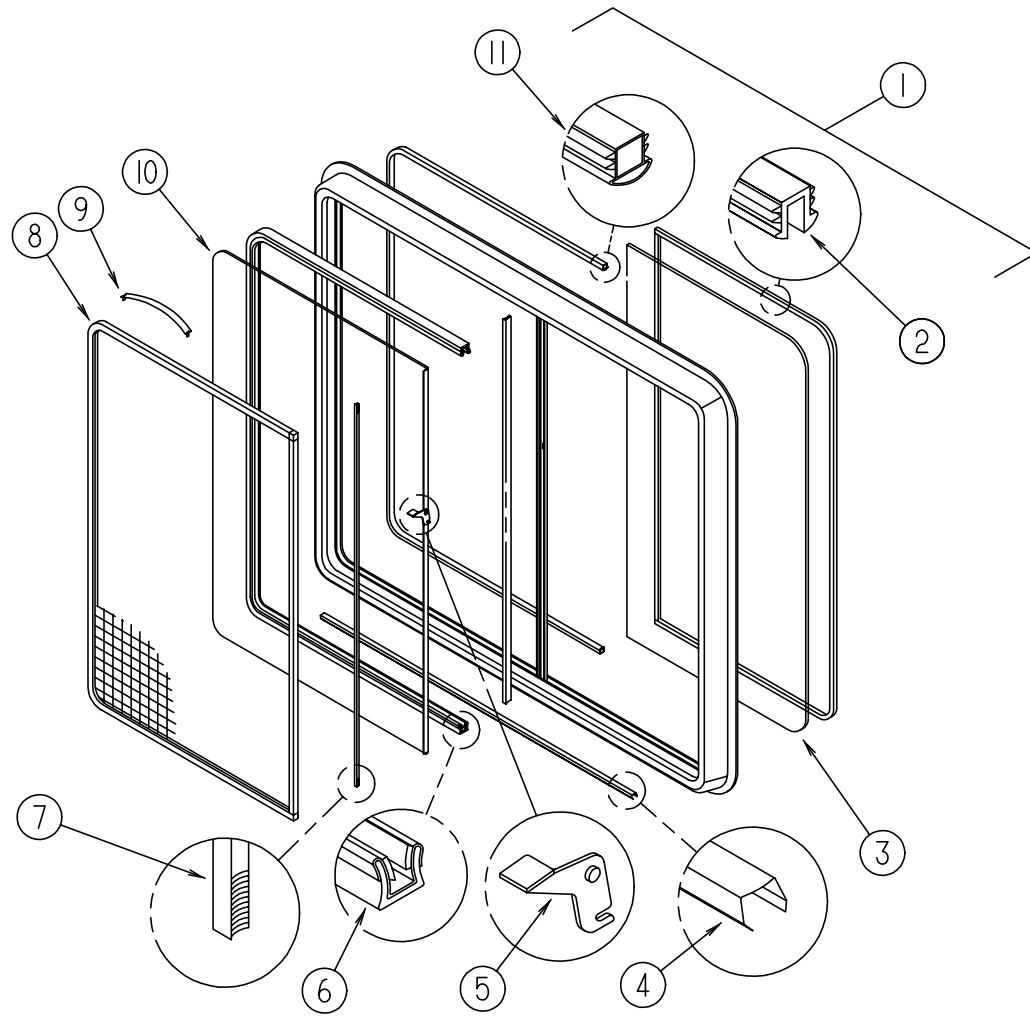

### OPTION SINGLE SLIDER WINDOW (EXCEL) (DRIVER SIDE LOUNGE)

KEY	PART NUMBER	U/M	DESCRIPTION	VENDOR NO.
	098647-22-01A	EA	WINDOW ASM - SLIDER - W/ INSIDE FRAME - H287-G2W66L	
1	098647-22-700	EA	WINDOW W/O TRIM	H287-G2L
	098647-23-702	EA	TRIM - INSIDE FRAME	W28766
2	100322-01-703	FT	GLAZING STRIP	132-010723
3	098647-23-703	EA	GLASS-STATIONARY	106-017622
4	098644-01-710	FT	TRACK-SPACER, FOR SCREEN 12'	132-017135
5	098644-01-700	EA	LATCH REPAIR KIT (BLACK)	B801-CK
6	098644-01-708	FT	CHANNEL-RUN, PIERCED - GLASS	122-016543
7	098644-01-711	FT	WEATHERSTRIP-SCREEN, BLACK	171-016965
8	098647-23-704	EA	SCREEN W/SPRING & WEATHERSTRIP	410-019066
9	098644-01-713	EA	SCREEN CLIPS (METAL)(BLK)	226-016966
10	098647-23-700	EA	GLASS SLIDING, W/SASH & LATCH	H287-G9
11	098644-01-706	FT	WEATHERSTRIP-GLASS	171-010668
	098644-01-716	FT	PLUG-FILLER	132-014470
	098644-01-717	FT	SPLINE-SCREEN MFG	132-004716
	098644-01-719	EA	STOP-SLIDER GLASS	132-014203

### STANDARD SINGLE SLIDER WINDOW (EXCEL) (DRIVER SIDE LOUNGE)

KEY	PART NUMBER	U/M	DESCRIPTION	VENDOR NO.
1	098647-39-01A	EA	WINDOW ASM-SLIDER,HORIZ B/OW EXCEL H442-G2W66L	
	112795-37-701	EA	TRIM (INSIDE)	W44266
2	098644-01-705	FT	GLAZING STRIP	132-010231
3	098647-39-700	EA	GLASS-STATIONARY	106-019793
4	098644-01-710	FT	TRACK-SPACER, FOR SCREEN 12'	132-017135
5	098644-01-700	EA	LATCH REPAIR KIT (BLACK)	B801-CK
6	098644-01-708	FT	CHANNEL-RUN, PIERCED - GLASS	122-016543
7	098644-01-711	FT	WEATHERSTRIP-SCREEN, BLACK	171-016965
8	112795-37-704	EA	SCREEN W/SPRING & WEATHERSTRIP	410-019501
9	098644-01-713	EA	SCREEN CLIPS (METAL)(BLK)	226-016966
10	098647-39-701	EA	GLASS-SLIDING W/SASH & LATCH	106-019704
11	098644-01-706	FT	WEATHERSTRIP-GLASS	171-010668
	098644-01-716	FT	PLUG-FILLER	132-014470
	098644-01-717	FT	SPLINE-SCREEN MFG	132-004716
	098644-01-719	EA	STOP-SLIDER GLASS	132-014203

**WINDOW, VENT & EXTERIOR DOOR GROUP (CONTINUED)**

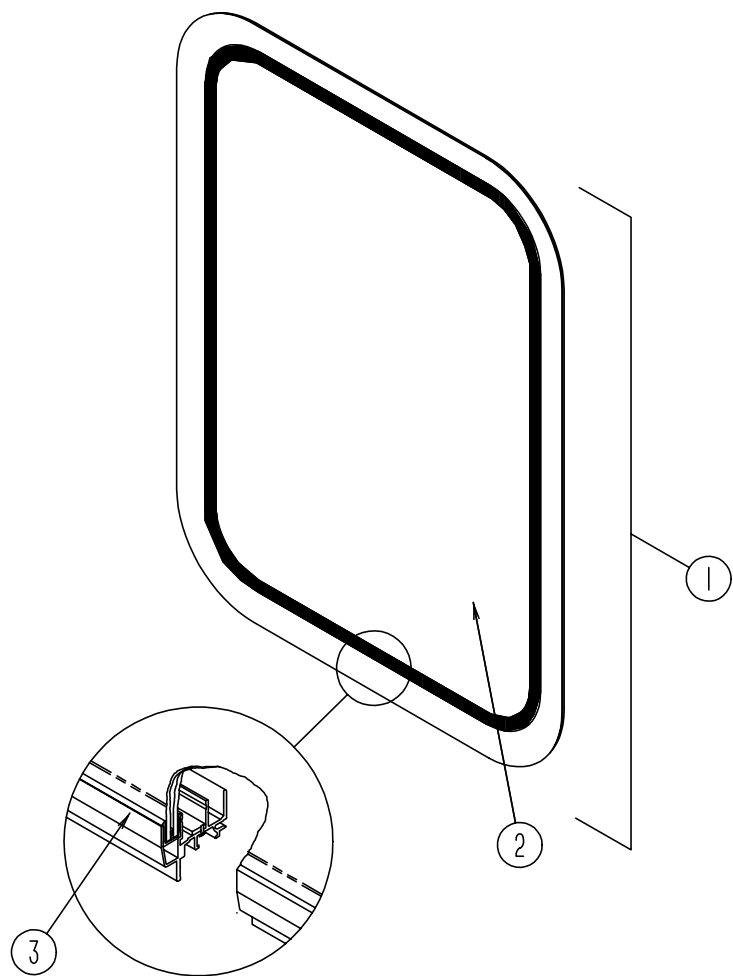

**EXCEL BACKWALL THERMOPANE STATIONARY WINDOW (TWIN BED)**

KEY	PART NUMBER	U/M DESCRIPTION	VENDOR NO.
1	113733-07-01A	EA WINDOW ASM-STATIONARY, THERMO - EXCEL DH377-G2W60	
	113733-07-700	EA WINDOW ASM. W/O TRIM	DH337-G2
2	113733-07-702	EA GLASS-STATIONARY	390-019051
3	113733-07-701	EA TRIM (W)	W28760

**EXCEL ENTRY DOOR THERMOPANE WINDOW**

KEY	PART NUMBER	U/M DESCRIPTION	VENDOR NO.
1	113733-01-01A	EA WINDOW ASM-STATIONARY, THERMO - EXCEL DH416-G2W66	
	113733-01-700	EA WINDOW ASM. W/O TRIM	DH416-G2
2	113733-01-702	EA GLASS-STATIONARY	390-019187
3	113733-01-701	EA TRIM (W)	W41666

**EXCEL ENTRY DOOR WINDOW**

KEY	PART NUMBER	U/M DESCRIPTION
	117053-02-F36	EA WINDOW ASM. - ENTRANCE DOOR - W/O INSIDE FRAME
	002181-25-000	EA GLASS-PICTURE, 655 X 417
	087561-01-000	FT EXTR-VINYL SEAL, TIPOUT/SLIDE

**WINDOW, VENT & EXTERIOR DOOR GROUP (CONTINUED)**

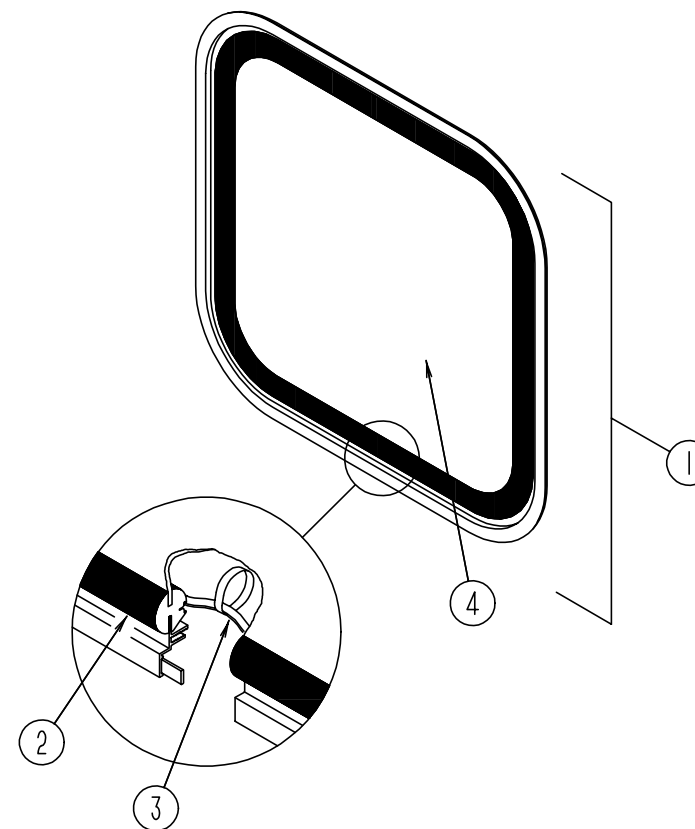

**BACKWALL ESCAPE WINDOW ( QUEEN BED)**

KEY	PART NUMBER	U/M DESCRIPTION
1	078528-06-E10	EA WINDOW - ESCAPE - 24.75" X 48.75" - W/O INSIDE FRAME
	074816-08-000	EA INSIDE FRAME - OFF WHITE
2	002282-09-000	EA WEATHERSTRIP - .125" VULCANIZED - 130.53" LONG - BLACK
3	002285-01-000	FT FILLER - WEATHER STRIP RUBBER - BLACK
4	076337-12-000	EA GLASS - WINDOW

**BACKWALL ESCAPE WINDOW (TWIN BED)**

KEY	PART NUMBER	U/M DESCRIPTION
1	078528-13-F11	EA WINDOW - ESCAPE - W/O INSIDE FRAME
	074816-15-000	EA INSIDE FRAME - OFF WHITE
2	002282-13-000	EA WEATHERSTRIP - .125" VULCANIZED - BLACK
3	002285-01-000	FT FILLER - WEATHER STRIP RUBBER - BLACK
4	076337-18-000	EA GLASS - WINDOW



**WINDOW, VENT & EXTERIOR DOOR GROUP (CONTINUED)**

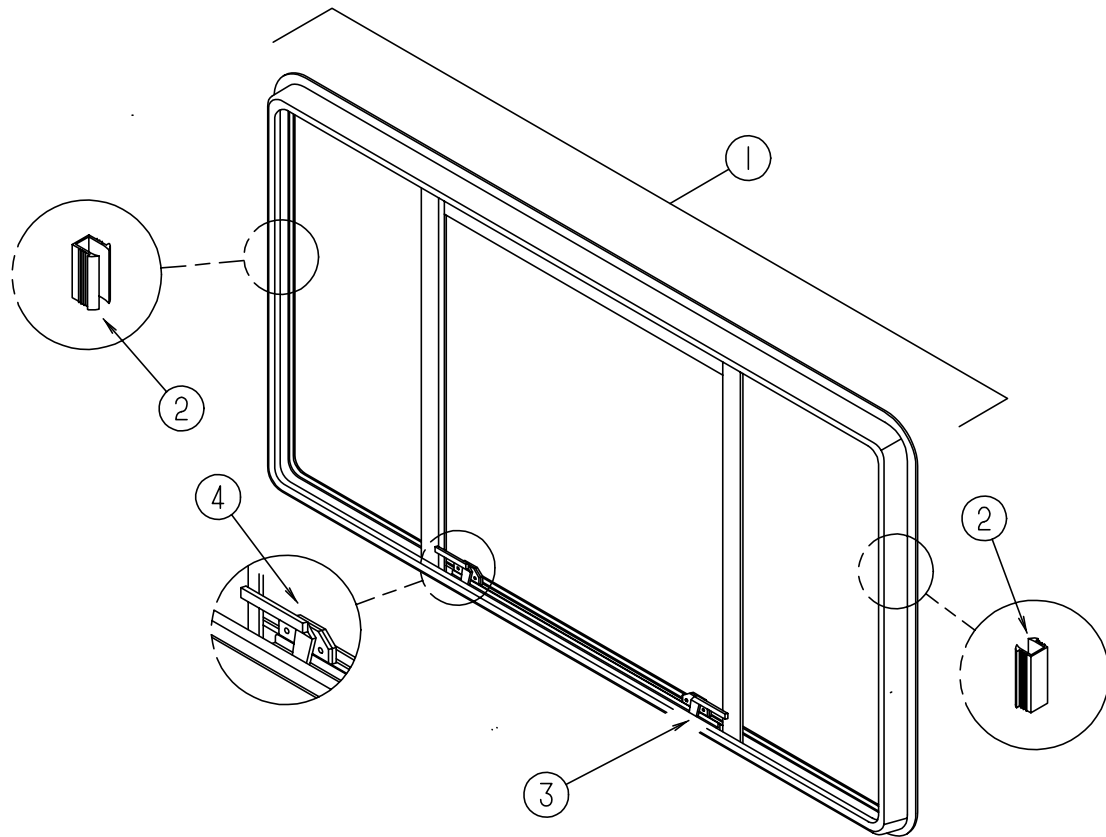

**EXCEL BACKWALL THERMOPANE ESCAPE WINDOW (KING OR QUEEN BED)**

KEY	PART NUMBER	U/M DESCRIPTION	VENDOR NO.
1	113502-01-01A	EA WINDOW ASM-REAR ESCAPE BLK/O/W - EXCEL DH153-G2W60	
2	098644-01-705	FT STRIP-GLAZING, BUTYL	132-010723
3	112898-06-704	EA HANDLE-LATCH, RED - RH	182-11293
4	112898-06-705	EA HANDLE-LATCH, RED - LH	182-11294

**WINDOW, VENT & EXTERIOR DOOR GROUP (CONTINUED)**

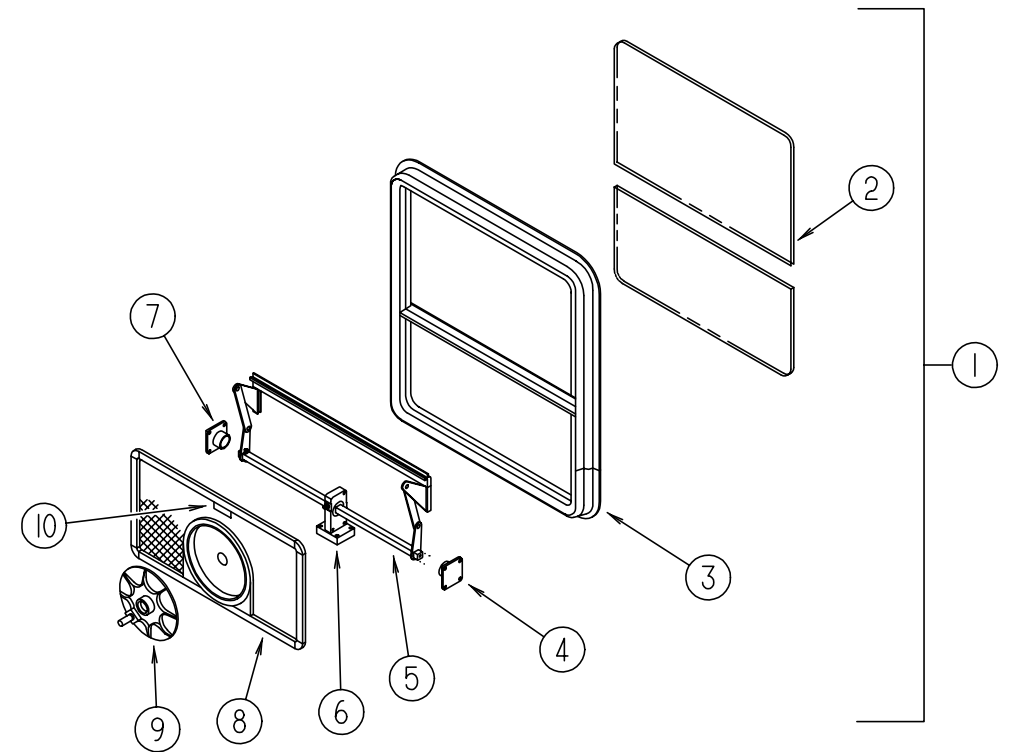

**EXCEL QUEEN BEDROOM WINDOW (EXCEL TIPOUT)**

KEY	PART NUMBER	U/M DESCRIPTION	VENDOR NO.
1	112463-01-01A	EA WINDOW ASM - TORQUE - TIPOUT - CH81-G2W59	
	112463-01-702	EA TRIM	CW8159
2	112463-01-700	EA GLASS - STATIONARY 62 % GP	106-018807
3	112463-01-701	EA WINDOW W/O TRIM	CH81-G2
4	113500-01-707	EA SUPPORT - TORQUE BAR, RH	130-015979
5	112463-01-704	EA OPERATOR & BAR ASSEMBLY	CH78-18
6	112463-01-703	EA VENT ASSEMBLY	CH81-G9
7	113500-01-708	EA SUPPORT - TORQUE BAR, LH	130-015978
8	112463-01-705	EA SCREEN ASSEMBLY	410-018811
9	100322-01-718	EA HANDLE - DIAL	410-016081
10	112519-01-706	EA CLIP - SCREEN	CH21-50
	100322-01-703	FT STRIP - GLAZING	132-010723

**EXCEL TWIN BEDROOM WINDOW (EXCEL TIPOUT)**

KEY	PART NUMBER	U/M DESCRIPTION	VENDOR NO.
1	112463-02-01A	EA WINDOW ASM - TORQUE - TIPOUT - CH82-G2W59	
	112463-02-701	EA TRIM	CW8259
2	112463-02-702	EA GLASS - STATIONARY 62 % GP	106-018809
3	112463-02-700	EA WINDOW W/O TRIM	CH82-G2
4	113500-01-707	EA SUPPORT - TORQUE BAR, RH	130-015979
5	112463-02-704	EA OPERATOR & BAR ASSEMBLY	CH82-18
6	112463-02-703	EA VENT ASSEMBLY	CH82-G9
7	113500-01-708	EA SUPPORT - TORQUE BAR, LH	130-015978
8	112463-02-705	EA SCREEN ASSEMBLY	410-018812
9	100322-01-718	EA HANDLE - DIAL	410-016081
10	112519-01-706	EA CLIP - SCREEN	CH21-50
	100322-01-703	FT STRIP - GLAZING	132-010723

## WINDOW, VENT & EXTERIOR DOOR GROUP (CONTINUED)

### EXCEL QUEEN BEDROOM THERMOPANE WINDOW

KEY	PART NUMBER	U/M	DESCRIPTION	VENDOR NO.
1	112898-08-01A	EA	WINDOW ASM-SLIDER, VERTICAL - THERMO - EXCEL	DH435-G2W66R
	112898-08-700	EA	WINDOW W/O TRIM	DH435-G2R
	112898-08-701	EA	TRIM	W43566
2	112795-01-700	EA	LATCH ASM., BLACK	DH287-CK
3	112898-04-703	EA	SASH LATCH KIT, RAISED	DH343-CK
4	112795-01-701	EA	SLIDE-STOP	132-019092
5	112898-08-702	EA	GLASS-STATIONARY	390-019462
6	112795-01-702	FT	PLUG-FILLER	122-018737
7	112898-08-703	EA	GLASS-ASSEMBLY SLIDING	DH435-G9
8	112795-01-703	IN	CHANNEL-RUN	122-018736
9	098644-01-713	EA	CLIP-SPRING, BLACK PLASTIC	226-016966
10	112898-08-704	EA	SCREEN ASSEMBLY	410-019473

### EXCEL TWIN BEDROOM THERMOPANE WINDOW

KEY	PART NUMBER	U/M	DESCRIPTION	VENDOR NO.
1	112898-09-01A	EA	WINDOW ASM-SLIDER, VERTICAL - THERMO - EXCEL	DH436-G2W64L
	112898-09-700	EA	WINDOW W/O TRIM	DH436-G2
	112898-09-701	EA	TRIM	W43664
2	112795-01-700	EA	LATCH ASM., BLACK	DH287-CK
3	112898-04-703	EA	SASH LATCH KIT, RAISED	DH343-CK
4	112795-01-701	EA	SLIDE-STOP	132-019092
5	112898-09-702	EA	GLASS-STATIONARY	390-019464
6	112795-01-702	FT	PLUG-FILLER	122-018737
7	112898-09-703	EA	GLASS-ASSEMBLY SLIDING	DH436-G9
8	112795-01-703	IN	CHANNEL-RUN	122-018736
9	098644-01-713	EA	CLIP-SPRING, BLACK PLASTIC	226-016966
10	112898-09-704	EA	SCREEN ASSEMBLY	410-019474

### EXCEL PASSENGER SIDE LOUNGE THERMOPANE WINDOW

KEY	PART NUMBER	U/M	DESCRIPTION	VENDOR NO.
1	112898-11-01A	EA	WINDOW ASM-SLIDER, VERTICAL - THERMO - EXCEL	DH446-G2W66
	112898-11-700	EA	WINDOW W/O TRIM	DH446-G2
	098644-09-701	EA	TRIM	W44666
2	112795-01-700	EA	LATCH ASM., BLACK	DH287-CK
3	112898-04-703	EA	SASH LATCH KIT, RAISED	DH343-CK
4	112795-01-701	EA	SLIDE-STOP	132-019092
5	112898-11-701	EA	GLASS-STATIONARY	390-019648
6	112795-01-702	FT	PLUG-FILLER	122-018737
7	112898-11-702	EA	GLASS-ASSEMBLY SLIDING	DH446-G9
8	112795-01-703	IN	CHANNEL-RUN	122-018736
9	098644-01-713	EA	CLIP-SPRING, BLACK PLASTIC	226-016966
10	098644-09-704	EA	SCREEN ASSEMBLY	410-019511

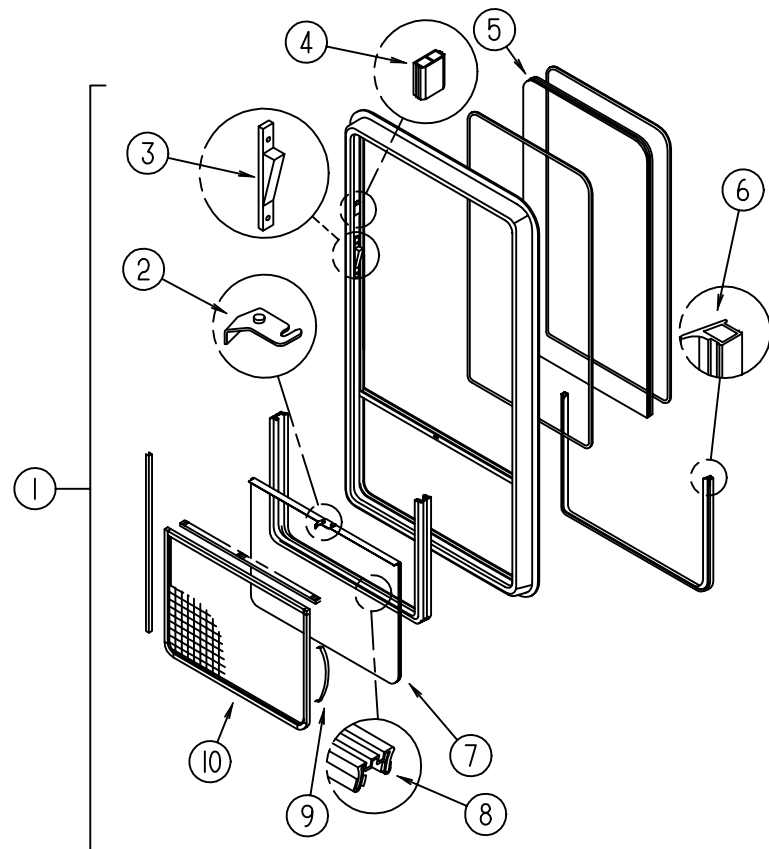

**WINDOW, VENT & EXTERIOR DOOR GROUP (CONTINUED)**

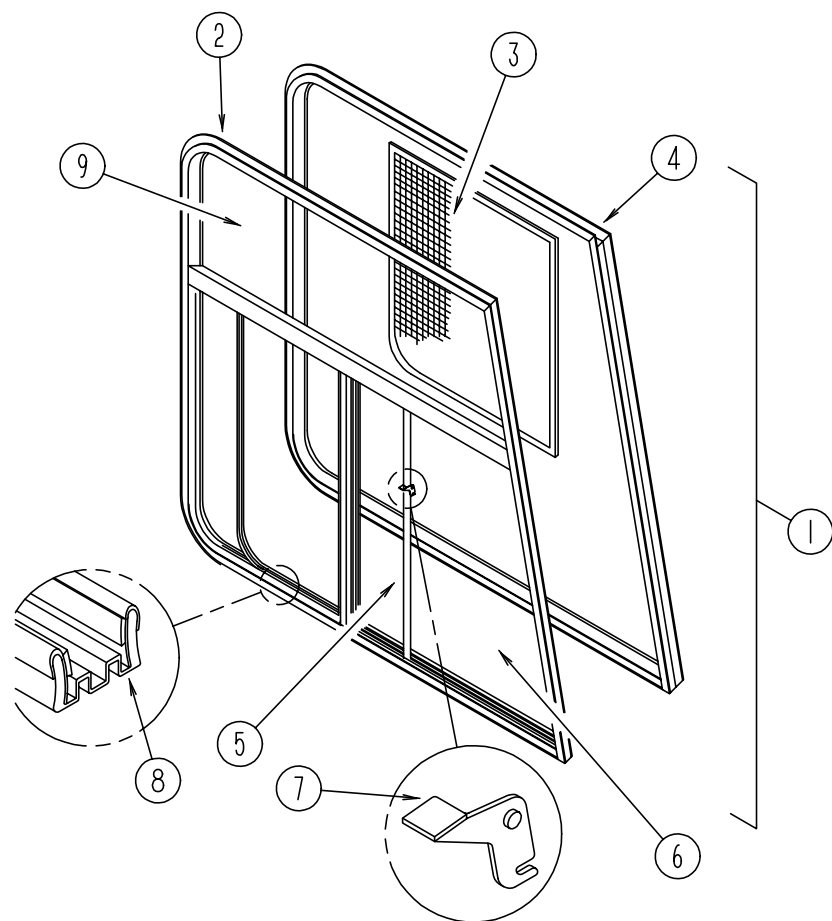

**FRONT CAB THERMOPANE WINDOWS (EXCEL)**

KEY	PART NUMBER	U/M	DESCRIPTION	VENDOR NO.
1	113501-01-01A	EA	WINDOW ASM-CAB,THERMOPANE - LH - EXCEL	DH374-A2B66L
1	113501-02-01A	EA	WINDOW ASM-CAB,THERMOPANE - RH - EXCEL	DH374-A2B66R
2	113501-01-700	EA	WINDOW W/O TRIM, LH	DH374-A2L
2	113501-02-700	EA	WINDOW W/O TRIM, RH	DH374-A2R
3	103658-01-700	EA	SCREEN ASM.-WINDOW, LH	H322-03L
3	103658-02-700	EA	SCREEN ASSEMBLY, RH	H322-03R
4	103658-09-702	EA	RETAINER-TRIM, LH	H37366L & 76L
4	103658-10-701	EA	RETAINER-TRIM, RH	H37366R & 76R
5	113501-01-703	EA	GLASS-SLIDE ASSEMBLY, LH	DH374-A9L
5	113501-02-702	EA	GLASS-SLIDE ASSEMBLY, RH	DH374-A9R
6	113501-01-702	EA	GLASS-STATIONARY-LOWER, LH	390-019139L
6	113501-02-701	EA	GLASS-STATIONARY-LOWER, RH	390-019138R
7	112795-01-700	EA	LATH ASM- BLACK	DH287-CK
8	112795-01-703	IN	CHANNEL-RUN	122-018736
9	113501-01-701	EA	GLASS-STATIONARY-UPPER	390-019137

**WINDOW, VENT & EXTERIOR DOOR GROUP (CONTINUED)**

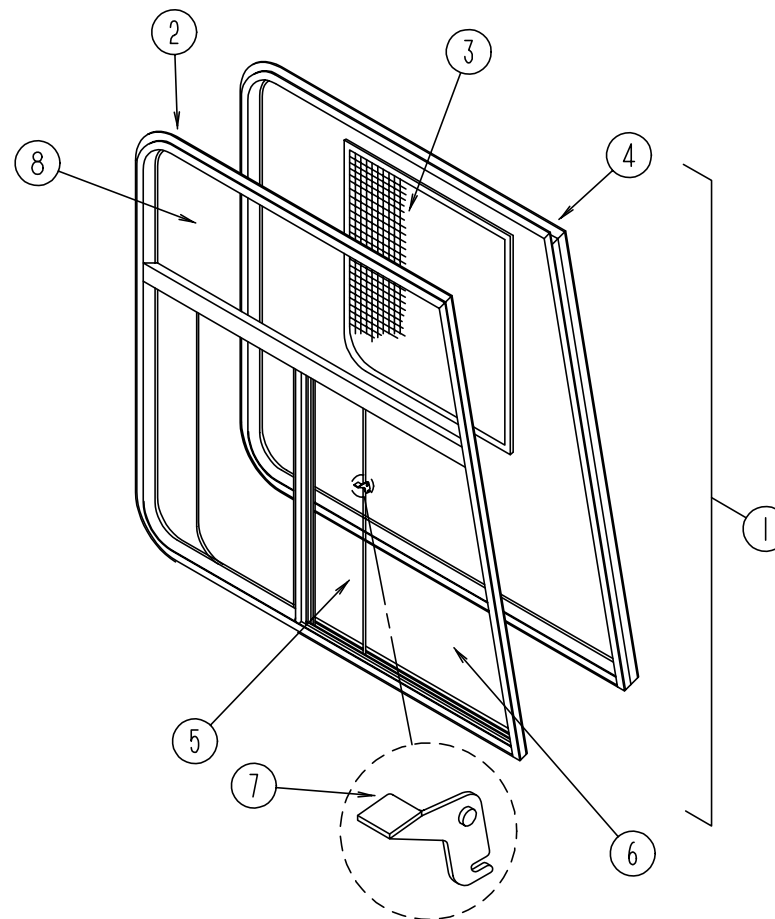

**FRONT CAB WINDOWS (EXCEL)**

KEY	PART NUMBER	U/M	DESCRIPTION
1	103658-07-01A	EA	WINDOW ASM. - CAB - W/ INSIDE FRAME - DRIVER SIDE
1	103658-08-01A	EA	WINDOW ASM. - CAB - W/ INSIDE FRAME - PASSENGER SIDE
2	103658-08-700	EA	WINDOW ASM. - SLIDER - W/O INSIDE FRAME - PASSENGER SIDE
2	103658-07-704	EA	WINDOW ASM. - SLIDER - W/O INSIDE FRAME - DRIVER SIDE
3	103658-01-700	EA	SCREEN ASM. - WINDOW - DRIVER SIDE
3	103658-02-700	EA	SCREEN ASM. - WINDOW - PASSENGER SIDE
	098644-01-717	FT	SCREEN SPLINE
	098644-01-713	EA	SCREEN CLIPS (METAL)(BLACK)
	098644-01-710	FT	TRACK - SPACER - FOR SCREEN 12'
	098644-01-711	FT	WEATHERSTRIP - SCREEN - BLACK
4	103658-08-701	EA	INSIDE FRAME - PASSENGER SIDE
4	103658-07-700	EA	INSIDE FRAME - DRIVER SIDE
5	103658-01-703	EA	GLASS - SLIDING - W/SASH & LATCH - DRIVER SIDE
5	103658-02-701	EA	GLASS - SLIDING - W/SASH & LATCH - PASSENGER SIDE
6	103658-01-702	EA	GLASS - STATIONARY - BOTTOM - DRIVER OR PASSENGER SIDE
7	098644-01-700	EA	LATCH - REPAIR KIT
8	103658-07-701	EA	GLASS - STATIONARY - TOP - DRIVER OR PASSENGER SIDE
	098644-01-708	FT	CHANNEL - PIERCED RUN
	098644-01-706	FT	WEATHERSTRIP - GLASS
	098644-01-716	FT	PLUG - FILLER

**WINDOW, VENT & EXTERIOR DOOR GROUP (CONTINUED)**

**EXCEL VISTA WINDOW**

KEY	PART NUMBER	U/M DESCRIPTION	VENDOR NO.
	106467-03-01A	EA WINDOW ASM-VISTA, LH - EXCEL H388-G2B27L	
	106467-03-700	EA GLASS-STATIONARY	106-018752
	106467-03-701	EA WINDOW	H388-G2L
	106467-03-702	EA RETAINER-TRIM, BLACK	H38827L

**EXCEL THERMOPANE VISTA WINDOW**

KEY	PART NUMBER	U/M DESCRIPTION
	116000-02-01A	EA WINDOW ASM-VISTA, LH - THERMOPANE - EXCEL DH388G2B27L

**EXCEL SLANT WINDOW**

KEY	PART NUMBER	U/M DESCRIPTION	VENDOR NO.
	106468-02-01A	EA WINDOW ASM-FRONT SLANT, LH - EXCEL H383-A2B27L	
	100322-01-703	FT STRIP-GLAZING, BUTYL	132-010723
	106468-02-700	EA WINDOW	H383-A2L
	106468-02-701	EA RETAINER-TRIM, BLACK	H383-27L
	106468-02-702	EA GLASS-STATIONARY	106-018740

**EXCEL THERMOPANE SLANT WINDOW**

KEY	PART NUMBER	U/M DESCRIPTION
	115999-02-01A	EA WINDOW ASM-FRONT SLANT, LH - THERMOPANE - EXCEL DH383A2B27L

**WINDOW, VENT & EXTERIOR DOOR GROUP (CONTINUED)**

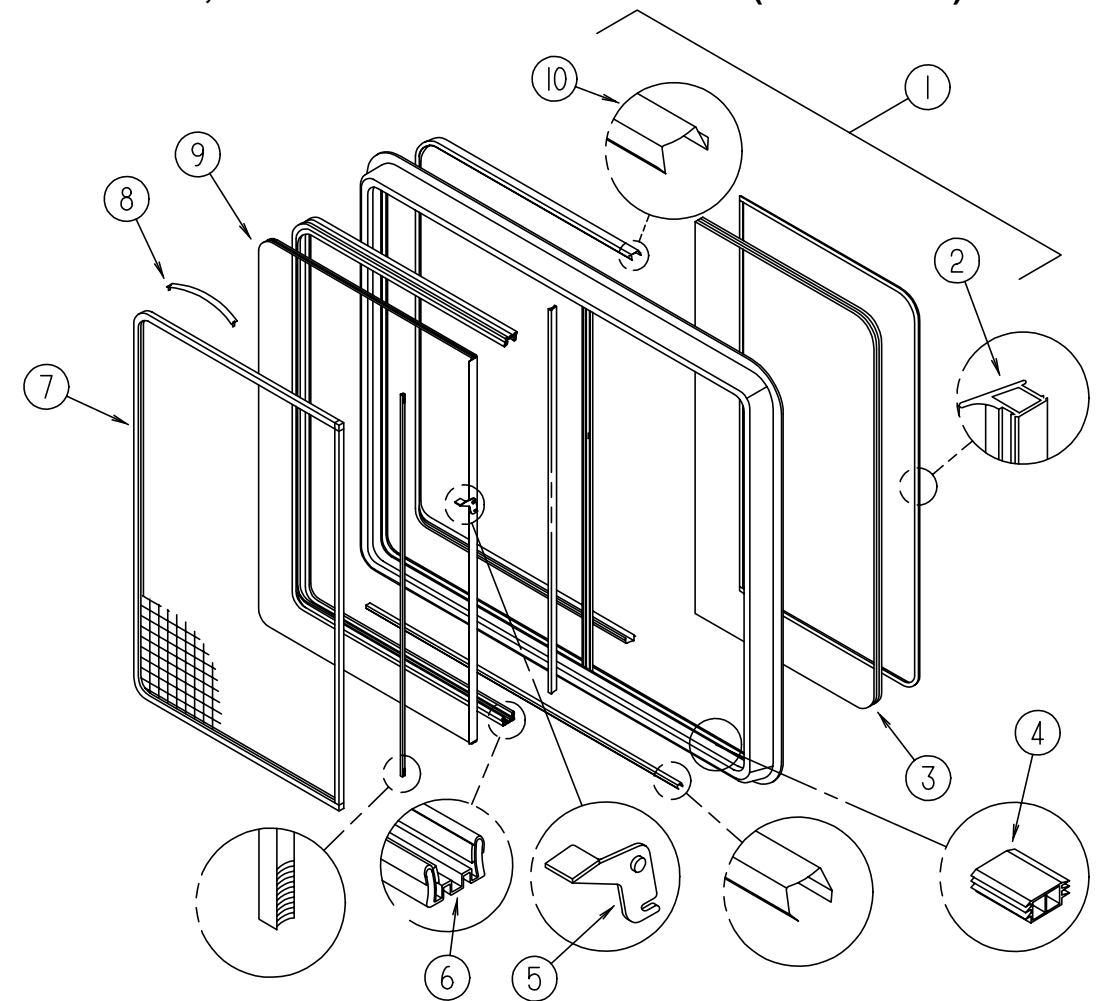

**STANDARD SINGLE SLIDER THERMOPANE WINDOW (EXCEL) (DRIVER SIDE LOUNGE)**

KEY	PART NUMBER	U/M DESCRIPTION	VENDOR NO.
1	112795-15-01A	EA WINDOW ASM-SLIDER, HORIZ THERMO - EXCEL DH287-G2W66L	
	112795-15-700	EA WINDOW W/O TRIM	DH287-G2L
	098647-23-702	EA RETAINER-TRIM, WHITE	W28766
2	112795-01-702	FT PLUG-FILLER	122-018737
3	112795-15-701	EA GLASS-STATIONARY	390-019045
4	112795-01-701	EA SLIDE-STOP	132-019092
5	112795-01-700	EA LATCH ASM., BLACK	DH287-CK
6	112795-01-703	IN CHANNEL-RUN	122-018736
7	098647-23-704	EA SCREEN ASM., W/SPRING CLIP	410-019066
8	098644-01-713	EA CLIP-SPRING, BLACK PLASTIC	226-016966
9	112795-15-702	EA GLASS-SLIDING, W/SASH & LATCH	DH287-G9
10	112795-01-704	FT VINYL-GLAZING	132-018280

**OPTION SINGLE SLIDER THERMOPANE WINDOW (EXCEL) (DRIVER SIDE LOUNGE)**

KEY	PART NUMBER	U/M DESCRIPTION	VENDOR NO.
1	112795-37-01A	EA WINDOW ASM-SLIDER, HORIZ THERMO - EXCEL DH442-G2W66L	
	112795-37-700	EA WINDOW W/O TRIM	DH442-G2L
	112795-37-701	EA RETAINER-TRIM, WHITE	W44266
2	112795-01-702	FT PLUG-FILLER	122-018737
3	112795-37-702	EA GLASS-STATIONARY	390-019499
4	112795-01-701	EA SLIDE-STOP	132-019092
5	112795-01-700	EA LATCH ASM., BLACK	DH287-CK
6	112795-01-703	IN CHANNEL-RUN	122-018736
7	112795-37-704	EA SCREEN ASM., W/SPRING CLIP	410-019501
8	098644-01-713	EA CLIP-SPRING, BLACK PLASTIC	226-016966
9	112795-37-703	EA GLASS-SLIDING, W/SASH & LATCH	DH442-G9
10	112795-01-704	FT VINYL-GLAZING	132-018280

**WINDOW, VENT & EXTERIOR DOOR GROUP (CONTINUED)**

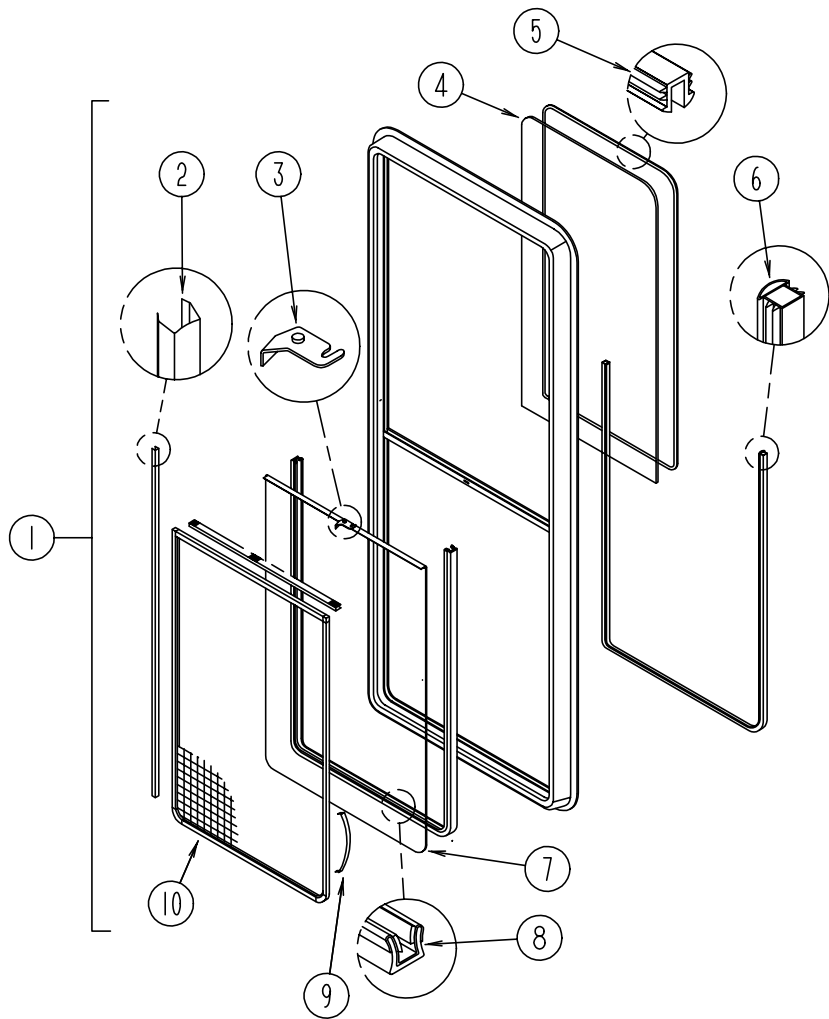

**EXCEL PASSENGER SIDE LOUNGE WINDOW**

KEY	PART NUMBER	U/M DESCRIPTION	VENDOR NO.
1	098644-09-01A	EA WINDOW ASM-SINGLE RAISE B/OW - EXCEL H446-G2W66	
	098644-09-700	EA WINDOW-SLIDER	H446-G2
	098644-09-701	EA RETAINER-TRIM, OFF WHITE	W44666
2	098644-01-710	FT TRACK-SCREEN SPACER, 12'	132-017135
	098644-01-711	FT WEATHERSTRIP-SCREEN, BLACK	171-016965
3	098644-01-700	EA LATCH-REPAIR KIT (BLACK)	B801-CK
4	098644-09-702	EA GLASS-STATIONARY	106-019509
5	100322-01-703	FT STRIP-GLAZING, BUTYL	132-010723
6	098644-01-706	FT WEATHERSTRIP-GLASS	171-010668
7	098644-09-703	EA GLASS-SLIDING, W/SASH & LATCH	H446-G9
8	098644-01-708	FT CHANNEL-RUN, PIERCED	122-016543
9	098644-01-713	EA CLIP-SPRING, BLACK PLASTIC	226-016966
10	098644-09-704	EA SCREEN ASM., W/SPRING CLIP	410-019511
	098644-01-716	FT PLUG-FILLER	132-014470
	098644-01-717	FT SPLINE-SCREEN	132-004716
	098644-01-719	EA STOP-SLIDER GLASS	132-014203
	112898-04-703	EA SASH LATCH KIT, RAISED	DH343-CK

**WINDOW, VENT & EXTERIOR DOOR GROUP (CONTINUED)**

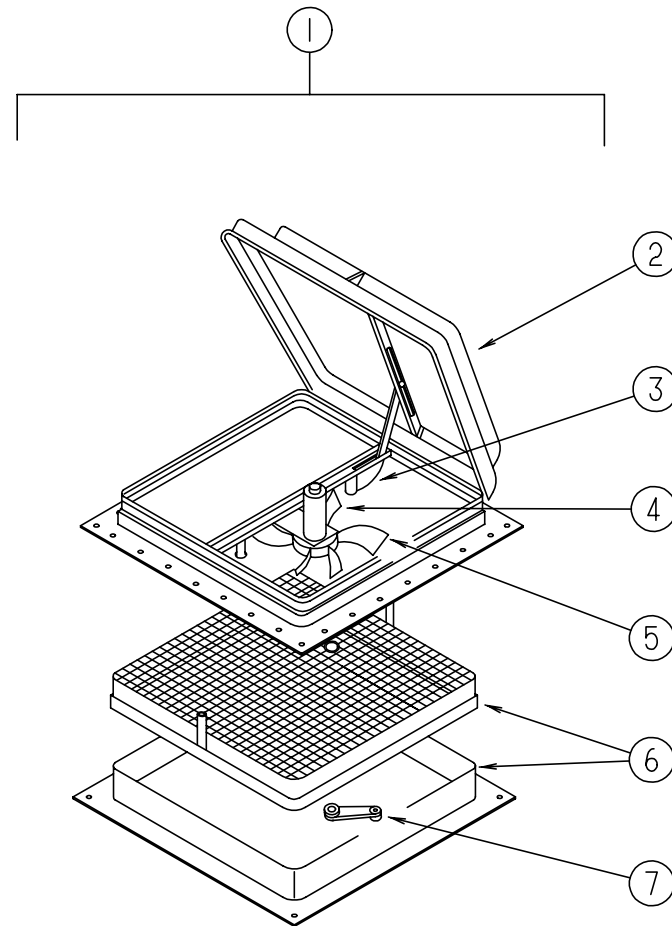

**POWERED ROOF VENT (US) (JENSEN)**

KEY	PART NUMBER	U/M DESCRIPTION	VENDOR NO.
1	110051-04-01A	EA VENT ASM. - ROOF - POWERED - 7797	
2	064470-01-700	EA COVER - ROOF VENT	7291
3	110051-01-702	EA GEAR - LIFT-ARM ASM.	RP-1000B
4	048648-01-000	EA MOTOR - 12V NONVENTED 1/8 SHAFT - 42-472-01	
5	048649-01-000	EA FAN - PLASTIC - 6 IN - 6 BLADED - RP-10002B	
6	110051-01-704	EA SCREEN & FRAME	29-688-03
7	110051-01-703	EA CRANK HANDLE	RP-1031-B
	064470-01-701	EA SLIDE BAR, (VENT-LID)	JRP1291B
	110051-02-700	EA GARNISH-INTERIOR, 4"	

**POWERED ROOF VENT (CANADIAN) (JENSEN)**

KEY	PART NUMBER	U/M DESCRIPTION	VENDOR NO.
1	110051-06-01A	EA VENT ASM. - ROOF - POWERED - C7797	
2	064470-01-700	EA COVER - ROOF VENT	7291
3	110051-01-702	EA GEAR - LIFT-ARM ASM.	RP-1000B
4	048648-01-000	EA MOTOR - 12V NONVENTED 1/8 SHAFT - 42-472-01	
5	048649-01-000	EA FAN - PLASTIC - 6 IN - 6 BLADED - RP-10002B	
6	110051-01-704	EA SCREEN & FRAME	29-688-03
7	110051-01-703	EA CRANK HANDLE	RP-1031-B
	064470-01-701	EA SLIDE BAR, (VENT-LID)	JRP1291B
	110051-02-700	EA GARNISH-INTERIOR, 4"	

**WINDOW, VENT & EXTERIOR DOOR GROUP (CONTINUED)**

**NON POWERED ROOF VENT (JENSEN)**

KEY	PART NUMBER	U/M DESCRIPTION	VENDOR NO.
	110051-02-01A	EA ROOF VENT - W/ SCREEN - 7727	
	064470-01-700	EA COVER - ROOF VENT	7291
	110051-01-702	EA GEAR - LIFT-ARM ASM.	RP-1000B
	110051-01-703	EA CRANK HANDLE	RP-1031-B
	110051-01-704	EA SCREEN & FRAME	29-688-03
	064470-01-701	EA SLIDE BAR, (VENT-LID)	JRP1291B
	110051-02-700	EA GARNISH-INTERIOR, 4"	

**POWERED ROOF VENT (FANTASTIC) (US)**

KEY	PART NUMBER	U/M DESCRIPTION	VENDOR NO.
	084079-14-000	EA VENT - EXHAUST - POWERED - OFF WHITE	
	084079-01-700	EA VENT COVER	1020K-19
	084079-01-701	EA SCREEN ASM. - OFF WHITE	1030-80
	084079-01-702	EA ARM LIFT ASSEMBLY - MANUAL	101105
	084079-01-703	EA KNOB - LIFT - W/ EXTENTION & SCREW	1140K-00
	084079-01-707	EA SWITCH - SAFETY	1122.05
	084079-01-709	EA SWITCH - MAIN POWER - 3 SPEED	1031-05
	084079-07-700	EA GARNISH - INTERIOR - 4" - OFF WHITE	2040-80
	084079-11-700	EA MOTOR, BRACKET, & FAN BLADE KIT	4017K-09
	084079-11-702	EA BASE - MAIN W/ DOME SWITCH	1010K-81

**POWERED ROOF VENT (FANTASTIC) (CSA)**

KEY	PART NUMBER	U/M DESCRIPTION	VENDOR NO.
	084079-15-000	EA VENT - EXHAUST - POWERED - OFF WHITE	
	084079-01-700	EA VENT COVER	1020K-19
	084079-01-701	EA SCREEN ASM. - OFF WHITE	1030-80
	084079-01-702	EA ARM LIFT ASSEMBLY - MANUAL	101105
	084079-01-703	EA KNOB - LIFT - W/ EXTENTION & SCREW	1140K-00
	084079-01-707	EA SWITCH - SAFETY	1122.05
	084079-01-709	EA SWITCH - MAIN POWER - 3 SPEED	1031-05
	084079-07-700	EA GARNISH - INTERIOR - 4" - OFF WHITE	2040-80
	084079-11-700	EA MOTOR, BRACKET, & FAN BLADE KIT	4017K-09
	084079-11-702	EA BASE - MAIN W/ DOME SWITCH	1010K-81

**WINDOW, VENT & EXTERIOR DOOR GROUP (CONTINUED)**

**ROOF VENTS**

KEY	PART NUMBER	U/M DESCRIPTION
	083558-04-000	EA VENT COVER - PLUMBING PIPE - ROOF - BUFF
	084073-05-000	EA COVER-ROOF VENT, REFRIGERATOR - BUFF - NORCOLD
	084073-04-000	EA BASE-ROOF VENT, REFRIGERATOR - BLACK - NORCOLD
	118369-01-01A	EA VENT-ROOF CAP, REFRIGERATOR - BUFF - DOMETIC
	118369-02-01A	EA VENT-ROOF BASE, REFRIGERATOR - BUFF - DOMETIC

**SIDEWALL VENTS**

KEY	PART NUMBER	U/M DESCRIPTION
	084616-06-000	EA SHROUD - RANGE HOOD VENT - BUFF
	084878-09-000	EA VENT - RANGE HOOD - SHORT - LVS

# WINDOW, VENT & EXTERIOR DOOR GROUP (CONTINUED)

## EXTERIOR DOORS

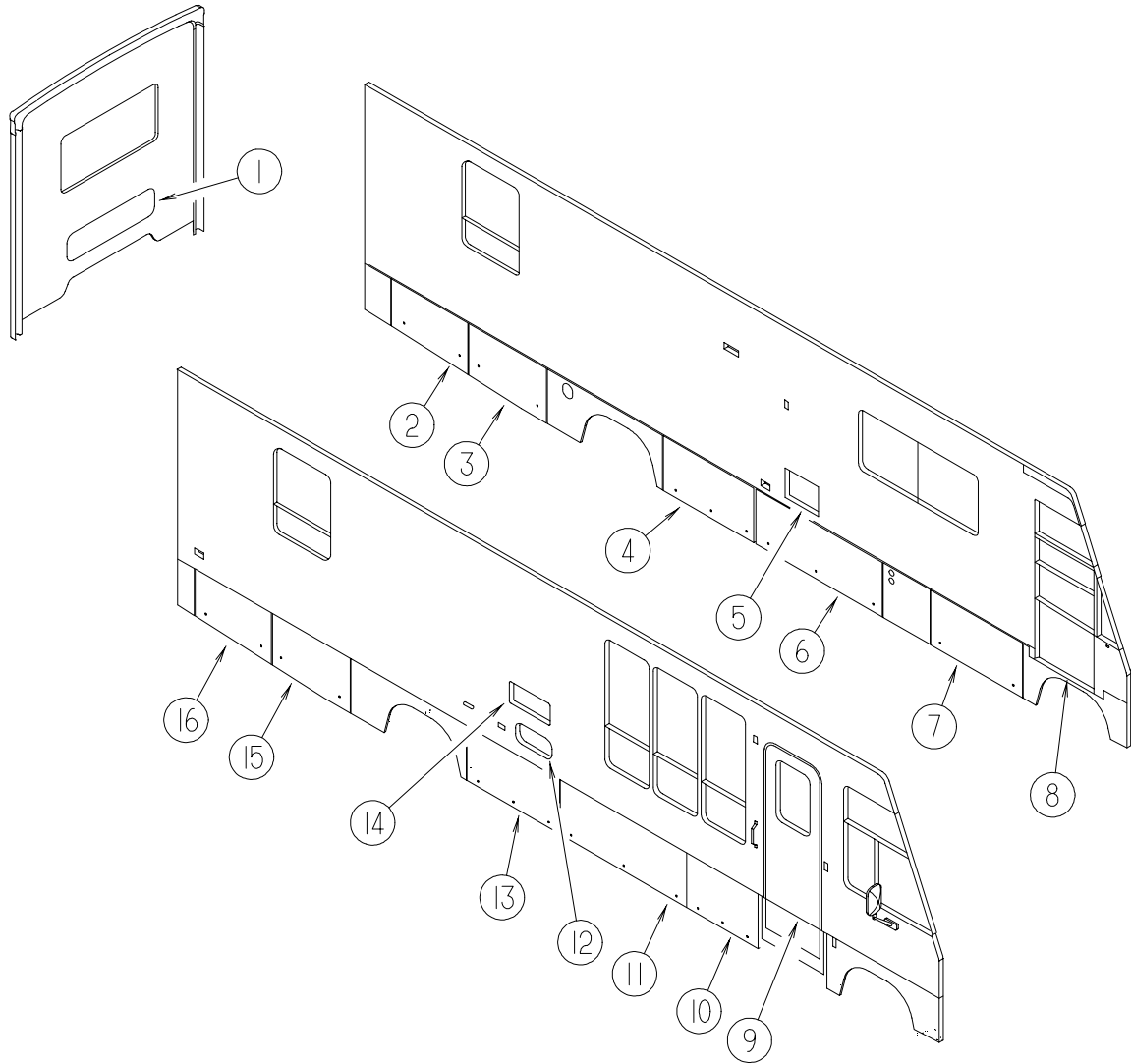

KEY	PART NUMBER	U/M	DESCRIPTION	
1	111013-13-G15	EA	DOOR ASM - STORAGE	
				FROM: 00-00-00 THRU: 11-19-95
1	111013-63-G15	EA	DOOR ASM - STORAGE	
				FROM: 11-20-95 THRU: 99-99-99
2	118789-04-G15	EA	DOOR ASM - STORAGE	
3	118789-02-G15	EA	DOOR ASM - STORAGE	
4	118791-24-G15	EA	DOOR ASM-STORAGE	
				FROM: 00-00-00 THRU: 11-19-95
4	121294-24-G15	EA	DOOR ASM-STORAGE	
				FROM: 11-20-95 THRU: 99-99-99
5	052009-04-000	EA	DOOR - WATER HEATER - BUFF	
6	118791-02-G15	EA	DOOR ASM-STORAGE	
				FROM: 00-00-00 THRU: 11-19-95
6	121294-02-G15	EA	DOOR ASM-STORAGE	
				FROM: 11-20-95 THRU: 99-99-99
7	118791-01-G15	EA	DOOR ASM-STORAGE	
				FROM: 00-00-00 THRU: 11-19-95
7	121294-01-G15	EA	DOOR ASM-STORAGE	
				FROM: 11-20-95 THRU: 99-99-99
8	106469-07-01A	EA	DOOR ASM - DRIVERS, BLACK - EXCEL V130-01L	
9	115108-02-G15	EA	DOOR - ENTRANCE - W/ SCREEN - W/O WINDOW	
9	115108-02-G16	EA	DOOR - ENTRANCE - W/ SCREEN - W/O WINDOW	
9	115108-02-G17	EA	DOOR - ENTRANCE - W/ SCREEN - W/O WINDOW	
10	118791-18-G15	EA	DOOR ASM-STORAGE	
				FROM: 00-00-00 THRU: 11-19-95
10	121294-18-G15	EA	DOOR ASM-STORAGE	
				FROM: 11-20-95 THRU: 99-99-99
11	118791-15-G15	EA	DOOR ASM-STORAGE	
				FROM: 00-00-00 THRU: 11-19-95
11	121294-27-G15	EA	DOOR ASM-STORAGE	
				FROM: 11-20-95 THRU: 99-99-99
12	111017-01-E10	EA	DOOR ASM - ACCESS - EXTERIOR RADIO	
13	118791-03-G15	EA	DOOR ASM-STORAGE	
				FROM: 00-00-00 THRU: 11-19-95
13	121294-03-G15	EA	DOOR ASM-STORAGE	
				FROM: 11-20-95 THRU: 99-99-99
14	118368-01-04A	EA	VENT-DOOR REFRIGERATOR, BUFF (SIDE BY SIDE)	
14	084103-06-000	EA	DOOR - REFRIGERATOR - VENTED - JAMB - BUFF	
14	084104-06-000	EA	JAMB - REFRIGERATOR - BUFF	
15	118789-01-G15	EA	DOOR ASM - STORAGE	
16	118789-03-G15	EA	DOOR ASM - STORAGE	

## WINDOW, VENT & EXTERIOR DOOR GROUP (CONTINUED)

### DRIVER DOOR INTERIOR COMPONENTS

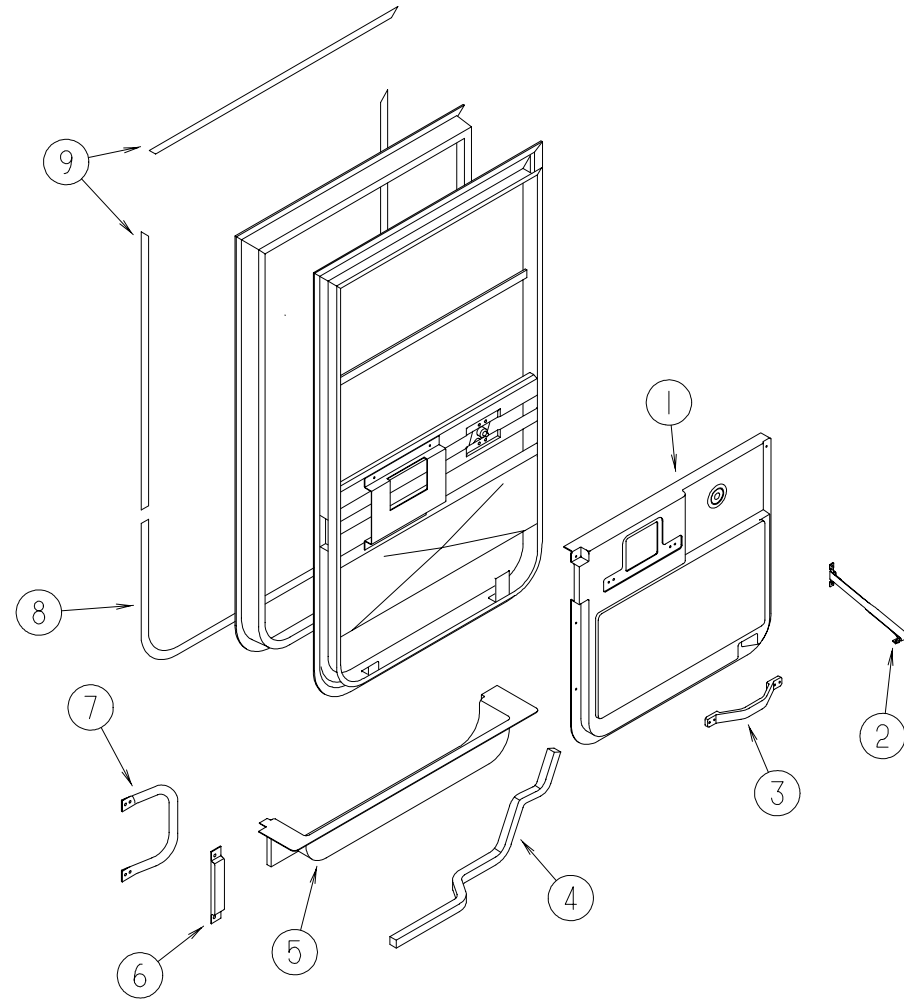

KEY	PART NUMBER	U/M DESCRIPTION
1	114973-01-02A	EA PANEL - DRIVER DOOR - INNER - WILLOW - PLASTIC
2	109378-01-000	EA STRAP - CHECK - DRIVER DOOR - 12.8"
3	110604-01-01A	EA HANDLE - ASSIST - DRIVERS DOOR
4	063977-12-000	EA STEP - DRIVER DOOR - LEFT - PAINTED
4	063977-11-000	EA STEP - DRIVER DOOR - LEFT - UNPAINTED
5	107818-01-01A	EA TRIM - STEP - DRIVERS DOOR - PLASTIC - WILLOW
	106746-01-000	EA PANEL - STEEL - STEPWELL
	106747-01-000	EA PANEL - STEEL - STEPWELL - END RH
	106747-02-000	EA PANEL - STEEL - STEPWELL - END LH
	102569-02-000	EA MAT - ANTI SLIP - LOWER

KEY	PART NUMBER	U/M DESCRIPTION
6	108654-01-01A	EA COVER - STRIKE - DRIVERS DOOR - BLACK
7	108832-01-02A	EA HANDLE - ASSIST - DRIVERS DOOR - METAL - OFF WHITE
	108833-01-01A	EA COVER - HANDLE - ASSIST - OFF WHITE
8	109235-01-05A	FT COVER - SCREW - BRIGHT WHITE - DAWN
9	109235-01-01A	FT COVER - SCREW - MATTE BLACK - DAWN
	108129-02-02A	EA GARNISH - DRIVERS DOOR - FRONT - BLACK
	108107-01-02A	EA GARNISH - DRIVERS DOOR - TOP - BLACK
	108108-04-02A	EA GARNISH - DRIVERS DOOR - REAR UPPER - BLACK
	108897-02-01A	EA GARNISH - DRIVERS DOOR - REAR LOWER - BLACK
	P01713-01-000	EA SWITCH - PUSH BUTTON - IN DOOR JAMB - METAL CHROME
	076725-06-000	EA COVER - ACCESS - DOOR JAMB PUSH BUTTON - BLACK



# WINDOW, VENT & EXTERIOR DOOR GROUP (CONTINUED)

## DRIVER DOOR (EXCEL)

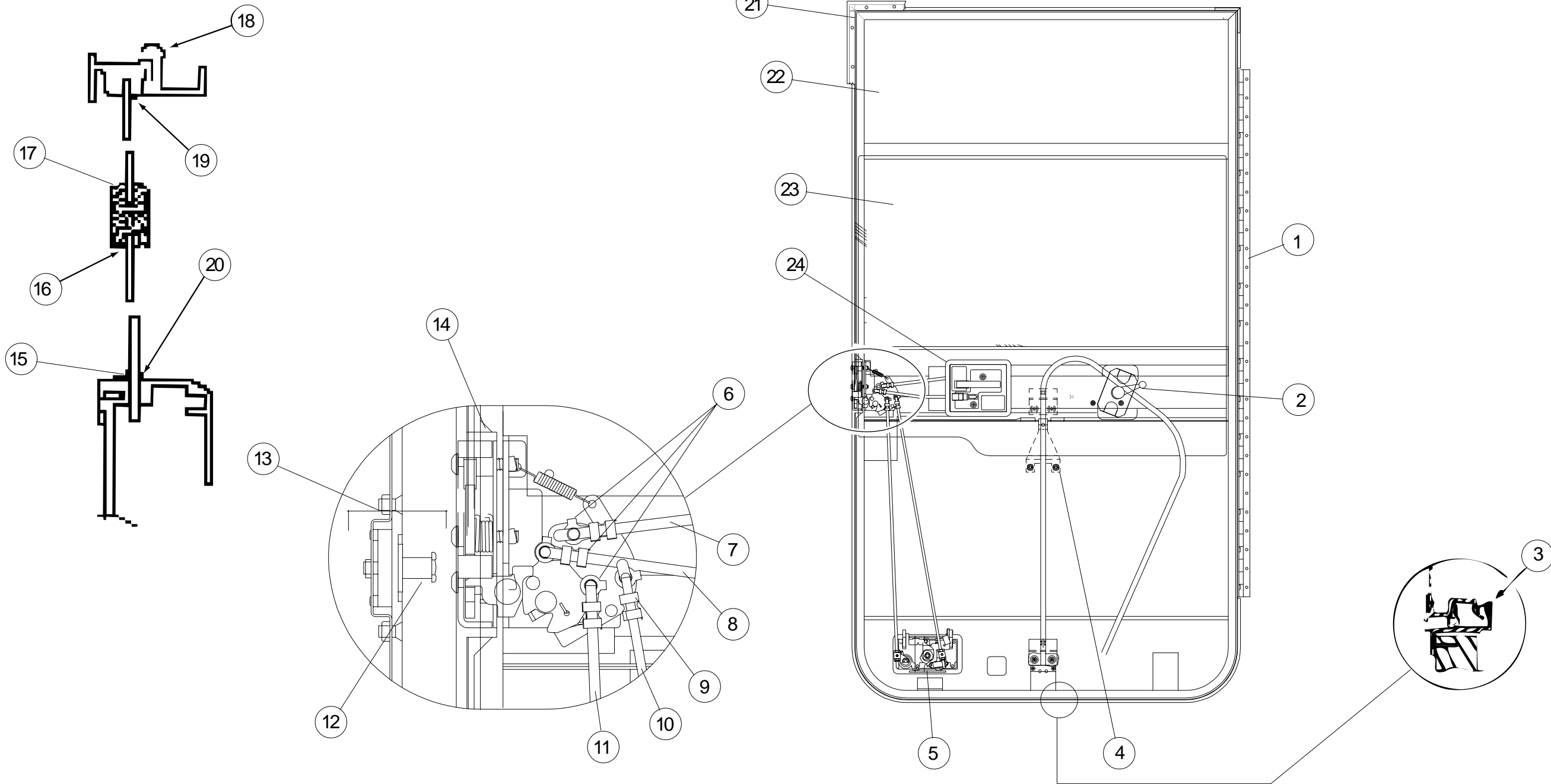

KEY	PART NUMBER	U/M DESCRIPTION	VENDOR NO.
	106469-07-01A	EA DOOR ASM. - DRIVERS - BLACK - V130-01L	
1	106469-05-702	EA HINGE - 42"	211-041194
2	106469-02-704	EA WINDOW HANDLE	V068-16
3	106469-01-723	EA SEAL - BULB ASM. (JAMB)	171-040985
4	106469-02-701	EA REGULATOR - MANUAL	V108-90L
5	106469-04-700	EA PADDLE ASSEMBLY-W/COLLAR	248-041237
5	106469-04-715	EA LATCH COMPLETE W/TUMBLER & KEYS	V123-15
6	106469-04-714	EA ROD CLIP R.H.	248-041153
7	106469-04-705	EA LATCH ROD - HORIZONTAL	203-041139
8	106469-04-711	EA LOCK ROD - HORIZONTAL	203-041137
9	106469-04-713	EA ROD CLIP L.H.	248-041154
10	106469-05-703	EA ROD - LOCK/VERTICAL ADJUST.	203-041239
11	106469-05-705	EA ROD - LATCH/VERTICAL ADJUST.	203-041279
12	106469-04-703	EA BOLT - STRIKER (W/ WASHER)	248-041152
13	106469-04-704	EA NUT ASSEMBLY - CAGED - W/STRIKER	248-041151

KEY	PART NUMBER	U/M DESCRIPTION	VENDOR NO.
14	106469-05-706	EA LATCH - ROTARY - W/LINKAGE	248-041150
15	106469-02-703	EA BELT WEATHERSTRIP (EXT) WDO	V047-57
16	106469-01-705	FT CHANNEL - RUN - SLIDING	122-010850
17	106469-08-700	EA MULLION RAIL	V103-84
18	106469-01-702	EA DOOR SEAL	122-040984
19	125581-02-705	EA HORIZONTAL GLAZING - VINYL	V108-87
20	106469-01-709	FT WEATHERSTRIP - FUZZY	171-040630
21	106469-07-700	EA MOUNTING FRAME ASSEMBLY	V130-30L
22	106469-02-702	EA GLASS - STATIONARY	106-041104
23	106469-01-704	EA GLASS - ROLL-UP W/BRACKET	V103-65L
24	106469-04-712	EA HANDLE/DOOR - INNER W/HARDWARE	248-041402
24	106469-04-716	EA LEVER - LOCKING - BLACK	80978-00
	106469-04-701	EA TUMBLER & KEYS (TRI-MARK)	248-041179
	106469-04-702	EA KEYS (BLANK)	248-041180
	125582-01-708	EA WEEPHOLE COVER - RIGHT HAND	130-026598
	125582-01-709	EA WEEPHOLE COVER - LEFT HAND	130-026599

## WINDOW, VENT & EXTERIOR DOOR GROUP (CONTINUED)

NOTE:  
 WHEN ORDERING THE LOCK CASE, THE KEY CODE MUST MATCH THE LAST DIGIT OF THE VEHICLE'S SERIAL NUMBER AND PART NUMBER; WHEN ORDERING THE KEYS, THE THIRD DIGIT OF THE KEY CODE MUST MATCH THE LAST DIGIT OF THE VEHICLE'S SERIAL NUMBER AND PART NUMBER

### BRIGGS & STRATTON LOCKS & COMPONENTS

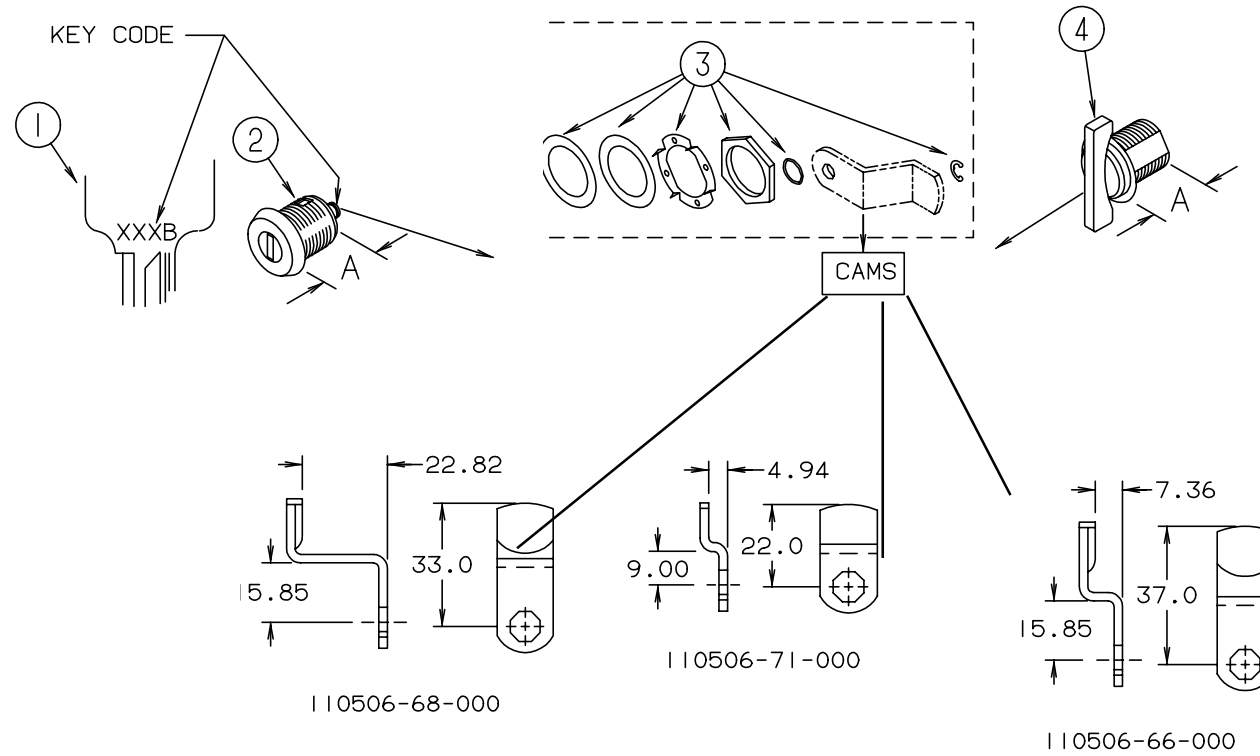

KEY	PART NUMBER	U/M	DESCRIPTION	VENDOR NO.	KEY	PART NUMBER	U/M	DESCRIPTION	VENDOR NO.
1	110506-59-000	EA	KEYS - SET OF TWO	596720	1	110506-59-006	EA	KEYS - SET OF TWO	596726
2	110506-52-000	EA	CASE - LOCK - A= 17 MM	702370	2	110506-52-006	EA	CASE - LOCK - A= 17 MM	702376
2	110506-53-000	EA	CASE - LOCK - A= 25 MM	702380	2	110506-53-006	EA	CASE - LOCK - A= 25 MM	702386
2	110506-54-000	EA	CASE - LOCK - A= 32 MM	703170	2	110506-54-006	EA	CASE - LOCK - A= 32 MM	703176
1	110506-59-001	EA	KEYS - SET OF TWO	596721	1	110506-59-007	EA	KEYS - SET OF TWO	596727
2	110506-52-001	EA	CASE - LOCK - A= 17 MM	702371	2	110506-52-007	EA	CASE - LOCK - A= 17 MM	702377
2	110506-53-001	EA	CASE - LOCK - A= 25 MM	702381	2	110506-53-007	EA	CASE - LOCK - A= 25 MM	702387
2	110506-54-001	EA	CASE - LOCK - A= 32 MM	703171	2	110506-54-007	EA	CASE - LOCK - A= 32 MM	703177
1	110506-59-002	EA	KEYS - SET OF TWO	596722	1	110506-59-008	EA	KEYS - SET OF TWO	596728
2	110506-52-002	EA	CASE - LOCK - A= 17 MM	702372	2	110506-52-008	EA	CASE - LOCK - A= 17 MM	702378
2	110506-53-002	EA	CASE - LOCK - A= 25 MM	702382	2	110506-53-008	EA	CASE - LOCK - A= 25 MM	702388
2	110506-54-002	EA	CASE - LOCK - A= 32 MM	703172	2	110506-54-008	EA	CASE - LOCK - A= 32 MM	703178
1	110506-59-003	EA	KEYS - SET OF TWO	596723	1	110506-59-009	EA	KEYS - SET OF TWO	596729
2	110506-52-003	EA	CASE - LOCK - A= 17 MM	702373	2	110506-52-009	EA	CASE - LOCK - A= 17 MM	702379
2	110506-53-003	EA	CASE - LOCK - A= 25 MM	702383	2	110506-53-009	EA	CASE - LOCK - A= 25 MM	702389
2	110506-54-003	EA	CASE - LOCK - A= 32 MM	703173	2	110506-54-009	EA	CASE - LOCK - A= 32 MM	703179
1	110506-59-004	EA	KEYS - SET OF TWO	596724	3	110506-40-700	EA	HARDWARE KIT	
2	110506-52-004	EA	CASE - LOCK - A= 17 MM	702374	4	110506-50-000	EA	CASE - TWIST LOCK - A= 17 MM	596952
2	110506-53-004	EA	CASE - LOCK - A= 25 MM	702384	4	110506-51-000	EA	CASE - TWIST LOCK - A= 25 MM	596669
2	110506-54-004	EA	CASE - LOCK - A= 32 MM	703174	4	110506-55-000	EA	CASE - TWIST LOCK - A= 32 MM	597312AA1
1	110506-59-005	EA	KEYS - SET OF TWO	596725		110506-40-000	EA	CLIP-E - LOCK ASM.	93981
2	110506-52-005	EA	CASE - LOCK - A= 17 MM	702375		110506-59-701	EA	KEY BLANK - GOLD	
2	110506-53-005	EA	CASE - LOCK - A= 25 MM	702385					
2	110506-54-005	EA	CASE - LOCK - A= 32 MM	703175					

# WINDOW - VENT & EXTERIOR DOOR GROUP (CONTINUED)

## ENTRY DOOR W/O WINDOW

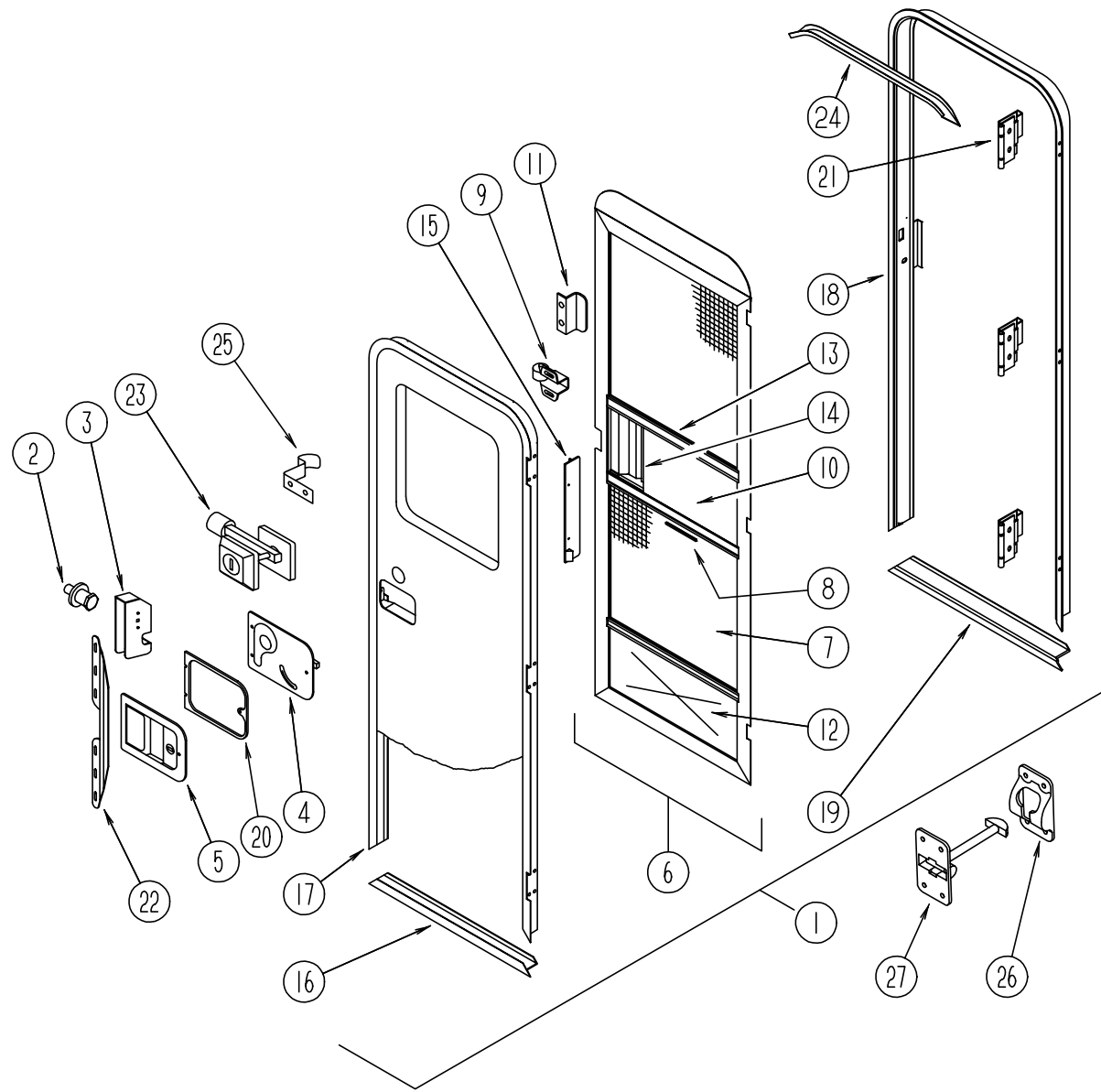

KEY	PART NUMBER	U/M	DESCRIPTION
1	115108-02-G15	EA	DOOR - ENTRANCE - W/ SCREEN - W/O WINDOW
1	115108-02-G16	EA	DOOR - ENTRANCE - W/ SCREEN - W/O WINDOW
1	115108-02-G17	EA	DOOR - ENTRANCE - W/ SCREEN - W/O WINDOW
2	039539-01-000	EA	STRIKE - LOCK - ENTRY DOOR - ROUND W/THREADED WASHER
	077461-03-000	EA	COVER - STRIKE - ENTRY DOOR - 6.5" X 2.5" - PLASTIC - OFF WHITE
3	039540-01-000	EA	LATCH MECHANISM - HOOK - ENTRY DOOR - INTERIOR
	039715-01-000	EA	NUT - SERT - 1/4" DIAMETER - 20 THREADS
4	039979-06-000	EA	COVER ASM - LATCH PLATE, RH - BLACK - T/M 11883-01
	039984-01-000	EA	CAP - ROUND - VINYL - .28" ID X .62" LONG - BLACK
	041546-05-000	EA	BRACKET - DOOR ANGLE - 5" X 1.9" - METAL - OFF WHITE
			FROM: 00-00-00 THRU: 10-22-95
	041546-07-000	EA	BRACKET - DOOR ANGLE - METAL - OFF WHITE
			FROM: 10-23-95 THRU: 99-99-99
5	045017-13-000	EA	LATCH - ENTRY DOOR - BLACK - T/M 11896-01
	045017-11-701	EA	KEY - BLANK - ROUND TOP - SILVER - TRI/ MARK
	058806-03-000	EA	PLUG - TAPERED - PLASTIC - 1.06" DIAMETER - RED
	063729-04-000	EA	RIVNUT - 10-32 UNF - .010-.080
	072893-01-000	EA	NUT-SERT - M5 X 0 8
	075671-04-000	FT	SEAL - SPONGE - LAZY T SHAPE - W/ADHESIVE STRIPE - .5" WIDE
6	079012-05-B10	EA	DOOR - SCREEN - ENTRANCE DOOR
7	002293-02-000	SF	SCREENING - WINDOW/DOOR - 26" - CHARCOAL
8	002294-01-000	FT	SPLINE - SCREENING - .135" X .138" - BLACK
9	100412-01-000	EA	CATCH - SCREEN DOOR
10	016454-01-000	EA	INSERT - CENTER - LEATHER GRAIN ALUMINUM - UNPAINTED
	001014-01-013	EA	SHEET - ALUMINUM - LEATHER GRAIN - 10.25" X 16.31" - UNPAINTED
11	050712-04-000	EA	HANDLE - SCREEN DOOR - ALUMINUM - OFF WHITE
12	078552-03-000	EA	KICK PANEL - SCREEN DOOR - LOWER INSERT - UNPAINTED
	078595-01-000	EA	TOP PLATE - SCREEN DOOR - CURVED TOP - 4.7" X 25.35"
13	078777-01-000	EA	CHANNEL - SLIDE - SCREEN DOOR CENTER SLIDER COVER
14	079086-02-000	EA	SLIDER - SCREEN DOOR - OFF WHITE
15	079087-02-000	EA	STRIKE - SLIDER - W/ LIP FOR ELBOW CATCH - 1.5" X 8.6" - OFF WHITE
16	089748-09-000	EA	FRAME - BOTTOM - ENTRY DOOR - 24.8" LONG - BUFF
	090340-02-000	FT	SEAL - FOAM - CLOSED CELL - 3/8" X 1/2" X 50'
17	095276-03-05A	EA	FRAME - ENTRANCE DOOR - BUFF
18	095277-04-05A	EA	JAMB - ENTRANCE DOOR - BUFF
19	051049-01-000	EA	JAMB - BOTTOM - ENTRY DOOR - 25.9" - UNPAINTED
20	096810-01-01A	EA	PLATE - LATCH - ENTRY DOOR - PLASTIC - BLACK
21	106719-01-01A	EA	HINGE - ENTRANCE DOOR - MILL
22	098173-01-04A	EA	STIFFENER - ENTRY DOOR - SUPPORTS LATCH/STRIKE AREA - UNPAINTED
	118929-01-01A	FT	SEAL - PILE, PUSH-ON - AMESBURY XC-964
23	101145-01-04A	EA	DEADBOLT - ENTRY DOOR - BUFF/BLACK
	095229-01-700	EA	KEY - BLANK, DEADBOLT - 81205-03
	101145-01-701	EA	CYLINDER - LOCK ASM, W/KEY - 81306-03
	101147-01-000	EA	BOLT - SECURITY - 4.12" BACKSET
	102524-01-000	EA	BUMPER - RUBBER - FLAT - BLACK
	040944-01-000	EA	LABEL - ENTRANCE DOOR - "OPEN"
24	044582-33-000	EA	CAP - DRIP - DOOR JAMB MOUNTED -
	115222-02-01A	EA	GARNISH - RADIUS - ENTRANCE DOOR - OFF WHITE
25	100412-01-000	EA	CATCH - SCREEN DOOR - THUMB CLIP
26	104099-02-01A	EA	CATCH - DOOR HOLDER - RETAINER - OFF WHITE
27	104099-01-01A	EA	CATCH - DOOR HOLDER - STRIKE - OFF WHITE
	009126-03-000	EA	HANDLE - ASSIST - BLACK TEXTURED - T/M 10087-01
	093673-01-01A	FT	TRIM - ENTRANCE DOOR - 1.4" WIDE X 8' LONG - OFF WHITE PLASTIC
	102248-01-000	EA	SHIM - DOOR

WINDOW, VENT & EXTERIOR DOOR GROUP (CONTINUED)

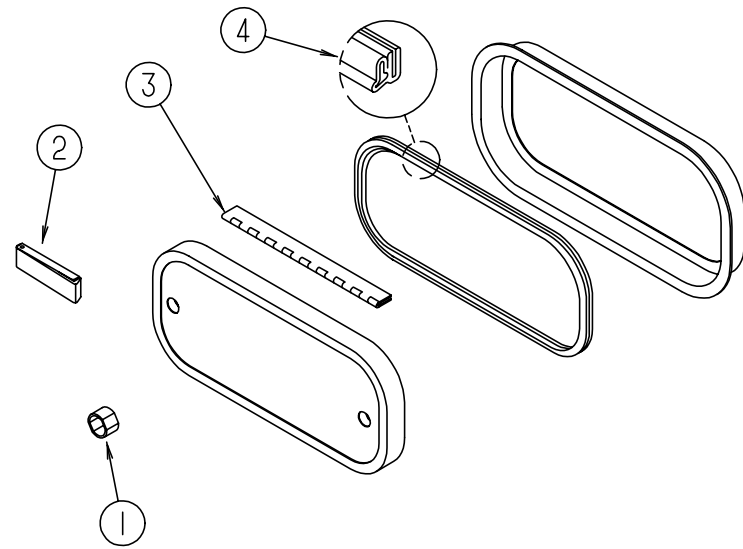

EXTERIOR DOOR HARDWARE

KEY	PART NUMBER	U/M DESCRIPTION
1	107997-51-001	EA SPACER - .86" X .6" - ALUMINUM
2	102768-01-000	EA HOLDER - COMPARTMENT/ ENTRY DOOR - METAL - MILL FINISH
3	081801-08-000	EA HINGE - PIANO - 2" X 96" - BUFF
4	064075-07-000	FT SEAL - BULB - W/ WIRED U CHANNEL - .3" X .5" CHANNEL - BLACK

WINDOW, VENT & EXTERIOR DOOR GROUP (CONTINUED)

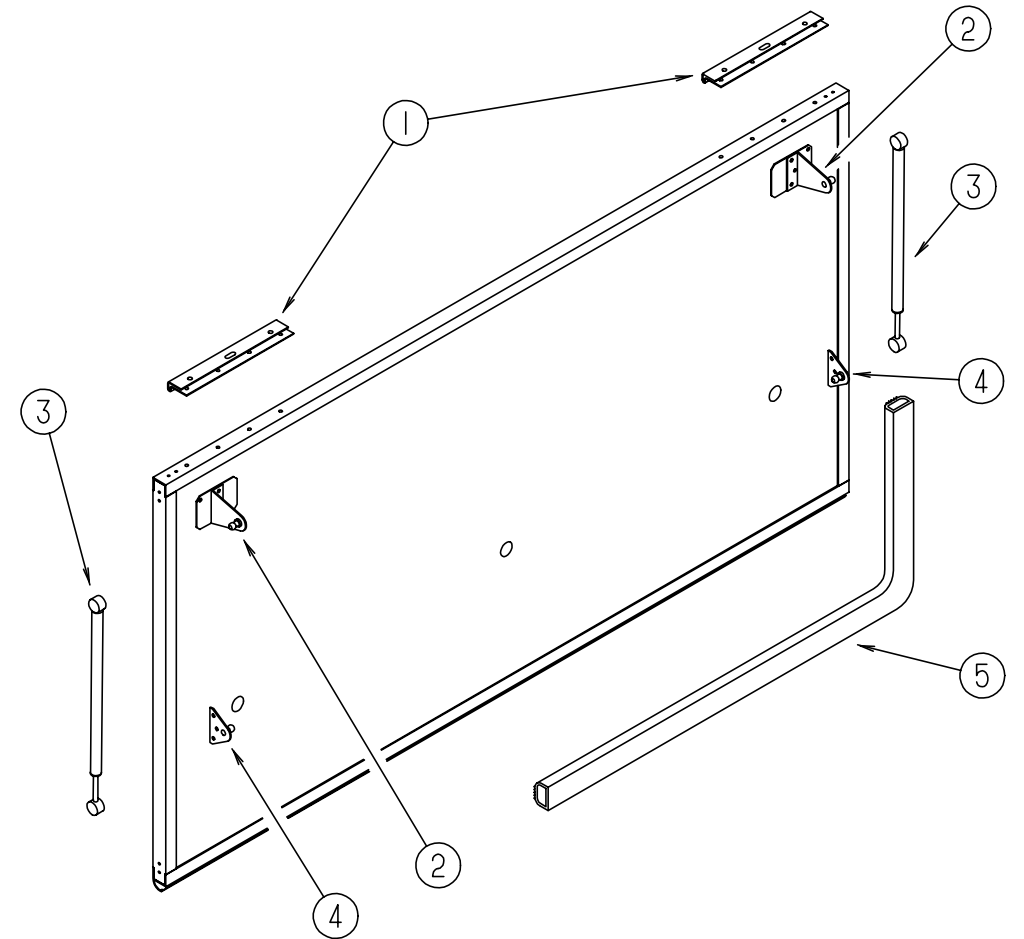

EXTERIOR DOOR HARDWARE

KEY	PART NUMBER	U/M DESCRIPTION
1	120774-01-02B	EA HINGE - 8.00 INCH - E-COAT
2	108998-02-000	EA BRACKET - L W/BALL STUD
3	107796-04-000	EA GAS SPRING - 12" COMPRESSED/ 20" EXTENDED - 20 LB
4	107796-05-000	EA BRACKET - GAS SPRING - FLAT
5	107721-01-000	EA SEAL - ACCESS DOOR

# WINDSHIELD & WIPER GROUP

## WINDSHIELD MOLDINGS & GLASS

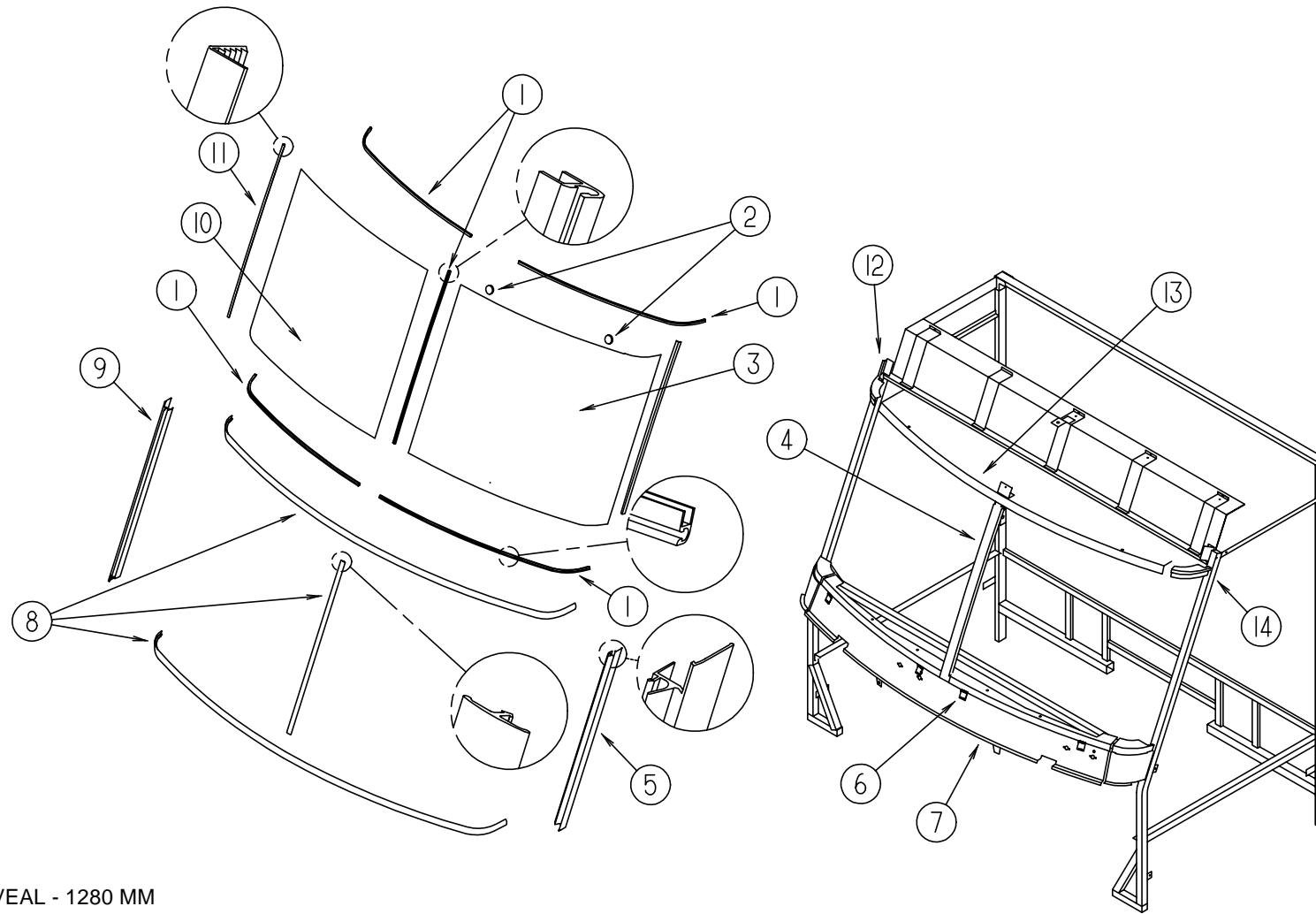

KEY	PART NUMBER	U/M	DESCRIPTION
1	110268-01-000	EA	CARRIER - REVEAL - 1280 MM
2	081914-01-000	EA	BUMPER - RUBBER - ROUND - .43" DIAMETER - BLACK
3	114432-02-000	EA	GLASS - WINDSHIELD - DRIVER SIDE
4	075710-01-000	EA	FRAME - WINDSHIELD - CENTER DIVIDER - INNER
5	103107-04-01A	EA	TRIM - WINDSHIELD - DRIVER SIDE - BLACK
6	104449-01-000	EA	BRACKET - WINDSHIELD SUPPORT
7	077847-05-000	EA	SUPPORT - WINDSHIELD - LOWER - W/O BRACKETS
	077847-03-000	EA	SUPPORT - WINDSHIELD - END - PASSENGER SIDE
	077847-04-000	EA	SUPPORT - WINDSHIELD - END - DRIVER SIDE
8	102936-01-000	FT	MOLDING - REVEAL - WINDSHIELD
9	103107-03-01A	EA	TRIM - WINDSHIELD - PASSENGER SIDE - BLACK
10	114432-01-000	EA	GLASS - WINDSHIELD - PASSENGER SIDE
11	098788-06-000	EA	CHANNEL - REVEAL - 49" WINDSHIELD
12	077922-03-000	EA	HEADER WINDSHIELD END - PASSENGER SIDE
	114583-01-01B	EA	HEADER - WINDSHIELD - FILLER - UPPER - MILL
13	077922-06-000	EA	HEADER WINDSHIELD - CENTER
14	077922-04-000	EA	HEADER WINDSHIELD END - DRIVER SIDE
	114583-02-01B	EA	HEADER - WINDSHIELD - FILLER - UPPER - MILL
	002328-02-000	EA	BLOCK - WINDSHIELD - .062" X .5" X .98"

# WINDSHIELD & WIPER GROUP (CONTINUED)

## WINDSHIELD WIPER ASM

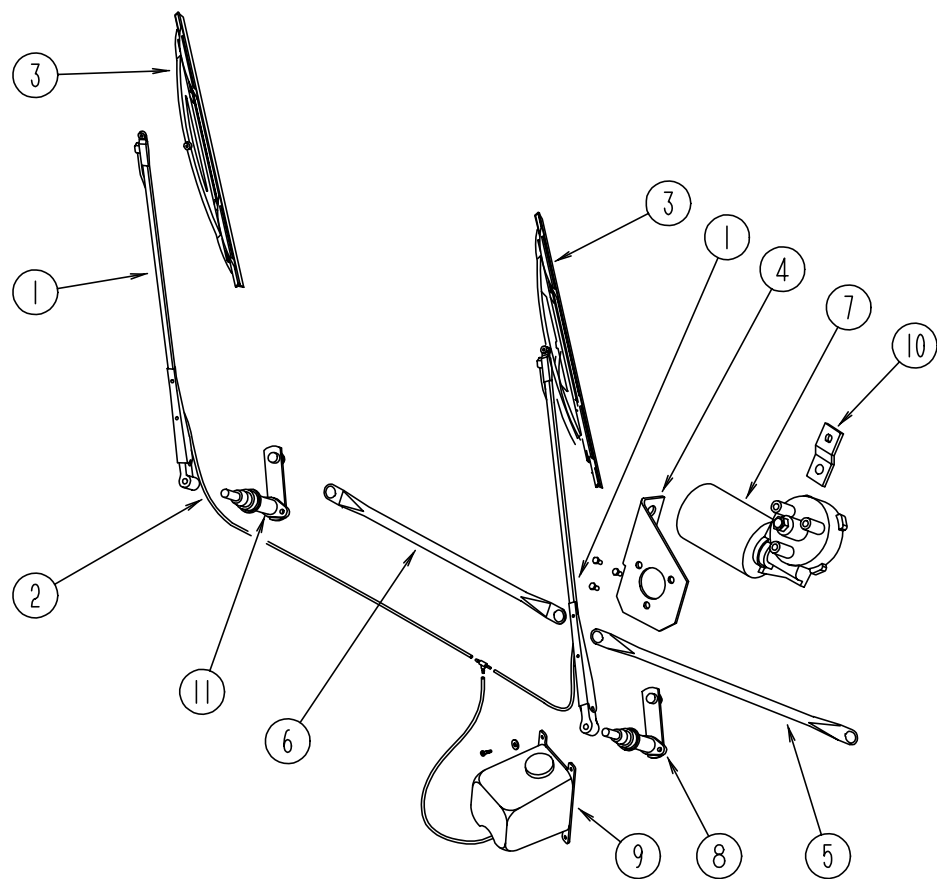

KEY	PART NUMBER	U/M	DESCRIPTION
1	103671-01-000	EA	ARM - WIPER - 24"
2	096931-01-700	FT	HOSE
3	095964-01-000	EA	BLADE - WIPER - WINDSHIELD - 24"
	095964-01-700	EA	BLADE - REFILL 24" (PAIR)
4	104549-01-000	EA	BRACKET ASM - WIPER MOTOR
5	117008-01-000	EA	LINK ASM - CONNECTING - 21.85" - DRIVER SIDE
6	117008-02-000	EA	LINK ASM - CONNECTING - 21.85" - PASSENGER SIDE
7	104346-05-000	EA	WIPER MOTOR (FORD)
7	104346-02-000	EA	WIPER MOTOR (CHEVY)
			FROM: 00-00-00 THRU: 11-10-95
7	104346-04-000	EA	WIPER MOTOR (CHEVY)
			FROM: 11-11-95 THRU: 99-99-99
	110178-01-000	EA	HOUSING - WIPER MOTOR
8	096505-06-000	EA	PIVOT & SHAFT ASM - WIPER - DRIVER SIDE
9	056000-04-000	EA	WINDSHIELD WASHER - BOTTLE & PUMP
	056000-01-700	EA	VACUUM HOSE 7/64 - 5/32
	096931-01-701	EA	NOZZLE & HARDWARE KIT, INCLUDES NOZZLE, NUT, SHORT THREAD SCREW, LONG THREAD SCREW, AND PLASTIC CAP
9	117766-02-000	EA	WASHER ASM - WINDSHIELD WIPER - MCCORD 600328
	110605-01-000	EA	TEE - PLAS - BARBED 1/8 X 1/8 X 3/16 BAYLOCK 3799721
	117765-03-000	EA	CONNECTOR - 5/32 W/SWSH - ITT H-BAYLOCK 116756
10	104347-01-000	EA	ARM - DRIVE - WIPER MOTOR - 1.54"
11	096505-05-000	EA	PIVOT & SHAFT ASM - WIPER - PASSENGER SIDE
	110742-01-000	EA	WIPER GASKET
	067188-01-000	EA	STUD - WIPER CRANK
	096505-02-703	EA	CAP - NUT (ACORN) HD W/.687 BARREL
	045794-01-000	FT	HOSE-WASHER, WINDSHEILD - 5/32" ID - BLACK
	061603-01-000	EA	GROMMET-SNAP, 3/16" ID - 3/8" HOLE - PLASTIC - BLACK