

1996
WCD30RQ

GB1

BLUE RIDGE (BLUE)

GC1

PAINTED DESERT (TAN / TEAL)

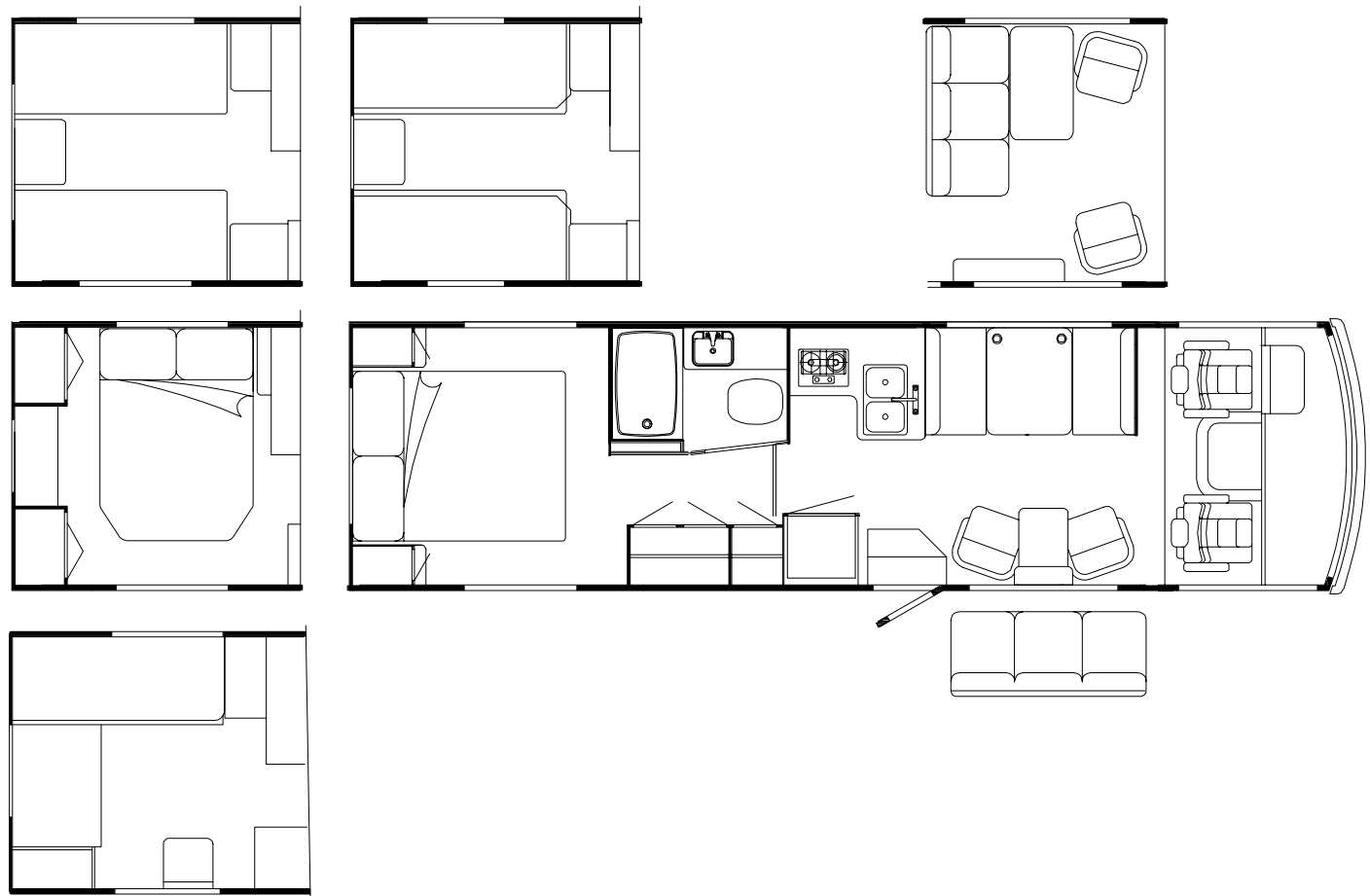

ACCESSORIES GROUP

OPERATOR MANUAL

KEY	PART NUMBER	U/M DESCRIPTION
	054185-D8-000	EA MANUAL-OPERATOR 96 WARRIOR D-SERIES
	092318-01-000	EA BINDER - 3 RING, MOTOR HOME MANUAL
	092319-01-000	EA POCKET PAGE - 3 RING BINDER, PLASTIC
	118476-01-000	DW TOP LEVEL DRAWING, 1996 D-SERIES

AUDIO VIDEO GROUP

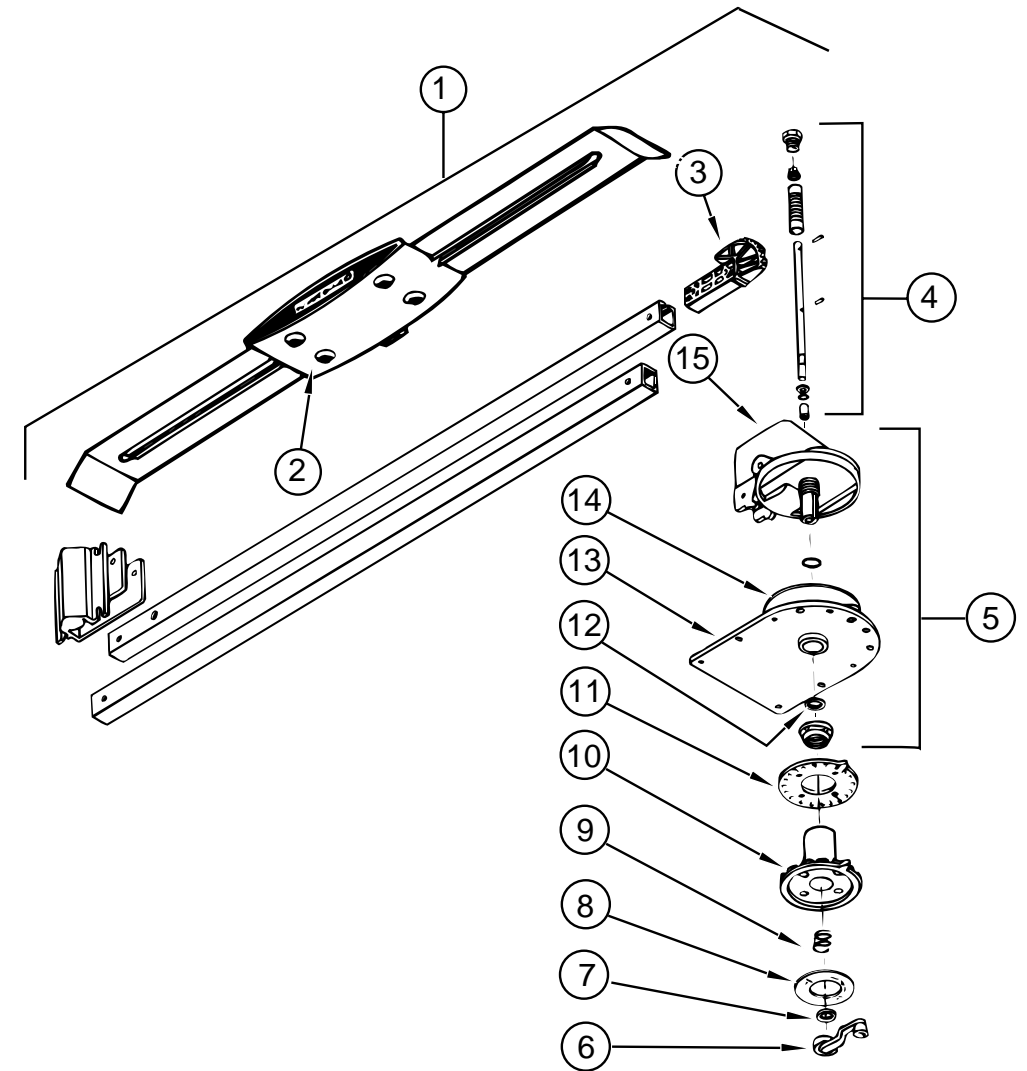

TV ANTENNA

ROOF MT 44.5 MAST WINEGARD #RVA-W02

KEY	PART NUMBER	U/M DESCRIPTION	VENDOR NO.
1	076319-01-000	EA ANTENNA - TV - ROOF MOUNT	
2	076319-01-700	EA HEAD - ANTENNA - AMPLIFIED	RVSA U/V
3	076319-01-701	EA GEAR - ELEVATING - PLASTIC	2200046
4	076319-01-702	EA SHAFT ASM - ELEVATING	RVP-400A
5	076319-01-711	EA BASE & LIFT ASM	2762802
6	076319-01-706	EA CRANK - ELEVATING - W/ SET SCREW	5755100
7	076319-01-705	EA BEARING - NYLON - 7/8"ID	3200658
8	076319-01-708	EA CRANK COVER DECAL	5413002
9	076319-01-707	EA SPRING - HANDLE	5160822
10	076319-01-709	EA PLATE - DIRECTIONAL - FOR HEAD	3200644
11	076319-01-712	EA CEILING PLATE	3200608
12	076319-01-704	EA BEARING - NYLON - 1.5"OD	3200657
13	076319-01-713	EA BASE PLATE	3100523
14	076319-01-703	EA BEARING - NYLON - 5"OD	3200656
15	076319-01-714	EA HOUSING, ROTATING GEAR	2200049
	076319-06-000	EA ADAPTOR-CABLE ROOF PLATE RPJ-1	
	076319-03-000	FT CABLE-COAXIAL, 75 OHM	
	076319-12-000	EA CONNECTOR-COAXIAL, ONE PIECE	
	086777-01-000	EA PLATE-WALL, CABLE - W/TV ANTENNA SWITCH - IVORY	

AUDIO VIDEO GROUP (CONTINUED)

RADIO SYSTEM & ANTENNA

KEY	PART NUMBER	U/M DESCRIPTION
	110267-01-000	EA RADIO-AM/FM STEREO AUDIOVOX IM-200
	110743-01-000	EA SPEAKER-RADIO, FADER CONTROL - ASA 1410000
	110469-01-000	EA SPEAKER - 4" X 6", OVAL - MAGNADYNE F46XB-12
	110470-01-01A	EA GRILLE-SPEAKER, OVAL - 4" X 6" - BLACK - MAGNADYNE G46WI
	077069-02-000	EA CABLE-ANTENNA, RADIO - EXTENSION 96" - ARA 6700667
	090944-01-000	EA ANTENNA-RADIO, 16" RUBBER
	110272-01-000	EA BRACKET-ANTENNA
	081059-02-000	EA WIRE ASM-9-PIN, RADIO - AUDIOVOX 112B-1761

TV & COMPONENTS

KEY	PART NUMBER	U/M DESCRIPTION	VENDOR NO.
	113684-01-000	EA TV-19" COLOR UL AND CSA - AUDIOVOX AVT-1975	
	113684-01-700	EA REMOTE	8822345
	082134-01-000	EA ADAPTER-TV, CABLE TO CABLE - WINEGARD F-81M	
	086777-01-000	EA WALLPLATE-TV CABLE, W/ANTENNA SWITCH - IVORY	
	076319-03-000	FT CABLE-COAXIAL, 75 OHM	
	076319-12-000	EA CONNECTOR-COAXIAL, ONE PIECE	
	076319-03-000	FT CABLE-COAXIAL, 75 OHM	
	076319-06-000	EA ADAPTOR-CABLE ROOF PLATE, WINEGARD RPJ-1	
	076319-09-000	EA WALLPLATE-CABLE RECEPTACLE, TV - SINGLE - BROWN	
	082136-01-000	EA NUT-HEX JAM 3/8-32, WINEGARD	

BATH GROUP

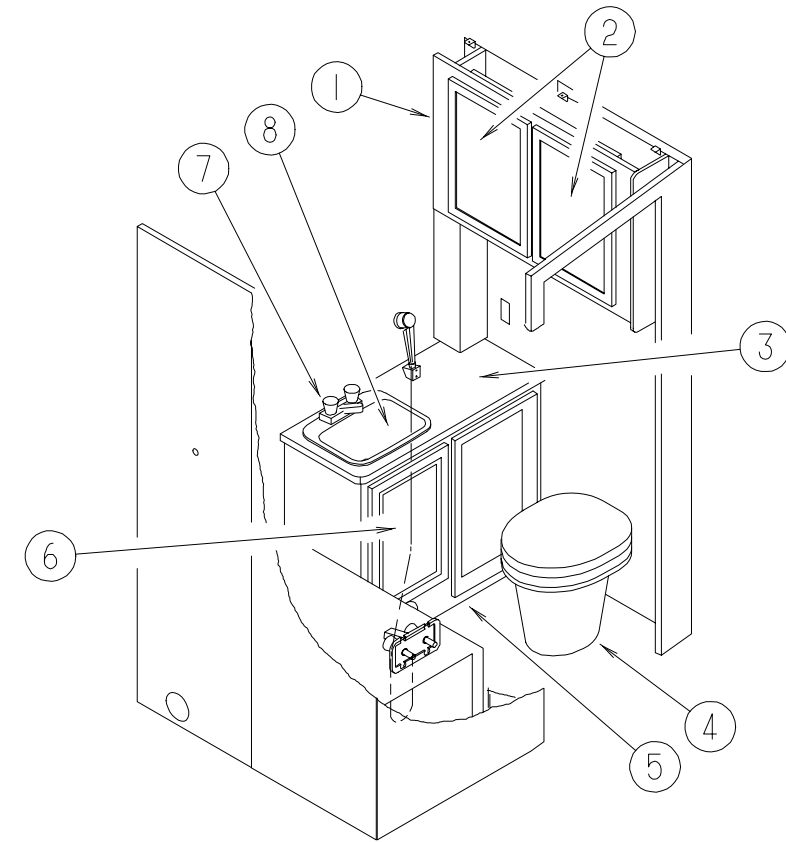

BATHROOM CABINET & COMPONENTS

KEY	PART NUMBER	U/M DESCRIPTION	VENDOR NO.
1	118126-01-GB1	EA CABINET ASM-LINEN/MEDICINE	
2	110140-41-GB1	EA DOOR-MITERED VINYL 0380 X 0555	
3	118124-11-GB1	EA COUNTERTOP ASM	
3	118124-11-GC1	EA COUNTERTOP ASM	
4	063740-01-000	EA TOILET-HIGH, HAND FLUSH - THETFORD 150120	
5	P18124-01-GB1	EA CABINET ASM-LAVATORY	
6	110140-04-G01	EA DOOR-MITERED VINYL 0365X0555	
	105394-01-05A	EA EXTR-DOOR JAMB	
	075452-02-000	EA HOLDER - TOILET TISSUE - BRASS	
	075453-02-000	EA BAR-TOWEL - 18" BRASS	
7	075240-06-000	EA FAUCET-LAVATORY, BONE	
	091253-01-000	EA GASKET-FAUCET, LAVATORY/GALLEY	
8	096927-01-01A	EA SINK-LAVATORY, RECTANGULAR - PLASTIC - BONE	
	096927-01-700	EA PLUG	M9801
	096927-01-701	EA TAILPIECE	M9802
	M87868-30-GB1	EA DOOR ASM - BATH	
	094485-03-01A	EA KNOB-DOOR, BRASS	
	102920-01-01A	EA HINGE-DOOR, SPRING LOADED - BRASS	
	110496-01-01A	EA HINGE-BRASS	

BATH GROUP (CONTINUED)

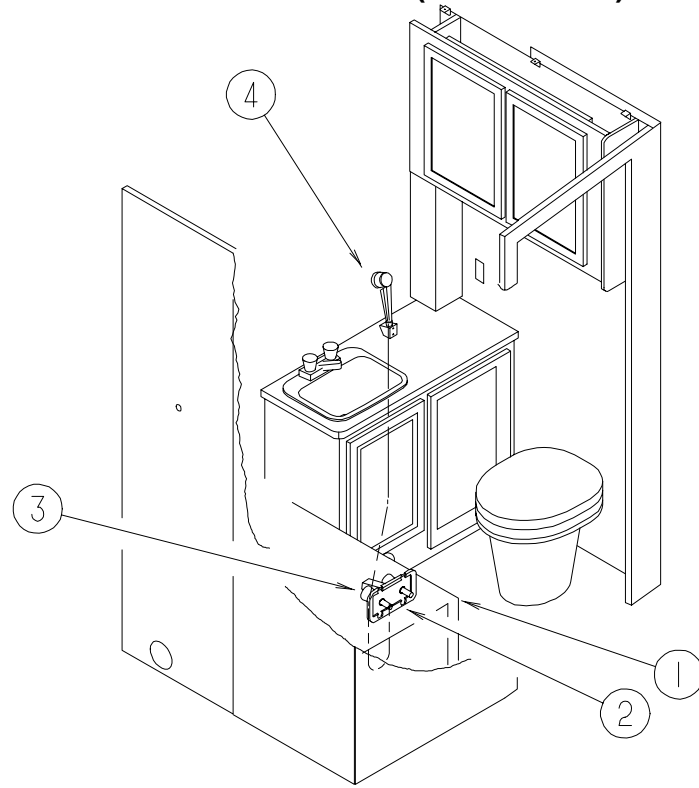

SHOWER CABINET & COMPONENTS

KEY	PART NUMBER	U/M DESCRIPTION	VENDOR NO.
1	M02630-30-GB1	EA SHOWER PAN ASM.	
	066436-01-000	EA NUT-SLIP, TAILPIECE - 1.5"	
	066729-01-000	EA STRAINER-TUB/SHOWER, W/PLUG	
1	115611-03-01A	EA SHOWER PAN O/W	
2	075606-01-000	EA PANEL-SHOWER FAUCET	
3	075242-04-000	EA FAUCET-TUB/SHOWER, BONE	
4	103092-01-000	EA SHOWER HEAD-W/60" HOSE	
4	103092-02-000	EA SHOWER HEAD-W/HOSE, ONDINE 23213NYLON B	
	103092-01-700	EA BRACKET-SHOWER HEAD, CLEAR	2328028 SPECIFY COL
	011048-03-700	EA BRACKET/F SHOWER HEAD	2328029-3
	117431-03-01A	EA DOOR-SHOWER,FABRIC,PLECTED	
	117431-01-700	EA TRACK-TOP, ALUM.IVORY INSERT	39 3/8
	117431-01-701	EA TRACK-BOTTOM, 39 3/8	39 3/8
	117431-01-702	EA RAIL-SIDE, 63"	63"
	117431-01-703	EA RAIL-STATIONARY, 63"	63"
	117431-01-704	EA RAIL-LEAD, 63"	63"
	117431-01-705	EA GLIDE-IVORY, TRAVELER	
	117431-01-706	EA GLIDE-IVORY LEAD, TRAVELER	
	117431-01-707	EA LATCH	
	117431-01-708	EA HANDLES & SCREWS	
	117431-01-709	EA STRAP-VINYL SHOWER	

BATH GROUP (CONTINUED)

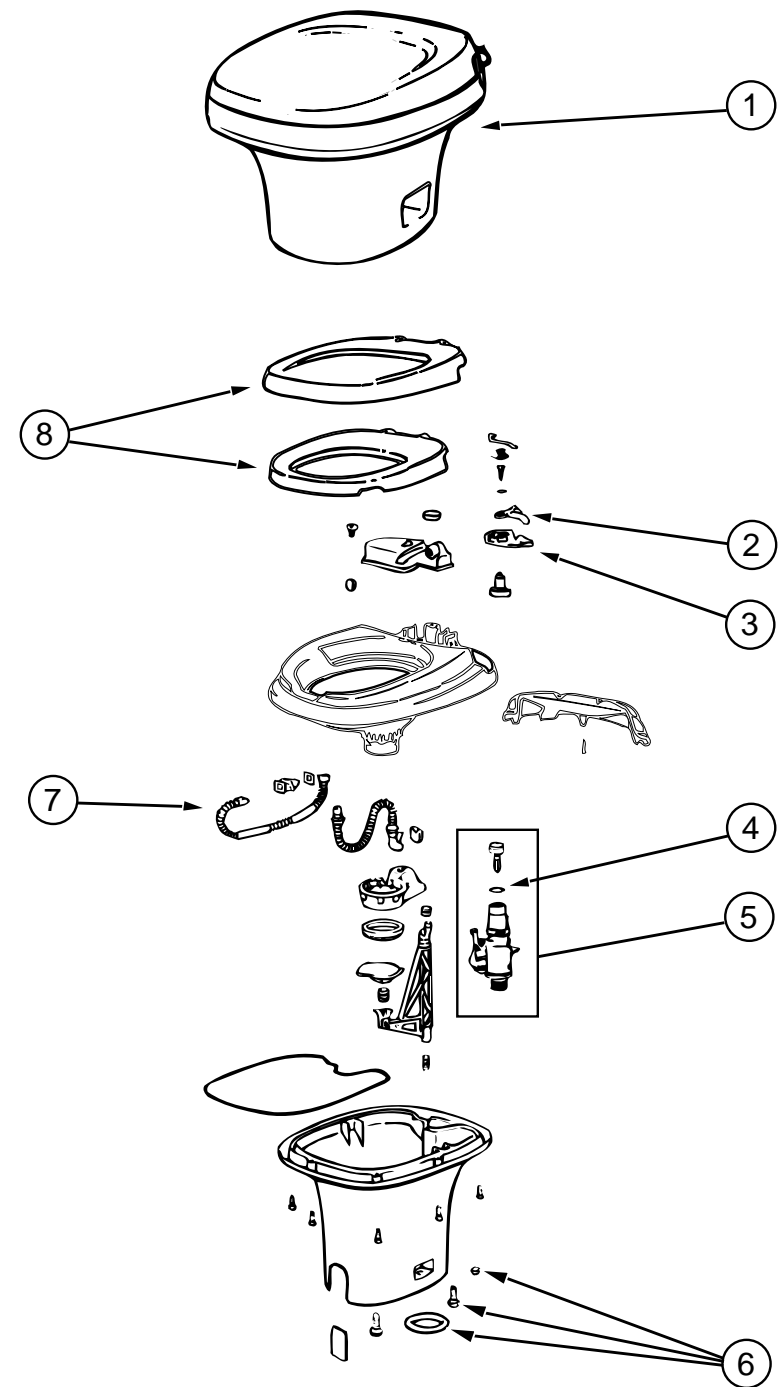

THETFORD AQUA MAGIC IV TOILET

KEY	PART NUMBER	U/M DESCRIPTION	VENDOR NO.
1	063740-01-000	EA TOILET-HIGH, HAND FLUSH 150120	
2	063740-01-700	EA LEVER-WATER, TOILET	12514
3	063740-01-701	EA LEVER-FLUSH	12515
4	063740-01-713	EA SEAL-BALL VALVE TO BOWL	12502
5	063740-01-714	EA VALVE ASSEMBLY, WATER W/FLOAT & BALL SEAL	13168
6	063740-01-706	EA BOLT PACKAGE-FLOOR FLANGE	12524
7	063740-01-717	EA TUBE-FLUSH	12509
8	063740-02-700	EA SEAT & COVER, PARCHMENT	2464157
	063740-01-720	EA LEVER KIT, WAT-FLUSH-BEARING	24629
	063740-01-721	EA BLADE ONLY	124832

BEDROOM GROUP

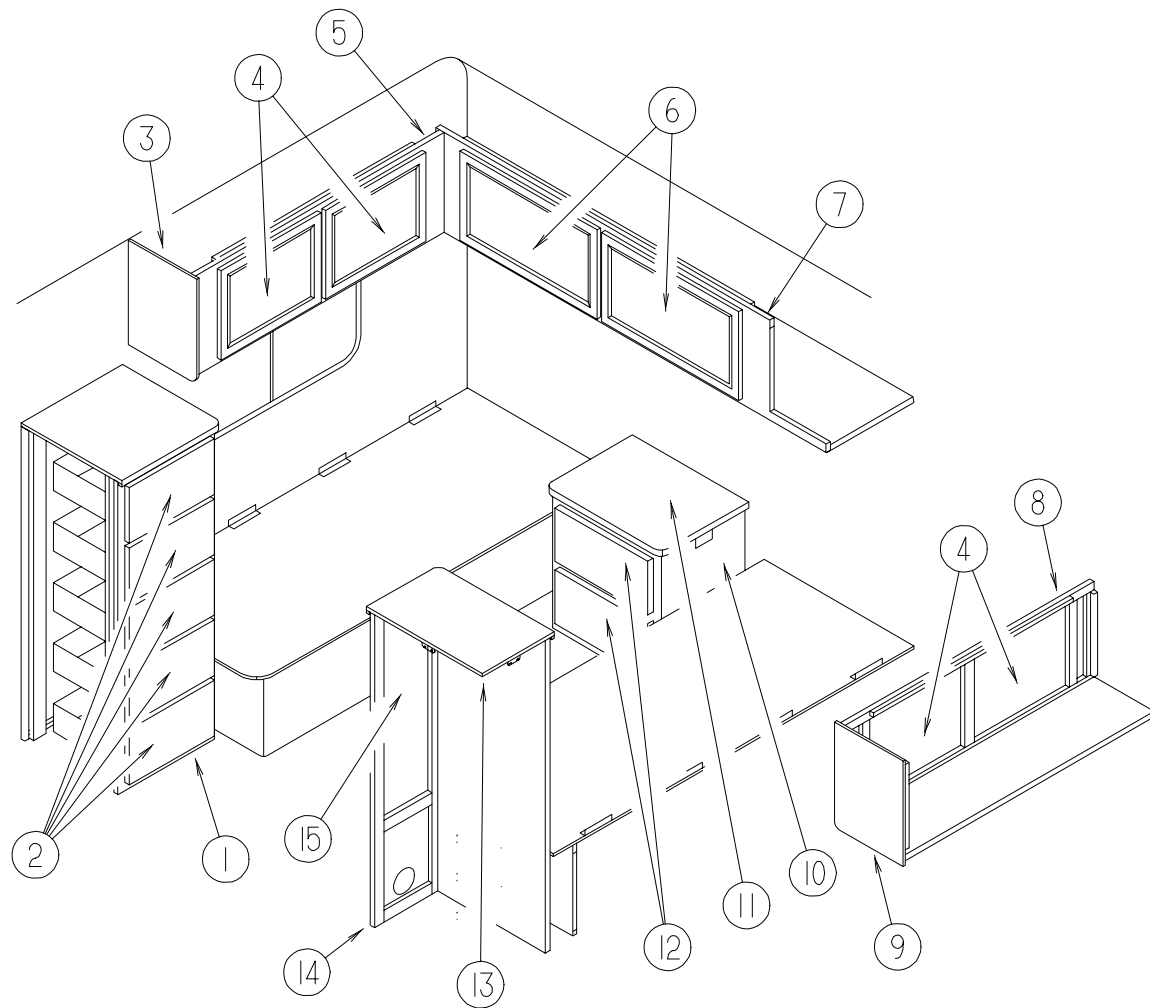

TWIN BEDROOM

KEY	PART NUMBER	U/M	DESCRIPTION
1	P18363-01-GB1	EA	CABINET ASM-DRESSER,RH,TW
	118363-11-GB1	EA	COUNTERTOP ASM
	118363-11-GC1	EA	COUNTERTOP ASM
2	P10163-N7-GB1	EA	DRAWER COMPLETE-SLIDE - DRESSER
3	109908-31-GB1	EA	CAP ASM-END-OVERHEAD
4	110140-27-G01	EA	DOOR ASM-MITERED - VINYL WRAP - 0400 X 0520
5	117093-01-GB1	EA	CABINET ASM-OVERHEAD - RIGHT - TWIN
6	110140-21-G01	EA	DOOR ASM-MITERED - VINYL WRAP - 0400 X 0710 W/ MIRROR
6	110140-18-G01	EA	DOOR ASM-MITERED - VINYL WRAP - 0400 X 0710 W/O MIRROR
7	117092-01-GB1	EA	CABINET ASM-OVERHEAD - REAR - TWIN
8	117093-02-GB1	EA	CABINET ASM-OVERHEAD - LEFT - TWIN
9	109908-30-GB1	EA	CAP ASM-END-OVERHEAD
10	P17071-01-GB1	EA	CABINET ASM-NIGHTSTAND
11	117071-11-GB1	EA	COUNTERTOP ASM
11	117071-11-GC1	EA	COUNTERTOP ASM
12	P10163-N3-GB1	EA	DRAWER COMPLETE-SLIDE
	P17070-01-GB1	EA	CABINET ASM-BED - TWIN - LEFT
	P17069-01-GB1	EA	CABINET ASM-BED - TWIN - RIGHT
13	118364-11-GB1	EA	COUNTERTOP ASM
13	118364-11-GC1	EA	COUNTERTOP ASM
14	118364-01-GB1	EA	CABINET ASM-CLOSET,SHIRT,LH
15	110140-75-GB1	EA	DOOR ASM-MITERED - VINYL WRAP - 0275 X 0925

BEDROOM GROUP (CONTINUED)

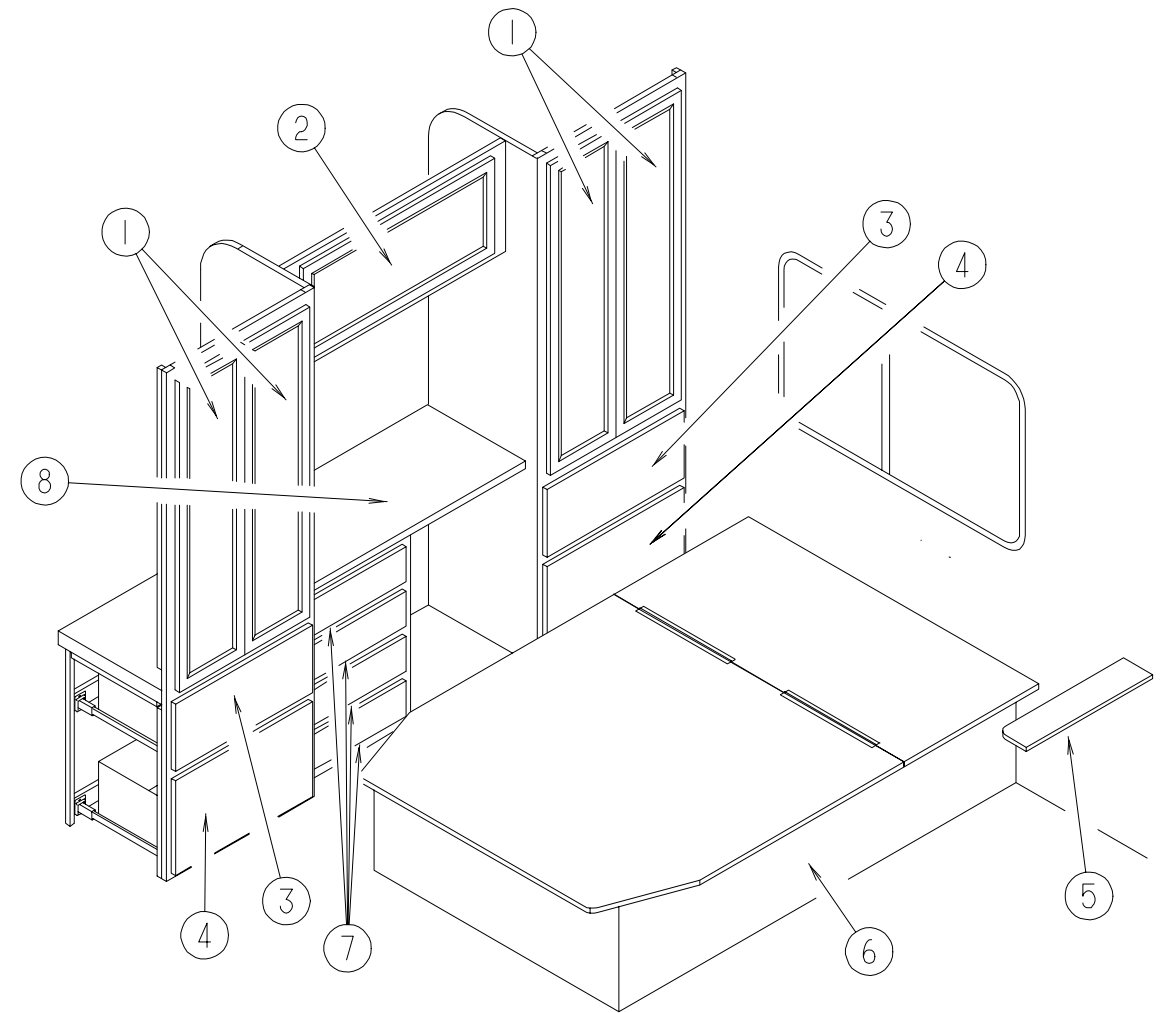

DOUBLE BEDROOM

KEY	PART NUMBER	U/M	DESCRIPTION
1	P16841-01-G01	EA	DOOR ASM-WARDROBE,BI-FOLD
2	P16836-01-GB1	EA	CABINET ASM-OVERHEAD - REAR
2	110140-65-G01	EA	DOOR ASM-MITERED - VINYL WRAP - 0365 X 0850 - W/MIRROR
2	110140-05-G01	EA	DOOR ASM-MITERED - VINYL WRAP - 0365 X 0850 - W/O MIRROR
2	108536-13-08A	EA	MIRROR - GLASS GALAXY FLOWER
3	P10163-M0-G01	EA	DRAWER COMPLETE - SLIDE
4	P10163-M1-G01	EA	DRAWER COMPLETE - SLIDE
5	116842-01-GB1	EA	SHELF ASM-DOUBLE BED
5	116842-01-GC1	EA	SHELF ASM-DOUBLE BED
6	P16839-01-GB1	EA	CABINET ASM-DOUBLE BED
	098442-02-GB1	EA	LEG ASM-BED
7	P10163-M2-G01	EA	DRAWER COMPLETE - SLIDE
	P16840-01-GB1	EA	CABINET ASM - DRESSER - REAR - DOUBLE BED
8	116840-11-GB1	EA	COUNTERTOP ASM
8	116840-11-GC1	EA	COUNTERTOP ASM
	116842-01-GB1	EA	SHELF ASM-DOUBLE BED
	116842-01-GC1	EA	SHELF ASM-DOUBLE BED

BEDROOM GROUP (CONTINUED)

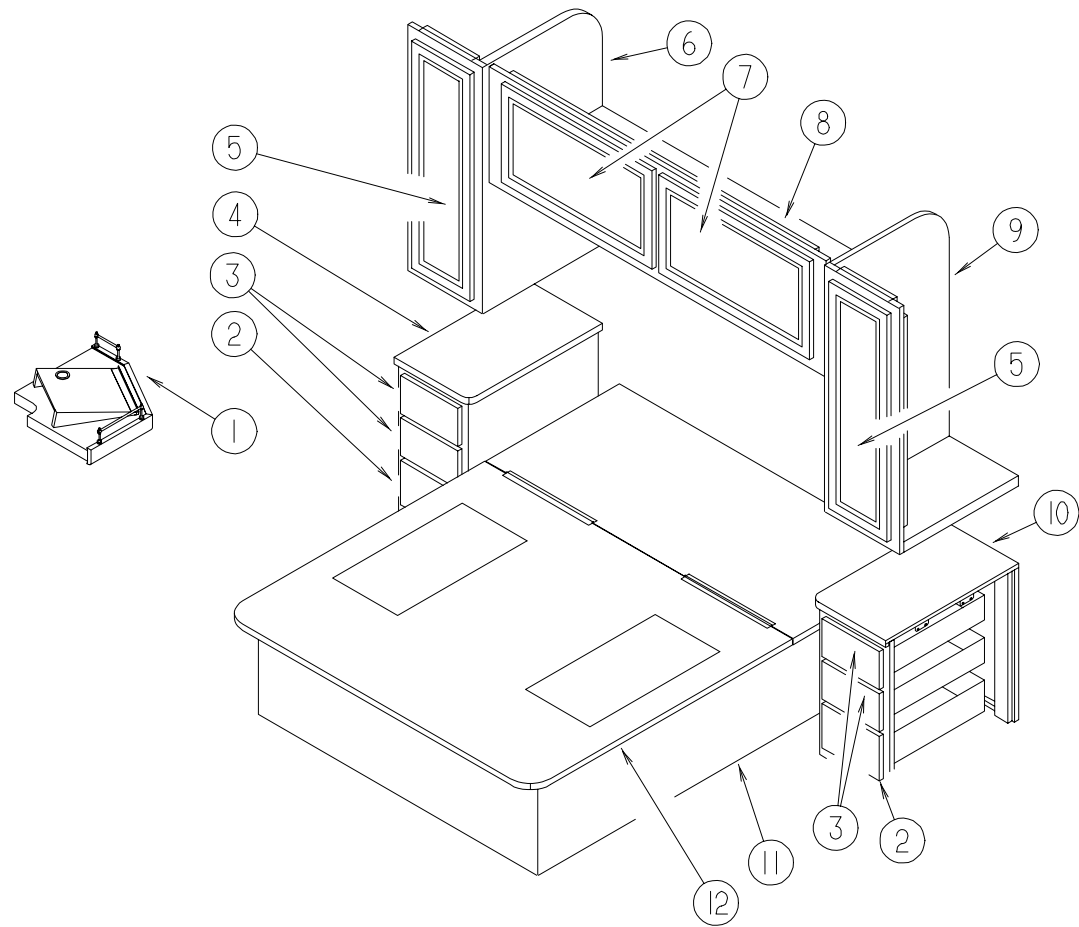

QUEEN BEDROOM

KEY	PART NUMBER	U/M	DESCRIPTION
1	116553-01-GB1	EA	CABINET ASM-TV SHELF
2	P10163-N8-GB1	EA	DRAWER COMPL-SLIDE
3	P10163-N9-GB1	EA	DRAWER COMPL-SLIDE
4	P18127-01-GB1	EA	CABINET ASM-NIGHTSTAND,QU,RH
5	110140-75-GB1	EA	DOOR-MITERED VINYL 0275 X 0925
6	118130-01-GB1	EA	CABINET ASM-OVHD,CL,SHIRT,RH
7	110140-21-G01	EA	DOOR ASM-MITERED,VINYL WRAP 0400 X 0710
8	P17061-01-GB1	EA	CABINET ASM - OVERHEAD - REAR - QUEEN BED
9	118131-01-GB1	EA	CABINET ASM-OVHD,CL,SHIRT,LH
10	P18128-01-GB1	EA	CABINET ASM-NIGHTSTAND,QU,LH
11	P16997-01-GB1	EA	CABINET ASM-BED,QUEEN
12	M07501-01-FB1	EA	QUEEN BED TOP
	000G67-10-10B	EA	SCREW-10-12 X 5/8 PPH ZN
	042438-51-019	EA	DOWEL-WOOD 1.0DIA. X 0324 MM
	067479-01-000	EA	BULB-12V NO1076 1.80AMP
	119257-03-01A	EA	SHADE-LAMP,LINEN WHT HARDBAC
	119258-02-01A	EA	LAMP-WALL,UL/CSA

BEDROOM GROUP (CONTINUED)

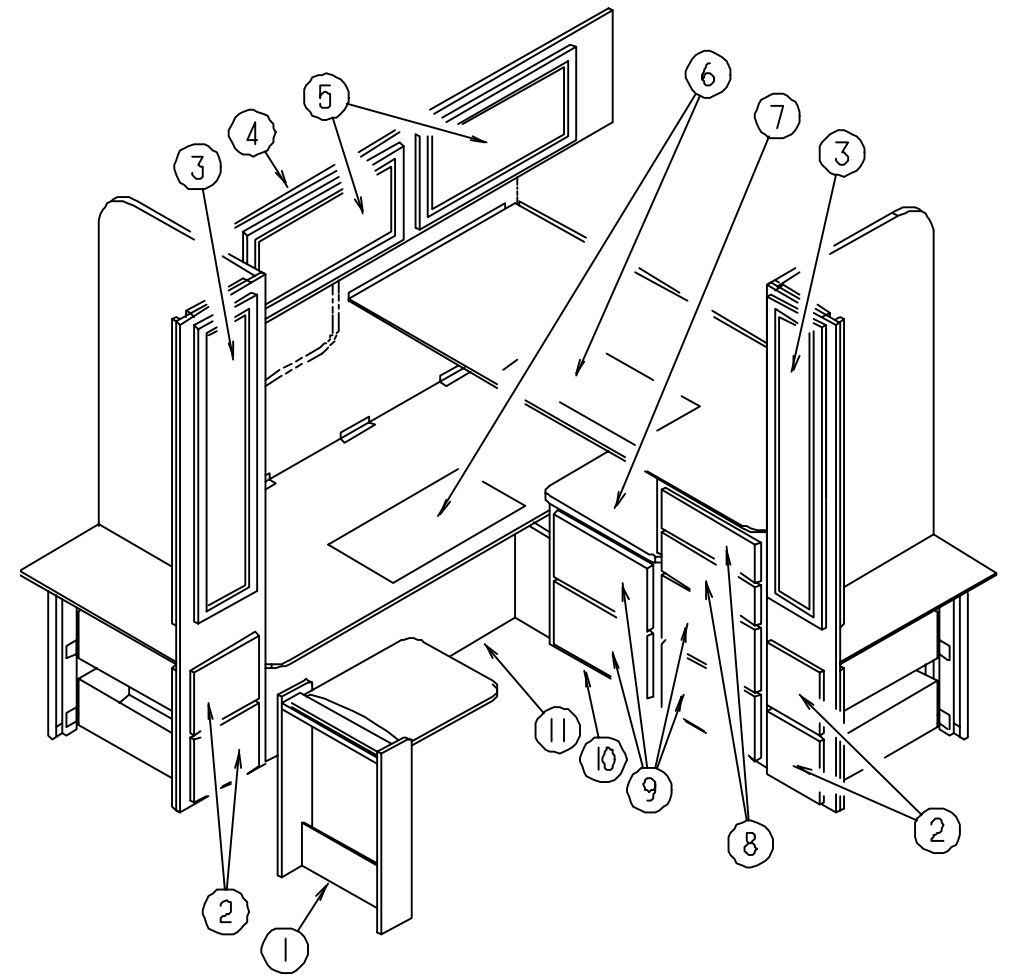

CROSSED TWIN BEDROOM

KEY	PART NUMBER	U/M	DESCRIPTION
1	M96873-01-G01	EA	TABLE ASM-PULLOUT
2	P10163-V6-GB1	EA	DRAWER COMPL-SLIDE
3	110140-22-G04	EA	DOOR-MITERED VINYL 0305 X 1220
4	120470-01-GB1	EA	CABINET ASM-OVERHEAD,REAR
5	110140-21-G01	EA	DOOR ASM-MITERED,VINYL WRAP OVERHEAD 0400 X 0710
	042438-51-012	EA	DOWEL-WOOD 1.0DIA. X 0320 MM
	042438-51-013	EA	DOWEL-WOOD 1.0DIA. X0270 MM
6	091261-01-000	FT	BACKING-NON-SKID, 12" X 100'
7	120442-11-GB1	EA	COUNTERTOP ASM
8	P10163-V8-GB1	EA	DRAWER COMPL-SLIDE
9	P10163-V7-GB1	EA	DRAWER COMPL-SLIDE
			FROM: 00-00-00 THRU: 08-20-95
9	P10163-W7-GB1	EA	DRAWER COMPL-SLIDE
			FROM: 08-21-95 THRU: 99-99-99
10	120442-01-GB1	EA	CABINET ASM-DRESSER,LH
11	P20469-01-GB1	EA	CABINET ASM-BED,TWIN,REAR
	116553-01-GB1	EA	CABINET ASM-TV SHELF

BEDROOM GROUP (CONTINUED)

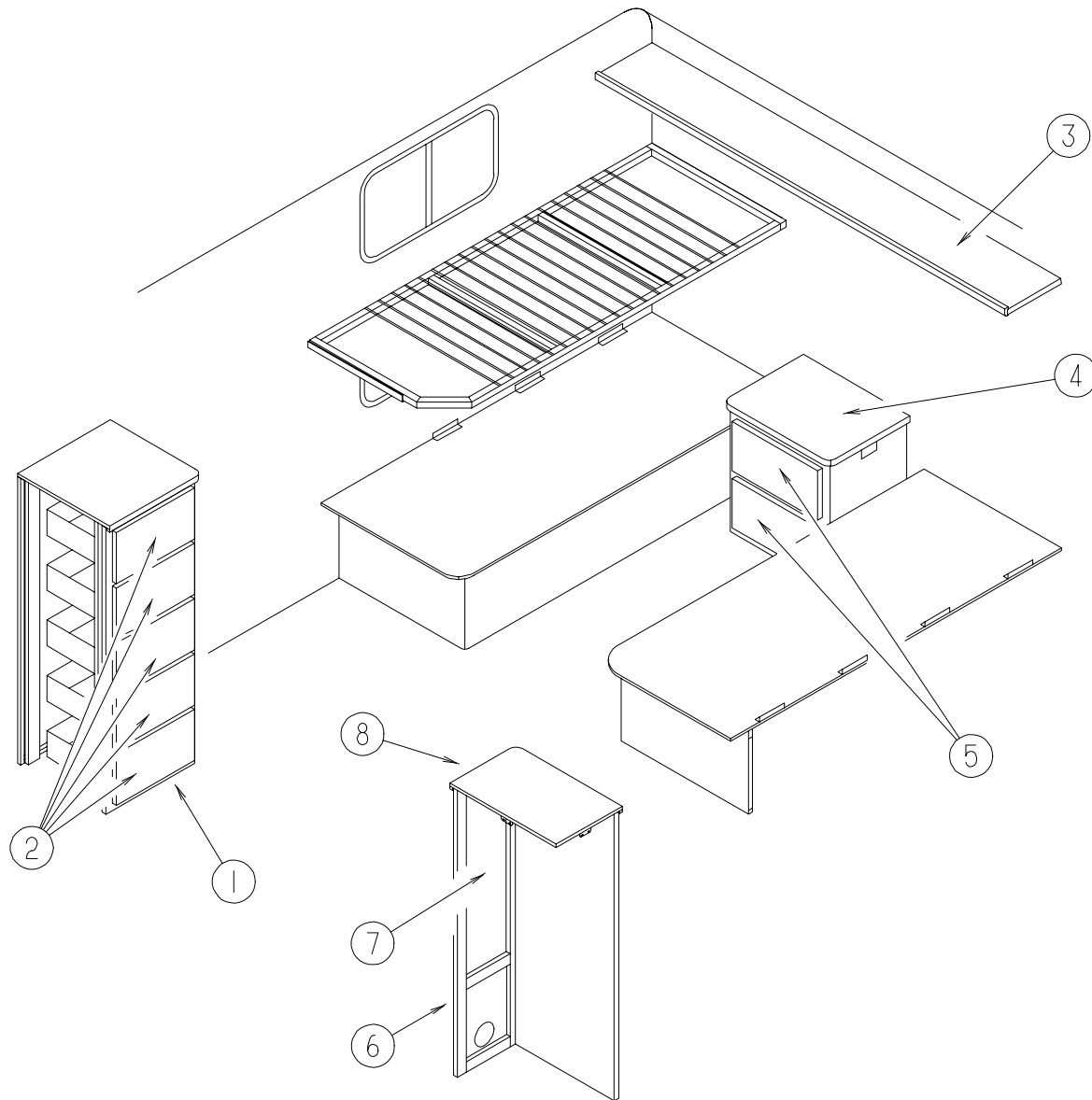

TWIN & BUNK BEDROOM

KEY	PART NUMBER	U/M DESCRIPTION
1	P18363-01-GB1	EA CABINET ASM-DRESSER,RH,TW
2	P10163-N7-GB1	EA DRAWER COMPLETE-SLIDE - DRESSER
3	117090-01-G01	EA CABINET ASM-OVHD,SHELF
	098442-02-GB1	EA LEG ASM-BED
	091261-01-000	FT BACKING-NON-SKID, 12" X 100'
	105376-01-02A	EA HINGE-CONTIN, 2" X 140MM O/W
	063701-37-000	EA COVER-PIPE O/WHT 318,0 MM
4	117071-11-GB1	EA COUNTERTOP ASM
4	117071-11-GC1	EA COUNTERTOP ASM
5	P10163-N3-GB1	EA DRAWER COMPL-SLIDE - NIGHTSTAND
6	118364-01-GB1	EA CABINET ASM-CLOSET,SHIRT,LH
7	110140-75-GB1	EA DOOR ASM-MITERED - VINYL WRAP - 0275 X 0925
8	118364-11-GB1	EA COUNTERTOP ASM
8	118364-11-GC1	EA COUNTERTOP ASM

CHASSIS GROUP

CHASSIS MISCELLANEOUS

KEY	PART NUMBER	U/M DESCRIPTION
	087234-01-000	EA NUT-JACK - 1/4" X 20 THREADS - MOLLY - MOUNTS LICENSE PLATES
	080208-01-000	EA LUG WRENCH - 1.06' X 1.00'
	080208-02-000	EA BAR-LEVERAGE - LUG WRENCH
	008042-01-000	FT TUBING-VINYL - .65" ID

FORD WHEELS, TIRES & WHEEL COVER

KEY	PART NUMBER	U/M DESCRIPTION	VENDOR NO.
	073322-08-GB1	EA COVER-TIRE,34"	
	073322-50-000	EA COVER-UNIVERSAL LINER - WHITE TIRE COVER	
	M00080-74-000	EA TIRE-WHL ASM,215/85R16 LRE - FORD SPPLIED RIM	
	051377-05-000	EA VALVE STEM ASM-VS938 - EATON VS-938 F53-92	
	083425-10-000	EA TIRE-LT215/85R16 LRE XCH4 - MICHELIN XCH4 ORBL	
	095853-02-000	EA WHEEL-STL,16X6K,F2TA-1015-NA - ACCURIDE 28513-7	
	098532-01-000	EA COVER-WHEEL, FORD - 16" - SET OF 4 - DICOR SH-SD-16 ORDER 098532-01-701 WHEEL COVER - 1 EACH, AND 098532-01-700 LUG NUT AS REQUIRED	
	098532-01-700	EA COVER-LUG NUT (CHROME)	SH-AU-LNC
	098532-01-701	EA COVER-WHEEL (FRT & REAR)	SH-SD-16COV 1 ONLY

CHEVY WHEELS, TIRES & WHEEL COVER

KEY	PART NUMBER	U/M DESCRIPTION	VENDOR NO.
	073322-08-GB1	EA COVER-TIRE,34"	
	073322-50-000	EA COVER-UNIVERSAL LINER - WHITE TIRE COVER	
	007324-04-000	EA TIRE-8R19.5 LRD, MICHELIN XZA	
	051377-01-000	EA STEM-VALVE, TR 500	
	064963-01-000	EA WHEEL-STEEL, 19.5" X 6" - GM 14005758	
	080208-01-000	EA LUG WRENCH, 1.06 X 1.00	
	080208-02-000	EA BAR-LEVERAGE, LUG WRENCH	
	105531-02-000	EA RETAINER ASM-SPARE TIRE	
	116671-01-02B	EA BRACKET ASM-SPARE TIRE,E-CT	
	109443-01-000	EA WHEEL COVER SET - (EA = 4 WHEEL COVERS W/HARDWARE) 19.5"	
	109443-01-700	EA COVER-WHEEL 19.5 FRT OR REAR	SHAG95
	109443-01-701	EA BRACKET-RET-FRONT WHEEL-INCLUDES THE JAMB NUTS	SHAG95-FBS
	109443-01-702	EA BRACKET-RET. REAR WHEEL	SHAG95-RBS
	109443-01-703	EA CAP-CENTER, HUB - DICOR	SP-AUCAP
	109443-01-704	EA CLIP-RETAINER	V160GM-PNT

FROM: 00-00-00 THRU: 07-17-95

CHASSIS GROUP (CONTINUED)

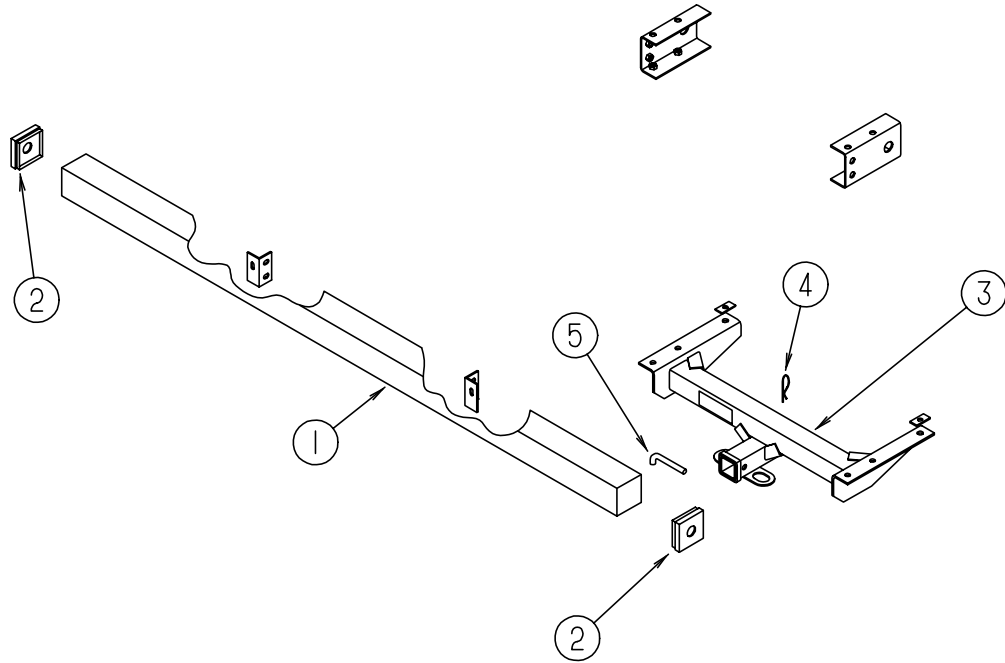

REAR BUMPER, TRAILER HITCH & COMPONENTS

KEY	PART NUMBER	U/M DESCRIPTION
1	110231-01-FB1	EA BUMPER ASM-REAR
2	039779-01-000	EA CAP-BUMPER, RUBBER - 4" X 4" - BLACK
3	107707-01-000	EA HITCH ASM-DRAWBAR, CLASS II
4	034513-01-000	EA PIN-HITCH, 3/16" WIRE
5	034512-01-000	EA PIN-LOCKING, DRAWBAR
	109738-01-01A	EA BRACKET-BUMPER MILL
	097744-02-000	EA HOUSING-TRAILER PIN, 48"
	097746-01-000	EA HOUSING CAP-TRAILER PIN
	097745-02-000	EA HOUSING-RECEPTACLE, TRAILER - 48" WIRE LENGTH
	113589-02-000	EA CONNECTOR-SOCKET, TRAILER - GENERAL 433601
	113589-01-000	EA CONNECTOR-PLUG, TRAILER - GENERAL 433501

CHASSIS GROUP (CONTINUED)

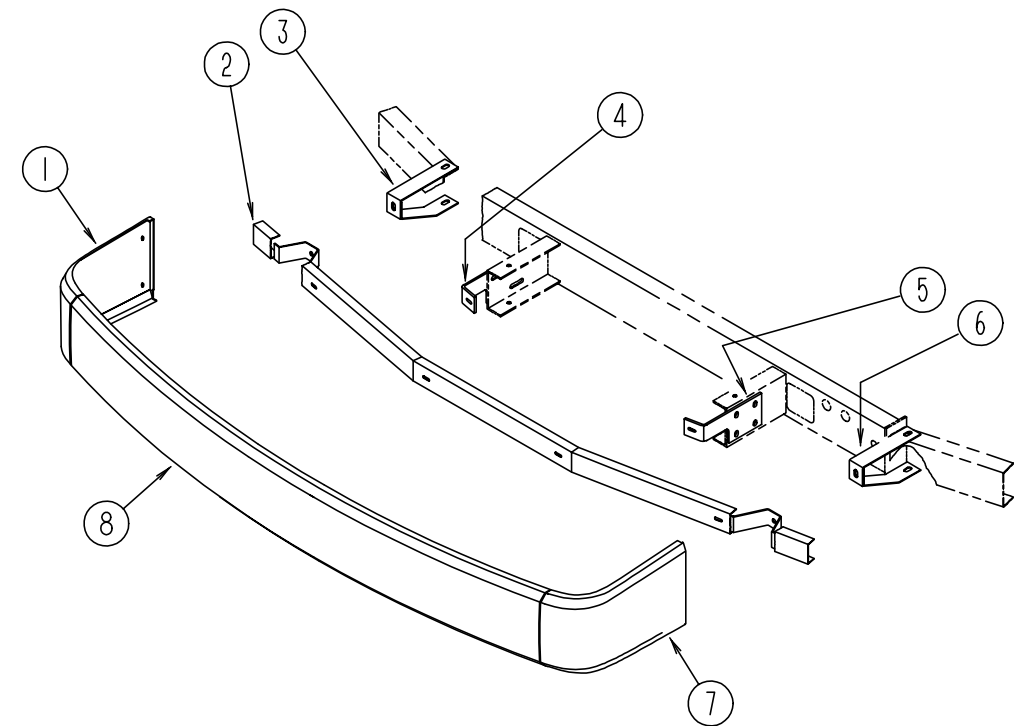

FRONT BUMPER

KEY	PART NUMBER	U/M DESCRIPTION
1	103625-01-04A	EA PANEL-FACIA, BUMPER FRONT RIGHT - BRIGHT WHITE
2	103512-01-000	EA CHANNEL ASM-BUMPER
3	103497-01-000	EA BRACE-BUMPER, FRONT
4	086140-03-000	EA SUPPORT-FRONT BUMPER, PASSENGER SIDE - 9.1" X 4" - STEEL
5	086140-04-000	EA SUPPORT-FRONT BUMPER, DRIVER SIDE - 9.1" X 4" - STEEL
6	103611-01-000	EA BRACE-BUMPER, FRONT
7	103625-02-04A	EA PANEL-FACIA, BUMPER FRONT LEFT - BRIGHT WHITE
8	103626-01-04A	EA PANEL-FACIA, BUMPER FRONT - BRIGHT WHITE
8	103634-01-FB1	EA BUMPER ASM-FRONT, W/RIGHT & LEFT FACIAS - BRIGHT WHITE
	094362-02-000	EA CLIP-CHRISTMAS TREE, FLAT HEAD - .5" X .95"

CHASSIS GROUP (CONTINUED)

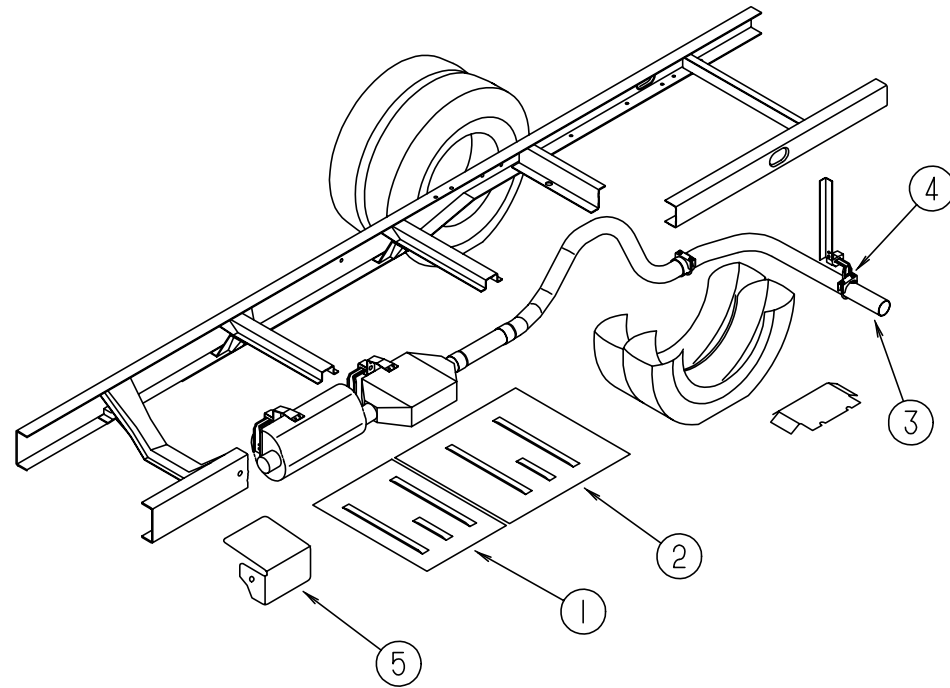

EXHAUST SYSTEM (GAS)

KEY	PART NUMBER	U/M DESCRIPTION
1	101544-05-000	EA SHIELD-HEAT, EXHAUST - 19.7" X 28.9" - STEEL
2	101544-02-000	EA SHIELD-HEAT - EXHAUST - 30" X 28.9" - STEEL
3	098762-05-000	EA PIPE-EXHAUST -STRAIGHT 3.0 IN
4	094918-01-000	EA CLAMP-EXHAUST - 3" - GUILLOTINE STYLE
5	119847-01-02B	EA SHIELD-A/C CONDENSER,E-COAT

CHASSIS GROUP (CONTINUED)

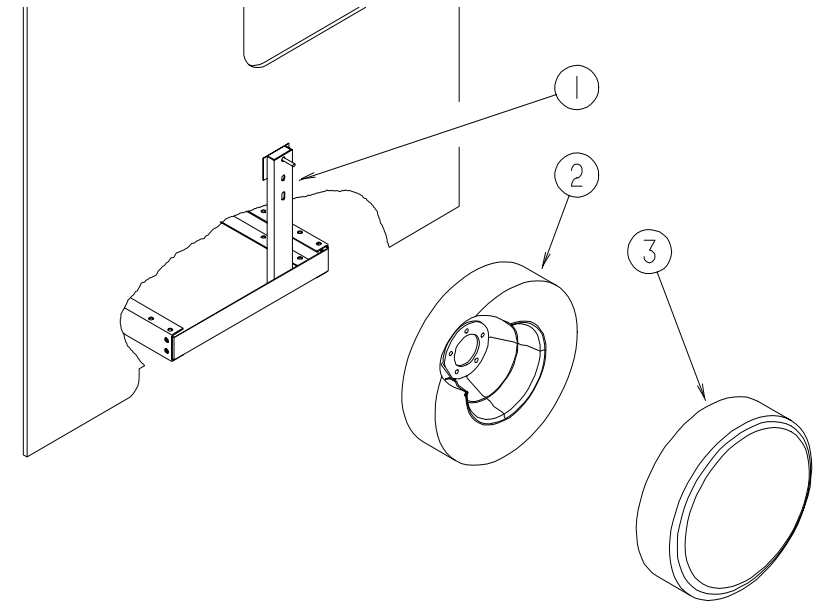

SPARE TIRE, LUG WRENCH & BAR

KEY	PART NUMBER	U/M DESCRIPTION
1	116671-01-02B	EA BRACKET ASM-SPARE TIRE,E-CT
2	064963-01-000	EA WHEEL-STEEL, 19.5" X 6" - GM 14005758
2	007324-04-000	EA TIRE-8R19.5 LRD, MICHELIN XZA
	051377-01-000	EA STEM-VALVE, TR 500
2	M00080-74-000	EA TIRE-WHL ASM,215/85R16 LRE - FORD SPPLIED RIM
2	083425-10-000	EA TIRE-LT215/85R16 LRE XCH4 - MICHELIN XCH4 ORBL
2	095853-02-000	EA WHEEL-STL,16X6K,F2TA-1015-NA - ACCURIDE 28513-7
	051377-05-000	EA VALVE STEM ASM-VS938 - EATON VS-938 F53-92
3	073322-08-GB1	EA COVER-TIRE,34"
	073322-50-000	EA COVER-UNIVERSAL LINER
	080208-01-000	EA LUG WRENCH, 1.06" X 1.00"
	080208-02-000	EA BAR - LEVERAGE, LUG WRENCH

CHASSIS GROUP (CONTINUED)

CHASSIS GROUP (CONTINUED)

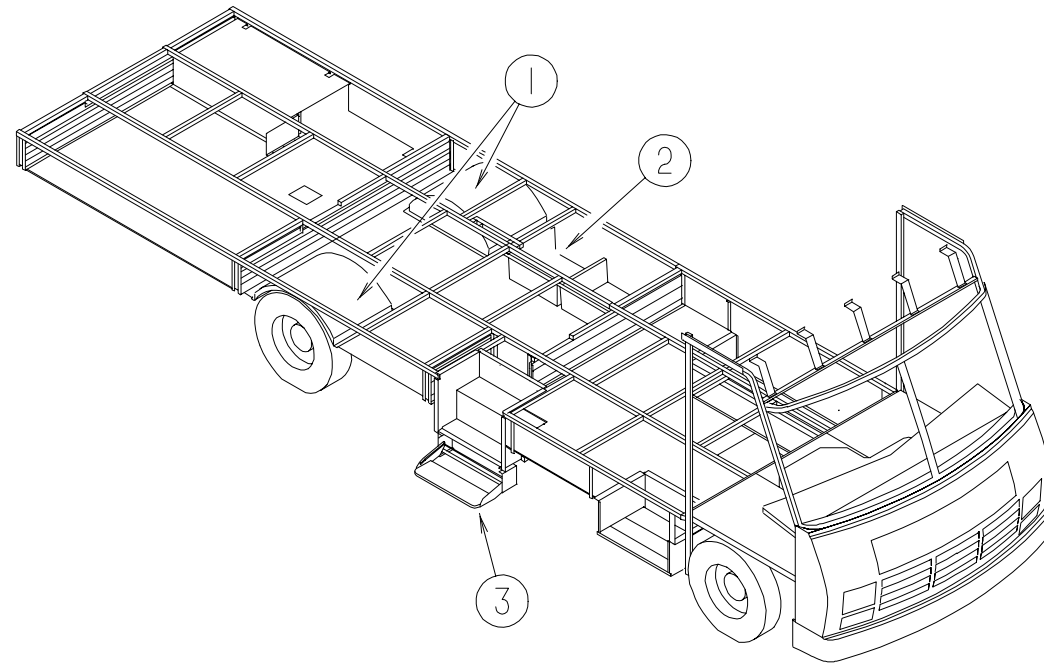

FUEL SYSTEM

KEY	PART NUMBER	U/M	DESCRIPTION
	102951-01-06A	EA	SHROUD-FUEL FILL,BRIGHT WHITE
	102951-01-01A	EA	SHROUD-FUEL FILL-UNFINISHED
	073220-02-000	EA	CAP-FILL, FUEL - NON LOCKING - GAS - GM 22525302
	095606-01-000	EA	NECK-FUEL FILL, W/CHECK VALVE - L-SHAPED - 18.2" LONG
	098803-01-000	EA	PIPE-FUEL,FILL - LOWER - W/BEND
	098803-02-000	EA	PIPE-FUEL,FILL
	100156-01-000	EA	HOSE-FUEL FILL, 8.3" LONG W/2" ID
	007111-02-000	EA	HOSE-FUEL FILL,2.00 ID - IN 3FT LENGTHS
	084884-01-000	EA	PLUG-BRASS, 3/8"
	087256-02-000	EA	NECK ASM-FUEL FILL
	078200-01-000	EA	GASKET-FUEL FILL, 3.5"OD X 2"ID
	066732-01-000	FT	HOSE-FUEL FILL, .62 ID
	007063-01-000	FT	HOSE-GAS 1/4"ID X 1/2"OD
	068382-06-000	EA	BUSHING-BRASS,3/8MPTX1/8FPT - PARKER 209P-6-2

STORAGE COMPARTMENTS & WHEELWELLS

KEY	PART NUMBER	U/M	DESCRIPTION
1	055080-01-000	EA	WHEELWELL-PLASTIC,REAR - BLACK - LEFT OR RIGHT
2	114676-01-F36	EA	COMPARTMENT ASM-STORAGE
2	M06991-03-F36	EA	HATCH ASM W/FOAM
2	114677-01-01A	EA	RETAINER-HATCH,COMPT MILL
2	114679-01-01A	EA	COMPARTMENT-STORAGE
3	077848-06-000	EA	STEP ASM-PULLOUT
	065450-05-000	EA	TIEDOWN-BATTERY, 8.4" TUBE
	103147-01-000	EA	TRAY-BATTERY
	094657-02-000	EA	TRAY-GENERATOR, 22.5" X 30.4" X 6.9" W/ANGLE & NUTS
	114070-02-02B	EA	SUPPORT ASM-GENERATOR,LT,E-C
	114071-02-02B	EA	SUPPORT ASM-GENERATOR,RT,E-C
	105376-01-02A	EA	HINGE-CONTIN,2"X140MM O/W
	115361-01-01A	EA	PLUG-PLASTIC
	103147-01-000	EA	TRAY-BATTERY
	017516-01-000	EA	FLAP-MUD, 14" X 18" - BLACK
	020167-03-000	EA	DIRT GUARD-STEEL 279.5MM LONG (11" LONG)
	001360-01-004	EA	STL-ROD CR.375DIAX028.25 IN
	033865-01-073	EA	STL-11GA HRP&O 02.00X027.40

CURTAIN & CUSHION GROUP

NOTICE

IN ORDER TO ASSIST OUR PARTS SALES DEPT. IN PROVIDING INTERIOR SOFTGOODS ITEMS, PLEASE INCLUDE THE SERIAL NUMBER AND THE COLOR CODE NUMBER FROM THE VEHICLE CERTIFICATION LABEL WHEN ORDERING. THIS LABEL IS LOCATED ON THE LEFT SIDEWALL AT THE END OF THE DASH (A-BODY), OR ON THE DRIVER'S DOOR LATCH PLATE (C-BODY).

AN EXAMPLE OF A COLOR CODE NUMBER IS B07, WHICH DESIGNATES AN OVERALL COLOR SCHEME OF A PARTICULAR UNIT. THE COLOR LISTED AFTER THE ITEM DESCRIPTION ON THE MICROFICHE, INDICATES THE OVERALL UNIT COLOR. ORDER THE ITEM YOU DESIRE ACCORDING TO UNIT COLOR CODE.

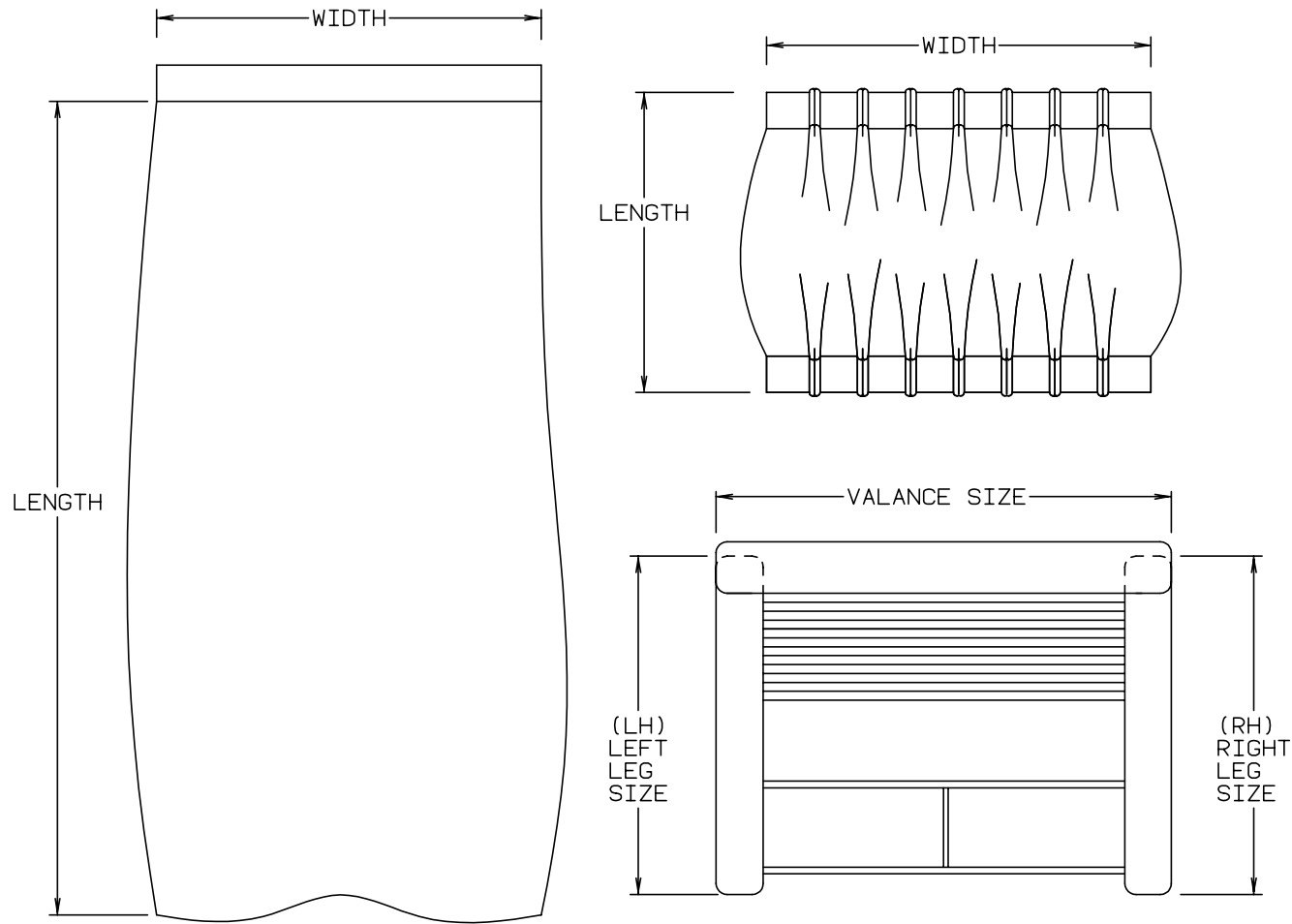

NOTE: USE THIS ILLUSTRATION WHEN DETERMINING LENGTH AND WIDTH MEASUREMENTS FOR CURTAINS. YOU WILL NOTE THE WIDTH MEASUREMENT IS TAKEN ON THE TOP OF THE CURTAIN WITH THE CURTAIN FULLY EXTENDED. THE LENGTH MEASUREMENT IS TAKEN FROM TOP TO BOTTOM. LEFT AND RIGHT WINDOW LEGS ARE DETERMINED WHEN FACING THE WINDOW.

CURTAIN & CUSHION GROUP (CONTINUED)

WARRIOR FABRICS

COLOR CODES	GB1	GCI
	BLUE RIDGE (BLUE)	PAINTED DESERT (TAN / TEAL)
BUCKET SEATS	108446-F7-000 108446-F4-000	108446-C5-000 108446-C6-000
DINETTE	108446-F1-000	108446-F2-000
DINETTE PADS	108446-F7-000	108446-C5-000
SOFA	108446-F1-000	108446-F2-000
SWIVEL CHAIR	108446-F4-000	108446-C6-000
LOUNGE WINDOWS	108446-F1-000 108446-F4-000	108446-F2-000 108446-C6-000
BEDROOM WINDOW	105745-B3-000	105745-A8-000
BEDSPREAD	105745-B3-000 105745-64-000	105745-A8-000 105745-45-000
PILLOW SHAMS	105745-B3-000 105745-64-000	105745-A8-000 105745-45-000
FRT WRAP AROUND	105745-64-000	105745-45-000
DIVIDER CURTAIN	105745-64-000 105745-B3-000	105745-45-000 105745-A8-000
DRAPERY LINING	087272-03-000	087272-03-000
VINYL-EXPANDED	103907-05-000 106569-01-01A 103907-01-01A	103907-05-000 106569-01-01A 103907-01-01A

NOTE: THE FABRIC LISTED FIRST IN A BLOCK, IS THE LARGEST QUANTITY OF FABRIC USED.

CURTAIN & CUSHION GROUP (CONTINUED)

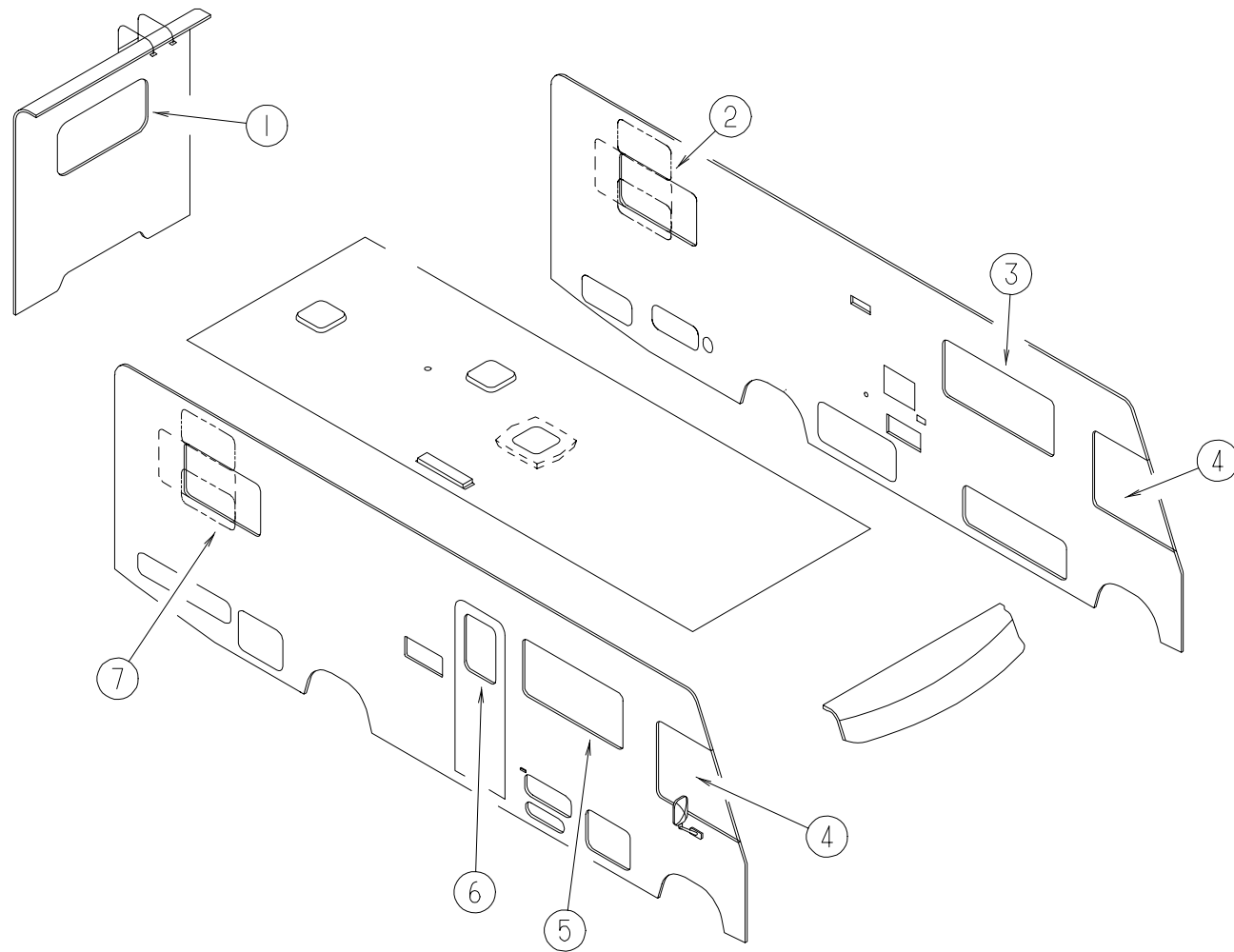

WINDOW TREATMENT

KEY	PART NUMBER	U/M DESCRIPTION
1	118064-01-GB1	EA VALANCE ASM-VALENCIA - 52"
1	118064-01-GC1	EA VALANCE ASM-VALENCIA - 52"
1	084755-92-F15	EA SHADE ASM-PULL - 50.25" (GB1, GC1)
1	111910-19-G22	EA BLIND - DAY/NIGHTER - 50 X 28 (GB1)
1	111910-19-GC1	EA BLIND - DAY/NIGHTER - 50 X 28 (GC1)
1	118064-03-GB1	EA VALANCE ASM-VALENCIA - 29"
1	118064-03-GC1	EA VALANCE ASM-VALENCIA - 29"
1	084755-57-E07	EA SHADE ASM-PULL - 27.25" (GB1, GC1)
1	111910-20-GB1	EA BLIND - DAY/NIGHTER - 28 X 28
1	111910-20-GC1	EA BLIND - DAY/NIGHTER - 28 X 28
2	118064-02-GB1	EA VALANCE ASM-VALENCIA - 44" (GB1)
2	118064-02-GC1	EA VALANCE ASM-VALENCIA - 44" (GC1)
2	084755-93-F15	EA SHADE ASM-PULL - 42.25 (GB1, GC1)
2	111910-46-G22	EA BLIND - DAY/NIGHTER - 43 X 26 (GB1)
2	111910-46-G02	EA BLIND - DAY/NIGHTER - 43 X 26 (GC1)
2	101034-49-GB1	EA CURTAIN - 19 X 19 - RIGHT - DART TAPE T&B
2	101034-49-GC1	EA CURTAIN - 19 X 19 - RIGHT - DART TAPE T&B
2	101034-50-GB1	EA CURTAIN - 19 X 19 - LEFT - DART TAPE T&B
2	101034-50-GC1	EA CURTAIN - 19 X 19 - LEFT - DART TAPE T&B
3	118078-05-GB1	EA VALANCE - QUEST (5") 64.5"
3	118078-05-GC1	EA VALANCE - QUEST (5") 64.5"

CURTAIN & CUSHION GROUP (CONTINUED)

WINDOW TREATMENT CONTINUED

KEY	PART NUMBER	U/M DESCRIPTION
3	119333-01-GB1	EA LEG-RIGHT - 25"-PLAIN - NO HOLE 3.5" FACE,WOOD
3	119333-01-GC1	EA LEG-RIGHT - 25"-PLAIN - NO HOLE 3.5" FACE,WOOD
3	119333-02-GB1	EA LEG-LEFT - 25"-PLAIN - NO HOLE 3.5" FACE,WOOD
3	119333-02-GC1	EA LEG-LEFT - 25"-PLAIN - NO HOLE 3.5" FACE,WOOD
3	084755-96-G01	EA SHADE ASM-PULL - 60.25 - NO TRIM (GB1, GC1)
3	111910-22-GB1	EA BLIND - DAY/NIGHTER - 60 X 28.5
3	111910-22-GC1	EA BLIND - DAY/NIGHTER - 60 X 28.5
4	101668-31-EB1	EA CURTAIN - TAPE TOP, 38" X 80" - DRIVERS (GB1)
4	101668-31-DC4	EA CURTAIN - TAPE TOP, 38" X 80" - DRIVERS (GC1)
4	101668-30-EB1	EA CURTAIN - TAPE TOP, 38" X 80" - PASSENGERS (GB1)
4	101668-30-DC4	EA CURTAIN - TAPE TOP, 38" X 80" - PASSENGERS (GC1)
4	073260-42-FB1	EA TIEBACK ASM-6X18 (GB1)
4	073260-42-GC1	EA TIEBACK ASM-6X18 (GC1)
5	118078-03-GB1	EA VALANCE - QUEST (5") 58.5"
5	118078-03-GC1	EA VALANCE - QUEST (5") 58.5"
5	119333-01-GB1	EA LEG-RIGHT - 25"-PLAIN - NO HOLE 3.5" FACE,WOOD
5	119333-01-GC1	EA LEG-RIGHT - 25"-PLAIN - NO HOLE 3.5" FACE,WOOD
5	119333-02-GB1	EA LEG-LEFT - 25"-PLAIN - NO HOLE 3.5" FACE,WOOD
5	119333-02-GC1	EA LEG-LEFT - 25"-PLAIN - NO HOLE 3.5" FACE,WOOD
5	084755-69-F15	EA SHADE ASM-PULL - 55.25 - NO TRIM (GB1, GC1)
5	111910-23-GB1	EA BLIND - DAY/NIGHTER - 54 X 28.5
5	111910-23-GC1	EA BLIND - DAY/NIGHTER - 54 X 28.5
6	118078-02-GB1	EA VALANCE ASM-29" QUEST
6	118078-02-GC1	EA VALANCE ASM-29" QUEST
6	084755-95-FB1	EA SHADE ASM-PULL - 25.5" NO TRIM (GB1, GC1)
7	118064-02-GB1	EA VALANCE ASM-VALENCIA - 44" (GB1)
7	118064-02-GC1	EA VALANCE ASM-VALENCIA - 44" (GC1)
7	084755-93-F15	EA SHADE ASM-PULL - 42.25 (GB1, GC1)
	101668-53-GB1	EA CURTAIN - 70" X 60" - ROOM DIVIDER - LINED - TAPE TOP
	101668-53-GC1	EA CURTAIN - 70" X 60" - ROOM DIVIDER - LINED - TAPE TOP
	073260-63-GB1	EA TIEBACK ASM - 4" X 15" (ROOM DIVIDER)
	073260-63-GC1	EA TIEBACK ASM - 4" X 15" (ROOM DIVIDER)

FABRIC TRIMS, SEAT BELTS & ASSIST HANDLE

KEY	PART NUMBER	U/M DESCRIPTION
	079349-04-GB1	YD WELT ASM-NARROW,ACCENT
	079349-04-F08	YD WELT ASM-NARROW,ACCENT (GC1)
	057759-01-000	EA WASHER BRACKET-SEAT BELT, 4" DIAMETER
	007021-01-000	EA BELT-SEAT, 2" X 90" - BLACK
	091990-04-01A	EA BELT-SEAT, 3 POINT - BLACK
	070578-02-B10	EA BUTTON-SCREW STUD, #30 - VINYL - OFF WHITE
	000C16-07-16B	EA BOLT-CARRIAGE, ASSIST HANDLE - 7/16" - 14 X 1" ZN
	000D20-07-00B	EA NUT-ACORN,ASSIST HANDLE - 7/16" X 14 ZN
	053552-02-AA8	EA HANDLE-ASSIST, INTERIOR - ENTRY DOOR - VINYL - OFF WHITE

CURTAIN & CUSHION GROUP (CONTINUED)

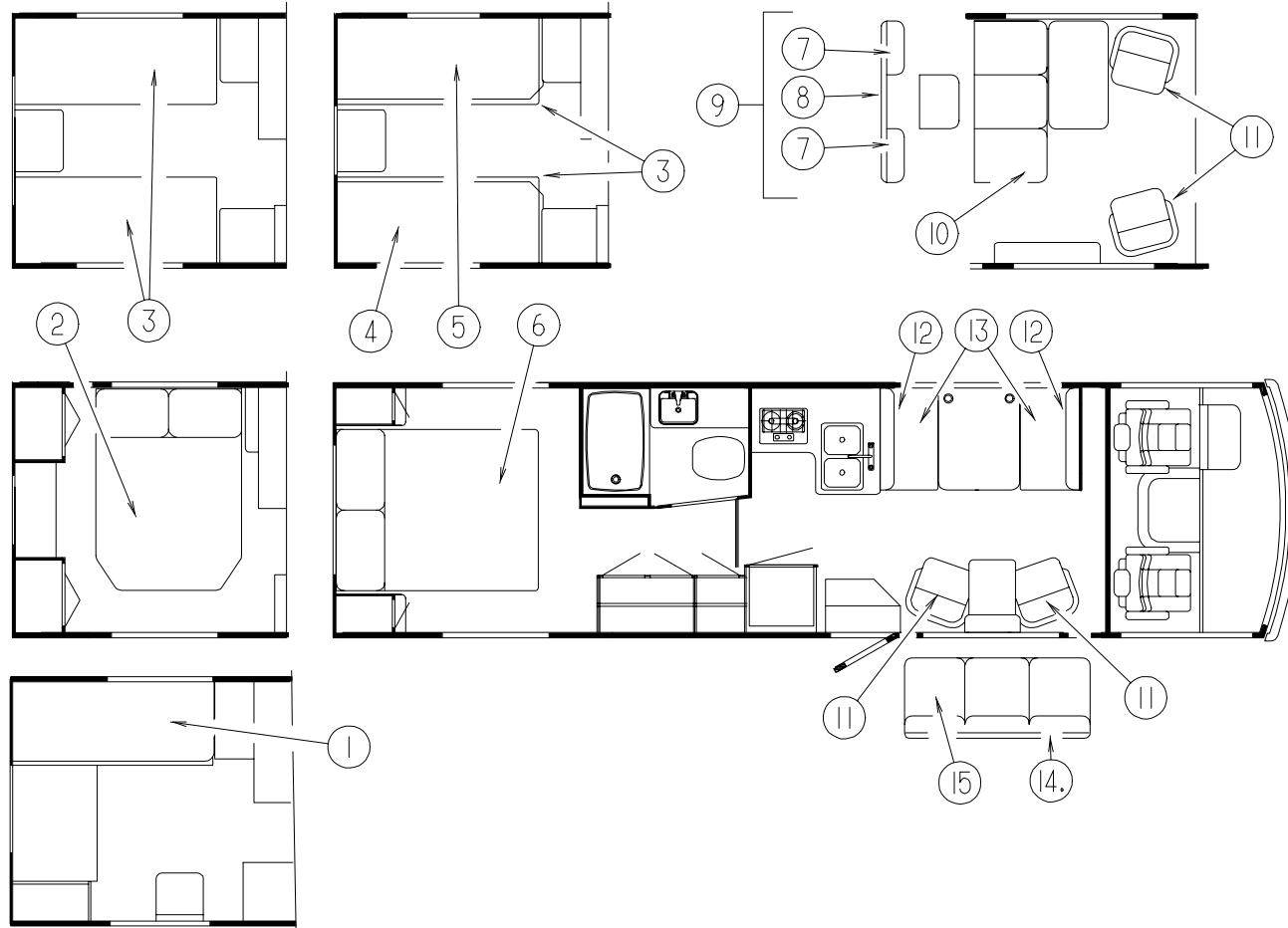

BUNKS BED CUSHIONS

KEY	PART NUMBER	U/M DESCRIPTION
4	101123-24-000	EA MATTRESS-COMPLETE-FOAM 30 X 76 X 4 - W/LT.CUT CORNER
	P01123-24-000	EA COVER-MATTRESS - 30 X 76 X 4
	117067 02 GB1	EA COVER-FITTED SHEET,LT.4"
	117067 02 GC1	EA COVER-FITTED SHEET,LT.4"
5	101123-23-000	EA MATTRESS-COMPLETE-FOAM 30 X 76 X 4 - W/RT.CUT CORNER
	P01123-23-000	EA COVER-MATTRESS - 30 X 76 X 4
	117067 01 GB1	EA COVER-FITTED SHEET,RT.4"
	117067 01 GC1	EA COVER-FITTED SHEET,RT.4"
	102161-35-GB1	EA SHAM - 1/2"NON-GATHERED WELT W/4" RUFFLE (20X33) (GB1)
	102161-35-GC1	EA SHAM - 1/2"NON-GATHERED WELT W/4" RUFFLE (20X33) (GC1)

QUEEN BED CUSHIONS

KEY	PART NUMBER	U/M DESCRIPTION
6	101123-26-000	EA MATTRESS COMPLETE-FOAM - 59" X 74" X 5" (GB1, GC1)
	P01123-26-000	EA COVER-MATTRESS - 59" X 74" X 5" (GB1, GC1)
6	085365-36-GB1	EA BEDSPREAD - 60" X 75" THROW,1/2" WELT NON-GATHERING
6	085365-36-GC1	EA BEDSPREAD - 60" X 75" THROW,1/2" WELT NON-GATHERING
	102161-35-GB1	EA SHAM - QUEEN - 1/2"NON-GATHERED WELT W/4" RUFFLE (20X33) (GB1)
	102161-35-GC1	EA SHAM - QUEEN - 1/2"NON-GATHERED WELT W/4" RUFFLE (20X33) (GC1)

CROSSED STACKED TWIN BED CUSHIONS

KEY	PART NUMBER	U/M DESCRIPTION
1	101123-19-000	EA MATTRESS-COMPLETE-FOAM 32" X 79" X 5" (GB1,GC1)
	P01123-19-000	EA COVER-MATTRESS - 32" X 74" X 5" (GB1, GC1)
	117067-03-GB1	EA COVER-FITTED SHEET,UNIV. 5"
	117067-03-GC1	EA COVER-FITTED SHEET,UNIV. 5"

DOUBLE BED

KEY	PART NUMBER	U/M DESCRIPTION
2	101123-22-000	EA MATTRESS COMPLETE-FOAM - W/2 CUT CORNERS - 54" X 74" X 5" (GB1, GC1)
	P01123-22-000	EA COVER-MATTRESS - 54" X 74" X 5" (GB1, GC1)
2	085365-37-GB1	EA BEDSPREAD - 54" THROW,1/2" WELT NON-GATHERING
2	085365-37-GC1	EA BEDSPREAD - 54" THROW,1/2" WELT NON-GATHERING
	102161-36-GB1	EA SHAM - 1/2"NON-GATHERED WELT W/4" RUFFLE (20X30) (GB1)
	102161-36-GC1	EA SHAM - 1/2"NON-GATHERED WELT W/4" RUFFLE (20X30) (GC1)

TWIN BED CUSHIONS

KEY	PART NUMBER	U/M DESCRIPTION
3	101123-19-000	EA MATTRESS-COMPLETE-FOAM 32" X 79" X 5" (GB1,GC1)
	P01123-19-000	EA COVER-MATTRESS - 32" X 74" X 5" (GB1, GC1)
	117067-03-GB1	EA COVER-FITTED SHEET,UNIV. 5"
	117067-03-GC1	EA COVER-FITTED SHEET,UNIV. 5"
3	085365-38-GB1	EA BEDSPREAD - 33" X 80" - W1/2" WELT NON-GATHERED
3	085365-38-GC1	EA BEDSPREAD - 33" X 80" - W1/2" WELT NON-GATHERED
	102161-35-GB1	EA SHAM - 1/2"NON-GATHERED WELT W/4" RUFFLE (20X33) (GB1)
	102161-35-GC1	EA SHAM - 1/2"NON-GATHERED WELT W/4" RUFFLE (20X33) (GC1)

CURTAIN & CUSHION GROUP (CONTINUED)

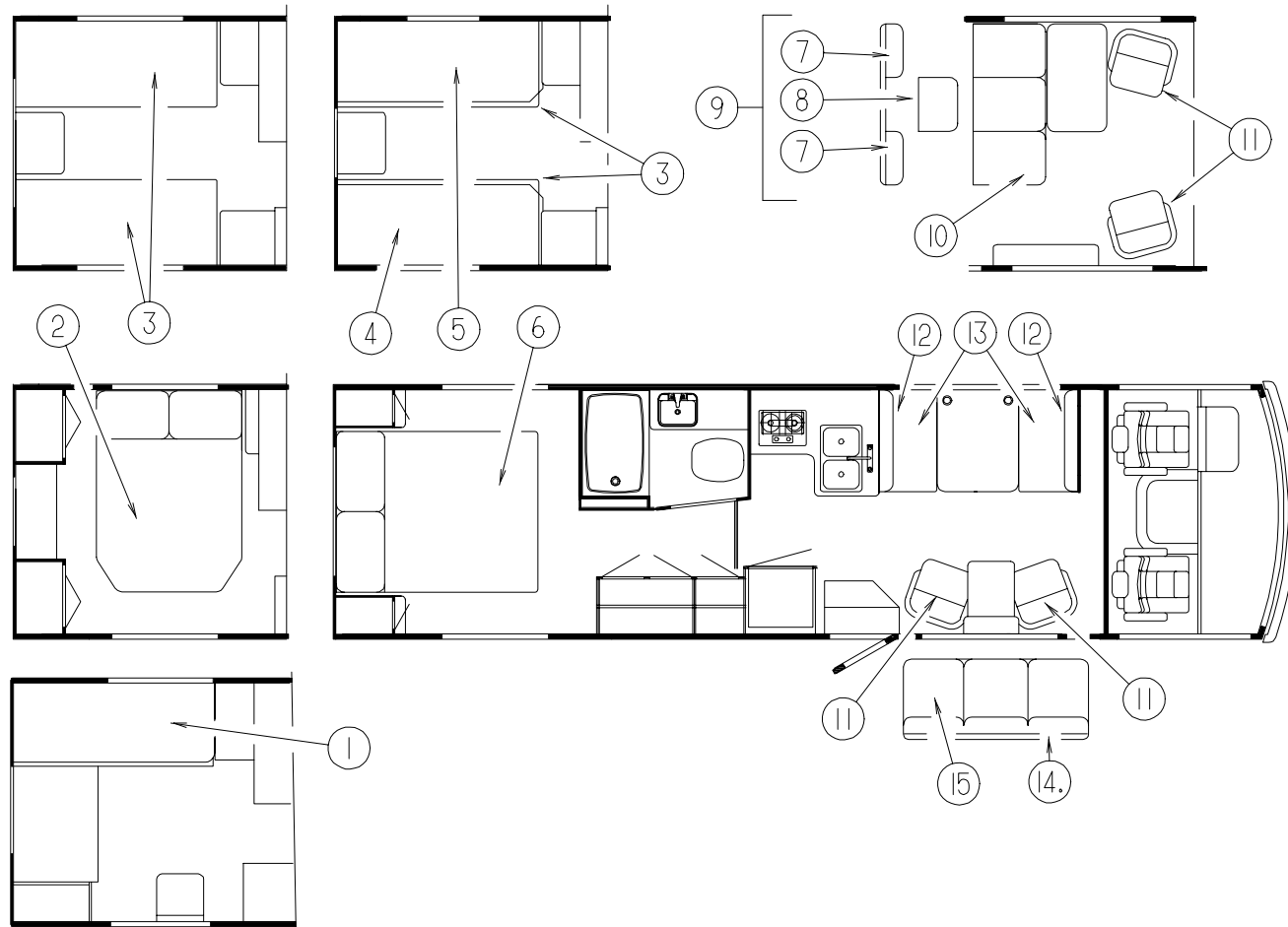

FORWARD FACING COUCH / BED

KEY	PART NUMBER	U/M DESCRIPTION
7	114969-02-GB1	EA BED - FORWARD FACING - BACK - END - JACK KNIFE
7	114969-02-GC1	EA BED - FORWARD FACING - BACK - END - JACK KNIFE
	P14969-02-GB1	EA COVER - FORWARD FACING - BACK - END - JACK KNIFE
	P14969-02-GC1	EA COVER - FORWARD FACING - BACK - END - JACK KNIFE
8	114969-03-GB1	EA BED - FORWARD FACING - CENTER END - JACK KNIFE
8	114969-03-GC1	EA BED - FORWARD FACING - CENTER END - JACK KNIFE
	P14969-03-GB1	EA COVER - FORWARD FACING - CENTER END - JACK KNIFE
	P14969-03-GC1	EA COVER - FORWARD FACING - CENTER END - JACK KNIFE
	114763-07-000	EA FRAME-FORWARD FACING LEGS
	114726-01-GB1	EA TRAY ASM-BEVERAGE
9	114969-01-GB1	EA BED - FORWARD FACING - BACK COMPLETE - JACK KNIFE
9	114969-01-GC1	EA BED - FORWARD FACING - BACK COMPLETE - JACK KNIFE
10	114969-04-GB1	EA BED - FORWARD FACING - SEAT ASM - JACK KNIFE
10	114969-04-GC1	EA BED - FORWARD FACING - SEAT ASM - JACK KNIFE
	P14969-04-GB1	EA COVER - FORWARD FACING - SEAT ASM - JACK KNIFE
	P14969-04-GC1	EA COVER - FORWARD FACING - SEAT ASM - JACK KNIFE
	116110-03-GB1	EA COUCH END - FORWARD FACING - RIGHT.
	116110-03-GC1	EA COUCH END - FORWARD FACING - RIGHT.

NOTE:

COUCH FRONT AND SIDEPANELS ARE FOUND IN THE LOUNGE GROUP.

CURTAIN & CUSHION GROUP (CONTINUED)

SIERRA CHAIR

KEY	PART NUMBER	U/M DESCRIPTION
11	115470-01-GB1	EA CHAIR ASM-SIERRA
	P15470-01-GB1	EA COVER-CHAIR,SIERRA
11	115470-01-F08	EA CHAIR ASM-SIERRA (GC1)
	P15470-01-F08	EA COVER-CHAIR,SIERRA (GC1)
	P07977-01-GB1	EA COVER-SKIRT,CHAIR,DIPLOMAT
	P07977-01-F08	EA COVER-SKIRT,CHAIR,DIPLOMAT (GC1)

DINETTE CUSHIONS

KEY	PART NUMBER	U/M DESCRIPTION
12	116134-01-GB1	EA CUSHION - BACKREST - 13" X 37.5" X 5"
12	116134-01-GC1	EA CUSHION - BACKREST - 13" X 37.5" X 5"
	P16134-01-GB1	EA COVER - BACKREST CUSHION - 13" X 37.5" X 5"
	P16134-01-GC1	EA COVER - BACKREST CUSHION - 13" X 37.5" X 5"
13	088927-87-GB1	EA CUSHION - SEAT, 23" X 37.5" X 5"
13	088927-87-GC1	EA CUSHION - SEAT, 23" X 37.5" X 5"
	M88927-87-GB1	EA COVER - CUSHION - SEAT, 23" X 37.5" X 5"
	M88927-87-GC1	EA COVER - CUSHION - SEAT, 23" X 37.5" X 5"
	078155-01-000	EA STRAP-SNAP - BACKREST CUSHION
	109995-01-GB1	EA PAD ASM-DINETTE
	109995-01-GC1	EA PAD ASM-DINETTE

PASSENGERS SIDE COUCH

KEY	PART NUMBER	U/M DESCRIPTION
14	100032-44-GB1	EA BED ASM. - TUCK BACK - JACK KNIFE - 66.5 - BACK N/ARMS FROM: 00-00-00 THRU: 07-23-95
14	100032-44-GC1	EA BED ASM. - TUCK BACK - JACK KNIFE - 66.5 - BACK N/ARMS FROM: 00-00-00 THRU: 07-23-95
14	120549-02-GB1	EA BED ASM-600 TUCK BACK - JACK KNIFE - 66.5" BACK FROM: 07-24-95 THRU: 99-99-99
14	120549-02-GC1	EA BED ASM-600 TUCK BACK - JACK KNIFE - 66.5" BACK FROM: 07-24-95 THRU: 99-99-99
15	100032-37-GB1	EA BED-3 PILLOW - SEAT,66.5 - JACK KNIFE
15	100032-37-GC1	EA BED-3 PILLOW - SEAT,66.5 - JACK KNIFE
	083125-07-000	EA BRACE-COUCH,O/W
	101085-09-000	EA FRAME-66.5X16 BACK
	101085-01-000	EA FRAME-66.5" SEAT
	101085-03-000	EA FRAME-66.5" BASE

NOTE:

COUCH FRONT AND SIDEPANELS ARE FOUND IN THE LOUNGE GROUP.

BUCKET SEAT

KEY	PART NUMBER	U/M DESCRIPTION
	110148-07-GB1	EA SEAT - ECONOMIZER III - ECONOMIZER ARM
	110148-07-GC1	EA SEAT - ECONOMIZER III - ECONOMIZER ARM

FRONT BUNK CUSHIONS

KEY	PART NUMBER	U/M DESCRIPTION
	079145-10-000	EA CUSHION-BUNK - 25" X 80" X 2.5"
	M79145-10-000	EA COVER-BUNK - 25" X 80" X 2.5"

CURTAIN & CUSHION GROUP (CONTINUED)

DRIVER & PASSENGER BUCKET SEATS

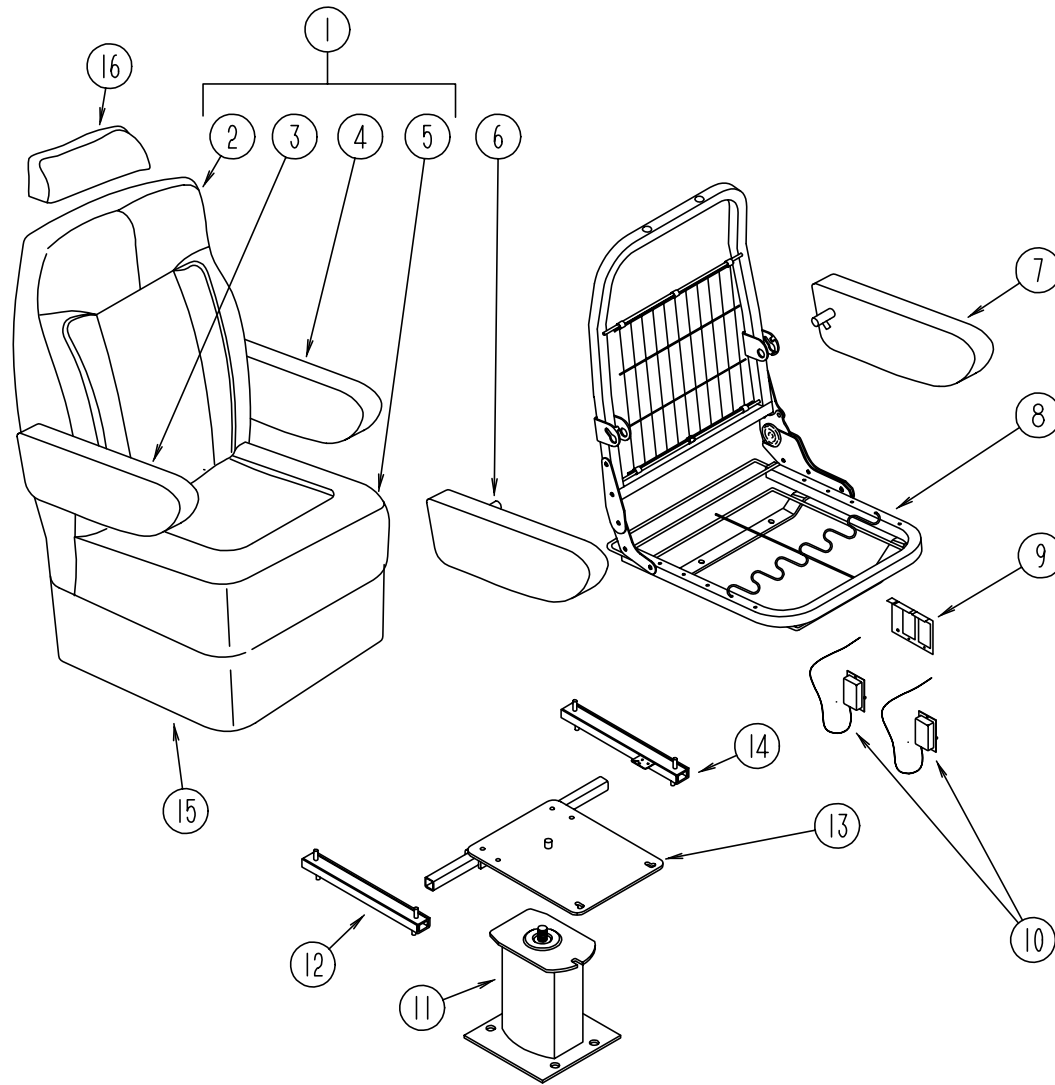

KEY	PART NUMBER	U/M	DESCRIPTION
1	110148-07-GB1	EA	SEAT-ECONOMIZER III - -ECONOMIZER ARM
1	110148-07-GC1	EA	SEAT-ECONOMIZER III - -ECONOMIZER ARM
2	M05962-17-GB1	EA	COVER-ECONOMIZER - BACK
2	M05962-17-G02	EA	COVER-ECONOMIZER - BACK (GC1)
3	115520-01-GB1	EA	ARMREST-RIGHT - FAN
3	115520-01-GC1	EA	ARMREST-RIGHT - FAN
	P15520-01-GB1	EA	COVER-ARMREST-RIGHT - FAN
	P15520-01-GC1	EA	COVER-ARMREST-RIGHT - FAN
4	115520-02-GB1	EA	ARMREST-LEFT - FAN
4	115520-02-GC1	EA	ARMREST-LEFT - FAN
	P15520-02-GB1	EA	COVER-ARMREST-LEFT - FAN
	P15520-02-GC1	EA	COVER-ARMREST-LEFT - FAN
5	M05962-18-GB1	EA	COVER-ECONOMIZER II - SEAT
5	M05962-18-G02	EA	COVER-ECONOMIZER II - SEAT (GC1)
6	115617-01-000	EA	BRACKET / ARMREST - RIGHT - MOLDED
7	115617-02-000	EA	BRACKET / ARMREST - LEFT - MOLDED
8	M80906-12-000	EA	FRAME ASM-SEAT & BACK & SPRING
9	108049-02-000	EA	CABLE-PEDESTAL CLIP
	080730-08-000	EA	HANDLE-30179907 KEIPER
	080730-09-000	EA	SHEILD-FLEXSTEEL
	080730-11-000	EA	SHIELD-RUBBER BOOT FLEXSTEEL
10	108049-03-000	EA	26" CONTROL CABLE - Z END W/SWITCH LEVER
11	107921-01-000	EA	PEDESTAL ASM-SEAT 9-3/4" - FLEXSTEEL 3060 MSPD
12	119952-04-000	EA	ADJUSTER-BUCKET SEAT W/ REMOTE - FORWARD AND BACK
13	107921-05-000	EA	TOP PLATE - FLEXSTEEL
	107921-06-000	EA	BEARING KIT - FLEXSTEEL
14	119952-02-000	EA	ADJUSTER-SEAT/CHAIR - W/O LOCK - FORWARD & BACK
	007221-01-000	EA	SPACER-SEAT - ADJUSTER
15	071126-41-GB1	EA	SKIRT ASM-SINGLE - 7" - W/SLOT
15	071126-41-GC1	EA	SKIRT ASM-SINGLE - 7" - W/SLOT
16	119698-01-GB1	EA	HEADREST-STRATON II
16	119698-01-GC1	EA	HEADREST-STRATON II
	P19698-01-GB1	EA	COVER-HEADREST STRATON II
	P19698-01-GC1	EA	COVER-HEADREST STRATON II
	113977-12-000	EA	HEADREST INSERT,W/O LOCK
	113977-13-000	EA	HEADREST INSERT,W/LOCK
	114791-05-000	EA	FRAME-HEADREST,STRATON,PLYF

CURTAIN & CUSHION GROUP (CONTINUED)

SWIVEL CHAIR (RECLINER)

KEY	PART NUMBER	U/M	DESCRIPTION
1	115470-01-GB1	EA	CHAIR ASM-SIERRA
	P15470-01-GB1	EA	COVER-CHAIR,SIERRA
1	115470-01-F08	EA	CHAIR ASM-SIERRA (GC1)
	P15470-01-F08	EA	COVER-CHAIR,SIERRA (GC1)
	P07977-01-GB1	EA	COVER-SKIRT,CHAIR,DIPLOMAT
	P07977-01-F08	EA	COVER-SKIRT,CHAIR,DIPLOMAT (GC1)
2	097683-02-000	EA	BRACKET - REMOTE - SIDE MOUNT
3	108049-03-000	EA	26" CONTROL CABLE - Z END W/SWITCH LEVER
	108049-02-000	EA	CLIP-CABLE, PEDESTAL
4	119952-01-000	EA	SLIDE-SEAT,HD,NONLOCKING 2ST - ATWOOD 83711
5	107921-08-000	EA	TOP PLATE-W/O SEAT BELT BAR
	107921-06-000	EA	BEARING KIT - PEDESTAL
6	107921-01-000	EA	FLOOR MOUNTED PEDESTAL - W/ 9.75" EXTENSION
7	108445-02-000	EA	SUB PLATE - FLOOR MOUNTED PEDESTAL
8	119952-03-000	EA	SLIDE-SEAT,HD,LOCKING 2STUDS - ATWOOD 83775
9	007221-01-000	EA	SPACER - SEAT ADJUSTER
	108452-G3-000	EA	FOAM-SEAT CORE - 95 SIERRA CHAIR
	117125-01-02B	EA	BRACKET-CABLE HOLDER,E-COAT
	117125-01-02B	EA	BRACKET-CABLE HOLDER,E-COAT
	007021-01-000	EA	SEAT BELT - 2" X 90" - BLACK

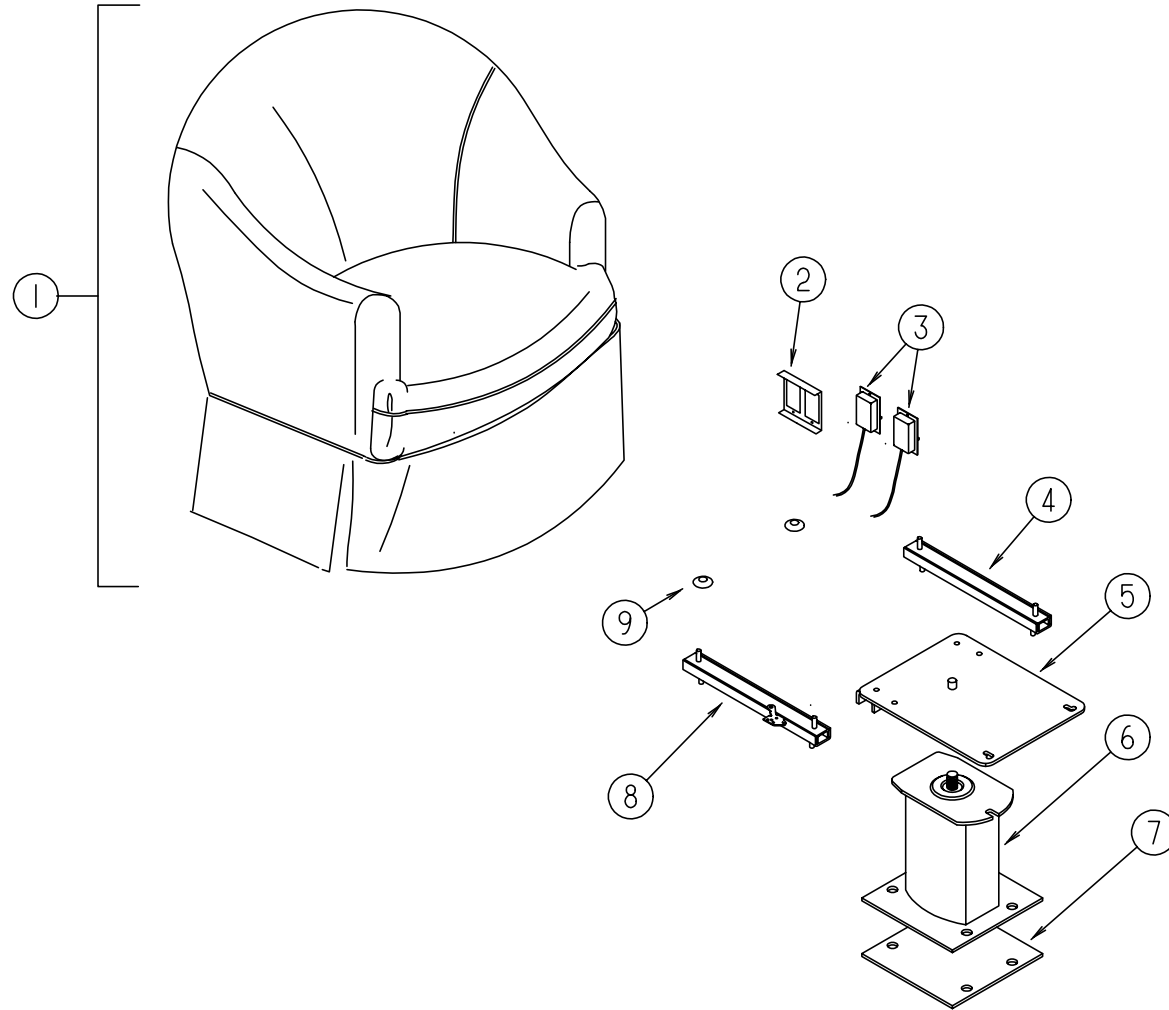

CURTAIN & CUSHION GROUP (CONTINUED)

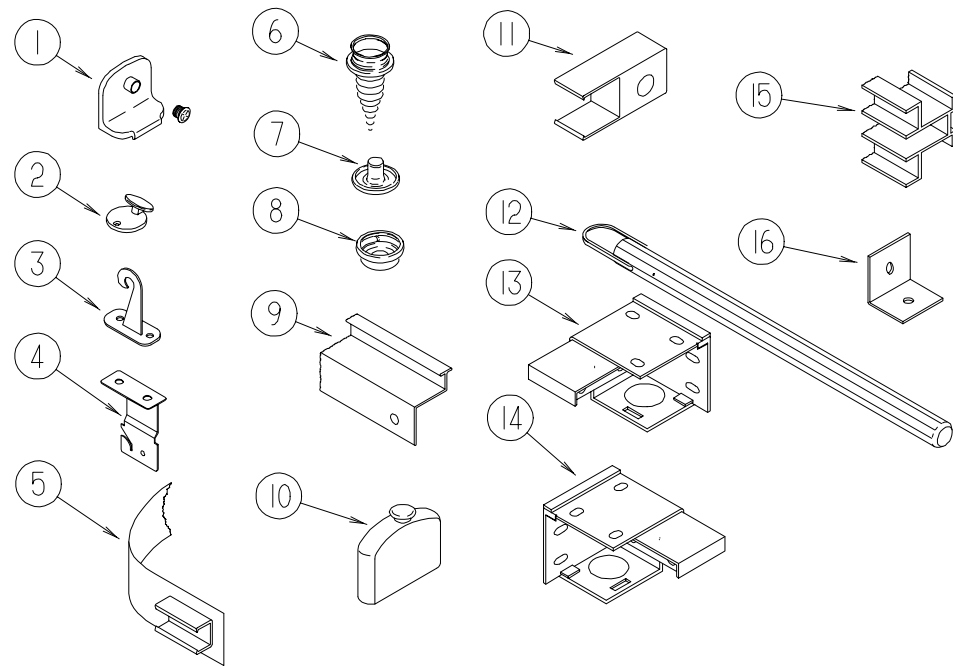

CURTAIN HARDWARE

KEY	PART NUMBER	U/M DESCRIPTION
1	106544-01-000	EA PULL-SHADE, BRASS
	106544-01-001	EA SCREW-BRASS, SHADE
2	102555-01-000	EA CLEAT-CORD, BLIND - OFF WHITE
3	109441-01-000	EA HOLD DOWN-BLIND, HOOK
4	084434-01-000	EA BRACKET-MOUNTING, ROLLER SHADE - 1 3/8"
	084433-05-000	EA SHADE-ROLLER, 72.25"
	096843-01-000	EA SPRING-REWIND, ROLLER SHADE
	084432-06-000	FT SLAT-ROLLER SHADE, PLASTIC
5	101031-01-000	YD TAPE-GLIDE, CURTAIN - 4.25" SPACING
6	029130-01-000	EA SCREW-SNAP SOCKET, 8 PH X 5/8"
7	029155-01-000	EA CAP-SNAP, 5/32" O.D. OF PIN
8	029156-01-000	EA SOCKET-SNAP, 9/16" O.D.
9	105324-02-01A	EA TRACK-CURTAIN, WRAPAROUND - PASSENGER SIDE - OFF WHITE
9	105324-03-01A	EA TRACK-CURTAIN, WRAPAROUND - DRIVER SIDE - OFF WHITE
9	105450-08-01A	EA TRACK-CURTAIN, 38" LONG - ALUMINUM - OFF WHITE
10	093475-01-701	EA END CAP-BLIND, W/STUD
11	101033-02-000	EA END CAP-TRACK, CLEAR
12	093475-01-700	EA WAND-BLIND, W/METAL CLIP - 8" LONG
13	083170-01-000	EA BRACKET-BLIND, RIGHT SIDE
14	083170-02-000	EA BRACKET-BLIND, LEFT SIDE
15	101033-03-000	EA TRACK-WALL, WHITE
16	083125-07-000	EA BRACE-COUCH,O/W
	046867-01-000	EA GROMMET-BRASS, 7/16" ID X 1" OD
	088792-01-000	YD VELCRO-HOOK, .75" WIDE - BEIGE
	088792-02-000	YD VELCRO TAPE-LOOP, ADHESIVE BACKED - .75" WIDE - BEIGE
	088792-06-000	YD VELCRO-3/4" NON-ADH.,LOOP BUF MED
	048394-02-000	YD VELCRO TAPE-HOOK, ADHESIVE BACK - .75" WIDE - BEIGE
	086276-01-000	EA TAPE-DOUBLE SIDED, 1/2"

DINETTE GROUP

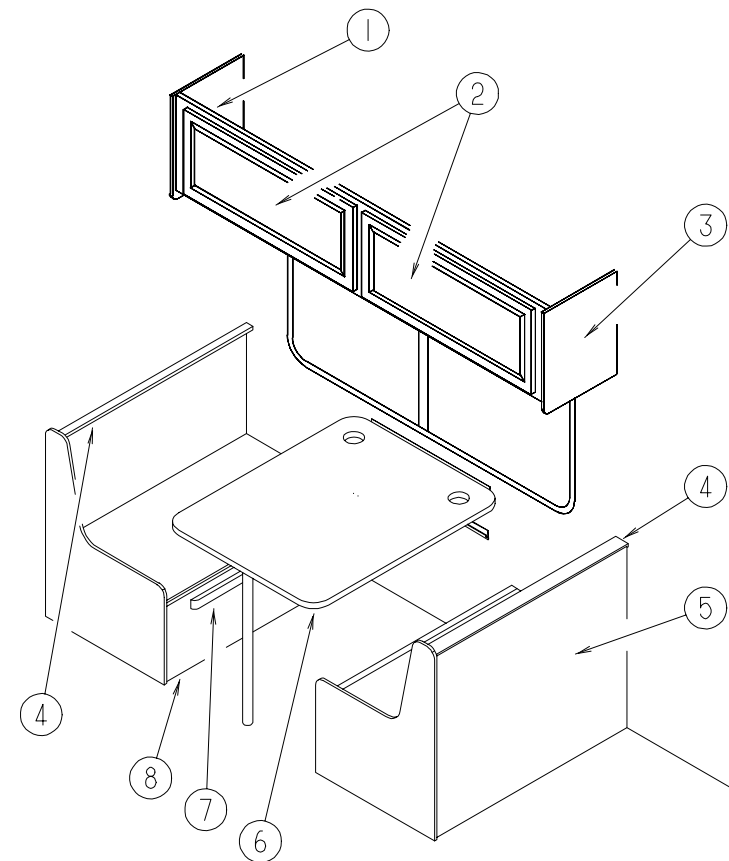

DINETTE CABINETRY

KEY	PART NUMBER	U/M DESCRIPTION
1	P16878-01-GB1	EA CABINET ASM-OVERHEAD - DINETTE
2	110140-65-G01	EA DOOR ASM-MITERED - VINYL WRAP W/MIRROR
2	110140-05-G01	EA DOOR ASM-MITERED - VINYL WRAP W/O MIRROR
3	109908-03-GB1	EA CAP ASM-END - OVERHEAD
4	109995-01-GB1	EA PAD ASM-DINETTE(GB1)
4	109995-01-GC1	EA PAD ASM-DINETTE(GC1)
	016604-05-000	EA BRACE-SEAT, OFF/WHITE
5	M04174-75-GB1	EA CABINET-SEATBACK - RIGHT
	M04175-75-GB1	EA CABINET-SEATBASE - RIGHT
6	081322-05-G31	EA TABLE ASM-DINETTE (GB1)
6	081322-05-G09	EA TABLE ASM-DINETTE (GC1)
7	081295-01-G01	EA SUPPORT-BED - DINETTE - 712 LG
8	M04175-76-GB1	EA CABINET-SEATBASE - LEFT

DINETTE GROUP (CONTINUED)

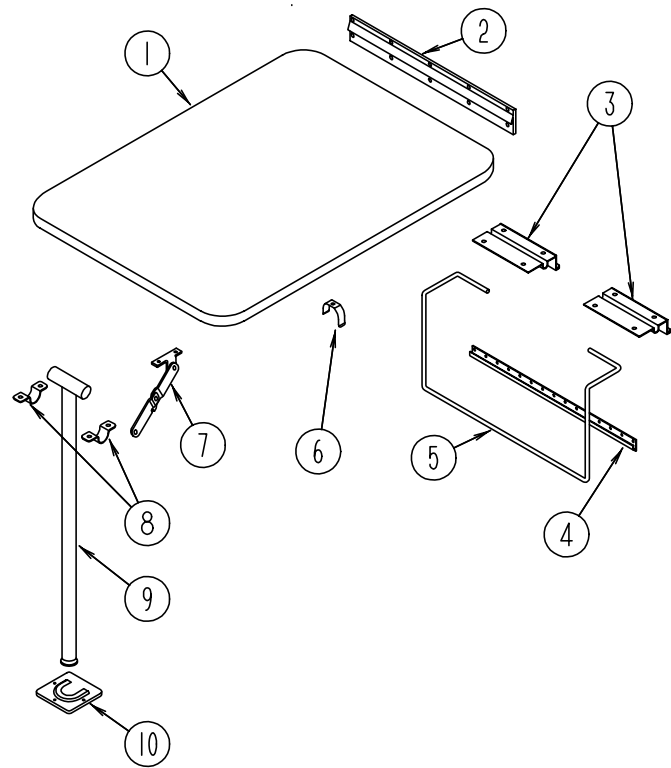

DINETTE TABLE

KEY	PART NUMBER	U/M	DESCRIPTION
1	081322-05-G31	EA	TABLE ASM-DINETTE (GB1)
1	081322-01-G09	EA	TABLE ASM-DINETTE (GC1)
2	053200-12-000	EA	SUPPORT-TABLE, 23.50" - OFF WHITE
3	088410-02-000	EA	HANGER-TABLE, OFF WHITE
4	024281-14-000	EA	BRACKET-TABLE LIFT, 22.12" - OFF WHITE
5	024275-12-000	EA	ROD-TABLE LIFT, OFF WHITE
6	024283-01-000	EA	CLIP-LEG, 1" - 1.125" OD - BLACK
7	024282-01-000	EA	BRACE-TABLE LEG, HINGED
8	064050-05-000	EA	HINGE-TABLE LEG, OFF WHITE
9	024276-23-000	EA	LEG ASM-TABLE OFF WHITE
10	049493-12-000	EA	CATCH-TABLE LEG, OFF WHITE
10	049493-11-700	EA	CATCH-LEG, FLOOR MOUNTED - 2.5" X 2.7" - METAL - E-COAT
	093550-01-000	EA	BRACKET-HINGE, MOUNTS TO LEG & TABLE TOP - 1.7" X 2.6"

DRIVERS COMPARTMENT GROUP

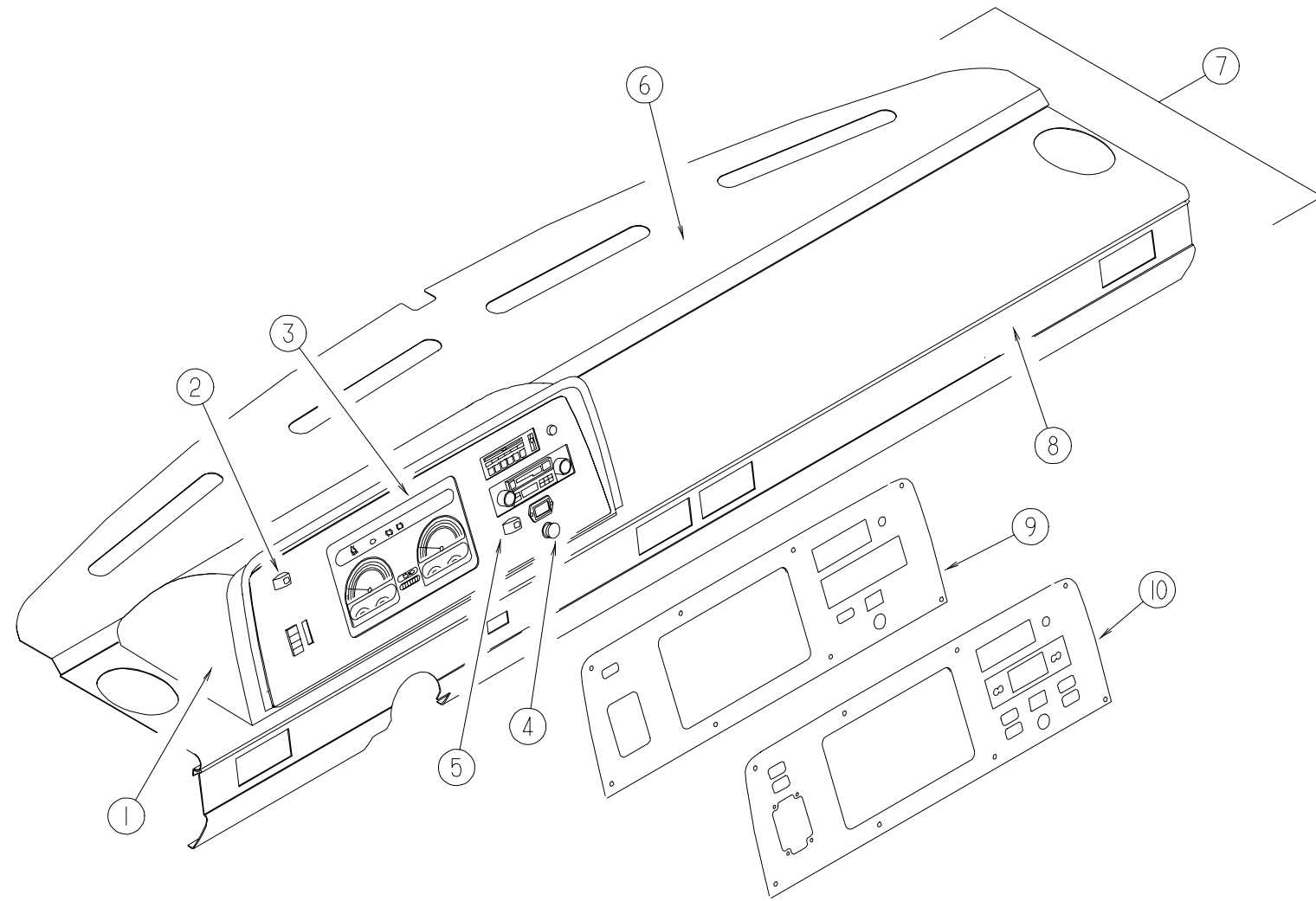

DASH

KEY	PART NUMBER	U/M	DESCRIPTION
	M05946-32-GB1	EA	DASH POD ASM CHEVY
1	110066-01-02A	EA	POD-INSTRUMENT PANEL
	079382-01-000	EA	SCREW-SOCKET, 8-18 X 1" - BLACK
	103603-01-000	EA	BULB - 12V, # 74 0.12A WEDGE
	077539-01-000	EA	BRACKET-MOUNTING, DASH PANEL - L/SHAPED - 2.5" X 1" X 1.5"
	100138-01-000	EA	MODULE-DAYTIME RUNNING LIGHT
	077031-01-000	EA	FILM-BLACK, 1" X 1.75"
	077031-03-000	EA	FILM-WHITE, .75" X 1.00"
	105615-01-000	FT	FILM-PROTECTIVE, CLEAR - 34" WIDE
2	108357-09-000	EA	SWITCH-ROCKER, SPDT ON/NONE/MOM - CARLING V5D1000B-0
2	108356-02-01A	EA	COVER-SWITCH W/DIMPLES, CARLING VVAZC00 BLA
3	094796-07-000	EA	CLUSTER-INSTRUMENT PANEL, KILOMETERS - GAS - GM #16201075 (CSA)
4	089294-01-000	EA	LIGHTER ASM-CIGARETTE, CASCO C213275
5	108357-10-000	EA	SWITCH-ROCKER, SPDT MOM/OFF/MOM - CARLING V8D1160B-0
5	108356-04-01A	EA	COVER-SWITCH W/DIMPLES & LENS, CARLING VVAGC00
	106569-02-04A	EA	VINYL-LAMINATE MADRID, CAMBRIDGE- 1/4" X 16" X 96"
6	105927-02-000	EA	PANEL ASM-DASH, TOP - W/STUD - STEEL
7	P03817-11-000	EA	DASH ASM, CHEVY - W/O VINYL & INSTRUMENT POD - STEEL
8	103812-01-05A	EA	TRIM-DASH, LOWER - GM
	103558-01-09A	EA	VENT-DEFROSTER, ABS
9	110073-01-01A	EA	APPLIQUE-BEZEL, INSTRUMENT PANEL - BLACK VELVET
10	109829-01-01A	EA	BEZEL-INSTRUMENT PANEL, BLACK

DRIVERS COMPARTMENT GROUP (CONTINUED)

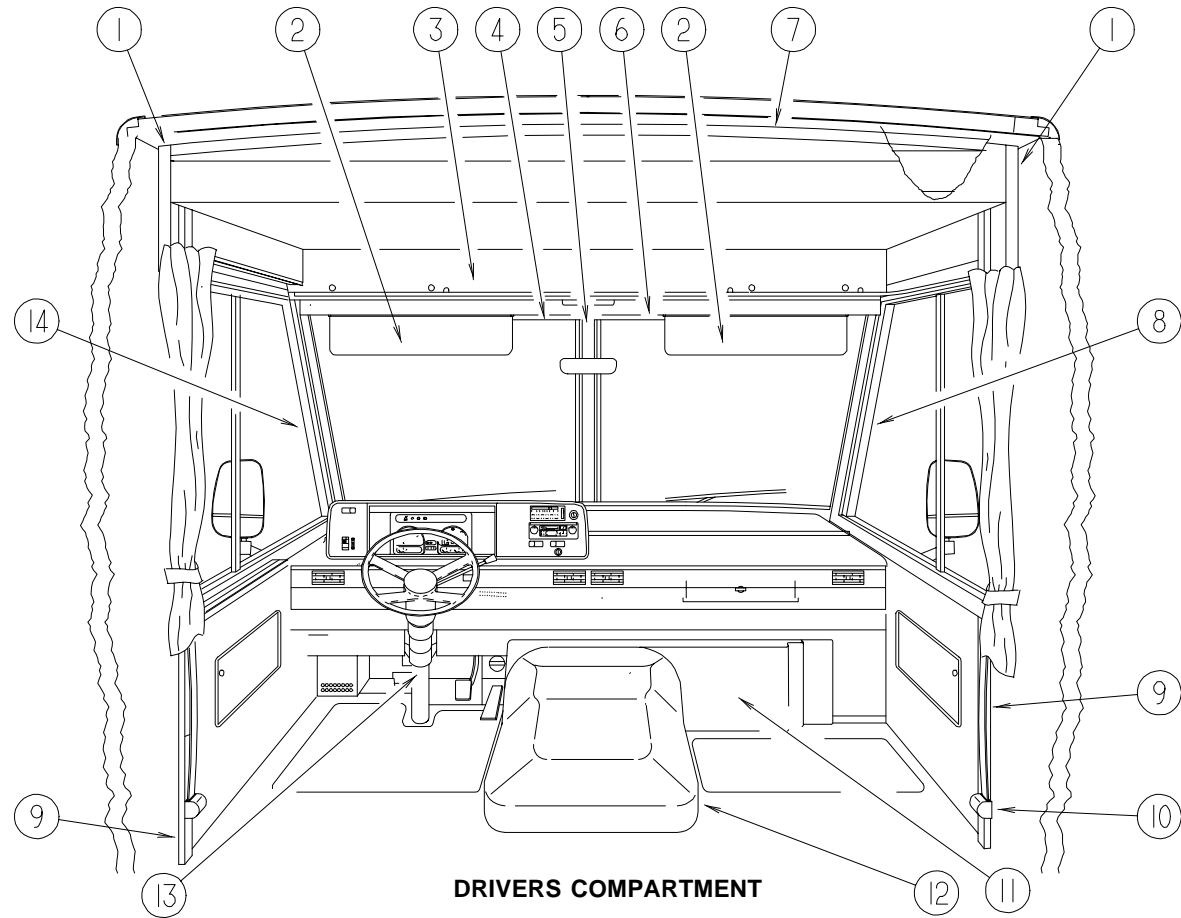

DRIVERS COMPARTMENT

KEY	PART NUMBER	U/M DESCRIPTION
1	024700-53-000	EA COVER-ROLL BAR,OFF WHITE 19.1" INCHES W/BUNK
2	082286-18-GB1	EA SUNVISOR ASM, W/O POCKET
		FROM: 00-00-00 THRU: 08-27-95
2	082286-18-D12	EA SUNVISOR ASM, W/O POCKET
		FROM: 08-28-95 THRU: 99-99-99
	007211-01-000	EA HINGE-SUNVISOR, 25.5" X 1.5" - METAL
	081987-05-000	EA ROD-SUNVISOR, BLACK
	074012-01-000	EA CLIP-SUNVISOR, SQUARE - PINCH ON
	102377-01-000	EA BRACKET-SUNVISOR, 1 PIECE - STEEL
3	109795-02-FB1	EA PANEL-HEADLINER
	078811-07-FB1	EA PANEL-HEADER, HORIZONTAL SECTION - W/LIGHT & SPEAKER CUTOUTS
4	078579-08-000	EA TRIM-WINDSHIELD, UPPER - INNER - DRIVER - OFF WHITE
5	079765-07-000	EA TRIM-WINDSHIELD, CENTER - PRECUT ENDS - OFF WHITE
5	079765-09-000	EA TRIM-WINDSHIELD, CENTER - UNCUT - OFF WHITE
6	078579-07-000	EA TRIM-WINDSHIELD, UPPER - INNER - PASSENGER - OFF WHITE
7	024700-51-000	EA COVER-ROLL BAR, OFF WHITE - 88.00"
8	103931-01-01A	EA COVER-INTERIOR, A-PILLAR - RIGHT - OFF WHITE
9	024700-44-000	EA COVER-SDW ROLL BAR,OFF WHITE 53.00 INCHES
	110056-01-01A	EA COVER-ROLL BAR 90° OFF WHITE
10	091990-04-01A	EA SEAT BELT - 3 POINT,BLACK
	103961-01-01A	EA COVER-BRACKET,SEATBELT O/W
	057759-01-000	EA WASHER BRACKET-SEAT BELT, 4" DIAMETER
11	095757-03-GB1	EA COVER ASM-HEATER
11	095757-03-F26	EA COVER ASM-HEATER (GC1)
	111618-01-GB1	EA TRAY ASM-BEVERAGE
12	115840-01-01A	EA COVER-MOTOR
	116833-01-02B	EA WRENCH-HEX,MOTOR COVER,E-CT
	115850-01-02B	EA RETAINER ASM-LATCH,MOTOR COVER
	116581-01-000	EA LATCH-MOTOR COVER
13	103498-06-000	EA BOOT-COLUMN
14	103931-02-01A	EA COVER-INTERIOR, A-PILLAR -LEFT - OFF WHITE
	084902-08-000	EA HOLDER-MUG, COLLAPSIBLE - BLACK
	119919-14-000	EA FRONT - STEP BOX INSERT

DRIVERS COMPARTMENT GROUP (CONTINUED)

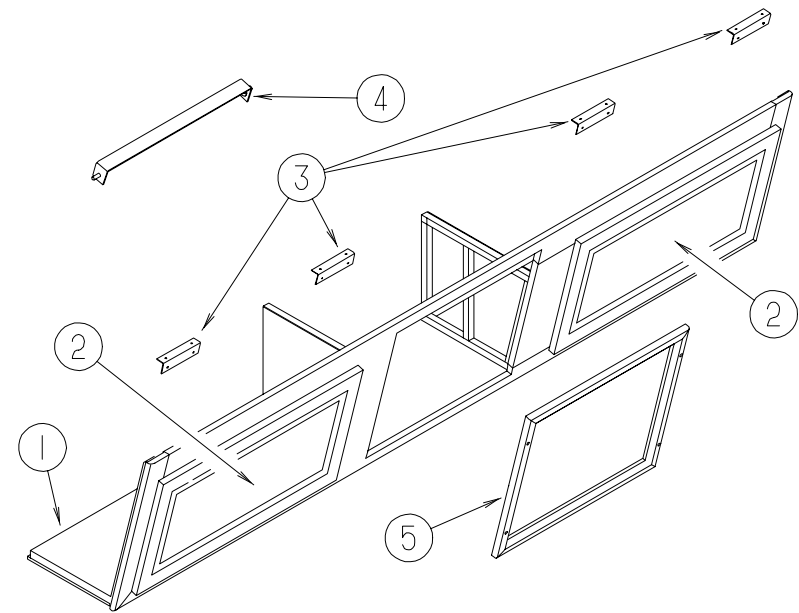

DRIVERS COMPARTMENT TV CABINET

KEY	PART NUMBER	U/M DESCRIPTION
1	120196-01-GB1	EA CABINET ASM-OVHD,TV
2	110140-18-G01	EA DOOR ASM-MITERED,VINYL WRAP
3	106699-01-01A	EA BRACKET-CABINET,OVHD TV O/W
	099717-03-000	EA TV TIEDOWN STRAP- W/5.1" FEMALE STRAP & 7.9" MALE STRAP
4	120175-02-02B	EA SUPPORT ASM-SHELF,TV,E-COAT
5	120198-01-GB1	EA CABINET ASM-FRAME,TV

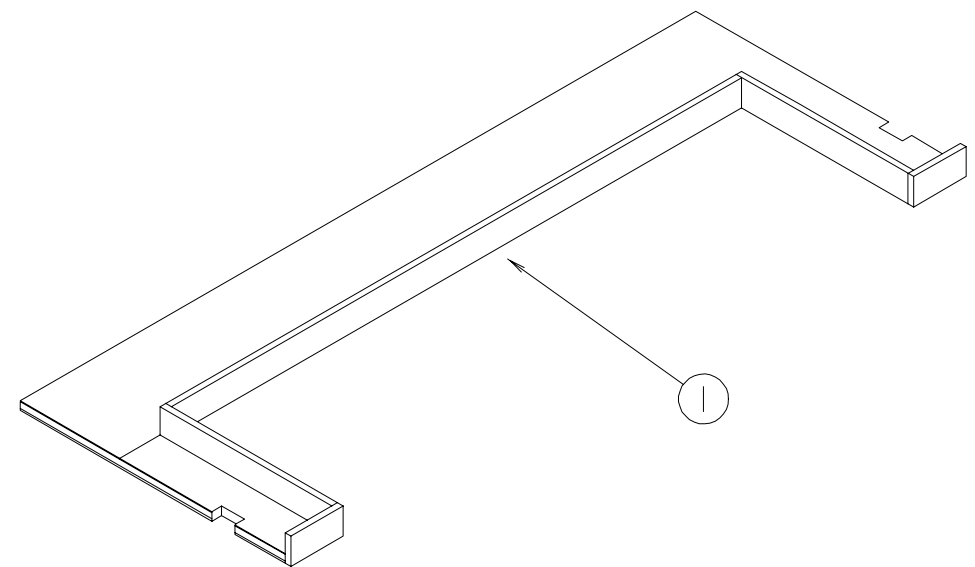

DRIVERS COMPARTMENT BLANKET CABINET

KEY	PART NUMBER	U/M DESCRIPTION
1	104417-02-GB1	EA CABINET ASM-BLANKET

DRIVERS COMPARTMENT GROUP (CONTINUED)

ELECTRICAL GROUP

OVERHEAD BUNK

KEY	PART NUMBER	U/M DESCRIPTION
	076760-04-000	EA BUNK HARDWARE-OVERHEAD KWIKEE #901401
	110007-01-GB1	EA BED ASM-BUNK,FRONT
	099717-03-000	EA TV TIEDOWN STRAP- W/5.1" FEMALE STRAP & 7.9" MALE STRAP

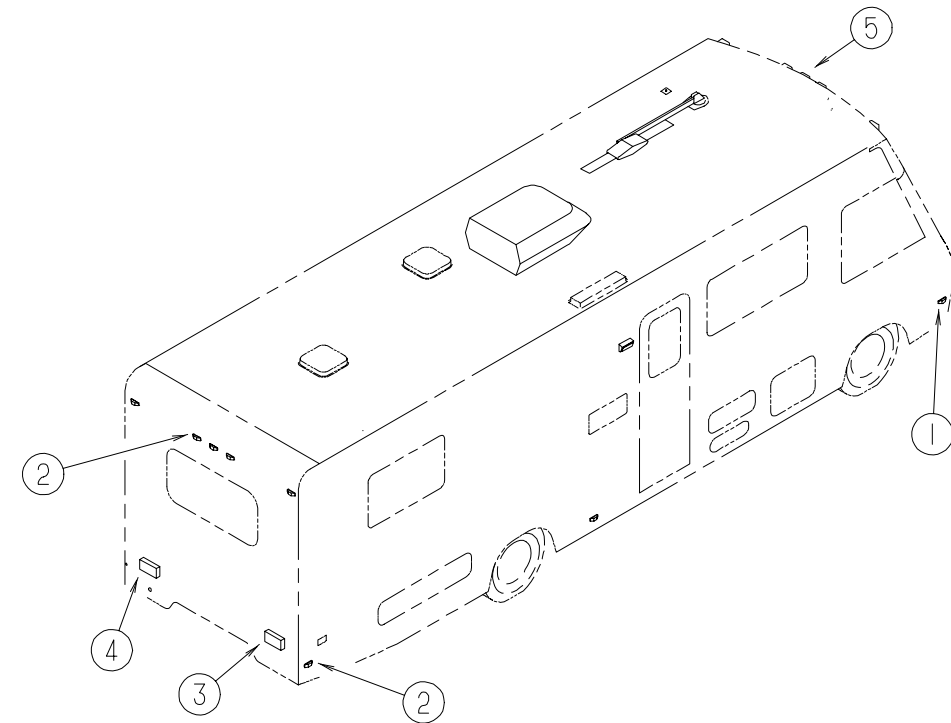

EXTERIOR LIGHTS

KEY	PART NUMBER	U/M DESCRIPTION
1	111102-01-000	EA BASE-CLEARANCE/SIDEMARKER LIGHT W/BULB - PLASTIC - WHITE
1	111102-02-000	EA LENS-CLEARANCE/SIDEMARKER LIGHT - W/REFLEX - AMBER
1	036196-01-000	EA BULB - 12V, #194 - .27AMP - BAYONETTE
1	091983-01-000	EA GASKET-CLEARANCE/SIDEMARKER LIGHT
2	111102-01-000	EA BASE-CLEARANCE/SIDEMARKER LIGHT - W/BULB - PLASTIC - WHITE
2	111102-03-000	EA LENS - CLEARANCE/SIDEMARKER LIGHT - W/REFLEX - RED
2	008213-01-000	EA BULB - 12 V - NO. 57 - .24 AMP
2	091983-01-000	EA GASKET-CLEARANCE/SIDEMARKER LIGHT
3	110456-01-01A	EA LAMP ASM-TAIL -COMBO BLACK - BARGMAN 30-91-110
4	110456-02-01A	EA LAMP ASM-TAIL-COMBO W/BRACKET - BARGMAN 30-91-111
	107256-01-03A	EA COVER-TAIL LIGHT - BLACK
5	111102-01-000	EA BASE-CLEARANCE/SIDEMARKER LIGHT W/BULB - PLASTIC - WHITE
5	111102-02-000	EA LENS-CLEARANCE/SIDEMARKER LIGHT - W/REFLEX - AMBER
5	036196-01-000	EA BULB - 12V, #194 - .27AMP - BAYONETTE
5	091983-01-000	EA GASKET-CLEARANCE/SIDEMARKER LIGHT
5	109566-01-000	EA BACKING-STEEL - LIGHT - ROOF CAP
	070907-01-000	EA HEADLAMP-RECTANGULAR - GM 5968097
	049359-01-000	EA SPRING-RETAINER - HEADLAMP - GM 496096
	110750-01-000	EA SCREW ASM-HEADLAMP ADJUSTING - T'MAN B62258-1428
	112823-01-000	EA SPLICE-REDUCER - 16-14 TO 18-22

ELECTRICAL GROUP (CONTINUED)
INTERIOR LIGHTS & RECEPTACLE

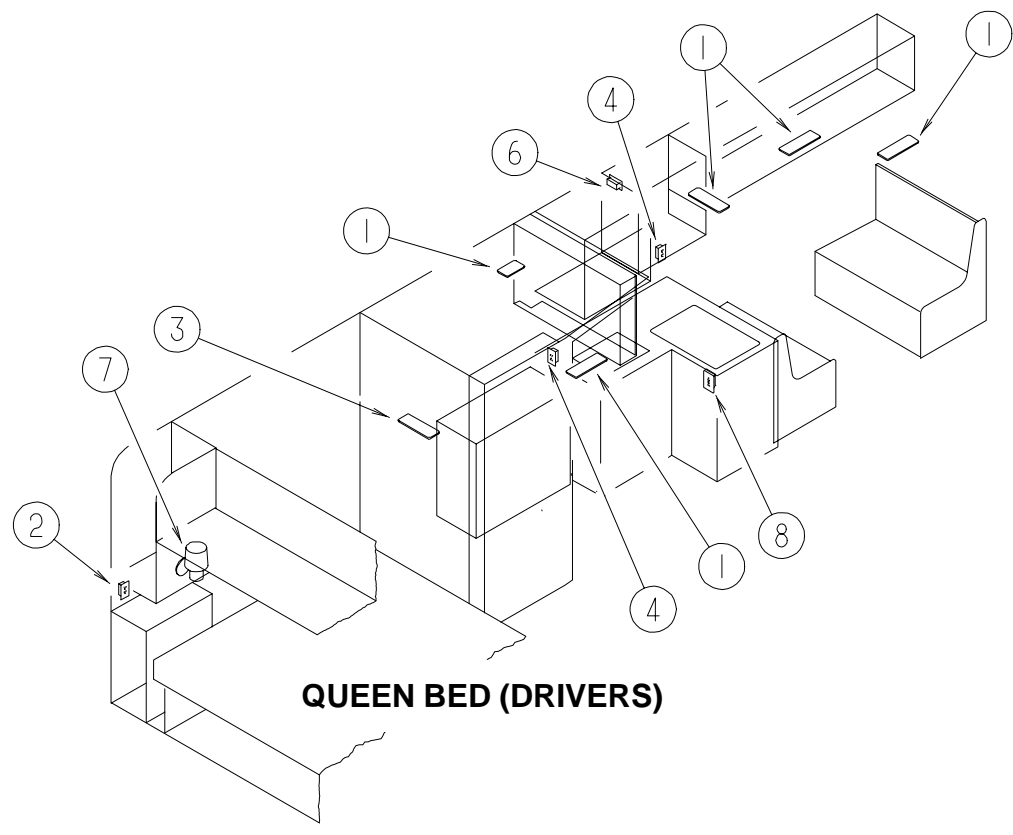

QUEEN BED (DRIVERS)

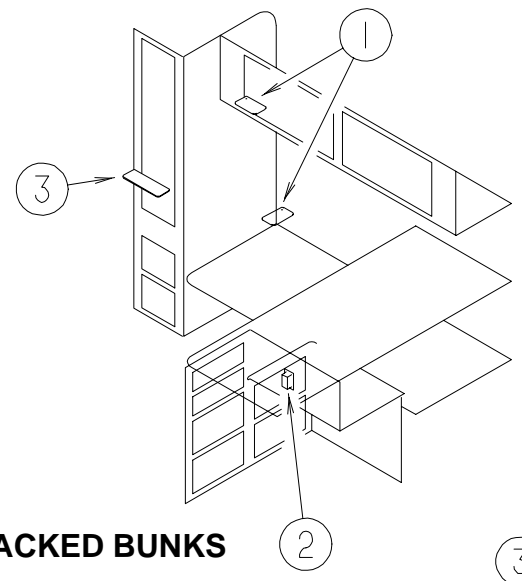

CROSS STACKED BUNKS

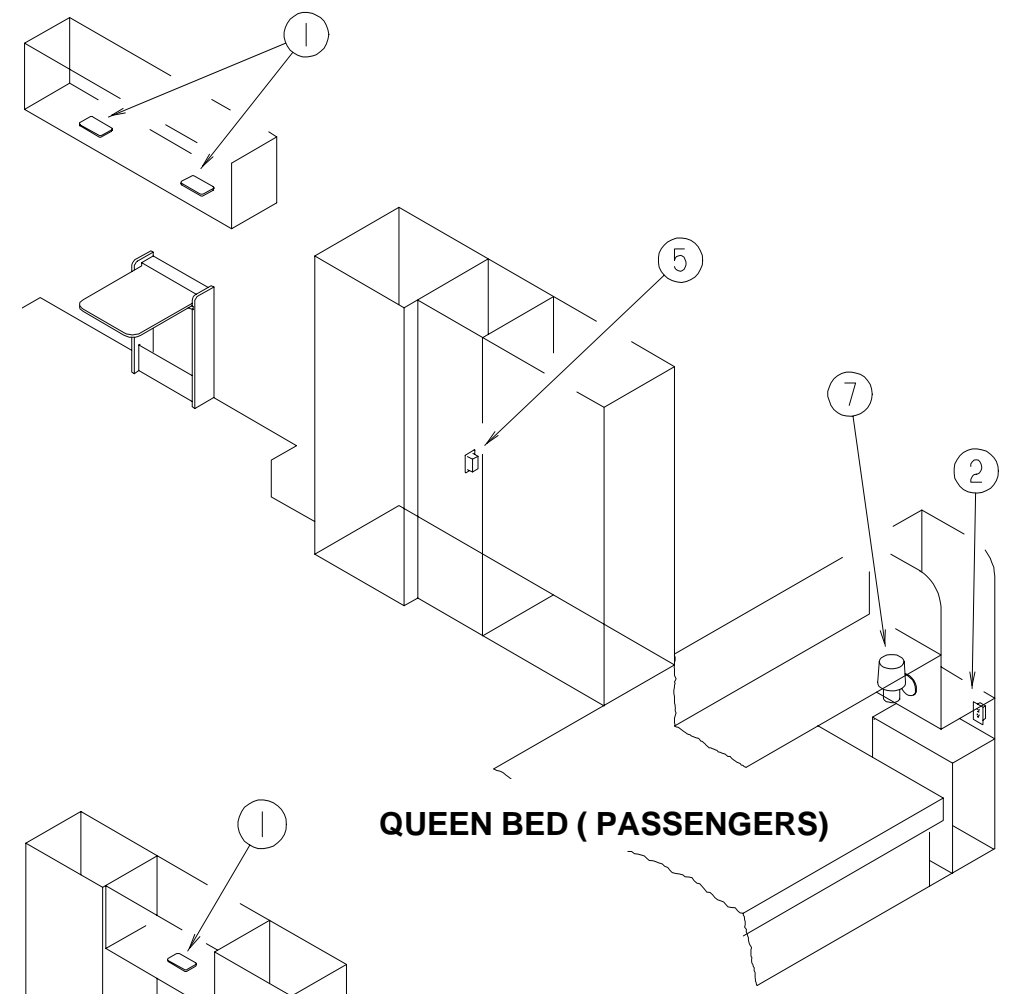

QUEEN BED (PASSENGERS)

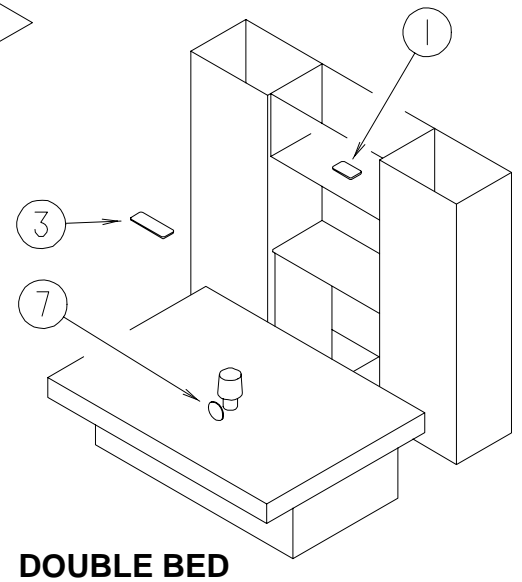

DOUBLE BED

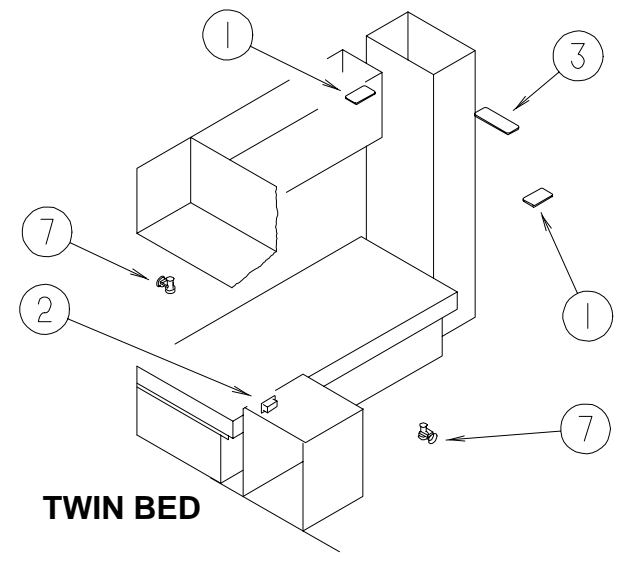

TWIN BED

KEY	PART NUMBER	U/M	DESCRIPTION	
1	098024-01-01A	EA	LIGHT-DOME - 1 BULB - US - IVORY	
	008218-01-000	EA	BULB-DOME LIGHT - 12V - NUMBER 1141	
	098024-01-700	EA	LENS-DOME LIGHT	
2	058708-01-000	EA	RECEPTACLE-ELECTRIC - DOUBLE - BROWN	
	3	098024-03-01A	EA	LIGHT-DOME - 2 BULB - IVORY
		008218-01-000	EA	BULB-DOME LIGHT - 12V - NUMBER 1141
4	098024-01-700	EA	LENS-DOME LIGHT	
	007940-01-000	EA	RECEPTACLE-SLIDE - 16 TO 12 AWG - FEMALE END	
	058708-02-000	EA	RECEPTACLE-ELECTRIC - DOUBLE - IVORY	
5	058707-01-000	EA	RECEPTACLE-ELECTRIC - SINGLE - BROWN	
	058707-02-000	EA	RECEPTACLE-BLANK,JUNCTION - WIRECON WDJ20BR	
	058708-05-000	EA	RECEPTACLE-SINGLE,BRN - WIRECON WDR15BRS	
7	104173-02-01A	EA	LIGHT-DESIGNER,BLACK 81-903 - A.W.ASPLUND	
	119257-03-01A	EA	SHADE-LAMP,LINEN WHT HARDBAC - 79-122X2BS	
		FROM: 07-10-95 THRU: 99-99-99		
119258-02-01A	EA	LAMP-WALL,UL/CSA - 53-503XK7YZ		
8	084076-02-000	EA	RECEPTACLE-GFI - 15A - 125V - BROWN	
	024924-02-000	EA	RECEPTACLE-POWER CORD - W/PARTIAL PLATE	
	075723-01-000	EA	SPACER-SWITCH - W/O HOLE - .2" X .9" X 2" - METAL - OFF WHITE	
102568-01-E90	EA	SPACER-RECEPTACLE - SIDEWALL		
104172-01-01A	EA	LIGHT-BULLET, BEIGE - #787 SERIES - BULB #93 12V		
097734-01-01A	EA	EXTENSION-RECEPTACLE, 3.2" X 5" X .7" - PLASTIC - IVORY		

ELECTRICAL GROUP (CONTINUED)
FUSES & CIRCUIT BREAKERS

KEY	PART NUMBER	U/M	DESCRIPTION
	062037-01-000	EA	HOUSING-AUTO FUSE, NATURAL
	062037-02-000	EA	HOUSING-AUTO FUSE, GREEN
	062037-03-000	EA	HOUSING-AUTO FUSE, BLACK
	062037-04-000	EA	HOUSING-AUTO FUSE, BLUE
	062037-05-000	EA	HOUSING-AUTO FUSE, GRAY
	062037-06-000	EA	HOUSING-AUTO FUSE, BROWN
	062037-07-000	EA	HOUSING-AUTO FUSE, RED - PACKARD 12004883
	062901-02-000	EA	FUSE-5 AMPS, AUTOMOTIVE
	062901-05-000	EA	FUSE-15 AMPS, AUTOMOTIVE
	062901-08-000	EA	FUSE-30 AMPS, AUTOMOTIVE
	083209-01-000	EA	CIRCUIT BREAKER - 15 AMP, 120V - BW G-15 - CANADIAN
	083209-02-000	EA	CIRCUIT BREAKER - 15/15AMP, 120V - BW H-15/15
	083209-03-000	EA	CIRCUIT BREAKER - 15/20AMP, 120V - BW 0-15/20
	083209-04-000	EA	CIRCUIT BREAKER - 30A, 120V - BW L-30
	083209-06-000	EA	CIRCUIT BREAKER - 30/15 AMP, 120V - BW D-30/15
	097611-01-000	EA	CIRCUIT BREAKER - 10A, 12V - VB3-A10-F57
	106655-02-000	EA	TERMINAL-FUSE BLOCK, 10-12AWG - PACKARD 12020400
	108669-01-000	EA	HOUSING-AUTO FUSE HOLDER, PACKARD 12010105
	119248-02-000	EA	HOUSING - 7POSN, FEM, METRI-PACK - PACKARD12059472

SWITCHES

KEY	PART NUMBER	U/M	DESCRIPTION
	079364-04-000	EA	SWITCH-ON/OFF, ROCKER - BLACK
	095188-01-01A	EA	SPACER-SWITCH, 2.3" X 3.4" - PLASTIC - DARK BROWN
	096241-03-000	EA	SWITCH-BLANK
	098351-06-01A	EA	PLATE-SWITCH, 2 GANG W/LABEL - JENSEN - POLISHED BRASS
	098351-07-01A	EA	PLATE-SWITCH, GEN SW - JENSEN-BRASS, POLISH
	108355-01-000	EA	HOUSING-SWITCH - CARLING VCH
	108356-02-01A	EA	SWITCH COVER W/ 2 DIMPLES - CARLING CCAZC00
	108356-04-01A	EA	SWITCH COVER W/DIMPLES - LIGHTED-CARLING VVAGC00
	108356-11-01A	EA	ACTUATOR-SWITCH GROOVES III - CARLING VVCZCXX-SW1
	108357-10-000	EA	ROCKER SWITCH, SPDT MOM/OFF/MOM - CARLING V8D1160B-0 LIGHTED

POWER CORD, CONVERTER & WIRE ASSEMBLIES

KEY	PART NUMBER	U/M	DESCRIPTION
	083208-01-000	EA	CONVERTOR-POWER, 32A - 120V/12V - BW 6332
	113132-01-000	EA	LOAD CENTER-120/240V, 60A - WESCO 2460SGNM
	008052-01-000	EA	CORD-POWER, 10/3 - 30 AMP - 25' - CANADIAN
	008054-01-000	EA	CORD-POWER, 10/3 - 30 AMP - 25'
	096449-01-000	EA	WIRE ASSEMBLY-WATER TANK TO MONITOR PANEL
	097618-01-000	EA	WIRE ASM-MONITOR PANEL, W/3 WIRES & ORANGE RESISTOR- LVS ORANGE RESISTOR W/3 (ORANGE-GREEN-BLUE) WIRES

ELECTRICAL BOXES & COVERS

KEY	PART NUMBER	U/M	DESCRIPTION
	008289-01-000	EA	BOX-ELECTRIC, STEEL - 1/2" AND 3/4" KNOCKOUTS - 4" X 4"
	008289-02-000	EA	BOX-ELECTRICAL, 4" X 4" - 1/2"&3/4" KNOCKOUTS - CANADIAN
	008294-01-000	EA	COVER-ELECTRICAL BOX, BLANK/STEEL - 4" X 4" - GRAY
	008294-02-000	EA	COVER-ELECTRICAL BOX, BLANK STEEL - 4" X 4" - CANADIAN
	069238-01-000	EA	COVER-ELECTRICAL BOX, W/HOLE - 4" X 4" - GRAY USED WITH 30 AMP RECEPTACLE
	091910-01-000	EA	BOX-ELECTRIC, 3.75" X 3.5" X 1.75" - PLASTIC
	091910-02-000	EA	BOX-ELECTRICAL, PLASTIC - 57 X 88MM
	111510-01-000	EA	DOOR-ELECTRICAL BOX, FRONT

ELECTRICAL GROUP (CONTINUED)
ELECTRICAL CONNECTORS

KEY	PART NUMBER	U/M	DESCRIPTION
	007940-01-000	EA	RECEPTACLE-SLIDE, 16 TO 12 AWG - FEMALE END
	007954-01-000	EA	RECEPTACLE-HSG-6 POSITION
	007956-05-000	EA	INSULATOR-SHRINK .25IDX1.50 - BLACK
	008311-01-000	EA	CONNECTOR-WIRE NUT, INSULATED - RED
	008314-01-000	EA	CONNECTOR-WIRE NUT, INSULATED - GRAY
	008326-01-000	EA	TERMINAL-RING, 16/14 WIRE - 3/8" STUD
	008328-01-000	EA	TERMINAL-RING, 12/10 WIRE - #10 STUD FIT
	008331-01-000	EA	TERMINAL-RING, TONGUE - #4 WIRE - 3/8" STUD - COPPER
	008348-01-000	EA	TERMINAL-RING, 3/8" STUD - #2 WIRE
	008355-01-000	EA	CONNECTOR-CABLE CLAMPING, 3/4"
	008356-01-000	EA	CONNECTOR-PLASTIC, 3/8" AVG
	035416-04-000	EA	TERMINAL-RING #10 STUD FIT, INSULATED BARREL #16/14
	041480-01-000	EA	CONNECTOR-STRAIGHT, 1/2" FLEX CONDUIT
	041953-01-000	FT	CONDUIT-CONVOLUTE SLIT, .5"ID
	041953-01-000	FT	CONDUIT-CONVOLUTE SLIT, .5"ID
	041953-05-000	FT	CONDUIT-CONVOLUTE SOLID, .62" ID
	041953-06-000	FT	CONDUIT-CONVOLUTE, SLIT .375"ID
	041953-07-000	FT	CONDUIT-CONVOLUTE, SLIT - .25" ID
	041953-09-000	FT	CONDUIT-CONVOLUTE, SLIT .50"ID
	047443-01-000	EA	TERMINAL-.250 RECEPTACLE FIT, INSULATED - 16/14 AWG
	058028-01-000	EA	CONNECTOR-ELECTRICAL PIGTAIL, NYLON - CLEAR
	062036-01-000	EA	TERMINAL-PACK-CON, 12/10 AWG - PACKARD 12033817
	062036-02-000	EA	TERMINAL-PACK-CON, 16/14 AWG - PACKARD 08917021
	077479-02-000	EA	BOOT-BATTERY TERMINAL, SINGLE CABLE
	080015-02-000	EA	RECEPTACLE-FLAG, .185 - 16/14 GA - AMP 3
	082741-01-000	EA	CONNECTOR BODY-2 CNCT MALE - SERV ELEC 2P-FYL
	087225-01-000	FT	SLEEVEING-1/2", TYPE H - VARFLEX
	088267-01-000	EA	TERMINAL-FEMALE, 1/4 - PACKARD 2962573
	088473-02-000	EA	HOUSING-PIN, 15 CAVITY - AMP 1-480710-0
	088473-03-000	EA	HOUSING-PIN, 9 CAVITY - AMP 1-480706-0
	088473-05-000	EA	HOUSING-PIN, 6 CAVITY - AMP 640585-1
	088473-08-000	EA	HOUSING-PIN, 4 CAVITY - AMP 1-480702-0
	088473-09-000	EA	HOUSING-PIN, 3 CAVITY - AMP 1-480700-0
	088473-10-000	EA	HOUSING-PIN, 2 CAVITY - AMP 1-480698-0
	088474-02-000	EA	HOUSING-SOCKET, 12 CAVITY - AMP 1-480711-0
	088474-03-000	EA	HOUSING-SOCKET, 9 CAVITY - AMP 1-480707-0
	088474-07-000	EA	HOUSING-SOCKET, 5 CAVITY - AMP 1-480764-0
	088474-08-000	EA	HOUSING-SOCKET, 4 CAVITY - AMP 1-480703-0
	088474-09-000	EA	HOUSING-SOCKET, 3 CAVITY - AMP 1-480701-0
	088474-10-000	EA	HOUSING-SOCKET, 2 CAVITY - AMP 1-480699-0
	088475-01-000	EA	PIN-CONNECTOR, 14 TO 20 AWG
	088475-02-000	EA	PIN-CONNECTOR, 10 TO 12 AWG
	088476-01-000	EA	SOCKET-CONNECTOR, BRASS - PRE-TIN
	088476-02-000	EA	SOCKET-CONNECTOR, 12-10 GA - PHOS. BRZ - PRE-TIN
	103987-02-000	EA	SEAL-SOLENOID ACCESS - 94 F,G-SERIES
	104100-01-000	EA	HOUSING-1 POSITION, 75 AMP - AMP 53884-1
	104100-03-000	EA	TERMINAL-75 AMP - AMP 53880-4 LOOSE
	106006-01-000	EA	HOUSING-1 POSITION, FEMALE - PACKARD 12015952
	106007-01-000	EA	TERMINAL-FEMALE, 14-16AWG - PACKARD 12015861-L
	106655-01-000	EA	TERMINAL-FUSE BLOCK, 14-16AWG - PACKARD 12020321
	113306-01-000	EA	TERMINAL-FEM, M/P, 480, 14-16 - PACKARD12048451
	113307-01-000	EA	TERMINAL-FEM, M/P, 150, 16-20 - PACKARD12048074
	113468-01-000	EA	HOUSING - 2 POSITION, FEMALE - 56-SERIES - PACKARD 02965981 USED ON WIPER/WASHER WIRE ASM

EXTERIOR BODY GROUP

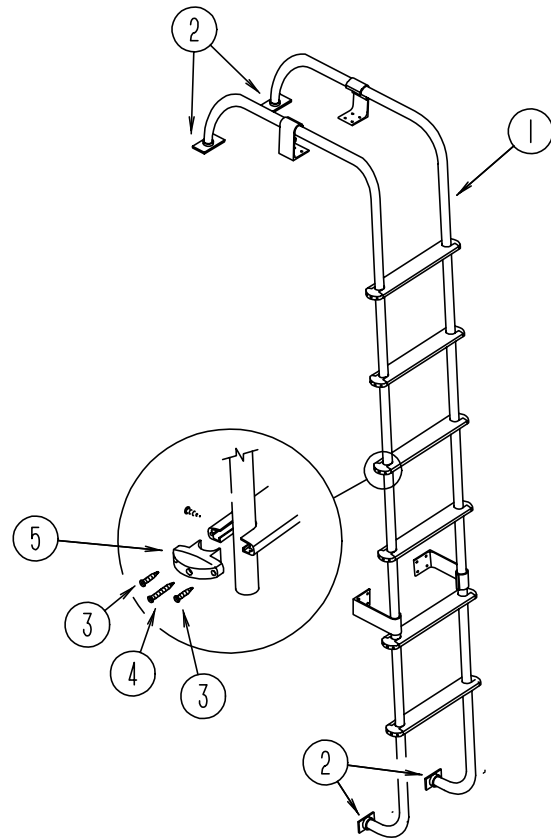

LADDER

KEY	PART NUMBER	U/M DESCRIPTION
1	102953-14-FB1	EA LADDER ASM
2	067165-01-000	EA BRACKET-MOUNTING, LADDER, LOWER
3	000G39-06-10T	EA SCREW-SELF DRIVING, 6-20 X 5/8" PPH - BLACK
4	000G67-10-36T	EA SCREW, 10-12 X 2.25" PPH - BLACK
5	076980-02-000	EA END CAP-STEP, BLACK
	069726-02-000	EA BUMPER - .88" DIAMETER X .40" - BLACK

FIBERGLASS, STYROFOAM, ALUMINUM & STEEL TUBING

KEY	PART NUMBER	U/M DESCRIPTION
	076054-P4-000	EA FIBERGLASS SHEET - 96" X 97" BRIGHT WHITE
	076054-R4-000	EA FIBERGLASS SHEET - 106.8" X 318.6" BRIGHT WHITE
	076054-S1-000	EA FIBERGLASS SHEET - 96" X 108" BRIGHT WHITE
	076054-T2-000	EA FIBERGLASS SHEET - 106.8" X 343.5" BRIGHT WHITE
	077517-62-000	EA SHEET-FIBERGLASS, 4' X 8' BRT. WHT., FLAT
	000870-05-000	SF STYROFOAM-.5" X 24" X 96", INCREMENTS OF 16 SF
	000870-08-000	SF STYROFOAM-.75 X 48" X 96"-PLANED
	100619-01-000	BF EXPANDED FOAM SHEET - 48" X 96" X 1.34"
	100619-04-000	BF FOAM-EXPANDED POLYSTYRENE - EPS 48" X 96" X .5
	100619-05-000	BF FOAM-EXPANDED POLYSTYRENE - 48" X 96" X .75"
	055278-51-259	EA TUBING-STEEL, .75" X 1.5" X 12.5'
	068716-01-001	EA BRACE - 90 DEGREE L-ANGLE, 192" - EXTRUDED ALUMINUM
	044487-01-001	EA SHEET-ALUMINUM, .019" X 96" X 360" - MILL FINISH
	044487-01-002	EA SHEET-ALUMINUM, .019" X 96" X 432" - MILL FINISH
	002726-01-001	EA GARNISH-U-CHANNEL, 1.38" X 19' - SERRATED - MILL ALUMINUM
	065747-01-000	SF INSULATION-MICROFOAM, .5" THICK X 72" X 112' ROLL
	089297-01-000	SF PLYWOOD-LUAN, OVERLAY GRADE - 4' X 8' - INC OF 32 SF

EXTERIOR BODY GROUP (CONTINUED)

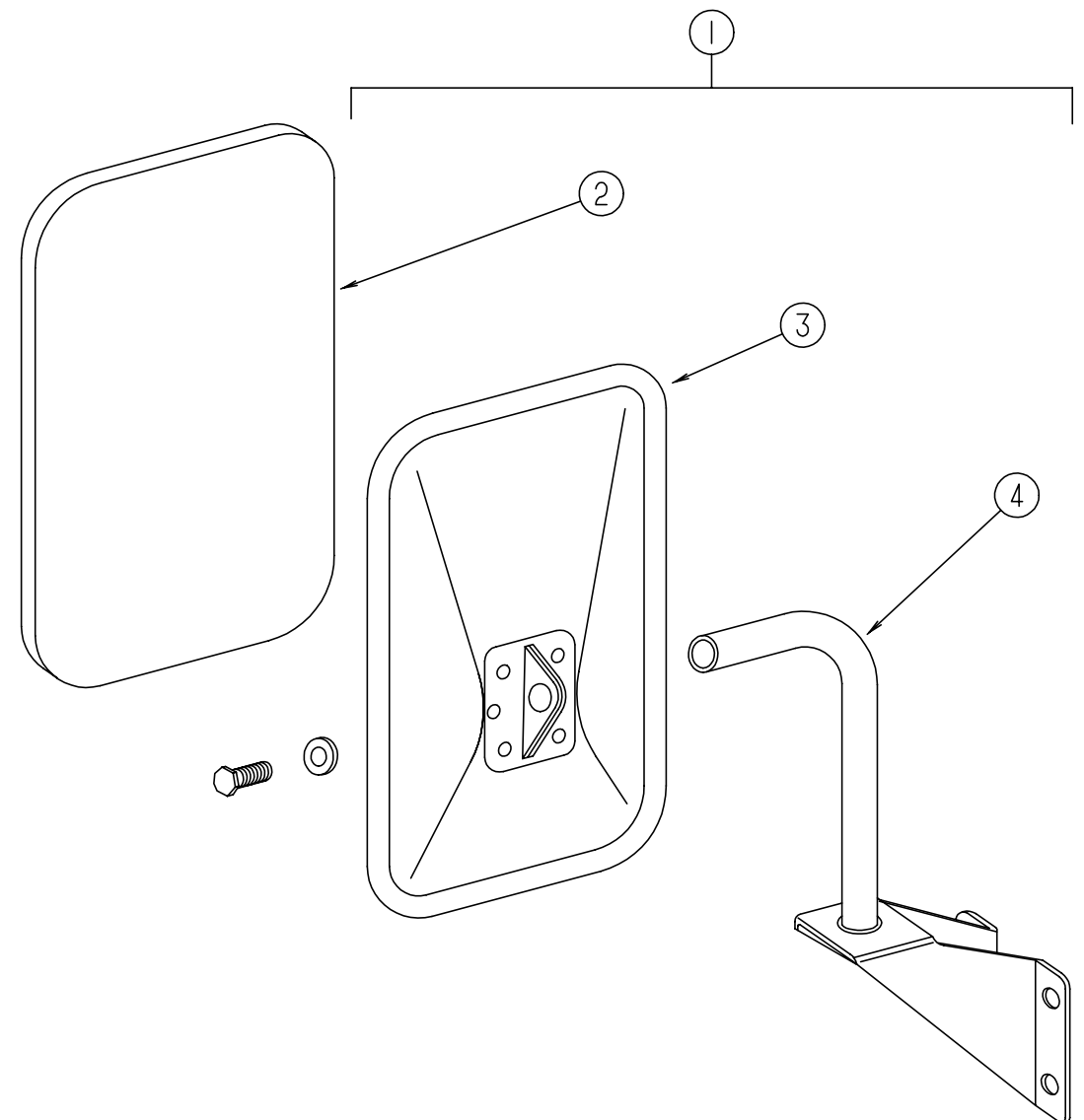

EXTERIOR MIRROR

KEY	PART NUMBER	U/M DESCRIPTION
1	105076-01-702	EA MIRROR ASM-LOW MOUNTING, BLACK - 713196
2	049347-01-700	EA GLASS-EXTERIOR MIRROR, 7.5" X 10.5"
3	105076-01-703	EA MIRROR HEAD ONLY, BLACK - 709001-8
4	105076-01-704	EA ARM, Q780521-9

EXTERIOR BODY GROUP (CONTINUED)
EXTERIOR BODY PANELS AND TRIM

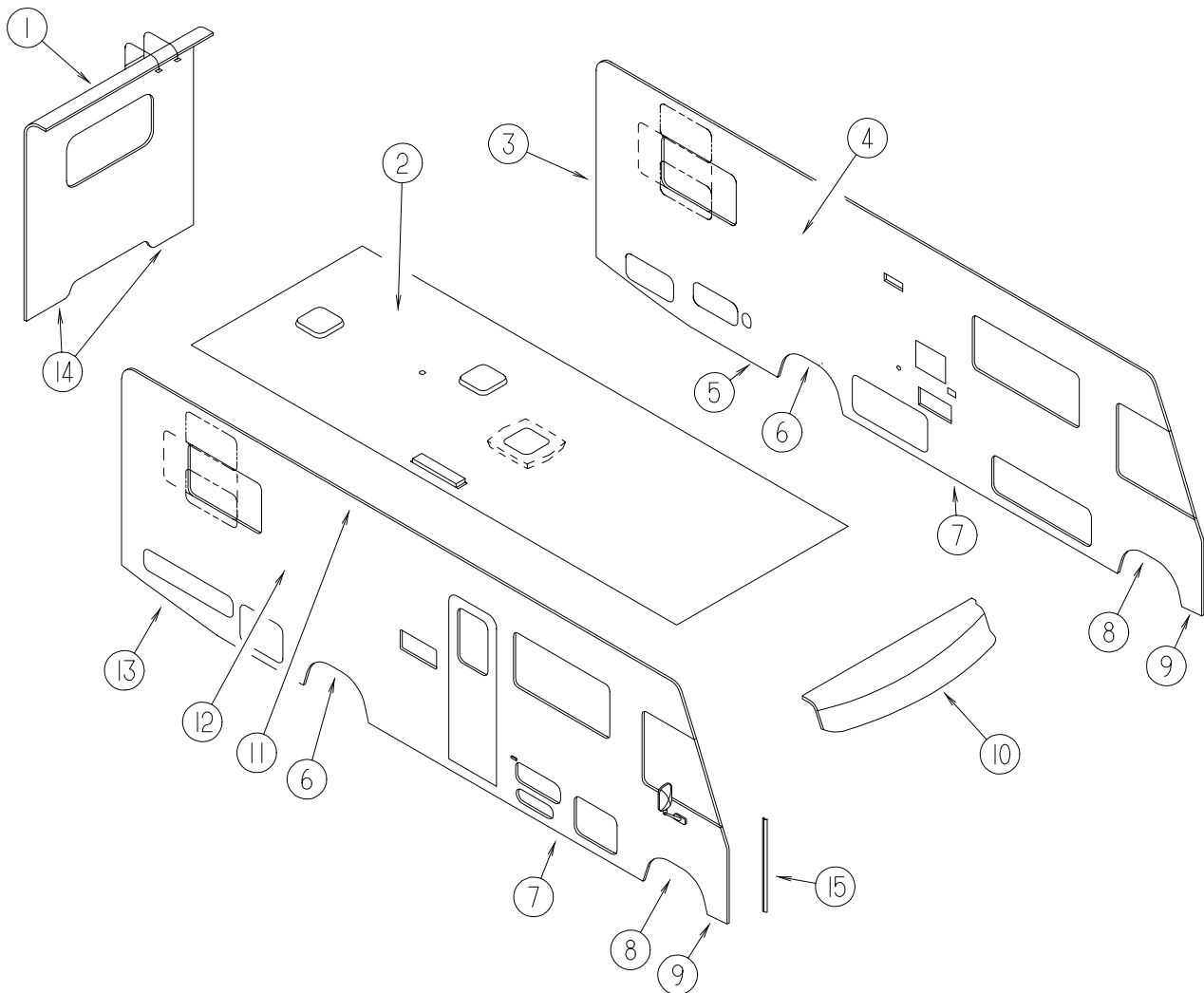

KEY	PART NUMBER	U/M	DESCRIPTION
1	M08063-02-GB1	EA	BACKWALL ASM - W/O WINDOW & TRIM - TWIN BED
1	M08063-02-GC1	EA	BACKWALL ASM - W/O WINDOW & TRIM - TWIN BED
1	M08063-03-GB1	EA	BACKWALL ASM - W/O WINDOW & TRIM - BUNK BED
1	M08063-03-GC1	EA	BACKWALL ASM - W/O WINDOW & TRIM - BUNK BED
1	M08063-04-GB1	EA	BACKWALL ASM - W/O WINDOW & TRIM - DOUBLE BED
1	M08063-04-GC1	EA	BACKWALL ASM - W/O WINDOW & TRIM - DOUBLE BED
1	M08063-05-GB1	EA	BACKWALL ASM - W/O WINDOW & TRIM - TWIN BED/CROSSED STACKED
1	M08063-05-GC1	EA	BACKWALL ASM - W/O WINDOW & TRIM - TWIN BED/CROSSED STACKED
1	M08063-01-GB1	EA	BACKWALL ASM - W/O WINDOW & TRIM - QUEENBED
1	M08063-01-GC1	EA	BACKWALL ASM - W/O WINDOW & TRIM - QUEENBED
2	P18105-01-GB1	EA	ROOF ASM. - QUEEN/DOUBLE BED - W/O ROOF VENTS
3	096854-04-02A	EA	TRIM-CONTOUR, W/O VINYL INSERT - BRIGHT WHITE
	105312-01-07A	FT	INSERT-CONTOUR TRIM, VINYL - BRIGHT WHITE
4	M07509-05-GB1	EA	SIDEWALL ASM-DRIVER SIDE - W/O WINDOWS & TRIM - QUEEN BED
4	M07509-05-GC1	EA	SIDEWALL ASM-DRIVER SIDE - W/O WINDOWS & TRIM - QUEEN BED
4	M07509-06-GB1	EA	SIDEWALL ASM-DRIVER SIDE - W/O WINDOWS & TRIM - TWIN BED
4	M07509-06-GC1	EA	SIDEWALL ASM-DRIVER SIDE - W/O WINDOWS & TRIM - TWIN BED
4	M07509-07-GB1	EA	SIDEWALL ASM-DRIVER SIDE - W/O WINDOWS & TRIM - BUNK BED
4	M07509-07-GC1	EA	SIDEWALL ASM-DRIVER SIDE - W/O WINDOWS & TRIM - BUNK BED
4	M07509-08-GB1	EA	SIDEWALL ASM-DRIVER SIDE - W/O WINDOWS & TRIM - DOUBLE BED
4	M07509-08-GC1	EA	SIDEWALL ASM-DRIVER SIDE - W/O WINDOWS & TRIM - DOUBLE BED
4	M07509-13-GB1	EA	SIDEWALL ASM-DRIVER SIDE - W/O WINDOWS & TRIM - CROSSED STACKED TWIN
4	M07509-13-GC1	EA	SIDEWALL ASM-DRIVER SIDE - W/O WINDOWS & TRIM - CROSSED STACKED TWIN
5	108038-31-01A	EA	TRIM-SIDEWALL, U-CHANNEL - 2597MM LONG - BOTTOM - REAR - BRIGHT WHITE
6	108070-01-04A	EA	TRIM-WHEELWELL, REAR - BRIGHT WHITE
7	108039-06-01A	EA	TRIM-SIDEWALL, U-CHANNEL - 3877MM LONG - BOTTOM - CENTER-BRIGHT WHITE
8	108069-05-01A	EA	TRIM-WHEELWELL, FRONT - BRIGHT WHITE
9	108109-01-04A	EA	TRIM-SIDEWALL, U-CHANNEL - 247MM LONG - LOW - FRONT - BRIGHT WHITE
10	M05922-03-FB1	EA	CAP ASM-FRONT, W/CLEARANCE LIGHTS & WIRING - BRIGHT WHITE
	117012-01-01A	EA	CAP-FRONT, W/O WIRING & CLEARANCE LIGHTS - BRIGHT WHITE
11	099583-55-003	EA	TRIM-CONTOUR,ROOF - AWNING RAIL, 3048 MM - BRIGHT WHITE - PASSENGERS
	096864-01-02A	EA	TRIM-CONTOUR,ROOF BRIGHT WHITE - DRIVERS
12	M07508-06-GB1	EA	SIDEWALL ASM-PASSENGER - W/O WINDOWS & DOORS - TWIN
12	M07508-06-GC1	EA	SIDEWALL ASM-PASSENGER - W/O WINDOWS & DOORS - TWIN
12	M07508-07-GB1	EA	SIDEWALL ASM-PASSENGER - W/O WINDOWS & DOORS - BUNK
12	M07508-07-GC1	EA	SIDEWALL ASM-PASSENGER - W/O WINDOWS & DOORS - BUNK
12	M07508-08-GB1	EA	SIDEWALL ASM-PASSENGER - W/O WINDOWS & DOORS - DOUBLE
12	M07508-08-GC1	EA	SIDEWALL ASM-PASSENGER - W/O WINDOWS & DOORS - DOUBLE
12	M07508-05-GB1	EA	SIDEWALL ASM-PASSENGER - W/O WINDOWS & DOORS - QUEEN
12	M07508-05-GC1	EA	SIDEWALL ASM-PASSENGER - W/O WINDOWS & DOORS - QUEEN
12	M07508-13-GB1	EA	SIDEWALL ASM-PASSENGER - W/O WINDOWS & DOORS - CROSSED STACKED TWIN
12	M07508-13-GC1	EA	SIDEWALL ASM-PASSENGER - W/O WINDOWS & DOORS - CROSSED STACKED TWIN
13	108038-39-02A	EA	TRIM-SIDEWALL, U-CHANNEL - 2597MM LONG - BOTTOM - REAR - BRIGHT WHITE
14	050406-21-000	EA	TRIM-BACKWALL, LOWER - BRIGHT WHITE
15	089922-26-000	EA	TRIM-FIBERGLASS, PANEL - BRIGHT WHITE
	108688-01-03A	EA	STRIP-FEATURE, BRIGHT WHITE (LOWER BACKWALL)
	108651-01-01A	EA	END CAP-FEATURE STRIP, MILL (LOWER BACKWALL)

EXTERIOR BODY GROUP (CONTINUED)
DECALS, FILM STRIPES & PAINT

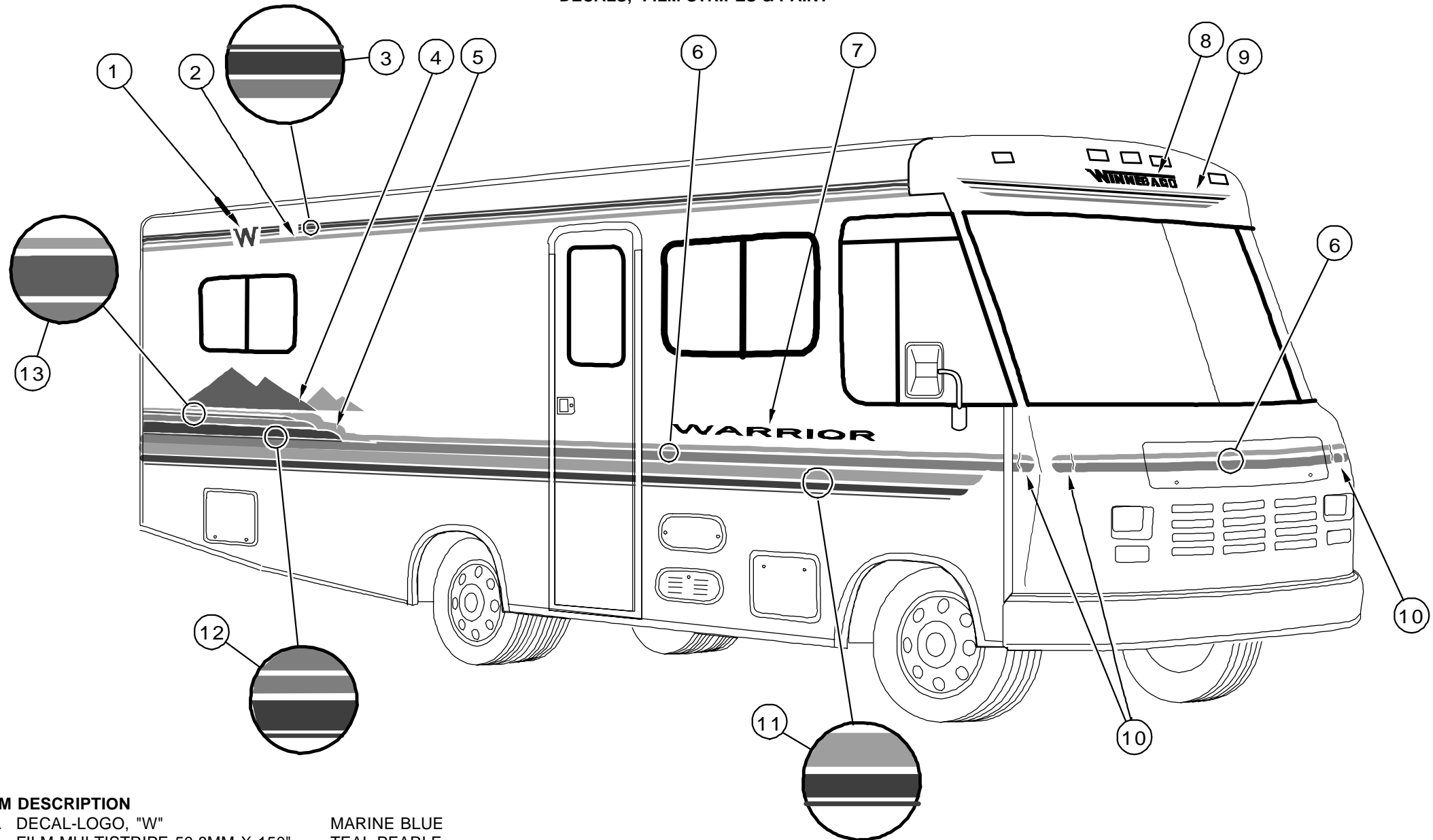

KEY	PART NUMBER	U/M DESCRIPTION	
1	114793-01-02A	EA DECAL-LOGO, "W"	MARINE BLUE
2	107385-02-08A	FT FILM-MULTISTRIPE 50.8MM X 150"	TEAL PEARLE
3	094443-24-02A	FT FILM-MULTISTRIPE 69.9MM X 150'	MARINE BLUE/MARINE BLUE/DEEP ROSE
4	114792-01-02A	EA DECAL-MOUNTAINS, PASSENGERS	MAJESTIC PURPLE/DEEP ROSE
	114792-02-02A	EA DECAL-MOUNTAINS, DRIVERS	MAJESTIC PURPLE/DEEP ROSE
5	114794-02-02A	EA DECAL-ROLLING HILLS, DRIVERS	SILVER/MARINE BLUE
	114794-01-02A	EA DECAL-ROLLING HILLS, PASSENGERS	SILVER/MARINE BLUE
6	116170-01-02A	EA DECAL-WARRIOR	MARINE BLUE/DEEP ROSE
7	107385-11-08A	FT FILM - 31.8MM X 150FT	MARINE BLUE
8	050313-62-000	EA DECAL-LOGO,WINNEBAGO,2.80	MARINE BLUE
9	116813-01-02A	EA DECAL-UPPER,FRONT,CAP	MARINE BLUE/MARINE BLUE/DEEP ROSE
10	107385-06-08A	FT FILM - 25.4MM X 150FT	DEEP ROSE
11	094443-30-02A	FT FILM-MULTISTRIPE 187.3MM X 150	TEAL PEARL/MARINE BLUE/MARINE BLUE
12	094443-23-02A	FT FILM-MULTISTRIPE 142.9MM X 150	TEAL PEARL/MARINE BLUE/MARINE BLUE
13	105781-11-10A	FT FILM-MULTISTRIPE 50.8MM X 150'	SILVER/MARINE BLUE
	041561-03-000	EA PAINT-LOW BAKE, OFF WHITE	REF:72897-01
	004308-01-000	EA PAINT-SPRAY, BLACK	
	083581-03-000	GL PAINT-OFF WHITE, USE DUPONT	L8723 TO OBTAIN LOCALLY
	099399-23-700	EA PAINT-BRIGHT WHITE	

EXTERIOR BODY GROUP (CONTINUED)

FRONT END COMPONENTS

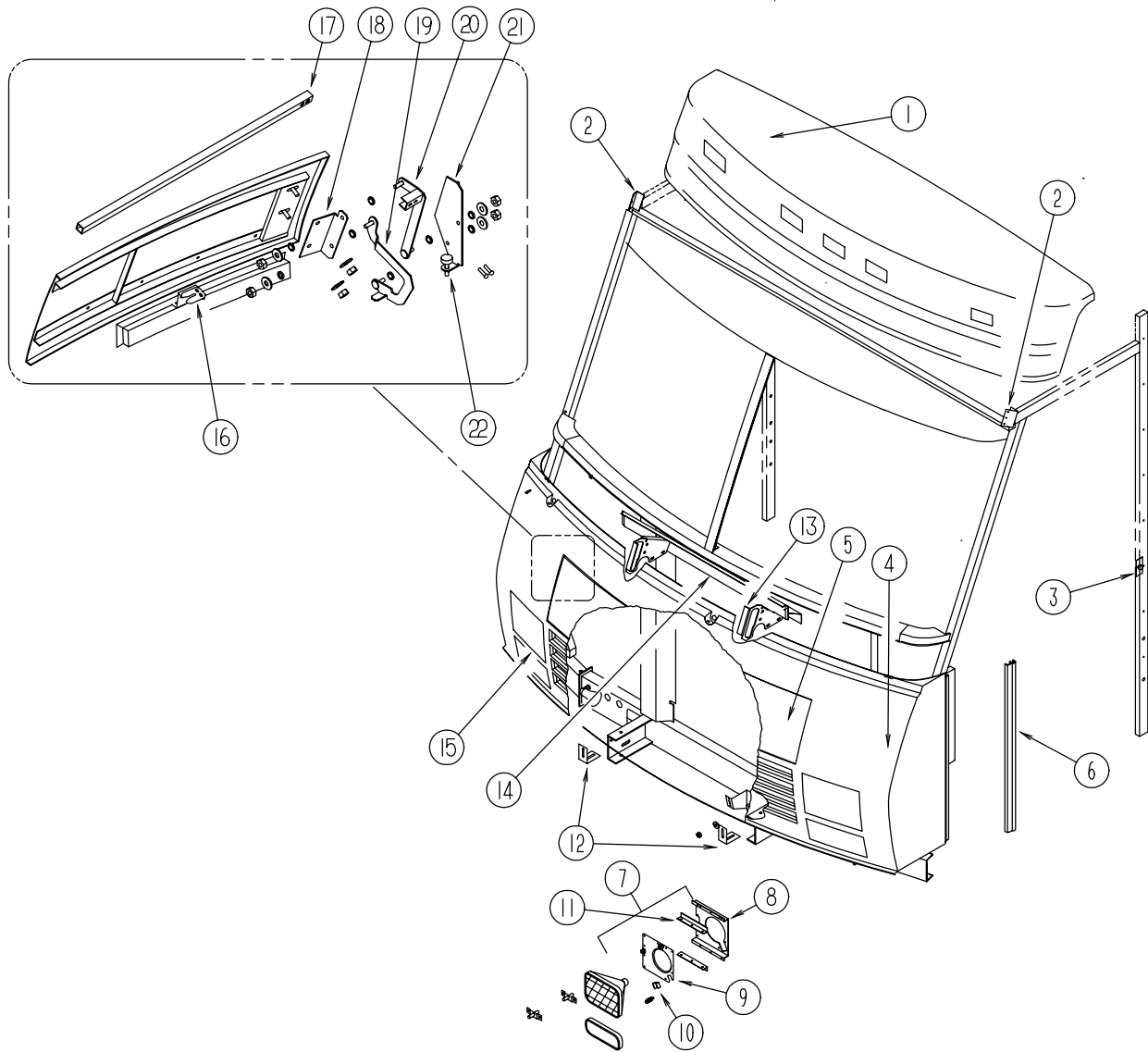

KEY	PART NUMBER	U/M	DESCRIPTION
1	M05922-03-FB1	EA	CAP ASM-FRONT, W/CLEARANCE LIGHTS & WIRING - BRIGHT WHITE
	117012-01-01A	EA	CAP-FRONT, W/O WIRING & CLEARANCE LIGHTS - BRIGHT WHITE
2	077001-01-000	EA	ANGLE-MOUNTING, ROOF PANEL - V ANGLE - 3" X 2.4" X 1.5"
3	070579-06-000	EA	PLATE-ANCHOR, W/7/16 WELD NUT - 1.5" X 3.3"
4	M05928-01-FB1	EA	FRONT END ASM-FIBERGLASS, COMPLETE W/HEADLIGHTS - BRIGHT WHITE
	109877-01-02A	EA	PANEL-FRONT, LOWER BRT/WHT
5	109931-01-FB1	EA	PANEL ASM-HOOD, W/O LOCK - BRIGHT WHITE
6	089922-26-000	EA	TRIM-FIBERGLASS, PANEL - BRIGHT WHITE
7	110712-02-D15	EA	PLATE ASM-HEADLAMP, DUAL - LEFT
8	110784-02-01A	EA	BRACKET-HEADLAMP, DUAL - LEFT - MILL
	110784-01-01A	EA	BRACKET-HEADLAMP, DUAL - RIGHT - MILL
9	110711-02-01A	EA	PLATE-HEADLAMP, DUAL - LEFT - MILL
	110711-01-01A	EA	PLATE-HEADLAMP, DUAL - RIGHT - MILL
10	110691-01-01A	EA	BRACKET-SPRING, HEADLAMP - MILL
11	110782-01-000	EA	ANGLE-SUPPORT, HEADLAMP - V-ANGLE - 160MM LONG
12	103628-01-000	EA	BRACKET-FRONT, LOWER - MOUNTING
13	103136-04-000	EA	BRACKET-SUPPORT, UPPER - HINGE - LEFT
	103136-03-000	EA	BRACKET-SUPPORT, UPPER - HINGE - RIGHT
14	102421-01-000	EA	PANEL-PLENUM, CENTER
15	110712-01-D15	EA	PLATE ASM-HEADLAMP, DUAL - RIGHT
16	109915-01-01A	EA	LATCH-HOOD, FRONT END - BLACK
17	105096-05-000	EA	TUBE-TIMING, HOOD HINGE
18	109927-01-000	EA	ANGLE-LINK, HOOD - RIGHT
	109927-02-000	EA	ANGLE-LINK, HOOD - LEFT
19	109930-03-000	EA	LINK ASM-HINGE, HOOD - LOWER - RIGHT - W/ WELD STUD
	109930-01-000	EA	LINK ONLY-HINGE, HOOD - LOWER - RIGHT
	109930-04-000	EA	LINK ASM-HINGE, HOOD - LOWER - LEFT - W/ WELD STUD
	109930-02-000	EA	LINK ONLY-HINGE, HOOD - LOWER - LEFT
20	109929-01-000	EA	LINK ASM-HINGE, HOOD - UPPER - RIGHT
	109929-02-000	EA	LINK ASM-HINGE, HOOD - UPPER - LEFT
21	109926-03-000	EA	BRACKET ASM-LINK, HINGE - RIGHT - W/WELD STUD & FERRULE
	109926-01-000	EA	BRACKET ONLY-LINK, HINGE - HOOD - RIGHT
	109926-04-000	EA	BRACKET ASM-LINK, HINGE - LEFT - W/WELD STUD & FERRULE
	109926-02-000	EA	BRACKET ONLY-LINK, HINGE - HOOD - LEFT
22	058786-01-000	EA	BOLT-ADJUSTING, HOOD - W/BLACK PAD - .31" #18 X 2"
22	000D39-05-00B	EA	NUT-HEX, SERRATED FLANGE LK - 5/16 - 18 - ZINC

GALLEY GROUP

GALLEY CABINETRY

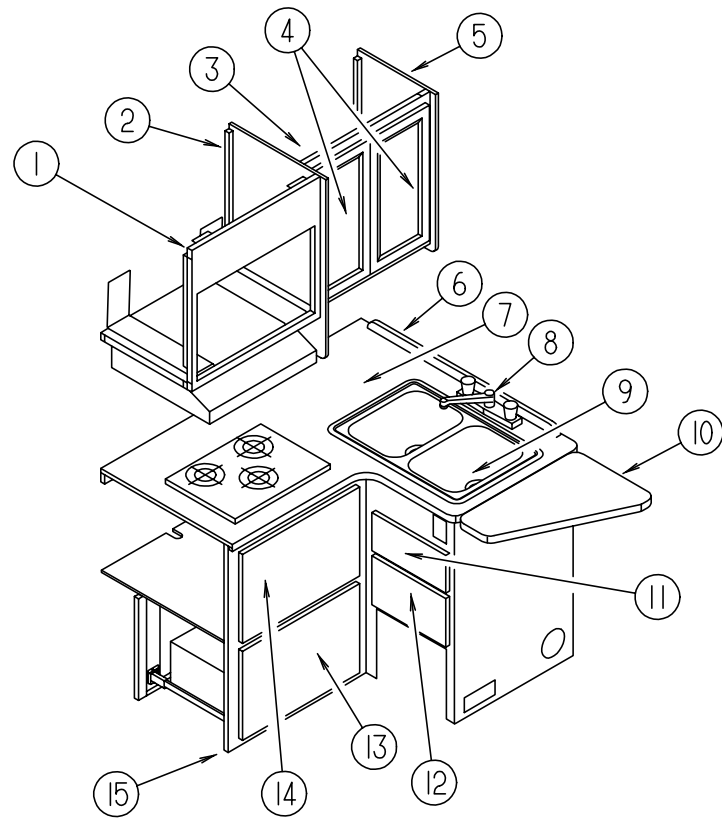

KEY	PART NUMBER	U/M	DESCRIPTION
1	116874-01-GB1	EA	CABINET ASM-MICROWAVE OVERHEAD
2	109908-28-GB1	EA	CAP ASM - END - OVERHEAD
3	116876-01-GB1	EA	CABINET ASM-OVERHEAD - GALLEY
	116876-11-GB1	EA	SHELF ASM
4	110140-26-G01	EA	DOOR ASM-MITERED - VINYL WRAP 0280X0555
5	109 908-27-GB1	EA	CAP ASM - END - OVERHEAD
6	098335-08-F05	EA	RAIL-GALLEY,896
7	119477-11-GB1	EA	COUNTERTOP ASM
7	119477-11-GC1	EA	COUNTERTOP ASM
8	103243-01-000	EA	FAUCET-GALLEY,DUAL CONTROL - P5043
9	102551-01-000	EA	SINK-STAINLESS STEEL, DOUBLE - 17" X 25"
	066437-01-000	EA	STRAINER-SINK, GALLEY W/BASKET
10	119477-12-GB1	EA	EXTENSION ASM - GALLEY
10	119477-12-GC1	EA	EXTENSION ASM - GALLEY
	104181-01-01A	EA	SUPPORT-LEAF,8 IN,SAF-T-RING
11	P10163-M4-GB1	EA	DRAWER COMPLETE-SLIDE
12	P10163-M5-GB1	EA	DRAWER COMPLETE-SLIDE
13	P10163-M7-GB1	EA	DRAWER COMPLETE-SLIDE
14	110140-77-GB1	EA	DOOR ASM-MITERED - VINYL WRAP - 0555 X 0305
15	119477-01-GB1	EA	CABINET ASM-GALLEY
15	119477-01-GC1	EA	CABINET ASM-GALLEY
	110012-02-GB1	EA	COVER ASM-SINK (GB1)
	110012-02-G01	EA	COVER ASM-SINK (GC1)
	110012-03-GB1	EA	COVER ASM-SINK (GB1)
	110012-03-GC1	EA	COVER ASM-SINK (GC1)
	090329-01-000	FT	SEAL-T, REFRIGERATOR CABINET - .6" WIDE TOP X 2" TAIL

GALLEY GROUP (CONTINUED)

NORCOLD SINGLE DOOR REFRIGERATOR - 2-WAY - MODEL 6162 RH

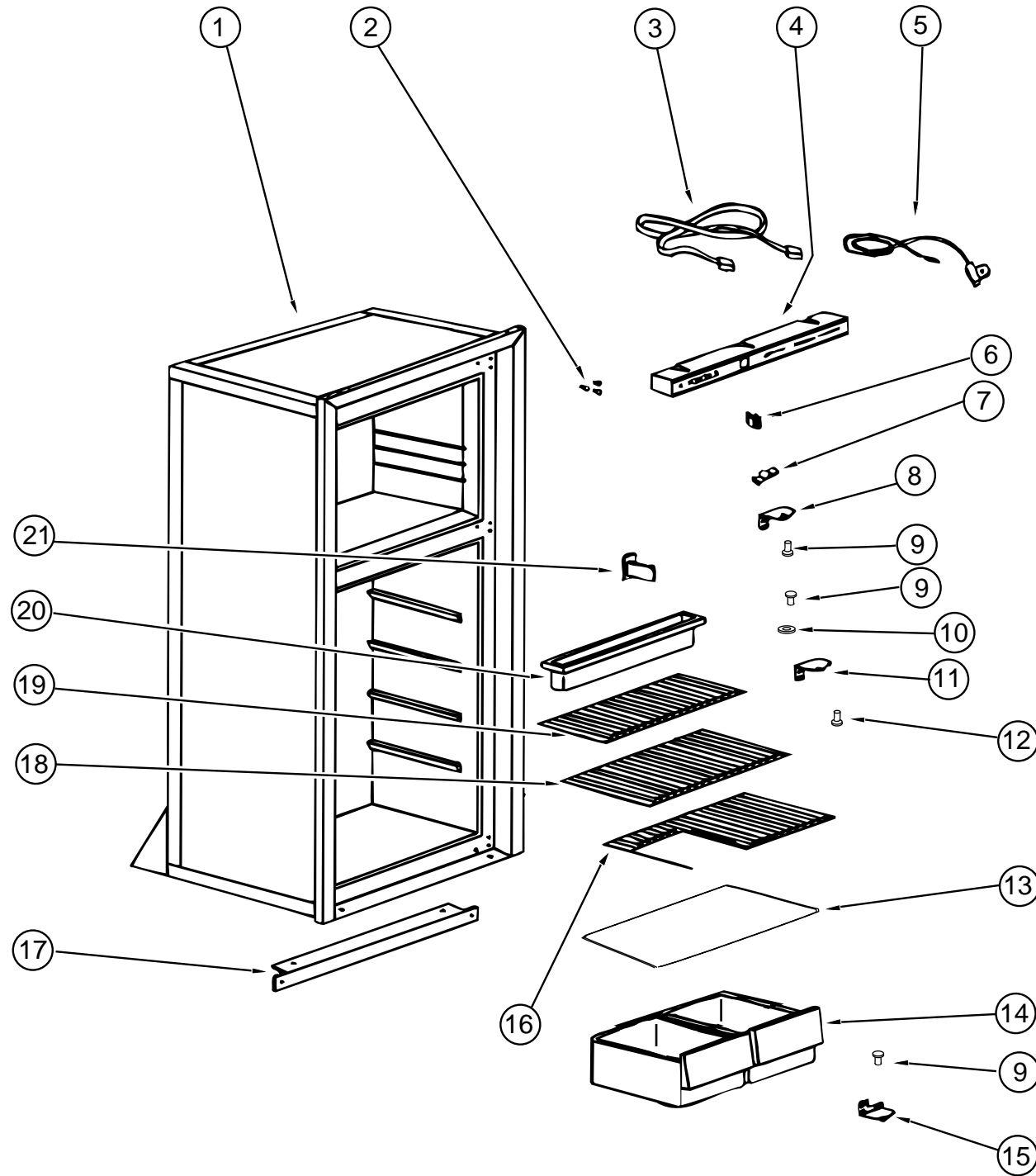

KEY	PART NUMBER	U/M DESCRIPTION	VENDOR NO.
	104138-04-01A	EA REFRIG SMALL DBL DOOR 2-WAY - NORCOLD 6162 RH BL N/A - USE P.N.#1041380201A REFRIGERATOR W/REVERSE HANDLE REPAIR PARTS ARE AVAILABLE FOR ORIGINAL REFRIGERATOR	
1	104138-04-701	EA FOAMED CAB ASM (BLK W/WHITE)	61725038
2	094039-01-722	EA HOLE PLUG (BLK) HINGE HOLES	61582030
3	084880-01-746	EA CABLE-PRINTED CIRCUIT BOARD TO POWER SUPPLY	61571522
4	104137-06-700	EA EYEBROW SHELL (2-WAY)	61726622
5	084880-01-753	EA THERMISTER 78"	61697822
6	075217-01-738	EA SWITCH-HUMIDITY	61525922
7	084880-01-760	EA CLIP (THERMISTER)	61689122
8	094039-01-723	EA HINGE BRACKET, TOP RH-BOTTOM LH BLK	61580838
9	094039-01-725	EA HINGE PIN (BLACK) (MALE)	61578130
	084880-03-702	EA HINGE PIN (BLACK) FEMALE	61580630
10	084880-01-749	EA HINGE BUSHING	61580722
11	094039-01-728	EA BRACKET-HINGE, CENTER BLACK	61566530
12	094039-01-730	EA HINGE PIN SHAFT (BLK) CENTER HINGE	61566730
13	084880-01-722	EA CRISPER COVER	61564122
14	104137-06-707	EA CRISPER (WHITE)	61571325
15	094039-01-724	EA BRACKET-HINGE, TOP LH - BOTTOM RH - BLK	61580938
16	094039-01-739	EA SHELF (CUTOUT)	61646722
17	094039-01-732	EA FRONT COVER (BLK) BOTTOM TRIM	61622130
18	094039-01-733	EA WIRE SHELF (MIDDLE)	61563822
19	094039-01-734	EA WIRE SHELF (TOP) W/RISER	61563722
20	094039-01-735	EA INSIDE DRIP TRAY (WHITE)	61572830
21	084880-01-732	EA LATCH	61578522
	094039-01-736	EA SWITCH-LIGHT, BLACK	61581022
	093646-05-000	EA BRACKET-TIEDOWN - REFRIGERATOR	
	065225-02-000	EA PLATE - TIEDOWN - REFRIGERATOR	
	054450-01-000	EA LEVEL-REFRIGERATOR	
	116751-01-01A	EA TRAY-DRIP, REFRIGERATOR - 24.6" X 6.3" - PLASTIC - BLACK	

GALLEY GROUP (CONTINUED)
NORCOLD TWO DOOR REFRIGERATOR - 2-WAY - MODEL 6162 RH

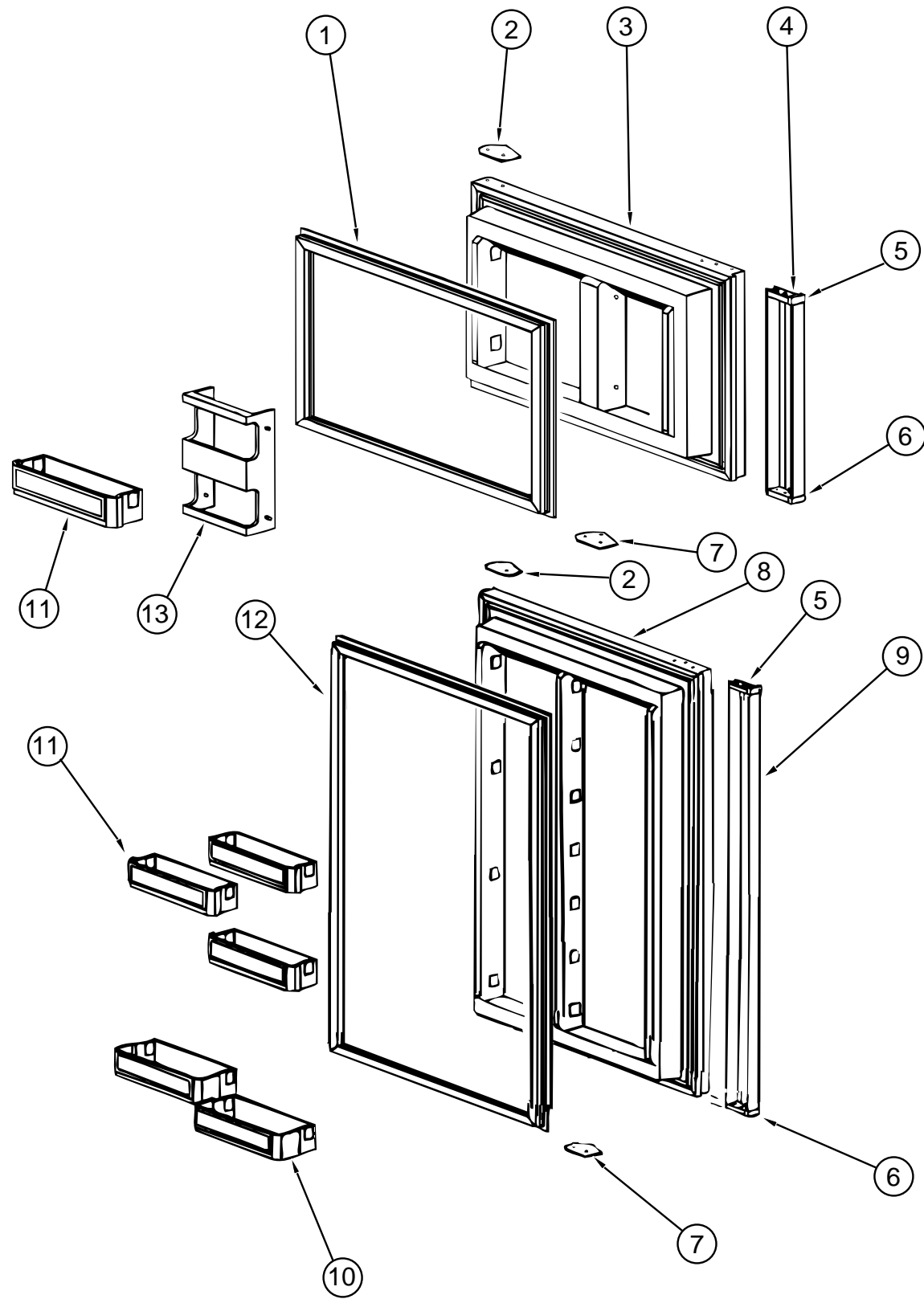

KEY	PART NUMBER	U/M DESCRIPTION	VENDOR NO.
1	094039-01-702	EA GASKET (GRAY) UPPER	61567830
2	094039-01-710	EA PLATE-HINGE, BLACK	61631330
3	094039-01-706	EA UPPER DOOR LINER (WHITE) BLACK	61581838-B
4	094039-01-708	EA HANDLE-DOOR, UPPER - BLACK	61650038
	084880-01-720	EA SPRING (FOR DOOR HANDLE)	61558822
5	084880-01-761	EA CAP-END, SPRING CATCH - UPPER	61593730
6	084880-01-740	EA CAP-END, STOP CATCH - LOWER	61593830
7	094039-01-704	EA PLATE-HINGE, BLACK	61631430
8	094038-01-702	EA LINER-DOOR, LOWER - BLACK/WHITE	61581938-B
9	094038-01-704	EA HANDLE-DOOR, LOWER - BLACK	61650138
	084880-01-720	EA SPRING (FOR DOOR HANDLE)	61558822
10	104137-06-704	EA MILK BIN (WHITE)	61579425
11	104137-06-703	EA BIN-DOOR SHELF (WHITE)	61564025
12	094038-01-700	EA GASKET-LOWER, GRAY	61567930
13	104137-06-702	EA RACK-JUICE (WHITE)	61580525

GALLEY GROUP (CONTINUED)
NORCOLD 6162 REFRIGERATOR CONTROL ASM.

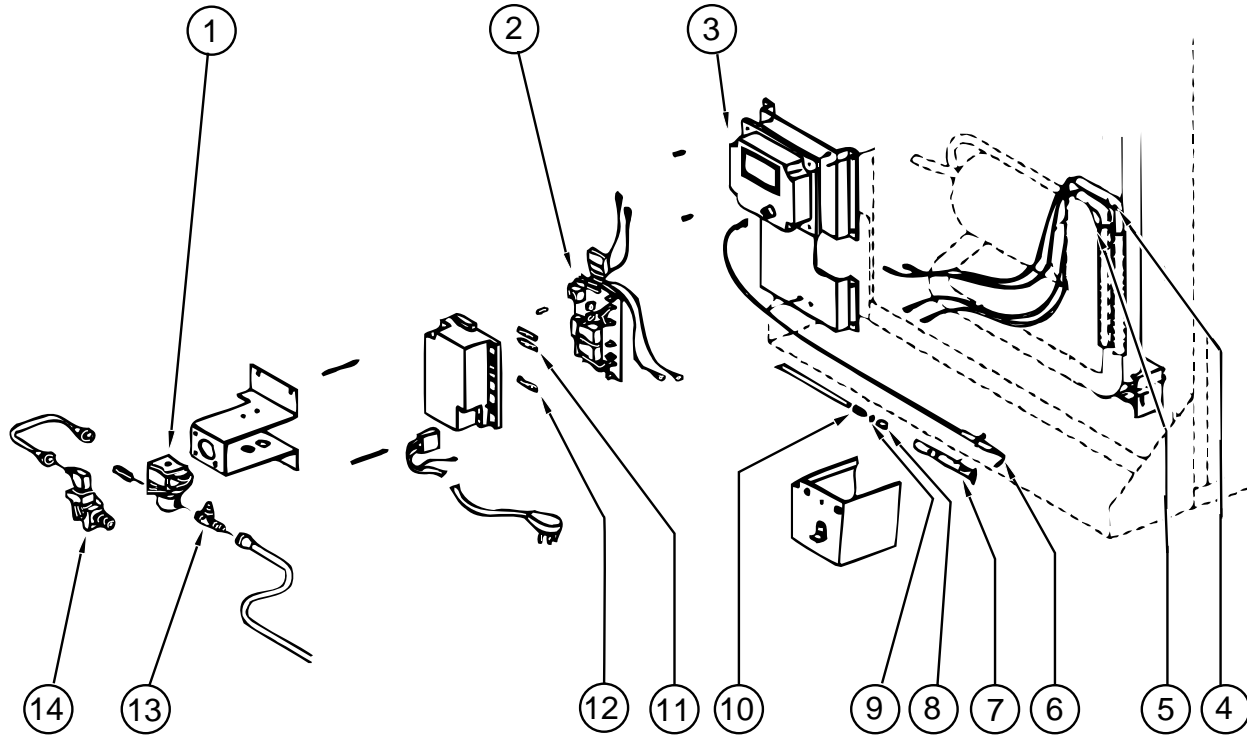

KEY	PART NUMBER	U/M	DESCRIPTION	VENDER NO.
1	084880-01-718	EA	VALVE-GAS	61551822
2	094039-04-702	EA	POWER SUPPLY (2-WAY)	61647422
3	102621-01-702	EA	IGNITION MODULE	61688922
4	088248-01-710	EA	HEATER-DC, (HORIZONTAL)	61562822
5	088248-01-709	EA	HEATER-AC, (HORIZONTAL)	61562722
6	104137-06-715	EA	SPARK/SENSE ELECTRODE (SINGLE)	61692222
7	104137-06-714	EA	BURNER ASSEMBLY (5-SLOT)	61705222
8	084880-01-705	EA	ORIFICE	61452122
9	104137-06-713	EA	ORIFICE GASKET	61475122
10	104137-06-712	EA	FITTING-GAS TUBE CONNECTION	61692722
11	075217-01-734	EA	FUSE - 3 AMP	61538822
12	104137-06-711	EA	FUSE - 5 AMP	61611622
13	104137-06-710	EA	PRESSURE TAP	61594422
14	104137-06-709	EA	VALVE SHUT-OFF-MANUAL ASM	61694922
	084879-03-700	EA	COIL-COOLING, FOR HORIZONTAL BURNER	61687240

GALLEY GROUP (CONTINUED)
NORCOLD 6162 REFRIGERATOR EYEBROW ASM.

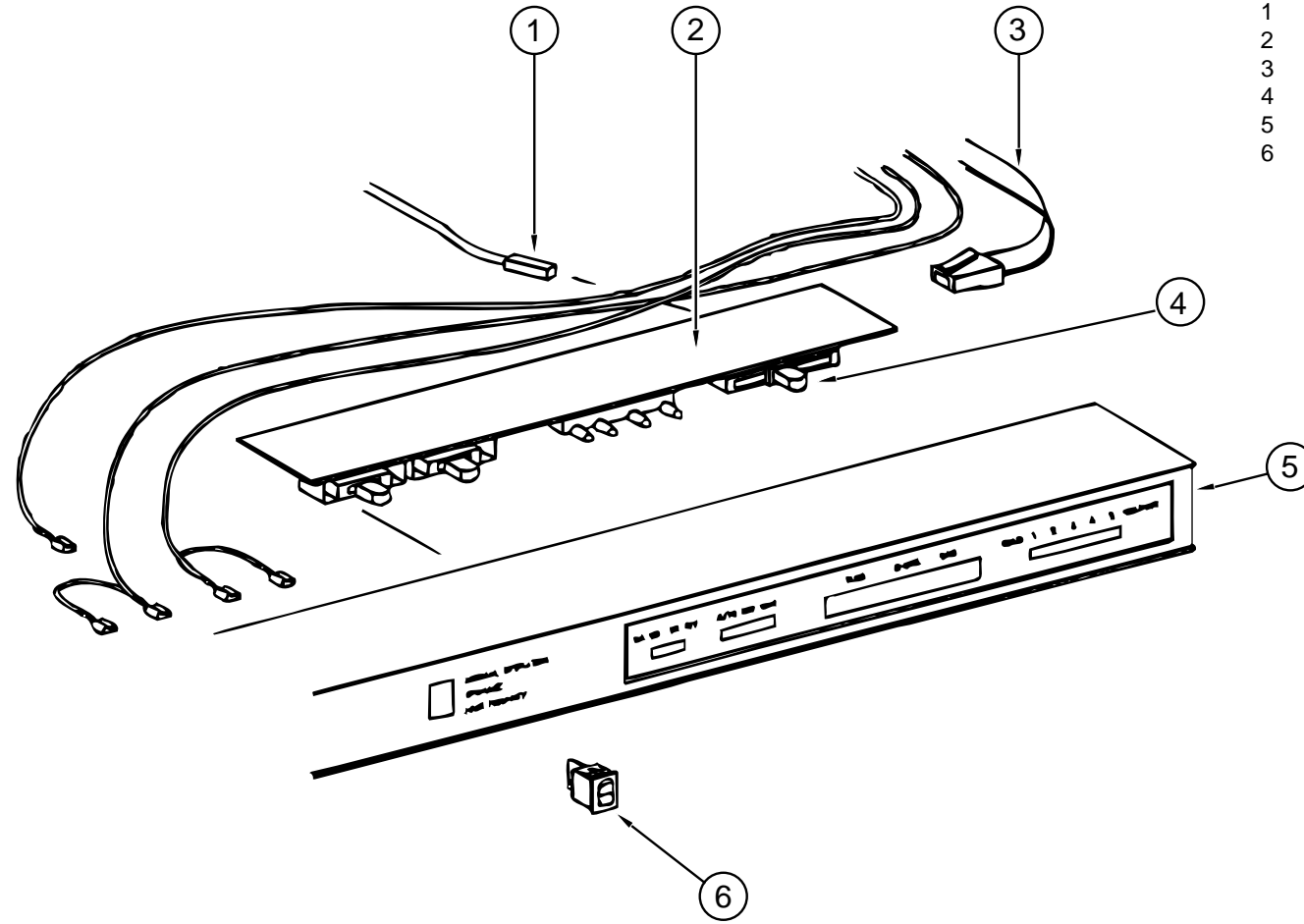

KEY	PART NUMBER	U/M	DESCRIPTION	VENDER NO.
1	084880-01-753	EA	THERMISTER 78"	61693822
2	094039-04-700	EA	PRINTED CIRCUIT BOARD - 2 WAY	61647322
3	084880-01-746	EA	CABLE- PRINTED CIRCUIT BOARD TO POWER SUPPLY	61571522
4	102621-01-703	EA	THERMOSTAT BUTTON	61587422
5	104137-06-700	EA	EYEBROW SHELL (2-WAY)	61726622
6	075217-01-738	EA	SWITCH-HUMIDITY	61525922

GALLEY GROUP (CONTINUED)

MICROWAVES, RANGE HOOD, & MONITOR PANEL

KEY	PART NUMBER	U/M DESCRIPTION	VENDOR NO.
	115303-01-000	EA MICROWAVE OVEN - 14 1/8"H X 21 7/8"H X13 1/4"D - .8 CU FT./700 WATT	
	115303-01-700	EA TRIM F/VENT, TOP	2100309
	115401-01-01A	EA TRIM-MICROWAVE BLACK	
	103386-02-01A	EA HOOD-RANGE POWERED BLK - VENTLINE	
	090973-01-700	EA MOTOR-12 VOLT, CSA & UL	CA508-1
	090973-01-702	EA BLADE-FAN	VA183-1
	092696-01-710	EA HOLDER-LAMP	CB267-2
	096983-01-707	EA FILTER-MESH	CC246
	103386-02-700	EA KNOB-SWITCH	CB-161
	103386-02-701	EA SWITCH	CB-164
	103386-02-702	EA SPRING-FILTER	CC245
	103386-02-703	EA DAMPER LOCK SPRING	-488
	100258-10-01A	EA GAUGE-HOUR METER - SCREW ON STYLE W/SWITCH	
	100258-10-701	EA GAUGE-HOUR METER - CLIP ON	L0775-00

RANGE MAGIC CHIEF

KEY	PART NUMBER	U/M DESCRIPTION	VENDOR NO.
	114030-01-01A	EA RANGE - 3 BURNER W/O OVEN ALMD 85RA-3B	
	102019-01-705	EA TRIM-REAR, BLACK	3608F009-70
	102020-01-709	EA BUMPER-GRATE	8007-P020-60
	102020-01-710	EA FILTER-PILOT	7507P046-60
	102020-01-711	EA GRATE-TOP	7518P012-60
	102020-01-721	EA VALVE-SHUT-OFF	7506P096-60
	102020-01-722	EA VALVE-TOP BURNER	7502P181-60
	102020-01-724	EA BUMPER-MAIN TOP	8003P008-60
	102022-01-708	EA REGULATOR-PRESS 1/4IN1/2 OUT	7510P041-60
	112881-01-700	EA TOP, MAIN-ALMOND	2001F110-84
	112881-01-703	EA VALVE-TOP BURNER HI-OUTPUT	7502P180-60
	112881-01-705	EA KNOB-TOP BURNER	7733P072-60
	112881-01-709	EA PIPE-MANIFOLD	7513P097-60
	114030-01-700	EA PILOT-BURNER	7505P147-60
	114030-01-701	EA PANEL-MANIFOLD	2616F078-70
	114030-01-702	EA TRIM-RIGHT, BLACK	3608W040-70
	114030-01-703	EA TRIM-LEFT, BLACK	3608W039-70

GENERATOR GROUP

4000 KW GENERATOR ONAN EMERALD PLUS BGE-FA/26100G

KEY	PART NUMBER	U/M DESCRIPTION
	100974-01-000	EA GENERATOR - 4.0KW EMERALD PLUS, ONAN BGE-FA/26100G
	008401-01-000	EA STRAP-CONDUIT, 3/4" - 1 HOLE - GALVANIZED STEEL
	007067-01-000	SF INSULATION-FIBERGLASS, 1" THICK X 4' - INCREMENTS OF 4 SF
	007125-03-000	EA CLAMP-MUFFLER, 1.5" DIA
	007125-04-000	EA CLAMP-MUFFLER, 1.1" DIA
	079654-05-000	EA PIPE-EXHAUST, ANGLED - W/FLANGE - 2" ID - ONAN# 154-2539
	081364-03-000	EA MUFFLER-GENERATOR, ONAN
	094059-01-000	EA SPACER-GENERATOR, ONAN
	007131-01-000	EA HANGER-TAILPIPE, 6 SLOTS
	NOTE:	GENERATOR TRAY AND COMPONENTS ARE FOUND IN THE CHASSIS GROUP.

4000 KW GENERATOR ONAN MICROLITE KY-FA/26100 B

KEY	PART NUMBER	U/M DESCRIPTION
	109982-03-000	EA GENERATOR - 4.0 MICROLITE, ONAN KY-FA/26100 B
	007125-03-000	EA CLAMP-MUFFLER, 1.5" DIA
	007131-01-000	EA HANGER-TAILPIPE, 6 SLOTS
	007125-04-000	EA CLAMP-MUFFLER, 1.1" DIA
	105958-01-000	EA PIPE-EXHAUST,GENERATOR
	NOTE:	GENERATOR TRAY AND COMPONENTS ARE FOUND IN THE CHASSIS GROUP.

HEATING & AIR CONDITIONING GROUP

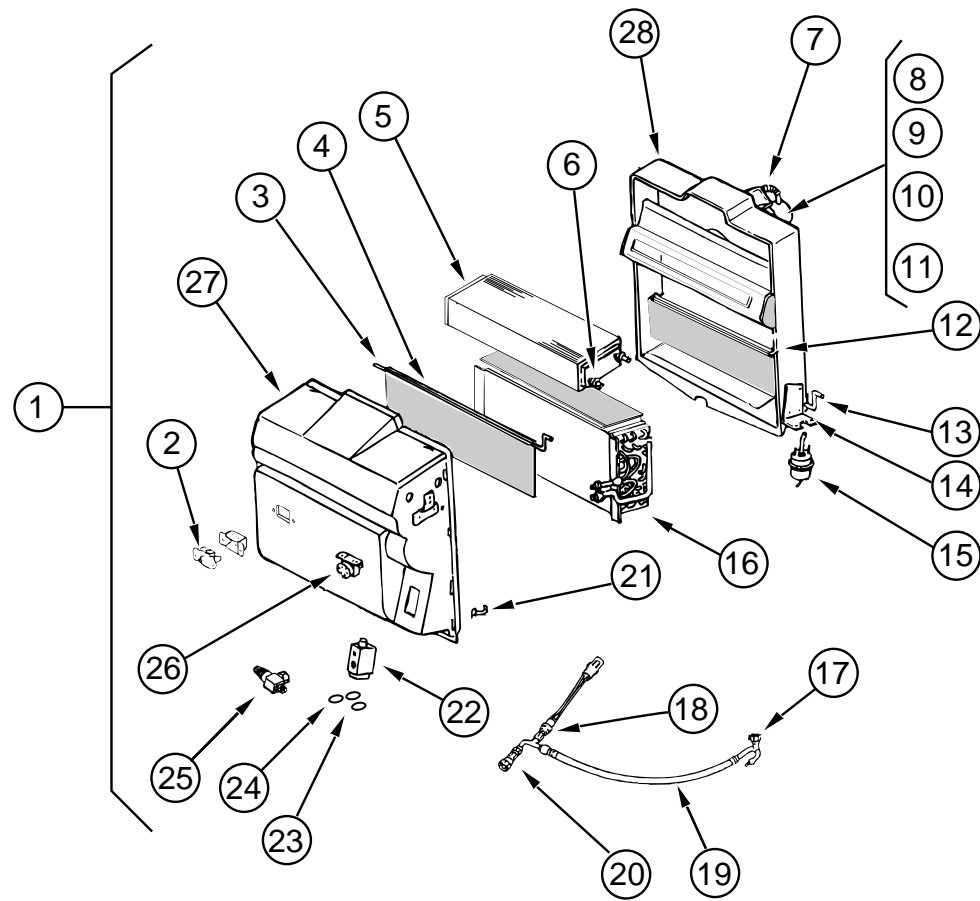

AUTO A/C - EVAPORATOR/HEATER

KEY	PART NUMBER	U/M DESCRIPTION	VENDOR NO.
1	103930-20-000	EA EVAPORATOR/HEATER CHEV R134A BLOCK	090-00083
2	103930-01-710	EA RESISTOR-FUSED	035-0006
3	103930-20-702	EA ROD - FRONT BLEND AIR DOOR	
4	103930-20-703	EA DOOR - BLEND AIR	
5	103930-01-703	EA COIL-HEATER	042-0010
6	110279-01-712	EA HEATER FITTING	050-0076
7	110279-01-703	EA HOSE-VENT, MOTOR BLOWER	051-0034
8	103930-20-707	EA BLOWER - HOUSING	
9	103930-01-720	EA MOTOR	030-0004
10	103930-01-717	EA WHEEL-CLOCKWISE	062-0010
11	103930-20-708	EA CLIP - FRONT MOTOR SHAFT	
12	103930-20-705	EA DOOR - PANEL - RECIRCULATING	
13	103930-20-704	EA ROD - DOOR- RECIRCULATING	
14	103930-01-708	EA BRACKET-VACUUM MOTOR	070-0113
15	103930-02-708	EA MOTOR-VACUUM SERVO, A/C	030-0002
16	103930-01-704	EA COIL EVAPORATOR	
17	103930-12-708	EA SWITCH-BINARY, R-134A	032-0048
18	103930-01-716	EA SWITCH-PRESSURE, FAN	032-0036
19	103930-20-701	EA HOSE ASSY #6 WINN GM 085-0138	
20	103930-12-709	EA FITTING-QUICK CONNECT	050-0120
21	103930-20-706	EA CLIP - RETAINER	
22	103930-20-700	EA VALVE EXPANSION BLOCK (2 TON)	034-0032
23	103930-17-702	EA GASKET OR SAE 015 #10 33-781	045-0127
24	113245-01-707	EA GASKET (#8)	045-0126
25	103930-20-709	EA SERVICE VALVE	
26	103930-01-711	EA THERMOSTAT	033-0003
27	103930-20-710	EA CASE-FRONT, SUB-ASSEMBLY	062-0146
28	103930-20-711	EA CASE-BACK, SUB-ASSEMBLY	062-0147
	056402-05-000	EA BRACKET-HEATER VENT, ROUND - W/BEND - BLACK	

HEATING & AIR CONDITIONING GROUP (CONTINUED)

GAS AUTO A/C - CONTROL PLENUM

KEY	PART NUMBER	U/M DESCRIPTION	VENDOR NO.
	103930-04-000	EA CONTROL/PLENUM SET - 093-00037	
			FROM: 05-06-94 THRU: 01-14-96
	072341-06-700	EA SWITCH-4 SPEED FAN	032-0043
	094831-01-709	EA CLAMP-ROD 3/16"	022-0025
	103930-02-700	EA PANEL-CONT.W/BEZEL W/O DECAL	032-0018
	103930-02-701	EA SWITCH-VACUUM	034-0015
	103930-02-702	EA DECAL-CONT. HEAD, (N) SERIES	058-0009
	103930-02-703	EA HARNESS-WIRE CONTROL	036-0048
	103930-02-704	EA HARNESS-VACUUM CONTROL	036-0049
	103930-02-705	EA CABLE-BOWDEN, 89"	074-0011
	103930-02-706	EA CLIP-CABLE CONTROL	022-0017
	103930-02-707	EA RELAY-BOSCH W/RESISTER	031-0001
	103930-02-708	EA MOTOR-VACUUM SERVO, A/C	030-0025
	103930-02-710	EA CANISTER-VACUUM	054-0002
	103930-02-711	EA VALVE-WATER, 2 PORT	034-0014
	103930-27-000	EA CONTROL/PLENUM SET F,G,&D	
			FROM: 01-15-96 THRU: 99-99-99
	094831-01-709	EA CLAMP-ROD 3/16"	022-0025
	103930-01-724	EA CLIP, SPRING, S TYPE	022-00002
	103930-02-701	EA SWITCH-VACUUM	034-0015
	103930-02-702	EA DECAL-CONT. HEAD, (N) SERIES	058-0009
	103930-02-704	EA HARNESS-VACUUM CONTROL	036-0049
	103930-02-705	EA CABLE-BOWDEN, 89"	074-0011
	103930-02-707	EA RELAY-BOSCH W/RESISTER	031-0001
	103930-02-708	EA MOTOR-VACUUM SERVO, A/C	030-0025
	103930-02-710	EA CANISTER-VACUUM	054-0002
	103930-02-712	EA PANEL-CONT. A/C BLACK BEZEL	032-0054
	103930-23-000	EA VALVE-WATER,2 PORT - SCS 034-00014	
	103930-24-000	EA VALVE-WATER,4 PORT	
	103016-01-000	EA PLENUM-TRANSITION	

GAS AUTO A/C - HOSE KIT

KEY	PART NUMBER	U/M DESCRIPTION	VENDOR NO.
	103930-17-000	EA HOSE KIT, 10 GM-SANDEN COMPRESSOR - SCS 093-00076	
	103930-01-708	EA BRACKET-VACUUM MOTOR	SCS 070-0113
	103930-17-700	EA PAD-FITTING, SANDEN COMPRESSOR SUCTION	SCS 050-0131
	103930-17-701	EA FITTING - 10.90, W/FERRULE - 1342CP	SCS 050-0132
	103930-17-702	EA GASKET OR SAE 015 10 33-781	SCS 045-0127
	103930-17-703	EA GASKET-SEAL, SANDEN COMPRESSOR 33-76	SCS 045-0142
	103930-17-704	EA HOSE ASSY #10	085-0113

GAS AUTO A/C SYSTEM

KEY	PART NUMBER	U/M DESCRIPTION
	007281-01-000	EA HOSE-FLEXIBLE PVC, 2.5"ID X 50' - ATCOFLEX A-182-355
	056402-05-000	EA BRACKET-HEATER VENT, ROUND - W/BEND - BLACK
	077075-01-000	EA GASKET-INSTRUMENT PANEL TO DEFROSTER PLENUM, .6" X 11.3"
	077075-03-000	EA GASKET-INSTRUMENT PANEL TO DEFROSTER PLENUM, .6" X 10.2"
	103017-01-000	EA PLENUM-DEFROSTER
	103558-01-09A	EA VENT-DEFROSTER, ABS PLASTIC - BISQ
	103796-01-01A	EA LOUVER ASM-A/C, 136.5 X 54.8MM - BLACK
	103930-05-000	EA MANUAL-OWNERS, HEATER-A/C SCS 057-0049
	024990-05-000	EA OUTLET-DEFROSTER W/SWIVEL - 2" - BLACK
	008042-01-000	FT TUBING-VINYL, .65" ID

HEATING & AIR CONDITIONING GROUP (CONTINUED)

FURNACE - SUBURBAN 30,000 BTU - SF-30 2273

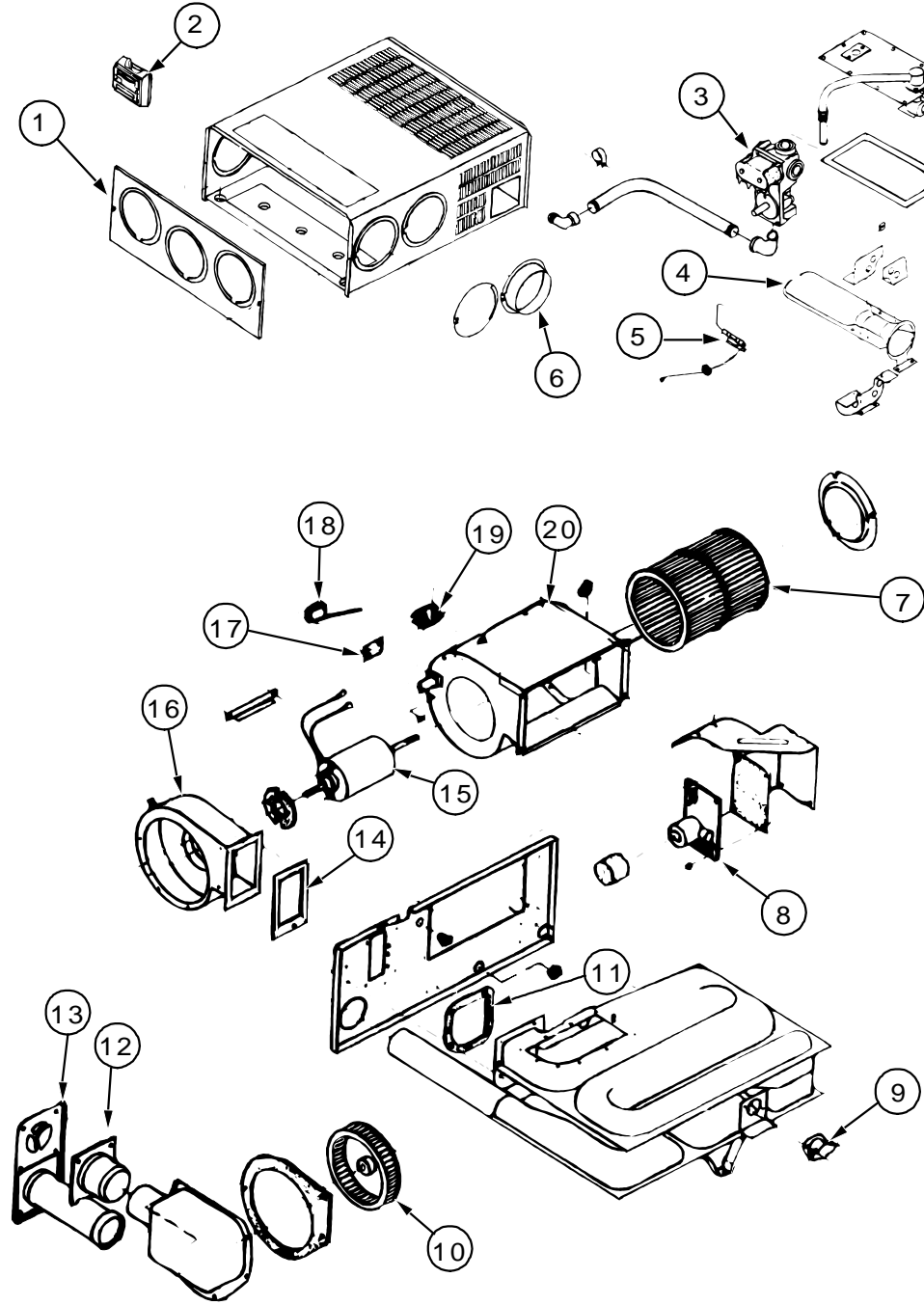

KEY	PART NUMBER	U/M DESCRIPTION	VENDER NO.
	098668-14-000	EA GASKET-FIBERGLASS, .5" X 18" X 18" - 070976	
	098668-20-000	EA FURNACE - 30,000 BTU - SF-30 2273	
1	098668-01-700	EA CABINET FRONT	101242
2	115764-01-01A	EA THERMOSTAT-FURNACE	160902
3	098668-01-714	EA VALVE-GAS	161070
4	098668-02-700	EA BURNER ASM. - COMPLETE	010762
5	098668-01-715	EA ELECTRODE ASM. - SINGLE PROBE	232166
6	075696-02-703	EA COLLAR-DUCT	050715
7	098668-01-711	EA WHEEL-ROOM AIR	350123
8	098668-01-712	EA BOARD-MODULE	231741
9	098668-21-701	EA SWITCH-LIMIT	231799
10	098668-01-706	EA WHEEL-COMBUSTION AIR	350122
11	098668-01-716	EA GASKET-FIREWALL, CHAMBER SIDE	070808
12	098668-01-713	EA TUBE ASM. - INTAKE VENT	051248
13	098668-01-707	EA VENT CAP & EXHAUST TUBE ASM.	260193
14	098668-01-717	EA GASKET-FIREWALL, BLOWER SIDE	070809
15	098668-01-709	EA MOTOR ASSEMBLY	231706
16	098668-01-708	EA BLOWER ASM. - COMBUSTION AIR	390441
17	101990-01-714	EA GASKET-MICROSWITCH	230877
18	098668-21-700	EA MICROSWITCH-W/O FLAG, 3 1/4"	232261
19	074466-01-702	EA RELAY-TIME DELAY	230625
20	098668-01-710	EA BLOWER ASSEMBLY-ROOM AIR	390440
	092300-02-701	EA ORIFICE-MAIN BURNER, SUBURBAN	180214
	098668-23-000	EA DOOR-ACCESS, FURNACE - BRIGHT WHITE	520574
	069636-02-000	EA CONNECTOR-DUCT, 4" ID - SUBURBAN	050715
	093614-01-01A	EA GRILLE-RETURN AIR, FURNACE - 15.6" X 7.6" - BROWN	
		FROM: 00-00-00 THRU: 03-29-95	
	093614-01-02A	EA GRILLE-RETURN AIR, FURNACE - BEIGE	
		FROM: 03-30-95 THRU: 99-99-99	
	056464-05-000	EA REGISTER-PLASTIC, W/O DAMPER - 4" DIAMETER - GOLDEN	
		FROM: 00-00-00 THRU: 03-29-95	
	056464-10-000	EA REGISTER-PLASTIC, W/O DAMPER - 4" DIAMETER	
		FROM: 03-30-95 THRU: 99-99-99	
	009198-01-000	FT DUCT-HEAT, FLEXIBLE - 4" ID X 25 FT	
	009200-01-000	EA TAPE-FURNACE, 1 1/2"	
	056464-09-000	EA REGISTER-HEAT/A/C, ROUND W/DAMPER - 4" - PLASTIC - BEIGE	
	056464-10-000	EA REGISTER-HEAT/A/C, ROUND W/O DAMPER - 4" - PLASTIC - BEIGE	
	092777-01-000	EA ADAPTER-DUCT, 4"	
	023146-01-000	EA CLAMP-SCREW TYPE - 4"	

HEATING & AIR CONDITIONING GROUP (CONTINUED)

14,800 BTU COLEMAN ROOF A/C

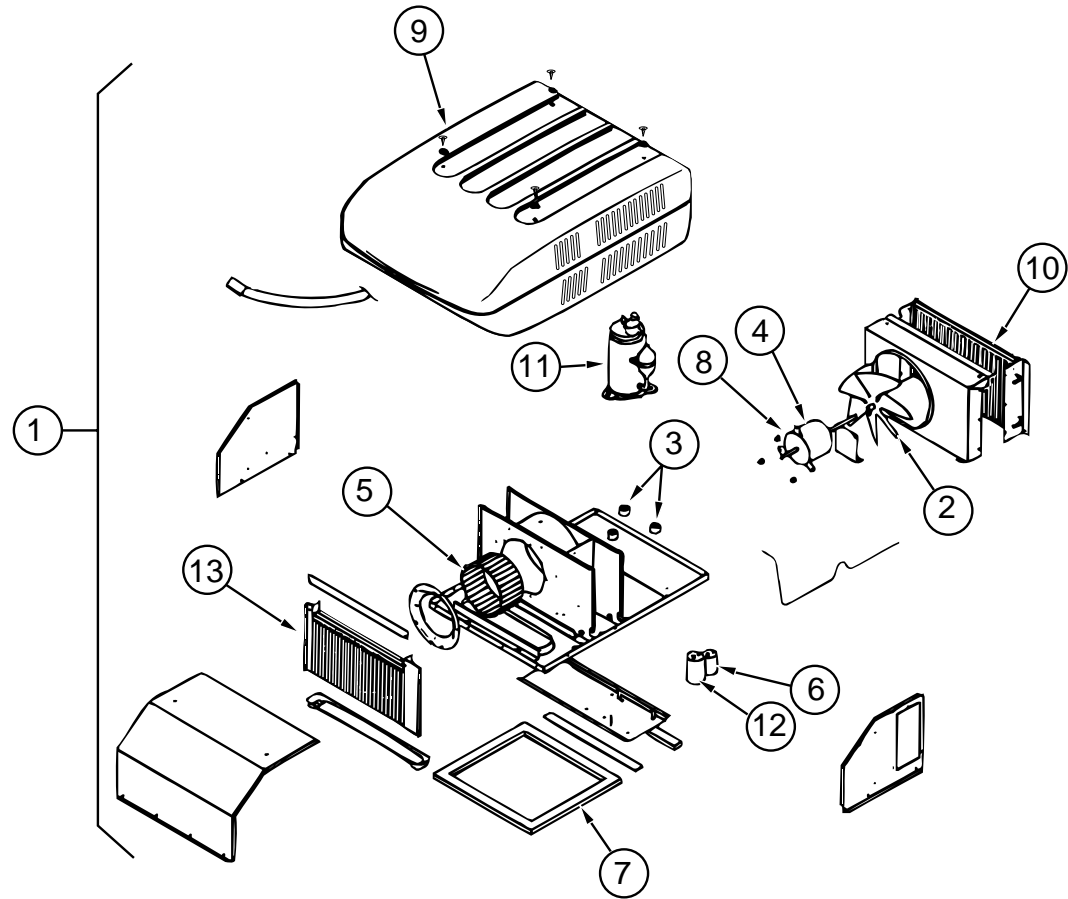

KEY	PART NUMBER	U/M DESCRIPTION	VENDOR NO.
1	115219-01-03A	EA A/C-ROOF,14,800 MACH 15 B/WT COLEMAN - 7335B896	
2	093763-01-712	EA FAN BLADE-CONDENSER	6733-3221
3	105620-01-706	EA FOOT PACKAGE-COMPRESSOR, 3 PER PACKAGE	6759-3081
4	108889-01-705	EA MOTOR - 115V, 60HZ	1468-3049
5	108889-01-706	EA IMPELLOR	1472-1041
6	108889-01-708	EA CAPACITOR-FAN, (7.5MFD.370U)	1499-5461
	108889-01-710	EA FILLER PAD-COND AIR SEAL	6759A3971
7	108889-01-711	EA GASKET PACKAGE	6792-3301
8	108889-01-715	EA MOTOR MOUNT & SHAFT SEAL KIT	6792-3361
9	108889-01-702	EA SHROUD	6759-6411
10	115219-01-700	EA CONDENSER COIL	1452-1321
11	115219-01-701	EA COMPRESSOR, PANASONIC	1450-2039
12	115219-01-702	EA CAPACITOR-RUN, COMPRESSOR	1499-5741
	115219-01-703	EA RELAY-START	1497-4151
13	115219-01-704	EA EVAPORATOR COIL	1452-1331
	115219-01-707	EA DISCHARGE LINE ASSEMBLY	7335A132
	115219-01-705	EA LINE-SUCTION, LOWER	7335-130
	115219-01-706	EA LINE-SUCTION, UPPER	7335-131
	093306-01-720	EA CAPACITOR-START	1497-3351
	093306-01-701	EA DECAL PACKAGE-LEFT & RIGHT	6798B3591
	102289-01-000	EA SPRING-SCREW, ROOF A/C GASKET - 6757-150	

COLEMAN CEILING ASSEMBLY 14,800 BTU A/C

KEY	PART NUMBER	U/M DESCRIPTION	VENDOR NO.
	108891-01-01A	EA CEILING ASM-A/C COOL TSR HO COLEMAN - 7330-714 IV	
	042204-01-709	EA THERMOSTAT-IN 64 OUT 58	6701-3401
	063903-01-702	EA LOUVER	6703A5191
	073742-01-701	EA SWITCH-SELECTOR,(5 TERMINAL)	6759-3251
	073742-01-702	EA DECAL-COOL	6759C3431
	076303-01-707	EA FILTER-6" X 143/4 X 1/2(24)	6703-A3151
	081606-01-712	EA SHROUD-CEILING, IVORY	6769-5061
	091225-01-713	EA KNOB	6701-3351
	091225-01-717	EA DECAL-THERMOSTAT, COOL ONLY	6799A3441
	093766-02-701	EA DECAL-LEFT	6799-3971
	108891-01-700	EA PARTS PKG. SGL KNOBS & NUTS	6792-5991
	108891-01-701	EA CLIP-FILTER RETAINER, 4 PER	6799-3141
	092633-02-02A	EA COVER-BLANK, ROOF A/C - 5.1" X 5.1" - PLASTIC - OFF WHITE	

**INTERIOR FINISH GROUP
CABINET HARDWARE**

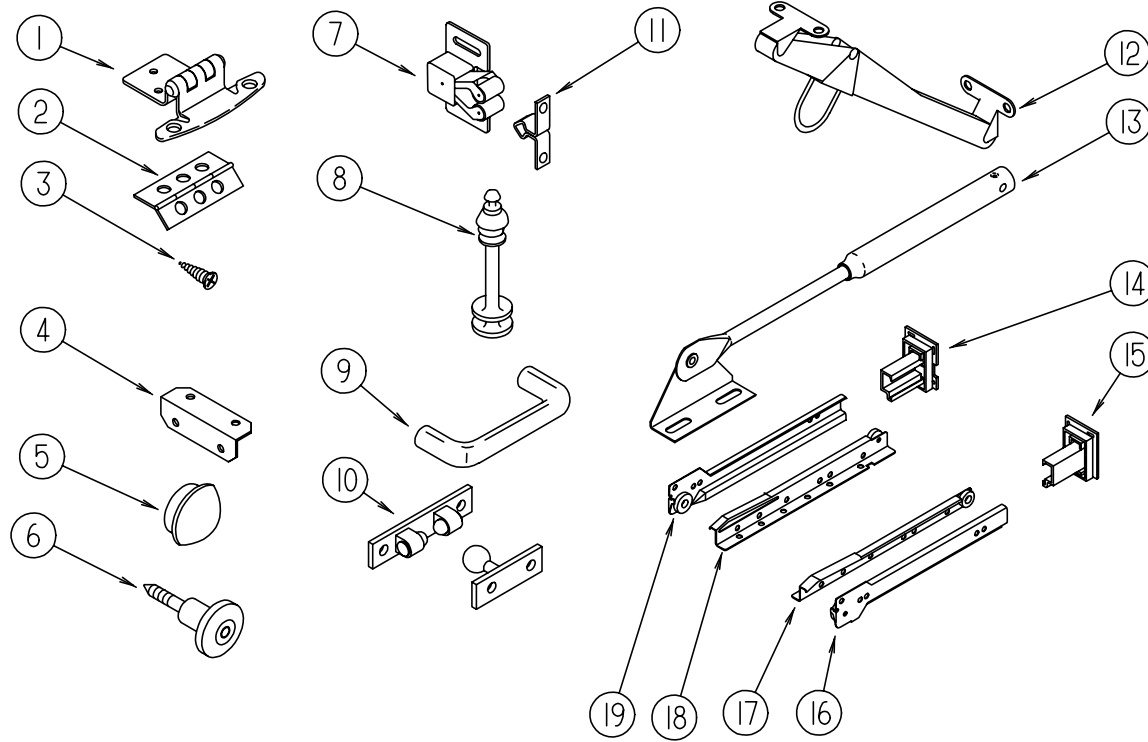

KEY	PART NUMBER	U/M	DESCRIPTION
1	108138-01-000	EA	HINGE-DOOR, CABINET - BURNISHED BRASS
2	009059-01-000	EA	HINGE-DOOR, 2" X 1.4" - BRASS
2	009059-02-000	EA	HINGE-DOOR, 2" X 2.7" - BRASS
3	000G13-06-10G	EA	SCREW - 6-20 X 5/8 PFH, ANTIQUE BRASS
3	076790-01-000	EA	SCREW, 6-20 X 1 1/4 PPH - BLACK
4	016604-01-000	EA	BRACE-CABINET, ANGLE - 2.5" - METAL - UNPAINTED
4	016604-05-000	EA	BRACE-CABINET, ANGLE - 2.5" - METAL - OFF WHITE
5	042356-01-000	EA	PLUG-BUTTON, MAHOGANY - 3/8" DIAMETER - WOOD
6	079921-01-000	EA	ROLLER-NYLON,W/SHAFT
7	093586-06-000	EA	CATCH-SPRING, ROLLER
8	084070-02-000	EA	POST-END,BRASS N-8655
9	112146-01-000	EA	PULL-CABINET, BRASS - AMEROCK 1180-3
10	084451-01-000	EA	CATCH-TV SHELF, BRASS
11	093586-05-000	EA	STRIKE-SPRING STEEL
12	104181-01-01A	EA	SUPPORT-LEAF, 5.3" - EXTENDS TO 7.5" - SAF-T-RING - METAL
13	074493-02-000	EA	SUPPORT-PISTON SPRING, CABINET DOOR
	004354-01-000	EA	BUMPER-RUBBER, .5" DIA - BROWN
	023320-01-000	EA	PAD-FELT, 3/8" DIAMETER - BROWN
	009112-01-000	EA	FLANGE - 1" ROD, CLOTHES - PLASTIC - OFF WHITE
	042438-01-000	EA	DOWEL-WOOD, CLOTHES ROD - 1" DIAMETER X 4'
	104886-03-EB1	EA	CATCH-WOOD,HIDDEN DRAWER
	114693-01-01A	EA	SUPPORT-TABLE BLACK
	114693-02-01A	EA	SUPPORT-TABLE BLACK
	118933-01-01A	EA	SUPPORT-HINGE LOCK O/WHT
14	114045-01-000	EA	BACKSOCKET-ADJUSTABLE,LEFT - HOUCK 751-1 N/A ORDER SLIDE KIT ACCORDINGLY TO LENGTH DRAWER SLIDE#114031-??-700
15	114045-02-000	EA	BACKSOCKET-ADJUSTABLE,RIGHT - HOUCK 751-2 N/A ORDER SLIDE KIT ACCORDINGLY TO LENGTH DRAWER SLIDE#114031-??-700
16	114031-06-000	EA	SLIDE-DRAWER,14" RIGHT CABT HOUCK 7200-RV-2 N/A ORDER #114031-05-700 SLIDE DRAWER KIT
16	114031-10-000	EA	SLIDE-DRAWER,16" RIGHT CABINET-HOUCK 7200-RV-2 N/A ORDER #114031-09-700 SLIDE DRAWER KIT

KEY	PART NUMBER	U/M	DESCRIPTION
16	114031-14-000	EA	SLIDE-DRAWER,18" RIGHT CABINET-HOUCK 7200-RV-2 N/A ORDER #114031-13-700 SLIDE DRAWER KIT
16	114031-18-000	EA	SLIDE-DRAWER,20" RIGHT CABT HOUCK 7200-RV-2 N/A ORDER #114031-17-700 SLIDE DRAWER KIT
17	114031-08-000	EA	SLIDE-DRAWER,14" RIGHT DRWR HOUCK 7200-RV-4 N/A ORDER #114031-05-700 SLIDE DRAWER KIT
17	114031-12-000	EA	SLIDE-DRAWER,16" RIGHT DRAWER -HOUCK 7200-RV-4 N/A ORDER #114031-09-700 SLIDE DRAWER KIT
17	114031-16-000	EA	SLIDE-DRAWER,18" RIGHT DRAWER -HOUCK 7200-RV-4 N/A ORDER #114031-13-700 SLIDE DRAWER KIT
17	114031-20-000	EA	SLIDE-DRAWER,20" RIGHT DRWR HOUCK 7200-RV-4 N/A ORDER #114031-17-700 SLIDE DRAWER KIT
17	114031-24-000	EA	SLIDE-DRAWER,22" RIGHT DRWR HOUCK 7200-RV-4 N/A ORDER #114031-21-700 SLIDE DRAWER KIT
18	114031-07-000	EA	SLIDE-DRAWER,14" LEFT DRWR HOUCK 7200-RV-3 N/A ORDER #114031-05-700 SLIDE DRAWER KIT
18	114031-11-000	EA	SLIDE-DRAWER,16" LEFT DRAWER - HOUCK 7200-RV-3 N/A ORDER #114031-09-700 SLIDE DRAWER KIT
18	114031-15-000	EA	SLIDE-DRAWER,18" LEFT DRAWER - HOUCK 7200-RV-3 N/A ORDER #114031-13-700 SLIDE DRAWER KIT
18	114031-19-000	EA	SLIDE-DRAWER,20" LEFT DRWR HOUCK 7200-RV-3 N/A ORDER #114031-17-700 SLIDE DRAWER KIT
18	114031-23-000	EA	SLIDE-DRAWER,22" LEFT DRWR HOUCK 7200-RV-3 N/A ORDER #114031-21-700 SLIDE DRAWER KIT
19	114031-05-000	EA	SLIDE-DRAWER,14" LEFT CABT HOUCK 7200-RV-1 N/A ORDER #114031-05-700 SLIDE DRAWER KIT
19	114031-13-000	EA	SLIDE-DRAWER,18" LEFT CABINET -HOUCK 7200-RV-1 N/A ORDER #114031-13-700 SLIDE DRAWER KIT
19	114031-09-000	EA	SLIDE-DRAWER,16" LEFT CABINET - HOUCK7200-RV-1 N/A ORDER #114031-09-700 SLIDE DRAWER KIT
19	114031-17-000	EA	SLIDE-DRAWER,20" LEFT CABT HOUCK 7200-RV-1 N/A ORDER #114031-17-700 SLIDE DRAWER KIT

INTERIOR FINISH GROUP (CONTINUED)
MOLDINGS, BATT STRIPS, & TRIM

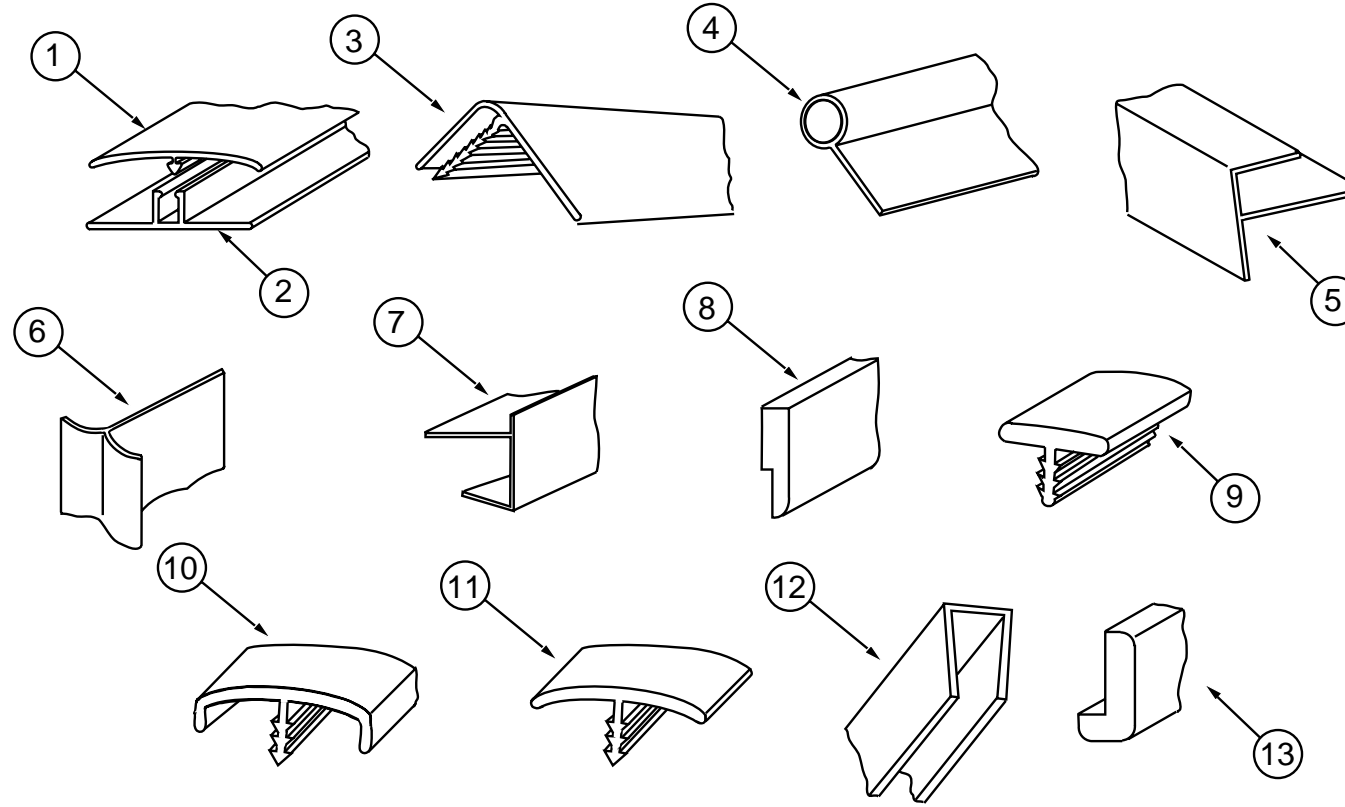

KEY	PART NUMBER	U/M DESCRIPTION
	085284-B1-000	FT STRIP-TAPE,METRO,MIST - ROBERT WEED (GB1)
	085284-A9-000	FT STRIP-TAPE,MONTERREY, RAIN FOREST -ROBERT WEED (GC1)
	085284-C9-000	FT TAPE-BATT STRIP, IMPACT PEARL
	088263-D6-000	EA BATT-STRIP,IMPACT PEARL
1	086229-13-000	EA BATTEN-1" CEILING MOD IVORY - W&B RN323 (GD1,GE1)
2	086229-01-000	EA RETAINER-3/4"
3	009809-28-001	EA MOLDING-CORNER, OUTSIDE - LARGE CABINET - PLASTIC - 2133 MM
3	009809-28-000	EA MOLDING-CORNER, OUTSIDE - PLASTIC 1" - WATERFORD OAK
4	009767-12-000	FT MOLDING-SIDEWALL TO CEILING/CABINET - WELTING - OFF WHITE
4	009767-15-000	FT WELTING-WATERFORD OAK
5	009812-24-000	EA MOLDING-CORNER, OUTSIDE - .5" - PLASTIC - IVORY
5	009812-29-001	EA MOLDING-CORNER, OUTSIDE - SMALL CABINET - PLASTIC - 2133MM
5	009812-29-000	EA MOLDING-CORNER, OUTSIDE, - PLASTIC - 1/2" - WATERFORD OAK
6	022992-11-000	FT MOLDING-REVERSE COVE, T-SHAPED - VINYL - IVORY
7	103186-01-05A	FT MOLDING-PLASTIC,SHELF - WATERFORD OAK
	076325-46-000	FT MOLDING-EDGE BAND,1035 CLOUD - 15/16 X .030 X 600 (GB1)
	076325-47-000	FT MOLDING-EDGE BAND,1032 SAND - 15/16 X .030 X 600 (GC1)
8	105004-01-05A	EA MOLDING-VINYL WRAP - WATERFORD OAK
9	104676-01-01A	FT T-MOLDING, 5/16" RIGID - GOLD
10	083620-12-000	FT T-MOLDING, 3/4 W/EDGE LIPS - WATERFORD OAK
10	104676-02-04A	FT T-MOLDING, 1/2 X 10 FT - WATERFORD OAK
11	105709-01-000	FT T-MOLDING-1", MODERN IVORY
12	070504-18-000	FT U-CHANNEL-PLASTIC, .065" WIDE - IVORY - INC. OF 8'
12	070504-19-000	FT U-CHANNEL-PLASTIC, .815" WIDE - BROWN - INC. OF 8'
12	070504-26-000	FT EXTRUSION-U CHANNEL,20.7 MODERN IVORY
13	077840-01-G01	EA MOLDING-CAP,WALL 2438
	103186-01-05A	FT MOLDING-PLASTIC,SHELF - WATERFORD OAK
	052372-02-000	BF LUMBER-CLASS II, 1 X 4 X RL - CONSTRUCTION GRADE

INTERIOR FINISH GROUP (CONTINUED)

PANELING, LAMINATES & PLASTIC

KEY	PART NUMBER	U/M DESCRIPTION
	000885-76-000	SF PART BD-3/8 X 48 X 96 WATERFORD - OAK VINYL 1 SIDED
	000885-77-000	SF PART BD-3/8, WATERFORD OAK-VINYL 2 SIDED
	000885-78-000	SF PART BD-1/2" X 48 X 96 WATERFORD OAK VINYL 2 SIDED
	000885-79-000	SF PART BD-3/4 X 48 X 96 WATERFORD OAK-VINYL 2 SIDED
	052372-02-000	BF LUMBER-CLASS II,1X4XRL
	074497-21-000	SF PANELING-WOODGRAIN, 4' X 8' - INCREMENTS OF 32 SF CONTACT PART SALES WITH SERIAL NUMBER
	074497-28-000	SF PANELING-WATERFORD OAK 48" X 96"
	074498-62-000	SF LAMINATE-PLASTIC,GREY FINESS (GB1)
	074498-54-000	SF LAMINATE-PLASTIC,SAND SPEKTER (GC1)
	074498-77-000	SF LAMINATE-PLASTIC,ART CABIN (GB1, GC1)
	080215-10-000	SF PANELING - 2 SIDE WATERFORD
	088272-D9-000	SF PANELING-MONTERREY,RAINFORES (GC1)
	088272-E0-000	SF PANELING-METRO,MIST (GB1)
	088272-98-000	SF PANELING-SHOWER, OFF WHITE - 4' X 7' - INC OF 28 SQ FT
	074497-34-000	SF PANELING-CEILING,IMPACT PEARL - 48X96
	093743-02-01A	SF PLASTIC-ABS, 20" WIDE ROLL - OFF WHITE THIS PLASTIC IS SOLD AS SQ.FT.,15 SQ.FT. MINIMUM ORDER QTY 15 SQ.FT. = 108" X 20" PIECE
	095688-01-000	SF VENEER - 3.6 MM 48 X 96 UNFINISH
	117267-E2-438	EA LUMBER-018 X 50.8 X 2438MM VINYL
	117267-G2-438	EA LUMBER-018 X 076 X 2438 MM VINYL

DETECTORS & FIRE EXTINGUISHER

KEY	PART NUMBER	U/M DESCRIPTION
	072852-01-000	EA DETECTOR-SMOKE, W/9 VOLT BATTERY - US
	072852-02-000	EA DETECTOR-SMOKE, W/9 VOLT BATTERY - CANADIAN
	094499-01-000	EA EXTINGUISHER-FIRE, DRY W/MOUNTING BRACKET - 10 BC BRACKET ONLY #094499-01-700
	094499-01-700	EA BRACKET MTG. W/PLAS. STRAP 294039
	112320-02-000	EA BATTERY/SENSOR-CO GAS, COSTAR 940001000 WHEN REPLACING THE ORGINAL (01 & 02) SYSYTEM, ORDER #11232003000 DETECTOR & #11232004000 SENSOR FROM: 00-00-00 THRU: 09-03-95
	112320-03-000	EA DETECTOR-CO GAS MODEL 9 D-I COSTAR 946000001 FROM: 09-04-95 THRU: 99-99-99
	112320-04-000	EA DETECTOR-CO SENSOR ASSEMBLY COSTAR 946001001 FROM: 09-04-95 THRU: 99-99-99

FLOOR COVERINGS & MATS

KEY	PART NUMBER	U/M DESCRIPTION
	075233-01-000	SY PAD-CARPET, 3/8" X 6' ROLL
	096060-96-000	SY CARPET-JUBILATION,CRYSTAL (GB1)
	096060-A2-000	SY CARPET-JUBILATION,NEW MEDOW (GC1)
	047034-02-000	SF PLASTIC-CARPET, 4' WIDE - CLEAR POLY
	093486-01-000	SY CARPET-COMPARTMENT, 54" WIDE - DARK GRAY

LABELS GROUP

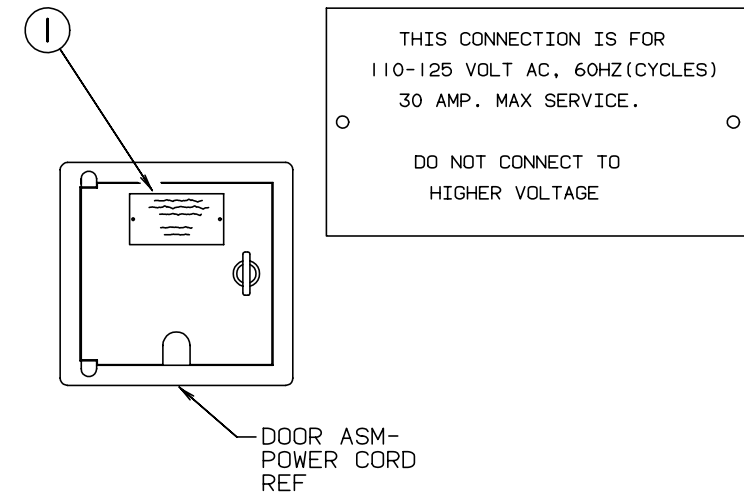

KEY	PART NUMBER	U/M DESCRIPTION
1	006062-01-000	EA TAG-ELECTRIC - 110V CONNECTION

MISCELLANEOUS LABELS

KEY	PART NUMBER	U/M DESCRIPTION
	098641-01-000	EA LABEL-FUEL - UNLEADED - DASH
	109522-01-000	EA LABEL-BUMPER, SEE OWNERS MANUAL
	087236-01-000	EA LABEL-CABLE, INPUT
	098379-04-000	EA LABEL-ELECTRICAL BOX,SIDE
	112518-01-000	EA LABEL-HANG TAG,CO DETECTOR

LABELS GROUP (CONTINUED)

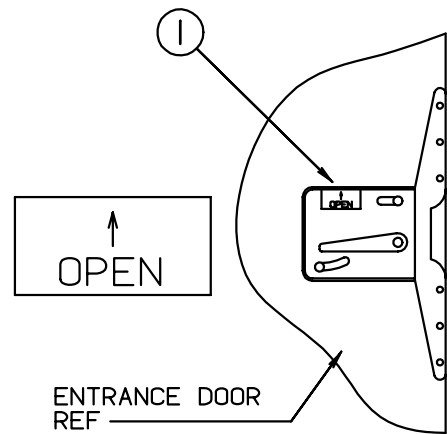

KEY	PART NUMBER	U/M DESCRIPTION
1	040944-01-000	EA LABEL-ENTRANCE DOOR - "OPEN"

LABELS GROUP (CONTINUED)

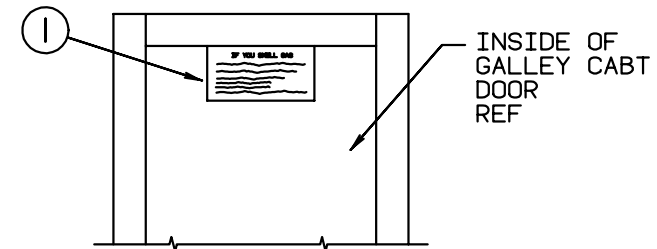

IF YOU SMELL GAS

1. EXTINGUISH ANY OPEN FLAME, PILOT LIGHTS AND ALL SMOKING MATERIALS.
2. SHUT OFF THE GAS SUPPLY AT THE TANK VALVE(OR GAS SUPPLY CONNECTION.
3. OPEN DOORS AND OTHER VENTILATING OPENINGS.
4. DO NOT TOUCH ELECTRICAL SWITCHES.
5. LEAVE THE AREA UNTIL ODOR CLEARS.
6. HAVE THE GAS SYSTEM CHECKED AND LEAKAGE SOURCE CORRECTED BEFORE USING AGAIN.

KEY	PART NUMBER	U/M DESCRIPTION
1	073998-01-000	EA LABEL-LPG ODOR WARNING

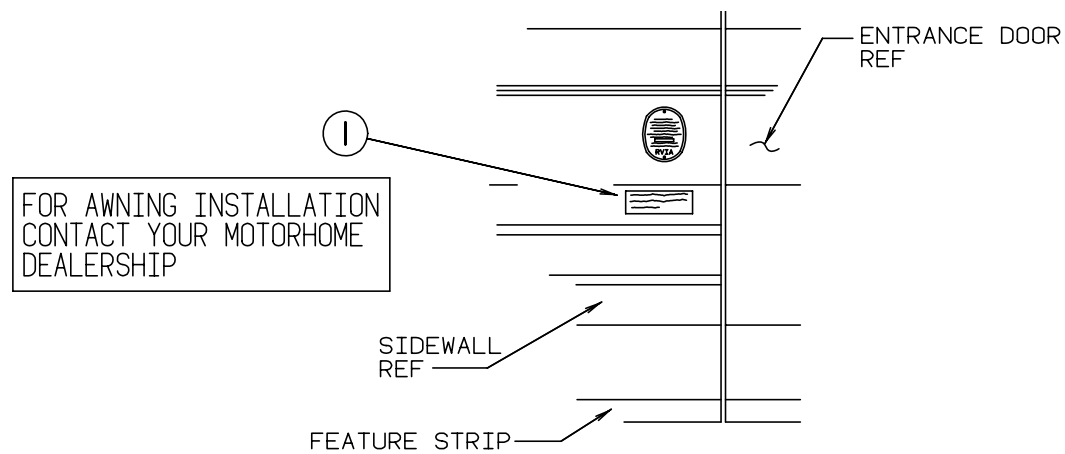

KEY	PART NUMBER	U/M DESCRIPTION
1	099509-01-000	EA LABEL-AWNING INSTALLATION

LABELS GROUP (CONTINUED)

CAUTION

THIS MOTOR HOME HAS BEEN DESIGNED, MANUFACTURED AND TESTED WITH CONCERN FOR THE PROTECTION OF IT'S OCCUPANTS. WE RECOMMEND YOU PERFORM THE FOLLOWING INSPECTIONS FOR YOUR SAFETY AND THE SAFETY OF YOUR PASSENGERS BEFORE STARTING YOUR VEHICLE.

1. LP GAS SYSTEM- TURN OFF AT TANK FOR TRAVELING. TEST FOR LEAKS UPON ARRIVAL AT DESTINATION. BEFORE LIGHTING PILOTS.
2. WHEELS- INSPECT FOR DAMAGE AND CHECK LUG NUTS FOR TIGHTNESS.
3. TIRES- INSPECT FOR WEAR AND DAMAGE AND CHECK FOR RECOMMENDED AIR PRESSURE.
4. LIGHTING- TEST FOR PROPER OPERATION OF ALL INTERIOR AND EXTERIOR LIGHTS INCLUDING DASH LIGHTS, HEADLIGHTS, TAIL LIGHTS, BRAKE LIGHTS, CLEARANCE LIGHTS AND TURN SIGNALS.
5. EXITS- INSPECT RELEASE MECHANISM ON EMERGENCY EXIT WINDOW, TEST BOTH LOCKS ON MAIN ENTRANCE DOOR FOR EASE OF OPERATION AND INSTRUCT PASSENGERS HOW TO USE BOTH MEANS OF EXIT.
6. SEAT BELTS- DIRECT PASSENGERS TO DESIGNATED SEATS AND REQUIRE USE OF SEAT BELTS.
7. APPLIANCES- TURN OFF AND LATCH OR LOCK DOORS WHERE PROVIDED.
8. LOOSE PARCELS- STORE SECURELY.
9. UTILITY SUPPLY LINES- DISCONNECT ALL ELECTRIC, SEWER AND WATER LINES AND SECURE PROPERLY.
10. ENTRANCE DOOR STEP- PLACE IN RETRACTED POSITION FOR TRAVELING.

READ YOUR MOTOR HOME AND CHASSIS OWNER'S MANUAL FOR FURTHER PRECAUTIONS

LABELS GROUP (CONTINUED)

DO NOT INSTALL IF HITCH OPTION IS RESTRICTED

DO NOT USE HITCH BEFORE READING OWNERS MANUAL REGARDING VEHICLE LOADING AND TOWING

KEY	PART NUMBER	U/M DESCRIPTION
1	111104-01-000	EA LABEL-HITCH - READ MANUAL

KEY	PART NUMBER	U/M DESCRIPTION
2	056259-01-000	EA LABEL-SAFETY CHECK LIST

SMOKE DETECTOR REF

WARNING: TEST SMOKE DETECTOR OPERATION AFTER VEHICLE HAS BEEN IN STORAGE, BEFORE EACH TRIP AND AT LEAST ONCE PER WEEK DURING USE.

KEY	PART NUMBER	U/M DESCRIPTION
1	077956-01-000	EA LABEL-WARNING - SMOKE DETECTOR

WARNING DISCONNECT BATTERIES BEFORE CONNECTING EXTERNAL CHARGING EQUIPMENT.

BATTERY COMPARTMENT REF

KEY	PART NUMBER	U/M DESCRIPTION
1	065748-01-000	EA LABEL-CAUTION - BATTERY CHARGING

LABELS GROUP (CONTINUED)

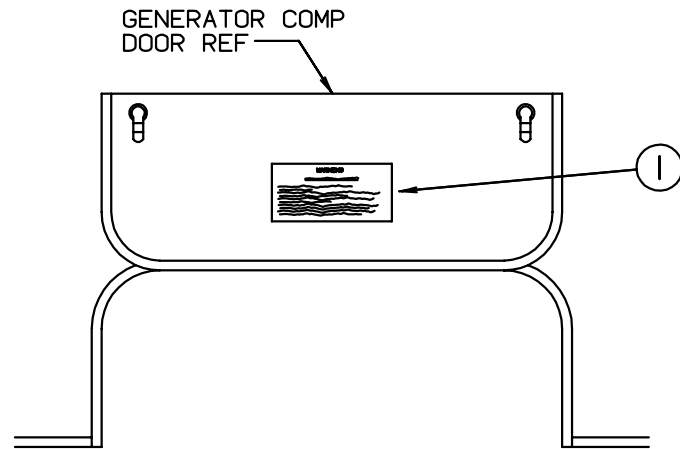

WARNING

WHEN ADDING A GENERATOR SET:

HIGH VOLTAGE-USE EXTREME CAUTION WHEN WORKING ON ELECTRICAL COMPONENTS.
 HAVE ALL ELECTRICAL INSTALLATION PERFORMED BY A QUALIFIED LICENSED ELECTRICIAN-FOLLOW ALL STATE AND LOCAL CODES.
 ONLY INSTALL GENERATOR SET APPROVED FOR R.V. APPLICATION. HAVE INSTALLED BY QUALIFIED TECHNICIAN.
 TO AVOID HEAT BUILD-UP AND TO GUARANTEE AN ADEQUATE AIR SUPPLY TO THE GENERATOR CARBURETOR, FOLLOW INSTALLATION INSTRUCTIONS.
 GENERATOR ENGINE EXHAUST GASES ARE TOXIC AND MUST NOT TERMINATE UNDER THE VEHICLE-DISCHARGE EXHAUST AWAY FROM VEHICLE.

KEY	PART NUMBER	U/M DESCRIPTION
1	077510-01-000	EA LABEL-GENERATOR PREP

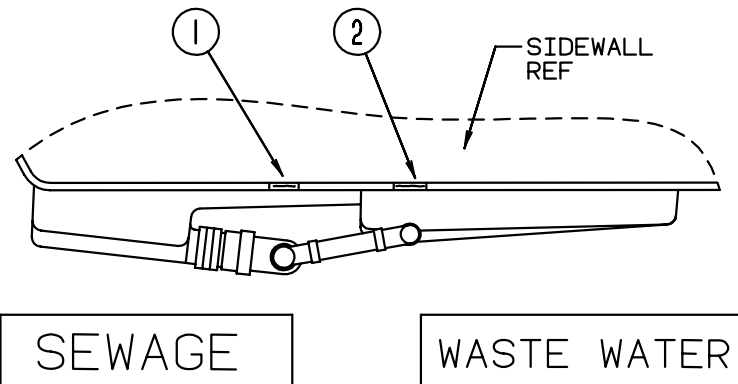

SEWAGE

WASTE WATER

KEY	PART NUMBER	U/M DESCRIPTION
1	006187-01-000	EA LABEL-SEWAGE
2	006188-01-000	EA LABEL-WASTE WATER

LABELS GROUP (CONTINUED)

WARNING

ALL PILOT LIGHTS AND APPLIANCES SHALL BE TURNED OFF DURING REFUELING OF MOTOR FUEL TANKS AND/OR PERMANENTLY MOUNTED LP-GAS CONTAINERS.

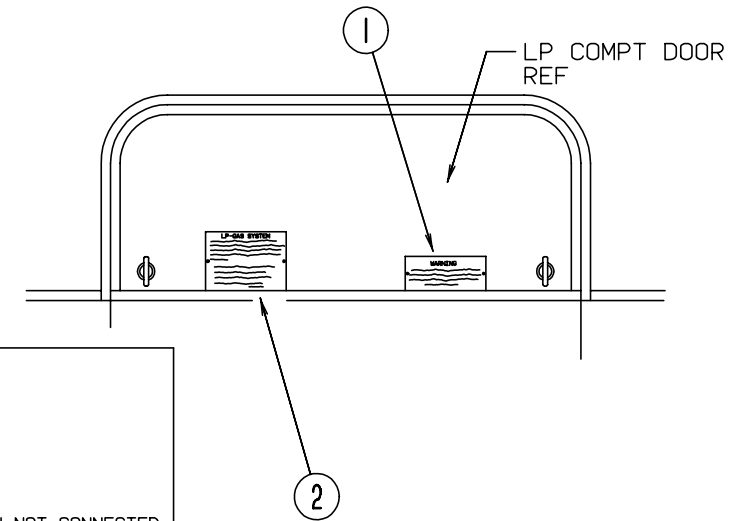

LP-GAS SYSTEM

THIS GAS PIPING SYSTEM IS DESIGNED FOR USE OF LIQUEFIED PETROLEUM GAS ONLY. DO NOT CONNECT NATURAL GAS TO THIS SYSTEM.

SECURELY CAP INLET(S) WHEN NOT CONNECTED FOR USE. AFTER TURNING ON GAS, EXCEPT AFTER NORMAL CONTAINER REPLACEMENT, TEST GAS PIPING AND CONNECTIONS TO APPLIANCE FOR LEAKAGE WITH SOAPY WATER OR BUBBLE SOLUTION. DO NOT USE PRODUCTS THAT CONTAIN AMMONIA OR CHLORINE.
 P.N. 54531

KEY	PART NUMBER	U/M DESCRIPTION
1	006040-01-000	EA TAG-GAS REFUELING WARNING
1	006040-02-000	EA TAG-GAS REFUEL WARNING - CANADIAN
2	054531-01-000	EA LABEL-LP GAS ONLY
2	023769-01-000	EA LABEL-WARNING - LPG - CANADIAN

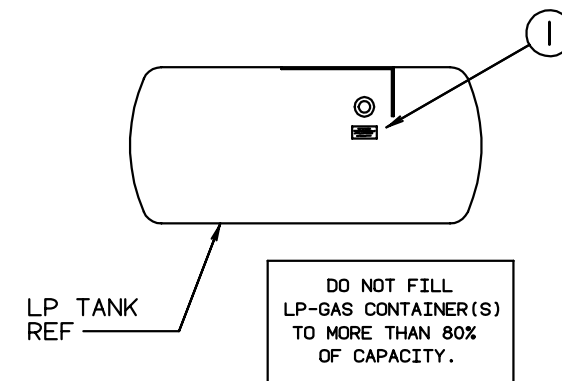

DO NOT FILL LP-GAS CONTAINER(S) TO MORE THAN 80% OF CAPACITY.

KEY	PART NUMBER	U/M DESCRIPTION
1	079965-01-000	EA LABEL-LPG 80% CAPACITY

LABELS GROUP (CONTINUED)

CAUTION	TO HELP AVOID PERSONAL INJURY DURING REMOVAL OF FUEL FILLER CAP, SLOWLY LOOSEN CAP 1/2 TURN TO ALLOW ANY FUEL PRESSURE TO BE RELIEVED BEFORE TURNING CAP FURTHER.
FUEL SPRAY MAY CAUSE PERSONAL INJURY	STOP ADDING FUEL AFTER FIRST SHUTOFF BY AUTOMATIC NOZZLE WHEN TANK IS NEARLY FULL. DO NOT OVERFILL FUEL TANK. SEE OWNERS MANUAL FOR ADDITIONAL INFORMATION.
	PRINTED IN U.S.A. MLC PT NO 15611763

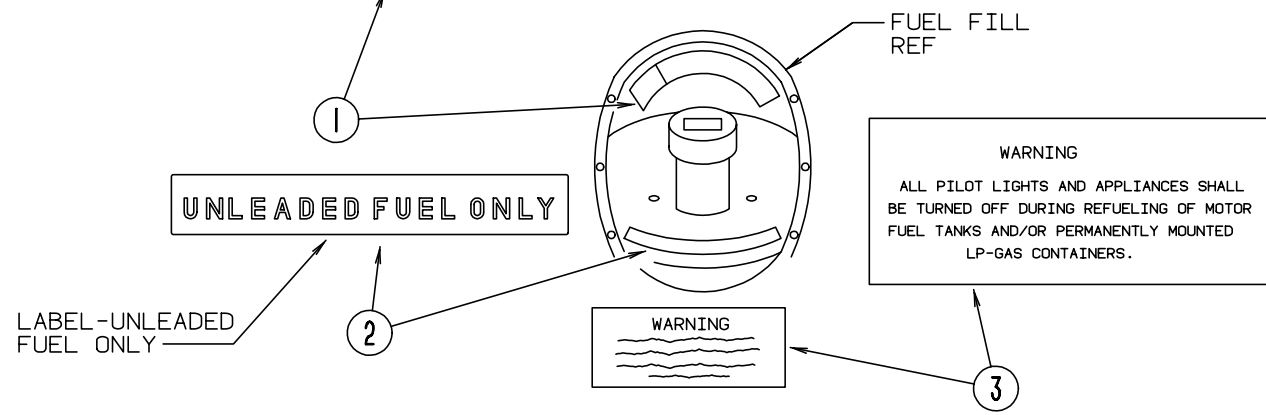

KEY	PART NUMBER	U/M	DESCRIPTION
1	087207-05-000	EA	LABEL-FUEL CAP REMOVAL - GM--15611763
2	062043-01-000	EA	LABEL-FUEL - UNLEADED
3	006040-01-000	EA	TAG-GAS REFUELING WARNING
3	006040-02-000	EA	TAG-GAS REFUEL WARNING - CANADIAN

LP GROUP

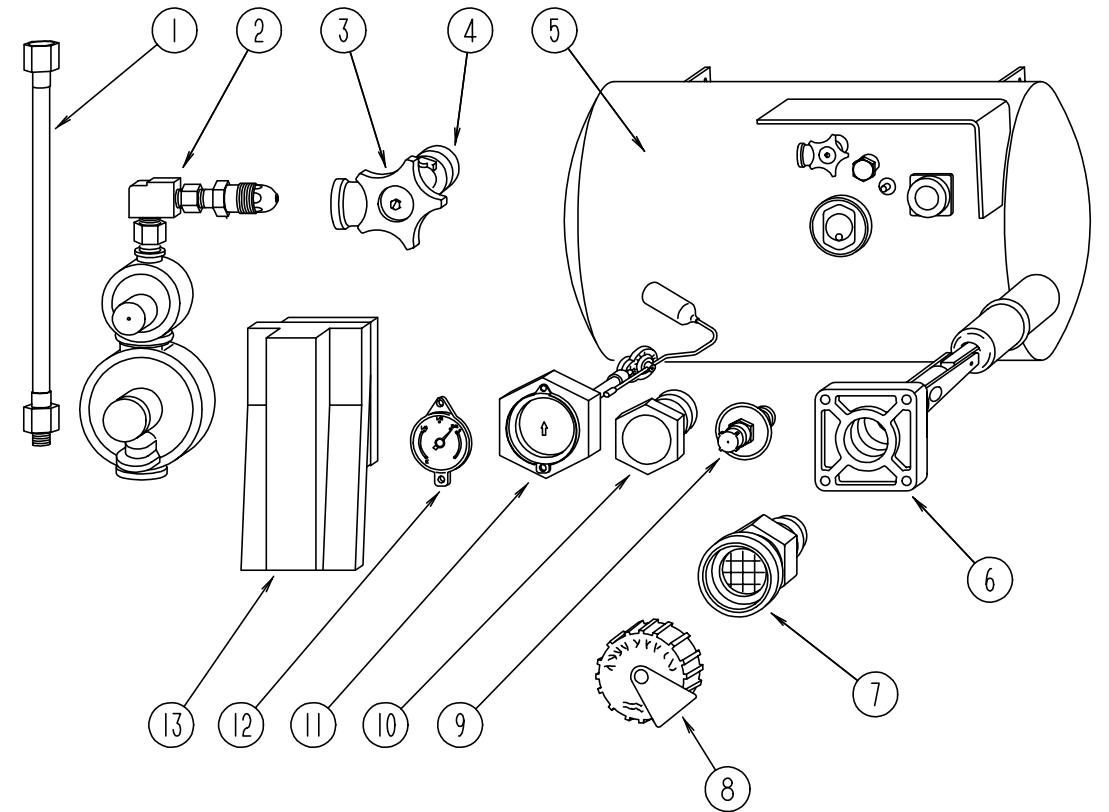

LP TANK & COMPONENTS

KEY	PART NUMBER	U/M	DESCRIPTION
1	045703-01-000	EA	HOSE-LP, 3/8" ID X 24" - 3/8 MPT X 1/2 F SWIVEL - U.S.
1	045703-02-000	EA	HOSE-LP, 3/8" ID X 24" - 3/8" MPT X 1/2" F SWIVEL - CANADA
2	106150-01-000	EA	REGULATOR-TWO STAGE, MARSHALL BRASS 293-00
3	040421-01-708	EA	HANDWHEEL-SERVICE VALVE, BRUNNER G-1015-A
4	040421-01-712	EA	VALVE-SERVICE W/O VAPOR RELIEF, 29000853
5	088253-01-000	EA	TANK-LP, 80 LB - 16" DIAMETER X 30" - BRUNNER
6	040421-01-711	EA	VALVE - 80% W/FLOAT, PLATE - BOLTS & GASKET - BRUNNER
7	040421-01-701	EA	VALVE-SHORT LP FILLER, W/YELLOW CAP - BRUNNER 75478
8	040421-01-702	EA	CAP-LP FILLER VALVE, PLASTIC - YELLOW - BRUNNER G-1014-A
9	040421-01-700	EA	VALVE-LIQUID LEVEL, 20% LP - BRUNNER G-1013
10	040421-01-713	EA	VALVE-VAPOR ONLY, 29000587
11	088253-01-700	EA	GAUGE-FLOAT ASSEMBLY, L.P.
12	040421-01-706	EA	DIAL-LP TANK VOLUME, VISIBLE FACE (5-1789) - BRUNNER MA-8 ROCHESTER
	040440-02-000	EA	DIAL-TRANSMITTER, 0-90 OHM
13	105658-01-000	EA	COMPARTMENT-LP REGULATOR
	010323-01-000	EA	ADAPTER-BRASS, 3/8F X 1/2MPT
	010377-02-000	EA	NUT-BRASS, 3/8 FEMALE - FORGED
	010380-02-000	EA	NUT-BRASS, 1/2 FEMALE - FORGED
	010329-01-000	EA	ADAPTER-BRASS, 1/2F X 1/2MPT
	010265-01-000	EA	ELBOW - 90 DEGREE, 3/8" F TO 1/2" FPT - BRASS
	010265-01-000	EA	ELBOW-BRASS, 90 DEGREE - 3/8"F X 1/2"FPT
	010252-01-000	EA	ELBOW-BRASS-90 3/8F X 1/2MPT
	035340-01-000	EA	ELBOW, 3/8" MPT X 1/2" F - BRASS
	103613-01-000	EA	DETECTOR-LP GAS

LOUNGE GROUP

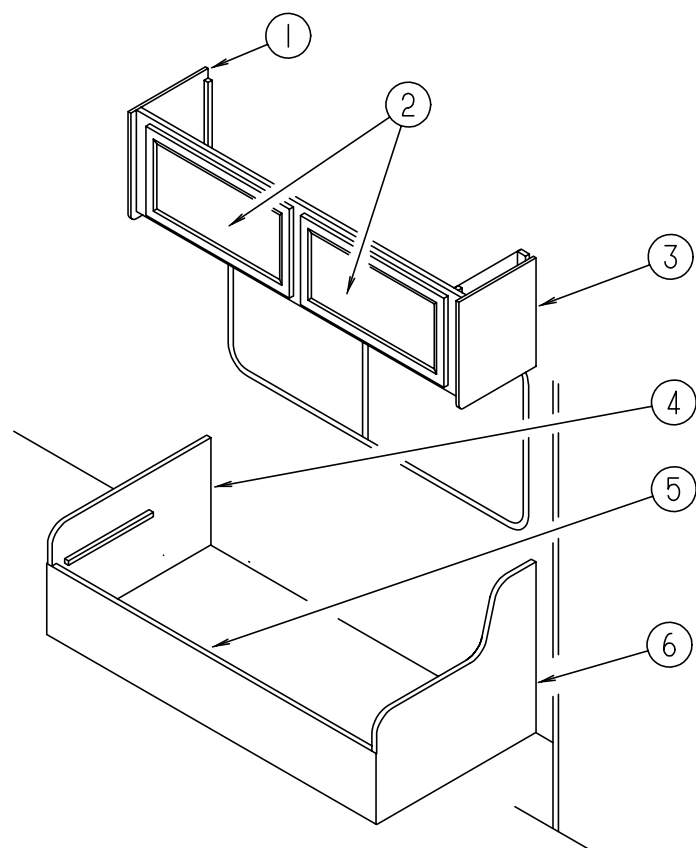

FRONT PASSENGER SIDE CABINET (COUCH)

KEY	PART NUMBER	U/M DESCRIPTION
1	109908-34-GB1	EA CAP ASM-END,OVERHEAD FRONT
2	110140-59-G01	EA DOOR ASM-MITERED - VINYL WRAP - OVERHEAD
3	109908-33-GB1	EA CAP ASM-END,OVERHEAD REAR
4	M04187-64-GB1	EA CABINET-COUCH W/FABRIC FRONT FACING PANEL
4	M04187-64-GC1	EA CABINET-COUCH W/FABRIC FRONT FACING PANEL
5	M04187-63-GB1	EA CABINET-COUCH W/FABRIC AISLE FACING PANEL
5	M04187-63-GC1	EA CABINET-COUCH W/FABRIC AISLE FACING PANEL
6	M04187-65-GB1	EA CABINET-COUCH W/FABRIC REAR FACING PANEL
6	M04187-65-GC1	EA CABINET-COUCH W/FABRIC REAR FACING PANEL

LOUNGE GROUP (CONTINUED)

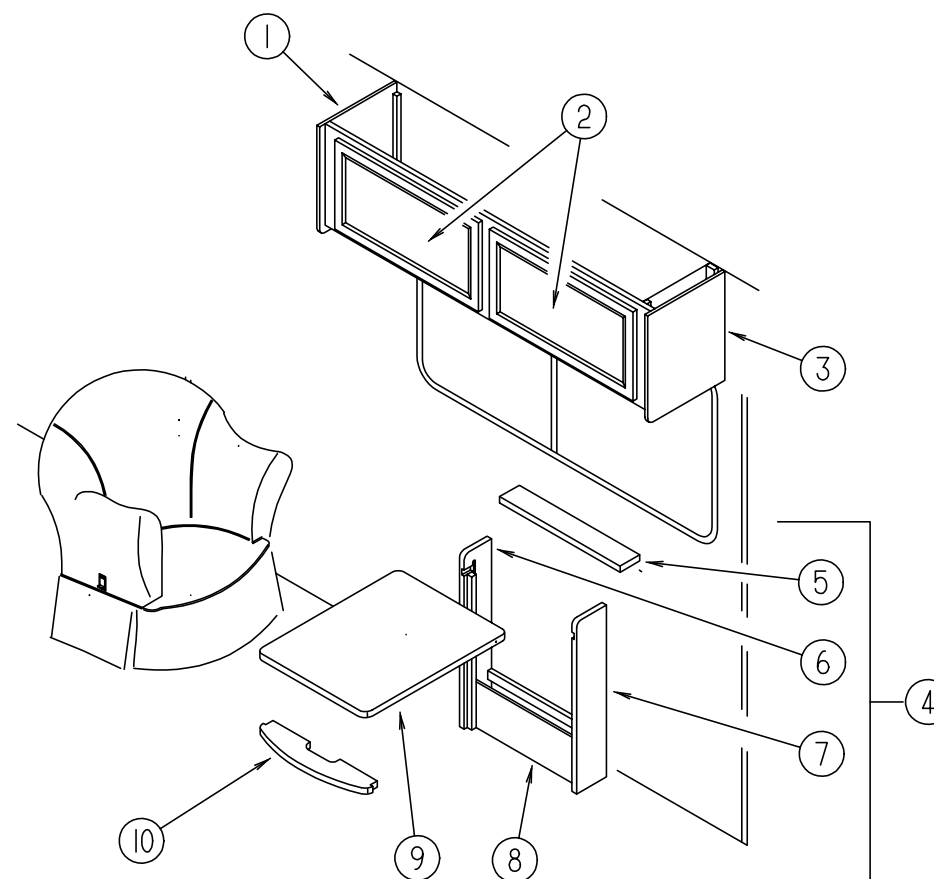

FRONT PASSENGER SIDE CABINET (CHAIR & TABLE)

KEY	PART NUMBER	U/M DESCRIPTION
1	109908-34-GB1	EA CAP ASM-END,OVERHEAD FRONT
2	110140-59-G01	EA DOOR ASM-MITERED - VINYL WRAP - OVERHEAD
3	109908-33-GB1	EA CAP ASM-END,OVERHEAD REAR
4	M96873-01-G01	EA CABINET ASM. - TABLE - W/O PULLOUT TOP
5	096873-15-G01	EA SHELF - SUPPORT - OVER PULL OUT TABLE TOP
6	096873-14-G01	EA SIDE END - TABLE - 28.7" X 5.7" - LEFT SIDE
7	096873-13-G01	EA SIDE END - TABLE - 28.7" X 5.7" - RIGHT SIDE
8	096873-16-G01	EA PANEL - TABLE - FRONT BOTTOM - 18.1" X 6.7"
9	096873-11-G01	EA PULLOUT TOP
	080736-01-000	EA PULL - RECESSED - 1.25" X 4" - OAK
	079921-01-000	EA NYLON ROLLER W/SHAFT
10	096873-12-G01	EA SHELF - SUPPORT - UNDER PULL OUT TABLE TOP

LOUNGE GROUP (CONTINUED)

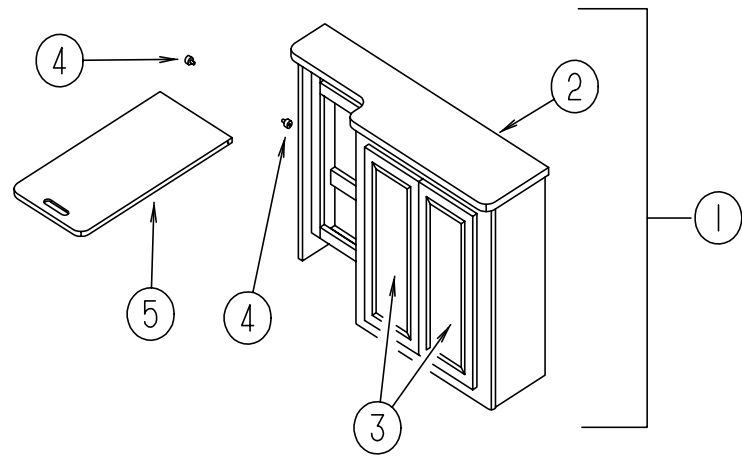

FRONT HUTCH CABINET

KEY	PART NUMBER	U/M DESCRIPTION
1	114796-01-GB1	EA CABINET ASM-HUTCH - FRONT RIGHT
2	114796-11-F02	EA COUNTERTOP ASM
3	110140-01-G01	EA DOOR ASM-MITERED,VINYL WRAP 0255 X 0640
4	079921-01-000	EA ROLLER-NYLON,W/SHAFT
5	114796-15-G04	EA TABLE ASM
	088792-01-000	YD VELCRO-5/8" HOOK, NON-ADHES

LOUNGE GROUP (CONTINUED)

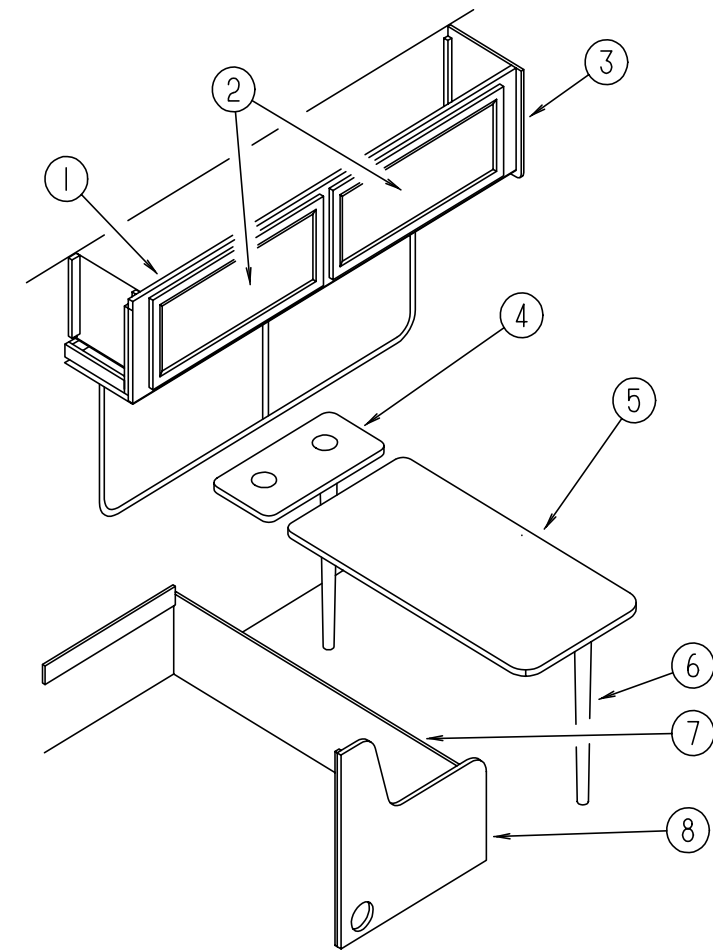

FORWARD FACING COUCH

KEY	PART NUMBER	U/M DESCRIPTION
1	P16878-01-GB1	EA CABINET ASM-OVERHEAD - DINETTE
2	110140-65-G01	EA DOOR ASM-MITERED - VINYL WRAP W/MIRROR
2	110140-05-G01	EA DOOR ASM-MITERED - VINYL WRAP W/O MIRROR
3	109908-03-GB1	EA CAP ASM-END - OVERHEAD
	P14725-02-000	EA COVER ASM-AIR RETURN,NO CRPT
4	114681-01-F02	EA TABLE ASM. W/CUPHOLDERS
5	081322-14-G04	EA TABLE ASM-DINETTE
	118933-01-01A	EA SUPPORT-HINGE LOCK OFF WHITE (MOUNTS ON WALL)
	102201-04-03A	EA SUPPORT-HINGE CATCH,BRIGHT WHITE (MOUNTS ON TABLE)
	114724-02-000	EA PLATE-LEG,METAL,THD
6	114724-01-03A	EA LEG-TABLE,WOOD,TAPERED WATERFORD
6	114724-01-01A	EA LEG-TABLE,WOOD,TAPERED UNFINISHED
7	M02634-01-GB1	EA PANEL - KICKBOARD - FORWARD FACING
7	M02634-01-GC1	EA PANEL - KICKBOARD - FORWARD FACING
8	116110-03-GB1	EA COUCH END - FORWARD FACING - RIGHT
8	116110-03-GC1	EA COUCH END - FORWARD FACING - RIGHT.
	083125-07-000	EA BRACE-COUCH,O/W
	118933-01-01A	EA SUPPORT-HINGE LOCK O/WHT
	114726-01-GB1	EA TRAY ASM-BEVERAGE
	114739-01-01A	EA PAD-NON-SKID,PSA

**SEALANTS & FASTENERS GROUP
ADHESIVE AND FASTENERS**

KEY	PART NUMBER	U/M DESCRIPTION
	002707-02-000	FT TAPE-SEALER, 5/16" X 1/2" - INCREMENTS OF 50 FT
	004020-01-000	QT ADHESIVE-ABS CEMENT, QUART
	034552-06-000	EA SILICONE-TUBE, 300 ML - OFF WHITE - W/O NOZZLE
	900390-03-000	EA NOZZLE SEPARATELY
	034552-15-000	EA SILICONE - TUBE 300 ML BRIGHT WHITE - W/O NOZZLE
	900390-03-000	EA NOZZLE
	053766-08-000	EA BEDDING COMPOUND-TUBE, GRAY - SCHNEE# 5522
	062917-03-000	EA ADHESIVE-LOCTITE 242 - LOCTITE 242,SIDE 41
	063642-01-000	FT TAPE-ADHESIVE, 10 MIL. X 1.5" WIDE X 180"
	067788-01-000	EA ADHESIVE-SPRAY, 3M 74 - 19.5 OZ AEROSOL CAN
	069640-01-000	FT SEALER-RIBBON, 1/4" DIAMETER - INCREMENTS OF 30'
	069640-02-000	FT SEALER-RIBBON, 1/2" X 1/8"- INCREMENTS OF 60'
	069640-03-000	FT SEALER-RIBBON, 3/4" X 1/8" - INCREMENTS OF 60'
	069640-07-000	FT SEALER-RIBBON, 2" X 3/32" - INCREMENTS OF 45'
	069640-09-000	FT SEALER-RIBBON, 1/32" X 2 1/2" - INCREMENTS OF 80'
	069640-14-000	FT SEALER-TAPE,1/16"X1"X100' - MANUS,GRAY
	072889-01-000	EA SEALANT-URETHANE, BLACK - 1/10 - ESSEX 552.2
	072889-09-000	EA SEALANT-URETHANE(TUBE) BLACK - MANUS 75AM
	076322-02-000	FT TAPE-FOAM, DOUBLE COATED ADHESIVE BACKED - 1" X 108'
	087211-01-000	GL PROMOTER-ADHESIVE
	091255-02-000	FT SEAL-ADHESIVE BACKED FOAM, .18" THICK X 1.5" WIDE
	102352-01-000	EA SEALER-PUMPABLE, BLACK - COLORIMETRIC MS101
	106206-01-000	EA SEALER-PUMPABLE - MANUS 30ABLACK
	108353-01-000	FT SEAL-FOAM,5/16X1/2,ADH BACK - LUNDELL #4773/1129
	110274-01-000	FT TAPE-FOAM,DBL COATED.045X1.0 - NORTON V-2800
	120074-01-01A	EA SILICONE TUBE - OFF WHITE W/O NOZZLE
	900390-03-000	EA NOZZLE

BOLTS, NUTS & WASHERS

KEY	PART NUMBER	U/M DESCRIPTION
	000C12-05-16B	EA BOLT-HEX, 5/16-18 X 1 - ZINC 5
	000C12-05-12B	EA BOLT-HEX-5/16-18X3/4 ZN 5
	000C12-06-16B	EA BOLT-HEX-3/8-16X1LG,ZN 5
	000C12-07-20B	EA BOLT-HEX, 7/16 - 14 X 1 1/4" - ZN5
	000C12-08-24B	EA BOLT-HEX, 1/2-13 X 1 1/2 - ZN 5
	000C12-09-20B	EA BOLT-HEX,9/16-12X1 1/4,ZN 5
	000C12-10-24B	EA BOLT-HEX, 5/8-11 X 1 1/2 ZN - 5
	000C13-07-24B	EA BOLT-HEX,7/16-20X1 1/2 GR 5
	000C13-07-48B	EA BOLT-HEX, 7/16 - 20 X 3 - ZN 5
	000C26-04-18B	EA BOLT-HEX-SER FLG 1/4-20X11/8 - ZN
	000C26-04-10B	EA BOLT-HEX, SER FLG - 1/4-20 X 5/8 ZINC
	000C26-05-16B	EA BOLT-HEX-SER FLG 5/16-18 X 1 - ZINC
	000C26-05-12B	EA BOLT-HEX-SER FLG 5/16-18X3/4 - ZN
	000C26-06-28B	EA BOLT-HEX-SER FLG 3/8-16X13/4 - ZN
	000D24-10-00B	EA NUT-HEX, SF/LK - 10-32 ZN
	000D29-05-00B	EA NUT-5/16-18 UNC,SF/LOCKING - NYLON WASHER INSERT
	000D29-09-00B	EA NUT-HEX SELFLOCK 9/16-12 ZN
	000D39-04-00B	EA NUT-HEX, SER FLG LK 1/4 - 20 ZN
	000D39-05-00B	EA NUT-HEX, SER FLG LK - 5/16 - 18 ZN
	000D39-06-00B	EA NUT-HEX, SER FLG LK - 3/8-16 ZN
	000D39-08-00B	EA NUT-HEX, SER FLG LK - 1/2-13 ZN
	000D44-07-00B	EA NUT-HEX, SER FLG LK - 7/16-20 ZN
	000D46-04-00A	EA NUT-HEX,WELD,1/4-20,PLAIN - SHORT PILOT
	000E11-07-00B	EA WASHER-LK-7/16 MED SPLIT ZN
	000E13-14-00B	EA WASHER-FL, 1/4" WIDE ZN
	000E13-18-00B	EA WASHER-FL-3/8 WIDE ZN
	000E13-20-00B	EA WASHER-FL, 7/16" WIDE - ZN
	040921-04-000	EA NUT-SPEED, U TYPE - NO. 8 - .59" LENGTH X .44" WIDTH
	044364-02-000	EA NUT-SPEED, FLAT - ROUND
	051387-06-000	EA BOLT-CARRIAGE, W/O HOLE - 5/16-18 X 9.5 ZN
	058716-02-000	EA WASHER-FLAT NYLON - .406 X .750 X .060
	063253-07-000	EA NUT-J, #8A .120- .130 PNL THK
	087234-01-000	EA NUT-JACK,1/4X20THD,MOLLY-ARDEN 8-L,JN BRASS MOUNTS LICENSE PLATES
	104369-01-000	EA NUT-HEX,HEAVY,5/8-11 UNC
	106166-01-000	EA BOLT-COLLARED HANGER - 8-32 X 1"
	106649-01-000	EA WASHER-SEALING,GALVANIZED - 92 F-SERIES 5/8 ID
	108067-03-000	EA STUD-WELD,1/4-20X1/2 CD - IMAGE
	110794-01-000	EA WASHER-FL-1IDX13/4OD - C-TECH 36T1043187

**SEALANTS & FASTENERS GROUP (CONTINUED)
SCREWS**

KEY	PART NUMBER	U/M DESCRIPTION
	0G3908-08-170	EA SCREW-SF/DR-8-18 X 1/2PPH - BRIGHT WHITE
	0G6710-08-170	EA SCREW-10-12 X 1/2 PPH,BRT WHT - TYPE A
	000G11-05-08B	EA SCREW-5-20 X 1/2 PPH ZN
	000G11-06-08B	EA SCREW-6-20 X 1/2 PPH ZINC
	000G11-06-06B	EA SCREW-6-20 X 3/8 PPH ZN
	000G11-06-10J	EA SCREW, 6-20 X 5/8 PPH - BRASS
	000G11-07-08B	EA SCREW, 7-19 X 1/2 PPH - ZN
	000G11-08-08B	EA SCREW, 8-18 X 1/2 PPH - ZN
	000G11-08-06B	EA SCREW, 8-18 X 3/8 PPH ZN
	000G11-08-20B	EA SCREW-8-18 X 11/4 PPH ZN
	000G11-08-16S	EA SCREW, 8-18 X 1.00 PPH - OFF WHITE
	000G11-08-12T	EA SCREW, 8-18 X 3/4 PPH - BLACK
	000G11-08-12S	EA SCREW, 8-18 X 3/4 PPH - OFF WHITE
	000G11-08-12P	EA SCREW, 8-18 X .75 PPH - DARK BROWN
	000G11-08-12D	EA SCREW, 8-18 X 3/4 PPH - BLACK
	000G11-08-12B	EA SCREW, 8-18 X 3/4 PPH ZN
	000G11-08-08T	EA SCREW, 8-18 X 1/2 PPH
	000G11-10-40B	EA SCREW-10 - 16 X 2 1/2 PPH CAD - 34927-01-000
	000G11-10-16B	EA SCREW, 10-16 X 1 - PPH ZN
	000G11-10-12S	EA SCREW-10-16 X .75 PPH OFF WHT
	000G13-06-08B	EA SCREW, 6-20 X 1/2 PFH ZN
	000G13-06-24J	EA SCREW-6-20 X 1.50 PFH BRASS
	000G13-06-16J	EA SCREW, 6-20 X 1.00 PFH - BRASS
	000G13-07-12B	EA SCREW, 7-19 X 3/4 PFH ZN
	000G13-08-10B	EA SCREW-8-18 X 5/8 PFH ZN - 90 CW922FV
	000G19-10-20B	EA SCREW-MACHINE, 10-32 X 1 1/14 PPH ZINK
	000G19-10-08B	EA SCREW-MACHINE, 10-32 X 1/2 PPH ZN
	000G39-06-08B	EA SCREW-DR-6-18 X 1/2 ZN
	000G39-06-10T	EA SCREW-SF/DR, 6-20 X 5/8 PPH - BLACK
	000G39-06-10T	EA SCREW-SF/DR, 6-20 X 5/8 PPH - BLACK
	000G39-08-08T	EA SCREW-SF/DR-8-18X.50 PPH - BLACK
	000G39-08-08S	EA SCREW-SF/DR, 8-18 X 1/2 PPH - OFF WHITE
	000G39-08-08B	EA SCREW-SF/DR, 8-18 X 1/2 PPH ZN
	000G39-08-24B	EA SCREW-SF/DR, 8-18 X 1 1/2 PPH ZN
	000G39-08-16T	EA SCREW-SF/DR, 8-18 X 1 PPH - BLACK
	000G39-08-16R	EA SCREW-SF/DR 8-18 X 1.00 PPH BEIGE
	000G39-08-16B	EA SCREW-SF/DR, 8-18 X 1 PPH ZN
	000G39-08-12B	EA SCREW-SF/DR, 8-18 X 3/4 PPH ZN
	000G39-10-12D	EA SCREW-SF/DR, 10-16 X 3/4 PPH - BLACK
	000G39-10-12B	EA SCREW-SF/DR,10-16 X .75 PPH ZN
	000G39-10-08B	EA SCREW-SF/DR 10-16 X .50 P&H - ZINC
	000G39-10-48T	EA SCREW-SF/DR-10-16X3.00 PPH - BLACK-FLUROCARBON
	000G39-10-20B	EA SCREW-SF/DR, 10-16 X 1 1/4 PPH ZN
	000G42-04-12B	EA SCREW-SF/DR 1/4-14 X 3/4HWH ZN
	000G46-08-24T	EA SCREW-MACHINE, 8-32-1.50 IN PFH - BLACK
	000G50-04-12B	EA SCREW-MACH, 1/4-20 X 3/4 PPH ZN
	000G51-08-08B	EA SCREW-8-18 X 1/2 PTH ZN
	000G52-08-18B	EA SCREW-MACH-8-32 X 11/8 PTH ZN
	000G54-04-20B	EA SCREW, 1/4-20 X 1 1/4 PTH - TYPE 23 - ZINC PLATED
	000G55-08-12S	EA SCREW-SF/DR-8-18X.75 PWH - *OFF WHITE
	000G56-12-48B	EA SCREW-WOOD, 12 - 11 X 3 POH - SPECIAL HARDENED
	000G57-10-16B	EA SCREW-10-13 X 1 PFH ZN
	000G60-10-28T	EA SCREW-SF/DR, 10-16 X 1.75 - BLACK
	000G67-08-32B	EA SCREW-8-15X 2 PPH ZN
	000G67-10-10B	EA SCREW, 10-12 X 5/8 PPH ZN - TYPE A
	000G67-10-08B	EA SCREW, 10-12 X 1/2 PPH ZN
	000G67-10-36T	EA SCREW-10-12 X 2.25PPHBLACK - STALGARD
	000G67-10-24B	EA SCREW, 10-12 X 1 1/2 PPH - ZN
	000G67-10-20D	EA SCREW, 10-12 X 1 1/4 PPH - BLACK
	000G67-10-120	EA SCREW, 10-12 X .75" PPH - TAN
	000G67-10-120	EA SCREW, 10-12 X .75" PPH - TAN
	000G67-10-12P	EA SCREW, 10-12 X .75" - PPH - DARK BROWN
	000G67-10-12B	EA SCREW, 10-12 X 3/4" PPH - ZN

SEALANTS & FASTENERS GROUP (CONTINUED)
SCREWS CONTINUED

KEY	PART NUMBER	U/M DESCRIPTION
	000G67-10-10S	EA SCREW, 10-12 X 5/8" - PPH - OFF WHITE
	000G67-10-10P	EA SCREW-10-12 X .62 PPH - DARK BROWN
	000G67-10-10P	EA SCREW-10-12 X .62 PPH - DARK BROWN
	000G67-10-10D	EA SCREW, 10-12 X 5/8 PPH - BLACK - TYPE A
	000G68-06-10G	EA SCREW, 6-18 X 5/8 POH - ANTIQUE BRASS
	075908-01-000	EA SCREW-MACHINE, 10-32 X .56 PTH - ZINC EXTERNAL TOOTH
	079382-01-000	EA SCREW-SOCKET, 8-18 X 1" - BLACK
	097974-01-000	EA SCREW-PART BD 7-9 X .75 PPH - FHM 0543 PLAIN
	101618-01-000	EA SCREW-1/4-20 X 3/4 HEX/TAPPING - STALGARD TYPE F
	116111-02-01A	EA SCREW-TAPTITE-1/4-20 X 3/8 PPH - *ZINC
	117322-01-000	EA SCREW-1/4-28UNF-2A,TORX - U.T. 6270020 SC25WJ

CLAMPS, GROMMETS AND FASTENERS

KEY	PART NUMBER	U/M DESCRIPTION
	000H16-06-10R	EA RIVET-POP-AL 3/16 X .501-.625
	007161-01-000	EA CLAMP-HOSE, SPRING TYPE - 1/2"
	010495-01-000	EA CLAMP-CABLE, 9/16"
	010495-02-000	EA CLAMP-CABLE, 3/8~
	010497-01-000	EA CLAMP-CLOSED, 5/8" ID
	010497-03-000	EA CLAMP-CLOSED, 1" ID - CUSHIONED
	010497-04-000	EA CLAMP-CLOSED, 1.62 ID - ADEL,945-2717
	010499-01-000	EA CLAMP-CLOSED, 3/8" ID
	016188-05-000	EA GROMMET-L/P LINE, 3/8" HOLE X 1 1/4" LONG - RUBBER
	023942-01-000	EA GROMMET-RUBBER, 2" OD
	062401-02-000	EA CLAMP-HOSE, WORMGEAR, 1.56" - 2.5"
	062401-03-000	EA CLAMP-HOSE, WORMGEAR - .22"- 1"
	062401-04-000	EA CLAMP-HOSE, WORMGEAR .69"- 1.25"
	062401-05-000	EA CLAMP-HOSE, WORMGEAR - 2" X 3"
	062401-06-000	EA CLAMP-HOSE, WORMGEAR .22"-.62"
	062401-11-000	EA CLAMP-HOSE, WORMGEAR 3.56"- 4.5"
	071015-11-000	EA GROMMET-1.00ID,FITS .12 MATL - MINOR RUBBER Z-3065
	075148-02-000	EA CLAMP-GROUNDING, BRONZE SCREWS
	077955-01-000	EA CLIP-J,VINYL COATED, 3/8"
	080734-02-000	EA CLIP-WIRE, NYLON
	083609-01-000	EA CLAMP-WIRE, DUAL EQUAL - 5/8" DIAMETER
	083610-01-000	EA CLAMP-WIRE, DUAL - UNEQUAL DIAMETERS - .75" & 1.25"
	094362-02-000	EA CLIP-CHRISTMAS TREE, FLAT HEAD - .5" X .95"

TIES & VELCRO

KEY	PART NUMBER	U/M DESCRIPTION
	008343-01-000	EA TIE-WIRE, 6"
	008343-02-000	EA TIE-WIRE, 14"
	029094-04-000	YD VELCRO TAPE-LOOP, 1" WIDE - BLACK
	029096-03-000	YD VELCRO TAPE-HOOK, 1" WIDE - BLACK
	029096-04-000	YD TAPE-HOOK, VELCRO - 1" WIDE - BLACK
	072889-10-000	EA SEALANT-URETHANE(TUBE)BRTWHT - MANUS 75AM
	108046-02-000	EA CABLE TIE-SCREW MOUNT 15" - DENNISON 10035

WATER & SEWAGE GROUP

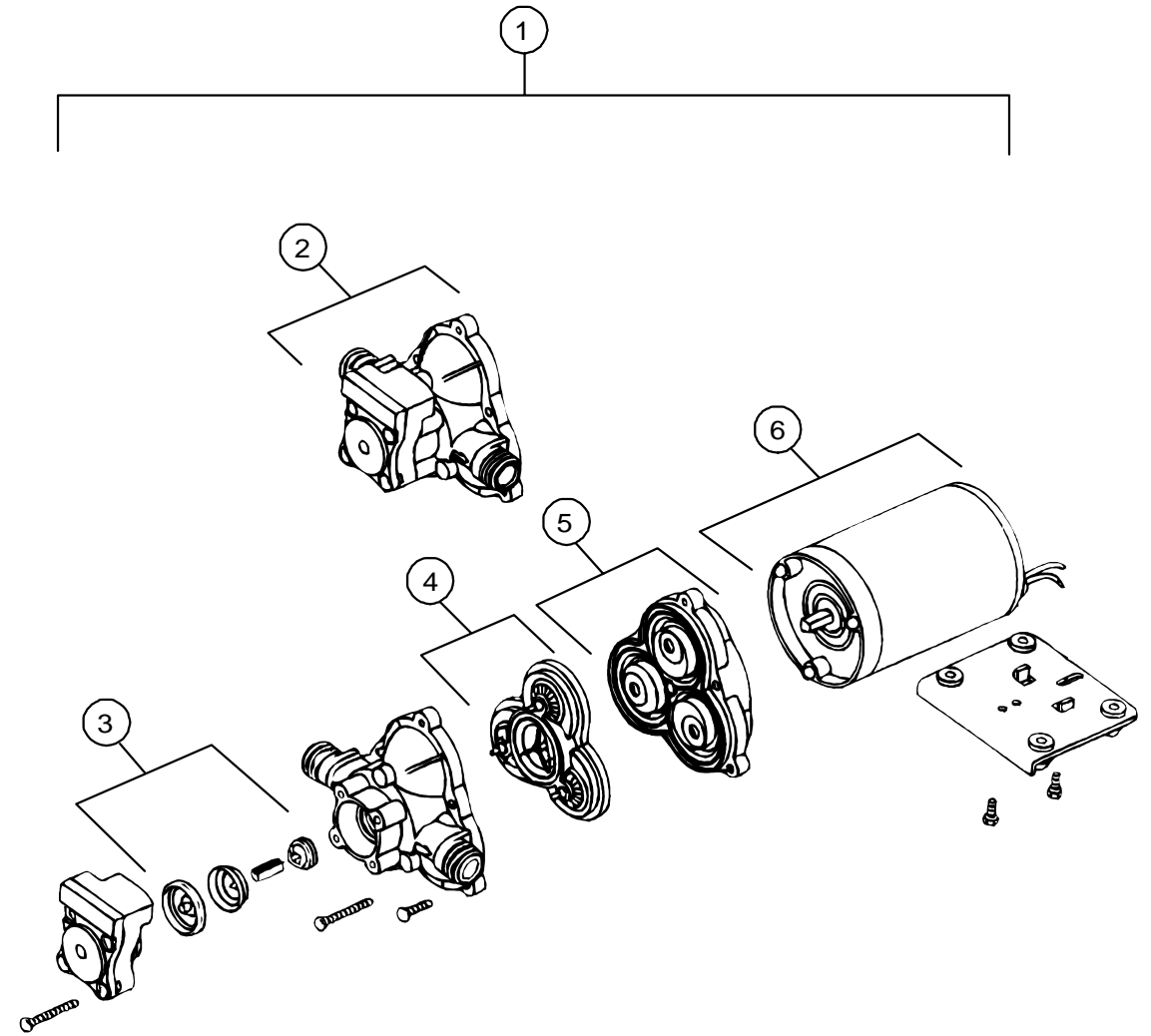

WATER PUMP

KEY	PART NUMBER	U/M DESCRIPTION	VENDOR NO.
1	098607-01-000	EA PUMP-WATER, W/.5" MPT FITTING - FLOW 2.8 GPM - UL	
	098607-01-701	EA DRIVE ASSEMBLY	94-234-03
	098607-01-704	EA HOUSING-UPPER	94-231-01
2	098607-01-706	EA UPPER HOUSING/ SWITCH KIT	94-231-20
3	098607-01-705	EA CHECK VALVE - KIT	94-237-00
4	098607-01-703	EA VALVE ASM	94-232-00
5	098607-01-702	EA DRIVE/ DIAPHRAGM - KIT	94-238-04
6	098607-01-707	EA MOTOR W/BASEPLATE	11-148-04

WATER & SEWAGE GROUP (CONTINUED)

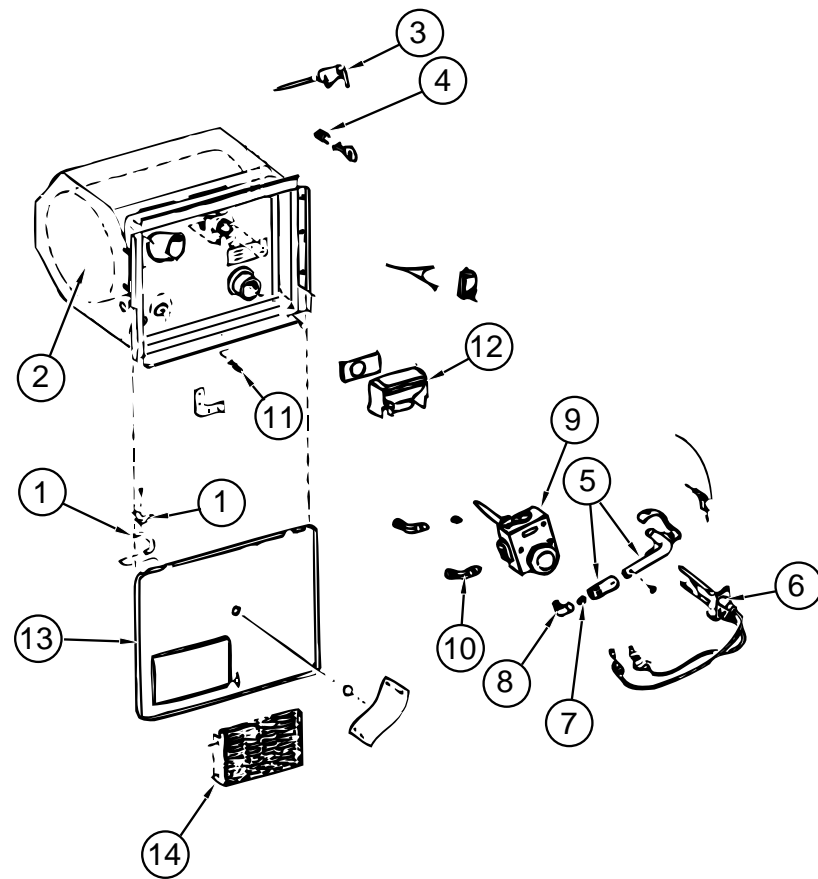

WATER HEATER W/MOTOR AID ATWOOD G6A-7

KEY	PART NUMBER	U/M DESCRIPTION	VENDOR NO.
	051391-01-A00	EA HEATER-WATER, ATWOOD - G6A-7	
1	051391-01-700	EA HINGE KIT, (PIN & CLIP)	92568 & 92559
2	051391-01-702	EA TANK-INNER F/G6A-2E-3E-6E	91412
3	051391-01-704	EA VALVE-RELIEF, 1/2" FITTING	91604
4	051391-01-705	EA FASTENER-CAMLOCK	92609
5	051391-04-703	EA BURNER-MAIN, 4E & 6E	91638
	051391-03-700	EA HOLDER-ORIFICE	91563
6	051391-01-709	EA PILOT ASM. W/THERMOCOUPLER	91603
7	051391-01-710	EA ORIFICE-MAIN BURNER	92742
8	051391-01-711	EA ELBOW-ORIFICE,MAIN BURNER	92741
9	051391-01-712	EA THERMOSTAT- 3/8" NPT INLET	91601
10	051391-01-714	EA FITTING-ELBOW 45,3/8F X 3/8 MPT	91044
11	051391-01-715	EA PLUG-DRAIN, 2 PER PKG	91857
12	051391-04-707	EA KIT (FLUE & GASKET)F/EXHAUST	90960
13	052009-06-000	EA DOOR-WATER HEATER, BRIGHT WHITE	
	116424-01-000	EA PROTECTOR-WATER HEATER LATCH, ATWOOD	92611
14	051391-01-717	EA GRILLE, F/WATER HEATER DOOR	92640
	051391-01-716	EA GRILLE - FLUE MOUNTED	

WATER & SEWAGE GROUP (CONTINUED)
WATER SYSTEM

KEY	PART NUMBER	U/M DESCRIPTION
	039800-02-000	FT TUBING-POLYBUTYL, 5/8" OD - INCREMENTS OF 20' - BLACK
	110915-01-01A	EA FILL-WATER, CITY - CHROME - KEVCO 64713
	114428-01-000	EA TEE-1/2P X 1/2P X 1/2P - FLAIR-IT 02820
	114428-02-000	EA TEE-SWIVEL,1/2PX1/2PX1/2FPT - FLAIR-IT 02821
	114429-01-000	EA ELBOW-1/2P X 1/2P - FLAIR-IT 02800
	114429-02-000	EA ELBOW-1/2P X 1/2MPT - FLAIR-IT 02803
	114429-03-000	EA ELBOW-SWIVEL,1/2PX1/2FPT - FLAIR-IT 02816
	114430-02-000	EA ADAPTER-SWIVEL,1/2P X 1/2FPT - FLAIR-IT -02873
	114430-03-000	EA ADAPTER-1/2P X 1/2MPT - FLAIR-IT 02842
	114431-03-000	EA WATER VALVE - 90 DEGREE ELBOW - "WATER DRAIN VALVE"
	114431-04-000	EA WATER VALVE - STRAIGHT THRU - "SHUT OFF VALVE"
	039861-01-000	EA SENDING UNIT-W/SCREW, WASHER, WELL NUT & TERMINAL RING
	010219-01-000	EA ELBOW-1 1/4" MPT X 1 1/4" BARB, WATER FILL - PLASTIC
	035539-01-000	EA ELBOW-PLASTIC, 3/8"MPT X 3/8"BARB
	074462-02-000	FT TUBING-VINYL, 3/8" ID X 20' - CLEAR
	077954-02-000	EA FILTER-WATER TANK, SCREEN IN TANK
	079381-01-000	FT TUBING-SMOOTH FLEXIBLE, 1 3/8" ID X 20'
	114430-03-000	EA ADAPTER-1/2P X 1/2MPT - FLAIR-IT 02842

WATER TANK

KEY	PART NUMBER	U/M DESCRIPTION
	116700-01-000	EA TANK-WATER,59 GAL
	116700-03-000	EA TANK ASM-WATER,59 GAL
	039861-01-000	EA SENDING UNIT-W/SCREW - WASHER, WELL NUT, & TERMINAL RING
	049032-01-000	EA PATCH-SPINWELD - 3/8" - PLASTIC
	042989-03-000	EA FITTING-WATER TANK - SPINWELD - 1 1/4"NPT - PLASTIC - WHITE
	042989-04-000	EA FITTING-WATER TANK - SPINWELD - 3/8" FPT - PLASTIC - WHITE
	042989-05-000	EA FITTING-WATER TANK - SPINWELD - 1/2" FPT - PLASTIC - WHITE
	077954-02-000	EA FILTER-WATER TANK - SCREEN IN TANK

WATER & SEWAGE GROUP (CONTINUED)

DRAINAGE SYSTEM

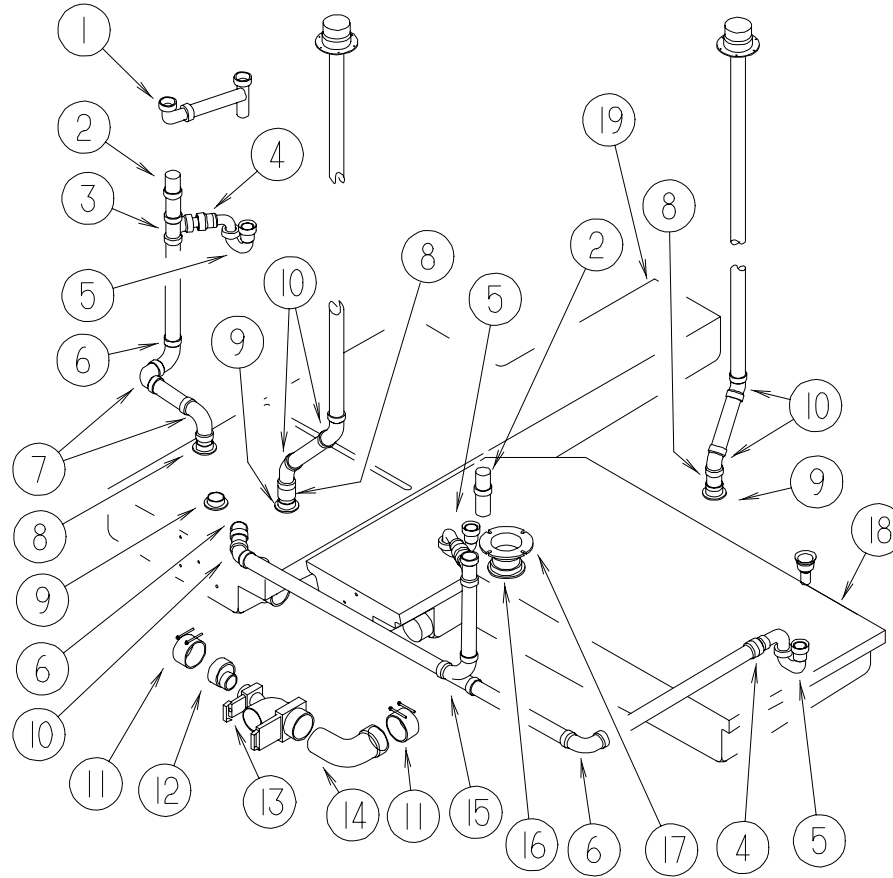

KEY	PART NUMBER	U/M DESCRIPTION
1	011091-02-000	EA PIPE-DRAIN, DOUBLE SINK - BAFFLE TEE - 1 1/2"
2	079968-01-000	EA VENT-MECH. TRAP ARM, ANTI-SIPHON - 2" DIA X 7.3" - PLASTIC
3	010071-01-000	EA TEE-SANITARY, 1 1/2" HUB X HUB X HUB - PLASTIC - BLACK
4	109571-01-000	EA ADAPTER-P TRAP, 1 1/2" P X 1 1/4" MPT
5	107538-01-000	EA P TRAP-PLAS 1 1/4 W/EXT ARM - KEVCO P814 1-1/4"
	069735-01-000	EA WASHER-STRAINER TO TAILPIECE PLASTIC, 1.5"
	011069-02-000	EA TAILPIECE-TUB/SHOWER, 1 1/2" X 1 1/4" X 4" - BRASS
6	010008-01-000	EA ELBOW - 90 DEG, 1/4 BEND - 1 1/2" HUB X HUB - BLACK PLASTIC
7	033761-01-000	EA ELBOW-TURN, 1/4 BEND X 1.5"HUB X 1.5"SPIGOT - BLK PLASTIC
8	010115-01-000	EA COUPLING-1 1/2" HUB X HUB, PLASTIC
8	010115-01-000	EA COUPLING-1 1/2" HUB X HUB, PLASTIC
	033761-01-000	EA ELBOW-TURN, 1/4 BEND X 1.5"HUB X 1.5"SPIGOT - BLK PLASTIC
9	061607-01-000	EA GROMMET-HOLDING TANK, 1 1/2" NPS
10	010006-01-000	EA ELBOW - 45 DEG, 1/8 BEND - 1 1/2" HUB X HUB - BLACK PLASTIC
11	078406-01-000	EA COUPLER-RUBBER, W/CLAMPS - 3" X 3"
12	062422-01-000	EA ADAPTER-OFFSET REDUCER, 3" X 1 1/2" - PLASTIC - BLACK
13	070916-01-000	EA VALVE-DUAL DUMP, W/CAP - 3" X 1 1/2" - PLASTIC - BLACK
13	070916-01-700	EA VALVE ONLY (WASTE) 3" T1003BU
13	070916-01-701	EA VALVE ONLY (WASTE 1 1/2" T1001BU

KEY	PART NUMBER	U/M DESCRIPTION
14	041956-01-000	EA ELBOW-STREET, PLASTIC - 1/4 BEND - 3" X 90 XLT
15	031365-02-000	EA TEE-PLAS, 1 1/2 EXT LG TURN NIBCO 5812-LR-11/
16	061607-02-000	EA GROMMET-HOLDING TANK, 3" NPS
17	116644-01-000	EA FLANGE-CLOSET 4 X 3 - SEALAND 345892
18	104351-01-000	EA TANK-HOLDING, 55 GALLON
19	111229-01-000	EA TANK-HOLDING, 56 GAL

WINDOW, VENT & EXTERIOR DOOR GROUP

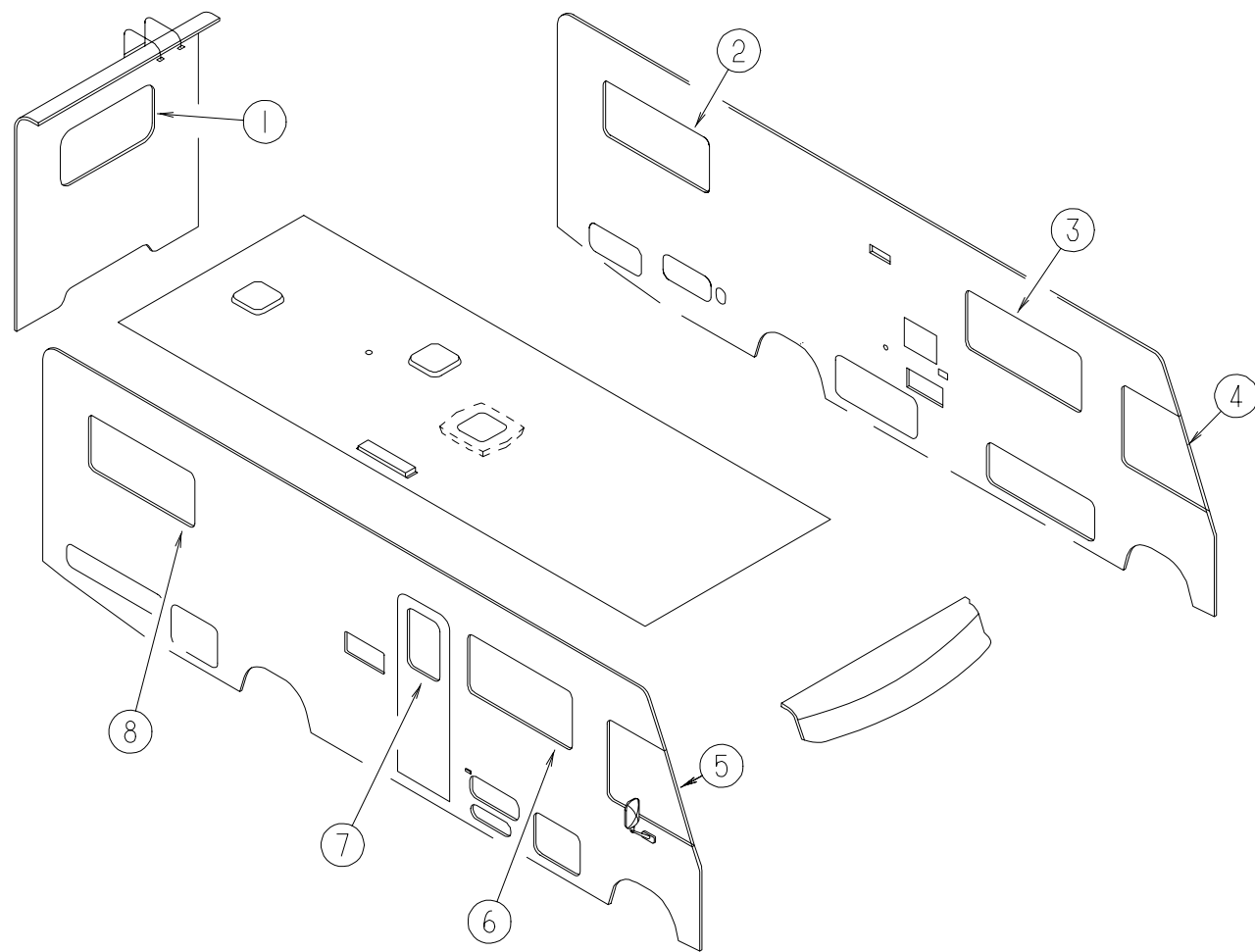

EXTERIOR WINDOWS

KEY	PART NUMBER	U/M DESCRIPTION
1	078528-07-FB1	EA WINDOW ASM-ESCAPE CLEAR USED WITH QUEEN BED / TWIN BED
1	116976-01-01A	EA WINDOW ASM-ESCAPE SINGLE USED WITH DOUBLE BED / BUNK BEDS
2	098647-30-01A	EA WINDOW ASM-SLIDER - HORIZONTAL
2	098647-32-01A	EA WINDOW ASM-SLIDER,HORIZ CLR EXCEL H425-C1W66L USED W/BUNK BEDS
3	098647-28-01A	EA WINDOW ASM-SLIDER - HORIZONTAL EXCEL H287-C1W66L
4	103658-09-01A	EA WINDOW ASM-CAB - DRIVER
5	103658-10-01A	EA WINDOW ASM-CAB - PASSENGER
6	098647-26-01A	EA WINDOW ASM-SLIDER - HORIZONTAL - EXCEL H415-C1W66R
7	117053-04-FB1	EA WINDOW ASM-PICTURE - ENTRANCE DOOR
	117054-02-02A	EA FRAME-WINDOW,INSIDE BRIGHT/WHITE - ENTRANCE DOOR
8	098647-29-01A	EA WINDOW ASM-SLIDER - HORIZONTAL
8	098647-31-01A	EA WINDOW ASM-SLIDER,HORIZ CLR - EXCEL H425-C1W66R USED W/BUNK BEDS

WINDOW, VENT & EXTERIOR DOOR GROUP (CONTINUED)

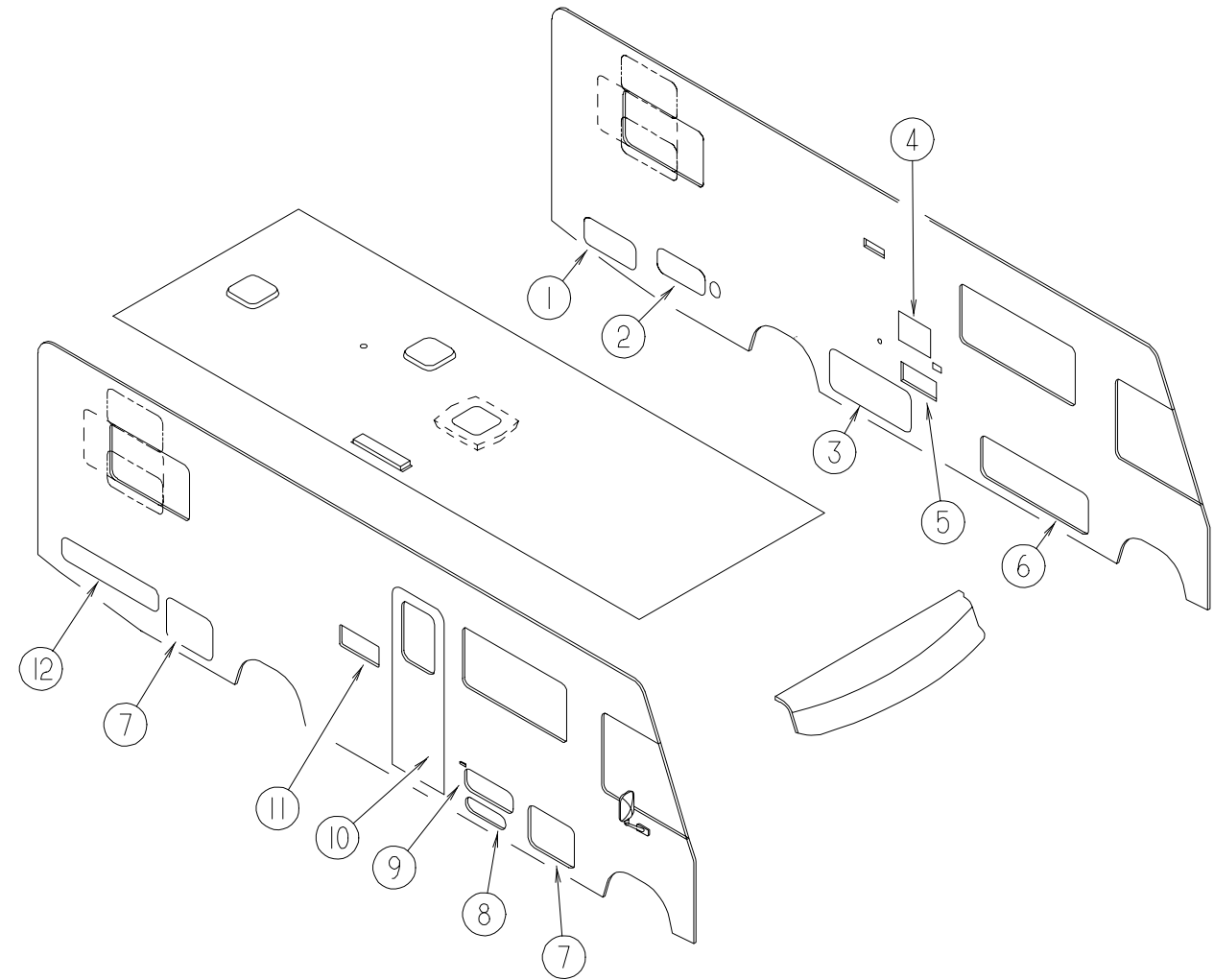

EXTERIOR DOORS & VENTS

KEY	PART NUMBER	U/M DESCRIPTION
1	104558-31-FB1	EA DOOR ASM-STORAGE
	107997-51-001	EA SPACER-.86" X .6", ALUMINUM
2	104558-30-FB1	EA DOOR ASM-STORAGE
		FROM: 10-16-95 THRU: 99-99-99
2	104558-33-FB1	EA DOOR ASM-STORAGE
		FROM: 00-00-00 THRU: 10-15-95
3	104558-32-GB1	EA DOOR ASM-STORAGE
		FROM: 07-31-95 THRU: 11-26-95
3	104558-52-GB1	EA DOOR ASM-STORAGE
		FROM: 11-27-95 THRU: 99-99-99
4	052009-06-000	EA DOOR-WATER HEATER - ATWOOD 5576-27 - BRIGHT WHITE
	103385-01-02A	EA VENT-RANGE HOOD, OUTSIDE - BRIGHT WHITE - VENTLINE
5	098668-23-000	EA DOOR - FURNACE - BRIGHT WHITE - SUBURBAN 520574
6	104558-24-FB1	EA DOOR ASM-STORAGE
7	104558-26-FB1	EA DOOR ASM-STORAGE
8	111009-01-F24	EA DOOR - COMPARTMENT - LP - 16.9" X 5.4" - ALUMINUM - BRIGHT WHITE
9	104558-29-FB1	EA DOOR ASM - STORAGE
	104564-16-02A	EA JAMB-DOOR - STORAGE - BRIGHT WHITE
10	115108-06-GB1	EA DOOR-ENTRANCE W/O WINDOW - W/SCREEN - FLAT - BRIGHT WHITE
10	115108-06-GC1	EA DOOR-ENTRANCE W/O WINDOW - W/SCREEN - FLAT - BRIGHT WHITE
11	084103-08-000	EA DOOR-REFRIGERATOR - VENTED - W/O JAMB - BRIGHT WHITE
	084104-08-000	EA JAMB-DOOR - REFRIGERATOR - BRIGHT WHITE
	084104-01-700	EA LOCK-MALE - FASTENER - REFRIGERATOR DOOR
	084104-01-701	EA LOCK-FEMALE - FASTENER - REFRIGERATOR DOOR
12	104558-27-FB1	EA DOOR ASM-STORAGE - BRIGHT WHITE
	104564-19-02A	EA JAMB-DOOR,STORAGE - BRIGHT WHITE
	081240-16-000	EA DOOR-WATER FILL - LOCKABLE - BRIGHT WHITE

WINDOW, VENT & EXTERIOR DOOR GROUP (CONTINUED)

BRIGGS & STRATTON LOCKS & COMPONENTS

NOTE:
 WHEN ORDERING THE LOCK CASE, THE KEY CODE MUST MATCH THE LAST DIGIT OF THE VEHICLE'S SERIAL NUMBER AND PART NUMBER; WHEN ORDERING THE KEYS, THE THIRD DIGIT OF THE KEY CODE MUST MATCH THE LAST DIGIT OF THE VEHICLE'S SERIAL NUMBER AND PART NUMBER

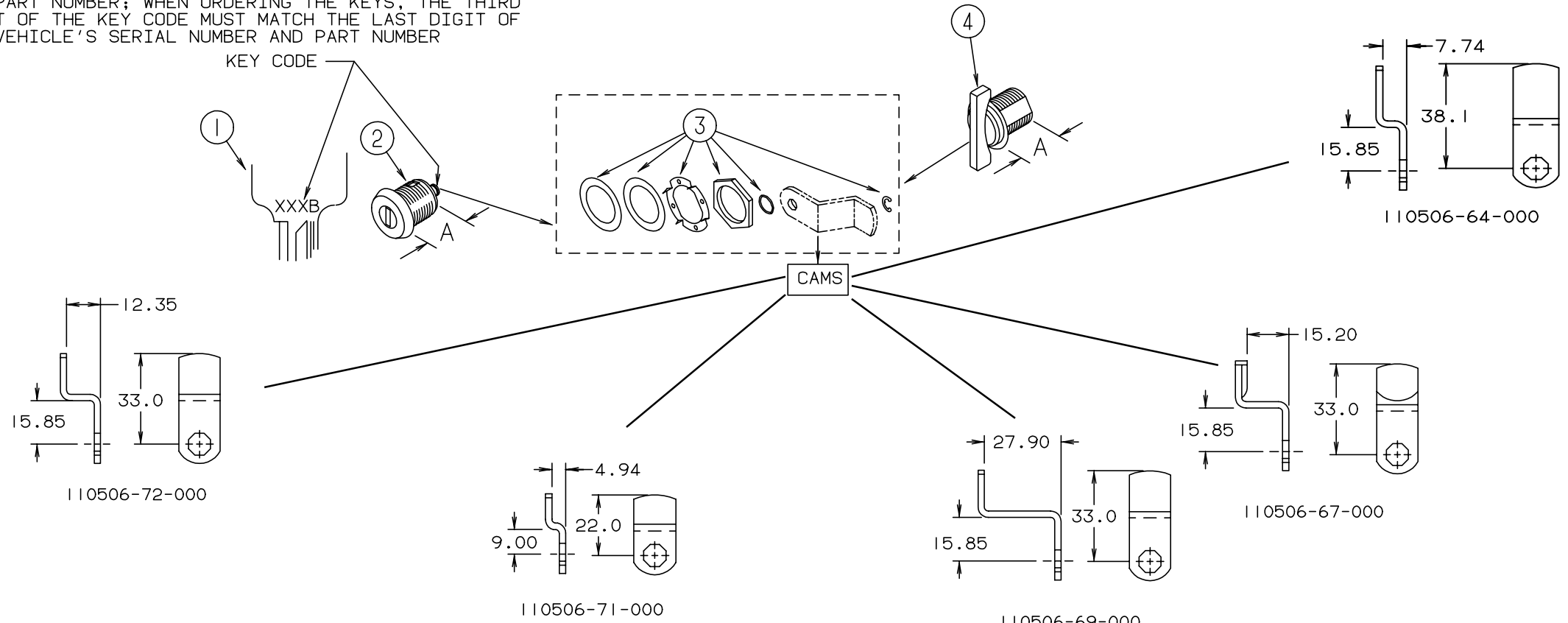

KEY	PART NUMBER	U/M	DESCRIPTION	VENDOR NO.
1	110506-59-000	EA	KEYS - SET OF TWO	596720
2	110506-52-000	EA	CASE - LOCK - A= 17 MM	702370
2	110506-53-000	EA	CASE - LOCK - A= 25 MM	702380
2	110506-54-000	EA	CASE - LOCK - A= 32 MM	703170
1	110506-59-001	EA	KEYS - SET OF TWO	596721
2	110506-52-001	EA	CASE - LOCK - A= 17 MM	702371
2	110506-53-001	EA	CASE - LOCK - A= 25 MM	702381
2	110506-54-001	EA	CASE - LOCK - A= 32 MM	703171
1	110506-59-002	EA	KEYS - SET OF TWO	596722
2	110506-52-002	EA	CASE - LOCK - A= 17 MM	702372
2	110506-53-002	EA	CASE - LOCK - A= 25 MM	702382
2	110506-54-002	EA	CASE - LOCK - A= 32 MM	703172
1	110506-59-003	EA	KEYS - SET OF TWO	596723
2	110506-52-003	EA	CASE - LOCK - A= 17 MM	702373
2	110506-53-003	EA	CASE - LOCK - A= 25 MM	702383
2	110506-54-003	EA	CASE - LOCK - A= 32 MM	703173
1	110506-59-004	EA	KEYS - SET OF TWO	596724
2	110506-52-004	EA	CASE - LOCK - A= 17 MM	702374
2	110506-53-004	EA	CASE - LOCK - A= 25 MM	702384
2	110506-54-004	EA	CASE - LOCK - A= 32 MM	703174
1	110506-59-005	EA	KEYS - SET OF TWO	596725
2	110506-52-005	EA	CASE - LOCK - A= 17 MM	702375
2	110506-53-005	EA	CASE - LOCK - A= 25 MM	702385
2	110506-54-005	EA	CASE - LOCK - A= 32 MM	703175

KEY	PART NUMBER	U/M	DESCRIPTION	VENDOR NO.
1	110506-59-006	EA	KEYS - SET OF TWO	596726
2	110506-52-006	EA	CASE - LOCK - A= 17 MM	702376
2	110506-53-006	EA	CASE - LOCK - A= 25 MM	702386
2	110506-54-006	EA	CASE - LOCK - A= 32 MM	703176
1	110506-59-007	EA	KEYS - SET OF TWO	596727
2	110506-52-007	EA	CASE - LOCK - A= 17 MM	702377
2	110506-53-007	EA	CASE - LOCK - A= 25 MM	702387
2	110506-54-007	EA	CASE - LOCK - A= 32 MM	703177
1	110506-59-008	EA	KEYS - SET OF TWO	596728
2	110506-52-008	EA	CASE - LOCK - A= 17 MM	702378
2	110506-53-008	EA	CASE - LOCK - A= 25 MM	702388
2	110506-54-008	EA	CASE - LOCK - A= 32 MM	703178
1	110506-59-009	EA	KEYS - SET OF TWO	596729
2	110506-52-009	EA	CASE - LOCK - A= 17 MM	702379
2	110506-53-009	EA	CASE - LOCK - A= 25 MM	702389
2	110506-54-009	EA	CASE - LOCK - A= 32 MM	703179
3	110506-40-700	EA	HARDWARE KIT	
4	110506-50-000	EA	CASE - TWIST LOCK - A= 17 MM	596952
4	110506-51-000	EA	CASE - TWIST LOCK - A= 25 MM	596669
4	110506-55-000	EA	CASE - TWIST LOCK - A= 32 MM	597312AA1
	110506-40-000	EA	CLIP-E - LOCK ASM.	93981
	110506-64-000	EA	CAM - LOCK	322280
	110506-68-000	EA	CAM - LOCK	322284
	110506-71-000	EA	CAM - LOCK	322287
	110506-59-701	EA	KEY BLANK - GOLD	

WINDOW, VENT & EXTERIOR DOOR GROUP (CONTINUED)

ENTRANCE DOOR

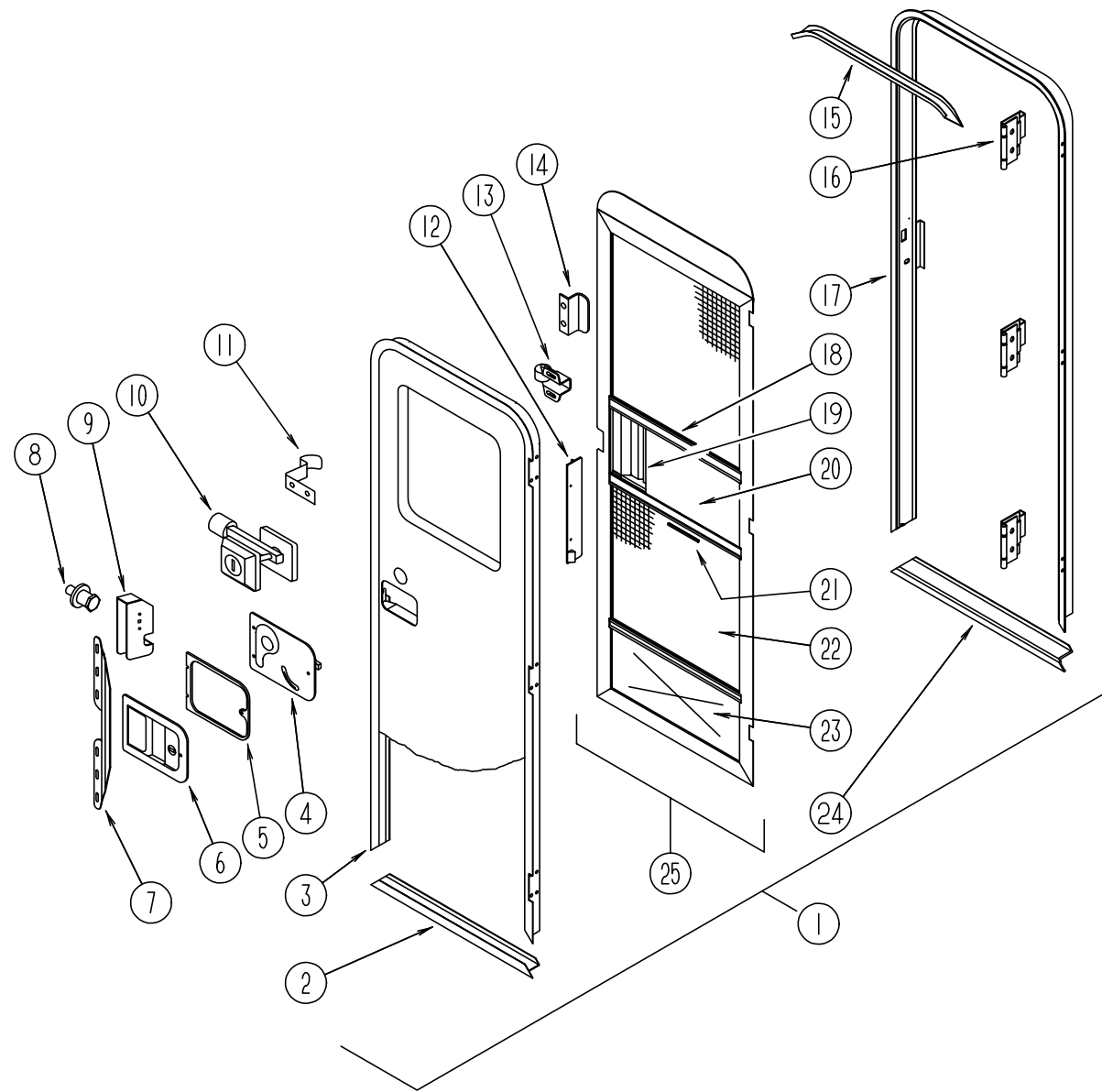

KEY	PART NUMBER	U/M	DESCRIPTION
1	115108-06-GB1	EA	DOOR-ENTRANCE, W/O WINDOW & SCREEN - FLAT - BRIGHT WHITE
1	115108-06-GC1	EA	DOOR-ENTRANCE, W/O WINDOW & SCREEN - FLAT - BRIGHT WHITE
2	089748-21-000	EA	FRAME-DOOR, ENTRANCE - BOTTOM - OFF WHITE
	090340-01-000	FT	SEAL-FOAM, CLOSED CELL - 1/4" X 1/2" X 50'
3	095276-03-06A	EA	FRAME-DOOR, ENTRANCE - TOP & SIDES - BRIGHT WHITE
4	039979-06-000	EA	COVER-INTERIOR LATCH, W/TRIP ARM - RIGHT - BLACK
	039984-01-000	EA	CAP-ROUND, VINYL - .28" ID X .62" LONG - BLACK
	041546-07-000	EA	BRACKET-DOOR ANGLE, 5" X 1.9" - OFF WHITE - METAL
5	096810-01-01A	EA	PLATE-LATCH, ENTRANCE DOOR - PLASTIC - BLACK
6	045017-13-000	EA	LATCH-ENTRANCE DOOR, BLK TEXT - *T/M #11896-01
	045017-11-701	EA	KEY-BLANK, F1 SERIES 81312-02
	045017-11-702	EA	KEY-MASTER, F SERIES 81313-02
			TO BE SOLD F/DEALER USE ONLY, NOT RETAIL !!!!!!!
	058025-02-000	EA	CLIP-ROLLER LATCH CATCH, SCREEN DOOR
	063729-04-000	EA	RIVNUT, 10-32 UNF - .010-.080
	075671-04-000	FT	SEAL-SPONGE, LAZY T SHAPE - W/ADHESIVE STRIPE - .5" WIDE
7	098173-01-07A	EA	STIFFENER-ENTRANCE DOOR, SUPPORTS LATCH/STRIKE AREA - BRIGHT WHITE
	098173-01-04A	EA	STIFFENER-ENTRY DOOR, SUPPORTS LATCH/STRIKE AREA UNPAINTED
	100128-02-000	FT	SEAL-PILE, ADHESIVE BACK - SCREEN DOOR - GRAY
8	039539-01-000	EA	STRIKE-LOCK, ENTRY DOOR - ROUND W/THREADED WASHER
9	045017-13-000	EA	LATCH MECHANISM-HOOK, ENTRY DOOR - INTERIOR
	039715-01-000	EA	NUT-SERT, 1/4" DIAMETER - 20 THREADS
10	101145-01-06A	EA	DEADBOLT-ENTRANCE DOOR, W/2 KEYS W/O BACK SET BOLT OR SCREWS
	095229-01-700	EA	KEY BLANK
	101145-01-701	EA	CYLINDER-LOCK ASM., W/KEY 81306-03
	101147-01-000	EA	BOLT-SECURITY, 4.12" BACKSET
	102524-01-000	EA	BUMPER-RUBBER, FLAT - BLACK
11	100412-01-000	EA	CATCH-SCREEN DOOR, THUMB CLIP W/BLACK PLASTIC CAP
	102768-01-000	EA	HOLDER-ENTRY DOOR, METAL - MILL FINISH
12	079087-03-000	EA	STRIKE-SLIDER, W/LIP FOR ELBOW CATCH - BRIGHT WHITE
13	100412-01-000	EA	CATCH-SCREEN DOOR
14	050712-06-000	EA	HANDLE-SCREEN DOOR, ALUMINUM - BRIGHT WHITE
15	044582-44-000	EA	CAP-DRIP, DOOR JAMB MOUNTED - BRIGHT WHITE
	115222-09-01A	EA	GARNISH-RADIUS, ENTRANCE DOOR - OFF WHITE
	077461-03-000	EA	COVER-STRIKE, ENTRANCE DOOR - 6.5" X 2.5" - PLASTIC - WHITE
	090340-01-000	FT	SEAL-FOAM, CLOSED CELL - 1/4" X 1/2" X 50'
16	106719-01-05A	EA	HINGE-ENTRANCE DOOR - BRIGHT WHITE
	102248-01-000	EA	SHIM-DOOR
17	120310-06-01A	EA	JAMB-ENTRANCE DOOR, BRIGHT WHITE
18	078777-01-000	EA	CHANNEL-SLIDE, SCREEN DOOR CENTER SLIDER COVER - 17.4"
19	079086-03-000	EA	SLIDER-SCREEN DOOR, BRIGHT WHITE
20	016454-01-000	EA	INSERT-CENTER
	001014-01-013	EA	INSERT-CENTER, 10.25" X 16.31" - UNPAINTED
21	002294-01-000	FT	SPLINE-SCREENING, .135" X .138" - BLACK
	002748-01-000	EA	CORNER KEY-DOOR
22	002293-02-000	SF	SCREENING-WINDOW & DOOR, 26" - CHARCOAL
23	078552-03-000	EA	INSERT-SCREEN DOOR, LOWER - UNPAINTED
	078595-01-000	EA	PLATE-SCREEN DOOR
24	051049-01-000	EA	JAMB-ENTRANCE DOOR, BOTTOM - UNPAINTED
25	079012-05-F01	EA	DOOR-SCREEN - BRIGHT WHITE

WINDOW, VENT & EXTERIOR DOOR GROUP (CONTINUED)

POWERED ROOF VENT

KEY	PART NUMBER	U/M DESCRIPTION
	110051-03-01A	EA VENT-ROOF, POWERED - 2" ROOF - US - JENSEN C7757 WHEAT
	110051-05-01A	EA VENT-ROOF, POWERED - 2" ROOF - CSA - JENSEN C7757 WHEAT
	048648-01-000	EA MOTOR-ROOF VENT, 1/8 SHAFT - 12V - JENSEN
	048649-01-000	EA FAN-ROOF VENT, 6 BLADES - 6" - JENSEN
	064470-01-700	EA COVER-VENT, W/O (SLIDE BAR) COMES W/O SLIDE BAR J7291
	064470-01-701	EA SLIDE BAR, (VENT-LID) JRP1291B
	110051-01-700	EA SCREEN-ROOF VENT
	110051-01-701	EA GARNISH W/SCREEN & FRAME 2"
	110051-01-702	EA HAND CRANK & OPERATOR ASM.
	110051-01-703	EA HANDLE CRANK

NONPOWERED ROOF VENT

KEY	PART NUMBER	U/M DESCRIPTION
	110051-01-01A	EA VENT-ROOF, NONPOWERED - 2" ROOF - JENSEN 7724 WHE
	064470-01-700	EA COVER ROOF VENT, 7291
	110051-01-700	EA SCREEN & FRAME 2" NON-POWER
	110051-01-701	EA GARNISH W/SCREEN & FRAME 2"
	110051-01-702	EA HAND CRANK & OPERATOR ASM.
	110051-01-703	EA HANDLE CRANK

VENTS & SHROUDS

KEY	PART NUMBER	U/M DESCRIPTION
	083558-03-000	EA VENT-PLUMBING PIPE ROOF, W/COVER - OFF WHITE
	084073-07-000	EA COVER-ROOF VENT, REFRIGERATOR - BRIGHT WHITE - NORCOLD
	084073-04-000	EA BASE-ROOF VENT, REFRIGERATOR - BLACK - NORCOLD
	105028-01-000	EA FLASHING ASM-VENT, REFRIGERATOR
	103385-01-02A	EA VENT-RANGE HOOD, OUTSIDE - BRIGHT WHITE - VENTLINE

SEALS AND HARDWARE FOR ACCESS DOORS

KEY	PART NUMBER	U/M DESCRIPTION
	075673-01-000	FT SEAL-PILE, ADHESIVE BACK - GRAY
	104692-01-000	FT SEAL-3/4" X 3/4" W/ADHESIVE BACK FOAM SEAL
	106850-01-000	FT SEAL - "E" - 11 X 19 SPONGE RUBBER
	102768-01-000	EA HOLDER-COMPARTMENT/ENTRY DOOR, METAL - MILL FINISH
	107997-51-001	EA SPACER-.86" X .6", ALUMINUM
	081801-V3-000	EA HINGE-AL,2 X 2438MM BRT WHT BRT/WHT
	034007-B3-000	EA HINGE-CONT AL 1.5 X 96"BRT WHT
	009065-01-000	EA HINGE-ALUMINUM, 1 1/2" X 96" - UNPAINTED

WINDOW, VENT & EXTERIOR DOOR GROUP (CONTINUED)

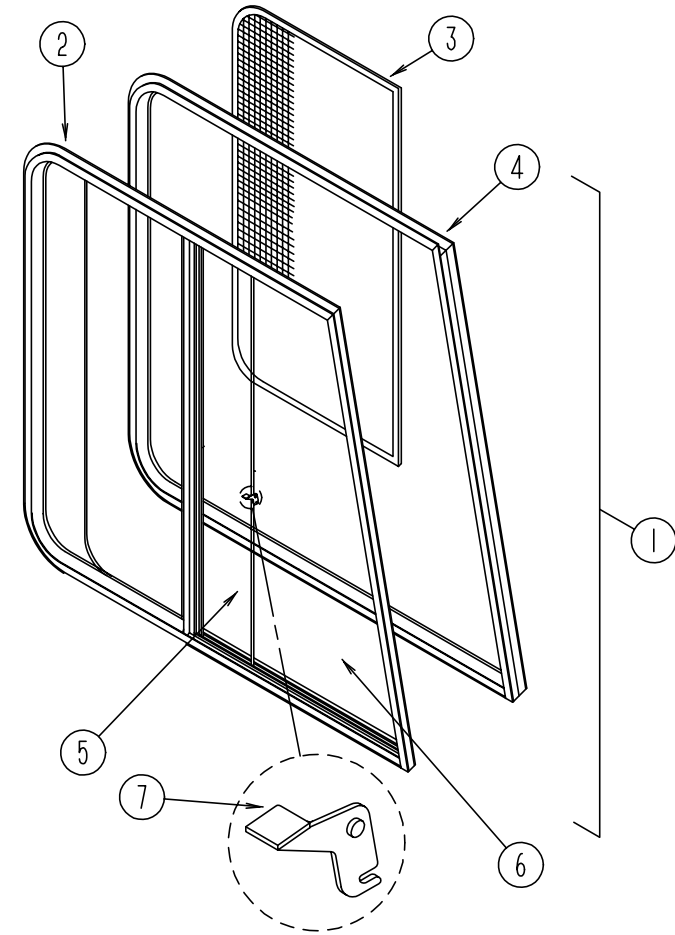

FRONT CAB WINDOWS (EXCEL)

KEY	PART NUMBER	U/M DESCRIPTION
	103658-09-01A	EA WINDOW ASM. - CAB - W/INSIDE FRAME - DRIVER SIDE H405-A2B66L
	103658-10-01A	EA WINDOW ASM. - CAB - W/INSIDE FRAME - PASSENGER SIDE H373-ARR
	103658-09-701	EA WINDOW ASM., W/O TRIM H405-A2L
	103658-10-700	EA WINDOW ASM., W/O TRIM H405-A2R
	103658-09-705	EA SCREEN ASM. - WINDOW - DRIVER SIDE 410-018973L
	103658-10-704	EA SCREEN ASM. - WINDOW - PASSENGER SIDE 410-018973R
	098644-01-717	FT SCREEN SPLINE 132-004716
	098644-01-713	EA SPRING-SCREEN FRAME (CLIP), PLASTIC - BLACK 226-016966
	098644-01-710	FT TRACK-SCREEN SPACER, 6' LENGTH - EXCEL M401-31 132-017135
	098644-01-711	FT WEATHERSTRIP-SCREEN, BLACK - EXCEL 171-016965
	103658-09-702	EA RETAINER-TRIM, LEFT H37366L
	103658-10-701	EA RETAINER-TRIM, RIGHT H37376R
	103658-10-703	EA GLASS - SLIDING - W/SASH & LATCH - PASSENGER H405-A9R
	103658-09-704	EA GLASS - SLIDING - W/SASH & LATCH - DRIVER H405-A9L
	103658-09-700	EA GLASS - STATIONARY - BOTTOM - DRIVER OR PASSENGER SIDE 106-018971
	098644-01-700	EA LATCH-REPAIR KIT, EXCEL B801-CK
	098644-01-708	FT CHANNEL-PIERCED RUN, EXCEL 122-016543
	098644-01-706	FT WEATHERSTRIP, EXCEL 171-010668
	098644-01-716	FT PLUG-FILLER, EXCEL 132-014470

WINDOW, VENT & EXTERIOR DOOR GROUP (CONTINUED)

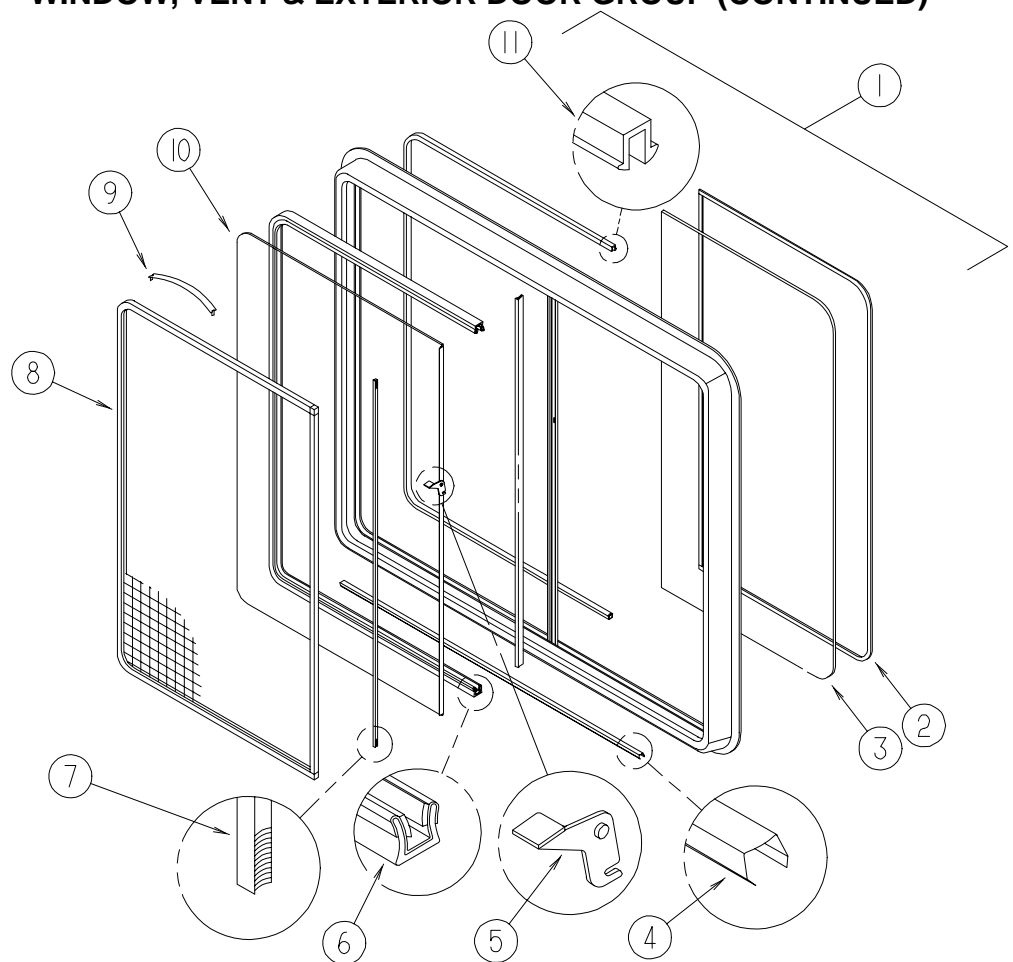

PASSENGERS SIDE BEDROOM SINGLE SLIDER WINDOW (EXCEL)

KEY	PART NUMBER	U/M DESCRIPTION	VENDOR NO.
	098647-29-01A	EA WINDOW ASM - SLIDER - W/ INSIDE FRAME (OFF WHITE) 26 3/8" HIGH	
1	098647-29-700	EA WINDOW W/O TRIM	H287-G2L
	098647-29-701	EA TRIM - INSIDE FRAME	W28766
2	098644-01-705	FT GLAZING STRIP	132-010723
3	098647-29-702	EA GLASS-STATIONARY	106-017622
4	098644-01-710	FT TRACK-SPACER, FOR SCREEN 12'	132-017135 EXCEL
5	098644-01-700	EA LATCH REPAIR KIT (BLACK)	B801-CK EXCEL
6	098644-01-708	FT CHANNEL-RUN, PIERCED - GLASS	122-016543 EXCEL
7	098644-01-711	FT WEATHERSTRIP-SCREEN, BLACK	171-016965 EXCEL
8	098647-29-704	EA SCREEN W/SPRING & WEATHERSTRIP	410-019066
9	098644-01-713	EA SCREEN CLIPS (METAL)(BLK)	226-016966 EXCEL
10	098647-29-703	EA GLASS SLIDING,W/SASH & LATCH	H287-G9
11	098644-01-706	FT WEATHERSTRIP-GLASS	171-010668 EXCEL
	098644-01-716	FT PLUG-FILLER	132-014470
	098644-01-717	FT SPLINE-SCREEN MFG	132-004716

SLIDER WINDOW (EXCEL)

KEY	PART NUMBER	U/M DESCRIPTION	VENDOR NO.
1	098647-26-01A	EA WINDOW ASM - SLIDER - W/ INSIDE FRAME (OFF WHITE) 26 3/8" HIGH	
2	098644-01-705	FT STRIP-GLAZING	132-010723
3	N/A	EA GLASS-STATIONARY	
4	098644-01-710	FT TRACK-SCREEN SPACER, 12'	132-017135
5	098644-01-700	EA LATCH-REPAIR KIT (BLACK)	B801-CK
6	098644-01-708	FT CHANNEL-RUN, PIERCED	122-016543 EXCEL
7	098644-01-711	FT WEATHERSTRIP-SCREEN, BLACK	171-016965 EXCEL
8	098647-36-704	EA SCREEN ASM., W/SPRING CLIP	410-017750
9	098644-01-713	EA CLIP-SPRING, BLACK PLASTIC	226-016966
10	N/A	EA GLASS SLIDING,W/SASH & LATCH	
11	098644-01-706	FT WEATHERSTRIP-GLASS	171-010668
	098644-01-716	FT PLUG-FILLER	132-014470
	098644-01-717	FT SPLINE-SCREEN	132-004716

WINDOW, VENT & EXTERIOR DOOR GROUP (CONTINUED)

SLIDER WINDOW (EXCEL)

KEY	PART NUMBER	U/M DESCRIPTION	VENDOR NO.
	098647-28-01A	EA WINDOW ASM - SLIDER - W/ INSIDE FRAME (OFF WHITE) 26 3/8" HIGH	
1	098647-28-700	EA WINDOW W/O TRIM	H287-G2L
	098647-27-701	EA TRIM - INSIDE FRAME	W28766
2	098644-01-705	FT GLAZING STRIP	132-010723
3	098647-27-703	EA GLASS-STATIONARY	106-017622
4	098644-01-710	FT TRACK-SPACER, FOR SCREEN 12'	132-017135
5	098644-01-700	EA LATCH REPAIR KIT (BLACK)	B801-CK
6	098644-01-708	FT CHANNEL-RUN, PIERCED - GLASS	122-016543
7	098644-01-711	FT WEATHERSTRIP-SCREEN, BLACK	171-016965
8	098647-23-704	EA SCREEN W/SPRING & WEATHERSTRIP	410-019066
9	098644-01-713	EA SCREEN CLIPS (METAL)(BLK)	226-016966
10	098647-27-703	EA GLASS SLIDING,W/SASH & LATCH	H287-G9
11	098644-01-706	FT WEATHERSTRIP-GLASS	171-010668
	098644-01-716	FT PLUG-FILLER	132-014470
	098644-01-717	FT SPLINE-SCREEN MFG	132-004716

SLIDER WINDOW (EXCEL) BUNK WINDOWS DRIVERS & PASSENGERS

KEY	PART NUMBER	U/M DESCRIPTION	VENDOR NO.
1	098647-31-01A	EA WINDOW ASM-SLIDER - H425-C1W66R	
	098647-31-700	EA WINDOW-SLIDER	H425-C1R
1	098647-32-01A	EA WINDOW ASM-SLIDER - H425-C1W66L	
	098647-32-700	EA WINDOW-SLIDER	H425-C1L
2	098644-01-705	FT GLAZING-STRIP	132-010231
3	098647-31-702	EA GLASS-STATIONARY	096-019299
4	098644-01-710	FT TRACK-SCREEN SPACER, 12'	132-017135
5	098644-01-700	EA LATCH-REPAIR KIT (BLACK)	B801-CK
6	098644-01-708	FT CHANNEL-RUN, PIERCED	122-016543
7	098644-01-711	FT WEATHERSTRIP-SCREEN, BLACK	171-016965
8	098647-31-704	EA SCREEN ASM., W/SPRING CLIP	410-019128
9	098644-01-713	EA CLIP-SPRING, BLACK PLASTIC	226-016966
10	098647-31-703	EA GLASS-SLIDING,W/SASH & LATCH	H425-C8
11	098644-01-706	FT WEATHERSTRIP-GLASS	171-010668
	098644-01-716	FT PLUG-FILLER	132-014470
	098644-01-717	FT SPLINE-SCREEN	132-004716
	098644-01-719	EA STOP-SLIDER GLASS	132-014203
	098647-31-701	EA RETAINER-TRIM, WHITE	CW2966

DRIVERS SIDE BEDROOM SINGLE SLIDER WINDOW (EXCEL)

KEY	PART NUMBER	U/M DESCRIPTION	VENDOR NO.
	098647-30-01A	EA WINDOW ASM - SLIDER - W/ INSIDE FRAME (OFF WHITE) 26 3/8" HIGH	
1	098647-30-700	EA WINDOW W/O TRIM	H287-G2L
	098647-29-701	EA TRIM - INSIDE FRAME	W28766
2	098644-01-705	FT GLAZING STRIP	132-010723
3	098647-29-702	EA GLASS-STATIONARY	106-017622
4	098644-01-710	FT TRACK-SPACER, FOR SCREEN 12'	132-017135 EXCEL
5	098644-01-700	EA LATCH REPAIR KIT (BLACK)	B801-CK EXCEL
6	098644-01-708	FT CHANNEL-RUN, PIERCED - GLASS	122-016543 EXCEL
7	098644-01-711	FT WEATHERSTRIP-SCREEN, BLACK	171-016965 EXCEL
8	098647-29-704	EA SCREEN W/SPRING & WEATHERSTRIP	410-019066
9	098644-01-713	EA SCREEN CLIPS (METAL)(BLK)	226-016966
10	098647-29-703	EA GLASS SLIDING,W/SASH & LATCH	H287-G9
11	098644-01-706	FT WEATHERSTRIP-GLASS	171-010668
	098644-01-716	FT PLUG-FILLER	132-014470
	098644-01-717	FT SPLINE-SCREEN MFG	132-004716

WINDOW, VENT & EXTERIOR DOOR GROUP (CONTINUED)

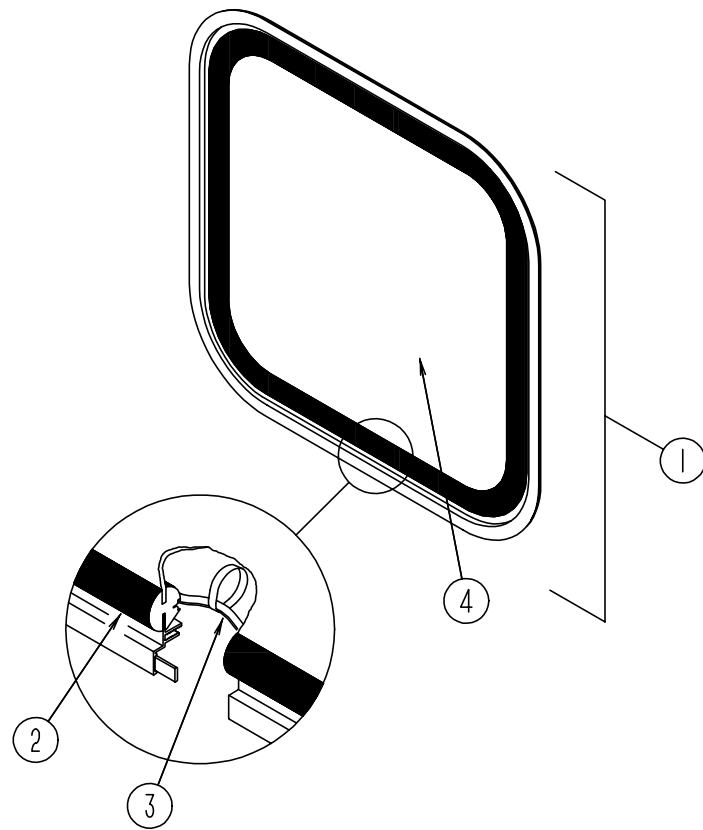

ESCAPE WINDOW

USED WITH QUEEN BED / TWIN BED

KEY	PART NUMBER	U/M DESCRIPTION
	074816-11-000	EA INSIDE FRAME- WINDOW - OFF WHITE
1	078528-07-FB1	EA WINDOW-ESCAPE - W/O INSIDE FRAME
2	002282-09-000	EA WEATHERSTRIP-.125" X 133.25" - BLACK
3	002285-01-000	FT FILLER-WEATHER STRIP - RUBBER - BLACK
4	076337-13-000	EA GLASS-EGRESS 1157 X 548
	102922-01-000	EA TAPE ASM-ESCAPE WINDOW - RED

ESCAPE WINDOW

USED WITH DOUBLE BED / BUNK BEDS

KEY	PART NUMBER	U/M DESCRIPTION	VENDOR NO.
	116976-01-01A	EA WINDOW ASM-REAR ESCAPE SINGLE	
	100322-01-701	FT SEAL-VENT	122-016071
	112898-06-704	EA HANDLE-LATCH, RED-RH	182-11293
	112898-06-705	EA HANDLE-LATCH, RED-LH	182-11294
	116976-01-700	EA GLASS	096-018786
	116976-01-701	EA TRIM	W38653
	116976-01-702	FT FILLER PLUG	132-016065

WINDOW, VENT & EXTERIOR DOOR GROUP (CONTINUED)

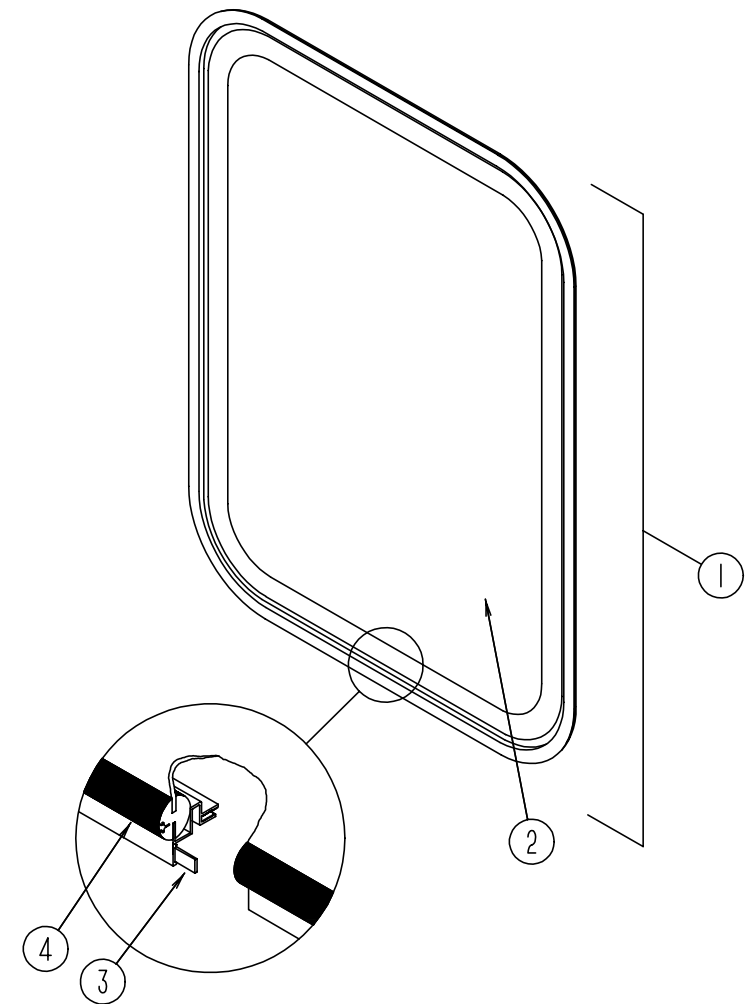

ENTRY DOOR WINDOW

KEY	PART NUMBER	U/M DESCRIPTION
	117054-02-02A	EA FRAME-WINDOW,INSIDE BRIGHT/WHITE - ENTRANCE DOOR
1	117053-04-FB1	EA WINDOW-ENTRANCE DOOR - GLASS
2	002181-27-000	EA GLASS-WINDOW, PICTURE 655 X 417 CLEAR 90%
3	069640-03-000	FT SEALER-TAPE,3/4" X 1/8" -BLACK
4	087561-01-000	FT SEAL-GLASS - EXTERIOR - .5" WIDE - VINYL - BLACK

WINDSHIELD & WIPER GROUP

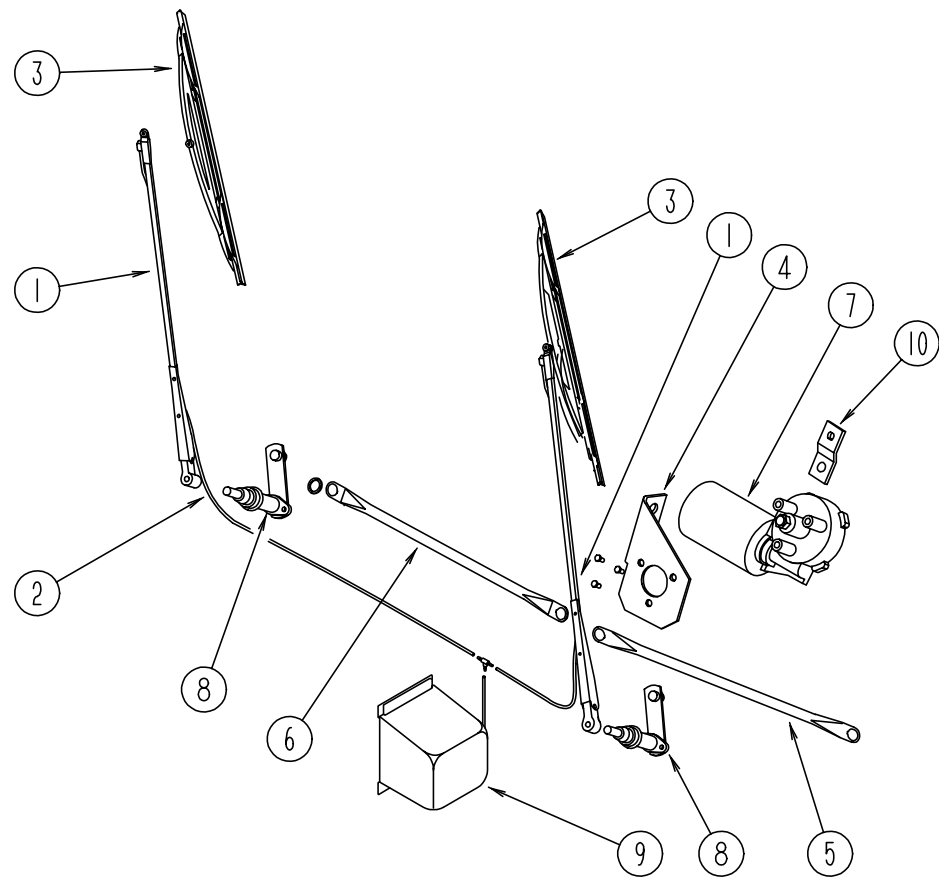

WIPER COMPONENTS

KEY	PART NUMBER	U/M DESCRIPTION
1	103671-01-000	EA ARM-WIPER - 24" - UT 52179-20LE27WC
2	096931-01-700	FT HOSE-WIPER - TO BLADE
	096931-01-701	EA NOZZLE-HARDWARE KIT - INCLUDES NOZZLE,NUT,SCREWS AND PLASTIC CAP
	110742-01-000	EA GASKET-WIPER
3	095964-01-000	EA BLADE-WIPER - WINDSHIELD - 24"
	095964-01-700	EA BLADE-REFILL 24" (PAIR) - 12360
4	104549-01-000	EA BRACKET ASM-WIPER
	096526-01-000	EA SCREW-HEX - 1/4 - 28
5	117008-01-000	EA LINK ASM-CONNECTING 21.85" - DRIVER SIDE - 64342-40
6	117008-02-000	EA LINK ASM-CONNECTING 21.85" - PASSENGER SIDE - 64341-40
7	104346-04-000	EA MOTOR-WIPER W/INT. BREAKER - UT 65714M02025WJ
8	096505-07-000	EA PIVOT SHAFT ASM - PASSENGER - 62901-20-SH25WJ
8	096505-08-000	EA PIVOT SHAFT ASM - DRIVER SIDE - 62900-20-SH25WJ
9	117766-02-000	EA RESERVOIR/PUMP ASM - MCCORD 600328
10	104347-01-000	EA ARM-DRIVE - WIPER MOTOR - 1.54" - 62543-20-LE25WJ
	110178-01-000	EA HOUSING-WIPER MOTOR - UT6237440-EC25WJ
	067188-01-000	EA STUD-CRANK - WIPER - WINDSHIELD - AMBAC 1903424SD27WC
	061603-01-000	EA GROMMET-SNAP - 3/16" ID - 3/8" HOLE - HEYCO SB-375-3
	045794-01-000	FT HOSE-WASHER, WINDSHIELD - 5/32" ID - BLACK

WINDSHIELD & WIPER GROUP (CONTINUED)

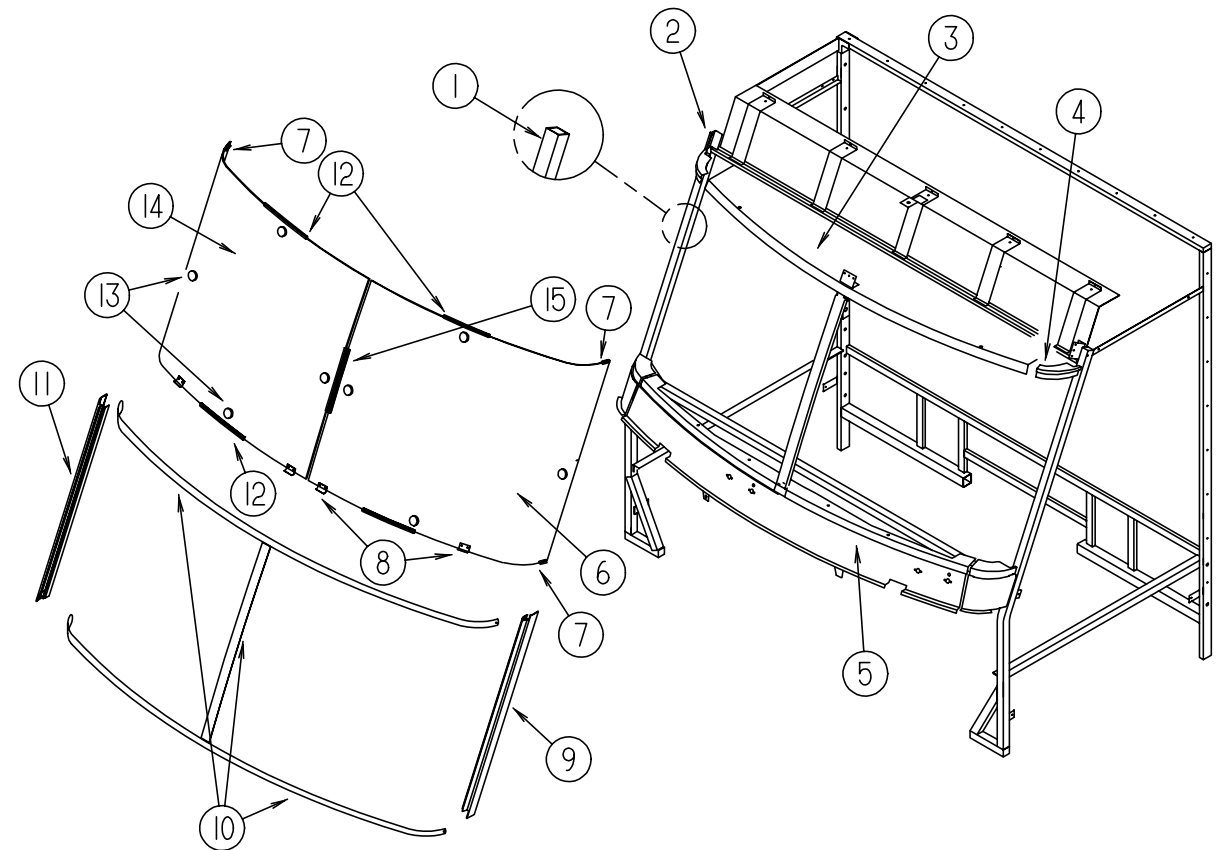

WINDSHIELD MOLDINGS & GLASS

KEY	PART NUMBER	U/M DESCRIPTION
1	098788-02-000	EA CHANNEL-RIGID
2	077922-03-000	EA HEADER-WINDSHIELD - RIGHT END
3	077922-05-000	EA HEADER-WINDSHIELD - CENTER
4	077922-04-000	EA HEADER-WINDSHIELD - LEFT END
5	077847-02-000	EA SUPPORT-WINDSHIELD - LOWER - W/O BRACKETS
6	088793-04-000	EA GLASS-WINDSHIELD - DRIVER
7	110268-02-000	EA CARRIER-REVEAL,WINDSHIELD 965
8	104449-01-000	EA SUPPORT-WINDSHIELD
9	103107-02-01A	EA TRIM-WINDSHIELD - SIDE BLACK
10	102936-01-000	FT MOLDING-REVEAL - WINDSHIELD
11	103107-01-01A	EA TRIM-WINDSHIELD - SIDE BLK
12	110268-07-000	EA CARRIER-REVEAL,WINDSHIELD 1070
13	081914-01-000	EA BUMPER-RUBBER - ROUND - .43" DIAMETER - BLACK
14	088793-03-000	EA GLASS-WINDSHIELD - PASSENGER
15	110268-02-000	EA CARRIER-REVEAL,WINDSHIELD 965