

**1996
ICF33RQ**

G29

PEBBLE BEACH (BROWN)

G30

NEPTUNE (TEAL)

G31

GALAXY (BLUE)

G32

ROUTE 66

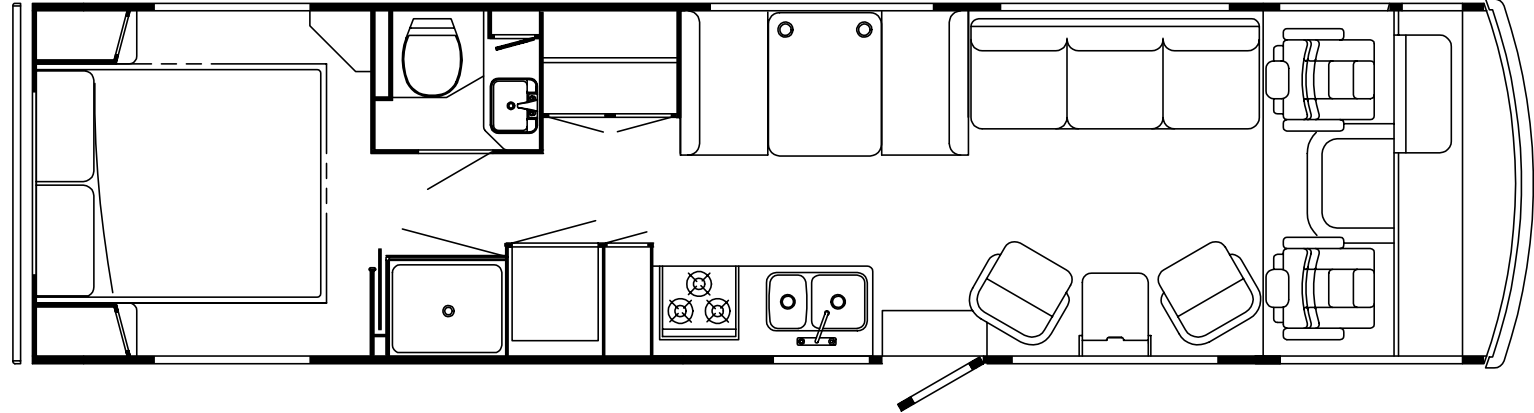
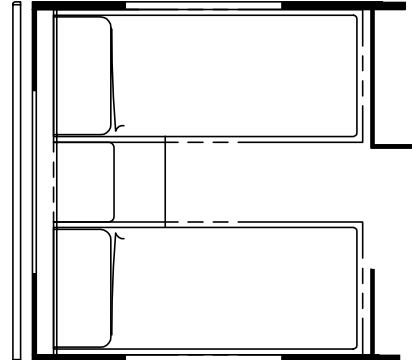
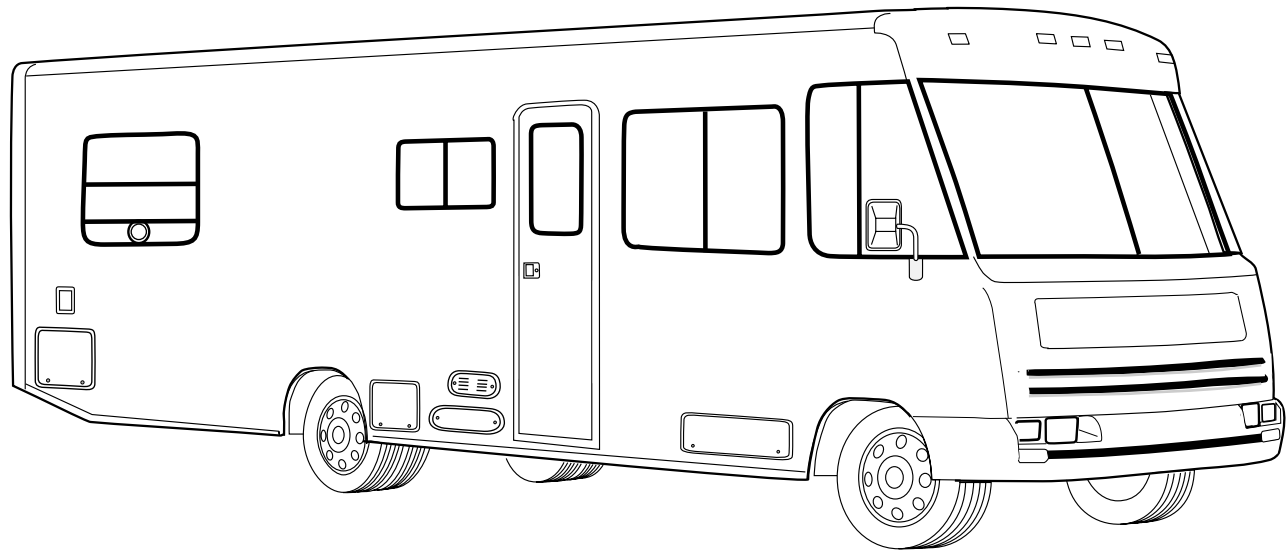

**ACCESSORIES GROUP
OPERATOR MANUAL**

KEY	PART NUMBER	U/M	DESCRIPTION
	054185-E7-000	EA	MANUAL-OPERATOR 96 SUNRISE
	092318-01-000	EA	BINDER - 3 RING, MOTOR HOME MANUAL
	092319-01-000	EA	POCKET PAGE - 3 RING BINDER, PLASTIC
	117907-01-000	DW	TOP LEVEL DRAWING-F, 1996

**AUDIO VIDEO GROUP
PATIO ENTERTAINMENT CENTER**

KEY	PART NUMBER	U/M	DESCRIPTION
	110469-01-000	EA	SPEAKER - 4" X 6", OVAL - MAGNADYNE F46XB-12
	110470-01-01A	EA	GRILLE-SPEAKER, OVAL - 4" X 6" - BLACK - MAGNADYNE G46WI
	077069-02-000	EA	CABLE-ANTENNA, RADIO - EXTENSION 96" - ARA 6700667
	090944-01-000	EA	ANTENNA-RADIO, 16" RUBBER
	109889-04-000	EA	EXTENDER-SHAFT, ANTENNA - 3" - MAGNADYNE RV71EX3
	087683-03-000	EA	RADIO-AM/FM STEREO W/CASSETTE - AUDIOVOX RS-100
	108847-01-000	EA	BRACKET-ANTENNA GROUND

RADIO SYSTEM, CD PLAYER & ANTENNA

KEY	PART NUMBER	U/M	DESCRIPTION
	110267-03-000	EA	RADIO-AM/FM STEREO, CASSETTE - AUDIOVOX IM-400
	116148-02-000	EA	RADIO-AM/FM STEREO, CD PLAYER - CLARION RDB515F FROM: 00-00-00 THRU: 03-14-96
	116148-03-000	EA	RADIO-AM/FM STEREO, CD PLAYER - CLARION RDB325D FROM: 03-15-96 THRU: 99-99-99
	077069-02-000	EA	CABLE-ANTENNA, RADIO - EXTENSION 96" - ARA 6700667
	090944-01-000	EA	ANTENNA-RADIO, 16" RUBBER
	081059-02-000	EA	WIRE ASM - 9-PIN, RADIO - AUDIOVOX 112B-1761
	089340-02-000	EA	GRILLE-SPEAKER, 6.5" SQUARE
	089340-03-000	EA	SPACER-GRILLE, 6.5" SQUARE - TAN - MAGNADYNE G514
	094097-01-000	EA	SPEAKER-RADIO/TV, W/O GRILLE - 5.25" DIA - AUDIOVOX 110C3030
	110469-01-000	EA	SPEAKER - 4" X 6", OVAL - MAGNADYNE F46XB-12
	110470-01-01A	EA	GRILLE-SPEAKER, OVAL - 4" X 6" - BLACK - MAGNADYNE G46WI

CB ANTENNA

KEY	PART NUMBER	U/M	DESCRIPTION
	105248-01-000	EA	ANTENNA-CB, ADVANCE 8604 FROM: 00-00-00 THRU: 06-14-96
	123256-01-000	EA	ANTENNA-CB W/O CABLE FROM: 06-15-96 THRU: 99-99-99
	123256-02-000	EA	CABLE-CB, COAX FROM: 06-15-96 THRU: 99-99-99
	115916-01-01B	EA	BRACKET-ANTENNA MOUNT, STEP SHAPED - 3" X 6" - STEEL

AUDIO VIDEO GROUP (CONTINUED)

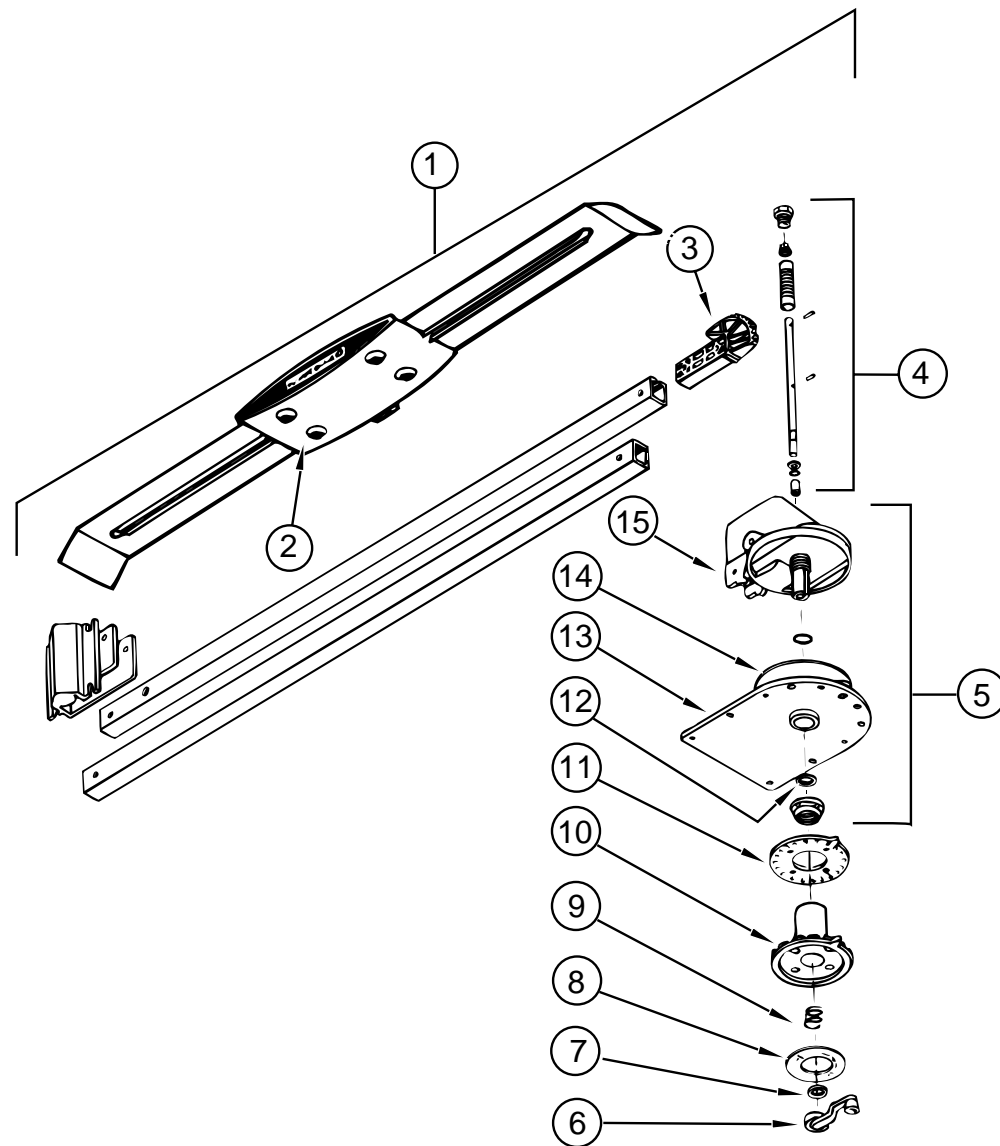

WINEGARD TV ANTENNA

KEY	PART NUMBER	U/M DESCRIPTION	VENDOR NO.
1	076319-18-000	EA ANTENNA-TV, ROOF MOUNT - WINEGARD WI-0094	
2	076319-01-700	EA HEAD-ANTENNA, AMPLIFIED	RVSA U/V
3	076319-01-701	EA GEAR-ELEVATING, PLASTIC	2200046
4	076319-01-702	EA SHAFT ASM-ELEVATING	RVP-400A
5	076319-01-711	EA BASE & LIFT ASM	2762802
6	076319-01-706	EA CRANK-ELEVATING, W/SET SCREW	5755100
7	076319-01-705	EA GROMMET-NYLON, 7/8" ID	3200658
8	076319-01-708	EA DECAL-CRANK	5413002
9	076319-01-707	EA SPRING-HANDLE	5160800
10	076319-01-709	EA PLATE-DIRECTIONAL, FOR HEAD	3200644
11	076319-01-712	EA PLATE-CEILING, DIRECTIONAL	3200608
12	076319-01-704	EA BEARING-NYLON, 1.25" OD	3200657
13	076319-01-713	EA PLATE-BASE, STEEL	3100523
14	076319-01-703	EA BEARING-NYLON, 5" OD	3200656
15	076319-01-714	EA HOUSING, ROTATING GEAR	2200049
	076319-01-715	EA NUT (GEAR HOUSING)	2200047

AUDIO VIDEO GROUP (CONTINUED)
TV CABLE, CONNECTORS, & WALLPLATES

KEY	PART NUMBER	U/M DESCRIPTION
	076319-03-000	FT CABLE-COAXIAL, 75 OHM
	076319-06-000	EA ADAPTER-CABLE ROOF PLATE, WINEGARD RPJ-1
	076319-08-000	EA WALLPLATE-CABLE RECEPTACLE, TV - SINGLE - IVORY - BEDROOM
	076319-09-000	EA WALLPLATE-CABLE RECEPTACLE, TV - SINGLE - BROWN - PATIO OPTION
	076319-12-000	EA CONNECTOR-COAXIAL, ONE PIECE
	082134-01-000	EA ADAPTER-TV, CABLE TO CABLE - WINEGARD F-81M
	086756-01-000	EA SPLITTER-TV, 2 WAY
	086777-01-000	EA PLATE-WALL, TV CABLE W/ANTENNA SWITCH - IVORY - WINEGARD RV-0710
	086777-05-000	EA PLATE-WALL, ANTENNA - 1 OUTPUT - IVORY - WINEGARD RV-0921
	114870-02-000	EA PLUG ASM - 3.5 MM AUDIO W/LEADS - OW - DONALD 35-P8

TV, VCR & CONTROL CENTER

KEY	PART NUMBER	U/M DESCRIPTION	VENDOR NO.
	092310-02-000	EA TV-COLOR, 9" - AC/DC - W/REMOTE - MAGNAVOX RD0945	
	092310-02-700	EA REMOTE-TV, MAGNAVOX	RD0945
	113684-01-000	EA TV - 19", COLOR UL/CSA - 19 3/8" W X 17 3/8" H X 18 1/4" D - AUDIOVOX AVT-1975	
		FROM: 00-00-00 THRU: 06-16-96	
	113684-01-700	EA REMOTE-TV, AUDIOVOX	8822345
		FROM: 00-00-00 THRU: 06-16-96	
	113684-02-000	EA TV - 19", COLOR UL/CSA - 1/8" JACK - AUDIOVOX AVT-1980	
		FROM: 06-17-96 THRU: 99-99-99	
	113684-02-700	EA REMOTE-TV, AUDIOVOX	0892355
		FROM: 06-17-96 THRU: 99-99-99	
	119120-01-000	EA VCR-VHS, CABLE READY - REMOTE - AUDIOVOX AVR-1075	
		FROM: 00-00-00 THRU: 12-10-95	
	119120-01-700	EA REMOTE-VCR - AUDIOVOX	8874570
	119120-02-000	EA VCR-VHS, CABLE READY - REMOTE - AUDIOVOX AVR-1170	
		FROM: 12-11-95 THRU: 99-99-99	
	119120-02-700	EA REMOTE-VCR - AUDIOVOX	0994569
	099717-01-000	EA TIEDOWN-TV, STRAP ON FEMALE END IS 22.8" LONG	
	099717-02-000	EA STRAP-TV TIE DOWN W/29.9" FEMALE STRAP & 14.2" MALE STRAP	
	098819-01-000	EA SPEAKER - 2 WATT, 8 OHM - 4"	
	093214-01-02A	EA GRILLE-SPEAKER, 4" - BROWN	
	086757-03-000	EA CONTROL CENTER-SWITCH, VCR/TV - MAGNADYNE VCS-6	

AUDIO VIDEO GROUP (CONTINUED)
WINEGARD SATELLITE TV ANTENNA

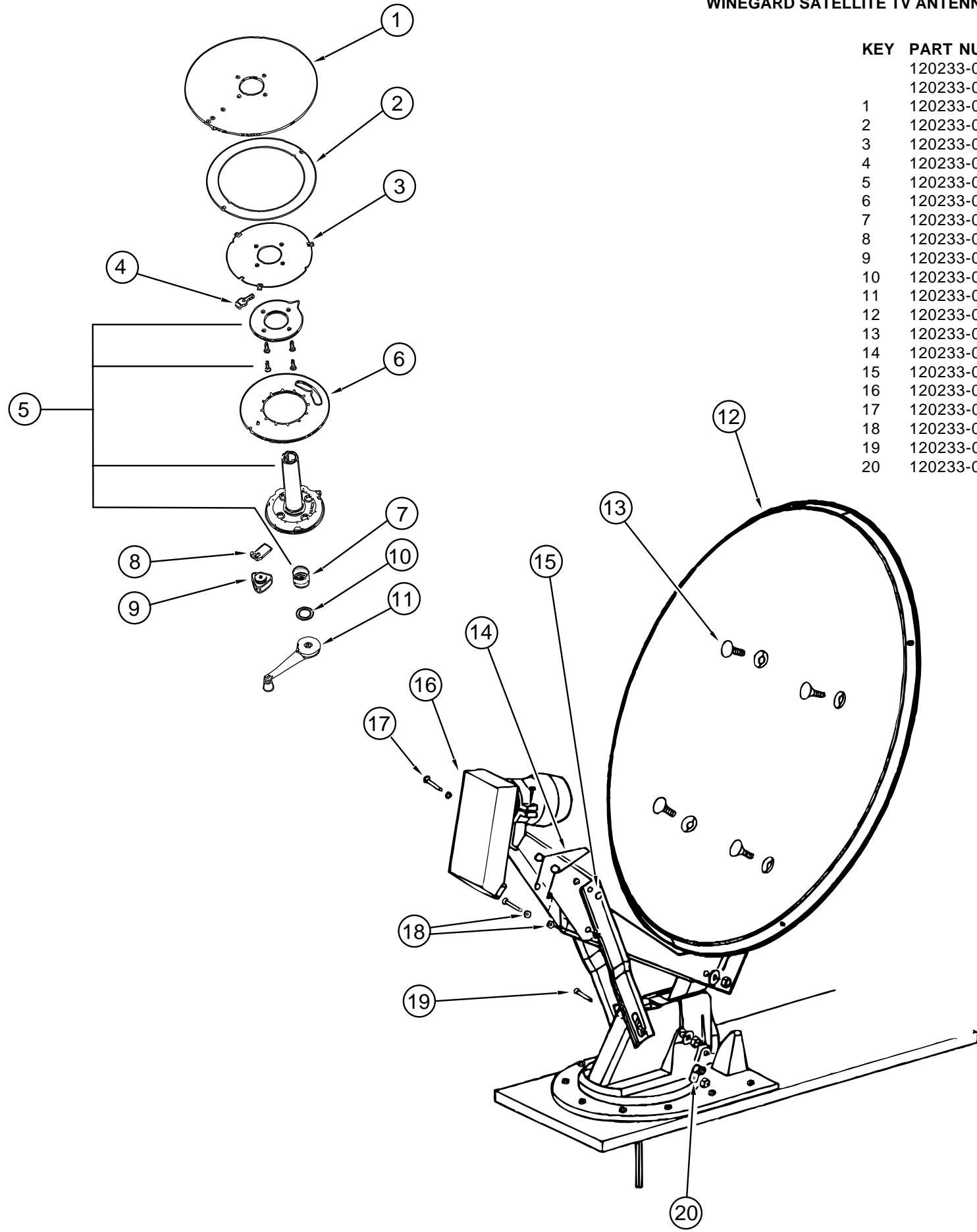

KEY	PART NUMBER	U/M	DESCRIPTION	VENDOR NO.
	120233-02-000	EA	RECEIVER-SATELLITE ONLY	
	120233-01-000	EA	ANTENNA-SATELLITE W/O RECEIVER (DISH & HDW KIT) MANUAL	
1	120233-01-700	EA	PLATE-FIXED	3750821
2	120233-01-701	EA	DIAL-DIRECTIONAL	2745056
3	120233-01-702	EA	PIVOT-DIAL-DIRECTIONAL	2745058
4	120233-01-703	EA	STOP-ROTATION	3711281
5	120233-01-704	EA	PLATE-CEILING W/DIRECTIONAL HANDLE	RP-6300
6	120233-01-705	EA	PLATE-ROTATE	3750820
7	120233-01-706	EA	SPRING	RP-6822
8	120233-01-707	EA	CLAMP-ROTATE	3711280
9	120233-01-708	EA	KNOB-CLAMP	160822
10	120233-01-709	EA	WASHER-NYLON	RP-2658
11	120233-01-710	EA	HANDLE-CRANK	RP-6795
12	120233-01-711	EA	REFLECTOR - 46 CM	2745304
13	120233-01-712	EA	BOLT-FLAT HEAD	2160253
14	120233-01-713	EA	SPRING	2160820
15	120233-01-714	EA	CLIP-E	5160818
16	120233-01-715	EA	RCA LNB	278015
17	120233-01-716	EA	PIN	2160814
18	120233-01-717	EA	BEARING-NYLON	2200728
19	120233-01-718	EA	PIN	5160817
20	120233-01-719	EA	CLAMP-CABLE	2200060

BATH GROUP
BATHROOM CABINET & COMPONENTS

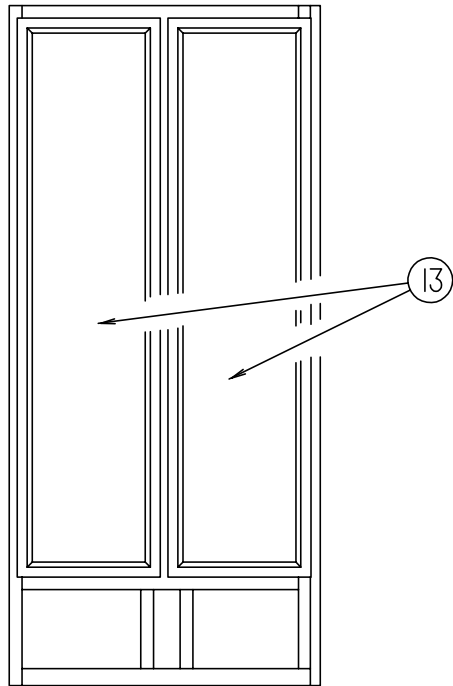
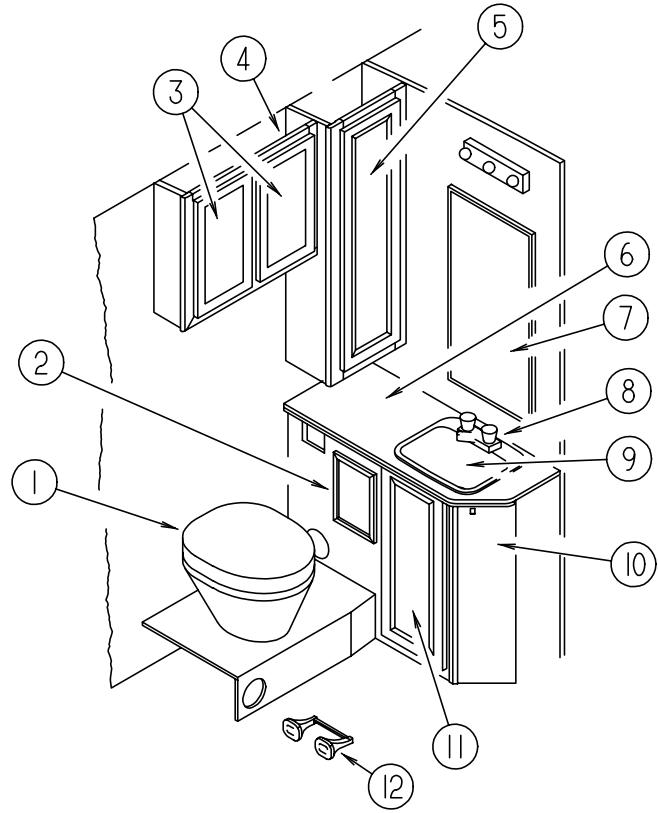

KEY	PART NUMBER	U/M	DESCRIPTION
1	067487-02-000	EA	TOILET - 12.37", IVORY - FOOT FLUSH - THETFORD
2	100013-13-G09	EA	BOX ASM-W/FACE FRAME, W/O HARDWARE
3	M06803-06-G09	EA	DOOR-W/O HARDWARE W/MIRROR - 285 MM X 500 MM
	076767-04-000	EA	CABLE-SUPPORT, 5.9" - STAINLESS STEEL
4	111178-01-G09	EA	CABINET ASM-LINEN
5	M06803-10-G09	EA	DOOR-W/O HARDWARE - 275 MM X 925 MM
6	100013-11-G29	EA	COUNTERTOP ASM (G29/G32)
6	100013-11-G30	EA	COUNTERTOP ASM (G30)
6	100013-11-F05	EA	COUNTERTOP ASM (G31)
7	058331-51-000	EA	MIRROR-GLASS,SAFETY - 660 MM X 1016MM
7	105004-01-05A	EA	MOLDING-MIRROR, VINYL WRAPPED - OAK
8	075240-06-000	EA	FAUCET-LAVATORY, BONE
	091253-01-000	EA	GASKET-FAUCET, LAVATORY/GALLEY
9	096927-01-01A	EA	SINK-LAVATORY, RECTANGULAR - PLASTIC - BONE
	096927-01-700	EA	SINK-STOPPER
	096927-01-701	EA	TAILPIECE-SINK
10	P00013-01-G29	EA	CABINET ASM-LAVATORY, W/O DOORS OR HARDWARE (G29/G32)
10	P00013-01-G30	EA	CABINET ASM-LAVATORY, W/O DOORS OR HARDWARE (G30)
10	P00013-01-G31	EA	CABINET ASM-LAVATORY, W/O DOORS OR HARDWARE (G31)
11	M06803-70-G09	EA	DOOR-W/O HARDWARE - 275 MM X 605 MM
	058331-52-000	EA	MIRROR-GLASS, SAFETY - 275 MM X 965 MM - WALL MOUNTED
	105004-01-05A	EA	MOLDING-MIRROR, VINYL WRAPPED - OAK
12	075452-02-000	EA	HOLDER-TOILET TISSUE, BRASS
	075453-02-000	EA	BAR-TOWEL, 18" BRASS
	100357-01-000	EA	ROD-TOWEL, BRASS W/ENDS BENT FOR BACK OF BATH DOOR
	102089-13-G09	EA	WOOD RAIL - TOWEL RACK - RIGHT SIDE - 26" LONG
	102089-14-G09	EA	WOOD RAIL - TOWEL RACK - LEFT SIDE - 26" LONG
	M87868-10-G09	EA	DOOR-CABINET BATH
	094485-03-01A	EA	KNOB-DOOR, BRASS - THUNADER L132PB
	102920-01-01A	EA	HINGE-DOOR, SPRING LOADED - BRASS
	104013-02-G09	EA	DOOR ASM-SLIDING
	103874-01-000	EA	HANGER-SLIDING DOOR
13	M06803-11-G09	EA	DOOR-W/O HARDWARE W/MIRROR - 410 MM X 1660 MM

BATH GROUP (CONTINUED)

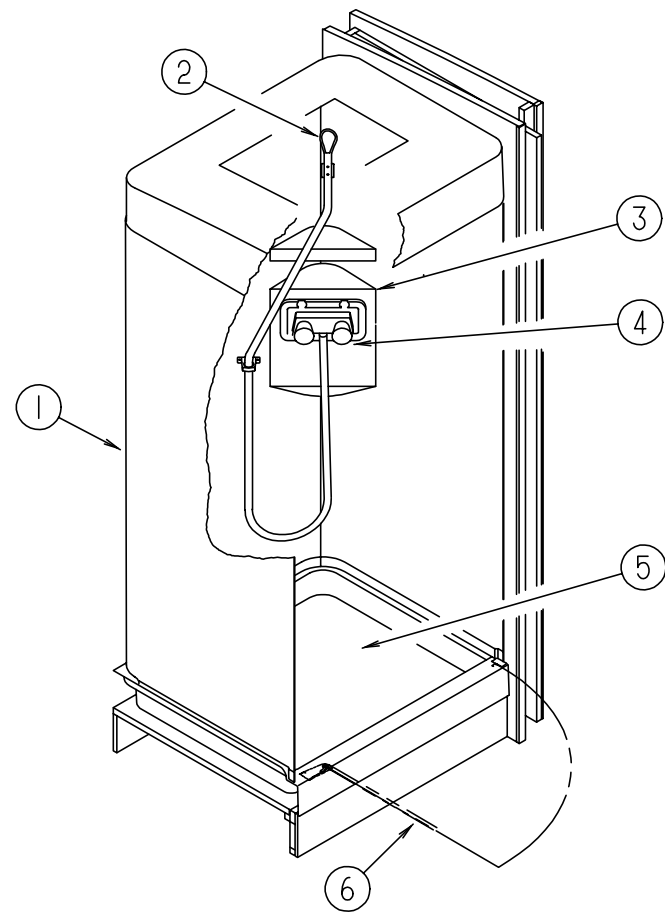

SHOWER & COMPONENTS

KEY	PART NUMBER	U/M DESCRIPTION	VENDOR NO.
1	101805-01-01A	EA SURROUND-SHOWER, OFF WHITE	
	113714-02-01A	EA RETAINER-SHELF, SHOWER 306 MM X 25 MM - PLASTIC - OFF WHITE	
2	103092-01-000	EA SHOWER HEAD-W/60" HOSE - US	
2	103092-02-000	EA SHOWER HEAD-W/60" HOSE - CANADIAN	
	103092-01-700	EA BRACKET ONLY-CLEAR, F/SHOWER HEAD - BPC	2328028
	103092-01-702	EA SEALS-SPRAY HEAD	24466
	011048-03-700	EA BRACKET/F SHOWER HEAD - BPC	2328029-3
3	075606-01-000	EA PANEL-FAUCET BACK, SHOWER - 5" X 9" - PLASTIC	
4	075241-05-000	EA FAUCET-SHOWER, BONE	
5	M02429-07-000	EA PAN-SHOWER	
	066436-01-000	EA NUT-SLIP, TAILPIECE - 1.5"	
6	089318-01-000	EA DOOR-SHOWER, HINGED - W/GOLD FRAME - PLASTIC - 29.8" WIDE	
	089318-01-700	EA STRAP F/SHOWER DOOR	
	089318-01-701	EA VINYL SWEEP	C171G
	089318-01-702	EA BUSHING W/ARM, LOWER	18712A
	089318-01-703	EA STRIKE-JAMB W/MAGNETIC STRIP	150G
	089318-01-704	EA BOLT-PIVOT, TOP OR BOTTOM	1428B
	089318-01-706	EA PLATE - PIVOT (UPPER/LOWER)	796
	092574-01-703	EA PULL-DOOR, GOLD - INSIDE	8149G
	092574-01-704	EA SCREW-GOLD, #6 3/8 - COASTAL	638G
	092574-01-705	EA MAGNETIC STRIP - 56.9" - COASTAL	98-41
	092574-01-707	EA PIVOT BUSHING	18712B
	092574-01-711	EA PULL-DOOR W/STUDS, GOLD - OUTSIDE	8153G
	107878-01-703	EA CAP-DRIP, PLUG SET	DCP2
	116814-01-700	EA BAR-TOWEL 17 5/16"	68G
	089318-02-000	EA JAMB-EXPANDER	
	057671-01-000	EA COVER-SCREW, #8 - PLASTIC - OFF WHITE	
	077902-01-000	EA COVER-SKYLIGHT, INSIDE - 15.6" X 22.5" - PLASTIC	
	080910-01-000	EA COVER-SKYLIGHT, OUTER - 15.25" X 22.25" - PLASTIC	

BATH GROUP (CONTINUED)

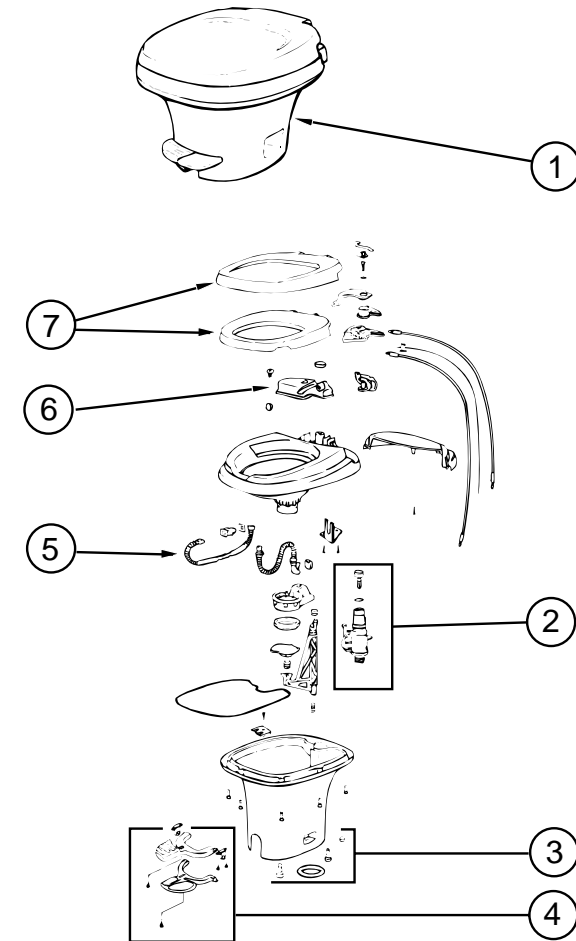

AQUA MAGIC IV - LOW - FOOT FLUSH TOILET

KEY	PART NUMBER	U/M DESCRIPTION	VENDOR NO.
1	067487-02-000	EA TOILET - 12.37", IVORY - FOOT FLUSH - THETFORD	
2	063740-01-714	EA VALVE ASM, W/GASKET & FLOAT	12492
3	063740-01-706	EA BOLT PACKAGE-FLOOR FLANGE	12524
4	067487-02-701	EA PEDAL PACKAGE (FOOT FLUSH)	20821
5	063740-01-717	EA TUBE-FLUSH	12509
6	063740-02-701	EA RESERVOIR (TANK ASSEMBLY)	24630
7	063740-02-700	EA SEAT & COVER, PARCHMENT	20829

BEDROOM GROUP
QUEEN BEDROOM CABINETS

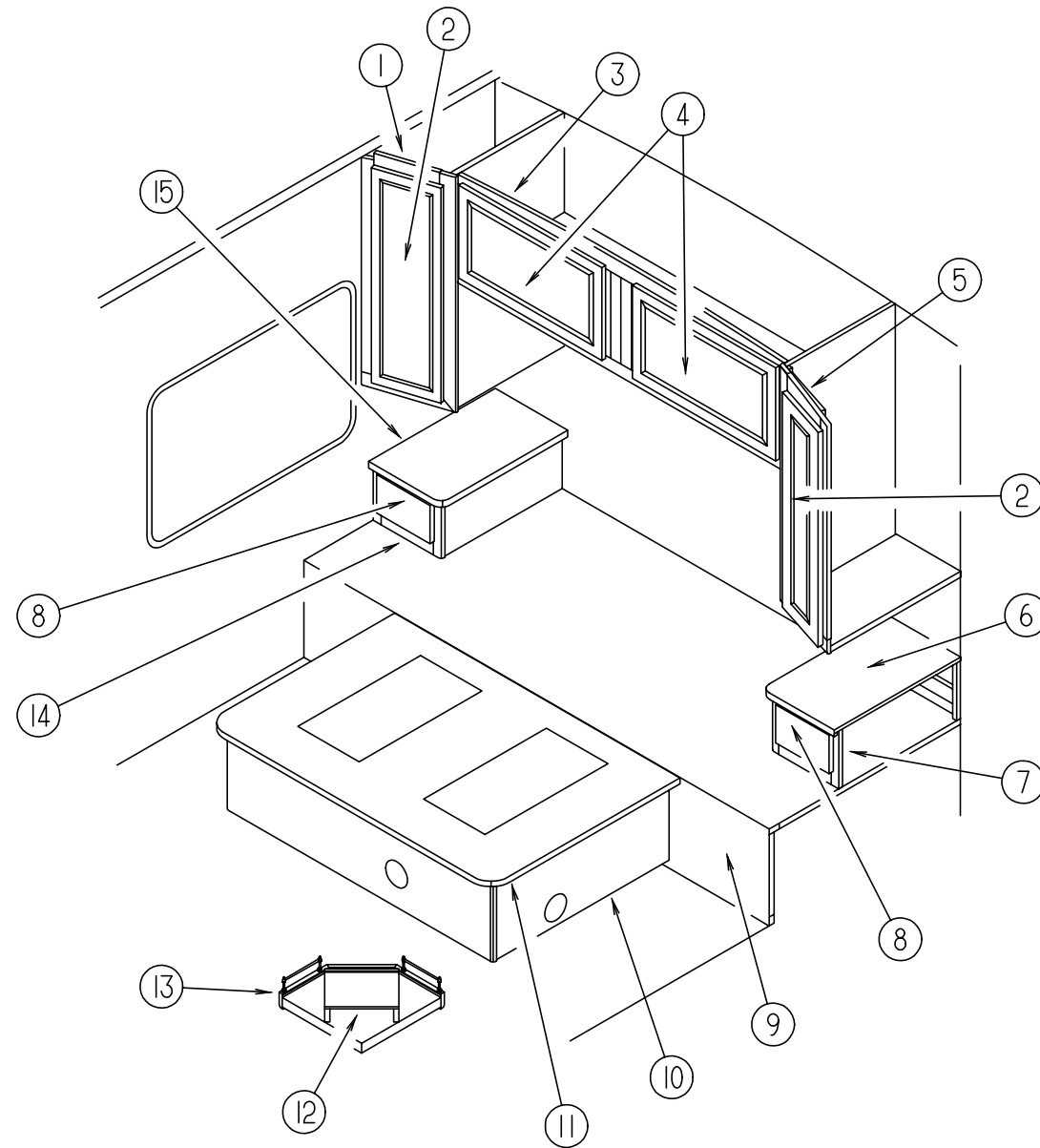

KEY	PART NUMBER	U/M	DESCRIPTION
1	110625-01-G09	EA	CABINET-SHIRT CLOSET, W/O DOOR OR HARDWARE
2	M06803-10-G09	EA	DOOR-W/O HARDWARE - 275 MM X 925 MM
3	106523-01-G09	EA	CABINET-OVERHEAD, W/O DOORS OR HARDWARE
4	M06803-13-G09	EA	DOOR-W/O HARDWARE W/MIRROR - 400 MM X 710 MM
4	M06803-02-G09	EA	DOOR-W/O HARDWARE W/O MIRROR - 400 MM X 710 MM DECORATOR DOOR OPTION - FLAT PANEL
5	110625-02-G09	EA	CABINET-SHIRT CLOSET, W/O DOOR OR HARDWARE
6	117901-12-G29	EA	COUNTERTOP-NIGHTSTAND (G29)
6	117901-12-G30	EA	COUNTERTOP-NIGHTSTAND (G30)
6	117901-12-G31	EA	COUNTERTOP-NIGHTSTAND (G31)
6	117901-12-G09	EA	COUNTERTOP-NIGHTSTAND (G32)
7	P17901-02-G29	EA	CABINET-NIGHTSTAND W/COUNTERTOP - W/O DRAWER (G29)
7	P17901-02-G30	EA	CABINET-NIGHTSTAND W/COUNTERTOP - W/O DRAWER (G30)
7	P17901-02-G31	EA	CABINET-NIGHTSTAND W/COUNTERTOP - W/O DRAWER (G31)
7	P17901-02-G09	EA	CABINET-NIGHTSTAND W/COUNTERTOP - W/O DRAWER (G32)
8	M05971-R3-G09	EA	DRAWER-CABINET, W/O HARDWARE
9	P10624-01-000	EA	CABINET-COMPARTMENT, W/O CARPET OR TOP

KEY	PART NUMBER	U/M	DESCRIPTION
10	P17899-01-G09	EA	CABINET-QUEEN BED W/O TOP
11	M05706-09-000	EA	TOP-QUEEN BED CABINET
12	116553-15-G09	EA	WEDGE-TV
13	116553-02-G09	EA	SHELF ASM-TV, W/BRASS RAILING & WEDGE - 444 MM X 424 MM
	105219-01-G09	EA	SHELF ASM-W/BRASS RAILING - 273 MM X 274 MM
	084070-02-000	EA	POST-END, 2.4" - BRASS
	084071-15-000	EA	ROD-BRASS, 210 MM LONG
	058331-17-000	EA	MIRROR-GLASS, SAFETY - 8.75" X 12.5"
	105004-01-05A	EA	MOLDING-MIRROR, VINYL WRAPPED - OAK
14	P17901-01-G29	EA	CABINET-NIGHTSTAND W/COUNTERTOP - W/O DRAWER (G29)
14	P17901-01-G30	EA	CABINET-NIGHTSTAND W/COUNTERTOP - W/O DRAWER (G30)
14	P17901-01-G31	EA	CABINET-NIGHTSTAND W/COUNTERTOP - W/O DRAWER (G31)
14	P17901-01-G09	EA	CABINET-NIGHTSTAND W/COUNTERTOP - W/O DRAWER (G32)
15	117901-11-G29	EA	COUNTERTOP-NIGHTSTAND (G29)
15	117901-11-G30	EA	COUNTERTOP-NIGHTSTAND (G30)
15	117901-11-G31	EA	COUNTERTOP-NIGHTSTAND (G31)
15	117901-11-G09	EA	COUNTERTOP-NIGHTSTAND (G32)

BEDROOM GROUP (CONTINUED)
TWIN BEDROOM CABINETS

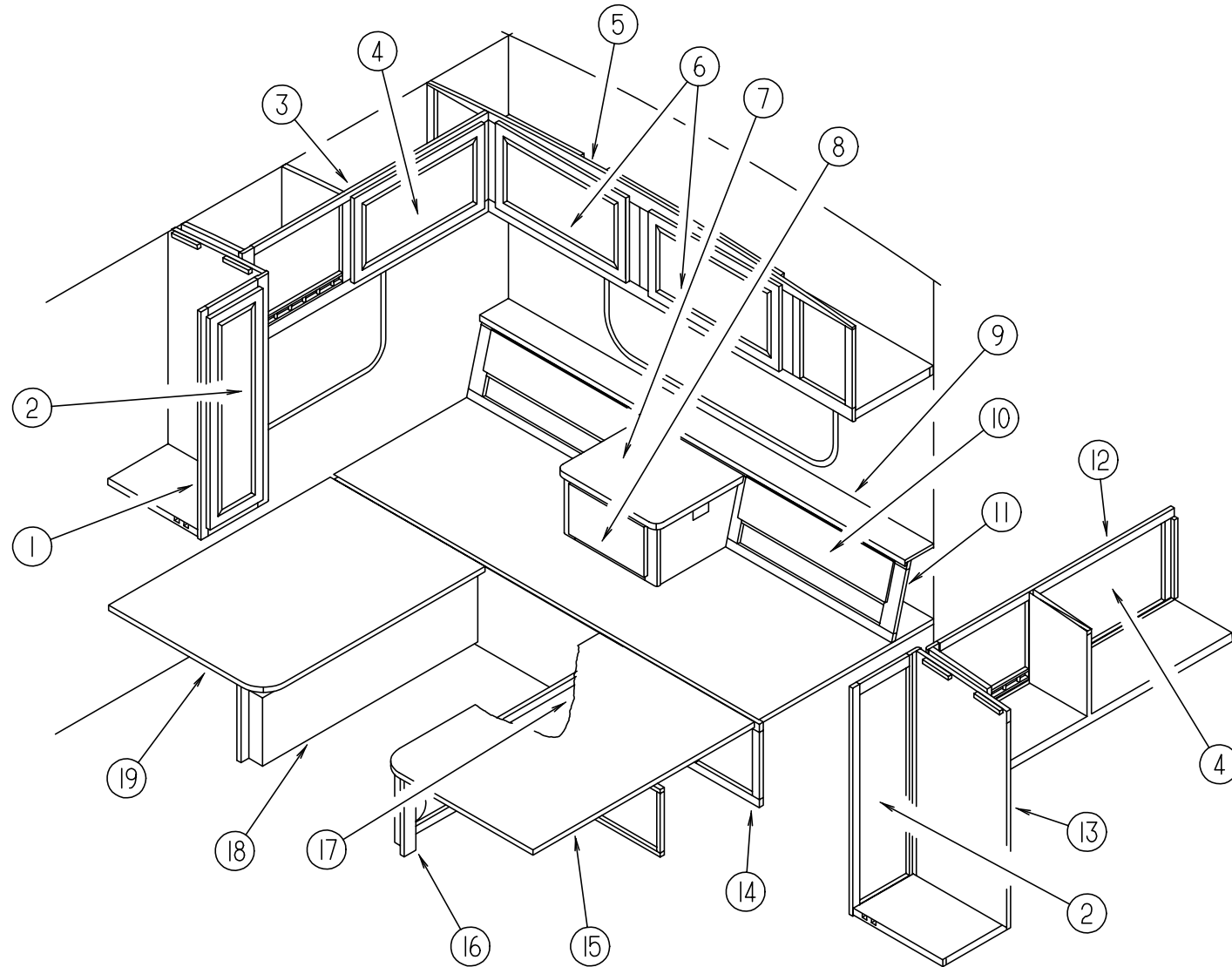

KEY	PART NUMBER	U/M	DESCRIPTION
1	110946-01-G09	EA	CABINET-SHIRT CLOSET, W/O DOOR OR HARDWARE
2	M06803-15-G09	EA	DOOR-W/O HARDWARE - 305 MM X 1015 MM
3	111185-01-G09	EA	CABINET-OVERHEAD, W/O DOOR OR HARDWARE
	058331-A5-000	EA	MIRROR-GLASS, SAFETY - 396 MM X 516 MM
4	M06803-02-G09	EA	DOOR-W/O HARDWARE - 400 MM X 710 MM
5	111239-01-G09	EA	CABINET-OVERHEAD, W/O DOORS OR HARDWARE
6	M06803-13-G09	EA	DOOR-W/O HARDWARE W/MIRROR - 400 MM X 710 MM
6	M06803-02-G09	EA	DOOR-W/O HARDWARE W/O MIRROR - 400 MM X 710 MM
			DECORATOR DOOR OPTION - FLAT PANEL
7	117906-13-G09	EA	COUNTERTOP-NIGHTSTAND CABINET (G29/G32)
7	117906-13-G30	EA	COUNTERTOP-NIGHTSTAND CABINET (G30)
7	117906-13-G31	EA	COUNTERTOP-NIGHTSTAND CABINET (G31)
8	M05971-R4-G09	EA	DRAWER-CABINET, W/O HARDWARE
9	117906-11-G09	EA	COUNTERTOP-NIGHTSTAND CABINET (G29/G32)
9	117906-11-G30	EA	COUNTERTOP-NIGHTSTAND CABINET (G30)
9	117906-11-G31	EA	COUNTERTOP-NIGHTSTAND CABINET (G31)

KEY	PART NUMBER	U/M	DESCRIPTION
10	117906-12-G29	EA	DOOR-W/O HDW - FABRIC COVERED - 176 MM X 802 MM - EITHER SIDE (G29)
10	117906-12-G30	EA	DOOR-W/O HDW - FABRIC COVERED - 176 MM X 802 MM - EITHER SIDE (G30)
10	117906-12-G31	EA	DOOR-W/O HDW - FABRIC COVERED - 176 MM X 802 MM - EITHER SIDE (G31)
10	117906-12-G12	EA	DOOR-W/O HDW - FABRIC COVERED - 176 MM X 802 MM - EITHER SIDE (G32)
11	117906-01-G29	EA	CABINET-NIGHTSTAND, W/COUNTERTOPS - W/O DOORS OR DRAWER (G29)
11	117906-01-G30	EA	CABINET-NIGHTSTAND, W/COUNTERTOPS - W/O DOORS OR DRAWER (G30)
11	117906-01-G31	EA	CABINET-NIGHTSTAND, W/COUNTERTOPS - W/O DOORS OR DRAWER (G31)
11	117906-01-G12	EA	CABINET-NIGHTSTAND, W/COUNTERTOPS - W/O DOORS OR DRAWER (G32)
12	111186-01-G09	EA	CABINET-OVERHEAD, W/O DOOR OR HARDWARE
	058331-A5-000	EA	MIRROR-GLASS, SAFETY - 396 MM X 516 MM
13	110947-01-G09	EA	CABINET-SHIRT CLOSET, W/O DOOR OR HARDWARE - DRIVER SIDE
14	P10877-01-000	EA	CABINET-COMPARTMENT, W/O TOP OR CARPET
15	M04170-08-000	EA	TOP-TWIN BED, DRIVER SIDE
16	P17904-01-G09	EA	CABINET-TWIN BED W/O TOP
17	M06803-68-G09	EA	DOOR-W/O HARDWARE - 305 MM X 555 MM - DRIVER SIDE TWIN BED CABINET
18	P17903-01-G09	EA	CABINET-TWIN BED W/O TOP
19	M04170-09-000	EA	TOP-TWIN BED, PASSENGER SIDE

BEDROOM GROUP (CONTINUED)

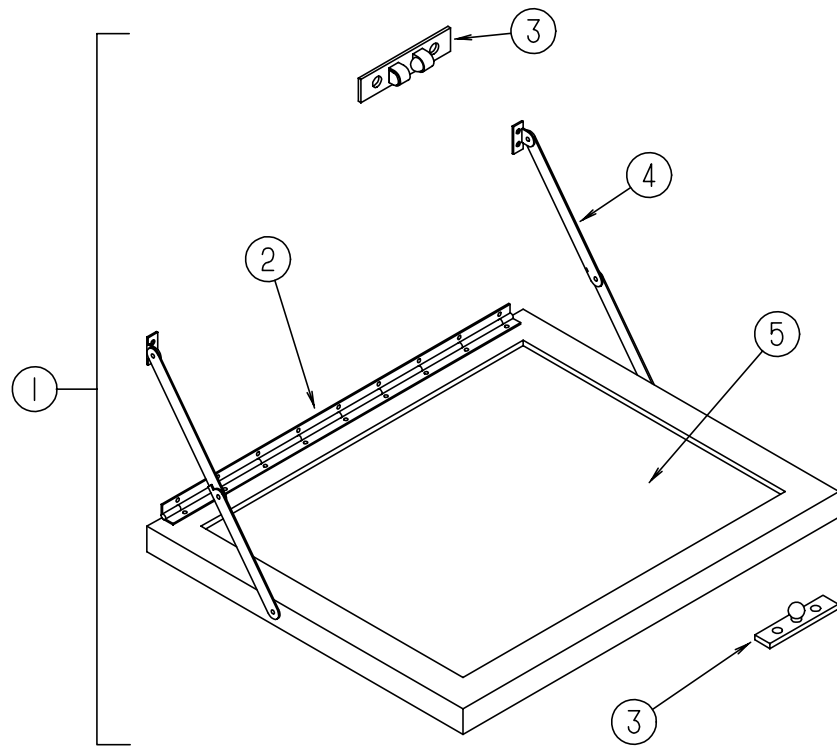

TV STAND

KEY	PART NUMBER	U/M	DESCRIPTION
1	084357-02-G09	EA	STAND-FOLD DOWN, TV - W/MIRROR
2	084413-01-000	EA	HINGE-CONTINUOUS, W/HOLES
3	084451-01-000	EA	CATCH-TV SHELF, BRASS
4	084412-01-000	EA	SUPPORT-HINGED (PAIR)
5	084356-08-000	EA	INSERT-TV STAND, W/SUPPORT HINGE - METAL - OFF WHITE
5	058331-14-000	EA	MIRROR-GLASS, SAFETY - 14" X 12.7"

BEDROOM GROUP (CONTINUED)

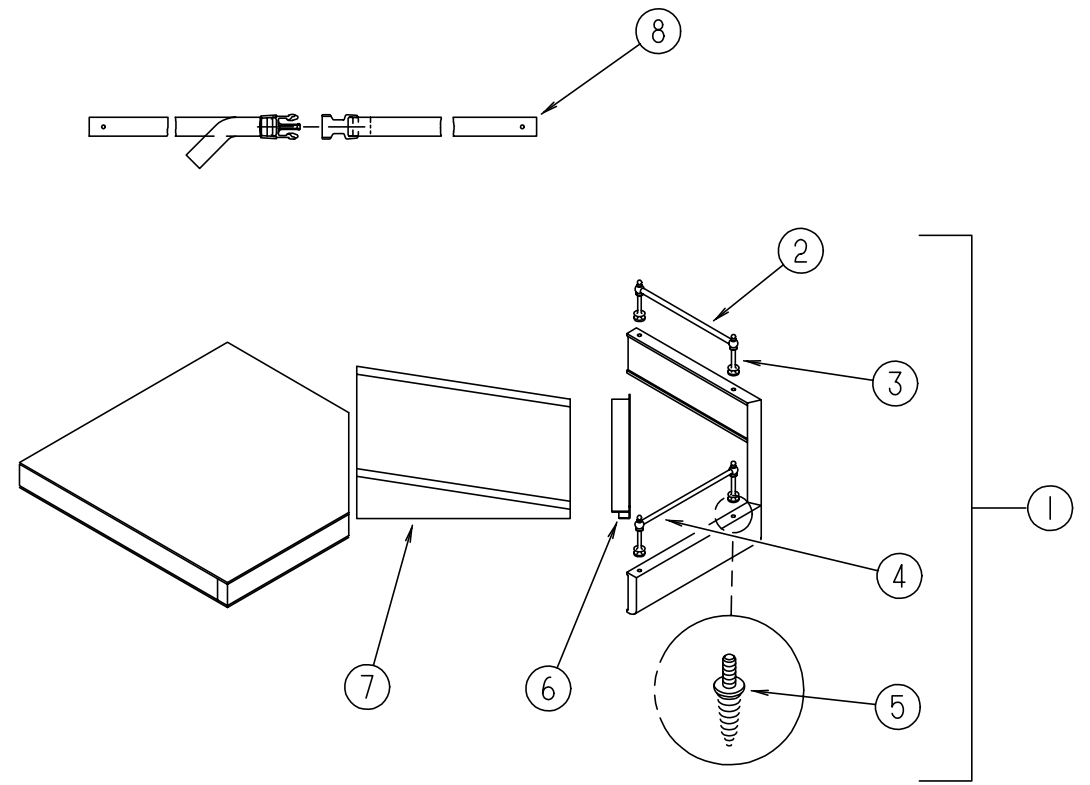

TV SHELF

KEY	PART NUMBER	U/M	DESCRIPTION
1	116553-02-G09	EA	SHELF ASM-TV, W/BRASS RAILING & WEDGE - 444 MM X 424 MM
2	084071-12-000	EA	ROD-BRASS, 104 MM LONG
3	084070-02-000	EA	POST-END, 2.4" - BRASS
4	084071-19-000	EA	ROD-BRASS, 198 MM LONG
5	106166-01-000	EA	BOLT-COLLARED HANGER, 8-32 X 1"
6	103186-01-05A	FT	MOLDING-EDGE, SHELF - .78" WIDE - PLASTIC - WATERFORD OAK
7	116553-15-G09	EA	WEDGE-TV
8	099717-01-000	EA	TIEDOWN-TV, STRAP ON FEMALE END IS 22.8" LONG

CHASSIS GROUP

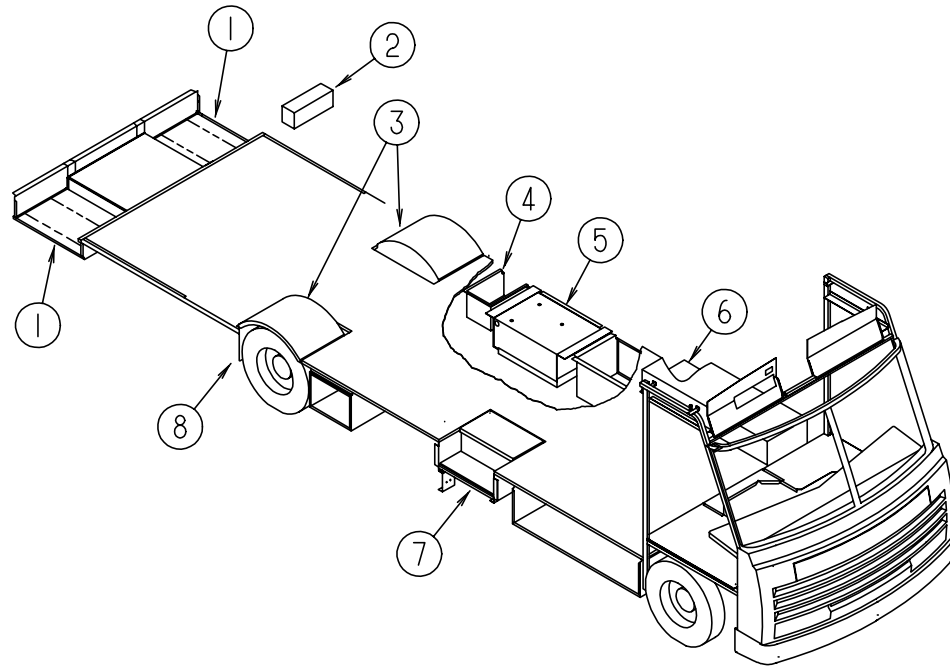

COMPARTMENTS & WHEELWELLS

KEY	PART NUMBER	U/M	DESCRIPTION
1	110820-02-000	EA	COMPARTMENT-STORAGE, STEEL - E-COAT
2	085967-01-000	EA	COMPARTMENT-SEWER HOSE, 6" X 6.6" X 17.8" - PLASTIC
3	102921-01-000	EA	WHEELWELL-PLASTIC
4	102979-01-000	EA	BOX-POWER CORD
5	078137-02-000	EA	TRAY-STORAGE COMPARTMENT, 27.18" WIDE X 21" DEEP
5	105732-02-000	EA	TRAY ASM-GENERATOR
6	103036-02-000	EA	COMPARTMENT ASM-STORAGE
7	077848-02-000	EA	STEP-PULLOUT
	091176-01-000	EA	SUPPORT-BASE-ENTRANCE STEP
	102569-04-000	EA	MAT-ANTI SLIP, 178 MM X 610 MM
8	017516-01-000	EA	FLAP-MUD, 14" X 18" - BLACK
8	020167-04-000	EA	GUARD-DIRT
	056748-01-000	EA	PLUG-CAP, 1.5" DIAMETER - BLACK
	115361-01-01A	EA	PLUG-PLASTIC, .55" DIAMETER HOLE - CAPLUG W-5

CHASSIS GROUP (CONTINUED)

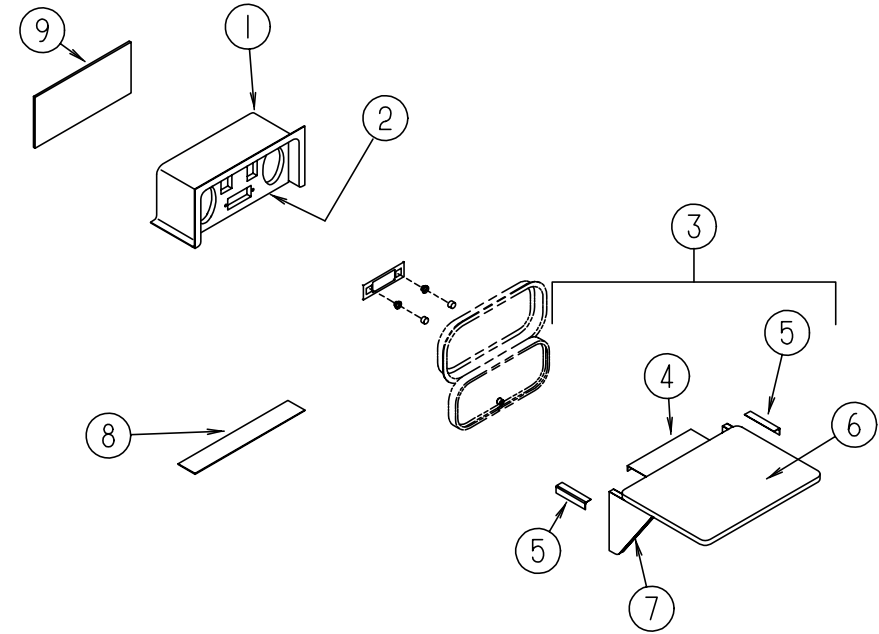

PATIO ENTERTAINMENT CENTER

KEY	PART NUMBER	U/M	DESCRIPTION
1	104897-03-02A	EA	BOX-ENTERTAINMENT CENTER - BRIGHT WHITE
2	104899-01-C05	EA	PLATE-RADIO MOUNTING
3	105230-01-E01	EA	SHELF ASSEMBLY
4	105377-01-01A	EA	BRACKET-TABLE HANGER, OFF WHITE
5	105376-01-02A	EA	HINGE-CONTINUOUS, 2" X 140 MM - OFF WHITE
6	105230-11-E01	EA	SHELF
7	105230-12-E01	EA	SUPPORT-SHELF
8	104898-01-02A	EA	PLATE-PLASTIC, BOTTOM - 19.38" X 3.1" - BRIGHT WHITE
9	104898-02-02A	EA	PLATE-PLASTIC, REAR - 16.1" X 6.3" - BRIGHT WHITE

CHASSIS GROUP (CONTINUED)

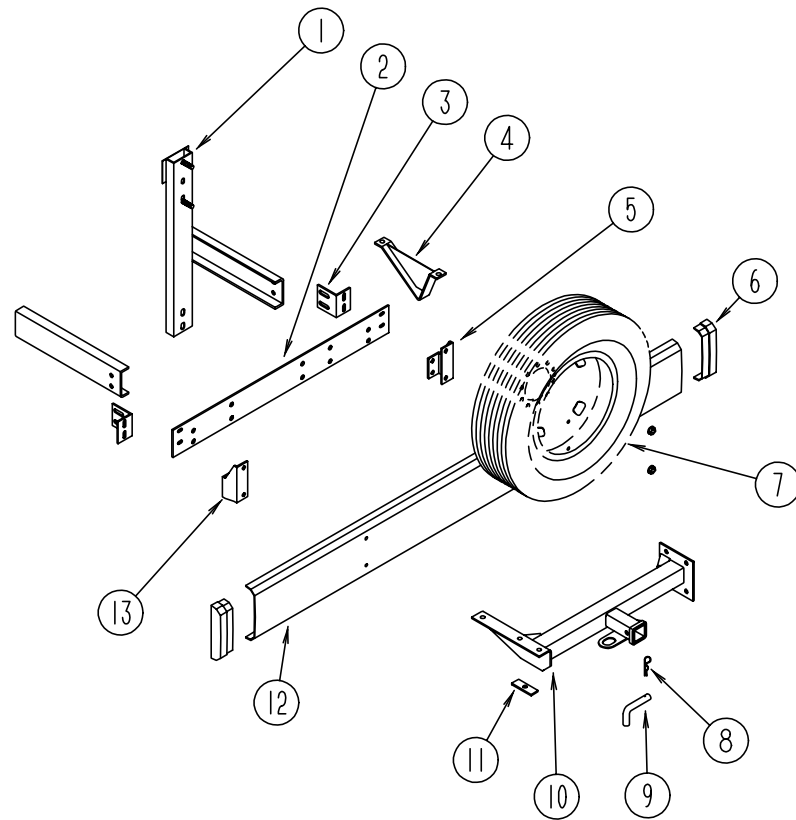

REAR BUMPER, TRAILER HITCH & COMPONENTS

KEY	PART NUMBER	U/M	DESCRIPTION
1	102944-05-000	EA	BRACKET ASM-TIRE CARRIER, CHEVY
1	102944-06-000	EA	BRACKET ASM-TIRE CARRIER, FORD OPTION
2	078678-02-000	EA	PLATE-MOUNTING, BUMPER - REAR
3	078668-01-000	EA	SUPPORT ANGLE-BUMPER, REAR
4	083376-01-000	EA	SKID PLATE
5	117950-03-02B	EA	BRACKET ASM-BUMPER, REAR - E-COAT
6	103228-01-06A	EA	CAP-END, BUMPER - REAR - DRIVER OR PASSENGER SIDE - BRIGHT WHITE
7	083425-05-000	EA	TIRE - LT235/85R16, LRE XPS RIB - MICHELIN - FORD OPTION
7	007324-03-000	EA	TIRE - 8R19.5 LRF, MICHELIN - CHEVY
7	007324-04-000	EA	TIRE - 8R19.5 LRD, MICHELIN XZA - CHEVY
	051377-01-000	EA	STEM-VALVE, TR 500
	051377-05-000	EA	STEM-VALVE, EATON VS-938 F53-92 - FORD OPTION
	077030-02-000	EA	EXTENSION-VALVE STEM, 1.25" - FORD OPTION
	064963-01-000	EA	WHEEL-STEEL, 19.5" X 6" - GM 14005758
	095853-02-000	EA	WHEEL-STEEL, 16" X 6K - F2TA-1015-NA - ACCURIDE 28513-7 - FORD OPTION
8	034513-01-000	EA	PIN-HITCH, 3/16 WIRE
9	034512-01-000	EA	PIN-LOCKING, DRAWBAR
10	107707-09-000	EA	HITCH ASM W/O DRAWBAR
11	070579-09-000	EA	PLATE-ANCHOR, 45.7 MM X 38 MM - STEEL - E-COAT
12	103099-01-06A	EA	BUMPER-REAR, BRIGHT WHITE
13	117950-04-02B	EA	BRACKET ASM-BUMPER, REAR - E-COAT
	113589-02-000	EA	CONNECTOR-SOCKET, TRAILER - GENERAL 433601
	113589-01-000	EA	CONNECTOR-PLUG, TRAILER - GENERAL 433501
	113588-02-01B	EA	BRACKET-CONNECTOR, TRAILER - MILL

CHASSIS GROUP (CONTINUED)

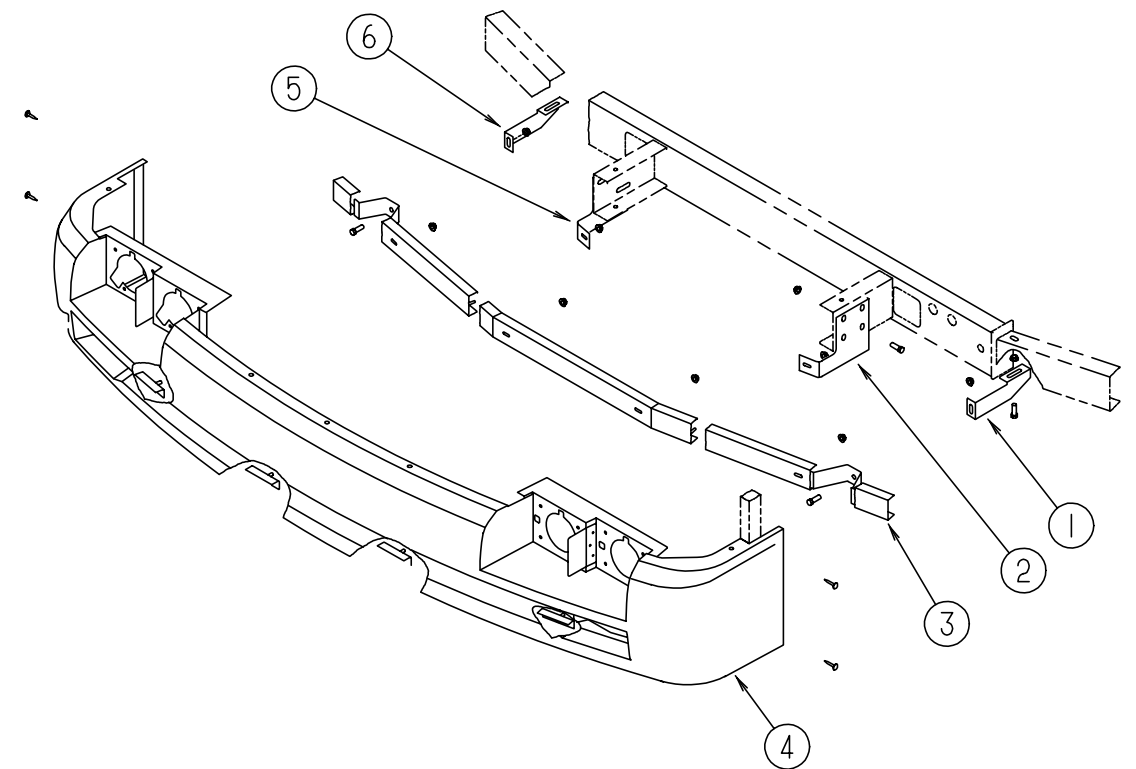

FRONT BUMPER

KEY	PART NUMBER	U/M	DESCRIPTION
1	118235-02-02B	EA	SUPPORT-BUMPER, OUTER - LH
2	118234-02-02B	EA	SUPPORT-BUMPER, INNER - LH
3	103512-01-000	EA	CHANNEL ASM-BUMPER
4	118193-01-G13	EA	BUMPER ASM-FRONT - UNPAINTED
5	118234-01-02B	EA	SUPPORT-BUMPER, INNER - RH
6	118235-01-02B	EA	SUPPORT-BUMPER, OUTER - RH

CHASSIS GROUP (CONTINUED)

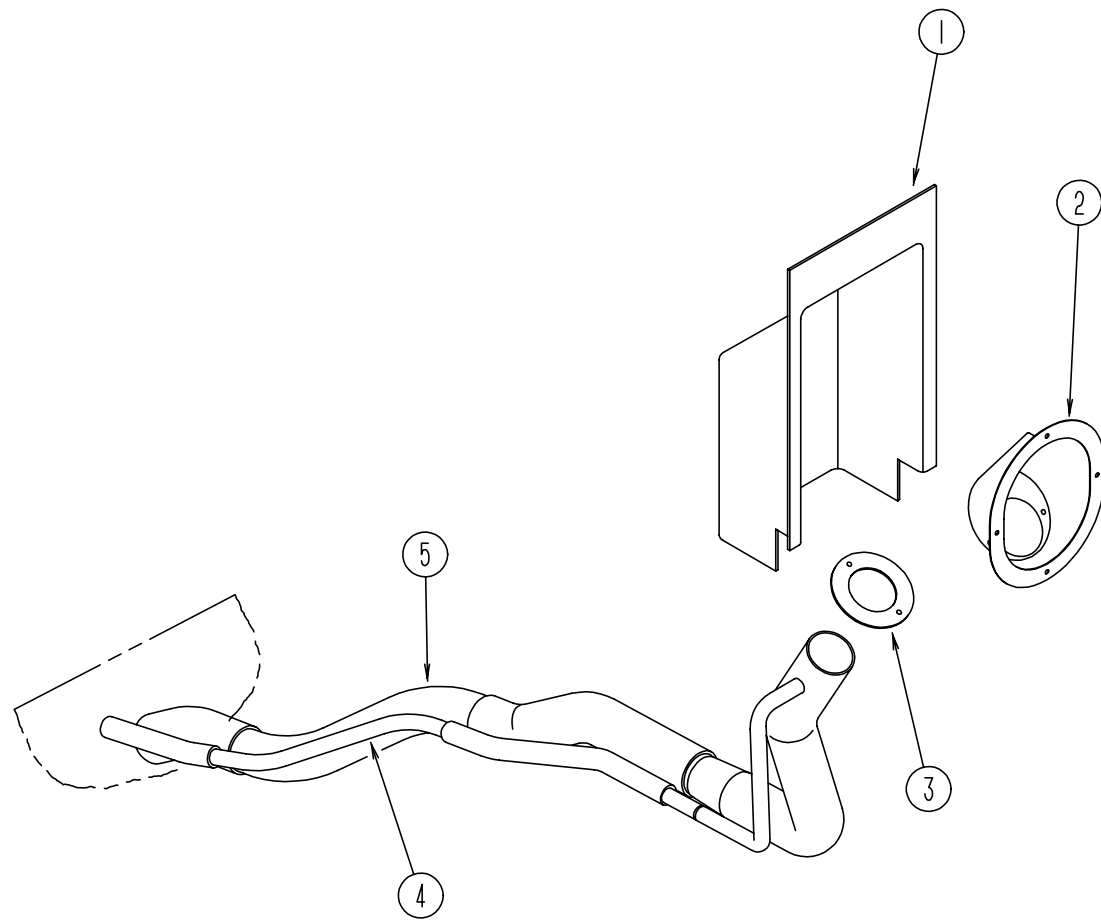

FUEL SYSTEM - CHEVY

KEY	PART NUMBER	U/M	DESCRIPTION
1	072447-09-000	EA	SHROUD-FUEL FILL, UPPER - PLASTIC
2	095854-01-04A	EA	SHROUD-FUEL FILL, BRIGHT WHITE
3	078200-01-000	EA	GASKET-FUEL FILL, 3.5" OD X 2" ID
4	098804-01-000	EA	PIPE-VENT, FUEL FILL - 12" LONG
5	098805-01-000	EA	PIPE-FUEL, FUEL FILL - 11.4" LONG
	084884-01-000	EA	PLUG-BRASS, 3/8"
	007063-01-000	FT	HOSE-GAS, 1/4" ID X 1/2" OD
	024138-01-000	FT	HOSE-FUEL, 5/16" ID

CHASSIS GROUP (CONTINUED)

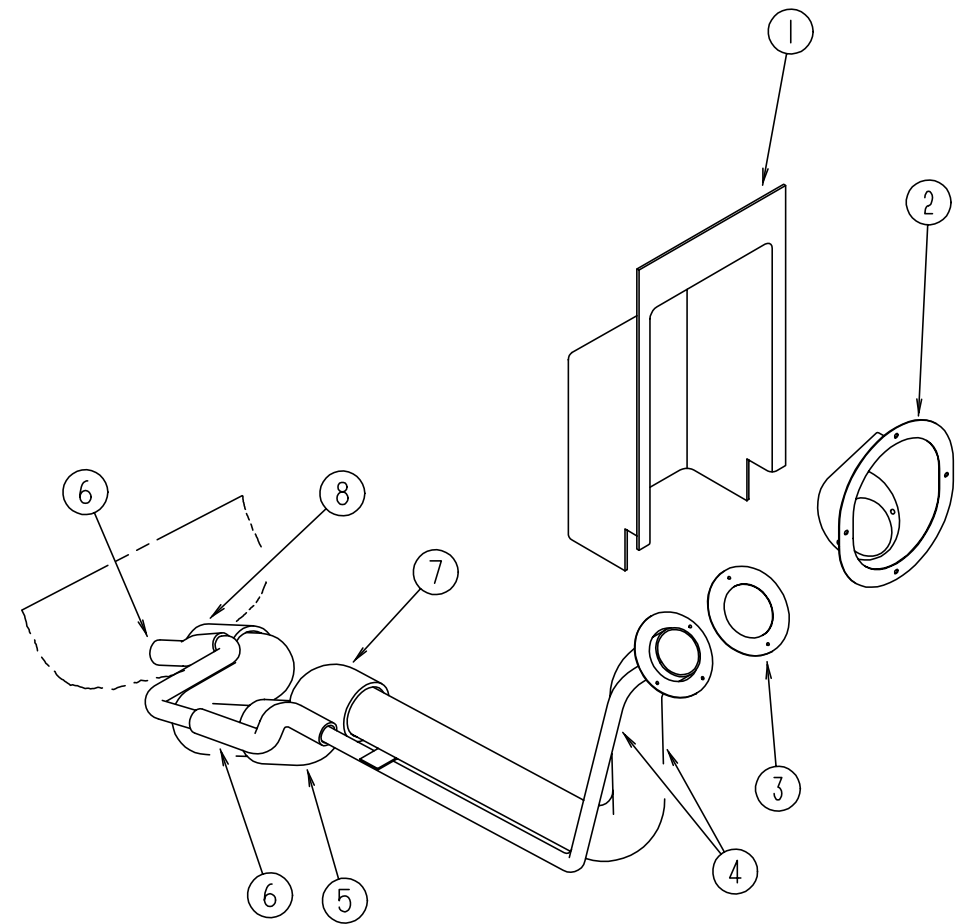

FUEL SYSTEM - FORD

KEY	PART NUMBER	U/M	DESCRIPTION
1	072447-09-000	EA	SHROUD-FUEL FILL, UPPER - PLASTIC
2	095854-01-04A	EA	SHROUD-FUEL FILL, BRIGHT WHITE
3	078200-01-000	EA	GASKET-FUEL FILL, 3.5" OD X 2" ID
4	095606-01-000	EA	NECK-FUEL FILL, W/CHECK VALVE - L-SHAPED - 18.2" LONG
5	100156-01-000	EA	HOSE-FUEL FILL, 8.3" LONG W/2" ID
6	066732-03-000	FT	HOSE-FUEL FILL, .75" ID
			FROM: 00-00-00 THRU: 01-07-96
6	066732-01-000	FT	HOSE-FUEL FILL, .62" ID
			FROM: 01-08-96 THRU: 99-99-99
7	100140-01-000	EA	TUBE-FUEL INLET - 91 W/IFF30EU
8	007111-02-000	EA	HOSE-FUEL FILL, 2.00 ID - IN 3FT LENGTHS
	007063-01-000	FT	HOSE-GAS, 1/4" ID X 1/2" OD
	084884-01-000	EA	PLUG-BRASS, 3/8"

CHASSIS GROUP (CONTINUED)

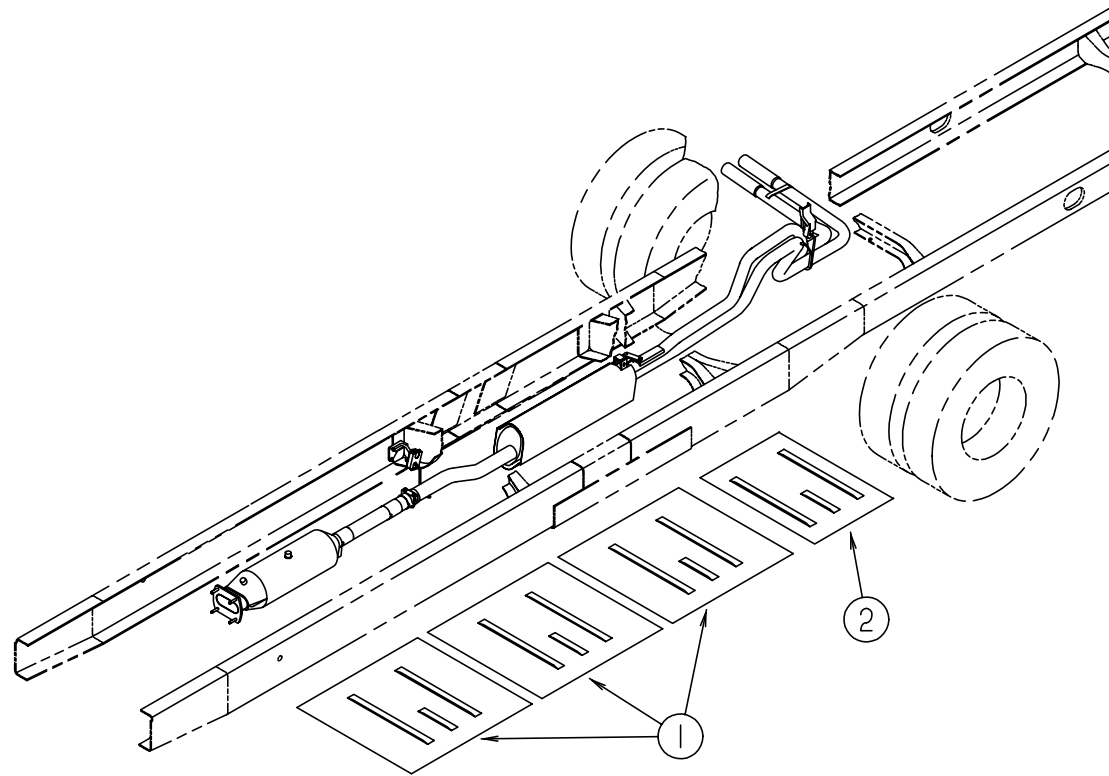

FORD EXHAUST HEAT SHIELDS

KEY	PART NUMBER	U/M	DESCRIPTION
1	101544-06-000	EA	SHIELD-HEAT, EXHAUST - 33.9" X 28.9" - STEEL
2	101544-01-000	EA	SHIELD-HEAT, EXHAUST - 19.7" X 28.9" - STEEL

CHASSIS GROUP (CONTINUED)

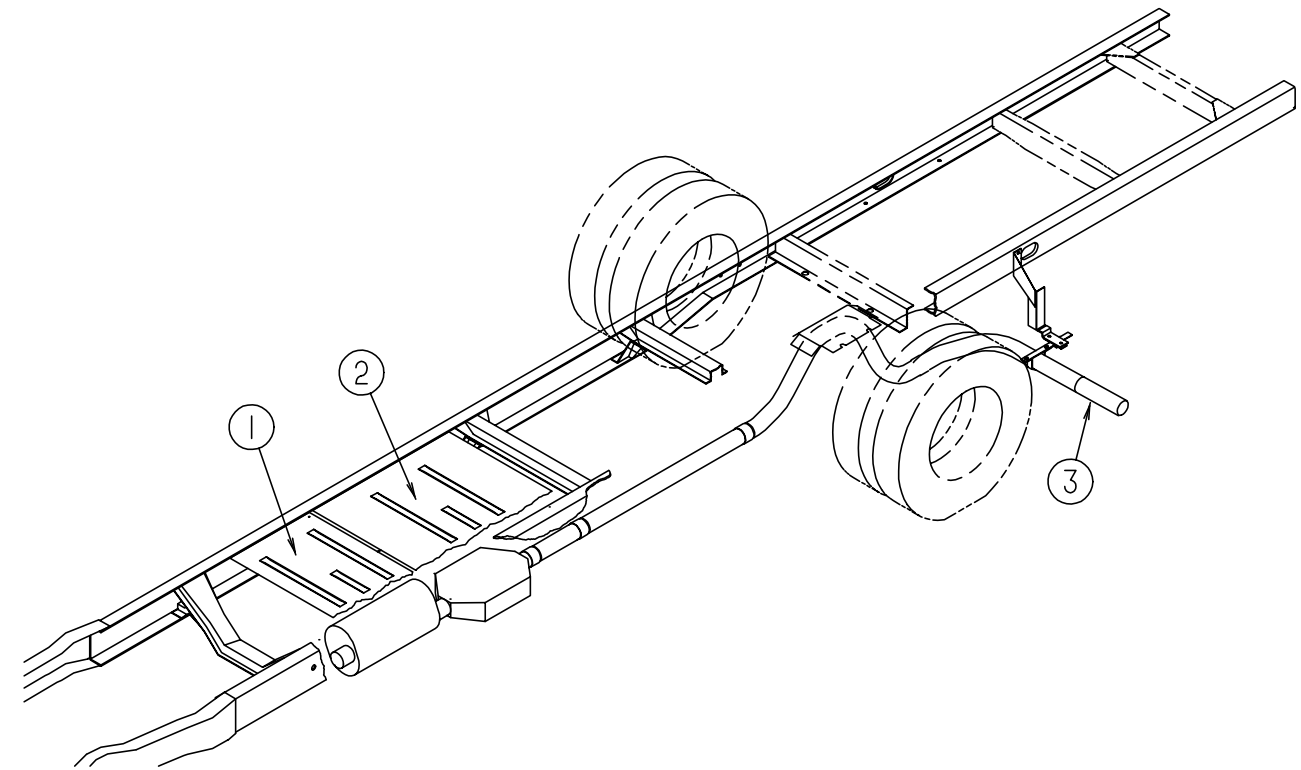

CHEVY EXHAUST SYSTEM

KEY	PART NUMBER	U/M	DESCRIPTION
1	101544-01-000	EA	SHIELD-HEAT, EXHAUST - 19.7" X 28.9" - STEEL
2	101544-02-000	EA	SHIELD-HEAT, EXHAUST - 30" X 28.9" - STEEL
3	098762-05-000	EA	EXTENSION-EXHAUST, STRAIGHT - 3" OD X 7.9" LONG - STAINLESS STEEL
	094918-01-000	EA	CLAMP-EXHAUST, 3" - GUILLOTINE STYLE

CHASSIS GROUP (CONTINUED)

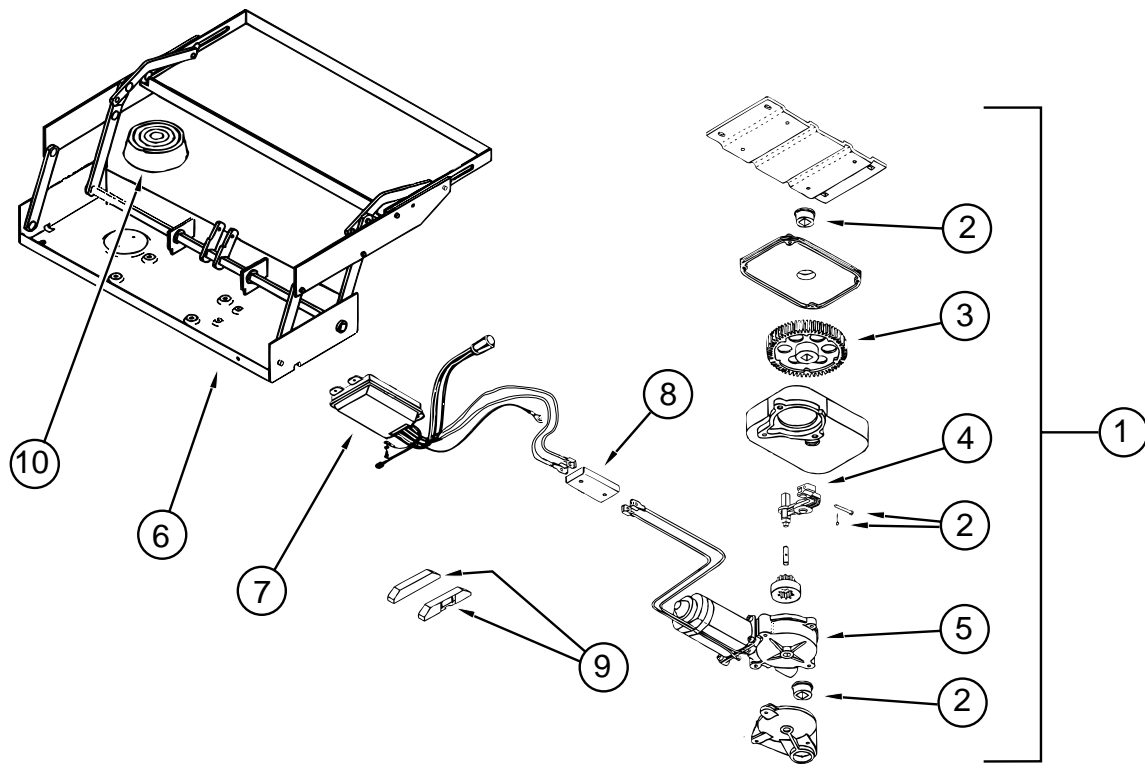

KWIKEE ELECTRIC ENTRY STEP

KEY	PART NUMBER	U/M DESCRIPTION	VENDOR NO.
1	094708-01-01A	EA STEP-ENTRY DOOR, ELECTRIC - SINGLE - KWIKEE 2813	
2	094707-02-703	EA PARTS KIT, (BEARINGS & PINS)	9530
3	094707-02-702	EA GEAR KIT - KWIKEE	9525
4	094708-03-700	EA LINKAGE ASM F/28 SERIES	9522
5	094707-02-700	EA MOTOR REPLACEMENT KIT - MODELS 32 & 28	9520
6	088746-01-709	EA FRAME W/SINGLE STEP, 2800 SERIES	908028
7	094707-02-705	EA CONTROL UNIT, WHITE	909513
8	094707-02-704	EA CONNECTOR KIT-MOTOR	9537
9	094707-02-707	EA TREAD-NON-SKID, BLACK - 6" X 21"	909333
9	116995-01-000	EA SWITCH/MAGNET-STEP, ELECTRIC - KWIKEE 905306	
10	088746-01-705	EA LIGHT-UNDER STEP	9004
	088733-01-700	EA BULB	9004

CHASSIS GROUP (CONTINUED) DICOR 19.5" CHEVY WHEEL COVERS

KEY	PART NUMBER	U/M DESCRIPTION	VENDOR NO.
	109443-01-000	EA WHEEL-COVER, 4/SET - 19.5" W/HARDWARE - DICOR SHAG95	
	109443-01-700	EA WHEEL-COVER, 1 - FRONT OR REAR - 19.5"	SHAG95 LONLY
	109443-01-701	EA SET-BRACKET, 1 FRONT WHEEL	SHAG95-FBS
	109443-01-702	EA SET-BRACKET, 1 REAR WHEEL	SHAG95-RBS
	109443-01-703	EA CAP-CENTER, HUB	SP-AUCAP
	109443-01-704	EA CLIP-RETAINER	V160GM-PNT

KAPER 19.5" CHEVY STAINLESS STEEL WHEEL LINERS (FROM: 00-00-00 THRU: 06-30-96)

KEY	PART NUMBER	U/M DESCRIPTION	VENDOR NO.
	091209-01-000	EA LINER-WHEEL, 19.5" - STAINLESS STEEL - SET OF 4 - KAPER 1954-ION	
	091209-01-700	EA LINER-WHEEL, 19.5" FRONT - 10 LUG - CHEVY P-30	37N
	091209-01-701	EA LINER-WHEEL, 19.5" REAR - 10 LUG - CHEVY P-30	38N
	091209-01-702	EA COVER-AXLE, 19.5" FRONT - 10 LUG - CHEVY P-30	34N
	091209-01-703	EA COVER-AXLE, 19.5" REAR - 10 LUG - CHEVY P-30	35N
	091209-01-704	EA COVER-LUG NUT	36
	077030-02-000	EA EXTENSION-VALVE STEM, 1.25"	

DICOR 19.5" CHEVY STAINLESS STEEL WHEEL LINERS (FROM: 07-01-96 THRU: 99-99-99)

KEY	PART NUMBER	U/M DESCRIPTION	VENDOR NO.
	110435-06-000	EA LINER-WHEEL SET (SET=4) 19.5" - V195P5 (OL)	
	110435-02-703	EA NUT (JAMB)	V160SD-JNT
	110435-02-704	EA COVER-LUG NUT	V160F0-LNC
	110435-02-705	EA TOOL F/ JAMB NUT, INSTALL.	V160F0-TOL
	110435-06-700	EA LINER-WHEEL, FRONT	V195P5-FWC
	110435-06-701	EA LINER-WHEEL, REAR	V195P5-RWC
	110435-06-702	EA BRACKET-BRIDGE	V195P5-BRK
	110435-06-703	EA NUT-JAM, BRIDGE BRACKET - 1 1/16	V195P5-BJN
	110435-06-704	EA STUD EXTENDERS - P30	V195P5-STX
	077030-02-000	EA EXTENSION-VALVE STEM, 1.25"	

DICOR 16" FORD WHEEL COVERS

KEY	PART NUMBER	U/M DESCRIPTION	VENDOR NO.
	098532-01-000	EA COVER-WHEEL, FORD - 16" - SET OF 4 - DICOR SH-SD-16	
	098532-01-700	EA COVER-LUG NUT, FORD - CHROME	SP-FM-CLN
	098532-01-701	EA COVER-WHEEL, FORD - 16"	

KAPER II 16" FORD CHROME WHEEL LINERS (FROM: 00-00-00 THRU: 03-17-96)

KEY	PART NUMBER	U/M DESCRIPTION	VENDOR NO.
	091209-14-000	EA LINER-WHEEL, SET OF 4 - 16" - CHROME - KAPER II 1611-4ULT4	
	091209-08-700	EA SIMULATOR-FRONT	157
	091209-14-700	EA SIMULATOR-REAR	159
	091209-08-706	EA FLAT NUT - .500, 9/16" STUD	
	091209-01-704	EA COVER-LUG NUT	
	077030-02-000	EA EXTENSION-VALVE STEM, 1.25"	

DICOR 16" FORD CHROME WHEEL LINERS (FROM: 03-18-96 THRU: 99-99-99)

KEY	PART NUMBER	U/M DESCRIPTION	VENDOR NO.
	110435-08-000	EA LINER-WHEEL SET (SET=4) 16" - DICOR V160SD(OL)	
	110435-08-700	EA LINER-WHEEL, FRONT	V160SD-FWC
	110435-08-701	EA LINER-WHEEL, REAR	V160SD-RWC
	110435-02-702	EA STUD EXTENDER	V160SD-STX
	110435-02-703	EA NUT (JAMB)	V160SD-JNT
	110435-02-704	EA COVER-LUG NUT	V160F0-LNC
	110435-02-705	EA TOOL F/ JAMB NUT, INSTALL.	V160F0-TOL
	077030-02-000	EA EXTENSION-VALVE STEM, 1.25"	

CHASSIS GROUP (CONTINUED)
BILSTEIN FRONT SHOCKS - CHEVY

KEY	PART NUMBER	U/M	DESCRIPTION
	104993-01-000	EA	SHOCK ABSORBER-GAS, P30 FRONT - BILSTEIN B46-1173 FROM: 00-00-00 THRU: 01-07-96
	104993-02-000	EA	SHOCK ABSORBER-GAS, P30 FRONT - BILSTEIN B46-2137 FROM: 01-08-96 THRU: 99-99-99
	122756-01-000	EA	SHOCK & STABILIZER-STEERING P30

TIRE COVERS

KEY	PART NUMBER	U/M	DESCRIPTION
	108163-02-01A	EA	COVER-TIRE, CHROME - EXTERIOR TRIM OPTION
	108560-03-03A	EA	INSERT-TIRE COVER, BRIGHT WHITE - EXTERIOR TRIM OPTION

LUG WRENCH & LEVERAGE BAR

KEY	PART NUMBER	U/M	DESCRIPTION
	080208-01-000	EA	LUG WRENCH, 1.06 X 1.00
	080208-02-000	EA	LEVERAGE BAR-LUG WRENCH

CHASSIS MISCELLANEOUS

KEY	PART NUMBER	U/M	DESCRIPTION
	055278-51-259	EA	TUBING-STEEL, .75" X 1.5" X 12.5"
	077298-55-003	EA	EXTR-TUBE, 0007MM - BLACK - 6060T6
	008042-01-000	FT	TUBING-VINYL, .65" ID
	065450-05-000	EA	TIEDOWN-BATTERY, 8.4" TUBE - STEEL
	087475-02-000	EA	BRACKET-TIE DOWN, BATTERY - 13.5" X 1.3" - FORD OPTION
	090604-06-000	EA	TRAY-BATTERY, AUTO - W/TWO HEX NUTS - FORD OPTION
	075307-03-000	EA	SHIELD-HEAT, LP 1016 MM X 178 MM - STEEL
	113875-01-000	EA	HOSE-HUMP, 3" - GRIFFITH HH3 - DIESEL OPTION
	119847-01-02B	EA	SHIELD-A/C COMPRESSOR, E-COAT
	123361-01-000	EA	DUCT-AIR INTAKE - VORTEC ENGINE OPTION FROM: 04-15-96 THRU: 99-99-99
	123362-01-000	EA	ELBOW-RUBBER, 90 DEGREE - 3.5" ID - VORTEC ENGINE OPTION FROM: 04-15-96 THRU: 99-99-99
	114254-01-000	EA	ADAPTER - 1/4" SINGLE BARB X 1/8" MPT
	113007-01-000	EA	PIN-SPRING, .375" X 3" - FORD
	068382-06-000	EA	BUSHING-BRASS, 3/8" MPT X 1/8" FPT
	104147-02-000	EA	SHIELD ASM-SPLASH, RH - 494 MM X 408 MM - W/STUDS - E-COATED STEEL

CURTAIN & CUSHION GROUP
NOTICE

IN ORDER TO ASSIST OUR PARTS SALES DEPT. IN PROVIDING INTERIOR SOFTGOODS ITEMS, PLEASE INCLUDE THE SERIAL NUMBER AND THE COLOR CODE NUMBER FROM THE VEHICLE CERTIFICATION LABEL WHEN ORDERING. THIS LABEL IS LOCATED ON THE LEFT SIDEWALL AT THE END OF THE DASH (A-BODY), OR ON THE DRIVER'S DOOR LATCH PLATE (C-BODY).

AN EXAMPLE OF A COLOR CODE NUMBER IS B07, WHICH DESIGNATES AN OVERALL COLOR SCHEME OF A PARTICULAR UNIT. THE COLOR LISTED AFTER THE ITEM DESCRIPTION ON THE MICROFICHE, INDICATES THE OVERALL UNIT COLOR. ORDER THE ITEM YOU DESIRE ACCORDING TO UNIT COLOR CODE.

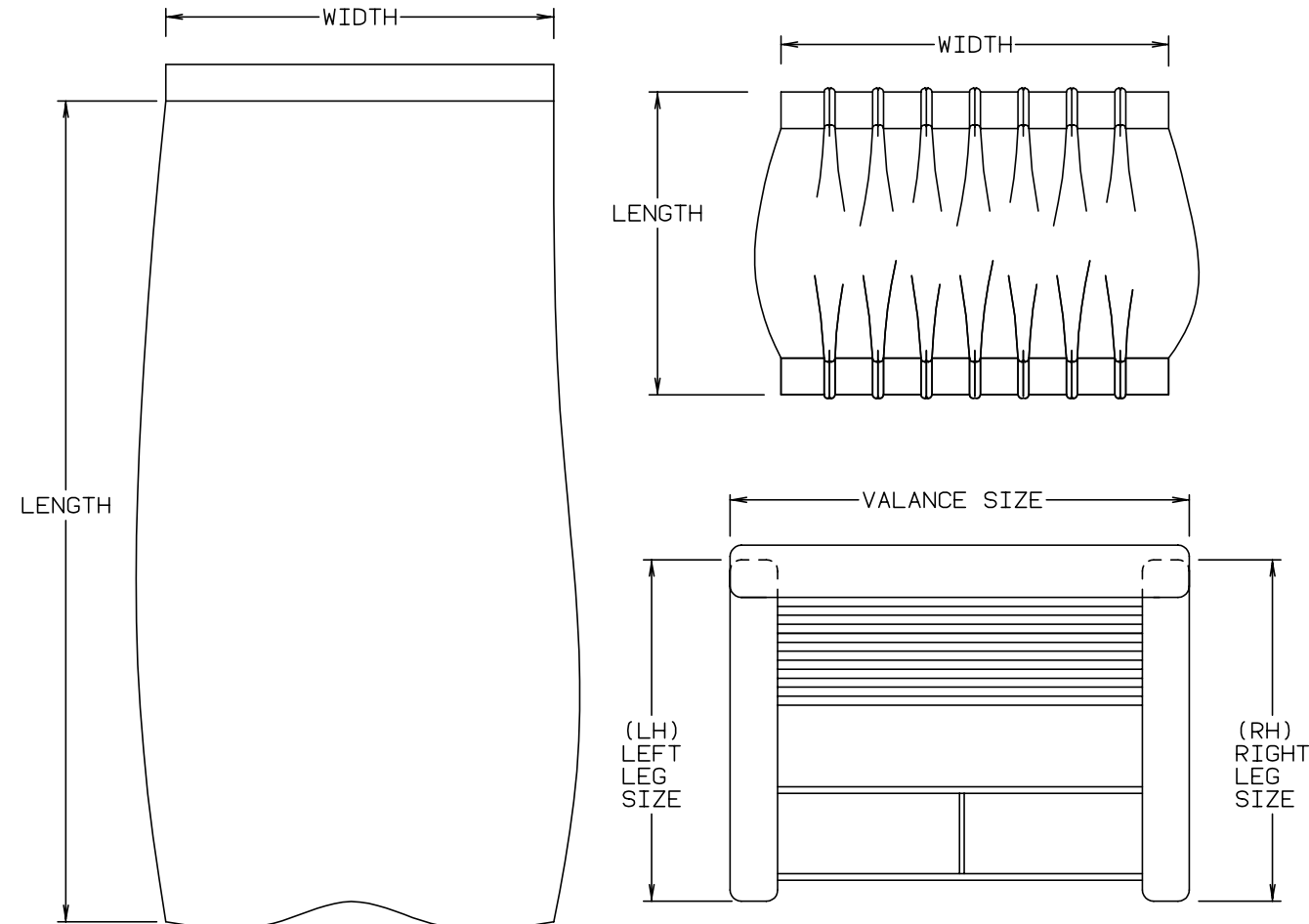

NOTE: USE THIS ILLUSTRATION WHEN DETERMINING LENGTH AND WIDTH MEASUREMENTS FOR CURTAINS. YOU WILL NOTE THE WIDTH MEASUREMENT IS TAKEN ON THE TOP OF THE CURTAIN WITH THE CURTAIN FULLY EXTENDED. THE LENGTH MEASUREMENT IS TAKEN FROM TOP TO BOTTOM. LEFT AND RIGHT WINDOW LEGS ARE DETERMINED WHEN FACING THE WINDOW.

CURTAIN & CUSHION GROUP (CONTINUED)
CURTAIN, BLIND HARDWARE & TRACKS

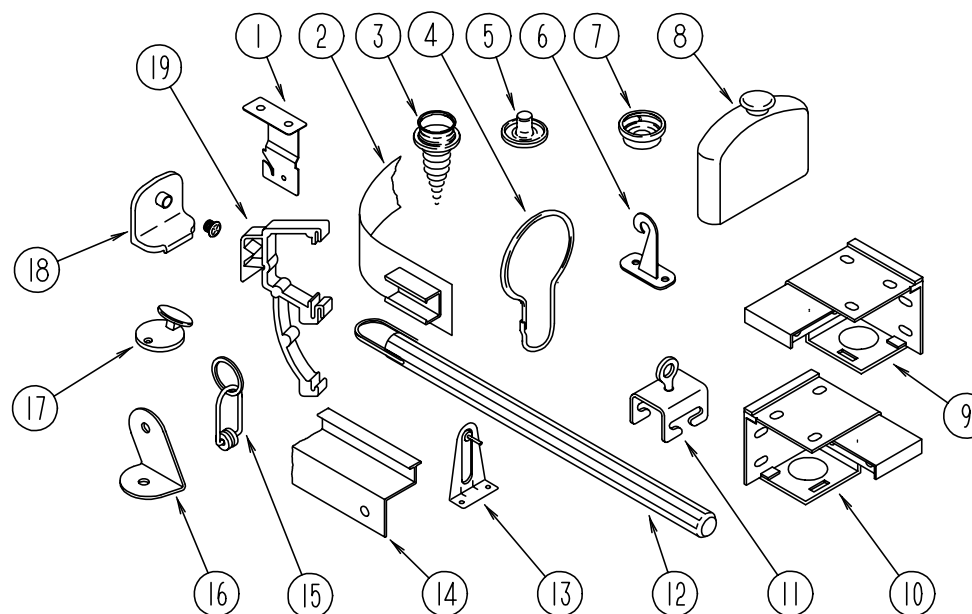

KEY	PART NUMBER	U/M	DESCRIPTION	KEY	PART NUMBER	U/M	DESCRIPTION
1	084434-01-000	EA	BRACKET-MOUNTING, ROLLER SHADE - 1 3/8"	14	114641-03-E10	EA	TRACK ASM-CURTAIN, RIGHT HAND WRAPAROUND - O/W - 6.95' - TV OPTIONS
	096843-01-000	EA	SPRING-REWIND, ROLLER SHADE				FROM: 00-00-00 THRU: 08-27-95
	086276-01-000	EA	TAPE-DOUBLE SIDED, 1/2"	14	114641-03-G29	EA	TRACK ASM-CURTAIN, RIGHT HAND WRAPAROUND - WILLOW - 6.95' - TV OPTIONS
2	101031-01-000	YD	TAPE-GLIDE, CURTAIN - 4.25" SPACING				FROM: 08-28-95 THRU: 09-23-95
3	029130-01-000	EA	SCREW-SNAP SOCKET, #8 PH X 5/8"	14	114641-07-G35	EA	TRACK ASM-CURTAIN, RIGHT HAND WRAPAROUND - WILLOW - 7.17' - TV OPTIONS
3	029130-03-000	EA	SCREW-SNAP SOCKET, #8 PH X 1"				FROM: 09-24-95 THRU: 99-99-99
4	009136-02-000	EA	HANGER-RING, PIN TYPE - CURTAIN - BRASS	14	114641-04-E10	EA	TRACK ASM-CURTAIN, LEFT HAND WRAPAROUND - O/W - 6.95' - TV OPTIONS
	046867-01-000	EA	GROMMET-BRASS - 7/16" ID X 1" OD				FROM: 00-00-00 THRU: 10-01-95
	046867-03-000	EA	GROMMET-HANDY BUTTON NO 3	14	114641-04-G29	EA	TRACK ASM-CURTAIN, LEFT HAND WRAPAROUND - WILLOW - 6.95' - TV OPTIONS
							FROM: 08-28-95 THRU: 09-23-95
5	029155-01-000	EA	CAP-SNAP, 5/32" O.D. OF PIN	14	114641-08-G35	EA	TRACK ASM-CURTAIN, LEFT HAND WRAPAROUND - WILLOW - 7.17' - TV OPTIONS
6	109441-01-000	EA	HOLD DOWN-BLIND, HOOK				FROM: 09-24-95 THRU: 99-99-99
	109441-02-000	EA	SPACER-HOLD DOWN, BLIND	15	009701-01-000	EA	CARRIER-CURTAIN, L-ROD
7	029156-01-000	EA	SOCKET-SNAP, 9/16" O.D.	16	099205-02-02A	EA	BRACKET-WRAPAROUND CURTAIN TRACK, OFF WHITE
8	093475-01-701	EA	END CAP-BLIND, W/STUD	17	102555-01-000	EA	CLEAT-BLIND CORD - CLEAR PLASTIC
9	083170-01-000	EA	BRACKET-BLIND, RIGHT HAND				FROM: 00-00-00 THRU: 04-10-96
10	083170-02-000	EA	BRACKET-BLIND, LEFT HAND	17	102555-03-000	EA	CLEAT-BLIND CORD - MILKY WHITE PLASTIC
11	009702-01-000	EA	END STOP-CURTAIN CARRIER, L ROD				FROM: 04-11-96 THRU: 99-99-99
12	093475-01-700	EA	WAND-BLIND, W/METAL CLIP - 8" LONG	18	106544-01-000	EA	PULL-SHADE, BRASS
13	095591-02-000	EA	BRACKET-HOLD DOWN, W/PIN - BLIND - METAL	18	106544-01-001	EA	SCREW-SHADE PULL, BRASS
14	101589-02-C05	EA	TRACK ASM W/BRKTS-CURTAIN, RIGHT HAND WRAPAROUND - OFF WHITE - 10'	19	109353-04-000	EA	CLIP-MOUNTING, VALANCE SLAT - CLEAR PLASTIC
			FROM: 00-00-00 THRU: 08-27-95				
14	101589-02-G29	EA	TRACK ASM W/BRKTS-CURTAIN, RIGHT HAND WRAPAROUND - QUICKSILVER - 10'	056003-01-000	EA	BRACKET-RETAIN, CURTAIN - RH	
			FROM: 08-28-95 THRU: 99-99-99	056003-02-000	EA	BRACKET-RETAIN, CURTAIN - LH	
14	105450-01-01A	EA	TRACK-CURTAIN, LEFT HAND WRAPAROUND - OFF WHITE - 30.8" LONG	083125-07-000	EA	BRACE-L-SHAPED W/HOLES, 64 MM X 35 MM X 19 MM - ALUMINUM - OFF WHITE	
			FROM: 00-00-00 THRU: 08-27-95	048394-02-000	YD	VELCRO TAPE-HOOK, ADHESIVE BACK - .75" WIDE - BEIGE	
14	105450-01-03A	EA	TRACK-CURTAIN, LEFT HAND WRAPAROUND - QUICKSILVER - 30.8" LONG	088792-01-000	YD	VELCRO-HOOK, .75" WIDE - BEIGE	
			FROM: 08-28-95 THRU: 99-99-99	088792-02-000	YD	VELCRO TAPE-LOOP, ADHESIVE BACKED - .75" WIDE - BEIGE	
				068716-01-001	EA	BRACE - 90 DEGREE L-ANGLE, 192" - EXTRUDED ALUMINUM	
				075943-06-000	EA	BRACE-L-SHAPED - 8" LONG - ALUMINUM - BEIGE	
				105648-01-02A	EA	BRACE-VALANCE, ANGLE - 1.5" X 1.5" X 14" - OFF WHITE	

CURTAIN & CUSHION GROUP (CONTINUED)

SUNRISE FABRIC

COLOR CODES	G29	G30	G31	G32
	PEBBLE BEACH (BROWN)	NEPTUNE (TEAL)	GALAXY (BLUE)	ROUTE 66
CEILING VINYL	089351-03-000	089351-03-000	089351-03-000	089351-03-000
OFF WHITE VINYL	106569-01-01A	106569-01-01A	106569-01-01A	106569-01-01A
QUICKSILVER VINYL	103907-01-05A	103907-01-05A	103907-01-05A	103907-01-05A
DRAPERY LINING	087272-03-000	087272-03-000	087272-03-000	087272-03-000
BUCKET SEATS	104233-14-000	108446-C5-000	098428-30-000	108446-55-000
DINETTE	108446-E1-000	108446-E2-000	108446-B1-000	108446-D3-000
DINETTE PADS	104233-14-000	108446-C5-000	108446-30-000	108446-55-000
SOFA	108446-E1-000	108446-E2-000	108446-B1-000	108446-D2-000
SOFA PILLOWS	108446-57-000	108446-C6-000	098428-30-000	108446-D3-000
SWIVEL CHAIR	108446-57-000	108446-C6-000	098428-30-000	108446-D3-000
LOUNGE WINDOWS	104233-14-000 108446-E1-000 108446-57-000	108446-C5-000 108446-C6-000 108446-E2-000	098428-30-000 108446-B1-000	108446-D4-000 108446-D2-000
BEDROOM WINDOW	105745-A1-000 105745-98-000	105745-45-000 105745-99-000	105745-61-000 105745-91-000	105745-D1-000 105745-D3-000
BEDSPREAD	105745-A1-000 105745-98-000	105745-45-000 105745-99-000	105745-61-000 105745-91-000	105745-D1-000
PILLOW SHAMS/ PILLOW CASES	105745-A1-000 105745-98-000	105745-45-000 105745-99-000	105745-61-000 105745-91-000	083272-03-000
BEDROOM PILLOWS	105745-A1-000 105745-98-000	105745-45-000 105745-99-000	105745-61-000 105745-91-000	105745-D3-000
FRONT WRAP AROUND	072333-90-000	072333-82-000	072333-82-000	072333-82-000
DIVIDER CURTAIN	072333-90-000	072333-82-000	072333-82-000	072333-82-000
MAP POCKETS	104233-14-000	108446-C5-000	098428-30-000	108446-55-000

CURTAIN & CUSHION GROUP (CONTINUED)

BUTTON, TRIM, ASSIST HANDLE & SEAT BELT

KEY	PART NUMBER	U/M DESCRIPTION
	079349-04-F01	YD WELT ASM-NARROW, ACCENT (G29)
	079349-04-F08	YD WELT ASM-NARROW, ACCENT (G30)
	079349-04-E04	YD WELT ASM-NARROW, ACCENT (G31)
	079349-04-G32	YD WELT ASM-NARROW, ACCENT (G32)
	057759-01-000	EA WASHER BRACKET-SEAT BELT, 4" DIAMETER
	007021-01-000	EA BELT-SEAT, 2" X 90" - BLACK
	056271-02-000	EA BELT-SEAT, 2" X 72" - BLACK
	069178-02-000	EA BRACKET-MOUNTING, ASSIST HANDLE - L ANGLE - W/HOLES - STEEL
	000C16-07-16B	EA BOLT-CARRIAGE, ASSIST HANDLE - 7/16" - 14 X 1" ZN
	000D20-07-00B	EA NUT-ACORN, ASSIST HANDLE - 7/16" X 14 ZN
	053552-02-AA8	EA HANDLE-ASSIST, INTERIOR - ENTRY DOOR - VINYL - OFF WHITE
	057534-03-000	EA TIEBACK/TIEDOWN-BED/CURTAIN/DOOR, 7.5" - PLASTIC - CLEAR

NOTE: FABRIC LISTED FIRST, IN A BLOCK, IS THE LARGEST QUANTITY OF FABRIC USED.

CURTAIN & CUSHION GROUP (CONTINUED)
WINDOW TREATMENT & SHOWER CURTAIN

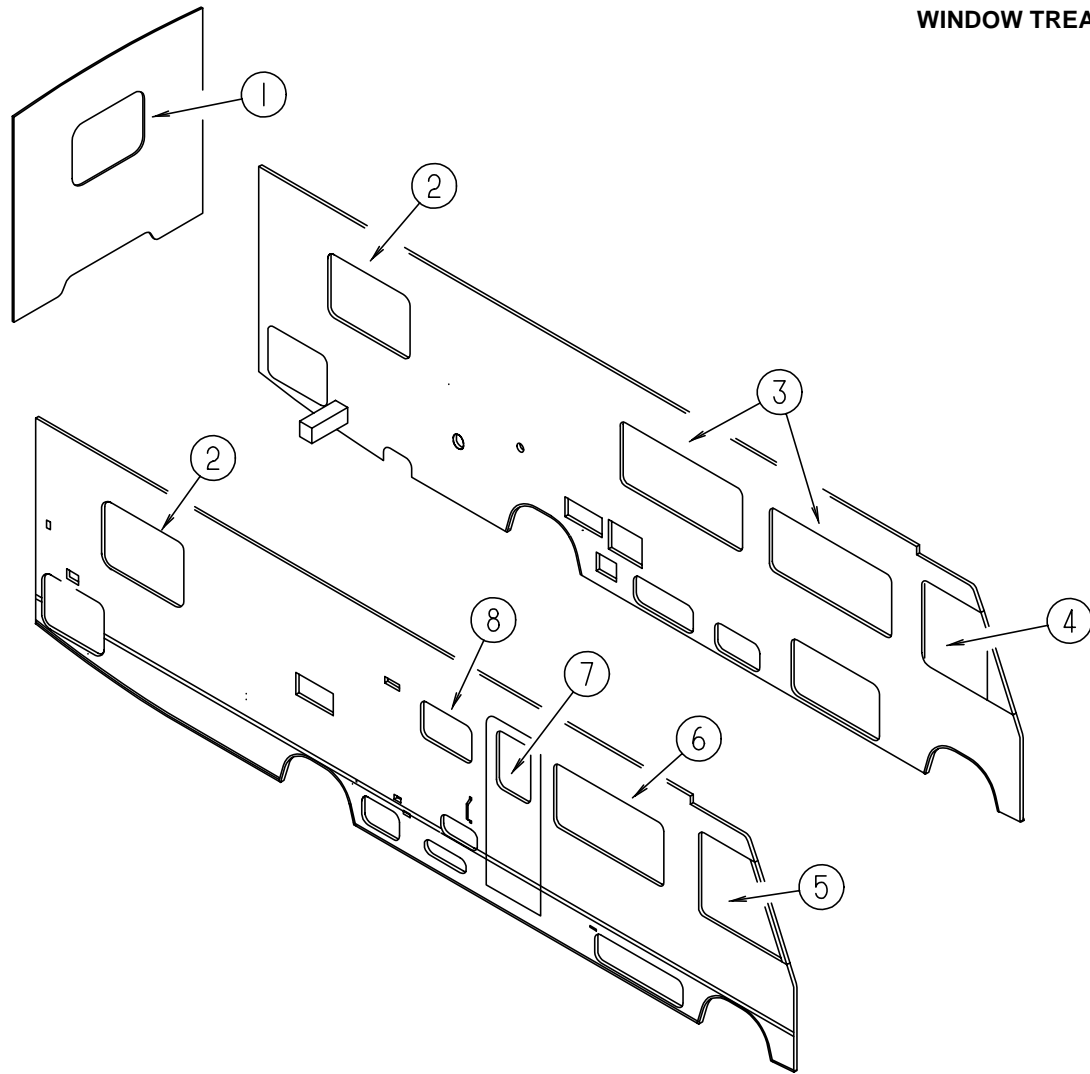

KEY	PART NUMBER	U/M DESCRIPTION
1	112113-10-G29	EA VALANCE - 52", VALERIE (G29)
1	112113-10-G30	EA VALANCE - 52", VALERIE (G30)
1	112113-10-G31	EA VALANCE - 52", VALERIE (G31)
1	119138-01-G12	EA VALANCE - 53", BELLINI W/BRAID TRIM (G32)
1	112986-11-G29	EA CURTAIN - 27.5" X 6", PLEATED TOP - POCKET BOTTOM
1	112986-11-G30	EA CURTAIN - 27.5" X 6", PLEATED TOP - POCKET BOTTOM
1	112986-11-G31	EA CURTAIN - 27.5" X 6", PLEATED TOP - POCKET BOTTOM
1	119333-63-G12	EA LEG - 25", RIGHT (G32)
1	119333-64-G12	EA LEG - 25", LEFT (G32)
1	093475-68-08A	EA BLIND-MINI, 48" X 27" DROP (G29/G32)
1	093475-68-07A	EA BLIND-MINI, 48" X 27" DROP (G30/G31)
2	112113-11-G29	EA VALANCE - 44", VALERIE (G29)
2	112113-11-G30	EA VALANCE - 44", VALERIE (G30)
2	112113-11-G31	EA VALANCE - 44", VALERIE (G31)
2	119138-02-G12	EA VALANCE - 45", BELLINI W/BRAID TRIM (G32)
2	112113-12-G29	EA VALANCE - 44", VALERIE - TWIN BEDS OPTION (G29)
2	112113-12-G30	EA VALANCE - 44", VALERIE - TWIN BEDS OPTION (G30)
2	112113-12-G31	EA VALANCE - 44", VALERIE - TWIN BEDS OPTION (G31)
2	119138-24-G12	EA VALANCE - 45", BELLINI W/BRAID TRIM - TWIN BEDS OPTION (G32)
2	112986-12-G29	EA CURTAIN - 29.5" X 6", PLEATED TOP - POCKET BOTTOM
2	112986-12-G30	EA CURTAIN - 29.5" X 6", PLEATED TOP - POCKET BOTTOM
2	112986-12-G31	EA CURTAIN - 29.5" X 6", PLEATED TOP - POCKET BOTTOM
2	112986-11-G29	EA CURTAIN - 27.5" X 6", PLEATED TOP - POCKET BOTTOM - TWIN BEDS OPTION
2	112986-11-G30	EA CURTAIN - 27.5" X 6", PLEATED TOP - POCKET BOTTOM - TWIN BEDS OPTION
2	112986-11-G31	EA CURTAIN - 27.5" X 6", PLEATED TOP - POCKET BOTTOM - TWIN BEDS OPTION
2	119333-63-G12	EA LEG - 25", RIGHT (G32)
2	119333-64-G12	EA LEG - 25", LEFT (G32)

KEY	PART NUMBER	U/M DESCRIPTION
2	093475-99-03A	EA BLIND-MINI, 41" X 28.5" DROP (G29/G32)
2	093475-99-02A	EA BLIND-MINI, 41" X 28.5" DROP (G30/G31)
2	109041-37-01A	EA BLIND-MINI, 41" X 26" DROP - TWIN BEDS OPTION (G29/G32)
2	109041-37-02A	EA BLIND-MINI, 41" X 26" DROP - TWIN BEDS OPTION (G30/G31)
3	118537-01-G29	EA VALANCE - 64.5", GALAXY
3	118537-01-G30	EA VALANCE - 64.5", GALAXY
3	118537-02-G31	EA VALANCE - 64.5", GALAXY
3	105923-46-G32	EA VALANCE - 64.5", RODEWAY
3	119333-11-G29	EA LEG - 25", RIGHT (G29)
3	119333-11-G30	EA LEG - 25", RIGHT (G30)
3	119333-11-G31	EA LEG - 25", RIGHT (G31)
3	119333-33-G12	EA LEG - 25", RIGHT (G32)
3	119333-12-G29	EA LEG - 25", LEFT (G29)
3	119333-12-G30	EA LEG - 25", LEFT (G30)
3	119333-12-G31	EA LEG - 25", LEFT (G31)
3	119333-34-G12	EA LEG - 25", LEFT (G32)
3	093475-76-06A	EA BLIND-MINI, 60" X 28.5" DROP (G29/G32)
3	093475-76-05A	EA BLIND-MINI, 60" X 28.5" DROP (G30/G31)
4	101668-57-G09	EA CURTAIN - 38" X 95", TAPE TOP - LEFT (G29/G32)
4	101668-57-G10	EA CURTAIN - 38" X 95", TAPE TOP - LEFT (G30/G31)
4	101668-32-D09	EA CURTAIN - 40" X 40", TAPE TOP (G29/G32) - FRONT BUNK OPTION
4	101668-32-D10	EA CURTAIN - 40" X 40", TAPE TOP (G30/G31) - FRONT BUNK OPTION
5	101668-56-G09	EA CURTAIN - 38" X 95", TAPE TOP - RIGHT (G29/G32)
5	101668-56-G10	EA CURTAIN - 38" X 95", TAPE TOP - RIGHT (G30/G31)
5	101668-33-D09	EA CURTAIN - 38" X 125", TAPE TOP (G29/G32) - FRONT BUNK OPTION
5	101668-33-D10	EA CURTAIN - 38" X 125", TAPE TOP (G30/G31) - FRONT BUNK OPTION
	073260-42-D09	EA TIEBACK - 6" X 18" (G29/G32)
	073260-42-D10	EA TIEBACK - 6" X 18" (G30/G31)
6	118537-13-G29	EA VALANCE - 58.5", GALAXY
6	118537-13-G30	EA VALANCE - 58.5", GALAXY
6	118537-14-G31	EA VALANCE - 58.5", GALAXY
6	105923-50-G32	EA VALANCE - 58.5", W/BUTTON
6	119333-11-G29	EA LEG - 25", RIGHT (G29)
6	119333-11-G30	EA LEG - 25", RIGHT (G30)
6	119333-11-G31	EA LEG - 25", RIGHT (G31)
6	119333-33-G12	EA LEG - 25", RIGHT (G32)
6	119333-12-G29	EA LEG - 25", LEFT (G29)
6	119333-12-G30	EA LEG - 25", LEFT (G30)
6	119333-12-G31	EA LEG - 25", LEFT (G31)
6	119333-34-G12	EA LEG - 25", LEFT (G32)
6	109041-28-02A	EA BLIND-MINI, 54" X 28.5" DROP (G29/G32)
6	109041-28-01A	EA BLIND-MINI, 54" X 28.5" DROP (G30/G31)
7	118537-15-G29	EA VALANCE - 30.5", W/BUTTON (G29)
7	118537-15-G30	EA VALANCE - 30.5", W/BUTTON (G30)
7	118537-16-G31	EA VALANCE - 30.5", W/BUTTON (G31)
7	113268-12-F27	EA VALANCE - 30.5", W/BUTTON (G32)
7	084755-57-E07	EA SHADE-PULL, 27.25"
8	109353-07-02A	EA VALANCE-SLAT, 31" - BEIGE (G29/G32)
		FROM: 00-00-00 THRU: 03-24-96
8	109353-07-01A	EA VALANCE-SLAT, 31" - SILVER (G30/G31)
		FROM: 00-00-00 THRU: 03-24-96
8	109353-10-02A	EA VALANCE-SLAT, 30.5" - BEIGE (G29/G32)
		FROM: 03-25-96 THRU: 99-99-99
8	109353-10-01A	EA VALANCE-SLAT, 30.5" - SILVER (G30/G31)
		FROM: 03-25-96 THRU: 99-99-99
8	109041-20-02A	EA BLIND-MINI, 31" X 18" DROP - BEIGE (G29/G32)
		FROM: 00-00-00 THRU: 03-24-96
8	109041-20-01A	EA BLIND-MINI, 31" X 18" DROP - SILVER (G30/G31)
		FROM: 00-00-00 THRU: 03-24-96
8	109041-44-02A	EA BLIND-MINI, 30.5" X 18" DROP - BEIGE (G29/G32)
		FROM: 03-25-96 THRU: 99-99-99
8	109041-44-01A	EA BLIND-MINI, 30.5" X 18" DROP - SILVER (G30/G31)
		FROM: 03-25-96 THRU: 99-99-99

CURTAIN & CUSHION GROUP (CONTINUED)

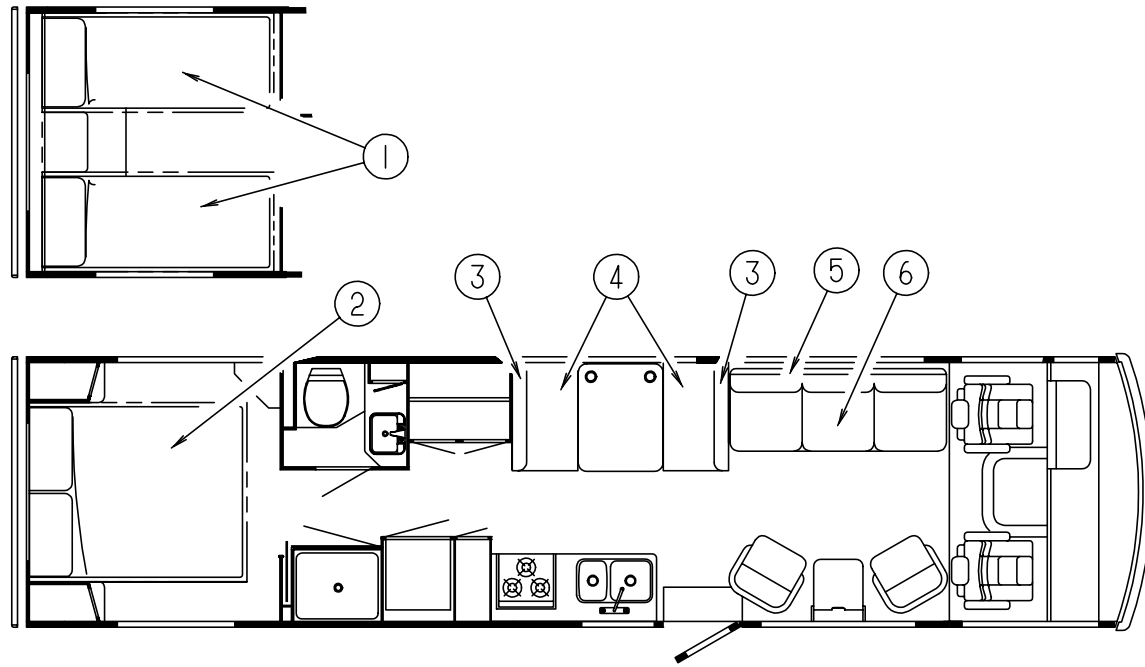

TWIN MATTRESSES, BEDSPREADS & PILLOW SHAMS

KEY	PART NUMBER	U/M DESCRIPTION
1	098176-10-000	EA MATTRESS-INNERSPRING, 32" X 79.5"
1	085365-34-G29	EA BEDSPREAD-THROW, 33" X 80" (G29)
1	085365-34-G30	EA BEDSPREAD-THROW, 33" X 80" (G30)
1	085365-34-F25	EA BEDSPREAD-THROW, 33" X 80" (G31)
1	119141-08-G12	EA BEDSPREAD-THROW, 33" X 80" (G32)
	111863-05-G29	EA PILLOW SHAM-W/O FOAM
	111863-05-G30	EA PILLOW SHAM-W/O FOAM
	111863-05-G31	EA PILLOW SHAM-W/O FOAM
	119249-01-000	EA PILLOW - CASE, 20" X 33" (G32)
	111862-03-G29	EA PILLOW-THROW, 15" X 15" (G29)
	111862-03-G30	EA PILLOW-THROW, 15" X 15" (G30)
	111862-03-G31	EA PILLOW-THROW, 15" X 15" (G31)
	109785-06-G12	EA PILLOW-THROW, 15" X 15" (G32)

QUEEN MATTRESS, BEDSPREADS & PILLOW SHAMS

KEY	PART NUMBER	U/M DESCRIPTION
2	098176-04-000	EA MATTRESS-QUEEN, INNERSPRING - 59" X 74"
2	085365-19-G29	EA BEDSPREAD-THROW, 60" X 75" (G29)
2	085365-19-G30	EA BEDSPREAD-THROW, 60" X 75" (G30)
2	085365-19-F25	EA BEDSPREAD-THROW, 60" X 75" (G31)
2	119141-07-G12	EA BEDSPREAD-THROW, 60" X 75" (G32)
	111863-05-G29	EA PILLOW SHAM-W/O FOAM
	111863-05-G30	EA PILLOW SHAM-W/O FOAM
	111863-05-G31	EA PILLOW SHAM-W/O FOAM
	119249-01-000	EA PILLOW - CASE, 20" X 33" (G32)
	111862-03-G29	EA PILLOW-THROW, 15" X 15" (G29)
	111862-03-G30	EA PILLOW-THROW, 15" X 15" (G30)
	111862-03-G31	EA PILLOW-THROW, 15" X 15" (G31)
	109785-06-G12	EA PILLOW-THROW, 15" X 15" (G32)

DINETTE CUSHIONS

KEY	PART NUMBER	U/M DESCRIPTION
3	111880-01-G29	EA CUSHION-BACK, 13.5" X 38" X 5" (G29)
3	111880-01-G30	EA CUSHION-BACK, 13.5" X 38" X 5" (G30)
3	111880-01-F25	EA CUSHION-BACK, 13.5" X 38" X 5" (G31)
3	111897-08-F27	EA CUSHION-BACK, 13.5" X 38" X 5" (G32)
3	P11880-01-G29	EA COVER-BACK CUSHION, 13.5" X 38" X 5" (G29)
3	P11880-01-G30	EA COVER-BACK CUSHION, 13.5" X 38" X 5" (G30)
3	P11880-01-F25	EA COVER-BACK CUSHION, 13.5" X 38" X 5" (G31)
3	P11897-08-F27	EA COVER-BACK CUSHION, 13.5" X 38" X 5" (G32)
	078155-01-000	EA STRAP-SNAP, BACKREST CUSHION
4	088927-87-G01	EA CUSHION-SEAT, 23" X 38" X 5" (G29)
4	088927-87-G02	EA CUSHION-SEAT, 23" X 38" X 5" (G30)
4	088927-87-F02	EA CUSHION-SEAT, 23" X 38" X 5" (G31)
4	105603-03-F27	EA CUSHION-SEAT, 23" X 38" X 5" (G32)
4	M88927-87-G01	EA COVER-SEAT CUSHION, 23" X 38" X 5" (G29)
4	M88927-87-G02	EA COVER-SEAT CUSHION, 23" X 38" X 5" (G30)
4	M88927-87-F02	EA COVER-SEAT CUSHION, 23" X 38" X 5" (G31)
4	P05603-03-F27	EA COVER-SEAT CUSHION, 23" X 38" X 5" (G32)

COUCH

KEY	PART NUMBER	U/M DESCRIPTION
5	112104-01-G29	EA COUCH-BACK, 74" W/O ARMS (G29)
5	112104-01-G30	EA COUCH-BACK, 74" W/O ARMS (G30)
5	112104-01-F25	EA COUCH-BACK, 74" W/O ARMS (G31)
5	111319-01-F07	EA COUCH-BACK, 74" W/O ARMS (G32)
5	P12104-01-G29	EA COVER-COUCH BACK (G29)
5	P12104-01-G30	EA COVER-COUCH BACK (G30)
5	P12104-01-F25	EA COVER-COUCH BACK (G31)
5	P11319-01-F07	EA COVER-COUCH BACK (G32)
	101085-10-000	EA FRAME - 74.5" X 16" BACK FRAME JACKKNIFE
6	100032-43-G01	EA COUCH-SEAT, 74" W/O ARMS (G29)
6	100032-43-G02	EA COUCH-SEAT, 74" W/O ARMS (G30)
6	100032-43-F25	EA COUCH-SEAT, 74" W/O ARMS (G31)
6	100032-43-F07	EA COUCH-SEAT, 74" W/O ARMS (G32)
6	P00032-43-G01	EA COVER-COUCH SEAT (G29)
6	P00032-43-G02	EA COVER-COUCH SEAT (G30)
6	P00032-43-F25	EA COVER-COUCH SEAT (G31)
6	P00032-43-F07	EA COVER-COUCH SEAT (G32)
	101085-04-000	EA FRAME-COUCH SEAT, 74"
	101085-06-000	EA FRAME-COUCH BASE, 74"
	111637-02-F06	EA PILLOW-THROW, 22" X 22" (G29)
	111637-02-F08	EA PILLOW-THROW, 22" X 22" (G30)
	111637-02-E04	EA PILLOW-THROW, 22" X 22" (G31)
	111637-02-F27	EA PILLOW-THROW, 22" X 22" (G32)

NOTE: COUCH FRONT AND SIDE PANELS ARE FOUND IN THE LOUNGE GROUP

BUNK CUSHION

KEY	PART NUMBER	U/M DESCRIPTION
	079145-06-000	EA CUSHION-BUNK, 30" X 77" X 4"
	M79145-06-000	EA COVER-CUSHION, BUNK

CURTAIN & CUSHION GROUP (CONTINUED)
SWIVEL CHAIR

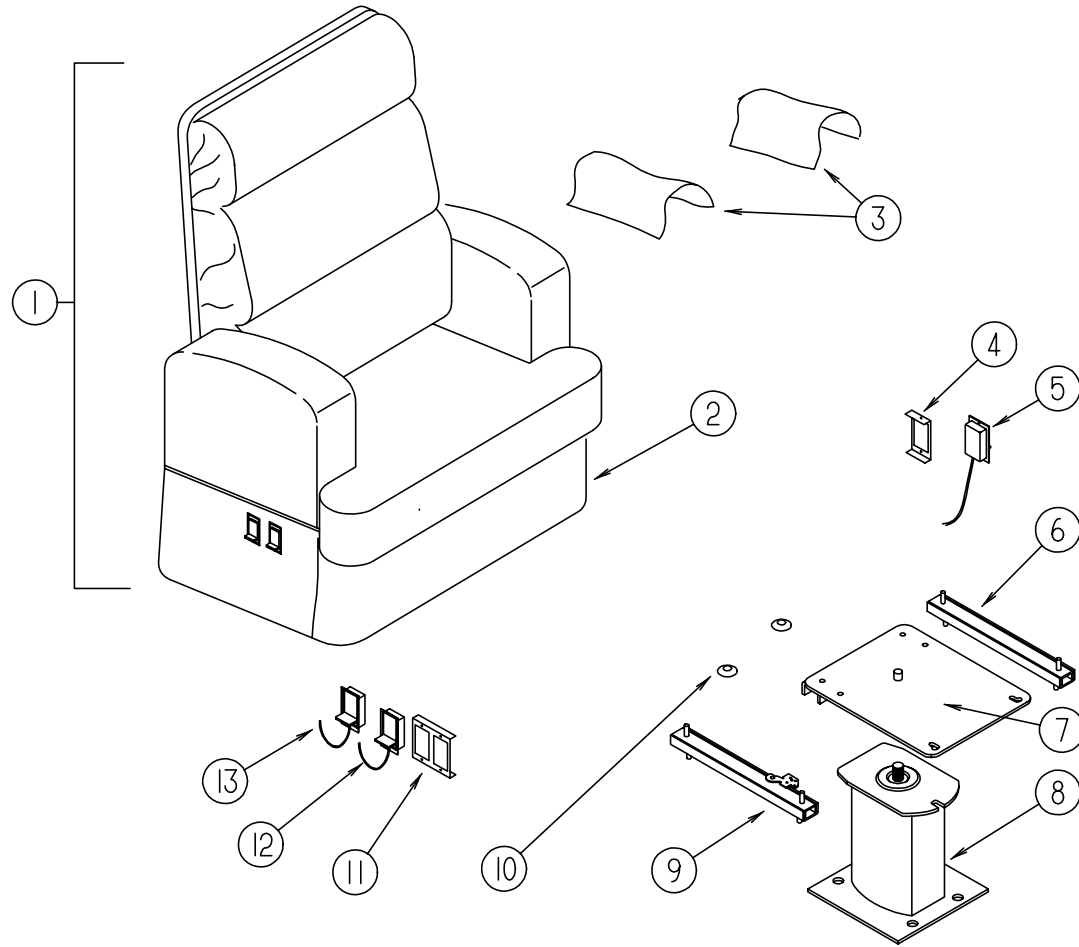

KEY	PART NUMBER	U/M	DESCRIPTION
1	118538-01-G29	EA	CHAIR-SWIVEL, W/O SKIRT
1	118538-01-G30	EA	CHAIR-SWIVEL, W/O SKIRT
1	118538-01-G31	EA	CHAIR-SWIVEL, W/O SKIRT
1	118538-01-G32	EA	CHAIR-SWIVEL, W/O SKIRT
	P18538-01-G29	EA	COVER-SWIVEL CHAIR
	P18538-01-G30	EA	COVER-SWIVEL CHAIR
	P18538-01-G31	EA	COVER-SWIVEL CHAIR
	P18538-01-G32	EA	COVER-SWIVEL CHAIR
2	118539-01-G29	EA	SKIRT-SWIVEL CHAIR
2	118539-01-G30	EA	SKIRT-SWIVEL CHAIR
2	118539-01-G31	EA	SKIRT-SWIVEL CHAIR
2	118539-01-G32	EA	SKIRT-SWIVEL CHAIR
3	P18538-27-G29	EA	COVER-ARM CAP, SWIVEL CHAIR - RH OR LH
3	P18538-27-G30	EA	COVER-ARM CAP, SWIVEL CHAIR - RH OR LH
3	P18538-27-G31	EA	COVER-ARM CAP, SWIVEL CHAIR - RH OR LH
3	P18538-27-G32	EA	COVER-ARM CAP, SWIVEL CHAIR - RH OR LH
4	097683-03-000	EA	BRACKET-REMOTE, SIDE MOUNT - SINGLE
5	108049-03-000	EA	CABLE W/SWITCH - 26", Z END CABLE - CMA
	108049-02-000	EA	CLIP-CABLE, PEDESTAL
6	119952-01-000	EA	SLIDE-SEAT W/O LOCK, HD - 2 STUDS - ATWOOD 83711
7	107921-08-000	EA	PLATE-TOP, W/O SEAT BELT BAR
	107921-06-000	EA	BEARING KIT-SEAT SWIVEL
8	107921-01-000	EA	PEDESTAL ASM-SEAT, 9 3/4" - FLEXSTEEL 3060 MSPD
9	119952-03-000	EA	SLIDE-SEAT W/LOCK, HD - 2 STUDS - ATWOOD 83775
10	007221-01-000	EA	SPACER-SEAT, ADJUSTER
11	097683-02-000	EA	BRACKET-REMOTE, SIDE MOUNT - DOUBLE
12	089368-05-000	EA	CABLE-RECLINER, W/SWITCH - BUCKET SEAT
13	108049-03-000	EA	CABLE W/SWITCH - 26", Z END CABLE - CMA
	108049-02-000	EA	CLIP-CABLE, PEDESTAL
	108445-02-000	EA	PLATE ASM-PEDESTAL, SEAT - 230 MM X 157 MM - W/WELDNUTS

CURTAIN & CUSHION GROUP (CONTINUED)
DRIVER & PASSENGER BUCKET SEATS

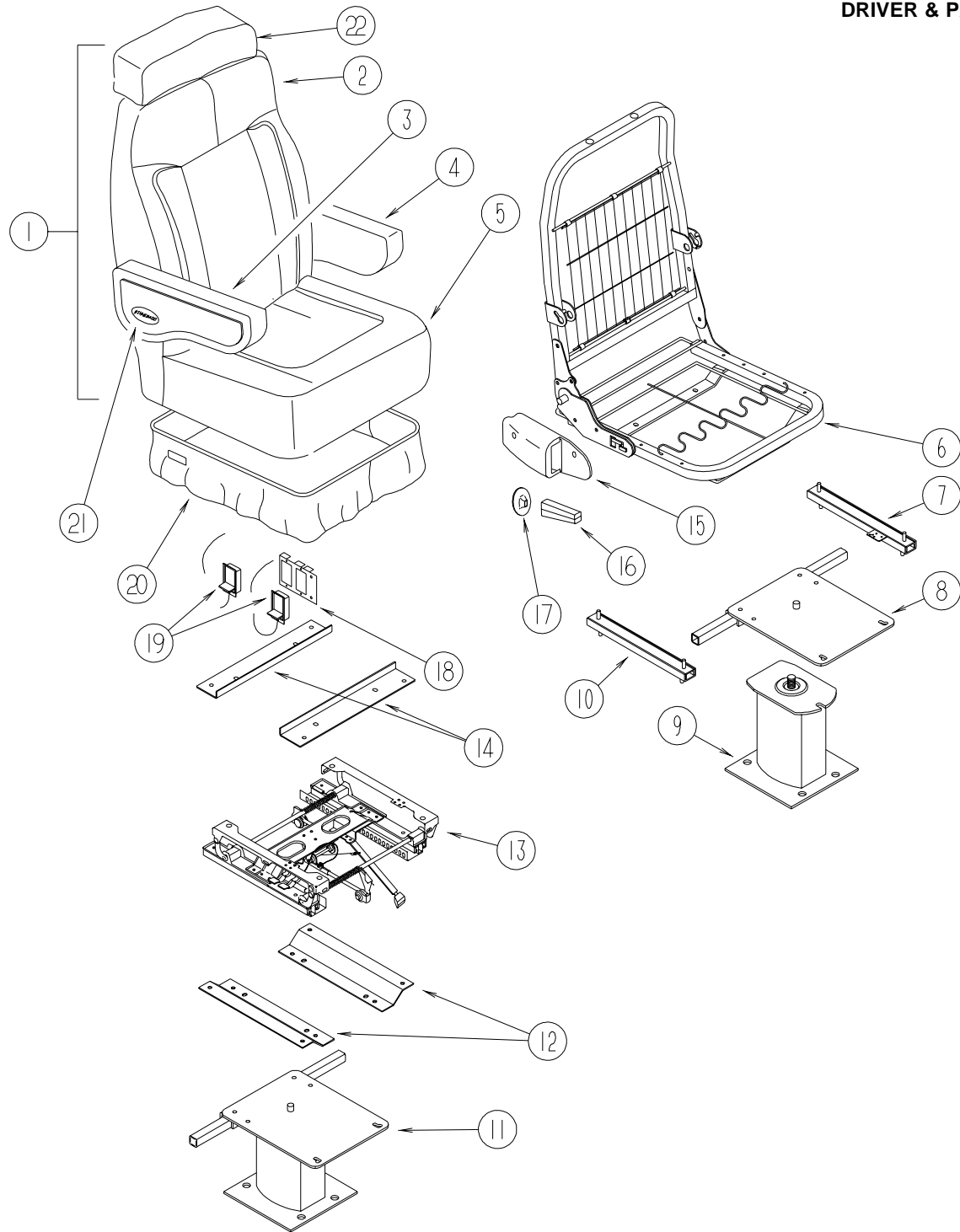

KEY	PART NUMBER	U/M DESCRIPTION
1	119508-03-G29	EA SEAT-BUCKET, W/ARMRESTS & HEADREST - W/O SKIRT
1	119508-03-G30	EA SEAT-BUCKET, W/ARMRESTS & HEADREST - W/O SKIRT
1	119508-03-G31	EA SEAT-BUCKET, W/ARMRESTS & HEADREST - W/O SKIRT
1	119508-03-G32	EA SEAT-BUCKET, W/ARMRESTS & HEADREST - W/O SKIRT
2	M05962-29-G29	EA COVER-BACK, BUCKET SEAT
2	M05962-29-G30	EA COVER-BACK, BUCKET SEAT
2	M05962-29-G31	EA COVER-BACK, BUCKET SEAT
2	M05962-29-G32	EA COVER-BACK, BUCKET SEAT

KEY	PART NUMBER	U/M DESCRIPTION
3	111320-03-G29	EA ARMREST-RIGHT, BUCKET SEAT (G29)
3	111320-03-G30	EA ARMREST-RIGHT, BUCKET SEAT (G30)
3	111320-03-G31	EA ARMREST-RIGHT, BUCKET SEAT (G31)
3	111320-03-G11	EA ARMREST-RIGHT, BUCKET SEAT (G32)
	P11320-03-G29	EA COVER-ARMREST, RIGHT (G29)
	P11320-03-G30	EA COVER-ARMREST, RIGHT (G30)
	P11320-03-G31	EA COVER-ARMREST, RIGHT (G31)
	P11320-03-G11	EA COVER-ARMREST, RIGHT (G32)
4	111320-04-G29	EA ARMREST-LEFT, BUCKET SEAT (G29)
4	111320-04-G30	EA ARMREST-LEFT, BUCKET SEAT (G30)
4	111320-04-G31	EA ARMREST-LEFT, BUCKET SEAT (G31)
4	111320-04-G11	EA ARMREST-LEFT, BUCKET SEAT (G32)
	P11320-04-G29	EA COVER-ARMREST, LEFT (G29)
	P11320-04-G30	EA COVER-ARMREST, LEFT (G30)
	P11320-04-G31	EA COVER-ARMREST, LEFT (G31)
	P11320-04-G11	EA COVER-ARMREST, LEFT (G32)
5	M05962-06-G29	EA COVER-SEAT, BUCKET SEAT
5	M05962-06-G30	EA COVER-SEAT, BUCKET SEAT
5	M05962-06-G31	EA COVER-SEAT, BUCKET SEAT
5	M05962-06-G32	EA COVER-SEAT, BUCKET SEAT
6	M80906-12-000	EA FRAME-SEAT, BACK & SPRING
7	119952-02-000	EA SLIDE-SEAT W/O LOCK, HD - 4 STUDS - ATWOOD 83731
8	107921-05-000	EA PLATE-TOP, W/SEAT BELT BAR
9	107921-01-000	EA PLATE-SUB, FLOOR MOUNTED PEDESTAL - W/9.75" EXTENSION
	107921-06-000	EA BEARING KIT-SEAT SWIVEL
10	119952-04-000	EA SLIDE-SEAT W/LOCK, HD - 4 STUDS - ATWOOD 83785
	117125-01-02B	EA BRACKET-CABLE MOUNT, ADJUSTER W/LOCK - STEEL - E-COAT
11	107921-14-000	EA BASE-FLOOR MOUNTED PEDESTAL, 5.75" - MANUAL SEAT OPTION
12	116215-03-000	EA PLATE - LOWER, 6-WAY MANUAL CONTROL
13	116215-01-000	EA SEAT - 6-WAY MANUAL CONTROL - DRIVER
14	116215-02-000	EA PLATE - UPPER, 6-WAY MANUAL CONTROL
15	080730-09-000	EA SHIELD-RECLINER HANDLE
16	080730-08-000	EA HANDLE-RECLINER, BLACK
17	080730-11-000	EA SHIELD-RUBBER BOOT
	108049-02-000	EA CLIP-CABLE, PEDESTAL
18	097683-02-000	EA BRACKET-REMOTE, SIDE MOUNT - DOUBLE
19	108049-03-000	EA CABLE W/SWITCH - 26", Z END CABLE - CMA
20	071126-43-F24	EA SKIRT-BUCKET SEAT (G29)
20	071126-43-F11	EA SKIRT-BUCKET SEAT (G30)
20	071126-43-F25	EA SKIRT-BUCKET SEAT (G31)
20	071126-43-F06	EA SKIRT-BUCKET SEAT (G32)
20	071126-54-F24	EA SKIRT-BUCKET SEAT (G29) - MANUAL SEAT OPTION
20	071126-54-F11	EA SKIRT-BUCKET SEAT (G30) - MANUAL SEAT OPTION
20	071126-54-F25	EA SKIRT-BUCKET SEAT (G31) - MANUAL SEAT OPTION
20	071126-54-F06	EA SKIRT-BUCKET SEAT (G32) - MANUAL SEAT OPTION
21	111169-01-000	EA PLATE-BACK, ARMREST
21	111169-05-000	EA INSERT-ARMREST, OVAL DECAL - ITASCA
22	119509-01-G29	EA HEADREST ASM (G29)
22	119509-01-G30	EA HEADREST ASM (G30)
22	119509-01-G31	EA HEADREST ASM (G31)
22	119509-01-G11	EA HEADREST ASM (G32)
	P19509-01-G29	EA COVER ASM-HEADREST (G29)
	P19509-01-G30	EA COVER ASM-HEADREST (G30)
	P19509-01-G31	EA COVER ASM-HEADREST (G31)
	P19509-01-G11	EA COVER ASM-HEADREST (G32)
	113977-12-000	EA HEADREST INSERT, W/O LOCK - BLACK PLASTIC - FLEXSTEEL
	113977-13-000	EA HEADREST INSERT, W/LOCK - BLACK PLASTIC - FLEXSTEEL
	007221-01-000	EA SPACER-SEAT, ADJUSTER
	114889-01-000	EA STOP BAR-UNIVERSAL, SHROCK

DINETTE GROUP

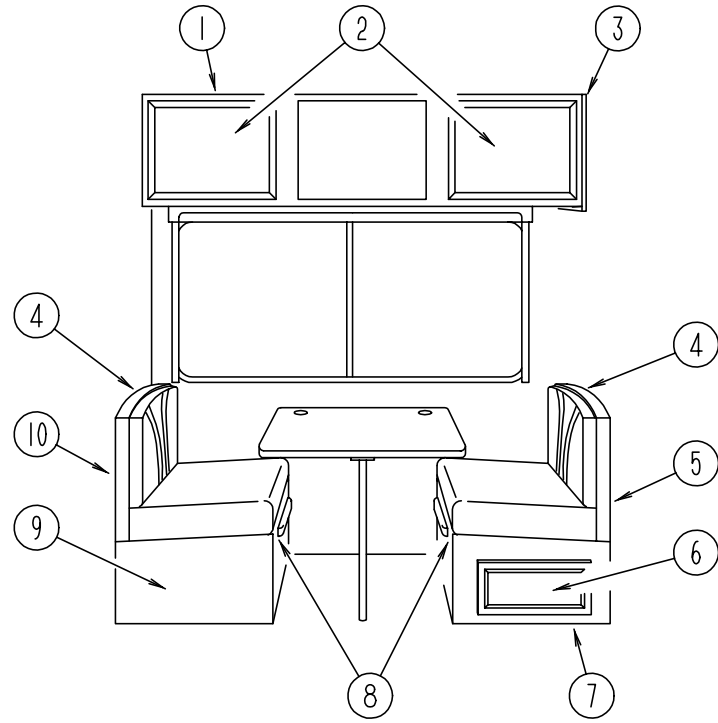

DINETTE CABINETRY

KEY	PART NUMBER	U/M	DESCRIPTION
1	117922-04-G11	EA	CABINET-OVERHEAD, W/O DOORS (G29)
1	117922-04-G30	EA	CABINET-OVERHEAD, W/O DOORS (G30)
1	117922-04-G31	EA	CABINET-OVERHEAD, W/O DOORS (G31)
1	117922-04-G32	EA	CABINET-OVERHEAD, W/O DOORS (G32)
1	117579-06-G11	EA	CABINET-OVERHEAD, W/O DOORS - COFFEEMAKER OPTION (G29)
1	117579-06-G30	EA	CABINET-OVERHEAD, W/O DOORS - COFFEEMAKER OPTION (G30)
1	117579-06-G31	EA	CABINET-OVERHEAD, W/O DOORS - COFFEEMAKER OPTION (G31)
1	117579-06-G32	EA	CABINET-OVERHEAD, W/O DOORS - COFFEEMAKER OPTION (G32)
2	M06803-02-G09	EA	DOOR-W/O HARDWARE W/O MIRROR - 400 MM X 710 MM
3	103128-01-G09	EA	CAP-END, OVERHEAD CABINET - FRONT
4	104787-04-F24	EA	PAD-DINETTE (G29)
4	104787-04-F11	EA	PAD-DINETTE (G30)
4	104787-04-F25	EA	PAD-DINETTE (G31)
4	104787-04-F06	EA	PAD-DINETTE (G32)
5	M04174-42-G09	EA	CABINET-SEATBACK, FRONT
6	M06803-07-G09	EA	DOOR-W/O HARDWARE W/MIRROR - 255 MM X 485 MM
7	M04175-42-G09	EA	CABINET-SEATBASE, FRONT
8	081295-01-G01	EA	SUPPORT-BED, DINETTE - 28" LONG - WOOD
9	M04175-24-G09	EA	CABINET-SEATBASE, REAR
10	M04174-24-G09	EA	CABINET-SEATBACK, REAR
	058331-47-000	EA	MIRROR-GLASS, SAFETY - 562 MM X 384 MM - WALL MOUNTED
	105004-01-05A	EA	MOLDING-MIRROR, VINYL WRAPPED - OAK
	122021-01-01A	EA	ANGLE-W/HOLES, 1" X 1" X 9" - MILL ALUMINUM

DINETTE GROUP (CONTINUED)

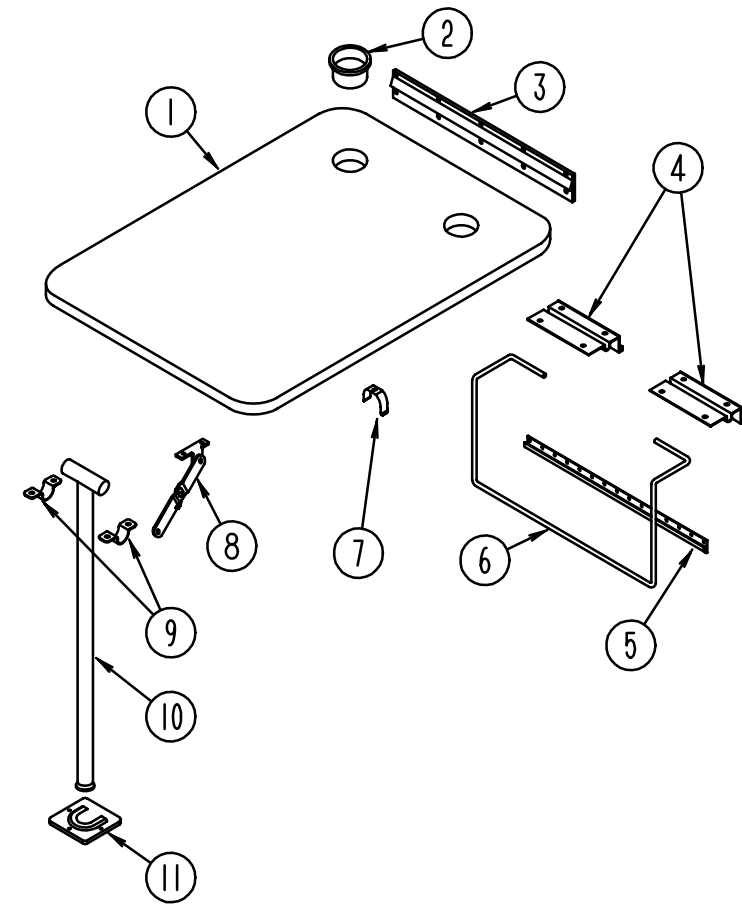

DINETTE TABLE

KEY	PART NUMBER	U/M	DESCRIPTION
1	081322-01-G29	EA	TABLE-DINETTE, W/O HARDWARE OR CUPHOLDERS (G29)
1	081322-01-G30	EA	TABLE-DINETTE, W/O HARDWARE OR CUPHOLDERS (G30)
1	081322-05-G31	EA	TABLE-DINETTE, W/O HARDWARE OR CUPHOLDERS (G31)
1	081322-01-G09	EA	TABLE-DINETTE, W/O HARDWARE OR CUPHOLDERS (G32)
2	064781-06-000	EA	HOLDER-CUP, TWO STEP - OFF WHITE
3	053200-12-000	EA	SUPPORT-TABLE, 23.5" - OFF WHITE
4	088410-02-000	EA	BRACKET-LIFT, TABLE MOUNTED - OFF WHITE
5	024281-14-000	EA	BRACKET-LIFT ROD, LOWER WALL MOUNTED - 22.12" - OFF WHITE
6	024275-12-000	EA	ROD-TABLE LIFT, OFF WHITE
7	024283-01-000	EA	CLIP-LEG, 1" X 1.125" OD - BLACK
8	024282-01-000	EA	BRACE-TABLE LEG, HINGED
9	064050-05-000	EA	HINGE-TABLE LEG, OFF WHITE
10	024276-24-000	EA	LEG-TABLE, METAL - OFF WHITE
11	049493-12-000	EA	CATCH-LEG, FLOOR MOUNTED - 2.5" X 2.7" - METAL - OFF WHITE
11	049493-11-700	EA	CATCH-LEG, FLOOR MOUNTED - 2.5" X 2.7" - METAL - E-COAT

DRIVERS COMPARTMENT GROUP
DRIVERS COMPARTMENT - UPPER

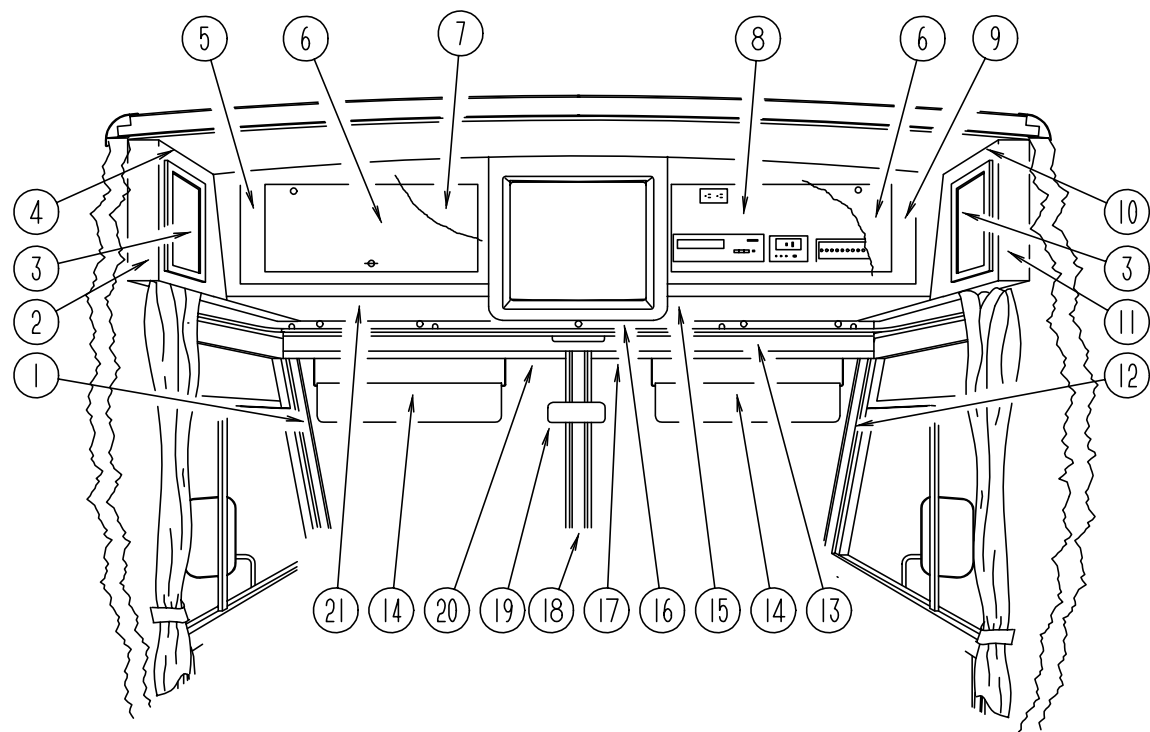

KEY	PART NUMBER	U/M	DESCRIPTION
1	103931-02-03A	EA	COVER-INNER, A-PILLAR - DRIVERS - QUICK SILVER
2	103128-09-G09	EA	CAP-END, FRONT OVERHEAD, DRIVERS SIDE
3	M06803-04-G09	EA	DOOR-CABINET, W/O HARDWARE - 255 MM X 485 MM
4	109561-02-G29	EA	CABINET-FRONT OVERHEAD W/O DOOR, DRIVERS SIDE
4	109561-02-G30	EA	CABINET-FRONT OVERHEAD W/O DOOR, DRIVERS SIDE
4	109561-02-G31	EA	CABINET-FRONT OVERHEAD W/O DOOR, DRIVERS SIDE
4	109561-02-G32	EA	CABINET-FRONT OVERHEAD W/O DOOR, DRIVERS SIDE
	P09561-02-E07	EA	BOTTOM-OFF WHITE VINYL COVERED, FRONT OVERHEAD - DRIVERS SIDE FROM: 00-00-00 THRU: 08-27-95
	P09561-02-G29	EA	BOTTOM-QUICK SILVER VINYL COVERED, FRONT OVERHEAD - DRIVERS SIDE FROM: 08-28-95 THRU: 99-99-99
	104289-02-C05	EA	PAD-VINYL COVERED, 769 MM X 245 MM - ANGLED - DRIVERS SIDE - OFF WHITE FROM: 00-00-00 THRU: 08-27-95
	104289-02-G29	EA	PAD-VINYL COVERED, 769 MM X 245 MM - ANGLED - DRIVERS SIDE-QUICK SILVER FROM: 08-28-95 THRU: 99-99-99
	104289-04-D12	EA	PAD-VINYL COVERED, 655 MM X 245 MM - ANGLED - DRIVERS SIDE - OFF WHITE TV OPTIONS FROM: 00-00-00 THRU: 08-27-95
	104289-04-G35	EA	PAD-VINYL COVERED, 655 MM X 245 MM - ANGLED - DRIVERS SIDE-QUICK SILVER TV OPTIONS FROM: 08-28-95 THRU: 99-99-99
5	114612-02-G09	EA	FACE-TV CABINET W/O DOORS, FRONT OVERHEAD - DRIVERS SIDE
	106699-01-01A	EA	BRACKET-L-ANGLE, TV CABINET FACE - 5.1" LONG - OFF WHITE STEEL
6	100708-12-000	EA	DOOR-GLASS, TV CABINET - 9.7" X 23.2" - W/O HARDWARE

KEY	PART NUMBER	U/M	DESCRIPTION
7	103040-01-G29	EA	PANEL-HEADLINER FRONT OVERHEAD, RH & LH - STANDARD
7	114661-12-G35	EA	PANEL-HEADLINER FRONT OVERHEAD, LH - TV OPTIONS
8	103040-01-G29	EA	PANEL-HEADLINER FRONT OVERHEAD, RH & LH - STANDARD
8	114661-13-G35	EA	PANEL-HEADLINER FRONT OVERHEAD, TV OPTIONS
8	114661-14-G35	EA	PANEL-HEADLINER FRONT OVERHEAD, TV/VCR OPTIONS
8	114661-15-G35	EA	PANEL-HEADLINER FRONT OVERHEAD, TV/VCR/INVERTER OPTION
8	114661-16-G35	EA	PANEL-HEADLINER FRONT OVERHEAD, TV/INVERTER OPTION
	100676-02-000	EA	STAND-VCR, STEEL
9	114612-01-G09	EA	FACE-TV CABINET W/O DOORS, FRONT OVERHEAD - PASSENGERS SIDE
10	109561-01-G29	EA	CABINET-FRONT OVERHEAD W/O DOOR, PASSENGERS SIDE
10	109561-01-G30	EA	CABINET-FRONT OVERHEAD W/O DOOR, PASSENGERS SIDE
10	109561-01-G31	EA	CABINET-FRONT OVERHEAD W/O DOOR, PASSENGERS SIDE
10	109561-01-G32	EA	CABINET-FRONT OVERHEAD W/O DOOR, PASSENGERS SIDE
11	103128-08-G09	EA	CAP-END, FRONT OVERHEAD, PASSENGERS SIDE
	P09561-01-E07	EA	BOTTOM-OFF WHITE VINYL COVERED, FRONT OVERHEAD - PASSENGERS SIDE FROM: 00-00-00 THRU: 08-27-95
	P09561-01-G29	EA	BOTTOM-QUICK SILVER VINYL COVERED, FRONT OVERHEAD - PASS SIDE FROM: 08-28-95 THRU: 99-99-99
	104289-01-C05	EA	PAD-VINYL COVERED, 769 MM X 245 MM - ANGLED - PASS SIDE - OFF WHITE FROM: 00-00-00 THRU: 08-27-95
	104289-01-G29	EA	PAD-VINYL COVERED, 769 MM X 245 MM - ANGLED - PASS SIDE - QUICKSILVER FROM: 08-28-95 THRU: 99-99-99
	104289-03-D12	EA	PAD-VINYL COVERED, 655 MM X 245 MM - ANGLED - PASS SIDE - OFF WHITE TV OPTIONS FROM: 00-00-00 THRU: 08-27-95
	104289-03-G35	EA	PAD-VINYL COVERED, 655 MM X 245 MM - ANGLED - PASS SIDE - QUICKSILVER TV OPTIONS FROM: 08-28-95 THRU: 99-99-99
12	103931-01-03A	EA	COVER-INNER, A-PILLAR - PASSENGERS - QUICK SILVER
13	078811-05-G29	EA	PANEL-HEADER W/RECEPTACLE CUTOUTS - 90.2" LONG - VINYL COVERED
14	082286-18-GB1	EA	SUNVISOR-DRIVER OR PASSENGER - W/O POCKET FROM: 00-00-00 THRU: 08-27-95
14	082286-18-G29	EA	SUNVISOR-DRIVER OR PASSENGER - W/O POCKET FROM: 08-28-95 THRU: 99-99-99
	102377-01-000	EA	BRACKET-SUNVISOR, 1 PIECE - STEEL
	007211-01-000	EA	HINGE-SUNVISOR
	074012-01-000	EA	CLIP-SUNVISOR, SQUARE PINCH-ON
	081987-05-000	EA	ROD-SUNVISOR, BLACK
15	P03077-08-G09	EA	SHELF-CABINET, PASSENGERS SIDE - OFF WHITE VINYL COVERED FROM: 00-00-00 THRU: 08-27-95
15	P03077-08-G35	EA	SHELF-CABINET, PASSENGERS SIDE - QUICKSILVER VINYL COVERED FROM: 08-28-95 THRU: 99-99-99
16	117974-01-02A	EA	COVER-TV CABINET, FRONT FACE - QUICK SILVER
16	118022-01-G29	EA	COVER ASM-TV CABINET, SIDES & BOTTOM (ASSEMBLED KIT)
17	078579-19-000	EA	TRIM - WINDSHIELD - UPPER INNER - RIGHT - QUICK SILVER
18	079765-12-000	EA	TRIM - WINDSHIELD - CENTER INNER - QUICK SILVER
19	040714-01-000	EA	MIRROR-REAR VIEW, W/ARM MOUNT & SET SCREW - GM 911722
	067490-01-000	EA	BUTTON-MIRROR, REAR VIEW - STANK S927H
20	078579-20-000	EA	TRIM - WINDSHIELD - UPPER INNER - LEFT - QUICK SILVER
21	P03077-07-G09	EA	SHELF-CABINET, DRIVERS SIDE - OFF WHITE VINYL COVERED FROM: 00-00-00 THRU: 08-27-95
21	P03077-07-G35	EA	SHELF-CABINET, DRIVERS SIDE - QUICKSILVER VINYL COVERED FROM: 08-28-95 THRU: 99-99-99
	104417-01-G29	EA	CABINET-BLANKET (STANDARD CABINET)

DRIVERS COMPARTMENT GROUP (CONTINUED)
DRIVERS COMPARTMENT - LOWER

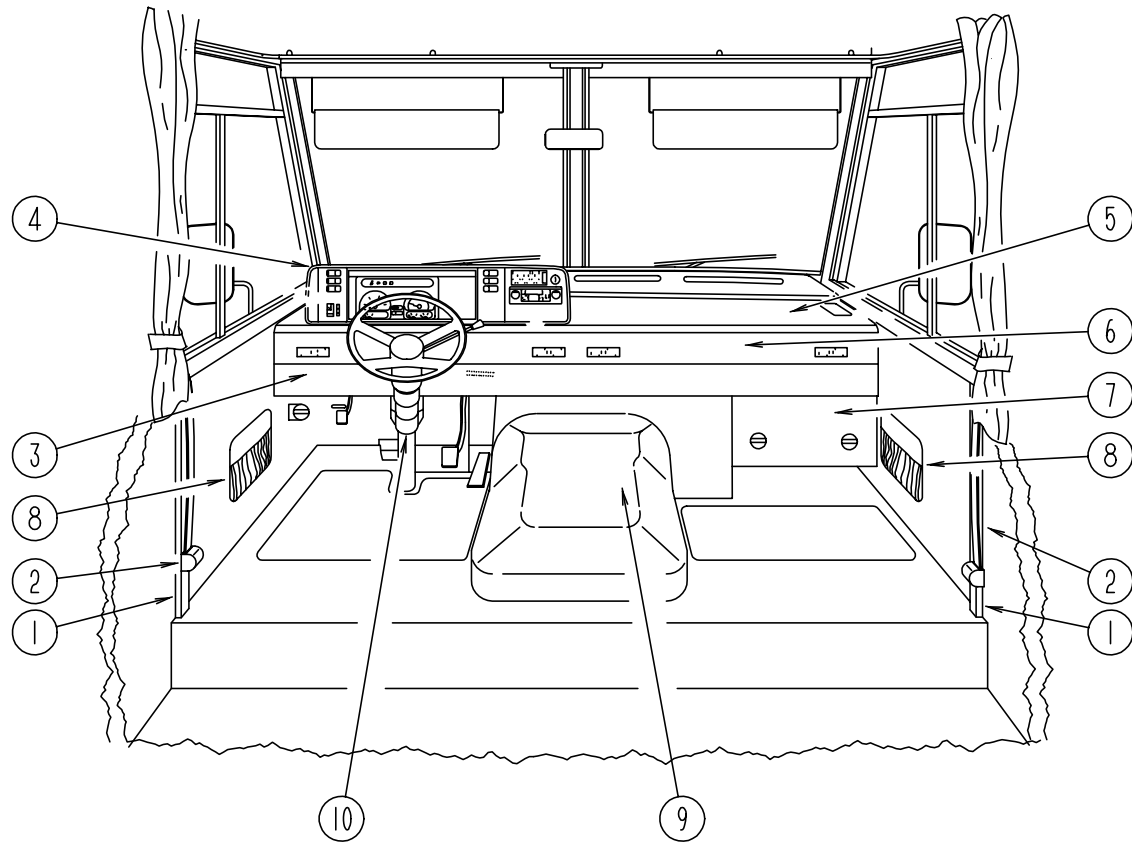

KEY	PART NUMBER	U/M	DESCRIPTION
1	024700-44-000	EA	COVER-SIDEWALL ROLL BAR, OFF WHITE - 53"
1	024700-45-000	EA	COVER-SIDEWALL ROLL BAR, OFF WHITE - 12.8"
	024700-47-000	EA	COVER-SIDEWALL ROLL BAR, OFF WHITE - 18.9" - DRIVER DOOR
	024700-48-000	EA	COVER-SIDEWALL ROLL BAR, OFF WHITE - 25" - DRIVER DOOR
2	091990-04-01A	EA	SEAT BELT-SHOULDER HARNESS - DRIVERS/PASSENGERS - BLACK
	091990-01-700	EA	BOLT COVER
	109146-01-000	EA	BOLT-SHOULDER, SEAT BELT
	103961-01-01A	EA	COVER-BRACKET, SEAT BELT - OFF WHITE
	103961-02-01A	EA	COVER-BRACKET, SEAT BELT - OFF WHITE - DRIVER DOOR
3	111528-05-05A	EA	TRIM-DASH, LOWER - 1648 MM LONG - QUICK SILVER - FORD
3	117306-01-G35	EA	TRIM-DASH, LOWER - 307 MM LONG - QUICK SILVER - FORD
3	103812-06-05A	EA	TRIM-DASH, LOWER - 2299 MM LONG - QUICK SILVER - CHEVY
4	111499-01-05A	EA	POD-INSTRUMENT PANEL, QUICK SILVER PLASTIC
5	P03817-11-000	EA	DASH ASM, W/O VINYL - CHEVY
5	P03817-10-000	EA	DASH ASM, W/O VINYL - FORD
	106569-02-05A	YD	VINYL-LAMINATE, 26 OZ - 54" WIDE - QUICK SILVER
	105927-02-000	EA	PANEL-DASH TOP, STEEL
6	104354-01-05A	EA	APPLIQUE-LOWER DASH, 2300 MM LONG
7	095757-03-F04	EA	COVER-HEATER W/CARPET (G29)
7	095757-03-F26	EA	COVER-HEATER W/CARPET (G30)
7	095757-03-F25	EA	COVER-HEATER W/CARPET (G31)
7	095757-03-G36	EA	COVER-HEATER W/CARPET (G32)
8	086120-01-F24	EA	PAD-MAP POCKET, 12" X 16' (G29)
8	086120-01-G30	EA	PAD-MAP POCKET, 12" X 16' (G30)
8	086120-01-F25	EA	PAD-MAP POCKET, 12" X 16' (G31)
8	086120-01-F06	EA	PAD-MAP POCKET, 12" X 16' (G32)
9	115840-01-01A	EA	COVER-MOTOR, W/CARPET - W/O HARDWARE (PLEASE SUPPLY SERIAL NUMBER FOR CARPET IDENTIFICATION)
9	115840-01-700	EA	COVER-MOTOR, W/O CARPET OR PAD
	115850-01-02B	EA	RETAINER-LATCH, MOTOR COVER
	116581-01-000	EA	LATCH-MOTOR COVER - SOUTHCO 2710074088
	115852-01-02B	EA	STRIKE ASM-MOTOR COVER, E-COAT
	116833-01-02B	EA	WRENCH-HEX, MOTOR COVER - E-COAT
	115860-01-01A	EA	TRIM-MOTOR COVER
	039623-01-000	FT	SEAL-MOTOR COVER, RUBBER BULB TYPE - BLACK
	111618-01-GB1	EA	TRAY ASM-BEVERAGE
	097872-04-000	EA	DOWEL-WOOD, 1" DIAMETER X 1.38" LONG - UNFINISHED
	111618-13-GB1	EA	LID-BEVERAGE TRAY ASM
	046886-03-000	EA	ASHTRAY-CHROME, W/COVER
10	103498-06-000	EA	BOOT-STEERING COLUMN, BLACK VINYL - CHEVY
	111521-03-01A	EA	COVER-STEERING COLUMN, BLACK PLASTIC - FORD
	112634-01-01A	EA	TRIM-STEERING COLUMN, RH BLACK PLASTIC - FORD
	112634-02-01A	EA	TRIM-STEERING COLUMN, LH BLACK PLASTIC - FORD
	108067-03-000	EA	STUD-WELD, 1/4" - 20 X 1/2" CD

DRIVERS COMPARTMENT GROUP (CONTINUED)

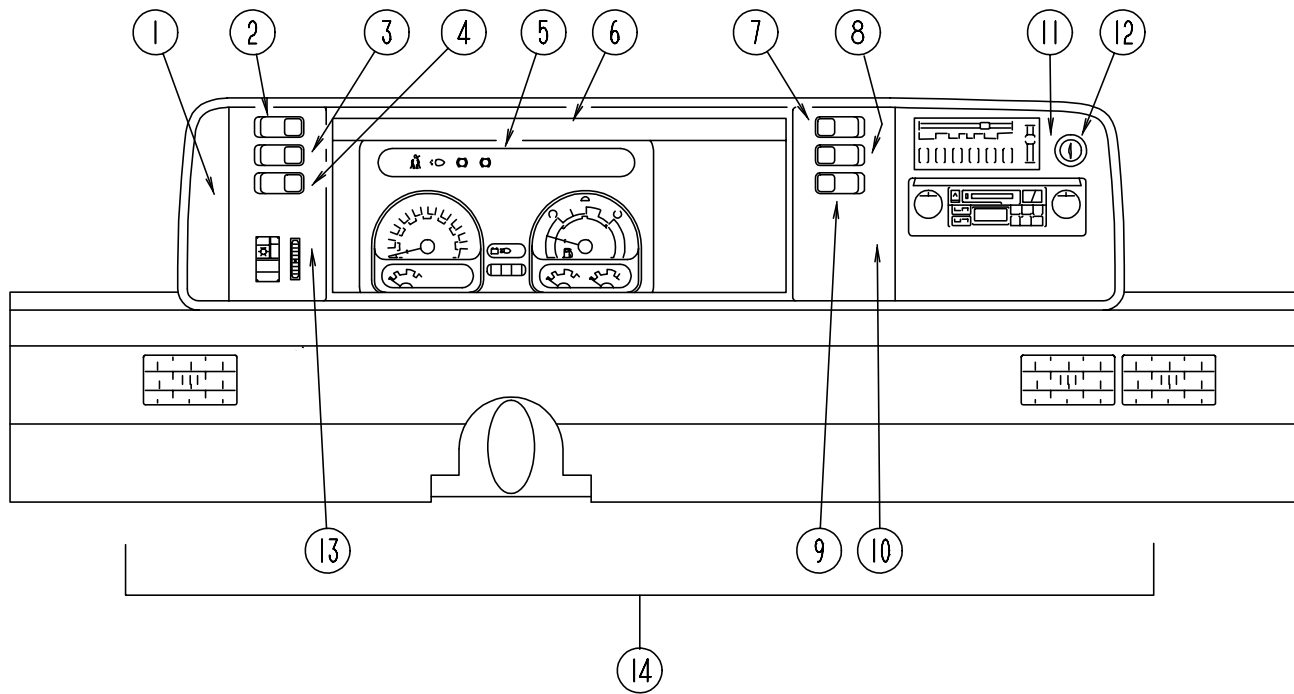

DASH, GAUGES & SWITCHES (CHEVY)

KEY	PART NUMBER	U/M	DESCRIPTION
1	104056-01-01A	EA	APPLIQUE-BEZEL, BLACK VELVET LEXAN
2	108356-02-01A	EA	COVER-SWITCH W/DIMPLES, CARLING VVAZC00 BLA
2	108357-05-000	EA	SWITCH-ROCKER, SPDT ON/NONE/ON - RADIO POWER - CARLING V4D1000B-0
3	108356-02-01A	EA	COVER-SWITCH W/DIMPLES, CARLING VVAZC00 BLA
3	108357-09-000	EA	SWITCH-ROCKER, SPDT ON/NONE/MOM - DUAL BATTERY - CARLING V5D1000B-0
4	108356-02-01A	EA	COVER-SWITCH W/DIMPLES, CARLING VVAZC00 BLA
4	108357-06-000	EA	SWITCH-ROCKER, DPDT MOM/OFF/MOM - CARLING VLD1000B-0 BATTERY DISCONNECT SWITCH OPTION
4	096241-03-000	EA	SWITCH-BLANK
5	094796-07-000	EA	CLUSTER-INSTRUMENT PANEL, KILOMETERS - GAS - GM# 16167145
6	103662-01-01A	EA	BEZEL-INSTRUMENT PANEL
7	108356-04-01A	EA	COVER-SWITCH W/DIMPLES & LENS, CARLING VVAGC00
7	108357-10-000	EA	SWITCH-ROCKER, SPDT MOM/OFF/MOM - LIGHTED - CARLING V8D1160B-0 GENERATOR OPTION
7	096241-03-000	EA	SWITCH-BLANK
8	108356-02-01A	EA	COVER-SWITCH W/DIMPLES, CARLING VVAZC00 BLA
8	108357-03-000	EA	SWITCH-ROCKER, SPDT ON/OFF/ON - CARLING V6D1000B-0 REAR HEATER OPTION
8	096241-03-000	EA	SWITCH-BLANK
9	096241-03-000	EA	SWITCH-BLANK
10	104056-21-01A	EA	APPLIQUE-BEZEL
11	104056-06-01A	EA	APPLIQUE-BEZEL, BLACK VELVET LEXAN
12	089294-01-000	EA	LIGHTER ASM-CIGARETTE - CASCO C213275
13	104056-22-01A	EA	APPLIQUE-BEZEL
14	M05946-26-G29	EA	DASH POD ASSEMBLY - CHEVY
	100138-01-000	EA	MODULE-DAYTIME RUNNING LIGHT - CANADIAN
	077031-01-000	EA	FILM-BLACK, 1" X 1.75"
	077031-03-000	EA	FILM-WHITE, .75" X 1"
	103603-01-000	EA	BULB - 12V, #74 - .12A WEDGE - GE 22-25 - USED IN DASH
	077539-01-000	EA	BRACKET-MOUNTING, DASH PANEL - L/SHAPED - 2.5" X 1" X 1.5"

DRIVERS COMPARTMENT GROUP (CONTINUED)

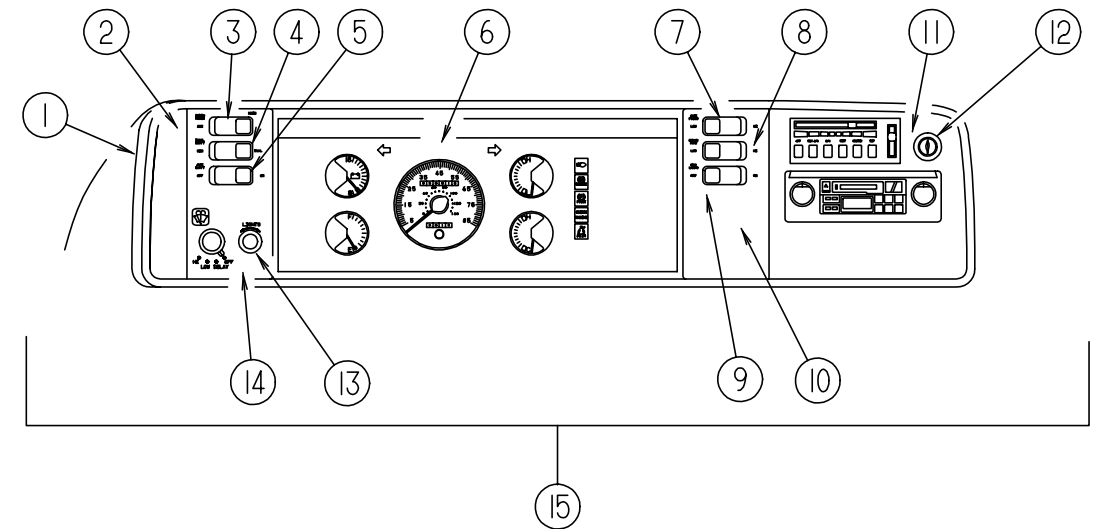

DASH, GAUGES & SWITCHES (FORD)

KEY	PART NUMBER	U/M	DESCRIPTION
1	103662-04-01A	EA	BEZEL-INSTRUMENT PANEL
2	104056-01-01A	EA	APPLIQUE-BEZEL, BLACK VELVET LEXAN
3	108356-02-01A	EA	COVER-SWITCH W/DIMPLES, CARLING VVAZC00 BLA
3	108357-05-000	EA	SWITCH-ROCKER, SPDT ON/NONE/ON - RADIO POWER - CARLING V4D1000B-0
4	108356-02-01A	EA	COVER-SWITCH W/DIMPLES, CARLING VVAZC00 BLA
4	108357-09-000	EA	SWITCH-ROCKER, SPDT ON/NONE/MOM - DUAL BATTERY - CARLING V5D1000B-0
5	108356-02-01A	EA	COVER-SWITCH W/DIMPLES, CARLING VVAZC00 BLA
5	108357-06-000	EA	SWITCH-ROCKER, DPDT MOM/OFF/MOM - CARLING VLD1000B-0 BATTERY DISCONNECT SWITCH OPTION
5	096241-03-000	EA	SWITCH-BLANK
6	094794-06-000	EA	CLUSTER-INSTRUMENT PANEL, KILOMETERS - FORD F5TD-10849-BB
6	094794-05-000	EA	CLUSTER-INSTRUMENT PANEL, MILES - FORD F4TD10849AA
7	108356-04-01A	EA	COVER-SWITCH W/DIMPLES & LENS, CARLING VVAGC00
7	108357-10-000	EA	SWITCH-ROCKER, SPDT MOM/OFF/MOM - LIGHTED - CARLING V8D1160B-0 GENERATOR OPTION
7	096241-03-000	EA	SWITCH-BLANK
8	108356-02-01A	EA	COVER-SWITCH W/DIMPLES, CARLING VVAZC00 BLA
8	108357-03-000	EA	SWITCH-ROCKER, SPDT ON/OFF/ON - CARLING V6D1000B-0 REAR HEATER OPTION
8	096241-03-000	EA	SWITCH-BLANK
9	096241-03-000	EA	SWITCH-BLANK
10	104056-21-01A	EA	APPLIQUE-BEZEL
11	104056-06-01A	EA	APPLIQUE-BEZEL, BLACK VELVET LEXAN
12	089294-01-000	EA	LIGHTER ASM-CIGARETTE - CASCO C213275
13	096674-01-000	EA	NUT-HEADLAMP KNOB, BLACK
13	096675-01-000	EA	KNOB - HEADLAMP - W/SHAFT
14	104056-24-01A	EA	APPLIQUE-BEZEL
15	M05946-27-G29	EA	DASH POD ASSEMBLY - FORD
	100138-01-000	EA	MODULE-DAYTIME RUNNING LIGHT - CANADIAN
	103603-01-000	EA	BULB - 12V, #74 - .12A WEDGE - GE 22-25 - USED IN DASH
	077031-01-000	EA	FILM-BLACK, 1" X 1.75"
	077031-03-000	EA	FILM-WHITE, .75" X 1"
	111904-01-000	EA	INDICATOR ASM-TRANSMISSION - FORD F2US-7B053

DRIVERS COMPARTMENT GROUP (CONTINUED)

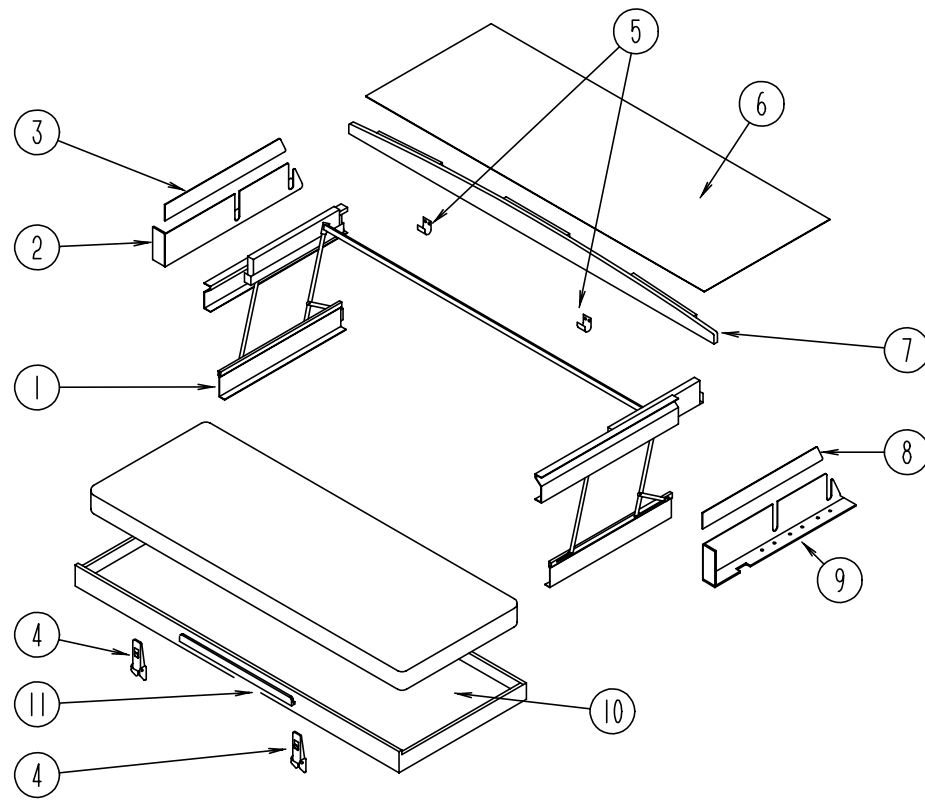

FRONT BUNK

KEY	PART NUMBER	U/M	DESCRIPTION
1	076760-02-000	EA	BUNK HARDWARE (COMPLETE)
	076760-02-700	EA	SPRING-GAS, BUNK HARDWARE
2	101499-06-C05	EA	PANEL ASM - BOTTOM DRIVERS - PADDED - OFF WHITE FROM: 00-00-00 THRU: 08-27-95
2	101499-06-G29	EA	PANEL ASM - BOTTOM DRIVERS - PADDED - QUICK SILVER FROM: 08-28-95 THRU: 99-99-99
3	101497-08-C05	EA	PANEL ASM - UPPER DRIVERS - PADDED - OFF WHITE FROM: 00-00-00 THRU: 08-27-95
3	101497-08-G29	EA	PANEL ASM - UPPER DRIVERS - PADDED - QUICK SILVER FROM: 08-28-95 THRU: 99-99-99
4	116975-01-01A	EA	LATCH-W/O STRIKE, BLACK
5	042541-05-000	EA	STRIKE-BRASS
6	103040-06-C05	EA	PANEL-HEADLINER FRONT OVERHEAD, PADDED - OFF WHITE FROM: 00-00-00 THRU: 08-27-95
6	103040-06-G29	EA	PANEL-HEADLINER FRONT OVERHEAD, PADDED - QUICK SILVER FROM: 08-28-95 THRU: 99-99-99
7	P03199-01-C05	EA	BOARD ASM-TRIM, BUNK - CEILING MOUNTED
8	101497-07-C05	EA	PANEL ASM - UPPER PASSENGERS - PADDED - OFF WHITE FROM: 00-00-00 THRU: 08-27-95
8	101497-07-G29	EA	PANEL ASM - UPPER PASSENGERS - PADDED - QUICK SILVER FROM: 08-28-95 THRU: 99-99-99
9	101499-05-C05	EA	PANEL ASM - BOTTOM PASSENGERS - PADDED - OFF WHITE FROM: 00-00-00 THRU: 08-27-95
9	101499-05-G29	EA	PANEL ASM - BOTTOM PASSENGERS - PADDED - QUICK SILVER FROM: 08-28-95 THRU: 99-99-99
10	081717-03-G09	EA	BED ASM-BUNK, FRONT
11	094658-01-G09	EA	HANDLE-BUNK, OAK

ELECTRICAL GROUP CIRCUIT BREAKERS

KEY	PART NUMBER	U/M	DESCRIPTION
	083209-01-000	EA	CIRCUIT BREAKER - 15 AMP, 120V - BW G-15
	083209-02-000	EA	CIRCUIT BREAKER - 15/15 AMP, 120V - BW H-15/15
	083209-03-000	EA	CIRCUIT BREAKER - 15/20 AMP, 120V - BW O-15/20
	083209-04-000	EA	CIRCUIT BREAKER - 30 AMP, 120V - BW L-30
	083209-06-000	EA	CIRCUIT BREAKER - 30/15 AMP, 120V - BW D-30/15
	083209-07-000	EA	CIRCUIT BREAKER - 20/20 AMP, 120V - BW K-20/20
	093655-03-000	EA	CIRCUIT BREAKER - 40 AMP, 12V - USD 17440-4E03A2A
	097611-01-000	EA	CIRCUIT BREAKER - 6 AMP, ATC - BLACK - FASCO VB3-A10-F57

WIRE ASSEMBLIES

KEY	PART NUMBER	U/M	DESCRIPTION
	090986-01-000	EA	WIRE ASM-ELECTRIC STEP, KWIKEE 9009
	096449-01-000	EA	WIRE ASM-WATER TANK TO MONITOR PANEL
	097618-01-000	EA	WIRE ASM-MONITOR PANEL, W/3 WIRES & ORANGE RESISTOR- LVS
	102636-02-000	EA	WIRE ASM-CLEARANCE LAMPS
	103328-06-000	EA	WIRE ASM-PUMP, EXTERIOR SHOWER
	104271-02-000	EA	WIRE ASM-SPEAKER, TV
	100677-01-000	EA	WIRE ASM-RADIO
	103342-02-000	EA	WIRE ASM-CLEARANCE, UPPER - LT
	103342-03-000	EA	WIRE ASM-CLEARANCE, UPPER - RT
	113134-03-000	EA	WIRE ASM-WIPER/WASHER
	108303-01-000	EA	WIRE ASM-REAR AUTO HEATER
	110256-01-000	EA	WIRE ASM-IP, GENERATOR
	111915-01-000	EA	WIRE ASM-DAY RUN LAMPS, FUSE - CHEVY
	111915-03-000	EA	WIRE ASM-DAY RUN LAMPS, FUSE - FORD
	119456-01-000	EA	WIRE ASM-IP, MAIN - FORD
	119459-01-000	EA	WIRE ASM-IP, MAIN - CHEVY
	P03784-01-000	EA	WIRE ASM-HEADLAMP - CHEVY
	P03784-02-000	EA	WIRE ASM-HEADLAMP - FORD

HOUSINGS, PINS & SOCKETS

KEY	PART NUMBER	U/M	DESCRIPTION
	088473-01-000	EA	HOUSING-PIN, 4 ROWS OF 3
	088473-02-000	EA	HOUSING-PIN, 15 CAVITY - AMP 1-480710-0
	088473-03-000	EA	HOUSING-PIN, 9 POSITION
	088473-05-000	EA	HOUSING-PIN, 6 POSITION (SINGLE ROW)
	088473-06-000	EA	HOUSING-PIN, 6 POSITION (TWO ROWS OF THREE)
	088473-08-000	EA	HOUSING-PIN, 4 POSITION
	088473-09-000	EA	HOUSING-PIN, 3 POSITION (SINGLE ROW)
	088473-10-000	EA	HOUSING-PIN, 2 POSITION
	088474-01-000	EA	HOUSING-SOCKET, 12 POSITIONS
	088474-02-000	EA	HOUSING-SOCKET, 12 CAVITY - AMP 1-480711-0
	088474-03-000	EA	HOUSING-SOCKET, 9 POSITION
	088474-06-000	EA	SOCKET-HOUSING, 6 POSITION (2 ROWS OF THREE)
	088474-07-000	EA	HOUSING-SOCKET, 5 CAVITY - AMP 1-480764-0
	088474-08-000	EA	SOCKET-HOUSING, 4 POSITION (SINGLE ROW)
	088474-09-000	EA	HOUSING-SOCKET, 3 POSITION
	088474-10-000	EA	HOUSING-SOCKET, 2 POSITION
	088475-01-000	EA	PIN-CONNECTOR, 14 TO 20 AWG
	088475-02-000	EA	PIN-CONNECTOR, 10 TO 12 AWG
	098265-02-000	EA	PIN-CONNECTOR, WEATHER PACK - PACKARD12089305
	088476-01-000	EA	SOCKET-CONNECTOR, BRASS - PRE-TIN
	088476-02-000	EA	SOCKET-CONNECTOR, 12-10 GA - PHOSPHATE BRONZE - PRE-TIN
	098261-02-000	EA	SOCKET-CONNECTOR, WEATHERPACK - PACKARD 12124580
	100690-01-000	EA	HOUSING - 5 PIN, WEATHER PACK
	103608-01-000	EA	SOCKET-WEDGE BASE W/LEADS, JKL 2944-6 OR EQUIVALENT
	104100-01-000	EA	HOUSING - 1 POSITION, 75 AMP - AMP 53884-1
	106006-01-000	EA	HOUSING - 1 POSITION, FEMALE - PACKARD 12015952
	108355-01-000	EA	HOUSING-SWITCH, CARLING VCH
	113468-01-000	EA	HOUSING - 2 POSITION, FEMALE - 56-SERIES - PACKARD 02965981 USED ON WIPER/WASHER WIRE ASM
	119248-02-000	EA	HOUSING - 7 POSITION, FEMALE - METRI-PACK - PACKARD 12059472

ELECTRICAL GROUP (CONTINUED)
CONVERTER & INVERTER

KEY	PART NUMBER	U/M	DESCRIPTION
	083208-02-000	EA	CONVERTER-POWER, 45A - 120V/12V - BW 6345
	099048-02-000	EA	INVERTER - 100 WATT - DUI-12/100TLW

CONNECTORS

KEY	PART NUMBER	U/M	DESCRIPTION
	008311-01-000	EA	CONNECTOR-WIRE NUT, INSULATED - RED
	008312-01-000	EA	CONNECTOR-WIRE NUT, INSULATED - BLUE
	008314-01-000	EA	CONNECTOR-WIRE NUT, INSULATED - GRAY
	008355-01-000	EA	CONNECTOR-CABLE CLAMPING, 3/4"
	008356-01-000	EA	CONNECTOR-PLASTIC, 3/8" AVG
	008398-01-000	EA	CONNECTOR - 1/2" X 90 DEGREE, FLEX CONDUIT - UL AND CSA
	041480-01-000	EA	CONNECTOR-STRAIGHT, 1/2" FLEX CONDUIT
	082741-01-000	EA	CONNECTOR BODY - 2 CONNECTOR - MALE - SERV ELEC 2P-FYL
	087695-03-000	EA	CONNECTOR-ASSEMBLY - EURAMTEC RT10484802 FROM: 09-01-95 THRU: 99-99-99
	058028-01-000	EA	CONNECTOR-ELECTRICAL PIGTAIL, NYLON - CLEAR
	098262-01-000	EA	SEAL-CONNECTOR, WEATHER PACK - PACKARD 12010293
	007940-01-000	EA	RECEPTACLE-SLIDE, 16 TO 12 AWG - FEMALE END
	007954-01-000	EA	RECEPTACLE-HOUSING, 6 POSITION
	080015-02-000	EA	RECEPTACLE-FLAG, .185 - 16/14 GA - AMP 3-520340-2

FUSES & FUSE HOUSINGS

KEY	PART NUMBER	U/M	DESCRIPTION
	008234-01-000	EA	FUSE - 10 AMPS, 12 VOLT
	062901-02-000	EA	FUSE - 5 AMPS, AUTOMOTIVE
	062901-05-000	EA	FUSE - 15 AMPS, AUTOMOTIVE
	062901-06-000	EA	FUSE - 20 AMPS, AUTOMOTIVE
	062901-07-000	EA	FUSE - 25 AMPS, AUTOMOTIVE
	062901-08-000	EA	FUSE - 30 AMPS, AUTOMOTIVE
	062037-01-000	EA	HOUSING-AUTO FUSE, NATURAL
	062037-02-000	EA	HOUSING-AUTO FUSE, GREEN
	062037-03-000	EA	HOUSING-AUTO FUSE, BLACK
	062037-04-000	EA	HOUSING-AUTO FUSE, BLUE
	062037-06-000	EA	HOUSING-AUTO FUSE, BROWN
	062037-07-000	EA	HOUSING-AUTO FUSE, RED
	108669-01-000	EA	HOUSING-AUTO FUSE HOLDER, PACKARD 12010105
	106655-02-000	EA	TERMINAL-FUSE BLOCK,10-12AWG - PACKARD 12020400
	106656-01-000	EA	FUSE BLOCK - 4 CAVITY AUTOFUSE - PACKARD 12004943

POWER CORDS

KEY	PART NUMBER	U/M	DESCRIPTION
	008052-01-000	EA	CORD-POWER, 10/3 - 30 AMP - 25' - CANADIAN
	008054-01-000	EA	CORD-POWER, 10/3 - 30 AMP - 25' - US
	121470-01-000	EA	CORD-EXTENSION, 6 FT - 16-2 WIRE - AWI 2030 - SATELLITE DISH OPTION

ELECTRICAL GROUP (CONTINUED)
TERMINALS

KEY	PART NUMBER	U/M	DESCRIPTION
	008326-01-000	EA	TERMINAL-RING, 16/14 WIRE - 3/8" STUD
	008328-01-000	EA	TERMINAL-RING, 12/10 WIRE - #10 STUD FIT
	008331-01-000	EA	TERMINAL-RING,TONGUE - #4 WIRE - 3/8" STUD - COPPER
	008348-01-000	EA	TERMINAL-RING, 3/8" STUD - #2 WIRE
	035416-04-000	EA	TERMINAL-RING #10 STUD FIT, INSULATED BARREL #16/14
	047443-01-000	EA	TERMINAL - .250 RECEPTACLE FIT, INSULATED - 16/14 AWG
	047443-02-000	EA	TERMINAL - .250 RECEPTACLE FIT, INSULATED - 12/10 AWG
	062036-01-000	EA	TERMINAL-PACK-CON,12/10 AWG - PACKARD 12033817
	062036-02-000	EA	TERMINAL-PACK-CON, 16/14 AWG
	088267-01-000	EA	TERMINAL-FEMALE, 1/4 - PACKARD 2962573
	104100-02-000	EA	TERMINAL - 75 AMP, AMP 53880-2 STRIP
	104100-03-000	EA	TERMINAL - 75 AMP, AMP 53880-4 LOOSE
	106007-01-000	EA	TERMINAL-FEMALE, 14-16AWG - PACKARD 12015861-L
	106655-01-000	EA	TERMINAL-FUSE BLOCK, 14-16 AWG - PACKARD 12020321
	113306-01-000	EA	TERMINAL-FEMALE, METRI-PACK - PACKARD 12048451
	113307-01-000	EA	TERMINAL-FEMALE, METRI-PACK - PACKARD 12048074

CONDUIT

KEY	PART NUMBER	U/M	DESCRIPTION
	041953-01-000	FT	CONDUIT-CONVOLUTE, SLIT - .5" ID
	041953-03-000	FT	CONDUIT-CONVOLUTE, SLIT - 1" ID (CLOTHES ROD COVER)
	041953-05-000	FT	CONDUIT-CONVOLUTE, SOLID - .62" ID
	041953-06-000	FT	CONDUIT-CONVOLUTE, SLIT - .375" ID
	041953-07-000	FT	CONDUIT-CONVOLUTE, SLIT - .25" ID
	041953-08-000	FT	CONDUIT-CONVOLUTE, SLIT - 1.50" ID
	041953-09-000	FT	CONDUIT-CONVOLUTE, SLIT - .50" ID
	041953-10-000	FT	CONDUIT-CONVOLUTE, SLIT - .75" ID
	041953-11-000	FT	CONDUIT-CONVOLUTE, SLIT - 1.06" ID
	041953-12-000	FT	CONDUIT-CONVOLUTE, NON SLIT - 1.1" ID

ELECTRIC BOXES & COVERS

KEY	PART NUMBER	U/M	DESCRIPTION
	008289-01-000	EA	BOX-ELECTRIC, STEEL - 1/2" AND 3/4" KNOCKOUTS - 4" X 4" - US
	008289-02-000	EA	BOX-ELECTRIC, 4" X 4" - 1/2" & 3/4" KNOCKOUTS - CANADIAN
	091910-01-000	EA	BOX-ELECTRIC, 3.75" X 3.5" X 1.75" - PLASTIC
	091910-02-000	EA	BOX-ELECTRIC, 57 MM X 88 MM - PLASTIC
	074890-01-000	EA	BOX-EXTENSION, STEEL - OPEN SIDES - 4" X 4" X 1 1/2"
	074897-01-000	EA	COVER-ELECTRIC BOX, 1 LARGE & 2 SMALL HOLES - 4" X 4"
	008294-01-000	EA	COVER-ELECTRICAL BOX, BLANK/STEEL - 4" X 4" - GRAY
	008294-02-000	EA	COVER-ELECTRICAL BOX, BLANK STEEL - 4" X 4" - CANADIAN
	073626-04-000	EA	COVER-ELECTRIC, 10.4" X 7.8" - BEIGE PLASTIC
	069238-01-000	EA	COVER-ELECTRICAL BOX, W/HOLE - 4" X 4" - GRAY USED WITH 30 AMP RECEPTACLE
	091927-01-000	EA	COVER-RECEPTACLE, DOUBLE - IVORY
	111509-01-000	EA	BOX ASM-ELECTRICAL, FRONT
	111510-01-000	EA	DOOR-ELECTRICAL BOX, FRONT

MISCELLANEOUS ELECTRICAL COMPONENTS

KEY	PART NUMBER	U/M	DESCRIPTION
	007093-01-000	EA	FLASHER-SIGNAL, STAT
	007956-05-000	EA	INSULATOR-SHRINK, .25" ID X 1.50"
	008188-01-000	EA	SOLENOID - 3 POST, BATTERY CHANGE OVER
	063910-01-000	EA	HOUSING-RELAY, BOSCH 3 334 485 008
	063912-02-000	EA	RELAY-CANISTER, SPDT - BOSCH 0332204101
	086233-01-000	EA	STUD-ISOLATED, 3/8" X 7/8" LONG
	086273-01-000	EA	RELAY-BATTERY DISCONNECT
	103987-02-000	EA	SEAL-SOLENOID ACCESS
	087225-01-000	FT	SLEEVING - 1/2", TYPE H - VARFLEX
	073328-B4-000	EA	CABLE ASSEMBLY-BATTERY, W/TERMINALS
	077479-01-000	EA	BOOT-BATTERY TERMINAL, DOUBLE CABLE
	077479-02-000	EA	BOOT-BATTERY TERMINAL, SINGLE CABLE

ELECTRICAL GROUP (CONTINUED)
LIGHTS, RECEPTACLES & SWITCHES - DRIVER SIDE

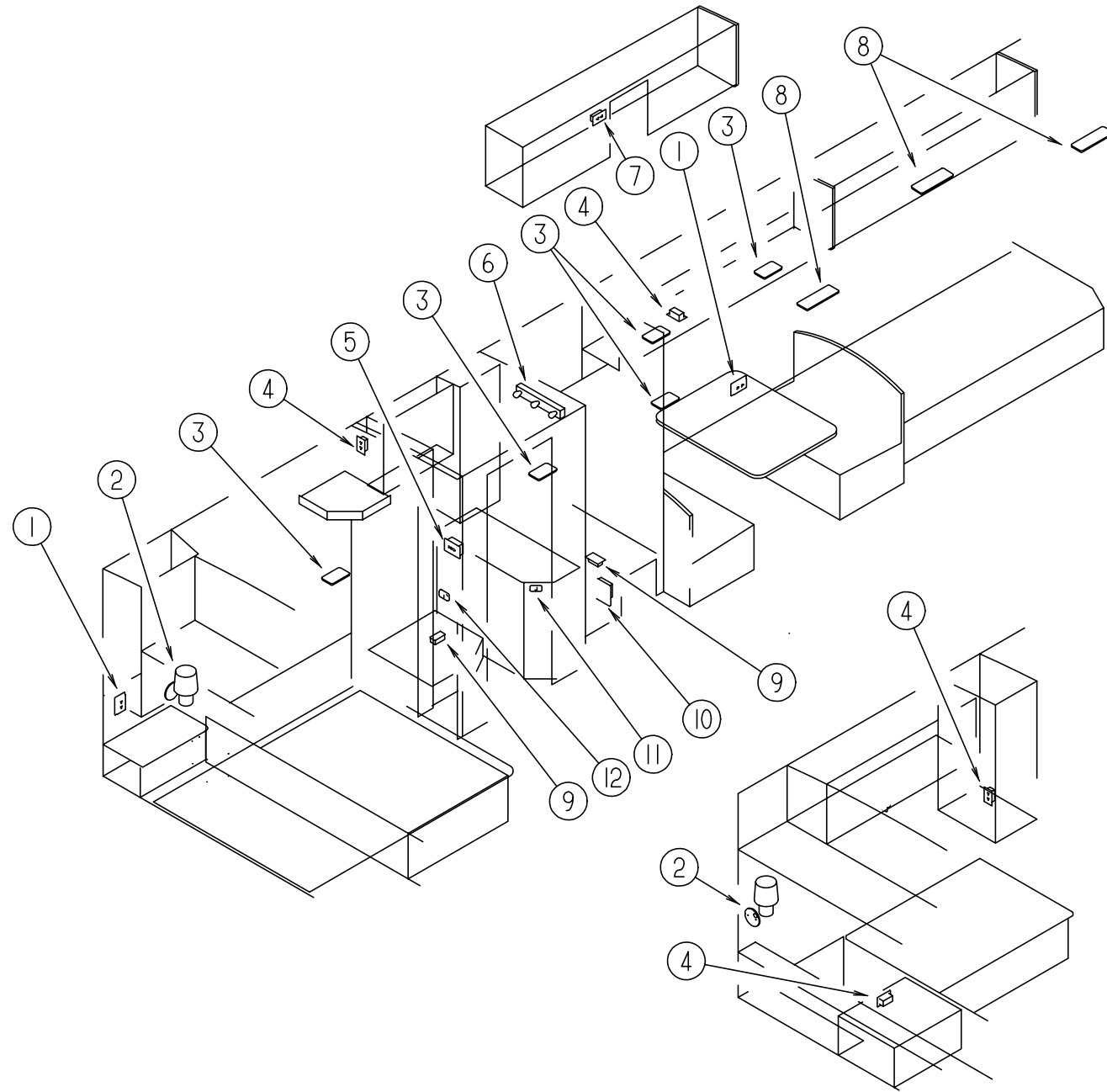

KEY	PART NUMBER	U/M	DESCRIPTION
1	058708-01-000	EA	RECEPTACLE-ELECTRIC, DOUBLE - BROWN
1	058708-02-000	EA	RECEPTACLE-ELECTRIC, DOUBLE - IVORY
1	102568-01-GB1	EA	SPACER-RECEPTACLE, SIDEWALL
2	065202-22-000	EA	LAMP-WALL W/O SHADE, BRASS - US & CANADIAN (G29/G30/G31)
2	065201-09-000	EA	SHADE-LAMP, FABRIC - PARCHMENT (G29/G30/G31)
2	067479-01-000	EA	BULB - 12V, NUMBER 1076
2	065202-30-000	EA	LAMP-WALL W/O SHADE, BRASS - US & CANADIAN (G32)
2	065201-09-000	EA	SHADE-LAMP, FABRIC - WHITE SWIRL (G32)
3	098024-01-01A	EA	LIGHT-DOME, 1 BULB - US - IVORY
3	008218-01-000	EA	BULB-DOME LIGHT, 12V - NUMBER 1141
3	098024-01-700	EA	LENS-DOME LIGHT
4	058708-01-000	EA	RECEPTACLE-ELECTRIC, DOUBLE - BROWN
4	058708-02-000	EA	RECEPTACLE-ELECTRIC, DOUBLE - IVORY
5	084076-01-000	EA	RECEPTACLE-GFI, 15A - 125V - IVORY
5	084076-02-000	EA	RECEPTACLE-GFI, 15A - 125V - BROWN
6	110235-01-01A	EA	LIGHT-MAKE UP, BRASS - 3 BULB PANLESS - PD PD200-621
6	081633-01-700	EA	BULB-MAKE UP LIGHT, JENSEN
7	058708-05-000	EA	RECEPTACLE-SINGLE, BROWN - WIRECON WDR15BRS
8	098024-03-01A	EA	LIGHT-DOME, 2 BULB - IVORY
8	008218-01-000	EA	BULB-DOME LIGHT, 12V - NUMBER 1141
8	098024-01-700	EA	LENS-DOME LIGHT
9	058707-02-000	EA	RECEPTACLE-BLANK, JUNCTION - WIRECON WDJ20BR
10	024924-02-000	EA	RECEPTACLE-POWER CORD, W/PARTIAL PLATE
11	098351-02-01A	EA	PLATE-SWITCH, 2 GANG - POLISHED BRASS - JENSEN
11	079364-01-000	EA	SWITCH-ON/OFF ROCKER, 2 PRONGS - BROWN
11	079364-03-000	EA	SWITCH-ON/OFF ROCKER, 3 PRONGS - BROWN
12	098351-01-01A	EA	PLATE-SWITCH, 1 GANG - POLISHED BRASS - JENSEN
12	095188-01-01A	EA	SPACER-SWITCH, 2.3" X 3.4" - PLASTIC - DARK BROWN
12	079364-01-000	EA	SWITCH-ON/OFF ROCKER, 2 PRONGS - BROWN
	086280-01-000	EA	LIGHT-SURFACE MOUNT, 12V - JENSEN 1236
	086280-01-700	EA	BULB - 12 VOLT, 6 WATT
	087695-01-000	EA	SWITCH-HEATER, EXTERIOR MIRROR - EURAMTEC
			FROM: 00-00-00 THRU: 09-10-95
	087695-02-000	EA	SWITCH-HEATER, EXTERIOR MIRROR - EURAMTEC DAV4720-12
			FROM: 09-11-95 THRU: 99-99-99
	087695-03-000	EA	CONNECTOR-ASSEMBLY - EURAMTEC RT10484802
	088246-01-000	EA	SWITCH-REMOTE, EXTERIOR MIRROR - SQUARE PUSH - VELVAC 7471290
	117806-01-000	EA	BULB-12V NO.912 1.0 AMPS
	103603-01-000	EA	BULB-12V, #74 - .12A WEDGE - GE 22-25 - USED IN DASH
	091927-01-000	EA	COVER-RECEPTACLE, DOUBLE - IVORY
	098351-05-01A	EA	PLATE-SWITCH, 3 GANG W/LABEL - POLISHED BRASS - JENSEN
	098351-06-01A	EA	PLATE-SWITCH, 2 GANG W/LABEL - POLISHED BRASS - JENSEN
	095188-02-01A	EA	SPACER-SWITCH, 2.3" X 4.1" - PLASTIC - DARK BROWN
	054250-01-000	EA	COVER-ANGLED, W/O HOLE - 3.6" X 4.5" - PLASTIC - BEIGE
			ELECTRICAL PLATE SUPPORT W/O HOLES
	073626-04-000	EA	COVER-ELECTRIC, 10.4" X 7.8" - BEIGE PLASTIC
	108355-01-000	EA	HOUSING-SWITCH, CARLING VCH

ELECTRICAL GROUP (CONTINUED)
LIGHTS, RECEPTACLES & SWITCHES - PASSENGER SIDE

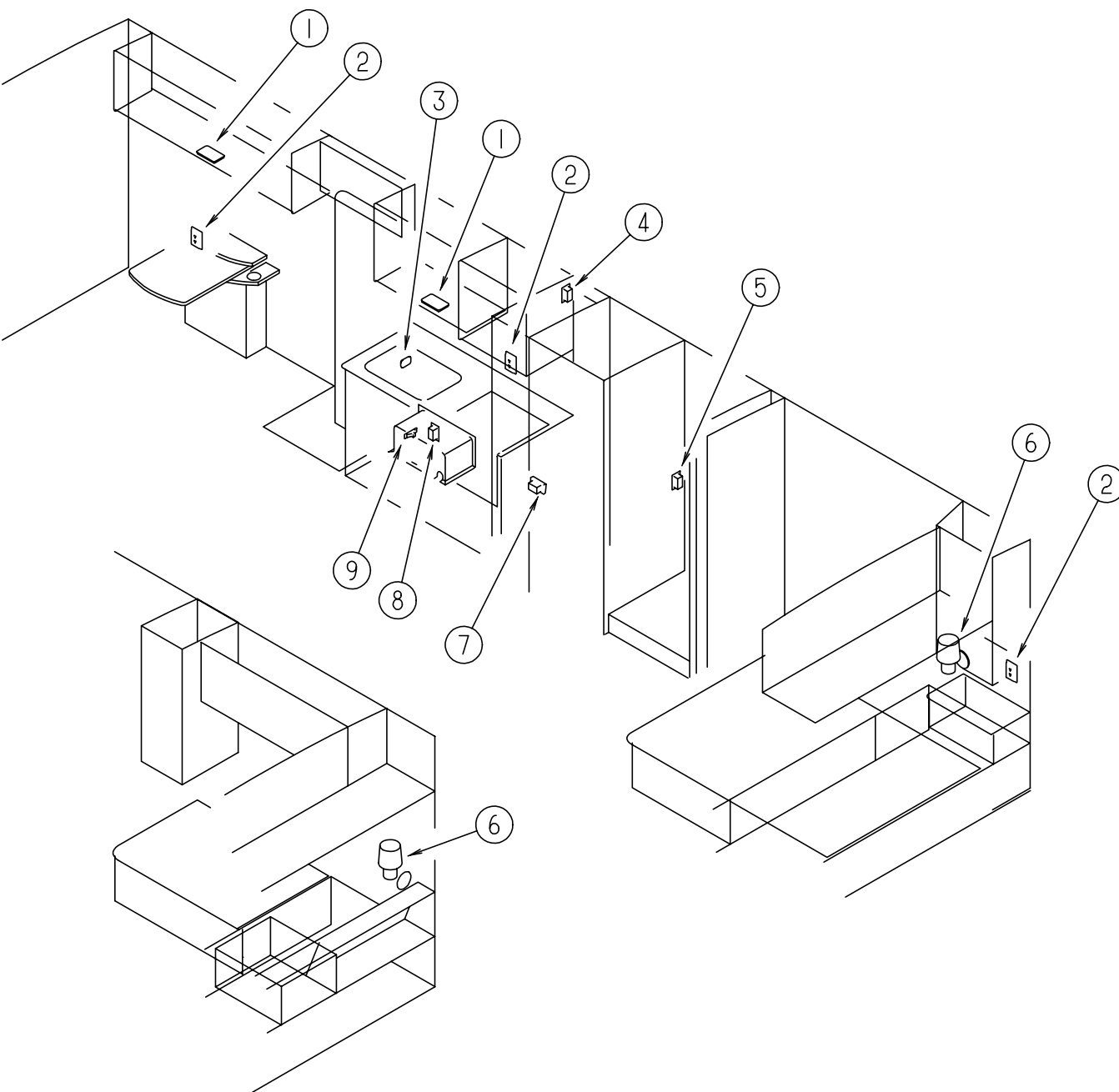

KEY	PART NUMBER	U/M	DESCRIPTION
1	098024-01-01A	EA	LIGHT-DOME, 1 BULB - US - IVORY
1	008218-01-000	EA	BULB-DOME LIGHT, 12V - NUMBER 1141
1	098024-01-700	EA	LENS-DOME LIGHT
2	058708-01-000	EA	RECEPTACLE-ELECTRIC, DOUBLE - BROWN
2	058708-02-000	EA	RECEPTACLE-ELECTRIC, DOUBLE - IVORY
2	102568-01-GB1	EA	SPACER-RECEPTACLE, SIDEWALL
3	084076-01-000	EA	RECEPTACLE-GFI, 15A - 125V - IVORY
3	084076-02-000	EA	RECEPTACLE-GFI, 15A - 125V - BROWN
4	058708-05-000	EA	RECEPTACLE-SINGLE, BROWN - WIRECON WDR15BRS
5	058707-01-000	EA	RECEPTACLE-ELECTRIC, SINGLE - BROWN
6	065202-22-000	EA	LAMP-WALL W/O SHADE, BRASS - US & CANADIAN (G29/G30/G31)
6	065201-09-000	EA	SHADE-LAMP, FABRIC - PARCHMENT (G29/G30/G31)
6	067479-01-000	EA	BULB - 12V, NUMBER 1076
6	065202-30-000	EA	LAMP-WALL W/O SHADE, BRASS - US & CANADIAN (G32)
6	065201-09-000	EA	SHADE-LAMP, FABRIC - WHITE SWIRL (G32)
7	112822-01-01A	EA	RECEPTACLE-EXTERIOR, DUPLEX - IVORY - WIRECON WDRU15IV
7	112824-01-03A	EA	COVER-EXTERIOR RECEPTACLE, WHITE - P&S 3780-SC-WH
8	058708-01-000	EA	RECEPTACLE-ELECTRIC, DOUBLE - BROWN
8	058708-02-000	EA	RECEPTACLE-ELECTRIC, DOUBLE - IVORY
9	061424-01-000	EA	LIGHT-AISLE, 12V - RECTANGULAR
9	008103-01-000	EA	BULB-DASH/AISLE LIGHT, #53 - 12 V - .12 AMP
	086280-01-000	EA	LIGHT-SURFACE MOUNT, 12V - JENSEN 1236
	086280-01-700	EA	BULB - 12 VOLT, 6 WATT
	087695-01-000	EA	SWITCH-HEATER, EXTERIOR MIRROR - EURAMTEC
			FROM: 00-00-00 THRU: 09-10-95
	087695-02-000	EA	SWITCH-HEATER, EXTERIOR MIRROR - EURAMTEC DAV4720-12
			FROM: 09-11-95 THRU: 99-99-99
	087695-03-000	EA	CONNECTOR-ASSEMBLY - EURAMTEC RT10484802
	088246-01-000	EA	SWITCH-REMOTE, EXTERIOR MIRROR - SQUARE PUSH - VELVAC 7471290
	117806-01-000	EA	BULB-12V NO.912 1.0 AMPS
	103603-01-000	EA	BULB-12V, #74 - .12A WEDGE - GE 22-25 - USED IN DASH
	091927-01-000	EA	COVER-RECEPTACLE, DOUBLE - IVORY
	098351-05-01A	EA	PLATE-SWITCH, 3 GANG W/LABEL - POLISHED BRASS - JENSEN
	098351-06-01A	EA	PLATE-SWITCH, 2 GANG W/LABEL - POLISHED BRASS - JENSEN
	095188-02-01A	EA	SPACER-SWITCH, 2.3" X 4.1" - PLASTIC - DARK BROWN
	054250-01-000	EA	COVER-ANGLED, W/O HOLE - 3.6" X 4.5" - PLASTIC - BEIGE
			ELECTRICAL PLATE SUPPORT W/O HOLES
	073626-04-000	EA	COVER-ELECTRIC, 10.4" X 7.8" - BEIGE PLASTIC
	108355-01-000	EA	HOUSING-SWITCH, CARLING VCH

ELECTRICAL GROUP (CONTINUED)
EXTERIOR LIGHTS

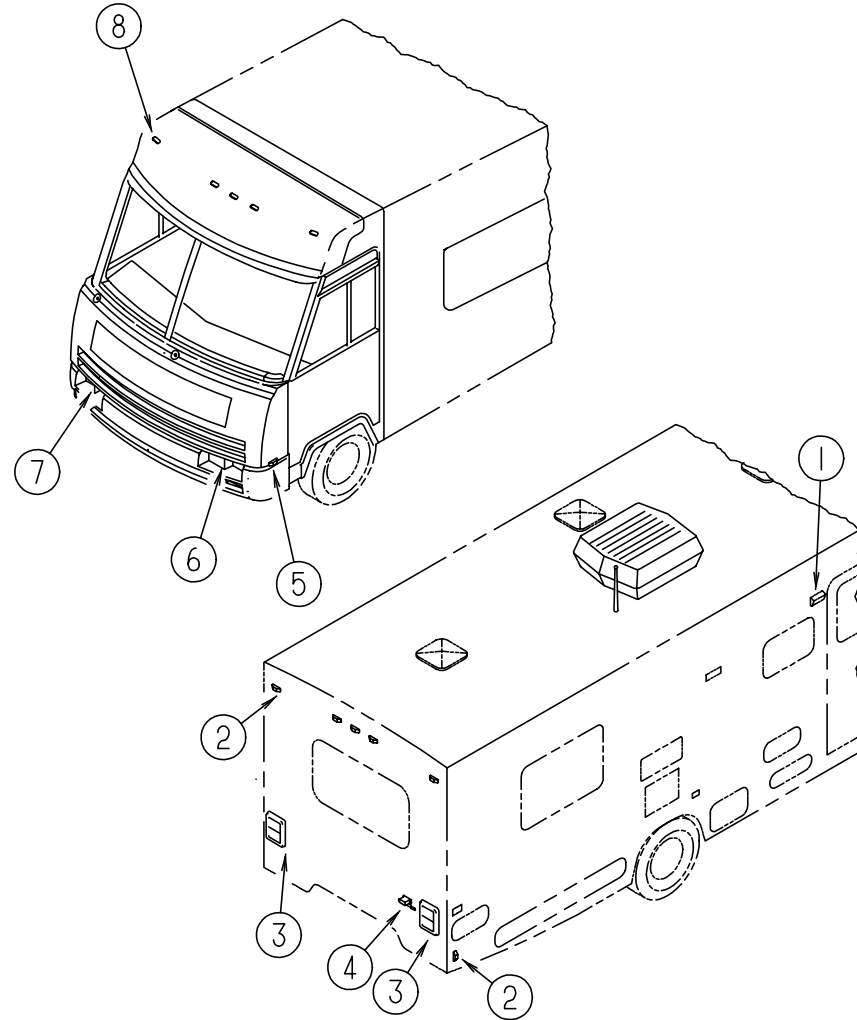

KEY	PART NUMBER	U/M	DESCRIPTION	VENDOR NO.
1	097917-01-06A	EA	LIGHT-PORCH, ENTRY DOOR - BRIGHT WHITE	
	008215-01-000	EA	BULB - 12V, #1003 - .94 AMP	
	097917-01-700	EA	LENS-LIGHT, PORCH	
2	111102-01-000	EA	LAMP-MARKER, BASE - TRIPLEX 117XAS	
2	111102-03-000	EA	LENS-MARKER LAMP, RED - TRIPLEX 117R	
	036196-01-000	EA	BULB - 12V, #194 - .27 AMP - BAYONETTE	
3	081638-01-000	EA	TAILLIGHT-DOUBLE, W/BLACK TRIM - DRIVER OR PASSENGER SIDE	
	037934-01-000	EA	BULB - 12V, #1156 - 2.1 AMP - CLEAR GLASS	
	037935-01-000	EA	BULB - 12V, #1157 OR #2057 - 2.1 AMP - CLEAR GLASS	
	081638-01-700	EA	LENS-TAILLIGHT, RED - BARGMAN	30-84-010
	081638-01-701	EA	LENS-TAILLIGHT, W/BACKUP - BARGMAN	30-84-700
	103355-01-05A	EA	POD-TAILLIGHT, BRIGHT WHITE	
4	066432-02-000	EA	LIGHT-LICENSE, BLACK	
	066432-03-000	EA	BRACKET-LICENSE PLATE - BARGMAN 30-60-030	
5	111102-01-000	EA	LAMP-MARKER, BASE - TRIPLEX 117XAS	
5	111102-02-000	EA	LENS-MARKER LAMP, AMBER - TRIPLEX 118A	
	036196-01-000	EA	BULB - 12V, #194 - .27 AMP - BAYONETTE	
6	049186-04-000	EA	HEADLAMP ASM-DRIVER, HIGH/LOW BEAM - HALOGEN - KD 92749-201	
	049188-04-000	EA	HEADLAMP ASM-DRIVER, HIGH BEAM - HALOGEN - KD 92750-201	
7	049185-04-000	EA	HEADLAMP ASM-PASS, HIGH/LOW BEAM - HALOGEN - KD 92751-201	
	049187-04-000	EA	HEADLAMP ASM-PASS, HIGH BEAM - HALOGEN - KD 92748-201	
	049359-01-000	EA	SPRING-RETAINER, HEADLAMP - GM 496096	
8	102520-01-000	EA	LIGHT-CLEARANCE, W/O SOCKET CONNECTIONS - AMBER	
	036196-01-000	EA	BULB - 12V, #194 - .27 AMP - BAYONETTE	
	102540-01-000	EA	SEAL-SCREW, ROUND - RUBBER	
	102541-01-000	EA	GASKET-CLEARANCE LIGHT	
	112823-01-000	EA	SPLICE-REDUCER, 16-14 TO 18-22 - ETC BA-631X	
	067789-02-000	EA	SOCKET-LAMP	

EXTERIOR BODY GROUP
EXTERIOR BODY PANELS AND TRIM

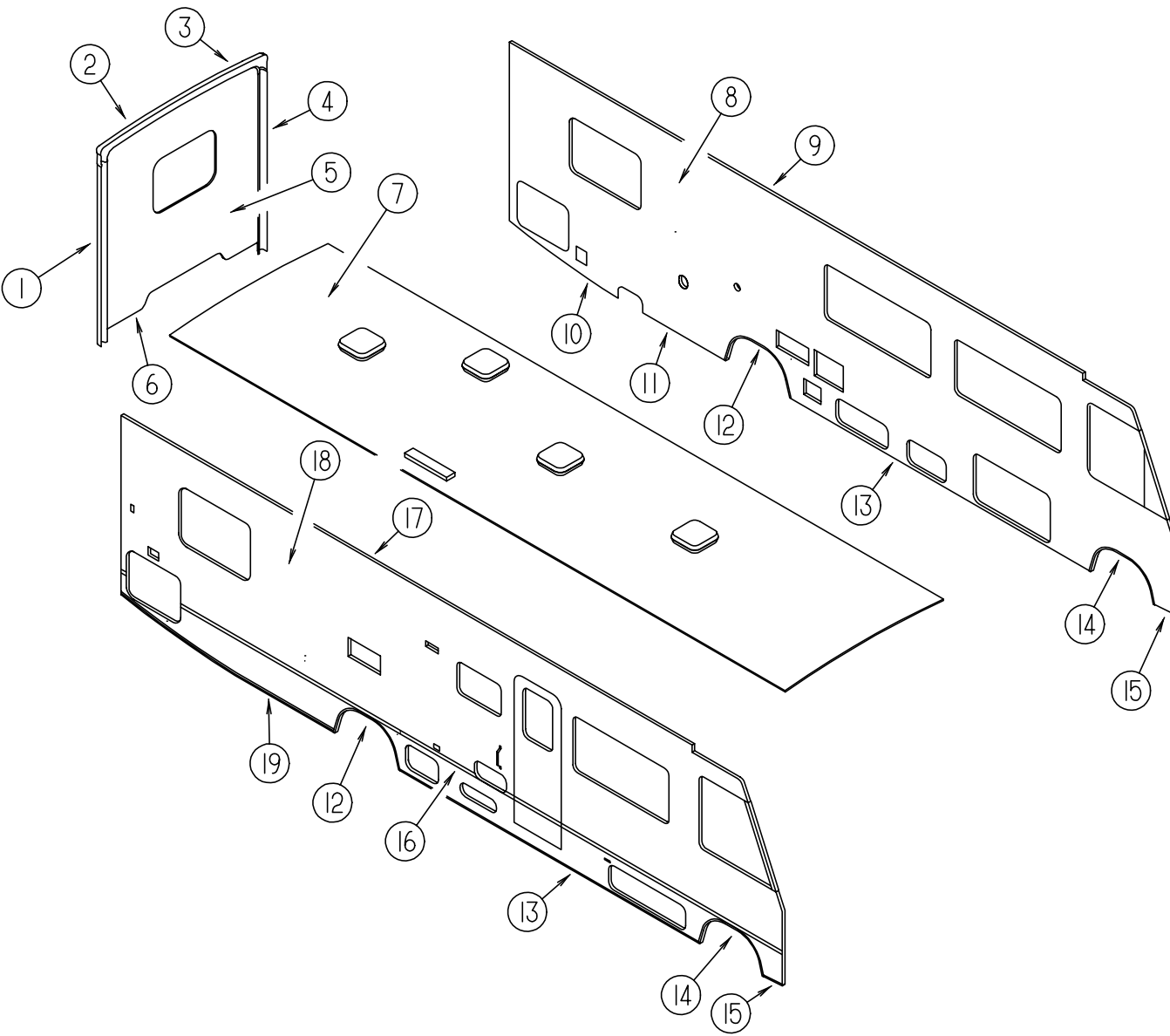

KEY	PART NUMBER	U/M DESCRIPTION
1	114874-05-12B	EA TRIM-BACKWALL SIDE, RIGHT - BRIGHT WHITE - STEEL
1	104033-11-02A	EA TRIM-J, BACKWALL - RIGHT - BRIGHT WHITE - ALUMINUM
2	114872-01-02A	EA TRIM-BACKWALL, TOP W/O CLEARANCE LIGHTS - RIGHT - BRIGHT WHITE PLASTIC
3	114873-01-02A	EA TRIM-BACKWALL, TOP W/O CLEARANCE LIGHTS - LEFT - BRIGHT WHITE PLASTIC
4	114874-06-12B	EA TRIM-BACKWALL SIDE, LEFT - BRIGHT WHITE - STEEL
4	104033-12-02A	EA TRIM-J, BACKWALL - LEFT - BRIGHT WHITE - ALUMINUM
5	M07419-07-G29	EA BACKWALL-W/O WINDOW, LIGHTS, OR DECALS - QUEEN BED - CHEVY (G29)
5	M07419-07-G30	EA BACKWALL-W/O WINDOW, LIGHTS, OR DECALS - QUEEN BED - CHEVY (G30)
5	M07419-07-G31	EA BACKWALL-W/O WINDOW, LIGHTS, OR DECALS - QUEEN BED - CHEVY (G31/G32)
5	M07419-08-G29	EA BACKWALL-W/O WINDOW, LIGHTS, OR DECALS - TWIN BEDS - CHEVY (G29)
5	M07419-08-G30	EA BACKWALL-W/O WINDOW, LIGHTS, OR DECALS - TWIN BEDS - CHEVY (G30)
5	M07419-08-G31	EA BACKWALL-W/O WINDOW, LIGHTS, OR DECALS - TWIN BEDS - CHEVY (G31/G32)
5	M07419-09-G29	EA BACKWALL-W/O WINDOW, LIGHTS, OR DECALS - QUEEN BED - FORD (G29)
5	M07419-09-G30	EA BACKWALL-W/O WINDOW, LIGHTS, OR DECALS - QUEEN BED - FORD (G30)
5	M07419-09-G31	EA BACKWALL-W/O WINDOW, LIGHTS, OR DECALS - QUEEN BED - FORD (G31/G32)
5	M07419-10-G29	EA BACKWALL-W/O WINDOW, LIGHTS, OR DECALS - TWIN BEDS - FORD (G29)
5	M07419-10-G30	EA BACKWALL-W/O WINDOW, LIGHTS, OR DECALS - TWIN BEDS - FORD (G30)
5	M07419-10-G31	EA BACKWALL-W/O WINDOW, LIGHTS, OR DECALS - TWIN BEDS - FORD (G31/G32)
6	050406-24-000	EA TRIM-BACKWALL, LOWER - DRIVER OR PASS SIDE - BRIGHT WHITE - ALUMINUM

KEY	PART NUMBER	U/M DESCRIPTION
7	M05702-20-G29	EA ROOF-W/O VENTS - QUEEN BED
7	M05702-21-G29	EA ROOF-W/O VENTS - TWIN BEDS OPTION
8	M05735-14-G29	EA SIDEWALL ASM-DRIVER SIDE, W/O WINDOWS & TRIM - QUEEN BED (G29)
8	M05735-14-G30	EA SIDEWALL ASM-DRIVER SIDE, W/O WINDOWS & TRIM - QUEEN BED (G30)
8	M05735-14-G31	EA SIDEWALL ASM-DRIVER SIDE, W/O WINDOWS & TRIM - QUEEN BED (G31/G32)
8	M05735-13-G29	EA SIDEWALL ASM-DRIVER SIDE, W/O WINDOWS & TRIM - TWIN BEDS (G29)
8	M05735-13-G30	EA SIDEWALL ASM-DRIVER SIDE, W/O WINDOWS & TRIM - TWIN BEDS (G30)
8	M05735-13-G31	EA SIDEWALL ASM-DRIVER SIDE, W/O WINDOWS & TRIM - TWIN BEDS (G31/G32)
8	M05735-17-G29	EA SIDEWALL ASM-DRIVER SIDE, W/O WINDOWS & TRIM - QUEEN BED (G29) DRIVER DOOR
8	M05735-17-G30	EA SIDEWALL ASM-DRIVER SIDE, W/O WINDOWS & TRIM - QUEEN BED (G30) DRIVER DOOR
8	M05735-17-G31	EA SIDEWALL ASM-DRIVER SIDE, W/O WINDOWS & TRIM - QUEEN BED (G31/G32) DRIVER DOOR
8	M05735-16-G29	EA SIDEWALL ASM-DRIVER SIDE, W/O WINDOWS & TRIM (G29) TWIN BEDS OPTION & DRIVER DOOR
8	M05735-16-G30	EA SIDEWALL ASM-DRIVER SIDE, W/O WINDOWS & TRIM (G30) TWIN BEDS OPTION & DRIVER DOOR
8	M05735-16-G31	EA SIDEWALL ASM-DRIVER SIDE, W/O WINDOWS & TRIM (G31/G32) TWIN BEDS OPTION & DRIVER DOOR
9	103801-02-05A	EA TRIM-ROOF, 16' LONG - W/O DRILLED HOLES - DRIVER SIDE FROM: 00-00-00 THRU: 09-23-95
9	120091-01-02A	EA TRIM-ROOF, 16' LONG - W/O DRILLED HOLES - DRIVER SIDE - BRIGHT WHITE FROM: 09-24-95 THRU: 99-99-99
10	111108-09-02A	EA TRIM-SIDEWALL, BOTTOM - DRIVER SIDE - BRIGHT WHITE
11	108038-11-03A	EA TRIM-SIDEWALL, BOTTOM - DRIVER SIDE - BRIGHT WHITE
12	108070-01-04A	EA TRIM-WHEELWELL, REAR - DRIVER OR PASSENGER SIDE - BRIGHT WHITE
13	108039-04-04A	EA TRIM-SIDEWALL, BOTTOM - CENTER - DRIVER OR PASS SIDE - BRIGHT WHITE
14	108069-04-03A	EA TRIM-WHEELWELL, FRONT - DRIVER OR PASSENGER SIDE - BRIGHT WHITE
15	108109-02-02A	EA TRIM-SIDEWALL, BOTTOM - FRONT - DRIVER OR PASS SIDE - BRIGHT WHITE
	116800-55-005	EA U-CHANNEL-EXTRUDED, 1.7" X 16' - BRIGHT WHITE
16	108688-01-03A	EA STRIP-FEATURE, W/O INSERT OR END CAPS - 15' LONG - BRIGHT WHITE
	108651-01-01A	EA END CAP-FEATURE STRIP
	105312-01-07A	FT INSERT-FEATURE STRIP
17	103802-02-05A	EA RAIL-AWNING, 16' LONG - W/O DRILLED HOLES - PASS SIDE - BRIGHT WHITE FROM: 00-00-00 THRU: 09-23-95
17	120092-01-02A	EA RAIL-AWNING, 16' LONG - W/O DRILLED HOLES - PASS SIDE - BRIGHT WHITE FROM: 09-24-95 THRU: 99-99-99
18	M05734-14-G29	EA SIDEWALL ASM-PASSENGER SIDE, W/O WINDOWS & TRIM - QUEEN BED (G29)
18	M05734-14-G30	EA SIDEWALL ASM-PASSENGER SIDE, W/O WINDOWS & TRIM - QUEEN BED (G30)
18	M05734-14-G31	EA SIDEWALL ASM-PASSENGER SIDE, W/O WINDOWS & TRIM - QUEEN BED (G31/G32)
18	M05734-13-G29	EA SIDEWALL ASM-PASSENGER SIDE, W/O WINDOWS & TRIM - TWIN BEDS (G29)
18	M05734-13-G30	EA SIDEWALL ASM-PASSENGER SIDE, W/O WINDOWS & TRIM - TWIN BEDS (G30)
18	M05734-13-G31	EA SIDEWALL ASM-PASSENGER SIDE, W/O WINDOWS & TRIM - TWIN BEDS (G31/G32)
19	108038-41-02A	EA TRIM-SIDEWALL, BOTTOM - PASSENGER SIDE - BRIGHT WHITE
	084852-51-003	EA ANGLE-EXTRUDED, 1.25" X .75" X 4600 MM - MILL ALUMINUM
	055278-51-259	EA TUBING-STEEL, .75" X 1.5" X 12.5' LONG
	119773-51-010	EA EXTR-ROOF/SIDEWALL, 8957 MM FROM: 09-24-95 THRU: 99-99-99
	002726-01-001	EA GARNISH-U-CHANNEL, 1.38" X 19' - SERRATED - MILL ALUMINUM
	069726-02-000	EA BUMPER - .88" DIAMETER X .40", BLACK

EXTERIOR BODY GROUP (CONTINUED)

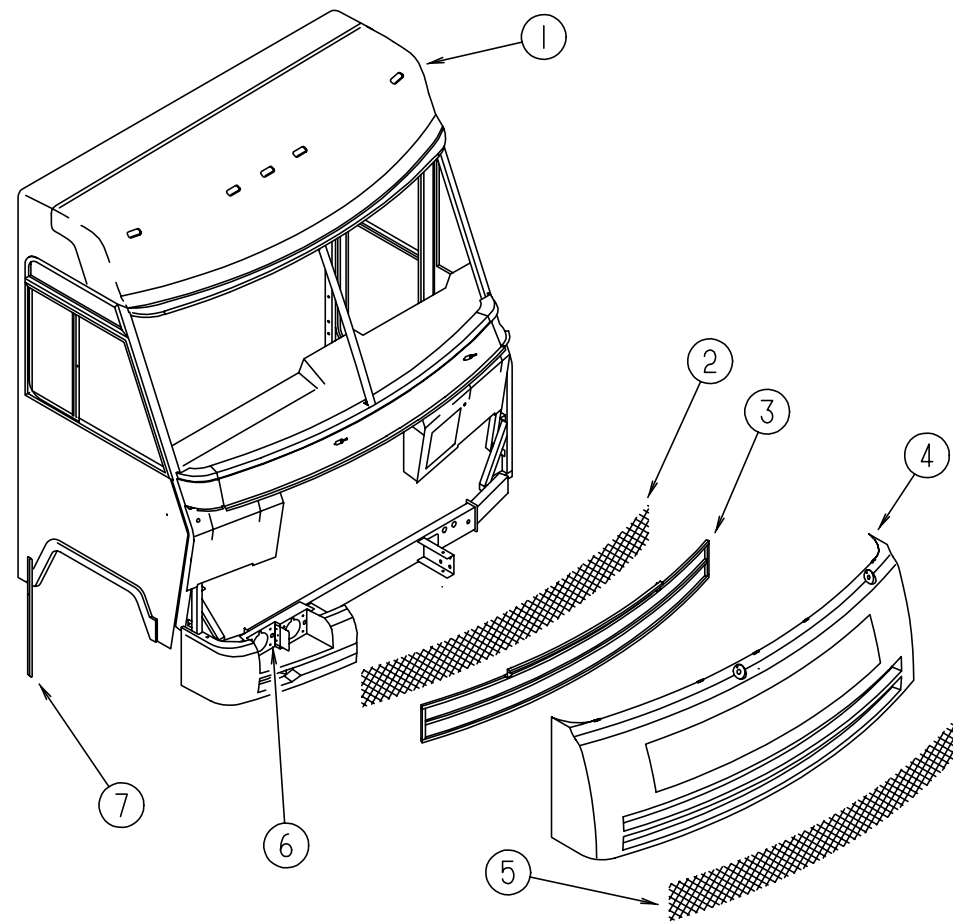

FRONT CAP AND FRONT END COMPONENTS

KEY	PART NUMBER	U/M	DESCRIPTION
1	115042-01-02A	EA	PANEL-ROOF CAP, BRIGHT WHITE
	070579-06-000	EA	PLATE-ANCHOR, W/7/16 WELD NUT - 1.5" X 3.3"
	077001-01-000	EA	ANGLE-MOUNTING, ROOF PANEL - V ANGLE - 3" X 2.4" X 1.5"
2	115924-03-02A	EA	GRILLE-WOVEN WIRE
3	118182-01-G09	EA	GRILLE ASSEMBLY-TUBE W/O MESH
4	M07546-01-G29	EA	FRONT END ASM-W/O GRILLES, HOOD OR HOOD HINGES - BRIGHT WHITE
5	115924-04-02A	EA	GRILLE-WOVEN WIRE
6	118191-01-01A	EA	BEZEL-HEADLIGHT, PASSENGER SIDE - BLACK
	118191-02-01A	EA	BEZEL-HEADLIGHT, DRIVER SIDE - BLACK
7	089922-30-000	EA	TRIM-FRONT END/SIDEWALL, DRIVER OR PASSENGER SIDE - BUFF
	099418-01-000	FT	D-SECTION SEAL W/ADHESIVE BACK - .44" X .44" - BLACK RUBBER
	110691-01-01A	EA	BRACKET-SPRING, HEADLAMP - DRIVER OR PASSENGER SIDE - UNPAINTED
	119445-01-02B	EA	PLATE-W/HOLES, 38 MM X 26 MM - STAINLESS STEEL - BLACK

EXTERIOR BODY GROUP (CONTINUED)

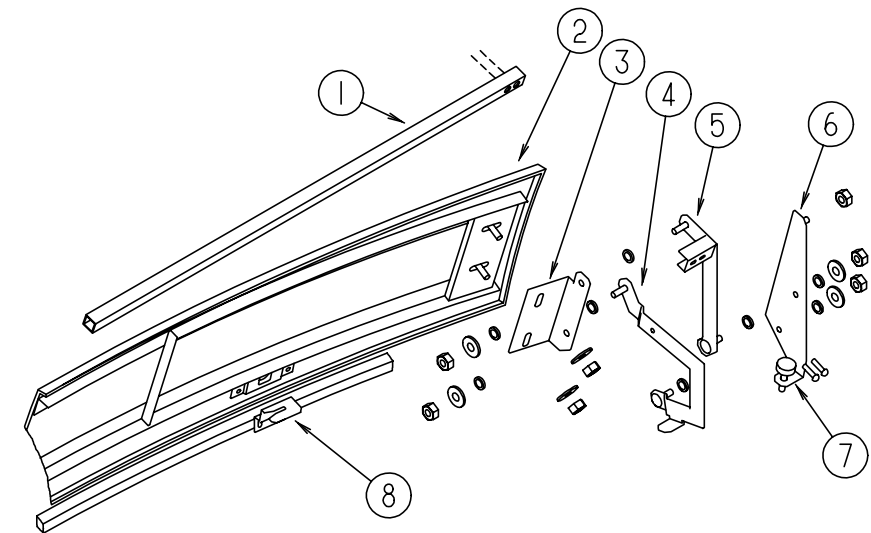

HOOD AND FRONT END COMPONENTS

KEY	PART NUMBER	U/M	DESCRIPTION
1	105096-10-000	EA	TUBE-TIMING, HOOD HINGE
2	115976-02-G29	EA	PANEL ASM-HOOD, BRIGHT WHITE
3	109927-03-000	EA	ANGLE-LINK, HOOD - RH
3	109927-04-000	EA	ANGLE LINK, HOOD - LH
4	109930-07-000	EA	LINK ASM-HINGE, HOOD - LOWER - RH
4	109930-08-000	EA	LINK ASM-HINGE, HOOD - LOWER - LH
5	109929-03-000	EA	LINK ASM-HINGE, HOOD - UPPER - RH
5	109929-04-000	EA	LINK ASM-HINGE, HOOD - UPPER - LH
6	109926-07-000	EA	BRACKET ASM-LINK, HINGE, HOOD - RH
6	109926-08-000	EA	BRACKET ASM-LINK, HINGE, HOOD - LH
7	058786-01-000	EA	BOLT-ADJUSTING, HOOD - W/BLACK PAD - .31" #18 X 2"
8	106748-02-000	EA	LATCH-HOOD, FRONT END
	103136-03-000	EA	BRACKET - SUPPORT UPPER - HINGE/RIGHT
	103136-04-000	EA	BRACKET - SUPPORT UPPER - HINGE/LEFT
	102330-02-000	EA	LOCK-SINGLE HOLE, VISE ACTION - SOUTHCOE 3-56-715-5
	102328-01-000	EA	KEY-BARREL, NICKEL PLATED - SOUTHCOE 3-26-715-19

EXTERIOR BODY GROUP (CONTINUED)

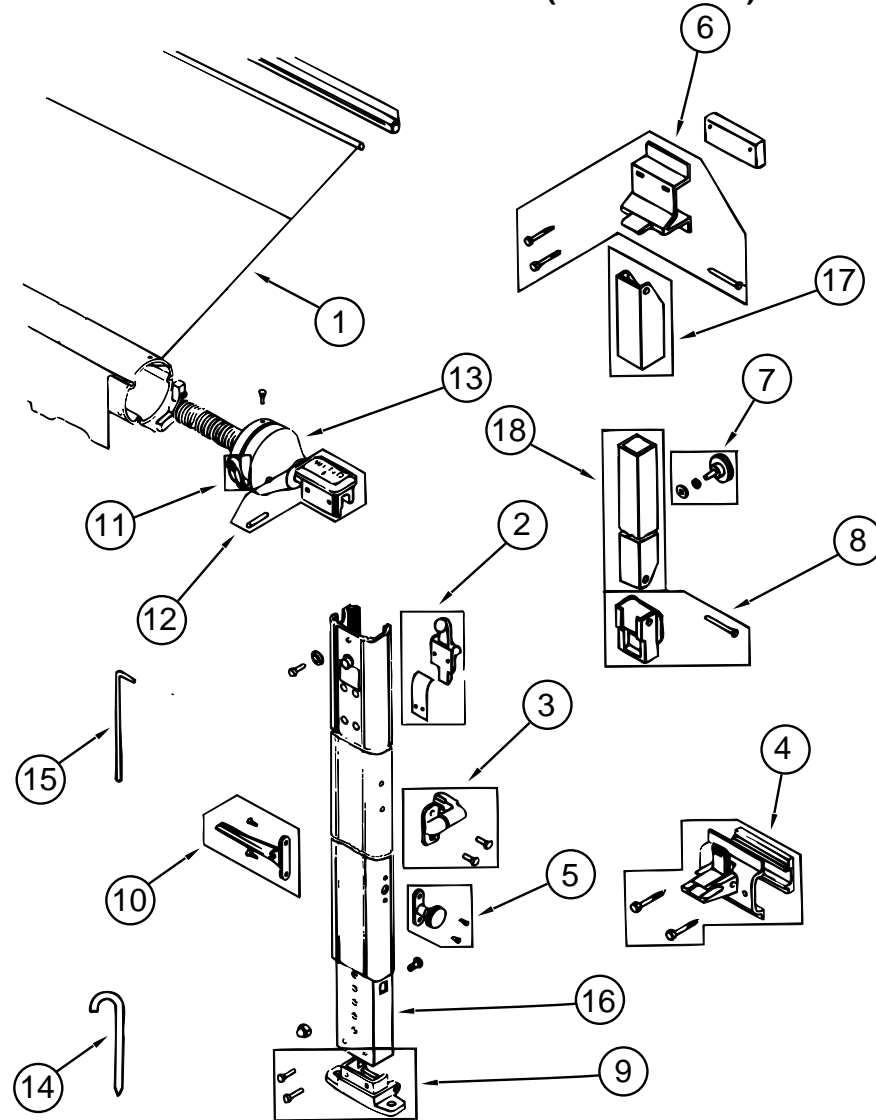

FAULKNER AWNING & HARDWARE

KEY	PART NUMBER	U/M DESCRIPTION	VENDOR NO.
1	110634-01-19A	EA AWNING-ROLLER ASSEMBLY, 18'	
	110634-02-04A	EA HARDWARE KIT-AWNING, BRIGHT WHITE	
2	110634-01-700	EA RAFTER LOCKING MECHANISM KIT	7605-0001
3	110634-01-701	EA SAFETY & LATCH KIT	7509-0001
4	110634-01-702	EA BOTTOM BRACKET KIT	7512-0001
5	110634-01-703	EA HEIGHT LOCK HANDLE KIT	7510-0001
6	110634-01-704	EA UPPER BRACKET KIT W/BOLTS	7505-0001
7	110634-01-705	EA ULTRA RAFTER KNOB KIT	7522-0001
8	110634-01-706	EA RAFTER SLIDE KIT	
9	110634-01-707	EA GROUND BRACKET KIT	7511-0001
10	110634-01-708	EA LIFT HANDLES W/RIVETS	7000-0001
11	110634-01-709	EA RATCHET HANDLE KIT	7507-0001
12	110634-01-710	EA ARM CAP KIT	7503-0001
13	110634-01-711	EA FRONT SPRING ASM	6598-0001
13	110634-01-712	EA REAR SPRING ASM	6599-0001
13	110634-01-713	EA REAR END CAP KIT	7504-0001
14	110634-01-714	EA STAKE - (4 PER BAG)	5208-0001
15	110634-01-715	EA WAND - PULL DOWN	7604-0001
16	110634-01-730	EA ARM-INNER, FRONT - BRIGHT WHITE	1002-0071
16	110634-01-731	EA ARM-INNER, REAR - BRIGHT WHITE	1003-0071
17	110634-01-732	EA RAFTER-OUTER, BRIGHT WHITE	1004-0071
18	110634-01-733	EA RAFTER-INNER, BRIGHT WHITE	1005-0071
	110634-01-735	EA HANDLE-PUSH BUTTON, BRIGHT WHITE	7000-9071
	111037-01-01A	EA SPACER-AWNING, UPPER - BLACK	
	111038-01-01A	EA SPACER-AWNING, LOWER - BLACK	

EXTERIOR BODY GROUP (CONTINUED)
FIBERGLASS, STYROFOAM & INSULATION

KEY	PART NUMBER	U/M DESCRIPTION
	044487-01-001	EA ALUMINUM SHEET - .019" X 96" X 360" - MILL FINISH
	044487-01-002	EA ALUMINUM SHEET - .019" X 96" X 432" - MILL FINISH
	044487-51-001	EA ALUMINUM SHEET - .019" X 758 MM X 317 MM - MILL FINISH
	076054-N2-000	EA FIBERGLASS SHEET-FLAT, 96" X 383.3" - BRIGHT WHITE
	076054-P4-000	EA FIBERGLASS SHEET-FLAT, 96" X 97" - BRIGHT WHITE
	077517-62-000	EA FIBERGLASS SHEET-FLAT, 48" X 96" - BRIGHT WHITE
	108535-04-701	EA FIBERGLASS SHEET-FLAT, 104" X 396" - BRIGHT WHITE (ROOF COVERING)
	108535-04-705	EA FIBERGLASS SHEET-FLAT, 6" X 34' - BRIGHT WHITE
	100619-01-000	BF FOAM-EXPANDED POLYSTYRENE, 1.34" X 48" X 96"
	100619-04-000	BF FOAM-EXPANDED POLYSTYRENE, .5" X 48" X 96"
	100619-05-000	BF FOAM-EXPANDED POLYSTYRENE, .75" X 48" X 96"
	100619-11-000	BF FOAM-EXPANDED POLYSTYRENE, 2" X 48" X 96"
	100619-13-000	BF FOAM-EXPANDED POLYSTYRENE, .34" X 48" X 96"
	000870-08-000	SF STYROFOAM - .75" X 48" X 96" - PLANED - INCREMENTS OF 32 SF
	105077-03-000	EA FOAM-PLUG, TUBE - 30.2 MM X 33.1 MM X 45 MM LONG - POLYSTYRENE FOAM FROM: 00-00-00 THRU: 09-23-95
	120107 03 000	EA FOAM-PLUG, TUBE - 29.6 MM X 54.5 MM X 45 MM LONG - POLYSTYRENE FOAM FROM: 09-24-95 THRU: 99-99-99
	105077-01-000	EA FOAM-COVE, ROOF - 50.85 MM X 2438 MM LONG - POLYSTYRENE FOAM FROM: 00-00-00 THRU: 09-23-95
	120107 01 000	EA FOAM-COVE, ROOF - 70.6 MM X 2438 MM LONG - POLYSTYRENE FOAM FROM: 09-24-95 THRU: 99-99-99
	105077-02-000	EA FOAM-PLUG, TUBE - 13.5 MM X 41.1 MM X 45 MM LONG - POLYSTYRENE FOAM FROM: 00-00-00 THRU: 09-23-95
	120107 02 000	EA FOAM-PLUG, TUBE - 57 MM X 74.3 MM X 45 MM LONG - POLYSTYRENE FOAM FROM: 09-24-95 THRU: 99-99-99

EXTERIOR BODY GROUP (CONTINUED)

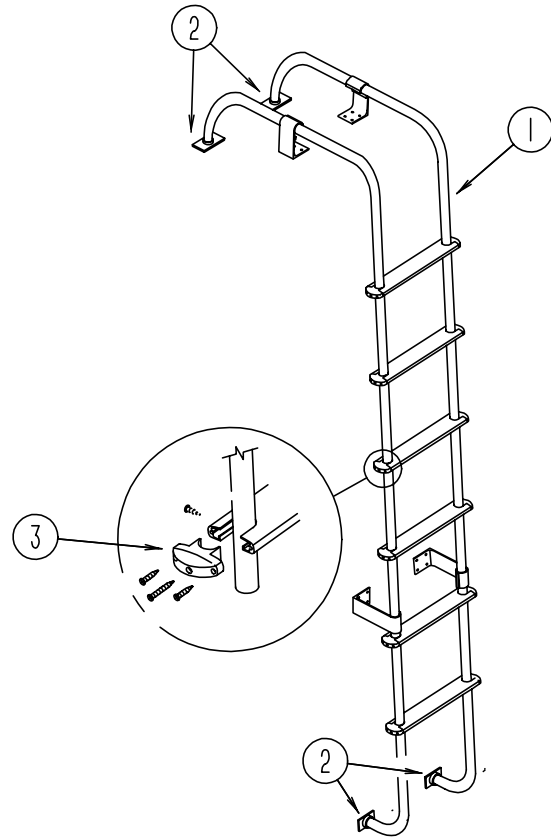

LADDER

KEY	PART NUMBER	U/M DESCRIPTION
1	102953-16-G09	EA LADDER ASSEMBLY
2	067165-01-000	EA MOUNTING BRACKET-LADDER, LOWER
3	076980-02-000	EA END CAP-STEP, BLACK

EXTERIOR BODY GROUP (CONTINUED)

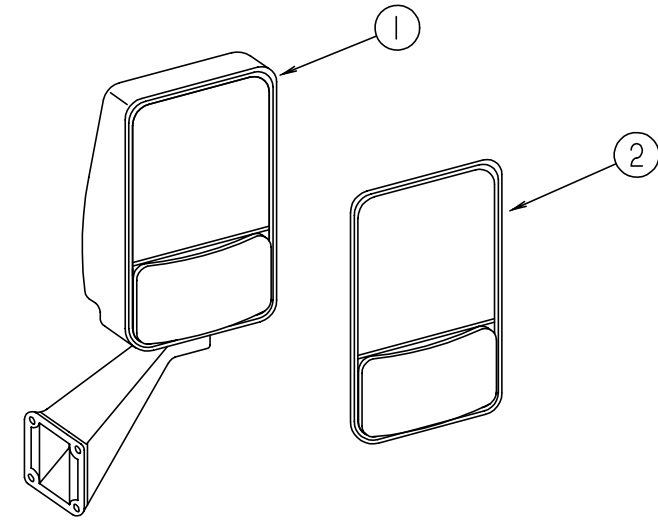

VELVAC HEATED EXTERIOR MIRRORS

KEY	PART NUMBER	U/M DESCRIPTION	VENDOR NO.
1	106015-05-01A	EA MIRROR ASM. - REMOTE/HEATED - W/O WIRING OR SWITCHES - PASS SIDE VELVAC 713170	
1	106015-06-01A	EA MIRROR ASM - REMOTE/HEATED - W/O WIRING OR SWITCHES - DRIVER SIDE VELVAC 713171	
2	086261-01-704	EA MIRROR KIT (BEZEL W/MIRRORS) PASSENGER SIDE	709268
2	086261-02-701	EA MIRROR KIT (BEZEL W/MIRRORS) DRIVER SIDE	709269
	087695-01-000	EA SWITCH-HEATER, EXTERIOR MIRROR - EURAMTEC FROM: 00-00-00 THRU: 09-10-95	
	087695-02-000	EA SWITCH-HEATER, EXTERIOR MIRROR - EURAMTEC DAV4720-12 FROM: 09-11-95 THRU: 99-99-99	
	087695-03-000	EA CONNECTOR-ASSEMBLY - EURAMTEC RT10484802	
	088246-01-000	EA SWITCH-REMOTE, EXTERIOR MIRROR - SQUARE PUSH 7471290	

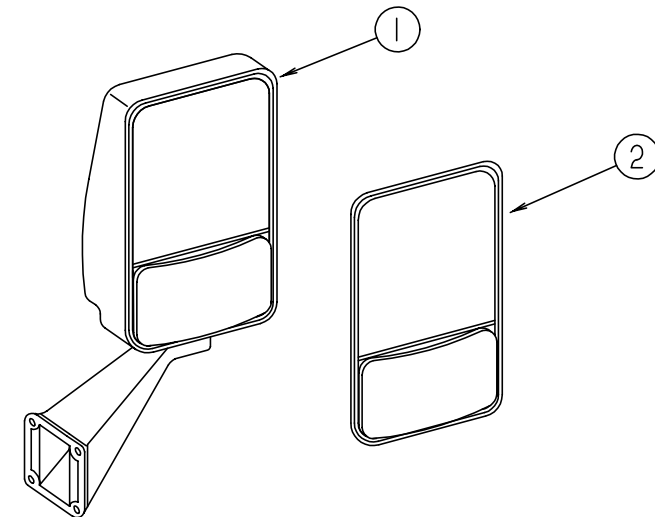

VELVAC EXTERIOR MIRRORS

KEY	PART NUMBER	U/M DESCRIPTION	VENDOR NO.
1	106015-09-01A	EA MIRROR ASM-EXTERIOR GLASS RIGHT - BLACK - VELVAC 713126	
1	106015-10-01A	EA MIRROR ASM-EXTERIOR ADJUST GLASS LEFT - BLACK - VELVAC 713125	
2	106015-01-703	EA MIRROR KIT (BEZEL W/MIRRORS) PASSENGER SIDE	709266
2	106015-02-702	EA MIRROR KIT (BEZEL W/MIRRORS) DRIVER SIDE	709267

EXTERIOR BODY GROUP (CONTINUED)
DECALS, FILM STRIPES & PAINT

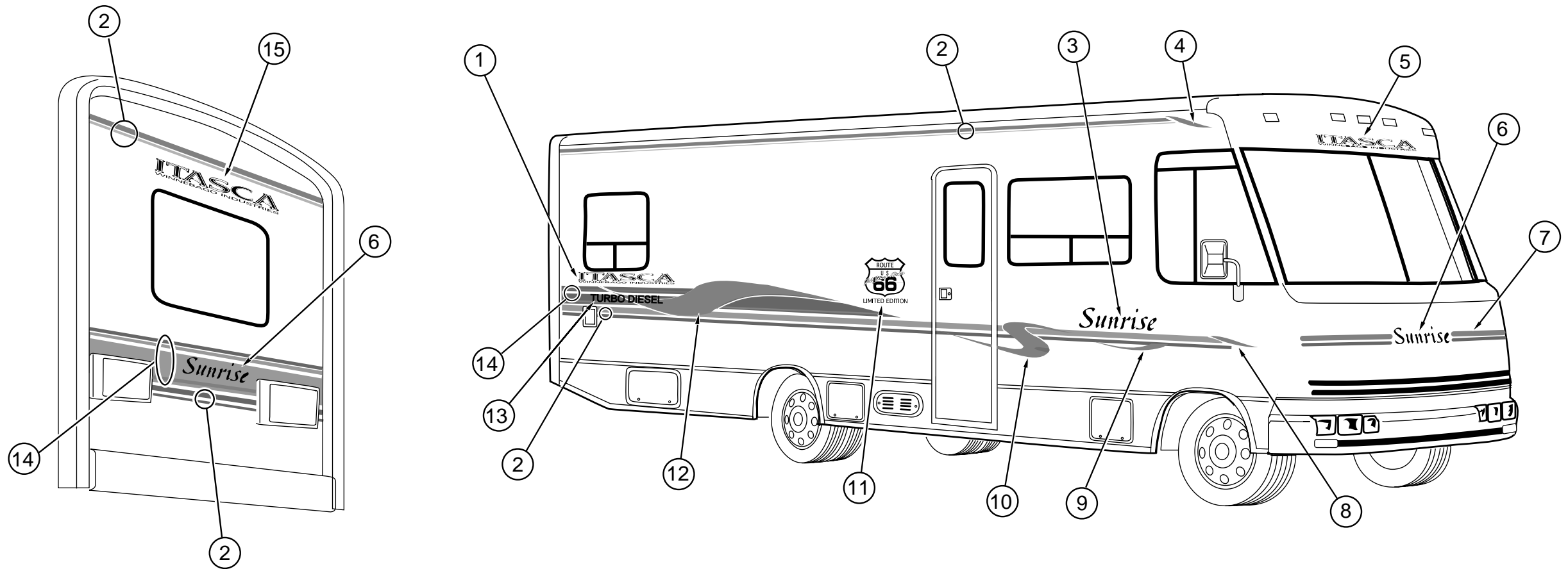

KEY	PART NUMBER	U/M	DESCRIPTION
1	116921-01-03A	EA	DECAL-LOGO, ITASCA WINN. IND. - MALIBU TEAL/MALIBU TEAL/MALIBU TEAL
2	105781-47-01A	FT	FILM-MULTISTRIFE, 82.5 MM WIDE - MEDIUM BLUE/SHADOW BLUE
3	118717-01-01A	EA	DECAL-LOGO, SUNRISE - LARGE - MEDIUM BLUE/SHADOW BLUE/BRIGHT WHITE
4	118715-01-01A	EA	DECAL-RIBBON, SMALL - RH - MALIBU TEAL/CHAMPAGNE/MEDIUM BLUE/WHITE
4	118715-02-01A	EA	DECAL-RIBBON, SMALL - LH - MALIBU TEAL/CHAMPAGNE/MEDIUM BLUE/WHITE
5	118312-01-02A	EA	DECAL-ITASCA, WINN. IND. - SWEEP - MALIBU TEAL/MALIBU TEAL/MALIBU TEAL
6	118717-02-01A	EA	DECAL-LOGO, SUNRISE - SMALL - MEDIUM BLUE/SHADOW BLUE/BRIGHT WHITE
7	118716-01-01A	EA	DECAL-HOOD - MEDIUM BLUE/SHADOW BLUE
8	118711-01-01A	EA	DECAL-RIBBON, #1 - RH - MALIBU TEAL/CHAMPAGNE STAR/MEDIUM BLUE/WHITE
8	118711-02-01A	EA	DECAL-RIBBON, #1 - LH - MALIBU TEAL/CHAMPAGNE STAR/MEDIUM BLUE/WHITE
9	118712-01-01A	EA	DECAL-RIBBON, #2 - RH - MALIBU TEAL/CHAMPAGNE STAR/MEDIUM BLUE/WHITE
9	118712-02-01A	EA	DECAL-RIBBON, #2 - LH - MALIBU TEAL/CHAMPAGNE STAR/MEDIUM BLUE/WHITE
10	118713-01-01A	EA	DECAL-RIBBON, #3 - RH - MALIBU TEAL/CHAMPAGNE STAR/MEDIUM BLUE/WHITE
10	118713-02-01A	EA	DECAL-RIBBON, #3 - LH - MALIBU TEAL/CHAMPAGNE STAR/MEDIUM BLUE/WHITE
11	116404-01-01A	EA	DECAL-ROUTE 66
12	118714-01-01A	EA	DECAL-RIBBON, #4 - RH - MALIBU TEAL/CHAMPAGNE STAR/MEDIUM BLUE/WHITE
12	118714-02-01A	EA	DECAL-RIBBON, #4 - LH - MALIBU TEAL/CHAMPAGNE STAR/MEDIUM BLUE/WHITE
13	111318-03-03A	EA	DECAL-TURBO DIESEL - BRIGHT WHITE
14	118710-01-01A	FT	FILM-MULTISTRIFE, 174.6 MM WIDE - SHADOW BLUE/AMETHYST FROST/ AMETHYST FROST/MEDIUM BLUE
15	116921-02-03A	EA	DECAL-LOGO, ITASCA WINN. IND. - MALIBU TEAL/MALIBU TEAL/MALIBU TEAL
	041561-03-000	EA	PAINT - 16 OZ SPRAY, OFF WHITE - ACRYLIC ENAMEL

DUPONT COLOR CODES

BRIGHT WHITE #B8951

**GALLEY GROUP
GALLEY CABINETRY**

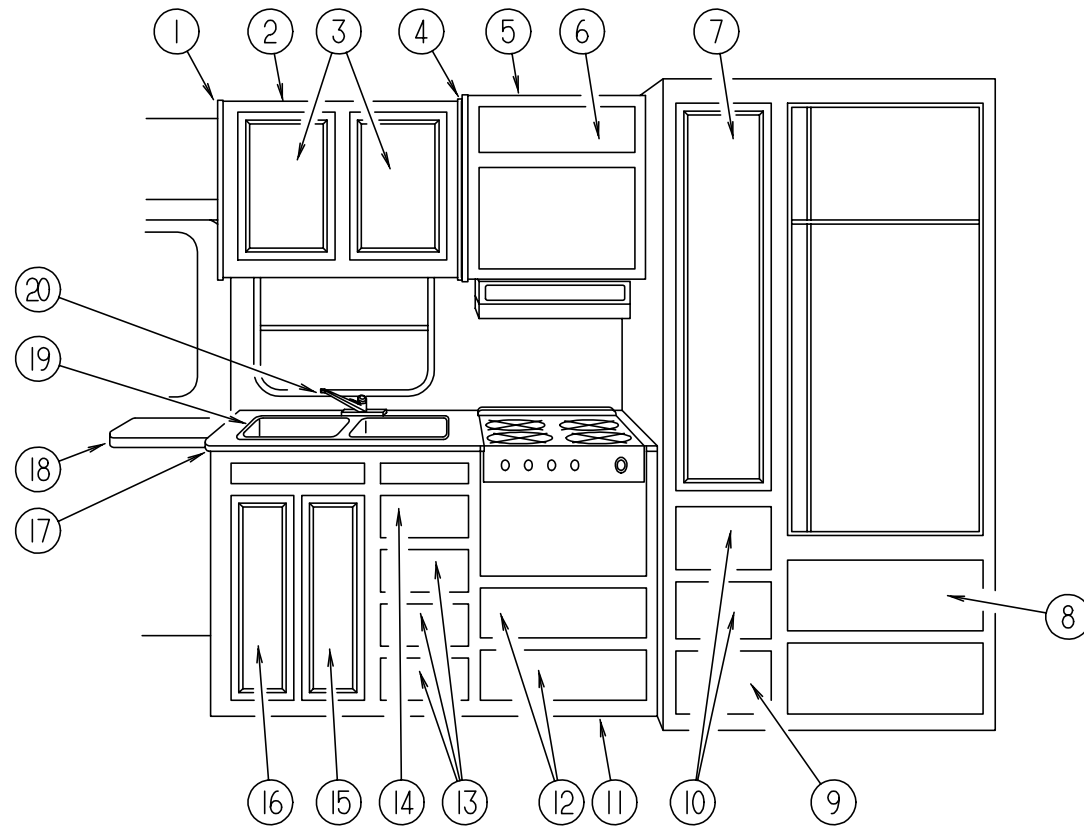

KEY	PART NUMBER	U/M	DESCRIPTION
1	081320-20-G09	EA	CAP-END, CABINET - FRONT
2	103276-02-G09	EA	CABINET ASM-OVERHEAD,GALLEY
	103276-11-G09	EA	SHELF ASM-GALLEY OVERHEAD CABINET
3	M06803-05-G09	EA	DOOR-CABINET, W/O HARDWARE - 365 MM X 555 MM
4	081320-16-G09	EA	CAP-END, CABINET - FRONT
5	114390-02-G35	EA	CABINET ASM-MICROWAVE OVERHEAD
6	M05992-11-G09	EA	DOOR-CABINET, W/O HARDWARE - 180 MM X 555 MM
7	M06803-40-G09	EA	DOOR-CABINET, W/O HARDWARE - 305 MM X 1220 MM
8	M05971-55-G09	EA	DRAWER COMPLETE-SLIDE, OGEE
9	M05971-54-G09	EA	DRAWER COMPLETE-SLIDE, OGEE
10	M05971-39-G09	EA	DRAWER COMPLETE-SLIDE, OGEE
11	M07426-01-G29	EA	CABINET ASM-GALLEY (G29/G32)
11	M07426-01-G30	EA	CABINET ASM-GALLEY (G30)
11	M07426-01-G31	EA	CABINET ASM-GALLEY (G31)
12	M05971-50-G09	EA	DRAWER COMPLETE-SLIDE, OGEE
13	M05971-11-G09	EA	DRAWER COMPLETE-SLIDE, OGEE
14	M05971-82-G09	EA	DRAWER COMPLETE-SLIDE, OGEE

KEY	PART NUMBER	U/M	DESCRIPTION
15	M06803-08-G09	EA	DOOR-CABINET, W/O HARDWARE - 230 MM X 675 MM
16	M06803-09-G09	EA	DOOR-CABINET, W/O HARDWARE - 230 MM X 675 MM
17	111243-11-G29	EA	COUNTERTOP ASM (G29/G32)
17	111243-11-G30	EA	COUNTERTOP ASM (G30)
17	111243-11-G31	EA	COUNTERTOP ASM (G31)
18	080812-04-G29	EA	EXTENSION ASM-GALLEY (G29/G32)
18	080812-04-G30	EA	EXTENSION ASM-GALLEY (G30)
18	080812-04-G31	EA	EXTENSION ASM-GALLEY (G31)
19	110654-01-000	EA	SINK-DOUBLE, LARGE/SMALL BASINS - SST - DAYTON FR2917
	092303-01-000	EA	STRAINER-SINK
	108464-04-E08	EA	COVER ASM-SINK (G29/G32)
	108464-04-F11	EA	COVER ASM-SINK (G30)
	108464-04-E38	EA	COVER ASM-SINK (G31)
20	103243-01-000	EA	FAUCET-GALLEY, DUAL CONTROL - 8" CENTERSET
	103635-01-000	EA	FAUCET-SINGLE CONTROL, (WATER PURIFIER) EVERPURE 5435-00
	090329-01-000	FT	SEAL-T, REFRIGERATOR CABINET - .6" WIDE TOP X 2" TAIL

GALLEY GROUP (CONTINUED)

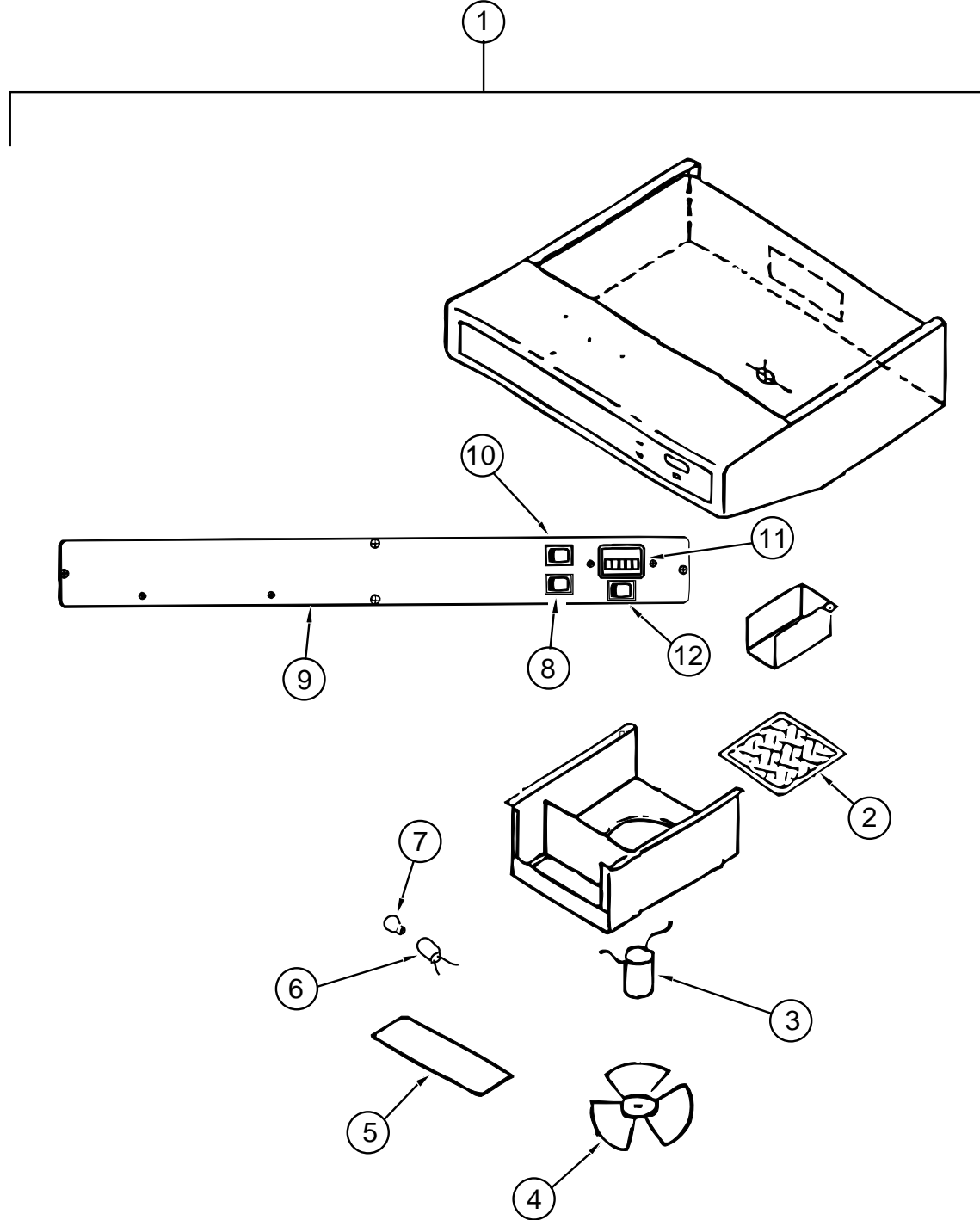

RANGE HOOD - CANADIAN

KEY	PART NUMBER	U/M	DESCRIPTION	VENDOR NO.
1	100258-17-04A	EA	HOOD-RANGE, W/O MONITOR PANEL VENTLINE TCS 500-NBCLG	
2	096983-01-707	EA	FILTER-GREASE, 8" X 8" - LVS	CC246
3	090973-01-700	EA	MOTOR - LVS	CA508-1
4	090973-01-702	EA	BLADE-FAN, LVS	VA183-1
5	092696-02-701	EA	LENS-LAMP, VENTLINE	CC179
6	092696-01-710	EA	SOCKET-LIGHT, VENTLINE	CB267-2
7	092696-01-709	EA	BULB - 912, VENTLINE	VA415
8	096983-01-700	EA	SWITCH-ON/OFF, VENTLINE	108
9	100258-01-700	EA	HOOD-NOSE LABEL	CC428
10	096983-01-700	EA	SWITCH-ON/OFF, VENTLINE	108
11	100258-10-01A	EA	METER-HOUR, SCREW ON - GENERATOR OPTIONS - VENTLINE	150
11	100258-10-701	EA	METER-HOUR, CLIP ON - GENERATOR OPTIONS - VENTLINE L0775-00	
12	096983-01-702	EA	SWITCH-TWO WAY MOMENTARY, VENTLINE	112

GALLEY GROUP (CONTINUED)

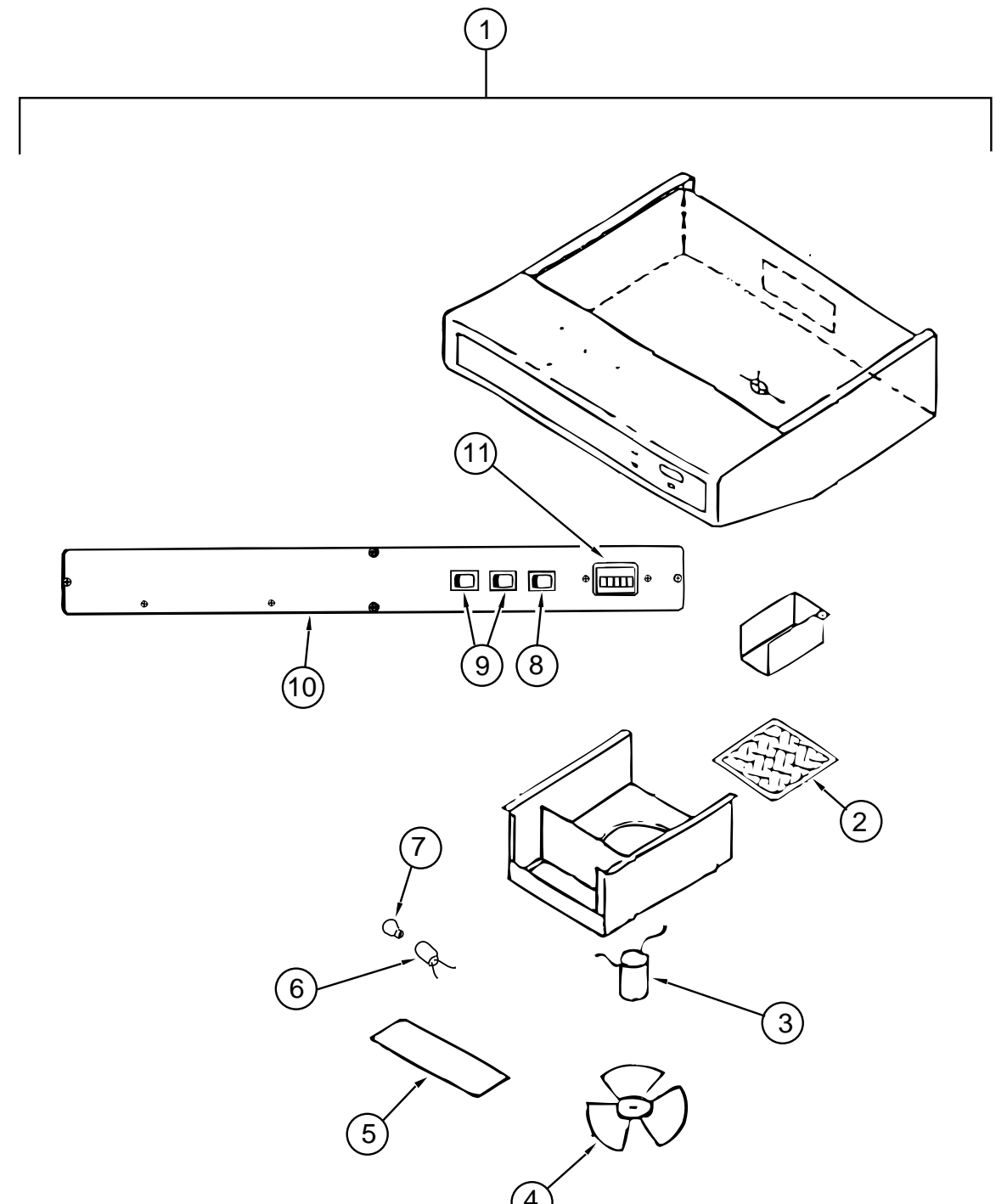

RANGE HOOD - US - GENERATOR OPTIONS

KEY	PART NUMBER	U/M	DESCRIPTION	VENDOR NO.
1	100258-18-03A	EA	HOOD-RANGE, W/O MONITOR PANEL - VENTLINE TP-55009-SBO-LG	
2	096983-01-707	EA	FILTER-GREASE, 8" X 8" - LVS	CC246
3	090973-01-700	EA	MOTOR - LVS	CA508-1
4	090973-01-702	EA	BLADE-FAN, LVS	VA183-1
5	092696-02-701	EA	LENS-LAMP, VENTLINE	CC179
6	092696-01-710	EA	SOCKET-LIGHT, VENTLINE	CB267-2
7	092696-01-709	EA	BULB - 912, VENTLINE	VA415
8	096983-01-702	EA	SWITCH-TWO WAY MOMENTARY, VENTLINE	112
9	096983-01-700	EA	SWITCH-ON/OFF, VENTLINE	108
10	100258-01-700	EA	HOOD-NOSE LABEL	CC428
11	100258-10-01A	EA	METER-HOUR, SCREW ON - GENERATOR OPTIONS - VENTLINE	150
11	100258-10-701	EA	METER-HOUR, CLIP ON - GENERATOR OPTIONS - VENTLINE L0775-00	

GALLEY GROUP (CONTINUED)

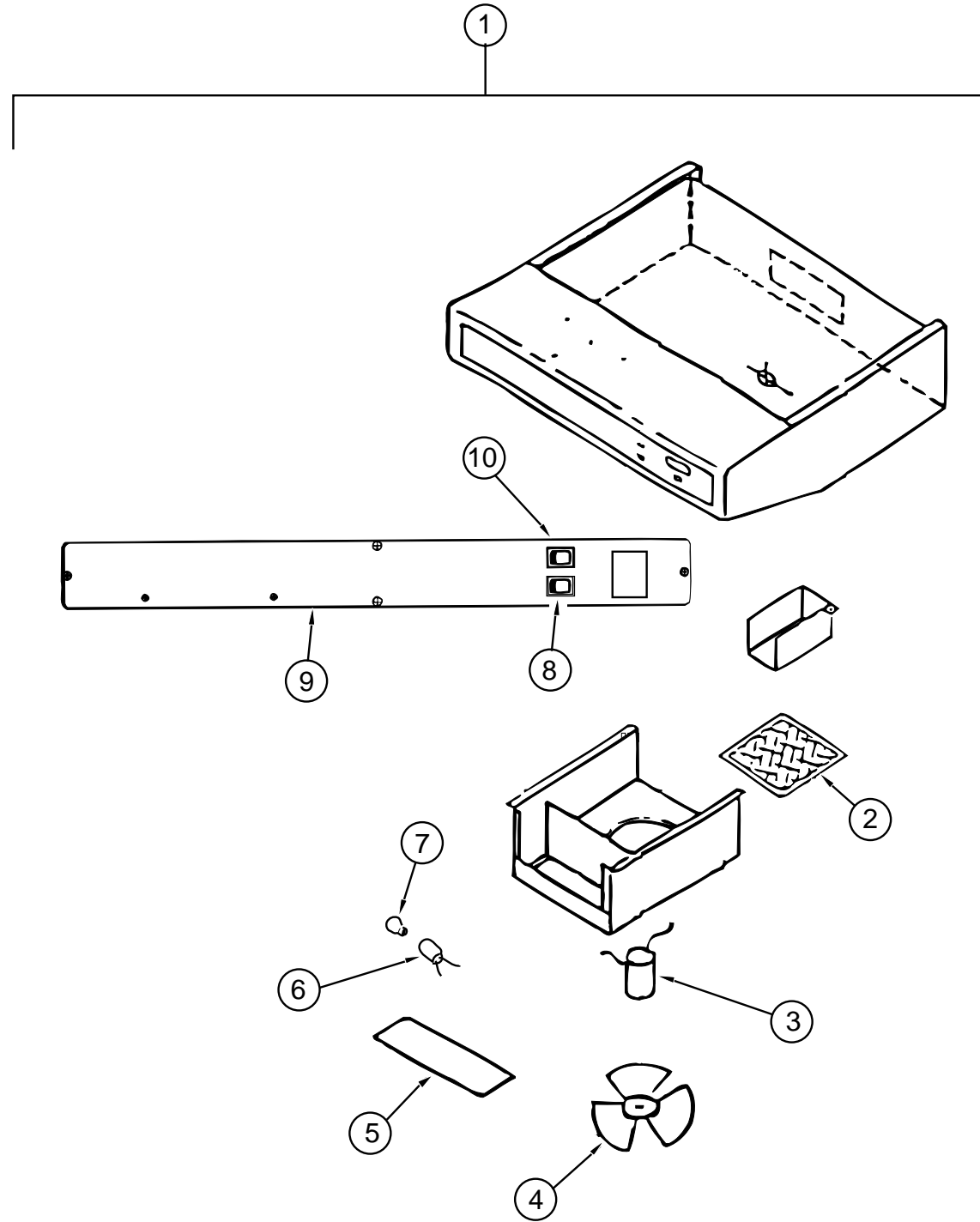

RANGE HOOD - US - STANDARD

KEY	PART NUMBER	U/M DESCRIPTION	VENDOR NO.
1	100258-16-04A	EA HOOD-RANGE, W/O MONITOR PANEL - VENTLINE TCS-5008-NBDLG	
2	096983-01-707	EA FILTER-GREASE, 8" X 8" - LVS	CC246
3	090973-01-700	EA MOTOR - LVS	CA508-1
4	090973-01-702	EA BLADE-FAN, LVS	VA183-1
5	092696-02-701	EA LENS-LAMP, VENTLINE	CC179
6	092696-01-710	EA SOCKET-LIGHT, VENTLINE	CB267-2
7	092696-01-709	EA BULB - 912, VENTLINE	VA415
8	096983-01-700	EA SWITCH-ON/OFF, VENTLINE	108
9	100258-01-700	EA HOOD-NOSE LABEL	CC428
10	096983-01-702	EA SWITCH-TWO WAY MOMENTARY, VENTLINE	112

GALLEY GROUP (CONTINUED)

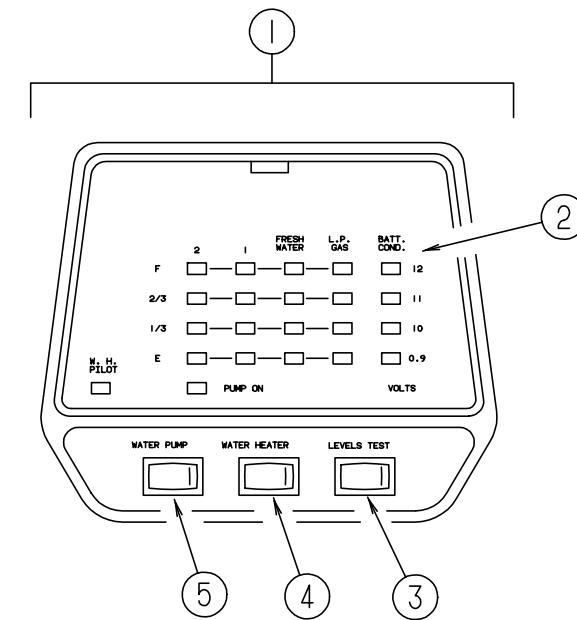

LVS MONITOR PANEL

KEY	PART NUMBER	U/M DESCRIPTION	VENDOR NO.
1	102765-04-01A	EA PANEL-MONITOR, W/PLUG - FOR 2 TANKS & WATER HEATER	
2	102765-04-700	EA BOARD-CIRCUIT, 2 HOLDING TANK	5076-11
3	097617-01-702	EA SWITCH (ALMOND)	107
4	097617-01-701	EA SWITCH-ON/OFF, ALMOND	106
5	102765-01-700	EA SWITCH-ON-ON, ALMOND	110-01

GALLEY GROUP (CONTINUED)

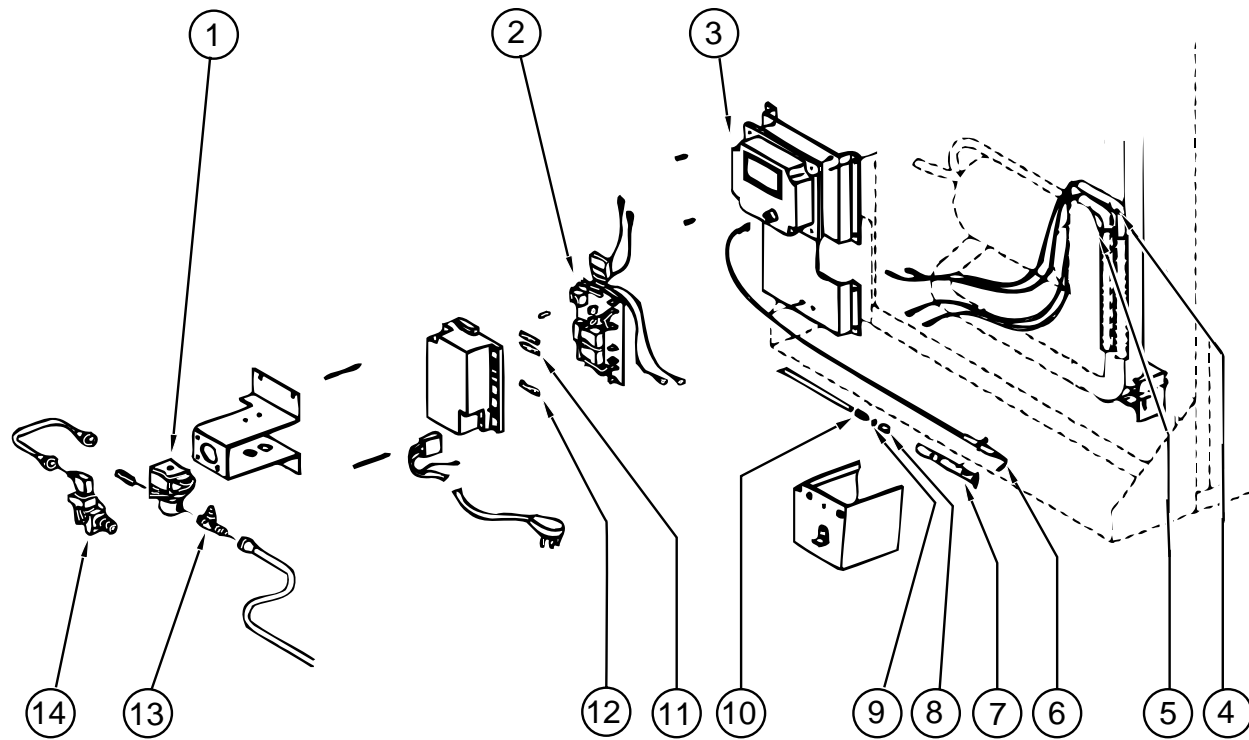

NORCOLD REFRIGERATOR MODEL 6162 CONTROL ASM

KEY	PART NUMBER	U/M	DESCRIPTION	VENDOR NO.
	104138-04-01A	EA	REFRIGERATOR-DOUBLE DOOR, 2-WAY - NORCOLD 6162 RH BL	
1	084880-01-718	EA	VALVE-GAS	61551822
2	094039-04-702	EA	POWER SUPPLY, (2 WAY)	61647422
3	102621-01-702	EA	IGNITION MODULE	61688922
4	088248-01-710	EA	HEATER-DC, (HORIZONTAL) - 3 WAY	615628
5	088248-01-709	EA	HEATER-AC, (HORIZONTAL)	615627
6	104137-06-715	EA	SPARK/SENSE ELECTRODE, (SINGLE)	61692222
7	104137-06-714	EA	BURNER ASSEMBLY, (5-SLOT)	61705222
8	084880-01-705	EA	ORIFICE	614522
9	104137-06-713	EA	ORIFICE GASKET	61475122
10	104137-06-712	EA	FITTING-GAS TUBE CONNECTION	61692722
11	075217-01-734	EA	FUSE, 3 AMP	61538822
12	104137-06-711	EA	FUSE, 5 AMP	61611622
13	104137-06-710	EA	PRESSURE TAP	61594422
14	104137-06-709	EA	VALVE, SHUT-OFF-MANUAL ASM	61694922

GALLEY GROUP (CONTINUED)

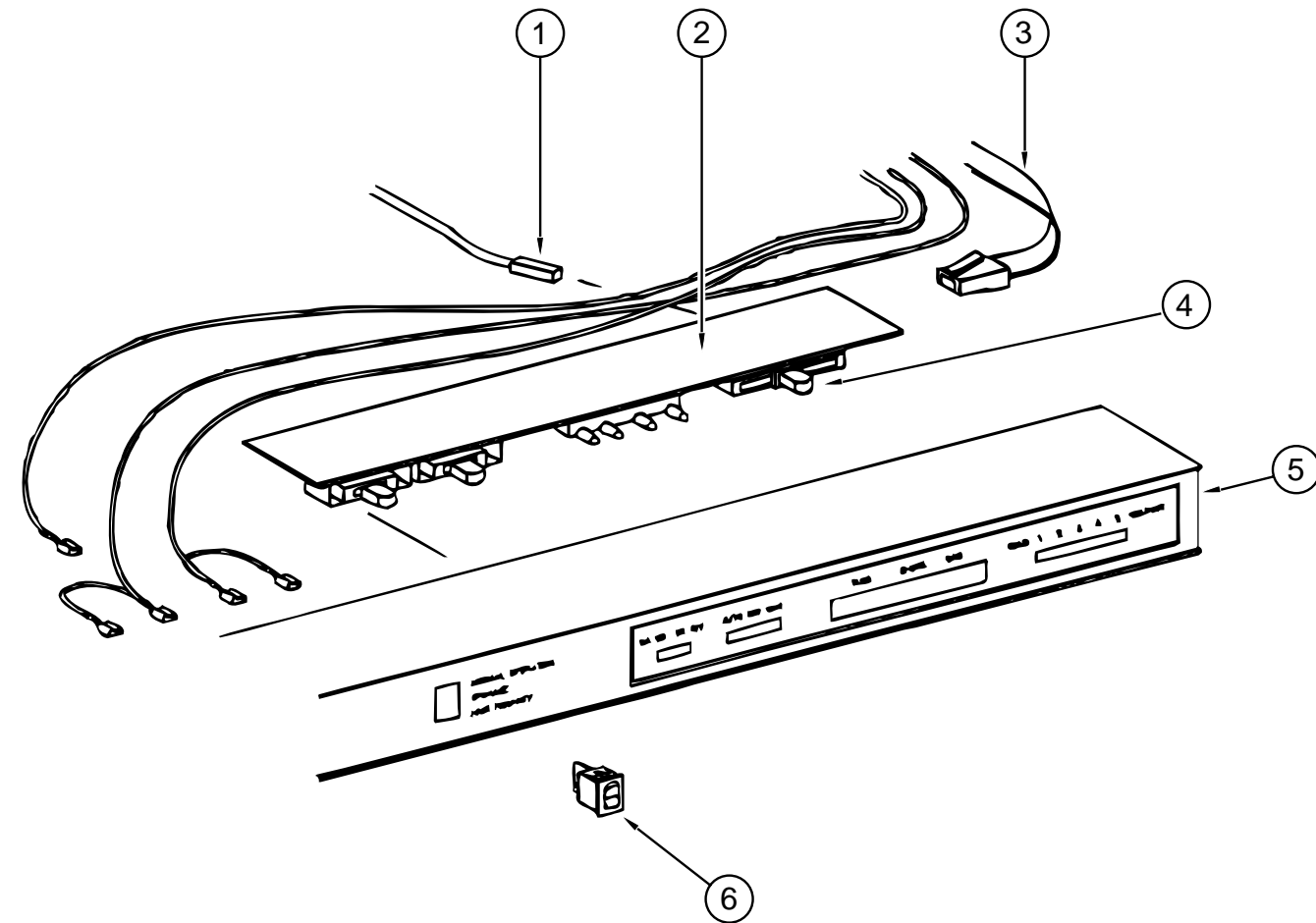

NORCOLD REFRIGERATOR MODEL 6162 EYEBROW ASM

KEY	PART NUMBER	U/M	DESCRIPTION	VENDOR NO.
	104138-04-01A	EA	REFRIGERATOR-DOUBLE DOOR, 2-WAY - NORCOLD 6162 RH BL	
1	084880-01-753	EA	THERMISTER - 78"	61693822
2	094039-04-700	EA	BOARD-PRINTED CIRCUIT, 2 WAY	61647322
3	084880-01-746	EA	CABLE	61571522
4	102621-01-703	EA	THERMOSTAT BUTTON	61587422
5	104137-06-700	EA	EYEBROW SHELL, (2-WAY)	61726622
6	075217-01-738	EA	SWITCH-HUMIDITY	61525922

GALLEY GROUP (CONTINUED)
NORCOLD REFRIGERATOR MODEL 6162 DOORS

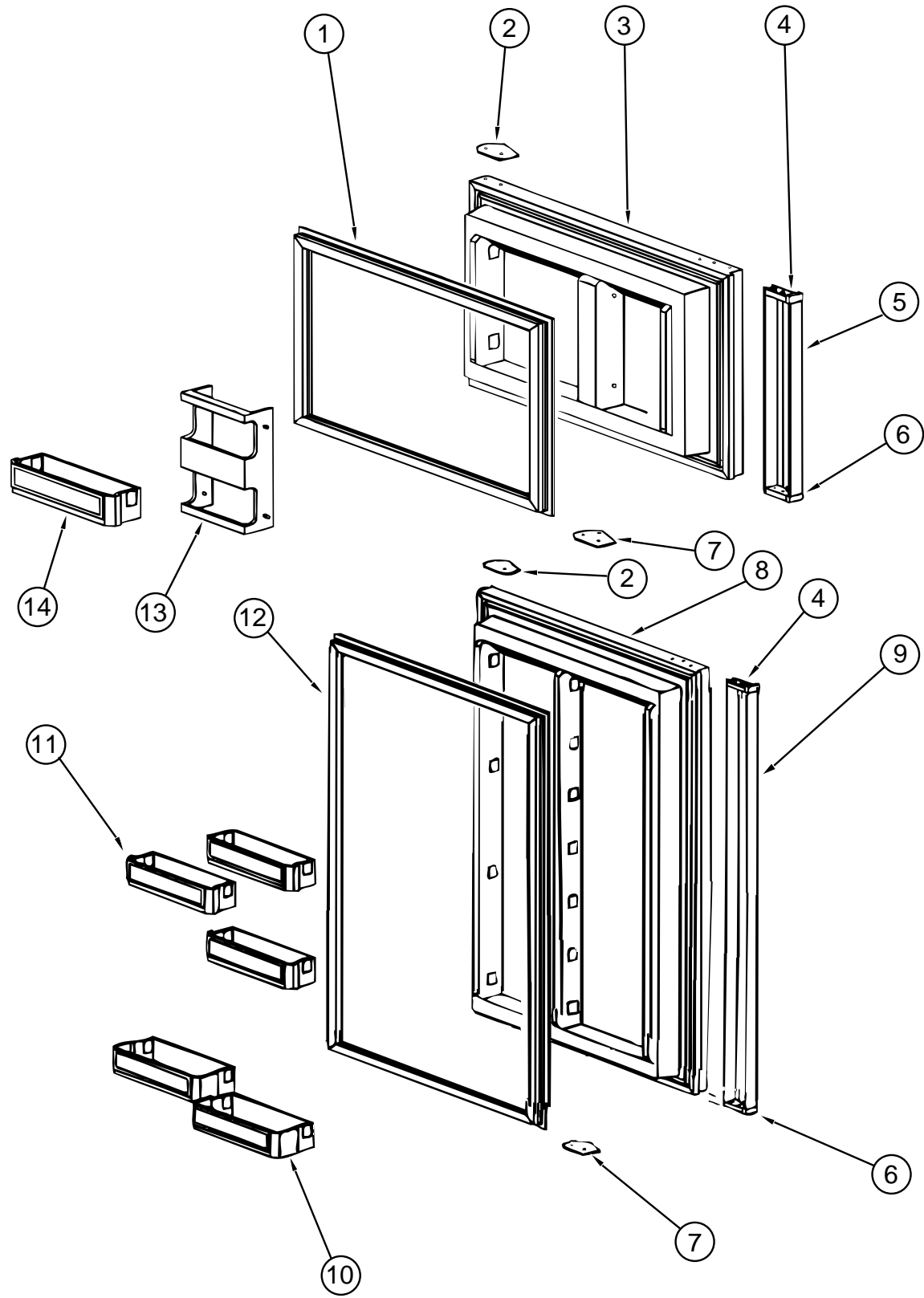

KEY	PART NUMBER	U/M	DESCRIPTION	VENDOR NO.
	104138-04-01A	EA	REFRIGERATOR-DOUBLE DOOR, 2-WAY - NORCOLD 6162 RH BL	
1	094039-01-702	EA	GASKET (GRAY) UPPER	61567830
2	094039-01-710	EA	PLATE-HINGE, TOP RH - LH BOTTOM - BLACK	61631330
3	094039-01-706	EA	UPPER DOOR LINER (WHITE) BLACK	61581838-B
4	084880-01-761	EA	END CAP (SPRING CATCH) BLACK - NORCOLD	61593730
5	094039-01-708	EA	HANDLE-DOOR, UPPER - BLACK - NORCOLD	61650038
6	084880-01-740	EA	END CAP (STOP CATCH)	61593830
7	094039-01-704	EA	PLATE-HINGE, BLACK	61631430
8	094038-01-702	EA	LINER-DOOR, LOWER - BLACK/WHITE	61581938-B
9	094038-01-704	EA	HANDLE-DOOR, LOWER - BLACK	61650138
10	104137-06-704	EA	MILK BIN - WHITE	61579425
11	104137-06-703	EA	BIN-DOOR SHELF, (WHITE)	61564025
12	094038-01-700	EA	GASKET-LOWER, GRAY	61567930
13	104137-06-702	EA	RACK-JUICE, WHITE	61580525
14	104137-06-703	EA	BIN-DOOR SHELF, WHITE	61564025
	084880-01-720	EA	SPRING (FOR DOOR HANDLE)	61558822

GALLEY GROUP (CONTINUED)
NORCOLD REFRIGERATOR MODEL 6162 CABINET ASM WITH TRAY, TIEDOWNS & LEVEL

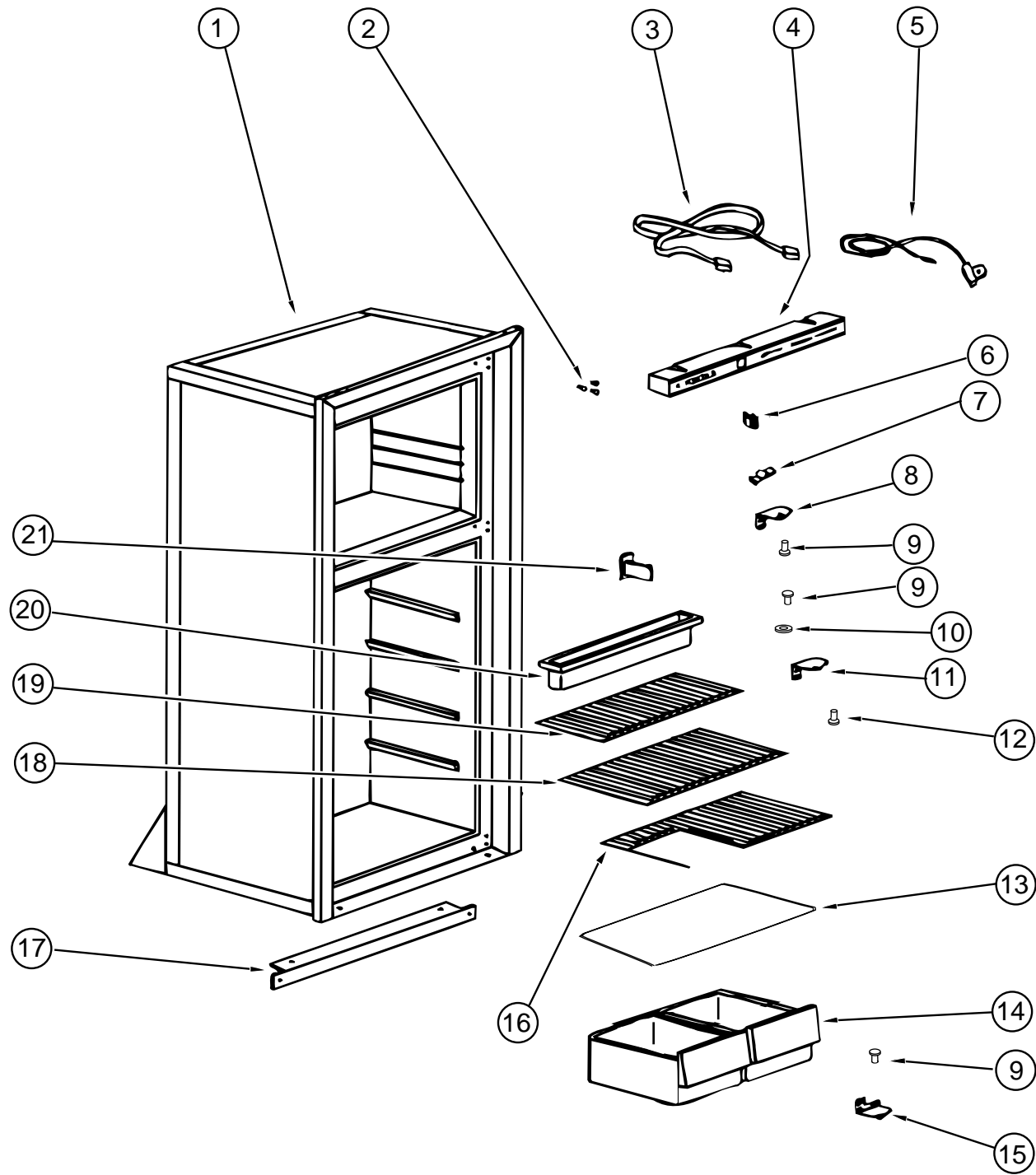

KEY	PART NUMBER	U/M	DESCRIPTION	VENDOR NO.
	104138-04-01A	EA	REFRIGERATOR-DOUBLE DOOR, 2-WAY - NORCOLD 6162 RH BL	
1	104138-04-701	EA	FOAMED CAB ASM BLACK W/WHITE	61725038
	084879-03-700	EA	COOLING UNIT - HORIZONTAL BURNER	61687237
2	094039-01-722	EA	HOLE PLUG, (BLACK) HINGE HOLES	61582030
3	084880-01-746	EA	CABLE-PRINTED CIRCUIT BOARD TO POWER SUPPLY	61571522
4	104137-06-700	EA	EYEBROW SHELL (2-WAY)	61726622
5	084880-01-753	EA	THERMISTER 78"	61697822
6	075217-01-738	EA	SWITCH-HUMIDITY	61525922
7	084880-01-760	EA	CLIP (THERMISTER)	61689122
8	094039-01-723	EA	HINGE BRACKET, TOP RH-BOTTOM LH BLACK	61580838
9	094039-01-725	EA	HINGE PIN, (BLACK) (MALE)	61578130
10	084880-01-749	EA	HINGE BUSHING	615807
11	094039-01-728	EA	HINGE BRACKET-CENTER HINGE, BLACK	61566530
12	094039-01-730	EA	HINGE PIN SHAFT, (BLACK) CENTER HINGE	61566730
13	084880-01-722	EA	CRISPER COVER	615641
14	104137-06-707	EA	CRISPER (WHITE)	61571325
15	094039-01-724	EA	BRACKET-HINGE, TOP LH - BOTTOM RH - BLACK	61580938
16	094039-01-739	EA	BOTTOM SHELF W/CUT-OUT - NORCOLD	61646722
17	094039-01-732	EA	FRONT COVER, (BLACK) BOTTOM TRIM - NORCOLD	61622130
18	094039-01-733	EA	SHELF-WIRE, CENTER - NORCOLD	61563822
19	104137-06-728	EA	SHELF-WIRE, TOP W/RISER - WHITE	618062
20	094039-01-735	EA	INSIDE DRIP TRAY, (WHITE)	61572830
21	084880-01-732	EA	LATCH	61578522
	084880-03-702	EA	PIN-HINGE, TOP/BOTTOM - FEMALE - BLACK	61580630
	104137-06-727	EA	FREEZER SHELF, WHITE	618057
	093646-03-000	EA	BRACKET-TIEDOWN, REFRIGERATOR - RH	
	093646-04-000	EA	BRACKET-TIEDOWN, REFRIGERATOR - LH	
	116751-01-01A	EA	TRAY-REFRIGERATOR, BLACK	
	065225-02-000	EA	PLATE-TIEDOWN, REFRIGERATOR	
	054450-01-000	EA	LEVEL-REFRIGERATOR	

GALLEY GROUP (CONTINUED)
MAGIC CHEF RANGE

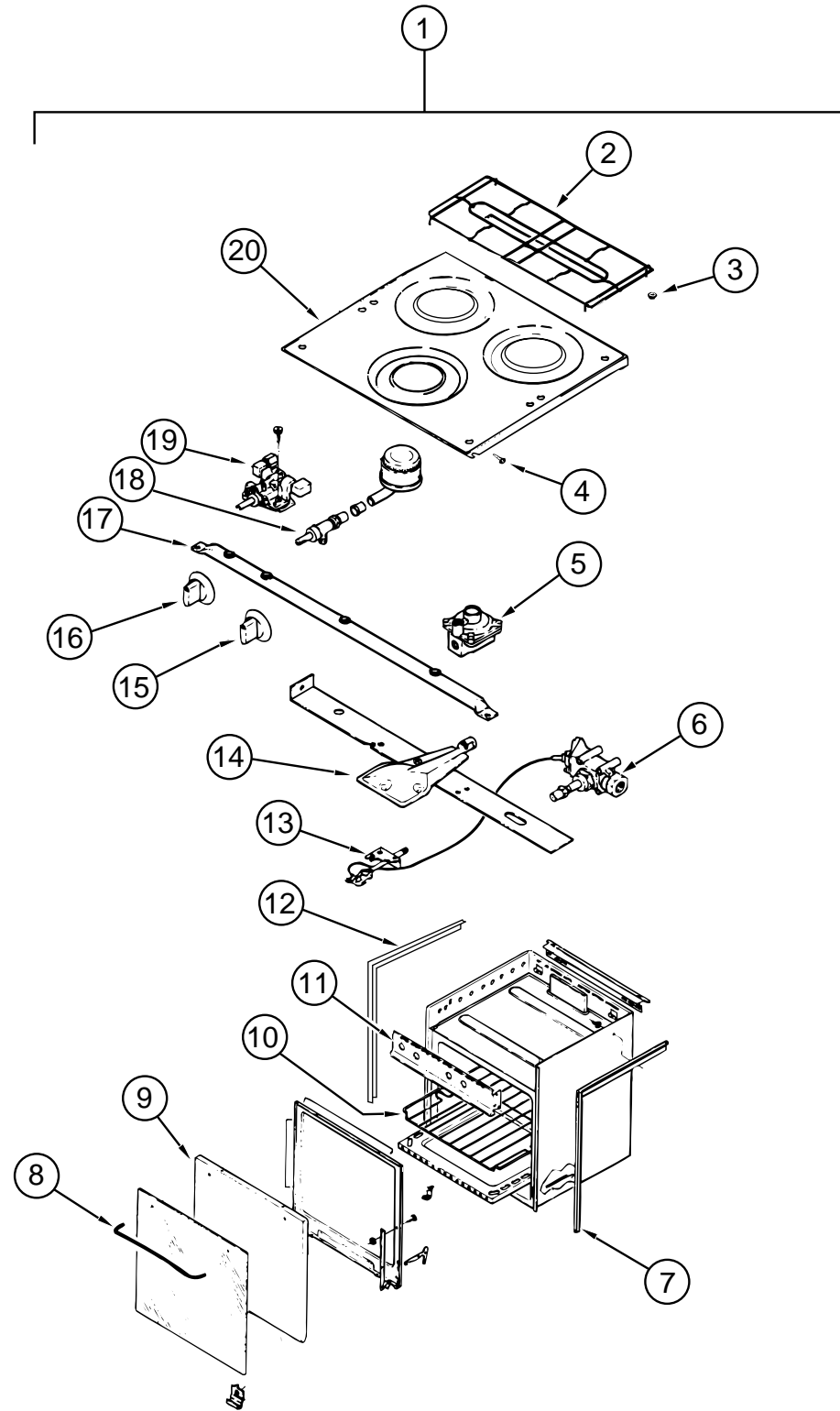

KEY	PART NUMBER	U/M	DESCRIPTION	VENDOR NO.
1	112881-01-04A	EA	RANGE - 16", 3 BURNER - MAGIC CHEF 16RB-3B49	
2	102020-01-711	EA	GRATE-TOP	7518P012-60
3	102020-01-709	EA	BUMPER-GRATE	8007-P020-60
4	102020-01-724	EA	BUMPER-MAIN TOP	8003P008-60
5	102022-01-708	EA	REGULATOR-PRESSURE, 1/4 IN 1/2 OUT	7510P041-60
6	112881-01-702	EA	VALVE-MERCURY, SAFETY VALVE	7501-P121-60
7	112881-01-708	EA	TRIM-FLAT, RIGHT - BLACK	3608W036-70
8	102020-01-701	EA	HANDLE-DOOR	7701P092-60
9	112881-01-713	EA	DOOR-OVEN, TEXTURED	2401F079-70
10	102020-01-700	EA	SHELF-OVEN	7801-P027-60
11	112881-01-701	EA	MANIFOLD PANEL	2616F091-70
12	112881-01-707	EA	TRIM-FLAT, LEFT - BLACK	3608W035-70
13	112881-01-710	EA	PILOT-OVEN	7505P202-60
14	112881-01-711	EA	BURNER ASSEMBLY-OVEN	3404W025045
15	112881-01-705	EA	KNOB-TOP BURNER	7733P072-60
15	112881-01-718	EA	KNOB-HIGH OUTPUT, FLAME INDICATOR, MAGIC CHEF	7733P072-60
16	112881-01-704	EA	KNOB-THERMOSTAT	7731P067-60
16	112881-01-716	EA	KNOB-THERMOSTAT, REF. SER. # 3C	7731P107-60
17	112881-01-709	EA	PIPE-MANIFOLD	7513P097-60
18	102020-01-722	EA	VALVE-TOP BURNER	7502P181-60
18	112881-01-703	EA	VALVE-TOP BURNER, HI-OUTPUT	7502P180-60
19	112881-01-706	EA	THERMOSTAT	12400026
19	112881-01-715	EA	THERMOSTAT - REF. SER. # 3C	7515P037-60
20	112881-01-712	EA	TOP-MAIN, BLACK	740101486
	105458-01-000	EA	TIEDOWN BRACKET - STOVE - RH	
	105458-02-000	EA	TIEDOWN BRACKET - STOVE - LH	

GALLEY GROUP (CONTINUED)
MAGIC CHEF MICROWAVE OVEN

KEY	PART NUMBER	U/M	DESCRIPTION	VENDOR NO.
	115303-01-000	EA	OVEN-MICROWAVE - MAGIC CHEF DM 15K-7B	
	115303-01-700	EA	TRIM F/VENT - TOP - MAGIC CHEF	2100309
	115401-01-01A	EA	TRIM-MICROWAVE, LOWER - BLACK	
	094750-07-000	EA	BRACKET-MICROWAVE, 89 DEGREE - STEEL	
	098916-14-01A	EA	BRACE-MICROWAVE CABINET, LEFT - 8.9" X 7.5" - STEEL	
	098916-15-01A	EA	BRACE-MICROWAVE CABINET, RIGHT - 8.9" X 7.5" - STEEL	

COFFEE MAKER

KEY	PART NUMBER	U/M	DESCRIPTION	VENDOR NO.
	103799-01-02A	EA	COFFEE MAKER-GRAY W/GLASS POT - BLACK & DECKER FROM: 00-00-00 THRU: 04-07-96	
	103799-02-01A	EA	COFFEE MAKER WITH CLOCK, WHITE - BLACK & DECKER SDC2B FROM: 04-08-96 THRU: 99-99-99	
	103799-01-700	EA	CARAFE-GLASS POT - BLACK & DECKER	679420
	103799-01-701	EA	BRACKETS-WHITE, PAIR - BLACK & DECKER	164734-06

GENERATOR GROUP
6,500 WATT ONAN EMERALD PLUS - GAS - US & CANADIAN

KEY	PART NUMBER	U/M	DESCRIPTION
	100975-01-000	EA	GENERATOR - 6.5 KW EMERALD PLUS, ONAN NHE-FA/26100G WITH ONAN TRAY #403-2218
	007067-01-000	SF	INSULATION-FIBERGLASS, 1" THICK X 4' - INCREMENTS OF 4 SF
	079654-05-000	EA	PIPE-EXHAUST, ANGLED - W/FLANGE - 2" ID - ONAN# 154-2539
	081364-03-000	EA	MUFFLER-GENERATOR, ONAN
	094059-01-000	EA	SPACER-GENERATOR, ONAN
	106602-01-000	EA	PIPE-EXHAUST, GENERATOR
	106607-01-000	EA	ANGLE-SUPPORT, EXHAUST
	007125-03-000	EA	CLAMP-MUFFLER - 1.5" DIA.
	007125-04-000	EA	CLAMP-MUFFLER - 1.1" DIA.
	007131-01-000	EA	HANGER-TAILPIPE, 6 SLOTS

5,000 WATT EMERALD PLUS - GAS - US & CANADIAN

KEY	PART NUMBER	U/M	DESCRIPTION
	109303-01-000	EA	GENERATOR - 5.0 KW EMERALD PLUS - ONAN WITH ONAN TRAY #403-2727
	007067-01-000	SF	INSULATION-FIBERGLASS, 1" THICK X 4' - INCREMENTS OF 4 SF
	007125-03-000	EA	CLAMP-MUFFLER - 1.5" DIA.
	007125-04-000	EA	CLAMP-MUFFLER - 1.1" DIA.
	007131-01-000	EA	HANGER-TAILPIPE, 6 SLOTS
	079654-05-000	EA	PIPE-EXHAUST, ANGLED - W/FLANGE - 2" ID - ONAN# 154-2539
	081364-03-000	EA	MUFFLER-GENERATOR, ONAN
	094059-01-000	EA	SPACER-GENERATOR, ONAN
	106602-01-000	EA	PIPE-EXHAUST, GENERATOR
	106607-01-000	EA	ANGLE-SUPPORT, EXHAUST

NOTE: ADDITIONAL GENERATOR COMPONENTS ARE FOUND IN THE CHASSIS GROUP

HEATING & AIR CONDITIONING GROUP
AUTO A/C & HEATER COMPONENTS

1996 CHEVY GAS CHASSIS

KEY	PART NUMBER	U/M	DESCRIPTION	VENDOR NO.
	007076-01-700	FT	HOSE-FLEXIBLE PVC - 2" ID	
	007108-01-000	FT	HOSE-HEATER, 5/8" ID	
	007281-01-000	EA	HOSE-FLEXIBLE PVC, 2.5" ID X 50'	
	007281-01-700	FT	HOSE-FLEXIBLE PVC, 2.5" ID	
	024990-05-000	EA	OUTLET-DEFROSTER, W/SWIVEL - 2" DIAMETER - BLACK	
	077075-01-000	EA	GASKET-INSTRUMENT PANEL TO DEFROSTER PLENUM - 1.8" X 12.5"	
	077075-03-000	EA	GASKET-INSTRUMENT PANEL TO DEFROSTER PLENUM - 1.8" X 12.25"	
	103016-01-000	EA	PLENUM-TRANSITION	
	103017-01-000	EA	PLENUM-DEFROSTER	
	103558-01-06A	EA	VENT-DEFROSTER, ABS - QUICK SILVER	
	103796-01-01A	EA	LOUVER ASM-A/C CARY PROD - BLACK	
	056402-05-000	EA	BRACKET-HEATER VENT, ROUND - W/BEND - BLACK	
	103930-05-000	EA	MANUAL-OWNERS, HEATER-A/C - SCS 057-0049	

1995 CHEVY CHASSIS

103930-17-000	EA	HOSE KIT #10 GM-SANDEN COMPRESSOR - SCS 093-00076	
103930-01-708	EA	BRACKET-VACUUM MOTOR, SCS	070-0113
103930-17-700	EA	FITTING-PAD COMPRESSOR SUCTION SANDEN - SCS	050-0131
103930-17-701	EA	FITTING #10.90 W/FERRULE/1342CP - SCS	050-0132
103930-17-702	EA	GASKET OR SAE 015 #10 33-781, SCS	045-0127
103930-17-703	EA	GASKET-SEAL, SANDEN COMPRESSOR 33-76 - SCS	045-0142
103930-17-704	EA	HOSE #10 - SCS	085-0113

1996 CHEVY CHASSIS

103930-28-000	EA	HOSE KIT #10 GM - L-19 - SCS 093-00426	
103930-17-702	EA	GASKET OR SAE 015 #10 33-781, SCS	045-0127
103930-28-700	EA	HOSE ASM #10 W/SELTEC COMPRESSOR	085-0347
103930-29-700	EA	HOSE ASM #10 W/HARRISON COMPRESSOR	085-0348
103930-29-701	EA	GASKET-GM, LP SW 1996	045-0483

1996 CHEVY VORTEC ENGINE CHASSIS

103930-29-000	EA	HOSE KIT #10 GM - L-29 & L-65 - SCS 093-00427	
103930-17-702	EA	GASKET OR SAE 015=#10 33-781	045-0127
103930-29-700	EA	HOSE ASM #10 W/HARRISON COMPRESSOR	085-0348
103930-29-701	EA	GASKET-GM, LP SW 1996	045-0483

1995 CHEVY OR FORD CHASSIS

103930-04-000	EA	CONTROL/PLENUM SET - SCS 093-00037	
072341-06-700	EA	SWITCH - 4 SPEED, FAN - ARA	0883502
094831-01-709	EA	CLAMPS-ROD, 3/16" - MOTIVAIR/SCS	ZGG14431
103930-02-712	EA	PANEL-CONTROL, BLACK BEZEL - SCS	032-0054
103930-02-701	EA	VALVE-CONTROL HEAD, SCS	034-0015
103930-02-702	EA	DECAL-FAN SWITCH, SCS	058-0008
103930-02-703	EA	HARNESS-WIRE CONTROL, SCS	036-0048
103930-02-704	EA	HARNESS-VACUUM CONTROL, SCS	036-0049
103930-02-705	EA	CABLE-CONTROL, BOWDEN - SCS	074-0011
103930-02-706	EA	CLIP-CABLE, CONTROL - SCS	022-0017
103930-02-707	EA	RELAY, SCS	031-0001
103930-02-708	EA	MOTOR-VACUUM SERVO, A/C - SCS	030-0002
103930-02-710	EA	CANISTER-VACUUM, SCS	054-0002
103930-23-000	EA	VALVE-WATER, 2 PORT - SCS 034-00014	

HEATING & AIR CONDITIONING GROUP (CONTINUED)
AUTO A/C & HEATER COMPONENTS (CONTINUED)

1996 CHEVY OR FORD CHASSIS

KEY	PART NUMBER	U/M	DESCRIPTION	VENDOR NO.
	103930-27-000	EA	CONTROL/PLENUM SET - SCS 093-00430	
	094831-01-709	EA	CLAMPS-ROD, 3/16" - MOTIVAIR/SCS	ZGG14431
	103930-01-724	EA	CLIP-SPRING, S TYPE	022-00002
	103930-02-701	EA	VALVE-CONTROL HEAD, SCS	034-0015
	103930-02-702	EA	DECAL-FAN SWITCH, SCS	058-0008
	103930-02-704	EA	HARNESS-VACUUM CONTROL, SCS	036-0049
	103930-02-705	EA	CABLE-CONTROL, BOWDEN - SCS	074-0011
	103930-02-707	EA	RELAY, SCS	031-0001
	103930-02-708	EA	MOTOR-VACUUM SERVO, A/C - SCS	030-0002
	103930-02-710	EA	CANISTER-VACUUM, SCS	054-0002
	103930-02-712	EA	PANEL-CONTROL, A/C - BLACK BEZEL	032-0054

HEATING & AIR CONDITIONING GROUP (CONTINUED)
30,000 BTU SUBURBAN FURNACE & WALL THERMOSTAT

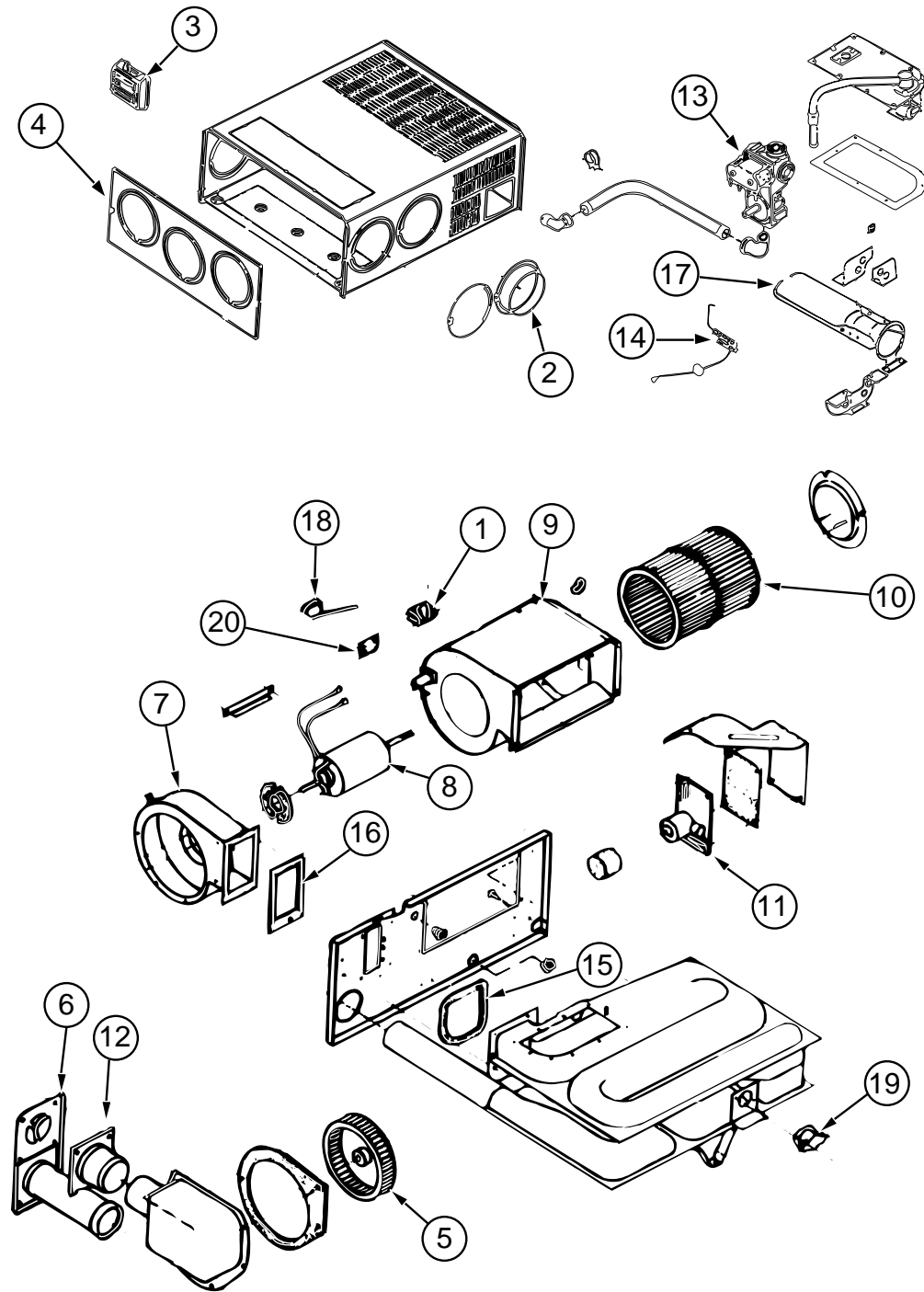

KEY	PART NUMBER	U/M	DESCRIPTION	VENDOR NO.
	098668-20-000	EA	FURNACE - 30,000 BTU - SUBURBAN SF30 2273	
1	074466-01-702	EA	RELAY-TIME DELAY	230625
2	075696-02-703	EA	COLLAR-DUCT	050715
3	115764-01-01A	EA	THERMOSTAT - WALL, FURNACE 160902	
4	098668-01-700	EA	CABINET-FRONT	101242
5	098668-01-706	EA	WHEEL-COMBUSTION AIR	350122
6	098668-01-707	EA	VENT ASSEMBLY-CAP AND TUBE	260193
7	098668-01-708	EA	BLOWER ASSEMBLY-COMBUSTION AIR	390441
8	098668-01-709	EA	MOTOR ASSEMBLY-F/SF-25, SF-30	231706
9	098668-01-710	EA	BLOWER ASSEMBLY-ROOM AIR	390440
10	098668-01-711	EA	WHEEL-ROOM AIR	350123
11	098668-01-712	EA	BOARD-MODULE	231741
12	098668-01-713	EA	INTAKE VENT TUBE ASSEMBLY	051044
13	098668-01-714	EA	VALVE-GAS, SF S.N. 921401821	161070
14	098668-01-715	EA	ELECTRODE ASSEMBLY-SINGLE PROBE	232166
15	098668-01-716	EA	GASKET-FIREWALL, CHAMBER SIDE	232166
16	098668-01-717	EA	GASKET-FIREWALL, BLOWER SIDE	070163
17	098668-02-700	EA	BURNER ASSEMBLY COMPLETE - (SF-30/SF35)	010745
18	098668-21-700	EA	MICROSWITCH W/O FLAG 3 1/4"	232261
19	098668-21-701	EA	LIMIT SWITCH	231799
20	101990-01-714	EA	MICROSWITCH GASKET	230877
	092300-02-701	EA	ORIFICE-(MAIN BURNER)	180214
	098668-23-000	EA	DOOR-ACCESS, FURNACE - BRIGHT WHITE - SUBURBAN 520574	
	056464-09-000	EA	REGISTER - 4" DIAMETER, PLASTIC	
	056464-10-000	EA	REGISTER-W/O DAMPER, 4" DIAMETER - DURA-BEIGE PLASTIC	
	093614-01-02A	EA	GRILLE-RETURN AIR, FURNACE - 15.6" X 7.6" - BEIGE	

HEATING & AIR CONDITIONING GROUP (CONTINUED)
35,000 BTU SUBURBAN FURNACE & WALL THERMOSTAT

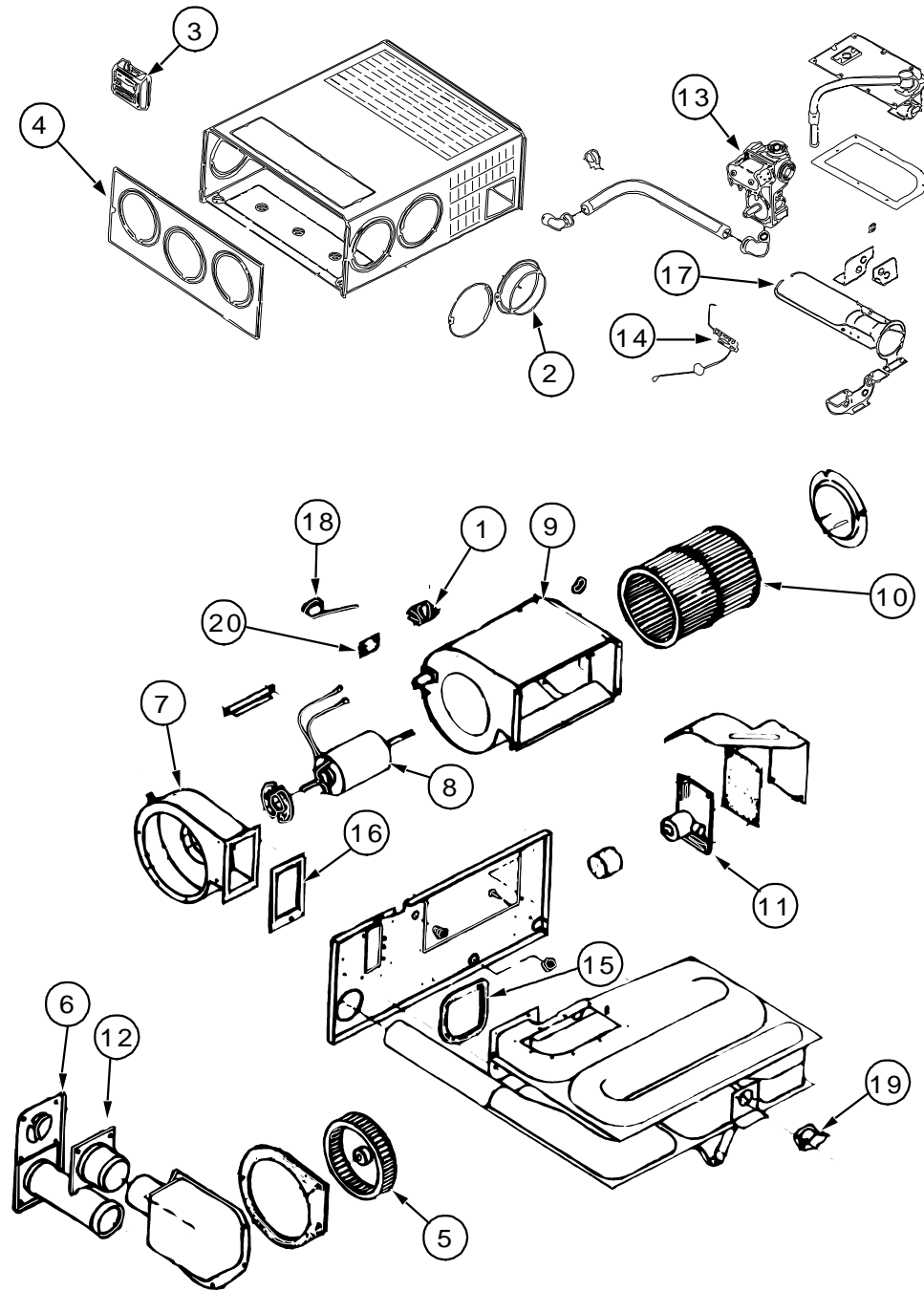

KEY	PART NUMBER	U/M	DESCRIPTION	VENDOR NO.
	098668-21-000	EA	FURNACE - 35,000 BTU - SUBURBAN SF35 2274	
1	074466-01-702	EA	RELAY-TIME DELAY	230625
2	075696-02-703	EA	COLLAR-DUCT	050715
3	115764-01-01A	EA	THERMOSTAT - WALL, FURNACE 160902	
4	098668-01-700	EA	CABINET-FRONT	101242
5	098668-01-706	EA	WHEEL-COMBUSTION AIR	350122
6	098668-01-707	EA	VENT ASSEMBLY-CAP AND TUBE	260193
7	098668-01-708	EA	BLOWER ASSEMBLY-COMBUSTION AIR	390441
8	098668-03-700	EA	MOTOR ASSEMBLY, SF-35	231707
9	098668-01-710	EA	BLOWER ASSEMBLY-ROOM AIR	390440
10	098668-01-711	EA	WHEEL-ROOM AIR	350123
11	098668-01-712	EA	BOARD-MODULE	231741
12	098668-01-713	EA	INTAKE VENT TUBE ASSEMBLY	051044
13	098668-01-714	EA	VALVE-GAS, SF S.N. 921401821	161070
14	098668-01-715	EA	ELECTRODE ASSEMBLY-SINGLE PROBE	232166
15	098668-01-716	EA	GASKET-FIREWALL, CHAMBER SIDE	232166
16	098668-01-717	EA	GASKET-FIREWALL, BLOWER SIDE	070163
17	098668-02-700	EA	BURNER ASSEMBLY COMPLETE - (SF-30/SF35)	010745
18	098668-21-700	EA	MICROSWITCH W/O FLAG 3 1/4"	232261
19	098668-21-701	EA	LIMIT SWITCH	231799
20	101990-01-714	EA	MICROSWITCH GASKET	230877
	069634-01-720	EA	ORIFICE-MAIN BURNER	0180222
	098668-23-000	EA	DOOR-ACCESS, FURNACE - BRIGHT WHITE - SUBURBAN 520574	
	056464-09-000	EA	REGISTER - 4" DIAMETER, PLASTIC	
	056464-10-000	EA	REGISTER-W/O DAMPER, 4" DIAMETER - DURA-BEIGE PLASTIC	
	093614-01-02A	EA	GRILLE-RETURN AIR, FURNACE - 15.6" X 7.6" - BEIGE	

HEATING & AIR CONDITIONING GROUP (CONTINUED)
EVANS REAR HEATER & COMPONENTS

KEY	PART NUMBER	U/M	DESCRIPTION	VENDOR NO.
	084405-01-000	EA	HEATER ASM-REAR, DUCTED - W/MOTOR AID - EVANS MPA 304055A	
	084405-01-700	EA	HEATER CORE-EVANS	FT200229
	084405-01-701	EA	FAN BLADES-EVANS	HV029931
	084405-01-702	EA	MOTOR ASM - 12 V, EVANS	200146
	009198-01-000	FT	DUCT-HEAT, FLEXIBLE - 4" ID - INCREMENTS OF 25'	
	009200-01-000	EA	TAPE-FURNACE, 1 1/2"	
	069636-02-000	EA	CONNECTOR-DUCT, 4" ID	
	007076-01-000	EA	HOSE-FLEXIBLE PVC - 2" ID - INCREMENTS OF 50'	
	007108-01-000	FT	HOSE-HEATER, 5/8" ID	
	008042-01-000	FT	TUBING-VINYL, .65" ID	
	061673-01-000	EA	BRACKET-MOTOR AID TUBES, 4" X 1.5" - STEEL	
	094600-05-01A	EA	REGISTER-HEAT, W/O DAMPER - LIMA 41, DURA-BEIGE	
	076776-01-000	EA	TEE-BARB, 5/8" X 5/8" X 5/8"	
	079059-01-000	EA	HOSE - 90 DEGREE, 5/8" ID X 4" X 36"	
	092777-01-000	EA	ADAPTER-DUCT, 4"	
	083081-01-000	EA	HOSE-FORMED, 90 DEGREES - 5/8" ID	
	056464-09-000	EA	REGISTER - 4" DIA, PLASTIC	

HEATING & AIR CONDITIONING GROUP (CONTINUED)

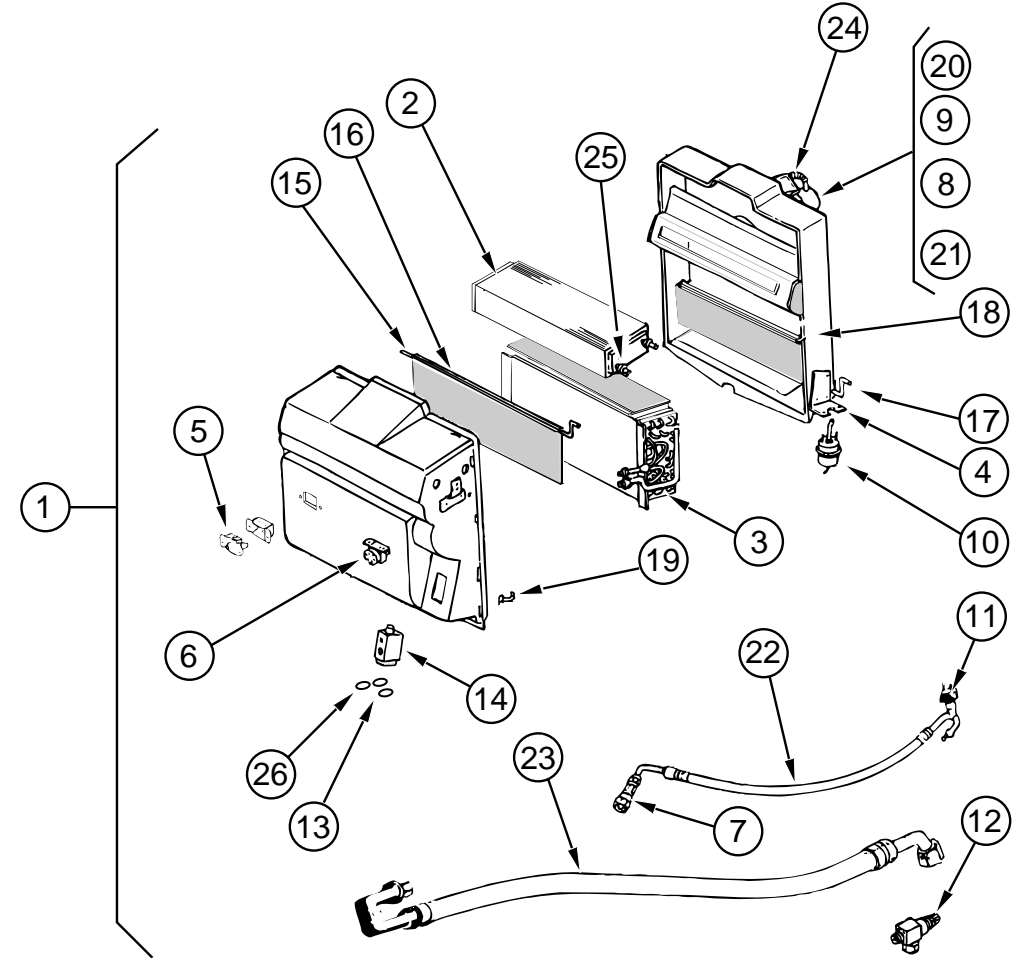

SCS EVAPORATOR/HEATER ASSEMBLY - FORD GAS CHASSIS

KEY	PART NUMBER	U/M	DESCRIPTION	VENDOR NO.
1	103930-21-000	EA	EVAPORATOR/HEATER ASSEMBLY - SCS 090-00084	
2	103930-01-703	EA	COIL-HEATER	042-0010
3	103930-01-704	EA	COIL EVAPORATOR	041-0017
4	103930-01-708	EA	BRACKET-VACUUM MOTOR	070-0113
5	103930-01-710	EA	RESISTOR-FUSED	035-0006
6	103930-01-711	EA	THERMOSTAT	033-0003
7	103930-01-713	EA	FITTING-QUICK CONNECT, #4	050-003
8	103930-01-717	EA	WHEEL-CLOCK-WISE	062-0010
9	103930-01-720	EA	MOTOR	030-0004
10	103930-02-708	EA	MOTOR-VACUUM SERVO, A/C	030-0002
11	103930-12-708	EA	SWITCH-BINARY, R-134A	032-0048
12	103930-13-702	EA	SERVICE VALVE	050-152
13	103930-17-702	EA	GASKET OR SAE 015 #10 33-781	045-0127
14	103930-20-700	EA	VALVE-EXPANSION BLOCK, 2 TON	034-0032
15	103930-20-702	EA	ROD-AIR BLEND DOOR	073-0039
16	103930-20-703	EA	DOOR-AIR BLEND	071-0212
17	103930-20-704	EA	ROD-RECIRCULATING DOOR	073-0018
18	103930-20-705	EA	DOOR-RECIRCULATING	071-0213
19	103930-20-706	EA	CLIP-RETAINER	022-0057
20	103930-20-707	EA	HOUSING-BLOWER	062-0145
21	103930-20-708	EA	CLIP F/MOTOR SHAFT	022-0001
	103930-20-710	EA	CASE-FRONT, SUB-ASSEMBLY	062-0146
	103930-20-711	EA	CASE-BACK, SUB-ASSEMBLY	062-0147
22	103930-21-700	EA	HOSE #6 - FORD	085-0139
23	103930-21-701	EA	HOSE #10 - FORD	085-0140
24	110279-01-703	EA	MOTOR-BLOWER	051-0034
25	110279-01-712	EA	FITTING-HEATER	050-0076
26	113245-01-707	EA	GASKET #8	045-0126

HEATING & AIR CONDITIONING GROUP (CONTINUED)

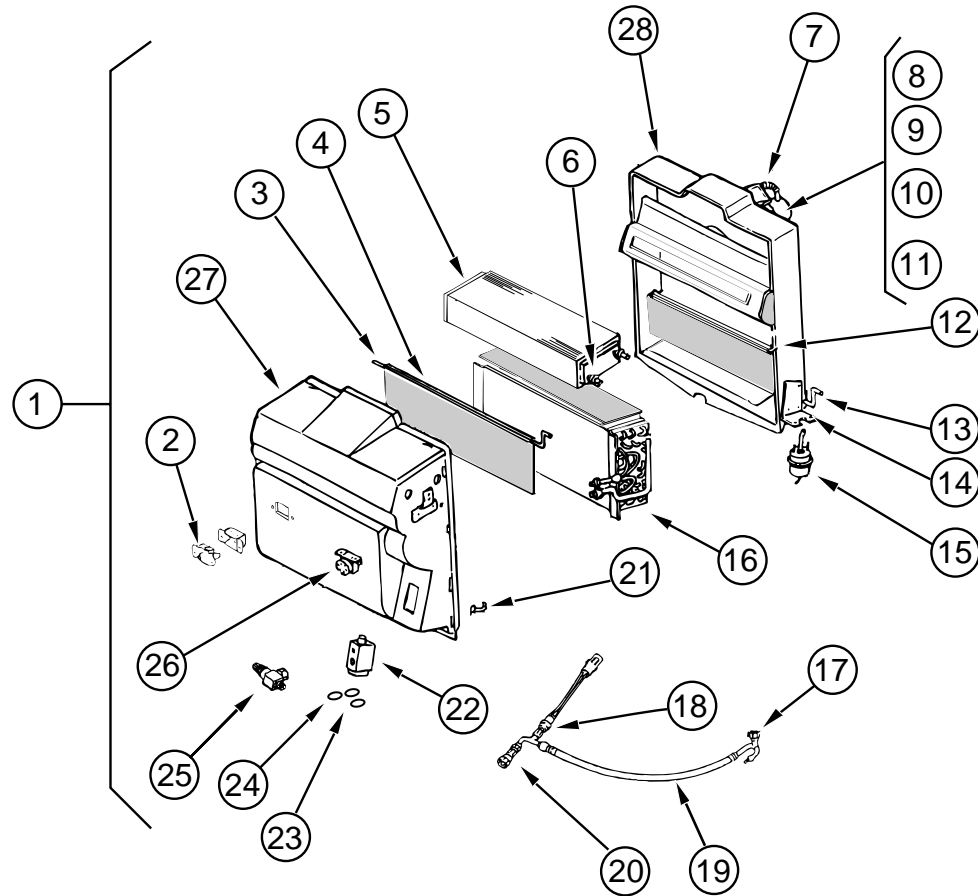

SCS EVAPORATOR/HEATER ASSEMBLY - 1995 CHEVY GAS CHASSIS

KEY	PART NUMBER	U/M DESCRIPTION	VENDOR NO.
1	103930-20-000	EA EVAPORATOR/HEATER ASSEMBLY - SCS 090-00083	
2	103930-01-710	EA RESISTOR-FUSED, SCS	035-0006
3	103930-20-702	EA ROD-AIR BLEND DOOR, SCS	073-0039
4	103930-20-703	EA DOOR-AIR BLEND, SCS	071-0212
5	103930-01-703	EA COIL-HEATER, SCS	042-0010
6	110279-01-712	EA FITTING-HEATER, SCS	050-0076
7	110279-01-703	EA MOTOR-BLOWER, SCS	051-0034
8	103930-20-707	EA HOUSING-BLOWER, SCS	062-0145
9	103930-01-720	EA MOTOR, SCS	030-0004
10	103930-01-717	EA WHEEL-CLOCK-WISE, SCS	062-0010
11	103930-20-708	EA CLIP F/MOTOR SHAFT, SCS	022-0001
12	103930-20-705	EA DOOR-RECIRCULATING, SCS	071-0213
13	103930-20-704	EA ROD-RECIRCULATING DOOR, SCS	073-0018
14	103930-01-708	EA BRACKET-VACUUM MOTOR, SCS	070-0113
15	103930-02-708	EA MOTOR-VACUUM SERVO, A/C - SCS	030-0002
16	103930-01-704	EA COIL-EVAPORATOR, SCS	041-0017
17	103930-12-708	EA SWITCH-BINARY, R-134A - SCS	032-0048
18	103930-01-716	EA SWITCH-PRESSURE, FAN - SCS	032-0036
19	103930-20-701	EA HOSE ASM - #6, SCS	085-0138
20	103930-12-709	EA FITTING-QUICK CONNECT - SCS	050-0120
21	103930-20-706	EA CLIP-RETAINER, SCS	022-0057
22	103930-20-700	EA VALVE-EXPANSION BLOCK, 2 TON - SCS	034-0032
23	103930-17-702	EA GASKET OR SAE 015 #10 33-781, SCS	045-0127
24	113245-01-707	EA GASKET #8, SCS	045-0126
25	103930-20-709	EA SERVICE VALVE - SCS	050-159
26	103930-01-711	EA THERMOSTAT, SCS	033-0003
27	103930-20-710	EA CASE-FRONT, SUB-ASSEMBLY - SCS	062-0146
28	103930-20-711	EA CASE-BACK, SUB-ASSEMBLY - SCS	062-0147

HEATING & AIR CONDITIONING GROUP (CONTINUED) SCS EVAPORATOR/HEATER ASSEMBLY - 1996 CHEVY GAS CHASSIS

KEY	PART NUMBER	U/M DESCRIPTION	VENDOR NO.
	103930-25-000	EA EVAPORATOR/HEATER ASSEMBLY - SCS 090-00296	
	103930-01-710	EA RESISTOR-FUSED, SCS	035-0006
	103930-20-702	EA ROD-AIR BLEND DOOR, SCS	073-0039
	103930-20-703	EA DOOR-AIR BLEND, SCS	071-0212
	103930-01-703	EA COIL-HEATER, SCS	042-0010
	110279-01-712	EA FITTING-HEATER, SCS	050-0076
	110279-01-703	EA MOTOR-BLOWER, SCS	051-0034
	103930-20-707	EA HOUSING-BLOWER, SCS	062-0145
	103930-01-720	EA MOTOR, SCS	030-0004
	103930-01-717	EA WHEEL-CLOCK-WISE, SCS	062-0010
	103930-20-708	EA CLIP F/MOTOR SHAFT, SCS	022-0001
	103930-20-705	EA DOOR-RECIRCULATING, SCS	071-0213
	103930-20-704	EA ROD-RECIRCULATING DOOR, SCS	073-0018
	103930-01-708	EA BRACKET-VACUUM MOTOR, SCS	070-0113
	103930-02-708	EA MOTOR-VACUUM SERVO, A/C - SCS	030-0002
	103930-01-704	EA COIL-EVAPORATOR, SCS	041-0017
	103930-12-709	EA FITTING-QUICK CONNECT - SCS	050-0120
	103930-20-706	EA CLIP-RETAINER, SCS	022-0057
	103930-20-700	EA VALVE-EXPANSION BLOCK, 2 TON - SCS	034-0032
	103930-17-702	EA GASKET OR SAE 015 #10 33-781, SCS	045-0127
	113245-01-707	EA GASKET #8, SCS	045-0126
	103930-20-709	EA SERVICE VALVE - SCS	050-159
	103930-01-711	EA THERMOSTAT, SCS	033-0003
	103930-20-710	EA CASE-FRONT, SUB-ASSEMBLY - SCS	062-0146
	103930-20-711	EA CASE-BACK, SUB-ASSEMBLY - SCS	062-0147
	094831-01-709	EA CLAMPS-ROD, 3/16" - MOTIVAIR/SCS	ZGG14431
	094831-01-746	EA CLAMP-BLEND CABLE - MOTIVAIR/SCS	77000-00
	103930-25-700	EA HOSE ASM - #6, SCS	085-0350
	103930-02-714	EA CLAMP-CLUTCH, BARREL - SCS	022-0006
	110279-02-702	EA GASKET - SCS	045-0125

HEATING & AIR CONDITIONING GROUP (CONTINUED)

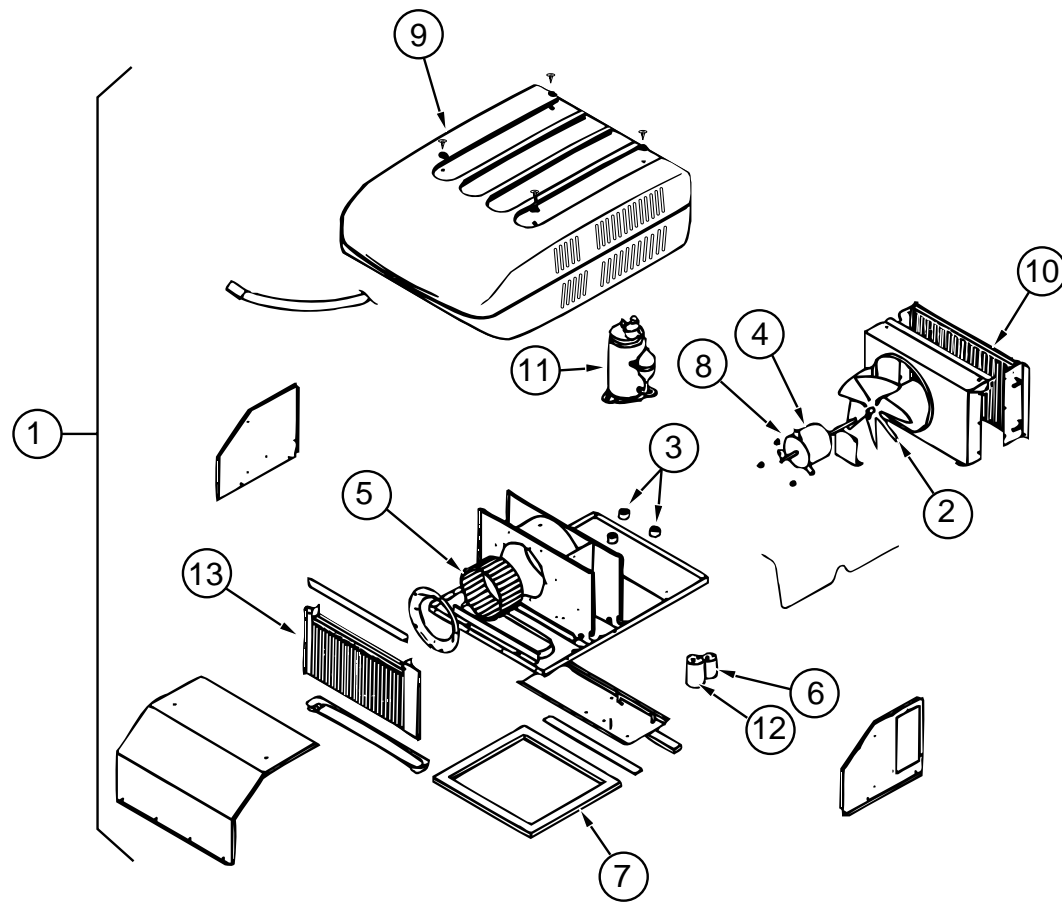

13,500 BTU COLEMAN ROOF A/C

KEY	PART NUMBER	U/M DESCRIPTION	VENDOR NO.
1	108889-01-05A	EA A/C-ROOF, 13,500 BTU TSR HO - BRIGHT WHITE - COLEMAN	7333A886
2	093763-01-712	EA FAN BLADE-CONDENSER	6733-3221
3	105620-01-706	EA FOOT PACKAGE-COMPRESSOR, 3 PER PACKAGE	6759-3081
4	108889-01-705	EA MOTOR - 115V, 60HZ	1468-3049
5	108889-01-706	EA IMPELLOR	1472-1041
6	093763-01-704	EA CAPACITOR-FAN	1499-5461
	108889-01-710	EA FILLER PAD-COND AIR SEAL	6759A3971
7	108889-01-711	EA GASKET PACKAGE	6792-3301
8	108889-01-715	EA MOTOR MOUNT & SHAFT SEAL KIT	6792-3361
9	108889-05-700	EA SHROUD - BRIGHT WHITE	7333-4601
10	108889-01-703	EA COIL-CONDENSER	1452A1301
11	105620-01-704	EA COMPRESSOR, RH & LH	1450-2009
12	108889-01-707	EA CAPACITOR-RUN, COMPRESSOR - 25MFD/370	1499-5661
	091225-01-709	EA RELAY-START	1497-4131
13	108889-01-709	EA COIL-EVAPORATOR	1452A1311
	108889-01-714	EA LINE ASSEMBLY-DISCHARGE	6792-531
	108889-01-712	EA LINE-SUCTION, REDUCER - 3/8" X 1/2"	1215-2161
	108889-01-713	EA LINE-SUCTION, 3/8" OD X 032 WALL	6792-130
	108889-01-704	EA OVERLOAD (MRA#98693)	6749-3541
	091225-01-710	EA CAPACITOR-START	1497-0881
	108889-01-720	EA TUBE-CAP	6792-1351
	093306-01-701	EA DECAL PACKAGE-LEFT & RIGHT	6798B3591
	102289-01-000	EA SPRING-SCREW, ROOF A/C GASKET - COLEMAN 6757-150	

HEATING & AIR CONDITIONING GROUP (CONTINUED)

COLEMAN CEILING ASSEMBLY 13,500 BTU A/C

KEY	PART NUMBER	U/M DESCRIPTION	VENDOR NO.
	108892-01-01A	EA CEILING ASM-A/C DUCTED - COLEMAN 7330-730IV	
	108892-01-700	EA PLUG ASSEMBLY	7330-540
	108892-01-701	EA BOARD-TERMINAL	7330-3201
	108892-01-702	EA BOARD-PRINTED CIRCUIT	7330A3211
	108892-01-703	EA FILTER	6798A3761
	108892-01-704	EA GRILLE (PLASTIC)	6798-3041
	108892-01-705	EA SMALL PARTS PKG	7330A6101
	117238-01-01A	EA THERMOSTAT-A/C AND FURNACE - COLEMAN 7330-3371	
	056464-06-000	EA REGISTER-HEAT/A/C, ROUND W/O DAMPER - 4" - OFF WHITE PLASTIC FROM: 00-00-00 THRU: 11-05-95	
	120134-01-01A	EA REGISTER - 4"-5" DIAMETER W/DAMPER - OFF WHITE - D&W 8840 FROM: 11-06-95 THRU: 99-99-99	

ROOF A/C COVER & AC SELECTOR SWITCH

KEY	PART NUMBER	U/M DESCRIPTION
	092633-02-02A	EA COVER-BLANK, ROOF A/C - 5.1" X 5.1" - PLASTIC - OFF WHITE
	022756-03-000	EA COVER-A/C, OFF WHITE - PLASTIC
	022756-02-000	EA COVER-PROTECTIVE, 5.5" ENDS X 8.2" - PLASTIC - OFF WHITE
	073937-03-000	EA SWITCH-ROTARY SELECTOR, 3 DECK - A/C - CA20-USA892
	088238-01-000	EA COVER-SWITCH, A/C SELECTOR - FRONT TO REAR A/C - 6,500 WATT GENERATOR
	088238-02-000	EA COVER-SWITCH, A/C SELECTOR FOR FRONT OR REAR - 5,000 WATT GENERATOR

INTERIOR FINISH GROUP

SMOKE DETECTOR, CO DETECTOR, FIRE EXTINGUISHER & CLOCK

KEY	PART NUMBER	U/M	DESCRIPTION
	072852-01-000	EA	DETECTOR-SMOKE, W/9 VOLT BATTERY - US
	072852-02-000	EA	DETECTOR-SMOKE, W/9 VOLT BATTERY - CANADIAN
	094499-01-000	EA	EXTINGUISHER-FIRE, DRY W/MOUNTING BRACKET - 10 BC
	094499-01-700	EA	BRACKET-MOUNTING, W/PLASTIC STRAP - FIRE EXTINGUISHER
	094499-01-701	EA	STRAP ONLY (METAL) - 320351
	094499-02-000	EA	EXTINGUISHER-FIRE, DRY - 1A10BC - CANADIAN
	112320-01-000	EA	DETECTOR-CO GAS, MODEL 9B-I - COSTAR 940000000 FROM: 00-00-00 THRU: 09-03-95
	112320-02-000	EA	BATTERY/SENSOR-CO GAS, COSTAR 940001000 FROM: 00-00-00 THRU: 09-03-95
	112320-03-000	EA	DETECTOR-CO GAS, MODEL 9D-I - COSTAR 946000001 FROM: 09-04-95 THRU: 99-99-99
	112320-04-000	EA	DETECTOR-CO SENSOR ASSEMBLY - COSTAR 946001001 FROM: 09-04-95 THRU: 99-99-99
	118081-01-01A	EA	CLOCK-WALL, ROUND 8" - BRASS

ANTISLIP & FLOOR MATS

KEY	PART NUMBER	U/M	DESCRIPTION
	091261-01-000	FT	SLIPNOT-ANTISLIP, 1' WIDE (100' ROLL)
	105924-01-F04	EA	MAT-FLOOR, 18" X 27" (G29)
	105924-01-F11	EA	MAT-FLOOR, 18" X 27" (G30)
	105924-01-F25	EA	MAT-FLOOR, 18" X 27" (G31)
	105924-01-F04	EA	MAT-FLOOR, 18" X 27" (G32)

CARPET

KEY	PART NUMBER	U/M	DESCRIPTION
	075233-01-000	SY	PAD-CARPET, 3/8" X 6' ROLL
	047034-06-000	SF	PLASTIC - CARPET - 2' WIDE - CLEAR POLY
	093486-01-000	SY	CARPET - COMPARTMENT, 54" WIDE - DARK GRAY
	096060-95-000	SY	CARPET - DOESKIN, 12' ROLL, INCREMENTS OF 4 SY (G29/G32)
	096060-A2-000	SY	CARPET - NEW MEADOW, 12' ROLL, INCREMENTS OF 4 SY (G30)
	096060-A8-000	SY	CARPET - BLUE LAGOON, 12' ROLL, INCREMENTS OF 4 SY (G31)

PANELING & PLYWOOD

KEY	PART NUMBER	U/M	DESCRIPTION
	074497-28-000	SF	PANELING-WOODGRAIN, 4' X 8' - INCREMENTS OF 32 SF
	088272-98-000	SF	PANELING-SHOWER, OFF WHITE - 4' X 7' - INCREMENTS OF 28 SF FROM: 00-00-00 THRU: 01-14-96
	088272-G1-000	SF	PANELING-SHOWER, PEBBLE EMBOSS ANTIQUE - 4' X 7' - INCREMENTS OF 28 SF FROM: 01-15-96 THRU: 99-99-99
	088272-E4-000	SF	PANELING-DECORATIVE, TRAVIS/PEBBLE - 4' X 7' - INCREMENTS OF 28 SF (G29) (MAIN WALL)
	088272-D6-000	SF	PANELING-DECORATIVE, ALLURE/MEADOW - 4' X 7' - INCREMENTS OF 28 SF (G30) (MAIN WALL)
	088272-E0-000	SF	PANELING-DECORATIVE, METRO/MIST - 4' X 7' - INCREMENTS OF 28 SF (G31/G32) (MAIN WALL)
	080215-10-000	SF	PANELING - 2 SIDED, WATERFORD OAK - 5 MM X 4' X 8' - INCREMENTS OF 32 SF
	074497-34-000	SF	PANELING-BUNK, IMPACT PEARL - 4' X 8' - INCREMENTS OF 32 SF
	000846-01-000	SF	PLYWOOD - 5/16" X 48" X 96.69"
	000846-02-000	SF	PLYWOOD-UNDR, 5/16" X 48" X 96.69"
	089297-01-000	SF	PLYWOOD-LUAN, OVERLAY GRADE - 4' X 8' - INCREMENTS OF 32 SF
	000885-76-000	SF	PARTICLE BOARD - 3/8" X 48" X 96" - WATERFORD OAK VINYL 1 SIDE
	000885-77-000	SF	PARTICLE BOARD - 3/8" X 48" X 96" - WATERFORD OAK VINYL 2 SIDES
	000885-79-000	SF	PARTICLE BOARD - 3/4" X 48" X 96" - WATERFORD OAK VINYL 2 SIDES

INTERIOR FINISH GROUP (CONTINUED)

PLASTIC LAMINATE & EDGE BAND MOLDING

KEY	PART NUMBER	U/M	DESCRIPTION
	074498-54-000	SF	LAMINATE-PLASTIC, SAND SPEKTRUM - 5' X 8' - INCREMENTS OF 40 SF (G29/G32) (GALLEY, DINETTE, BATH & BEDROOM)
	074498-73-000	SF	LAMINATE-PLASTIC, PEPPERMINT SANTOS - 5' X 8' - INCREMENTS OF 40 SF (G30) (GALLEY, DINETTE, BATH & BEDROOM)
	074498-62-000	SF	LAMINATE-PLASTIC, GREY FINESSE - 5' X 8' - INCREMENTS OF 40 SF (G31) (GALLEY, DINETTE, BATH & BEDROOM)
	074498-67-000	SF	LAMINATE-PLASTIC, ORCHID MIST - 5' X 8' - INCREMENTS OF 40 SF (PATIO ENTERTAINMENT CENTER TABLE)
	076325-34-000	FT	MOLDING-EDGE BAND, 1233 ORCHID MIST - 1 5/16" X .030" X 600" (PATIO ENTERTAINMENT CENTER TABLE)
	076325-47-000	FT	MOLDING-EDGE BAND, 1032 SAND - 1 5/16" X .030" X 600" (G29/G32) (DINETTE/BEDROOM)
	076325-65-000	FT	MOLDING-EDGE BAND, 1179 PEPPERMINT - 1 5/16" X .030" X 600" (G30) (DINETTE/BEDROOM)
	076325-46-000	FT	MOLDING-EDGE BAND, 1035 CLOUD - 1 5/16" X .030" X 600" (G31) (DINETTE/BEDROOM)
	076325-44-000	FT	MOLDING-EDGE BAND, 1032 SAND - .875" X .024" X 600" (G29/G32) (DINETTE/BEDROOM)
	076325-66-000	FT	MOLDING-EDGE BAND, 1179 PEPPERMINT - .875" X .024" X 600" (G30) (DINETTE/BEDROOM)
	076325-43-000	FT	MOLDING-EDGE BAND, 1035 CLOUD - .875" X .024" X 600" (G31) (DINETTE/BEDROOM)
	074498-77-000	SF	LAMINATE-PLASTIC, ART CAGIN OAK - 5' X 8' - INCREMENTS OF 40 SF (PULL OUT TABLE)
	076325-68-000	FT	MOLDING-EDGE BAND, WATERFORD OAK - 1 5/16" X .030" X 600" (PULL OUT TABLE)

BATT STRIPS

KEY	PART NUMBER	U/M	DESCRIPTION
	069733-83-000	EA	BATT STRIP-WOODGRAIN, 8' - WATERFORD OAK
	079653-28-000	EA	BATT STRIP-WOODGRAIN, 8' - KERFED - WATERFORD OAK
	088263-78-000	EA	BATT STRIP-SHOWER, 8' - OFF WHITE FROM: 00-00-00 THRU: 01-14-96
	088263-E3-000	EA	BATT STRIP-SHOWER, 8' - PEBBLE EMBOSS ANTIQUE FROM: 01-15-96 THRU: 99-99-99
	088263-C3-000	EA	BATT STRIP-DECORATIVE, TRAVIS/PEBBLE - 8' LONG (G29) (MAIN WALL)
	088263-B3-000	EA	BATT STRIP-DECORATIVE, ALLURE/MEADOW - 8' LONG (G30) (MAIN WALL)
	088263-B8-000	EA	BATT STRIP-DECORATIVE, METRO/MIST - 8' LONG (G31/G32) (MAIN WALL)
	085284-B5-000	FT	BATT - TAPE, WATERFORD OAK WOODGRAIN - ADHESIVE BACKED
	085284-76-000	FT	BATT - TAPE, SHOWER - OFF WHITE - ADHESIVE BACKED FROM: 00-00-00 THRU: 01-14-96
	085284-D6-000	FT	BATT - TAPE, SHOWER - PEBBLE EMBOSS ANTIQUE - ADHESIVE BACKED FROM: 01-15-96 THRU: 99-99-99
	085284-B6-000	FT	BATT - TAPE, TRAVIS-PEBBLE - ADHESIVE BACKED (G29) (MAIN WALL)
	085284-A4-000	FT	BATT - TAPE, ALLURE-MEADOW - ADHESIVE BACKED (G30) (MAIN WALL)
	085284-B1-000	FT	BATT - TAPE, METRO MIST - ADHESIVE BACKED (G31/G32) (MAIN WALL)
	086229-13-000	EA	BATTEN-CEILING, 1" WIDE - MODERN IVORY - 7.6' FROM: 00-00-00 THRU: 06-09-96
	086229-20-000	EA	BATTEN-CEILING, 1" WIDE - BEIGE - 7.6' FROM: 06-10-96 THRU: 99-99-99
	086229-01-000	EA	RETAINER-BATTEN, CEILING - .75" WIDE - IVORY - 7.6'

INTERIOR FINISH GROUP (CONTINUED)
MOLDINGS & TRIM

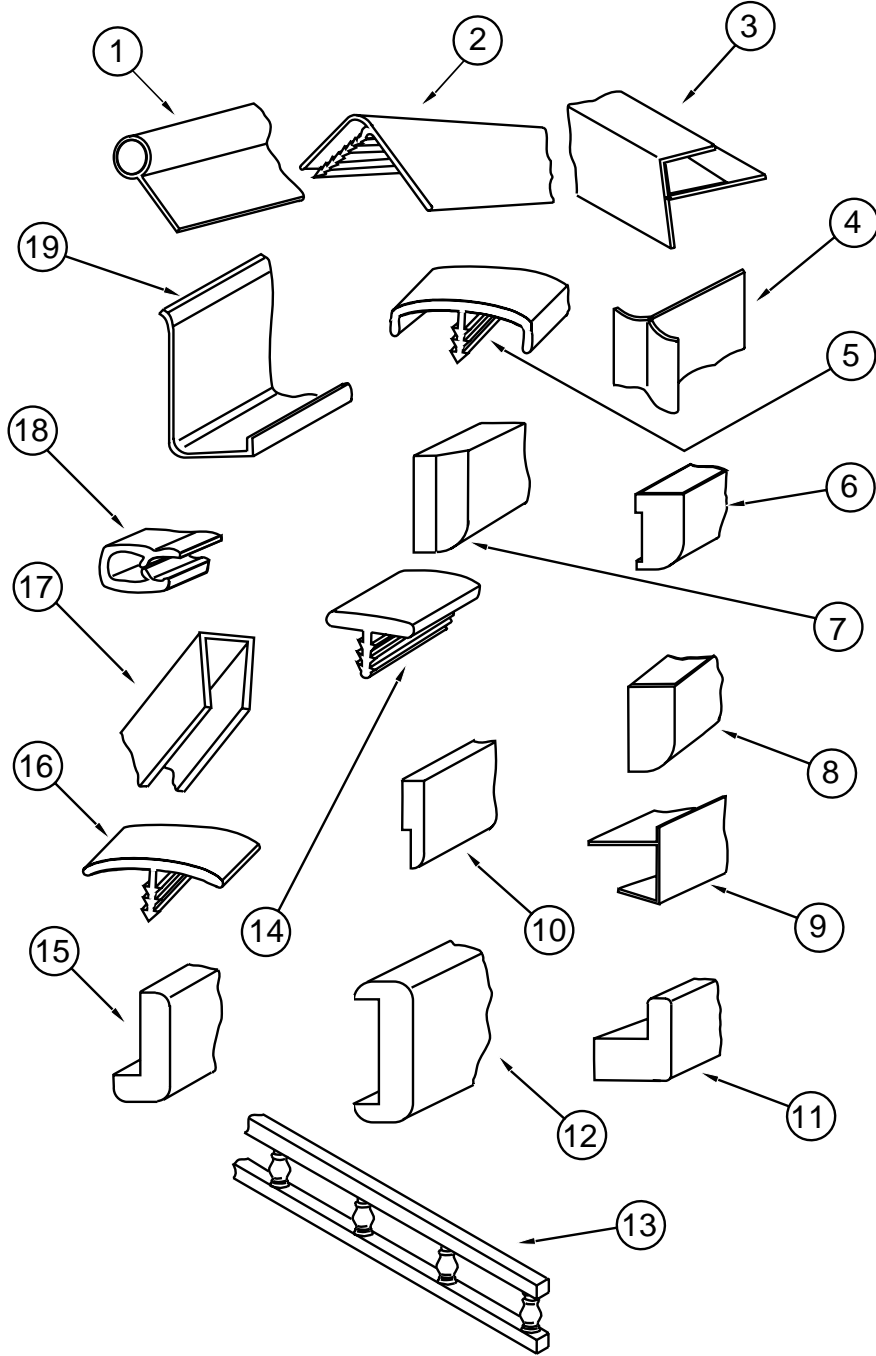

KEY	PART NUMBER	U/M	DESCRIPTION
1	009767-12-000	FT	MOLDING-SIDEWALL TO CEILING/CABINET - WELTING - OFF WHITE
1	009809-23-000	EA	MOLDING-CORNER, OUTSIDE - 1" - PLASTIC - IVORY
2	009809-28-000	EA	MOLDING-CORNER, OUTSIDE - 1" - PLASTIC - WATERFORD OAK
3	009812-29-000	EA	MOLDING-CORNER, OUTSIDE - .5" X 7' - PLASTIC - WATERFORD OAK
4	022992-11-000	FT	MOLDING-REVERSE COVE, T-SHAPED - VINYL - IVORY
5	083620-12-000	FT	MOLDING-T, END CAP EDGE - W/EDGE LIPS - .75" - WATERFORD OAK
6	117268-D2-134	EA	MOLDING-VINYL WRAPPED, .7" X 1.6" X 7' - WATERFORD OAK
6	117268-F2-134	EA	MOLDING-VINYL WRAPPED, .7" X 2.6" X 7' - WATERFORD OAK
6	117268-F2-438	EA	MOLDING-VINYL WRAPPED, 18 MM X 65 MM X 2438 MM - WATERFORD OAK
7	100659-01-G09	EA	MOLDING-TRIM, VINYL FLOOR
8	100818-01-05A	EA	MOLDING-VINYL WRAPPED, 1.65" X .4" X 7' - WATERFORD OAK
9	103186-01-05A	FT	MOLDING-EDGE, SHELF - .78" WIDE - PLASTIC - WATERFORD OAK
9	103186-02-05A	FT	MOLDING-EDGE, SHELF - 1.3" WIDE - PLASTIC - WATERFORD OAK
10	105004-01-05A	EA	MOLDING-VINYL WRAPPED, 1" X 8' - WATERFORD OAK
11	100819-01-05A	EA	MOLDING-VINYL WRAPPED, DOOR - WATERFORD OAK
12	078323-06-G15	EA	MOLDING-CAP, WALL - 2022 MM LONG
13	075249-01-000	EA	RAILING-OAK, 72" - UNFINISHED
14	104676-01-01A	FT	T-MOLDING, 5/16 - RIGID - GOLD
15	077840-01-G01	EA	MOLDING-CAP, WALL - 2438 MM LONG
16	105709-01-000	FT	T-MOLDING, 1", IVORY
17	009778-21-000	FT	U - CHANNEL, 1" WIDE X 8' INCREMENTS - PLASTIC - WATERFORD OAK
17	070504-18-000	FT	U-CHANNEL-PLASTIC, .065" WIDE - IVORY - INCREMENTS OF 8'
17	070504-19-000	FT	U-CHANNEL-PLASTIC, .815" WIDE - BROWN - INCREMENTS OF 8'
17	070504-36-000	FT	U-CHANNEL-PLASTIC, 1.65" WIDE - WATERFORD OAK - INCREMENTS OF 8'
17	070504-37-000	FT	U-CHANNEL-PLASTIC, .815" WIDE - WATERFORD OAK - INCREMENTS OF 8'
18	072368-02-000	EA	TRIM-VINYL, EDGE - BLACK - GM 14004305
19	085746-01-000	FT	TRIM-J, CARPET - 1.2" X .5" ANGLE - 10' LONG - PVC - BEIGE
	117267-D2-438	EA	LUMBER-VINYL WRAPPED, .7" X 1 1/2" X 8' - WATERFORD OAK
	117267-E2-438	EA	LUMBER-VINYL WRAPPED, .7" X 2" X 8' - WATERFORD OAK
	117267-G2-438	EA	LUMBER-VINYL WRAPPED, .7" X 3" X 8' - WATERFORD OAK

INTERIOR FINISH GROUP (CONTINUED)
CABINET HARDWARE

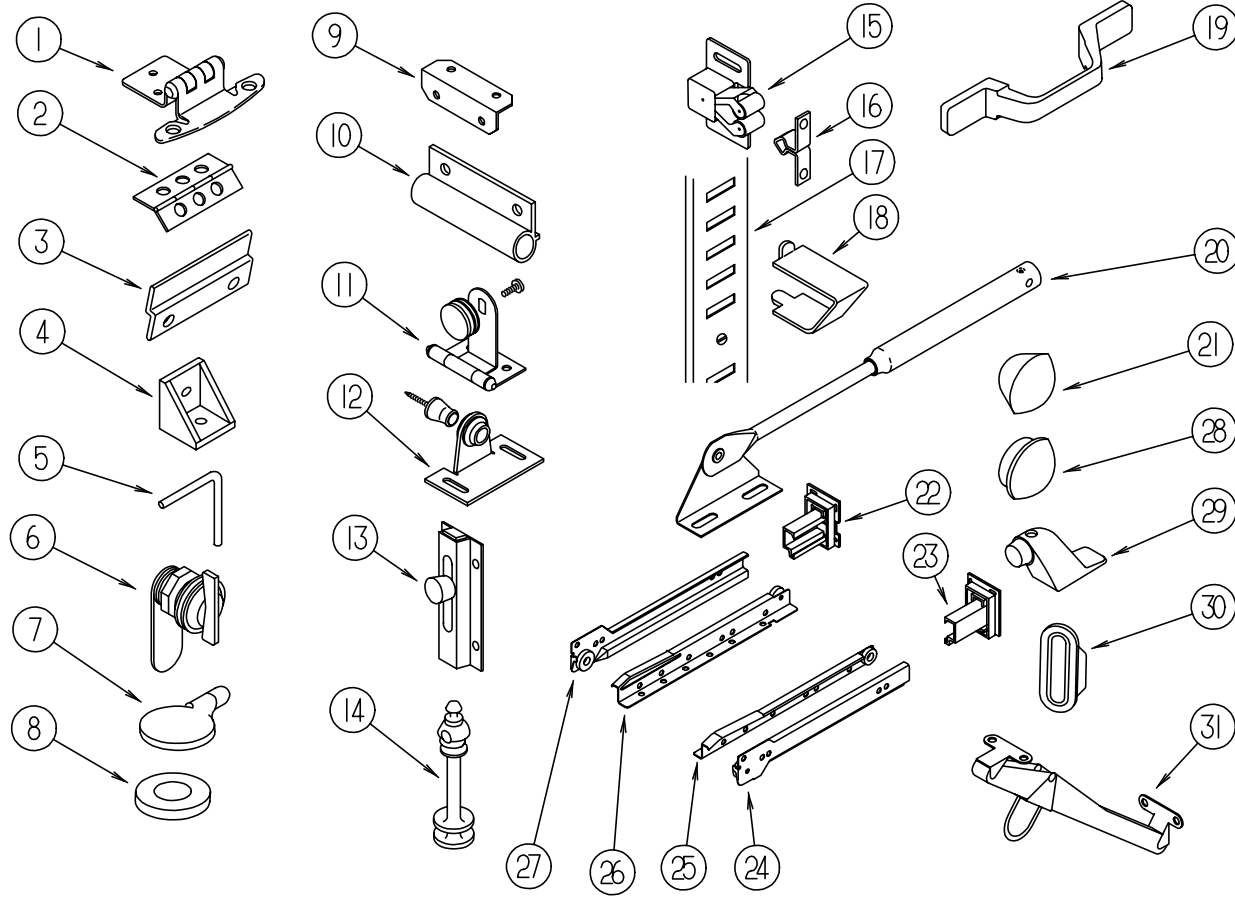

KEY	PART NUMBER	U/M	DESCRIPTION
11	100711-01-01A	EA	HINGE-DOOR, GLASS
12	009013-01-000	EA	CATCH-MALE & FEMALE BULLDOG, ANTIQUE COPPER
13	061604-01-000	EA	SLIDE-BOLT, BRIGHT BRASS - GM HDW BB-789-BW/S
14	084070-02-000	EA	POST-END, 2.4" - BRASS
15	093586-06-000	EA	CATCH-SPRING, ROLLER
16	093586-05-000	EA	STRIKE-SPRING STEEL
17	098980-01-000	EA	PILASTER-ADJUSTABLE SHELF, 18" LONG
17	098980-02-000	EA	PILASTER-ADJUSTABLE SHELF, 12" LONG
17	098980-03-000	EA	PILASTER-ADJUSTABLE SHELF, 9" LONG
18	098979-01-000	EA	CLIP-ADJUSTABLE SHELF
19	117801-01-01A	EA	PULL-CABINET, BRASS
20	074493-02-000	EA	SUPPORT-PISTON SPRING, CABINET DOOR
21	042356-01-000	EA	PLUG-BUTTON, MAHOGANY - 3/8" DIAMETER - WOOD
22	114045-01-000	EA	BACKSOCKET-ADJUSTABLE, LEFT PLEASE REFER TO PARTS BULLETIN #140 FOR INTERCHANGEABILITY
23	114045-02-000	EA	BACKSOCKET-ADJUSTABLE, RIGHT PLEASE REFER TO PARTS BULLETIN #140 FOR INTERCHANGEABILITY
24	114031-14-000	EA	SLIDE-DRAWER, CABINET - RIGHT SIDE - 18" REFERENCE DEALER PARTS BULLETIN #7SB010-96-12Z.
24	114031-22-000	EA	SLIDE-DRAWER, CABINET - RIGHT SIDE - 22" REFERENCE DEALER PARTS BULLETIN #7SB010-96-12Z.
24	114031-26-000	EA	SLIDE-DRAWER, CABINET - RIGHT SIDE - 24" REFERENCE DEALER PARTS BULLETIN #7SB010-96-12Z.
25	114031-16-000	EA	SLIDE-DRAWER, DRAWER MOUNT - RIGHT SIDE - 18" REFERENCE DEALER PARTS BULLETIN #7SB010-96-12Z.
25	114031-24-000	EA	SLIDE-DRAWER, DRAWER MOUNT - RIGHT SIDE - 22" REFERENCE DEALER PARTS BULLETIN #7SB010-96-12Z.
25	114031-28-000	EA	SLIDE-DRAWER, DRAWER MOUNT - RIGHT SIDE - 24" REFERENCE DEALER PARTS BULLETIN #7SB010-96-12Z.
26	114031-15-000	EA	SLIDE-DRAWER, DRAWER MOUNT - LEFT SIDE - 18" REFERENCE DEALER PARTS BULLETIN #7SB010-96-12Z.
26	114031-23-000	EA	SLIDE-DRAWER, DRAWER MOUNT - LEFT SIDE - 22" REFERENCE DEALER PARTS BULLETIN #7SB010-96-12Z.
26	114031-27-000	EA	SLIDE-DRAWER, DRAWER MOUNT - LEFT SIDE - 24" REFERENCE DEALER PARTS BULLETIN #7SB010-96-12Z.
27	114031-13-000	EA	SLIDE-DRAWER, CABINET - LEFT SIDE - 18" REFERENCE DEALER PARTS BULLETIN #7SB010-96-12Z.
27	114031-21-000	EA	SLIDE-DRAWER, CABINET - LEFT SIDE - 22" REFERENCE DEALER PARTS BULLETIN #7SB010-96-12Z.
27	114031-25-000	EA	SLIDE-DRAWER, CABINET - LEFT SIDE - 24" REFERENCE DEALER PARTS BULLETIN #7SB010-96-12Z.
28	074045-07-000	EA	PLUG-WOOD, 1/2"
29	103257-01-000	EA	STOP-DOOR
30	098410-01-01A	EA	PULL-FINGER, OVAL - BRASS
31	104181-01-01A	EA	SUPPORT-LEAF, 5.3" - EXTENDS TO 7.5" - SAFETY RING - METAL
	004354-01-000	EA	BUMPER-RUBBER, .5" DIA - BROWN
	009112-01-000	EA	FLANGE - 1" ROD, CLOTHES - PLASTIC - OFF WHITE
	023320-01-000	EA	PAD-FELT, 3/8" DIAMETER - BROWN
	039984-01-000	EA	CAP-ROUND, VINYL - .28" ID X .62" LONG - BLACK
	042438-01-000	EA	DOWEL-WOOD, CLOTHES ROD - 1" DIAMETER X 4'
	042438-02-000	EA	DOWEL-WOOD, 2" X 2"
	097872-04-000	EA	DOWEL-WOOD, 1" DIA X 1.38" LONG - UNFINISHED
	111866-01-02A	EA	BRACE-SEAT, ANGLE - OFF WHITE (FOR DINETTE BACK PADS)

KEY	PART NUMBER	U/M	DESCRIPTION
1	108138-01-000	EA	HINGE-CABINET DOOR, BURNISHED BRASS
2	009059-01-000	EA	HINGE-DOOR, 2" X 1.4" - BRASS
2	009059-02-000	EA	HINGE-DOOR, 2" X 2.7" - BRASS
3	101272-01-000	EA	CATCH-DOOR, GLASS
4	065740-01-000	EA	BRACE-CABINET CORNER, PLASTIC
5	108487-02-01A	EA	SUPPORT-PROP ROD, OVERHEAD - BLACK
6	100710-01-01A	EA	LOCK-GLASS DOOR, TWIST TYPE - BRASS
7	101766-01-000	EA	PIN-SUPPORT, GLASS DOOR
8	100707-01-000	EA	SPACER-DOOR, GLASS - .8" DIA - .3" HOLE - PLASTIC
9	016604-01-000	EA	BRACE-CABINET, ANGLE - 2.5" - METAL - UNPAINTED
9	016604-05-000	EA	BRACE-CABINET, ANGLE - 2.5" - METAL - OFF WHITE
10	108486-01-01A	EA	BRACKET-PROP ROD, OVERHEAD - BLACK

LABELS GROUP

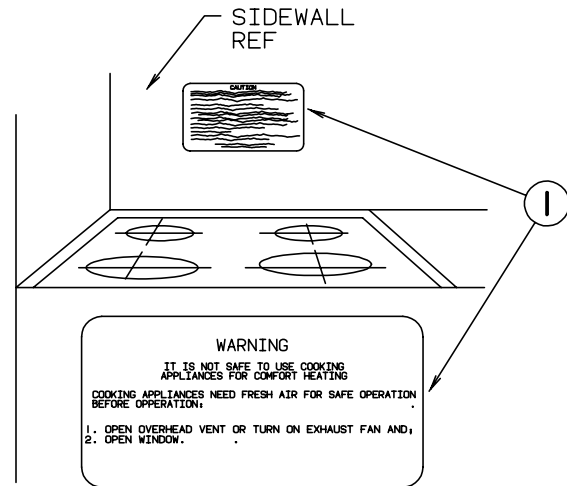

KEY	PART NUMBER	U/M DESCRIPTION
1	050225-01-000	EA LABEL-WARNING, STOVE VENT - US
1	050222-01-000	EA LABEL-WARNING, STOVE VENT - CANADIAN

LABELS GROUP (CONTINUED)

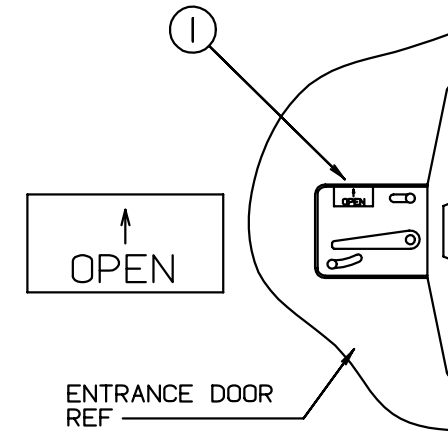

KEY	PART NUMBER	U/M DESCRIPTION
1	040944-01-000	EA LABEL-ENTRANCE DOOR, "OPEN"

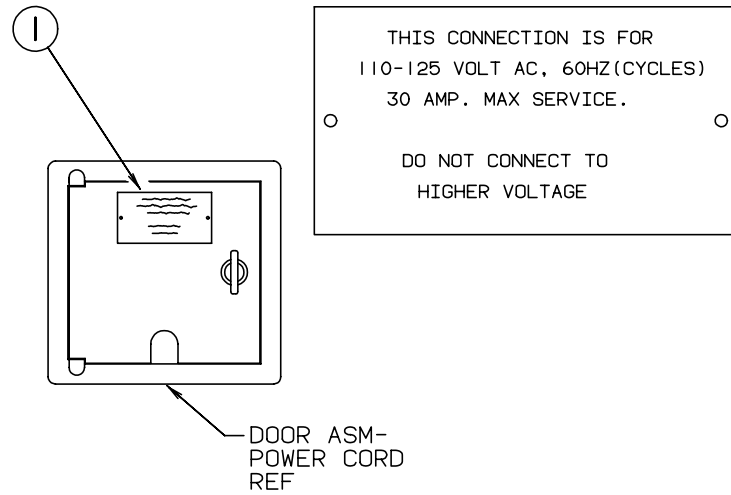

KEY	PART NUMBER	U/M DESCRIPTION
1	006062-01-000	EA LABEL-ELECTRIC, 110V CONNECTION

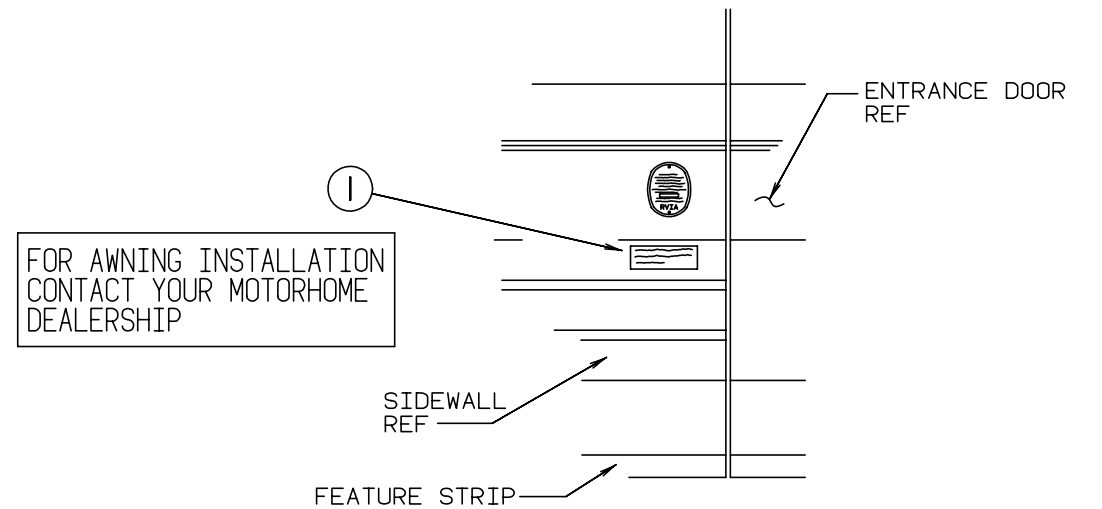

KEY	PART NUMBER	U/M DESCRIPTION
1	099509-01-000	EA LABEL-AWNING INSTALLATION

LABELS GROUP (CONTINUED)

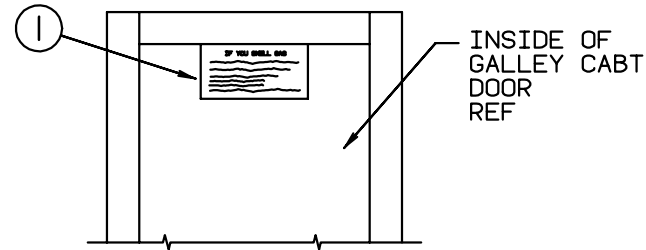

IF YOU SMELL GAS

1. EXTINGUISH ANY OPEN FLAME, PILOT LIGHTS AND ALL SMOKING MATERIALS.
2. SHUT OFF THE GAS SUPPLY AT THE TANK VALVE(OR GAS SUPPLY CONNECTION.
3. OPEN DOORS AND OTHER VENTILATING OPENINGS.
4. DO NOT TOUCH ELECTRICAL SWITCHES.
5. LEAVE THE AREA UNTIL ODOR CLEARS.
6. HAVE THE GAS SYSTEM CHECKED AND LEAKAGE SOURCE CORRECTED BEFORE USING AGAIN.

KEY	PART NUMBER	U/M DESCRIPTION
1	073998-01-000	EA LABEL-LPG ODOR WARNING

LABELS GROUP (CONTINUED)

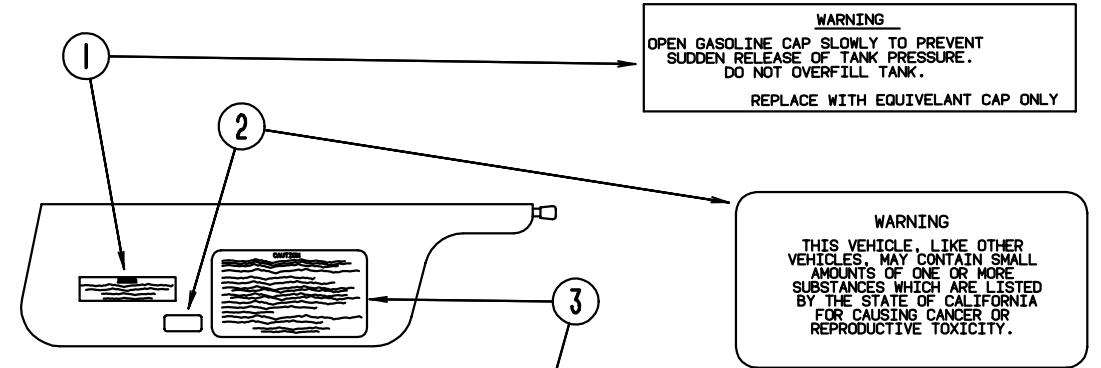

WARNING
 OPEN GASOLINE CAP SLOWLY TO PREVENT SUDDEN RELEASE OF TANK PRESSURE. DO NOT OVERFILL TANK.
 REPLACE WITH EQUIVELANT CAP ONLY

WARNING
 THIS VEHICLE, LIKE OTHER VEHICLES, MAY CONTAIN SMALL AMOUNTS OF ONE OR MORE SUBSTANCES WHICH ARE LISTED BY THE STATE OF CALIFORNIA FOR CAUSING CANCER OR REPRODUCTIVE TOXICITY.

CAUTION

THIS MOTOR HOME HAS BEEN DESIGNED, MANUFACTURED AND TESTED WITH CONCERN FOR THE PROTECTION OF IT'S OCCUPANTS. WE RECOMMEND YOU PERFORM THE FOLLOWING INSPECTIONS FOR YOUR SAFETY AND THE SAFETY OF YOUR PASSENGERS BEFORE STARTING YOUR VEHICLE.

1. LP GAS SYSTEM- TURN OFF AT TANK FOR TRAVELING. TEST FOR LEAKS UPON ARRIVAL AT DESTINATION. BEFORE LIGHTING PILOTS.
2. WHEELS- INSPECT FOR DAMAGE AND CHECK LUG NUTS FOR TIGHTNESS.
3. TIRES- INSPECT FOR WEAR AND DAMAGE AND CHECK FOR RECOMMENDED AIR PRESSURE.
4. LIGHTING- TEST FOR PROPER OPERATION OF ALL INTERIOR AND EXTERIOR LIGHTS INCLUDING DASH LIGHTS, HEADLIGHTS, TAIL LIGHTS, BRAKE LIGHTS, CLEARANCE LIGHTS AND TURN SIGNALS.
5. EXITS- INSPECT RELEASE MECHANISM ON EMERGENCY EXIT WINDOW, TEST BOTH LOCKS ON MAIN ENTRANCE DOOR FOR EASE OF OPERATION AND INSTRUCT PASSENGERS HOW TO USE BOTH MEANS OF EXIT.
6. SEAT BELTS- DIRECT PASSENGERS TO DESIGNATED SEATS AND REQUIRE USE OF SEAT BELTS.
7. APPLIANCES- TURN OFF AND LATCH OR LOCK DOORS WHERE PROVIDED.
8. LOOSE PARCELS- STORE SECURELY.
9. UTILITY SUPPLY LINES- DISCONNECT ALL ELECTRIC, SEWER AND WATER LINES AND SECURE PROPERLY.
10. ENTRANCE DOOR STEP- PLACE IN RETRACTED POSITION FOR TRAVELING.

READ YOUR MOTOR HOME AND CHASSIS OWNER'S MANUAL FOR FURTHER PRECAUTIONS

KEY	PART NUMBER	U/M DESCRIPTION
1	087207-05-000	EA LABEL-FUEL CAP REMOVAL
2	099689-01-000	EA LABEL-WARNING, CANCER/TOXICITY
3	056259-01-000	EA LABEL-SAFETY CHECK LIST

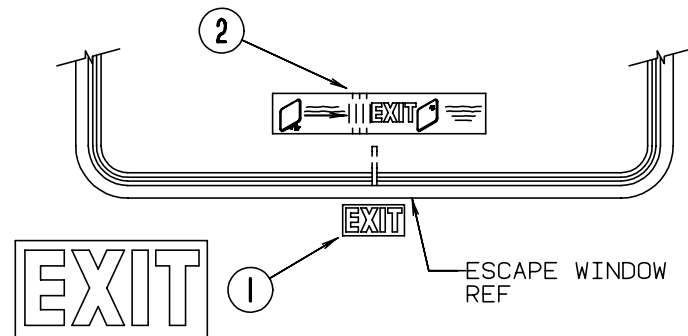
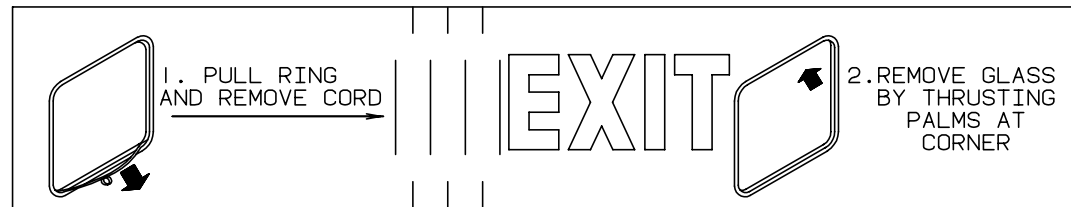

KEY	PART NUMBER	U/M DESCRIPTION
1	039290-01-000	EA LABEL-WARNING, EXIT
2	107571-01-000	EA LABEL-ESCAPE EXIT, WINDOW

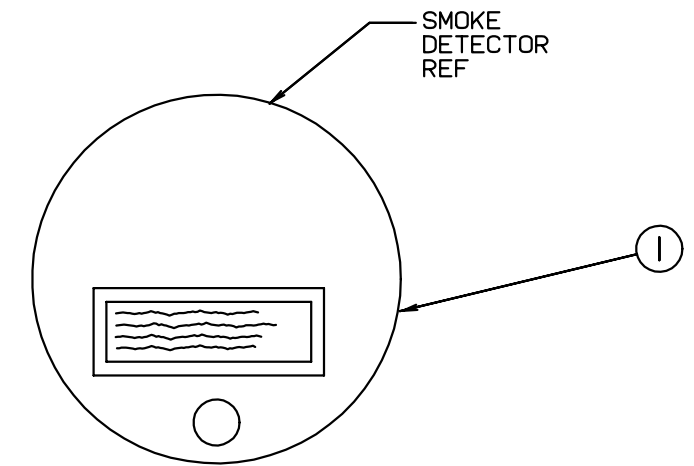

WARNING: TEST SMOKE DETECTOR OPERATION AFTER VEHICLE HAS BEEN IN STORAGE. BEFORE EACH TRIP AND AT LEAST ONCE PER WEEK DURING USE.

KEY	PART NUMBER	U/M DESCRIPTION
1	077956-01-000	EA LABEL-WARNING, SMOKE DETECTOR

LABELS GROUP (CONTINUED)

NOTE: TUNE ANTENNA PER MANUFACTURER'S DIRECTIONS. FAILURE TO COMPLY COULD RESULT IN DAMAGE TO CB.

CB POWER PROVISION
 RED +12 V
 BLACK GROUND
 COAX ANTENNA
 (SEE REVERSE ALSO)

KEY PART NUMBER U/M DESCRIPTION
 1 104678-01-000 EA LABEL-CB PREP

WARNING
 MUST BE STOWED
 IN LATCHED POSITION
 WHILE VEHICLE IS IN MOTION

KEY PART NUMBER U/M DESCRIPTION
 1 079966-01-000 EA LABEL-WARNING, STOWED, MOTION

DO NOT USE HITCH BEFORE
 READING OWNERS MANUAL REGARDING
 VEHICLE LOADING AND TOWING

KEY PART NUMBER U/M DESCRIPTION
 1 111104-01-000 EA LABEL-HITCH, READ MANUAL

WIRE IDENTITY :
 YELLOW - LEFT TURN LAMP
 GREEN - RIGHT TURN LAMP
 RED - BRAKE LAMP
 BROWN - RUNNING LAMP
 BLACK - BACKUP LAMP

KEY PART NUMBER U/M DESCRIPTION
 1 091224-02-000 EA LABEL-TRAILER LIGHTING

LABELS GROUP (CONTINUED)

WARNING DISCONNECT BATTERIES BEFORE
 CONNECTING EXTERNAL CHARGING EQUIPMENT.

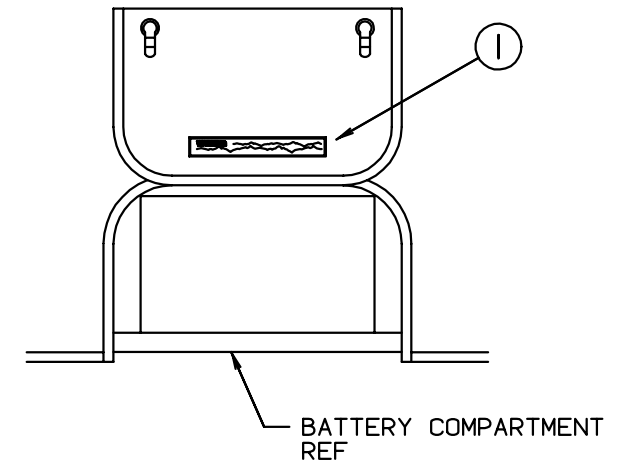

KEY PART NUMBER U/M DESCRIPTION
 1 065748-01-000 EA LABEL-CAUTION, BATTERY CHARGING

GENERATOR COMP
 DOOR REF

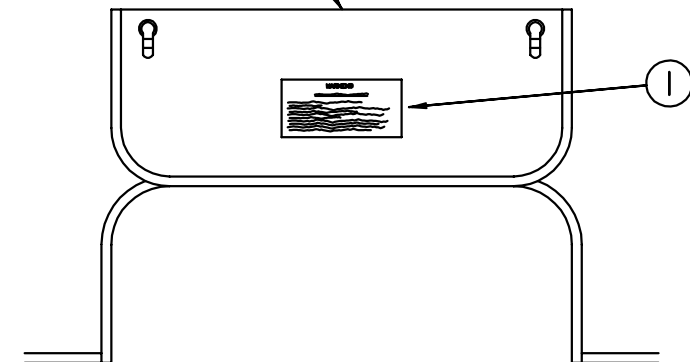

WARNING
 WHEN ADDING A GENERATOR SET:
 HIGH VOLTAGE-USE EXTREME CAUTION WHEN WORKING ON ELECTRICAL COMPONENTS.
 HAVE ALL ELECTRICAL INSTALLATION PERFORMED BY A QUALIFIED LICENSED ELECTRICIAN-FOLLOW ALL STATE AND LOCAL CODES.
 ONLY INSTALL GENERATOR SET APPROVED FOR R.V. APPLICATION. HAVE INSTALLED BY QUALIFIED TECHNICIAN.
 TO AVOID HEAT BUILD-UP AND TO GUARANTEE AN ADEQUATE AIR SUPPLY TO THE GENERATOR CARBURETOR, FOLLOW INSTALLATION INSTRUCTIONS.
 GENERATOR ENGINE EXHAUST GASES ARE TOXIC AND MUST NOT TERMINATE UNDER THE VEHICLE-DISCHARGE EXHAUST AWAY FROM VEHICLE.

KEY PART NUMBER U/M DESCRIPTION
 1 077510-01-000 EA LABEL-GENERATOR PREP

LABELS GROUP (CONTINUED)

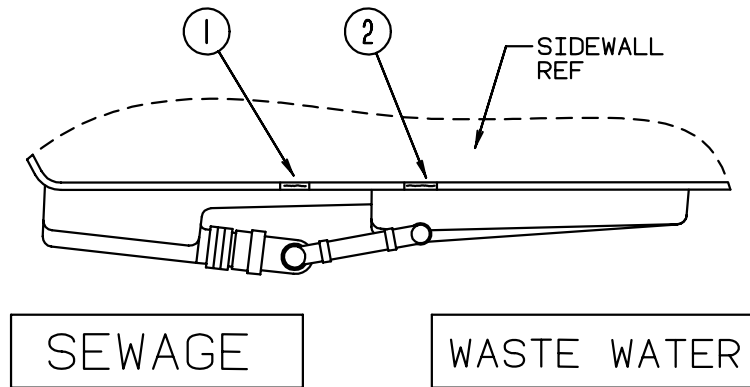

KEY	PART NUMBER	U/M	DESCRIPTION
1	006187-01-000	EA	LABEL-SEWAGE
2	006188-01-000	EA	LABEL-WASTE WATER

LABELS GROUP (CONTINUED)

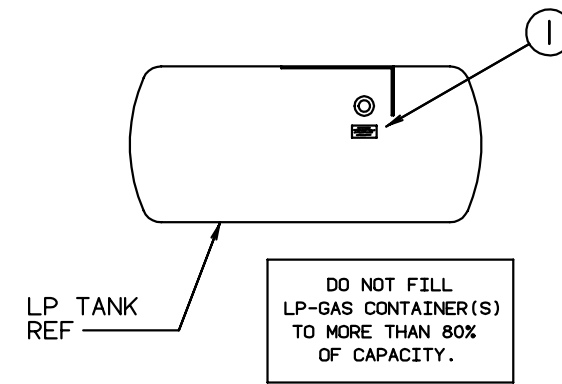

KEY	PART NUMBER	U/M	DESCRIPTION
1	079965-01-000	EA	LABEL-LPG, 80 LB CAPACITY

CAUTION	TO HELP AVOID PERSONAL INJURY DURING REMOVAL OF FUEL FILLER CAP, SLOWLY LOOSEN CAP 1/2 TURN TO ALLOW ANY FUEL PRESSURE TO BE RELIEVED BEFORE TURNING CAP FURTHER.
FUEL SPRAY MAY CAUSE PERSONAL INJURY	STOP ADDING FUEL AFTER FIRST SHUTOFF BY AUTOMATIC NOZZLE WHEN TANK IS NEARLY FULL. DO NOT OVERFILL FUEL TANK. SEE OWNERS MANUAL FOR ADDITIONAL INFORMATION.
	PRINTED IN U.S.A. MLC PT NO 15611763

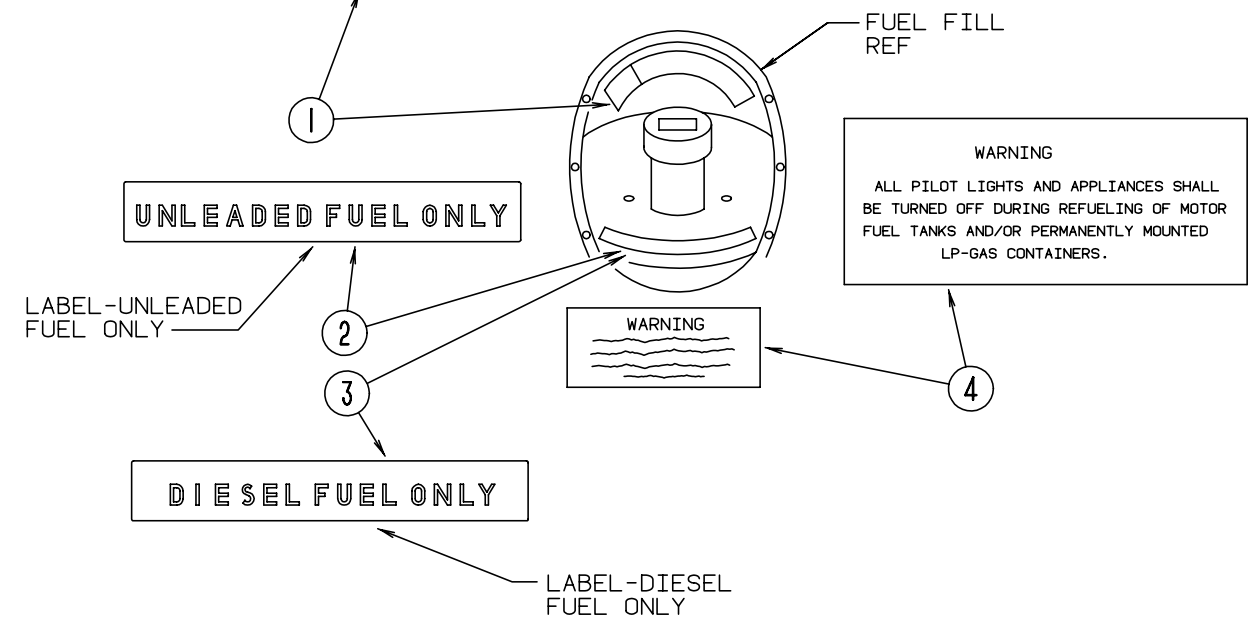

KEY	PART NUMBER	U/M	DESCRIPTION
1	087207-05-000	EA	LABEL-FUEL CAP REMOVAL
2	062043-01-000	EA	LABEL-FUEL, UNLEADED
3	068383-01-000	EA	LABEL-DIESEL FUEL
4	006040-01-000	EA	TAG-GAS REFUELING WARNING
4	006040-02-000	EA	TAG-GAS REFUEL WARNING, CANADIAN

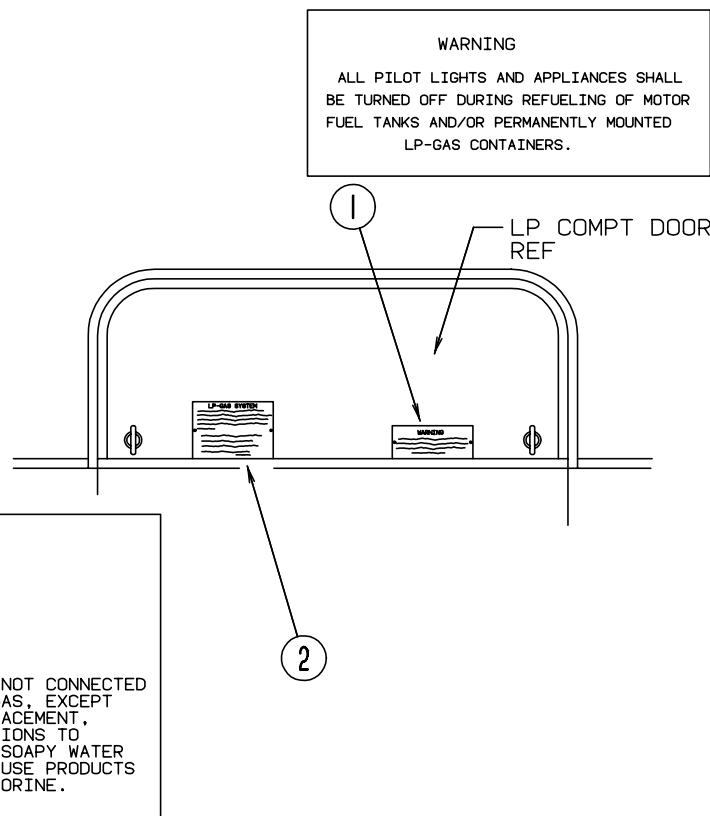

KEY	PART NUMBER	U/M	DESCRIPTION
1	006040-01-000	EA	TAG-GAS REFUELING WARNING
1	006040-02-000	EA	TAG-GAS REFUEL WARNING, CANADIAN
2	054531-01-000	EA	LABEL-LP GAS ONLY
2	023769-01-000	EA	LABEL-WARNING, LPG - CANADIAN

LABELS GROUP (CONTINUED)

AIR CONDITIONING CIRCUIT.
THIS CONNECTION IS FOR
AIR CONDITIONERS RATED 110-
125 VOLT AC, 60 HZ, 16
AMPERES MAXIMUM. DO NOT
EXCEED CIRCUIT RATING.



KEY	PART NUMBER	U/M DESCRIPTION
1	091243-01-000	EA LABEL-A/C COVER, "AIR CONDITIONING CIRCUIT. ETC."

ATTENTION

DEALER MUST INSTALL BATTERY AND
SENSOR IN CO DETECTOR WHEN THIS
MOTOR HOME IS PURCHASED. PARTS
ARE IN LOOSE PARTS BOX.

KEY	PART NUMBER	U/M DESCRIPTION
1	112518-01-000	EA LABEL-HANG TAG, CO DETECTOR

FROM: 00-00-00 THRU: 09-11-95

MISCELLANEOUS LABELS

KEY	PART NUMBER	U/M DESCRIPTION
	006064-01-000	EA LABEL-SEAT W/O SEATBELT "NOT INTENDED FOR USE WHILE COACH INMOTION"
	098379-04-000	EA LABEL-ELECTRICAL BOX, SIDE
	098641-01-000	EA LABEL-FUEL, UNLEADED - DASH
	111537-07-000	EA LABEL-FUSES
	111802-01-000	EA LABEL-CFC WARNING

LP GROUP

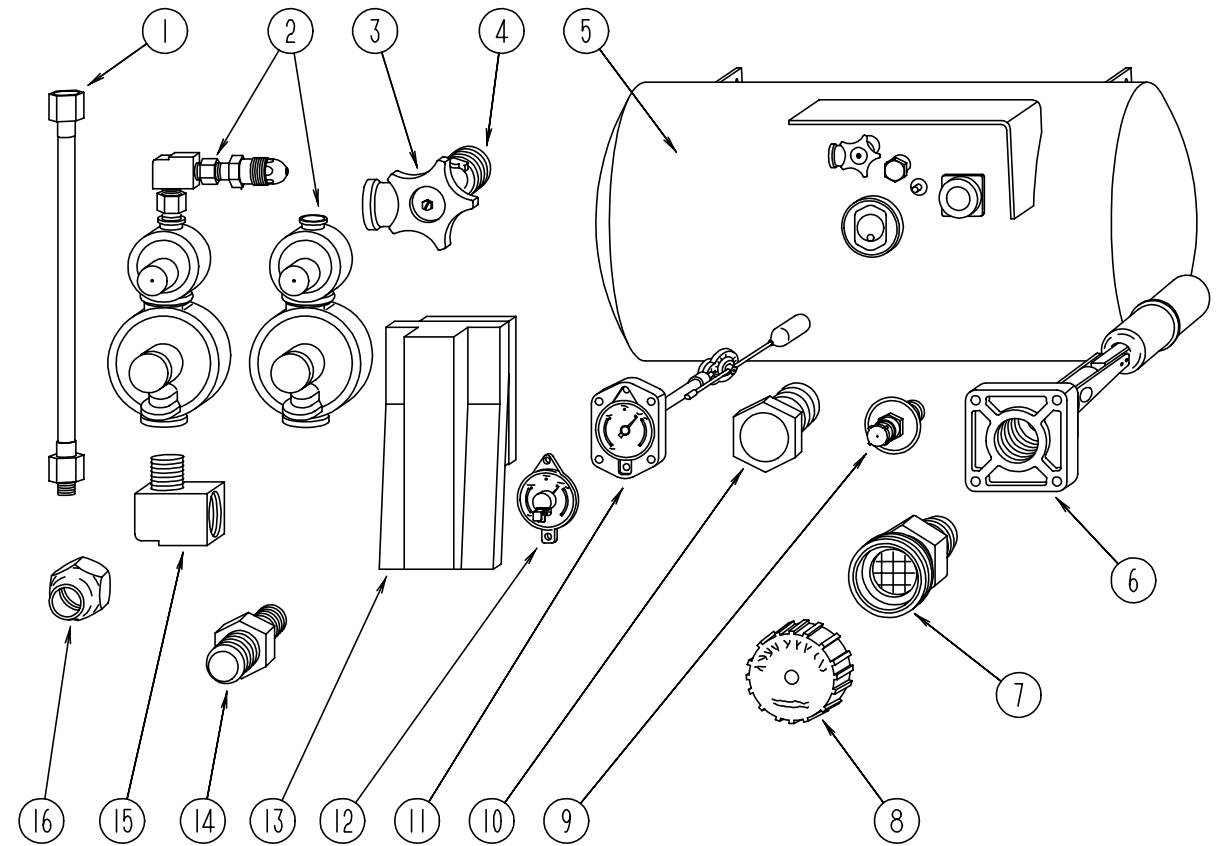

BRUNNER LP TANK & COMPONENTS

KEY	PART NUMBER	U/M DESCRIPTION	VENDOR NO.
1	045703-01-000	EA HOSE-LP, 3/8" ID X 24" - 3/8" MPT X 1/2" F SWIVEL - US	
1	045703-02-000	EA HOSE-LP, 3/8" ID X 24" - 3/8" MPT X 1/2" F SWIVEL - CANADIAN	
2	106150-01-000	EA REGULATOR-TWO STAGE	
2	106150-02-000	EA REGULATOR-TWO STAGE - EUROPEAN	
3	040421-01-708	EA HANDWHEEL-VAPOR RELIEF VALVE, BRUNNER	G-1015-A
4	040421-01-712	EA VALVE-SERVICE W/O VAPOR RELIEF	29000853
5	088253-03-000	EA TANK-LP, 100 LB - 16"D X 36" - SPL	
6	040421-01-711	EA VALVE - 80% W/FLOAT, PLATE, BOLTS & GASKET - BRUNNER	
7	040421-01-701	EA VALVE-SHORT LP FILLER W/YELLOW CAP - BRUNNER	75478
8	040421-01-702	EA CAP-LP FILLER VALVE, PLASTIC - YELLOW - BRUNNER	G-1014-A
9	040421-01-700	EA GAUGE-LIQUID LEVEL, 20% LP - BRUNNER	G-1013
10	040421-01-713	EA PRESSURE RELIEF VALVE	
11	088253-01-700	EA GAUGE-FLOAT W/VISIBLE DIAL - BRUNNER	16C
12	040440-02-000	EA TRANSMITTER-DIAL, 90 OHM	
13	105658-01-000	EA COMPARTMENT-LP REGULATOR	
14	010323-01-000	EA ADAPTER-BRASS, 3/8" F X 1/2" MPT	
15	065318-02-000	EA ELBOW - 90 DEGREE, 3/8" MPT TO 3/8" FPT	
16	010377-02-000	EA NUT-BRASS, 3/8 FEMALE - FORGED	
	008042-01-000	FT TUBING-VINYL, .65" ID	
	071391-02-000	EA NIPPLE-HEX, 1/4 PIPE - 3325X4 WEATHERHEAD	
	103613-01-000	EA DETECTOR-LP GAS	

**LOUNGE GROUP
DRIVERS SIDE COUCH**

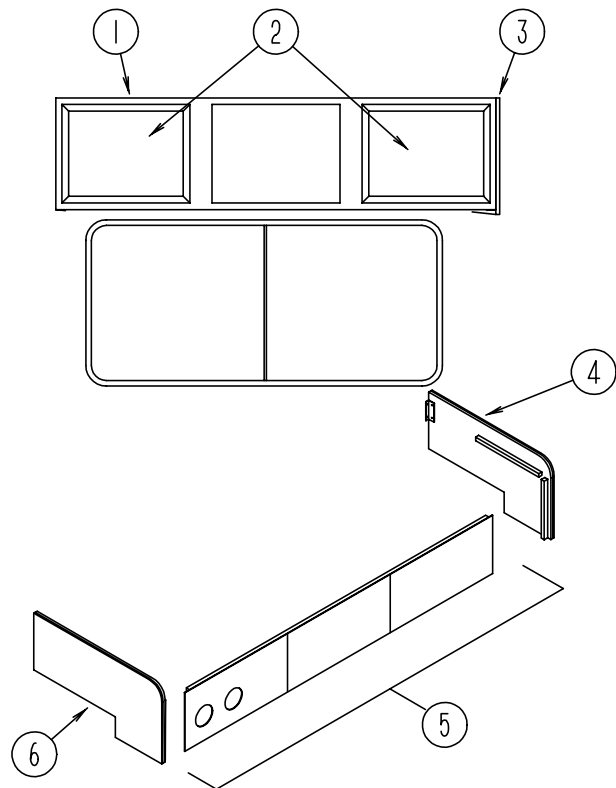

KEY	PART NUMBER	U/M	DESCRIPTION
1	103275-01-G09	EA	CABINET-OVERHEAD, W/O DOORS
2	M06803-03-G09	EA	DOOR-W/O HARDWARE W/MIRROR - 400 MM X 520 MM
2	M06803-41-G09	EA	DOOR-W/O HARDWARE W/O MIRROR - 400 MM X 520 MM DECORATOR DOOR OPTION - FLAT PANEL
3	103128-01-G09	EA	CAP-END, OVERHEAD CABINET - FRONT
4	M04187-44-G29	EA	PANEL-COUCH CABINET - LEFT SIDE - FABRIC COVERED (G29)
4	M04187-44-G30	EA	PANEL-COUCH CABINET - LEFT SIDE - FABRIC COVERED (G30)
4	M04187-44-F25	EA	PANEL-COUCH CABINET - LEFT SIDE - FABRIC COVERED (G31)
4	M04187-44-F27	EA	PANEL-COUCH CABINET - LEFT SIDE - FABRIC COVERED (G32)
5	M04187-47-G29	EA	PANEL-COUCH CABINET - FRONT - W/DOOR - FABRIC COVERED (G29)
5	M04187-47-G30	EA	PANEL-COUCH CABINET - FRONT - W/DOOR - FABRIC COVERED (G30)
5	M04187-47-G31	EA	PANEL-COUCH CABINET - FRONT - W/DOOR - FABRIC COVERED (G31)
5	M04187-47-G12	EA	PANEL-COUCH CABINET - FRONT - W/DOOR - FABRIC COVERED (G32)
6	M04187-43-G29	EA	PANEL-COUCH CABINET - RIGHT SIDE - W/FABRIC (G29)
6	M04187-43-G30	EA	PANEL-COUCH CABINET - RIGHT SIDE - W/FABRIC (G30)
6	M04187-43-F25	EA	PANEL-COUCH CABINET - RIGHT SIDE - W/FABRIC (G31)
6	M04187-43-F27	EA	PANEL-COUCH CABINET - RIGHT SIDE - W/FABRIC (G32)
	105947-01-000	EA	BRACKET-HOLD DOWN, COUCH - CANADIAN
	082525-01-000	EA	BRACE-COUCH, FLOOR MOUNT - ANGLE 3" LONG - METAL
	083125-07-000	EA	BRACE-ANGLE, COUCH - 2.5" - OFF WHITE

LOUNGE GROUP (CONTINUED)

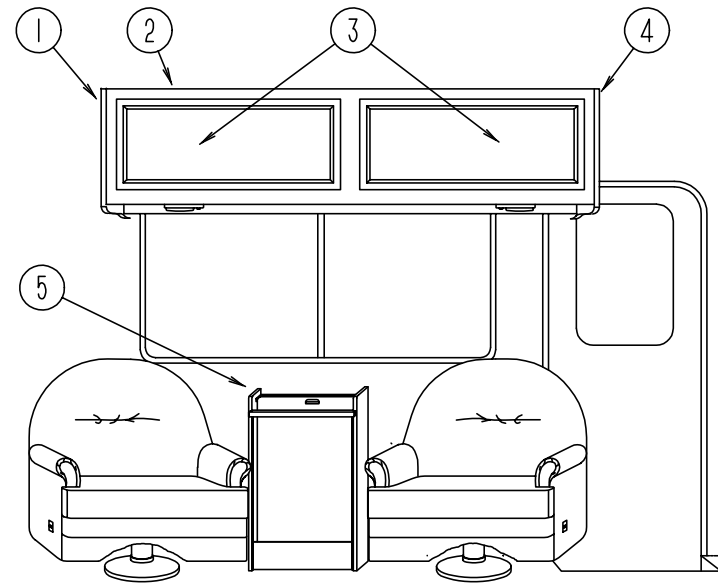

PASSENGER SIDE SWIVEL CHAIRS & TABLE

KEY	PART NUMBER	U/M	DESCRIPTION
1	103128-02-G09	EA	CAP-END, OVERHEAD CABINET
2	106483-01-G09	EA	CABINET-OVERHEAD, W/O DOORS
3	M06803-02-G09	EA	DOOR-W/O HARDWARE W/O MIRROR - 400 MM X 710 MM
4	103128-01-G09	EA	CAP-END, OVERHEAD CABINET
5	M96873-01-G01	EA	CABINET ASSEMBLY-TABLE, W/O PULLOUT TOP
	104006-01-C05	EA	LID-ENTRANCE STEP COMPARTMENT, W/O CARPET OR HARDWARE
	101222-01-02A	EA	BRACKET-CATCH, LID - 60 MM X 36.7 MM - STEEL - OFF WHITE
	107941-01-02A	EA	SUPPORT-LID, ENTRANCE STEP - 645 MM X 378 MM - STEEL - OFF WHITE
	116975-01-01A	EA	LATCH ASM-UNDERCENTER, BLACK - SOUTHCO 91-522-69

LOUNGE GROUP (CONTINUED)

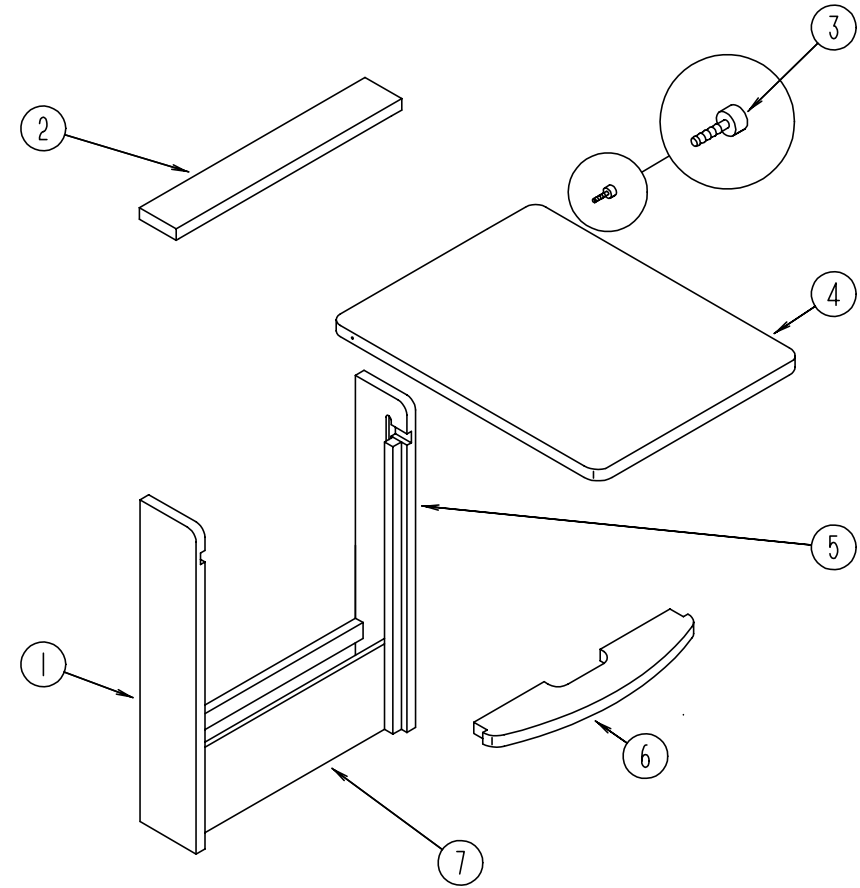

PULLOUT TABLE

KEY	PART NUMBER	U/M	DESCRIPTION
	M96873-01-G01	EA	CABINET ASM-PULLOUT TABLE W/O PULLOUT TOP
1	096873-14-G01	EA	SIDE END-TABLE, 28.7" X 5.7" - LEFT SIDE
2	096873-15-G01	EA	SHELF-SUPPORT, OVER PULL OUT TABLE TOP
3	079921-01-000	EA	NYLON ROLLER W/SHAFT
4	096873-11-G01	EA	TOP-PULLOUT
5	096873-13-G01	EA	SIDE END-TABLE, 28.7" X 5.7" - RIGHT SIDE
6	096873-12-G01	EA	SHELF-SUPPORT, UNDER PULL OUT TABLE TOP
7	096873-16-G01	EA	PANEL-TABLE, FRONT BOTTOM - 18.1" X 6.7"
	080736-01-000	EA	PULL-RECESSED, 1.25" X 4" - OAK

**SEALANTS & FASTENERS GROUP
ADHESIVE**

KEY	PART NUMBER	U/M DESCRIPTION
	004020-01-000	QT ADHESIVE-ABS CEMENT, QUART
	081377-01-700	EA ADHESIVE-CYANOACRYLATE, 10 GRAM TUBE
	087211-01-000	GL ADHESIVE-PROMOTER
	004006-05-700	EA ADHESIVE - 5 GALLON - NATURAL STARCH
	062917-03-000	EA ADHESIVE-LOCTITE 242
	067788-01-000	EA ADHESIVE-SPRAY, 19.5 OZ AEROSOL CAN 3M 74

CLAMPS, GROMMETS AND MISCELLANEOUS FASTENERS

KEY	PART NUMBER	U/M DESCRIPTION
	000H16-04-06R	EA RIVET-POP, 1/8 X .313 - .375 - AL
	000H16-06-10R	EA RIVET-POP, 3/16 X .501 - .625 - AL
	007161-01-000	EA CLAMP-HOSE, SPRING TYPE - 1/2"
	010495-01-000	EA CLAMP-CABLE, 9/16"
	010497-01-000	EA CLAMP-CLOSED, 5/8" ID
	010497-03-000	EA CLAMP-CLOSED, 1" ID - CUSHIONED
	010497-04-000	EA CLAMP-CLOSED, 1.62" ID
	010499-01-000	EA CLAMP-CLOSED, 3/8" ID
	062401-01-000	EA CLAMP-HOSE, WORMGEAR .25" - 1"
	062401-02-000	EA CLAMP-HOSE, WORMGEAR 1.56" - 2.5"
	062401-03-000	EA CLAMP-HOSE, WORMGEAR .22" - 1"
	062401-04-000	EA CLAMP-HOSE, WORMGEAR .69" - 1.25"
	062401-06-000	EA CLAMP-HOSE, WORMGEAR .22" - .62"
	062401-11-000	EA CLAMP-HOSE, WORMGEAR 3.56" - 4.5"
	075148-02-000	EA CLAMP-GROUNDING, BRONZE SCREWS
	080734-02-000	EA CLIP-WIRE, NYLON
	083609-01-000	EA CLAMP-WIRE, DUAL EQUAL - 5/8" DIAMETER
	083610-01-000	EA CLAMP-WIRE, DUAL - UNEQUAL DIAMETERS - .75" & 1.25"
	083610-02-000	EA CLAMP-WIRE, DUAL - UNEQUAL DIAMETERS
	008380-01-000	EA GROMMET-RUBBER, 5/8" HOLE X 1 1/2" DIAMETER - BLACK
	016188-03-000	EA GROMMET-L/P LINE, 3/8" HOLE X 2 1/2" LONG - RUBBER
	016188-05-000	EA GROMMET-L/P LINE, 3/8" HOLE X 1 1/4" LONG - RUBBER
	023942-01-000	EA GROMMET-RUBBER, 2" OD
	114208-02-000	EA GROMMET-EDGE LINER, FITS .625 - HEYCO 2073
	088787-12-000	EA STUD-WELD, 1/4-20 X 1.0 LG MN - ARDEN MN-1420-S-100
	057671-01-000	EA COVER - SCREW - #8 - PLASTIC - OFF WHITE
	102540-01-000	EA SEAL-SCREW, ROUND - RUBBER
	102540-03-000	EA SEAL-SCREW, EPDM - 80 DUR - GRUMEN
		FROM: 02-12-96 THRU: 99-99-99
	108067-03-000	EA STUD-WELD, 1/4-20X1/2 CD - IMAGE
	049176-01-000	EA HEDLOCK II - 3/4 DIAMETER, SCREW MOUNT
	056134-02-000	EA HOLDER-RING, 1.8" DIAMETER - METAL
	086285-01-000	EA SPACER-NYLON, .5" OD X .257" ID
	077955-01-000	EA J CLIP-VINYL COATED, 3/8" USED IN WIRING TO CLEARANCE LIGHTS
	081211-05-000	EA PLUG-PLASTIC, .188 DIA - NATURAL
	029094-04-000	YD VELCRO TAPE-LOOP, 1" WIDE - BLACK
	029096-03-000	YD VELCRO TAPE-HOOK, 1" WIDE - BLACK
	085774-01-000	FT FASTENER-DUAL HOOK, 1" WIDE - ADHESIVE BACK - BLACK
	085774-02-000	FT FASTENER-DUAL LOOP, 1" WIDE - ADHESIVE BACK - BLACK
	008343-01-000	EA TIE-WIRE, 6"
	008343-02-000	EA TIE-WIRE, 14"
	108046-02-000	EA CABLE-TIE, SCREW MOUNT - 15"
	080211-03-000	EA CLIP-MOUNTING, XMAS TREE - DECORATIVE PADS
	091952-02-000	EA CLIP-GRIPPER, 3/4"
	094362-02-000	EA CLIP-XMAS TREE, FLAT HEAD

**SEALANTS & FASTENERS GROUP (CONTINUED)
BOLTS**

KEY	PART NUMBER	U/M DESCRIPTION
	000C12-05-12B	EA BOLT-HEX, 5/16-18 X 3/4 - ZINC 5
	000C12-05-16B	EA BOLT-HEX, 5/16-18 X 1 - ZINC 5
	000C12-06-16B	EA BOLT-HEX, 3/8-16 X 1 LG - ZINC 5
	000C12-07-20B	EA BOLT-HEX, 7/16 - 14 X 1 1/4" - ZINC 5
	000C12-08-24B	EA BOLT-HEX, 1/2-13 X 1 1/2 - ZINC 5
	000C12-09-20B	EA BOLT-HEX, 9/16-12 X1 1/4 - ZINC 5
	000C12-10-24B	EA BOLT-HEX, 5/8-11 X 1 1/2 - ZINC 5
	000C13-07-48B	EA BOLT-HEX, 7/16 - 20 X 3 - ZINC 5
	000C18-05-40A	EA BOLT-ELEVATOR, 5/16"-18 X 2 1/2" - PL
	000C26-04-10B	EA BOLT-HEX, SER FLG - 1/4-20 X 5/8 - ZINC
	000C26-04-14B	EA BOLT-HEX, SER FLG - 1/4-20 X 7/8 - ZINC
	000C26-04-18B	EA BOLT-HEX, SER FLG - 1/4-20 X 1 1/8 - ZINC
	000C26-05-12B	EA BOLT-HEX, SER FLG - 5/16-18 X 3/4 - ZINC
	000C26-05-16B	EA BOLT-HEX, SER FLG - 5/16-18 X 1 - ZINC
	000C26-06-12B	EA BOLT-HEX, SER FLG - 3/8-16 X 3/4 - ZINC
	000C26-06-28B	EA BOLT-HEX, SER FLG - 3/8-16 X 1 3/4 - ZINC
	000C27-10-32B	EA BOLT-CARRIAGE, 5/8-11 X 2.00
	000G45-05-16B	EA BOLT-LAG, 5/16 - 9 X 1 - ZINC
	051387-06-000	EA BOLT-CARRIAGE, W/O HOLE - 5/16-18 X 9.5 - ZINC
	102333-01-06A	EA BOLT-CARRIAGE, 7/16 - 14 SST CAP - BRIGHT WHITE BUMPER BOLT
	106166-01-000	EA BOLT-COLLARED HANGER, 8-32 X 1"

WASHERS

KEY	PART NUMBER	U/M DESCRIPTION
	000E11-07-00B	EA WASHER-LK, 7/16" MED SPLIT - ZINC
	000E11-08-00B	EA WASHER-LK, 1/2" MED SPLIT - ZINC
	000E13-14-00B	EA WASHER-FL, 1/4" WIDE - ZINC
	000E13-18-00B	EA WASHER-FL, 3/8" WIDE - ZINC
	000E13-20-00B	EA WASHER-FL, 7/16" WIDE - ZINC
	000E13-21-00B	EA WASHER-FL, W/2 NAR - ZINC
	000E14-10-00B	EA WASHER-LK, NO 10 EXT TOOTH - ZINC
	044533-01-000	EA WASHER-PLASTIC, 1 3/8" OD - FOR BUTTONS
	058716-02-000	EA WASHER-FLAT, NYLON - .406 X .750 X .060
	077071-01-000	EA WASHER-FENDER, 3/16" ID X 1" OD
	106649-01-000	EA WASHER-SEALING, 5/8" ID - GALVANIZED
	110794-01-000	EA WASHER-FL, 1" ID X 1 3/4" OD - C-TECH 36T1043187

NUTS

KEY	PART NUMBER	U/M DESCRIPTION
	000D24-10-00B	EA NUT-HEX, SF/LK - 10-32 - ZINC
	000D29-05-00B	EA NUT-HEX, SELFLOCK - 5/16 - 18 - UNC
	000D29-09-00B	EA NUT-HEX, SELFLOCK - 9/16 - 12 - ZINC
	000D34-06-00B	EA NUT-HEX, LK - 3/8 - 16 GRADE C - ZINC - PREVAILING TORQUE
	000D39-04-00B	EA NUT-HEX, SER FLG LK - 1/4-20 - ZINC
	000D39-05-00B	EA NUT-HEX, SER FLG LK - 5/16-18 - ZINC
	000D39-06-00B	EA NUT-HEX, SER FLG LK - 3/8-16 - ZINC
	000D39-07-00B	EA NUT-HEX, SER FLG LK - 7/16-14 - ZINC
	000D39-08-00B	EA NUT-HEX, SER FLG LK - 1/2-13 - ZINC
	000D44-07-00B	EA NUT-HEX, SER FLG LK - 7/16-20 - ZINC
	000D46-04-00A	EA NUT-HEX, WELD - 1/4-20 - PLAIN - SHORT PILOT
	044364-02-000	EA NUT-SPEED, FLAT - ROUND
	063253-07-000	EA NUT-J, #8A - .120-.130 PANEL THICKNESS
	104369-01-000	EA NUT-HEX, HEAVY - 5/8-11 UNC
	040921-01-000	EA NUT-SPEED-U TYPE 10-24 - BLACK
	040921-03-000	EA NUT-SPEED, U TYPE - NO 10
	040921-04-000	EA NUT-SPEED, U TYPE - NO 8 - .59" LENGTH X .44" WIDTH
	040921-09-000	EA NUT-SPEED, U TYPE - NO 8 - TINNEMAN C9812-8A
	083163-06-000	EA PUSHNUT-FLAT TYPE 3/8 STUD - FORD ONLY TO RETAIN THE AIR BAFFLE ON THE OIL DIPSTICK TUBE
	087234-01-000	EA NUT-JACK, 1/4 X 20 THD, MOLLY - BRASS - ARDEN 8-L,JN MOUNTS LICENSE PLATES

SEALANTS & FASTENERS GROUP (CONTINUED)

SCREWS

KEY	PART NUMBER	U/M DESCRIPTION
	000G11-05-08B	EA SCREW, 5-20 X 1/2 PPH - ZINC
	000G11-06-08B	EA SCREW, 6-20 X 1/2 PPH - ZINC
	000G11-06-10J	EA SCREW, 6-20 X 5/8 PPH - BRASS
	000G11-06-10B	EA SCREW, 6-20 X 5/8 PPH - ZINC
	000G11-07-08B	EA SCREW, 7-19 X 1/2 PPH - ZINC
	000G11-08-06B	EA SCREW, 8-18 X 3/8 PPH - ZINC
	000G11-08-08B	EA SCREW, 8-18 X 1/2 PPH - ZINC
	000G11-08-12S	EA SCREW, 8-18 X 3/4 PPH - OFF WHITE
	000G11-08-12P	EA SCREW, 8-18 X 3/4 PPH - DARK BROWN
	000G11-08-12D	EA SCREW, 8-18 X 3/4 PPH - BLACK PHOS
	000G11-08-12B	EA SCREW, 8-18 X 3/4 PPH - ZINC
	000G11-08-12T	EA SCREW, 8-18 X .75 PPH - BLACK
	000G11-08-16S	EA SCREW, 8-18 X 1.00 PPH - OFF WHITE
	000G11-08-20B	EA SCREW, 8-18 X 1 1/4 PPH - ZINC
	000G11-10-12S	EA SCREW, 10-16 X .75 PPH - OFF WHITE
	000G11-10-12D	EA SCREW, 10-16 X 3/4 PPH - BLACK
	000G11-10-40B	EA SCREW, 10-16 X 2 1/2 PPH CAD - 34927-01-000
	000G11-10-16B	EA SCREW, 10-16 X 1 - PPH - ZINC
	000G12-06-08T	EA SCREW, 6-20 X .50 POH - BLACK
	000G12-08-16S	EA SCREW, 8-18 X 1.00 POH - OFF WHITE
	000G13-06-08B	EA SCREW, 6-20 X .50 PFH - ZINC
	000G13-06-08G	EA SCREW, 6-20 X 1/2 PFH - ANTIQUE BRASS
	000G13-06-10G	EA SCREW, 6-20 X 5/8 PFH - ANTIQUE BRASS
	000G13-06-16J	EA SCREW, 6-20 X 1.00 PFH - BRASS
	000G13-07-12B	EA SCREW, 7-19 X .75 PFH - ZINC
	000G13-08-10B	EA SCREW, 8-18 X 5/8 PFH - ZINC
	000G18-08-22B	EA SCREW-MACHINE, 8-32 X 1 3/8 PPH - ZINC
	000G19-10-20B	EA SCREW-MACHINE, 10-32 X 1 1/14 PPH - ZINC
	000G19-10-08B	EA SCREW-MACHINE, 10-32 X 1/2 PPH - ZINC
	000G19-10-12F	EA SCREW-MACHINE, 10-32 X .75 PPH - SST
	000G32-10-06B	EA SCREW, 10-32 X 3/8" - PPH - ZINC
	000G39-06-10T	EA SCREW-SF/DR, 6-20 X 5/8 PPH - BLACK
	000G39-06-16T	EA SCREW-SF/DR, 6-20 X 1.00 PPH - BLACK
	000G39-08-08B	EA SCREW-SF/DR, 8-18 X 1/2 PPH - ZINC
	000G39-08-06B	EA SCREW-SF/DR, 8-18 X 3/8 PPH - ZINC
	000G39-08-08S	EA SCREW-SF/DR, 8-18 X 1/2 PPH - OFF WHITE
	000G39-08-12B	EA SCREW-SF/DR, 8-18 X 3/4 PPH - ZINC
	000G39-08-12T	EA SCREW-SF/DR, 8-18 X 3/4 PPH - BLACK
	000G39-08-16B	EA SCREW-SF/DR, 8-18 X 1 PPH - ZINC
	000G39-08-16T	EA SCREW-SF/DR, 8-18 X 1 PPH - BLACK
	000G39-08-32B	EA SCREW-SF/DR, 8-18 X 2 PPH - ZINC
	000G39-10-08B	EA SCREW-SF/DR, 10-16 X .50 PPH - ZINC
	000G39-10-12B	EA SCREW-SF/DR, 10-16 X .75 PPH - ZINC
	000G39-10-12D	EA SCREW-SF/DR, 10-16 X 3/4 PPH - BLACK
	000G39-10-129	EA SCREW-SF/DR, 10-16 X 3/4 PPH - FLUOROCARBON SILVER
	000G39-10-20B	EA SCREW-SF/DR, 10-16 X 1 1/4 PPH - ZINC
	000G39-10-209	EA SCREW-SF/DR, 10-16 X 1.25 PPH - FLUOROCARBON SILVER
	000G39-10-48B	EA SCREW-SF/DR, 10-16 X 3.00 PPH - ZINC
	000G42-04-12B	EA SCREW-SF/DR, 1/4-14 X 3/4 HWH - ZINC
	000G43-06-24B	EA SCREW-MACHINE, 8-32 X 1.50 PFH - BLACK
	000G46-08-24T	EA SCREW-MACHINE, 8-32 X 1.50 PFH - BLACK
	000G50-04-08B	EA SCREW-MACHINE, 1/4-20 X 1/2 PTH - ZINC
	000G50-04-12B	EA SCREW-MACHINE, 1/4-20 X 3/4 PPH - ZINC
	000G52-08-18B	EA SCREW-MACHINE, 8-32 X 11/8 PTH - ZINC
	000G54-04-20B	EA SCREW, 1/4-20 X 1 1/4 PTH - TYPE 23 - ZINC PLATED
	000G55-08-12S	EA SCREW-SF/DR, 8-18 X .75 PWH - OFF WHITE
	000G55-08-16S	EA SCREW-SF/DR, 8-18 X 1.00 PWH - OFF WHITE
	000G56-12-48B	EA SCREW-WOOD, 12-11 X 3 POH - SPECIAL HARDENED
	000G60-10-20B	EA SCREW-SF/DR, 10-16 X 1.25 POH - ZINC
	000G60-10-28T	EA SCREW-SF/DR, 10-16 X 1.75 - BLACK
	000G67-10-08B	EA SCREW, 10-12 X 1/2 PPH - ZINC
	000G67-10-08R	EA SCREW, 10-12 X 1/2 PPH - BEIGE - TYPE A
	000G67-10-36T	EA SCREW, 10-12 X 2.25 PPH - BLACK - STALGAURD
	000G67-10-24B	EA SCREW, 10-12 X 1 1/2 PPH - ZINC

SEALANTS & FASTENERS GROUP (CONTINUED)

SCREWS (CONTINUED)

KEY	PART NUMBER	U/M DESCRIPTION
	000G67-10-20D	EA SCREW, 10-12 X 1 1/4 PPH - BLACK
	000G67-10-120	EA SCREW, 10-12 X .75" PPH - TAN
	000G67-10-12B	EA SCREW, 10-12 X 3/4" PPH - ZINC
	000G67-10-10D	EA SCREW, 10-12 X 5/8 PPH - BLACK - TYPE A
	000G67-10-10B	EA SCREW, 10-12 X 5/8 PPH - ZINC - TYPE A
	000G67-10-08R	EA SCREW, 10-12 X 1/2 PPH - BEIGE - TYPE A
	000G68-06-10G	EA SCREW, 6-18 X 5/8 POH - ANTIQUE BRASS
	0G3908-08-170	EA SCREW-SF/DR, 8-18 X .50 PPH - BRIGHT WHITE
	0G6008-16-170	EA SCREW-SF/DR, 8-18 X 1.00 POH - BRIGHT WHITE
	049465-03-000	EA SCREW, 10-16 X 1 POH W/WASHER - OFF WHITE
	049465-04-000	EA SCREW, 10-16 X 1 PTH W/WASHER - BEIGE
	049465-17-000	EA SCREW, 10-16 X 1 POH W/WASHER - BRIGHT WHITE
	054434-02-000	EA SCREW-SF/DR, 10-16 X 2 - ZN - TORQ'S #25 HEAD
	075908-01-000	EA SCREW-MACHINE, 10-32 X .56 PTH - ZINC - EXTERNAL TOOTH
	076790-01-000	EA SCREW, 6-20 X 1 1/4 PPH - BLACK
	086256-01-000	EA SCREW-SF/DR, 8 X .75 HWH LG
	097974-01-000	EA SCREW-PARTICLE BOARD, 7-9 X .75 PPH
	101618-01-000	EA SCREW, 1/4-20 X 3/4 HEX/TAPPING - STALGARD TYPE F

SEALERS

KEY	PART NUMBER	U/M DESCRIPTION
	069640-01-000	FT SEALER-RIBBON - 1/4" DIAMETER - INCREMENTS OF 30'
	069640-03-000	FT SEALER-RIBBON, 3/4" X 1/8" - INCREMENTS OF 60'
	069640-09-000	FT SEALER-RIBBON, 1/32" X 2 1/2" - INCREMENTS OF 80'
	069640-11-000	FT SEALER-TAPE, 3/16" X 3/8", BLACK - INCREMENTS OF 40'
	069640-13-000	FT SEALER-TAPE, 3/32" X 2" - BLACK
	069640-14-000	FT SEALER-TAPE, 1/16" X 1" - GRAY - INCREMENTS OF 60'
	063642-01-000	FT TAPE-ADHESIVE - 10 MIL. X 1.5" WIDE X 180"
	091255-01-000	FT SEAL-FOAM, 3.2 MM X 4.8 MM
	090340-01-000	FT SEAL-FOAM, CLOSED CELL - 1/4" X 1/2" X 50'
	100128-02-000	FT SEAL-FOAM, ADHESIVE BACK - .37" W X .37" THICK
	108353-03-000	FT SEAL-FOAM, 4.76 MM X 6.35 MM - LUNDELL
	900390-01-000	EA TIP - 2 1/2" X 1/8" ORIFICE, ELLSWORTH TS216
	900390-03-000	EA NOZZLES-SILICONE TUBE, CSL D10
	034552-02-000	EA SILICONE-TUBE, 300 ML - CLEAR - W/O NOZZLE
	034552-15-000	EA SILICONE-TUBE, 300 ML - BRIGHT WHITE - W/O NOZZLE
	039518-01-000	EA SILICONE-TUBE, 300 ML - BLACK - W/O NOZZLE
	053766-02-000	EA BEDDING COMPOUND-TUBE, WHITE - SCHNEE 5522
	053766-06-000	EA BEDDING COMPOUND-TUBE, CLEAR
	053766-08-000	EA BEDDING COMPOUND-TUBE, GRAY - SCHNEE 5522
	072889-01-000	EA SEALANT-URETHANE, BLACK - 1/10 - ESSEX 552.2
	072889-09-000	EA SEALANT-URETHANE, TUBE - BLACK - MANUS 75AM
	072889-10-000	EA SEALANT-URETHANE(HV) - BRIGHT WHITE - MANUS 75AM
		FROM: 05-06-96 THRU: 99-99-99
	072889-12-000	EA SEALANT-URETHANE(LV) - BRIGHT WHITE - MANUS 75AM
		FROM: 05-06-96 THRU: 99-99-99
	102352-01-000	EA SEALER-PUMPABLE, BLACK - COLORIMETRIC MS101
	106206-01-000	EA SEALER-PUMPABLE, BLACK - MANUS 30A
	108716-01-000	EA SILICONE-TUBE, OFF WHITE - SELF LEVELING - CSL 510

TAPES

KEY	PART NUMBER	U/M DESCRIPTION
	076314-02-000	FT TAPE-CARPET SEAM, HEAT-BOND - 4" WIDE
	076322-01-000	FT TAPE-FOAM, DOUBLE COATED ADHESIVE BACKED - .75" X 216'
	076322-02-000	FT TAPE-FOAM, DOUBLE COATED ADHESIVE BACKED - 1" X 108'
	076322-05-000	FT TAPE-FOAM, DOUBLE COATED - .025" X 1.5" X 108'
	076322-07-000	FT TAPE-FOAM, DOUBLE COATED - .045" X .50" X 200' - NORTON V2000
	110274-01-000	FT TAPE-FOAM, DOUBLE COATED - .045" X 1.00" - NORTON V-2800
	002707-02-000	FT TAPE-SEALER, 5/16" X 1/2" - INCREMENTS OF 50 FT
	118085-02-01A	FT TAPE-FOIL, 1" X 150' - INNOV. ENERGY

WATER & SEWAGE GROUP

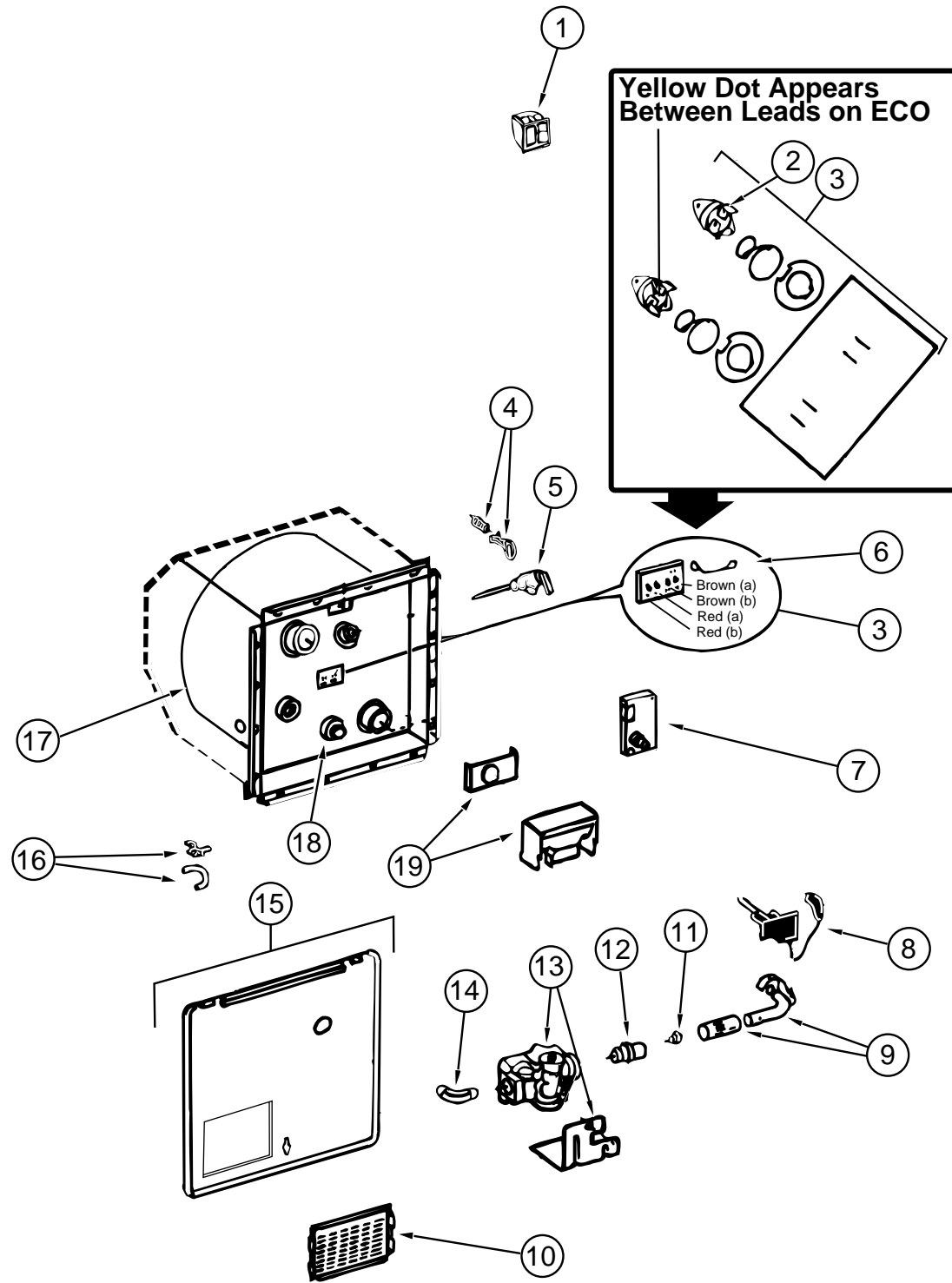

KEY	PART NUMBER	U/M DESCRIPTION	VENDOR NO.
	051393-01-000	EA WATER HEATER-W/MOTOR AID, PILOTLESS IGNITION - ATWOOD GH6-7E	
1	051393-01-701	EA SWITCH PACKAGE - ATWOOD	91959
2	051391-04-701	EA THERMOSTAT 12 VDC - 120 PRESET, FRONT MOUNT - ATWOOD	91470
3	051393-01-721	EA ECO & THERMOSTAT ASM-FRONT MOUNT, 140 DEGREE - ATWOOD	91447
4	051391-01-705	EA FASTENER-CAMLOC, ATWOOD	92609
5	051391-01-704	EA VALVE-RELIEF, 1/2" FITTING - ATWOOD	91604
6	051393-01-723	EA SWITCH-THERMAL CUT-OFF 2/PKG, ATWOOD	93866
7	051393-01-724	EA CIRCUIT BOARD-SPADE TERMINAL, ATWOOD	93867
8	051393-01-725	EA ELECTRODE-SINGLE SPADE CONNECT - ATWOOD	93868
9	051391-04-703	EA BURNER-MAIN, ATWOOD	91638
10	051391-01-717	EA GRILLE ONLY - ATWOOD	92640
11	051391-01-710	EA ORIFICE-MAIN BURNER, ATWOOD	92742
12	051391-03-700	EA ORIFICE HOLDER - ATWOOD	91563
13	051393-01-726	EA SOLENOID VALVE AND BRACKET - ATWOOD	93870
14	051391-01-714	EA ELBOW - 45 DEGREE, 3/8" F X 3/8" MPT - ATWOOD	91044
15	052009-04-000	EA DOOR-WATER HEATER, BUFF - ATWOOD	
16	051391-01-700	EA HINGE KIT-W/CLIP, ATWOOD	92568 & 92559
17	051393-03-701	EA TANK-INNER - ATWOOD	91642
18	051391-01-715	EA DRAIN PLUG, ATWOOD	91561
19	051391-01-706	EA FLUE, & GASKET - ATWOOD	92787
	116424-01-000	EA PROTECTOR-WATER HEATER LATCH - ATWOOD 92611	
	101814-01-000	EA COUPLING-FEMALE, 1/2" X 1/2" FPT W/COMP. SLEEVE - GRAY	
	110438-01-000	EA VALVE-CHECK, BRASS - G784	

ATWOOD WATER HEATER W/MOTOR AID (GH6-8E)

KEY	PART NUMBER	U/M DESCRIPTION	VENDOR NO.
	051393-01-000	EA WATER HEATER-W/MOTOR AID, PILOTLESS IGNITION - ATWOOD GH6-8E	
1	051393-01-701	EA SWITCH PACKAGE - ATWOOD	91959
2	051391-04-701	EA THERMOSTAT 12 VDC - 120 PRESET, FRONT MOUNT - ATWOOD	91470
3	051393-01-721	EA ECO & THERMOSTAT ASM-FRONT MOUNT, 140 DEGREE - ATWOOD	91447
4	051391-01-705	EA FASTENER-CAMLOC, ATWOOD	92609
5	051391-01-704	EA VALVE-RELIEF, 1/2" FITTING - ATWOOD	91604
6	051393-01-723	EA SWITCH-THERMAL CUT-OFF 2/PKG, ATWOOD	93866
7	051393-01-724	EA CIRCUIT BOARD-SPADE TERMINAL, ATWOOD	93867
8	051393-01-725	EA ELECTRODE-SINGLE SPADE CONNECT - ATWOOD	93868
9	051391-04-703	EA BURNER-MAIN, ATWOOD	91638
10	051391-01-717	EA GRILLE ONLY - ATWOOD	92640
11	051391-01-710	EA ORIFICE-MAIN BURNER, ATWOOD	92742
12	051391-03-700	EA ORIFICE HOLDER - ATWOOD	91563
13	051393-01-726	EA SOLENOID VALVE AND BRACKET - ATWOOD	93870
14	051391-01-714	EA ELBOW - 45 DEGREE, 3/8" F X 3/8" MPT - ATWOOD	91044
15	052009-04-000	EA DOOR-WATER HEATER, BUFF - ATWOOD	
16	051391-01-700	EA HINGE KIT-W/CLIP, ATWOOD	92568 & 92559
17	051391-04-704	EA TANK-INNER - ATWOOD	91642
18	051391-01-715	EA DRAIN PLUG, ATWOOD	91561
19	051391-04-707	EA FLUE, & GASKET - ATWOOD	90960
	111129-01-711	EA BRACKET-CORNER, SET OF FOUR	91928
	116424-01-000	EA PROTECTOR-WATER HEATER LATCH - ATWOOD 92611	
	101814-01-000	EA COUPLING-FEMALE, 1/2" X 1/2" FPT W/COMP. SLEEVE - GRAY	
	110438-01-000	EA VALVE-CHECK, BRASS - G784	

WATER & SEWAGE GROUP (CONTINUED)
SHURFLO WATER PUMP

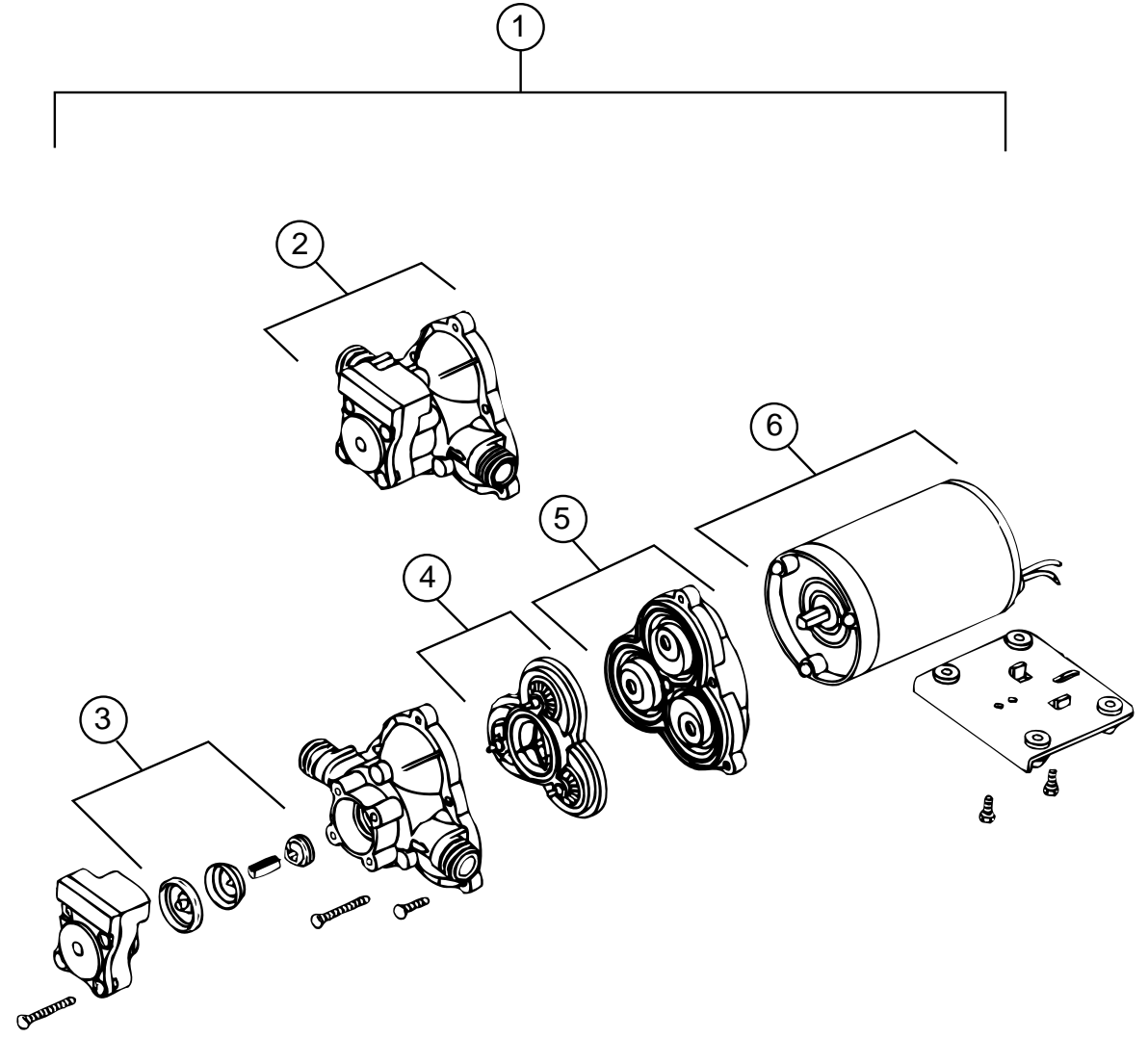

KEY	PART NUMBER	U/M	DESCRIPTION	VENDOR NO.
1	098607-01-000	EA	PUMP-WATER, W/.5" MPT FITTING - FLOW 2.8 GPM - UL	
2	098607-01-706	EA	HOUSING W/SWITCH ONLY	94-231-20
3	098607-01-705	EA	VALVE-CHECK, KIT	94-237-00
4	098607-01-703	EA	VALVE KIT	94-232-00
5	098607-01-702	EA	DIAPHRAGM/DRIVE ASSEMBLY KIT	94-238-04
6	098607-01-707	EA	MOTOR W/BASEPLATE	94-234-03

WATER & SEWAGE GROUP (CONTINUED)
WATER TANK QUEEN BED

KEY	PART NUMBER	U/M DESCRIPTION
	117898-02-000	EA TANK ASSEMBLY-WATER 1066 MM X 674 MM X 390 MM - W/FITTINGS
	117898-01-000	EA TANK-WATER, 1066 MM X 674 MM X 390 MM - W/O FITTINGS
	039861-01-000	EA SENDING UNIT-W/SCREW, WASHER, WELL NUT & TERMINAL RING
	042989-03-000	EA FITTING-WATER TANK, SPINWELD - 1 1/4" NPT - PLASTIC - WHITE
	042989-04-000	EA FITTING-WATER TANK, SPINWELD - 3/8" FPT - PLASTIC - WHITE
	042989-05-000	EA FITTING-WATER TANK, SPINWELD - 1/2" FPT - PLASTIC - WHITE
	049032-01-000	EA PATCH-SPINWELD, 3/8" - PLASTIC
	044927-01-000	EA ADAPTER-HOSE TO PIPE, 1 1/4" MPT X 1 1/4" BARB - PLASTIC - BLACK
	114429-02-000	EA ELBOW - 1/2" P X 1/2" MPT - FLAIR-IT 02803
	074462-02-000	FT TUBING-VINYL, 3/8" ID X 20' - CLEAR
	077954-02-000	EA FILTER-WATER TANK, SCREEN IN TANK
	079381-01-000	FT TUBING-SMOOTH FLEXIBLE, 1 1/4" ID X 20'

WATER TANK TWIN BED

KEY	PART NUMBER	U/M DESCRIPTION
	117898-03-000	EA TANK ASSEMBLY-WATER 1066 MM X 674 MM X 390 MM - W/FITTINGS
	117898-01-000	EA TANK-WATER, 1066 MM X 674 MM X 390 MM - W/O FITTINGS
	039861-01-000	EA SENDING UNIT-W/SCREW, WASHER, WELL NUT & TERMINAL RING
	010219-01-000	EA ELBOW - 1 1/4" MPT X 1 1/4" BARB, WATER FILL - PLASTIC
	010224-01-000	EA ADAPTER-HOSE TO PIPE, 3/8" MPT X 3/8" BARB - BLACK PLASTIC
	035539-01-000	EA ELBOW-PLASTIC, 3/8" MPT X 3/8" BARB
	114430-03-000	EA ADAPTER - 1/2" P X 1/2" MPT - FLAIR-IT 02842
	042989-03-000	EA FITTING-WATER TANK, SPINWELD - 1 1/4" NPT - PLASTIC - WHITE
	042989-04-000	EA FITTING-WATER TANK, SPINWELD - 3/8" FPT - PLASTIC - WHITE
	042989-05-000	EA FITTING-WATER TANK, SPINWELD - 1/2" FPT - PLASTIC - WHITE
	049032-01-000	EA PATCH-SPINWELD, 3/8" - PLASTIC
	074462-02-000	FT TUBING-VINYL, 3/8" ID X 20' - CLEAR
	077954-02-000	EA FILTER-WATER TANK, SCREEN IN TANK
	079381-01-000	FT TUBING-SMOOTH FLEXIBLE, 1 1/4" ID X 20'

WATER & SEWAGE GROUP (CONTINUED)
WATER SYSTEM

KEY	PART NUMBER	U/M DESCRIPTION
	039800-02-000	FT TUBING-POLYBUTYL, 5/8" OD - INCREMENTS OF 20' - BLACK
	039808-03-000	EA ELBOW - 1/2" MPT X 1/2" MPT, PLASTIC - KEVCO 17296
	091208-01-000	EA WASHER-RUBBER, .06" X .75" X .5"
	103798-01-000	EA CONNECTOR - 1/4" OD X 3/8" MPT
	110915-01-01A	EA FILL-WATER, CITY - CHROME - KEVCO 64713
	111039-02-000	EA BRACKET-FAUCET
	114427-01-000	EA CAP - 1/2" P - FLAIR-IT 02860
	114428-01-000	EA TEE - 1/2" P X 1/2" P X 1/2" P - FLAIR-IT 02820
	114428-02-000	EA TEE-SWIVEL, 1/2" P X 1/2" P X 1/2" FPT - FLAIR-IT 02821
	114429-01-000	EA ELBOW - 1/2" P X 1/2" P - FLAIR-IT 02800
	114429-02-000	EA ELBOW - 1/2" P X 1/2" MPT - FLAIR-IT 02803
	114429-03-000	EA ELBOW-SWIVEL, 1/2" P X 1/2" FPT - FLAIR-IT 02816
	114429-04-000	EA ELBOW - 1/2" P X 3/8" MPT - FLAIR-IT 02810
	114430-02-000	EA ADAPTER-SWIVEL, 1/2" P X 1/2" FPT - FLAIR-IT 02873
	114430-03-000	EA ADAPTER - 1/2" P X 1/2" MPT - FLAIR-IT 02842
	114431-01-000	EA VALVE-LINE DRAIN, 1/2" P - FLAIR-IT 02914
	114431-02-000	EA VALVE - 1/2" P, BYPASS - FLAIR-IT 02910
	117089-01-000	FT HOSE - 1/2" ID, GARDEN - KEVCO 49154

EXTERIOR SHOWER

KEY	PART NUMBER	U/M DESCRIPTION	VENDOR NO.
	114429-03-000	EA ELBOW-SWIVEL, 1/2" P X 1/2" FPT - FLAIR-IT 02816	
	046128-01-000	EA VALVE-DRAIN, PLASTIC - 1/2" FPT	
	075241-05-000	EA FAUCET-SHOWER, BONE	
	103092-01-000	EA SHOWER HEAD-W/60" HOSE - US	
	103092-02-000	EA SHOWER HEAD-W/60" HOSE - CANADIAN	
	103092-01-700	EA BRACKET ONLY-CLEAR, F/SHOWER HEAD - BPC	2328028
	103092-01-702	EA SEALS-SPRAY HEAD	24466
	011048-03-700	EA BRACKET/F SHOWER HEAD - BPC	2328029-3
	108356-02-01A	EA COVER-SWITCH W/DIMPLES, CARLING VVAZC00 BLA	
	108357-08-000	EA SWITCH-ROCKER, DPDT ON/NONE/ON - CARLING VDD1S00C-0	
	114293-01-01A	EA PAN-DRIP, 280 MM X 250 MM - OFF WHITE PLASTIC	

WATER PURIFICATION SYSTEM

KEY	PART NUMBER	U/M DESCRIPTION	VENDOR NO.
	701069-01-000	EA WATER PURIFICATION SYSTEM - EVERPURE 9252	
	701069-03-700	EA CARTRIDGE-WATER FILTER, AC - EVERPURE	9601-11

WATER & SEWAGE GROUP (CONTINUED)
DRAINAGE SYSTEM

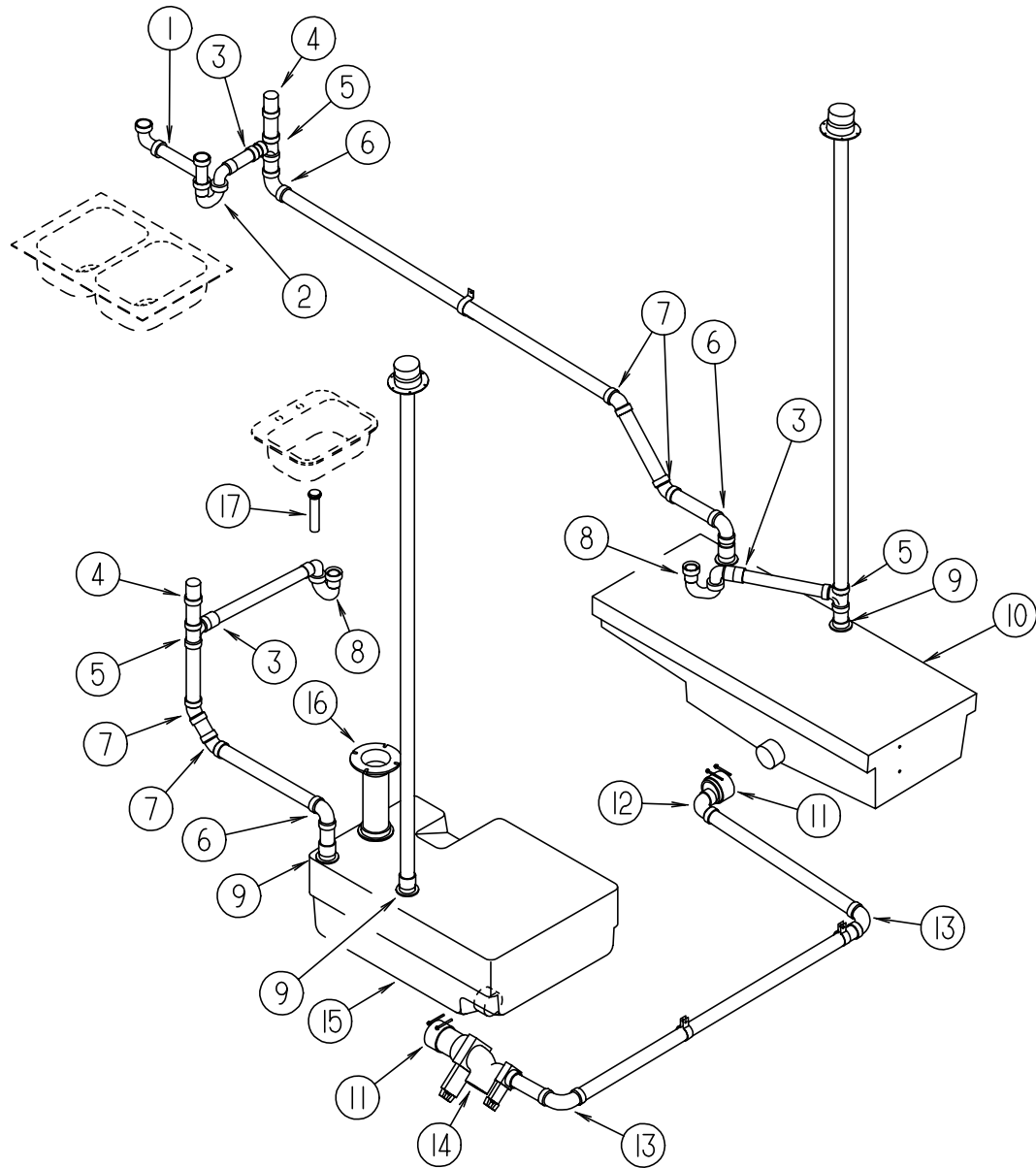

KEY	PART NUMBER	U/M DESCRIPTION
1	011091-03-000	EA PIPE-DRAIN, W/SEALS - DOUBLE SINK - EXTENDS 9" TO 16" - CANADIAN
1	011091-02-000	EA PIPE-DRAIN, DOUBLE SINK - BAFFLE TEE - 1 1/2" - US
2	107538-01-000	EA P-TRAP-PLASTIC, 1 1/4" W/EXT ARM
2	011071-01-000	EA P-TRAP, 1 1/2" - PLASTIC - CANADIAN
3	109571-01-000	EA ADAPTER-P TRAP, 1 1/2" P X 1 1/4" MPT - US
4	079968-01-000	EA VENT-MECHANICAL TRAP ARM, ANTI-SIPHON - 2" DIA X 7.3" - PLASTIC
5	010071-01-000	EA TEE-SANITARY, 1 1/2" HUB X HUB X HUB - PLASTIC - BLACK
6	034250-01-000	EA ELBOW - 90 DEGREE, LONG TURN - 1 1/2" HUB X HUB - ABS
7	010006-01-000	EA ELBOW - 45 DEGREE, 1/8 BEND - 1 1/2" HUB X HUB - BLACK PLASTIC
8	107538-01-000	EA P TRAP-PLASTIC, 1 1/4" W/EXT ARM - US
8	011066-03-700	EA P TRAP KIT-PLASTIC, 1 1/2" X 1 1/2" - CANADIAN
8	010121-01-000	EA BUSHING-REDUCER, 1 1/2" SMOOTH X 1 1/4" HUB - BLACK PLASTIC - CANADIAN
8	011066-03-701	EA P TRAP-PLASTIC - CANADIAN
8	011066-03-702	EA ADAPTER-P TRAP, 1 1/2" - CANADIAN
	011069-02-000	EA TAILPIECE-TUB/SHOWER, 1 1/2" X 1 1/4" X 4" - BRASS
	066440-01-000	EA STRAINER-SHOWER, W/RUBBER WASHER
	069735-01-000	EA WASHER-STRAINER TO TAILPIECE PLASTIC, 1.5"
9	010115-01-000	EA COUPLING - 1 1/2" HUB X HUB, PLASTIC
10	061805-01-000	EA TANK-HOLDING W/O FITTINGS - 40 GALLONS - 1349 MM X 526 MM X 311 MM
	061607-01-000	EA GROMMET-HOLDING TANK, 1 1/2" NPS
	039861-01-000	EA SENDING UNIT-W/SCREW, WASHER, WELL NUT & TERMINAL RING
11	078406-01-000	EA COUPLER-RUBBER, W/CLAMPS - 3" X 3"
	062422-01-000	EA ADAPTER-OFFSET REDUCER, 3" X 1 1/2" - PLASTIC - BLACK
12	033761-01-000	EA ELBOW-TURN, 1/4 BEND X 1.5"HUB X 1.5"SPIGOT - BLACK PLASTIC
13	010008-01-000	EA ELBOW - 90 DEG, 1/4 BEND - 1 1/2" HUB X HUB - BLACK PLASTIC
14	070916-01-000	EA VALVE-DUAL DUMP, W/CAP - 3" X 1 1/2" - PLASTIC - BLACK
	070916-01-700	EA VALVE ONLY, 3"
	070916-01-701	EA VALVE ONLY, 1 1/2"
	010201-01-000	EA HOSE-SEWER, 3" ID X 8'
	062416-01-000	EA ADAPTER-SEWER HOSE TO 3" PIPE
15	106598-01-000	EA TANK-HOLDING W/O FITTINGS - 44 GALLONS - 902 MM X 635 MM X 376 MM
	061607-01-000	EA GROMMET-HOLDING TANK, 1 1/2" NPS
	061607-02-000	EA GROMMET-HOLDING TANK, 3" NPS
	039861-01-000	EA SENDING UNIT-W/SCREW, WASHER, WELL NUT & TERMINAL RING
16	116644-01-000	EA FLANGE-CLOSET, TOILET - 4" X 3" - SEALAND 345892 - US
16	010147-02-000	EA FLANGE-CLOSET, TOILET - 4" X 3" FPT - CANADIAN
17	011069-02-000	EA TAILPIECE-TUB/SHOWER, 1 1/2" X 1 1/4" X 4" - BRASS

WINDOW, VENT & EXTERIOR DOOR GROUP
WINDOWS

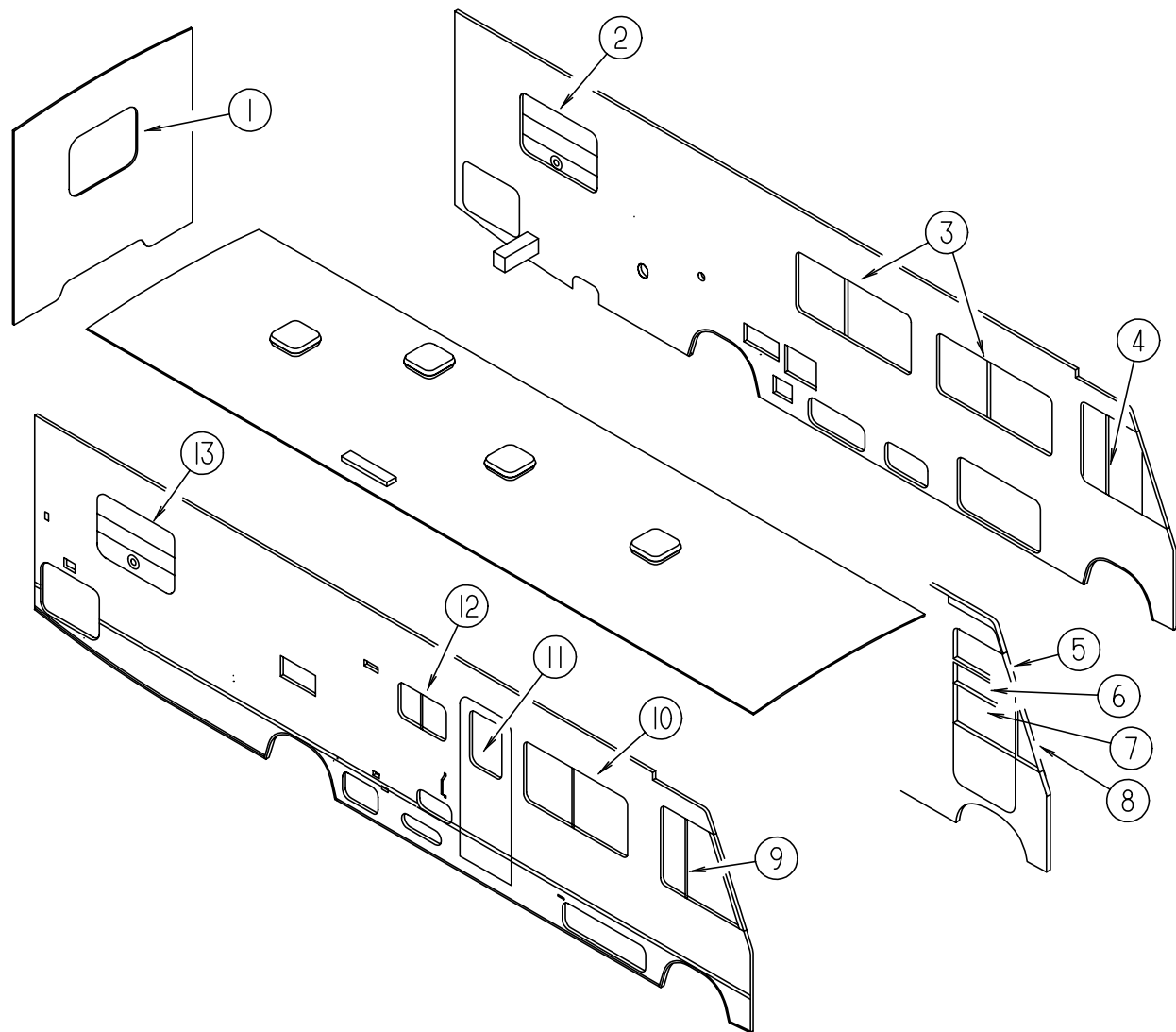

KEY	PART NUMBER	U/M	DESCRIPTION	VENDOR NO.
1	078528-06-E10	EA	WINDOW-ESCAPE, BACKWALL - W/O RETAINER	
1	113502-01-01A	EA	WINDOW ASM-ESCAPE, BACKWALL - W/RETAINER - EXCEL DH153-G2W66 THERMOPANE WINDOW OPTION	
2	113500-01-01A	EA	WINDOW ASM-TIPOUT, DOUBLE - W/RETAINER - EXCEL CH04-G2W59	
2	112795-23-01A	EA	WINDOW ASM-HORIZONTAL SLIDER, W/RETAINER - EXCEL DC04-G2W66L THERMOPANE WINDOW OPTION	
3	098647-22-01A	EA	WINDOW ASM-HORIZONTAL SLIDER, 26 3/8" X 60" - EXCEL H287-G2W66L	
3	112795-15-01A	EA	WINDOW ASM-HORIZONTAL SLIDER, 26 3/8" X 60" - EXCEL DH287-G2W66L THERMOPANE WINDOW OPTION	
4	103658-09-01A	EA	WINDOW ASM-CAB, W/RETAINER - DRIVER SIDE - EXCEL H373-ARL	
4	113501-03-01A	EA	WINDOW ASM-CAB, W/RETAINER- DRIVER SIDE - EXCEL DH405-A2B66L THERMOPANE WINDOW OPTION	
5	106467-02-01A	EA	WINDOW-VISTA - DRIVER SIDE - EXCEL - DRIVER DOOR	
5	116000-05-01A	EA	WINDOW-VISTA - DRIVER SIDE - EXCEL - DRIVER DOOR THERMOPANE WINDOW OPTION	
6	106469-02-702	EA	GLASS-STATIONARY, EXCEL	106-041104
7	106469-01-704	EA	ROLL-UP GLASS ASM W/BRACKET, EXCEL	V103-65L
8	106468-02-01A	EA	WINDOW-FRONT SLANT - DRIVER SIDE - DRIVER DOOR - EXCEL DH383-A2B27L	
8	115999-02-01A	EA	WINDOW-FRONT SLANT - DRIVER SIDE - EXCEL - DRIVER DOOR THERMOPANE WINDOW OPTION	
9	103658-10-01A	EA	WINDOW-CAB, W/RETAINER - PASSENGER SIDE - EXCEL H373-ARR	
9	113501-04-01A	EA	WINDOW-CAB, W/RETAINER - PASSENGER SIDE - EXCEL DH405-A2B66R THERMOPANE WINDOW OPTION	
10	098647-24-01A	EA	WINDOW-SLIDING, W/RETAINER - EXCEL H415-G2W66R	
10	112795-17-01A	EA	WINDOW-SLIDING, W/RETAINER - EXCEL DC80-G2W66R THERMOPANE WINDOW OPTION	
11	117053-02-F36	EA	WINDOW-PICTURE, W/O RETAINER	
11	113733-01-01A	EA	WINDOW ASM-PICTURE, 26 3/8" X 17" - EXCEL DH416-G2W66 THERMOPANE WINDOW OPTION	
12	098647-33-01A	EA	WINDOW-SLIDING, W/RETAINER - EXCEL H425-G2W66R	
12	112795-19-01A	EA	WINDOW-SLIDING, W/RETAINER - EXCEL DC29-G2466R THERMOPANE WINDOW OPTION	
13	113500-01-01A	EA	WINDOW-TIPOUT, DOUBLE - W/RETAINER - EXCEL CH04-G2W59	
13	112795-21-01A	EA	WINDOW ASM-HORIZONTAL SLIDER, 24 1/2" X 41 1/4" - EXCEL DC04-G2W66R THERMOPANE WINDOW OPTION	
	117046-02-000	EA	BUMPER-RUBBER, ROUND END - LAKEVIEW 22073 THERMOPANE WINDOW OPTION	

WINDOW, VENT & EXTERIOR DOOR GROUP (CONTINUED)

EXTERIOR DOORS

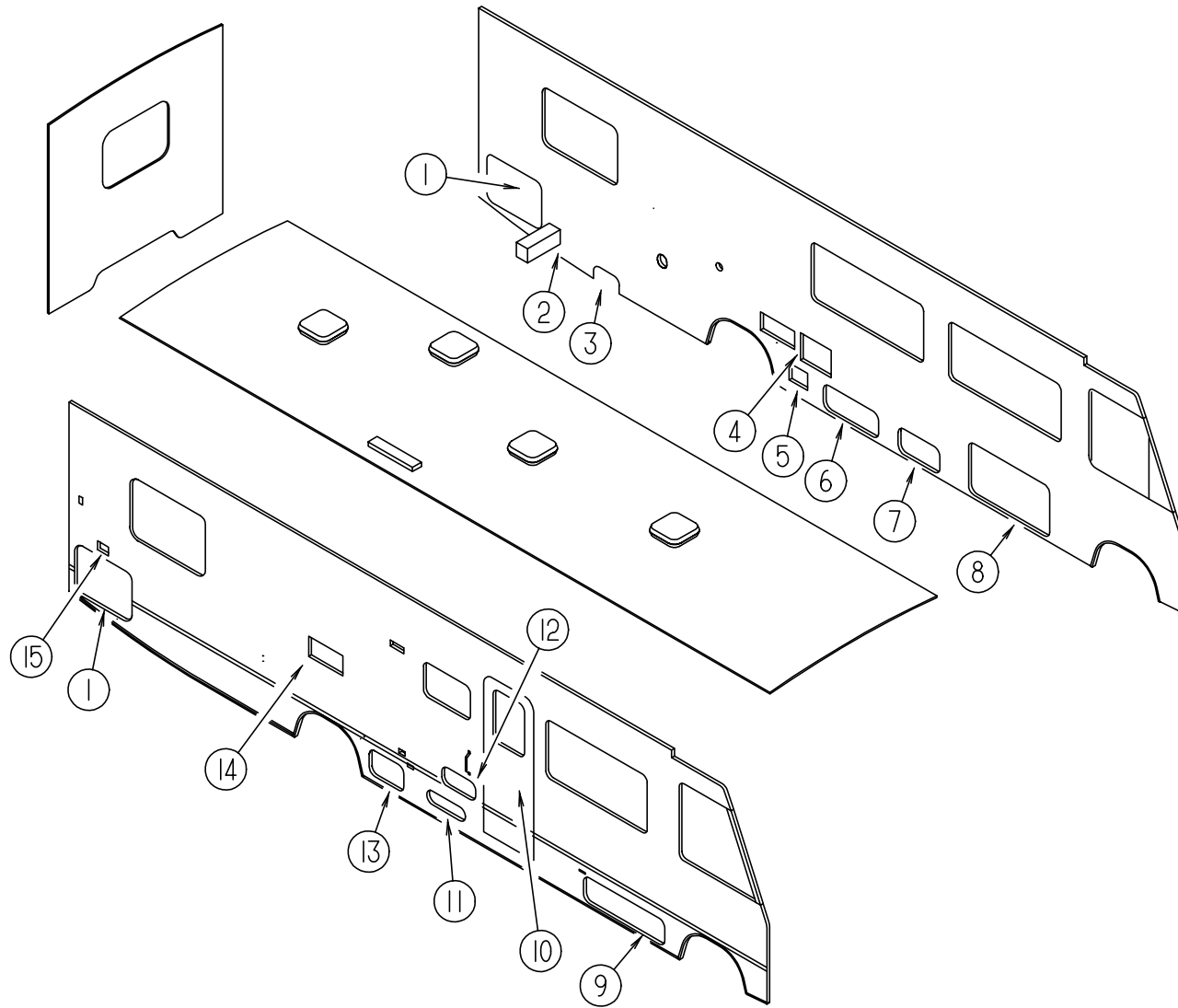

KEY	PART NUMBER	U/M	DESCRIPTION
1	111013-53-G29	EA	DOOR-STORAGE, BRIGHT WHITE
2	052423-07-000	EA	DOOR-ACCESS, 6.6" X 6.3" - PLASTIC - BRIGHT WHITE - SEWER HOSE DOOR
2	052424-06-000	EA	JAMB-DOOR, 8" X 7.7" - PLASTIC - BRIGHT WHITE - SEWER HOSE DOOR
3	111012-12-G29	EA	DOOR-ACCESS, BRIGHT WHITE - SEWER VALVE DOOR
4	052009-06-000	EA	DOOR-WATER HEATER, BRIGHT WHITE - ATWOOD
5	088794-06-000	EA	DOOR-POWER CORD, W/HATCH - BRIGHT WHITE
6	111018-03-G29	EA	DOOR-GENERATOR/STORAGE, BRIGHT WHITE
7	111013-04-F24	EA	DOOR-STORAGE, 22.1" X 11.6" - BRIGHT WHITE
8	111013-09-F24	EA	DOOR-STORAGE, BRIGHT WHITE
9	111013-14-F24	EA	DOOR-STORAGE, BRIGHT WHITE
10	115108-05-G29	EA	DOOR-ENTRY W/SCREEN DOOR & JAMB - W/O WINDOW (G29)
10	115108-05-G30	EA	DOOR-ENTRY W/SCREEN DOOR & JAMB - W/O WINDOW (G30)
10	115108-05-G31	EA	DOOR-ENTRY W/SCREEN DOOR & JAMB - W/O WINDOW (G31/G32)
11	111009-01-F24	EA	DOOR-COMPARTMENT, LP - 6.5" X 20.8" - BRIGHT WHITE
12	111017-01-F24	EA	DOOR-PATIO ENTERTAINMENT CENTER, 17.8" X 8.1" - BRIGHT WHITE
13	111013-05-F24	EA	DOOR-STORAGE, BRIGHT WHITE
14	084103-08-000	EA	DOOR-REFRIGERATOR, VENTED - W/O JAMB - BRIGHT WHITE
14	084104-08-000	EA	JAMB-DOOR, REFRIGERATOR - BRIGHT WHITE
	084104-01-700	EA	LOCK-MALE, FASTENER - REFRIGERATOR DOOR
	084104-01-701	EA	LOCK-FEMALE, FASTENER - REFRIGERATOR DOOR
15	081240-16-000	EA	DOOR-WATER FILL, LOCKABLE W/O LOCK, 4" X 4 5/8" - BRIGHT WHITE

WINDOW, VENT & EXTERIOR DOOR GROUP (CONTINUED)
ENTRANCE DOOR W/O WINDOW

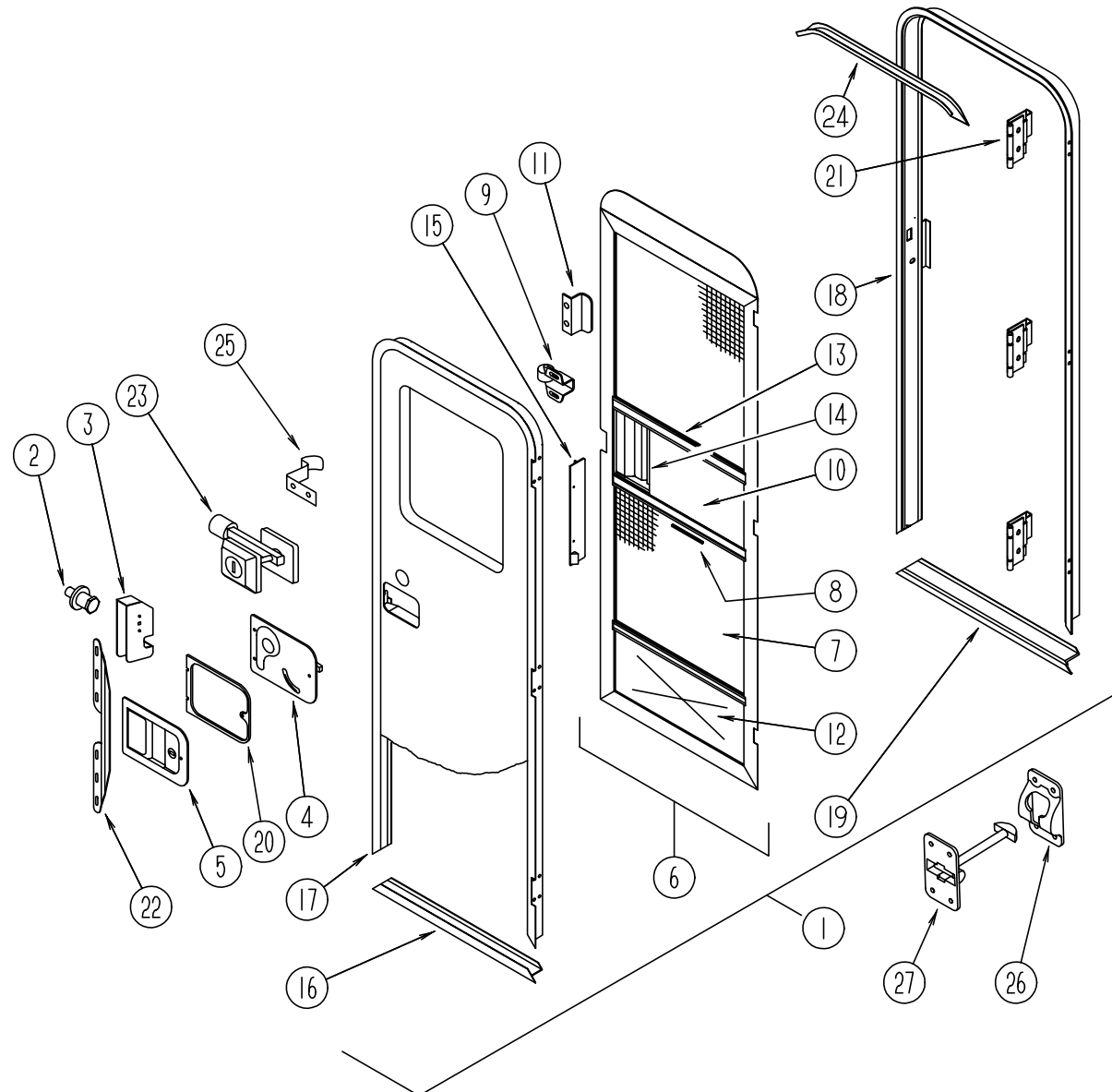

KEY	PART NUMBER	U/M	DESCRIPTION	VENDOR NO.
1	115108-05-G29	EA	DOOR-ENTRY W/SCREEN DOOR & JAMB - W/O WINDOW (G29)	
1	115108-05-G30	EA	DOOR-ENTRY W/SCREEN DOOR & JAMB - W/O WINDOW (G30)	
1	115108-05-G31	EA	DOOR-ENTRY W/SCREEN DOOR & JAMB - W/O WINDOW (G31/G32)	
2	039539-01-000	EA	STRIKE-LOCK, ENTRY DOOR - ROUND W/THREADED WASHER	
3	039540-01-000	EA	LATCH MECHANISM-HOOK, ENTRY DOOR - INTERIOR	
4	039715-01-000	EA	NUT-SERT, 1/4" DIAMETER - 20 THREADS	
4	039979-04-000	EA	COVER-INTERIOR LATCH, W/TRIP ARM - RIGHT - BLACK - TRI/MARK	11883-12
			FROM: 00-00-00 THRU: 09-10-95	
4	039979-06-000	EA	COVER-INTERIOR LATCH, W/TRIP ARM - RIGHT - BLACK - TRI/MARK	11883-01
			FROM: 09-11-95 THRU: 99-99-99	
	039984-01-000	EA	CAP-ROUND, VINYL - .28" ID X .62" LONG - BLACK	
	041546-05-000	EA	BRACKET-DOOR ANGLE, 5" X 1.9" - OFF WHITE - METAL	
			FROM: 00-00-00 THRU: 10-22-95	
	041546-07-000	EA	BRACKET-DOOR ANGLE, 5" X 1.9" - OFF WHITE - METAL	
			FROM: 10-23-95 THRU: 99-99-99	
5	045017-11-000	EA	LATCH-ENTRY DOOR, W/LOCK & KEY - BLACK - TRI/MARK	11896-12
			FROM: 00-00-00 THRU: 09-10-95	
5	045017-13-000	EA	LATCH-ENTRY DOOR, W/LOCK & KEY - BLACK - TRI/MARK	11896-01
			FROM: 09-11-95 THRU: 99-99-99	
	045017-11-701	EA	KEY BLANK	
	045017-11-703	EA	CYLINDER-LOCK ASSEMBLY W/KEYS - TRIMARK	81266-09
	036618-02-000	EA	E RING-EXTERNAL, LYNOR DOOR LOCK - 3/16" SHAFT DIAMETER	
	063729-04-000	EA	RIVNUT, 10-32 UNF - .010-.080	
			FROM: 00-00-00 THRU: 03-17-96	
	072893-04-000	EA	NUTSERT, 10-32	
			FROM: 03-18-96 THRU: 99-99-99	
	075671-04-000	FT	SEAL-SPONGE, LAZY T SHAPE - W/ADHESIVE STRIPE - .5" WIDE	
6	079012-09-F24	EA	DOOR ASM-SCREEN	
			FROM: 00-00-00 THRU: 03-17-96	
	121899-03-GB1	EA	DOOR ASM-SCREEN	
			FROM: 03-18-96 THRU: 99-99-99	
	075673-01-000	FT	SEAL-PILE, ADHESIVE BACK - GRAY	
7	002293-02-000	SF	SCREENING-WINDOW/DOOR, 26" - CHARCOAL	
8	002294-01-000	FT	SPLINE-SCREENING, .135" X .138" - BLACK	
9	109403-01-000	EA	CATCH-ASM-SINGLE ROLLER	
10	016454-01-000	EA	INSERT-CENTER, LEATHER GRAIN ALUMINUM - UNPAINTED	
10	001014-01-013	EA	INSERT-CENTER, 10.25" X 16.31" - UNPAINTED	
11	050712-06-000	EA	HANDLE-SCREEN DOOR, ALUMINUM - BRIGHT WHITE	
12	078552-03-000	EA	KICK PANEL-SCREEN DOOR, LOWER INSERT - UNPAINTED	
	078595-01-000	EA	TOP PLATE-SCREEN DOOR, CURVED TOP - 4.7" X 25.35"	
13	078777-01-000	EA	CHANNEL-SLIDE, SCREEN DOOR CENTER SLIDER COVER	
14	079086-03-000	EA	SLIDER-SCREEN DOOR, BRIGHT WHITE	
15	079087-03-000	EA	STRIKE-SLIDER, W/LIP FOR ELBOW CATCH - 1.5" X 8.6" - BRIGHT WHITE	

WINDOW, VENT & EXTERIOR DOOR GROUP (CONTINUED)
ENTRANCE DOOR W/O WINDOW (CONTINUED)

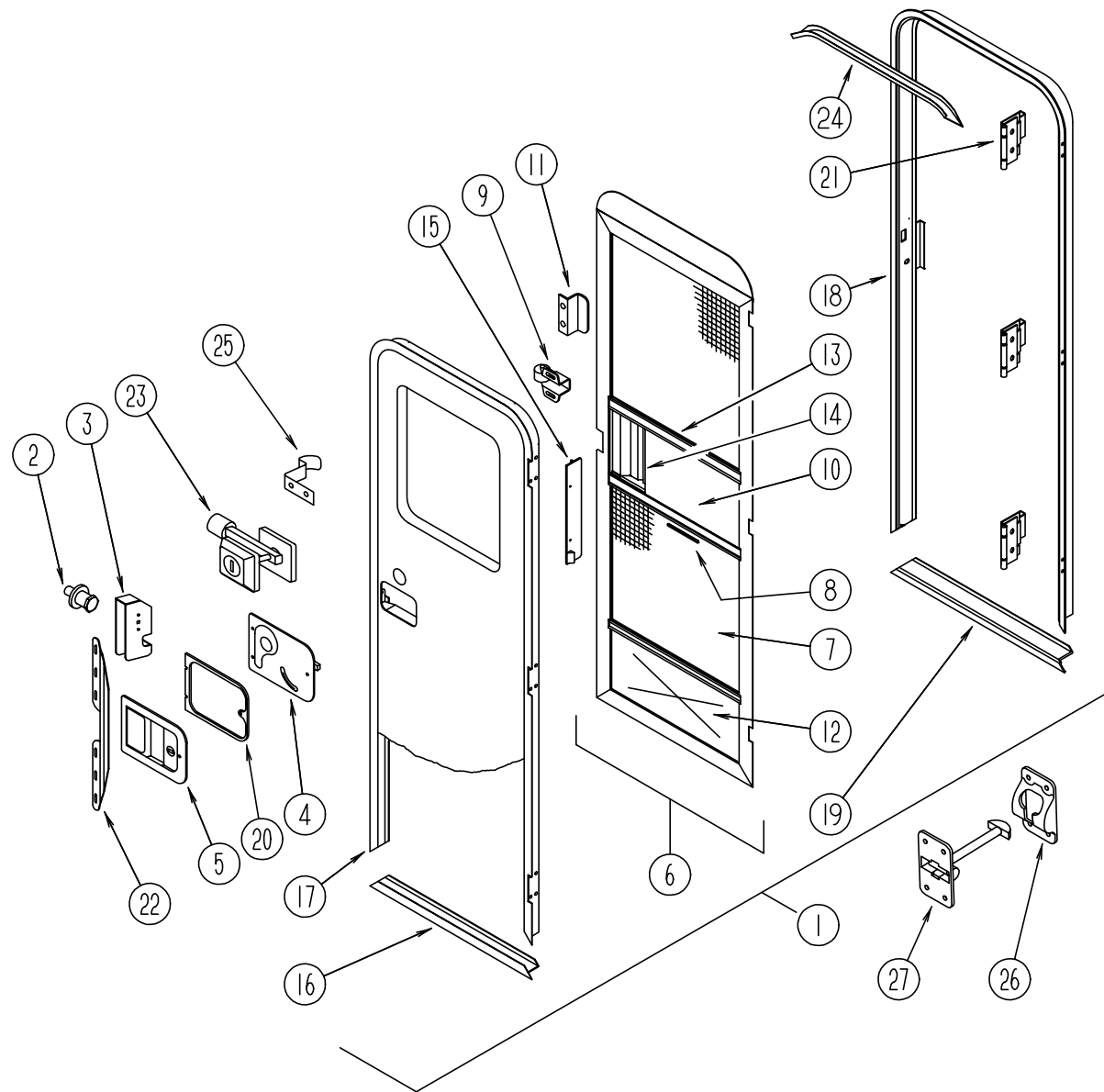

KEY	PART NUMBER	U/M	DESCRIPTION	VENDOR NO.
	081914-01-000	EA	BUMPER-RUBBER, ROUND - .43" DIAMETER - BLACK	
	104692-01-000	FT	SEAL - 3/4" X 3/4", ADHESIVE BACK	
16	089748-21-000	EA	FRAME-BOTTOM, ENTRY DOOR - 24.8" LONG - BRIGHT WHITE	
			FROM: 00-00-00 THRU: 03-17-96	
16	121893-01-01A	EA	FRAME-BOTTOM, ENTRY DOOR - 25" LONG - BRIGHT WHITE	
			FROM: 03-18-96 THRU: 99-99-99	
17	095276-07-03A	EA	FRAME-ENTRY DOOR, W/O BOTTOM - BRIGHT WHITE	
			FROM: 00-00-00 THRU: 03-17-96	
17	121894-07-01A	EA	FRAME-ENTRY DOOR, W/O BOTTOM - BRIGHT WHITE	
			FROM: 03-18-96 THRU: 99-99-99	
18	120310-05-01A	EA	JAMB-ENTRY DOOR, W/BOTTOM - BRIGHT WHITE	
			FROM: 00-00-00 THRU: 03-17-96	
18	121898-04-01A	EA	JAMB-ENTRY DOOR, W/BOTTOM - BUFF	
			FROM: 03-18-96 THRU: 99-99-99	
19	051049-01-000	EA	JAMB-BOTTOM, ENTRY DOOR - 25.9" - UNPAINTED	
20	096810-01-01A	EA	PLATE-LATCH, ENTRY DOOR - PLASTIC - BLACK	
21	106719-01-01A	EA	HINGE-ENTRY DOOR, UNPAINTED	
22	098173-01-07A	EA	STIFFENER-ENTRY DOOR, SUPPORTS LATCH/STRIKE AREA - BRIGHT WHITE	
	118929-01-01A	FT	SEAL-PILE, PUSH-ON - AMESBURY XC-964	
23	101145-01-01A	EA	DEADBOLT-ENTRY DOOR, W/2 KEYS W/O BACK SET BOLT OR SCREWS	
			TRI/MARK 11840-58	
			FROM: 00-00-00 THRU: 09-10-95	
	101145-01-06A	EA	DEADBOLT ASM-BLACK TEXTURED - TRI/MARK 11840-02	
			FROM: 09-11-95 THRU: 99-99-99	
	095229-01-700	EA	KEY BLANK FOR DEADBOLT	
	101145-01-701	EA	CYLINDER-LOCK ASM, W/KEY	81306-03
	101147-01-000	EA	BOLT-SECURITY, 4.12" BACKSET	
	102524-01-000	EA	BUMPER-RUBBER, FLAT - BLACK	
24	044582-44-000	EA	CAP-DRIP, ENTRY DOOR - JAMB MOUNTED - ALUMINUM - BRIGHT WHITE	
	115222-01-01A	EA	GARNISH-RADIUS, ENTRY DOOR - OFF WHITE	
	077461-03-000	EA	COVER-STRIKE, ENTRY DOOR - 6.5" X 2.5" - PLASTIC - WHITE	
25	100412-01-000	EA	CATCH-SCREEN DOOR, THUMB CLIP W/BLACK PLASTIC CAP	
26	104099-02-04A	EA	CATCH-DOOR HOLDER, RETAINER - BRIGHT WHITE	
27	104099-01-04A	EA	CATCH-DOOR HOLDER, STRIKE - BRIGHT WHITE	
	009126-02-000	EA	HANDLE-ASSIST, ENTRY DOOR - BLACK	
			FROM: 00-00-00 THRU: 09-10-95	
	009126-03-000	EA	HANDLE-ASSIST, ENTRY DOOR - BLACK TEXTURED	
			FROM: 09-11-95 THRU: 99-99-99	
	102248-01-000	EA	SHIM-DOOR	
	038327-01-000	EA	TAPE-ANTI SLIP, 2" X 60'	
	063729-01-000	EA	RIVNUT, 1/4 X 20 UNC - .030 - .125	
	076725-06-000	EA	COVER-ACCESS, HINGE - DOOR - BLACK - APV	
	086285-05-000	EA	SPACER-NYLON, 17.80 OD X 14.3 - MICROPLAS 17W07051	
			FROM: 10-23-95 THRU: 99-99-99	
	090340-01-000	FT	SEAL-FOAM, CLOSED CELL - 1/4" X 1/2" X 50'	
	116111-02-01A	EA	SCREW - TAPTITE - 1/4-20 X 3/8 PPH - ZINC	

WINDOW, VENT & EXTERIOR DOOR GROUP (CONTINUED)
EXCEL DRIVERS DOOR MODEL V130-01L

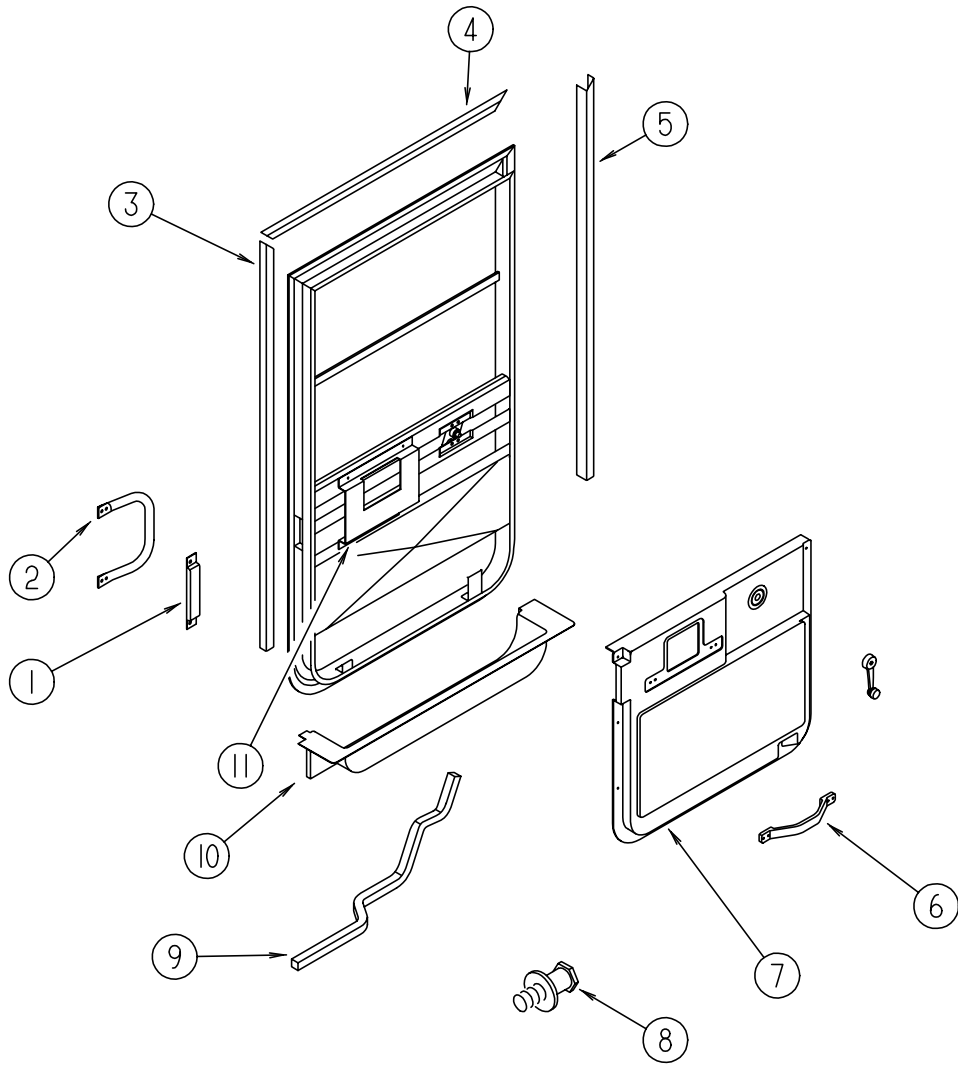

KEY	PART NUMBER	U/M	DESCRIPTION
	106469-07-01A	EA	DOOR - DRIVERS - BLACK - EXCEL
1	108654-01-01A	EA	COVER - STRIKE - DRIVERS DOOR - BLACK
2	108832-01-02A	EA	HANDLE - ASSIST - DRIVERS DOOR - METAL - OFF WHITE
	108833-01-01A	EA	COVER - HANDLE - ASSIST - OFF WHITE
3	108129-02-02A	EA	GARNISH - DRIVERS DOOR - BLACK
4	108107-01-02A	EA	GARNISH - DRIVERS DOOR - BLACK
5	108108-04-02A	EA	GARNISH - DRIVERS DOOR - BLACK
6	110604-01-01A	EA	HANDLE - ASSIST - DRIVERS DOOR - 10.8" LONG - BLACK
7	114973-01-04A	EA	PANEL - DRIVER DOOR - INNER - QUICKSILVER - PLASTIC
8	106469-04-703	EA	STRIKER ASSEMBLY - (SUPPLIED W/DRIVERS DOOR) - EXCEL
9	063977-12-000	EA	STEP - DRIVER DOOR - LEFT - PAINTED BLACK
9	063977-11-000	EA	STEP - DRIVER DOOR - LEFT - UNPAINTED
10	107818-01-07A	EA	TRIM - STEP - DRIVERS DOOR - PLASTIC - QUICKSILVER
	102569-02-000	EA	MAT-ANTISLIP, 4" X 22"
11	115051-01-01B	EA	BRACKET - HANDLE - MOUNT
	108897-02-01A	EA	GARNISH - DOOR - DRIVERS - U-CHANNEL - BLACK
	109378-01-000	EA	STRAP - CHECK - DRIVERS DOOR - BLACK
	076725-06-000	EA	COVER - ACCESS, HINGE - BLACK
	090340-01-000	FT	SEAL-FOAM, CLOSED CELL - 1/4" X 1/2" X 50'
	109235-01-01A	FT	COVER - SCREW - MAT BLACK
	109235-01-05A	FT	COVER - SCREW - BRIGHT WHITE
	106746-01-000	EA	PANEL-STEPWELL, 789 MM LONG - STEEL
	106747-01-000	EA	PANEL-STEPWELL, RH END - STEEL
	106747-02-000	EA	PANEL-STEPWELL, LH END - STEEL

VENDOR NO.

248-041152

WINDOW, VENT & EXTERIOR DOOR GROUP (CONTINUED)
EXCEL DRIVERS DOOR MODEL V130-01L (CONTINUED)

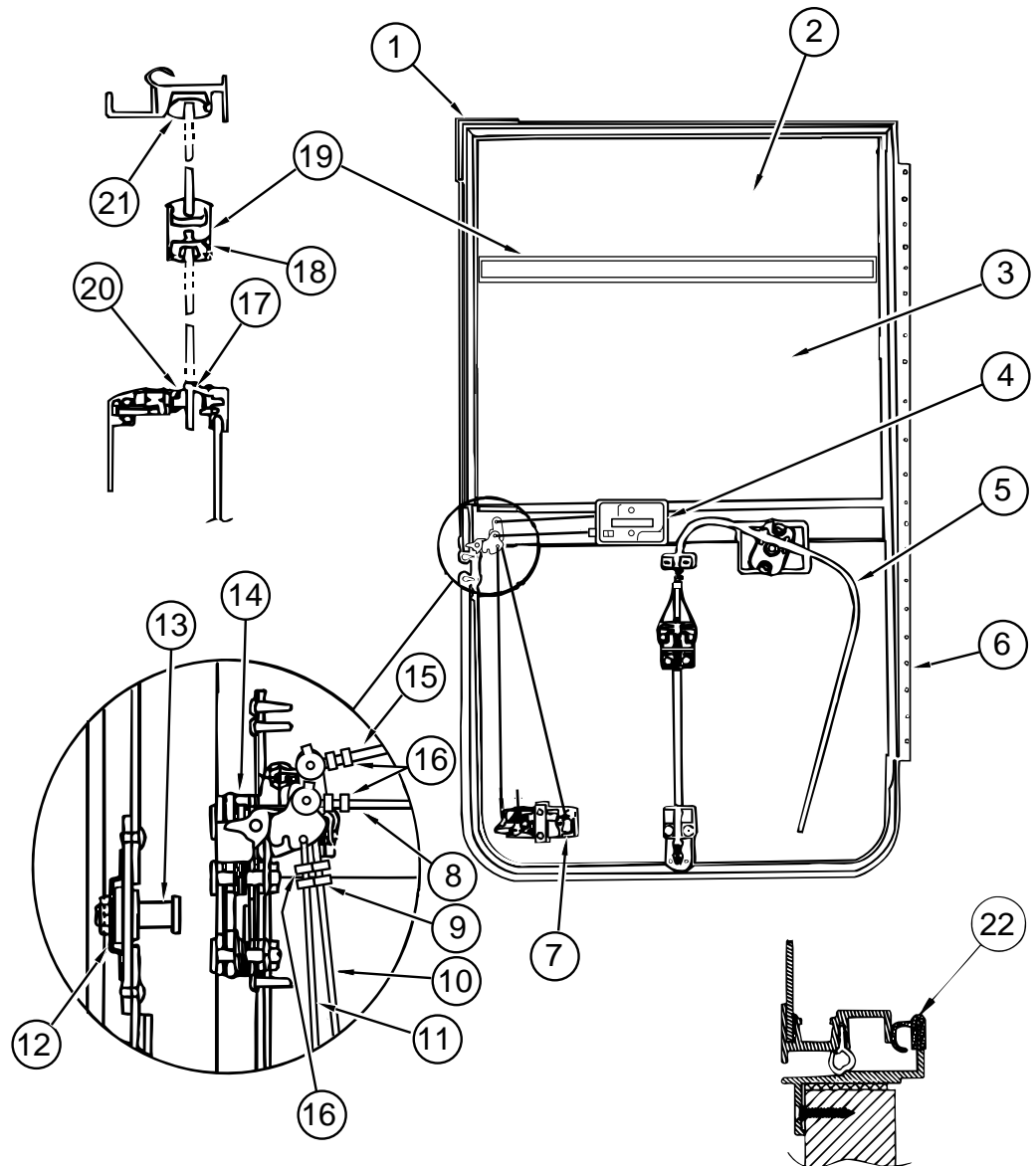

KEY	PART NUMBER	U/M	DESCRIPTION	VENDOR NO.
1	106469-01-702	EA	DOOR SEAL, EXCEL	122-040984
2	106469-02-702	EA	GLASS-STATIONARY, EXCEL	106-041104
3	106469-01-704	EA	ROLL-UP GLASS ASM W/BACKET, EXCEL	V103-65L
4	106469-04-712	EA	INNER HANDLE HARDWARE - LH, EXCEL	248-041148
5	106469-02-701	EA	REGULATOR ASSEMBLY, EXCEL	V108-90L
6	106469-05-702	EA	HINGE - 42", EXCEL	211-041194
7	106469-04-700	EA	PADDLE ASM. W/COLLAR, EXCEL	248-041237
	106469-04-701	EA	TUMBLER & KEYS (TRI-MARK), EXCEL	248-041179
	106469-04-715	EA	LATCH COMPLETE W/TUMBLER & KEYS, EXCEL	V123-15
	045017-11-701	EA	KEY-BLANK, TRIMARK	81312-02
8	106469-04-711	EA	LOCK ROD, HORIZONTAL, EXCEL	203-041137
9	106469-04-713	EA	ROD CLIP-LH, EXCEL	248-041154
10	106469-05-703	EA	LATCH ROD, VERTICAL ADJ, EXCEL	203-041239
11	106469-05-705	EA	LOCK ROD, VERTICAL ADJ, EXCEL	203-041279
12	106469-04-704	EA	CAGED NUT ASSEMBLY (STRIKER), EXCEL	248-041151
13	106469-04-703	EA	STRIKER BOLT (W/WASHER), EXCEL	248-041152
14	106469-05-706	EA	ROTARY LATCH & LINKAGE, EXCEL	248-041150
15	106469-04-705	EA	LATCH ROD-HORIZONTAL, EXCEL	203-041139
16	106469-04-714	EA	ROD CLIP-RH, EXCEL	248-041153
17	106469-02-703	EA	BELT-WEATHERSTRIP, EXTERIOR - ROLL-UP GLASS - EXCEL	V047-57
18	106469-01-705	FT	RUN-CHANNEL, EXCEL	122-010850
19	106469-01-719	EA	MULLION RAIL, EXCEL	V103-84
20	106469-01-709	FT	WEATHERSTRIP-FUZZY, EXCEL	171-040630
21	106469-02-705	EA	HORIZONTAL GLAZING VINYL, EXCEL	V108-87
22	106469-01-723	EA	BULB SEAL ASM-DRIVERS DOOR JAMB - PREFORMED - EXCEL	171-040985
	106469-02-704	EA	PARTS BAG (HANDLE WINDOW), EXCEL	V068-16
	106469-07-700	EA	MOUNTING FRAME ASSEMBLY, EXCEL	V130-30L

WINDOW, VENT & EXTERIOR DOOR GROUP (CONTINUED)
EXTERIOR DOOR COMPONENTS & HOLDER

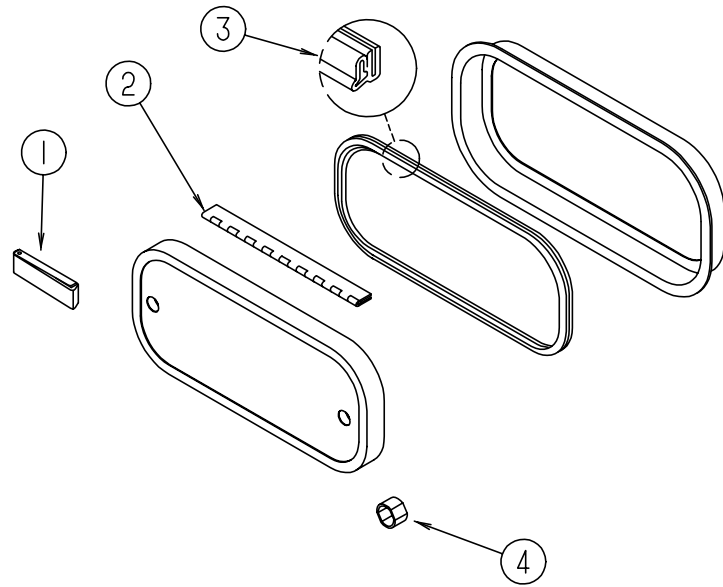

KEY	PART NUMBER	U/M	DESCRIPTION
1	102768-01-000	EA	HOLDER-COMPARTMENT/ENTRY DOOR, METAL - MILL FINISH
2	081801-02-000	EA	HINGE - 2" X 96", OFF WHITE
2	081801-V3-000	EA	HINGE - 2" X 96", BRIGHT WHITE
2	034007-B3-000	EA	HINGE-PIANO, 1.5" X 96" - ALUMINUM - BRIGHT WHITE
2	009065-01-000	EA	HINGE-PIANO, 1.5" X 96" - ALUMINUM - UNPAINTED
3	064075-07-000	FT	SEAL-BULB, W/WIRED U CHANNEL - .3" X .5" CHANNEL - BLACK
4	107997-51-001	EA	SPACER - .86" X .6", ALUMINUM
	081914-01-000	EA	BUMPER-RUBBER, ROUND - .43" DIAMETER - BLACK
	104692-01-000	FT	SEAL - 3/4" X 3/4", ADHESIVE BACK
	112160-01-000	FT	SEAL - D SECTION, 6 X 10 FOAM RUBBER - LAUREN 1153 BLACK
	099418-01-000	FT	SEAL - D SECTION W/ ADHESIVE BACK - .44" X .44" - BLACK RUBBER
	116424-01-000	EA	PROTECTOR-WATER HEATER LATCH - ATWOOD 92611

WINDOW, VENT & EXTERIOR DOOR GROUP (CONTINUED)
BRIGGS & STRATTON LOCKS & COMPONENTS

NOTE:
 WHEN ORDERING THE LOCK CASE, THE KEY CODE MUST MATCH THE LAST DIGIT OF THE UNIT'S SERIAL NUMBER AND PART NUMBER; WHEN ORDERING THE KEYS, THE THIRD DIGIT OF THE KEY CODE MUST MATCH THE LAST DIGIT OF THE UNIT'S SERIAL NUMBER AND PART NUMBER.

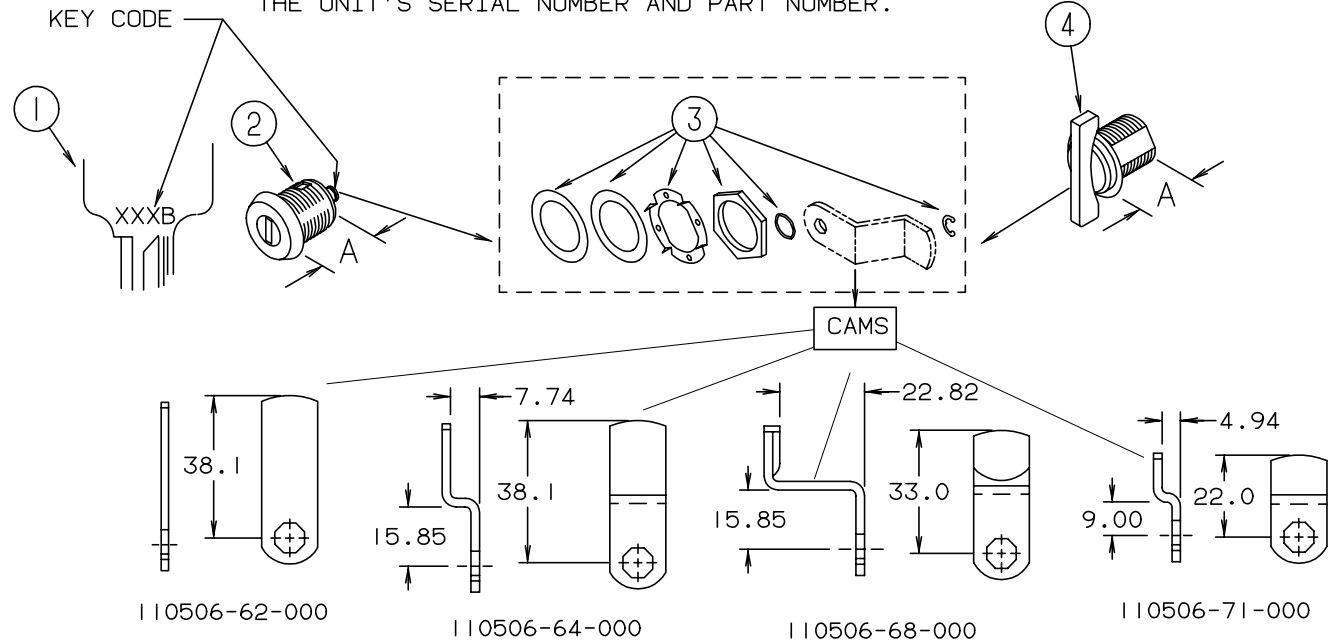

KEY	PART NUMBER	U/M	DESCRIPTION	VENDOR NO.
1	110506-59-000	EA	KEYS-SET OF 2	596720
2	110506-52-000	EA	CASE-LOCK, A=17 MM	702370
2	110506-53-000	EA	CASE-LOCK, A=25 MM	702380
2	110506-54-000	EA	CASE-LOCK, A=32 MM	703170
1	110506-59-001	EA	KEYS-SET OF 2	596721
2	110506-52-001	EA	CASE-LOCK, A=17 MM	702371
2	110506-53-001	EA	CASE-LOCK, A=25 MM	702381
2	110506-54-001	EA	CASE-LOCK, A=32 MM	703171
1	110506-59-002	EA	KEYS-SET OF 2	596722
2	110506-52-002	EA	CASE-LOCK, A=17 MM	702372
2	110506-53-002	EA	CASE-LOCK, A=25 MM	702382
2	110506-54-002	EA	CASE-LOCK, A=32 MM	703172
1	110506-59-003	EA	KEYS-SET OF 2	596723
2	110506-52-003	EA	CASE-LOCK, A=17 MM	702373
2	110506-53-003	EA	CASE-LOCK, A=25 MM	702383
2	110506-54-003	EA	CASE-LOCK, A=32 MM	703173
1	110506-59-004	EA	KEYS-SET OF 2	596724
2	110506-52-004	EA	CASE-LOCK, A=17 MM	702374
2	110506-53-004	EA	CASE-LOCK, A=25 MM	702384
2	110506-54-004	EA	CASE-LOCK, A=32 MM	703174
1	110506-59-005	EA	KEYS-SET OF 2	596725
2	110506-52-005	EA	CASE-LOCK, A=17 MM	702375
2	110506-53-005	EA	CASE-LOCK, A=25 MM	702385
2	110506-54-005	EA	CASE-LOCK, A=32 MM	703175
1	110506-59-006	EA	KEYS-SET OF 2	596726
2	110506-52-006	EA	CASE-LOCK, A=17 MM	702376
2	110506-53-006	EA	CASE-LOCK, A=25 MM	702386
2	110506-54-006	EA	CASE-LOCK, A=32 MM	703176
1	110506-59-007	EA	KEYS-SET OF 2	596727
2	110506-52-007	EA	CASE-LOCK, A=17 MM	702377
2	110506-53-007	EA	CASE-LOCK, A=25 MM	702387
2	110506-54-007	EA	CASE-LOCK, A=32 MM	703177
1	110506-59-008	EA	KEYS-SET OF 2	596728
2	110506-52-008	EA	CASE-LOCK, A=17 MM	702378
2	110506-53-008	EA	CASE-LOCK, A=25 MM	702388
2	110506-54-008	EA	CASE-LOCK, A=32 MM	703178
1	110506-59-009	EA	KEYS-SET OF 2	596729
2	110506-52-009	EA	CASE-LOCK, A=17 MM	702379
2	110506-53-009	EA	CASE-LOCK, A=25 MM	702389
2	110506-54-009	EA	CASE-LOCK, A=32 MM	703179
3	110506-40-700	EA	HARDWARE KIT-LOCK, W/GASKET, NUT, CLIP & WASHERS	
4	110506-50-000	EA	CASE-TWIST LOCK, A=17 MM	596932
4	110506-51-000	EA	CASE-TWIST LOCK, A=25 MM	596669
4	110506-55-000	EA	CASE-TWIST LOCK, A=32 MM	597312AA1
	110506-59-701	EA	KEY BLANK	

WINDOW, VENT & EXTERIOR DOOR GROUP (CONTINUED)

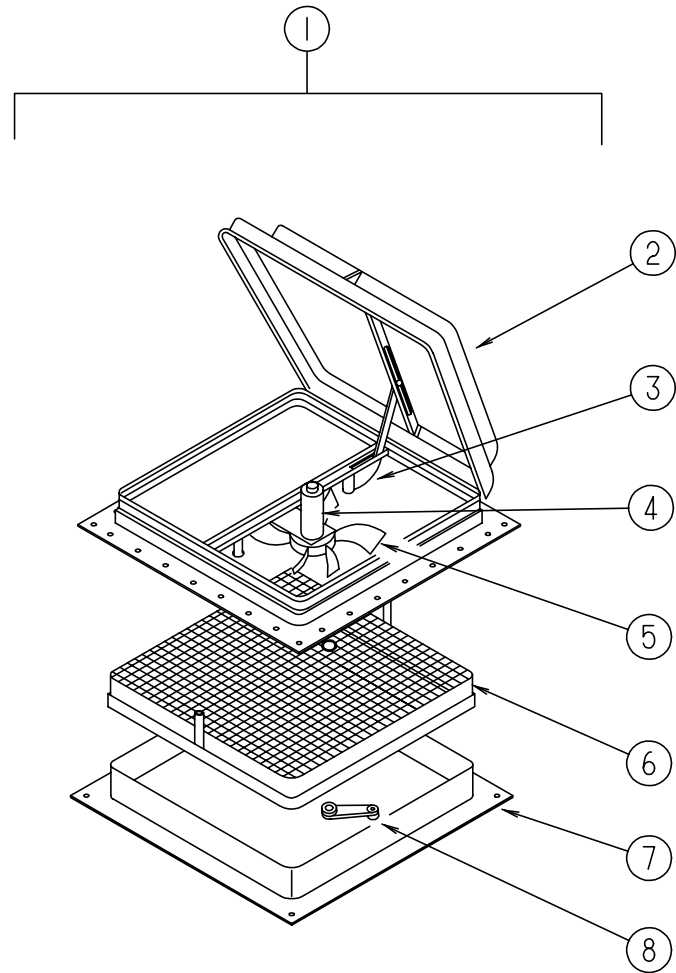

JENSEN POWERED ROOF VENT

KEY	PART NUMBER	U/M	DESCRIPTION
1	110051-04-01A	EA	VENT-ROOF, POWERED - 4" ROOF - JENSEN 7797 WHE
1	110051-06-01A	EA	VENT-ROOF, POWERED - 4" ROOF - CSA - JENSEN C7797 WHE
2	064470-01-700	EA	COVER-ROOF VENT, JENSEN
	064470-01-701	EA	SLIDE BAR-VENT LID, JENSEN
3	110051-01-702	EA	LIFT ASM-VENT LID W/O CRANK, JENSEN
4	048648-01-000	EA	MOTOR-ROOF VENT, 1/8 SHAFT - 12V - JENSEN 42-472-01
5	048649-01-000	EA	FAN-ROOF VENT, 6 BLADES - 6" - JENSEN RP-1002B
6	110051-01-704	EA	SCREEN & FRAME - 4", JENSEN
7	110051-02-700	EA	GARNISH-INTERIOR - 4", JENSEN
8	110051-01-703	EA	CRANK, JENSEN
	110051-03-700	EA	SWITCH-PUSH BUTTON, BLACK

VENDOR NO.

7291
JRP 1291B
RP-1000B

29-688-03

RP-1031-B
27-0164

WINDOW, VENT & EXTERIOR DOOR GROUP (CONTINUED)

JENSEN NONPOWERED ROOF VENT

KEY	PART NUMBER	U/M	DESCRIPTION	VENDOR NO.
	110051-02-01A	EA	VENT-ROOF, NONPOWERED - 4" ROOF - JENSEN 7727 WHE	
	064470-01-700	EA	COVER-ROOF VENT, JENSEN	7291
	064470-01-701	EA	SLIDE BAR-VENT LID, JENSEN	JRP 1291B
	110051-01-702	EA	LIFT ASM-VENT LID W/O CRANK, JENSEN	RP-1000B
	110051-01-703	EA	CRANK, JENSEN	RP-1031-B
	110051-01-704	EA	SCREEN & FRAME - 4", JENSEN	29-688-03
	110051-02-700	EA	GARNISH-INTERIOR - 4", JENSEN	

VENTS, SHROUDS & ROOF COVERS

KEY	PART NUMBER	U/M	DESCRIPTION
	083558-03-000	EA	VENT-PLUMBING PIPE ROOF W/COVER - OFF WHITE
	084616-07-000	EA	SHROUD-RANGE HOOD VENT, PLASTIC - BRIGHT WHITE
	084878-09-000	EA	VENT-RANGE HOOD, SHORT - LVS
	084073-07-000	EA	COVER-ROOF VENT, REFRIGERATOR - BRIGHT WHITE - NORCOLD
	084073-04-000	EA	BASE-ROOF VENT, REFRIGERATOR - BLACK - NORCOLD

WINDOW, VENT & EXTERIOR DOOR GROUP (CONTINUED)

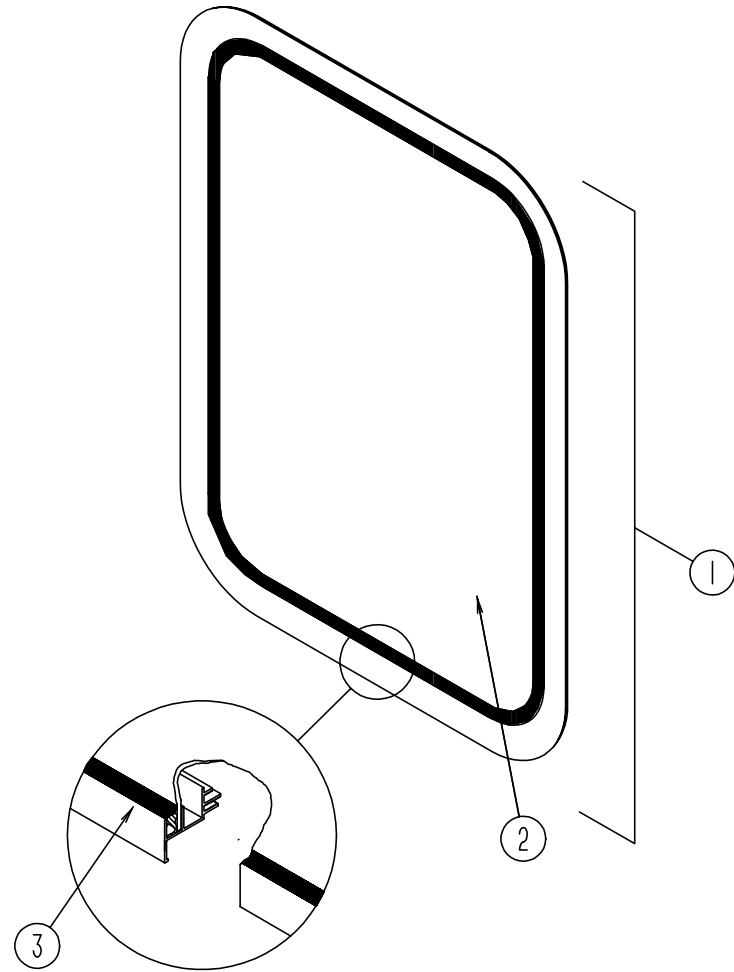

ENTRANCE DOOR WINDOW

KEY	PART NUMBER	U/M	DESCRIPTION
	117054-02-02A	EA	RETAINER-TRIM, ENTRY DOOR WINDOW - BRIGHT WHITE
1	117053-02-F36	EA	WINDOW-PICTURE, W/O RETAINER
2	002181-25-000	EA	GLASS-PICTURE WINDOW, 655 MM X 417 MM
3	087561-01-000	FT	SEAL-GLASS, EXTERIOR - .5" WIDE - VINYL - BLACK

EXCEL ENTRANCE DOOR WINDOW - THERMOPANE WINDOW OPTION

KEY	PART NUMBER	U/M	DESCRIPTION
	113733-01-01A	EA	WINDOW ASM-PICTURE, W/RETAINER - EXCEL DH416-G2W66
	113733-01-700	EA	WINDOW-PICTURE, W/O RETAINER - EXCEL
	113733-01-701	EA	RETAINER-TRIM, ENTRY DOOR WINDOW - EXCEL
	113733-01-702	EA	GLASS-STATIONARY - EXCEL
	112795-01-705	FT	VINYL-GLAZING

VENDOR NO.
DH416-G2
W41666
390-019187
132-019702

WINDOW, VENT & EXTERIOR DOOR GROUP (CONTINUED)

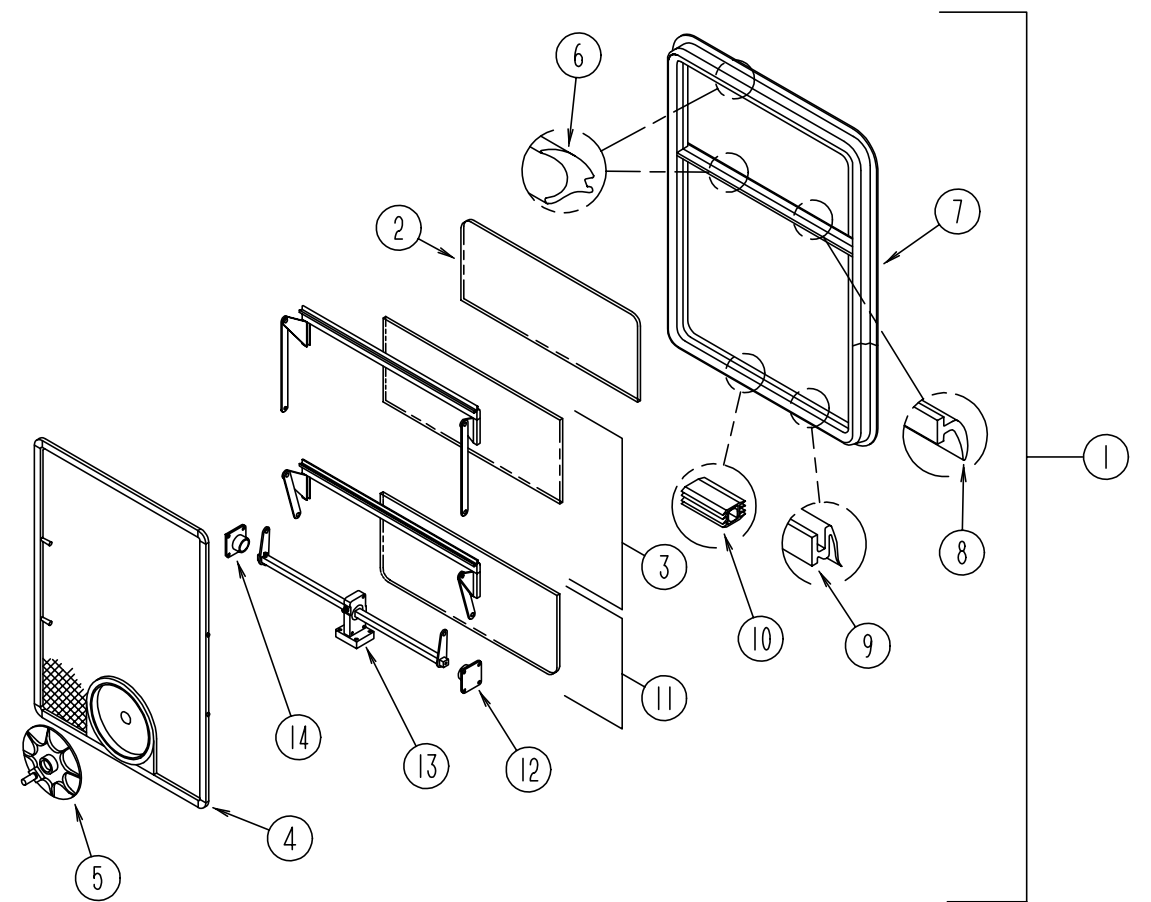

EXCEL BEDROOM DOUBLE TIPOUT WINDOW - DRIVER OR PASSENGER SIDE

KEY	PART NUMBER	U/M	DESCRIPTION	VENDOR NO.
1	113500-01-01A	EA	WINDOW-DOUBLE TIPOUT, W/OFF WHITE RETAINER - EXCEL CH04-G2W59	
	113500-01-702	EA	RETAINER-TRIM, OFF WHITE - EXCEL	CW0459
2	113500-01-703	EA	GLASS-TOP, STATIONARY - EXCEL	106-015970
	100322-01-704	EA	TAPE-BUTYL, WINDOW - EXCEL	154-016083
3	113500-01-704	EA	GLASS-VENT, UPPER - EXCEL	CH04-G7
4	113500-01-700	EA	SCREEN W/SPRING & WEATHERSTRIP - EXCEL	410-016020
5	100322-01-718	EA	HANDLE-DIAL, WINDOW - EXCEL	410-016081
6	100322-01-703	EA	GLAZING STRIP-BUTYL, GLASS - EXCEL	132-010723
7	113500-01-701	EA	WINDOW-DOUBLE TIPOUT, W/O INSIDE FRAME - EXCEL	CH04-G2
8	100322-01-702	FT	WEATHERSTRIP-HORIZONTAL RAIL - EXCEL	132-015976
9	100322-01-701	FT	SEAL-VENT, WINDOW - EXCEL	122-016071
10	098644-01-716	EA	PLUG-FILLER, EXCEL	132-014470
11	113500-01-705	EA	GLASS-VENT, LOWER - EXCEL	CH04-G9
12	113500-01-708	EA	SUPPORT-TORQUE BAR - EXCEL	132-015978
13	113500-01-706	EA	OPERATOR & BAR ASSEMBLY - EXCEL	CH04-15
	112519-01-702	EA	OPERATOR-VENT, EXCEL	410-016123
14	113500-01-707	EA	SUPPORT-TORQUE BAR - EXCEL	132-015979
	100322-01-717	EA	E-RING, WINDOW - EXCEL	245-015975

WINDOW, VENT & EXTERIOR DOOR GROUP (CONTINUED)

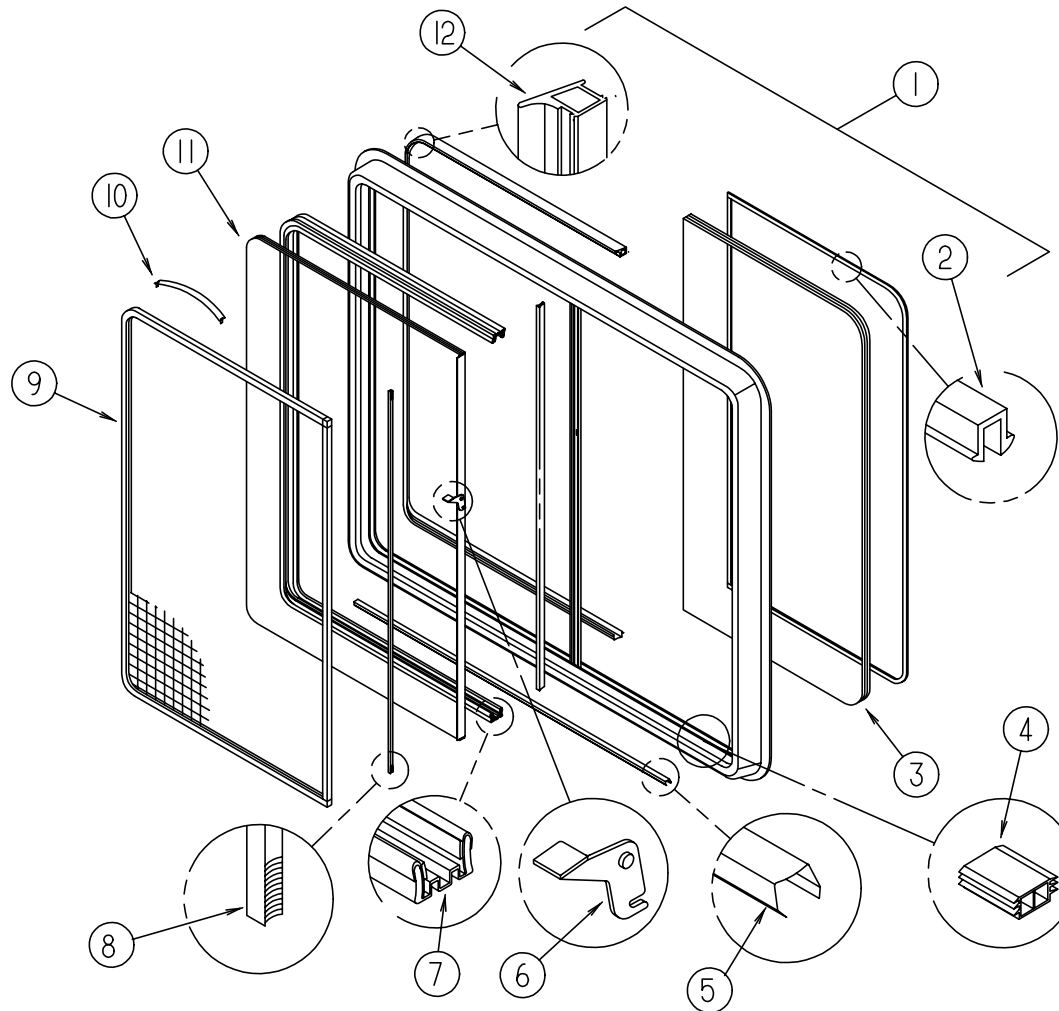

EXCEL GALLEY WINDOW - THERMOPANE WINDOW OPTION

KEY	PART NUMBER	U/M DESCRIPTION	VENDOR NO.
	112795-19-01A	EA WINDOW-HORIZONTAL SLIDER, W/RETAINER - EXCEL DC29-G2W66R	
	098647-31-701	EA RETAINER-TRIM, OFF WHITE - EXCEL	CW2966
1	112795-19-700	EA WINDOW-HORIZONTAL SLIDER, W/O RETAINER - EXCEL	DC29-G2R
2	112795-01-705	FT VINYL-GLAZING - EXCEL	132-019702
3	112795-19-701	EA GLASS-STATIONARY - EXCEL	390-019134
4	112795-01-701	EA SLIDE-STOP - EXCEL	132-019092
5	098644-01-710	FT TRACK-SCREEN SPACER, 12' LENGTH - EXCEL	M401-31
6	112795-01-700	EA LATCH ASM-BLACK - EXCEL	DH287-CK
7	112795-01-703	IN RUN CHANNEL - EXCEL	122-018736
8	098644-01-711	FT WEATHERSTRIP-SCREEN, BLACK - EXCEL	171-016965
9	098647-31-704	EA SCREEN W/SPRING & WEATHERSTRIP - EXCEL	410-019128
10	098644-01-713	EA CLIP-SPRING, BLACK PLASTIC - EXCEL	226-016966
11	112795-19-702	EA GLASS-SLIDING, W/SASH & LATCH - EXCEL	DC29-G9
12	112795-01-704	FT PLUG-FILLER (DOUBLE GLAZED) - EXCEL	122-018737

EXCEL BEDROOM HORIZONTAL SLIDER WINDOW - DRIVER SIDE - THERMOPANE WINDOW OPTION

KEY	PART NUMBER	U/M DESCRIPTION	VENDOR NO.
	112795-23-01A	EA WINDOW-HORIZONTAL SLIDER, W/RETAINER - EXCEL DC04-G2W66L	
	098647-29-701	EA RETAINER-TRIM, OFF WHITE - EXCEL	CW0466
1	112795-23-700	EA WINDOW-HORIZONTAL SLIDER, W/O RETAINER - EXCEL	DC04-G2L
2	112795-01-705	FT VINYL-GLAZING - EXCEL	132-019702
3	112795-21-701	EA GLASS-STATIONARY - EXCEL	390-019132
4	112795-01-701	EA SLIDE-STOP - EXCEL	132-019092
5	098644-01-710	FT TRACK-SCREEN SPACER, 12' LENGTH - EXCEL	M401-31

EXCEL BEDROOM HORIZONTAL SLIDER WINDOW - DR SIDE - THERMOPANE WINDOW OPTION (CONTINUED)

KEY	PART NUMBER	U/M DESCRIPTION	VENDOR NO.
6	112795-01-700	EA LATCH ASM-BLACK - EXCEL	DH287-CK
7	112795-01-703	IN RUN CHANNEL - EXCEL	122-018736
8	098644-01-711	FT WEATHERSTRIP-SCREEN, BLACK - EXCEL	171-016965
9	098647-29-704	EA SCREEN W/SPRING & WEATHERSTRIP - EXCEL	410-018864
10	098644-01-713	EA CLIP-SPRING, BLACK PLASTIC - EXCEL	226-016966
11	112795-21-702	EA GLASS-SLIDING, W/SASH & LATCH - EXCEL	DC04-G9
12	112795-01-704	FT PLUG-FILLER (DOUBLE GLAZED) - EXCEL	122-018737

EXCEL BEDROOM HORIZONTAL SLIDER WINDOW - PASSENGER SIDE - THERMOPANE WINDOW OPTION

KEY	PART NUMBER	U/M DESCRIPTION	VENDOR NO.
	112795-21-01A	EA WINDOW-HORIZONTAL SLIDER, W/RETAINER - EXCEL DC04G2W66R	
	098647-29-701	EA RETAINER-TRIM, OFF WHITE - EXCEL	CW0466
1	112795-21-700	EA WINDOW-HORIZONTAL SLIDER, W/O RETAINER - EXCEL	DC04-G2R
2	112795-01-705	FT VINYL-GLAZING - EXCEL	132-019702
3	112795-21-701	EA GLASS-STATIONARY - EXCEL	390-019132
4	112795-01-701	EA SLIDE-STOP - EXCEL	132-019092
5	098644-01-710	FT TRACK-SCREEN SPACER, 12' LENGTH - EXCEL	M401-31
6	112795-01-700	EA LATCH ASM-BLACK - EXCEL	DH287-CK
7	112795-01-703	IN RUN CHANNEL - EXCEL	122-018736
8	098644-01-711	FT WEATHERSTRIP-SCREEN, BLACK - EXCEL	171-016965
9	098647-29-704	EA SCREEN W/SPRING & WEATHERSTRIP - EXCEL	410-018864
10	098644-01-713	EA CLIP-SPRING, BLACK PLASTIC - EXCEL	226-016966
11	112795-21-702	EA GLASS-SLIDING, W/SASH & LATCH - EXCEL	DC04-G9
12	112795-01-704	FT PLUG-FILLER (DOUBLE GLAZED) - EXCEL	122-018737

EXCEL DINETTE OR COUCH SINGLE SLIDING WINDOW - DRIVERS SIDE - THERMOPANE WINDOW OPTION

KEY	PART NUMBER	U/M DESCRIPTION	VENDOR NO.
	112795-15-01A	EA WINDOW-HORIZONTAL SLIDER, W/RETAINER - EXCEL DH287-G2W66L	
	098647-23-702	EA RETAINER-TRIM, OFF WHITE - EXCEL	W28766
1	112795-15-700	EA WINDOW-HORIZONTAL SLIDER, W/O RETAINER - EXCEL	DH287-G2L
2	112795-01-705	FT VINYL-GLAZING	132-019702
3	112795-15-701	EA GLASS-STATIONARY - EXCEL	390-019045
4	112795-01-701	EA SLIDE-STOP - EXCEL	132-019092
5	098644-01-710	FT TRACK-SCREEN SPACER, 12' LENGTH - EXCEL	M401-31
6	112795-01-700	EA LATCH ASM-BLACK - EXCEL	DH287-CK
7	112795-01-703	IN RUN CHANNEL - EXCEL	122-018736
8	098644-01-711	FT WEATHERSTRIP-SCREEN, BLACK - EXCEL	171-016965
9	098647-23-704	EA SCREEN W/SPRING & WEATHERSTRIP - EXCEL	410-019066
10	098644-01-713	EA SPRING-SCREEN FRAME (CLIP), PLASTIC - BLACK - EXCEL	226-016966
11	112795-15-702	EA GLASS-SLIDING, W/SASH & LATCH - EXCEL	DH287-G9
12	112795-01-704	FT PLUG FILLER (DOUBLE GLAZED) - EXCEL	122-018737

EXCEL SWIVEL CHAIRS SINGLE SLIDING WINDOW - PASS SIDE - THERMOPANE WINDOW OPTION

KEY	PART NUMBER	U/M DESCRIPTION	VENDOR NO.
	112795-17-01A	EA WINDOW-HORIZONTAL SLIDER, W/RETAINER- EXCEL DC80G2W66R	
	112795-17-703	EA RETAINER-TRIM, WHITE - EXCEL	CW8066
2	112795-01-705	FT VINYL-GLAZING	132-019702
3	112795-17-700	EA GLASS-STATIONARY - EXCEL	390-019041
4	112795-01-701	EA SLIDE-STOP - EXCEL	132-019092
5	098644-01-710	FT TRACK-SCREEN SPACER, 12' LENGTH - EXCEL	M401-31
6	112795-01-700	EA LATCH ASM-BLACK - EXCEL	DH287-CK
7	112795-01-703	IN RUN CHANNEL - EXCEL	122-018736
8	098644-01-711	FT WEATHERSTRIP-SCREEN, BLACK - EXCEL	171-016965
9	112795-17-702	EA SCREEN W/SPRING & WEATHERSTRIP - EXCEL	410-019064
10	098644-01-713	EA SPRING-SCREEN FRAME (CLIP), PLASTIC - BLACK - EXCEL	226-016966
11	112795-17-701	EA GLASS-SLIDING, W/SASH & LATCH - EXCEL	DH80-G9
12	112795-01-704	FT PLUG FILLER (DOUBLE GLAZED) - EXCEL	122-018737

WINDOW, VENT & EXTERIOR DOOR GROUP (CONTINUED)

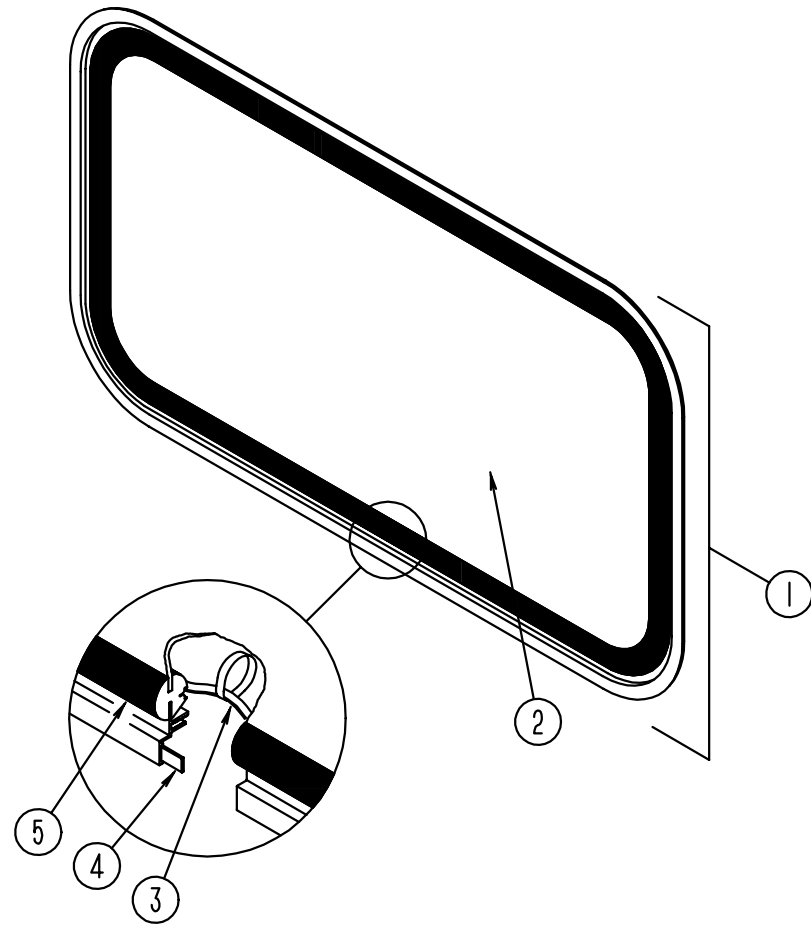

BACKWALL ESCAPE WINDOW

KEY	PART NUMBER	U/M DESCRIPTION
	074816-11-000	EA RETAINER-TRIM, ESCAPE WINDOW - OFF WHITE
1	078528-06-E10	EA WINDOW-ESCAPE, BACKWALL - W/O RETAINER
2	076337-12-000	EA GLASS-WINDOW, ESCAPE - 1157.4 MM X 548.1 MM
3	002285-01-000	FT FILLER-WEATHER STRIP, RUBBER - BLACK
	077066-01-702	EA TAPE ASM-ESCAPE WINDOW, RED
4	069640-10-000	FT SEALER-RIBBON, 1/32" X 1 1/2" - INCREMENTS OF 90'
5	002282-09-000	EA WEATHERSTRIP-WINDOW, .125" X 130.53" - BLACK

EXCEL BACKWALL ESCAPE WINDOW - THERMOPANE WINDOW OPTION

KEY	PART NUMBER	U/M DESCRIPTION	VENDOR NO.
	113502-01-01A	EA WINDOW-ESCAPE, BACKWALL - W/INSIDE FRAME - EXCEL DH153-G2W60	
	098644-01-705	FT GLAZING-STRIP	132-010231
	112898-06-704	EA LOCK-HANDLE, CAM - RED - RH	182-11293
	112898-06-705	EA LOCK-HANDLE, CAM - RED - LH	182-11294
	113502-01-703	EA GLASS-STATIONARY, RT & LT	390-019083
	113502-01-704	EA GLASS-EGRESS, CENTER-ESCAPE	390-019084

WINDOW, VENT & EXTERIOR DOOR GROUP (CONTINUED)

EXCEL FRONT SLANT WINDOW - DRIVERS SIDE - DRIVER DOOR

KEY	PART NUMBER	U/M DESCRIPTION	VENDOR NO.
	106468-02-01A	EA WINDOW-FRONT SLANT, W/RETAINER - EXCEL H383-A2B27L	
	100322-01-703	FT STRIP-GLAZING, BUTYL - EXCEL	132-010723
	106468-02-701	EA RETAINER-TRIM - EXCEL	H383-27L
	106468-02-702	EA GLASS-STATIONARY - EXCEL	106-018740

EXCEL FRONT SLANT WINDOW - DRIVERS SIDE - DRIVER DOOR & THERMOPANE WINDOW OPTION

KEY	PART NUMBER	U/M DESCRIPTION	VENDOR NO.
	115999-02-01A	EA WINDOW-FRONT SLANT, W/RETAINERS - EXCEL	
	115999-01-701	EA RETAINER-TRIM - EXCEL	H358-27L
	115999-02-700	EA RETAINER-TRIM RAIL, REAR - EXCEL	H383-41L
	115999-03-701	EA GLASS-STATIONARY - EXCEL	390-019550
	116000-01-704	FT STRIP-GLAZING, VINYL- EXCEL	132-018161

EXCEL VISTA WINDOW - DRIVERS SIDE - DRIVER DOOR & THERMOPANE WINDOW OPTION

KEY	PART NUMBER	U/M DESCRIPTION	VENDOR NO.
	116000-05-01A	EA WINDOW-VISTA, W/RETAINERS - EXCEL	
	116000-01-704	FT STRIP-GLAZING, VINYL- EXCEL	132-018161
	116000-04-701	EA RETAINER-TRIM RAIL, TOP/REAR - EXCEL	H382-41L
	116000-04-702	EA RETAINER-TRIM RAIL, FRONT - EXCEL	H382-42L
	116000-04-703	EA RETAINER-TRIM RAIL, BOTTOM - EXCEL	H382-43L
	116000-05-700	EA GLASS-STATIONARY - EXCEL	390-019688

WINDOW, VENT & EXTERIOR DOOR GROUP (CONTINUED)

EXCEL DINETTE OR COUCH SINGLE SLIDING WINDOW - DRIVERS SIDE

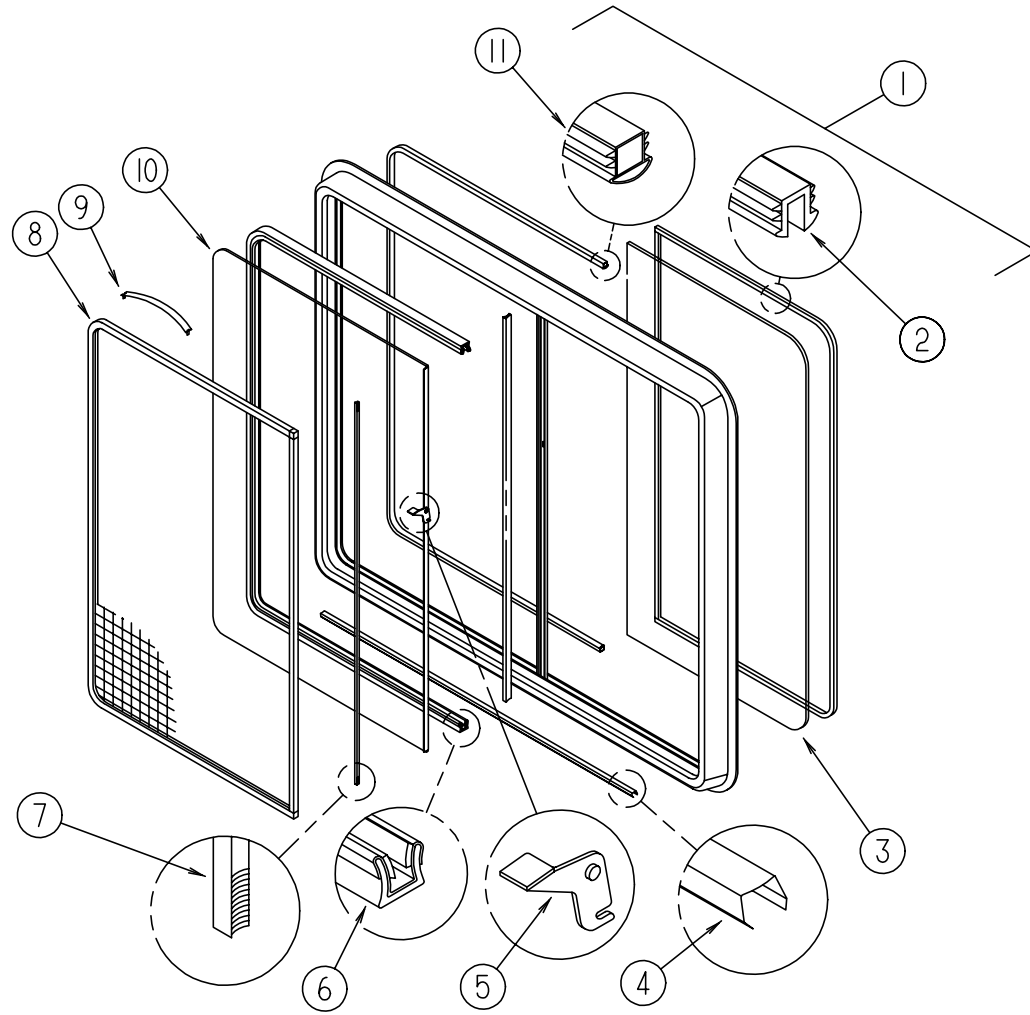

KEY	PART NUMBER	U/M	DESCRIPTION	VENDOR NO.
	098647-22-01A	EA	WINDOW-HORIZONTAL SLIDER, W/RETAINER - EXCEL H287-G2W66L	
	098647-23-702	EA	RETAINER-TRIM, OFF WHITE - EXCEL W28766	
1	098647-22-700	EA	WINDOW-HORIZONTAL SLIDER, W/O RETAINER - EXCEL	H287-G2L
2	098644-01-705	FT	STRIP-GLAZING - EXCEL	132-010231
3	098647-23-703	EA	GLASS-STATIONARY - EXCEL	106-017622
4	098644-01-710	FT	TRACK-SCREEN SPACER, 12' LENGTH - EXCEL	M401-31
5	098644-01-700	EA	LATCH-REPAIR KIT, EXCEL	B801-CK
6	098644-01-708	FT	CHANNEL-PIERCED RUN, EXCEL	122-016543
7	098644-01-711	FT	WEATHERSTRIP-SCREEN BLACK - EXCEL	171-016965
8	098647-23-704	EA	SCREEN W/SPRING & WEATHERSTRIP - EXCEL	410-019066
9	098644-01-713	EA	SPRING-SCREEN FRAME (CLIP), PLASTIC - BLACK - EXCEL	226-016966
10	098647-23-700	EA	GLASS-SLIDING, W/SASH & LATCH - EXCEL	H287-G9
11	098644-01-716	FT	PLUG-FILLER, EXCEL	132-014470
	098644-01-706	FT	WEATHERSTRIP, EXCEL	171-010668
	098644-01-717	FT	SPLINE-SCREEN - EXCEL	132-004716
	098644-01-719	EA	STOP-SLIDER GLASS, EXCEL	132-014203

EXCEL SWIVEL CHAIRS SINGLE SLIDING WINDOW - PASSENGERS SIDE

KEY	PART NUMBER	U/M	DESCRIPTION	VENDOR NO.
	098647-24-01A	EA	WINDOW-HORIZONTAL SLIDER, W/RETAINER - EXCEL H415-G2W66R	
	098647-36-701	EA	RETAINER-TRIM, OFF WHITE - EXCEL	CW8066
1	098647-24-700	EA	WINDOW-HORIZONTAL SLIDER, W/O RETAINER - EXCEL	H415-G2R
2	098644-01-705	FT	STRIP-GLAZING - EXCEL	132-010231
3	098647-35-701	EA	GLASS-STATIONARY - EXCEL	106-019119
4	098644-01-710	FT	TRACK-SCREEN SPACER, 12' LENGTH - EXCEL	M401-31
5	098644-01-700	EA	LATCH-REPAIR KIT, EXCEL	B801-CK
6	098644-01-708	FT	CHANNEL-PIERCED RUN, EXCEL	122-016543
7	098644-01-711	FT	WEATHERSTRIP-SCREEN BLACK - EXCEL	171-016965
8	098647-36-704	EA	SCREEN W/SPRING & WEATHERSTRIP - EXCEL	410-017550
9	098644-01-713	EA	SPRING-SCREEN FRAME (CLIP), PLASTIC - BLACK - EXCEL	226-016966
10	098647-35-702	EA	GLASS-SLIDING, W/SASH & LATCH - EXCEL	H279-G9
11	098644-01-716	FT	PLUG-FILLER, EXCEL	132-014470
	098644-01-706	FT	WEATHERSTRIP, EXCEL	171-010668
	098644-01-717	FT	SPLINE-SCREEN, EXCEL	132-004716
	098644-01-719	EA	STOP-SLIDER GLASS, EXCEL	132-014203

EXCEL GALLEY WINDOW

KEY	PART NUMBER	U/M	DESCRIPTION	VENDOR NO.
	098647-33-01A	EA	WINDOW-HORIZONTAL SLIDER, W/RETAINER - EXCEL H425-G2W66R	
	098647-33-701	EA	RETAINER-TRIM, OFF WHITE - EXCEL	CW2966
1	098647-33-700	EA	WINDOW-HORIZONTAL SLIDER, W/O RETAINER - EXCEL	H425-G2R
2	098644-01-705	FT	STRIP-GLAZING - EXCEL	132-010231
3	098647-33-702	EA	GLASS-STATIONARY - EXCEL	106-019297
4	098644-01-710	FT	TRACK-SCREEN SPACER, 12' LENGTH - EXCEL	M401-31
5	098644-01-700	EA	LATCH-REPAIR KIT, EXCEL	B801-CK
6	098644-01-708	FT	CHANNEL-PIERCED RUN, EXCEL	122-016543
7	098644-01-711	FT	WEATHERSTRIP-SCREEN BLACK - EXCEL	171-016965
8	098647-33-704	EA	SCREEN W/SPRING & WEATHERSTRIP - EXCEL	410-019134
9	098644-01-713	EA	SPRING-SCREEN FRAME (CLIP), PLASTIC - BLACK - EXCEL	226-016966
10	098647-33-703	EA	GLASS-SLIDING, W/SASH & LATCH - EXCEL	H425-G9
11	098644-01-716	FT	PLUG-FILLER, EXCEL	132-014470
	098644-01-706	FT	WEATHERSTRIP, EXCEL	171-010668
	098644-01-717	FT	SPLINE-SCREEN, EXCEL	132-004716
	098644-01-719	EA	STOP-SLIDER GLASS, EXCEL	132-014203

WINDOW, VENT & EXTERIOR DOOR GROUP (CONTINUED)

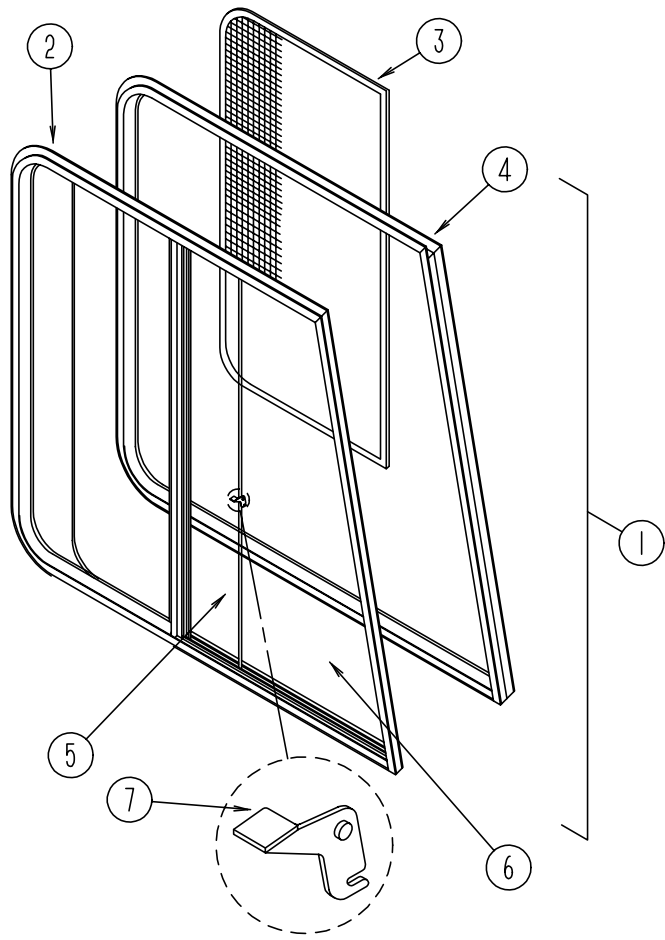

EXCEL CAB WINDOWS

KEY	PART NUMBER	U/M DESCRIPTION	VENDOR NO.
1	103658-09-01A	EA WINDOW-CAB W/RETAINER - DRIVER SIDE - EXCEL	H405-A2B66L
1	103658-10-01A	EA WINDOW-CAB W/RETAINER - PASSENGER SIDE - EXCEL	H405-A2B66R
2	103658-09-701	EA WINDOW ASM, W/O RETAINER - DRIVER SIDE	H405-A2L
2	103658-10-700	EA WINDOW ASM, W/O RETAINER - PASSENGER SIDE	H405-A2R
3	103658-09-705	EA SCREEN ASSEMBLY - DRIVER SIDE	410-018973L
3	103658-10-704	EA SCREEN ASSEMBLY - PASSENGER SIDE	410-018973R
	098644-01-717	FT SPLINE-SCREEN	132-004716
	098644-01-713	EA CLIP-SPRING, BLACK PLASTIC	226-016966
	098644-01-710	FT TRACK-SCREEN SPACER, 12'	132-017135
	098644-01-711	FT WEATHERSTRIP-SCREEN, BLACK	171-016965
4	103658-09-702	EA RETAINER-TRIM, DRIVER SIDE	H37366L & H37376L
4	098647-10-701	EA RETAINER-TRIM, PASSENGER SIDE	H37366R & H37376R
5	103658-09-704	EA GLASS-SLIDING, W/SASH & LATCH - DRIVER SIDE	H405-A9L
5	103658-10-703	EA GLASS-SLIDING, W/SASH & LATCH - PASSENGER SIDE	H405-A9R
6	103658-09-700	EA GLASS-STATIONARY, BOTTOM - DR OR PASS SIDE	106-018971
7	098644-01-700	EA LATCH-REPAIR KIT (BLACK)	B801-CK
	098644-01-706	FT WEATHERSTRIP-GLASS	171-010668
	098644-01-708	FT CHANNEL-RUN, PIERCED	122-016543
	098644-01-716	FT PLUG-FILLER	132-014470

WINDOW, VENT & EXTERIOR DOOR GROUP (CONTINUED)

EXCEL CAB WINDOW - DRIVER SIDE - THERMOPANE WINDOW OPTION

KEY	PART NUMBER	U/M DESCRIPTION	VENDOR NO.
	113501-03-01A	EA WINDOW-CAB, SINGLE SLIDER - W/RETAINER - EXCEL	DH405-A2B66
	103658-09-702	EA RETAINER-TRIM, EXCEL	H37366L & H37376L
	113501-03-700	EA WINDOW-SINGLE SLIDER, W/O RETAINER - EXCEL	DH405-A2L
	098644-01-711	FT WEATHERSTRIP-SCREEN, BLACK - EXCEL	171-016965
	098644-01-713	EA CLIP-SPRING, BLACK PLASTIC - EXCEL	226-016966
	098644-01-717	FT SPLINE-SCREEN	132-004716
	103658-09-705	EA SCREEN ASSEMBLY - EXCEL	410-018973L
	112795-01-700	EA LATCH ASM, BLACK - EXCEL	DH287-CK
	112795-01-701	EA SLIDE-STOP - EXCEL	132-019092
	112795-01-703	IN CHANNEL-RUN - EXCEL	122-018736
	112795-01-704	FT PLUG FILLER (DOUBLE GLAZED) - EXCEL	122-018737
	112795-01-705	FT VINYL-GLAZING - EXCEL	132-019702
	112898-04-703	EA SASH LATCH KIT, RAISED - EXCEL	DH343-CK
	113501-03-701	EA GLASS-STATIONARY - EXCEL	390-019397L
	113501-03-702	EA GLASS-SLIDE ASSEMBLY - EXCEL	DH405-A9L

EXCEL CAB WINDOW - PASSENGER SIDE - THERMOPANE WINDOW OPTION

KEY	PART NUMBER	U/M DESCRIPTION	VENDOR NO.
	113501-04-01A	EA WINDOW-CAB, SINGLE SLIDER - W/RETAINER - EXCEL	DH405-A2B66
	103658-10-701	EA RETAINER-TRIM, EXCEL	H37366R & H37376R
	113501-04-700	EA WINDOW-SINGLE SLIDER, W/O RETAINER - EXCEL	DH405-A2R
	113501-04-701	EA GLASS-STATIONARY - EXCEL	390-019395R
	113501-04-702	EA GLASS-SLIDING, W/SASH & LATCH - EXCEL	DH405-A9R
	103658-10-704	EA SCREEN W/SPRING & WEATHERSTRIP - EXCEL	410-018973R
	098644-01-711	FT WEATHERSTRIP-SCREEN, BLACK - EXCEL	171-016965
	098644-01-713	EA CLIP-SPRING, BLACK PLASTIC - EXCEL	226-016966
	098644-01-717	FT SPLINE-SCREEN	132-004716
	112795-01-700	EA LATCH ASM., BLACK - EXCEL	DH287-CK
	112795-01-701	EA SLIDE-STOP - EXCEL	132-019092
	112795-01-703	IN CHANNEL-RUN - EXCEL	122-018736
	112795-01-704	FT PLUG FILLER (DOUBLE GLAZED) - EXCEL	122-018737
	112795-01-705	FT VINYL-GLAZING - EXCEL	132-019702
	112898-04-703	EA SASH LATCH KIT, RAISED - EXCEL	DH343-CK

**WINDSHIELD & WIPER GROUP
WIPER COMPONENTS**

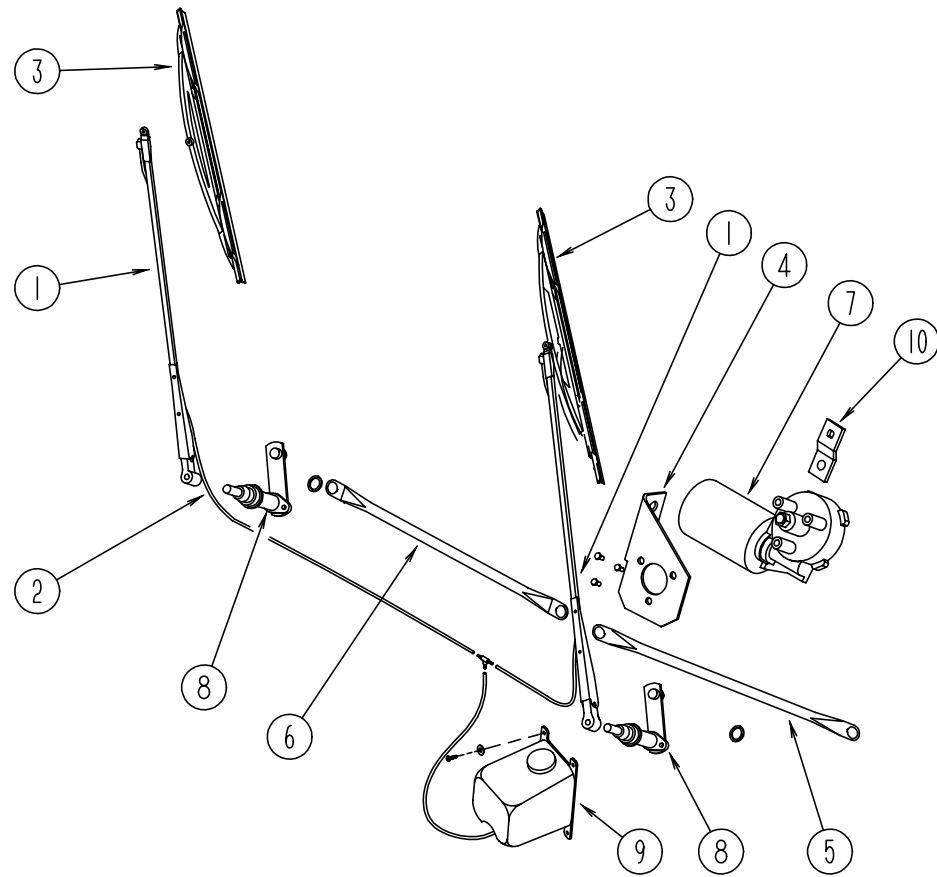

KEY	PART NUMBER	U/M	DESCRIPTION	VENDOR NO.
1	103671-01-000	EA	ARM-WIPER, PANTOGRAPH - 24"	
	096931-01-700	FT	HOSE-WIPER, TO BLADE	
	096931-01-701	EA	NOZZLE-HARDWARE KIT, INCLUDES NOZZLE, NUT, SHORT THREAD SCREW, LONG THREAD SCREW, AND PLASTIC CAP	
2	045794-01-000	FT	HOSE-WASHER, WINDSHIELD - 5/32" ID - BLACK	
3	095964-01-000	EA	BLADE-WIPER, 24"	
	095964-01-700	EA	REFILL-WIPER BLADE, 24" - PAIR	
4	104549-01-000	EA	BRACKET ASSEMBLY-WIPER MOTOR	
5	117008-01-000	EA	LINK ASM - CONNECTING - DRIVERS SIDE	
6	117008-02-000	EA	LINK ASM - CONNECTING - PASSENGERS SIDE	
7	104346-03-000	EA	MOTOR-WIPER, FORD CHASSIS	
				FROM: 00-00-00 THRU: 08-31-95
7	104346-05-000	EA	MOTOR-WIPER, FORD CHASSIS	
7	104346-02-000	EA	MOTOR-WIPER, CHEVY CHASSIS - UT 63098-20-M012WJ	
				FROM: 09-01-95 THRU: 99-99-99
7	104346-04-000	EA	MOTOR-WIPER, CHEVY CHASSIS - UT 65714M02025WJ	
				FROM: 00-00-00 THRU: 11-19-95
				FROM: 11-20-95 THRU: 99-99-99
	110178-01-000	EA	HOUSING-WIPER MOTOR - UT 6237440-EC25WJ	
	117322-01-000	EA	SCREW - 1/4-28 UNF-2A, TORX - U.T. 6270020 SC25WJ	
8	096505-05-000	EA	PIVOT & SHAFT ASM-WIPER, PASSENGER WINDSHIELD	
8	096505-06-000	EA	PIVOT & SHAFT ASM-WIPER, DRIVER WINDSHIELD	
	096505-02-700	EA	DRIVER-KNURLED,(HD) BRL .687	NT721017
	096505-02-701	EA	NUT-HEX (HD) W/.687 BARREL	NT721021
	096505-02-702	EA	CAP-RUBBER (HD) BARREL .687	CP721084
	096505-02-703	EA	CAP-NUT(ACORN) HD W/.687 BRL	51065-40-NT27WC
9	117766-02-000	EA	WASHER-WINDSHIELD, BOTTLE & PUMP - MCCORD 600328	
	110605-01-000	EA	TEE-BARBED, 1/8 X 1/8 X 3/16 - BAYLOCK 3799721	
	110934-01-000	EA	CONNECTOR-BARB, 5/16" - PLASTIC - KEVCO TC 7055	
	117765-03-000	EA	CONNECTOR - 5/32 W/SWSH - ITT H-BAYLOCK 116756	
10	104347-01-000	EA	ARM-DRIVE, WIPER MOTOR - 1.54"	
	061603-01-000	EA	GROMMET-SNAP, 3/16 ID - 3/8 HOLE - PLASTIC - BLACK	
	067188-01-000	EA	STUD-CRANK, WIPER	
	110742-01-000	EA	GASKET-WIPER	

WINDSHIELD & WIPER GROUP (CONTINUED)
WINDSHIELD MOLDINGS & GLASS

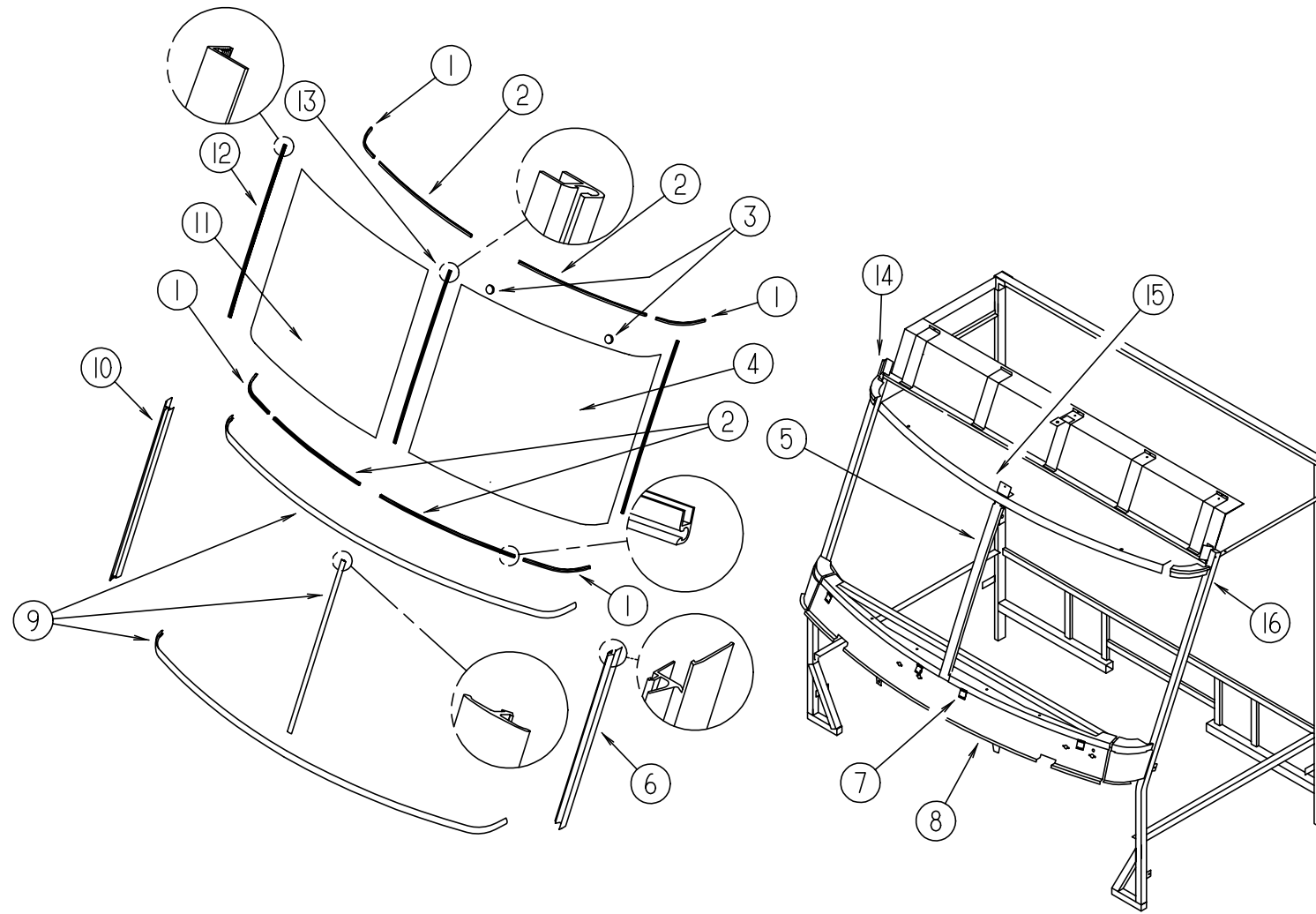

KEY	PART NUMBER	U/M DESCRIPTION
1	110268-01-000	EA CARRIER - REVEAL - 50.4" WINDSHIELD
2	110268-01-000	EA CARRIER - REVEAL - 50.4" WINDSHIELD
3	081914-01-000	EA BUMPER - RUBBER - ROUND - .43" DIAMETER - BLACK
4	088793-04-000	EA GLASS-WINDSHIELD, DRIVER
5	075710-03-000	EA FRAME-WINDSHIELD, CENTER DIVIDER - INNER
6	103107-02-01A	EA TRIM-WINDSHIELD, DRIVER SIDE - BLACK
7	104449-01-000	EA BRACKET - WINDSHIELD SUPPORT
8	077847-02-000	EA SUPPORT - WINDSHIELD - LOWER - W/O BRACKETS
9	102936-01-000	FT MOLDING - REVEAL - WINDSHIELD
10	103107-01-01A	EA TRIM - WINDSHIELD - PASSENGER SIDE - BLACK

KEY	PART NUMBER	U/M DESCRIPTION
11	088793-03-000	EA GLASS-WINDSHIELD, PASSENGER
12	098788-06-000	EA CHANNEL - 49" PVC, DRIVER OR PASSENGER SIDE
13	110268-01-000	EA CARRIER - REVEAL - 50.4" WINDSHIELD
14	077922-03-000	EA HEADER WINDSHIELD END - PASSENGER SIDE
15	077922-05-000	EA HEADER WINDSHIELD - CENTER
16	077922-04-000	EA HEADER WINDSHIELD END - DRIVER SIDE
	002328-02-000	EA BLOCK-WINDSHIELD, .062" X .5" X .98"