

**1996
ICF31RQ**

G29

PEBBLE BEACH (BROWN)

G30

NEPTUNE (TEAL)

G31

GALAXY (BLUE)

G32

ROUTE 66

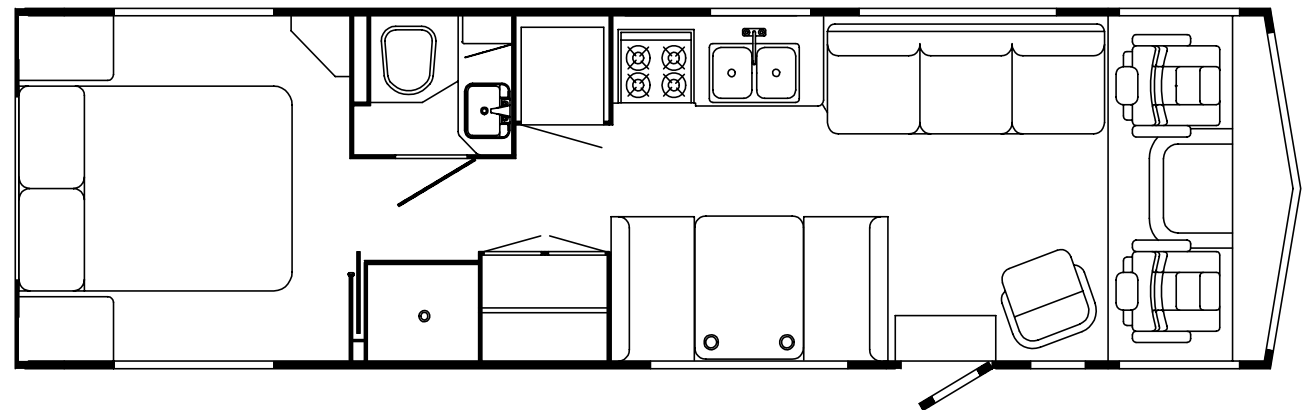
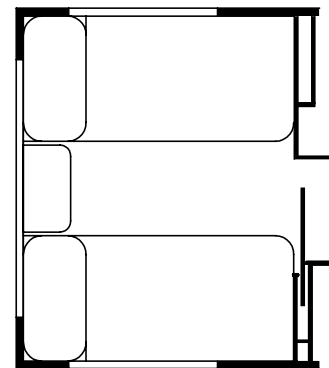
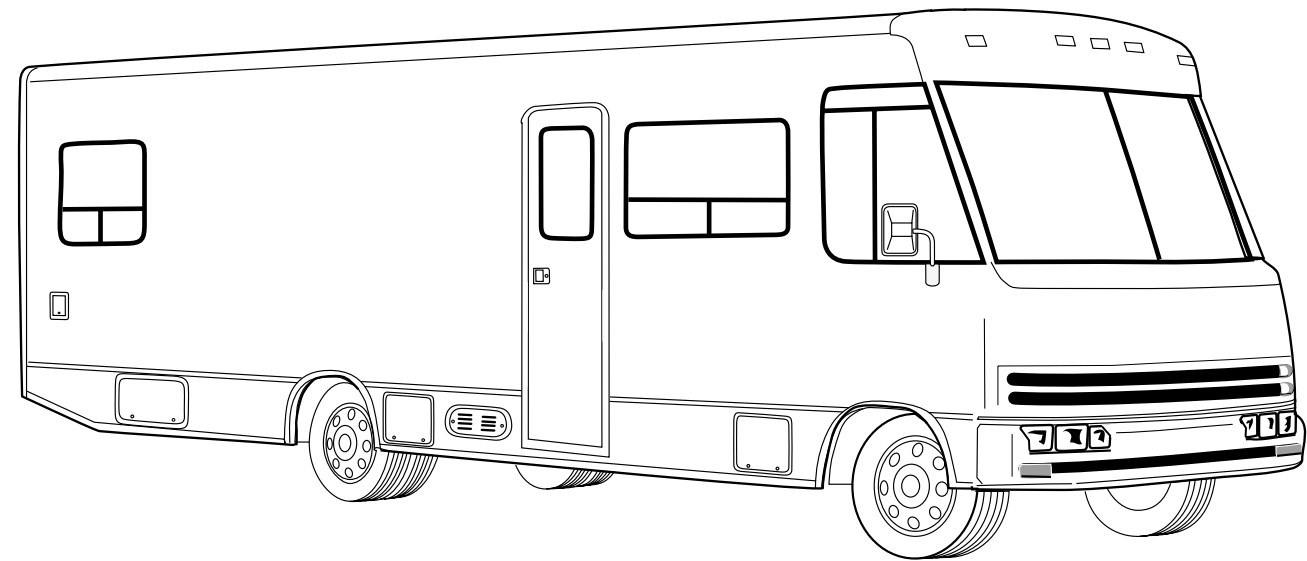

**ACCESSORIES GROUP
OPERATOR MANUAL**

KEY	PART NUMBER	U/M DESCRIPTION
	054185-E7-000	EA MANUAL, OPERATOR 96 SUNRISE - F-SERIES
	092318-01-000	EA BINDER - 3 RING, MOTOR HOME MANUAL
	092319-01-000	EA POCKET PAGE - RING BINDER, PLASTIC
	117907-01-000	DW TOP LEVEL DRAWING-F, 1996

**AUDIO VIDEO GROUP
PATIO ENTERTAINMENT CENTER**

KEY	PART NUMBER	U/M DESCRIPTION
	077069-02-000	EA CABLE-ANTENNA, RADIO - EXTENSION 96" - ARA 6700667
	087683-03-000	EA RADIO-AM/FM STEREO CASSETTE - AUDIOVOX RS-100
	090944-01-000	EA ANTENNA-RADIO, 16" RUBBER
	108847-01-000	EA BRACKET-ANTENNA GROUND
	109889-04-000	EA ANTENNA-SHAFT EXTENDER 3" - MAGNADYNE RV71EX3
	110469-01-000	EA SPEAKER - 4 X 6 OVAL, COAXIAL - MAGNADYNE F46XB-12
	110470-01-01A	EA GRILLE-SPEAKER, OVAL 4 X 6 BLK - MAGNADYNE G46WI

RADIO SYSTEM & ANTENNA

KEY	PART NUMBER	U/M DESCRIPTION
	116148-02-000	EA RADIO-AM/FM STEREO, CD PLAYER - CLARION RDB515F
	110267-03-000	EA RADIO-AM/FM STEREO - AUDIOVOX IM-400
	077069-02-000	EA CABLE-ANTENNA, RADIO - EXTENSION 96" - ARA 6700667
	090944-01-000	EA ANTENNA-RADIO, 16" RUBBER
	081059-02-000	EA WIRE ASM - 9-PIN, RADIO - AUDIOVOX 112B-1761
	089340-02-000	EA GRILLE-SPEAKER, 6.5" SQUARE
	089340-03-000	EA SPACER-GRILLE, 6.5" SQUARE - TAN - MAGNADYNE G514
	094097-01-000	EA SPEAKER-RADIO, W/O GRILLE - 5.25" DIA - AUDIOVOX 110C3030
	110469-01-000	EA SPEAKER - 4" X 6", OVAL - MAGNADYNE F46XB-12
	110470-01-01A	EA GRILLE-SPEAKER, OVAL - 4" X 6" - BLACK - MAGNADYNE G46WI

CB ANTENNA

KEY	PART NUMBER	U/M DESCRIPTION
	105248-01-000	EA ANTENNA-CB - ADVANCE 8604
	115916-01-01B	EA BRACKET-ANTENNA MOUNT, MILL

TV, VCR & COMPONENTS

KEY	PART NUMBER	U/M DESCRIPTION	VENDER NO.
	113684-01-000	EA TV - 19" COLOR UL AND CSA - AUDIOVOX AVT-1975	
	113684-01-700	EA REMOTE	8822345
	119120-01-000	EA VCR-VHS, CABLE READY - REMOTE - AUDIOVOX AVR-1075	
	119120-01-700	EA VCR-REMOTE	8874570
	092310-02-000	EA TV-COLOR, 9" - AC/DC - W/REMOTE - MAGNAVOX RD0945	
	092310-02-700	EA REMOTE-TV	0822334
	086757-03-000	EA CONTROL CENTER-SWITCH, VCR/TV - AUDIOVOX AVCC-100	
	086777-05-000	EA PLATE-WALL, ANTENNA 1 OUTPUT IVORY - WINEGARD RV-0921	
	093214-01-02A	EA GRILL-SPEAKER, 4" BROWN	
	098819-01-000	EA SPEAKER - 2 WATT, 8 OHM - 4"	
	099717-01-000	EA TIEDOWN-TV, STRAP ON FEMALE END IS 22.8" LONG	
	099717-02-000	EA TIEDOWN-TV, STRAP ON FEMALE END IS 28.7" LONG	
	076319-09-000	EA WALLPLATE-CABLE RECEPTACLE, TV - SINGLE - BROWN	
	076319-08-000	EA WALLPLATE-CABLE RECEPTACLE, TV - SINGLE - IVORY	
	086777-01-000	EA WALLPLATE-TV CABLE, W/ANTENNA SWITCH - IVORY	
	086777-03-000	EA PLATE-WALL, CABLE - W/TV ANTENNA SWITCH & BOOSTER - IVORY	
	076319-12-000	EA CONNECTOR-COAXIAL, ONE PIECE	
	082134-01-000	EA ADAPTER-TV, CABLE TO CABLE - WINEGARD F-81M	
	086756-01-000	EA SPLITTER-TV, 2 WAY	
	076319-03-000	FT CABLE-COAXIAL, 75 OHM	
	076319-06-000	EA ADAPTOR-CABLE ROOF PLATE - WINEGARD RPJ-1	
	114870-02-000	EA PLUG ASM - 3.5MM AUDIO W/LEADS - OW - DONALD 35-P8	

AUDIO VIDEO GROUP (CONTINUED)
SATELLITE DISK (WINEGARD)

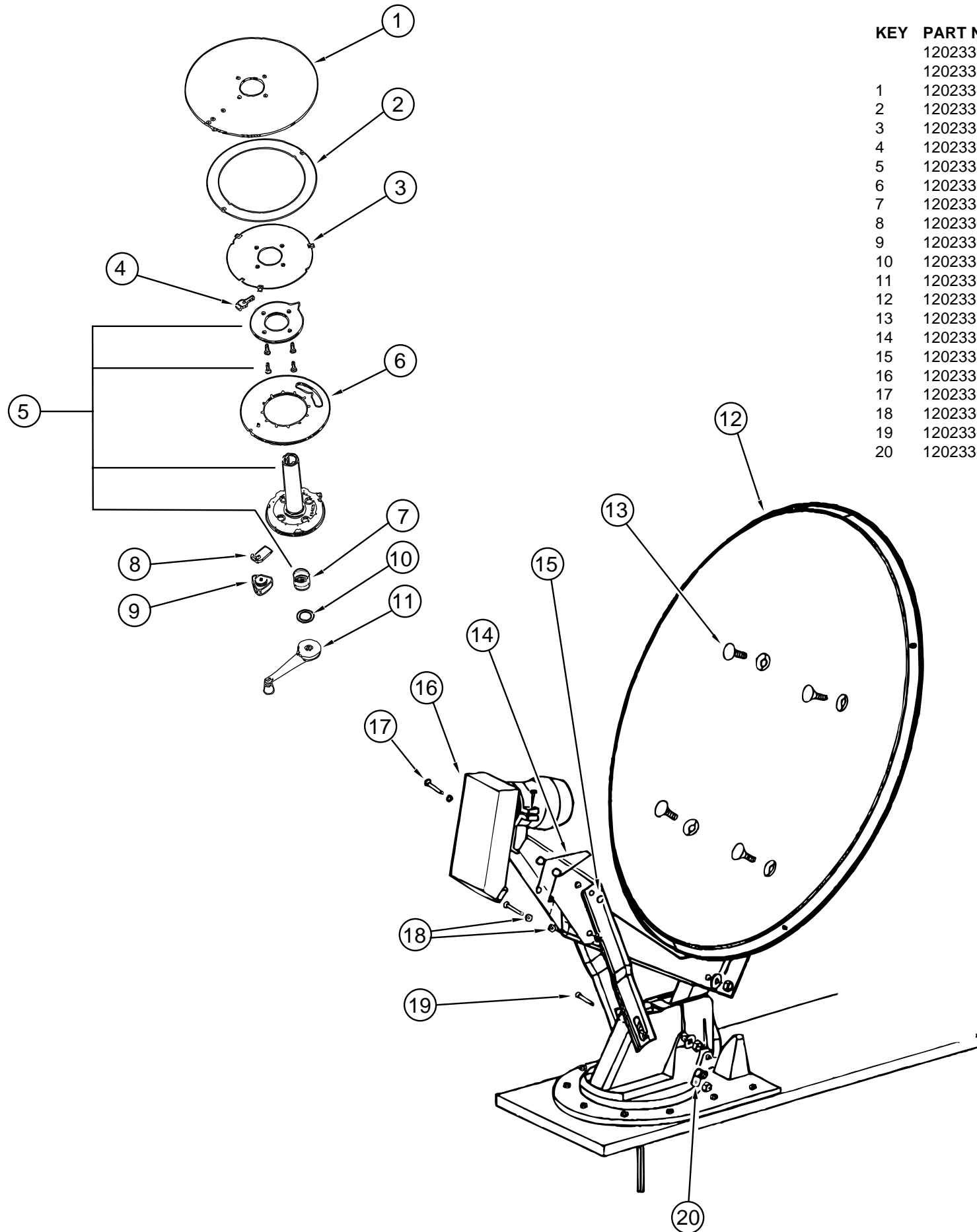

KEY	PART NUMBER	U/M	DESCRIPTION	VENDER NO.
	120233-02-000	EA	ANTENNA-SATELLITE W/RECEIVER - RD-1046	
	120233-01-000	EA	ANTENNA-SATELLITE DSS - RD-4600	
1	120233-01-700	EA	PLATE-FIXED	3750821
2	120233-01-701	EA	DIAL-DIRECTIONAL	2745056
3	120233-01-702	EA	PIVOT-DIAL-DIRECTIONAL	2745058
4	120233-01-703	EA	STOP-ROTATION	3711281
5	120233-01-704	EA	PLATE-CEILING W/DIRECTIONAL HANDLE	RP-6300
6	120233-01-705	EA	PLATE-ROTATE	3750820
7	120233-01-706	EA	SPRING	RP-6822
8	120233-01-707	EA	CLAMP-ROTATE	3711280
9	120233-01-708	EA	KNOB-CLAMP	160822
10	120233-01-709	EA	WASHER-NYLON	RP-2658
11	120233-01-710	EA	HANDLE-CRANK	RP-6795
12	120233-01-711	EA	REFLECTOR - 46 CM	2745304
13	120233-01-712	EA	BOLT-FLAT HEAD	2160253
14	120233-01-713	EA	SPRING	2160820
15	120233-01-714	EA	CLIP-E	5160818
16	120233-01-715	EA	RCA LNB	278015
17	120233-01-716	EA	PIN	2160814
18	120233-01-717	EA	BEARING-NYLON	2200728
19	120233-01-718	EA	PIN	5160817
20	120233-01-719	EA	CLAMP-CABLE	2200060

AUDIO VIDEO GROUP (CONTINUED)

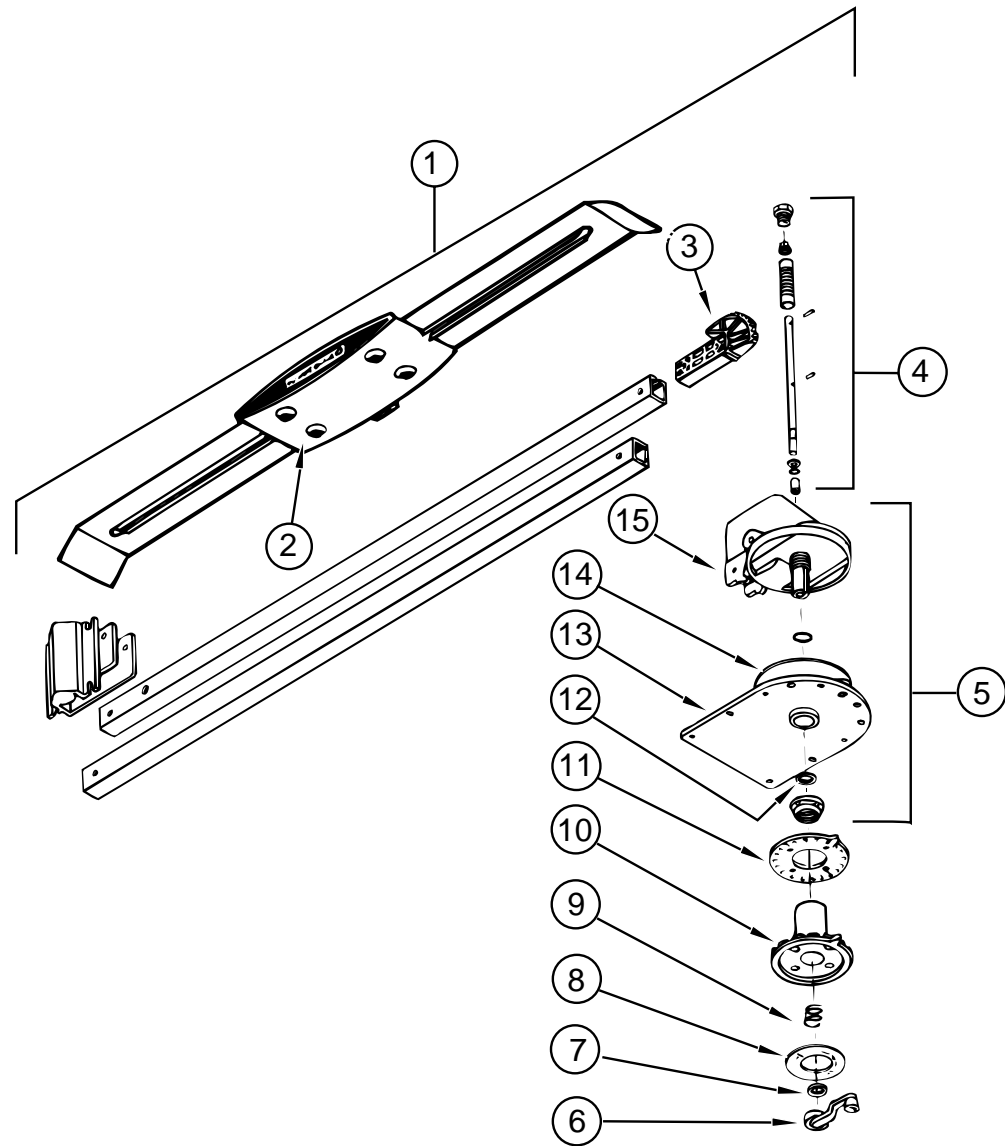

TV ANTENNA (WINEGARD)

KEY	PART NUMBER	U/M DESCRIPTION	VENDER NO.
1	076319-18-000	EA ANTENNA-TV, ROOF MOUNT - WI-0094	
2	076319-01-700	EA HEAD-ANTENNA, AMPLIFIED	RVSA U/V
3	076319-01-701	EA GEAR-ELEVATING, PLASTIC	2200046
4	076319-01-702	EA SHAFT ASM-ELEVATING	RVP-400A
5	076319-01-711	EA BASE & LIFT ASM	2762802
6	076319-01-706	EA CRANK-ELEVATING, W/SET SCREW	5755100
7	076319-01-705	EA GROMMET-NYLON, 7/8"ID	3200658
8	076319-01-708	EA CRANK COVER DECAL	5413002
9	076319-01-707	EA SPRING-HANDLE	5160800
10	076319-01-709	EA PLATE-DIRECTIONAL, FOR HEAD	3200644
11	076319-01-712	EA PLATE-CEILING	3200608
12	076319-01-704	EA BEARING-NYLON, 1.25"OD	3200657
13	076319-01-713	EA PLATE-BASE	3100523
14	076319-01-703	EA BEARING-NYLON, 5"OD	3200656
15	076319-01-714	EA HOUSING, ROTATING GEAR	2200049

BATH GROUP

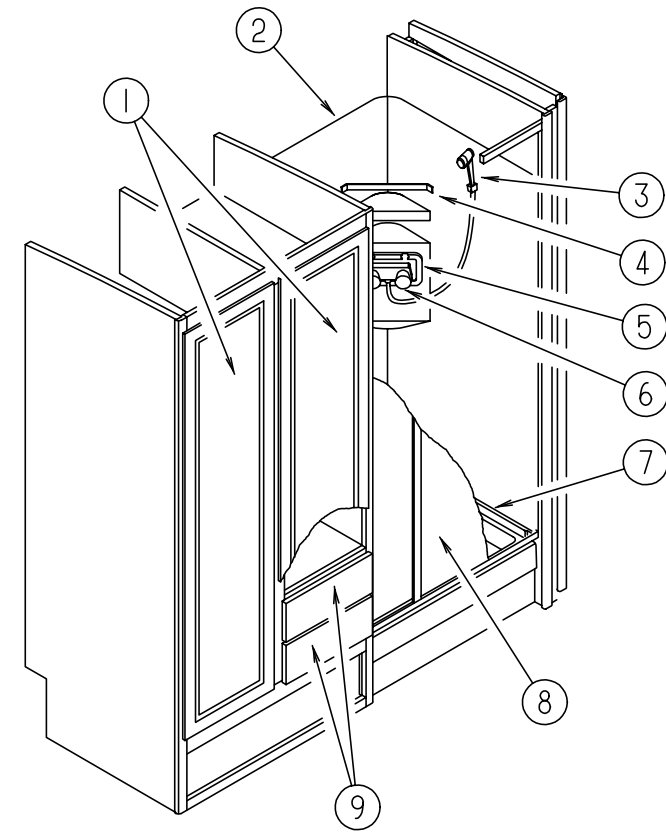

WARDROBE & SHOWER COMPONENTS

KEY	PART NUMBER	U/M DESCRIPTION	VENDER NO.
1	M06803-11-G09	EA DOOR ASM-W/O HARDWARE - 410 X 1660	
2	101805-01-01A	EA SURROUND-SHOWER, OFF WHITE	
3	103092-02-000	EA SHOWER HEAD-W/HOSE, CANADIAN	
3	103092-01-000	EA SHOWER HEAD-W/60" HOSE, US	
	103092-01-700	EA BRACKET ONLY-CLEAR FOR SHOWER	2328028
	011048-03-700	EA BRACKET ONLY-BONE FOR SHOWER	2328029-3
4	113714-02-01A	EA RETAINER-SHELF, SHOWER O/W	
5	075606-01-000	EA PANEL-FAUCET BACK, SHOWER - 5" X 9" - PLASTIC	
6	075241-05-000	EA FAUCET-SHOWER, BONE	
7	M02429-07-000	EA PAN-SHOWER	
	066436-01-000	EA NUT-SLIP, TAILPIECE - 1.5"	
	066440-01-000	EA STRAINER-SHOWER, W/RUBBER WASHER	
	011069-02-000	EA TAILPIECE-TUB/SHOWER, 1 1/2" X 1 1/4" X 4" - BRASS	
8	089318-01-000	EA DOOR-SHOWER, HINGED - W/GOLD FRAME - PLASTIC - 29.8" WIDE	
	089318-02-000	EA JAMB-EXPANDER	
	057671-01-000	EA COVER-SCREW, #8 - PLASTIC - OFF WHITE	
	089318-01-700	EA STRAP F/SHOWER DOOR	
	089318-01-701	EA VINYL SWEEP	C171G
	089318-01-702	EA BUSHING W/ARM	18712A
	089318-01-703	EA STRIKE-JAMB, W/MAGNETIC STRIP	150G
	092574-01-703	EA GOLD DOOR PULL	COASTAL 8149G
	092574-01-704	EA SCREW-GOLD, #6 3/8	COASTAL 638G
	092574-01-705	EA MAGNETIC STRIP - 56.9"	COASTAL 98-41
	092574-01-707	EA PIVOT BUSHING	18712B
	107878-01-702	EA BAR-TOWEL	68
9	P11023-03-G09	EA DRAWER COMPLETE-SLIDE	

BATH GROUP (CONTINUED)

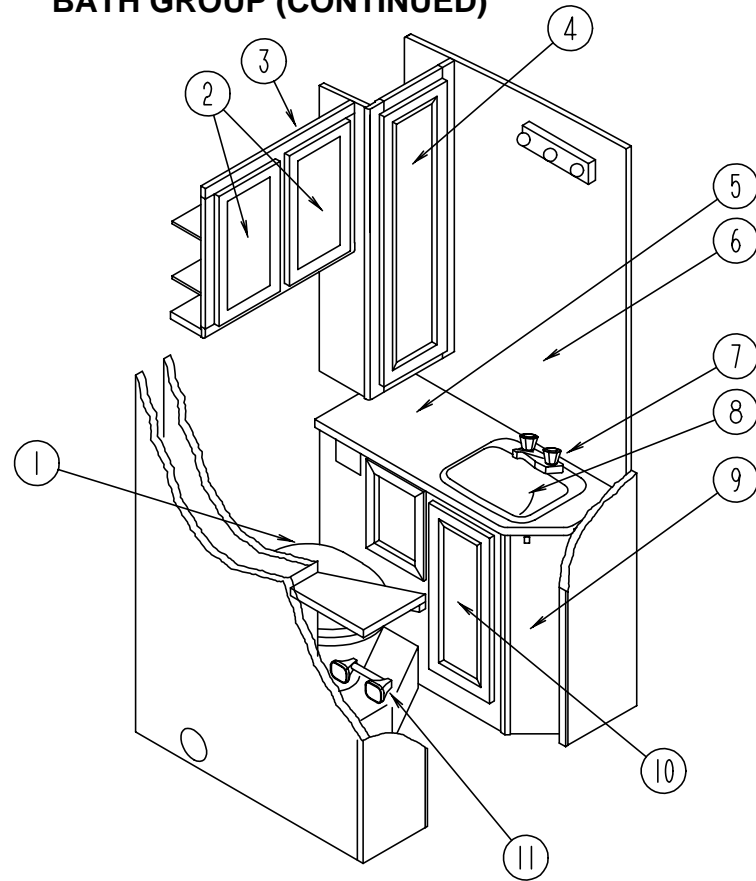

BATHROOM CABINET & COMPONENTS

KEY	PART NUMBER	U/M	DESCRIPTION	VENDER NO.
1	067487-02-000	EA	TOILET-12.37", IVORY - FOOT FLUSH - THETFORD	
	116644-01-000	EA	FLANGE-CLOSET, TOILET - 4" X 3" - US	
	024676-02-000	EA	FLANGE-CLOSET, 4" X 3" - ABS - CANADIAN	
2	M06803-13-G09	EA	DOOR-W/O HARDWARE - 285 X 500MM	
3	111178-01-G09	EA	CABINET ASM-LINEN	
4	M06803-10-G09	EA	DOOR-W/O HARDWARE - 275 X 925MM	
5	106300-11-G29	EA	COUNTERTOP ASM	
5	106300-11-G30	EA	COUNTERTOP ASM	
5	106300-11-F05	EA	COUNTERTOP ASM (G31)	
6	058331-51-000	EA	MIRROR-GLASS, SAFETY - 660 X 1016MM	
7	075240-06-000	EA	FAUCET-LAVATORY, BONE	
	091253-01-000	EA	GASKET-FAUCET, LAVATORY/GALLEY	
8	096927-01-01A	EA	SINK-LAVATORY, RECTANGULAR - PLASTIC - BONE	
	096927-01-700	EA	SINK-STOPPER	M9801
	096927-01-701	EA	TAILPIECE-SINK	M9802
9	P06300-01-G29	EA	CABINET ASM-LAVATORY, W/O DOORS OR HARDWARE	
9	P06300-01-G30	EA	CABINET ASM-LAVATORY, W/O DOORS OR HARDWARE	
9	P06300-01-G31	EA	CABINET ASM-LAVATORY, W/O DOORS OR HARDWARE	
9	P06300-01-G32	EA	CABINET ASM-LAVATORY, W/O DOORS OR HARDWARE	
10	M06803-12-G09	EA	DOOR-W/O HARDWARE - 285 X 500MM	
11	075452-02-000	EA	HOLDER-TOILET TISSUE, BRASS	
	075453-02-000	EA	BAR-TOWEL, 18" BRASS	
	100357-01-000	EA	ROD-TOWEL, BRASS W/ENDS BENT FOR BACK OF BATH DOOR	
	102089-13-E07	EA	WOOD RAIL - TOWEL RACK - RIGHT SIDE - 26" LONG	
	102089-14-E07	EA	WOOD RAIL - TOWEL RACK - LEFT SIDE - 26" LONG	
	M87868-10-G09	EA	BATH DOOR - FULL SWING	
	094485-03-01A	EA	KNOB-DOOR, BRASS - THUNADER	L132PB
	102920-01-01A	EA	HINGE-DOOR, SPRING LOADED - BRASS	
	104013-02-G09	EA	DOOR ASM-SLIDING	
	103874-01-000	EA	HANGER-SLIDING DOOR	
	103868-02-01A	EA	TRACK-DOOR, 1234 - O/W	

BATH GROUP (CONTINUED)

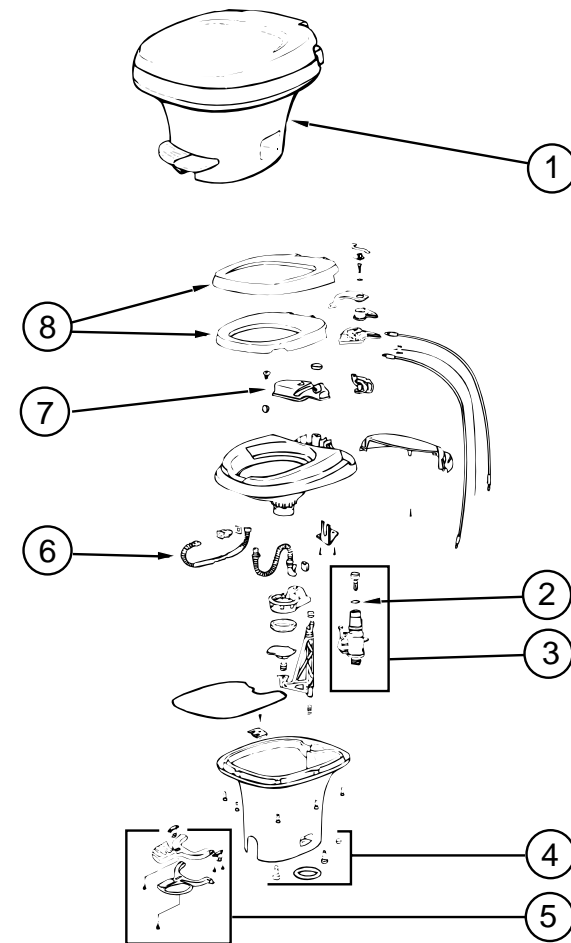

AQUA MAGIC IV - LOW - FOOT FLUSH TOILET (THETFORD)

KEY	PART NUMBER	U/M	DESCRIPTION	VENDER NO.
1	067487-02-000	EA	TOILET-AQUA MAGIC IV - LOW - FOOT FLUSH	
2	063740-01-713	EA	SEAL-BALL VALVE TO BOWL	12502
3	063740-01-714	EA	VALVE ASSEMBLY, WATER W/FLOAT & BALL SEAL	13168
4	063740-01-706	EA	BOLT PACKAGE-FLOOR FLANGE	12524
5	067487-02-701	EA	PEDAL PACKAGE (FOOT FLUSH)	20821
6	063740-01-717	EA	TUBE-FLUSH	12509
7	063740-02-701	EA	RESERVOIR (TANK ASM.)	24630
8	063740-02-700	EA	SEAT & COVER, PARCHMENT	2464157

BEDROOM GROUP
QUEEN BEDROOM CABINETS

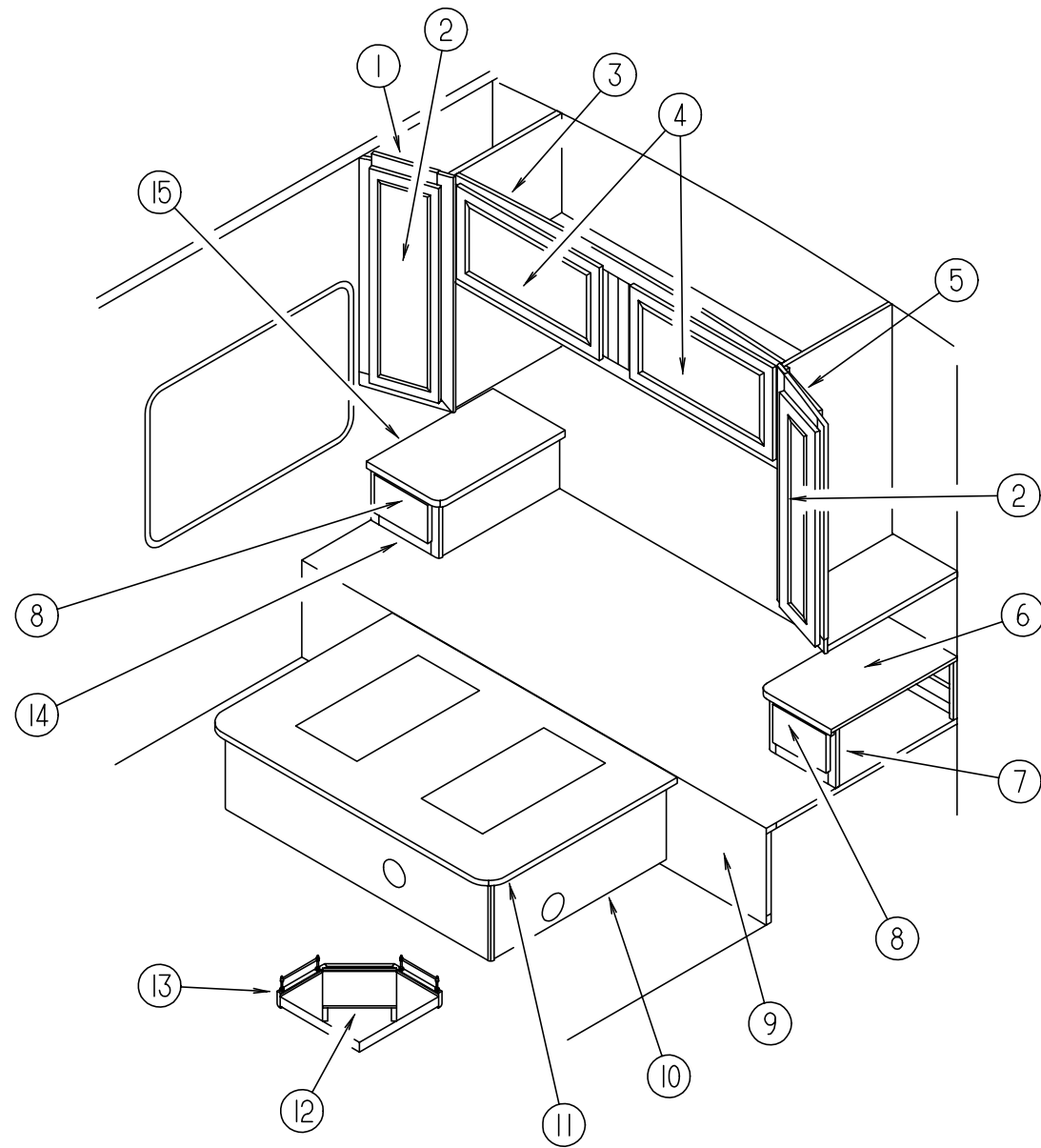

KEY	PART NUMBER	U/M	DESCRIPTION
1	110625-01-G09	EA	CABINET-SHIRT CLOSET, W/O DOOR OR HARDWARE
	009112-01-000	EA	FLANGE-1" ROD, CLOTHES - PLASTIC - OFF WHITE
	042438-01-000	EA	DOWEL-WOOD, CLOTHES ROD - 1" DIAMETER X 4'
2	M06803-10-G09	EA	DOOR-W/O HARDWARE - 275 MM X 925 MM
3	106523-01-G09	EA	CABINET-OVERHEAD, W/O DOORS OR HARDWARE
4	M06803-13-G09	EA	DOOR-W/O HARDWARE W/MIRROR - 400 MM X 710 MM
5	110625-02-G09	EA	CABINET-SHIRT CLOSET, W/O DOOR OR HARDWARE
	009112-01-000	EA	FLANGE-1" ROD, CLOTHES - PLASTIC - OFF WHITE
	042438-01-000	EA	DOWEL-WOOD, CLOTHES ROD - 1" DIAMETER X 4'
6	117901-12-G29	EA	COUNTERTOP-NIGHTSTAND
6	117901-12-G30	EA	COUNTERTOP-NIGHTSTAND
6	117901-12-G31	EA	COUNTERTOP-NIGHTSTAND
6	117901-12-G09	EA	COUNTERTOP-NIGHTSTAND (G32)
7	P17901-02-G29	EA	CABINET-NIGHTSTAND W/COUNTERTOP
7	P17901-02-G30	EA	CABINET-NIGHTSTAND W/COUNTERTOP
7	P17901-02-G31	EA	CABINET-NIGHTSTAND W/COUNTERTOP
7	P17901-02-G09	EA	CABINET-NIGHTSTAND W/COUNTERTOP (G32)
8	M05971-R3-G09	EA	DRAWER-CABINET, W/O HARDWARE - 155 MM X 290 MM FACE SIZE
9	P10624-01-000	EA	CABINET-COMPARTMENT, W/O CARPET OR TOP
10	P10623-01-G09	EA	CABINET-QUEEN BED W/O TOP
11	M05706-09-000	EA	TOP-QUEEN BED CABINET
12	116553-15-G09	EA	WEDGE-TV
13	116553-02-G09	EA	SHELF ASM-TV, W/BRASS RAILING & WEDGE - 420 MM X 410 MM
	084070-02-000	EA	POST-END, 2.4" - BRASS
	084071-12-000	EA	ROD-BRASS, 104 MM LONG
	084071-19-000	EA	ROD-BRASS, 198 MM LONG
	105219-01-G09	EA	CABINET ASM-SHELF
14	P17901-01-G29	EA	CABINET-NIGHTSTAND W/COUNTERTOP
14	P17901-01-G30	EA	CABINET-NIGHTSTAND W/COUNTERTOP
14	P17901-01-G31	EA	CABINET-NIGHTSTAND W/COUNTERTOP
14	P17901-01-G09	EA	CABINET-NIGHTSTAND W/COUNTERTOP (G32)
15	117901-11-G29	EA	COUNTERTOP-NIGHTSTAND
15	117901-11-G30	EA	COUNTERTOP-NIGHTSTAND
15	117901-11-G31	EA	COUNTERTOP-NIGHTSTAND
15	117901-11-G09	EA	COUNTERTOP-NIGHTSTAND (G32)

BEDROOM GROUP (CONTINUED)
TWIN BEDROOM CABINETS

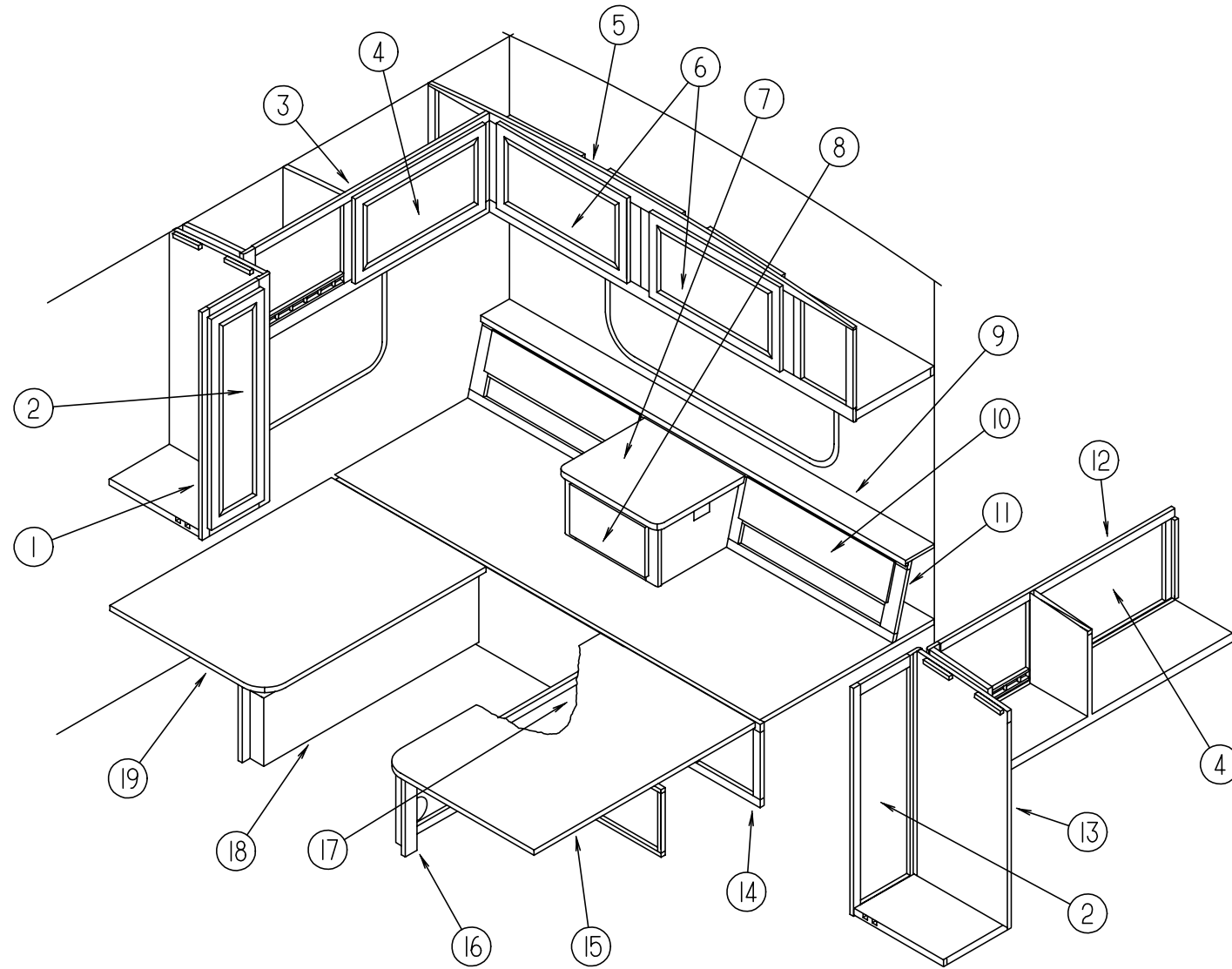

KEY	PART NUMBER	U/M	DESCRIPTION
1	110946-01-G09	EA	CABINET-SHIRT CLOSET, W/O DOOR OR HARDWARE
	009112-01-000	EA	FLANGE - 1" ROD, CLOTHES - PLASTIC - OFF WHITE
	042438-01-000	EA	DOWEL-WOOD, CLOTHES ROD - 1" DIAMETER X 4'
2	M06803-15-G09	EA	DOOR-W/O HARDWARE - 305 MM X 1015 MM
3	111185-01-G09	EA	CABINET-OVERHEAD, W/O DOOR OR HARDWARE
	111775-04-02A	EA	RAIL-DECORATIVE, 478 MM - WATERFORD OAK
	058331-A5-000	EA	MIRROR-GLASS, SAFETY - 396 MM X 516 MM
4	M06803-02-G09	EA	DOOR-W/O HARDWARE - 400 MM X 710 MM
5	111239-01-G09	EA	CABINET-OVERHEAD, W/O DOORS OR HARDWARE
6	M06803-13-G09	EA	DOOR-W/O HARDWARE W/MIRROR - 400 MM X 710 MM
7	117906-13-G09	EA	COUNTERTOP-NIGHTSTAND CABINET (G29,G32)
7	117906-13-G30	EA	COUNTERTOP-NIGHTSTAND CABINET
7	117906-13-G31	EA	COUNTERTOP-NIGHTSTAND CABINET
8	M05971-R4-G09	EA	DRAWER-CABINET, W/O HARDWARE
9	117906-11-G09	EA	COUNTERTOP-NIGHTSTAND CABINET (G29,G32)
9	117906-11-G30	EA	COUNTERTOP-NIGHTSTAND CABINET
9	117906-11-G31	EA	COUNTERTOP-NIGHTSTAND CABINET

KEY	PART NUMBER	U/M	DESCRIPTION
10	117906-12-G29	EA	DOOR-W/O HARDWARE - FABRIC COVERED - 176 MM X 802 MM - EITHER SIDE
10	117906-12-G30	EA	DOOR-W/O HARDWARE - FABRIC COVERED - 176 MM X 802 MM - EITHER SIDE
10	117906-12-G31	EA	DOOR-W/O HARDWARE - FABRIC COVERED - 176 MM X 802 MM - EITHER SIDE
10	117906-12-G12	EA	DOOR-W/O HARDWARE - FABRIC COVERED - 176 MM X 802 MM - EITHER SIDE (G32)
11	117906-01-G29	EA	CABINET-NIGHTSTAND, W/COUNTERTOPS - W/O DOORS OR DRAWER
11	117906-01-G30	EA	CABINET-NIGHTSTAND, W/COUNTERTOPS - W/O DOORS OR DRAWER
11	117906-01-G31	EA	CABINET-NIGHTSTAND, W/COUNTERTOPS - W/O DOORS OR DRAWER
11	117906-01-G12	EA	CABINET-NIGHTSTAND, W/COUNTERTOPS - W/O DOORS OR DRAWER (G32)
12	111186-01-G09	EA	CABINET-OVERHEAD, W/O DOOR OR HARDWARE
	111775-04-02A	EA	RAIL-DECORATIVE, 478 MM - WATERFORD OAK
	058331-A5-000	EA	MIRROR-GLASS, SAFETY - 396 MM X 516 MM
13	110947-01-G09	EA	CABINET-SHIRT CLOSET, W/O DOOR OR HARDWARE - DRIVER SIDE
	009112-01-000	EA	FLANGE-1" ROD, CLOTHES - PLASTIC - OFF WHITE
	042438-01-000	EA	DOWEL-WOOD, CLOTHES ROD - 1" DIAMETER X 4'
14	P17905-01-000	EA	CABINET-COMPARTMENT, W/O TOP OR CARPET
15	M04170-08-000	EA	TOP-TWIN BED
16	P17904-01-G09	EA	CABINET-TWIN BED W/O TOP
17	M06803-68-G09	EA	DOOR-W/O HARDWARE - 305 MM X 555 MM - DRIVER SIDE TWIN BED CABINET
18	P17903-01-G09	EA	CABINET-TWIN BED W/O TOP
19	M04170-09-000	EA	TOP-TWIN BED, PASSENGER SIDE

BEDROOM GROUP (CONTINUED)

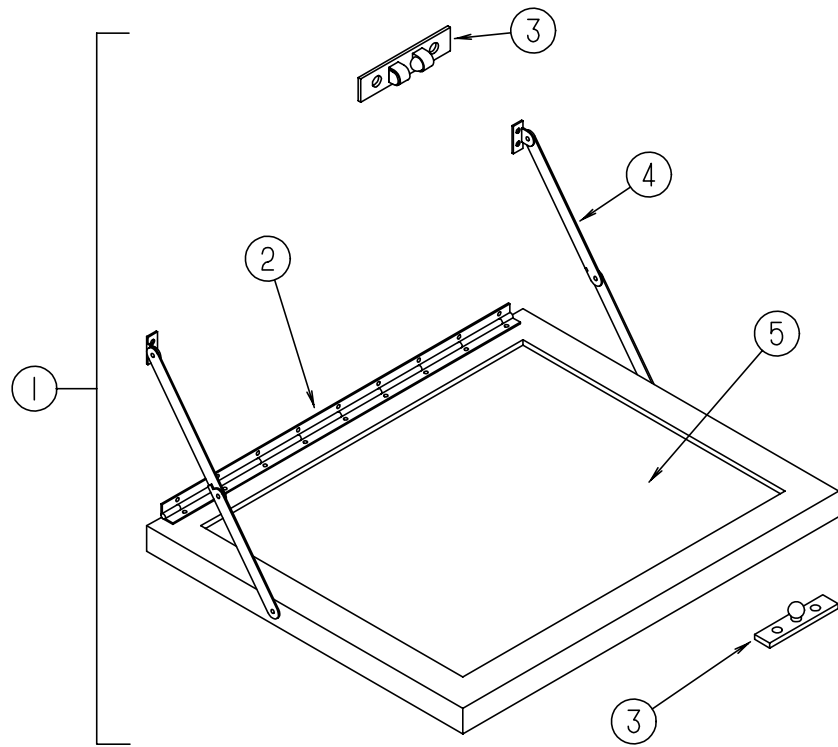

TV STAND

KEY	PART NUMBER	U/M	DESCRIPTION
1	084357-02-G09	EA	STAND-FOLD DOWN, TV - W/MIRROR
2	084413-01-000	EA	HINGE-CONTINUOUS, W/HOLES
3	084451-01-000	EA	CATCH-TV SHELF, BRASS
4	084412-01-000	EA	SUPPORT-HINGED (PAIR)
5	084356-08-000	EA	INSERT-TV STAND, W/SUPPORT HINGE - METAL - OFF WHITE
5	058331-14-000	EA	MIRROR-GLASS, SAFETY - 14" X 12.7"

BEDROOM GROUP (CONTINUED)

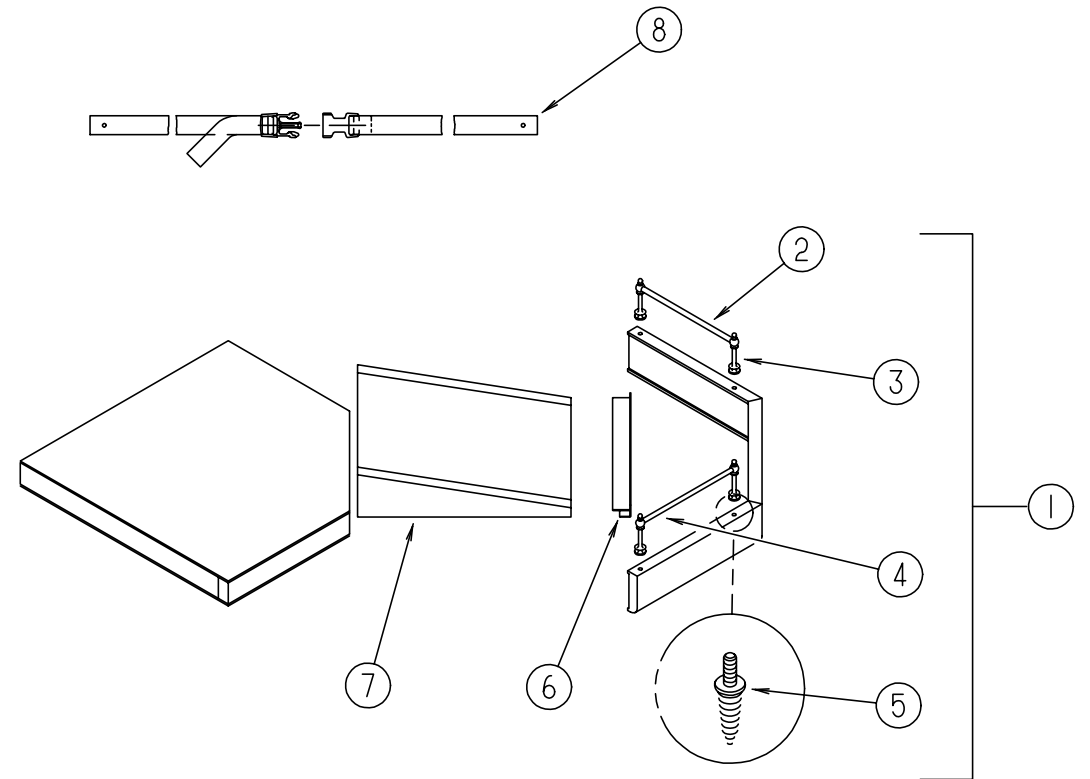

TV SHELVES

KEY	PART NUMBER	U/M	DESCRIPTION
1	116553-02-G09	EA	SHELF ASM-TV, W/BRASS RAILING & WEDGE - 420 MM X 410 MM
2	084071-12-000	EA	ROD-BRASS, 104 MM LONG
3	084070-02-000	EA	POST-END, 2.4" - BRASS
4	084071-19-000	EA	ROD-BRASS, 198 MM LONG
5	106166-01-000	EA	BOLT-COLLARED HANGER
6	P03186-01-G01	FT	MOLDING-EDGE, SHELF - .78" WIDE - PLASTIC - WATERFORD OAK
7	116553-15-G09	EA	WEDGE-TV
8	099717-01-000	EA	TIEDOWN-TV, STRAP ON FEMALE END IS 22.8" LONG

CHASSIS GROUP

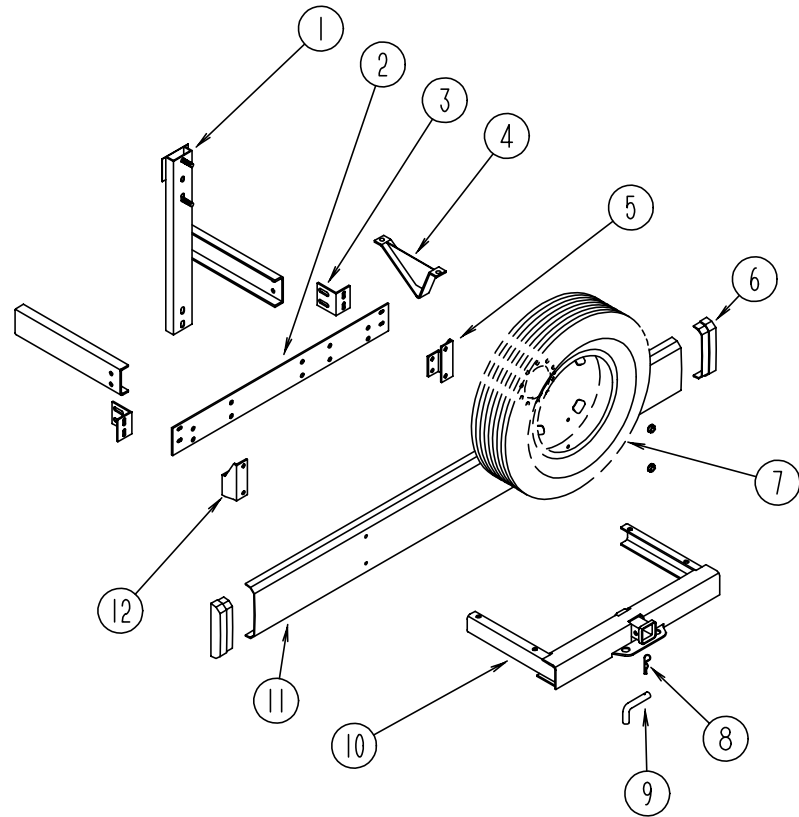

REAR BUMPER, TRAILER HITCH & COMPONENTS

KEY	PART NUMBER	U/M	DESCRIPTION
1	102944-05-000	EA	BRACKET ASM-TIRE CARRIER
1	102944-06-000	EA	BRACKET ASM-TIRE CARRIER, FORD OPTION
2	078678-02-000	EA	PLATE-MOUNTING, BUMPER - REAR
3	078668-01-000	EA	SUPPORT ANGLE-BUMPER, REAR
4	083376-01-000	EA	SKID PLATE
5	117950-03-02B	EA	BRACKET ASM-BUMPER, REAR
6	103228-01-06A	EA	CAP-END, BUMPER - REAR - DRIVER OR PASSENGER SIDE
7	083425-10-000	EA	TIRE-LT215/85R16, LRE XCH4 - MICHELIN XCH4 ORBL - FORD OPTION
7	007324-04-000	EA	TIRE - 8R19.5 LRD, MICHELIN XZA - CHEVY
	051377-01-000	EA	STEM-VALVE, TR 500
	051377-05-000	EA	STEM-VALVE, EATON VS-938 F53-92 - FORD OPTION
	095853-02-000	EA	WHEEL-STEEL, 16" X 6K - F2TA-1015-NA - ACCURIDE 28513-7 - FORD OPTION
8	034513-01-000	EA	PIN-HITCH - 3/16" WIRE
9	034512-01-000	EA	PIN-LOCKING-DRAWBAR
10	107707-01-000	EA	HITCH ASM W/O DRAWBAR
11	103099-01-06A	EA	BUMPER-REAR, BRIGHT WHITE
12	117950-04-02B	EA	BRACKET ASM-BUMPER, REAR
	113589-02-000	EA	CONNECTOR-SOCKET, TRAILER - GENERAL 433601
	113589-01-000	EA	CONNECTOR-PLUG, TRAILER - GENERAL 433501

CHASSIS GROUP (CONTINUED)

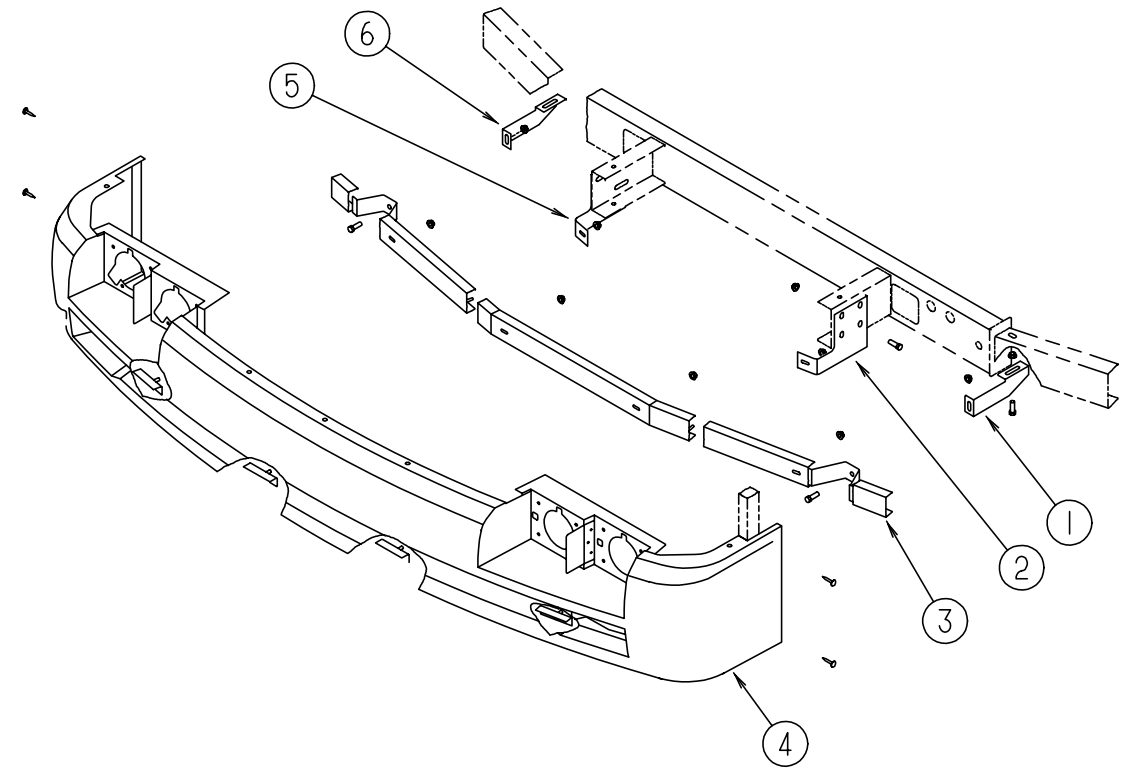

FRONT BUMPER

KEY	PART NUMBER	U/M	DESCRIPTION
1	118235-02-02B	EA	SUPPORT-BUMPER, OUTER - LH
2	118234-02-02B	EA	SUPPORT-BUMPER, INNER - LH
3	103512-01-000	EA	CHANNEL ASM-BUMPER
4	118193-01-G29	EA	BUMPER ASM-FRONT
5	118234-01-02B	EA	SUPPORT-BUMPER, INNER - RH
6	118235-01-02B	EA	SUPPORT-BUMPER, OUTER - RH

CHASSIS GROUP (CONTINUED)

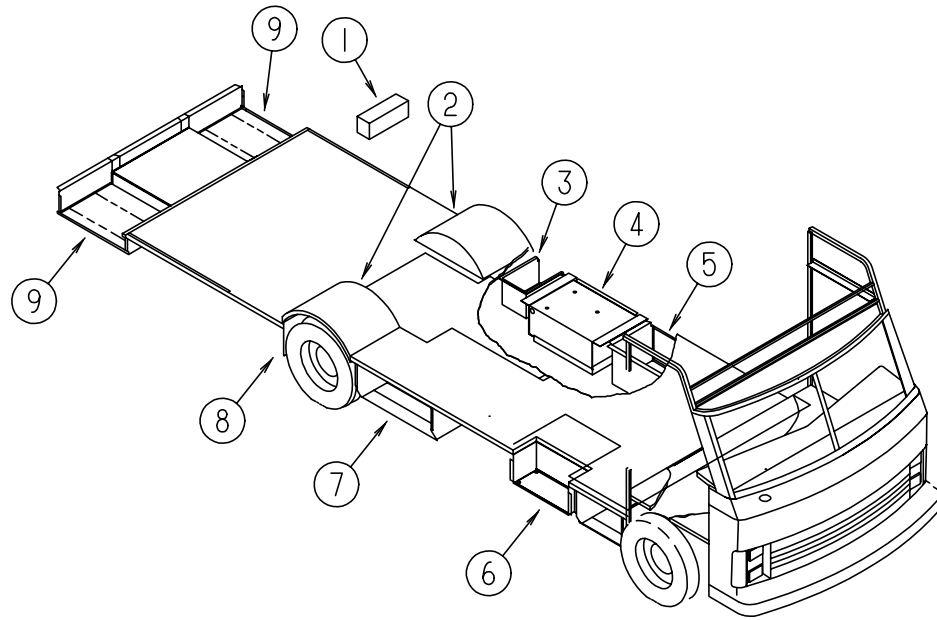

STORAGE COMPARTMENTS & WHEELWELLS

KEY	PART NUMBER	U/M	DESCRIPTION
1	085967-01-000	EA	COMPARTMENT-SEWER HOSE, 6" X 6.6" X 17.8" - PLASTIC
2	102921-01-000	EA	WHEELWELL - PLASTIC
3	102979-01-000	EA	BOX-POWER CORD
4	078137-04-000	EA	TRAY-COMPARTMENT, GENERATOR - 29.1" WIDE X 22.4" DEEP
5	103036-02-000	EA	COMPARTMENT ASM-STORAGE
6	077848-02-000	EA	STEP-PULLOUT
	077848-01-000	EA	STEP-PULLOUT, W/BRACKETS - BLACK
	091176-01-000	EA	SUPPORT-BASE-ENTRANCE STEP
7	103032-06-000	EA	COMPARTMENT ASM-STORAGE
8	017516-01-000	EA	FLAP-MUD, 14" X 18" - BLACK
	020167-04-000	EA	GUARD-DIRT
9	110820-01-000	EA	COMPARTMENT ASM-STORAGE
	065450-05-000	EA	TIEDOWN-BATTERY, 8.4" TUBE
	056748-01-000	EA	PLUG-CAP, 1.5" DIAMETER - BLACK
	061420-01-000	EA	PLUG-PLASTIC, 1.75" - BROWN
	105732-02-000	EA	TRAY ASM-GENERATOR

CHASSIS GROUP (CONTINUED)

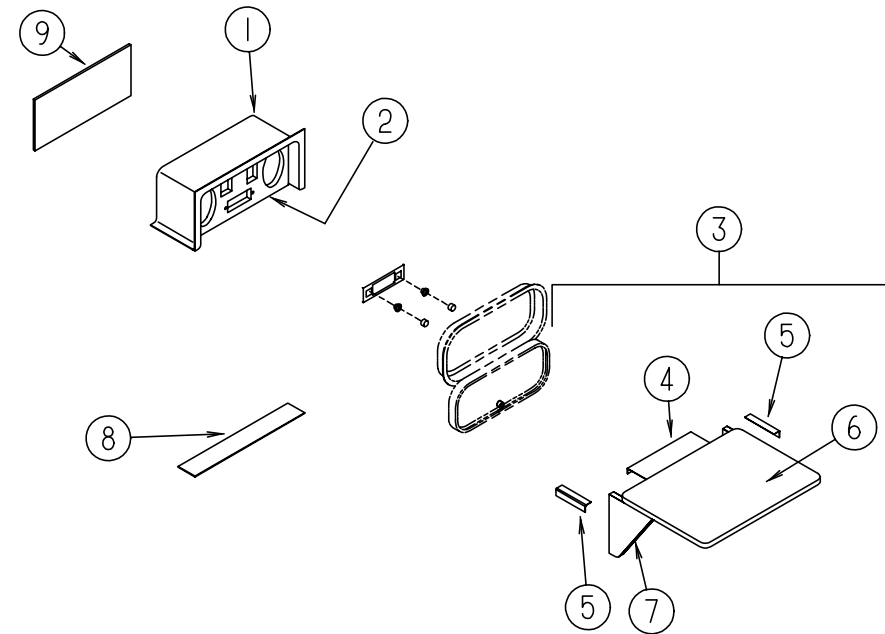

PATIO ENTERTAINMENT CENTER

KEY	PART NUMBER	U/M	DESCRIPTION
1	104897-01-02A	EA	BOX-ENTERTAINMENT CENTER - BRIGHT WHITE
2	104899-01-C05	EA	PLATE-RADIO MOUNTING
3	105230-01-E01	EA	SHELF
4	105377-01-01A	EA	BRACKET-TABLE HANGER, OFF WHITE
5	105376-01-03A	EA	HINGE-CONTINUOUS, 2" X 140 MM - BRIGHT WHITE
6	105230-11-E01	EA	SHELF
7	105230-12-E01	EA	SUPPORT-SHELF
8	104898-01-02A	EA	PLATE-PLASTIC, BOTTOM - 19.38" X 3.1" - BRIGHT WHITE
9	104898-02-02A	EA	PLATE-PLASTIC, REAR - 16.1" X 6.3" - BRIGHT WHITE

CHASSIS GROUP (CONTINUED)
CHASSIS MISCELLANEOUS

KEY	PART NUMBER	U/M DESCRIPTION
	070579-06-000	EA PLATE-ANCHOR, W/7/16 WELD NUT - 1.5" X 3.3"
	077001-01-000	EA ANGLE-MOUNTING, ROOF PANEL - V ANGLE - 3" X 2.4" X 1.5"
	103136-01-000	EA BRACKET-SUPPORT, UPPER - HINGE - RH
	103136-02-000	EA BRACKET-SUPPORT, UPPER - HINGE - LH
	110934-01-000	EA CONNECTOR-PLASTIC, BARB 5/16 KEVCO TC 7055
	113007-01-000	EA PIN-SPRING, .375 X 3.00 IN (FORD)
	083163-06-000	EA PUSHNUT-FLAT TYPE 3/8 STUD
	113875-01-000	EA HOSE-HUMP, 3" GRIFFITH HH3
	087234-01-000	EA NUT-JACK, 1/4 X 20THD,MOLLY ARDEN 8-L,JN BRASS MOUNTS LICENSE PLATES
	093719-01-000	EA HOSE-OIL FILL, PREFORMED 90 DEGREE BEND
	076310-01-000	EA SHEET-RUBBER, RADIATOR BAFFLE - .12" X 15" X 62" - BLACK
	098443-03-000	EA SUPPORT-SHIELD, EXHAUST - 1.5" X 29.2" - STEEL - PRIMED
	075307-03-000	EA SHIELD-HEAT, LP
	101544-01-000	EA SHIELD-HEAT, EXHAUST - 19.7" X 28.9" - STEEL

FRONT SHOCKS

KEY	PART NUMBER	U/M DESCRIPTION
	104993-01-000	EA SHOCK ABSORBER-GAS, P30 FRONT - BILSTEIN B46-1173

TIRE COVERS

KEY	PART NUMBER	U/M DESCRIPTION
	108163-01-01A	EA COVER ASM-TIRE 16" CHEVY - KEMBERLY CHROME USED W/CHEVY & FORD CHASSIS W/16" WHEEL AND LT215 TIRE NOTE: IF FORD WHEEL HAS AN LT235 TIRE USE #1081630201A
	108560-02-03A	EA INSERT-TIRE COVER 16" GM, BRIGHT WHITE
	108163-02-01A	EA COVER ASM-TIRE,19.5 CHEVY - KEMBERLY CHROME USED W/CHEVY 19.5" WHEEL AND FORD 16" WHEEL-W/LT235 TIRE
	108560-03-03A	EA INSERT-TIRE COVER 19.5 GM, BRIGHT WHITE

CHASSIS GROUP (CONTINUED)
19.5" CHEVY STAINLESS STEEL WHEEL LINERS

KEY	PART NUMBER	U/M DESCRIPTION	VENDER NO.
	091209-01-000	EA LINER-WHEEL, 19.5" - SST - SET OF 4 - KAPER 1954-ION	
	091209-01-700	EA LINER-WHEEL FRT 10 LUG ALSO ORDER P.N.#091209-01-702 COVER	37N KAPER
	091209-01-701	EA LINER-WHEEL RR 10 LUG ALSO ORDER P.N.#091209-01-703 COVER	38N KAPER
	091209-01-702	EA COVER-AXLE, FRT 19.5 10 LUG	34N KAPER
	091209-01-703	EA COVER-AXLE, REAR 19.5 10 LUG	35N KAPER
	091209-01-704	EA COVER-LUG NUT W/O FLANGE LUG NUT COVER - NO SHOULDER OR FLANGE AT BASE	36 KAPER
	095012-03-000	EA EXTENSION-VALVE STEM, DUAL WHEEL	
	095012-04-000	EA STABILIZER-VALVE STEM EXTENSION - DICOR AG-STA-2	
	077030-02-000	EA EXTENSION-VALVE STEM, 1.25"	

16" FORD CHROME WHEEL LINERS

KEY	PART NUMBER	U/M DESCRIPTION	VENDER NO.
	091209-14-000	EA LINER-WHEEL,SET/4 F53/1PC	
	091209-01-704	EA COVER-LUG NUT W/O FLANGE LUG NUT COVER - NO SHOULDER OR FLANGE AT BASE	36 KAPER
	091209-08-700	EA LINER-WHEEL, FRT.,W/AXLE CVR HAS 8 PRESS-IN NUT COVERS WHICH ARE N/A, AND 2 SNAP-ON NUT COVERS #09120901704	157 KAPER
	091209-08-706	EA NUT-FLAT .500, 9/16 STUD	165
	091209-14-700	EA LINER-WHEEL	159
	095012-03-000	EA EXTENSION-VALVE STEM, DUAL WHEEL	
	095012-04-000	EA STABILIZER-VALVE STEM EXTENSION - DICOR AG-STA-2	
	077030-02-000	EA EXTENSION-VALVE STEM, 1.25"	

16" FORD WHEEL COVERS

KEY	PART NUMBER	U/M DESCRIPTION	VENDER NO.
	098532-01-000	EA COVER-WHEEL, FORD - 16" - SET OF 4 - DICOR SH-SD-16	
	098532-01-700	EA COVER-LUG NUT (CHROME)	SH-AU-LNC
	098532-01-701	EA COVER-WHEEL (FRT & REAR)	SH-SD-16

19.5" CHEVY WHEEL COVERS

KEY	PART NUMBER	U/M DESCRIPTION	VENDER NO.
	109443-01-000	EA WHEEL-COVER 4/SET 19.5 W/HDW	
	109443-01-700	EA COVER-WHEEL 19.5 FRT. & REAR	SHAG95
	109443-01-701	EA BRACKET-RET. FRONT WHEEL INCLUDES THE JAMB NUTS	SHAG95-FBS
	109443-01-702	EA BRACKET-RET. REAR WHEEL	SHAG95-RBS
	109443-01-703	EA CAP-CENTER, HUB - DICOR	SP-AUCAP
	109443-01-704	EA CLIP-RETAINER	V160GM-PNT

LUG WRENCH & LEVERAGE BAR

KEY	PART NUMBER	U/M DESCRIPTION
	080208-01-000	EA LUG WRENCH, 1.06 X 1.00 (CHEVY)
	080208-02-000	EA BAR-LEVERAGE, LUG WRENCH (CHEVY)

CHASSIS GROUP (CONTINUED)

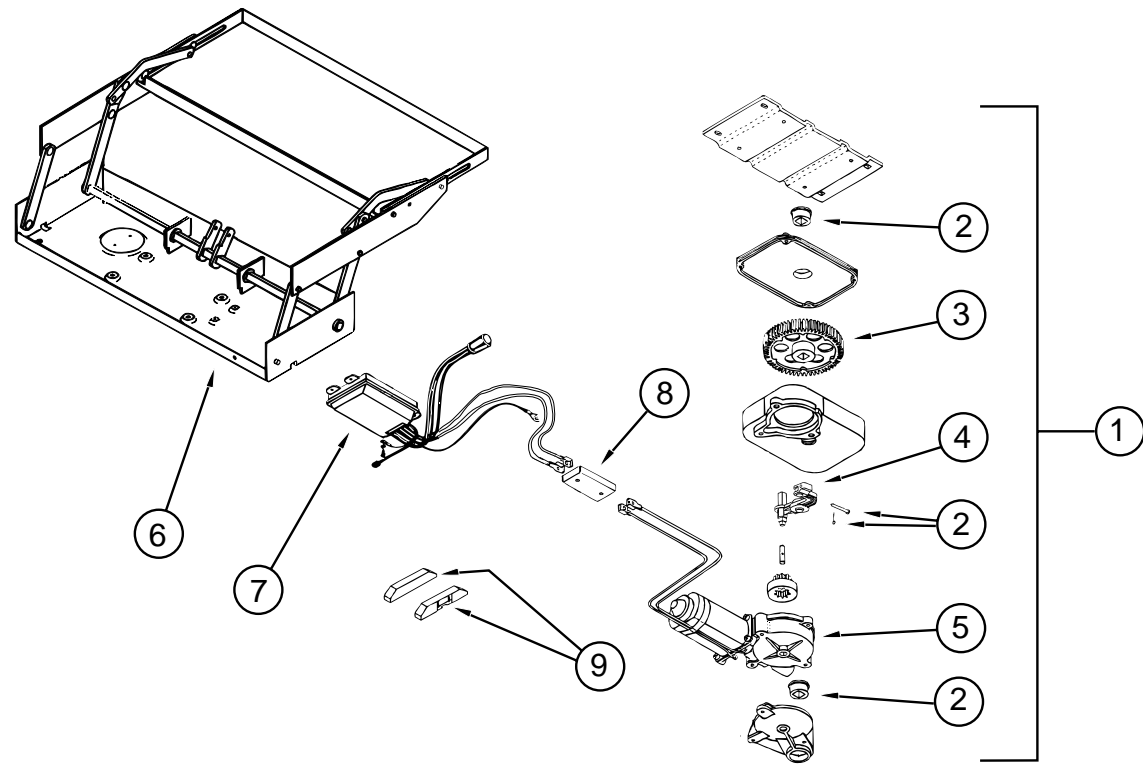

ELECTRIC STEP (KWIKEE)

KEY	PART NUMBER	U/M DESCRIPTION	VENDER NO.
1	094708-01-01A	EA STEP-ENTRY DOOR, ELECTRIC - SINGLE - 2813	
2	094707-02-703	EA BEARING & PINS	909530
3	094707-02-702	EA GEAR KIT, W/BEARINGS,PIN-CASE	909525
4	094708-03-700	EA LINKAGE ASSEMBLY-SERIES 28	909533
5	094707-02-700	EA MOTOR ASM.,W/BEARINGS & PINS	909520
6	088746-01-709	EA FRAME W/SGL STEP, 2800 SERIES	908028
7	094707-02-705	EA CONTROL UNIT, WHITE	909513
8	094707-02-704	EA CONNECTOR-MOTOR ASM.W/PLATES	909537
	094707-02-707	EA TREAD-NON SKID, BLACK 6" X 21"	909333
9	116995-01-000	EA SWITCH/MAGNET-STEP, ELECTRIC	

CHASSIS GROUP (CONTINUED)

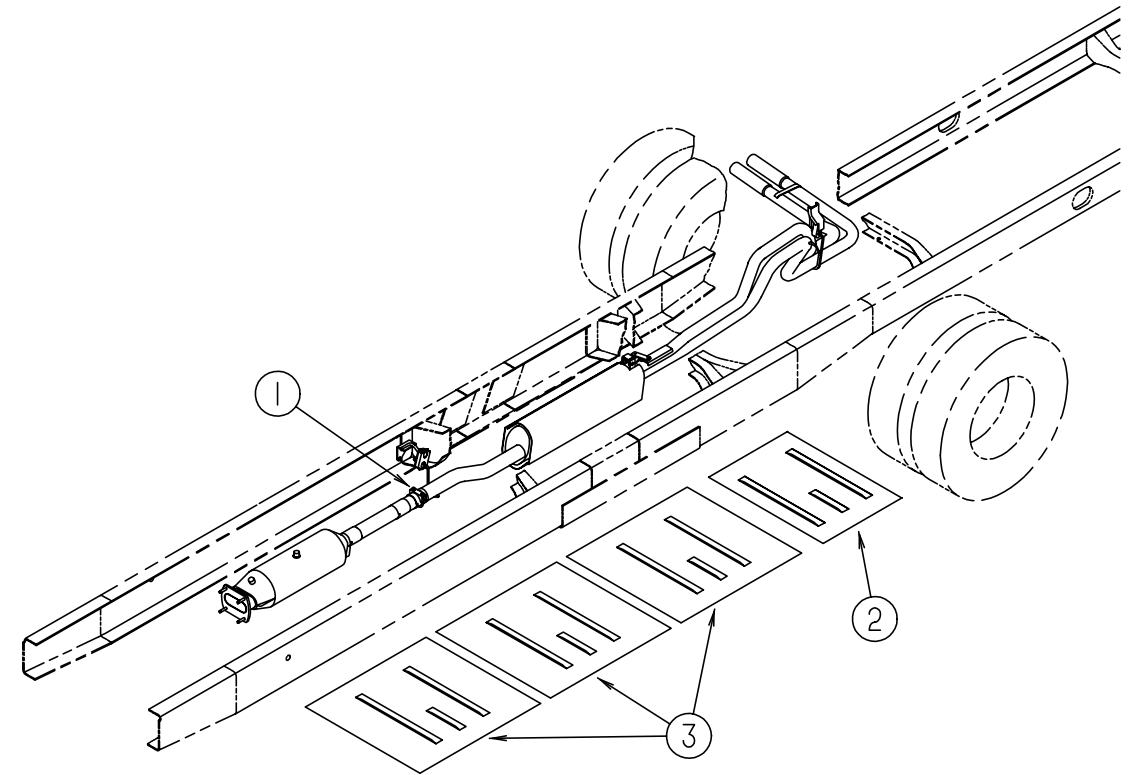

EXHAUST SYSTEM (FORD)

KEY	PART NUMBER	U/M DESCRIPTION
1	094918-03-000	EA CLAMP-EXHAUST, 2.5"
2	101544-01-000	EA SHIELD-HEAT, EXHAUST - 19.7" X 28.9" - STEEL
3	101544-06-000	EA SHIELD-HEAT, EXHAUST, FORD

CHASSIS GROUP (CONTINUED)

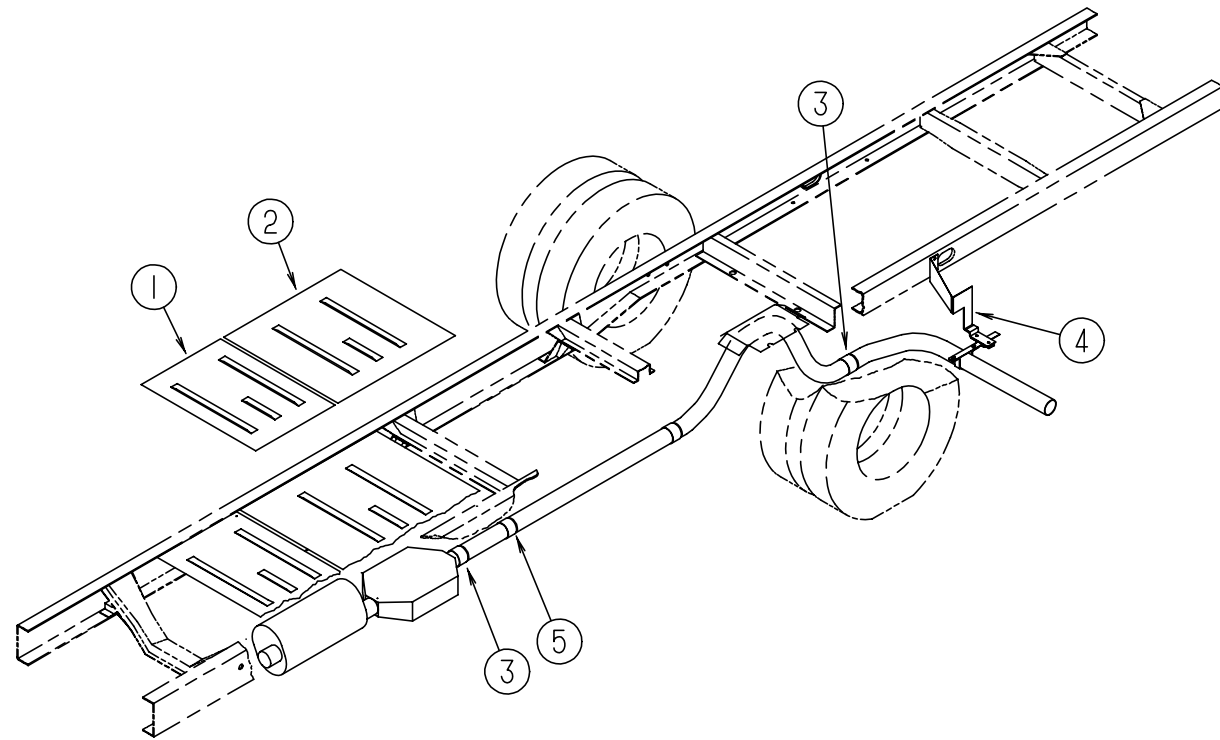

EXHAUST SYSTEM (CHEVY)

KEY	PART NUMBER	U/M DESCRIPTION
1	101544-01-000	EA SHIELD-HEAT, EXHAUST - 19.7" X 28.9" - STEEL
2	101544-02-000	EA SHIELD-HEAT, EXHAUST - 30" X 28.9" - STEEL
3	094918-01-000	EA CLAMP-EXHAUST, 3" - GUILLOTINE STYLE
4	098833-02-000	EA BRACKET-EXHAUST, HANGER
5	098762-05-000	EA EXTENSION-EXHAUST, STRAIGHT - 3" OD X 7.9" LONG - SST
	110236-01-000	EA PIPE-EXHAUST, EXTENSION
	081918-01-000	EA EXTENSION-EXHAUST, 2.25"OD X 9.44" - STAINLESS STEEL
	M98762-05-000	EA PIPE-EXHAUST, STRAIGHT 3"

CHASSIS GROUP (CONTINUED)

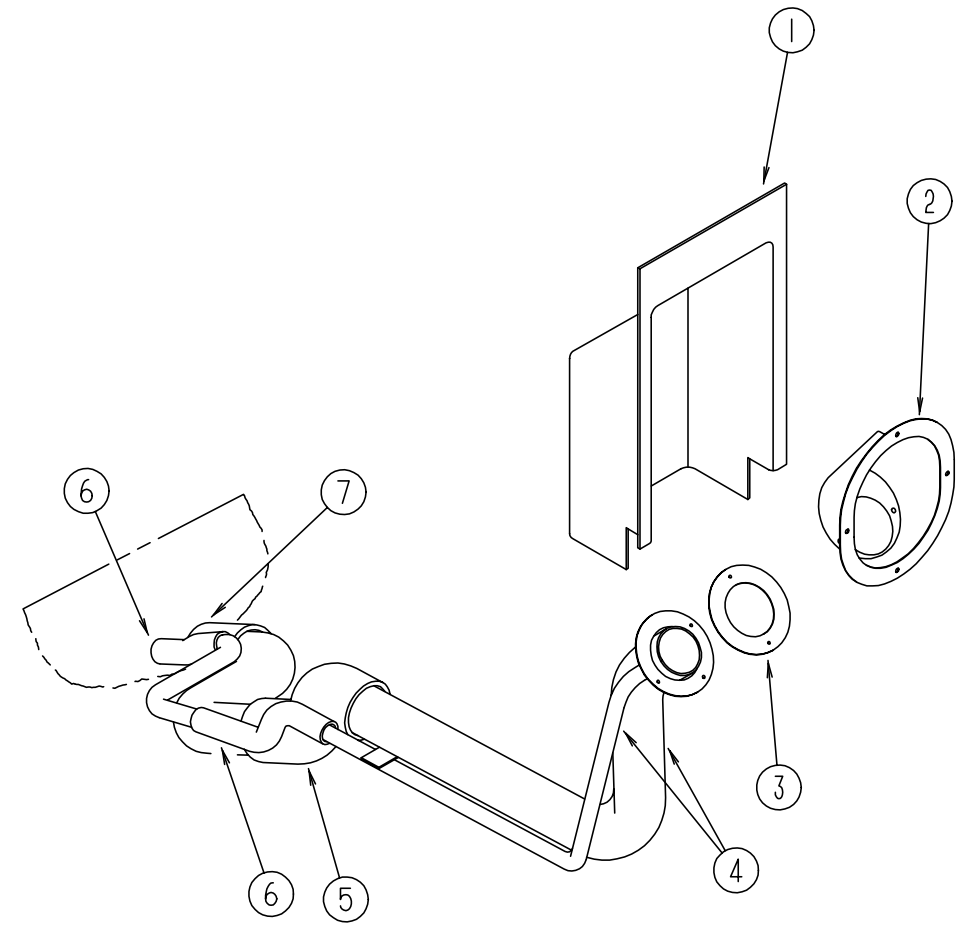

FUEL SYSTEM (FORD)

KEY	PART NUMBER	U/M DESCRIPTION
1	072447-04-000	EA SHROUD-FUEL FILL, UPPER - PLASTIC
2	095854-01-05A	EA SHROUD-FUEL FILL, BUFF
3	078200-01-000	EA GASKET-FUEL FILL, 3.5"OD X 2"ID
4	095606-01-000	EA NECK-FUEL FILL, W/CHECK VALVE - L-SHAPED - 18.2" LONG
5	100156-01-000	EA HOSE-FUEL FILL, 8.3" LONG W/2" ID
6	066732-03-000	FT HOSE-FUEL FILL, .75" ID
7	007111-02-000	EA HOSE-FUEL FILL, 2.00 ID - IN 3FT LENGTHS
	007063-01-000	FT HOSE-GAS 1/4"ID X 1/2"OD
	084884-01-000	EA PLUG-BRASS, 3/8"
	080081-01-000	EA STRAP-MOUNTING, FUEL LINE - 2" X 32"

CHASSIS GROUP (CONTINUED)

CURTAIN & CUSHION GROUP NOTICE

IN ORDER TO ASSIST OUR PARTS SALES DEPT. IN PROVIDING INTERIOR SOFTGOODS ITEMS, PLEASE INCLUDE THE SERIAL NUMBER AND THE COLOR CODE NUMBER FROM THE VEHICLE CERTIFICATION LABEL WHEN ORDERING. THIS LABEL IS LOCATED ON THE LEFT SIDEWALL AT THE END OF THE DASH (A-BODY), OR ON THE DRIVER'S DOOR LATCH PLATE (C-BODY).

AN EXAMPLE OF A COLOR CODE NUMBER IS B07, WHICH DESIGNATES AN OVERALL COLOR SCHEME OF A PARTICULAR UNIT. THE COLOR LISTED AFTER THE ITEM DESCRIPTION ON THE MICROFICHE, INDICATES THE OVERALL UNIT COLOR. ORDER THE ITEM YOU DESIRE ACCORDING TO UNIT COLOR CODE.

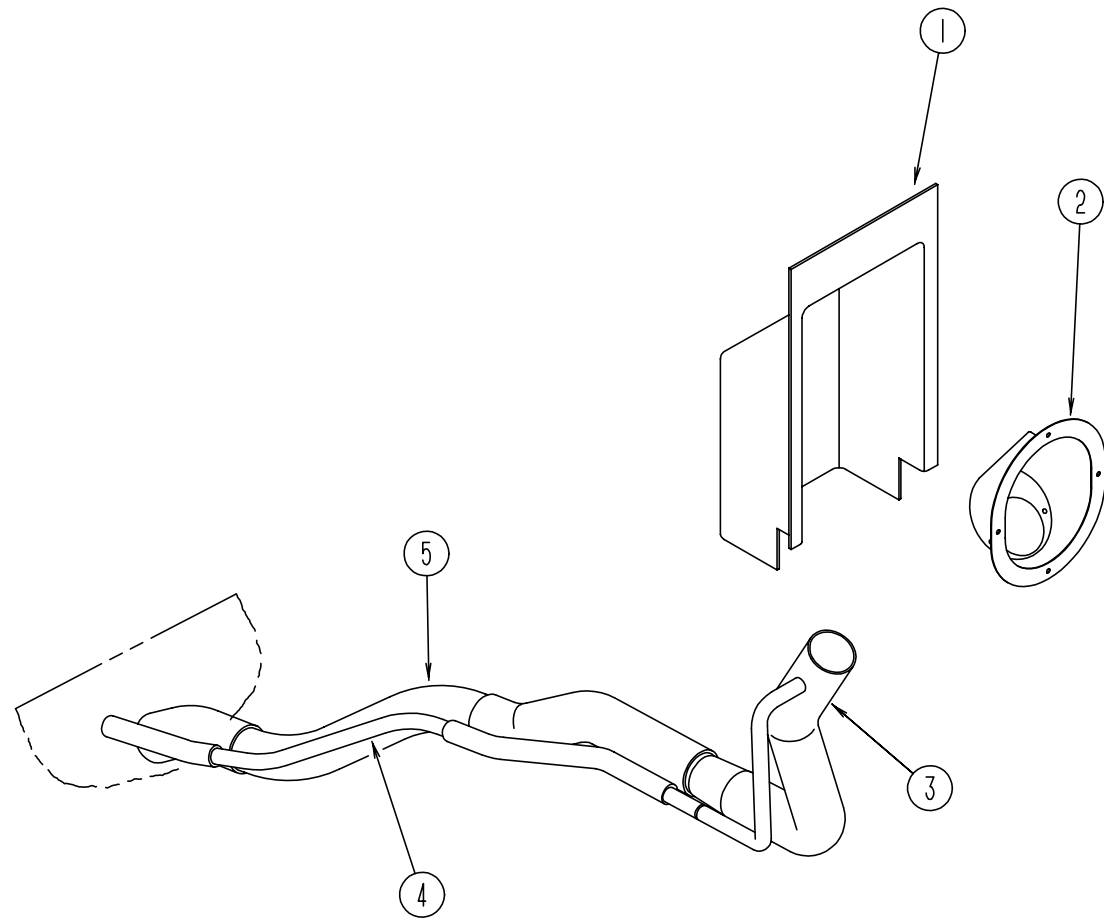

FUEL SYSTEM (CHEVY)

KEY	PART NUMBER	U/M	DESCRIPTION
1	072447-04-000	EA	SHROUD-FUEL FILL, UPPER - PLASTIC
2	095854-01-04A	EA	SHROUD-FUEL FILL, BRIGHT WHITE
3	078200-01-000	EA	GASKET-FUEL FILL, 3.5"OD X 2"ID
4	098804-01-000	EA	PIPE-VENT, FUEL FILL - 12" LONG
5	098805-01-000	EA	PIPE-FUEL, FUEL FILL - 11.4" LONG
	084884-01-000	EA	PLUG-BRASS, 3/8"
	007063-01-000	FT	HOSE-GAS 1/4"ID X 1/2"OD
	044317-01-000	EA	HOSE-FUEL, 3/8" ID - DIESEL OPTION

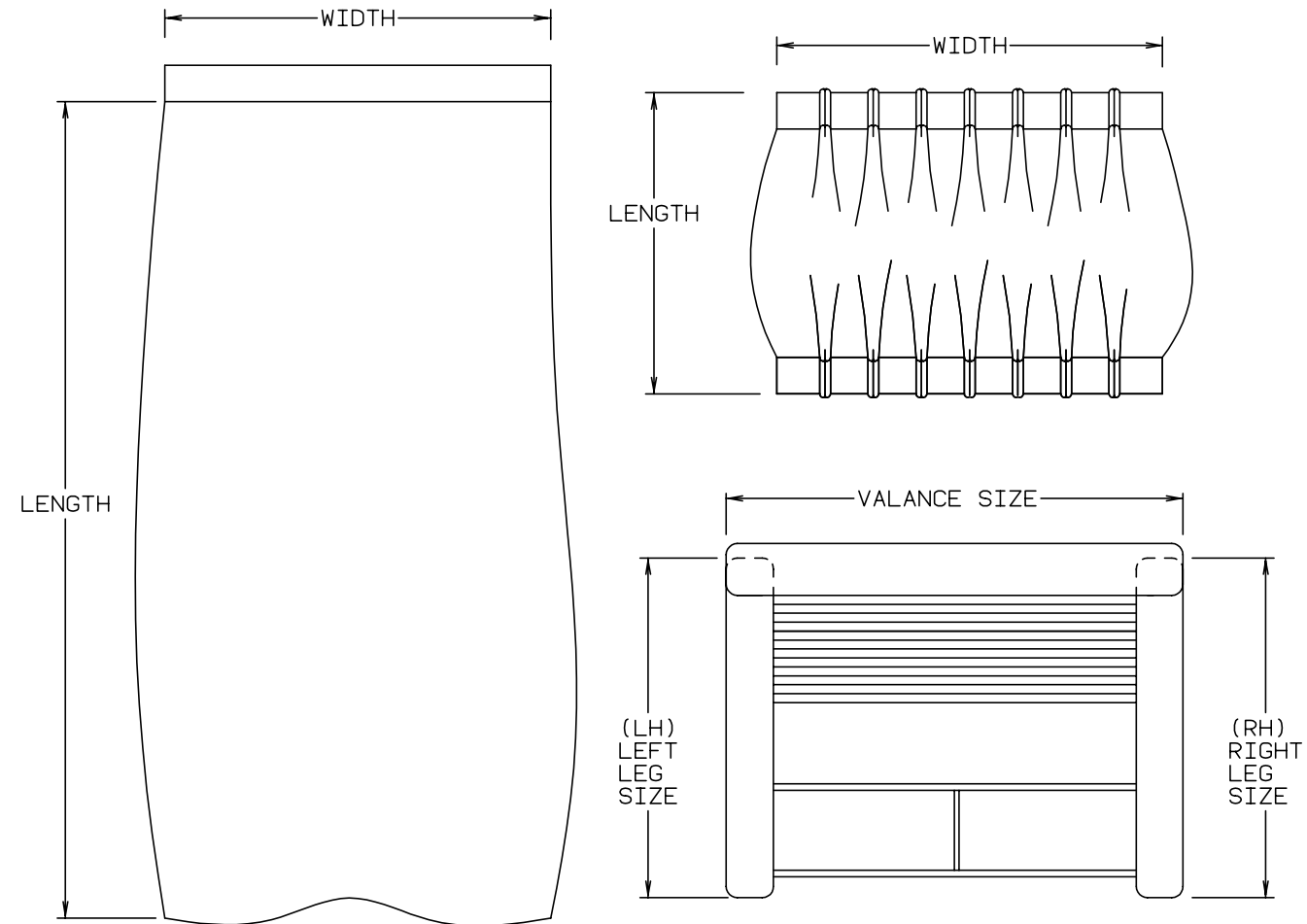

NOTE: USE THIS ILLUSTRATION WHEN DETERMINING LENGTH AND WIDTH MEASUREMENTS FOR CURTAINS. YOU WILL NOTE THE WIDTH MEASUREMENT IS TAKEN ON THE TOP OF THE CURTAIN WITH THE CURTAIN FULLY EXTENDED. THE LENGTH MEASUREMENT IS TAKEN FROM TOP TO BOTTOM. LEFT AND RIGHT WINDOW LEGS ARE DETERMINED WHEN FACING THE WINDOW.

CURTAIN & CUSHION GROUP (CONTINUED)
CURTAIN, BLIND HARDWARE & TRACKS

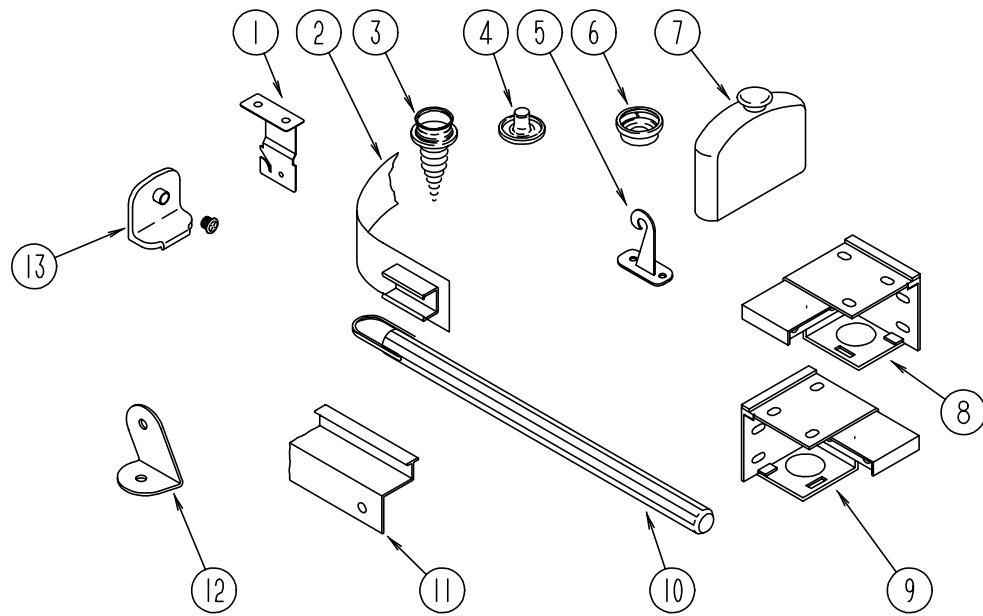

KEY	PART NUMBER	U/M	DESCRIPTION
1	084434-01-000	EA	BRACKET-MOUNTING, ROLLER SHADE - 1 3/8"
2	101031-01-000	YD	TAPE-GLIDE, CURTAIN - 4.25" SPACING
3	029130-01-000	EA	SCREW-SNAP SOCKET, #8 PH X 5/8"
3	029130-03-000	EA	SCREW-SNAP SOCKET, #8 PH X 1"
4	029155-01-000	EA	CAP-SNAP, 5/32" O.D. OF PIN
5	109441-01-000	EA	HOLD DOWN-BLIND, HOOK
6	029156-01-000	EA	SOCKET-SNAP, 9/16" O.D.
7	093475-01-701	EA	END CAP-BLIND, W/STUD
8	083170-01-000	EA	BRACKET-BLIND, LEFT SIDE WHEN FACING WINDOW
9	083170-02-000	EA	BRACKET-BLIND, RIGHT SIDE WHEN FACING WINDOW
10	093475-01-700	EA	WAND-BLIND, W/METAL CLIP - 8" LONG
11	105450-01-01A	EA	TRACK-CURTAIN, 30.8" LONG - ALUMINUM - OFF WHITE FROM: 00-00-00 THRU: 08-27-95
12	099205-02-02A	EA	BRACKET-WRAPAROUND O/W
13	106544-01-000	EA	PULL-SHADE, BRASS
	106544-01-001	EA	SCREW-BRASS, SHADE
	046867-01-000	EA	GROMMET-BRASS - 7/16" ID X 1" OD
	048394-02-000	YD	VELCRO TAPE-HOOK, ADHESIVE BACK - .75" WIDE - BEIGE
	075943-09-000	EA	BRACE-VALANCE, O/WHT 8.00 IN
	088792-01-000	YD	VELCRO-HOOK, .75" WIDE - BEIGE
	088792-02-000	YD	VELCRO TAPE-LOOP, ADHESIVE BACKED - .75" WIDE - BEIGE
	089522-02-000	EA	PANEL-LEG, TWO SIDED 31.5" LONG - PLASTIC - BLACK - LH SIDE
	096843-01-000	EA	SPRING-REWIND, ROLLER SHADE
	101589-02-C05	EA	TRACK ASM-CURTAIN, WRAPAROUND O/W FROM: 00-00-00 THRU: 08-27-95
	101589-02-G29	EA	TRACK ASM-CURTAIN, WRAPAROUND QUICK SILVER FROM: 08-28-95 THRU: 99-99-99
	105324-01-01A	EA	TRACK-CURTAIN, WRAPAROUND O/W FROM: 00-00-00 THRU: 08-27-95
	105324-01-04A	EA	TRACK-CURTAIN, WRAPAROUND QUICK SILVER FROM: 08-28-95 THRU: 99-99-99
	114641-03-E10	EA	TRACK-CURTAIN, WRAPAROUND - PASSENGER SIDE - OFF WHITE FROM: 00-00-00 THRU: 08-27-95
	114641-03-G29	EA	TRACK-CURTAIN, WRAPAROUND - PASSENGER SIDE - QUICK SILVER FROM: 08-28-95 THRU: 99-99-99
	114641-04-E10	EA	TRACK-CURTAIN, WRAPAROUND - DRIVER SIDE - OFF WHITE FROM: 00-00-00 THRU: 08-27-95
	114641-04-G29	EA	TRACK-CURTAIN, WRAPAROUND - DRIVER SIDE - QUICK SILVER FROM: 08-28-95 THRU: 99-99-99
	086276-01-000	EA	TAPE-DOUBLE SIDED, 1/2"
	056003-01-000	EA	BRACKET-DRAPERY RETAINING, FRONT - METAL
	056003-02-000	EA	BRACKET-DRAPERY RETAINING, REAR - METAL
	109441-02-000	EA	HOLD DOWN-SPACER
	102555-01-000	EA	CLEAT-CORD, BLIND - OFF WHITE OR CLEAR
	117237-01-000	EA	BRACKET ASM-MOUNTING, 2.5 X .75

CURTAIN & CUSHION GROUP (CONTINUED)
WINDOW TREATMENT

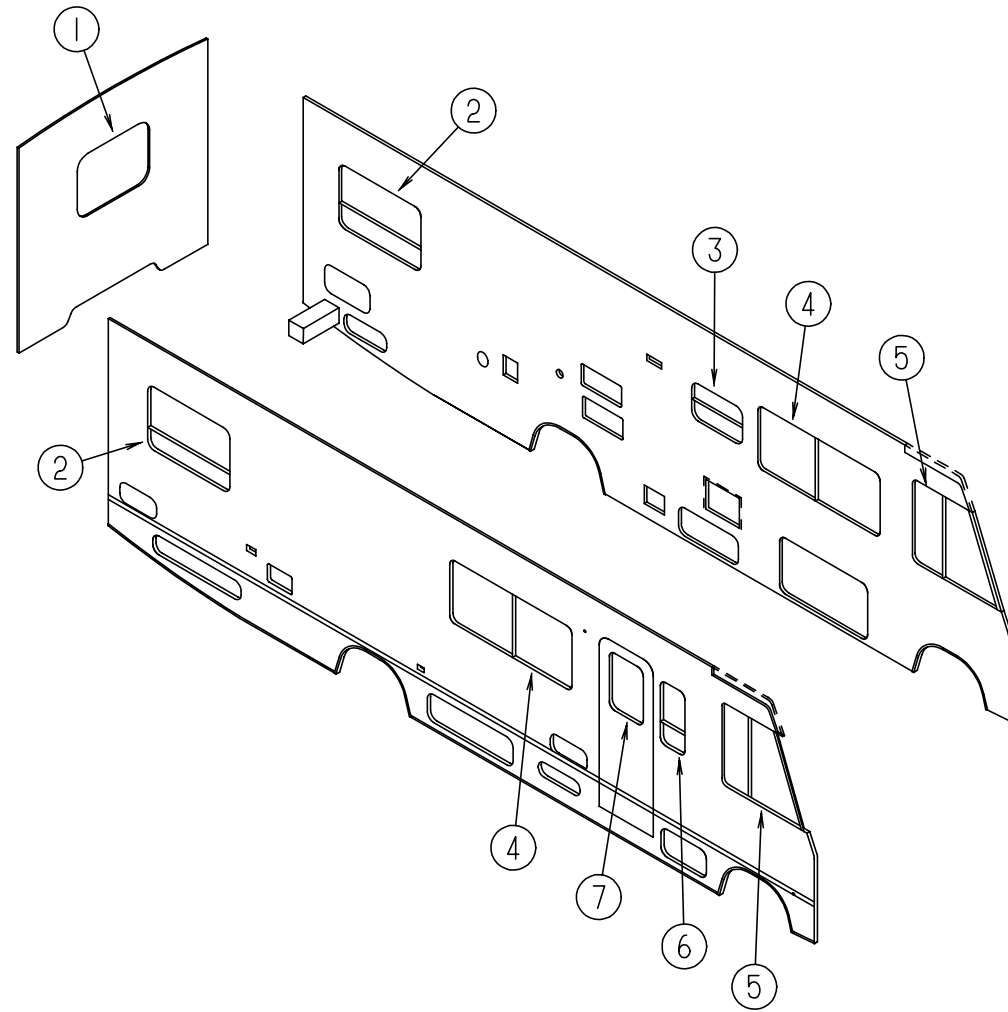

KEY	PART NUMBER	U/M DESCRIPTION
1	112113-10-G29	EA VALANCE ASM-VALERIE, 52" - W/O HEADER
1	112113-10-G30	EA VALANCE ASM-VALERIE, 52" - W/O HEADER
1	112113-10-G31	EA VALANCE ASM-VALERIE, 52" - W/O HEADER
1	119138-01-G12	EA VALANCE ASM-BELLINI, 53" - W/WELT (G32)
1	112986-11-G29	EA CURTAIN - 27.5 X 6, PENCIL PLEAT TOP, POCKET BOTTOM
1	112986-11-G30	EA CURTAIN - 27.5 X 6, PENCIL PLEAT TOP, POCKET BOTTOM
1	112986-11-G31	EA CURTAIN - 27.5 X 6, PENCIL PLEAT TOP, POCKET BOTTOM
1	119333-63-G12	EA LEG-RH., 25" - PLAIN - W/O HOLE (G32)
1	119333-64-G12	EA LEG-LH., 25" - PLAIN - W/O HOLE (G32)
1	093475-68-08A	EA BLIND-MINI, 48 X 27 DROP (G29,G32)
1	093475-68-07A	EA BLIND-MINI, 48 X 27 DROP (G30,G31)
2	112113-11-G29	EA VALANCE ASM-VALERIE, 44" - W/HEADER
2	112113-11-G30	EA VALANCE ASM-VALERIE, 44" - W/HEADER
2	112113-11-G31	EA VALANCE ASM-VALERIE, 44" - W/HEADER
2	119138-02-G12	EA VALANCE ASM-BELLINI, 45" - W/WELT (G32)
2	112986-04-G29	EA CURTAIN - 29.5 X 6, PENCIL PLEAT TOP, POCKET BOTTOM
2	112986-04-G30	EA CURTAIN - 29.5 X 6, PENCIL PLEAT TOP, POCKET BOTTOM
2	112986-04-F25	EA CURTAIN - 29.5 X 6, PENCIL PLEAT TOP, POCKET BOTTOM (G31)
2	119333-63-G12	EA LEG-RH., 25" - PLAIN - W/O HOLE (G32)
2	119333-64-G12	EA LEG-LH., 25" - PLAIN - W/O HOLE (G32)
2	093475-99-03A	EA BLIND-MINI, 41 X 28.5 DROP (G29,G32)
2	093475-99-02A	EA BLIND-MINI, 41 X 28.5 DROP (G30,G31)

KEY	PART NUMBER	U/M DESCRIPTION
2	112113-12-G29	EA VALANCE ASM-VALERIE, 44" - W/O HEADER - TWIN BED OPTION
2	112113-12-G30	EA VALANCE ASM-VALERIE, 44" - W/O HEADER - TWIN BED OPTION
2	112113-12-G31	EA VALANCE ASM-VALERIE, 44" - W/O HEADER - TWIN BED OPTION
2	119138-24-G12	EA VALANCE ASM-BELLINI, 45" - W/WELT - TWIN BED OPTION (G32)
2	112986-11-G29	EA CURTAIN - 27.5 X 6, PENCIL PLEAT TOP, POCKET BOTTOM - TWIN BED OPTION
2	112986-11-G30	EA CURTAIN - 27.5 X 6, PENCIL PLEAT TOP, POCKET BOTTOM - TWIN BED OPTION
2	112986-11-G31	EA CURTAIN - 27.5 X 6, PENCIL PLEAT TOP, POCKET BOTTOM - TWIN BED OPTION
2	109041-37-01A	EA BLIND-MINI, 41 X 26 DROP - TWIN BED OPTION (G29,G32)
2	109041-37-02A	EA BLIND-MINI, 41 X 26 DROP - TWIN BED OPTION (G30,G31)
3	109041-20-02A	EA BLIND-MINI, 31 X 18 DROP (G29,G32)
3	109041-20-01A	EA BLIND-MINI, 31 X 18 DROP (G30,G31)
3	109353-07-02A	EA BLIND-SLAT, 31" (G29,G32)
3	109353-07-01A	EA BLIND-SLAT, 31" (G30,G31)
3	109353-04-000	EA CLIP-VALANCE SLAT MOUNTING, CLEAR PLASTIC - PAR
4	118537-01-G29	EA VALANCE - 64.5" GALAXY
4	118537-01-G30	EA VALANCE - 64.5" GALAXY
4	118537-02-G31	EA VALANCE - 64.5" GALAXY
4	105923-46-G32	EA VALANCE - 64.5" RODEWAY - W/O INSERT
4	119333-11-G29	EA LEG-RH., 25" - WOOD - W/O HOLE
4	119333-11-G30	EA LEG-RH., 25" - WOOD - W/O HOLE
4	119333-11-G31	EA LEG-RH., 25" - WOOD - W/O HOLE
4	119333-33-G12	EA LEG-RH., 25" - PLAIN - W/O HOLE (G32)
4	119333-12-G29	EA LEG-LH., 25" - WOOD - W/O HOLE
4	119333-12-G30	EA LEG-LH., 25" - WOOD - W/O HOLE
4	119333-12-G31	EA LEG-LH., 25" - WOOD - W/O HOLE
4	119333-34-G12	EA LEG-LH., 25" - PLAIN - W/O HOLE (G32)
4	093475-76-06A	EA BLIND-MINI, 60 X 28.5 DROP (G29,G32)
4	093475-76-05A	EA BLIND-MINI, 60 X 28.5 DROP (G30,G31)
5	101668-56-G09	EA CURTAIN - 38 X 95 TAPE TOP, RH (G29,G32)
5	101668-56-G10	EA CURTAIN - 38 X 95 TAPE TOP, RH (G30,G31)
5	101668-57-G09	EA CURTAIN - 38 X 95 TAPE TOP, LH (G29,G32)
5	101668-57-G10	EA CURTAIN - 38 X 95 TAPE TOP, LH (G30,G31)
5	101668-32-D09	EA CURTAIN ASM - 40 X 40, TAPE TOP - LH - BUNK OPTION (G29,G32)
5	101668-32-D10	EA CURTAIN ASM - 40 X 40, TAPE TOP - LH - BUNK OPTION (G30,G31)
5	101668-33-D09	EA CURTAIN ASM - 38 X 125, TAPE TOP - RH - BUNK OPTION (G29,G32)
5	101668-33-D10	EA CURTAIN ASM - 38 X 125, TAPE TOP - RH - BUNK OPTION (G30,G31)
5	073260-42-D09	EA TIEBACK ASM - 6 X 18 (G29,G32)
5	073260-42-D10	EA TIEBACK ASM - 6 X 18 (G30,G31)
6	118537-03-G29	EA VALANCE - 17", GALAXY
6	118537-03-G30	EA VALANCE - 17", GALAXY
6	118537-04-G31	EA VALANCE - 17", GALAXY
6	105923-32-F27	EA VALANCE - 17" RODEWAY - W/O INSERT (G32)
6	109041-30-02A	EA BLIND-MINI, 15.5 X 33 (G29,G32)
6	109041-30-01A	EA BLIND-MINI, 15.5 X 33 (G30,G31)
7	118537-05-G29	EA VALANCE - 11 X 33.75", GALAXY - FLAT
7	118537-05-G30	EA VALANCE - 11 X 33.75", GALAXY - FLAT
7	118537-06-G31	EA VALANCE - 11 X 33.75", GALAXY - FLAT
7	113268-28-G32	EA VALANCE - 11 X 33.75", FLAT
7	084755-57-E07	EA SHADE ASM-PULL, 27.25 - W/O TRIM

CURTAIN & CUSHION GROUP (CONTINUED)

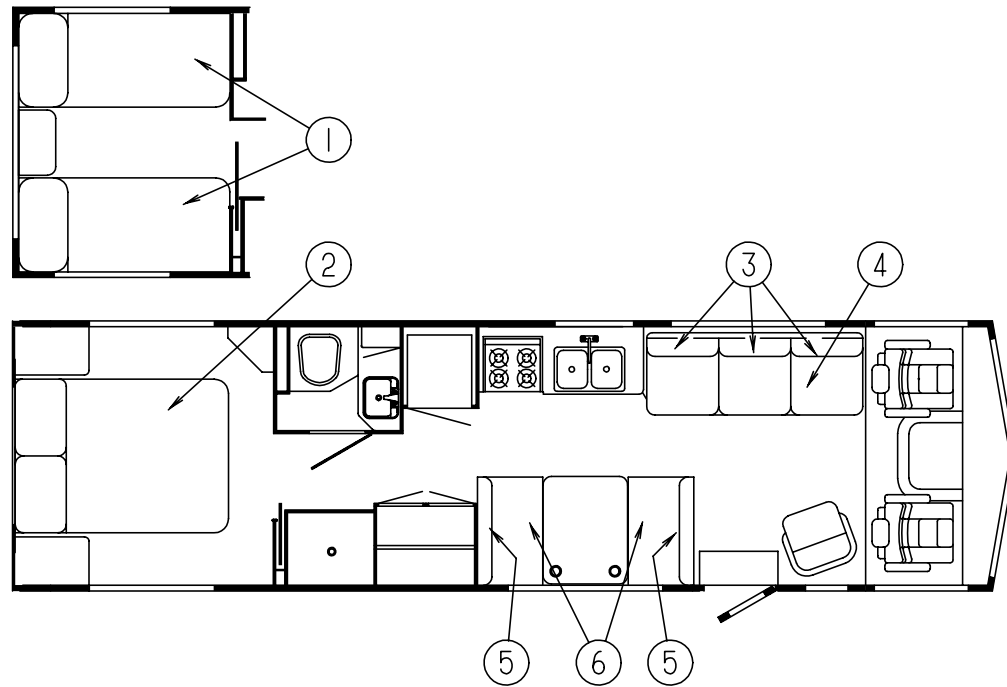

TWIN MATTRESS & BEDSPREAD

KEY	PART NUMBER	U/M DESCRIPTION
1	098176-10-000	EA MATTRESS-INNERSPRING, 32 X 79.5 - SEALY
1	085365-34-G29	EA BEDSPREAD - 33 X 80, THROW W/ 1" GATHERED WELT
1	085365-34-G30	EA BEDSPREAD - 33 X 80, THROW W/ 1" GATHERED WELT
1	085365-34-F25	EA BEDSPREAD - 33 X 80, THROW W/ 1" GATHERED WELT (G31)
1	119141-08-G12	EA BEDSPREAD - 32 X 80, THROW W/ REVERSE SHAM (G32)
	111862-03-G29	EA PILLOW - 15 X 15 ACCENT W/.5"MAIN
	111862-03-G30	EA PILLOW - 15 X 15 ACCENT W/.5"MAIN
	111862-03-G31	EA PILLOW - 15 X 15 ACCENT W/.5"MAIN
	109785-06-G12	EA PILLOW - 15 X 15 W/CORNER PLEAT & WELT (G32)

QUEEN MATTRESS & BEDSPREAD

KEY	PART NUMBER	U/M DESCRIPTION
2	098176-04-000	EA MATTRESS-QUEEN, INNERSPRING - 59" X 74" - SEALY
2	085365-19-G29	EA BEDSPREAD - 60 THROW, W/1" GATHERED WELT
2	085365-19-G30	EA BEDSPREAD - 60 THROW, W/1" GATHERED WELT
2	085365-19-F25	EA BEDSPREAD - 60 THROW, W/1" GATHERED WELT (G31)
2	119141-07-G12	EA BEDSPREAD - 60 X 75, THROW W/ REVERSE SHAM (G32)
	111863-05-G29	EA PILLOW SHAM - 1" GATHERED WELT
	111863-05-G30	EA PILLOW SHAM - 1" GATHERED WELT
	111863-05-G31	EA PILLOW SHAM - 1" GATHERED WELT
	111863-05-G12	EA PILLOW SHAM - 1" GATHERED WELT (G32)

COUCH

KEY	PART NUMBER	U/M DESCRIPTION
3	112104-01-G29	EA BED ASM - 74" CHANNEL - JACK KNIFE BACK
3	112104-01-G30	EA BED ASM - 74" CHANNEL - JACK KNIFE BACK
3	112104-01-F25	EA BED ASM - 74" CHANNEL - JACK KNIFE BACK (G31)
3	111319-01-F07	EA BED ASM - 74" JACK KNIFE BACK - KNIFE EDGE (G32)
3	P12104-01-G29	EA COVER-BED, CHANNEL - JACK KNIFE BACK, 74
3	P12104-01-G30	EA COVER-BED, CHANNEL - JACK KNIFE BACK, 74
3	P12104-01-F25	EA COVER-BED, CHANNEL - JACK KNIFE BACK, 74 (G31)
3	P11319-01-F07	EA COVER-BED, JACK KNIFE EDGE BACK - 74" (G32)
4	100032-43-G01	EA BED-JACK KNIFE, SEAT - 74" TUCK - W/O ARMS (G29)
4	100032-43-G02	EA BED-JACK KNIFE, SEAT - 74" TUCK - W/O ARMS (G30)
4	100032-43-F02	EA BED-JACK KNIFE, SEAT - 74" TUCK - W/O ARMS (G31)
4	100032-43-F07	EA BED-JACK KNIFE, SEAT - 74" TUCK - W/O ARMS (G32)
4	P00032-43-G01	EA COVER-JACK KNIFE SEAT, 74" TUCK - W/O ARM (G29)
4	P00032-43-G02	EA COVER-JACK KNIFE SEAT, 74" TUCK - W/O ARM (G30)
4	P00032-43-F02	EA COVER-JACK KNIFE SEAT, 74" TUCK - W/O ARM (G31)
4	P00032-43-F07	EA COVER-JACK KNIFE SEAT, 74" TUCK - W/O ARM (G31)
	101085-04-000	EA FRAME-SEAT, 74.75"
	101085-06-000	EA FRAME-BASE, 74.75"
	101085-10-000	EA FRAME - 74.5 X 16 BACK FRAME - JACKKNIFE
	111637-02-F06	EA PILLOW ASM - 22 X 22, KNIFE EDGE W/WELT (G29)
	111637-02-F08	EA PILLOW ASM - 22 X 22, KNIFE EDGE W/WELT (G30)
	111637-02-E04	EA PILLOW ASM - 22 X 22, KNIFE EDGE W/WELT (G31)
	111637-02-F27	EA PILLOW ASM - 22 X 22, KNIFE EDGE W/WELT (G32)

NOTE: COUCH FRONT AND SIDE PANELS ARE FOUND IN THE LOUNGE GROUP

CURTAIN & CUSHION GROUP (CONTINUED)

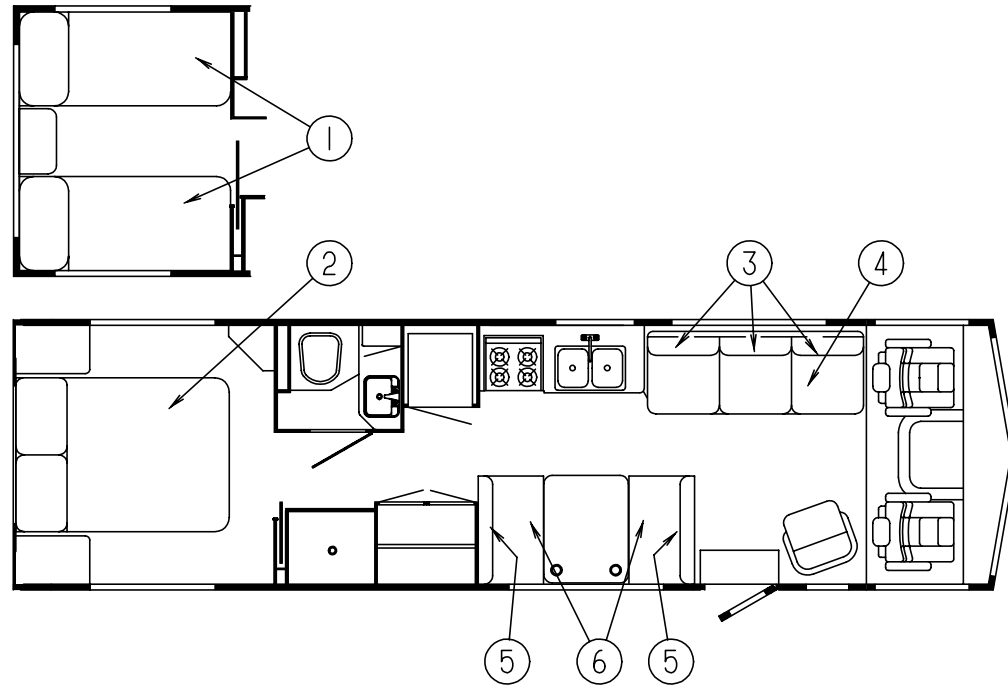

DINETTE CUSHIONS

KEY	PART NUMBER	U/M	DESCRIPTION
5	111880-01-G29	EA	CUSHION - 13.5 X 38 X 5 CHANNEL BACK
5	111880-01-G30	EA	CUSHION - 13.5 X 38 X 5 CHANNEL BACK
5	111880-01-F25	EA	CUSHION - 13.5 X 38 X 5 CHANNEL BACK (G31)
5	111897-08-F27	EA	CUSHION - 13.5 X 38 X 5 CLUB BACK (G32)
5	P11880-01-G29	EA	COVER - 13.5 X 38 X 5 CHANNEL BACK
5	P11880-01-G30	EA	COVER - 13.5 X 38 X 5 CHANNEL BACK
5	P11880-01-F25	EA	COVER - 13.5 X 38 X 5 CHANNEL BACK (G31)
5	P11897-08-F27	EA	COVER - 13.5 X 38 X 5 CLUB BACK (G32)
5	078155-01-000	EA	STRAP-SNAP, BACKREST CUSHION
6	088927-87-G01	EA	CUSHION - 23 X 38 X 5, DINETTE SEAT (G29)
6	088927-87-G02	EA	CUSHION - 23 X 38 X 5, DINETTE SEAT (G30)
6	088927-87-F02	EA	CUSHION - 23 X 38 X 5, DINETTE SEAT (G31)
6	105603-03-F27	EA	CUSHION - 23 X 38 X 5, DINETTE SEAT (G32)
6	M88927-87-G01	EA	COVER - 23 X 38 X 5, DINETTE SEAT (G29)
6	M88927-87-G02	EA	COVER - 23 X 38 X 5, DINETTE SEAT (G30)
6	M88927-87-F02	EA	COVER - 23 X 38 X 5, DINETTE SEAT (G31)
6	P05603-03-F27	EA	COVER - 23 X 38 X 5, DINETTE SEAT (G32)

BUNK CUSHION

KEY	PART NUMBER	U/M	DESCRIPTION
	079145-06-000	EA	CUSHION-BUNK, 30" X 77" X 4"
	M79145-06-000	EA	COVER-CUSHION, BUNK
	079970-10-000	YD	TAPE-MATRESS, 7/8"

CURTAIN & CUSHION GROUP (CONTINUED)

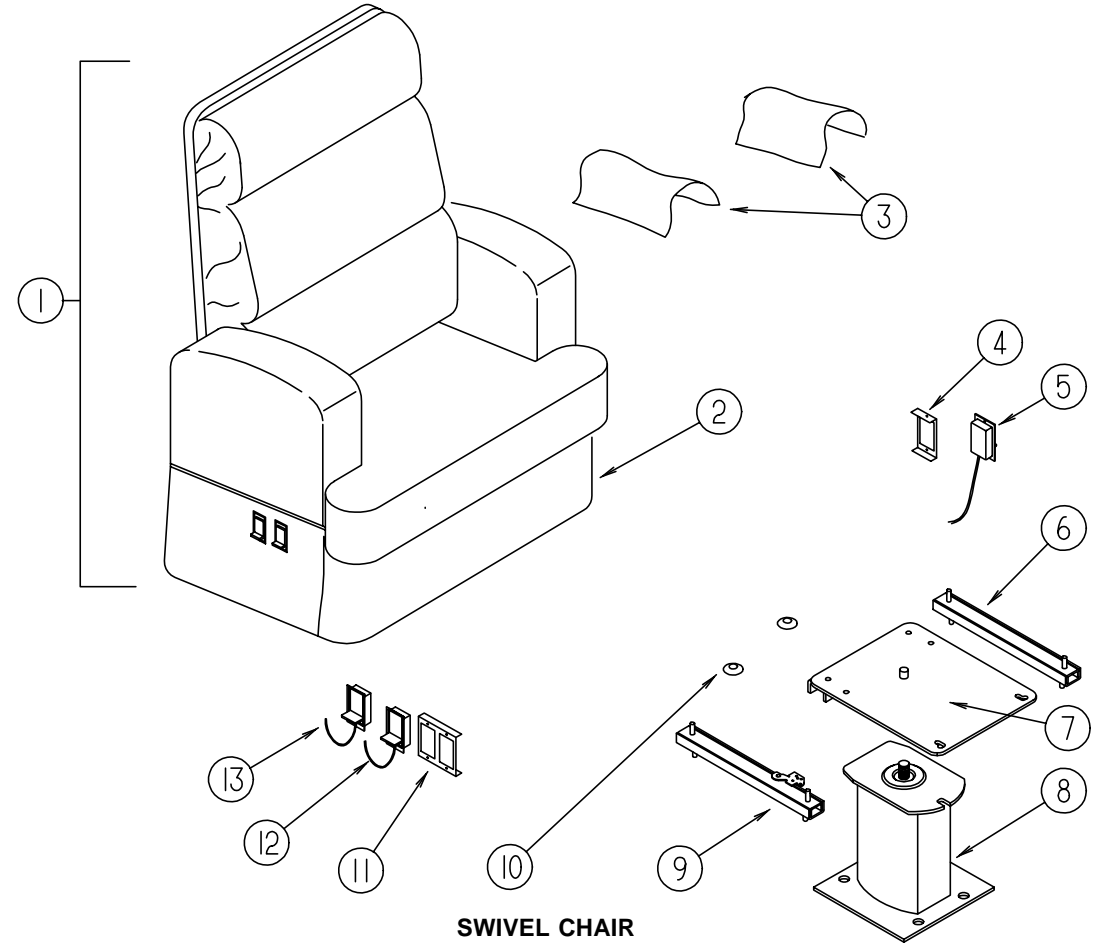

SWIVEL CHAIR

KEY	PART NUMBER	U/M	DESCRIPTION
1	118538-01-G29	EA	CHAIR-SWIVEL, W/O SKIRT
1	118538-01-G30	EA	CHAIR-SWIVEL, W/O SKIRT
1	118538-01-G31	EA	CHAIR-SWIVEL, W/O SKIRT
1	118538-01-G32	EA	CHAIR-SWIVEL, W/O SKIRT
	P18538-01-G29	EA	COVER-SWIVEL CHAIR
	P18538-01-G30	EA	COVER-SWIVEL CHAIR
	P18538-01-G31	EA	COVER-SWIVEL CHAIR
	P18538-01-G32	EA	COVER-SWIVEL CHAIR
2	118539-01-G29	EA	SKIRT-SWIVEL CHAIR
2	118539-01-G30	EA	SKIRT-SWIVEL CHAIR
2	118539-01-G31	EA	SKIRT-SWIVEL CHAIR
2	118539-01-G32	EA	SKIRT-SWIVEL CHAIR
3	P18538-27-G29	EA	COVER-ARM, RH
3	P18538-27-G30	EA	COVER-ARM, RH
3	P18538-27-G31	EA	COVER-ARM, RH
3	P18538-27-G32	EA	COVER-ARM, RH
3	P18538-28-G29	EA	COVER-ARM, LH
3	P18538-28-G30	EA	COVER-ARM, LH
3	P18538-28-G31	EA	COVER-ARM, LH
3	P18538-28-G32	EA	COVER-ARM, LH
4	097683-03-000	EA	BRACKET-REMOTE, SIDE MOUNT - SINGLE
5	108049-03-000	EA	CABLE - 26" Z END CABLE - CMA
	108049-02-000	EA	CLIP-CABLE, PEDESTAL
6	119952-01-000	EA	SLIDE-SEAT, HD - NONLOCKING - 2 STUDS - ATWOOD 83711
7	107921-08-000	EA	TOP PLATE-W/O SEAT BELT BAR - FLEXSTEEL 2759PDTP
	107921-06-000	EA	BEARING KIT-SEAT SWIVEL - FLEXSTEEL
8	107921-01-000	EA	PEDESTAL ASM-SEAT 9 3/4 IN - FLEXSTEEL 3060 MSPD
9	119952-03-000	EA	SLIDE-SEAT, HD - LOCKING - 2 STUDS - ATWOOD 83775
10	007221-01-000	EA	SPACER-SEAT, ADJUSTER
11	097683-02-000	EA	BRACKET-MOUNT, REMOTE
12	089368-05-000	EA	CABLE-RECLINER, W/SWITCH
13	108049-03-000	EA	CABLE - 26" Z END CABLE - CMA
	108049-02-000	EA	CLIP-CABLE, PEDESTAL

CURTAIN & CUSHION GROUP (CONTINUED)
DRIVER & PASSENGER BUCKET SEATS

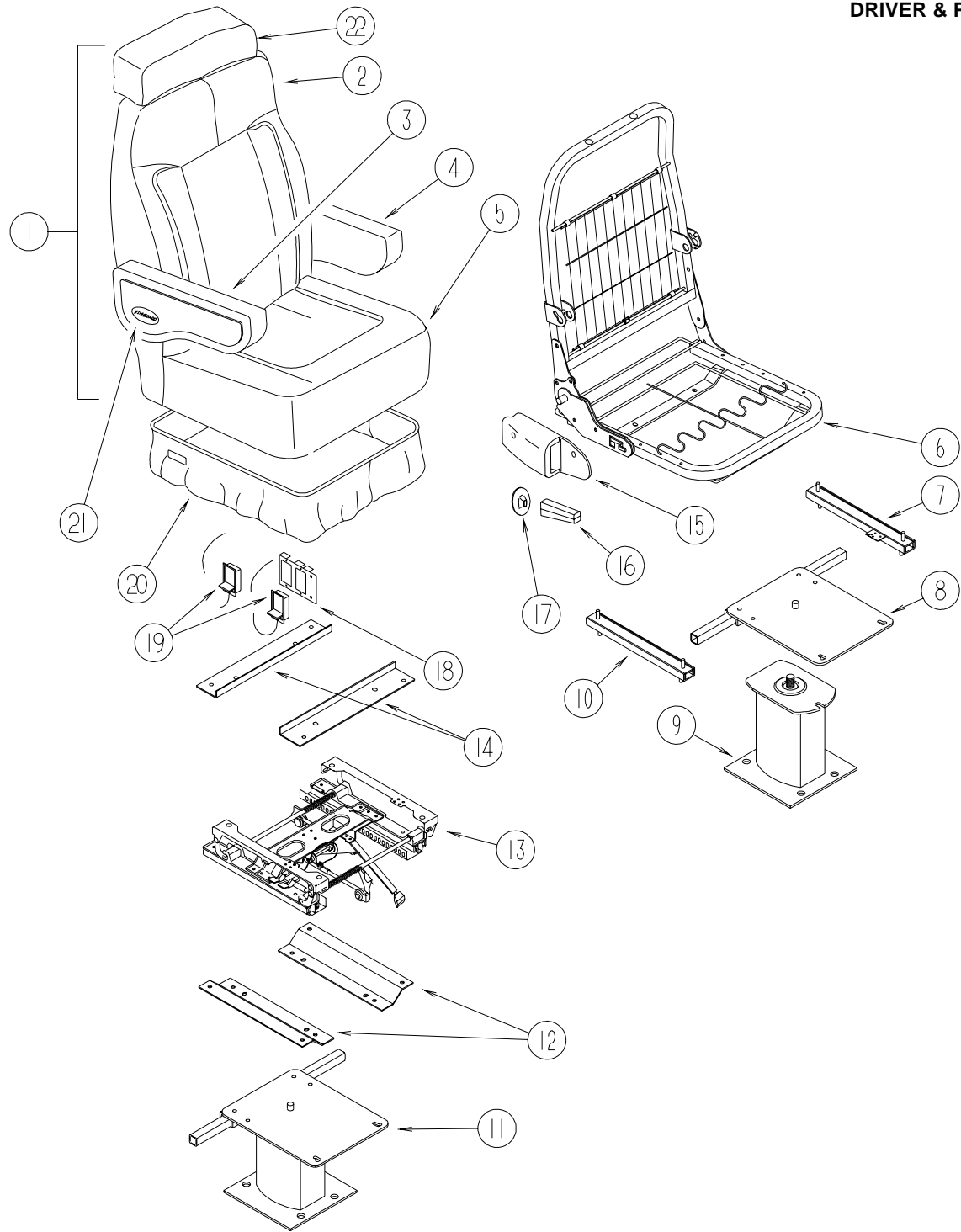

KEY	PART NUMBER	U/M	DESCRIPTION
1	119508-03-G29	EA	SEAT-BUCKET, W/ARMRESTS - W/O SKIRT
1	119508-03-G30	EA	SEAT-BUCKET, W/ARMRESTS - W/O SKIRT
1	119508-03-G31	EA	SEAT-BUCKET, W/ARMRESTS - W/O SKIRT
1	119508-03-G32	EA	SEAT-BUCKET, W/ARMRESTS - W/O SKIRT
2	M05962-29-G29	EA	COVER-BACK, BUCKET SEAT
2	M05962-29-G30	EA	COVER-BACK, BUCKET SEAT
2	M05962-29-G31	EA	COVER-BACK, BUCKET SEAT
2	M05962-29-G32	EA	COVER-BACK, BUCKET SEAT

KEY	PART NUMBER	U/M	DESCRIPTION
3	111320-03-G29	EA	ARMREST-RIGHT, BUCKET SEAT
3	111320-03-G30	EA	ARMREST-RIGHT, BUCKET SEAT
3	111320-03-G31	EA	ARMREST-RIGHT, BUCKET SEAT
3	111320-03-G11	EA	ARMREST-RIGHT, BUCKET SEAT (G32)
	P11320-03-G29	EA	COVER-ARMREST, RIGHT
	P11320-03-G30	EA	COVER-ARMREST, RIGHT
	P11320-03-G31	EA	COVER-ARMREST, RIGHT
	P11320-03-G11	EA	COVER-ARMREST, RIGHT (G32)
4	111320-04-G29	EA	ARMREST-LEFT, BUCKET SEAT
4	111320-04-G30	EA	ARMREST-LEFT, BUCKET SEAT
4	111320-04-G31	EA	ARMREST-LEFT, BUCKET SEAT
4	111320-04-G11	EA	ARMREST-LEFT, BUCKET SEAT (G32)
	P11320-04-G29	EA	COVER-ARMREST, LEFT
	P11320-04-G30	EA	COVER-ARMREST, LEFT
	P11320-04-G31	EA	COVER-ARMREST, LEFT
	P11320-04-G11	EA	COVER-ARMREST, LEFT (G32)
5	M05962-06-G29	EA	COVER-SEAT, BUCKET SEAT
5	M05962-06-G30	EA	COVER-SEAT, BUCKET SEAT
5	M05962-06-G31	EA	COVER-SEAT, BUCKET SEAT
5	M05962-06-G32	EA	COVER-SEAT, BUCKET SEAT
6	M80906-12-000	EA	FRAME-SEAT, BACK & SPRING
7	119952-04-000	EA	SLIDE-SEAT, HD - LOCKING - 4 STUDS - ATWOOD 83785
8	107921-05-000	EA	PLATE-TOP, W/SEAT BELT BAR - FLEXSTEEL 2759PDTP
9	107921-01-000	EA	PEDESTAL ASM-SEAT 9 3/4 IN - FLEXSTEEL 3060 MSPD
	107921-06-000	EA	BEARING KIT-SEAT SWIVEL - FLEXSTEEL
10	119952-02-000	EA	SLIDE-SEAT, HD - NONLOCKING - 4 STUDS - ATWOOD 83731
11	107921-14-000	EA	PEDESTAL ASM-SEAT 5.75 IN - MANUAL SEAT OPTION - FLEXSTEEL XP1774
12	116215-03-000	EA	PLATE-LOWER, MANUAL - 6-WAY - MANUAL SEAT OPTION - ATWOOD 83835
13	116215-01-000	EA	SEAT-MANUAL, 6-WAY - DRIVER - MANUAL SEAT OPTION - ATWOOD 83805
14	116215-02-000	EA	PLATE-UPPER, MANUAL - 6-WAY - MANUAL SEAT OPTION - ATWOOD 85118
15	080730-09-000	EA	SHIELD - FLEXSTEEL
16	080730-08-000	EA	HANDLE - KEIPER 30179907
17	080730-11-000	EA	SHIELD-RUBBER BOOT - FLEXSTEEL
18	097683-02-000	EA	BRACKET-MOUNT, REMOTE
19	108049-03-000	EA	CABLE - 26" Z END CABLE - CMA
	108049-02-000	EA	CLIP-CABLE, PEDESTAL
20	071126-43-F24	EA	SKIRT-BUCKET SEAT (G29)
20	071126-43-F11	EA	SKIRT-BUCKET SEAT (G30)
20	071126-43-F25	EA	SKIRT-BUCKET SEAT (G31)
20	071126-43-F06	EA	SKIRT-BUCKET SEAT (G32)
20	071126-54-F24	EA	SKIRT-BUCKET SEAT (G29) - MANUAL SEAT OPTION
20	071126-54-F11	EA	SKIRT-BUCKET SEAT (G30) - MANUAL SEAT OPTION
20	071126-54-F25	EA	SKIRT-BUCKET SEAT (G31) - MANUAL SEAT OPTION
20	071126-54-F06	EA	SKIRT-BUCKET SEAT (G32) - MANUAL SEAT OPTION
21	111169-01-000	EA	PLATE-BACK, ARMREST
21	111169-05-000	EA	INSERT-ARMREST, OVAL DECAL - ITASCA
22	119509-01-G29	EA	HEADREST ASM
22	119509-01-G30	EA	HEADREST ASM
22	119509-01-G31	EA	HEADREST ASM
22	119509-01-G11	EA	HEADREST ASM (G32)
	P19509-01-G29	EA	COVER ASM-HEADREST
	P19509-01-G30	EA	COVER ASM-HEADREST
	P19509-01-G31	EA	COVER ASM-HEADREST
	P19509-01-G11	EA	COVER ASM-HEADREST (G32)
	007221-01-000	EA	SPACER-SEAT, ADJUSTER
	089323-01-000	FT	STRIP-POLYETHYLENE, J-CHANNEL - FLEX-O-LATORS
	114889-01-000	EA	STOP BAR-UNIVERSAL - SHROCK

CURTAIN & CUSHION GROUP (CONTINUED)
BUTTON, TRIM, ASSIST HANDLE & SEAT BELT

KEY	PART NUMBER	U/M DESCRIPTION
	118337-01-G29	EA BUTTON ASM-#60
	118337-01-G30	EA BUTTON ASM-#60
	118337-01-G31	EA BUTTON ASM-#60
	118337-01-G11	EA BUTTON ASM-#60 (G32)
	074494-02-000	EA BUTTON-RETAINING PIVOT #60
	074494-03-000	EA BUTTON-SERRATED PIVOT TACK 3/8
	070578-02-B10	EA BUTTON-SCREW STUD, #30 - VINYL - OFF WHITE
	079349-04-F01	YD WELT ASM-NARROW, ACCENT (G29)
	079349-04-F08	YD WELT ASM-NARROW, ACCENT (G30)
	079349-04-E04	YD WELT ASM-NARROW, ACCENT (G31)
	079349-04-G32	YD WELT ASM-NARROW, ACCENT
	057759-01-000	EA WASHER BRACKET-SEAT BELT, 4" DIAMETER
	007021-01-000	EA BELT-SEAT, 2" X 90" - BLACK
	056271-02-000	EA BELT-SEAT, 2" X 72" - BLACK
	069178-02-000	EA BRACKET-MOUNTING, ASSIST HANDLE - L ANGLE - W/HOLES - STEEL
	053552-02-AA8	EA HANDLE-ASSIST, INTERIOR - ENTRY DOOR - VINYL - OFF WHITE
	057534-01-000	EA TIEBACK/TIEDOWN-BED/CURTAIN/DOOR, 6" - PLASTIC - CLEAR

CURTAIN & CUSHION GROUP (CONTINUED)
SUNRISE FABRIC

COLOR CODES	G29	G30	G31	G32
	PEBBLE BEACH (BROWN)	NEPTUNE (TEAL)	GALAXY (BLUE)	ROUTE 66
CEILING VINYL	089351-03-000	089351-03-000	089351-03-000	089351-03-000
OFF WHITE VINYL	106569-01-01A	106569-01-01A	106569-01-01A	106569-01-01A
QUICKSILVER VINYL	103907-01-05A	103907-01-05A	103907-01-05A	103907-01-05A
DRAPERY LINING	087272-03-000	087272-03-000	087272-03-000	087272-03-000
BUCKET SEATS	104233-14-000	108446-C5-000	098428-30-000	108446-55-000
DINETTE	108446-E1-000	108446-E2-000	108446-B1-000	108446-D3-000
DINETTE PADS	104233-14-000	108446-C5-000	108446-30-000	108446-55-000
SOFA	108446-E1-000	108446-E2-000	108446-B1-000	108446-D2-000
SOFA PILLOWS	108446-57-000	108446-C6-000	098428-30-000	108446-D3-000
SWIVEL CHAIR	108446-57-000	108446-C6-000	098428-30-000	108446-D3-000
LOUNGE WINDOWS	104233-14-000 108446-E1-000 108446-57-000	108446-C5-000 108446-C6-000 108446-E2-000	098428-30-000 108446-B1-000	108446-D4-000 108446-D2-000
BEDROOM WINDOW	105745-A1-000 105745-98-000	105745-45-000 105745-99-000	105745-61-000 105745-91-000	105745-D1-000 105745-D3-000
BEDSPREAD	105745-A1-000 105745-98-000	105745-45-000 105745-99-000	105745-61-000 105745-91-000	105745-D1-000
PILLOW SHAMS	105745-A1-000 105745-98-000	105745-45-000 105745-99-000	105745-61-000 105745-91-000	105745-D1-000 105745-D3-000
BEDROOM PILLOWS	105745-A1-000 105745-98-000	105745-45-000 105745-99-000	105745-61-000 105745-91-000	105745-D3-000
FRONT WRAP AROUND	072333-90-000	072333-82-000	072333-82-000	072333-82-000
DIVIDER CURTAIN	072333-90-000	072333-82-000	072333-82-000	072333-82-000
MAP POCKETS	104233-14-000	108446-C5-000	098428-30-000	108446-55-000

NOTE: FABRIC LISTED FIRST IN A BLOCK IS THE LARGEST QUANTITY OF FABRIC USED

DINETTE GROUP
DINETTE CABINERY

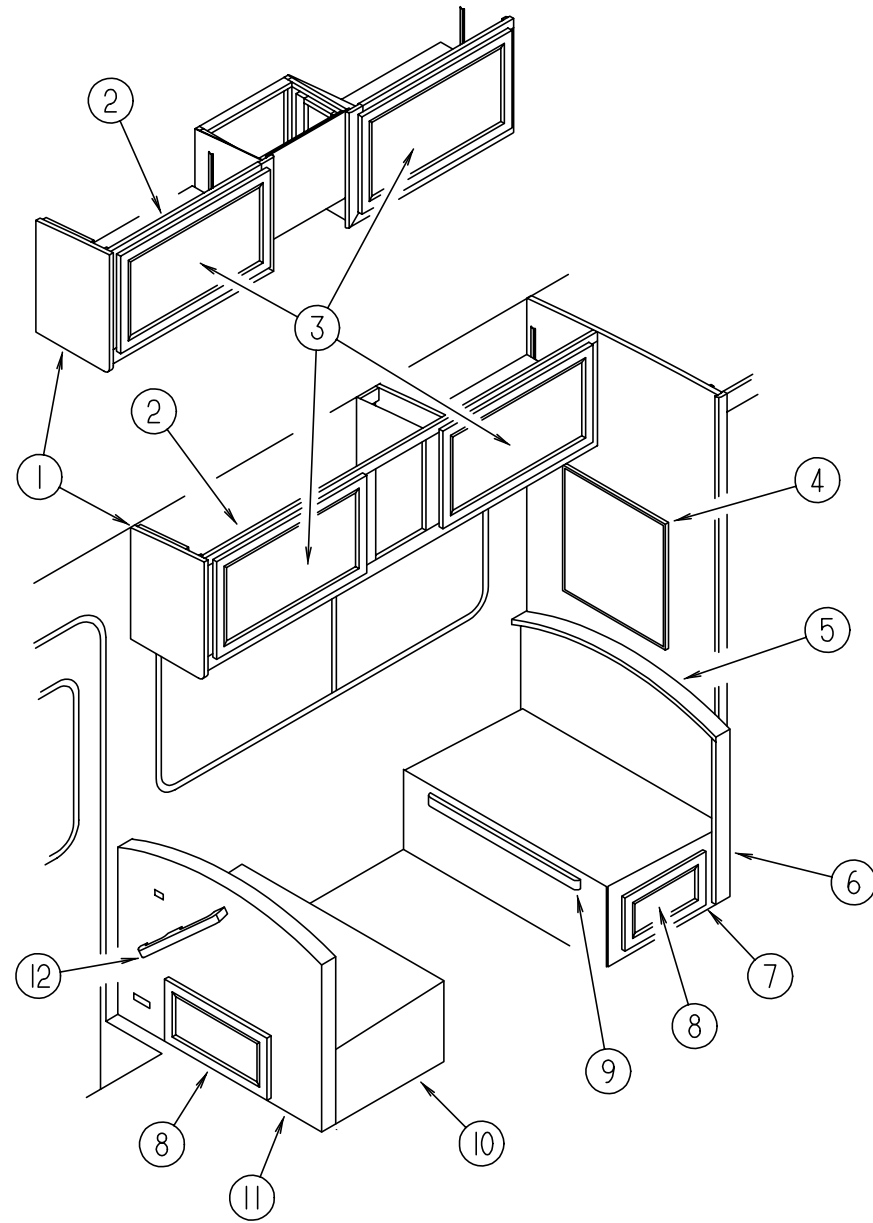

KEY	PART NUMBER	U/M	DESCRIPTION
1	103128-02-G09	EA	END CAP ASM, OVERHEAD
2	117902-01-G29	EA	CABINET ASM-OVHD DINETTE, W/O COFFEEMAKER
2	117902-01-G30	EA	CABINET ASM-OVHD DINETTE, W/O COFFEEMAKER
2	117902-01-G31	EA	CABINET ASM-OVHD DINETTE, W/O COFFEEMAKER
2	117902-01-G32	EA	CABINET ASM-OVHD DINETTE, W/O COFFEEMAKER
2	117579-01-G11	EA	CABINET ASM-OVHD DINETTE, W/COFFEEMAKER (G29)
2	117579-01-G30	EA	CABINET ASM-OVHD DINETTE, W/COFFEEMAKER
2	117579-01-G31	EA	CABINET ASM-OVHD DINETTE, W/COFFEEMAKER
2	117579-01-G32	EA	CABINET ASM-OVHD DINETTE, W/COFFEEMAKER
3	M06803-02-G09	EA	DOOR ASM-W/O HARDWARE - 400 X 710
4	058331-47-000	EA	MIRROR-GLASS, SAFETY - 562 X 384
5	104787-04-F24	EA	PAD ASM-DINETTE (G29)
5	104787-04-F11	EA	PAD ASM-DINETTE (G30)
5	104787-04-F25	EA	PAD ASM-DINETTE (G31)
5	104787-04-F06	EA	PAD ASM-DINETTE (G32)
6	M04174-68-G09	EA	CABINET-SEATBACK RH
7	M04175-68-G09	EA	CABINET-SEATBASE RH
8	M06803-07-G09	EA	DOOR ASM-W/O HARDWARE - 255 X 485
9	081295-01-G01	EA	SUPPORT-BED, DINETTE, 712 LG
10	M04175-69-G09	EA	CABINET-SEATBASE LH
11	M04174-69-G09	EA	CABINET-SEATBACK LH
12	091257-08-000	EA	HANDLE-ASSIST, RAMBLING OAK

DINETTE GROUP (CONTINUED)
DINETTE TABLE

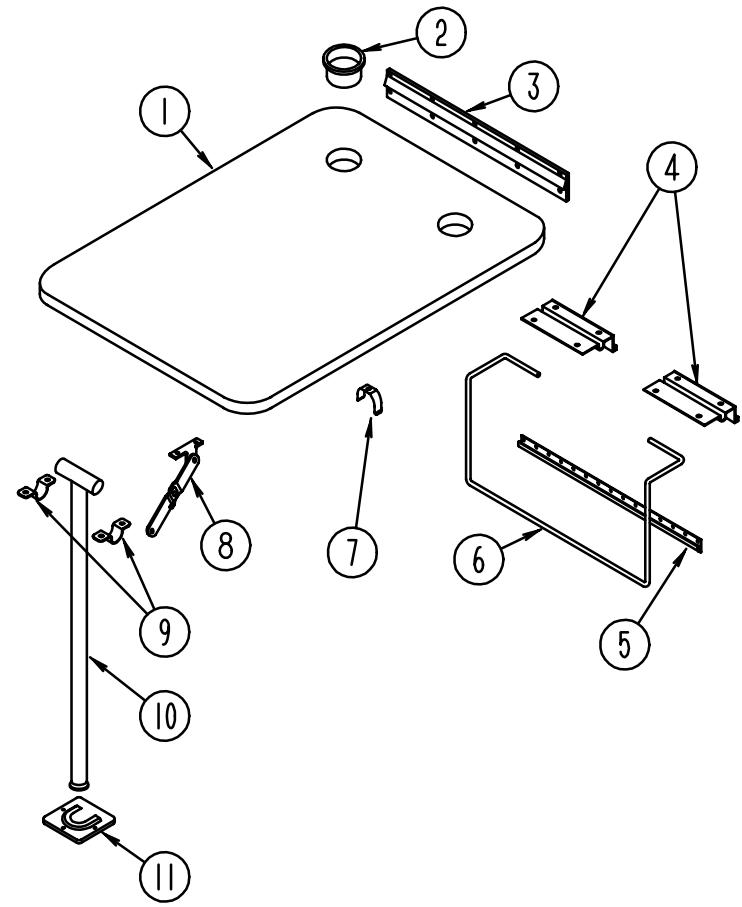

KEY	PART NUMBER	U/M	DESCRIPTION
1	081322-01-G29	EA	TABLE-DINETTE, W/O HARDWARE
1	081322-05-G30	EA	TABLE-DINETTE, W/O HARDWARE
1	081322-05-G31	EA	TABLE-DINETTE, W/O HARDWARE
1	081322-05-G09	EA	TABLE-DINETTE, W/O HARDWARE (G32)
2	064781-06-000	EA	HOLDER-CUP, TWO STEP - OFF WHITE
3	053200-12-000	EA	SUPPORT-TABLE, 23.5" - BEIGE
4	088410-02-000	EA	BRACKET-LIFT, TABLE MOUNTED - OFF WHITE
5	024281-14-000	EA	BRACKET-LIFT ROD, LOWER WALL MOUNTED - 22.12" - OFF WHITE
6	024275-12-000	EA	ROD-TABLE LIFT, OFF WHITE
7	024283-01-000	EA	CLIP-LEG, 1" X 1.125" OD - BLACK
8	024282-01-000	EA	BRACE-TABLE LEG, HINGED
9	064050-05-000	EA	HINGE-TABLE LEG, OFF WHITE
10	024276-23-000	EA	LEG-TABLE, METAL - OFF WHITE
11	049493-12-000	EA	CATCH-LEG, FLOOR MOUNTED - 2.5" X 2.7" - METAL - OFF WHITE
11	049493-11-700	EA	CATCH-LEG, FLOOR MOUNTED - 2.5" X 2.7" - METAL - E-COAT

DRIVERS COMPARTMENT GROUP
DRIVERS COMPARTMENT - UPPER

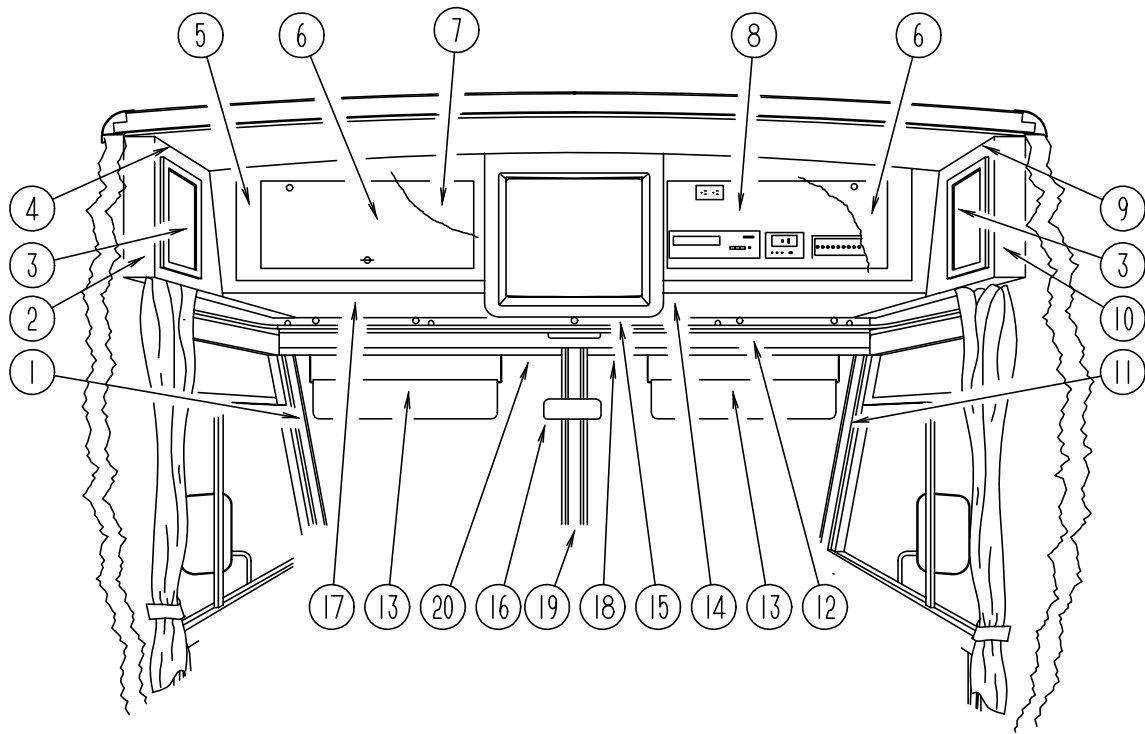

KEY	PART NUMBER	U/M	DESCRIPTION
1	103931-02-03A	EA	COVER-INNER, A-PILLAR - DRIVERS - QUICK SILVER
2	103128-09-G09	EA	CAP-END, FRONT OVERHEAD, DRIVERS SIDE
3	M06803-04-G09	EA	DOOR-CABINET, W/O HARDWARE - 255 MM X 485 MM
4	109561-02-G29	EA	CABINET-FRONT OVERHEAD W/O DOOR, DRIVERS SIDE
4	109561-02-G30	EA	CABINET-FRONT OVERHEAD W/O DOOR, DRIVERS SIDE
4	109561-02-G31	EA	CABINET-FRONT OVERHEAD W/O DOOR, DRIVERS SIDE
4	109561-02-G32	EA	CABINET-FRONT OVERHEAD W/O DOOR, DRIVERS SIDE
	P09561-02-E07	EA	BOTTOM-VINYL COVERED, FRONT OVERHEAD - DRIVERS SIDE
	104289-02-G29	EA	PAD-VINYL COVERED, 30.3" X 9.6" - ANGLED - DRIVERS SIDE
5	114612-02-G09	EA	CABINET ASM-FACE, OVHD TV - LH
	106699-01-01A	EA	BRACKET-L-ANGLE, TV CABINET FACE - 5.1" LONG - OFF WHITE STEEL
6	100708-12-000	EA	DOOR-GLASS, TV CABINET - W/O HARDWARE - 246 X 590
	100710-01-01A	EA	LOCK-TWIST TYPE, BRASS
	100711-01-01A	EA	HINGE-DOOR, GLASS
	100707-01-000	EA	SPACER-DOOR, GLASS - .8" DIA - .3" HOLE - PLASTIC
	101272-01-000	EA	CATCH-GLASS DOOR
	101766-01-000	EA	PIN-SUPPORT, GLASS DOOR
7	114661-12-G35	EA	PANEL ASM-LINER, OVHD TV - LH
8	114661-13-G35	EA	PANEL ASM-LINER, OVHD TV - RH - TV OPTION
8	114661-14-G35	EA	PANEL ASM-LINER, OVHD TV - RH - TV/VCR OPTION
8	114661-15-G35	EA	PANEL ASM-LINER, OVHD TV - RH - TV/VCR/INVERTER OPTION
8	114661-16-G35	EA	PANEL ASM-LINER, OVHD TV - RH - TV/INVERTER OPTION
9	114188-01-G29	EA	CABINET-FRONT OVERHEAD W/O DOOR, PASSENGERS SIDE
9	114188-01-G30	EA	CABINET-FRONT OVERHEAD W/O DOOR, PASSENGERS SIDE
9	114188-01-G31	EA	CABINET-FRONT OVERHEAD W/O DOOR, PASSENGERS SIDE
9	114188-01-G32	EA	CABINET-FRONT OVERHEAD W/O DOOR, PASSENGERS SIDE
10	103128-08-G09	EA	CAP-END, FRONT OVERHEAD, PASSENGERS SIDE
	P14188-01-E07	EA	BOTTOM-VINYL COVERED, FRONT OVERHEAD - PASSENGERS SIDE
	104289-01-G29	EA	PAD-VINYL COVERED, 30.3" X 9.6" - ANGLED - DRIVERS SIDE
11	103931-01-03A	EA	COVER-INNER, A-PILLAR - PASSENGERS
12	078811-05-G29	EA	PANEL-HEADER W/RECEPTACLE CUTOUTS - 90.2" LONG - VINYL COVERED
13	082286-18-G09	EA	SUNVISOR-DRIVER OR PASSENGER - W/O POCKET
	102377-01-000	EA	BRACKET-SUNVISOR, 1 PIECE - STEEL
	007211-01-000	EA	HINGE-SUNVISOR
	074012-01-000	EA	CLIP-SUNVISOR, SQUARE PINCH-ON
14	P03077-07-G35	EA	SHELF-CABINET, PASSENGERS SIDE - VINYL COVERED
15	117974-01-02A	EA	COVER-TV FACE, OVHD FRONT - QUICK SILVER
	118022-01-G29	EA	FRONT TV COVER ASM-OVHD (ASSEMBLED KIT)
	100628-02-000	EA	SHELF ASM-TV, STEEL
	101150-01-000	EA	SUPPORT-SHELF, TV - PASSENGER SIDE - STEEL
	101150-02-000	EA	SUPPORT-SHELF, TV - DRIVER SIDE - STEEL
	104417-01-G09	EA	CABINET-BLANKET (STANDARD CABINET)
16	040714-01-000	EA	MIRROR-REAR VIEW, W/ARM MOUNT & SET SCREW - GM# 911722
	067490-01-000	EA	BUTTON-MIRROR, REAR VIEW - STANK S927H
17	P03077-08-G35	EA	SHELF-CABINET, DRIVERS SIDE - VINYL COVERED
18	078579-19-000	EA	TRIM - WINDSHIELD - UPPER INNER - RIGHT - QUICK SILVER
19	079765-13-000	EA	TRIM - WINDSHIELD - CENTER INNER - QUICK SILVER
20	078579-20-000	EA	TRIM - WINDSHIELD - UPPER INNER - LEFT - QUICK SILVER

DRIVERS COMPARTMENT GROUP (CONTINUED)
DRIVERS COMPARTMENT - LOWER

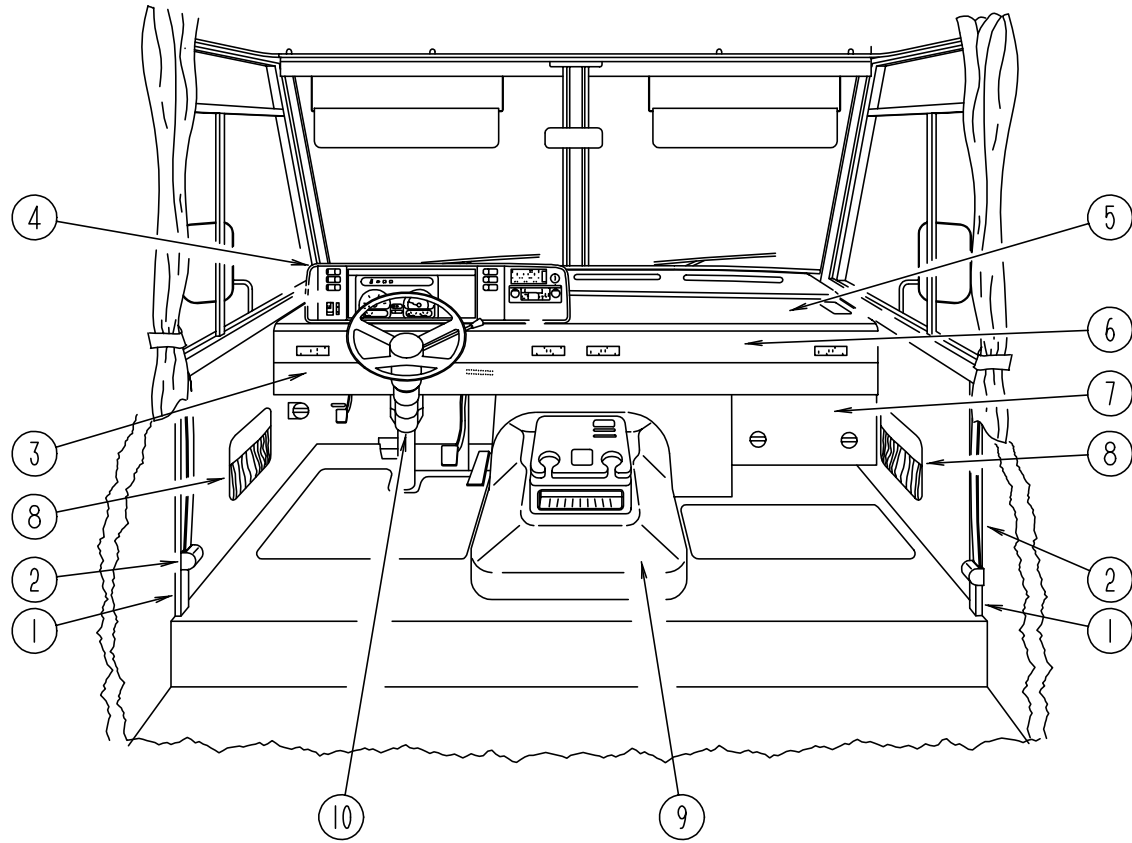

KEY	PART NUMBER	U/M DESCRIPTION
1	024700-44-000	EA COVER-SIDEWALL ROLL BAR, OFF WHITE - 53"
1	024700-45-000	EA COVER-SIDEWALL ROLL BAR, OFF WHITE - 12.8"
2	091990-04-01A	EA SEAT BELT-SHOULDER HARNESS - DRIVERS/PASSENGERS - BLACK
	091990-01-700	EA BOLT COVER
	109146-01-000	EA BOLT-SHOULDER, SEAT BELT
	103961-01-01A	EA COVER-BRACKET, SEATBELT - OFF WHITE
	103961-02-01A	EA COVER-BRACKET, SEATBELT - OFF WHITE - DRIVER DOOR OPTION
3	103812-06-05A	EA TRIM-DASH, LOWER - QUICK SILVER - CHEVY
3	117306-01-G35	EA TRIM-DASH, LOWER - QUICK SILVER - FORD
4	M05946-26-G29	EA DASH POD ASM-CHEVY
4	M05946-27-G29	EA DASH POD ASM-FORD
5	P03817-10-000	EA DASH ASM, W/O VINYL - FORD
5	P03817-11-000	EA DASH ASM, W/O VINYL - CHEVY
	105927-02-000	EA PANEL-DASH TOP, STEEL
6	104354-01-05A	EA APPLIQUE-LOWER DASH, 2300 MM LONG - CHEVY
6	104354-08-01A	EA APPLIQUE-LOWER DASH, 2300 MM LONG - FORD
7	095757-03-F04	EA COVER-HEATER W/CARPET (G29)
7	095757-03-F26	EA COVER-HEATER W/CARPET (G30)
7	095757-03-F25	EA COVER-HEATER W/CARPET (G31)
7	095757-03-G36	EA COVER-HEATER W/CARPET (G32)
8	086120-01-F24	EA PAD-MAP POCKET, 12" X 16" (G29)
8	086120-01-G30	EA PAD-MAP POCKET, 12" X 16"
8	086120-01-F25	EA PAD-MAP POCKET, 12" X 16" (G31)
8	086120-01-F06	EA PAD-MAP POCKET, 12" X 16" (G32)
9	115840-01-01A	EA COVER-MOTOR, W/O CARPET - GAS OR 6.5 DIESEL OPTION
	115850-01-02B	EA RETAINER-LATCH, MOTOR COVER - GAS OR 6.5 DIESEL OPTION
	116581-01-000	EA LATCH-MOTOR COVER - SOUTHCO 2710074088 - GAS OR 6.5 DIESEL OPTION
	116833-01-02B	EA WRENCH-HEX, MOTOR COVER - E-COAT - GAS OR 6.5 DIESEL OPTION
	115860-01-01A	EA TRIM-MOTOR COVER - GAS OR 6.5 DIESEL OPTION
	039623-01-000	FT SEAL-MOTOR COVER, RUBBER BULB TYPE - BLACK
	111618-01-GB1	EA TRAY ASM-BEVERAGE
	111618-13-GB1	EA LID-BEVERAGE TRAY ASM
	046886-03-000	EA ASHTRAY-CHROME, W/COVER
10	103498-06-000	EA BOOT-STEERING COLUMN, BLACK VINYL
	111521-01-04A	EA COVER-STEERING COLUMN, BLACK
	112634-01-01A	EA TRIM-STEERING COLUMN, RH BLK
	112634-02-01A	EA TRIM-STEERING COLUMN, LH BLK

DRIVERS COMPARTMENT GROUP (CONTINUED)
DASH, GAUGES & SWITCHES (CHEVY)

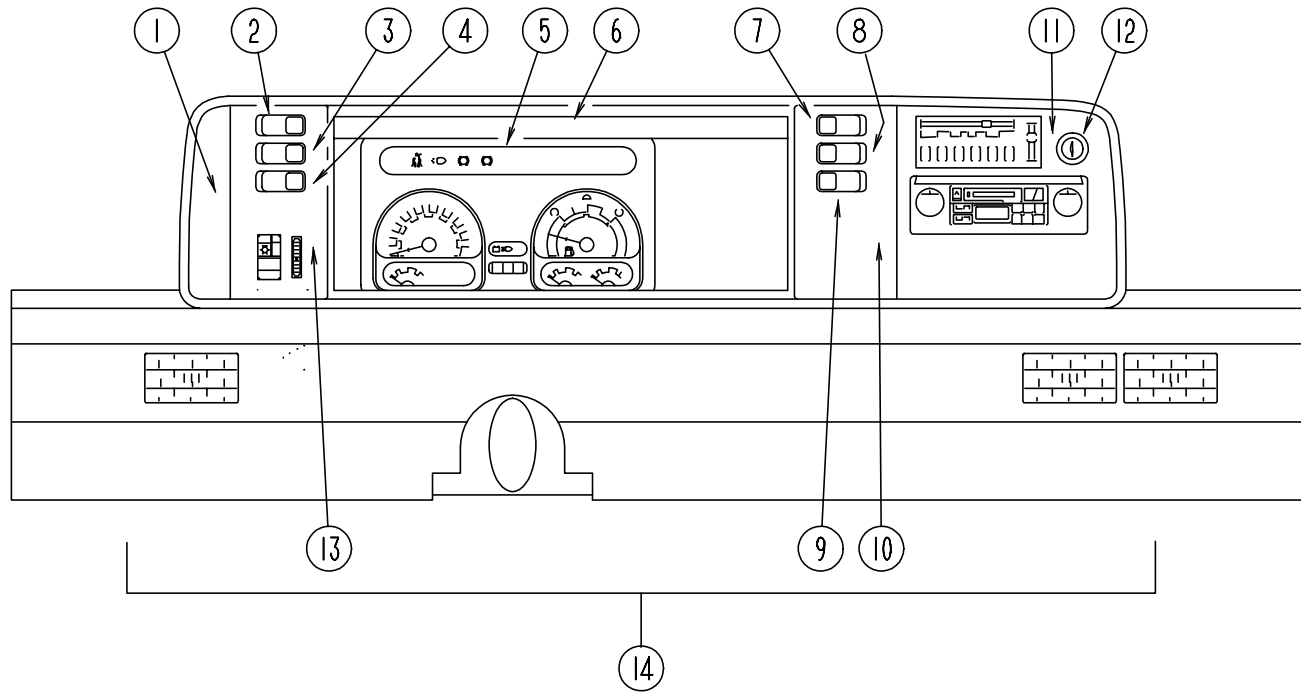

KEY	PART NUMBER	U/M	DESCRIPTION
1	104056-01-01A	EA	APPLIQUE-BEZEL
2	108356-02-01A	EA	COVER-SWITCH W/DIMPLES - CARLING VVAZC00 BLA
2	108357-05-000	EA	SWITCH-ROCKER, SPDT ON/NONE/ON - RADIO POWER - CARLING V4D1000B-0
3	108356-02-01A	EA	COVER-SWITCH W/DIMPLES - CARLING VVAZC00 BLA
3	108357-09-000	EA	SWITCH-ROCKER, SPDT ON/NONE/MOM - DUAL BATTERY - CARLING V5D1000B-0
4	108356-02-01A	EA	COVER-SWITCH W/DIMPLES - CARLING VVAZC00 BLA
4	108357-06-000	EA	SWITCH-ROCKER, DPDT MOM/OFF/MOMD - CARLING VLD1000B-0 BATTERY DISCONNECT SWITCH OPTION
4	096241-03-000	EA	SWITCH-BLANK
5	094796-07-000	EA	CLUSTER-INSTRUMENT PANEL, KILOMETERS - GM #16167145 (GAS)
5	094796-08-000	EA	CLUSTER-INSTRUMENT PANEL, KILOMETERS - GM #16164645 (DIESEL)
6	103662-01-01A	EA	BEZEL-INSTRUMENT PANEL
7	108356-04-01A	EA	COVER-SWITCH W/DIMPLES & LENS - CARLING VVAGC00
7	108357-10-000	EA	SWITCH-ROCKER, SPDT MOM/OFF/MOM - LIGHTED - CARLING V8D1160B-0 GENERATOR OPTION
7	096241-03-000	EA	SWITCH-BLANK
8	108356-02-01A	EA	COVER-SWITCH W/DIMPLES - CARLING VVAZC00 BLA
8	108357-03-000	EA	SWITCH-ROCKER, SPDT ON/OFF/ON - CARLING V6D1000B-0 REAR HEATER OPTION
8	096241-03-000	EA	SWITCH-BLANK
9	096241-03-000	EA	SWITCH-BLANK
10	104056-21-01A	EA	APPLIQUE-BEZEL
11	104056-06-01A	EA	APPLIQUE-BEZEL
12	089294-01-000	EA	LIGHTER ASM-CIGARETTE - CASCO C213275
13	104056-22-01A	EA	APPLIQUE-BEZEL
14	M05946-26-G29	EA	DASH POD ASM-CHEVY
	100138-01-000	EA	MODULE-DAYTIME RUNNING LIGHT - CANADIAN
	077031-01-000	EA	FILM-BLACK, 1" X 1.75"
	077031-02-000	EA	FILM-AMBER, 1" X 1.75"
	077031-03-000	EA	FILM-WHITE, .75" X 1"
	103603-01-000	EA	BULB-12V NO.74 0.12A WEDGE
	105615-01-000	FT	FILM-PROTECTIVE CLEAR
	077539-01-000	EA	BRACKET-MOUNTING, DASH PANEL - L/SHAPED - 2.5" X 1" X 1.5"
	062901-02-000	EA	FUSE - 5 AMPS, AUTOMOTIVE
	062901-05-000	EA	FUSE - 15 AMPS, AUTOMOTIVE
	062901-07-000	EA	FUSE - 25 AMPS, AUTOMOTIVE

DRIVERS COMPARTMENT GROUP (CONTINUED)

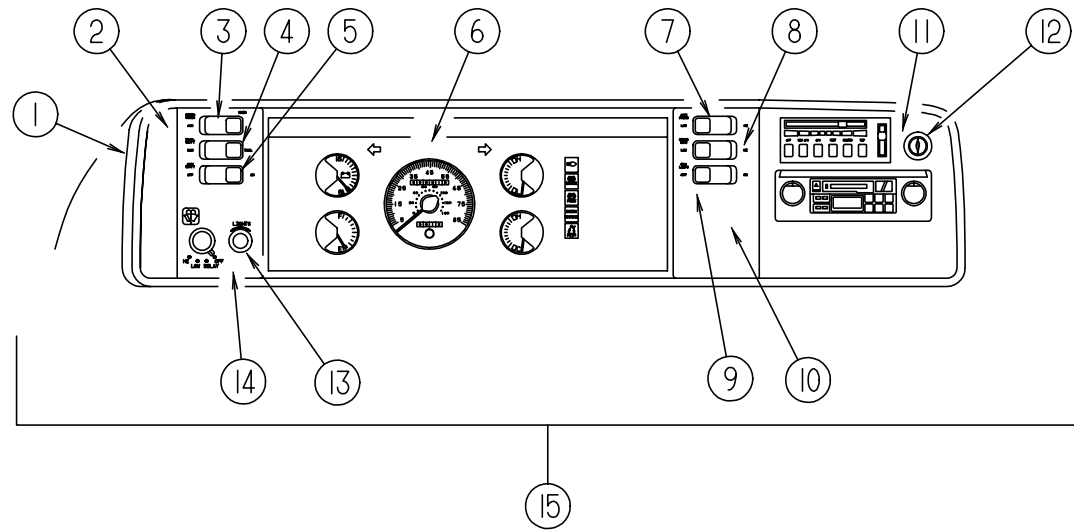

DASH, GAUGES & SWITCHES (FORD)

KEY	PART NUMBER	U/M	DESCRIPTION
1	103662-04-01A	EA	BEZEL-INSTRUMENT PANEL
2	104056-01-01A	EA	APPLIQUE-BEZEL
3	108356-02-01A	EA	COVER-SWITCH W/DIMPLES - CARLING VVAZC00 BLA
3	108357-05-000	EA	SWITCH-ROCKER, SPDT ON/NONE/ON - RADIO POWER - CARLING V4D1000B-0
4	108356-02-01A	EA	COVER-SWITCH W/DIMPLES - CARLING VVAZC00 BLA
4	108357-09-000	EA	SWITCH-ROCKER, SPDT ON/NONE/MOM - DUAL BATTERY - CARLING V5D1000B-0
5	108356-02-01A	EA	COVER-SWITCH W/DIMPLES - CARLING VVAZC00 BLA
5	108357-06-000	EA	SWITCH-ROCKER, DPDT MOM/OFF/MOM - CARLING VLD1000B-0 BATTERY DISCONNECT SWITCH OPTION
5	096241-03-000	EA	SWITCH-BLANK
6	094794-04-000	EA	CLUSTER-INSTRUMENT PANEL, KILOMETERS - FORD F3TD-10849-BA
7	108356-04-01A	EA	COVER-SWITCH W/DIMPLES & LENS - CARLING VVAGC00
7	108357-10-000	EA	SWITCH-ROCKER, SPDT MOM/OFF/MOM - LIGHTED - CARLING V8D1160B-0 GENERATOR OPTION
7	096241-03-000	EA	SWITCH-BLANK
8	108356-02-01A	EA	COVER-SWITCH W/DIMPLES - CARLING VVAZC00 BLA
8	108357-03-000	EA	SWITCH-ROCKER, SPDT ON/OFF/ON - CARLING V6D1000B-0 REAR HEATER OPTION
8	096241-03-000	EA	SWITCH-BLANK
9	096241-03-000	EA	SWITCH-BLANK
10	104056-21-01A	EA	APPLIQUE-BEZEL
11	104056-06-01A	EA	APPLIQUE-BEZEL
12	089294-01-000	EA	LIGHTER ASM-CIGARETTE - CASCO C213275
13	096674-01-000	EA	NUT-HEADLAMP KNOB, BLACK
13	096675-01-000	EA	KNOB - HEADLAMP - W/SHAFT
14	104056-24-01A	EA	APPLIQUE-BEZEL
15	M05946-27-G29	EA	DASH POD ASM-FORD
	100138-01-000	EA	MODULE-DAYTIME RUNNING LIGHT - CANADIAN
	111915-03-000	EA	WIRE ASM-DAY RUN LAMPS, FUSE - CANADIAN
	103603-01-000	EA	BULB-12V NO.74 0.12A WEDGE
	077031-01-000	EA	FILM-BLACK, 1" X 1.75"
	077031-03-000	EA	FILM-WHITE, .75" X 1"
	105615-01-000	FT	FILM-PROTECTIVE CLEAR
	111904-01-000	EA	INDICATOR ASM-TRANSMISSION - FORD F2US-7B053

DRIVERS COMPARTMENT GROUP (CONTINUED)

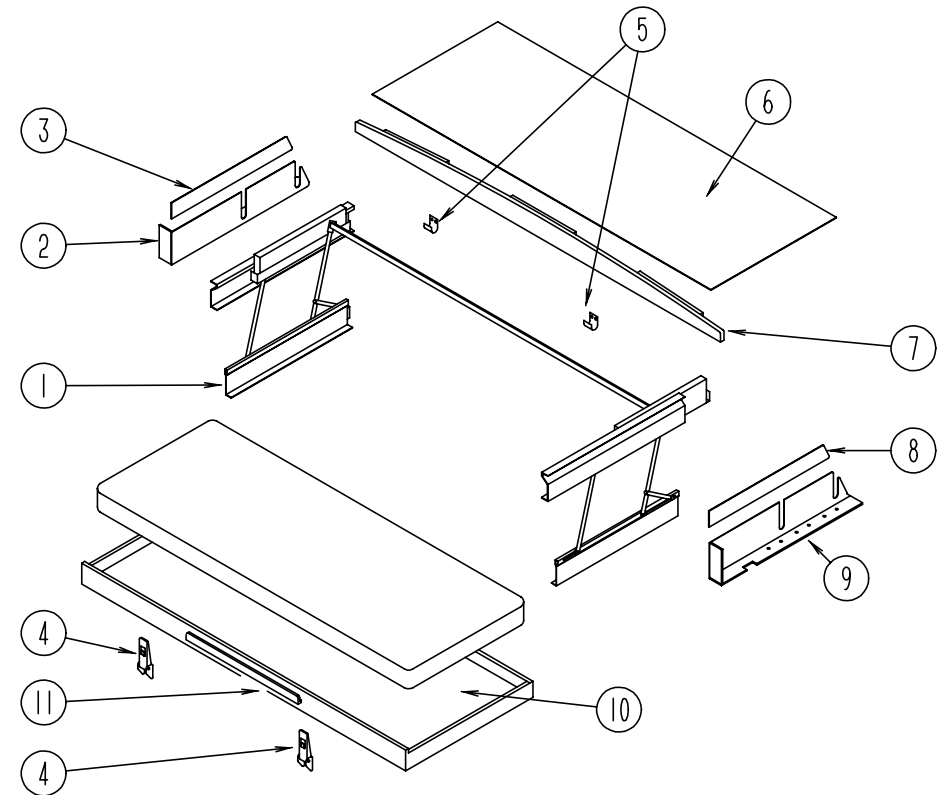

FRONT BUNK

KEY	PART NUMBER	U/M	DESCRIPTION
1	076760-02-000	EA	BUNK HARDWARE (COMPLETE)
	076760-02-700	EA	SPRING-GAS-BUNK HARDWARE
2	101499-06-G29	EA	PANEL ASM.- BOTTOM DRIVERS - PADDED - USED W/BUNK
3	101497-08-G29	EA	PANEL ASM.- UPPER DRIVERS - PADDED - USED W/BUNK
4	042541-04-000	EA	LATCH-W/O STRIKE, BRASS
5	042541-05-000	EA	STRIKE-BRASS
6	103040-06-G29	EA	PANEL-HEADLINER FRONT OVERHEAD - PADDED - USED W/BUNK
7	P03199-01-C05	EA	BOARD ASM-TRIM, BUNK - CEILING MOUNTED
8	101497-07-G29	EA	PANEL ASM.- UPPER PASSENGERS - PADDED - USED W/BUNK
9	101499-05-G29	EA	PANEL ASM.- BOTTOM PASSENGERS - PADDED - USED W/BUNK
10	081717-03-E07	EA	BED ASM-BUNK, FRONT
11	094658-01-E07	EA	HANDLE-BUNK, OAK

ELECTRICAL GROUP
EXTERIOR LIGHTS

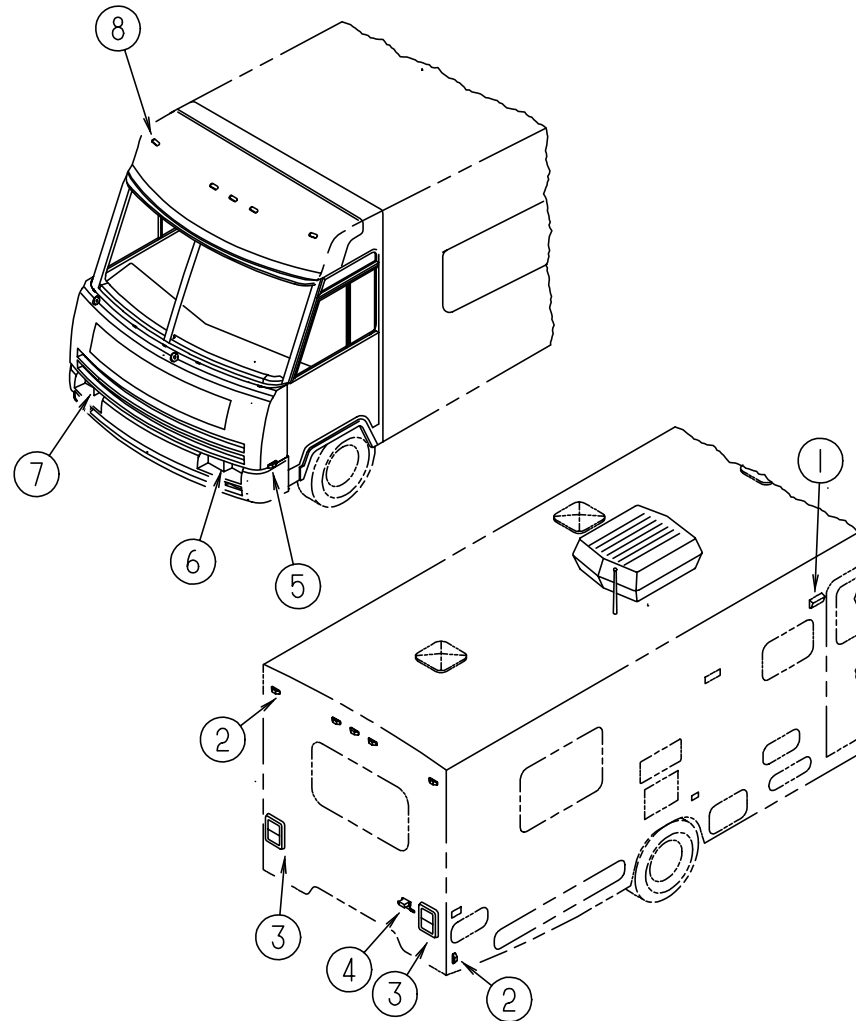

KEY	PART NUMBER	U/M DESCRIPTION
1	097917-01-06A	EA LIGHT-PORCH, ENTRY DOOR - BRIGHT WHITE
	008215-01-000	EA BULB - 12V, #1003 - .94 AMP
	097917-01-700	EA LENS-LIGHT, PORCH
2	111102-01-000	EA LAMP-MARKER, BASE - TRIPLEX 117XAS
2	111102-03-000	EA LENS-MARKER LAMP, RED - TRIPLEX 117R
	036196-01-000	EA BULB - 12V, #194 - .27 AMP - BAYONETTE
3	081638-01-000	EA TAILLIGHT-DOUBLE, W/BLACK TRIM - DRIVER OR PASSENGER SIDE
	037934-01-000	EA BULB - 12V, #1156 - 2.1 AMP - CLEAR GLASS
	037935-01-000	EA BULB - 12V, #1157 OR #2057 - 2.1 AMP - CLEAR GLASS
	081638-01-700	EA LENS-TAILLIGHT, RED - BARGMAN 30-84-010
	081638-01-701	EA LENS-TAILLIGHT, W/BACKUP - BARGMAN 30-84-700
	103355-01-05A	EA POD-TAILLIGHT, BRIGHT WHITE
4	066432-02-000	EA LIGHT-LICENSE, BLACK
	066432-03-000	EA BRACKET-LICENSE PLATE - BARGMAN 30-60-030
5	111102-01-000	EA LAMP-MARKER, BASE - TRIPLEX 117XAS
5	111102-02-000	EA LENS-MARKER LAMP, AMBER - TRIPLEX 118A
	036196-01-000	EA BULB - 12V, #194 - .27 AMP - BAYONETTE
6	049186-04-000	EA HEADLAMP CAPSULE-DRIVER, HIGH/LOW BEAM - RECTANGULAR
	049188-04-000	EA HEADLAMP CAPSULE-DRIVER, HIGH BEAM - RECTANGULAR
7	049185-04-000	EA HEADLAMP CAPSULE-PASSENGER, HIGH/LOW BEAM - RECTANGULAR
	049187-04-000	EA HEADLAMP CAPSULE-PASSENGER, HIGH BEAM - RECTANGULAR
	P03783-01-000	EA WIRE ASM-HEADLAMP
	049359-01-000	EA SPRING-RETAINER, HEADLAMP - GM 496096
	110750-01-000	EA SCREW-ADJUSTING, HEADLAMP
	110783-01-01A	EA BRACKET-HEADLAMP, QUAD - PASSENGER - UNPAINTED
	110783-02-01A	EA BRACKET-HEADLAMP, QUAD - DRIVER - UNPAINTED
	089292-01-000	EA LIGHT-TURN, DRIVER OR PASSENGER - W/AMBER LENS
	037935-01-000	EA BULB - 12V, #1157 OR #2057 - 2.1 AMP - CLEAR GLASS
8	102520-01-000	EA LIGHT-CLEARANCE, W/O SOCKET CONNECTIONS - AMBER
	036196-01-000	EA BULB - 12V, #194 - .27 AMP - BAYONETTE
	102540-01-000	EA SEAL-SCREW, ROUND - RUBBER
	102541-01-000	EA GASKET-CLEARANCE LIGHT
	102582-01-000	EA BRACKET-LIGHT, CLEARANCE - L-SHAPED METAL - 2.2" X 4.7"
	112823-01-000	EA SPLICE-REDUCER, 16-14 TO 18-22 - ETC BA-631X
	067789-02-000	EA SOCKET-LAMP

ELECTRICAL GROUP (CONTINUED)
LIGHTS & RECEPTACLES PASSENGER SIDE

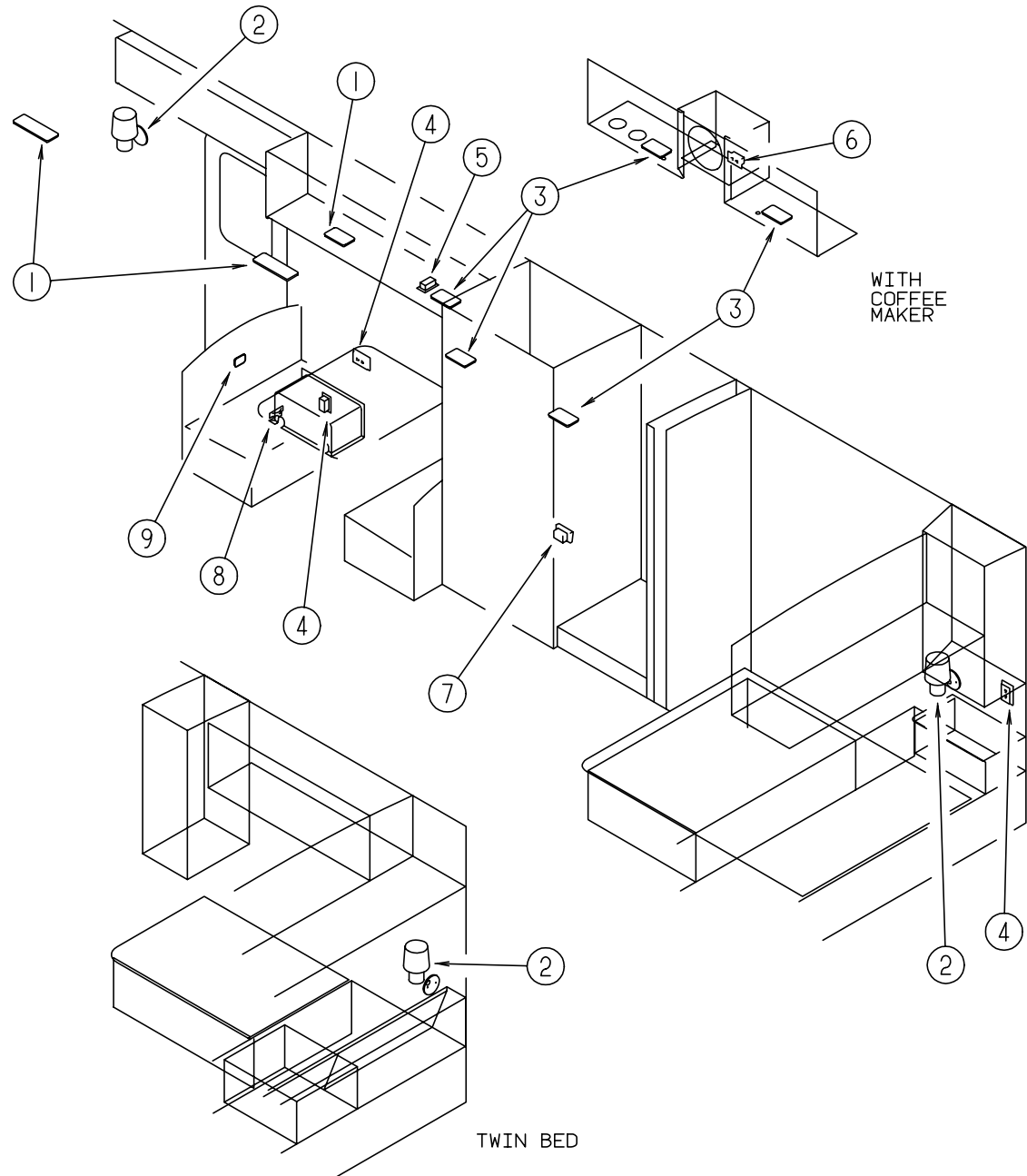

KEY	PART NUMBER	U/M	DESCRIPTION	VENDER NO.
1	098024-03-01A	EA	LIGHT-DOME, 2 BULB - IVORY	
	008218-01-000	EA	BULB-DOME LIGHT, 12V - 1141	
	098024-01-700	EA	LENS-LIGHT	807877
2	065202-22-000	EA	LAMP-WALL, BRASS UL/CSA - GUSTAFSON L512X0	
	065201-09-000	EA	SHADE-LAMP, FABRIC - PARCHMENT	
3	098024-01-01A	EA	LIGHT-DOME, 1 BULB - US - IVORY	
	008218-01-000	EA	BULB-DOME LIGHT, 12V - 1141	
	098024-01-700	EA	LENS-LIGHT	807877
4	058708-02-000	EA	RECEPTACLE-ELECTRIC, DOUBLE - IVORY	
5	058708-01-000	EA	RECEPTACLE-ELECTRIC, DOUBLE - BROWN	
6	058708-05-000	EA	RECEPTACLE-SINGLE, BROWN - WIRECON WDR15BRS	
7	112822-01-01A	EA	RECEPTACLE-DUPLEX, IVORY - WIRECON WDRU15IV	
	112824-01-03A	EA	COVER-EXTERIOR DUPLEX RECEPTACLE, WHITE - P&S 3780-SC-WH	
8	061424-01-000	EA	LIGHT-AISLE, 12V - RECTANGULAR	
	008103-01-000	EA	BULB-DASH/AISLE LIGHT, #53 - 12 V - .12 AMP	
9	098351-05-01A	EA	PLATE-SWITCH, 3 GANG - POLISH BRASS - W/LABEL - JENSEN - W/ELECTIC STEP	
	079364-01-000	EA	SWITCH-ON/OFF ROCKER, 2 PRONGS - BROWN	
	095188-02-01A	EA	SPACER-SWITCH, 2.3" X 4.1" - PLASTIC - DARK BROWN	
9	098351-06-01A	EA	PLATE-SWITCH, 2 GANG W/LABEL - JENSEN - POLISHED BRASS - W/O ELECTIC STEP	
	079364-01-000	EA	SWITCH-ON/OFF ROCKER, 2 PRONGS - BROWN	
	095188-01-01A	EA	SPACER-SWITCH, 2.3" X 3.4" - PLASTIC - DARK BROWN	

ELECTRICAL GROUP (CONTINUED)
LIGHTS & RECEPTACLES DRIVERS SIDE

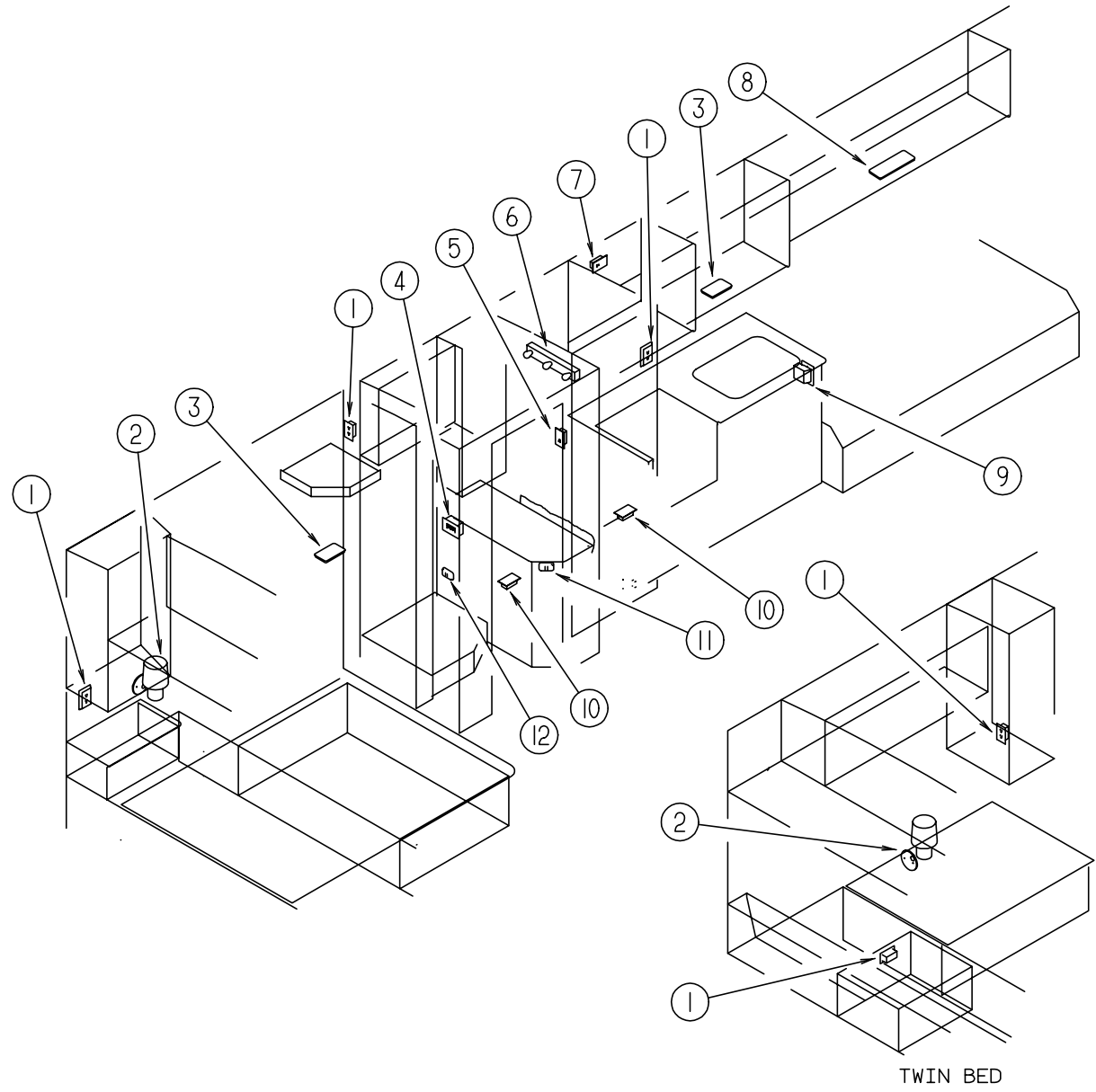

KEY	PART NUMBER	U/M	DESCRIPTION	VENDER NO.
1	058708-02-000	EA	RECEPTACLE-ELECTRIC, DOUBLE - IVORY	
2	065202-22-000	EA	LAMP-WALL, BRASS UL/CSA - GUSTAFSON L512X0	
	065201-09-000	EA	SHADE-LAMP, FABRIC - PARCHMENT	
3	098024-01-01A	EA	LIGHT-DOME, 1 BULB - US - IVORY	
	008218-01-000	EA	BULB-DOME LIGHT, 12V - 1141	
	098024-01-700	EA	LENS-LIGHT	807877
4	084076-02-000	EA	RECEPTACLE-GFI, 15A - 125V - BROWN	
5	058707-01-000	EA	RECEPTACLE-ELECTRIC, SINGLE - BROWN	
6	110235-01-01A	EA	LIGHT-MAKE UP, 3 BULB PANLESS - BRASS - PD PD200-621	
	081633-01-700	EA	BULB-LIGHT, MAKE-UP	RP1041
7	058708-05-000	EA	RECEPTACLE-SINGLE, BROWN - WIRECON WDR15BRS	
8	098024-03-01A	EA	LIGHT-DOME, 2 BULB - IVORY	
	008218-01-000	EA	BULB-DOME LIGHT, 12V - 1141	
9	058708-01-000	EA	RECEPTACLE-ELECTRIC, DOUBLE - BROWN - CANADIAN	
9	084076-02-000	EA	RECEPTACLE-GFI, 15A - 125V - BROWN - US	
10	058707-02-000	EA	RECEPTACLE-BLANK, JUNCTION - WIRECON WDJ20BR	
11	098351-02-01A	EA	PLATE-SWITCH, 2 GANG - POLISHED BRASS - JENSEN	
	079364-01-000	EA	SWITCH-ON/OFF ROCKER, 2 PRONGS - BROWN	
	079364-03-000	EA	SWITCH-ON/OFF ROCKER, 3 PRONGS - BROWN	
	095188-01-01A	EA	SPACER-SWITCH, 2.3" X 3.4" - PLASTIC - DARK BROWN	
12	098351-01-01A	EA	PLATE-SWITCH, 1 GANG - POLISHED BRASS - JENSEN	
	079364-01-000	EA	SWITCH-ON/OFF ROCKER, 2 PRONGS - BROWN	
	095188-01-01A	EA	SPACER-SWITCH, 2.3" X 3.4" - PLASTIC - DARK BROWN	

ELECTRICAL GROUP (CONTINUED)

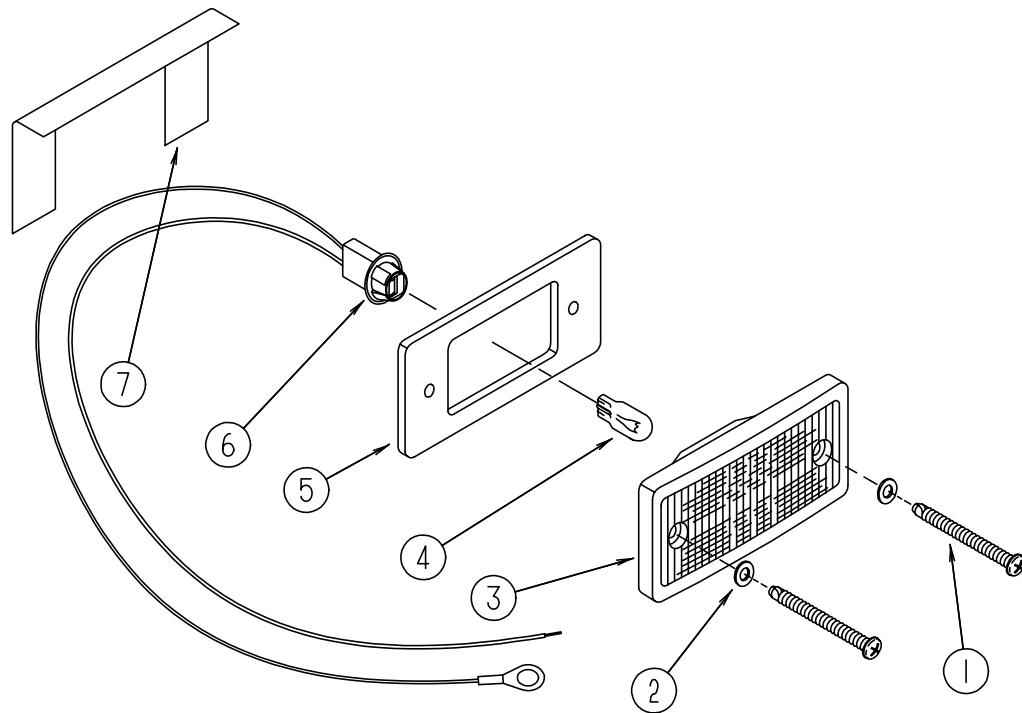

EXTERIOR CLEARANCE LIGHTS

KEY	PART NUMBER	U/M DESCRIPTION
1	000G39-08-24B	EA SCREW, SELF DRIVING
2	102540-01-000	EA SEAL-SCREW, ROUND - RUBBER
3	102520-01-000	EA LIGHT-CLEARANCE, W/O SOCKET CONNECTIONS - AMBER
4	036196-01-000	EA BULB - #1194 - CLEARANCE LIGHT
5	102541-01-000	EA GASKET-CLEARANCE LIGHT
6	067789-02-000	EA SOCKET ASM.-CAB MARKER
7	102582-01-000	EA BRACKET-LIGHT, CLEARANCE - L-SHAPED METAL - 2.2" X 4.7"

ELECTRICAL GROUP (CONTINUED) FUSES & CIRCUIT BREAKERS

KEY	PART NUMBER	U/M DESCRIPTION
	008234-01-000	EA FUSE - 12V, 10 AMP
	062037-01-000	EA HOUSING-AUTO FUSE, NATURAL
	062037-02-000	EA HOUSING-AUTO FUSE, GREEN
	062037-03-000	EA HOUSING-AUTO FUSE, BLACK
	062037-04-000	EA HOUSING-AUTO FUSE, BLUE
	062037-07-000	EA HOUSING-AUTO FUSE, RED
	062037-06-000	EA HOUSING-AUTO FUSE, BROWN
	062901-02-000	EA FUSE - 5 AMPS, AUTOMOTIVE
	062901-05-000	EA FUSE - 15 AMPS, AUTOMOTIVE
	062901-06-000	EA FUSE - 20 AMPS, AUTOMOTIVE
	062901-07-000	EA FUSE-AUTOMOTIVE, 25 AMPS
	062901-08-000	EA FUSE - 30 AMPS, AUTOMOTIVE
	083209-01-000	EA CIRCUIT BREAKER - 15 AMP, 120V - BW G-15 - CANADIAN
	083209-02-000	EA CIRCUIT BREAKER - 15/15AMP, 120V - BW H-15/15
	083209-03-000	EA CIRCUIT BREAKER - 15/20AMP, 120V - BW O-15/20
	083209-04-000	EA CIRCUIT BREAKER - 30A, 120V - BW L-30
	083209-05-000	EA CIRCUIT BREAKER - 20A, 120V - BW J-20
	083209-06-000	EA CIRCUIT BREAKER - 30/15 AMP, 120V - BW D-30/15
	093655-03-000	EA CIRCUIT BREAKER - 40A, 12V - USD 17440-4E03A2A
	097611-01-000	EA CIRCUIT BREAKER - 10A, 12V - VB3-A10-F57
	106655-02-000	EA TERMINAL-FUSE BLOCK, 10-12AWG - PACKARD 12020400
	106656-01-000	EA FUSE BLOCK - 4 CAVITY AUTO FUSE - PACKARD 12004943
	108669-01-000	EA HOUSING-AUTO FUSE HOLDER - PACKARD 12010105
	119248-02-000	EA HOUSING - 7 POSITION, FEM - METRI-PACK - PARKARD 12059472

TERMINALS

KEY	PART NUMBER	U/M DESCRIPTION
	008326-01-000	EA TERMINAL-RING, 16/14 WIRE - 3/8" STUD
	008328-01-000	EA TERMINAL-RING, 12/10 WIRE - #10 STUD FIT
	008331-01-000	EA TERMINAL-RING, TONGUE - #4 WIRE - 3/8" STUD - COPPER
	008348-01-000	EA TERMINAL-RING, 3/8" STUD - #2 WIRE
	047443-01-000	EA TERMINAL - .250 RECEPTACLE FIT, INSULATED - 16/14 AWG
	062036-01-000	EA TERMINAL-PACK-CON, 12/10 AWG - PACKARD 12033817
	062036-02-000	EA TERMINAL-PACK-CON, 16/14 AWG
	035416-04-000	EA TERMINAL-RING #10 STUD FIT, INSULATED BARREL #16/14
	106655-01-000	EA TERMINAL-FUSE BLOCK, 14-16 AWG - PACKARD 12020321
	113306-01-000	EA TERMINAL-FEMALE, METRI-PACK - PACKARD12048451
	113307-01-000	EA TERMINAL-FEMALE, METRI-PACK - PACKARD12048074
	104100-03-000	EA TERMINAL - 75 AMP - AMP 53880-4 LOOSE
	106007-01-000	EA TERMINAL-FEMALE, 14-16 - PACKARD 12015861-L
	088267-01-000	EA TERMINAL-FEMALE, 1/4 - PARKARD 2962573

ELECTRIC BOXES & CORDS

KEY	PART NUMBER	U/M DESCRIPTION
	008052-01-000	EA CORD-POWER, 10/3 - 30 AMP - 25' - CANADIAN
	008054-01-000	EA CORD-POWER, 10/3 - 30 AMP - 25'
	008289-01-000	EA BOX-ELECTRIC, STEEL - 1/2" AND 3/4" KNOCKOUTS - 4" X 4"
	008289-02-000	EA BOX-ELECTRICAL, 4" X 4" - 1/2" & 3/4" KNOCKOUTS - CANADIAN
	008294-01-000	EA COVER-ELECTRICAL BOX, BLANK/STEEL - 4" X 4" - GRAY
	008294-02-000	EA COVER-ELECTRICAL BOX, BLANK STEEL - 4" X 4" - CANADIAN
	069238-01-000	EA COVER-ELECTRICAL BOX, W/HOLE - 4" X 4" - GRAY USED WITH 30 AMP RECEPTACLE
	074890-01-000	EA BOX-EXTENSION, STEEL - OPEN SIDES - 4" X 4" X 1 1/2"
	074897-01-000	EA COVER-ELECTRIC BOX, 1 LARGE & 2 SMALL HOLES - 4" X 4"
	091910-01-000	EA BOX-ELECTRIC, 3.75" X 3.5" X 1.75" - PLASTIC
	091910-02-000	EA BOX-ELECTRICAL, PLASTIC - 57 X 88MM
	111510-01-000	EA DOOR-ELECTRICAL BOX, FRONT

ELECTRICAL GROUP (CONTINUED)
HOUSINGS, CONNECTORS & MISCELLANEOUS

KEY	PART NUMBER	U/M	DESCRIPTION
	088473-01-000	EA	HOUSING-PIN, 12 CAVITY - AMP 1-480708-0
	088473-02-000	EA	HOUSING-PIN, 15 CAVITY - AMP 1-480710-0
	088473-03-000	EA	HOUSING-PIN, 9 CAVITY - AMP 1-480706-0
	088473-05-000	EA	HOUSING-PIN, 6 CAVITY - AMP 640585-1
	088473-06-000	EA	HOUSING-PIN, 6 CAVITY - AMP 1-480704-0
	088473-08-000	EA	HOUSING-PIN, 4 CAVITY - AMP 1-480702-0
	088473-09-000	EA	HOUSING-PIN, 3 CAVITY - AMP 1-480700-0
	088473-10-000	EA	HOUSING-PIN, 2 CAVITY - AMP 1-480698-0
	088474-01-000	EA	HOUSING-SOCKET, 12 CAVITY - AMP 1-480709-0
	088474-02-000	EA	HOUSING-SOCKET, 12 CAVITY - AMP 1-480711-0
	088474-03-000	EA	HOUSING-SOCKET, 9 CAVITY - AMP 1-480707-0
	088474-06-000	EA	HOUSING-SOCKET, 6 CAVITY - AMP 1-480705-0
	088474-07-000	EA	HOUSING-SOCKET, 5 CAVITY - AMP 1-480764-0
	088474-08-000	EA	HOUSING-SOCKET, 4 CAVITY - AMP 1-480703-0
	088474-09-000	EA	HOUSING-SOCKET, 3 CAVITY - AMP 1-480701-0
	088474-10-000	EA	HOUSING-SOCKET, 2 CAVITY - AMP 1-480699-0
	101571-01-000	EA	HOUSING - 2 POSITION, MALE
	104100-01-000	EA	HOUSING - 1 POSITION, 75 AMP - AMP 53884-1
	106006-01-000	EA	HOUSING - 1 POSITION, FEMALE - PACKARD 12015952
	063910-01-000	EA	HOUSING-RELAY - BOSCH 3 334 485 008
	113468-01-000	EA	HOUSING - 2 POSITION, FEMALE - 56-SERIES - PACKARD 02965981 USED ON WIPER/WASHER WIRE ASM
	007949-01-000	EA	TAB-HOUSING, 1 POSITION
	007940-01-000	EA	RECEPTACLE-SLIDE, 16 TO 12 AWG - FEMALE END
	080015-02-000	EA	RECEPTACLE-FLAG, .185 - 16/14 GA - AMP 3
	007954-01-000	EA	RECEPTACLE-HSG - 6 POSITION
	007956-05-000	EA	INSULATOR-SHRINK, .25ID X 1.50 - BLACK
	008311-01-000	EA	CONNECTOR-WIRE NUT, INSULATED - RED
	008312-01-000	EA	CONNECTOR-WIRE NUT, INSULATED - BLUE
	008314-01-000	EA	CONNECTOR-WIRE NUT, INSULATED - GRAY
	008355-01-000	EA	CONNECTOR-CABLE CLAMPING, 3/4"
	008356-01-000	EA	CONNECTOR-PLASTIC, 3/8" AVG
	008398-01-000	EA	CONNECTOR - 1/2" X 90 DEGREE, FLEX CONDUIT - UL AND CSA
	082740-01-000	EA	CONNECTOR-PLASTIC BODY, FOR 2 MALE SPADES
	082741-01-000	EA	CONNECTOR BODY - 2 CONNECTOR MALE
	058028-01-000	EA	CONNECTOR-ELECTRICAL PIGTAIL, NYLON - CLEAR
	088475-01-000	EA	PIN-CONNECTOR, 14 TO 20 AWG
	088475-02-000	EA	PIN-CONNECTOR, 10 TO 12 AWG
	088476-01-000	EA	SOCKET-CONNECTOR, BRASS - PRE-TIN
	088476-02-000	EA	SOCKET-CONNECTOR, 12-10 GA - PHOS. BRZ - PRE-TIN
	103608-01-000	EA	SOCKET-WEDGE BASE W/LEADS - JKL 2944-6 OR EQUIVLANT
	036346-02-000	EA	BUSHING-STEEL 3/4MPT X 318FPT
	077479-01-000	EA	BOOT-BATTERY TERMINAL, DOUBLE CABLE
	077479-02-000	EA	BOOT-BATTERY TERMINAL, SINGLE CABLE
	087225-01-000	FT	SLEEVING - 1/2",TYPE H - VARFLEX
	087225-02-000	FT	SLEEVING - 5/8",TYPE H - VARFLEX VARGLAS
	103987-02-000	EA	SEAL-SOLENOID ACCESS
	104100-03-000	EA	TERMINAL - 75 AMP - AMP 53880-4 LOOSE
	106655-01-000	EA	TERMINAL-FUSE BLOCK,14-16AWG - PACKARD 12020321
	007093-01-000	EA	FLASHER-SIGNAL, STAT
	008188-01-000	EA	SOLENOID- 3 POST, BATTERY CHANGE OVER
	067789-02-000	EA	SOCKET-LAMP
	086233-01-000	EA	STUD-ISOLATED, 3/8" X 7/8" LONG
	086273-01-000	EA	RELAY-BATTERY DISCONNECT
	063912-02-000	EA	RELAY-CANISTER, SPDT - BOSCH 0332204101

ELECTRICAL GROUP (CONTINUED)
WIRE ASSEMBLIES

KEY	PART NUMBER	U/M	DESCRIPTION
	073328-B4-000	EA	CABLE ASSEMBLY-BATTERY, W/TERMINALS
	096449-01-000	EA	WIRE ASSEMBLY-WATER TANK TO MONITOR PANEL
	097618-01-000	EA	WIRE ASM-MONITOR PANEL, W/3 WIRES & ORANGE RESISTOR- LVS ORANGE RESISTOR W/3 (ORANGE-GREEN-BLUE) WIRES
	102636-02-000	EA	WIRE ASM-CLEARANCE LAMPS
	103328-06-000	EA	WIRE ASM-PUMP,EXTERIOR SHOWER
	119456-01-000	EA	WIRE ASM-INSTRUMENT PANEL, MAIN (GM)
	119459-01-000	EA	WIRE ASM-INSTRUMENT PANEL, MAIN (FORD)
	111915-01-000	EA	WIRE ASM-DAY RUN LAMPS, FUSE - GM
	111915-03-000	EA	WIRE ASM-DAY RUN LAMPS, FUSE - FORD
	P03783-01-000	EA	WIRE ASM-HEADLAMP (GM)
	P03783-02-000	EA	WIRE ASM-HEADLAMP(FORD)
	108303-01-000	EA	WIRE ASM-REAR AUTO HEATER

CONDUIT

KEY	PART NUMBER	U/M	DESCRIPTION
	041953-01-000	FT	CONDUIT-CONVOLUTE SLIT, .5"ID
	041953-03-000	FT	CONDUIT-CONVOLUTE SLIT, 1" ID (CLOTHES ROD COVER)
	041953-05-000	FT	CONDUIT-CONVOLUTE SOLID, .62" ID
	041953-06-000	FT	CONDUIT-CONVOLUTE, SLIT .375"ID
	041953-07-000	FT	CONDUIT-CONVOLUTE, SLIT - .25" ID
	041953-08-000	FT	CONDUIT-CONVOLUTE, SLIT,1.50"ID
	041953-09-000	FT	CONDUIT-CONVOLUTE, SLIT .50"ID
	041953-10-000	FT	CONDUIT-CONVOLUTE, SLIT - .75" ID
	041953-11-000	FT	CONDUIT-CONVOLUTE, SLIT- 1.06" ID
	041953-12-000	FT	CONDUIT-CONVOLUTE, NON SLIT 1.1" ID

CONVERTER & INVERTER

KEY	PART NUMBER	U/M	DESCRIPTION
	083208-02-000	EA	CONVERTER-POWER, 45A - 120V/12V - BW 6345
	099048-02-000	EA	INVERTER - 100 WATT, W/EXTRA SURGE CAPACITY

EXTERIOR BODY GROUP
EXTERIOR BODY PANELS AND TRIM

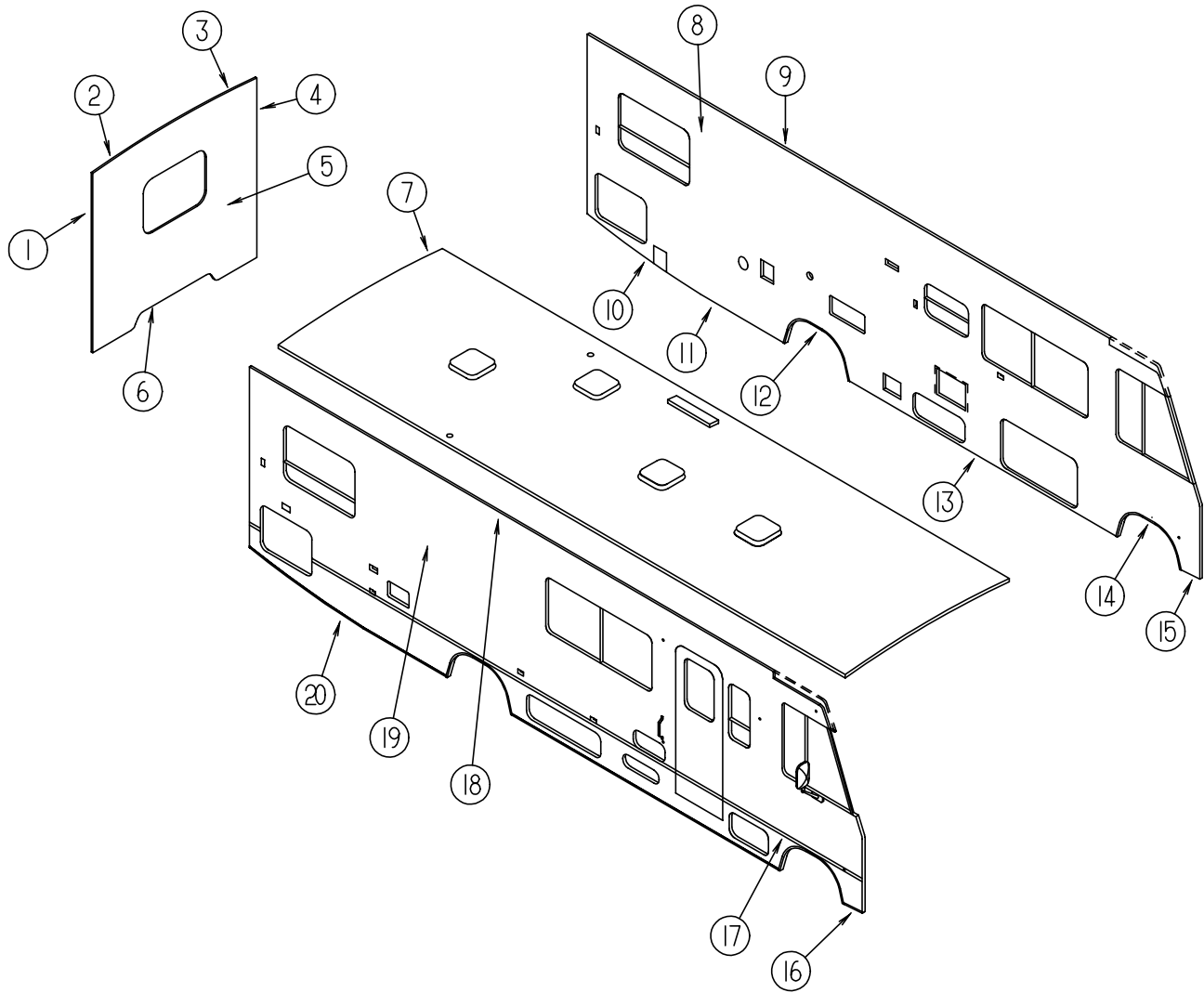

KEY	PART NUMBER	U/M	DESCRIPTION
1	114874-05-12B	EA	TRIM-BACKWALL, SIDE - RIGHT - BRIGHT WHITE
1	104033-11-02A	EA	TRIM-J, BACKWALL - RIGHT - BRIGHT WHITE
2	114872-01-02A	EA	TRIM-BACKWALL, TOP - RIGHT - BRIGHT WHITE
3	114873-01-02A	EA	TRIM-BACKWALL, TOP - LEFT - BRIGHT WHITE
4	114874-06-12B	EA	TRIM-BACKWALL, SIDE - LEFT - BRIGHT WHITE
4	104033-12-02A	EA	TRIM-J, BACKWALL - LEFT - BRIGHT WHITE
5	M07419-09-G29	EA	BACKWALL ASM W/QUEEN BED FORD
5	M07419-09-G30	EA	BACKWALL ASM W/QUEEN BED FORD
5	M07419-09-G31	EA	BACKWALL ASM W/QUEEN BED FORD (G31,G32)
5	M07419-07-G29	EA	BACKWALL ASM W/QUEEN BED GM
5	M07419-07-G30	EA	BACKWALL ASM W/QUEEN BED GM
5	M07419-07-G31	EA	BACKWALL ASM W/QUEEN BED GM (G31,G32)

KEY	PART NUMBER	U/M	DESCRIPTION
5	M07419-10-G29	EA	BACKWALL ASM W/TWIN BED FORD
5	M07419-10-G30	EA	BACKWALL ASM W/TWIN BED FORD
5	M07419-10-G31	EA	BACKWALL ASM W/TWIN BED FORD (G31,G32)
5	M07419-08-G29	EA	BACKWALL ASM W/TWIN BED GM
5	M07419-08-G30	EA	BACKWALL ASM W/TWIN BED GM
5	M07419-08-G31	EA	BACKWALL ASM W/TWIN BED GM (G31,G32)
6	050406-24-000	EA	TRIM-BACKWALL, LOWER - BRIGHT WHITE
7	M05702-16-G29	EA	ROOF ASM W/TWIN
7	M05702-15-G29	EA	ROOF ASM W/QUEEN
8	M05705-39-G29	EA	SIDEWALL ASM-LH W/TWIN
8	M05705-39-G30	EA	SIDEWALL ASM-LH W/TWIN
8	M05705-39-G31	EA	SIDEWALL ASM-LH W/TWIN (G31,G32)
8	M05705-42-G29	EA	SIDEWALL ASM-LH W/TWIN - DRIVERS DOOR OPTION
8	M05705-42-G30	EA	SIDEWALL ASM-LH W/TWIN - DRIVERS DOOR OPTION
8	M05705-42-G31	EA	SIDEWALL ASM-LH W/TWIN - DRIVERS DOOR OPTION (G31,G32)
8	M05705-40-G29	EA	SIDEWALL ASM-LH W/QUEEN
8	M05705-40-G30	EA	SIDEWALL ASM-LH W/QUEEN
8	M05705-40-G31	EA	SIDEWALL ASM-LH W/QUEEN (G31,G32)
8	M05705-51-G29	EA	SIDEWALL ASM-LH W/QUEEN - DRIVERS DOOR OPTION
8	M05705-51-G30	EA	SIDEWALL ASM-LH W/QUEEN - DRIVERS DOOR OPTION
8	M05705-51-G31	EA	SIDEWALL ASM-LH W/QUEEN - DRIVERS DOOR OPTION (G31,G32)
9	103801-02-05A	EA	TRIM-ROOF, W/O DRILLED HOLES
10	111108-05-03A	EA	TRIM-SIDEWALL, BOTTOM - REAR - 1243MM - BRIGHT WHITE
11	108038-33-01A	EA	TRIM-SIDEWALL, BOTTOM - REAR - 1286MM - BRIGHT WHITE
12	108070-01-04A	EA	TRIM-WHEELWELL, REAR - DR. OR PASS. SIDE - BRIGHT WHITE
13	108039-03-04A	EA	TRIM-SIDEWALL, BOTTOM - CENTER - BRIGHT WHITE
14	108069-04-03A	EA	TRIM-WHEELWELL, FRONT - BRIGHT WHITE
15	108109-01-04A	EA	TRIM-SIDEWALL, LOW - FRONT - DRIVER OR PASSENGER - BRIGHT WHITE
16	108109-01-04A	EA	TRIM-SIDEWALL, LOW - FRONT - DRIVER OR PASSENGER - BRIGHT WHITE
17	108688-01-03A	EA	FEATURE STRIP-W/HOLES - BRIGHT WHITE
	108651-01-01A	EA	END CAP-FEATURE STRIP
	105312-01-07A	EA	INSERT-FEATURE STRIP, BRIGHT WHITE
18	103802-02-05A	EA	RAIL-AWNING, W/O DRILLED HOLES - BRIGHT WHITE
19	M05704-40-G29	EA	SIDEWALL ASM-RH W/QUEEN
19	M05704-40-G30	EA	SIDEWALL ASM-RH W/QUEEN
19	M05704-40-G31	EA	SIDEWALL ASM-RH W/QUEEN (G31,G32)
19	M05704-39-G29	EA	SIDEWALL ASM-RH W/TWIN
19	M05704-39-G30	EA	SIDEWALL ASM-RH W/TWIN
19	M05704-39-G31	EA	SIDEWALL ASM-RH W/TWIN (G31,G32)
20	108038-32-01A	EA	TRIM-SIDEWALL, BOTTOM - REAR - BRIGHT WHITE
	058267-01-000	FT	CHANNEL-STEEL, W/HOLES - SIDEWALL STIFFENER - 2" X 20'
	002754-01-001	EA	ANGLE-EXTRUDED, .75" X .75" X 18' - MILL ALUMINUM
	086180-55-015	EA	U-CHANNEL-EXTRUDED, 1.7" X 16' - BRIGHT WHITE - SERRATED
	086754-07-000	EA	CAP-JOINT, ROOF TO SIDEWALL TRIM - 2" X 1.25" - MILL
	002726-01-001	EA	GARNISH-U-CHANNEL, 1.38" X 19' - SERRATED - MILL ALUMINUM
	093673-01-05A	FT	TRIM-ENTRANCE DOOR, 1.3" WIDE - BUFF
	103814-01-000	EA	BRACKET-TRIM ATTACHMENT

EXTERIOR BODY GROUP (CONTINUED)

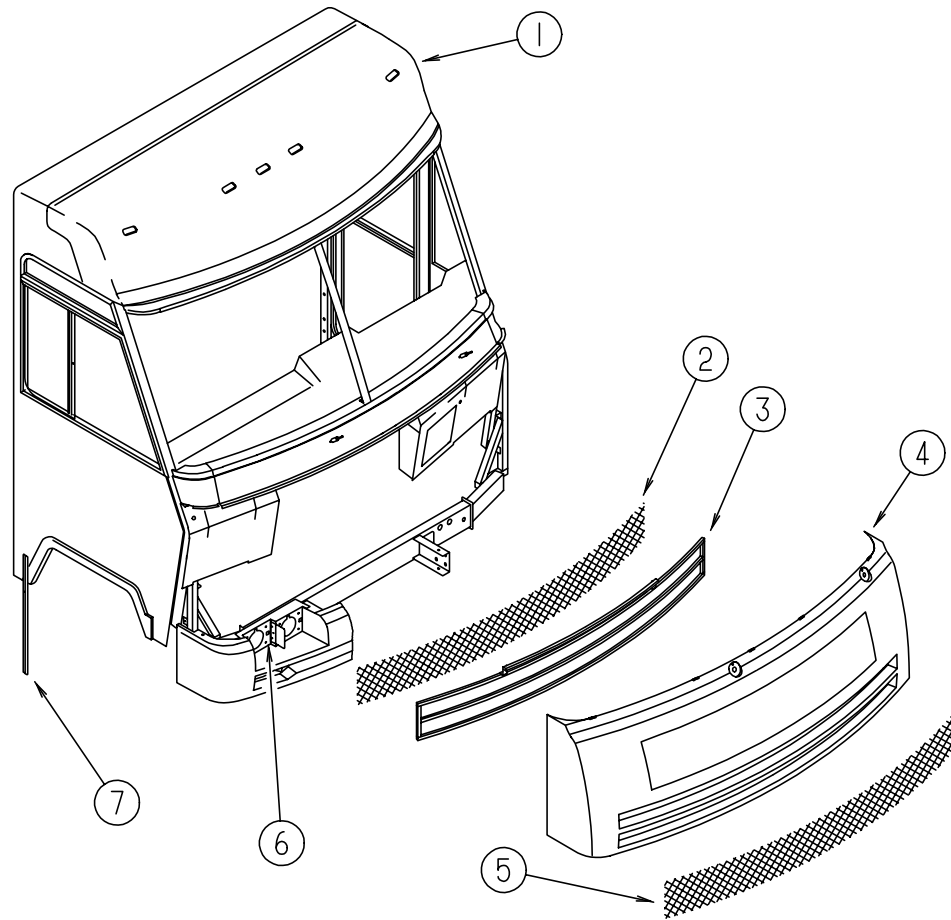

FRONT END COMPONENTS

KEY	PART NUMBER	U/M DESCRIPTION
1	115042-01-02A	EA PANEL-ROOF CAP, BRIGHT WHITE
	077001-01-000	EA ANGLE-MOUNTING, ROOF PANEL - V ANGLE - 3" X 2.4" X 1.5"
	070579-06-000	EA PLATE-ANCHOR, W/7/16 WELD NUT - 1.5" X 3.3"
2	115924-03-01A	EA GRILLE-WOVEN WIRE
3	118182-01-G09	EA GRILLE ASM
4	M07546-01-G29	EA FRONT END ASM-FIBERGLASS, BRIGHT WHITE
5	115924-04-01A	EA GRILLE-WOVEN WIRE
6	118191-01-01A	EA BEZEL-HEADLAMP, QUAD - RH - BLK
	118191-02-01A	EA BEZEL-HEADLAMP, QUAD - LH - BLK
7	089922-27-000	EA TRIM-FIBERGLASS, PANEL - BRIGHT WHITE

EXTERIOR BODY GROUP (CONTINUED)

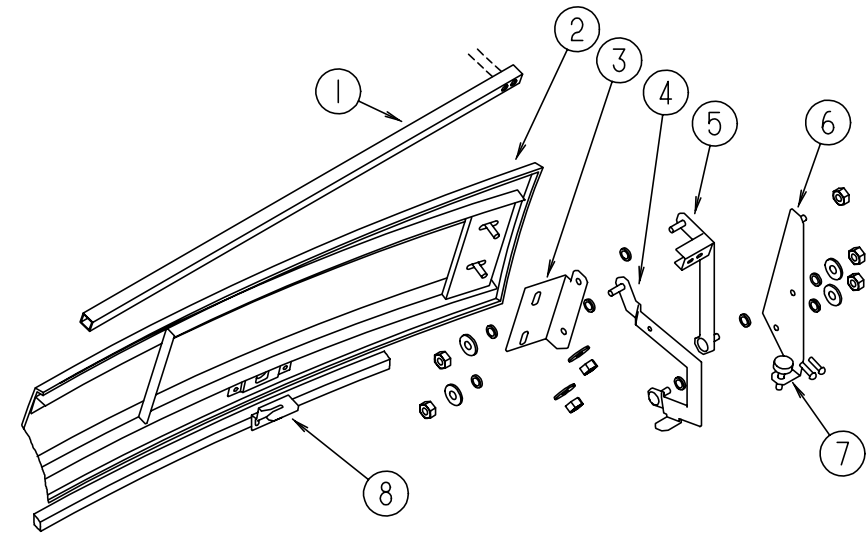

HOOD & COMPONENTS

KEY	PART NUMBER	U/M DESCRIPTION
1	105096-10-000	EA TUBE-TIMING, HOOD HINGE
2	115976-02-G29	EA PANEL ASM-HOOD
3	109927-03-000	EA ANGLE-LINK, HOOD - RH
3	109927-04-000	EA ANGLE-LINK, HOOD - LH
4	109930-07-000	EA LINK ASM-HINGE, HOOD - LOWER - RH
4	109930-08-000	EA LINK ASM-HINGE, HOOD - LOWER - LH
5	109929-03-000	EA LINK ASM-HINGE, HOOD - UPPER - RH
5	109929-04-000	EA LINK ASM-HINGE, HOOD - UPPER - LH
6	109926-07-000	EA BRACKET ASM-LINK, HINGE - HOOD - RH
6	109926-08-000	EA BRACKET ASM-LINK, HINGE - HOOD - LH
7	058786-01-000	EA BOLT-HOOD, ADJUSTING
8	106748-02-000	EA LATCH-HOOD, FRONT END

EXTERIOR BODY GROUP (CONTINUED)
FIBERGLASS, STYROFOAM, ALUMINUM & INSULATION

KEY	PART NUMBER	U/M	DESCRIPTION
	000870-08-000	SF	STYROFOAM - .75 X 48 X 96 - PLANED
	002726-01-001	EA	GARNISH-U-CHANNEL, 1.38" X 19' - SERRATED - MILL ALUMINUM
	033381-17-001	FT	STL-TUBE 16GA 1.5 X 1.5 X 192.00 - HOT FORMED ASTM A50
	034073-27-011	EA	PLAS-ABS .200 X 28.00 X 068.00 IN - ANY BLK 0/MIL SM/SM FROM: 00-00-00 THRU: 08-06-95
	044487-51-001	EA	AL - .019 X 0758 X 0317 MILL - FINISH
	055278-51-259	FT	TUBING-STEEL, 18 GA. - .75" X 1.5" X 3831MM
	068716-01-001	EA	BRACE - 90 DEGREE L-ANGLE, 192" - EXTRUDED ALUMINUM
	076054-N1-000	EA	FIBERGLASS-SHEET, 96" X 355.5" - BRIGHT WHITE
	076054-P4-000	EA	FIBERGLASS-SHEET, 96" X 97" - BRIGHT WHITE
	077517-62-000	EA	FIBERGLASS-SHEET, 48 X 96 - BRIGHT WHITE, FLAT
	089297-01-000	SF	PLYWOOD-LUAN, OVERLAY GRADE - 4' X 8'
	100619-01-000	BF	EXPANDED FOAM SHEET - 48" X 96" X 1.34"
	100619-04-000	BF	FOAM-EXPANDED POLYSTYRENE, 48" X 96" X .5
	100619-05-000	BF	FOAM-EXPANDED POLYSTYRENE, 48" X 96" X .75"
	100619-11-000	BF	FOAM-EXPANDED POLYSTYRENE, 48" X 96" X 2"
	105077-03-000	EA	FOAM-PLUG, SIDEWALL TUBE - WISCONSIN EPS FROM: 00-00-00 THRU: 09-23-95
	105077-04-000	EA	FOAM-COVE, ROOF FROM: 00-00-00 THRU: 09-23-95
	120107-01-000	EA	FOAM-COVE, ROOF - WISCONSIN EPS FROM: 09-24-95 THRU: 99-99-99
	120107-02-000	EA	FOAM-PLUG, ROOF TUBE - WISCONSIN EPS FROM: 09-24-95 THRU: 99-99-99
	120107-03-000	EA	FOAM-PLUG, ROOF TUBE - WISCONSIN EPS FROM: 09-24-95 THRU: 99-99-99

ASSIST HANDLE

KEY	PART NUMBER	U/M	DESCRIPTION
	009126-02-000	EA	HANDLE-ASSIST, ENTRY DOOR - BLACK
	069726-02-000	EA	BUMPER - .88" DIA X .40", BLACK

EXTERIOR BODY GROUP (CONTINUED)

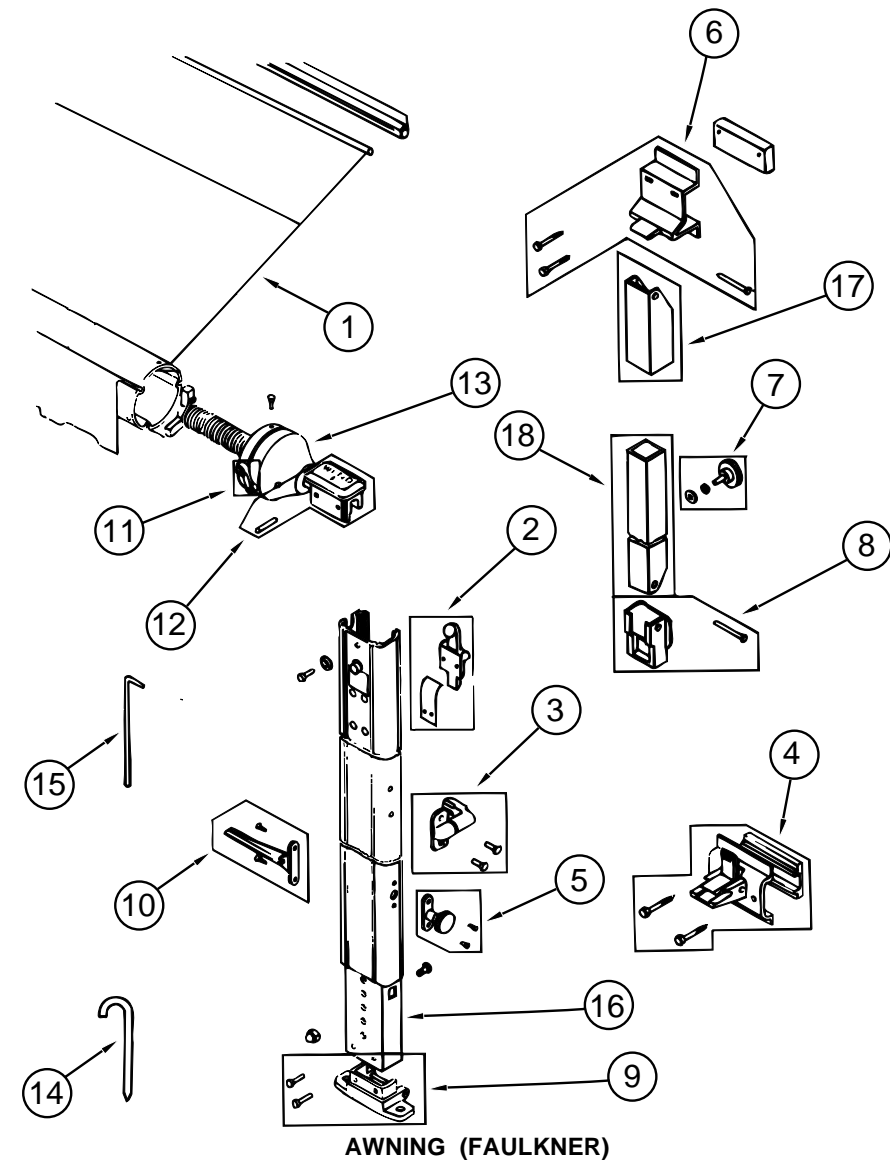

AWNING (FAULKNER)

KEY	PART NUMBER	U/M	DESCRIPTION	VENDER NO.
1	110634-01-19A	EA	AWNING-ROLLER ASM, 18'	
	110634-02-04A	EA	AWNING-HARDWARE KIT, BRIGHT WHITE	
	111037-01-01A	EA	SPACER-AWNING, UPPER BLACK	
	111038-01-01A	EA	SPACER-AWNING, LOWER BLACK	
2	110634-01-700	EA	RAFTER LOCKING MECH KIT	7605-0001
3	110634-01-701	EA	SAFETY & LATCH KIT	7509-0001
4	110634-01-702	EA	BOTTOM BRACKET KIT	7512-0001
5	110634-01-703	EA	HEIGHT LOCK HANDLE KIT	7510-0001
6	110634-01-704	EA	UPPER BRACKET KIT W/BOLTS	7505-0001
7	110634-01-705	EA	ULTRA RAFTER KNOB KIT	7522-0001
8	110634-01-706	EA	RAFTER SLIDE KIT	7806-0001
9	110634-01-707	EA	GROUND BRACKET KIT	7511-0001
10	110634-01-708	EA	LIFT HANDLES W/RIVETS	7000-0001
11	110634-01-709	EA	RATCHET HANDLE KIT	7507-0001
12	110634-01-710	EA	ARM CAP KIT	7503-0001
13	110634-01-711	EA	FRONT SPRING ASM	6598-0001
13	110634-01-712	EA	REAR SPRING ASM	6599-0001
13	110634-01-713	EA	REAR END CAP KIT	7504-0001
14	110634-01-714	EA	STAKE-(4 PER BAG)	5208-0001
15	110634-01-715	EA	WAND, PULL DOWN	7604-0001
16	110634-01-721	EA	ARM-INNER, FRONT, BUFF	5686-0001
16	110634-01-722	EA	ARM-INNER, REAR, BUFF	5687-0001
17	110634-01-723	EA	RAFTER-OUTER, BUFF	5688A0001
18	110634-01-724	EA	RAFTER-INNER, BUFF	5689A0001

EXTERIOR BODY GROUP (CONTINUED)

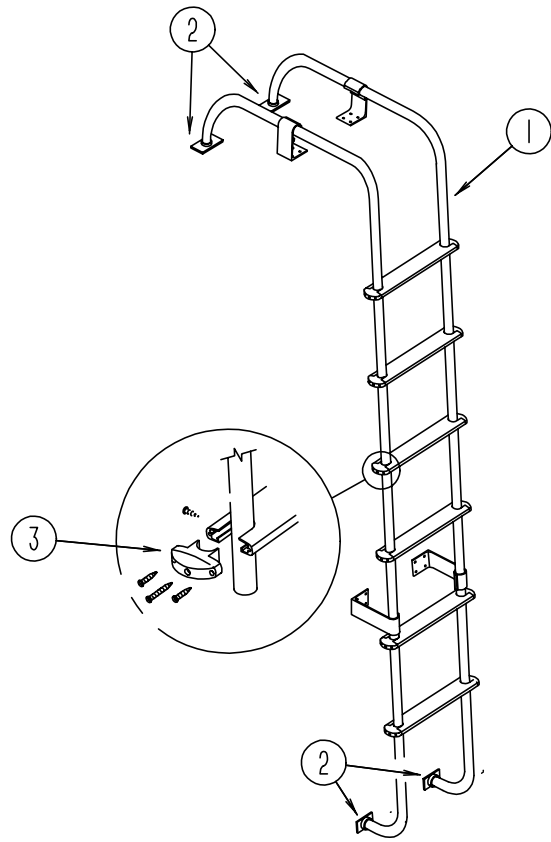

LADDER

KEY	PART NUMBER	U/M DESCRIPTION
1	102953-16-G09	EA LADDER ASM
2	067165-01-000	EA MOUNTING BRACKET-LADDER, LOWER
3	076980-02-000	EA END CAP-STEP, BLACK

EXTERIOR BODY GROUP (CONTINUED)

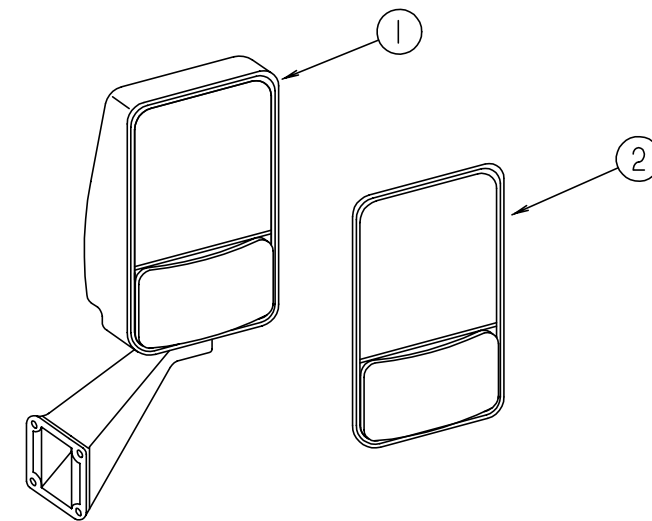

HEATED EXTERIOR MIRROR (VELVAC)

KEY	PART NUMBER	U/M DESCRIPTION	VENDER NO.
1	106015-05-01A	EA MIRROR ASM. - REMOTE/HEATED - W/O WIRING OR SWITCHES - PASS. SIDE 713170	
1	106015-06-01A	EA MIRROR ASM - REMOTE/HEATED - W/O WIRING OR SWITCHES - DR. SIDE 713171	
2	086261-01-704	EA MIRROR KIT (BEZEL W/MIRRORS) PASSENGER SIDE	709268
2	086261-02-701	EA MIRROR KIT (BEZEL W/MIRRORS) DRIVER SIDE	709269
	087695-01-000	EA SWITCH-HEATER, EXTERIOR MIRROR	
	088246-01-000	EA SWITCH-REMOTE, EXTERIOR MIRROR - SQUARE PUSH - 7471290	

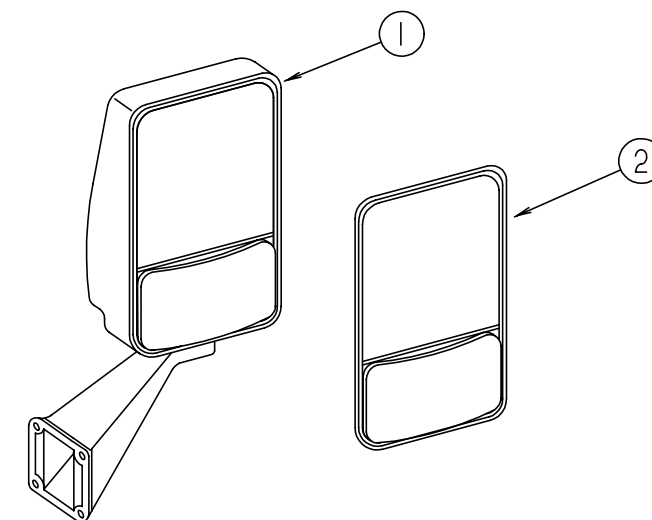

EXTERIOR MIRROR (VELVAC)

KEY	PART NUMBER	U/M DESCRIPTION	VENDER NO.
1	106015-09-01A	EA MIRROR ASM-EXTERIOR GLASS RIGHT - BLACK - 713126	
1	106015-10-01A	EA MIRROR ASM-EXTERIOR ADJUST GLASS LEFT - BLACK - 713125	
2	106015-01-703	EA MIRROR KIT (BEZEL W/MIRRORS) PASSENGER SIDE	709266
2	106015-02-702	EA MIRROR KIT (BEZEL W/MIRRORS) DRIVER SIDE	709267

EXTERIOR BODY GROUP (CONTINUED)
DECALS, FILM STRIPES & PAINT

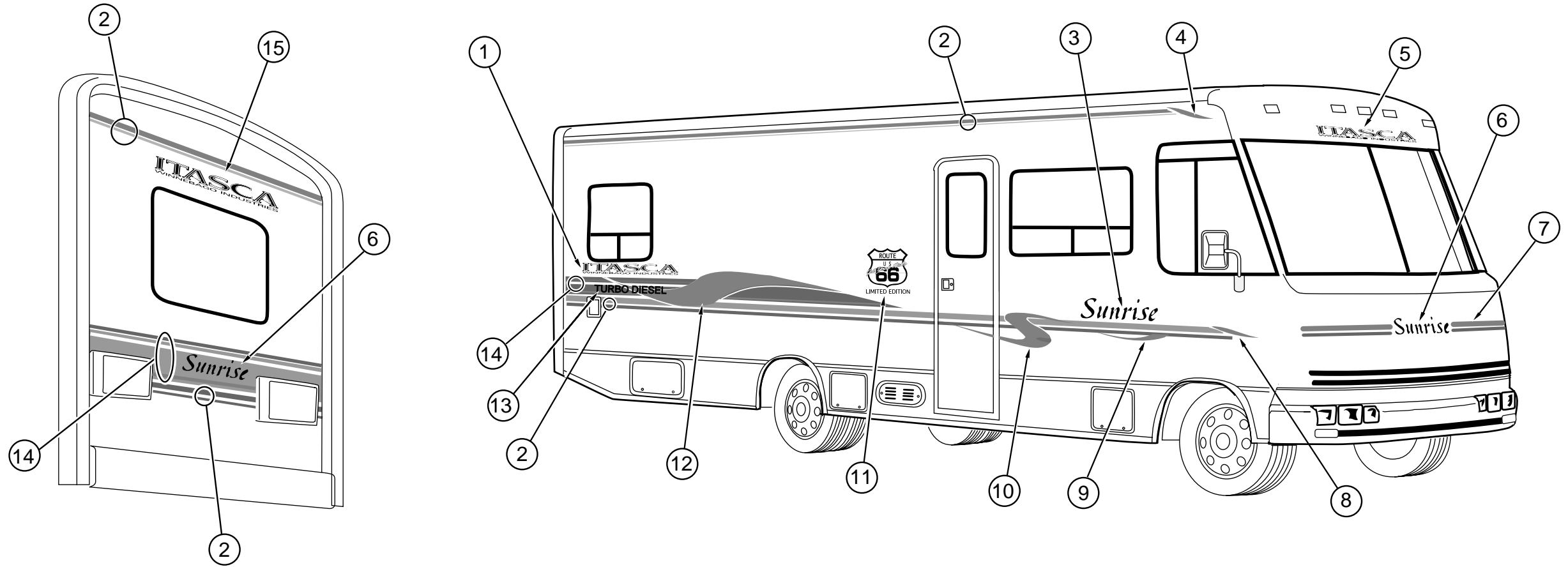

KEY	PART NUMBER	U/M	DESCRIPTION
1	116921-01-03A	EA	DECAL-LOGO, ITASCA WINN. IND. - MALIBU TEAL/MALIBU TEAL/MALIBU TEAL
2	105781-47-01A	FT	FILM-MULTISTRIFE 82.5MM X 150' - MEDIUM BLUE/SHADOW BLUE
3	118717-01-01A	EA	DECAL-LOGO, SUNRISE - LARGE - MEDIUM BLUE/SHADOW BLUE/BRIGHT WHT
4	118715-01-01A	EA	DECAL-RIBBON, SMALL - RH - MALIBU TEAL/CHAMPAGNE STAR/MEDIUM BLUE/WHT
4	118715-02-01A	EA	DECAL-RIBBON, SMALL - LH - MALIBU TEAL/CHAMPAGNE STAR/MEDIUM BLUE/WHT
5	118312-01-02A	EA	DECAL-ITASCA, WINN IND - SWEEP - MALIBU TEAL/MALIBU TEAL/MALIBU TEAL
6	118717-02-01A	EA	DECAL-LOGO, SUNRISE - SMALL - MEDIUM BLUE/SHADOW BLUE/BRIGHT WHT
7	118716-01-01A	EA	DECAL-HOOD, MEDIUM BLUE/SHADOW BLUE
8	118711-01-01A	EA	DECAL-RIBBON, #1 - RH - MALIBU TEAL/CHAMPAGNE STAR/MEDIUM BLUE/WHT
8	118711-02-01A	EA	DECAL-RIBBON, #1 - LH - MALIBU TEAL/CHAMPAGNE STAR/MEDIUM BLUE/WHT
9	118712-01-01A	EA	DECAL-RIBBON, #2 - RH - MALIBU TEAL/CHAMPAGNE STAR/MEDIUM BLUE/WHT
9	118712-02-01A	EA	DECAL-RIBBON, #2 - LH - MALIBU TEAL/CHAMPAGNE STAR/MEDIUM BLUE/WHT
10	118713-01-01A	EA	DECAL-RIBBON, #3 - LH - MALIBU TEAL/CHAMPAGNE STAR/MEDIUM BLUE/WHT
10	118713-02-01A	EA	DECAL-RIBBON, #3 - LH - MALIBU TEAL/CHAMPAGNE STAR/MEDIUM BLUE/WHT
11	116404-01-01A	EA	DECAL-ROUTE 66
12	118714-01-01A	EA	DECAL-RIBBON, #4 - RH - MALIBU TEAL/CHAMPAGNE STAR/MEDIUM BLUE/WHT
12	118714-02-01A	EA	DECAL-RIBBON, #4 - LH - MALIBU TEAL/CHAMPAGNE STAR/MEDIUM BLUE/WHT
13	111318-03-03A	EA	DECAL-TURBO DIESEL, BRIGHT WHITE
14	118710-01-01A	FT	FILM-MULTISTRIFE, 174.6MM X 150' - SHADOW BLUE /AMETHYST FROST/AMETHYST FROST/MEDIUM BLUE
15	116921-02-03A	EA	DECAL-LOGO, ITASCA WINN. IND. - MALIBU TEAL/MALIBU TEAL/MALIBU TEAL
	099399-23-700	EA	PAINT - 16OZ SRAY, BRIGHT WHITE
	099399-23-000	EA	TOUCH UP - 6OZ BOTTLE

DUPONT COLOR CODES
BRIGHT WHITE #B8951

GALLEY GROUP
GALLEY CABINETRY

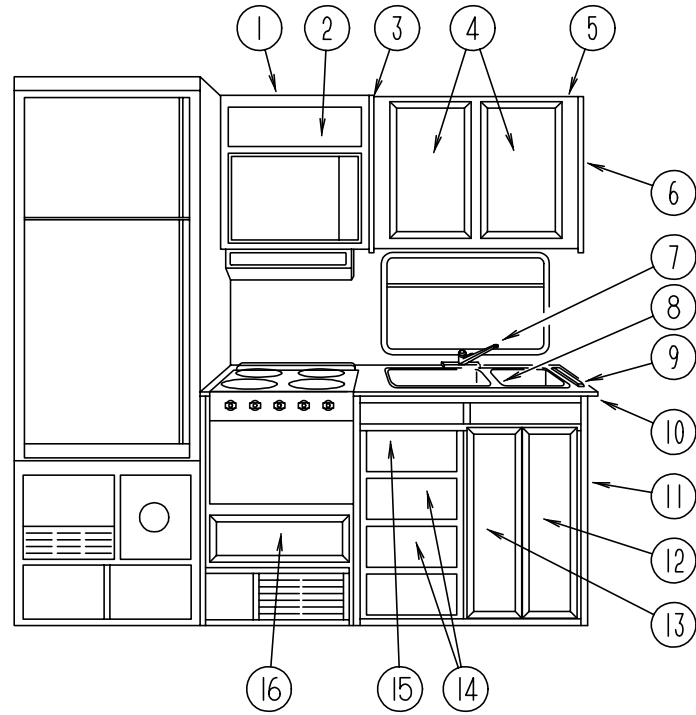

KEY	PART NUMBER	U/M	DESCRIPTION
1	114390-01-G09	EA	CABINET ASM-MICROWAVE OVERHEAD
2	M05992-11-G09	EA	DOOR-CABINET, W/O HARDWARE - 180 X 555MM
3	081320-16-G09	EA	CAP-END, OVERHEAD
4	M06803-05-G09	EA	DOOR-CABINET, W/O HARDWARE - 365 X 555MM
5	103276-01-G09	EA	CABINET ASM-OVERHEAD, GALLEY
6	081320-17-G09	EA	CAP ASM-END, OVERHEAD
7	103635-01-000	EA	FAUCET-SINGLE CONTROL, EVERPURE 5435-00
7	104114-02-01A	EA	FAUCET-GALLEY,SGL CONTROL 20PL1038-8" CHROME THIS FAUCETS WATER CONNECTIONS AND RETAINING STUD ARE COMBINED
8	110654-01-000	EA	SINK-SST, DOUBLE/SMALL BASIN - DAYTON FR2917
	092303-01-000	EA	STRAINER-SINK
	108464-04-E08	EA	COVER ASM-SINK (G29,G32)
	108464-04-F11	EA	COVER ASM-SINK (G30)
	108464-04-E38	EA	COVER ASM-SINK (G31)
9	098335-02-G29	EA	RAIL-GALLEY, 565
9	098335-02-G30	EA	RAIL-GALLEY, 565
9	098335-02-E04	EA	RAIL-GALLEY, 565 (G31)
9	098335-02-E28	EA	RAIL-GALLEY, 565 (G32)
10	111181-13-G29	EA	COUNTERTOP ASM
10	111181-13-G30	EA	COUNTERTOP ASM
10	111181-13-F05	EA	COUNTERTOP ASM (G31)
10	111181-13-E08	EA	COUNTERTOP ASM (G32)
11	M07536-04-G29	EA	CABINET ASM-GALLEY
11	M07536-04-G30	EA	CABINET ASM-GALLEY
11	M07536-04-G31	EA	CABINET ASM-GALLEY
11	M07426-03-G32	EA	CABINET ASM-GALLEY
12	M06803-09-G09	EA	DOOR-CABINET, W/O HARDWARE - 230 X 675MM
13	M06803-08-G09	EA	DOOR-CABINET, W/O HARDWARE - 230 X 675MM
14	M05971-11-G09	EA	DRAWER-CABINET, W/O HARDWARE
15	M05971-83-G09	EA	DRAWER-CABINET, W/O HARDWARE
16	M05971-50-G09	EA	DRAWER-CABINET, W/O HARDWARE
	103445-01-01A	EA	HOLDER-PAPER TOWEL - PLASTIC - ALMOND
	090329-01-000	FT	SEAL-T, REFRIGERATOR CABINET - .6" WIDE TOP X 2" TAIL

GALLEY GROUP (CONTINUED)

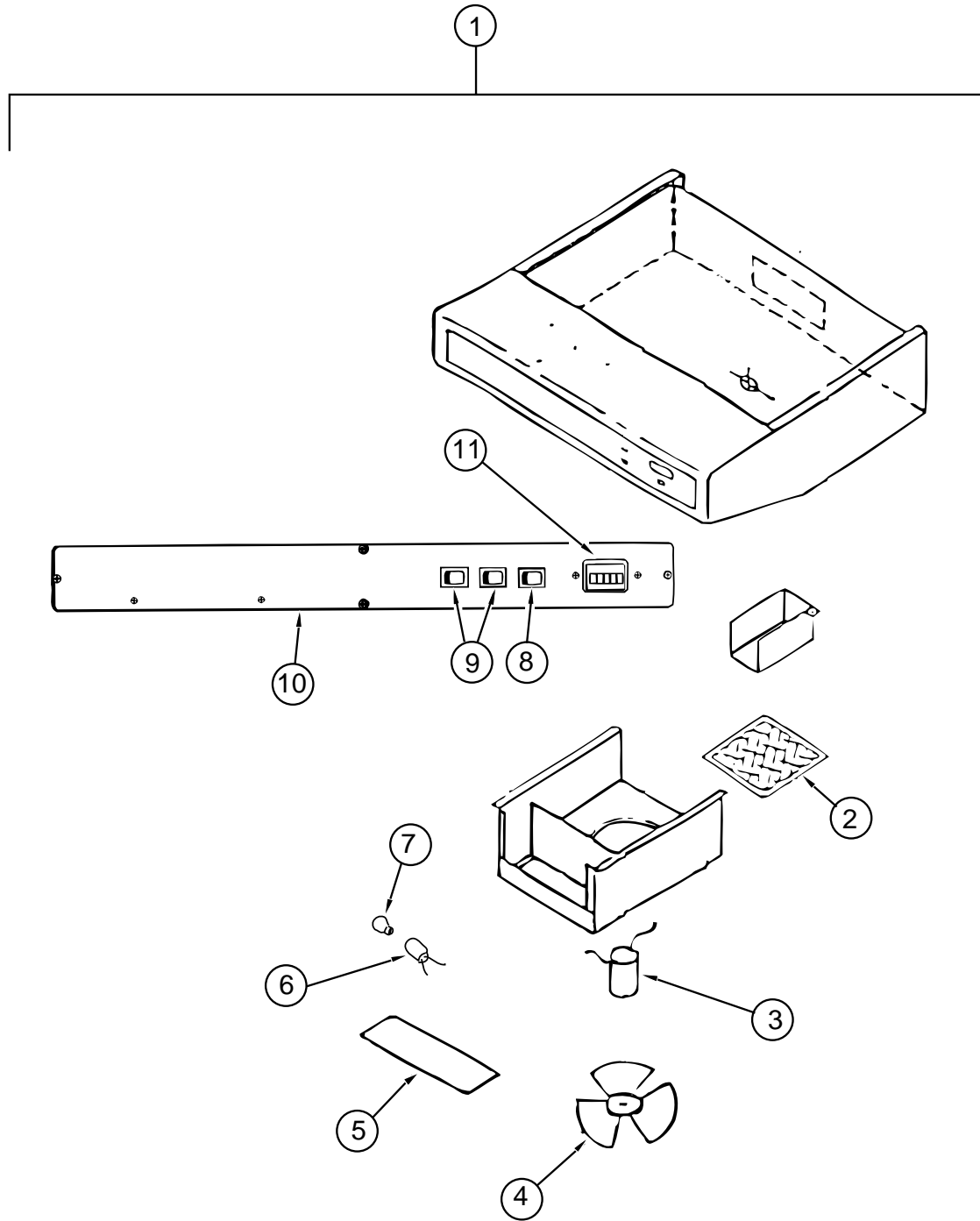

VENTLINE RANGE HOOD W/HOUR METER (US) - TP55009-SBO-LG

KEY	PART NUMBER	U/M	DESCRIPTION	VENDER NO.
1	100258-18-03A	EA	HOOD-RANGE, W/O MONITOR PANEL - TP55009-SBO-LG	
2	096983-01-707	EA	FILTER-MESH	CC246
3	090973-01-700	EA	MOTOR-12 VOLT, CSA & UL	CA508-1
4	090973-01-702	EA	BLADE-FAN	VA183-1
5	092696-02-701	EA	LENS-LAMP	CC179-2
6	092696-01-710	EA	HOLDER-LAMP	CB267-2
7	092696-01-709	EA	LAMP #912	VA415
8	096983-01-702	EA	SWITCH-MOM/MOM	112
9	096983-01-700	EA	SWITCH-ON/OFF	108
10	100258-01-700	EA	LABEL-HOOD NOSE	CC428
11	100258-10-01A	EA	GAUGE-HOUR METER W/SWITCH - SCREW ON STYLE - 150	
11	100258-10-701	EA	GAUGE-HOUR METER, CLIP ON	L0775-00

GALLEY GROUP (CONTINUED)

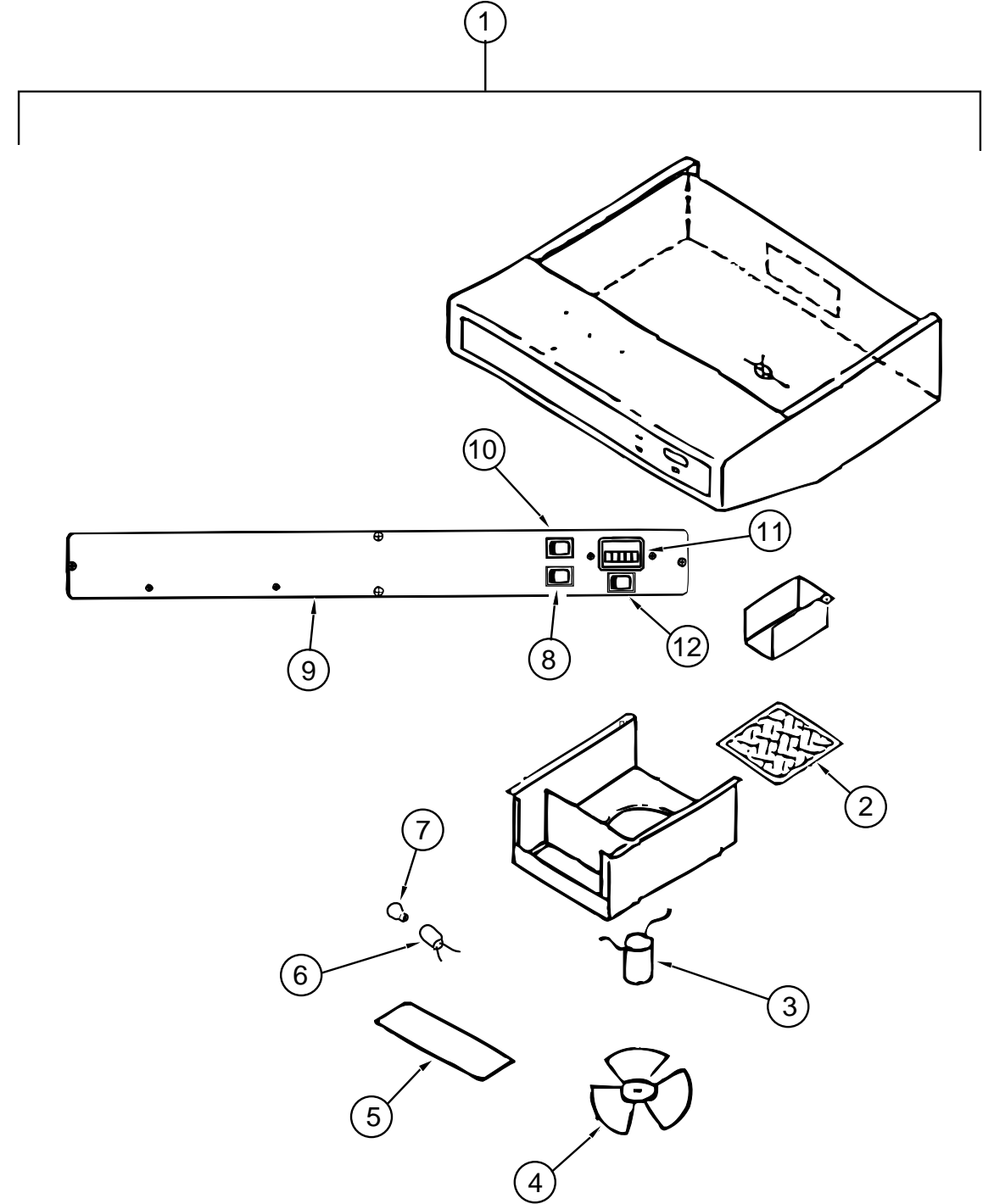

VENTLINE RANGE HOOD W/O HOUR METER (CANADIAN) - TCS-500-NBCLG

KEY	PART NUMBER	U/M	DESCRIPTION	VENDER NO.
1	100258-17-04A	EA	HOOD-RANGE, W/O MONITOR PANEL - TCS-500-NBCLG	
2	096983-01-707	EA	FILTER-MESH	CC246
3	090973-01-700	EA	MOTOR-12 VOLT, CSA & UL	CA508-1
4	090973-01-702	EA	BLADE-FAN	VA183-1
5	092696-02-701	EA	LENS-LAMP	CC179-2
6	092696-01-710	EA	HOLDER-LAMP	CB267-2
7	092696-01-709	EA	LAMP #912	VA415
8	096983-01-700	EA	SWITCH-ON/OFF	108
9	100258-01-700	EA	LABEL-HOOD NOSE	CC428
10	096983-01-702	EA	SWITCH-MOM/MOM	112
11	100258-10-01A	EA	GAUGE-HOUR METER W/SWITCH - SCREW ON (OPTION) - 150	
11	100258-10-701	EA	GAUGE-HOUR METER, CLIP ON (OPTION)	L0775-00
12	096983-01-702	EA	SWITCH-MOM/MOM (OPTION)	112

GALLEY GROUP (CONTINUED)

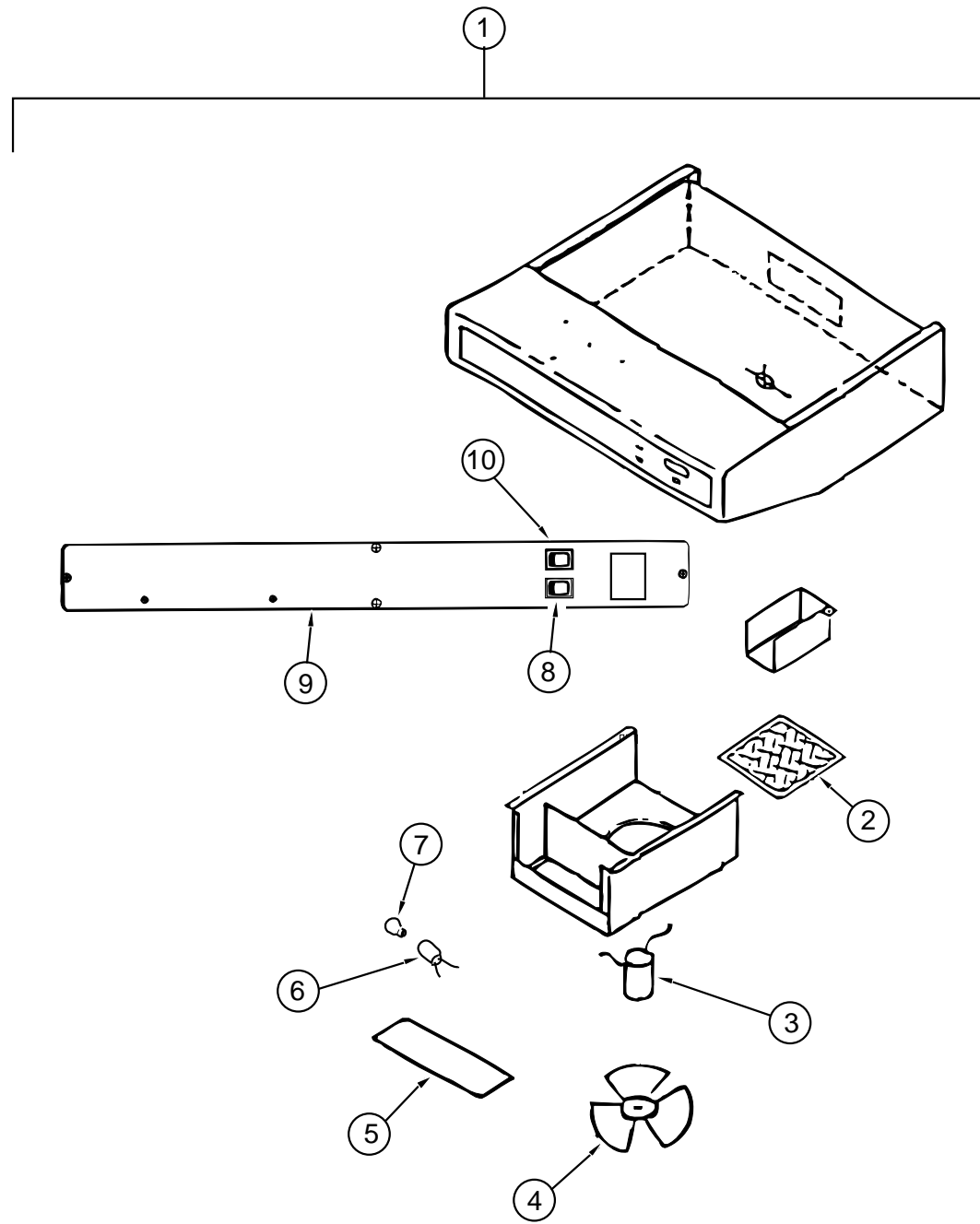

VENTLINE RANGE HOOD W/O HOUR METER (US) - TCS-5008-NBDLG

KEY	PART NUMBER	U/M DESCRIPTION	VENDER NO.
1	100258-16-04A	EA HOOD-RANGE, W/O MONITOR PANEL - TCS-5008-NBDLG	
2	096983-01-707	EA FILTER-MESH	CC246
3	090973-01-700	EA MOTOR-12 VOLT, CSA & UL	CA508-1
4	090973-01-702	EA BLADE-FAN	VA183-1
5	092696-02-701	EA LENS-LAMP	CC179-2
6	092696-01-710	EA HOLDER-LAMP	CB267-2
7	092696-01-709	EA LAMP #912	VA415
8	096983-01-700	EA SWITCH-ON/OFF	108
9	100258-01-700	EA LABEL-HOOD NOSE	CC428
10	096983-01-702	EA SWITCH-MOM/MOM	112

GALLEY GROUP (CONTINUED)

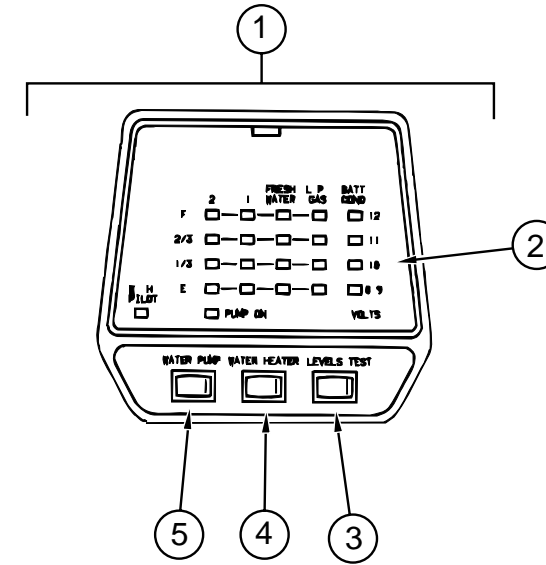

LVS MONITOR PANEL

KEY	PART NUMBER	U/M DESCRIPTION	VENDER NO.
1	102765-03-01A	EA PANEL-MONITOR 3 TANK WATER HEATER - W/PLUG ALMOND	
2	102765-03-700	EA BOARD-CIRCUIT, 3 HOLDING TANK	5076-12
3	097617-01-702	EA SWITCH (ALMOND)	107
4	097617-01-701	EA SWITCH-ON/OFF, ALMOND	106
5	102765-01-700	EA SWITCH-ON-ON, ALMOND	110-01

GALLEY GROUP (CONTINUED)
MAGIC CHEF RANGE - 16RB-3B49

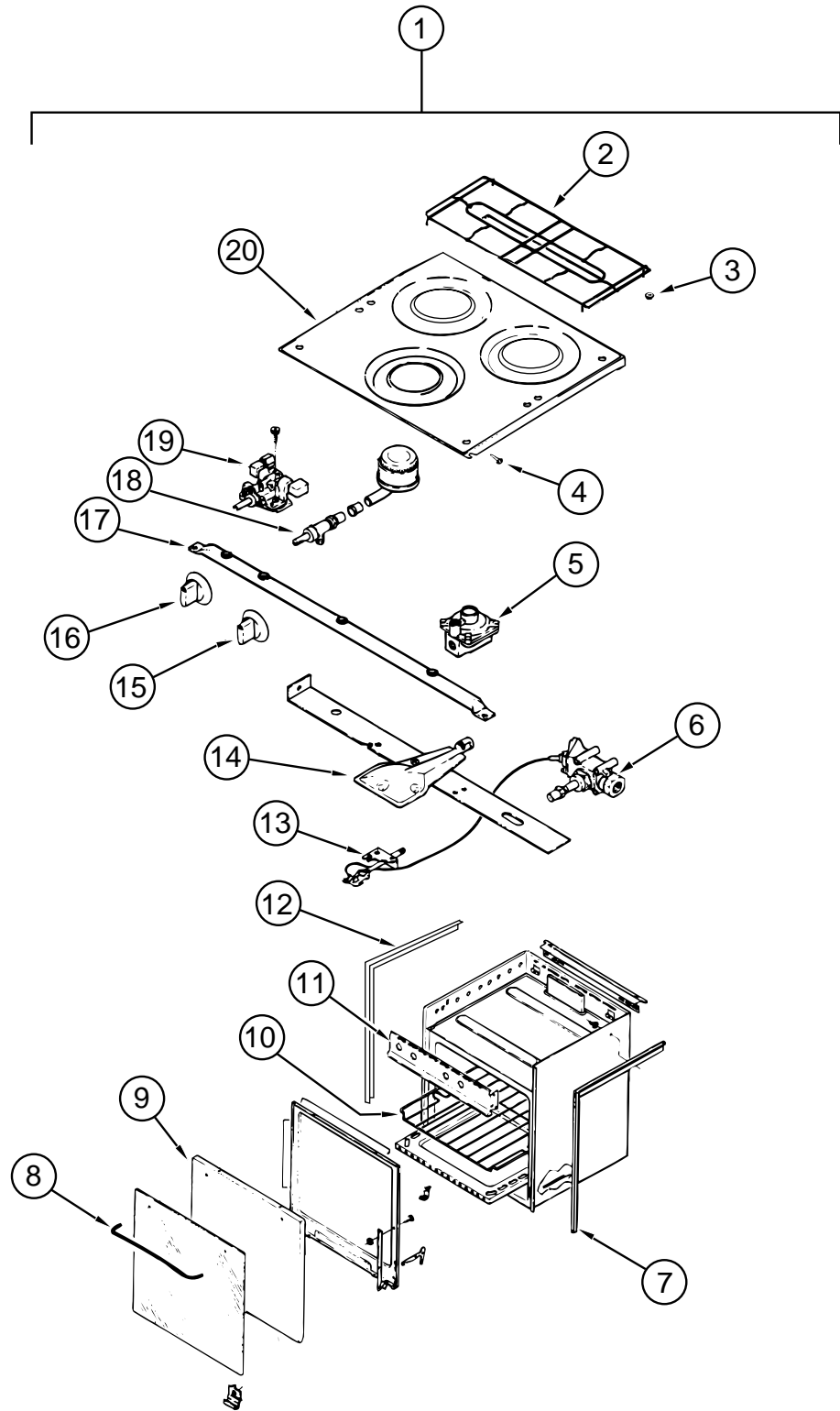

KEY	PART NUMBER	U/M DESCRIPTION	VENDER NO.
1	112881-01-04A	EA RANGE-16" 3 BURNER BLACK - DOOR BLACK - 16RB-3B49	
2	102020-01-711	EA GRATE, TOP	7518P012-60
3	102020-01-709	EA BUMPER, GRATE	8007-P020-60
4	102020-01-724	EA BUMPER, MAIN TOP	8003P008-60
5	102022-01-708	EA REGULATOR PRESSURE 1/4 IN 1/2 OUT	7510P041-60
6	112881-01-702	EA VALVE-MERCURY (SAFETY VALVE)	7501-P121-60
7	112881-01-708	EA TRIM-FLAT (RIGHT) (BLK)	3608W036-70
8	102020-01-701	EA HANDLE, DOOR	7701P092-60
9	112881-01-713	EA DOOR-OVEN, TEXTURED - BLACK	2401F126-70
10	102020-01-700	EA SHELF-OVEN	7801-P027-60
11	112881-01-701	EA MANIFOLD PANEL	2616F091-70
12	112881-01-707	EA TRIM-FLAT (LEFT) (BLK)	3608W035-70
13	112881-01-710	EA OVEN PILOT	7505P202-60
14	112881-01-711	EA OVEN BURNER	3403W025045
15	112881-01-705	EA KNOB-TOP BURNER	7733P072-60
16	112881-01-704	EA KNOB-THERMOSTAT	7731P067-60
16	112881-01-716	EA KNOB, THERMOSTAT-SER# 3C	7731P107-60
17	112881-01-709	EA PIPE-MANIFOLD	7513P097-60
18	112881-01-703	EA VALVE-TOP BURNER HI-OUTPUT	7502P180-60
18	102020-01-722	EA VALVE, TOP BURNER	7502P181-60
19	112881-01-706	EA THERMOSTAT	12400026
19	112881-01-715	EA THERMOSTAT, REF. SER. # 3C	7515P037-60
20	112881-01-712	EA TOP, MAIN-BLACK	740101486
	105458-01-000	EA TIEDOWN BRACKET - STOVE - RH	
	105458-02-000	EA TIEDOWN BRACKET - STOVE - LH	

GALLEY GROUP (CONTINUED)
MICROWAVE OVEN

KEY	PART NUMBER	U/M DESCRIPTION
	115303-01-000	EA OVEN-MICROWAVE - MCD-DM15K-7B
	115401-01-01A	EA TRIM-MICROWAVE, BLACK
	094750-07-000	EA BRACKET-MICROWAVE, 89 DEGREE - STEEL
	098916-14-01A	EA BRACE-MICROWAVE
	098916-15-01A	EA BRACE-MICROWAVE

COFFEE MAKER

KEY	PART NUMBER	U/M DESCRIPTION
	103799-01-02A	EA COFFEE MAKER - GRAY - BLACK & DECKER - W/GLASS POT
	103799-01-700	EA POT-CARAFE, GLASS
	103799-01-701	EA BRACKETS, WHITE PAIR

GALLEY GROUP (CONTINUED)

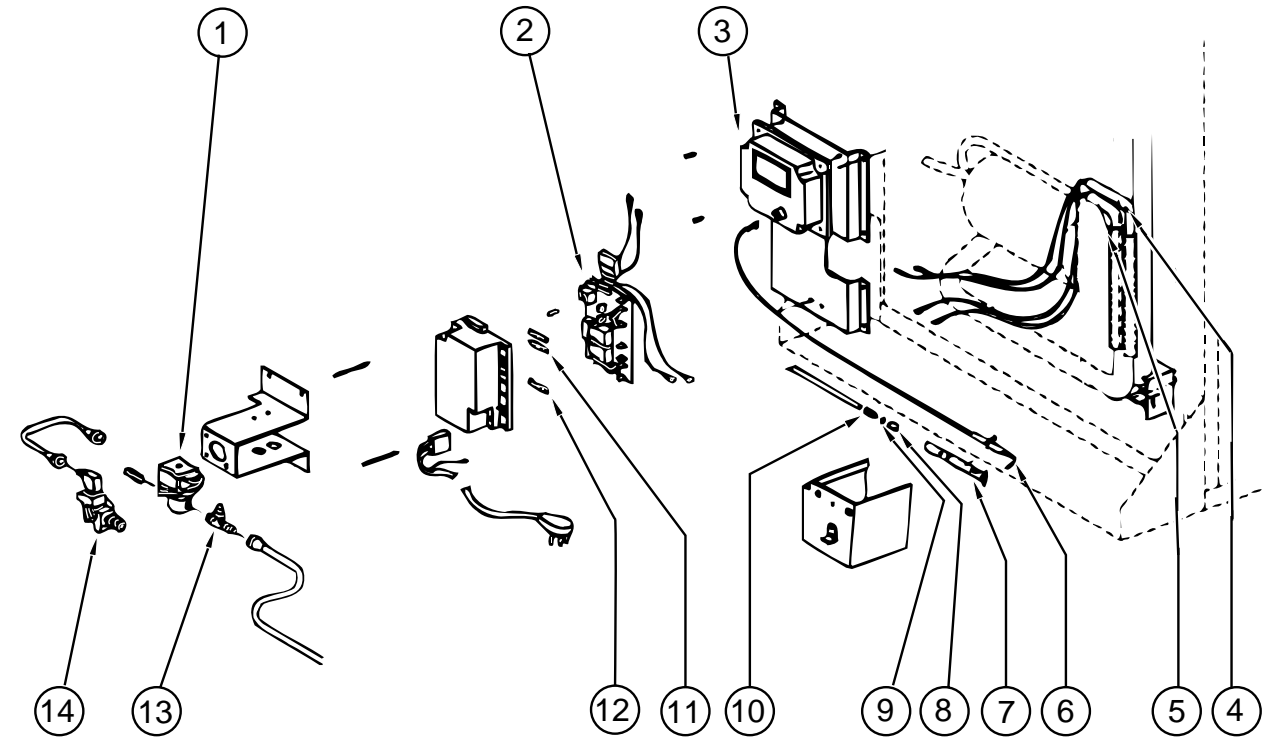

NORCOLD 6162 REFRIGERATOR CONTROL ASM.

KEY	PART NUMBER	U/M DESCRIPTION	VENDER NO.
1	084880-01-718	EA VALVE-GAS	61551822
2	094039-04-702	EA POWER SUPPLY (2-WAY)	61647422
3	102621-01-702	EA IGNITION MODULE	61688922
4	088248-01-710	EA HEATER-DC, (HORIZONTAL)	61562822
5	088248-01-709	EA HEATER-AC, (HORIZONTAL)	61562722
6	104137-06-715	EA SPARK/SENSE ELECTRODE (SINGLE)	61692222
7	104137-06-714	EA BURNER ASSEMBLY (5-SLOT)	61705222
8	084880-01-705	EA ORIFICE	61452122
9	104137-06-713	EA ORIFICE GASKET	61475122
10	104137-06-712	EA FITTING-GAS TUBE CONNECTION	61692722
11	075217-01-734	EA FUSE - 3 AMP	61538822
12	104137-06-711	EA FUSE - 5 AMP	61611622
13	104137-06-710	EA PRESSURE TAP	61594422
14	104137-06-709	EA VALVE SHUT-OFF-MANUAL ASM	61694922
	084879-03-700	EA COIL-COOLING, FOR HORIZONTAL BURNER	61687240

GALLEY GROUP (CONTINUED)
NORCOLD 6162 REFRIGERATOR DOORS

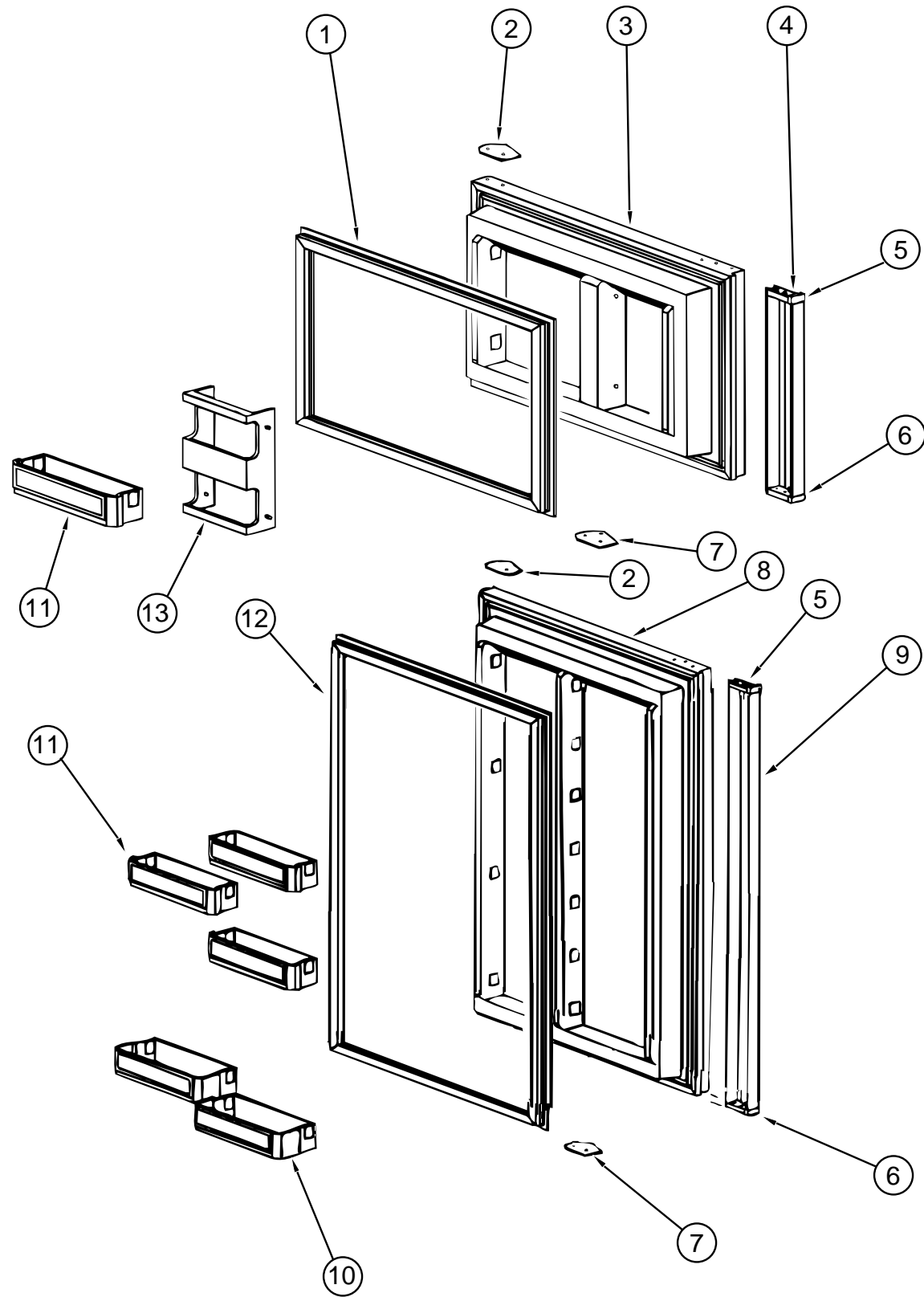

KEY	PART NUMBER	U/M DESCRIPTION	VENDER NO.
1	094039-01-702	EA GASKET (GRAY) UPPER	61567830
2	094039-01-710	EA PLATE-HINGE, BLACK	61631330
3	094039-01-706	EA UPPER DOOR LINER (WHITE) BLACK	61581838-B
4	094039-01-708	EA HANDLE-DOOR, UPPER - BLACK	61650038
	084880-01-720	EA SPRING (FOR DOOR HANDLE)	61558822
5	084880-01-761	EA CAP-END, SPRING CATCH - UPPER	61593730
6	084880-01-740	EA CAP-END, STOP CATCH - LOWER	61593830
7	094039-01-704	EA PLATE-HINGE, BLACK	61631430
8	094038-01-702	EA LINER-DOOR, LOWER - BLACK/WHITE	61581938-B
9	094038-01-704	EA HANDLE-DOOR, LOWER - BLACK	61650138
	084880-01-720	EA SPRING (FOR DOOR HANDLE)	61558822
10	104137-06-704	EA MILK BIN (WHITE)	61579425
11	104137-06-703	EA BIN-DOOR SHELF (WHITE)	61564025
12	094038-01-700	EA GASKET-LOWER, GRAY	61567930
13	104137-06-702	EA RACK-JUICE (WHITE)	61580525

GALLEY GROUP (CONTINUED)
NORCOLD 6162 REFRIGERATOR CABINET ASM.

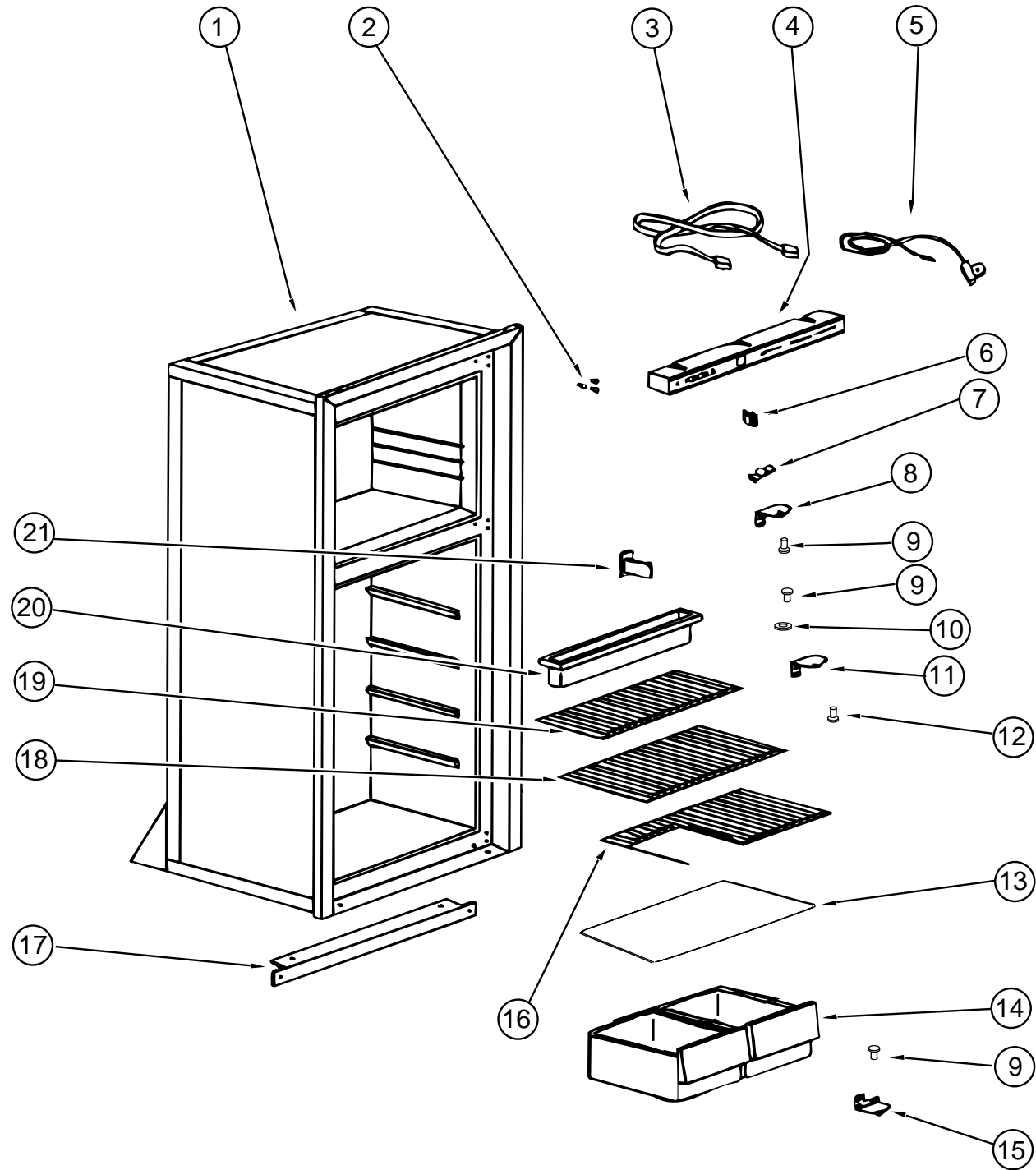

KEY	PART NUMBER	U/M	DESCRIPTION	VENDER NO.
	104138-05-01A	EA	REFRIGERATOR SMALL DOUBLE DOOR 2-WAY - 6162 LH BL	
1	104138-04-701	EA	FOAMED CAB ASM (BLK W/WHITE)	61725038
2	094039-01-722	EA	HOLE PLUG (BLK) HINGE HOLES	61582030
3	084880-01-746	EA	CABLE-PRINTED CIRCUIT BOARD TO POWER SUPPLY	61571522
4	104137-06-700	EA	EYEBROW SHELL (2-WAY)	61726622
5	084880-01-753	EA	THERMISTER 78"	61697822
6	075217-01-738	EA	SWITCH-HUMIDITY	61525922
7	084880-01-760	EA	CLIP (THERMISTER)	61689122
8	094039-01-723	EA	HINGE BRACKET, TOP RH-BOTTOM LH BLK	61580838
9	094039-01-725	EA	HINGE PIN (BLACK) (MALE)	61578130
	084880-03-702	EA	HINGE PIN (BLACK) FEMALE	61580630
10	084880-01-749	EA	HINGE BUSHING	61580722
11	094039-01-728	EA	BRACKET-HINGE, CENTER BLACK	61566530
12	094039-01-730	EA	HINGE PIN SHAFT (BLK) CENTER HINGE	61566730
13	084880-01-722	EA	CRISPER COVER	61564122
14	104137-06-707	EA	CRISPER (WHITE)	61571325
15	094039-01-724	EA	BRACKET-HINGE, TOP LH - BOTTOM RH - BLK	61580938
16	094039-01-739	EA	SHELF (CUTOUT)	61646722
17	094039-01-732	EA	FRONT COVER (BLK) BOTTOM TRIM	61622130
18	094039-01-733	EA	WIRE SHELF (MIDDLE)	61563822
19	094039-01-734	EA	WIRE SHELF (TOP) W/RISER	61563722
20	094039-01-735	EA	INSIDE DRIP TRAY (WHITE)	61572830
21	084880-01-732	EA	LATCH	61578522
	094039-01-736	EA	SWITCH-LIGHT, BLACK	61581022

GALLEY GROUP (CONTINUED)

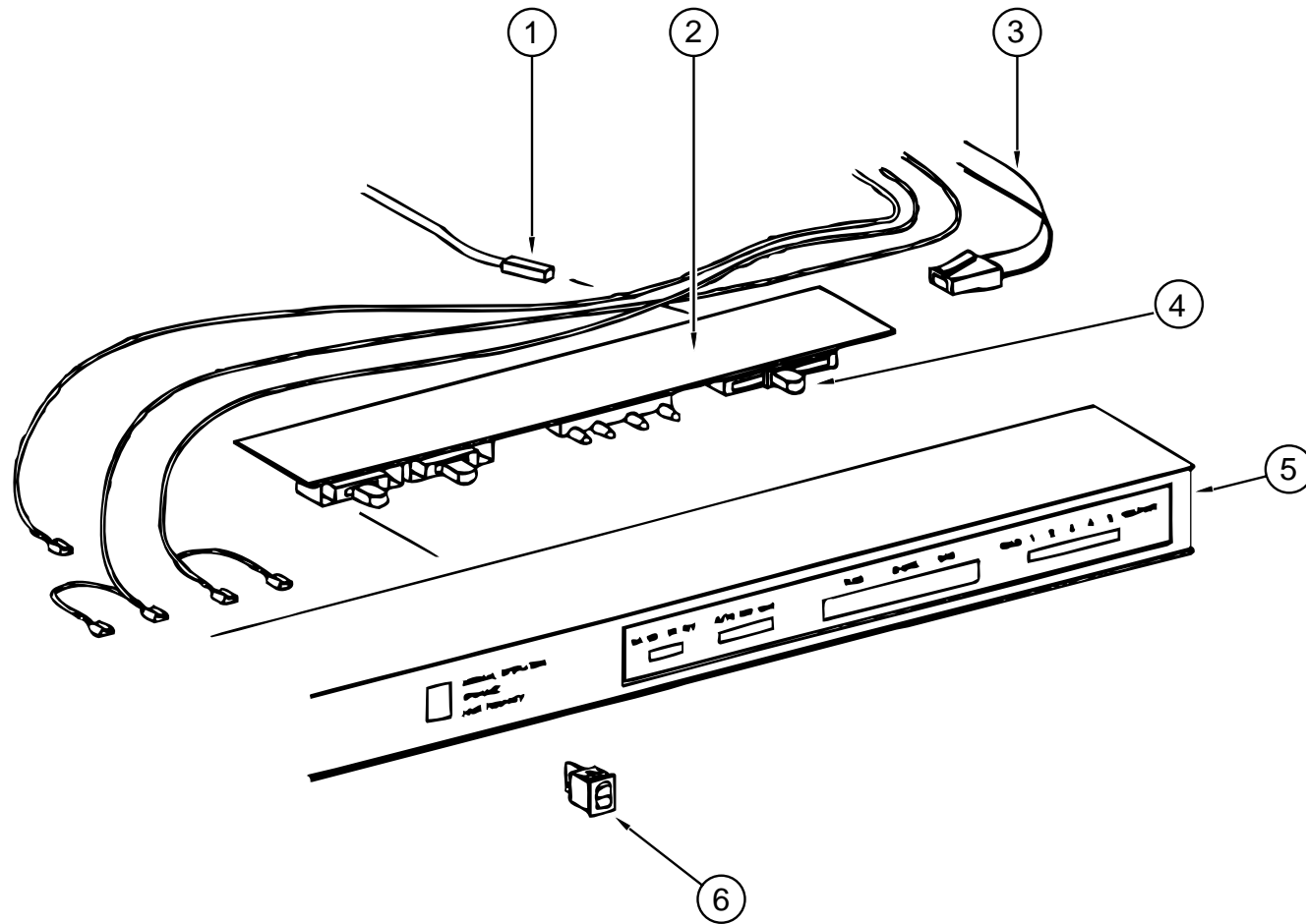

NORCOLD 6162 REFRIGERATOR EYEBROW ASM.

KEY	PART NUMBER	U/M	DESCRIPTION	VENDER NO.
1	084880-01-753	EA	THERMISTER 78"	61693822
2	094039-04-700	EA	PRINTED CIRCUIT BOARD - 2 WAY	61647322
3	084880-01-746	EA	CABLE- PRINTED CIRCUIT BOARD TO POWER SUPPLY	61571522
4	102621-01-703	EA	THERMOSTAT BUTTON	61587422
5	104137-06-700	EA	EYEBROW SHELL (2-WAY)	61726622
6	075217-01-738	EA	SWITCH-HUMIDITY	61525922

GENERATOR GROUP 3.3 ONAN GENERATOR MICROLITE

KEY	PART NUMBER	U/M	DESCRIPTION
	109982-05-000	EA	GENERATOR - 3.3 MICROLITE - KY-FR/26119
	007125-04-000	EA	CLAMP-ASM-MUFFLER 1.12 DIA
	071015-26-000	EA	GROMMET - 1.5 ID, F ITS .06 MATL - MINOR Z-2276
	105958-10-000	EA	PIPE-EXHAUST, GENERATOR
	114070-02-02B	EA	SUPPORT ASM-GENERATOR, LH
	114071-02-02B	EA	SUPPORT ASM-GENERATOR, RH

4.0 ONAN EMERALD PLUS EXPORT

KEY	PART NUMBER	U/M	DESCRIPTION
	100974-04-000	EA	GENERATOR - 4.0KW EMERALD PLUS - BGE-FN/29236G WITH ONAN TRAY #403-2218 - IF INSTALLING BELOW FLOOR ORDER ONAN TRAY #403-2727
	007125-03-000	EA	CLAMP-ASM-MUFFLER 1.50 DIA
	007125-04-000	EA	CLAMP-ASM-MUFFLER 1.12 DIA
	007131-01-000	EA	HANGER-TAILPIPE
	008289-01-000	EA	BOX-ELEC-STEEL, 4 X 4 - 1/2 & 3/4 UL
	008294-01-000	EA	COVER-PLT-BLN STEEL 4 X 4 USA
	079654-05-000	EA	PIPE-EXHAUST, ANGLED - W/FLANGE - 2" ID - 154-2539
	082272-01-000	EA	MUFFLER-GENERATOR
	094059-01-000	EA	SPACER-GENERATOR, ONAN
	105732-02-000	EA	TRAY ASM-GENERATOR
	105958-03-000	EA	PIPE-EXHAUST, GENERATOR

4.0 KW ONAN EMERALD PLUS US

KEY	PART NUMBER	U/M	DESCRIPTION
	100974-01-000	EA	GENERATOR - 4.0KW EMERALD PLUS - BGE-FA/26100G WITH ONAN TRAY #403-2218 - IF INSTALLING BELOW FLOOR ORDER ONAN TRAY #403-2727
	007067-01-000	SF	INSULATION-FIBERGLASS - 1 IN
	007125-04-000	EA	CLAMP-ASM-MUFFLER 1.12 DIA
	008289-01-000	EA	BOX-ELEC-STEEL, 4 X 4 - 1/2 & 3/4 UL
	008398-01-000	EA	CONNECTOR - 1/2 X 90 - FLEX CDT
	023942-01-000	EA	GROMMET-RUBBER - 2 OD
	079654-05-000	EA	PIPE-EXHAUST, ANGLED - W/FLANGE - 2" ID - 154-2539
	082272-01-000	EA	MUFFLER-GENERATOR
	094059-01-000	EA	SPACER-GENERATOR, ONAN
	105732-02-000	EA	TRAY ASM-GENERATOR
	105958-03-000	EA	PIPE-EXHAUST, GENERATOR

4.0 KW ONAN EMERALD PLUS CANADIAN

KEY	PART NUMBER	U/M	DESCRIPTION
	100974-01-000	EA	GENERATOR - 4.0KW EMERALD PLUS - GE-FA/26100G WITH ONAN TRAY #403-2218 - IF INSTALLING BELOW FLOOR ORDER ONAN TRAY #403-2727
	007067-01-000	SF	INSULATION-FIBERGLASS-1 IN
	007125-04-000	EA	CLAMP-ASM-MUFFLER 1.12 DIA
	008289-02-000	EA	BOX-ELEC-STEEL, 4 X 4 - 1/2 & 3/4 CSA
	008398-01-000	EA	CONNECTOR - 1/2 X 90 - FLEX CDT
	023942-01-000	EA	GROMMET-RUBBER - 2 OD
	079654-05-000	EA	PIPE-EXHAUST, ANGLED - W/FLANGE - 2" ID - 154-2539
	082272-01-000	EA	MUFFLER-GENERATOR
	094059-01-000	EA	SPACER-GENERATOR, ONAN
	105732-02-000	EA	TRAY ASM-GENERATOR
	105958-03-000	EA	PIPE-EXHAUST, GENERATOR

GENERATOR GROUP (CONTINUED)
6.5 KW ONAN EMERALD PLUS

KEY	PART NUMBER	U/M DESCRIPTION
	100975-01-000	EA GENERATOR - 6.5KW EMERALD PLUS - NHE-FA/26100G WITH ONAN TRAY #403-2218
	007067-01-000	SF INSULATION-FIBERGLASS, 1" THICK X 4' - INCREMENTS OF 4 SF
	008289-01-000	EA BOX-ELEC-STEEL, 4 X 4 - 1/2 & 3/4 UL
	079654-05-000	EA PIPE-EXHAUST, ANGLED - W/FLANGE - 2" ID - 154-2539
	082272-01-000	EA MUFFLER-GENERATOR
	094059-01-000	EA SPACER-GENERATOR, ONAN
	105732-02-000	EA TRAY ASM-GENERATOR
	105958-03-000	EA PIPE-EXHAUST,GENERATOR
	008398-01-000	EA CONNECTOR - 1/2 X 90 - FLEX CDT
	023942-01-000	EA GROMMET-RUBBER - 2 OD
	007125-04-000	EA CLAMP-MUFFLER - 1.1" DIA.

6.5 KW ONAN EMERALD PLUS CANADIAN

KEY	PART NUMBER	U/M DESCRIPTION
	100975-01-000	EA GENERATOR - 6.5KW EMERALD PLUS - NHE-FA/26100G WITH ONAN TRAY #403-2218
	007067-01-000	SF INSULATION-FIBERGLASS, 1" THICK X 4' - INCREMENTS OF 4 SF
	008289-02-000	EA BOX-ELEC-STEEL, 4 X 4 - 1/2 & 3/4 CSA
	079654-05-000	EA PIPE-EXHAUST, ANGLED - W/FLANGE - 2" ID - 154-2539
	082272-01-000	EA MUFFLER-GENERATOR
	094059-01-000	EA SPACER-GENERATOR, ONAN
	105732-02-000	EA TRAY ASM-GENERATOR
	105958-03-000	EA PIPE-EXHAUST,GENERATOR
	008398-01-000	EA CONNECTOR - 1/2 X 90 - FLEX CDT
	023942-01-000	EA GROMMET-RUBBER - 2 OD
	007125-04-000	EA CLAMP-MUFFLER - 1.1" DIA.

5.0 KW ONAN EMERALD PLUS EXPORT

KEY	PART NUMBER	U/M DESCRIPTION
	100975-03-000	EA GENERATOR - 5.0KW EMERALD PLUS - NHE-FN/29236G
	007125-03-000	EA CLAMP-ASM-MUFFLER 1.50 DIA
	007125-04-000	EA CLAMP-ASM-MUFFLER 1.12 DIA
	007131-01-000	EA HANGER-TAILPIPE
	008289-01-000	EA BOX-ELEC-STEEL, 4 X 4 - 1/2 & 3/4 UL
	008294-01-000	EA COVER-PLT-BLN STEEL 4 X 4 USA
	079654-05-000	EA PIPE-EXHAUST, ANGLED - W/FLANGE - 2" ID - 154-2539
	082272-01-000	EA MUFFLER-GENERATOR
	094059-01-000	EA SPACER-GENERATOR, ONAN
	105732-02-000	EA TRAY ASM-GENERATOR
	105958-03-000	EA PIPE-EXHAUST, GENERATOR

HEATING & AIR CONDITIONING GROUP
EVANS REAR HEATER & COMPONENTS

KEY	PART NUMBER	U/M DESCRIPTION	VENDER NO.
	084405-01-000	EA HEATER ASM-REAR, DUCTED - W/MOTOR AID	
	084405-01-700	EA HEATER CORE	FT200229
	084405-01-701	EA FAN BLADES	HV029931
	084405-01-702	EA MOTOR ASM - 12 V	200146
	007076-01-000	EA HOSE-FLEXIBLE PVC - 2" ID - INCREMENTS OF 50'	
	007108-01-000	FT HOSE-HEATER, 5/8" ID - HI-TEMP - FORD ESE-M2D192-A	
	061673-01-000	EA BRACKET-MOTOR AID TUBES, 4" X 1.5" - STEEL	
	089353-01-000	EA UNION - 5/8,TUBE TO TUBE	
	088753-01-000	FT TUBE-GALVANIZED STEEL, 5/8" - 18 GAUGE	
	079059-01-000	EA HOSE - 90 DEGREE, 5/8"ID X 4" X 36"	

THERMOSTAT

KEY	PART NUMBER	U/M DESCRIPTION
	117238-01-01A	EA THERMOSTAT-A/C AND FURNACE - COLEMAN 7330-3371
	117238-02-01A	EA THERMOSTAT-A/C ONLY - COLEMAN 7330-3381
	073937-03-000	EA SWITCH-ROTARY SELECTOR, 3 DECK - A/C - CA20-USA892

HEATING & AIR CONDITIONING GROUP (CONTINUED)
SUBURBAN 30,000 BTU FURNACE

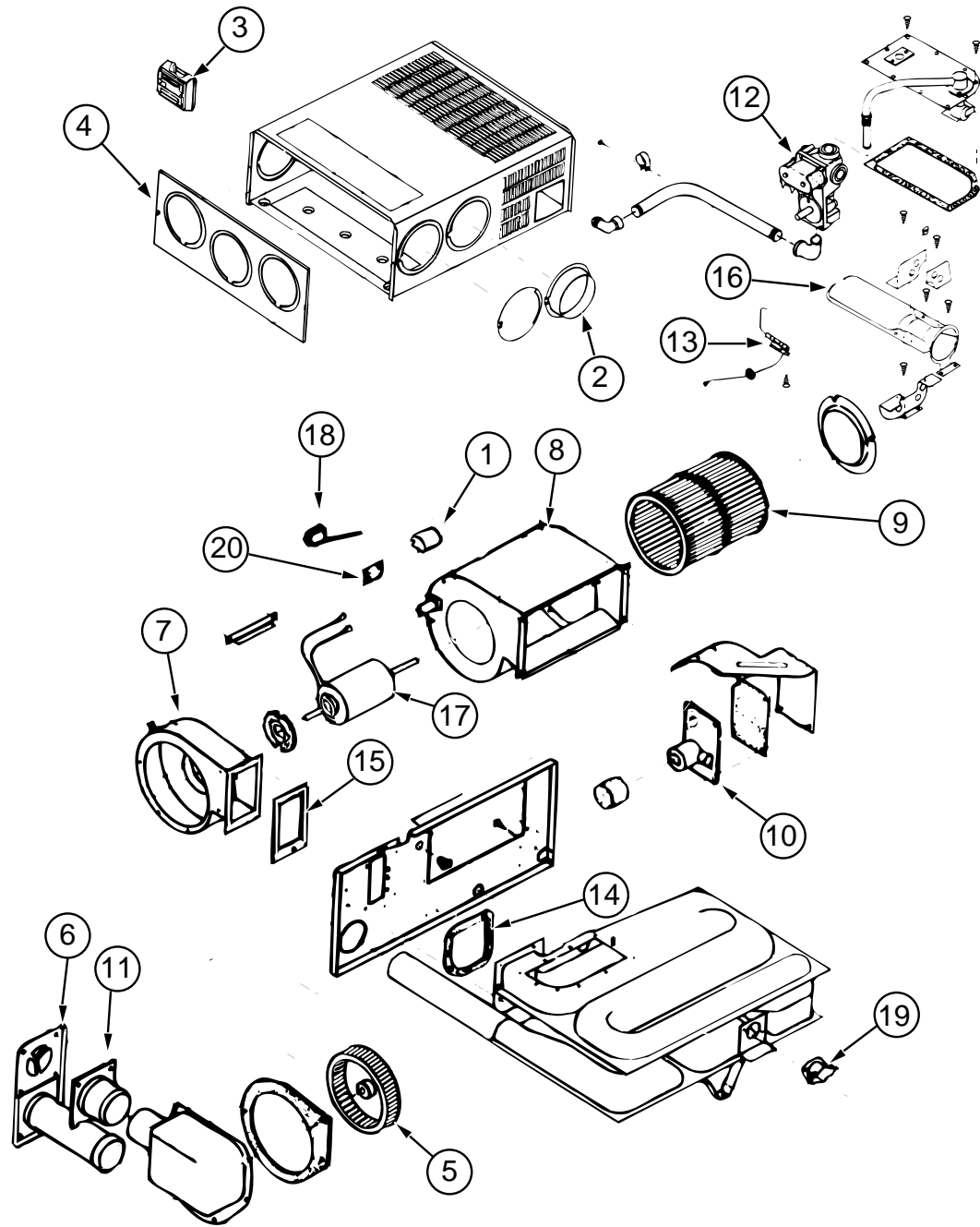

KEY	PART NUMBER	U/M	DESCRIPTION	VENDER NO.
	098668-14-000	EA	GASKET-FIBERGLASS, .5" X 18" X 18" - 070976	
	098668-20-000	EA	FURNACE - 30,000 BTU - SF-30 2273	
	092300-02-701	EA	ORFICE-MAIN BURNER	0180214
1	074466-01-702	EA	RELAY, TIME DELAY 205&L&45000	230625
2	075696-02-703	EA	DUCT COLLAR	050715
3	115764-01-01A	EA	THERMOSTAT-WALL, FURNACE - 0160902	
4	098668-01-700	EA	CABINET FRONT	101242
5	098668-01-706	EA	WHEEL-AIR	350122
6	098668-01-707	EA	VENT CAP & EXHAUST TUBE ASM	260193
7	098668-01-708	EA	BLOWER ASSM.(COMBUSTION AIR)	390441
8	098668-01-710	EA	BLOWER ASM (ROOM AIR)	390440
9	098668-01-711	EA	WHEEL-ROOM AIR	350129
10	098668-01-712	EA	BOARD-MODULE	520741
11	098668-01-713	EA	INTAKE VENT TUBE ASM	051044
12	098668-01-714	EA	GAS VALVE (WHITE ROGERS)	161070
13	098668-01-715	EA	ELECTRODE ASM.(SGL PROBE)	232166
14	098668-01-716	EA	GASKET FIREWALL(CHAMBER SIDE)	070808
15	098668-01-717	EA	GASKET FIREWALL(BLOWER SIDE)	070809
16	098668-02-700	EA	BURNER ASM	010745
17	098668-01-709	EA	MOTOR ASM	231706
18	098668-21-700	EA	MICROSWITCH, W/O FLAG 3 1/4"	232261
19	098668-21-701	EA	LIMIT SWITCH	231799
20	101990-01-714	EA	MICROSWITCH GASKET	230877
	024990-05-000	EA	OUTLET-DEFROSTER, W/SWIVEL - 2" DIAMETER - BLACK	
	009198-01-000	FT	DUCT-HEAT- FLEXIBLE - 4" ID X 25 FT	
	094600-01-02A	EA	REGISTER-HEAT, W/O DAMPER - 3.6" X 11.2" - BROWN	
	094600-05-01A	EA	REGISTER-HEAT, W/DAMPER	
	093614-01-02A	EA	GRILLE-RETURN AIR- FURNACE - 15.6" X 7.6" - BEIGE	
	009200-01-000	EA	TAPE-FURNACE, 1 1/2"	
	056464-09-000	EA	REGISTER-HEAT/A/C, ROUND W/DAMPER - 4" - PLASTIC - BEIGE	
	056464-10-000	EA	REGISTER-HEAT/A/C, ROUND W/O DAMPER - 4" - PLASTIC - BEIGE	
	069636-02-000	EA	CONNECTOR-DUCT, 4" ID - 050715	
	092777-01-000	EA	ADAPTER-DUCT, 4"	
	023146-01-000	EA	CLAMP-SCREW TYPE - 4"	

HEATING & AIR CONDITIONING GROUP (CONTINUED)
SUBURBAN 35,000 BTU FURNACE

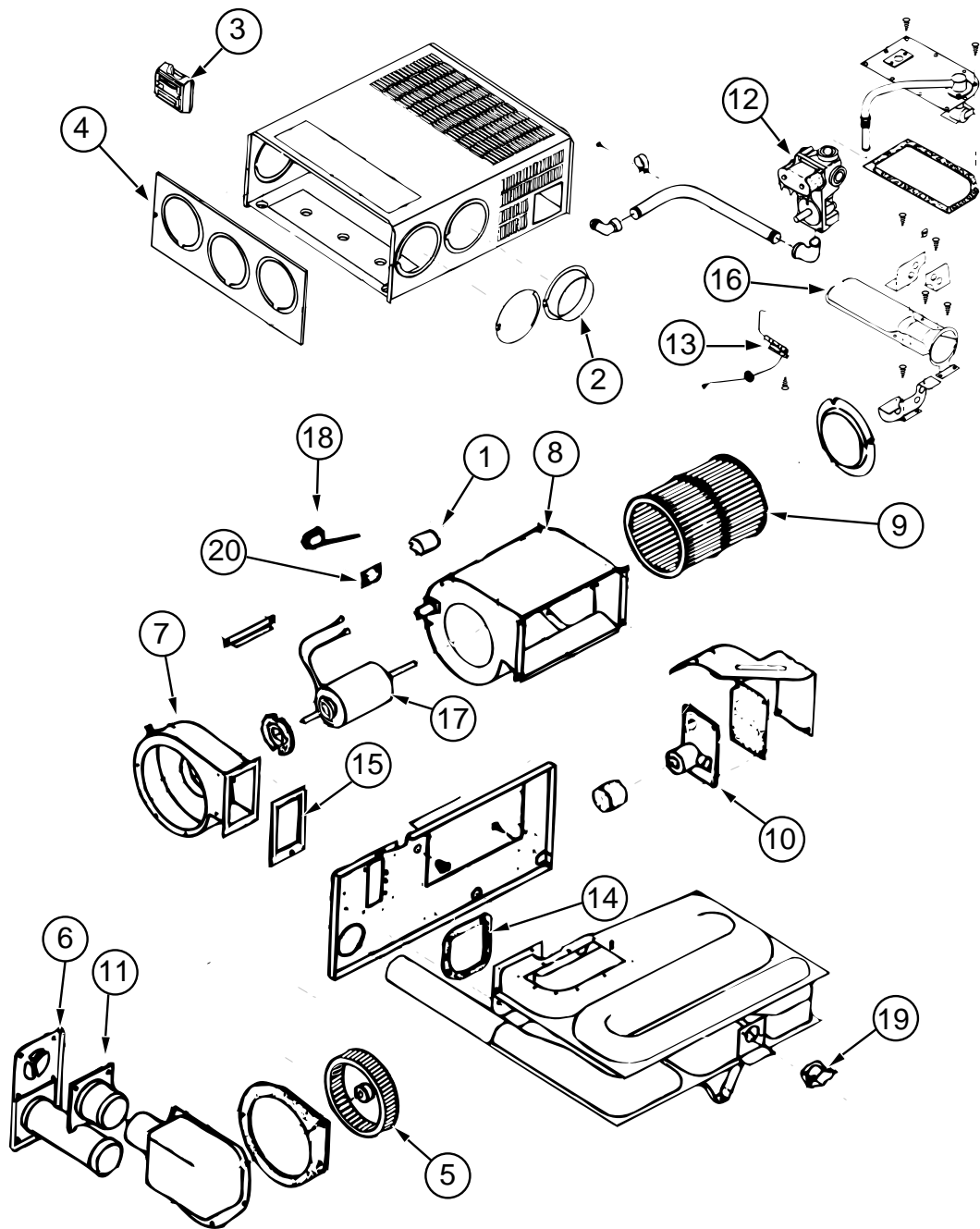

KEY	PART NUMBER	U/M	DESCRIPTION	VENDER NO.
	098668-13-000	EA	GASKET-FIBERGLASS, .5" X 16.37" X 17.56" - 070977	
	098668-21-000	EA	FURNACE - 35,000 BTU - SF-35 2274	
	069634-01-720	EA	ORFICE-MAIN BURNER	0180222
1	074466-01-702	EA	RELAY, TIME DELAY 205&L&45000	230625
2	075696-02-703	EA	DUCT COLLAR	050715
3	115764-01-01A	EA	THERMOSTAT-WALL, FURNACE - 0160902	
4	098668-01-700	EA	CABINET FRONT	101242
5	098668-01-706	EA	WHEEL-AIR	350122
6	098668-01-707	EA	VENT CAP & EXHAUST TUBE ASM	260193
7	098668-01-708	EA	BLOWER ASSM.(COMBUSTION AIR)	390441
8	098668-01-710	EA	BLOWER ASM (ROOM AIR)	390440
9	098668-01-711	EA	WHEEL-ROOM AIR	350129
10	098668-01-712	EA	BOARD-MODULE	520741
11	098668-01-713	EA	INTAKE VENT TUBE ASM	051044
12	098668-01-714	EA	GAS VALVE (WHITE ROGERS)	161070
13	098668-01-715	EA	ELECTRODE ASM.(SGL PROBE)	232166
14	098668-01-716	EA	GASKET FIREWALL(CHAMBER SIDE)	070808
15	098668-01-717	EA	GASKET FIREWALL(BLOWER SIDE)	070809
16	098668-02-700	EA	BURNER ASM	010745
17	098668-03-700	EA	MOTOR ASM	231707
18	098668-21-700	EA	MICROSWITCH, W/O FLAG 3 1/4"	232261
19	098668-21-701	EA	LIMIT SWITCH	231799
20	101990-01-714	EA	MICROSWITCH GASKET	230877
	024990-05-000	EA	OUTLET-DEFROSTER, W/SWIVEL - 2" DIAMETER - BLACK	
	009198-01-000	FT	DUCT-HEAT- FLEXIBLE - 4" ID X 25 FT	
	094600-01-02A	EA	REGISTER-HEAT, W/O DAMPER - 3.6" X 11.2" - BROWN	
	094600-05-01A	EA	REGISTER-HEAT, W/DAMPER	
	093614-01-02A	EA	GRILLE-RETURN AIR- FURNACE - 15.6" X 7.6" - BEIGE	
	009200-01-000	EA	TAPE-FURNACE, 1 1/2"	
	056464-09-000	EA	REGISTER-HEAT/A/C, ROUND W/DAMPER - 4" - PLASTIC - BEIGE	
	056464-10-000	EA	REGISTER-HEAT/A/C, ROUND W/O DAMPER - 4" - PLASTIC - BEIGE	
	069636-02-000	EA	CONNECTOR-DUCT, 4" ID - 050715	
	092777-01-000	EA	ADAPTER-DUCT, 4"	
	023146-01-000	EA	CLAMP-SCREW TYPE - 4"	

HEATING & AIR CONDITIONING GROUP (CONTINUED)
SCS EVAPORATOR/HEATER ASSEMBLY - FORD GAS CHASSIS

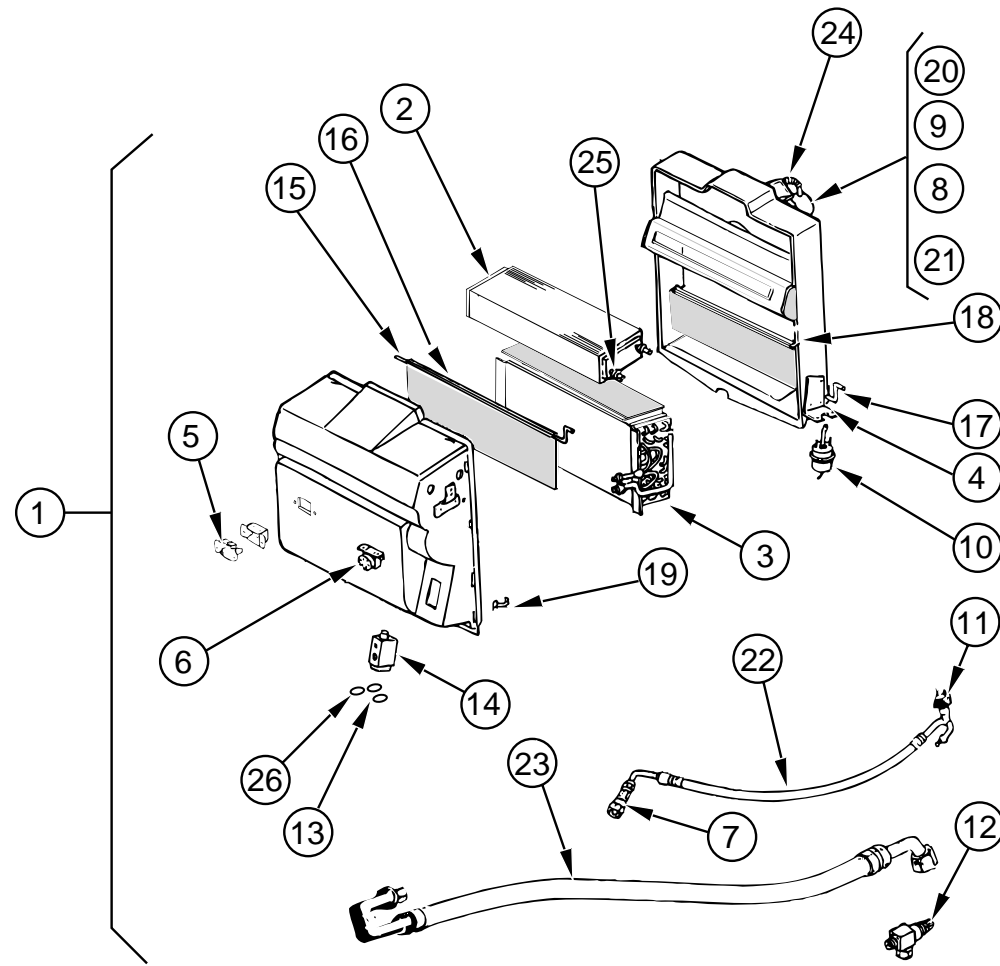

KEY	PART NUMBER	U/M	DESCRIPTION	VENDER NO.
1	103930-21-000	EA	EVAPORATOR/HEATER ASSEMBLY - 090-00084	
2	103930-01-703	EA	COIL-HEATER	042-0010
3	103930-01-704	EA	COIL EVAPORATOR	041-0017
4	103930-01-708	EA	BRACKET-VACUUM MOTOR	070-0113
5	103930-01-710	EA	RESISTOR-FUSED	035-0006
6	103930-01-711	EA	THERMOSTAT	033-0003
7	103930-01-713	EA	FITTING-QUICK CONNECT, #4	050-003
8	103930-01-717	EA	WHEEL-CLOCK-WISE	062-0010
9	103930-01-720	EA	MOTOR	030-0004
10	103930-02-708	EA	MOTOR-VACUUM SERVO, A/C	030-0002
11	103930-12-708	EA	SWITCH-BINARY, R-134A	032-0048
12	103930-13-702	EA	SERVICE VALVE	050-152
13	103930-17-702	EA	GASKET OR SAE 015 #10 33-781	045-0127
14	103930-20-700	EA	VALVE-EXPANSION BLOCK, 2 TON	034-0032
15	103930-20-702	EA	ROD-AIR BLEND DOOR	073-0039
16	103930-20-703	EA	DOOR-AIR BLEND	071-0212
17	103930-20-704	EA	ROD-RECIRCULATING DOOR	073-0018
18	103930-20-705	EA	DOOR-RECIRCULATING	071-0213
19	103930-20-706	EA	CLIP-RETAINER	022-0057
20	103930-20-707	EA	HOUSING-BLOWER	062-0145
21	103930-20-708	EA	CLIP F/MOTOR SHAFT	022-0001
22	103930-21-700	EA	HOSE #6 - FORD	085-0139
23	103930-21-701	EA	HOSE #10 - FORD	085-0140
24	110279-01-703	EA	HOSE-VENT, BLOWER MOTOR	051-0034
25	110279-01-712	EA	FITTING-HEATER	050-0076
26	113245-01-707	EA	GASKET #8	045-0126
	103930-20-710	EA	CASE-FRONT, SUB-ASSEMBLY	062-0146
	103930-20-711	EA	CASE-BACK, SUB-ASSEMBLY	062-0147

HEATING & AIR CONDITIONING GROUP (CONTINUED)

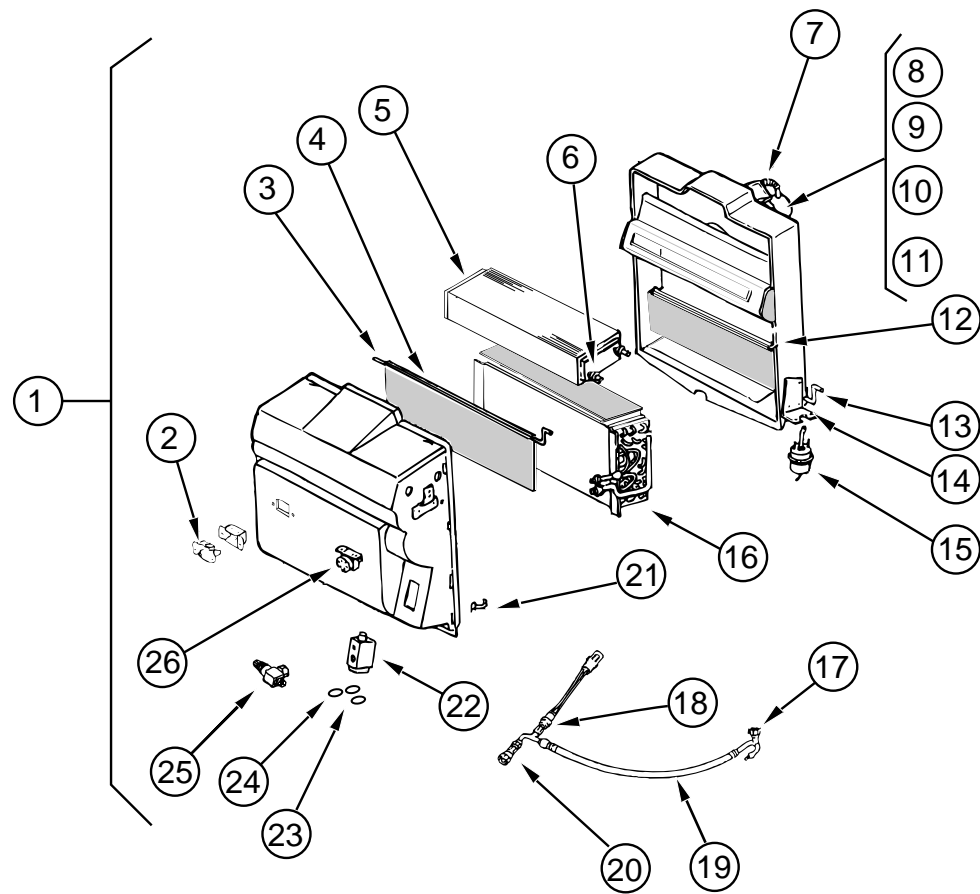

SCS EVAPORATOR/HEATER ASSEMBLY - CHEVY GAS & DIESEL CHASSIS

KEY	PART NUMBER	U/M DESCRIPTION	VENDER NO.
1	103930-20-000	EA EVAPORATOR/HEATER ASSEMBLY - 090-00083	
2	103930-01-710	EA RESISTOR-FUSED	035-0006
3	103930-20-702	EA ROD-AIR BLEND DOOR	073-0039
4	103930-20-703	EA DOOR-AIR BLEND	071-0212
5	103930-01-703	EA COIL-HEATER	042-0010
6	110279-01-712	EA FITTING-HEATER	050-0076
7	110279-01-703	EA MOTOR-BLOWER	051-0034
8	103930-20-707	EA HOUSING-BLOWER	062-0145
9	103930-01-720	EA MOTOR	030-0004
10	103930-01-717	EA WHEEL-CLOCK-WISE	062-0010
11	103930-20-708	EA CLIP F/MOTOR SHAFT	022-0001
12	103930-20-705	EA DOOR-RECIRCULATING	071-0213
13	103930-20-704	EA ROD-RECIRCULATING DOOR	073-0018
14	103930-01-708	EA BRACKET-VACUUM MOTOR	070-0113
15	103930-02-708	EA MOTOR-VACUUM SERVO, A/C	030-0002
16	103930-01-704	EA COIL EVAPORATOR	041-0017
17	103930-12-708	EA SWITCH-BINARY, R-134A	032-0048
18	103930-01-716	EA SWITCH-PRESSURE, FAN	032-0036
19	103930-20-701	EA HOSE ASM - #6	085-0138
20	103930-12-709	EA FITTING-QUICK CONNECT	050-0120
21	103930-20-706	EA CLIP-RETAINER	022-0057
22	103930-20-700	EA VALVE-EXPANSION BLOCK, 2 TON	034-0032
23	103930-17-702	EA GASKET OR SAE 015 #10 33-781	045-0127
24	113245-01-707	EA GASKET #8	045-0126
25	103930-20-709	EA SERVICE VALVE	050-159
26	103930-01-711	EA THERMOSTAT	033-0003
	103930-20-710	EA CASE-FRONT, SUB-ASSEMBLY	062-0146
	103930-20-711	EA CASE-BACK, SUB-ASSEMBLY	062-0147

HEATING & AIR CONDITIONING GROUP (CONTINUED)

AUTOMOTIVE HEATER MISCELLANEOUS

KEY	PART NUMBER	U/M DESCRIPTION	VENDER NO.
	007281-01-000	EA HOSE-FLEXIBLE PVC, 2.5"ID X 50' - ATCOFLEX A-182-355	
	024990-05-000	EA 4" DIAMETER OUTLET W/SWIVEL DEFLECTORS	
	056402-05-000	EA BRACKET-HEATER VENT, ROUND - W/BEND - BLACK	
	077075-01-000	EA GASKET-INSTRUMENT PANEL TO DEFROSTER PLENUM - .6" X 11.3"	
	077075-03-000	EA GASKET-NSTRUMENT PANEL TO DEFROSTER PLENUM,SPL	
	103016-01-000	EA PLENUM-TRANSITION	
	103017-01-000	EA PLENUM-DEFROSTER	
	103558-01-06A	EA VENT-DEFROST,ABS QUICK SILVER	
	103796-01-01A	EA LOUVER ASM-A/C CARY PROD BLK, 268-3B,100-2-4-8	
	097494-02-000	EA TEE-BRASS, BARB - 3/8 X 5/32 X 3/8 - PARKER 224-8-8-4	
	103930-05-000	EA MANUAL-OWNERS, HEATER-A/C - SCS 057-0049	
	103930-20-700	EA VALVE EXP. BLOCK (2 TON)	034-0032
	103930-20-701	EA HOSE ASSY #6 WINN GM	085-0138

SCS CONTROL/PLENUM

KEY	PART NUMBER	U/M DESCRIPTION	VENDER NO.
	103930-04-000	EA CONTROL/PLENUM SET - 093-00037	
	072341-06-700	EA SWITCH - 4 SPEED, FAN	0883502
	094831-01-709	EA CLAMPS-ROD, 3/16"	ZGG14431
	103930-02-712	EA PANEL-CONTROL	032-0054
	103930-02-701	EA VALVE-CONTROL HEAD	034-0015
	103930-02-702	EA DECAL-FAN SWITCH	058-0008
	103930-02-703	EA HARNESS-WIRE CONTROL	036-0048
	103930-02-704	EA HARNESS-VACUUM CONTROL	036-0049
	103930-02-705	EA CABLE-CONTROL, BOWDEN SHEATH LENGTH IS 84 1/4" - CABLE LENGTH IS 89" LONG	074-0011
	103930-02-706	EA CLIP-CABLE, CONTROL	022-0017
	103930-02-707	EA RELAY	031-0001
	103930-02-708	EA MOTOR-VACUUM SERVO, A/C	030-0002
	103930-02-710	EA CANISTER-VACUUM	054-0002
	103930-23-000	EA VALVE-WATER - 034-00014	

HOSE KITS

KEY	PART NUMBER	U/M DESCRIPTION	VENDER NO.
	103930-18-000	EA HOSE KIT #10 GM-HARRISON COM - SCS 093-00077	
	103930-17-701	EA FTG #10.90 W/FERRULE/1342CP	050-0132
	103930-17-702	EA GASKET OR SAE 015 #10 33-781	SCS 045-0127
	103930-17-703	EA GASKET-SEAL,SANDEW COMP33-76	045-0142
	103930-18-700	EA FTG,PAD,COMP SUCTION	HARRISON 050-00133
	103930-18-701	EA HOSE ASSY #10	085-0114
	103930-18-702	EA GASKET SEAL	HARRISON 045-0143
	110279-01-708	EA HOSE, REFG. BARRIER#10SAEJ51	051-0008
	103930-17-000	EA HOSE KIT #10 GM-SANDEN COMP - SCS 093-00076	
	103930-01-708	EA BRACKET-VACUUM MOTOR	SCS 070-0113
	103930-17-700	EA FTG. PAD COMP. SUCTION SAN	050-0131
	103930-17-701	EA FTG #10.90 W/FERRULE/1342CP	050-0132
	103930-17-702	EA GASKET OR SAE 015 #10 33-781	SCS 045-0127
	103930-17-703	EA GASKET-SEAL,SANDEW COMP33-76	045-0142
	103930-17-704	EA HOSE ASSY #10	085-0113

ROOF A/C COVER

KEY	PART NUMBER	U/M DESCRIPTION
	092633-02-02A	EA COVER-BLANK, ROOF A/C - 5.1" X 5.1" - PLASTIC - OFF WHITE
	022756-03-000	EA COVER-A/C, OFF WHITE - PLASTIC
	022756-02-000	EA COVER-PROTECTIVE, 5.5" ENDS X 8.2" - PLASTIC - OFF WHITE

HEATING & AIR CONDITIONING GROUP (CONTINUED)
13,500 BTU COLEMAN ROOF A/C & CEILING ASSEMBLY

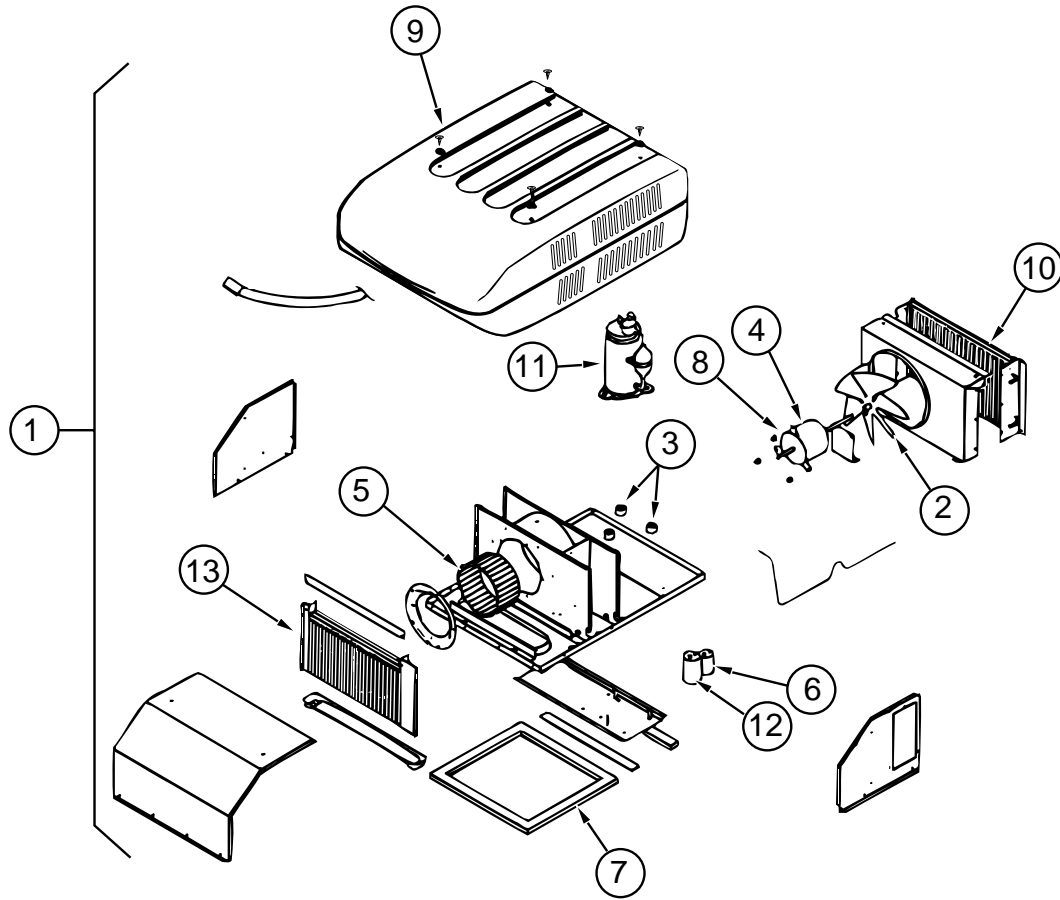

KEY	PART NUMBER	U/M DESCRIPTION	VENDER NO.
1	108889-01-05A	EA A/C-ROOF, 13,500 TSR HO BRIGHT WHITE - 7333A888	
2	093763-01-712	EA FAN BLADE-CONDENSER	6733-3221
3	105620-01-706	EA FOOT PACKAGE-COMPRESSOR, 3 PER PACKAGE	6759-3081
4	108889-01-705	EA MOTOR-115V, 60HZ	1468-3049
5	108889-01-706	EA IMPELLOR	1472-1041
6	108889-01-708	EA CAPACITOR-FAN, (7.5MFD.370U)	1499-5461
	108889-01-710	EA FILLER PAD-COND AIR SEAL	6759A3971
7	108889-01-711	EA GASKET PACKAGE	6792-3301
8	108889-01-715	EA MOTOR MOUNT & SHAFT SEAL KIT	6792-3361
9	108889-05-700	EA SHROUD-(BRIGHT WHITE), W/O LOGO	6759-6411
10	108889-01-703	EA CONDENSER COIL	1452-1301
11	105620-01-704	EA COMPRESSOR, RH & LH	1450-2009
12	108889-01-707	EA CAPACITOR-RUN, COMPRESSOR-25MFD/370	1499-5661
	091225-01-709	EA RELAY-START	1497-4131
13	108889-01-709	EA EVAPORATOR COIL	1452-1311
	108889-01-714	EA DISCHARGE LINE ASSEMBLY	6792-531
	108889-01-712	EA REDUCER-SUCTION LINE, (3/8" X 1/2")	1215-2161
	108889-01-713	EA SUCTION LINE, (3/8" OD X .032" WALL)	6792-130
	091225-01-710	EA CAPACITOR-START	1497-0881
	093306-01-701	EA DECAL PACKAGE-LEFT & RIGHT	6798B3591
	108889-01-704	EA OVERLOAD	6749-3541
	102289-01-000	EA SPRING-SCREW, ROOF A/C GASKET - 6757-150	
	108892-01-01A	EA CEILING ASM-A/C DUCTED - 7330-730 IV	
	108892-01-700	EA PLUG ASSEMBLY	7330-540
	108892-01-701	EA BOARD-TERMINAL	7330-3201
	108892-01-702	EA BOARD-PRINTED CIRCUIT	7330A3211
	108892-01-703	EA FILTER	6798A3761
	108892-01-704	EA GRILLE (PLASTIC)	6798-3041
	108892-01-705	EA SMALL PARTS PKG	7330A6101

HEATING & AIR CONDITIONING GROUP (CONTINUED)

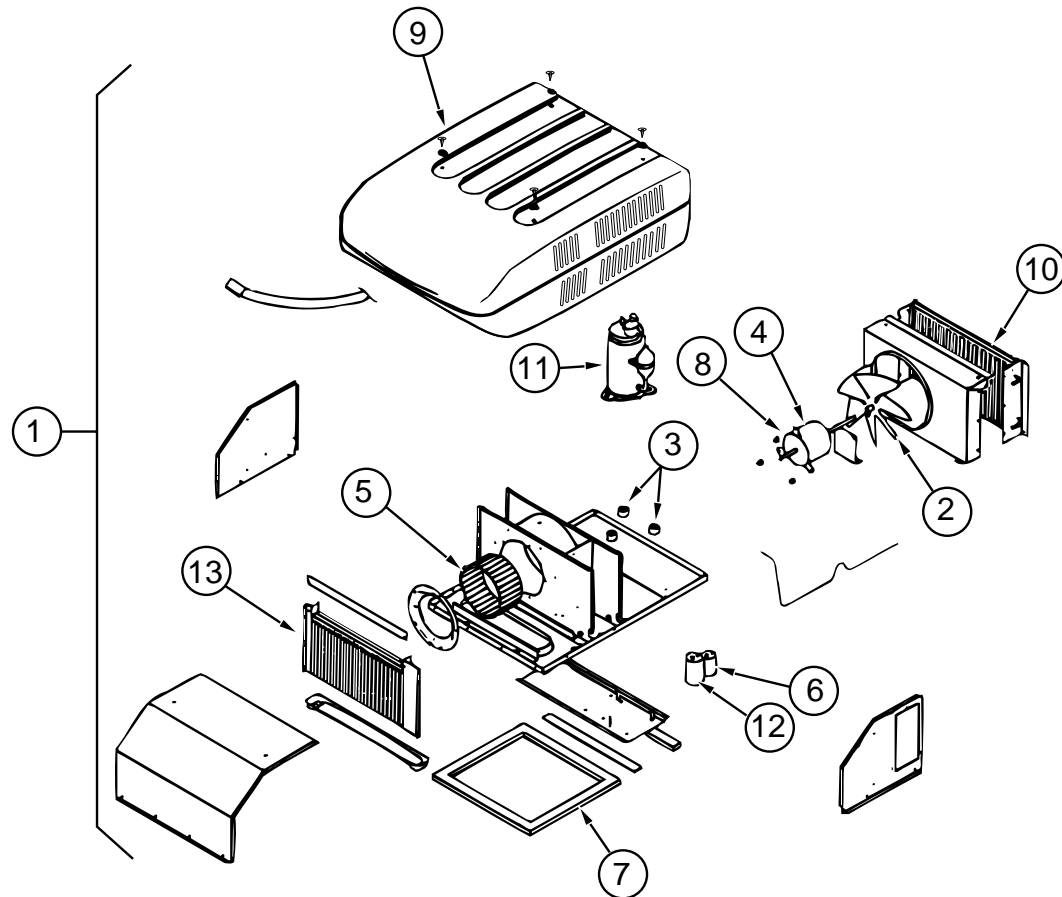

13,500 BTU COLEMAN ROOF A/C & CEILING ASSEMBLY - EUROPEAN

KEY	PART NUMBER	U/M	DESCRIPTION	VENDER NO.
1	108889-02-03A	EA	A/C-ROOF, 13,500 TSR 220 BRIGHT WHITE - 7373-597	
2	093763-01-712	EA	FAN BLADE-CONDENSER	6733-3221
3	105620-01-706	EA	FOOT PACKAGE-COMPRESSOR, 3 PER PACKAGE	6759-3081
4	108889-02-701	EA	MOTOR - 115V, 60HZ	1468-3059
5	108889-01-706	EA	IMPELLOR	1472-1041
6	108889-01-708	EA	CAPACITOR-FAN, (7.5MFD.370U)	1499-5461
	108889-01-710	EA	FILLER PAD-COND AIR SEAL	6759A3971
7	108889-01-711	EA	GASKET PACKAGE	6792-3301
8	108889-01-715	EA	MOTOR MOUNT & SHAFT SEAL KIT	6792-3361
9	063903-05-700	EA	SHROUD	6759-4601
10	108889-01-703	EA	CONDENSER COIL	1452-1301
11	108889-02-700	EA	COMPRESSOR, TECUMSEH	1452-2029
12	108889-01-707	EA	CAPACITOR-RUN, COMPRESSOR-25MFD/370	1499-5661
	108889-02-703	EA	RELAY-START	1497-4141
13	108889-01-709	EA	EVAPORATOR COIL	1452-1311
	108889-01-714	EA	DISCHARGE LINE ASSEMBLY	6792-531
	108889-01-712	EA	REDUCER-SUCTION LINE, (3/8" X 1/2")	1215-2161
	108889-01-713	EA	SUCTION LINE, (3/8" OD X .032" WALL)	6792-130
	108889-02-702	EA	CAPACITOR-START	1497-0891
	093306-01-701	EA	DECAL PACKAGE-LEFT & RIGHT	6798B3591
	105620-01-705	EA	OVERLOAD	6759-3791
	102289-01-000	EA	SPRING-SCREW, ROOF A/C GASKET - 6757-150	
	108892-01-01A	EA	CEILING ASM-A/C DUCTED - 7330-730 IV	
	108892-01-700	EA	PLUG ASSEMBLY	7330-540
	108892-01-701	EA	BOARD-TERMINAL	7330-3201
	108892-01-702	EA	BOARD-PRINTED CIRCUIT	7330A3211
	108892-01-703	EA	FILTER	6798A3761
	108892-01-704	EA	GRILLE (PLASTIC)	6798-3041
	108892-01-705	EA	SMALL PARTS PKG	7330A6101

HEATING & AIR CONDITIONING GROUP (CONTINUED)

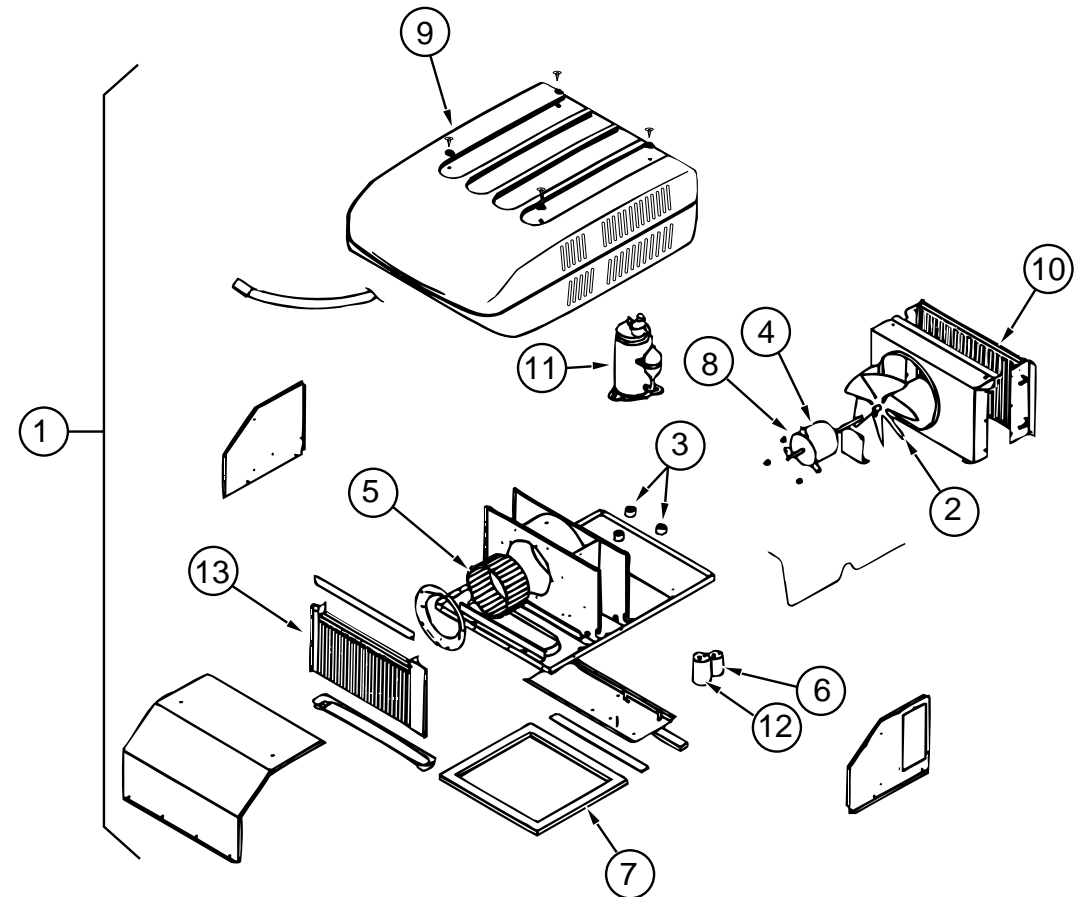

14,800 BTU COLEMAN ROOF A/C & CEILING ASSEMBLY

KEY	PART NUMBER	U/M	DESCRIPTION	VENDER NO.
1	115219-01-03A	EA	A/C-ROOF, 14,800 MACH 15 BRIGHT WHITE - 7335B896	
2	093763-01-712	EA	FAN BLADE-CONDENSER	6733-3221
3	105620-01-706	EA	FOOT PACKAGE-COMPRESSOR, 3 PER PACKAGE	6759-3081
4	108889-01-705	EA	MOTOR - 115V, 60HZ	1468-3049
5	108889-01-706	EA	IMPELLOR	1472-1041
6	108889-01-708	EA	CAPACITOR-FAN, (7.5MFD.370U)	1499-5461
	108889-01-710	EA	FILLER PAD-COND AIR SEAL	6759A3971
7	108889-01-711	EA	GASKET PACKAGE	6792-3301
8	108889-01-715	EA	MOTOR MOUNT & SHAFT SEAL KIT	6792-3361
9	108889-05-700	EA	SHROUD	7333-4601
10	115219-01-700	EA	CONDENSER COIL	1452-1321
11	115219-01-701	EA	COMPRESSOR, PANASONIC	1450-2039
12	115219-01-702	EA	CAPACITOR-RUN, COMPRESSOR	1499-5741
	115219-01-703	EA	RELAY-START	1497-4151
13	115219-01-704	EA	EVAPORATOR COIL	1452-1331
	115219-01-707	EA	DISCHARGE LINE ASSEMBLY	7335A132
	115219-01-705	EA	LINE-SUCTION, LOWER	7335-130
	115219-01-706	EA	LINE-SUCTION, UPPER	7335-131
	093306-01-720	EA	CAPACITOR-START	1497-3351
	093306-01-701	EA	DECAL PACKAGE-LEFT & RIGHT	6798B3591
	105620-01-705	EA	OVERLOAD	6759-3791
	102289-01-000	EA	SPRING-SCREW, ROOF A/C GASKET - 6757-150	
	108892-01-01A	EA	CEILING ASM-A/C DUCTED - 7330-730 IV	
	108892-01-700	EA	PLUG ASSEMBLY	7330-540
	108892-01-701	EA	BOARD-TERMINAL	7330-3201
	108892-01-702	EA	BOARD-PRINTED CIRCUIT	7330A3211
	108892-01-703	EA	FILTER	6798A3761
	108892-01-704	EA	GRILLE (PLASTIC)	6798-3041
	108892-01-705	EA	SMALL PARTS PKG	7330A6101

INTERIOR FINISH GROUP
MOLDINGS & TRIMS

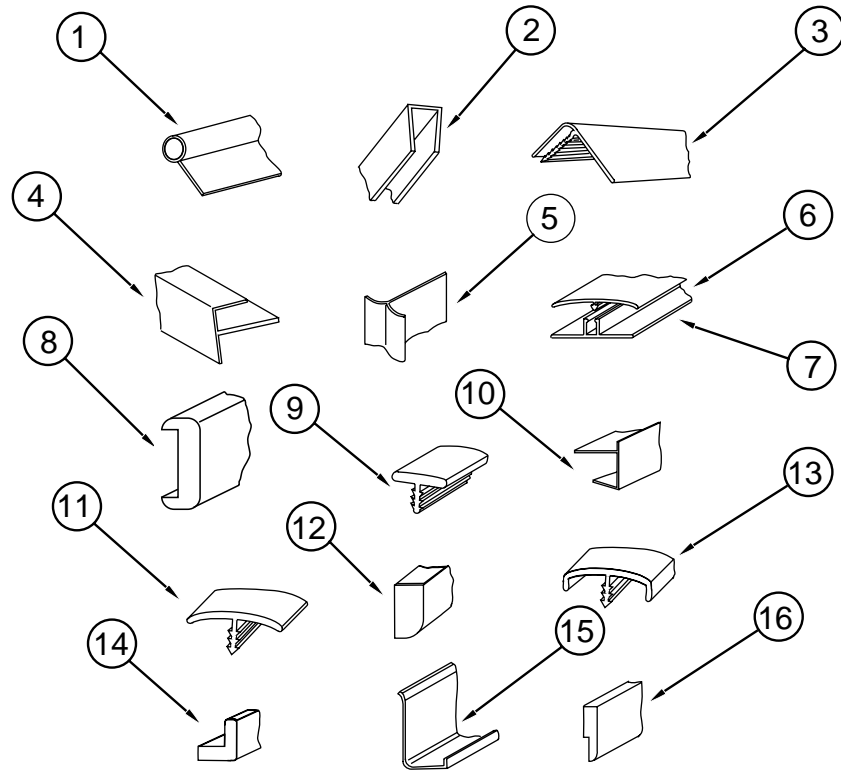

KEY	PART NUMBER	U/M	DESCRIPTION
1	009767-12-000	FT	MOLDING-SIDEWALL TO CEILING/CABINET - WELTING - OFF WHITE
2	009778-21-000	FT	U-CHANNEL - 1" - WATERFORD OAK
2	070504-18-000	FT	U-CHANNEL-PLASTIC, .065" WIDE - IVORY - INC. OF 8'
2	070504-19-000	FT	U-CHANNEL-PLASTIC, .815" WIDE - BROWN - INC OF 8'
2	070504-36-000	FT	EXTRUSION-U CHANNEL,1.65 - WATERFORD OAK
3	009809-28-001	EA	MOLDING-O/S LARGE CABINET, 2133MM
3	009809-28-000	EA	MOLDING-PLAS, CORNER - 1" - WATERFORD OAK
4	009812-29-001	EA	MOLDING-O/S SMALL CABINET, 2133MM
4	009812-29-000	EA	MOLDING-PLAS, CORNER - O/S 1/2" - WATERFORD OAK
5	022992-11-000	FT	MOLDING-REVERSE COVE, T-SHAPED - VINYL - IVORY
6	086229-13-000	EA	BATTEN - 1" CEILING MOD IVORY - W&B RN323
7	086229-01-000	EA	RETAINER-BATTEN, CEILING - .75" WIDE - 7.6'
8	078323-06-G15	EA	MOLDING-CAP, WALL 2022
9	104676-01-01A	FT	T-MOLDING, 5/16 RIGID - GOLD
10	103186-01-05A	FT	MOLDING-PLASTIC, SHELF - WATERFORD OAK
10	103186-02-05A	FT	MOLDING-PLASTIC, SHELF - WATERFORD OAK
11	105709-01-000	FT	T-MOLDING - 1", MODERN IVORY
12	100818-01-05A	EA	MOLDING-VINYL WRAP, TRIM - WATERFORD OAK
13	083620-12-000	FT	T-MOLDING, 3/4 W/EDGE LIPS - WATERFORD OAK
14	100819-01-05A	EA	MOLDING-VINYL WRAPPED, L-SHAPED, 1.5" X 1.5" X 7' - OAK
15	085746-01-000	FT	TRIM-J, CARPET - 1.2" X .5" ANGLE - 10' LONG - PVC - BEIGE
16	105004-01-05A	EA	MOLDING-VINYL WRAP - WATERFORD OAK
	117268-D2-134	EA	MOLDING - 018 X 040 X 2134 M VINYL - WRAPPED-WATERFORD
	117268-F2-438	EA	MOLDING - 018 X 065 X 2438 - WRAPPED WATERFORD
	117268-F2-134	EA	MOLDING - 018 X 065 X 2134 - WRAPPED WATERFORD
	077840-01-W30	EA	MOLDING-CAP, WALL
	109736-01-01A	EA	T-MOLDING, 1" - BRASS/BLACK

INTERIOR FINISH GROUP (CONTINUED)
BATT STRIPS

KEY	PART NUMBER	U/M DESCRIPTION
	085284-76-000	FT BATT STRIP-SHOWER, ADHESIVE BACKED - OFF WHITE
	069733-83-000	EA BATT STRIP-WOODGRAIN, 8' - WATERFORD OAK
	088263-78-000	EA BATT STRIP-SHOWER, 8' - OFF WHITE
	088263-C3-000	EA BATT STRIP-DECORATIVE, TRAVIS/PEBBLE - 8' LONG (G29) (MAIN WALL)
	088263-B3-000	EA BATT STRIP-DECORATIVE, ALLURE/MEADOW - 8' LONG (G30) (MAIN WALL)
	088263-B8-000	EA BATT STRIP-DECORATIVE, METRO/MIST - 8' LONG (G31,G32) (MAIN WALL)
	085284-B5-000	FT BATT STRIP-WOODGRAIN, ADHESIVE BACKED - WATERFORD OAK
	085284-B6-000	FT BATT STRIP-DECORATIVE, ADHESIVE BACKED (G29) (MAIN WALL)
	085284-A4-000	FT BATT STRIP-DECORATIVE, ADHESIVE BACKED (G30) (MAIN WALL)
	085284-B1-000	FT BATT STRIP-DECORATIVE, ADHESIVE BACKED (G31,G32) (MAIN WALL)
	086229-04-000	EA BATTEN-CEILING, 1" WIDE - IVORY - 7.6'

LUMBER

KEY	PART NUMBER	U/M DESCRIPTION
	100040-01-000	EA LUMBER-VINYL WRAPPED, .71" X 1.5" X 8' - RAMBLING OAK
	100040-03-000	EA LUMBER-VINYL WRAPPED, .71" X 2" X 8' - RAMBLING OAK
	100040-06-000	EA LUMBER-VINYL WRAPPED, 766 RAMBLING OAK
	100040-07-000	EA LUMBER-VINYL WRAPPED, 766 RAMBLING OAK

PLASTIC LAMINATE

KEY	PART NUMBER	U/M DESCRIPTION
	074498-54-000	SF LAMINATE-PLASTIC, SAND SPEKTRUM - 5' X 8' - INCREMENTS OF 40 SF (G29,G32) (GALLEY, DINETTE, BATH & BEDROOM)
	074498-73-000	SF LAMINATE-PLASTIC, PEPPERMINT SANTOS - 5' X 8' - INCREMENTS OF 40 SF (G30) (GALLEY, DINETTE, BATH & BEDROOM)
	074498-62-000	SF LAMINATE-PLASTIC, GREY FINESSE - 5' X 8' - INCREMENTS OF 40 SF (G31) (GALLEY, DINETTE, BATH & BEDROOM)
	074498-67-000	SF LAMINATE-PLASTIC, ORCHID MIST - 5' X 8' - INCREMENTS OF 40SF (PATIO ENTERTAINMENT CENTER TABLE)
	076325-34-000	FT MOLDING-EDGE BAND, 1233 ORCHID MIST - 1 5/16" X .030" X 600" (PATIO ENTERTAINMENT CENTER TABLE)
	076325-47-000	FT MOLDING-EDGE BAND, 1032 SAND - 1 5/16" X .030" X 600" (G29,G32) (DINETTE/BEDROOM)
	076325-65-000	FT MOLDING-EDGE BAND, 1179 PEPPERMINT - 1 5/16" X .030" X 600" (G30) (DINETTE/BEDROOM)
	076325-46-000	FT MOLDING-EDGE BAND, 1035 CLOUD - 1 5/16" X .030" X 600" (G31) (DINETTE/BEDROOM)
	076325-44-000	FT MOLDING-EDGE BAND, 1032 SAND - .875 "X .024" X 600" (G29,G32) (DINETTE/BEDROOM)
	076325-66-000	FT MOLDING-EDGE BAND, 1179 PEPPERMINT - .875 "X .024" X 600" (G30) (DINETTE/BEDROOM)
	076325-43-000	FT MOLDING-EDGE BAND, 1035 CLOUD - .875 "X .024" X 600" (G31) (DINETTE/BEDROOM)
	074498-77-000	SF LAMINATE-PLASTIC, ART CAGIN OAK - 5' X 8' - INCREMENTS OF 40SF (PULL OUT TABLE)
	076325-68-000	FT MOLDING-EDGE BAND, WATERFORD OAK - 1 5/16" X .030" X 600" (PULL OUT TABLE)

INTERIOR FINISH GROUP (CONTINUED)
DETECTORS, FIRE EXTINGUISHER & CLOCK

KEY	PART NUMBER	U/M DESCRIPTION	VENDER NO.
	072852-02-000	EA DETECTOR-SMOKE, W/9 VOLT BATTERY - CANADIAN	
	072852-01-000	EA DETECTOR-SMOKE, W/9 VOLT BATTERY - US	
	094499-02-000	EA EXTINGUISHER-FIRE, DRY - 1A10BC - CANADIAN	
	094499-01-000	EA EXTINGUISHER-FIRE, DRY W/MOUNTING BRACKET - 10 BC	
	094499-01-700	EA BRACKET ONLY	
	094499-01-700	EA BRACKET MTG. W/PLAS. STRAP	294039
	112320-02-000	EA BATTERY/SENSOR-CO GAS - COSTAR 940001000 WHEN REPLACING THE ORIGINAL (01 & 02) SYSYTEM, ORDER #112320-03-000 DETECTOR & #112320-04-000 SENSOR	
	112320-03-000	EA DETECTOR-CO GAS MODEL 9D-I - COSTAR 946000001	FROM: 00-00-00 THRU: 09-03-95
	112320-04-000	EA DETECTOR-CO SENSOR ASSEMBLY - COSTAR 946001001	FROM: 09-04-95 THRU: 99-99-99
	118081-01-01A	EA CLOCK-WALL, ROUND 8" BRASS	FROM: 09-04-95 THRU: 99-99-99

ANTISLIP & FLOOR MATS

KEY	PART NUMBER	U/M DESCRIPTION
	091261-01-000	FT SLIPNOT-ANTISLIP, 1' WIDE (100' ROLL)
	105924-01-F04	EA MAT-FLOOR 18 X 27 (G29,G32)
	105924-01-F11	EA MAT-FLOOR 18 X 27 (G30)
	105924-01-F25	EA MAT-FLOOR 18 X 27 (G31)

CARPET & VINYL FLOOR COVERING

KEY	PART NUMBER	U/M DESCRIPTION
	075233-01-000	SY PAD-CARPET, 3/8" X 6' ROLL
	093486-01-000	SY CARPET-COMPARTMENT, 54" WIDE - DARK GRAY
	096060-95-000	SY CARPET - 12' ROLL, INCREMENTS OF 4 SY (G29)
	096060-A2-000	SY CARPET - 12' ROLL, INCREMENTS OF 4 SY (G30)
	096060-A8-000	SY CARPET - 12' ROLL, INCREMENTS OF 4 SY (G31)
	096060-B9-000	SY CARPET - 12' ROLL, INCREMENTS OF 4 SY (G32)
	042720-12-000	SY VINYL-FLOOR COVERING, MODULATIONS

PANELING, PLYWOOD & CEILING VINYL

KEY	PART NUMBER	U/M DESCRIPTION
	074497-28-000	SF PANELING-WOODGRAIN, 4' X 8' - INCREMENTS OF 32 SF
	088272-98-000	SF PANELING-SHOWER, OFF WHITE - 4' X 7' - INCREMENTS OF 28 SF
	088272-E4-000	SF PANELING-DECORATIVE, TRAVIS/PEBBLE - 4' X 7' - INCREMENTS OF 28 SF (G29) (MAIN WALL)
	088272-D6-000	SF PANELING-DECORATIVE, ALLURE/MEADOW - 4' X 7' - INCREMENTS OF 28 SF (G30) (MAIN WALL)
	088272-E0-000	SF PANELING-DECORATIVE, METRO/MIST - 4' X 7' - INCREMENTS OF 28 SF (G31,G32) (MAIN WALL)
	080215-10-000	SF PANELING - 2 SIDED, WATERFORD
	095688-01-000	SF VENEER-FLAT LUANA, 4' X 8' - INCREMENTS OF 32 SF
	089351-03-000	YD VINYL-CEILING, DIAMOND DESIGN - 54" WIDE

INTERIOR FINISH GROUP (CONTINUED)
CABINET HARDWARE

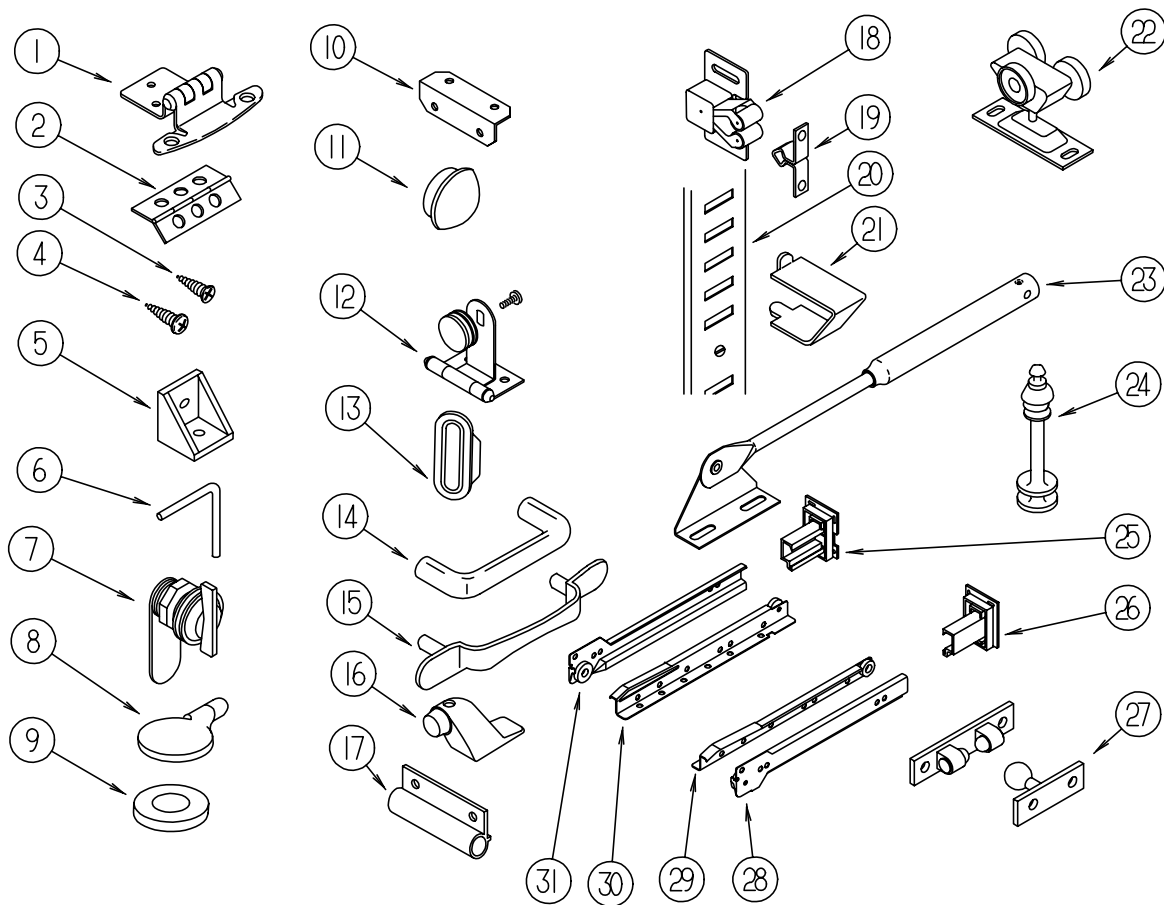

KEY	PART NUMBER	U/M	DESCRIPTION
1	108138-01-000	EA	HINGE-DOOR, CABINET - BURNISHED BRASS
2	009059-01-000	EA	HINGE-DOOR, 2" X 1.4" - BRASS
2	009059-02-000	EA	HINGE-DOOR, 2" X 2.7" - BRASS
3	000G13-06-10G	EA	SCREW - PHILLIPS - FLAT HEAD - 6-20 X 5/8" - ANTIQUE BRASS
4	000G68-06-10G	EA	SCREW - PHILLIPS - OVAL HEAD - 6-18 X 5/8" - ANTIQUE BRASS
5	065740-01-000	EA	BRACE-CABINET CORNER, PLASTIC
6	108487-02-01A	EA	SUPPORT-PROP ROD,OVHD,BLACK
7	100710-01-01A	EA	LOCK-GLASS DOOR, TWIST TYPE - BRASS
8	101766-01-000	EA	PIN-SUPPORT, GLASS DOOR
9	100707-01-000	EA	SPACER-DOOR, GLASS - .8" DIA - .3" HOLE - PLASTIC
10	016604-01-000	EA	BRACE-CABINET, ANGLE - 2.5" - METAL - UNPAINTED
10	016604-05-000	EA	BRACE-CABINET, L ANGLE - 2.5" - METAL - OFF WHITE
11	074045-07-000	EA	PLUG-WOOD, 1/2"
12	100711-01-01A	EA	HINGE-DOOR, GLASS
13	098410-01-01A	EA	PULL-FINGER, OVAL - BRASS
14	111093-01-000	EA	PULL-CABINET,BRASS
15	117801-01-01A	EA	PULL-CABINET,BRASS
16	103257-01-000	EA	STOP-DOOR
17	108486-01-01A	EA	BRACKET-PROP ROD,OVHD,BLACK

KEY	PART NUMBER	U/M	DESCRIPTION
18	093586-06-000	EA	CATCH-SPRING, ROLLER
19	093586-05-000	EA	STRIKE-SPRING STEEL
20	098980-01-000	EA	PILASTER-ADJUSTABLE SHELF, 18" LONG WOODGRAIN APPEARANCE
20	098980-02-000	EA	PILASTER-ADJUSTABLE SHELF, 12" LONG WOODGRAIN APPEARANCE
20	098980-03-000	EA	PILASTER-ADJUSTABLE SHELF, 9" LONG WOODGRAIN APPEARANCE
21	098979-01-000	EA	CLIP-ADJUSTABLE SHELF
22	103874-01-000	EA	HANGER-SLIDING DOOR
23	074493-02-000	EA	SUPPORT-PISTON SPRING, CABINET DOOR
24	084070-02-000	EA	POST-END, 2.4" - BRASS
25	114045-01-000	EA	BACKSOCKET-ADJUSTABLE,LEFT N/A USE KIT NUMBER ACCORDING TO DRAWER SLIDE LENGTH
26	114045-02-000	EA	BACKSOCKET-ADJUSTABLE,RIGHT N/A USE KIT NUMBER ACCORDING TO DRAWER SLIDE LENGTH
27	084451-01-000	EA	CATCH-TV SHELF, BRASS
28	114031-14-000	EA	SLIDE-DRAWER,18" RIGHT CABT N/A ORDER #114031-13-700 SLIDE DRAWER KIT
28	114031-22-000	EA	SLIDE-DRAWER,22" RIGHT CABT N/A ORDER #114031-21-700 SLIDE DRAWER KIT
28	114031-26-000	EA	SLIDE-DRAWER,24" RIGHT CABT N/A ORDER #114031-25-700 SLIDE DRAWER KIT
29	114031-16-000	EA	SLIDE-DRAWER,18" RIGHT DRWR N/A ORDER #114031-13-700 SLIDE DRAWER KIT
29	114031-24-000	EA	SLIDE-DRAWER,22" RIGHT DRWR N/A ORDER #114031-21-700 SLIDE DRAWER KIT
29	114031-28-000	EA	SLIDE-DRAWER,24" RIGHT DRWR N/A ORDER #114031-25-700 SLIDE DRAWER KIT
30	114031-15-000	EA	SLIDE-DRAWER,18" LEFT DRWR N/A ORDER #114031-13-700 SLIDE DRAWER KIT
30	114031-23-000	EA	SLIDE-DRAWER,22" LEFT DRWR N/A ORDER #114031-21-700 SLIDE DRAWER KIT
30	114031-27-000	EA	SLIDE-DRAWER,24" LEFT DRWR N/A ORDER #114031-25-700 SLIDE DRAWER KIT
31	114031-13-000	EA	SLIDE-DRAWER,18" LEFT CABT N/A ORDER #114031-13-700 SLIDE DRAWER KIT
31	114031-21-000	EA	SLIDE-DRAWER,22" LEFT CABT N/A ORDER #114031-21-700 SLIDE DRAWER KIT
31	114031-25-000	EA	SLIDE-DRAWER,24" LEFT CABT N/A ORDER #114031-25-700 SLIDE DRAWER KIT
	101272-01-000	EA	CATCH-DOOR, GLASS
	004354-01-000	EA	BUMPER-RUBBER, .5" DIA - BROWN
	009059-02-000	EA	HINGE-DOOR, 2" X 2.7" - BRASS
	009112-01-000	EA	FLANGE-ROD, 1" - COTHES ROD - PLASTIC - OFF WHITE
	023320-01-000	EA	PAD-FELT, 3/8" DIAMETER - BROWN
	042356-01-000	EA	PLUG-BUTTON, MAHOGANY - 3/8" DIAMETER - WOOD
	042438-01-000	EA	DOWEL-WOOD, CLOTHES ROD - 1" DIAMETER X 4'
	076790-01-000	EA	SCREW, 6-20 X 1 1/4 PPH - BLACK
	111866-01-02A	EA	BRACE-SEAT,ANGLE OFF/WHT
	116975-01-01A	EA	LATCH ASM-UNDERCENTER,BLACK

LABELS GROUP

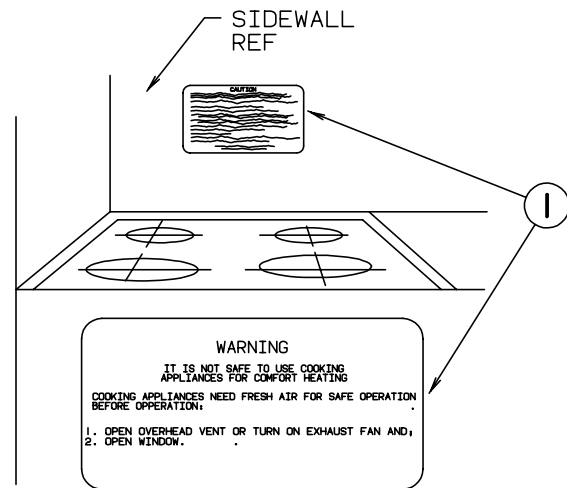

KEY	PART NUMBER	U/M DESCRIPTION
1	050225-01-000	EA LABEL-WARNING, STOVE VENT - US
1	050222-01-000	EA LABEL-WARNING, STOVE VENT - CANADIAN

LABELS GROUP (CONTINUED)

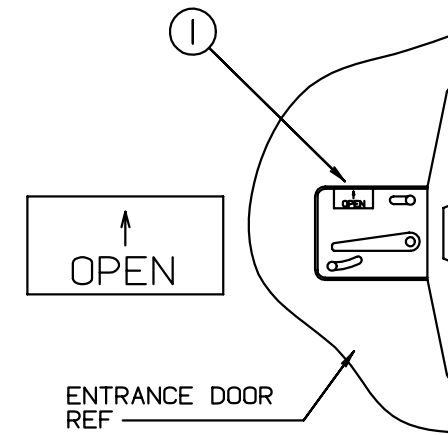

KEY	PART NUMBER	U/M DESCRIPTION
1	040944-01-000	EA LABEL-ENTRANCE DOOR, "OPEN"

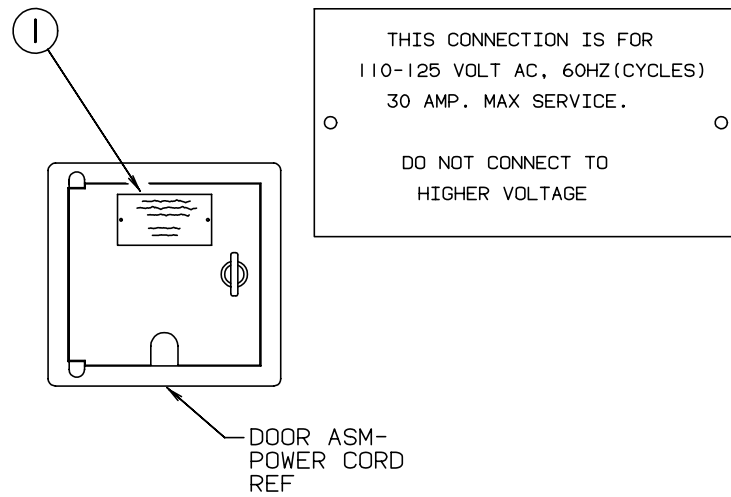

KEY	PART NUMBER	U/M DESCRIPTION
1	006062-01-000	EA TAG-ELECTRIC, 110V CONNECTION

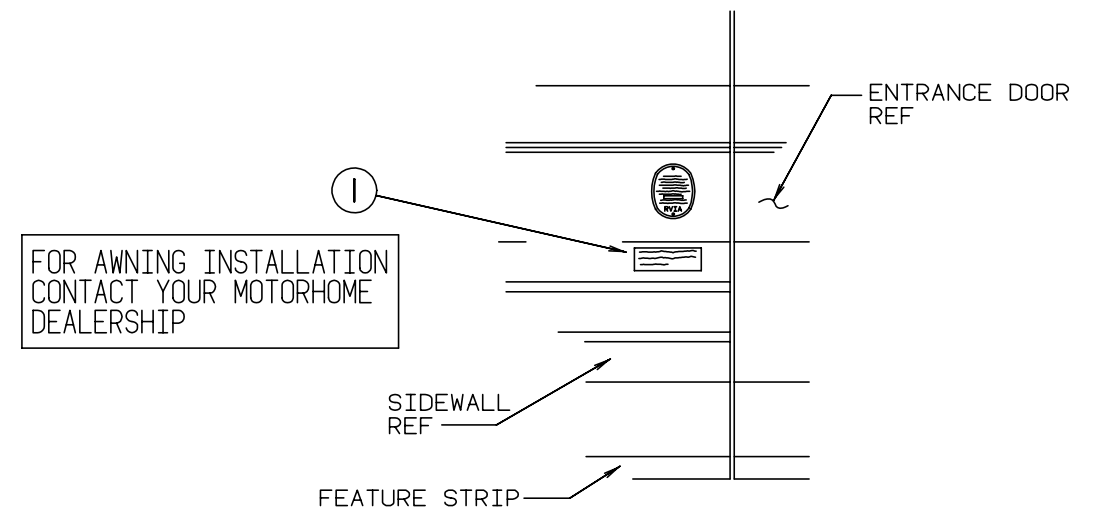

KEY	PART NUMBER	U/M DESCRIPTION
1	099509-01-000	EA LABEL-AWNING INSTALLATION

LABELS GROUP (CONTINUED)

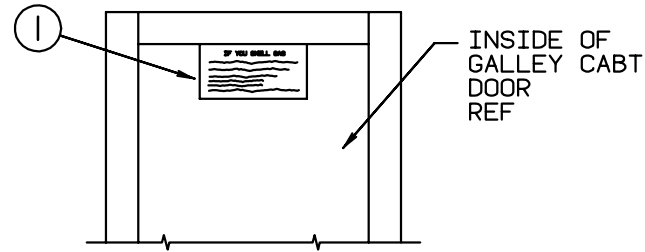

IF YOU SMELL GAS

1. EXTINGUISH ANY OPEN FLAME, PILOT LIGHTS AND ALL SMOKING MATERIALS.
2. SHUT OFF THE GAS SUPPLY AT THE TANK VALVE(OR GAS SUPPLY CONNECTION.
3. OPEN DOORS AND OTHER VENTILATING OPENINGS.
4. DO NOT TOUCH ELECTRICAL SWITCHES.
5. LEAVE THE AREA UNTIL ODOR CLEARS.
6. HAVE THE GAS SYSTEM CHECKED AND LEAKAGE SOURCE CORRECTED BEFORE USING AGAIN.

KEY	PART NUMBER	U/M DESCRIPTION
1	073998-01-000	EA LABEL-LPG ODOR WARNING

LABELS GROUP (CONTINUED)

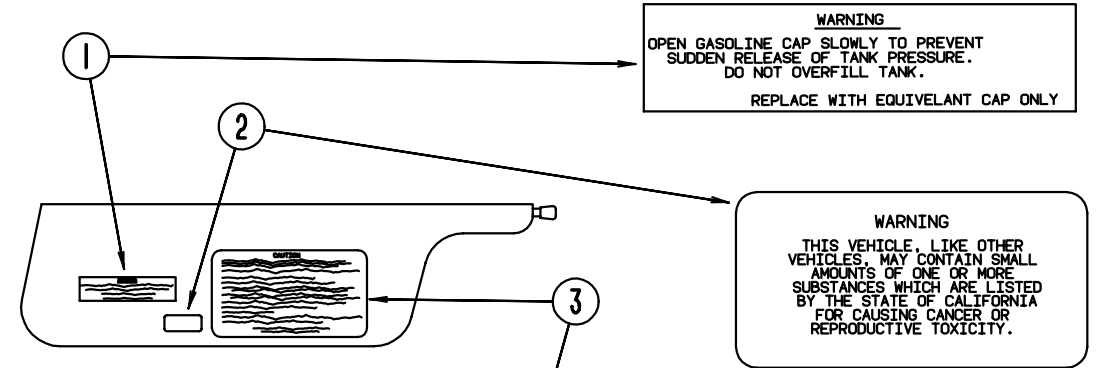

WARNING
 OPEN GASOLINE CAP SLOWLY TO PREVENT SUDDEN RELEASE OF TANK PRESSURE. DO NOT OVERFILL TANK.
 REPLACE WITH EQUIVELANT CAP ONLY

WARNING
 THIS VEHICLE, LIKE OTHER VEHICLES, MAY CONTAIN SMALL AMOUNTS OF ONE OR MORE SUBSTANCES WHICH ARE LISTED BY THE STATE OF CALIFORNIA FOR CAUSING CANCER OR REPRODUCTIVE TOXICITY.

CAUTION

THIS MOTOR HOME HAS BEEN DESIGNED, MANUFACTURED AND TESTED WITH CONCERN FOR THE PROTECTION OF IT'S OCCUPANTS. WE RECOMMEND YOU PERFORM THE FOLLOWING INSPECTIONS FOR YOUR SAFETY AND THE SAFETY OF YOUR PASSENGERS BEFORE STARTING YOUR VEHICLE.

1. LP GAS SYSTEM- TURN OFF AT TANK FOR TRAVELING. TEST FOR LEAKS UPON ARRIVAL AT DESTINATION. BEFORE LIGHTING PILOTS.
2. WHEELS- INSPECT FOR DAMAGE AND CHECK LUG NUTS FOR TIGHTNESS.
3. TIRES- INSPECT FOR WEAR AND DAMAGE AND CHECK FOR RECOMMENDED AIR PRESSURE.
4. LIGHTING- TEST FOR PROPER OPERATION OF ALL INTERIOR AND EXTERIOR LIGHTS INCLUDING DASH LIGHTS, HEADLIGHTS, TAIL LIGHTS, BRAKE LIGHTS, CLEARANCE LIGHTS AND TURN SIGNALS.
5. EXITS- INSPECT RELEASE MECHANISM ON EMERGENCY EXIT WINDOW, TEST BOTH LOCKS ON MAIN ENTRANCE DOOR FOR EASE OF OPERATION AND INSTRUCT PASSENGERS HOW TO USE BOTH MEANS OF EXIT.
6. SEAT BELTS- DIRECT PASSENGERS TO DESIGNATED SEATS AND REQUIRE USE OF SEAT BELTS.
7. APPLIANCES- TURN OFF AND LATCH OR LOCK DOORS WHERE PROVIDED.
8. LOOSE PARCELS- STORE SECURELY.
9. UTILITY SUPPLY LINES- DISCONNECT ALL ELECTRIC, SEWER AND WATER LINES AND SECURE PROPERLY.
10. ENTRANCE DOOR STEP- PLACE IN RETRACTED POSITION FOR TRAVELING.

READ YOUR MOTOR HOME AND CHASSIS OWNER'S MANUAL FOR FURTHER PRECAUTIONS

KEY	PART NUMBER	U/M DESCRIPTION
1	087207-05-000	EA LABEL-FUEL CAP REMOVAL
2	099689-01-000	EA LABEL-WARNING, CANCER/TOXICITY
3	056259-01-000	EA LABEL-SAFETY CHECK LIST

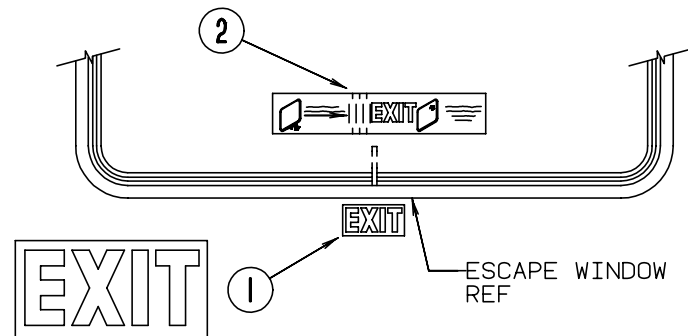
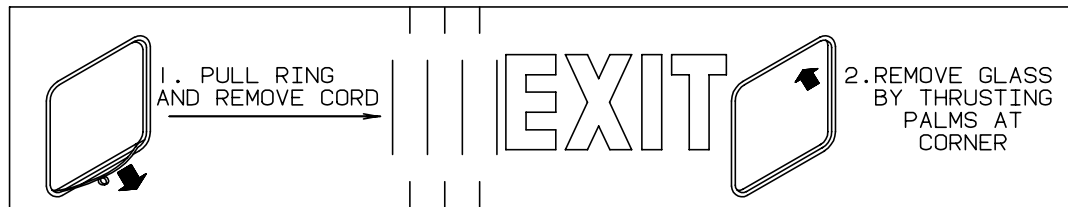

KEY	PART NUMBER	U/M DESCRIPTION
1	039290-01-000	EA LABEL-WARNING, EXIT
2	107571-01-000	EA LABEL-ESCAPE EXIT, WINDOW

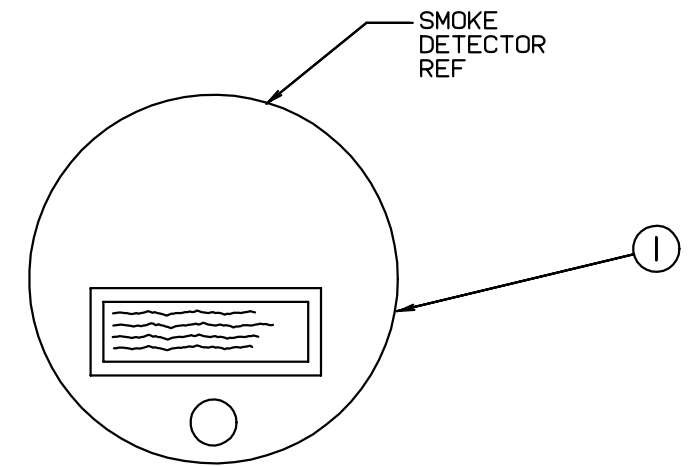

WARNING: TEST SMOKE DETECTOR OPERATION AFTER VEHICLE HAS BEEN IN STORAGE. BEFORE EACH TRIP AND AT LEAST ONCE PER WEEK DURING USE.

KEY	PART NUMBER	U/M DESCRIPTION
1	077956-01-000	EA LABEL-WARNING, SMOKE DETECTOR

LABELS GROUP (CONTINUED)

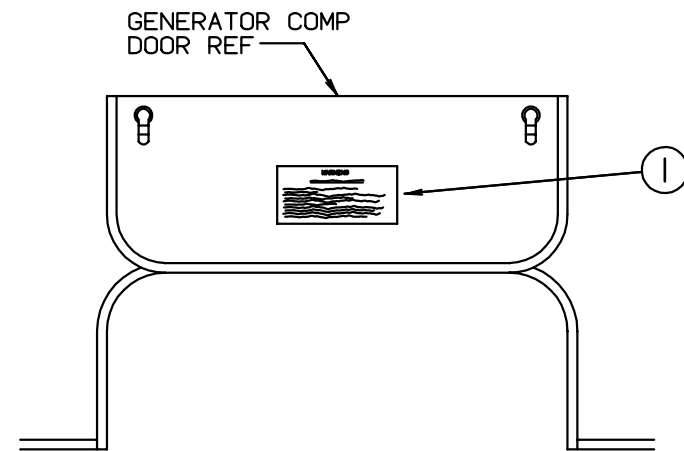

WARNING

WHEN ADDING A GENERATOR SET:

HIGH VOLTAGE-USE EXTREME CAUTION WHEN WORKING ON ELECTRICAL COMPONENTS.
 HAVE ALL ELECTRICAL INSTALLATION PERFORMED BY A QUALIFIED LICENSED ELECTRICIAN-FOLLOW ALL STATE AND LOCAL CODES.
 ONLY INSTALL GENERATOR SET APPROVED FOR R.V. APPLICATION. HAVE INSTALLED BY QUALIFIED TECHNICIAN.
 TO AVOID HEAT BUILD-UP AND TO GUARANTEE AN ADEQUATE AIR SUPPLY TO THE GENERATOR CARBURETOR, FOLLOW INSTALLATION INSTRUCTIONS.
 GENERATOR ENGINE EXHAUST GASES ARE TOXIC AND MUST NOT TERMINATE UNDER THE VEHICLE-DISCHARGE EXHAUST AWAY FROM VEHICLE.

KEY	PART NUMBER	U/M DESCRIPTION
1	077510-01-000	EA LABEL-GENERATOR PREP

LABELS GROUP (CONTINUED)
MISCELLANEOUS LABELS

KEY	PART NUMBER	U/M DESCRIPTION
	068383-01-000	EA LABEL-DIESEL FUEL, GM 557005
	074983-01-000	EA LABEL-SWITCH, A/C SELECTOR FOR FRONT OR REAR
	091224-02-000	EA LABEL-TRAILER LIGHTING
	091243-01-000	EA LABEL-A/C COVER, "AIR CONDITIONING CIRCUIT. ETC."
	098379-04-000	EA LABEL-ELECTRICAL BOX, SIDE
	098641-01-000	EA LABEL-FUEL, UNLEADED - DASH
	104678-01-000	EA LABEL-CB PREP
	111537-04-000	EA LABEL-FUSES
	111802-01-000	EA LABEL-CFC WARNING
	112518-01-000	EA LABEL-HANG TAG, CO DETECTOR
	093236-01-000	EA LABEL-CIRCUIT BREAKER, MAIN
	093237-01-000	EA LABEL-CIRCUIT BREAKER, FRONT - BATTERY CONDITION/RADIO
	093237-03-000	EA LABEL-CIRCUIT BREAKER, FRONT - POWER SEAT (LIFT)
	093237-06-000	EA LABEL-CIRCUIT BREAKER, FRONT - REAR PANEL
	093237-07-000	EA LABEL-CIRCUIT BREAKER, FRONT - REAR PANEL/CONVERTER
	093237-09-000	EA LABEL-CIRCUIT BREAKER, FRONT - INVERTER
	116424-01-000	EA LABEL-WATER HEATER DOOR TRAVEL LATCH PROTECTOR

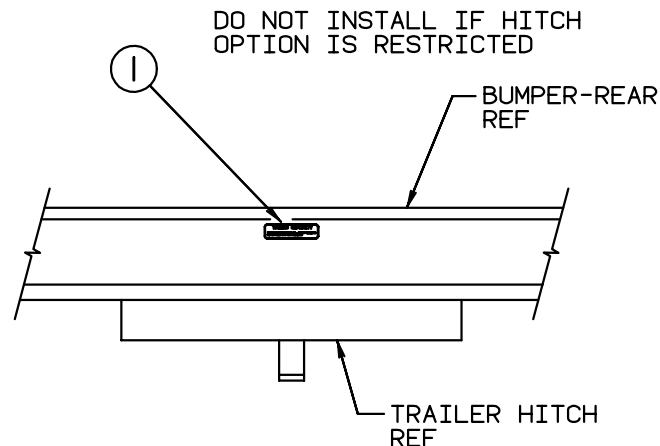

TOWING CAPACITY

TOWED VEHICLE 3500 LB. GROSS MAXIMUM
 HITCH BALL 200 LB. MAXIMUM

KEY	PART NUMBER	U/M DESCRIPTION
1	111104-01-000	EA LABEL-HITCH,READ MANUAL

LABELS GROUP (CONTINUED)

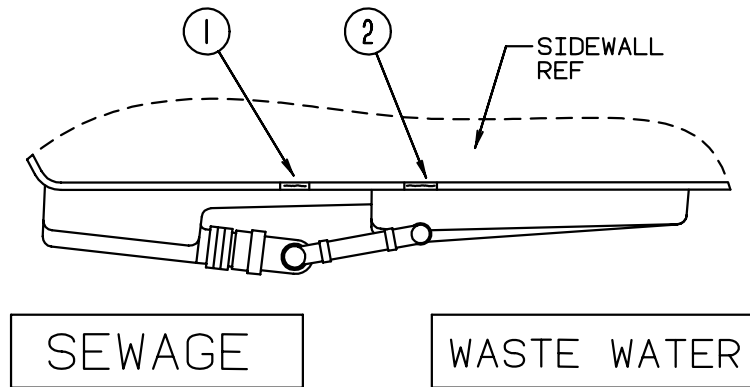

KEY	PART NUMBER	U/M DESCRIPTION
1	006187-01-000	EA LABEL-SEWAGE
2	006188-01-000	EA LABEL-WASTE WATER

LABELS GROUP (CONTINUED)

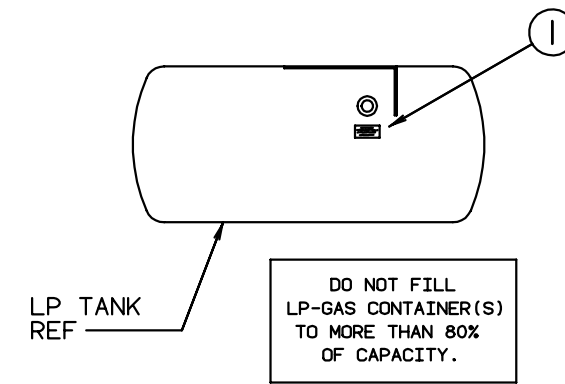

KEY	PART NUMBER	U/M DESCRIPTION
1	079965-01-000	EA LABEL-LPG 80 CAPACITY

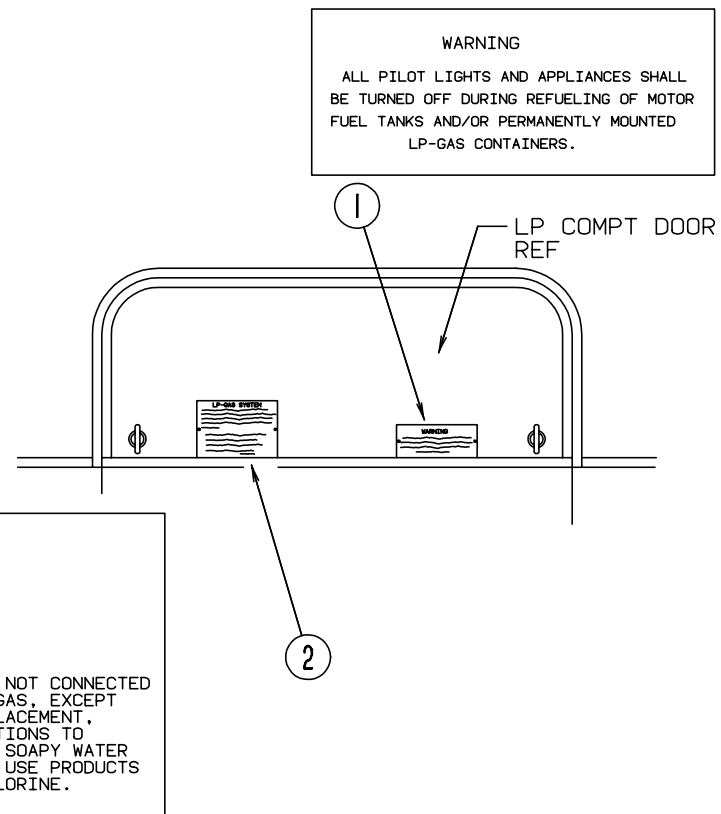

KEY	PART NUMBER	U/M DESCRIPTION
1	006040-01-000	EA TAG-GAS REFUELING WARNING
1	006040-02-000	EA TAG-GAS REFUEL WARNING, CANADIAN
2	054531-01-000	EA LABEL-LP GAS ONLY
2	023769-01-000	EA LABEL-WARNING, LPG - CANADIAN

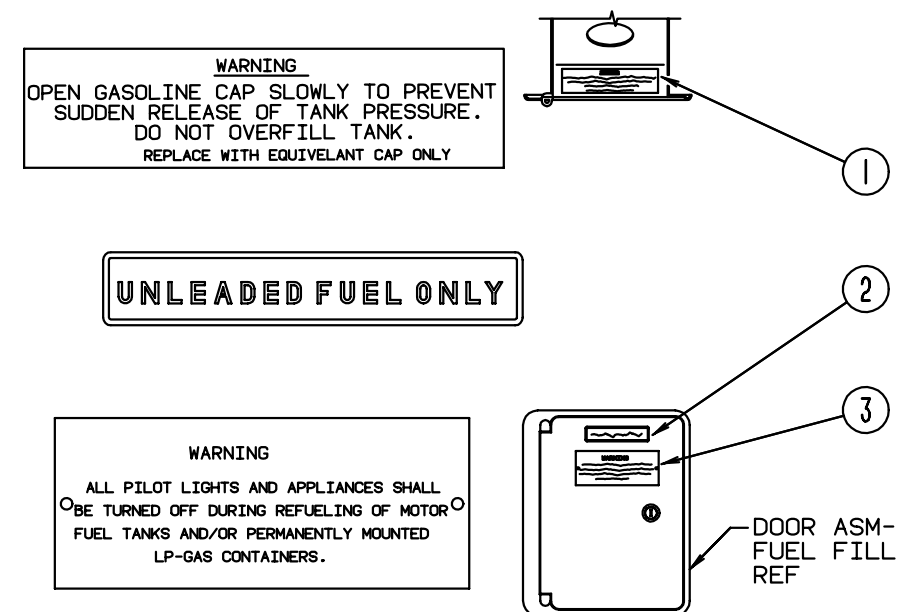

KEY	PART NUMBER	U/M DESCRIPTION
1	087207-05-000	EA LABEL-FUEL CAP REMOVAL
2	062043-01-000	EA LABEL-FUEL, UNLEADED
3	006040-01-000	EA TAG-GAS REFUELING WARNING
3	006040-02-000	EA TAG-GAS REFUEL WARNING, CANADIAN

LP GROUP

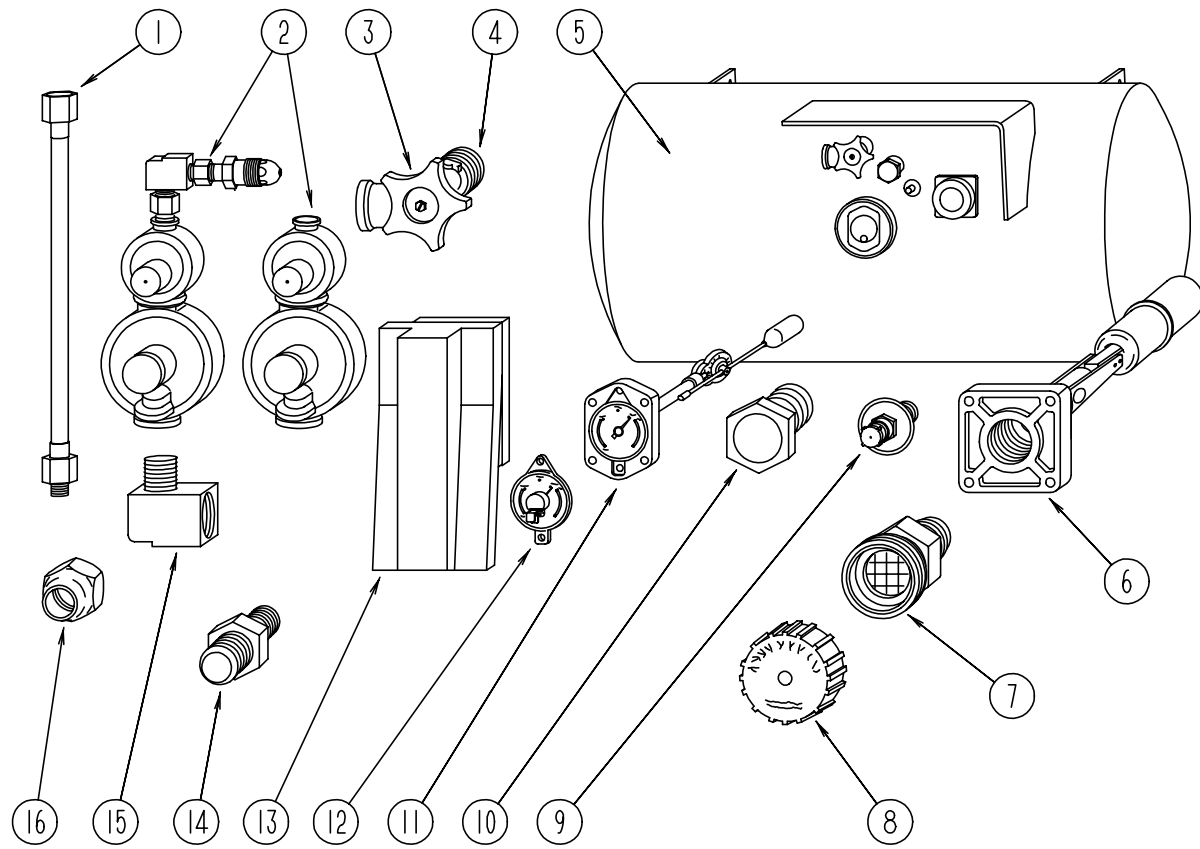

LP TANK & COMPONENTS

KEY	PART NUMBER	U/M	DESCRIPTION	VENDER NO.
1	045703-01-000	EA	HOSE-LP, 3/8" ID X 24" - 3/8" MPT X 1/2" F SWIVEL - US	
1	045703-02-000	EA	HOSE-LP, 3/8" ID X 24" - 3/8" MPT X 1/2" F SWIVEL - CANADIAN	
1	045703-03-000	EA	HOSE-LP, 3/8" ID X 18" - 3/8" MPT X 1/2" F SWIVEL - EXPORT LP GENERATOR	
2	106150-01-000	EA	REGULATOR-TWO STAGE	
2	106150-02-000	EA	REGULATOR-TWO STAGE - EUROPEAN EXPORT OPTION	
3	040421-01-708	EA	HANDWHEEL-VAPOR RELIEF VALVE, BRUNNER	G-1015-A
4	040421-01-712	EA	VALVE-SERVICE W/O VAPOR RELIEF	29000853
5	088253-03-000	EA	TANK-LP, 100 LB - 16" X 36" LONG	
6	040421-01-711	EA	VALVE - 80% W/FLOAT, PLATE, BOLTS & GASKET - BRUNNER	
7	040421-01-701	EA	VALVE-SHORT LP FILLER W/YELLOW CAP - BRUNNER	75478
8	040421-01-702	EA	CAP-LP FILLER VALVE, PLASTIC - YELLOW - BRUNNER	G-1014-A
9	040421-01-700	EA	GAUGE-LIQUID LEVEL, 20% LP - BRUNNER	G-1013
10	040421-01-713	EA	PRESSURE RELIEF VALVE	
11	040421-01-707	EA	GAUGE-FLOAT W/VISIBLE DIAL - BRUNNER	MA-9 6244-4
12	040440-02-000	EA	TRANSMITTER-DIAL, 90 OHM	
13	105658-01-000	EA	COMPARTMENT-LP REGULATOR	
14	010329-01-000	EA	ADAPTER-BRASS, 1/2" F X 1/2" MPT	
14	010323-01-000	EA	ADAPTER-BRASS, 3/8" F X 1/2" MPT	
15	065318-02-000	EA	ELBOW - 90 DEGREE, 3/8" MPT TO 3/8" FPT	
16	010377-02-000	EA	NUT-BRASS, 3/8" FEMALE - FORGED	
	024250-01-000	EA	ADAPTER-BRASS, 3/8" F X 1/2" FPT	
	036346-01-000	EA	BUSHING-STEEL, 3/4" MPT X 1/2" FPT - EUROPEAN EXPORT OPTION	
	008042-01-000	FT	TUBING-VINYL, .65" ID	
	074458-01-000	EA	ELBOW - 3/8" M FL X 3/8" F FL SWIVEL - ANCHOR BRASS A800	
	095624-01-000	EA	ELBOW - 90 DEGREE, 1/4" FPT X 1/4" FPT - BRASS	
	010380-02-000	EA	NUT-BRASS, 1/2" FEMALE - FORGED	
	103613-01-000	EA	DETECTOR-LP GAS	

LOUNGE GROUP

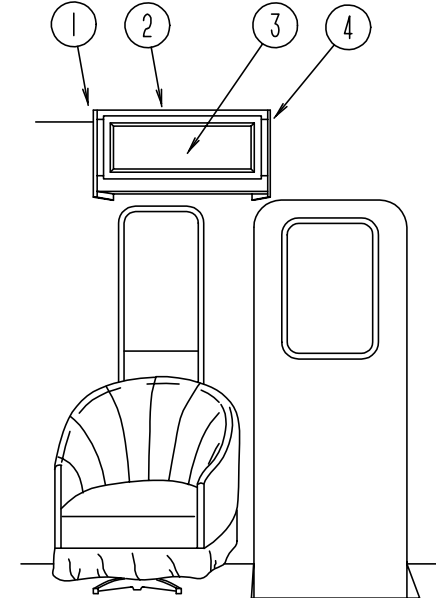

PASSENGER SIDE LOUNGE FRONT BUNK OPTION

KEY	PART NUMBER	U/M	DESCRIPTION
1	103128-09-G09	EA	CAP ASM-END, OVHD - LH
2	114189-01-G09	EA	CABINET ASM-OVERHEAD
3	M06803-04-G09	EA	DOOR-CABINET, W/O HARDWARE - 255 MM X 485 MM
4	103128-08-G09	EA	CAP ASM-END, OVHD - RH
	104006-01-C05	EA	LID-ENTRANCE STEP COMPARTMENT, W/O CARPET
	101222-01-02A	EA	BRACKET-CATCH, LID - O/W
	107941-01-02A	EA	SUPPORT-LID, ENTRY STEP - O/W

LOUNGE GROUP (CONTINUED)
DRIVERS SIDE LOUNGE

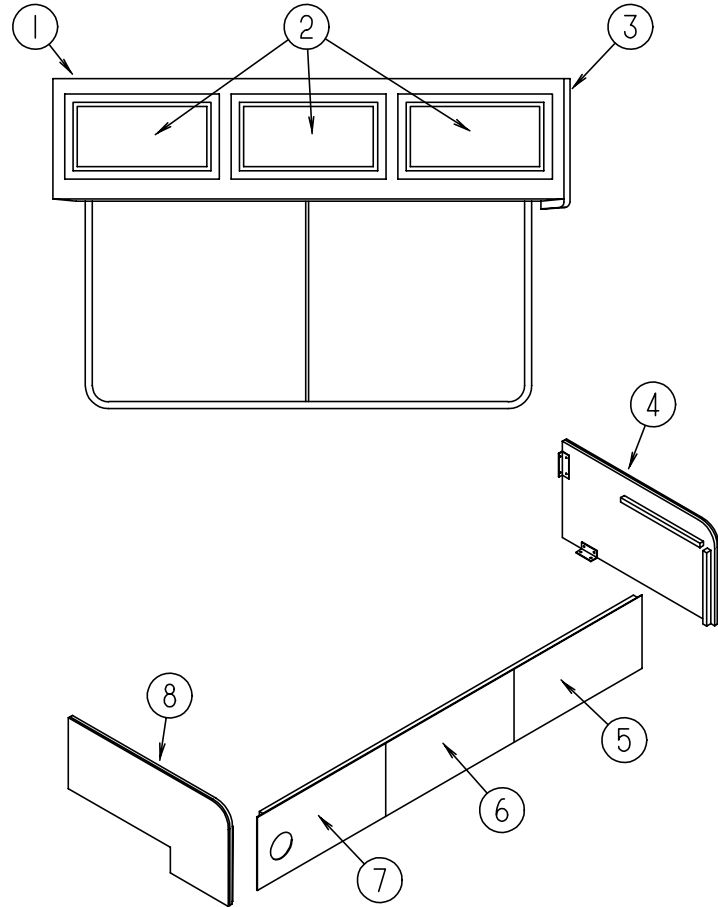

KEY	PART NUMBER	U/M	DESCRIPTION
1	103275-01-G09	EA	CABINET ASM-OVERHEAD, FRONT - LEFT
	103275-12-G29	EA	SHELF ASM
2	M06803-03-G09	EA	DOOR ASM. W/DECORATIVE MIRROR INSERT - 400 X 520
3	103128-01-G09	EA	CAP ASM-END, OVERHEAD
4	M04187-44-G29	EA	PANEL-COUCH CABINET - FABRIC COVERED
4	M04187-44-G30	EA	PANEL-COUCH CABINET - FABRIC COVERED
4	M04187-44-F25	EA	PANEL-COUCH CABINET - FABRIC COVERED (G31)
4	M04187-44-F27	EA	PANEL-COUCH CABINET - FABRIC COVERED (G32)
5	M04187-47-G29	EA	PANEL-COUCH CABINET - FABRIC COVERED
5	M04187-47-G30	EA	PANEL-COUCH CABINET - FABRIC COVERED
5	M04187-47-G31	EA	PANEL-COUCH CABINET - FABRIC COVERED
5	M04187-47-G12	EA	PANEL-COUCH CABINET - FABRIC COVERED (G32)
6	M04187-46-G29	EA	PANEL-COUCH CABINET - FABRIC COVERED
6	M04187-46-G30	EA	PANEL-COUCH CABINET - FABRIC COVERED
6	M04187-46-F25	EA	PANEL-COUCH CABINET - FABRIC COVERED (G31)
6	M04187-46-F27	EA	PANEL-COUCH CABINET - FABRIC COVERED (G32)
7	M04187-45-G29	EA	PANEL-COUCH CABINET - FABRIC COVERED
7	M04187-45-G30	EA	PANEL-COUCH CABINET - FABRIC COVERED
7	M04187-45-F25	EA	PANEL-COUCH CABINET - FABRIC COVERED (G31)
7	M04187-45-F27	EA	PANEL-COUCH CABINET - FABRIC COVERED (G32)
8	M04187-43-G29	EA	PANEL-COUCH CABINET - FABRIC COVERED
8	M04187-43-G30	EA	PANEL-COUCH CABINET - FABRIC COVERED
8	M04187-43-F25	EA	PANEL-COUCH CABINET - FABRIC COVERED (G31)
8	M04187-43-F27	EA	PANEL-COUCH CABINET - FABRIC COVERED (G32)
	105947-01-000	EA	BRACKET-HOLD DOWN, COUCH - CSA UNITS
	049176-01-000	EA	HEDLOCK II - 3/4 DIA SCREW MT
	083125-07-000	EA	BRACE-COUCH, O/W
	082525-01-000	EA	BRACE-COUCH, FLOOR MOUNT - ANGLE 3" LONG - METAL
	083125-07-000	EA	BRACE-COUCH, O/W

SEALANTS & FASTENERS GROUP
SEALANTS & ADHESIVE

KEY	PART NUMBER	U/M DESCRIPTION
	002707-02-000	FT TAPE-SEALER, 5/16" X 1/2" - INCREMENTS OF 50 FT
	034552-02-000	EA SILICONE-TUBE, 300 ML - CLEAR
	034552-15-000	EA SILICONE-TUBE, 300 ML - BRIGHT WHITE
	053766-02-000	EA BEDDING COMPOUND-TUBE, WHITE SCHNEE# 5522
	053766-06-000	EA BEDDING COMPOUND-TUBE, CLEAR
	053766-08-000	EA BEDDING COMPOUND-TUBE, GRAY - SCHNEE# 5522
	062917-03-000	EA ADHESIVE-LOCTITE 242
	063642-01-000	FT TAPE-ADHESIVE, 10 MM X 1.5" WIDE X 180'
	067788-01-000	EA ADHESIVE-SPRAY, 19.5 OZ
	069640-02-000	FT SEALER-RIBBON, 1/2" X 1/8" - INCREMENTS OF 60'
	069640-03-000	FT SEALER-RIBBON, 3/4" X 1/8" - INCREMENTS OF 60'
	069640-07-000	FT SEALER-RIBBON, 2" X 3/32" - INCREMENTS OF 30' OR 45'
	069640-09-000	FT SEALER-RIBBON, 1/32" X 2 1/2" - INCREMENTS OF 80'
	069640-11-000	FT SEALER-TAPE, 3/16" X 3/8", BLACK - MANUS
	069640-13-000	FT SEALER-TAPE, 3/32" X 2" BLACK - MANUS
	069640-14-000	FT SEALER-TAPE, 1/16" X 1" GRAY - MANUS
	072889-01-000	EA SEALANT-URETHANE, BLACK - 1/10 - ESSEX 552.2
	076314-02-000	FT TAPE-CARPET SEAM, HEAT-BOND - 4" WIDE
	076322-01-000	FT TAPE-FOAM, DOUBLE COATED ADHESIVE BACKED - .75" X 216'
	076322-02-000	FT TAPE-FOAM, DOUBLE COATED ADHESIVE BACKED - 1" X 108'
	076322-05-000	FT TAPE-FOAM, DOUBLE COATED - .025" X 1.5" X 108'
	076322-07-000	FT TAPE-FOAM, DOUBLE COATED - .045" X .50"
	110274-01-000	FT TAPE-FOAM, DOUBLE COATED - .045" X 1.0"
	087211-01-000	GL PROMOTER-ADHESIVE
	102352-01-000	EA SEALER-PUMPABLE, BLACK - COLORIMETRIC MS101
	106206-01-000	EA SEALER-PUMPABLE
	108716-01-000	EA SILICONE-TUBE, OFF WHITE - SELF LEVELING - CSL 510
	900390-01-000	EA TIP - 2 1/2" X 1/8" ORIFICE, ELLSWORTH#TS216
	900390-03-000	EA NOZZLES-SILICONE TUBE, CSL# D10
	114311-01-000	GL ADHESIVE-GLUE
	091255-01-000	FT SEAL-FOAM, 3.2MM X 4.8MM

BOLTS, NUTS & WASHERS

KEY	PART NUMBER	U/M DESCRIPTION
	000C12-05-12B	EA BOLT-HEX, 5/16-18 X 3/4 ZN 5
	000C12-05-16B	EA BOLT-HEX, 5/16-18 X 1 - ZINC 5
	000C12-06-16B	EA BOLT-HEX, 3/8-16 X 1LG,ZN 5
	000C12-07-20B	EA BOLT-HEX, 7/16 - 14 X 1 1/4" - ZN5
	000C12-08-24B	EA BOLT-HEX, 1/2-13 X 1 1/2 - ZN 5
	000C12-09-20B	EA BOLT-HEX, 9/16-12 X 1 1/4,ZN 5
	000C12-10-24B	EA BOLT-HEX, 5/8-11 X 1 1/2 ZN - 5
	000C13-07-48B	EA BOLT-HEX, 7/16 - 20 X 3 - ZN 5
	000C18-05-40A	EA BOLT-ELEV, 5/16"-18 X 2 1/2" PL
	000C26-04-14B	EA BOLT-HEX, SER FLG - 1/4-20 X 7/8 ZINC
	000C26-04-10B	EA BOLT-HEX, SER FLG - 1/4-20 X 5/8 ZINC
	000C26-05-12B	EA BOLT-HEX, SER FLG 5/16-18 X 3/4 ZN
	000C26-06-28B	EA BOLT-HEX, SER FLG 3/8-16 X 13/4 ZN
	000C26-06-12B	EA BOLT-HEX, SER FLG 3/8-16 X 3/4 ZN
	000C27-10-32B	EA BOLT-CARR 5/8-11 X 2.00
	000D14-04-00B	EA NUT-HEX, 1/4-20 ZN
	000D24-10-00B	EA NUT-HEX, SF/LK - 10-32 ZN
	000D29-09-00B	EA NUT-HEX SELFLOCK 9/16-12 ZN
	000D34-06-00B	EA NUT-HEX, LK - 3/8 - 16 GRADE C ZN - PREVAILING TORQUE
	000D39-04-00B	EA NUT-HEX, SER FLG LK 1/4 - 20 ZN
	000D39-05-00B	EA NUT-HEX, SER FLG LK - 5/16 - 18 ZN
	000D39-06-00B	EA NUT-HEX, SER FLG LK - 3/8-16 ZN
	000D39-08-00B	EA NUT-HEX, SER FLG LK - 1/2-13 ZN
	000D44-07-00B	EA NUT-HEX, SER FLG LK - 7/16-20 ZN
	000D46-04-00A	EA NUT-HEX, WELD - 1/4-20 - PLAIN
	087234-01-000	EA NUT-JACK, 1/4 X 20THD - MOLLY
	041322-01-000	EA WASHER-FL, 15/32ID X 2 3/8OD - FOR SEAT BELT MOUNT
	058716-02-000	EA WASHER-FLAT NYLON, .406 X .750 X .060
	000E11-07-00B	EA WASHER-LK - 7/16 MED SPLIT ZN

SEALANTS & FASTENERS GROUP (CONTINUED)
BOLTS, NUTS & WASHERS (CONTINUED)

KEY	PART NUMBER	U/M DESCRIPTION
	000E13-14-00B	EA WASHER-FL, 1/4" WIDE ZN
	000E13-18-00B	EA WASHER-FLARE, 3/8" WIDE ZN
	000E13-20-00B	EA WASHER-FL, 7/16" WIDE - ZN
	000E13-21-00B	EA WASHER-FL - W/2 NAR ZN
	000E14-10-00B	EA WASHER-LK - NO 10 EXT TOOTH - ZN
	000G45-05-16B	EA BOLT-LAG 5/16 - 9 X 1 ZN
	040921-03-000	EA NUT-SPEED, U TYPE - NO 10
	040921-04-000	EA NUT-SPEED, U TYPE - NO. 8 - .59" LENGTH X .44" WIDTH
	044364-02-000	EA NUT-SPEED, FLAT - ROUND
	044533-01-000	EA WASHER-PLASTIC, 1 3/8"OD - FOR BUTTONS
	051387-06-000	EA BOLT-CARRIAGE, W/O HOLE - 5/16-18 X 9.5 ZN
	063253-07-000	EA NUT-J, #8A .120- .130 PNL THK
	077071-01-000	EA WASHER-FENDER, 3/16" ID X 1" OD
	095094-01-000	EA NUT-ACORN, 1/4 - 20 ALUMINUM
	102333-01-02A	EA BOLT-CARRIAGE, 7/16 - 14 SST CAP O/W BUMPER BOLT
	104369-01-000	EA NUT-HEX,HEAVY,5/8-11 UNC
	105247-01-000	EA INSERT NUT 8-32 THD X .394LG - STAFAST PRODUCTS
	106649-01-000	EA WASHER-SEALING,GALVANIZED - 5/8 ID
	106649-02-000	EA WASHER-SEALING,GALVANIZED - 9/16 ID

SCREWS

KEY	PART NUMBER	U/M DESCRIPTION
	000G11-05-08B	EA SCREW - 5-20 X 1/2 PPH ZN
	000G11-06-08B	EA SCREW - 6-20 X 1/2 PPH ZINC
	000G11-06-06B	EA SCREW - 6-20 X 3/8 PPH ZN
	000G11-06-10J	EA SCREW, 6-20 X 5/8 PPH - BRASS
	000G11-06-10B	EA SCREW, 6-20 X 5/8 PPH ZN
	000G11-07-08B	EA SCREW, 7-19 X 1/2 PPH - ZN
	000G11-08-06B	EA SCREW, 8-18 X 3/8 PPH ZN
	000G11-08-20B	EA SCREW - 8-18 X 1 1/4 PPH ZN
	000G11-08-16S	EA SCREW, 8-18 X 1.00 PPH - OFF WHITE
	000G11-08-12T	EA SCREW, 8-18 X 3/4 PPH - BLACK
	000G11-08-12S	EA SCREW, 8-18 X 3/4 PPH - OFF WHITE
		MAY NEED TO PAINT THIS SCREW - USED AS A REPLACEMENT FOR VARIOUS COLORED SCREWS
	000G11-08-12P	EA SCREW, 8-18 X .75 PPH - DARK BROWN
	000G11-08-12D	EA SCREW, 8-18 X 3/4 PPH - BLACK
	000G11-08-12B	EA SCREW, 8-18 X 3/4 PPH ZN
	000G11-08-08B	EA SCREW, 8-18 X 1/2 PPH - ZN
	000G11-10-40B	EA SCREW - 10 - 16 X 2 1/2 PPH CAD
	000G11-10-16B	EA SCREW, 10-16 X 1 - PPH ZN
	000G11-10-12S	EA SCREW - 10-16 X .75 PPH OFF WHT
	000G11-10-12D	EA SCREW, 10-16 X 3/4 PPH - BLACK
	000G12-06-08T	EA SCREW, 6-20 X .50 POH - BLACK
	000G12-08-283	EA SCREW - 8-18 X 1.75 POH - BUFF
	000G12-08-16S	EA SCREW, 8-18 X 1.00 POH - OFF WHITE
	000G13-06-08B	EA SCREW, 6-20 X 1/2 PFH ZN
	000G13-06-16J	EA SCREW, 6-20 X 1.00 PFH - BRASS
	000G13-06-08G	EA SCREW, 6-20 X 1/2 PFH - ANTIQUE BRASS
	000G13-07-12B	EA SCREW, 7-19 X 3/4 PFH ZN
	000G13-08-10B	EA SCREW - 8-18 X 5/8 PFH ZN
	000G18-08-22B	EA SCREW-MACH, 8-32 X 1 3/8 PPH ZN
	000G19-10-20B	EA SCREW-MACHINE, 10-32 X 1 1/14 PPH ZINK
	000G19-10-08B	EA SCREW-MACHINE, 10-32 X 1/2 PPH ZN
	000G32-10-06B	EA SCREW - 10-32 X 3/8" - PPH - ZINC
	000G39-06-16T	EA SCREW-SF/DR, 6-20 X 1 PPH - BLACK
	000G39-06-10T	EA SCREW-SF/DR, 6-20 X 5/8 PPH - BLACK
	000G39-08-06B	EA SCREW-SF/DR, 8-18 X 3/8 PPH ZN
	000G39-08-32B	EA SCREW-SF/DR, 8-18 X 2 PPH - ZINC

SEALANTS & FASTENERS GROUP (CONTINUED)
SCREWS (CONTINUED)

KEY	PART NUMBER	U/M DESCRIPTION
	000G39-08-243	EA SCREW-SF/DR 8-18 X 1.50 PPH - BUFF
	000G39-08-16T	EA SCREW-SF/DR, 8-18 X 1 PPH - BLACK
	000G39-08-16S	EA SCREW-SF/DR, 8-18 X 1.00 PPH, OFF WHITE
	000G39-08-16B	EA SCREW-SF/DR, 8-18 X 1 PPH ZN
	000G39-08-12T	EA SCREW-SF/DR, 8-18 X 3/4 PPH - BLACK
	000G39-08-12B	EA SCREW-SF/DR, 8-18 X 3/4 PPH ZN
	000G39-08-08S	EA SCREW-SF/DR, 8-18 X 1/2 PPH - OFF WHITE
	000G39-08-08B	EA SCREW-SF/DR, 8-18 X 1/2 PPH ZN
	000G39-10-12B	EA SCREW-SF/DR,10-16 X .75 PPH ZN
	000G39-10-10B	EA SCREW-SF/DR 10-16 X .625 - ZN
	000G39-10-08B	EA SCREW-SF/DR 10-16 X .50 P&H - ZINC
	000G39-10-20B	EA SCREW-SF/DR, 10-16 X 1 1/4 PPH ZN
	000G39-10-129	EA SCREW-SF/DR, 10-16 X 3/4 PPH - FLUOROCARBON SILVER
	000G39-10-123	EA SCREW-SF/DR, 10-16 X .75 PPH - BUFF
	000G39-10-12D	EA SCREW-SF/DR, 10-16 X 3/4 PPH - BLACK
	000G42-04-12B	EA SCREW-SF/DR 1/4-14 X 3/4 HWH ZN
	000G43-06-24B	EA SCREW-MACHINE, 6-32" X 1 1/2" ZN
	000G46-08-24T	EA SCREW-MACHINE, 8-32-1.50 IN PFH - BLACK
	000G50-04-12B	EA SCREW-MACH, 1/4-20 X 3/4 PPH ZN
	000G52-08-18B	EA SCREW-MACH - 8-32 X 1 1/8 PTH ZN
	000G54-04-20B	EA SCREW, 1/4-20 X 1 1/4 PTH - TYPE 23 - ZINC PLATED
	000G55-08-12S	EA SCREW-SF/DR - 8-18 X .75 PWH - OFF WHITE
	000G56-12-48B	EA SCREW-WOOD, 12 - 11 X 3 POH - SPECIAL HARDENED
	000G60-10-28T	EA SCREW-SF/DR, 10-16 X 1.75 - BLACK
	000G67-10-10B	EA SCREW, 10-12 X 5/8 PPH ZN - TYPE A
	000G67-10-08R	EA SCREW, 10-12 X 1/2 PPH - BEIGE - TYPE A
	000G67-10-08B	EA SCREW, 10-12 X 1/2 PPH ZN
	000G67-10-120	EA SCREW, 10-12 X .75" PPH - TAN
	000G67-10-12S	EA SCREW - 10-12 X .75 PPH OFFWHITE
	000G67-10-12B	EA SCREW, 10-12 X 3/4" PPH - ZN
	000G67-10-10D	EA SCREW, 10-12 X 5/8 PPH - BLACK - TYPE A
	000G67-10-36T	EA SCREW - 10-12 X 2.25PPH BLACK - STALGARD
	000G67-10-24B	EA SCREW, 10-12 X 1 1/2 PPH - ZN
	000G67-10-20D	EA SCREW, 10-12 X 1 1/4 PPH - BLACK
	000G68-06-10G	EA SCREW, 6-18 X 5/8 POH - ANTIQUE BRASS
	049465-01-000	EA SCREW, 10-16 W/WASHER PTH - DARK BROWN
	049465-03-000	EA SCREW, 10-16 X 1 POH W/WASHER - OFF WHITE
	049465-04-000	EA SCREW, 10-16 X 1 PTH W/WASHER - BEIGE
	075908-01-000	EA SCREW-MACHINE, 10-32 X .56 PTH - ZINC EXTERNAL TOOTH
	086256-01-000	EA SCREW ASM-SF/DR 8 X .75 HWH LG - PL BODY PNL MT
	101618-01-000	EA SCREW - 1/4-20 X 3/4 HEX/TAPPING - STALGARD TYPE F
	116111-02-01A	EA SCREW-TAPTITE - 1/4-20 X 3/8 PPH - ZINC
	117322-01-000	EA SCREW - 1/4-28 UNF-2A,TORX - U.T. 6270020 SC25WJ

SEALANTS & FASTENERS GROUP (CONTINUED)
CLAMPS

KEY	PART NUMBER	U/M DESCRIPTION
	007161-01-000	EA CLAMP-HOSE, SPRING TYPE - 1/2"
	010495-01-000	EA CLAMP-CABLE, 9/16"
	010497-01-000	EA CLAMP-CLOSED, 5/8" ID
	010497-03-000	EA CLAMP-CLOSED, 1" ID - CUSHIONED
	010497-05-000	EA CLAMP-CLOSED, 1/2" ID
	010499-01-000	EA CLAMP-CLOSED, 3/8" ID
	062401-01-000	EA CLAMP-HOSE, WORMGEAR .25" - 1"
	062401-02-000	EA CLAMP-HOSE, WORMGEAR, 1.56" - 2.5"
	062401-03-000	EA CLAMP-HOSE, WORMGEAR, .22" - 1"
	062401-04-000	EA CLAMP-HOSE, WORMGEAR .69"- 1.25"
	062401-06-000	EA CLAMP-HOSE, WORMGEAR .22"-.62"
	062401-11-000	EA CLAMP-HOSE, WORMGEAR 3.56"- 4.5"
	075148-02-000	EA CLAMP-GROUNDING, BRONZE SCREWS
	083609-01-000	EA CLAMP-WIRE, DUAL EQUAL - 5/8" DIAMETER
	083610-01-000	EA CLAMP-WIRE, DUAL - UNEQUAL DIAMETERS - .75" & 1.25"

RIVETS, GROMMETS & MISCELLANEOUS

KEY	PART NUMBER	U/M DESCRIPTION
	000H16-04-06R	EA RIVET-POP, AL 1/8 X .313-.375
	000H16-06-10R	EA RIVET-POP, AL 3/16 X .501-.625
	008380-01-000	EA GROMMET-RUBBER, 5/8" HOLE X 1 1/2" DIA - BLACK
	016188-03-000	EA GROMMET-L/P LINE, 3/8" HOLE X 2 1/2" LONG - RUBBER
	016188-05-000	EA GROMMET-L/P LINE, 3/8" HOLE X 1 1/4" LONG - RUBBER
	023942-01-000	EA GROMMET-RUBBER, 2" OD
	056134-02-000	EA HOLDER-RING, 1.8" DIAMETER - METAL
	077955-01-000	EA CLIP-J,VINYL COATED, 3/8"
	080211-03-000	EA CLIP-MOUNTING, (XMAS TREE) - DECORATIVE PADS
	080734-02-000	EA CLIP-WIRE, NYLON
	094362-02-000	EA CLIP-CHRISTMAS TREE, FLAT HEAD - .5" X .95"
	091952-02-000	EA CLIP-GRIPPER, 3/4"
	099637-01-000	EA GROMMET-RUBBER, .37" X .94" DIAMETER - BLACK
	071015-26-000	EA GROMMET-RUBBER, 1.5" ID X 2.12 " OD W/.06" GROOVE - BLACK
	008343-01-000	EA TIE-WIRE, 6"
	008343-02-000	EA TIE-WIRE, 14"
	029094-04-000	YD VELCRO TAPE-LOOP, 1" WIDE - BLACK
	029096-03-000	YD VELCRO TAPE-HOOK, 1" WIDE - BLACK
	029096-04-000	YD TAPE-HOOK, VELCRO - 1" WIDE - BLACK
	085774-01-000	FT FASTENER-DUAL HOOK, 1" WIDE - ADHESIVE BACK - BLACK
	085774-02-000	FT FASTENER-DUAL LOOP, 1" WIDE - ADHESIVE BACK - BLACK
	086285-01-000	EA SPACER-NYLON, .5" OD X .257" ID
	081211-05-000	EA PLUG-PLASTIC, .188 DIA - NATURAL
	108046-02-000	EA CABLE TIE-SCREW MOUNT 15" - DENNISON 10035
	114208-02-000	EA GROMMET-EDGE LINER, FITS .625 - HEYCO 2073

WATER & SEWAGE GROUP
ATWOOD WATER HEATER W/MOTOR AID

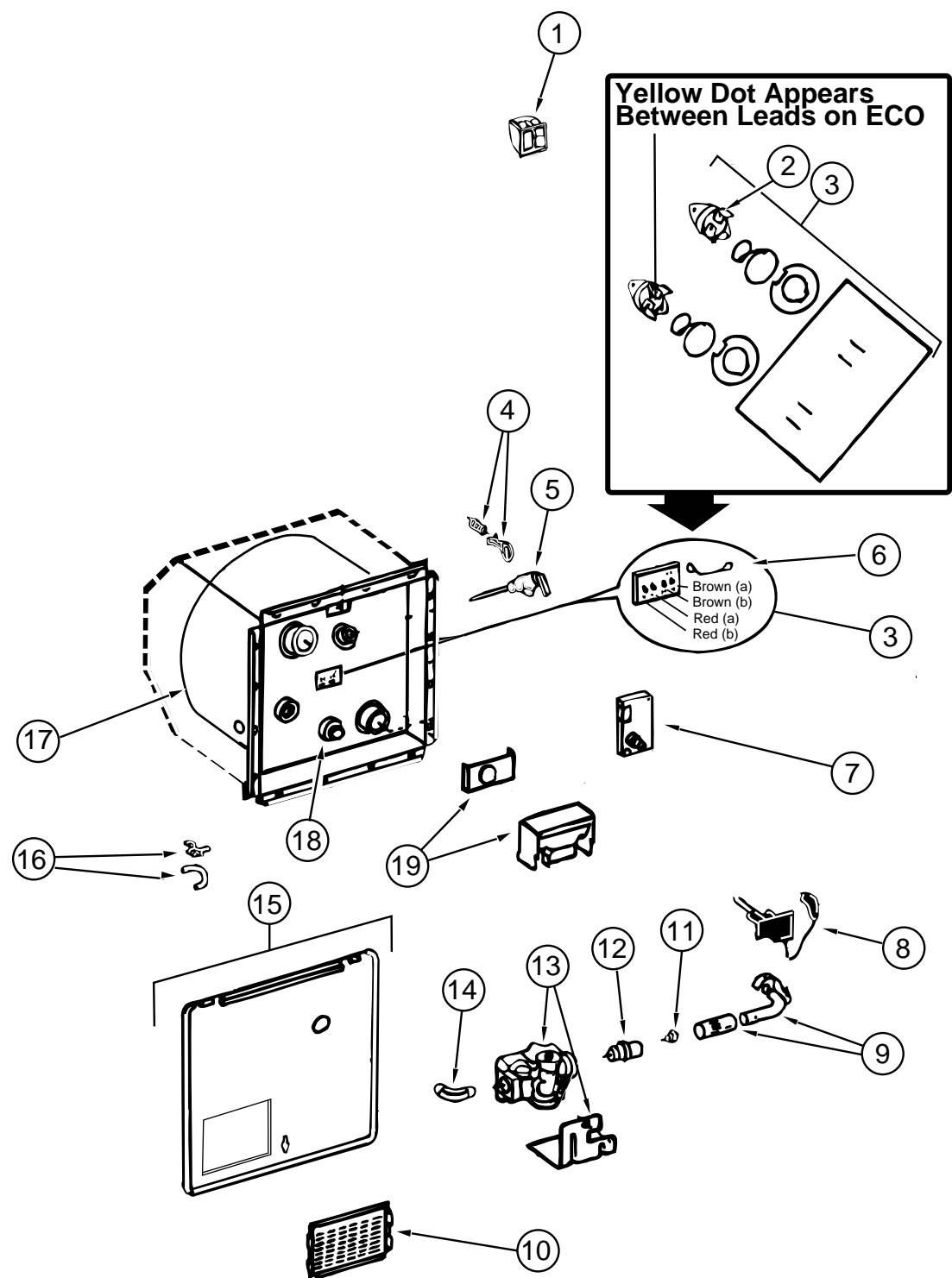

KEY	PART NUMBER	U/M	DESCRIPTION	VENDER NO.
	051393-01-000	EA	WATER HEATER-W/MOTOR AID, PILOTLESS IGNITION GH6-7E	
1	097967-01-000	EA	SWITCH-WATER HEATER, REMOTE W/LIGHT - 91959	
2	051391-04-701	EA	THERMOSTAT 12VDC-120 PRESET	91470
3	051393-01-721	EA	THERMOSTAT W/ECO, 140 FRT MT	91447
4	051391-01-705	EA	FASTENER-CAMLOCK	92609
5	051391-01-704	EA	VALVE-RELIEF, 1/2" FITTING	91604
6	051393-01-723	EA	SWITCH-THERMAL-CUT OFF 2/PKG	93866
7	051393-01-724	EA	BOARD-CIRCUIT, SPADE TERMINAL	93867
8	051393-01-725	EA	ELECTRODE-SGL SPADE CONNECT	93868
9	051391-04-703	EA	BURNER-MAIN, 4E & 6E	91638
10	051391-01-717	EA	GRILLE, F/WATER HEATER DOOR	92640
11	051391-01-710	EA	ORIFICE-MAIN BURNER	92742
12	051391-03-700	EA	HOLDER-ORIFICE	91563
13	051393-01-726	EA	VALVE-SOLENOID, W/BRACKET	93870
14	051391-01-714	EA	FITTING-ELBOW 45, 3/8F X 3/8MPT	91044
15	052009-06-000	EA	DOOR-WATER HEATER, BRIGHT WHITE	
16	051391-01-700	EA	HINGE KIT, (PIN & CLIP)	92568 & 92559
17	051391-04-704	EA	TANK-INNER (FRT-MT) GH6-4E & 6E	91642
18	051391-01-715	EA	PLUG-DRAIN, 1 EA = 2 PER PKG	91857
19	051391-04-707	EA	KIT (FLU & GASKET) F/EXHAUST	90960

WATER & SEWAGE GROUP (CONTINUED)

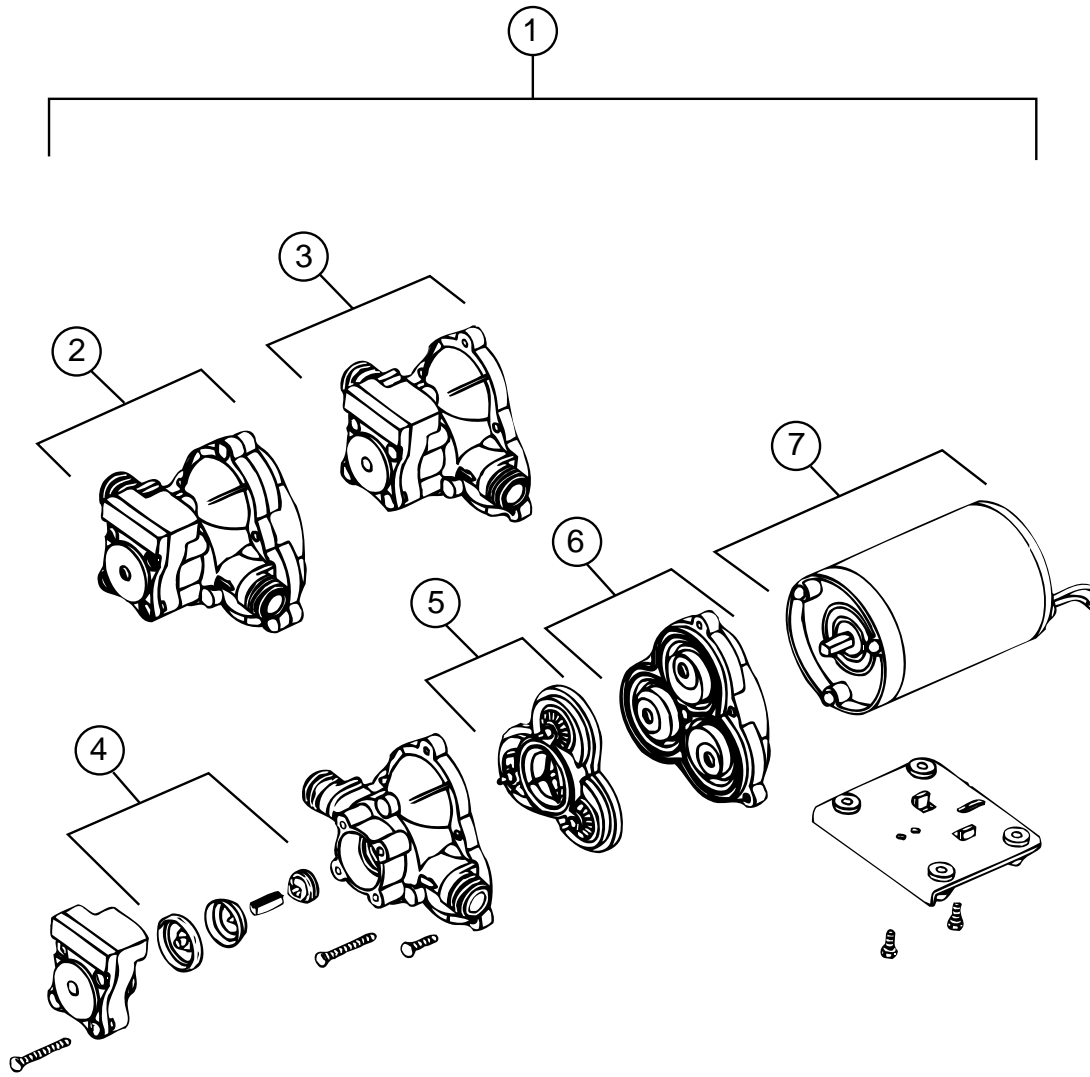

WATER PUMP (SHURFLO)

KEY	PART NUMBER	U/M DESCRIPTION	VENDER NO.
1	098607-01-000	EA PUMP-WATER, W/.5" MPT FITTING - FLOW 2.8 GPM - UL	
2	098607-01-700	EA PUMPHEAD-REPLACEMENT	94-236-08
3	098607-01-706	EA UPPER HOUSING/ SWITCH KIT	94-231-20
4	098607-01-705	EA CHECK VALVE - KIT	94-237-00
5	098607-01-703	EA VALVE ASM	94-232-00
6	098607-01-702	EA DRIVE/ DIAPHRAGM - KIT	94-238-04
7	098607-01-707	EA MOTOR W/BASEPLATE	11-148-04

WATER & SEWAGE GROUP (CONTINUED)
WATER TANK

KEY	PART NUMBER	U/M DESCRIPTION
	117898-03-000	EA TANK ASM-WATER 50 GAL - W/FITTINGS - TWIN BED
	117898-01-000	EA TANK-WATER BASE, 50 GAL - W/O FITTINGS
	117898-02-000	EA TANK ASM-WATER 50 GAL - W/FITTINGS - QUEEN BED
	117898-01-000	EA TANK-WATER BASE, 50 GAL - W/O FITTINGS
	039861-01-000	EA SENDING UNIT-W/SCREW, WASHER, WELL NUT & TERMINAL RING
	010224-01-000	EA ADAPTER-HOSE TO PIPE, 3/8" MPT X 3/8" BARB - PLASTIC BLACK
	042989-03-000	EA FITTING-WATER TANK, SPINWELD - 1 1/4"NPT - PLASTIC - WHITE
	042989-04-000	EA FITTING-WATER TANK, SPINWELD - 3/8" FPT - PLASTIC - WHITE
	042989-05-000	EA FITTING-WATER TANK, SPINWELD - 1/2" FPT - PLASTIC - WHITE
	044927-01-000	EA ADAPTER-HOSE TO PIPE, 1 1/4"MPT X 1 1/4"BARB-BLACK PLASTIC
	049032-01-000	EA PATCH-SPINWELD, 3/8" - PLASTIC
	052955-01-000	EA TEE-1/2"F X 1/2"F X 1/2"MPT - PLASTIC
	074462-02-000	FT TUBING-VINYL, 3/8" ID - CLEAR - INCREMENTS OF 20'
	077954-02-000	EA FILTER-WATER TANK, SCREEN IN TANK
	079381-01-000	FT TUBING-SMOOTH FLEXIBLE, 1 1/4" ID - INCREMENTS OF 20'

EXTERIOR SHOWER KIT

KEY	PART NUMBER	U/M DESCRIPTION
	046128-01-000	EA VALVE-DRAIN-PLAS 1/2FPT
	075241-05-000	EA FAUCET-SHOWER CONTROL, BONE - P442VB
	103092-01-000	EA SHOWER HEAD-W/60 IN HOSE - ONDINE 213RUB
	114429-03-000	EA ELBOW-SWIVEL, 1/2P X 1/2FPT - FLAIR-IT 02816

WATER SYSTEM

KEY	PART NUMBER	U/M DESCRIPTION
	114427-01-000	EA CAP - 1/2P - FLAIR-IT 02860
	114427-02-000	EA PLUG - 1/2P - FLAIR-IT 02863
	114428-01-000	EA TEE - 1/2P X 1/2P X 1/2P - FLAIR-IT 02820
	114428-02-000	EA TEE-SWIVEL - 1/2P X 1/2P X 1/2FPT - FLAIR-IT 02821
	114428-03-000	EA TEE - 1/2P X 1/2P X 1/2MPT - FLAIR-IT 02822
	114429-01-000	EA ELBOW - 1/2P X 1/2P - FLAIR-IT 02800
	114429-02-000	EA ELBOW - 1/2P X 1/2MPT - FLAIR-IT 02803
	114429-03-000	EA ELBOW-SWIVEL - 1/2P X 1/2FPT - FLAIR-IT 02816
	114429-04-000	EA ELBOW - 1/2P X 3/8MPT - FLAIR-IT 02810
	114429-05-000	EA ELBOW - 1/2P X 3/4MPT - FLAIR-IT 02812
	114429-06-000	EA ELBOW-SWIVEL - 1/2P X 3/4FPT - FLAIR-IT 02811
	114430-01-000	EA ADAPTER - 1/2P X 1/2P - FLAIR-IT 02840
	114430-02-000	EA ADAPTER-SWIVEL - 1/2P X 1/2FPT - FLAIR-IT 02873
	114430-03-000	EA ADAPTER - 1/2P X 1/2MPT - FLAIR-IT 02842
	114431-01-000	EA VALVE-LINE DRAIN 1/2P - FLAIR-IT 02914
	114431-02-000	EA VALVE - 1/2P - BYPASS - FLAIR-IT 02910
	114431-03-000	EA VALVE - 1/2P X 1/2P - FLAIR-IT 02884
	114431-04-000	EA VALVE-STOP - 1/2P X 1/2P - FLAIR-IT 02880
	039800-02-000	FT TUBING-POLYBUTYL, 5/8" OD - INCREMENTS OF 20' - BLACK
	110915-01-01A	EA FILL-WATER, CITY - CHROME - KEVCO 64713
	010219-01-000	EA ELBOW - 1 1/4" MPT X 1 1/4" BARB, WATER FILL - PLASTIC
	035539-01-000	EA ELBOW-PLASTIC, 3/8"MPT X 3/8"BARB
	052956-01-000	EA TEE - 1/2" F X 1/2" MPT X 1/2" F - PLASTIC
	052957-01-000	EA ELBOW-PLASTIC, 1/2" F X 3/8" MPT
	039808-03-000	EA ELBOW - 1/2" MPT X 1/2" MPT, PLASTIC - KEVCO 17296
	101814-01-000	EA COUPLING-FEMALE, 1/2" X 1/2" FPT W/COMP. SLEEVE - GRAY
	046128-01-000	EA VALVE-DRAIN, PLASTIC - 1/2" FPT
	039800-01-000	FT TUBING-POLYBUTYL, 1/2" OD - INCREMENTS OF 20' - BLACK
	052952-01-000	EA NUT-PLASTIC, 1/2" F X 1/2" TUBE - GRAY
	052952-02-000	EA NUT-PLASTIC, 5/8" FLARE
	052958-01-000	EA TEE, 1/2" F X 1/2" F X 1/2" F - PLASTIC - GRAY
	113698-01-000	EA VALVE-LINE DRAIN, 1/2F X 1/2F PLASTIC-WATER
	055290-01-000	EA ELBOW - 5/8"F X 1/2"MPT
	057457-02-000	EA ELBOW-UNION, 5/8" X 5/8" FL - WATER
	079317-01-000	EA ADAPTER-SWIVEL, 1/2" TUBE X 1/2" FPT - PLASTIC - GRAY
	106258-01-000	EA CAP-INSERTABLE, 1/2" FLARE
	091208-01-000	EA WASHER-RUBBER, .06" X .75" X .5"

WINDOW, VENT & EXTERIOR DOOR GROUP
EXCEL EXTERIOR WINDOWS

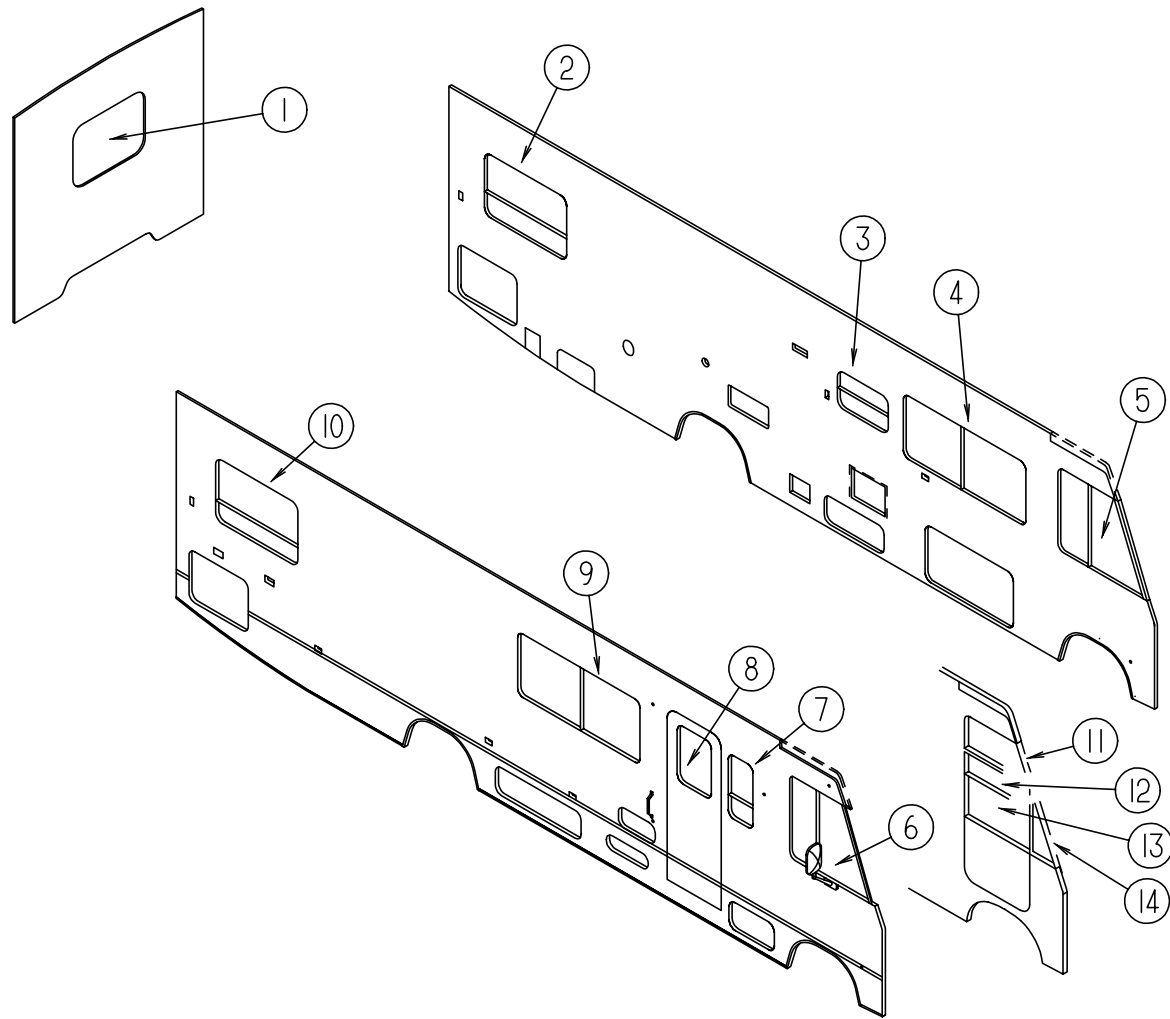

KEY	PART NUMBER	U/M	DESCRIPTION
1	078528-06-E10	EA	WINDOW ASM-ESCAPE
1	113502-01-01A	EA	WINDOW ASM- REAR ESCAPE BLK/OW - THERMOPANE - DH153-G2W60
2	113500-01-01A	EA	WINDOW ASM-TIPOUT, DOUBLE - BLK/OW - CH04-G2W59
2	112795-23-01A	EA	WINDOW ASM-SLIDER, HORIZONTAL - THERMOPANE - DRIVER SIDE DC04-G2W66L
3	098647-34-01A	EA	WINDOW ASM-SLIDER, HORIZONTAL - H425-G2W66L
3	112795-20-01A	EA	WINDOW ASM-SLIDER, HORIZONTAL - THERMOPANE - DC29-G2W66L
4	098647-22-01A	EA	WINDOW ASM-SLIDER, HORIZONTAL BLK/OW - H287-G2W66L
4	112795-15-01A	EA	WINDOW ASM-SLIDER, HORIZONTAL - THERMOPANE - DH287-G2W66L
5	103658-09-01A	EA	WINDOW ASM-CAB DRIVER - H405-A2B66L
5	113501-03-01A	EA	WINDOW ASM-CAB DRIVER - THERMOPANE - DH405-A2B66L
6	103658-10-01A	EA	WINDOW ASM-CAB, PASSENGER - H405-A2B66R
6	113501-04-01A	EA	WINDOW ASM-CAB, PASSENGER - THERMOPANE - DH405-A2B66R
7	098644-07-01A	EA	WINDOW ASM-SINGLE RAISE BLK/OW - H170-G2W66
7	112898-04-01A	EA	WINDOW ASM-SLIDER, VERTICAL - THERMOPANE - DC02-G2W66
8	117053-02-F36	EA	WINDOW-ENTRY DOOR, PICTURE
8	113733-01-01A	EA	WINDOW ASM-STATIONARY, THERMOPANE - DH416-G2W66
9	098647-23-01A	EA	WINDOW ASM-SLIDER, HORIZONTAL BLK/OW - H287-G2W66R
9	112795-16-01A	EA	WINDOW ASM-SLIDER, HORIZONTAL - THERMOPANE - DH287-G2W66R
10	113500-01-01A	EA	WINDOW ASM-TIPOUT, DOUBLE - BLK/OW - CH04-G2W59
10	112795-21-01A	EA	WINDOW ASM-SLIDER, HORIZONTAL - THERMOPANE - PASSENGER SIDE DC04-G2W66R
11	106467-02-01A	EA	WINDOW-VISTA, DRIVER SIDE
11	116000-05-01A	EA	WINDOW ASM-VISTA, LH - THERMOPANE
12	106469-02-702	EA	WINDOW-DRIVER DOOR, STATIONARY GLASS
13	106469-01-704	EA	WINDOW-DRIVER DOOR, ROLL-UP GLASS ASM. - W/BACKET
14	106468-02-01A	EA	WINDOW-FRONT SLANT - H383-A2B27L
14	115999-02-01A	EA	WINDOW ASM-FRONT SLANT, LH - THERMOPANE

WINDOW, VENT & EXTERIOR DOOR GROUP (CONTINUED)

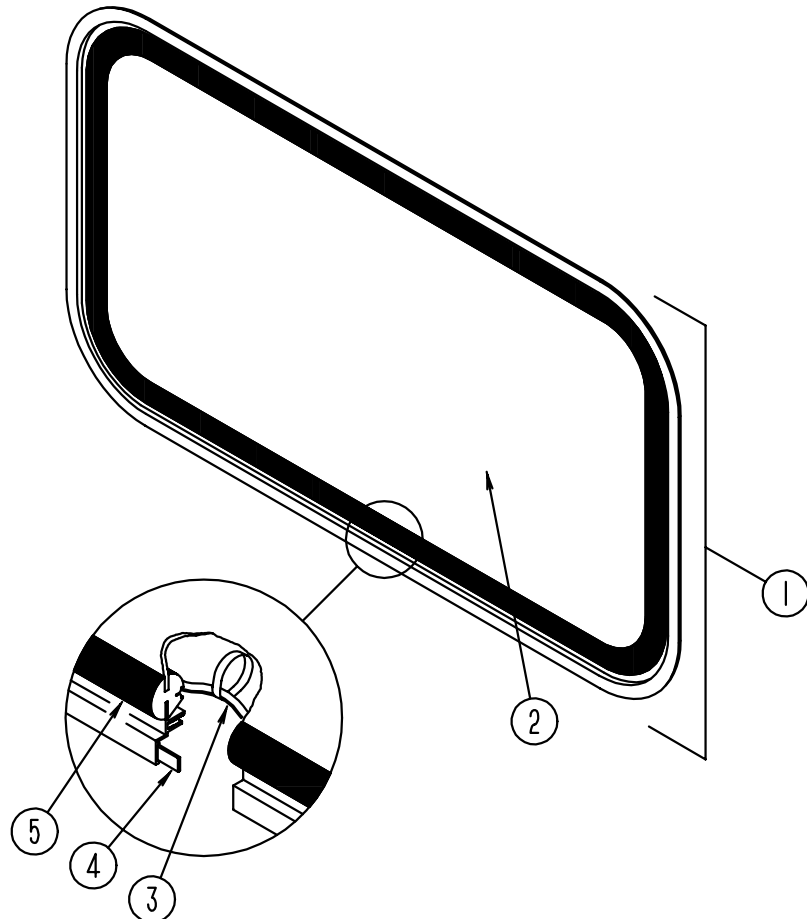

BACKWALL ESCAPE WINDOW

KEY	PART NUMBER	U/M DESCRIPTION
	074816-11-000	EA FRAME-WINDOW, INSIDE - ESCAPE - OFF WHITE
1	078528-06-E10	EA WINDOW-ESCAPE, BACKWALL - W/O INSIDE FRAME
2	076337-12-000	EA GLASS-WINDOW, 1157.4 X 548.1
3	002285-01-000	FT FILLER-WEATHER STRIP, RUBBER - BLACK
	077066-01-702	EA RED POLY.005 X .500" X 150' ROLL
4	069640-10-000	FT SEALER-RIBBON, 1/32" X 1 1/2" INCREMENTS OF 90'
5	002282-09-000	EA WEATHERSTRIP-WINDOW, .125" X 130.53 - VULCANIZED - BLACK

EXCEL BACKWALL ESCAPE WINDOW THERMOPANE

KEY	PART NUMBER	U/M DESCRIPTION	VENDER NO.
	113502-01-01A	EA WINDOW ASM-REAR ESCAPE BLK/OW - DH153-G2W60	
	100322-01-703	FT STRIP-GLAZING, BUTYL	132-010723
	112898-06-704	EA HANDLE-LATCH, RED - RH	182-11293
	112898-06-705	EA HANDLE-LATCH, RED -	

WINDOW, VENT & EXTERIOR DOOR GROUP (CONTINUED)

EXCEL DRIVER SIDE BEDROOM WINDOW

KEY	PART NUMBER	U/M DESCRIPTION	VENDER NO.
	113500-01-01A	EA WINDOW ASM-TIPOUT, DOUBLE - BLK/OW - CH04-G2W59	
	100322-01-703	FT STRIP-GLAZING, BUTYL	132-010723
	098644-01-716	FT PLUG-FILLER	132-014470
	100322-01-701	FT SEAL-VENT	122-016071
	100322-01-702	EA WEATHERSTRIP-HORIZONTAL RAIL FOR TOP OF TIP OUT WINDOW	132-015976
	100322-01-703	FT STRIP-GLAZING, BUTYL	132-010723
	100322-01-704	FT TAPE-BUTYL	154-016083
	100322-01-717	EA E-RING	245-015975
	100322-01-718	EA HANDLE-DIAL	410-016081
	112519-01-702	EA OPERATOR-VENT	410-016123
	113500-01-700	EA SCREEN ASM.	410-016020
	113500-01-701	EA WINDOW W/O TRIM	CH04-G2
	113500-01-702	EA TRIM	CW0459
	113500-01-703	EA GLASS-TOP STATIONARY	106-015970
	113500-01-704	EA GLASS-UPPER VENT ASSEMBLY	CH04-G7
	113500-01-705	EA GLASS-LOWER VENT ASSEMBLY	CH04-G9
	113500-01-706	EA OPERATOR & BAR ASSEMBLY	CH04-18
	113500-01-707	EA SUPPORT-TORQUE BAR, RH	130-015979
	113500-01-708	EA SUPPORT-TORQUE BAR, LH	130-015978

EXCEL DRIVER SIDE BEDROOM THERMOPANE WINDOW

KEY	PART NUMBER	U/M DESCRIPTION	VENDER NO.
	112795-23-01A	EA WINDOW ASM-SLIDER, HORIZ THERMO - DC04-G2W66L	
	098644-01-713	EA CLIP-SPRING, BLACK PLASTIC	226-016966
	098647-29-701	EA RETAINER-TRIM, WHITE	CW0466
	098647-29-704	EA SCREEN ASM., W/SPRING CLIP	410-018864
	112795-01-700	EA LATCH ASM., BLACK	DH287-CK
	112795-01-701	EA SLIDE-STOP	132-019092
	112795-01-702	FT PLUG-FILLER	122-018737
	112795-01-703	FT CHANNEL-RUN	122-018736
	112795-01-704	FT VINYL-GLAZING	132-018280
	112795-21-701	EA GLASS-STATIONARY	390-019132
	112795-21-702	EA GLASS-SLIDING, W/SASH & LATCH	DC04-G9
	112795-23-700	EA WINDOW W/O TRIM	DC04-G2L

EXCEL DRIVER SIDE GALLEY WINDOW

KEY	PART NUMBER	U/M DESCRIPTION	VENDER NO.
	098647-34-01A	EA WINDOW ASM-SLIDER HORIZ - H425-G2W66L	
	098644-01-700	EA LATCH-REPAIR KIT (BLACK)	B801-CK
	100322-01-703	FT STRIP-GLAZING, BUTYL	132-010723
	098644-01-706	FT WEATHERSTRIP-GLASS	171-010668
	098644-01-708	FT CHANNEL-RUN, PIERCED	122-016543
	098644-01-710	FT TRACK-SCREEN SPACER, 12'	132-017135
	098644-01-711	FT WEATHERSTRIP-SCREEN, BLACK	171-016965
	098644-01-713	EA CLIP-SPRING, BLACK PLASTIC	226-016966
	098644-01-716	FT PLUG-FILLER	132-014470
	098644-01-717	FT SPLINE-SCREEN	132-004716
	098647-31-701	EA RETAINER-TRIM, WHITE	CW2966
	098647-33-702	EA GLASS-STATIONARY	106-019297
	098647-33-703	EA GLASS-SLIDING, W/SASH & LATCH	H425-G9
	098647-33-704	EA SCREEN ASM., W/SPRING CLIP	410-019134
	098647-34-700	EA WINDOW-SLIDER	H425-G2L

WINDOW, VENT & EXTERIOR DOOR GROUP (CONTINUED)
EXCEL DRIVER SIDE GALLEY THERMOPANE WINDOW

KEY	PART NUMBER	U/M DESCRIPTION	VENDER NO.
	112795-20-01A	EA WINDOW ASM-SLIDER, HORIZ THERMO - DC29-G2W66L	
	098644-01-713	EA CLIP-SPRING, BLACK PLASTIC	226-01666
	098647-31-701	EA RETAINER-TRIM, WHITE	CW2966
	098647-31-704	EA SCREEN ASM., W/SPRING CLIP	410-019128
	112795-01-700	EA LATCH ASM., BLACK	DH287-CK
	112795-01-701	EA SLIDE-STOP	132-019092
	112795-01-702	FT PLUG-FILLER	122-018737
	112795-01-703	FT CHANNEL-RUN	122-018736
	112795-01-704	FT VINYL-GLAZING	132-018280
	112795-19-701	EA GLASS-STATIONARY	390-019134
	112795-19-702	EA GLASS-SLIDING, W/SASH & LATCH	DC29-G9
	112795-20-700	EA WINDOW W/O TRIM	DC29-G2L

EXCEL DRIVER SIDE LOUNGE WINDOW

KEY	PART NUMBER	U/M DESCRIPTION	VENDER NO.
	098647-22-01A	EA WINDOW ASM-SLIDER, HORIZ BLK/OW - H287-G2W66L	
	098644-01-700	EA LATCH-REPAIR KIT (BLACK)	B801-CK
	100322-01-703	FT STRIP-GLAZING, BUTYL	132-010723
	098644-01-706	FT WEATHERSTRIP-GLASS	171-010668
	098644-01-708	FT CHANNEL-RUN, PIERCED	122-016543
	098644-01-710	FT TRACK-SCREEN SPACER, 12'	132-017135
	098644-01-711	FT WEATHERSTRIP-SCREEN, BLACK	171-016965
	098644-01-713	EA CLIP-SPRING, BLACK PLASTIC	226-016966
	098644-01-716	FT PLUG-FILLER	132-014470
	098644-01-717	FT SPLINE-SCREEN	132-004716
	098647-22-700	EA WINDOW-SLIDER	H287-G2L
	098647-23-700	EA GLASS SLIDING,W/SASH & LATCH	H287-G9
	098647-23-702	EA RETAINER-TRIM, WHITE	W28766
	098647-23-703	EA GLASS-STATIONARY	106-017622
	098647-23-704	EA SCREEN ASM., W/SPRING CLIP	410-019066

EXCEL DRIVER SIDE LOUNGE THERMOPANE WINDOW

KEY	PART NUMBER	U/M DESCRIPTION	VENDER NO.
	112795-15-01A	EA WINDOW ASM-SLIDER, HORIZ THERMO - DH287-G2W66L	
	098644-01-713	EA CLIP-SPRING, BLACK PLASTIC	226-016966
	098647-23-702	EA RETAINER-TRIM, WHITE	W28766
	098647-23-704	EA SCREEN ASM., W/SPRING CLIP	410-019066
	112795-01-700	EA LATCH ASM., BLACK	DH287-CK
	112795-01-701	EA SLIDE-STOP	132-019092
	112795-01-702	FT PLUG-FILLER	122-018737
	112795-01-703	FT CHANNEL-RUN	122-018736
	112795-01-704	FT VINYL-GLAZING	132-018280
	112795-15-700	EA WINDOW W/O TRIM	DH287-G2L
	112795-15-701	EA GLASS-STATIONARY	390-019045
	112795-15-702	EA GLASS-SLIDING, W/SASH & LATCH	DH287-G9

EXCEL DRIVER SIDE CAB WINDOW

KEY	PART NUMBER	U/M DESCRIPTION	VENDER NO.
	103658-09-01A	EA WINDOW ASM-CAB, DRIVER - H405-A2B66L	
	098644-01-700	EA LATCH-REPAIR KIT (BLACK)	B801-CK
	098644-01-706	FT WEATHERSTRIP-GLASS	171-010668
	098644-01-708	FT CHANNEL-RUN, PIERCED	122-016543
	098644-01-710	FT TRACK-SCREEN SPACER, 12'	132-017135
	098644-01-711	FT WEATHERSTRIP-SCREEN, BLACK	171-016965
	098644-01-713	EA CLIP-SPRING, BLACK PLASTIC	226-016966
	098644-01-716	FT PLUG-FILLER	132-014470
	098644-01-717	FT SPLINE-SCREEN	132-004716
	103658-09-700	EA GLASS-STATIONARY, RT OR LT	106-018971
	103658-09-701	EA WINDOW ASM., W/O TRIM	H405-A2L
	103658-09-704	EA GLASS-SLIDING,W/SASH & LATCH	H405-A9L
	103658-09-705	EA SCREEN ASSEMBLY	410-018973L

WINDOW, VENT & EXTERIOR DOOR GROUP (CONTINUED)
EXCEL DRIVER SIDE CAB THERMOPANE WINDOW

KEY	PART NUMBER	U/M DESCRIPTION	VENDER NO.
	113501-03-01A	EA WINDOW ASM-CAB, THERMOPANE LH - DH405-A2B66L	
	098644-01-711	FT WEATHERSTRIP-SCREEN, BLACK	171-016965
	098644-01-713	EA CLIP-SPRING, BLACK PLASTIC	226-016966
	103658-09-705	EA SCREEN ASSEMBLY	410-018973L
	112795-01-700	EA LATCH ASM., BLACK	DH287-CK
	112795-01-701	EA SLIDE-STOP	132-019092
	112795-01-702	FT PLUG-FILLER	122-018737
	112795-01-703	FT CHANNEL-RUN	122-018736
	112898-04-703	EA SASH LATCH KIT, RAISED	DH343-CK
	113501-03-700	EA WINDOW W/O TRIM	DH405-A2L
	113501-03-701	EA GLASS-STATIONARY	390-019397L
	113501-03-702	EA GLASS-SLIDE ASSEMBLY	DH405-A9L

EXCEL PASSENGER SIDE CAB WINDOW

KEY	PART NUMBER	U/M DESCRIPTION	VENDER NO.
	103658-10-01A	EA WINDOW ASM-CAB, PASSENGER - H405-A2B66R	
	098644-01-700	EA LATCH-REPAIR KIT (BLACK)	B801-CK
	098644-01-706	FT WEATHERSTRIP-GLASS	171-010668
	098644-01-708	FT CHANNEL-RUN, PIERCED	122-016543
	098644-01-710	FT TRACK-SCREEN SPACER, 12'	132-017135
	098644-01-711	FT WEATHERSTRIP-SCREEN, BLACK	171-016965
	098644-01-713	EA CLIP-SPRING, BLACK PLASTIC	226-016966
	098644-01-716	FT PLUG-FILLER	132-014470
	098644-01-717	FT SPLINE-SCREEN	132-004716
	103658-09-700	EA GLASS-STATIONARY, RT OR LT	106-018971
	103658-10-700	EA WINDOW ASM., W/O TRIM	H405-A2R
	103658-10-703	EA GLASS-SLIDING,W/SASH & LATCH	H405-A9R
	103658-10-704	EA SCREEN ASSEMBLY	410-018973R

EXCEL PASSENGER SIDE CAB THERMOPANE WINDOW

KEY	PART NUMBER	U/M DESCRIPTION	VENDER NO.
	113501-04-01A	EA WINDOW ASM-CAB,THERMOPANE RH - DH405-A2B66R	
	098644-01-711	FT WEATHERSTRIP-SCREEN, BLACK	171-016965
	098644-01-713	EA CLIP-SPRING, BLACK PLASTIC	226-016966
	103658-10-704	EA SCREEN ASSEMBLY	410-018973R
	112795-01-700	EA LATCH ASM., BLACK	DH287-CK
	112795-01-701	EA SLIDE-STOP	132-019092
	112795-01-702	FT PLUG-FILLER	122-018737
	112795-01-703	FT CHANNEL-RUN	122-018736
	112898-04-703	EA SASH LATCH KIT, RAISED	DH343-CK
	113501-04-700	EA WINDOW W/O TRIM	DH405-A2R
	113501-04-701	EA GLASS-STATIONARY	390-019395R
	113501-04-702	EA GLASS-SLIDE ASSEMBLY	DH405-A9R

EXCEL PASSENGER SIDE LOUNGE WINDOW

KEY	PART NUMBER	U/M DESCRIPTION	VENDER NO.
	098644-07-01A	EA WINDOW ASM-SINGLE RAISE BLK/OW - H170-G2W66	
	098644-01-700	EA LATCH-REPAIR KIT (BLACK)	B801-CK
	100322-01-703	FT STRIP-GLAZING, BUTYL	132-010723
	098644-01-706	FT WEATHERSTRIP-GLASS	171-010668
	098644-01-708	FT CHANNEL-RUN, PIERCED	122-016543
	098644-01-710	FT TRACK-SCREEN SPACER, 12'	132-017135
	098644-01-711	FT WEATHERSTRIP-SCREEN, BLACK	171-016965
	098644-01-713	EA CLIP-SPRING, BLACK PLASTIC	226-016966
	098644-01-716	FT PLUG-FILLER	132-014470
	098644-01-717	FT SPLINE-SCREEN	132-004716
	098644-07-700	EA WINDOW-SLIDER	H170-G2
	098644-07-701	EA RETAINER-TRIM, OFF WHITE	CW0266
	098644-07-702	EA GLASS-STATIONARY	106-015777
	098644-07-703	EA GLASS-SLIDING,W/SASH & LATCH	H170-G9
	098644-07-704	EA SCREEN ASM., W/SPRING CLIP	410-018863

WINDOW, VENT & EXTERIOR DOOR GROUP (CONTINUED)
EXCEL PASSENGER SIDE LOUNGE THERMOPANE WINDOW

KEY	PART NUMBER	U/M DESCRIPTION	VENDER NO.
	112898-04-01A	EA WINDOW ASM-SLIDER, VERTICAL - THERMO - DC02-G2W66	
	098644-01-713	EA CLIP-SPRING, BLACK PLASTIC	226-016966
	098644-07-701	EA RETAINER-TRIM, OFF WHITE	CW0266
	098644-07-704	EA SCREEN ASM., W/SPRING CLIP	410-018863
	112795-01-700	EA LATCH ASM., BLACK	DH287-CK
	112795-01-701	EA SLIDE-STOP	132-019092
	112898-04-700	EA WINDOW W/O TRIM	DC02-G2
	112898-04-701	EA GLASS-STATIONARY	390-019130
	112898-04-702	EA GLASS ASSEMBLY, SLIDING	DC02-G9
	112898-04-703	EA SASH LATCH KIT, RAISED	DH343-CK

ENTRY DOOR WINDOW

KEY	PART NUMBER	U/M DESCRIPTION
	117053-02-F36	EA WINDOW-ENTRY DOOR, PICTURE
	117055-02-01A	EA FRAME-WINDOW, PICTURE - MAIN - BLK
	000H13-04-07B	EA RIVET-SEMITUB-STL 1/8 X .219
	002181-25-000	EA GLASS-PICTURE 655 X 417
	004012-02-000	QT ADHESIVE - 3M 4475 (QUART)
	053752-08-000	GL SEAM SEALER - 5 GAL, BLACK
	075201-01-000	GL SEALANT-ACRYLIC, CLEAR
	087561-01-000	FT EXTR-VINYL SEAL, TIPOUT/SLIDE
	090907-51-002	EA EXTR-STRAP

ENTRY DOOR THERMOPANE WINDOW

KEY	PART NUMBER	U/M DESCRIPTION	VENDER NO.
	113733-01-01A	EA WINDOW ASM-STATIONARY, THERMOPANE - DH416-G2W66	
	113733-01-700	EA WINDOW ASM. W/O TRIM	DH416-G2
	113733-01-701	EA TRIM (W)	W41666
	113733-01-702	EA GLASS-STATIONARY	390-019187

EXCEL PASSENGER SIDE DINETTE WINDOW

KEY	PART NUMBER	U/M DESCRIPTION	VENDER NO.
	098647-23-01A	EA WINDOW ASM-SLIDER, HORIZ BLK/OW - H287-G2W66R	
	098644-01-700	EA LATCH-REPAIR KIT (BLACK)	B801-CK
	100322-01-703	FT STRIP-GLAZING, BUTYL	132-010723
	098644-01-706	FT WEATHERSTRIP-GLASS	171-010668
	098644-01-708	FT CHANNEL-RUN, PIERCED	122-016543
	098644-01-710	FT TRACK-SCREEN SPACER, 12'	132-017135
	098644-01-711	FT WEATHERSTRIP-SCREEN, BLACK	171-016965
	098644-01-713	EA CLIP-SPRING, BLACK PLASTIC	226-016966
	098644-01-716	FT PLUG-FILLER	132-014470
	098644-01-717	FT SPLINE-SCREEN	132-004716
	098647-23-700	EA GLASS SLIDING,W/SASH & LATCH	H287-G9
	098647-23-701	EA WINDOW-SLIDER	H287-G2R
	098647-23-702	EA RETAINER-TRIM, WHITE	W28766
	098647-23-703	EA GLASS-STATIONARY	106-017622
	098647-23-704	EA SCREEN ASM., W/SPRING CLIP	410-019066

WINDOW, VENT & EXTERIOR DOOR GROUP (CONTINUED)
EXCEL PASSENGER SIDE DINETTE THERMOPANE WINDOW

KEY	PART NUMBER	U/M DESCRIPTION	VENDER NO.
	112795-16-01A	EA WINDOW ASM-SLD, HORIZ THERMO - DH287-G2W66R	
	098644-01-713	EA CLIP-SPRING, BLACK PLASTIC	226-016966
	098647-23-702	EA RETAINER-TRIM, WHITE	W28766
	098647-23-704	EA SCREEN ASM., W/SPRING CLIP	410-019066
	112795-01-700	EA LATCH ASM., BLACK	DH287-CK
	112795-01-701	EA SLIDE-STOP	132-019092
	112795-01-702	FT PLUG-FILLER	122-018737
	112795-01-703	FT CHANNEL-RUN	122-018736
	112795-01-704	FT VINYL-GLAZING	132-018280
	112795-15-701	EA GLASS-STATIONARY	390-019045
	112795-15-702	EA GLASS-SLIDING, W/SASH & LATCH	DH287-G9
	112795-16-700	EA WINDOW W/O TRIM	DH287-G2R

EXCEL PASSENGER SIDE BEDROOM WINDOW

KEY	PART NUMBER	U/M DESCRIPTION	VENDER NO.
	113500-01-01A	EA WINDOW ASM-TIPOUT, DOUBLE - BLK/OW - CH04-G2W59	
	100322-01-703	FT STRIP-GLAZING, BUTYL	132-010723
	098644-01-716	FT PLUG-FILLER	132-014470
	100322-01-701	FT SEAL-VENT	122-016071
	100322-01-702	EA WEATHERSTRIP-HORIZONTAL RAIL FOR TOP OF TIP OUT WINDOW	132-015976
	100322-01-703	FT STRIP-GLAZING, BUTYL	132-010723
	100322-01-704	FT TAPE-BUTYL	154-016083
	100322-01-717	EA E-RING	245-015975
	100322-01-718	EA HANDLE-DIAL	410-016081
	112519-01-702	EA OPERATOR-VENT	410-016123
	113500-01-700	EA SCREEN ASM.	410-016020
	113500-01-701	EA WINDOW W/O TRIM	CH04-G2
	113500-01-702	EA TRIM	CW0459
	113500-01-703	EA GLASS-TOP STATIONARY	106-015970
	113500-01-704	EA GLASS-UPPER VENT ASSEMBLY	CH04-G7
	113500-01-705	EA GLASS-LOWER VENT ASSEMBLY	CH04-G9
	113500-01-706	EA OPERATOR & BAR ASSEMBLY	CH04-18
	113500-01-707	EA SUPPORT-TORQUE BAR, RH	130-015979
	113500-01-708	EA SUPPORT-TORQUE BAR, LH	130-015978

EXCEL PASSENGER SIDE BEDROOM THERMOPANE WINDOW

KEY	PART NUMBER	U/M DESCRIPTION	VENDER NO.
	112795-21-01A	EA WINDOW ASM-SLIDER, HORIZ THERMO - DC04-G2W66R	
	098644-01-713	EA CLIP-SPRING, BLACK PLASTIC	226-016966
	098647-29-701	EA RETAINER-TRIM, WHITE	CW0466
	098647-29-704	EA SCREEN ASM., W/SPRING CLIP	410-018864
	112795-01-700	EA LATCH ASM., BLACK	DH287-CK
	112795-01-701	EA SLIDE-STOP	132-019092
	112795-01-702	FT PLUG-FILLER	122-018737
	112795-01-703	FT CHANNEL-RUN	122-018736
	112795-01-704	FT VINYL-GLAZING	132-018280
	112795-21-700	EA WINDOW W/O TRIM	DC04-G2R
	112795-21-701	EA GLASS-STATIONARY	390-019132
	112795-21-702	EA GLASS-SLIDING, W/SASH & LATCH	DC04-G9
	112898-06-704	EA HANDLE-LATCH, RED-RH	182-11293
	112898-06-705	EA HANDLE-LATCH, RED-LH	182-11294

EXCEL DRIVERS DOOR SLANT WINDOW

KEY	PART NUMBER	U/M DESCRIPTION	VENDER NO.
	106468-02-01A	EA WINDOW ASM-FRONT SLANT, LH - H383-A2B27L	
	100322-01-703	FT STRIP-GLAZING, BUTYL	132-010723
	106468-02-700	EA WINDOW	H383-A2L
	106468-02-701	EA RETAINER-TRIM, BLACK	H383-27L
	106468-02-702	EA GLASS-STATIONARY	106-018740

WINDOW, VENT & EXTERIOR DOOR GROUP (CONTINUED)
EXTERIOR DOORS & VENTS

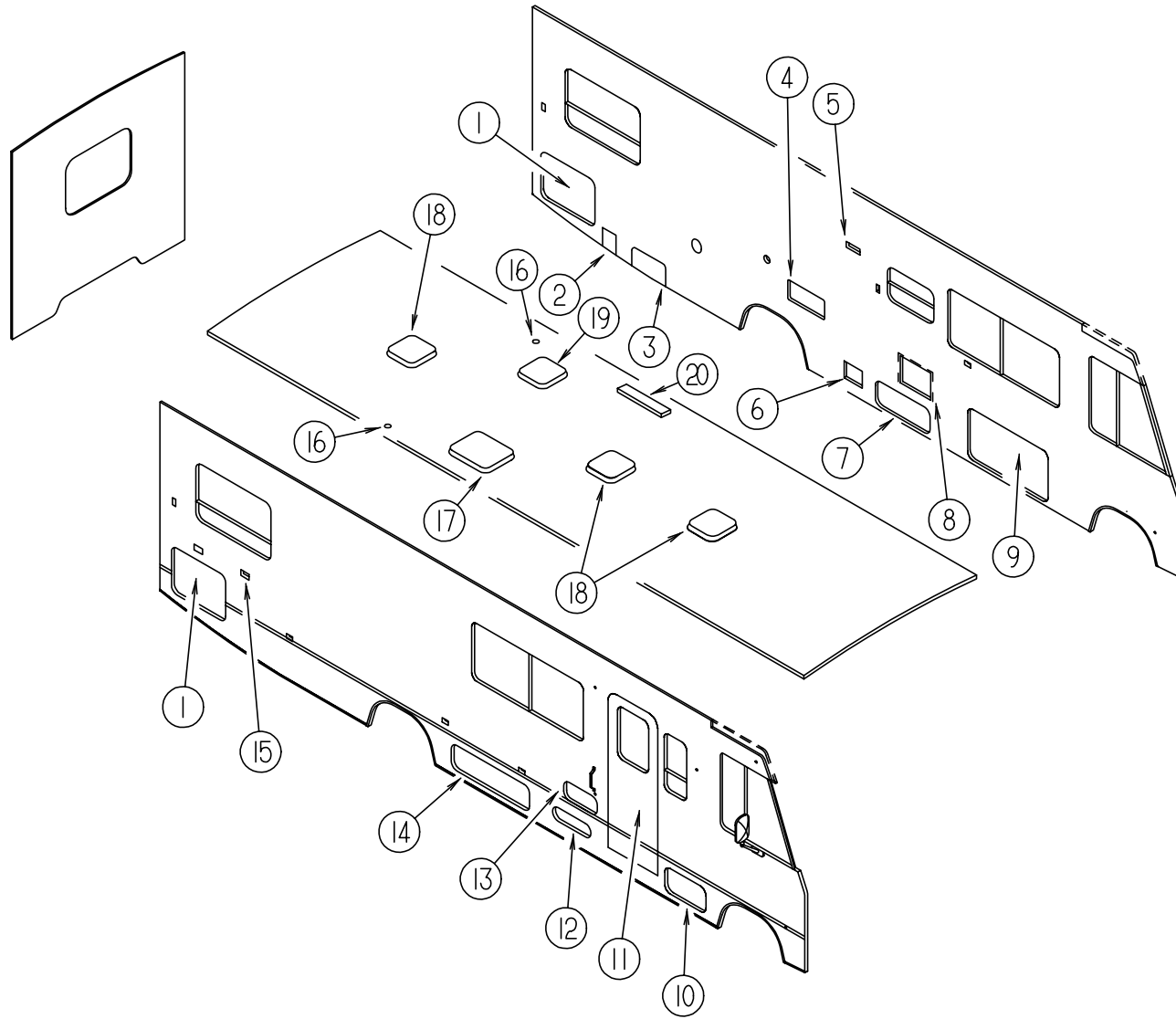

KEY	PART NUMBER	U/M	DESCRIPTION
1	111013-53-G29	EA	DOOR ASM-STORAGE
2	052423-07-000	EA	DOOR-ACCESS, 6.6" X 6.3" - PLASTIC - BRIGHT WHITE
	052424-06-000	EA	JAMB-DOOR, 8" X 7.7" - PLASTIC - BRIGHT WHITE
3	111012-07-G29	EA	DOOR ASM-STORAGE
4	084103-08-000	EA	DOOR-REFRIGERATOR, VENTED - W/O JAMB - BRIGHT WHITE
	084104-08-000	EA	JAMB-DOOR, REFRIGERATOR - BRIGHT WHITE
	084104-01-700	EA	LOCK-MALE, FASTENER - REFRIGERATOR DOOR
	084104-01-701	EA	LOCK-FEMALE, FASTENER - REFRIGERATOR DOOR
5	084616-07-000	EA	SHROUD-RANGE HOOD VENT, BRIGHT WHITE
	084878-09-000	EA	VENT-RANGE HOOD, SHORT - LVS
6	088794-06-000	EA	DOOR-POWER CORD, W/HATCH - BRIGHT WHITE
7	111018-03-G29	EA	DOOR ASM-GENERATOR
8	052009-06-000	EA	DOOR-WATER HEATER, BRIGHT WHITE
9	111013-09-F24	EA	DOOR ASM-STORAGE
10	111013-04-F24	EA	DOOR ASM-STORAGE
11	115108-05-G29	EA	DOOR-ENTRY W/SCREEN DOOR - W/O WINDOW
11	115108-05-G30	EA	DOOR-ENTRY W/SCREEN DOOR - W/O WINDOW
11	115108-05-G31	EA	DOOR-ENTRY W/SCREEN DOOR - W/O WINDOW
12	111009-01-F24	EA	DOOR-COMPARTMENT, LP - 16.9" X 5.4" - ALUMINUM
13	111017-01-F24	EA	DOOR-STORAGE
14	111013-13-F24	EA	DOOR ASM-STORAGE
15	081240-16-000	EA	FILL-WATER, LOCKABLE W/O LOCK - BRIGHT WHITE
	110506-02-000	EA	LOCK-KEYED, 13.64 MM - BRIGGS & STRATTON
16	083558-03-000	EA	VENT-PLUMBING PIPE ROOF, W/COVER - OFF WHITE
17	080910-01-000	EA	PANEL-SKYLITE, OUTER
			FROM: 09-11-95 THRU: 99-99-99
	077902-01-000	EA	COLLAR-SKYLITE, INNER
			FROM: 09-11-95 THRU: 99-99-99
18	110051-02-01A	EA	VENT-ROOF, NONPOWERED - 4" ROOF
19	110051-04-01A	EA	VENT-ROOF, POWERED - 4" ROOF - US
19	110051-06-01A	EA	VENT-ROOF, POWERED - 4" ROOF - CANADIAN
20	084073-07-000	EA	COVER-ROOF VENT, REFRIGERATOR - BRIGHT WHITE - NORCOLD
	084073-04-000	EA	BASE-ROOF VENT, REFRIGERATOR - BLACK - NORCOLD

WINDOW, VENT & EXTERIOR DOOR GROUP (CONTINUED)

ENTRANCE DOOR

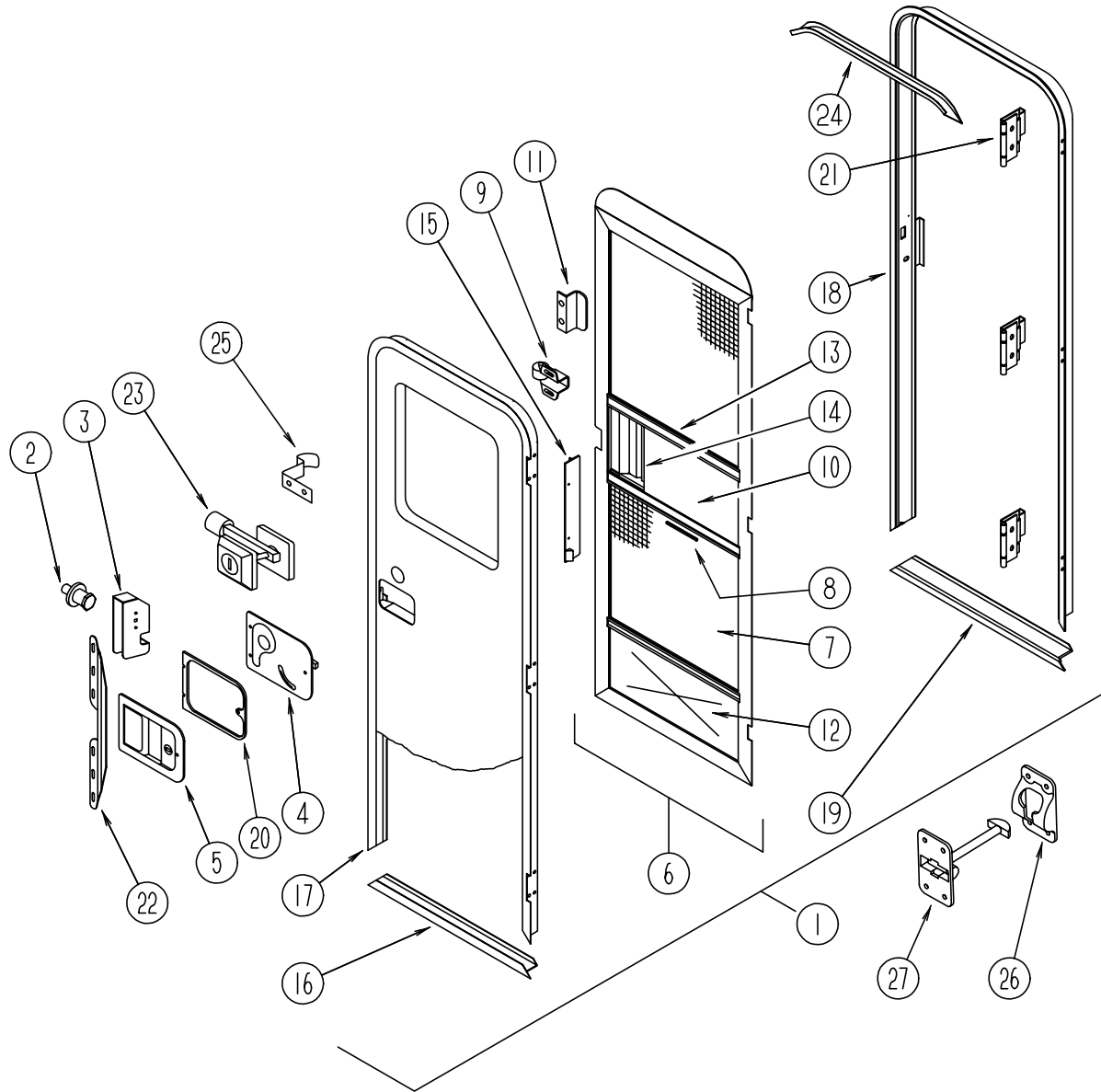

KEY	PART NUMBER	U/M	DESCRIPTION
1	115108-05-G29	EA	DOOR-ENTRY W/SCREEN DOOR - W/O WINDOW
1	115108-05-G30	EA	DOOR-ENTRY W/SCREEN DOOR - W/O WINDOW
1	115108-05-G31	EA	DOOR-ENTRY W/SCREEN DOOR - W/O WINDOW (G31,G32)
2	039539-01-000	EA	STRIKE-LOCK, ENTRY DOOR - ROUND W/THREADED WASHER
3	039540-01-000	EA	LATCH MECHANISM-HOOK, ENTRY DOOR - INTERIOR
	039715-01-000	EA	NUT-SERT, 1/4" DIAMETER - 20 THREADS
4	039979-04-000	EA	COVER-INTERIOR LATCH, W/TRIP ARM - RIGHT - BLACK
			FROM: 00-00-00 THRU: 09-10-95
4	039979-06-000	EA	COVER-INTERIOR LATCH, W/TRIP ARM - RIGHT - BLACK
			FROM: 09-11-95 THRU: 99-99-99
	039984-01-000	EA	CAP-ROUND, VINYL - .28" ID X .62" LONG - BLACK
	041546-05-000	EA	BRACKET-DOOR ANGLE, 5" X 1.9" - O/W - METAL

KEY	PART NUMBER	U/M	DESCRIPTION
5	045017-11-000	EA	LATCH-ENTRY DOOR, MECHANISM W/LOCK & KEY - BLACK
			FROM: 00-00-00 THRU: 09-10-95
5	045017-13-000	EA	LATCH-ENTRY DOOR, MECHANISM W/LOCK & KEY - BLACK
			FROM: 09-11-95 THRU: 99-99-99
	045017-11-701	EA	KEY BLANK
	058025-02-000	EA	CLIP-ROLLER LATCH CATCH, SCREEN DOOR
	063729-04-000	EA	RIVNUT, 10-32 UNF - .010-.080
	072893-01-000	EA	NUTSERT-M5 X 0, 8
	075671-04-000	FT	SEAL-SPONGE, LAZY T SHAPE - W/ADHESIVE STRIPE - .5" WIDE
6	079012-09-F24	EA	DOOR-SCREEN
	100128-02-000	FT	SEAL-FOAM, ADHESIVE BACK - SCREEN DOOR - GRAY
			FROM: 00-00-00 THRU: 07-30-95
6	1118929-01-01A	FT	SEAL-PILE, PUSH-ON
			FROM: 07-31-95 THRU: 99-99-99
7	002293-02-000	SF	SCREENING-WINDOW/DOOR, 26" - CHARCOAL
8	002294-01-000	FT	SPLINE-SCREENING, .135" X .138" - BLACK
	002748-01-000	EA	CORNER KEY-DOOR
9	109403-01-000	EA	CATCH-ASM-SINGLE ROLLER
10	016454-01-000	EA	INSERT-CENTER, LEATHER GRAIN ALUMINUM - UNPAINTED
10	001014-01-013	EA	INSERT-CENTER, 10.25" X 16.31" - UNPAINTED
11	050712-06-000	EA	HANDLE-SCREEN DOOR, ALUMINUM - BRIGHT WHITE
12	078552-03-000	EA	KICK PANEL-SCREEN DOOR, LOWER INSERT - UNPAINTED
	078595-01-000	EA	TOP PLATE-SCREEN DOOR, CURVED TOP - 4.7" X 25.35"
13	078777-01-000	EA	CHANNEL-SLIDE, SCREEN DOOR CENTER SLIDER COVER
14	079086-03-000	EA	SLIDER-SCREEN DOOR, BRIGHT WHITE
15	079087-03-000	EA	STRIKE-SLIDER, W/LIP FOR ELBOW CATCH - 1.5" X 8.6" - BRIGHT WHITE
16	089748-21-000	EA	FRAME-BOTTOM, ENTRY DOOR - 24.8" LONG - BRIGHT WHITE
	090340-01-000	FT	SEAL-FOAM, CLOSED CELL - 1/4" X 1/2" X 50'
17	095276-07-03A	EA	FRAME-ENTRY DOOR, W/O BOTTOM - BRIGHT WHITE
18	095277-09-02A	EA	JAMB-ENTRY DOOR, W/BOTTOM - BRIGHT WHITE
			FROM: 00-00-00 THRU: 07-30-95
18	120310-05-01A	EA	JAMB-ENTRY DOOR, W/BOTTOM - BRIGHT WHITE
			FROM: 07-31-95 THRU: 99-99-99
19	051049-01-000	EA	JAMB-BOTTOM, ENTRY DOOR - 25.9" - UNPAINTED
20	096810-01-01A	EA	PLATE-LATCH, ENTRY DOOR - PLASTIC - BLACK
21	106719-01-01A	EA	HINGE-ENTRY DOOR, UNPAINTED
	076725-06-000	EA	COVER-HINGE, ENTRY DOOR - 6" X 3.2" - PLASTIC
22	098173-01-04A	EA	STIFFENER-ENTRY DOOR, SUPPORTS LATCH/STRIKE AREA - UNPAINTED
23	101145-01-01A	EA	DEADBOLT-ENTRY DOOR, W/2 KEYS W/O BACK SET BOLT OR SCREWS
			FROM: 00-00-00 THRU: 09-10-95
23	101145-01-06A	EA	DEADBOLT-ENTRY DOOR, W/2 KEYS W/O BACK SET BOLT OR SCREWS
			FROM: 09-11-95 THRU: 99-99-99
	095229-01-700	EA	KEY BLANK FOR DEADBOLT
	101147-01-000	EA	BOLT-SECURITY, 4.12" BACKSET
	102524-01-000	EA	BUMPER-RUBBER, FLAT - BLACK
24	044582-44-000	EA	CAP-DRIP, ENTRY DOOR - JAMB MOUNTED - ALUMINUM - BRIGHT WHITE
	115222-01-01A	EA	GARNISH-RADIUS, ENTRY DOOR - OFF WHITE
	077461-03-000	EA	COVER-STRIKE, ENTRY DOOR - 6.5" X 2.5" - PLASTIC - WHITE
	091876-01-000	EA	RETAINER-DOOR, 1.9" X .8" - METAL
25	100412-01-000	EA	CATCH-SCREEN DOOR, THUMB CLIP W/BLACK PLASTIC CAP
26	104099-01-04A	EA	CATCH-DOOR HOLDER, STRIKE - BRIGHT WHITE
27	104099-02-04A	EA	CATCH-DOOR HOLDER, RETAINER - BRIGHT WHITE
	009126-02-000	EA	HANDLE-ASSIST, ENTRY DOOR - BLACK
			FROM: 00-00-00 THRU: 09-10-95
	009126-03-000	EA	HANDLE-ASSIST, BLACK - TEXTURED
			FROM: 09-11-95 THRU: 99-99-99
	102248-01-000	EA	SHIM-DOOR
	093673-01-01A	FT	TRIM-ENTRANCE DOOR, 1.4" WIDE X 8' LONG - OFF WHITE PLASTIC

WINDOW, VENT & EXTERIOR DOOR GROUP (CONTINUED)

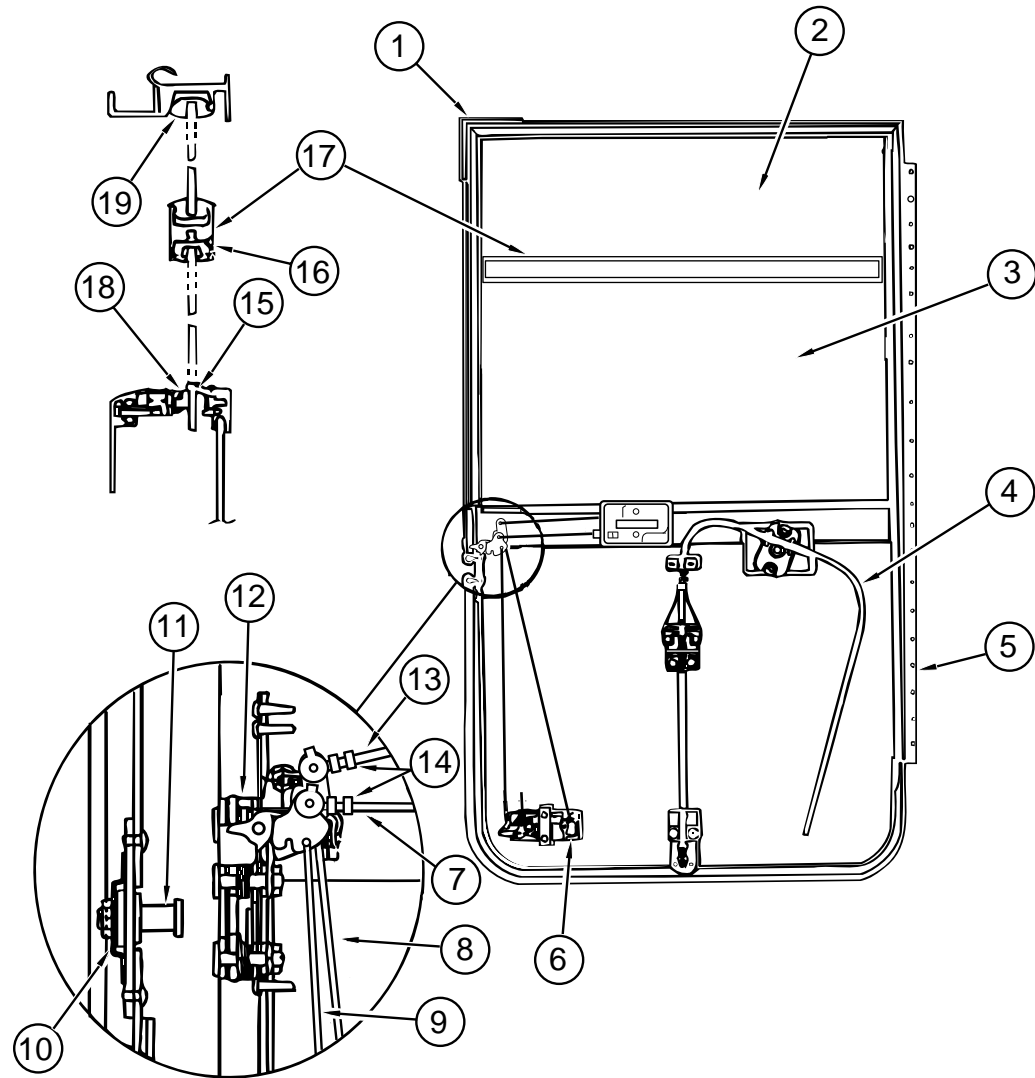

EXCEL DRIVERS DOOR

KEY	PART NUMBER	U/M	DESCRIPTION	VENDER NO.
1	106469-01-702	EA	DOOR SEAL	122-040984
2	106469-02-702	EA	GLASS-STATIONARY	106-041104
3	106469-01-704	EA	ROLL-UP GLASS ASM W/BRACKET	V103-65L
4	106469-02-701	EA	REGULATOR ASSEMBLY	V108-90L
5	106469-05-702	EA	HINGE - 42"	211-041194
6	106469-04-700	EA	PADDLE ASM. W/COLLAR	248-041237
7	106469-04-711	EA	LOCK ROD, HORIZONTAL	203-041137
8	106469-05-703	EA	LATCH ROD 9VERTICAL) ADJ.	203-041239
9	106469-05-705	EA	LOCK ROD (VERTICAL) ADJ.	203-041279
10	106469-04-704	EA	CAGED NUT ASSEMBLY (STRIKER)	248-041151
11	106469-04-703	EA	STRIKER BOLT (W/WASHER)	248-041152
12	106469-05-706	EA	ROTARY LATCH & LINKAGE	248-041150
13	106469-04-705	EA	LATCH-ROD, HORIZONTAL	203-041139
14	106469-04-714	EA	ROD CLIP RH	248-041153
	106469-04-713	EA	ROD CLIP LH	248-041154
15	106469-02-703	EA	BELT WEATHERSTRIP (EXT) WDO.	V047-57
16	106469-01-705	FT	RUN-CHANNEL	122-010850
17	106469-01-719	EA	MULLION RAIL	V103-84
18	106469-01-709	FT	WEATHERSTRIP - FUZZY	171-040630
19	106469-02-705	EA	HORIZONTAL GLAZING VINYL	V108-87
	106469-04-701	EA	TUMBLER & KEYS (TRI-MARK)	248-041179
	106469-04-702	EA	KEYS (BLANK)	248-041180

WINDOW, VENT & EXTERIOR DOOR GROUP (CONTINUED)

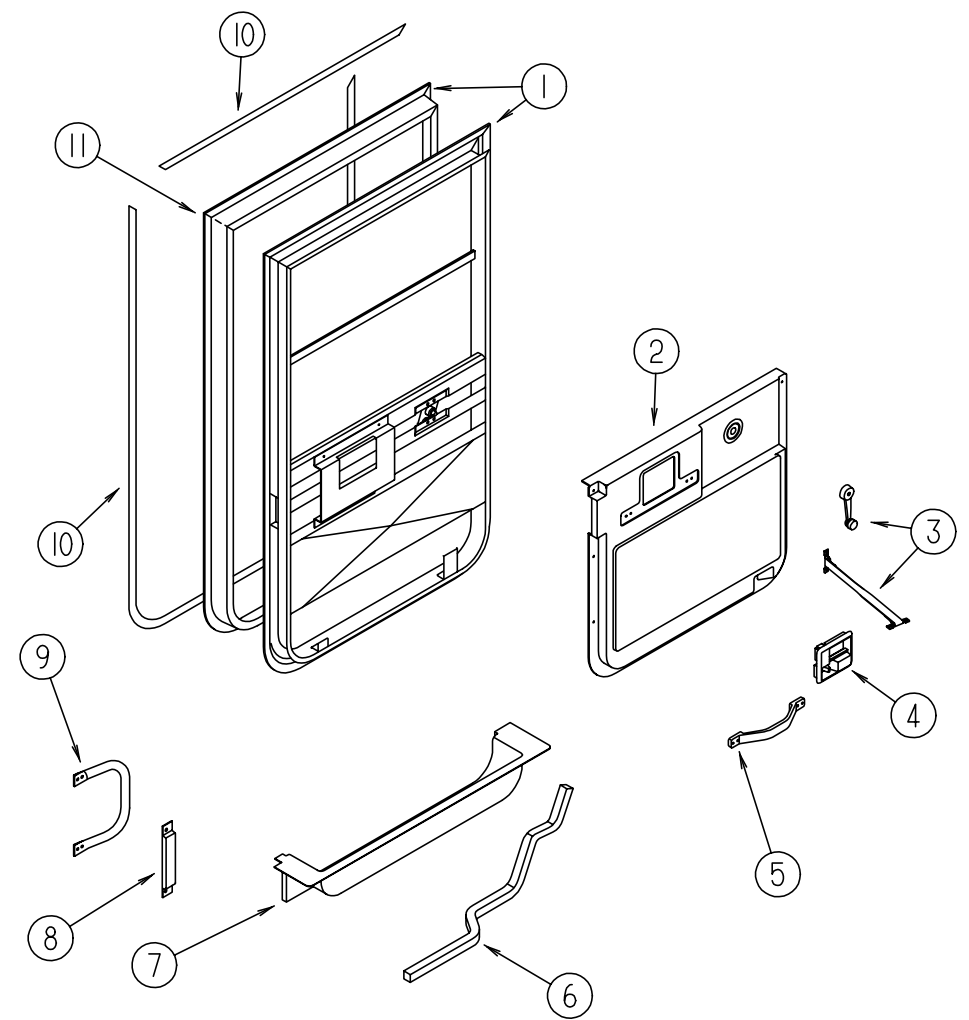

EXCEL DRIVERS DOOR

KEY	PART NUMBER	U/M	DESCRIPTION	VENDER NO.
1	106469-07-01A	EA	DOOR - DRIVERS - BLACK - V130-01L	
2	114973-01-04A	EA	PANEL - DRIVER DOOR - INNER - QUICK SILVER - PLASTIC	
3	106469-02-704	EA	PARTS BAG (WINDOW HANDLE & CRANK STRAP)	V068-16
4	106469-04-712	EA	INNER HANDLE HARDWARE LH	248-041148
5	110604-01-01A	EA	HANDLE - ASSIST - DRIVERS DOOR	
6	063977-12-000	EA	STEP-DRIVER DOOR, LH - PAINTED	
6	063977-11-000	EA	STEP-DRIVER DOOR, LH - UNPAINTED	
7	107818-01-07A	EA	TRIM-STEP, DRIVERS DOOR - PLASTIC - QUICK SILVER	
	106746-01-000	EA	PANEL-STEEL, STEPWELL	
	106747-01-000	EA	PANEL-STEEL, STEPWELL - END RH	
	106747-02-000	EA	PANEL-STEEL, STEPWELL - END LH	
	102569-02-000	EA	MAT-ANTISLIP, 4" X 22"	
8	108654-01-01A	EA	COVER-STRIKE, DRIVER DOOR - BLACK	
9	108832-01-02A	EA	HANDLE-ASSIST, DRIVER DOOR - METAL - O/W	
	108833-01-01A	EA	COVER-HANDLE, ASSIST - O/W	
10	109235-01-01A	FT	COVER - SCREW - MAT BLACK - 132-081046	
11	106469-07-700	EA	MOUNTING FRAME ASM.	V130-30L
	108129-02-02A	EA	GARNISH - DOOR - DRIVERS - FRONT - BLACK	
	108107-01-02A	EA	GARNISH - DOOR - DRIVERS - TOP - BLACK	
	108108-02-02A	EA	GARNISH - DOOR - DRIVERS - REAR UPPER - BLACK	
	108897-02-01A	EA	GARNISH - DOOR - DRIVERS - REAR LOWER - BLACK	
	P01713-01-000	EA	SWITCH-PUSH BUTTON, IN DOOR JAMB - METAL CHROME	
	076725-06-000	EA	COVER-ACCESS, DOOR JAMB PUSH BUTTON - BLACK	

WINDOW, VENT & EXTERIOR DOOR GROUP (CONTINUED)
BRIGGS & STRATION LOCKS & DOOR COMPONENTS

NOTE:
 WHEN ORDERING THE LOCK CASE, THE KEY CODE MUST MATCH THE LAST DIGIT OF THE VEHICLE'S SERIAL NUMBER AND PART NUMBER; WHEN ORDERING THE KEYS, THE THIRD DIGIT OF THE KEY CODE MUST MATCH THE LAST DIGIT OF THE VEHICLE'S SERIAL NUMBER AND PART NUMBER

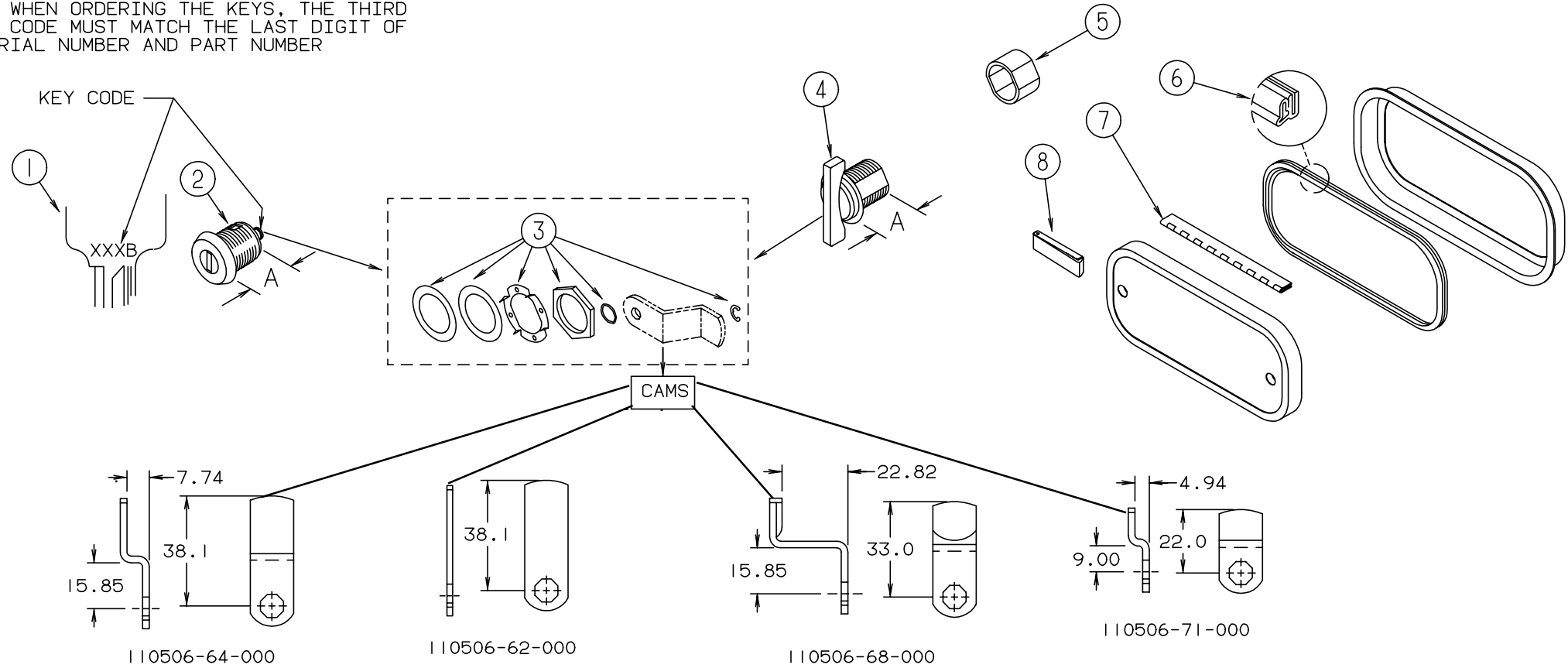

KEY	PART NUMBER	U/M DESCRIPTION	VENDER NO.
1	110506-59-000	EA KEYS - SET OF TWO	596720
2	110506-52-000	EA CASE - LOCK - A= 17 MM	702370
2	110506-53-000	EA CASE - LOCK - A= 25 MM	702380
1	110506-59-001	EA KEYS - SET OF TWO	596721
2	110506-52-001	EA CASE - LOCK - A= 17 MM	702371
2	110506-53-001	EA CASE - LOCK - A= 25 MM	702381
1	110506-59-002	EA KEYS - SET OF TWO	596722
2	110506-52-002	EA CASE - LOCK - A= 17 MM	702372
2	110506-53-002	EA CASE - LOCK - A= 25 MM	702382
1	110506-59-003	EA KEYS - SET OF TWO	596723
2	110506-52-003	EA CASE - LOCK - A= 17 MM	702373
2	110506-53-003	EA CASE - LOCK - A= 25 MM	702383
1	110506-59-004	EA KEYS - SET OF TWO	596724
2	110506-52-004	EA CASE - LOCK - A= 17 MM	702374
2	110506-53-004	EA CASE - LOCK - A= 25 MM	702384
1	110506-59-005	EA KEYS - SET OF TWO	596725
2	110506-52-005	EA CASE - LOCK - A= 17 MM	702375
2	110506-53-005	EA CASE - LOCK - A= 25 MM	702385
1	110506-59-006	EA KEYS - SET OF TWO	596726
2	110506-52-006	EA CASE - LOCK - A= 17 MM	702376
2	110506-53-006	EA CASE - LOCK - A= 25 MM	702386

KEY	PART NUMBER	U/M DESCRIPTION	VENDER NO.
1	110506-59-007	EA KEYS - SET OF TWO	596727
2	110506-52-007	EA CASE - LOCK - A= 17 MM	702377
2	110506-53-007	EA CASE - LOCK - A= 25 MM	702387
1	110506-59-008	EA KEYS - SET OF TWO	596728
2	110506-52-008	EA CASE - LOCK - A= 17 MM	702378
2	110506-53-008	EA CASE - LOCK - A= 25 MM	702388
1	110506-59-009	EA KEYS - SET OF TWO	596729
2	110506-52-009	EA CASE - LOCK - A= 17 MM	702379
2	110506-53-009	EA CASE - LOCK - A= 25 MM	702389
3	110506-40-700	EA HARDWARE KIT	596950AAL
	110506-59-701	EA KEY BLANK	
4	110506-08-000	EA LOCK - TWIST TYPE (A= 17 MM)	
4	110506-13-000	EA LOCK - TWIST TYPE (A= 25 MM)	
5	107997-51-001	EA SPACER - .86" X .6" - ALUMINUM	
6	064075-07-000	FT SEAL - BULB - W/ WIRED U CHANNEL - .3" X .5" CHANNEL - BLACK	
7	081801-V3-000	EA HINGE - PIANO - 2" X 96" - ALUMINUM - BRIGHT WHITE	
8	102768-01-000	EA HOLDER - COMPARTMENT/ ENTRY DOOR - METAL - MILL FINISH	
	081914-01-000	EA BUMPER - RUBBER - ROUND - .43" DIAMETER - BLACK	
	104692-01-000	FT SEAL - 3/4" X 3/4" - ADHESIVE BACK	
	091876-01-000	EA RETAINER - DOOR - 1.9" X .8" - METAL	

WINDOW, VENT & EXTERIOR DOOR GROUP (CONTINUED)
JENSEN POWERED ROOF VENT

KEY	PART NUMBER	U/M DESCRIPTION	VENDER NO.
	110051-04-01A	EA VENT-ROOF, POWERED - 4" ROOF - 7797 WHE	
	048648-01-000	EA MOTOR-ROOF VENT, 1/8 SHAFT - 12V	
	048649-01-000	EA FAN-ROOF VENT, 6 BLADES - 6"	
	064470-01-700	EA COVER-ROOF VENT	7291
	110051-01-704	EA GARNISH W/SCREEN & FRAME - 4"	29-688-03
	110051-01-702	EA LIFT ASM-VENT LID W/O CRANK	RP-1000B
	110051-01-703	EA CRANK	RP-1031-B

JENSEN NONPOWERED ROOF VENT

KEY	PART NUMBER	U/M DESCRIPTION	VENDER NO.
	110051-02-01A	EA VENT-ROOF, NONPOWERED - 4" ROOF - 7727 WHE	
	064470-01-700	EA COVER-ROOF VENT	7291
	110051-01-704	EA GARNISH W/SCREEN & FRAME - 4"	29-688-03
	110051-01-702	EA LIFT ASM-VENT LID W/O CRANK	RP-1000B
	110051-01-703	EA CRANK	RP-1031-B

VENTS, SHROUDS & ROOF COVERS

KEY	PART NUMBER	U/M DESCRIPTION
	083558-03-000	EA VENT-PLUMBING PIPE ROOF W/COVER - OFF WHITE
	084616-07-000	EA SHROUD-RANGE HOOD VENT, PLASTIC -BRIGHT WHITE
	084878-09-000	EA VENT-RANGE HOOD, SHORT - LVS
	084073-07-000	EA COVER-ROOF VENT, REFRIGERATOR - BRIGHT WHITE - NORCOLD
	084073-04-000	EA BASE-ROOF VENT, REFRIGERATOR - BLACK - NORCOLD
	105028-01-000	EA FLASHING ASM-VENT, REFRIGERATOR

WINDOW, VENT & EXTERIOR DOOR GROUP (CONTINUED)

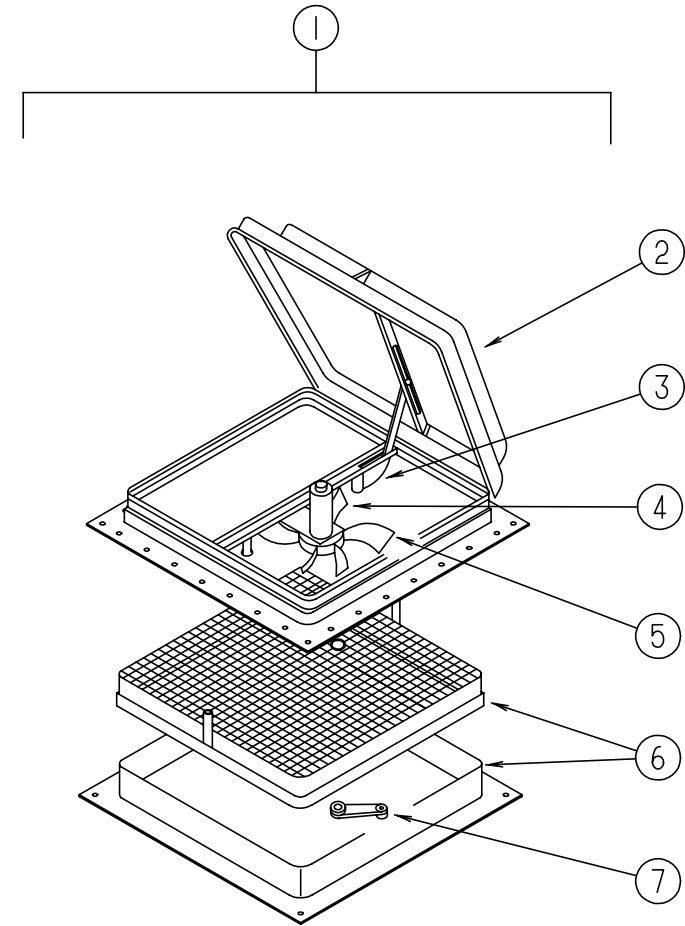

POWERED ROOF VENT - JENSEN - CANADIAN

KEY	PART NUMBER	U/M DESCRIPTION	VENDER NO.
1	110051-06-01A	EA VENT-ROOF, POWERED - 4" ROOF - CSA - C7797 WHE	
2	064470-01-700	EA COVER-ROOF VENT	7291
3	110051-01-702	EA LIFT ASM-VENT LID W/O CRANK	RP-1000B
4	048648-01-000	EA MOTOR-ROOF VENT, 1/8 SHAFT - 12V	
5	048649-01-000	EA FAN-ROOF VENT, 6 BLADES - 6"	
6	110051-01-704	EA GARNISH W/SCREEN & FRAME-4"	29-688-03
7	110051-01-703	EA CRANK HANDLE-ROOF VENT	RP-1031-B

WINDSHIELD & WIPER GROUP

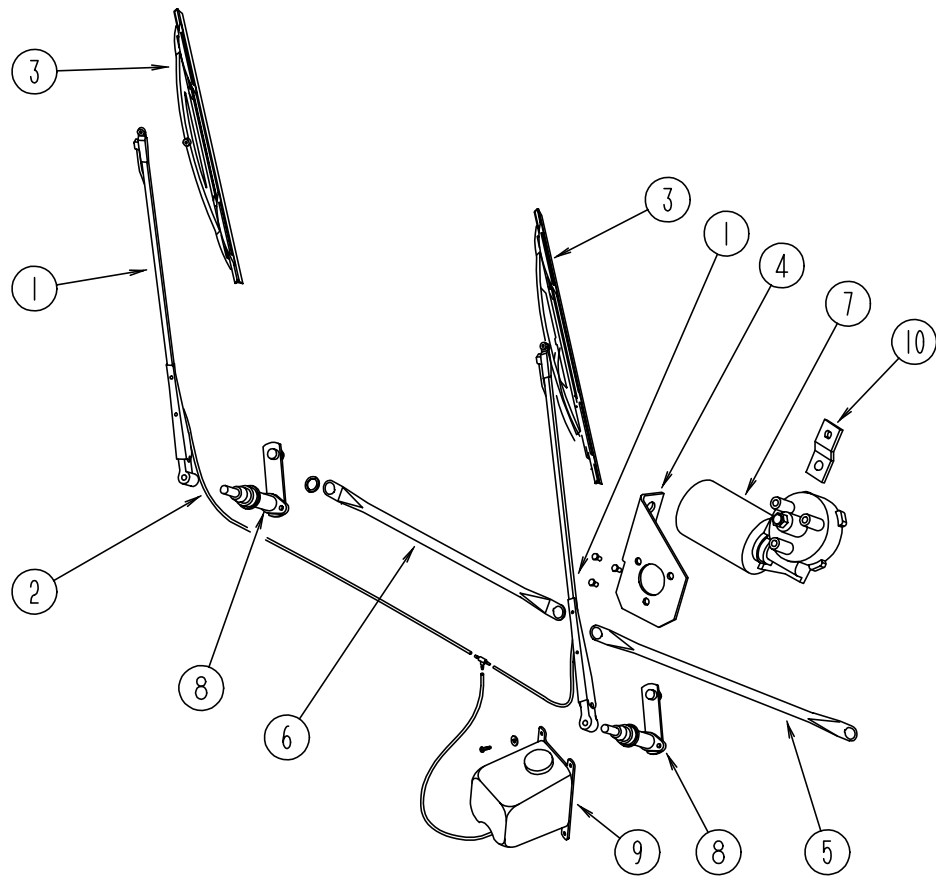

WIPER COMPONENTS

KEY	PART NUMBER	U/M	DESCRIPTION	VENDER NO.
1	103671-01-000	EA	ARM-WIPER, PANTOGRAPH - 24" - UT 52179-20LE27WC	
	096931-01-700	FT	HOSE-WIPER, TO BLADE	XTU-66-0001
	096931-01-701	EA	NOZZLE-HARDWARE KIT, INCLUDES NOZZEL, NUT, SHORT THREAD SCREW, LONG THREAD SCREW, AND PLASTIC CAP	
2	045794-01-000	FT	HOSE-WASHER, WINDSHIELD - 5/32" ID - BLACK	
3	095964-01-000	EA	BLADE-WIPER, 24"	
	095964-01-700	EA	REFILL-WIPER BLADE, 24" - PAIR	12360
4	104549-01-000	EA	BRACKET ASSEMBLY-WIPER MOTOR	
5	117008-01-000	EA	LINK ASM - CONNECTING - DRIVERS - 6476720 LK25WJ	
6	117008-02-000	EA	LINK ASM - CONNECTING - PASSENGERS - 6476620 LK25WJ	
7	104346-04-000	EA	MOTOR-WIPER, CHEVY - UT 65714M02025WJ	
7	104346-05-000	EA	MOTOR-WIPER, FORD - UT 6571M09095WJ	
8	096505-05-000	EA	PIVOT & SHAFT ASM-WIPER, PASSENGER WINDSHIELD - 62871-20-SH25WJ	
8	096505-06-000	EA	PIVOT & SHAFT ASM-WIPER, DRIVER WINDSHIELD - 62870-20-SH25WJ	
	096526-01-000	EA	SCREW-HEX, 1/4 - 28	
9	110605-01-000	EA	TEE-PLASTIC, BARBED - 1/8 X 1/8 X 3/16 - BAYLOCK 3799721	
9	117765-03-000	EA	CONNECTOR - 5/32 - ITT H-BAYLOCK 116756	
9	117766-02-000	EA	RESERVOIR/PUMP ASM - MCCORD 600328	
10	104347-01-000	EA	ARM-DRIVE, WIPER MOTOR - 1.54"	
	056000-01-700	FT	VACUUM HOSE 7/64 - 5/32	
	061603-01-000	EA	GROMMET-SNAP, 3/16 ID - 3/8 HOLE - PLASTIC - BLACK	
	067188-01-000	EA	STUD-CRANK, WIPER - AMBAC 1903424SD27WC	
	110742-01-000	EA	GASKET-WIPER	
	110178-01-000	EA	HOUSING-WIPER MOTOR - UT6237440-EC25WJ	

WINDSHIELD & WIPER GROUP (CONTINUED)

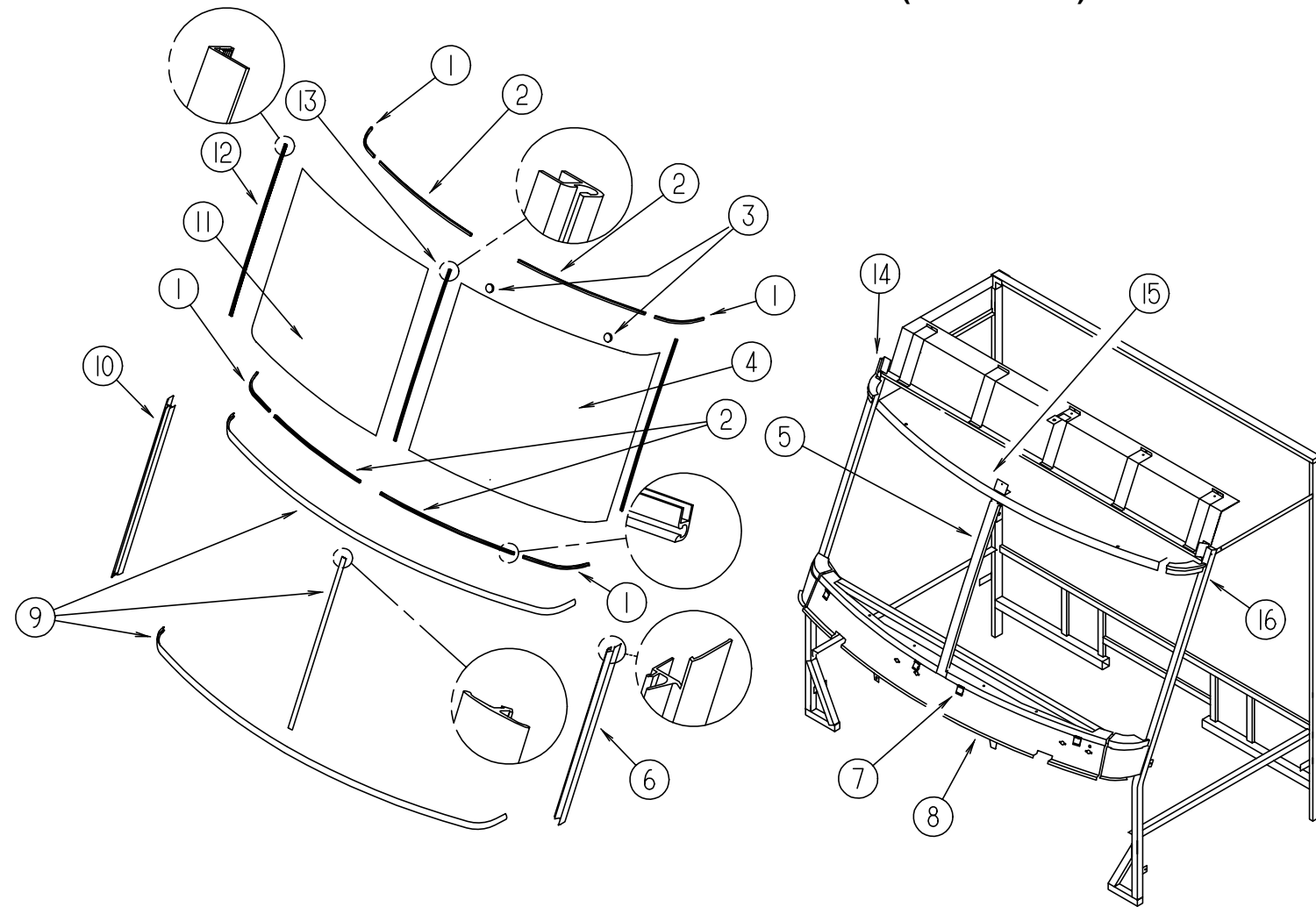

WINDSHIELD MOLDINGS & GLASS

KEY	PART NUMBER	U/M	DESCRIPTION
1	102935-08-000	EA	CARRIER-REVEAL, 2" - WINDSHIELD
2	110268-01-000	EA	CARRIER-REVEAL, 50.4" - WINDSHIELD
3	081914-01-000	EA	BUMPER-RUBBER, ROUND - .43" DIAMETER - BLACK
4	088793-04-000	EA	GLASS-WINDSHIELD, DRIVER
5	075710-03-000	EA	FRAME-WINDSHIELD, CENTER DIVIDER - INNER
6	103107-02-01A	EA	TRIM-WINDSHIELD, DRIVER SIDE - BLACK
7	104449-01-000	EA	BRACKET-WINDSHIELD SUPPORT
8	077847-02-000	EA	SUPPORT-WINDSHIELD, LOWER - W/O BRACKETS
9	102936-01-000	FT	MOLDING - REVEAL - WINDSHIELD
10	103107-01-01A	EA	TRIM - WINDSHIELD - PASSENGER SIDE - BLACK
11	088793-03-000	EA	GLASS-WINDSHIELD, PASSENGER
12	098788-06-000	EA	CHANNEL - 49" PCV, DRIVER OR PASSENGER SIDE
13	110268-02-000	EA	CARRIER-REVEAL, 38" - WINDSHIELD
14	077922-03-000	EA	HEADER WINDSHIELD END - RIGHT - STEEL
15	077922-05-000	EA	HEADER WINDSHIELD - CENTER - STEEL
16	077922-04-000	EA	HEADER WINDSHIELD END - LEFT - STEEL