

**1996  
ICD32RQ**

**GD1**

**"MISTY MORN" (PARCHMENT)**

**GE1**

**"MESA" (BRICK/TAN)**

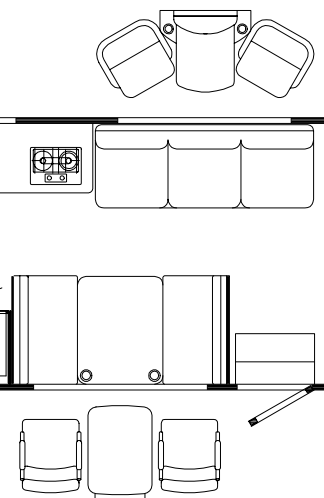
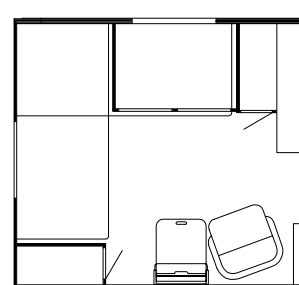
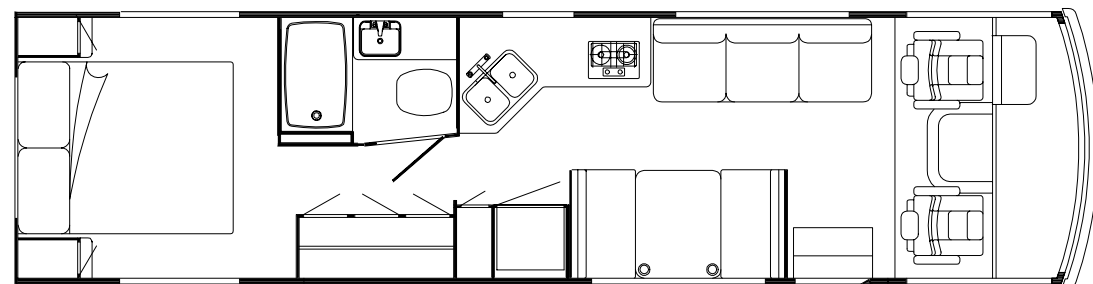
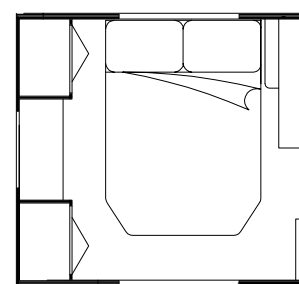
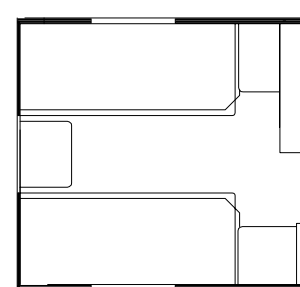
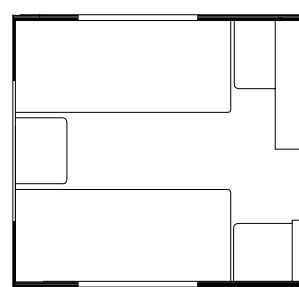

## ACCESSORIES GROUP

### OPERATOR MANUAL

KEY	PART NUMBER	U/M DESCRIPTION
	054185-E6-000	EA MANUAL-OPERATOR 96 PASSAGE D-SERIES
	092318-01-000	EA BINDER - 3 RING, MOTOR HOME MANUAL
	092319-01-000	EA POCKET PAGE - 3 RING BINDER, PLASTIC
	118476-01-000	DW TOP LEVEL DRAWING, 1996 D-SERIES

## AUDIO VIDEO GROUP

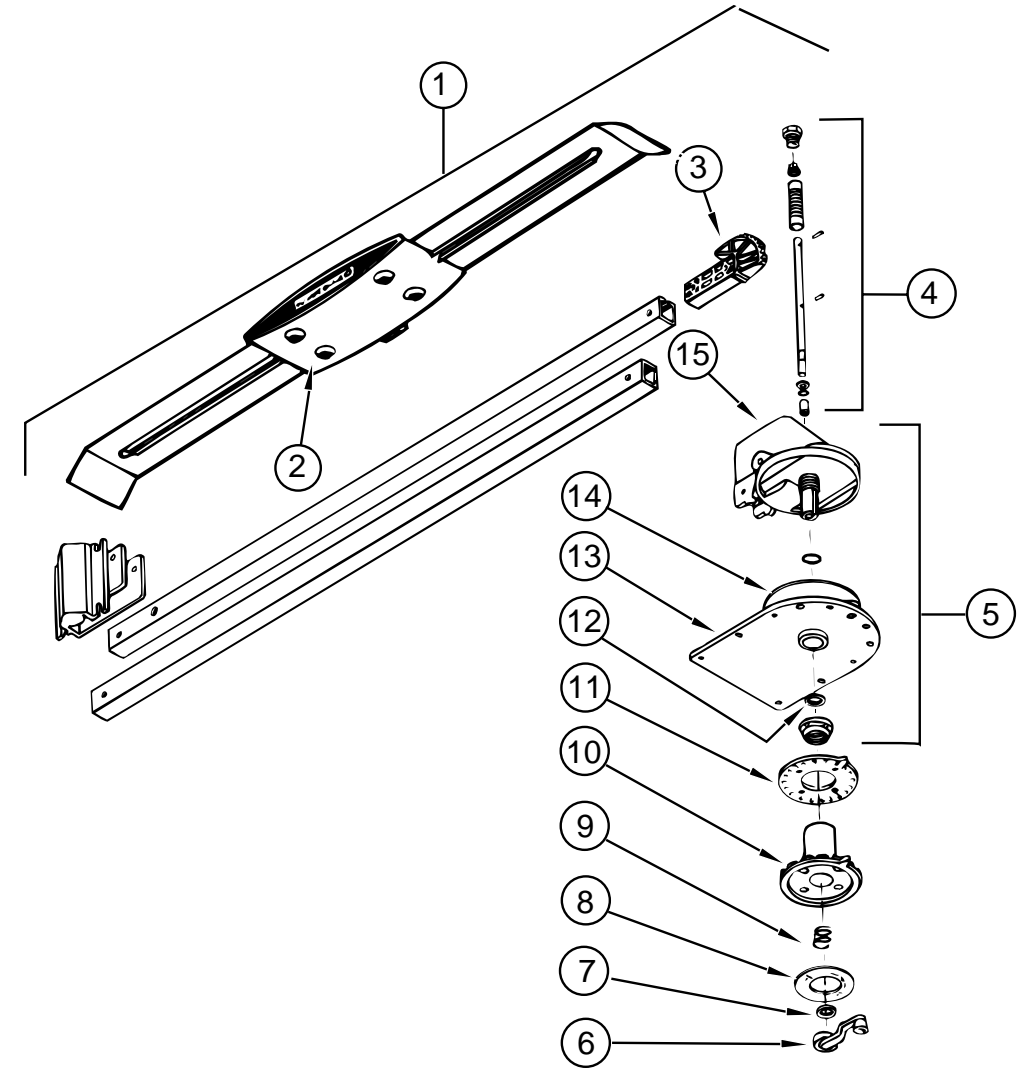

### TV ANTENNA

#### ROOF MT 44.5 MAST WINEGARD #RVA-W02

KEY	PART NUMBER	U/M DESCRIPTION	VENDOR NO.
1	076319-01-000	EA ANTENNA - TV - ROOF MOUNT	
2	076319-01-700	EA HEAD - ANTENNA - AMPLIFIED	RVSA U/V
3	076319-01-701	EA GEAR - ELEVATING - PLASTIC	2200046
4	076319-01-702	EA SHAFT ASM - ELEVATING	RVP-400A
5	076319-01-711	EA BASE & LIFT ASM	2762802
6	076319-01-706	EA CRANK - ELEVATING - W/ SET SCREW	5755100
7	076319-01-705	EA BEARING - NYLON - 7/8"ID	3200658
8	076319-01-708	EA CRANK COVER DECAL	5413002
9	076319-01-707	EA SPRING - HANDLE	5160822
10	076319-01-709	EA PLATE - DIRECTIONAL - FOR HEAD	3200644
11	076319-01-712	EA CEILING PLATE	3200608
12	076319-01-704	EA BEARING - NYLON - 1.5"OD	3200657
13	076319-01-713	EA BASE PLATE	3100523
14	076319-01-703	EA BEARING - NYLON - 5"OD	3200656
15	076319-01-714	EA HOUSING, ROTATING GEAR	2200049
	076319-06-000	EA ADAPTOR-CABLE ROOF PLATE RPJ-1	
	076319-03-000	FT CABLE-COAXIAL, 75 OHM	
	076319-12-000	EA CONNECTOR-COAXIAL, ONE PIECE	
	086777-01-000	EA PLATE-WALL, CABLE - W/TV ANTENNA SWITCH - IVORY	

## AUDIO VIDEO GROUP (CONTINUED)

### RADIO SYSTEM & ANTENNA

KEY	PART NUMBER	U/M	DESCRIPTION
	110267-01-000	EA	RADIO-AM/FM STEREO, AUDIOVOX IM-200
	081059-02-000	EA	WIRE ASM-9-PIN, RADIO - AUDIOVOX 112B-1761
	077069-02-000	EA	CABLE-RADIO ANTENNA, 96" EXTENSION
	110469-01-000	EA	SPEAKER-4" X 6" OVAL COAXIAL
	110470-01-01A	EA	GRILLE-4" X 6" BLACK OVAL SPEAKER
	110272-01-000	EA	BRACKET-ANTENNA
	074979-08-000	EA	SHIELD-SPEAKER, BACK - MOLDED PLASTIC - LIGHT OAK
	090944-01-000	EA	ANTENNA-RADIO, 16" RUBBER

### TV & COMPONENTS

KEY	PART NUMBER	U/M	DESCRIPTION	VENDOR NO.
	113684-01-000	EA	TV-19" COLOR UL AND CSA	
				FROM: 00-00-00 THRU: 06-16-96
	113684-02-000	EA	TV-19"COLOR UL/CSA 1/8" JACK	
				FROM: 06-17-96 THRU: 99-99-99
	113684-01-700	EA	REMOTE	8822345
	082134-01-000	EA	ADAPTER-TV, CABLE TO CABLE - WINEGARD F-81M	
	086777-01-000	EA	WALLPLATE-TV CABLE, W/ANTENNA SWITCH - IVORY	
	076319-03-000	FT	CABLE-COAXIAL, 75 OHM	
	076319-12-000	EA	CONNECTOR-COAXIAL, ONE PIECE	
	076319-06-000	EA	ADAPTOR-CABLE ROOF PLATE, WINEGARD RPJ-1	
	076319-09-000	EA	WALLPLATE-CABLE RECEPTACLE, TV - SINGLE - BROWN	
	082136-01-000	EA	NUT-HEX JAM 3/8-32, WINEGARD	

## BATH GROUP

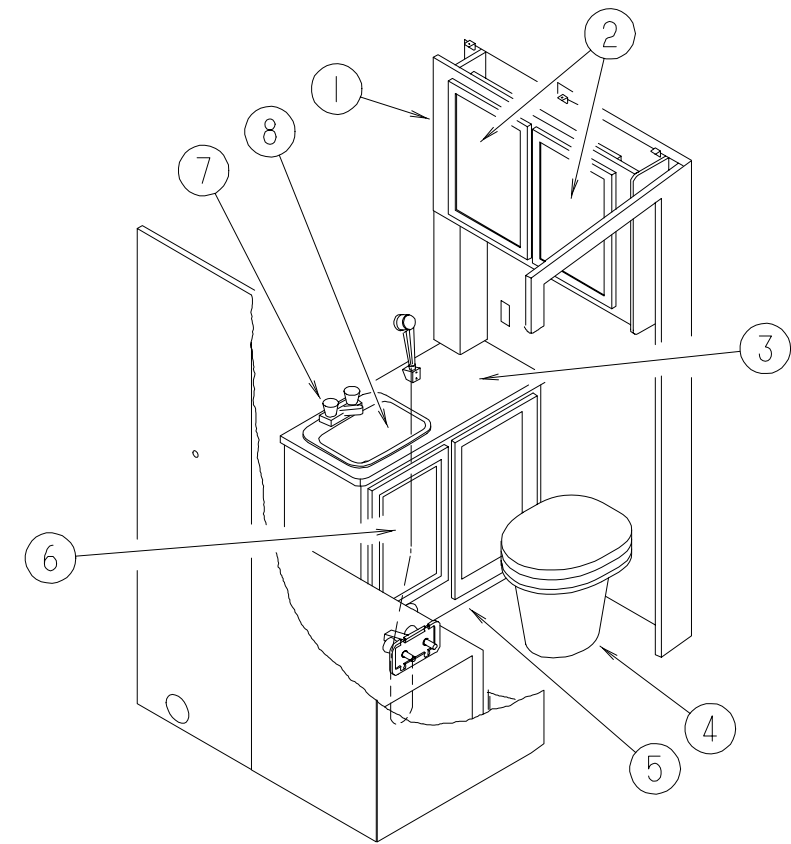

### BATHROOM CABINET & COMPONENTS

KEY	PART NUMBER	U/M	DESCRIPTION	VENDOR NO.
1	118126-01-GB1	EA	CABINET ASM-LINEN/MEDICINE	
	118126-11-GB1	EA	SHELF ASM-W/PLASTIC EDGE TRIM	
2	110140-41-GB1	EA	DOOR ASM-MITERED,VINYL WRAP	
3	118124-11-GD1	EA	COUNTERTOP ASM (GD1)	
3	118124-11-GC1	EA	COUNTERTOP ASM (GE1)	
4	067487-01-000	EA	TOILET-12.37", IVORY - HAND FLUSH - THETFORD 150110	
5	118124-01-GD1	EA	CABINET ASM-LAVATORY	
6	110140-04-G01	EA	DOOR ASM-MITERED,VINYL WRAP	
	075452-02-000	EA	HOLDER - TOILET TISSUE - BRASS	
	075453-02-000	EA	BAR-TOWEL - 18" BRASS	
7	075240-06-000	EA	FAUCET-LAVATORY, BONE	
	091253-01-000	EA	GASKET-FAUCET, LAVATORY/GALLEY	
8	096927-01-01A	EA	SINK-LAVATORY, RECTANGULAR - PLASTIC - BONE	
	096927-01-700	EA	PLUG	M9801
	096927-01-701	EA	TAILPIECE	M9802
	M87868-30-GB1	EA	DOOR ASM - BATH	
	094485-03-01A	EA	KNOB-DOOR,BRASS	
	102920-01-01A	EA	HINGE-DOOR, SPRING LOADED - BRASS	
	110496-01-01A	EA	HINGE-BRASS	

### WARDROBE CABINET DOORS

KEY	PART NUMBER	U/M	DESCRIPTION
	110140-52-G01	EA	DOOR ASM-MITERED,VINYL

**BATH GROUP (CONTINUED)**

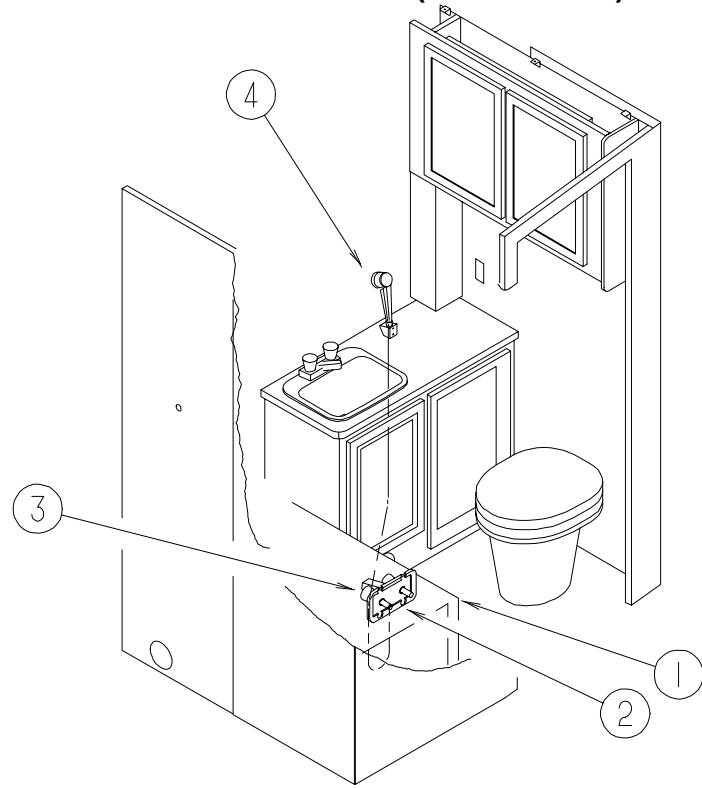

**SHOWER CABINET & COMPONENTS**

KEY	PART NUMBER	U/M DESCRIPTION	VENDOR NO.
1	115611-03-01A	EA SHOWER PAN O/W	
	066436-01-000	EA NUT-SLIP, TAILPIECE - 1.5"	
	066729-01-000	EA STRAINER-TUB/SHOWER, W/PLUG	
2	075606-01-000	EA PANEL-SHOWER FAUCET	
3	075242-04-000	EA FAUCET-TUB/SHOWER, BONE	
4	103092-01-000	EA SHOWER HEAD-W/60" HOSE	
4	103092-02-000	EA SHOWER HEAD-W/HOSE, ONDINE 23213NYLON B	
	103092-01-700	EA BRACKET-F/SHOWER HEAD, CLEAR	2328028
	011048-03-700	EA BRACKET-F/SHOWER HEAD	2328029-3

**BATH GROUP (CONTINUED)**

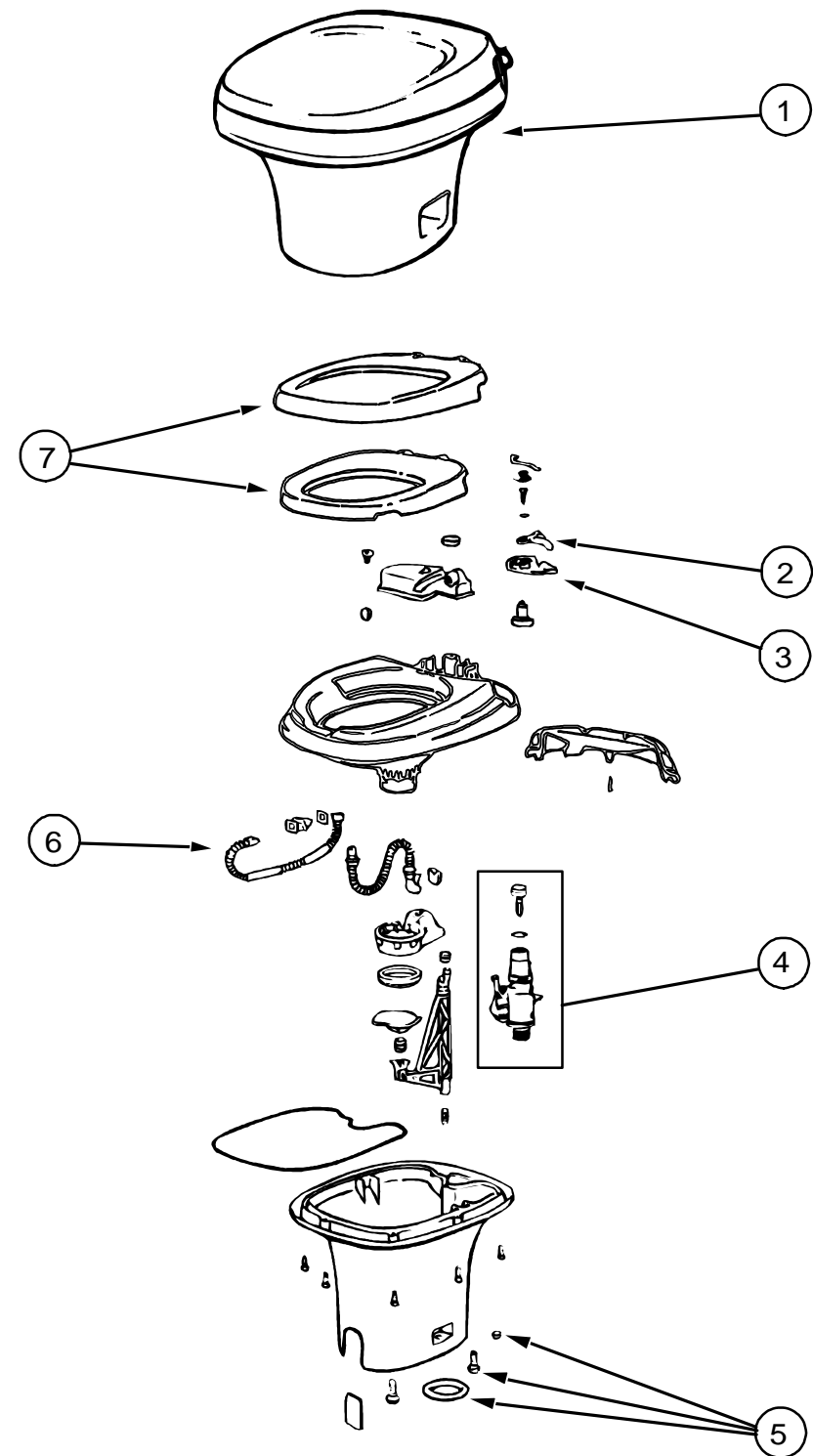

**THETFORD AQUA MAGIC IV TOILET**

KEY	PART NUMBER	U/M DESCRIPTION	VENDOR NO.
1	067487-01-000	EA TOILET-12.37", IVORY - HAND FLUSH - THETFORD 150110	
2	063740-01-700	EA LEVER-WATER, TOILET	12514
3	063740-01-701	EA LEVER-FLUSH	12515
4	063740-01-714	EA VALVE ASSEMBLY, WATER W/FLOAT & BALL SEAL	13168
5	063740-01-706	EA BOLT PACKAGE-FLOOR FLANGE	12524
6	063740-01-717	EA TUBE-FLUSH	12509
7	063740-02-700	EA SEAT & COVER, PARCHMENT	2464157
	067487-02-702	EA TANK-RESERVOIR	12507

**BATH GROUP (CONTINUED)**  
**SHOWER DOOR**

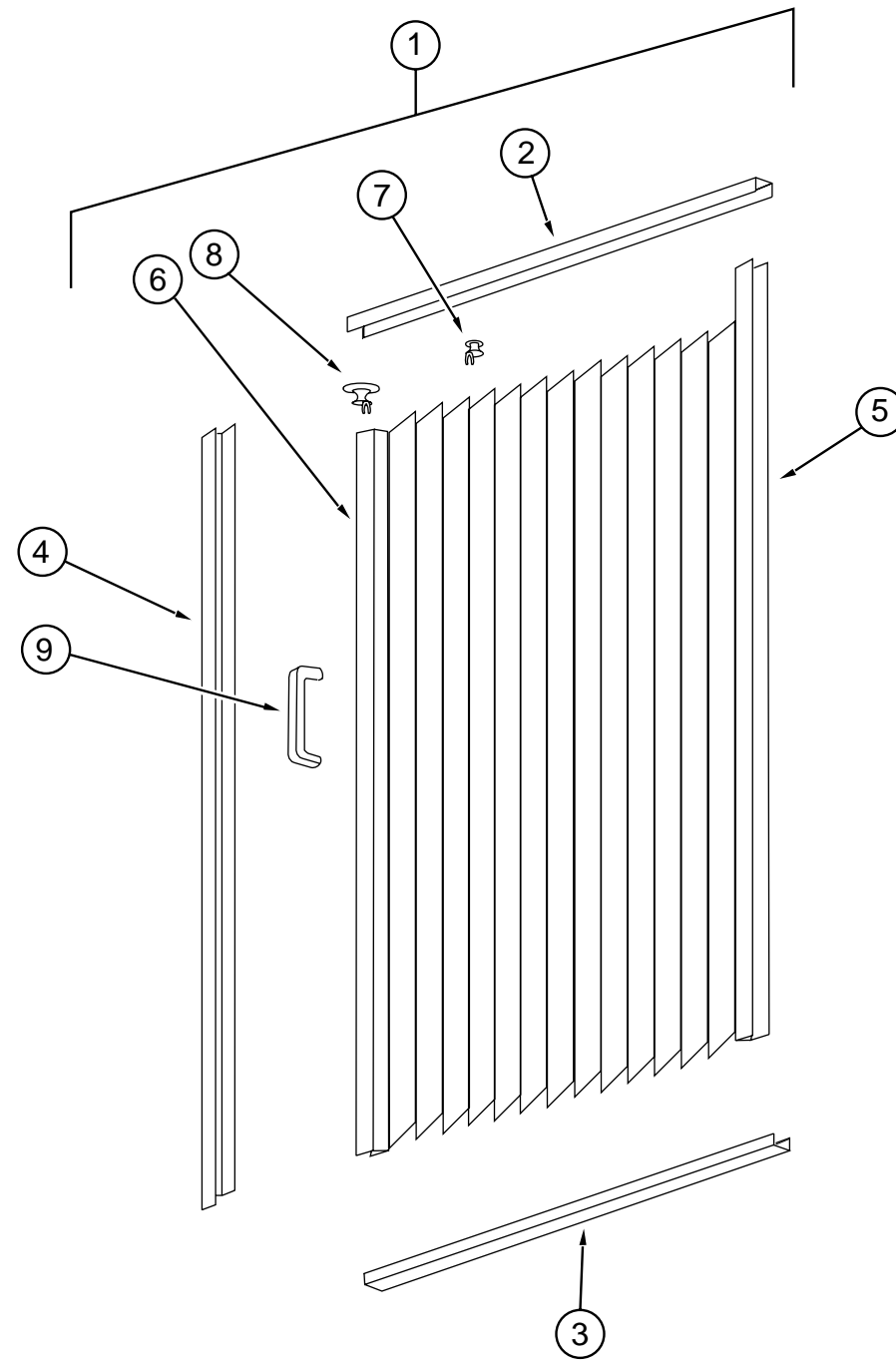

KEY	PART NUMBER	U/M	DESCRIPTION
1	117431-03-01A	EA	DOOR-SHOWER,FABRIC,PLEATED
2	117431-01-700	EA	TRACK-TOP, ALUM.IVORY INSERT 39 3/8
3	117431-01-701	EA	TRACK-BOTTOM, 39 3/8
4	117431-01-702	EA	RAIL-SIDE, 63"
5	117431-01-703	EA	RAIL-STATIONARY, 63"
6	117431-01-704	EA	RAIL-LEAD, 63"
7	117431-01-705	EA	GLIDE-IVORY, TRAVELER
8	117431-01-706	EA	GLIDE-IVORY LEAD, TRAVELER
	117431-01-707	EA	LATCH
9	117431-01-708	EA	HANDLES & SCREWS
	117431-01-709	EA	STRAP-VINYL SHOWER

### BEDROOM GROUP

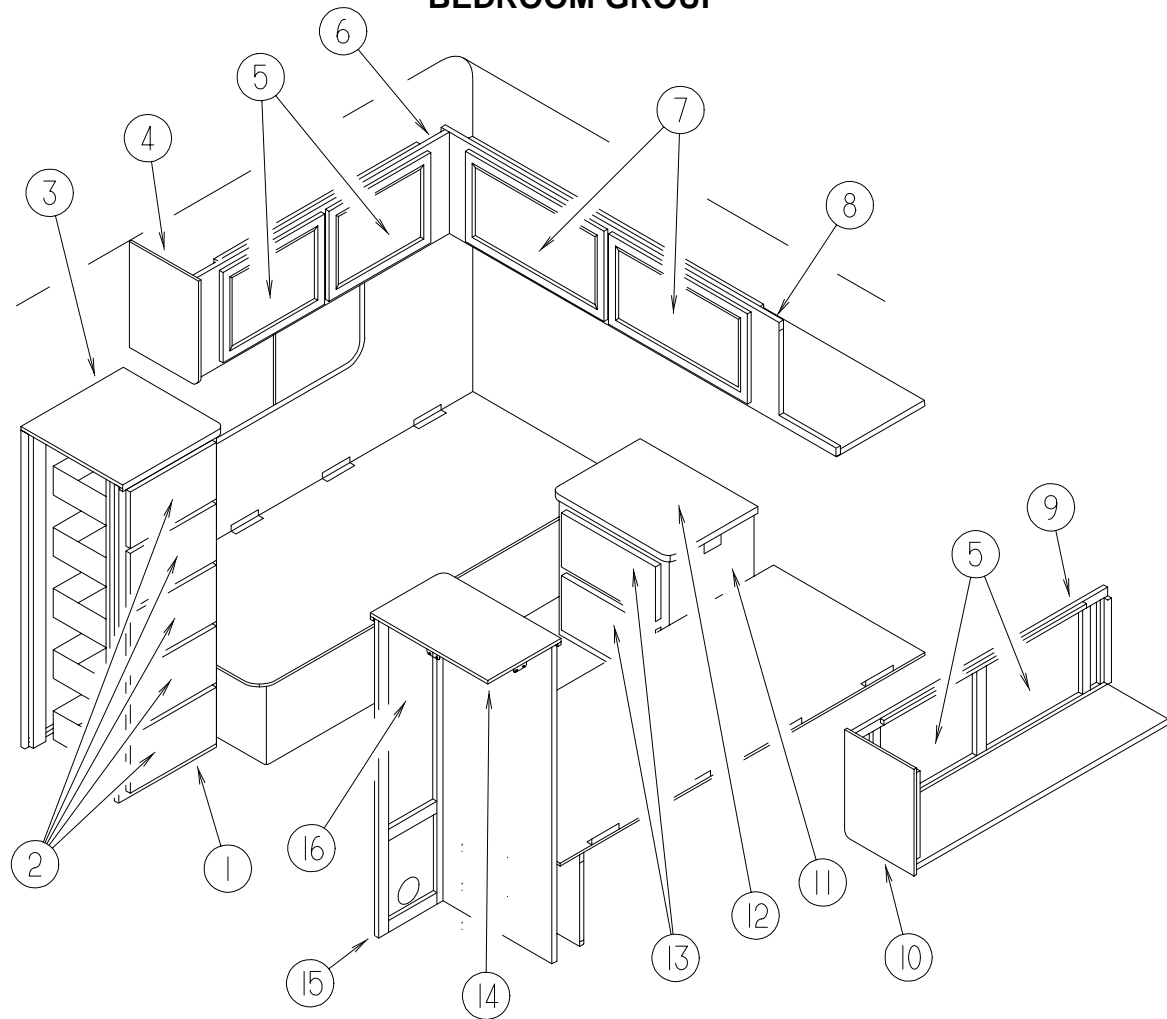

**TWIN BEDROOM**

KEY	PART NUMBER	U/M	DESCRIPTION
1	P18363-01-GD1	EA	CABINET ASM-DRESSER,RH,TW
2	P10163-N7-GB1	EA	DRAWER COMPLETE-SLIDE - DRESSER
3	118363-11-GD1	EA	COUNTERTOP ASM (GD1)
3	118363-11-GC1	EA	COUNTERTOP ASM (GE1)
4	109908-31-GB1	EA	CAP ASM-END-OVERHEAD
5	110140-27-G01	EA	DOOR ASM-MITERED - VINYL WRAP - 0400 X 0520
6	117093-01-GB1	EA	CABINET ASM-OVHD,REAR,RH,TW
7	110140-21-G01	EA	DOOR ASM-MITERED - VINYL WRAP - 0400 X 0710 W/ MIRROR
7	110140-18-G01	EA	DOOR ASM-MITERED - VINYL WRAP - 0400 X 0710 W/O MIRROR
8	117092-01-GB1	EA	CABINET ASM-OVHD,REAR,TWIN
9	117093-02-GB1	EA	CABINET ASM-OVHD,REAR,LH,TW
10	109908-30-GB1	EA	CAP ASM-END-OVERHEAD
11	P17071-01-GD1	EA	CABINET ASM-NIGHTSTAND
12	117071-11-GD1	EA	COUNTERTOP ASM (GD1)
12	117071-11-GC1	EA	COUNTERTOP ASM (GE1)
13	P10163-N3-GB1	EA	DRAWER COMPLETE-SLIDE
	P17070-01-GB1	EA	CABINET ASM-BED,TWIN,LH
	P17069-01-GB1	EA	CABINET ASM-BED,TWIN,RH
14	118364-11-GD1	EA	COUNTERTOP ASM (GD1)
14	118364-11-GC1	EA	COUNTERTOP ASM (GE1)
15	118364-01-GD1	EA	CABINET ASM-CLOSET,SHIRT,LH
16	110140-75-GB1	EA	DOOR ASM-MITERED - VINYL WRAP - 0275 X 0925

### BEDROOM GROUP (CONTINUED)

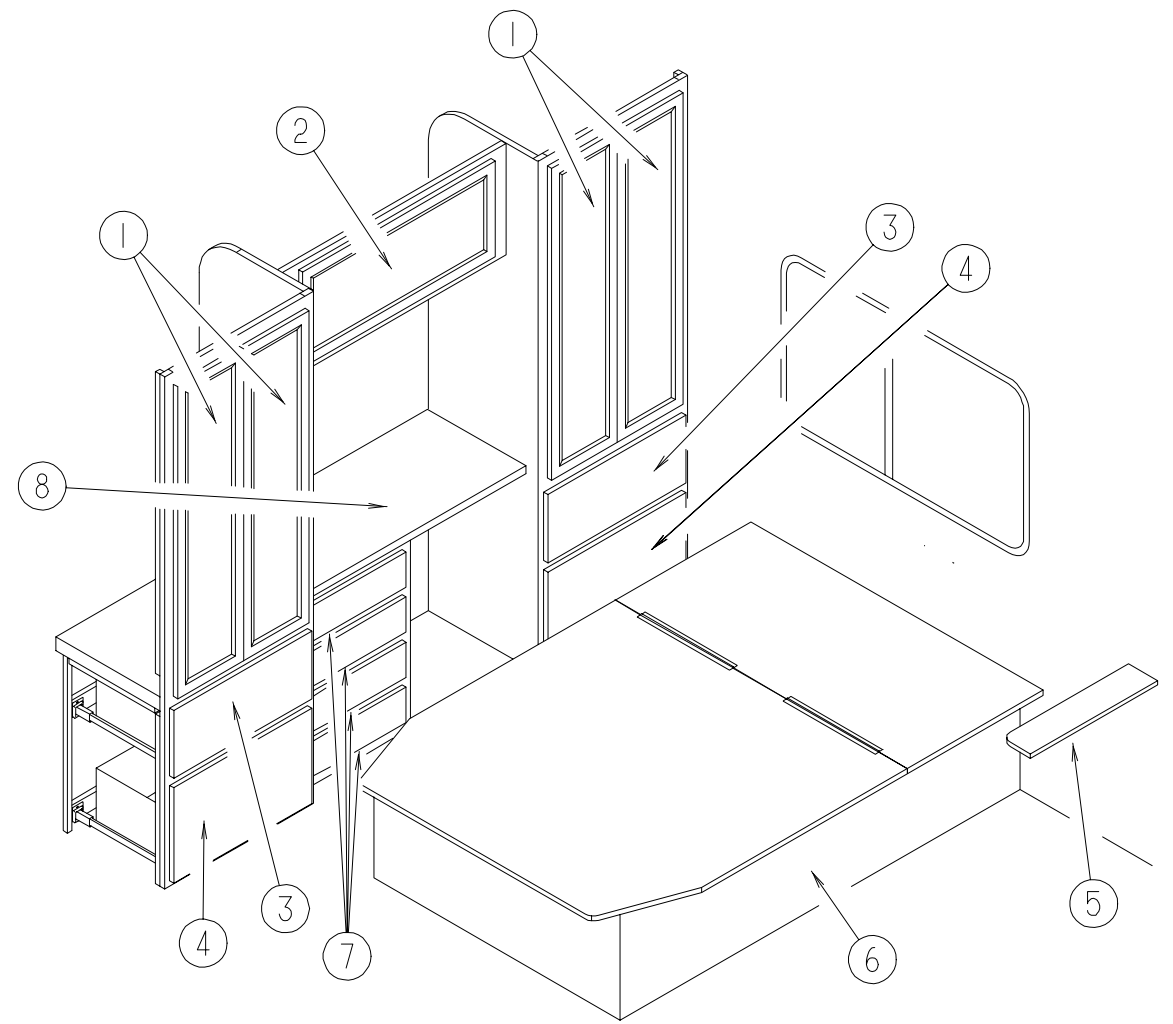

**DOUBLE BEDROOM**

KEY	PART NUMBER	U/M	DESCRIPTION
1	P16841-01-GB1	EA	DOOR ASM-WARDROBE,BI-FOLD
	P16836-01-GE1	EA	CABINET ASM-OVHD,REAR,DBLBED
2	110140-65-G01	EA	DOOR ASM.-W/MIRROR-W/O HRDWE-MITERED-VINYL WRAP
2	110140-05-G01	EA	DOOR ASM-MITERED,VINYL WRAP
3	P10163-M0-G01	EA	DRAWER COMPL-SLIDE
4	P10163-M1-G01	EA	DRAWER COMPL-SLIDE
5	116842-01-GD1	EA	SHELF ASM-DOUBLE BED (GD1)
5	116842-01-GC1	EA	SHELF ASM-DOUBLE BED (GE1)
6	P16839-01-GB1	EA	CABINET ASM-DOUBLE BED
	098442-02-GB1	EA	LEG ASM-BED
7	P10163-M2-G01	EA	DRAWER COMPLETE - SLIDE
7	P16840-01-GD1	EA	CABINET ASM-DRESSER,REAR,DB
8	116840-11-GD1	EA	COUNTERTOP ASM (GD1)
8	116840-11-GC1	EA	COUNTERTOP ASM (GE1)

## BEDROOM GROUP (CONTINUED)

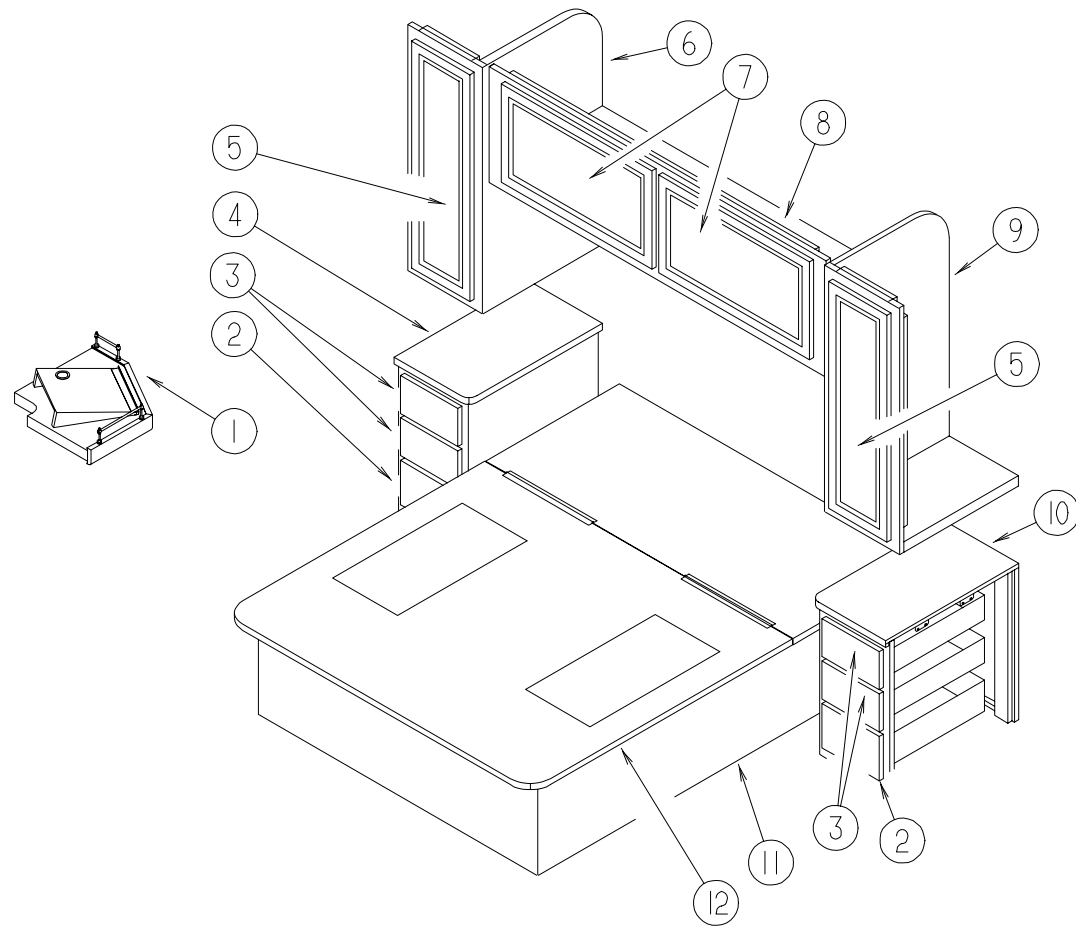

QUEEN BEDROOM

KEY	PART NUMBER	U/M	DESCRIPTION
1	116553-01-GB1	EA	CABINET ASM-TV SHELF
	084070-02-000	EA	POST-END,BRASS N-8655
	084071-12-000	EA	ROD-BRASS,104MM LONG
	084071-19-000	EA	ROD-BRASS,198MM LONG
	106166-01-000	EA	BOLT-COLLARED HANGER
2	P10163-N8-GB1	EA	DRAWER COMPL-SLIDE
3	P10163-N9-GB1	EA	DRAWER COMPL-SLIDE
4	P18127-01-GD1	EA	CABINET ASM-NIGHTSTAND,QU,RH (GD1)
4	P18127-01-GC1	EA	CABINET ASM-NIGHTSTAND,QU,RH (GE1)
4	118127-11-GD1	EA	COUNTERTOP ASM (GD1)
4	118127-11-GC1	EA	COUNTERTOP ASM (GE1)
5	110140-75-GB1	EA	DOOR ASM-MITERED,VINYL WRAP
6	118130-01-GB1	EA	CABINET ASM-OVHD,CL,SHIRT,RH
7	110140-21-G01	EA	DOOR ASM-MITERED,VINYL WRAP
8	P17061-01-GB1	EA	CABINET ASM-OVHD,REAR,QUEEN
9	118131-01-GB1	EA	CABINET ASM-OVHD,CL,SHIRT,LH
10	P18128-01-GD1	EA	CABINET ASM-NIGHTSTAND,QU,LH (GD1)
10	P18128-01-GC1	EA	CABINET ASM-NIGHTSTAND,QU,LH (GE1)
10	118128-11-GD1	EA	COUNTERTOP ASM (GD1)
10	118127-11-GC1	EA	COUNTERTOP ASM (GE1)
11	P16997-01-GB1	EA	CABINET ASM-BED,QUEEN
12	M07501-01-FB1	EA	QUEEN BED TOP
	000G67-10-10B	EA	SCREW-10-12 X 5/8 PPH ZN
	067479-01-000	EA	BULB-12V NO1076 1.80AMP
	119257-03-01A	EA	SHADE-LAMP,LINEN WHT HARDBAC
	119258-02-01A	EA	LAMP-WALL,UL/CSA

## BEDROOM GROUP (CONTINUED)

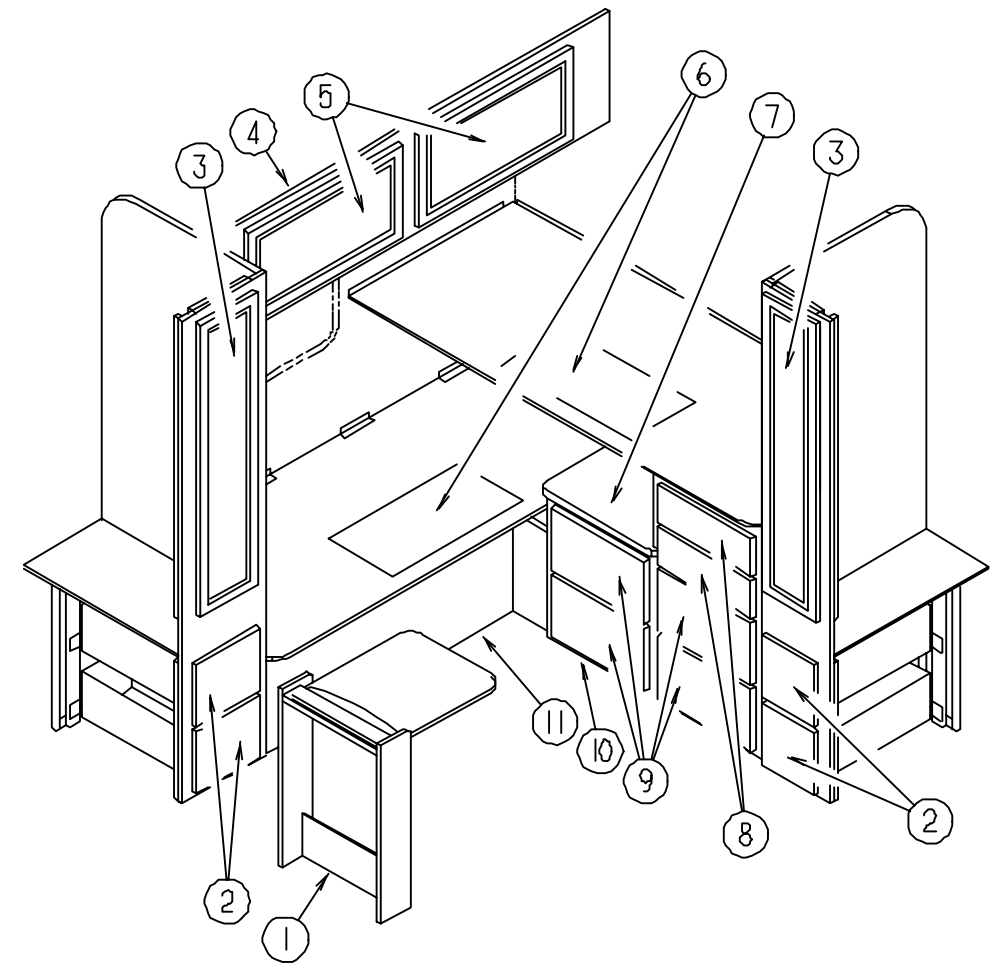

CROSSED TWIN BEDROOM

KEY	PART NUMBER	U/M	DESCRIPTION
1	M96873-01-G01	EA	TABLE ASM-PULLOUT - PARTS BREAKDOWN SHOWN ON PAGE I-14
2	P10163-V6-GB1	EA	DRAWER COMPL-SLIDE
3	110140-22-G04	EA	DOOR ASM-MITERED,VINYL WRAP
4	120470-01-GC1	EA	CABINET ASM-OVERHEAD,REAR
5	110140-21-G01	EA	DOOR ASM-MITERED,VINYL WRAP
6	091261-01-000	FT	BACKING-NON-SKID, 12"X100'
	117066-02-GB1	EA	FRAME ASM-FABRIC,CROSS BUNK
7	120442-11-GB1	EA	COUNTERTOP ASM (GD1)
7	120442-11-GC1	EA	COUNTERTOP ASM (GE1)
8	P10163-V8-GB1	EA	DRAWER COMPL-SLIDE
9	P10163-W7-GB1	EA	DRAWER COMPL-SLIDE
10	120442-01-GB1	EA	CABINET ASM-DRESSER,LH (GD1)
10	120442-01-GC1	EA	CABINET ASM-DRESSER,LH (GE1)
11	P20469-01-GC1	EA	CABINET ASM-BED,TWIN,REAR
	116553-01-GB1	EA	CABINET ASM-TV SHELF

## BEDROOM GROUP (CONTINUED)

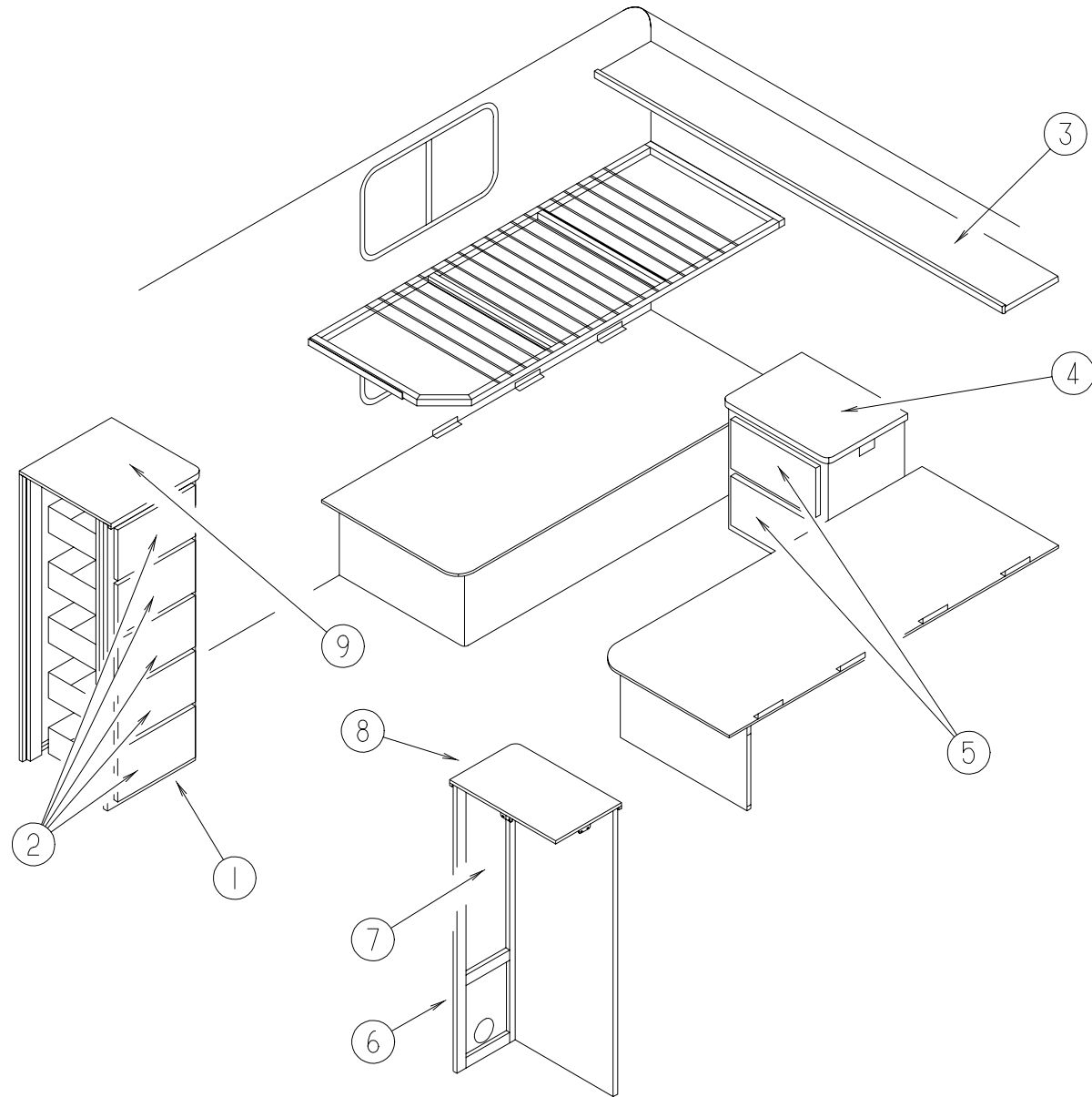

**TWIN & BUNK BEDROOM**

KEY	PART NUMBER	U/M DESCRIPTION
1	P18363-01-GD1	EA CABINET ASM-DRESSER,RH,TW
2	P10163-N7-GB1	EA DRAWER COMPLETE-SLIDE - DRESSER
	117066-01-GB1	EA FRAME ASM-FABRIC,DBL. BUNK
3	117090-01-G01	EA CABINET ASM-OVHD,SHELF
	098442-02-GB1	EA LEG ASM-BED
	091261-01-000	FT BACKING-NON-SKID, 12" X 100'
	105376-01-02A	EA HINGE-CONTIN, 2" X 140MM O/W
	063701-37-000	EA COVER-PIPE O/WHT 318,0 MM
4	117071-11-GD1	EA COUNTERTOP ASM (GD1)
4	117071-11-GC1	EA COUNTERTOP ASM (GE1)
5	P10163-N3-GB1	EA DRAWER COMPL-SLIDE - NIGHTSTAND
6	118364-01-GD1	EA CABINET ASM-CLOSET,SHIRT,LH
7	110140-75-GB1	EA DOOR ASM-MITERED - VINYL WRAP - 0275 X 0925
8	118364-11-GD1	EA COUNTERTOP ASM (GD1)
8	118364-11-GC1	EA COUNTERTOP ASM (GE1)
9	118363-11-GD1	EA COUNTERTOP ASM (GD1)
9	118363-11-GC1	EA COUNTERTOP ASM (GE1)

## CHASSIS GROUP

### CHASSIS MISCELLANEOUS

KEY	PART NUMBER	U/M DESCRIPTION
	087234-01-000	EA NUT-JACK - 1/4" X 20 THREADS - MOLLY - MOUNTS LICENSE PLATES
	080208-01-000	EA LUG WRENCH - 1.06' X 1.00'
	080208-02-000	EA BAR-LEVERAGE - LUG WRENCH
	008042-01-000	FT TUBING-VINYL - .65" ID

### FORD WHEELS, TIRES & WHEEL COVER

KEY	PART NUMBER	U/M DESCRIPTION	VENDOR NO.
	073322-07-F15	EA COVER-TIRE,31"	
	073322-50-000	EA COVER-UNIVERSAL LINER - WHITE TIRE COVER	
	M00080-74-000	EA TIRE-WHL ASM,215/85R16 LRE	
	051377-05-000	EA VALVE STEM ASM-VS938 - EATON VS-938 F53-92	
	083425-10-000	EA TIRE-LT215/85R16 LRE XCH4 - MICHELIN XCH4 ORBL	
	095853-02-000	EA WHEEL-STL,16X6K,F2TA-1015-NA	
	098532-01-000	EA COVER-WHEEL, FORD - 16" - SET OF 4 - DICOR SH-SD-16 ORDER 098532-01-701 WHEEL COVER - 1 EACH, AND 098532-01-700 LUG NUT AS REQUIRED	
	098532-01-700	EA COVER-LUG NUT (CHROME)	SH-AU-LNC
	098532-01-701	EA COVER-WHEEL (FRT & REAR)	SH-SD-16COV 1 ONLY
	116671-02-02B	EA BRACKET ASM-SPARE TIRE,E-CT	

### CHEVY WHEELS, TIRES & WHEEL COVER

KEY	PART NUMBER	U/M DESCRIPTION	VENDOR NO.
	073322-08-GB1	EA COVER-TIRE,34"	
	073322-50-000	EA COVER-UNIVERSAL LINER - WHITE TIRE COVER	
	M00080-88-000	EA TIRE-WHEEL ASM-RAD 8R19.5LRD - GM-CHASSIS	
	007324-03-000	EA TIRE-MICHELIN, 8R 19.8 LRF	
	007324-04-000	EA TIRE-8R19.5 LRD, MICHELIN XZA	
	051377-01-000	EA STEM-VALVE, TR 500	
	064963-01-000	EA WHEEL-STEEL, 19.5" X 6" - GM 14005758	
	080208-01-000	EA LUG WRENCH, 1.06 X 1.00	
	080208-02-000	EA BAR-LEVERAGE, LUG WRENCH	
	116671-01-02B	EA BRACKET ASM-SPARE TIRE,E-CT	
	109443-01-000	EA WHEEL COVER SET - (EA = 4 WHEEL COVERS W/HARDWARE) 19.5"	
	109443-01-700	EA COVER-WHEEL 19.5 FRT OR REAR	SHAG95
	109443-01-701	EA BRACKET-RET-FRONT WHEEL-INCLUDES THE JAMB NUTS	SHAG95-FBS
	109443-01-702	EA BRACKET-RET. REAR WHEEL	SHAG95-RBS
	109443-01-703	EA CAP-CENTER, HUB - DICOR	SP-AUCAP
	109443-01-704	EA CLIP-RETAINER	V160GM-PNT



## CHASSIS GROUP (CONTINUED)

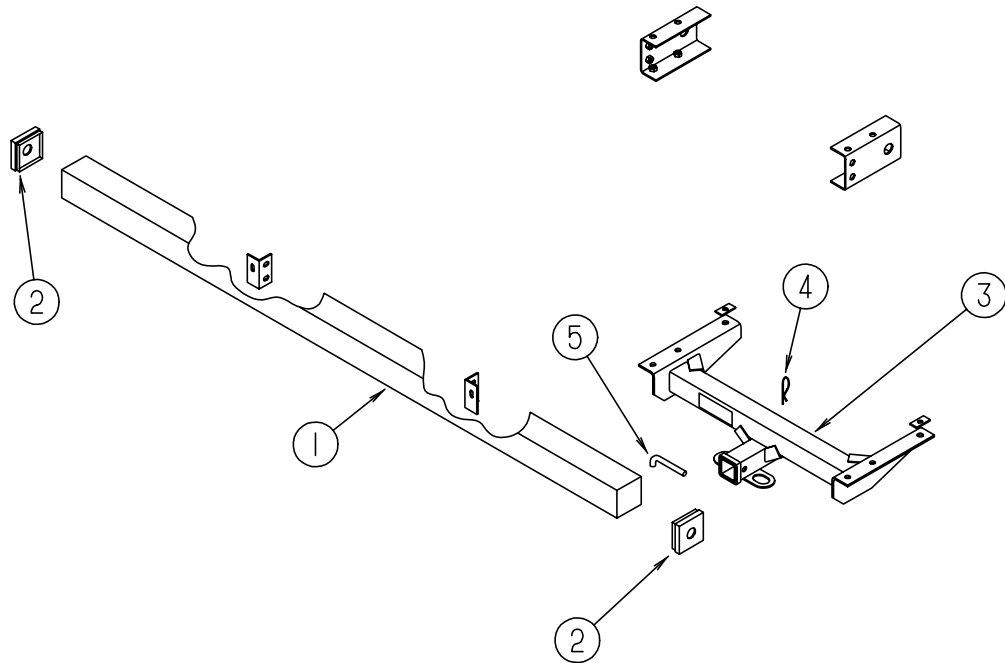

### REAR BUMPER, TRAILER HITCH & COMPONENTS

KEY	PART NUMBER	U/M DESCRIPTION
1	110231-01-FB1	EA BUMPER ASM-REAR
2	039779-01-000	EA CAP-BUMPER, RUBBER - 4" X 4" - BLACK
3	107707-01-000	EA DRAWBAR ASM-HITCH, CLASS II
4	034513-01-000	EA PIN-HITCH, 3/16" WIRE
5	034512-01-000	EA PIN-LOCKING, DRAWBAR
	109738-01-01A	EA BRACKET-BUMPER MILL
	097744-02-000	EA HOUSING-TRAILER PIN, 48"
	097746-01-000	EA HOUSING CAP-TRAILER PIN
	097745-02-000	EA HOUSING-RECEPTACLE, TRAILER - 48" WIRE LENGTH
	113588-01-01B	EA BRACKET-CONNECTOR, TRAILER W/LIP
	113588-02-01B	EA BRACKET-CONNECTOR, TRAILER W/O LIP
	113589-02-000	EA CONNECTOR-SOCKET, TRAILER - GENERAL 433601
	113589-01-000	EA CONNECTOR-PLUG, TRAILER - GENERAL 433501
	070579-09-000	EA PLATE ASM ANCHOR

## CHASSIS GROUP (CONTINUED)

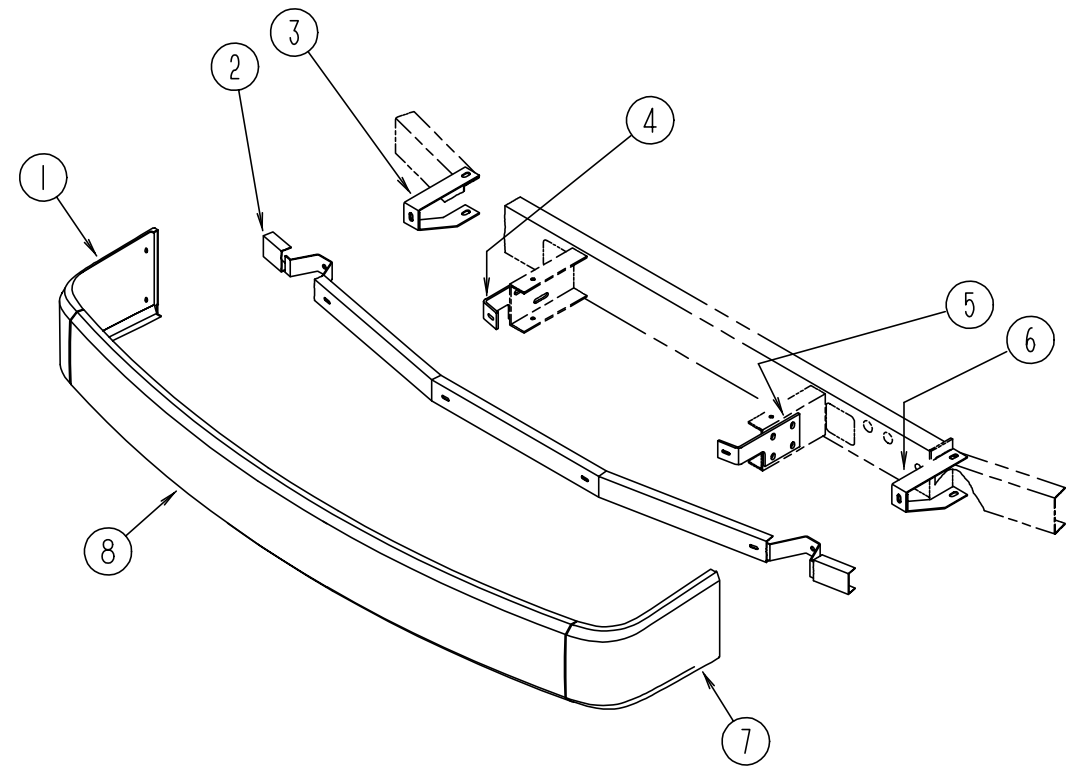

### FRONT BUMPER

KEY	PART NUMBER	U/M DESCRIPTION
1	103625-01-04A	EA PANEL-FACIA, BUMPER FRONT RIGHT - BRIGHT WHITE
2	103512-01-000	EA CHANNEL ASM-BUMPER
3	103497-01-000	EA BRACE-BUMPER, FRONT
4	086140-03-000	EA SUPPORT-FRONT BUMPER, PASSENGER SIDE - 9.1" X 4" - STEEL
5	086140-04-000	EA SUPPORT-FRONT BUMPER, DRIVER SIDE - 9.1" X 4" - STEEL
6	103611-01-000	EA BRACE-BUMPER, FRONT
7	103625-02-04A	EA PANEL-FACIA, BUMPER FRONT LEFT - BRIGHT WHITE
8	103626-01-04A	EA PANEL-FACIA, BUMPER FRONT - BRIGHT WHITE
8	103634-01-FB1	EA BUMPER ASM-FRONT, W/RIGHT & LEFT FACIAS - BRIGHT WHITE
	103592-01-05A	EA BUMPER-INNER, FRONT/WINN BLK
	094362-02-000	EA CLIP-CHRISTMAS TREE, FLAT HEAD - .5" X .95"

### CHASSIS GROUP (CONTINUED)

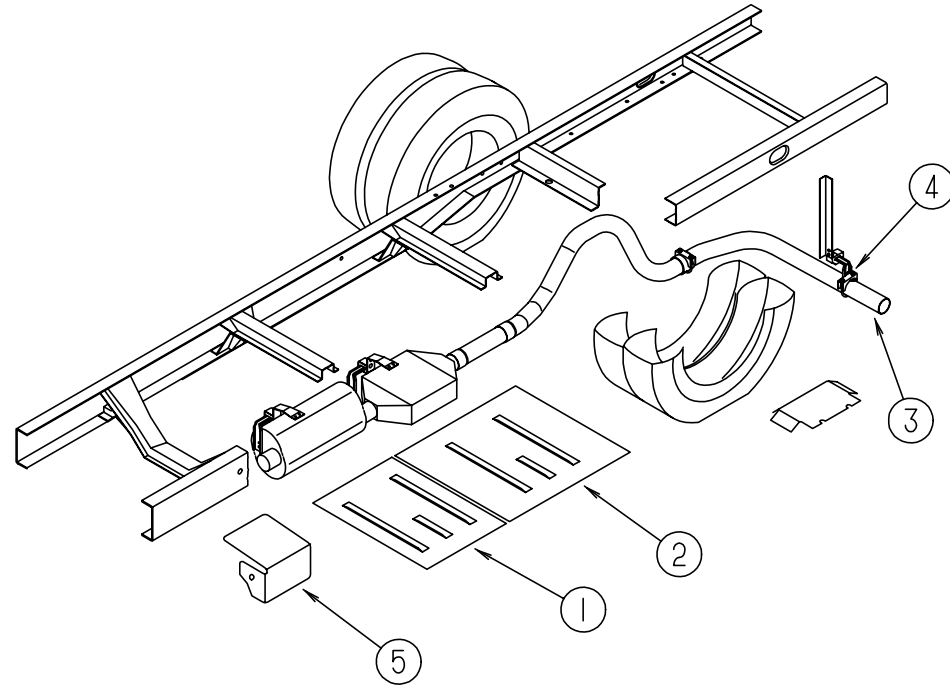

### EXHAUST SYSTEM (GAS)

KEY	PART NUMBER	U/M	DESCRIPTION
1	101544-05-000	EA	SHIELD-HEAT, EXHAUST - 19.7" X 28.9" - STEEL
2	101544-02-000	EA	SHIELD-HEAT - EXHAUST - 30" X 28.9" - STEEL
3	098762-05-000	EA	PIPE-EXHAUST -STRAIGHT 3.0 IN
4	094918-01-000	EA	CLAMP-EXHAUST - 3" - GUILLOTINE STYLE
5	119847-01-02B	EA	SHIELD-A/C CONDENSER,E-COAT
	101544-06-000	EA	SHIELD-HEAT, EXHAUST

### CHASSIS GROUP (CONTINUED)

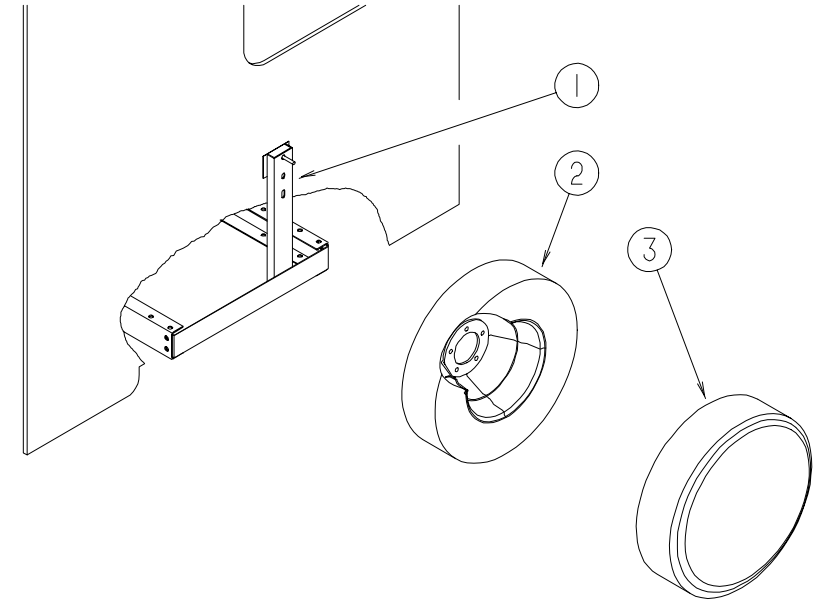

### SPARE TIRE, LUG WRENCH & BAR

KEY	PART NUMBER	U/M	DESCRIPTION
1	116671-01-02B	EA	BRACKET ASM-SPARE TIRE,E-CT
	116671-02-02B	EA	BRACKET - SPARE TIRE
2	064963-01-000	EA	WHEEL-STEEL, 19.5" X 6" - GM 14005758
2	007324-04-000	EA	TIRE-8R19.5 LRD, MICHELIN XZA
	051377-01-000	EA	STEM-VALVE, TR 500
2	M00080-74-000	EA	TIRE-WHL ASM,215/85R16 LRE - FORD SPPLIED RIM
2	083425-05-000	EA	TIRE-MICHELIN, LT235/85R16 LRE - XPS RIB
2	095853-02-000	EA	WHEEL-STL,16X6K,F2TA-1015-NA - ACCURIDE 28513-7
	051377-05-000	EA	VALVE STEM ASM-VS938 - EATON VS-938 F53-92
3	073322-08-GB1	EA	COVER-TIRE,34"
	073322-50-000	EA	COVER-UNIVERSAL LINER
	080208-01-000	EA	LUG WRENCH, 1.06" X 1.00"
	080208-02-000	EA	BAR - LEVERAGE, LUG WRENCH

## CHASSIS GROUP (CONTINUED)

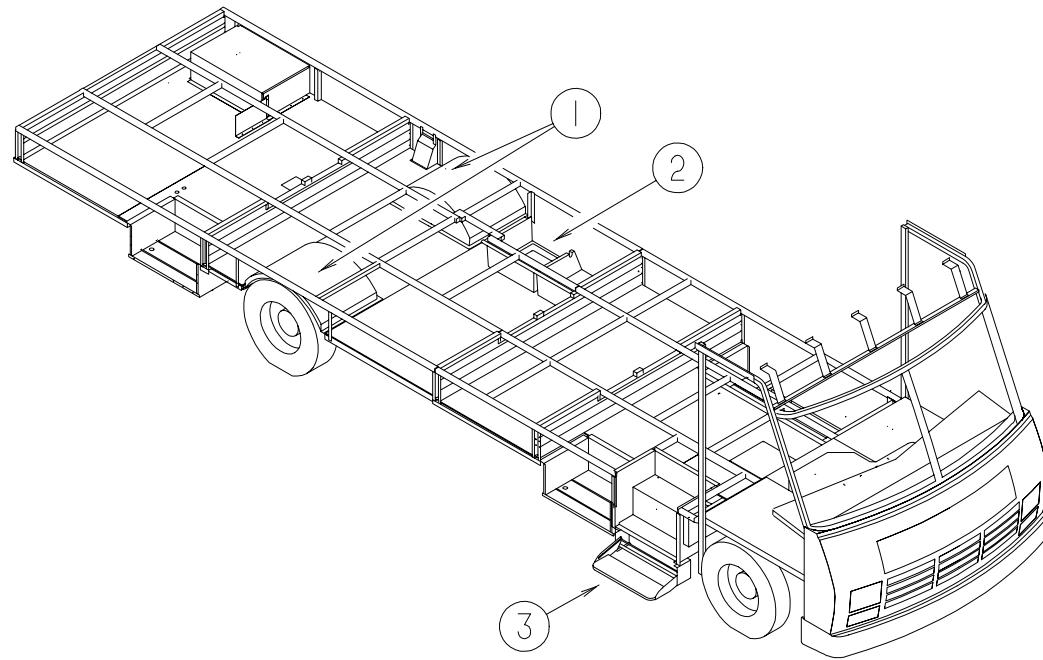

### STORAGE COMPARTMENTS & WHEELWELLS

KEY	PART NUMBER	U/M	DESCRIPTION
1	055080-01-000	EA	WHEELWELL-PLASTIC,REAR - BLACK - LEFT OR RIGHT
2	114676-01-F36	EA	COMPARTMENT ASM-STORAGE
2	M06991-03-F36	EA	HATCH ASM W/FOAM
2	114677-01-01A	EA	RETAINER-HATCH,COMPT MILL
2	114679-01-01A	EA	COMPARTMENT-STORAGE
3	077848-06-000	EA	STEP ASM-PULLOUT
	065450-05-000	EA	TIEDOWN-BATTERY, 8.4" TUBE
	103147-01-000	EA	TRAY-BATTERY
	114070-02-02B	EA	SUPPORT ASM-GENERATOR,LT,E-C
	114071-02-02B	EA	SUPPORT ASM-GENERATOR,RT,E-C
	105376-01-02A	EA	HINGE-CONTIN,2"X140MM O/W
	115361-01-01A	EA	PLUG-PLASTIC
	017516-01-000	EA	FLAP-MUD, 14" X 18" - BLACK
	001360-01-004	EA	STL-ROD CR.375DIA X 0 28.25 IN
	033865-01-073	EA	STL-11GA HRP&O 02.00X027.40

## CHASSIS GROUP (CONTINUED)

### FUEL SYSTEM

KEY	PART NUMBER	U/M	DESCRIPTION
	068382-06-000	EA	BUSHING-BRASS,3/8MPTX1/8FPT - PARKER 209P-6-2
	114254-01-000	EA	ADAPTER-1/4SGL BARBX1/8MPT - WEATHERHEAD 1537
	007063-01-000	FT	HOSE-GAS 1/4"ID X 1/2"OD
	007111-02-000	EA	HOSE-FUEL FILL,2.00 ID - IN 3FT LENGTHS
	066732-01-000	FT	HOSE-FUEL FILL, .62" ID
	084884-01-000	EA	PLUG-BRASS, 3/8"
	073220-02-000	EA	CAP-FILL, FUEL - NON LOCKING - GAS - GM 22525302
	087256-07-000	EA	NECK-FUEL FILL
			FROM: 11-16-95 THRU: 99-99-99
	095606-01-000	EA	NECK-FUEL FILL, W/CHECK VALVE - L-SHAPED - 18.2" LONG
			FROM: 00-00-00 THRU: 11-15-95
	098806-01-000	EA	PIPE-FILL VENT, 90 DEGREE BEND - .625" OD - STEEL
	104932-02-000	EA	PANEL ASM-FUEL FILL
	068382-06-000	EA	BUSHING-BRASS,3/8MPTX1/8FPT - PARKER 209P-6-2
	114254-01-000	EA	ADAPTER-1/4SGL BARBX1/8MPT - WEATHERHEAD 1537
	087256-10-000	EA	NECK-FUEL FILL
	098803-01-000	EA	PIPE-FUEL FILL, 90 DEGREE BEND - 13.2" - 1 3/4" OD - STEEL
			FROM: 00-00-00 THRU: 01-08-96
	098803-02-000	EA	PIPE-FUEL,FILL
			FROM: 01-09-96 THRU: 99-99-99
	098807-01-000	EA	PIPE-FUEL FILL, 90 DEGREE BEND - 6.6" - 1 3/4" OD - STEEL
	078200-01-000	EA	GASKET-FUEL FILL, 3.5"OD X 2"ID
	102951-01-06A	EA	SHROUD-FUEL FILL,BRIGHT WHT
	102951-01-01A	EA	SHROUD-FUEL FILL - UNFINISHED

## CURTAIN & CUSHION GROUP

### NOTICE

IN ORDER TO ASSIST OUR PARTS SALES DEPT. IN PROVIDING INTERIOR SOFTGOODS ITEMS, PLEASE INCLUDE THE SERIAL NUMBER AND THE COLOR CODE NUMBER FROM THE VEHICLE CERTIFICATION LABEL WHEN ORDERING. THIS LABEL IS LOCATED ON THE LEFT SIDEWALL AT THE END OF THE DASH (A-BODY), OR ON THE DRIVER'S DOOR LATCH PLATE (C-BODY).

AN EXAMPLE OF A COLOR CODE NUMBER IS B07, WHICH DESIGNATES AN OVERALL COLOR SCHEME OF A PARTICULAR UNIT. THE COLOR LISTED AFTER THE ITEM DESCRIPTION ON THE MICROFICHE, INDICATES THE OVERALL UNIT COLOR. ORDER THE ITEM YOU DESIRE ACCORDING TO UNIT COLOR CODE.

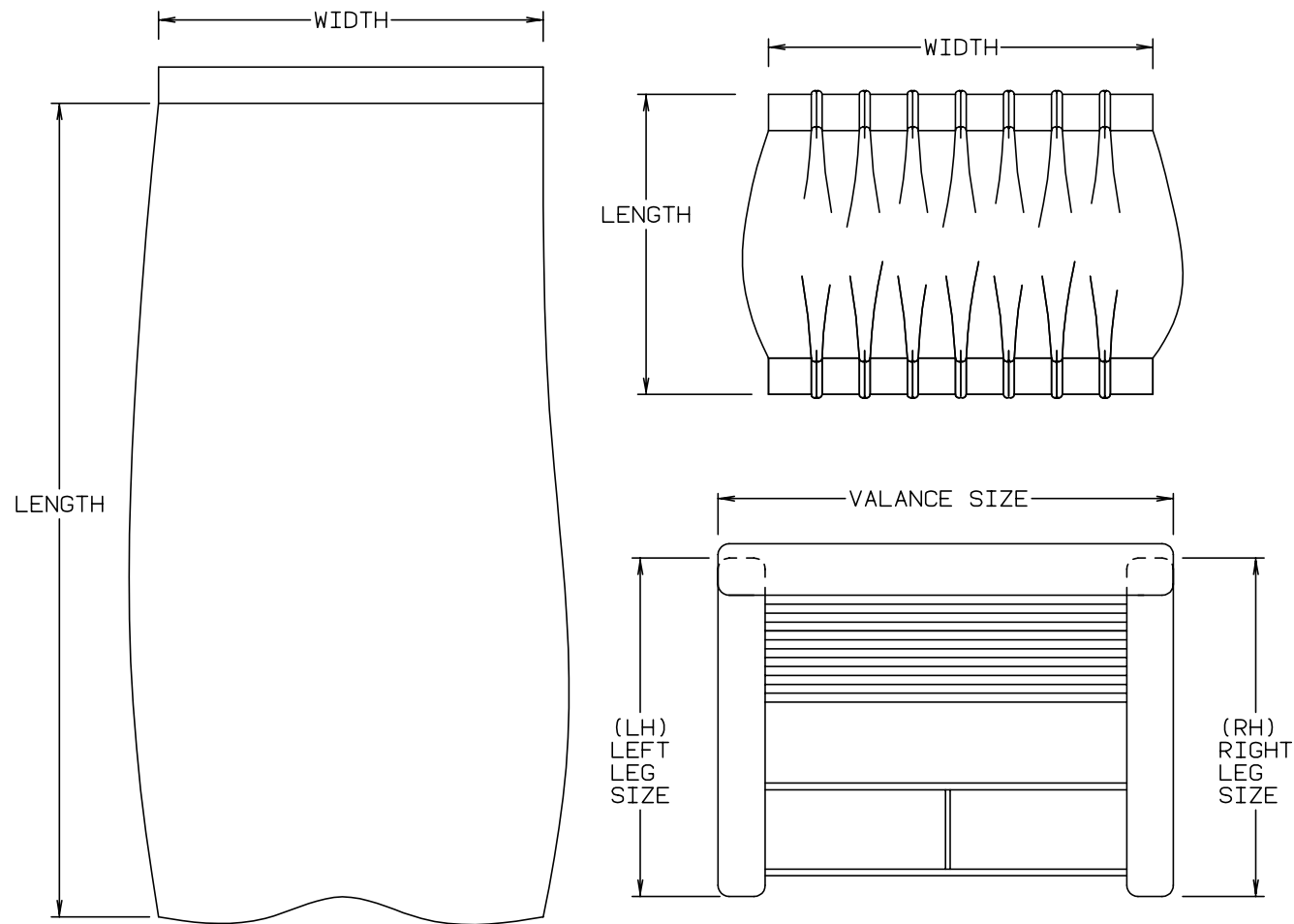

NOTE: USE THIS ILLUSTRATION WHEN DETERMINING LENGTH AND WIDTH MEASUREMENTS FOR CURTAINS. YOU WILL NOTE THE WIDTH MEASUREMENT IS TAKEN ON THE TOP OF THE CURTAIN WITH THE CURTAIN FULLY EXTENDED. THE LENGTH MEASUREMENT IS TAKEN FROM TOP TO BOTTOM. LEFT AND RIGHT WINDOW LEGS ARE DETERMINED WHEN FACING THE WINDOW.

## CURTAIN & CUSHION GROUP (CONTINUED)

### PASSAGE FABRICS

COLOR CODES	GD1	GE1
<b>MARKETING COLORS</b>	<b>MISTY MORN (PARCHMENT)</b>	<b>MESA (BRICK/TAN)</b>
<b>BUCKET SEATS</b>	108446-B4-000 108446-G4-000	108446-G5-000 108446-F3-000
<b>DINETTE</b>	108446-E9-000	108446-F0-000
<b>DINETTE PADS</b>	108446-B4-000	108446-G5-000
<b>SOFA</b>	108446-E9-000	108446-F0-000
<b>SWIVEL CHAIR</b>	108446-G4-000	108446-F3-000
<b>LOUNGE WINDOWS</b>	108446-B4-000 108446-G4-000	108446-G5-000 108446-F3-000
<b>BEDROOM WINDOW</b>	105745-B3-000	105745-A8-000
<b>BEDSPREAD</b>	105745-B3-000 105745-62-000	105745-A8-000 105745-A9-000
<b>PILLOW SHAMS</b>	105745-B3-000 105745-62-000	105745-A8-000 105745-A9-000
<b>PULL SHADE BEDROOM</b>	084416-29-000	084416-29-000
<b>BUNK BED</b>	105745-B3-000	105745-A8-000
<b>FRONT WRAP AROUND</b>	105745-62-000	105745-A9-000
<b>DIVIDER CURTAIN</b>	105745-62000 105745-B3-000	105745-A9-000 105745-A8-000
<b>SHOWER CURTAIN</b>	075244-07-000	075244-03-000
<b>VINYL - OFF WHITE</b>	103907-01-01A	103907-01-01A
<b>DRAPERY LINING</b>	087272-03-000	087272-03-000
<b>VINYL - SUNVISOR</b>	106569-01-01A	106569-01-01A

NOTE: THE FABRIC LISTED FIRST, IN A BLOCK, IS THE LARGEST QUANTITY OF FABRIC USED.

**CURTAIN & CUSHION GROUP (CONTINUED)**

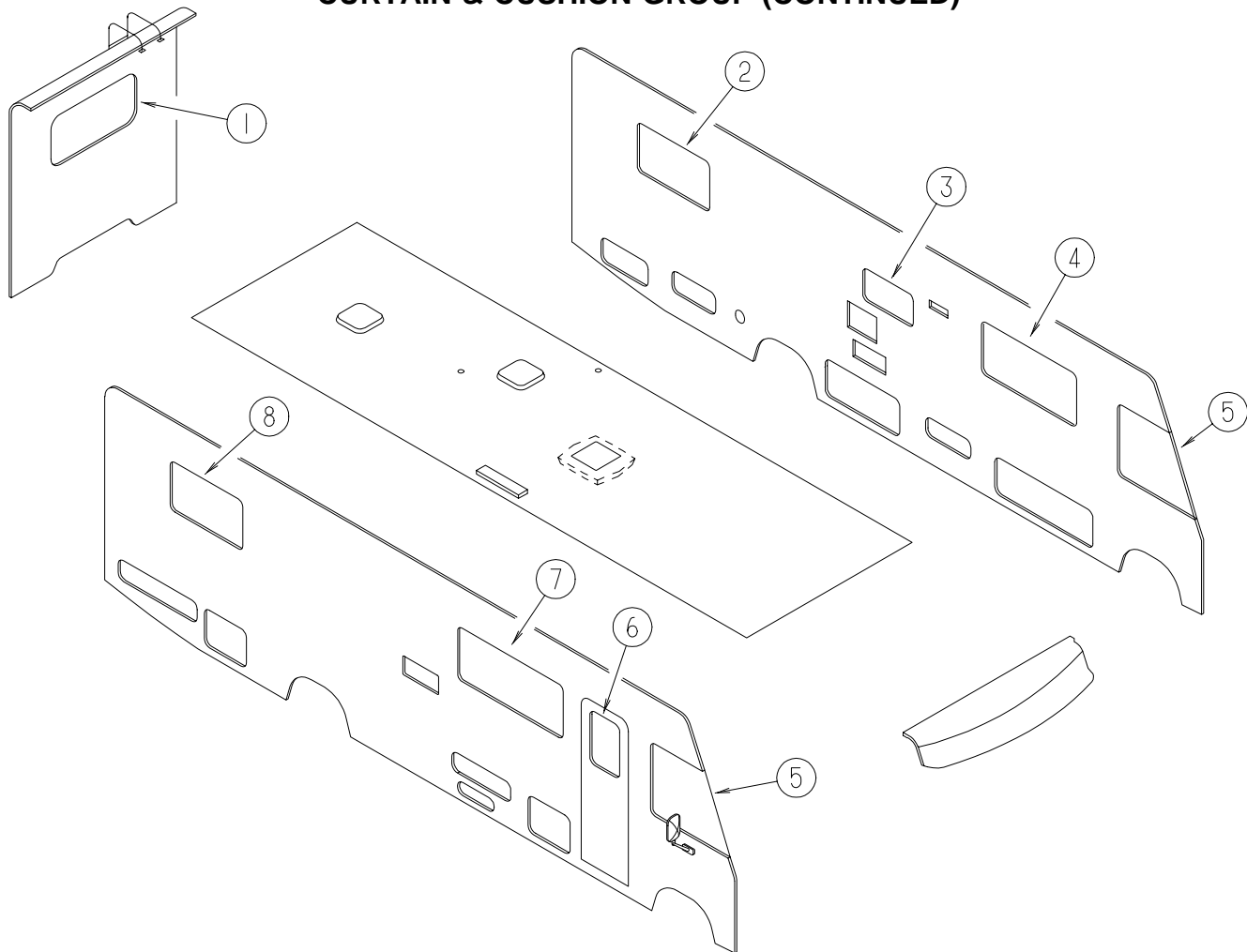

**WINDOW TREATMENT**

KEY	PART NUMBER	U/M	DESCRIPTION
1	118064-01-GB1	EA	VALANCE ASM-VALENCIA - 52"(GD1)
1	118064-01-GC1	EA	VALANCE ASM-VALENCIA - 52"(GE1)
1	084755-92-F15	EA	SHADE ASM-PULL - 50.25"
1	111910-19-G22	EA	BLIND - DAY/NIGHTER - 50 X 28 (GD1)
1	111910-19-F09	EA	BLIND - DAY/NIGHTER - 50 X 28 (GE1)
1	118064-03-GB1	EA	29" VALENCIA VALANCE (GD1)
1	118064-03-GC1	EA	29" VALENCIA VALANCE (4.5"TB) (GE1)
1	084755-57-E07	EA	SHADE ASM-PULL - 27.25"
1	111910-20-GB1	EA	BLIND - DAY/NIGHTER - 28 X 28 (GD1)
1	111910-20-F09	EA	BLIND - DAY/NIGHTER - 28 X 28 (GE1)
2	118064-02-GB1	EA	VALANCE ASM-VALENCIA - 44" (GD1)
2	118064-02-GC1	EA	VALANCE ASM-VALENCIA - 44" (GE1)
2	084755-93-F15	EA	SHADE ASM-PULL - 42.25
2	118064-02-GB1	EA	VALANCE ASM-VALENCIA - 44" (GD1)
2	118064-02-GC1	EA	VALANCE ASM-VALENCIA - 44" (GE1)
2	084755-93-F15	EA	SHADE ASM-PULL - 42.25
2	111910-46-G22	EA	BLIND - DAY/NIGHTER - 43 X 26 (GD1)
2	111910-46-GE1	EA	BLIND - DAY/NIGHTER - 43 X 26 (GE1)
2	101034-49-GB1	EA	CURT-19X19,RT.DART TAPE T&B 9FAB07,W/LINING (GD1)
2	101034-49-GC1	EA	CURT-19X19,RT.DART TAPE T&B 9FAB07,W/LINING (GE1)
2	101034-50-GB1	EA	CURT-19X19,LT.DART TAPE T&B 9FAB07,W/LINING (GD1)
2	101034-50-GC1	EA	CURT-19X19,LT.DART TAPE T&B 9FAB07,W/LINING (GE1)
3	109041-20-01A	EA	BLIND-MINI, 31 X 18 DRP - PURE SILVER (GD1) FROM: 00-00-00 THRU: 03-24-96
3	109041-44-01A	EA	BLIND-MINI,30.5 X 18 - PURE SILVER (GD1) FROM: 03-25-96 THRU: 99-99-99
3	109041-20-02A	EA	BLIND-MINI, 31X18 DRP. - BEIGE (GE1) FROM 00-00-00 THRU 03-24-96
3	109041-44-02A	EA	BLIND-MINI,30.5X18 - BEIGE (GE1) FROM 03-25-96 THRU 99-99-99
4	118071-03-GD1	EA	VAL-58.5" SUNDANCE (5")
4	118071-03-GE1	EA	VAL-58.5" SUNDANCE (5")

**CURTAIN & CUSHION GROUP (CONTINUED)**  
**WINDOW TREATMENT (CONTINUED)**

KEY	PART NUMBER	U/M	DESCRIPTION
4	119333-01-GD1	EA	LEG-RT.,25",PLAIN,NO HOLE
4	119333-01-GE1	EA	LEG-RT.,25",PLAIN,NO HOLE
4	119333-02-GD1	EA	LEG-LT.,25",PLAIN,NO HOLE
4	119333-02-GE1	EA	LEG-LT.,25",PLAIN,NO HOLE
4	084755-69-F15	EA	SHADE ASM-PULL - 55.25 - NO TRIM
4	111910-23-GB1	EA	BLIND - DAY/NIGHTER - 54 X 28.5 (GD1)
4	111910-23-GE1	EA	BLIND-DAY/NIGHTER,54X28.5 (GE1)
5	101668-31-FC1	EA	CURTAIN - TAPE TOP, 38" X 80" - DRIVERS (GD1)
5	101668-31-GE1	EA	CURTAIN - TAPE TOP, 38" X 80" - DRIVERS (GE1)
5	101668-30-FC1	EA	CURTAIN - TAPE TOP, 38" X 80" - PASSENGERS (GD1)
5	101668-30-GE1	EA	CURTAIN - TAPE TOP, 38" X 80" - PASSENGERS (GE1)
5	073260-42-FC1	EA	TIEBACK ASM-6X18 (GD1)
5	073260-42-GE1	EA	TIEBACK ASM-6X18 (GE1)
6	118071-02-GD1	EA	VAL-29" SUNDANCE (5")
6	118071-02-GE1	EA	VAL-29" SUNDANCE (5")
6	084755-95-FB1	EA	SHADE ASM-PULL - 25.5" NO TRIM
7	118071-05-GD1	EA	VAL-64.5" SUNDANCE (5")
7	118071-05-GE1	EA	VAL-64.5" SUNDANCE (5")
7	119333-01-GD1	EA	LEG-RT.,25",PLAIN,NO HOLE 9FAB06,3.5"FACE,WO
7	119333-01-GE1	EA	LEG-RT.,25",PLAIN,NO HOLE 9FAB06,3.5"FACE,WO
7	119333-02-GD1	EA	LEG-LT.,25",PLAIN,NO HOLE
7	119333-02-GE1	EA	LEG-LT.,25",PLAIN,NO HOLE
7	084755-96-G01	EA	SHADE ASM-PULL - 60.25 - NO TRIM
7	111910-22-GB1	EA	BLIND - DAY/NIGHTER - 60 X 28.5 (GD1)
7	111910-22-G08	EA	BLIND - DAY/NIGHTER - 60 X 28.5 (GE1)
8	118064-02-GB1	EA	VALANCE ASM-VALENCIA - 44" (GD1)
8	118064-02-GC1	EA	VALANCE ASM-VALENCIA - 44" (GE1)
8	084755-93-F15	EA	SHADE ASM-PULL - 42.25
8	111910-46-G22	EA	BLIND - DAY/NIGHTER - 43 X 26 (GD1)
8	111910-46-GE1	EA	BLIND - DAY/NIGHTER - 43 X 26 (GE1)
8	101034-49-GB1	EA	CURT-19X19,RT.DART TAPE T&B 9FAB07,W/LINING (GD1)
8	101034-49-GC1	EA	CURT-19X19,RT.DART TAPE T&B 9FAB07,W/LINING (GE1)
8	101034-50-GB1	EA	CURT-19X19,LT.DART TAPE T&B 9FAB07,W/LINING (GD1)
8	101034-50-GC1	EA	CURT-19X19,LT.DART TAPE T&B 9FAB07,W/LINING (GE1)
8	101034-53-GB1	EA	CURT-30.5X19,RT.DRT TAPE T&B - W/LINING (GD1)
8	101034-54-GB1	EA	CURT-30.5X19,LT.DRT TAPE T&B - W/LINING (GD1)
8	101034-53-GC1	EA	CURT-30.5X19,RT.DRT TAPE T&B - W/LINING (GE1)
8	101034-54-GC1	EA	CURT-30.5X19,LT.DRT TAPE T&B - W/LINING (GE1)
	101668-53-GD1	EA	CURT ASM 70 X 60 TAPE TOP (GD1)
	101668-53-GE1	EA	CURT ASM 70 X 60 TAPE TOP (GE1)
	073260-63-GB1	EA	TIEBACK ASM - 4" X 15" (ROOM DIVIDER) (GD1)
	073260-63-GC1	EA	TIEBACK ASM - 4" X 15" (ROOM DIVIDER) (GE1)

**FABRIC TRIMS, SEAT BELTS & ASSIST HANDLE**

KEY	PART NUMBER	U/M	DESCRIPTION
	007021-01-000	EA	BELT-SEAT, 2" X 90" - BLACK
	070578-02-B10	EA	BUTTON-SCREW STUD, #30 - VINYL - OFF WHITE
	070578-02-B29	EA	BUTTON-SCREW, STUD - #30 - VINYL
	056271-01-000	EA	BELT-SEAT, 2" X 102" - BLACK
	079349-04-F16	YD	WELT ASM-NARROW,ACCENT (GD1)
	079349-04-GE1	YD	WELT ASM-NARROW,ACCENT (GE1)
	079349-04-GD1	YD	WELT ASM-NARROW,ACCENT
	057759-01-000	EA	WASHER BRACKET-SEAT BELT, 4" DIAMETER
	007021-01-000	EA	BELT-SEAT, 2" X 90" - BLACK
	056271-01-000	EA	BELT-SEAT, 2" X 102" - BLACK
	057759-01-000	EA	WASHER BRACKET-SEAT BELT, 4" DIAMETER
	069178-02-000	EA	BRACKET-MOUNTING, ASSIST HANDLE - L ANGLE - W/HOLES - ST
	000C16-07-16B	EA	BOLT-CARRIAGE, ASSIST HANDLE - 7/16" - 14 X 1" ZN
	000D20-07-00B	EA	NUT-ACORN,ASSIST HANDLE - 7/16" X 14 ZN
	053552-02-AA8	EA	HANDLE-ASSIST, INTERIOR - ENTRY DOOR - VINYL - OFF WHITE

## CURTAIN & CUSHION GROUP (CONTINUED)

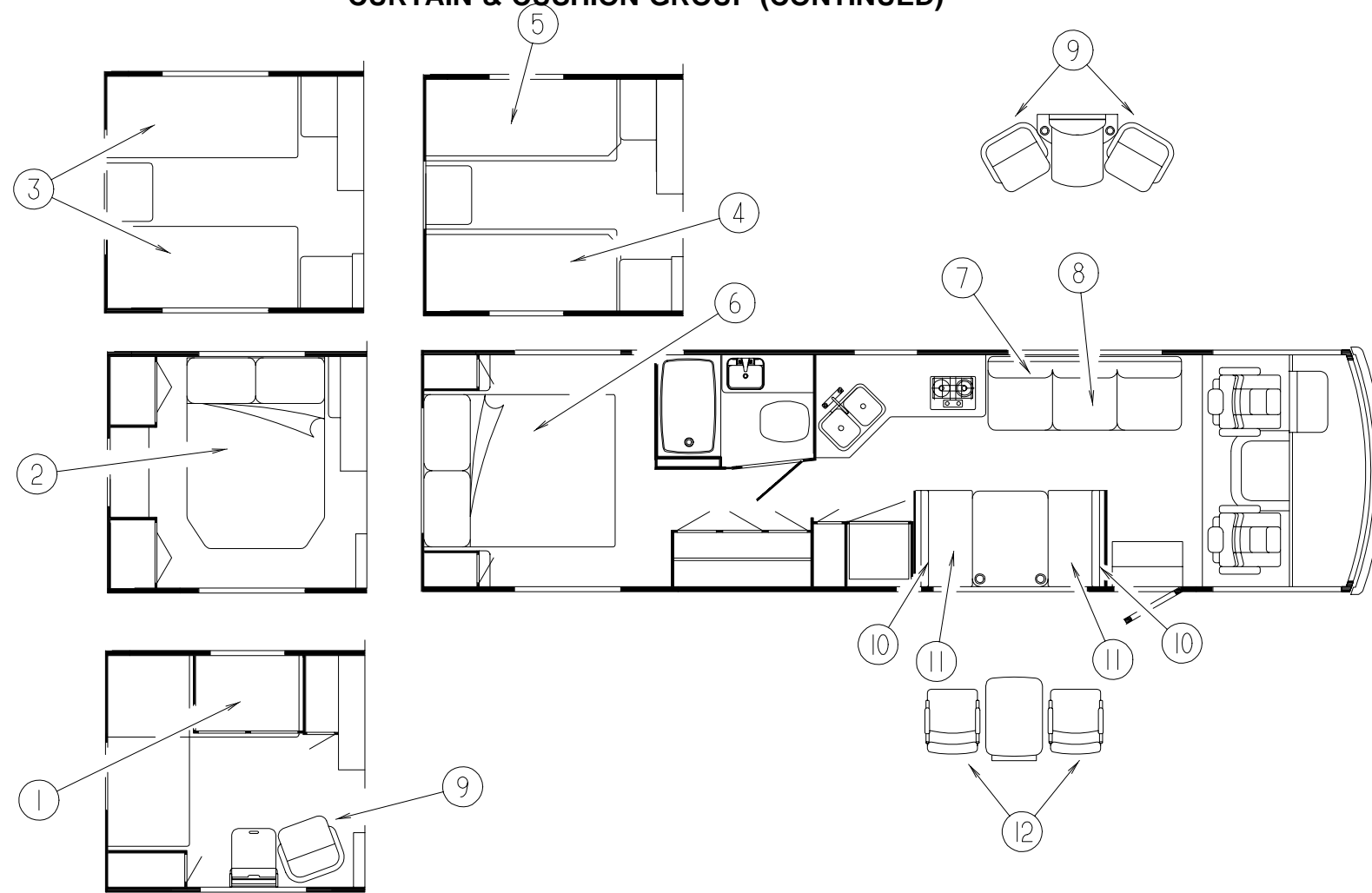

### CROSSED STACKED TWIN BED CUSHIONS

KEY	PART NUMBER	U/M	DESCRIPTION
1	101123-19-000	EA	MATTRESS-COMPLETE-FOAM 32" X 79" X 5"
	P01123-19-000	EA	COVER-MATTRESS - 32" X 74" X 5"
	117067-03-GB1	EA	COVER-FITTED SHEET,UNIV. 5" (GD1)
	117067-03-GC1	EA	COVER-FITTED SHEET,UNIV. 5" (GE1)

### DOUBLE BED

KEY	PART NUMBER	U/M	DESCRIPTION
2	101123-22-000	EA	MATTRESS COMPLETE-FOAM - W/2 CUT CORNERS - 54" X 74" X 5"
	P01123-22-000	EA	COVER-MATTRESS - 54" X 74" X 5"
2	085365-37-GD1	EA	BEDSPREAD - 54" THROW,1/2" WELT NON-GATHERING
2	085365-37-GE1	EA	BEDSPREAD - 54" THROW,1/2" WELT NON-GATHERING
	102161-36-GD1	EA	SHAM - 1/2"NON-GATHERED WELT (20 X 30)
	102161-36-GE1	EA	SHAM - 1/2"NON-GATHERED WELT (20 X 30)

### TWIN BED CUSHIONS

KEY	PART NUMBER	U/M	DESCRIPTION
3	101123-19-000	EA	MATTRESS-COMPLETE-FOAM 32" X 79" X 5"
	P01123-19-000	EA	COVER-MATTRESS - 32" X 74" X 5"
	117067-03-GB1	EA	COVER-FITTED SHEET,UNIV. 5" (GD1)
	117067-03-GC1	EA	COVER-FITTED SHEET,UNIV. 5" (GE1)
3	085365-38-GD1	EA	BEDSPREAD - 33" X 80" - W1/2" WELT NON-GATHERED
3	085365-38-GE1	EA	BEDSPREAD - 33" X 80" - W1/2" WELT NON-GATHERED
	102161-36-GD1	EA	SHAM - 1/2"NON-GATHERED WELT W/4" RUFFLE (20 X 30)
	102161-36-GE1	EA	SHAM - 1/2"NON-GATHERED WELT W/4" RUFFLE (20 X 30)

### BUNKS BED CUSHIONS

KEY	PART NUMBER	U/M	DESCRIPTION
4	101123-24-000	EA	MATTRESS-COMPLETE-FOAM 30 X 76 X 4 - W/LT.CUT CORNER
	P01123-24-000	EA	COVER-MATTRESS - 30 X 76 X 4
	117067-02-GB1	EA	COVER-FITTED SHEET,LT.4"(GD1)
	117067-02-GC1	EA	COVER-FITTED SHEET,LT.4" (GE1)
	102161-36-GD1	EA	SHAM - 1/2"NON-GATHERED WELT W/4" RUFFLE (20X30)
	102161-36-GE1	EA	SHAM - 1/2"NON-GATHERED WELT W/4" RUFFLE (20X30)
5	101123-23-000	EA	MATTRESS-COMPLETE-FOAM 30 X 76 X 4 - W/RT.CUT CORNER
	P01123-23-000	EA	COVER-MATTRESS - 30 X 76 X 4
	117067-01-GB1	EA	COVER-FITTED SHEET,RT.4" (GD1)
	117067-01-GC1	EA	COVER-FITTED SHEET,RT.4" (GE1)

### QUEEN BED CUSHIONS

KEY	PART NUMBER	U/M	DESCRIPTION
6	101123-26-000	EA	MATTRESS COMPLETE-FOAM - 59" X 74" X 5"
	P01123-26-000	EA	COVER-MATTRESS - 59" X 74" X 5"
	085365-36-GD1	EA	BEDSPREAD - 60" X 75" THROW,1/2" WELT NON-GATHERING
6	085365-36-GE1	EA	BEDSPREAD - 60" X 75" THROW,1/2" WELT NON-GATHERING
	102161-35-GD1	EA	SHAM - QUEEN - 1/2"NON-GATHERED WELT W/4" RUFFLE (20X33)
	102161-35-GE1	EA	SHAM - QUEEN - 1/2"NON-GATHERED WEALT W/4" RUFFLE (20X33)

**CURTAIN & CUSHION GROUP (CONTINUED)**

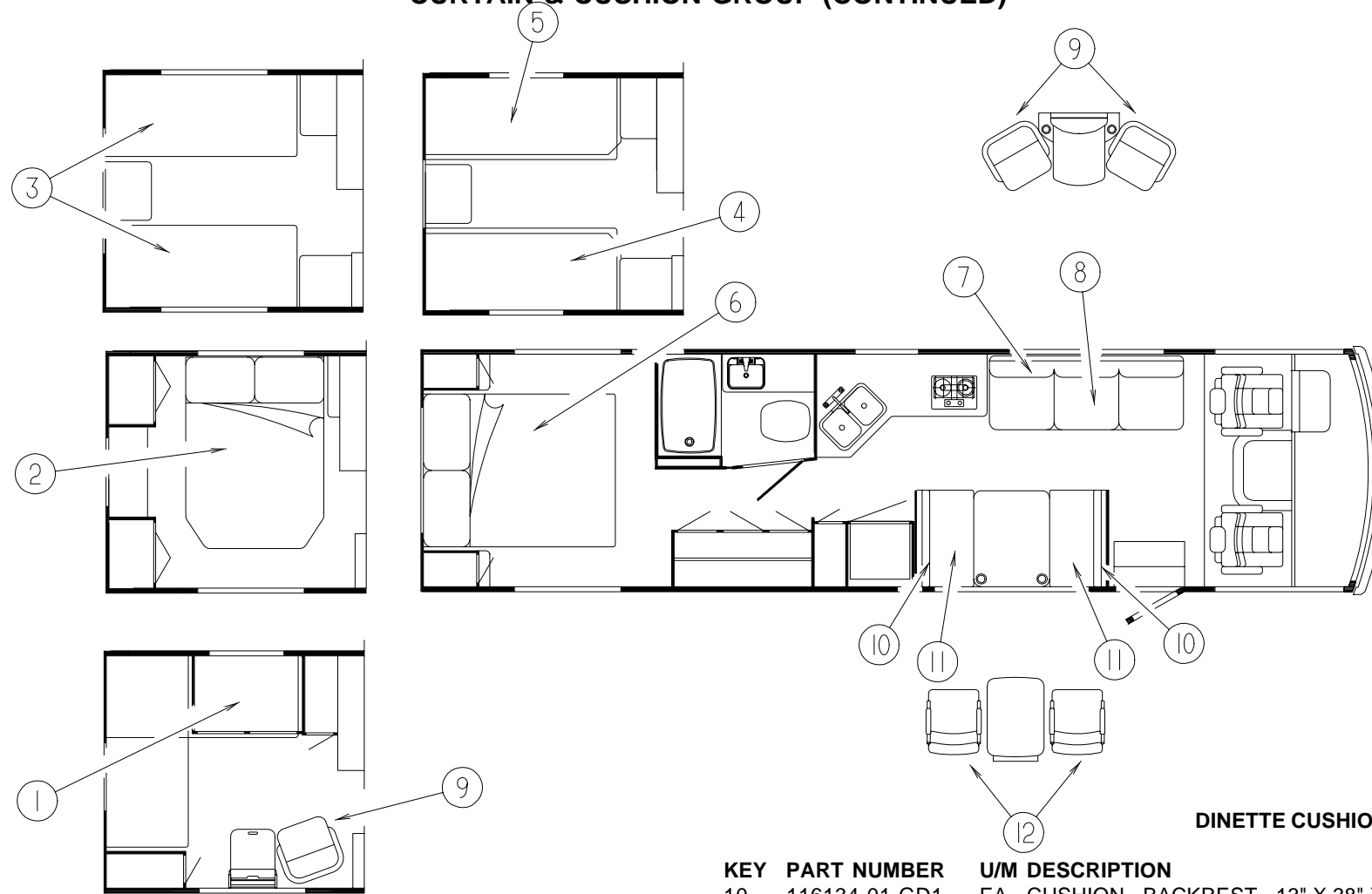

**DRIVERS SIDE COUCH**

KEY	PART NUMBER	U/M	DESCRIPTION
7	120549-01-GD1	EA	BED ASM-600 TBJK,74" BACK
7	120549-01-GE1	EA	BED ASM-600 TBJK,74" BACK
	P20549-01-GD1	EA	CVR ASM-600 TBJK,74" BACK
	P20549-01-GE1	EA	CVR ASM-600 TBJK,74" BACK
	101085-10-000	EA	FRAME-74.5X16 BACK FRAME
8	100032-43-GD1	EA	BED-J.K.,SEAT,74" TUCK,N/ARMS
8	100032-43-GE1	EA	BED-J.K.,SEAT,74" TUCK,N/ARMS
	P00032-43-GD1	EA	COVER-J.K.SEAT,74" TUCK,N/ARM
	P00032-43-GE1	EA	COVER-J.K.SEAT,74" TUCK,N/ARM
	101085-04-000	EA	FRAME-74.75" SEAT
	101085-06-000	EA	FRAME-74.75" BASE

NOTE: COUCH FRONT AND SIDE PANELS ARE FOUND IN THE LOUNGE GROUP.

**SIERRA CHAIR**

KEY	PART NUMBER	U/M	DESCRIPTION
9	115470-01-GD1	EA	CHAIR ASM-SIERRA
	P15470-01-GD1	EA	COVER-CHAIR,SIERRA
9	115470-01-GE1	EA	CHAIR ASM-SIERRA
	P15470-01-GE1	EA	COVER-CHAIR,SIERRA
	P07977-01-GD1	EA	COVER-SKIRT,CHAIR,DIPLOMAT
	P07977-01-GE1	EA	COVER-SKIRT,CHAIR,DIPLOMAT

**DINETTE CUSHIONS**

KEY	PART NUMBER	U/M	DESCRIPTION
10	116134-01-GD1	EA	CUSHION - BACKREST - 13" X 38" X 5"
10	116134-01-GE1	EA	CUSHION - BACKREST - 13" X 38" X 5"
	P16134-01-GD1	EA	COVER - BACKREST CUSHION - 13" X 38" X 5"
	P16134-01-GE1	EA	COVER - BACKREST CUSHION - 13" X 38" X 5"
11	088927-87-GD1	EA	CUSH-23X38X5,DINETTE SEAT
11	088927-87-GE1	EA	CUSH-23X38X5,DINETTE SEAT
	M88927-87-GD1	EA	COVER - CUSHION - SEAT, 23" X 38" X 5"
	M88927-87-GE1	EA	COVER - CUSHION - SEAT, 23" X 38" X 5"
	078155-01-000	EA	STRAP-SNAP - BACKREST CUSHION
	109995-01-F16	EA	PAD ASM-DINETTE (GD1)
	109995-01-GE1	EA	PAD ASM-DINETTE (GE1)

**CHAIR**

KEY	PART NUMBER	U/M	DESCRIPTION
12	119108-01-GD1	EA	CHAIR ASM- 200 KC
12	119108-01-GE1	EA	CHAIR ASM- 200 KC
	106477-01-000	EA	SCREW-14-10X3.00 PFH
	116080-02-G35	EA	COVER-CHAIR LEG

**BUCKET SEAT**

KEY	PART NUMBER	U/M	DESCRIPTION
	110148-07-GD1	EA	SEAT - ECONOMIZER III - ECONOMIZER ARM
	110148-07-GE1	EA	SEAT - ECONOMIZER III - ECONOMIZER ARM

**FRONT BUNK CUSHIONS**

KEY	PART NUMBER	U/M	DESCRIPTION
	079145-10-000	EA	CUSHION-BUNK - 25" X 80" X 2.5"
	M79145-10-000	EA	COVER-BUNK - 25" X 80" X 2.5"

## CURTAIN & CUSHION GROUP (CONTINUED)

### DRIVER & PASSENGER BUCKET SEATS

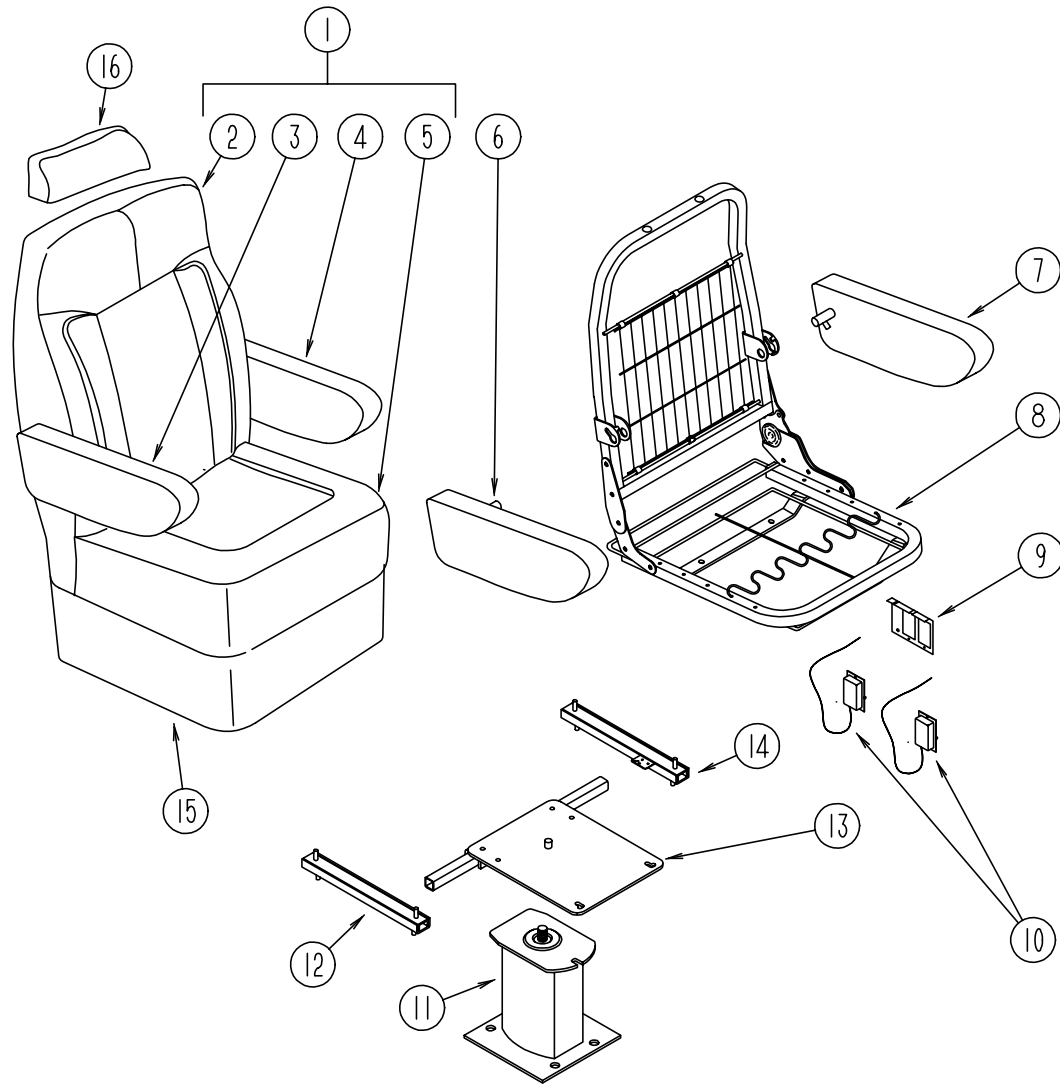

KEY	PART NUMBER	U/M	DESCRIPTION
1	110148-07-GD1	EA	SEAT-ECONOMIZER III - -ECONOMIZER ARM
1	110148-07-GE1	EA	SEAT-ECONOMIZER III - -ECONOMIZER ARM
2	M05962-17-GD1	EA	COVER-ECONOMIZER - BACK
2	M05962-17-GE1	EA	COVER-ECONOMIZER - BACK
3	115520-01-FC1	EA	ARMREST-RT. ECONO N/SEWLINES (GD1)
3	115520-01-GE1	EA	ARMREST-RT. ECONO N/SEWLINES (GE1)
	P15520-01-FC1	EA	CVR ASM-ARM,RT. ECONO N/SEWL (GD1)
	P15520-01-GE1	EA	CVR ASM-ARM,RT. ECONO N/SEWL (GE1)
4	115520-02-FC1	EA	ARMREST-LT. ECONO N/SEWLINES (GD1)
4	115520-02-GE1	EA	ARMREST-LT. ECONO N/SEWLINES (GE1)
	P15520-02-FC1	EA	CVR ASM-ARM,LT. ECONO N/SEWL (GD1)
	P15520-02-GE1	EA	CVR ASM-ARM,LT. ECONO N/SEWL (GE1)
5	M05962-18-GD1	EA	COVER-ECONOMIZER II - SEAT (GD1)
5	M05962-18-GE1	EA	COVER-ECONOMIZER II - SEAT (GE1)
6	115617-01-000	EA	BRACKET / ARMREST - RIGHT - MOLDED
7	115617-02-000	EA	BRACKET / ARMREST - LEFT - MOLDED
8	M80906-12-000	EA	FRAME ASM-SEAT & BACK & SPRING
9	108049-02-000	EA	CLIP-CABLE, PEDESTAL
	080730-08-000	EA	HANDLE - 30179907 KEIPER
	080730-09-000	EA	SHIELD-FLEXSTEEL
	080730-11-000	EA	SHIELD-RUBBER BOOT FLEXSTEEL
10	108049-03-000	EA	CABLE - 26" Z END CABLE
11	107921-01-000	EA	PEDESTAL ASM-SEAT 9-3/4" - FLEXSTEEL 3060 MSPD
12	119952-04-000	EA	ADJUSTER-BUCKET SEAT W/ REMOTE - FORWARD AND BACK
13	107921-05-000	EA	TOP PLATE - FLEXSTEEL
	107921-06-000	EA	BEARING KIT - FLEXSTEEL
14	119952-02-000	EA	ADJUSTER-SEAT/CHAIR - W/O LOCK - FORWARD & BACK
	007221-01-000	EA	SPACER-SEAT - ADJUSTER
15	071126-41-FC1	EA	SKIRT ASM-SINGLE - 7" - W/SLOT (GD1)
15	071126-41-GE1	EA	SKIRT ASM-SINGLE - 7" - W/SLOT (GE1)
16	119698-01-GD1	EA	HEADREST-STRATON II
16	119698-01-GE1	EA	HEADREST-STRATON II
	P19698-01-GD1	EA	COVER-HEADREST STRATON II
	P19698-01-GE1	EA	COVER-HEADREST STRATON II
	113977-12-000	EA	HEADREST INSERT,W/O LOCK
	113977-13-000	EA	HEADREST INSERT,W/LOCK
	114791-05-000	EA	FRAME-HEADREST,STRATON,PLYF
	080730-09-000	EA	SHIELD-FLEXSTEEL
	080730-11-000	EA	SHIELD-RUBBER BOOT
	080730-08-000	EA	HANDLE - RECLINER



## CURTAIN & CUSHION GROUP (CONTINUED)

### SWIVEL CHAIR (RECLINER)

KEY	PART NUMBER	U/M	DESCRIPTION
1	115470-01-GD1	EA	CHAIR ASM-SIERRA
	P15470-01-GD1	EA	COVER-CHAIR,SIERRA
1	115470-01-GE1	EA	CHAIR ASM-SIERRA
	P15470-01-GE1	EA	COVER-CHAIR,SIERRA
	P07977-01-GD1	EA	COVER-SKIRT,CHAIR,DIPLOMAT
	P07977-01-GE1	EA	COVER-SKIRT,CHAIR,DIPLOMAT
2	097683-02-000	EA	BRACKET - REMOTE - SIDE MOUNT
3	108049-03-000	EA	REMOTE & CABLE
4	119952-01-000	EA	SLIDE-SEAT,HD,NONLOCKING 2ST - ATWOOD 83711
5	107921-08-000	EA	TOP PLATE-W/O SEAT BELT BAR
	107921-06-000	EA	BEARING KIT - PEDESTAL
6	107921-01-000	EA	FLOOR MOUNTED PEDESTAL - W/ 9.75" EXTENSION
7	108445-02-000	EA	SUB PLATE - FLOOR MOUNTED PEDESTAL
8	119952-03-000	EA	SLIDE-SEAT,HD,LOCKING 2STUDS - ATWOOD 83775
9	007221-01-000	EA	SPACER - SEAT ADJUSTER
	108452-G3-000	EA	FOAM-SEAT CORE - 95 SIERRA CHAIR
	117125-01-02B	EA	BRACKET-CABLE HOLDER,E-COAT
	117125-01-02B	EA	BRACKET-CABLE HOLDER,E-COAT
	007021-01-000	EA	SEAT BELT - 2" X 90" - BLACK
	108049-02-000	EA	CLIP-CABLE, PEDESTAL

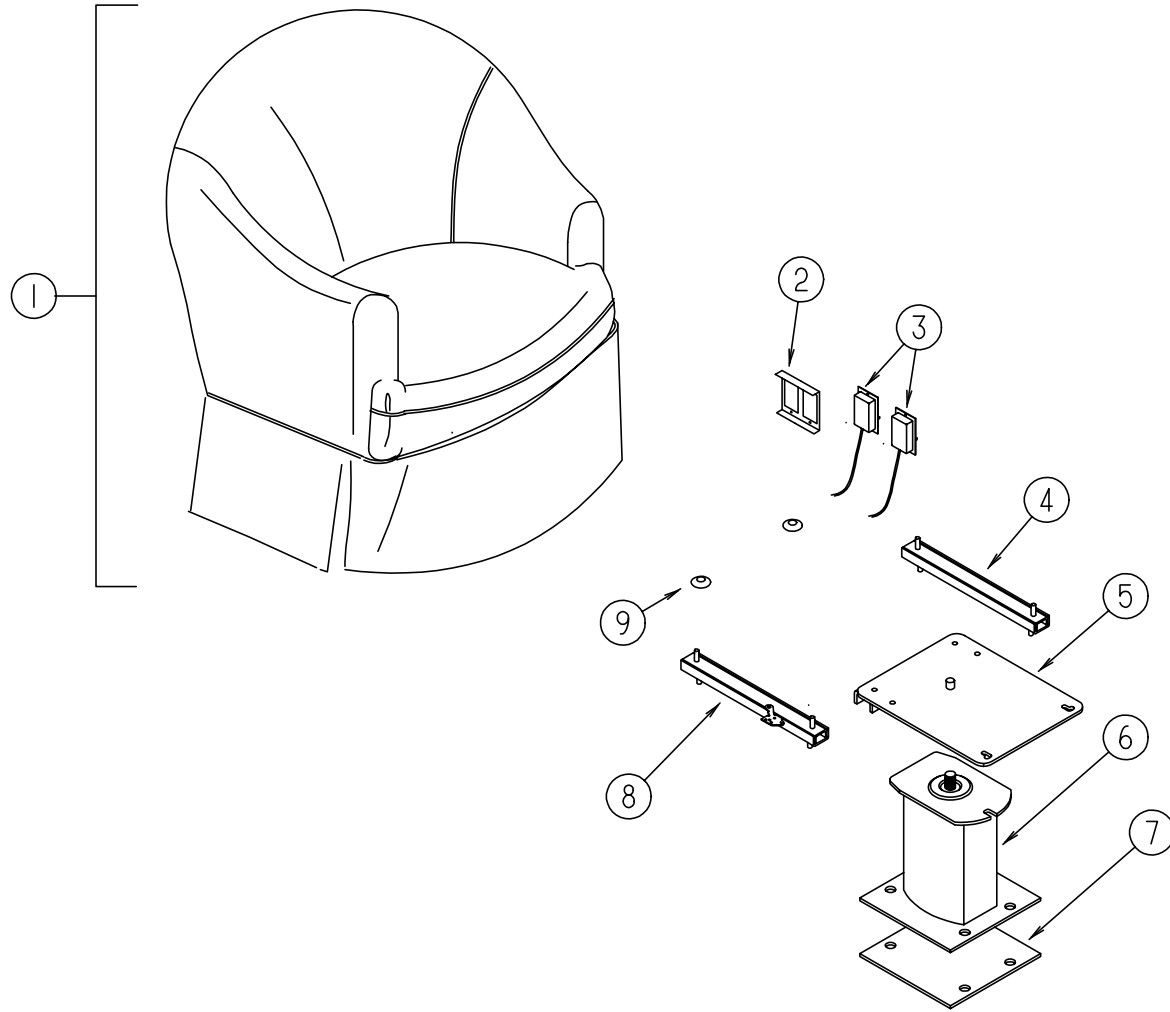

## CURTAIN & CUSHION GROUP (CONTINUED)

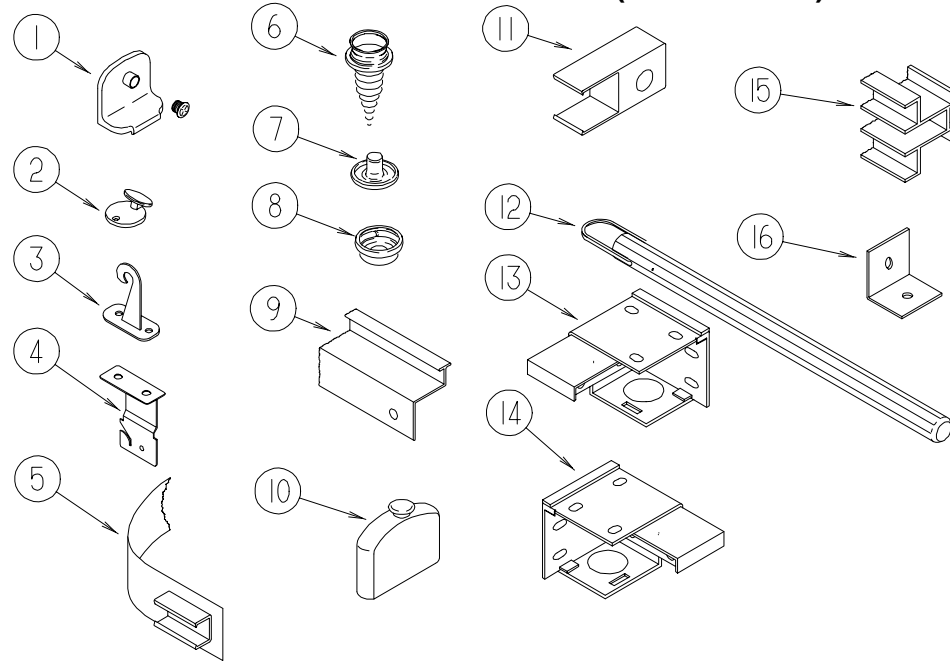

### CURTAIN HARDWARE

KEY	PART NUMBER	U/M	DESCRIPTION
1	106544-01-000	EA	PULL-SHADE, BRASS
	106544-01-001	EA	SCREW-BRASS, SHADE
2	102555-01-000	EA	CLEAT-CORD, BLIND - OFF WHITE
3	109441-03-000	EA	HOLD DOWN-BLIND (CLOUDY)
4	084434-01-000	EA	BRACKET-MOUNTING, ROLLER SHADE - 1 3/8"
	084433-05-000	EA	SHADE-ROLLER, 72.25"
	096843-01-000	EA	SPRING-REWIND, ROLLER SHADE
	084432-06-000	FT	SLAT-ROLLER SHADE, PLASTIC
5	101031-01-000	YD	TAPE-GLIDE, CURTAIN - 4.25" SPACING
6	029130-01-000	EA	SCREW-SNAP SOCKET, 8 PH X 5/8"
7	029155-01-000	EA	CAP-SNAP, 5/32" O.D. OF PIN
8	029156-01-000	EA	SOCKET-SNAP, 9/16" O.D.
9	105324-02-01A	EA	TRACK-CURTAIN, WRAPAROUND - PASSENGER SIDE - OFF WHITE
9	105324-03-01A	EA	TRACK-CURTAIN, WRAPAROUND - DRIVER SIDE - OFF WHITE
9	105450-08-01A	EA	TRACK-CURTAIN, 38" LONG - ALUMINUM - OFF WHITE
9	105450-01-01A	EA	TRACK-CURTAIN, 30.8" LONG - ALUMINUM - OFF WHITE
10	093475-01-701	EA	END CAP-BLIND, W/STUD
11	101033-02-000	EA	END CAP-TRACK, CLEAR
12	093475-01-700	EA	WAND-BLIND, W/METAL CLIP - 8" LONG
13	083170-01-000	EA	BRACKET-BLIND, RIGHT SIDE
14	083170-02-000	EA	BRACKET-BLIND, LEFT SIDE
15	101033-03-000	EA	TRACK-WALL, WHITE
16	083125-07-000	EA	BRACE-COUCH,O/W
	046867-01-000	EA	GROMMET-BRASS, 7/16" ID X 1" OD
	046867-03-000	EA	GROMMET-HANDY BUTTON NO 3
	088792-01-000	YD	VELCRO-HOOK, .75" WIDE - BEIGE
	088792-02-000	YD	VELCRO TAPE-LOOP, ADHESIVE BACKED - .75" WIDE - BEIGE
	088792-06-000	YD	VELCRO-3/4" NON-ADH., LOOP BUF MED
	048394-02-000	YD	VELCRO TAPE-HOOK, ADHESIVE BACK - .75" WIDE - BEIGE
	086276-01-000	EA	TAPE-DOUBLE SIDED, 1/2"
	094896-02-000	EA	GROMMET-CORD, PLEATED BLIND - NYLON - GRAY
	094907-02-000	EA	END CAP-TOP, PLEATED BLIND - PLASTIC - GRAY
	094907-04-000	EA	HRDW.-END CAP,BTM ,PULL TYPE
	096843-01-000	EA	SPRING-REWIND, ROLLER SHADE
	097564-01-000	EA	HANDLE-T, EZ LIFT SHADE
	097591-01-000	EA	SPRING-EXTENSION, PLEATED BLIND
	097592-01-000	EA	SPOOL-CORD, ELEVATED BLIND HOLDUP - CLEAR PLASTIC
	097593-06-000	FT	CORD-BLIND, PLEATED - PEWTER

## DINETTE GROUP

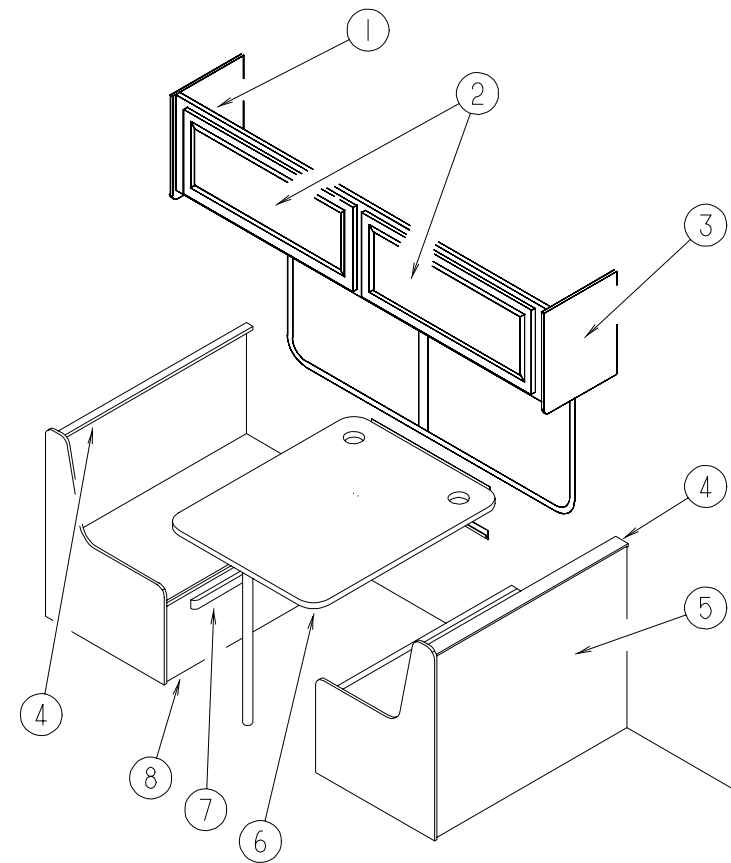

### DINETTE CABINETRY

KEY	PART NUMBER	U/M	DESCRIPTION
1	120370-01-GB1	EA	CABINET ASM-OVHD,DINETTE
2	110140-65-G01	EA	DOOR ASM.-W/MIRROR-W/O HRDWE-MITERED-VINYL WRAP
2	110140-05-G01	EA	DOOR ASM-MITERED,VINYL WRAP
3	109908-35-GB1	EA	CAP ASM-END,OVHD
4	109995-01-F16	EA	PAD ASM-DINETTE(GD1)
4	109995-01-GE1	EA	PAD ASM-DINETTE (GE1)
5	M04175-75-GB1	EA	CABINET-SEATBASE RH
	M04174-75-GB1	EA	CABINET-SEATBACK RH
6	081322-04-GD1	EA	TABLE ASM-DINETTE(GD1)
			FROM: 00-00-00 THRU: 11-19-95
6	081322-04-GC1	EA	TABLE ASM-DINETTE (GE1)
			FROM: 00-00-00 THRU: 11-19-95
6	081322-17-GD1	EA	TABLE ASM-DINETTE(GD1)
			FROM: 11-20-95 THRU: 99-99-99
6	081322-17-GC1	EA	TABLE ASM-DINETTE (GE1)
			FROM: 11-20-95 THRU: 99-99-99
7	081295-01-G01	EA	SUPPORT-BED - DINETTE - 712 LG
8	M04175-48-GB1	EA	CABINET-SEATBASE LH
	M04174-48-GB1	EA	CABINET-SEATBACK LH

## DINETTE GROUP (CONTINUED)

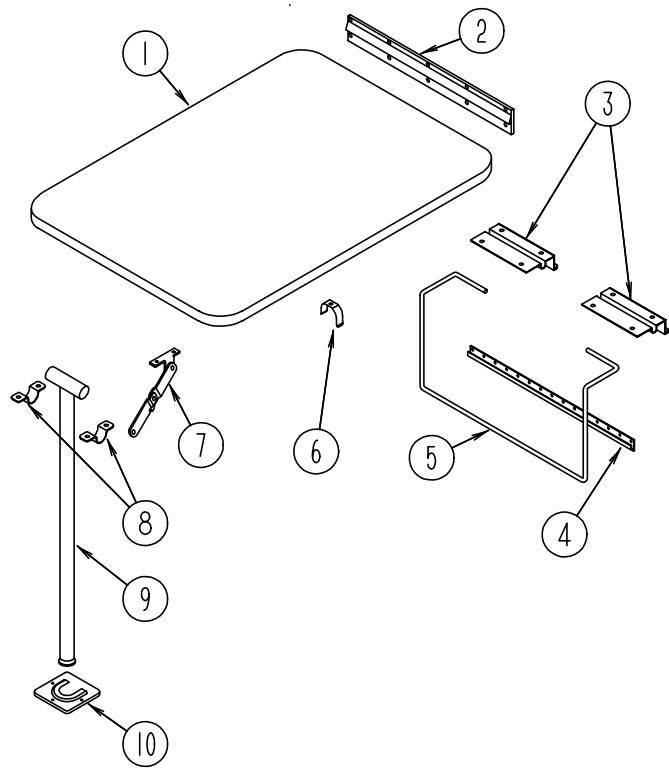

**DINETTE TABLE**

KEY	PART NUMBER	U/M	DESCRIPTION
1	081322-04-GD1	EA	TABLE ASM-DINETTE (GD1)
			FROM 00-00-00 THRU 11-19-95
1	081322-04-GC1	EA	TABLE ASM-DINETTE (GE1)
			FROM 00-00-00 THRU 11-19-95
1	081322-17-GD1	EA	TABLE ASM-DINETTE(GD1)
			FROM 11-20-95 THRU 99-99-99
1	081322-17-GC1	EA	TABLE ASM-DINETTE (GE1)
			FROM 11-20-95 THRU 99-99-99
2	053200-12-000	EA	SUPPORT-TABLE, 23.50" - OFF WHITE
3	088410-02-000	EA	HANGER-TABLE, OFF WHITE
4	024281-14-000	EA	BRACKET-TABLE LIFT, 22.12" - OFF WHITE
5	024275-12-000	EA	ROD-TABLE LIFT, OFF WHITE
6	024283-01-000	EA	CLIP-LEG, 1" - 1.125" OD - BLACK
7	024282-01-000	EA	BRACE-TABLE LEG, HINGED
8	064050-05-000	EA	HINGE-TABLE LEG, OFF WHITE
9	024276-23-000	EA	LEG ASM-TABLE OFF WHITE
10	049493-12-000	EA	CATCH-TABLE LEG, OFF WHITE
10	049493-11-700	EA	CATCH-LEG, FLOOR MOUNTED - 2.5" X 2.7" - METAL - E-COAT
	093550-01-000	EA	BRACKET-HINGE, MOUNTS TO LEG & TABLE TOP - 1.7" X 2.6"

## DRIVERS COMPARTMENT GROUP

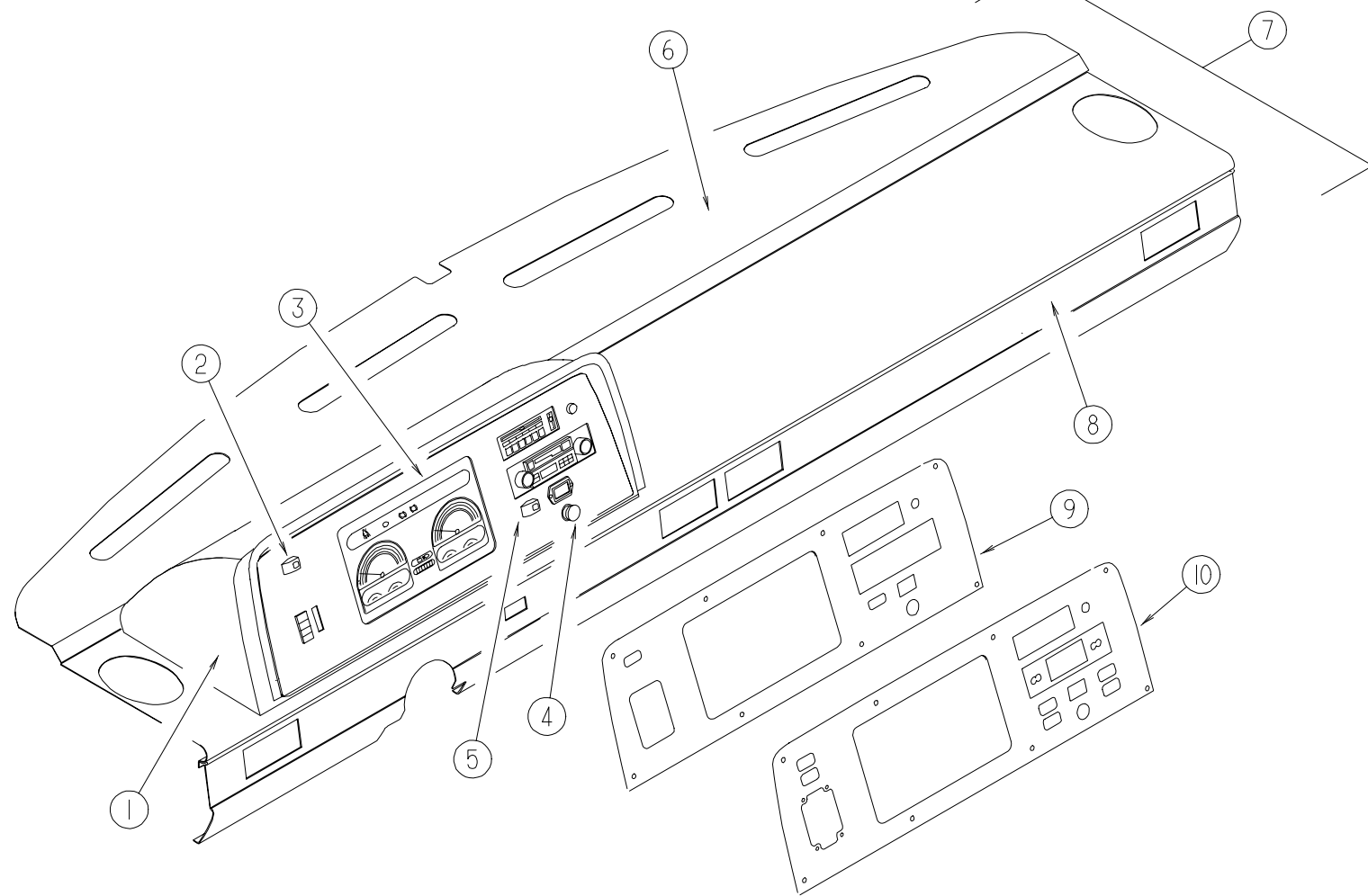

**DASH**

KEY	PART NUMBER	U/M	DESCRIPTION
	M05946-32-GB1	EA	DASH POD ASM - CHEVY - W/O INSTRUMENT CLUSTER
			FROM: 00-00-00 THRU: 01-28-96
	M05946-37-GB1	EA	DASH POD ASM-CHEVY,RLC
			FROM: 01-29-96 THRU: 99-99-99
1	110066-01-02A	EA	POD-INSTRUMENT PANEL
			FROM: 00-00-00 THRU: 01-28-96
1	121118-01-01A	EA	POD-INSTR PANEL,CAMB BISQUE
			FROM: 01-29-96 THRU: 99-99-99
	079382-01-000	EA	SCREW-SOCKET, 8-18 X 1" - BLACK
	103603-01-000	EA	BULB - 12V, # 74 0.12A WEDGE
	077539-01-000	EA	BRACKET-MOUNTING, DASH PANEL - L/SHAPED - 2.5" X 1" X 1.5"
	100138-01-000	EA	MODULE-DAYTIME RUNNING LIGHT
	077031-01-000	EA	FILM-BLACK, 1" X 1.75"
	077031-03-000	EA	FILM-WHITE, .75" X 1.00"
	105615-01-000	FT	FILM-PROTECTIVE, CLEAR - 34" WIDE
2	108357-09-000	EA	ROCKER SWITCH, SPDT ON/NONE/MOM - CARLING V5D1000B-0
2	108356-02-01A	EA	COVER-SWITCH W/DIMPLES, CARLING VVAZC00 BLA
3	094796-07-000	EA	CLUSTER-INSTRUMENT PANEL, KILOMETERS - GAS - GM #16201075 (CSA)
4	089294-01-000	EA	CIGARETT LIGHTER ASM. W/O WIRES - CASCO #C213275
5	108357-10-000	EA	SWITCH-ROCKER, SPDT MOM/OFF/MOM - CARLING V8D1160B-0
5	108356-04-01A	EA	COVER-SWITCH W/DIMPLES & LENS, CARLING VVAGC00
	106569-02-04A	EA	VINYL-LAMINATE MADRID, CAMBRIDGE- 1/4" X 16" X 96"
6	105927-02-000	EA	PANEL ASM-DASH, TOP - W/STUD - STEEL
7	P03817-11-000	EA	DASH ASM, CHEVY - W/O VINYL & INSTRUMENT POD - STEEL
8	103812-01-05A	EA	TRIM-DASH, LOWER - GM
	103558-01-09A	EA	VENT-DEFROSTER, ABS
9	110073-01-01A	EA	APPLIQUE-BEZEL, INSTRUMENT PANEL - BLACK VELVET
10	109829-01-01A	EA	BEZEL-INSTRUMENT PANEL, BLACK

**DRIVERS COMPARTMENT GROUP (CONTINUED)**

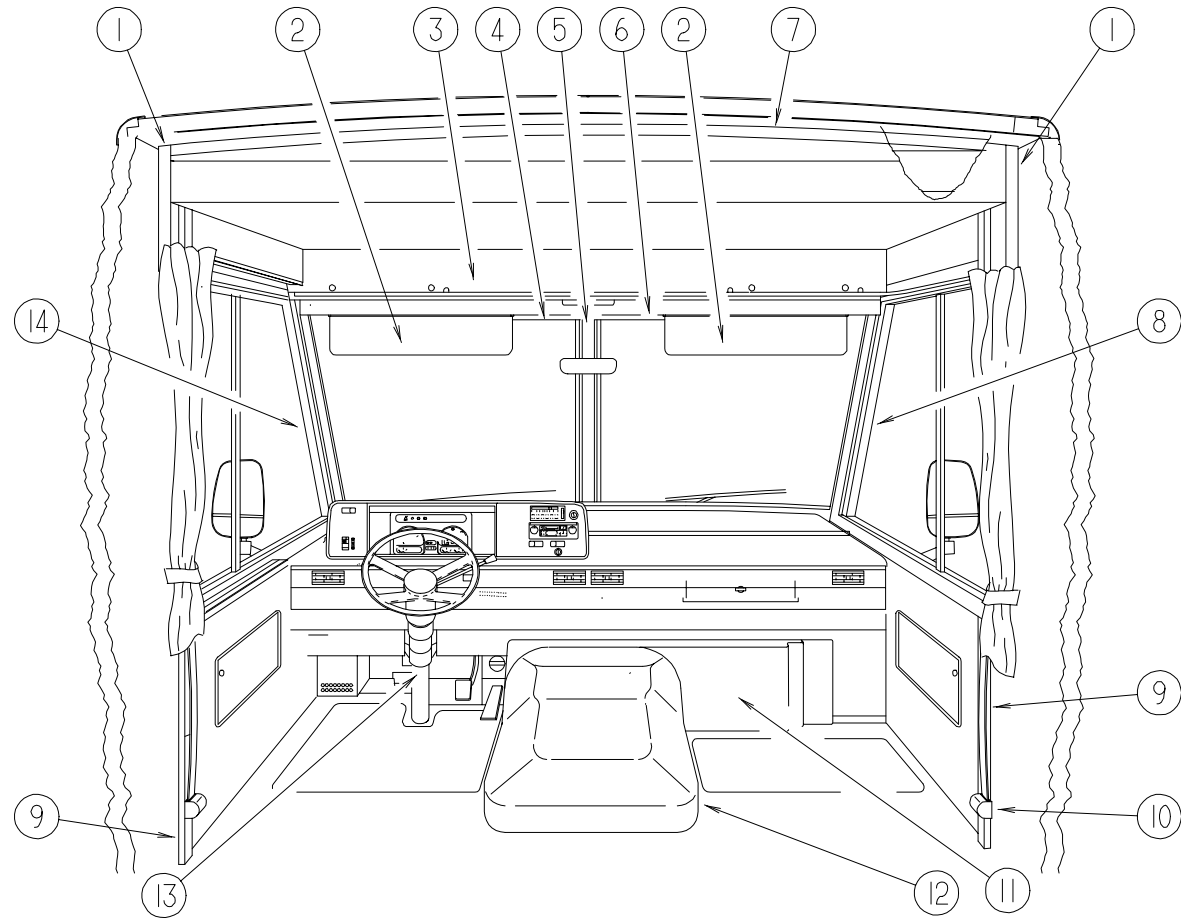

**DRIVERS COMPARTMENT**

KEY	PART NUMBER	U/M	DESCRIPTION
1	024700-50-000	EA	COVER-ROLL BAR,OFF WHITE 8.00 INCHES W/BUNK
2	082286-18-D12	EA	SUNVISOR ASM, W/O POCKET
	007211-01-000	EA	HINGE-SUNVISOR, 25.5" X 1.5" - METAL
	081987-05-000	EA	ROD-SUNVISOR, BLACK
	074012-01-000	EA	CLIP-SUNVISOR, SQUARE - PINCH ON
	102377-01-000	EA	BRACKET-SUNVISOR, 1 PIECE - STEEL
3	109795-02-FB1	EA	PANEL-HEADLINER
	078811-07-FB1	EA	PANEL-HEADER, HORIZONTAL SECTION - W/LIGHT & SPEAKER CUTOUTS
4	078579-08-000	EA	TRIM-WINDSHIELD, UPPER - INNER - DRIVER - OFF WHITE
5	079765-07-000	EA	TRIM-WINDSHIELD, CENTER - PRECUT ENDS - OFF WHITE
	079765-09-000	EA	TRIM-WINDSHIELD, CENTER - UNCUT - OFF WHITE
6	078579-07-000	EA	TRIM-WINDSHIELD, UPPER - INNER - PASSENGER - OFF WHITE
7	024700-51-000	EA	COVER-ROLL BAR, OFF WHITE - 88.00"
8	103931-01-01A	EA	COVER-INTERIOR, A-PILLAR - RIGHT - OFF WHITE
9	024700-44-000	EA	COVER-SDW ROLL BAR,OFF WHITE 53.00 INCHES
	110056-01-01A	EA	COVER-ROLL BAR 90° OFF WHITE
10	091990-04-01A	EA	SEAT BELT - 3 POINT,BLACK
	103961-01-01A	EA	COVER-BRACKET,SEATBELT O/W
	057759-01-000	EA	WASHER BRACKET-SEAT BELT, 4" DIAMETER
11	095757-03-FC1	EA	COVER ASM-HEATER (GD1)
	095757-03-GE1	EA	COVER ASM-HEATER (GE1)
	111618-01-GB1	EA	TRAY ASM-BEVERAGE
12	115840-01-01A	EA	COVER-MOTOR
	115850-01-02B	EA	RETAINER ASM-LATCH,MOTOR COVER
	116581-01-000	EA	LATCH-MOTOR COVER
13	103498-06-000	EA	BOOT-COLUMN
14	103931-02-01A	EA	COVER-INT,A-PILLAR,LH,O/W
	119919-14-000	EA	FRONT - STEP BOX INSERT

**DRIVERS COMPARTMENT GROUP (CONTINUED)**

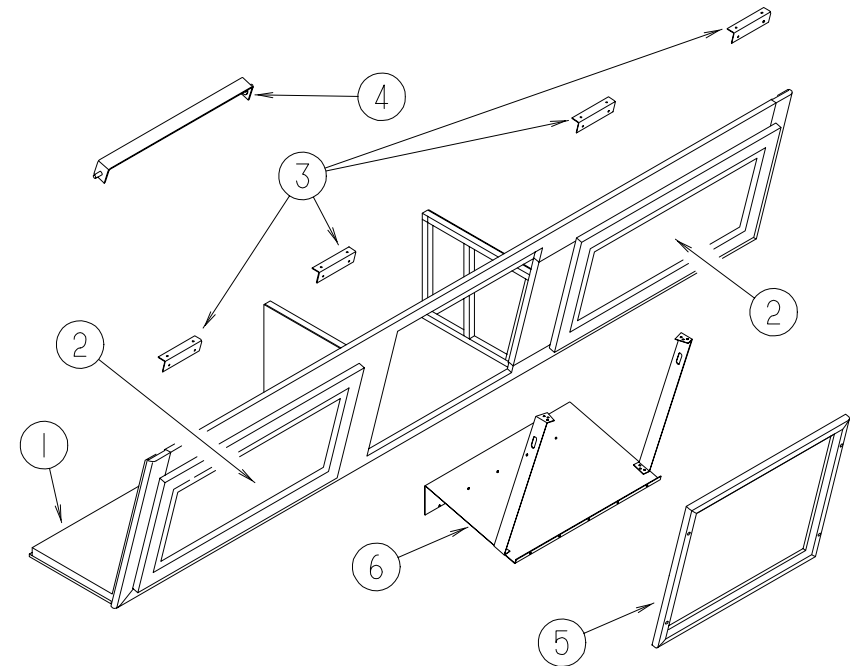

**DRIVERS COMPARTMENT TV CABINET**

KEY	PART NUMBER	U/M	DESCRIPTION
1	120196-01-GB1	EA	CABINET ASM-OVHD,TV
2	110140-18-G01	EA	DOOR ASM-MITERED,VINYL WRAP
3	106699-01-01A	EA	BRACKET-CABINET,OVHD TV O/W
	099717-03-000	EA	STRAP-TV TIE DOWN W/5.1" FEMALE STRAP & 7.9" MALE STRAP
4	120175-02-02B	EA	SUPPORT ASM-SHELF,TV,E-COAT
5	120198-01-GB1	EA	CABINET ASM-FRAME,TV
6	120178-01-01B	EA	SHELF ASM-TV

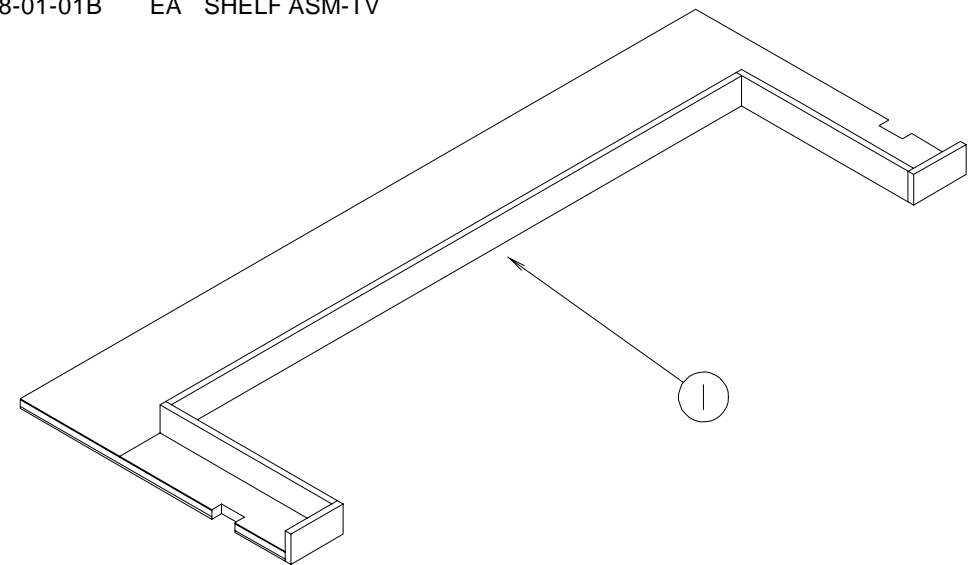

**DRIVERS COMPARTMENT BLANKET CABINET**

KEY	PART NUMBER	U/M	DESCRIPTION
1	104417-02-GB1	EA	CABINET ASM-BLANKET

## DRIVERS COMPARTMENT GROUP (CONTINUED)

## ELECTRICAL GROUP

### OVERHEAD BUNK

KEY	PART NUMBER	U/M DESCRIPTION
	076760-04-000	EA BUNK HARDWARE-OVERHEAD KWIKEE #901401
	110007-01-GB1	EA BED ASM-BUNK,FRONT
	099717-03-000	EA TIEDOWNASM-TV

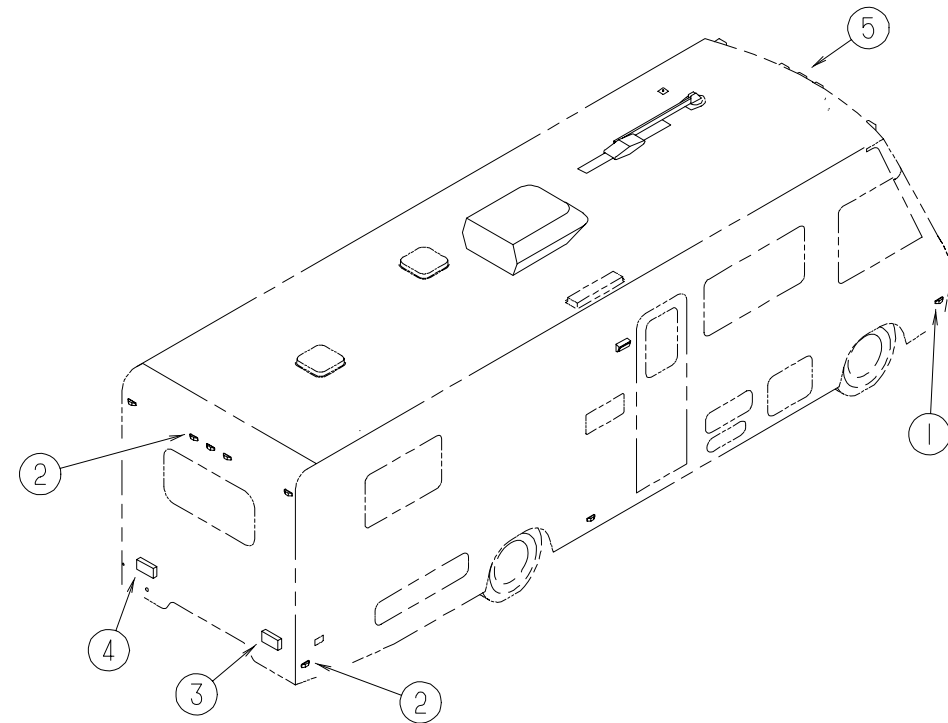

### EXTERIOR LIGHTS

KEY	PART NUMBER	U/M DESCRIPTION
1	111102-01-000	EA BASE-CLEARANCE/SIDEMARKER LIGHT W/BULB - PLASTIC - WHITE
1	111102-02-000	EA LENS-CLEARANCE/SIDEMARKER LIGHT - W/REFLEX - AMBER
1	036196-01-000	EA BULB - 12V, #194 - .27AMP - BAYONETTE
1	091983-01-000	EA GASKET-CLEARANCE/SIDEMARKER LIGHT
2	111102-01-000	EA BASE-CLEARANCE/SIDEMARKER LIGHT - W/BULB - PLASTIC - WHITE
2	111102-03-000	EA LENS - CLEARANCE/SIDEMARKER LIGHT - W/REFLEX - RED
2	008213-01-000	EA BULB - 12 V - NO. 57 - .24 AMP
2	091983-01-000	EA GASKET-CLEARANCE/SIDEMARKER LIGHT
3	110456-01-01A	EA LAMP ASM-TAIL -COMBO BLACK - BARGMAN 30-91-110
4	110456-02-01A	EA LAMP ASM-TAIL-COMBO W/BRACKET - BARGMAN 30-91-111
	107256-01-03A	EA TAIL LIGHT BEZEL - BLACK
5	111102-01-000	EA BASE-CLEARANCE/SIDEMARKER LIGHT W/BULB - PLASTIC - WHITE
5	111102-02-000	EA LENS-CLEARANCE/SIDEMARKER LIGHT - W/REFLEX - AMBER
5	036196-01-000	EA BULB - 12V, #194 - .27AMP - BAYONETTE
5	091983-01-000	EA GASKET-CLEARANCE/SIDEMARKER LIGHT
5	109566-01-000	EA BACKING-STEEL - LIGHT - ROOF CAP
	070907-01-000	EA HEADLAMP-RECTANGULAR - GM 5968097
	049359-01-000	EA SPRING-RETAINER - HEADLAMP - GM 496096
	110750-01-000	EA SCREW ASM-HEADLAMP ADJUSTING - T'MAN B62258-1428
	112823-01-000	EA SPLICE-REDUCER - 16-14 TO 18-22

**ELECTRICAL GROUP (CONTINUED)**  
**INTERIOR LIGHTS & RECEPTACLE**

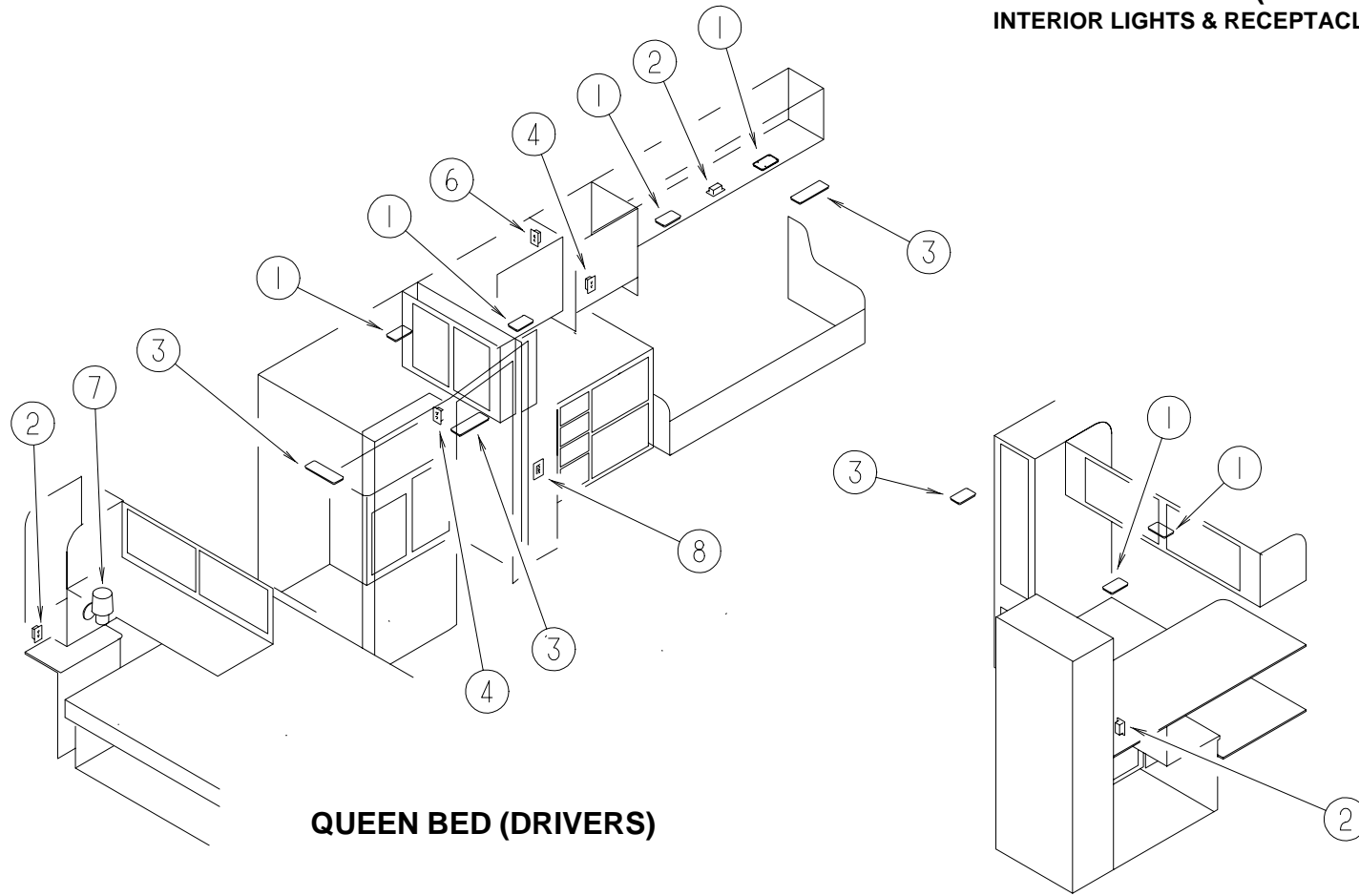

**QUEEN BED (DRIVERS)**

**CROSS STACKED BUNKS**

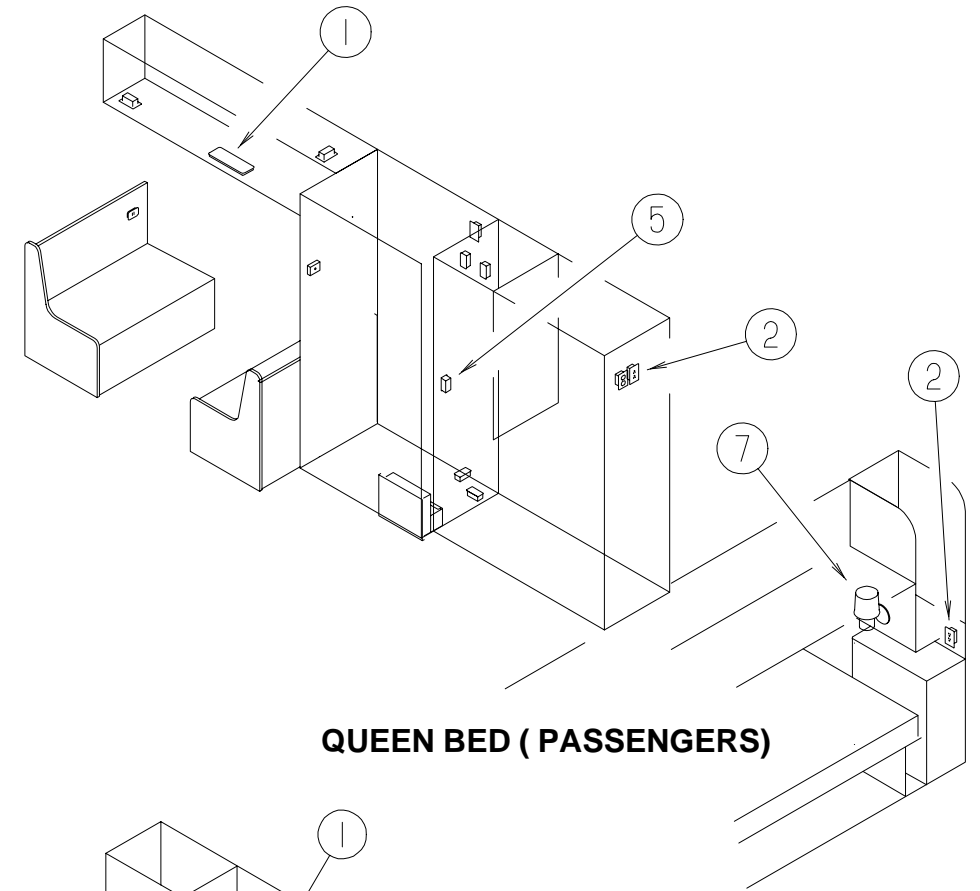

**QUEEN BED (PASSENGERS)**

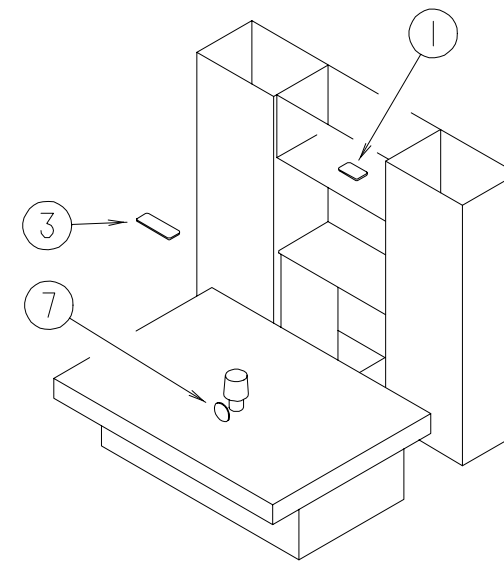

**DOUBLE BED**

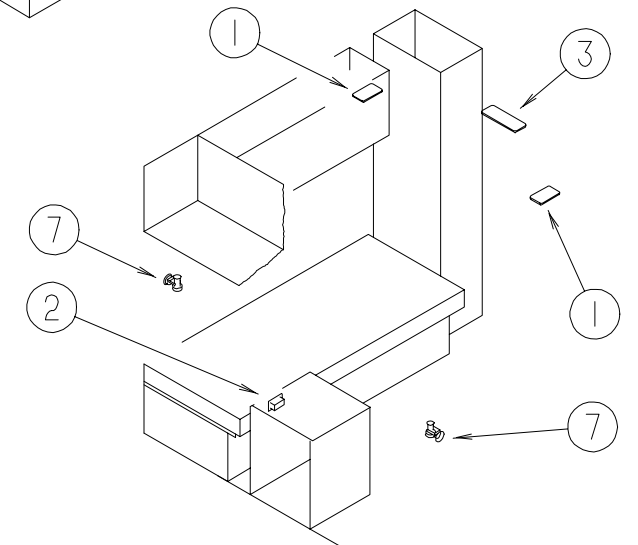

**TWIN BED**

KEY	PART NUMBER	U/M	DESCRIPTION
1	098024-01-01A	EA	LIGHT-DOME - 1 BULB - US - IVORY
	008218-01-000	EA	BULB-DOME LIGHT - 12V - NUMBER 1141
	098024-01-700	EA	LENS-DOME LIGHT
2	058708-01-000	EA	RECEPTACLE-ELECTRIC - DOUBLE - BROWN
3	098024-03-01A	EA	LIGHT-DOME - 2 BULB - IVORY
	008218-01-000	EA	BULB- DOME LIGHT - 12V - NUMBER 1141
	098024-01-700	EA	LENS-DOME LIGHT
	007940-01-000	EA	RECEPTACLE-SLIDE - 16 TO 12 AWG - FEMALE END
4	058708-02-000	EA	RECEPTACLE-ELECTRIC - DOUBLE - IVORY
5	058707-01-000	EA	RECEPTACLE-ELECTRIC - SINGLE - BROWN
	058707-02-000	EA	RECEPTACLE-BLANK,JUNCTION - WIRECON WDJ20BR
6	058708-05-000	EA	RECEPTACLE-SINGLE,BRN - WIRECON WDR15BRS
7	104173-02-01A	EA	LIGHT-DESIGNER,BLACK 81-903 - A.W.ASPLUND
7	119258-02-01A	EA	LAMP-WALL,UL/CSA - 53-503XK7YZ
	119257-03-01A	EA	SHADE-LAMP,LINEN WHT HARDBAC - 79-122X2BS
8	084076-02-000	EA	RECEPTACLE-GFI - 15A - 125V - BROWN
	024924-02-000	EA	RECEPTACLE-POWER CORD - W/PARTIAL PLATE
	075723-01-000	EA	SPACER-SWITCH - W/O HOLE - .2" X .9" X 2" - METAL - OFF WHITE
	102568-01-E90	EA	SPACER-RECEPTACLE - SIDEWALL
	104172-01-01A	EA	LIGHT-BULLET, BEIGE - #787 SERIES - BULB #93 12V
	097734-01-01A	EA	EXTENSION-RECEPTACLE, 3.2" X 5" X .7" - PLASTIC - IVORY

**ELECTRICAL GROUP (CONTINUED)**  
**FUSES & CIRCUIT BREAKERS**

KEY	PART NUMBER	U/M	DESCRIPTION
	062037-01-000	EA	HOUSING-AUTO FUSE, NATURAL
	062037-02-000	EA	HOUSING-AUTO FUSE, GREEN
	062037-03-000	EA	HOUSING-AUTO FUSE, BLACK
	062037-04-000	EA	HOUSING-AUTO FUSE, BLUE
	062037-05-000	EA	HOUSING-AUTO FUSE, GRAY
	062037-06-000	EA	HOUSING-AUTO FUSE, BROWN
	062037-07-000	EA	HOUSING-AUTO FUSE, RED - PACKARD 12004883
	062901-02-000	EA	FUSE-5 AMPS, AUTOMOTIVE
	062901-05-000	EA	FUSE-15 AMPS, AUTOMOTIVE
	062901-07-000	EA	FUSE-AUTOMOTIVE, 25 AMPS
	062901-08-000	EA	FUSE-30 AMPS, AUTOMOTIVE
	083209-01-000	EA	CIRCUIT BREAKER 15 AMP 120V BW G-15 - CANADIAN
	083209-02-000	EA	CIRCUIT BREAKER 15/15AMP 120V BW H-15/15
	083209-03-000	EA	CIRCUIT BREAKER 15/20AMP 120V BW 0-15/20
	083209-04-000	EA	CIRCUIT BREAKER 30AMP 120V BW L-30
	083209-06-000	EA	CIRCUIT BREAKER 30/15 AMP 120V BW D-30/15
	106655-02-000	EA	TERMINAL-FUSE BLOCK, 10-12AWG - PACKARD 12020400
	108669-01-000	EA	HOUSING-AUTO FUSE HOLDER, PACKARD 12010105
	119248-02-000	EA	HOUSING 7 POSN FEM METRI-PAC - PACKARD12059472

**SWITCHES**

KEY	PART NUMBER	U/M	DESCRIPTION
	079364-04-000	EA	SWITCH-ON/OFF, ROCKER - BLACK
	095188-01-01A	EA	SPACER-SWITCH, 2.3" X 3.4" - PLASTIC - DARK BROWN
	096241-03-000	EA	SWITCH-BLANK
	098351-06-01A	EA	PLATE-SWITCH, 2 GANG W/LABEL - JENSEN - POLISHED BRASS
	098351-07-01A	EA	PLATE-SWITCH, GEN SW - *JENSEN-BRASS, POLISH
	108355-01-000	EA	HOUSING-SWITCH - CARLING VCH
	108356-11-01A	EA	ACTUATOR-SWITCH GROOVES III - *CARLING VVCZCXX-SW1

**POWER CORD, ELECTRICAL BOXES & COVERS**

KEY	PART NUMBER	U/M	DESCRIPTION
	008052-01-000	EA	CORD-POWER, 10/3 - 30 AMP - 25' - CANADIAN
	008054-01-000	EA	CORD-POWER, 10/3 - 30 AMP - 25'
	008289-01-000	EA	BOX-ELECTRIC, STEEL - 1/2" AND 3/4" KNOCKOUTS - 4" X 4"
	008289-02-000	EA	BOX-ELEC., 4" X 4", W/1/2" & 3/4" KNOCKOUTS, CANADIAN
	008294-01-000	EA	COVER-ELECTRICAL BOX, BLANK/STEEL - 4" X 4" - GRAY
	008294-02-000	EA	COVER-ELECTRICAL BOX, BLANK STEEL - 4" X 4" - CANADIAN
	069238-01-000	EA	COVER-ELECTRICAL BOX, W/HOLE - 4" X 4" - GRAY USED WITH 30 AMP RECEPTACLE
	091910-01-000	EA	BOX-ELECTRIC, 3.75" X 3.5" X 1.75" - PLASTIC
	091910-02-000	EA	BOX-ELECTRICAL, PLASTIC - 57 X 88MM
	093603-01-000	EA	BOX-ELECTRIC, 4" X 2 1/8" X 2 1/8" - STEEL
	111509-01-000	EA	BOX ASM-ELECTRICAL, FRONT
	111510-01-000	EA	DOOR-ELECTRICAL BOX, FRONT

**RECEPTACLE AND WIRE ASSEMBLIES**

KEY	PART NUMBER	U/M	DESCRIPTION
	024924-02-000	EA	RECEPTACLE-POWER CORD, W/PARTIAL PLATE
	058707-01-000	EA	RECEPTACLE-ELECTRIC, SINGLE - BROWN
	058707-02-000	EA	RECEPTACLE-BLANK, JUNCTION - WIRECON WDJ20BR
	058708-02-000	EA	RECEPTACLE-ELECTRIC, DOUBLE - IVORY
	058708-05-000	EA	RECEPTACLE-SINGLE, BRN - *WIRECON WDR15BRS
	084076-02-000	EA	RECEPTACLE-GFI, 15A - 125V - BROWN
	091927-01-000	EA	COVER-RECEPTACLE, DOUBLE - IVORY
	097734-01-01A	EA	EXTENSION-RECEPTACLE, 3.2" X 5" X .7" - PLASTIC - IVORY
	102568-01-GB1	EA	SPACER-RECEPTACLE, SIDEWALL - 91 MOTORHOMES
	096449-01-000	EA	WIRE ASSEMBLY-WATER TANK TO MONITOR PANEL
	097618-01-000	EA	WIRE ASM-MONITOR PANEL, W/3 WIRES & ORANGE RESISTOR- LVS ORANGE RESISTOR W/3 (ORANGE-GREEN-BLUE) WIRES
	113134-03-000	EA	WIRE ASM-WIPER/WASHER

**ELECTRICAL GROUP (CONTINUED)**  
**ELECTRICAL CONNECTORS**

KEY	PART NUMBER	U/M	DESCRIPTION
	007954-01-000	EA	RECEPTACLE-HSG-6 POSITION
	007956-05-000	EA	INSULATOR-SHRINK .25IDX1.50 - BLACK
	008311-01-000	EA	CONNECTOR-WIRE NUT, INSULATED - RED
	008313-01-000	EA	CONNECTOR-WIRE NUT, INSULATED - YELLOW
	008314-01-000	EA	CONNECTOR-WIRE NUT, INSULATED - GRAY
	008326-01-000	EA	TERMINAL-RING, 16/14 WIRE - 3/8" STUD
	008328-01-000	EA	TERMINAL-RING, 12/10 WIRE - #10 STUD FIT
	008331-01-000	EA	TERMINAL-RING, TONGUE - #4 WIRE - 3/8" STUD - COPPER
	008348-01-000	EA	TERMINAL-RING, 3/8" STUD - #2 WIRE
	008355-01-000	EA	CONNECTOR-CABLE CLAMPING, 3/4"
	008356-01-000	EA	CONNECTOR-PLASTIC, 3/8" AVG
	035416-04-000	EA	TERMINAL-RING #10 STUD FIT, INSULATED BARREL #16/14
	041953-01-000	FT	CONDUIT-CONVOLUTE SLIT, .5"ID
	041953-01-000	FT	CONDUIT-CONVOLUTE SLIT, .5"ID
	041953-03-000	FT	CONDUIT-CONVOLUTE SLIT, 1" ID (CLOTHES ROD COVER)
	041953-05-000	FT	CONDUIT-CONVOLUTE SOLID, .62" ID
	041953-06-000	FT	CONDUIT-CONVOLUTE, SLIT .375"ID
	041953-07-000	FT	CONDUIT-CONVOLUTE, SLIT - .25" ID
	041953-08-000	FT	CONDUIT-CONVOLUTE, SLIT, 1.50"ID
	041953-09-000	FT	CONDUIT-CONVOLUTE, SLIT .50"ID
	041953-10-000	FT	CONDUIT-CONVOLUTE, SLIT - .75" ID
	041953-11-000	FT	CONDUIT-CONVOLUTE, SLIT - 1.06" ID
	047443-01-000	EA	TERMINAL-.250 RECEPTACLE FIT, INSULATED - 16/14 AWG
	058028-01-000	EA	CONNECTOR-ELECTRICAL PIGTAIL, NYLON - CLEAR
	062036-01-000	EA	TERMINAL-PACK-CON, 12/10 AWG - PACKARD 12033817
	062036-02-000	EA	TERMINAL-PACK-CON, 16/14 AWG - PACKARD 08917021
	080015-02-000	EA	RECEPTACLE-FLAG, .185 - 16/14 GA - AMP 3
	082741-01-000	EA	CONNECTOR BODY-2 CNCT MALE - SERV ELEC 2P-FYL
	087225-01-000	FT	SLEEVING-1/2", TYPE H - VARFLEX
	088267-01-000	EA	TERMINAL-FEMALE, 1/4 - PACKARD 12033824
	088473-02-000	EA	HOUSING-PIN, 15 CAVITY - AMP 1-480710-0
	088473-03-000	EA	HOUSING-PIN, 9 CAVITY - AMP 1-480706-0
	088473-05-000	EA	HOUSING-PIN, 6 CAVITY - AMP 640585-1
	088473-08-000	EA	HOUSING-PIN, 4 CAVITY - AMP 1-480702-0
	088473-09-000	EA	HOUSING-PIN, 3 CAVITY - AMP 1-480700-0
	088473-10-000	EA	HOUSING-PIN, 2 CAVITY - AMP 1-480698-0
	088474-02-000	EA	HOUSING-SOCKET, 12 CAVITY - AMP 1-480711-0
	088474-03-000	EA	HOUSING-SOCKET, 9 CAVITY - AMP 1-480707-0
	088474-07-000	EA	HOUSING-SOCKET, 5 CAVITY - AMP 1-480764-0
	088474-08-000	EA	HOUSING-SOCKET, 4 CAVITY - AMP 1-480703-0
	088474-09-000	EA	HOUSING-SOCKET, 3 CAVITY - AMP 1-480701-0
	088474-10-000	EA	HOUSING-SOCKET, 2 CAVITY - AMP 1-480699-0
	088475-01-000	EA	PIN-CONNECTOR, 14 TO 20 AWG
	088475-02-000	EA	PIN-CONNECTOR, 10 TO 12 AWG
	088476-01-000	EA	SOCKET-CONNECTOR, BRASS - PRE-TIN
	088476-02-000	EA	SOCKET-CONNECTOR, 12-10 GA - PHOS. BRZ - PRE-TIN
	103987-02-000	EA	SEAL-SOLENOID ACCESS - 94 F,G-SERIES
	104100-01-000	EA	HOUSING-1 POSITION, 75 AMP - AMP 53884-1
	104100-03-000	EA	TERMINAL-75 AMP - AMP 53880-4 LOOSE
	106006-01-000	EA	HOUSING-1 POSITION, FEMALE - PACKARD 12015952
	106007-01-000	EA	TERMINAL-FEMALE, 14-16AWG - PACKARD 12015861-L
	106655-01-000	EA	TERMINAL-FUSE BLOCK, 14-16AWG - PACKARD 12020321
	110178-01-000	EA	HOUSING-WIPER MOTOR - UT6237440-EC25WJ
	113306-01-000	EA	TERMINAL-FEM, M/P, 480, 14-16 - PACKARD12048451
	113307-01-000	EA	TERMINAL-FEM, M/P, 150, 16-20 - PACKARD12048074
	113468-01-000	EA	HOUSING-2 POSITION, FEMALE - 56-SERIES - PACKARD 02965981 USED ON WIPER/WASHER WIRE ASM
	115556-01-000	EA	HOUSING-3 POSN, FEM, 59-SERIES - PACKARD 02965810
	115556-02-000	EA	HOUSING-2 POSN, FEM, 59-SERIES - PACKARD 02965809

**POWER CONVERTER**

KEY	PART NUMBER	U/M	DESCRIPTION
	083208-01-000	EA	CONVERTER-POWER, 32A - 120V/12V - BW 6332

## EXTERIOR BODY GROUP

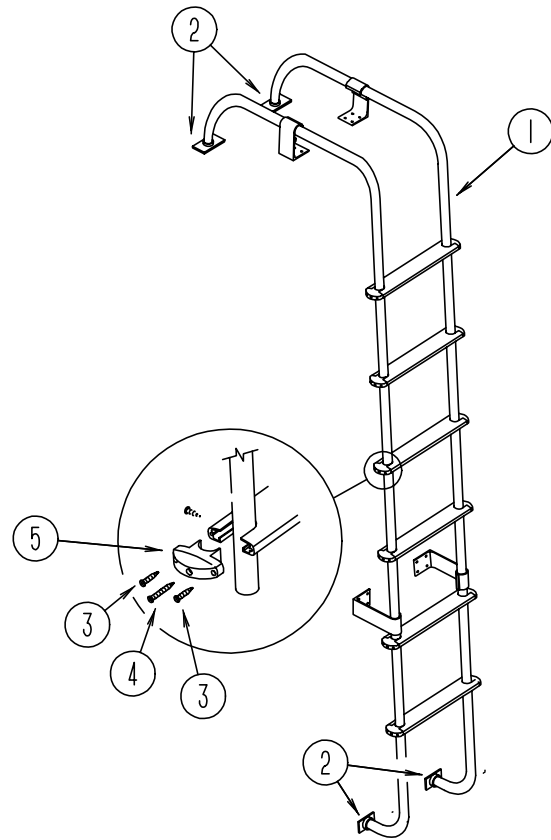

LADDER

KEY	PART NUMBER	U/M DESCRIPTION
1	102953-14-FB1	EA LADDER ASM
2	067165-01-000	EA BRACKET-MOUNTING, LADDER, LOWER
3	000G39-06-10T	EA SCREW-SELF DRIVING, 6-20 X 5/8" PPH - BLACK
4	000G67-10-36T	EA SCREW, 10-12 X 2.25" PPH - BLACK
5	076980-02-000	EA END CAP-STEP, BLACK
	069726-02-000	EA BUMPER - .88" DIAMETER X .40" - BLACK
	038327-01-000	EA TAPE-ANTI SLIP, 2" X 60'

### FIBERGLASS, STYROFOAM, ALUMINUM & STEEL TUBING

KEY	PART NUMBER	U/M DESCRIPTION
	076054-P4-000	EA FIBERGLASS SHEET - 96" X 97" BRIGHT WHITE
	076054-R4-000	EA FIBERGLASS SHEET - 106.8" X 318.7" BRIGHT WHITE
	076054-S1-000	EA FIBERGLASS SHEET - 96" X 108" BRIGHT WHITE
	076054-T7-000	EA FIBERGLASS SHEET 108.8" X 362.2" BRIGHT WHITE
	076054-N9-000	EA FIBERGLASS SHEET - 96" X 102" BRIGHT WHITE
	000870-05-000	SF STYROFOAM-.5" X 2' X 8' INCREMENTS OF 16 SF
	000870-08-000	SF STYROFOAM - .75" X 4' X 8' - PLANED
	100619-01-000	BF EXPANDED FOAM SHEET - 4' X 8' X 1.34"
	100619-04-000	BF FOAM - EXPANDED POLYSTYRENE - .5" X 4' X 8'
	100619-05-000	BF FOAM - EXPANDED POLYSTYRENE - .75" X 4' X 8'
	058267-01-000	FT CHANNEL-STEEL, W/HOLES - SIDEWALL STIFFENER - 2" X 20'
	068716-01-001	EA BRACE-90 DEGREE L-ANGLE - 16'
	044487-01-001	EA ALUMINUM SKIN - .019" X 9' X 30' - MILL FINISH
	044487-01-002	EA ALUMINUM SKIN - .019" X 8' X 36'
	055278-51-323	EA STL-TUBE 18GA .75X1.5X0510MM CR
	065747-01-000	SF INSULATION-MICROFOAM, .5" THICK X 72" X 112' ROLL
	089297-01-000	SF PLYWOOD-LUAN, OVERLAY GRADE - 4' X 8'

## EXTERIOR BODY GROUP (CONTINUED)

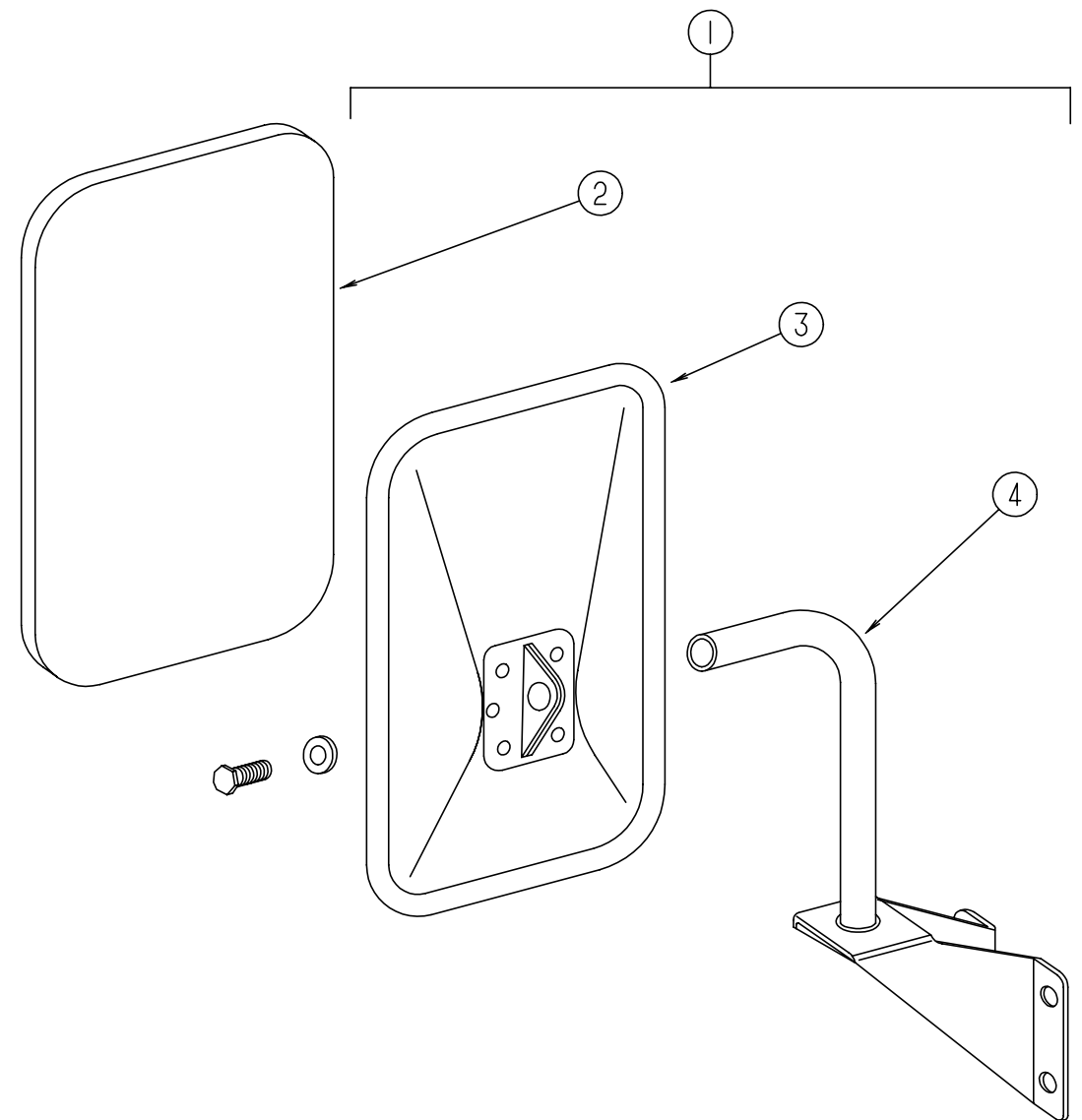

EXTERIOR MIRROR

KEY	PART NUMBER	U/M DESCRIPTION	VENDOR NO.
1	105076-01-702	EA MIRROR-RH/LH COMP 1EA=1 ONLY	713196
2	049347-01-700	EA GLASS-EXT. MIRROR 7.5 X 10.5	702081
3	105076-01-703	EA MIRROR-HEAD, FLAT BLACK	709275-8
4	105076-01-704	EA ARM	Q780521-9



**EXTERIOR BODY GROUP (CONTINUED)**  
**EXTERIOR BODY PANELS AND TRIM**

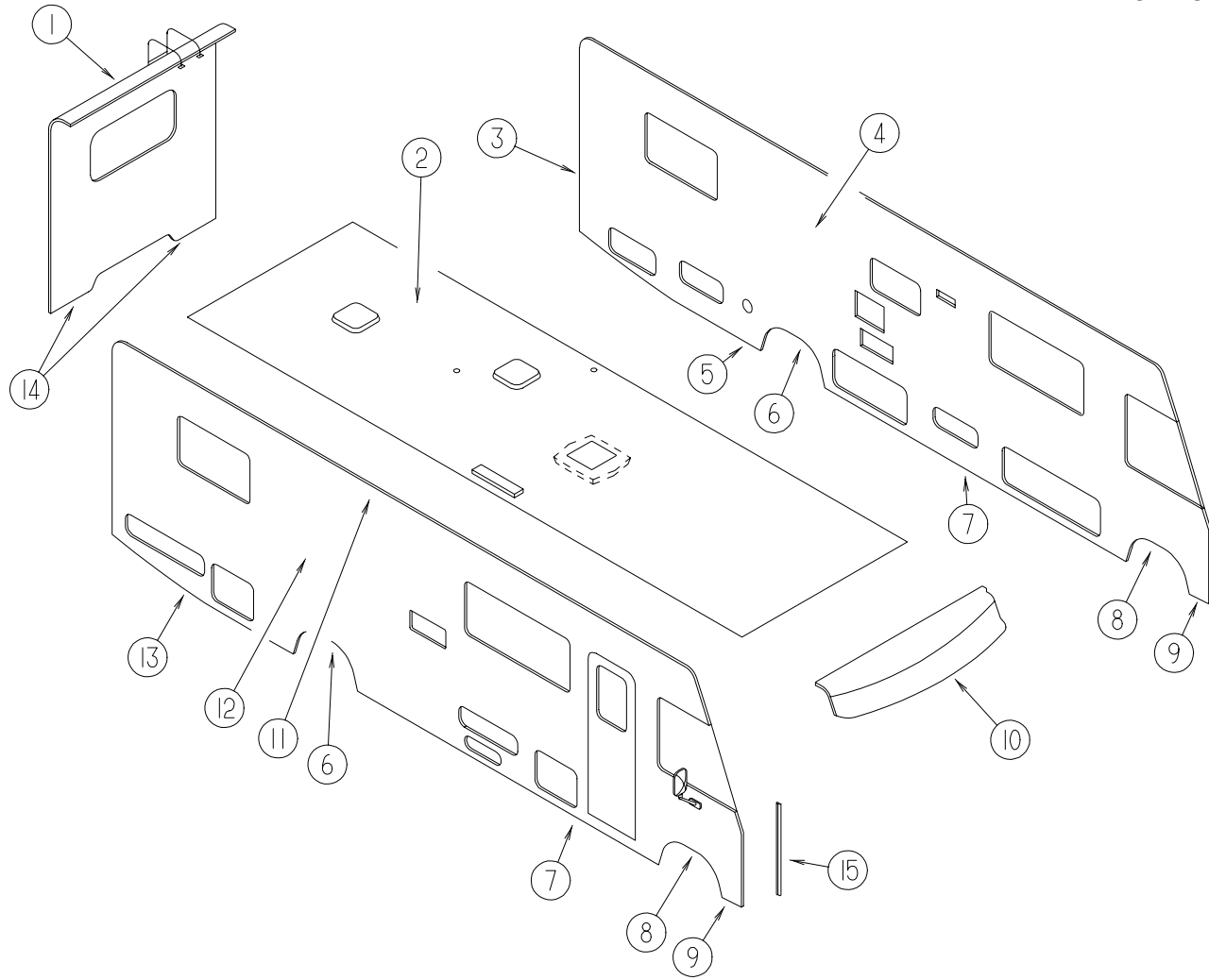

KEY	PART NUMBER	U/M	DESCRIPTION
5	108038-09-03A	EA	TRIM-S/W,BTM,RR B/WHT 2626,0
6	108070-01-04A	EA	TRIM-WHEELWELL,REAR,BRT/WHT
7	108039-04-04A	EA	TRIM-S/W,BTM,CTR B/WT 4323,0
8	108069-05-01A	EA	TRIM-WHEELWELL,FRONT BRT/WHT
9	108109-01-04A	EA	TRIM-SIDEWALL,LOW,FRT,B/WHT
10	M05922-03-FB1	EA	CAP ASM-FRONT, W/CLEARANCE LIGHTS & WIRING - BRIGHT WHITE
	117012-01-01A	EA	CAP-FRONT, W/O WIRING & CLEARANCE LIGHTS - BRIGHT WHITE
11	099583-55-003	EA	AWNING RAIL,3048 MM B/W
	096864-01-02A	EA	TRIM-CONTOUR,ROOF BRT WHT
12	M08043-03-GB1	EA	SIDEWALL ASM-RIGHT TWIN (GD1)
12	M08043-03-GE1	EA	SIDEWALL ASM-RIGHT TWIN (GE1)
12	M08043-04-GB1	EA	SIDEWALL ASM-RIGHT BUNK (GD1)
12	M08043-04-GE1	EA	SIDEWALL ASM-RIGHT BUNK (GE1)
12	M08043-05-GB1	EA	SIDEWALL ASM-RIGHT DOUBLE (GD1)
12	M08043-05-GE1	EA	SIDEWALL ASM-RIGHT DOUBLE (GE1)
12	M08043-02-GB1	EA	SIDEWALL ASM-RIGHT CROSS STACKED (GD1)
12	M08043-02-GE1	EA	SIDEWALL ASM-RIGHT CROSS STACKED (GE1)
12	M08043-01-GB1	EA	SIDEWALL ASM-RIGHT QUEEN (GD1)
12	M08043-01-GE1	EA	SIDEWALL ASM-RIGHT QUEEN (GE1)
13	108038-09-03A	EA	TRIM-S/W,BTM,RR B/WHT 2626,0
14	050406-21-000	EA	TRIM-BACKWALL,LOWER BRT WHT
15	089922-26-000	EA	TRIM-FIBERGLAS,PANEL,BRT/WHT
	108688-01-03A	EA	STRIP-FEATURE,BRT WHT,4623MM
	108651-01-01A	EA	CAP-FEATURE STRIP MILL
	105312-01-07A	FT	EXTR-INSERT,VINYL,BRIGHT WHT

KEY	PART NUMBER	U/M	DESCRIPTION
1	M08063-07-GD1	EA	BACKWALL ASM - W/O WINDOW & TRIM - TWIN BED (GD1)
1	M08063-07-GE1	EA	BACKWALL ASM - W/O WINDOW & TRIM - TWIN BED (GE1)
1	M08063-06-GD1	EA	BACKWALL ASM - W/O WINDOW & TRIM - QUEEN BED (GD1)
1	M08063-06-GE1	EA	BACKWALL ASM - W/O WINDOW & TRIM - QUEEN BED (GE1)
1	M08063-08-GD1	EA	BACKWALL ASM - W/O WINDOW & TRIM - BUNK BED (GD1)
1	M08063-08-GE1	EA	BACKWALL ASM - W/O WINDOW & TRIM - BUNK BED (GE1)
1	M08063-10-GD1	EA	BACKWALL ASM - W/O WINDOW & TRIM - CROSS/STACKED TWIN (GD1)
1	M08063-10-GE1	EA	BACKWALL ASM - W/O WINDOW & TRIM - CROSS/STACKED TWIN (GE1)
1	M08063-09-GD1	EA	BACKWALL ASM - W/O WINDOW & TRIM - DOUBLE BED (GD1)
1	M08063-09-GE1	EA	BACKWALL ASM - W/O WINDOW & TRIM - DOUBLE BED (GE1)
2	M08052-01-GB1	EA	ROOF ASM-D32RQ QUEEN
2	M08052-02-GB1	EA	ROOF ASM-D32RQ DOUBLE
2	M08052-04-GB1	EA	ROOF ASM-D32RQ TWIN
2	M08052-03-GB1	EA	ROOF ASM-D32RQ CROSS STACKED
3	096854-04-02A	EA	TRIM-CONTOUR,BRIGHT WHITE
	105312-01-07A	FT	EXTR-INSERT,VINYL,BRIGHT WHT
4	M08044-03-GB1	EA	SIDEWALL ASM-LEFT,TWIN BED (GD1)
4	M08044-03-GE1	EA	SIDEWALL ASM-LEFT,TWIN BED (GE1)
4	M08044-04-GB1	EA	SIDEWALL ASM-LEFT,BUNK BED (GD1)
4	M08044-04-GE1	EA	SIDEWALL ASM-LEFT,BUNK BED (GE1)
4	M08044-05-GB1	EA	SIDEWALL ASM-LEFT,DBL BED (GD1)
4	M08044-05-GE1	EA	SIDEWALL ASM-LEFT,DBL BED (GE1)
4	M08044-02-GB1	EA	SIDEWALL ASM-LEFT,CROSS STACK (GD1)
4	M08044-02-GE1	EA	SIDEWALL ASM-LEFT,CROSS STACK (GE1)
4	M08044-01-GB1	EA	SIDEWALL ASM-LEFT,QUEEN BED (GD1)
4	M08044-01-GE1	EA	SIDEWALL ASM-LEFT,QUEEN BED (GE1)

**EXTERIOR BODY GROUP (CONTINUED)**  
DECALS, FILM STRIPES & PAINT

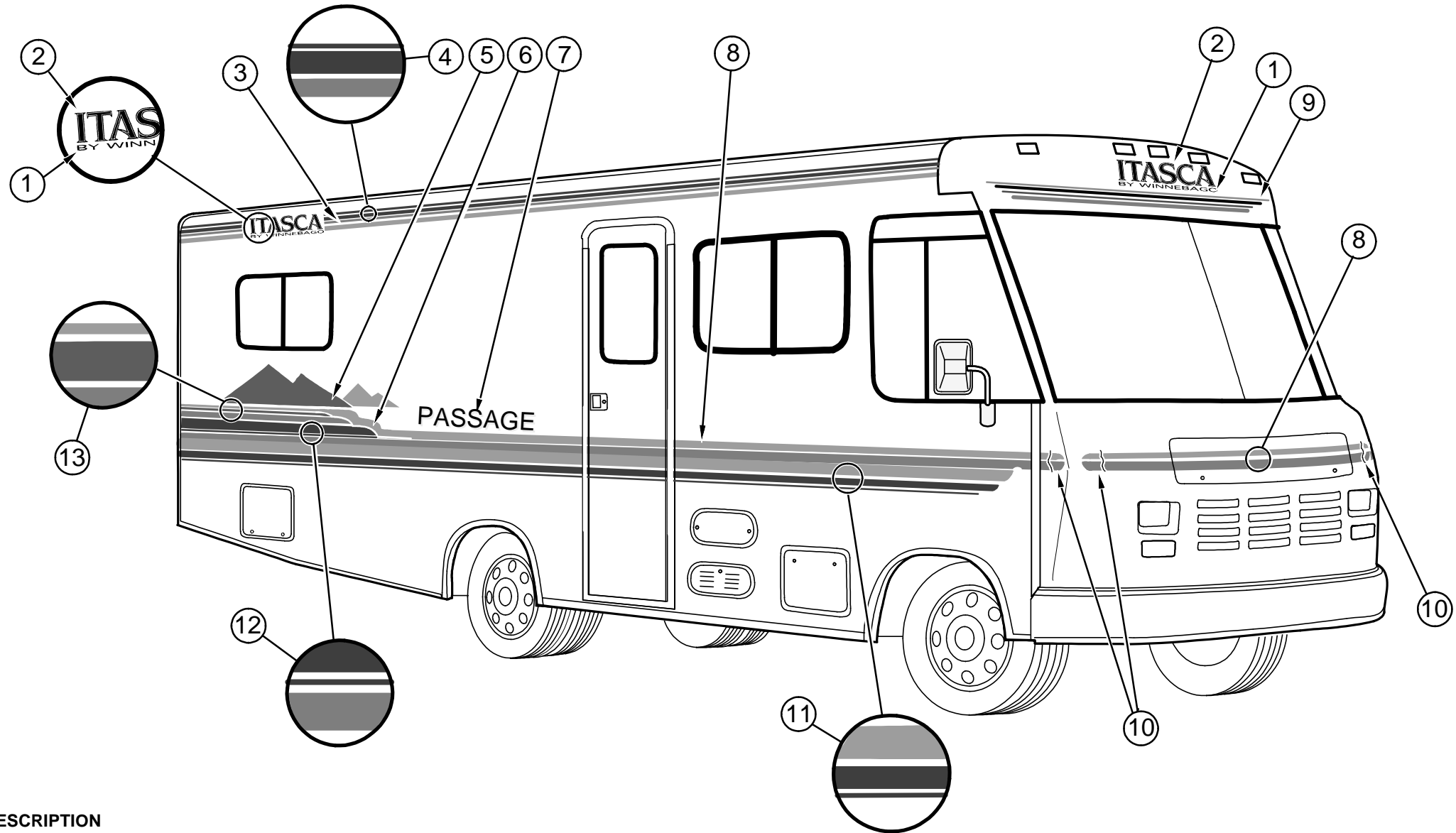

KEY	PART NUMBER	U/M	DESCRIPTION	
1	117018-01-02A	EA	DECAL-LOGO,WINNEBAGO INDUSTR	MED BLUE
2	118793-01-02A	EA	DECAL-LOGO,ITASCA	MED BLU/MED BLU
3	107385-02-08A	FT	FILM-MULTISTRIPE 50.8MM X 150"	TEAL PEARLE
4	094443-24-02A	FT	FILM-MULTISTRIPE 69.9MM X 150'	MARINE BLUE/MARINE BLUE/DEEP ROSE
5	114792-01-02A	EA	DECAL-MOUNTAINS, PASSENGERS	MAJESTIC PURPLE/DEEP ROSE
	114792-02-02A	EA	DECAL-MOUNTAINS, DRIVERS	MAJESTIC PURPLE/DEEP ROSE
6	114794-01-02A	EA	DECAL-ROLLING HILLS, PASSENGERS	SILVER/MARINE BLUE
	114794-02-02A	EA	DECAL-ROLLING HILLS, DRIVERS	SILVER/MARINE BLUE
7	116169-01-02A	EA	DECAL-LOGO,PASSAGE	MEDBLUE/DEEPROSE
8	107385-11-08A	FT	FILM - 31.8MM X 150FT	MARINE BLUE
9	116813-01-02A	EA	DECAL-UPPER,FRONT,CAP	MARINE BLUE/MARINE BLUE/DEEP ROSE
10	107385-06-08A	FT	FILM - 25.4MM X 150FT	DEEP ROSE
11	094443-30-02A	FT	FILM-MULTISTRIPE 187.3MM X 150	TEAL PEARL/MARINE BLUE/MARINE BLUE
12	094443-23-02A	FT	FILM-MULTISTRIPE 142.9MM X 150	TEAL PEARL/MARINE BLUE/MARINE BLUE
13	105781-11-10A	FT	FILM-MULTISTRIPE 50.8MM X 150'	SILVER/MARINE BLUE
	041561-03-000	EA	PAINT-LOW BAKE, OFF WHITE	REF:72897-01
	004308-01-000	EA	PAINT-SPRAY, BLACK	

## EXTERIOR BODY GROUP (CONTINUED)

### FRONT END COMPONENTS

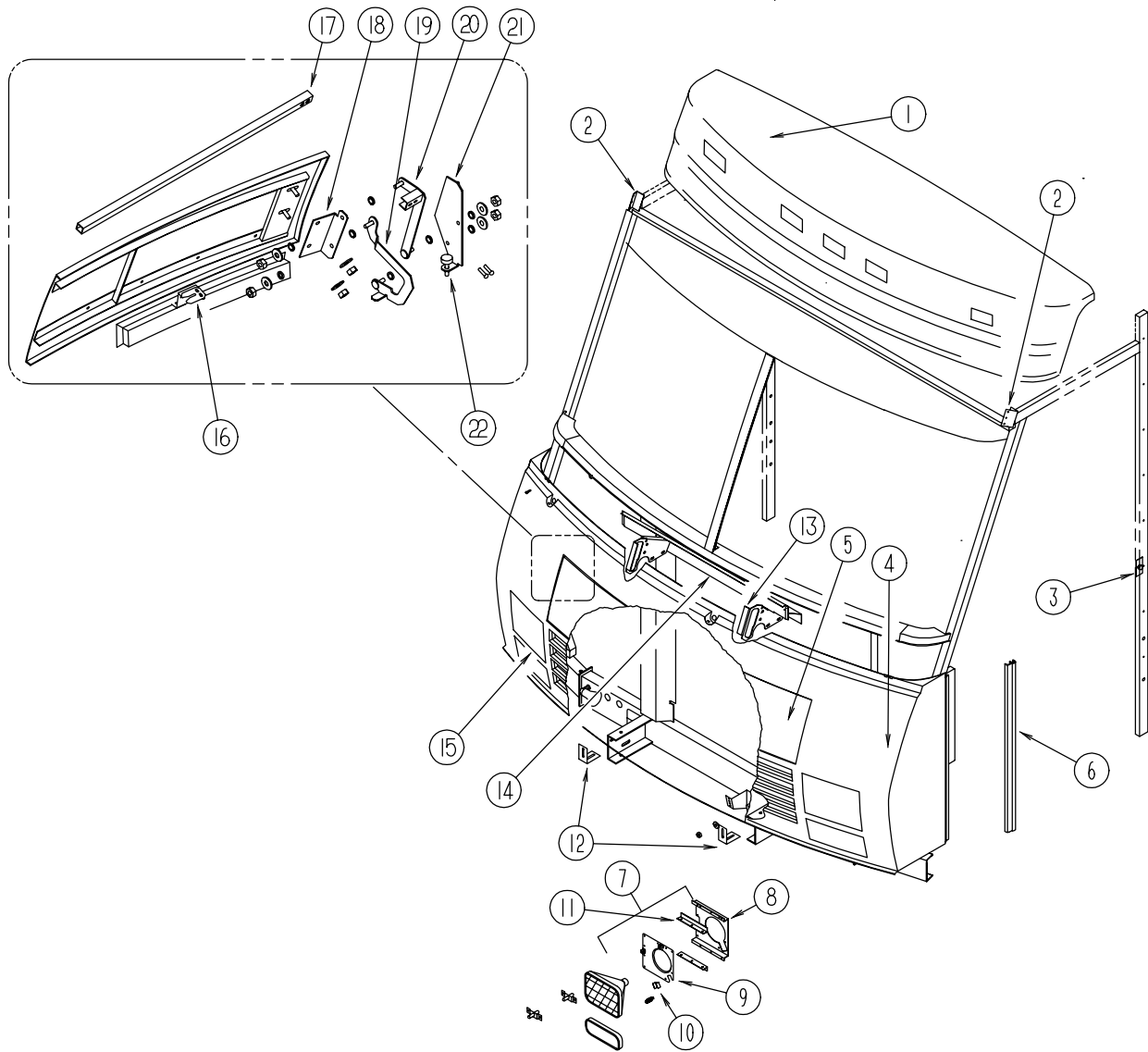

KEY	PART NUMBER	U/M	DESCRIPTION
1	M05922-03-FB1	EA	CAP ASM-FRONT, W/CLEARANCE LIGHTS & WIRING - BRIGHT WHITE
	117012-01-01A	EA	CAP-FRONT, W/O WIRING & CLEARANCE LIGHTS - BRIGHT WHITE
2	077001-01-000	EA	ANGLE-MOUNTING, ROOF PANEL - V ANGLE - 3" X 2.4" X 1.5"
3	070579-06-000	EA	PLATE-ANCHOR, W/7/16 WELD NUT - 1.5" X 3.3"
4	M05928-01-FB1	EA	FRONT-END ASM-FIBERGLASS, COMPLETE W/HEADLIGHTS - BRIGHT WHITE
	109877-01-02A	EA	PANEL-FRONT, LOWER BRT/WHT
5	109881-01-02A	EA	PANEL ASM-HOOD, W/O LOCK - BRIGHT WHITE
6	089922-26-000	EA	TRIM-FIBERGLASS, PANEL - BRIGHT WHITE
7	110712-02-D15	EA	PLATE ASM-HEADLAMP, DUAL - LEFT
8	110784-02-01A	EA	BRACKET-HEADLAMP, DUAL - LEFT - MILL
	110784-01-01A	EA	BRACKET-HEADLAMP, DUAL - RIGHT - MILL
9	110711-02-01A	EA	PLATE-HEADLAMP, DUAL - LEFT - MILL
	110711-01-01A	EA	PLATE-HEADLAMP, DUAL - RIGHT - MILL
10	110691-01-01A	EA	BRACKET-SPRING, HEADLAMP - MILL
11	110782-01-000	EA	ANGLE-SUPPORT, HEADLAMP - V-ANGLE - 160MM LONG
12	103628-01-000	EA	BRACKET-FRONT, LOWER - MOUNTING
13	103136-04-000	EA	BRACKET - SUPPORT UPPER - HINGE/LEFT
	103136-03-000	EA	BRACKET - SUPPORT UPPER - HINGE/RIGHT
14	102421-01-000	EA	PANEL-PLENUM, CENTER
15	110712-01-D15	EA	PLATE ASM-HEADLAMP, DUAL - RIGHT
16	109915-01-01A	EA	LATCH-HOOD, FRONT END - BLACK
17	105096-06-000	EA	TUBE-TIMING, HOOD HINGE
18	109927-01-000	EA	ANGLE-LINK, HOOD - RIGHT
	109927-02-000	EA	ANGLE-LINK, HOOD - LEFT
19	109930-03-000	EA	LINK - HINGE/HOOD - LOWER RIGHT HAND - W/WELD STUD
	109930-04-000	EA	LINK - HINGE/HOOD - LOWER LEFT HAND - W/WELD STUD
20	109929-01-000	EA	LINK - HINGE/HOOD - UPPER RIGHT HAND
	109929-02-000	EA	LINK - HINGE/HOOD - UPPER LEFT HAND
21	109926-03-000	EA	BRACKET - LINK/HINGE - RIGHT HAND
	109926-04-000	EA	BRACKET - LINK/HINGE - LEFT HAND
22	058786-01-000	EA	BOLT-ADJUSTING, HOOD - W/BLACK PAD - .31" #18 X 2"
22	000D39-05-00B	EA	NUT-HEX, SERRATED FLANGE LK - 5/16 - 18 - ZINC

### GALLEY GROUP

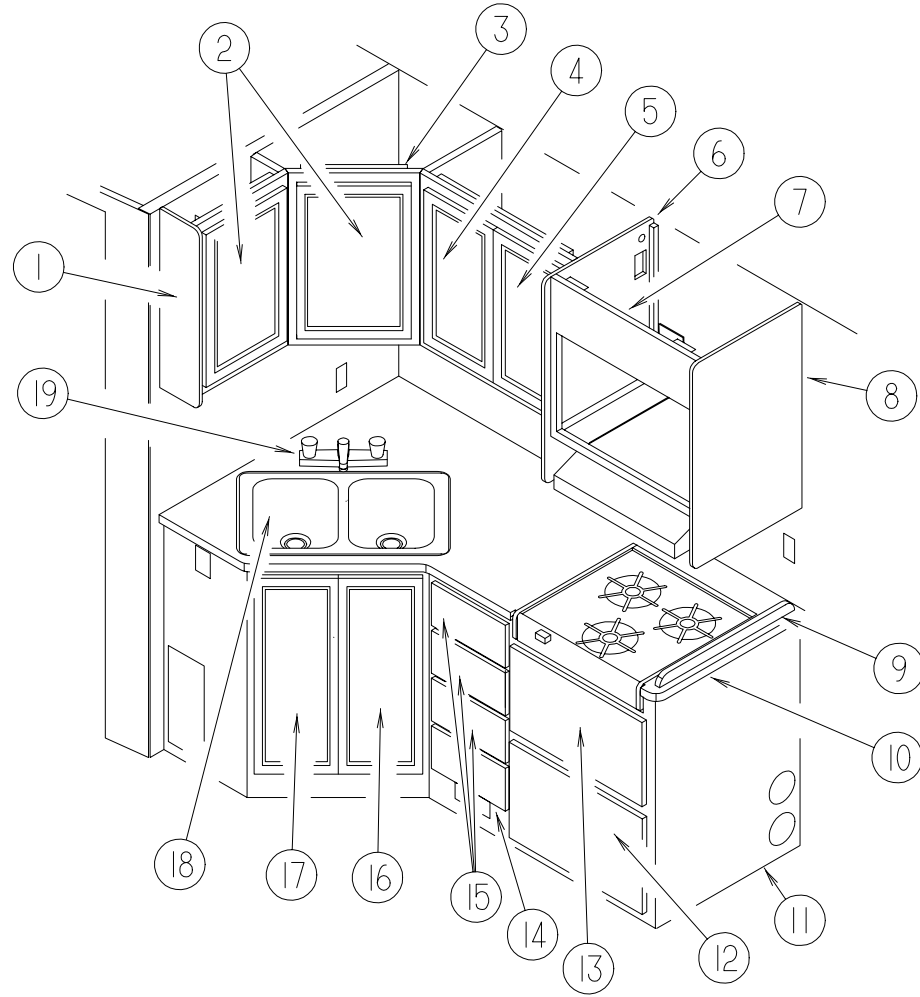

### GALLEY CABINETRY

KEY	PART NUMBER	U/M	DESCRIPTION
1	109908-38-GB1	EA	CAP ASM-END,OVHD
2	M05930-D5-GB1	EA	DOOR-MITERED VINYL 0340X0555
3	120403-01-GB1	EA	CABINET ASM-OVHD,GALLEY
4	M05930-D2-GB1	EA	DOOR-MITERED VINYL 0290X0555
5	M05930-C2-GB1	EA	DOOR-MITERED VINYL 0290X0555
6	109908-37-GB1	EA	CAP ASM-END,OVHD
7	120369-01-GB1	EA	CABINET ASM-OVHD,MICROWAVE
8	109908-36-GB1	EA	CAP ASM-END,OVHD
9	098335-02-F12	EA	RAIL-GALLEY,565 (GD1)
9	098335-02-E08	EA	RAIL-GALLEY,565 (GE1)
10	120529-12-GD1	EA	COUNTERTOP ASM (GD1)
10	120529-12-GC1	EA	COUNTERTOP ASM (GE1)
11	120529-01-GD1	EA	CABINET ASM-GALLEY (GD1)
11	120529-01-GC1	EA	CABINET ASM-GALLEY (GE1)
12	P10163-M6-GB1	EA	DRAWER COMPL-SLIDE
13	M05930-D3-GB1	EA	DOOR-MITERED VINYL 0555X0305
14	P10163-M7-GB1	EA	DRAWER COMPL-SLIDE
15	P10163-V5-GB1	EA	DRAWER COMPL-SLIDE
16	M05930-C3-GB1	EA	DOOR-MITERED VINYL 0250X0710
17	M05930-D4-GB1	EA	DOOR-MITERED VINYL 0250X0710
18	102551-01-000	EA	SINK-STAINLESS STEEL, DOUBLE - 17" X 25"
	092303-01-000	EA	STRAINER-SINK
19	103243-01-000	EA	FAUCET-GALLEY,DUAL CONTROL - P5043
	110012-02-G22	EA	COVER ASM-SINK (GD1)
	110012-02-G01	EA	COVER ASM-SINK (GE1)
	110012-03-GD1	EA	COVER ASM-SINK (GD1)
	110012-03-GC1	EA	COVER ASM-SINK (GE1)
	090329-01-000	FT	SEAL-T, REFRIGERATOR CABINET - .6" WIDE TOP X 2" TAIL

### GALLEY GROUP (CONTINUED)

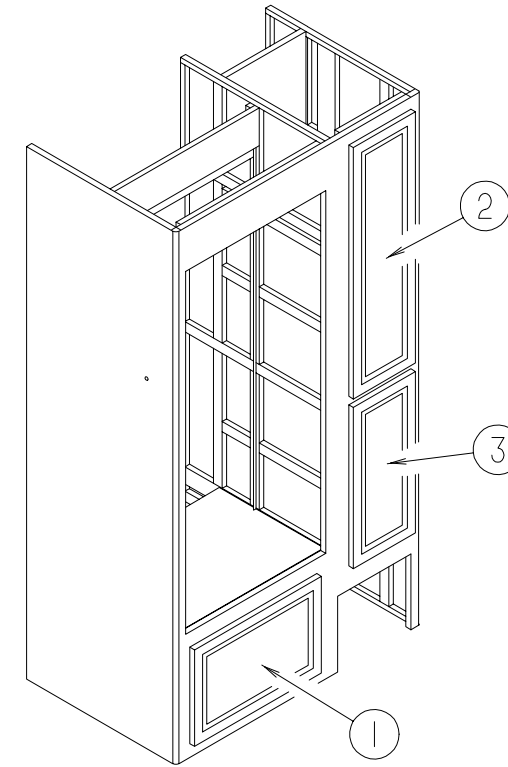

### REFRIGERATOR CABINET DOORS

KEY	PART NUMBER	U/M	DESCRIPTION
1	110140-04-G01	EA	DOOR ASM-MITERED,VINYL WRAP
2	110140-75-GB1	EA	DOOR ASM-MITERED,VINYL WRAP
3	110140-78-GB1	EA	DOOR ASM-MITERED,VINYL WRAP

**GALLEY GROUP (CONTINUED)**  
**REFRIGERATOR CABINET ASM. & COMPONENTS - 2-WAY - NORCOLD MODEL 6162 RH**

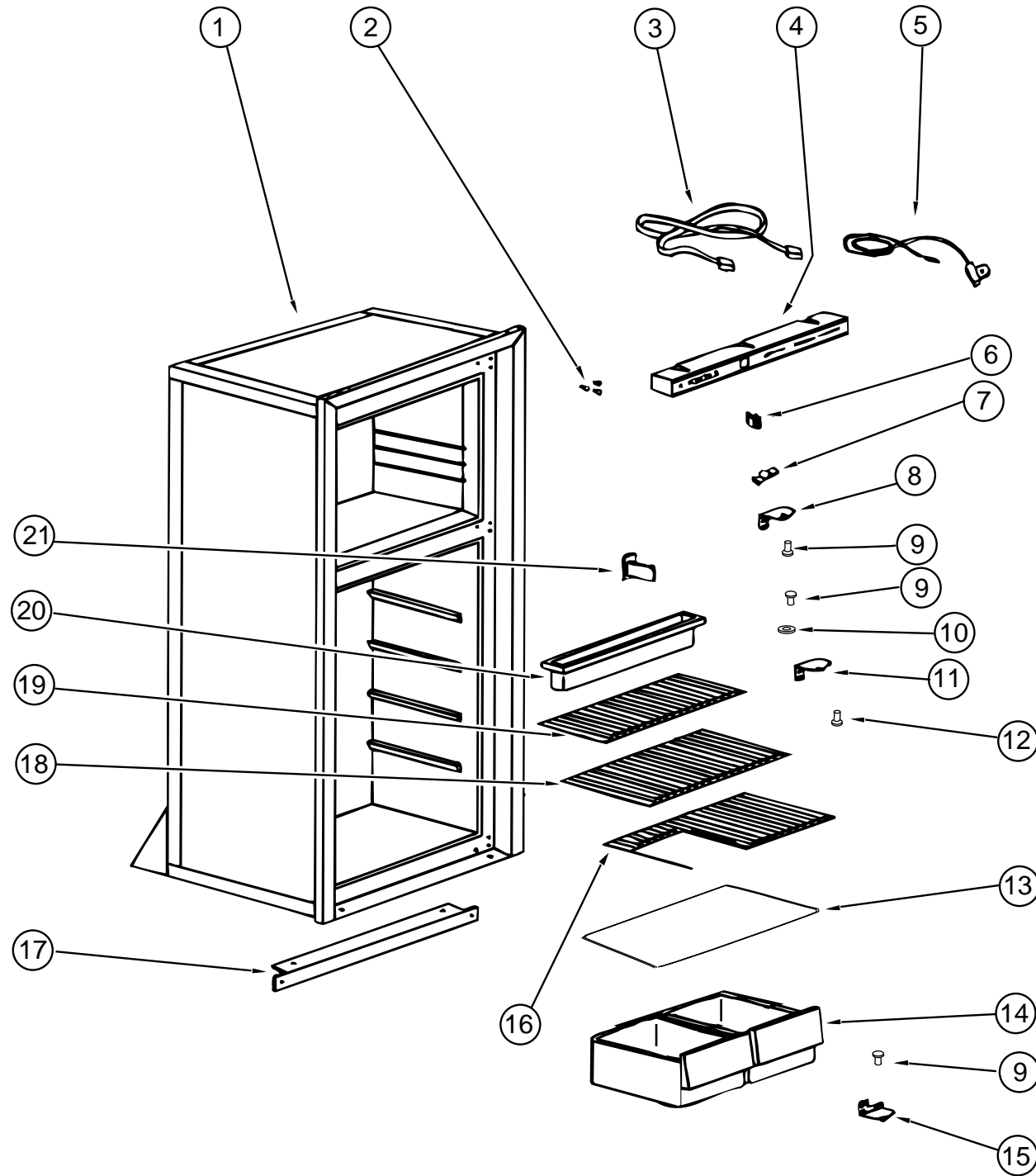

KEY	PART NUMBER	U/M	DESCRIPTION	VENDOR NO.
	104138-04-01A	EA	REFRIG SMALL DBL DOOR 2-WAY - NORCOLD 6162 RH BL N/A - USE P.N.#1041380201A REFRIGERATOR W/REVERSE HANDLE REPAIR PARTS ARE AVAILABLE FOR ORIGINAL REFRIGERATOR	
1	104138-04-701	EA	FOAMED CAB ASM (BLK W/WHITE)	61725038
2	094039-01-722	EA	HOLE PLUG (BLK) HINGE HOLES	61582030
3	084880-01-746	EA	CABLE-PRINTED CIRCUIT BOARD TO POWER SUPPLY	61571522
4	104137-06-700	EA	EYEBROW SHELL (2-WAY)	61726622
5	084880-01-753	EA	THERMISTER 78"	61697822
6	075217-01-738	EA	SWITCH-HUMIDITY	61525922
7	084880-01-760	EA	CLIP (THERMISTER)	61689122
8	094039-01-723	EA	HINGE BRACKET, TOP RH-BOTTOM LH BLK	61580838
9	094039-01-725	EA	HINGE PIN (BLACK) (MALE)	61578130
	084880-03-702	EA	HINGE PIN (BLACK) FEMALE	61580630
10	084880-01-749	EA	HINGE BUSHING	61580722
11	094039-01-728	EA	BRACKET-HINGE, CENTER BLACK	61566530
12	094039-01-730	EA	HINGE PIN SHAFT (BLK) CENTER HINGE	61566730
13	084880-01-722	EA	CRISPER COVER	61564122
14	104137-06-707	EA	CRISPER (WHITE)	61571325
15	094039-01-724	EA	BRACKET-HINGE, TOP LH - BOTTOM RH - BLK	61580938
16	094039-01-739	EA	SHELF (CUTOUT)	61646722
17	094039-01-732	EA	FRONT COVER (BLK) BOTTOM TRIM61622130	
18	094039-01-733	EA	WIRE SHELF (MIDDLE)	61563822
19	094039-01-734	EA	WIRE SHELF (TOP) W/RISE	61563722
20	094039-01-735	EA	INSIDE DRIP TRAY (WHITE)	61572830
21	084880-01-732	EA	LATCH	61578522
	094039-01-736	EA	SWITCH-LIGHT, BLACK	61581022
	093646-05-000	EA	BRACKET-TIEDOWN - REFRIGERATOR	
	065225-02-000	EA	PLATE - TIEDOWN - REFRIGERATOR	
	054450-01-000	EA	LEVEL-REFRIGERATOR	
	116751-01-01A	EA	TRAY-DRIP, REFRIGERATOR - 24.6" X 6.3" - PLASTIC - BLACK	

**GALLEY GROUP (CONTINUED)**  
**REFRIGERATOR DOORS - 2-WAY - NORCOLD MODEL 6162 RH**

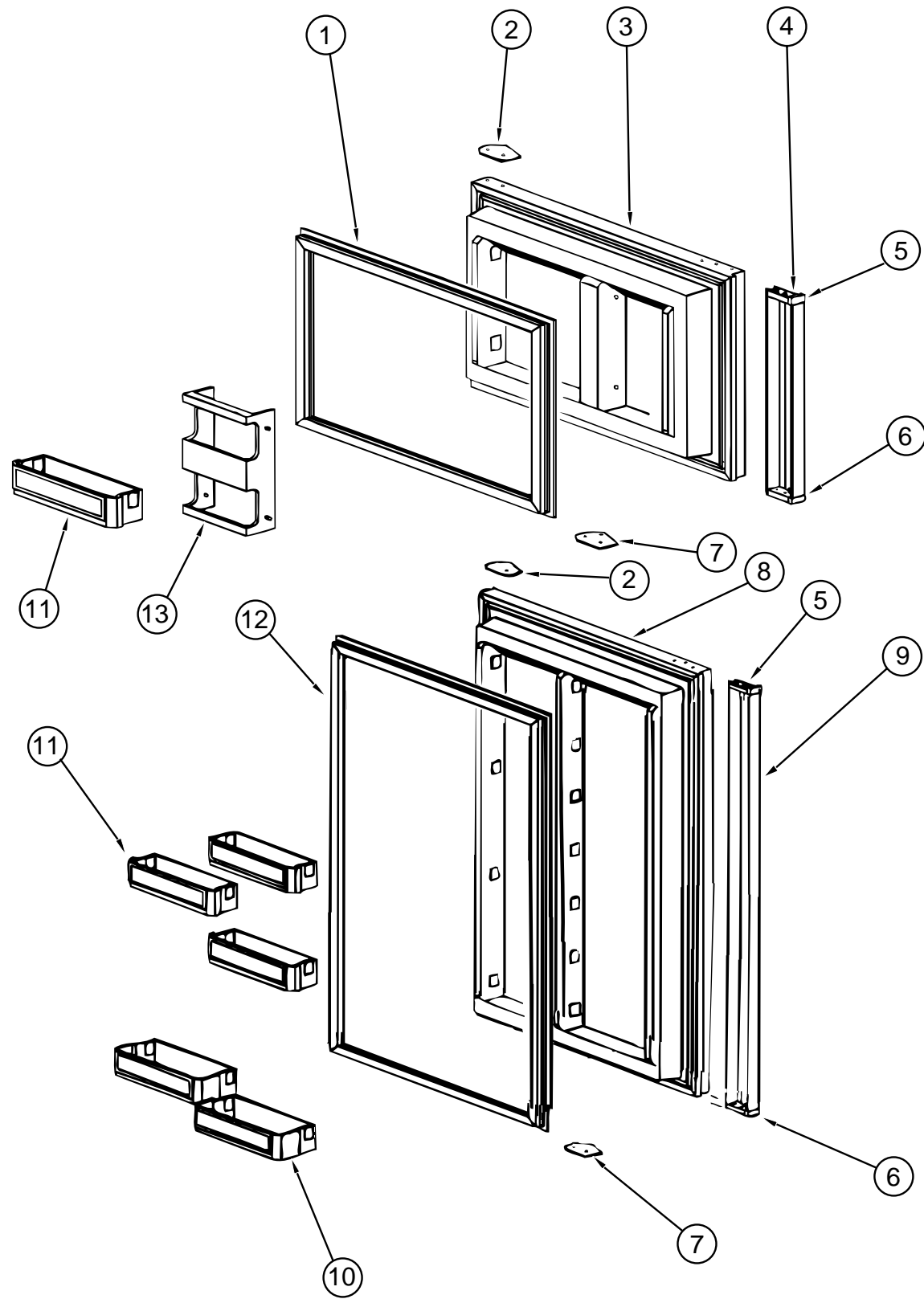

KEY	PART NUMBER	U/M	DESCRIPTION	VENDOR NO.
1	094039-01-702	EA	GASKET (GRAY) UPPER	61567830
2	094039-01-710	EA	PLATE-HINGE, BLACK	61631330
3	094039-01-706	EA	UPPER DOOR LINER (WHITE) BLACK	61581838-B
4	094039-01-708	EA	HANDLE-DOOR, UPPER - BLACK	61650038
	084880-01-720	EA	SPRING (FOR DOOR HANDLE)	61558822
5	084880-01-761	EA	CAP-END, SPRING CATCH - UPPER	61593730
6	084880-01-740	EA	CAP-END, STOP CATCH - LOWER	61593830
7	094039-01-704	EA	PLATE-HINGE, BLACK	61631430
8	094038-01-702	EA	LINER-DOOR, LOWER - BLACK/WHITE	61581938-B
9	094038-01-704	EA	HANDLE-DOOR, LOWER - BLACK	61650138
	084880-01-720	EA	SPRING (FOR DOOR HANDLE)	61558822
10	104137-06-704	EA	MILK BIN (WHITE)	61579425
11	104137-06-703	EA	BIN-DOOR SHELF (WHITE)	61564025
12	094038-01-700	EA	GASKET-LOWER, GRAY	61567930
13	104137-06-702	EA	RACK-JUICE (WHITE)	61580525

**GALLEY GROUP (CONTINUED)**  
**NORCOLD 6162 REFRIGERATOR CONTROL ASM.**

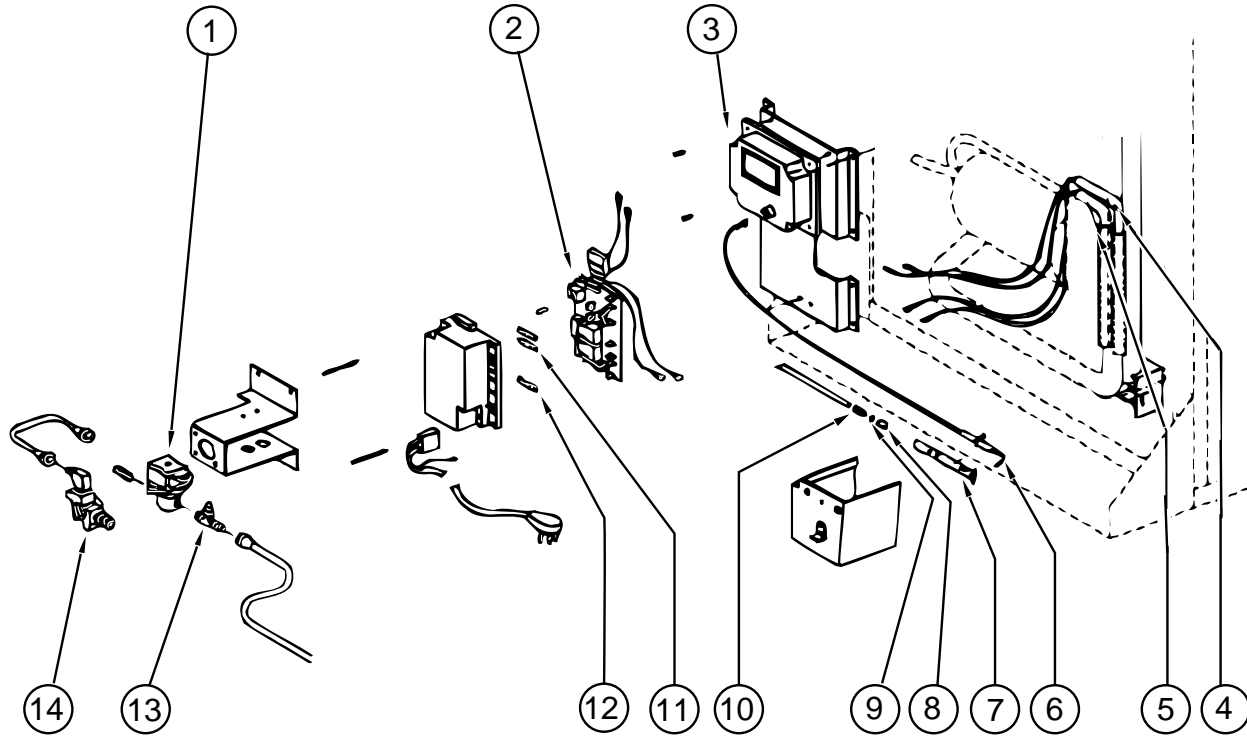

KEY	PART NUMBER	U/M	DESCRIPTION	VENDOR NO.
1	084880-01-718	EA	VALVE-GAS	61551822
2	094039-04-702	EA	POWER SUPPLY (2-WAY)	61647422
3	102621-01-702	EA	IGNITION MODULE	61688922
4	088248-01-710	EA	HEATER-DC, (HORIZONTAL)	61562822
5	088248-01-709	EA	HEATER-AC, (HORIZONTAL)	61562722
6	104137-06-715	EA	SPARK/SENSE ELECTRODE (SINGLE)	61692222
7	104137-06-714	EA	BURNER ASSEMBLY (5-SLOT)	61705222
8	084880-01-705	EA	ORIFICE	61452122
9	104137-06-713	EA	ORIFICE GASKET	61475122
10	104137-06-712	EA	FITTING-GAS TUBE CONNECTION	61692722
11	075217-01-734	EA	FUSE - 3 AMP	61538822
12	104137-06-711	EA	FUSE - 5 AMP	61611622
13	104137-06-710	EA	PRESSURE TAP	61594422
14	104137-06-709	EA	VALVE SHUT-OFF-MANUAL ASM	61694922
	084879-03-700	EA	COIL-COOLING, FOR HORIZONTAL BURNER	61687240

**GALLEY GROUP (CONTINUED)**  
**NORCOLD 6162 REFRIGERATOR EYEBROW ASM.**

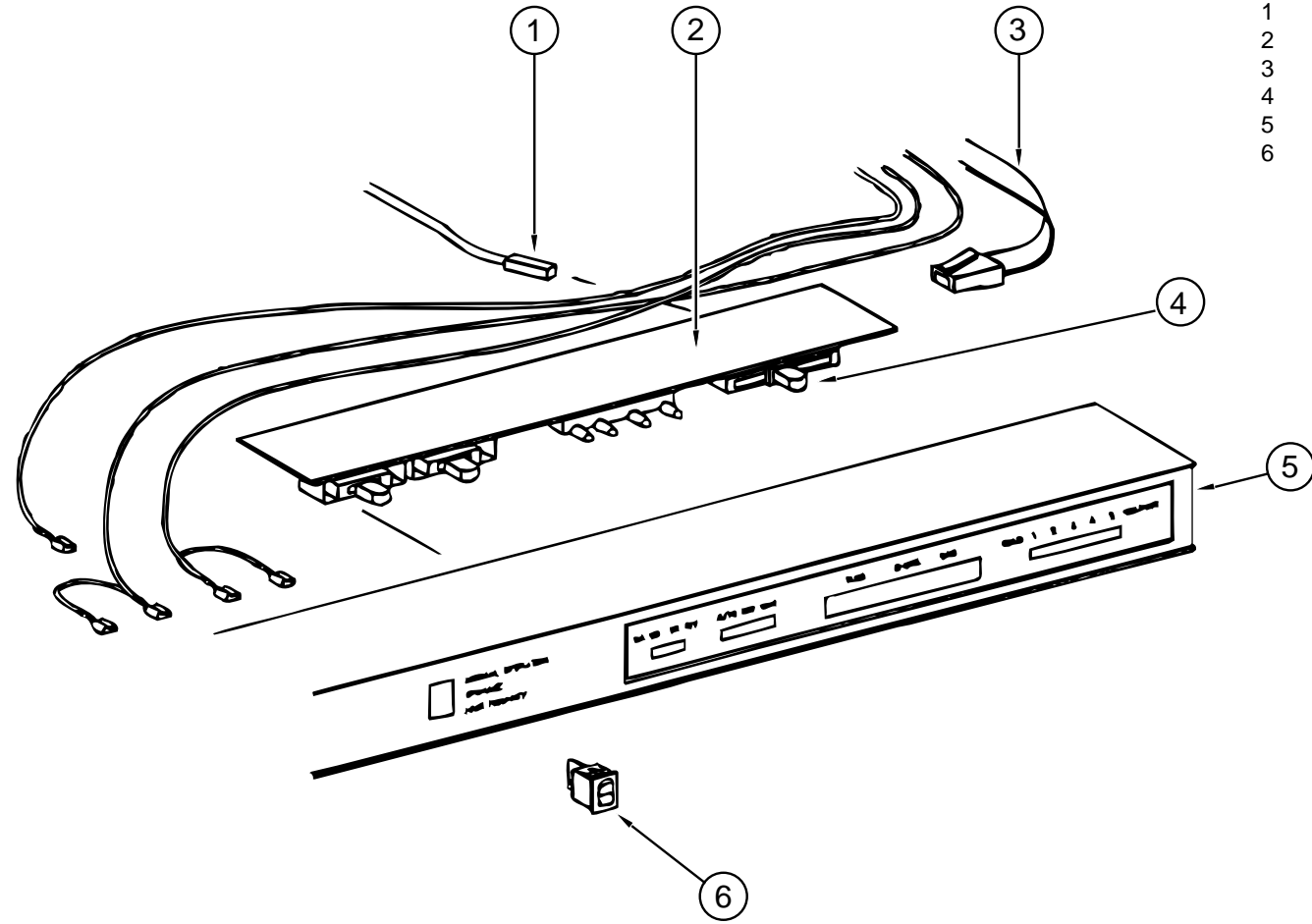

KEY	PART NUMBER	U/M	DESCRIPTION	VENDOR NO.
1	084880-01-753	EA	THERMISTER 78"	61693822
2	094039-04-700	EA	PRINTED CIRCUIT BOARD - 2 WAY	61647322
3	084880-01-746	EA	CABLE- PRINTED CIRCUIT BOARD TO POWER SUPPLY	61571522
4	102621-01-703	EA	THERMOSTAT BUTTON	61587422
5	104137-06-700	EA	EYEBROW SHELL (2-WAY)	61726622
6	075217-01-738	EA	SWITCH-HUMIDITY	61525922



**GALLEY GROUP (CONTINUED)****MICROWAVES, RANGE HOOD, & MONITOR PANEL**

KEY	PART NUMBER	U/M DESCRIPTION	VENDOR NO.
	115303-01-000	EA MICROWAVE OVEN - 14 1/8"H X 21 7/8"H X13 1/4"D - .8 CU FT./700 WATT	
	115303-01-700	EA TRIM F/VENT, TOP	2100309
	115401-01-01A	EA TRIM-MICROWAVE BLACK	
	103386-02-01A	EA HOOD-RANGE POWERED BLK - VENTLINE	
	090973-01-700	EA MOTOR-12 VOLT, CSA & UL	CA508-1
	090973-01-702	EA BLADE-FAN	VA183-1
	092696-01-710	EA HOLDER-LAMP	CB267-2
	096983-01-707	EA FILTER-MESH	CC246
	103386-02-700	EA KNOB-SWITCH	CB-161
	103386-02-701	EA SWITCH	CB-164
	103386-02-702	EA SPRING-FILTER	CC245
	103386-02-703	EA DAMPER LOCK SPRING	-488
	100258-10-01A	EA GAUGE-HOUR METER - SCREW ON STYLE W/SWITCH	
	100258-10-701	EA GAUGE-HOUR METER - CLIP ON	L0775-00

**RANGE MAGIC CHIEF 85RA-3B**

KEY	PART NUMBER	U/M DESCRIPTION	VENDOR NO.
	114030-01-01A	EA RANGE - 3 BURNER W/O OVEN ALMD 85RA-3B	
	102019-01-705	EA TRIM-REAR, BLACK	3608F009-70
	102020-01-709	EA BUMPER-GRATE	8007-P020-60
	102020-01-710	EA FILTER-PILOT	7507P046-60
	102020-01-711	EA GRATE-TOP	7518P012-60
	102020-01-721	EA VALVE-SHUT-OFF	7506P096-60
	102020-01-722	EA VALVE-TOP BURNER	7502P181-60
	102020-01-724	EA BUMPER-MAIN TOP	8003P008-60
	102022-01-708	EA REGULATOR, 1/4 & 1/2 OUT	7510P041-60
	112881-01-700	EA TOP, MAIN-ALMOND	2001F110-84
	112881-01-703	EA VALVE-TOP BURNER HI-OUTPUT	7502P180-60
	112881-01-705	EA KNOB-TOP BURNER	7733P072-60
	112881-01-709	EA PIPE-MANIFOLD	7513P097-60
	114030-01-700	EA PILOT-BURNER	7505P147-60
	114030-01-701	EA PANEL-MANIFOLD	2616F078-70
	114030-01-702	EA TRIM-RIGHT, BLACK	3608W040-70
	114030-01-703	EA TRIM-LEFT, BLACK	3608W039-70

**GENERATOR GROUP****4000 KW GENERATOR ONAN MICROLITE KY-FA/26100 B**

KEY	PART NUMBER	U/M DESCRIPTION
	109982-03-000	EA GENERATOR - 4.0 MICROLITE, ONAN KY-FA/26100 B
	007125-03-000	EA CLAMP-MUFFLER, 1.5" DIA
	007131-01-000	EA HANGER-TAILPIPE, 6 SLOTS
	007125-04-000	EA CLAMP-MUFFLER, 1.1" DIA
	105958-01-000	EA PIPE-EXHAUST, GENERATOR

NOTE: ADDITIONAL GENERATOR COMPONENTS ARE FOUND IN THE CHASSIS GROUP.

## HEATING & AIR CONDITIONING GROUP

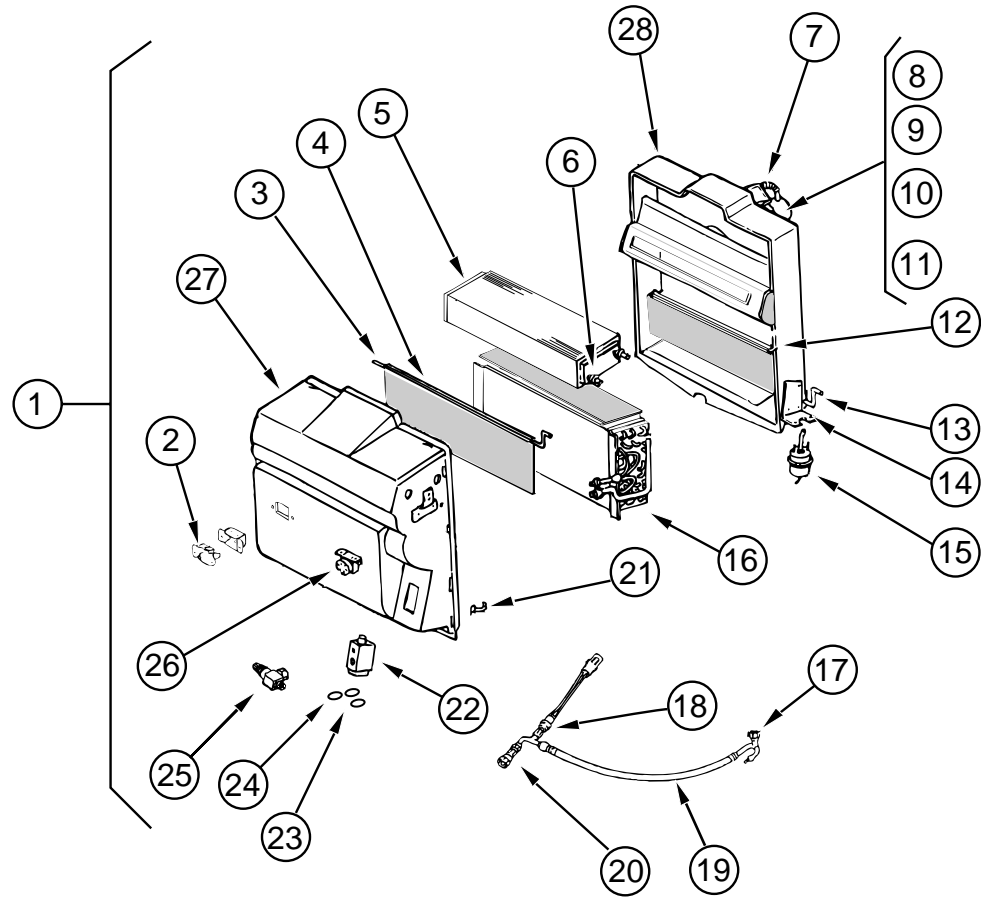

**AUTO A/C - EVAPORATOR/HEATER**  
FROM: 00-00-00 THRU: 01-14-96

KEY	PART NUMBER	U/M	DESCRIPTION	VENDOR NO.
1	103930-20-000	EA	EVAPORATOR/HEATER CHEV R134A BLOCK 090-00083	
2	103930-01-710	EA	RESISTOR-FUSED	035-0006
3	103930-20-702	EA	ROD - FRONT BLEND AIR DOOR	
4	103930-20-703	EA	DOOR - BLEND AIR	
5	103930-01-703	EA	COIL-HEATER	042-0010
6	110279-01-712	EA	HEATER FITTING	050-0076
7	110279-01-703	EA	HOSE-VENT, MOTOR BLOWER	051-0034
8	103930-20-707	EA	BLOWER - HOUSING	
9	103930-01-720	EA	MOTOR	030-0004
10	103930-01-717	EA	WHEEL-CLOCKWISE	062-0010
11	103930-20-708	EA	CLIP - FRONT MOTOR SHAFT	
12	103930-20-705	EA	DOOR - PANEL - RECIRCULATING	
13	103930-20-704	EA	ROD - DOOR- RECIRCULATING	
14	103930-01-708	EA	BRACKET-VACUUM MOTOR	070-0113
15	103930-02-708	EA	MOTOR-VACUUM SERVO, A/C	030-0002
16	103930-01-704	EA	COIL EVAPORATOR	
17	103930-12-708	EA	SWITCH-BINARY, R-134A	032-0048
18	103930-01-716	EA	SWITCH-PRESSURE, FAN	032-0036
19	103930-20-701	EA	HOSE ASSY #6 WINN GM	085-0138
20	103930-12-709	EA	FITTING-QUICK CONNECT	050-0120
21	103930-20-706	EA	CLIP - RETAINER	
22	103930-20-700	EA	VALVE EXPANSION BLOCK (2 TON)	034-0032
23	103930-17-702	EA	GASKET OR SAE 015 #10 33-781	045-0127
24	113245-01-707	EA	GASKET (#8)	045-0126
25	103930-20-709	EA	SERVICE VALVE	
26	103930-01-711	EA	THERMOSTAT	033-0003
27	103930-20-710	EA	CASE-FRONT, SUB-ASSEMBLY	062-0146
28	103930-20-711	EA	CASE-BACK, SUB-ASSEMBLY	062-0147
	056402-05-000	EA	BRACKET-HEATER VENT, ROUND - W/BEND - BLACK	

## HEATING & AIR CONDITIONING GROUP (CONTINUED)

**AUTO A/C - EVAPORATOR/HEATER**  
FROM: 01-15-96 THRU: 99-99-99

KEY	PART NUMBER	U/M	DESCRIPTION	VENDOR NO.
	103930-25-000	EA	EVAPORATOR/HEATER-CHEVY "96"	
	094831-01-709	EA	CLAMP-ROD 3/16"	022-0025
	094831-01-746	EA	CLAMP-BLEND AIR CABLE	022-0031
	103930-01-703	EA	CORE-HEATER	042-0010
	103930-01-704	EA	COIL-EVAPORATOR	041-0017
	103930-01-708	EA	BRACKET-VACUUM MOTOR	070-0113
	103930-01-710	EA	RESISTOR-FUSED, A/C	035-0006
	103930-01-711	EA	THERMOSTAT	033-0003
	103930-01-717	EA	WHEEL-BLOWER, CLOCKWISE	062-0010
	103930-01-720	EA	MOTOR-BLOWER, (PM105)	030-0004
	103930-02-708	EA	MOTOR-VACUUM SERVO, A/C	030-0025
	103930-02-714	EA	CLAMP-CLUTCH, BARREL	022-0006
	103930-12-709	EA	FITTING-QUICK CONNECT	050-0120
	103930-17-702	EA	O'RING #10	045-0127
	103930-20-700	EA	VALVE-EXPANSION-BLOCK, 2 TON	034-0032
	103930-20-702	EA	ROD-DOOR, BLEND AIR	073-0039
	103930-20-703	EA	DOOR-BLEND AIR	071-0212
	103930-20-704	EA	ROD-DOOR-RECIRCULATING	073-0018
	103930-20-705	EA	PANEL-DOOR, RECIRCULATING	071-0213
	103930-20-706	EA	CLIP-RETAINER	022-0057
	103930-20-707	EA	HOUSING-BLOWER	062-0145
	103930-20-708	EA	CLIP-MOTOR SHAF	022-0001
	103930-20-709	EA	VALVE-SERVICE	050-0159
	103930-20-710	EA	CASE-FRONT, SUB-ASSEMBLY	062-0146
	103930-20-711	EA	CASE-BACK, SUB-ASSEMBLY	062-0147
	103930-25-700	EA	HOSE ASM., #6 EVAP TO DRIER	085-0350
	110279-01-703	EA	HOSE-VENT, BLOWER MOTOR	051-0034
	110279-01-712	EA	FITTING-HEATER	050-0076
	110279-02-702	EA	O'RING #12	045-0125
	113245-01-707	EA	O'RING #8	045-0126

### GAS AUTO A/C - CONTROL PLENUM

KEY	PART NUMBER	U/M	DESCRIPTION	VENDOR NO.
	103930-04-000	EA	CONTROL/PLENUM SET - 093-00037	
			FROM: 00-00-00 THRU: 01-14-96	
	072341-06-700	EA	SWITCH-4 SPEED FAN	032-0043
	094831-01-709	EA	CLAMP-ROD 3/16"	022-0025
	103930-02-700	EA	PANEL-CONT.W/BEZEL W/O DECAL	032-0018
	103930-02-701	EA	SWITCH-VACUUM	034-0015
	103930-02-702	EA	DECAL-CONT. HEAD, (N) SERIES	058-0009
	103930-02-703	EA	HARNES-WIRE CONTROL	036-0048
	103930-02-704	EA	HARNES-VACUUM CONTROL	036-0049
	103930-02-705	EA	CABLE-BOWDEN, 89"	074-0011
	103930-02-706	EA	CLIP-CABLE CONTROL	022-0017
	103930-02-707	EA	RELAY-BOSCH W/RESISTER	031-0001
	103930-02-708	EA	MOTOR-VACUUM SERVO, A/C	030-0025
	103930-02-710	EA	CANISTER-VACUUM	054-0002
	103930-02-711	EA	VALVE-WATER, 2 PORT	034-0014
	103930-27-000	EA	CONTROL/PLENUM SET F,G,&D	
			FROM: 01-15-96 THRU: 99-99-99	
	094831-01-709	EA	CLAMP-ROD 3/16"	022-0025
	103930-01-724	EA	CLIP, SPRING, S TYPE	022-00002
	103930-02-701	EA	SWITCH-VACUUM	034-0015
	103930-02-702	EA	DECAL-CONT. HEAD, (N) SERIES	058-0009
	103930-02-704	EA	HARNES-VACUUM CONTROL	036-0049
	103930-02-705	EA	CABLE-BOWDEN, 89"	074-0011
	103930-02-707	EA	RELAY-BOSCH W/RESISTER	031-0001
	103930-02-708	EA	MOTOR-VACUUM SERVO, A/C	030-0025
	103930-02-710	EA	CANISTER-VACUUM	054-0002
	103930-02-712	EA	PANEL-CONT. A/C BLACK BEZEL	032-0054
	103930-24-000	EA	VALVE-WATER, 4 PORT	
	103016-01-000	EA	PLENUM-TRANSITION	

**HEATING & AIR CONDITIONING GROUP (CONTINUED)**

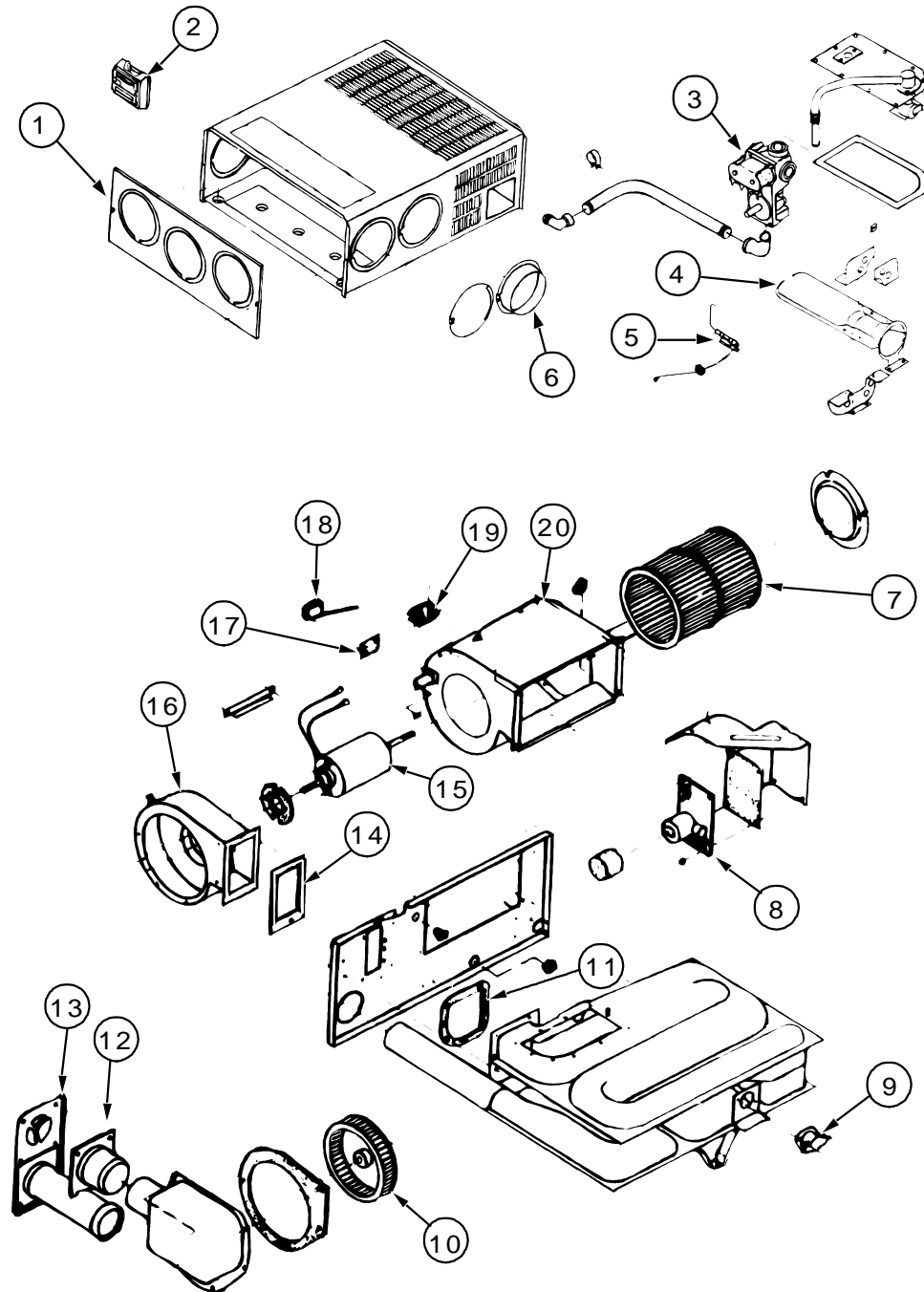

**HEATING & AIR CONDITIONING GROUP (CONTINUED)**

FURNACE - SUBURBAN 30,000 BTU - SF-30 2273

KEY	PART NUMBER	U/M DESCRIPTION	VENDOR NO.
	098668-14-000	EA GASKET-FIBERGLASS, .5" X 18" X 18" - 070976	
	098668-20-000	EA FURNACE - 30,000 BTU - SF-30 2273	
1	098668-01-700	EA CABINET FRONT	101242
2	115764-01-01A	EA THERMOSTAT-FURNACE 160902	
3	098668-01-714	EA VALVE-GAS	161070
4	098668-02-700	EA BURNER ASM. -COMPLETE	010762
5	098668-01-715	EA ELECTRODE ASM. - SINGLE PROBE	232166
6	075696-02-703	EA COLLAR-DUCT	050715
7	098668-01-711	EA WHEEL-ROOM AIR	350123
8	098668-01-712	EA BOARD-MODULE	231741
9	098668-21-701	EA SWITCH-LIMIT	231799
10	098668-01-706	EA WHEEL-COMBUSTION AIR	350122
11	098668-01-716	EA GASKET-FIREWALL, CHAMBER SIDE	070808
12	098668-01-713	EA TUBE ASM. - INTAKE VENT	051248
13	098668-01-707	EA VENT CAP & EXHAUST TUBE ASM.	260193
14	098668-01-717	EA GASKET-FIREWALL, BLOWER SIDE	070809
15	098668-01-709	EA MOTOR ASSEMBLY	231706
16	098668-01-708	EA BLOWER ASM. - COMBUSTION AIR	390441
17	101990-01-714	EA GASKET-MICROSWITCH	230877
18	098668-21-700	EA MICROSWITCH-W/O FLAG, 3 1/4"	232261
19	074466-01-702	EA RELAY-TIME DELAY	230625
20	098668-01-710	EA BLOWER ASSEMBLY-ROOM AIR	390440
	092300-02-701	EA ORIFICE-MAIN BURNER, SUBURBAN	180214
	098668-23-000	EA DOOR-ACCESS, FURNACE - BRIGHT WHITE 520574	
	069636-02-000	EA CONNECTOR-DUCT, 4" ID - SUBURBAN 050715	
	093614-01-02A	EA GRILLE-RETURN AIR, FURNACE - BEIGE	
	056464-10-000	EA REGISTER-PLASTIC, W/O DAMPER - 4" DIAMETER	
	009198-01-000	FT DUCT-HEAT, FLEXIBLE - 4" ID X 25 FT	
	009200-01-000	EA TAPE-FURNACE, 1 1/2"	
	056464-09-000	EA REGISTER-HEAT/A/C, ROUND W/DAMPER - 4" - PLASTIC - BEIGE	
	056464-10-000	EA REGISTER-HEAT/A/C, ROUND W/O DAMPER - 4" - PLASTIC - BEIGE	
	092777-01-000	EA ADAPTER-DUCT, 4"	
	023146-01-000	EA CLAMP-SCREW TYPE - 4"	

**GAS AUTO A/C - HOSE KIT**

KEY	PART NUMBER	U/M DESCRIPTION	VENDOR NO.
	103930-17-000	EA HOSE KIT, 10 GM-SANDEN COMPRESSOR - SCS 093-00076	
	103930-01-708	EA BRACKET-VACUUM MOTOR	SCS 070-0113
	103930-17-700	EA PAD-FITTING, SANDEN COMPRESSOR SUCTION	SCS 050-0131
	103930-17-701	EA FITTING - 10.90, W/FERRULE - 1342CP	SCS 050-0132
	103930-17-702	EA GASKET OR SAE 015 10 33-781	SCS 045-0127
	103930-17-703	EA GASKET-SEAL, SANDEN COMPRESSOR 33-76	SCS 045-0142
	103930-17-704	EA HOSE ASSY #10	085-0113

**GAS AUTO A/C SYSTEM**

KEY	PART NUMBER	U/M DESCRIPTION
	007281-01-000	EA HOSE-FLEXIBLE PVC, 2.5"ID X 50' - ATCOFLEX A-182-355
	056402-05-000	EA BRACKET-HEATER VENT, ROUND - W/BEND - BLACK
	077075-01-000	EA GASKET-INSTRUMENT PANEL TO DEFROSTER PLENUM, .6" X 11.3"
	077075-03-000	EA GASKET-INSTRUMENT PANEL TO DEFROSTER PLENUM, .6" X 10.2"
	103017-01-000	EA PLENUM-DEFROSTER
	103558-01-09A	EA VENT-DEFROSTER, ABS PLASTIC - BISQ
	103796-01-01A	EA LOUVER ASM-A/C, 136.5 X 54.8MM - BLACK
	103930-05-000	EA MANUAL-OWNERS, HEATER-A/C SCS 057-0049
	024990-05-000	EA OUTLET-DEFROSTER W/SWIVEL - 2" - BLACK
	008042-01-000	FT TUBING-VINYL, .65" ID

HEATING & AIR CONDITIONING GROUP (CONTINUED)

14,800 BTU COLEMAN ROOF A/C

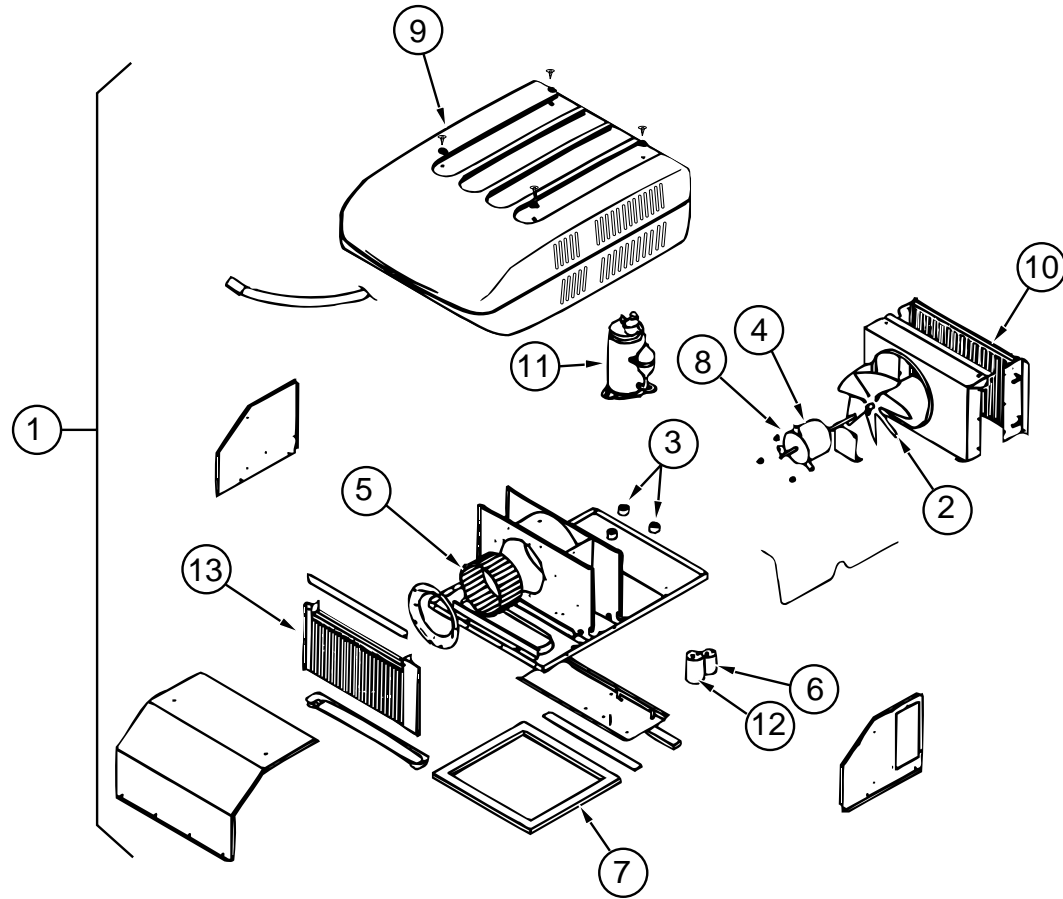

KEY	PART NUMBER	U/M	DESCRIPTION	VENDOR NO.
1	115219-01-03A	EA	A/C-ROOF,14,800 MACH 15 B/WT COLEMAN - 7335B896	
2	093763-01-712	EA	FAN BLADE-CONDENSER	6733-3221
3	105620-01-706	EA	FOOT PACKAGE-COMPRESSOR, 3 PER PACKAGE	6759-3081
4	108889-01-705	EA	MOTOR - 115V, 60HZ	1468-3049
5	108889-01-706	EA	IMPELLOR	1472-1041
6	108889-01-708	EA	CAPACITOR-FAN, (7.5MFD.370U)	1499-5461
	108889-01-710	EA	FILLER PAD-COND AIR SEAL	6759A3971
7	108889-01-711	EA	GASKET PACKAGE	6792-3301
8	108889-01-715	EA	MOTOR MOUNT & SHAFT SEAL KIT	6792-3361
9	108889-01-702	EA	SHROUD	6759-6411
10	115219-01-700	EA	CONDENSER COIL	1452-1321
11	115219-01-701	EA	COMPRESSOR, PANASONIC	1450-2039
12	115219-01-702	EA	CAPACITOR-RUN, COMPRESSOR	1499-5741
	115219-01-703	EA	RELAY-START	1497-4151
13	115219-01-704	EA	EVAPORATOR COIL	1452-1331
	115219-01-707	EA	DISCHARGE LINE ASSEMBLY	7335A132
	115219-01-705	EA	LINE-SUCTION, LOWER	7335-130
	115219-01-706	EA	LINE-SUCTION, UPPER	7335-131
	093306-01-720	EA	CAPACITOR-START	1497-3351
	093306-01-701	EA	DECAL PACKAGE-LEFT & RIGHT	6798B3591
	102289-01-000	EA	SPRING-SCREW, ROOF A/C GASKET - 6757-150	

COLEMAN CEILING ASSEMBLY 14,800 BTU A/C

KEY	PART NUMBER	U/M	DESCRIPTION	VENDOR NO.
	108891-01-01A	EA	CEILING ASM-A/C COOL TSR HO COLEMAN - 7330-714 IV	
	042204-01-709	EA	THERMOSTAT-IN 64 OUT 58	6701-3401
	063903-01-702	EA	LOUVER	6703A5191
	073742-01-701	EA	SWITCH-SELECTOR,(5 TERMINAL)	6759-3251
	073742-01-702	EA	DECAL-COOL	6759C3431
	076303-01-707	EA	FILTER-6" X 143/4 X 1/2(24)	6703-A3151
	081606-01-712	EA	SHROUD-CEILING, IVORY	6769-5061
	091225-01-713	EA	KNOB	6701-3351
	091225-01-717	EA	DECAL-THERMOSTAT, COOL ONLY	6799A3441
	093766-02-701	EA	DECAL-LEFT	6799-3971
	108891-01-700	EA	PARTS PKG. SGL KNOBS & NUTS	6792-5991
	108891-01-701	EA	CLIP-FILTER RETAINER, 4 PER	6799-3141
	092633-02-02A	EA	COVER-BLANK, ROOF A/C - 5.1" X 5.1" - PLASTIC - OFF WHITE	

**INTERIOR FINISH GROUP  
CABINET HARDWARE**

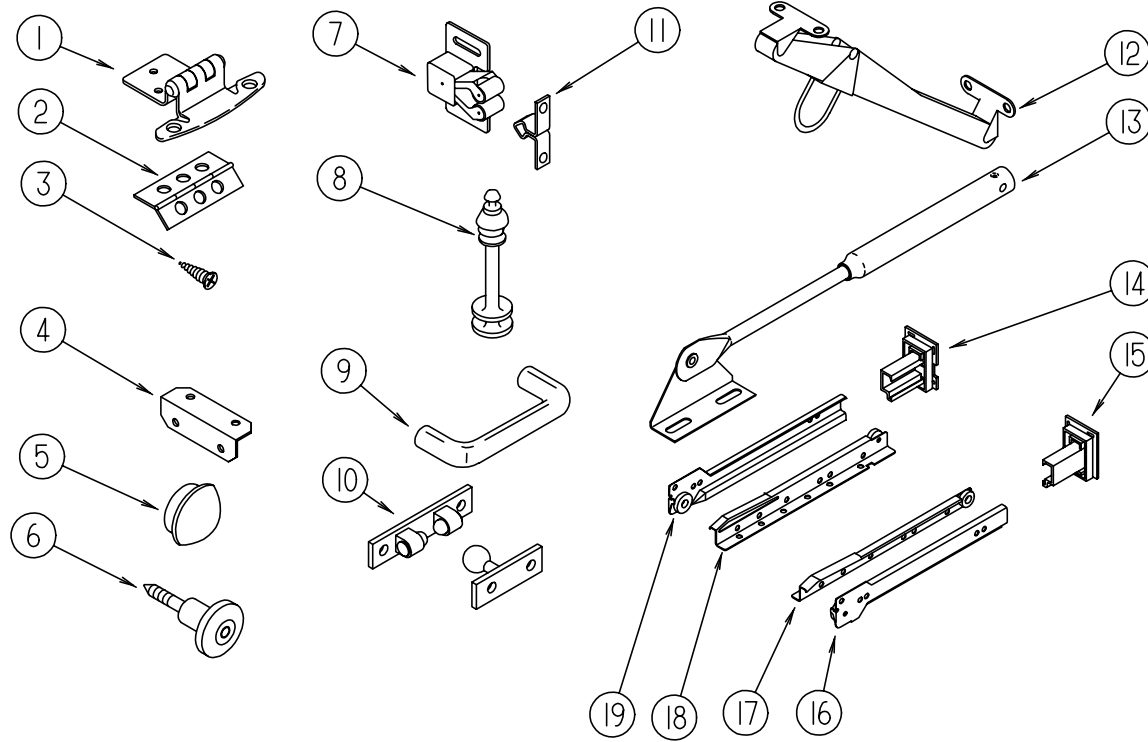

KEY	PART NUMBER	U/M	DESCRIPTION
1	108138-01-000	EA	HINGE-DOOR, CABINET - BURNISHED BRASS
2	009059-01-000	EA	HINGE-DOOR, 2" X 1.4" - BRASS
2	009059-02-000	EA	HINGE-DOOR, 2" X 2.7" - BRASS
3	000G13-06-10G	EA	SCREW - 6-20 X 5/8 PFH, ANTIQUE BRASS
3	076790-01-000	EA	SCREW, 6-20 X 1 1/4 PPH - BLACK
4	016604-01-000	EA	BRACE-CABINET, ANGLE - 2.5" - METAL - UNPAINTED
4	016604-05-000	EA	BRACE-CABINET, ANGLE - 2.5" - METAL - OFF WHITE
5	042356-01-000	EA	PLUG-BUTTON, MAHOGANY - 3/8" DIAMETER - WOOD
6	079921-01-000	EA	ROLLER-NYLON,W/SHAFT
7	093586-06-000	EA	CATCH-SPRING, ROLLER
8	084070-02-000	EA	POST-END,BRASS N-8655
9	112146-01-000	EA	PULL-CABINET, BRASS - AMEROCK 1180-3
10	084451-01-000	EA	CATCH-TV SHELF, BRASS
11	093586-05-000	EA	STRIKE-SPRING STEEL
12	104181-01-01A	EA	SUPPORT-LEAF, 5.3" - EXTENDS TO 7.5" - SAF-T-RING - METAL
13	074493-02-000	EA	SUPPORT-PISTON SPRING, CABINET DOOR
	004354-01-000	EA	BUMPER-RUBBER, .5" DIA - BROWN
	023320-01-000	EA	PAD-FELT, 3/8" DIAMETER - BROWN
	009112-01-000	EA	FLANGE - 1" ROD, CLOTHES - PLASTIC - OFF WHITE
	042438-01-000	EA	DOWEL-WOOD, CLOTHES ROD - 1" DIAMETER X 4'
	114693-01-01A	EA	SUPPORT-TABLE BLACK
	114693-02-01A	EA	SUPPORT-TABLE BLACK
	118933-01-01A	EA	SUPPORT-HINGE LOCK O/WHT
14	114045-01-000	EA	BACKSOCKET-ADJUSTABLE,LEFT - HOUCK 751-1 N/A ORDER SLIDE KIT ACCORDING TO LENGTH-SEE NUMERICAL LISTING OF #114031-??-700 IN THE \$ FICHE F/DESIRED LENGTH
15	114045-02-000	EA	BACKSOCKET-ADJUSTABLE,RIGHT - HOUCK 751-2 N/A ORDER SLIDE KIT ACCORDING TO LENGTH-SEE NUMERICAL LISTING OF #114031-??-700 IN THE \$ FICHE F/DESIRED LENGTH
16	114031-06-000	EA	SLIDE-DRAWER,14" RIGHT CABT HOUCK 7200-RV-2 N/A ORDER #114031-05-700 SLIDE DRAWER KIT
16	114031-10-000	EA	SLIDE-DRAWER,16" RIGHT CABINET-HOUCK 7200-RV-2 N/A ORDER #114031-09-700 SLIDE DRAWER KIT

KEY	PART NUMBER	U/M	DESCRIPTION
16	114031-14-000	EA	SLIDE-DRAWER,18" RIGHT CABINET-HOUCK 7200-RV-2 N/A ORDER #114031-13-700 SLIDE DRAWER KIT
16	114031-18-000	EA	SLIDE-DRAWER,20" RIGHT CABT HOUCK 7200-RV-2 N/A ORDER #114031-17-700 SLIDE DRAWER KIT
17	114031-08-000	EA	SLIDE-DRAWER,14" RIGHT DRWR HOUCK 7200-RV-4 N/A ORDER #114031-05-700 SLIDE DRAWER KIT
17	114031-12-000	EA	SLIDE-DRAWER,16" RIGHT DRAWER -HOUCK 7200-RV-4 N/A ORDER #114031-09-700 SLIDE DRAWER KIT
17	114031-16-000	EA	SLIDE-DRAWER,18" RIGHT DRAWER -HOUCK 7200-RV-4 N/A ORDER #114031-13-700 SLIDE DRAWER KIT
17	114031-20-000	EA	SLIDE-DRAWER,20" RIGHT DRWR HOUCK 7200-RV-4 N/A ORDER #114031-17-700 SLIDE DRAWER KIT
17	114031-24-000	EA	SLIDE-DRAWER,22" RIGHT DRWR HOUCK 7200-RV-4 N/A ORDER #114031-21-700 SLIDE DRAWER KIT
18	114031-07-000	EA	SLIDE-DRAWER,14" LEFT DRWR HOUCK 7200-RV-3 N/A ORDER #114031-05-700 SLIDE DRAWER KIT
18	114031-11-000	EA	SLIDE-DRAWER,16" LEFT DRAWER - HOUCK 7200-RV-3 N/A ORDER #114031-09-700 SLIDE DRAWER KIT
18	114031-15-000	EA	SLIDE-DRAWER,18" LEFT DRAWER - HOUCK 7200-RV-3 N/A ORDER #114031-13-700 SLIDE DRAWER KIT
18	114031-19-000	EA	SLIDE-DRAWER,20" LEFT DRWR HOUCK 7200-RV-3 N/A ORDER #114031-17-700 SLIDE DRAWER KIT
18	114031-23-000	EA	SLIDE-DRAWER,22" LEFT DRWR HOUCK 7200-RV-3 N/A ORDER #114031-21-700 SLIDE DRAWER KIT
19	114031-05-000	EA	SLIDE-DRAWER,14" LEFT CABT HOUCK 7200-RV-1 N/A ORDER #114031-05-700 SLIDE DRAWER KIT
19	114031-13-000	EA	SLIDE-DRAWER,18" LEFT CABINET -HOUCK 7200-RV-1 N/A ORDER #114031-13-700 SLIDE DRAWER KIT
19	114031-09-000	EA	SLIDE-DRAWER,16" LEFT CABINET - HOUCK7200-RV-1 N/A ORDER #114031-09-700 SLIDE DRAWER KIT
19	114031-17-000	EA	SLIDE-DRAWER,20" LEFT CABT HOUCK 7200-RV-1 N/A ORDER #114031-17-700 SLIDE DRAWER KIT

**INTERIOR FINISH GROUP (CONTINUED)**  
**MOLDINGS, BATT STRIPS, & TRIM**

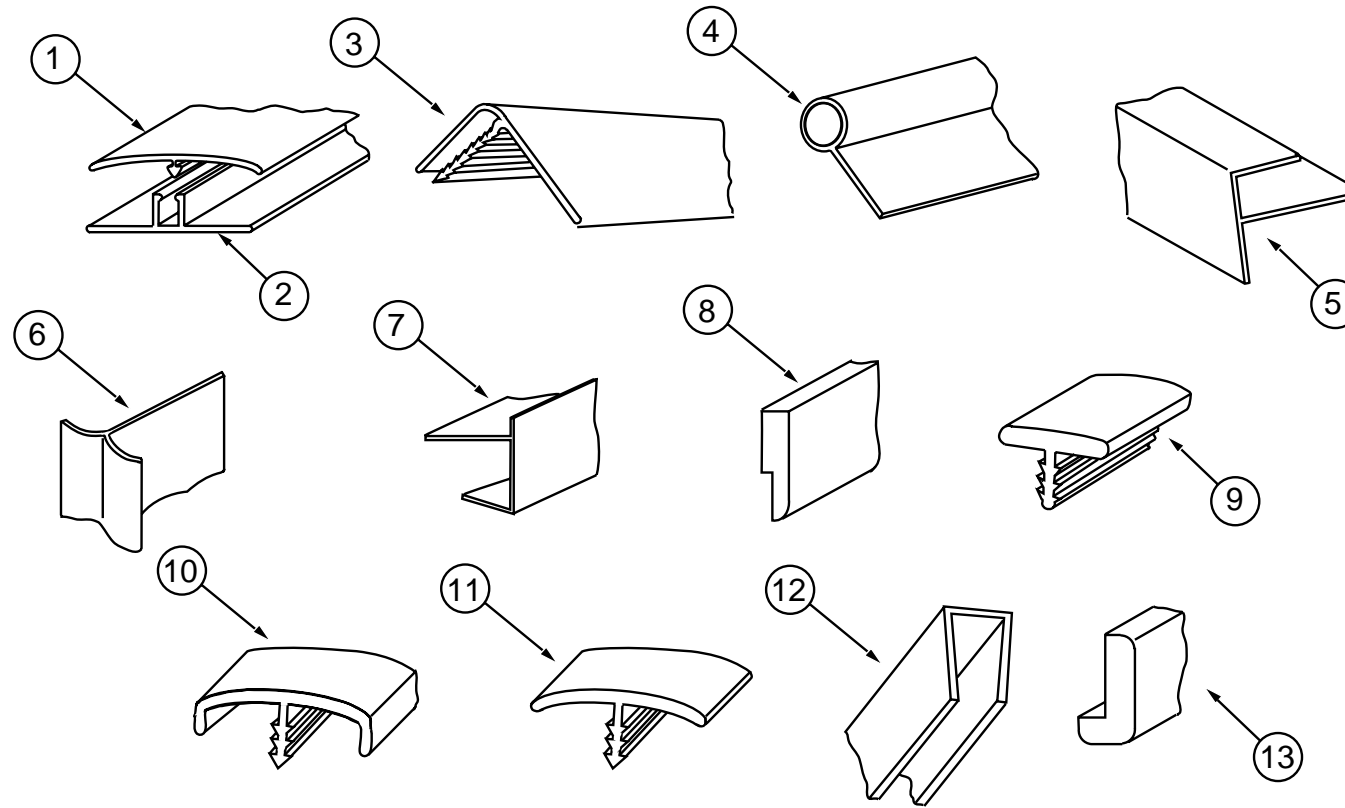

KEY	PART NUMBER	U/M	DESCRIPTION
	085284-B1-000	FT	BATT TAPE - ADHESIVE BACKED - DECORATIVE - METRO/MIST (GD1)
	085284-A9-000	FT	BATT TAPE- ADHESIVE BACKED-DECORATIVE-MONTERREY/RAINFORREST (GE1)
	085284-C9-000	FT	BATT TAPE - ADHESIVE BACKED - CEILING - IMPACT PEARL
	085284-76-000	FT	BATT TAPE - ADHESIVE BACKED - SHOWER - ANTIQUE WHITE
	069733-83-000	EA	BATT STRIP - WOODGRAINED/WATERFORD OAK - 8' LONG
	088263-D6-000	EA	BATT STRIP - DECORATIVE - IMPACT PEARL - 8' LONG
1	086229-13-000	EA	BATTEN-1" CEILING MOD IVORY (GD1,GE1)
2	086229-01-000	EA	RETAINER-BATTEN, CEILING - .75" WIDE - 7.6'
3	009809-28-001	EA	MOLDING-CORNER, OUTSIDE - LARGE CABINET - PLASTIC - 2133 MM
3	009809-28-000	EA	MOLDING-CORNER, OUTSIDE - PLASTIC 1" - WATERFORD OAK
4	009767-12-000	FT	MOLDING-SIDEWALL TO CEILING/CABINET - WELTING - OFF WHITE
4	009767-15-000	FT	WELTING-WATERFORD OAK
5	009812-24-000	EA	MOLDING-CORNER, OUTSIDE - .5" - PLASTIC - IVORY
5	009812-29-001	EA	MOLDING-CORNER, OUTSIDE - SMALL CABINET - PLASTIC - 2133MM
5	009812-29-000	EA	MOLDING-CORNER, OUTSIDE - PLASTIC - 1/2" - WATERFORD OAK
6	022992-11-000	FT	MOLDING-REVERSE COVE, T-SHAPED - VINYL - IVORY
7	103186-01-05A	FT	MOLDING-PLASTIC,SHELF - WATERFORD OAK
	117268-F2-134	EA	MOLDING - VINYL WRAPPED .7" X 2.6" X 7' - WATERFORD
	117268-F2-438	EA	MOLDING - VINYL WRAPPED - .7" X 2.6" X 8' - WATERFORD
8	105004-01-05A	EA	MOLDING-VINYL WRAP - WATERFORD OAK
9	104676-01-01A	FT	T-MOLDING, 5/16" RIGID - GOLD
10	083620-12-000	FT	T-MOLDING - 3/4" W/EDGE LIPS - WATERFORD OAK
10	104676-02-04A	FT	T-MOLDING, 1/2 X 10 FT - WATERFORD OAK
11	105709-01-000	FT	T-MOLDING-1", MODERN IVORY
	009778-21-000	FT	U-CHANNEL-1" - WATERFORD OAK
	070504-01-000	FT	U-CHANNEL-PLASTIC, .065" WIDE - LIGHT BROWN - INC OF 8'
12	070504-18-000	FT	U-CHANNEL-PLASTIC, .065" WIDE - IVORY - INC. OF 8'
12	070504-19-000	FT	U-CHANNEL-PLASTIC, .815" WIDE - BROWN - INC. OF 8'
12	070504-26-000	FT	EXTRUSION-U CHANNEL,20.7 MODERN IVORY
13	077840-01-G01	EA	MOLDING-CAP,WALL 2438
	052372-02-000	BF	LUMBER-CLASS II, 1 X 4 X RL - CONSTRUCTION GRADE
	093873-01-01A	EA	TRIM-CARPET, L-ANGLE - 1.1" X 1.3" X 12' - VINYL - GRAY

## INTERIOR FINISH GROUP (CONTINUED)

### PANELING, LAMINATES & PLASTIC

KEY	PART NUMBER	U/M	DESCRIPTION
	000885-76-000	SF	PART BD-3/8 X 4' X 8' WATERFORD OAK VINYL 1 SIDE
	000885-77-000	SF	PARTICLE BOARD 3/8" X 4' X 8'-WATERFORD OAK VINYL 2 SIDED
	000885-78-000	SF	PART BD-1/2 X 4' X 8' WATERFORD OAK VINYL 2 SIDES
	000885-79-000	SF	PART BD-3/4, 4' X 8' WATERFORD OAK VINYL 2 SIDES
	052372-02-000	BF	LUMBER-CLASS II,1X4XRL
	074497-28-000	SF	PANELING - WATERFORD OAK - 4' X 8'
	074497-34-000	SF	PANELING - CEILING - IMPACT PEARL - 4' X 8'
	074498-71-000	SF	LAMINATE - PLASTIC NEUTRAL SANTOS - 5' X 8' INCREMENTS (GD1)
	074498-77-000	SF	LAMINATE - PLASTIC ART CABIN 5' X 8' INCR OF 40 SQ FT
	080215-10-000	SF	PANELING - 2 SIDE - WATERFORD - 4' X 8'
	088272-E0-000	SF	PANELING - DECORATIVE METRO/MIST - 4' X 7' (GD1)
	088272-B8-000	SF	PANELING - DESERT/SESAME - 4' X 8' (GE1)
	088272-G1-000	SF	PANELING - PEBBLE EMOSS ANTIQUE - 4' X 7'-INC OF 28 SQ FT
			FROM: 01-15-96 THRU: 99-99-99
	088272-98-000	SF	PANELING-SHOWER, OFF WHITE - 4' X 7' - INC OF 28 SQ FT
			FROM: 00-00-00 THRU: 01-14-96
	093743-02-01A	SF	PLASTIC-ABS, 20" WIDE ROLL - OFF WHITE THIS PLASTIC IS SOLD AS SQ.FT.,15 SQ.FT. MINIMUM ORDER QTY 15 SQ.FT. = 108" X 20" PIECE
	117267-E2-438	EA	LUMBER-018X50.8X2438MM VINYL
	117267-G2-438	EA	LUMBER-018X076X2438 MM VINYL

### DETECTORS & FIRE EXTINGUISHER

KEY	PART NUMBER	U/M	DESCRIPTION
	072852-01-000	EA	DETECTOR-SMOKE, W/9 VOLT BATTERY - US
	094499-01-000	EA	EXTINGUISHER-FIRE, DRY W/MOUNTING BRACKET - 10 BC BRACKET ONLY #094499-01-700
	094499-01-700	EA	BRACKET MTG. W/PLAS. STRAP 294039
	112320-03-000	EA	DETECTOR-CO GAS MODEL 9D-I
	112320-04-000	EA	BATTERY/SENSOR MODULE - CO (BLACK MODULE) F/9D-I SYSTEM

### FLOOR COVERINGS & MATS

KEY	PART NUMBER	U/M	DESCRIPTION
	075233-01-000	SY	PAD-CARPET, 3/8" X 6' ROLL
	096060-A1-000	SY	CARPET-JUBILATION,ARTIC GRAY (GD1)
	096060-B2-000	SY	CARPET-JUBILATION,32199 COPP (GE1)
	093486-01-000	SY	CARPET-COMPARTMENT, 54" WIDE - DARK GRAY

## LABELS GROUP

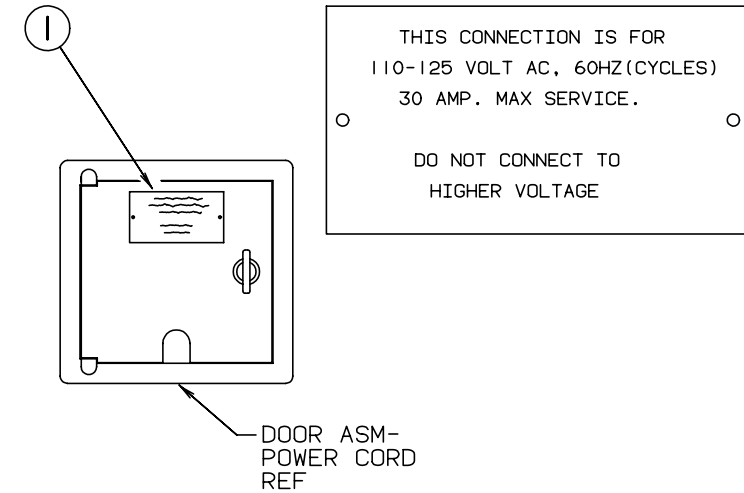

KEY	PART NUMBER	U/M	DESCRIPTION
1	006062-01-000	EA	TAG-ELECTRIC - 110V CONNECTION

### MISCELLANEOUS LABELS

KEY	PART NUMBER	U/M	DESCRIPTION
	098641-01-000	EA	LABEL-FUEL - UNLEADED - DASH
	109522-01-000	EA	LABEL-BUMPER, SEE OWNERS MANUAL
	087236-01-000	EA	LABEL-CABLE, INPUT
	098379-04-000	EA	LABEL-ELECTRICAL BOX,SIDE
	112518-01-000	EA	LABEL-HANG TAG,CO DETECTOR

**LABELS GROUP (CONTINUED)**

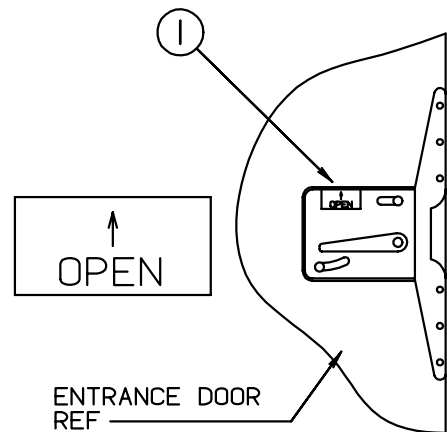

KEY	PART NUMBER	U/M DESCRIPTION
1	040944-01-000	EA LABEL-ENTRANCE DOOR - "OPEN"

**LABELS GROUP (CONTINUED)**

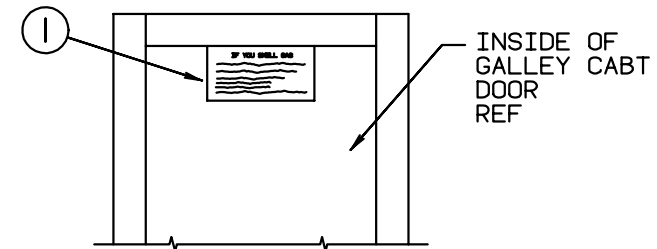

**IF YOU SMELL GAS**

1. EXTINGUISH ANY OPEN FLAME, PILOT LIGHTS AND ALL SMOKING MATERIALS.
2. SHUT OFF THE GAS SUPPLY AT THE TANK VALVE( OR GAS SUPPLY CONNECTION.
3. OPEN DOORS AND OTHER VENTILATING OPENINGS.
4. DO NOT TOUCH ELECTRICAL SWITCHES.
5. LEAVE THE AREA UNTIL ODOR CLEARS.
6. HAVE THE GAS SYSTEM CHECKED AND LEAKAGE SOURCE CORRECTED BEFORE USING AGAIN.

KEY	PART NUMBER	U/M DESCRIPTION
1	073998-01-000	EA LABEL-LPG ODOR WARNING

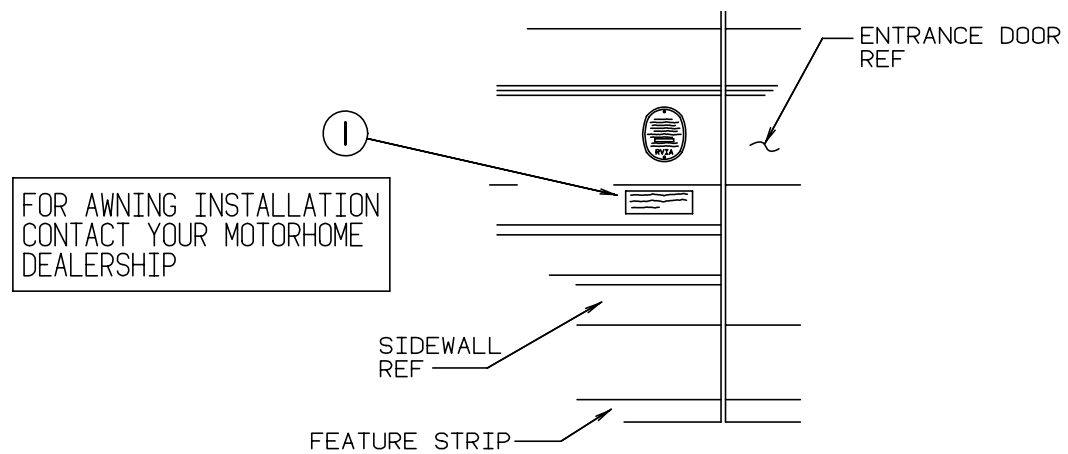

KEY	PART NUMBER	U/M DESCRIPTION
1	099509-01-000	EA LABEL-AWNING INSTALLATION



**LABELS GROUP (CONTINUED)**

CAUTION

THIS MOTOR HOME HAS BEEN DESIGNED, MANUFACTURED AND TESTED WITH CONCERN FOR THE PROTECTION OF IT'S OCCUPANTS. WE RECOMMEND YOU PERFORM THE FOLLOWING INSPECTIONS FOR YOUR SAFETY AND THE SAFETY OF YOUR PASSENGERS BEFORE STARTING YOUR VEHICLE.

1. LP GAS SYSTEM- TURN OFF AT TANK FOR TRAVELING. TEST FOR LEAKS UPON ARRIVAL AT DESTINATION. BEFORE LIGHTING PILOTS.
2. WHEELS- INSPECT FOR DAMAGE AND CHECK LUG NUTS FOR TIGHTNESS.
3. TIRES- INSPECT FOR WEAR AND DAMAGE AND CHECK FOR RECOMMENDED AIR PRESSURE.
4. LIGHTING- TEST FOR PROPER OPERATION OF ALL INTERIOR AND EXTERIOR LIGHTS INCLUDING DASH LIGHTS, HEADLIGHTS, TAIL LIGHTS, BRAKE LIGHTS, CLEARANCE LIGHTS AND TURN SIGNALS.
5. EXITS- INSPECT RELEASE MECHANISM ON EMERGENCY EXIT WINDOW, TEST BOTH LOCKS ON MAIN ENTRANCE DOOR FOR EASE OF OPERATION AND INSTRUCT PASSENGERS HOW TO USE BOTH MEANS OF EXIT.
6. SEAT BELTS- DIRECT PASSENGERS TO DESIGNATED SEATS AND REQUIRE USE OF SEAT BELTS.
7. APPLIANCES- TURN OFF AND LATCH OR LOCK DOORS WHERE PROVIDED.
8. LOOSE PARCELS- STORE SECURELY.
9. UTILITY SUPPLY LINES- DISCONNECT ALL ELECTRIC, SEWER AND WATER LINES AND SECURE PROPERLY.
10. ENTRANCE DOOR STEP- PLACE IN RETRACTED POSITION FOR TRAVELING.

READ YOUR MOTOR HOME AND CHASSIS OWNER'S MANUAL FOR FURTHER PRECAUTIONS

**LABELS GROUP (CONTINUED)**

DO NOT INSTALL IF HITCH OPTION IS RESTRICTED

DO NOT USE HITCH BEFORE READING OWNERS MANUAL REGARDING VEHICLE LOADING AND TOWING

KEY	PART NUMBER	U/M DESCRIPTION
1	111104-01-000	EA LABEL-HITCH - READ MANUAL

KEY	PART NUMBER	U/M DESCRIPTION
1	056259-01-000	EA LABEL-SAFETY CHECK LIST

SMOKE DETECTOR REF

**WARNING:** TEST SMOKE DETECTOR OPERATION AFTER VEHICLE HAS BEEN IN STORAGE, BEFORE EACH TRIP AND AT LEAST ONCE PER WEEK DURING USE.

**WARNING** DISCONNECT BATTERIES BEFORE CONNECTING EXTERNAL CHARGING EQUIPMENT.

BATTERY COMPARTMENT REF

KEY	PART NUMBER	U/M DESCRIPTION
1	065748-01-000	EA LABEL-CAUTION - BATTERY CHARGING

KEY	PART NUMBER	U/M DESCRIPTION
1	077956-01-000	EA LABEL-WARNING - SMOKE DETECTOR

**LABELS GROUP (CONTINUED)**

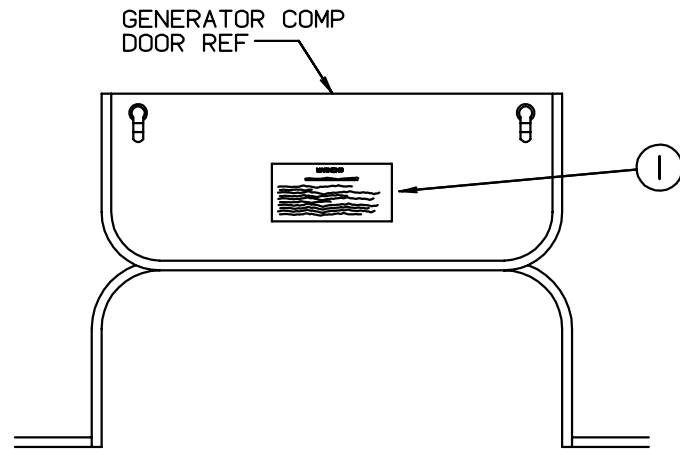

**WARNING**

WHEN ADDING A GENERATOR SET:

HIGH VOLTAGE-USE EXTREME CAUTION WHEN WORKING ON ELECTRICAL COMPONENTS.  
 HAVE ALL ELECTRICAL INSTALLATION PERFORMED BY A QUALIFIED LICENSED ELECTRICIAN-FOLLOW ALL STATE AND LOCAL CODES.  
 ONLY INSTALL GENERATOR SET APPROVED FOR R.V. APPLICATION. HAVE INSTALLED BY QUALIFIED TECHNICIAN.  
 TO AVOID HEAT BUILD-UP AND TO GUARANTEE AN ADEQUATE AIR SUPPLY TO THE GENERATOR CARBURETOR, FOLLOW INSTALLATION INSTRUCTIONS.  
 GENERATOR ENGINE EXHAUST GASES ARE TOXIC AND MUST NOT TERMINATE UNDER THE VEHICLE-DISCHARGE EXHAUST AWAY FROM VEHICLE.

KEY	PART NUMBER	U/M DESCRIPTION
1	077510-01-000	EA LABEL-GENERATOR PREP

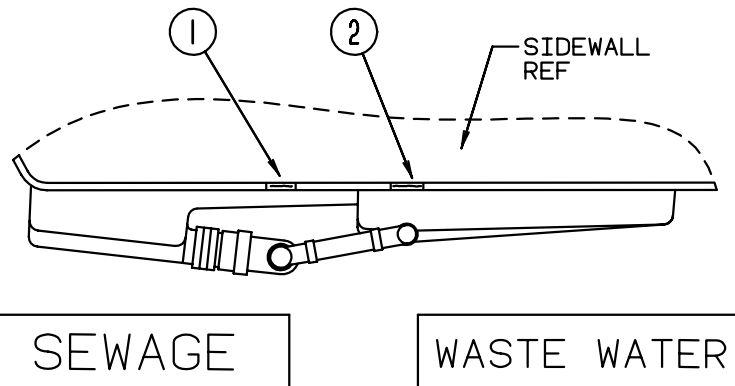

SEWAGE

WASTE WATER

KEY	PART NUMBER	U/M DESCRIPTION
1	006187-01-000	EA LABEL-SEWAGE
2	006188-01-000	EA LABEL-WASTE WATER

**LABELS GROUP (CONTINUED)**

**WARNING**

ALL PILOT LIGHTS AND APPLIANCES SHALL BE TURNED OFF DURING REFUELING OF MOTOR FUEL TANKS AND/OR PERMANENTLY MOUNTED LP-GAS CONTAINERS.

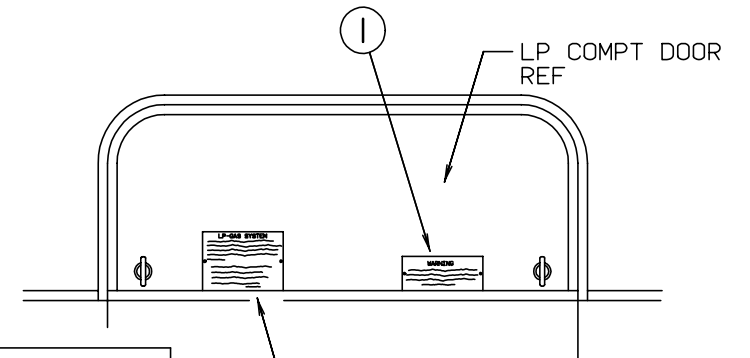

**LP-GAS SYSTEM**

THIS GAS PIPING SYSTEM IS DESIGNED FOR USE OF LIQUEFIED PETROLEUM GAS ONLY. DO NOT CONNECT NATURAL GAS TO THIS SYSTEM.

SECURELY CAP INLET(S) WHEN NOT CONNECTED FOR USE. AFTER TURNING ON GAS, EXCEPT AFTER NORMAL CONTAINER REPLACEMENT, TEST GAS PIPING AND CONNECTIONS TO APPLIANCE FOR LEAKAGE WITH SOAPY WATER OR BUBBLE SOLUTION. DO NOT USE PRODUCTS THAT CONTAIN AMMONIA OR CHLORINE.  
 P.N. 54531

KEY	PART NUMBER	U/M DESCRIPTION
1	006040-01-000	EA TAG-GAS REFUELING WARNING
1	006040-02-000	EA TAG-GAS REFUEL WARNING - CANADIAN
2	054531-01-000	EA LABEL-LP GAS ONLY
2	023769-01-000	EA LABEL-WARNING - LPG - CANADIAN

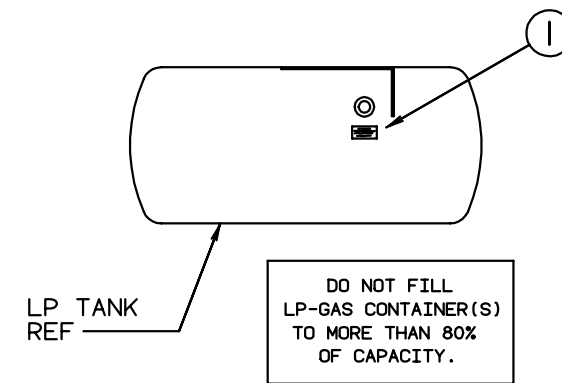

**DO NOT FILL LP-GAS CONTAINER(S) TO MORE THAN 80% OF CAPACITY.**

KEY	PART NUMBER	U/M DESCRIPTION
1	079965-01-000	EA LABEL-LPG 80% CAPACITY

## LABELS GROUP (CONTINUED)

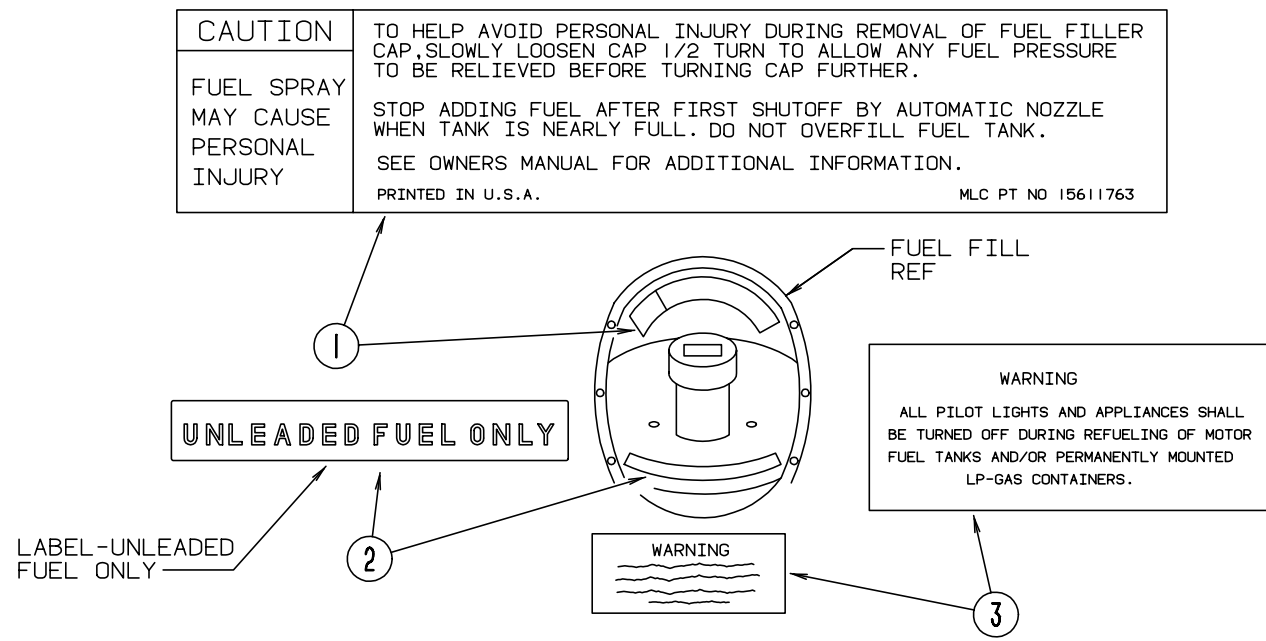

KEY	PART NUMBER	U/M	DESCRIPTION
1	087207-05-000	EA	LABEL-FUEL CAP REMOVAL - GM--15611763
2	062043-01-000	EA	LABEL-FUEL - UNLEADED
3	006040-01-000	EA	TAG-GAS REFUELING WARNING
3	006040-02-000	EA	TAG-GAS REFUEL WARNING - CANADIAN

## LP GROUP

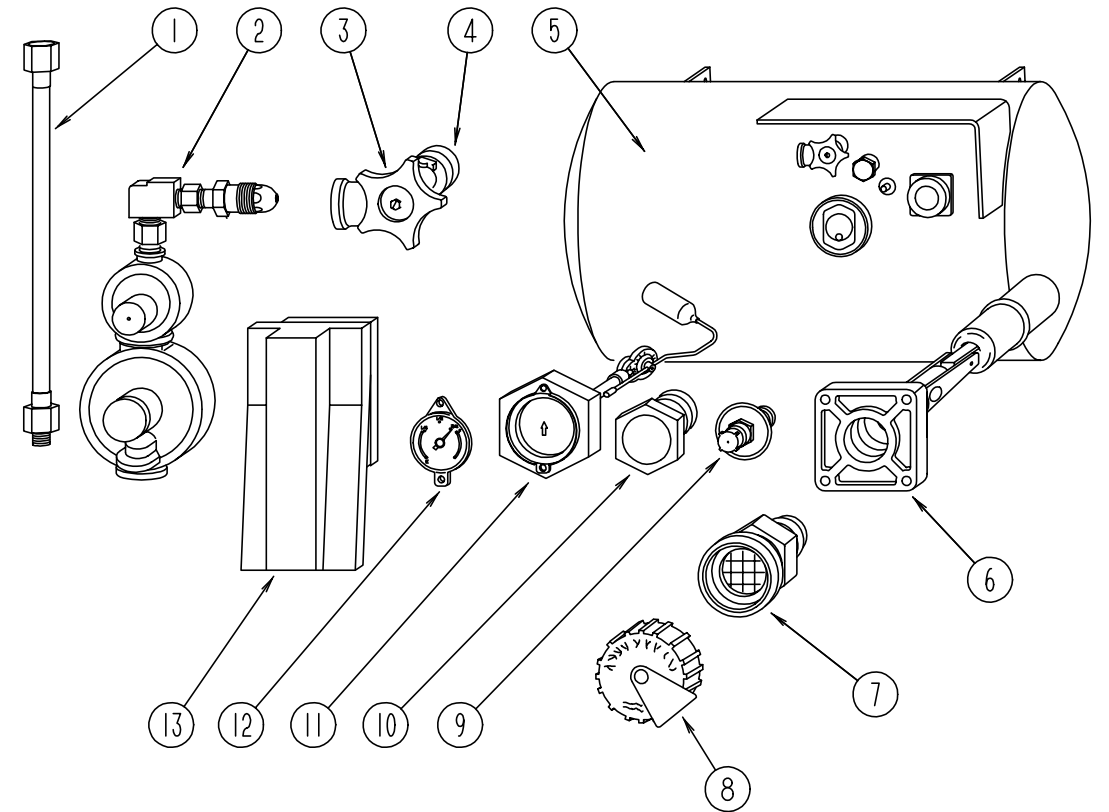

## LP TANK & COMPONENTS

KEY	PART NUMBER	U/M	DESCRIPTION	VENDOR NO.
1	045703-01-000	EA	HOSE-LP, 3/8" ID X 24" - 3/8 MPT X 1/2 F SWIVEL - U.S.	
1	045703-02-000	EA	HOSE-LP, 3/8" ID X 24" - 3/8" MPT X 1/2" F SWIVEL - CANADA	
2	106150-01-000	EA	REGULATOR-TWO STAGE, MARSHALL BRASS 293-00	
3	040421-01-708	EA	HANDWHEEL-SERVICE VALVE,	G-1015-A
4	040421-01-712	EA	VALVE-SERVICE W/O VAPOR RELIEF	29000853
5	088253-01-000	EA	TANK-LP, 80 LB - 16" DIAMETER X 30" - BRUNNER	
6	040421-01-711	EA	VALVE-80% FILL W/AUTO STOP LLL/TL3	
7	040421-01-701	EA	VALVE-FILL-SHORT, LP	75478
8	040421-01-702	EA	CAP-FILL VALVE, PLASTIC	G-1014-A
9	040421-01-700	EA	VALVE-LIQUID LEVEL, 20%	G-1013
10	040421-01-713	EA	VALVE-VAPOR ONLY	29000587
11	088253-01-700	EA	GAUGE-FLOAT ASSEMBLY, L.P.	
12	040421-01-706	EA	DIAL-VISIBLE FACE, LP TANK	MA-8 ROCHST
	040440-02-000	EA	TRANSMITTER-DIAL, 0-90 OHM - 2 TERMINAL (POWER & GROUND)	
13	105658-01-000	EA	COMPARTMENT-LP REGULATOR	
	010323-01-000	EA	ADAPTER-BRASS, 3/8F X 1/2MPT	
	010377-02-000	EA	NUT-BRASS, 3/8 FEMALE - FORGED	
	010380-02-000	EA	NUT-BRASS, 1/2 FEMALE - FORGED	
	010329-01-000	EA	ADAPTER-BRASS, 1/2F X 1/2MPT	
	010265-01-000	EA	ELBOW - 90 DEGREE, 3/8" F TO 1/2" FPT - BRASS	
	010265-01-000	EA	ELBOW-BRASS, 90 DEGREE - 3/8"F X 1/2"FPT	
	010252-01-000	EA	ELBOW-BRASS-90 3/8F X 1/2MPT	
	035340-01-000	EA	ELBOW, 3/8" MPT X 1/2" F - BRASS	
	103613-01-000	EA	DETECTOR-LP GAS	

## LOUNGE GROUP

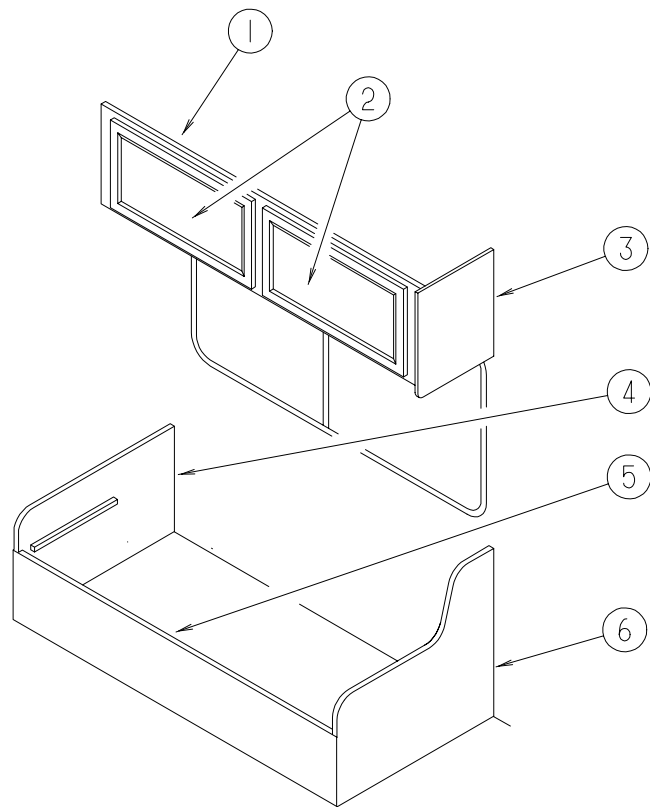

### FRONT DRIVER SIDE CABINET (COUCH)

KEY	PART NUMBER	U/M	DESCRIPTION
1	120402-01-GB1	EA	CABINET ASM-OVHD, LOUNGE, LH
2	110140-65-G01	EA	DOOR ASM.-W/MIRROR-W/O HRDWE-MITERED-VINYL WRAP
2	110140-65-G01	EA	DOOR ASM-MITERED, VINYL WRAP
3	109908-42-GB1	EA	CAP ASM-END, OVHD
4	M04187-92-GD1	EA	CABT-COUCH W/FAB DTL A
4	M04187-92-GE1	EA	CABT-COUCH W/FAB DTL A
5	M04187-91-GD1	EA	CABT-COUCH W/FAB DTL C
5	M04187-91-GE1	EA	CABT-COUCH W/FAB DTL C
6	M04187-93-GD1	EA	CABT-COUCH W/FAB DTL B
6	M04187-93-GE1	EA	CABT-COUCH W/FAB DTL B
	082525-01-000	EA	BRACE-COUCH, FLOOR MOUNT - ANGLE 3" LONG - METAL

## LOUNGE GROUP (CONTINUED)

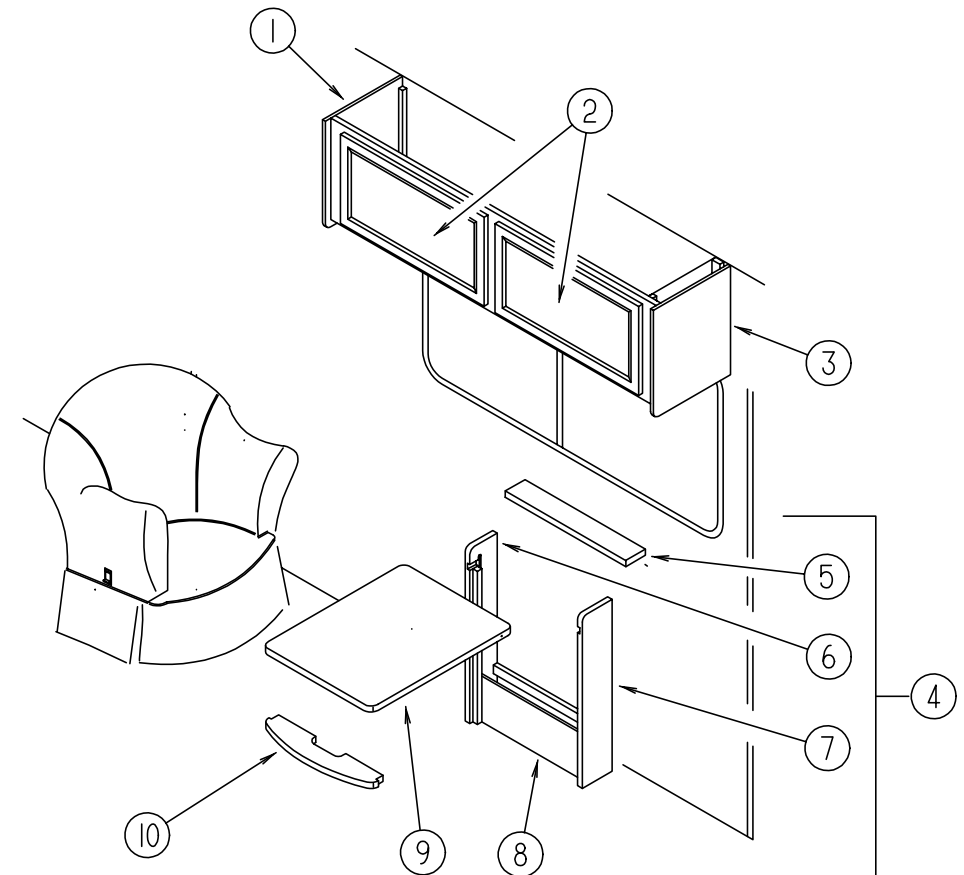

### FRONT DRIVER SIDE CABINET & PULLOUT TABLE

KEY	PART NUMBER	U/M	DESCRIPTION
1	120370-01-GB1	EA	CABINET ASM-OVHD, DINETTE
2	110140-65-G01	EA	DOOR ASM.-W/MIRROR-W/O HRDWE-MITERED-VINYL WRAP
2	110140-05-G01	EA	DOOR ASM-MITERED, VINYL WRAP
3	109908-35-GB1	EA	CAP ASM-END, OVHD
4	M96873-01-G01	EA	CABINET ASM. - TABLE - W/O PULLOUT TOP
5	096873-15-G01	EA	SHELF - SUPPORT - OVER PULL OUT TABLE TOP
6	096873-14-G01	EA	SIDE END - TABLE - 28.7" X 5.7" - LEFT SIDE
7	096873-13-G01	EA	SIDE END - TABLE - 28.7" X 5.7" - RIGHT SIDE
8	096873-16-G01	EA	PANEL - TABLE - FRONT BOTTOM - 18.1" X 6.7"
9	096873-11-G01	EA	PULLOUT TOP
	080736-01-000	EA	PULL - RECESSED - 1.25" X 4" - OAK
	079921-01-000	EA	NYLON ROLLER W/SHAFT
10	096873-12-G01	EA	SHELF - SUPPORT - UNDER PULL OUT TABLE TOP

**LOUNGE GROUP (CONTINUED)**  
**FRONT PASSENGER SIDE CABINET (CHAIR & TABLE)**

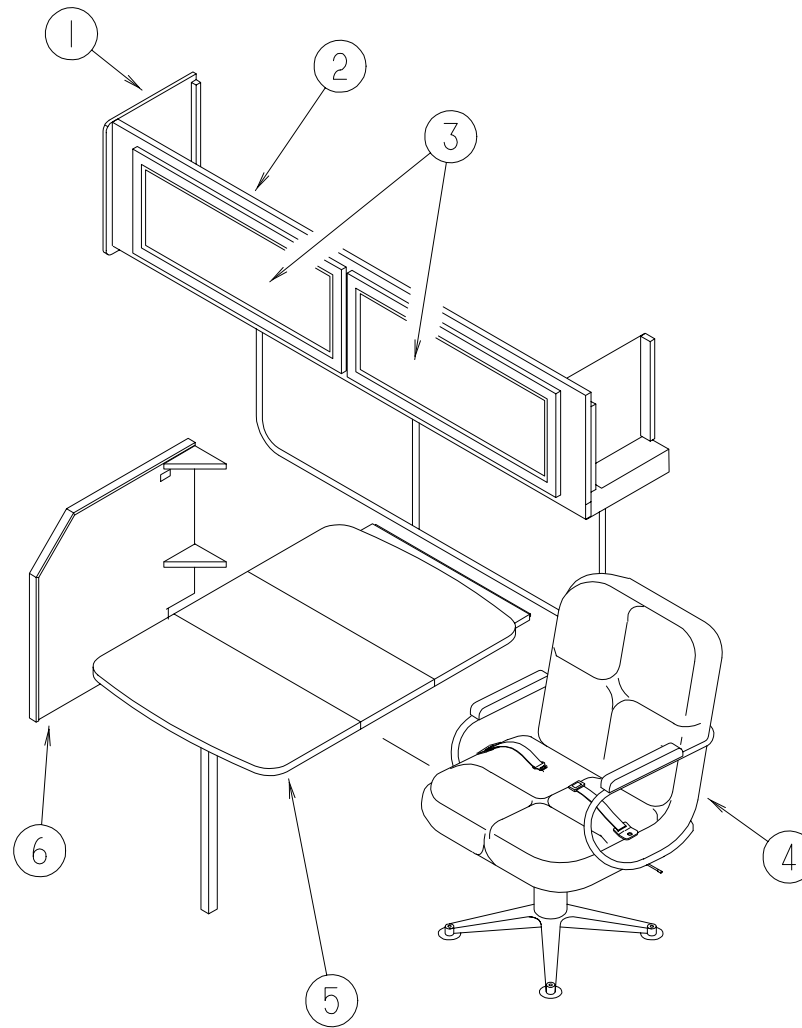

KEY	PART NUMBER	U/M	DESCRIPTION
1	109908-35-GB1	EA	CAP ASM-END,OVHD
2	120370-01-GB1	EA	CABINET ASM-OVHD,DINETTE
3	110140-65-G01	EA	DOOR ASM.-W/MIRROR-W/O HRDWE-MITERED-VINYL WRAP
3	110140-05-G01	EA	DOOR ASM-MITERED,VINYL WRAP
4	119108-01-GD1	EA	CHAIR ASM- 200 KC (GD1)
4	119108-01-GC1	EA	CHAIR ASM- 200 KC (GE1)
5	120498-01-GD1	EA	TABLE ASM-PULLOUT (GD1)
5	120498-01-GC1	EA	TABLE ASM-PULLOUT (GE1)
	092708-10-GB1	EA	LEG ASM-TABLE
	009050-02-000	EA	LEVELER-TABLE TOP
	009050-03-000	EA	LEVELER-TABLE TOP
	102810-01-02A	EA	BRACE-LEG,TABLE, O/W
	102194-01-000	EA	GUIDE-PLASTIC
	110749-01-000	EA	SLIDE-TABLE 19 3/4 LONG
	102200-02-02A	EA	SUPPORT-HINGE LOCK,OFF WHITE
6	120497-01-GB1	EA	CABINET ASM-WALL,STEP
	120497-11-GB1	EA	PANEL
	120497-12-GB1	EA	PANEL

**SEALANTS & FASTENERS GROUP  
ADHESIVE AND FASTENERS**

KEY	PART NUMBER	U/M DESCRIPTION
	002707-02-000	FT TAPE-SEALER, 5/16" X 1/2" - INCREMENTS OF 50 FT
	004020-01-000	QT ADHESIVE-ABS CEMENT, QUART
	034552-06-000	EA SILICONE-TUBE, 300 ML - OFF WHITE - W/O NOZZLE
	900390-03-000	EA NOZZLE SEPARATELY
	034552-15-000	EA SILICONE - TUBE 300 ML BRIGHT WHITE - W/O NOZZLE
	900390-03-000	EA NOZZLE
	053766-08-000	EA BEDDING COMPOUND-TUBE, GRAY - SCHNEE# 5522
	062917-03-000	EA ADHESIVE-LOCTITE 242 - LOCTITE 242,SIDE 41
	063642-01-000	FT TAPE-ADHESIVE, 10 MIL. X 1.5" WIDE X 180"
	067788-01-000	EA ADHESIVE-SPRAY, 3M 74 - 19.5 OZ AEROSOL CAN
	069640-01-000	FT SEALER-RIBBON, 1/4" DIAMETER - INCREMENTS OF 30'
	069640-02-000	FT SEALER-RIBBON, 1/2" X 1/8"- INCREMENTS OF 60'
	069640-03-000	FT SEALER-RIBBON, 3/4" X 1/8" - INCREMENTS OF 60'
	069640-07-000	FT SEALER-RIBBON, 2" X 3/32" - INCREMENTS OF 45'
	069640-09-000	FT SEALER-RIBBON, 1/32" X 2 1/2" - INCREMENTS OF 80'
	069640-14-000	FT SEALER-TAPE,1/16"X1"X100' - MANUS,GRAY
	072889-01-000	EA SEALANT-URETHANE, BLACK - 1/10 - ESSEX 552.2
	072889-09-000	EA SEALANT-URETHANE(TUBE) BLACK - MANUS 75AM
	076322-02-000	FT TAPE-FOAM, DOUBLE COATED ADHESIVE BACKED - 1" X 108'
	087211-01-000	GL PROMOTER-ADHESIVE
	091255-02-000	FT SEAL-ADHESIVE BACKED FOAM, .18" THICK X 1.5" WIDE
	102352-01-000	EA SEALER-PUMPABLE, BLACK - COLORIMETRIC MS101
	106206-01-000	EA SEALER-PUMPABLE - MANUS 30ABLACK
	108353-01-000	FT SEAL-FOAM,5/16X1/2,ADH BACK - LUNDELL #4773/1129
	110274-01-000	FT TAPE-FOAM,DBL COATED.045X1.0 - NORTON V-2800
	120074-01-01A	EA SILICONE TUBE - OFF WHITE W/O NOZZLE
	900390-03-000	EA NOZZLE

**BOLTS, NUTS & WASHERS**

KEY	PART NUMBER	U/M DESCRIPTION
	000C12-05-16B	EA BOLT-HEX, 5/16-18 X 1 - ZINC 5
	000C12-05-12B	EA BOLT-HEX-5/16-18 X 3/4 ZN 5
	000C12-06-16B	EA BOLT-HEX-3/8-16X1LG,ZN 5
	000C12-07-20B	EA BOLT-HEX, 7/16 - 14 X 1 1/4" - ZN5
	000C12-08-24B	EA BOLT-HEX, 1/2-13 X 1 1/2 - ZN 5
	000C12-09-20B	EA BOLT-HEX,9/16-12X1 1/4,ZN 5
	000C12-10-24B	EA BOLT-HEX, 5/8-11 X 1 1/2 ZN - 5
	000C13-07-24B	EA BOLT-HEX,7/16-20X1 1/2 GR 5
	000C13-07-48B	EA BOLT-HEX, 7/16 - 20 X 3 - ZN 5
	000C26-04-18B	EA BOLT-HEX-SER FLG 1/4-20X11/8 - ZN
	000C26-04-10B	EA BOLT-HEX, SER FLG - 1/4-20 X 5/8 ZINC
	000C26-05-16B	EA BOLT-HEX-SER FLG 5/16-18 X 1 - ZINC
	000C26-05-12B	EA BOLT-HEX-SER FLG 5/16-18 X 3/4 - ZN
	000C26-06-28B	EA BOLT-HEX-SER FLG 3/8-16X13/4 - ZN
	000D24-10-00B	EA NUT-HEX, SF/LK - 10-32 ZN
	000D29-05-00B	EA NUT-5/16-18 UNC,SF/LOCKING - NYLON WASHER INSERT
	000D29-09-00B	EA NUT-HEX SELFLOCK 9/16-12 ZN
	000D39-04-00B	EA NUT-HEX, SER FLG LK 1/4 - 20 ZN
	000D39-05-00B	EA NUT-HEX, SER FLG LK - 5/16 - 18 ZN
	000D39-06-00B	EA NUT-HEX, SER FLG LK - 3/8-16 ZN
	000D39-08-00B	EA NUT-HEX, SER FLG LK - 1/2-13 ZN
	000D44-07-00B	EA NUT-HEX, SER FLG LK - 7/16-20 ZN
	000D46-04-00A	EA NUT-HEX,WELD,1/4-20,PLAIN - SHORT PILOT
	000E11-07-00B	EA WASHER-LK-7/16 MED SPLIT ZN
	000E13-14-00B	EA WASHER-FL, 1/4" WIDE ZN
	000E13-18-00B	EA WASHER-FL-3/8 WIDE ZN
	000E13-20-00B	EA WASHER-FL, 7/16" WIDE - ZN
	040921-04-000	EA NUT-SPEED, U TYPE - NO. 8 - .59" LENGTH X .44" WIDTH
	044364-02-000	EA NUT-SPEED, FLAT - ROUND
	051387-06-000	EA BOLT-CARRIAGE, W/O HOLE - 5/16-18 X 9.5 ZN
	058716-02-000	EA WASHER-FLAT NYLON - .406 X .750 X .060
	063253-07-000	EA NUT-J, #8A .120- .130 PNL THK
	087234-01-000	EA NUT-JACK,1/4X20THD,MOLLY-ARDEN 8-L,JN BRASS MOUNTS LICENSE PLATES
	104369-01-000	EA NUT-HEX,HEAVY,5/8-11 UNC
	106166-01-000	EA BOLT-COLLARED HANGER - 8-32 X 1"
	106649-01-000	EA WASHER-SEALING,GALVANIZED - 92 F-SERIES 5/8 ID
	108067-03-000	EA STUD-WELD,1/4-20X1/2 CD - IMAGE
	110794-01-000	EA WASHER-FL-1ID X 13/4OD - C-TECH 36T1043187

**SEALANTS & FASTENERS GROUP (CONTINUED)  
SCREWS**

KEY	PART NUMBER	U/M DESCRIPTION
	0G3908-08-170	EA SCREW-SF/DR-8-18 X 1/2PPH - BRIGHT WHITE
	0G6710-08-170	EA SCREW-10-12 X 1/2 PPH,BRT WHT - TYPE A
	000G11-05-08B	EA SCREW-5-20 X 1/2 PPH ZN
	000G11-06-08B	EA SCREW-6-20 X 1/2 PPH ZINC
	000G11-06-06B	EA SCREW-6-20 X 3/8 PPH ZN
	000G11-06-10J	EA SCREW, 6-20 X 5/8 PPH - BRASS
	000G11-07-08B	EA SCREW, 7-19 X 1/2 PPH - ZN
	000G11-08-08B	EA SCREW, 8-18 X 1/2 PPH - ZN
	000G11-08-06B	EA SCREW, 8-18 X 3/8 PPH ZN
	000G11-08-20B	EA SCREW-8-18 X 11/4 PPH ZN
	000G11-08-16S	EA SCREW, 8-18 X 1.00 PPH - OFF WHITE
	000G11-08-12T	EA SCREW, 8-18 X 3/4 PPH - BLACK
	000G11-08-12S	EA SCREW, 8-18 X 3/4 PPH - OFF WHITE
	000G11-08-12P	EA SCREW, 8-18 X .75 PPH - DARK BROWN
	000G11-08-12D	EA SCREW, 8-18 X 3/4 PPH - BLACK
	000G11-08-12B	EA SCREW, 8-18 X 3/4 PPH ZN
	000G11-08-08T	EA SCREW, 8-18 X 1/2 PPH
	000G11-10-40B	EA SCREW-10 - 16 X 2 1/2 PPH CAD - 34927-01-000
	000G11-10-16B	EA SCREW, 10-16 X 1 - PPH ZN
	000G11-10-12S	EA SCREW-10-16 X .75 PPH OFF WHT
	000G13-06-08B	EA SCREW, 6-20 X 1/2 PFH ZN
	000G13-06-24J	EA SCREW-6-20 X 1.50 PFH BRASS
	000G13-06-16J	EA SCREW, 6-20 X 1.00 PFH - BRASS
	000G13-07-12B	EA SCREW, 7-19 X 3/4 PFH ZN
	000G13-08-10B	EA SCREW-8-18 X 5/8 PFH ZN - 90 CW922FV
	000G19-10-20B	EA SCREW-MACHINE, 10-32 X 1 1/14 PPH ZINK
	000G19-10-08B	EA SCREW-MACHINE, 10-32 X 1/2 PPH ZN
	000G39-06-08B	EA SCREW-DR-6-18 X 1/2 ZN
	000G39-06-10T	EA SCREW-SF/DR, 6-20 X 5/8 PPH - BLACK
	000G39-06-10T	EA SCREW-SF/DR, 6-20 X 5/8 PPH - BLACK
	000G39-08-08T	EA SCREW-SF/DR-8-18X.50 PPH - BLACK
	000G39-08-08S	EA SCREW-SF/DR, 8-18 X 1/2 PPH - OFF WHITE
	000G39-08-08B	EA SCREW-SF/DR, 8-18 X 1/2 PPH ZN
	000G39-08-24B	EA SCREW-SF/DR, 8-18 X 1 1/2 PPH ZN
	000G39-08-16T	EA SCREW-SF/DR, 8-18 X 1 PPH - BLACK
	000G39-08-16R	EA SCREW-SF/DR 8-18 X 1.00 PPH BEIGE
	000G39-08-16B	EA SCREW-SF/DR, 8-18 X 1 PPH ZN
	000G39-08-12B	EA SCREW-SF/DR, 8-18 X 3/4 PPH ZN
	000G39-10-12D	EA SCREW-SF/DR, 10-16 X 3/4 PPH - BLACK
	000G39-10-12B	EA SCREW-SF/DR,10-16 X .75 PPH ZN
	000G39-10-08B	EA SCREW-SF/DR 10-16 X .50 P&H - ZINC
	000G39-10-48T	EA SCREW-SF/DR-10-16X3.00 PPH - BLACK-FLUROCARBON
	000G39-10-20B	EA SCREW-SF/DR, 10-16 X 1 1/4 PPH ZN
	000G42-04-12B	EA SCREW-SF/DR 1/4-14 X 3/4HWH ZN
	000G46-08-24T	EA SCREW-MACHINE, 8-32-1.50 IN PFH - BLACK
	000G50-04-12B	EA SCREW-MACH, 1/4-20 X 3/4 PPH ZN
	000G51-08-08B	EA SCREW-8-18 X 1/2 PTH ZN
	000G52-08-18B	EA SCREW-MACH-8-32 X 11/8 PTH ZN
	000G54-04-20B	EA SCREW, 1/4-20 X 1 1/4 PTH - TYPE 23 - ZINC PLATED
	000G55-08-12S	EA SCREW-SF/DR-8-18 X .75 PWH - *OFF WHITE
	000G56-12-48B	EA SCREW-WOOD, 12 - 11 X 3 POH - SPECIAL HARDENED
	000G57-10-16B	EA SCREW-10-13 X 1 PFH ZN
	000G60-10-28T	EA SCREW-SF/DR, 10-16 X 1.75 - BLACK
	000G67-08-32B	EA SCREW-8-15 X 2 PPH ZN
	000G67-10-10B	EA SCREW, 10-12 X 5/8 PPH ZN - TYPE A
	000G67-10-08B	EA SCREW, 10-12 X 1/2 PPH ZN
	000G67-10-36T	EA SCREW-10-12 X 2.25PPHBLACK - STALGARD
	000G67-10-24B	EA SCREW, 10-12 X 1 1/2 PPH - ZN
	000G67-10-20D	EA SCREW, 10-12 X 1 1/4 PPH - BLACK
	000G67-10-120	EA SCREW, 10-12 X .75" PPH - TAN
	000G67-10-120	EA SCREW, 10-12 X .75" PPH - TAN
	000G67-10-12P	EA SCREW, 10-12 X .75" - PPH - DARK BROWN
	000G67-10-12B	EA SCREW, 10-12 X 3/4" PPH - ZN

**SEALANTS & FASTENERS GROUP (CONTINUED)**  
**SCREWS CONTINUED**

KEY	PART NUMBER	U/M DESCRIPTION
	000G67-10-10S	EA SCREW, 10-12 X 5/8" - PPH - OFF WHITE
	000G67-10-10P	EA SCREW-10-12 X .62 PPH - DARK BROWN
	000G67-10-10P	EA SCREW-10-12 X .62 PPH - DARK BROWN
	000G67-10-10D	EA SCREW, 10-12 X 5/8 PPH - BLACK - TYPE A
	000G68-06-10G	EA SCREW, 6-18 X 5/8 POH - ANTIQUE BRASS
	075908-01-000	EA SCREW-MACHINE, 10-32 X .56 PTH - ZINC EXTERNAL TOOTH
	079382-01-000	EA SCREW-SOCKET, 8-18 X 1" - BLACK
	097974-01-000	EA SCREW-PART BD 7-9 X .75 PPH - FHM 0543 PLAIN
	101618-01-000	EA SCREW-1/4-20 X 3/4 HEX/TAPPING - STALGARD TYPE F
	116111-02-01A	EA SCREW-TAPTITE-1/4-20 X 3/8 PPH - *ZINC
	117322-01-000	EA SCREW-1/4-28UNF-2A,TORX - U.T. 6270020 SC25WJ

**CLAMPS, GROMMETS AND FASTENERS**

KEY	PART NUMBER	U/M DESCRIPTION
	000H16-06-10R	EA RIVET-POP-AL 3/16 X .501-.625
	007161-01-000	EA CLAMP-HOSE, SPRING TYPE - 1/2"
	010495-01-000	EA CLAMP-CABLE, 9/16"
	010495-02-000	EA CLAMP-CABLE, 3/8~
	010497-01-000	EA CLAMP-CLOSED, 5/8" ID
	010497-03-000	EA CLAMP-CLOSED, 1" ID - CUSHIONED
	010497-04-000	EA CLAMP-CLOSED, 1.62 ID - ADEL,945-2717
	010499-01-000	EA CLAMP-CLOSED, 3/8" ID
	016188-05-000	EA GROMMET-L/P LINE, 3/8" HOLE X 1 1/4" LONG - RUBBER
	023942-01-000	EA GROMMET-RUBBER, 2" OD
	062401-02-000	EA CLAMP-HOSE, WORMGEAR, 1.56" - 2.5"
	062401-03-000	EA CLAMP-HOSE, WORMGEAR - .22"- 1"
	062401-04-000	EA CLAMP-HOSE, WORMGEAR .69"- 1.25"
	062401-05-000	EA CLAMP-HOSE, WORMGEAR - 2" X 3"
	062401-06-000	EA CLAMP-HOSE, WORMGEAR .22"-.62"
	062401-11-000	EA CLAMP-HOSE, WORMGEAR 3.56"- 4.5"
	071015-11-000	EA GROMMET-1.00ID,FITS .12 MATL - MINOR RUBBER Z-3065
	075148-02-000	EA CLAMP-GROUNDING, BRONZE SCREWS
	077955-01-000	EA CLIP-J,VINYL COATED, 3/8"
	080734-02-000	EA CLIP-WIRE, NYLON
	083609-01-000	EA CLAMP-WIRE, DUAL EQUAL - 5/8" DIAMETER
	083610-01-000	EA CLAMP-WIRE, DUAL - UNEQUAL DIAMETERS - .75" & 1.25"
	094362-02-000	EA CLIP-CHRISTMAS TREE, FLAT HEAD - .5" X .95"

**TIES & VELCRO**

KEY	PART NUMBER	U/M DESCRIPTION
	008343-01-000	EA TIE-WIRE, 6"
	008343-02-000	EA TIE-WIRE, 14"
	029094-04-000	YD VELCRO TAPE-LOOP, 1" WIDE - BLACK
	029096-03-000	YD VELCRO TAPE-HOOK, 1" WIDE - BLACK
	029096-04-000	YD TAPE-HOOK, VELCRO - 1" WIDE - BLACK
	072889-10-000	EA SEALANT-URETHANE(TUBE)BRTWHT - MANUS 75AM
	108046-02-000	EA CABLE TIE-SCREW MOUNT 15" - DENNISON 10035

**WATER & SEWAGE GROUP**

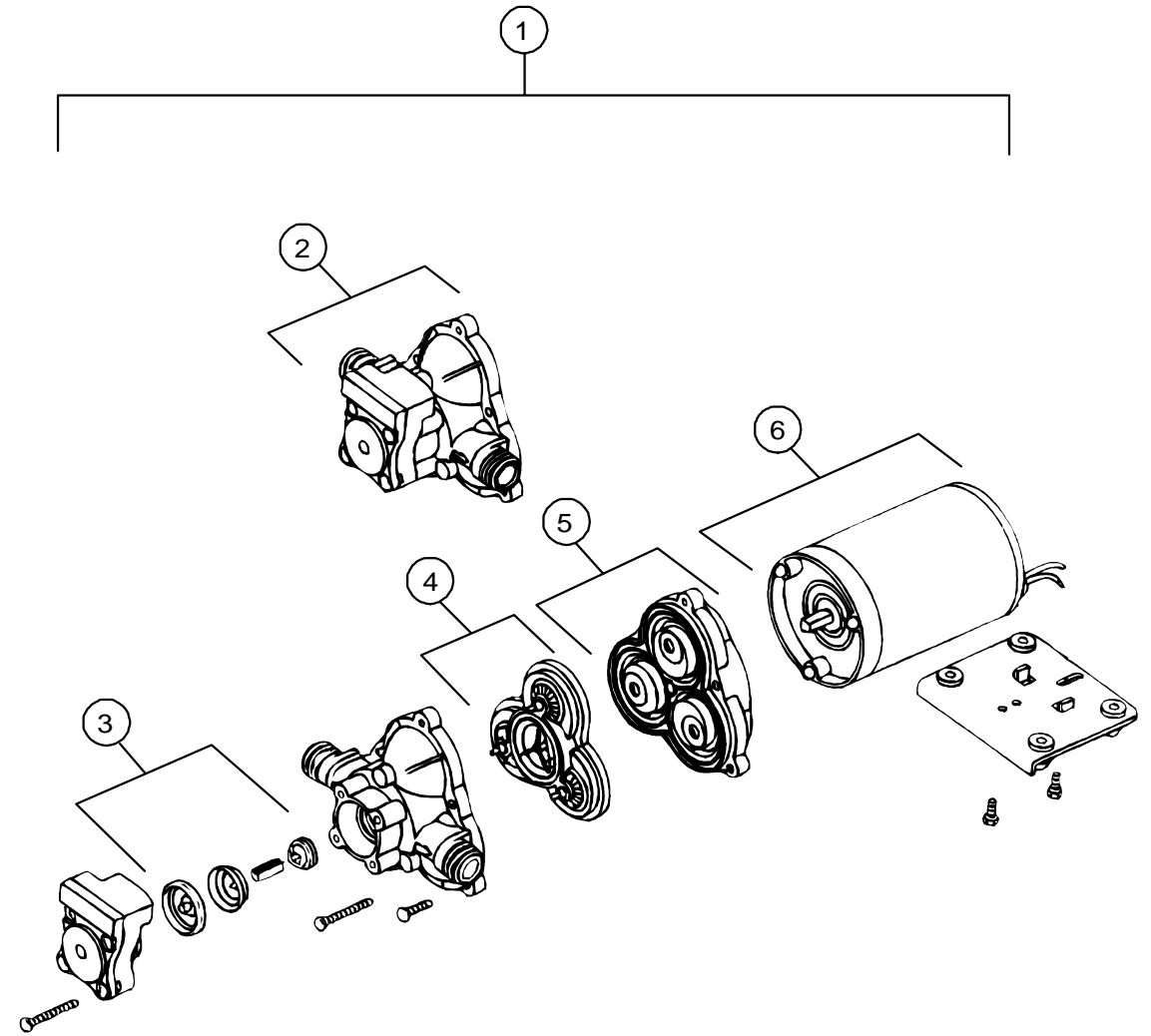

**WATER PUMP**

KEY	PART NUMBER	U/M DESCRIPTION	VENDOR NO.
1	098607-01-000	EA PUMP-WATER, W/.5" MPT FITTING - FLOW 2.8 GPM - UL	
2	098607-01-706	EA HOUSING, W/SWITCH ONLY	94-231-20
3	098607-01-705	EA VALVE-CHECK, KIT	94-237-00
4	098607-01-703	EA VALVE KIT	94-232-00
5	098607-01-702	EA DIAPHRAGM/DRIVE ASSEMBLY KIT	94-238-04
6	098607-01-707	EA MOTOR W/BASEPLATE	11-148-04

**WATER & SEWAGE GROUP (CONTINUED)**

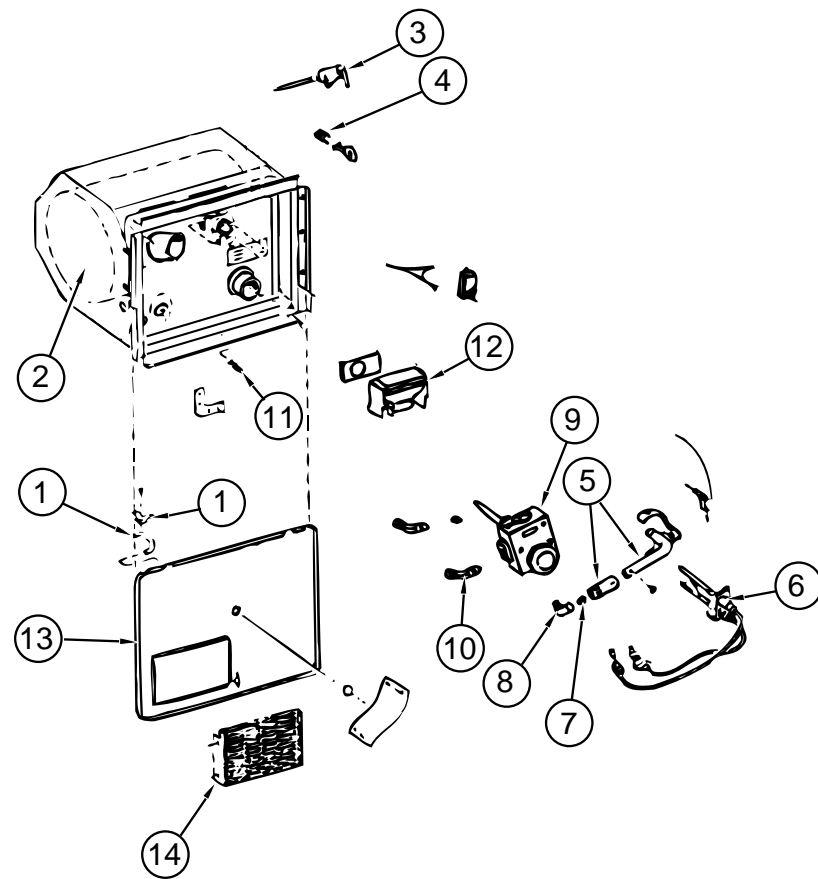

**WATER HEATER W/MOTOR AID ATWOOD G6A-7**

KEY	PART NUMBER	U/M DESCRIPTION	VENDOR NO.
	051391-01-000	EA HEATER-WATER, ATWOOD G6A-7	
1	051391-01-700	EA HINGE KIT, (PIN & CLIP)	92568&92559
2	051391-01-702	EA TANK-INNER F/G6A-2E-3E-6E	91412
3	051391-01-704	EA VALVE-RELIEF, 1/2" FITTING	91604
4	051391-01-705	EA FASTENER-CAMLOCK	92609
5	051391-01-708	EA BURNER-MAIN	92615
	051391-03-700	EA HOLDER-ORIFICE	91563
6	051391-01-709	EA PILOT ASM. W/THERMOCOUPLER	91603
7	051391-01-710	EA ORIFICE-MAIN BURNER	92742
8	051391-01-711	EA ELBOW-ORIFICE,MAIN BURNER	92741
9	051391-01-712	EA THERMOSTAT-3/8"NPT INLET	91601
10	051391-01-714	EA FITTING-ELBOW 45,3/8F X 3/8	MPT 1044
11	051391-01-715	EA PLUG-DRAIN, 1 EA = 2 PER PKG	91857
	051391-04-703	EA BURNER-MAIN	91638
12	051391-04-707	EA KIT-EXHAUST, (FLUE & GASKET)	90960
13	052009-06-000	EA DOOR-WATER HEATER, BRIGHT WHITE	
14	051391-01-717	EA GRILLE-WATER HEATER DOOR	92640
	051391-01-716	EA GRILL ONLY (GOES ON FLUE BOX)	91786

**WATER & SEWAGE GROUP (CONTINUED)**  
**WATER SYSTEM**

KEY	PART NUMBER	U/M DESCRIPTION
	039861-01-000	EA SENDING UNIT-W/SCREW, WASHER, WELL NUT & TERMINAL RING
	010219-01-000	EA ELBOW-1 1/4" MPT X 1 1/4" BARB, WATER FILL - PLASTIC
	035539-01-000	EA ELBOW-PLASTIC, 3/8"MPT X 3/8"BARB
	074462-02-000	FT TUBING-VINYL, 3/8" ID X 20' - CLEAR
	077954-02-000	EA FILTER-WATER TANK, SCREEN IN TANK
	079381-01-000	FT TUBING-SMOOTH FLEXIBLE, 1 3/8" ID X 20'
	114430-03-000	EA ADAPTER-1/2P X 1/2MPT - FLAIR-IT 02842
	116700-03-000	EA TANK - WATER 59 GALLONS W/FITTINGS
	042989-03-000	EA FITTING-WATER TANK, SPINWELD - 1 1/4"NPT - PLASTIC - WHITE
	042989-04-000	EA FITTING-WATER TANK, SPINWELD - 3/8" FPT - PLASTIC - WHITE
	042989-05-000	EA FITTING-WATER TANK, SPINWELD - 1/2" FPT - PLASTIC - WHITE
	049032-01-000	EA PATCH-SPINWELD, 3/8" - PLASTIC
	116700-01-000	EA TANK - WATER - 59 GALLONS W/O FITTINGS
	010230-05-000	EA CITY WATER FILL W/CHECK VALVE
	039800-02-000	FT TUBING-POLYBUTYL, 5/8" OD - INCREMENTS OF 20' - BLACK
	110915-01-01A	EA FILL-WATER, CITY - CHROME - KEVCO 64713
	114428-01-000	EA TEE-1/2P X 1/2P X 1/2P - FLAIR-IT 02820
	114428-02-000	EA TEE-SWIVEL,1/2PX1/2PX1/2FPT - FLAIR-IT 02821
	114429-01-000	EA ELBOW-1/2P X 1/2P - FLAIR-IT 02800
	114429-02-000	EA ELBOW-1/2P X 1/2MPT - FLAIR-IT 02803
	114429-03-000	EA ELBOW- FLAIR-IT SWIVEL 1/2"P X 1/2"FPT
	114430-02-000	EA ADAPTER-SWIVEL,1/2P X 1/2FPT - FLAIR-IT -02873
	114431-03-000	EA WATER VALVE - 90 DEGREE ELBOW - "WATER DRAIN VALVE"
	114431-04-000	EA WATER VALVE - STRAIGHT THRU - "SHUT OFF VALVE"

**WATER TANK**

KEY	PART NUMBER	U/M DESCRIPTION
	116700-01-000	EA TANK - WATER - 59 GALLONS W/O FITTINGS
	116700-03-000	EA TANK - WATER 59 GALLONS W/FITTINGS
	039861-01-000	EA SENDING UNIT-W/SCREW - WASHER, WELL NUT, & TERMINAL RING
	049032-01-000	EA PATCH-SPINWELD - 3/8" - PLASTIC
	042989-03-000	EA FITTING-WATER TANK - SPINWELD - 1 1/4"NPT - PLASTIC - WHITE
	042989-04-000	EA FITTING-WATER TANK - SPINWELD - 3/8" FPT - PLASTIC - WHITE
	042989-05-000	EA FITTING-WATER TANK - SPINWELD - 1/2" FPT - PLASTIC - WHITE
	077954-02-000	EA FILTER-WATER TANK - SCREEN IN TANK



# WATER & SEWAGE GROUP (CONTINUED)

## DRAINAGE SYSTEM

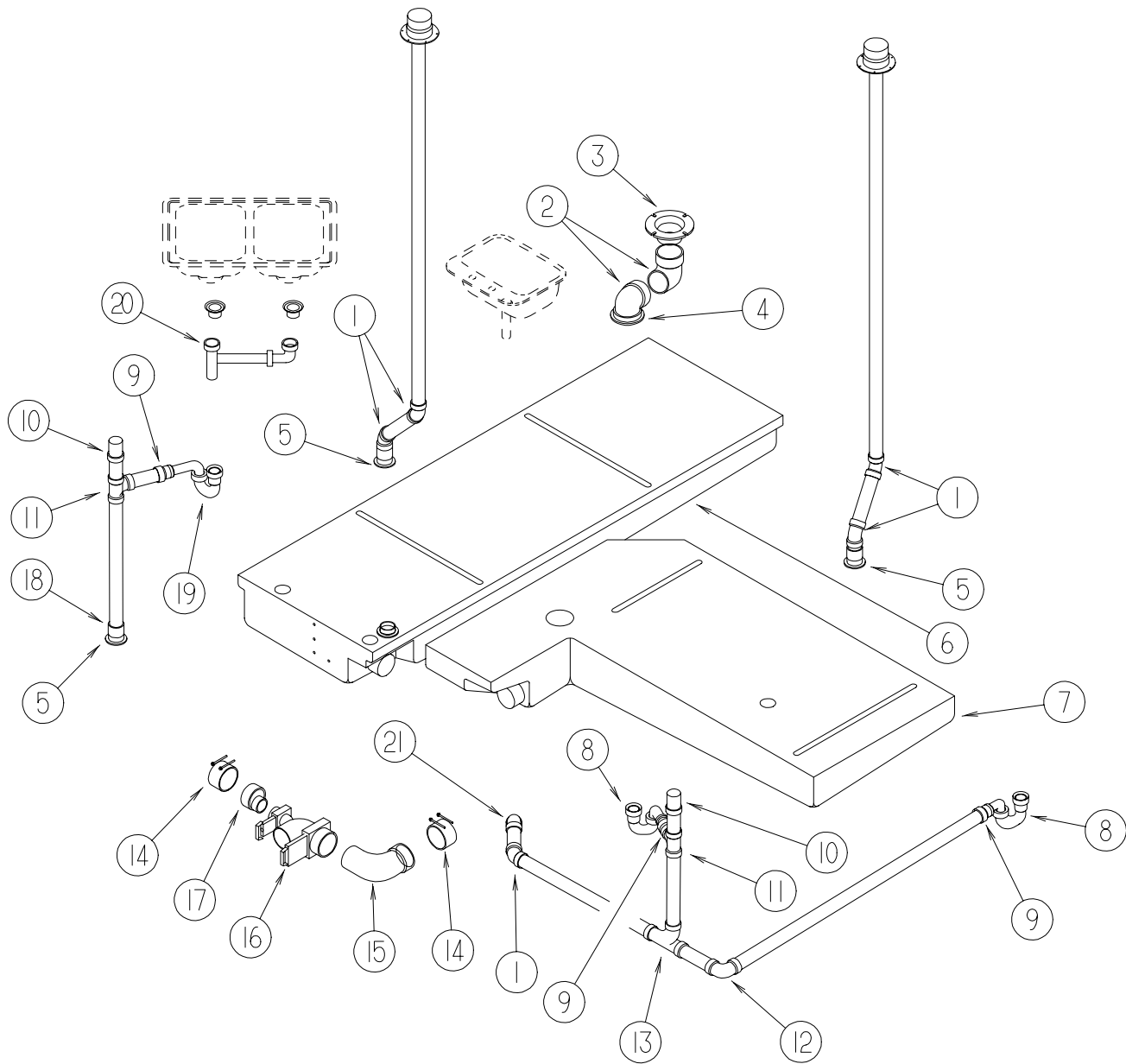

KEY	PART NUMBER	U/M	DESCRIPTION
1	010006-01-000	EA	ELBOW-45 DEG, 1/8 BEND - 1 1/2" HUB X HUB - BLACK PLASTIC
2	010061-01-000	EA	ELBOW-45 DEGREE, STREET - 1/8 BEND - 3" S X H - PLASTIC
3	063641-01-000	EA	FLANGE-CLOSET, 4" X 3"
3	116644-01-000	EA	FLANGE - CLOSET, 4" X 3"
4	061607-02-000	EA	GROMMET-HOLDING TANK, 3" NPS
5	061607-01-000	EA	GROMMET-HOLDING TANK, 1 1/2" NPS
6	104352-01-000	EA	TANK-HOLDING, 50 GALLON (GRAY)
7	112789-01-000	EA	TANK-HOLDING - 46 GALLON W/O FITTINGS
	010071-01-000	EA	TEE-SANITARY, 1 1/2" HUB X HUB X HUB - PLASTIC - BLACK
	010115-01-000	EA	COUPLING-1 1/2" HUB X HUB, PLASTIC
8	011066-02-000	EA	P TRAP-1 1/4" HUB X SLIP JOINT, W/UNION - ABS - CANADIAN N/A USE P.N.#01106603700 P-TRAP KIT
8	107538-01-000	EA	P TRAP-PLAS 1 1/4 W/EXT ARM - KEVCO P814 1-1/4"
9	109571-01-000	EA	ADAPTER-P TRAP, 1 1/2" P X 1 1/4" MPT
10	079968-01-000	EA	VENT-MECH. TRAP ARM, ANTI-SIPHON - 2" DIA X 7.3" - PLASTIC
11	010071-01-000	EA	TEE-SANITARY, 1 1/2" HUB X HUB X HUB - PLASTIC - BLACK
12	010008-01-000	EA	ELBOW-90 DEG, 1/4 BEND - 1 1/2" HUB X HUB - BLACK PLASTIC
			FROM: 00-00-00 THRU: 11-21-95
12	033761-01-000	EA	ELBOW-TURN, 1/4 BEND X 1.5"HUB X 1.5"SPIGOT - BLK PLASTIC
			FROM: 11-22-95 THRU: 99-99-99
13	031365-02-000	EA	TEE-PLAS,1 1/2 EXT LG TURN - NIBCO 5812-LR-11/2
			FROM: 11-25-95 THRU: 99-99-99
14	078406-01-000	EA	COUPLER-RUBBER, W/CLAMPS - 3" X 3"
15	041956-01-000	EA	ELBOW-STREET, PLASTIC - 1/4 BEND - 3" X 90 XLT
16	070916-01-000	EA	VALVE-DUAL DUMP, W/CAP - 3" X 1 1/2" - PLASTIC - BLACK
	070916-01-700	EA	VALVE ONLY (WASTE) 3" T1003BU
	070916-01-701	EA	VALVE ONLY (WASTE 1 1/2" ) T1001BU
	109571-01-000	EA	ADAPTER-P TRAP, 1 1/2" P X 1 1/4" MPT
	069735-01-000	EA	WASHER-STRAINER TO TAILPIECE PLASTIC, 1.5"
17	062422-01-000	EA	ADAPTER-OFFSET REDUCER, 3" X 1 1/2" - PLASTIC - BLACK
18	010115-01-000	EA	COUPLING-1 1/2" HUB X HUB, PLASTIC
19	011071-01-000	EA	P TRAP-PLAS 1 1/2 - NIBCO 5892 1 1/2
19	107538-01-000	EA	P TRAP-PLAS 1 1/4 W/EXT ARM - KEVCO P814 1-1/4"
	011069-04-000	EA	TAILPIECE, 1 1/2 X 1 1/4 X 8 - BRASS
20	011091-05-000	EA	WASTE-CONT,DBL SINK - J&B PRODUCTS
			FROM: 11-25-95 THRU: 02-11-96
20	011091-02-000	EA	PIPE-DRAIN, DOUBLE SINK - BAFFLE TEE - 1 1/2"
			ONE PIPE W/TEE TO DRAIN BOTH SIDES OF SINK
			FROM: 02-12-96 THRU: 99-99-99
21	033761-01-000	EA	ELBOW-TURN, 1/4 BEND X 1.5"HUB X 1.5"SPIGOT - BLK PLASTIC

**WINDOW, VENT & EXTERIOR DOOR GROUP**

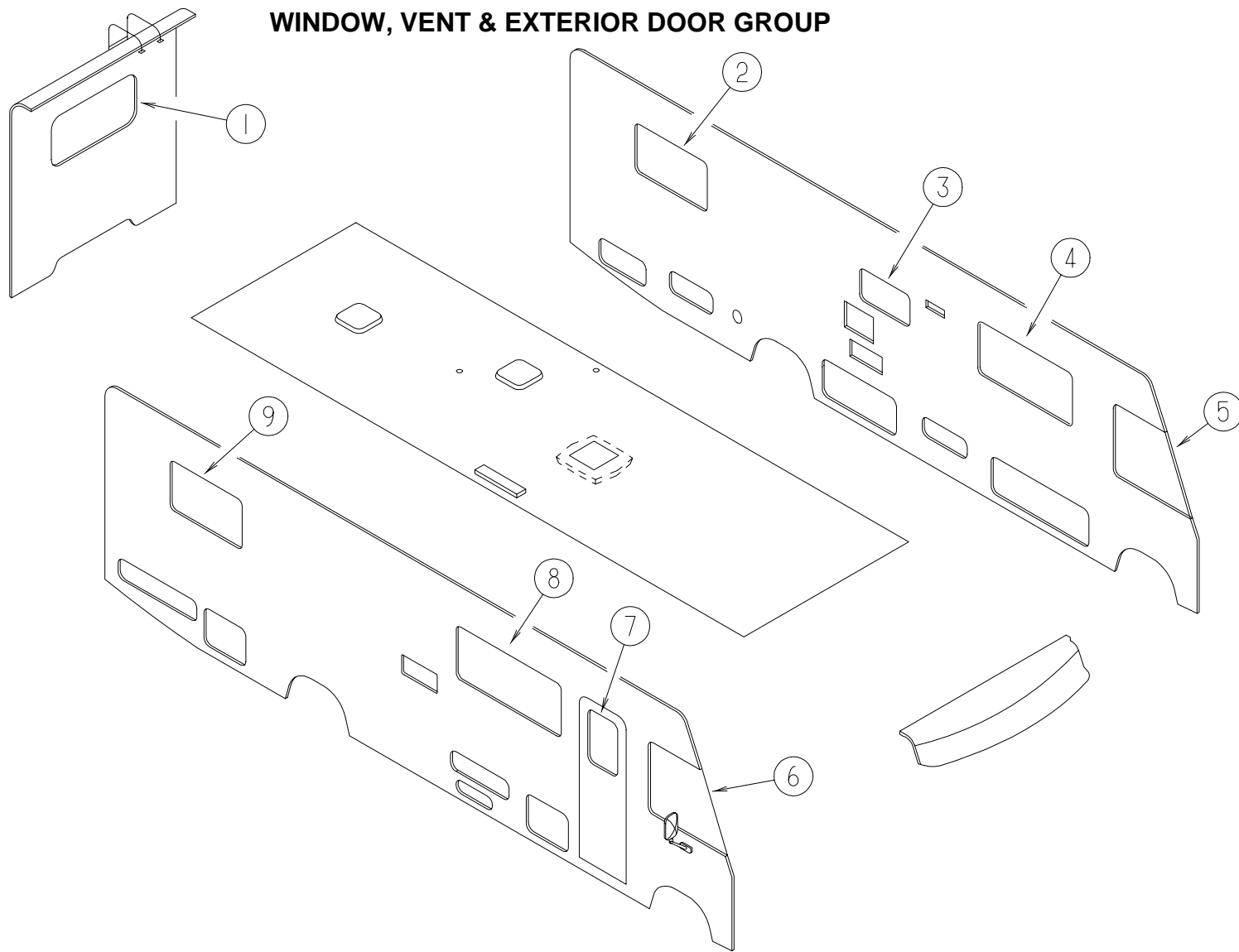

**EXTERIOR WINDOWS**

KEY	PART NUMBER	U/M	DESCRIPTION
1	078528-07-FB1	EA	WINDOW-ESCAPE W/O INSIDE TRIM - CLEAR - 48.5" X 24.5"
1	116976-01-01A	EA	WINDOW-REAR ESCAPE 26.4" X 26.25"
2	098647-30-01A	EA	WINDOW-DRIVERS HORIZONTAL SLIDER - CLEAR - 24.2" X 41"
2	098647-32-01A	EA	WINDOW-DRIVERS HORIZONTAL SLIDER - CLEAR - 15.7" X 28.5"
3	098647-32-01A	EA	WINDOW-DRIVERS HORIZONTAL SLIDER - CLEAR - 15.7" X 28.5"
4	098647-36-01A	EA	WINDOW-DRIVERS HORIZONTAL SLIDER - CLEAR - 26.1" X 53.8"
5	103658-09-01A	EA	WINDOW ASM-CAB - DRIVER
6	103658-10-01A	EA	WINDOW ASM-CAB - PASSENGER
7	117053-04-FB1	EA	WINDOW-PICTURE 17" X 26.4"
	117054-02-02A	EA	RETAINER - TRIM, BRIGHT/WHITE
8	098647-27-01A	EA	WINDOW-PASSENGER HORIZONTAL SLIDER - CLEAR - 26.1" X 59.7"
9	098647-29-01A	EA	WINDOW-PASSENGER HORIZONTAL SLIDER - CLEAR - 24.2" X 41"
9	098647-31-01A	EA	WINDOW-PASSENGER HORIZONTAL SLIDER - CLEAR - 15.7" X 28.5"

**WINDOW, VENT & EXTERIOR DOOR GROUP (CONTINUED)**

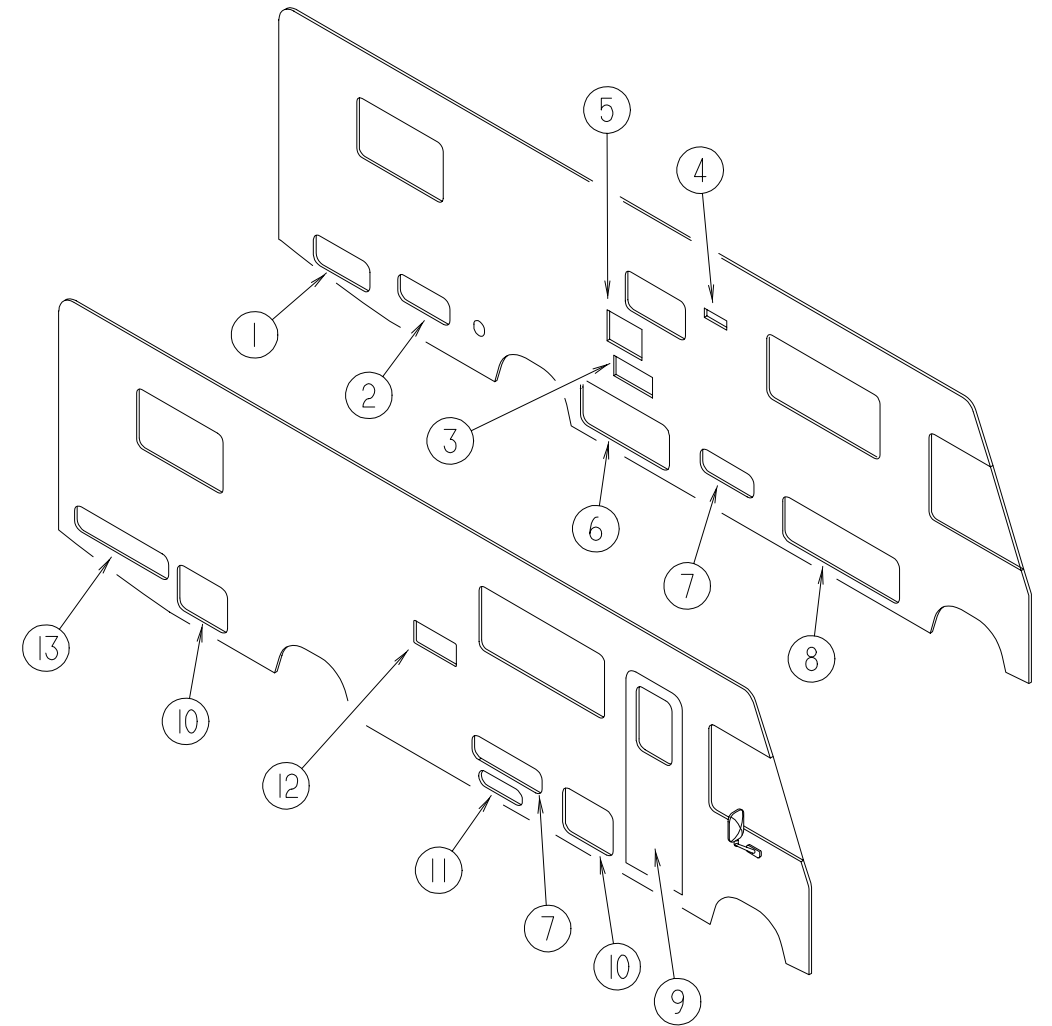

**EXTERIOR DOORS & VENTS**

KEY	PART NUMBER	U/M	DESCRIPTION
1	104558-31-FB1	EA	DOOR ASM-STORAGE
	107997-51-001	EA	SPACER-.86" X .6", ALUMINUM
2	104558-30-FB1	EA	DOOR ASM-STORAGE
3	052009-06-000	EA	DOOR-WATER HEATER - ATWOOD 5576-27 - BRIGHT WHITE
4	103385-01-02A	EA	VENT-RANGE HOOD, OUTSIDE - BRIGHT WHITE - VENTLINE
5	098668-23-000	EA	DOOR - FURNACE - BRIGHT WHITE - SUBURBAN 520574
6	104558-32-GB1	EA	DOOR-STORAGE W/RADIUS CORNERS 42" X 18.1"
			FROM: 00-00-00 THRU: 01-01-96
6	104558-52-GB1	EA	DOOR-STORAGE W/RADIUS CORNERS 42" X 17.6"
			FROM: 01-02-96 THRU: 99-99-99
7	104558-29-FB1	EA	DOOR ASM - STORAGE
	104564-16-02A	EA	JAMB-DOOR - STORAGE - BRIGHT WHITE
8	104558-24-FB1	EA	DOOR ASM-STORAGE
9	115108-06-GD1	EA	DOOR - ENTRY, W/SCREEN DOOR - W/O WINDOW
9	115108-06-GE1	EA	DOOR - ENTRY, W/SCREEN DOOR - W/O WINDOW
10	104558-26-FB1	EA	DOOR ASM-STORAGE
11	111009-01-GB1	EA	DOOR - COMPARTMENT - LP - 16.9" X 5.4" - ALUMINUM - BRIGHT WHITE
12	084103-08-000	EA	DOOR-REFRIGERATOR - VENTED - W/O JAMB - BRIGHT WHITE
	084104-08-000	EA	JAMB-DOOR - REFRIGERATOR - BRIGHT WHITE
	084104-01-700	EA	LOCK-MALE - FASTENER - REFRIGERATOR DOOR
	084104-01-701	EA	LOCK-FEMALE - FASTENER - REFRIGERATOR DOOR
13	104558-42-GB1	EA	DOOR ASM-STORAGE
	081240-16-000	EA	DOOR-WATER FILL - LOCKABLE - BRIGHT WHITE

# WINDOW, VENT & EXTERIOR DOOR GROUP (CONTINUED)

## BRIGGS & STRATTON LOCKS & COMPONENTS

**NOTE:**  
 WHEN ORDERING THE LOCK CASE, THE KEY CODE MUST MATCH THE LAST DIGIT OF THE VEHICLE'S SERIAL NUMBER AND PART NUMBER; WHEN ORDERING THE KEYS, THE THIRD DIGIT OF THE KEY CODE MUST MATCH THE LAST DIGIT OF THE VEHICLE'S SERIAL NUMBER AND PART NUMBER

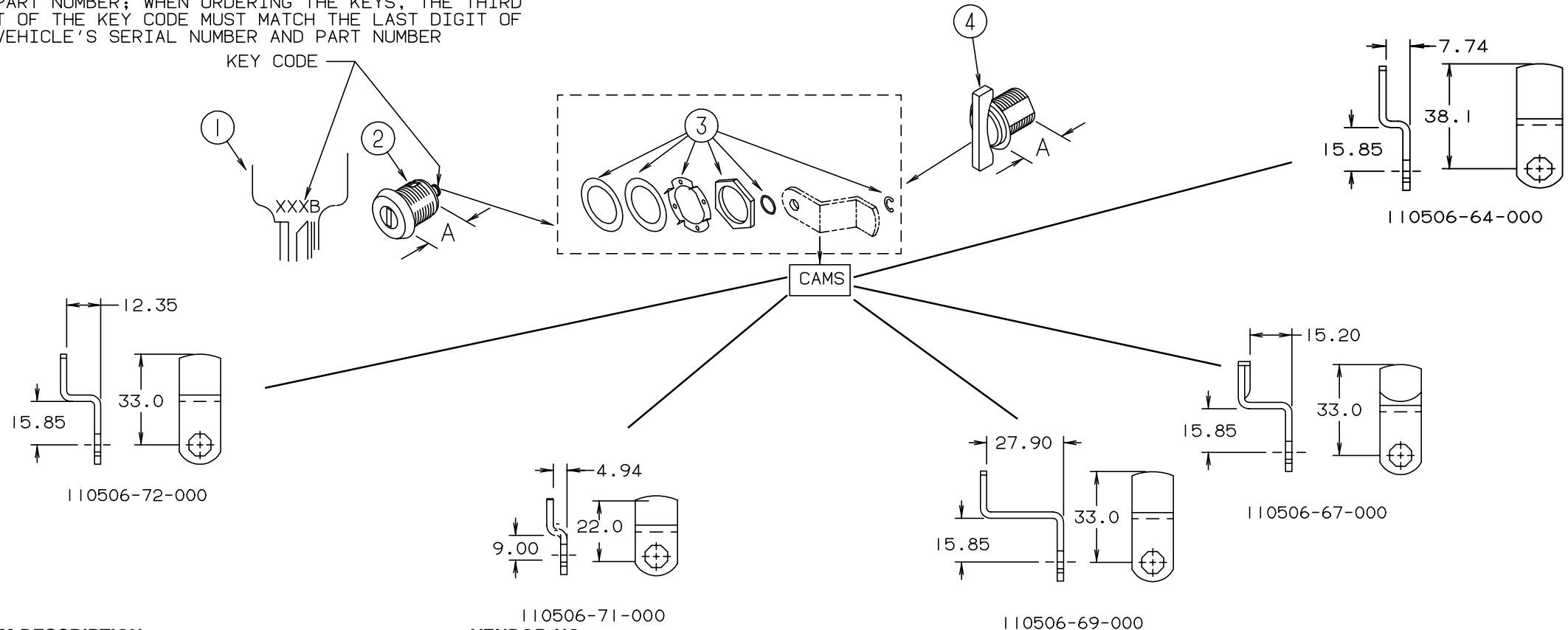

KEY	PART NUMBER	U/M	DESCRIPTION	VENDOR NO.
1	110506-59-000	EA	KEYS - SET OF TWO	596720
2	110506-52-000	EA	CASE - LOCK - A= 17 MM	702370
2	110506-53-000	EA	CASE - LOCK - A= 25 MM	702380
2	110506-54-000	EA	CASE - LOCK - A= 32 MM	703170
1	110506-59-001	EA	KEYS - SET OF TWO	596721
2	110506-52-001	EA	CASE - LOCK - A= 17 MM	702371
2	110506-53-001	EA	CASE - LOCK - A= 25 MM	702381
2	110506-54-001	EA	CASE - LOCK - A= 32 MM	703171
1	110506-59-002	EA	KEYS - SET OF TWO	596722
2	110506-52-002	EA	CASE - LOCK - A= 17 MM	702372
2	110506-53-002	EA	CASE - LOCK - A= 25 MM	702382
2	110506-54-002	EA	CASE - LOCK - A= 32 MM	703172
1	110506-59-003	EA	KEYS - SET OF TWO	596723
2	110506-52-003	EA	CASE - LOCK - A= 17 MM	702373
2	110506-53-003	EA	CASE - LOCK - A= 25 MM	702383
2	110506-54-003	EA	CASE - LOCK - A= 32 MM	703173
1	110506-59-004	EA	KEYS - SET OF TWO	596724
2	110506-52-004	EA	CASE - LOCK - A= 17 MM	702374
2	110506-53-004	EA	CASE - LOCK - A= 25 MM	702384
2	110506-54-004	EA	CASE - LOCK - A= 32 MM	703174
1	110506-59-005	EA	KEYS - SET OF TWO	596725
2	110506-52-005	EA	CASE - LOCK - A= 17 MM	702375
2	110506-53-005	EA	CASE - LOCK - A= 25 MM	702385
2	110506-54-005	EA	CASE - LOCK - A= 32 MM	703175

KEY	PART NUMBER	U/M	DESCRIPTION	VENDOR NO.
1	110506-59-006	EA	KEYS - SET OF TWO	596726
2	110506-52-006	EA	CASE - LOCK - A= 17 MM	702376
2	110506-53-006	EA	CASE - LOCK - A= 25 MM	702386
2	110506-54-006	EA	CASE - LOCK - A= 32 MM	703176
1	110506-59-007	EA	KEYS - SET OF TWO	596727
2	110506-52-007	EA	CASE - LOCK - A= 17 MM	702377
2	110506-53-007	EA	CASE - LOCK - A= 25 MM	702387
2	110506-54-007	EA	CASE - LOCK - A= 32 MM	703177
1	110506-59-008	EA	KEYS - SET OF TWO	596728
2	110506-52-008	EA	CASE - LOCK - A= 17 MM	702378
2	110506-53-008	EA	CASE - LOCK - A= 25 MM	702388
2	110506-54-008	EA	CASE - LOCK - A= 32 MM	703178
1	110506-59-009	EA	KEYS - SET OF TWO	596729
2	110506-52-009	EA	CASE - LOCK - A= 17 MM	702379
2	110506-53-009	EA	CASE - LOCK - A= 25 MM	702389
2	110506-54-009	EA	CASE - LOCK - A= 32 MM	703179
3	110506-40-700	EA	HARDWARE KIT	
4	110506-50-000	EA	CASE - TWIST LOCK - A= 17 MM	596952
4	110506-51-000	EA	CASE - TWIST LOCK - A= 25 MM	596669
4	110506-55-000	EA	CASE - TWIST LOCK - A= 32 MM	597312AA1
	110506-40-000	EA	CLIP-E - LOCK ASM.	93981
	110506-64-000	EA	CAM - LOCK	322280
	110506-68-000	EA	CAM - LOCK	322284
	110506-71-000	EA	CAM - LOCK	322287
	110506-59-701	EA	KEY BLANK - GOLD	

# WINDOW, VENT & EXTERIOR DOOR GROUP (CONTINUED)

## ENTRANCE DOOR

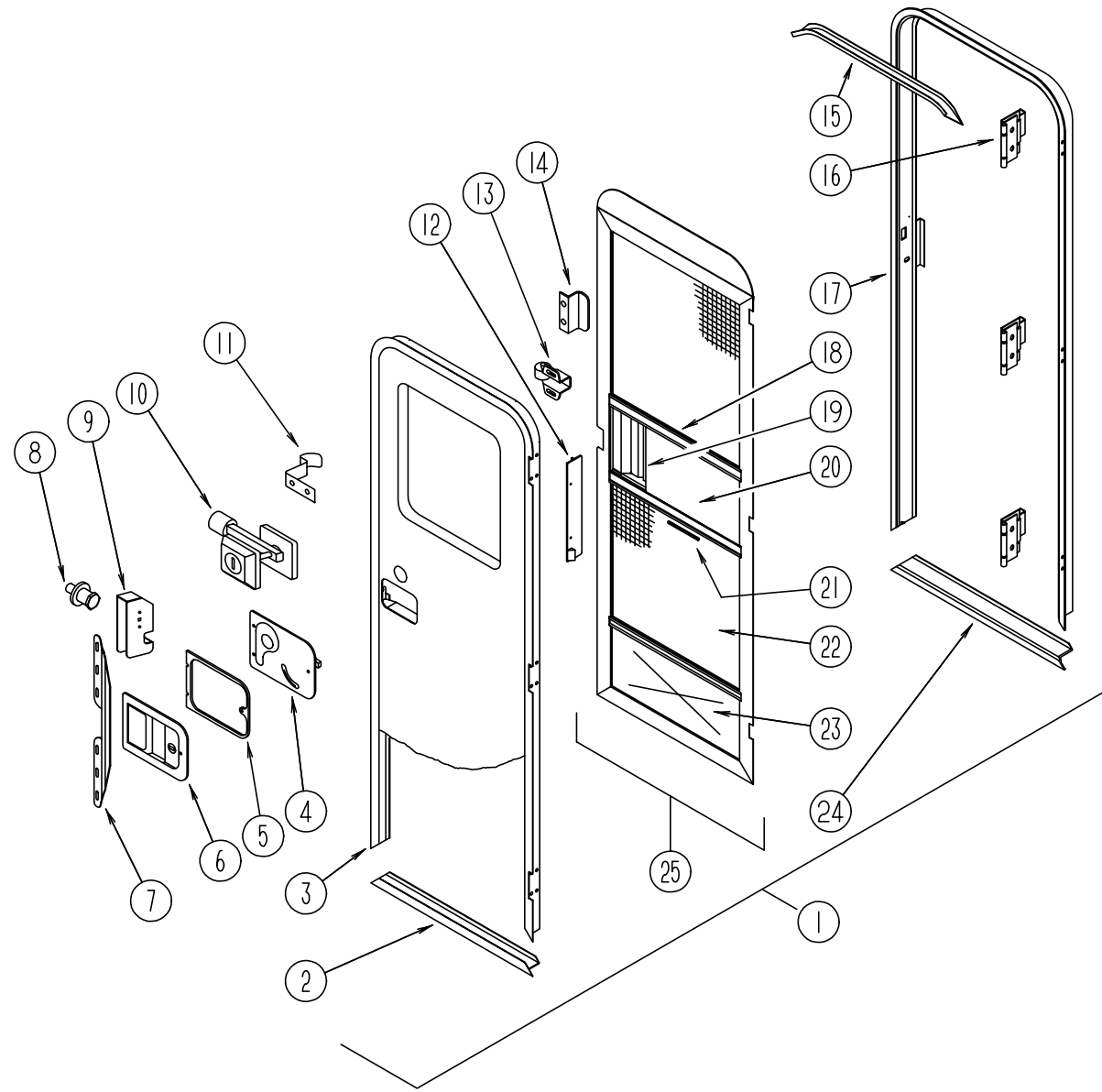

KEY	PART NUMBER	U/M	DESCRIPTION
1	115108-06-GD1	EA	DOOR - ENTRY, W/SCREEN DOOR - W/O WINDOW
1	115108-06-GE1	EA	DOOR - ENTRY, W/SCREEN DOOR - W/O WINDOW
2	089748-21-000	EA	FRAME-DOOR, ENTRANCE - BOTTOM - OFF WHITE
	090340-01-000	FT	SEAL-FOAM, CLOSED CELL - 1/4" X 1/2" X 50'
3	095276-03-06A	EA	FRAME-DOOR, ENTRANCE - TOP & SIDES - BRIGHT WHITE
4	039979-06-000	EA	COVER-INTERIOR LATCH, W/TRIP ARM - RIGHT - BLACK
	039984-01-000	EA	CAP-ROUND, VINYL - .28" ID X .62" LONG - BLACK
	041546-07-000	EA	BRACKET-DOOR ANGLE, 5" X 1.9" - OFF WHITE - METAL
5	096810-01-01A	EA	PLATE-LATCH, ENTRANCE DOOR - PLASTIC - BLACK
6	045017-13-000	EA	LATCH-ENTRANCE DOOR, BLK TEXT - *T/M #11896-01
	045017-11-701	EA	KEY-BLANK, F1 SERIES 81312-02
	045017-11-702	EA	KEY-MASTER, F SERIES 81313-02
			TO BE SOLD F/DEALER USE ONLY, NOT RETAIL !!!!!!!
	058025-02-000	EA	CLIP-ROLLER LATCH CATCH, SCREEN DOOR
	063729-04-000	EA	RIVNUT, 10-32 UNF - .010-.080
	075671-04-000	FT	SEAL-SPONGE, LAZY T SHAPE - W/ADHESIVE STRIPE - .5" WIDE
7	098173-01-07A	EA	STIFFENER-ENTRANCE DOOR, SUPPORTS LATCH/STRIKE AREA - BRIGHT WHITE
	098173-01-04A	EA	STIFFENER-ENTRY DOOR, SUPPORTS LATCH/STRIKE AREA UNPAINTED
	100128-02-000	FT	SEAL-PILE, ADHESIVE BACK - SCREEN DOOR - GRAY
8	039539-01-000	EA	STRIKE-LOCK, ENTRY DOOR - ROUND W/THREADED WASHER
9	045017-13-000	EA	LATCH MECHANISM-HOOK, ENTRY DOOR - INTERIOR
	039715-01-000	EA	NUT-SERT, 1/4" DIAMETER - 20 THREADS
10	101145-01-06A	EA	DEADBOLT-ENTRANCE DOOR, W/2 KEYS W/O BACK SET BOLT OR SCREWS
	095229-01-700	EA	KEY BLANK
	101145-01-701	EA	CYLINDER-LOCK ASM., W/KEY 81306-03
	101147-01-000	EA	BOLT-SECURITY, 4.12" BACKSET
	102524-01-000	EA	BUMPER-RUBBER, FLAT - BLACK
11	100412-01-000	EA	CATCH-SCREEN DOOR, THUMB CLIP W/BLACK PLASTIC CAP
	102768-01-000	EA	HOLDER-ENTRY DOOR, METAL - MILL FINISH
12	079087-03-000	EA	STRIKE-SLIDER, W/LIP FOR ELBOW CATCH - BRIGHT WHITE
13	100412-01-000	EA	CATCH-SCREEN DOOR
14	050712-06-000	EA	HANDLE-SCREEN DOOR, ALUMINUM - BRIGHT WHITE
15	044582-44-000	EA	CAP-DRIP, DOOR JAMB MOUNTED - BRIGHT WHITE
	115222-09-01A	EA	GARNISH-RADIUS, ENTRANCE DOOR - OFF WHITE
	077461-03-000	EA	COVER-STRIKE, ENTRANCE DOOR - 6.5" X 2.5" - PLASTIC - WHITE
	090340-01-000	FT	SEAL-FOAM, CLOSED CELL - 1/4" X 1/2" X 50'
16	106719-01-05A	EA	HINGE-ENTRANCE DOOR - BRIGHT WHITE
	102248-01-000	EA	SHIM-DOOR
17	120310-06-01A	EA	JAMB-ENTRANCE DOOR, BRIGHT WHITE
18	078777-01-000	EA	CHANNEL-SLIDE, SCREEN DOOR CENTER SLIDER COVER - 17.4"
19	079086-03-000	EA	SLIDER-SCREEN DOOR, BRIGHT WHITE
20	016454-01-000	EA	INSERT-CENTER
	001014-01-013	EA	INSERT-CENTER, 10.25" X 16.31" - UNPAINTED
21	002294-01-000	FT	SPLINE-SCREENING, .135" X .138" - BLACK
	002748-01-000	EA	CORNER KEY-DOOR
22	002293-02-000	SF	SCREENING-WINDOW & DOOR, 26" - CHARCOAL
23	078552-03-000	EA	INSERT-SCREEN DOOR, LOWER - UNPAINTED
	078595-01-000	EA	PLATE-SCREEN DOOR
24	051049-01-000	EA	JAMB-ENTRANCE DOOR, BOTTOM - UNPAINTED
25	079012-05-F01	EA	DOOR-SCREEN - BRIGHT WHITE

**WINDOW, VENT & EXTERIOR DOOR GROUP (CONTINUED)**

**POWERED ROOF VENT**

KEY	PART NUMBER	U/M DESCRIPTION
	110051-03-01A	EA VENT-ROOF, POWERED - 2" ROOF - US - JENSEN C7757 WHEAT
	110051-05-01A	EA VENT-ROOF, POWERED - 2" ROOF - CSA - JENSEN C7757 WHEAT
	048648-01-000	EA MOTOR-ROOF VENT, 1/8 SHAFT - 12V - JENSEN
	048649-01-000	EA FAN-ROOF VENT, 6 BLADES - 6" - JENSEN
	064470-01-700	EA COVER-VENT, W/O (SLIDE BAR) COMES W/O SLIDE BAR J7291
	064470-01-701	EA SLIDE BAR, (VENT-LID) JRP1291B
	110051-01-700	EA SCREEN-ROOF VENT
	110051-01-701	EA GARNISH W/SCREEN & FRAME 2"
	110051-01-702	EA HAND CRANK & OPERATOR ASM.
	110051-01-703	EA HANDLE CRANK

**NONPOWERED ROOF VENT**

KEY	PART NUMBER	U/M DESCRIPTION
	110051-01-01A	EA VENT-ROOF, NONPOWERED - 2" ROOF - JENSEN 7724 WHE
	064470-01-700	EA COVER ROOF VENT, 7291
	110051-01-700	EA SCREEN & FRAME 2" NON-POWER
	110051-01-701	EA GARNISH W/SCREEN & FRAME 2"
	110051-01-702	EA HAND CRANK & OPERATOR ASM.
	110051-01-703	EA HANDLE CRANK

**VENTS & SHROUDS**

KEY	PART NUMBER	U/M DESCRIPTION
	083558-03-000	EA VENT-PLUMBING PIPE ROOF, W/COVER - OFF WHITE
	084073-07-000	EA COVER-ROOF VENT, REFRIGERATOR - BRIGHT WHITE - NORCOLD
	084073-04-000	EA BASE-ROOF VENT, REFRIGERATOR - BLACK - NORCOLD
	105028-01-000	EA FLASHING ASM-VENT, REFRIGERATOR
	103385-01-02A	EA VENT-RANGE HOOD, OUTSIDE - BRIGHT WHITE - VENTLINE

**SEALS AND HARDWARE FOR ACCESS DOORS**

KEY	PART NUMBER	U/M DESCRIPTION
	076767-06-000	EA CABLE-SUPPORT, 25.6" - STAINLESS STEEL
	089329-01-000	EA CLIP-SPRING, 3/8" - METAL
	081801-02-000	EA HINGE-2" X 96", OFF WHITE
	081801-V3-000	EA HINGE-AL, 2" X 8' BRT WHT
	081801-T3-000	EA HINGE-AL,2X0522MM BRT WHT
	034007-B3-000	EA HINGE-CONT AL 1.5X96"BRT WHT
	009065-01-000	EA HINGE-ALUMINUM, 1 1/2" X 96" - UNPAINTED
	104692-01-000	FT SEAL-3/4" X 3/4", ADHESIVE BACK FOAM SEAL
	107721-01-000	FT "D" SHAPED BULB SEAL W/ADHESIVE ON FLAT SIDE
	106850-01-000	FT SEAL-E,11X19 SPONGE RUBBER
	107997-51-001	EA SPACER-.86" X .6", ALUMINUM
	102768-01-000	EA HOLDER-COMPARTMENT/ENTRY DOOR, METAL - MILL FINISH

**WINDOW, VENT & EXTERIOR DOOR GROUP (CONTINUED)**

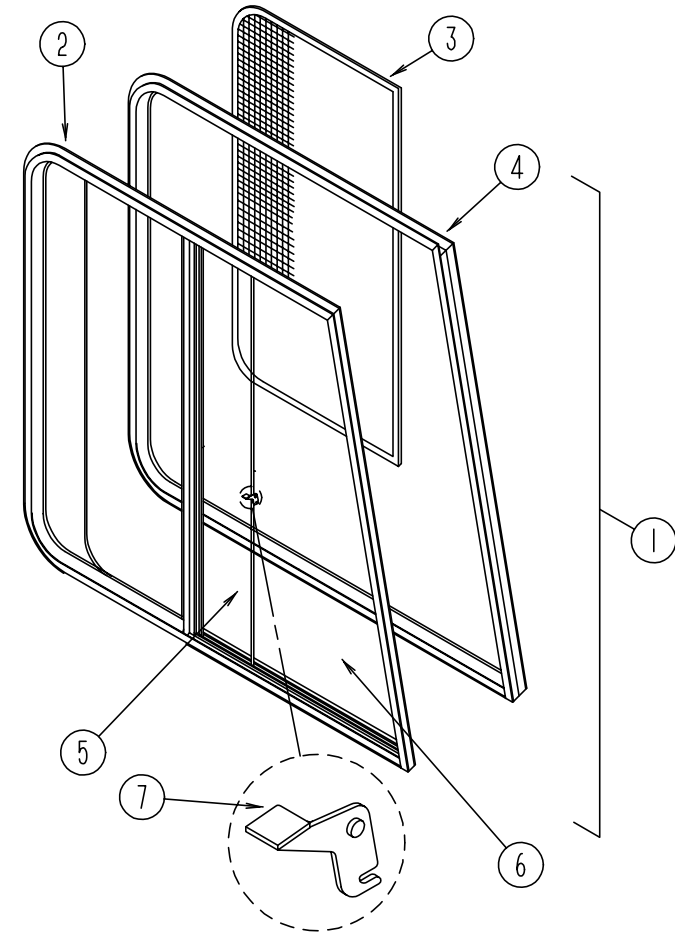

**FRONT CAB WINDOWS (EXCEL)**

KEY	PART NUMBER	U/M DESCRIPTION	VENDOR NO.
1	103658-09-01A	EA WINDOW ASM. - CAB - W/INSIDE FRAME - DRIVER SIDE	H405-A2B66L
1	103658-10-01A	EA WINDOW ASM. - CAB - W/INSIDE FRAME - PASSENGER SIDE	H373-ARR
2	103658-09-701	EA WINDOW ASM., W/O TRIM	H405-A2L
2	103658-10-700	EA WINDOW ASM., W/O TRIM	H405-A2R
3	103658-09-705	EA SCREEN ASM. - WINDOW - DRIVER SIDE	410-018973L
3	103658-10-704	EA SCREEN ASM. - WINDOW - PASSENGER SIDE	410-018973R
	098644-01-717	FT SCREEN SPLINE	132-004716
	098644-01-713	EA SPRING-SCREEN FRAME (CLIP), PLASTIC - BLACK	226-016966
	098644-01-710	FT TRACK-SCREEN SPACER, 6' LENGTH - EXCEL	M401-31 132-017135
	098644-01-711	FT WEATHERSTRIP-SCREEN, BLACK - EXCEL	171-016965
4	103658-09-702	EA RETAINER-TRIM, LEFT	H37366L
4	103658-10-701	EA RETAINER-TRIM, RIGHT	H37376R
5	103658-10-703	EA GLASS - SLIDING - W/SASH & LATCH - PASSENGER	H405-A9R
5	103658-09-704	EA GLASS - SLIDING - W/SASH & LATCH - DRIVER	H405-A9L
6	103658-09-700	EA GLASS - STATIONARY - BOTTOM - DRIVER OR PASSENGER SIDE	106-018971
7	098644-01-700	EA LATCH-REPAIR KIT, EXCEL	B801-CK
	098644-01-708	FT CHANNEL-PIERCED RUN, EXCEL	122-016543
	098644-01-706	FT WEATHERSTRIP, EXCEL	171-010668
	098644-01-716	FT PLUG-FILLER, EXCEL	132-014470

**WINDOW, VENT & EXTERIOR DOOR GROUP (CONTINUED)**

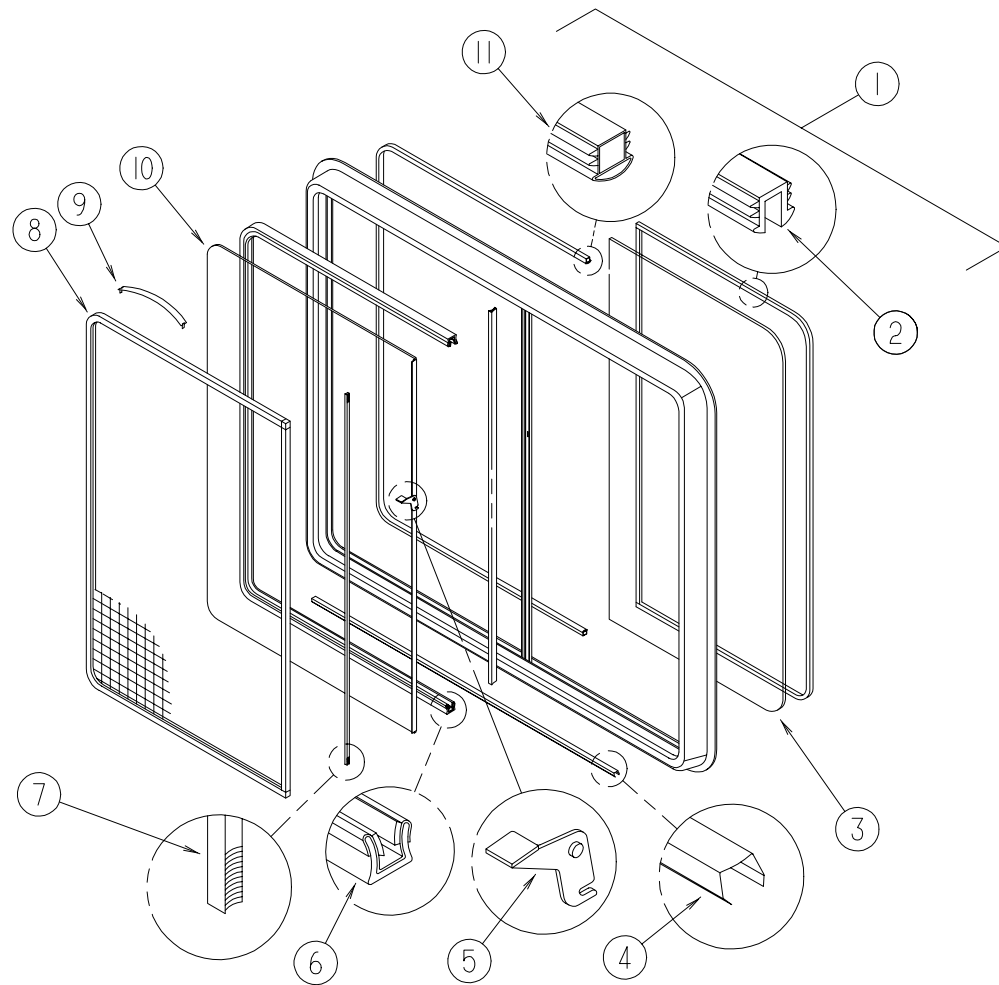

**PASSENGERS SIDE BEDROOM SINGLE SLIDER WINDOW (EXCEL)**

KEY	PART NUMBER	U/M DESCRIPTION	VENDOR NO.
	098647-29-01A	EA WINDOW ASM-SLIDER HORIZ CLR - *EXCEL H172-C1W66R	
1	098647-29-700	EA WINDOW W/O TRIM	H287-G2L
	098647-29-701	EA TRIM - INSIDE FRAME	W28766
2	098644-01-705	FT GLAZING STRIP	132-010723
3	098647-29-702	EA GLASS-STATIONARY	106-017622
4	098644-01-710	FT TRACK-SPACER, FOR SCREEN 12'	132-017135
5	098644-01-700	EA LATCH-REPAIR KIT (BLACK)	B801-CK
6	098644-01-708	FT CHANNEL-RUN, PIERCED - GLASS	122-016543
7	098644-01-711	FT WEATHERSTRIP-SCREEN, BLACK	171-016965
8	098647-29-704	EA SCREEN W/SPRING & WEATHERSTRIP	410-019066
9	098644-01-713	EA SCREEN CLIPS (METAL)(BLK)	226-016966
	098647-29-704	EA SCREEN ASM., W/SEAL & CLIPS	410-018864
10	098647-29-703	EA GLASS SLIDING, W/SASH & LATCH	H287-G9
	098644-01-706	FT WEATHERSTRIP-GLASS	171-010668
11	098644-01-716	FT PLUG-FILLER	132-014470
	098644-01-717	FT SPLINE-SCREEN MFG	132-004716
	098644-01-719	EA STOP-SLIDER GLASS	132-014203

**WINDOW, VENT & EXTERIOR DOOR GROUP (CONTINUED)**

**DRIVERS SIDE BEDROOM SINGLE SLIDER WINDOW (EXCEL)**

KEY	PART NUMBER	U/M DESCRIPTION	VENDOR NO.
	098647-30-01A	EA WINDOW ASM-SLIDER,HORIZ CLR - *EXCEL H172-C1W66L	
1	098647-30-700	EA WINDOW W/O TRIM	H287-G2L
	098647-29-701	EA TRIM - INSIDE FRAME	W28766
2	098644-01-705	FT GLAZING STRIP	132-010723
3	098647-29-702	EA GLASS-STATIONARY	106-017622
4	098644-01-710	FT TRACK-SPACER, FOR SCREEN 12'	132-017135
5	098644-01-700	EA LATCH-REPAIR KIT (BLACK)	B801-CK
6	098644-01-708	FT CHANNEL-RUN, PIERCED - GLASS	122-016543
7	098644-01-711	FT WEATHERSTRIP-SCREEN, BLACK	171-016965
8	098647-29-704	EA SCREEN W/SPRING & WEATHERSTRIP	410-019066
9	098644-01-713	EA SCREEN CLIPS (METAL)(BLK)	226-016966
	098647-29-704	EA SCREEN ASM., W/SEAL & CLIPS	410-018864
10	098647-29-703	EA GLASS SLIDING, W/SASH & LATCH	H287-G9
	098644-01-706	FT WEATHERSTRIP-GLASS	171-010668
11	098644-01-716	FT PLUG-FILLER	132-014470
	098644-01-717	FT SPLINE-SCREEN MFG	132-004716
	098644-01-719	EA STOP-SLIDER GLASS	132-014203

**PASSENGERS DINETTE SLIDER WINDOW (EXCEL)**

KEY	PART NUMBER	U/M DESCRIPTION	VENDOR NO.
	098647-27-01A	EA WINDOW ASM-SLIDER,HORIZ CLR - *EXCEL H287-C1W66R	
1	098647-27-700	EA WINDOW-SLIDER	H287-C1R
	098647-27-701	EA RETAINER-TRIM, WHITE	W28766
2	098644-01-705	FT GLAZING STRIP	132-010723
3	098647-27-702	EA GLASS-STATIONARY	096-017868
4	098644-01-710	FT TRACK-SPACER, FOR SCREEN 12'	132-017135
5	098644-01-700	EA LATCH REPAIR KIT (BLACK)	B801-CK
6	098644-01-708	FT CHANNEL-RUN, PIERCED - GLASS	122-016543
7	098644-01-711	FT WEATHERSTRIP-SCREEN, BLACK	171-016965
8	098647-23-704	EA SCREEN W/SPRING & WEATHERSTRIP	410-019066
9	098644-01-713	EA SCREEN CLIPS (METAL)(BLK)	226-016966
10	098647-27-703	EA GLASS-SLIDING, W/SASH & LATCH	H287-C8
	098644-01-706	FT WEATHERSTRIP-GLASS	171-010668
11	098644-01-716	FT PLUG-FILLER	132-014470
	098644-01-717	FT SPLINE-SCREEN MFG	132-004716
	098644-01-719	EA STOP-SLIDER GLASS	132-014203

**DRIVERS LOUNGE SLIDER WINDOW (EXCEL)**

KEY	PART NUMBER	U/M DESCRIPTION	VENDOR NO.
	098647-36-01A	EA WINDOW ASM-SLIDER,HORIZ CLR - *EXCEL H415-C1W66L	
1	098647-36-700	EA WINDOW-SLIDER	H415-C1L
	098647-36-701	EA RETAINER-TRIM, WHITE	CW8066
2	098644-01-705	FT GLAZING STRIP	132-010723
3	098647-36-702	EA GLASS-STATIONARY	096-019430
4	098644-01-710	FT TRACK-SPACER, FOR SCREEN 12'	132-017135
5	098644-01-700	EA LATCH REPAIR KIT (BLACK)	B801-CK
6	098644-01-708	FT CHANNEL-RUN, PIERCED - GLASS	122-016543
7	098644-01-711	FT WEATHERSTRIP-SCREEN, BLACK	171-016965
8	098647-36-704	EA SCREEN ASM., W/SEAL & CLIPS	410-017750
9	098644-01-713	EA SCREEN CLIPS (METAL)(BLK)	226-016966
10	098647-36-703	EA GLASS-SLIDING, W/SASH & LATCH	H279-C8
	098644-01-706	FT WEATHERSTRIP-GLASS	171-010668
11	098644-01-716	FT PLUG-FILLER	132-014470
	098644-01-717	FT SPLINE-SCREEN MFG	132-004716
	098644-01-719	EA STOP-SLIDER GLASS	
	002181-27-000	EA GLASS-PICTURE 655 X 417 59R - CLEAR 90%	
	087561-01-000	FT SEAL-GLASS, EXTERIOR - .5" WIDE - VINYL - BLACK	
	117054-02-02A	EA FRAME-WINDOW,INSIDE BRT/WHT	132-014203

**WINDOW, VENT & EXTERIOR DOOR GROUP (CONTINUED)**

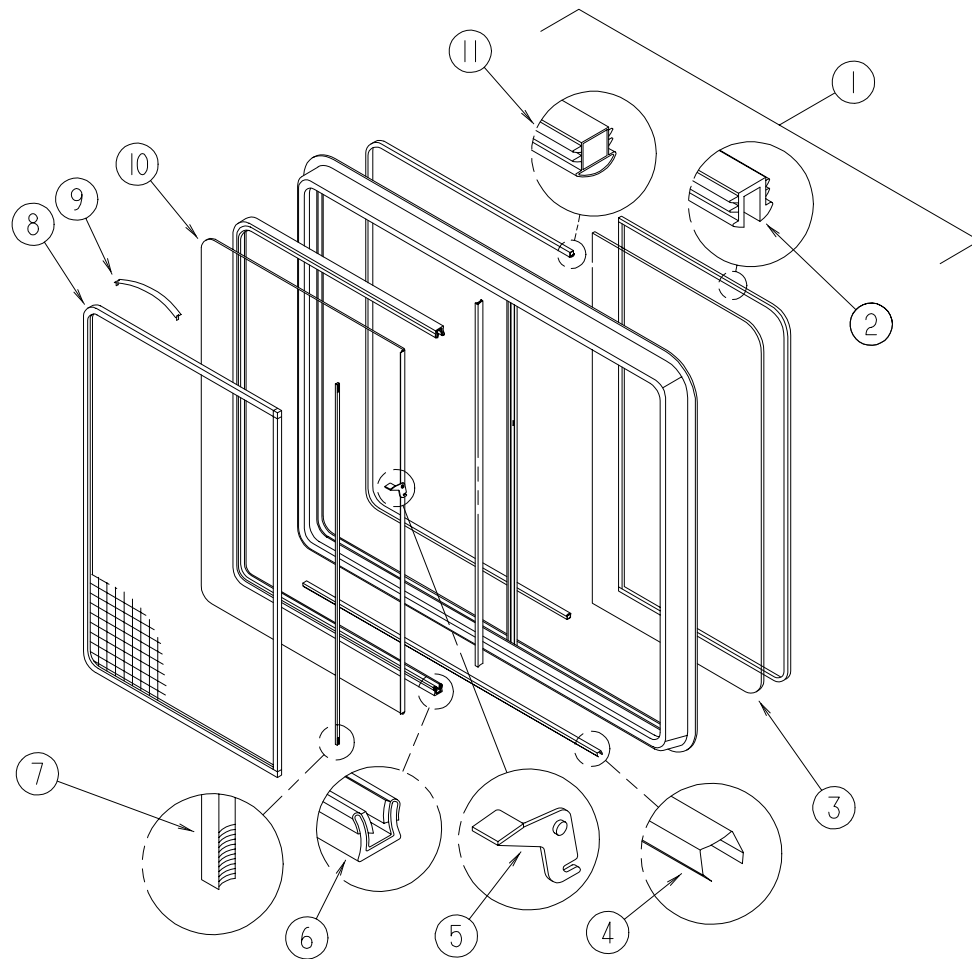

**PASSENGERS SLIDER WINDOW (EXCEL) BUNK WINDOWS**

KEY	PART NUMBER	U/M DESCRIPTION	VENDOR NO.
1	098647-31-01A	EA WINDOW ASM-SLIDER,HORIZ CLR EXCEL H425-C1W66R	
	098647-31-700	EA WINDOW-SLIDER	H425-C1R
	098647-31-701	EA RETAINER-TRIM, WHITE	CW2966
2	098644-01-705	FT GLAZING-STRIP	132-010231
3	098647-31-702	EA GLASS-STATIONARY	096-019299
4	098644-01-710	FT TRACK-SCREEN SPACER, 12'	132-017135
5	098644-01-700	EA LATCH-REPAIR KIT (BLACK)	B801-CK
6	098644-01-708	FT CHANNEL-RUN, PIERCED	122-016543 EXCEL
7	098644-01-711	FT WEATHERSTRIP-SCREEN, BLACK	171-016965 EXCEL
8	098647-31-704	EA SCREEN ASM., W/SPRING CLIP	410-019128
9	098644-01-713	EA CLIP-SPRING, BLACK PLASTIC	226-016966
10	098647-31-703	EA GLASS-SLIDING,W/SASH & LATCH	H425-C8
	098644-01-706	FT WEATHERSTRIP-GLASS	171-010668
11	098644-01-716	FT PLUG-FILLER	132-014470
	098644-01-717	FT SPLINE-SCREEN	132-004716
	098644-01-719	EA STOP-SLIDER GLASS	132-014203

**WINDOW, VENT & EXTERIOR DOOR GROUP (CONTINUED)**

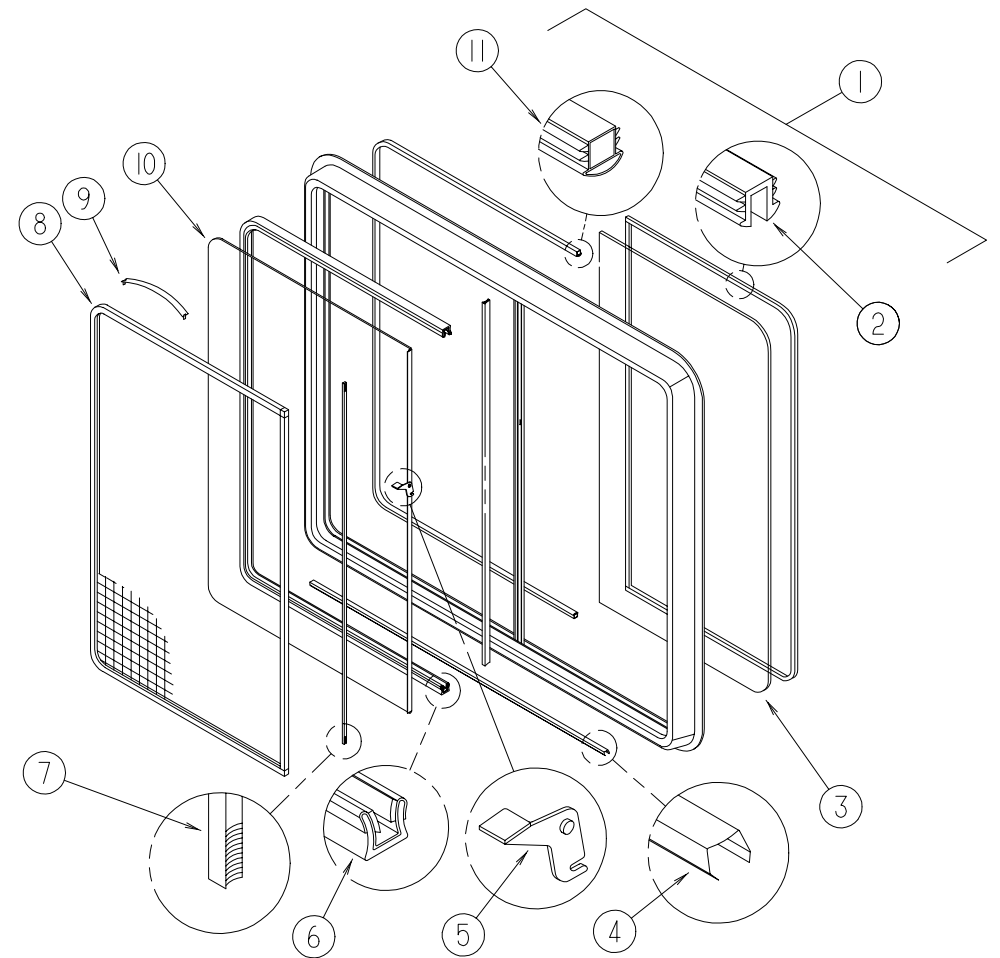

**DRIVERS SLIDER WINDOW (EXCEL) BUNK WINDOWS**

KEY	PART NUMBER	U/M DESCRIPTION	VENDOR NO.
	098647-32-01A	EA WINDOW ASM-SLIDER,HORIZ CLR - *EXCEL H425-C1W66L	
1	098647-32-700	EA WINDOW-SLIDER	H425-C1L
	098647-31-701	EA RETAINER-TRIM, WHITE	CW2966
2	098644-01-705	FT GLAZING STRIP	132-010723
3	098647-31-702	EA GLASS-STATIONARY	096-019299
4	098644-01-710	FT TRACK-SPACER, FOR SCREEN 12'	132-017135 EXCEL
5	098644-01-700	EA LATCH REPAIR KIT (BLACK)	B801-CK EXCEL
6	098644-01-708	FT CHANNEL-RUN, PIERCED - GLASS	122-016543 EXCEL
7	098644-01-711	FT WEATHERSTRIP-SCREEN, BLACK	171-016965 EXCEL
8	098647-31-704	EA SCREEN ASM., W/SEAL & CLIPS	410-019128
9	098644-01-713	EA SCREEN CLIPS (METAL)(BLK)	226-016966
10	098647-31-703	EA GLASS-SLIDING,W/SASH & LATCH	H425-C8
	098644-01-706	FT WEATHERSTRIP-GLASS	171-010668
11	098644-01-716	FT PLUG-FILLER	132-014470
	098644-01-717	FT SPLINE-SCREEN MFG	132-004716

**WINDOW, VENT & EXTERIOR DOOR GROUP (CONTINUED)**

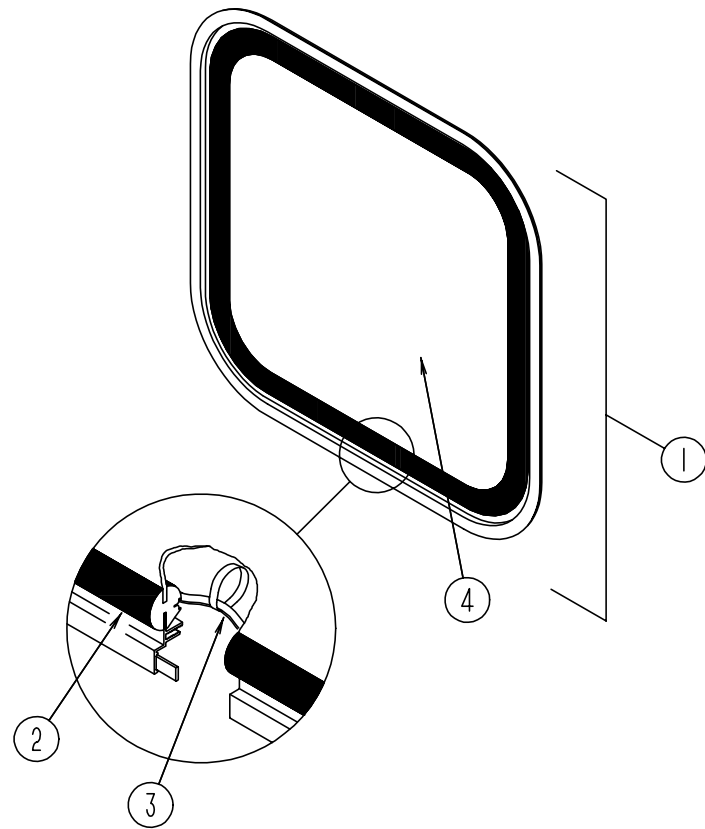

**ESCAPE WINDOW**

**USED WITH QUEEN BED / TWIN BED**

KEY	PART NUMBER	U/M DESCRIPTION
	074816-11-000	EA INSIDE FRAME- WINDOW - OFF WHITE
1	078528-07-FB1	EA WINDOW-ESCAPE - W/O INSIDE FRAME
2	002282-09-000	EA WEATHERSTRIP-.125" X 133.25" - BLACK
3	002285-01-000	FT FILLER-WEATHER STRIP - RUBBER - BLACK
4	076337-13-000	EA GLASS-EGRESS 1157 X 548
	102922-01-000	EA TAPE ASM-ESCAPE WINDOW - RED

**ESCAPE WINDOW**

**USED WITH DOUBLE BED / BUNK BEDS**

KEY	PART NUMBER	U/M DESCRIPTION	VENDOR NO.
	116976-01-01A	EA WINDOW ASM-REAR ESCAPE SINGLE	
	100322-01-701	FT SEAL-VENT	122-016071
	112898-06-704	EA HANDLE-LATCH, RED-RH	182-11293
	112898-06-705	EA HANDLE-LATCH, RED-LH	182-11294
	116976-01-700	EA GLASS	096-018786
	116976-01-701	EA TRIM	W38653
	116976-01-702	FT FILLER PLUG	132-016065

**WINDOW, VENT & EXTERIOR DOOR GROUP (CONTINUED)**

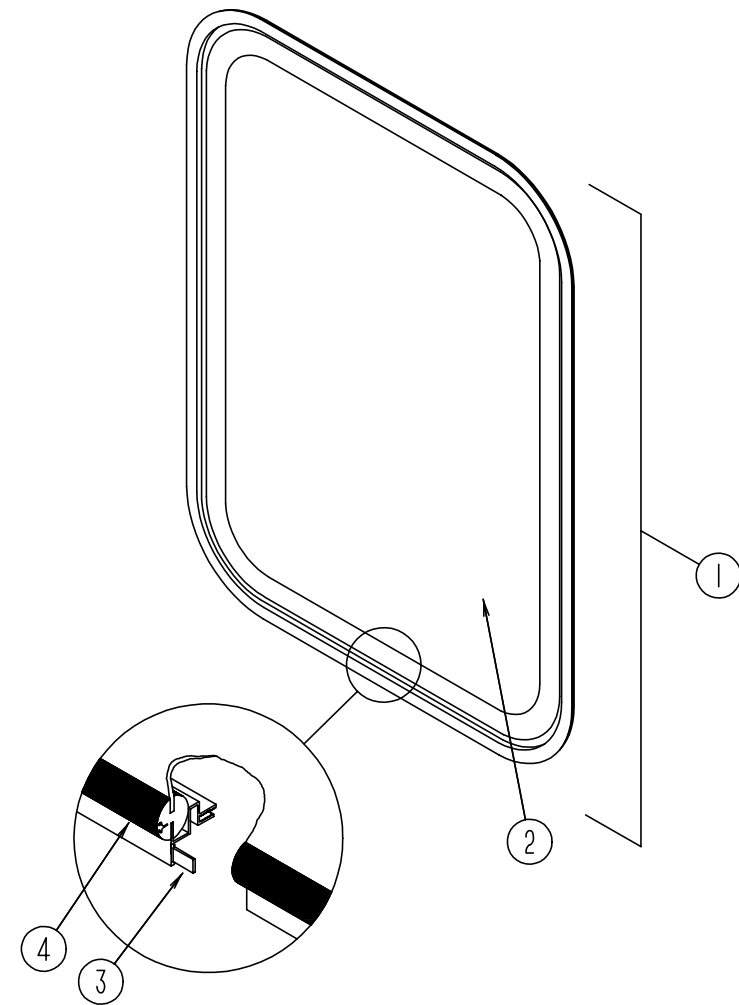

**ENTRY DOOR WINDOW**

KEY	PART NUMBER	U/M DESCRIPTION
	117054-02-02A	EA FRAME-WINDOW,INSIDE BRIGHT/WHITE - ENTRANCE DOOR
1	117053-04-FB1	EA WINDOW-ENTRANCE DOOR - GLASS
2	002181-27-000	EA GLASS-WINDOW, PICTURE 655 X 417 CLEAR 90%
3	069640-03-000	FT SEALER-TAPE,3/4" X 1/8" -BLACK
4	087561-01-000	FT SEAL-GLASS - EXTERIOR - .5" WIDE - VINYL - BLACK



## WINDSHIELD & WIPER GROUP

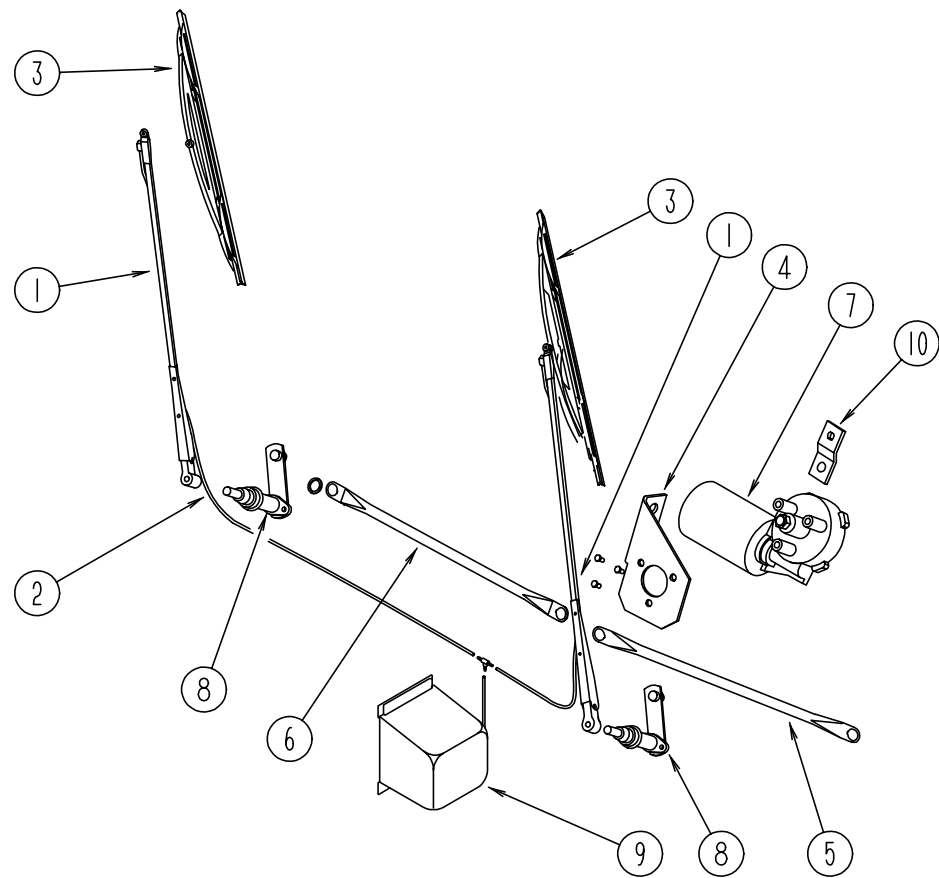

### WIPER COMPONENTS

KEY	PART NUMBER	U/M DESCRIPTION
1	103671-01-000	EA ARM-WIPER - 24" - UT 52179-20LE27WC
2	096931-01-700	FT HOSE-WIPER - TO BLADE
	096931-01-701	EA NOZZLE-HARDWARE KIT - INCLUDES NOZZLE,NUT,SCREWS AND PLASTIC CAP
	110742-01-000	EA GASKET-WIPER
3	095964-01-000	EA BLADE-WIPER - WINDSHIELD - 24"
	095964-01-700	EA BLADE-REFILL 24" (PAIR) - 12360
4	104549-01-000	EA BRACKET ASM-WIPER
	096526-01-000	EA SCREW-HEX - 1/4 - 28
5	117008-01-000	EA LINK ASM-CONNECTING 21.85" - DRIVER SIDE - 64342-40
6	117008-02-000	EA LINK ASM-CONNECTING 21.85" - PASSENGER SIDE - 64341-40
7	104346-02-000	EA WIPER MOTOR -"COAST TO PARK" - USE ON 1994 & UP CHEV. CHASSIS NOTE: THIS PART CHANGES TO #10434604000 F/1996 MODELS FROM: 00-00-00 THRU: 11-19-95
7	104346-04-000	EA MOTOR-WIPER W/INT. BREAKER - UT 65714M02025WJ FROM: 11-20-95 THRU: 99-99-99
	117322-01-000	EA SCREW-1/4-28UNF-2A,TORX - U.T. 6270020 SC25WJ USED TO ATTACH WIPER MOTOR TO MOUNTING PLATE
8	096505-07-000	EA PIVOT SHAFT ASM - PASSENGER - 62901-20-SH25WJ
8	096505-08-000	EA PIVOT SHAFT ASM - DRIVER SIDE - 62900-20-SH25WJ
9	117766-02-000	EA RESERVOIR/PUMP ASM - MCCORD 600328
10	104347-01-000	EA ARM-DRIVE - WIPER MOTOR - 1.54" - 62543-20-LE25WJ
	110178-01-000	EA HOUSING-WIPER MOTOR - UT6237440-EC25WJ
	067188-01-000	EA STUD-CRANK - WIPER - WINDSHIELD - AMBAC 1903424SD27WC
	061603-01-000	EA GROMMET-SNAP - 3/16" ID - 3/8" HOLE - HEYCO SB-375-3
	045794-01-000	FT HOSE-WASHER, WINDSHIELD - 5/32" ID - BLACK

## WINDSHIELD & WIPER GROUP (CONTINUED)

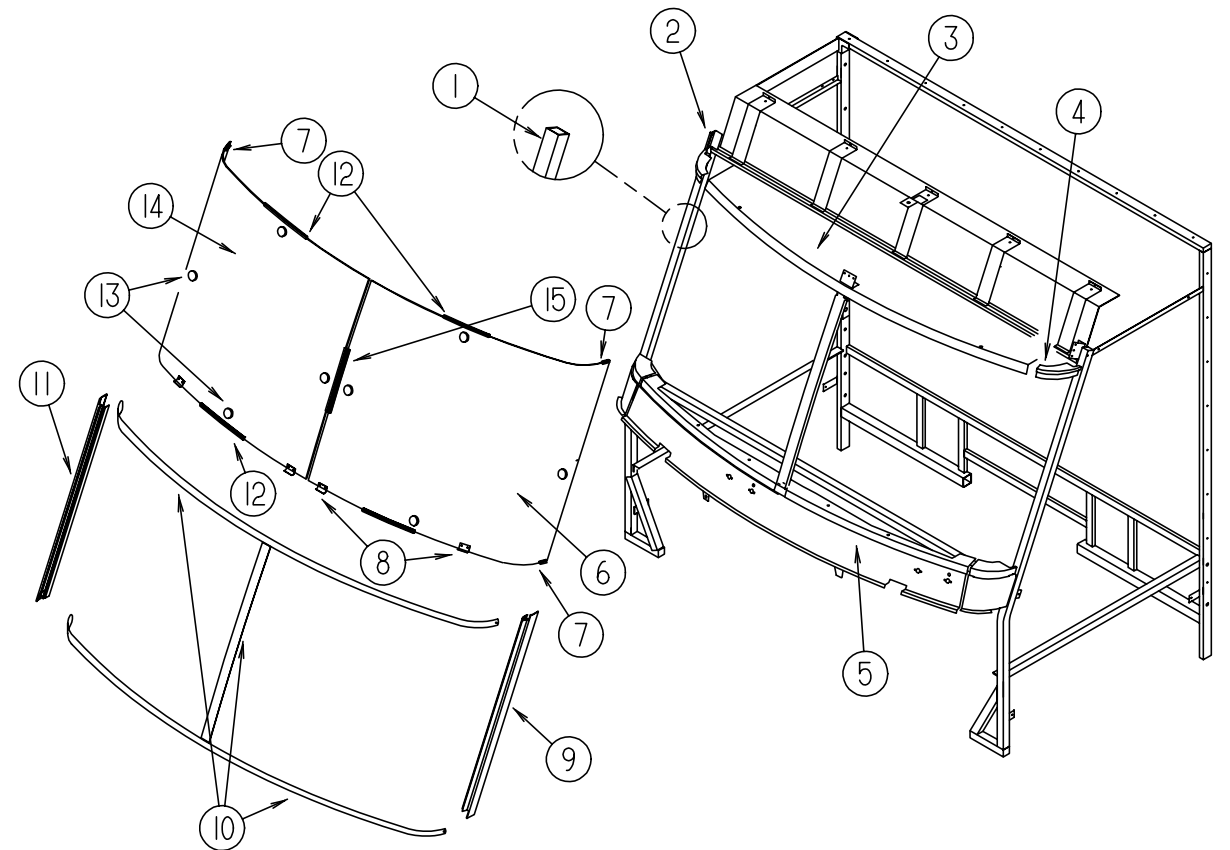

### WINDSHIELD MOLDINGS & GLASS

KEY	PART NUMBER	U/M DESCRIPTION
1	098788-02-000	EA CHANNEL-RIGID
2	077922-03-000	EA HEADER-WINDSHIELD - RIGHT END
3	077922-05-000	EA HEADER-WINDSHIELD - CENTER
4	077922-04-000	EA HEADER-WINDSHIELD - LEFT END
5	077847-02-000	EA SUPPORT-WINDSHIELD - LOWER - W/O BRACKETS
6	088793-04-000	EA GLASS-WINDSHIELD - DRIVER
7	110268-01-000	EA WINDSHIELD CARRIER - 50.40"
8	104449-01-000	EA SUPPORT-WINDSHIELD
9	103107-02-01A	EA TRIM-WINDSHIELD - SIDE BLACK
10	102936-01-000	FT MOLDING-REVEAL - WINDSHIELD
11	103107-01-01A	EA TRIM-WINDSHIELD - SIDE BLK
12	110268-01-000	EA WINDSHIELD CARRIER - 50.40"
13	081914-01-000	EA BUMPER-RUBBER - ROUND - .43" DIAMETER - BLACK
14	088793-03-000	EA GLASS-WINDSHIELD - PASSENGER
15	110268-01-000	EA WINDSHIELD CARRIER - 50.40"