

**1996  
ICD28RQ**

**GD1**

**"MISTY MORN" (PARCHMENT)**

**GE1**

**"MESA" (BRICK/TAN)**



## ACCESSORIES GROUP

### OPERATOR MANUAL

KEY	PART NUMBER	U/M DESCRIPTION
	054185-E6-000	EA MANUAL-OPERATOR 96 PASSAGE D-SERIES
	092318-01-000	EA BINDER - 3 RING, MOTOR HOME MANUAL
	092319-01-000	EA POCKET PAGE - 3 RING BINDER, PLASTIC
	118476-01-000	DW TOP LEVEL DRAWING, 1996 D-SERIES

## AUDIO VIDEO GROUP

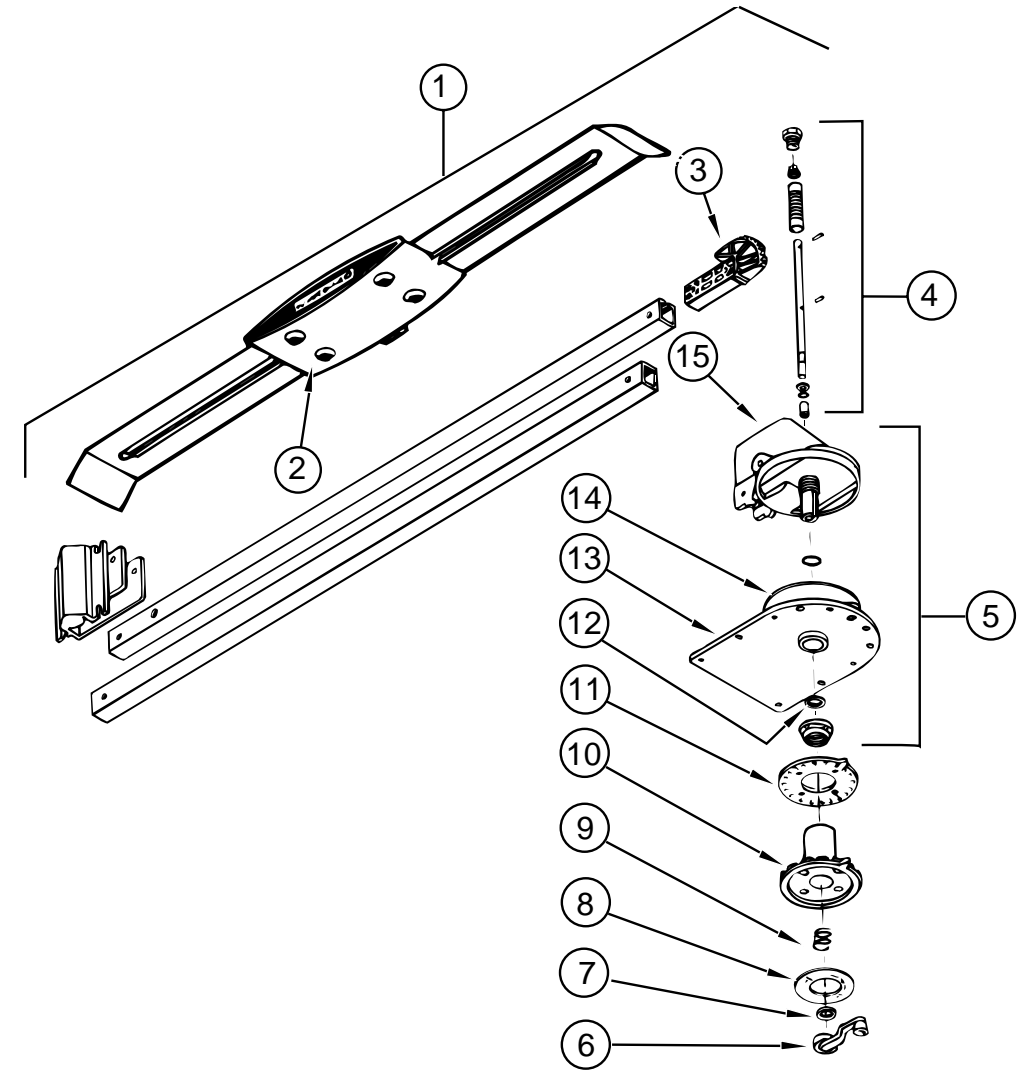

### TV ANTENNA ROOF MT 44.5 MAST WINEGARD #RVA-W02

KEY	PART NUMBER	U/M DESCRIPTION	VENDOR NO.
1	076319-01-000	EA ANTENNA - TV - ROOF MOUNT	
2	076319-01-700	EA HEAD - ANTENNA - AMPLIFIED	RVSA U/V
3	076319-01-701	EA GEAR - ELEVATING - PLASTIC	2200046
4	076319-01-702	EA SHAFT ASM - ELEVATING	RVP-400A
5	076319-01-711	EA BASE & LIFT ASM	2762802
6	076319-01-706	EA CRANK - ELEVATING - W/ SET SCREW	5755100
7	076319-01-705	EA BEARING - NYLON - 7/8"ID	3200658
8	076319-01-708	EA CRANK COVER DECAL	5413002
9	076319-01-707	EA SPRING - HANDLE	5160822
10	076319-01-709	EA PLATE - DIRECTIONAL - FOR HEAD	3200644
11	076319-01-712	EA CEILING PLATE	3200608
12	076319-01-704	EA BEARING - NYLON - 1.5"OD	3200657
13	076319-01-713	EA BASE PLATE	3100523
14	076319-01-703	EA BEARING - NYLON - 5"OD	3200656
15	076319-01-714	EA HOUSING, ROTATING GEAR	2200049
	076319-06-000	EA ADAPTOR-CABLE ROOF PLATE RPJ-1	
	076319-03-000	FT CABLE-COAXIAL, 75 OHM	
	076319-12-000	EA CONNECTOR-COAXIAL, ONE PIECE	
	086777-01-000	EA PLATE-WALL, CABLE - W/TV ANTENNA SWITCH - IVORY	

## AUDIO VIDEO GROUP (CONTINUED)

### RADIO SYSTEM & ANTENNA

KEY	PART NUMBER	U/M	DESCRIPTION
	110267-01-000	EA	RADIO-AM/FM STEREO, AUDIOVOX IM-200
	081059-02-000	EA	WIRE ASM-9-PIN, RADIO - AUDIOVOX 112B-1761
	077069-02-000	EA	CABLE-ANTENNA, RADIO - EXTENSION 96" - ARA 6700667
	110469-01-000	EA	SPEAKER-4" X 6" OVAL COAXIAL MAGNADYNE F46XB-12
	110470-01-01A	EA	GRILLE-SPEAKER, OVAL 4X6 BLK - *MAGNADYNE G46WI
	110272-01-000	EA	BRACKET-ANTENNA
	090944-01-000	EA	ANTENNA-RADIO, 16" RUBBER

### TV

KEY	PART NUMBER	U/M	DESCRIPTION	VENDOR NO.
	086777-01-000	EA	WALLPLATE-TV CABLE, W/ANTENNA SWITCH - IVORY	
	113684-01-000	EA	TV-19" COLOR UL AND CSA - AUDIOVOX AVT-1975	
	113684-01-700	EA	REMOTE	8822345
	076319-03-000	FT	CABLE-COAXIAL, 75 OHM	
	076319-12-000	EA	CONNECTOR-COAXIAL, ONE PIECE	
	082134-01-000	EA	ADAPTER-TV, CABLE TO CABLE - WINEGARD F-81M	
	076319-06-000	EA	ADAPTER-CABLE ROOF PLATE, WINEGARD RPJ-1	
	076319-08-000	EA	WALLPLATE-CABLE RECEPTACLE, TV - SINGLE - IVORY	
	082136-01-000	EA	NUT-HEX JAM 3/8-32, WINEGARD	

## BATH GROUP

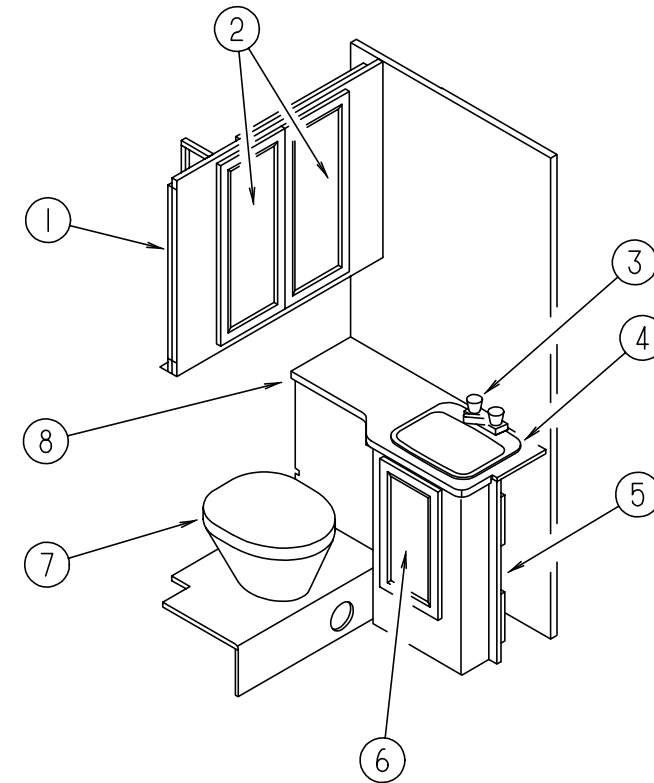

### BATHROOM CABINET & COMPONENTS

KEY	PART NUMBER	U/M	DESCRIPTION	VENDOR NO.
1	116877-01-GB1	EA	CABINET ASM-LINEN/MEDICINE	
2	110140-64-G01	EA	DOOR-MTRD/RAD VNYL 0305 X 0740	
3	075240-06-000	EA	FAUCET-LAVATORY, BONE	
	091253-01-000	EA	GASKET-FAUCET, LAVATORY/GALLEY	
4	096927-01-01A	EA	SINK-LAVATORY, RECTANGULAR - PLASTIC - BONE	
	096927-01-700	EA	PLUG	M9801
	096927-01-701	EA	TAILPIECE	M9802
5	P16875-01-GD1	EA	CABINET ASM-LAVATORY	
6	110140-33-G01	EA	DOOR ASM - MITERED - VINYL WRAP - 0305 X 0555	
	105394-01-05A	EA	EXTR-DOOR JAMB	
	075452-02-000	EA	HOLDER - TOILET TISSUE - BRASS	
	075453-02-000	EA	BAR-TOWEL - 18" BRASS	
7	067487-01-000	EA	TOILET-12.37", IVORY - HAND FLUSH - THETFORD 150110	
8	116875-11-GD1	EA	COUNTERTOP ASM	
	116875-11-GC1	EA	COUNTERTOP ASM	
	M87868-29-GB1	EA	DOOR ASM - BATH	
	094485-03-01A	EA	KNOB-DOOR, BRASS	
	102920-01-01A	EA	HINGE-DOOR, SPRING LOADED - BRASS	
	110496-01-01A	EA	HINGE-BRASS	

## BATH GROUP (CONTINUED)

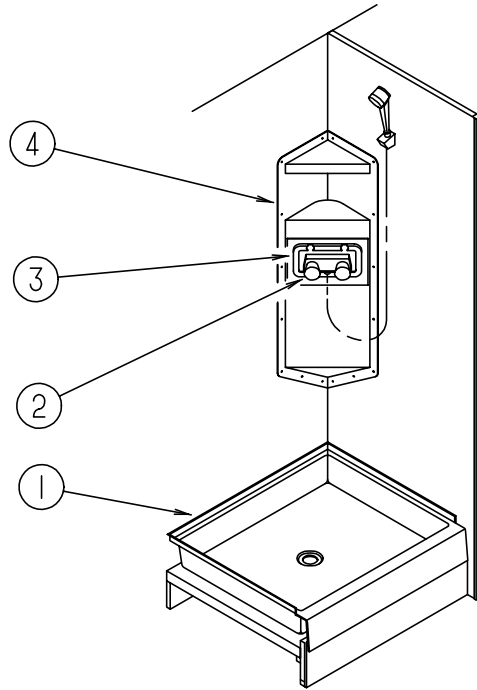

### BATHROOM SHOWER & COMPONENTS

KEY	PART NUMBER	U/M DESCRIPTION
1	M02673-05-B13	EA PAN-SHOWER, 29.8" X 22.7" .X 5.7" - OFF WHITE - PLASTIC
	066436-01-000	EA NUT-SLIP, TAILPIECE - 1.5"
	066440-01-000	EA STRAINER-SHOWER, W/RUBBER WASHER
	069735-01-000	EA WASHER-STRAINER TO TAILPIECE PLASTIC, 1.5"
2	109801-01-01A	EA FAUCET-SHOWER CONTROL - PARCHMENT - BPC 20-154P01
3	075606-01-000	EA PANEL-FAUCET BACK - SHOWER - 5" X 9" - PLASTIC
4	105707-01-01A	EA CADDY-SHOWER
	117431-01-01A	EA DOOR-SHOWER, FABRIC, PLEATED 29.6 X 63.0 - UNITED SH
	117431-01-700	EA TRACK-TOP, ALUM. IVORY INSERT 39 3/8
	117431-01-701	EA TRACK-BOTTOM, 39 3/8
	117431-01-702	EA RAIL-SIDE, 63"
	117431-01-703	EA RAIL-STATIONARY, 63"
	117431-01-704	EA RAIL-LEAD, 63"
	117431-01-705	EA GLIDE-IVORY, TRAVELER
	117431-01-706	EA GLIDE-IVORY LEAD, TRAVELER
	117431-01-707	EA LATCH
	117431-01-708	EA HANDLES & SCREWS
	117431-01-709	EA STRAP-VINYL SHOWER

## BATH GROUP (CONTINUED)

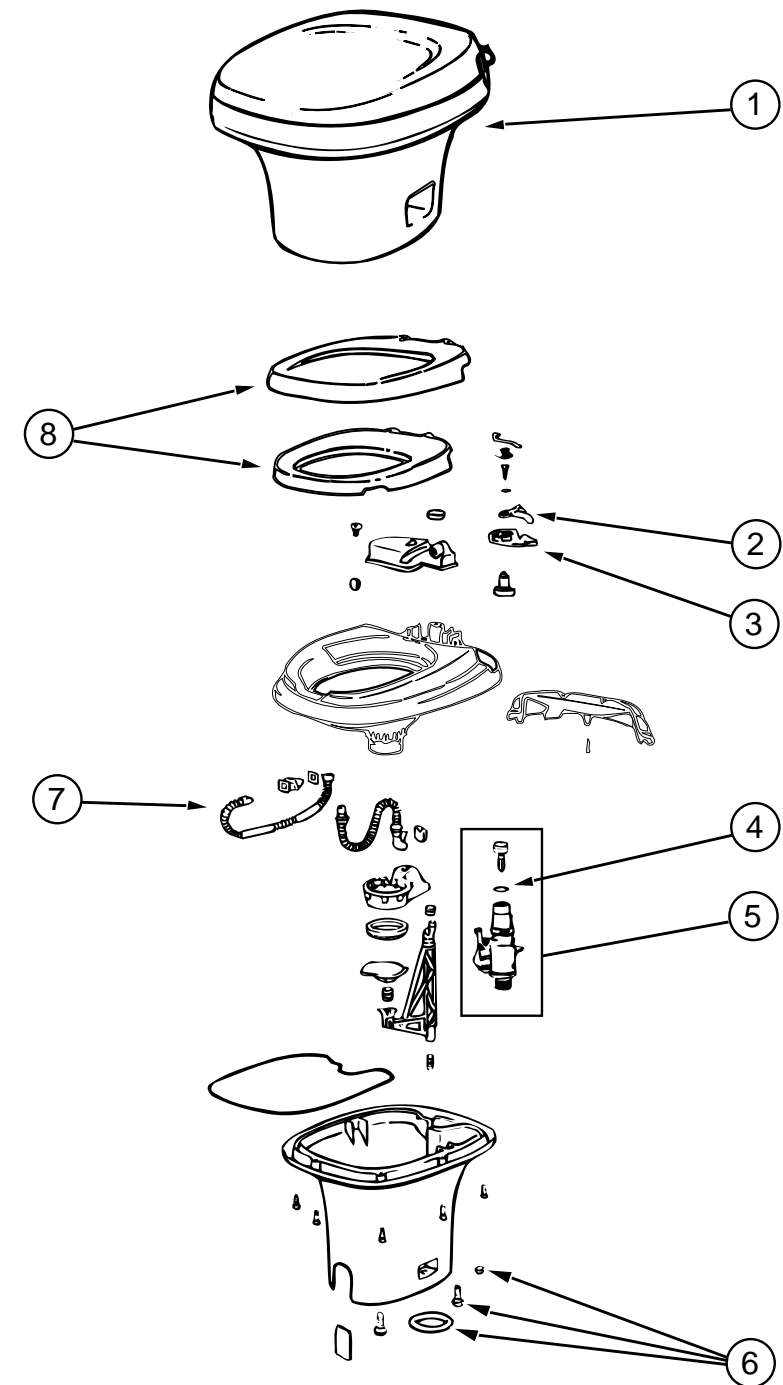

### AQUA MAGIC IV TOILET (THETFORD)

KEY	PART NUMBER	U/M DESCRIPTION	VENDOR NO.
1	067487-01-000	EA TOILET-AQUA MAGIC IV, LOW 150110	
2	063740-01-700	EA LEVER-WATER	12514
3	063740-01-701	EA LEVER-FLUSH	12515
4	063740-01-713	EA SEAL-BALL VALVE TO BOWL	12502
5	063740-01-714	EA VALVE ASSEMBLY, WATER W/FLOAT & BALL SEAL	13168
6	063740-01-706	EA BOLT PACKAGE-FLOOR FLANGE	12524
7	063740-01-717	EA TUBE-FLUSH	12509
8	063740-02-700	EA SEAT & COVER, PARCHMENT	2464157

## BEDROOM GROUP

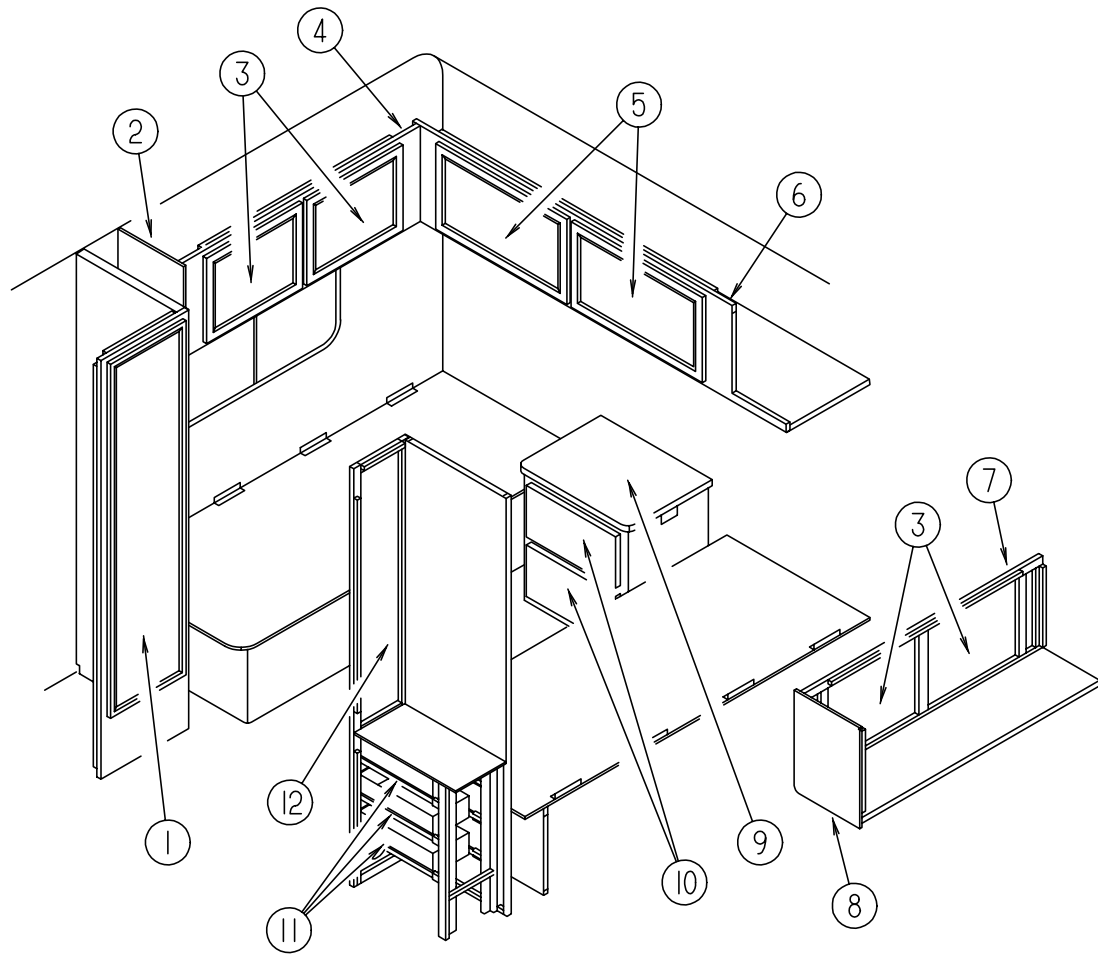

### TWIN BEDROOM

KEY	PART NUMBER	U/M	DESCRIPTION
1	110140-73-GB1	EA	DOOR ASM-MITERED - VINYL WRAP - 0410 X 1660
2	109908-31-GB1	EA	CAP ASM-END-OVERHEAD
3	110140-27-G01	EA	DOOR ASM-MITERED - VINYL WRAP - 0400 X 0520
4	117093-01-GB1	EA	CABINET ASM-OVERHEAD - RIGHT - TWIN
5	110140-21-G01	EA	DOOR ASM-MITERED - VINYL WRAP - 0400 X 0710 W/ MIRROR
5	110140-18-G01	EA	DOOR ASM-MITERED - VINYL WRAP - 0400 X 0710 W/O MIRROR
6	117092-01-GB1	EA	CABINET ASM-OVERHEAD - REAR - TWIN
7	117093-02-GB1	EA	CABINET ASM-OVERHEAD - LEFT - TWIN
8	109908-30-GB1	EA	CAP ASM-END-OVERHEAD
9	117071-11-GD1	EA	COUNTERTOP ASM
9	117071-11-GC1	EA	COUNTERTOP ASM (GE1)
10	P10163-N3-GB1	EA	DRAWER COMPLETE-SLIDE
	P17071-01-GD1	EA	CABINET ASM-NIGHTSTAND
	P17070-01-GB1	EA	CABINET ASM-BED - TWIN - LEFT
	P17069-01-GB1	EA	CABINET ASM-BED - TWIN - RIGHT
	098442-02-GB1	EA	LEG ASM-BED
11	P10163-N0-GB1	EA	DRAWER COMPL-SLIDE
12	110140-72-GB1	EA	DOOR ASM-MITERED - VINYL WRAP - 0255 X 1220

## BEDROOM GROUP (CONTINUED)

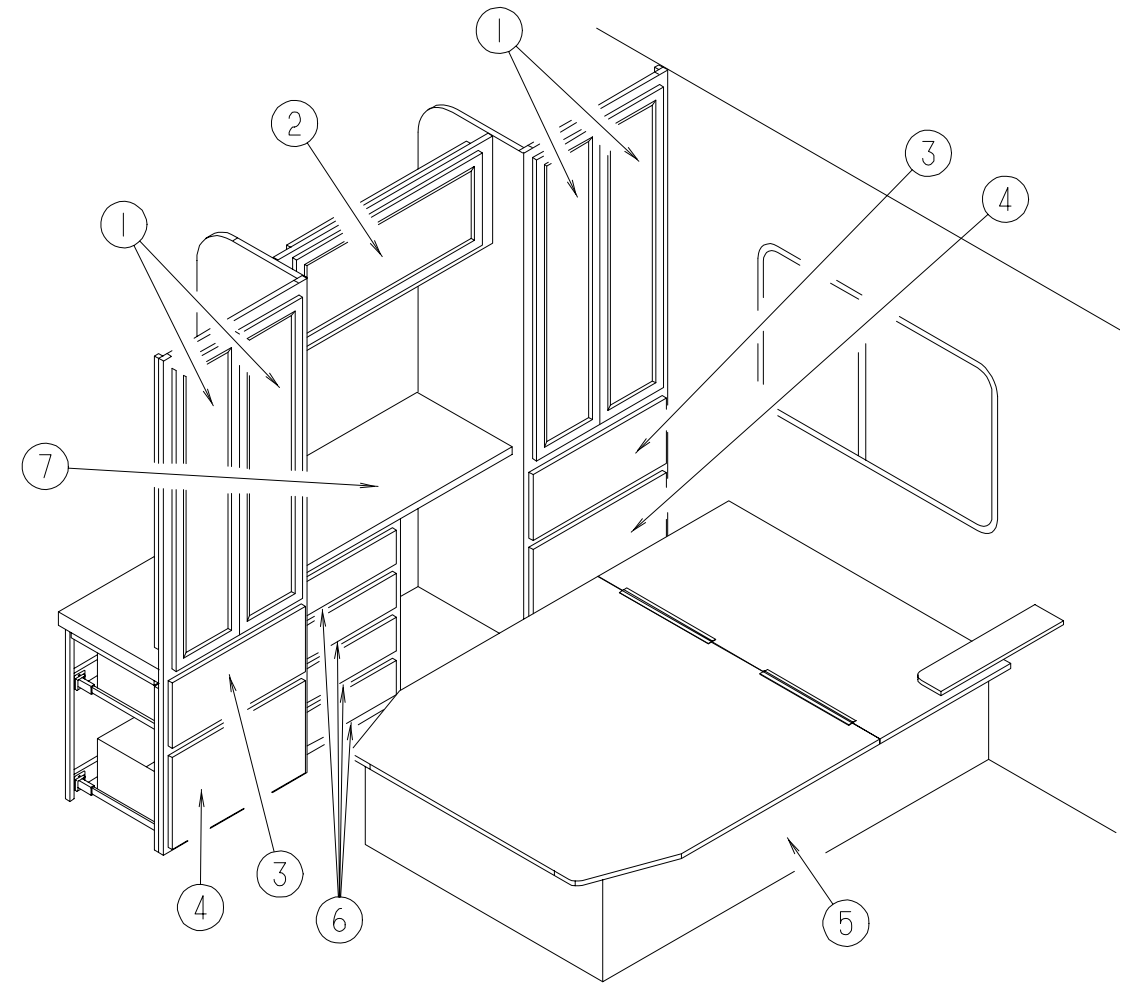

### DOUBLE BEDROOM

KEY	PART NUMBER	U/M	DESCRIPTION
1	P16841-01-G01	EA	DOOR ASM-WARDROBE,BI-FOLD
2	P16836-01-GB1	EA	CABINET ASM-OVERHEAD - REAR
2	110140-65-G01	EA	DOOR ASM-MITERED - VINYL WRAP - 0365 X 0850 - W/MIRROR
2	110140-05-G01	EA	DOOR ASM-MITERED - VINYL WRAP - 0365 X 0850 - W/O MIRROR
2	108536-13-08A	EA	MIRROR - GLASS GALAXY FLOWER
3	P10163-M0-G01	EA	DRAWER COMPLETE - SLIDE
4	P10163-M1-G01	EA	DRAWER COMPLETE - SLIDE
5	P16839-01-GB1	EA	CABINET ASM-DOUBLE BED
	098442-02-GB1	EA	LEG ASM-BED
6	P10163-M2-G01	EA	DRAWER COMPLETE - SLIDE
	P16840-01-GD1	EA	CABINET ASM - DRESSER - REAR - DOUBLE BED
7	116840-11-GD1	EA	COUNTERTOP ASM
7	116840-11-GC1	EA	COUNTERTOP ASM (GE1)

### BEDROOM GROUP (CONTINUED)

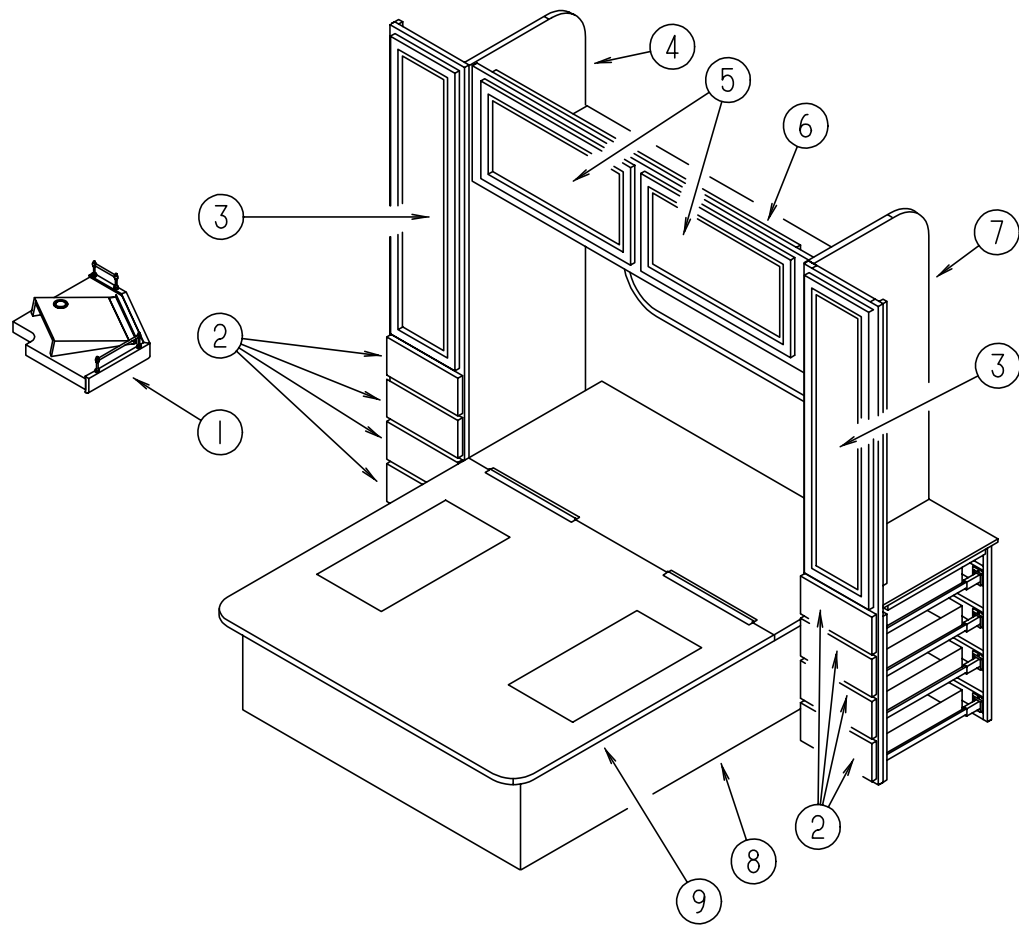

**QUEEN BEDROOM**

KEY	PART NUMBER	U/M	DESCRIPTION
1	120676-01-GB1	EA	CABINET ASM-TV,REAR
2	P10163-M6-GB1	EA	DRAWER COMPL-SLIDE
3	110140-22-G04	EA	DOOR-MITERED VINYL 0305 X 1220
4	P17288-01-GB1	EA	CABINET ASM-WARDROBE,REAR,RH
5	110140-21-G01	EA	DOOR ASM-MITERED,VINYL WRAP 0400 X 0710
6	P17061-01-GB1	EA	CABINET ASM - OVERHEAD - REAR - QUEEN BED
7	P17064-01-GB1	EA	CABINET ASM - WARDROBE,REAR,LH
8	P16997-01-GB1	EA	CABINET ASM-BED,QUEEN
9	M07501-01-FB1	EA	QUEEN BED TOP
	119670-01-GB1	EA	CABINET ASM-BATH

### BEDROOM GROUP (CONTINUED)

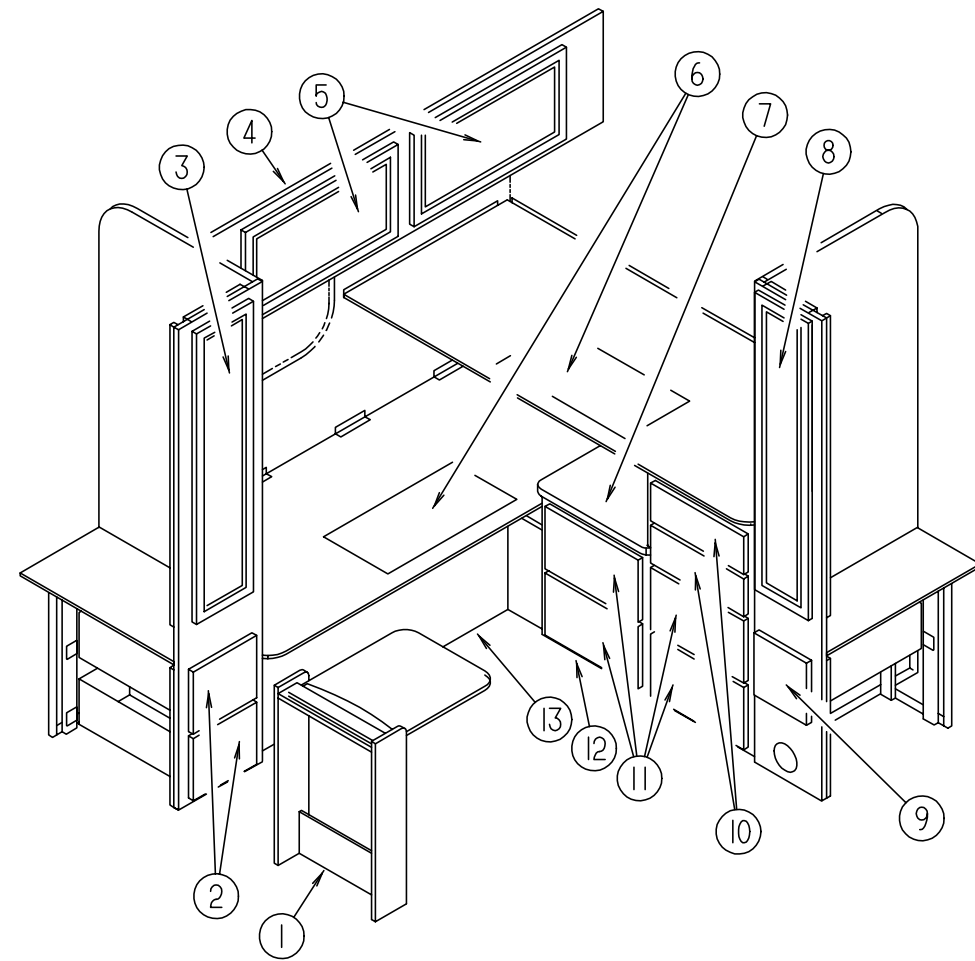

**CROSSED TWIN BEDROOM**

KEY	PART NUMBER	U/M	DESCRIPTION
1	M96873-01-G01	EA	TABLE ASM-PULLOUT - PARTS BREAKDOWN SHOWN ON PAGE D-22
2	P10163-V6-GB1	EA	DRAWER COMPL-SLIDE
3	110140-22-G04	EA	DOOR-MITERED VINYL 0305 X 1220
4	120470-01-GB1	EA	CABINET ASM-OVERHEAD,REAR
5	110140-21-G01	EA	DOOR ASM-MITERED,VINYL WRAP OVERHEAD 0400 X 0710
	042438-51-012	EA	DOWEL-WOOD 1.0DIA. X 0320 MM
	042438-51-013	EA	DOWEL-WOOD 1.0DIA. X 0270 MM
6	091261-01-000	FT	BACKING-NON-SKID, 12"X100'
7	120442-11-GD1	EA	COUNTERTOP ASM
7	120442-11-GC1	EA	COUNTERTOP ASM (GE1)
8	110140-72-GB1	EA	DOOR-MTRD/RAD VNYL 0255 X 1220
9	P10163-W6-GB1	EA	DRAWER COMPL-SLIDE
10	P10163-V8-GB1	EA	DRAWER COMPL-SLIDE
11	P10163-V7-GB1	EA	DRAWER COMPL-SLIDE
11	P10163-W7-GB1	EA	DRAWER COMPL-SLIDE
12	120442-01-GD1	EA	CABINET ASM-DRESSER,LH
13	P20469-01-GB1	EA	CABINET ASM-BED,TWIN,REAR

FROM: 00-00-00 THRU: 08-20-95

FROM: 08-21-95 THRU: 99-99-99

**BEDROOM GROUP (CONTINUED)**

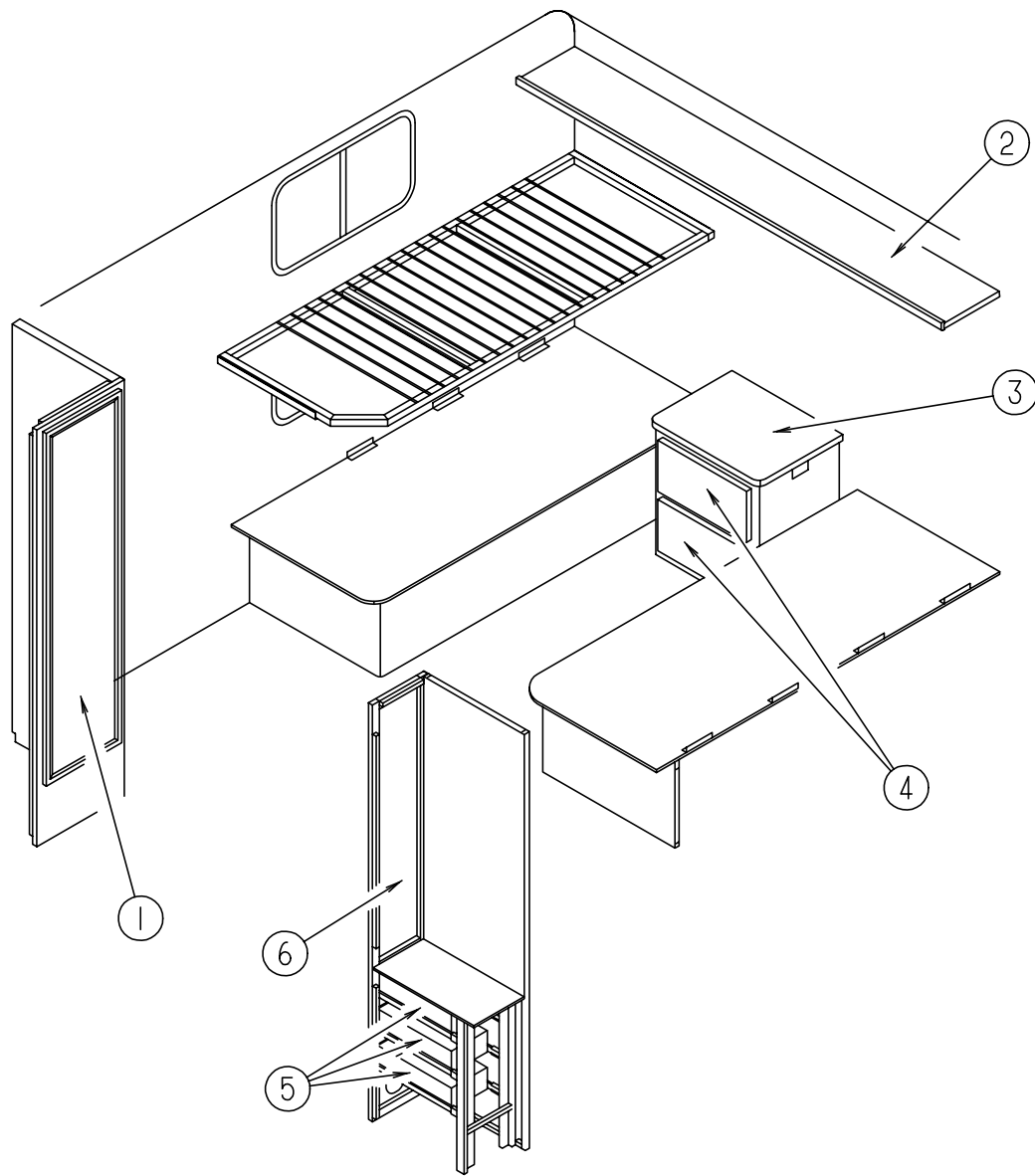

**TWIN & BUNK BEDROOM**

KEY	PART NUMBER	U/M	DESCRIPTION
1	110140-73-GB1	EA	DOOR ASM-MITERED - VINYL WRAP - 0410 X 1660
2	117090-01-G01	EA	CABINET ASM-OVHD,SHELF
	098442-02-GB1	EA	LEG ASM-BED
	091261-01-000	FT	BACKING-NON-SKID, 12" X 100'
	105376-01-02A	EA	HINGE-CONTIN, 2" X 140MM O/W
3	117071-11-GD1	EA	COUNTERTOP ASM
3	117071-11-GC1	EA	COUNTERTOP ASM (GE1)
	P17071-01-GD1	EA	CABINET ASM-NIGHTSTAND
4	P10163-N3-GB1	EA	DRAWER COMPL-SLIDE - NIGHTSTAND
5	P10163-N0-GB1	EA	DRAWER COMPL-SLIDE - WARDROBE
6	110140-72-GB1	EA	DOOR ASM-MITERED - VINYL WRAP - 0255 X 1220

**BEDROOM GROUP (CONTINUED)**

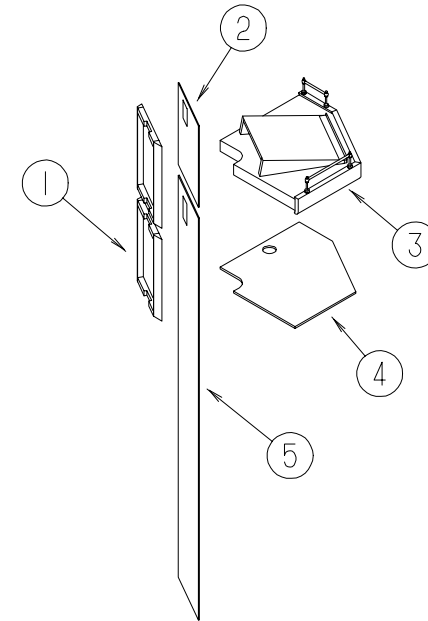

**T.V. SHELF USED W/ QUEEN BED & CROSSED STACKED TWIN BED**

KEY	PART NUMBER	U/M	DESCRIPTION
1	120676-19-000	EA	FRAME ASM - WALL - TV CABINET
2	120676-20-GB1	EA	PANEL - UPPER CORNER WALL - TV CABINET
3	120676-01-GB1	EA	CABINET ASM-TV,REAR
4	120676-12-GB1	EA	PANEL - LOWER - TV CABINET
5	120676-21-GB1	EA	PANEL - LOWER CORNER WALL - TV CABINET

### CHASSIS GROUP

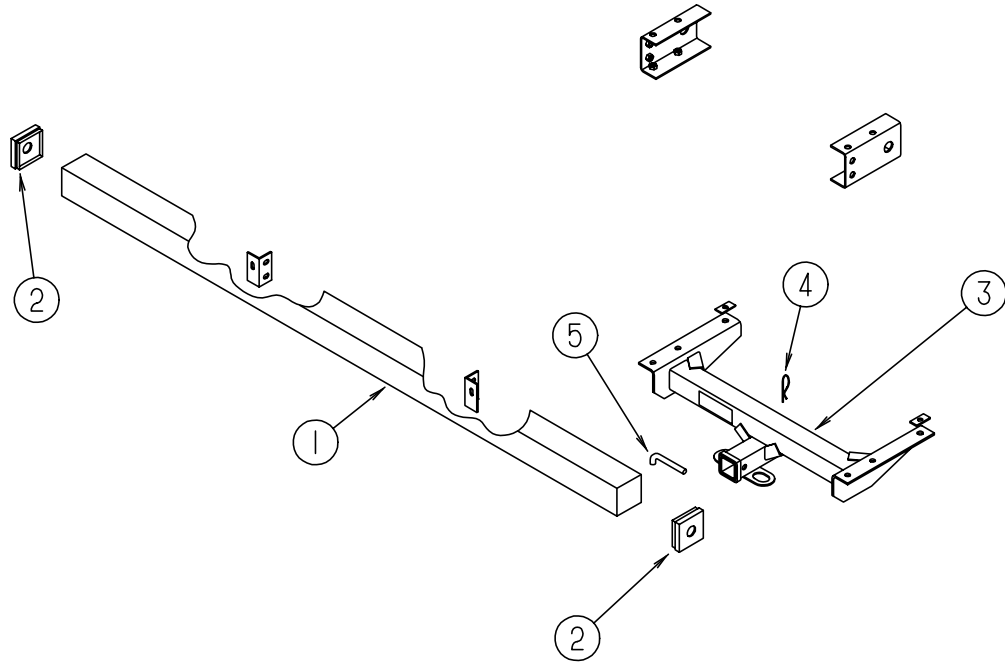

### CHASSIS GROUP (CONTINUED)

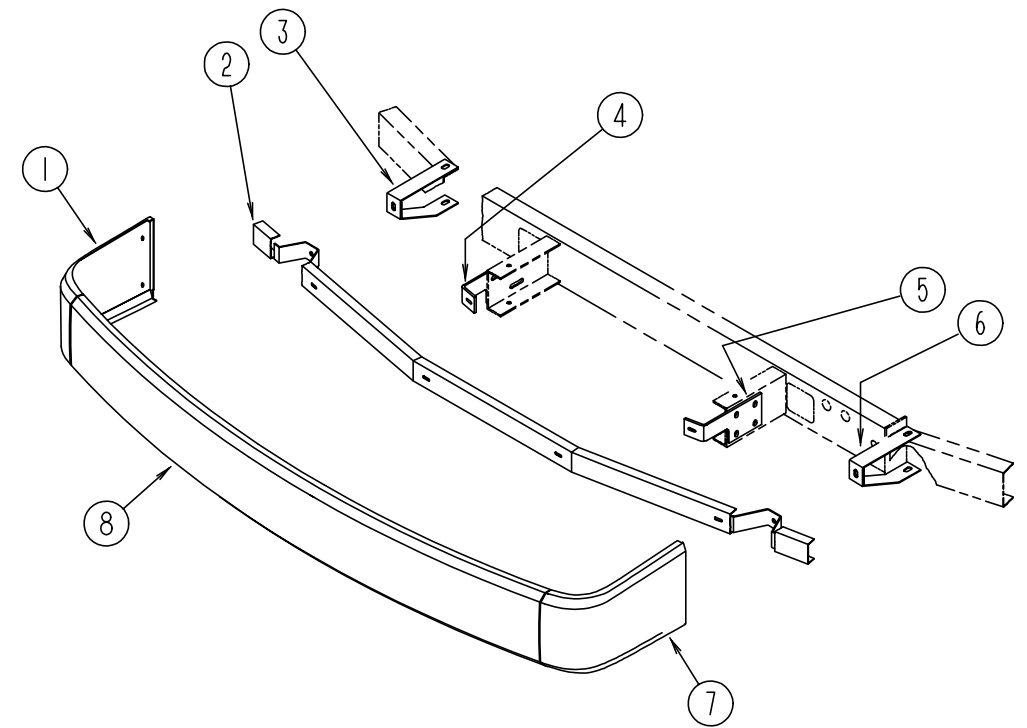

#### REAR BUMPER, TRAILER HITCH & COMPONENTS

KEY	PART NUMBER	U/M	DESCRIPTION
1	110231-01-FB1	EA	BUMPER ASM-REAR
2	039779-01-000	EA	CAP-BUMPER, RUBBER - 4" X 4" - BLACK
3	107707-01-000	EA	HITCH ASM-DRAWBAR, CLASS II
4	034513-01-000	EA	PIN-HITCH, 3/16" WIRE
5	034512-01-000	EA	PIN-LOCKING, DRAWBAR
	113588-02-01B	EA	BRACKET-CONNECTOR,TRLR,MILL
	109738-01-01A	EA	BRACKET-BUMPER MILL
	113589-02-000	EA	CONNECTOR-SOCKET, TRAILER - GENERAL 433601
	113589-01-000	EA	CONNECTOR-PLUG, TRAILER - GENERAL 433501

#### FRONT BUMPER

KEY	PART NUMBER	U/M	DESCRIPTION
1	103625-01-04A	EA	PANEL-FACIA, BUMPER FRONT RIGHT - BRIGHT WHITE
2	103512-01-000	EA	CHANNEL ASM-BUMPER
3	103497-01-000	EA	BRACE-BUMPER, FRONT
4	086140-03-000	EA	SUPPORT-FRONT BUMPER, PASSENGER SIDE - 9.1" X 4" - STEEL
5	086140-04-000	EA	SUPPORT-FRONT BUMPER, DRIVER SIDE - 9.1" X 4" - STEEL
6	103611-01-000	EA	BRACE-BUMPER, FRONT
7	103625-02-04A	EA	PANEL-FACIA, BUMPER FRONT LEFT - BRIGHT WHITE
8	103626-01-04A	EA	PANEL-FACIA, BUMPER FRONT - BRIGHT WHITE
8	103634-01-FB1	EA	BUMPER ASM-FRONT, W/RIGHT & LEFT FACIAS - BRIGHT WHITE
	094362-02-000	EA	CLIP-CHRISTMAS TREE, FLAT HEAD - .5" X .95"



**CHASSIS GROUP (CONTINUED)****CHASSIS MISCELLANEOUS**

<b>KEY</b>	<b>PART NUMBER</b>	<b>U/M</b>	<b>DESCRIPTION</b>
	087234-01-000	EA	NUT-JACK - 1/4" X 20 THREADS - MOLLY - MOUNTS LICENSE PLATES
	080208-01-000	EA	LUG WRENCH - 1.06' X 1.00'
	080208-02-000	EA	BAR-LEVERAGE - LUG WRENCH
	008042-01-000	FT	TUBING-VINYL - .65" ID

**CHASSIS GROUP (CONTINUED)****WHEELS, TIRES & WHEEL COVER**

<b>KEY</b>	<b>PART NUMBER</b>	<b>U/M</b>	<b>DESCRIPTION</b>	<b>VENDOR NO.</b>
	109443-01-000	EA	WHEEL COVER SET - (EA = 4 WHEEL COVERS W/HARDWARE) 19.5"	
	109443-01-700	EA	COVER-WHEEL 19.5	SHAG95
	109443-01-701	EA	BRACKET-RET. FRONT WHEEL	SHAG95-FBS
	109443-01-702	EA	BRACKET-RET. REAR WHEEL	SHAG95-RBS
	109443-01-703	EA	CAP-CENTER, HUB - DICOR	SP-AUCAP
	109443-01-704	EA	CLIP-RETAINER	V160GM-PNT

### CHASSIS GROUP (CONTINUED)

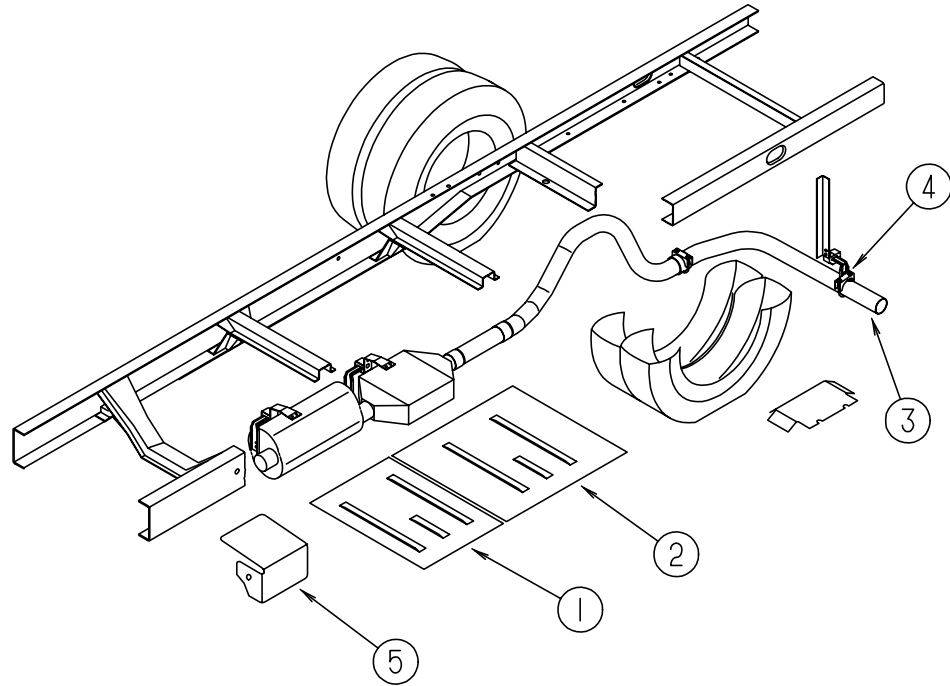

### EXHAUST SYSTEM (GAS)

KEY	PART NUMBER	U/M	DESCRIPTION
1	101544-01-000	EA	SHIELD-HEAT, EXHAUST - 19.7" X 28.9" - STEEL
2	101544-02-000	EA	SHIELD-HEAT, EXHAUST - 30" X 28.9" - STEEL
			FROM: 00-00-00 THRU: 02-11-96
2	101544-06-000	EA	SHIELD-HEAT, EXHAUST
			FROM: 02-12-96 THRU: 99-99-99
3	098762-05-000	EA	EXTENSION-EXHAUST, STRAIGHT - 3" OD X 7.9" LONG - SST
			FROM: 00-00-00 THRU: 11-26-95
4	094918-01-000	EA	CLAMP-EXHAUST - 3" - GUILLOTINE STYLE
5	119847-01-02B	EA	SHIELD-A/C CONDENSER, E-COAT
	095190-01-000	EA	HANGER-EXHAUST, 4" X 1.4"
	095222-06-000	EA	BRACKET-EXHAUST, UPPER
	095222-05-000	EA	BRACKET-EXHAUST, UPPER
	095223-03-000	EA	BRACKET-EXHAUST, LOWER
	095523-04-000	EA	BRACKET ASM-EXHAUST, UPPER
	098608-02-000	EA	PIPE-EXHAUST, SINGLE
			FROM: 00-00-00 THRU: 11-26-95
098608-03-000	EA	PIPE-EXHAUST	- BAUER WELDING
			FROM: 11-27-95 THRU: 99-99-99

### CHASSIS GROUP (CONTINUED)

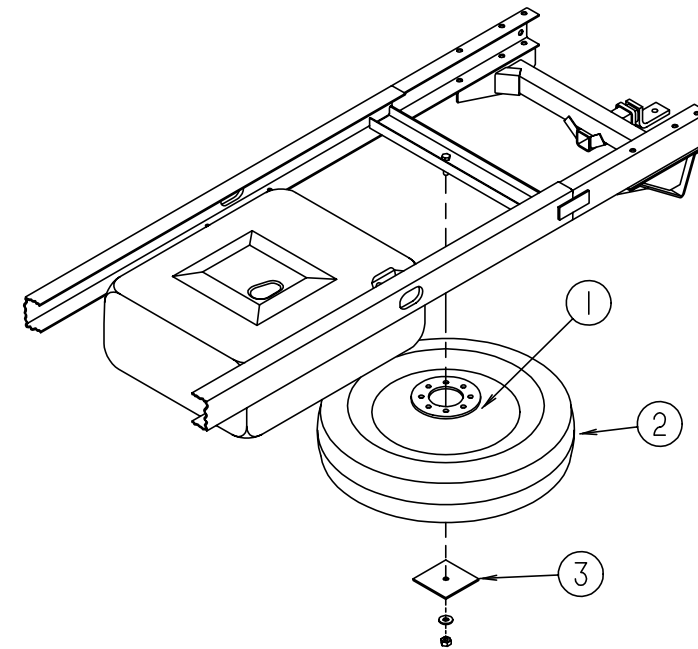

### SPARE TIRE, LUG WRENCH & BAR

KEY	PART NUMBER	U/M	DESCRIPTION
1	064963-01-000	EA	WHEEL-STEEL, 19.5" X 6" - GM 14005758
2	007324-04-000	EA	TIRE-8R19.5 LRD, MICHELIN XZA
	051377-01-000	EA	STEM-VALVE, TR 500
3	111685-01-000	EA	PLATE - SPARE TIRE
	080208-01-000	EA	LUG WRENCH, 1.06" X 1.00"
	080208-02-000	EA	BAR - LEVERAGE, LUG WRENCH

## CHASSIS GROUP (CONTINUED)

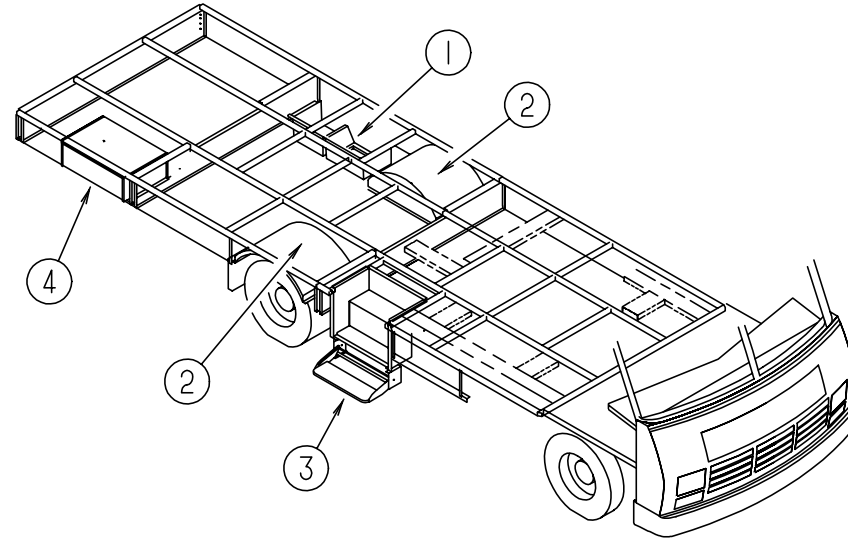

### STORAGE COMPARTMENTS & WHEELWELLS

KEY	PART NUMBER	U/M DESCRIPTION
1	M06991-04-FB1	EA HATCH ASM W/FOAM
	M06991-02-FQ0	EA HATCH ASM WATER COMPARTMENT - W/FOAM
	114677-01-01A	EA RETAINER-HATCH,COMPT MILL
	116926-01-01A	EA COMPARTMENT-SEWER
2	055080-01-000	EA WHEELWELL-PLASTIC -REAR - BLACK - LEFT OR RIGHT
	065450-05-000	EA TIEDOWN-BATTERY, 8.4" TUBE
	103147-01-000	EA TRAY-BATTERY
3	077848-06-000	EA STEP-PULLOUT - W/BRACKETS - BLACK
	115361-01-01A	EA PLUG-PLASTIC
4	094657-02-000	EA TRAY-GENERATOR, 22.5" X 30.4" X 6.9" W/ANGLE & NUTS
	114070-02-02B	EA SUPPORT ASM-GENERATOR,LT,E-C
	114071-02-02B	EA SUPPORT ASM-GENERATOR,RT,E-C
	105376-01-02A	EA HINGE-CONTINUOUS,2"X140MM O/W
	017516-01-000	EA FLAP-MUD, 14" X 18" - BLACK
	001360-01-004	EA STL-ROD CR.375DIA X 028.25 IN
	033865-01-073	EA STL-11GA HRP&O 02.00 X 027.40
	119847-01-02B	EA SHIELD-A/C CONDENSER,E-COAT

## CHASSIS GROUP (CONTINUED)

### FUEL SYSTEM

KEY	PART NUMBER	U/M DESCRIPTION
	102951-01-06A	EA SHROUD-FUEL FILL,BRIGHT WHITE
	102951-01-01A	EA SHROUD-FUEL FILL-UNFINISHED
	073220-02-000	EA CAP-FILL, FUEL - NON LOCKING - GAS - GM 22525302
	078200-01-000	EA GASKET-FUEL FILL, 3.5"OD X 2"ID
	098803-01-000	EA PIPE-FUEL FILL, 90 DEGREE BEND - 13.2" - 1 3/4" OD - STEEL FROM: 00-00-00 THRU: 01-08-96
	098803-02-000	EA PIPE-FUEL,FILL FROM: 01-09-96 THRU: 99-99-99
	098807-01-000	EA PIPE-FUEL,FILL - CENTER - W/BEND
	087256-10-000	EA NECK ASM-FUEL FILL
	N/A	EA NECK-FUEL FILL, LOWER W/BEND - 9.3" LONG - GM14042359
	066732-01-000	FT HOSE-FUEL FILL,.62 ID
	007063-01-000	FT HOSE-GAS 1/4"ID X 1/2"OD
	098806-01-000	EA PIPE-FILL VENT, 90 DEGREE BEND - .625" OD - STEEL
	068382-06-000	EA BUSHING-BRASS,3/8MPTX1/8FPT - PARKER 209P-6-2 FROM: 03-20-95 THRU: 99-99-99
	084884-01-000	EA PLUG-BRASS, 3/8"

## CURTAIN & CUSHION GROUP

### NOTICE

IN ORDER TO ASSIST OUR PARTS SALES DEPT. IN PROVIDING INTERIOR SOFTGOODS ITEMS, PLEASE INCLUDE THE SERIAL NUMBER AND THE COLOR CODE NUMBER FROM THE VEHICLE CERTIFICATION LABEL WHEN ORDERING. THIS LABEL IS LOCATED ON THE LEFT SIDEWALL AT THE END OF THE DASH (A-BODY), OR ON THE DRIVER'S DOOR LATCH PLATE (C-BODY).

AN EXAMPLE OF A COLOR CODE NUMBER IS B07, WHICH DESIGNATES AN OVERALL COLOR SCHEME OF A PARTICULAR UNIT. THE COLOR LISTED AFTER THE ITEM DESCRIPTION ON THE MICROFICHE, INDICATES THE OVERALL UNIT COLOR. ORDER THE ITEM YOU DESIRE ACCORDING TO UNIT COLOR CODE.

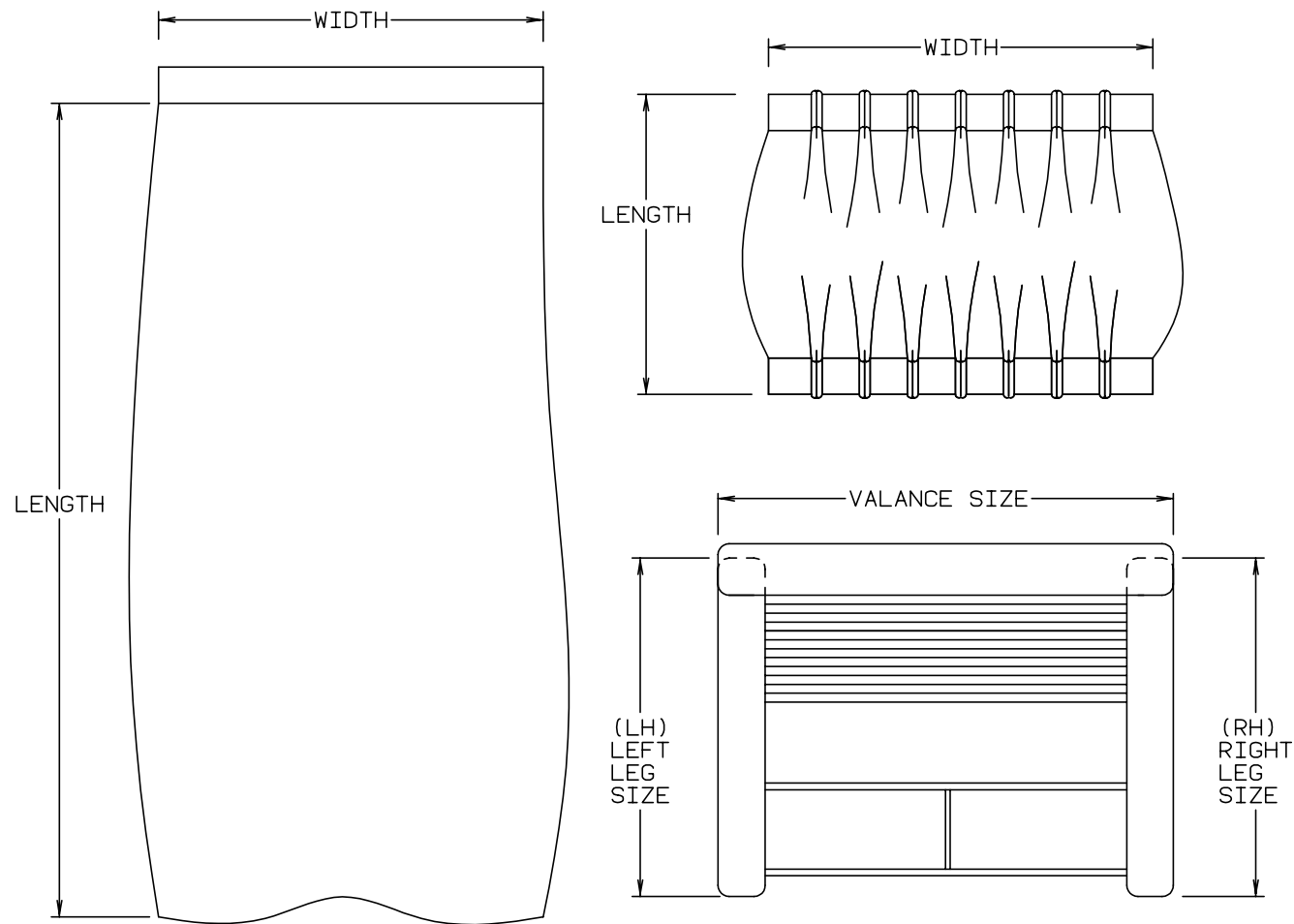

NOTE: USE THIS ILLUSTRATION WHEN DETERMINING LENGTH AND WIDTH MEASUREMENTS FOR CURTAINS. YOU WILL NOTE THE WIDTH MEASUREMENT IS TAKEN ON THE TOP OF THE CURTAIN WITH THE CURTAIN FULLY EXTENDED. THE LENGTH MEASUREMENT IS TAKEN FROM TOP TO BOTTOM. LEFT AND RIGHT WINDOW LEGS ARE DETERMINED WHEN FACING THE WINDOW.

## CURTAIN & CUSHION GROUP (CONTINUED)

### PASSAGE FABRICS

COLOR CODES	GD1	GE1
MARKETING COLORS	MISTY MORN (PARCHMENT)	MESA (BRICK/TAN)
BUCKET SEATS	108446-B4-000 108446-G4-000	108446-G5-000 108446-F3-000
DINETTE	108446-E9-000	108446-F0-000
DINETTE PADS	108446-B4-000	108446-G5-000
SOFA	108446-E9-000	108446-F0-000
SWIVEL CHAIR	108446-G4-000	108446-F3-000
LOUNGE WINDOWS	108446-B4-000 108446-G4-000	108446-G5-000 108446-F3-000
BEDROOM WINDOW	105745-B3-000	105745-A8-000
BEDSPREAD	105745-B3-000 105745-62-000	105745-A8-000 105745-A9-000
PILLOW SHAMS	105745-B3-000 105745-62-000	105745-A8-000 105745-A9-000
PULL SHADE BEDROOM	084416-29-000	084416-29-000
BUNK BED	105745-B3-000	105745-A8-000
FRONT WRAP AROUND	105745-62-000	105745-A9-000
DIVIDER CURTAIN	105745-62000 105745-B3-000	105745-A9-000 105745-A8-000
SHOWER CURTAIN	075244-07-000	075244-03-000
VINYL - OFF WHITE	103907-01-01A	103907-01-01A
DRAPERY LINING	087272-03-000	087272-03-000
VINYL - SUNVISOR	106569-01-01A	106569-01-01A

NOTE: THE FABRIC LISTED FIRST, IN A BLOCK, IS THE LARGEST QUANTITY OF FABRIC USED.

**CURTAIN & CUSHION GROUP (CONTINUED)**

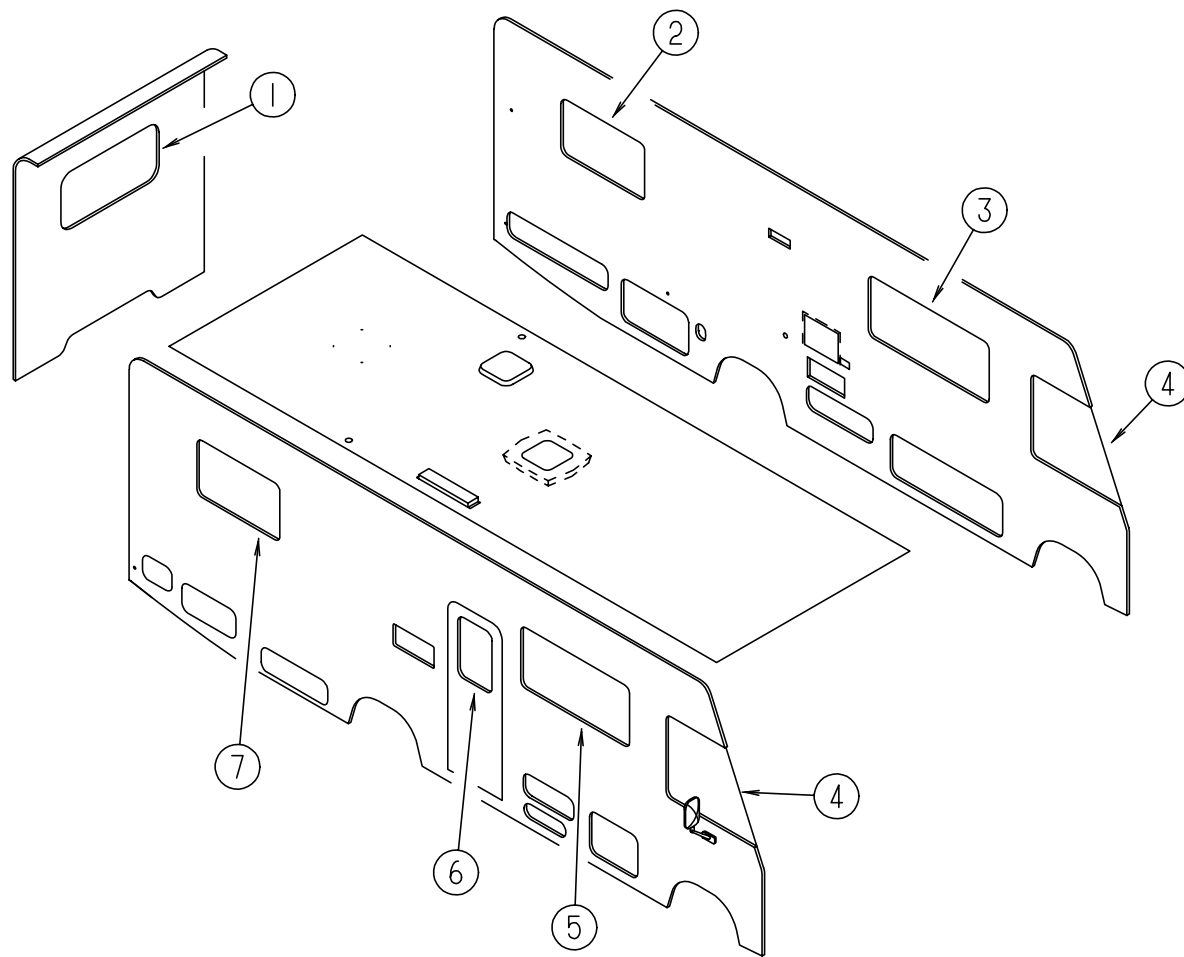

**WINDOW TREATMENT**

KEY	PART NUMBER	U/M DESCRIPTION
1	118064-01-GB1	EA VALANCE ASM-VALENCIA - 52"(GD1)
1	118064-01-GC1	EA VALANCE ASM-VALENCIA - 52"(GE1)
1	084755-92-F15	EA SHADE ASM-PULL - 50.25" (GD1, GE1)
1	111910-19-G22	EA BLIND - DAY/NIGHTER - 50 X 28 (GD1)
1	111910-19-F09	EA BLIND - DAY/NIGHTER - 50 X 28 (GE1)
1	118071-02-GD1	EA VAL-29" SUNDANCE (5") (GD1)
1	118071-02-GE1	EA VAL-29" SUNDANCE (5") (GE1)
1	084755-57-E07	EA SHADE ASM-PULL - 27.25" (GD1, GE1)
1	111910-20-GB1	EA BLIND - DAY/NIGHTER - 28 X 28 (GD1)
1	111910-20-F09	EA BLIND - DAY/NIGHTER - 28 X 28 (GE1)
2	118064-02-GB1	EA VALANCE ASM-VALENCIA - 44" (GD1)
2	118064-02-GC1	EA VALANCE ASM-VALENCIA - 44" (GE1)
2	084755-93-F15	EA SHADE ASM-PULL - 42.25 (GD1, GE1)
2	111910-46-G22	EA BLIND - DAY/NIGHTER - 43 X 26 (GD1)
2	111910-46-GE1	EA BLIND - DAY/NIGHTER - 43 X 26 (GE1)
2	101034-49-GB1	EA CURTAIN - 19 X 19 - RIGHT - DART TAPE T&B (GD1)
2	101034-49-GC1	EA CURTAIN - 19 X 19 - RIGHT - DART TAPE T&B (GE1)
2	101034-50-GB1	EA CURTAIN - 19 X 19 - LEFT - DART TAPE T&B (GD1)
2	101034-50-GC1	EA CURTAIN - 19 X 19 - LEFT - DART TAPE T&B (GE1)
3	118071-05-GD1	EA VAL-64.5" SUNDANCE (5")
3	118071-05-GE1	EA VAL-64.5" SUNDANCE (5")
3	119333-01-GD1	EA LEG-RIGHT - 25"-PLAIN - NO HOLE 3.5" FACE,WOOD

**CURTAIN & CUSHION GROUP (CONTINUED)**

**WINDOW TREATMENT (CONTINUED)**

KEY	PART NUMBER	U/M DESCRIPTION
3	119333-01-GE1	EA LEG-RT.,25",PLAIN,NO HOLE
3	119333-02-GD1	EA LEG-LT.,25",PLAIN,NO HOLE
3	119333-02-GE1	EA LEG-LT.,25",PLAIN,NO HOLE
3	084755-96-G01	EA SHADE ASM-PULL - 60.25 - NO TRIM (GD1, GE1)
3	111910-22-GB1	EA BLIND - DAY/NIGHTER - 60 X 28.5 (GD1)
3	111910-22-G08	EA BLIND - DAY/NIGHTER - 60 X 28.5 (GE1)
4	101668-31-FC1	EA CURTAIN - TAPE TOP, 38" X 80" - DRIVERS (GD1)
4	101668-31-GE1	EA CURTAIN - TAPE TOP, 38" X 80" - DRIVERS (GE1)
4	101668-30-FC1	EA CURTAIN - TAPE TOP, 38" X 80" - PASSENGERS (GD1)
4	101668-30-GE1	EA CURTAIN - TAPE TOP, 38" X 80" - PASSENGERS (GE1)
4	073260-42-FC1	EA TIEBACK ASM-6X18 (GD1)
4	073260-42-GE1	EA TIEBACK ASM-6X18 (GE1)
5	118071-03-GD1	EA VAL-58.5" SUNDANCE (5")
5	118071-03-GE1	EA VAL-58.5" SUNDANCE (5")
5	119333-01-GD1	EA LEG-RT.,25",PLAIN,NO HOLE
5	119333-01-GE1	EA LEG-RT.,25",PLAIN,NO HOLE
5	119333-02-GD1	EA LEG-LT.,25",PLAIN,NO HOLE
5	119333-02-GE1	EA LEG-LT.,25",PLAIN,NO HOLE
5	084755-69-F15	EA SHADE ASM-PULL - 55.25 - NO TRIM (GD1, GE1)
5	111910-23-GB1	EA BLIND - DAY/NIGHTER - 54 X 28.5 (GD1)
5	111910-23-GE1	EA BLIND-DAY/NIGHTER,54X28.5 (GE1)
6	118071-02-GD1	EA VAL-29" SUNDANCE (5") (GD1)
6	118071-02-GE1	EA VAL-29" SUNDANCE (5") (GE1)
6	084755-95-FB1	EA SHADE ASM-PULL - 25.5" NO TRIM (GD1, GE1)
7	118064-02-GB1	EA VALANCE ASM-VALENCIA - 44" (GD1)
7	118064-02-GC1	EA VALANCE ASM-VALENCIA - 44" (GE1)
7	084755-93-F15	EA SHADE ASM-PULL - 42.25 (GD1, GE1)
	101668-53-GD1	EA CURT ASM 70 X 60 TAPE TOP (GD1)
	101668-53-GE1	EA CURT ASM 70 X 60 TAPE TOP (GE1)
	073260-63-GB1	EA TIEBACK ASM - 4" X 15" (ROOM DIVIDER)
	073260-63-GC1	EA TIEBACK ASM - 4" X 15" (ROOM DIVIDER)

**FABRIC TRIMS, SEAT BELTS & ASSIST HANDLE**

KEY	PART NUMBER	U/M DESCRIPTION
	007021-01-000	EA BELT-SEAT, 2" X 90" - BLACK
	070578-02-B10	EA BUTTON-SCREW STUD, #30 - VINYL - OFF WHITE
	070578-02-B29	EA BUTTON-SCREW, STUD - #30 - VINYL
	056271-01-000	EA BELT-SEAT, 2" X 102" - BLACK
	079349-04-F16	YD WELT ASM-NARROW,ACCENT (GD1)(GE1)
	079349-04-GE1	YD WELT ASM-NARROW,ACCENT (GE1)
	079349-04-GD1	YD WELT ASM-NARROW,ACCENT (GD1)
	057759-01-000	EA WASHER BRACKET-SEAT BELT, 4" DIAMETER
	007021-01-000	EA BELT-SEAT, 2" X 90" - BLACK
	056271-01-000	EA BELT-SEAT, 2" X 102" - BLACK
	057759-01-000	EA WASHER BRACKET-SEAT BELT, 4" DIAMETER
	069178-02-000	EA BRACKET-MOUNTING, ASSIST HANDLE - L ANGLE - W/HOLES - ST
	000C16-07-16B	EA BOLT-CARRIAGE, ASSIST HANDLE - 7/16" - 14 X 1" ZN
	000D20-07-00B	EA NUT-ACORN,ASSIST HANDLE - 7/16" X 14 ZN
	053552-02-AA8	EA HANDLE-ASSIST, INTERIOR - ENTRY DOOR - VINYL - OFF WHITE

## CURTAIN & CUSHION GROUP (CONTINUED)

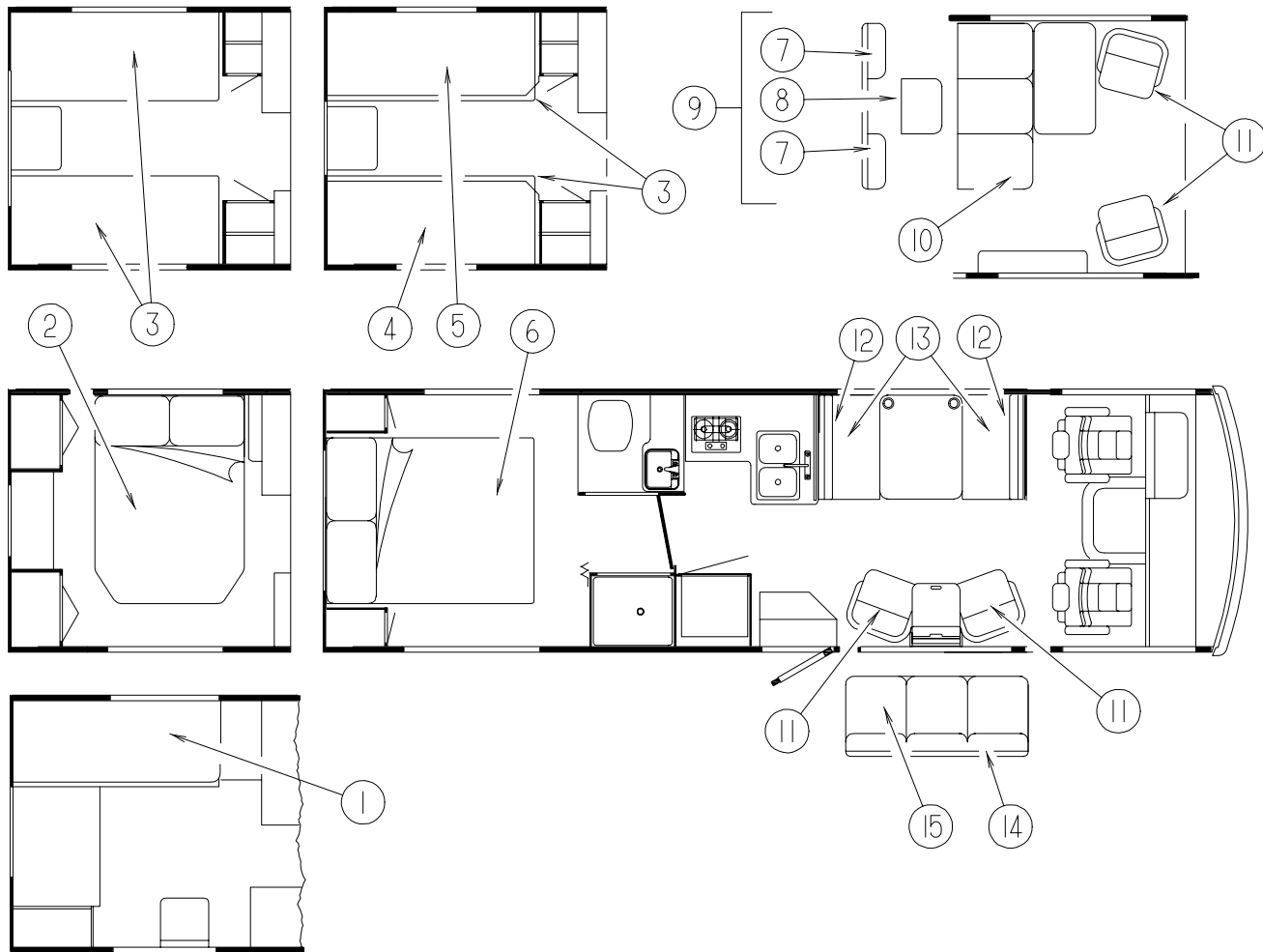

### BUNKS BED CUSHIONS

KEY	PART NUMBER	U/M DESCRIPTION
4	101123-24-000	EA MATTRESS-COMPLETE-FOAM 30 X 76 X 4 - W/LT.CUT CORNER
	P01123-24-000	EA COVER-MATTRESS - 30 X 76 X 4
	117067-02-GB1	EA COVER-FITTED SHEET,LT.4"(GD1)
	117067-02-GC1	EA COVER-FITTED SHEET,LT.4" (GE1)
	102161-36-GD1	EA SHAM - 1/2"NON-GATHERED WELT W/4" RUFFLE (20X30)
5	101123-23-000	EA MATTRESS-COMPLETE-FOAM 30 X 76 X 4 - W/RT.CUT CORNER
	P01123-23-000	EA COVER-MATTRESS - 30 X 76 X 4
	117067-01-GB1	EA COVER-FITTED SHEET,RT.4" (GD1)
	117067-01-GC1	EA COVER-FITTED SHEET,RT.4" (GE1)

### QUEEN BED CUSHIONS

KEY	PART NUMBER	U/M DESCRIPTION
6	101123-26-000	EA MATTRESS COMPLETE-FOAM - 59" X 74" X 5" (GD1, GE1)
	P01123-26-000	EA COVER-MATTRESS - 59" X 74" X 5" (GD1, GE1)
6	085365-36-GD1	EA BEDSPREAD - 60" X 75" THROW,1/2" WELT NON-GATHERING
6	085365-36-GE1	EA BEDSPREAD - 60" X 75" THROW,1/2" WELT NON-GATHERING
6	102161-35-GD1	EA SHAM - QUEEN - 1/2"NON-GATHERED WELT W/4" RUFFLE (20X33)
	102161-35-GE1	EA SHAM - QUEEN - 1/2"NON-GATHERED WEALT W/4" RUFFLE (20X33)

### CROSSED STACKED TWIN BED CUSHIONS

KEY	PART NUMBER	U/M DESCRIPTION
1	101123-19-000	EA MATTRESS-COMPLETE-FOAM 32" X 79" X 5" (GD1,GE1)
	P01123-19-000	EA COVER-MATTRESS - 32" X 74" X 5" (GD1, GE1)
	117067-03-GB1	EA COVER-FITTED SHEET,UNIV. 5" (GD1)
	117067-03-GC1	EA COVER-FITTED SHEET,UNIV. 5" (GE1)

### DOUBLE BED

KEY	PART NUMBER	U/M DESCRIPTION
2	101123-22-000	EA MATTRESS COMPLETE-FOAM - W/2 CUT CORNERS - 54" X 74" X 5" (GD1, GE1)
	P01123-22-000	EA COVER-MATTRESS - 54" X 74" X 5" (GD1, GE1)
2	085365-37-GD1	EA BEDSPREAD - 54" THROW,1/2" WELT NON-GATHERING
2	085365-37-GE1	EA BEDSPREAD - 54" THROW,1/2" WELT NON-GATHERING
2	102161-36-GD1	EA SHAM - 1/2"NON-GATHERED WELT (20X30)
	102161-36-GE1	EA SHAM - 1/2"NON-GATHERED WELT (20X30)

### TWIN BED CUSHIONS

KEY	PART NUMBER	U/M DESCRIPTION
3	101123-19-000	EA MATTRESS-COMPLETE-FOAM 32" X 79" X 5" (GD1,GE1)
	P01123-19-000	EA COVER-MATTRESS - 32" X 74" X 5" (GD1, GE1)
	117067-03-GB1	EA COVER-FITTED SHEET,UNIV. 5" (GD1)
	117067-03-GC1	EA COVER-FITTED SHEET,UNIV. 5" (GE1)
3	085365-38-GD1	EA BEDSPREAD - 33" X 80" - W1/2" WELT NON-GATHERED
3	085365-38-GE1	EA BEDSPREAD - 33" X 80" - W1/2" WELT NON-GATHERED
3	102161-36-GD1	EA SHAM - 1/2"NON-GATHERED WELT W/4" RUFFLE (20X30)
	102161-36-GE1	EA SHAM - 1/2"NON-GATHERED WELT W/4" RUFFLE (20X30)

**CURTAIN & CUSHION GROUP (CONTINUED)**

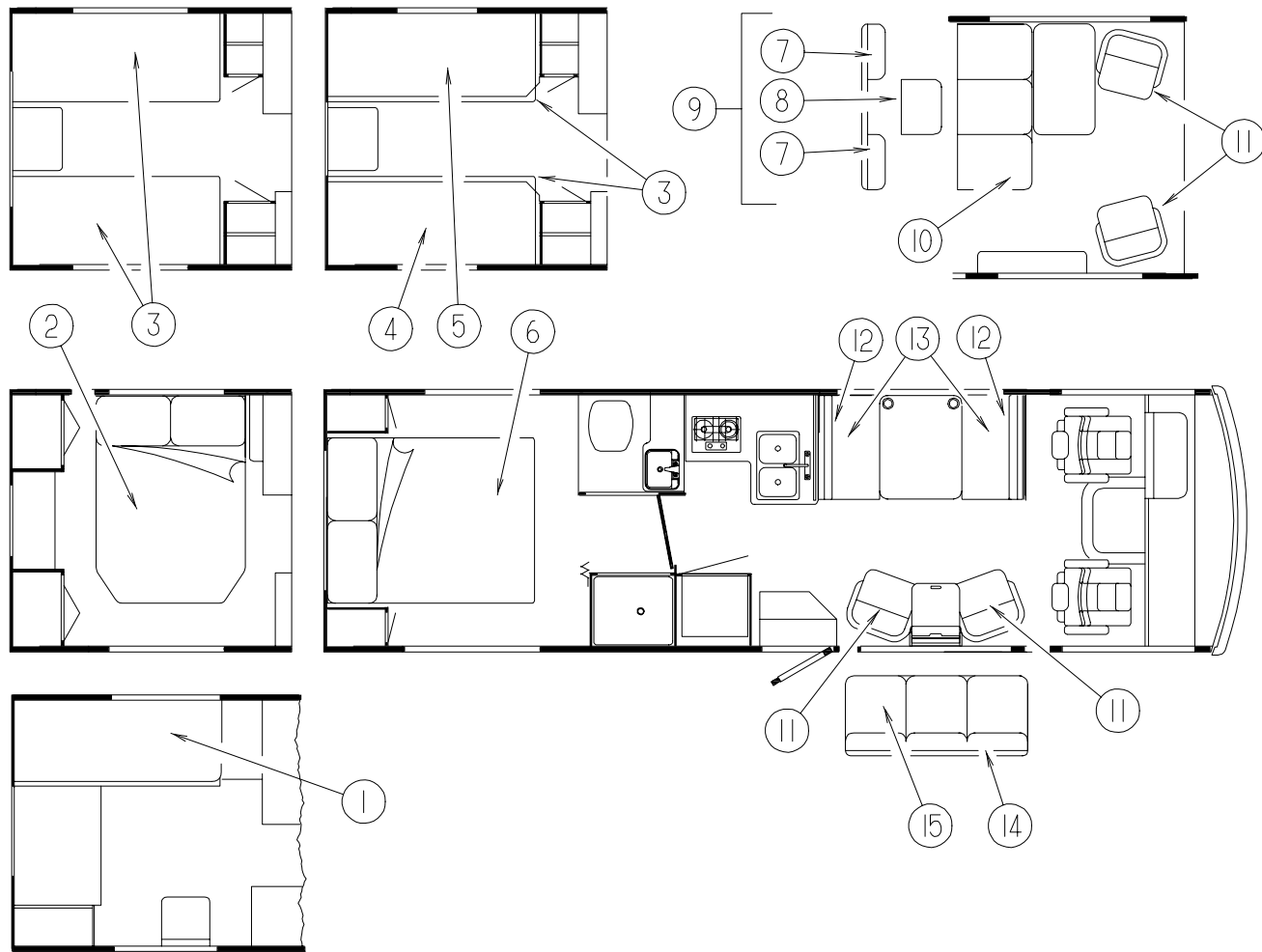

**FORWARD FACING COUCH / BED**

KEY	PART NUMBER	U/M DESCRIPTION
7	114969-02-GD1	EA BED - FORWARD FACING - BACK - END - JACK KNIFE
7	114969-02-GE1	EA BED - FORWARD FACING - BACK - END - JACK KNIFE
	P14969-02-GD1	EA COVER - FORWARD FACING - BACK - END - JACK KNIFE
	P14969-02-GE1	EA COVER - FORWARD FACING - BACK - END - JACK KNIFE
8	114969-03-GD1	EA BED - FORWARD FACING - CENTER END - JACK KNIFE
8	114969-03-GE1	EA BED - FORWARD FACING - CENTER END - JACK KNIFE
	P14969-03-GD1	EA COVER - FORWARD FACING - CENTER END - JACK KNIFE
	P14969-03-GE1	EA COVER - FORWARD FACING - CENTER END - JACK KNIFE
	114763-07-000	EA FRAME-FORWARD FACING LEGS
	114726-01-GB1	EA TRAY ASM-BEVERAGE (GD1, GE1)
9	114969-01-GD1	EA BED - FORWARD FACING - BACK COMPLETE - JACK KNIFE
9	114969-01-GE1	EA BED - FORWARD FACING - BACK COMPLETE - JACK KNIFE
10	114969-04-GD1	EA BED - FORWARD FACING - SEAT ASM - JACK KNIFE
10	114969-04-GE1	EA BED - FORWARD FACING - SEAT ASM - JACK KNIFE
	P14969-04-GD1	EA COVER - FORWARD FACING - SEAT ASM - JACK KNIFE
	P14969-04-GE1	EA COVER - FORWARD FACING - SEAT ASM - JACK KNIFE
	116110-03-GD1	EA COUCH END - FORWARD FACING - RIGHT.
	116110-03-GE1	EA COUCH END - FORWARD FACING - RIGHT.

NOTE:COUCH FRONT AND SIDE PANELS ARE FOUND IN THE LOUNGE GROUP.

**CURTAIN & CUSHION GROUP (CONTINUED)**

**SIERRA CHAIR**

KEY	PART NUMBER	U/M DESCRIPTION
11	115470-01-GD1	EA CHAIR ASM-SIERRA
	P15470-01-GD1	EA COVER-CHAIR,SIERRA
11	115470-01-GE1	EA CHAIR ASM-SIERRA
	P15470-01-GE1	EA COVER-CHAIR,SIERRA
	P07977-01-GD1	EA COVER-SKIRT,CHAIR,DIPLOMAT
	P07977-01-GE1	EA COVER-SKIRT,CHAIR,DIPLOMAT

**DINETTE CUSHIONS**

KEY	PART NUMBER	U/M DESCRIPTION
12	116134-01-GD1	EA CUSHION - BACKREST - 13" X 38" X 5"
12	116134-01-GE1	EA CUSHION - BACKREST - 13" X 38" X 5"
	P16134-01-GD1	EA COVER - BACKREST CUSHION - 13" X 38" X 5"
	P16134-01-GE1	EA COVER - BACKREST CUSHION - 13" X 38" X 5"
13	088927-87-GD1	EA CUSHION - SEAT, 23" X 38" X 5"
13	088927-87-GE1	EA CUSHION - SEAT, 23" X 38" X 5"
	M88927-87-GD1	EA COVER - CUSHION - SEAT, 23" X 38" X 5"
	M88927-87-GE1	EA COVER - CUSHION - SEAT, 23" X 38" X 5"
	078155-01-000	EA STRAP-SNAP - BACKREST CUSHION
	108452-18-000	EA FOAM-BOTTOM.BACK,VICTORIAN.TUCK II
	109995-01-F16	EA PAD ASM-DINETTE (GD1)
	109995-01-GE1	EA PAD ASM-DINETTE

**PASSENGERS SIDE COUCH**

KEY	PART NUMBER	U/M DESCRIPTION
14	100032-44-GD1	EA BED ASM. - TUCK BACK - JACK KNIFE - 66.5 - BACK N/ARMS FROM: 00-00-00 THRU: 07-23-95
14	100032-44-GE1	EA BED ASM. - TUCK BACK - JACK KNIFE - 66.5 - BACK N/ARMS FROM: 00-00-00 THRU: 07-23-95
14	120549-02-GD1	EA BED ASM-600 TUCK BACK - JACK KNIFE - 66.5" BACK FROM: 07-24-95 THRU: 99-99-99
14	120549-02-GE1	EA BED ASM-600 TUCK BACK - JACK KNIFE - 66.5" BACK FROM: 07-24-95 THRU: 99-99-99
15	100032-37-GD1	EA BED - 3 PILLOW - SEAT,66.5 - JACK KNIFE
15	100032-37-GE1	EA BED - 3 PILLOW - SEAT,66.5 - JACK KNIFE
	083125-07-000	EA BRACE-COUCH,O/W
	101085-09-000	EA FRAME- 66.5 X 16 BACK
	101085-01-000	EA FRAME- 66.5" SEAT
	101085-03-000	EA FRAME- 66.5" BASE

NOTE:COUCH FRONT AND SIDE PANELS ARE FOUND IN THE LOUNGE GROUP.

**BUCKET SEAT**

KEY	PART NUMBER	U/M DESCRIPTION
	110148-07-GD1	EA SEAT - ECONOMIZER III - ECONOMIZER ARM
	110148-07-GE1	EA SEAT - ECONOMIZER III - ECONOMIZER ARM

**FRONT BUNK CUSHIONS**

KEY	PART NUMBER	U/M DESCRIPTION
	079145-10-000	EA CUSHION-BUNK - 25" X 80" X 2.5"
	M79145-10-000	EA COVER-BUNK - 25" X 80" X 2.5"

## CURTAIN & CUSHION GROUP (CONTINUED)

### DRIVER & PASSENGER BUCKET SEATS

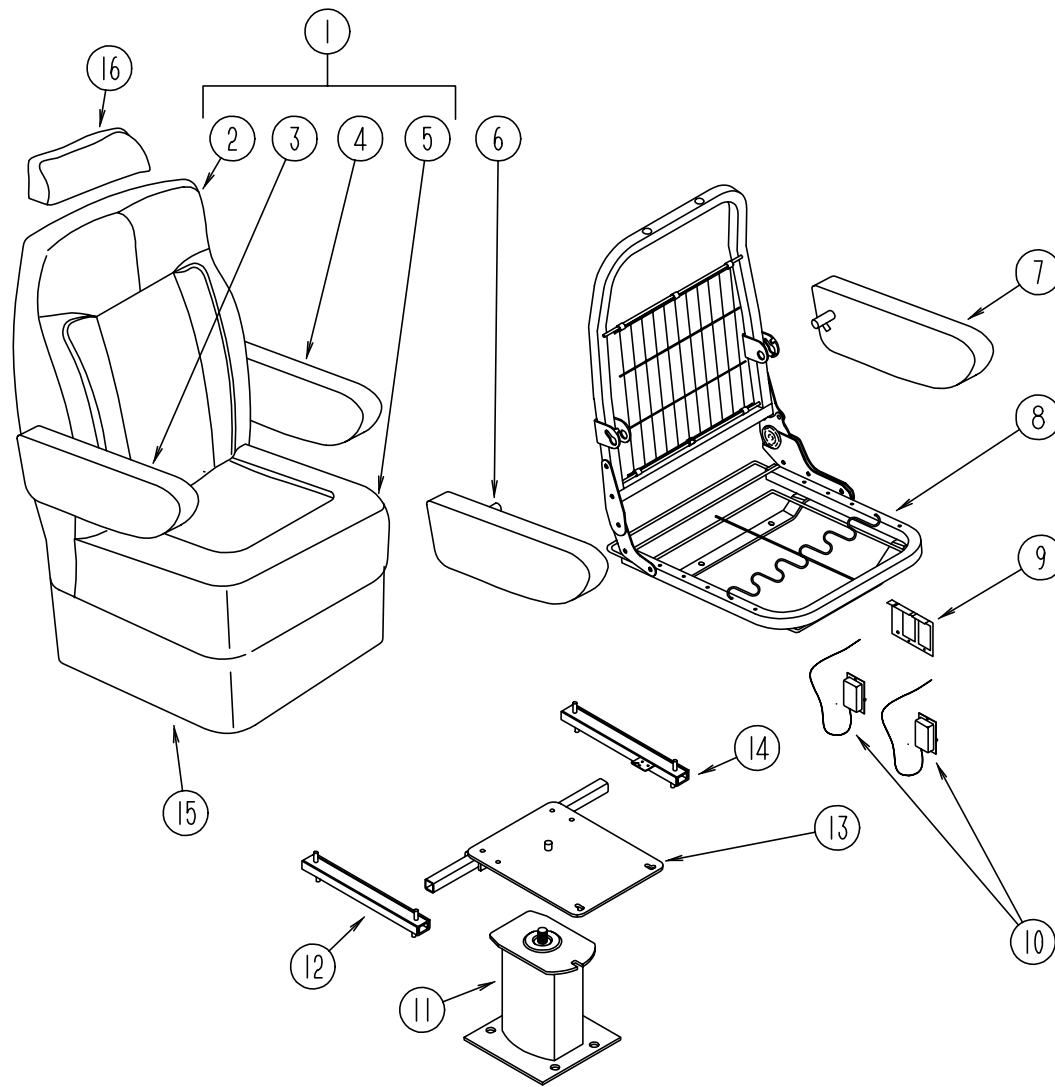

KEY	PART NUMBER	U/M	DESCRIPTION
1	110148-07-GD1	EA	SEAT-ECONOMIZER III - -ECONOMIZER ARM
1	110148-07-GE1	EA	SEAT-ECONOMIZER III - -ECONOMIZER ARM
2	M05962-17-GD1	EA	COVER-ECONOMIZER - BACK
2	M05962-17-GE1	EA	COVER-ECONOMIZER - BACK
3	115520-01-FC1	EA	ARMREST-RIGHT - FAN (GD1)
3	115520-01-GE1	EA	ARMREST-RIGHT - FAN
	P15520-01-FC1	EA	COVER-ARMREST-RIGHT - FAN (GD1)
	P15520-01-GE1	EA	COVER-ARMREST-RIGHT - FAN
4	115520-02-FC1	EA	ARMREST-LEFT - FAN (GD1)
4	115520-02-GE1	EA	ARMREST-LEFT - FAN
	P15520-02-GC1	EA	COVER-ARMREST-LEFT - FAN (GD1)
	P15520-02-GE1	EA	COVER-ARMREST-LEFT - FAN
5	M05962-18-GD1	EA	COVER-ECONOMIZER II - SEAT (GD1)
5	M05962-18-GE1	EA	COVER-ECONOMIZER II - SEAT
6	115617-01-000	EA	BRACKET / ARMREST - RIGHT - MOLDED
7	115617-02-000	EA	BRACKET / ARMREST - LEFT - MOLDED
8	M80906-12-000	EA	FRAME ASM-SEAT & BACK & SPRING
9	108049-02-000	EA	CABLE-PEDESTAL CLIP
	080730-08-000	EA	HANDLE - 30179907 KEIPER
	080730-09-000	EA	SHIELD-FLEXSTEEL
	080730-11-000	EA	SHIELD-RUBBER BOOT FLEXSTEEL
10	108049-03-000	EA	CABLE - 26" Z END CABLE
11	107921-01-000	EA	PEDESTAL ASM-SEAT 9-3/4" - FLEXSTEEL 3060 MSPD
12	119952-04-000	EA	ADJUSTER-BUCKET SEAT W/ REMOTE - FORWARD AND BACK
13	107921-05-000	EA	TOP PLATE - FLEXSTEEL
	107921-06-000	EA	BEARING KIT - FLEXSTEEL
14	119952-02-000	EA	ADJUSTER-SEAT/CHAIR - W/O LOCK - FORWARD & BACK
	007221-01-000	EA	SPACER-SEAT - ADJUSTER
15	071126-41-FC1	EA	SKIRT ASM-SINGLE - 7" - W/SLOT (GD1)
15	071126-41-GE1	EA	SKIRT ASM-SINGLE - 7" - W/SLOT
16	119698-01-GD1	EA	HEADREST-STRATON II
16	119698-01-GE1	EA	HEADREST-STRATON II
	P19698-01-GD1	EA	COVER-HEADREST STRATON II
	P19698-01-GE1	EA	COVER-HEADREST STRATON II
	113977-12-000	EA	HEADREST INSERT,W/O LOCK
	113977-13-000	EA	HEADREST INSERT,W/LOCK
	114791-05-000	EA	FRAME-HEADREST,STRATON,PLYF
	080730-09-000	EA	SHIELD-FLEXSTEEL
	080730-11-000	EA	SHIELD-RUBBER BOOT
	080730-08-000	EA	HANDLE-30179907



## CURTAIN & CUSHION GROUP (CONTINUED)

### SWIVEL CHAIR

KEY	PART NUMBER	U/M	DESCRIPTION
1	115470-01-GD1	EA	CHAIR ASM-SIERRA
	P15470-01-GD1	EA	COVER-CHAIR,SIERRA
1	115470-01-GE1	EA	CHAIR ASM-SIERRA
	P15470-01-GE1	EA	COVER-CHAIR,SIERRA
	P07977-01-GD1	EA	COVER-SKIRT,CHAIR,DIPLOMAT
	P07977-01-GE1	EA	COVER-SKIRT,CHAIR,DIPLOMAT
2	097683-02-000	EA	BRACKET - REMOTE - SIDE MOUNT
3	108049-03-000	EA	REMOTE & CABLE
4	119952-01-000	EA	SLIDE-SEAT,HD,NONLOCKING 2ST - ATWOOD 83711
5	107921-08-000	EA	TOP PLATE-W/O SEAT BELT BAR
	107921-06-000	EA	BEARING KIT - PEDESTAL
6	107921-01-000	EA	FLOOR MOUNTED PEDESTAL - W/ 9.75" EXTENSION
7	108445-02-000	EA	SUB PLATE - FLOOR MOUNTED PEDESTAL
8	119952-03-000	EA	SLIDE-SEAT,HD,LOCKING 2STUDS - ATWOOD 83775
9	007221-01-000	EA	SPACER - SEAT ADJUSTER
	108452-G3-000	EA	FOAM-SEAT CORE - 95 SIERRA CHAIR
	117125-01-02B	EA	BRACKET-CABLE HOLDER,E-COAT
	117125-01-02B	EA	BRACKET-CABLE HOLDER,E-COAT
	007021-01-000	EA	SEAT BELT - 2" X 90" - BLACK
	108049-02-000	EA	CLIP-CABLE, PEDESTAL

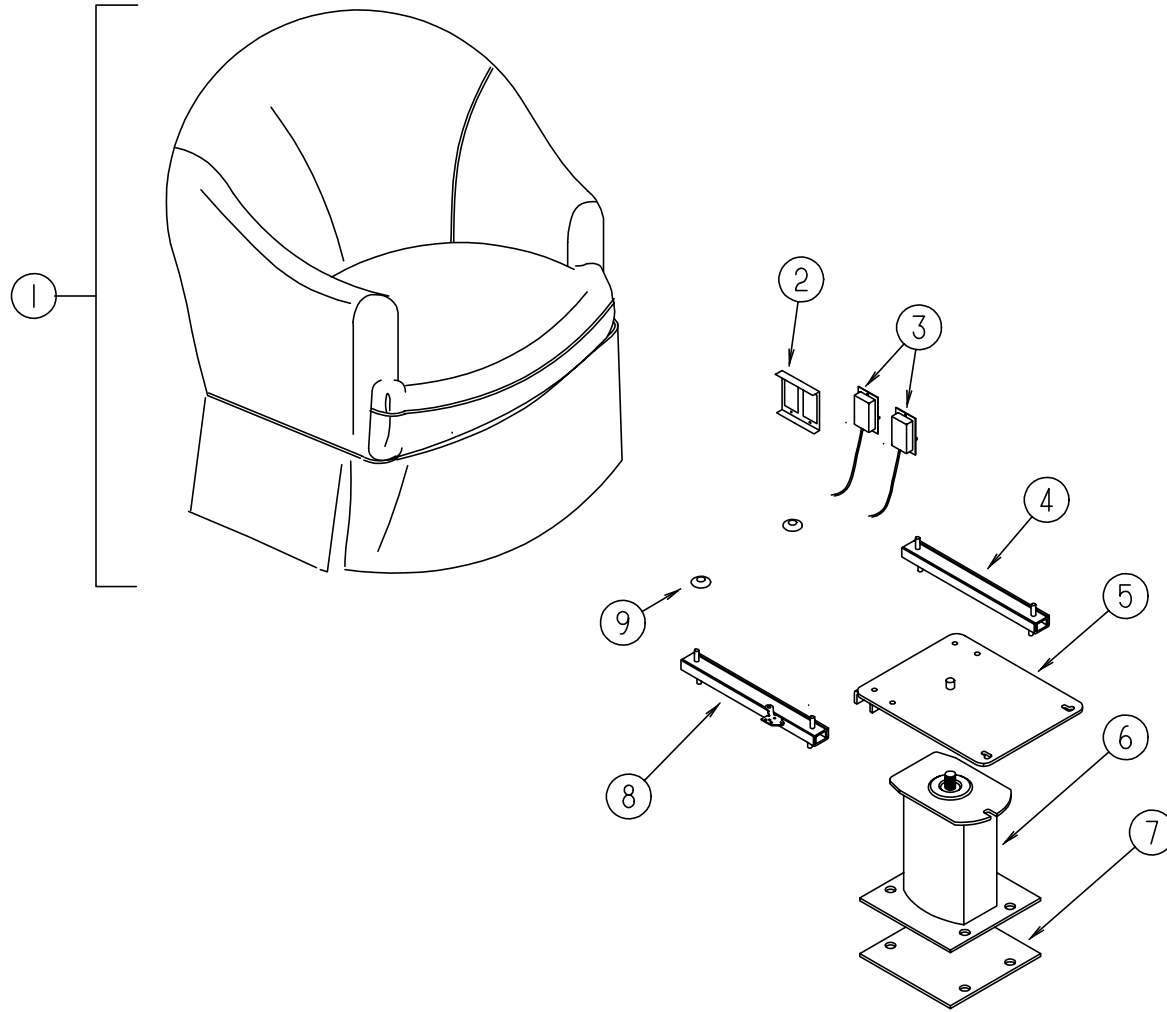

## CURTAIN & CUSHION GROUP (CONTINUED)

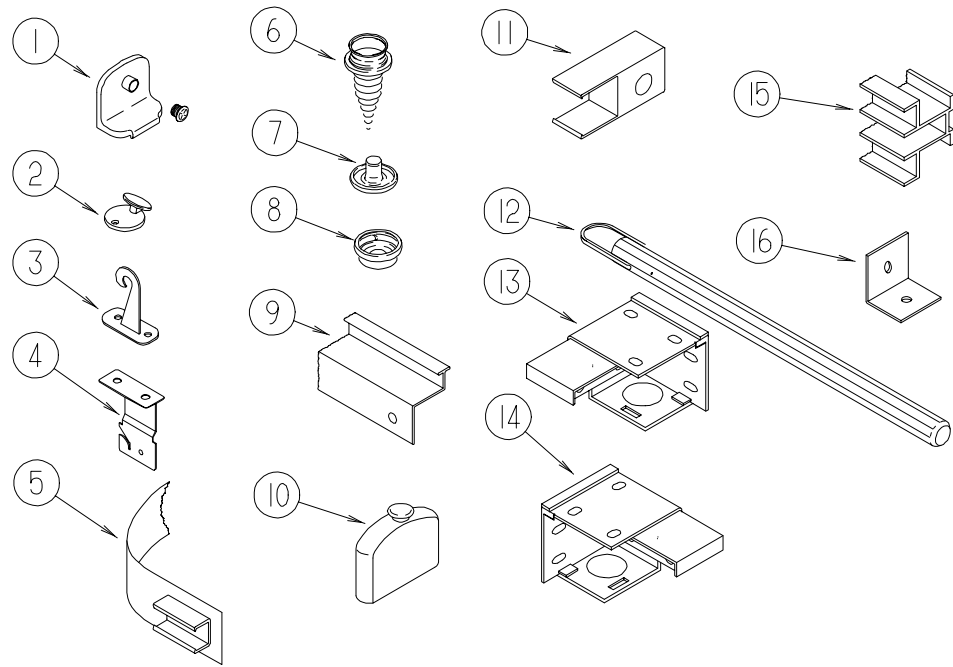

**CURTAIN HARDWARE & COMPONENTS**

KEY	PART NUMBER	U/M	DESCRIPTION
1	106544-01-000	EA	PULL-SHADE, BRASS
	106544-01-001	EA	SCREW-BRASS, SHADE
2	102555-01-000	EA	CLEAT-CORD, BLIND - OFF WHITE
3	109441-03-000	EA	HOLD DOWN-BLIND (CLOUDY)
4	084434-01-000	EA	BRACKET-MOUNTING, ROLLER SHADE - 1 3/8"
	084433-05-000	EA	SHADE-ROLLER, 72.25"
	096843-01-000	EA	SPRING-REWIND, ROLLER SHADE
	084432-06-000	FT	SLAT-ROLLER SHADE, PLASTIC
5	101031-01-000	YD	TAPE-GLIDE, CURTAIN - 4.25" SPACING
6	029130-01-000	EA	SCREW-SNAP SOCKET, 8 PH X 5/8"
7	029155-01-000	EA	CAP-SNAP, 5/32" O.D. OF PIN
8	029156-01-000	EA	SOCKET-SNAP, 9/16" O.D.
9	105324-02-01A	EA	TRACK-CURTAIN, WRAPAROUND - PASSENGER SIDE - OFF WHITE
9	105324-03-01A	EA	TRACK-CURTAIN, WRAPAROUND - DRIVER SIDE - OFF WHITE
9	105450-08-01A	EA	TRACK-CURTAIN, 38" LONG - ALUMINUM - OFF WHITE
9	105450-01-01A	EA	TRACK-CURTAIN, 30.8" LONG - ALUMINUM - OFF WHITE
10	093475-01-701	EA	END CAP-BLIND, W/STUD
11	101033-02-000	EA	END CAP-TRACK, CLEAR
12	093475-01-700	EA	WAND-BLIND, W/METAL CLIP - 8" LONG
13	083170-01-000	EA	BRACKET-BLIND, RIGHT SIDE
14	083170-02-000	EA	BRACKET-BLIND, LEFT SIDE
15	101033-03-000	EA	TRACK-WALL, WHITE
16	083125-07-000	EA	BRACE-COUCH,O/W
	046867-01-000	EA	GROMMET-BRASS, 7/16" ID X 1" OD
	046867-03-000	EA	GROMMET-HANDY BUTTON NO 3
	088792-01-000	YD	VELCRO-HOOK, .75" WIDE - BEIGE
	088792-02-000	YD	VELCRO TAPE-LOOP, ADHESIVE BACKED - .75" WIDE - BEIGE
	088792-06-000	YD	VELCRO-3/4" NON-ADH.,LOOP BUF MED
	048394-02-000	YD	VELCRO TAPE-HOOK, ADHESIVE BACK - .75" WIDE - BEIGE
	086276-01-000	EA	TAPE-DOUBLE SIDED, 1/2"
	094896-02-000	EA	GROMMET-CORD, PLEATED BLIND - NYLON - GRAY
	094907-02-000	EA	END CAP-TOP, PLEATED BLIND - PLASTIC - GRAY
	094907-04-000	EA	HRDW.-END CAP,BTM ,PULL TYPE
	096843-01-000	EA	SPRING-REWIND, ROLLER SHADE
	097564-01-000	EA	HANDLE-T, EZ LIFT SHADE
	097591-01-000	EA	SPRING-EXTENSION, PLEATED BLIND
	097592-01-000	EA	SPOOL-CORD, ELEVATED BLIND HOLDUP - CLEAR PLASTIC
	097593-06-000	FT	CORD-BLIND, PLEATED - PEWTER
	117335-09-000	EA	CARRIER-REVEAL,WINDSHIELD

## DINETTE GROUP

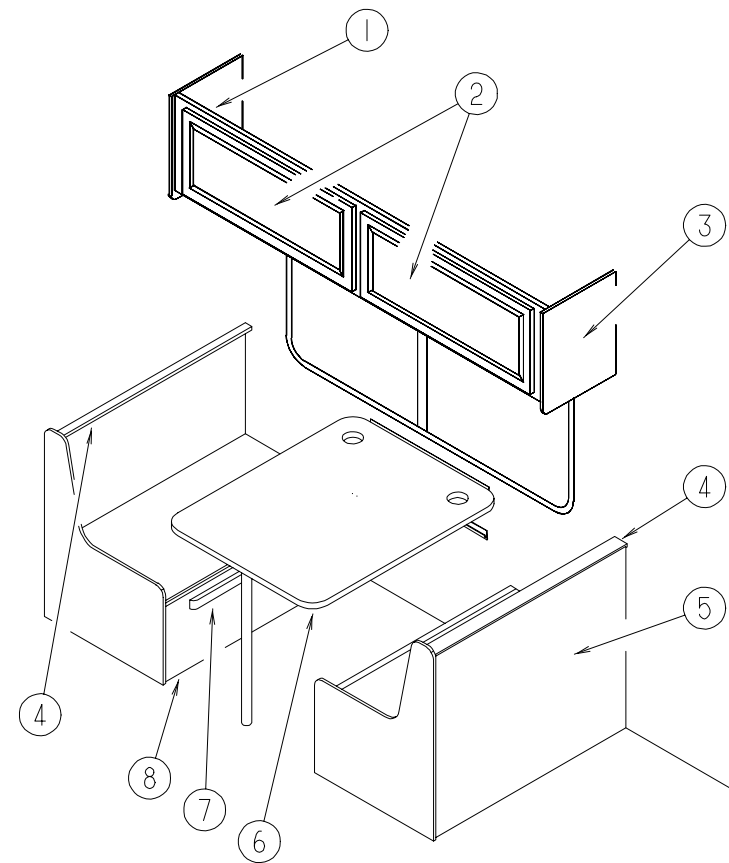

**DINETTE CABINETRY**

KEY	PART NUMBER	U/M	DESCRIPTION
1	P16878-01-GB1	EA	CABINET ASM-OVERHEAD - DINETTE
2	110140-65-G01	EA	DOOR ASM-MITERED - VINYL WRAP W/MIRROR
2	110140-05-G01	EA	DOOR ASM-MITERED - VINYL WRAP W/O MIRROR
3	109908-03-GB1	EA	CAP ASM-END - OVERHEAD
4	109995-01-F16	EA	PAD ASM-DINETTE(GD1)
4	109995-01-GE1	EA	PAD ASM-DINETTE
5	M04175-75-GB1	EA	CABINET-SEATBASE - RIGHT
	M04174-75-GB1	EA	CABINET-SEATBACK - RIGHT
6	081322-01-G10	EA	PANEL KIT-DINETTE TABLE (GD1)
6	081322-01-G09	EA	PANEL KIT-DINETTE TABLE (GE1)
7	081295-01-G01	EA	SUPPORT-BED - DINETTE - 712 LG
8	M04175-76-GB1	EA	CABINET-SEATBASE - LEFT

## DINETTE GROUP (CONTINUED)

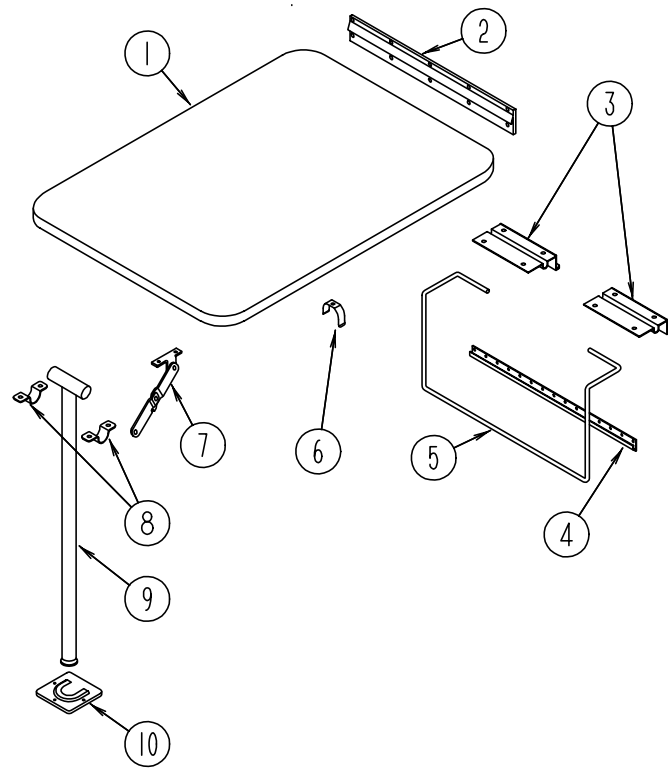

**DINETTE TABLE**

KEY	PART NUMBER	U/M	DESCRIPTION
1	081322-01-G10	EA	TABLE-DINETTE, W/O HARDWARE (GD1)
1	081322-01-G09	EA	TABLE-DINETTE, W/O HARDWARE (GE1)
2	053200-12-000	EA	SUPPORT-TABLE, 23.50" - OFF WHITE
3	088410-02-000	EA	HANGER-TABLE, OFF WHITE
4	024281-14-000	EA	BRACKET-TABLE LIFT, 22.12" - OFF WHITE
5	024275-12-000	EA	ROD-TABLE LIFT, OFF WHITE
6	024283-01-000	EA	CLIP-LEG, 1" - 1.125" OD - BLACK
7	024282-01-000	EA	BRACE-TABLE LEG, HINGED
8	064050-05-000	EA	HINGE-TABLE LEG, OFF WHITE
9	024276-23-000	EA	LEG ASM-TABLE OFF WHITE
10	049493-12-000	EA	CATCH-TABLE LEG, OFF WHITE
10	049493-11-700	EA	CATCH-LEG, FLOOR MOUNTED - 2.5" X 2.7" - METAL - E-COAT
	093550-01-000	EA	BRACKET-HINGE, MOUNTS TO LEG & TABLE TOP - 1.7" X 2.6"

## DRIVERS COMPARTMENT GROUP

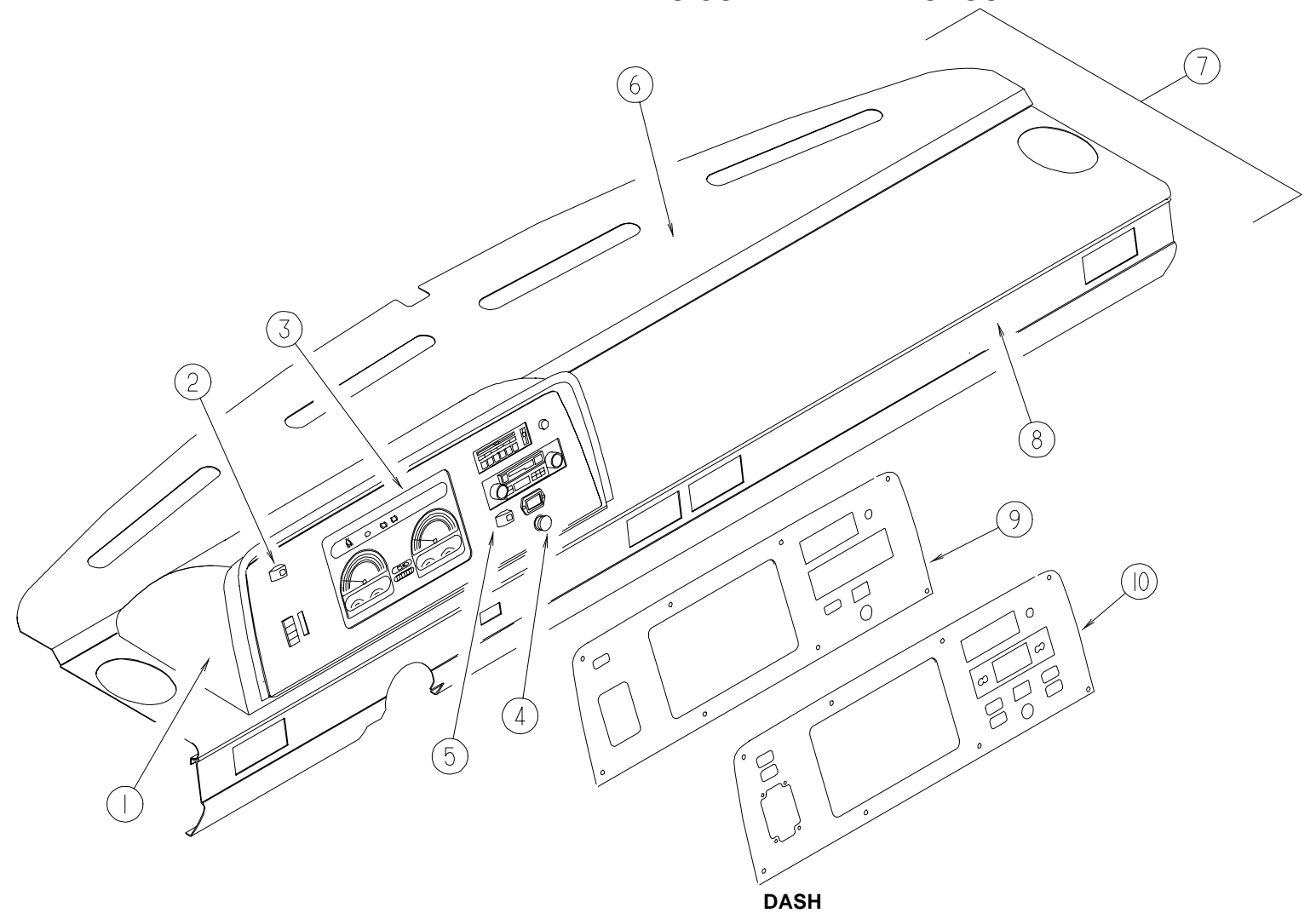

**DASH**

KEY	PART NUMBER	U/M	DESCRIPTION
	M05946-32-GB1	EA	DASH POD ASM - CHEVY - W/O INSTRUMENT CLUSTER FROM: 00-00-00 THRU: 01-28-96
	M05946-37-GB1	EA	DASH POD ASM-CHEVY,RLC FROM: 01-29-96 THRU: 99-99-99
1	110066-01-02A	EA	POD-INSTRUMENT PANEL - CAMB BISQUE FROM: 00-00-00 THRU: 01-28-96
1	121118-01-01A	EA	POD-INSTRUMENT PANEL - CAMB BISQUE FROM: 01-29-96 THRU: 99-99-99
	079382-01-000	EA	SCREW-SOCKET, 8-18 X 1" - BLACK
	103603-01-000	EA	BULB - 12V, # 74 0.12A WEDGE
	077539-01-000	EA	BRACKET-MOUNTING, DASH PANEL - L/SHAPED - 2.5" X 1" X 1.5"
	100138-01-000	EA	MODULE-DAYTIME RUNNING LIGHT
	077031-01-000	EA	FILM-BLACK, 1" X 1.75"
	077031-03-000	EA	FILM-WHITE, .75" X 1.00"
	105615-01-000	FT	FILM-PROTECTIVE, CLEAR - 34" WIDE
2	108357-09-000	EA	ROCKER SWITCH, SPDT ON/NONE/MOM - CARLING V5D1000B-0
2	108356-02-01A	EA	COVER-SWITCH W/DIMPLES, CARLING VVAZC00 BLA
3	094796-07-000	EA	CLUSTER-INSTRUMENT PANEL, KILOMETERS - GAS - GM #16201075 (CSA)
4	089294-01-000	EA	CIGARETTE LIGHTER - W/O WIRES
5	108357-10-000	EA	SWITCH-ROCKER, SPDT MOM/OFF/MOM - CARLING V8D1160B-0
5	108356-04-01A	EA	COVER-SWITCH W/DIMPLES & LENS, CARLING VVAGC00
	106569-02-04A	EA	VINYL-LAMINATE MADRID, CAMBRIDGE- 1/4" X 16" X 96"
6	105927-02-000	EA	PANEL ASM-DASH, TOP - W/STUD - STEEL
7	P03817-11-000	EA	DASH ASM, CHEVY - W/O VINYL & INSTRUMENT POD - STEEL
8	103812-01-05A	EA	TRIM-DASH, LOWER - GM
	103558-01-09A	EA	VENT-DEFROSTER, ABS
9	110073-01-01A	EA	APPLIQUE-BEZEL, INSTRUMENT PANEL - BLACK VELVET
10	109829-01-01A	EA	BEZEL-INSTRUMENT PANEL, BLACK

**DRIVERS COMPARTMENT GROUP (CONTINUED)**

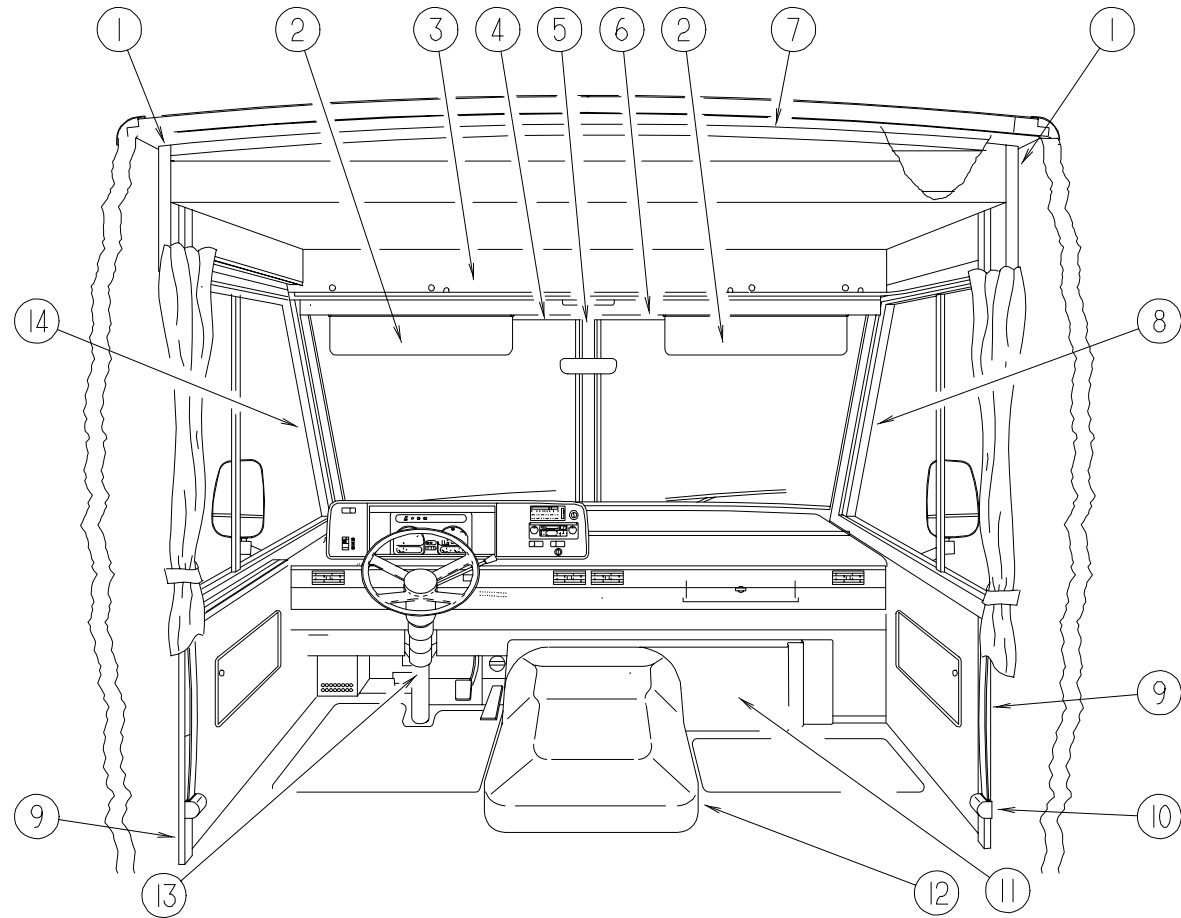

**DRIVERS COMPARTMENT**

KEY	PART NUMBER	U/M DESCRIPTION
1	024700-50-000	EA COVER-ROLL BAR,OFF WHITE 8.00 INCHES
2	082286-18-GB1	EA SUNVISOR ASM, W/O POCKET
		FROM: 00-00-00 THRU: 08-27-95
2	082286-18-D12	EA SUNVISOR ASM, W/O POCKET
		FROM: 08-28-95 THRU: 99-99-99
	007211-01-000	EA HINGE-SUNVISOR, 25.5" X 1.5" - METAL
	081987-05-000	EA ROD-SUNVISOR, BLACK
	074012-01-000	EA CLIP-SUNVISOR, SQUARE - PINCH ON
	102377-01-000	EA BRACKET-SUNVISOR, 1 PIECE - STEEL
3	109795-02-FB1	EA PANEL-HEADLINER
	078811-07-FB1	EA PANEL-HEADER, HORIZONTAL SECTION - W/LIGHT & SPEAKER CUTOUTS
4	078579-08-000	EA TRIM-WINDSHIELD, UPPER - INNER - DRIVER - OFF WHITE
5	079765-07-000	EA TRIM-WINDSHIELD, CENTER - PRECUT ENDS - OFF WHITE
5	079765-09-000	EA TRIM-WINDSHIELD, CENTER - UNCUT - OFF WHITE
6	078579-07-000	EA TRIM-WINDSHIELD, UPPER - INNER - PASSENGER - OFF WHITE
7	024700-51-000	EA COVER-ROLL BAR, OFF WHITE - 88.00"
8	103931-01-01A	EA COVER-INTERIOR, A-PILLAR - RIGHT - OFF WHITE
9	024700-44-000	EA COVER-SDW ROLL BAR,OFF WHITE 53.00 INCHES
	110056-01-01A	EA COVER-ROLL BAR 90° OFF WHITE
10	091990-04-01A	EA SEAT BELT - 3 POINT,BLACK
	103961-01-01A	EA COVER-BRACKET,SEATBELT O/W
	057759-01-000	EA WASHER BRACKET-SEAT BELT, 4" DIAMETER
11	095757-03-FC1	EA COVER ASM-HEATER (GD1)
11	095757-03-GE1	EA COVER ASM-HEATER (GC1)
12	111618-01-GB1	EA TRAY ASM-BEVERAGE
	115840-01-01A	EA COVER-MOTOR
	115850-01-02B	EA RETAINER ASM-LATCH,MOTOR COVER
	116581-01-000	EA LATCH-MOTOR COVER
13	103498-06-000	EA BOOT-COLUMN
14	103931-02-01A	EA COVER-INTERIOR, A-PILLAR -LEFT - OFF WHITE
	119919-14-000	EA FRONT - STEP BOX INSERT

**DRIVERS COMPARTMENT GROUP (CONTINUED)**

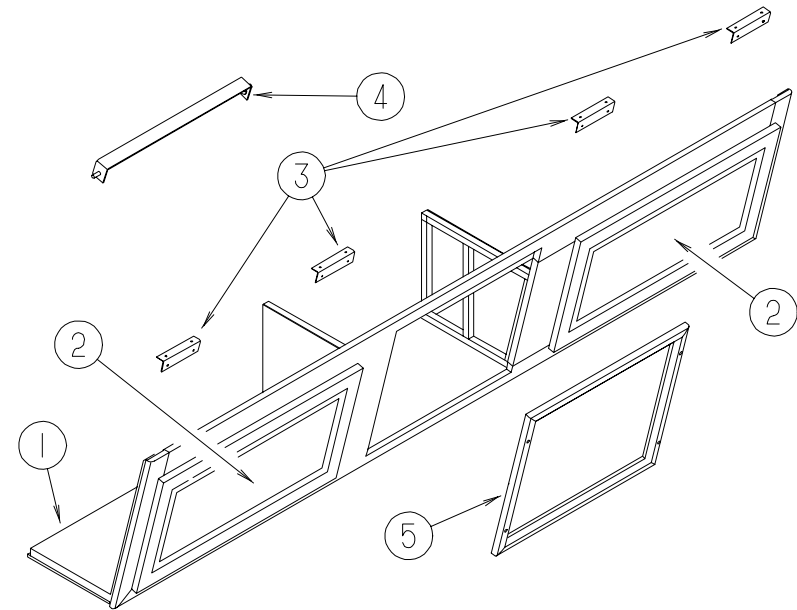

**DRIVERS COMPARTMENT TV CABINET**

KEY	PART NUMBER	U/M DESCRIPTION
1	120196-01-GB1	EA CABINET ASM-OVHD,TV
2	110140-18-G01	EA DOOR ASM-MITERED,VINYL WRAP
3	106699-01-01A	EA BRACKET-CABINET,OVHD TV O/W
	099717-03-000	EA TV TIEDOWN STRAP- W/5.1" FEMALE STRAP & 7.9" MALE STRAP
4	120175-02-02B	EA SUPPORT ASM-SHELF,TV,E-COAT
5	120198-01-GB1	EA CABINET ASM-FRAME,TV

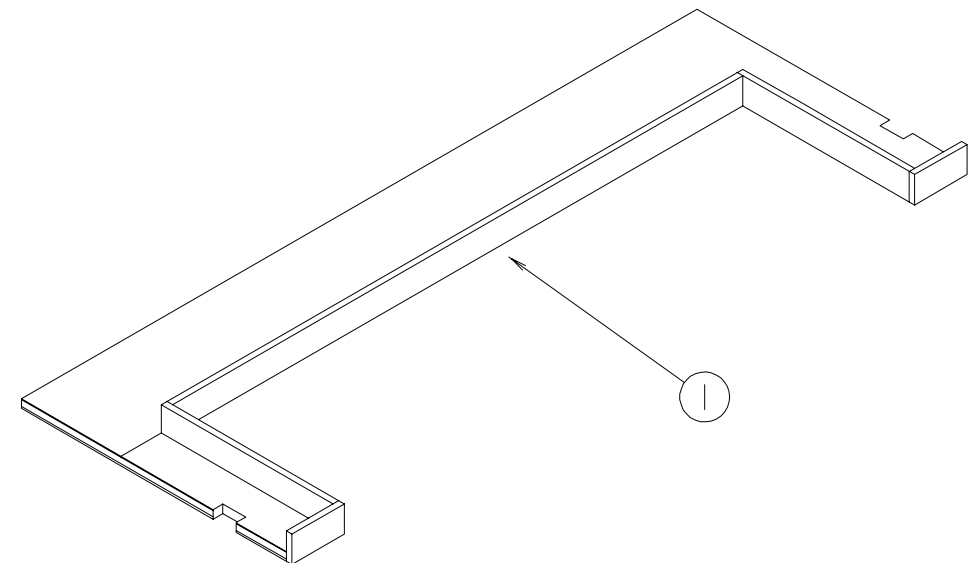

**DRIVERS COMPARTMENT BLANKET CABINET**

KEY	PART NUMBER	U/M DESCRIPTION
1	104417-02-GB1	EA CABINET ASM-BLANKET

## DRIVERS COMPARTMENT GROUP (CONTINUED)

### OVERHEAD BUNK

KEY	PART NUMBER	U/M DESCRIPTION	
	076760-04-000	EA BUNK HARDWARE-OVERHEAD	KWIKEE #901401
	110007-01-GB1	EA BED ASM-BUNK,FRONT	
	099717-03-000	EA TIEDOWN ASM-TV	

## ELECTRICAL GROUP

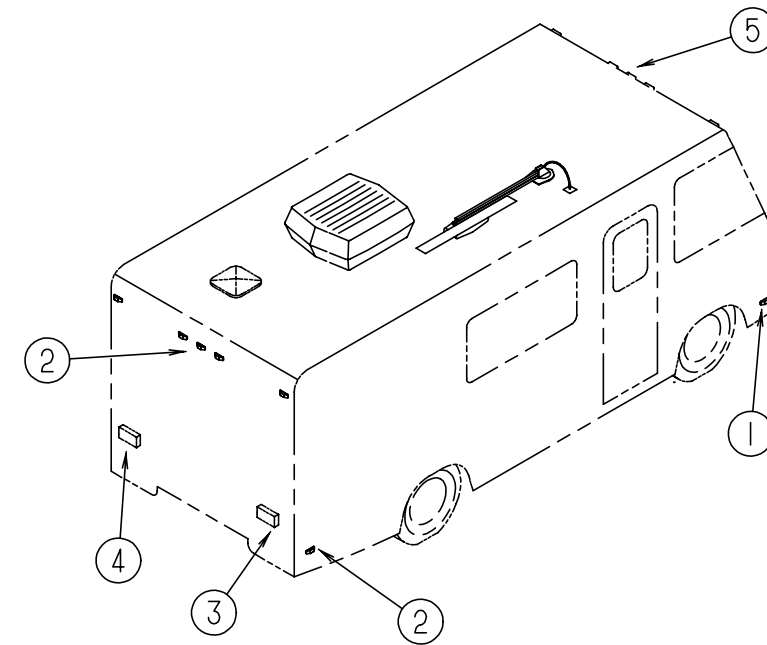

### EXTERIOR LIGHTS

KEY	PART NUMBER	U/M DESCRIPTION
1	111102-01-000	EA BASE-CLEARANCE/SIDEMARKER LIGHT W/BULB - PLASTIC - WHITE
1	111102-02-000	EA LENS-CLEARANCE/SIDEMARKER LIGHT - W/REFLEX - AMBER
1	036196-01-000	EA BULB - 12V, #194 - .27AMP - BAYONETTE
1	091983-01-000	EA GASKET-CLEARANCE/SIDEMARKER LIGHT
2	111102-01-000	EA BASE-CLEARANCE/SIDEMARKER LIGHT - W/BULB - PLASTIC - WHITE
2	111102-03-000	EA LENS - CLEARANCE/SIDEMARKER LIGHT - W/REFLEX - RED
2	008213-01-000	EA BULB - 12 V - NO. 57 - .24 AMP
2	091983-01-000	EA GASKET-CLEARANCE/SIDEMARKER LIGHT
3	110456-01-01A	EA LAMP ASM-TAIL -COMBO BLACK - BARGMAN 30-91-110
4	110456-02-01A	EA LAMP ASM-TAIL-COMBO W/BRACKET - BARGMAN 30-91-111
	107256-01-03A	EA COVER-TAIL LIGHT - BLACK
5	111102-01-000	EA BASE-CLEARANCE/SIDEMARKER LIGHT W/BULB - PLASTIC - WHITE
5	111102-02-000	EA LENS-CLEARANCE/SIDEMARKER LIGHT - W/REFLEX - AMBER
5	036196-01-000	EA BULB - 12V, #194 - .27AMP - BAYONETTE
5	091983-01-000	EA GASKET-CLEARANCE/SIDEMARKER LIGHT
5	109566-01-000	EA BACKING-STEEL - LIGHT - ROOF CAP
	070907-01-000	EA HEADLAMP-RECTANGULAR - GM 5968097
	049359-01-000	EA SPRING-RETAINER - HEADLAMP - GM 496096
	110750-01-000	EA SCREW ASM-HEADLAMP ADJUSTING - T'MAN B62258-1428
	112823-01-000	EA SPLICE-REDUCER - 16-14 TO 18-22

**ELECTRICAL GROUP (CONTINUED)**  
**LIGHTS, RECEPTACLE & ,SWITCHES**

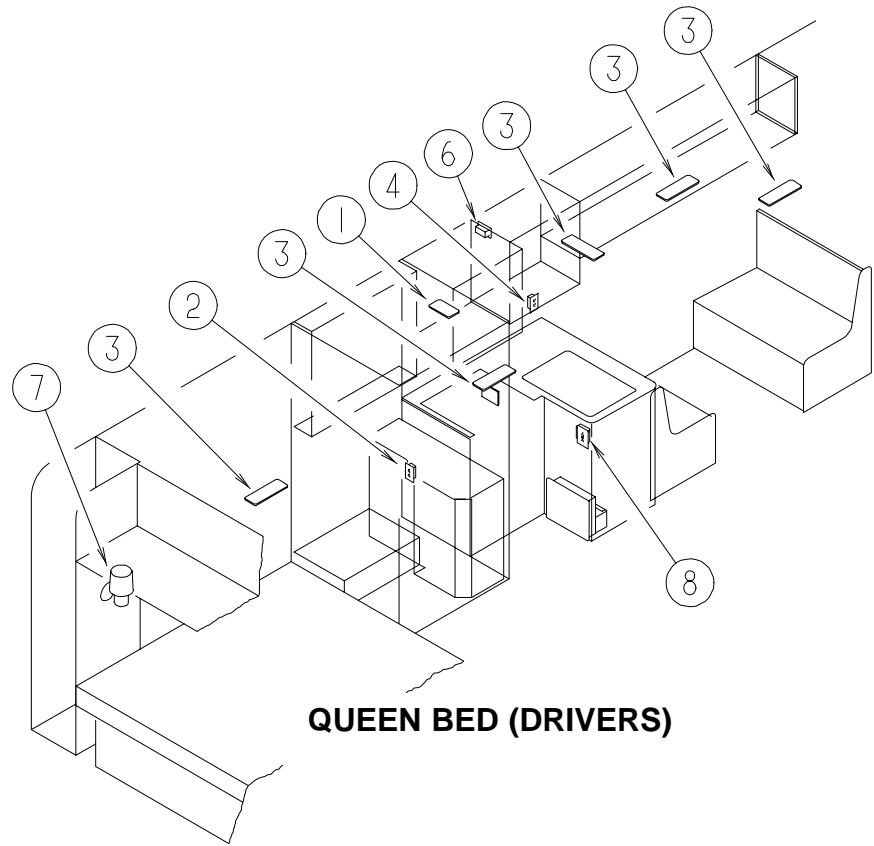

**QUEEN BED (DRIVERS)**

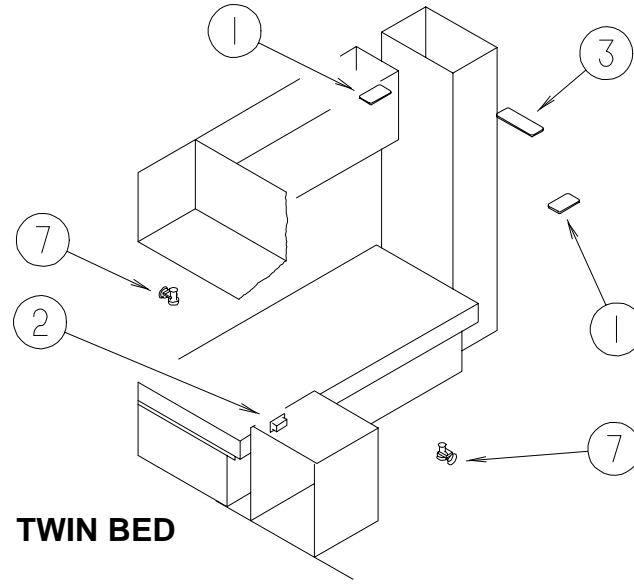

**TWIN BED**

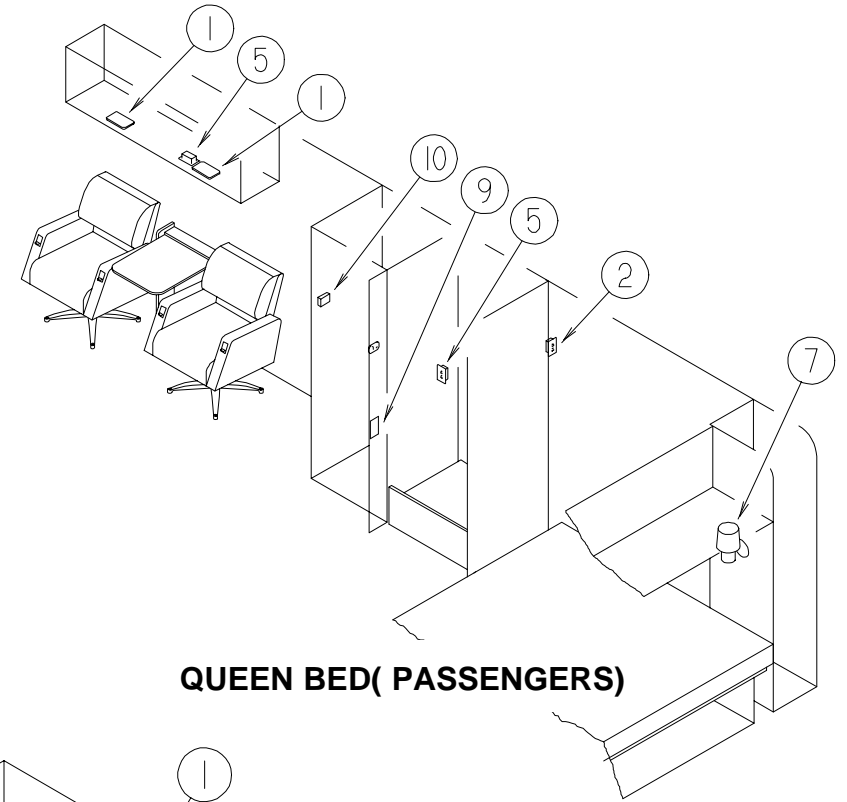

**QUEEN BED( PASSENGERS)**

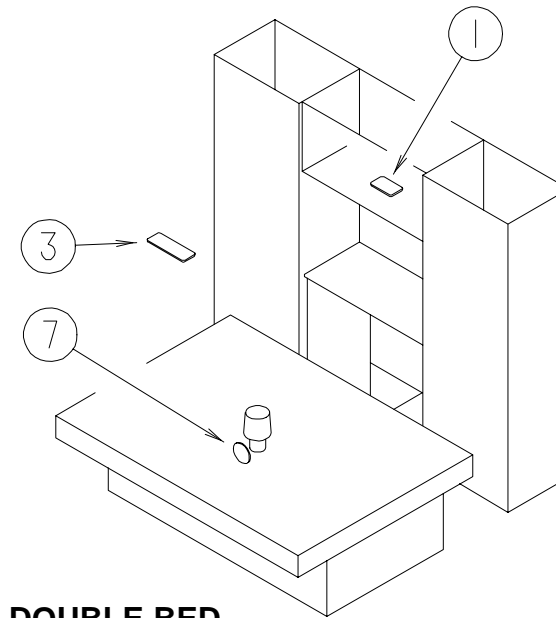

**DOUBLE BED**

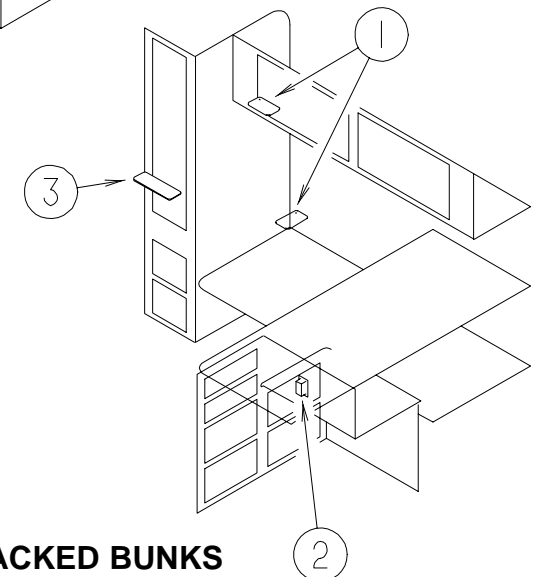

**CROSS STACKED BUNKS**

KEY	PART NUMBER	U/M	DESCRIPTION	
1	098024-01-01A	EA	LIGHT-DOME - 1 BULB - US - IVORY	
	008218-01-000	EA	BULB-DOME LIGHT - 12V - NUMBER 1141	
	098024-01-700	EA	LENS-DOME LIGHT	
2	058708-01-000	EA	RECEPTACLE-ELECTRIC - DOUBLE - BROWN	
	3	098024-03-01A	EA	LIGHT-DOME - 2 BULB - IVORY
		008218-01-000	EA	BULB-DOME LIGHT - 12V - NUMBER 1141
4	098024-01-700	EA	LENS-DOME LIGHT	
	007940-01-000	EA	RECEPTACLE-SLIDE - 16 TO 12 AWG - FEMALE END	
	058708-02-000	EA	RECEPTACLE-ELECTRIC - DOUBLE - IVORY	
5	058707-01-000	EA	RECEPTACLE-ELECTRIC - SINGLE - BROWN	
	058707-02-000	EA	RECEPTACLE-BLANK,JUNCTION - WIRECON WDJ20BR	
6	058708-05-000	EA	RECEPTACLE-SINGLE,BRN - WIRECON WDR15BRS	
	7	104173-02-01A	EA	LIGHT-DESIGNER,BLACK 81-903 - A.W.ASPLUND
				FROM: 00-00-00 THRU: 07-09-95
119257-03-01A	EA	SHADE-LAMP,LINEN WHT HARDBAC - 79-122X2BS		
			FROM: 07-10-95 THRU: 99-99-99	
7	119258-02-01A	EA	LAMP-WALL,UL/CSA - 53-503XK7YZ	
			FROM: 07-10-95 THRU: 99-99-99	
8	084076-02-000	EA	RECEPTACLE-GFI - 15A - 125V - BROWN	
	024924-02-000	EA	RECEPTACLE-POWER CORD - W/PARTIAL PLATE	
	075723-01-000	EA	SPACER-SWITCH - W/O HOLE - .2" X .9" X 2" - METAL - OFF WHITE	
	102568-01-E90	EA	SPACER-RECEPTACLE - SIDEWALL	
	104172-01-01A	EA	LIGHT-BULLET, BEIGE - #787 SERIES - BULB #93 12V	
9	097734-01-01A	EA	EXTENSION-RECEPTACLE, 3.2" X 5" X .7" - PLASTIC - IVORY	
	108356-11-01A	EA	ACTUATOR-SWITCH GROOVES III *CARLING VVCZCX-SW1	
10	079364-04-000	EA	SWITCH-ON/OFF, ROCKER - C-02	

**ELECTRICAL GROUP (CONTINUED)**  
**FUSES & CIRCUIT BREAKERS**

KEY	PART NUMBER	U/M DESCRIPTION
	062037-01-000	EA HOUSING-AUTO FUSE, NATURAL
	062037-02-000	EA HOUSING-AUTO FUSE, GREEN
	062037-03-000	EA HOUSING-AUTO FUSE, BLACK
	062037-04-000	EA HOUSING-AUTO FUSE, BLUE
	062037-05-000	EA HOUSING-AUTO FUSE, GRAY
	062037-06-000	EA HOUSING-AUTO FUSE, BROWN
	062037-07-000	EA HOUSING-AUTO FUSE,RED - PACKARD 12004883
	062901-02-000	EA FUSE-5 AMPS, AUTOMOTIVE
	062901-05-000	EA FUSE-15 AMPS, AUTOMOTIVE
	062901-08-000	EA FUSE-30 AMPS,AUTOMOTIVE
	083209-01-000	EA CIRCUIT BREAKER 15 AMP 120V BW G-15 - CANADIAN
	083209-02-000	EA CIRCUIT BREAKER 15/15AMP 120V BW H-15/15
	083209-03-000	EA CIRCUIT BREAKER 15/20AMP 120V BW 0-15/20
	083209-04-000	EA CIRCUIT BREAKER 30AMP 120V BW L-30
	083209-06-000	EA CIRCUIT BREAKER 30/15 AMP 120V BW D-30/15
	106655-02-000	EA TERMINAL-FUSE BLOCK,10-12AWG - PACKARD 12020400
	108669-01-000	EA HOUSING-AUTO FUSE HOLDER, PACKARD 12010105
	119248-02-000	EA HOUSING 7 POSN FEM METRI-PAC - PACKARD12059472

**SWITCHES**

KEY	PART NUMBER	U/M DESCRIPTION
	079364-04-000	EA SWITCH-ON/OFF, ROCKER - BLACK
	095188-01-01A	EA SPACER-SWITCH, 2.3" X 3.4" - PLASTIC - DARK BROWN
	096241-03-000	EA SWITCH-BLANK
	098351-06-01A	EA PLATE-SWITCH, 2 GANG W/LABEL - JENSEN - POLISHED BRASS
	098351-07-01A	EA PLATE-SWITCH,GEN SW - JENSEN-BRASS,POLISH
	108355-01-000	EA HOUSING-SWITCH - CARLING VCH
	108356-02-01A	EA SWITCH COVER W/ 2 DIMPLES - CARLING CCAZC00
	108356-04-01A	EA SWITCH COVER W/DIMPLES - LIGHTED-CARLING VVAGC00
	108356-11-01A	EA ACTUATOR-SWITCH GROOVES III - CARLING VVCZCX-SW1
	108357-10-000	EA ROCKER SWITCH, SPDT MOM/OFF/MOM - CARLING V8D1160B-0 LIGHTED

**ELECTRICAL BOXES, COVERS & RELAYS**

KEY	PART NUMBER	U/M DESCRIPTION
	008289-01-000	EA BOX-ELECTRIC, STEEL - 1/2" AND 3/4" KNOCKOUTS - 4" X 4"
	008289-02-000	EA BOX-ELEC., 4" X 4", W/1/2" & 3/4" KNOCKOUTS, CANADIAN
	008294-01-000	EA COVER-ELECTRICAL BOX, BLANK/STEEL - 4" X 4" - GRAY
	008294-02-000	EA COVER-ELECTRICAL BOX, BLANK STEEL - 4" X 4" - CANADIAN
	069238-01-000	EA COVER-ELECTRICAL BOX, W/HOLE - 4" X 4" - GRAY USED WITH 30 AMP RECEPTACLE
	091910-01-000	EA BOX-ELECTRIC, 3.75" X 3.5" X 1.75" - PLASTIC
	091910-02-000	EA BOX-ELECTRICAL, PLASTIC - 57 X 88MM
	111509-01-000	EA BOX ASM-ELECTRICAL,FRONT - 94 F,G-SERIES
	111510-01-000	EA DOOR-ELECTRICAL BOX,FRONT - 94 F,G-SERIES
	007093-01-000	EA FLASHER-SIGNAL, STAT
	008188-01-000	EA SOLENOID-3 POST, BATTERY CHANGE OVER
	063910-01-000	EA HOUSING-RELAY, BOSCH 3 334 485 008
	086273-01-000	EA RELAY-BATTERY DISCONNECT

**ELECTRICAL GROUP (CONTINUED)**  
**ELECTRICAL CONNECTORS**

KEY	PART NUMBER	U/M DESCRIPTION
	007954-01-000	EA RECEPTACLE-HSG-6 POSITION
	007956-05-000	EA INSULATOR-SHRINK .25IDX1.50 - BLACK
	008311-01-000	EA CONNECTOR-WIRE NUT, INSULATED - RED
	008314-01-000	EA CONNECTOR-WIRE NUT, INSULATED - GRAY
	008326-01-000	EA TERMINAL-RING, 16/14 WIRE - 3/8" STUD
	008328-01-000	EA TERMINAL-RING, 12/10 WIRE - #10 STUD FIT
	008331-01-000	EA TERMINAL-RING,TONGUE - #4 WIRE - 3/8" STUD - COPPER
	008348-01-000	EA TERMINAL-RING, 3/8" STUD - #2 WIRE
	008355-01-000	EA CONNECTOR-CABLE CLAMPING, 3/4"
	008356-01-000	EA CONNECTOR-PLASTIC, 3/8" AVG
	035416-04-000	EA TERMINAL-RING #10 STUD FIT, INSULATED BARREL #16/14
	041480-01-000	EA CONNECTOR-STRAIGHT, 1/2" FLEX CONDUIT
	041953-01-000	FT CONDUIT-CONVOLUTE SLIT, .5"ID
	041953-01-000	FT CONDUIT-CONVOLUTE SLIT, .5"ID
	041953-05-000	FT CONDUIT-CONVOLUTE SOLID, .62" ID
	041953-06-000	FT CONDUIT-CONVOLUTE,SLIT .375"ID
	041953-07-000	FT CONDUIT-CONVOLUTE, SLIT - .25" ID
	041953-09-000	FT CONDUIT-CONVOLUTE,SLIT .50"ID
	047443-01-000	EA TERMINAL-.250 RECEPTACLE FIT, INSULATED - 16/14 AWG
	058028-01-000	EA CONNECTOR-ELECTRICAL PIGTAIL, NYLON - CLEAR
	062036-01-000	EA TERMINAL-PACK-CON,12/10 AWG - PACKARD 12033817
	062036-02-000	EA TERMINAL-PACK-CON, 16/14 AWG - PACKARD 08917021
	077479-02-000	EA BOOT-BATTERY TERMINAL, SINGLE CABLE
	080015-02-000	EA RECEPTACLE-FLAG, .185 - 16/14 GA - AMP 3
	082741-01-000	EA CONNECTOR BODY-2 CNCT MALE - SERV ELEC 2P-FYL
	087225-01-000	FT SLEEVING-1/2",TYPE H - VARFLEX
	088267-01-000	EA TERMINAL-FEMALE,1/4 - PACKARD 2962573
	088473-02-000	EA HOUSING-PIN, 15 CAVITY - AMP 1-480710-0
	088473-03-000	EA HOUSING-PIN, 9 CAVITY - AMP 1-480706-0
	088473-05-000	EA HOUSING-PIN, 6 CAVITY - AMP 640585-1
	088473-08-000	EA HOUSING-PIN, 4 CAVITY - AMP 1-480702-0
	088473-09-000	EA HOUSING-PIN, 3 CAVITY - AMP 1-480700-0
	088473-10-000	EA HOUSING-PIN, 2 CAVITY - AMP 1-480698-0
	088474-02-000	EA HOUSING-SOCKET, 12 CAVITY - AMP 1-480711-0
	088474-03-000	EA HOUSING-SOCKET, 9 CAVITY - AMP 1-480707-0
	088474-07-000	EA HOUSING-SOCKET, 5 CAVITY - AMP 1-480764-0
	088474-08-000	EA HOUSING-SOCKET, 4 CAVITY - AMP 1-480703-0
	088474-09-000	EA HOUSING-SOCKET, 3 CAVITY - AMP 1-480701-0
	088474-10-000	EA HOUSING-SOCKET, 2 CAVITY - AMP 1-480699-0
	088475-01-000	EA PIN-CONNECTOR, 14 TO 20 AWG
	088475-02-000	EA PIN-CONNECTOR, 10 TO 12 AWG
	088476-01-000	EA SOCKET-CONNECTOR, BRASS - PRE-TIN
	088476-02-000	EA SOCKET-CONNECTOR, 12-10 GA - PHOS. BRZ - PRE-TIN
	103987-02-000	EA SEAL-SOLENOID ACCESS - 94 F,G-SERIES
	104100-01-000	EA HOUSING-1 POSITION, 75 AMP - AMP 53884-1
	104100-03-000	EA TERMINAL-75 AMP - AMP 53880-4 LOOSE
	106006-01-000	EA HOUSING-1 POSITION, FEMALE - PACKARD 12015952
	106007-01-000	EA TERMINAL-FEMALE,14-16AWG - PACKARD 12015861-L
	106655-01-000	EA TERMINAL-FUSE BLOCK,14-16AWG - PACKARD 12020321
	110178-01-000	EA HOUSING-WIPER MOTOR - UT6237440-EC25WJ
	113306-01-000	EA TERMINAL-FEM,M/P,480,14-16 - PACKARD12048451
	113307-01-000	EA TERMINAL-FEM,M/P,150,16-20 - PACKARD12048074
	113468-01-000	EA HOUSING-2 POSITION, FEMALE - 56-SERIES - PACKARD 02965981 USED ON WIPER/WASHER WIRE ASM

**POWER CORD, CONVERTER & WIRE ASSEMBLIES**

KEY	PART NUMBER	U/M DESCRIPTION
	083208-01-000	EA CONVERTER-POWER, 32A - 120V/12V - BW 6332
	113132-01-000	EA LOAD CENTER-120/240V,60A - WESCO 2460SGNM
	008052-01-000	EA CORD-POWER, 10/3 - 30 AMP - 25' - CANADIAN
	008054-01-000	EA CORD-POWER, 10/3 - 30 AMP - 25'
	096449-01-000	EA WIRE ASSEMBLY-WATER TANK TO MONITOR PANEL
	097618-01-000	EA WIRE ASM-MONITOR PANEL, W/3 WIRES & ORANGE RESISTOR- LVS ORANGE RESISTOR W/3 (ORANGE-GREEN-BLUE) WIRES
	113134-03-000	EA WIRE ASM-WIPER/WASHER

## EXTERIOR BODY GROUP

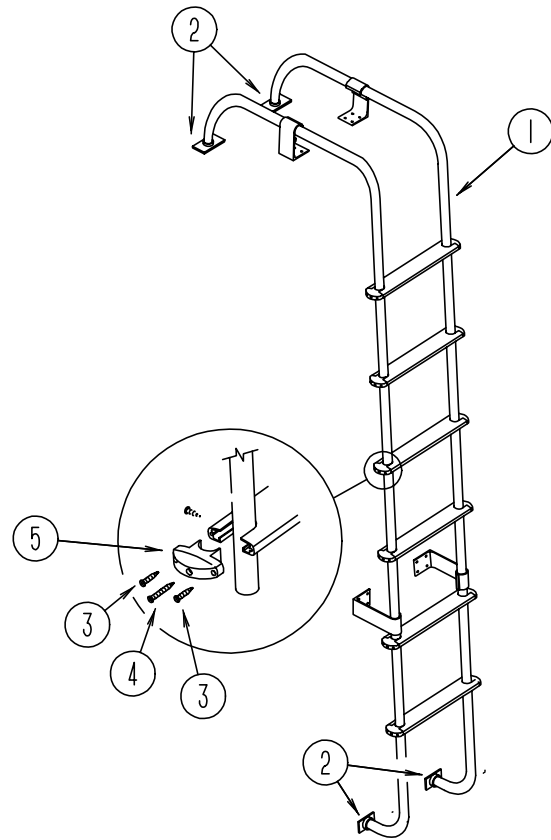

LADDER

KEY	PART NUMBER	U/M DESCRIPTION
1	102953-14-FB1	EA LADDER ASM
2	067165-01-000	EA BRACKET-MOUNTING, LADDER, LOWER
3	000G39-06-10T	EA SCREW-SELF DRIVING, 6-20 X 5/8" PPH - BLACK
4	000G67-10-36T	EA SCREW, 10-12 X 2.25" PPH - BLACK
5	076980-02-000	EA END CAP-STEP, BLACK
	069726-02-000	EA BUMPER - .88" DIAMETER X .40" - BLACK
	038327-01-000	EA TAPE-ANTI SLIP, 2" X 60'

### FIBERGLASS, STYROFOAM, ALUMINUM & STEEL TUBING

KEY	PART NUMBER	U/M DESCRIPTION
	076054-P4-000	EA FIBERGLASS SHEET 2438 X 2463 BRIGHT WHITE
	076054-R4-000	EA FIBERGLASS SHEET - 106.8" X 318.6" BRIGHT WHITE
	076054-S1-000	EA FIBERGLASS SHEET - 96" X 108" BRIGHT WHITE
	077517-62-000	EA FIBERGLASS-SHEET,48 X 96 BRIGHT WHITE,FLAT
	000870-05-000	SF STYROFOAM-.5" X 24" X 96", INCREMENTS OF 16 SF
	000870-08-000	SF STYROFOAM-.75 X 48" X 96"-PLANED
	100619-01-000	BF EXPANDED FOAM SHEET - 48" X 96" X 1.34"
	100619-04-000	BF FOAM-EXPANDED POLYSTYRENE - EPS 48" X 96" X .5
	100619-05-000	BF FOAM-EXPANDED POLYSTYRENE - 48" X 96" X .75"
	055278-01-001	FT TUBING-STEEL, .75" X 1.5" X 288"
	068716-01-001	EA BRACE - 90 DEGREE L-ANGLE, 192" - EXTRUDED ALUMINUM
	044487-01-001	EA SHEET-ALUMINUM, .019" X 96" X 360" - MILL FINISH
	044487-01-002	EA SHEET-ALUMINUM, .019" X 96" X 432" - MILL FINISH
	002726-01-001	EA GARNISH-U-CHANNEL, 1.38" X 19' - SERRATED - MILL ALUMINUM
	065747-01-000	SF INSULATION-MICROFOAM, .5" THICK X 72" X 112' ROLL
	089297-01-000	SF PLYWOOD-LUAN, OVERLAY GRADE - 4' X 8' - INC OF 32 SF

## EXTERIOR BODY GROUP (CONTINUED)

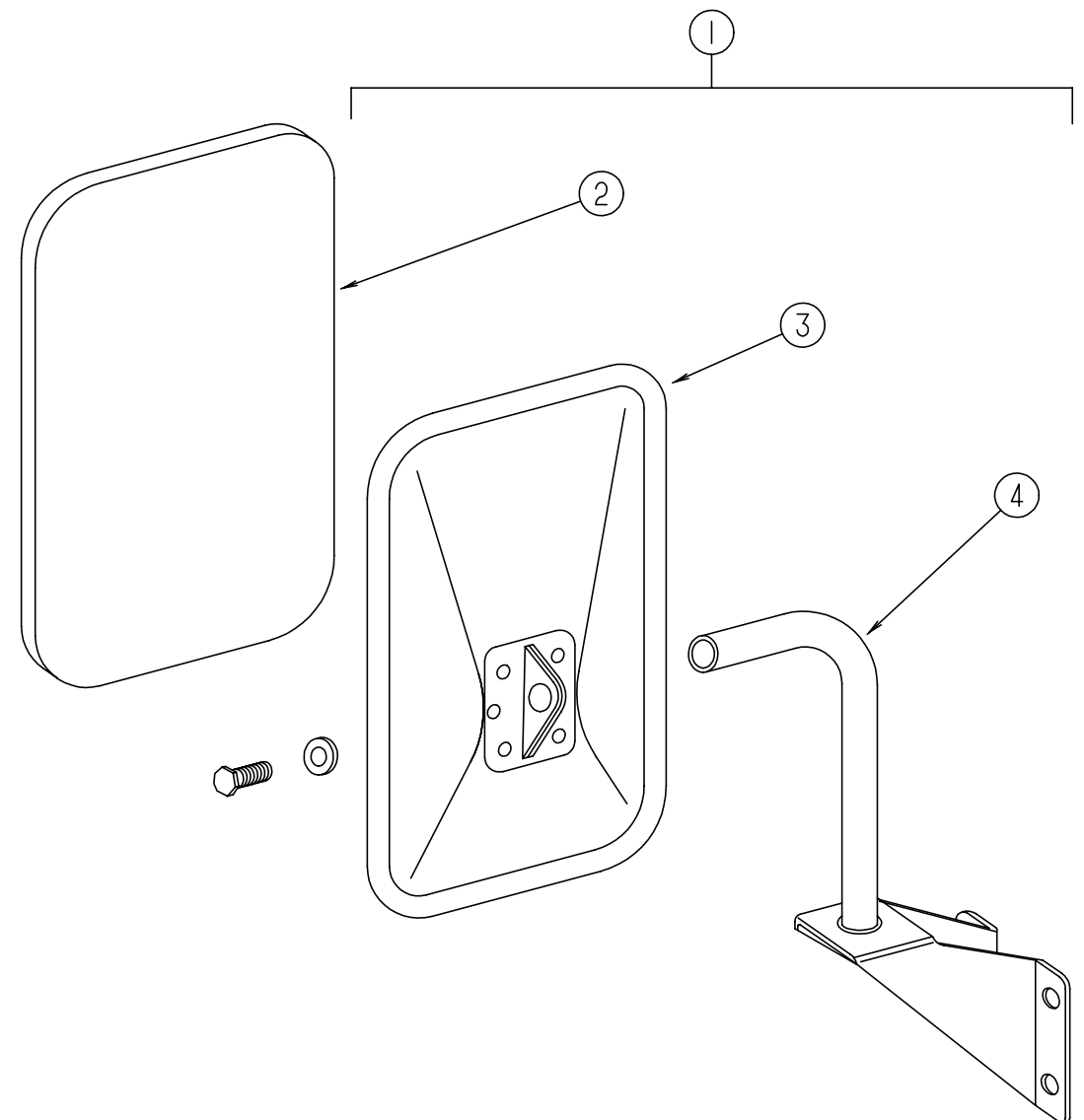

EXTERIOR MIRROR

KEY	PART NUMBER	U/M DESCRIPTION
1	105076-01-702	EA MIRROR ASM-LOW MOUNTING, BLACK - 713196
2	049347-01-700	EA GLASS-EXTERIOR MIRROR, 7.5" X 10.5"
3	105076-01-703	EA MIRROR HEAD ONLY, BLACK - 709001-8
4	105076-01-704	EA ARM, Q780521-9



**EXTERIOR BODY GROUP (CONTINUED)**  
**EXTERIOR BODY PANELS AND TRIM**

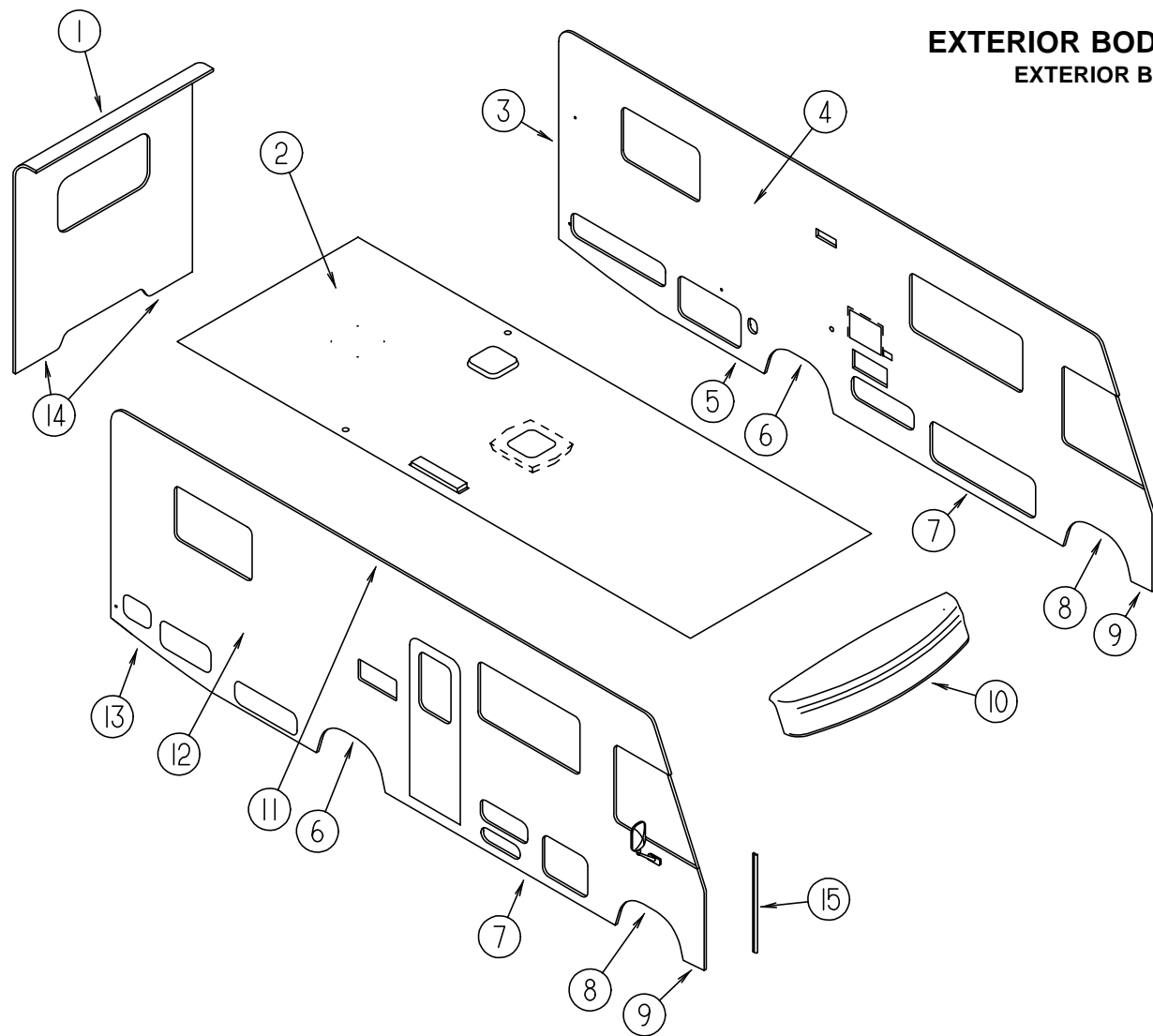

KEY	PART NUMBER	U/M	DESCRIPTION
1	M07506-16-GD1	EA	BACKWALL ASM - W/O WINDOW & VENT - DBL BED FROM: 00-00-00 THRU: 08-13-95
1	M07506-16-GE1	EA	BACKWALL ASM - W/O WINDOW & VENT - DBL BED FROM: 00-00-00 THRU: 08-13-95
1	M08063-09-GD1	EA	BACKWALL ASM - W/O WINDOW & TRIM - DOUBLE BED FROM: 08-14-95 THRU: 99-99-99
1	M08063-09-GE1	EA	BACKWALL ASM - W/O WINDOW & TRIM - DOUBLE BED FROM: 08-14-95 THRU: 99-99-99
2	P19253-01-GB1	EA	ROOF ASM - W/O ROOF VENTS
3	096854-04-02A	EA	TRIM-CONTOUR, W/O VINYL INSERT - BRIGHT WHITE
	105312-01-07A	FT	INSERT-CONTOUR TRIM, VINYL - BRIGHT WHITE
4	M07509-10-GB1	EA	SEAWALL ASM-LEFT,TWIN BED (GD1)
4	M07509-10-GE1	EA	SEAWALL ASM-LEFT,TWIN BED
4	M07509-11-GB1	EA	SEAWALL ASM-LEFT,BUNK BED (GD1)
4	M07509-11-GE1	EA	SEAWALL ASM-LEFT,BUNK BED
4	M07509-12-GB1	EA	SEAWALL ASM-LEFT,DBL BED (GD1)
4	M07509-12-GE1	EA	SEAWALL ASM-LEFT,DBL BED
4	M07509-14-GB1	EA	SEAWALL ASM-LEFT,C/S TWIN (GD1)
4	M07509-14-GE1	EA	SEAWALL ASM-LEFT,C/S TWIN
4	M07509-09-GB1	EA	SEAWALL ASM-LEFT,QUEEN BED (GD1)
4	M07509-09-GE1	EA	SEAWALL ASM-LEFT,QUEEN BED
5	108038-29-01A	EA	TRIM-SIDEWALL, U-CHANNEL - 2777MM LONG - BOTTOM - REAR - BRIGHT WHITE
6	108070-01-04A	EA	TRIM-WHEELWELL, REAR - BRIGHT WHITE
7	108039-01-04A	EA	TRIM-SIDEWALL, U-CHANNEL - 3065MM LONG - BOTTOM-CENTER-BRIGHT WHITE
8	108069-05-01A	EA	TRIM-WHEELWELL, FRONT - BRIGHT WHITE
9	108109-01-04A	EA	TRIM-SIDEWALL, U-CHANNEL - 247MM LONG - LOW - FRONT - BRIGHT WHITE
10	M05922-03-FB1	EA	CAP ASM-FRONT, W/CLEARANCE LIGHTS & WIRING - BRIGHT WHITE
	117012-01-01A	EA	CAP-FRONT, W/O WIRING & CLEARANCE LIGHTS - BRIGHT WHITE
11	099583-55-003	EA	TRIM-CONTOUR,ROOF - AWNING RAIL, 3048 MM - BRIGHT WHITE - PASSENGERS
	096864-01-02A	EA	TRIM-CONTOUR,ROOF BRIGHT WHITE - DRIVERS
12	M07508-10-GB1	EA	SEAWALL ASM-RH,TWIN (GD1)
12	M07508-10-GE1	EA	SEAWALL ASM-RH,TWIN
12	M07508-11-GB1	EA	SEAWALL ASM-RH,BUNK (GD1)
12	M07508-11-GE1	EA	SEAWALL ASM-RH,BUNK
12	M07508-12-GB1	EA	SEAWALL ASM-RH,DBL (GD1)
12	M07508-12-GE1	EA	SEAWALL ASM-RH,DBL
12	M07508-14-GB1	EA	SEAWALL ASM-RIGHT C/S TWIN (GD1)
12	M07508-14-GE1	EA	SEAWALL ASM-RIGHT C/S TWIN
12	M07508-09-GB1	EA	SEAWALL ASM-RH,QUEEN (GD1)
12	M07508-09-GE1	EA	SEAWALL ASM-RH,QUEEN
13	108038-29-01A	EA	TRIM-SIDEWALL, U-CHANNEL - 2777MM LONG - BOTTOM - REAR - BRIGHT WHITE
14	050406-21-000	EA	TRIM-BACKWALL, LOWER - BRIGHT WHITE
15	089922-26-000	EA	TRIM-FIBERGLASS, PANEL - BRIGHT WHITE
	108688-01-03A	EA	STRIP-FEATURE, BRIGHT WHITE (LOWER BACKWALL)
	108651-01-01A	EA	END CAP-FEATURE STRIP, MILL (LOWER BACKWALL)

KEY	PART NUMBER	U/M	DESCRIPTION
1	M07506-14-GD1	EA	BACKWALL ASM - W/O WINDOW & TRIM - TWIN BED FROM: 00-00-00 THRU: 08-13-95
1	M07506-14-GE1	EA	BACKWALL ASM - W/O WINDOW & TRIM - TWIN BED FROM: 00-00-00 THRU: 08-13-95
1	M08063-07-GD1	EA	BACKWALL ASM - W/O WINDOW & TRIM - TWIN BED FROM: 08-14-95 THRU: 99-99-99
1	M08063-07-GE1	EA	BACKWALL ASM - W/O WINDOW & TRIM - TWIN BED FROM: 08-14-95 THRU: 99-99-99
1	M07506-13-GD1	EA	BACKWALL ASM - W/O WINDOW & TRIM - QUEEN BED FROM: 00-00-00 THRU: 08-13-95
1	M07506-13-GE1	EA	BACKWALL ASM - W/O WINDOW & TRIM - QUEEN BED FROM: 00-00-00 THRU: 08-13-95
1	M08063-06-GD1	EA	BACKWALL ASM - W/WINDOW & TRIM - QUEEN BED FROM: 08-14-95 THRU: 99-99-99
1	M08063-06-GE1	EA	BACKWALL ASM - W/WINDOW & TRIM - QUEEN BED FROM: 08-14-95 THRU: 99-99-99
1	M07506-15-GD1	EA	BACKWALL ASM - W/O WINDOW & TRIM - BUNK BED FROM: 00-00-00 THRU: 08-13-95
1	M07506-15-GE1	EA	BACKWALL ASM - W/O WINDOW & TRIM - BUNK BED FROM: 00-00-00 THRU: 08-13-95
1	M08063-08-GD1	EA	BACKWALL ASM - W/O WINDOW & TRIM - BUNK BED FROM: 08-14-95 THRU: 99-99-99
1	M08063-08-GE1	EA	BACKWALL ASM - W/O WINDOW & TRIM - BUNK BED FROM: 08-14-95 THRU: 99-99-99
1	M08063-10-GD1	EA	BACKWALL ASM - W/O WINDOW & TRIM - CROSS/STACKED TWIN
1	M08063-10-GE1	EA	BACKWALL ASM - W/O WINDOW & TRIM - CROSS/STACKED TWIN

**EXTERIOR BODY GROUP (CONTINUED)**  
DECALS, FILM STRIPES & PAINT

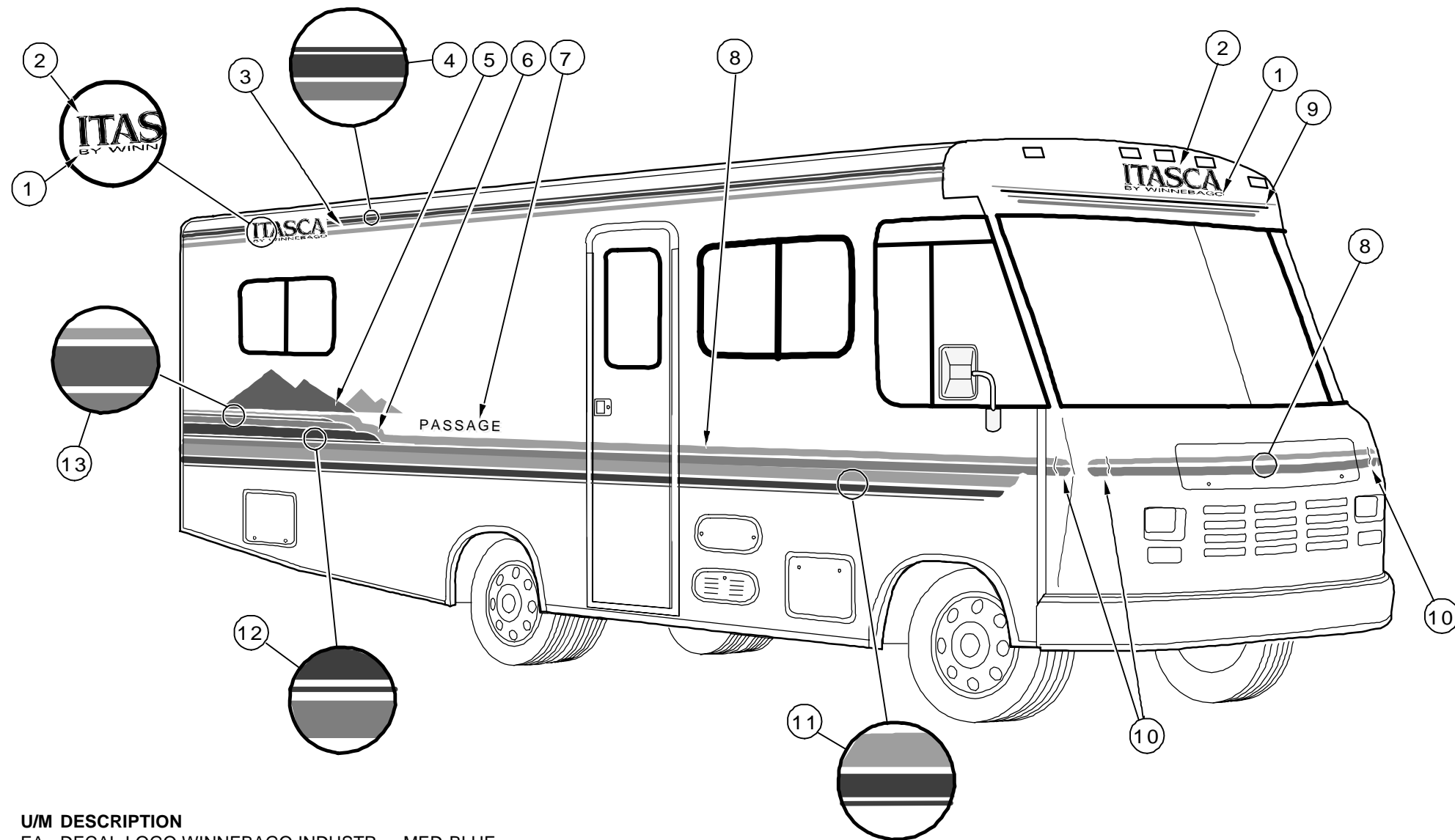

KEY	PART NUMBER	U/M	DESCRIPTION	
1	117018-01-02A	EA	DECAL-LOGO,WINNEBAGO INDUSTR	MED BLUE
2	118793-01-02A	EA	DECAL-LOGO,ITASCA	MED BLU/MED BLU
3	107385-02-08A	FT	FILM-MULTISTRIPE 50.8MM X 150"	TEAL PEARLE
4	094443-24-02A	FT	FILM-MULTISTRIPE 69.9MM X 150'	MARINE BLUE/MARINE BLUE/DEEP ROSE
5	114792-01-02A	EA	DECAL-MOUNTAINS, PASSENGERS	MAJESTIC PURPLE/DEEP ROSE
	114792-02-02A	EA	DECAL-MOUNTAINS, DRIVERS	MAJESTIC PURPLE/DEEP ROSE
6	114794-01-02A	EA	DECAL-ROLLING HILLS, PASSENGERS	SILVER/MARINE BLUE
	114794-02-02A	EA	DECAL-ROLLING HILLS, DRIVERS	SILVER/MARINE BLUE
7	116169-01-02A	EA	DECAL-LOGO,PASSAGE	MEDBLUE/DEEPROSE
8	107385-11-08A	FT	FILM - 31.8MM X 150FT	MARINE BLUE
9	116813-01-02A	EA	DECAL-UPPER,FRONT,CAP	MARINE BLUE/MARINE BLUE/DEEP ROSE
10	107385-06-08A	FT	FILM - 25.4MM X 150FT	DEEP ROSE
11	094443-30-02A	FT	FILM-MULTISTRIPE 187.3MM X 150	TEAL PEARL/MARINE BLUE/MARINE BLUE
12	094443-23-02A	FT	FILM-MULTISTRIPE 142.9MM X 150	TEAL PEARL/MARINE BLUE/MARINE BLUE
13	105781-11-10A	FT	FILM-MULTISTRIPE 50.8MM X 150'	SILVER/MARINE BLUE
	041561-03-000	EA	PAINT-LOW BAKE, OFF WHITE	REF:72897-01
	004308-01-000	EA	PAINT-SPRAY, BLACK	

## EXTERIOR BODY GROUP (CONTINUED)

### FRONT END COMPONENTS

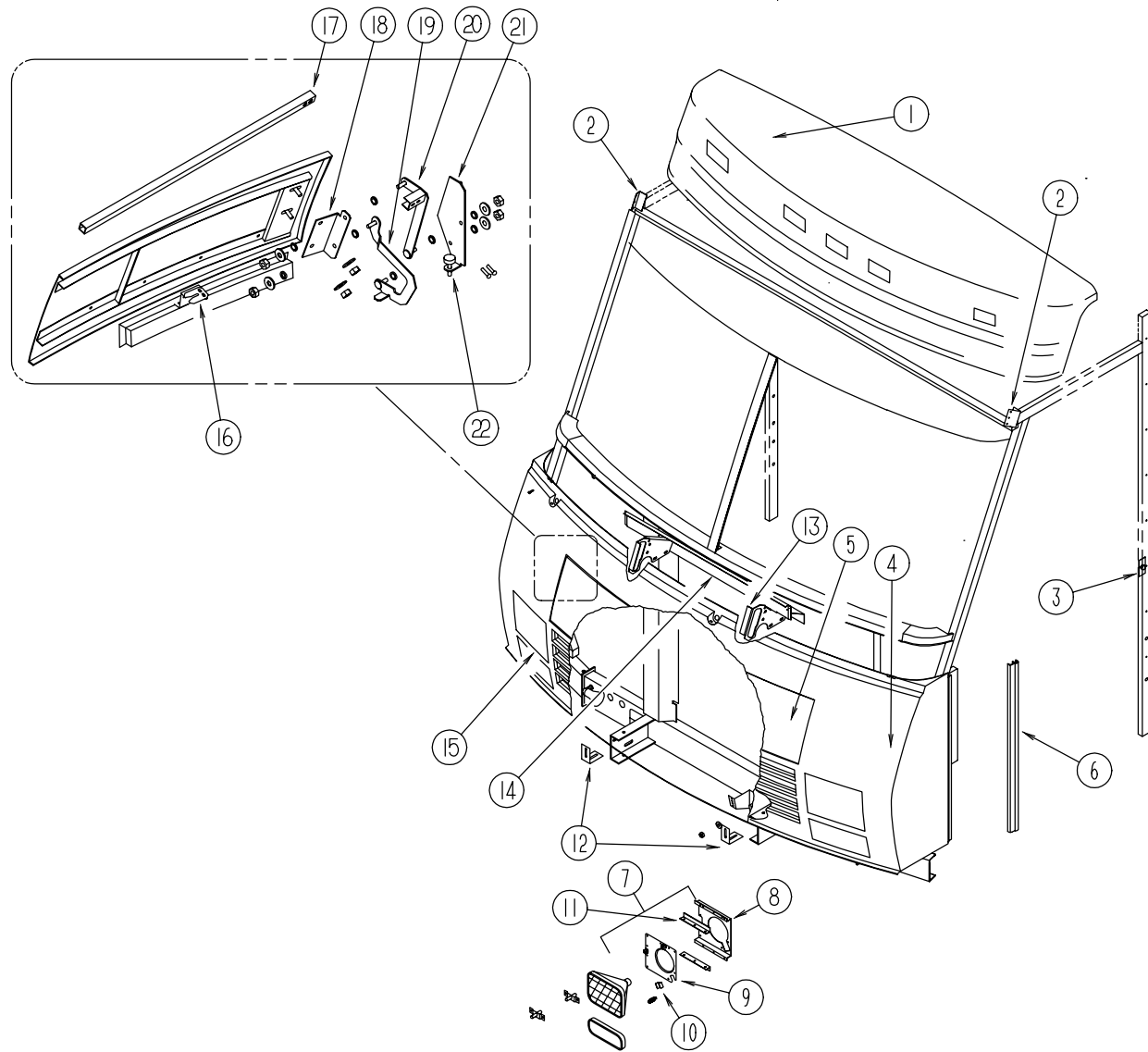

KEY	PART NUMBER	U/M	DESCRIPTION
1	M05922-03-FB1	EA	CAP ASM-FRONT, W/CLEARANCE LIGHTS & WIRING - BRIGHT WHITE
	117012-01-01A	EA	CAP-FRONT, W/O WIRING & CLEARANCE LIGHTS - BRIGHT WHITE
2	077001-01-000	EA	ANGLE-MOUNTING, ROOF PANEL - V ANGLE - 3" X 2.4" X 1.5"
3	070579-06-000	EA	PLATE-ANCHOR, W/7/16 WELD NUT - 1.5" X 3.3"
4	M05928-01-FB1	EA	FRONT END ASM-FIBERGLASS, COMPLETE W/HEADLIGHTS - BRIGHT WHITE
	109877-01-02A	EA	PANEL-FRONT,LOWER BRT/WHT
5	109881-01-02A	EA	PANEL ASM-HOOD, W/O LOCK - BRIGHT WHITE
6	089922-26-000	EA	TRIM-FIBERGLASS, PANEL - BRIGHT WHITE
7	110712-02-D15	EA	PLATE ASM-HEADLAMP, DUAL - LEFT
8	110784-02-01A	EA	BRACKET-HEADLAMP, DUAL - LEFT - MILL
	110784-01-01A	EA	BRACKET-HEADLAMP, DUAL - RIGHT - MILL
9	110711-02-01A	EA	PLATE-HEADLAMP, DUAL - LEFT - MILL
	110711-01-01A	EA	PLATE-HEADLAMP, DUAL - RIGHT - MILL
10	110691-01-01A	EA	BRACKET-SPRING, HEADLAMP - MILL
11	110782-01-000	EA	ANGLE-SUPPORT, HEADLAMP - V-ANGLE - 160MM LONG
12	103628-01-000	EA	BRACKET-FRONT, LOWER - MOUNTING
13	103136-04-000	EA	BRACKET-SUPPORT, UPPER - HINGE - LEFT
	103136-03-000	EA	BRACKET-SUPPORT, UPPER - HINGE - RIGHT
14	102421-01-000	EA	PANEL-PLENUM, CENTER
15	110712-01-D15	EA	PLATE ASM-HEADLAMP, DUAL - RIGHT
16	109915-01-01A	EA	LATCH-HOOD, FRONT END - BLACK
17	105096-06-000	EA	TUBE-TIMING, HOOD HINGE
18	109927-01-000	EA	ANGLE-LINK, HOOD - RIGHT
	109927-02-000	EA	ANGLE-LINK, HOOD - LEFT
19	109930-03-000	EA	LINK ASM-HINGE, HOOD - LOWER - RIGHT - W/ WELD STUD
	109930-04-000	EA	LINK ASM-HINGE, HOOD - LOWER - LEFT - W/ WELD STUD
20	109929-01-000	EA	LINK ASM-HINGE, HOOD - UPPER - RIGHT
	109929-02-000	EA	LINK ASM-HINGE, HOOD - UPPER - LEFT
21	109926-03-000	EA	BRACKET ASM-LINK, HINGE - RIGHT - W/WELD STUD & FERRULE
	109926-04-000	EA	BRACKET ASM-LINK, HINGE - LEFT - W/WELD STUD & FERRULE
22	058786-01-000	EA	BOLT-ADJUSTING, HOOD - W/BLACK PAD - .31" #18 X 2"
22	000D39-05-00B	EA	NUT-HEX, SERRATED FLANGE LK - 5/16 - 18 - ZINC

# GALLEY GROUP

## GALLEY CABINETRY

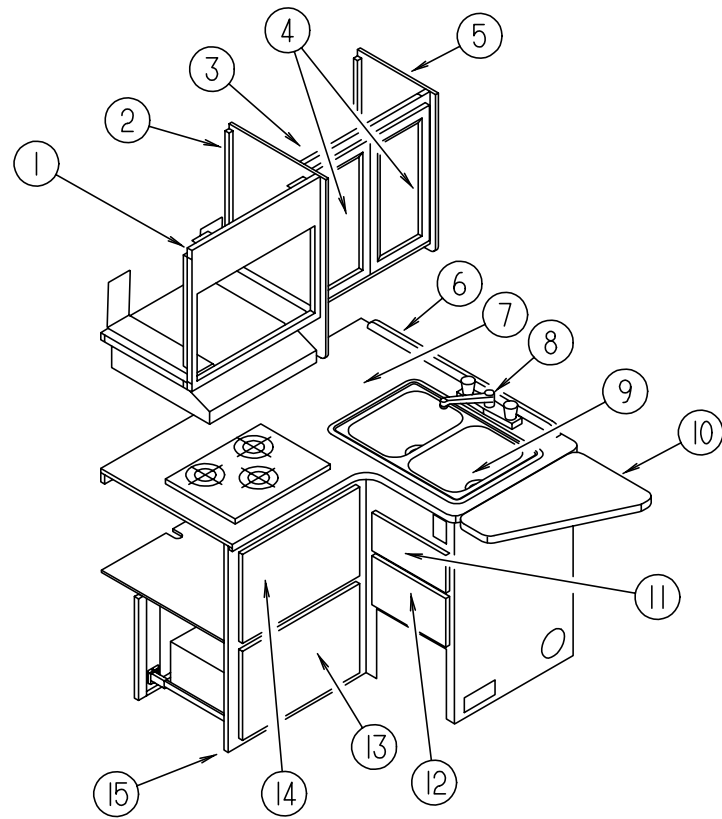

KEY	PART NUMBER	U/M	DESCRIPTION
1	116874-01-GB1	EA	CABINET ASM-MICROWAVE OVERHEAD
2	109908-28-GB1	EA	CAP ASM - END - OVERHEAD
3	116876-01-GB1	EA	CABINET ASM-OVERHEAD - GALLEY
	116876-11-GB1	EA	SHELF ASM
4	110140-26-G01	EA	DOOR ASM-MITERED - VINYL WRAP 0280X0555
5	109908-27-GB1	EA	CAP ASM - END - OVERHEAD
6	098335-08-F12	EA	RAIL-GALLEY,896
7	119477-11-GD1	EA	COUNTERTOP ASM
7	119477-11-GC1	EA	COUNTERTOP ASM (GE1)
8	103243-01-000	EA	FAUCET-GALLEY,DUAL CONTROL - P5043
9	102551-01-000	EA	SINK-STAINLESS STEEL, DOUBLE - 17" X 25"
	066437-01-000	EA	STRAINER-SINK, GALLEY W/BASKET
10	119477-12-GD1	EA	EXTENSION ASM - GALLEY
10	119477-12-GC1	EA	EXTENSION ASM - GALLEY (GE1)
	104181-01-01A	EA	SUPPORT-LEAF,8 IN,SAF-T-RING
11	P10163-M4-GB1	EA	DRAWER COMPLETE-SLIDE
12	P10163-M5-GB1	EA	DRAWER COMPLETE-SLIDE
13	P10163-M7-GB1	EA	DRAWER COMPLETE-SLIDE
14	110140-77-GB1	EA	DOOR ASM-MITERED - VINYL WRAP - 0555 X 0305
15	P19477-01-GD1	EA	CABINET ASM-GALLEY
15	P19477-01-GC1	EA	CABINET ASM-GALLEY (GE1)
	110012-02-G22	EA	COVER ASM-SINK (GD1)
	110012-02-G01	EA	COVER ASM-SINK (GE1)
	110012-03-GD1	EA	COVER ASM-SINK
	110012-03-GC1	EA	COVER ASM-SINK (GE1)
	090329-01-000	FT	SEAL-T, REFRIGERATOR CABINET - .6" WIDE TOP X 2" TAIL

## GALLEY GROUP (CONTINUED)

NORCOLD SINGLE DOOR REFRIGERATOR - 2-WAY - MODEL 6162 RH

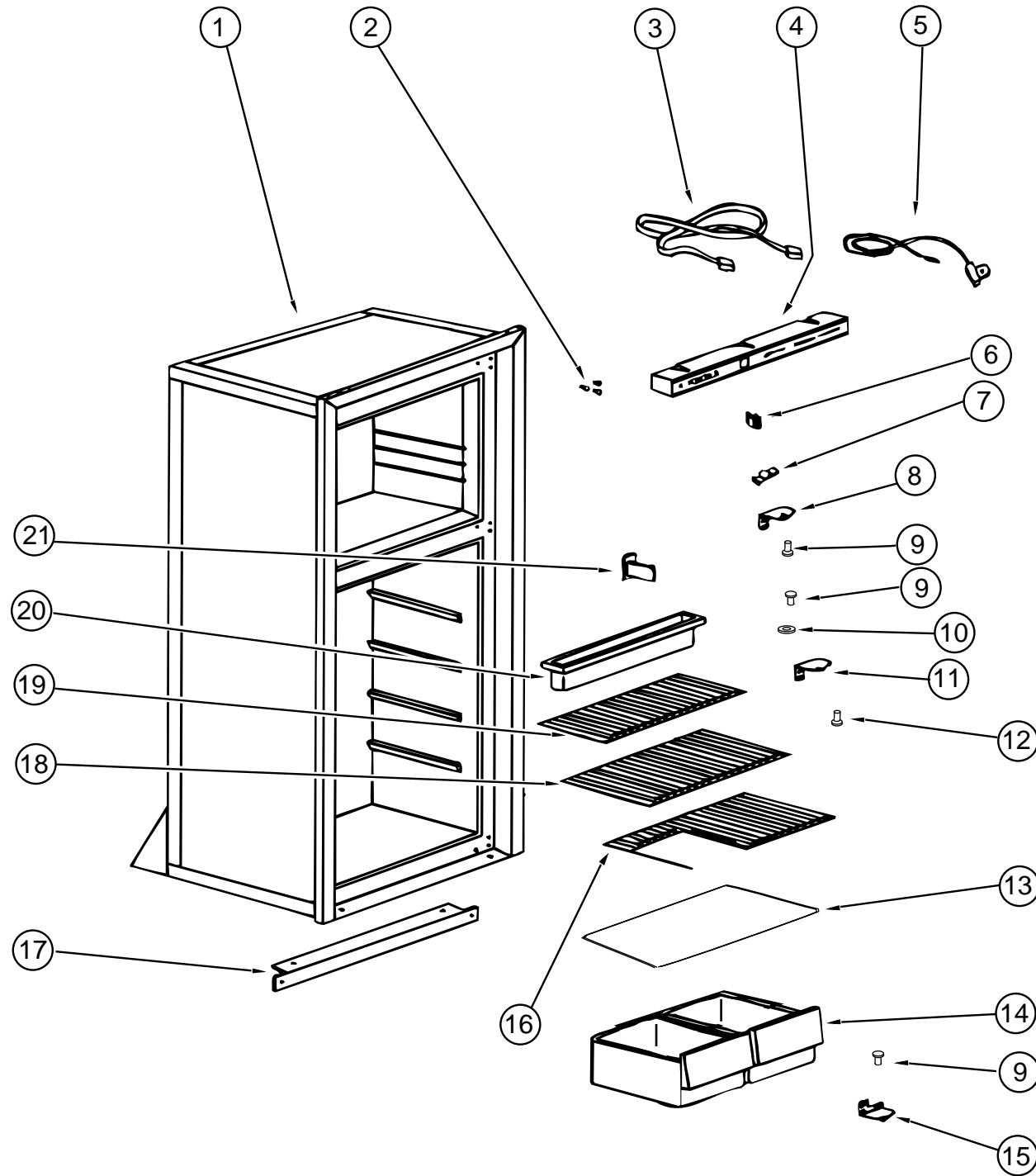

KEY	PART NUMBER	U/M	DESCRIPTION	VENDOR NO.
	104138-04-01A	EA	REFRIGERATOR SMALL DBL DOOR 2-WAY - NORCOLD 6162 RH BL N/A - USE P.N.#1041380201A REFRIGERATOR W/REVERSE HANDLE REPAIR PARTS ARE AVAILABLE FOR ORIGINAL REFRIGERATOR	
1	104138-04-701	EA	FOAMED CAB ASM (BLK W/WHITE)	61725038
2	094039-01-722	EA	PLUG-HOLE, BLACK	61582030
3	084880-01-746	EA	CABLE-PC BD TO POWER SUPPLY	61571522
4	104137-06-700	EA	SHELL-EYEBROW.2-WAY, W/HUM	61726622
5	084880-01-753	EA	THERMISTER 78"	61697822
6	075217-01-738	EA	SWITCH-HUMIDITY	61525922
7	084880-01-760	EA	CLIP (THERMISTER)	61689122
8	094039-01-723	EA	BRACKET-HINGE, TOP RH-BTM LH	61580838
9	094039-01-725	EA	PIN-HINGE, BLACK	61578130
	084880-03-702	EA	PIN-HINGE, TOP/BTM, FEMALE	61580630
10	084880-01-749	EA	HINGE BUSHING	61580722
11	094039-01-728	EA	BRACKET-HINGE, CENTER BLACK	61566530
12	094039-01-730	EA	PIN-HINGE, CENTER, BLACK	61566730
13	084880-01-722	EA	COVER-CRISPER, GLASS	61564122
14	104137-06-707	EA	CRISPER (WHITE)	61571325
15	094039-01-724	EA	BRACKET-HINGE, TOP LH-BTM RH	61580938
16	104137-06-730	EA	SHELF-BOTTOM, W/CUTOUT WHITE	618055
17	094039-01-732	EA	TRIM-FRONT LOWER, BLACK	61622130
18	104137-06-729	EA	SHELF-MIDDLE, WHITE	618052
19	104137-06-728	EA	SHELF W/RISER, WHITE	618062
20	094039-01-735	EA	TRAY-DRIP, WHITE	61572830
21	084880-01-732	EA	LATCH	61578522
	094039-01-736	EA	SWITCH-LIGHT, BLACK	61581022
	093646-01-000	EA	BRACKET ASM-TIEDOWN, REFRIGERATOR	
	065225-02-000	EA	PLATE - TIEDOWN - REFRIGERATOR	
	054450-01-000	EA	LEVEL-REFRIGERATOR	
	116751-05-01A	EA	TRAY-DRIP, REFRIGERATOR - 24.6" X 6.3" - PLASTIC - BLACK	
	104137-06-706	EA	SHELF-WIRE, SHORT	61718222
	104137-06-725	EA	SHELF-SHORT, WHITE,W/O RISER	618059
	104137-06-727	EA	SHELF-FREEZER, WHITE	618057

**GALLEY GROUP (CONTINUED)**  
**NORCOLD TWO DOOR REFRIGERATOR - 2-WAY - MODEL 6162 RH**

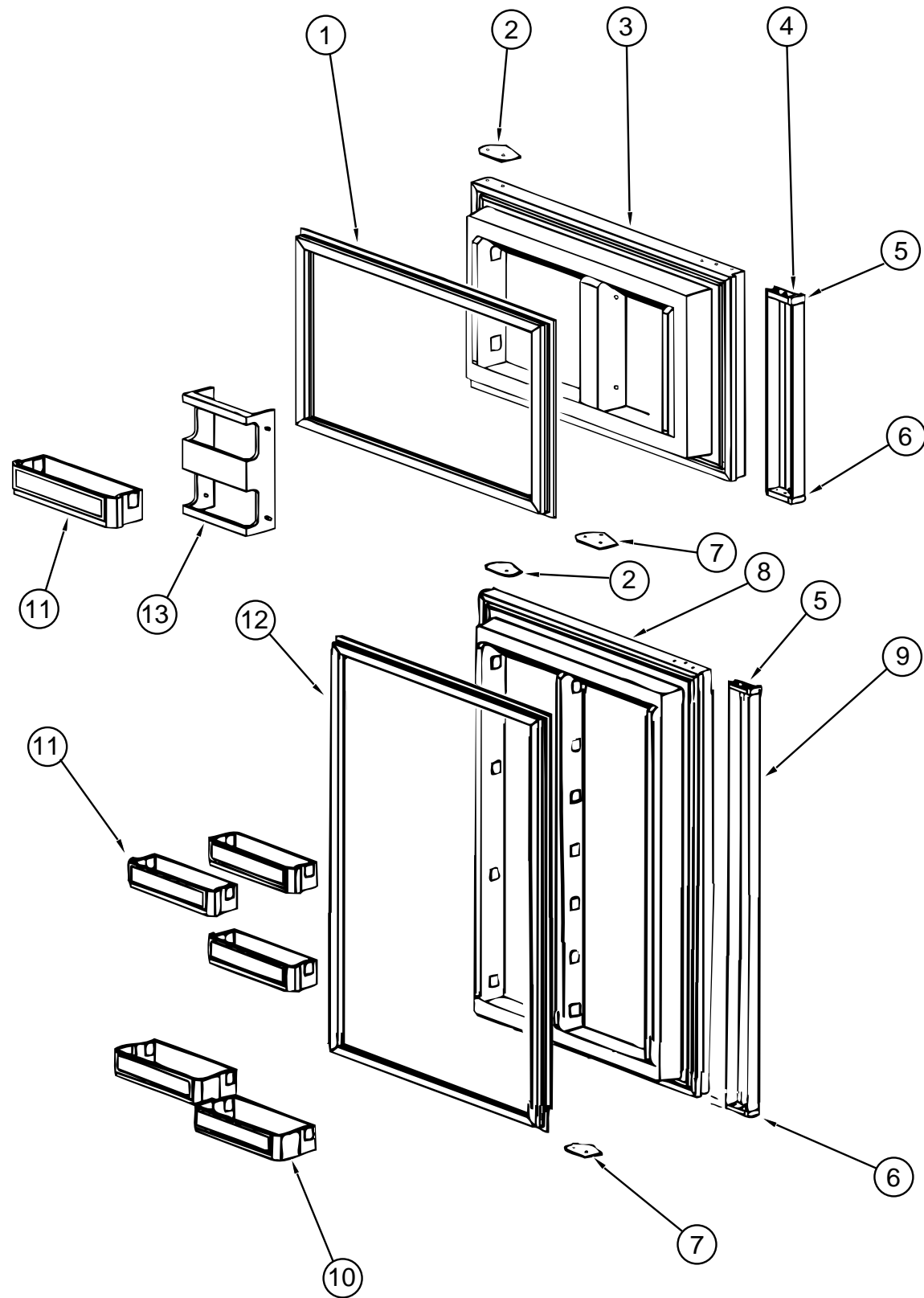

KEY	PART NUMBER	U/M DESCRIPTION	VENDOR NO.
1	094039-01-702	EA GASKET (GRAY) UPPER	61567830
2	094039-01-710	EA PLATE-HINGE,RHTOP,LHBTM, BLK	61631330
3	094039-01-706	EA LINER-UPPER DOOR,WHITE/BLACK	61581838-B
4	094039-01-708	EA HANDLE-UPPER DOOR ASM. BLACK	61650038
	084880-01-720	EA SPRING (FOR DOOR HANDLE)	61558822
5	084880-01-761	EA CAP-END, CATCH, UPPER, BLACK	61593730
6	084880-01-740	EA CAP-END, STOP CATCH, LWR.BLK	61593830
7	094039-01-704	EA PLATE-HINGE,TOPLH,RHBTM BLK	61631430
8	094038-01-702	EA LINER-DOOR, LOWER (BLK/WHT)	61581938-B
9	094038-01-704	EA HANDLE-DOOR, LOWER ASM BLACK	61650138
	084880-01-720	EA SPRING (FOR DOOR HANDLE)	61558822
10	104137-06-704	EA BIN-MILK, WHITE	61579425
11	104137-06-703	EA BIN-DOOR SHELF, WHITE	61564025
12	094038-01-700	EA GASKET-LOWER, GRAY	61567930
13	104137-06-702	EA RACK-JUICE, WHITE	61580525

**GALLEY GROUP (CONTINUED)**  
**NORCOLD 6162 REFRIGERATOR CONTROL ASM.**

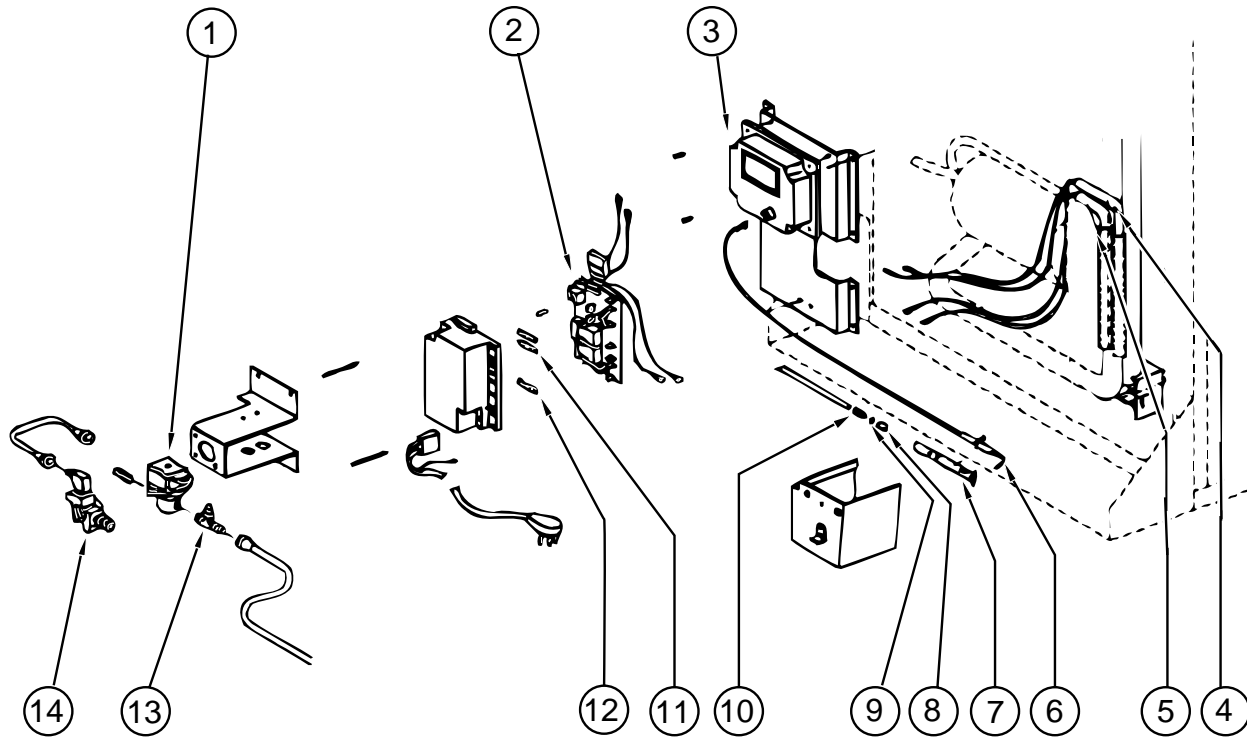

KEY	PART NUMBER	U/M	DESCRIPTION	VENDOR NO.
1	084880-01-718	EA	VALVE-GAS, (ASCO)	61551822
2	094039-04-702	EA	POWER SUPPLY (2 WAY)	61647422
3	104137-02-700	EA	CHANNEL-CONTROL MODULE	61717037
4	088248-01-710	EA	HEATER DC (HORIZONTAL) 3 WAY	61562822
5	088248-01-709	EA	HEATER-AC (HORIZONTAL)	61562722
6	104137-06-715	EA	ELECTRODE-SPARK/SENSOR, SGL	61692222
7	104137-06-714	EA	BURNER ASSEMBLY, 5-SLOT	61705222
8	084880-01-705	EA	ORIFICE	61452122
9	104137-06-713	EA	GASKET-ORIFICE	61475122
10	104137-06-712	EA	FITTING-GAS, TUBE CONNECTION	61692722
11	075217-01-734	EA	FUSE - 3 AMP	61538822
12	104137-06-711	EA	FUSE-5 AMP	61611622
13	104137-06-710	EA	TAP-PRESSURE	61594422
14	104137-06-709	EA	VALVE-SHUT OFF, MANUAL	61694922
	084879-03-700	EA	COIL-COOLING,F/HORIZ-BURNER	61687240

**GALLEY GROUP (CONTINUED)**  
**NORCOLD 6162 REFRIGERATOR EYEBROW ASM.**

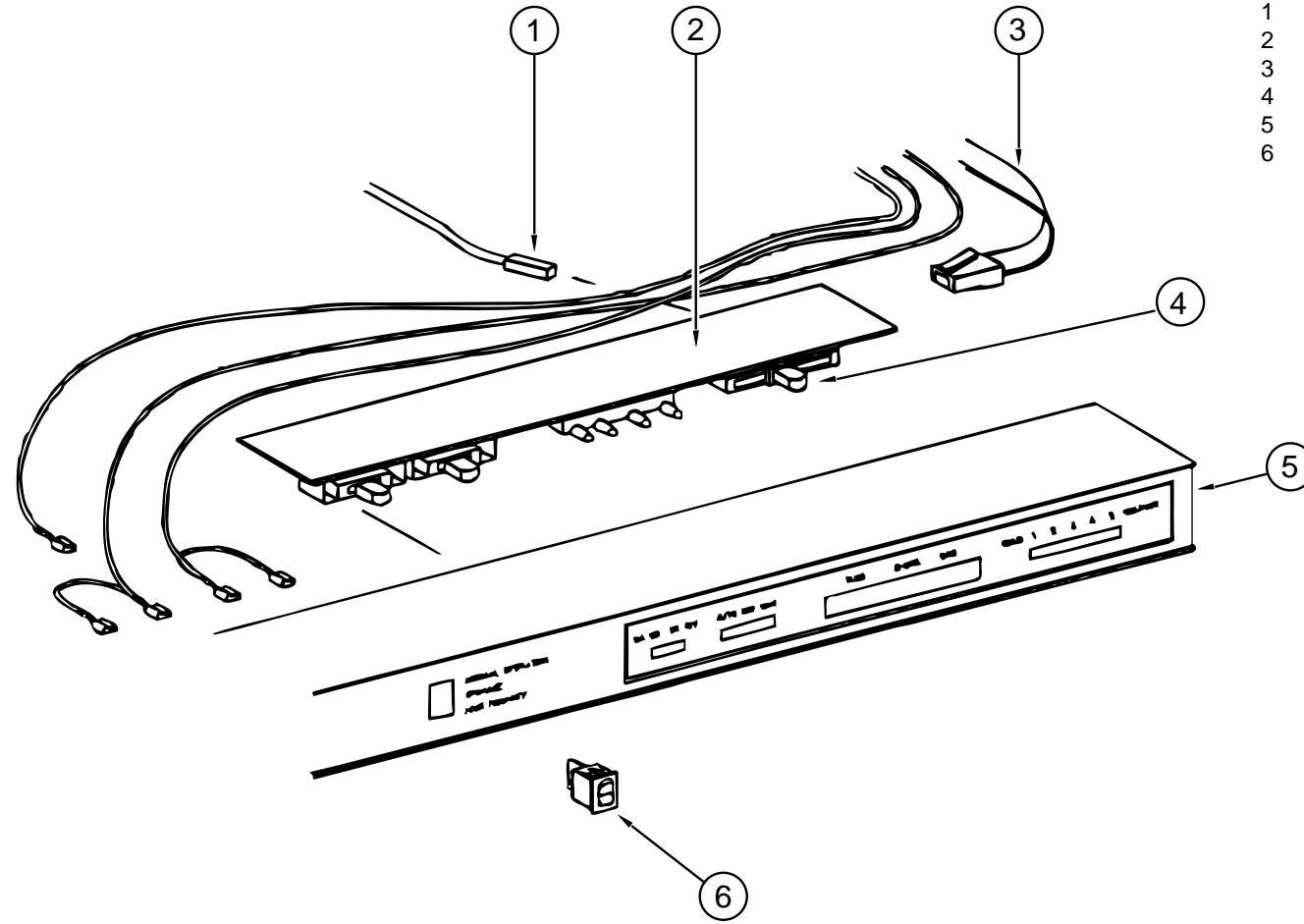

KEY	PART NUMBER	U/M	DESCRIPTION
1	084880-01-753	EA	THERMISTER 78"
2	094039-04-700	EA	BOARD-PC, 2 WAY
3	084880-01-746	EA	CABLE-PC BD TO POWER SUPPLY
4	102621-01-703	EA	BUTTON-THERMOSTAT,ADJUSTABLE
5	104137-06-700	EA	SHELL-EYEBROW.2-WAY, W/HUM
6	075217-01-738	EA	SWITCH-HUMIDITY

VENDOR NO.
61693822
61647322
61571522
61587422
61726622
61525922



**GALLEY GROUP (CONTINUED)**

**MICROWAVES, RANGE HOOD, & MONITOR PANEL**

KEY	PART NUMBER	U/M DESCRIPTION	VENDOR NO.
	115303-01-000	EA MICROWAVE OVEN - 14 1/8"H X 21 7/8"H X13 1/4"D - .8 CU FT./700 WATT	
	115303-01-700	EA TRIM F/VENT, TOP	2100309
	115401-01-01A	EA TRIM-MICROWAVE BLACK	
	103386-02-703	EA DAMPER LOCK SPRING	C-488
	103386-02-01A	EA HOOD-RANGE POWERED BLK VENTLINE	
	090973-01-700	EA MOTOR-12 VOLT, CSA & UL	CA508-1
	090973-01-702	EA BLADE-FAN	VA183-1
	092696-01-710	EA HOLDER-LAMP	CB267-2
	096983-01-707	EA FILTER-MESH	CC246
	103386-02-700	EA KNOB-SWITCH	CB-161
	103386-02-701	EA SWITCH	CB-164
	103386-02-702	EA SPRING-FILTER	CC245
	103386-02-703	EA DAMPER LOCK SPRING	C-488
	100258-10-01A	EA GAUGE-HOUR METER W/SWITCH - SCREW ON STYLE	
	100258-10-701	EA GAUGE-HOUR METER, CLIP ON	L0775-00
	096983-01-702	EA SWITCH-MOM/MOM	112

**RANGE MAGIC CHIEF**

KEY	PART NUMBER	U/M DESCRIPTION	VENDOR NO.
	114030-01-01A	EA RANGE, 3 BURNER TOP COMP. (ALMOND)	
	102019-01-705	EA TRIM-REAR, BLACK	3608F009-70
	102020-01-709	EA BUMPER-GRATE	8007-P020-60
	102020-01-710	EA FILTER-PILOT	7507P046-60
	102020-01-711	EA GRATE-TOP	7518P012-60
	102020-01-721	EA VALVE-SHUT-OFF	7506P096-60
	102020-01-722	EA VALVE-TOP BURNER	7502P181-60
	102020-01-724	EA BUMPER-MAIN TOP	8003P008-60
	102022-01-708	EA REGULATOR, 1/4 & 1/2 OUT	7510P041-60
	112881-01-700	EA TOP-RANGE, 3-BURNER, ALMOND	2001F110-84
		THIS RANGE TOP WAS USED UNTIL 6/19/94 -FOR RANGE TOPS USED FROM 6/20/94 & UP ORDER #11288101712	
	112881-01-703	EA VALVE-TOP BURNER HI-OUTPUT	7502P180-60
	112881-01-705	EA KNOB-TOP BURNER	7733P072-60
	112881-01-709	EA PIPE-MANIFOLD	7513P097-60
	112881-01-718	EA KNOB, HIGH OUTPUT(FLAME IND)	74001794
	114030-01-700	EA PILOT-BURNER	7505P147-60
	114030-01-701	EA PANEL-MANIFOLD	2616F078-70
	114030-01-702	EA TRIM-RIGHT, BLACK	3608W040-70
	114030-01-703	EA TRIM-LEFT, BLACK	3608W039-70

**GENERATOR GROUP**

**4000 KW GENERATOR ONAN EMERALD PLUS BGE-FA/26100G**

KEY	PART NUMBER	U/M DESCRIPTION	
	007067-01-000	SF INSULATION-FIBERGLASS, 1" THICK X 4' - INCREMENTS OF 4 SF	
	007125-03-000	EA CLAMP-MUFFLER, 1.5" DIA	
	007125-04-000	EA CLAMP-MUFFLER, 1.1" DIA	
	079654-05-000	EA PIPE-EXHAUST, ANGLED - W/FLANGE - 2" ID - ONAN# 154-2539	
	081364-03-000	EA MUFFLER-GENERATOR, ONAN	
	094059-01-000	EA SPACER-GENERATOR, ONAN	
	100974-01-000	EA GENERATOR - 4.0KW EMERALD PLUS, ONAN BGE-FA/26100G	
		WITH ONAN GENERATOR TRAY #403-2218 - IF INSTALLING BELOW FLOOR ORDER ONAN TRAY #403-2727	
	007125-03-000	EA CLAMP-MUFFLER, 1.5" DIA	
	007131-01-000	EA HANGER-TAILPIPE, 6 SLOTS	
	007125-04-000	EA CLAMP-MUFFLER, 1.1" DIA	
	105958-01-000	EA PIPE-EXHAUST,GENERATOR	FROM: 00-00-00 THRU: 10-19-95
	105958-10-000	EA PIPE-EXHAUST,GENERATOR	FROM: 10-20-95 THRU: 99-99-99

**4000 KW GENERATOR ONAN MICROLITE KY-FA/26100 B**

KEY	PART NUMBER	U/M DESCRIPTION	
	109982-03-000	EA GENERATOR - 4.0 MICROLITE, ONAN KY-FA/26100 B	
	007125-03-000	EA CLAMP-MUFFLER, 1.5" DIA	
	007131-01-000	EA HANGER-TAILPIPE, 6 SLOTS	
	007125-04-000	EA CLAMP-MUFFLER, 1.1" DIA	
	105958-01-000	EA PIPE-EXHAUST,GENERATOR	FROM: 00-00-00 THRU: 10-19-95
	105958-10-000	EA PIPE-EXHAUST,GENERATOR	FROM: 10-20-95 THRU: 99-99-99
		NOTE: ADDITIONAL GENERATOR COMPONENTS ARE FOUND IN THE CHASSIS GROUP.	

## HEATING & AIR CONDITIONING GROUP

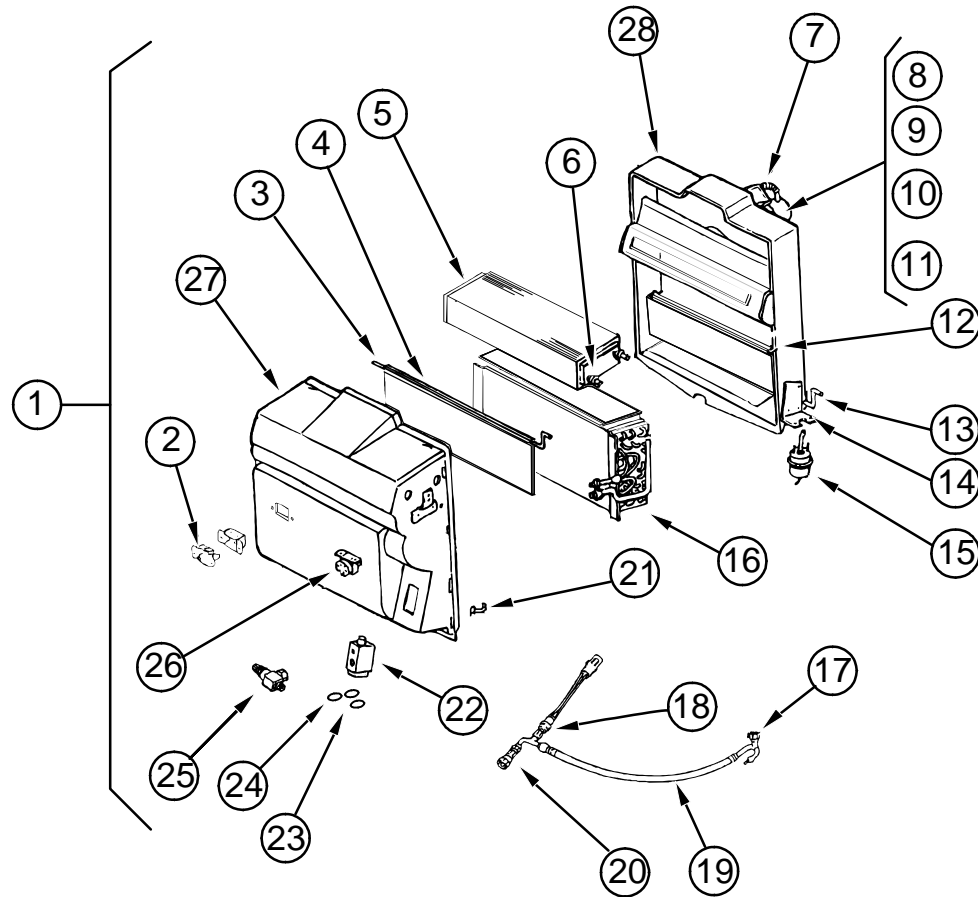

### AUTO A/C - EVAPORATOR/HEATER

KEY	PART NUMBER	U/M DESCRIPTION	VENDOR NO.
1	103930-20-000	EA EVAPORATOR/HEATER CHEV R134A BLOCK - SCS	090-00083
2	103930-01-710	EA RESISTOR-FUSED	SCS 035-0006
3	103930-20-702	EA ROD - FRONT BLEND AIR DOOR	
4	103930-20-703	EA DOOR - BLEND AIR	
5	103930-01-703	EA COIL-HEATER	SCS 042-0010
6	110279-01-712	EA HEATER FITTING	050-0076
7	110279-01-703	EA HOSE-VENT, MOTOR BLOWER	SCS 051-0034
8	103930-20-707	EA BLOWER - HOUSING	
9	103930-01-720	EA MOTOR	SCS 030-0004
10	103930-01-717	EA WHEEL-CLOCKWISE	SCS 062-0010
11	103930-20-708	EA CLIP - FRONT MOTOR SHAFT	
12	103930-20-705	EA DOOR - PANEL - RECIRCULATING	
13	103930-20-704	EA ROD - DOOR- RECIRCULATING	
14	103930-01-708	EA BRACKET-VACUUM MOTOR	SCS 070-0113
15	103930-02-708	EA MOTOR-VACUUM SERVO, A/C	SCS 030-0002
16	103930-01-704	EA COIL EVAPORATOR	
17	103930-12-708	EA SWITCH-BINARY, R-134A	SCS 032-0048
18	103930-01-716	EA SWITCH-PRESSURE, FAN	SCS 032-0036
19	103930-20-701	EA HOSE ASSY #6 WINN GM 085-0138	
20	103930-12-709	EA FITTING-QUICK CONNECT	SCS 050-0120
21	103930-20-706	EA CLIP - RETAINER	
22	103930-20-700	EA VALVE EXPANSION BLOCK (2 TON)	034-0032
23	103930-17-702	EA GASKET OR SAE 015 #10 33-781	SCS 045-0127
24	113245-01-707	EA GASKET (#8)	045-0126
25	103930-20-709	EA SERVICE VALVE	
26	103930-01-711	EA THERMOSTAT	SCS 033-0003
	056402-05-000	EA BRACKET-HEATER VENT, ROUND - W/BEND - BLACK	
27	103930-20-711	EA CASE-BACK, SUB-ASSEMBLY	062-0147
28	103930-20-710	EA CASE-FRONT, SUB-ASSEMBLY	062-0146

## HEATING & AIR CONDITIONING GROUP (CONTINUED)

### GAS AUTO A/C - CONTROL PLENUM

KEY	PART NUMBER	U/M DESCRIPTION	VENDOR NO.
	103930-04-000	EA CONTROL/PLENUM SET, SCS 093-00037	
	103930-02-712	EA PANEL-CONT. A/C BLACK BEZEL	032-0054
		THIS CONTROL PANEL HAS A BLACK FACE. THE CHROME FACE CONTROL PANEL IS N/A FROM THE VENDOR	
	049401-01-700	EA VALVE-WATER CONTROL	SCS 22498
	103930-02-711	EA VALVE-WATER	SCS 034-00114
	103930-23-000	EA VALVE-WATER, 2 PORT - SCS 034-00014	
	103930-24-000	EA VALVE-WATER, 4 PORT	
	072341-06-700	EA SWITCH - 4 SPEED, FAN - ARA	0883502
	094831-01-707	EA WIRING HARNESS-UNIT, MOTIVAIR/SCS	ZGG15050
	094831-01-746	EA CLAMP-BLEND CABLE, MOTIVAIR/SCS	77000-00
	103930-02-708	EA MOTOR-VACUUM SERVO, A/C	SCS 030-0002
	103930-02-700	EA ROD-AIR BLEND DOOR	SCS 073-0017
	103930-02-702	EA DECAL-FAN SWITCH	SCS 058-0008
	103930-02-703	EA HARNESS-WIRE CONTROL	SCS 036-0048
	103930-02-707	EA RELAY	SCS 031-0001
	103930-02-710	EA CANISTER-VACUUM	SCS 054-0002
	103930-11-700	EA CABLE, DOUBLE - RING W/HOOK	SCS 074-0003
	094831-01-709	EA CLAMPS-ROD, 3/16" - MOTIVAIR/SCS	ZGG14431
	103930-02-701	EA VALVE-CONTROL HEAD	SCS 034-0015
	103930-02-704	EA HARNESS-VACUUM CONTROL	SCS 036-0049
	103930-02-705	EA CABLE-CONTROL, BOWDEN	SCS 074-0011
	103930-02-706	EA CLIP-CABLE, CONTROL	SCS 022-0017
	103016-01-000	EA PLENUM-TRANSITION	

### GAS AUTO A/C - HOSE KIT

KEY	PART NUMBER	U/M DESCRIPTION	VENDOR NO.
	103930-17-000	EA HOSE KIT, 10 GM-SANDEN COMPRESSOR - SCS 093-00076	
	103930-01-708	EA BRACKET-VACUUM MOTOR	SCS 070-0113
	103930-17-700	EA PAD-FITTING, SANDEN COMPRESSOR SUCTION	SCS 050-0131
	103930-17-701	EA FITTING - 10.90, W/FERRULE - 1342CP	SCS 050-0132
	103930-17-702	EA GASKET OR SAE 015 10 33-781	SCS 045-0127
	103930-17-703	EA GASKET-SEAL, SANDEN COMPRESSOR 33-76	SCS 045-0142
	103930-17-704	EA HOSE ASSY #10	085-0113

### GAS AUTO A/C SYSTEM

KEY	PART NUMBER	U/M DESCRIPTION
	007281-01-000	EA HOSE-FLEXIBLE PVC, 2.5"ID X 50' - ATCOFLEX A-182-355
	056402-05-000	EA BRACKET-HEATER VENT, ROUND - W/BEND - BLACK
	077075-01-000	EA GASKET-INSTRUMENT PANEL TO DEFROSTER PLENUM, .6" X 11.3"
	077075-03-000	EA GASKET-INSTRUMENT PANEL TO DEFROSTER PLENUM, .6" X 10.2"
	103017-01-000	EA PLENUM-DEFROSTER
	103558-01-09A	EA VENT-DEFROSTER, ABS PLASTIC - BISQ
	103796-01-01A	EA LOUVER ASM-A/C, 136.5 X 54.8MM - BLACK
	103930-05-000	EA MANUAL-OWNERS, HEATER-A/C SCS 057-0049
	024990-05-000	EA OUTLET-DEFROSTER W/SWIVEL - 2" - BLACK
	008042-01-000	FT TUBING-VINYL, .65" ID

# HEATING & AIR CONDITIONING GROUP (CONTINUED)

## FURNACE - SUBURBAN 30,000 BTU - SF-30 2273

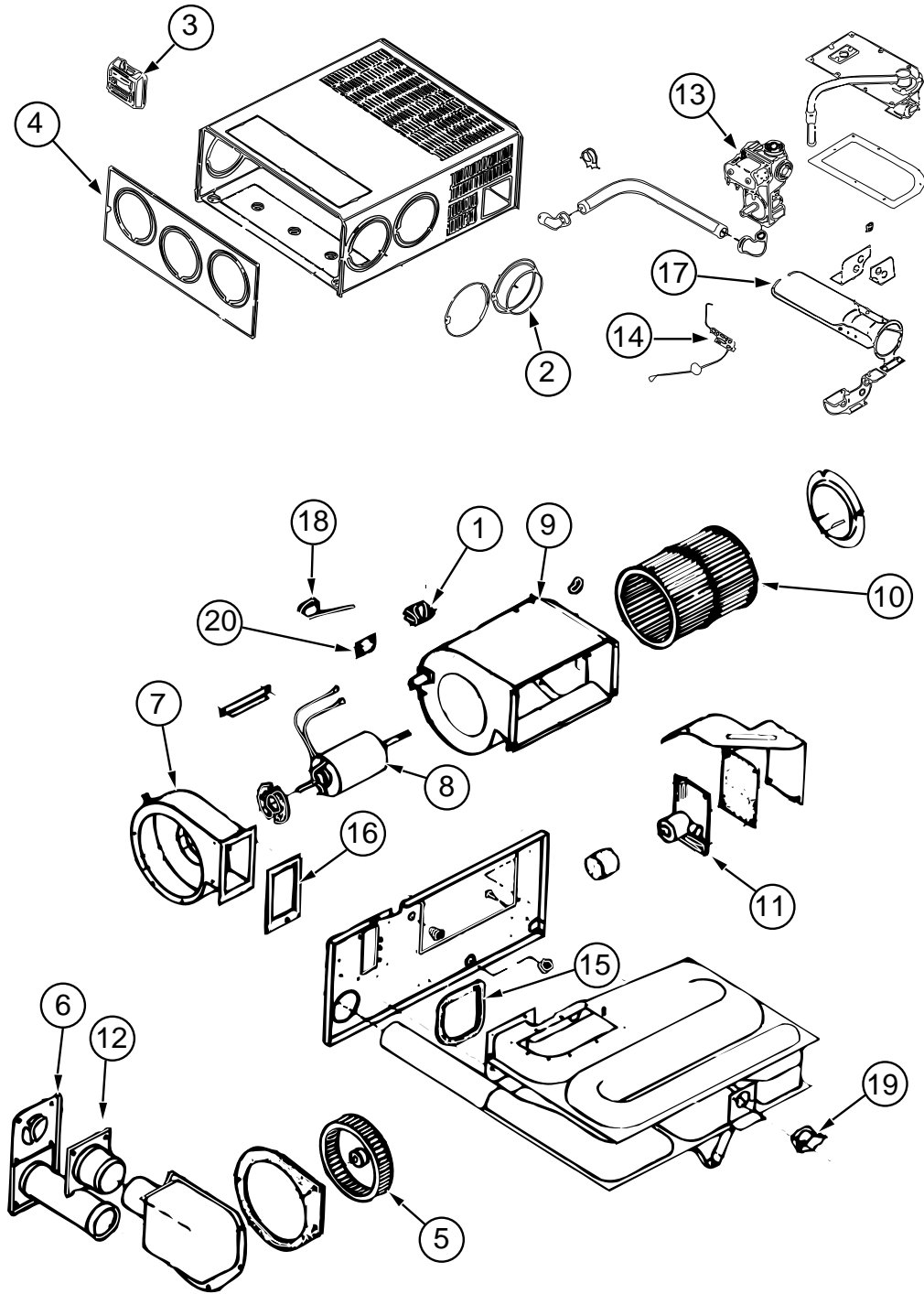

KEY	PART NUMBER	U/M	DESCRIPTION	VENDOR NO.
	098668-20-000	EA	FURNACE - 30,000 BTU, SUBURBAN SF30 2273	
1	074466-01-702	EA	RELAY-TIME DELAY	230625
2	075696-02-703	EA	COLLAR-DUCT	050715
3	115764-01-01A	EA	THERMOSTAT - WALL, FURNACE 160902	
4	098668-01-700	EA	CABINET-FRONT	101242
5	098668-01-706	EA	WHEEL-COMBUSTION AIR	350122
6	098668-01-707	EA	VENT ASSEMBLY-CAP AND TUBE	260193
7	098668-01-708	EA	BLOWER ASSEMBLY-COMBUSTION AIR	390441
8	098668-01-709	EA	MOTOR ASSEMBLY-F/SF-25, SF-30	231706
9	098668-01-710	EA	BLOWER ASSEMBLY-ROOM AIR	390440
10	098668-01-711	EA	WHEEL-ROOM AIR	350123
11	098668-01-712	EA	BOARD-MODULE	231741
12	098668-01-713	EA	INTAKE VENT TUBE ASSEMBLY	051044
13	098668-01-714	EA	VALVE-GAS, (WHITE ROGERS)	161070
14	098668-01-715	EA	ELECTRODE ASSEMBLY-SINGLE PROBE	232166
15	098668-01-716	EA	GASKET-FIREWALL, CHAMBER SIDE	232166
16	098668-01-717	EA	GASKET-FIREWALL, BLOWER SIDE	070163
17	098668-02-700	EA	BURNER ASSEMBLY COMPLETE - (SF-30/SF35)	010745
18	098668-21-700	EA	MICROSWITCH W/O FLAG 3 1/4"	232261
19	098668-21-701	EA	LIMIT SWITCH	231799
20	101990-01-714	EA	MICROSWITCH GASKET	230877
	092300-02-701	EA	ORIFICE- MAIN BURNER - (NT-30BW)	180214
	098668-12-000	EA	DOOR-ACCESS, FURNACE - BUFF 520732	
	024990-05-000	EA	OUTLET-DEFROSTER, W/SWIVEL - 2" DIAMETER - BLACK	
	009198-01-000	FT	DUCT-HEAT- FLEXIBLE - 4" ID X 25 FT	
	094600-01-02A	EA	REGISTER-HEAT, W/O DAMPER - 3.6" X 11.2" - BROWN	
	094600-05-01A	EA	REGISTER-HEAT, W/DAMPER	
	093614-01-02A	EA	GRILLE-RETURN AIR- FURNACE - 15.6" X 7.6" - BEIGE	
	009200-01-000	EA	TAPE-FURNACE, 1 1/2"	
	056464-09-000	EA	REGISTER-HEAT/A/C, ROUND W/DAMPER - 4" - PLASTIC - BEIGE	
	056464-10-000	EA	REGISTER-HEAT/A/C, ROUND W/O DAMPER - 4" - PLASTIC - BEIGE	
	069636-02-000	EA	CONNECTOR-DUCT, 4" ID - 050715	
	092777-01-000	EA	ADAPTER-DUCT, 4"	
	023146-01-000	EA	CLAMP-SCREW TYPE - 4"	

**HEATING & AIR CONDITIONING GROUP (CONTINUED)**  
**13,500 BTU COLEMAN ROOF A/C**

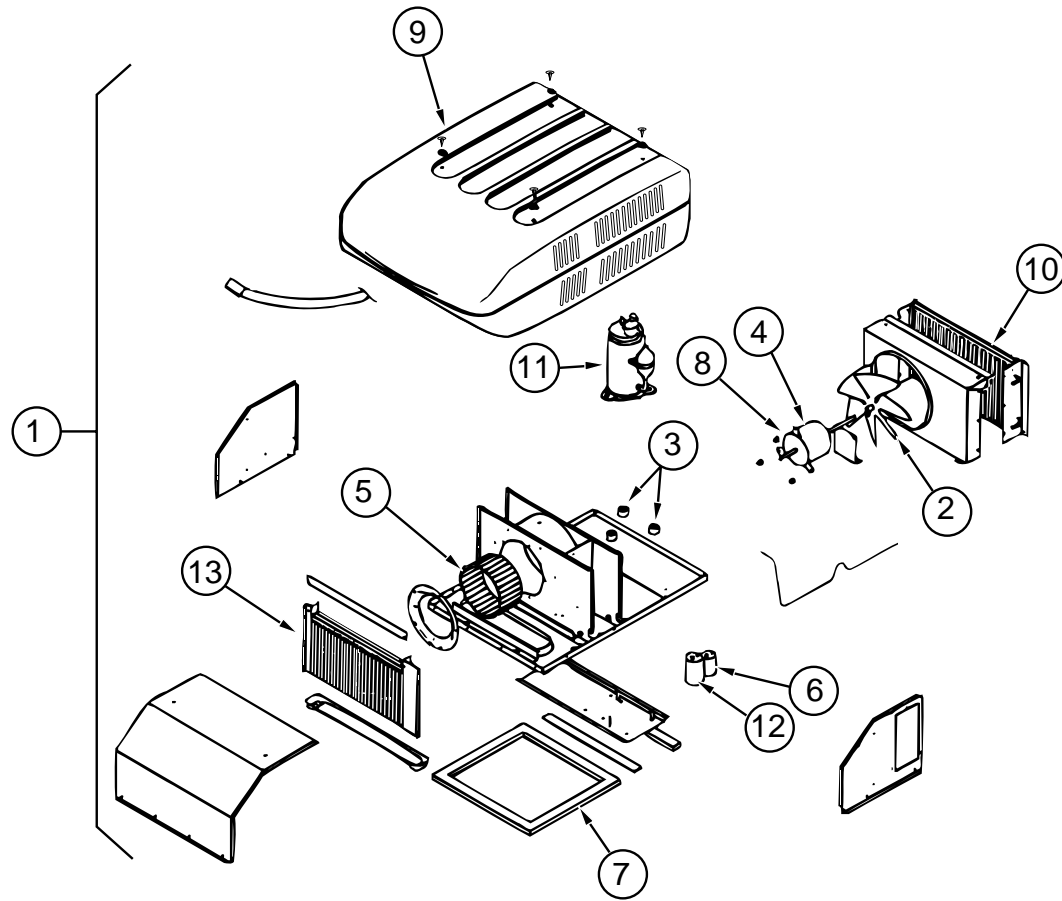

KEY	PART NUMBER	U/M DESCRIPTION	VENDOR NO.
1	108889-01-05A	EA A/C-ROOF,13,500 TSR HO B/WHT 7333A886	
2	093763-01-712	EA FAN BLADE-CONDENSER	6733-3221
3	105620-01-706	EA FOOT PACKAGE-COMPRESSOR, 3 PER PACKAGE	6759-3081
4	108889-01-705	EA MOTOR-115V, 60HZ - COLEMAN	1468-3049
5	108889-01-706	EA IMPELLOR - COLEMAN	1472-1041
6	108889-01-708	EA CAPACITOR-FAN, (7.5MFD.370U)	1499-5461
7	108889-01-711	EA GASKET PACKAGE	6792-3301
8	108889-01-715	EA MOTOR MOUNT & SHAFT SEAL KIT	6792-3361
9	108889-05-700	EA SHROUD-BRIGHT/WHITE. W/O LOGO	7333-4601
10	108889-01-703	EA CONDENSER COIL	1452-1301
11	105620-01-704	EA COMPRESSOR, RH & LH	1450-2009
	108889-01-704	EA OVERLOAD	6749-3541
12	108889-01-707	EA CAPACITOR-RUN, COMPRESSOR-25MFD/370	1499-5661
13	108889-01-709	EA EVAPORATOR COIL	1452-1311
	091225-01-709	EA RELAY-START	1497-4131
	093306-01-701	EA DECAL PACKAGE-LEFT & RIGHT	6798B3591
	108889-01-710	EA FILLER PAD-COND AIR SEAL	6759A3971
	108889-01-712	EA REDUCER-SUCTION LINE, (3/8" X 1/2")	1215-2161
	108889-01-713	EA SUCTION LINE, (3/8" OD X .032" WALL)	6792-130
	108889-01-714	EA DISCHARGE LINE ASSEMBLY	6792-531
	102289-01-000	EA SPRING-SCREW, ROOF A/C GASKET 6757-150	
	108891-01-01A	EA CEILING ASM-A/C COOL TSR HO COLEMAN 7330-714 IV	
	042204-01-709	EA THERMOSTAT-IN 64 OUT 58	
	063903-01-702	EA LOUVER	
	073742-01-701	EA SWITCH-SELECTOR,(5 TERMINAL)	
	073742-01-702	EA DECAL-COOL	
	076303-01-707	EA FILTER-6" X 143/4 X 1/2(24)	
	081606-01-712	EA SHROUD-CEILING, IVORY	
	091225-01-713	EA KNOB	
	091225-01-717	EA DECAL-THERMOSTAT, COOL ONLY	
	093766-02-701	EA DECAL-LEFT	
	108891-01-700	EA PARTS PKG. SGL KNOBS & NUTS	
	108891-01-701	EA CLIP-FILTER RETAINER, 4 PER	

**INTERIOR FINISH GROUP  
CABINET HARDWARE**

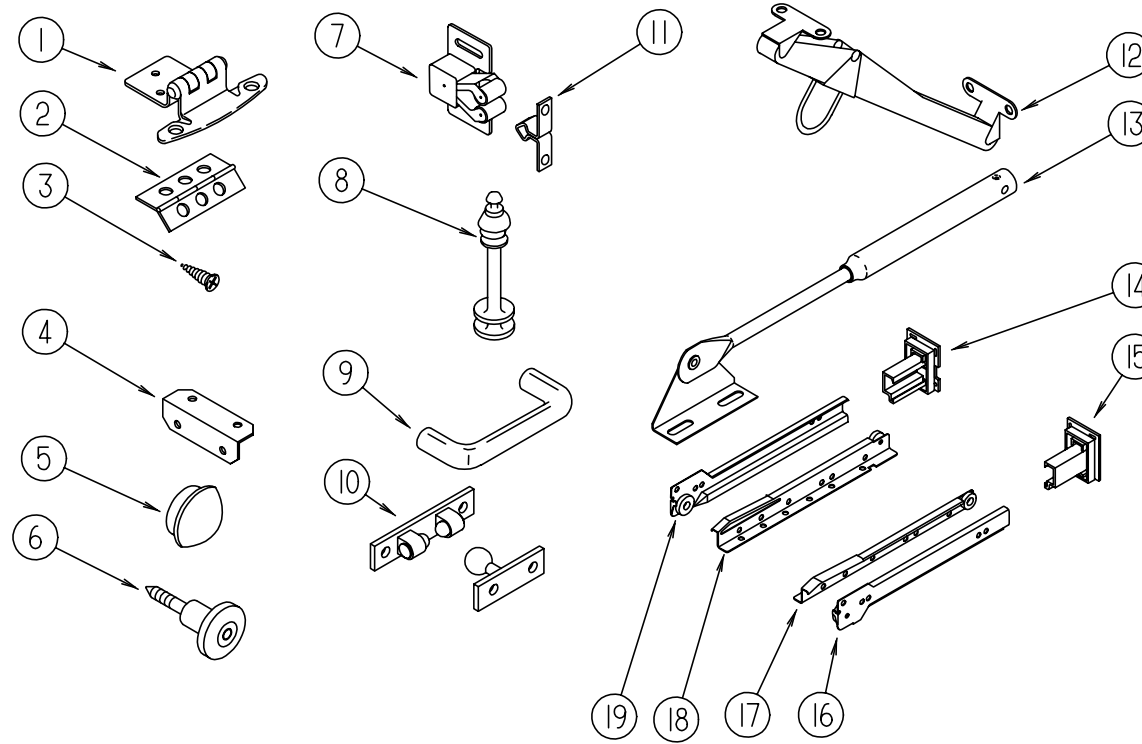

KEY	PART NUMBER	U/M	DESCRIPTION
1	108138-01-000	EA	HINGE-DOOR, CABINET - BURNISHED BRASS
2	009059-01-000	EA	HINGE-DOOR, 2" X 1.4" - BRASS
2	009059-02-000	EA	HINGE-DOOR, 2" X 2.7" - BRASS
3	000G13-06-10G	EA	SCREW - 6-20 X 5/8 PFH, ANTIQUE BRASS
3	076790-01-000	EA	SCREW, 6-20 X 1 1/4 PPH - BLACK
4	016604-01-000	EA	BRACE-CABINET, ANGLE - 2.5" - METAL - UNPAINTED
4	016604-05-000	EA	BRACE-CABINET, ANGLE - 2.5" - METAL - OFF WHITE
5	042356-01-000	EA	PLUG-BUTTON, MAHOGANY - 3/8" DIAMETER - WOOD
6	079921-01-000	EA	ROLLER-NYLON,W/SHAFT
7	093586-06-000	EA	CATCH-SPRING, ROLLER
8	084070-02-000	EA	POST-END,BRASS N-8655
9	112146-01-000	EA	PULL-CABINET, BRASS - AMEROCK 1180-3
10	084451-01-000	EA	CATCH-TV SHELF, BRASS
11	093586-05-000	EA	STRIKE-SPRING STEEL
12	104181-01-01A	EA	SUPPORT-LEAF, 5.3" - EXTENDS TO 7.5" - SAF-T-RING - METAL
13	074493-02-000	EA	SUPPORT-PISTON SPRING, CABINET DOOR
	004354-01-000	EA	BUMPER-RUBBER, .5" DIA - BROWN
	023320-01-000	EA	PAD-FELT, 3/8" DIAMETER - BROWN
	009112-01-000	EA	FLANGE - 1" ROD, CLOTHES - PLASTIC - OFF WHITE
	042438-01-000	EA	DOWEL-WOOD, CLOTHES ROD - 1" DIAMETER X 4'
	114693-01-01A	EA	SUPPORT-TABLE BLACK
	114693-02-01A	EA	SUPPORT-TABLE BLACK
	118933-01-01A	EA	SUPPORT-HINGE LOCK O/WHT
14	114045-01-000	EA	BACKSOCKET-ADJUSTABLE,LEFT - HOUCK 751-1 N/A ORDER SLIDE KIT ACCORDING TO LENGTH-SEE NUMERICAL LISTING OF #114031-??-700 IN THE \$ FICHE F/DESIRED LENGTH
15	114045-02-000	EA	BACKSOCKET-ADJUSTABLE,RIGHT - HOUCK 751-2 N/A ORDER SLIDE KIT ACCORDING TO LENGTH-SEE NUMERICAL LISTING OF #114031-??-700 IN THE \$ FICHE F/DESIRED LENGTH
16	114031-06-000	EA	SLIDE-DRAWER,14" RIGHT CABT HOUCK 7200-RV-2 N/A ORDER #114031-05-700 SLIDE DRAWER KIT
16	114031-10-000	EA	SLIDE-DRAWER,16" RIGHT CABINET-HOUCK 7200-RV-2 N/A ORDER #114031-09-700 SLIDE DRAWER KIT

KEY	PART NUMBER	U/M	DESCRIPTION
16	114031-14-000	EA	SLIDE-DRAWER,18" RIGHT CABINET-HOUCK 7200-RV-2 N/A ORDER #114031-13-700 SLIDE DRAWER KIT
16	114031-18-000	EA	SLIDE-DRAWER,20" RIGHT CABT HOUCK 7200-RV-2 N/A ORDER #114031-17-700 SLIDE DRAWER KIT
17	114031-08-000	EA	SLIDE-DRAWER,14" RIGHT DRWR HOUCK 7200-RV-4 N/A ORDER #114031-05-700 SLIDE DRAWER KIT
17	114031-12-000	EA	SLIDE-DRAWER,16" RIGHT DRAWER -HOUCK 7200-RV-4 N/A ORDER #114031-09-700 SLIDE DRAWER KIT
17	114031-16-000	EA	SLIDE-DRAWER,18" RIGHT DRAWER -HOUCK 7200-RV-4 N/A ORDER #114031-13-700 SLIDE DRAWER KIT
17	114031-20-000	EA	SLIDE-DRAWER,20" RIGHT DRWR HOUCK 7200-RV-4 N/A ORDER #114031-17-700 SLIDE DRAWER KIT
17	114031-24-000	EA	SLIDE-DRAWER,22" RIGHT DRWR HOUCK 7200-RV-4 N/A ORDER #114031-21-700 SLIDE DRAWER KIT
18	114031-07-000	EA	SLIDE-DRAWER,14" LEFT DRWR HOUCK 7200-RV-3 N/A ORDER #114031-05-700 SLIDE DRAWER KIT
18	114031-11-000	EA	SLIDE-DRAWER,16" LEFT DRAWER - HOUCK 7200-RV-3 N/A ORDER #114031-09-700 SLIDE DRAWER KIT
18	114031-15-000	EA	SLIDE-DRAWER,18" LEFT DRAWER - HOUCK 7200-RV-3 N/A ORDER #114031-13-700 SLIDE DRAWER KIT
18	114031-19-000	EA	SLIDE-DRAWER,20" LEFT DRWR HOUCK 7200-RV-3 N/A ORDER #114031-17-700 SLIDE DRAWER KIT
18	114031-23-000	EA	SLIDE-DRAWER,22" LEFT DRWR HOUCK 7200-RV-3 N/A ORDER #114031-21-700 SLIDE DRAWER KIT
19	114031-05-000	EA	SLIDE-DRAWER,14" LEFT CABT HOUCK 7200-RV-1 N/A ORDER #114031-05-700 SLIDE DRAWER KIT
19	114031-13-000	EA	SLIDE-DRAWER,18" LEFT CABINET -HOUCK 7200-RV-1 N/A ORDER #114031-13-700 SLIDE DRAWER KIT
19	114031-09-000	EA	SLIDE-DRAWER,16" LEFT CABINET - HOUCK7200-RV-1 N/A ORDER #114031-09-700 SLIDE DRAWER KIT
19	114031-17-000	EA	SLIDE-DRAWER,20" LEFT CABT HOUCK 7200-RV-1 N/A ORDER #114031-17-700 SLIDE DRAWER KIT

**INTERIOR FINISH GROUP (CONTINUED)**  
**MOLDINGS, BATT STRIPS, & TRIM**

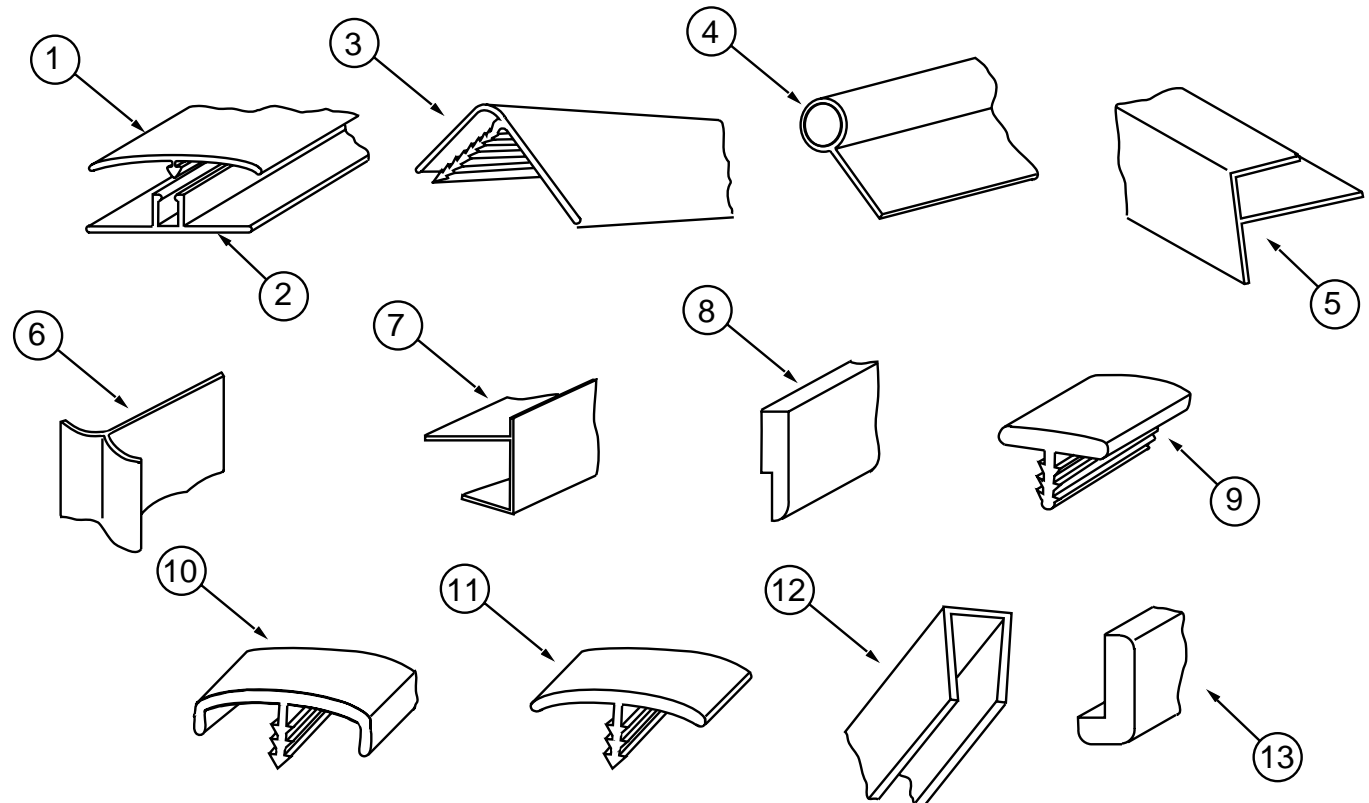

KEY	PART NUMBER	U/M	DESCRIPTION
	085284-B1-000	FT	STRIP-TAPE,METRO,MIST - ROBERT WEED (GD1)
	085284-A9-000	FT	STRIP-TAPE,MONTERREY, RAIN FOREST -ROBERT WEED (GC1)
	085284-76-000	FT	BATT STRIP-SHOWER, ADHESIVE BACKED - OFF WHITE
	069733-83-000	EA	BATT-STRIP,WATERFORD OAK - ROBERT WEED
1	086229-13-000	EA	BATTEN-1" CEILING MOD IVORY - W&B RN323 (GD1,GE1)
2	086229-01-000	EA	RETAINER-3/4"
3	009809-28-001	EA	MOLDING-CORNER, OUTSIDE - LARGE CABINET - PLASTIC - 2133 MM
3	009809-28-000	EA	MOLDING-CORNER, OUTSIDE - PLASTIC 1" - WATERFORD OAK
4	009767-12-000	FT	MOLDING-SIDEWALL TO CEILING/CABINET - WELTING - OFF WHITE (GD1)
4	009767-15-000	FT	WELTING-WATERFORD OAK
5	009812-24-000	EA	MOLDING-CORNER, OUTSIDE - .5" - PLASTIC - IVORY
5	009812-29-001	EA	MOLDING-CORNER, OUTSIDE - SMALL CABINET - PLASTIC - 2133MM
5	009812-29-000	EA	MOLDING-CORNER, OUTSIDE, - PLASTIC - 1/2" - WATERFORD OAK
6	022992-11-000	FT	MOLDING-REVERSE COVE, T-SHAPED - VINYL - IVORY
7	103186-01-05A	FT	MOLDING-PLASTIC,SHELF - WATERFORD OAK
	076325-46-000	FT	MOLDING-EDGEBAND,1035 CLOUD - 15/16 X .030 X 600 (GB1)
	076325-47-000	FT	MOLDING-EDGEBAND,1032 SAND - 15/16 X .030 X 600 (GD1)(GE1)
8	105004-01-05A	EA	MOLDING-VINYL WRAP - WATERFORD OAK
9	104676-01-01A	FT	T-MOLDING, 5/16" RIGID - GOLD
10	083620-12-000	FT	T-MOLDING, 3/4 W/EDGE LIPS - WATERFORD OAK
10	104676-02-04A	FT	T-MOLDING, 1/2 X 10 FT - WATERFORD OAK
11	105709-01-000	FT	T-MOLDING-1", MODERN IVORY
12	070504-18-000	FT	U-CHANNEL-PLASTIC, .065" WIDE - IVORY - INC. OF 8'
12	070504-19-000	FT	U-CHANNEL-PLASTIC, .815" WIDE - BROWN - INC. OF 8'
12	070504-26-000	FT	EXTRUSION-U CHANNEL,20.7 MODERN IVORY
13	077840-01-G01	EA	MOLDING-CAP,WALL 2438
	052372-02-000	BF	LUMBER-CLASS II, 1 X 4 X RL - CONSTRUCTION GRADE

## INTERIOR FINISH GROUP (CONTINUED)

### PANELING, LAMINATES & PLASTIC

KEY	PART NUMBER	U/M DESCRIPTION
	000885-76-000	SF PART BD-3/8 X 4' X 8' WATERFORD OAK VINYL 1 SIDE
	000885-77-000	SF PART BD-3/8, WATERFORD OAK-VINYL 2 SIDED
	000885-78-000	SF PART BD-1/2 X 4' X 8' WATERFORD OAK VINYL 2 SIDES
	000885-79-000	SF PART BD-3/4, 4' X 8' WATERFORD OAK VINYL 2 SIDES
	052372-02-000	BF LUMBER-CLASS II,1X4XRL
	074497-21-000	SF PANELING-WOODGRAIN, 4' X 8' - INCREMENTS OF 32 SF CONTACT PART SALES WITH SERIAL NUMBER
	074497-28-000	SF PANELING-WATERFORD OAK, 48X96
	074497-34-000	SF PANELING-CEILING,IMPACT PEARL - 48X96
	074498-71-000	SF LAMINATE-PLAS,NEUTRAL SANTOS
	074498-77-000	SF LAMINATE-PLASTIC,ART CABIN
	080215-10-000	SF PANELING-2 SIDE WATERFORD, 48X96
	088272-E0-000	SF PANELING-METRO,MIST
	088272-G1-000	SF PANELING-PEBBLE EMBOSS,ANTIQ
	088272-98-000	SF PANELING-SHOWER, OFF WHITE - 4' X 7' - INC OF 28 SQ FT NOTE:PRODUCTION DEVIATION 6/94 THRU 7/94 USED #088272E3000 WHICH IS N/A FROM THE VENDOR
	093743-02-01A	SF PLASTIC-ABS, 20" WIDE ROLL - OFF WHITE THIS PLASTIC IS SOLD AS SQ.FT.,15 SQ.FT. MINIMUM ORDER QTY 15 SQ.FT. = 108" X 20" PIECE
	095688-01-000	SF VENEER-3.6 MM 48X96 UNFINISH
	117267-E2-438	EA LUMBER-018X50.8X2438MM VINYL
	117267-G2-438	EA LUMBER-018X076X2438 MM VINYL

### DETECTORS & FIRE EXTINGUISHER

KEY	PART NUMBER	U/M DESCRIPTION
	072852-01-000	EA DETECTOR-SMOKE, W/9 VOLT BATTERY - US
	094499-01-000	EA EXTINGUISHER-FIRE, DRY W/MOUNTING BRACKET - 10 BC BRACKET ONLY #094499-01-700
	094499-01-700	EA BRACKET MTG. W/PLAS. STRAP 294039
	112320-02-000	EA BATTERY/SENSOR-CO GAS, COSTAR 940001000 WHEN REPLACING THE ORIGINAL (01 & 02) SYSYTEM, ORDER #11232003000 DETECTOR & #11232004000 SENSOR
	112320-03-000	EA DETECTOR-CO GAS MODEL 9D-I COSTAR 946000001
	112320-04-000	EA DETECTOR-CO SENSOR ASSEMBLY COSTAR 946001001

### FLOOR COVERINGS & MATS

KEY	PART NUMBER	U/M DESCRIPTION
	075233-01-000	SY PAD-CARPET, 3/8" X 6' ROLL
	096060-A1-000	SY CARPET-JUBILATION,ARTIC GRAY (GD1)
	096060-B2-000	SY CARPET-JUBILATION,32199 COPP (GE1)
	093486-01-000	SY CARPET-COMPARTMENT, 54" WIDE - DARK GRAY

## LABELS GROUP

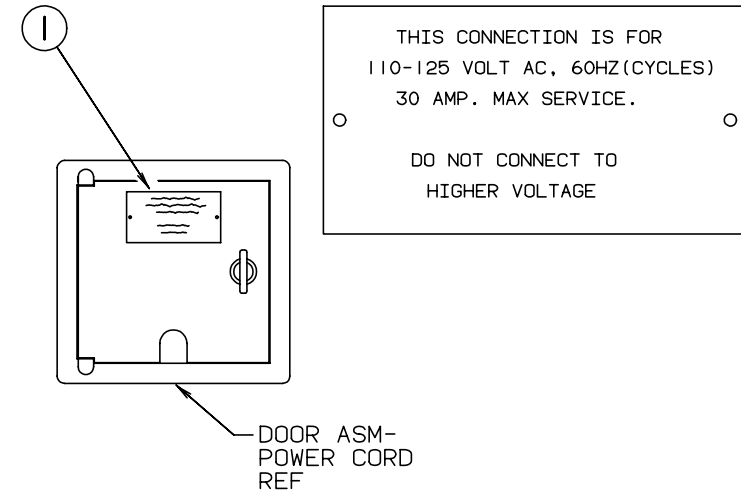

KEY	PART NUMBER	U/M DESCRIPTION
1	006062-01-000	EA TAG-ELECTRIC - 110V CONNECTION

### MISCELLANEOUS LABELS

KEY	PART NUMBER	U/M DESCRIPTION
	098641-01-000	EA LABEL-FUEL - UNLEADED - DASH
	109522-01-000	EA LABEL-BUMPER, SEE OWNERS MANUAL
	087236-01-000	EA LABEL-CABLE, INPUT
	098379-04-000	EA LABEL-ELECTRICAL BOX,SIDE
	112518-01-000	EA LABEL-HANG TAG,CO DETECTOR

**LABELS GROUP (CONTINUED)**

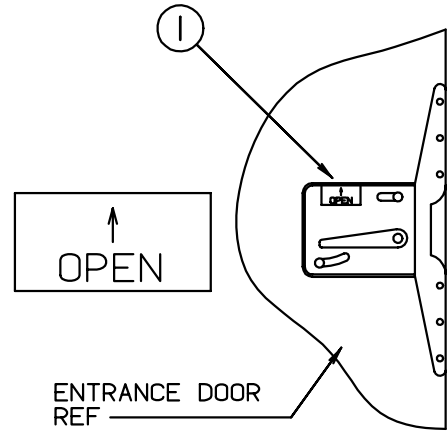

KEY	PART NUMBER	U/M DESCRIPTION
1	040944-01-000	EA LABEL-ENTRANCE DOOR - "OPEN"

**LABELS GROUP (CONTINUED)**

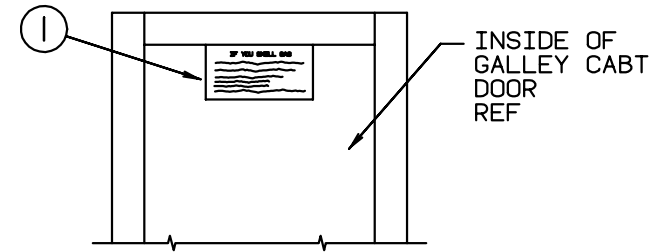

**IF YOU SMELL GAS**

1. EXTINGUISH ANY OPEN FLAME, PILOT LIGHTS AND ALL SMOKING MATERIALS.
2. SHUT OFF THE GAS SUPPLY AT THE TANK VALVE( OR GAS SUPPLY CONNECTION.
3. OPEN DOORS AND OTHER VENTILATING OPENINGS.
4. DO NOT TOUCH ELECTRICAL SWITCHES.
5. LEAVE THE AREA UNTIL ODOOR CLEARS.
6. HAVE THE GAS SYSTEM CHECKED AND LEAKAGE SOURCE CORRECTED BEFORE USING AGAIN.

KEY	PART NUMBER	U/M DESCRIPTION
1	073998-01-000	EA LABEL-LPG ODOR WARNING

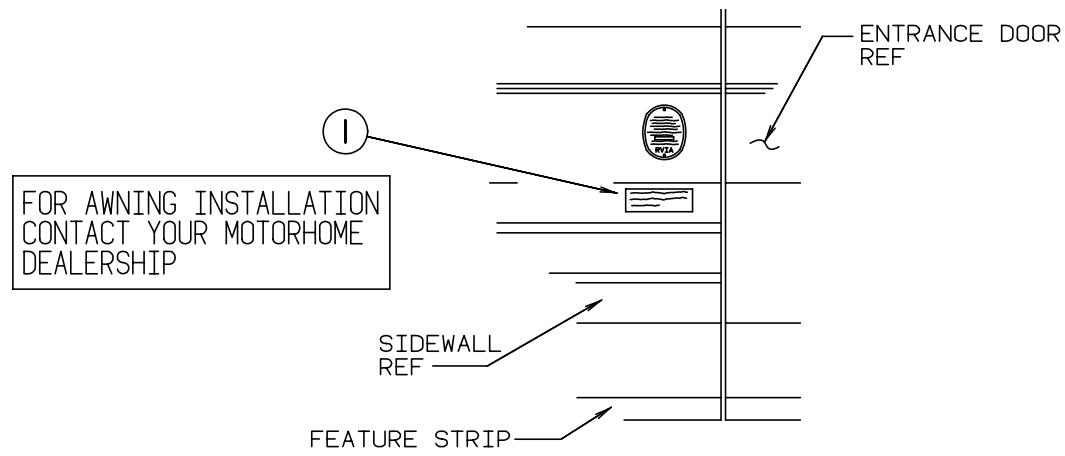

KEY	PART NUMBER	U/M DESCRIPTION
1	099509-01-000	EA LABEL-AWNING INSTALLATION



**LABELS GROUP (CONTINUED)**

CAUTION

THIS MOTOR HOME HAS BEEN DESIGNED, MANUFACTURED AND TESTED WITH CONCERN FOR THE PROTECTION OF IT'S OCCUPANTS. WE RECOMMEND YOU PERFORM THE FOLLOWING INSPECTIONS FOR YOUR SAFETY AND THE SAFETY OF YOUR PASSENGERS BEFORE STARTING YOUR VEHICLE.

1. LP GAS SYSTEM- TURN OFF AT TANK FOR TRAVELING. TEST FOR LEAKS UPON ARRIVAL AT DESTINATION. BEFORE LIGHTING PILOTS.
2. WHEELS- INSPECT FOR DAMAGE AND CHECK LUG NUTS FOR TIGHTNESS.
3. TIRES- INSPECT FOR WEAR AND DAMAGE AND CHECK FOR RECOMMENDED AIR PRESSURE.
4. LIGHTING- TEST FOR PROPER OPERATION OF ALL INTERIOR AND EXTERIOR LIGHTS INCLUDING DASH LIGHTS, HEADLIGHTS, TAIL LIGHTS, BRAKE LIGHTS, CLEARANCE LIGHTS AND TURN SIGNALS.
5. EXITS- INSPECT RELEASE MECHANISM ON EMERGENCY EXIT WINDOW, TEST BOTH LOCKS ON MAIN ENTRANCE DOOR FOR EASE OF OPERATION AND INSTRUCT PASSENGERS HOW TO USE BOTH MEANS OF EXIT.
6. SEAT BELTS- DIRECT PASSENGERS TO DESIGNATED SEATS AND REQUIRE USE OF SEAT BELTS.
7. APPLIANCES- TURN OFF AND LATCH OR LOCK DOORS WHERE PROVIDED.
8. LOOSE PARCELS- STORE SECURELY.
9. UTILITY SUPPLY LINES- DISCONNECT ALL ELECTRIC, SEWER AND WATER LINES AND SECURE PROPERLY.
10. ENTRANCE DOOR STEP- PLACE IN RETRACTED POSITION FOR TRAVELING.

READ YOUR MOTOR HOME AND CHASSIS OWNER'S MANUAL FOR FURTHER PRECAUTIONS

**LABELS GROUP (CONTINUED)**

DO NOT INSTALL IF HITCH OPTION IS RESTRICTED

DO NOT USE HITCH BEFORE READING OWNERS MANUAL REGARDING VEHICLE LOADING AND TOWING

KEY	PART NUMBER	U/M DESCRIPTION
1	111104-01-000	EA LABEL-HITCH - READ MANUAL

KEY	PART NUMBER	U/M DESCRIPTION
1	056259-01-000	EA LABEL-SAFETY CHECK LIST

SMOKE DETECTOR REF

**WARNING:** TEST SMOKE DETECTOR OPERATION AFTER VEHICLE HAS BEEN IN STORAGE, BEFORE EACH TRIP AND AT LEAST ONCE PER WEEK DURING USE.

**WARNING** DISCONNECT BATTERIES BEFORE CONNECTING EXTERNAL CHARGING EQUIPMENT.

BATTERY COMPARTMENT REF

KEY	PART NUMBER	U/M DESCRIPTION
1	065748-01-000	EA LABEL-CAUTION - BATTERY CHARGING

KEY	PART NUMBER	U/M DESCRIPTION
1	077956-01-000	EA LABEL-WARNING - SMOKE DETECTOR

**LABELS GROUP (CONTINUED)**

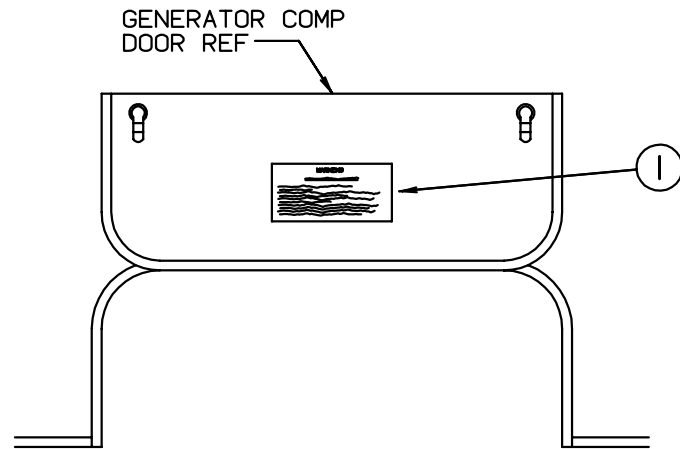

**WARNING**

WHEN ADDING A GENERATOR SET:

HIGH VOLTAGE-USE EXTREME CAUTION WHEN WORKING ON ELECTRICAL COMPONENTS.  
 HAVE ALL ELECTRICAL INSTALLATION PERFORMED BY A QUALIFIED LICENSED ELECTRICIAN-FOLLOW ALL STATE AND LOCAL CODES.  
 ONLY INSTALL GENERATOR SET APPROVED FOR R.V. APPLICATION. HAVE INSTALLED BY QUALIFIED TECHNICIAN.  
 TO AVOID HEAT BUILD-UP AND TO GUARANTEE AN ADEQUATE AIR SUPPLY TO THE GENERATOR CARBURETOR, FOLLOW INSTALLATION INSTRUCTIONS.  
 GENERATOR ENGINE EXHAUST GASES ARE TOXIC AND MUST NOT TERMINATE UNDER THE VEHICLE-DISCHARGE EXHAUST AWAY FROM VEHICLE.

KEY	PART NUMBER	U/M DESCRIPTION
1	077510-01-000	EA LABEL-GENERATOR PREP

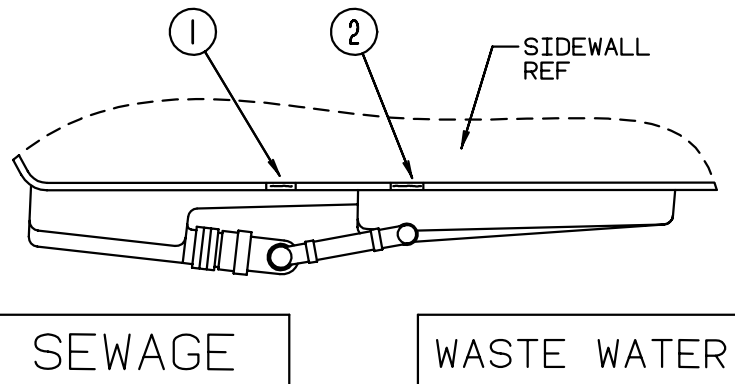

SEWAGE

WASTE WATER

KEY	PART NUMBER	U/M DESCRIPTION
1	006187-01-000	EA LABEL-SEWAGE
2	006188-01-000	EA LABEL-WASTE WATER

**LABELS GROUP (CONTINUED)**

**WARNING**

ALL PILOT LIGHTS AND APPLIANCES SHALL BE TURNED OFF DURING REFUELING OF MOTOR FUEL TANKS AND/OR PERMANENTLY MOUNTED LP-GAS CONTAINERS.

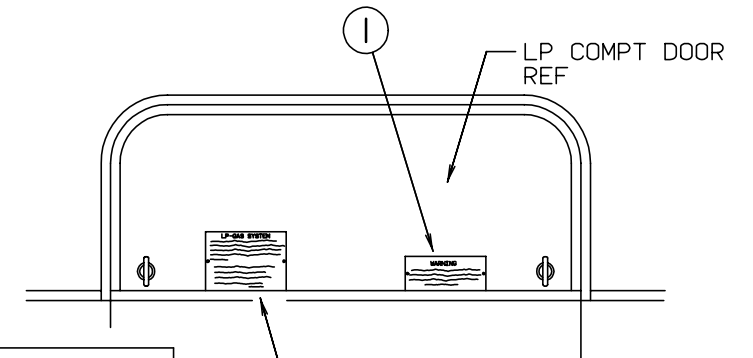

**LP-GAS SYSTEM**

THIS GAS PIPING SYSTEM IS DESIGNED FOR USE OF LIQUEFIED PETROLEUM GAS ONLY. DO NOT CONNECT NATURAL GAS TO THIS SYSTEM.

SECURELY CAP INLET(S) WHEN NOT CONNECTED FOR USE. AFTER TURNING ON GAS, EXCEPT AFTER NORMAL CONTAINER REPLACEMENT, TEST GAS PIPING AND CONNECTIONS TO APPLIANCE FOR LEAKAGE WITH SOAPY WATER OR BUBBLE SOLUTION. DO NOT USE PRODUCTS THAT CONTAIN AMMONIA OR CHLORINE.  
 P.N. 54531

KEY	PART NUMBER	U/M DESCRIPTION
1	006040-01-000	EA TAG-GAS REFUELING WARNING
1	006040-02-000	EA TAG-GAS REFUEL WARNING - CANADIAN
2	054531-01-000	EA LABEL-LP GAS ONLY
2	023769-01-000	EA LABEL-WARNING - LPG - CANADIAN

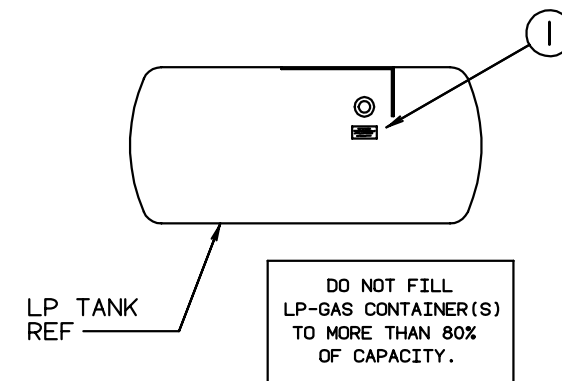

**DO NOT FILL LP-GAS CONTAINER(S) TO MORE THAN 80% OF CAPACITY.**

KEY	PART NUMBER	U/M DESCRIPTION
1	079965-01-000	EA LABEL-LPG 80% CAPACITY

## LABELS GROUP (CONTINUED)

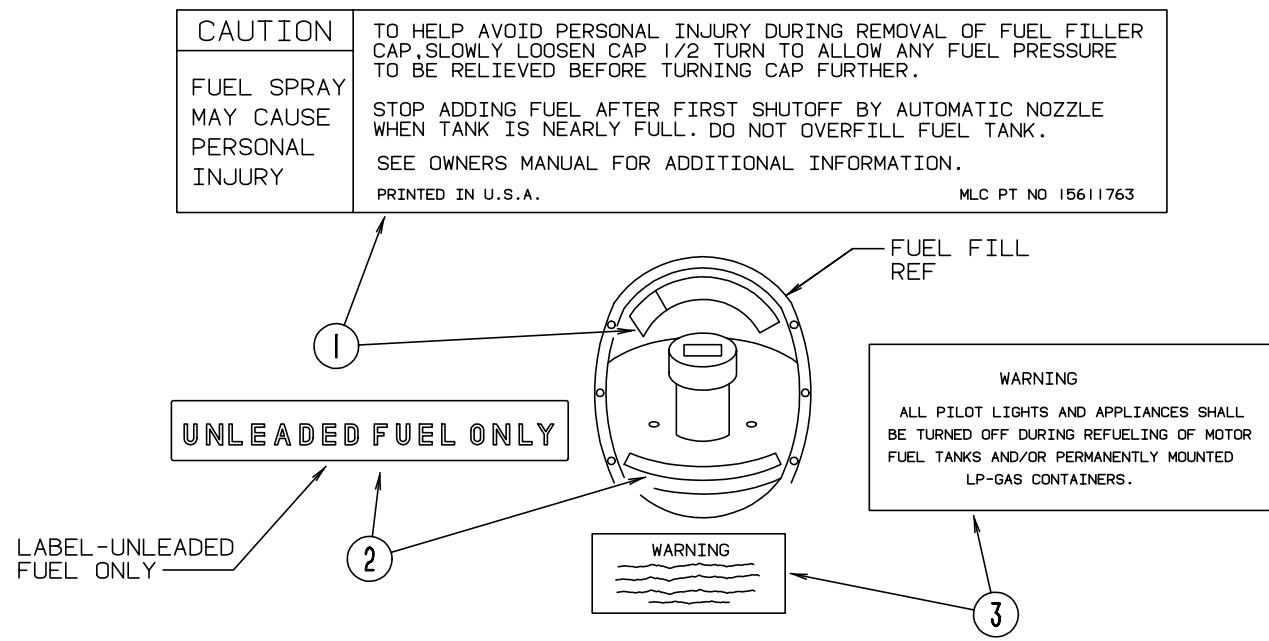

KEY	PART NUMBER	U/M	DESCRIPTION
1	087207-05-000	EA	LABEL-FUEL CAP REMOVAL - GM--15611763
2	062043-01-000	EA	LABEL-FUEL - UNLEADED
3	006040-01-000	EA	TAG-GAS REFUELING WARNING
3	006040-02-000	EA	TAG-GAS REFUEL WARNING - CANADIAN

## LP GROUP

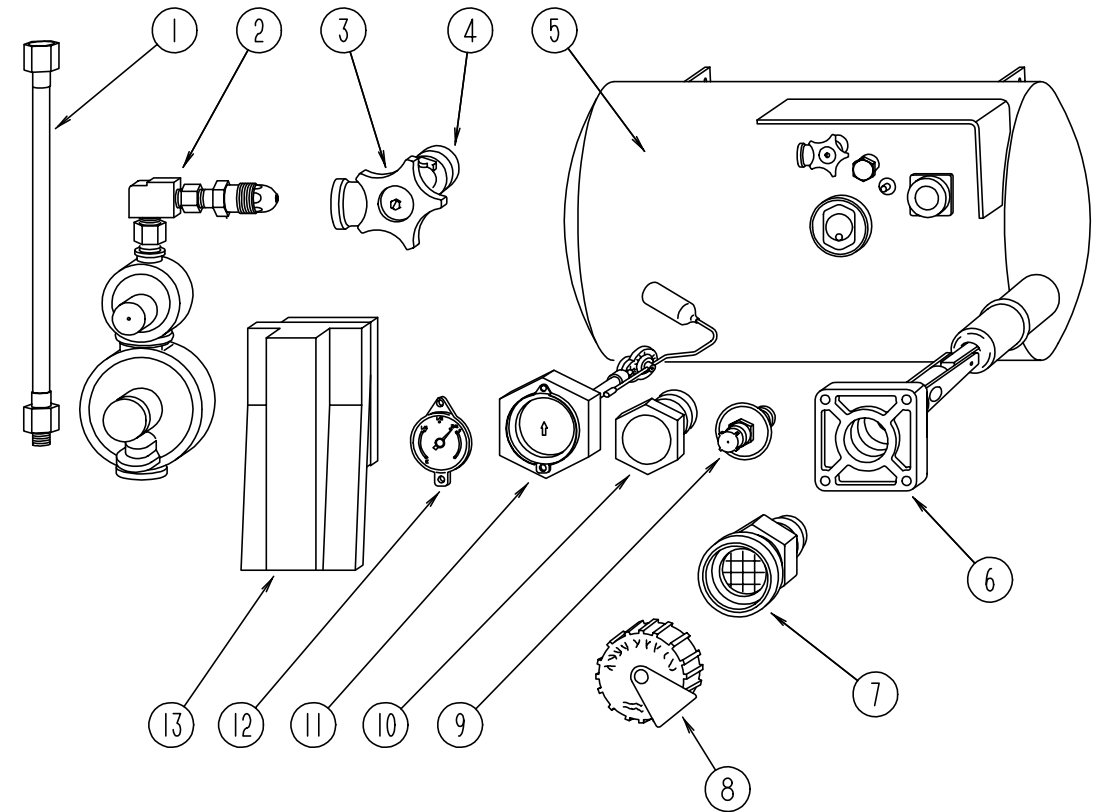

## LP TANK & SYSTEM COMPONENTS

KEY	PART NUMBER	U/M	DESCRIPTION	VENDOR NO.
1	045703-01-000	EA	HOSE-LP, 3/8" ID X 24" - 3/8 MPT X 1/2 F SWIVEL - U.S.	
1	045703-02-000	EA	HOSE-LP, 3/8" ID X 24" - 3/8" MPT X 1/2" F SWIVEL - CANADA	
2	106150-01-000	EA	REGULATOR-TWO STAGE M'BRASS 290-303	
3	040421-01-708	EA	HANDWHEEL-SERVICE VALVE, BRUNNER	G-1015-A
4	040421-01-712	EA	VALVE-SERVICE W/O VAPOR RELIEF,	29000853
5	088253-01-000	EA	TANK-LP, 80 LB - 16" DIAMETER X 30" - BRUNNER	
6	040421-01-711	EA	VALVE - 80% W/FLOAT, PLATE - BOLTS & GASKET - BRUNNER	
7	040421-01-701	EA	VALVE-SHORT LP FILLER, W/YELLOW CAP - BRUNNER	75478
8	040421-01-702	EA	CAP-LP FILLER VALVE, PLASTIC - YELLOW - BRUNNER	G-1014-A
9	040421-01-700	EA	VALVE-LIQUID LEVEL, 20% LP - BRUNNER	G-1013
10	040421-01-713	EA	VALVE-VAPOR ONLY,	29000587
11	088253-01-700	EA	GAUGE-FLOAT ASSEMBLY, L.P.	
12	040421-01-706	EA	DIAL-LP TANK VOLUME, VISIBLE FACE (5-1789) - BRUNNER	MA-8 ROCHESTER
	040440-02-000	EA	TRANSMITTER-DIAL, 0-90 OHM - 2 TERMINAL (POWER & GROUND)	
13	105658-01-000	EA	COMPARTMENT-LP REGULATOR	
	010323-01-000	EA	ADAPTER-BRASS, 3/8F X 1/2MPT	
	010377-02-000	EA	NUT-BRASS, 3/8" FLARE - FORGED	
	010380-02-000	EA	NUT-BRASS, 1/2" FLARE - FORGED	
	010329-01-000	EA	ADAPTER-BRASS, 1/2" F X 1/2" MPT	
	010265-01-000	EA	ELBOW-BRASS, 90 DEGREE - 3/8" F X 1/2" FPT	
	010252-01-000	EA	ELBOW-BRASS, 90 DEG, 3/8F X 1/2MPT	
	035340-01-000	EA	ELBOW - 3/8" MPT X 1/2" F - BRASS	
	103613-01-000	EA	DETECTOR-LP GAS - CCI 7730/PRE-TELL	

### LOUNGE GROUP

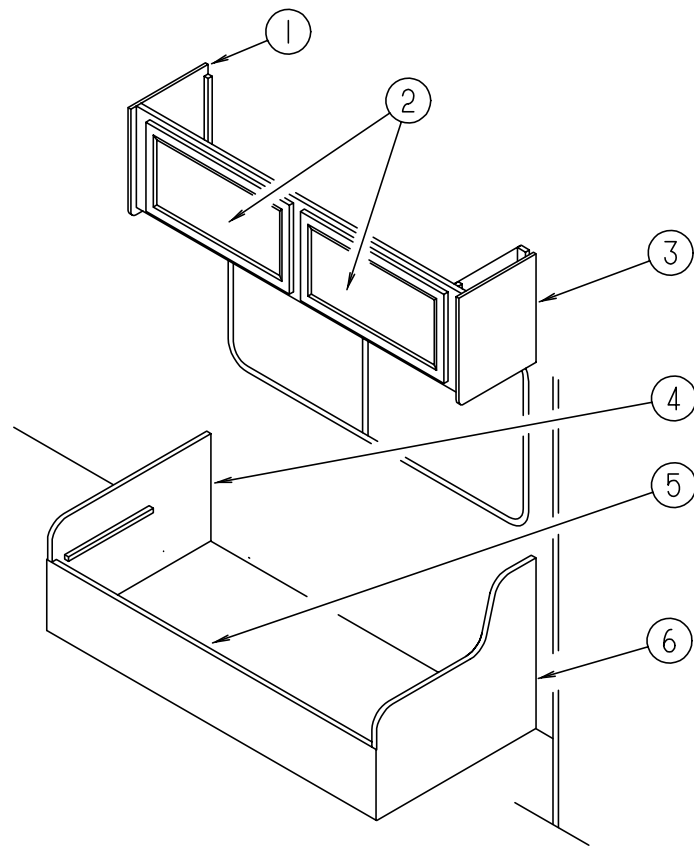

**FRONT PASSENGER SIDE CABINET (COUCH)**

KEY	PART NUMBER	U/M	DESCRIPTION
1	109908-34-GB1	EA	CAP ASM-END,OVERHEAD FRONT
2	110140-59-G01	EA	DOOR ASM-MITERED - VINYL WRAP - OVERHEAD
3	109908-33-GB1	EA	CAP ASM-END,OVERHEAD REAR
4	M04187-64-GD1	EA	CABINET-COUCH W/FABRIC FRONT FACING PANEL
4	M04187-64-GE1	EA	CABINET-COUCH W/FABRIC FRONT FACING PANEL
5	M04187-63-GD1	EA	CABINET-COUCH W/FABRIC AISLE FACING PANEL
5	M04187-63-GE1	EA	CABINET-COUCH W/FABRIC AISLE FACING PANEL
6	M04187-65-GD1	EA	CABINET-COUCH W/FABRIC REAR FACING PANEL
6	M04187-65-GE1	EA	CABINET-COUCH W/FABRIC REAR FACING PANEL

### LOUNGE GROUP (CONTINUED)

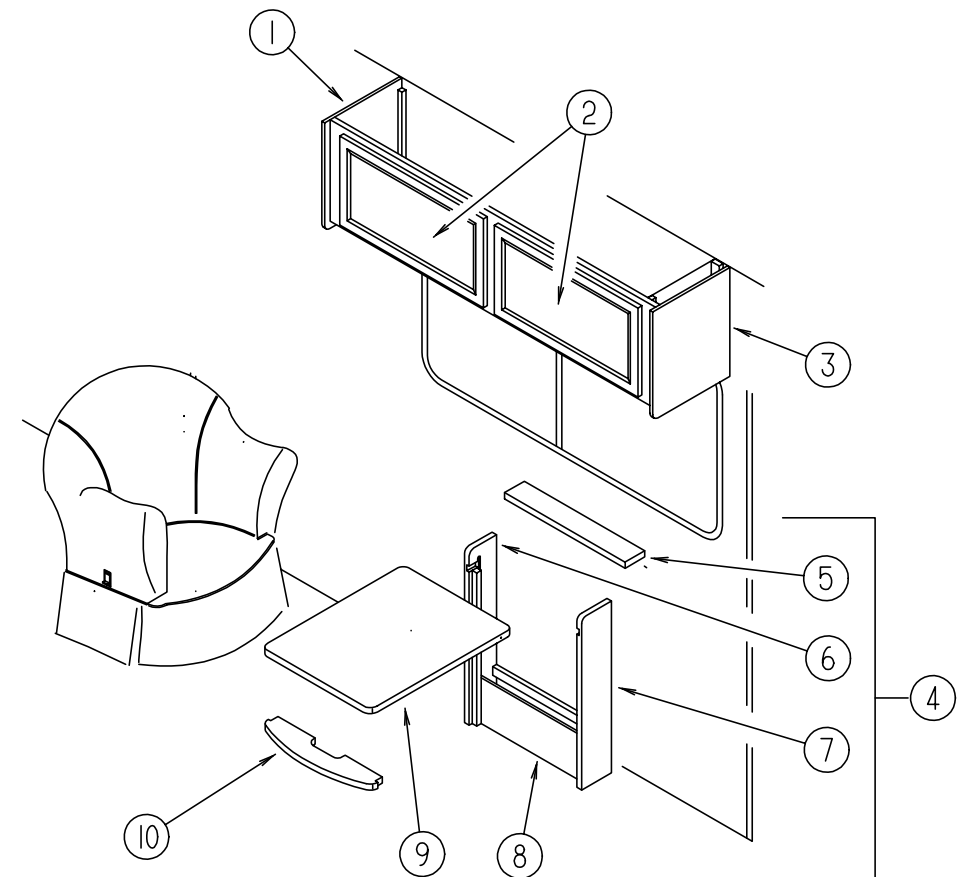

**FRONT PASSENGER SIDE CABINET (CHAIR & TABLE)**

KEY	PART NUMBER	U/M	DESCRIPTION
1	109908-34-GB1	EA	CAP ASM-END,OVERHEAD FRONT
2	110140-59-G01	EA	DOOR ASM-MITERED - VINYL WRAP - OVERHEAD
3	109908-33-GB1	EA	CAP ASM-END,OVERHEAD REAR
4	M96873-01-G01	EA	CABINET ASM. - TABLE - W/O PULLOUT TOP
5	096873-15-G01	EA	SHELF - SUPPORT - OVER PULL OUT TABLE TOP
6	096873-14-G01	EA	SIDE END - TABLE - 28.7" X 5.7" - LEFT SIDE
7	096873-13-G01	EA	SIDE END - TABLE - 28.7" X 5.7" - RIGHT SIDE
8	096873-16-G01	EA	PANEL - TABLE - FRONT BOTTOM - 18.1" X 6.7"
9	096873-11-G01	EA	PULLOUT TOP
	080736-01-000	EA	PULL - RECESSED - 1.25" X 4" - OAK
	079921-01-000	EA	NYLON ROLLER W/SHAFT
10	096873-12-G01	EA	SHELF - SUPPORT - UNDER PULL OUT TABLE TOP

## LOUNGE GROUP (CONTINUED)

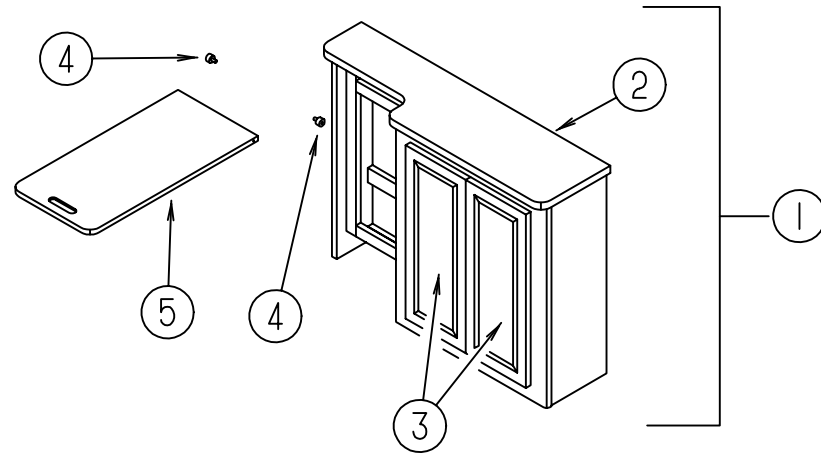

**FRONT CABINET (DRIVER SIDE)**

KEY	PART NUMBER	U/M DESCRIPTION
1	114796-01-GD1	EA CABINET ASM-HUTCH - FRONT RIGHT
2	114796-11-F09	EA COUNTERTOP ASM
3	110140-01-G01	EA DOOR ASM-MITERED,VINYL WRAP 0255 X 0640
4	079921-01-000	EA ROLLER-NYLON,W/SHAFT
5	114796-15-G04	EA TABLE ASM
	088792-01-000	YD VELCRO - 5/8" HOOK, NON-ADHES

## LOUNGE GROUP (CONTINUED)

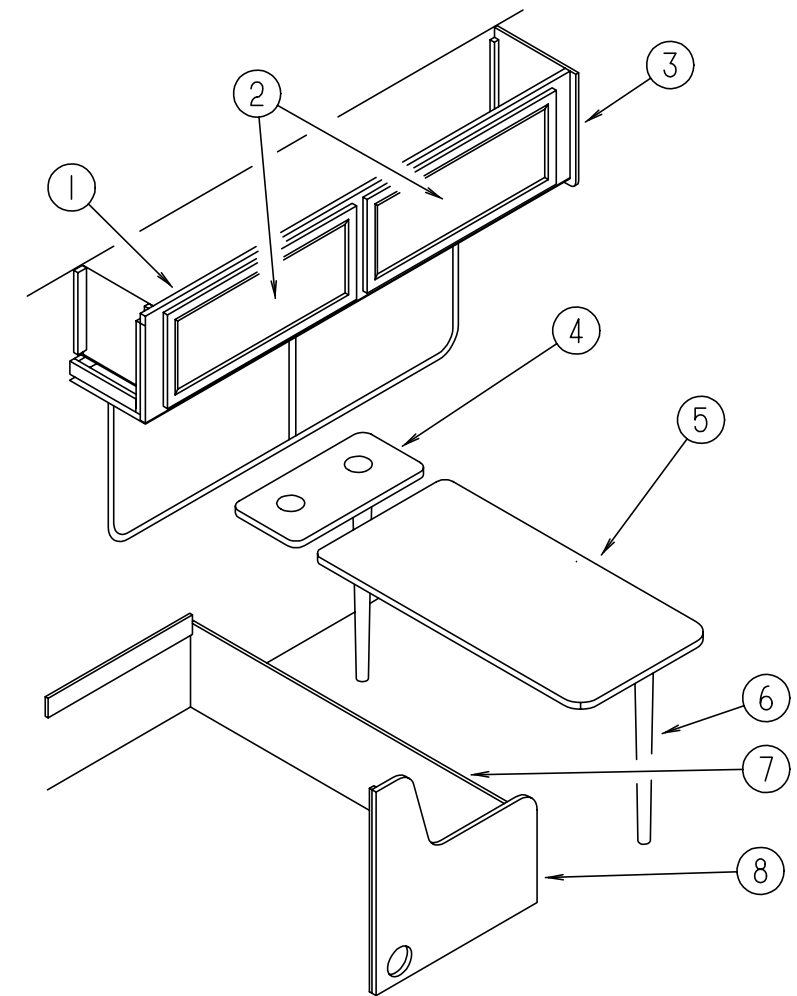

**FORWARD FACING COUCH**

KEY	PART NUMBER	U/M DESCRIPTION
1	P16878-01-GB1	EA CABINET ASM-OVERHEAD - DINETTE
2	110140-65-G01	EA DOOR ASM-MITERED - VINYL WRAP W/MIRROR
2	110140-05-G01	EA DOOR ASM-MITERED - VINYL WRAP W/O MIRROR
3	109908-03-GB1	EA CAP ASM-END - OVERHEAD
4	114681-01-F09	EA TABLE ASM. W/CUPHOLDERS (GD1)
4	114681-01-E01	EA TABLE ASM. W/CUPHOLDERS (GE1)
5	081322-14-G04	EA TABLE ASM-DINETTE
	118933-01-01A	EA SUPPORT-HINGE LOCK OFF WHITE (MOUNTS ON WALL)
	102201-04-03A	EA SUPPORT-HINGE CATCH,BRIGHT WHITE (MOUNTS ON TABLE)
	114724-02-000	EA PLATE-LEG,METAL,THD
6	114724-01-03A	EA LEG-TABLE,WOOD,TAPERED WATERFORD
6	114724-01-01A	EA LEG-TABLE,WOOD,TAPERED UNFINISHED
7	M02634-01-GD1	EA PANEL - KICKBOARD - FORWARD FACING
7	M02634-01-GE1	EA PANEL - KICKBOARD - FORWARD FACING
8	116110-03-GD1	EA COUCH END - FORWARD FACING - RIGHT
8	116110-03-GE1	EA COUCH END - FORWARD FACING - RIGHT.
	083125-07-000	EA BRACE-COUCH,O/W
	118933-01-01A	EA SUPPORT-HINGE LOCK O/WHT
	114726-01-GB1	EA TRAY ASM-BEVERAGE

## SEALANTS & FASTENERS GROUP

### ADHESIVE AND FASTENERS

KEY	PART NUMBER	U/M DESCRIPTION
	062917-03-000	EA ADHESIVE-LOCTITE 242
	053766-08-000	EA BEDDING COMPOUND-TUBE - GRAY - SCHNEE# 5522
	087211-01-000	GL PROMOTER-ADHESIVE
	034552-02-000	EA SILICONE-TUBE - 300 ML - CLEAR - W/O NOZZLE
	034552-06-000	EA SILICONE-TUBE - 300 ML - OFF WHITE W/O NOZZLE
	102352-01-000	EA SEALER-PUMPABLE - BLACK - COLORIMETRIC MS101
	069640-01-000	FT SEALER-RIBBON - 1/4" DIAMETER - INCREMENTS OF 30'
	069640-02-000	FT SEALER-RIBBON - 1/2" X 1/8" - INCREMENTS OF 30' OR 60'
	069640-03-000	FT SEALER-RIBBON - 3/4" X 1/8" - INCREMENTS OF 60'
	069640-07-000	FT SEALER-RIBBON - 2" X 3/32" - INCREMENTS OF 30' OR 45'
	069640-09-000	FT SEALER-RIBBON - 1/32" X 2 1/2" - INCREMENTS OF 80'
	069640-11-000	FT SEALER-TAPE - 3/16" X 3/8" - BLACK
	069640-14-000	FT SEALER-TAPE - 1/16" X 1" - GRAY
	110744-01-000	EA SEALANT-FOAM - POLYURETHANE
	072889-01-000	EA SEALANT-URETHANE - BLACK - 1/10 - ESSEX 552.2
	076314-02-000	FT TAPE-CARPET SEAM - HEAT-BOND - 4" WIDE
	076322-02-000	FT TAPE-FOAM - DOUBLE COATED ADHESIVE BACKED - 1" X 108'
	076322-05-000	FT TAPE-FOAM - DOUBLE COATED - .025" X 1.5" X 108'
	002707-02-000	FT TAPE-SEALER - 5/16" X 1/2" - INCREMENTS OF 50'
	900390-01-000	EA TIP - 2 1/2" X 1/8" ORIFICE - ELLSWORTH#TS216
	900390-02-000	EA TIP - 6"LN - 1/16" X 1/4" ORFICE - SEMCO#8607
	900390-03-000	EA NOZZLES-SILICONE TUBE - CSL# D10
	120074-01-01A	EA SILICONE-OFF/WHT W/O NOZZLE

### BOLTS, NUTS & WASHERS

KEY	PART NUMBER	U/M DESCRIPTION
	051387-06-000	EA BOLT-CARRIAGE - W/O HOLE - 5/16-18 X 9.5 ZINC
	000C12-05-12B	EA BOLT-HEX - 5/16 - 18 X .75" - ZINC 5
	000C12-05-16B	EA BOLT-HEX - 5/16 - 18 X 1" - ZINC 5
	000C12-05-40B	EA BOLT-HEX - 5/16 - 18 X 2.5" - ZINC 5
	000C12-07-20B	EA BOLT-HEX - 7/16 - 14 X 1.25" - ZINC5
	000C12-08-24B	EA BOLT-HEX - 1/2 - 13 X 1.50" - ZINC 5
	000C13-07-48B	EA BOLT-HEX - 7/16 - 20 X 3" - ZINC 5
	000C13-07-24B	EA BOLT-HEX - 7/16 - 20 X 1 1/2" - GR 5
	000C13-07-48B	EA BOLT-HEX - 7/16 - 20 X 3" - ZINC 5
	000C26-04-10B	EA BOLT-HEX - SERRATED FLANGE - 1/4-20 X 5/8" - ZINC
	000C26-05-12B	EA BOLT-HEX - SERRATED FLANGE 5/16-18 X 3/4" - ZINC
	000C26-06-28B	EA BOLT-HEX - SERRATED FLANGE 3/8-16 X 1.75" - ZINC
	000D14-05-00B	EA NUT-HEX - 5/16-18 - ZINC 5
	000D24-10-00B	EA NUT-HEX - SELF LOCKING - 10-32 ZINC
	000D39-04-00B	EA NUT-HEX - SERRATED FLANGE LOCKING 1/4" - 20 - ZINC
	000D39-05-00B	EA NUT-HEX - SERRATED FLANGE LOCKING - 5/16" - 18 - ZINC
	000D39-06-00B	EA NUT-HEX - SERRATED FLANGE LOCKING - 3/8" - 16 - ZINC
	000D39-08-00B	EA NUT-HEX - SERRATED FLANGE LOCKING - 1/2" - 13 - ZINC
	000D44-07-00B	EA NUT-HEX - SERRATED FLANGE LOCKING - 7/16" - 20 - ZINC
	104369-01-000	EA NUT-HEX - HEAVY - 5/8" - 11 UNC - SPARE TIRE INSTL
	063253-07-000	EA NUT-J - #8A .120- .130 PNL THICK
	040921-04-000	EA NUT-SPEED - U TYPE - NO. 8 - .59" LENGTH X .44" WIDTH
	044364-02-000	EA NUT-SPEED - FLAT - ROUND
	044533-01-000	EA WASHER-PLASTIC - 1 3/8" OD - FOR BUTTONS
	000E11-07-00B	EA WASHER-LOCKING - 7/16" MEDIUM SPLIT - ZINC
	000E13-20-00B	EA WASHER-FLANGE - 7/16" WIDE - ZINC
	106649-01-000	EA WASHER-SEALING - GALVANIZED - 5/8" ID

## SEALANTS & FASTENERS GROUP (CONTINUED)

### SCREWS

KEY	PART NUMBER	U/M DESCRIPTION
	000G68-06-10G	EA SCREW - 6-18 X 5/8" POH - ANTIQUE BRASS
	000G12-06-08T	EA SCREW - 6-20 X .50" POH - BLACK
	000G13-06-08B	EA SCREW - 6-20 X .50" PFH - ZINC
	000G13-07-12B	EA SCREW - 7-19 X 3/4" PFH - ZINC
	000G11-08-06B	EA SCREW - 8-18 X 3/8" PPH - ZINC
	000G11-08-08B	EA SCREW - 8-18 X 1/2" PPH - ZINC
	000G11-08-12B	EA SCREW - 8-18 X 3/4" PPH - ZINC
	000G11-08-12D	EA SCREW - 8-18 X 3/4" PPH - BLACK
	000G11-08-12S	EA SCREW - 8-18 X 3/4" PPH - OFF WHITE
	000G11-08-12T	EA SCREW - 8-18 X 3/4" PPH - BLACK
	000G12-08-16S	EA SCREW - 8-18 X 1" POH - OFF WHITE
	000G13-08-10B	EA SCREW - 8-18 X 5/8" PFH - ZINC
	000G67-10-08B	EA SCREW - 10-12 X 1/2" PPH - ZINC
	000G67-10-10B	EA SCREW - 10-12 X 5/8" PPH - ZINC - TYPE A
	000G67-10-10R	EA SCREW - 10-12 X 5/8" PPH - TYPE A - BEIGE
	000G67-10-10S	EA SCREW - 10-12 X 5/8" PPH - OFF WHITE
	000G67-10-12B	EA SCREW - 10-12 X 3/4" PPH - ZINC
	000G67-10-120	EA SCREW - 10-12 X .75" PPH - TAN
	000G67-10-12P	EA SCREW - 10-12 X .75" PPH - DARK BROWN
	000G67-10-20D	EA SCREW - 10-12 X 1.25" PPH - BLACK
	000G67-10-36T	EA SCREW - 10-12 X 2.25" PPH - BLACK
	000G67-10-48B	EA SCREW - 10-12 X 3" PPH - ZINC
	000G57-10-16B	EA SCREW - 10-13 X 1" PFH - ZINC
	000G11-10-12S	EA SCREW - 10-16 X .75" PPH - OFF WHITE
	000G13-10-12B	EA SCREW - 10-16 X 3/4" PFH - ZINC
	000G11-10-40B	EA SCREW - 10-16 X 2.5" PPH - CAD
	000G36-10-12E	EA SCREW - 10-24 X 3/4" PFH - TYPE 23 - CHROME PLATED
	000G19-10-20B	EA SCREW-MACHINE - 10-32 X 1 1/4" - PPH - STAINLESS STEEL
	075908-01-000	EA SCREW-MACHINE - 10-32 X .56" PTH - ZINC EXTERNAL TOOTH
	000G50-04-12B	EA SCREW-MACHINE - 1/4-20 X 3/4" PPH - ZINC
	000G53-04-06B	EA SCREW-MACHINE - 1/4-20 X 3/8" PPH - ZINC - UNDERCUT HEAD
	000G39-06-08B	EA SCREW-DR - 6-18 X 1/2" - ZINC
	000G39-06-10T	EA SCREW-SF/DR - 6-20 X 5/8" PPH - BLACK
	000G39-08-08B	EA SCREW-SF/DR - 8-18 X .50" PPH - ZINC
	000G39-08-08R	EA SCREW-SF/DR - 8-18 X .50" PPH - BEIGE
	000G39-08-08S	EA SCREW-SF/DR - 8-18 X .50" PPH - OFF WHITE
	000G39-08-12B	EA SCREW-SF/DR - 8-18 X 3/4" PPH - ZINC
	000G39-08-16B	EA SCREW-SF/DR - 8-18 X 1" PPH - ZINC
	000G39-08-16T	EA SCREW-SF/DR - 8-18 X 1 PPH - BLACK
	000G39-10-12D	EA SCREW-SF/DR - 10-16 X 3/4" PPH - BLACK
	000G39-10-10B	EA SCREW-SF/DR - 10-16 X .625" PPH - ZINC
	000G60-10-28T	EA SCREW-SF/DR - 10-16 X 1.75" - BLACK
	000G42-04-16B	EA SCREW-SF/DR - 1/4-14 X 1" HWH - ZINC
	000G42-04-24B	EA SCREW-SF/DR - 1/4-14 X 1 1/2" - ZINC
	000G42-04-20B	EA SCREW-SF/DR - 1/4-14 X 1 1/4" - ZINC
	000G42-04-12B	EA SCREW-SF/DR - 1/4-14 X 3/4" HWH - ZINC
	000G54-04-20B	EA SCREW - 1/4-20 X 1 1/4 PTH - TYPE 23 - ZINC PLATED
	049465-01-000	EA SCREW - 10-16 W/WASHER PTH - DARK BROWN
	096526-01-000	EA SCREW-HEX - 1/4 - 28 UNF
	079382-01-000	EA SCREW-SOCKET - 8-18 X 1" - BLACK

## SEALANTS & FASTENERS GROUP (CONTINUED)

### CLAMPS, GROMMETS AND FASTENERS

KEY	PART NUMBER	U/M	DESCRIPTION
	007125-03-000	EA	CLAMP-MUFFLER - 1.5" DIA
	007125-04-000	EA	CLAMP-MUFFLER - 1.1" DIA
	007161-01-000	EA	CLAMP-HOSE - SPRING TYPE - 1/2"
	010497-01-000	EA	CLAMP-CLOSED - 5/8" ID
	010497-03-000	EA	CLAMP-CLOSED - 1" ID - CUSHIONED
	010497-04-000	EA	CLAMP-CLOSED - 1.62 ID ADEL - 945-2717
	010497-05-000	EA	CLAMP-CLOSED - 1/2" ID
	010499-01-000	EA	CLAMP-CLOSED - 3/8" ID
	062401-01-000	EA	CLAMP-HOSE - WORMGEAR .25" - 1"
	062401-04-000	EA	CLAMP-HOSE - WORMGEAR .69" - 1.25"
	062401-06-000	EA	CLAMP-HOSE - WORMGEAR .22" - .62"
	062401-08-000	EA	CLAMP-HOSE - WORMGEAR 4.06" - 5.0"
	083609-01-000	EA	CLAMP-WIRE - DUAL EQUAL - 5/8" DIAMETER
	083610-01-000	EA	CLAMP-WIRE - DUAL - UNEQUAL DIAMETERS - .75" & 1.25"
	016188-05-000	EA	GROMMET-L/P LINE - 3/8" HOLE X 1 1/4" LONG - RUBBER
	061603-01-000	EA	GROMMET-SNAP - 3/16" ID - 3/8" HOLE - PLASTIC - BLACK
	023942-01-000	EA	GROMMET-RUBBER - 2" OD
	071015-11-000	EA	GROMMET-1.00" ID - FITS .12" MATERIAL - MINOR RUBBER Z-3065
	075148-02-000	EA	CLAMP-GROUNDING - BRONZE SCREWS
	077955-01-000	EA	CLIP-J - VINYL COATED - 3/8" - USED TO SUPPORT WIRING TO LIGHTS
	080734-02-000	EA	CLIP-WIRE - NYLON
	094362-02-000	EA	CLIP-CHRISTMAS TREE - FLAT HEAD - .5" X .95"
	029094-04-000	YD	VELCRO TAPE-LOOP - 1" WIDE - BLACK
	029094-03-000	YD	VELCRO TAPE-HOOK - 1" WIDE - BLACK
	081211-05-000	EA	PLUG-PLASTIC, .188 DIAMETER - NATURAL
	008343-01-000	EA	TIE-WIRE - 6"
	008343-02-000	EA	TIE-WIRE - 14"

## WATER & SEWAGE GROUP

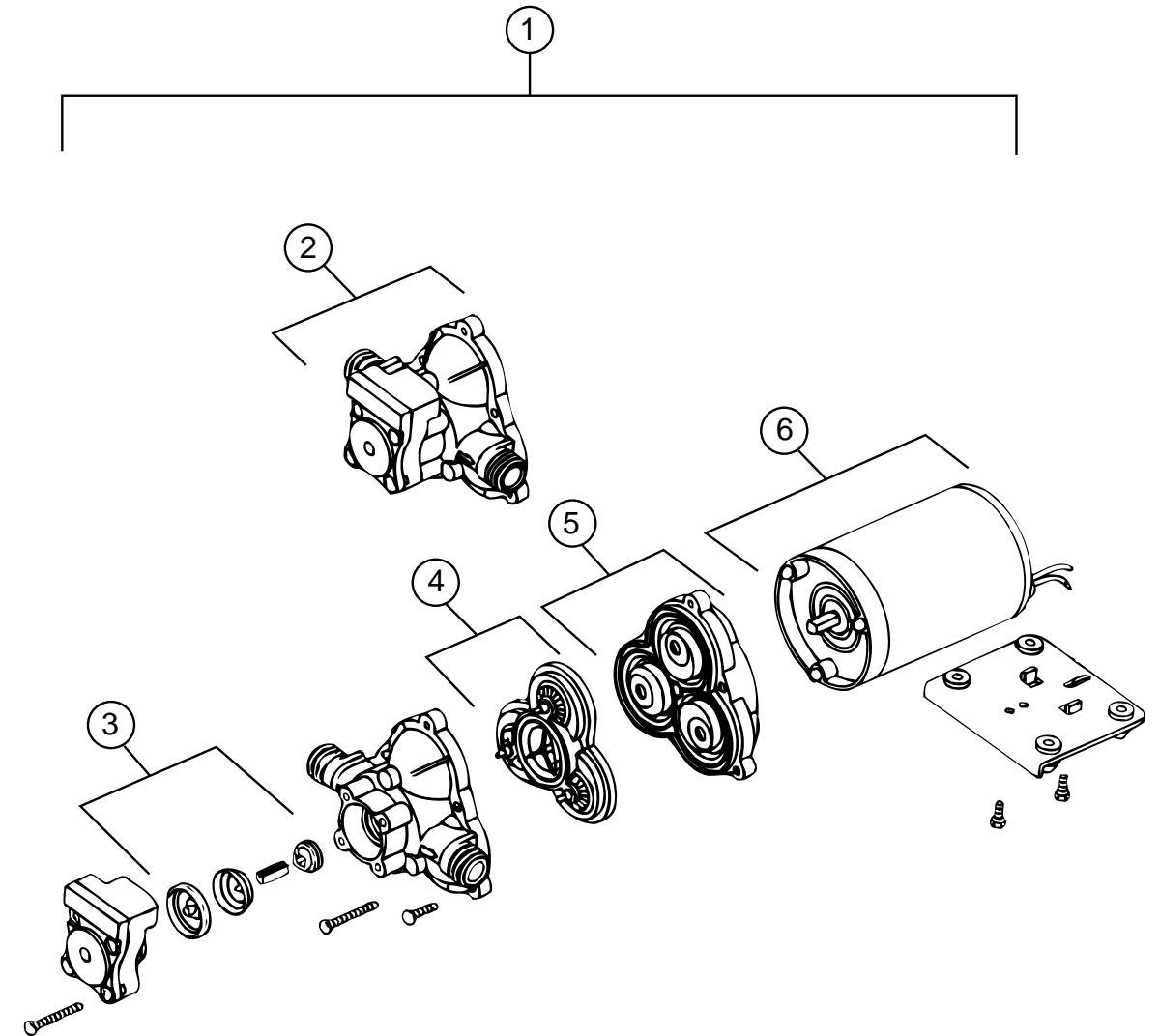

### WATER PUMP SHURFLO

KEY	PART NUMBER	U/M	DESCRIPTION	VENDOR NO.
1	098607-01-000	EA	PUMP-WATER, W/5" MPT FITTING - FLOW 2.8 GPM - UL	
2	098607-01-706	EA	UPPER HOUSING/ SWITCH KIT	94-231-20
3	098607-01-705	EA	CHECK VALVE - KIT	94-237-00
4	098607-01-703	EA	VALVE ASM	94-232-00
5	098607-01-702	EA	DRIVE/ DIAPHRAGM - KIT	94-238-04
6	098607-01-707	EA	MOTOR W/BASEPLATE	11-148-04

**WATER & SEWAGE GROUP (CONTINUED)**

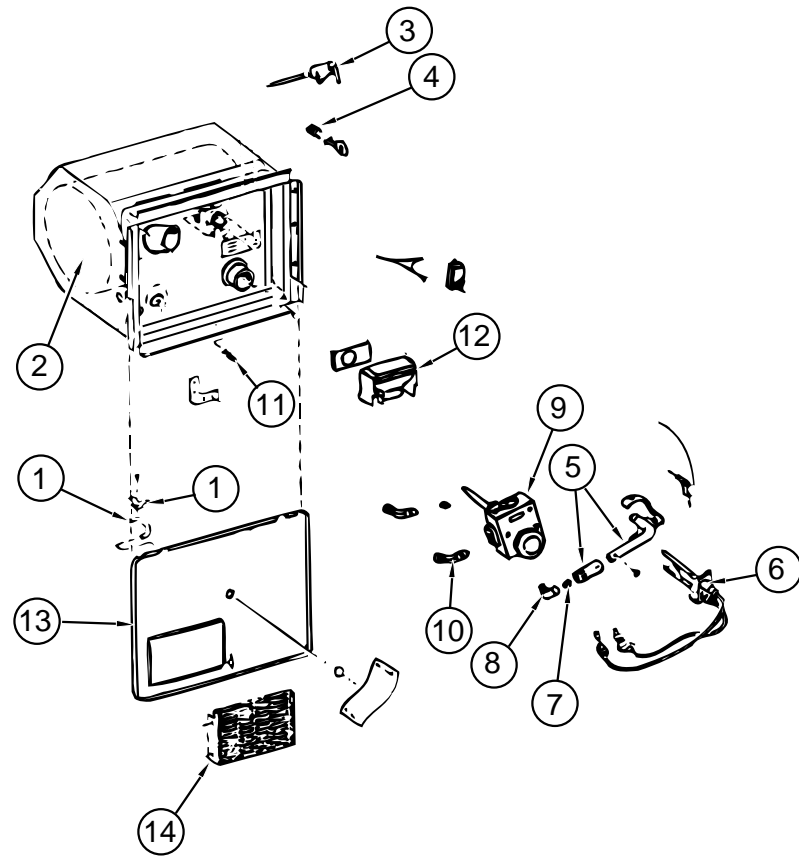

**WATER HEATER W/MOTOR AID ATWOOD G6A-3**

KEY	PART NUMBER	U/M DESCRIPTION	VENDOR NO.
	051391-01-A00	EA HEATER-WATER, ATWOOD G6A-3	
1	051391-01-700	EA HINGE KIT, (PIN & CLIP)	92568 & 92559
2	051391-01-702	EA TANK-INNER F/G6A-2E-3E-6E	91412
3	051391-01-704	EA VALVE-RELIEF, 1/2" FITTING	91604
4	051391-01-705	EA FASTENER-CAMLOCK	92609
5	051391-01-708	EA BURNER-MAIN	92615
	051391-03-700	EA HOLDER-ORIFICE	91563
6	051391-01-709	EA PILOT ASM. W/THERMOCOUPLER	91603
7	051391-01-710	EA ORIFICE-MAIN BURNER	92742
8	051391-01-711	EA ELBOW-ORIFICE,MAIN BURNER	92741
9	051391-01-712	EA THERMOSTAT- 3/8" NPT INLET	91601
10	051391-01-714	EA FITTING-ELBOW 45,3/8F X 3/8 MPT	91044
11	051391-01-715	EA PLUG-DRAIN, 2 PER PKG	91857
	051391-04-703	EA BURNER-MAIN, 4E & 6E	91638
12	051391-04-707	EA KIT (FLUE & GASKET)F/EXHAUST	90960
13	052009-06-000	EA DOOR-WATER HEATER, BRIGHT WHITE	
14	051391-01-717	EA GRILLE, F/WATER HEATER DOOR	92640

**WATER & SEWAGE GROUP (CONTINUED)**  
**WATER SYSTEM**

KEY	PART NUMBER	U/M DESCRIPTION
	101814-01-000	EA COUPLING-FEMALE, 1/2" X 1/2" FPT W/COMP. SLEEVE - GRAY
	114430-02-000	EA ADAPTER-SWIVEL,1/2P X 1/2FPT FLAIR-IT -02873
	114430-03-000	EA ADAPTER-1/2P X 1/2MPT - FLAIR-IT 02842
	010219-01-000	EA ELBOW - 1 1/4" MPT X 1 1/4" BARB, WATER FILL - PLASTIC
	035539-01-000	EA ELBOW-PLASTIC, 3/8" MPT X 3/8" BARB
	074462-02-000	FT TUBING-VINYL, 3/8" ID - CLEAR
	079381-01-000	FT TUBING-SMOOTH FLEXIBLE, 1 1/4" ID X 20'
	042989-03-000	EA FITTING-WATER TANK, SPINWELD - 1 1/4" NPT - PLASTIC - WHITE
	042989-04-000	EA FITTING-WATER TANK, SPINWELD - 3/8" FPT - PLASTIC - WHITE
	042989-05-000	EA FITTING-WATER TANK, SPINWELD - 1/2" FPT - PLASTIC - WHITE
	110915-01-01A	EA FILL-WATER, CITY - CHROME - KEVCO 64713
	039800-02-000	FT TUBING-POLYBUTYL, 5/8" OD - INCREMENTS OF 20' - BLACK
	046128-01-000	EA VALVE-DRAIN, PLASTIC - 1/2" FPT
	114428-01-000	EA TEE - 1/2P X 1/2P X 1/2P FLAIR-IT 02820
	114428-02-000	EA TEE-SWIVEL,1/2P X 1/2P X 1/2 FPT - FLAIR-IT 02821
	114429-01-000	EA ELBOW-1/2P X 1/2P FLAIR-IT 02800
	114429-02-000	EA ELBOW-1/2P X 1/2MPT - FLAIR-IT 02803
	114429-03-000	EA ELBOW-SWIVEL,1/2P X 1/2FPT FLAIR-IT 02816
	114430-02-000	EA ADAPTER-SWIVEL,1/2P X 1/2FPT - FLAIR-IT -02873
	114430-03-000	EA ADAPTER-1/2P X 1/2MPT - FLAIR-IT 02842

**WATER TANK**

KEY	PART NUMBER	U/M DESCRIPTION
	116700-01-000	EA TANK-WATER,59 GAL
	116700-02-000	EA TANK - WATER, 59 GAL - W/FITTINGS
	039861-01-000	EA SENDING UNIT-W/SCREW - WASHER, WELL NUT, & TERMINAL RING
	049032-01-000	EA PATCH-SPINWELD - 3/8" - PLASTIC
	042989-03-000	EA FITTING-WATER TANK - SPINWELD - 1 1/4"NPT - PLASTIC - WHITE
	042989-04-000	EA FITTING-WATER TANK - SPINWELD - 3/8" FPT - PLASTIC - WHITE
	042989-05-000	EA FITTING-WATER TANK - SPINWELD - 1/2" FPT - PLASTIC - WHITE
	077954-02-000	EA FILTER-WATER TANK - SCREEN IN TANK



# WATER & SEWAGE GROUP (CONTINUED)

## DRAINAGE SYSTEM

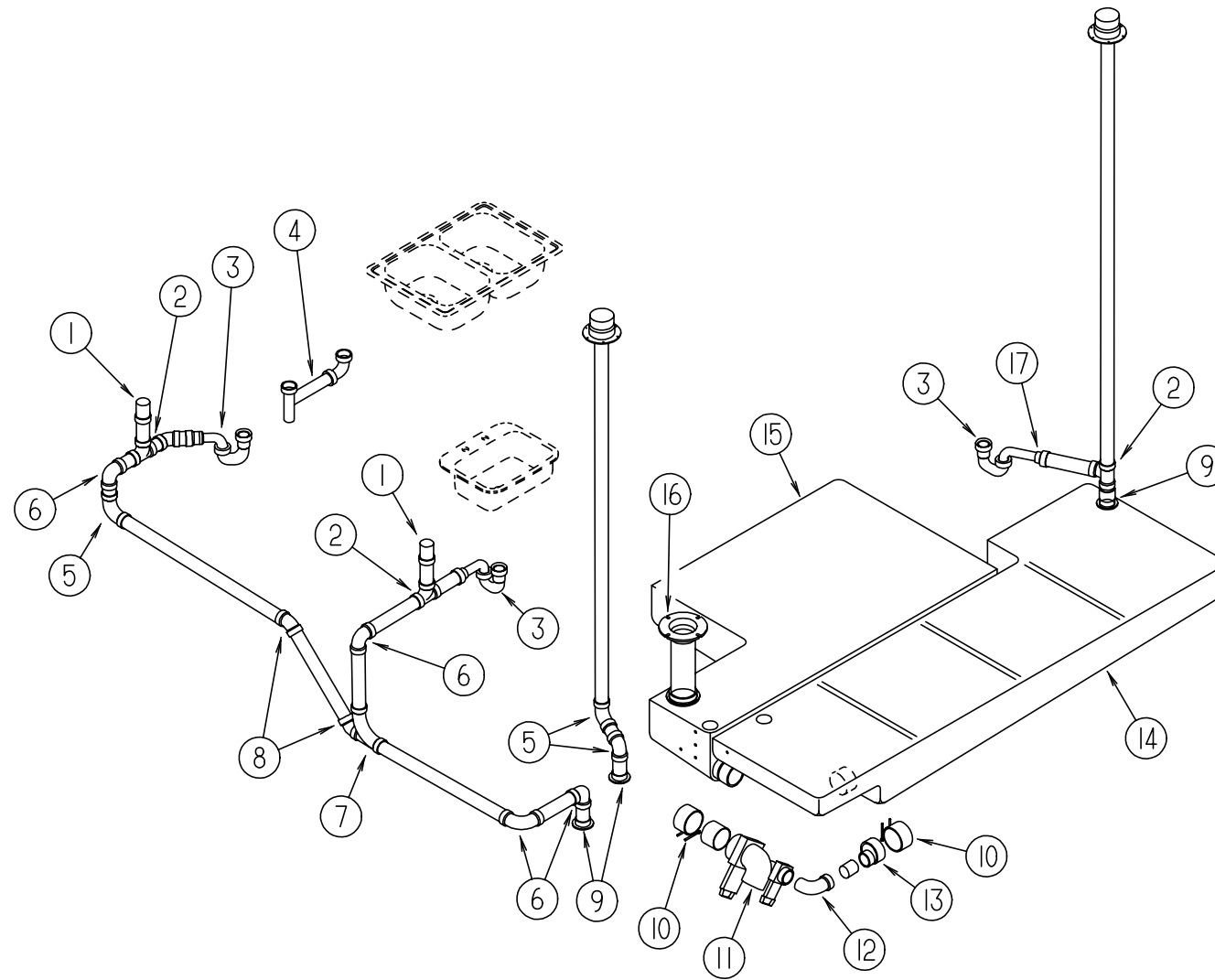

KEY	PART NUMBER	U/M DESCRIPTION
1	079968-01-000	EA VENT-MECHANICAL TRAP ARM - ANTI-SIPHON - 2" DIA X 7.3" - PLASTIC
2	010071-01-000	EA TEE-SANITARY - 1 1/2" HUB X HUB X HUB - PLASTIC - BLACK
3	107538-01-000	EA P-TRAP - PLASTIC - 1 1/4" W/EXT ARM (US)
3	011066-02-000	EA P TRAP - PLASTIC - 1 1/4 - 1 1/2" - PLASTIC (CSA)
3	109571-01-000	EA ADAPTER-P-TRAP - 1 1/2" P X 1 1/4" MPT (US)
4	011091-02-000	EA PIPE-DRAIN - DOUBLE SINK - BAFFLE TEE - 1 1/2"
5	010008-01-000	EA ELBOW - 90 DEGREE - 1/4 BEND - 1 1/2" HUB X HUB - BLACK PLASTIC
6	034250-01-000	EA ELBOW - 90 DEGREE - LONG TURN - 1 1/2" HUB X HUB - ABS
7	031365-02-000	EA TEE-PLAS, 1 1/2 EXT LG TURN - NIBCO 5812-LR-11/2
8	010006-01-000	EA ELBOW - 45 DEGREE - 1/8 BEND - 1 1/2" HUB X HUB - BLACK PLASTIC
9	061607-01-000	EA GROMMET-HOLDING TANK - 1 1/2" NPS
10	078406-01-000	EA COUPLER-RUBBER - W/CLAMPS - 3" X 3"
11	070916-01-000	EA VALVE-DUAL DUMP, W/CAP - 3" X 1 1/2" - PLASTIC - BLACK
	070916-01-700	EA VALVE ONLY (WASTE) 3" T1003BU
	070916-01-701	EA VALVE ONLY (WASTE) 1 1/2" T1001BU
12	010008-01-000	EA ELBOW - 90 DEGREE - 1/4 BEND - 1 1/2" HUB X HUB - BLACK PLASTIC
13	062422-01-000	EA ADAPTER-OFFSET REDUCER - 3" X 1 1/2" - PLASTIC - BLACK

KEY	PART NUMBER	U/M DESCRIPTION
14	116703-01-000	EA TANK-HOLDING, 41 GAL
15	116705-01-000	EA TANK-HOLDING - 38 GAL - BLANK
16	061607-02-000	EA GROMMET-HOLDING TANK - 3" NPS
16	116644-01-000	EA FLANGE-CLOSET 4 X 3 - SEALAND 345892
17	109571-01-000	EA ADAPTER-11/2P X 11/4MPT
	010115-01-000	EA COUPLING - 1 1/2" HUB X HUB - PLASTIC
	069735-01-000	EA WASHER-STRAINER TO TAILPIECE PLASTIC, 1.5"
	011069-02-000	EA TAILPIECE-TUB/SHOWER - 1 1/2" X 1 1/4" X 4" - BRASS
	011069-04-000	EA TAILPIECE, 1 1/2 X 1 1/4 X 8 - BRASS

## WINDOW, VENT & EXTERIOR DOOR GROUP

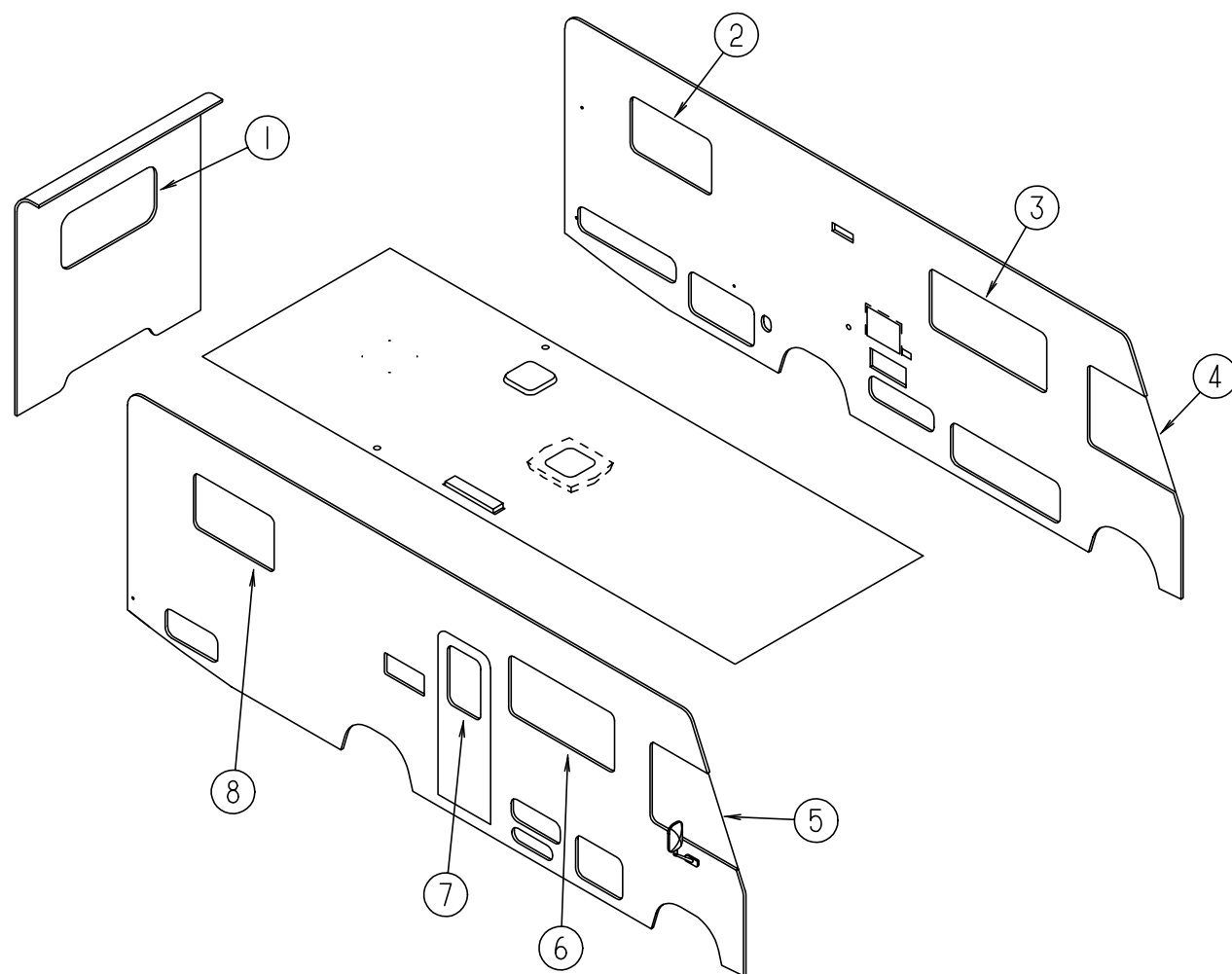

**EXTERIOR WINDOWS**

KEY	PART NUMBER	U/M	DESCRIPTION
1	078528-07-FB1	EA	WINDOW ASM-ESCAPE CLEAR USED WITH QUEEN BED / TWIN BED
1	116976-01-01A	EA	WINDOW ASM-ESCAPE SINGLE USED WITH DOUBLE BED / BUNK BEDS
2	098647-30-01A	EA	WINDOW ASM-SLIDER - HORIZONTAL - QUEEN BED / TWIN BED/ DOUBLE BED
2	098647-32-01A	EA	WINDOW ASM-SLIDER,HORIZ CLR EXCEL H425-C1W66L / BUNK BEDS
3	098647-28-01A	EA	WINDOW ASM-SLIDER - HORIZONTAL EXCEL H287-C1W66L
4	103658-09-01A	EA	WINDOW ASM-CAB - DRIVER
5	103658-10-01A	EA	WINDOW ASM-CAB - PASSENGER
6	098647-26-01A	EA	WINDOW ASM-SLIDER - HORIZONTAL - EXCEL H415-C1W66R
7	117053-04-FB1	EA	WINDOW ASM-PICTURE - ENTRANCE DOOR
	117054 02 02A	EA	FRAME-WINDOW,INSIDE BRIGHT/WHITE - ENTRANCE DOOR
8	098647-29-01A	EA	WINDOW ASM-SLIDER - HORIZONTAL - QUEEN BED / TWIN BED/ DOUBLE BED
8	098647-31-01A	EA	WINDOW ASM-SLIDER,HORIZ CLR - EXCEL H425-C1W66R / BUNK BEDS

## WINDOW, VENT & EXTERIOR DOOR GROUP (CONTINUED)

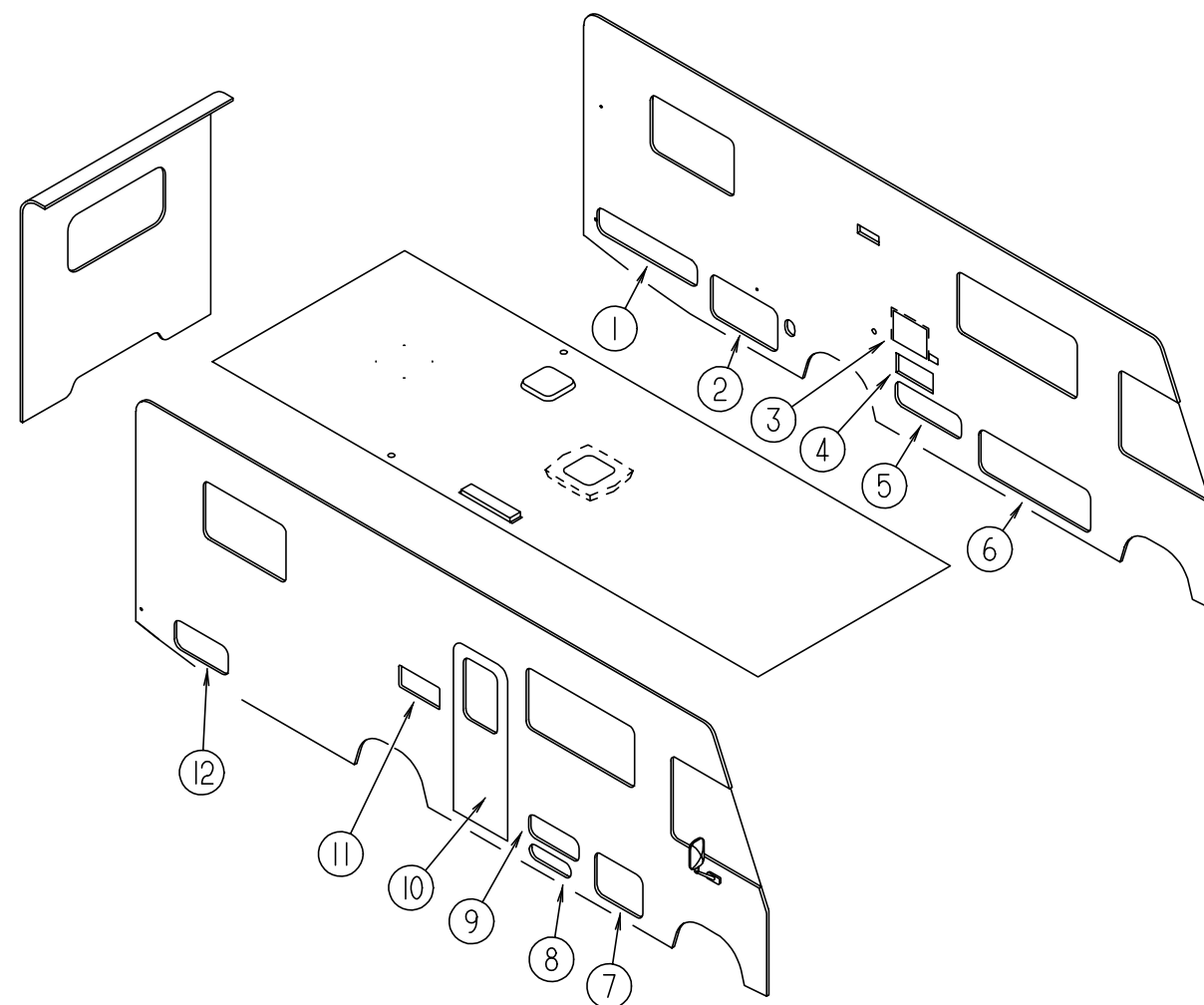

**EXTERIOR DOORS & VENTS**

KEY	PART NUMBER	U/M	DESCRIPTION
1	104558-27-FB1	EA	DOOR ASM-STORAGE - BRIGHT WHITE
	107997-51-001	EA	SPACER - .86" X .6", ALUMINUM
2	104558-25-FB1	EA	DOOR ASM-STORAGE - BRIGHT WHITE
3	052009-06-000	EA	DOOR-WATER HEATER - ATWOOD 5576-27 - BRIGHT WHITE
4	098668-23-000	EA	DOOR - FURNACE - BRIGHT WHITE - SUBURBAN 520574
5	104558-30-FB1	EA	DOOR ASM-STORAGE - BRIGHT WHITE
6	104558-24-FB1	EA	DOOR ASM-STORAGE
7	104558-26-FB1	EA	DOOR ASM-STORAGE
8	111009-01-F24	EA	DOOR - COMPARTMENT - LP - 16.9" X 5.4" - ALUMINUM - BRIGHT WHITE
9	104558-29-FB1	EA	DOOR ASM - STORAGE
	104564-16-02A	EA	JAMB-DOOR - STORAGE - BRIGHT WHITE
10	115108-06-GB1	EA	DOOR-ENTRANCE W/O WINDOW - W/SCREEN - FLAT - BRIGHT WHITE (GD1)
10	115108-06-GE1	EA	DOOR-ENTRANCE W/O WINDOW - W/SCREEN - FLAT - BRIGHT WHITE
11	084103-08-000	EA	DOOR-REFRIGERATOR - VENTED - W/O JAMB - BRIGHT WHITE
	084104-08-000	EA	JAMB-DOOR - REFRIGERATOR - BRIGHT WHITE
	084104-01-700	EA	LOCK-MALE - FASTENER - REFRIGERATOR DOOR
	084104-01-701	EA	LOCK-FEMALE - FASTENER - REFRIGERATOR DOOR
12	104558-31-FB1	EA	DOOR ASM-STORAGE
	104564-19-02A	EA	JAMB-DOOR,STORAGE - BRIGHT WHITE
	081240-16-000	EA	DOOR-WATER FILL - LOCKABLE - BRIGHT WHITE
	103385-01-02A	EA	VENT-RANGE HOOD, OUTSIDE - BRIGHT WHITE - VENTLINE

# WINDOW, VENT & EXTERIOR DOOR GROUP (CONTINUED)

## BRIGGS & STRATTON LOCKS & COMPONENTS

NOTE:  
WHEN ORDERING THE LOCK CASE, THE KEY CODE MUST MATCH THE LAST DIGIT OF THE VEHICLE'S SERIAL NUMBER AND PART NUMBER; WHEN ORDERING THE KEYS, THE THIRD DIGIT OF THE KEY CODE MUST MATCH THE LAST DIGIT OF THE VEHICLE'S SERIAL NUMBER AND PART NUMBER

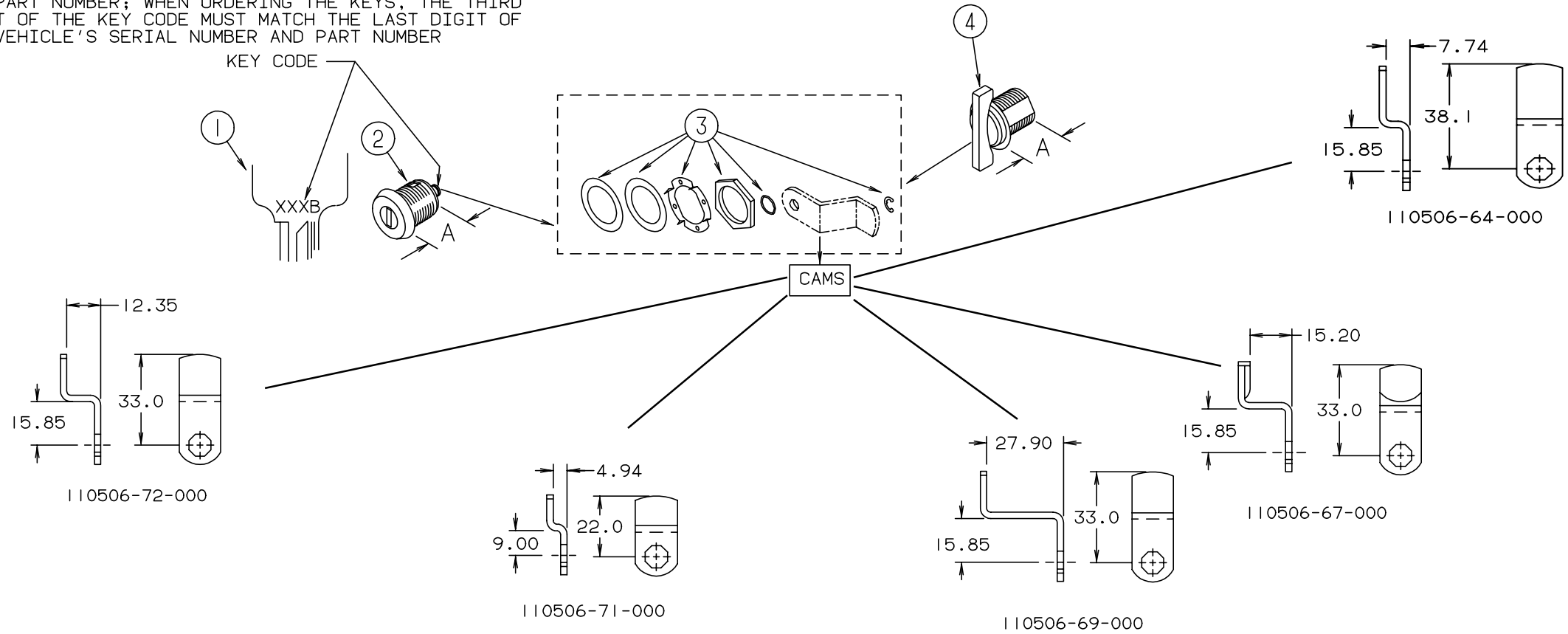

KEY	PART NUMBER	U/M	DESCRIPTION	VENDOR NO.
1	110506-59-000	EA	KEYS - SET OF TWO	596720
2	110506-52-000	EA	CASE - LOCK - A= 17 MM	702370
2	110506-53-000	EA	CASE - LOCK - A= 25 MM	702380
1	110506-59-001	EA	KEYS - SET OF TWO	596721
2	110506-52-001	EA	CASE - LOCK - A= 17 MM	702371
2	110506-53-001	EA	CASE - LOCK - A= 25 MM	702381
1	110506-59-002	EA	KEYS - SET OF TWO	596722
2	110506-52-002	EA	CASE - LOCK - A= 17 MM	702372
2	110506-53-002	EA	CASE - LOCK - A= 25 MM	702382
1	110506-59-003	EA	KEYS - SET OF TWO	596723
2	110506-52-003	EA	CASE - LOCK - A= 17 MM	702373
2	110506-53-003	EA	CASE - LOCK - A= 25 MM	702383
1	110506-59-004	EA	KEYS - SET OF TWO	596724
2	110506-52-004	EA	CASE - LOCK - A= 17 MM	702374
2	110506-53-004	EA	CASE - LOCK - A= 25 MM	702384
1	110506-59-005	EA	KEYS - SET OF TWO	596725
2	110506-52-005	EA	CASE - LOCK - A= 17 MM	702375
2	110506-53-005	EA	CASE - LOCK - A= 25 MM	702385
1	110506-59-006	EA	KEYS - SET OF TWO	596726
2	110506-52-006	EA	CASE - LOCK - A= 17 MM	702376
2	110506-53-006	EA	CASE - LOCK - A= 25 MM	702386

KEY	PART NUMBER	U/M	DESCRIPTION	VENDOR NO.
1	110506-59-007	EA	KEYS - SET OF TWO	96727
2	110506-52-007	EA	CASE - LOCK - A= 17 MM	702377
2	110506-53-007	EA	CASE - LOCK - A= 25 MM	702387
1	110506-59-008	EA	KEYS - SET OF TWO	596728
2	110506-52-008	EA	CASE - LOCK - A= 17 MM	702378
2	110506-53-008	EA	CASE - LOCK - A= 25 MM	702388
1	110506-59-009	EA	KEYS - SET OF TWO	596729
2	110506-52-009	EA	CASE - LOCK - A= 17 MM	702379
2	110506-53-009	EA	CASE - LOCK - A= 25 MM	702389
3	110506-40-700	EA	HARDWARE KIT	
4	110506-50-000	EA	CASE - TWIST LOCK - A= 17 MM	596952
4	110506-51-000	EA	CASE - TWIST LOCK - A= 25 MM	596669
	110506-08-000	EA	LOCK ASM - TWIST - 25.38MM	
	110506-20-000	EA	LOCK ASM - TWIST - 41.64MM	
	110506-16-000	EA	LOCK ASM - KEYED - 41.65MM	
	110506-40-000	EA	CLIP-E - LOCK ASM	93981
	110506-64-000	EA	CAM - LOCK	322280
	110506-67-000	EA	CAM - LOCK	322283
	110506-71-000	EA	CAM - LOCK	322287
	110506-72-000	EA	CAM - LOCK	322354
	110506-59-701	EA	KEY BLANK - GOLD	

# WINDOW, VENT & EXTERIOR DOOR GROUP (CONTINUED)

## ENTRANCE DOOR

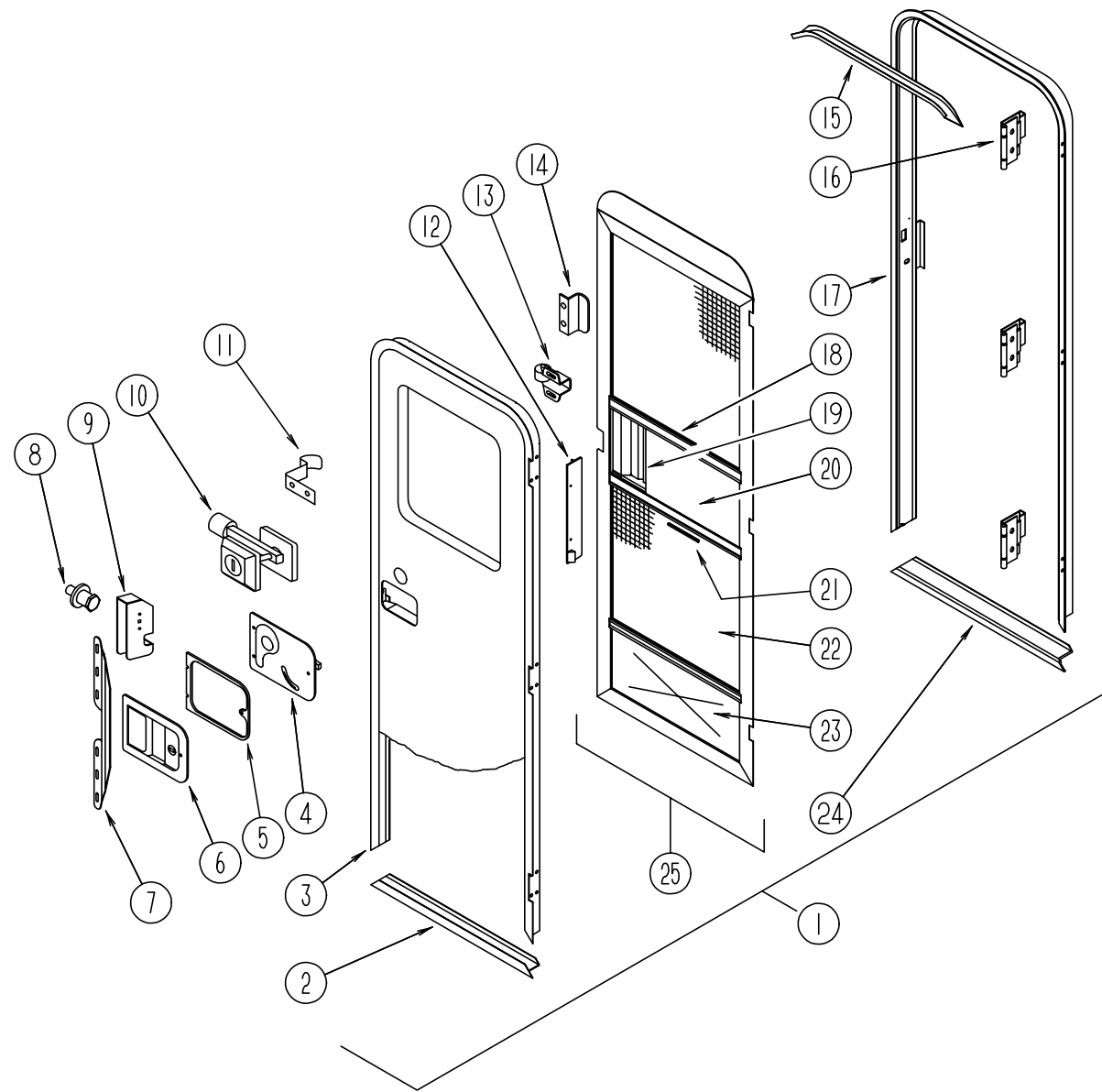

KEY	PART NUMBER	U/M	DESCRIPTION
1	115108-06-GB1	EA	DOOR-ENTRANCE, W/O WINDOW & SCREEN - FLAT - BRIGHT WHITE (GD1)
1	115108-06-GE1	EA	DOOR-ENTRANCE, W/O WINDOW & SCREEN - FLAT - BRIGHT WHITE
2	089748-21-000	EA	FRAME-DOOR, ENTRANCE - BOTTOM - OFF WHITE
	090340-01-000	FT	SEAL-FOAM, CLOSED CELL - 1/4" X 1/2" X 50'
3	095276-03-06A	EA	FRAME-DOOR, ENTRANCE - TOP & SIDES - BRIGHT WHITE
4	039979-06-000	EA	COVER-INTERIOR LATCH, W/TRIP ARM - RIGHT - BLACK
	039984-01-000	EA	CAP-ROUND, VINYL - .28" ID X .62" LONG - BLACK
	041546-07-000	EA	BRACKET-DOOR ANGLE, 5" X 1.9" - OFF WHITE - METAL
5	096810-01-01A	EA	PLATE-LATCH, ENTRANCE DOOR - PLASTIC - BLACK
6	045017-13-000	EA	LATCH-ENTRANCE DOOR, BLK TEXT - *T/M #11896-01
	045017-11-701	EA	KEY-BLANK, F1 SERIES 81312-02
	045017-11-702	EA	KEY-MASTER, F SERIES 81313-02
			TO BE SOLD F/DEALER USE ONLY, NOT RETAIL !!!!!!!!
	058025-02-000	EA	CLIP-ROLLER LATCH CATCH, SCREEN DOOR
	063729-04-000	EA	RIVNUT, 10-32 UNF - .010-.080
	075671-04-000	FT	SEAL-SPONGE, LAZY T SHAPE - W/ADHESIVE STRIPE - .5" WIDE
7	098173-01-07A	EA	STIFFENER-ENTRANCE DOOR, SUPPORTS LATCH/STRIKE AREA - BRIGHT WHITE
	098173-01-04A	EA	STIFFENER-ENTRY DOOR, SUPPORTS LATCH/STRIKE AREA UNPAINTED
	100128-02-000	FT	SEAL-PILE, ADHESIVE BACK - SCREEN DOOR - GRAY
8	039539-01-000	EA	STRIKE-LOCK, ENTRY DOOR - ROUND W/THREADED WASHER
9	045017-13-000	EA	LATCH MECHANISM-HOOK, ENTRY DOOR - INTERIOR
	039715-01-000	EA	NUT-SERT, 1/4" DIAMETER - 20 THREADS
10	101145-01-06A	EA	DEADBOLT-ENTRANCE DOOR, W/2 KEYS W/O BACK SET BOLT OR SCREWS
	095229-01-700	EA	KEY BLANK
	101145-01-701	EA	CYLINDER-LOCK ASM., W/KEY 81306-03
	101147-01-000	EA	BOLT-SECURITY, 4.12" BACKSET
	102524-01-000	EA	BUMPER-RUBBER, FLAT - BLACK
11	100412-01-000	EA	CATCH-SCREEN DOOR, THUMB CLIP W/BLACK PLASTIC CAP
	102768-01-000	EA	HOLDER-ENTRY DOOR, METAL - MILL FINISH
12	079087-03-000	EA	STRIKE-SLIDER, W/LIP FOR ELBOW CATCH - BRIGHT WHITE
13	100412-01-000	EA	CATCH-SCREEN DOOR
14	050712-06-000	EA	HANDLE-SCREEN DOOR, ALUMINUM - BRIGHT WHITE
15	044582-44-000	EA	CAP-DRIP, DOOR JAMB MOUNTED - BRIGHT WHITE
	115222-09-01A	EA	GARNISH-RADIUS, ENTRANCE DOOR - OFF WHITE
	077461-03-000	EA	COVER-STRIKE, ENTRANCE DOOR - 6.5" X 2.5" - PLASTIC - WHITE
	090340-01-000	FT	SEAL-FOAM, CLOSED CELL - 1/4" X 1/2" X 50'
16	106719-01-05A	EA	HINGE-ENTRANCE DOOR - BRIGHT WHITE
	102248-01-000	EA	SHIM-DOOR
17	120310-06-01A	EA	JAMB-ENTRANCE DOOR, BRIGHT WHITE
18	078777-01-000	EA	CHANNEL-SLIDE, SCREEN DOOR CENTER SLIDER COVER - 17.4"
19	079086-03-000	EA	SLIDER-SCREEN DOOR, BRIGHT WHITE
20	016454-01-000	EA	INSERT-CENTER
	001014-01-013	EA	INSERT-CENTER, 10.25" X 16.31" - UNPAINTED
21	002294-01-000	FT	SPLINE-SCREENING, .135" X .138" - BLACK
	002748-01-000	EA	CORNER KEY-DOOR
22	002293-02-000	SF	SCREENING-WINDOW & DOOR, 26" - CHARCOAL
23	078552-03-000	EA	INSERT-SCREEN DOOR, LOWER - UNPAINTED
	078595-01-000	EA	PLATE-SCREEN DOOR
24	051049-01-000	EA	JAMB-ENTRANCE DOOR, BOTTOM - UNPAINTED
25	079012-05-F01	EA	DOOR-SCREEN - BRIGHT WHITE

## WINDOW, VENT & EXTERIOR DOOR GROUP (CONTINUED)

### POWERED ROOF VENT

KEY	PART NUMBER	U/M	DESCRIPTION
	110051-03-01A	EA	VENT-ROOF, POWERED - 2" ROOF - US - JENSEN C7757 WHEAT
	110051-05-01A	EA	VENT-ROOF, POWERED - 2" ROOF - CSA - JENSEN C7757 WHEAT
	048648-01-000	EA	MOTOR-ROOF VENT, 1/8 SHAFT - 12V - JENSEN
	048649-01-000	EA	FAN-ROOF VENT, 6 BLADES - 6" - JENSEN
	064470-01-700	EA	COVER-VENT, W/O (SLIDE BAR) COMES W/O SLIDE BAR J7291
	064470-01-701	EA	SLIDE BAR, (VENT-LID) JRP1291B
	110051-01-700	EA	SCREEN-ROOF VENT
	110051-01-701	EA	GARNISH W/SCREEN & FRAME 2"
	110051-01-702	EA	HAND CRANK & OPERATOR ASM.
	110051-01-703	EA	HANDLE CRANK

### NONPOWERED ROOF VENT

KEY	PART NUMBER	U/M	DESCRIPTION
	110051-01-01A	EA	VENT-ROOF, NONPOWERED - 2" ROOF - JENSEN 7724 WHE
	064470-01-700	EA	COVER ROOF VENT, 7291
	110051-01-700	EA	SCREEN & FRAME 2" NON-POWER
	110051-01-701	EA	GARNISH W/SCREEN & FRAME 2"
	110051-01-702	EA	HAND CRANK & OPERATOR ASM.
	110051-01-703	EA	HANDLE CRANK

### VENTS & SHROUDS

KEY	PART NUMBER	U/M	DESCRIPTION
	083558-03-000	EA	VENT-PLUMBING PIPE ROOF, W/COVER - OFF WHITE
	084073-07-000	EA	COVER-ROOF VENT, REFRIGERATOR - BRIGHT WHITE - NORCOLD
	084073-04-000	EA	BASE-ROOF VENT, REFRIGERATOR - BLACK - NORCOLD
	105028-01-000	EA	FLASHING ASM-VENT, REFRIGERATOR
	103385-01-02A	EA	VENT-RANGE HOOD, OUTSIDE - BRIGHT WHITE - VENTLINE

### SEALS AND HARDWARE FOR ACCESS DOORS

KEY	PART NUMBER	U/M	DESCRIPTION
	075673-01-000	FT	SEAL-PILE, ADHESIVE BACK - GRAY
	104692-01-000	FT	SEAL-3/4" X 3/4" W/ADHESIVE BACK FOAM SEAL
	106850-01-000	FT	SEAL - "E" - 11X19 SPONGE RUBBER
	102768-01-000	EA	HOLDER-COMPARTMENT/ENTRY DOOR, METAL - MILL FINISH
	107997-51-001	EA	SPACER-.86" X .6", ALUMINUM
	081801-V3-000	EA	HINGE-AL,2X2438MM BRT WHT BRT/WHT
	034007-B3-000	EA	HINGE-CONT AL 1.5X96"BRT WHT
	009065-01-000	EA	HINGE-ALUMINUM, 1 1/2" X 96" - UNPAINTED

## WINDOW, VENT & EXTERIOR DOOR GROUP (CONTINUED)

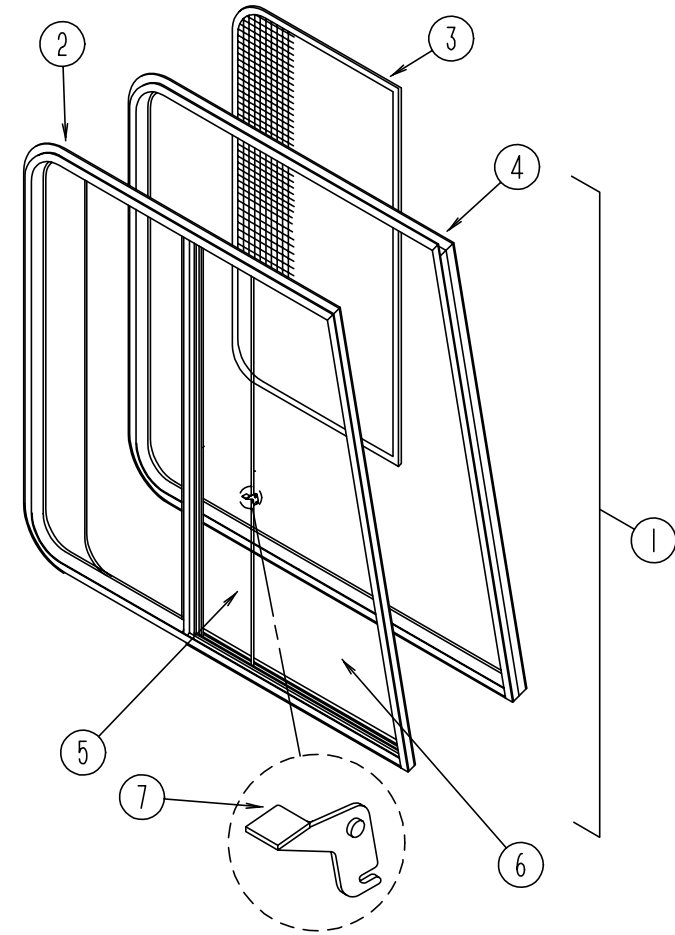

### FRONT CAB WINDOWS (EXCEL)

KEY	PART NUMBER	U/M	DESCRIPTION
1	103658-09-01A	EA	WINDOW ASM. - CAB - W/INSIDE FRAME - DRIVER SIDE H373-ARL
1	103658-10-01A	EA	WINDOW ASM. - CAB - W/INSIDE FRAME - PASSENGER SIDE H373-ARR
2	103658-09-702	EA	WINDOW ASM. - SLIDER - W/O INSIDE FRAME - DRIVER SIDE
2	103658-10-700	EA	WINDOW ASM. - SLIDER - W/O INSIDE FRAME - PASSENGER SIDE
3	103658-09-705	EA	SCREEN ASM. - WINDOW - DRIVER SIDE
3	103658-10-704	EA	SCREEN ASM. - WINDOW - PASSENGER SIDE
	098644-01-717	FT	SCREEN SPLINE
	098644-01-713	EA	SCREEN CLIPS (METAL)(BLACK)
	098644-01-710	FT	TRACK - SPACER - FOR SCREEN 12'
	098644-01-711	FT	WEATHERSTRIP - SCREEN - BLACK
4	103658-09-702	EA	INSIDE FRAME - DRIVER SIDE
4	103658-10-701	EA	INSIDE FRAME - PASSENGER SIDE
5	103658-10-703	EA	GLASS - SLIDING - W/SASH & LATCH - PASSENGER
5	103658-09-704	EA	GLASS - SLIDING - W/SASH & LATCH - DRIVER
6	103658-09-700	EA	GLASS - STATIONARY - BOTTOM - DRIVER OR PASSENGER SIDE
7	098644-01-700	EA	LATCH - REPAIR KIT
	098644-01-708	FT	CHANNEL - PIERCED RUN
	098644-01-706	FT	WEATHERSTRIP - GLASS
	098644-01-716	FT	PLUG - FILLER

**WINDOW, VENT & EXTERIOR DOOR GROUP (CONTINUED)**

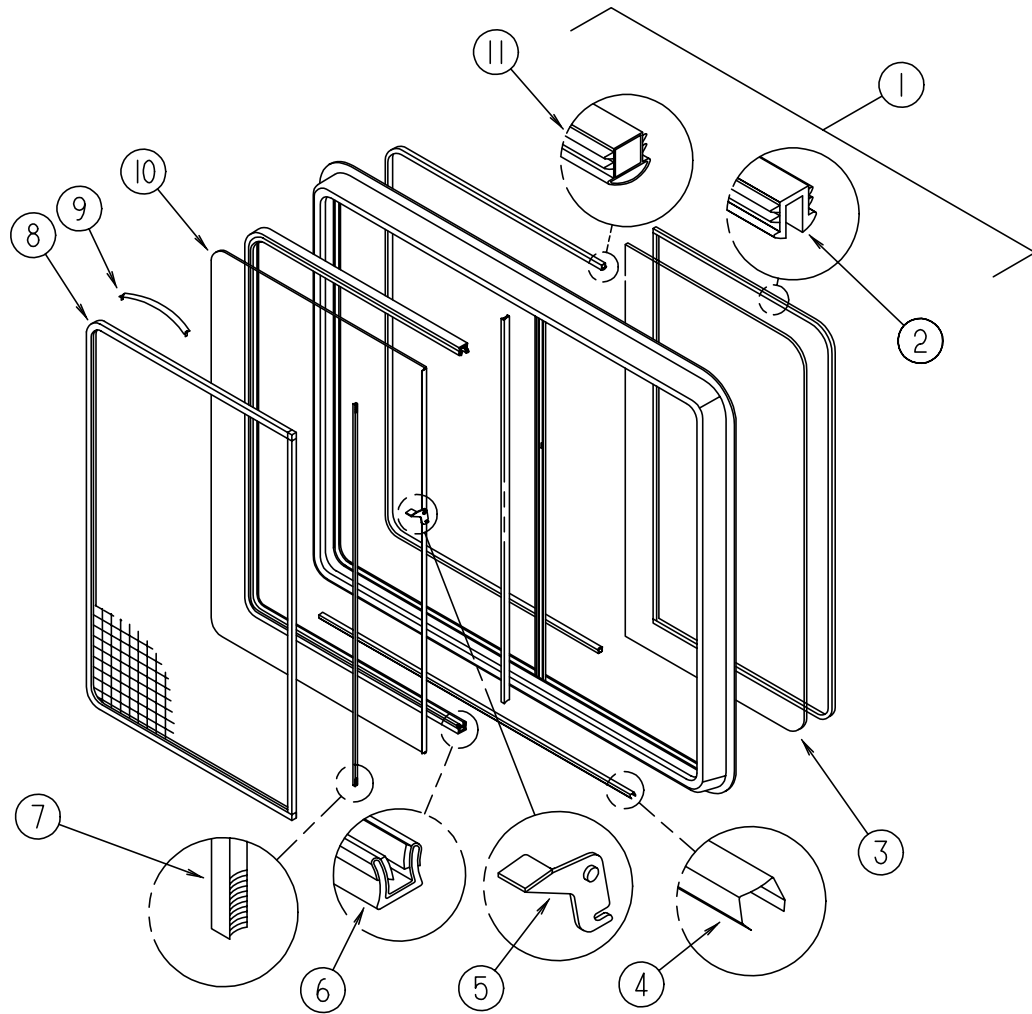

**PASSENGERS SIDE BEDROOM SINGLE SLIDER WINDOW (EXCEL)**

KEY	PART NUMBER	U/M DESCRIPTION	VENDOR NO.
	098647-29-01A	EA WINDOW ASM - SLIDER - W/ INSIDE FRAME (OFF WHITE) 26 3/8" HIGH	
1	098647-29-700	EA WINDOW W/O TRIM	H287-G2L
	098647-29-701	EA TRIM - INSIDE FRAME	W28766
2	098644-01-705	FT GLAZING STRIP	132-010723
3	098647-29-702	EA GLASS-STATIONARY	106-017622
4	098644-01-710	FT TRACK-SPACER, FOR SCREEN 12'	132-017135 EXCEL
5	098644-01-700	EA LATCH REPAIR KIT (BLACK)	B801-CK EXCEL
6	098644-01-708	FT CHANNEL-RUN, PIERCED - GLASS	122-016543 EXCEL
7	098644-01-711	FT WEATHERSTRIP-SCREEN, BLACK	171-016965 EXCEL
8	098647-29-704	EA SCREEN W/SPRING & WEATHERSTRIP	410-019066
9	098644-01-713	EA SCREEN CLIPS (METAL)(BLK)	226-016966 EXCEL
10	098647-29-703	EA GLASS SLIDING,W/SASH & LATCH	H287-G9
11	098644-01-706	FT WEATHERSTRIP-GLASS	171-010668 EXCEL
	098644-01-716	FT PLUG-FILLER	132-014470
	098644-01-717	FT SPLINE-SCREEN MFG	132-004716

**WINDOW, VENT & EXTERIOR DOOR GROUP (CONTINUED)**

**DRIVERS SIDE BEDROOM SINGLE SLIDER WINDOW (EXCEL)**

KEY	PART NUMBER	U/M DESCRIPTION	VENDOR NO.
	098647-30-01A	EA WINDOW ASM - SLIDER - W/ INSIDE FRAME (OFF WHITE) 26 3/8" HIGH	
1	098647-30-700	EA WINDOW W/O TRIM	H287-G2L
	098647-29-701	EA TRIM - INSIDE FRAME	W28766
2	098644-01-705	FT GLAZING STRIP	132-010723
3	098647-29-702	EA GLASS-STATIONARY	106-017622
4	098644-01-710	FT TRACK-SPACER, FOR SCREEN 12'	132-017135 EXCEL
5	098644-01-700	EA LATCH REPAIR KIT (BLACK)	B801-CK EXCEL
6	098644-01-708	FT CHANNEL-RUN, PIERCED - GLASS	122-016543 EXCEL
7	098644-01-711	FT WEATHERSTRIP-SCREEN, BLACK	171-016965 EXCEL
8	098647-29-704	EA SCREEN W/SPRING & WEATHERSTRIP	410-019066
9	098644-01-713	EA SCREEN CLIPS (METAL)(BLK)	226-016966
10	098647-29-703	EA GLASS SLIDING,W/SASH & LATCH	H287-G9
11	098644-01-706	FT WEATHERSTRIP-GLASS	171-010668
	098644-01-716	FT PLUG-FILLER	132-014470
	098644-01-717	FT SPLINE-SCREEN MFG	132-004716

**SLIDER WINDOW (EXCEL)**

KEY	PART NUMBER	U/M DESCRIPTION	VENDOR NO.
	098647-28-01A	EA WINDOW ASM - SLIDER - W/ INSIDE FRAME (OFF WHITE) 26 3/8" HIGH	
1	098647-28-700	EA WINDOW W/O TRIM	H287-G2L
	098647-27-701	EA TRIM - INSIDE FRAME	W28766
2	098644-01-705	FT GLAZING STRIP	132-010723
3	098647-27-703	EA GLASS-STATIONARY	106-017622
4	098644-01-710	FT TRACK-SPACER, FOR SCREEN 12'	132-017135
5	098644-01-700	EA LATCH REPAIR KIT (BLACK)	B801-CK
6	098644-01-708	FT CHANNEL-RUN, PIERCED - GLASS	122-016543
7	098644-01-711	FT WEATHERSTRIP-SCREEN, BLACK	171-016965
8	098647-23-704	EA SCREEN W/SPRING & WEATHERSTRIP	410-019066
9	098644-01-713	EA SCREEN CLIPS (METAL)(BLK)	226-016966
10	098647-27-703	EA GLASS SLIDING,W/SASH & LATCH	H287-G9
11	098644-01-706	FT WEATHERSTRIP-GLASS	171-010668
	098644-01-716	FT PLUG-FILLER	132-014470
	098644-01-717	FT SPLINE-SCREEN MFG	132-004716

**SLIDER WINDOW (EXCEL)**

KEY	PART NUMBER	U/M DESCRIPTION	VENDOR NO.
1	098647-26-01A	EA WINDOW ASM - SLIDER - W/ INSIDE FRAME (OFF WHITE) 26 3/8" HIGH	
2	098644-01-705	FT STRIP-GLAZING	132-010723
3	N/A	EA GLASS-STATIONARY	
4	098644-01-710	FT TRACK-SCREEN SPACER, 12'	132-017135
5	098644-01-700	EA LATCH-REPAIR KIT (BLACK)	B801-CK
6	098644-01-708	FT CHANNEL-RUN, PIERCED	122-016543
7	098644-01-711	FT WEATHERSTRIP-SCREEN, BLACK	171-016965
8	098647-36-704	EA SCREEN ASM., W/SPRING CLIP	410-017750
9	098644-01-713	EA CLIP-SPRING, BLACK PLASTIC	226-016966
10	N/A	EA GLASS SLIDING,W/SASH & LATCH	
11	098644-01-706	FT WEATHERSTRIP-GLASS	171-010668
	098644-01-716	FT PLUG-FILLER	132-014470
	098644-01-717	FT SPLINE-SCREEN	132-004716

**WINDOW, VENT & EXTERIOR DOOR GROUP (CONTINUED)**

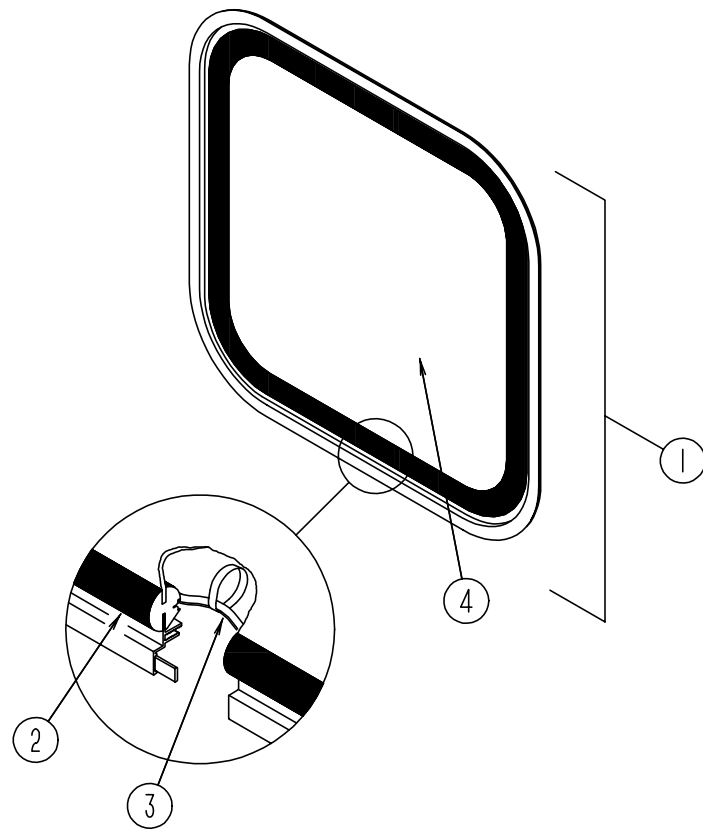

**ESCAPE WINDOW  
USED WITH QUEEN BED / TWIN BED**

KEY	PART NUMBER	U/M DESCRIPTION
	074816-11-000	EA INSIDE FRAME- WINDOW - OFF WHITE
1	078528-07-FB1	EA WINDOW-ESCAPE - W/O INSIDE FRAME
2	002282-09-000	EA WEATHERSTRIP-.125" X 133.25" - BLACK
3	002285-01-000	FT FILLER-WEATHER STRIP - RUBBER - BLACK
4	076337 13 000	EA GLASS-EGRESS 1157 X 548
	102922-01-000	EA TAPE ASM-ESCAPE WINDOW - RED

**ESCAPE WINDOW  
USED WITH DOUBLE BED / BUNK BEDS**

KEY	PART NUMBER	U/M DESCRIPTION	VENDOR NO.
	116976-01-01A	EA WINDOW ASM-REAR ESCAPE SINGLE	
	100322-01-701	FT SEAL-VENT	122-016071
	112898-06-704	EA HANDLE-LATCH, RED-RH	182-11293
	112898-06-705	EA HANDLE-LATCH, RED-LH	182-11294
	116976-01-700	EA GLASS	096-018786
	116976-01-701	EA TRIM	W38653
	116976-01-702	FT FILLER PLUG	132-016065

**WINDOW, VENT & EXTERIOR DOOR GROUP (CONTINUED)**

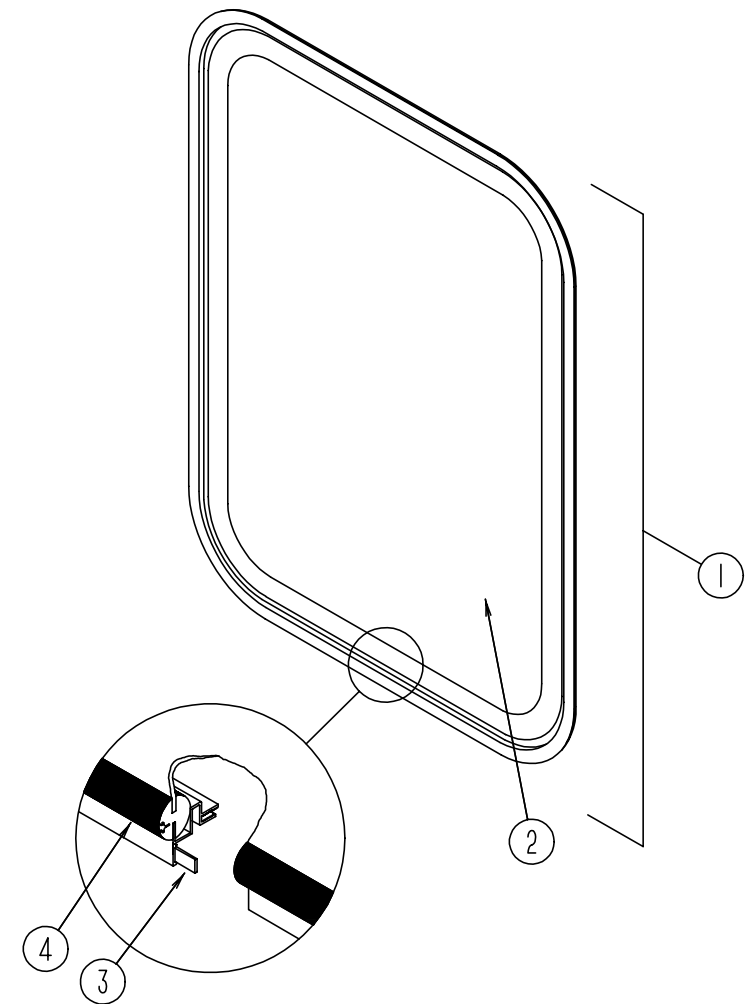

**ENTRY DOOR WINDOW**

KEY	PART NUMBER	U/M DESCRIPTION
	117055-02-01A	EA FRAME-WINDOW - ENTRY DOOR - BLACK
1	117053-04-FB1	EA WINDOW-ENTRANCE DOOR - GLASS
2	002181-27-000	EA GLASS-WINDOW, PICTURE 655 X 417 CLEAR 90%
3	069640-03-000	FT SEALER-TAPE, 3/4" X 1/8" -BLACK
4	087561-01-000	FT SEAL-GLASS - EXTERIOR - .5" WIDE - VINYL - BLACK

## WINDSHIELD & WIPER GROUP

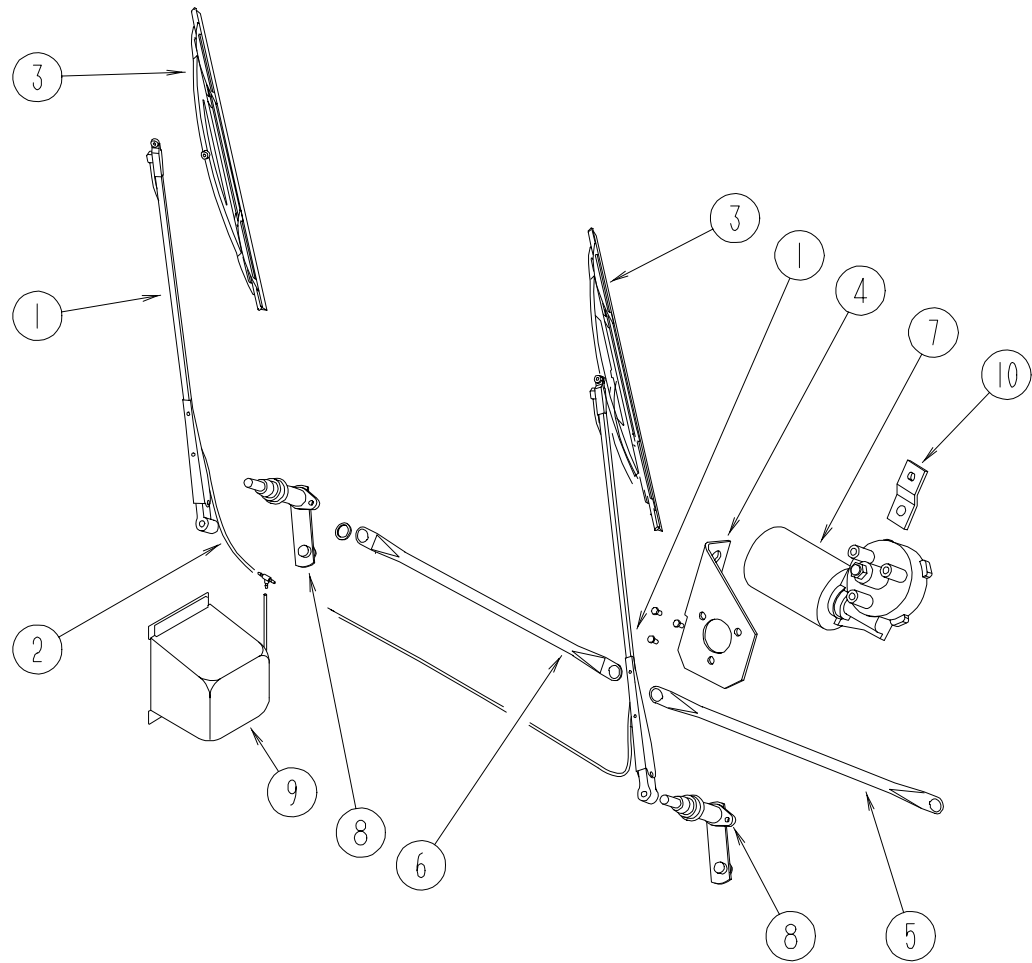

WIPER COMPONENTS

KEY	PART NUMBER	U/M DESCRIPTION
1	103671-01-000	EA ARM-WIPER - 24" - UT 52179-20LE27WC
2	096931-01-700	FT HOSE-WIPER - TO BLADE
	096931-01-701	EA NOZZLE-HARDWARE KIT - INCLUDES NOZZLE,NUT,SCREWS AND PLASTIC CAP
	110742-01-000	EA GASKET-WIPER
3	095964-01-000	EA BLADE-WIPER - WINDSHIELD - 24"
	095964-01-700	EA BLADE-REFILL 24" (PAIR) - 12360
4	104549-01-000	EA BRACKET ASM-WIPER
	096526-01-000	EA SCREW-HEX - 1/4 - 28
5	117008-01-000	EA LINK ASM.- WIPER CONNECTING - DRIVERS SIDE
6	117008-02-000	EA LINK ASM. - WIPER CONNECTING - PASSENGER
7	104346-02-000	EA WIPER MOTOR -"COAST TO PARK - USE ON 1994 & UP CHEV. CHASSIS NOTE: THIS PART CHANGES TO #10434604000 F/1996 MODELS FROM: 00-00-00 THRU: 11-19-95
7	104346-04-000	EA MOTOR-WIPER W/INT. BREAKER - UT 65714M02025WJ FROM: 11-20-95 THRU: 99-99-99
	117322-01-000	EA SCREW-1/4-28UNF-2A,TORX - U.T. 6270020 SC25WJ USED TO ATTACH WIPER MOTOR TO MOUNTING PLATE
8	096505-07-000	EA PIVOT SHAFT ASM - PASSENGER - 62901-20-SH25WJ
8	096505-08-000	EA PIVOT SHAFT ASM - DRIVER SIDE - 62900-20-SH25WJ
9	117766-02-000	EA RESERVOIR/PUMP ASM - MCCORD 600328
10	104347-01-000	EA ARM-DRIVE - WIPER MOTOR - 1.54" - 62543-20-LE25WJ
	110178-01-000	EA HOUSING-WIPER MOTOR - UT6237440-EC25WJ
	067188-01-000	EA STUD-CRANK - WIPER - WINDSHIELD - AMBAC 1903424SD27WC
	061603-01-000	EA GROMMET-SNAP - 3/16" ID - 3/8" HOLE - HEYCO SB-375-3
	045794-01-000	FT HOSE-WASHER, WINDSHIELD - 5/32" ID - BLACK

## WINDSHIELD & WIPER GROUP (CONTINUED)

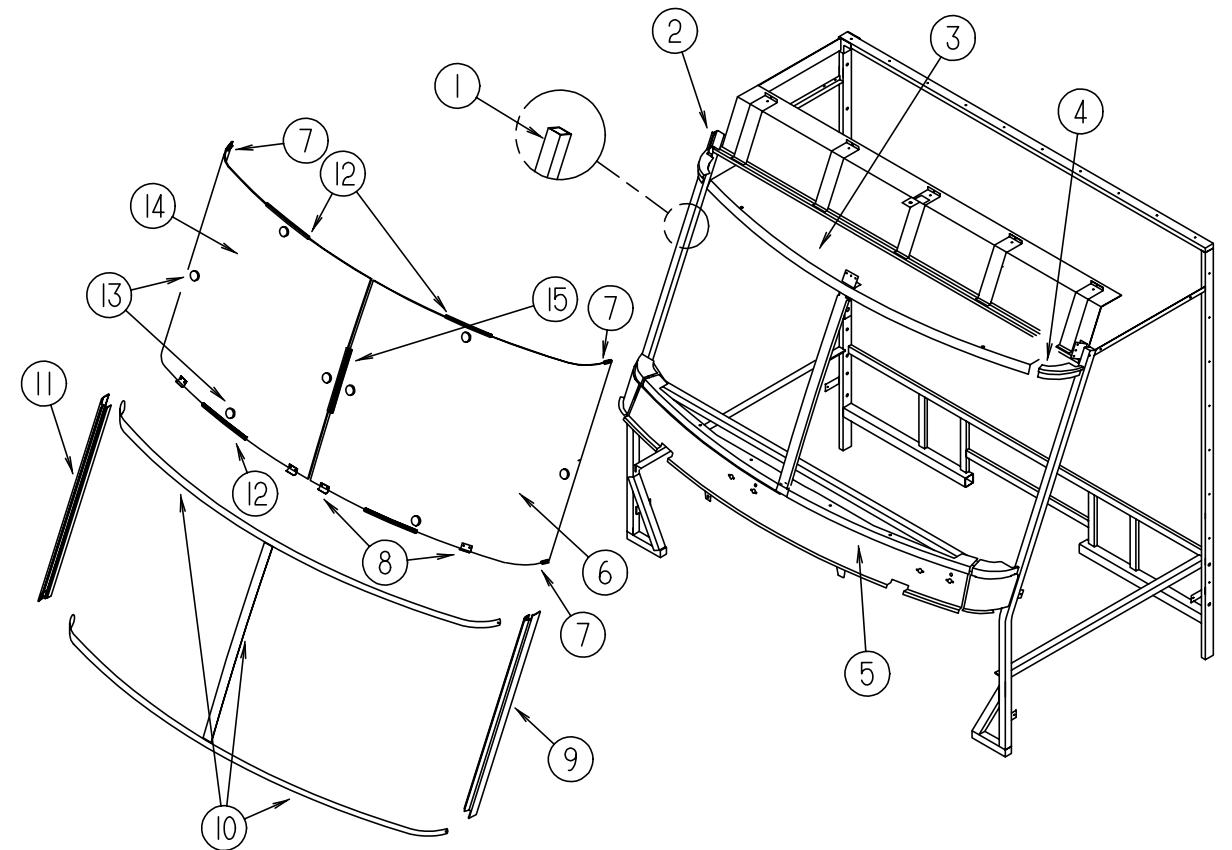

WINDSHIELD MOLDINGS & GLASS

KEY	PART NUMBER	U/M DESCRIPTION
1	098788-02-000	EA CHANNEL-RIGID
2	077922-03-000	EA HEADER-WINDSHIELD - RIGHT END
3	077922-05-000	EA HEADER-WINDSHIELD - CENTER
4	077922-04-000	EA HEADER-WINDSHIELD - LEFT END
5	077847-02-000	EA SUPPORT-WINDSHIELD - LOWER - W/O BRACKETS
6	088793-04-000	EA GLASS-WINDSHIELD - DRIVER
7	110268-01-000	EA WINDSHIELD CARRIER - 50.4"
8	104449-01-000	EA SUPPORT-WINDSHIELD
9	103107-02-01A	EA TRIM-WINDSHIELD - SIDE BLACK
10	102936-01-000	FT MOLDING-REVEAL - WINDSHIELD
11	103107-01-01A	EA TRIM-WINDSHIELD - SIDE BLK
12	110268-01-000	EA WINDSHIELD CARRIER - 50.40"
13	081914-01-000	EA BUMPER-RUBBER - ROUND - .43" DIAMETER - BLACK
14	088793-03-000	EA GLASS-WINDSHIELD - PASSENGER
15	110268-01-000	EA WINDSHIELD CARRIER - 50.40"