

**1996**  
**IF431WQ**

**G24**  
**HARBOUR**

**G25**  
**SAND DOLLAR**

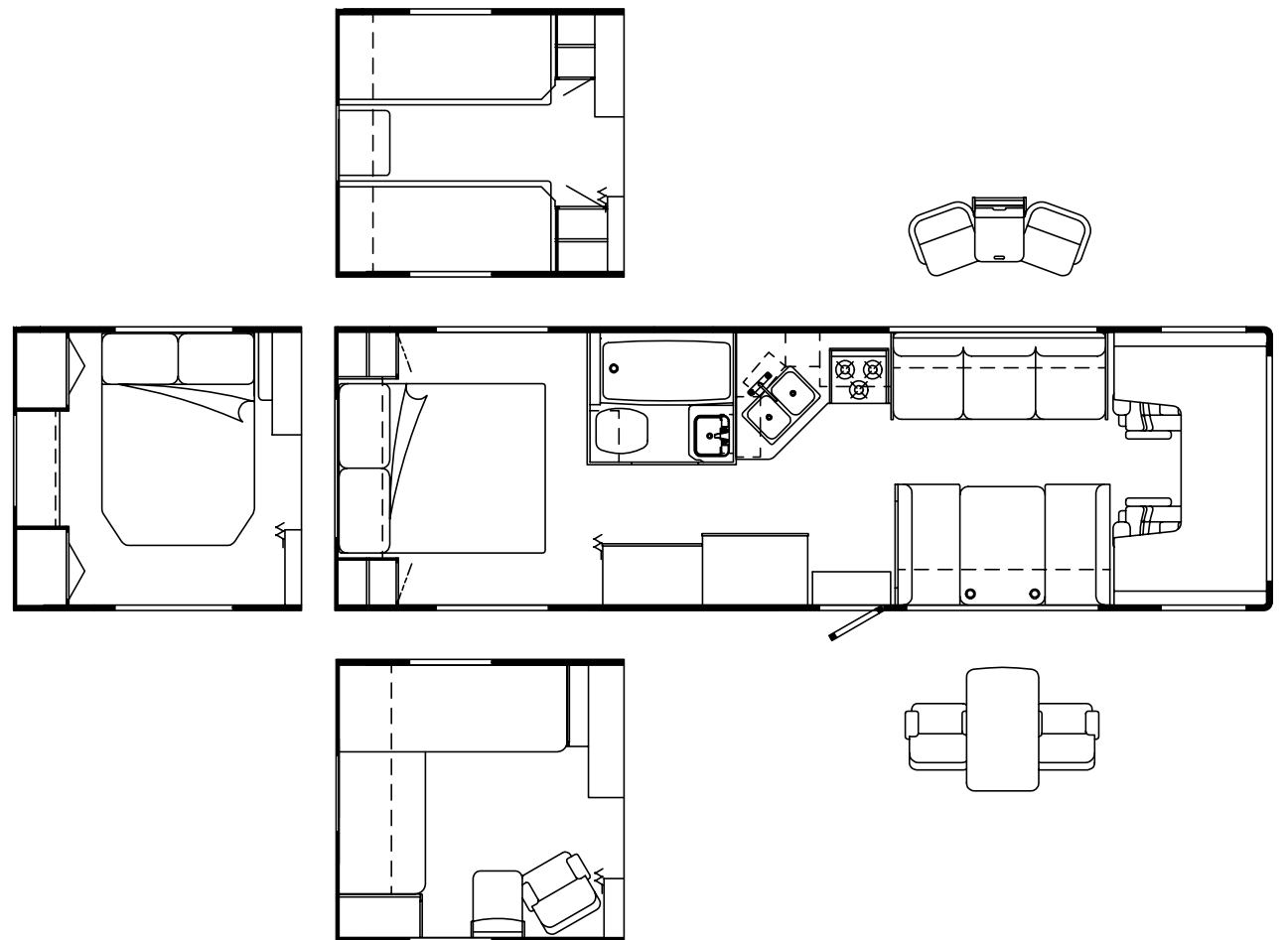

## ACCESSORIES GROUP

### OPERATORS MANUAL

KEY	PART NUMBER	U/M	DESCRIPTION
	054185-E5-000	EA	MANUAL-OPERATOR - 96 SUNDANCER - 400 SERIES
	092318-01-000	EA	BINDER - 3 RING - MOTOR HOME MANUAL
	092319-01-000	EA	PAGE-POCKET - 3 RING BINDER - PLASTIC
	117936-01-000	DW	TOP LEVEL DRAWING - 1996 C-BODY

## AUDIO VIDEO GROUP

### RADIO SYSTEM & ANTENNA

KEY	PART NUMBER	U/M	DESCRIPTION
			N/A
	111177-01-01A	EA	SPEAKER - 5" X 7" OVAL - FORD F2UF-18814-CD
	087683-03-000	EA	GRILLE-SPEAKER-OVAL 5" X 7" GRAY - MAGNADYNE SB68
	090944-01-000	EA	RADIO-AM/FM STEREO CASSETTE - AUDIOVOX RS-100
	077069-02-000	EA	ANTENNA-RADIO - 16" RUBBER
	108137-01-000	EA	CABLE-ANTENNA - RADIO - EXTENSION 96" - ARA 6700667
	108847-01-000	EA	PLUG-ANTENNA HOLE - WARD PRODUCTS
	109889-01-000	EA	BRACKET-ANTENNA GROUND
	110469-01-000	EA	ANTENNA-SHAFT EXTENDER 1" - MAGNADYNE RV71EX1
	110470-01-01A	EA	SPEAKER - 4" X 6" OVAL - COAXIAL - MAGNADYNE F46XB-12
		EA	GRILLE-SPEAKER - OVAL 4" X 6" - BLACK - MAGNADYNE G46WI

### TV & VCR SYSTEMS

KEY	PART NUMBER	U/M	DESCRIPTION	VENDOR NO.
	113684-01-000	EA	TELEVISION-19" COLOR - 19 3/8"W X 17 3/8"H X 18 1/4"D	
			FROM: 00-00-00 THRU: 06-09-96	
	113684-01-700	EA	REMOTE	8822345
			FROM: 00-00-00 THRU: 06-16-96	
	113684-02-000	EA	TV-19"COLOR UL/CSA 1/8" JACK - AUDIOVOX AVT-1980	
			FROM: 06-10-96 THRU: 99-99-99	
	113684-02-700	EA	REMOTE	0892355
			FROM: 06-17-96 THRU: 99-99-99	
	119120-02-000	EA	VCR-VHS - CABLE READY - REMOTE - AUDIOVOX AVR-1170	
	119120-02-700	EA	REMOTE	0994569
	082134-01-000	EA	ADAPTER-TV - CABLE TO CABLE - WINEGARD F-81M	
	082136-01-000	EA	NUT-HEX JAM 3/8-32 - WINEGARD	
	076319-09-000	EA	WALLPLATE-CABLE RECEPTACLE - TV - SINGLE - BROWN	
	076319-08-000	EA	WALLPLATE-CABLE RECEPTACLE - TV - SINGLE - IVORY	
	086777-02-000	EA	WALLPLATE-TV CABLE - W/ANTENNA SWITCH - BROWN	
	086777-06-000	EA	WALLPLATE-TV CABLE - 1 OUTPUT - BROWN - WINEGARD RV-0931	
	086756-01-000	EA	SPLITTER-TV - 2 WAY	
	086757-03-000	EA	CONTROL CENTER-SWITCH - VCR/TV - MAGNADYNE VCS-6	
	093901-03-000	EA	PLATE-COAXIAL CABLE	
	099717-02-000	EA	STRAP-TV TIE DOWN W/29.9" FEMALE STRAP & 14.2" MALE STRAP	

## AUDIO VIDEO GROUP (CONTINUED)

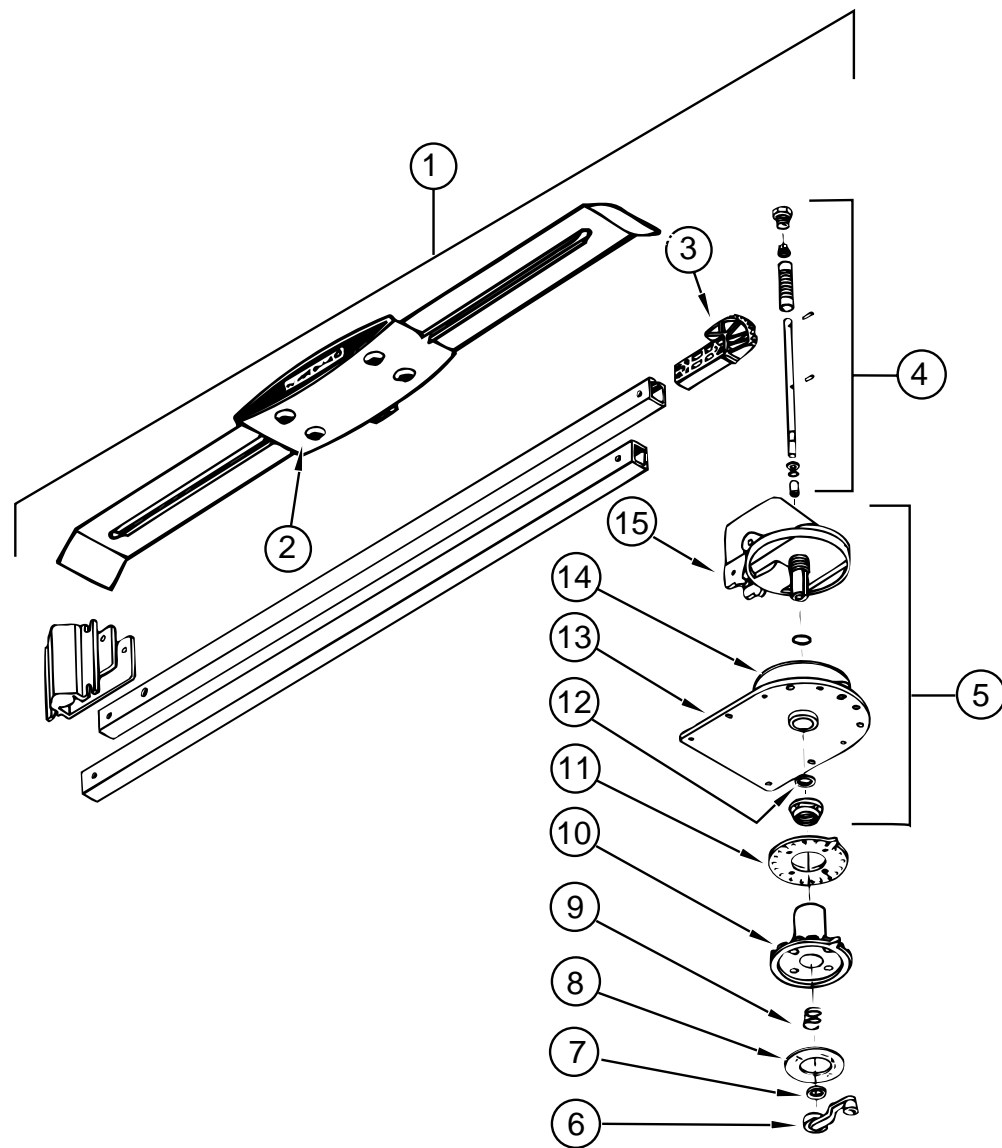

TV ANTENNA - WINEGARD - MODEL RVA W02

KEY	PART NUMBER	U/M	DESCRIPTION	VENDOR NO.
1	076319-01-000	EA	ANTENNA-TV, ROOF MOUNT - 44.5" MAST - RVA W02	
1	076319-18-000	EA	ANTENNA-TV ROOF MOUNTED	
2	076319-01-700	EA	HEAD-ANTENNA, AMPLIFIED	RVSA U/V
3	076319-01-701	EA	GEAR-ELEVATING, PLASTIC	2200046
4	076319-01-702	EA	SHAFT ASM-ELEVATING	RVP-400A
5	076319-01-711	EA	BASE & LIFT ASM	2762802
6	076319-01-706	EA	CRANK-ELEVATING, W/SET SCREW UNIVERSAL	2750897
7	076319-01-705	EA	GROMMET-NYLON, 7/8"ID	3200658
8	076319-01-708	EA	DECAL-CRANK	5413002
9	076319-01-707	EA	SPRING, HANDLE	5160822
10	076319-01-709	EA	PLATE-DIRECTIONAL F/HEAD	3200621
11	076319-01-712	EA	PLATE-CEILING, DIRECTIONAL	3200608
12	076319-01-704	EA	BEARING-NYLON, 1.25"OD	3200657
13	076319-01-713	EA	PLATE-BASE, STEEL	3100523
14	076319-01-703	EA	BEARING-NYLON, 5" OD	3200656
15	076319-01-714	EA	HOUSING, ROTATING GEAR	2200049
	076319-01-715	EA	NUT (GEAR HOUSING)	2200047
	076319-03-000	FT	CABLE-COAXIAL, 75 OHM	
	076319-12-000	EA	CONNECTOR-COAXIAL, ONE PIECE	

## BATH GROUP

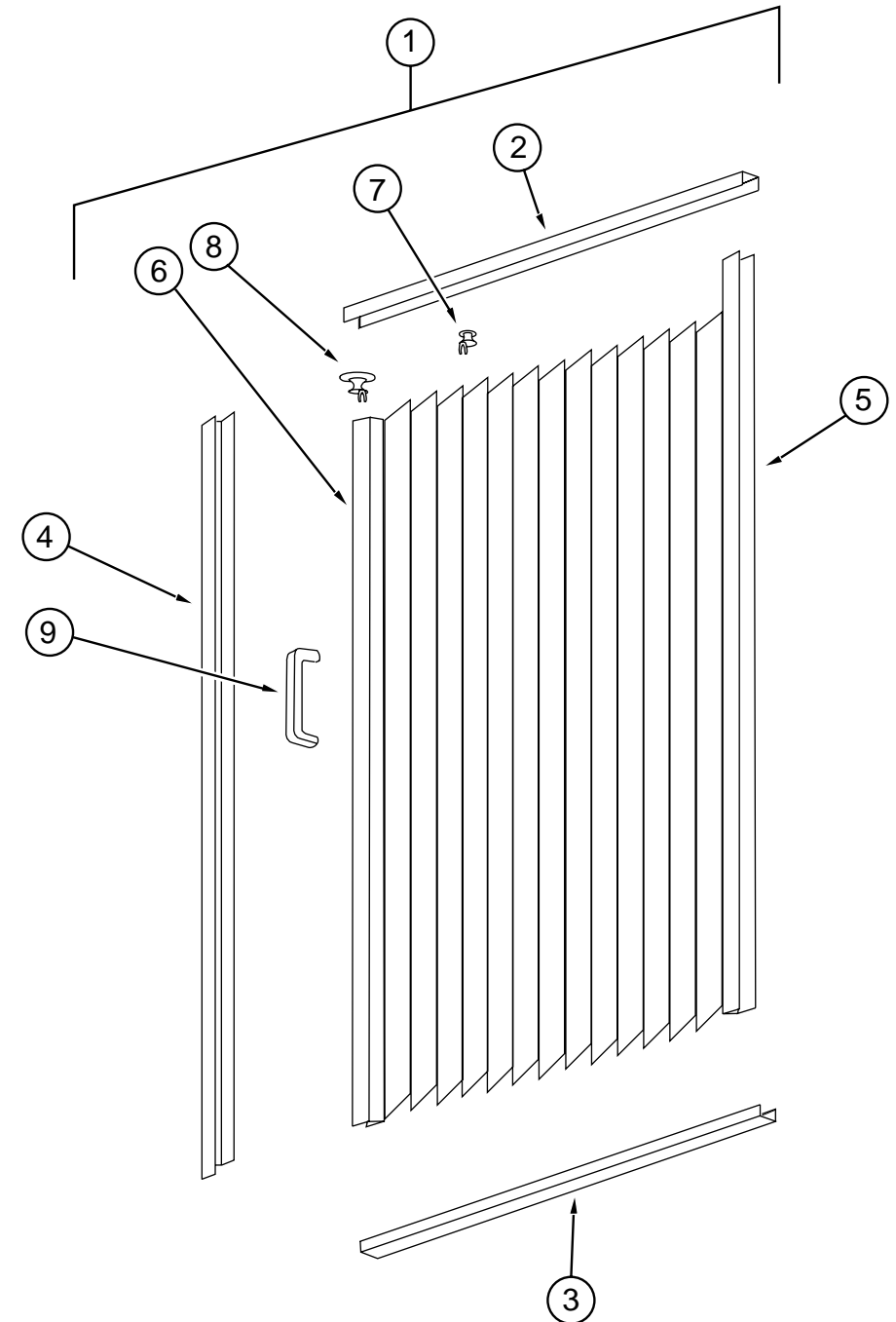

SHOWER DOOR

KEY	PART NUMBER	U/M	DESCRIPTION
1	117431-05-01A	EA	DOOR-SHOWER,FABRIC,PLEATED - 46.9X59.3
2	117431-01-700	EA	TRACK-TOP, ALUM.IVORY INSERT
3	117431-01-701	EA	TRACK-BOTTOM, 40 "
4	117431-01-702	EA	RAIL-SIDE, 67"
5	117431-01-703	EA	RAIL-STATIONARY, 67"
6	117431-01-704	EA	RAIL-LEAD, 67"
7	117431-01-705	EA	GLIDE-IVORY, TRAVELER
8	117431-01-706	EA	GLIDE-IVORY LEAD, TRAVELER
9	117431-01-708	EA	HANDLES & SCREWS
	117431-01-707	EA	LATCH
	117431-01-709	EA	STRAP-VINYL SHOWER
	105394-01-05A	EA	EXTR-DOOR JAMB

**BATH GROUP (CONTINUED)**

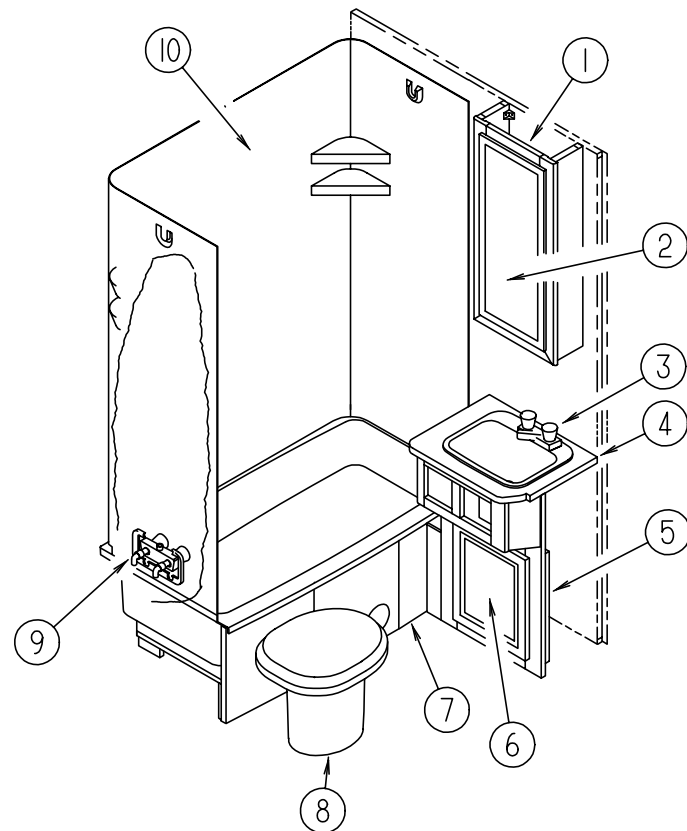

**BATHROOM CABINETS & FIXTURES**

KEY	PART NUMBER	U/M	DESCRIPTION	VENDOR NO.
1	114744-01-G04	EA	CABINET ASM - MEDICINE - W/O DOORS/HARDWARE	
	114744-11-G04	EA	SHELF ASM	
2	110140-64-G01	EA	DOOR - MITERED CORNER/VINYL WRAP - 12" X 29.1" W/O HDW	
3	075240-06-000	EA	FAUCET-LAVATORY - BONE	
3	096927-01-01A	EA	SINK-LAVATORY - RECTANGULAR - PLASTIC - BONE	
	096927-01-700	EA	SINK-STOPPER	M9801
	096927-01-701	EA	TAILPIECE-SINK	M9802
	121282-12-G24	EA	COUNTERTOP - LAVATORY	
4	121282-12-G25	EA	COUNTERTOP - LAVATORY	
5	121282-01-G24	EA	CABINET - LAVATORY - W/O DOORS/DRAWERS/HARDWARE	
5	121282-01-G25	EA	CABINET - LAVATORY - W/O DOORS/DRAWERS/HARDWARE	
6	110140-12-G04	EA	DOOR ASM-MITERED,VINYL WRAP	
7	121389-01-G24	EA	CABINET ASM-TUB/SURROUND	
7	121389-01-G25	EA	CABINET ASM-TUB/SURROUND	
8	063740-01-000	EA	TOILET-HIGH, HAND FLUSH - THETFORD 150120	
	121325-01-G04	EA	CABINET ASM-LINEN	
9	110140-92-G04	EA	DOOR ASM-MITERED,VINYL WRAP	
	075242-04-000	EA	FAUCET-TUB/SHOWER, BONE	
10	066729-01-000	EA	STRAINER-TUB/SHOWER - W/PLUG	
	103092-01-000	EA	HEAD-SHOWER - W/60" HOSE	
	103092-02-000	EA	SHOWER HEAD-W/HOSE - CSA	
	103092-01-700	EA	BRACKET ONLY-CLEAR - F/SHOWER HEAD	2328028
	011048-03-700	EA	BRACKET/F SHOWER HEAD	2328029-3
	075606-01-000	EA	PANEL-FAUCET BACK - SHOWER - 5" X 9" - PLASTIC	
	110541-03-01A	EA	SURROUND-SHOWER/TUB W/MOLDED ROD BRACKET	
	102075-10-01A	EA	ROD-CURTAIN - SHOWER - OFF WHITE	
	085278-01-000	EA	HOLDER-TOILET PAPER - RECESSED - BRASS	
	080507-01-000	EA	PANEL-SKYLIGHT OUTER - PLEXIGLASS - 23.25" X 20.3"	
080508-01-000	EA	PANEL-SKYLIGHT, INNER - PLEXIGLASS - 23.25" X 20.3"		
075241-05-000	EA	FAUCET-SHOWER, BONE W/ 3/4" MPT X 1.4" LONG INLET PIPES		

**BATH GROUP (CONTINUED)**

**BATH DOOR**

KEY	PART NUMBER	U/M	DESCRIPTION
	121449-01-G04	EA	DOOR ASM-BATH
	110496-01-01A	EA	HINGE-BRASS
	102920-01-01A	EA	HINGE-DOOR - SPRING LOADED - BRASS
	094485-03-01A	EA	KNOB-DOOR - BRASS - THUNADER L132PB
	121449-12-G04	EA	RACK ASM
	100357-01-000	EA	ROD-TOWEL - BRASS W/ENDS BENT FOR BACK OF BATH DOOR

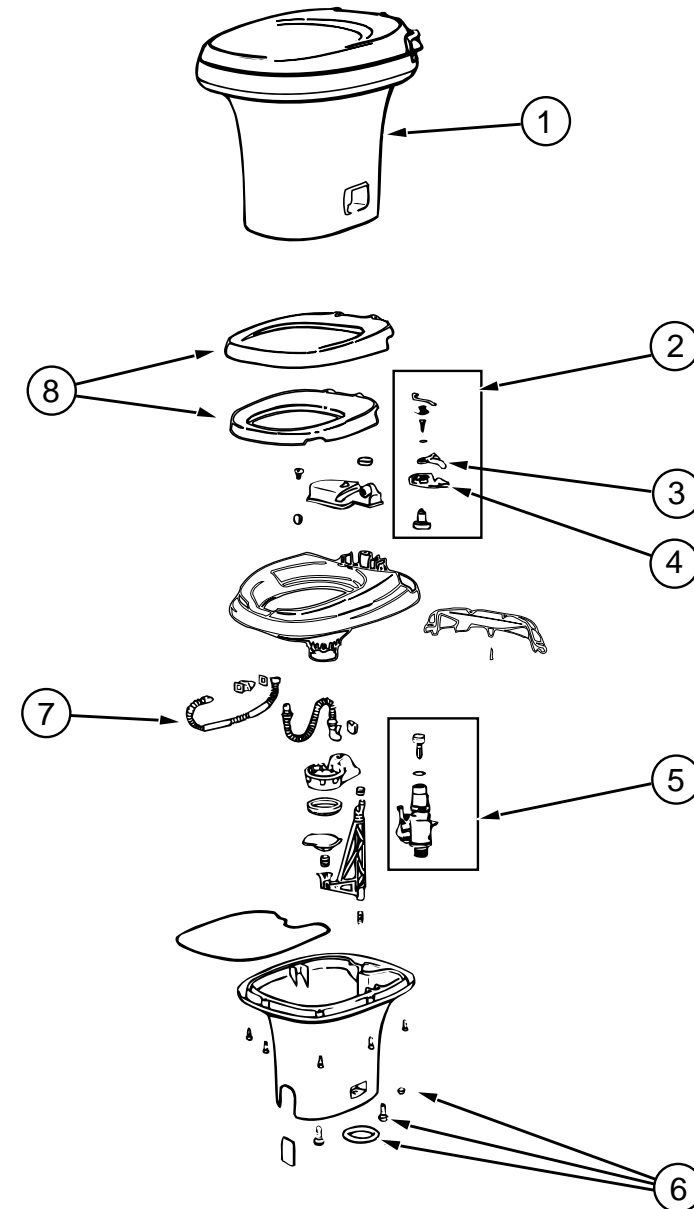

**AQUA MAGIC IV LOW TOILET - THETFORD**

KEY	PART NUMBER	U/M	DESCRIPTION	VENDOR NO.
1	063740-01-000	EA	TOILET-HIGH - HAND FLUSH - THETFORD 150120	
2	063740-01-720	EA	LEVER KIT - WAT-FLUSH-BEARING	24629
3	063740-01-700	EA	LEVER-WATER	12514
4	063740-01-701	EA	LEVER-FLUSH	12515
5	063740-01-714	EA	VALVE ASM. - W/GASKET & FLOAT	13168
6	063740-01-706	EA	BOLT PACKAGE-FLOOR FLANGE	12524
7	063740-01-717	EA	TUBE-FLUSH	12509
8	063740-02-700	EA	SEAT & COVER, PARCHMENT	2464157
	063740-01-721	EA	BLADE ONLY	124832

## BEDROOM GROUP

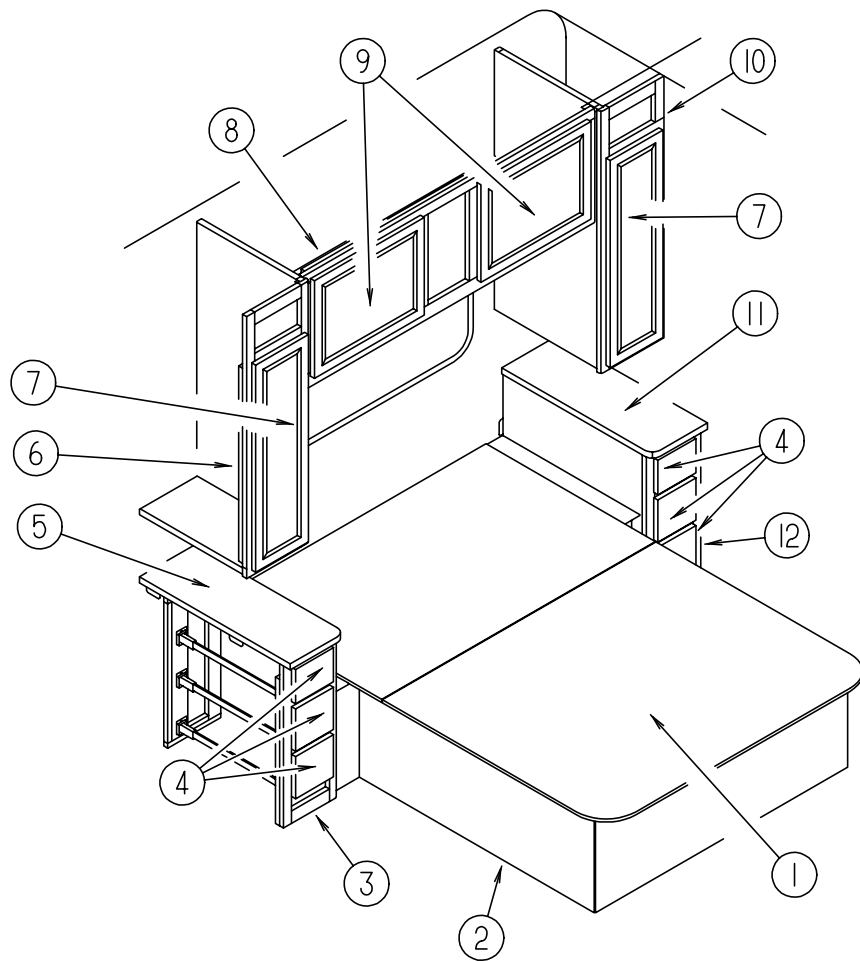

**CENTER QUEEN BEDROOM**

KEY	PART NUMBER	U/M	DESCRIPTION
1	M07550-02-000	EA	QUEEN BED TOP - W/O HARDWARE
	084413-01-000	EA	HINGE-CONTINUOUS, ALUMINUM - 1" X 72" - W/HOLES
	091261-01-000	FT	SLIPNOT-ANTISLIP, 1' WIDE (100' ROLL)
	107796-05-000	EA	BRACKET-GAS SPRING,FLAT - SPDI SPD-1020
	107796-06-000	EA	SPRING-GAS 20" LENGTH,120 LB SPDI SPD-2300-120
	107796-07-000	EA	BRACKET-GAS SPRING - SPDI SPD-1080
	097872-04-000	EA	DOWEL-WOOD,1.00DIA X 1.38LG *UNFINISHED
	091952-01-000	EA	CLIP-GRIPPER - 1"
2	P18430-04-G04	EA	CABINET ASM-QUEEN BED
3	P21159-01-G24	EA	CABINET - NIGHTSTAND - RIGHT HAND - W/O DOORS/DRAWERS/HDW
3	P21159-01-G25	EA	CABINET - NIGHTSTAND - RIGHT HAND - W/O DOORS/DRAWERS/HDW
4	M05970-11-G04	EA	DRAWER COMPL-SLIDE RAD
5	121159-11-G24	EA	COUNTERTOP NIGHTSTAND
5	121159-11-G25	EA	COUNTERTOP NIGHTSTAND
6	121108-01-G04	EA	CABINET ASM-OVHD,CL,SHIRT RH
7	110140-86-G04	EA	DOOR ASM-MITERED,VINYL WRAP
8	121165-01-G04	EA	CABINET ASM-OVERHEAD,REAR
9	110140-18-G01	EA	DOOR - MITERED CORNER/VINYL WRAP - 15.7" X 27.9" - W/O HDW
9	110140-21-G01	EA	DOOR-W/MIRROR-MTRD CRNR/OGEE EDGE - 15.7" X 27.9" W/O HDW
10	121112-01-G04	EA	CABINET ASM-OVHD,CL,SHIRT,LH
11	121158-11-G24	EA	COUNTERTOP - NIGHTSTAND - W/EDGE BAND
11	121158-11-G25	EA	COUNTERTOP - NIGHTSTAND - W/EDGE BAND
12	P21158-01-G24	EA	CABINET - NIGHTSTAND - LEFT HAND - W/O DOORS/DRAWERS/HDW
12	P21158-01-G25	EA	CABINET - NIGHTSTAND - LEFT HAND - W/O DOORS/DRAWERS/HDW

## BEDROOM GROUP (CONTINUED)

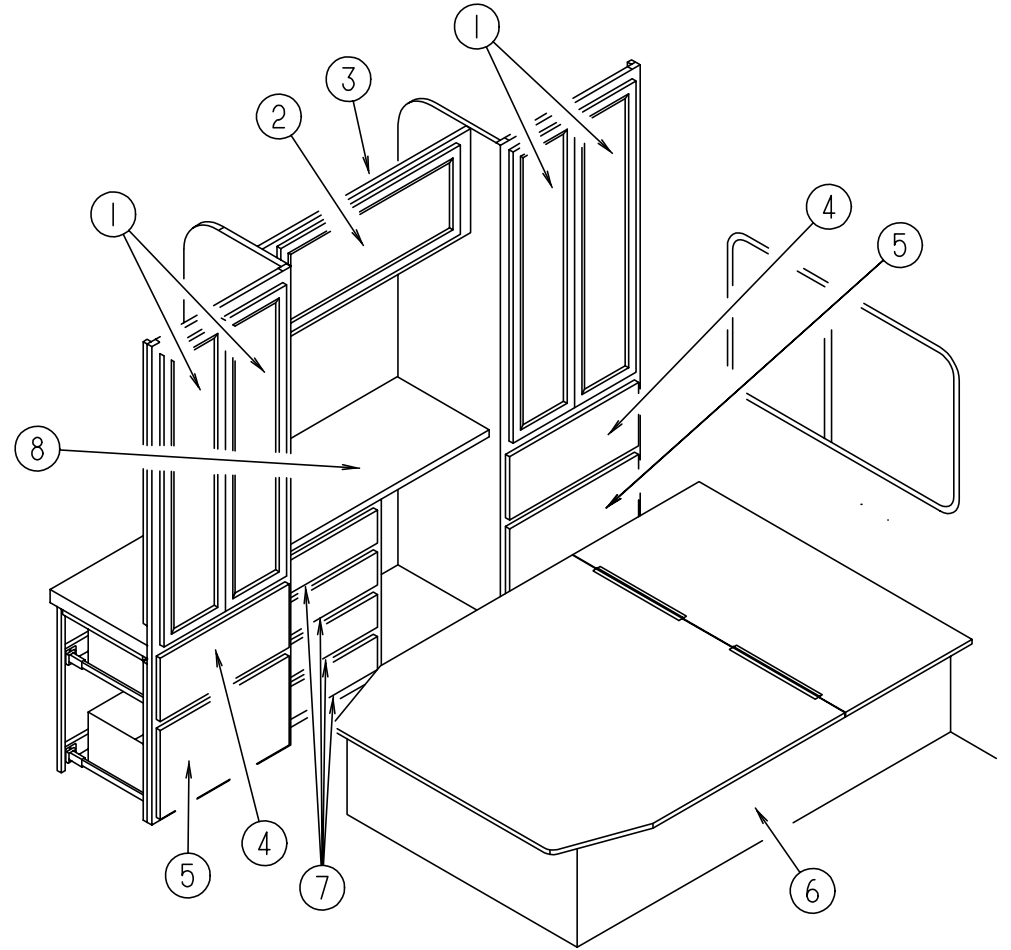

**DOUBLE BED & WARDROBE CABINETRY**

KEY	PART NUMBER	U/M	DESCRIPTION
1	110140-23-G01	EA	DOOR - MIRROR/MTRD CRNR/VINYL WRAP - 12" X 48" - W/O HDW
2	110140-65-G01	EA	DOOR - MIRROR/MTRD CORNER/VINYL WRAP - 14.3" X 33.4" W/O HDW
2	110140-05-G01	EA	DOOR - MITERED CORNER/VINYL WRAP - 14.3" X 33.4" W/O HDW
3	118677-01-G05	EA	CABINET - REAR OVERHEAD - W/O DOORS/HARDWARE(G24)
3	118677-01-G25	EA	CABINET - REAR OVERHEAD - W/O DOORS/HARDWARE(G25)
4	M05970-T3-G04	EA	DRAWER COMPL-SLIDE RAD
5	M05970-T4-G04	EA	DRAWER COMPL-SLIDE RAD
6	P19644-02-G04	EA	CABINET ASM- DOUBLE BED
	093550-01-000	EA	BRACKET-HINGE, MOUNTS TO LEG & TABLE TOP - 1.7" X 2.6"
	084413-01-000	EA	HINGE-CONTINUOUS, ALUMINUM - 1" X 72" - W/HOLES
	091261-01-000	FT	SLIPNOT-ANTISLIP, 1' WIDE (100' ROLL)
	107796-05-000	EA	BRACKET-GAS SPRING,FLAT - SPDI SPD-1020
	107796-06-000	EA	SPRING-GAS 20" LENGTH,120 LB SPDI SPD-2300-120
	107796-07-000	EA	BRACKET-GAS SPRING - SPDI SPD-1080
	097872-04-000	EA	DOWEL-WOOD,1.00DIA X 1.38LG *UNFINISHED
	091952-01-000	EA	CLIP-GRIPPER - 1"
7	M05970-T5-G04	EA	DRAWER COMPL-SLIDE RAD
8	118676-11-G24	EA	COUNTERTOP - VANITY
8	118676-11-G25	EA	COUNTERTOP - VANITY
	P18676-01-G24	EA	CABINET - VANITY - W/O DOORS/DRAWERS/HARDWARE
	P18676-01-G25	EA	CABINET - VANITY - W/O DOORS/DRAWERS/HARDWARE

### BEDROOM GROUP (CONTINUED)

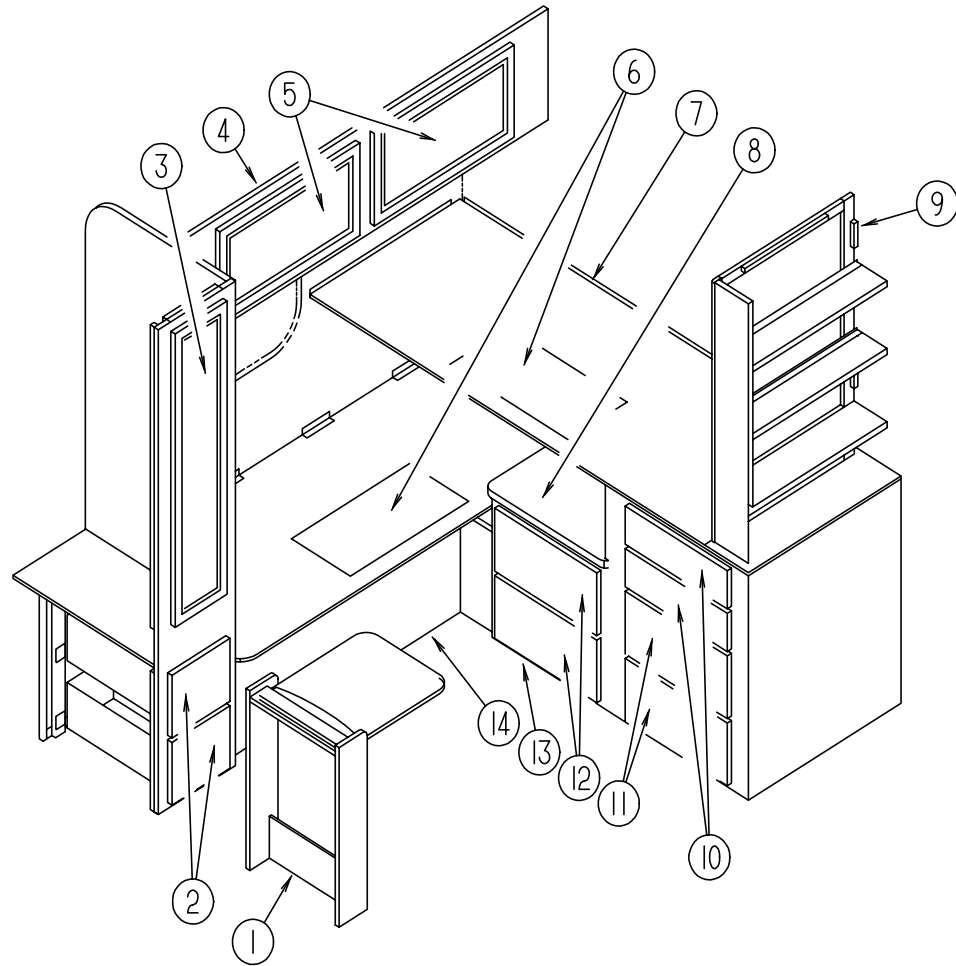

### CROSSED STACKED TWIN BEDS

KEY	PART NUMBER	U/M	DESCRIPTION
1	M96873-01-G01	EA	CABINET - PULLOUT TABLE
2	M05970-Y6-G04	EA	DRAWER COMPL-SLIDE RAD
3	110140-23-G01	EA	DOOR - W/MIRROR - MTRD CRNR/VINYL WRAP-6.7" X 29.5"W/O HDW
4	121603-01-G04	EA	CABINET ASM-OVHD,REAR
5	110140-18-G01	EA	DOOR - MITERED CORNER/VINYL WRAP - 15.7" X 27.9" - W/O HDW
5	110140-21-G01	EA	DOOR-W/MIRROR-MTRD CRNR/OGEE EDGE - 15.7" X 27.9" W/O HDW
6	091261-01-000	EA	BACKING-NON-SKID - 12" X 180'
7	117066-03-G24	EA	FRAME ASM-FABRIC,CROSS BUNK
7	117066-03-G25	EA	FRAME ASM-FABRIC,CROSS BUNK
8	120951-11-G24	EA	COUNTERTOP ASM
8	120951-11-G25	EA	COUNTERTOP ASM
9	120965-01-G04	EA	CABINET ASM-SHELF
10	M05970-X8-G04	EA	DRAWER COMPL-SLIDE RAD
11	M05970-X5-G04	EA	DRAWER COMPL-SLIDE RAD
12	M05970-X6-G04	EA	DRAWER COMPL-SLIDE RAD
13	P20951-01-G24	EA	CABINET - DRESSER - LEFT HAND - W/O DOORS/DRAWERS/HARDWARE
13	P20951-01-G25	EA	CABINET - DRESSER - LEFT HAND - W/O DOORS/DRAWERS/HARDWARE
14	P20952-01-G04	EA	CABINET ASM-BED,TWIN,REAR
	098442-02-GB1	EA	LEG - TWIN BED - CROSS BUNK
	084413-01-000	EA	HINGE-CONTINUOUS, ALUMINUM - 1" X 72" - W/HOLES
	107796-05-000	EA	BRACKET-GAS SPRING,FLAT - SPDI SPD-1020
	107796-06-000	EA	SPRING-GAS 20" LENGTH,120 LB SPDI SPD-2300-120
	107796-07-000	EA	BRACKET-GAS SPRING - SPDI SPD-1080
	097872-04-000	EA	DOWEL-WOOD,1.00DIA X 1.38LG *UNFINISHED
	091952-01-000	EA	CLIP-GRIPPER - 1"

### BEDROOM GROUP (CONTINUED)

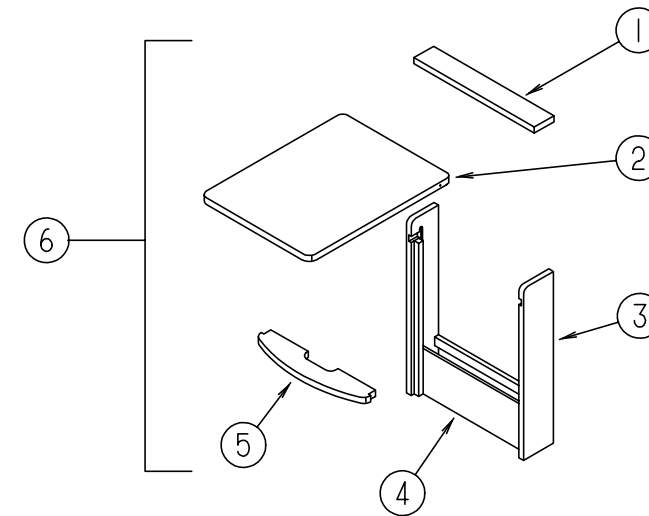

### PASSENGER SIDE PULL OUT TABLE

KEY	PART NUMBER	U/M	DESCRIPTION
1	096873-15-G01	EA	SHELF - SUPPORT OVER PULLOUT TABLE
2	096873-11-G01	EA	PANEL - PULLOUT TABLE
	080736-01-000	EA	PULL-RECESSED, 1.25" X 4" - OAK
3	096873-14-G01	EA	SIDE END - TABLE 28.7" X 5.7" - LEFT
	096873-13-G01	EA	SIDE END - TABLE 28.7" X 5.7" - RIGHT SIDE
4	096873-16-G01	EA	PANEL - TABLE FRONT BOTTOM - 18.1" X 6.7"
5	096873-12-G01	EA	SHELF - SUPPORT UNDER TABLE TOP
6	M96873-01-G01	EA	TABLE ASM-PULLOUT

**BEDROOM GROUP (CONTINUED)**

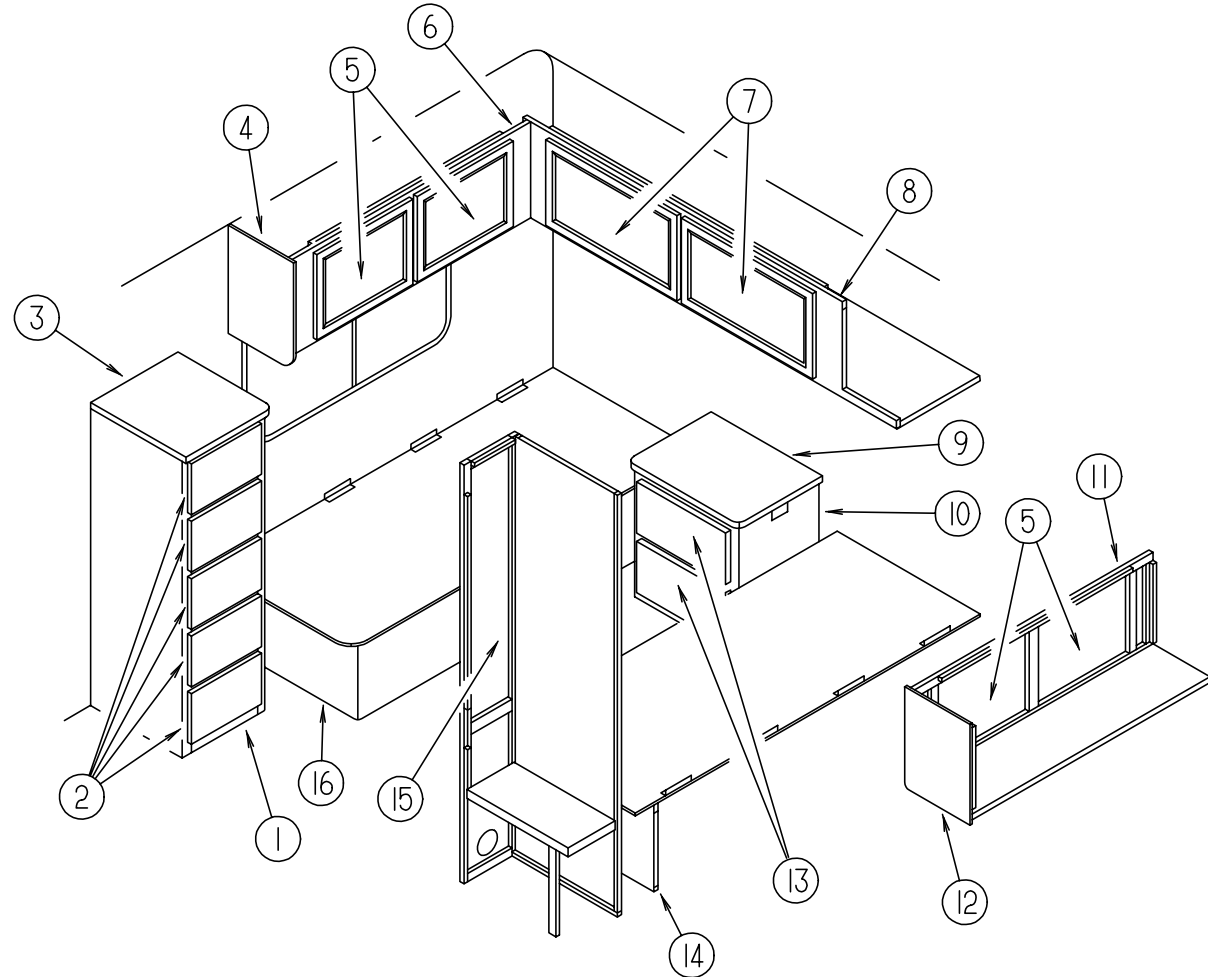

**TWIN BEDS & CABINERY**

KEY	PART NUMBER	U/M	DESCRIPTION
1	P21604-01-G24	EA	CABINET ASM-DRESSER,RH,TW
1	P21604-01-G25	EA	CABINET ASM-DRESSER,RH,TW
2	M05970-X1-G04	EA	DRAWER COMPL-SLIDE RAD - 5 USED
3	121604-11-G24	EA	COUNTERTOP ASM
3	121604-11-G25	EA	COUNTERTOP ASM
4	109908-31-GB1	EA	CAP ASM-END,OVHD
5	110140-27-G01	EA	DOOR - MITERED CORNER/VINYL WRAP - 14.3" X 33.4" W/O HDW
6	121345-01-G04	EA	CABINET ASM-OVHD,REAR,RH,TW
7	110140-18-G01	EA	DOOR - MITERED CORNER/VINYL WRAP - 15.7" X 27.9" - W/O HDW
7	110140-21-G01	EA	DOOR-W/MIRROR-MTRD CRNR/OGEE EDGE - 15.7" X 27.9" W/O HDW
8	121210-01-G04	EA	CABINET ASM-OVHD,REAR,TW
9	121166-11-G24	EA	COUNTERTOP ASM
9	121166-11-G25	EA	COUNTERTOP ASM
10	P21166-01-G24	EA	CABINET ASM-NIGHTSTAND
10	P21166-01-G25	EA	CABINET ASM-NIGHTSTAND
11	121345-02-G04	EA	CABINET ASM-OVHD,REAR,LH,TW
12	109908-30-GB1	EA	CAP ASM-END,OVHD
13	M05970-Y7-G04	EA	DRAWER COMPL-SLIDE RAD - 2 USED
14	P21137-01-G04	EA	CABINET ASM-BED,TWIN,LH
15	110140-91-G04	EA	DOOR ASM-MITERED,VINYL WRAP
16	P21138-01-G04	EA	CABINET ASM-BED,TWIN,RH
	084413-01-000	EA	HINGE-CONTINUOUS, ALUMINUM - 1" X 72" - W/HOLES
	091261-01-000	FT	SLIPNOT-ANTISLIP, 1' WIDE (100' ROLL)
	107796-05-000	EA	BRACKET-GAS SPRING,FLAT - SPDI SPD-1020
	107796-06-000	EA	SPRING-GAS 20" LENGTH,120 LB SPDI SPD-2300-120
	107796-07-000	EA	BRACKET-GAS SPRING - SPDI SPD-1080
	097872-04-000	EA	DOWEL-WOOD,1.00DIA X 1.38LG *UNFINISHED
	091952-01-000	EA	CLIP-GRIPPER - 1"

**BEDROOM GROUP (CONTINUED)**

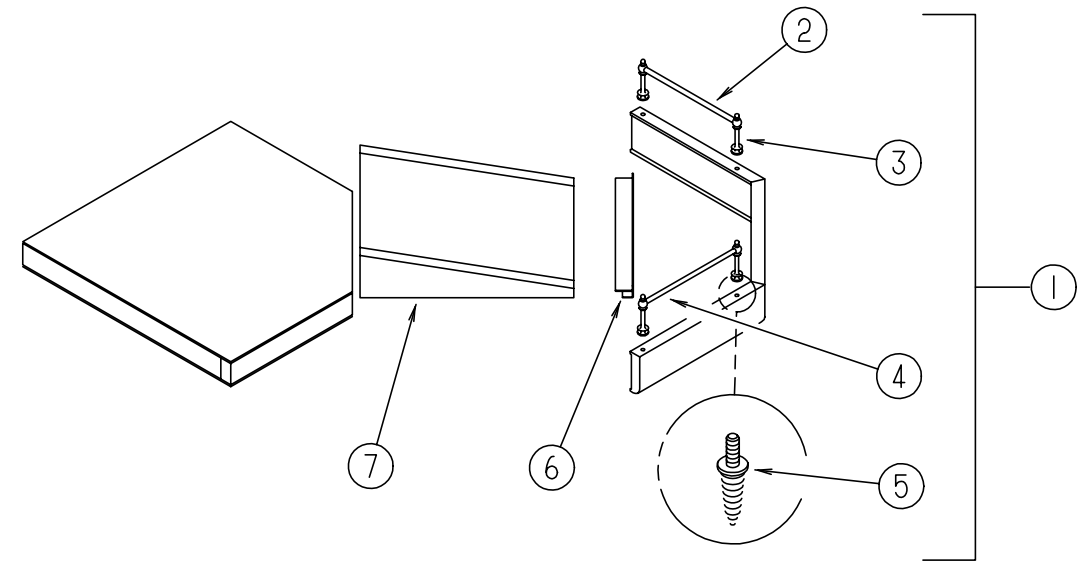

**TV SHELF - BEDROOM**

KEY	PART NUMBER	U/M	DESCRIPTION
1	116553-01-GB1	EA	CABINET ASM - TV SHELF
2	084071-12-000	EA	ROD-BRASS - 104 MM LONG
3	084070-02-000	EA	POST-END 2.4" - BRASS
4	084071-19-000	EA	ROD-BRASS - 198 MM LONG
5	106166-01-000	EA	BOLT-COLLARED HANGER
6	103186-01-05A	FT	MOLDING-PLASTIC,SHELF - WATERFORD OAK
7	116553-15-GB1	EA	WEDGE ASM

**FOLDING DOOR & HARDWARE**

KEY	PART NUMBER	U/M	DESCRIPTION
	042488-10-000	EA	DOOR-FOLDING - FABRIC - 37" X 75" - OFF WHITE
	080224-01-703	EA	ALMOND HANDLE W/LATCH AND CATCH
	080224-01-705	EA	ALMOND LATCH AND CATCH ASM.
	094856-10-01A	EA	TRACK-DOOR - FOLDING - OFF WHITE

## CHASSIS GROUP

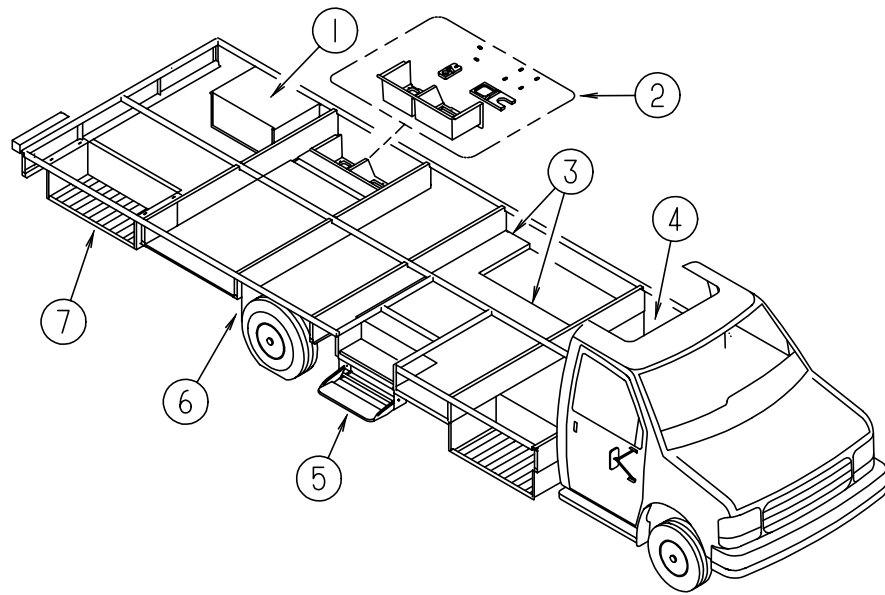

## CHASSIS GROUP (CONTINUED)

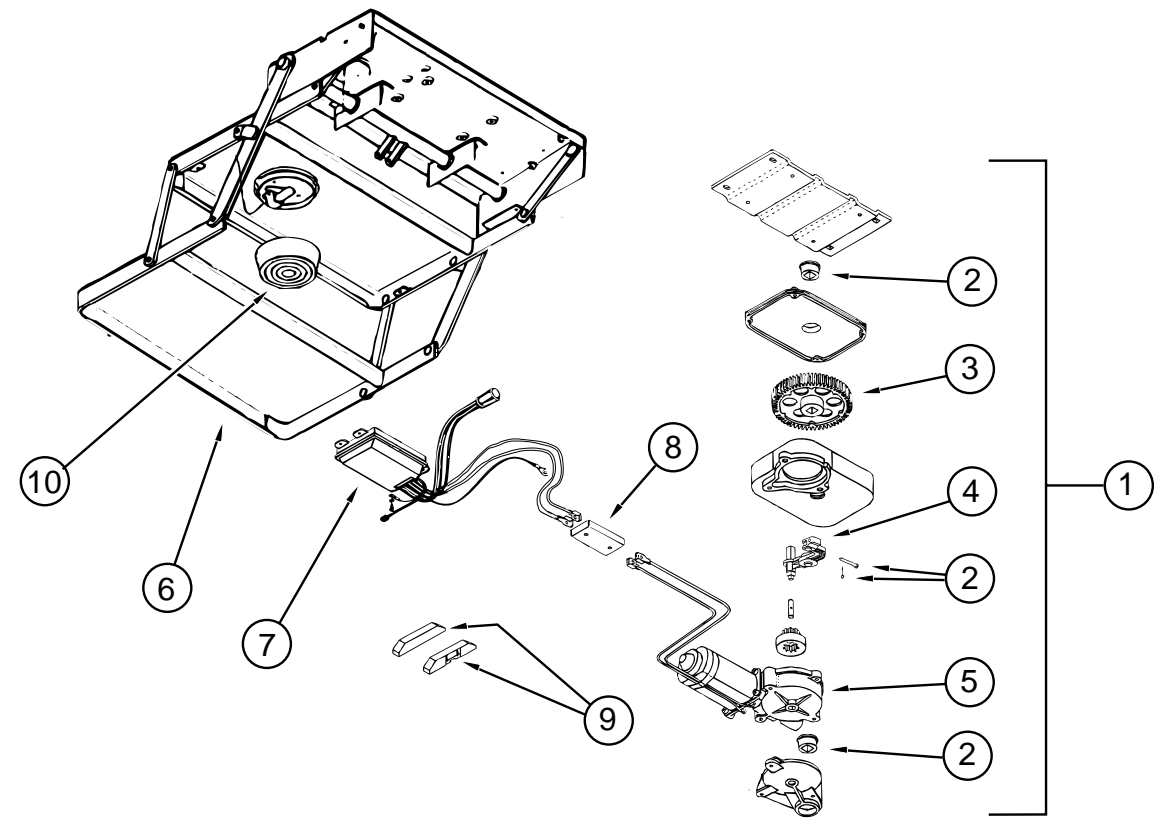

### COMPARTMENTS, PLUGS & SEALS

KEY	PART NUMBER	U/M	DESCRIPTION
1	118248-01-02B	EA	BRACKET - GENERATOR - E-COATED - .74" X 16.9"
1	118248-02-02B	EA	BRACKET - GENERATOR - E-COATED - 2.1" X 14.2"
2	117186-02-G04	EA	COMPARTMENT ASM-STORAGE
2	116926-02-01A	EA	COMPARTMENT-SEWER
2	M06991-02-FQ0	EA	HATCH ASM W/FOAM
2	M06991-04-FB1	EA	HATCH ASM W/FOAM
2	121175-01-01A	EA	LATCH-SWELL, BLACK
3	117928-05-01A	EA	COMPARTMENT-STORAGE GRAY
4	117928-06-01A	EA	COMPARTMENT-STORAGE
	065450-05-000	EA	TIEDOWN-BATTERY, 8.4" TUBE
5	094707-01-01A	EA	STEP-DOUBLE, ELECTRIC - KWIKEE 3218
	091176-01-000	EA	SUPPORT-BASE-ENTRANCE STEP
6	017516-01-000	EA	FLAP-MUD, 14" X 18" - BLACK
7	093873-01-01A	EA	TRIM-CARPET, L-ANGLE - 1.1" X 1.3" X 12' - VINYL - GRAY
7	093873-01-02A	EA	TRIM-CARPET, L-ANGLE - 1.1" X 1.3" X 12' - VINYL - TAN
	084993-01-000	EA	STRAP-BATTERY
	119845-01-01A	EA	PLUG-PLASTIC,BLACK *CAPLUG FP 241
	088270-01-000	FT	SEAL-BULB - W/WIRE RIGID U-CHANNEL - .5" - RUBBER - BLACK
	121948-01-000	EA	SHIELD-SIGHT

### STEP ASSEMBLY (3200 SERIES)

KEY	PART NUMBER	U/M	DESCRIPTION	VENDOR NO.
1	094707-01-01A	EA	STEP-DOUBLE, ELECTRIC - KWIKEE 3218	
2	094707-02-703	EA	BEARING & PINS	909530
3	094707-02-702	EA	GEAR KIT,W/BEARINGS,PIN-CASE	909525
4	094707-02-701	EA	LINKAGE ASM. W/BEARINGS-PINS	909534
5	094707-02-700	EA	MOTOR ASM.,W/BEARINGS & PINS	909520
6	094707-01-702	EA	FRAME W/DBL STEP,3200 SERIES	908032
7	094707-02-705	EA	CONTROL UNIT, WHITE	909513
8	094707-02-704	EA	CONNECTOR-MOTOR ASM.W/PLATES	909537
	094707-02-707	EA	TREAD-NON SKID, BLACK 6"X21"	909333
9	116995-01-000	EA	SWITCH/MAGNET-STEP, ELECTRIC, KWIKEE - 905306	
10	088746-01-705	EA	LIGHT-UNDER STEP	9004
	088733-01-700	EA	BULB	9004



**CHASSIS GROUP (CONTINUED)**

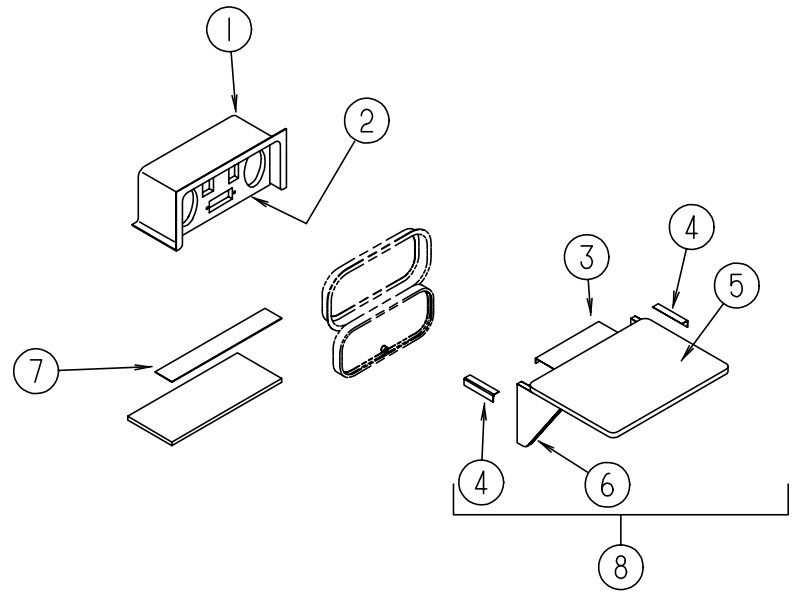

**ENTERTAINMENT COMPARTMENT**

KEY	PART NUMBER	U/M	DESCRIPTION
1	104897-02-02A	EA	BOX - ENTERTAINMENT CENTER
2	104899-01-C05	EA	PLATE-RADIO MOUNTING
3	105377-01-01A	EA	BRACKET-TABLE HANGER O/W
4	105376-01-02A	EA	HINGE-CONTIN,2"X140MM O/W
5	105230-11-E01	EA	SHELF ASM
6	105230-12-F11	EA	SUPPORT ASM
7	104898-01-02A	EA	PLATE-PLASTIC BOTTOM BRT/WHT
8	105230-01-F11	EA	SHELF ASM-EXTERIOR TV
	099717-04-000	EA	STRAP-TV TIE DOWN W/21.3" FEMALE STRAP & 27.2" MALE STRAP

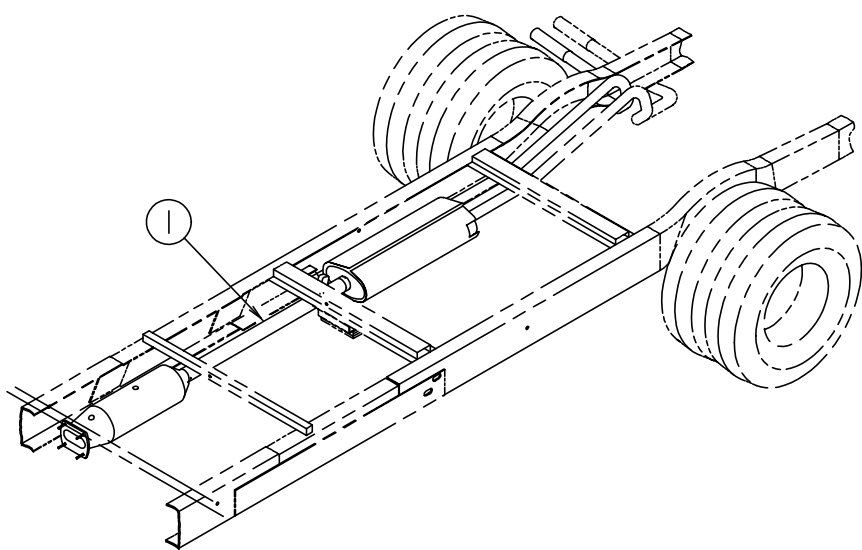

**EXHAUST SYSTEM COMPONENTS**

KEY	PART NUMBER	U/M	DESCRIPTION
1	111478-03-000	EA	PIPE-EXHAUST FORD CHAS,158-205
	094918-06-000	EA	CLAMP-EXHAUST 3.00 HVY DUTY - HECO 24698
	098762-15-000	EA	PIPE-EXHAUST,STRAIGHT,3.5 IN

**CHASSIS GROUP (CONTINUED)**

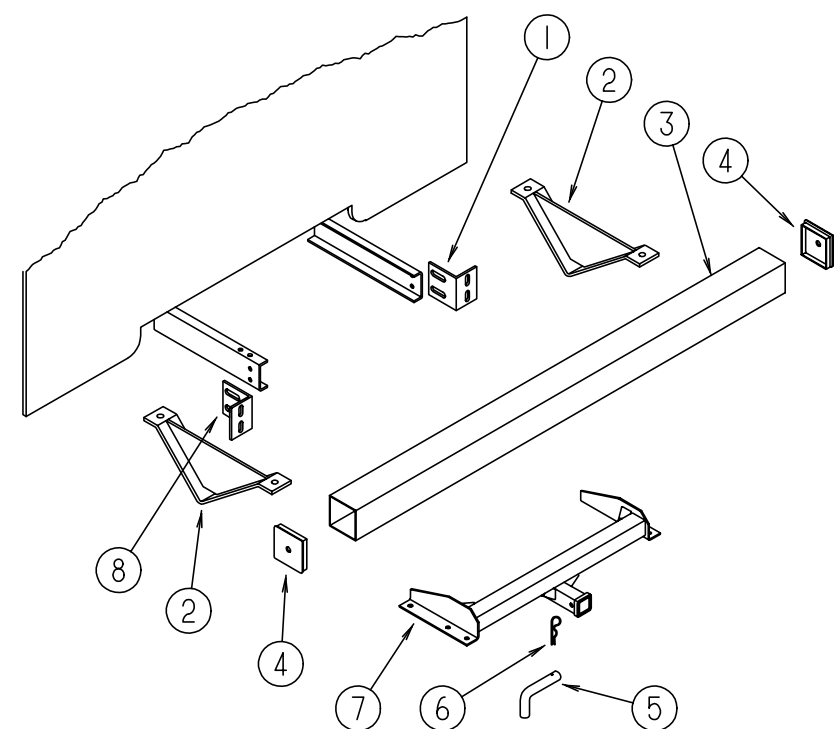

**REAR BUMPER & HITCH**

KEY	PART NUMBER	U/M	DESCRIPTION
1	104420-01-000	EA	SUPPORT-ANGLE,BUMPER REAR
2	083376-01-000	EA	PLATE-SKID, 13.2" X 6" X 2" - STEEL
3	103422-05-02A	EA	BUMPER-SQUARE,AL BRT/WHT
4	039779-01-000	EA	CAP-BUMPER, RUBBER - 4" X 4" - BLACK
5	034512-01-000	EA	PIN-LOCKING, DRAWBAR
6	034513-01-000	EA	PIN-HITCH, 3/16" WIRE
7	107707-08-000	EA	DRAWBAR ASM-HITCH,CLASS II
8	104420-02-000	EA	SUPPORT-ANGLE,BUMPER REAR
	097744-02-000	EA	HOUSING-TRAILER PIN, 48"
	097745-02-000	EA	HOUSING-RECEPTACLE, TRAILER - 48" WIRE LENGTH
	113634-01-000	EA	WIRE ASM-TRAILER,ADAPTER
	113589-02-000	EA	CONNECTOR-SOCKET, TRAILER - GENERAL 433601
	113589-01-000	EA	CONNECTOR-PLUG, TRAILER - GENERAL 433501
	113588-02-01B	EA	BRACKET-CONNECTOR, TRAILER W/O LIP
	070579-09-000	EA	PLATE ASM ANCHOR

**DRIVESHAFT & BRAKE LINE FLARE UNION**

KEY	PART NUMBER	U/M	DESCRIPTION
	103653-10-000	EA	DRIVESHAFT ASM-BALANCED PAIR - E350 190"WB (158)
	115043-02-000	EA	BUSHING-INCREASE 2.5OD-3.5OD - NEAPCO FORD DIESEL
	074833-01-000	EA	SPACER-BEARING, DRIVESHAFT - 2" X 8" X .5" THICK -
	085771-03-000	EA	NUT-HEX, FLARE TORQUE - GRADE G DRIVE SHAFT
	088498-01-000	EA	UNION-INVERTED FLARE, BRASS - 3/16 - 3/8 - 24 THD-BRAKE LINE
	103653-22-000	EA	BOLT-U-JOINT,5/16,STRAP&NUT - DANA 3-70-58,1410
	103653-23-000	EA	BOLT-U-JOINT 5/16-24X.75 - DANA 231142
	103653-24-000	EA	STRAP-U-JOINT 1410 SERIES - DANA 3-70-89

## CHASSIS GROUP (CONTINUED)

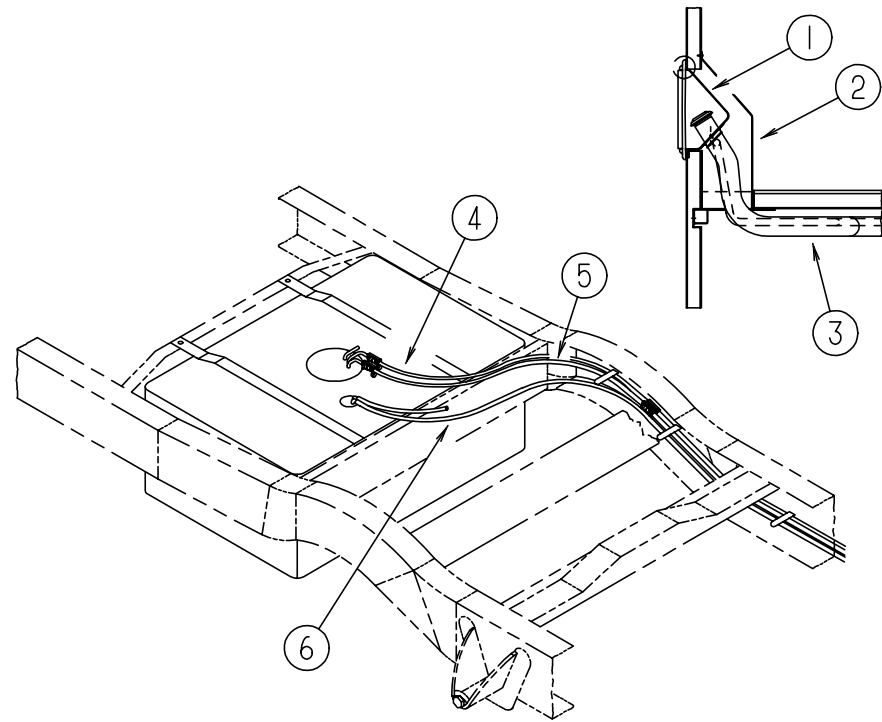

**FUEL SYSTEM COMPONENTS**

KEY	PART NUMBER	U/M	DESCRIPTION
1	095854-01-04A	EA	SHROUD-FUEL FILL,BRIGHT WHITE
2	078040-06-000	EA	SHROUD-FUEL FILL,UPPER
3	117934-01-000	EA	NECK-FILLER,FUEL FILL - BAUER WELD UNLEAD
3	117934-02-000	EA	NECK-FILLER,FUEL FILL - BAUER WELD DIESEL
	078200-01-000	EA	GASKET-FUEL FILL, 3.5"OD X 2"ID
4	N/A	EA	FUEL LINE ASM-FORD - 3/8 HP
5	N/A	EA	FUEL LINE ASM-FORD - 5/16 HP
6	007063-01-000	FT	HOSE-GAS 1/4"ID X 1/2"OD
	044317-01-000	FT	HOSE-FUEL, 3/8" ID
	084884-01-000	EA	PLUG-BRASS, 3/8"

## CHASSIS GROUP (CONTINUED)

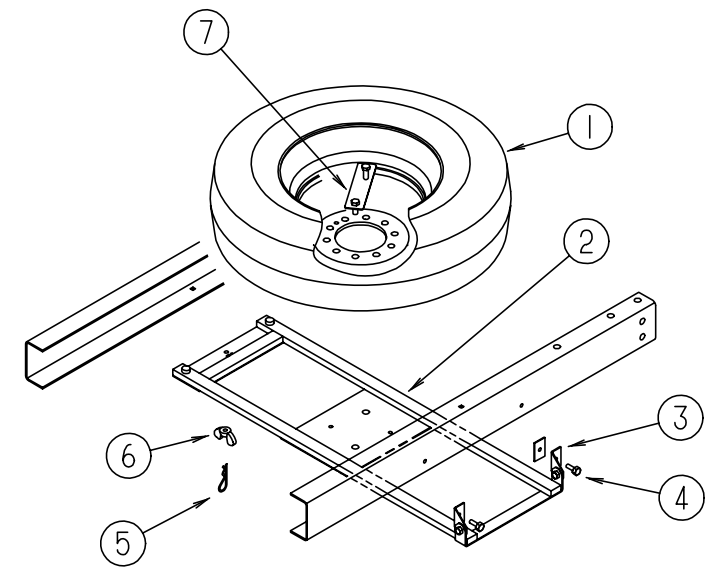

**SPARE TIRE**

KEY	PART NUMBER	U/M	DESCRIPTION
1	070917-06-000	EA	TIRE-LT225/75R16E,R4S,M/S - FIRESTONE STEELTEX
1	083617-03-000	EA	WHEEL-STL.16.0X6,92 E350 - ACCURIDE 28618
	095012-05-000	EA	EXTENSION-VALVE STEM,LIVE 5"
	095012-06-000	EA	STABILIZER-VALVE EXTENSION,L
	112358-01-000	EA	WRENCH-LUG,7/8,L-SHAPE - FORD F2UA-17035-CA
2	116348-01-02B	EA	CRADLE ASM-SPARE TIRE,E-COAT
3	116349-01-02B	EA	BRACKET-HINGE,SPARE TIRE,E-C
4	000C26-06-12B	EA	BOLT-HEX-SER FLANGE - 3/8-16 X 3/4 - ZINC
4	000E13-17-00B	EA	WASHER-FLANGE - 3/8" AR ZINC
4	000D34-06-00B	EA	NUT-HEX, LK - 3/8 - 16 GRADE C ZN - PREVAILING TORQUE
5	034513-01-000	EA	PIN-HITCH - 3/16" WIRE
6	064081-03-000	EA	NUT-WING,3/8-16,W/WELD NUT
7	116338-02-02B	EA	BRACKET-CLAMP,SPARE TIRE,E-C
	000D29-09-00B	EA	NUT-HEX SELFLOCK 9/16-12 ZN
	115580-01-000	EA	STRAP-SPARE TIRE

## WHEEL LINERS & COVERS

KEY	PART NUMBER	U/M	DESCRIPTION	VENDOR NO.
	109443-05-000	EA	WHEEL COVER-4/SET,16"SS - DICOR SHFM16	
	098532-01-700	EA	COVER-LUG NUT (CHROME)	SHAU-LNC
	109443-05-700	EA	COVER-WHEEL, 16" SS EA=1	SHFM16-CVR
	110435-02-000	EA	LINER-WHEEL,SET 4 E350 DICOR V160F2	
	110435-02-700	EA	LINER-WHEEL,FRONT	V160F2-FWC
	110435-02-701	EA	LINER-WHEEL,REAR	V160F2-RWC
	110435-02-702	EA	STUD EXTENDER	V160SD-STX
	110435-02-703	EA	NUT (JAMB)	V160SD-JNT
	110435-02-704	EA	COVER-LUG NUT	V160F0-LNC
	110435-02-705	EA	TOOL F/ JAMB NUT, INSTALL.	V160F0-TOL

## CURTAIN & CUSHION GROUP

### NOTICE

IN ORDER TO ASSIST OUR PARTS SALES DEPT. IN PROVIDING INTERIOR SOFTWARE ITEMS, PLEASE INCLUDE THE SERIAL NUMBER AND THE COLOR CODE NUMBER FROM THE VEHICLE CERTIFICATION LABEL WHEN ORDERING. THIS LABEL IS LOCATED ON THE LEFT SIDEWALL AT THE END OF THE DASH (A-BODY), OR ON THE DRIVER'S DOOR LATCH PLATE (C-BODY).

AN EXAMPLE OF A COLOR CODE NUMBER IS B07, WHICH DESIGNATES AN OVERALL COLOR SCHEME OF A PARTICULAR UNIT. THE COLOR LISTED AFTER THE ITEM DESCRIPTION ON THE MICROFICHE, INDICATES THE OVERALL UNIT COLOR. ORDER THE ITEM YOU DESIRE ACCORDING TO UNIT COLOR CODE.

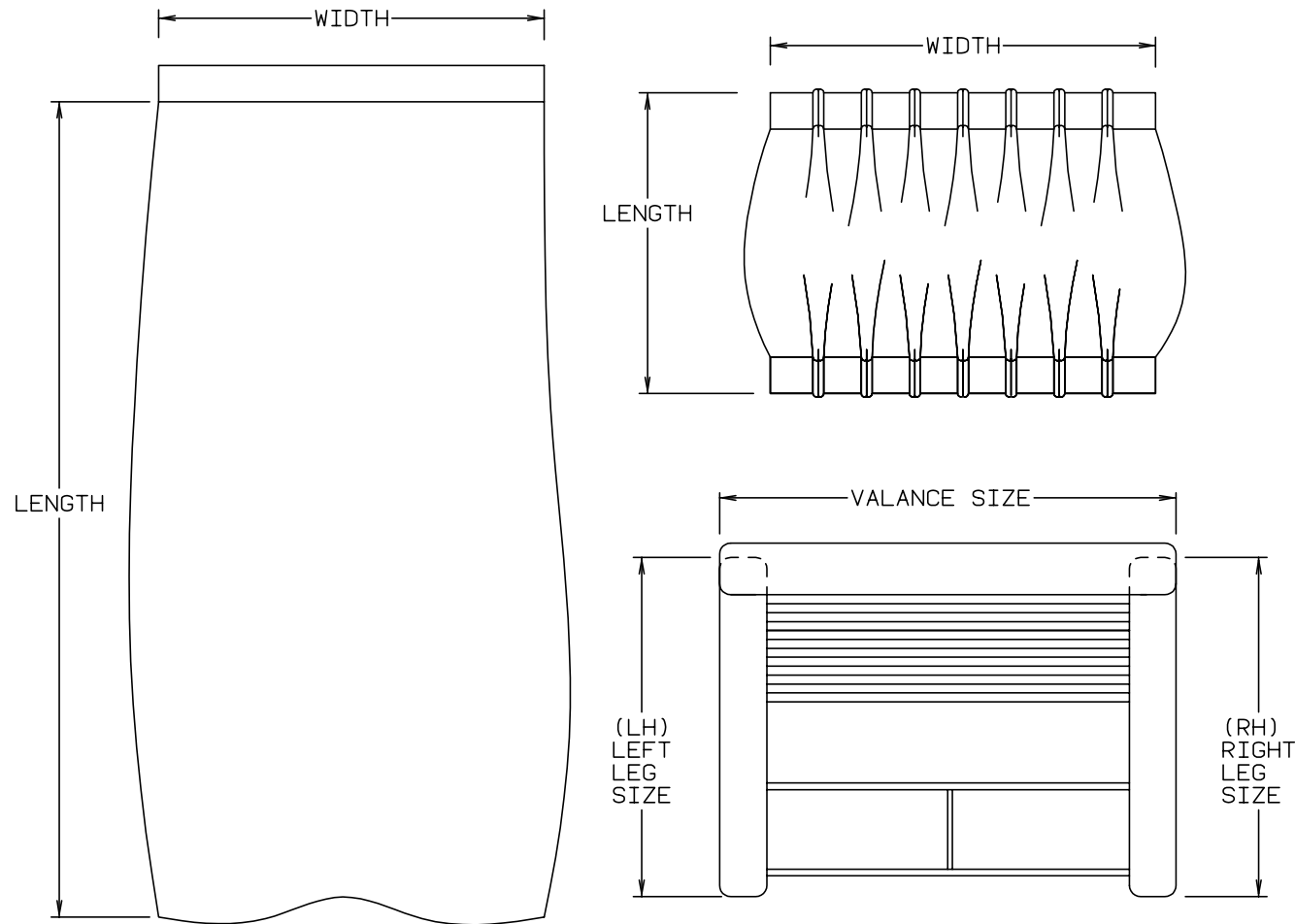

NOTE: USE THIS ILLUSTRATION WHEN DETERMINING LENGTH AND WIDTH MEASUREMENTS FOR CURTAINS. YOU WILL NOTE THE WIDTH MEASUREMENT IS TAKEN ON THE TOP OF THE CURTAIN WITH THE CURTAIN FULLY EXTENDED. THE LENGTH MEASUREMENT IS TAKEN FROM TOP TO BOTTOM. LEFT AND RIGHT WINDOW LEGS ARE DETERMINED WHEN FACING THE WINDOW.

## CURTAIN & CUSHION GROUP (CONTINUED)

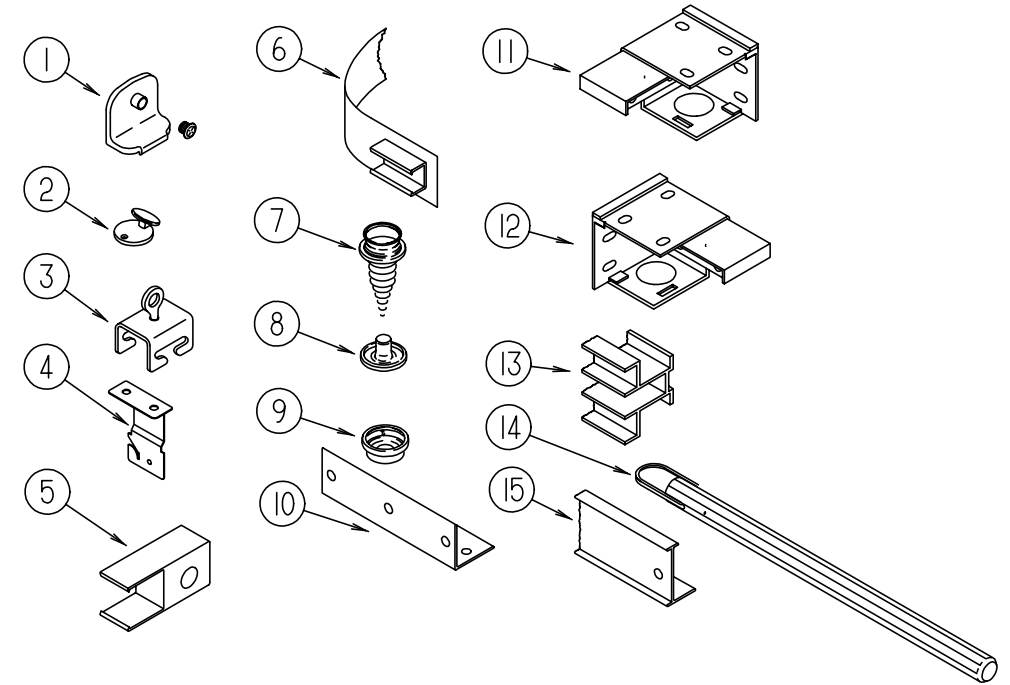

### CURTAIN & BLIND HARDWARE

KEY	PART NUMBER	U/M	DESCRIPTION
1	106544-01-000	EA	PULL - SHADE/BRASS
	106544-01-001	EA	SCREW-BRASS, SHADE
2	102555-01-000	EA	CLEAT - BLIND CORD - CLEAR PLASTIC
2	102555-03-000	EA	CLEAT - BLIND CORD - MILKY WHITE PLASTIC
3	009702-01-000	EA	END STOP-CURTAIN CARRIER, L ROD
4	084434-01-000	EA	BRACKET-MOUNTING, ROLLER SHADE - 1 3/8"
5	101033-02-000	EA	END CAP-TRACK, CLEAR
6	101031-01-000	YD	TAPE-GLIDE, CURTAIN - 4.25" SPACING
7	029130-01-000	EA	SCREW-SNAP SOCKET, #8 PH X 5/8"
8	029155-01-000	EA	CAP-SNAP, 5/32" O.D. OF PIN
9	029156-01-000	EA	SOCKET-SNAP, 9/16" O.D.
10	105648-01-02A	EA	BRACE-VALANCE OFF/WHT
11	083170-01-000	EA	BRACKET-BLIND, LEFT SIDE WHEN FACING WINDOW
12	083170-02-000	EA	BRACKET-BLIND, RIGHT SIDE WHEN FACING WINDOW
13	101033-03-000	FT	TRACK-WALL/WHITE - 8.5'
14	093475-01-700	EA	WAND-BLIND W/METAL CLIP, 8" NONE
15	009700-04-002	EA	TRACK, L-SHAPED 195.5" - OFF WHITE
	109441-03-000	EA	HOLD DOWN-BLIND (CLOUDY)
	046867-03-000	EA	GROMMET-HANDY BUTTON NO 3
	048394-02-000	YD	VELCRO TAPE-HOOK, ADHESIVE BACK - .75" WIDE - BEIGE
	093475-01-701	EA	CAP-END, WITH INVERTED STUD PAR
	088792-01-000	YD	VELCRO-HOOK, .75" WIDE - BEIGE
	088792-02-000	YD	VELCRO TAPE-LOOP, ADHESIVE BACKED - .75" WIDE - BEIGE
	083125-07-000	EA	BRACE-CURTAIN LEG - OFF WHITE
	088792-06-000	YD	VELCRO-3/4" NON-ADH., LOOP BUF MED
	096843-01-000	EA	SPRING-REWIND, ROLLER SHADE
	086276-01-000	EA	TAPE-DOUBLE SIDED, 1/2"

## CURTAIN & CUSHION GROUP (CONTINUED)

### DOUBLE BED BEDSPREAD, PILLOW & MATTRESS

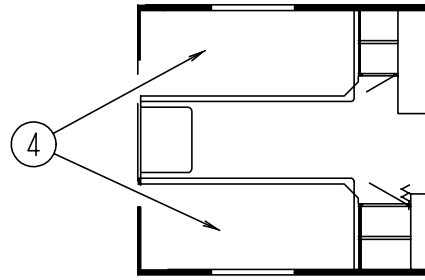

KEY	PART NUMBER	U/M	DESCRIPTION
3	101123-01-000	EA	MATTRESS-DOUBLE, 53" X 74" - TICKING COVERED
3	P01123-01-000	EA	COVER - MATTRESS 53" X 74" - DOUBLE BED
	085365-23-G24	EA	BEDSPREAD/THROW - 54"
	085365-23-G25	EA	BEDSPREAD/THROW - 54"
	111863-06-G24	EA	PILLOW SHAM
	111863-06-G25	EA	PILLOW SHAM
	111862-03-G24	EA	PILLOW - ACCENT - 15" X 15"
	111862-03-G25	EA	PILLOW - ACCENT - 15" X 15"

### TWIN BED BEDSPREAD, PILLOW & MATTRESS

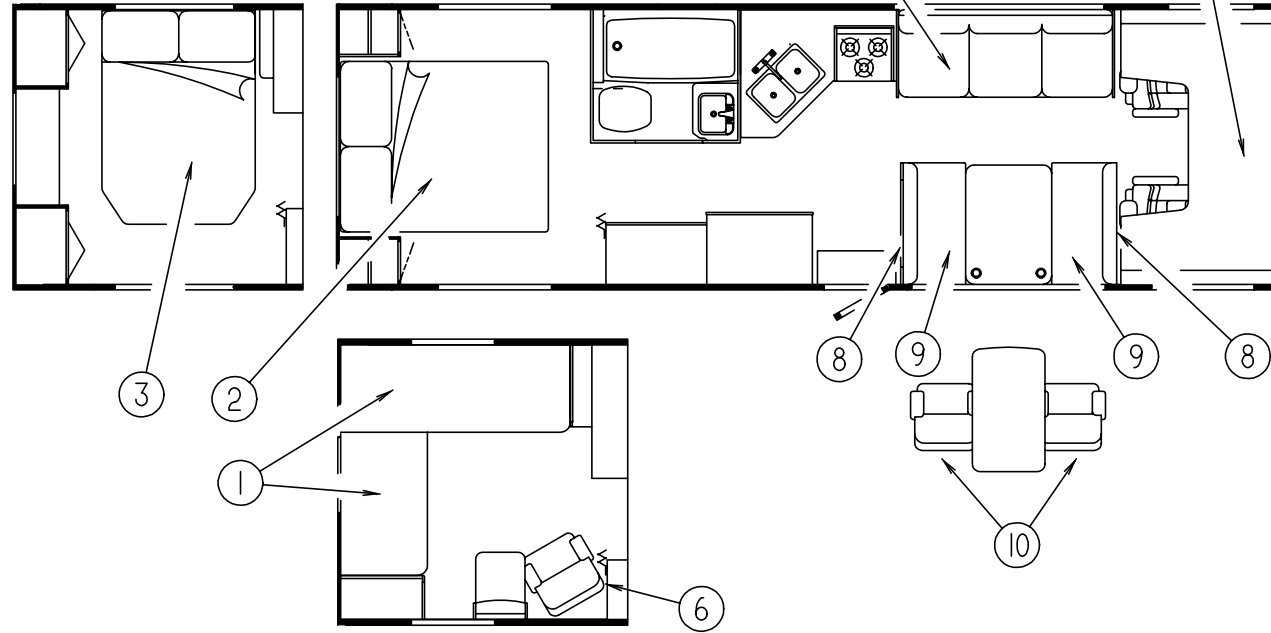

KEY	PART NUMBER	U/M	DESCRIPTION
4	101123-29-000	EA	MATTRESS - FOAM - 35" X 74"
4	P01123-29-000	EA	COVER - MATTRESS - 35" X 74"
	085365-32-G24	EA	BEDSPREAD - THROW - 36"
	085365-32-G25	EA	BEDSPREAD - THROW - 36"
	111863-07-G24	EA	PILLOW SHAM
	111863-07-G25	EA	PILLOW SHAM
	111862-03-G24	EA	PILLOW - ACCENT - 15" X 15"
	111862-03-G25	EA	PILLOW - ACCENT - 15" X 15"

### COUCH

KEY	PART NUMBER	U/M	DESCRIPTION
5	100032-43-G24	EA	SEAT - SOFA/BED - JACK/KNIFE 74"
5	100032-43-G25	EA	SEAT - SOFA/BED - JACK/KNIFE 74"
	P00032-43-G24	EA	COVER - SEAT - SOFA/BED JACK KNIFE 74"
	P00032-43-G25	EA	COVER - SEAT - SOFA/BED JACK KNIFE 74"
	111319-01-G24	EA	BED ASM-J.K.BCK,KNIFE EDG,74
	111319-01-G25	EA	BED ASM-J.K.BCK,KNIFE EDG,74
	P11319-01-G24	EA	COVER-BED,J.K.KNF.EDG.BCK,74
	P11319-01-G25	EA	COVER-BED,J.K.KNF.EDG.BCK,74
	111637-02-G24	EA	PILLOW ASM-22" X 22"
	111637-02-G25	EA	PILLOW ASM-22" X 22"
	101085-04-000	EA	FRAME - SEAT COUCH/BED - 74.75"
	101085-06-000	EA	FRAME - BASE COUCH/BED - 74.75"
	101085-10-000	EA	FRAME - 74.5" X 16" SOFA/BED BACK

**NOTE: COUCH FRONT AND SIDE PANELS ARE FOUND IN THE LOUNGE GROUP.**

### CROSS STACKED TWIN BED BEDSPREAD, PILLOW & MATTRESS

KEY	PART NUMBER	U/M	DESCRIPTION
1	101123-18-000	EA	MATTRESS - FOAM - 32" X 79" X 5"
1	P01123-18-000	EA	COVER - MATTRESS - 32" X 79" X 5"
	117067-10-G24	EA	COVER - FITTED SHEET - 32" X 80" X 5"
	117067-10-G25	EA	COVER - FITTED SHEET - 32" X 80" X 5"
	P17066-03-G24	EA	COVER-FRAME,SLIP,CROSS BUNK
	P17066-03-G25	EA	COVER-FRAME,SLIP,CROSS BUNK
	111862-03-G24	EA	PILLOW - ACCENT - 15" X 15"
	111862-03-G25	EA	PILLOW - ACCENT - 15" X 15"

### QUEEN BED BEDSPREAD, PILLOW & MATTRESS

KEY	PART NUMBER	U/M	DESCRIPTION
2	101123-08-000	EA	MATTRESS - QUEEN - 60" X 75" - TICKING COVERED
2	P01123-08-000	EA	COVER - MATTRESS - QUEEN - 60" X 75"
	085365-19-G24	EA	BEDSPREAD - THROW 60"
	085365-19-G25	EA	BEDSPREAD - THROW 60"
	111863-05-G24	EA	PILLOW SHAM
	111863-05-G25	EA	PILLOW SHAM
	111862-03-G24	EA	PILLOW - ACCENT - 15" X 15"
	111862-03-G25	EA	PILLOW - ACCENT - 15" X 15"

### SWIVEL CHAIR

KEY	PART NUMBER	U/M	DESCRIPTION
6	115470-01-F16	EA	CHAIR - SWIVEL (G24)
6	115470-01-G25	EA	CHAIR - SWIVEL (G25)
	P15470-01-F16	EA	COVER - SWIVEL CHAIR (G24)
	P15470-01-G25	EA	COVER - SWIVEL CHAIR (G25)

### BUNK CUSHIONS

KEY	PART NUMBER	U/M	DESCRIPTION
7	105573-10-G24	EA	CUSHION - REAR - OVERHEAD BUNK - 27" X 23" X 80" X 5"
7	105573-10-G25	EA	CUSHION - REAR - OVERHEAD BUNK - 27" X 23" X 80" X 5"
	P05573-10-G24	EA	COVER - OVERHEAD REAR BUNK CUSHION - 27" X 23" X 80" X 5"
	P05573-10-G25	EA	COVER - OVERHEAD REAR BUNK CUSHION - 27" X 23" X 80" X 5"
	105573-09-F16	EA	CUSHION - FRONT OVERHEAD BUNK - 32.5" X 80" X 5" (G24)
	105573-09-G25	EA	CUSHION - FRONT OVERHEAD BUNK - 32.5" X 80" X 5" (G25)
	P05573-09-F16	EA	COVER - OVERHEAD FRONT BUNK CUSHION - 32.5" X 80" X 5" (G24)
	P05573-09-G25	EA	COVER - OVERHEAD FRONT BUNK CUSHION - 32.5" X 80" X 5" (G25)
	079145-08-000	EA	CUSHION-BUNK 25" X 74" X 3.5"-FRONT ENTERTAINMENT CENTER
	M79145-08-000	EA	COVER-CUSHION BUNK-25" X 74" X 3.5"-FRONT ENTERTAIN CTR
	094658-02-G04	EA	HANDLE-OAK

**CURTAIN & CUSHION GROUP (CONTINUED)**

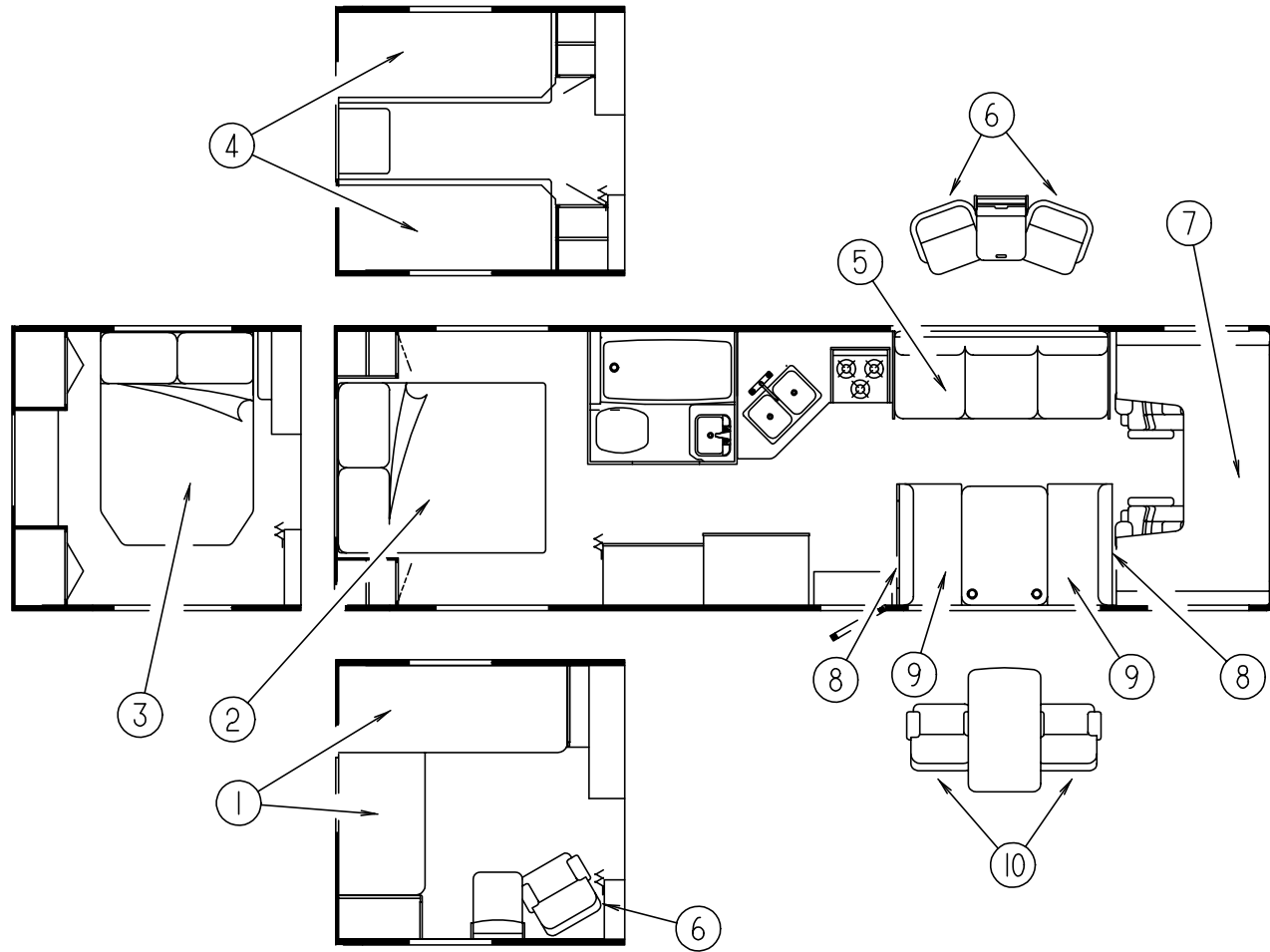

**DINETTE CUSHIONS**

KEY	PART NUMBER	U/M	DESCRIPTION
8	111897-05-G24	EA	CUSHION - DINETTE BACK - 13.5" X 42" X 5"
8	111897-05-G25	EA	CUSHION - DINETTE BACK - 13.5" X 42" X 5"
	P11897-05-G24	EA	COVER - DINETTE BACK - 13.5" X 42" X 5"
	P11897-05-G25	EA	COVER - DINETTE BACK - 13.5" X 42" X 5"
9	105603-15-G24	EA	CUSHION - DINETTE SEAT - 23" X 42" X 5"
9	105603-15-G25	EA	CUSHION - DINETTE SEAT - 23" X 42" X 5"
	P05603-15-G24	EA	COVER - DINETTE SEAT - 23" X 42" X 5"
	P05603-15-G25	EA	COVER - DINETTE SEAT - 23" X 42" X 5"
	078155-01-000	EA	STRAP-SNAP, BACKREST CUSHION

**DINETTE CHAIRS**

KEY	PART NUMBER	U/M	DESCRIPTION
10	119108-01-G24	EA	CHAIR ASM - 200 KC
10	119108-01-G25	EA	CHAIR ASM - 200 KC

**FOLDING CHAIRS**

KEY	PART NUMBER	U/M	DESCRIPTION
	101604-01-03A	EA	CHAIR-DINETTE, FOLDING-W/O FABRIC #3053 WATERFORD OAK

**CURTAIN & CUSHION GROUP (CONTINUED)**

**SUNDANCER FABRICS**

Family - 400's	G24 Harbour	G25 Sand Dollar
Bucket Seats	104233-B4-000	108446-55-000
Dinette	108446-J2-000	108446-C1-000
Dinette Pads	104233-B4-000	108446-55-000
Sofa	108446-J2-000	108446-C1-000
Swivel Chair	108446-B6-000	108446-J1-000
Lounge Pillow	108446-B6-000	108446-J1-000
Lounge Windows	108446-B6-000 108446-J2-000	108446-C1-000 108446-J1-000
Overhead Bunk	108446-B6-000	108446-J1-000
Bedroom Window	105745-D2-000 105745-62-000	105745-A1-000 105745-C0-000
Bedroom Legs	105745-62-000	105745-A1-000
Bedroom Pillow	105745-62-000 105745-D2-000	105745-A1-000 105745-C0-000
Bedspread	105745-D2-000 105745-62-000	105745-C0-000 105745-A1-000
Pillow Shams	105745-D2-000 105745-62-000	105745-C0-000 105745-A1-000
Front Wraparound	072333-82-000	072333-90-000
Overhead Curtain	105745-D2-000	105745-C0-000
Headliner	103907-01-01A	103907-01-01A
Bedspread Lining	087272-01-01A	087272-01-01A
Entertainment Bunk	079680-07-000	079680-07-000

NOTE: THE FABRIC LISTED FIRST, IN A BLOCK, IS THE LARGEST QUANTITY OF FABRIC USED.

**CURTAIN & CUSHION GROUP (CONTINUED)**

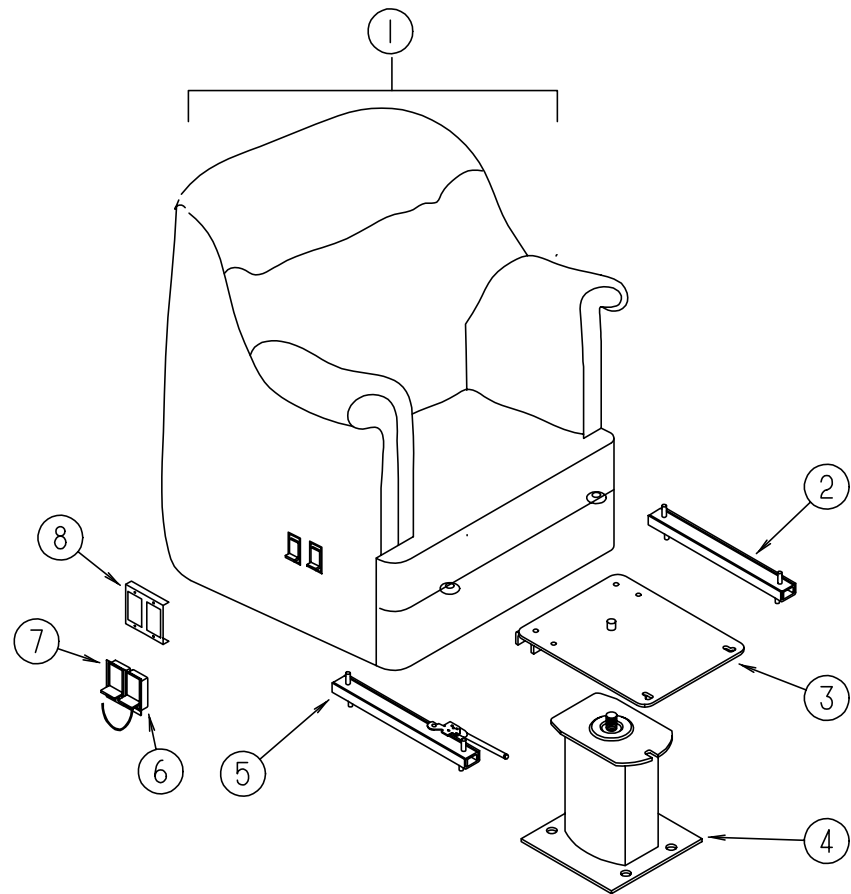

**SWIVEL CHAIR**

KEY	PART NUMBER	U/M	DESCRIPTION
1	115470-01-F16	EA	CHAIR - SWIVEL (G24)
1	115470-01-G25	EA	CHAIR - SWIVEL (G25)
	P15470-01-F16	EA	COVER - SWIVEL CHAIR (G24)
	P15470-01-G25	EA	COVER - SWIVEL CHAIR (G25)
2	119952-03-000	EA	SLIDE - SEAT/ HEAVY DUTY/LOCKING W/2 STUDS
3	107921-08-000	EA	TOP PLATE - PEDESTAL- WO SEAT BELT BAR
	107921-06-000	EA	BEARING KIT-PEDESTAL
4	107921-01-000	EA	PEDESTAL FLOOR MOUNTED - W/9.75" EXTENSION
5	119952-01-000	EA	SLIDE-SEAT,HD,NONLOCKING 2ST - ATWOOD 83711
	007221-01-000	EA	SPACER-SEAT, ADJUSTER - 4 USED PER SWIVEL CHAIR
6	108049-03-000	EA	CABLE-W/CONTROL 25.5" SHEATH/28.5" CABLE W/DOG LEG
	108049-02-000	EA	CLIP-CABLE, PEDESTAL
7	089368-04-000	EA	CABLE-SWIVEL/SLIDE - W/SWITCH
8	097683-02-000	EA	BRACKET-MOUNT, REMOTE
	108445-02-000	EA	PLATE - FLOOR MOUNTED PEDESTAL/SEAT
	114889-01-000	EA	STOP BAR-UNIVERSAL - SHROCK
	097683-02-000	EA	BRACKET-MOUNT, REMOTE

**CURTAIN & CUSHION GROUP (CONTINUED)**

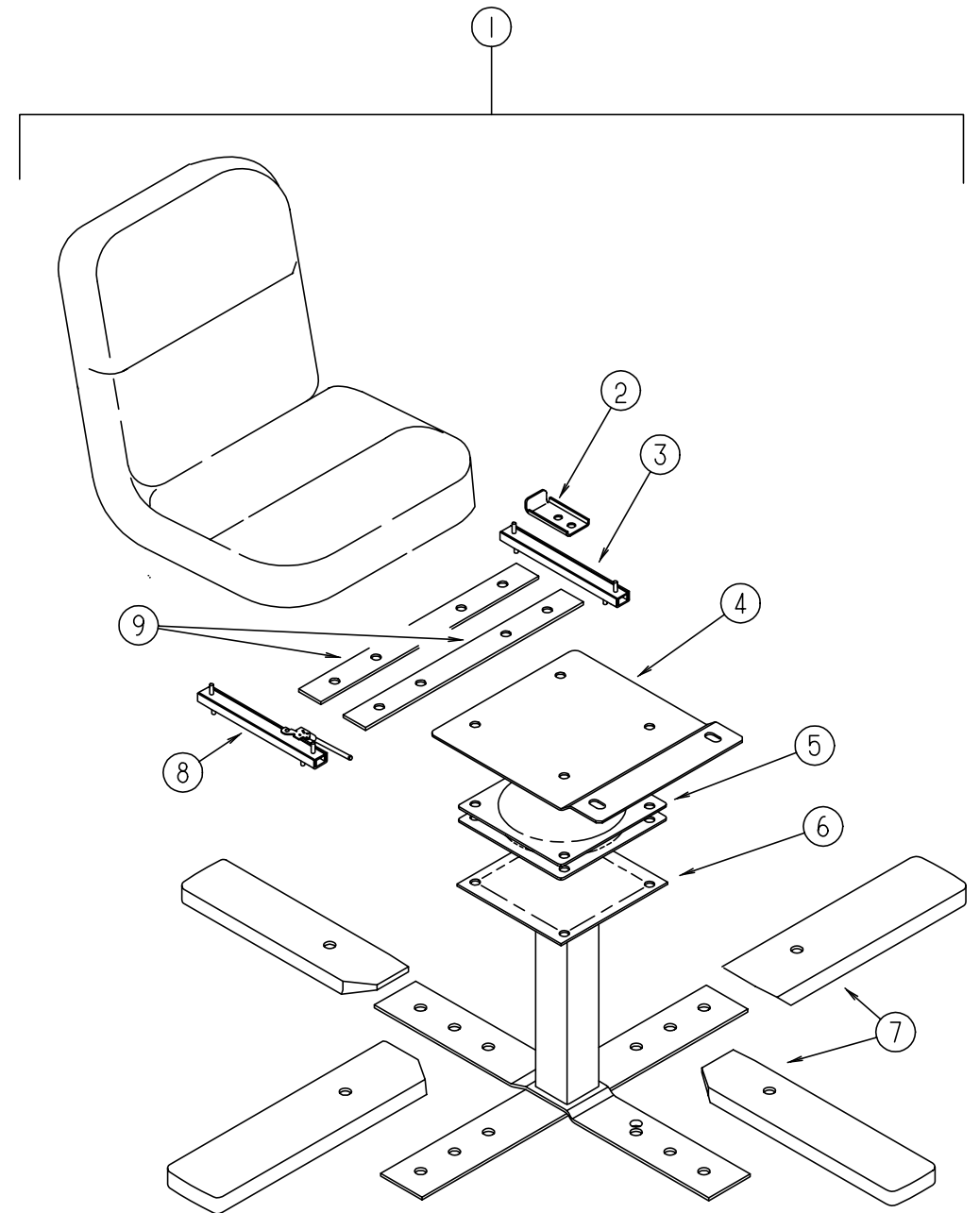

**DINETTE SWIVEL CHAIR**

KEY	PART NUMBER	U/M	DESCRIPTION
1	119108-01-G24	EA	CHAIR ASM - 200 KC
1	119108-01-G25	EA	CHAIR ASM - 200 KC
2	114889-01-000	EA	STOP BAR - UNIVERSAL
3	119952-02-000	EA	SLIDE - SEAT - HEAVY DUTY NONLOCKING
4	119705-11-02B	EA	PLATE-SEAT E-COAT
5	119105-01-000	EA	PLATE - SWIVEL, RETURN-0-MATIC
6	119705-02-03B	EA	PEDESTAL ASM,O/W
7	116080-02-G35	EA	COVER-CHAIR LEG
8	119952-05-000	EA	SLIDE - SEAT - HEAVY DUTY NONLOCKING
9	120109-01-02B	EA	ADAPTER BRKT-CHAIR ASM 200KC

**CURTAIN & CUSHION GROUP (CONTINUED)**

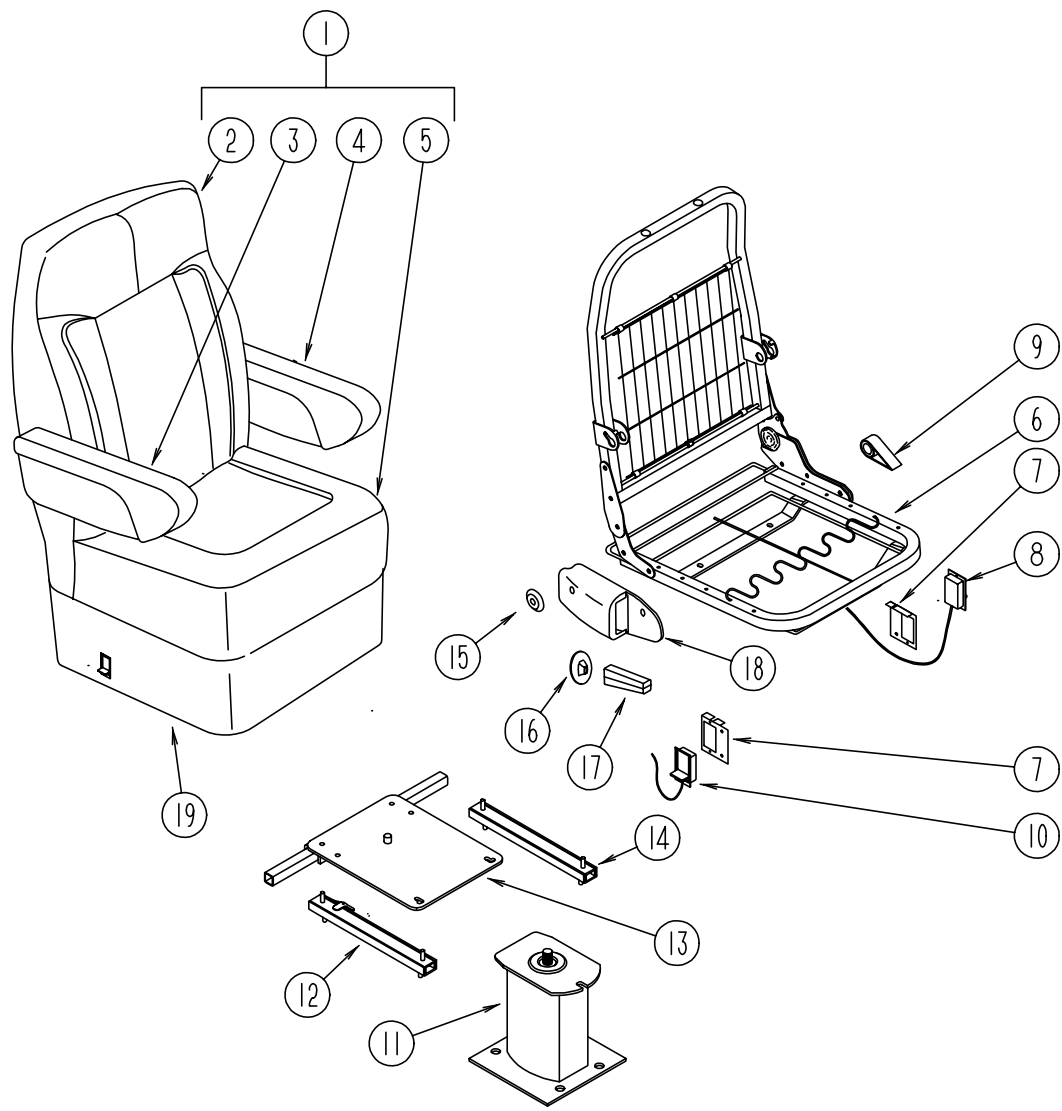

**BUCKET SEATS**

KEY	PART NUMBER	U/M	DESCRIPTION
1	119508-05-G24	EA	SEAT/BUCKET - MANUAL RECLINING
1	119508-05-G25	EA	SEAT/BUCKET - MANUAL RECLINING
2	M05962-30-G24	EA	COVER - BACKREST - BUCKET SEAT
2	M05962-30-G25	EA	COVER - BACKREST - BUCKET SEAT
	119509-01-G24	EA	HEADREST - BUCKET SEAT (G24)
	119509-01-G11	EA	HEADREST - BUCKET SEAT (G25)
	P19509-01-G24	EA	COVER - HEADREST - BUCKET SEAT (G24)
	P19509-01-G11	EA	COVER - HEADREST - BUCKET SEAT (G25)
	113977-12-000	EA	HEADREST INSERT - W/O LOCK
	113977-13-000	EA	HEADREST INSERT,W/LOCK - FLEXSTEEL
	114791-03-000	EA	FRAME-HEADREST,180013 MAGNUM - PLYFOAM
3	111320-03-G24	EA	ARMREST - RIGHT HAND - F/BUCKET SEAT (G24)
3	111320-03-G11	EA	ARMREST - RIGHT HAND - F/BUCKET SEAT (G25)
	P11320-03-G24	EA	COVER - ARMREST - RIGHT HAND - F/BUCKET SEAT (G24)
	P11320-03-G11	EA	COVER - ARMREST - RIGHT HAND - F/BUCKET SEAT (G25)
	111169-01-000	EA	PLATE-BACK, ARMREST
	111839-01-000	EA	BRACKET-ARM RT, MOLDED - GOSHEN
4	111320-04-G24	EA	ARMREST - LEFT HAND - F/BUCKET SEAT (G24)
4	111320-04-G11	EA	ARMREST - LEFT HAND - F/BUCKET SEAT (G25)
	P11320-04-G24	EA	COVER - ARMREST - LEFT HAND - F/BUCKET SEAT (G24)
	P11320-04-G11	EA	COVER - ARMREST - LEFT HAND - F/BUCKET SEAT (G25)
	111169-01-000	EA	PLATE-BACK, ARMREST
	111839-02-000	EA	BRACKET-ARM LT, MOLDED - GOSHEN

**CURTAIN & CUSHION GROUP (CONTINUED)**

**BUCKET SEATS (CONTINUED)**

KEY	PART NUMBER	U/M	DESCRIPTION
5	M05962-06-G24	EA	COVER - SEAT - F/BUCKET
5	M05962-06-G11	EA	COVER - SEAT - F/BUCKET
6	M80906-12-000	EA	FRAME - SEAT/BACK & SPRING
7	097683-02-000	EA	BRACKET-MOUNT, REMOTE
8	080730-09-000	EA	SHIELD-FLEXSTEEL
	089323-01-000	FT	STRIP-POLYENTHYLENE,J-CHANEL - FLEX-O-LATORS
9	080730-08-000	EA	HANDLE - RECLINER
10	108049-03-000	EA	CABLE-W/CONTROL 25.5" SHEATH/28.5" CABLE W/DOG LEG
	108049-02-000	EA	CLIP-CABLE, PEDESTAL
11	107921-09-000	EA	PEDESTAL ASM-SEAT FORD - FLEXSTEEL 3067-PDMB
12	119952-04-000	EA	SLIDE - SEAT, HEAVY DUTY LOCKING
13	107921-08-000	EA	TOP PLATE - PEDESTAL- WO SEAT BELT BAR
	107921-06-000	EA	BEARING KIT-PEDESTAL
14	119952-02-000	EA	SLIDE - SEAT, HEAVY DUTY NONLOCKING
15	000G39-10-12B	EA	SCREW-SF/DR - 10-16 X .75 PPH - ZINC
	111169-05-000	EA	INSERT-OVAL - ITASCA
16	080730-09-000	EA	SHIELD-FLEXSTEEL
17	080730-08-000	EA	HANDLE - RECLINER
18	080730-11-000	EA	SHIELD-RUBBER BOOT
19	071126-42-F16	EA	SKIRT-7",W/OPEN BK CRNS (G24)
19	071126-42-E22	EA	SKIRT-7",W/OPEN BK CRNS (G25)
	114889-01-000	EA	STOP BAR-UNIVERSAL - SHROCK
	117125-01-02B	EA	BRACKET-CABLE HOLDER,E-COAT

**VINYL ASSIST HANDLE, BUTTONS, WELTING & SEATBELTS**

KEY	PART NUMBER	U/M	DESCRIPTION
	079349-04-GD1	YD	WELT - NARROW ACCENT (G24)
	079349-04-G32	YD	WELT - NARROW ACCENT (G25)
	057534-06-000	EA	TIEBACK/TIEDOWN - VINYL - 6" BEIGE
	069178-02-000	EA	BRACKET - MOUNTING ASSIST HANDLE
	053552-02-AA8	EA	HANDLE-ASSIST, INTERIOR - ENTRY DOOR - VINYL - OFF WHITE
	000C16-07-16B	EA	BOLT-CARRIAGE, ASSIST HANDLE - 7/16" - 14 X 1" ZN
	000D20-07-00B	EA	NUT-ACORN,ASSIST HANDLE - 7/16" X 14 ZN
	057759-01-000	EA	WASHER BRACKET - SEAT BELT - 4" DIAMETER
	007021-01-000	EA	BELT-SEAT, 2" X 90" - BLACK

## CURTAIN & CUSHION GROUP (CONTINUED)

### CURTAINS, SHADES, VALANCES & BLINDS

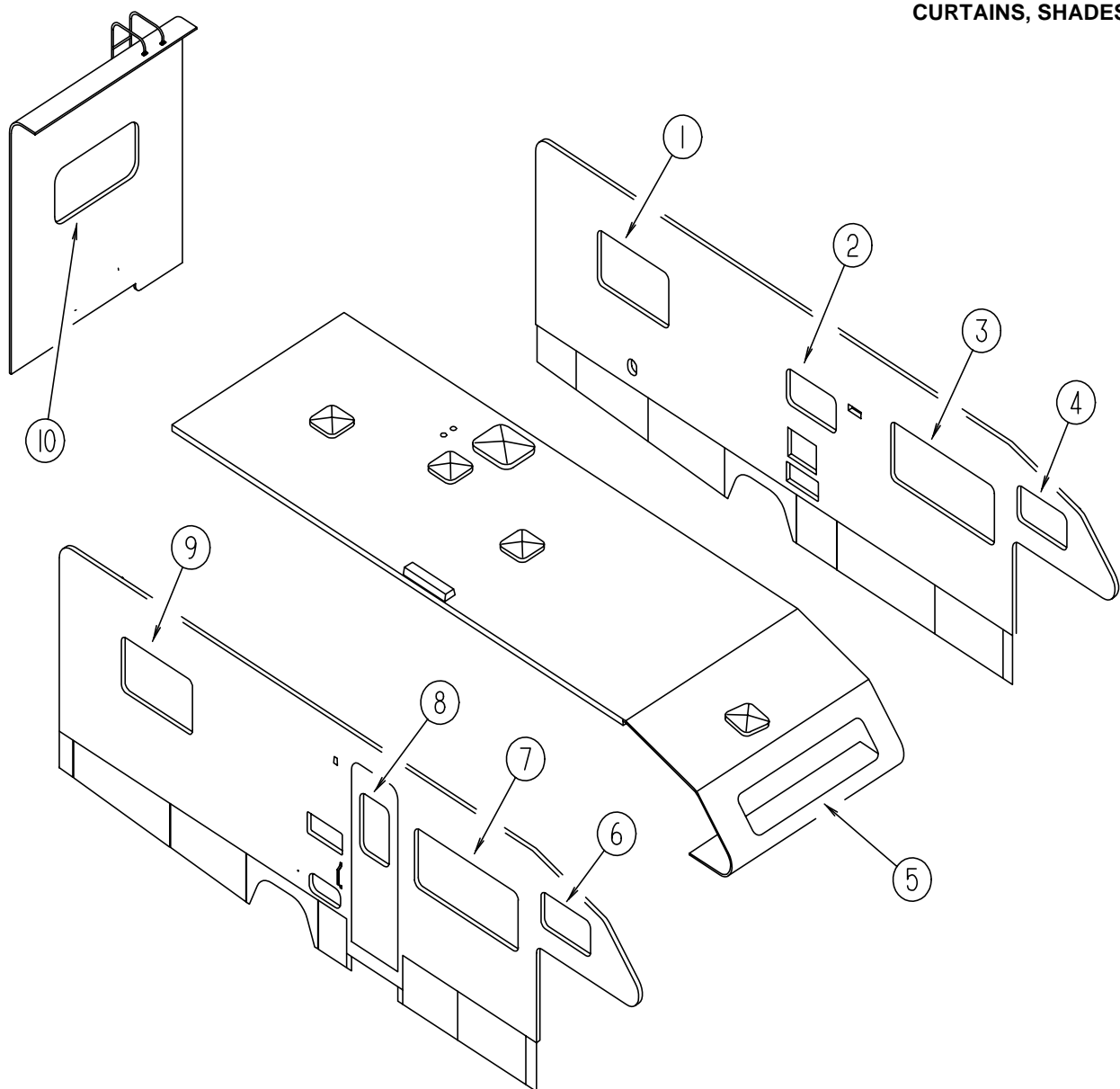

KEY	PART NUMBER	U/M	DESCRIPTION
1	119263-05-G24	EA	VALANCE - STARBUCK - 45" (QUEEN)
1	119138-25-G25	EA	VALANCE - BELLINI - 45" (QUEEN)
1	119263-04-G24	EA	VALANCE - STARBUCK - 53" (TWIN/DOUBLE)
1	119138-01-G25	EA	VALANCE - BELLINI - 53" (TWIN/DOUBLE)
1	119333-03-G24	EA	LEG - RIGHT - 25" (QUEEN/TWIN/DOUBLE)
1	119333-03-G25	EA	LEG - RIGHT - 25" (QUEEN/TWIN/DOUBLE)
1	119333-04-G24	EA	LEG - LEFT - 25" (QUEEN/TWIN/DOUBLE)
1	119333-04-G25	EA	LEG - LEFT - 25" (QUEEN/TWIN/DOUBLE)
1	101034-49-G24	EA	CURTAIN - RIGHT HAND - 19" X 19"(CROSS STACKED)
1	101034-49-G25	EA	CURTAIN - RIGHT HAND - 19" X 19"(CROSS STACKED)
1	101034-50-G24	EA	CURTAIN - LEFT HAND - 19" X 19"(CROSS STACKED)
1	101034-50-G25	EA	CURTAIN - LEFT HAND - 19" X 19" (CROSS STACKED)
1	109041-33-01A	EA	BLIND - MINI - 42" X 28" DROP(QUEEN)(G24)
1	109041-33-02A	EA	BLIND - MINI - 42" X 28" DROP(QUEEN)(G25)
1	093475-55-03A	EA	BLIND - MINI - 48" X 28" DROP (TWIN/DOUBLE)(G24)
1	093475-55-04A	EA	BLIND - MINI - 48" X 28" DROP (TWIN/DOUBLE)(G25)
2	109353-08-01A	EA	BLIND-SLAT,28" PURE SILVER (G24)
2	109353-08-02A	EA	BLIND-SLAT,28" C011 BEIGE (G25)
2	109041-43-01A	EA	BLIND-MINI,27X20 (G24)
2	109041-43-02A	EA	BLIND-MINI,27X20 (G25)
3	119263-01-G24	EA	VALANCE - STARBUCK - 64.5"
3	119138-12-G25	EA	VALANCE - BELLINI - 64.5"
3	109041-01-02A	EA	BLIND - MINI - 62" X 28.5" DROP(G24)
3	109041-01-03A	EA	BLIND - MINI - 62" X 28.5" DROP(G25)
4	101034-51-G24	EA	CURTAIN - RIGHT HAND - 19" X 34"
4	101034-51-G25	EA	CURTAIN - RIGHT HAND - 19" X 34"
4	101034-52-G24	EA	CURTAIN - LEFT HAND - 19" X 34"
4	101034-52-G25	EA	CURTAIN - LEFT HAND - 19" X 34"
5	101034-33-G24	EA	CURTAIN - RIGHT HAND - 21" X 60"
5	101034-33-G25	EA	CURTAIN - RIGHT HAND - 21" X 60"
5	101034-34-G24	EA	CURTAIN - LEFT HAND - 21" X 60"
5	101034-34-G25	EA	CURTAIN - LEFT HAND - 21" X 60"
6	101034-51-G24	EA	CURTAIN - RIGHT HAND - 19" X 34"
6	101034-51-G25	EA	CURTAIN - RIGHT HAND - 19" X 34"
6	101034-52-G24	EA	CURTAIN - LEFT HAND - 19" X 34"
6	101034-52-G25	EA	CURTAIN - LEFT HAND - 19" X 34"
7	119263-01-G24	EA	VALANCE - STARBUCK - 64.5"
7	119138-12-G25	EA	VALANCE - BELLINI - 64.5"
7	109041-01-02A	EA	BLIND - MINI - 62" X 28.5" DROP(G24)
7	109041-01-03A	EA	BLIND - MINI - 62" X 28.5" DROP(G25)
8	119263-07-G24	EA	VALANCE - STARBUCK FLAT - 31.75"
8	119138-11-G25	EA	VALANCE - BELLINI - 31.75"
8	084755-57-E07	EA	SHADE - PULL - 27.25"
9	119263-05-G24	EA	VALANCE - STARBUCK - 45" (QUEEN/CROSS STACKED)
9	119138-25-G25	EA	VALANCE - BELLINI - 45" (QUEEN/CROSS STACKED)
9	119263-04-G24	EA	VALANCE - STARBUCK - 53" (TWIN/DOUBLE)
9	119138-01-G25	EA	VALANCE - BELLINI - 53" (TWIN/DOUBLE)
9	119333-03-G24	EA	LEG - RIGHT - 25"
9	119333-03-G25	EA	LEG - RIGHT - 25"
9	119333-04-G24	EA	LEG - LEFT - 25"
9	119333-04-G25	EA	LEG - LEFT - 25"
9	109041-33-01A	EA	BLIND - MINI - 42" X 28" DROP(QUEEN/QUEEN/CROSS STACKED)(G24)
9	109041-33-02A	EA	BLIND - MINI - 42" X 28" DROP(QUEEN/QUEEN/CROSS STACKED)(G25)
9	093475-55-03A	EA	BLIND - MINI - 48" X 28" DROP (TWIN/DOUBLE)(G24)
9	093475-55-04A	EA	BLIND - MINI - 48" X 28" DROP (TWIN/DOUBLE)(G25)
10	119263-04-G24	EA	VALANCE - STARBUCK - 53" (QUEEN/TWIN)
10	119138-01-G25	EA	VALANCE - BELLINI - 53" (QUEEN/TWIN)
10	119263-06-G24	EA	VALANCE - STARBUCK - 31" (DOUBLE)
10	119138-05-G25	EA	VALANCE - BELLINI - 31" (DOUBLE)
10	119333-03-G24	EA	LEG - RIGHT - 25" (QUEEN/TWIN)
10	119333-03-G25	EA	LEG - RIGHT - 25" (QUEEN/TWIN)
10	119333-04-G24	EA	LEG - LEFT - 25" (QUEEN/TWIN)
10	119333-04-G25	EA	LEG - LEFT - 25" (QUEEN/TWIN)
10	119333-37-G24	EA	LEG - RIGHT - 25" (DOUBLE)
10	119333-37-G25	EA	LEG - RIGHT - 25" (DOUBLE)
10	119333-38-G24	EA	LEG - LEFT - 25" (DOUBLE)
10	119333-38-G25	EA	LEG - LEFT - 25" (DOUBLE)
10	101034-53-G24	EA	CURTAIN - RIGHT HAND - 30.5" X 19"(CROSS STACKED)
10	101034-53-G25	EA	CURTAIN - RIGHT HAND - 30.5" X 19"(CROSS STACKED)
10	101034-54-G24	EA	CURTAIN - LEFT HAND - 30.5" X 19"(CROSS STACKED)
10	101034-54-G25	EA	CURTAIN - LEFT HAND - 30.5" X 19"(CROSS STACKED)
10	093475-55-03A	EA	BLIND - MINI - 48" X 28" DROP(QUEEN/TWIN)(G24)
10	093475-55-04A	EA	BLIND - MINI - 48" X 28" DROP(QUEEN/TWIN)(G25)
10	093475-28-06A	EA	BLIND - MINI - 28" X 28" DROP(DOUBLE) (G24)
10	093475-28-07A	EA	BLIND - MINI - 28" X 28" DROP(DOUBLE) (G25)
	093487-10-01A	EA	PLEATED CURTAIN - 31" X 100" BUNK PRIVACY
	076892-23-G05	EA	CURTAIN - 44" X 80" (G24)
	076892-23-G04	EA	CURTAIN - 44" X 80" (G25)
	057534-06-000	EA	TIEBACK/TIEDOWN - VINYL - 6" BEIGE



### DINETTE GROUP

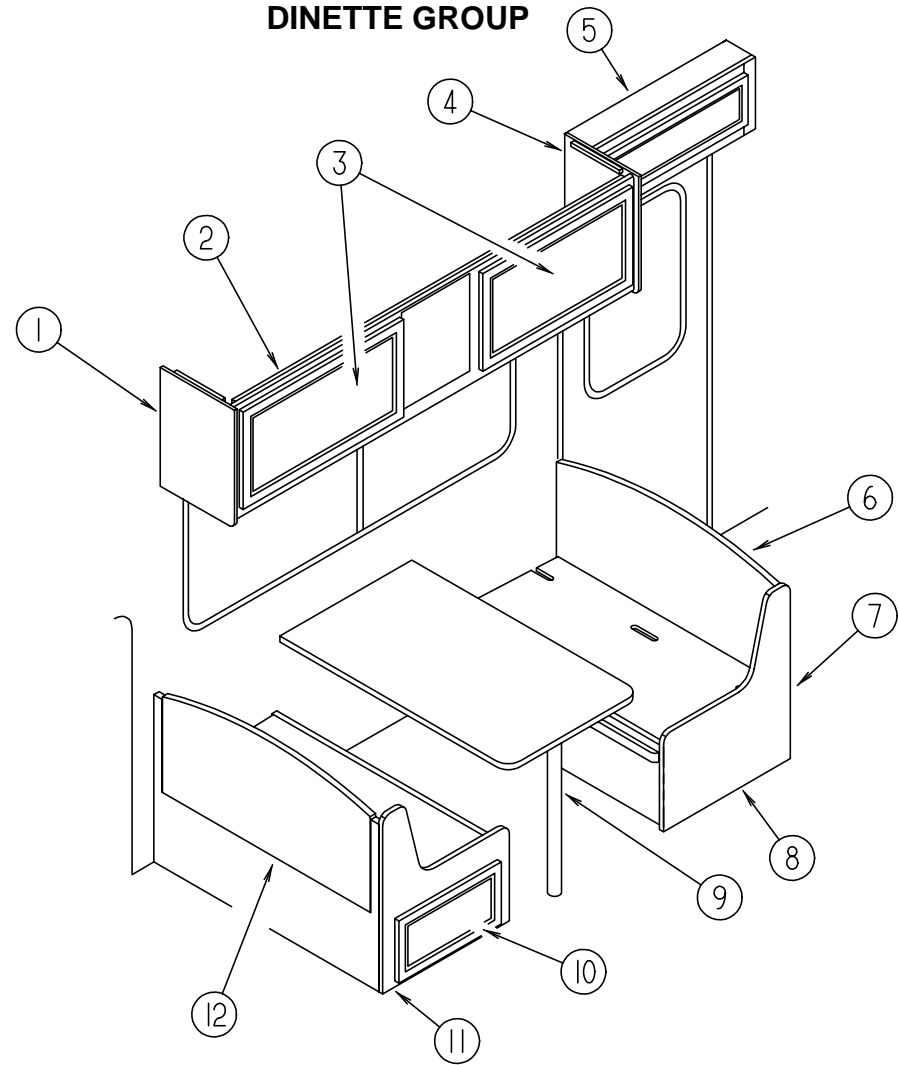

### DINETTE CABINETRY

KEY	PART NUMBER	U/M	DESCRIPTION
1	109908-08-G04	EA	END CAP - OVERHEAD CABINET
2	121405-01-G24	EA	CABINET ASM-OVHD,FRONT RH
2	121405-01-G25	EA	CABINET ASM-OVHD,FRONT RH
3	110140-38-G04	EA	DOOR - MITERED CORNER/VINYL WRAP - 8.1" X 24.8" - W/O HDW
4	109908-09-G04	EA	END CAP - OVERHEAD CABINET
5	112964-01-G04	EA	CABINET - OVERHEAD ENTRANCE - W/O DOORS/HARDWARE
6	110140-60-G04	EA	DOOR - MITERED CORNER/VINYL WRAP - 6.7" X 29.5" - W/O HDW
7	M08123-03-G04	EA	CABINET-SEATBACK RH
	111338-06-F16	EA	PAD - DINETTE BACKREST (G24)
	111338-06-E22	EA	PAD - DINETTE BACKREST (G25)
8	M08122-03-G04	EA	CABINET-SEATBASE RH
	081295-01-G01	EA	SUPPORT - BED/DINETTE - 28"
9	081322-16-G24	EA	TABLE ASM-DINETTE
9	081322-16-G25	EA	TABLE ASM-DINETTE
10	110140-88-G04	EA	DOOR ASM-MITERED,VINYL WRAP
11	M08122-04-G04	EA	CABINET-SEATBASE LH
	081295-01-G01	EA	SUPPORT - BED/DINETTE - 28"
12	M08123-04-G04	EA	CABINET-SEATBACK LH
	P14437-02-000	EA	CABINET - LID ENTRANCE DOOR - W/O CARPET
	101222-01-02A	EA	BRACKET-CATCH,LID, OFF WHITE

### DINETTE GROUP (CONTINUED)

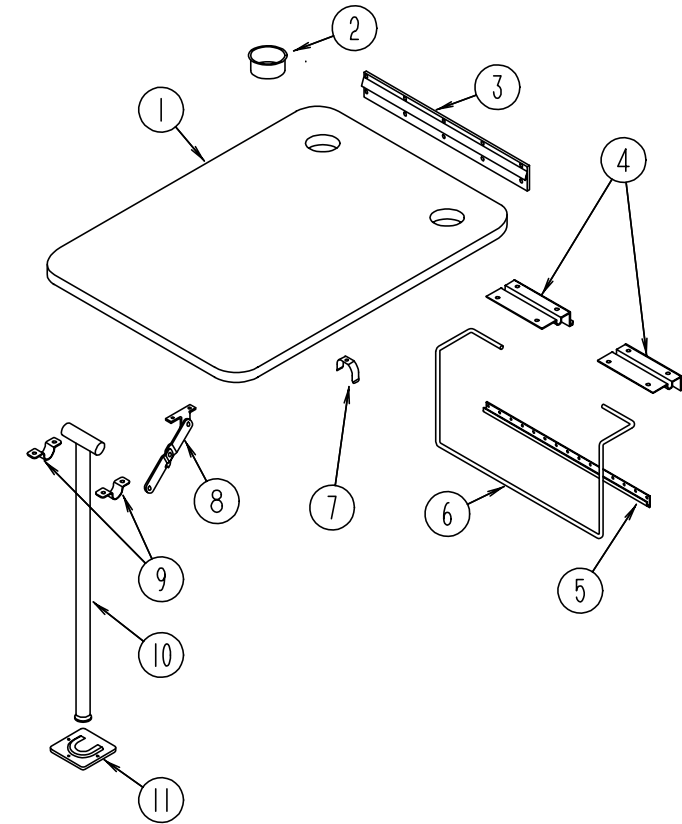

### DINETTE TABLE

KEY	PART NUMBER	U/M	DESCRIPTION
1	081322-16-G24	EA	TABLE ASM-DINETTE
1	081322-16-G25	EA	TABLE ASM-DINETTE
2	064781-06-000	EA	HOLDER-CUP TWO STEP - OFF WHITE
3	053200-12-000	EA	BRACKET - TABLE SUPPORT - UPPER WALL MOUNTED 23.50"
4	088410-02-000	EA	BRACKET - LIFT - TABLE MOUNTED
5	024281-14-000	EA	BRACKET - LIFT ROD LOWER WALL MOUNTED - 22.12"
6	024275-12-000	EA	ROD - TABLE LIFT
7	024283-01-000	EA	CLIP-LEG, 1" - 1.125" OD - BLACK
8	024282-01-000	EA	BRACE-TABLE LEG, HINGED
9	064050-05-000	EA	HINGE-TABLE LEG, OFF WHITE
10	024276-23-000	EA	LEG - TABLE, METAL
11	049493-11-700	EA	CATCH-TABLE LEG,E-COAT
	049493-12-000	EA	CATCH - LEG FLOOR MOUNTED 2.5" X 2.7"
	002929-01-001	EA	EXTR- BRACKET TABLE

### DINETTE GROUP (CONTINUED)

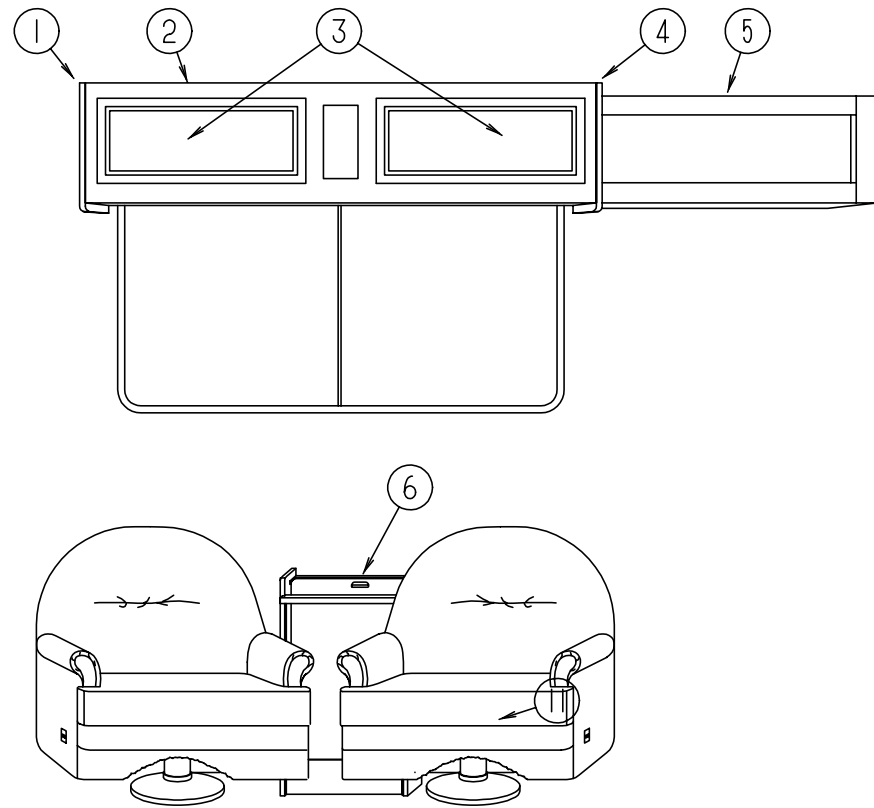

### PASSENGER SIDE LOUNGE WITH CHAIR

KEY	PART NUMBER	U/M	DESCRIPTION
1	109908-08-G04	EA	END CAP - OVERHEAD CABINET
2	121405-01-G24	EA	CABINET ASM-OVHD,FRONT RH
2	121405-01-G25	EA	CABINET ASM-OVHD,FRONT RH
3	110140-38-G04	EA	DOOR - MITERED CORNER/VINYL WRAP - 8.1" X 24.8" - W/O HDW
4	109908-09-G04	EA	END CAP - OVERHEAD CABINET
5	112964-01-G04	EA	CABINET - OVERHEAD ENTRANCE - W/O DOORS/HARDWARE
6	120898-02-G24	EA	TABLE - DROPLEAF - W/O LEG
6	120898-02-G25	EA	TABLE - DROPLEAF - W/O LEG
	P14437-02-000	EA	CABINET - LID ENTRANCE DOOR - W/O CARPET
	101222-01-02A	EA	BRACKET-CATCH,LID, OFF WHITE

### DINETTE GROUP (CONTINUED)

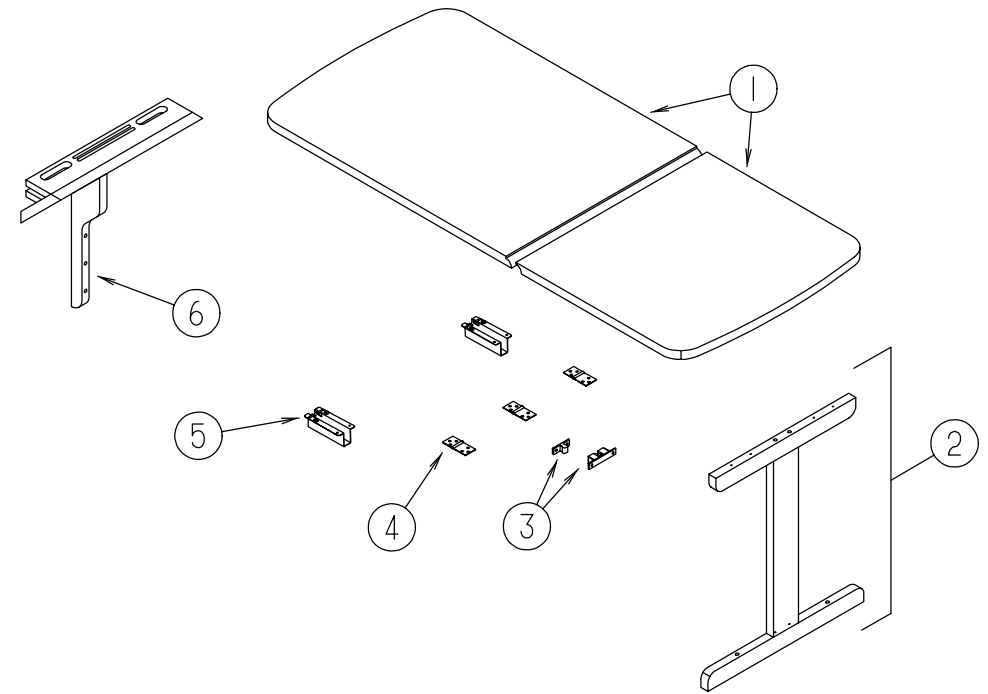

### FOLDOUT TABLE

KEY	PART NUMBER	U/M	DESCRIPTION
1	120898-21-G24	EA	COUNTERTOP ASM
1	120898-21-G25	EA	COUNTERTOP ASM
2	120898-26-G04	EA	LEG ASM.
3	084451-01-000	EA	CATCH-TV SHELF - BRASS
4	120972-01-01A	EA	HINGE-TABLE,DROP LEAF,ANTBRS
5	120973-01-000	EA	SUPPORT-TABLE,DROP LEAF,PAIR
6	M08091-01-G04	EA	SUPPORT ASM-TABLE/DTL H-H

### DRIVERS COMPARTMENT GROUP

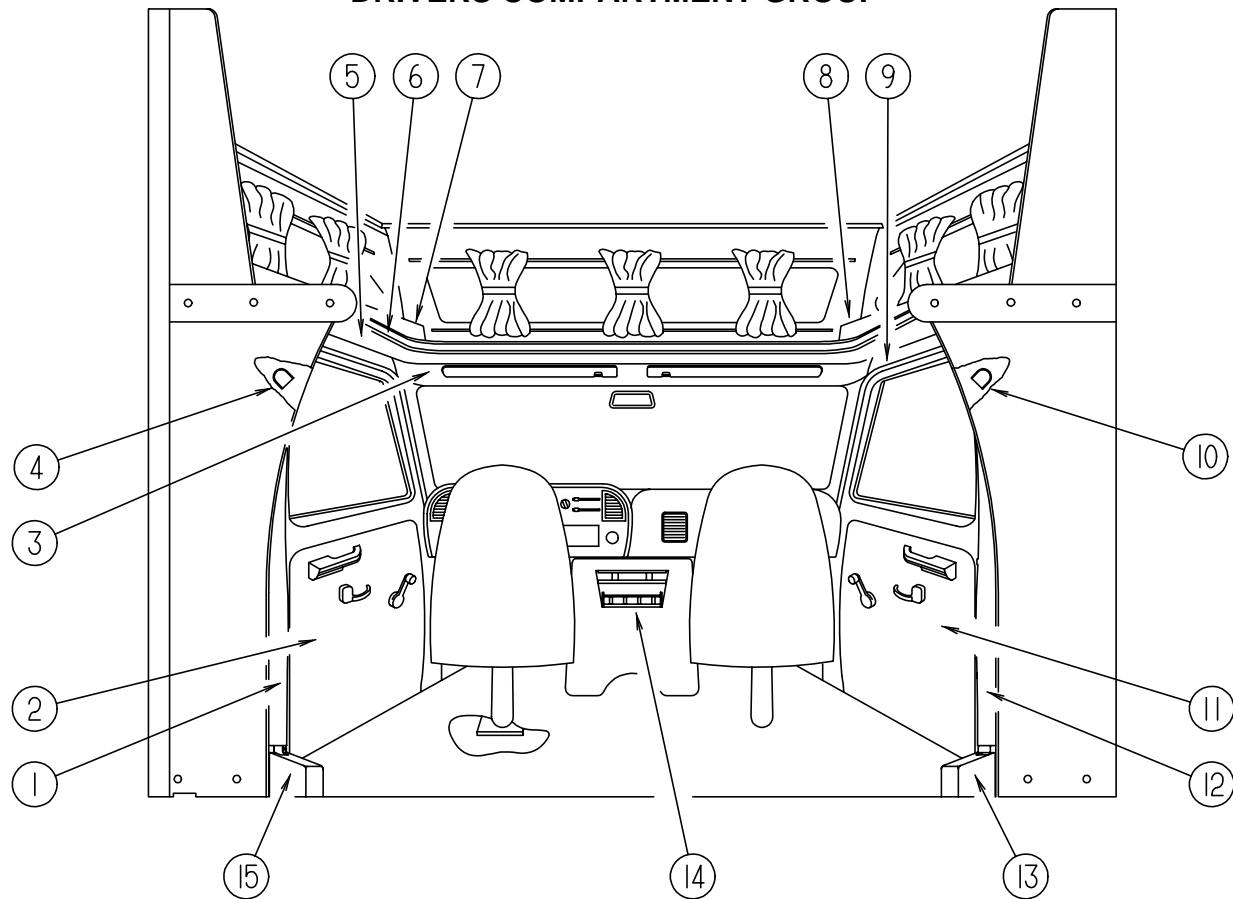

DRIVERS COMPARTMENT

KEY	PART NUMBER	U/M	DESCRIPTION
1	106446-02-C52	EA	TRIM - CAB B-PILLAR - DRIVERS SIDE (FORD)
2	N/A	EA	CHASSIS SUPPLIED
3	106448-01-C52	EA	HEADLINER-VINYL (FORD)
4	115038-02-01A	EA	COVER - SEAT BELT UPPER LEFT HAND
5	106447-02-C52	EA	TRIM - CAB DOOR UPPER - DRIVER SIDE (FORD)
6	119520-01-01A	FT	T-MOLDING - 1 W/EDGE LIPS
7	109894-01-G24	EA	CABINET - HAMPER - DRIVER
7	109894-01-G25	EA	CABINET - HAMPER - DRIVER
8	109894-03-G24	EA	CABINET - HAMPER - PASSENGER
8	109894-03-G25	EA	CABINET - HAMPER - PASSENGER
9	106447-01-C52	EA	TRIM - CAB DOOR UPPER - PASSENGER SIDE (FORD)
10	115038-01-01A	EA	COVER - SEAT BELT UPPER RIGHT HAND
11	N/A	EA	CHASSIS SUPPLIED
12	106446-01-C52	EA	TRIM - CAB B-PILLAR - PASSENGER SIDE (FORD)
13	106431-01-01A	EA	COVER - SEATBELT RECOIL - PASSENGER SIDE - OFF WHITE(FORD)
14	108899-01-G04	EA	TRAY-BEVERAGE LOW-PROFILE 2 CUP ONLY
14	112185-02-G01	EA	TRAY-BEVERAGE W/SLOTTED FACE
14	122717-04-01A	EA	PAD - NON SKID
			FROM: 07-05-96 THRU: 99-99-99
	069885-23-F16	EA	COVER - MOTOR W/POCKET (FORD)(G24)
	069885-23-F29	EA	COVER - MOTOR W/POCKET (FORD)(G25)
15	106431-02-01A	EA	COVER-RECOIL, SEATBELT - DRIVER SIDE - OFF WHITE (FORD)
	106025-03-01A	EA	LADDER-BUNK(BLACK),1197 MM
	106025-01-700	EA	BRACKET SET-F/BUNK LADDER 08-0030-00
	091952-01-000	EA	CLIP-GRIPPER - 1"
	109804-03-G24	EA	CAP - SLEEPERBOARD
	109804-03-G25	EA	CAP - SLEEPERBOARD
	106025-03-01A	EA	LADDER-BUNK(BLACK),1197 MM
	106025-01-700	EA	BRACKET SET-F/BUNK LADDER 08-0030-00

### DRIVERS COMPARTMENT GROUP (CONTINUED)

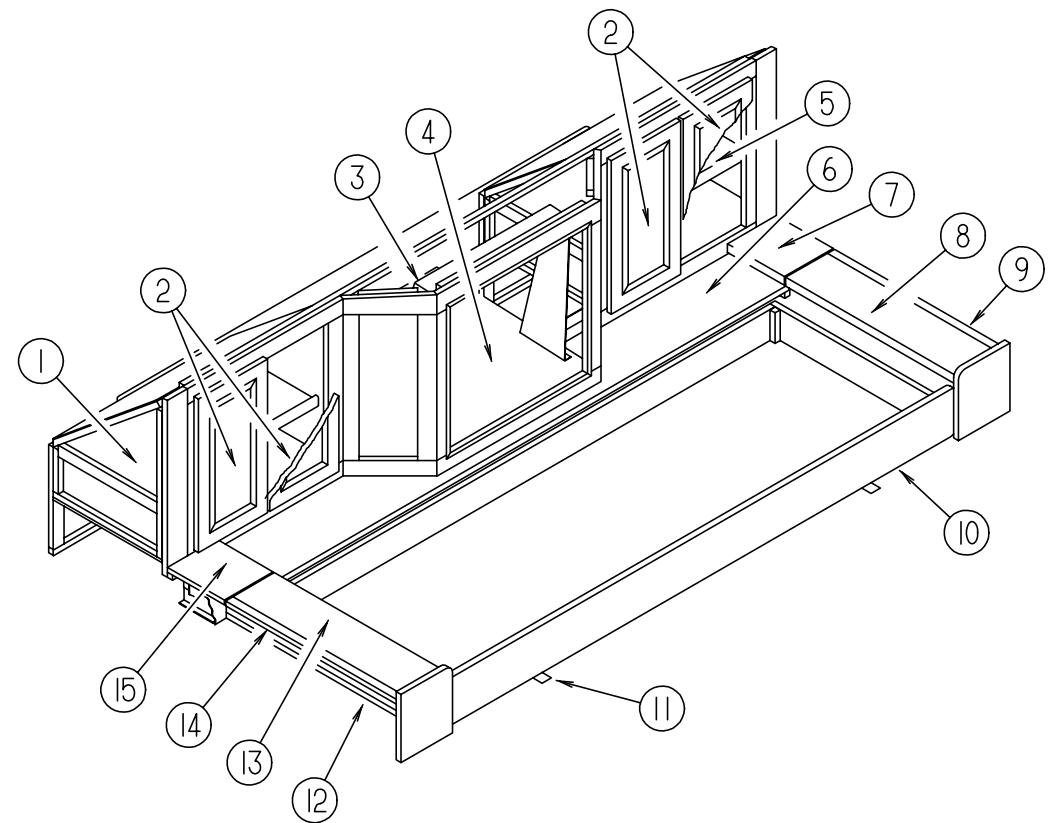

FRONT ENTERTAINMENT CENTER

KEY	PART NUMBER	U/M	DESCRIPTION
1	113156-02-G04	EA	CABINET - ENTERTAINMENT CENTER /SHELF- W/O DOORS/HARDWARE
	121563-01-G04	EA	CABINET - ENTERTAINMENT CENTER FACE - W/DUCTED ROOF AIR
2	110140-25-G01	EA	DOOR - MITERED CORNER/VINYL WRAP - 10.6" X 19.9" - W/O HDW
3	110790-02-000	EA	BRACKET-TIEDOWN,TV
4	111356-01-G01	EA	SHELF - TV
5	113156-01-G04	EA	CABINET - ENTERTAINMENT CENTER /SHELF
6	118603-12-G04	EA	SHELF-W/PLASTIC EDGE TRIM
7	113155-11-F02	EA	COUNTERTOP - ENTERTAINMENT CENTER (G24)
7	113155-11-F09	EA	COUNTERTOP - ENTERTAINMENT CENTER (G25)
8	113155-12-G24	EA	COUNTERTOP - ENTERTAINMENT CENTER (G24)
8	113155-12-G07	EA	COUNTERTOP - ENTERTAINMENT CENTER (G25)
9	113155-01-G24	EA	CABINET - ENTERTAINMENT - W/O DOORS/DRAWERS/HARDWARE
9	113155-01-G25	EA	CABINET - ENTERTAINMENT - W/O DOORS/DRAWERS/HARDWARE
10	100847-01-G24	EA	DRAWER - ENTERTAINMENT - 76.7" X 26.7" W/O HARDWARE
10	100847-01-G25	EA	DRAWER - ENTERTAINMENT - 76.7" X 26.7" W/O HARDWARE
11	093673-01-01A	FT	TRIM-ENTRANCE DOOR, 1.4" WIDE X 8' LONG- OFF WHITE PLASTIC
12	113155-02-G24	EA	CABINET - ENTERTAINMENT - W/O DOORS/DRAWERS/HARDWARE
12	113155-02-G25	EA	CABINET - ENTERTAINMENT - W/O DOORS/DRAWERS/HARDWARE
13	113155-18-G24	EA	COUNTERTOP - ENTERTAINMENT CENTER STORAGE (G24)
13	113155-18-G07	EA	COUNTERTOP - ENTERTAINMENT CENTER STORAGE (G25)
14	113155-21-F02	EA	COUNTERTOP - STATIONARY (G24)
14	113155-21-F09	EA	COUNTERTOP - STATIONARY (G25)
15	113155-19-F02	EA	COUNTERTOP - ENTERTAINMENT CENTER (G24)
15	113155-19-F09	EA	COUNTERTOP - ENTERTAINMENT CENTER (G25)
	106699-01-01A	EA	BRACKET-CABINET - OVERHEAD - TV - OFF WHITE

### INSTRUMENT CLUSTERS & BATTERY SWITCH

KEY	PART NUMBER	U/M	DESCRIPTION
	094795-09-000	EA	CLUSTER-IP,KM, GAS/DSL - FORD F5UZ-10849-B
	100138-01-000	EA	MODULE-DAYTIME RUNNING LIGHT
	108357-09-000	EA	SWITCH - ROCKER SPDT ON/NONE/MOM 3 TERMINAL
	108357-06-000	EA	SWITCH - ROCKER DPDT MON/OFF/MOM 6 TERMINAL

## ELECTRICAL GROUP

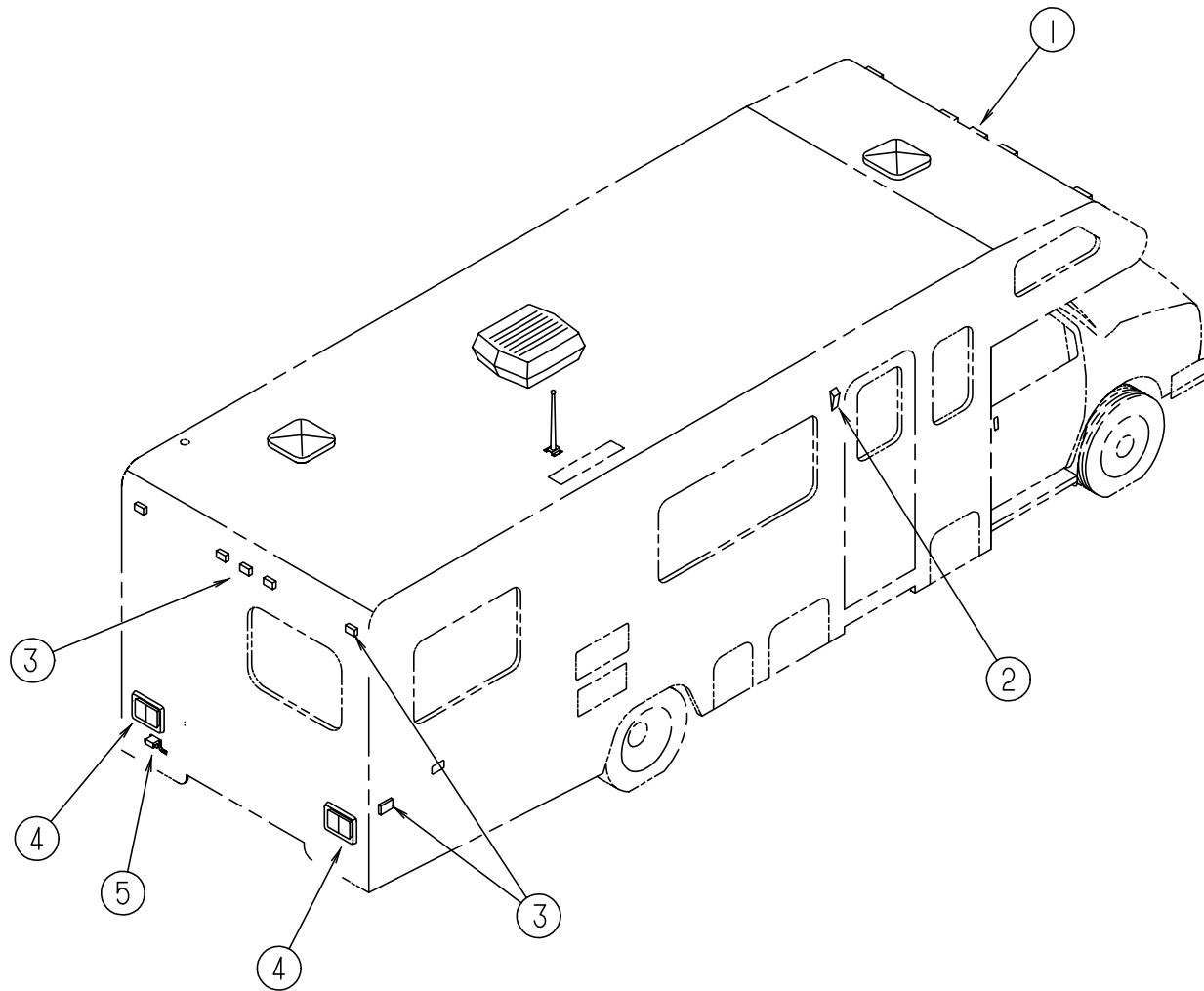

### EXTERIOR LIGHTS

KEY	PART NUMBER	U/M	DESCRIPTION
1	111102-01-000	EA	LAMP-MARKER, BASE
1	111102-02-000	EA	LENS-MARKER LAMP, AMBER
	036196-01-000	EA	BULB-12V, #194 - .27AMP - BAYONETTE
2	097917-01-06A	EA	LIGHT-PORCH,BRT WHT - *BARGMAN 30-78-531
2	097917-01-700	EA	LENS-LIGHT, CLEAR 30-78-021
2	008215-01-000	EA	BULB - 12V - #1003 - .94AMP
	008089-02-000	EA	LIGHT-PORCH, RECESSED - CANADIAN
2	008089-01-700	EA	LENS-LIGHT,RECESSED,PORCH DECO
2	008214-01-000	EA	BULB-12V NO67 0.59AMP
2	091981-01-000	EA	GASKET-PORCH LIGHT
3	111102-01-000	EA	LAMP-MARKER, BASE -
3	111102-03-000	EA	LENS-MARKER LAMP, RED
	036196-01-000	EA	BULB-12V, #194 - .27AMP - BAYONETTE
4	081638-01-000	EA	TAILLIGHT-DOUBLE, W/BLACK TRIM - DRIVER & PASSENGER SIDE
	037934-01-000	EA	BULB # 1156 (BACK UP & TURN SIGNAL)
	037935-01-000	EA	BULB # 2057 OR #1157 (BRAKE LIGHT)
4	081638-01-700	EA	LENS-TAILLIGHT, RED 30-84-010
4	081638-01-701	EA	LENS-TAILLIGHT, W/BACKUP 30-84-700
	008215-01-000	EA	BULB-12V, #1003 - .94AMP
	103355-01-05A	EA	POD-TAILLIGHT, BRIGHT WHITE
5	066432-02-000	EA	LIGHT-LICENSE BLACK
	066432-03-000	EA	BRACKET - LICENSE PLATE

## ELECTRICAL GROUP (CONTINUED)

### FUSES & CIRCUIT BREAKERS

KEY	PART NUMBER	U/M	DESCRIPTION
	062901-02-000	EA	FUSE-5 AMPS, AUTOMOTIVE
	062901-05-000	EA	FUSE-15 AMPS, AUTOMOTIVE
	008235-01-000	EA	FUSE-AUTOMOTIVE, 12V - 15AMP
	100341-01-000	EA	FUSE HOLDER-IN LINE TYPE, WESCO 8931-92020
	093654-01-000	EA	CIRCUIT BREAKER 6AMP 12V USD 17406-4E12A2A
	093654-03-000	EA	CIRCUIT BREAKER-20A, 12V - USD 17420-4E12A2A
	083209-02-000	EA	CIRCUIT BREAKER 15/15AMP 120V BW H-15/15
	083209-03-000	EA	CIRCUIT BREAKER 15/20AMP 120V BW 0-15/20
	083209-04-000	EA	CIRCUIT BREAKER 30AMP 120V BW L-30
	083209-06-000	EA	CIRCUIT BREAKER 30/15 AMP 120V BW D-30/15
	093655-01-000	EA	CIRCUIT BREAKER 25AMP 12V USD 17425-4E03A2A
	093655-02-000	EA	CIRCUIT BREAKER 30AMP 12V USD 17430-4E03A2A
	108669-01-000	EA	HOUSING-AUTO FUSE HOLDER, PACKARD 12010105

### POWER CONVERTER & INVERTER

KEY	PART NUMBER	U/M	DESCRIPTION
	123058-02-000	EA	CONVERTER - 45 AMP, ELECTRONIC - 4 1/8"H X 7"W X 12 3/8"L
	099048-02-000	EA	INVERTER-100 WATT
			FROM: 00-00-00 THRU: 06-16-96
	099048-03-000	EA	INVERTER-130 WATT
			FROM: 06-17-96 THRU: 99-99-99
	113132-01-000	EA	LOAD CENTER-120/240V,60A - WESCO 2460SGNM
			FROM: 06-02-96 THRU: 99-99-99

### ELECTRIC BOXES, COVERS & POWER CORDS

KEY	PART NUMBER	U/M	DESCRIPTION
	107165-01-01A	EA	BOX-CIRCUIT BREAKER MOUNT, 14.6" X 4" - BLACK PLASTIC
	107165-03-01A	EA	BOX-CIRCUIT BREAKER MNT BLK - *96 400 SERIES
	008289-01-000	EA	BOX-ELECTRIC, STEEL - 1/2" AND 3/4" KNOCKOUTS - 4" X 4"
	008289-02-000	EA	BOX-ELECTRICAL - 4" X 4" - 1/2" & 3/4" KNOCKOUTS - CANADIAN
	091910-01-000	EA	BOX-ELECTRIC, 3.75" X 3.5" X 1.75" - PLASTIC
	091910-02-000	EA	BOX-ELECTRICAL, PLASTIC - 57 X 88MM
	093257-02-000	EA	BOX-ELECTRIC, CIRCUIT BREAKER - B&W RV80-9
	093603-01-000	EA	BOX-ELECTRIC, 4" X 2 1/8" X 2 1/8" - STEEL
	008054-01-000	EA	CORD-POWER, 10/3 - 30 AMP - 25'
	008052-01-000	EA	CORD-POWER, 10/3 - 30 AMP - 25' - CANADIAN
	069238-01-000	EA	COVER-ELECTRICAL BOX, W/HOLE - 4" X 4" - GRAY
	008294-01-000	EA	COVER-ELECTRICAL BOX-BLANK/STEEL - 4" X 4" - GRAY

### RELAY HOUSING & SOLENOID

KEY	PART NUMBER	U/M	DESCRIPTION
	008188-01-000	EA	SOLENOID-3 POST, BATTERY CHANGE OVER
	063910-01-000	EA	HOUSING-RELAY, BOSCH 3 334 485 008
	086273-01-000	EA	RELAY-BATTERY DISCONNECT

## ELECTRICAL GROUP (CONTINUED)

### LIGHTS, SWITCHES & RECEPTACLES

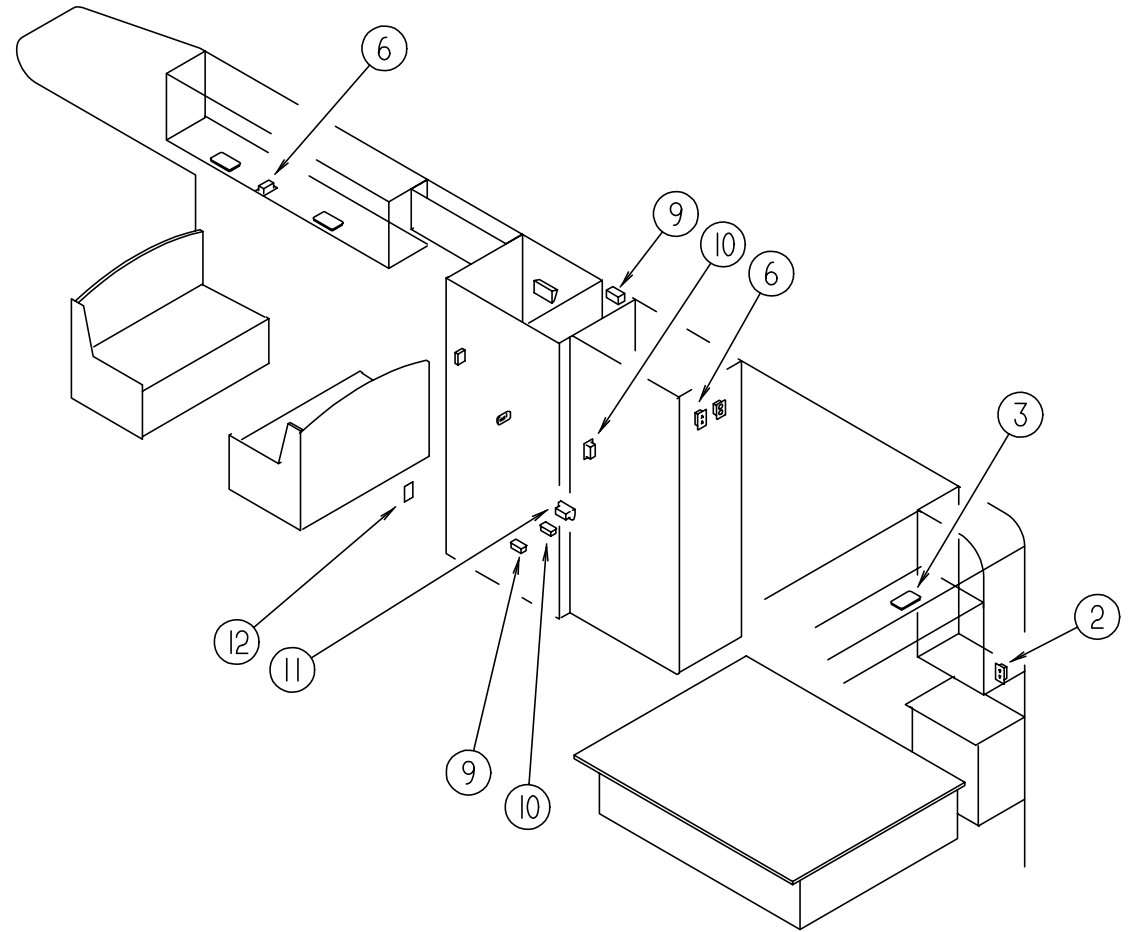
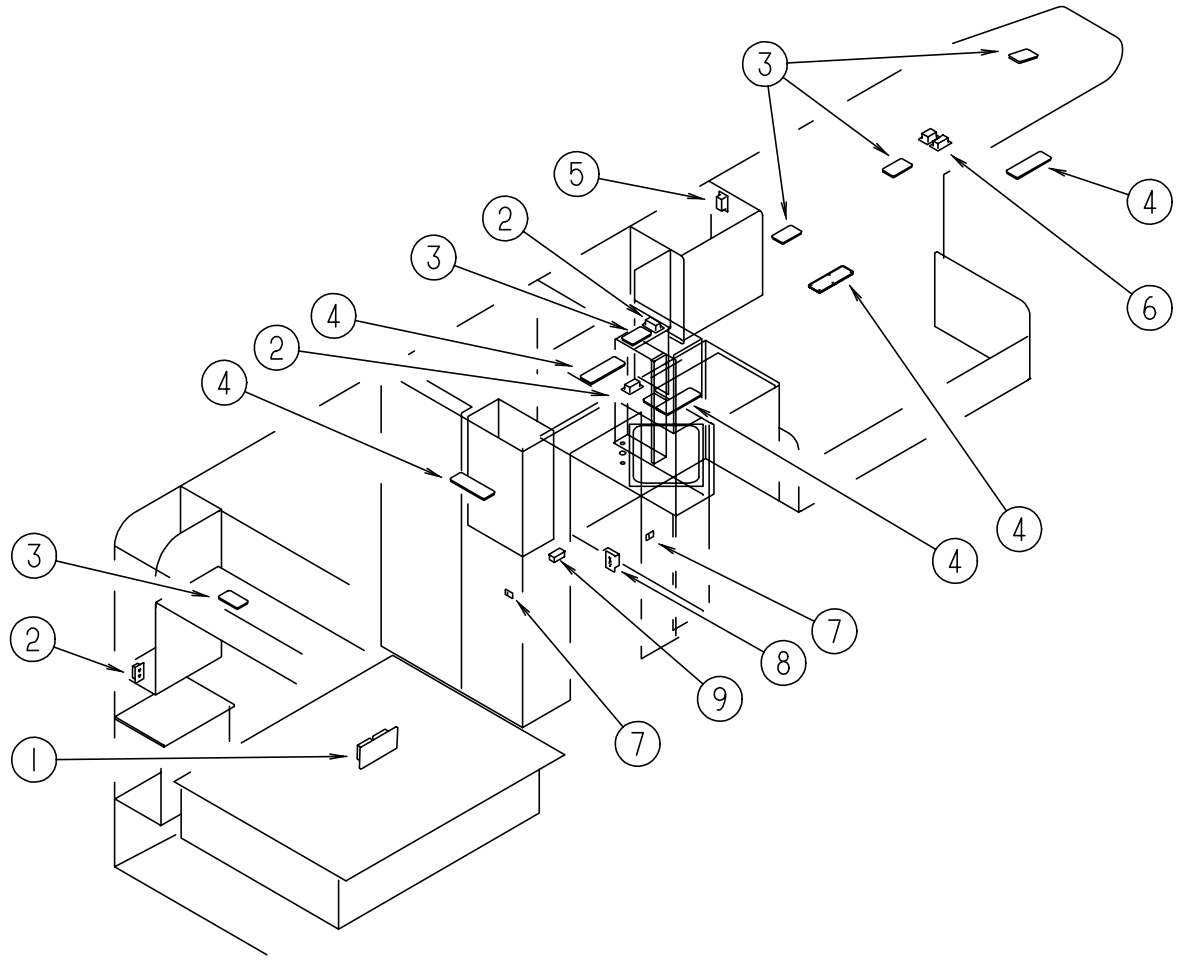

KEY	PART NUMBER	U/M	DESCRIPTION	VENDOR NO.
1	024924-02-000	EA	RECEPTACLE-POWER CORD, W/PARTIAL PLATE	
2	058708-01-000	EA	RECEPTACLE-ELECTRIC, DOUBLE - BROWN	
2	058708-02-000	EA	RECEPTACLE-ELECTRIC, DOUBLE - IVORY	
	102568-01-GB1	EA	SPACER-SIDEWALL RECEPTACLE	
3	098024-01-01A	EA	LIGHT-DOME, 1 BULB - US - IVORY	
3	008218-01-000	EA	BULB-DOME LIGHT, 12V - NUMBER 1141	
3	098024-01-700	EA	LENS-LIGHT	807877
4	098024-03-01A	EA	LIGHT-DOME, 2 BULB - IVORY	
4	008218-01-000	EA	BULB-DOME LIGHT, 12V - NUMBER 1141	
4	098024-01-700	EA	LENS-LIGHT	807877
4	058707-01-000	EA	RECEPTACLE-ELECTRIC, SINGLE - BROWN	
5	058708-05-000	EA	RECEPTACLE-SINGLE, BRN - WIRECON WDR15BRS	
6	058708-01-000	EA	RECEPTACLE-ELECTRIC, DOUBLE - BROWN	
6	058708-02-000	EA	RECEPTACLE-ELECTRIC, DOUBLE - IVORY	
7	079364-01-000	EA	SWITCH-ON/OFF ROCKER, 2 PRONGS - BROWN	
7	098351-01-01A	EA	PLATE-SWITCH, 1 GANG - POLISHED BRASS - JENSEN	
7	095188-01-01A	EA	SPACER-SWITCH, 2.3" X 3.4" - PLASTIC - DARK BROWN	
8	084076-02-000	EA	RECEPTACLE-GFI, 15A - 125V - BROWN	
8	097734-01-02A	EA	EXTENSION-RECEPTACLE, 3.2" X 5" X .7" - PLASTIC - BROWN	
9	058707-02-000	EA	RECEPTACLE-BLANK, JUNCTION - WIRECON WDJ20BR	
10	058707-01-000	EA	RECEPTACLE-ELECTRIC, SINGLE - BROWN	

KEY	PART NUMBER	U/M	DESCRIPTION	VENDOR NO.
11	112822-01-01A	EA	RECEPTACLE-DUPLEX, IVORY - *WIRECON WDRU15IV	
11	112824-01-03A	EA	COVER-EXTERIOR DUPLEX RECEPTACLE, WHITE - P&S 3780-SC-WH	
11	112822-01-01A	EA	RECEPTACLE-DUPLEX, IVORY - *WIRECON WDRU15IV	
11	112824-01-03A	EA	COVER-EXTERIOR DUPLEX RECEPTACLE, WHITE - P&S 3780-SC-WH	
12	098351-06-01A	EA	PLATE-SWITCH, 2 GANG W/LABEL - JENSEN - POLISHED BRASS	
12	079364-01-000	EA	SWITCH-ON/OFF ROCKER, 2 PRONGS - BROWN	
12	095188-02-01A	EA	SPACER-SWITCH, 2.3" X 4.1" - PLASTIC - DARK BROWN	
	098024-01-01A	EA	LIGHT-DOME, 1 BULB - US - IVORY	
	008218-01-000	EA	BULB-DOME LIGHT, 12V - NUMBER 1141	
	098024-01-700	EA	LENS-LIGHT	807877
	098351-05-01A	EA	PLATE-SWITCH, 3 GANG - POLISH BRASS - W/LABEL - JENSEN	
	098351-07-01A	EA	PLATE-SWITCH, GEN SW - *JENSEN-BRASS, POLISH	
	108356-11-01A	EA	ACTUATOR-SWITCH GROOVES III - *CARLING VVCZCXX-SW1	
	086280-01-000	EA	LIGHT-SURFACE MOUNT, 12V - JENSEN 1236	
	086280-01-700	EA	BULB, 12V	ARP1089
	087202-01-000	EA	SWITCH-4 POSITION, W/KNOB	
	108355-01-000	EA	HOUSING-SWITCH - CARLING VCH	
	108356-02-01A	EA	SWITCH COVER W/ 2 DIMPLES - CARLING CCAZC00	
	108357-08-000	EA	SWITCH - ROCKER DPDT ON/NONE/ON 6 TERMINAL	
	108356-07-01A	EA	SWITCH COVER W/ 2 DIMPLES - CARLING VVAZCXX-XWB	
	081994-06-000	EA	PLATE-SWITCH, AUXILIARY START	
	117806-01-000	EA	BULB-12V NO.912 1.0 AMPS	

## ELECTRICAL GROUP (CONTINUED)

### LIGHTS, SWITCHES & RECEPTACLES (OPTIONAL BEDROOMS)

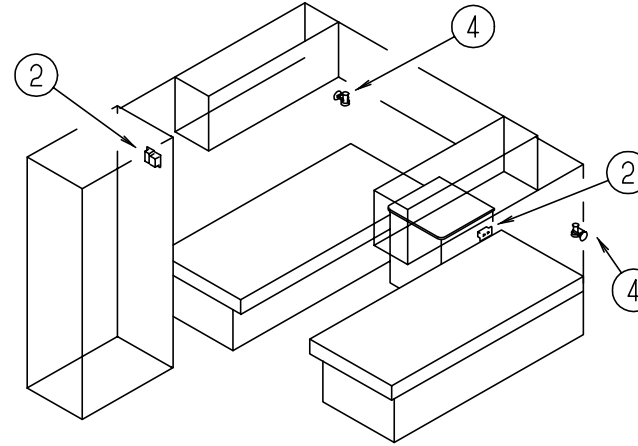
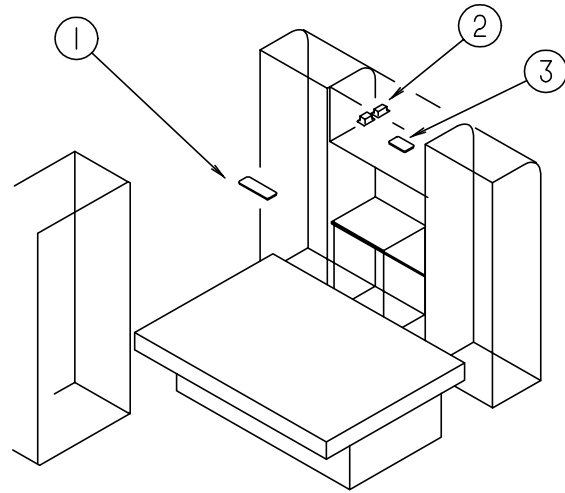

TWIN BEDS

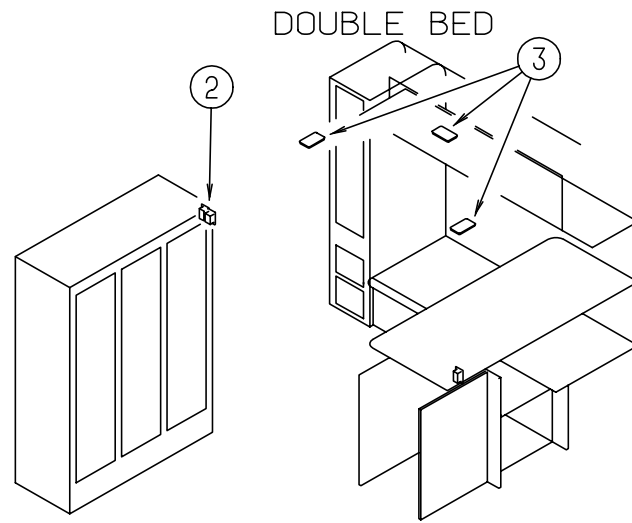

DOUBLE BED

TWIN CROSS-STACKED BEDS

KEY	PART NUMBER	U/M	DESCRIPTION	VENDOR NO.
1	098024-03-01A	EA	LIGHT-DOME, 2 BULB - IVORY	
1	008218-01-000	EA	BULB-DOME LIGHT, 12V - NUMBER 1141	
1	098024-01-700	EA	LENS-LIGHT	807877
1	058707-01-000	EA	RECEPTACLE-ELECTRIC, SINGLE - BROWN	
2	058708-01-000	EA	RECEPTACLE-ELECTRIC, DOUBLE - BROWN	
2	058708-02-000	EA	RECEPTACLE-ELECTRIC, DOUBLE - IVORY	
3	098024-01-01A	EA	LIGHT-DOME, 1 BULB - US - IVORY	
3	008218-01-000	EA	BULB-DOME LIGHT, 12V - NUMBER 1141	
3	098024-01-700	EA	LENS-LIGHT	807877
4	104173-01-01A	EA	LIGHT-DESIGNER, BRASS - #81-905	
	104173-01-700	EA	BULB	81900
4	104172-01-01A	EA	LIGHT-BULLET, BEIGE - #787 SERIES	

## ELECTRICAL GROUP (CONTINUED)

### CONDUIT, CONNECTORS, HOUSINGS & TERMINALS

KEY	PART NUMBER	U/M	DESCRIPTION
	077479-01-000	EA	BOOT-BATTERY TERMINAL, DOUBLE CABLE
	077479-02-000	EA	BOOT-BATTERY TERMINAL, SINGLE CABLE
	087949-01-000	EA	BUSS BAR - 2 POSITION - .6" X 1.5"
	041953-01-000	FT	CONDUIT-CONVOLUTE SLIT, .5"ID
	041953-03-000	FT	CONDUIT-CONVOLUTE SLIT, 1" ID (CLOTHES ROD COVER)
	041953-05-000	FT	CONDUIT-CONVOLUTE SOLID, .62" ID
	041953-06-000	FT	CONDUIT-CONVOLUTE,SLIT .375"ID
	041953-07-000	FT	CONDUIT-CONVOLUTE, SLIT - .25" ID
	041953-08-000	FT	CONDUIT-CONVOLUTE,SLIT,1.50"ID
	041953-09-000	FT	CONDUIT-CONVOLUTE,SLIT .50"ID
	041953-10-000	FT	CONDUIT-CONVOLUTE, SLIT - .75" ID
	041953-11-000	FT	CONDUIT-CONVOLUTE, SLIT- 1.06" ID
	041953-12-000	FT	CONDUIT-CONVOLUTE, NON SLIT 1.1" ID
	008355-01-000	EA	CONNECTOR-CABLE CLAMPING, 3/4"
	058028-01-000	EA	CONNECTOR-ELECTRICAL PIGTAIL, NYLON - CLEAR
	088475-01-000	EA	PIN-CONNECTOR, 14 TO 20 AWG
	088475-02-000	EA	PIN-CONNECTOR, 10 TO 12 AWG
	008356-01-000	EA	CONNECTOR-PLASTIC, 3/8" AVG
	088476-01-000	EA	SOCKET-CONNECTOR, BRASS - PRE-TIN
	088476-02-000	EA	SOCKET-CONNECTOR, 12-10 GA - PHOS. BRZ - PRE-TIN
	008311-01-000	EA	CONNECTOR-WIRE NUT, INSULATED - RED
	008313-01-000	EA	CONNECTOR-WIRE NUT, INSULATED - YELLOW
	008314-01-000	EA	CONNECTOR-WIRE NUT, INSULATED - GRAY
	088473-01-000	EA	HOUSING-PIN, 12 CAVITY - AMP 1-480708-0
	088473-02-000	EA	HOUSING-PIN, 15 CAVITY - AMP 1-480710-0
	088473-03-000	EA	HOUSING-PIN, 9 CAVITY - AMP 1-480706-0
	088473-05-000	EA	HOUSING-PIN, 6 CAVITY - AMP 640585-1
	088473-08-000	EA	HOUSING-PIN, 4 CAVITY - AMP 1-480702-0
	088473-09-000	EA	HOUSING-PIN, 3 CAVITY - AMP 1-480700-0
	088473-10-000	EA	HOUSING-PIN, 2 CAVITY - AMP 1-480698-0
	088474-01-000	EA	HOUSING-SOCKET, 12 CAVITY - AMP 1-480709-0
	088474-02-000	EA	HOUSING-SOCKET, 12 CAVITY - AMP 1-480711-0
	088474-03-000	EA	HOUSING-SOCKET, 9 CAVITY - AMP 1-480707-0
	088474-07-000	EA	HOUSING-SOCKET, 5 CAVITY - AMP 1-480764-0
	088474-08-000	EA	HOUSING-SOCKET, 4 CAVITY - AMP 1-480703-0
	088474-09-000	EA	HOUSING-SOCKET, 3 CAVITY - AMP 1-480701-0
	088474-10-000	EA	HOUSING-SOCKET, 2 CAVITY - AMP 1-480699-0
	007956-05-000	EA	INSULATOR-SHRINK .25IDX1.50 - BLACK
	080015-02-000	EA	RECEPTACLE-FLAG, .185 - 16/14 GA - AMP 3
	080015-03-000	EA	RECEPTACLE-FLAG, .250 - 14/16 GA
	112823-01-000	EA	SPLICE-REDUCER 16-14T018-22 - ETC BA-631X
	008326-01-000	EA	TERMINAL-RING, 16/14 WIRE - 3/8" STUD
	008328-01-000	EA	TERMINAL-RING, 12/10 WIRE - #10 STUD FIT
	008331-01-000	EA	TERMINAL-RING,TONGUE - #4 WIRE - 3/8" STUD - COPPER
	008348-01-000	EA	TERMINAL-RING, 3/8" STUD - #2 WIRE
	035416-04-000	EA	TERMINAL-RING #10 STUD FIT, INSULATED BARREL #16/14
	047443-01-000	EA	TERMINAL-.250 RECEPTACLE FIT, INSULATED - 16/14 AWG
	102777-02-000	EA	TERMINAL-RING #6 STUD, 10 AWG
	106655-01-000	EA	TERMINAL-FUSE BLOCK,14-16AWG - PACKARD 12020321
	106655-02-000	EA	TERMINAL-FUSE BLOCK,10-12AWG - PACKARD 12020400

### WIRING ASSEMBLIES

KEY	PART NUMBER	U/M	DESCRIPTION
	106851-01-000	EA	WIRE ASM-DAY RUN LAMP,FUSE
	097618-01-000	EA	WIRE ASM-MONITOR PANEL, W/3 WIRES & ORANGE RESISTOR- LVS
	096449-01-000	EA	WIRE ASSEMBLY-WATER TANK TO MONITOR PANEL
	116894-01-000	EA	WIRE ASM-SPEED SENSOR EXTEND, JFB L-322B
	073328-B4-000	EA	CABLE ASSEMBLY-BATTERY, W/TERMINALS
	090986-01-000	EA	WIRE ASM-ELECTRIC STEP, KWIKEE 9009

## EXTERIOR BODY GROUP

### FIBERGLASS, STYROFOAM & ALUMINUM CHANNEL

KEY	PART NUMBER	U/M	DESCRIPTION
	100619-01-000	BF	EXPANDED FOAM SHEET - 4' X 8' X 1.34"
	100619-02-000	BF	FOAM - EXPANDED POLYSTYRENE - 1.5" X 48" X 96"
	100619-04-000	BF	FOAM - EXPANDED POLYSTYRENE - .5" X 4' X 8'
	100619-05-000	BF	FOAM - EXPANDED POLYSTYRENE - .75" X 4' X 8'
	100619-11-000	BF	FOAM - EXPANDED POLYSTYRENE - 2" X 48" X 96"
	117754-03-01A	EA	FIBERGLASS SHEET - 10.5" X 96" BRIGHT WHITE
	076054-P9-000	EA	FIBERGLASS SHEET - 37.4" X 99.25" BRIGHT WHITE
	076054-R1-000	EA	FIBERGLASS SHEET - 24" X 65.9" BRIGHT WHITE
	076054-S3-000	EA	FIBERGLASS SHEET - 101.4" X 106.9" BRIGHT WHITE
	076054-W2-000	EA	FIBERGLASS SHEET 85" X 339" BRIGHT WHITE
	076054-W5-000	EA	FIBERGLASS-SHEET 2576 X 2760 - *BRT WHT
	076054-N9-000	EA	FIBERGLASS SHEET - 96" X 102" BRIGHT WHITE
	000870-08-000	SF	STYROFOAM - .75" X 4' X 8' - PLANED
	068716-01-001	EA	BRACE-90 DEGREE L-ANGLE - 16'
	002726-01-001	EA	GARNISH-U-CHANNEL, 1.38" X 19' - SERRATED - MILL ALUMINUM
	002754-01-001	EA	ANGLE-EXTRUDED, .75" X .75" X 18' - MILL ALUMINUM
	002766-01-001	EA	ANGLE-EXTRUDED, 1" X 1.5" X 17'
	089297-01-000	SF	PLYWOOD-LUAN, OVERLAY GRADE - 4' X 8'

### RUNNING BOARDS

KEY	PART NUMBER	U/M	DESCRIPTION	VENDOR NO.
	072884-27-000	EA	RUNNING BOARD-FORD 39.00	- KEM K12 15539
	072884-27-700	EA	BRACKET SET 12" 92	RB2BRK/M
	072884-27-701	EA	RUNNING BOARD-FORD 39",RT&LT	
	072884-27-702	FT	TREAD TAPE	RB9202
	072884-27-703	EA	MUD FLAP W/HOLES, 1EA=PAIR	99171
	072884-27-704	EA	CAP-ENDS, 1EA=PAIR	99148

## EXTERIOR BODY GROUP (CONTINUED)

### DECALS, STRIPES & PAINT

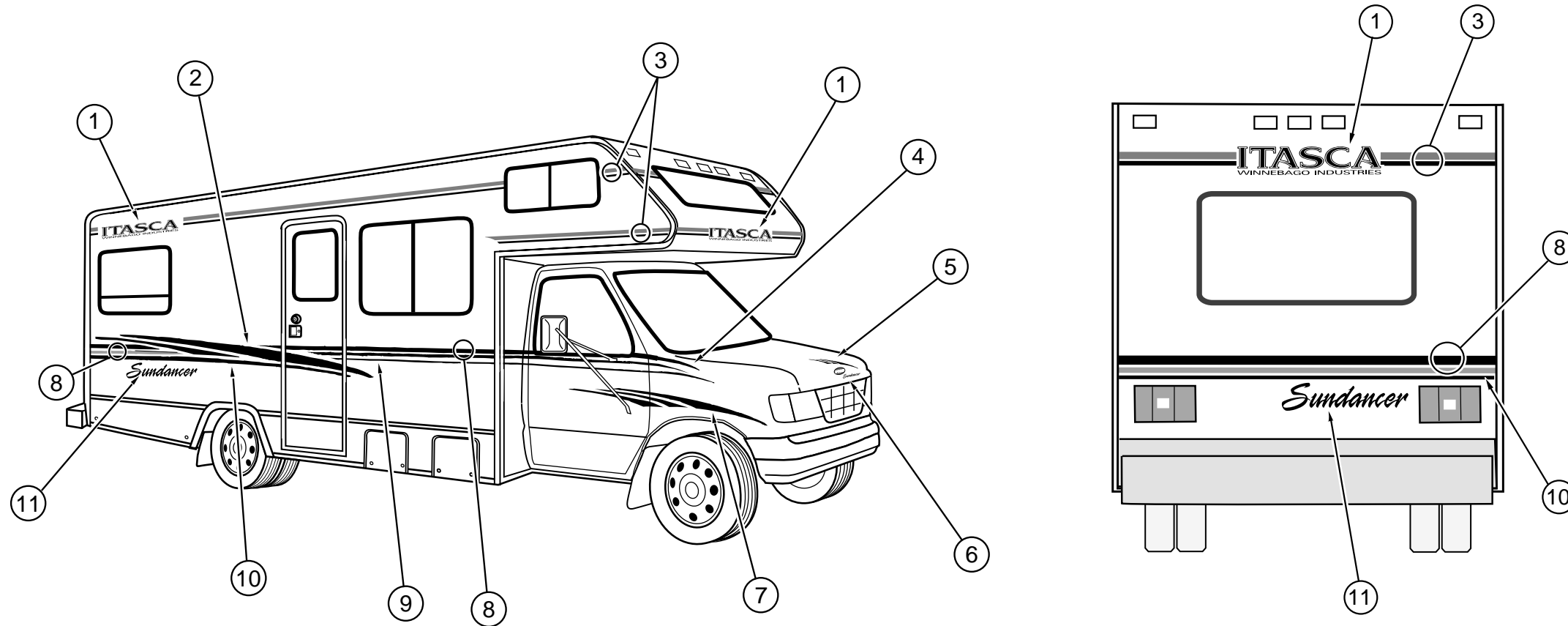

KEY	PART NUMBER	U/M	DESCRIPTION
1	118793-01-01A	EA	DECAL-LOGO - ITASCA - BLUE LAGOON/BLUE LAGOON
	117018-01-01A	EA	DECAL-LOGO - WINNEBAGO INDUSTRIES - BLUE LAGOON
2	117019-01-01A	EA	DECAL-SLASH - RH - BLUE LAGOON/CASSIS/RASPBERRY
	117019-02-01A	EA	DECAL-SLASH - LH - BLUE LAGOON/CASSIS/RASPBERRY
3	105781-43-01A	FT	FILM-MULTISTRIPE 57.2 MM X 150' - BLUE LAGOON/CASSIS
4	117022-01-01A	EA	DECAL-END CAP - RH - BLUE LAGOON/CASSIS/RASPBERRY
	117022-02-01A	EA	DECAL-END CAP - LH - BLUE LAGOON/CASSIS/RASPBERRY
5	117021-01-01A	EA	DECAL-SLASH - HOOD - BLUE LAGOON/CASSIS/RASPBERRY
6	110869-03-01A	EA	DECAL-LOGO - SUNDANCER - BLUE LAGOON
7	117020-01-01A	EA	DECAL-SLASH - CAB - RH - BLUE LAGOON/CASSIS/RASPBERRY
	117020-02-01A	EA	DECAL-SLASH - CAB - LH - BLUE LAGOON/CASSIS/RASPBERRY
8	105781-44-01A	FT	FILM-MULTISTRIPE 101.6 MM X 150 - BLUE LAGOON/CASSIS
9	093681-42-03A	FT	FILM-19.1MM X 150FT - RASPBERRY
10	093681-37-02A	FT	FILM-57.2MM X 150FT - RASPBERRY
11	110869-01-03A	EA	DECAL-LOGO - SUNDANCER - LG - BRTWHT/BLUE LAGOON
	041561-03-000	EA	PAINT-16OZ SPRAY-OFF WHITE - ACRYLIC ENAMEL

#### DUPONT COLOR CODES

OFF WHITE	L8723A
BRIGHT WHITE	B8951
BLUE LAGOON	
CASSIS	
RASPBERRY	



## EXTERIOR BODY GROUP (CONTINUED)

### BODY PANELS & TRIMS

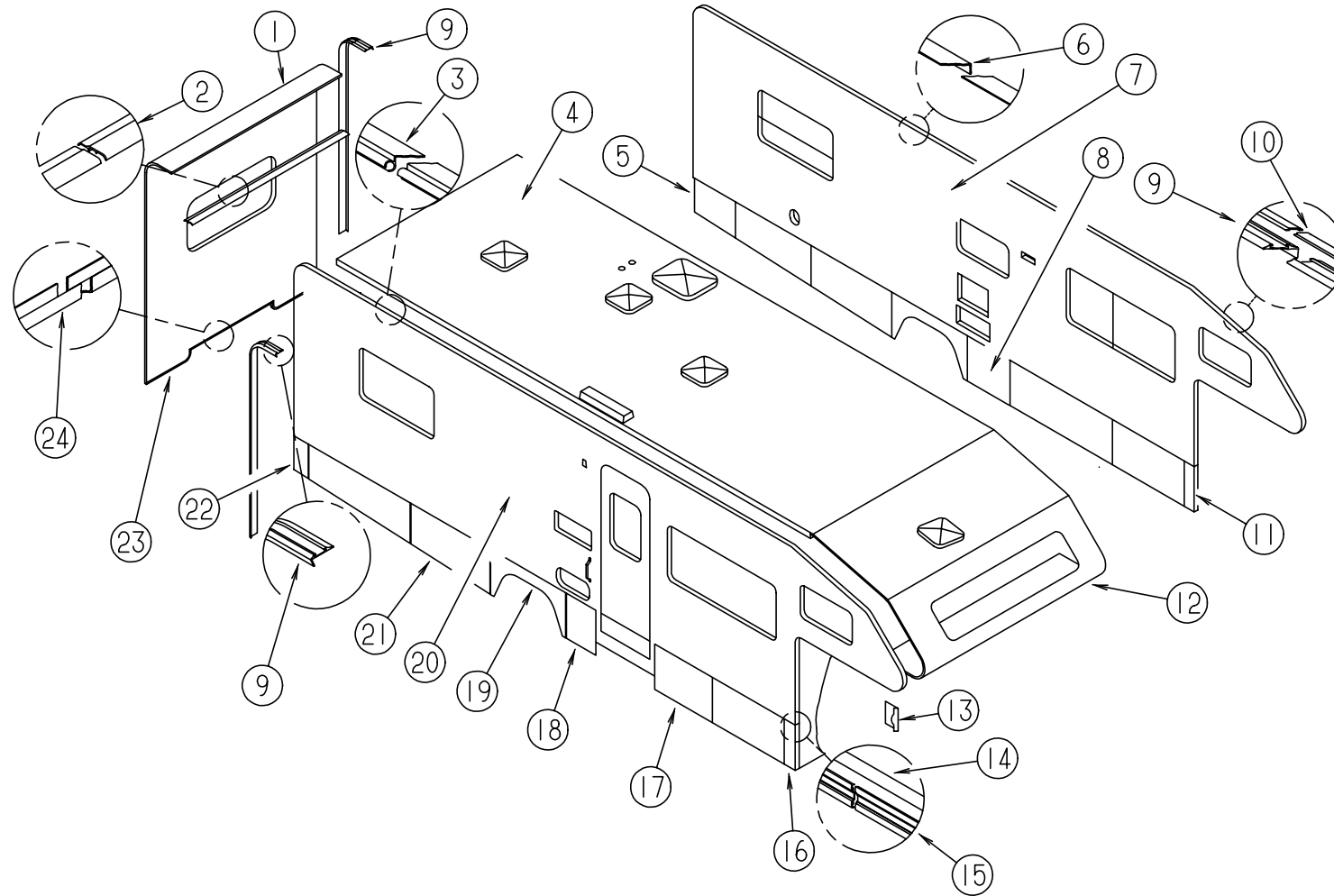

KEY	PART NUMBER	U/M	DESCRIPTION
1	P21287-01-G24	EA	BACKWALL ASM QN/BD
1	P21287-01-G25	EA	BACKWALL ASM QN/BD
1	P21287-02-G24	EA	BACKWALL ASM TN/BD
1	P21287-02-G25	EA	BACKWALL ASM TN/BD
1	P21287-03-G24	EA	BACKWALL ASM DB/BD
1	P21287-03-G25	EA	BACKWALL ASM DB/BD
1	P21287-05-G24	EA	BACKWALL ASM CROSS/BK
1	P21287-05-G25	EA	BACKWALL ASM CROSS/BK
2	078580-02-000	EA	TRIM-ROOF/FRONT CAP MILL
3	100483-02-02A	EA	TRIM-CONTOUR,ROOF BRIGHT WHITE - 133.9"
	099583-55-004	EA	AWNING RAIL,3400 MM B/W
4	M08120-01-G04	EA	ROOF ASM 431WQ QN/BD
4	M08120-02-G04	EA	ROOF ASM 431WQ DBL/BD
4	M08120-03-G04	EA	ROOF ASM 431WQ TWN/BD
4	M08120-05-G04	EA	ROOF ASM 431WQ CROSS/BNK
5	121763-01-G04	EA	PANEL ASM-VALANCE
6	096864-02-02A	EA	TRIM-CONTOUR,ROOF BRT WHITE
7	M08099-01-G24	EA	SIDEWALL ASM-LEFT,QN/BD
7	M08099-01-G25	EA	SIDEWALL ASM-LEFT,QN/BD
7	M08099-02-G24	EA	SIDEWALL ASM-LEFT,DBL/BD
7	M08099-02-G25	EA	SIDEWALL ASM-LEFT,DBL/BD
7	M08099-03-G24	EA	SIDEWALL ASM-LEFT,TN/BD
7	M08099-03-G25	EA	SIDEWALL ASM-LEFT,TN/BD
7	M08099-05-G24	EA	SIDEWALL ASM-LEFT,CROSS/BNK
7	M08099-05-G25	EA	SIDEWALL ASM-LEFT,CROSS/BNK
8	118658-03-G04	EA	PANEL ASM,VALANCE
9	096854-05-02A	EA	TRIM-CONTOUR - BRIGHT WHITE - PASSENGER OR DRIVERS SIDE
10	105312-01-07A	FT	INSERT - FEATURE STRIP VINYL - BRIGHT WHITE
11	121764-02-G04	EA	PANEL ASM-VALANCE
12	P21337-01-G04	EA	ROOF ASM-FRONT W/BASES
13	108651-01-01A	EA	END CAP - FEATURE STRIP

KEY	PART NUMBER	U/M	DESCRIPTION
14	105312-01-07A	FT	INSERT - FEATURE STRIP VINYL - BRIGHT WHITE
15	108688-01-03A	EA	STRIP - FEATURE - W/O INSERT/END CAPS - 15'
16	121764-01-G04	EA	PANEL ASM-VALANCE
17	118480-55-004	EA	EXTR-U CH,PAN,B/WHT,4877 MM
18	118658-04-G04	EA	PANEL ASM,VALANCE
19	121304-01-01A	EA	PANEL - WHEEL LIP, REAR
20	M08103-01-G24	EA	SIDEWALL ASM-RIGHT,QN/BD
20	M08103-01-G25	EA	SIDEWALL ASM-RIGHT,QN/BD
20	M08103-02-G24	EA	SIDEWALL ASM-RIGHT,DBL/BD
20	M08103-02-G25	EA	SIDEWALL ASM-RIGHT,DBL/BD
20	M08103-03-G24	EA	SIDEWALL ASM-RIGHT,TWN/BD
20	M08103-03-G25	EA	SIDEWALL ASM-RIGHT,TWN/BD
20	M08103-05-G24	EA	SIDEWALL ASM-RIGHT,CROSS/BNK
20	M08103-05-G25	EA	SIDEWALL ASM-RIGHT,CROSS/BNK
21	118657-03-G04	EA	PANEL ASM-VALANCE
	118611-14-03A	EA	TRIM-WHEEL LIP,HINGE, BRT/WH
22	121763-02-G04	EA	PANEL ASM-VALANCE
23	103334-03-02A	EA	TRIM-BACKWALL,LOWER BRT/WHT
24	103335-02-02A	EA	TRIM-BACKWALL,LOWER BRT/WHT
	002726-01-001	EA	GARNISH-U-CHANNEL, 1.38" X 19' - SERRATED - MILL ALUMINUM
	002754-01-001	EA	ANGLE-EXTRUDED, .75" X .75" X 18' - MILL ALUMINUM
	002766-01-001	EA	ANGLE-EXTRUDED, 1" X 1.5" X 17'
	107865-01-000	EA	ROD-SUPPORT,VALANCE PANEL
	107865-07-000	EA	ROD-SUPPORT,VALANCE PANEL
	118442-55-003	EA	EXTR-PAN,ROCK,B/W,4877 MM
	118480-55-004	EA	EXTR-U CH,PAN,B/WHT,4877 MM
	121735-55-001	EA	EXTR-H CHANNEL,BWHT, 4877 MM

## EXTERIOR BODY GROUP (CONTINUED)

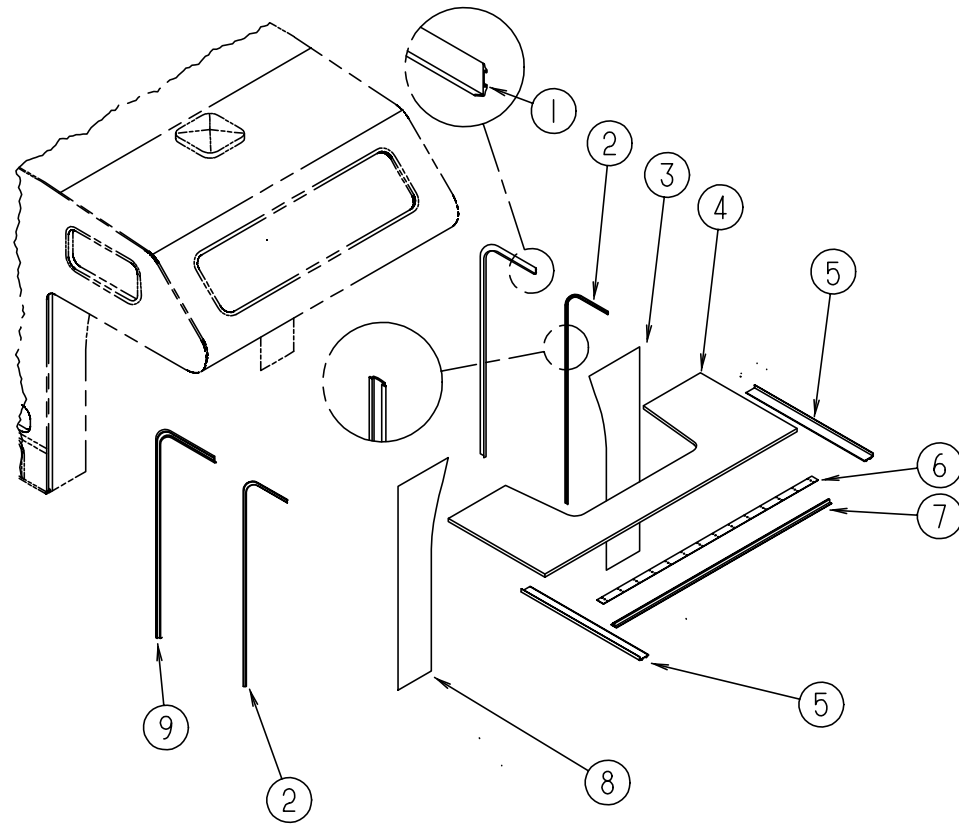

**WINGWALL, SLEEPERBOARD & TRIM**

KEY	PART NUMBER	U/M	DESCRIPTION
1	104479-06-02A	EA	TRIM - FRONT CONTOUR - BRIGHT WHITE
2	105312-01-07A	FT	INSERT - FEATURE STRIP VINYL - BRIGHT WHITE
3	118334-02-G04	EA	WINGWALL - DRIVER - BRIGHT WHITE
4	P18335-01-G04	EA	SLEEPERBOARD
5	096854-05-02A	EA	TRIM-CONTOUR - BRIGHT WHITE - PASSENGER OR DRIVERS SIDE
6	100086-04-01A	EA	TRIM - SLEEPER BOARD/ROOF - BRIGHT WHITE - 2" X 96.6"
7	100085-05-01A	EA	TRIM-STRAP,SLEEPERBRD O/W
8	118334-01-G04	EA	WINGWALL - PASSENGER - BRIGHT WHITE
9	104479-05-02A	EA	TRIM - FRONT CONTOUR
	002365-03-006	EA	U CHANNEL - EXTRUDED/POWDER PAINTED 1" X 192"

## EXTERIOR BODY GROUP (CONTINUED)

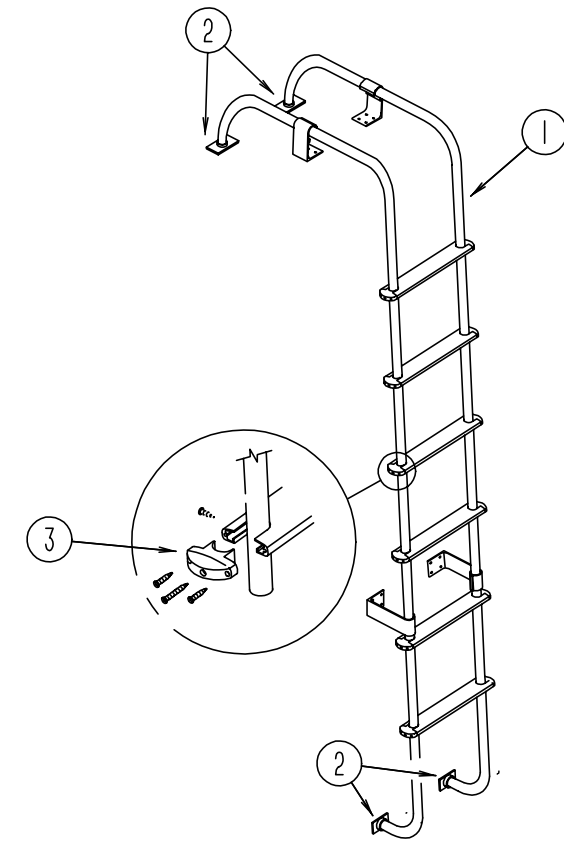

**LADDER**

KEY	PART NUMBER	U/M	DESCRIPTION
1	102953-15-G04	EA	LADDER ASM
2	067165-01-000	EA	MOUNTING BRACKET-LADDER, LOWER
	000G39-06-10T	EA	SCREW-SF/DR - 6-20 X 5/8 PPH - BLACK
	000G68-10-36T	EA	SCREW-10-12 X 2.25 POH BLACK
3	076980-02-000	EA	END CAP-STEP, BLACK
	081114-01-000	EA	CAP-INSERT, ROUND - 1" DIAMETER - PLASTIC - BLACK
	038327-01-000	EA	TAPE-ANTI SLIP, 2" X 60'

**EXTERIOR BODY GROUP (CONTINUED)**

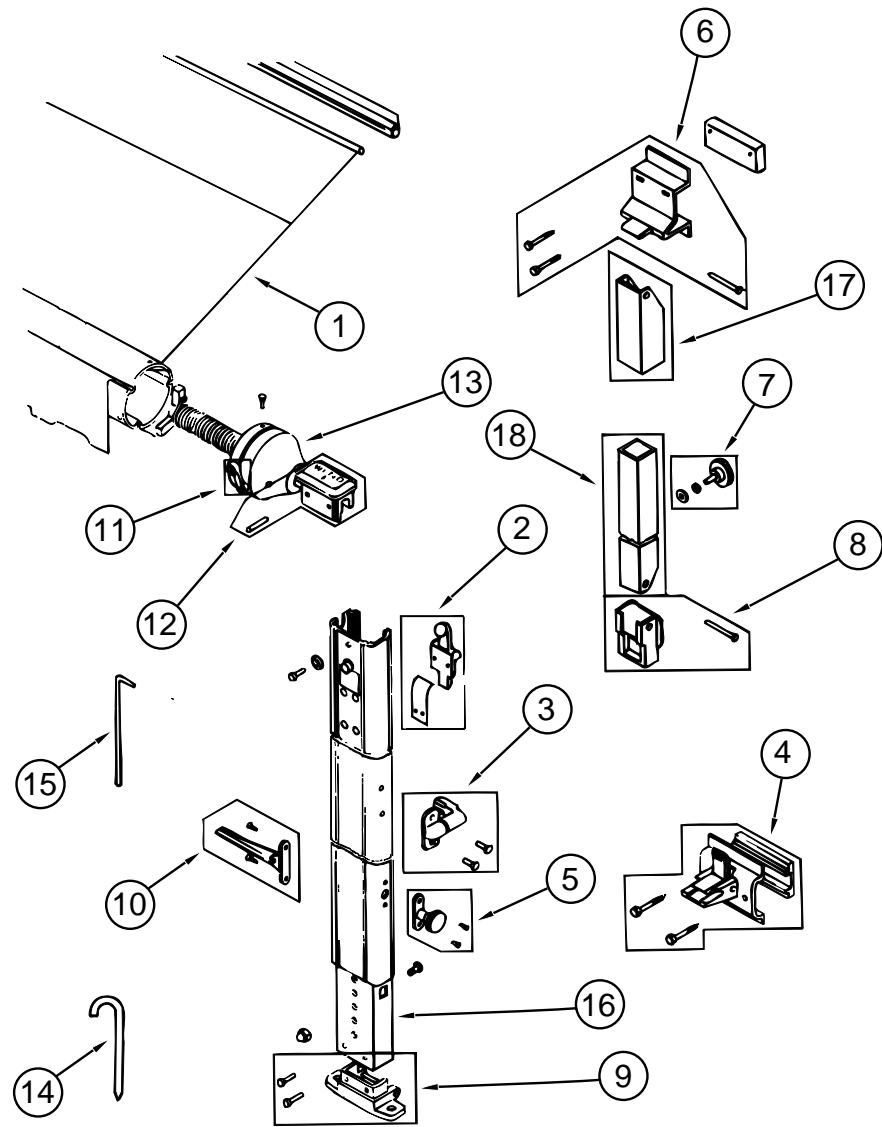

**AWNING & HARDWARE - FAULKNER**

KEY	PART NUMBER	U/M	DESCRIPTION	VENDOR NO.
1	110634-08-17A	EA	AWNING-ROLLER ASM,14'	
	110634-02-04A	EA	AWNING-HARDWARE KIT,BRT WHT	
2	110634-01-700	EA	RAFTER LOCKING MECH KIT	7605-0001
3	110634-01-701	EA	SAFETY LATCH KIT	7509-0001
4	110634-01-702	EA	BRACKET KIT, BOTTOM	7512-0001
5	110634-01-703	EA	HANDLE KIT, HEIGHT CONTROL	7510-0001
6	110634-01-704	EA	BRACKET KIT, UPPER W/BOLTS	7505-0001
7	110634-01-705	EA	KNOB KIT-RAFTER, ULTRA	7508-0001
8	110634-01-706	EA	SLIDE KIT, RAFTER	
9	110634-01-707	EA	BRACKET-GROUND KIT	7511-0001
10	110634-01-708	EA	HANDLE-LIFT, W/RIVETS	7000-0001
11	110634-01-709	EA	HANDLE-RACHET KIT	7507-0001
12	110634-01-710	EA	CAP-ARM KIT	7503-0001
13	110634-01-711	EA	SPRING ASSEMBLY, FRONT	6598-0001
	110634-01-712	EA	SPRING ASSEMBLY REAR	6599-0001
	110634-01-713	EA	CAP KIT, REAR END	7504-0001
14	110634-01-714	EA	STAKE-(4 PER BAG)	5208-0001
15	110634-01-715	EA	WAND, PULL DOWN	7604-0001
16	110634-01-730	EA	ARM-INNER, FRONT, BRT/WHT	1002-0071
	110634-01-731	EA	ARM-INNER,REAR, BRT/WHT	1003-0071
17	110634-01-732	EA	RAFTER-OUTER, BRT/WHT	1004-0071
18	110634-01-733	EA	RAFTER-INNER, BRT/WHT	1005-0071
	111038-01-01A	EA	SPACER-AWNING,LOWER BLACK	
	110634-01-735	EA	HANDLE-PUSH BUTTON-BRT/WHT	7000-9071

**EXTERIOR BODY GROUP (CONTINUED)**

**EXTERIOR MIRRORS - VELVAC**

KEY	PART NUMBER	U/M	DESCRIPTION	VENDOR NO.
	120269-03-01A	EA	MIRROR - PASSENGER - 102" BRIGHT WHITE	
	120269-04-01A	EA	MIRROR - DRIVERS - 102" BRIGHT WHITE	
	120269-01-700	EA	GLASS KIT W/BEZEL RH/LH	709407-8
	120269-05-01A	EA	MIRROR - PASSENGER W/HEAT & REMOTE - 102" BRIGHT WHITE	
	120269-06-01A	EA	MIRROR - DRIVERS W/HEAT & REMOTE - 102" BRIGHT WHITE	
	120269-05-701	EA	GLASS ONLY REPLACEMENT RH/LH	709411-8
	120269-07-01A	EA	PANEL-DRIVERS DOOR MIRROR CONTROL W/SWITCHES & PIGTAIL	
	120269-08-000	EA	HARNES-ELECT MIRROR - VELVAC 748304-8	

# GALLEY GROUP

## CABINET & COMPONENTS NORCOLD 6162 REFRIGERATOR

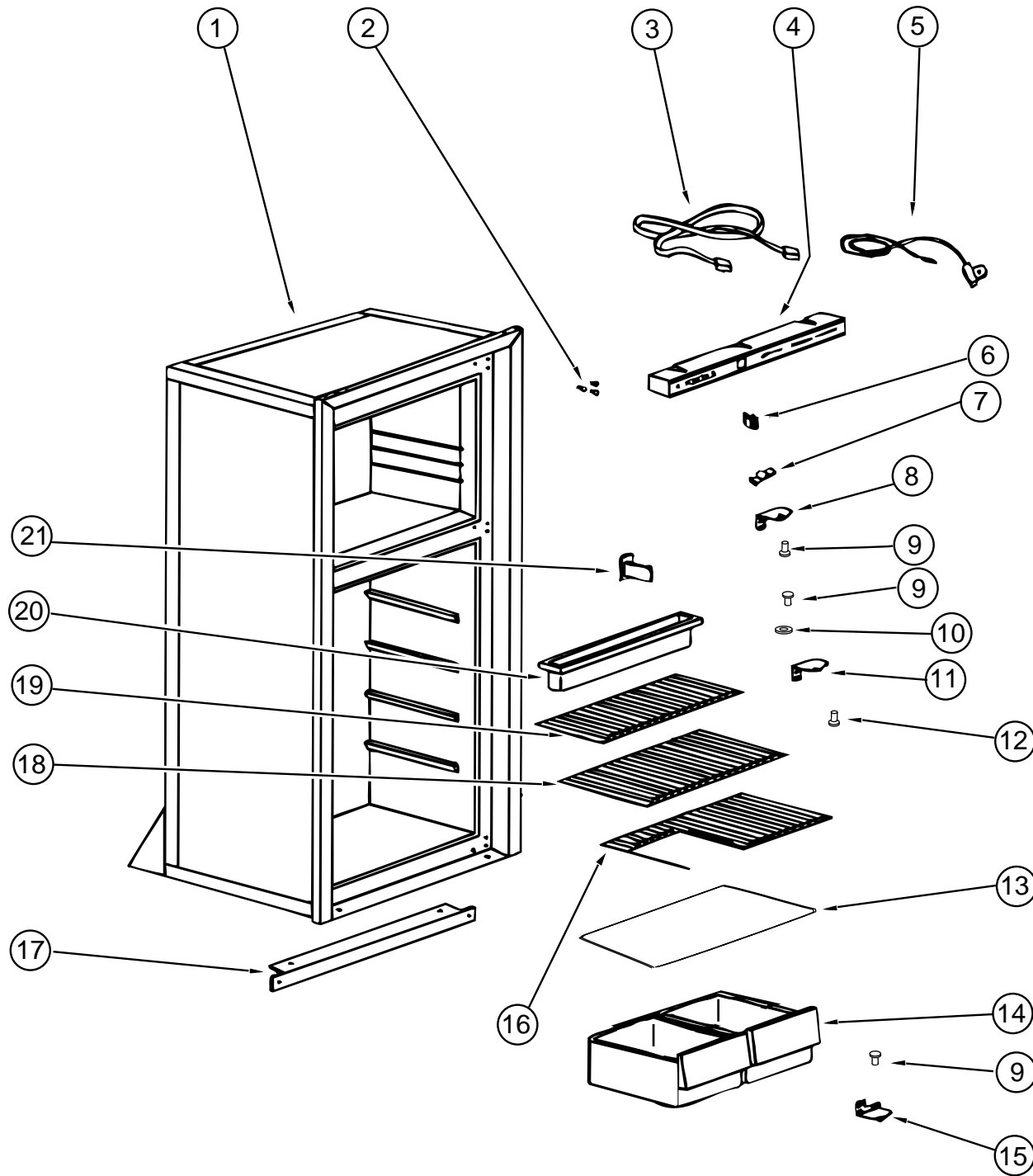

KEY	PART NUMBER	U/M	DESCRIPTION	VENDOR NO.
1	104138-04-01A	EA	REFRIG SMALL DBL DOOR 2-WAY - NORCOLD 6162 RH BL	
2	094039-01-722	EA	PLUG-HOLE, BLACK	61582030
3	084880-01-746	EA	CABLE-PRINTED CIRCUIT BOARD TO POWER SUPPLY	
4	104137-06-700	EA	SHELL-EYEBROW.2-WAY, W/HUM	61726622
5	084880-01-753	EA	THERMISTER-78" W/O CLIP	61693822
6	075217-01-738	EA	SWITCH-HUMIDITY	61525922
7	084880-01-760	EA	CLIP (THERMISTER)	61689122
8	094039-01-723	EA	BRACKET-HINGE, TOP RH-BTM LH	61580830
9	094039-01-725	EA	PIN-HINGE, BLACK	61578130
	084880-03-702	EA	PIN-HINGE, TOP/BTM, FEMALE	61580630 - BLACK
10	084880-01-749	EA	BUSHING-HINGE	61580722
11	094039-01-728	EA	BRACKET-HINGE, CENTER BLACK	61566530
12	094039-01-730	EA	PIN-HINGE, CENTER, BLACK	61566730
13	084880-01-722	EA	COVER-CRISPER, GLASS	61564122
14	104137-06-707	EA	CRISPER, WHITE	61571325
15	094039-01-724	EA	BRACKET-HINGE, TOP LH-BTM RH	61580930
16	104137-06-730	EA	SHELF - CUTOUT	618055
17	094039-01-732	EA	TRIM-FRONT LOWER, BLACK	61622130
18	104137-06-729	EA	SHELF - MIDDLE - WHITE	618052
19	104137-06-725	EA	SHELF - SHORT - WHITE W/O RISER	618059
20	094039-01-735	EA	TRAY-DRIP, WHITE	61572830
21	084880-01-732	EA	LATCH	61578522
	094039-01-736	EA	SWITCH-LIGHT, BLACK	61581022
	104138-04-701	EA	CABINET-BLACK TRIM & WHT INT	61725038
	117089-01-000	FT	HOSE-1/2 ID, GARDEN - KEVCO 49154	
	054450-01-000	EA	LEVEL-REFRIGERATOR	
	065225-02-000	EA	PLATE-TIEDOWN, REFRIGERATOR	
	093646-01-000	EA	BRACKET - TIEDOWN/REFRIGERATOR - RIGHT HAND	
	093646-02-000	EA	BRACKET - TIEDOWN/REFRIGERATOR - LEFT HAND	
	116751-05-01A	EA	TRAY-REFRIGERATOR BLK	
	104137-02-700	EA	MODULE-IGNITION	61717037
	104137-06-706	EA	SHELF-WIRE, SHORT	61718222
	104137-09-01A	EA	FREEZER SHELF - GRAY	
	104137-06-728	EA	SHELF W/RISER ,WHITE	618062

**GALLEY GROUP (CONTINUED)**

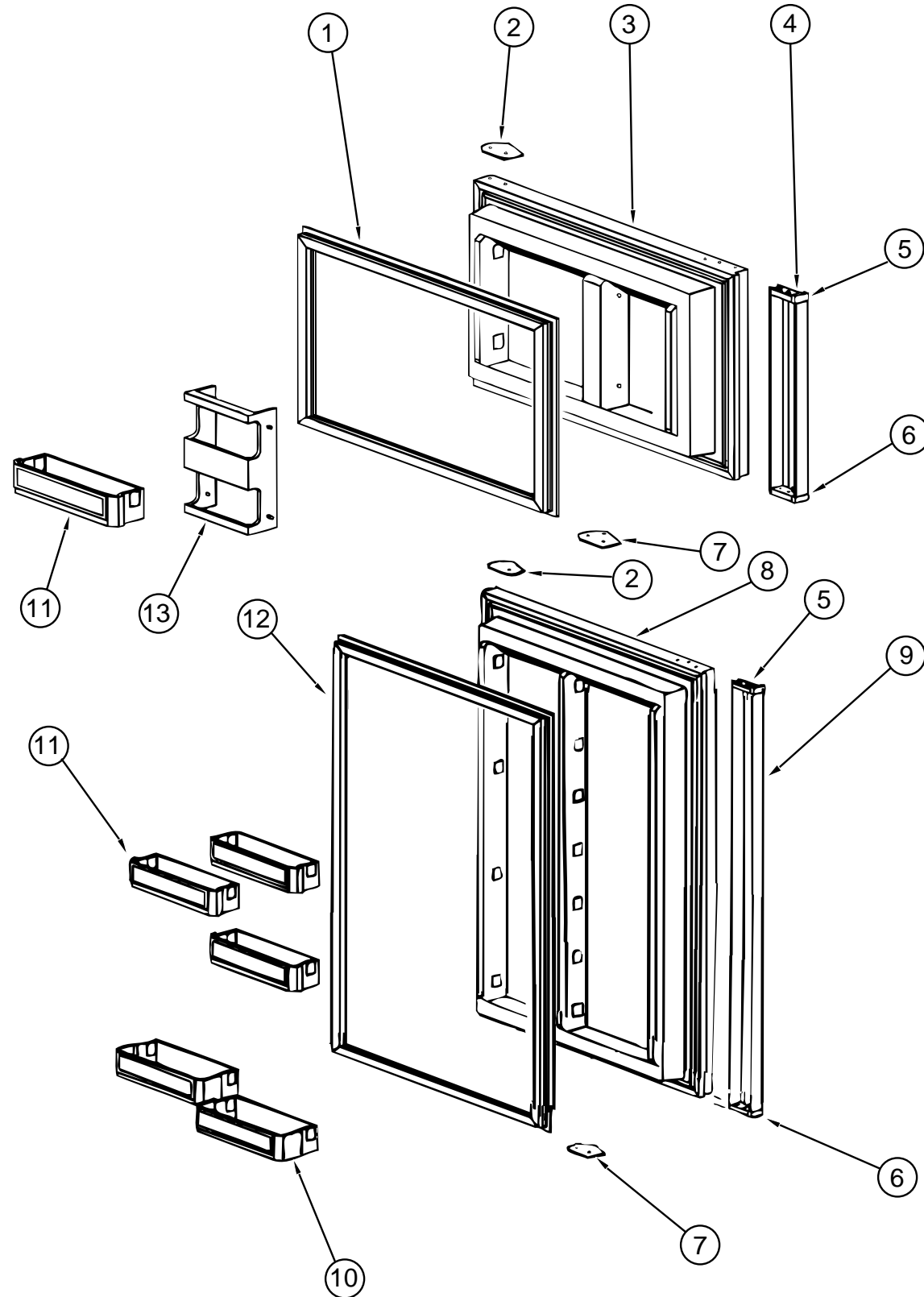

**REFRIGERATOR DOOR - NORCOLD**

KEY	PART NUMBER	U/M	DESCRIPTION	VENDOR NO.
1	094039-01-702	EA	GASKET (GRAY) UPPER	61567830
2	094039-01-710	EA	PLATE-HINGE,RHTOP,LHBTM, BLK	61631330
3	094039-01-706	EA	LINER-UPPER DOOR,WHITE/BLACK	61581838-B
4	094039-01-708	EA	HANDLE-UPPER DOOR ASM. BLACK	61650038
	084880-01-720	EA	SPRING (FOR DOOR HANDLE)	61558822
5	084880-01-761	EA	CAP-END, CATCH, UPPER, BLACK	61593730
6	084880-01-740	EA	CAP-END, STOP CATCH, LWR.BLK	61593830 BLACK

**GALLEY GROUP (CONTINUED)**

**REFRIGERATOR DOOR - NORCOLD (CONTINUED)**

KEY	PART NUMBER	U/M	DESCRIPTION	VENDOR NO.
7	094039-01-704	EA	PLATE-HINGE,TOPLH,RHBTM BLK	61631430
8	094038-01-702	EA	LINER-DOOR, LOWER (BLK/WHT)	61581938-B
9	094038-01-704	EA	HANDLE-DOOR, LOWER ASM BLACK	61650138
10	104137-06-704	EA	BIN-MILK, WHITE	61579425
11	104137-06-703	EA	BIN-DOOR SHELF, WHITE	61564025
12	094038-01-700	EA	GASKET-LOWER, GRAY	61567930
13	104137-06-702	EA	RACK-JUICE, WHITE	61580525

**MICROWAVE**

KEY	PART NUMBER	U/M	DESCRIPTION	VENDOR NO.
	115303-01-000	EA	MICROWAVE OVEN- 14 1/8"H X 21 7/8"W X13 1/4"D	
	115303-01-700	EA	TRIM F/VENT, TOP	2100309
	115401-01-01A	EA	TRIM-MICROWAVE,BLACK	
	098916-14-01A	EA	BRACE - MICROWAVE CABINET LEFT HAND - E COATED	
	098916-15-01A	EA	BRACE - MICROWAVE CABINET - RIGHT HAND - E-COATED	
	094750-07-000	EA	BRACKET-MICROWAVE,89 DEGREE	
	094756-02-01A	EA	BRACKET-L, MICROWAVE - 6.1" LONG X 3.9" WIDE - STEEL - TAN	

**COFFEE MAKER - BLACK & DECKER**

KEY	PART NUMBER	U/M	DESCRIPTION	VENDOR NO.
	103799-01-02A	EA	MAKER-COFFEE - GRAY - W/GLASS POT	
			FROM: 00-00-00 THRU: 04-07-96	
	103799-02-01A	EA	COFFEEMAKER WITH CLOCK	
			FROM: 04-08-96 THRU: 99-99-99	
	103799-01-700	EA	POT-CARAFE - GLASS	679420
	103799-01-701	EA	BRACKETS - WHITE PAIR	164734-06

### GALLEY GROUP (CONTINUED)

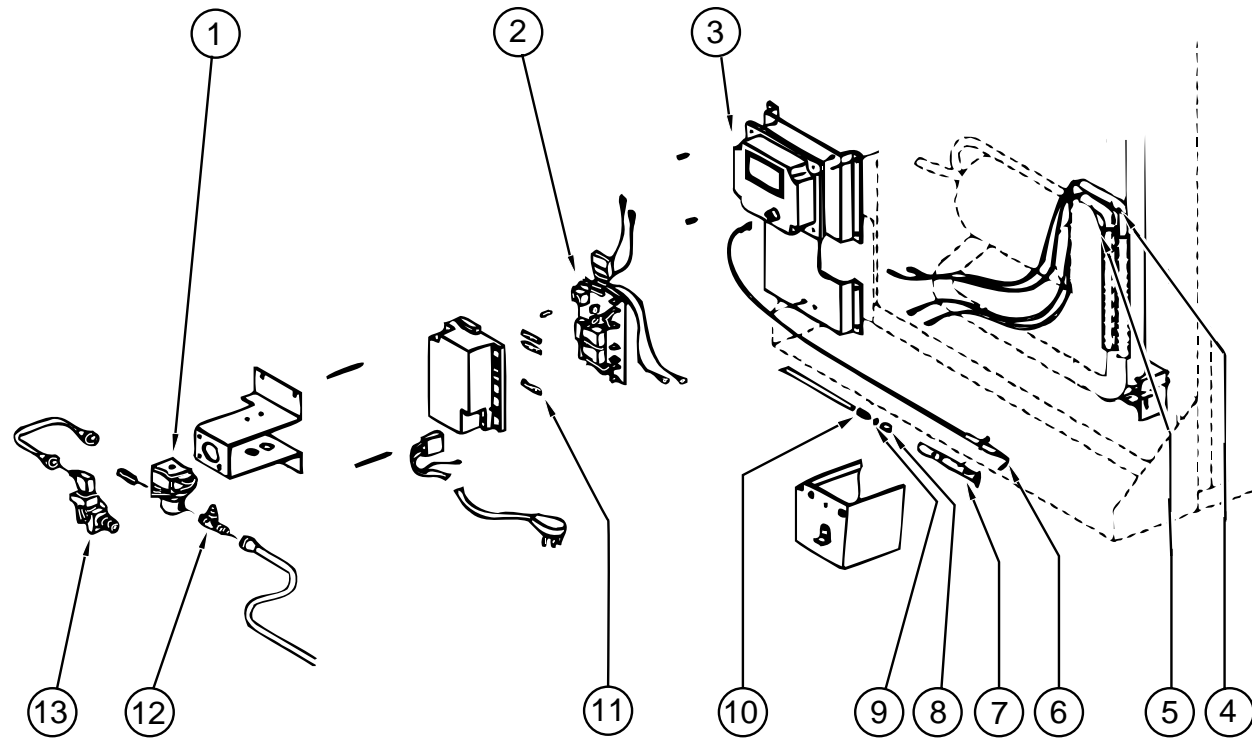

REFRIGERATOR CONTROL CENTER - NORCOLD

KEY	PART NUMBER	U/M	DESCRIPTION	VENDOR NO.
1	084880-01-718	EA	VALVE-GAS, (ASCO)	61551822
2	094039-04-702	EA	POWER SUPPLY (2 WAY)	61647422
3	104137-02-700	EA	CHANNEL CONTROL MODULE	61717037
4	088248-01-710	EA	HEATER DC (HORIZONTAL)	61562822
5	088248-01-709	EA	HEATER-AC (HORIZONTAL)	61562722
6	104137-06-715	EA	ELECTRODE-SPARK/SENSOR, SGL	61692222
7	104137-06-714	EA	BURNER ASSEMBLY, 5-SLOT	61705222
8	084880-01-705	EA	ORIFICE	61452222
9	104137-06-713	EA	GASKET-ORIFICE	61475122
10	104137-06-712	EA	FITTING-GAS, TUBE CONNECTION	61692722
11	104137-06-711	EA	FUSE-5 AMP	61611622
12	104137-06-710	EA	TAP-PRESSURE	61594422
13	104137-06-709	EA	VALVE-SHUT OFF, MANUAL	61694922
	084879-03-700	EA	COIL-COOLING,F/HORIZ-BURNER	61687240

### GALLEY GROUP (CONTINUED)

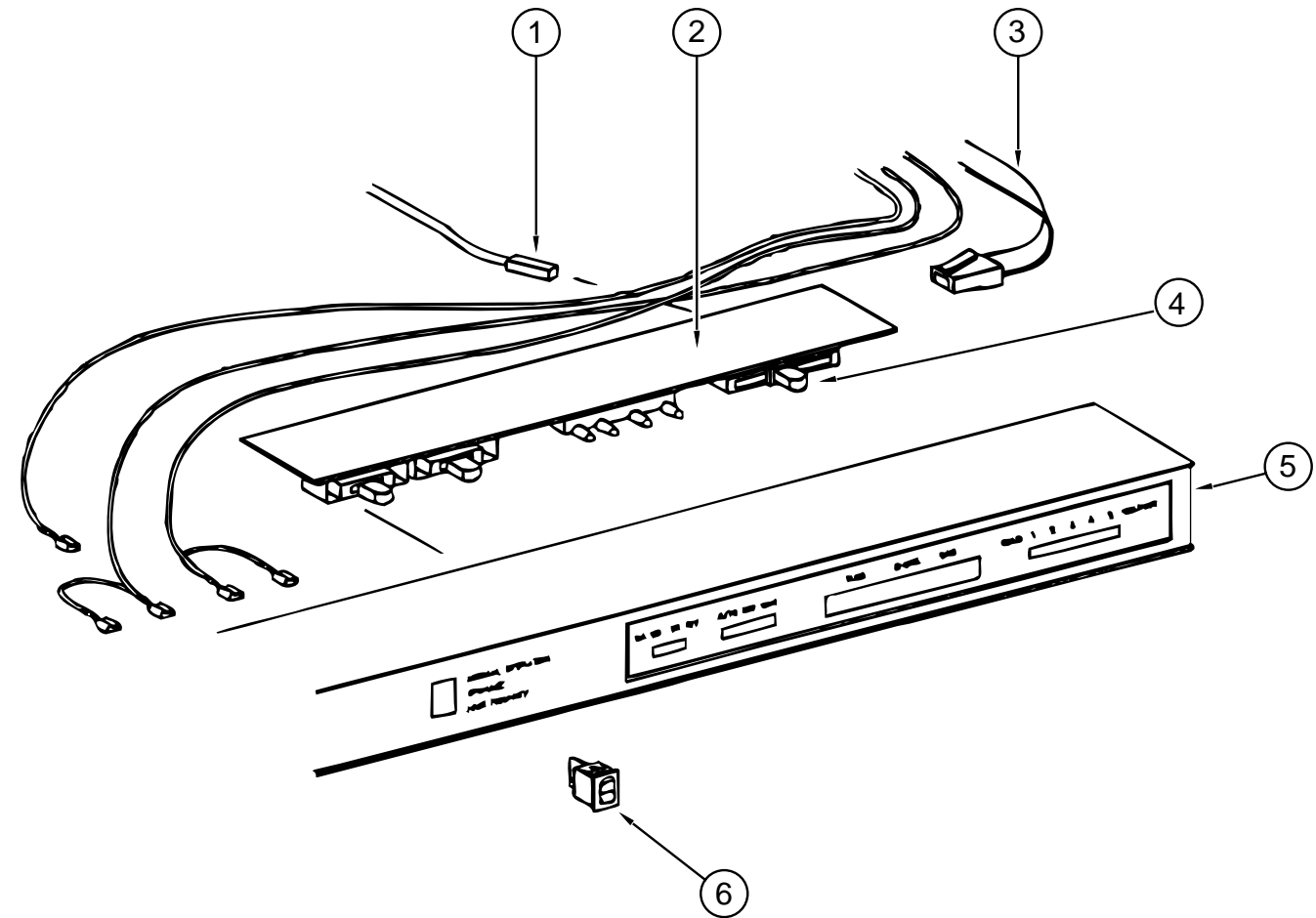

EYEBROW ASSEMBLY - NORCOLD

KEY	PART NUMBER	U/M	DESCRIPTION	VENDOR NO.
1	084880-01-753	EA	THERMISTER-78" W/O CLIP	61693822
	084880-01-760	EA	CLIP (THERMISTER)	61689122
2	094039-04-700	EA	BOARD-PC, 2 WAY	61647322
3	084880-01-746	EA	CABLE-PRINTED CIRCUIT BOARD TO POWER SUPPLY	
4	102621-01-703	EA	BUTTON-THERMOSTAT,ADJUSTABLE	61587422
5	104137-06-700	EA	SHELL-EYEBROW.2-WAY, W/HUM	61726622
6	075217-01-738	EA	SWITCH-HUMIDITY	61525922

**GALLEY GROUP (CONTINUED)**

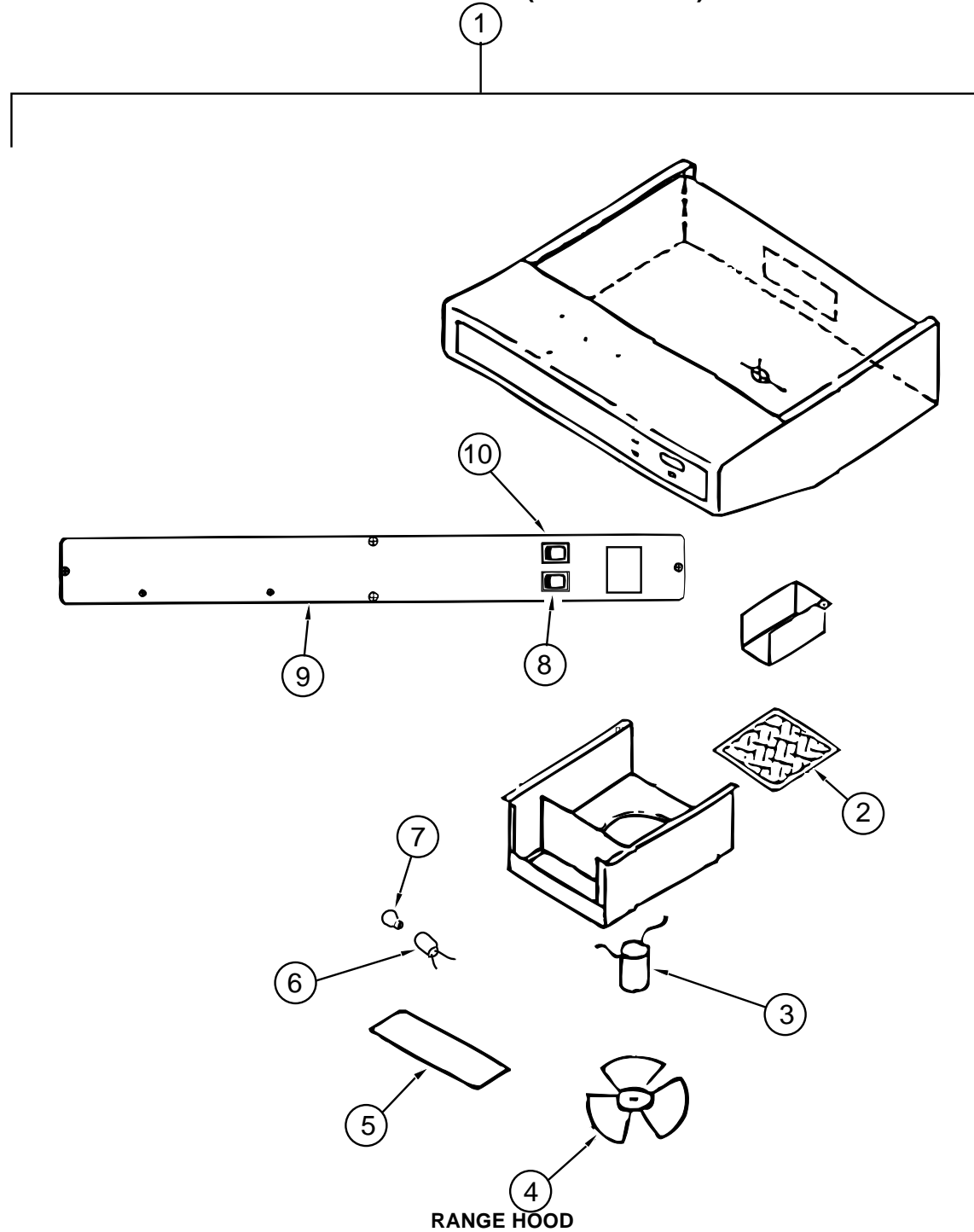

**RANGE HOOD**

KEY	PART NUMBER	U/M	DESCRIPTION	VENDOR NO.
1	100258-16-04A	EA	HOOD-RANGE W/O MONT PNL TEX - *VENT TCS-5008-NBDLG (US)	
1	100258-17-04A	EA	HOOD-RANGE W/O MONT PNL TEX - *VENT-TCS 500-NBCLG (CSA)	
2	096983-01-707	EA	FILTER-MESH	CC246
3	090973-01-700	EA	MOTOR-12 VOLT, CSA & UL	CA508-1
4	090973-01-702	EA	BLADE-FAN	VA183-1
5	092696-02-701	EA	LENS-LAMP	CC179-2
6	092696-01-710	EA	HOLDER-LAMP	CB267-2
7	092696-01-709	EA	LAMP #912	VA415
	117806-01-000	EA	BULB-12V NO.912 1.0 AMPS	
8	096983-01-700	EA	SWITCH-ON/OFF	108
9	100258-01-700	EA	LABEL-HOOD NOSE	CC428
10	096983-01-702	EA	SWITCH-MOM/OFF/MOM, 3 TERM	112
	100258-10-01A	EA	GAUGE-HOUR METER W/SWITCH - SCREW ON STYLE	
	096983-01-702	EA	SWITCH-MOM/OFF/MOM, 3 TERM	112
	100258-10-701	EA	GAUGE-HOUR METER, CLIP ON	L0775-00

**GALLEY GROUP (CONTINUED)**

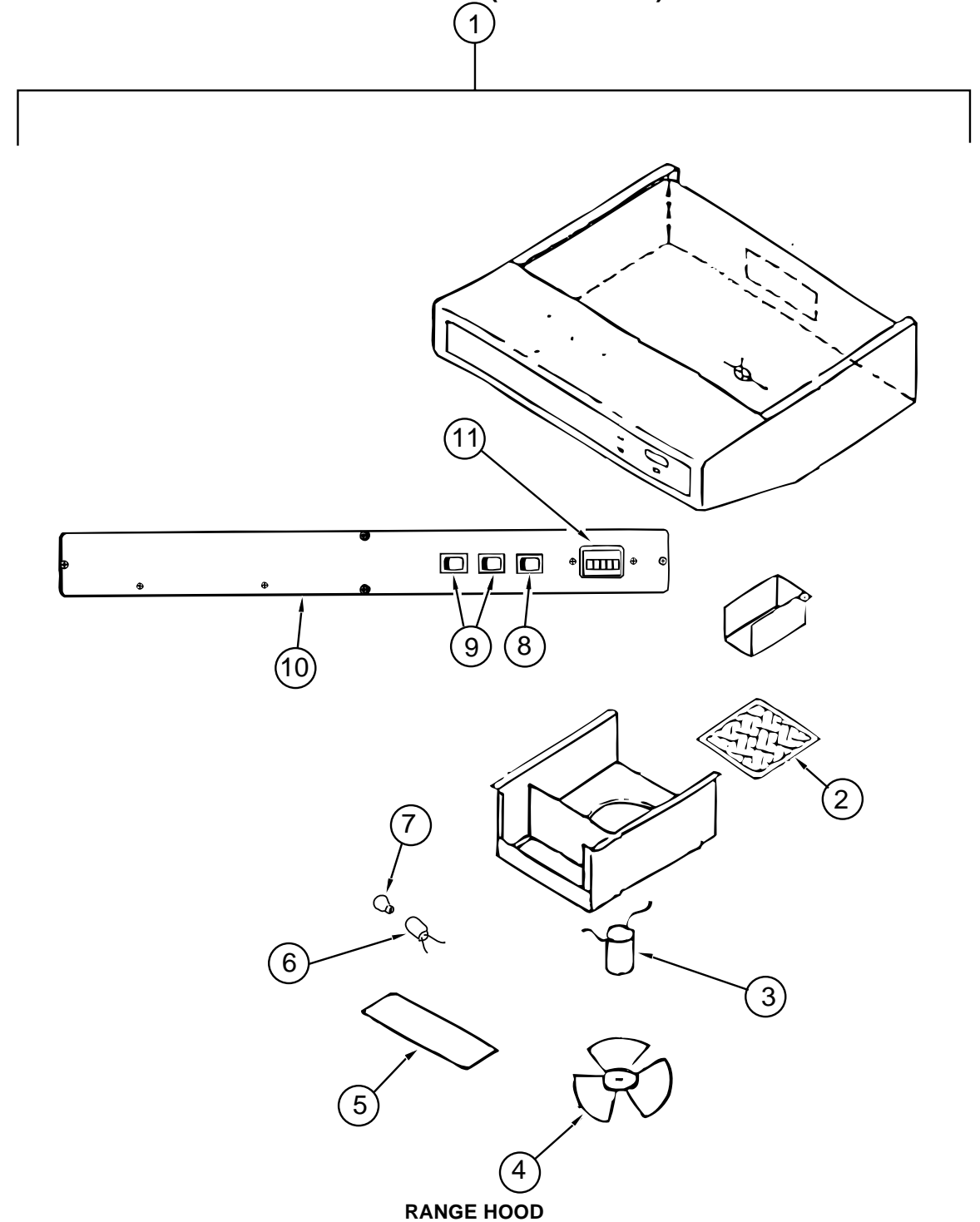

**RANGE HOOD**

KEY	PART NUMBER	U/M	DESCRIPTION	VENDOR NO.
1	100258-18-03A	EA	HOOD-RANGE W/O MONT PNL TEX - *VENT TP55009-SBO-LG	
2	096983-01-707	EA	FILTER-MESH	CC246
3	090973-01-700	EA	MOTOR-12 VOLT, CSA & UL	CA508-1
4	090973-01-702	EA	BLADE-FAN	VA183-1
5	092696-02-701	EA	LENS-LAMP	CC179-2
6	092696-01-710	EA	HOLDER-LAMP	CB267-2
7	092696-01-709	EA	LAMP #912	VA415
	117806-01-000	EA	BULB-12V NO.912 1.0 AMPS	
8	096983-01-702	EA	SWITCH-MOM/OFF/MOM, 3 TERM	112
9	096983-01-700	EA	SWITCH-ON/OFF	108
10	100258-01-700	EA	LABEL-HOOD NOSE	CC428
11	100258-10-01A	EA	GAUGE-HOUR METER W/SWITCH - SCREW ON STYLE	
	096983-01-702	EA	SWITCH-MOM/OFF/MOM, 3 TERM	112
	100258-10-701	EA	GAUGE-HOUR METER, CLIP ON	L0775-00

## GALLEY GROUP (CONTINUED)

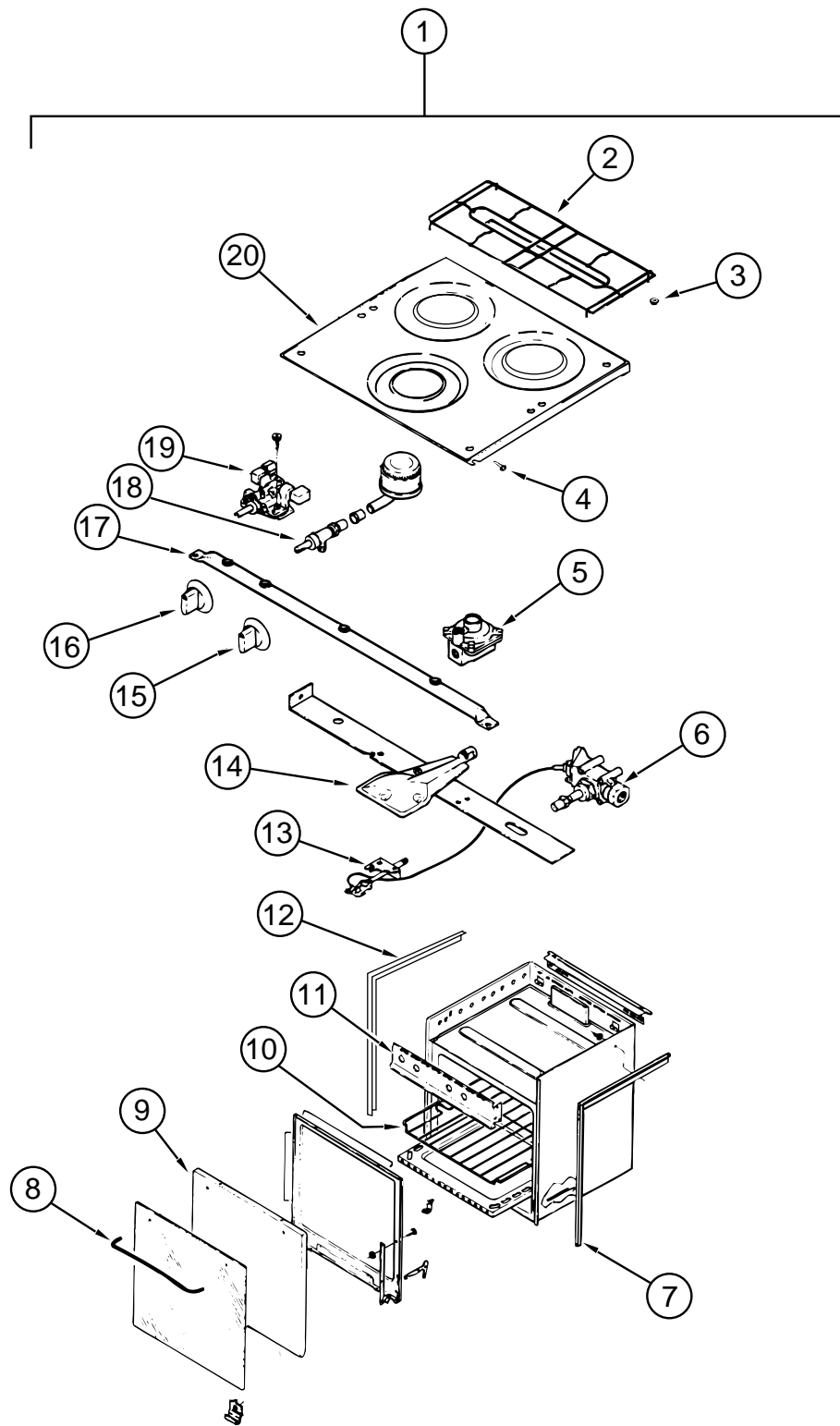

KEY	PART NUMBER	U/M	DESCRIPTION	VENDOR NO.
1	112881-01-04A	EA	RANGE-16"3BUR BLK DR BLK TEX - *M'CHEF 16RB-3B49	
2	102020-01-711	EA	GRATE-TOP	7518P012-60
3	102020-01-709	EA	BUMPER-GRATE	8007-P020-60
4	102020-01-724	EA	BUMPER-MAIN TOP	8003P008-60
5	102022-01-708	EA	REGULATOR, 1/4 & 1/2 OUT	7510P041-60
6	112881-01-702	EA	VALVE-MERCURY (SAFETY VALVE)	7501-P121-60
7	112881-01-708	EA	TRIM-FLAT (RIGHT) (BLK)	3608W036-70
8	102020-01-701	EA	HANDLE,DOOR	7701P092-60
9	112881-01-713	EA	DOOR-OVEN-TEXTURED, BLACK	2401F126-70
10	102020-01-700	EA	SHELF-OVEN	7801-P027-60
11	112881-01-701	EA	PANEL-MANIFOLD	2616F091-70
12	112881-01-707	EA	TRIM-FLAT (LEFT) (BLK)	3608W035-70
13	112881-01-710	EA	OVEN PILOT	7505P202-60
14	112881-01-711	EA	BURNER-OVEN	3403W025045
15	112881-01-705	EA	KNOB-TOP BURNER	7733P072-60
16	112881-01-704	EA	KNOB-THERMOSTAT	7731P067-60
16	112881-01-718	EA	KNOB, HIGH OUTPUT(FLAME IND)	74001794
16	112881-01-716	EA	KNOB, THERMOSTAT-SER# 3C	7731P107-60
17	112881-01-709	EA	PIPE-MANIFOLD	7513P097-60
18	102020-01-722	EA	VALVE-TOP BURNER	7502P181-60
18	112881-01-703	EA	VALVE-TOP BURNER HI-OUTPUT	7502P180-60
19	112881-01-706	EA	THERMOSTAT SER#02C	7515P031-60
19	112881-01-715	EA	THERMOSTAT, REF. SER. # 3C	7515P037-60
19	112881-01-722	EA	THERMOSTAT	7515P029-60
20	112881-01-712	EA	RANGE TOP-MAIN BLACK	740101486
	105458-01-000	EA	TIEDOWN BRACKET - STOVE - RH	
	105458-02-000	EA	TIEDOWN BRACKET - STOVE - LH	

## GALLEY GROUP (CONTINUED)

RANGE - MAGIC CHEF - MODEL 16RB-3B49

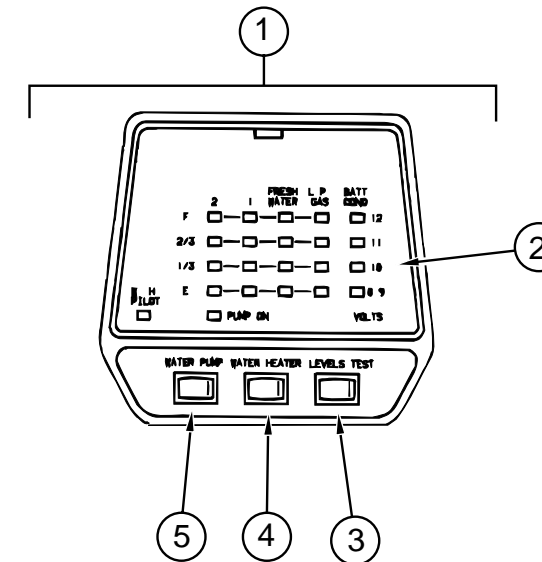

MONITOR PANEL - LVS

KEY	PART NUMBER	U/M	DESCRIPTION	VENDOR NO.
1	102765-04-01A	EA	PANEL-MONITOR 2 TANK WTR HTR - *LVS W/PLUG ALMOND	
2	102765-04-700	EA	BOARD-CIRCUIT,2 HOLDING TANK	5076-11
3	097617-01-702	EA	SWITCH (ALMOND)	107
4	097617-01-701	EA	SWITCH-ON/OFF, ALMOND	106
5	102765-01-700	EA	SWITCH-ON-ON, ALMOND	110-01
	097618-01-000	EA	WIRE ASM-MONITOR PANEL, W/3 WIRES & ORANGE RESISTOR- LVS	



## GALLEY GROUP (CONTINUED)

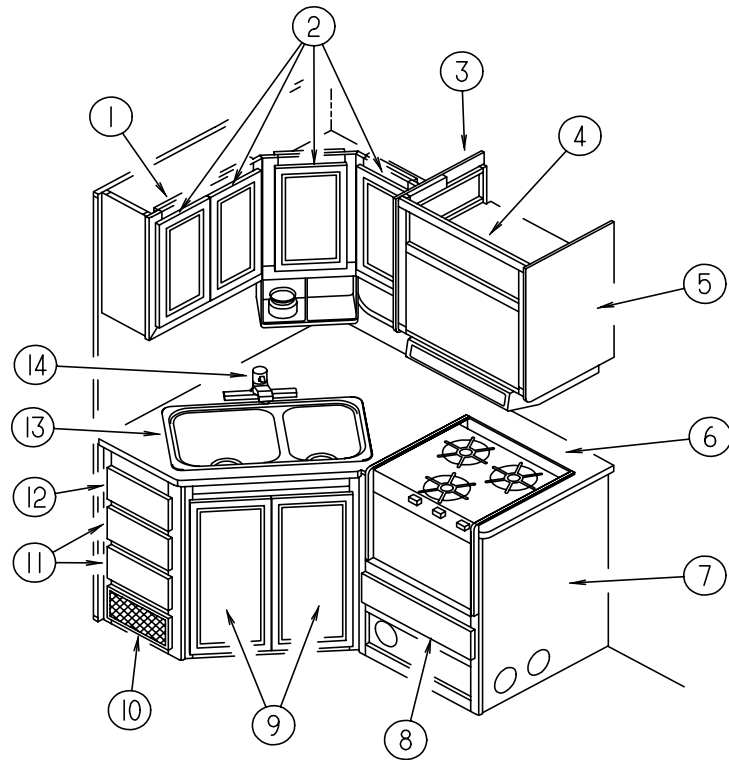

**GALLEY CABINETRY**

KEY	PART NUMBER	U/M	DESCRIPTION
1	121393-01-G04	EA	CABINET ASM-OVHD GALLEY
2	110140-85-G04	EA	DOOR ASM-MITERED,VINYL WRAP
3	109908-07-G04	EA	CAP ASM-END,OVHD
4	115956-01-G04	EA	CABINET - MICROWAVE - W/O DOORS/HARDWARE
5	109908-21-G04	EA	END CAP - OVERHEAD CABINET
6	121281-16-G24	EA	COUNTERTOP ASM (G24)
6	121281-16-G07	EA	COUNTERTOP ASM (G25)
7	P21281-01-G24	EA	CABINET ASM-GALLEY
7	P21281-01-G25	EA	CABINET ASM-GALLEY
8	M05970-X4-G04	EA	DRAWER COMPL-SLIDE RAD
9	110140-60-G04	EA	DOOR - MITERED CORNER/VINYL WRAP - 6.7" X 29.5" - W/O HDW
10	118200-01-01A	SF	MESH-PLASTIC,1/2 INCH,BLACK
	118200-04-01A	EA	MESH-PLASTIC,1/2 INCH BLK
11	M05970-X2-G04	EA	DRAWER COMPL-SLIDE RAD
12	M05970-X3-G04	EA	DRAWER COMPL-SLIDE RAD
13	104113-01-000	EA	SINK-SST,DOUBLE
	066437-01-000	EA	STRAINER-SINK, GALLEY W/BASKET
	103610-01-E04	EA	COVER ASM-SINK (G24)
	103610-01-F09	EA	COVER ASM-SINK (G25)
14	104114-02-01A	EA	FAUCET-GALLEY,SGL CONTROL 20PL1038-8" CHROME
	098335-10-G45	EA	RAIL-GALLEY - 1638 (G24)
	098335-10-F16	EA	RAIL-GALLEY - 1638 (G25)

## GALLEY GROUP (CONTINUED)

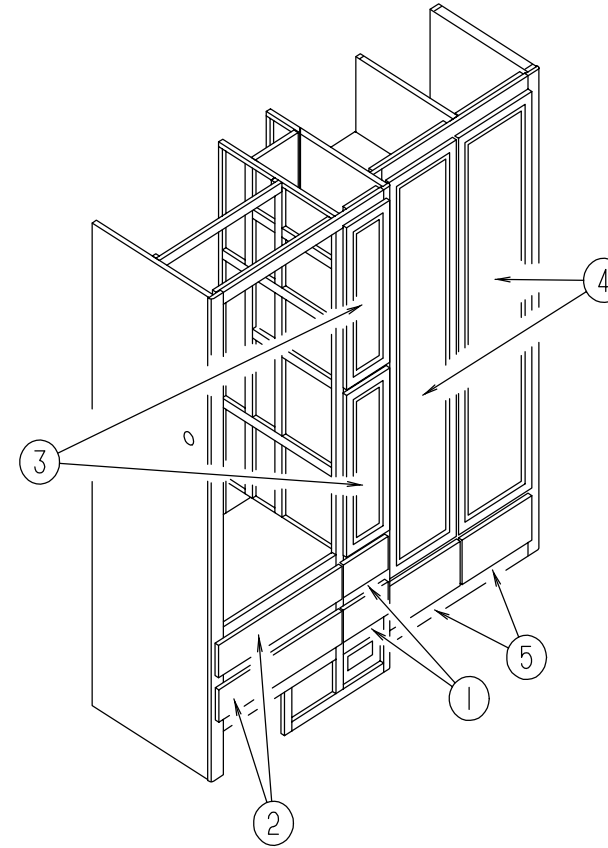

**REFRIGERATOR & WARDROBE CABINETRY**

KEY	PART NUMBER	U/M	DESCRIPTION
1	M05970-BA-G04	EA	DRAWER COMPL-SLIDE RAD
2	M05970-L9-G04	EA	DRAWER - RADIUS EDGE - W/O SLIDES/HARDWARE
	091257-10-000	EA	HANDLE-ASSIST WATERFORD OAK
3	110140-93-G04	EA	DOOR ASM-MITERED,VINYL WRAP
4	110140-52-G01	EA	DOOR - MTRD CRNR/VINYL WRAP-W/MIRROR-12.9" X 65" W/O HDW
5	M05970-X1-G04	EA	DRAWER COMPL-SLIDE RAD
	090329-01-000	FT	SEAL-T, REFRIGERATOR CABINET - .6" WIDE TOP X 2" TAIL

## GENERATOR GROUP

### 4 KW ONAN GAS GENERATOR

KEY	PART NUMBER	U/M	DESCRIPTION
	109982-03-000	EA	GENERATOR, 4.0 MICROLITE, ONAN# KY-FA/2600 B
	109982-04-000	EA	GENERATOR-3.6 MICROLITE, ONAN KY-FA/26120 B
	007067-01-000	SF	INSULATION-FIBERGLASS, 1" THICK X 4' - INCREMENTS OF 4 SF
	118248-01-02B	EA	BRACKET - GENERATOR - E-COATED - .74" X 16.9"
	118248-02-02B	EA	BRACKET - GENERATOR - E-COATED - 2.1" X 14.2"
	007125-04-000	EA	CLAMP-MUFFLER, 1.1" DIA
	105958-09-000	EA	PIPE-EXHAUST,GENERATOR

**NOTE: ADDITIONAL GENERATOR COMPONENTS ARE FOUND IN THE CHASSIS GROUP.**

## HEATING & AIR CONDITIONING GROUP

### HEATING SYSTEM

KEY	PART NUMBER	U/M	DESCRIPTION
	089367-02-000	EA	TEE - 4" X 2" X 4"
	069636-02-000	EA	CONNECTOR-DUCT, 4" ID - SUBURBAN 050715
	009198-01-000	FT	DUCT-HEAT, FLEXIBLE - 4" ID X 25 FT
	009198-02-000	FT	DUCT-FLEXIBLE-2IN ID X 25FT
	093614-01-02A	EA	GRILLE-RETURN AIR,DURA BEIGE
	093614-02-02A	EA	GRILL-RETURN AIR,DURA-BEIGE - LIMA,19H-8X8BR-RAG
	079059-01-000	EA	HOSE-90 DEGREE, 5/8"ID X 4" X 36"
	007108-01-000	FT	HOSE-HEATER, 5/8" ID - HI-TEMP - FORD ESE-M2D192-A
	094600-05-01A	EA	REGISTER-HEAT,W/O DAMPER - LIMA 41,DURA-BEIGE
	056464-10-000	EA	REGISTER-W/O DAMPER, 4" DIAMETER - DURA-BEIGE
	120134-01-01A	EA	REGISTER - 4-5" DIAMETER W/DAMPER
	009200-01-000	EA	TAPE-FURNACE, 1 1/2"
	117238-01-01A	EA	THERMOSTAT-A/C AND FURNACE - *COLEMAN 7330-3371
	008042-01-000	FT	TUBING-VINYL - .65" ID

### REAR HEATER - EVANS

KEY	PART NUMBER	U/M	DESCRIPTION	VENDOR NO.
	084405-01-000	EA	HEATER ASM-REAR, DUCTED - W/MOTOR AID - EVANS	
	084405-01-700	EA	CORE-HEATER	FT200229
	084405-01-701	EA	FAN BLADES	HV029931
	084405-01-702	EA	MOTOR ASSEMBLY, 12 VOLT	R0200180
	087202-01-000	EA	SWITCH - 4 POSITION - W/KNOB	

### CEILING ASM. - A/C - COLEMAN

KEY	PART NUMBER	U/M	DESCRIPTION	VENDOR NO.
	108892-01-01A	EA	CEILING ASM-A/C DUCTED - *COLEMAN 7330-730 IV	
	108892-01-700	EA	PLUG ASSEMBLY	7330-540
	108892-01-701	EA	BOARD-TERMINAL	7330-3201
	108892-01-702	EA	BOARD-P.C.	7330A3211
	108892-01-703	EA	FILTER	6798A3761
	108892-01-704	EA	GRILLE (PLASTIC)	6798-3041
	108892-01-705	EA	SMALL PARTS PKG	7330A6101

# HEATING & AIR CONDITIONING GROUP (CONTINUED)

## FURNACE - SUBURBAN - MODEL SF-30 2273

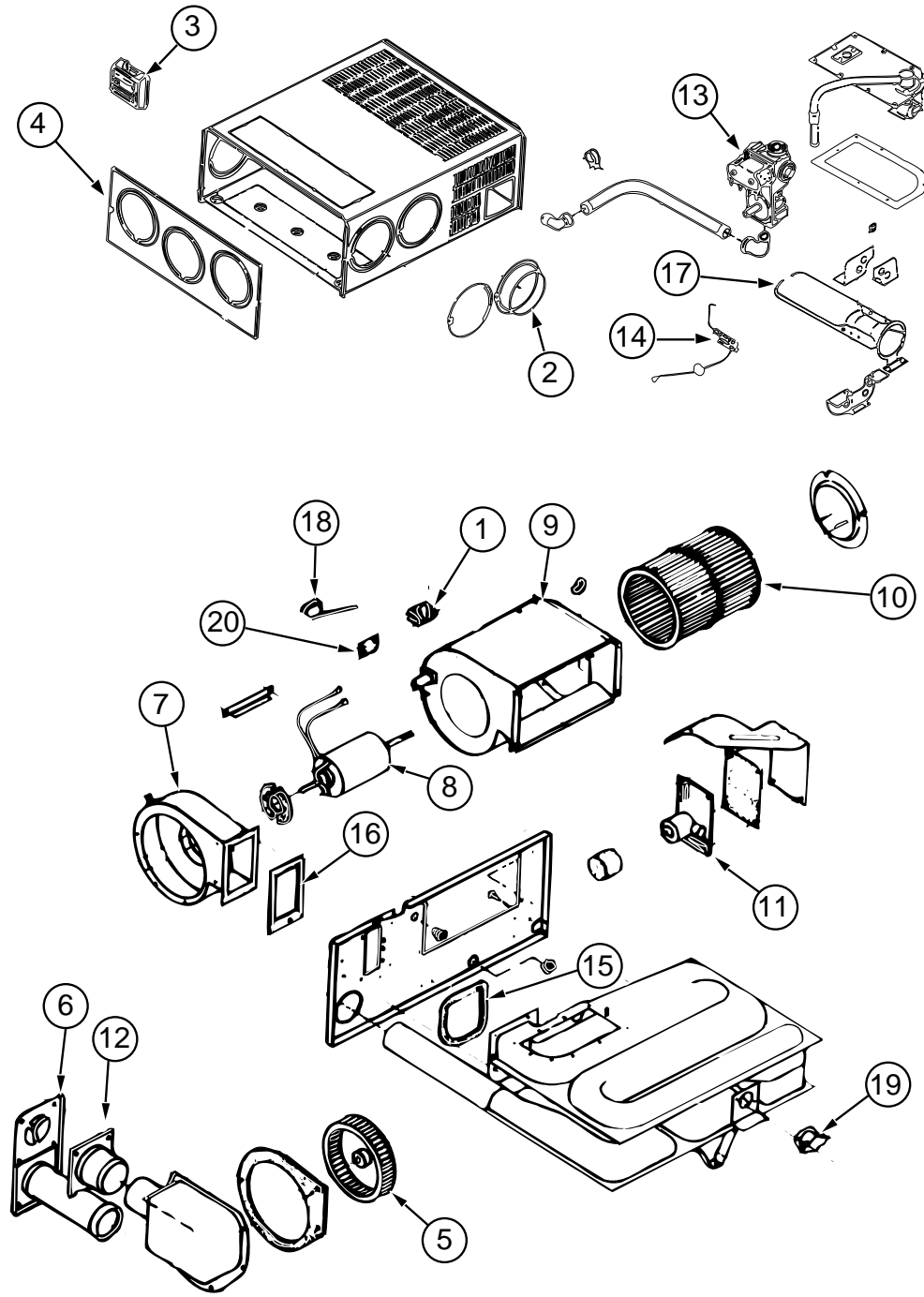

KEY	PART NUMBER	U/M	DESCRIPTION	VENDOR NO.
	098668-20-000	EA	FURNACE-30000 BTU, SUBURBAN SF-30 2273	
1	074466-01-702	EA	RELAY, TIME DELAY	230625
2	075696-02-703	EA	COLLAR-DUCT	050715
3	115764-01-01A	EA	THERMOSTAT-FURNACE, SUBURBAN	160902
4	098668-01-700	EA	CABINET FRONT	101242
5	098668-01-706	EA	WHEEL-COMBUSTION AIR	350128
6	098668-01-707	EA	TUBE ASSEMBLY, EXHAUST W/CAP	260231
7	098668-01-708	EA	HOUSING-BLOWER, COMBUSTION	390441
8	098668-01-709	EA	MOTOR ASM., F/SF-25, SF-30	231706
9	098668-01-710	EA	HOUSING-BLOWER, ROOM AIR	390440
10	098668-01-711	EA	WHEEL-BLOWER, ROOM AIR	350129
11	098668-01-712	EA	BOARD-MODULE	520741
12	098668-01-713	EA	TUBE ASSEMBLY, INTAKE	051248
13	098668-01-714	EA	VALVE-GAS,SF S.N. 921401821	161070
14	098668-01-715	EA	ELECTRODE ASM., SINGLE PROBE	232166
15	098668-01-716	EA	GASKET-FIREWALL,CHAMBER SIDE	070808
16	098668-01-717	EA	GASKET-FIREWALL, BLOWER SIDE	070809
17	098668-02-700	EA	BURNER ASSEMBLY,SF-30 & SF35	010745
18	098668-21-700	EA	SWITCH-MICRO,W/O FLAG 3 1/4"	232261
19	098668-21-701	EA	SWITCH-LIMIT	231799
20	101990-01-714	EA	GASKET-MICROSWITCH	230877
	092300-02-701	EA	ORIFICE-MAIN BURNER (NT-30BW)	180214
	098668-23-000	EA	DOOR - ACCESS - FURNACE	

## HEATING & AIR CONDITIONING GROUP (CONTINUED)

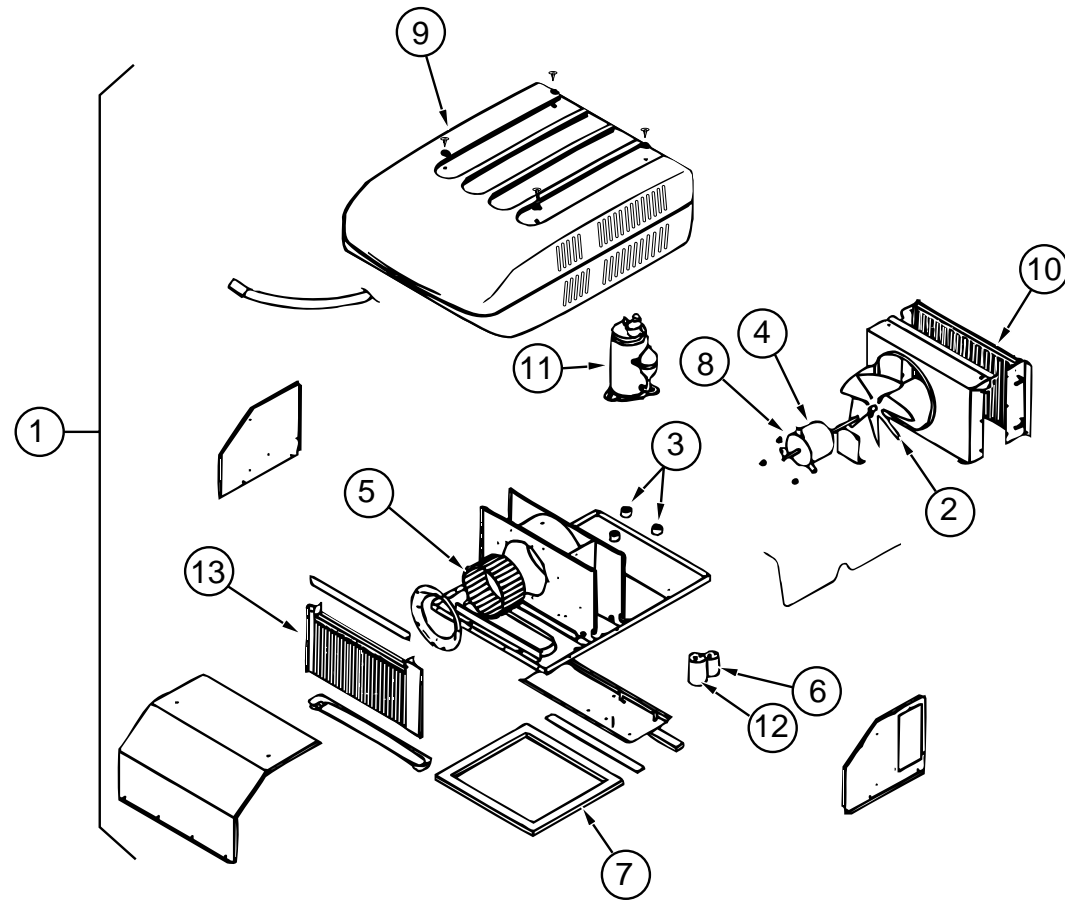

**ROOF A/C - COLEMAN - 14,800 MACH 15**

KEY	PART NUMBER	U/M	DESCRIPTION	VENDOR NO.
1	115219-01-03A	EA	A/C-ROOF,14,800 MACH 15 B/WT - *COLEMAN 7335B896	
2	093763-01-712	EA	BLADE-FAN-CONDENSER	6733-3221
3	105620-01-706	EA	MOUNTING PKG.,COMP., 3 PER	6759-3081
4	108889-01-705	EA	MOTOR (115, 60HZ)	1468-3049
5	108889-01-706	EA	IMPELLOR	1472-1041
6	093763-01-704	EA	CAPACITOR-FAN	1499-5461
7	108889-01-711	EA	GASKET PKG	6792-3301
8	108889-01-715	EA	MOTOR MOUNT & SHAFT SEAL KIT	6792-3361
9	108889-05-700	EA	SHROUD-BRIGHT/WHT. W/O LOGO	7333-4601
10	115219-01-700	EA	COIL-CONDENSER	1452-1321
11	115219-01-701	EA	COMPRESSOR - PANASONIC	1450-2039
12	115219-01-702	EA	CAPACITOR-RUN, COMPRESSOR	1499-5741
	115219-01-703	EA	RELAY-START	1497-4151
13	115219-01-704	EA	COIL-EVAPORATOR	1452-1331
	115219-01-705	EA	LINE-SUCTION, LOWER	7335-130
	115219-01-706	EA	LINE-SUCTION, UPPER	7335-131
	115219-01-707	EA	LINE ASSEMBLY, DISCHARGE	7335A132
	093306-01-701	EA	DECAL PACKAGE, LEFT & RIGHT	6798B3591
	093306-01-720	EA	CAPACITOR-START, 21-25 MFD33	1497-3351
	102289-01-000	EA	SPRING-SCREW, ROOF A/C GASKET - COLEMAN 6757-150	
	084077-03-000	EA	COVER-BLANK, ROOF A/C - 5.2" X 3.5" - IVORY	

## INTERIOR FINISH GROUP

### FIRE EXTINGUISHER, DETECTORS & CLOCK

KEY	PART NUMBER	U/M	DESCRIPTION	VENDOR NO.
	072852-01-000	EA	DETECTOR - SMOKE - W/9 VOLT BATTERY - US	
	072852-02-000	EA	DETECTOR - SMOKE - W/9/VOLT BATTERY - CANADIAN	
	094499-01-000	EA	EXTINGUISHER - FIRE - DRY W/MOUNTING BRACKET - 10 B:C	
	094499-02-000	EA	EXTINGUISHER - FIRE - DRY - 1A10BC - CANADIAN	
	094499-01-700	EA	BRACKET MTG. W/PLAS. STRAP	294039
	094499-01-701	EA	STRAP ONLY (METAL)	320351
	118081-01-01A	EA	CLOCK - WALL - ROUND 8" - BRASS	
	103613-02-000	EA	DETECTOR - LP GAS	
	112320-03-000	EA	DETECTOR - CO GASS MODEL 9D-I	
	112320-04-000	EA	BATTERY/SENSOR MODULE - CO (BLACK MODULE) F/9D-I SYSTEM	

### CARPETING & FLOOR MATS

KEY	PART NUMBER	U/M	DESCRIPTION
	096060-A1-000	SY	CARPET - ARTIC GRAY - INCREMENTS OF 4 SQ YD (G24)
	096060-95-000	SY	CARPET-DOESKIN - INCREMENTS OD 4 SQ YD (G25)
	093486-01-000	SY	CARPET-COMPARTMENT, 54" WIDE - DARK GRAY
	093873-01-01A	EA	TRIM-CARPET, L-ANGLE - 1.1" X 1.3" X 12' - VINYL - GRAY
	081075-04-000	EA	MAT-FLOOR ENTRANCE,ITASCA
	106884-03-000	EA	MAT-FLOOR,FRONT,RH,"I",FORD
	106884-04-000	EA	MAT-FLOOR,FRONT,LH"I",FORD

### PANELING, LAMINATES & PLASTIC

KEY	PART NUMBER	U/M	DESCRIPTION
	074497-28-000	SF	PANELING-WATERFORD OAK - 4' X 8'
	074497-33-000	SF	PANELING-CEILING - IMPACT PEARL - 4' X 9'
	074497-34-000	SF	PANELING-CEILING - IMPACT PEARL - 4' X 8'
	088272-98-000	SF	PANELING-SHOWER, OFF WHITE - 4' X 7' - INC OF 28 SQ FT
	074498-62-000	SF	LAMINATE-PLASTIC GREY FITNESS - 5' X 8' INCREMENTS 40 SF (G24)
	074498-71-000	SF	LAMINATE-PLASTIC - NEUTRAL SANTOS - 5' X 8' INCREMENTS (G25)
	074498-67-000	SF	LAMINATE-PLASTIC, ORCHID MIST (ALL) 5' X 8' INCR OF 40 SF
	074498-77-000	SF	LAMINATE-PLASTIC ART CABIN 5' X 8' INCR OF 40 SQ FT
	080215-10-000	SF	PANELING-2 SIDE - WATERFORD - 4' X 8'
	088272-E0-000	SF	PANELING-DECORATIVE METRO MIST - 4' X 7' (G24)
	088272-E2-000	SF	PANELING-DECORATIVE BIARRITZ,TRAVERTINE - 4' X 7' (G25)
	088272-G1-000	SF	PANELING-PEBBLE EMBOSS ANTIQUE - 4' X 7'-INC OF 28 SQ FT
	000885-76-000	SF	PARTICLE BOARD-3/8" X 4' X 8' WATERFORD OAK VINYL 1 SIDE
	000885-77-000	SF	PARTICLE BOARD-3/8" X 4' X 8'-WATERFORD OAK VINYL 2 SIDED
	000885-78-000	SF	PARTICLE BOARD-1/2" X 4' X 8' WATERFORD OAK-VINYL 2 SIDE
	000885-79-000	SF	PARTICLE BOARD-3/4" X 4' X 8' WATERFORD OAK VINYL 2 SIDED
	117267-E2-438	EA	LUMBER-VINYL WRAPPED .7" X 2" X 8'
	117267-G2-438	EA	LUMBER-VINYL WRAPPED - .7" X 3" X 8'
	117267-D2-438	EA	LUMBER-018X038X2438 MM VINYL - WRAPPED WATERFORD
	093743-05-01A	SF	PLASTIC-ABS COIL BRIGHT WHITE 20" X 500"
	098531-03-000	SF	PLYWOOD-ASH 1/2"
	000846-01-000	SF	PLYWOOD-5/16' X 4' X 8'
	000846-02-000	SF	PLYWOOD-UNDR - 5/16" X 4' X 8'

## INTERIOR FINISH GROUP (CONTINUED)

### MOLDINGS & TRIMS

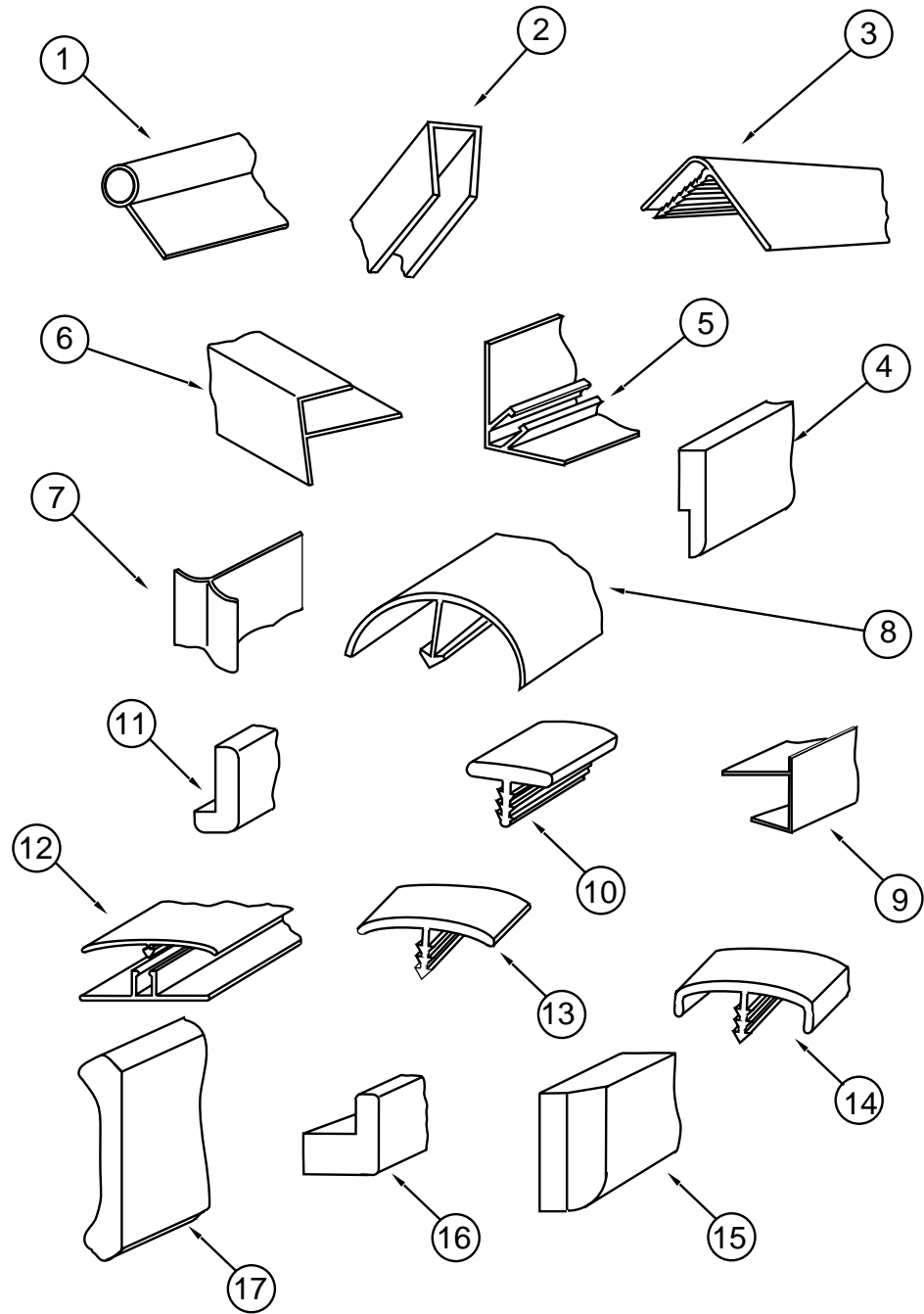

KEY	PART NUMBER	U/M	DESCRIPTION
10	104676-01-01A	FT	T-MOLDING,5/16 RIGID - *GOLD
10	104676-02-04A	FT	T-MOLDING,1/2 X 10FT - WATERFORD OAK
11	077840-01-G01	EA	MOLDING-CAP,WALL 2438
12	086229-13-000	EA	BATTEN - 1" CEILING MODERN IVORY
12	086229-11-000	EA	RETAINER-OFFSET - W&B
12	086229-12-000	EA	BATTEN-1.5",OFFSET,MOD IVORY - W&B
12	086229-14-000	EA	RETAINER-3/4 - W&B RN 391
12	086229-20-000	EA	BATTEN-1"CEILING,BEIGE
FROM: 06-10-96 THRU: 99-99-99			
13	105709-01-000	FT	T-MOLDING - 1" MODERN IVORY
14	119520-01-01A	FT	T-MOLDING - 1" W/EDGE LIPS
14	083620-09-000	FT	T-MOLDING,3/4 W/EDGE LIPS - *MODERN IVORY
14	083620-12-000	FT	T-MOLDING - 3/4" W/EDGE LIPS - WATERFORD OAK
14	104676-02-04A	FT	T-MOLDING,1/2 X 10FT - *WATERFORD OAK
15	100659-01-G09	EA	MOLDING-TRIM - VINYL FLOOR
16	100819-01-05A	EA	MOLDING-VINYL WRAP,DOOR - *WATERFORD OAK
17	113794-01-01A	FT	MOLDING-CROWN - ASH
	076325-68-000	FT	MOLDING - EDGE BAND - 1 5/16" X .038 - WATERORD OAK
	076325-67-000	FT	MOLDING - EDGE BAND - .93" X .024" WATERFORD OAK
	076325-43-000	FT	MOLDING - EDGE BAND. .875" WIDE - CLOUD (G24)
	076325-46-000	FT	MOLDING - EDGE BAND, 1 5/16" WIDE - CLOUD (G24)
	076325-40-000	FT	MOLDING-EDGE BAND - .875 X .024 X 600 (G25)
	076325-39-000	FT	MOLDING-EDGE BAND - 1 5/16 X .030 X 600 (G25)
	076325-34-000	FT	MOLDING - EDGE BAND - 1 5/16" X .030" - ORCHID MIST
	088263-D6-000	EA	BATT STRIP - DECORATIVE - IMPACT PEARL - 8' LONG
	088263-B8-000	EA	BATT STRIP - DECORATIVE - METRO/MIST - 8' LONG (G24)
	085284-B1-000	FT	BATT TAPE - ADHESIVE BACKED - DECORATIVE - METRO/MIST (G24)
	088263-C1-000	EA	BATT STRIP - DECORATIVE - BIARRITZ,TRAVERTINE - 8' LONG (G25)
	085284-B3-000	FT	BATT TAPE - DECORATIVE - BIARRITZ,TRAVERTINE - 8' LONG (G25)
	069733-83-000	EA	BATT STRIP - WOODGRAINED/WATERFORD OAK - 8' LONG
	085284-B5-000	FT	BATT TAPE - ADHESIVE BACKED - WOODGRAINED/WATERFORD OAK
	117268-D2-134	EA	MOLDING - VINYL WRAPPED .7" X 1.6" X 7' WATERFORD
	117268-F2-134	EA	MOLDING - VINYL WRAPPED .7" X 2.6" X 7' - WATERFORD
	117268-F2-438	EA	MOLDING - VINYL WRAPPED - .7" X 2.6" X 8' - WATERFORD

KEY	PART NUMBER	U/M	DESCRIPTION
1	009767-12-000	FT	MOLDING-SIDEWALL TO CEILING/CABINET - WELTING - OFF WHITE
2	009778-21-000	FT	U - CHANNEL, 1" WIDE X 8' INCREMENTS - PLASTIC
2	009778-20-700	EA	U-CHANNEL, 1"X55" - MODERN IVORY
2	070504-18-000	FT	U-CHANNEL-PLASTIC, .065" WIDE - IVORY - INC. OF 8'
2	070504-36-000	FT	U - CHANNEL, PLASTIC, 1.65" WIDE - INCREMENTS OF 8'
2	070504-37-000	FT	U - CHANNEL - PLASTIC .815" WIDE - INCREMENTS OF 8'
3	009809-23-000	EA	MOLDING-CORNER, OUTSIDE - 1" - PLASTIC - IVORY
3	009809-28-000	EA	MOLDING-PLAS,CORNER-1" - WATERFORD OAK
4	105004-01-05A	EA	MOLDING-VINYL WRAP - WATERFORD OAK
5	081521-02-007	EA	MOUNT-METAL MOLDING, FOR RADIUS CORNER MOLDING - 12.5' EA
6	009812-29-000	EA	MOLDING-PLAS,CORNER,O/S 1/2" - WATERFORD OAK
6	009812-24-000	EA	MOLDING-PLASTIC, OUTSIDE CORNER - .50" - IVORY
6	009815-09-000	FT	MOLDING-T, .75" - IVORY
7	022992-11-000	FT	MOLDING-REVERSE COVE, T-SHAPED - VINYL - IVORY
8	042357-20-000	EA	MOLDING-CORNER,RADIUS PLAS - WATERFORD OAK
9	103186-01-05A	FT	MOLDING-PLASTIC,SHELF - WATERFORD OAK

## INTERIOR FINISH GROUP (CONTINUED)

### CABINET & TABLE HARDWARE

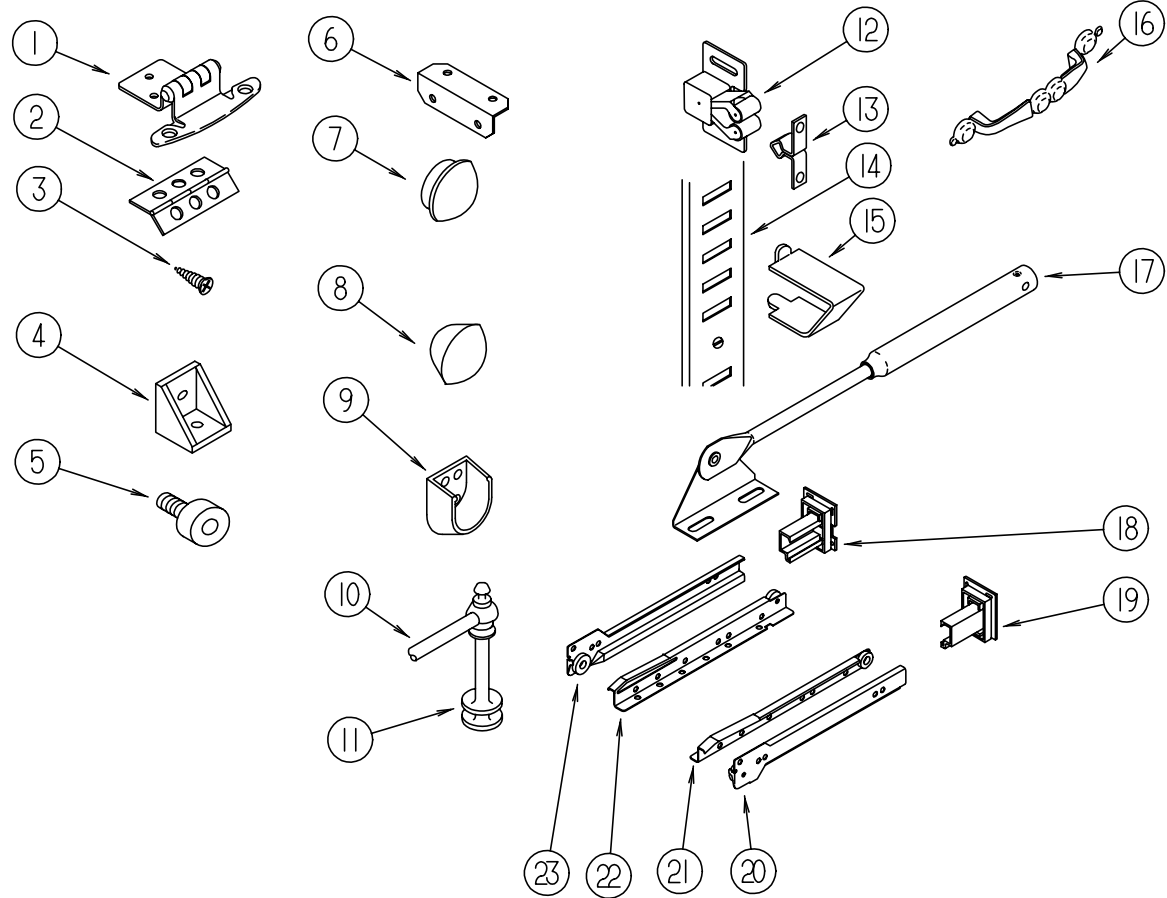

KEY	PART NUMBER	U/M	DESCRIPTION
20	114031-06-000	EA	SLIDE - 14" - RIGHT SIDE/CABINET REFERENCE DEALER PARTS BULLETIN #7SB010-96-12Z.
20	114031-10-000	EA	SLIDE - 16" - RIGHT SIDE/CABINET REFERENCE DEALER PARTS BULLETIN #7SB010-96-12Z.
20	114031-14-000	EA	SLIDE - 18" - RIGHT SIDE/CABINET REFERENCE DEALER PARTS BULLETIN #7SB010-96-12Z.
20	114031-18-000	EA	SLIDE - 20" - RIGHT SIDE/CABINET REFERENCE DEALER PARTS BULLETIN #7SB010-96-12Z.
20	114031-22-000	EA	SLIDE - 22" - RIGHT SIDE/CABINET REFERENCE DEALER PARTS BULLETIN #7SB010-96-12Z.
21	114031-08-000	EA	SLIDE - 14" - RIGHT SIDE/DRAWER REFERENCE DEALER PARTS BULLETIN #7SB010-96-12Z.
21	114031-12-000	EA	SLIDE - 16" - RIGHT SIDE/DRAWER REFERENCE DEALER PARTS BULLETIN #7SB010-96-12Z.
21	114031-16-000	EA	SLIDE - 18" - RIGHT SIDE/DRAWER REFERENCE DEALER PARTS BULLETIN #7SB010-96-12Z.
21	114031-20-000	EA	SLIDE - 20" - RIGHT SIDE/DRAWER REFERENCE DEALER PARTS BULLETIN #7SB010-96-12Z.
21	114031-24-000	EA	SLIDE - 22" - RIGHT SIDE/DRAWER REFERENCE DEALER PARTS BULLETIN #7SB010-96-12Z.
22	114031-07-000	EA	SLIDE - 14" - LEFT SIDE/DRAWER REFERENCE DEALER PARTS BULLETIN #7SB010-96-12Z.
22	114031-11-000	EA	SLIDE - 16" - LEFT SIDE/DRAWER REFERENCE DEALER PARTS BULLETIN #7SB010-96-12Z.
22	114031-15-000	EA	SLIDE - 18" - LEFT SIDE/DRAWER REFERENCE DEALER PARTS BULLETIN #7SB010-96-12Z.
22	114031-19-000	EA	SLIDE - 20" - LEFT SIDE/DRAWER REFERENCE DEALER PARTS BULLETIN #7SB010-96-12Z.
22	114031-23-000	EA	SLIDE - 22" - LEFT SIDE/DRAWER REFERENCE DEALER PARTS BULLETIN #7SB010-96-12Z.
23	114031-05-000	EA	SLIDE - 14" - LEFT SIDE/CABINET REFERENCE DEALER PARTS BULLETIN #72B010-96-12Z.
23	114031-09-000	EA	SLIDE - 16" - LEFT SIDE/CABINET REFERENCE DEALER PARTS BULLETIN #7SB010-96-12Z.
23	114031-13-000	EA	SLIDE - 18" - LEFT SIDE/CABINET REFERENCE DEALER PARTS BULLETIN #7SB010-96-12Z.
23	114031-17-000	EA	SLIDE - 20" - LEFT SIDE/CABINET REFERENCE DEALER PARTS BULLETIN #7SB010-97-12Z.
23	114031-21-000	EA	SLIDE - 22" - LEFT SIDE/CABINET REFERENCE DEALER PARTS BULLETIN #7SB010-96-12Z.
	076790-01-000	EA	SCREW, 6-20 X 1 1/4 PPH - BLACK
	076790-05-000	EA	SCREW-6-20 X 1/2" - PPH - BLACK THREADCUTTING - WOOD
	004354-01-000	EA	BUMPER-RUBBER, .5" DIA - BROWN
	023320-01-000	EA	PAD-FELT, 3/8" DIAMETER - BROWN
	009112-01-000	EA	FLANGE-1" CLOTHES ROD- OFF WHITE PLASTIC
	000G13-06-10G	EA	SCREW - 6-20 X 5/8 PFH - ANTIQUE BRASS
	042438-01-000	EA	DOWEL-WOOD, CLOTHES ROD - 1" DIAMETER X 4'
	102194-01-000	EA	GUIDE-PLASTIC
	103256-01-000	EA	LATCH-SLIDE
	104181-01-01A	EA	SUPPORT-LEAF - 5.3" - EXTENDS TO 7.5" - SAFETY RING - METAL
	116975-01-01A	EA	LATCH ASM-UNDERCENTER,BLACK *SOUTHCO 91-522-69
	042541-05-000	EA	STRIKE
	041389-35-000	EA	HINGE-PIANO,O/W,0787.4
	080728-01-000	EA	HANDLE-PULL 1.3" X 4.4" - PLASTIC - BROWN
	084451-01-000	EA	CATCH - TV SHELF - BRASS

KEY	PART NUMBER	U/M	DESCRIPTION
1	108138-01-000	EA	HINGE-DOOR, CABINET - BURNISHED BRASS
2	009059-01-000	EA	HINGE-DOOR, 2" X 1.4" - BRASS
3	000G13-06-10G	EA	SCREW-6-20 X 5/8 PFH, ANTIQUE BRASS
4	065740-01-000	EA	BRACE-CABINET CORNER, PLASTIC
5	079921-01-000	EA	ROLLER-NYLON, W/STEEL SHAFT - BARBED
6	016604-01-000	EA	BRACE-CABINET, ANGLE - 2.5" - UNPAINTED
6	016604-05-000	EA	BRACE-CABINET, L ANGLE - 2.5" - OFF WHITE
7	074045-07-000	EA	PLUG-WOOD, 1/2"
8	042356-01-000	EA	PLUG-BUTTON - MAHOGANY - 3/8" DIAMETER - WOOD
9	113236-01-01A	EA	BRACKET-CLOTHES ROD
10	084071-12-000	EA	ROD-BRASS - 104 MM LONG
10	084071-15-000	EA	ROD-BRASS - 210 MM LONG
10	084071-19-000	EA	ROD-BRASS - 198 MM LONG
11	084070-02-000	EA	POST-END - BRASS
12	093586-06-000	EA	CATCH-SPRING, ROLLER - FASTEC C411-AC
13	093586-05-000	EA	STRIKE-SPRING STEEL, FASTEC S411-AC
14	098980-01-000	EA	PILASTER-ADJUSTABLE SHELF, 18" LONG
15	098979-01-000	EA	CLIP-ADJUSTABLE SHELF
16	117801-01-01A	EA	PULL-CABINET,BRASS
17	074493-02-000	EA	SUPPORT-PISTON SPRING, CABINET DOOR
18	114045-01-000	EA	BACKSOCKET - ADJUSTABLE LEFT PLEASE REFER TO PARTS BULLETIN #140 FOR INTERCHANGEABILITY
19	114045-02-000	EA	BACKSOCKET - ADJUSTABLE RIGHT PLEASE REFER TO PARTS BULLETIN #140 FOR INTERCHANGEABILITY

**LABELS GROUP**

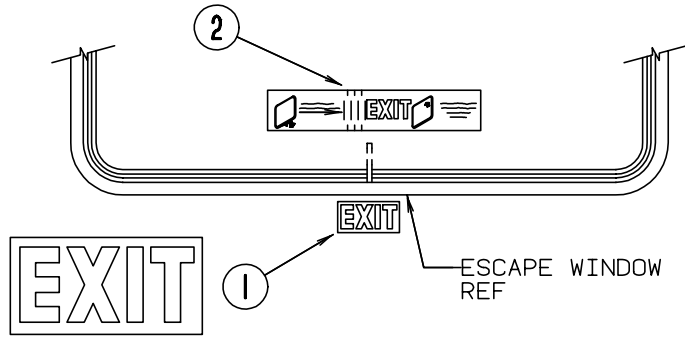
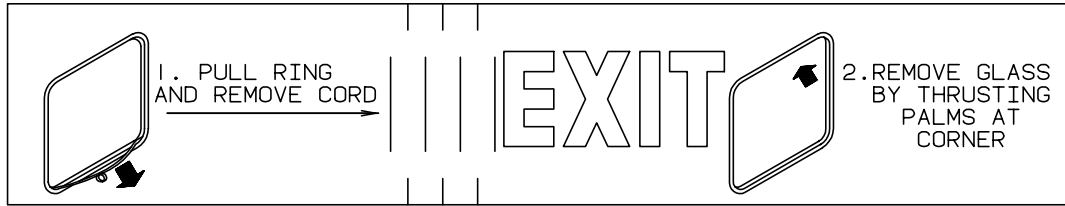

KEY	PART NUMBER	U/M DESCRIPTION
1	039290-01-000	EA LABEL-WARNING - EXIT
2	107571-01-000	EA LABEL-EXIT/ESCAPE WINDOW

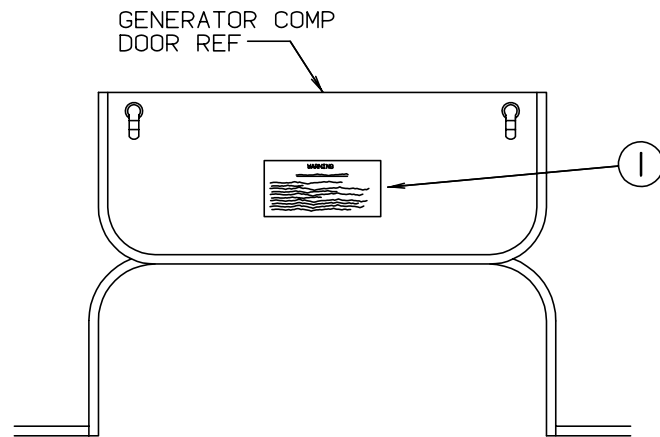

**WARNING**

WHEN ADDING A GENERATOR SET:

HIGH VOLTAGE-USE EXTREME CAUTION WHEN WORKING ON ELECTRICAL COMPONENTS. HAVE ALL ELECTRICAL INSTALLATION PERFORMED BY A QUALIFIED LICENSED ELECTRICIAN-FOLLOW ALL STATE AND LOCAL CODES. ONLY INSTALL GENERATOR SET APPROVED FOR R.V. APPLICATION. HAVE INSTALLED BY QUALIFIED TECHNICIAN. TO AVOID HEAT BUILD-UP AND TO GUARANTEE AN ADEQUATE AIR SUPPLY TO THE GENERATOR CARBURETOR, FOLLOW INSTALLATION INSTRUCTIONS. GENERATOR ENGINE EXHAUST GASES ARE TOXIC AND MUST NOT TERMINATE UNDER THE VEHICLE-DISCHARGE EXHAUST AWAY FROM VEHICLE.

KEY	PART NUMBER	U/M DESCRIPTION
1	077510-01-000	EA LABEL-GENERATOR PREP

**LABELS GROUP (CONTINUED)**

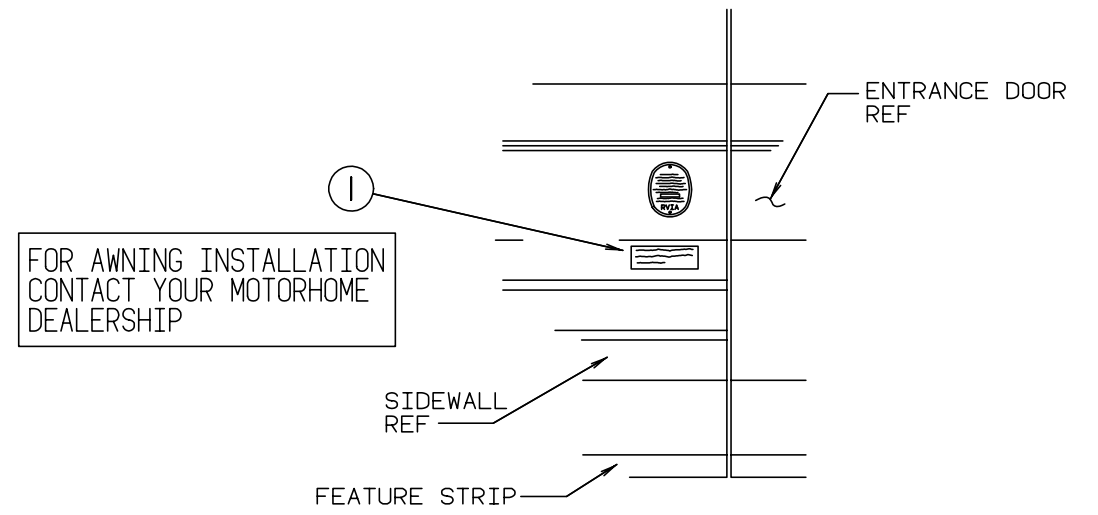

KEY	PART NUMBER	U/M DESCRIPTION
1	099509-01-000	EA LABEL-AWNING INSTALLATION

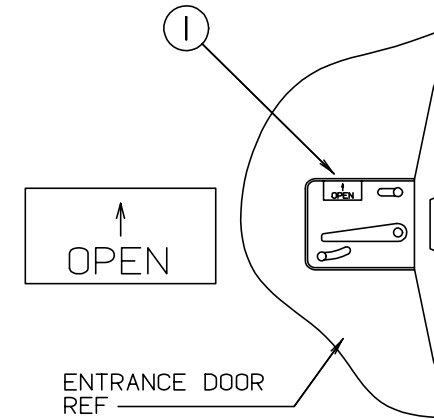

KEY	PART NUMBER	U/M DESCRIPTION
1	040944-01-000	EA LABEL-ENTRANCE DOOR, "OPEN"

**LABELS GROUP (CONTINUED)**

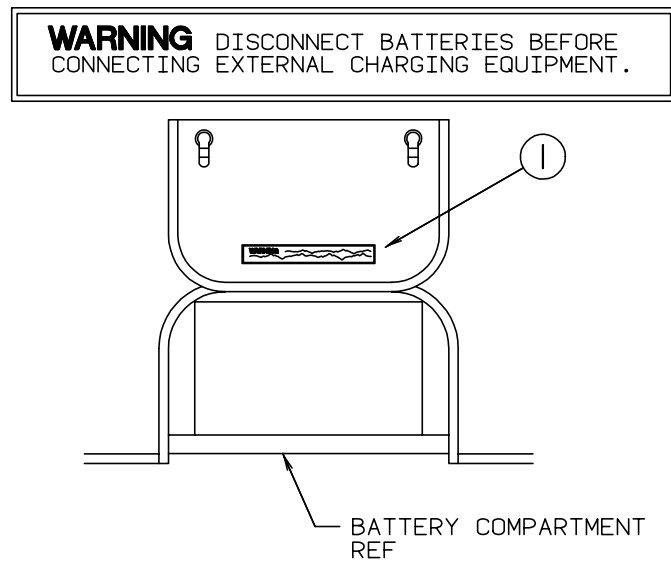

KEY	PART NUMBER	U/M	DESCRIPTION
1	065748-01-000	EA	LABEL-CAUTION, BATTERY CHARGING

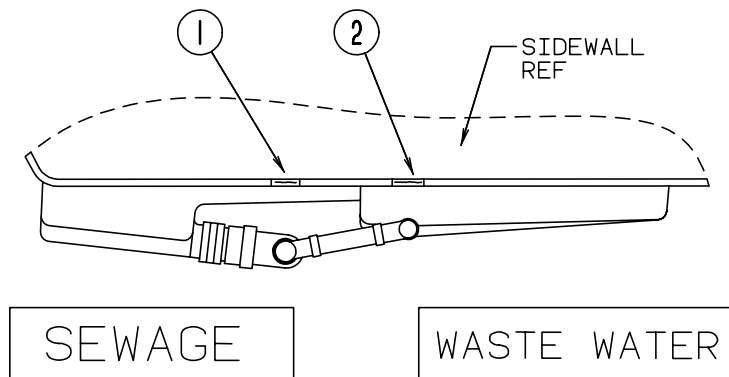

KEY	PART NUMBER	U/M	DESCRIPTION
1	006187-01-000	EA	LABEL-SEWAGE
2	006188-01-000	EA	LABEL-WASTE WATER

**LABELS GROUP (CONTINUED)**

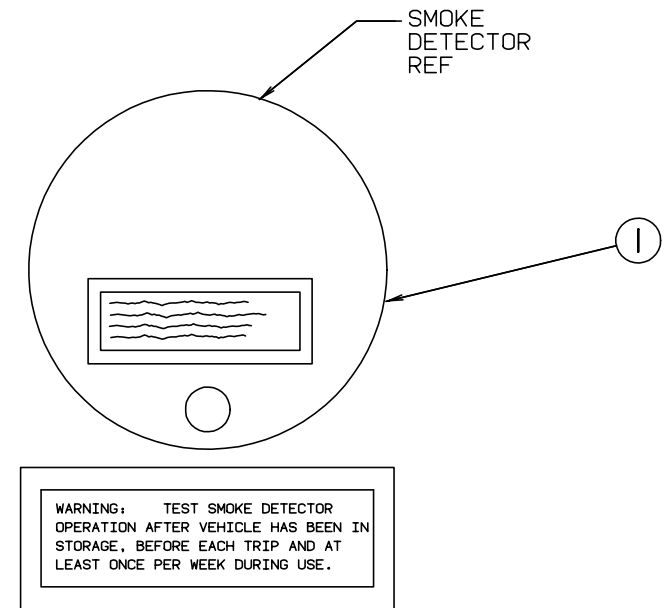

KEY	PART NUMBER	U/M	DESCRIPTION
1	077956-01-000	EA	LABEL-WARNING, SMOKE DETECTOR

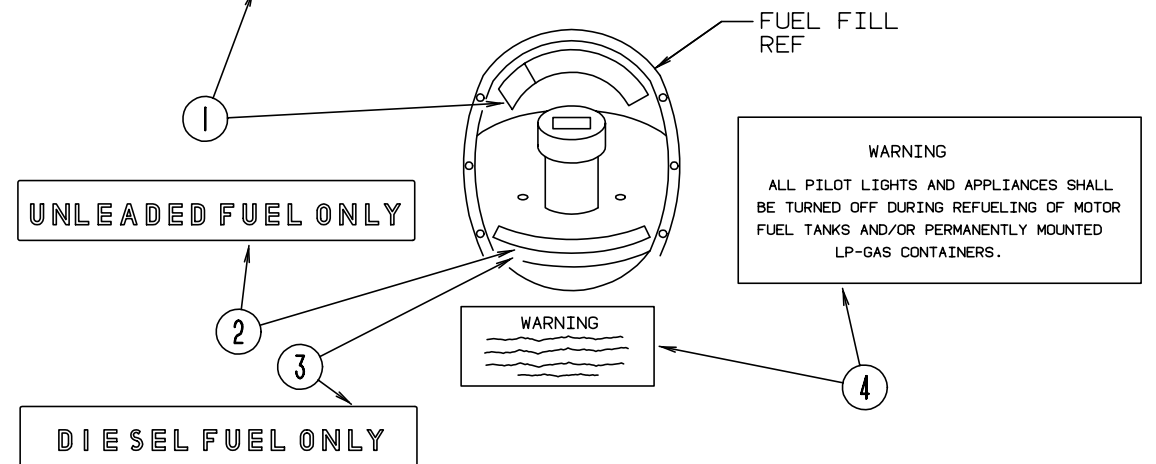
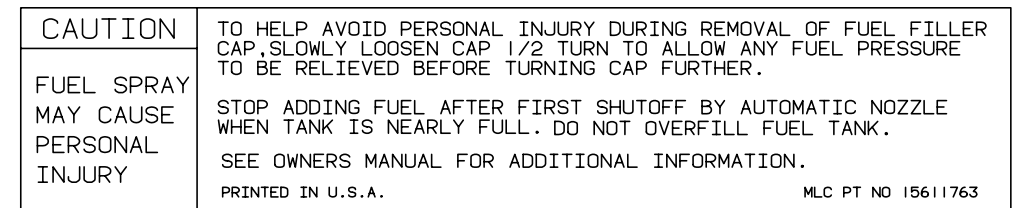

KEY	PART NUMBER	U/M	DESCRIPTION
1	087207-05-000	EA	LABEL-FUEL CAP REMOVAL
2	062043-01-000	EA	LABEL-FUEL, UNLEADED
3	068383-01-000	EA	LABEL-FUEL - DIESEL
4	006040-01-000	EA	TAG-GAS REFUELING WARNING
4	006040-02-000	EA	TAG-GAS REFUELING WARNING, CANADIAN



**LABELS GROUP (CONTINUED)**

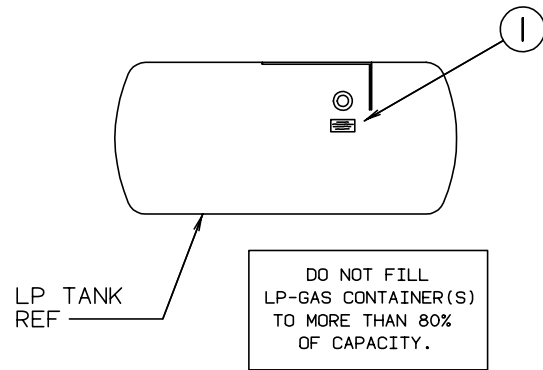

KEY	PART NUMBER	U/M DESCRIPTION
1	054531-01-000	EA LABEL-LP GAS ONLY

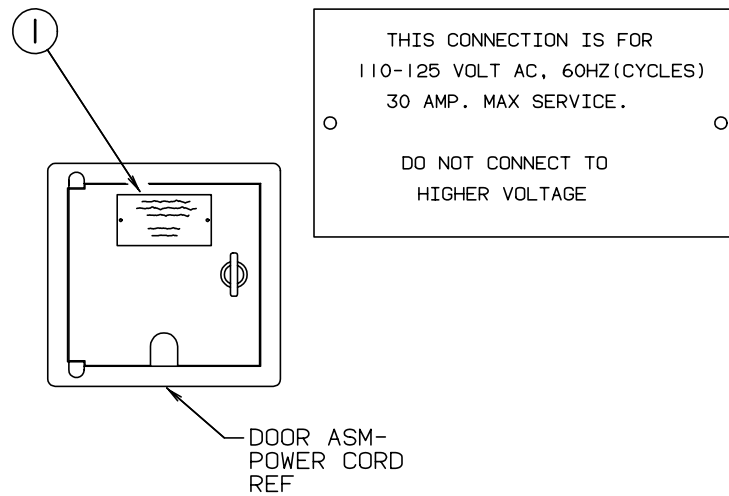

KEY	PART NUMBER	U/M DESCRIPTION
1	006062-01-000	EA LABEL-ELECTRIC, 110V CONNECTION

**MISCELLANEOUS LABELS**

KEY	PART NUMBER	U/M DESCRIPTION
	104236-01-000	EA LABEL-GENERATOR CIRCUIT
	006064-01-000	EA LABEL-SEAT W/O SEATBELT
	006064-02-000	EA LABEL-SEAT W/O SEATBELT (CSA) NOT INTENDED FOR USE WHILE COACH IN MOTION
	091243-01-000	EA LABEL-A/C COVER, "AIR CONDITIONING CIRCUIT. ETC."
	093236-08-000	EA LABEL-CIRCUIT BREAKER
	111104-01-000	EA LABEL-HITCH,READ MANUAL
	061417-01-000	EA LABEL-FUEL,ON FUEL FILL DOOR
	073998-01-000	EA LABEL-LPG ODOR WARNING
	112518-01-000	EA LABEL-HANG TAG,CO DETECTOR

**LABELS GROUP (CONTINUED)**

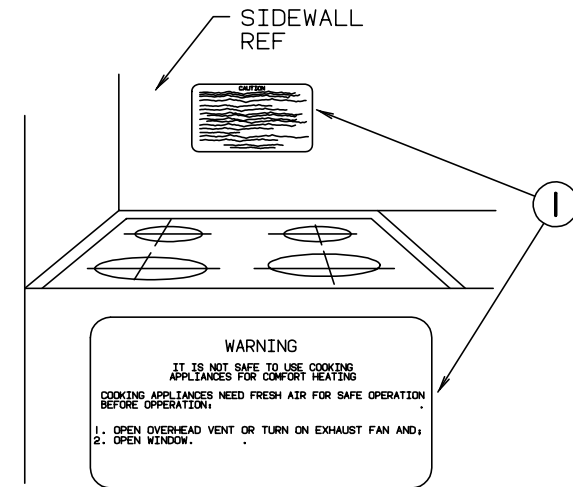

KEY	PART NUMBER	U/M DESCRIPTION
1	050225-01-000	EA LABEL-WARNING, STOVE VENT - US

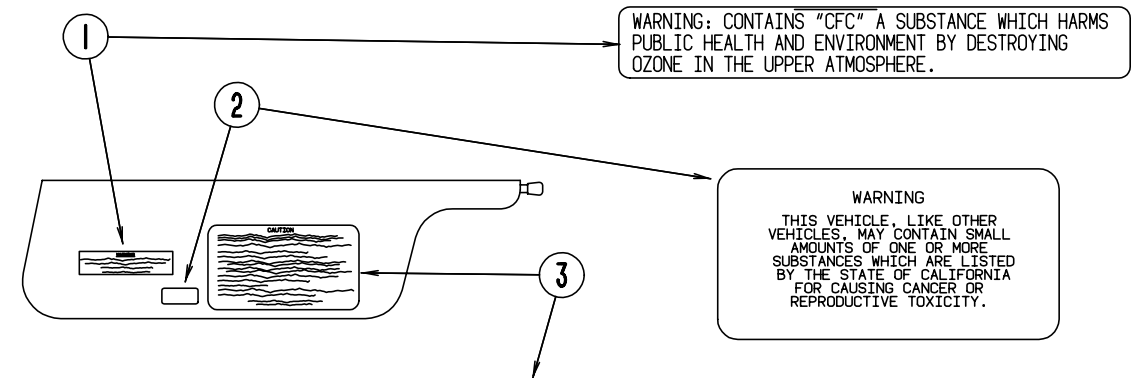

**CAUTION**

THIS MOTOR HOME HAS BEEN DESIGNED, MANUFACTURED AND TESTED WITH CONCERN FOR THE PROTECTION OF IT'S OCCUPANTS. WE RECOMMEND YOU PERFORM THE FOLLOWING INSPECTIONS FOR YOUR SAFETY AND THE SAFETY OF YOUR PASSENGERS BEFORE STARTING YOUR VEHICLE.

1. LP GAS SYSTEM- TURN OFF AT TANK FOR TRAVELING. TEST FOR LEAKS UPON ARRIVAL AT DESTINATION. BEFORE LIGHTING PILOTS.
2. WHEELS- INSPECT FOR DAMAGE AND CHECK LUG NUTS FOR TIGHTNESS.
3. TIRES- INSPECT FOR WEAR AND DAMAGE AND CHECK FOR RECOMMENDED AIR PRESSURE.
4. LIGHTING- TEST FOR PROPER OPERATION OF ALL INTERIOR AND EXTERIOR LIGHTS INCLUDING DASH LIGHTS, HEADLIGHTS, TAIL LIGHTS, BRAKE LIGHTS, CLEARANCE LIGHTS AND TURN SIGNALS.
5. EXITS- INSPECT RELEASE MECHANISM ON EMERGENCY EXIT WINDOW. TEST BOTH LOCKS ON MAIN ENTRANCE DOOR FOR EASE OF OPERATION AND INSTRUCT PASSENGERS HOW TO USE BOTH MEANS OF EXIT.
6. SEAT BELTS- DIRECT PASSENGERS TO DESIGNATED SEATS AND REQUIRE USE OF SEAT BELTS.
7. APPLIANCES- TURN OFF AND LATCH OR LOCK DOORS WHERE PROVIDED.
8. LOOSE PARCELS- STORE SECURELY.
9. UTILITY SUPPLY LINES- DISCONNECT ALL ELECTRIC, SEWER AND WATER LINES AND SECURE PROPERLY.
10. ENTRANCE DOOR STEP- PLACE IN RETRACTED POSITION FOR TRAVELING.

READ YOUR MOTOR HOME AND CHASSIS OWNER'S MANUAL FOR FURTHER PRECAUTIONS

KEY	PART NUMBER	U/M DESCRIPTION
1	111802-01-000	EA LABEL-CFC WARNING
2	099689-01-000	EA LABEL-WARNING, CANCER/TOXICITY
3	056259-01-000	EA LABEL-SAFETY CHECK LIST

**LP GROUP**

**LP SYSTEM**

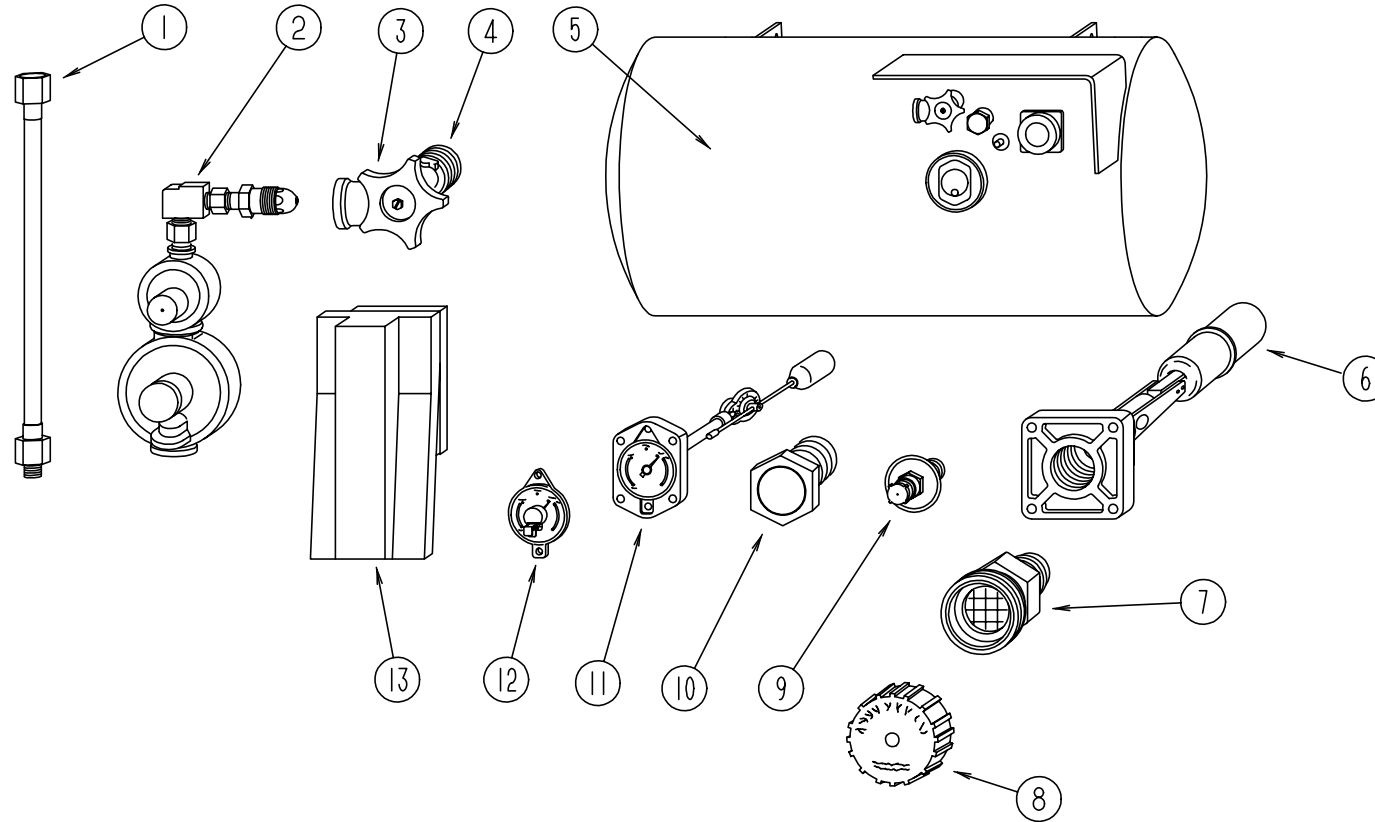

KEY	PART NUMBER	U/M	DESCRIPTION	VENDOR NO.
1	045703-01-000	EA	HOSE-LP, 3/8" ID X 24" - 3/8 MPT X 1/2 F SWIVEL - U.S.	
1	045703-05-000	EA	HOSE-LP, 3/8" ID X 28" - 3/8 MPT X 1/2 F SWIVEL - US	
1	045703-06-000	EA	HOSE-LP, 3/8" ID X 28" - 3/8 MPT X 1/2 F SWIVEL - CANADIAN	
	045703-09-000	EA	HOSE ASM-LP 3/8IDX24 US&CGA 3/8F SWI X 3/8F SWI	
2	106150-01-000	EA	REGULATOR-TWO STAGE	
	106150-02-000	EA	REGULATOR-TWO STAGE M'BRASS 290-00	
3	040421-01-708	EA	HANDWHEEL-SERVICE VALVE	G-1015-A
4	040421-01-712	EA	VALVE,SERV. W/O VAPOR RELIEF	29000853
5	097821-01-000	EA	TANK-LP, 60 LB BRUNNER - 14" X 30"	
6	040421-01-711	EA	VALVE-80% FILL W/AUTO STOP	LLL/TL3
7	040421-01-701	EA	VALVE-FILL-SHORT, LP	75478
8	040421-01-702	EA	CAP-FILL VALVE, PLASTIC	G-1014-A
9	040421-01-700	EA	VALVE-LIQUID LEVEL, 20%	G-1013
10	040421-01-713	EA	VALVE-VAPOR ONLY	29000587
11	040421-01-707	EA	FLOAT ASM.(SIGHT GAUGE) 14"	14C
12	040440-02-000	EA	TRANSMITTER-DIAL, 0-90 OHM - 2 TERMINAL (POWER & GROUND)	
13	105658-01-000	EA	COMPARTMENT-LP REGULATOR	
	010265-01-000	EA	ELBOW-BRASS, 90 DEGREE - 3/8"F X 1/2"FPT	
	010323-01-000	EA	ADAPTER-BRASS, 3/8F X 1/2MPT	
	010377-02-000	EA	NUT-BRASS, 3/8" FLARE - FORGED	
	065318-02-000	EA	ELBOW-90 DEGREE, 3/8" MPT TO 3/8" FPT	
	024250-01-000	EA	ADAPTER-BRASS, 3/8"F X 1/2" FPT	
			FROM: 07-11-96 THRU: 99-99-99	
	010252-01-000	EA	ELBOW-BRASS, 90 DEG, 3/8F X 1/2MPT	
	103613-01-000	EA	DETECTOR-LP GAS	
	M01526-59-000	EA	LP REGULATOR ASM-24"HOSE,DSL	

### LOUNGE GROUP

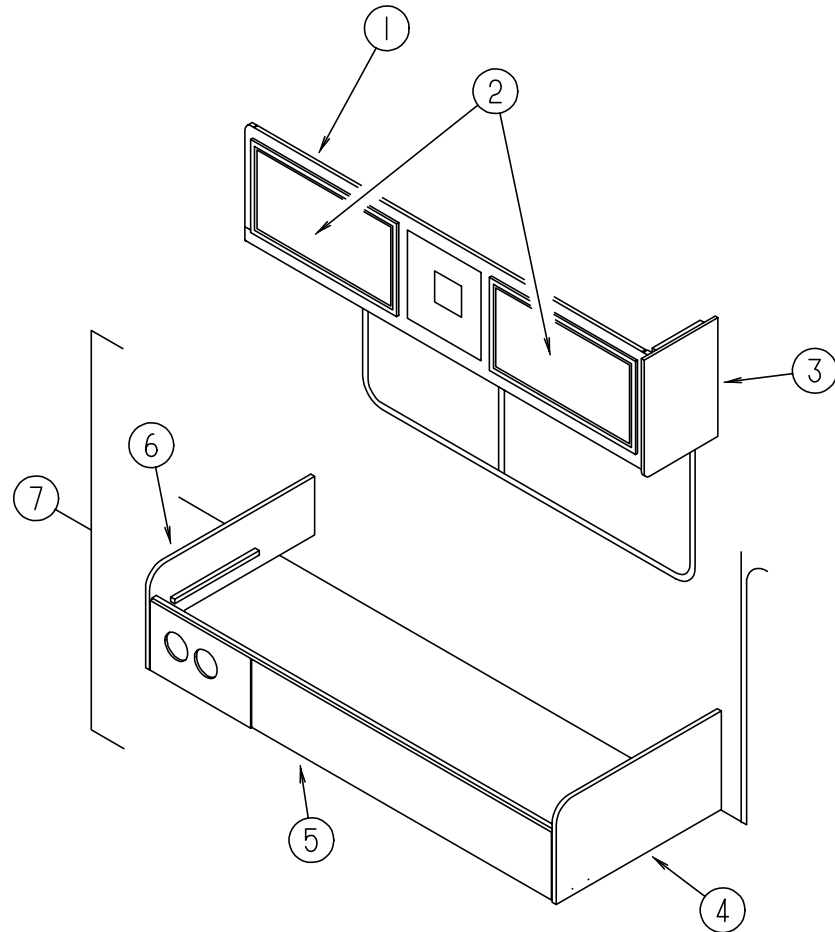

FRONT DRIVER'S SIDE OVERHEAD CABINETRY & LOUNGE CABINETRY

KEY	PART NUMBER	U/M	DESCRIPTION
1	111166-03-G24	EA	CABINET - OVERHEAD - W/O DOORS/HARDWARE
1	111166-03-G25	EA	CABINET - OVERHEAD - W/O DOORS/HARDWARE
2	110140-21-G01	EA	DOOR-W/MIRROR-MTRD CRNR/OGEE EDGE - 15.7" X 27.9" W/O HDW
2	110140-18-G01	EA	DOOR - MITERED CORNER/VINYL WRAP - 15.7" X 27.9" - W/O HDW
3	109908-09-G04	EA	END CAP - OVERHEAD CABINET
4	M08107-01-G24	EA	CABT-COUCH W/FAB DTL A
4	M08107-01-G25	EA	CABT-COUCH W/FAB DTL A
5	M08107-18-G24	EA	CABINET - COUCH FACE - FABRIC COVERED
5	M08107-18-G25	EA	CABINET - COUCH FACE - FABRIC COVERED
	M08107-03-G24	EA	CABT-COUCH W/FAB DTL C
	M08107-03-G25	EA	CABT-COUCH W/FAB DTL C
	M08107-04-G24	EA	CABINET - COUCH, W/FABRIC - W/O HARDWARE
	M08107-04-G25	EA	CABINET - COUCH, W/FABRIC - W/O HARDWARE
6	M08107-02-G24	EA	CABT-COUCH W/FAB DTL B
6	M08107-02-G25	EA	CABT-COUCH W/FAB DTL B
7	121263-01-G24	EA	CABINET ASM-COUCH
7	121263-01-G25	EA	CABINET ASM-COUCH
	083125-07-000	EA	BRACE-COUCH - OFF WHITE
	082525-01-000	EA	BRACE-COUCH - FLOOR MOUNT - ANGLE 3" LONG - METAL

### LOUNGE GROUP (CONTINUED)

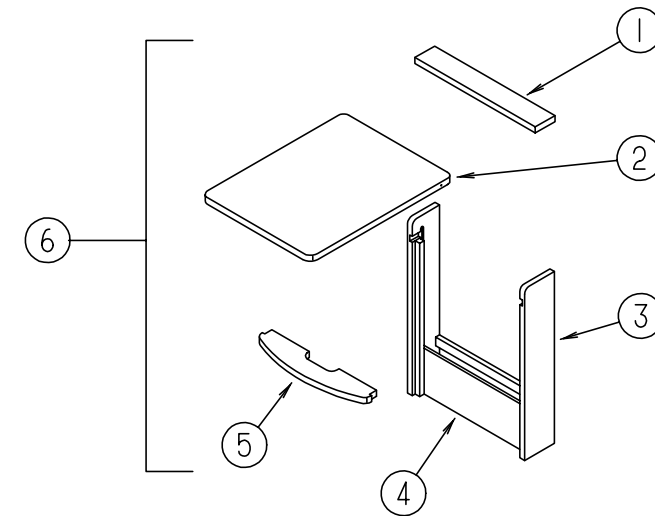

REAR PASSENGERS SIDE PULL OUT TABLE FOR CROSS STACKED TWIN BEDS

KEY	PART NUMBER	U/M	DESCRIPTION
1	096873-15-G01	EA	SHELF - SUPPORT OVER PULLOUT TABLE
2	096873-11-G01	EA	PANEL - PULLOUT TABLE
	080736-01-000	EA	PULL - RECESSED - 1.25 X 4" - OAK
3	096873-14-G01	EA	SIDE END - TABLE 28.7" X 5.7" - LEFT
	096873-13-G01	EA	SIDE END - TABLE 28.7" X 5.7" - RIGHT SIDE
4	096873-16-G01	EA	PANEL - TABLE FRONT BOTTOM - 18.1" X 6.7"
5	096873-12-G01	EA	SHELF - SUPPORT UNDER TABLE TOP
6	M96873-01-G01	EA	CABINET - TABLE - W/O PULLOUT TOP

**LOUNGE GROUP (CONTINUED)**

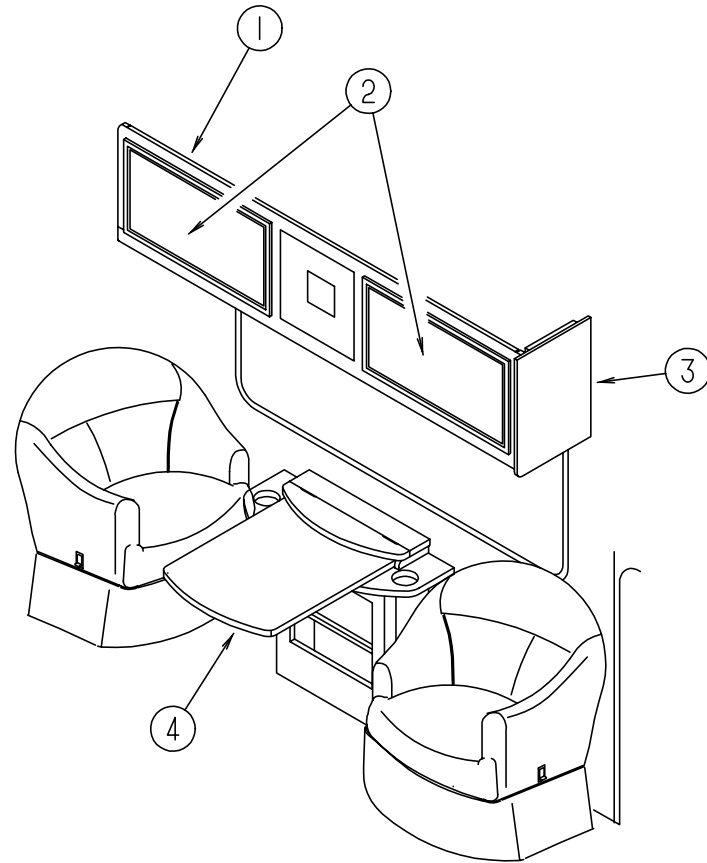

**FRONT DRIVER'S SIDE PULL OUT TABLE**

KEY	PART NUMBER	U/M	DESCRIPTION
1	111166-03-G24	EA	CABINET - OVERHEAD - W/O DOORS/HARDWARE
1	111166-03-G25	EA	CABINET - OVERHEAD - W/O DOORS/HARDWARE
2	110140-21-G01	EA	DOOR-W/MIRROR-MTRD CRNR/OGEE EDGE - 15.7" X 27.9" W/O HDW
2	110140-18-G01	EA	DOOR - MITERED CORNER/VINYL WRAP - 15.7" X 27.9" - W/O HDW
3	109908-09-G04	EA	END CAP - OVERHEAD CABINET
4	096928-04-G04	EA	CABINET - F/TABLE - W/O TOP

**LOUNGE GROUP (CONTINUED)**

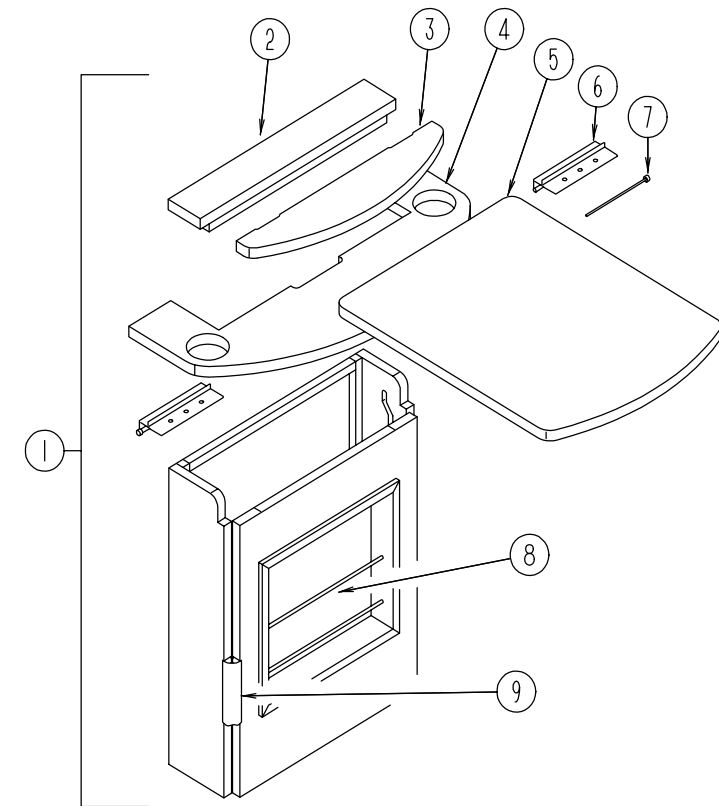

**FRONT DRIVER'S SIDE PULLOUT TABLE**

KEY	PART NUMBER	U/M	DESCRIPTION
1	096928-04-G04	EA	CABINET - F/TABLE - W/O TOP
2	096928-23-G04	EA	COVER - TOP/BACK PULLOUT TABLE
3	096928-13-G04	EA	SHELF - SUPPORT OVER PULLOUT TABLE
4	096928-24-G04	EA	TOP - PULLOUT TABLE W/CUP HOLES
5	096928-11-G04	EA	TOP - PULLOUT TABLE
6	009059-01-000	EA	HINGE-DOOR, 2" X 1.4" - BRASS
7	079921-01-000	EA	ROLLER-NYLON, W/STEEL SHAFT - BARBED
8	097208-01-H07	EA	RACK-MAGAZINE - OAK
9	042357-20-000	EA	MOLDING-CORNER,RADIUS PLAS - WATERFORD OAK
	079789-02-000	EA	SUPPORT-TABLE,PULLOUT,O/W
	096928-21-G04	EA	SIDE END - TABLE - RIGHT SIDE - 27.6" X 6.2"
	096928-22-G04	EA	SIDE END - TABLE - LEFT SIDE - 27.6" X 6.2"
	016604-01-000	EA	BRACE-CABINET, ANGLE - 2.5" - UNPAINTED
	080728-01-000	EA	HANDLE-PULL 1.3" X 4.4" - PLASTIC - BROWN

**SEALANTS & FASTENERS GROUP****SCREWS**

KEY	PART NUMBER	U/M	DESCRIPTION
	101618-01-000	EA	SCREW - 1/4-20 X .75 HEX - TAPPING - STALGARD TYPE F
	000G54-04-20B	EA	SCREW - 1/4-20 X 1 1/4 PTH - TYPE 23 - ZINC PLATED
	000G13-05-10B	EA	SCREW - 5-12 X 5/8 PFH - ZINC
	000G11-05-08B	EA	SCREW - 5-20 X .50 PPH - ZINC
	000G68-06-10G	EA	SCREW - 6-18 X 5/8 POH - ANTIQUE BRASS
	000G11-06-08B	EA	SCREW - 6-20 X .50 PPH - ZINC
	000G12-06-08T	EA	SCREW - 6-20 X .50 POH - BLACK
	000G11-06-06B	EA	SCREW - 6-20 X 3/8 PPH - ZINC
	000G11-06-10J	EA	SCREW - 6-20 X 5/8 PPH - BRASS
	000G13-06-08B	EA	SCREW - 6-20 X .50 PFH - ZINC
	000G13-06-16J	EA	SCREW - 6-20 X 1.00 PFH - BRASS
	000G13-06-24J	EA	SCREW - 6-20 X 1.50 PFH - BRASS
	000G11-07-08B	EA	SCREW - 7-19 X .50 PPH - ZINC
	000G13-07-12B	EA	SCREW - 7-19 X .75 PFH - ZINC
	000G11-08-06B	EA	SCREW - 8-18 X 3/8 PPH - ZINC
	000G11-08-08B	EA	SCREW - 8-18 X .50 PPH - ZINC
	000G13-08-10B	EA	SCREW - 8-18 X 5/8 PFH - ZINC
	000G11-08-12B	EA	SCREW - 8-18 X .75 PPH - ZINC
	000G11-08-12D	EA	SCREW - 8-18 X .75 PPH - BLACK
	000G11-08-12E	EA	SCREW - 8-18 X .75 PPH - CHROME
	000G11-08-12P	EA	SCREW - 8-18 X .75 PPH - DARK BROWN
	0G1108-12-170	EA	SCREW - 8-18 X .75 PPH - BRIGHT WHITE
	000G12-08-12S	EA	SCREW - 8-18 X .75 POH - OFF WHITE
	0G1208-12-170	EA	SCREW - 8-18 X .75 POH - BRIGHT WHITE
	000G11-08-12S	EA	SCREW - 8-18 X .75 PPH - OFF WHITE
	000G11-08-12T	EA	SCREW - 8-18 X .75 PPH - BLACK
	000G11-08-16S	EA	SCREW - 8-18 X 1.00 PPH - OFF WHITE
	000G11-08-16B	EA	SCREW - 8-18 X 1.00 PFH - ZINC
	000G11-08-20B	EA	SCREW - 8-18 X 1.25 PPH - ZINC
	000G67-10-120	EA	SCREW - 10-12 X .75 PPH - TAN
	000G11-10-12S	EA	SCREW - 10-16 X .75 PPH - OFF WHITE
	000G11-10-10X	EA	SCREW - 10-16 X 5/8 PPH - GRAY
	000G32-10-06B	EA	SCREW - 10-32 X 3/8 - PPH - ZINC
	000G67-10-08B	EA	SCREW - 10-12 X 1/2 PPH - ZINC
	000G67-10-08R	EA	SCREW - 10-12 X 1/2 PPH - BEIGE - TYPE A
	000G67-10-10B	EA	SCREW - 10-12 X 5/8 PPH - ZINC - TYPE A
	000G67-10-10D	EA	SCREW - 10-12 X 5/8 PPH - BLACK - TYPE A
	000G67-10-10S	EA	SCREW - 10-12 X 5/8 - PPH - OFF WHITE
	000G67-10-12B	EA	SCREW - 10-12 X 3/4 PPH - ZINC
	000G67-10-12P	EA	SCREW - 10-12 X .75 - PPH - DARK BROWN
	000G67-10-12R	EA	SCREW - 10-12 X .75 PPH - BEIGE
	000G67-10-16B	EA	SCREW - 10-12 X 1 PPH - ZINC
	000G67-10-20D	EA	SCREW - 10-12 X 1.25 PPH - BLACK
	000G67-10-24B	EA	SCREW - 10-12 X 1.50 PPH - ZINC
	000G67-10-32B	EA	SCREW - 10-12 X 2 PPH - ZINC
	000G67-10-36T	EA	SCREW - 10-12 X 2.25 PPH - BLACK - STALGARD
	000G50-04-12B	EA	SCREW - MACHINE - 1/4 - 20 X 3/4 PPH - ZINC
	000G46-08-24T	EA	SCREW - MACHINE - 8-32 X 1.5 PFH - BLACK
	000G52-08-18B	EA	SCREW - MACHINE - 8-32 X 1 1/8 PTH - ZINC
	075908-01-000	EA	SCREW - MACHINE - 10-32 X .56 PTH - ZINC EXTERNAL TOOTH
	000G42-04-16B	EA	SCREW - SF/DR - .25-14 X 1 HWH - ZINC
	000G39-06-08B	EA	SCREW - SF/DR - 6-18 X .50 - ZINC
	000G39-06-10T	EA	SCREW - SF/DR - 6-20 X 5/8 PPH - BLACK
	000G39-06-16T	EA	SCREW - SF/DR - 6-20 X 1 PPH - BLACK
	000G39-08-06B	EA	SCREW - SF/DR - 8-18 X 3/8 PPH - ZINC
	000G39-08-08B	EA	SCREW - SF/DR - 8-18 X .50 PPH - ZINC
	000G39-08-08T	EA	SCREW - SF/DR - 8-18 X .50 PPH - BLACK
	000G39-08-08S	EA	SCREW - SF/DR - 8-18 X .50 PPH - OFF WHITE
	0G3908-08-170	EA	SCREW - SF/DR - 8-18 X .50 PPH - BRIGHT WHITE
	000G39-08-12B	EA	SCREW - SF/DR - 8-18 X .75 PPH - ZINC
	000G39-08-16B	EA	SCREW - SF/DR - 8-18 X 1.00 PPH - ZINC
	000G39-08-16R	EA	SCREW - SF/DR - 8-18 X 1.00 PPH - BEIGE
	000G39-08-24B	EA	SCREW - SF/DR - 8-18 X 1.50 PPH - ZINC

**SEALANTS & FASTENERS GROUP (CONTINUED)****SCREWS (CONTINUED)**

KEY	PART NUMBER	U/M	DESCRIPTION
	0G3908-24-170	EA	SCREW - SF/DR - 8-18 X 1.50 PPH - BRIGHT WHITE
	000G39-10-08B	EA	SCREW - SF/DR - 10-16 X .50 PPH - ZINC
	000G39-10-12D	EA	SCREW - SF/DR - 10-16 X .75 PPH - BLACK
	000G39-10-129	EA	SCREW - SF/DR - 10-16 X .75 PPH - FLUOROCARBON SILVER
	000G39-10-12B	EA	SCREW - SF/DR - 10-16 X .75 PPH - ZINC
	000G39-10-12R	EA	SCREW - SF/DR - 10-16 X .75 PPH - BEIGE
	000G39-10-20B	EA	SCREW - SF/DR - 10-16 X 1.25 PPH - ZINC
	000G60-10-28T	EA	SCREW - SF/DR - 10-16 X 1.75 PPH - BLACK
	000G39-10-32B	EA	SCREW - SF/DR - 10-16 X 2.00 PPH - ZINC
	054434-02-000	EA	SCREW - SF/DR - 10-16 X 2.00 PWH - ZINC - W/O WINGS
	000G39-12-12E	EA	SCREW - SF/DR - 12-14 X .75 PPH - CHROME
	086256-01-000	EA	SCREW - SF/DR - 8 X .75 HWH LONG - PL BODY PNL MT
	087721-01-000	EA	SCREW - FLAT HEAD - TAPPING - 1/4" X 1 1/4" LONG - ZINC
	097974-01-000	EA	SCREW - PART BD 7-9 X .75 PPH - FHM 0543 PLAIN

**BOLTS, NUTS & WASHERS**

KEY	PART NUMBER	U/M	DESCRIPTION
	0MC31K-08-020	EA	BOLT - HEX - SERRATED FLANGE - M8 X 020
	000C12-05-16B	EA	BOLT - HEX - 5/16-18 X 1 - ZINC 5
	000C12-06-16B	EA	BOLT - HEX - 3/8-16 X 1 LG - ZINC 5
	000C12-09-20B	EA	BOLT - HEX - 9/16-12 X 1.25 - ZINC 5
	000C12-07-24B	EA	BOLT - HEX - 7/16-14 X 1.50 - ZINC 5
	000C12-08-24B	EA	BOLT - HEX - 1/2-13 X 1.50 - ZINC 5
	000C12-10-24B	EA	BOLT - HEX - 5/8-11 X 1.50 - ZINC - 5
	000C13-07-48B	EA	BOLT - HEX - 7/16-20 X 3 - ZINC 5
	000C18-05-40A	EA	BOLT - ELEVATOR - 5/16-18 X 2.50 - PL
	000C18-06-48B	EA	BOLT - ELEVATOR - 3/8-16 X 3 - ZINC - GRADE 5
	000C26-04-14B	EA	BOLT - HEX - SERRATED FLANGE - 1/4 X 20 X 7/8 - ZINC
	000C26-04-10B	EA	BOLT - HEX - SERRATED FLANGE - 1/4-20 X 5/8 - ZINC
	000C26-05-12B	EA	BOLT - HEX - SERRATED FLANGE - 5/16-18 X 3/4 - ZINC
	000C26-06-12B	EA	BOLT - HEX - SERRATED FLANGE - 3/8-16 X 3/4 - ZINC
	091274-03-000	EA	BOLT - J - 3/8-16 X 12.0
	000G45-05-16B	EA	BOLT - LAG 5/16-9 X 1 - ZINC
	051387-06-000	EA	BOLT - CARRIAGE - W/O HOLE - 5/16-18 X 9.5 - ZINC
	102333-01-06A	EA	BOLT - CARR, 7/16-14 SST CAP
	106166-01-000	EA	BOLT COLLARED HANGER - 8-32 X 1
	000D34-06-00B	EA	NUT - HEX - LOCKING - 3/8-16 GRADE C ZINC - PREVAILING TORQUE
	000D24-10-00B	EA	NUT - HEX - SF/LOCKING - 10-32 - ZINC
	000D29-09-00B	EA	NUT - HEX SELFLOCKING - 9/16-12 - ZINC
	000D29-06-00B	EA	NUT - HEX - W/NYLON LOCK - 3/8 - 16 - ZINC
	000D39-04-00B	EA	NUT - HEX - SERRATED FLANGE LOCKING 1/4-20 - ZINC
	000D39-05-00B	EA	NUT - HEX - SERRATED FLANGE LOCKING - 5/16-18 - ZINC
	000D39-06-00B	EA	NUT - HEX - SERRATED FLANGE LOCKING - 3/8-16 - ZINC
	000D39-08-00B	EA	NUT - HEX - SERRATED FLANGE LOCKING - 1/2-13 - ZINC
	000D44-07-00B	EA	NUT - HEX - SERRATED FLANGE LOCKING - 7/16-20 - ZINC
	087234-01-000	EA	NUT - JACK - 1/4 X 20 THD - MOLLY
	044364-02-000	EA	NUT - SPEED - FLAT - ROUND - T'MN C9186-014-1
	000E11-07-00B	EA	WASHER - LOCKING - 7/16 MED SPLIT - ZINC
	041322-01-000	EA	WASHER - FLANGE - 15/32 ID X 2 3/8 OD - FOR SEAT BELT MOUNT
	000E13-21-00B	EA	WASHER - FLANGE - W/2 NAR - ZINC
	000E13-14-00B	EA	WASHER - FLANGE - 1/4" WIDE - ZINC
	000E13-17-00B	EA	WASHER - FLANGE - 3/8" AR - ZINC
	000E13-18-00B	EA	WASHER - FLANGE - 3/8 WIDE - ZINC
	000E13-20-00B	EA	WASHER - FLANGE - 7/16" WIDE - ZINC
	044533-01-000	EA	WASHER - PLASTIC - 1 3/8 OD - FOR BUTTONS

## SEALANTS & FASTENERS GROUP (CONTINUED)

### CLAMPS, GROMMETS, CLIPS & RIVETS

KEY	PART NUMBER	U/M	DESCRIPTION
	007161-01-000	EA	CLAMP - HOSE - SPRING TYPE - 1/2"
	010495-01-000	EA	CLAMP - CABLE - 9/16"
	010497-01-000	EA	CLAMP - CLOSED - 5/8" ID
	010497-03-000	EA	CLAMP - CLOSED - 1" ID - CUSHIONED
	010497-04-000	EA	CLAMP - CLOSED - 1.62" ID - ADEL - 945-2717
	010499-01-000	EA	CLAMP - CLOSED - 3/8" ID
	016188-05-000	EA	GROMMET - L/P LINE - 3/8" HOLE X 1 1/4" LONG - RUBBER
	023942-01-000	EA	GROMMET-RUBBER - 2" OD
	056134-02-000	EA	HOLDER - RING - 1.8" DIAMETER - METAL
	062401-01-000	EA	CLAMP - HOSE - WORMGEAR .25" - 1"
	062401-02-000	EA	CLAMP - HOSE - WORMGEAR - 1.56" - 2.5"
	062401-03-000	EA	CLAMP - HOSE - WORMGEAR - .22"- 1"
	062401-04-000	EA	CLAMP - HOSE - WORMGEAR .69"- 1.25"
	062401-06-000	EA	CLAMP - HOSE - WORMGEAR .22"-.62"
	062401-11-000	EA	CLAMP - HOSE - WORMGEAR 3.56"- 4.5"
	071015-26-000	EA	GROMMET - RUBBER - 1.5" ID X 2.12" OD W/.06" GROOVE - BLACK
	114208-02-000	EA	GROMMET - EDGE LINER - FITS .625 - HEYCO 2073
	075148-02-000	EA	CLAMP - GROUNDING - BRONZE SCREWS
	083609-01-000	EA	CLAMP - WIRE - DUAL EQUAL - 5/8" DIAMETER
	083610-01-000	EA	CLAMP - WIRE - DUAL - UNEQUAL DIAMETERS - .75" & 1.25"
	083610-02-000	EA	CLAMP-WIRE - DUAL UNEQUAL DIA
	101447-01-000	EA	CLIP - U-TYPE - TINNEMAN - HOLDS SHOWER SURROUND TOGETHER
	091952-01-000	EA	CLIP - GRIPPER - 1"
	091952-02-000	EA	CLIP - GRIPPER - 3/4"
	080734-02-000	EA	CLIP - WIRE - NYLON
	080211-03-000	EA	CLIP - MOUNTING - (XMAS TREE) - DECORATIVE PADS
	069592-02-000	EA	RIVET-T - POP - 1/4 X .093 - .156
	108046-01-000	EA	CABLE TIE - SCREW MOUNT 8" - DENNISON 08415
	108046-02-000	EA	CABLE TIE - SCREW MOUNT 15" - DENNISON 10035
	008343-01-000	EA	TIE - WIRE - 6"
	085774-01-000	FT	FASTENER - DUAL HOOK - 1" WIDE - ADHESIVE BACK - BLACK
	085774-02-000	FT	FASTENER - DUAL LOOP - 1" WIDE - ADHESIVE BACK - BLACK

## SEALANTS & FASTENERS GROUP (CONTINUED)

### ADHESIVE & FASTENERS

KEY	PART NUMBER	U/M	DESCRIPTION	VENDOR NO.
	034552-02-000	EA	SILICONE - TUBE - 300 ML - W/O NOZZLE - CLEAR	
	034552-06-000	EA	SILICONE - TUBE - 300 ML - W/O NOZZLE - OFF WHITE	
	034552-15-000	EA	SILICONE - TUBE - 300 ML - W/O NOZZLE - BRIGHT WHITE	
	900390-01-000	EA	TIP - 2 1/2" X 1/8" ORIFICE	
	900390-03-000	EA	NOZZLES - #CSL D10	
	002707-02-000	FT	TAPE - SEALER - 6/16" X 1/2"	
	053766-06-000	EA	BEDDING COMPOUND - TUBE - CLEAR	
	063642-01-000	FT	TAPE - ADHESIVE - 10 MM X 1.5" WIDE X 180'	
	069640-01-000	FT	SEALER - RIBBON - 1/4" X 30'	
	069640-02-000	FT	SEALER - RIBBON - 1/2" X 1/8" X 60'	
	069640-03-000	FT	SEALER - RIBBON - 3/4" X 1/8" X 60'	
	069640-07-000	FT	SEALER - RIBBON - 2" X 3/32" - INCREMENTS OF 45'	
	069640-10-000	FT	SEALER - RIBBON - 1/32" X 1.50" X 90'	
	069640-11-000	FT	SEALER - TAPE - 3/16" X 3/8" X 40' - BLACK - MANUS	
	076314-02-000	FT	TAPE - CARPET SEAM - HEAT-BOND - 4" WIDE	
	076322-01-000	FT	TAPE - FOAM - DOUBLE COATED ADHESIVE BACKED - .75" X 216'	
	076322-03-000	FT	TAPE - FOAM - DOUBLE COATED ADHESIVE BACKED - .5" X 108'	
	076322-05-000	FT	TAPE - FOAM - DOUBLE COATED ADHESIVE BACKED - .025" X 1.5" X 108'	
	087211-01-000	GL	PROMOTER - ADHESIVE	
	094401-01-000	EA	SEALER - BODY SEAM SEALER - 3M FLEXICLEAR - TUBE - 12 PER CASE	
	102352-01-000	EA	SEALER - PUMPABLE - BLACK - COLORIMETRIC MS101	
	106206-01-000	EA	SEALER - PUMPABLE - MANUS 30A - BLACK	
	108716-01-000	EA	SILICONE - TUBE - OFF WHITE LEVEL	
	120074-01-01A	EA	SILICONE TUBE - OFF WHITE - W/O NOZZLE	
	120534-01-01A	EA	TAPE-SCOTCH 3M 1/2" FINE LINE - #471 GREEN	
	091255-02-000	FT	SEAL-ADHESIVE BACKED FOAM - .18" THICK X 1.5" WIDE	
	102540-03-000	EA	SEAL-SCREW	
	004006-05-700	EA	ADHESIVE-NAT. STARCH (5 GAL)	0802
	004020-01-000	QT	ADHESIVE-ABS CEMENT - QUART	

## WATER & SEWAGE GROUP

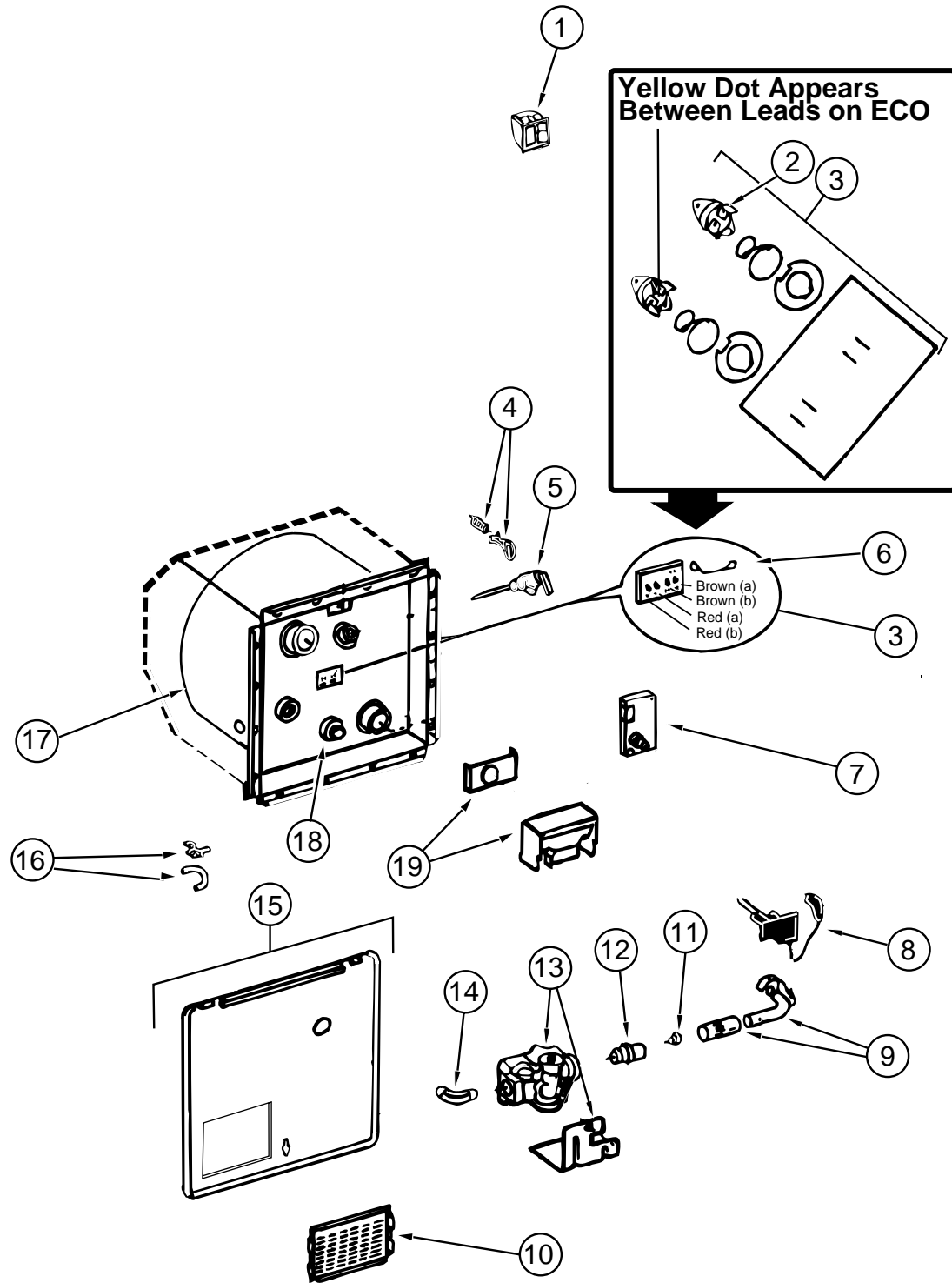

### WATER HEATER W/ELECRIC IGNITION ATWOOD (G6A-7E)

KEY	PART NUMBER	U/M DESCRIPTION	VENDOR NO.
	051391-03-000	EA WATER HEATER ATWOOD G6A-7E ELECTRONIC IGNITION	
1	097967-01-000	EA SWITCH-WATER HEATER, REMOTE W/LIGHT - ATWOOD 91959	
2	051391-04-701	EA THERMOSTAT 12VDC-120 PRESET	91470
3	051393-01-721	EA THERMOSTAT W/ECO, 140 FRT MT	91447
4	051391-01-705	EA FASTENER-CAMLOCK	92609
5	051391-01-704	EA VALVE-RELIEF, 1/2" FITTING	91604
6	051393-01-723	EA SWITCH-THERMAL-CUT OFF 2/PKG	93866
7	051393-01-724	EA BOARD-CIRCUIT, SPADE TERMINAL	93865
8	051393-01-725	EA ELECTRODE-SGL SPADE CONNECT.	93868
9	051391-04-703	EA BURNER-MAIN	91638
10	051391-01-717	EA GRILLE-WATER HEATER DOOR	92640
11	051391-01-710	EA ORIFICE-MAIN BURNER	92742
12	051391-03-700	EA HOLDER-ORIFICE	91563
13	051393-01-726	EA VALVE-SOLENOID, W/BRACKET	93870
14	051391-01-714	EA FITTING-ELBOW 45,3/8F X 3/8 MPT	1044
15	052009-06-000	EA DOOR-WATER HEATER - ATWOOD - BRIGHT WHITE	
	116424-01-000	EA PROTECTOR-WATER HEATER LATCH	
16	051391-01-700	EA HINGE KIT, (PIN & CLIP)	92568&92559
17	051391-04-706	EA TANK-INNER,G6A-4E&6E FRT. MT	91641
18	051391-01-715	EA PLUG-DRAIN, 1 EA = 2 PER PKG	91857
19	051391-04-707	EA KIT-EXHAUST, (FLUE & GASKET)	90960
	110438-01-000	EA VALVE-BRASS CHECK	

### WATER HEATER W/MOTOR AID ATWOOD (GH6-7E)

KEY	PART NUMBER	U/M DESCRIPTION	VENDOR NO.
	051393-01-A00	EA WATER HEATER - ATWOOD #GH6-7E W/ELECTRONIC IGNITION	
1	097967-01-000	EA SWITCH-WATER HEATER, REMOTE W/LIGHT - ATWOOD 91959	
2	051391-04-701	EA THERMOSTAT 12VDC-120 PRESET	91470
3	051393-01-721	EA THERMOSTAT W/ECO, 140 FRT MT	91447
4	051391-01-705	EA FASTENER-CAMLOCK	92609
5	051391-01-704	EA VALVE-RELIEF, 1/2" FITTING	91604
6	051393-01-723	EA SWITCH-THERMAL-CUT OFF 2/PKG	93866
7	051393-01-724	EA BOARD-CIRCUIT, SPADE TERMINAL	93865
8	051393-01-725	EA ELECTRODE-SGL SPADE CONNECT.	93868
9	051391-04-703	EA BURNER-MAIN	91638
10	051391-01-717	EA GRILLE-WATER HEATER DOOR	92640
11	051391-01-710	EA ORIFICE-MAIN BURNER	92742
12	051391-03-700	EA HOLDER-ORIFICE	91563
13	051393-01-726	EA VALVE-SOLENOID, W/BRACKET	93870
14	051391-01-714	EA FITTING-ELBOW 45,3/8F X 3/8 MPT	1044
15	052009-06-000	EA DOOR-WATER HEATER - ATWOOD - BRIGHT WHITE	
	116424-01-000	EA PROTECTOR-WATER HEATER LATCH	
16	051391-01-700	EA HINGE KIT, (PIN & CLIP)	92568&92559
17	051391-04-704	EA TANK-INNER (FRT-MT)	91642
18	051391-01-715	EA PLUG-DRAIN, 1 EA = 2 PER PKG	91857
19	051391-04-707	EA KIT-EXHAUST, (FLUE & GASKET)	90960
	110438-01-000	EA VALVE-CHECK - BRASS	

## WATER & SEWAGE GROUP (CONTINUED)

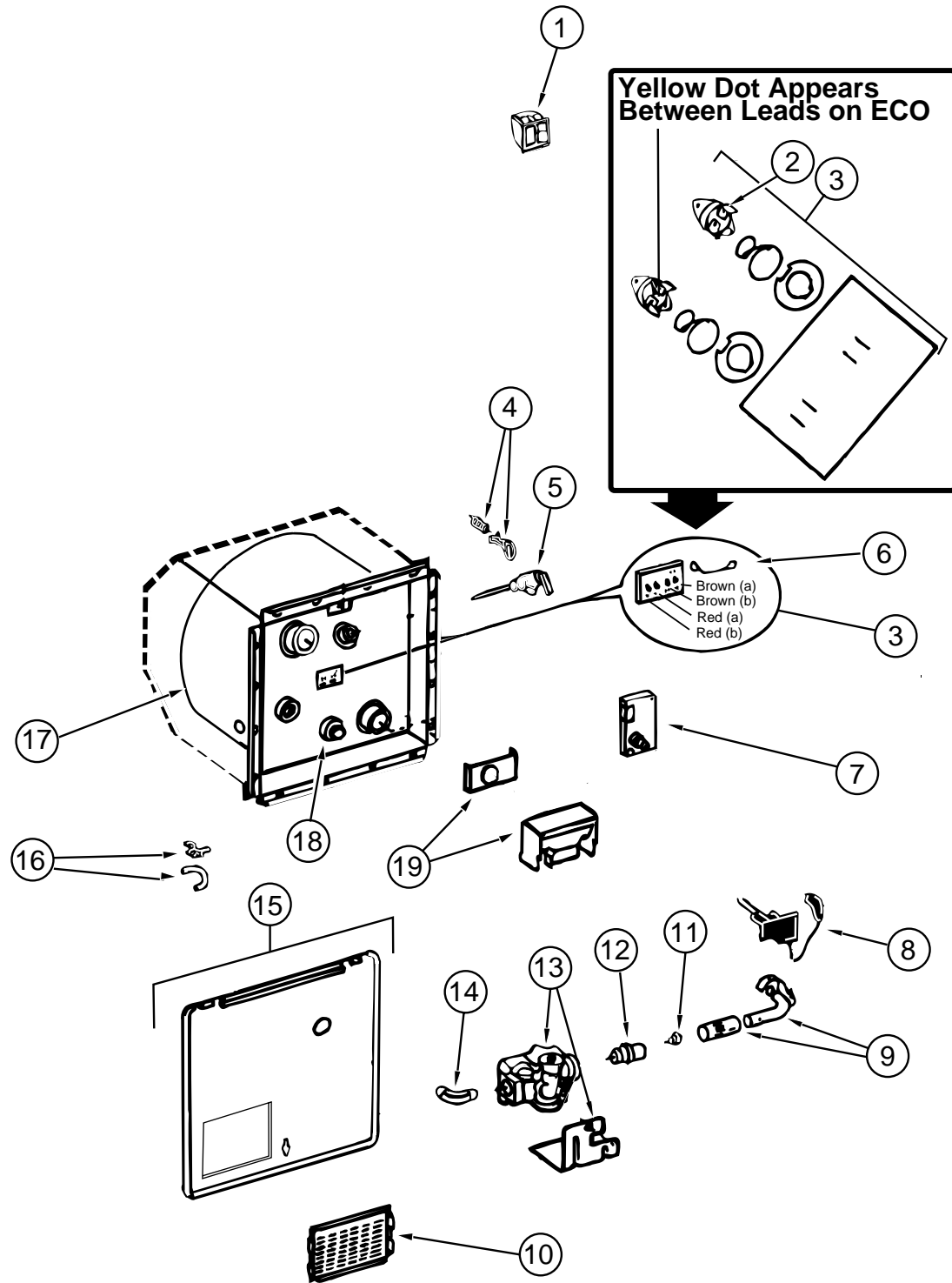

### WATER HEATER W/ELECRIC IGNITION ATWOOD (G6A-8E)

KEY	PART NUMBER	U/M	DESCRIPTION	VENDOR NO.
	051391-03-000	EA	WATER HEATER - ATWOOD G6A-8E W/ELECTRONIC IGNITION	
1	097967-01-000	EA	SWITCH-WATER HEATER, REMOTE W/LIGHT - ATWOOD 91959	
2	051391-04-701	EA	THERMOSTAT 12VDC-120 PRESET	91470
3	051393-01-721	EA	THERMOSTAT W/ECO, 140 FRT MT	91447
4	051391-01-705	EA	FASTENER-CAMLOCK	92609
5	051393-01-704	EA	BOARD-CIRCUIT	91420
6	051393-01-723	EA	SWITCH-THERMAL-CUT OFF 2/PKG	93866
7	051393-01-724	EA	BOARD-CIRCUIT, SPADE TERMINAL	93865
8	051393-01-725	EA	ELECTRODE-SGL SPADE CONNECT.	93868
9	051391-04-703	EA	BURNER-MAIN	91638
10	051391-01-717	EA	GRILLE-WATER HEATER DOOR	92640
11	051391-01-710	EA	ORIFICE-MAIN BURNER	92742
12	051391-03-700	EA	HOLDER-ORIFICE	91563
13	051393-01-726	EA	VALVE-SOLENOID, W/BRACKET	93870
14	051391-01-714	EA	FITTING-ELBOW 45 - 3/8 F X 3/8 MPT	1044
15	052009-06-000	EA	DOOR-WATER HEATER - ATWOOD - BRIGHT WHITE	
	116424-01-000	EA	PROTECTOR-WATER HEATER LATCH	
16	051391-01-700	EA	HINGE KIT-W/CLIP	92568 & 92559
17	051391-04-706	EA	TANK-INNER, G6A-4E&6E FRT. MT	91641
18	051391-01-715	EA	PLUG-DRAIN, 1 EA = 2 PER PKG	91857
19	051391-04-707	EA	KIT-EXHAUST, (FLUE & GASKET)	90960
	111129-01-711	EA	BRACKET-CORNER, SET OF FOUR	91928

### WATER HEATER W/MOTOR AID ATWOOD (GH6-8E)

KEY	PART NUMBER	U/M	DESCRIPTION	VENDOR NO.
	051393-01-000	EA	WATER HEATER - W/ MOTOR AID - PILOTLESS IGNITION	
1	097967-01-000	EA	SWITCH-REMOTE W/LIGHT - ATWOOD #91959	
2	051391-04-701	EA	THERMOSTAT 12 VDC-120 PRESET	91470
3	051393-01-721	EA	ECO & THERMOSTAT ASM-FRONT MOUNT, 140 DEGREE	91447
4	051391-01-705	EA	FASTENER-CAMLOCK	92609
5	051391-01-704	EA	VALVE-RELIEF - 1/2" FITTING	91604
6	051393-01-723	EA	SWITCH-THERMAL-CUT OFF (2/PKG)	93866
7	051393-01-724	EA	CIRCUIT BOARD-SPADE TERMINAL-ELECTRIC IGNITION	93865
8	051393-01-725	EA	ELECTRODE-SINGLE SPADE CONNECT.-SPARK PROBE	93868
9	051391-04-703	EA	BURNER-MAIN - 4E AND 6E MODELS	91638
10	051391-01-717	EA	GRILLE-WATER HEATER DOOR	92640
11	051391-01-710	EA	ORIFICE-MAIN BURNER	92742
12	051391-03-700	EA	ORIFICE-HOLDER	91563
13	051393-01-726	EA	SOLENOID VALVE AND BRACKET-WHITE-ROGERS	93870
14	051391-01-714	EA	FITTING-ELBOW 45 - 3/8 F X 3/8 MPT	1044
15	052009-06-000	EA	DOOR-WATER HEATER - ATWOOD - BRIGHT WHITE	
	116424-01-000	EA	PROTECTOR-WATER HEATER LATCH	
16	051391-01-700	EA	HINGE KIT-W/CLIP	92568 & 92559
17	051391-04-704	EA	TANK-INNER - FRONT MOUNT	91642
18	051391-01-715	EA	PLUG-DRAIN, 1 EA = 2 PER PKG	91857
19	051391-04-707	EA	KIT-(FLUE & GASKET) FOR EXHAUST	90960
	111129-01-711	EA	BRACKET-CORNER, SET OF FOUR	91928



## WATER & SEWAGE GROUP (CONTINUED)

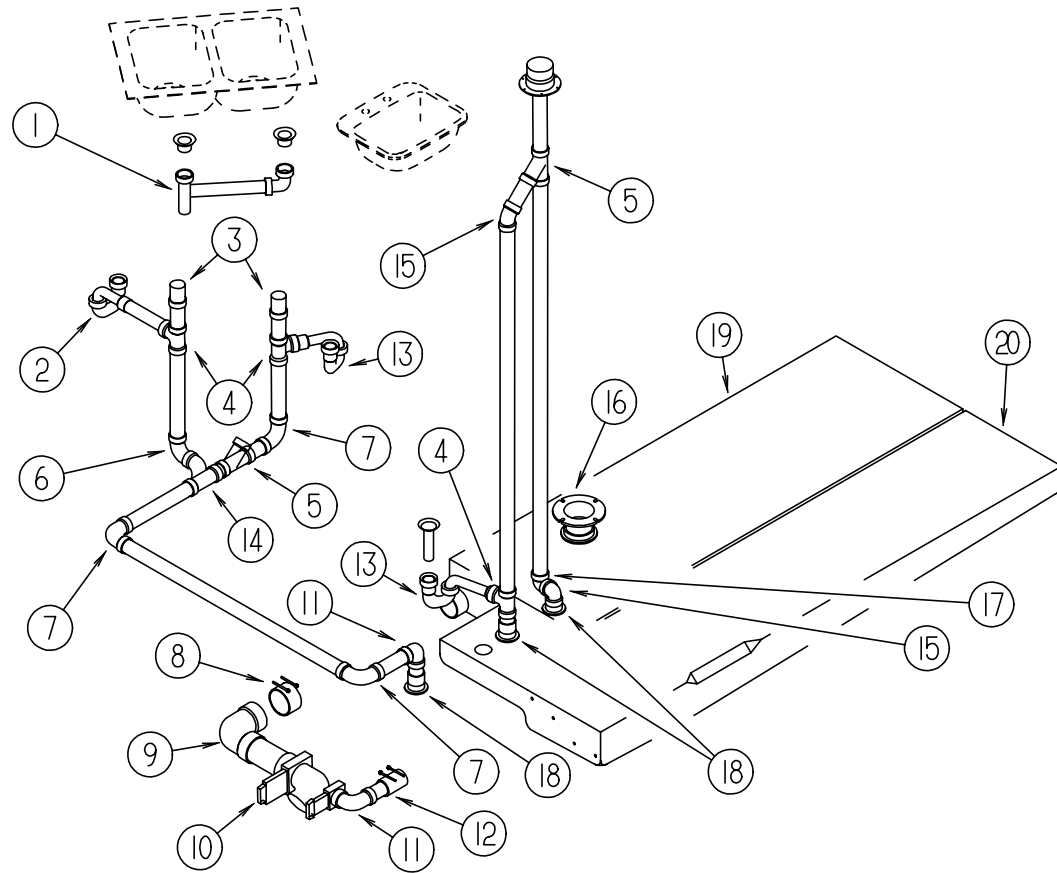

**DRAINAGE SYSTEM**

KEY	PART NUMBER	U/M	DESCRIPTION
1	011091-02-000	EA	PIPE-DRAIN, DOUBLE SINK - BAFFLE TEE - 1 1/2"
2	109571-01-000	EA	ADAPTER-P TRAP, 1 1/2" P X 1 1/4" MPT
2	107538-01-000	EA	P-TRAP - PLASTIC - 1 1/4" W/EXTENSION ARM
2	011071-01-000	EA	P-TRAP-PLASTIC 1 1/2" - NIBCO 5892 1 1/2(CSA)
3	079968-01-000	EA	VENT-MECHANICAL TRAP ARM-ANTI-SIPHON 2" DIA X 7.3" PLASTIC
4	010071-01-000	EA	TEE-SANITARY, 1 1/2" HUB X HUB X HUB - PLASTIC - BLACK
5	010073-01-000	EA	WYE-45 DEGREE, 1 1/2" HUB X HUB X HUB - PLASTIC - BLACK
5	010166-01-000	EA	PLUG-THREADED, 1 1/4" DIAMETER - PLASTIC - BLACK
6	033761-01-000	EA	ELBOW-TURN, 1/4 BEND X 1.5"HUB X 1.5"SPIGOT - BLK PLASTIC
7	010008-01-000	EA	ELBOW-90 DEG, 1/4 BEND - 1 1/2" HUB X HUB - BLACK PLASTIC
8	078406-01-000	EA	COUPLER-RUBBER, W/CLAMPS - 3" X 3"
9	031126-01-000	EA	ELBOW-1/4 BEND, 3 X 90 XLT - PLASTIC - BLACK
10	070916-01-000	EA	VALVE-DUAL DUMP, W/CAP - 3" X 1 1/2" - PLASTIC - BLACK
	070916-01-700	EA	VALVE ONLY (WASTE) 3" T1003BU
	070916-01-701	EA	VALVE ONLY (WASTE 11/2") T1001BU
10	062415-01-000	EA	CAP-SEWER, 3" DIAMETER
	062415-01-700	EA	STRING-SEWER CAP V#SV7 STRAP
	010201-01-000	EA	HOSE-SEWER - 3" ID X 8'
	062416-01-000	EA	ADAPTER-SEWER HOSE TO 3" PIPE
11	034250-01-000	EA	ELBOW - 90 DEGREE - LONG TURN - 1 1/2" HUB X HUB - ABS
12	089355-01-000	EA	COUPLER-RUBBER, 1 1/2" X 1 1/2"
13	109571-01-000	EA	ADAPTER-P TRAP, 1 1/2" P X 1 1/4" MPT
13	107538-01-000	EA	P-TRAP - PLASTIC - 1 1/4" W/EXTENSION ARM
13	011066-03-700	EA	P TRAP-1 1/4" HUB X SLIP JOINT - W/UNION - ABS - CANADIAN
13	069735-01-000	EA	WASHER-STRAINER TO TAILPIECE PLASTIC, 1.5"

## WATER & SEWAGE GROUP (CONTINUED)

### DRAINAGE SYSTEM (CONTINUED)

KEY	PART NUMBER	U/M	DESCRIPTION
14	031365-02-000	EA	TEE - PLASTIC - 1 1/2" EXT LG TURN
15	010006-01-000	EA	ELBOW-45 DEG, 1/8 BEND - 1 1/2" HUB X HUB - BLACK PLASTIC
16	061607-02-000	EA	GROMMET-HOLDING TANK, 3" NPS
16	024676-01-000	EA	FLANGE-CLOSET, TOILET - 4" X 3" - RED
17	010051-01-000	EA	ELBOW, 45 DEG., 1 1/2 " SPIGOT & HUB, PLASTIC-BLACK
18	061607-01-000	EA	GROMMET-HOLDING TANK, 1 1/2" NPS
18	010115-01-000	EA	COUPLING-1 1/2" HUB X HUB, PLASTIC
19	117573-01-000	EA	TANK-HOLDING,33 GALLON
20	117580-01-000	EA	TANK-HOLDING,33 GALLON
	109571-02-000	EA	ADAPTER-11/2 HUB X 11/2 MPT - NIBCO 5801-7

### FRESH WATER TANK & WATER SYSTEM

KEY	PART NUMBER	U/M	DESCRIPTION
	119109-06-000	EA	TANK-WATER,40 GAL
	119109-01-000	EA	TANK-WATER,40 GAL
	077954-02-000	EA	FILTER-WATER TANK, SCREEN IN TANK
	042989-03-000	EA	FITTING-WATER TANK, SPINWELD - 1 1/4"NPT - PLASTIC - WHITE
	042989-04-000	EA	FITTING-WATER TANK, SPINWELD - 3/8" FPT - PLASTIC - WHITE
	042989-05-000	EA	FITTING-WATER TANK SPINWELD - 1/2" FPT - PLASTIC - WHITE
	049032-01-000	EA	PATCH-SPINWELD, 3/8" - PLASTIC
	039861-01-000	EA	SENDING UNIT-W/SCREW, WASHER, WELL NUT & TERMINAL RING
	079381-01-000	FT	TUBING-SMOOTH FLEXIBLE, 1 3/8" ID X 20'
	114430-02-000	EA	ADAPTER-SWIVEL,1/2P X 1/2FPT - FLAIR-IT -02873
	114430-03-000	EA	ADAPTER-1/2P X 1/2MPT - FLAIR-IT 02842
	010224-01-000	EA	ADAPTER-HOSE TO PIPE, 3/8" MPT X 3/8" BARB - BLACK PLASTIC
	044927-01-000	EA	ADAPTER-HOSE TO PIPE, 1 1/4"MPT X 1 1/4"BARB-BLACK PLASTIC
	101814-01-000	EA	COUPLING-FEMALE, 1/2" X 1/2" FPT W/COMP. SLEEVE - GRAY
	114429-01-000	EA	ELBOW-1/2P X 1/2P - FLAIR-IT 02800
	114429-02-000	EA	ELBOW-1/2P X 1/2MPT - FLAIR-IT 02803
	114429-03-000	EA	ELBOW- FLAIR-IT SWIVEL 1/2"P X 1/2"FPT
	010230-05-000	EA	CITY WATER FILL W/CHECK VALVE
	114428-01-000	EA	TEE-1/2P X 1/2P X 1/2P - FLAIR-IT 02820
	114428-02-000	EA	TEE-SWIVEL,1/2PX1/2PX1/2FPT - FLAIR-IT 02821
	114428-03-000	EA	TEE-1/2PX1/2PX1/2MPT - FLAIR-IT 02822
	039800-02-000	FT	TUBING-POLYBUTYL, 5/8" OD - INCREMENTS OF 20' - BLACK
	074462-02-000	FT	TUBING-VINYL, 3/8" ID X 20' - CLEAR
	114431-03-000	EA	WATER VALVE - 90 DEGREE ELBOW - "WATER DRAIN VALVE"
	046128-01-000	EA	VALVE-DRAIN, PLASTIC - 1/2" FPT
	091208-01-000	EA	WASHER-RUBBER, .06" X .75" X .5"
	031365-02-000	EA	TEE-PLAS,1 1/2 EXT LG TURN - NIBCO 5812-LR-11/2
	010201-01-000	EA	HOSE-SEWER, 3" ID X 8'

**WATER & SEWAGE GROUP (CONTINUED)**

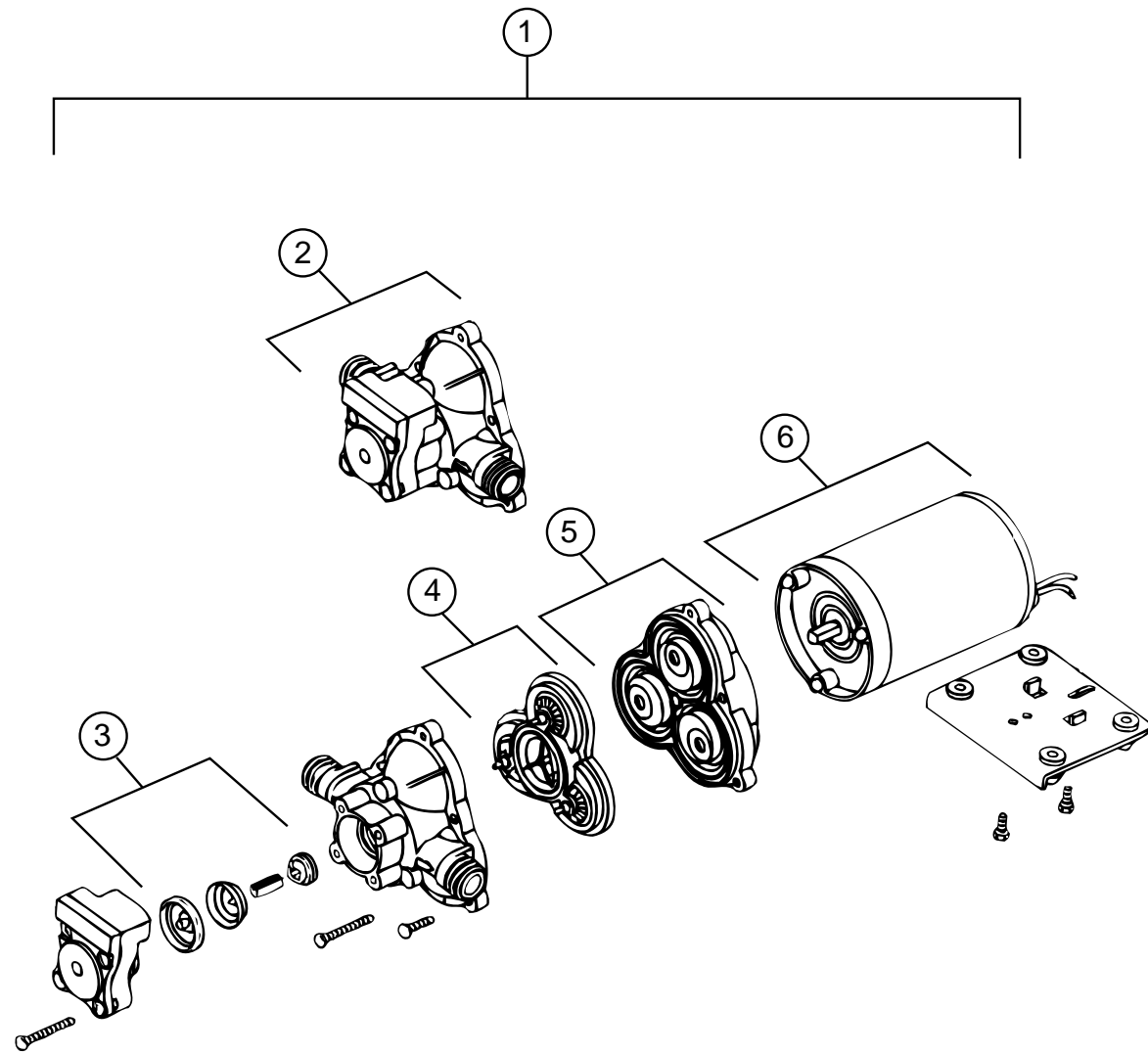

**WATER PUMP - SHURFLO**

KEY	PART NUMBER	U/M DESCRIPTION	VENDOR NO.
1	098607-01-000	EA PUMP-WATER, W/.5" MPT FITTING - FLOW 2.8 GPM - UL	
2	098607-01-706	EA HOUSING, W/SWITCH ONLY	94-231-20
3	098607-01-705	EA VALVE-CHECK, KIT	94-237-00
4	098607-01-703	EA VALVE KIT	94-232-00
5	098607-01-702	EA DIAPHRAGM/DRIVE ASSEMBLY KIT	94-238-04
6	098607-01-707	EA MOTOR W/BASEPLATE	11-148-04

**WINDOW, VENT & EXTERIOR DOOR GROUP**

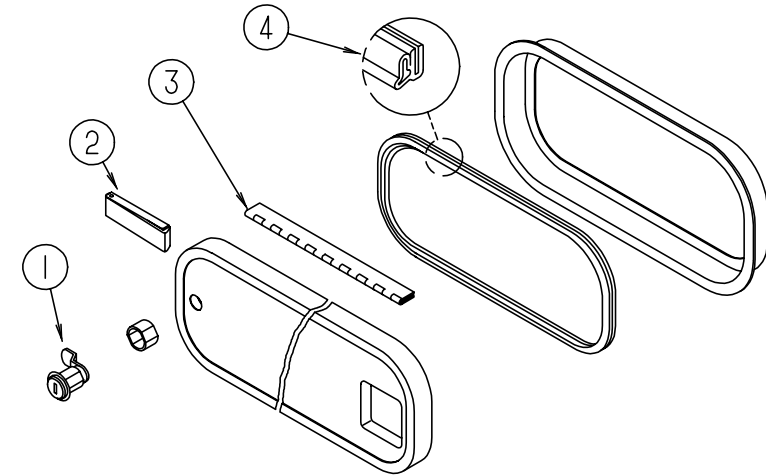

**EXTERIOR DOOR COMPONENTS**

KEY	PART NUMBER	U/M DESCRIPTION	VENDOR NO.
1	110506-55-000	EA CASE - TWIST LOCK - A= 32 MM	597312AA1
1	110506-51-000	EA CASE ASM-TWIST LOCK 25 MM - BRIGGS & STRATTON	#596669
2	102768-01-000	EA HOLDER-COMPARTMENT/ENTRY DOOR, METAL - MILL FINISH	
3	081801-02-000	EA HINGE - DOOR -PIANO - 2" X 96"	
3	081801-V3-000	EA HINGE-AL, 2" X 8' BRT WHT	
3	009065-01-000	EA HINGE-ALUMINUM, 1 1/2" X 96" - UNPAINTED	
3	034007-B3-000	EA HINGE-CONTINUOUS - 1 1/2" X 96" - ALUMINUM - BRIGHT WHITE	
4	064075-07-000	FT SEAL-BULB, W/WIRED U CHANNEL - .3" X .5" CHANNEL - BLACK	
	099418-01-000	FT SEAL-D - W/SIDE ADHESIVE - .4" X .1" - SPONGE RUBBER - BLACK	
	104692-01-000	FT SEAL-3/4" X 3/4", ADHESIVE BACK FOAM SEAL	
	110530-01-000	FT SEAL-SPONGE,.31X.62	
	107721-01-000	FT "D" SHAPED BULB SEAL W/ADHESIVE ON FLAT SIDE	
	106850-01-000	FT SEAL-E - 11 X 19 SPONGE RUBBER	
	107997-51-001	EA SPACER-.86" X .6", ALUMINUM	
	110506-40-700	EA HARDWARE KIT	596950ALL

# WINDOW, VENT & EXTERIOR DOOR GROUP (CONTINUED)

## EXTERIOR DOORS

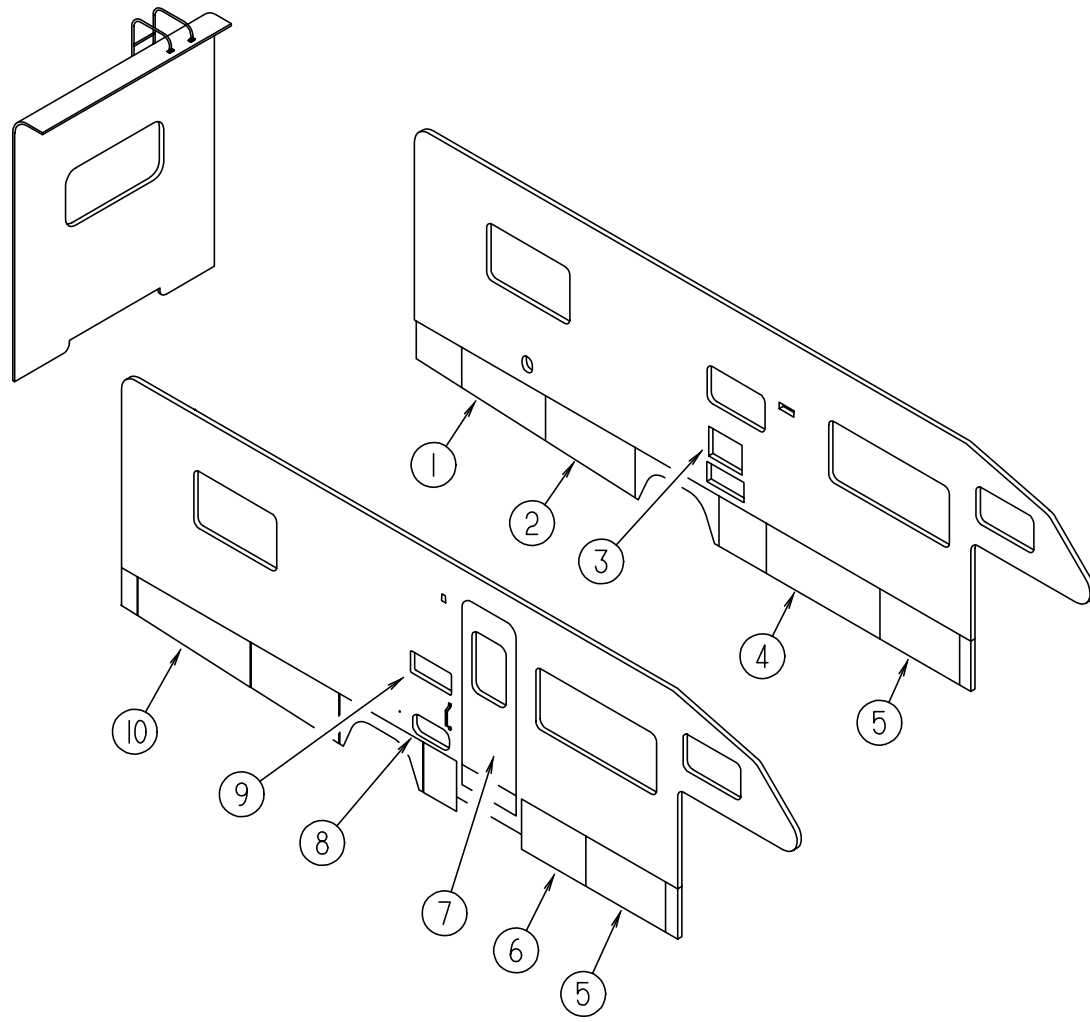

KEY	PART NUMBER	U/M	DESCRIPTION
1	118789-16-G04	EA	DOOR ASM-STORAGE
	107796-04-000	EA	GAS SPRING - 12" COMPRESSED/20" EXTENDED - 20LB.
2	118789-15-G04	EA	DOOR ASM-STORAGE
	107796-04-000	EA	GAS SPRING - 12" COMPRESSED/20" EXTENDED - 20LB.
3	052009-06-000	EA	DOOR - WATER HEATER - W/O LATCHES
	116424-01-000	EA	PROTECTOR - WATER HEATER LATCH
4	121294-30-G04	EA	DOOR ASM-STORAGE
	107796-04-000	EA	GAS SPRING - 12" COMPRESSED/20" EXTENDED - 20LB.
5	121294-28-G04	EA	DOOR ASM-STORAGE
	107796-04-000	EA	GAS SPRING - 12" COMPRESSED/20" EXTENDED - 20LB.
6	121294-29-G04	EA	DOOR ASM-STORAGE
	107796-04-000	EA	GAS SPRING - 12" COMPRESSED/20" EXTENDED - 20LB.
	123478-01-G04	EA	DOOR ASM
7	115108-06-G24	EA	DOOR - ENTRY, W/SCREEN DOOR - W/O WINDOW
7	115108-06-G25	EA	DOOR - ENTRY, W/SCREEN DOOR - W/O WINDOW
8	111017-01-F24	EA	DOOR - PATIO/ENTERTAINMENT CENTER W/O LATCH - 17.8" X 8.1"
	079775-D3-000	EA	JAMB-DOOR STORAGE,BRT WHT
	110506-12-000	EA	LOCK ASM-KEYED,49.26MM
9	084103-08-000	EA	DOOR - REFRIGERATOR - VENTED - W/O JAMB
	084104-08-000	EA	JAMB - REFRIGERATOR DOOR
	084104-01-700	EA	LOCK-MALE - FASTENER - REFRIGERATOR DOOR
	084104-01-701	EA	LOCK-FEMALE - FASTENER - REFRIGERATOR DOOR
10	118789-14-G04	EA	DOOR ASM-STORAGE
	107796-17-000	EA	SPRING-GAS 15" LENGTH,20 LB
	108998-02-000	EA	BRACKET-L W/BALL STUD
	081240-16-000	EA	DOOR - WATER FILL - LOCKABLE W/O LOCK - 4" X 4 5/8"
	110506-02-000	EA	LOCK-KEYED, 13.64 MM - BRIGGS & STRATTON

## WINDOW, VENT & EXTERIOR DOOR GROUP (CONTINUED)

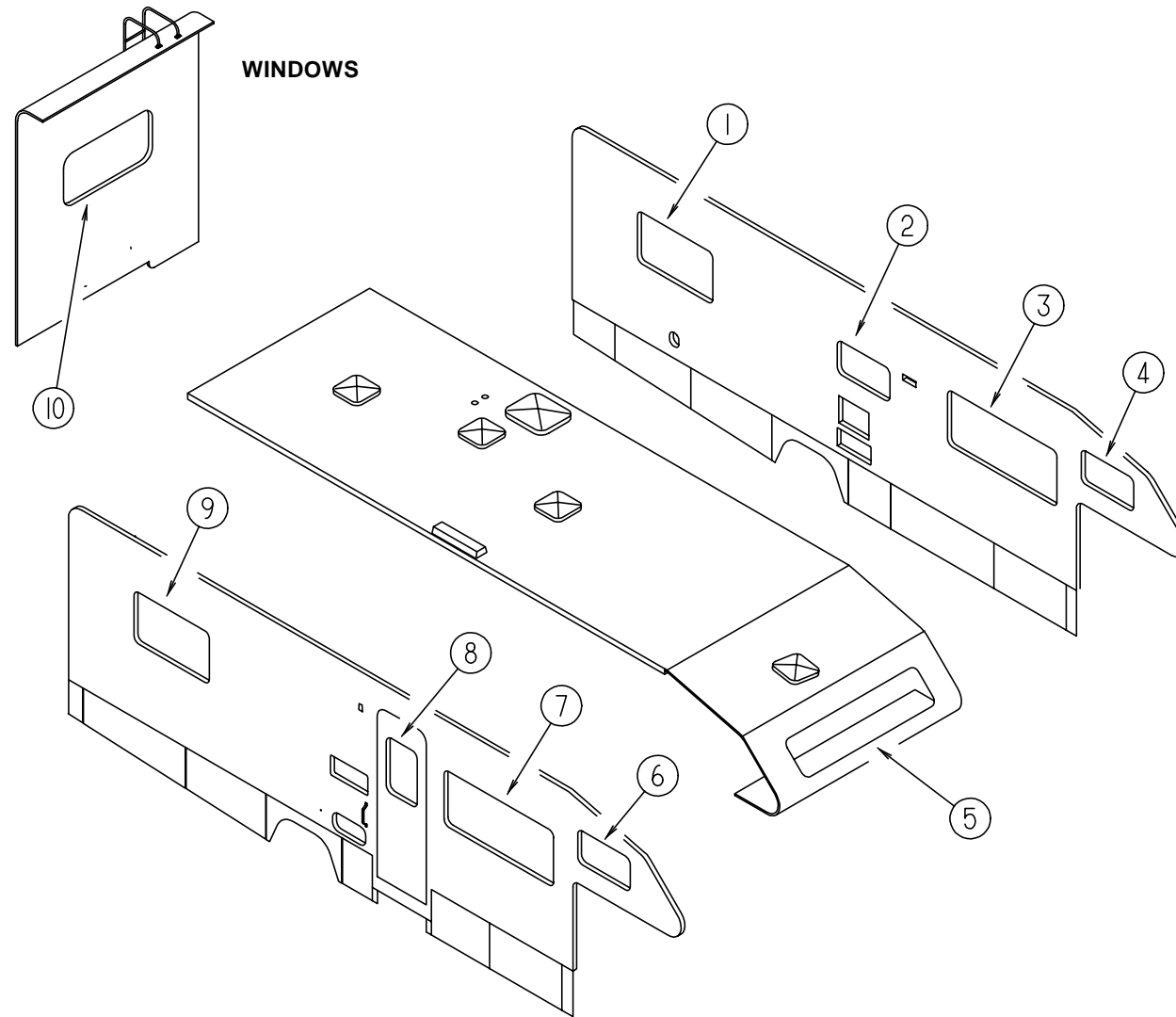

KEY	PART NUMBER	U/M	DESCRIPTION
1	113500-01-01A	EA	WINDOW - DOUBLE TIPOUT 24.5 X 41.3" (QUEEN)
1	112795-23-01A	EA	WINDOW-DRIVERS HORIZONTAL SLIDER THERMO 24 1/2" X 41 1/2"(QUEEN)
1	104691-13-01A	EA	WINDOW - TIPOUT SINGLE - 26.3" X 47.9" (DOUBLE/TWIN)
1	112795-25-01A	EA	WINDOW-DRIVERS HORIZONTAL SLIDER THERMO 26 3/8" X 48"(DOUBLE/TWIN)
1	098647-34-01A	EA	WINDOW - DRIVERS HORIZONTAL SLIDER 15.7" X 28.5"(CROSS STACKED)
1	112795-20-01A	EA	WINDOW-DRIVER HORIZONTAL SLIDER THERMO 16" X 28 3/4"(CROSS STACKED)
2	098647-07-02A	EA	WINDOW - DRIVERS HORIZONTAL SLIDER 15" X 23.75"
2	112795-56-01A	EA	WINDOW-DRIVER HORIZONTAL SLIDE THERMO 15.2" X 24"
3	098647-22-01A	EA	WINDOW - DRIVERS HORIZONTAL SLIDER 26.1" X 59.7"
3	112795-15-01A	EA	WINDOW-DRIVERS HORIZONTAL SLIDER THERMO 26 3/8" X 60"
4	098647-34-01A	EA	WINDOW - DRIVERS HORIZONTAL SLIDER 15.7" X 28.5"
4	112795-20-01A	EA	WINDOW-DRIVER HORIZONTAL SLIDER THERMO 16" X 28 3/4"
5	103313-03-F15	EA	WINDOW-PICTURE/ESCAPE 23.3" X 71.3"
5	115630-01-01A	EA	WINDOW-STATIONARY 17.2" X 72"
6	098647-33-01A	EA	WINDOW - PASSENGER HORIZONTAL SLIDER 15.7" X 28.5"
6	112795-19-01A	EA	WINDOW-PASSENGER HORIZONTAL SLIDER THERMO 16" X 28 3/4"
7	098647-23-01A	EA	WINDOW - PASSENGER HORIZONTAL SLIDER 26.1" X 59.7"
7	112795-16-01A	EA	WINDOW-PASSENGER HORIZONTAL SLIDER THERMO 26 3/8" X 60"
8	117053-02-F36	EA	WINDOW-PICTURE 17" X 26.4"
8	113733-01-01A	EA	WINDOW-STATIONARY THERMOPANE 26.4" X 17"
9	113500-01-01A	EA	WINDOW - DOUBLE TIPOUT 24.5 X 41.3" (QUEEN & CROSS STACKED)
9	112795-21-01A	EA	WINDOW-PASSENGER HORIZONTAL SLIDER THERMO 24.5" X 41 1/4 (QUEEN & CROSS STACKED)
9	104691-13-01A	EA	WINDOW - TIPOUT SINGLE - 26.3" X 47.9"(DOUBLE/TWIN)
9	112795-22-01A	EA	WINDOW-PASSENGER HORIZONTAL SLIDER THERMO 26 3/8" X 48" (DOUBLE/TWIN)
10	078528-06-E10	EA	WINDOW - ESCAPE W/O INSIDE TRIM - 48.5" X 24.5" (QUEEN/TWIN)
10	113502-01-01A	EA	WINDOW-REAR ESCAPE THERMO - 24.8" X 48.7" (QUEEN/TWIN)
10	116976-02-01A	EA	WINDOW-REAR TINTED ESCAPE 26.4" X 26.25" (DOUBLE & CROSS STACKED)
10	113502-04-01A	EA	WINDOW-REAR ESCAPE THERMO - 26.4" X 26.25" (DOUBLE & CROSS STACKED)

# WINDOW, VENT & EXTERIOR DOOR GROUP (CONTINUED)

## BRIGGS & STRATTON LOCKS & COMPONENTS

**NOTE:**

WHEN ORDERING THE LOCK CASE, THE KEY CODE MUST MATCH THE LAST DIGIT OF THE VEHICLE'S SERIAL NUMBER AND PART NUMBER; WHEN ORDERING THE KEYS, THE THIRD DIGIT OF THE KEY CODE MUST MATCH THE LAST DIGIT OF THE VEHICLE'S SERIAL NUMBER AND PART NUMBER.

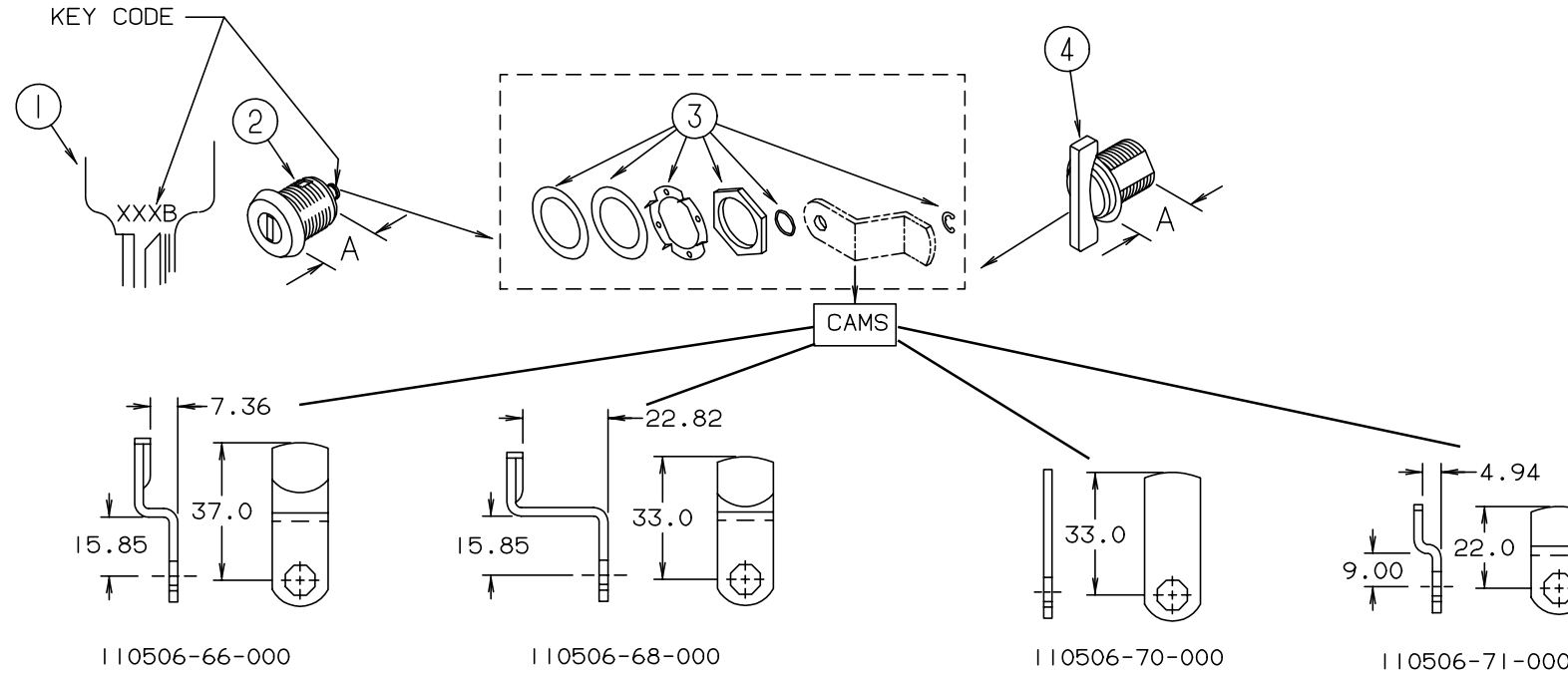

KEY	PART NUMBER	U/M	DESCRIPTION	VENDOR NO.
1	110506-59-000	EA	KEYS - SET OF TWO	596720
2	110506-52-000	EA	CASE - LOCK - A= 17 MM	702370
2	110506-53-000	EA	CASE - LOCK - A= 25MM	702380
2	110506-54-000	EA	CASE - LOCK - A= 32 MM	703170
1	110506-59-001	EA	KEYS - SET OF TWO	596721
2	110506-52-001	EA	CASE - LOCK - A= 17 MM	702371
2	110506-53-001	EA	CASE - LOCK - A= 25 MM	702381
2	110506-54-001	EA	CASE - LOCK - A= 32 MM	703171
1	110506-59-002	EA	KEYS - SET OF TWO	596722
2	110506-52-002	EA	CASE - LOCK - A= 17 MM	702372
2	110506-53-002	EA	CASE - LOCK - A= 25 MM	702382
2	110506-54-002	EA	CASE - LOCK - A- 32 MM	703172
1	110506-59-003	EA	KEYS - SET OF TWO	596723
2	110506-52-003	EA	CASE - LOCK - A- 17 MM	702373
2	110506-53-003	EA	CASE - LOCK - A- 25 MM	702383
2	110506-54-003	EA	CASE - LOCK - A= 32 MM	703173
1	110506-59-004	EA	KEYS - SET OF TWO	596724
2	110506-52-004	EA	CASE - LOCK - A- 17 MM	702374
2	110506-53-004	EA	CASE - LOCK - A= 25 MM	702384
2	110506-54-004	EA	CASE - LOCK - A- 32 MM	703174
1	110506-59-005	EA	KEYS - SET OF TWO	596725
2	110506-52-005	EA	CASE - LOCK - A= 17 MM	702375
2	110506-53-005	EA	CASE - LOCK - A= 25 MM	702385
2	110506-54-005	EA	CASE - LOCK - A= 32 MM	703175

KEY	PART NUMBER	U/M	DESCRIPTION	VENDOR NO.
1	110506-59-006	EA	KEYS - SET OF TWO	596726
2	110506-54-006	EA	CASE - LOCK - A- 32 MM	703176
2	110506-52-006	EA	CASE - LOCK - A= 17 MM	702376
2	110506-53-006	EA	CASE - LOCK - A= 25 MM	702386
1	110506-59-007	EA	KEYS - SET OF TWO	596727
2	110506-54-007	EA	CASE - LOCK - A= 32 MM	703177
2	110506-52-007	EA	CASE - LOCK - A= 17 MM	702377
2	110506-53-007	EA	CASE - LOCK - A= 25 MM	702387
1	110506-59-008	EA	KEYS - SET OF TWO	596728
2	110506-52-008	EA	CASE - LOCK - A= 17 MM	702378
2	110506-53-008	EA	CASE - LOCK - A= 25 MM	702388
2	110506-54-008	EA	CASE - LOCK - A= 32 MM	703178
1	110506-59-009	EA	KEYS - SET OF TWO	596729
2	110506-52-009	EA	CASE - LOCK - A= 17 MM	702379
2	110506-53-009	EA	CASE - LOCK - A= 25 MM	702389
2	110506-54-009	EA	CASE - LOCK - A= 32 MM	703179
3	110506-40-700	EA	HARDWARE PACKAGE-CYLINDER/CASE	
4	110506-55-000	EA	CASE - TWIST LOCK - A= 32 MM	597312AA1
	110506-01-000	EA	LOCK ASM-KEYED,17.65MM	
	110506-26-000	EA	LOCK ASM-KEYED,47.00MM	
	110506-66-000	EA	CAM-LOCKING	322282
	110506-68-000	EA	CAM-LOCKING	322284
	110506-70-000	EA	CAM-LOCKING	322286
	110506-71-000	EA	CAM-LOCKING	322287
	110506-59-701	EA	KEY BLANK - GOLD	

## WINDOW, VENT & EXTERIOR DOOR GROUP (CONTINUED)

### ENTRANCE DOOR

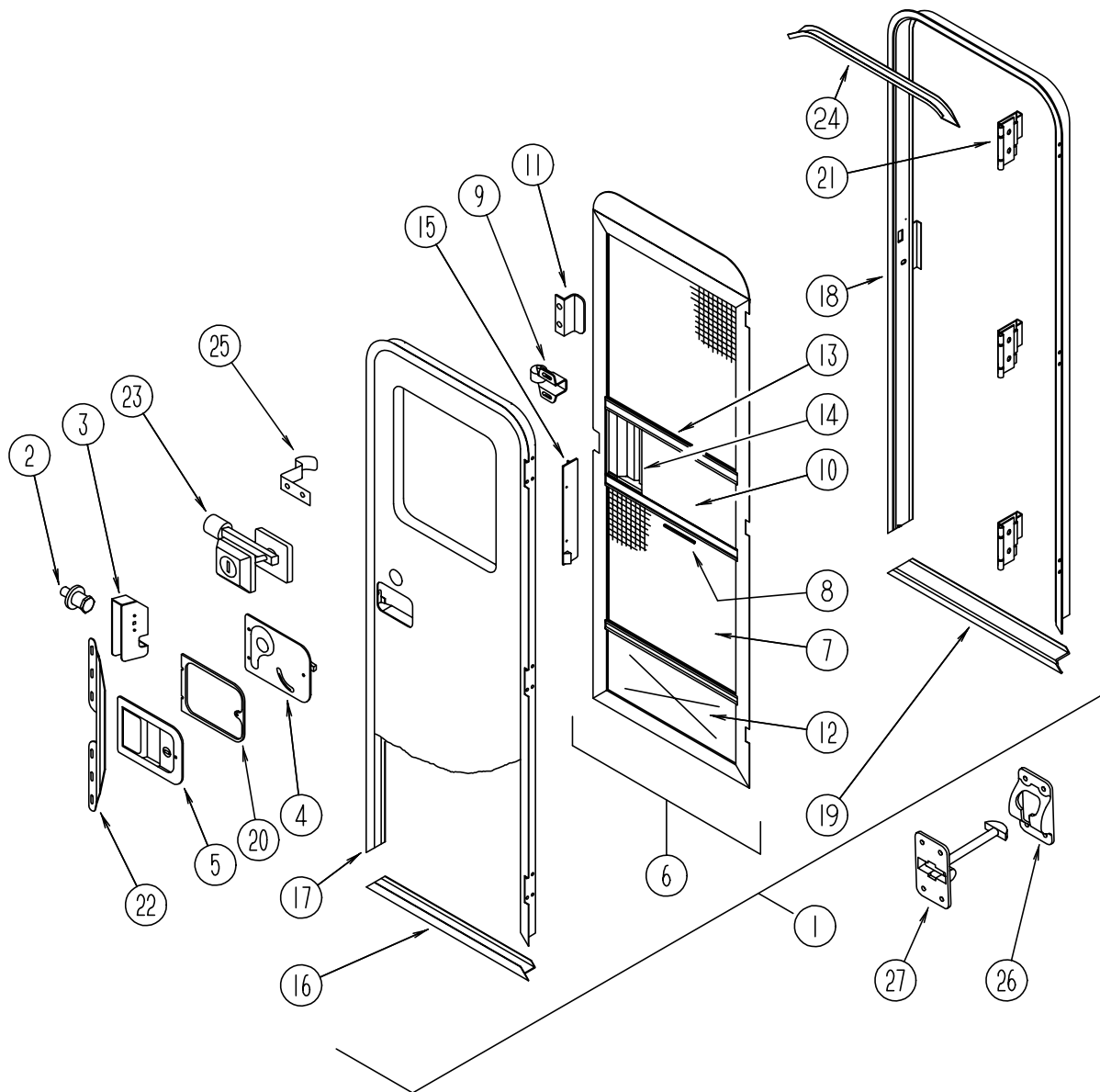

KEY	PART NUMBER	U/M	DESCRIPTION	VENDOR NO.
1	115108-06-G24	EA	DOOR - ENTRY, W/SCREEN DOOR - W/O WINDOW	
1	115108-06-G25	EA	DOOR-ENTRY - W/SCREEN DOOR - W/O WINDOW	
2	039539-01-000	EA	STRIKE-LOCK, ENTRY DOOR - ROUND W/THREADED WASHER	
3	039540-01-000	EA	LATCH MECHANISM-HOOK, ENTRY DOOR - INTERIOR	
	039715-01-000	EA	NUT-SERT, 1/4" DIAMETER - 20 THREADS	
4	039979-06-000	EA	COVER-RH LATCH PLATE - BLACK TEXTURED	
	041546-07-000	EA	BRACKET-ASM-DOOR ANGLE O/WHT - *1996	
5	045017-13-000	EA	LATCH-ENTRANCE DOOR,BLK TEXT - *T/M #11896-01	
	045017-11-701	EA	KEY-BLANK, F1 SERIES	81312-02
	045017-11-703	EA	CYLINDER-LOCK ASM. W/KEYS	81266-09
	072893-04-000	EA	NUTSERT-10-32	
	075671-04-000	FT	SEAL-SPONGE, LAZY T SHAPE - W/ADHESIVE STRIPE - .5" WIDE	
6	121899-01-G04	EA	DOOR ASM-SCREEN	
7	002293-02-000	SF	SCREENING-WINDOW/DOOR, 26" - CHARCOAL	
8	002294-01-000	FT	SPLINE-SCREENING, .135" X .138" - BLACK	
9	109403-01-000	EA	CATCH-SINGLE ROLLER - SCREEN DOOR	
10	001014-01-013	EA	INSERT-CENTER, 10.25" X 16.31" - UNPAINTED	
11	050712-06-000	EA	HANDLE-DOOR-SHOWER BRT WHT	
12	078552-03-000	EA	KICK PANEL-SCREEN DOOR, LOWER INSERT - UNPAINTED	
	016454-01-000	EA	INSERT-CENTER, LEATHER GRAIN ALUMINUM - UNPAINTED	
	078595-01-000	EA	TOP PLATE-SCREEN DOOR, CURVED TOP - 4.7" X 25.35"	
13	078777-01-000	EA	CHANNEL-SLIDE, SCREEN DOOR CENTER SLIDER COVER	
14	079086-03-000	EA	SLIDER-SCREEN DOOR BRT WHITE	
15	079087-03-000	EA	STRIKE-SLIDER,SCREEN DOOR BRT WHITE	
	077461-05-000	EA	COVER-BRACKET,STRIKE OFF/WHT	
	076725-02-000	EA	COVER-HINGE, ENTRY DOOR - 6" X 3.2"	
16	121893-01-01A	EA	FRAME-DOOR,ENTRANCE B/W	
17	121894-03-01A	EA	FRAME-DOOR,ENTRANCE B/W	
18	121898-05-01A	EA	JAMB ASM-DOOR,ENTRANCE B/W	
19	051049-01-000	EA	JAMB-BOTTOM, ENTRY DOOR - 25.9" - UNPAINTED	
20	096810-01-01A	EA	PLATE-LATCH, ENTRY DOOR - PLASTIC - BLACK	
21	106719-01-05A	EA	HINGE-ENTRANCE DOOR,BRT/WHT	
21	106719-01-01A	EA	HINGE-ENTRANCE DOOR MILL	
	116111-02-01A	EA	SCREW - TAPTITE - 1/4-20 X 3/8 PPH - ZINC	
22	098173-01-04A	EA	STIFFENER-ENTRY DOOR, SUPPORTS LATCH/STRIKE AREA	
	098173-01-07A	EA	STIFFENER-ENT DOOR,BRT WHT	
	075673-01-000	FT	SEAL-PILE, ADHESIVE BACK - GRAY	
	118929-01-01A	FT	SEAL-PILE, PUSH-ON - AMESBURY 5250148	
23	101145-01-06A	EA	DEADBOLT ASM-BLACKTEXD/BLACK - T/M #11840-02	
	095229-01-700	EA	KEY-BLANK, DEADBOLT	81205-03
	101145-01-701	EA	CYLINDER-LOCK ASM., W/KEY	81306-03
	036618-02-000	EA	E RING-EXTERNAL, LYNOR DOOR LOCK - 3/16" SHAFT DIAMETER	
	101147-01-000	EA	BOLT-SECURITY, 4.12" BACKSET	
24	044582-44-000	EA	CAP-DRIP-JAMB MTD-BRT WHITE *B/L 33100	
	115222-13-01A	EA	GARNISH-RADIUS,ENTR DOOR O/W	
25	100412-01-000	EA	CATCH-SCREEN DOOR	
26	104099-02-04A	EA	CATCH-DOOR HOLDER,RETAINER - BRIGHT WHITE	
27	104099-01-04A	EA	CATCH-DOOR HOLDER,STRIKE - BRIGHT WHITE	
	009126-03-000	EA	HANDLE-ASSIST,BLACK TEXTURED - T/M #10087-01	
	122241-01-01A	EA	BUMPER-FOAM RUBBER - BLACK	
	086285-05-000	EA	SPACER-NYLON,17.80ODX14.3 - MICROPLAS 17W07051	
	102248-01-000	EA	SHIM-DOOR	

**WINDOW, VENT & EXTERIOR DOOR GROUP (CONTINUED)**

**WINDOW, VENT & EXTERIOR DOOR GROUP (CONTINUED)**

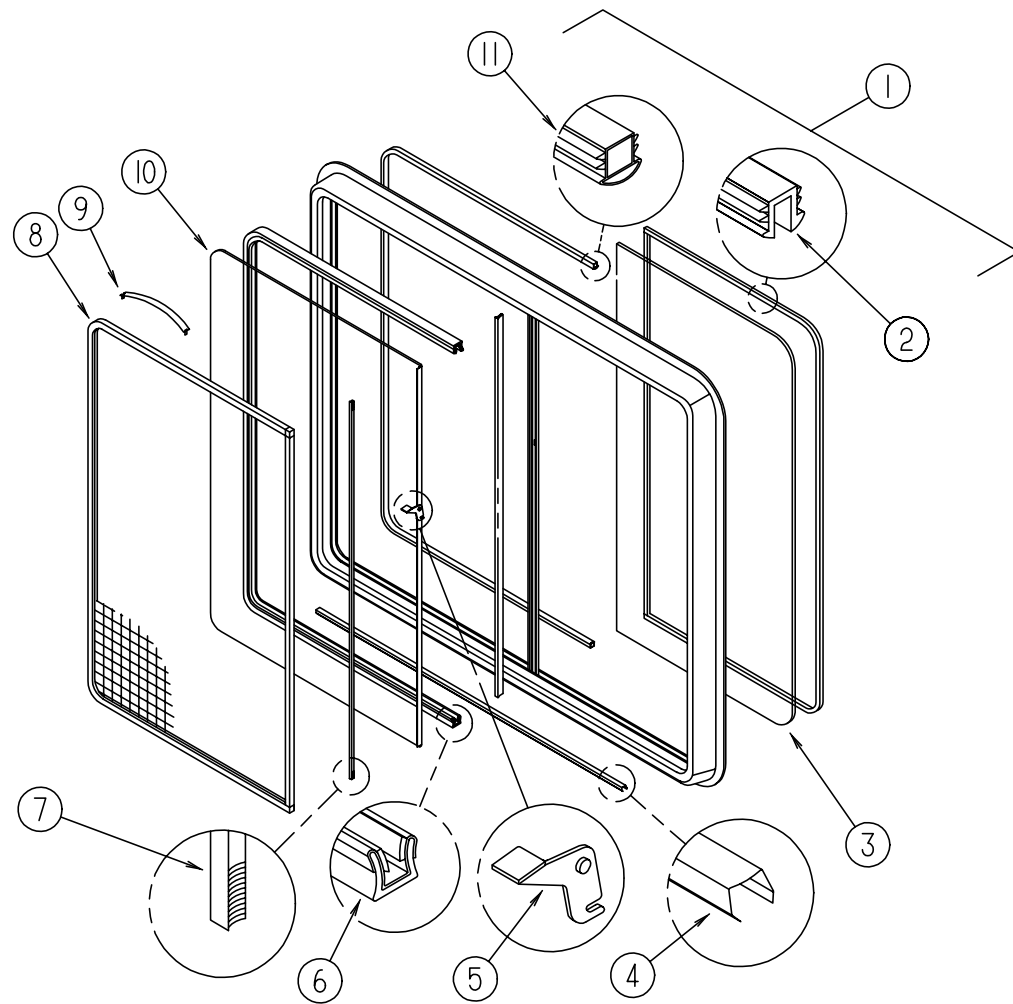

**DRIVER & PASSENGER SIDE WINDOW - EXCEL**

KEY	PART NUMBER	U/M	DESCRIPTION	VENDOR NO.
1	098647-34-01A	EA	WINDOW - DRIVERS HORIZONTAL SLIDER 15.7" X 28.5"	
1	098647-33-01A	EA	WINDOW - PASSENGER HORIZONTAL SLIDER 15.7" X 28.5"	
1	098647-34-700	EA	WINDOW - SLIDER W/O RETAINER	H425-G2L
1	098647-33-700	EA	WINDOW - SLIDER W/O RETAINER	H425-G2R
	098647-31-701	EA	RETAINER-TRIM	CW29-66
2	098644-01-705	FT	GLAZING - STRIP	132-010231
3	098647-33-702	EA	GLASS-STATIONARY	106-019297
4	098644-01-710	FT	TRACK - SCREEN SPACER 12'	132-017135
5	098644-01-700	EA	LATCH REPAIR KIT (BLACK)	B801-CK
6	098644-01-708	FT	CHANNEL-PIERCED RUN	122-016543
7	098644-01-711	FT	WEATHERSTRIP-SCREEN BLACK	171-016965
8	098647-33-704	EA	SCREEN ASM - W/SEALS & CLIPS	
9	098644-01-713	EA	CLIP - SPRING - METAL	226-016966
10	098647-33-703	EA	GLASS-SLIDING W/SASH & LATCH	H425-G9
	098644-01-706	FT	WEATHERSTRIP - GLASS	171-010668
	098644-01-719	EA	STOP-SLIDER GLASS	132-014203
11	098644-01-716	FT	PLUG-FILLER	132-014470
	098644-01-717	FT	SPLINE-SCREEN	32-004716

**DRIVERS SIDE WINDOW - EXCEL**

KEY	PART NUMBER	U/M	DESCRIPTION	VENDOR NO.
1	098647-07-02A	EA	WINDOW - DRIVERS HORIZONTAL SLIDER 15" X 23.75"	
1	098647-07-700	EA	WINDOW - SLIDER LEFT HAND	B969-G2L
	098647-06-706	EA	RETAINER - TRIM	V969-67
2	098644-01-705	FT	GLAZING - STRIP	132-010231
3	098647-06-700	EA	GLASS - STATIONARY 10.9X13.8	106-016921
4	098644-01-710	FT	TRACK - SCREEN SPACER 12'	132-017135
5	098644-01-700	EA	LATCH - REPAIR KIT (BLACK)	B801-CK
6	098644-01-708	FT	CHANNEL - RUN PIERCED	122-016543
7	098644-01-711	FT	WEATHERSTRIP - SCREEN BLACK	171-016965
8	098647-06-703	EA	SCREEN ASM - W/SEALS & CLIPS	410-016477
9	098644-01-713	EA	CLIP - SPRING - METAL	226-016966
10	098647-06-702	EA	GLASS-SLIDING W/SASH & LATCH	B969-G9
	098644-01-719	EA	STOP-SLIDER GLASS	132-014203
	098644-01-706	FT	WEATHERSTRIP - GLASS	171-010668
11	098644-01-716	FT	PLUG - FILLER	132-014470
	098644-01-717	FT	SPLINE - SCREEN	132-004716

**DRIVER & PASSENGER SIDE WINDOW - EXCEL**

KEY	PART NUMBER	U/M	DESCRIPTION	VENDOR NO.
1	098647-22-01A	EA	WINDOW - DRIVERS HORIZONTAL SLIDER 26.1" X 59.7"	
1	098647-23-01A	EA	WINDOW - PASSENGER HORIZONTAL SLIDER 26.1" X 59.7"	
1	098647-22-700	EA	WINDOW-SLIDING W/O RETAINER	H287-G2L
1	098647-23-701	EA	WINDOW - SLIDER W/O RETAINER	H287-G2R
	098647-23-702	EA	RETAINER-TRIM	W287-66
2	098644-01-705	FT	GLAZING - STRIP	132-010231
3	098647-23-703	EA	GLASS-STATIONARY	106-017622
4	098644-01-710	FT	TRACK - SCREEN SPACER 12'	132-017135
5	098644-01-700	EA	LATCH REPAIR KIT (BLACK)	B801-CK
6	098644-01-708	FT	CHANNEL-PIERCED RUN	122-016543
7	098644-01-711	FT	WEATHERSTRIP-SCREEN BLACK	171-016965
8	098647-23-704	EA	SCREEN ASM - W/SEALS & CLIPS	
9	098644-01-713	EA	CLIP - SPRING - METAL	226-016966
10	098647-23-700	EA	GLASS-SLIDING - W/SASH & LATCH	H287-G9
	098644-01-706	FT	WEATHERSTRIP - GLASS	171-010668
	098644-01-719	EA	STOP-SLIDER GLASS	132-014203
11	098644-01-716	FT	PLUG-FILLER	132-014470
	098644-01-717	FT	SPLINE-SCREEN	32-004716

**WINDOW, VENT & EXTERIOR DOOR GROUP (CONTINUED)**

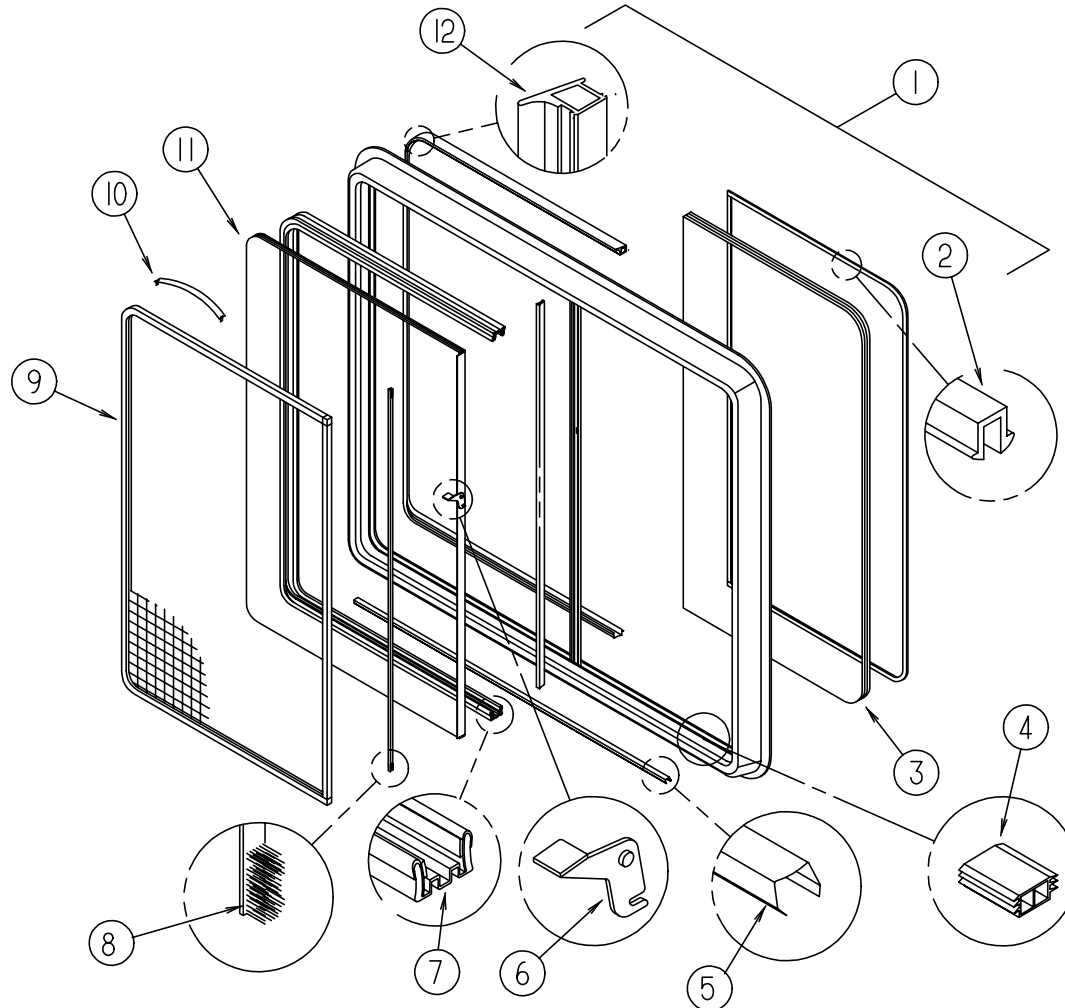

**DRIVER & PASSENGER THERMOPANE WINDOWS - EXCEL**

KEY	PART NUMBER	U/M	DESCRIPTION	VENDOR NO.
1	112795-20-01A	EA	WINDOW-DRIVER HORIZONTAL SLIDER THERMO 16" X 28 3/4"	
1	112795-19-01A	EA	WINDOW-PASSENGER HORIZONTAL SLIDER THERMO 16" X 28 3/4"	
	112795-20-700	EA	WINDOW W/O TRIM	DC29-G2L
	112795-19-700	EA	WINDOW W/O TRIM	DC29-G2R
	098647-31-701	EA	RETAINER - TRIM	CW29-66
2	112795-01-705	FT	VINYL-GLAZING	132-019702
3	112795-19-701	EA	GLASS - STATIONARY	390-019134
4	112795-01-701	EA	SLIDE-STOP	132-019092
5	098644-01-710	FT	TRACK - SCREEN SPACER 12'	132-017135
6	112795-01-700	EA	LATCH ASM., BLK.,(BOLT ON)	DH287-CK
7	112795-01-703	IN	CHANNEL-RUN (INCHES)	122-018736
8	098644-01-711	FT	WEATHERSTRIP - SCREEN BLACK	171-016965
9	098647-31-704	EA	SCREEN ASM - W/SEALS & CLIPS	410-019128
10	098644-01-713	EA	CLIP - SPRING - METAL	226-016966
11	112795-19-702	EA	GLASS-SLIDING W/SASH & LATCH	DC29-G9
12	112795-01-704	FT	PLUG FILLER (DOUBLE GLAZED)	122-018737

**DRIVER & PASSENGER THERMOPANE SLIDER WINDOW - EXCEL**

KEY	PART NUMBER	U/M	DESCRIPTION	VENDOR NO.
1	112795-22-01A	EA	WINDOW-PASSENGER HORIZONTAL SLIDER THERMO 26 3/8" X 48"	
1	112795-25-01A	EA	WINDOW-DRIVERS HORIZONTAL SLIDER THERMO 26 3/8" X 48"	
	112795-22-701	EA	RETAINER - (TRIM)	W30366
2	112795-01-705	FT	VINYL-GLAZING	132-019702

**WINDOW, VENT & EXTERIOR DOOR GROUP (CONTINUED)**

**DRIVER & PASSENGER THERMOPANE SLIDER WINDOW - EXCEL (CONTINUED)**

KEY	PART NUMBER	U/M	DESCRIPTION	VENDOR NO.
3	112795-22-702	EA	GLASS-STATIONARY	390-019039
4	112795-01-701	EA	SLIDE-STOP	132-019092
5	098644-01-710	EA	TRACK - SCREEN SPACER 12'	132-017135
6	112795-01-700	EA	LATCH ASM., BLK.,(BOLT ON)	DH287-CK
7	112795-01-703	IN	CHANNEL-RUN (INCHES)	122-018736
8	098644-01-711	EA	WEATHERSTRIP - SCREEN BLACK	171-016965
9	098647-31-704	EA	SCREEN ASM., W/SEAL & CLIPS	410-019128
10	098644-01-713	EA	CLIP-SPRING, BLACK PLASTIC	226-016966
11	112795-19-702	EA	GLASS-SLIDING, W/SASH&LATCH	DC29-G9
12	112795-01-704	FT	PLUG-FILLER (DOUBLE GLAZED)	122-018737

**DRIVER & PASSENGER THERMOPANE SLIDER WINDOW - EXCEL**

KEY	PART NUMBER	U/M	DESCRIPTION	VENDOR NO.
1	112795-21-01A	EA	WINDOW-PASSENGER HORIZONTAL SLIDER THERMO 24.5" X 41 1/4"	
1	112795-23-01A	EA	WINDOW-DRIVERS HORIZONTAL SLIDER THERMO 24 1/2" X 41 1/2"	
	098647-29-701	EA	RETAINER - TRIM	CW04-66
2	112795-01-705	FT	VINYL-GLAZING	132-019702
3	112795-21-701	EA	GLASS - STATIONARY	390-019132
4	112795-01-701	EA	SLIDE-STOP	132-019092
5	098644-01-710	FT	TRACK - SCREEN SPACER 12'	132-017135
6	112795-01-700	EA	LATCH ASM., BLK.,(BOLT ON)	DH287-CK
7	112795-01-703	IN	CHANNEL-RUN (INCHES)	122-018736
8	098644-01-711	FT	WEATHERSTRIP - SCREEN BLACK	171-016965
9	098647-29-704	EA	SCREEN ASM - W/SEALS & CLIPS	410-018864
10	098644-01-713	EA	CLIP - SPRING - METAL	226-016966
11	112795-21-702	EA	GLASS-SLIDING W/SASH & LATCH	DC04-G9
12	112795-01-704	FT	PLUG FILLER (DOUBLE GLAZED)	122-018737

**DRIVER & PASSENGER THERMOPANE SLIDER WINDOW - EXCEL**

KEY	PART NUMBER	U/M	DESCRIPTION	VENDOR NO.
1	112795-15-01A	EA	WINDOW-DRIVERS HORIZONTAL SLIDER-THERMO-26 3/8" X 60"	
1	112795-16-01A	EA	WINDOW-PASSENGER HORIZONTAL SLIDER-THERMO-26 3/8" X 60"	
	098647-23-702	EA	RETAINER-TRIM - WHITE	W28766
2	112795-01-705	FT	VINYL-GLAZING	132-019702
3	112795-15-701	EA	GLASS-STATIONARY	390-019045
4	112795-01-701	EA	SLIDE-STOP	132-019092
5	098644-01-710	EA	TRACK - SCREEN SPACER 12'	132-017135
6	112795-01-700	EA	LATCH ASM. - BLACK	DH287-CK
7	112795-01-703	IN	CHANNEL-RUN	122-018736
8	098644-01-711	EA	WEATHERSTRIP - SCREEN BLACK	171-016965
9	098647-31-704	EA	SCREEN ASM., W/SEAL & CLIPS	410-019128
10	098644-01-713	EA	CLIP-SPRING, BLACK PLASTIC	226-016966
11	112795-19-702	EA	GLASS-SLIDING, W/SASH&LATCH	DC29-G9
12	112795-01-704	FT	PLUG-FILLER (DOUBLE GLAZED)	122-018737

**DRIVER THERMOPANE SLIDER WINDOW - EXCEL**

KEY	PART NUMBER	U/M	DESCRIPTION	VENDOR NO.
1	112795-56-01A	EA	WINDOW-DRIVER HORIZONTAL SLIDE THERMO 15.2" X 24"	
	112795-56-703	EA	RETAINER - TRIM	V969-66
2	112795-01-705	FT	VINYL-GLAZING	132-019702
3	112795-56-701	EA	GLASS - STATIONARY	390-019412
4	112795-01-701	EA	SLIDE-STOP	132-019092
5	098644-01-710	EA	TRACK - SCREEN SPACER 12'	132-017135
6	112795-01-700	EA	LATCH ASM. - BLACK	DH287-CK
7	112795-01-703	IN	CHANNEL-RUN	122-018736
8	098644-01-711	EA	WEATHERSTRIP - SCREEN BLACK	171-016965
9	098647-56-702	EA	SCREEN ASM - W/SEALS & CLIPS	410-019414
10	098644-01-713	EA	CLIP-SPRING, BLACK PLASTIC	226-016966
11	112795-56-700	EA	GLASS-SLIDING W/SASH & LATCH	DB969-G9
12	112795-01-704	FT	PLUG-FILLER (DOUBLE GLAZED)	122-018737



**WINDOW, VENT & EXTERIOR DOOR GROUP (CONTINUED)**

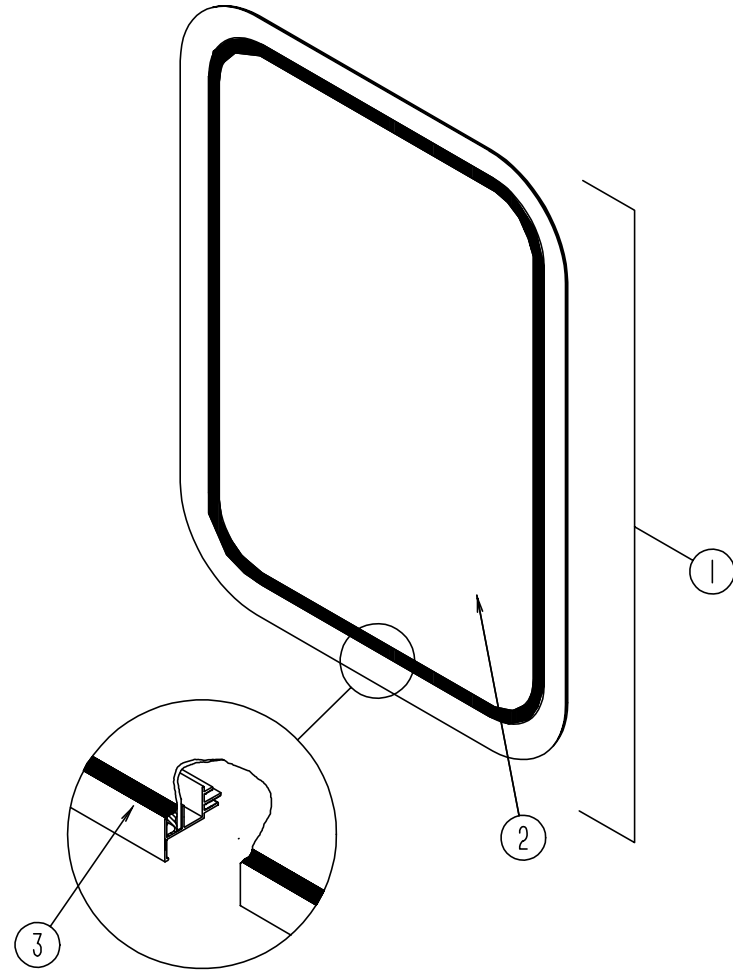

**ENTRY DOOR WINDOW**

KEY	PART NUMBER	U/M	DESCRIPTION
	117054-02-02A	EA	FRAME-WINDOW - ENTRY DOOR - BRIGHT WHITE
1	117053-02-F36	EA	WINDOW ASM-PICTURE
2	002181-25-000	EA	GLASS-WINDOW - 655 X 417 - GRAY
	069640-11-000	FT	SEALER-TAPE - 3/16" X 3/8" - BLACK
3	087561-01-000	FT	SEAL-GLASS - EXTERIOR - .5" WIDE - VINYL - BLACK

**THERMOPANE ENTRY DOOR WINDOW - EXCEL**

KEY	PART NUMBER	U/M	DESCRIPTION	VENDOR NO.
	113733-01-01A	EA	WINDOW ASM-STATIONARY-THERMOPANE - EXCEL	DH416-G2W66
	113733-01-700	EA	WINDOW ASM. W/O TRIM	DH416-G2
	113733-01-701	EA	TRIM (W)	W41666
	113733-01-702	EA	GLASS-STATIONARY	390-019187

**WINDOW, VENT & EXTERIOR DOOR GROUP (CONTINUED)**

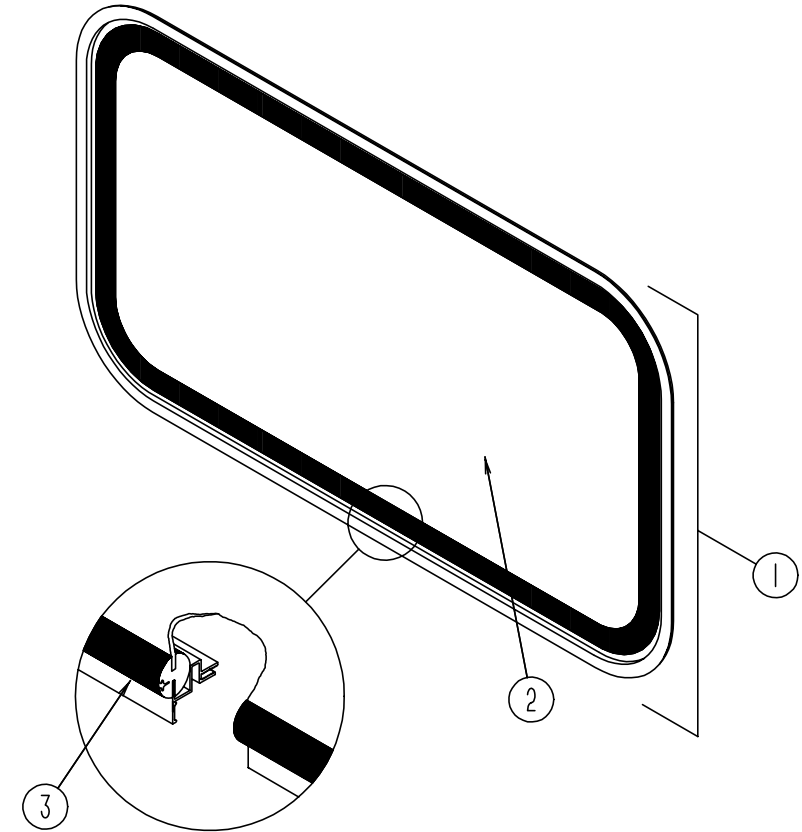

**OVERHEAD BUNK FRONT WINDOW**

KEY	PART NUMBER	U/M	DESCRIPTION
	117054-01-01A	EA	FRAME-INSIDE - WINDOW
1	103313-03-F15	EA	WINDOW-PICTURE - W/O INSIDE FRAME
	077066-01-702	EA	TAPE ASM-ESCAPE WINDOW, RED
2	002181-29-000	EA	GLASS-PICTURE - 1808 X 416 - GRAY - 31%
	069640-11-000	FT	SEALER-TAPE - 3/16" X 3/8" - BLACK
3	099154-01-000	FT	CHANNEL-GLAZING - STATIONARY GLASS - .62" X .45" - BLACK

**THERMOPANE OVERHEAD BUNK FRONT WINDOW - EXCEL**

KEY	PART NUMBER	U/M	DESCRIPTION	VENDOR NO.
	115630-01-01A	EA	WINDOW-STATIONARY 17.2" X 72"	
	100322-01-703	FT	STRIP-GLAZING - BUTYL	132-010723
	115630-01-700	EA	WINDOW W/O TRIM	DH438-G2
	115630-01-701	EA	TRIM	W43858
	115630-01-702	EA	GLASS-STATIONARY	390-019467

**WINDOW, VENT & EXTERIOR DOOR GROUP (CONTINUED)**

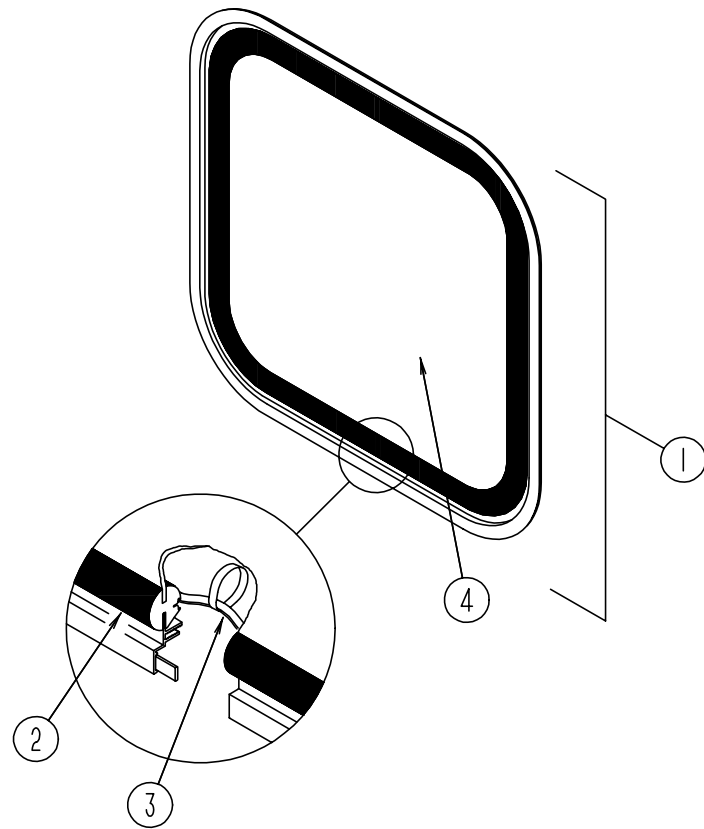

**QUEEN & TWIN BED ESCAPE WINDOW**

KEY	PART NUMBER	U/M	DESCRIPTION
	074816-11-000	EA	FRAME-WINDOW INSIDE ESCP.O/W
1	078528-06-E10	EA	WINDOW-ESCAPE W/O INSIDE TRIM - 48.5" X 24.5"
2	002282-09-000	EA	WEATHERSTRIP-WINDOW- .125" X 130.5" BLACK
3	002285-01-000	FT	FILLER-WEATHER STRIP, RUBBER - BLACK
4	076337-12-000	EA	GLASS - EGRESS - 45.5" X 21.5"
	077066-01-702	EA	TAPE ASM-ESCAPE WINDOW

**QUEEN & TWIN BED THERMOPANE ESCAPE WINDOW - EXCEL**

KEY	PART NUMBER	U/M	DESCRIPTION	VENDOR NO.
	113502-01-01A	EA	WINDOW-REAR ESCAPE THERMO - 24.8" X 48.7"	
	098644-01-705	FT	GLAZING - STRIP	132-010231
	112898-06-704	EA	HANDLE-LATCH - RED-RH	182-11293
	112898-06-705	EA	HANDLE-LATCH - RED-LH	182-11294
	113502-01-703	EA	GLASS-STATIONARY - RT & LT	390-019083
	113502-01-704	EA	GLASS-EGRESS -CENTER-ESCAPE	390-019084

**WINDOW, VENT & EXTERIOR DOOR GROUP (CONTINUED)**

**DOUBLE & CROSS STACKED ESCAPE WINDOW - EXCEL**

KEY	PART NUMBER	U/M	DESCRIPTION	VENDOR NO.
	116976-02-01A	EA	WINDOW-REAR TINTED ESCAPE 26.4" X 26.25"	
	100322-01-701	FT	SEAL VENT	122-016071
	112898-06-704	EA	HANDLE-LATCH, RED-RH	182-11293
	112898-06-705	EA	HANDLE-LATCH, RED-LH	182-11294
	113502-04-700	EA	FILLER PLUG	132-016065
	116976-01-701	EA	TRIM	W38653
	116976-02-700	EA	GLASS	106-018785

**DOUBLE & CROSS STACKED ESCAPE THERMOPANE WINDOW - EXCEL**

KEY	PART NUMBER	U/M	DESCRIPTION	VENDOR NO.
	113502-04-01A	EA	WINDOW-REAR ESCAPE THERMO - 26.4" X 26.25"	
	098644-01-705	FT	GLAZING - STRIP	132-010231
	112898-06-704	EA	HANDLE-LATCH, RED-RH	182-11293
	112898-06-705	EA	HANDLE-LATCH, RED-LH	182-11294
	113502-04-700	EA	WINDOW W/O TRIM	DH449-G2
	113502-04-701	EA	TRIM	W44958
	113502-04-702	EA	GLASS-STATIONARY	390-019460

**WINDOW, VENT & EXTERIOR DOOR GROUP (CONTINUED)**

**TWIN & DOUBLE BED SLIDING WINDOW - EXCEL**

KEY	PART NUMBER	U/M	DESCRIPTION	VENDOR NO.
	104691-13-01A	EA	WINDOW ASM-TIPOUT - BLACK/OFF WHITE -EXCEL CH37-G2W59	
	100322-01-701	FT	SEAL-VENT	122-016071
	100322-01-702	EA	WEATHERSTRIP-HORIZONTAL RAIL	132-015976
	100322-01-703	FT	STRIP-GLAZING, BUTYL	132-010723
	100322-01-704	FT	TAPE-BUTYL	154-016083
	100322-01-714	EA	SUPPORT-TORQUE BAR, LH	130-015978
	100322-01-715	EA	SUPPORT-TORQUE BAR, RH	130-015979
	100322-01-718	EA	HANDLE-DIAL	410-016081
	104691-13-700	EA	WINDOW	CH37-G2
	104691-13-701	EA	RETAINER-TRIM, WHITE	W30359
	104691-13-702	EA	GLASS-STATIONARY	106-017670
	104691-13-703	EA	GLASS-VENT ASSEMBLY	CH37-G9
	104691-13-704	EA	OPERATOR & BAR ASSEMBLY	CH36-18
	104691-13-705	EA	SCREEN ASSEMBLY	410-017763
	112519-01-702	EA	OPERATOR VENT	410-016123
	112519-01-706	EA	CLIP SCREEN	CH21-50
	116976-01-702	FT	FILLER PLUG	132-016065

**QUEEN BED PICTURE WINDOW - EXCEL**

KEY	PART NUMBER	U/M	DESCRIPTION	VENDOR NO.
	113500-01-01A	EA	WINDOW-REAR TINTED PICTURE 26.4" X 26.25"	
	098644-01-716	FT	PLUG - FILLER	132-014470
	100322-01-701	FT	SEAL-VENT	122-016071
	100322-01-702	EA	WEATHERSTRIP-HORIZONTAL RAIL	132-015976
	100322-01-703	FT	VINYL-GLAZING, BUTYL	132-010723
	100322-01-704	FT	TAPE-BUTYL	154-016083
	100322-01-717	EA	E-RING	245-015975
	100322-01-718	EA	HANDLE-DIAL	410-016081
	112519-01-702	EA	OPERATOR-VENT	410-016123
	113500-01-700	EA	SCREEN ASM - W/SEALS & CLIPS	410-016020
	113500-01-701	EA	WINDOW W/O TRIM	CH04-G2
	113500-01-702	EA	RETAINER - TRIM	CW04-59
	113500-01-703	EA	GLASS - TOP STATIONARY	106-015970
	113500-01-704	EA	GLASS - UPPER VENT ASSEMBLY	CH04-G7
	113500-01-705	EA	GLASS - LOWER VENT ASSEMBLY	CH04-G9
	113500-01-706	EA	OPERATOR & BAR ASSEMBLY	CH04-15
	113500-01-707	EA	SUPPORT - TORQUE BAR RH	130-015979
	113500-01-708	EA	SUPPORT - TORQUE BAR LH	130-015978

**WINDOW, VENT & EXTERIOR DOOR GROUP (CONTINUED)**

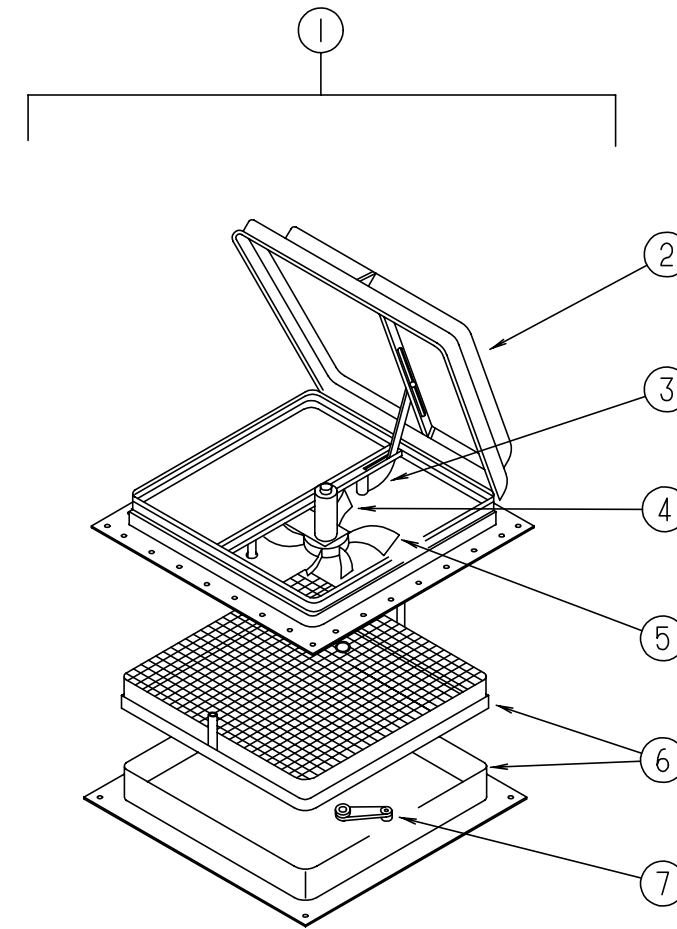

**POWERED ROOF VENT - JENSEN**

KEY	PART NUMBER	U/M	DESCRIPTION	VENDOR NO.
1	110051-03-01A	EA	VENT-ROOF - POWERED - 2" ROOF - JENSEN 7757	
1	110051-05-01A	EA	VENT-ROOF - POWERED - 2" ROOF - JENSEN C7757 (CANADIAN)	
2	064470-01-700	EA	COVER-ROOF VENT - JENSEN	7291
	064470-01-701	EA	SLIDE BAR, (VENT-LID)	JRP1291B
3	110051-01-702	EA	ARM LIFT ASSEMBLY W/O HANDLE	RP-1000B
4	048648-01-000	EA	MOTOR-12V NONVENTED 1/8 SFT	
5	048649-01-000	EA	FAN-PLASTIC - 6" - 6 BLADED	
6	110051-01-700	EA	SCREEN & FRAME 2" NON-POWER	29-800-02
7	110051-01-703	EA	HANDLE-CRANK	RP-1031-B
	110051-01-706	EA	GARNISH-INTERIOR - 2"	

## WINDOW, VENT & EXTERIOR DOOR GROUP (CONTINUED)

### POWERED ROOF VENTILATOR - US - FANTASTIC

KEY	PART NUMBER	U/M	DESCRIPTION	VENDOR NO.
	084079-03-000	EA	VENT-CEILING, POWERED EXHAUST-OFF WHITE-FANTASTIC VENT	
	084079-01-700	EA	COVER-VENT, W/HINGE & SLIDE	1020K-19
	084079-01-703	EA	KNOB-LIFT, W/EXT. & SCREW	1140K-00
	084079-01-704	EA	BLADE-FAN	1070-00
	084079-01-705	EA	MOTOR	1080-00
	084079-01-707	EA	SWITCH-SAFETY	1122.05
	084079-01-709	EA	SWITCH-MAIN, 3 SPEED	1031-05
	084079-01-711	EA	H-MOLDING, F/MOTOR MOUNT	
	084079-01-712	EA	GARNISH INT. FIN. 1 7/8" O/W	1040-80

### POWERED ROOF VENTILATOR - CSA - FANTASTIC

KEY	PART NUMBER	U/M	DESCRIPTION	VENDOR NO.
	084079-08-000	EA	VENT-CEILING - EXHAUST - POWER - OFF WHITE CSA	
	084079-01-700	EA	COVER-VENT - W/HINGE & SLIDE	1020K-19
	084079-01-703	EA	KNOB-LIFT - W/EXT - & SCREW	1140K-00
	084079-01-704	EA	BLADE-FAN	1070-00
	084079-01-707	EA	SWITCH-SAFETY	1122.05
	084079-01-709	EA	SWITCH-MAIN - 3 SPEED	1031-05
	084079-01-711	EA	H-MOLDING - F/MOTOR MOUNT	
	084079-01-712	EA	GARNISH INTERIOR FIN - 1 7/8" - OFF WHITE	1040-80
	084079-08-700	EA	MOTOR-THIN ROOF	101703

### NONPOWERED ROOF VENT

KEY	PART NUMBER	U/M	DESCRIPTION	VENDOR NO.
	110051-01-01A	EA	VENT-ROOF - NONPOWERED - 2" ROOF-JENSEN 7724 WHE	
	064470-01-700	EA	COVER-VENT - W/O (SLIDE BAR)	J7291
	064470-01-701	EA	SLIDE BAR - (VENT-LID)	JRP1291B
	110051-01-700	EA	SCREEN & FRAME 2" NON-POWER	29-800-02
	110051-01-702	EA	ARM LIFT ASSEMBLY W/O HANDLE	RP-1000B
	110051-01-703	EA	HANDLE-CRANK	RP-1031-B
	110051-01-706	EA	GARNISH-INTERIOR - 2"	

### VENTS, SHROUDS AND ROOF COVERS

KEY	PART NUMBER	U/M	DESCRIPTION
	084073-07-000	EA	COVER-ROOF VENT - REFRIGERATOR - BRIGHT WHITE - NORCOLD
	084073-04-000	EA	BASE-ROOF VENT - REFRIGERATOR - BLACK - NORCOLD
	084616-07-000	EA	SHROUD-RANGE HOOD VENT - BRIGHT WHITE
	084878-09-000	EA	VENT-RANGE HOOD - SHORT - LVS
	083558-03-000	EA	VENT-PLUMBING PIPE - ROOF W/COVER - OFF WHITE