

1995
WCG34WK
F11
F12

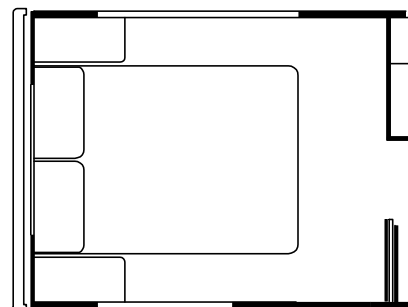
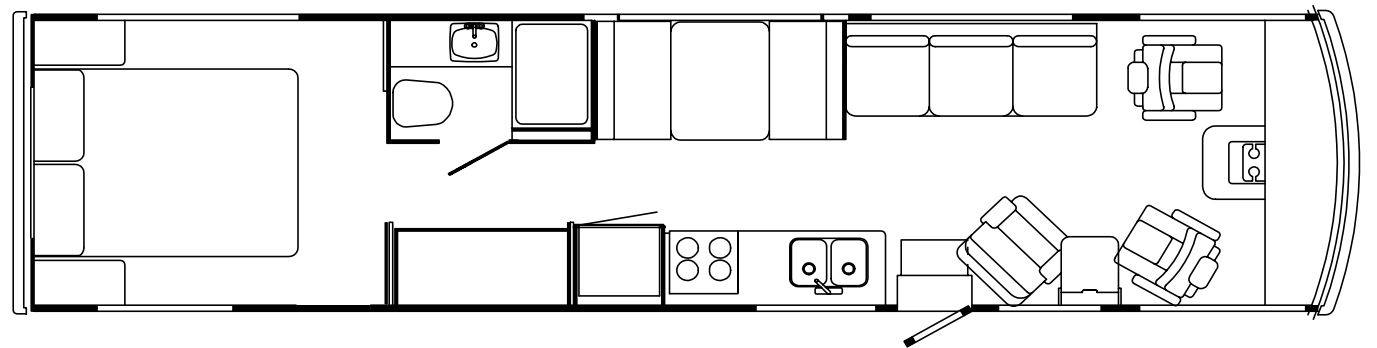
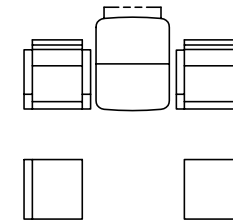
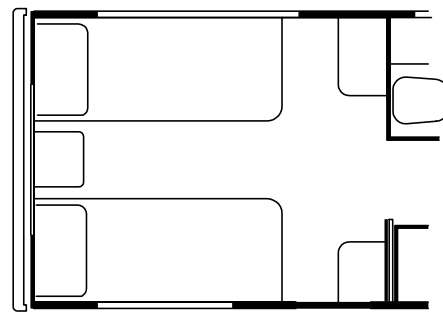

ACCESSORIES GROUP

OPERATOR MANUAL

KEY	PART NUMBER	U/M	DESCRIPTION
	054185-C6-000	EA	MANUAL - OPERATOR 95 ADVENTURE - G-SERIES
	092318-01-000	EA	BINDER - 3 RING - MOTOR HOME MANUAL
	092319-01-000	EA	POCKET PAGE - 3 RING BINDER - PLASTIC
	114399-01-000	EA	TOP LEVEL DRAWING NUMBER

AUDIO VIDEO GROUP

RADIO SYSTEMS & ANTENNA

KEY	PART NUMBER	U/M	DESCRIPTION	VENDOR NO.
	087683-03-000	EA	RADIO - AM/ FM STEREO CASSETTE - AUDIOVOX	RS-100
	110267-03-000	EA	RADIO - AM/ FM STEREO CD COMPAT - AUDIOVOX	IM-400
	116148-01-000	EA	RADIO - AM/ FM STEREO - CD PLAYER - CLARION	5633CD
	077069-02-000	EA	CABLE - ANTENNA - RADIO - EXTENSION 96"	ARA 6700667
	110469-01-000	EA	SPEAKER - OVAL - 4" X 6" - BLACK	
	110470-01-01A	EA	GRILLE - SPEAKER - OVAL - 4" X 6" - BLACK	
	081059-02-000	EA	WIRE ASM - 9-PIN - RADIO - AUDIOVOX	112B-1761
	105248-01-000	EA	ANTENNA - CB - ADVANCE	8604
	090944-01-000	EA	ANTENNA - RADIO - 16" RUBBER	
	108847-01-000	EA	BRACKET - ANTENNA GROUND	
	115916-01-01B	EA	BRACKET - ANTENNA MOUNT	
	074979-08-000	EA	SHIELD - SPEAKER - BACK - MOLDED PLASTIC - LIGHT OAK	
	089340-02-000	EA	GRILLE - SPEAKER - 6.5" SQUARE	
	089340-03-000	EA	SPACER - GRILLE - 6.5" SQUARE - TAN - MAGNADYNE	G514
	094097-01-000	EA	SPEAKER - RADIO - W/O GRILLE - 5.25" DIA - AUDIOVOX	110C3030

REAR MONITOR SYSTEM

KEY	PART NUMBER	U/M	DESCRIPTION	VENDOR NO.
	093040-05-000	EA	TELEVISION SYSTEM - REAR VIEW 7" - SONY	YM-RVF7AM
	093040-04-700	EA	CAMERA - W/BRACKET & WIRING - REAR VIEW	SSC-520AM
	093040-05-700	EA	MONITOR - 7" W/POWER HARNESS	SSM721AM
	093040-06-000	EA	WIRE ASM. - MONITOR - SONY	SM-HRN7
	093041-01-000	EA	CABLE - MONITOR/ CAMERA - INTERNAL USE	
	093041-02-000	EA	CABLE - MONITOR/ CAMERA - EXTERNAL USE	
	093041-03-000	EA	CABLE - MONITOR/ CAMERA - SONY	UK121A
	096717-03-000	EA	WIRE ASM. - REAR MONITOR - UPPER	
	108885-01-000	EA	WIRE ASM. - INSTRUMENT PANEL - REAR MONITOR (CHEVY)	

PATIO ENTERTAINMENT CENTER

KEY	PART NUMBER	U/M	DESCRIPTION	VENDOR NO.
	110469-01-000	EA	SPEAKER - OVAL - 4" X 6" - BLACK	
	110470-01-01A	EA	GRILLE - SPEAKER - OVAL - 4" X 6" - BLACK	
	077069-02-000	EA	CABLE - ANTENNA - RADIO - EXTENSION 96"	ARA 6700667
	087683-03-000	EA	RADIO - AM/ FM STEREO W/ CASSETTE - AUDIOVOX	
	090944-01-000	EA	ANTENNA - RADIO - 16" RUBBER	
	108847-01-000	EA	BRACKET - ANTENNA GROUND	
	109889-02-000	EA	ANTENNA - 2" SHAFT EXTENDER - MAGNADYNE	RV71EX2

AUDIO VIDEO GROUP (CONTINUED)

AUDIO VIDEO GROUP (CONTINUED)

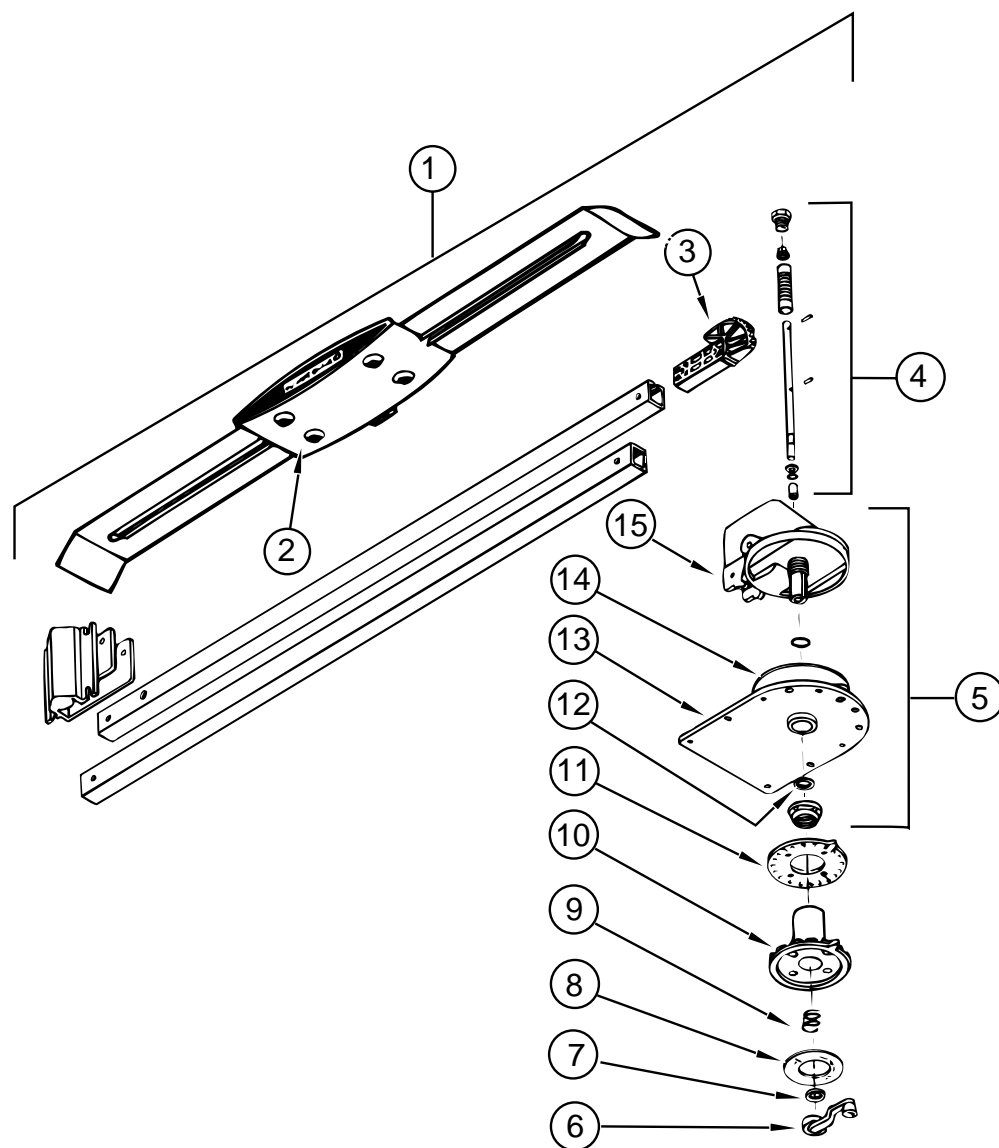

TV ANTENNA (WINEGARD)

KEY	PART NUMBER	U/M DESCRIPTION	WINEGARD VENDOR NO.
1	076319-18-000	EA ANTENNA - TV - ROOF MOUNT	
2	076319-01-700	EA HEAD - ANTENNA - AMPLIFIED	RVSA U/V
3	076319-01-701	EA GEAR - ELEVATING - PLASTIC	2200046
4	076319-01-702	EA SHAFT ASM - ELEVATING	RVP-400A
5	076319-01-711	EA BASE & LIFT ASM	2762802
6	076319-01-706	EA CRANK - ELEVATING - W/ SET SCREW	5755100
7	076319-01-705	EA BEARING - NYLON - 7/8"ID	3200658
8	076319-01-708	EA CRANK COVER DECAL	5413002
9	076319-01-707	EA SPRING - HANDLE	5160822
10	076319-01-709	EA PLATE - DIRECTIONAL - FOR HEAD	3200644
11	076319-01-712	EA CEILING PLATE	3200608
12	076319-01-704	EA BEARING - NYLON - 1.5"OD	3200657
13	076319-01-713	EA BASE PLATE	3100523
14	076319-01-703	EA BEARING - NYLON - 5"OD	3200656
15	076319-01-714	EA HOUSING - ROTATING GEAR	2200049

TV - VCR SYSTEMS

KEY	PART NUMBER	U/M DESCRIPTION	VENDOR NO.
	082134-01-000	EA ADAPTER - TV - CABLE TO CABLE - WINEGARD	F-81M
	086756-01-000	EA SPLITTER - TV - 2 WAY	
	076319-03-000	FT CABLE - COAXIAL - 75 OHM	
	076319-12-000	EA CONNECTOR - COAXIAL - ONE PIECE	
	086757-03-000	EA CONTROL CENTER - SWITCH - VCR/TV - MAGNADYNE	VCS-6
	098446-06-700	EA REMOTE F/ MODEL #9210 - 0974584	
	098446-07-000	EA VCR - VHS - CABLE READY - REMOTE - MAGNAVOX VR9320	
	113684-01-000	EA TV - 19" COLOR UL AND CSA - AUDIOVOX	AVT-1975
	113684-01-700	EA REMOTE - 8822345	
	092310-02-000	EA TV - COLOR - 9"- AC/ DC - MAGNAVOX (REAR TV)	RD0945
	092310-02-700	EA REMOTE - F/TV MAGNAVOX RD0945 - 0822334	
	098819-01-000	EA SPEAKER - 2 WATT - 8 OHM - 4"	
	093214-01-02A	EA GRILL - SPEAKER, 4" BROWN	
	099717-01-000	EA TIEDOWN - TV STRAP - 38.2" LONG	
	109889-04-000	EA EXTENDER - SHAFT - ANTENNA 3" - MAGNADYNE	RV71EX3
	082136-01-000	EA JAM NUT - HEX 3/8-32 - WINEGARD	
	076319-08-000	EA WALLPLATE - CABLE RECEPTACLE - TV - SINGLE - IVORY	
	076319-09-000	EA WALLPLATE - CABLE RECEPTACLE - TV - SINGLE - BROWN	
	086777-01-000	EA WALLPLATE - TV CABLE - W/ ANTENNA SWITCH - IVORY	
	086777-03-000	EA WALLPLATE - CABLE - W/ TV ANTENNA SWITCH & BOOSTER - IVORY	
	086757-03-000	EA CONTROL CENTER - SWITCH - VCR/TV - MAGNADYNE	VCS-6

BATH GROUP

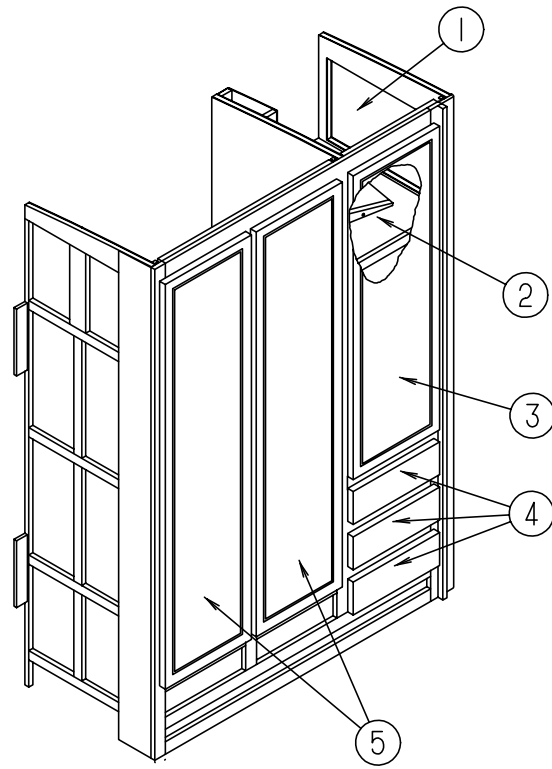

WARDROBE CABINET

KEY	PART NUMBER	U/M	DESCRIPTION
1	M06803-05-E07	EA	DOOR ASM. - RAIL - W/O HARDWARE 0365 X 0555 MM
2	115823-12-F31	EA	TV WEDGE SHELF
3	M06803-L8-F11	EA	DOOR ASM. - RAIL - W/O HARDWARE 0425 X1220 MM
4	M05970-L3-F11	EA	DRAWER ASM.
5	M06803-11-E07	EA	DOOR ASM. - RAIL - W/O HARDWARE 0410 X 1660 MM
	042438-01-000	EA	DOWEL - CLOTHES ROD - 1" DIAMETER - WOOD
	009112-01-000	EA	FLANGE - 1" CLOTHES ROD - PLASTIC - OFF WHITE

BATH GROUP (CONTINUED)

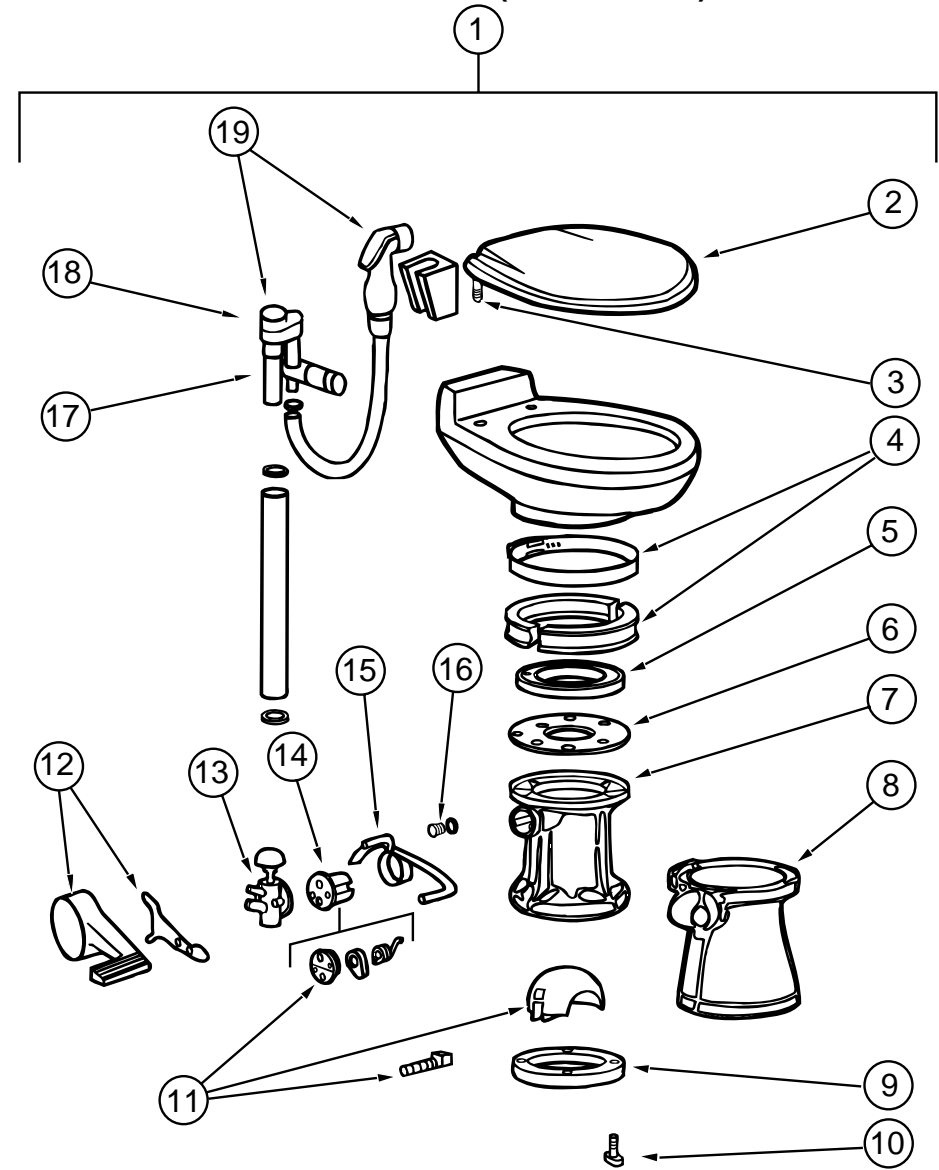

TOILET (SEALAND MODEL 910 W/ SPRAYER)

KEY	PART NUMBER	U/M	DESCRIPTION	VENDOR NO.
1	085330-06-000	EA	TOILET-CHINA - STANDARD (BONE)	591003
2	085330-06-700	EA	SEAT ASSEMBLY (BONE)	340591
3	085330-06-702	EA	HINGE HARDWARE (BONE) SET	342131
4	085330-01-703	EA	RING & HALF CLAMPS ASM (BONE)	385310048
5	085330-01-704	EA	TEFLON & RUBBER SEALS	385316140
6	085330-01-705	EA	SUPPORT - SEAL - PLASTIC	390346405
7	085330-02-700	EA	BASE ASM	310121
8	085330-02-702	EA	PEDESTAL COVER KIT (BONE)	510 - 310112
9	085330-01-714	EA	SEAL - FLANGE - FLOOR	390343892
10	085330-01-717	EA	BOLT MOUNTING PACKAGE	385310064
	085330-01-718	EA	SEAL & BOLT MOUNTING PACKAGE	385310063
11	085330-01-706	EA	BALL - SHAFT & CARTRIDGE	385318162
12	085330-02-703	EA	PEDAL COVER KIT (BONE) NEW STYLE	310115
13	085330-01-709	EA	VALVE - WATER	385314349
14	085330-01-707	EA	CARTRIDGE - SPRING	381236096
15	085330-06-703	EA	FLUSH LEVER	340873
16	085330-01-710	EA	PLUG - DRAIN - & CAP - W/ SEAL	385316142
17	085330-06-701	EA	VALVE W/ DIVERTER (VACUUM BREAKER)	230335
18	085330-06-704	EA	VACUUM BREAKER KIT	316906
19	085330-04-706	EA	BREAKER - VACUUM - W/ HAND SPRAY	385319055

BATH GROUP (CONTINUED)

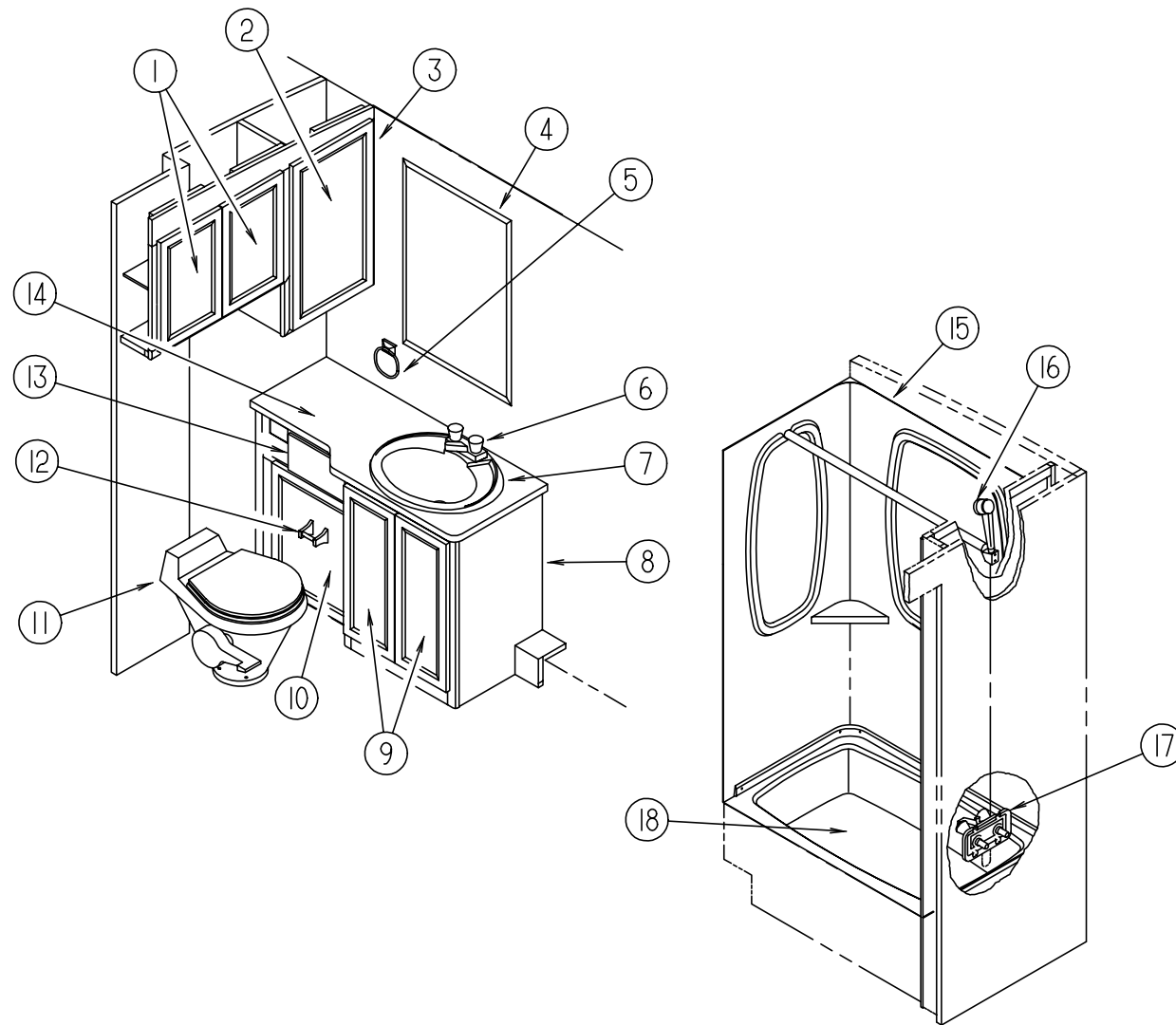

BATH CABINETS & SHOWER COMPONENTS

KEY	PART NUMBER	U/M DESCRIPTION
1	M06803-G0-F11	EA DOOR - CABINET - W/O HARDWARE - 305 X 475 MM
2	M06803-82-E10	EA DOOR - CABINET - W/O HARDWARE - 400 X 710 MM
3	P16188-01-F11	EA CABINET - MEDICINE - W/O DOORS
4	058331-51-000	EA MIRROR - GLASS - SAFETY - 660 X 1016 MM
5	075454-02-000	EA RING - TOWEL - W/ MOUNTING HARDWARE - BRASS
6	075240-06-000	EA FAUCET - LAVATORY - BONE
	105218-01-01A	EA SPACER - FAUCET - LAVATORY SINK - 2" X 5.9" - ABS PLASTIC - OFF WHITE
7	105921-01-01A	EA SINK - LAVATORY - LARGE OVAL - 17" X 20" - PLASTIC - OFF WHITE
	106116-01-01A	EA STRAINER - SINK - W/ STOPPER - TAILPIECE - GASKET & NUT - PLASTIC
	011069-02-000	EA TAILPIECE - 1 1/2 X 1 1/4 X 4 - BRASS
8	P16196-01-F11	EA CABINET - LAVATORY - W/O DOORS
8	P16196-01-F12	EA CABINET - LAVATORY - W/O DOORS
9	M06803-04-E07	EA DOOR - CABINET - W/O HARDWARE - 255 X 485 MM

BATH GROUP (CONTINUED)

BATH CABINETS & SHOWER COMPONENTS (CONTINUED)

KEY	PART NUMBER	U/M DESCRIPTION
10	116237-01-F11	EA DRAWER - HAMPER - W/O HARDWARE
11	085330-06-000	EA TOILET - CHINA - STANDARD - W/SPRAYER - SEALAND 591003 - BONE
12	075452-02-000	EA HOLDER - TOILET TISSUE - BRASS
13	M05971-L4-F11	EA DRAWER - CABINET - W/O HARDWARE
14	116196-12-F11	EA COUNTERTOP - LAVATORY CABINET
14	116196-12-F12	EA COUNTERTOP - LAVATORY CABINET
15	115612-01-01A	EA SURROUND - SHOWER - OFF WHITE
	113714-02-01A	EA RETAINER - SHELF - SHOWER - OFF WHITE
	104462-02-01A	EA CADDY - SHOWER - OFF WHITE
16	103092-01-000	EA SHOWER HEAD - W/ 60" HOSE (US)
16	103092-02-000	EA SHOWER HEAD - W/ HOSE (CSA)
	103092-01-700	EA BRACKET ONLY - SHOWER HEAD - CLEAR
	011048-03-700	EA BRACKET ONLY - SHOWER HEAD - BONE
17	075242-04-000	EA FAUCET - TUB/ SHOWER - BONE
	075606-01-000	EA PANEL - FAUCET BACK - SHOWER - 5" X 9" - PLASTIC
18	M02630-27-F11	EA SHOWER PAN ASSEMBLY
	066436-01-000	EA NUT - SLIP - TAILPIECE - 1.5"
	066729-01-000	EA STRAINER - TUB/SHOWER - W/PLUG
	069735-01-000	EA WASHER - STRAINER TO TAILPIECE - 1.5" - PLASTIC
	057671-01-000	EA COVER - SCREW - #8 - PLASTIC - OFF WHITE

BIFOLD PRIVACY DOOR

KEY	PART NUMBER	U/M DESCRIPTION
	M03866-04-F31	EA DOOR PANEL ASM 72.67" X 13.38"
	093170-06-02A	EA HEADER - DOOR - BATH - 1032 MM - OFF WHITE
	084451-01-000	EA CATCH - BIFOLD DOOR - BRASS
	009059-01-000	EA HINGE - DOOR - 2" X 1.4" - BRASS
	009059-02-000	EA HINGE - DOOR - 2" X 2.7" - BRASS
	092652-01-000	EA GUIDE WHEEL - DOOR - TOP MOUNT
	093832-01-01A	EA KNOB - DOOR - BRIGHT BRASS
	102920-01-01A	EA HINGE - SPRING LOADED
	117978-01-01A	EA KNOB - DOOR - BRIGHT BRASS

FROM: 00-00-00 THRU: 01-15-95

FROM: 01-16-95 THRU: 99-99-99

BATH DOOR

KEY	PART NUMBER	U/M DESCRIPTION
	M87868-13-E10	EA DOOR-CABINET - BATH - W/O HARDWARE
	094485-03-01A	EA KNOB-DOOR - BRASS
	100357-01-000	EA ROD-TOWEL - W/ ENDS BENT FOR BACK OF BATH DOOR - BRASS
	102089-13-E07	EA MOUNT-RAIL - RIGHT SIDE - TOWEL ROD - 26" LONG - WOOD - RAMBLING ASH
	102089-14-E07	EA MOUNT-RAIL - LEFT SIDE - TOWEL ROD - 26" LONG - WOOD - RAMBLING ASH

SLIDER PRIVACY DOOR

KEY	PART NUMBER	U/M DESCRIPTION
	104013-03-E10	EA DOOR-SLIDING - BATH/GALLEY
	103874-01-000	EA ROLLER HANGER-SLIDING DOOR
	103868-03-01A	EA TRACK-DOOR - 1250MM - OFF WHITE
	103908-07-F11	EA HEADER-SLIDING DOOR TRACK - OFF WHITE
	064467-01-000	EA GUIDE-POCKET - SLIDING DOOR - WALL MOUNTED
	103874-01-000	EA HANGER-SLIDING DOOR
	098410-01-01A	EA PULL-FINGER - OVAL - BRASS
	057534-01-000	EA TIEBACK-CLEAR PLASTIC - BATH/GALLEY DOOR

BEDROOM GROUP

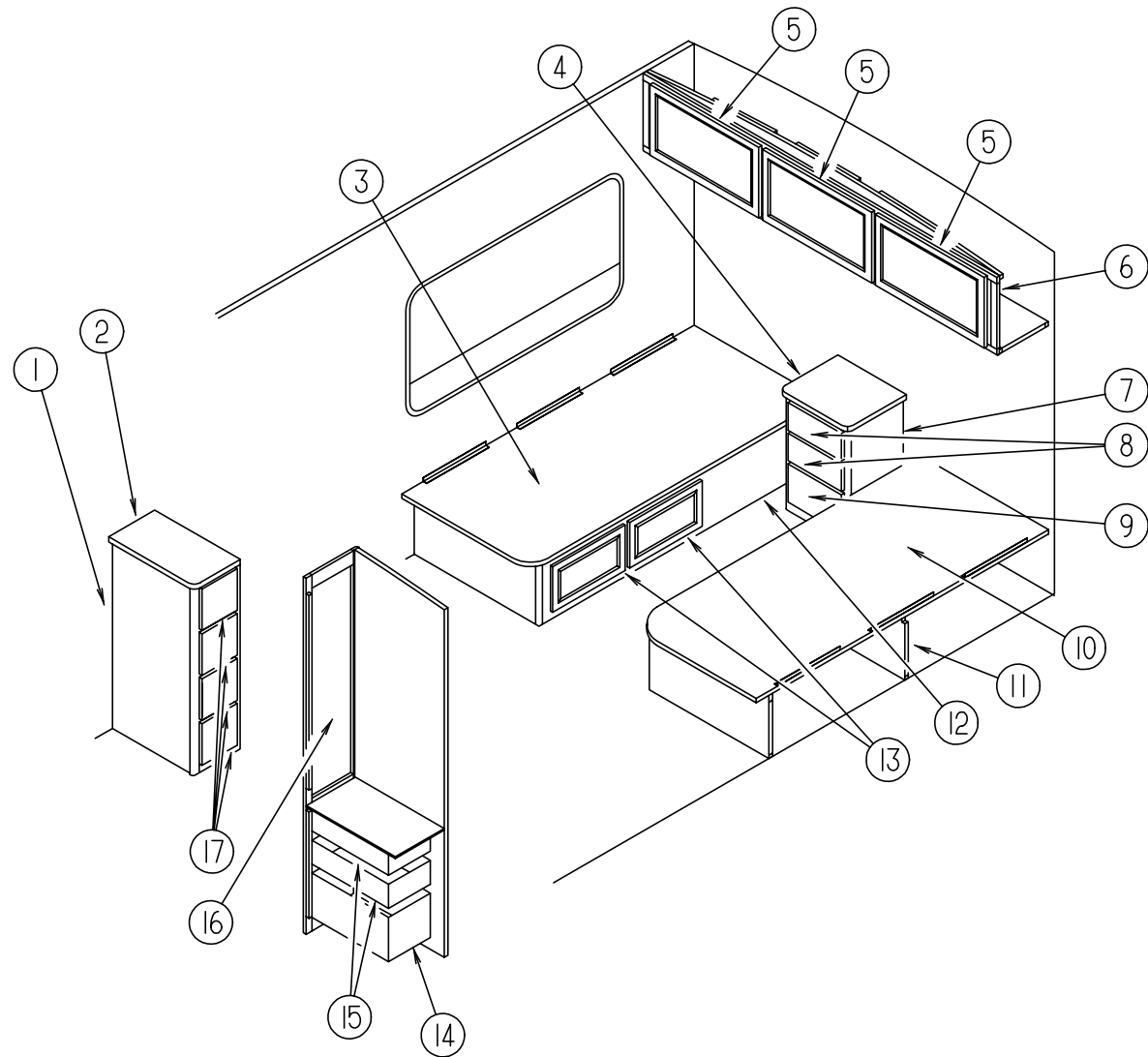

TWIN BEDROOM

KEY	PART NUMBER	U/M DESCRIPTION
1	116192-01-F11	EA CABINET ASM - CHEST
1	116192-01-F12	EA CABINET ASM - CHEST
2	116192-11-F11	EA COUNTERTOP ASM
2	116192-11-F12	EA COUNTERTOP ASM
3	M07464-01-000	EA CABINET ASM. - TWIN BED TOP - PASSENGER SIDE
4	104507-11-F11	EA COUNTERTOP ASM.
4	104507-11-F12	EA COUNTERTOP ASM.
5	M06803-13-E10	EA DOOR ASM - RAIL - W/O HARDWARE - 400 X 710 MM - W/ MIRROR
6	M06838-24-F11	EA CABINET ASM. - OVERHEAD - W/O DOORS & HARDWARE
7	104507-01-F11	EA CABINET ASM - NIGHTSTAND
7	104507-01-F12	EA CABINET ASM - NIGHTSTAND
8	M05971-65-E10	EA DRAWER ASM. - W/O HARDWARE
9	M05971-74-E10	EA DRAWER ASM. - W/O HARDWARE
10	M07464-02-000	EA CABINET ASM. - TWIN BED TOP - DRIVER SIDE
11	P16194-02-F11	EA CABINET ASM. - TWIN BED BASE - DRIVER SIDE
12	P16194-01-F11	EA CABINET ASM. - TWIN BED BASE - PASSENGER SIDE
13	M06803-68-E07	EA DOOR ASM - W/O HARDWARE - 305 X 555 MM
14	M05971-L7-F11	EA DRAWER ASM. - W/O HARDWARE
15	M05971-58-E07	EA DRAWER ASM. - W/O HARDWARE
16	M06803-E9-F11	EA DOOR ASM - W/O HARDWARE - 305 X 1220 MM
17	M05971-71-F11	EA DRAWER ASM. - W/O HARDWARE
	091952-01-000	EA CLIP-GRIPPER - 1."
	097872 04 000	EA DOWEL - WOOD - 1." DIA X 1.38" LONG
	107796-05-000	EA BRACKET - GAS SPRING - FLAT
	107796-06-000	EA GAS SPRING - 20" LENGTH - 120 LB
	107796-07-000	EA BRACKET - GAS SPRING

BEDROOM GROUP (CONTINUED)

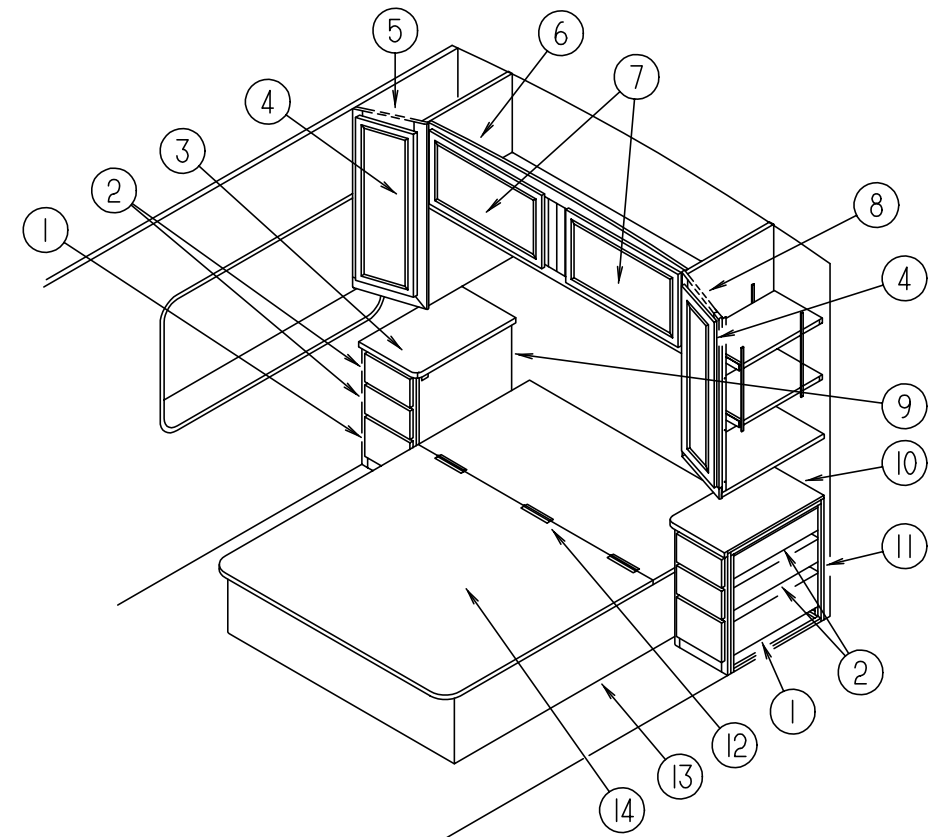

QUEEN BEDROOM

KEY	PART NUMBER	U/M DESCRIPTION
1	M05971-L6-F11	EA DRAWER ASM - CABINET - W/O HARDWARE
2	M05971-L5-F11	EA DRAWER ASM - CABINET - W/O HARDWARE
3	116193-11-F11	EA COUNTERTOP ASM.
3	116193-11-F12	EA COUNTERTOP ASM.
4	M06803-G1-F11	EA DOOR ASM - RAIL - W/O HARDWARE - 365 X 925 MM
4	058331-D4-000	EA MIRROR - CABINET DOOR - 282 X 842 MM
5	116142-01-F11	EA CABINET - SHIRT CLOSET - PASSENGER SIDE
6	M06852-01-E10	EA CABINET - OVERHEAD - REAR
7	M06803-82-E10	EA DOOR - CABINET - W/O HARDWARE - 400MM X 710MM
8	116142-02-F11	EA CABINET - SHIRT CLOSET - DRIVER SIDE
9	116193-01-F11	EA CABINET - NIGHTSTAND - PASSENGER SIDE
9	116193-01-F12	EA CABINET - NIGHTSTAND - PASSENGER SIDE
10	116193-12-F11	EA COUNTERTOP - NIGHTSTAND
10	116193-12-F12	EA COUNTERTOP - NIGHTSTAND
11	116193-02-F11	EA CABINET - NIGHTSTAND - DRIVER SIDE
11	116193-02-F12	EA CABINET - NIGHTSTAND - DRIVER SIDE
12	041389-25-000	EA PIANO HINGE - MILL FINISH - 55"
13	P16195-01-F11	EA CABINET - QUEEN BED - W/O TOP
14	M07465-01-F11	EA TOP - QUEEN BED CABINET
	091952-01-000	EA CLIP-GRIPPER - 1."
	097872 04 000	EA DOWEL - WOOD - 1." DIA X 1.38" LONG
	107796-05-000	EA BRACKET - GAS SPRING - FLAT
	107796-06-000	EA GAS SPRING - 20" LENGTH - 120 LB
	107796-07-000	EA BRACKET - GAS SPRING

BEDROOM GROUP (CONTINUED)

KING BEDROOM

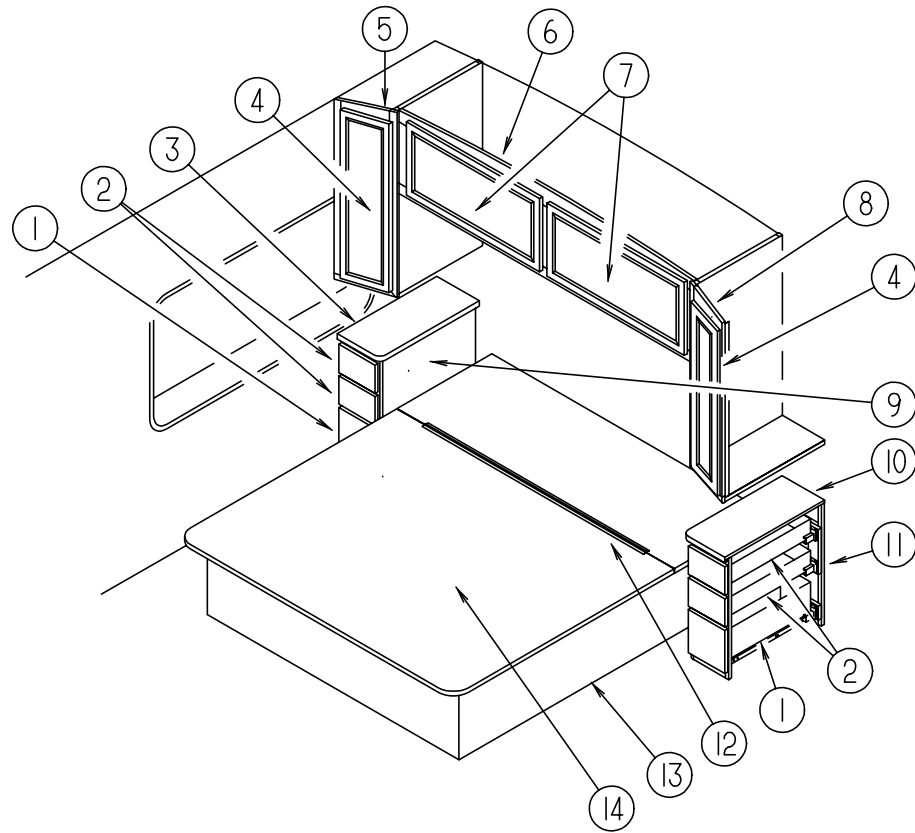

KEY	PART NUMBER	U/M	DESCRIPTION
1	M05971-N1-F11	EA	DRAWER ASM - CABINET - W/O HARDWARE
2	M05971-N2-F11	EA	DRAWER ASM - CABINET - W/O HARDWARE
3	117173-11-F11	EA	COUNTERTOP ASM.
3	117173-11-F12	EA	COUNTERTOP ASM.
4	M06803-37-E10	EA	DOOR ASM - RAIL - W/O HARDWARE - 365 X 925 MM
4	058331-A7-000	EA	MIRROR - CABINET DOOR - 192 X 842 MM
5	117175-01-F11	EA	CABINET - SHIRT CLOSET - PASSENGER SIDE
6	P17240-01-F11	EA	CABINET - OVERHEAD - REAR
7	M06803-L7-F11	EA	DOOR - CABINET - W/O HARDWARE - 400 X 710 MM
8	117175-02-F11	EA	CABINET - SHIRT CLOSET - DRIVER SIDE
9	117173-01-F11	EA	CABINET - NIGHTSTAND - PASSENGER SIDE
9	117173-01-F12	EA	CABINET - NIGHTSTAND - PASSENGER SIDE
10	117173-12-F11	EA	COUNTERTOP - NIGHTSTAND
10	117173-12-F12	EA	COUNTERTOP - NIGHTSTAND
11	117173-02-F11	EA	CABINET - NIGHTSTAND - DRIVER SIDE
11	117173-02-F12	EA	CABINET - NIGHTSTAND - DRIVER SIDE
12	041389-25-000	EA	PIANO HINGE - MILL FINISH - 55"
13	P17174-01-F11	EA	CABINET - KING BED - W/O TOP
14	M07513-01-F11	EA	TOP - KING BED CABINET
	091952-01-000	EA	CLIP-GRIPPER - 1."
	097872 04 000	EA	DOWEL - WOOD - 1." DIA X 1.38" LONG
	107796-05-000	EA	BRACKET - GAS SPRING - FLAT
	107796-06-000	EA	GAS SPRING - 20" LENGTH - 120 LB
	107796-07-000	EA	BRACKET - GAS SPRING

CHASSIS GROUP

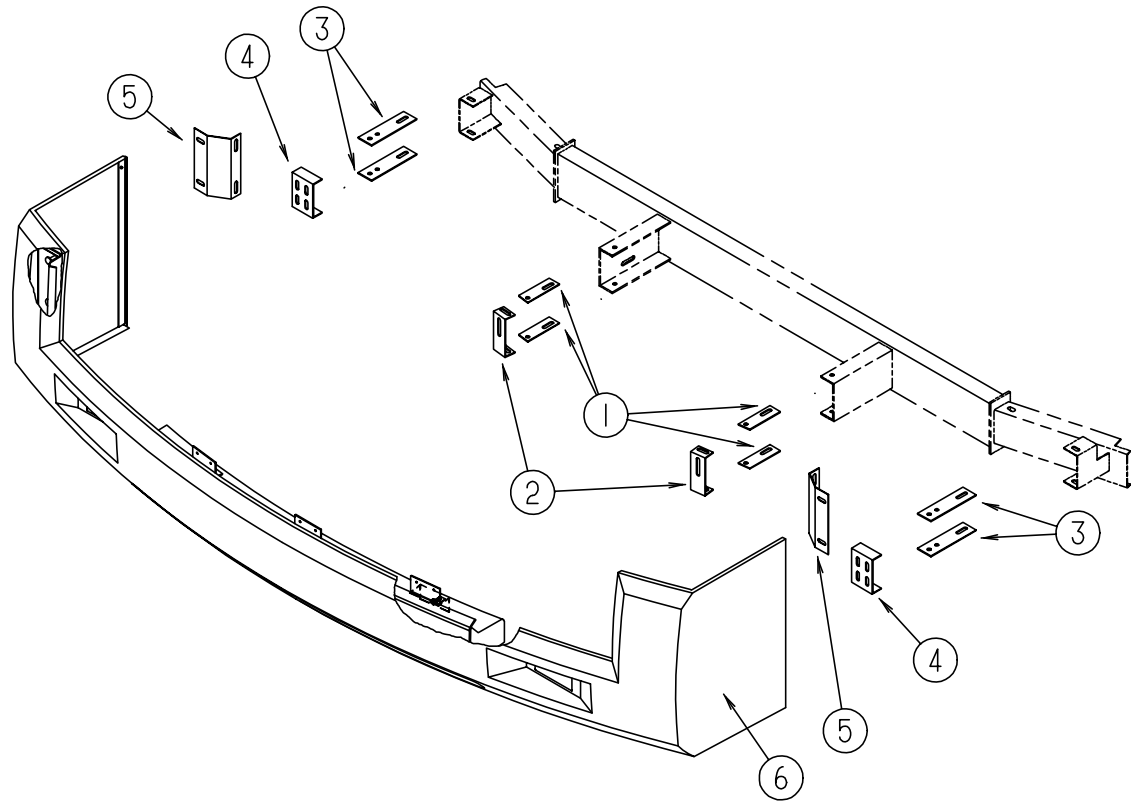

FRONT BUMPER

KEY	PART NUMBER	U/M	DESCRIPTION
1	112527-03-02B	EA	STRAP - BRACE - FRONT BUMPER - E COAT
2	112526-04-02B	EA	CHANNEL - BRACE - FRONT BUMPER - E COAT
3	112527-02-02B	EA	STRAP - BRACE - FRONT BUMPER - E COAT
4	112526-02-02B	EA	CHANNEL - BRACE - FRONT BUMPER - E COAT
5	116068-01-02B	EA	BRACKET - FRONT BUMPER - E COAT
6	115970-01-F11	EA	BUMPER - FRONT - BUFF

CHASSIS GROUP (CONTINUED)

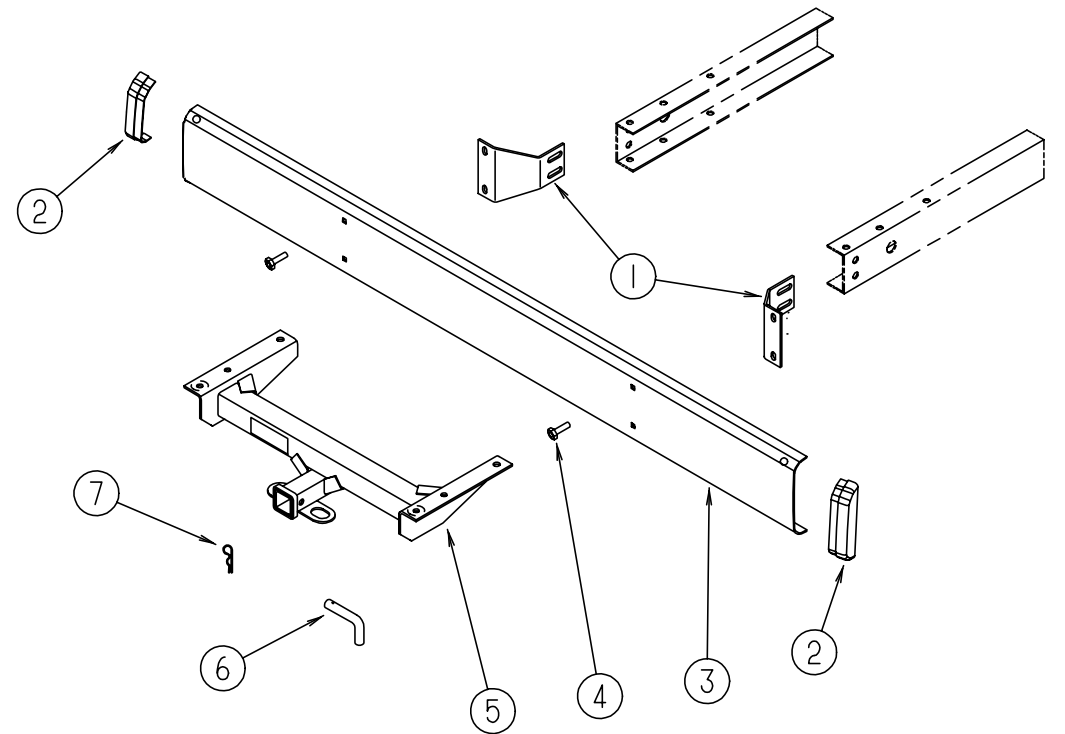

REAR BUMPER

KEY	PART NUMBER	U/M	DESCRIPTION
1	104418-07-000	EA	ANGLE - SUPPORT - BUMPER REAR
2	103228-01-05A	EA	END CAP - BUMPER REAR - BLACK
3	103099-04-01A	EA	REAR BUMPER - OFF WHITE
4	102333-01-02A	EA	BOLT - 7/16"
5	107707-01-000	EA	HITCH ASM - CLASS II
6	034512-01-000	EA	PIN
7	034513-01-000	EA	PIN - 3/16" WIRE
	113589-01-000	EA	CONNECTOR - PLUG - TRAILER
	113589-02-000	EA	CONNECTOR - SOCKET - TRAILER

CHASSIS GROUP (CONTINUED)

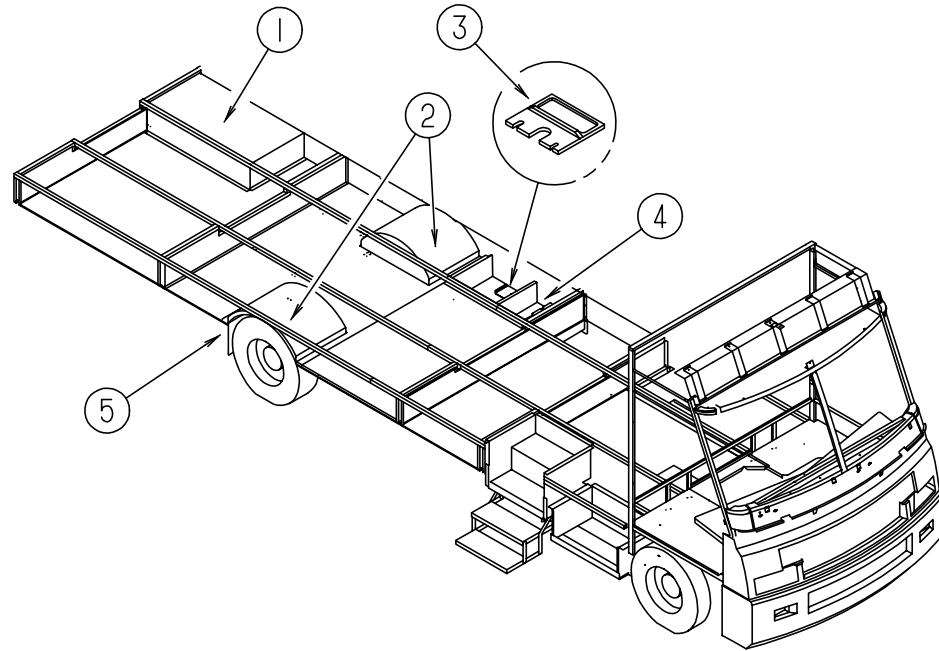

COMPARTMENTS & TRAYS

KEY	PART NUMBER	U/M	DESCRIPTION
1	094657-02-000	EA	TRAY - GENERATOR - 22.5" X 30.4" X 6.9" W/ANGLE & NUTS
2	055374-03-000	EA	REAR WHEELWELL - PLASTIC
3	M06991-03-F36	EA	HATCH ASM - W/ FOAM
	114677-01-01A	EA	RETAINER - HATCH - SEWER HOSE
4	114679-01-01A	EA	COMPARTMENT-STORAGE
5	020167-05-000	EA	GUARD - DIRT
5	017516-01-000	EA	FLAP - MUD - 14" X 18" - BLACK
	093287-07-01A	EA	NET - CARGO - 254 MM X 865 MM
	093287-09-01A	EA	NET - CARGO - 254 MM X 1510 MM
	065450-05-000	EA	TIEDOWN - BATTERY - 8.4" TUBE

CHASSIS GROUP (CONTINUED)

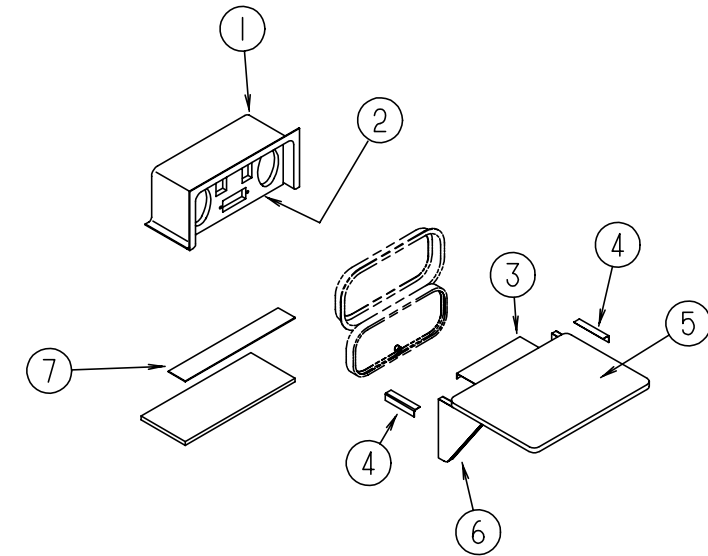

COMPARTMENT (ENTERTAINMENT CENTER)

KEY	PART NUMBER	U/M	DESCRIPTION
1	104897-03-01A	EA	BOX - ENTERTAINMENT CENTER - OFF WHITE
2	104899-01-C05	EA	PLATE - RADIO MOUNTING
3	105377-01-01A	EA	BRACKET - TABLE HANGER - OFF WHITE
4	105376-01-02A	EA	HINGE - CONTINUED - 2" X 140 MM - OFF WHITE
5	105230-11-E01	EA	SHELF ASM.
6	105230-12-F11	EA	SUPPORT ASM.
	105230-01-F11	EA	SHELF & SUPPORT ASM.
7	104898-01-01A	EA	PLATE - PLASTIC BOTTOM - OFF WHITE (CSA)
7	104898-02-01A	EA	PLATE - PLASTIC BOTTOM - OFF WHITE (US)

CHASSIS GROUP (CONTINUED)

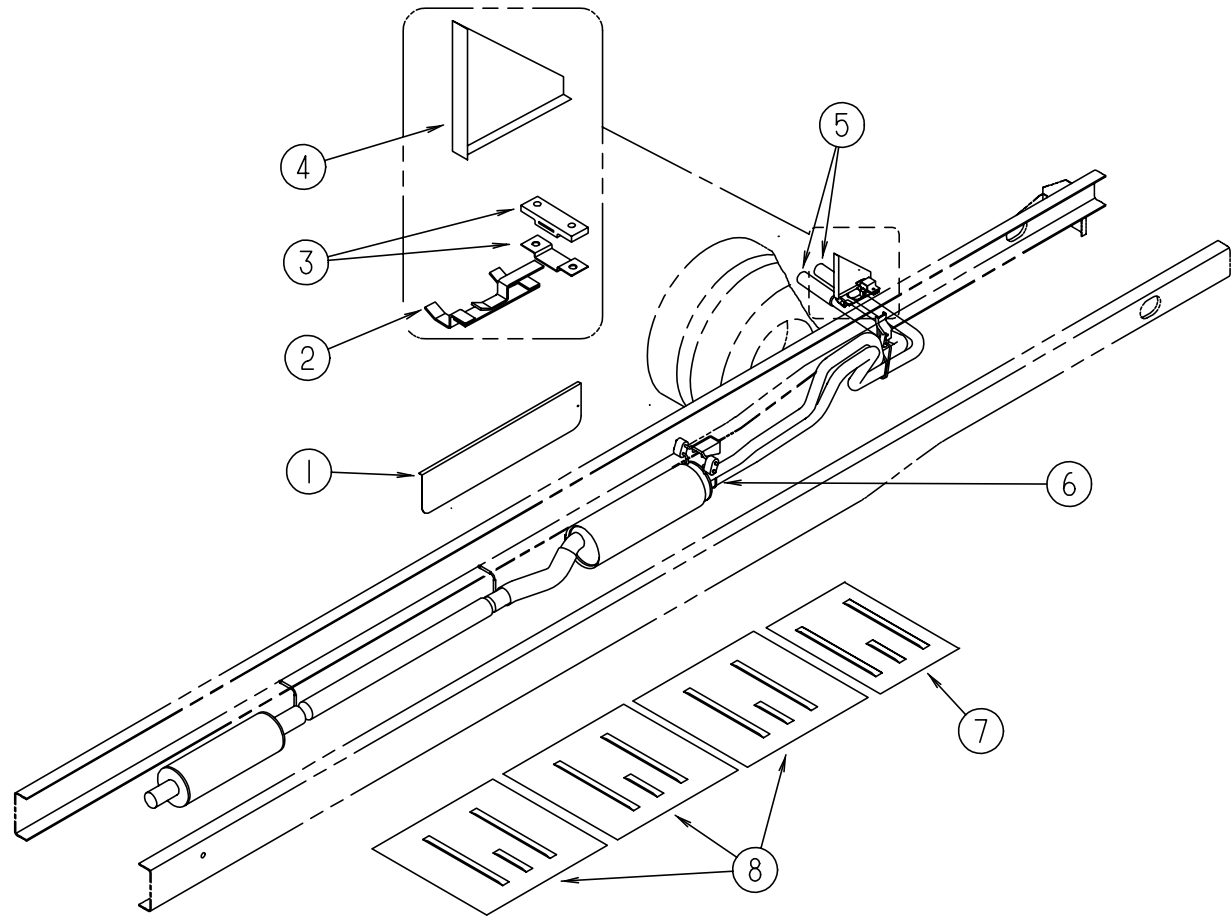

EXHAUST SYSTEM (FORD)

KEY	PART NUMBER	U/M	DESCRIPTION
1	075307-03-000	EA	SHIELD - HEAT - LP
2	096055-05-000	EA	SUPPORT - EXHAUST PIPE
3	095190-01-000	EA	HANGER ASM - EXHAUST
4	102117-06-000	EA	HANGER ASM -TAILPIPE
5	098762-12-000	EA	PIPE -EXHAUST -STRAIGHT -2.25 IN
	007125-07-000	EA	CLAMP - MUFFLER - 2.50" DIAMETER
6	007125-05-000	EA	CLAMP - MUFFLER - 2" DIAMETER
7	101544-01-000	EA	SHIELD - EXHAUST
8	101544-06-000	EA	SHIELD - EXHAUST

CHASSIS GROUP (CONTINUED)

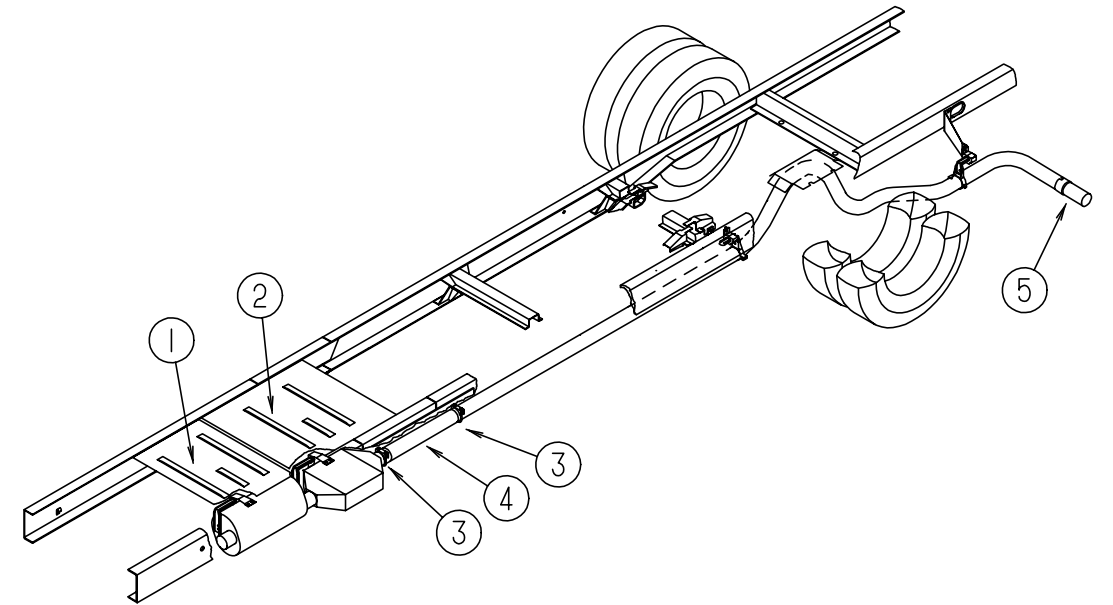

EXHAUST SYSTEM (CHEVY)

KEY	PART NUMBER	U/M	DESCRIPTION
1	101544-01-000	EA	SHIELD - HEAT - EXHAUST - 19.7" X 28.9" - STEEL
2	101544-02-000	EA	SHIELD - HEAT - EXHAUST - 30" X 28.9" - STEEL
3	094918-01-000	EA	CLAMP - EXHAUST - 3"
4	098762-06-000	EA	PIPE - EXHAUST - STRAIGHT - 3.0" X 22"
5	098762-11-000	EA	PIPE - EXHAUST - STRAIGHT - 3.0" X 11.8"

CHASSIS GROUP (CONTINUED)

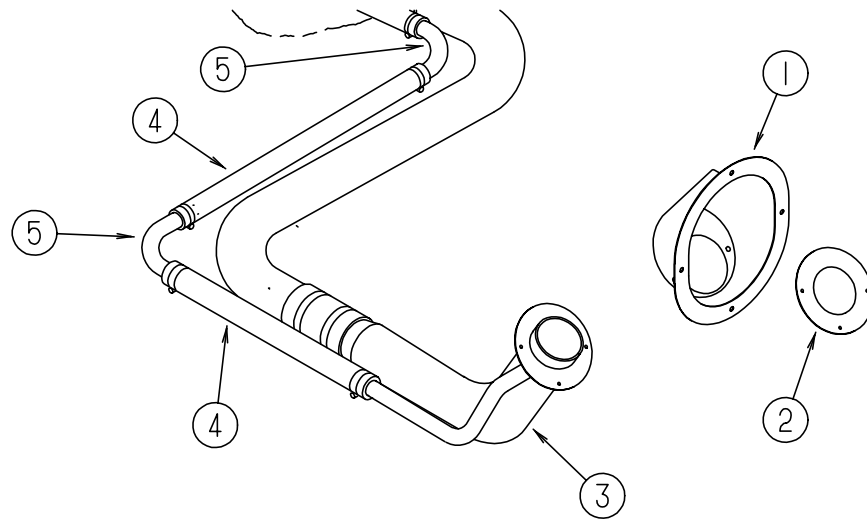

FUEL SYSTEM (FORD)

KEY	PART NUMBER	U/M DESCRIPTION
1	095854-01-01A	EA SHROUD - FUEL FILL
2	078200-01-000	EA GASKET - FUEL FILL - 3.5"OD X 2"ID
3	087256-07-000	EA NECK ASM - FUEL FILL
4	066732-01-000	FT HOSE - FUEL FILL - .62" ID
5	098806-01-000	EA PIPE - FILL VENT - 90 DEGREE BEND - .625" OD - STEEL
	007063-01-000	FT HOSE - GAS 1/4" ID X 1/2"OD
	084884-01-000	EA PLUG - BRASS - 3/8"
	007111-02-000	EA HOSE - FUEL FILL - 2" ID - IN 3FT LENGTHS

CHASSIS GROUP (CONTINUED)

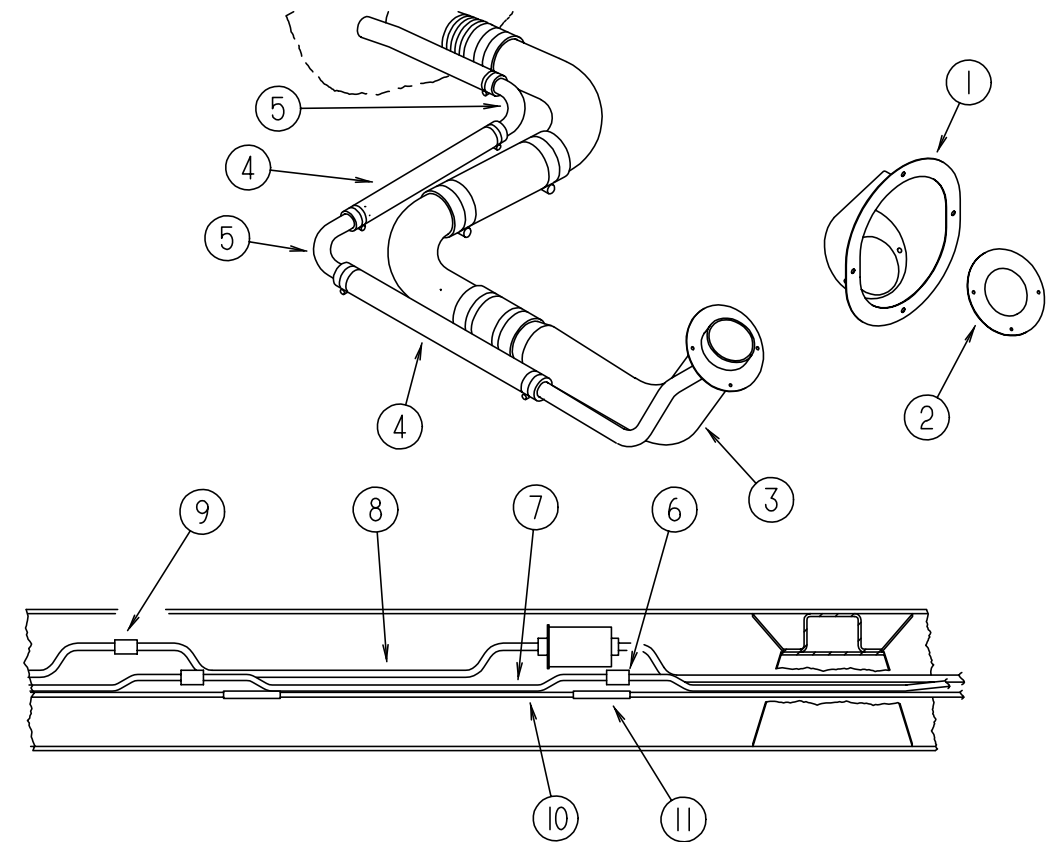

FUEL SYSTEM (CHEVY)

KEY	PART NUMBER	U/M DESCRIPTION
1	095854-01-01A	EA SHROUD - FUEL FILL
2	078200-01-000	EA GASKET - FUEL FILL - 3.5"OD X 2"ID
3	087256-06-000	EA NECK ASM. - FUEL FILL
		FROM: 00-00-00 THRU: 02-05-95
3	087256-10-000	EA NECK ASM. - FUEL FILL
		FROM: 02-06-95 THRU: 99-99-99
4	066732-01-000	FT HOSE - FUEL FILL - .62" ID
5	098806-01-000	EA PIPE - FILL VENT - 90 DEGREE BEND - .625" OD - STEEL
6	098779-01-000	EA COUPLER - FUEL LINE M14 X 1.5-6H - GM 15550219
7	098758-02-000	EA FUEL LINE ASM - RETURN - 5/16 - 508 LONG
8	098759-02-000	EA FUEL LINE ASM - SUPPLY - 3/8 - 508 LONG
9	098779-02-000	EA COUPLER - FUEL LINE M16 X 1.5-6H
10	074800-18-000	EA TUBE - EXTENSION - MAIN FUEL - 90 N,208 TO 228
11	007063-01-000	FT HOSE - GAS 1/4"ID X 1/2"OD
	098803-02-000	EA PIPE - FUEL FILL
		FROM: 00-00-00 THRU: 02-05-95
	098803-01-000	EA PIPE - FUEL FILL - 90 DEGREE BEND - 13.2" - 1 3/4" OD - STEEL
		FROM: 02-06-95 THRU: 99-99-99
	024138-01-000	FT HOSE - FUEL, 5/16" ID
	075466-01-000	EA UNION - INVERTED FLARE TUBE - 1/4"
	084884-01-000	EA PLUG - BRASS - 3/8

CHASSIS GROUP (CONTINUED)**TIRE & WHEEL HARDWARE (FORD)**

KEY	PART NUMBER	U/M DESCRIPTION
	077030-02-000	EA EXTENSION - VALVE STEM - 1.25"
	095012-03-000	EA EXTENSION - VALVE STEM - DUAL WHEEL
	095012-04-000	EA STABILIZER - VALVE EXTENSION
	M00080-60-000	EA FORD TIRE & WHEEL
	051377-05-000	EA VALVE STEM ASM - VS938
	083425-05-000	EA TIRE - MICHELIN - LT235/85R16 LRE - XPS RIB
	095853-02-000	EA WHEEL - STEEL - 16" X 6K - F2TA- 1015 - NA

WHEEL LINERS, KAPER (FORD)

KEY	PART NUMBER	U/M DESCRIPTION	VENDOR NO.
	091209-08-000	EA WHEEL LINER SET W/ FRONT HUB COVER 16" (SET OF 4)	1610-4ULT4-2
	091209-08-700	EA LINER - WHEEL - 16" FRONT W/AXLE COVER - 10 LUG	157
	091209-08-701	EA LINER - WHEEL - 16" REAR - 10 LUG	158
	091209-08-702	EA COVER - AXLE - 16" REAR	155
	091209-08-703	EA COVER - LUG NUT	52
	091209-08-704	EA FRONT LINER	207
	091209-08-705	EA REAR LINER	208
	091209-08-706	EA FLAT NUT .500 - 9/16 STUD	165
	091209-01-704	EA LUG NUT COVER (WHEEL LINER)	
	091209-11-702	EA JAMB NUT (LONG) REAR WHEEL	

WHEEL COVERS, DICOR (FORD)

KEY	PART NUMBER	U/M DESCRIPTION
	098532-01-000	EA COVER - WHEEL - FORD - 16" - SET OF 4
	098532-01-700	EA COVER - LUG NUT - CHROME
	098532-01-701	EA COVER - WHEEL - 16"

CHASSIS GROUP (CONTINUED)**TIRE & WHEEL HARDWARE (CHEVY)**

KEY	PART NUMBER	U/M DESCRIPTION
	077030-02-000	EA EXTENSION - VALVE STEM - 1.25"
	095012-03-000	EA EXTENSION - VALVE STEM - DUAL WHEEL
	095012-04-000	EA STABILIZER - VALVE EXTENSION
	M00080-38-000	EA TIRE & VALVE STEM
	007324-03-000	EA TIRE - 8R19.8 LRF - MICHELIN XZA
	051377-01-000	EA STEM - VALVE - TR 500
	080208-01-000	EA LUG WRENCH - 1.06 X 1.00
	080208-02-000	EA BAR - LEVERAGE - LUG WRENCH

WHEEL LINERS, KAPER (CHEVY)

KEY	PART NUMBER	U/M DESCRIPTION	VENDOR NO.
	091209-01-000	EA LINER - WHEEL - 19.5" - SST - SET OF 4	1954-ION
	091209-01-700	EA LINER - WHEEL - 19.5" FRONT - 10 LUG	37N
	091209-01-701	EA LINER - WHEEL - 19.5" REAR - 10 LUG	38N
	091209-01-702	EA COVER - AXLE - 19.5" FRONT - 10 LUG	34N
	091209-01-703	EA COVER - AXLE - 19.5" REAR - 10 LUG	35N
	091209-01-704	EA COVER - LUG NUT	36

WHEEL COVERS, DICOR (CHEVY)

KEY	PART NUMBER	U/M DESCRIPTION
	109443-01-000	EA COVER - WHEEL - 4/ SET 19.5 W/ HARDWARE
	109443-01-700	EA COVER - WHEEL - 19.5 - FRONT & REAR
	109443-01-701	EA SET - BRACKET - 1 FRONT WHEEL
	109443-01-702	EA SET - BRACKET - 1 REAR WHEEL
	109443-01-703	EA CAP - CENTER - HUB

CHASSIS GROUP (CONTINUED)**STEP ASSEMBLY (KWIKEE 3213)**

KEY	PART NUMBER	U/M DESCRIPTION	VENDOR NO.
	094707-01-01A	EA STEP ASSEMBLY	
	094707-02-700	EA MOTOR ASSEMBLY	909520
	094707-02-701	EA LINKAGE ASSEMBLY - SERIES 32	909523
	094707-02-702	EA GEAR KIT	909525
	094707-02-703	EA BEARING & PINS - ASSEMBLY	909530
	094707-02-704	EA CONNECTOR - MOTOR ASSEMBLY	909537
	094707-02-705	EA CONTROL UNIT - WHITE	909513
	094707-02-707	EA TREAD - NON SKID - BLACK - 6"X21"	909333

DRIVESHAFT & BRAKE LINE (CHEVY)

KEY	PART NUMBER	U/M DESCRIPTION
	088498-01-000	EA UNION - INVERTED FLARE - BRASS - 3/16 - 3/8 - 24 THREAD - BRAKE LINE
	074833-01-000	EA SPACER - BEARING - DRIVESHAFT - 2" X 8" X .5" THICK
	074833-04-000	EA SPACER - BEARING - DRIVESHAFT - 8" X 2" - STEEL
	075302-09-000	EA DRIVESHAFT ASM. - YOKE/ YOKE - 50"
	075302-25-000	EA DRIVESHAFT ASM. - BAL.PR-20/21
	075302-20-000	EA DRIVESHAFT ASM. - YOKE/ BEARING/ SPLINE
	075302-21-000	EA DRIVESHAFT ASM. - SLIP - YOKE/ YOKE
	107212-01-000	EA CROSSMEMBER ASM. - BREARING SUPPORT
	088497-02-000	EA NUT - INVERTED FLARE - 1/4"
	085771-03-000	EA NUT - HEX - FL. PREV. TORQUE - GRADE G DRIVE SHAFT

SHOCK ABSORBER (CHEVY)

KEY	PART NUMBER	U/M DESCRIPTION
	104993-01-000	EA SHOCK ABSORBER - GAS - P30 FRONT

CHASSIS GROUP (CONTINUED)**HWH HYDRAULIC LEVELING SYSTEM (AP0758) (CHEVY, FORD)**

KEY	PART NUMBER	U/M DESCRIPTION	VENDOR NO.
	100532-08-000	EA LEVELING SYSTEM - HYDRAULIC - JOYSTICK	
	100532-01-704	EA SWITCH - MERCURY F/ 6K & 9K JACK	RAP1010
	100532-01-705	EA SPRING KIT - 9K JACK	R1171
	100532-02-700	EA 6K TALL JACK ASM	RAP7164
	100532-02-701	EA SPRING KIT - 6K JACK	R6824
	100532-02-704	EA ACTIVATOR CABLE - 6K JACK	RAP7194
	100532-02-705	EA PUMP/ RESERVOIR ASM - MONARCH	RAP8178
	100532-03-710	EA SENSING UNIT 21' MTA	RAP6798
	100532-03-715	EA CAP - BREATHER	RAP7876
	100532-08-700	EA POWER UNIT ASM.	RAP0595
	100532-08-701	EA BI-AXIS CONTROL - 200 SYSTEM	RAP0612
	100532-08-702	EA VALVE - BI-AXIS	RAP9589
	100532-08-703	EA PANEL ASM. - 200 BI - AXIS SYSTEM	RAP9755
	100532-08-704	EA JACK ASM. - 9K TALL 200 SYSTEM	RAP7002
	100532-08-705	EA KNOB - 3/4" BLACK - SET OF FOUR	RAP1379
	100532-08-706	EA KNOB - 1 3/16" BLACK	RAP9734
	100532-08-707	EA BEZEL W/ GASKET - F/ SYSTEM 200	RAP9592
	100532-09-707	EA ACTUATOR ASM. - 9K - REAR JACKS	RAP0547
	100532-09-709	EA ACTUATOR ASM. - 6K - FRONT JACKS	RAP0448
	100532-09-710	EA SOLENOID - 4 POST INT. DUTY	RAP0533
	100533-05-000	EA BRACKETS - FRONT LEVELING JACKS (GM)	
	100533-06-000	EA BRACKETS - FRONT LEVELING JACKS (FORD)	
	100534 12 000	EA BRACKETS - REAR LEVELING JACKS (GM)	
	100534-06-000	EA BRACKETS - REAR LEVELING JACKS (FORD)	
	100536-10-000	EA HOSE KIT	
	100536-09-700	EA HOSE - HYDRAULIC - 324"	RAP2464
	100536-09-701	EA HOSE - HYDRAULIC - 60"	RAP4073
	100536-09-702	EA HOSE - HYDRAULIC - 354"	RAP4311
	100536-10-700	EA HOSE - HYDRAULIC - 84"	RAP1412
	100536-10-701	EA HOSE - HYDRAULIC - 116"	RAP5384
	107890-01-000	EA ELBOW - STEEL 90D 1/4 X 37D FLARE PARKER 4-C6X-S	
	112236-01-E10	EA BEZEL - MONITOR - UNDER DASH - LEFT SIDE	

CURTAIN & CUSHION GROUP

NOTICE

IN ORDER TO ASSIST OUR PARTS SALES DEPT. IN PROVIDING INTERIOR SOFTGOODS ITEMS, PLEASE INCLUDE THE SERIAL NUMBER AND THE COLOR CODE NUMBER FROM THE VEHICLE CERTIFICATION LABEL WHEN ORDERING. THIS LABEL IS LOCATED ON THE LEFT SIDEWALL AT THE END OF THE DASH (A-BODY), OR ON THE DRIVER'S DOOR LATCH PLATE (C-BODY).

AN EXAMPLE OF A COLOR CODE NUMBER IS B07, WHICH DESIGNATES AN OVERALL COLOR SCHEME OF A PARTICULAR UNIT. THE COLOR LISTED AFTER THE ITEM DESCRIPTION ON THE MICROFICHE, INDICATES THE OVERALL UNIT COLOR. ORDER THE ITEM YOU DESIRE ACCORDING TO UNIT COLOR CODE.

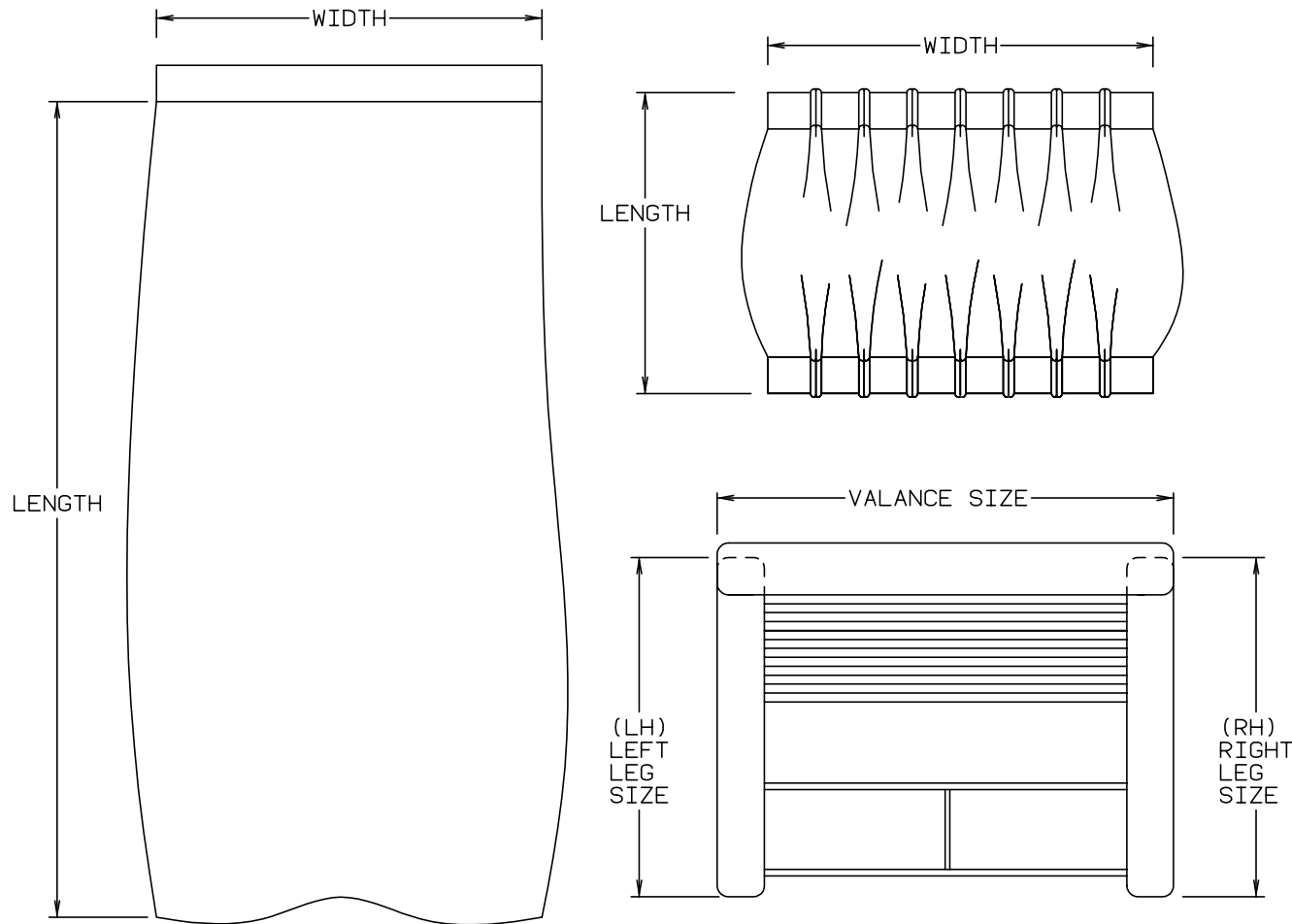

NOTE: USE THIS ILLUSTRATION WHEN DETERMINING LENGTH AND WIDTH MEASUREMENTS FOR CURTAINS. YOU WILL NOTE THE WIDTH MEASUREMENT IS TAKEN ON THE TOP OF THE CURTAIN WITH THE CURTAIN FULLY EXTENDED. THE LENGTH MEASUREMENT IS TAKEN FROM TOP TO BOTTOM. LEFT AND RIGHT WINDOW LEGS ARE DETERMINED WHEN FACING THE WINDOW.

CURTAIN & CUSHION GROUP (CONTINUED)

FABRIC & TRIMS

KEY	PART NUMBER	U/M DESCRIPTION
	072333-85-000	YD FABRIC - DRAPERY - TEXTURED PLAIN - 54" - MUSHROOM
	087272-03-000	YD LINING - DRAPERY 54" IVORY
	105745-45-000	YD FABRIC - BEDSPREAD - ACCENT - GREEN MIST (F11)
	105745-62-000	YD FABRIC - BEDSPREAD - ACCENT - LILAC (F12)
	105745-90-000	YD FABRIC - BEDSPREAD - MAIN - TEAL (F11)
	105745-50-000	YD FABRIC - BEDSPREAD - MAIN - ALABASTER (F12)
	108446-C4-000	YD FABRIC - UPHOLSTERY - MAIN - AQUA FROST (F11)
	108446-69-000	YD FABRIC - UPHOLSTERY - MAIN - PARCHMENT (F12)
	108446-C5-000	YD FABRIC - UPHOLSTERY - PLAIN ACCENT - AQUA FROST (F11)
	108446-77-000	YD FABRIC - UPHOLSTERY - PLAIN ACCENT - PARCHMENT (F12)
	108446-C6-000	YD FABRIC - UPHOLSTERY - PATTERN ACCENT - CELADON (F11)
	108446-78-000	YD FABRIC - UPHOLSTERY - PATTERN ACCENT - ALABASTER (F12)
	079680-07-000	YD FABRIC - VINYL - 54" WIDE - BEIGE
	103907-01-01A	YD FABRIC - VINYL - 54" WIDE - OFF WHITE
	089351-03-000	YD VINYL - CEILING - DIAMOND DESIGN - 54" WIDE
	106569-01-01A	YD VINYL - LAMINATE - MADRID - OFF WHITE

TRIMS & BUTTONS

KEY	PART NUMBER	U/M DESCRIPTION
	079349-04-F11	YD WELT - NARROW - ACCENT (F11)
	079349-04-E24	YD WELT - NARROW - ACCENT (F12)
	070578-02-B29	EA BUTTON - SCREW - STUD - #30 - VINYL

ASSIST HANDLE & SEAT BELTS

KEY	PART NUMBER	U/M DESCRIPTION
	056271-01-000	EA BELT - SEAT - 2" X 102" - BLACK
	069178-02-000	EA BRACKET - MOUNTING - ASSIST HANDLE - L ANGLE - W/HOLES
	000C16-07-16B	EA BOLT - CARRIAGE - ASSIST HANDLE - 7/16-14 X 1" - ZINC
	000D20-07-00B	EA NUT - ACORN - ASSIST HANDLE - 7/16" X 14 - ZINC
	053552-02-AA8	EA HANDLE - ASSIST - INTERIOR - ENTRY DOOR - VINYL - OFF WHITE
	108808-02-02A	EA HANDRAIL - STEP - ENTRANCE - OFF WHITE

SHOWER CURTAINS & TIEBACK

KEY	PART NUMBER	U/M DESCRIPTION
	084481-29-F11	EA CURTAIN-SHOWER - GROMMET TOP - 67" X 42"
	084481-29-F12	EA CURTAIN-SHOWER - GROMMET TOP - 67" X 42"
	073260-54-E01	EA TIEBACK-SHOWER CURTAIN - 3" X 16"(F11, F12)

CURTAIN & CUSHION GROUP (CONTINUED)

CURTAINS & WINDOW TREATMENT

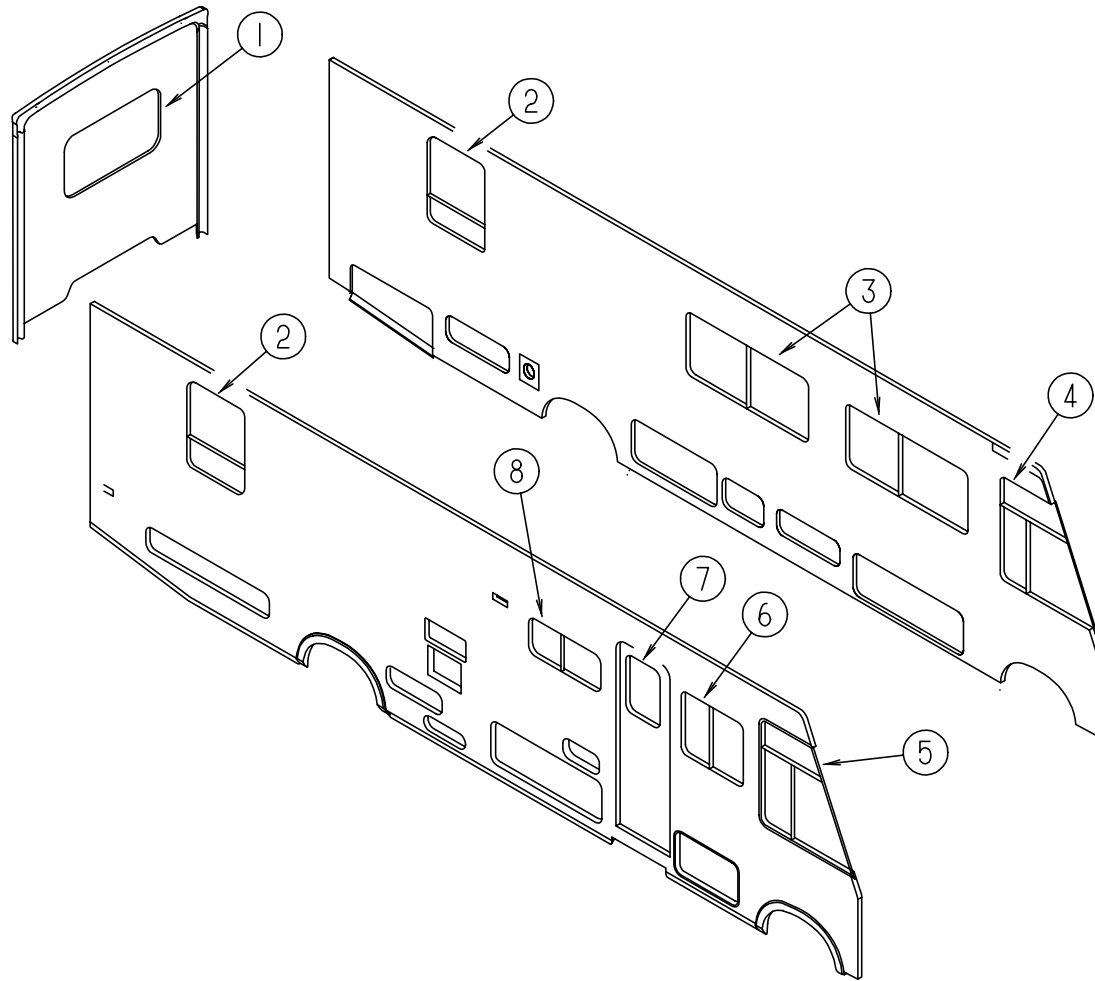

KEY	PART NUMBER	U/M	DESCRIPTION
1	104657-21-F11	EA	VALANCE - GEORGETOWN - 52" - W/HEADER
1	104657-21-F12	EA	VALANCE - GEORGETOWN - 52" - W/HEADER
1	112986-04-F11	EA	CURTAIN - PENCIL PLEAT TOP - POCKET BOTTOM - 29.5" X 6"
1	112986-04-F12	EA	CURTAIN - PENCIL PLEAT TOP - POCKET BOTTOM - 29.5" X 6"
1	109802-36-F11	EA	BLIND - PLEATED - 49" X 29" DROP - OCEAN SPRAY (W/ KING OR QUEEN BED)
1	109802-36-F12	EA	BLIND - PLEATED - 49" X 29" DROP - LINEN BEIGE (W/ KING OR QUEEN BED)
1	109802-10-F11	EA	BLIND - PLEATED - 60" X 28.5" DROP - OCEAN SPRAY (W/ TWIN BEDS)
1	109802-10-E05	EA	BLIND - PLEATED - 60" X 28.5" DROP - LINEN BEIGE (F12) (W/ TWIN BEDS)
2	104657-26-F11	EA	VALANCE - GEORGETOWN - 30" - W/ HEADER (W/ KING OR QUEEN BED)
2	104657-26-F12	EA	VALANCE - GEORGETOWN - 30" - W /HEADER (W/ KING OR QUEEN BED)
2	104657-27-F11	EA	VALANCE - GEORGETOWN - 30" - W/O HEADER (W/ TWIN BEDS)
2	104657-27-F12	EA	VALANCE - GEORGETOWN - 30" - W/O HEADER (W/ TWIN BEDS)
2	112986-07-F11	EA	CURTAIN - PENCIL PLEAT TOP - POCKET BOTTOM - 38.5" X 6"
2	112986-07-F12	EA	CURTAIN - PENCIL PLEAT TOP - POCKET BOTTOM - 38.5" X 6"
2	109802-37-F11	EA	BLIND - PLEATED - 27.5" X 38.5" DROP - OCEAN SPRAY
2	109802-37-F12	EA	BLIND - PLEATED - 27.5" X 38.5" DROP - LINEN BEIGE
3	112094-18-F11	EA	VALANCE ASSEMBLY - VICTORIA - 63.5"
3	112094-18-F12	EA	VALANCE ASSEMBLY - VICTORIA - 63.5"
3	109234-29-F11	EA	LEG - WINDOW - W/O GATHERS - W/O HOLE - 27" - 3.5" FACE - RH
3	109234-29-F09	EA	LEG - WINDOW - W/O GATHERS - W/O HOLE - 27" - 3.5" FACE - RH (F12)
3	109234-30-F11	EA	LEG - WINDOW - W/O GATHERS - W/O HOLE - 27" - 3.5" FACE - LH
3	109234-30-F09	EA	LEG - WINDOW - W/O GATHERS - W/O HOLE - 27" - 3.5" FACE - LH (F12)
3	109802-10-F11	EA	BLIND - PLEATED - 60" X 28.5" DROP - OCEAN SPRAY
3	109802-10-E05	EA	BLIND - PLEATED - 60" X 28.5" DROP - LINEN BEIGE (F12)
4	101668-46-E91	EA	CURTAIN - PRIVACY - LINED - TAPE TOP - 48" X 95" - LH
4	073260-42-C18	EA	TIEBACK - PRIVACY CURTAIN - 6" X 18"
5	101668-45-E91	EA	CURTAIN - PRIVACY - LINED - TAPE TOP - 48" X 95" - RH
5	073260-42-C18	EA	TIEBACK - PRIVACY CURTAIN - 6" X 18"
6	112094-07-F11	EA	VALANCE ASSEMBLY - VICTORIA - 33.5"
6	112094-07-F12	EA	VALANCE ASSEMBLY - VICTORIA - 33.5"
6	109234-29-F11	EA	LEG - WINDOW - W/O GATHERS - W/O HOLE - 27" - 3.5" FACE - RH
6	109234-29-F09	EA	LEG - WINDOW - W/O GATHERS - W/O HOLE - 27" - 3.5" FACE - RH (F12)
6	109234-30-F11	EA	LEG - WINDOW - W/O GATHERS - W/O HOLE - 27" - 3.5" FACE - LH
6	109234-30-F09	EA	LEG - WINDOW - W/O GATHERS - W/O HOLE - 27" - 3.5" FACE - LH (F12)
6	109802-11-F11	EA	BLIND - PLEATED - 29" X 28.5" DROP - OCEAN SPRAY
6	109802-11-F12	EA	BLIND - PLEATED - 29" X 28.5" DROP - LINEN BEIGE
7	084755-57-E07	EA	SHADE - PULL - W/O TRIM - 27.25"
8	109041-20-01A	EA	MINI BLIND - 31" X 18" - SILVER
8	109353-07-01A	EA	BLIND SLAT - 31" - SILVER

CURTAIN & CUSHION GROUP (CONTINUED)

BUCKET SEAT

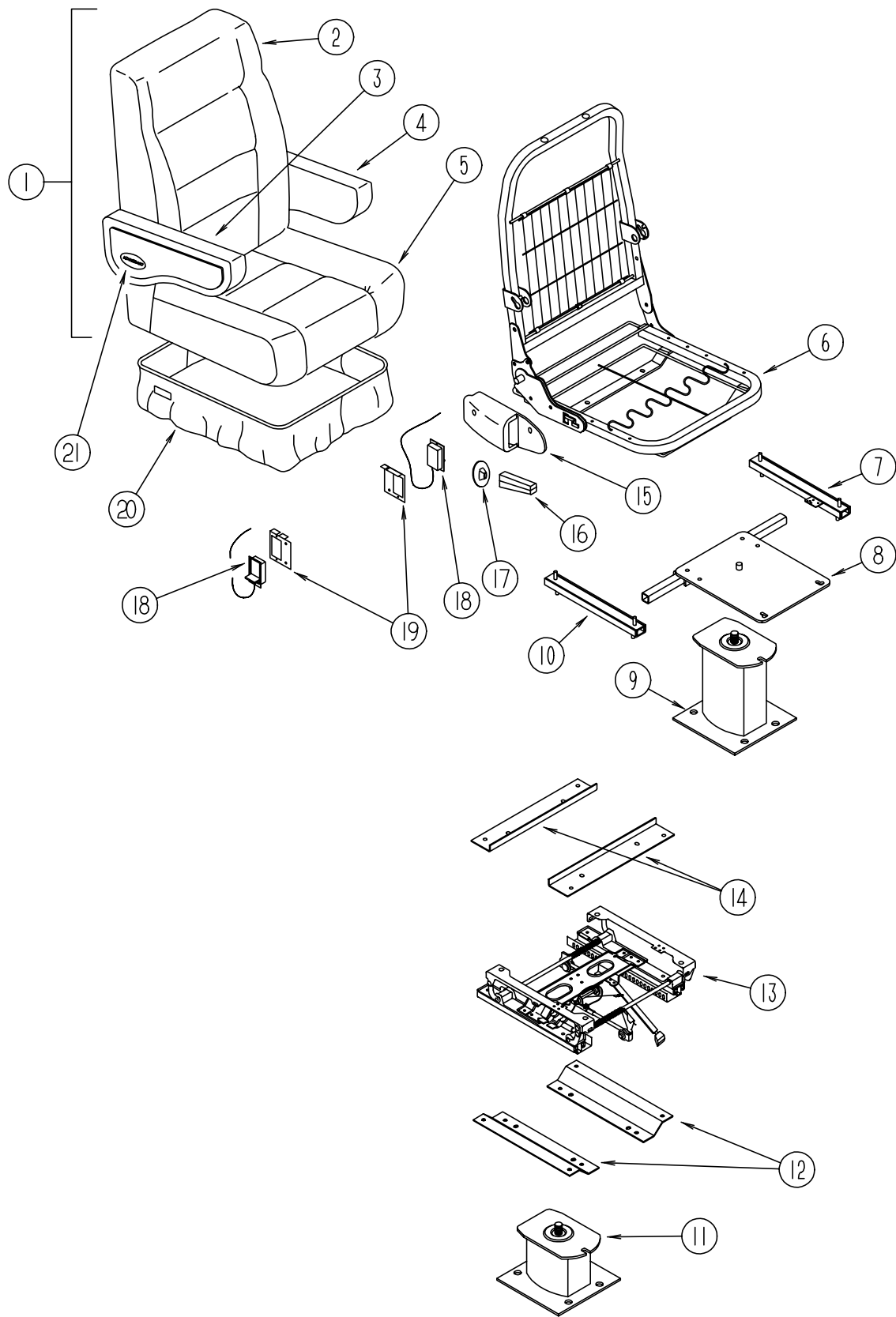

KEY	PART NUMBER	U/M	DESCRIPTION
1	111855-03-F11	EA	WINDSOR MANUAL RECLINER - W/ EXECUTIVE ARMRESTS
1	111855-03-E24	EA	WINDSOR MANUAL RECLINER - W/ EXECUTIVE ARMRESTS (F12)
2	M05962-03-F11	EA	COVER - BACK - WINDSOR
2	M05962-03-E24	EA	COVER - BACK - WINDSOR (F12)
3	111320-03-F11	EA	ARMREST - RIGHT HAND
3	111320-03-E24	EA	ARMREST - RIGHT HAND (F12)
3	P11320-03-F11	EA	COVER - ARMREST - W/ PAD - RIGHT HAND
3	P11320-03-E24	EA	COVER - ARMREST - W/ PAD - RIGHT HAND (F12)
4	111320-04-F11	EA	ARMREST - LEFT HAND
4	111320-04-E24	EA	ARMREST - LEFT HAND (F12)
4	P11320-04-F11	EA	COVER - ARMREST - W/PAD - LEFT HAND
4	P11320-04-E24	EA	COVER - ARMREST - W/PAD - LEFT HAND (F12)
5	M05962-04-F11	EA	COVER - SEAT - WINDSOR
5	M05962-04-E24	EA	COVER - SEAT - WINDSOR (F12)
6	M80906-11-000	EA	FRAME - SEAT - BACK & SPRING
7	069246-14-000	EA	ADJUSTER SIDE - W/ LOCK - FORWARD & BACK
	069246-99-000	EA	SPRING - ADJUSTER - FOR REMOTE - LIGHT BLUE
	117125 01 02B	EA	BRACKET - CABLE HOLDER - STEEL
	069246-05-701	EA	CLIP - CABLE - FOR REMOTE
8	107921-05-000	EA	TOP PLATE - PEDESTAL - W/ SEATBELT BAR
9	107921-01-000	EA	PEDESTAL - FLOOR MOUNTED - W/ 9.75" EXTENSION
	107921-06-000	EA	BEARING KIT - PEDESTAL
10	069246-15-000	EA	ADJUSTER SLIDE - W/O LOCK - FORWARD & BACK
11	107921-14-000	EA	PEDESTAL - FLOOR MOUNTED - W/ 5.75" EXTENSION
12	116215-03-000	EA	PLATE - LOWER - 6 WAY MANUAL CONTROL
13	116215-03-000	EA	CONTROL - MANUAL - 6 WAY
14	116215-03-000	EA	PLATE - UPPER - 6 WAY MANUAL CONTROL
15	080730-09-000	EA	SHIELD - RECLINER HANDLE
	080730-10-000	EA	SCREW - RECLINER HANDLE SHIELD
16	080730-08-000	EA	HANDLE - RECLINER - BLACK
17	080730-11-000	EA	SHIELD - RUBBER BOOT
18	108049-03-000	EA	REMOTE & CABLE - 26"
	108049-02-000	EA	CLIP - CABLE
19	097683-03-000	EA	BRACKET - REMOTE - SIDE MOUNT - SINGLE
20	071126-43-F11	EA	SKIRT - SINGLE - 10.5" - W/OPEN BACK
20	071126-43-F06	EA	SKIRT - SINGLE - 10.5" - W/OPEN BACK (F12)
20	071126-54-F11	EA	SKIRT - SINGLE - 10.5" - W/OPEN BACK - 6 WAY MANUAL CONTROL
20	071126-54-F32	EA	SKIRT - SINGLE - 10.5" - W/OPEN BACK - 6 WAY MANUAL CONTROL (F12)
21	111169-01-000	EA	BACK PLATE - EMBLEM
21	111169-02-000	EA	EMBLEM - "WINNEBAGO"

CURTAIN & CUSHION GROUP (CONTINUED)

SWIVEL CHAIR (RECLINER)

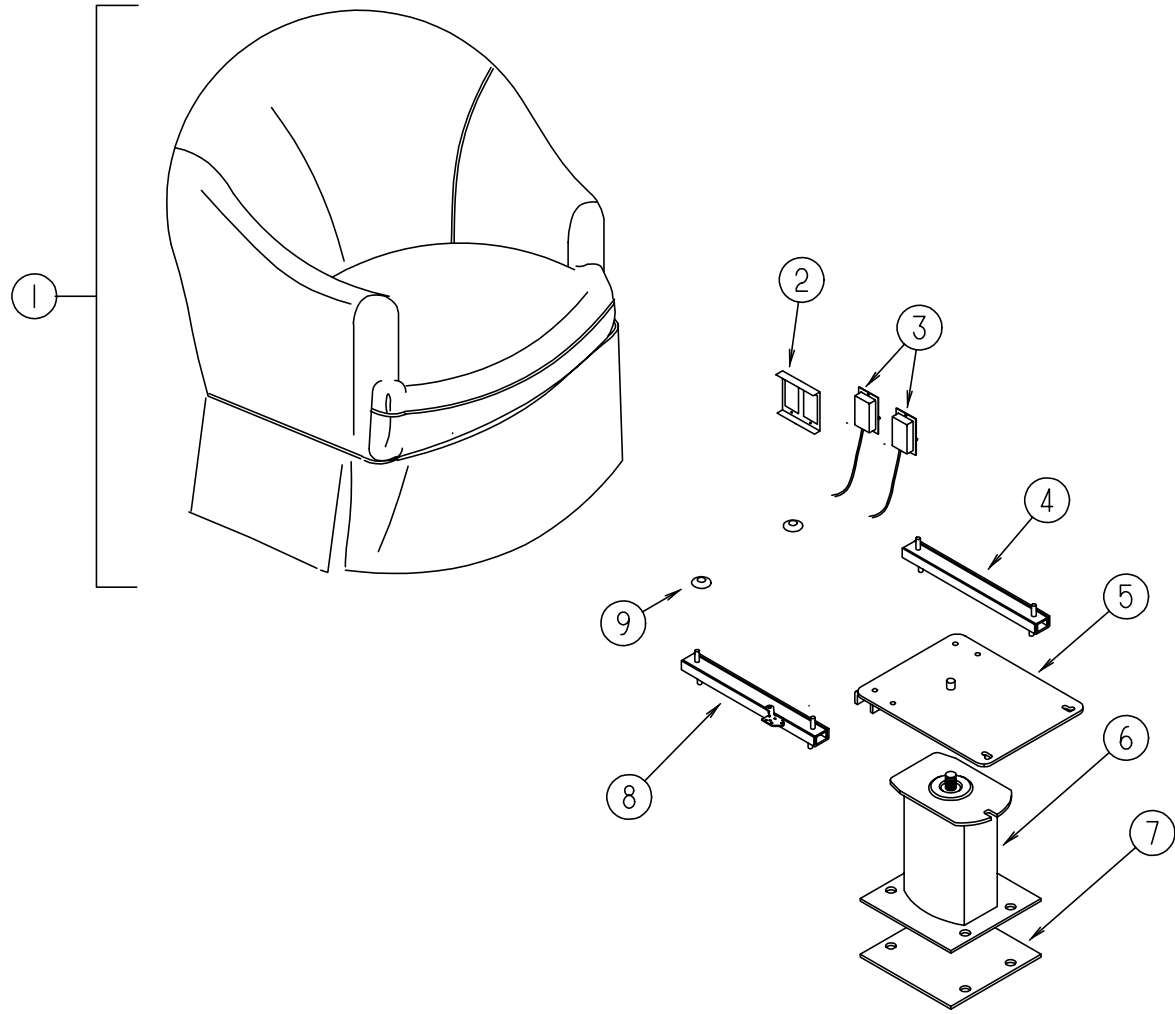

KEY	PART NUMBER	U/M	DESCRIPTION
1	115470-01-F11	EA	CHAIR ASM-SIERRA
1	115470-01-F09	EA	CHAIR ASM-SIERRA (F12)
	P15470-01-F11	EA	COVER-CHAIR,SIERRA
	P15470-01-F09	EA	COVER-CHAIR,SIERRA (F12)
	P07977-01-F11	EA	COVER-SKIRT,CHAIR,DIPLOMAT
	P07977-01-F09	EA	COVER-SKIRT,CHAIR,DIPLOMAT (F12)
2	097683-02-000	EA	BRACKET - REMOTE - SIDE MOUNT
3	108049-03-000	EA	REMOTE & CABLE
4	069246-13-000	EA	ADJUSTER SLIDE - W/O LOCKING ARM
5	107921-08-000	EA	TOP PLATE-W/O SEAT BELT BAR
	107921-06-000	EA	BEARING KIT - PEDESTAL
6	107921-01-000	EA	FLOOR MOUNTED PEDESTAL - W/ 9.75" EXTENSION
7	108445-02-000	EA	SUB PLATE - FLOOR MOUNTED PEDESTAL
8	069246-12-000	EA	ADJUSTER SLIDE - W/ LOCKING ARM
9	007221-01-000	EA	SPACER - SEAT ADJUSTER
	117125-01-02B	EA	BRACKET-CABLE HOLDER,E-COAT
	007021-01-000	EA	SEAT BELT - 2" X 90" - BLACK

CURTAIN & CUSHION GROUP (CONTINUED)

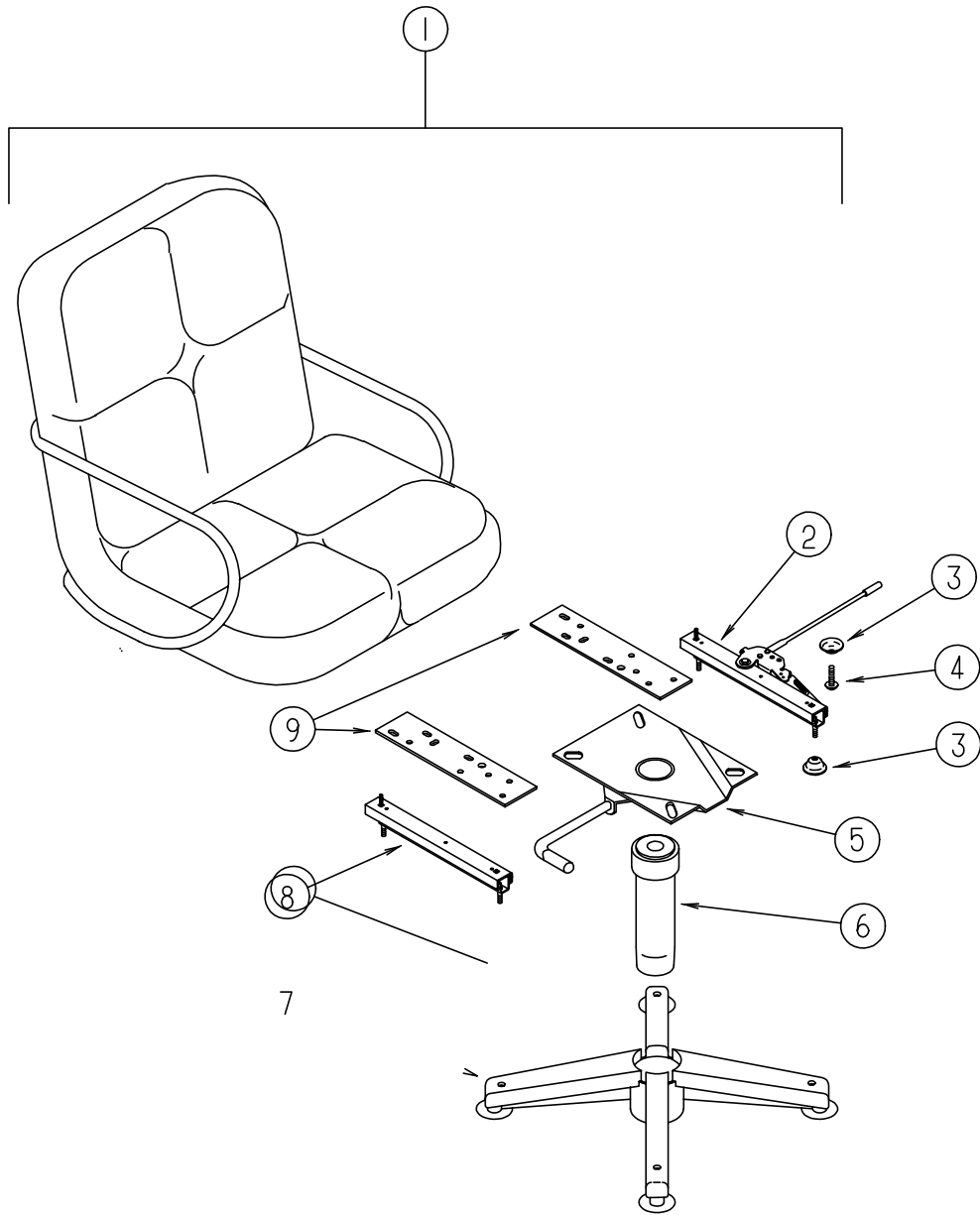

CHROME CRAFT CHAIRS

KEY	PART NUMBER	U/M DESCRIPTION
1	109379-02-F11	EA CHAIR ASM - CHROME CRAFT II
1	109379-02-E33	EA CHAIR ASM - CHROME CRAFT II (F12)
2	069246-16-000	EA ADJUSTER SLIDE - SWIVEL CHAIR - W/ LOCKING ARM - FORWARD & BACK
3	007221-01-000	EA SPACER - SEAT ADJUSTER
4	000G16-04-24B	EA BOLT - MACHINE - 1/4-20 X 1-1/2 PPH
	029127-01-000	EA NUT - T-1/4
5	088245-03-000	EA TOP PLATE - SWIVEL W/O TILT - W/ LOCK
6	105799-01-006	EA STEM UPRIGHT - LOCKOUT
7	105799-01-003	EA LEG - WOOD COVER BASE (CHAIR)
8	069246-13-000	EA ADJUSTER SLIDE - SWIVEL CHAIR - W/O LOCK - FORWARD & BACK
9	069705-02-000	EA BAR - 2.5 X 12.75 (ADAPTER PLATE)

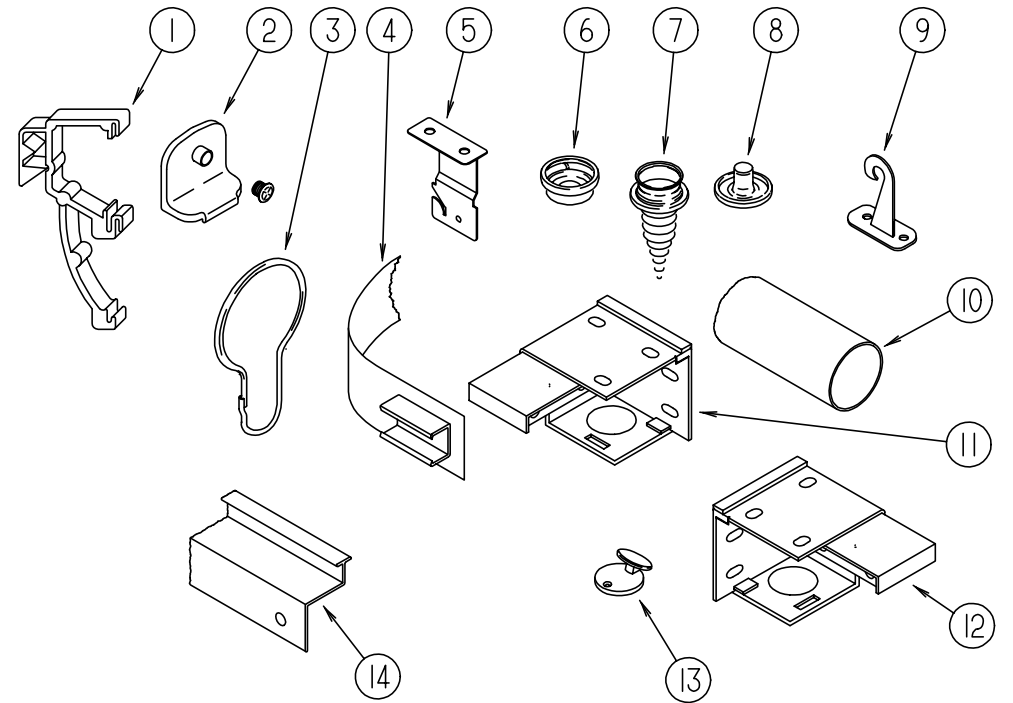

CURTAIN & BLIND HARDWARE

KEY	PART NUMBER	U/M DESCRIPTION
1	109353-04-000	EA CLIP - VALANCE SLAT MOUNTING - CLEAR PLASTIC - PAR
2	106544-01-000	EA SHADE PULL - BRASS
	106544-01-001	EA SCREW - SHADE PULL - BRASS
3	009136-02-000	EA HANGER - RING - PIN TYPE - CURTAIN - BRASS
4	101031-01-000	YD TAPE - GLIDE - CURTAIN - 4.25" SPACING
5	084434-01-000	EA BRACKET - MOUNTING - ROLLER SHADE - 1 3/8"
	096843-01-000	EA SPRING - REWIND - ROLLER SHADE
6	029156-01-000	EA SOCKET - SNAP - 9/16" O.D
7	029130-01-000	EA SCREW - SNAP SOCKET - 8 PH X 5/8"
8	029155-01-000	EA CAP - SNAP - 5/32" O.D. OF PIN
	046867-01-000	EA GROMMET - BRASS - 7/16" ID X 1" OD
9	109441-01-000	EA HOLD DOWN - BLIND, HOOK
10	102075-06-01A	EA SHOWER ROD
	009136-02-000	EA BRASS SHOWER RINGS
	009112-01-000	EA FLANGE - SHOWER ROD
11	083170-02-000	EA BRACKET - BLIND - LEFT SIDE
12	083170-01-000	EA BRACKET - BLIND - RIGHT SIDE
13	102555-01-000	EA CLEAT - CORD - BLIND - OFF WHITE
14	114641 07 F11	EA TRACK - WRAPAROUND CURTAIN - OFF WHITE (PASSENGER SIDE)
14	114641 08 F11	EA TRACK - WRAPAROUND CURTAIN - OFF WHITE (DRIVER SIDE)
	048394-02-000	YD VELCRO TAPE - HOOK - ADHESIVE BACK - .75" WIDE - BEIGE
	088792-02-000	YD VELCRO TAPE - LOOP - ADHESIVE BACKED - .75" WIDE - BEIGE
	068716-01-001	EA BRACKET - 90 DEGREE L-ANGLE - 192" - EXTRUDED ALUMINUM
	075943-01-000	EA BRACE - WINDOW VALANCE - 1" X 1.5" X 20" - ALUMINUM - BEIGE
	094896-02-000	EA GROMMET - CORD - PLEATED BLIND - NYLON - GRAY
	094907-02-000	EA END CAP - TOP - PLEATED BLIND - PLASTIC - GRAY
	094907-04-000	EA END CAP - BOTTOM - PULL TYPE SPECIALITY WINDOW
	097564-01-000	EA T-HANDLE - EZ LIFT SHADE
	097565-01-000	EA BRACKET - MOUNTING - PLEATED BLIND
	097591-01-000	EA SPRING - EXTENSION - PLEATED BLIND
	097592-01-000	EA SPOOL - CORD - ELEVATED BLIND HOLDUP - CLEAR PLASTIC
	089916-01-000	EA MOUNT - WINDOW LEG - 23.75" LONG - ALUMINUM - BLACK
	056003-01-000	EA BRACKET - DRAPERY RETAINING - FRONT - METAL
	056003-02-000	EA BRACKET - DRAPERY RETAINING - REAR - METAL
	086276-01-000	EA TAPE - DOUBLE SIDED - 1/2"
	097593-07-000	FT CORD - BLIND - .9 MM - PALE JADE
	097593-02-000	FT CORD - BLIND - .9 MM - DAWN GREY
	103986-01-000	FT TRIM - VALANCE - U-CHANNEL - .75" WIDE - BRASS

CURTAIN & CUSHION GROUP (CONTINUED)

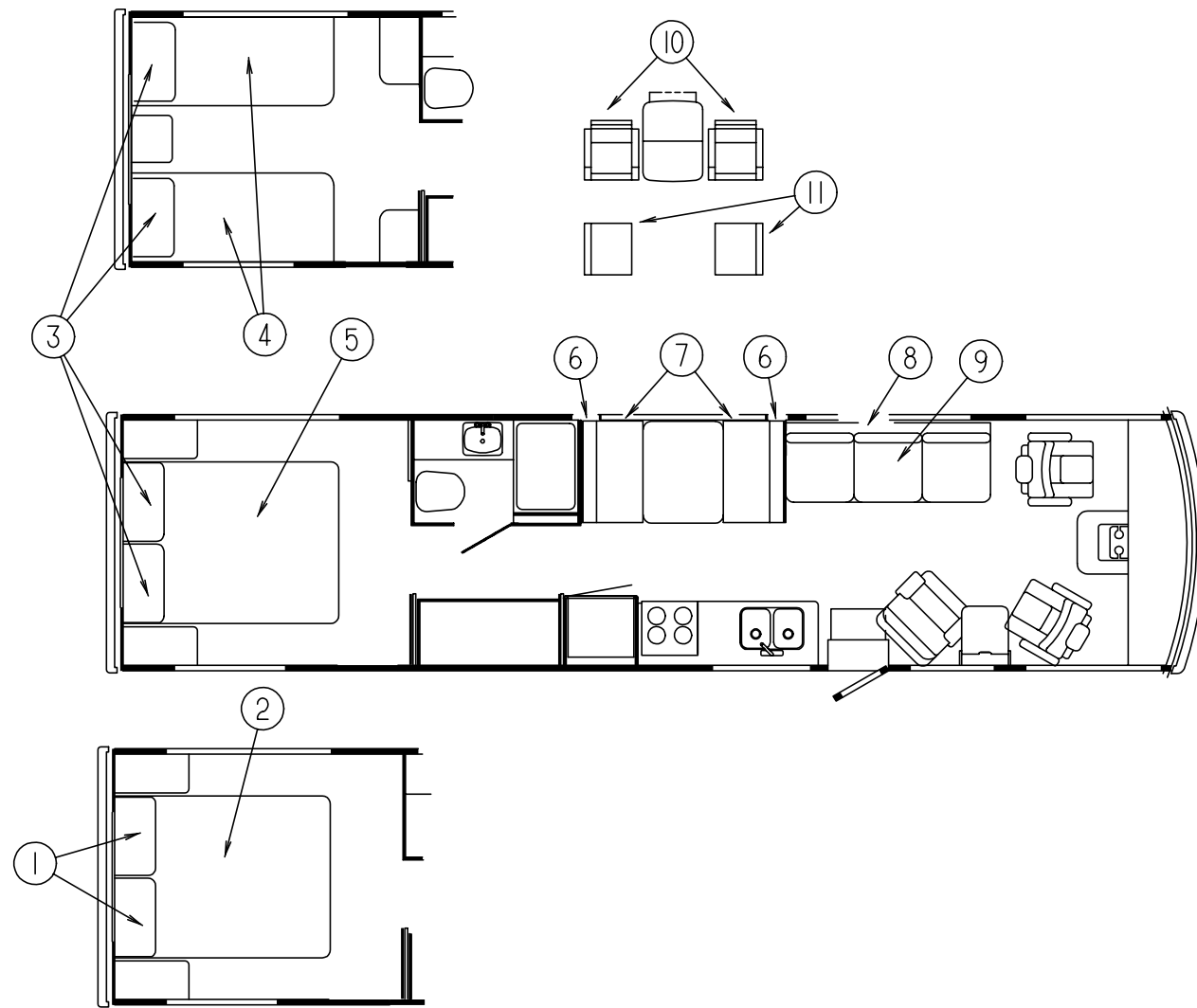

KING BED

KEY	PART NUMBER	U/M DESCRIPTION
3	102161-28-F11	EA PILLOW SHAM - W/ 1/2" GATHERED ACCENT WELT
3	102161-28-F12	EA PILLOW SHAM - W/ 1/2" GATHERED ACCENT WELT
5	101123-25-000	EA MATTRESS - FOAM - 72"X 80"
5	P01123-25-000	EA COVER - MATTRESS
5	085365-31-F11	EA BEDSPREAD - 72" THROW - W/ 1" GATHERED ACCENT WELT
5	085365-31-F12	EA BEDSPREAD - 72" THROW - W/ 1" GATHERED ACCENT WELT
	111862-04-F11	EA PILLOW ASM - 15" X 15" W/ 1/2" GATHERED WELT
	111862-04-F09	EA PILLOW ASM - 15" X 15" W/ 1/2" GATHERED WELT (F12)

DINETTE CUSHIONS

KEY	PART NUMBER	U/M DESCRIPTION
6	111880-05-F08	EA CUSHION ASM. - CHANNEL STYLE BACK - W/ STRAP - 13.5" X 42" X 5" (F11)
6	111880-05-F09	EA CUSHION ASM. - CHANNEL STYLE BACK - W/ STRAP - 13.5" X 42" X 5" (F12)
6	P11880-05-F08	EA COVER - CHANNEL STYLE BACK - W/ STRAP (F11)
6	P11880-05-F09	EA COVER - CHANNEL STYLE BACK - W/ STRAP (F12)
7	105603-15-F08	EA CUSHION ASM. - 23" X 42" X 5" - DINETTE SEAT (F11)
7	105603-15-F09	EA CUSHION ASM. - 23" X 42" X 5" - DINETTE SEAT (F12)
7	P05603-15-F08	EA COVER - CUSHION - 23" X 42" X 5" - DINETTE SEAT (F11)
7	P05603-15-F09	EA COVER - CUSHION - 23" X 42" X 5" - DINETTE SEAT (F12)

COUCH BED

KEY	PART NUMBER	U/M DESCRIPTION
8	112104-01-F11	EA COUCH BED - BACK - 74" - W/O ARMREST
8	112104-01-E24	EA COUCH BED - BACK - 74" - W/O ARMREST (F12)
8	P12104-01-F11	EA COVER - BED - BACK 74"
8	P12104-01-E24	EA COVER - BED - BACK 74" (F12)
	101085-10-000	EA FRAME - BACK - 74.75"
9	100032-43-F11	EA COUCH BED - SEAT - 74" W/O ARMREST
9	100032-43-E24	EA COUCH BED - SEAT - 74" W/O ARMREST
9	P00032-43-F11	EA COVER - BED - SEAT 74" W/O ARMREST
9	P00032-43-E24	EA COVER - BED - SEAT 74" W/O ARMREST
	101085-04-000	EA FRAME - SEAT - 74.75"
	101085-06-000	EA FRAME - BASE - 74.75"
	111637-02-F11	EA PILLOW ASM - 15" X 15" THROW
	111637-02-E24	EA PILLOW ASM - 15" X 15" THROW (F12)

NOTE: COUCH FRONT & SIDE PANELS ARE FOUND IN LOUNGE GROUP

DINETTE OPTION

KEY	PART NUMBER	U/M DESCRIPTION
10	109379-02-F11	EA CHAIR ASM - CHROME CRAFT II
10	109379-02-E33	EA CHAIR ASM - CHROME CRAFT II (F12)
11	101604-01-01A	EA CHAIR - FOLDING - DINETTE - OAK

QUEEN BED

KEY	PART NUMBER	U/M DESCRIPTION
1	102161-29-F11	EA PILLOW SHAM - W/ 1/2" GATHERED ACCENT WELT
1	102161-29-F12	EA PILLOW SHAM - W/ 1/2" GATHERED ACCENT WELT
2	101123-06-000	EA MATTRESS - FOAM - 60" X 80"
2	P01123-06-000	EA COVER - MATTRESS
2	085365-21-F11	EA BEDSPREAD - 60" THROW - W/ 1" GATHERED ACCENT WELT
2	085365-21-E33	EA BEDSPREAD - 60" THROW - W/ 1" GATHERED ACCENT WELT (F12)

TWIN BEDS

KEY	PART NUMBER	U/M DESCRIPTION
3	102161-28-F11	EA PILLOW SHAM - W/ 1/2" GATHERED ACCENT WELT
3	102161-28-F12	EA PILLOW SHAM - W/ 1/2" GATHERED ACCENT WELT
4	101123-21-000	EA MATTRESS - FOAM - 35" X 79"
4	P01123-21-000	EA COVER - MATTRESS
4	085365-35-F11	EA BEDSPREAD - 36" THROW - W/ 1" GATHERED ACCENT WELT
4	085365-35-F12	EA BEDSPREAD - 36" THROW - W/ 1" GATHERED ACCENT WELT
	111862-04-F11	EA PILLOW ASM - 15" X 15" W/ 1/2" GATHERED WELT
	111862-04-F09	EA PILLOW ASM - 15" X 15" W/ 1/2" GATHERED WELT (F12)

DINETTE GROUP

DINETTE & OVERHEAD CABINERY

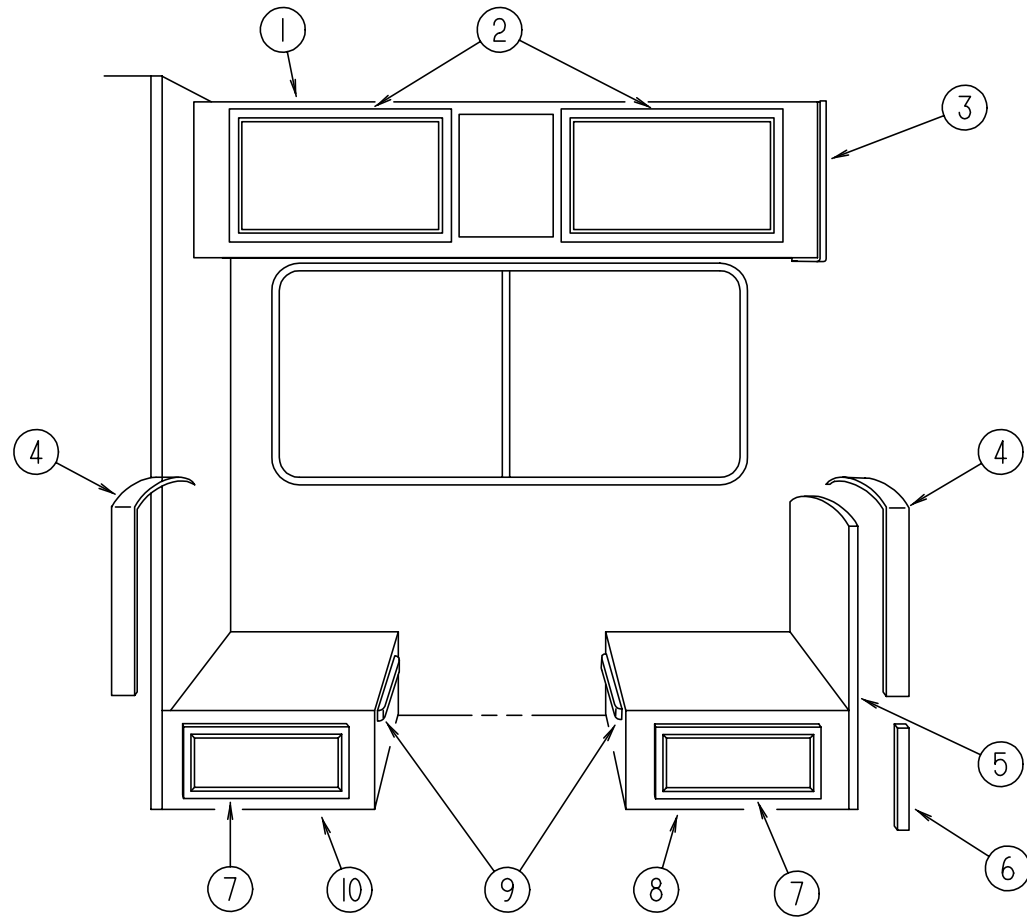

KEY	PART NUMBER	U/M	DESCRIPTION
1	M06838-06-F11	EA	CABINET - DINETTE OVERHEAD
1	M06838-06-F12	EA	CABINET - DINETTE OVERHEAD
2	M06803-30-E10	EA	DOOR ASM - W/O HARDWARE - 395 X 750 MM
3	103128-01-F11	EA	END CAP ASM. - RIGHT HAND
4	104787-08-F11	EA	PAD ASM. - DINETTE
4	104787-08-F12	EA	PAD ASM. - DINETTE
5	M07514-01-F11	EA	CABINET - SEATBACK - RIGHT HAND
6	111338-10-F11	EA	PAD ASM. - DINETTE
6	111338-10-F12	EA	PAD ASM. - DINETTE
7	M05971-81-E10	EA	DRAWER ASM. - W/O HARDWARE
8	M07515-01-F11	EA	CABINET - SEATBASE - RIGHT HAND
9	081295-01-AA8	EA	BED SUPPORT - DINETTE
10	M07515-02-F11	EA	CABINET - SEATBASE - LEFT HAND

DINETTE GROUP (CONTINUED)

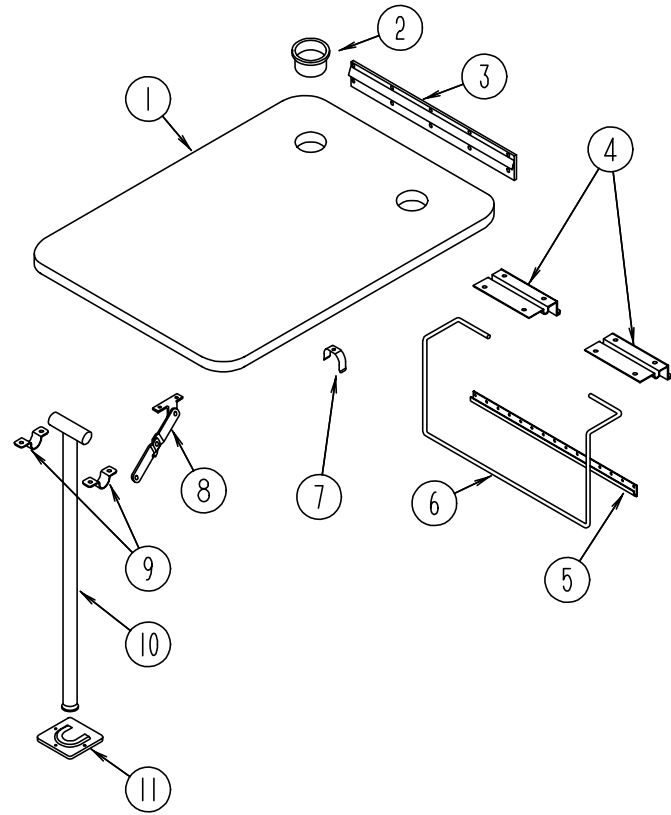

DINETTE TABLE ASM.

KEY	PART NUMBER	U/M DESCRIPTION
1	081322-15-F11	EA DINETTE TABLE
1	081322-15-F12	EA DINETTE TABLE
2	064781-06-000	EA CUP HOLDER - 2 STEP
3	053200-12-000	EA BRACKET - TABLE SUPPORT - UPPER WALL MOUNTED - 23.5" - OFF WHITE
4	088410-02-000	EA BRACKET - TABLE MOUNTED - OFF WHITE
5	024281-14-000	EA BRACKET - LIFT ROD - LOWER WALL MOUNTED - 22.12" - OFF WHITE
6	024275-12-000	EA ROD - TABLE LIFT - 8" X 23.5" - OFF WHITE
7	024283-01-000	EA CLIP - LEG - 1" - 1.125" OD - BLACK
8	024282-01-000	EA BRACE - TABLE LEG - HINGED
9	064050-05-000	EA CLAMP - SADDLE - LEG HINGE - OFF WHITE
10	024276-23-000	EA TABLE LEG - METAL - OFF WHITE
11	049493-12-000	EA LEG CATCH - FLOOR MOUNTED - 2.5" X 2.7" - METAL - E-COAT

DINETTE GROUP (CONTINUED)

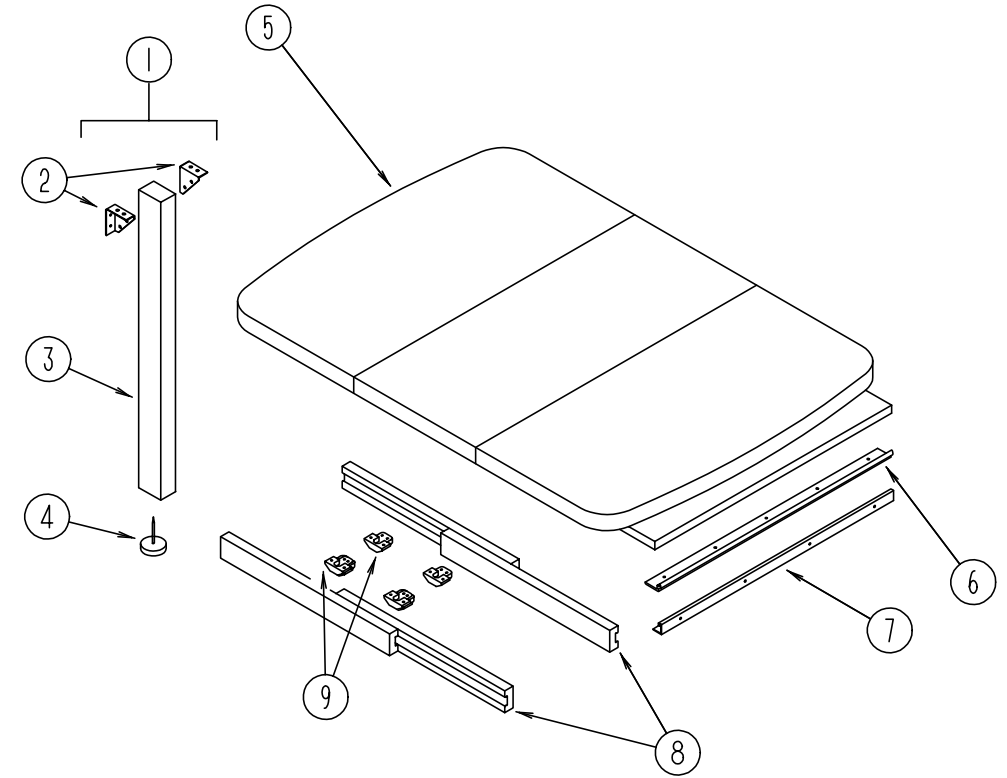

DINETTE TABLE ASM.

KEY	PART NUMBER	U/M DESCRIPTION
1	092708-09-E10	EA LEG ASM - TABLE
2	102810-01-02A	EA BRACE - TABLE LEG - OFF WHITE
3	092707-08-01A	EA LEG MOLDING - OAK - RAMBLING OAK
4	102194-01-000	EA GUIDE - PLASTIC
5	P02056-05-E10	EA TABLE ASM. - W/ DROP LEAF
6	102201-02-01A	EA SUPPORT - HINGE CATCH
7	102200-02-02A	EA SUPPORT - HINGE LOCK - OFF WHITE
8	110749-01-000	EA SLIDE - TABLE - 19 3/4 LONG
9	009050-02-000	EA LEVELER - TABLE TOP - MALE END W/ SCREWS - PLASTIC
9	009050-03-000	EA LEVELER - TABLE TOP - FEMALE END W/ SCREWS - PLASTIC

**DRIVERS COMPARTMENT GROUP
UPPER & LOWER DRIVER COMPARTMENT**

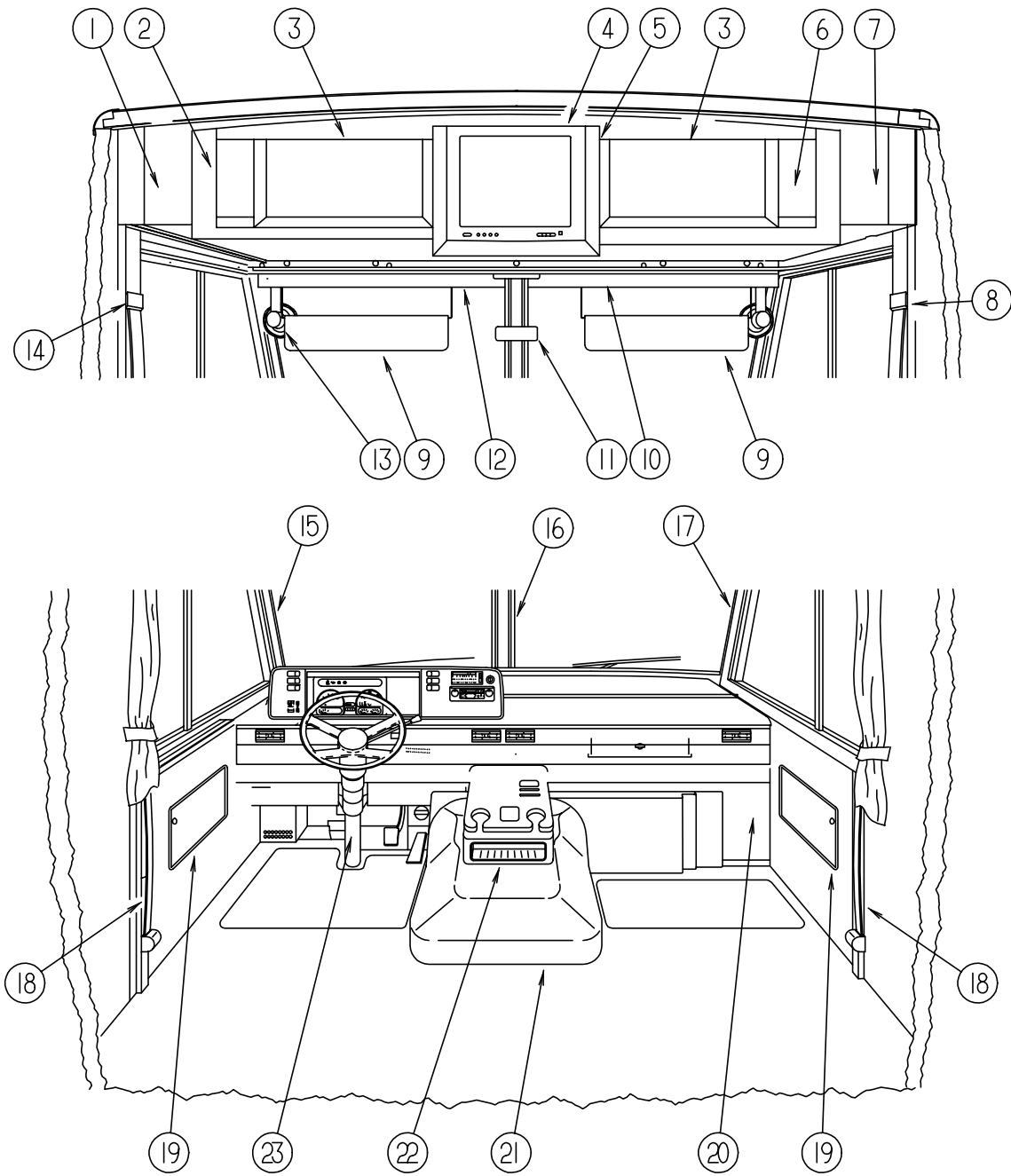

KEY	PART NUMBER	U/M DESCRIPTION
4	M06803-C1-E10	EA DOOR - CABINET - W/O TV - 425 X 460 MM
5	116791-01-F31	EA FRAME ASSEMBLY - CABINET - W/ TV
	114615-02-F31	EA COVER ASSEMBLY - TV - WITH VINYL
		FROM: 00-00-00 THRU: 01-17-95
	P18192-01-F31	EA COVER ASSEMBLY - TV - WITH VINYL
		FROM: 01-18-95 THRU: 99-99-99
	115639-01-F31	EA PANEL ASSEMBLY - LINER-W/O TV - DRIVER
6	114612-03-F11	EA FACE ASSEMBLY - CABINET - PASSENGER SIDE OVERHEAD
	106699-01-01A	EA BRACKET - OVERHEAD CABINET - OFF WHITE
	P03077-06-F11	EA SHELF - BASE - CABINET - PASSENGER OVERHEAD
	100676-02-000	EA STAND - VCR
	114661-03-E10	EA PANEL ASSEMBLY - LINER - PASSENGER OVERHEAD - W/ TV
	114661-08-F11	EA PANEL ASSEMBLY - LINER - PASSENGER OVERHEAD - W/ TV & VCR
	114661-09-F11	EA PANEL ASSEMBLY - LINER - PASSENGER OVERHEAD - W/ TV - VCR/ INVERTER
	114661-10-E10	EA PANEL ASSEMBLY - LINER - PASSENGER OVERHEAD - W/ TV & INVERTER
7	104289-03-D12	EA PANEL - SIDE - PASSENGER OVERHEAD - VINYL
8	103961-01-01A	EA COVER-BRACKET - SEATBELT - OFF WHITE
9	082286-19-F11	EA SUNVISOR ASSEMBLY
	007211-01-000	EA HINGE - SUNVISOR - 25.5" X 1.5" - METAL
	074012-01-000	EA CLIP - SUNVISOR - SQUARE - PINCH ON
	116093-01-02A	EA BRACKET - SUNVISOR - W/ ROD - RH - BLACK
	116093-02-02A	EA BRACKET - SUNVISOR - W/ ROD - LH - BLACK
10	078579-17-000	EA TRIM - WINDSHIELD - UPPER INNER - RH - WILLOW
11	040714-01-000	EA MIRROR - REAR VIEW - W/ARM MOUNT & SET SCREW
	067490-01-000	EA BUTTON - MIRROR - REAR VIEW - STANK S927H
12	078579-18-000	EA TRIM - WINDSHIELD - UPPER INNER - LH - WILLOW
13	036420-02-000	EA FAN - DEFROSTER - 2 SPEED - 6" DIAMETER
14	103961-01-01A	EA COVER - BRACKET - SEATBELT - W/O DRIVER DOOR - OFF WHITE
14	103961-02-01A	EA COVER - BRACKET - SEATBELT - W/ DRIVER DOOR - OFF WHITE
	R77030-53-447	EA WASHER - FLAT
15	103931-04-03A	EA COVER - INTERIOR - A-PILLAR - DRIVER SIDE - WILLOW
16	079765-11-000	EA TRIM - WINDSHIELD - CENTER - WILLOW
17	103931-03-03A	EA COVER - INTERIOR - A-PILLAR - PASSENGER SIDE - WILLOW
	024700-46-000	EA COVER - ROLL BAR - DRIVER & PASSENGER SIDE UPPER - OFF WHITE - 21.2"
	024700-44-000	EA COVER - ROLL BAR - DRIVER & PASSENGER SIDE LOWER - 53" (W/O DRIVER DOOR)
	024700-47-000	EA COVER - ROLL BAR - DRIVER SIDE LOWER - 18.9" (W/ DRIVER DOOR)
	024700-48-000	EA COVER - ROLL BAR - DRIVER SIDE CENTER - 25" (W/ DRIVER DOOR)
18	091990-04-01A	EA SEAT BELT - 3 POINT - BLACK - INTERTEK A8408
	109146-01-000	EA BOLT - SHOULDER - SEAT BELT
19	086120-10-F11	EA PAD - MAP POCKET - 12" X 16"
19	086120-10-E33	EA PAD - MAP POCKET - 12" X 16"
20	095757-04-F11	EA COVER - HEATER
20	095757-04-F12	EA COVER - HEATER
21	115840-01-01A	EA COVER - MOTOR
	115850-01-02B	EA RETAINER ASM - MOTOR COVER LATCH
	116581-01-000	EA LATCH - MOTOR COVER
	115860-01-01A	EA TRIM - MOTOR COVER MILL
	115852-01-02B	EA STRIKE ASM. - MOTOR COVER
	116833-01-02B	EA WRENCH - HEX - MOTOR COVER
22	111618-01-E10	EA TRAY - BEVERAGE
22	111618-13-E07	EA LID ASM. - TRAY - BEVERAGE
	046886-03-000	EA ASHTRAY - CHROME - W/ COVER
23	103498-06-000	EA BOOT - COLUMN - UNIVERSAL
	112634-01-01A	EA TRIM - STEERING COLUMN - RH BLACK
	112634-02-01A	EA TRIM - STEERING COLUMN - LH BLACK
	111521-01-04A	EA COVER - STEERING COLUMN - BLACK
		FROM: 00-00-00 THRU: 02-05-95
	111521-03-01A	EA COVER - STEERING COLUMN - BLACK
		FROM: 02-06-95 THRU: 99-99-99

KEY	PART NUMBER	U/M DESCRIPTION
1	104289-04-D12	EA PANEL - SIDE - DRIVER - OVERHEAD - VINYL
2	114612-04-F11	EA FACE ASSEMBLY - OVERHEAD CABINET - DRIVER SIDE - W/TV
	106699-01-01A	EA BRACKET - OVERHEAD CABINET - OFF WHITE
	P03077-05-F11	EA SHELF - BASE - OVERHEAD CABINET - DRIVER
	114661-11-F11	EA PANEL ASSEMBLY - LINER - DRIVER OVERHEAD
	078811-09-F11	EA PANEL - TRIM - HEADER - LOWER - BETWEEN OVERHEAD AND W/S TRIM
3	100708-13-000	EA DOOR - CABINET - GLASS - 246 X 658 MM
	100710-01-01A	EA LOCK ASSEMBLY - TWIST TYPE - BRASS
	100711-01-01A	EA HINGE - GLASS DOOR
	100707- 01-000	EA SPACER - GLASS DOOR - .8" DIAMETER - .3" HOLE - PLASTIC
	101272-01-000	EA CATCH - GLASS DOOR
	101766-01-000	EA PIN - SUPPORT - GLASS DOOR
	108487-02-01A	EA SUPPORT - PROP ROD - PASSENGER OVERHEAD - BLACK
	108486-01-01A	EA BRACKET - PROP ROD - PASSENGER OVERHEAD - BLACK

DRIVERS COMPARTMENT GROUP (CONTINUED)

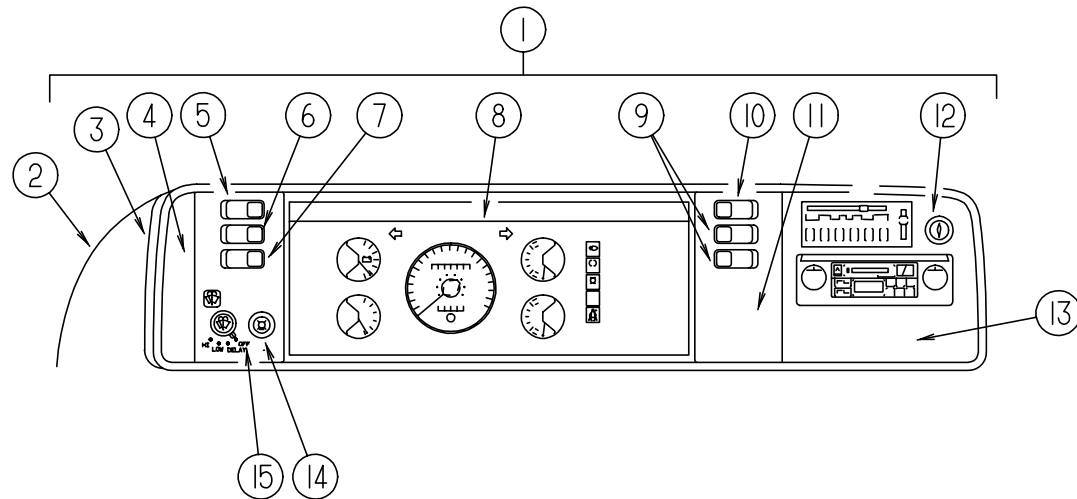

DASH, GAUGES & SWITCHES (FORD)

KEY	PART NUMBER	U/M DESCRIPTION
1	M05946-22-F11	EA DASH POD ASM.
2	111499-01-03A	EA POD - INSTRUMENT PANEL - WILLOW
3	103662-04-01A	EA BEZEL - INSTRUMENT PANEL
4	104056-01-02A	EA APPLIQUE - BEZEL - LEFT - DRESS UP
5	108357-05-000	EA SWITCH - ROCKER - SPDT ON/ NONE/ ON
5	108356-02-01A	EA SWITCH COVER - W/ DIMPLES - CARLING VVAZC00 BLA
6	108357-09-000	EA SWITCH - ROCKER - SPDT ON/ NONE/ MOM
6	108356-02-01A	EA SWITCH COVER - W/ DIMPLES - CARLING VVAZC00 BLA
7	108357-06-000	EA SWITCH - ROCKER - DPDT MOM/ OFF/ MOM
7	108356-02-01A	EA SWITCH COVER - W/ DIMPLES - CARLING VVAZC00 BLA
8	094794-05-000	EA CLUSTER - INSTRUMENT PANEL- MILES (US)
8	094794-04-000	EA CLUSTER - INSTRUMENT PANEL- KILOMETER (CSA)
9	108357-03-000	EA SWITCH - ROCKER - SPDT ON/ OFF/ ON
9	108356-02-01A	EA SWITCH COVER - W/ DIMPLES - CARLING VVAZC00 BLA
10	108357-10-000	EA SWITCH - ROCKER - SPDT MOM/ OFF/ MOM
10	108356-04-01A	EA SWITCH COVER - W/ DIMPLES & LENS - CARLING VVAGC00
	096241-03-000	EA SWITCH - BLANK
11	104056-21-01A	EA APPLIQUE - BEZEL - SWITCH RIGHT
12	089294-01-000	EA LIGHTER ASM. - CIGARETTE
13	104056-06-02A	EA APPLIQUE - BEZEL - RIGHT DRESS UP
14	096675-01-000	EA KNOB - HEADLAMP SWITCH - W/SHAFT
	096674-01-000	EA NUT - HEADLAMP SWITCH - BLACK
15	104056-24-01A	EA APPLIQUE - BEZEL - SWITCH LEFT
	106569-07-01A	EA VINYL - LAMINATE MADRID WILLOW - 1/4" X 17" X 100"
	100138-01-000	EA MODULE - DAYTIME RUNNING LIGHT (CSA)
	077031-01-000	EA FILM - BLACK - 1" X 1.75"
	077031-03-000	EA FILM - WHITE .75" X 1"
	104354-08-01A	EA APPLIQUE - LOWER DASH - FORD
	112235-01-01A	EA BEZEL - MONITOR - LEVELING JACK - WILLOW
	111528-03-02A	EA TRIM - DASH - LOWER - RIGHT HAND - WILLOW
	117306-02-F11	EA TRIM ASM - DASH - LOWER, FORD
	P14614-02-F11	EA DASH ASM - FORD - W/O VINYL
	108067-03-000	EA STUD - WELD - 1/4-20 X 1/2 CD

DRIVERS COMPARTMENT GROUP (CONTINUED)

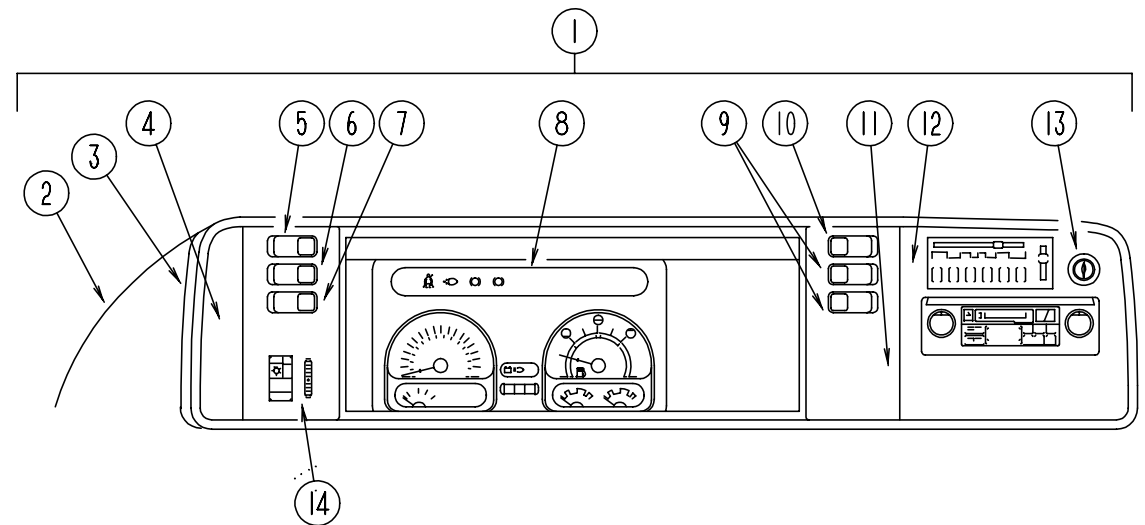

DASH, GAUGES & SWITCHES (CHEVY)

KEY	PART NUMBER	U/M DESCRIPTION
1	M05946-21-F11	EA DASH POD ASM.
2	111499-01-03A	EA POD - INSTRUMENT PANEL - WILLOW
3	103662-01-01A	EA BEZEL - INSTRUMENT PANEL
4	104056-01-02A	EA APPLIQUE - BEZEL - LEFT - DRESS UP
5	108357-05-000	EA SWITCH - ROCKER - SPDT ON/ NONE/ ON
5	108356-02-01A	EA SWITCH COVER - W/ DIMPLES - CARLING VVAZC00 BLA
6	108357-09-000	EA SWITCH - ROCKER - SPDT ON/ NONE/ MOM
6	108356-02-01A	EA SWITCH COVER - W/ DIMPLES - CARLING VVAZC00 BLA
7	108357-06-000	EA SWITCH - ROCKER - DPDT MOM/ OFF/ MOM
7	108356-02-01A	EA SWITCH COVER - W/ DIMPLES - CARLING VVAZC00 BLA
8	094796-07-000	EA CLUSTER - INSTRUMENT PANEL - KILOMETER (CSA)
9	108357-03-000	EA SWITCH - ROCKER - SPDT ON/ OFF/ ON
9	108356-02-01A	EA SWITCH COVER - W/ DIMPLES - CARLING VVAZC00 BLA
10	108357-10-000	EA SWITCH - ROCKER - SPDT MOM/ OFF/ MOM
10	108356-04-01A	EA SWITCH COVER - W/ DIMPLES & LENS - CARLING VVAGC00

ELECTRICAL GROUP

EXTERIOR LIGHTS

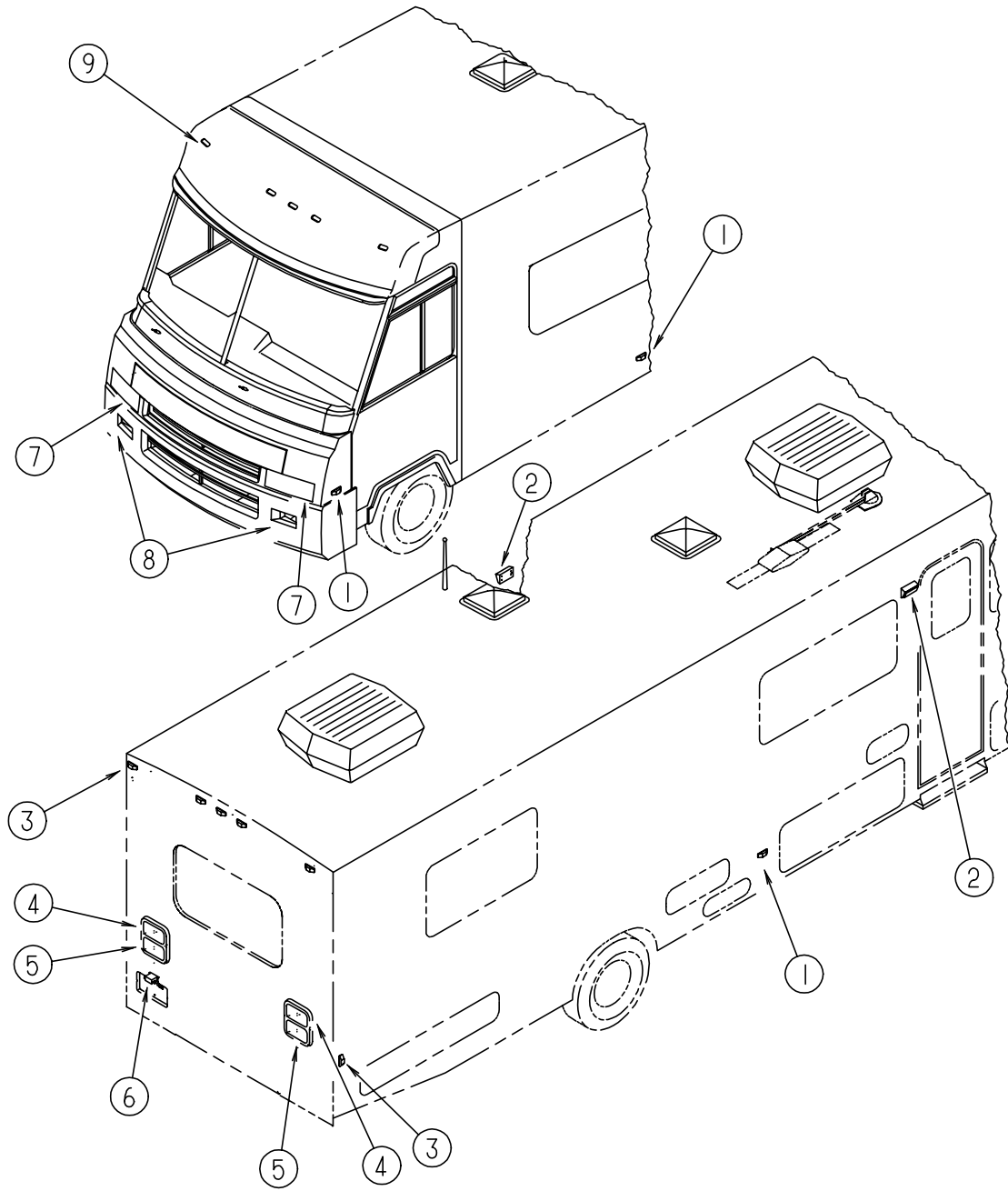

KEY	PART NUMBER	U/M	DESCRIPTION
1	111102-01-000	EA	LAMP - MARKER - BASE - TRIPLEX 117XAS
1	036196-01-000	EA	BULB - 12V - #194 - .27 AMP - BAYONETTE
1	111102-02-000	EA	LENS - MARKER LAMP - AMBER - TRIPLEX 118A
1	112823-01-000	EA	SPLICE - REDUCER
2	097917-01-04A	EA	LIGHT - PORCH - ENTRY DOOR - BUFF
2	008215-01-000	EA	BULB - 12V - #1003 - .94 AMP
2	097917-01-700	EA	LENS - LIGHT - PORCH
3	111102-01-000	EA	LAMP - MARKER - BASE - TRIPLEX 117XAS
3	036196-01-000	EA	BULB - 12V - #194 - .27 AMP - BAYONETTE
3	111102-03-000	EA	LENS - MARKER LAMP - RED - TRIPLEX 117R
3	112823-01-000	EA	SPLICE - REDUCER
4	115632-01-02A	EA	LIGHT - STOP/TURN/TAIL RED - BARGMAN 3092106
4	115632-03-02A	EA	LIGHT - STOP/TAIL/BACKUP - BARGMAN 3092107
	117379-01-01A	EA	TRIM - TAIL LIGHT - REAR - BUFF
5	115632-03-02A	EA	LIGHT - STOP/TAIL/BACK UP - BARGMAN 3092107
6	066432-02-000	EA	LIGHT - LICENSE
	066432-03-000	EA	BRACKET - LICENSE PLATE - BARGMAN 30-60-030
7	070907-01-000	EA	HEADLAMP - RECTANGULAR - GM 5968097
	049359-01-000	EA	SPRING - RETAINER - HEADLAMP - GM 496096
	110691-01-01A	EA	BRACKET - SPRING - HEADLAMP - MILL FINISH
	110750-01-000	EA	SCREW - HEADLAMP ADJUSTING
	106687-02-000	EA	SOCKET - LIGHT - 3-WIRE TRIPLEX 376
	116152-01-01A	EA	BEZEL - HEADLAMP - PASSENGER SIDE - BUFF
	116152-02-01A	EA	BEZEL - HEADLAMP - DRIVER SIDE - BUFF
8	106688-02-000	EA	LIGHT - TURN - AMBER TRIPLEX 146-W
	037934-01-000	EA	BULB - 12V - #1156 - 2.1AMP - CLEAR GLASS - BACK UP & TURN SIGNAL BULB
9	102520-01-000	EA	LIGHT - CLEARANCE - W/O SOCKET CONNECTIONS - AMBER
	102540-01-000	EA	SEAL - SCREW - ROUND - RUBBER
	088474-09-000	EA	HOUSING - SOCKET - 3 CAVITY - AMP 1-480701-0
	088476-01-000	EA	SOCKET - CONNECTOR - BRASS - PRE-TIN
	102541-01-000	EA	GASKET - CLEARANCE LIGHT
	067789-02-000	EA	SOCKET - LAMP

ELECTRICAL GROUP (CONTINUED)**ELECTRIC COMPONENTS**

KEY	PART NUMBER	U/M	DESCRIPTION
	008326-01-000	EA	TERMINAL - RING - 16/14 WIRE - 3/8" STUD
	008328-01-000	EA	TERMINAL - RING - 12/10 WIRE - #10 STUD FIT
	008331-01-000	EA	TERMINAL - RING - TONGUE - #4 WIRE - 3/8" STUD - COPPER
	008348-01-000	EA	TERMINAL - RING - 3/8" STUD - #2 WIRE
	035416-04-000	EA	TERMINAL - RING #10 STUD FITTING - INSULATED BARREL #16/14
	047443-01-000	EA	TERMINAL - .250 RECEPTACLE FITTING - INSULATED - 16/14 AWG
	062036-02-000	EA	TERMINAL - PACK - CONNECTOR - 16/14 AWG
	104100-03-000	EA	TERMINAL - 75 AMP AMP 53880-4 LOOSE
	106655-02-000	EA	TERMINAL - FUSE BLOCK - 10-12AWG
	113306-01-000	EA	TERMINAL - FEMALE - METRI-PACK
	113307-01-000	EA	TERMINAL - FEMALE - METRI-PACK
	103603-01-000	EA	BULB - 12V NO.74 0.12A WEDGE
	008218-01-000	EA	BULB - DOME LIGHT - 12V - NUMBER 1141
	067479-01-000	EA	BULB - 12V - NUMBER 1076
	103608-01-000	EA	SOCKET - WEDGE BASE W/LEADS
	077479-01-000	EA	BOOT - BATTERY TERMINAL - DOUBLE CABLE
	077479-02-000	EA	BOOT - BATTERY TERMINAL - SINGLE CABLE
	086233-01-000	EA	STUD - ISOLATED - 3/8" X 7/8" LONG
	086273-01-000	EA	RELAY - BATTERY DISCONNECT
	087949-01-000	EA	BUSS BAR - 2 POSITION - .6' X 1.5" - ALUMINUM
	087949-02-000	EA	BUSS BAR - 3 POSITION
	007093-01-000	EA	FLASHER - SIGNAL - STAT
	008188-01-000	EA	SOLENOID - 3 POST - BATTERY CHANGE OVER
	075723-02-000	EA	SPACER - SWITCH - W/HOLE - .2" X .9" X 2" - METAL - OFF WHITE FOR ELECTRIC STEP DOOR JAMB SWITCH
	095188-01-01A	EA	SPACER - SWITCH - 2.3" X 3.4" - PLASTIC - DARK BROWN
	102568-01-E90	EA	SPACER - RECEPTACLE - SIDEWALL
	103987-02-000	EA	SEAL - SOLENOID ACCESS
	063910-01-000	EA	HOUSING - RELAY - BOSCH 3 334 485 008
	063912-02-000	EA	RELAY - CANISTER - SPDT - BOSCH 0332204101
	115504-01-000	EA	PANEL - SOLAR 10 WATT
	115505-01-000	EA	MONITOR - SOLAR CHARGER
	087225-01-000	FT	SLEEVING - 1/2" - TYPE H
	087225-02-000	FT	SLEEVING - 5/8" - TYPE H

CONVERTER & LOAD CENTER

KEY	PART NUMBER	U/M	DESCRIPTION
	113132-01-000	EA	LOAD CENTER - 120/ 240V - 60A WESCO 2460SGNM
	083208-02-000	EA	CONVERTER - POWER - 45A - 120V/12V - BW 6345
	099048-01-000	EA	INVERTER - 100 WATT

ELECTRICAL GROUP (CONTINUED)**ELECTRICAL HOUSINGS**

KEY	PART NUMBER	U/M	DESCRIPTION
	088473-01-000	EA	PIN HOUSING - 12 POSITION
	088473-02-000	EA	PIN HOUSING - 15 POSITION
	088473-03-000	EA	PIN HOUSING - 9 POSITION
	088473-05-000	EA	PIN HOUSING - 6 POSITION (SINGLE ROW)
	088473-06-000	EA	PIN HOUSING - 6 POSITION (TWO ROWS OF THREE)
	088473-08-000	EA	PIN HOUSING - 4 POSITION
	088473-09-000	EA	PIN HOUSING - 3 POSITION (SINGLE ROW)
	088473-10-000	EA	PIN HOUSING - 2 POSITION
	088474-01-000	EA	HOUSING - SOCKET - 12 POSITIONS
	088474-02-000	EA	HOUSING - SOCKET - 15 POSITION (3 ROWS OF 5)
	088474-03-000	EA	HOUSING - SOCKET - 9 POSITION
	088474-06-000	EA	HOUSING - SOCKET - 6 POSITION (2 ROWS OF THREE)
	088474-07-000	EA	HOUSING - SOCKET - 5 POSITION
	088474-08-000	EA	HOUSING - SOCKET - 4 POSITION (SINGLE ROW)
	088474-09-000	EA	HOUSING - SOCKET - 3 POSITION
	088474-10-000	EA	HOUSING - SOCKET - 2 POSITION
	101571-01-000	EA	HOUSING - 2 POSITION - MALE
	104100-01-000	EA	HOUSING - 1 POSITION - 75 AMP - AMP 53884-1
	106006-01-000	EA	HOUSING - 1 POSITION - FEMALE - PACKARD 12015952
	113468-01-000	EA	HOUSING - 2 POSITION - FEMALE (WIPER/WASHER WIRE ASM)
	108355-01-000	EA	HOUSING - SWITCH - CARLING VCH

INTERIOR LIGHTS

KEY	PART NUMBER	U/M	DESCRIPTION
	117806-01-000	EA	BULB - 12V NO.912 1.0 AMPS VA415
	098024-01-01A	EA	LIGHT - DOME - 1 BULB - US - IVORY
	008218-01-000	EA	BULB - DOME LIGHT - 12V - NUMBER 1141
	098024-01-700	EA	LENS - DOME LIGHT
	065201-09-000	EA	SHADE - LAMP - FABRIC - PARCHMENT
	065202-22-000	EA	LAMP - WALL - BRASS UL/ CSA - GUSTAFSON L512X0
	067479-01-000	EA	BULB - 12V - NUMBER 1076
	086280-01-000	EA	LIGHT - SURFACE MOUNT - 12V - JENSEN 1236
	086280-01-700	EA	BULB - 12 VOLT - 6 WATT
	087694-01-000	EA	LIGHT - WARDROBE/ CLOSET - W/SWITCH
	087694-01-700	EA	BULB - WARDROBE/ CLOSET LIGHT GE561
	098024-03-01A	EA	LIGHT - DOME - 2 BULB - IVORY
	008218-01-000	EA	BULB - DOME LIGHT - 12V - NUMBER 1141
	098024-01-700	EA	LENS - DOME LIGHT
	108354-01-01A	EA	LIGHT - COURTESY - ITC 81395-B
	108354-01-700	EA	BULB - COURTESY LIGHT 12842
	110235-02-01A	EA	LIGHT - MAKE UP - 4 BULB PANLESS - PD PD200-622 BRASS
	081633-01-700	EA	BULB - MAKE UP LIGHT - JENSEN
	113371-03-000	EA	LIGHT - FLUORESCENT - 42" STRIP - THIN-LITE 147 UL/CS

ELECTRICAL GROUP (CONTINUED)

SWITCHES, RECEPTACLES & COVERS

KEY	PART NUMBER	U/M DESCRIPTION
	108357-05-000	EA SWITCH - ROCKER - SPDT ON/ NONE/ ON
	108356-02-01A	EA SWITCH COVER - W/ DIMPLES - CARLING VVAZC00 BLA
	108357-09-000	EA SWITCH - ROCKER - SPDT ON/ NONE/ MOM
	108356-02-01A	EA SWITCH COVER - W/ DIMPLES - CARLING VVAZC00 BLA
	108357-06-000	EA SWITCH - ROCKER - DPDT MOM/ OFF/ MOM
	108356-02-01A	EA SWITCH COVER - W/ DIMPLES - CARLING VVAZC00 BLA
	108357-03-000	EA SWITCH - ROCKER - SPDT ON/ OFF/ ON
	108356-02-01A	EA SWITCH COVER - W/ DIMPLES - CARLING VVAZC00 BLA
	108357-10-000	EA SWITCH - ROCKER - SPDT MOM/ OFF/ MOM
	108356-04-01A	EA SWITCH COVER - W/ DIMPLES & LENS - CARLING VVAGC00
	096241-03-000	EA SWITCH - BLANK
	077942-01-000	EA SWITCH - DUMMY - BLACK
	079364-01-000	EA SWITCH - ON/OFF - ROCKER - 2 PRONGS - BROWN
	079364-03-000	EA SWITCH - ON/OFF - ROCKER - 3 PRONGS - BROWN
	098351-01-01A	EA PLATE - SWITCH - 1 GANG - POLISHED BRASS
	098351-02-01A	EA PLATE - SWITCH - 2 GANG - POLISHED BRASS
	098351-05-01A	EA PLATE - SWITCH - 3 GANG - POLISH BRASS - JENSEN
	080015-02-000	EA RECEPTACLE - FLAG - .185 - 16/14 GA - AMP 3
	084076-02-000	EA RECEPTACLE - GFI - 15A - 125V - BROWN
	058707-01-000	EA RECEPTACLE - ELECTRIC - SINGLE - BROWN
	058707-02-000	EA RECEPTACLE - BLANK - JUNCTION WIRECON
	058708-01-000	EA RECEPTACLE - ELECTRIC - DOUBLE - BROWN
	058708-02-000	EA RECEPTACLE - ELECTRIC - DOUBLE - IVORY
	007940-01-000	EA RECEPTACLE - SLIDE - 16 TO 12 AWG - FEMALE END
	007954-01-000	EA RECEPTACLE - HSG - 6 POSITION
	024924-02-000	EA RECEPTACLE - POWER CORD - W/PARTIAL PLATE
	091927-01-000	EA COVER - RECEPTACLE - DOUBLE - IVORY
	102568-01-E90	EA SPACER - RECEPTACLE - SIDEWALL
	112822-01-01A	EA RECEPTACLE - DUPLEX - IVORY
	112824-01-02A	EA COVER - EXTERIOR DUPLEX RECEPTACLE - OFF WHITE

ELECTRICAL WIRING & BOXES

KEY	PART NUMBER	U/M DESCRIPTION
	008052-01-000	EA CORD - POWER - 10/3 - 30 AMP - 25' - CANADIAN
	008054-01-000	EA CORD - POWER - 10/3 - 30 AMP - 25'
	008289-01-000	EA BOX - ELECTRIC - STEEL - 1/2" AND 3/4" KNOCKOUTS - 4" X 4"
	008289-02-000	EA BOX - ELECTRICAL - 4" X 4" - 1/2" & 3/4" KNOCKOUTS - CANADIAN
	074890-01-000	EA BOX - EXTENSION - STEEL - OPEN SIDES - 4" X 4" X 1 1/2"
	091910-01-000	EA BOX - ELECTRIC - 3.75" X 3.5" X 1.75" - PLASTIC
	091910-02-000	EA BOX - ELECTRIC - 57 X 88 MM - PLASTIC
	008294-01-000	EA COVER - ELECTRICAL BOX - BLANK/STEEL - 4" X 4" - GRAY
	008294-02-000	EA COVER - ELECTRICAL BOX - BLANK STEEL - 4" X 4" - CANADIAN
	074897-01-000	EA COVER - ELECTRIC BOX - 1 LARGE & 2 SMALL HOLES - 4" X 4"
	069238-01-000	EA COVER - ELECTRICAL BOX - W/HOLE - 4" X 4" - GRAY USED WITH 30 AMP RECEPTACLE
	111510-01-000	EA DOOR - ELECTRICAL BOX - FRONT
	108304-01-000	EA WIRE ASM. - AUX FANS
	090986-01-000	EA WIRE ASM - ELECTRIC STEP
	096449-01-000	EA WIRE ASSEMBLY - WATER TANK TO MONITOR PANEL
	097618-01-000	EA WIRE ASM - MONITOR PANEL - W/ 3 WIRES & ORANGE RESISTOR - LVS ORANGE RESISTOR W/3 (ORANGE-GREEN-BLUE) WIRES
	108303-01-000	EA WIRE ASM - REAR AUTO HEATER
	111915-03-000	EA WIRE ASM - DAY RUN LAMPS - FUSE - FORD
	111915-01-000	EA WIRE ASM - DAY RUN LAMPS - FUSE (GM)
	P03784-02-000	EA WIRE ASM. - HEADLAMP(FORD)
	P03784-01-000	EA WIRE ASM. - HEADLAMP(GM)
	073328-B4-000	EA CABLE ASSEMBLY - BATTERY - W/TERMINALS

ELECTRICAL GROUP (CONTINUED)

ELECTRICAL CONNECTORS & CONDUIT

KEY	PART NUMBER	U/M DESCRIPTION
	041953-01-000	FT CONDUIT - CONVOLUTE - SLIT - .5"ID
	041953-03-000	FT CONDUIT - CONVOLUTE - SLIT - 1" ID (CLOTHES ROD COVER)
	041953-05-000	FT CONDUIT - CONVOLUTE - SOLID - .62" ID
	041953-06-000	FT CONDUIT - CONVOLUTE - SLIT .375"ID
	041953-07-000	FT CONDUIT - CONVOLUTE - SLIT - .25" ID
	041953-08-000	FT CONDUIT - CONVOLUTE - SLIT - 1.50"ID
	041953-09-000	FT CONDUIT - CONVOLUTE - SLIT .50"ID
	041953-10-000	FT CONDUIT - CONVOLUTE - SLIT - .75" ID
	041953-11-000	FT CONDUIT - CONVOLUTE - SLIT - 1.06" ID
	041953-12-000	FT CONDUIT - CONVOLUTE - NON SLIT 1.1" ID
	008311-01-000	EA CONNECTOR - WIRE NUT - INSULATED - RED
	008312-01-000	EA CONNECTOR - WIRE NUT - INSULATED - BLUE
	008314-01-000	EA CONNECTOR - WIRE NUT - INSULATED - GRAY
	008355-01-000	EA CONNECTOR - CABLE CLAMPING - 3/4"
	008356-01-000	EA CONNECTOR - PLASTIC - 3/8" AVG
	082741-01-000	EA CONNECTOR - BODY - 2 CONNECTOR - MALE
	058028-01-000	EA CONNECTOR - ELECTRICAL PIGTAIL - NYLON - CLEAR
	041480-01-000	EA CONNECTOR - STRAIGHT - 1/2" FLEX CONDUIT
	088475-01-000	EA PIN-CONNECTOR - 14 TO 20 AWG
	088476-01-000	EA SOCKET - CONNECTOR - BRASS - PRE - TIN
	088476-02-000	EA SOCKET - CONNECTOR - 12-10 GA - PHOS. BRZ - PRE - TIN

CIRCUIT BREAKERS & FUSES

KEY	PART NUMBER	U/M DESCRIPTION
	097611-01-000	EA CIRCUIT BREAKER - 6AMP - ATC - BLACK
	093655-03-000	EA CIRCUIT BREAKER - 40 AMP USD 17440-4E03A2A
	083209-02-000	EA CIRCUIT BREAKER - 15/15AMP - 120V - BW H - 15/15
	083209-03-000	EA CIRCUIT BREAKER - 15/20AMP - 120V - BW - 0-15/20
	083209-04-000	EA CIRCUIT BREAKER - 30A - 120V - BW L - 30
	083209-06-000	EA CIRCUIT BREAKER - 30/15 AMP - 120V - BW D - 30/15
	083209-07-000	EA CIRCUIT BREAKER - 20/20A - 120V - BW K - 20/20
	083209-08-000	EA CIRCUIT BREAKER - BLANK - BW
	062901-02-000	EA FUSE - 5 AMP - AUTOMOTIVE
	062901-05-000	EA FUSE - 15 AMPS - AUTOMOTIVE
	062901-07-000	EA FUSE - AUTOMOTIVE - 25 AMPS
	062901-08-000	EA FUSE - 30 AMPS - AUTOMOTIVE
	106656-01-000	EA FUSE BLOCK - 4 CAVITY AUTOFUSE
	108669-01-000	EA HOUSING - AUTO FUSE HOLDER
	062037-01-000	EA HOUSING - AUTO FUSE - NATURAL
	062037-03-000	EA HOUSING - AUTO FUSE - BLACK
	062037-04-000	EA HOUSING - AUTO FUSE - BLUE
	062037-06-000	EA HOUSING - AUTO FUSE - BROWN

EXTERIOR BODY GROUP

EXTERIOR BODY PANELS & TRIM

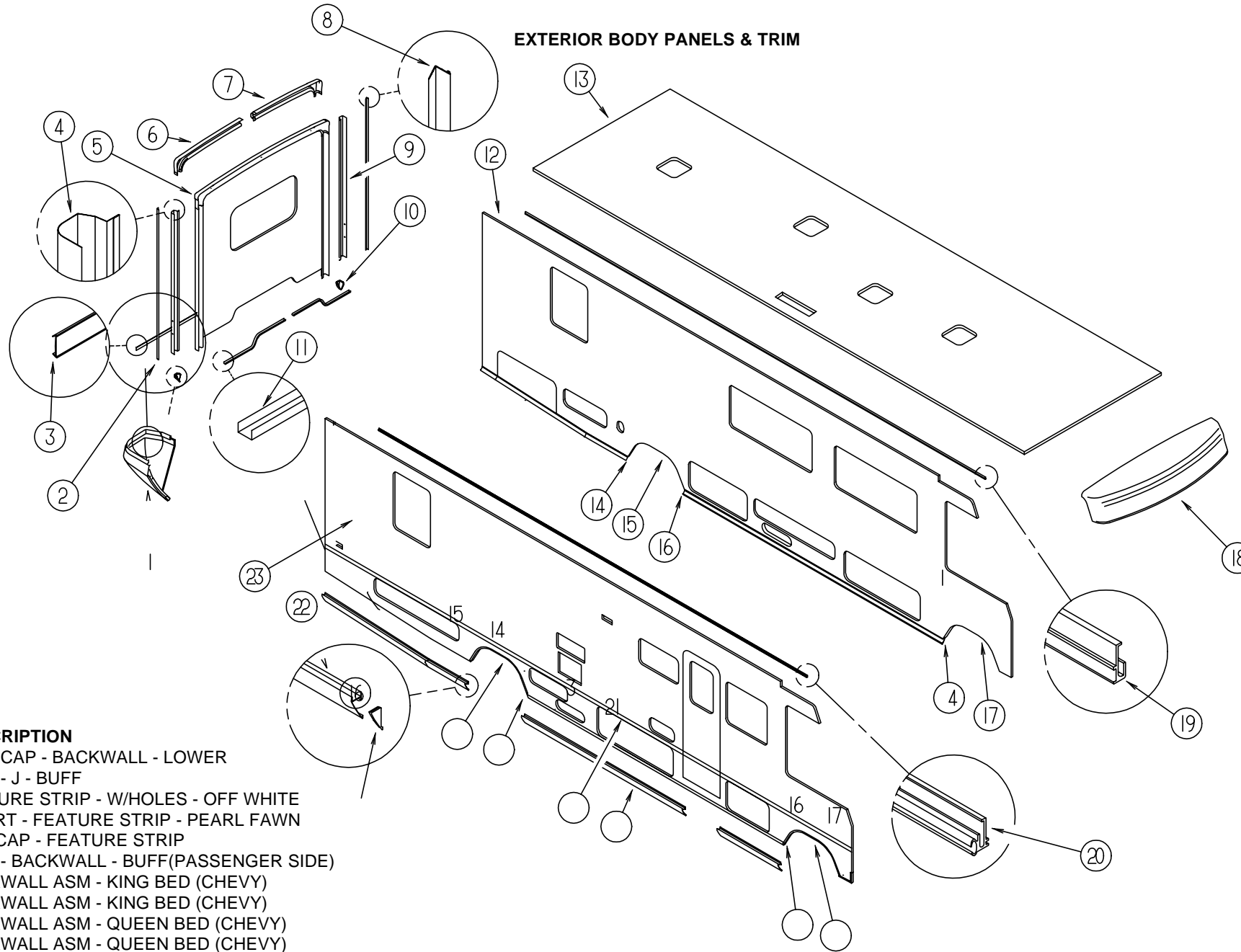

KEY	PART NUMBER	U/M	DESCRIPTION
1	115848-01-01A	EA	TRIM CAP - BACKWALL - LOWER
2	104033-05-01A	EA	TRIM - J - BUFF
3	108688-01-01A	EA	FEATURE STRIP - W/HOLES - OFF WHITE
	105312-01-06A	FT	INSERT - FEATURE STRIP - PEARL FAWN
	108651-01-02A	EA	END CAP - FEATURE STRIP
4	114874-01-07B	EA	TRIM - BACKWALL - BUFF(PASSENGER SIDE)
5	M06886-11-F11	EA	BACKWALL ASM - KING BED (CHEVY)
5	M06886-11-F12	EA	BACKWALL ASM - KING BED (CHEVY)
5	M06886-07-F11	EA	BACKWALL ASM - QUEEN BED (CHEVY)
5	M06886-07-F12	EA	BACKWALL ASM - QUEEN BED (CHEVY)
5	M06886-08-F11	EA	BACKWALL ASM - TWIN BED (CHEVY)
5	M06886-08-F12	EA	BACKWALL ASM - TWIN BED (CHEVY)
5	M06887-11-F11	EA	BACKWALL ASM - KING BED (FORD)
5	M06887-11-F12	EA	BACKWALL ASM - KING BED (FORD)
5	M06887-07-F11	EA	BACKWALL ASM - QUEEN BED (FORD)
5	M06887-07-F12	EA	BACKWALL ASM - QUEEN BED (FORD)
5	M06887-08-F11	EA	BACKWALL ASM - TWIN BED (FORD)
5	M06887-08-F12	EA	BACKWALL ASM - TWIN BED (FORD)
6	114872-02-01A	EA	TRIM - BACKWALL - TOP - BUFF (PASSENGER SIDE)
7	114873-02-01A	EA	TRIM - BACKWALL - TOP - BUFF (DRIVER SIDE)
8	104033-05-04A	EA	TRIM - J - BUFF
9	114874-02-07B	EA	TRIM - BACKWALL - BUFF (DRIVER SIDE)
10	115848-02-01A	EA	TRIM CAP - BACKWALL - LOWER
11	050406-20-000	EA	TRIM - BACKWALL - LOWER LEFT OR RIGHT SIDE - BUFF

KEY	PART NUMBER	U/M	DESCRIPTION
12	M07519-02-F11	EA	SIDEWALL ASM (DRIVER SIDE) (W/ DRIVER DOOR)
12	M07519-02-F12	EA	SIDEWALL ASM (DRIVER SIDE) (W/ DRIVER DOOR)
12	M07519-01-F11	EA	SIDEWALL ASM (DRIVER SIDE) (W/O DRIVER DOOR)
12	M07519-01-F12	EA	SIDEWALL ASM (DRIVER SIDE) (W/O DRIVER DOOR)
13	M07520-01-F11	EA	ROOF ASM. (KING BED)
13	M07520-02-F11	EA	ROOF ASM. (QUEEN BED)
13	M07520-03-F11	EA	ROOF ASM. (TWIN BED)
14	116054-02-01A	EA	TRIM CAP - ROCKER PANEL
15	116048-02-01A	EA	TRIM - WHEELWELL - REAR (DRIVER OR PASSENGER SIDE)
16	116054-01-01A	EA	TRIM CAP - ROCKER PANEL
17	116048-01-01A	EA	TRIM - WHEELWELL - FRONT (DRIVER OR PASSENGER SIDE)
18	M05145-08-F11	EA	CAP ASM - FRONT - W/O TRIM - BUFF
19	103801-02-04A	EA	TRIM - ROOF
20	103802-02-04A	EA	RAIL - AWNING
21	109140-55-001	EA	ROCKER PANEL 192" BUFF
22	115471-13-F11	EA	PANEL ASM - ROCKER - REAR - RH
	115471-10-F11	EA	PANEL ASM - ROCKER - REAR - LH
23	P17178-01-F11	EA	SIDEWALL ASM -(PASSENGER SIDE)
23	P17178-01-F12	EA	SIDEWALL ASM - (PASSENGER SIDE)

EXTERIOR BODY GROUP (CONTINUED)

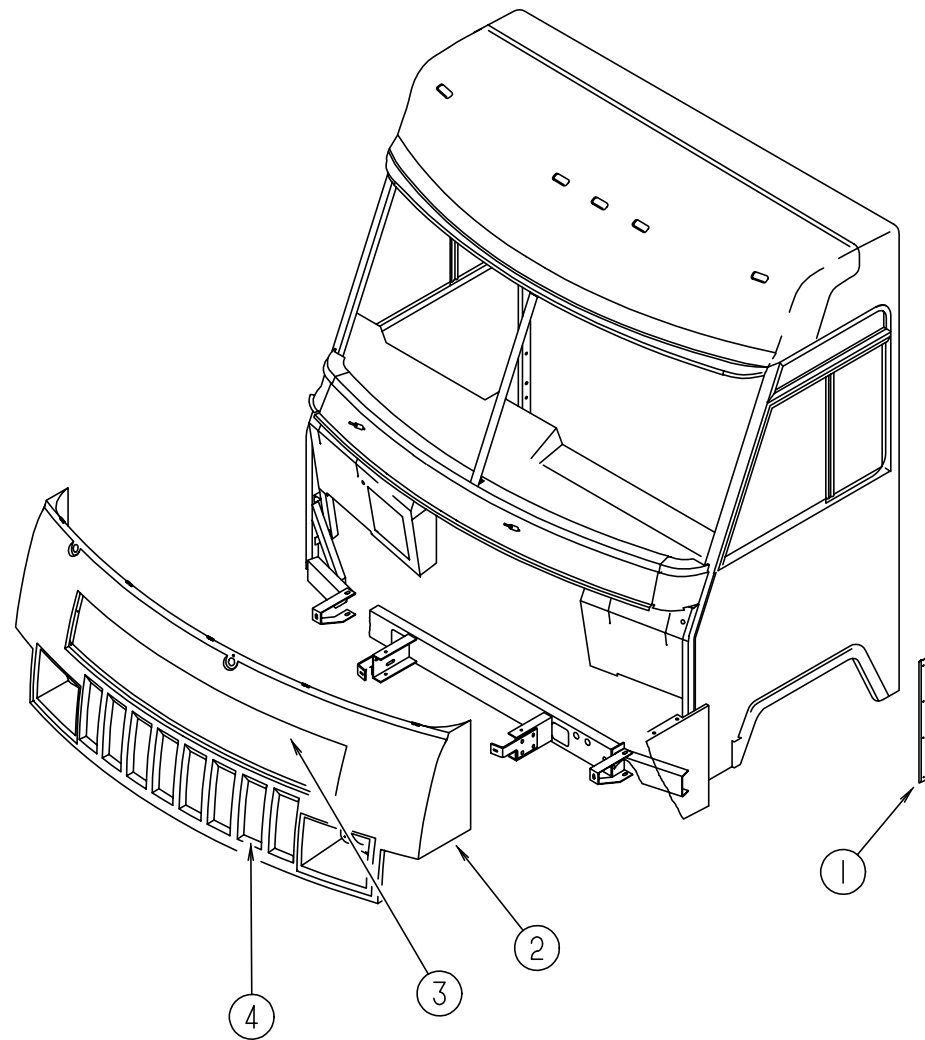

FRONT END ASSEMBLY

KEY	PART NUMBER	U/M DESCRIPTION
1	089922-15-000	EA TRIM - FIBERGLASS - BUFF
2	115973-01-F11	EA PANEL - FRONT - LOWER - BUFF
3	115976-01-F11	EA PANEL - HOOD - BUFF
4	115972-01-F11	EA GRILLE ASSEMBLY - FRONT - LOWER
	115924-01-02A	EA GRILLE - WOVEN WIRE - FLAT BLACK - KENT 5815P
	115924-01-01A	EA GRILLE - WOVEN WIRE - MILL - KENT 5815P
	070579-06-000	EA PLATE - ANCHOR - W/7/16 WELD NUT - 1.5" X 3.3"
	077001-01-000	EA ANGLE - MOUNTING - ROOF PANEL - V ANGLE - 3" X 2.4" X 1.5"
	106765-01-000	EA SUPPORT - BOLT - HOOD ADJUSTING
	058786-01-000	EA BOLT - ADJUSTING - HOOD - W/BLACK PAD - .31" #18 X 2"
	102330-02-000	EA LATCH - SINGLE HOLE - VISE ACTION - SOUTHCOE 3-56-715-5

EXTERIOR BODY GROUP (CONTINUED)

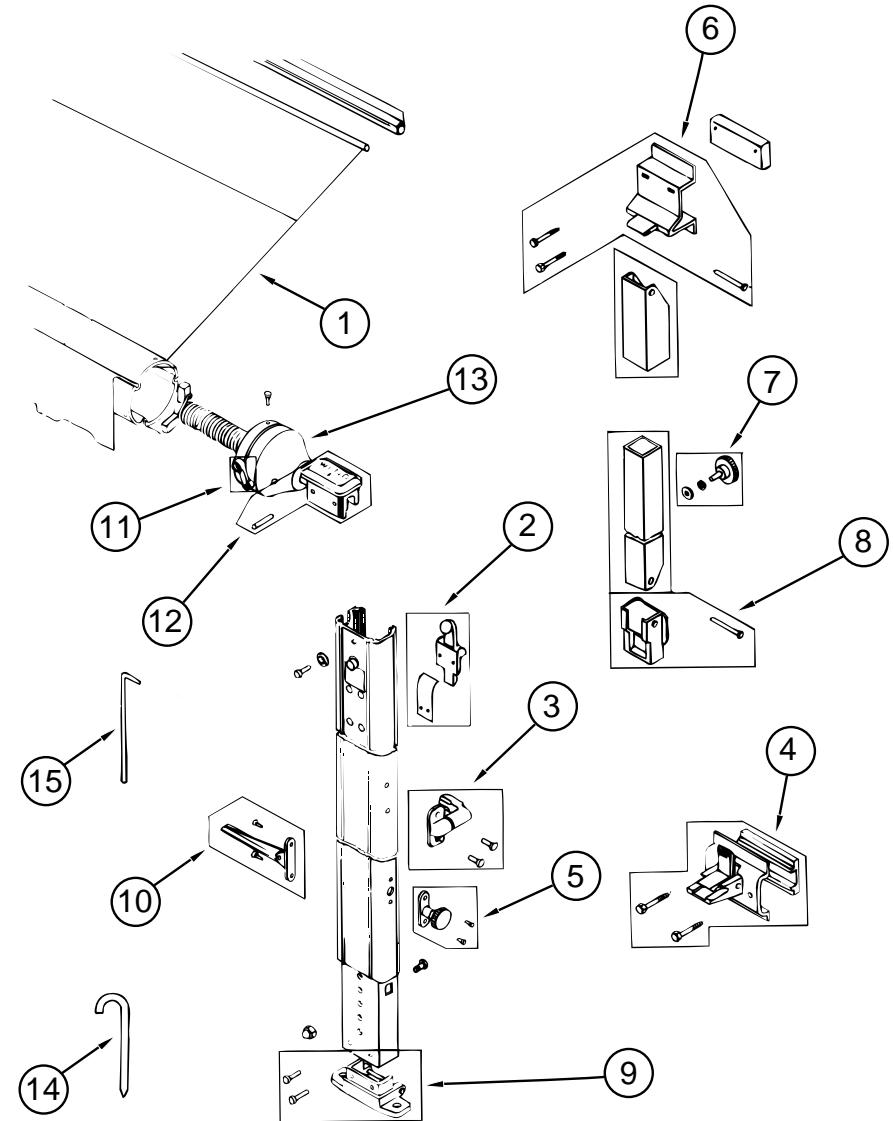

EXTERIOR AWNING (FAULKNER)

KEY	PART NUMBER	U/M DESCRIPTION	FAULKNER VENDOR NO.
	110634-02-01A	EA AWNING - HARDWARE KIT - BUFF	
1	110634-07-12A	EA AWNING - ROLLER ASM - 19'	
2	110634-01-700	EA RAFTER LOCKING MECHANICAL KIT	7605-0001
3	110634-01-701	EA SAFETY & LATCH KIT	7509-0001
4	110634-01-702	EA BOTTOM BRACKET KIT	7512-0001
	111038-01-01A	EA SPACER - AWNING - LOWER - BLACK	
5	110634-01-703	EA HEIGHT LOCK HANDLE KIT	7510-0001
6	110634-01-704	EA UPPER BRACKET KIT W/BOLTS	7505-0001
	111037-01-01A	EA SPACER - AWNING - UPPER - BLACK	
7	110634-01-705	EA ULTRA RAFTER KNOB KIT	7522-0001
8	110634-01-706	EA RAFTER SLIDE KIT	
9	110634-01-707	EA GROUND BRACKET KIT	7511-0001
10	110634-01-708	EA LIFT HANDLES W/ RIVETS	7000-0001
11	110634-01-709	EA RATCHET HANDLE KIT	7507-0001
12	110634-01-710	EA ARM CAP KIT	7503-0001
13	110634-01-711	EA FRONT SPRING ASM	6598-0001
	110634-01-712	EA REAR SPRING ASM	6599-0001
	110634-01-713	EA REAR END CAP KIT	7504-0001
14	110634-01-714	EA STAKE (4 PER BAG)	5208-0001
15	110634-01-715	EA PULL DOWN WAND	7604-0001
	110634-01-721	EA ARM - INNER - FRONT - BUFF	5686-0001
	110634-01-722	EA ARM - INNER - REAR - BUFF	5687-0001
	110634-01-723	EA RAFTER - OUTER - BUFF	5688A0001
	110634-01-724	EA RAFTER - INNER - BUFF	5689A0001

EXTERIOR BODY GROUP (CONTINUED)

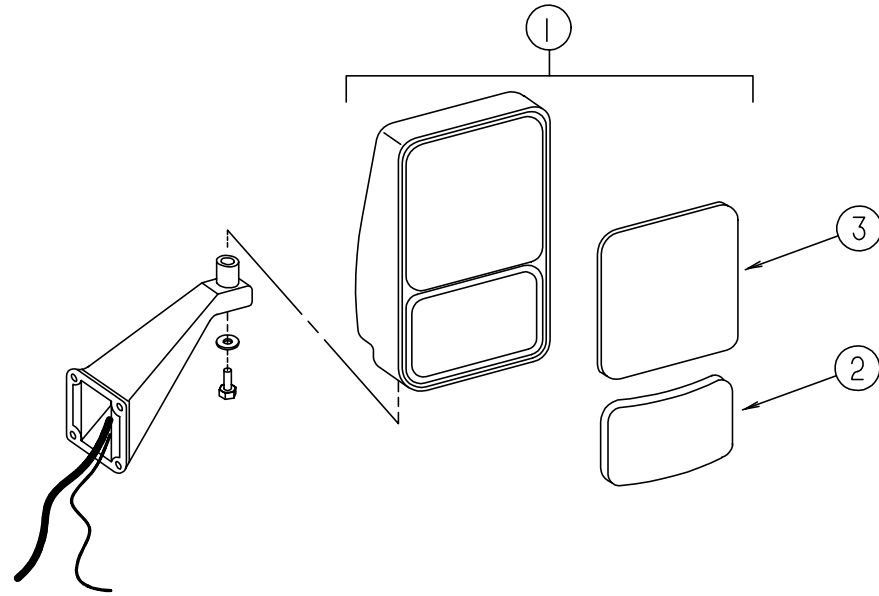

EXTERIOR BODY GROUP (CONTINUED)

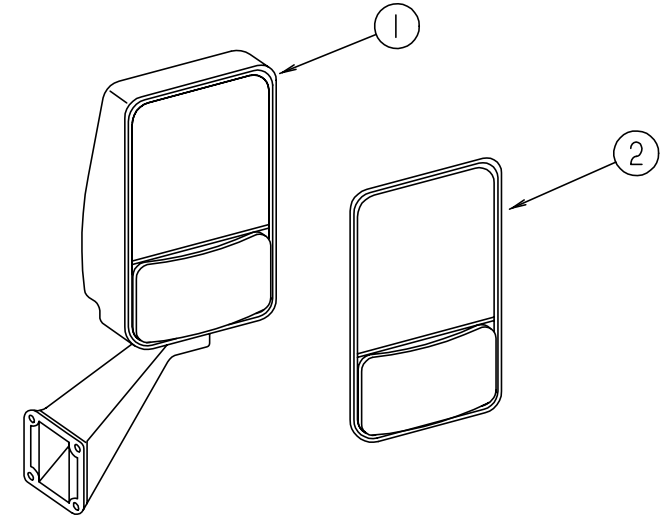

EXTERIOR MIRROR OPTION (REMOTE & HEAT)

KEY	PART NUMBER	U/M	DESCRIPTION
1	106015-05-01A	EA	MIRROR ASM - EXTERIOR REMOTE & HEAT - PASSENGER SIDE
1	106015-06-01A	EA	MIRROR ASM - EXTERIOR REMOTE & HEAT - DRIVER SIDE
2	086261-02-700	EA	CONVEX REPLACEMENT - INNER HOUSING & BEZEL - DRIVER SIDE
2	086261-01-703	EA	CONVEX REPLACEMENT - INNER HOUSING & BEZEL - PASSENGER SIDE
3	086261-01-702	EA	GLASS - FLAT - HEATED - W/ BEZEL
	087695-01-000	EA	SWITCH - HEATER - EXTERIOR MIRROR
	088246-01-000	EA	SWITCH - REMOTE - EXTERIOR MIRROR - SQUARE PUSH
	086261-02-701	EA	KIT - EXTERIOR MIRROR - W/ BEZEL - FLAT & CONVEX GLASS - DRIVER SIDE KIT INCLUDES: BEZEL - CONVEX GLASS - HEATED FLAT GLASS FOR CURRENT AND OLD STYLE MIRROR
	086261-01-704	EA	KIT - EXTERIOR MIRROR - W/ BEZEL - FLAT & CONVEX GLASS - PASSENGER SIDE KIT INCLUDES: BEZEL - CONVEX GLASS - HEATED FLAT GLASS FOR CURRENT AND OLD STYLE MIRROR

EXTERIOR MIRROR

KEY	PART NUMBER	U/M	DESCRIPTION
1	106015-09-01A	EA	MIRROR ASM - PASSENGER SIDE
1	106015-10-01A	EA	MIRROR ASM - DRIVER SIDE
2	106015-01-703	EA	MIRROR KIT (BEZEL W/MIRRORS) PASSENGER SIDE
2	106015-02-702	EA	MIRROR KIT (BEZEL W/MIRRORS) DRIVER SIDE

EXTERIOR BODY GROUP (CONTINUED)

DECALS, FILM STRIPES & PAINT

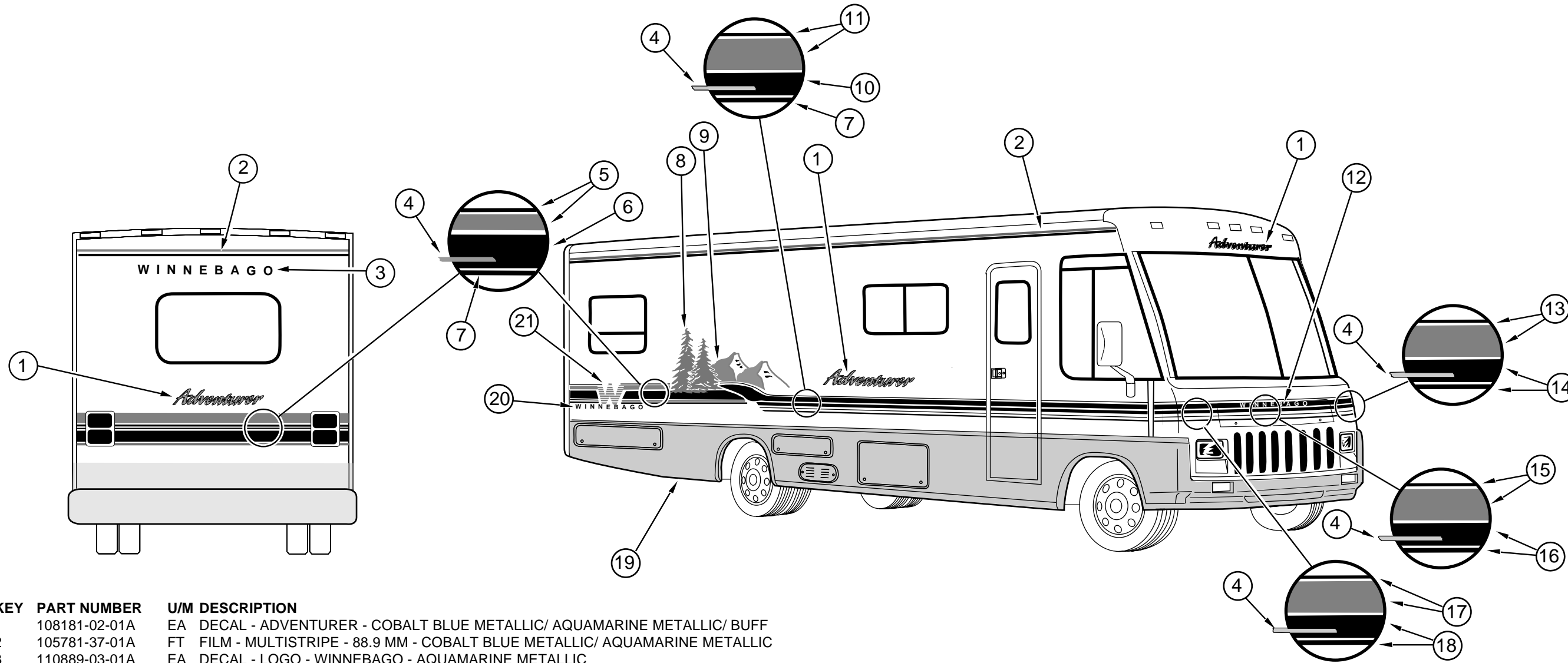

KEY	PART NUMBER	U/M	DESCRIPTION
1	108181-02-01A	EA	DECAL - ADVENTURER - COBALT BLUE METALLIC/ AQUAMARINE METALLIC/ BUFF
2	105781-37-01A	FT	FILM - MULTISTRIPE - 88.9 MM - COBALT BLUE METALLIC/ AQUAMARINE METALLIC
3	110889-03-01A	EA	DECAL - LOGO - WINNEBAGO - AQUAMARINE METALLIC
4	093681-47-01A	FT	FILM - SINGLE STRIPE - 6.4 MM - WHITE REFLECTIVE
5	105781-39-01A	FT	FILM - MULTISTRIPE 50.8 MM - COBALT BLUE METALLIC/ COBALT BLUE METALLIC
6	093681-46-01A	FT	FILM - SINGLE STRIPE - 114.3 MM - AQUAMARINE METALLIC
7	093681-42-02A	FT	FILM - SINGLE STRIPE - 19.1 MM - MEDIUM SWEDISH BLUE METALLIC
8	115758-03-01A	EA	DECAL - TREES - RH - BLUE LAGOON/ AQUAMARINE METALLIC
8	115758-04-01A	EA	DECAL - TREES - LH - BLUE LAGOON/ AQUAMARINE METALLIC
9	115758-01-01A	EA	DECAL - MOUNTAIN SCENE - RH - MED SWEDISH BLUE METALLIC/ COBALT BLUE MET
9	115758-02-01A	EA	DECAL - MOUNTAIN SCENE - LH - MED SWEDISH BLUE METALLIC / COBALT BLUE MET
10	093681-40-05A	FT	FILM - SINGLE STRIPE - 50.8 MM - AQUAMARINE METALLIC
11	105781-32-02A	FT	FILM - MULTISTRIPE - 114.3 MM - COBALT BLUE METALLIC/ COBALT BLUE METALLIC
12	110889-03-02A	EA	DECAL - LOGO - WINNEBAGO - BUFF
13	115761-02-01A	EA	DECAL - CORNER - FRONT - UPPER LH - COBALT BLUE METALLIC/ COBALT BLUE MET
14	115762-02-01A	EA	DECAL - CORNER - FRONT - LOWER LH - AQUA METALLIC/ WHITE REFL/ MED SWED BLUE MET
15	115759-01-01A	EA	DECAL - HOOD - UPPER - COBALT BLUE METALLIC
16	115760-01-01A	EA	DECAL - HOOD - LOWER - AQUAMARINE METALLIC/ WHITE REFLECTIVE/ MED SWED BLUE MET
17	115761-01-01A	EA	DECAL - CORNER - FRONT - UPPER RH - COBALT BLUE METALLIC/ COBALT BLUE MET
18	115762-01-01A	EA	DECAL - CORNER - FRONT - LOWER RH - AQUA METALLIC/ WHITE REFL/ MED SWED BLU MET
19	N / P / N		PAINT - GRAPHITE METALLIC (DUPONT H8235)
20	110889-03-01A	EA	DECAL - LOGO - WINNEBAGO - AQUAMARINE METALLIC
21	110207-02-01A	EA	DECAL - W - LASER - COBALT BLUE METALLIC

DUPONT PAINT COLOR CODES

GRAPHITE METALLIC	H8235
OFF WHITE	L8723
BUFF	G9692

EXTERIOR BODY GROUP (CONTINUED)

STYROFOAM & FIBERGLASS SHEETING

KEY	PART NUMBER	U/M	DESCRIPTION
	000870-08-000	SF	STYROFOAM - .75" X 48" X 96" - PLANED
	083574-03-000	SF	STYROFOAM - 3/4" X 48" X 96"
	083574-05-000	SF	STYROFOAM - 2.0" X 48" X 96"
	065747-01-000	SF	INSULATION - MICROFOAM - .5" X 72" X 112' ROLL
	034073-27-011	EA	PLASTIC - ABS .200 X 28.00 X 068.00" - ANY BLK 0/MIL SM/SM
	076054-J7-000	EA	FIBERGLASS SHEET - 102" X 385.2" - BUFF
	076054-P8-000	EA	FIBERGLASS SHEET - 101.25" X 102" - BUFF
	077517-24-000	EA	SHEET-FIBERGLASS - FLAT - 48" X 96" - OFF WHITE
	077517-59-000	EA	FIBERGLASS SHEET - 48" X 96" - BUFF PAINTING IS REQUIRED WHEN USED ON OLDER COACHES
	100619-01-000	BF	FOAM - EXPANDED POLYSTYRENE - 48" X 96" X 1.34"
	100619-04-000	BF	FOAM - EXPANDED POLYSTYRENE - EPS 48" X 96" X .5
	100619-05-000	BF	FOAM - EXPANDED POLYSTYRENE - 48" X 96" X .75"
	100619-09-000	BF	FOAM - EXPANDED POLYSTYRENE - 3.0" X 48" X 92.50"
	100619-13-000	BF	FOAM - EXPANDED POLYSTYRENE - 48" X 96" X .34"
	108535-03-700	EA	FRP FLAT 110" X 396" - BUFF
	105077-03-000	EA	FOAM - PLUG - SIDEWALL TUBE
	105077-04-000	EA	FOAM - ROOF COVE - 8'
	105077-05-000	EA	FOAM - ENDCAP - ROOF COVE

EXTERIOR BODY HARDWARE

KEY	PART NUMBER	U/M	DESCRIPTION
	002726-01-001	EA	GARNISH - U-CHANNEL - 1.38" X 19' - SERRATED - MILL ALUMINUM
	002754-01-001	EA	ANGLE - EXTRUDED - .75" X .75" X 18' - MILL ALUMINUM
	033381-17-001	FT	STEEL - TUBE 16GA 1.5 X 1.5 X 288.00 HOT FORMED ASTM A50
	044487-01-002	EA	ALUMINUM - .019 X 96.00 X 432"
	055278-51-259	EA	TUBING - STEEL - 12.5'
	058267-01-000	FT	CHANNEL - STEEL - W/ HOLES - SIDEWALL STIFFENER - 2" X 20'
	068716-01-001	EA	BRACE - 90 DEGREE L-ANGLE - 192" - EXTRUDED ALUMINUM
	089297-01-000	SF	PLYWOOD - LUAN - OVERLAY GRADE - 4' X 8'
	089297-02-000	SF	PLYWOOD - LUAN GRADE CC LFE 2.7 MM X 48 X 108

EXTERIOR BODY GROUP (CONTINUED)

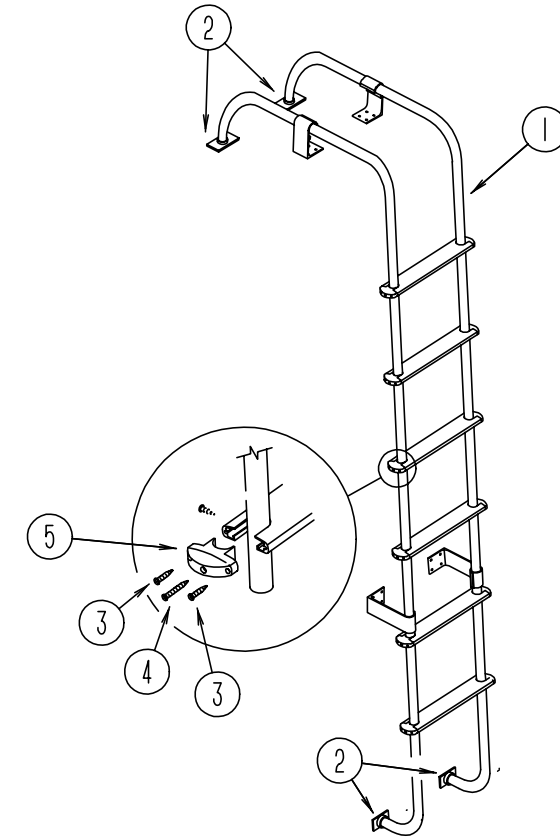

LADDER

KEY	PART NUMBER	U/M	DESCRIPTION
1	102953-11-F31	EA	LADDER ASM
2	067165-01-000	EA	MOUNTING BRACKET - LADDER - LOWER
3	000G39-06-10T	EA	SCREW-SF/ DR - 6 - 20 X 5/8 PPH - BLACK
4	000G68-10-36T	EA	SCREW - 10 - 12 X 2.25 POH BLACK
5	076980-02-000	EA	END CAP - STEP - BLACK
	038327-01-000	FT	TAPE - ANTI SLIP - 2" X 60FT

GALLEY GROUP

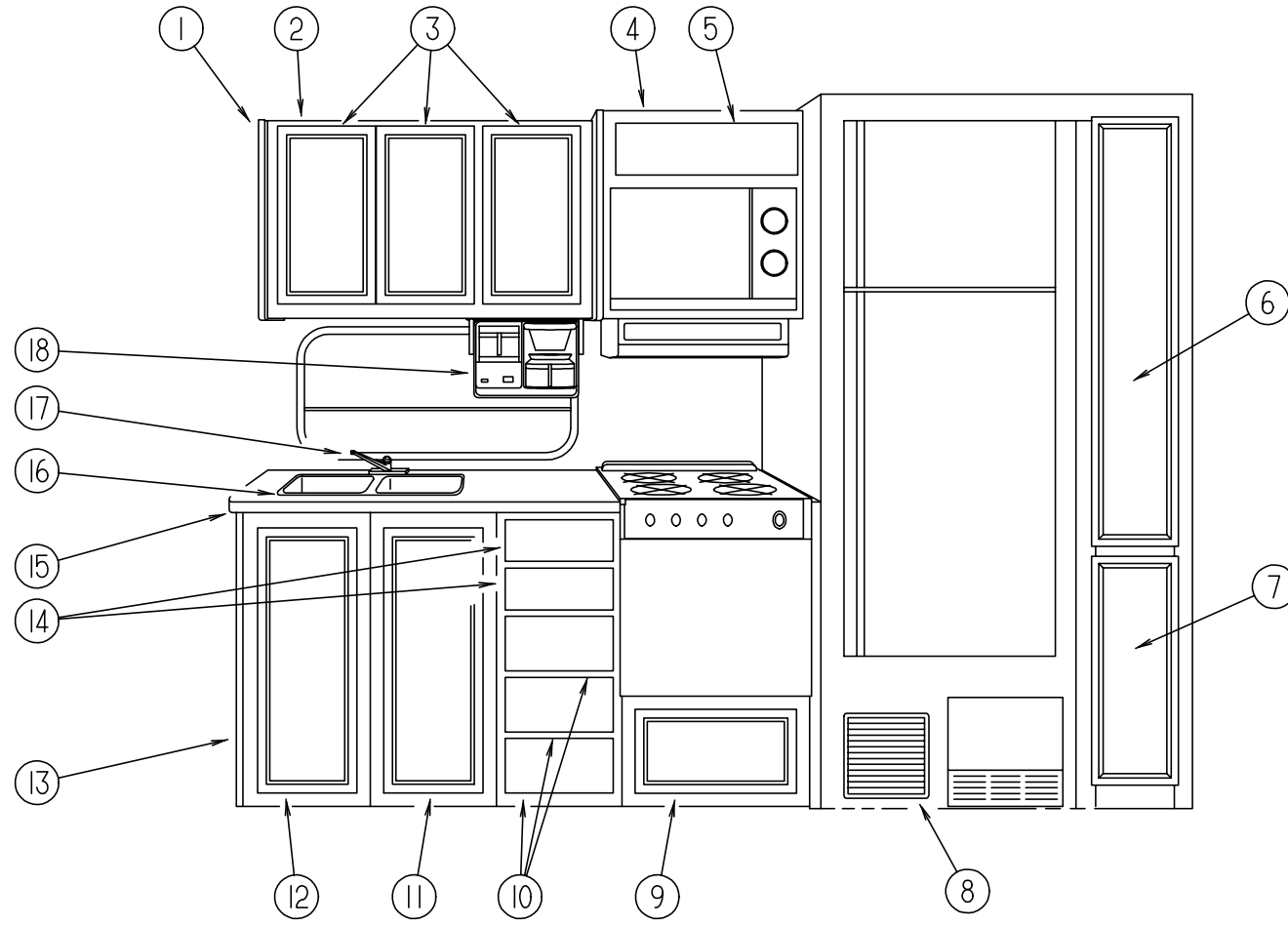

GALLEY CABINETRY & FIXTURES

KEY	PART NUMBER	U/M DESCRIPTION
1	081319-20-C27	EA END CAP ASM. - OVERHEAD
2	P15842-01-F11	EA CABINET ASM - GALLEY - OVERHEAD
	115842-11-F11	EA SHELF ASM - GALLEY - OVERHEAD - 312 X 634 MM
	115842-12-F11	EA SHELF ASM - GALLEY - OVERHEAD - 312 X 336 MM
3	M06803-29-E10	EA DOOR ASM - W/O HARDWARE - 555 X 240 MM
4	114390-02-F11	EA CABINET ASM - MICROWAVE OVHD
	116592-02-F31	EA CABINET ASM - A/C SWITCH
5	M05992-11-E07	EA DOOR ASM - RAIL - W/O HARDWARE - 180 X 555 MM
6	M06803-C9-F11	EA DOOR ASM - W/O HARDWARE - 215 X 1220 MM
7	M06803-K1-F11	EA DOOR ASM - W/O HARDWARE - 215 X 485 MM
8	093614 02 01A	EA GRILL - RETURN AIR - BROWN
9	M05971-68-E10	EA DRAWER ASM. - W/O HARDWARE
10	M05971-11-E07	EA DRAWER ASM. - W/O HARDWARE
11	M06803-33-E10	EA DOOR ASM - W/O HARDWARE
12	M06803-32-E10	EA DOOR ASM - W/O HARDWARE
13	M06843-01-F11	EA GALLEY CABINET ASM.
13	M06843-01-F12	EA GALLEY CABINET ASM.
14	M05971-68-E10	EA DRAWER ASM. - W/O HARDWARE
15	111440-12-F11	EA COUNTERTOP ASM.
15	111440-12-F12	EA COUNTERTOP ASM.
	108464-04-F11	EA COVER ASM - SINK
	108464-04-F40	EA COVER ASM - SINK (F12)
16	110654-01-000	EA SINK - STAINLES STEEL - DOUBLE - LARGE/SMALL BASIN
	092303-01-000	EA STRAINER - SINK
17	103243-01-000	EA FAUCET - GALLEY - DUAL CONTROL
18	103799-01-02A	EA COFFEE MAKER GRAY
	103799-01-700	EA CARAFE GLASS POT
	103799-01-701	EA BRACKETS - WHITE PAIR
	104610-01-000	EA STRAP ASM - COFFEE MAKER
	090329-01-000	FT T-SEAL - REFRIGERATOR CABINET - .6" WIDE TOP X 2" TAIL

GALLEY GROUP (CONTINUED)

REFRIGERATOR, NORCOLD (6182)

KEY	PART NUMBER	U/M DESCRIPTION	VENDOR NO.
	104137-06-01A	EA REFRIGERATOR - LARGE DBL DOOR 2-WAY	
	075217-01-734	EA FUSE - 3 AMP	61538822
	075217-01-738	EA SWITCH - HUMIDITY	61525922
	084880-01-705	EA ORIFICE	614522
	084880-01-718	EA VALVE - GAS	61551822
	084880-01-720	EA SPRING (FOR DOOR HANDLE)	61558822
	084880-01-722	EA CRISPER COVER	615641
	084880-01-732	EA LATCH	61578522
	084880-01-740	EA END CAP (STOP CATCH)	61593830
	084880-01-746	EA CABLE	61571522
	084880-01-749	EA HINGE BUSHING	615807
	084880-01-753	EA THERMISTER 78"	61693822
	084880-01-760	EA CLIP (THERMISTER)	61689122
	084880-01-761	EA END CAP (SPRING CATCH) BLACK	61593730
	084880-03-701	EA COOLING UNIT (HORIZ BURNER)	61687337
	084880-03-702	EA HINGE PIN TOP/BTM FEMALE	61580630
	088248-01-709	EA HEATER - AC (HORIZONTAL)	615627
	088248-01-710	EA HEATER - DC (HORIZONTAL) 3 WAY	615628
	094039-01-702	EA GASKET (GRAY) UPPER	61567830
	094039-01-704	EA PLATE - HINGE - BLACK	61631430
	094039-01-706	EA UPPER DOOR LINER (WHITE) BLACK	61581838-B
	094039-01-708	EA DOOR HANDLE ASM - UPPER - BLACK	61650038
	094039-01-710	EA PLATE - HINGE - BLACK	61631330
	094039-01-713	EA DOOR GASKET (LOWER) GRAY	61568030
	094039-01-715	EA LOWER DOOR LINER (BLACK/WHITE)	61581738-B
	094039-01-717	EA DOOR HANDLE ASM - LOWER (BLACK)	61649938
	094039-01-722	EA HOLE PLUG (BLACK) HINGE HOLES	61582030
	094039-01-723	EA HINGE BRACKET - TOP RH - BOTTOM - LH - BLACK	61580838
	094039-01-724	EA HINGE BRACKET - TOP LH - BOTTOM - RH - BLACK	61580938
	094039-01-725	EA HINGE PIN (BLACK)(MALE)	61578130
	094039-01-730	EA HINGE PIN SHAFT (BLACK) CENTER HINGE	61566730
	094039-01-732	EA FRONT COVER (BLACK) BOTTOM TRIM	61622130
	094039-01-733	EA WIRE SHELF (MIDDLE)	61563822
	094039-01-735	EA INSIDE DRIP TRAY (WHITE)	61572830
	094039-01-739	EA SHELF (CUTOUT)	61646722
	094039-04-700	EA PRINTED CIRCUIT BOARD - 2 WAY	1647322
	094039-04-702	EA POWER SUPPLY (2 WAY)	61647422
	104137-02-700	EA MODULE - CONTROL - CHANNEL	61717037
	104137-06-700	EA EYEBROW SHELL (2-WAY)	61726622
	094039-01-708	EA HANDLE - DOOR - UPPER - BLACK	61650038
	104137-06-702	EA RACK - JUICE (WHITE)	61580525
	104137-06-703	EA BIN - DOOR SHELF (WHITE)	61564025
	104137 06 704	EA BIN - MILK (WHITE)	61579425
	104137-06-706	EA WIRE SHELF (SHORT)	61718222
	104137-06-707	EA CRISPER (WHITE)	61571325
	104137-06-708	EA FOAMED CAB ASM (BLACK W/ WHITE)	61725138
	104137-06-709	EA VALVE SHUT - OFF - MANUAL ASM	61694922
	104137-06-710	EA PRESSURE TAP	61594422
	104137-06-711	EA FUSE 5 AMP	61611622
	104137-06-712	EA FITTING - GAS TUBE CONNECTION	61692722
	104137-06-713	EA ORIFICE GASKET	61475122
	104137-06-714	EA BURNER ASSEMBLY (5-SLOT)	61705222
	104137-06-715	EA SPARK/ SENSE ELECTRODE (SINGLE)	61692222
	104137-08-01A	EA LIGHT KIT - REFRIG	61771022
	093646-01-000	EA BRACKET ASM - TIEDOWN - REFRIGERATOR	
	093646-02-000	EA BRACKET ASM - TIEDOWN - REFRIGERATOR	
	054450-01-000	EA LEVEL - REFRIGERATOR	
	065225-02-000	EA PLATE - TIEDOWN - REFRIG	

GALLEY GROUP (CONTINUED)

WEDGEWOOD RANGE, 4 BURNER (BLACK) 21"(R2145BG)

KEY	PART NUMBER	U/M DESCRIPTION	VENDOR NO.
	107323-01-01A	EA RANGE - 21" 4 - BURNER BLACK	
	106693-01-702	EA RUBBER BUMPER 1/2" - RANGE COVER	53018
	101593-01-703	EA KNOB - BURNER	53000
	106689-01-701	EA SPARK - IGNITOR ASM - HIGH OUTPUT	53078
	106689-01-702	EA PIEZO PUSH BUTTON	52279
	106689-01-703	EA VALVE - HIGH OUTPUT	53047
	106689-01-704	EA REGULATOR W/EXTREME PRESSURE	52154
	106689-01-705	EA VALVE - BURNER	52123
	107246-01-701	EA GRATE	53050
	107323-01-700	EA RANGE TOP	53513
	107323-01-702	EA TRIM LEFT	53023
	107323-01-703	EA TRIM RIGHT	53024
	107323-01-704	EA MANIFOLD COVER	53556
	107323-01-705	EA TRIM VENT	53525
	107323-01-706	EA TRIM BOTTOM	53526
	107323-01-709	EA HANDLE END CAP - W/O HOLE	53424
	107323-01-710	EA GRATE CLIP	53301
	107323-01-711	EA RUBBER GRATE CUSHION	53008
	107246-01-703	EA THERMOSTAT ROBERT SHAW	52122
	107323-01-713	EA BLACKGLASS INSERT - W/ HOLE	53426
	107323-01-714	EA HANDLE FOR W/HOLE GLASS	51112
	107323-01-715	EA SAFETY VALVE (HARPER WYMAN)	51136
	107323-01-716	EA GRATE CLIP - GREEN	50005
	107323-01-717	EA BURNER - OVEN	52244
	107314-01-01A	EA RANGE COVER - BIFOLD 21" BLACK	BFC 5B
	105458-03-000	EA BRACKET - TIEDOWN - STOVE - RIGHT	
	105458-04-000	EA BRACKET - TIEDOWN - STOVE - LEFT	

MICROWAVE OVEN (MCD-DM15K-7B-N)

KEY	PART NUMBER	U/M DESCRIPTION
	115303-01-000	EA OVEN - MICROWAVE
	115401-01-01A	EA TRIM - MICROWAVE - BLACK
	098916-14-01A	EA BRACE - MICROWAVE CABINET - LEFT
	098916-15-01A	EA BRACE - MICROWAVE CABINET - RIGHT
	094756-02-01A	EA BRACKET - MICROWAVE - 6.1" LONG X 3.9" WIDE - STEEL - TAN
	094756-01-02A	EA BRACKET - ANGLE - W/ HOLES - MILL

GALLEY GROUP (CONTINUED)

RANGE HOOD , W/O HOUR METER - VENTLINE, TCS 5008-NBCLG (CANADIAN)

KEY	PART NUMBER	U/M DESCRIPTION	VENDOR NO.
	100258-17-04A	EA HOOD - RANGE - W/O MONITOR PANEL	
	090973-01-700	EA MOTOR - LVS	CA508-1
	090973-01-702	EA BLADE - FAN - LVS	VA183-1
	092696-01-709	EA BULB - 912	VA415
	092696-01-710	EA SOCKET - LIGHT	CB267-2
	096983-01-700	EA SWITCH - ON/OFF	108
	096983-01-702	EA SWITCH - TWO WAY MOMENTARY	112
	096983-01-707	EA FILTER - GREASE - 8" X 8" - LVS	CC246
	092696-02-701	EA LENS - LAMP	CC179
	100258-01-700	EA HOOD NOSE LABEL	CC428
	100258-10-01A	EA GAUGE - HOUR METER W/ SWITCH - SCREW ON	150
	100258-10-701	EA GAUGE - HOUR METER - CLIP ON	72367

RANGE HOOD , W/O HOUR METER - VENTLINE, TCS-5008-NBDG (USA)

KEY	PART NUMBER	U/M DESCRIPTION	VENDOR NO.
	100258-16-04A	EA HOOD - RANGE - W/O MONITOR PANEL	
	090973-01-700	EA MOTOR - LVS	CA508-1
	090973-01-702	EA BLADE - FAN - LVS	VA183-1
	092696-01-709	EA BULB - 912	VA415
	092696-01-710	EA SOCKET - LIGHT	CB267-2
	096983-01-700	EA SWITCH - ON/OFF	108
	096983-01-702	EA SWITCH - TWO WAY MOMENTARY	112
	096983-01-707	EA FILTER - GREASE - 8" X 8" - LVS	CC246
	092696-02-701	EA LENS - LAMP	CC179
	100258-01-700	EA HOOD NOSE LABEL	CC428

RANGE HOOD , W/HOUR METER - VENTLINE, TPS-5009-SBDLG (USA)

KEY	PART NUMBER	U/M DESCRIPTION	VENDOR NO.
	100258-18-03A	EA HOOD - RANGE 22W W/O MONITOR PANEL	
	090973-01-700	EA MOTOR - LVS	CA508-1
	090973-01-702	EA BLADE - FAN - LVS	VA183-1
	092696-01-709	EA BULB - 912	VA415
	092696-01-710	EA SOCKET - LIGHT	CB267-2
	096983-01-700	EA SWITCH - ON/OFF	108
	096983-01-702	EA SWITCH - TWO WAY MOMENTARY	112
	096983-01-707	EA FILTER - GREASE - 8" X 8" - LVS	CC246
	092696-02-701	EA LENS - LAMP	CC179
	100258-01-700	EA HOOD NOSE LABEL	CC428
	100258-10-01A	EA GAUGE - HOUR METER W/ SWITCH - SCREW ON	150
	100258-10-701	EA GAUGE - HOUR METER - CLIP ON	72367

PHILUPS VENTLINE MONITOR PANEL (2 WATER TANKS & WATER HEATER)

KEY	PART NUMBER	U/M DESCRIPTION	VENDOR NO.
	102765-04-01A	EA PANEL - MONITOR - W/ PLUG	CP9016
	097617 01 701	EA SWITCH - ON/OFF - ALMOND	106
	097617 01 702	EA SWITCH (ALMOND)	107
	102765 01 700	EA SWITCH - ON-ON - ALMOND	110-01
	102765 04 700	EA BOARD - CIRCUIT - 2 HOLDING TANK	5076-11

GENERATOR GROUP

ONAN GENERATOR, 5.0 KW EMERALD PLUS (US, CSA)

KEY	PART NUMBER	U/M DESCRIPTION
	109303-01-000	EA GENERATOR - 5.0 KW EMERALD PLUS
	007125-03-000	EA CLAMP - MUFFLER - 1.5" DIA
	007125-04-000	EA CLAMP - MUFFLER - 1.1" DIA
	082272-01-000	EA MUFFLER
	079654-05-000	EA PIPE - EXHAUST - ANGLED - W/ FLANGE - 2" ID - ONAN# 154-2539
	105958-03-000	EA PIPE - EXHAUST - 90° TURN
	094059-01-000	EA SPACER
	068382-06-000	EA BUSHING - BRASS - 3/8 MPT X 1/8 FPT

FROM: 03-20-95 THRU: 99-99-99

ONAN GENERATOR, 3.5 KW EMERALD PLUS (BGE-FN/29236G) (EXPORT)

KEY	PART NUMBER	U/M DESCRIPTION
	100974-04-000	EA GENERATOR - 4.0 KW EMERALD PLUS
	105958-03-000	EA PIPE - EXHAUST - GENERATOR
	007125-03-000	EA CLAMP - MUFFLER - 1.5" DIA
	007125-04-000	EA CLAMP - MUFFLER - 1.1" DIA
	079654-05-000	EA PIPE - EXHAUST - ANGLED - W/FLANGE - 2" ID - ONAN# 154-2539
	082272-01-000	EA MUFFLER
	094059-01-000	EA SPACER

ONAN GENERATOR, 6.5 KW EMERALD PLUS (NHE-FA/26100G) (US, CSA)

KEY	PART NUMBER	U/M DESCRIPTION
	100975-01-000	EA GENERATOR - 6.5 KW EMERALD PLUS
	105958-03-000	EA PIPE - EXHAUST - GENERATOR
	007125-03-000	EA CLAMP - MUFFLER - 1.5" DIA
	007125-04-000	EA CLAMP - MUFFLER - 1.1" DIA
	079654-05-000	EA PIPE - EXHAUST - ANGLED - W/FLANGE - 2" ID - ONAN# 154-2539
	082272-01-000	EA MUFFLER
	094059-01-000	EA SPACER

HEATING & AIR CONDITIONING GROUP

REAR HEATER W/ MOTOR AID (EVANS)

KEY	PART NUMBER	U/M DESCRIPTION	VENDOR NO.
	084405-01-000	EA HEATER ASM - REAR - DUCTED - W/ MOTOR AID	
	084405-01-700	EA HEATER CORE	FT200229
	084405-01-701	EA FAN BLADES	HV029931
	084405-01-702	EA MOTOR ASM - 12 V	200146
	061673-01-000	EA BRACKET - MOTOR AID TUBES - 4" X 1.5" - STEEL	
	088753-01-000	FT TUBE - ALUMINIZED STEEL - 5/8" - 18 GAUGE	
	007076-01-000	EA HOSE - FLEXIBLE PVC - 2" ID X 50'	
	007108-01-000	FT HOSE - HEATER, 5/8" ID - HI-TEMP	
	079059-01-000	EA HOSE - 90 DEGREE - 5/8" ID X 4" X 36"	
	079059-02-000	EA HOSE - 90 DEGREE - .61" ID X 4" X 6"	
	079059-03-000	EA HOSE - 90 DEGREE - .61" ID X 4" X 18"	
	089353-01-000	EA UNION - 5/8 - TUBE TO TUBE	

HEATING & AIR CONDITIONING GROUP (CONTINUED)

FURNACE (SUBURBAN SF-42 2275)

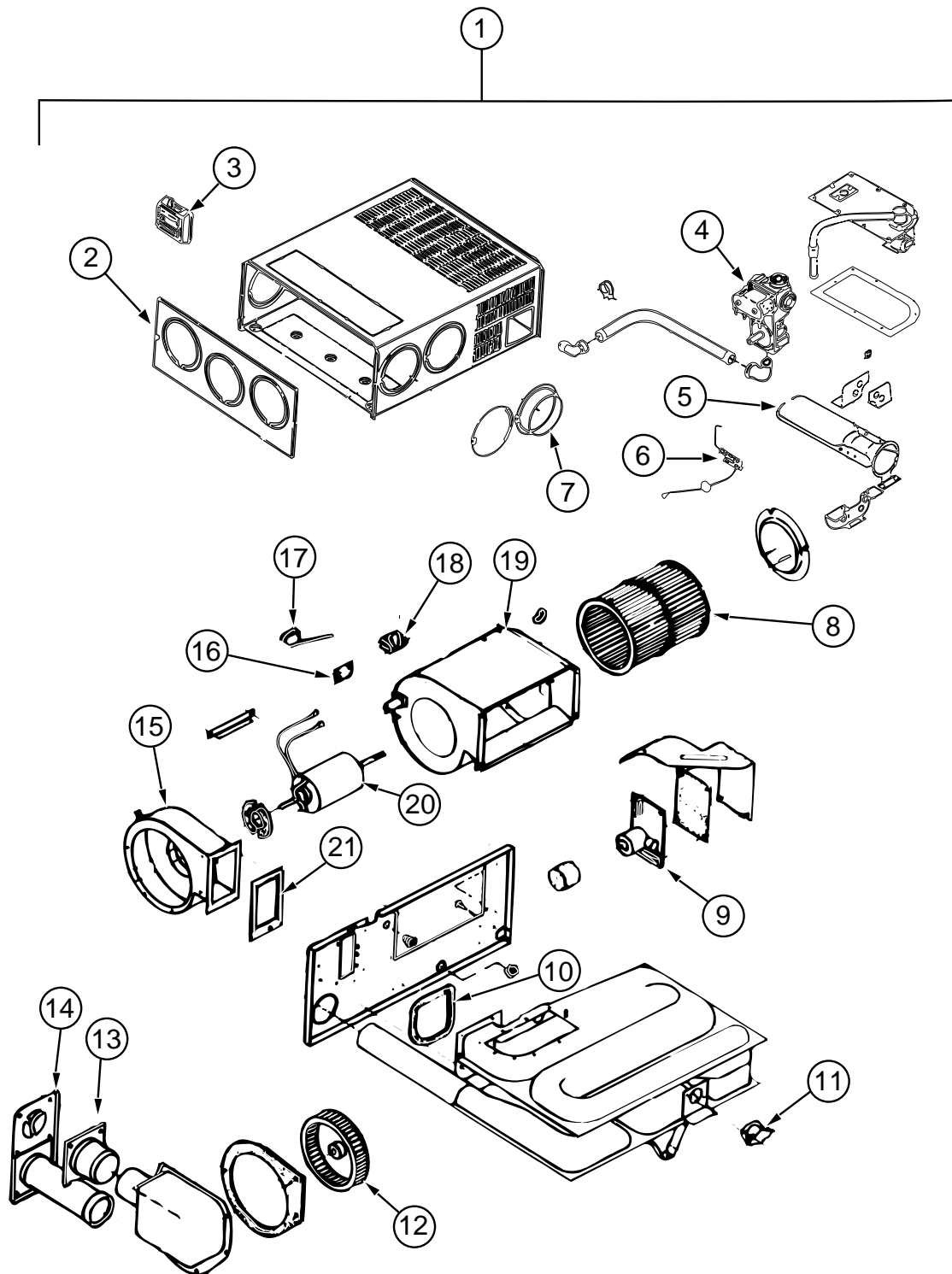

KEY	PART NUMBER	U/M DESCRIPTION	SUBURBAN VENDOR NO.
1	098668-22-000	EA FURNACE - 40,000 BTU	
2	098668-01-700	EA CABINET FRONT	101242
3	115764-01-01A	EA THERMOSTAT - WALL - FURNACE	160902
4	098668-01-714	EA GAS VALVE (WHITE ROGERS)	161070
5	098668-11-701	EA BURNER ASM COMP (SF-42F)	010799
	098668-11-700	EA ORIFICE - MAIN BURNER SF-42F	180216
6	098668-01-715	EA ELECTRODE ASM. (SGL PROBE)	232166
7	075696-02-703	EA DUCT COLLAR	050715
8	098668-01-711	EA WHEEL - ROOM AIR	350123
9	098668-01-712	EA BOARD - MODULE	231741
10	098668-01-716	EA GASKET FIREWALL (CHAMBER SIDE)	070808
11	098668-11-706	EA LIMIT SWITCH (SF-42F)	232231
12	098668-22-702	EA WHEEL COMB. AIR	350183
13	098668-01-713	EA INTAKE VENT TUBE ASM	051044
14	098668-01-707	EA VENT CAP & EXHAUST TUBE ASM	260193
15	098668-01-708	EA BLOWER ASM (COMBUSTION AIR)	390441
16	101990-01-714	EA MICROSWITCH GASKET	230877
17	098668-11-703	EA SWITCH - SAIL ASM (SF-42F)	232216
18	074466-01-702	EA RELAY - TIME DELAY	230625
19	098668-11-704	EA BLOWER ASM ROOM AIR (SF-42F)	390698
20	098668-11-702	EA MOTOR ASM COMP (SF-42F)	232212
21	098668-01-717	EA GASKET FIREWALL (BLOWER SIDE)	070809
	009198-01-000	FT DUCT - HEAT - FLEXIBLE - 4" ID X 25 FT	
	009200-01-000	EA TAPE - FURNACE - 1 1/2"	
	069636-02-000	EA CONNECTOR - DUCT - 4" ID	050715
	093741-01-000	EA BOX - BOOT - FLOOR REGISTER	
	098668-13-000	EA GASKET - FIBERGLASS - .5" X 16.37" X 17.56"	070977
	098668-14-000	EA GASKET - FIBERGLASS - .5" X 18" X 18"	070976
	098668-12-000	EA DOOR - ACCESS - FURNACE - BUFF	
	056464-05-000	EA REGISTER - PLASTIC W/O DAMPER - 4" DIAMETER - GOLDEN	
	093614-02-01A	EA GRILL - RETURN AIR - BROWN	
			FROM: 00-00-00 THRU: 04-16-95
	093614-02-02A	EA GRILL - RETURN AIR - DURA - BEIGE	
			FROM: 04-17-95 THRU: 99-99-99
	093614-04-01A	EA GRILL - RETURN AIR - BROWN	
			FROM: 00-00-00 THRU: 04-16-95
	093614-04-02A	EA GRILL - RETURN AIR - DURA - BEIGE	
			FROM: 04-17-95 THRU: 99-99-99
	094600-01-02A	EA HEAT REGISTER - W/O DAMPER - 3.6" X 11.2" - BROWN	
			FROM: 00-00-00 THRU: 04-16-95
	094600-05-01A	EA HEAT REGISTER - W/O DAMPER - BEIGE	
			FROM: 04-17-95 THRU: 99-99-99

HEATING & AIR CONDITIONING GROUP (CONTINUED)

COLEMAN ROOF AIR 13,500 BTU (US, CSA)

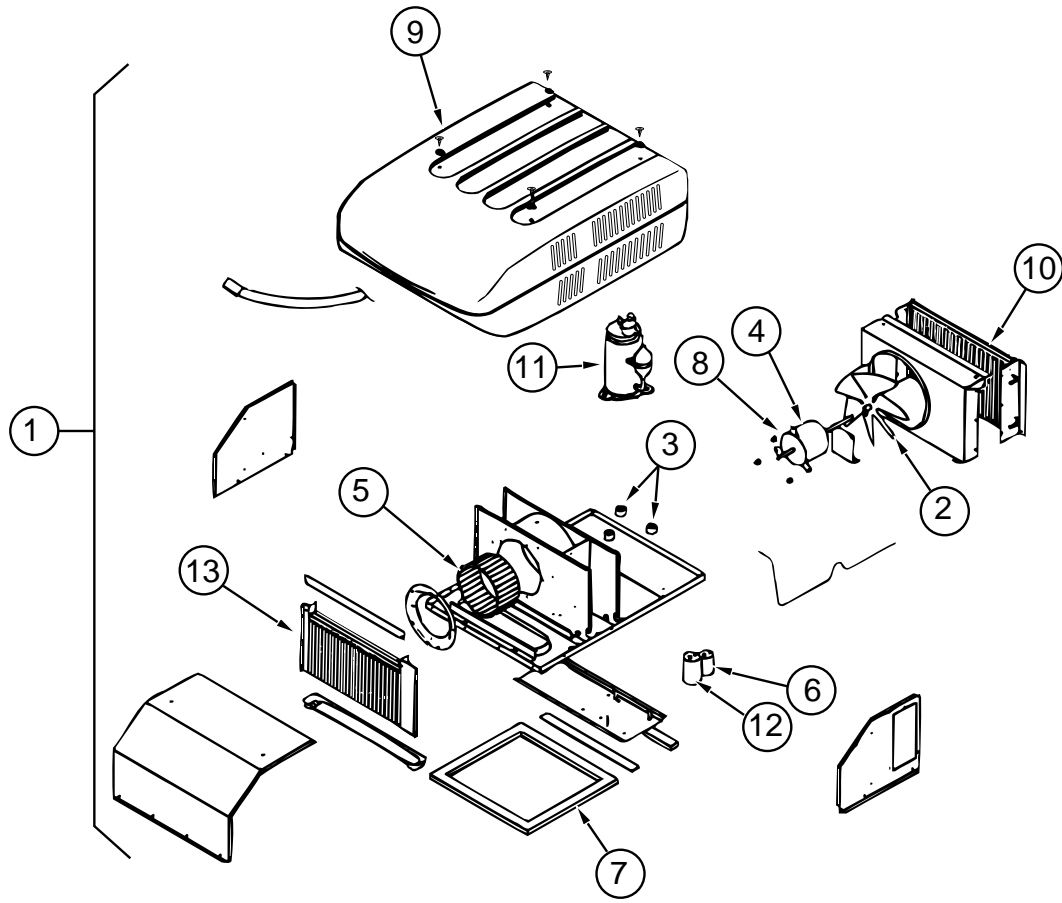

KEY	PART NUMBER	U/M	DESCRIPTION	COLEMAN VENDOR NO.
1	108889-01-03A	EA	A/C - ROOF - 13,500 TSR HO IVORY	7333A888
2	093763-01-712	EA	FAN BLADE - CONDENSER	6733-3221
3	105620-01-706	EA	FOOT PKG - COMPRESSOR - 3 PER PACKAGE	6759-3081
4	108889-01-705	EA	MOTOR (115 - 60HZ)	1468-3049
5	108889-01-706	EA	IMPELLOR	1472-1041
6	093763-01-704	EA	CAPACITOR - FAN	1499-3461
7	108889-01-711	EA	GASKET PACKAGE	6792-3301
8	108889-01-715	EA	MOTOR MOUNT & SHAFT SEAL KIT	6792-3361
9	108889-01-702	EA	SHROUD (BUFF/ BUFF) LESS LOGO	6759-6411
10	108889-01-703	EA	CONDENSER COIL	1452A1301
11	105620-01-704	EA	COMPRESSOR - RH & LH	1450-2009
	108889-01-704	EA	OVERLOAD (MRA#98693)	6749-3541
12	108889-01-707	EA	RUN CAPACITOR (COMP-25MFD/ 370)	1499-5661
13	108889-01-709	EA	EVAPORATOR COIL	1452A1311
	091225-01-709	EA	START RELAY	1497-4131
	091225-01-710	EA	START CAPACITOR	1497-0881
	093306-01-701	EA	DECAL PKG - LEFT & RIGHT	6798B3591
	108889-01-710	EA	FILLER PAD - COND AIR SEAL	6759A3971
	108889-01-712	EA	SUCTION LINE REDUCER (3/8 X 1/2)	1215-2161
	108889-01-713	EA	SUCTION LINE (3/8 OD X .032 WALL)	6792-130
	108889-01-714	EA	DISCHARGE LINE ASM.	6792-531
	108892-01-01A	EA	CEILING ASM - A/C DUCTED	7330-730 IV
	108892-01-700	EA	PLUG ASSEMBLY	7330-540
	108892-01-701	EA	TERMINAL BOARD	7330-3201
	108892-01-702	EA	PRINTED CIRCUIT BOARD	7330-3211
	108892-01-703	EA	FILTER	6798A3761
	108892-01-704	EA	GRILLE (PLASTIC)	6798-3041
	108892-01-705	EA	SMALL PARTS PKG	7330A6101
	108892-01-706	EA	COIL - SENSOR	7330-6111
	110403-01-F31	EA	SPACER ASM - RETURN AIR -OAK	
	117238-01-01A	EA	THERMOSTAT - A/C AND FURNACE	7330-3371
	117238-02-01A	EA	THERMOSTAT - A/C ONLY	7330-3381
	088238-01-000	EA	COVER - SWITCH - A/C SELECTOR - FRONT TO REAR A/C	
	073937-03-000	EA	SWITCH - ROTARY SELECTOR - 3 DECK - A/C - CA20-USA892	
	088238-02-000	EA	COVER - SWITCH - A/C SELECTOR FOR FRONT OR REAR	

HEATING & AIR CONDITIONING GROUP (CONTINUED)

AUTOMOTIVE AIR CONDITIONING (FORD)

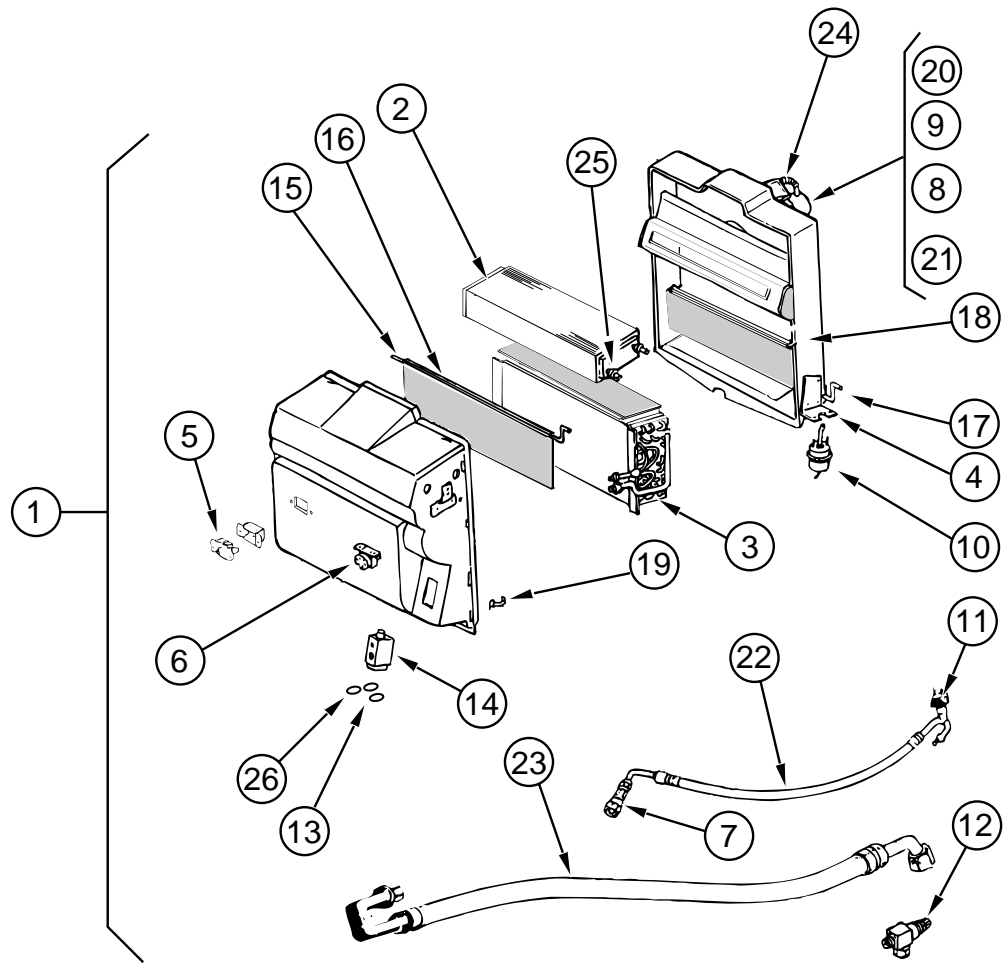

KEY	PART NUMBER	U/M	DESCRIPTION	VENDOR NO.
1	103930-21-000	EA	EVAPORATOR/ HEATER ASSEMBLY	SCS 090-00084
2	103930-01-703	EA	COIL - HEATER	SCS 042-0010
3	103930-01-704	EA	COIL EVAPORATOR	041-0017
4	103930-01-708	EA	BRACKET - VACUUM MOTOR	SCS 070-0113
5	103930-01-710	EA	RESISTOR - FUSED	SCS 035-0006
6	103930-01-711	EA	THERMOSTAT	SCS 033-0003
7	103930-01-713	EA	FITTING - QUICK CONNECT - #4	SCS 050-003
8	103930-01-717	EA	WHEEL - CLOCKWISE	SCS 062-0010
9	103930-01-720	EA	MOTOR	SCS 030-0004
10	103930-02-708	EA	MOTOR - VACUUM SERVO - A/C	SCS 030-0002
11	103930-12-708	EA	SWITCH - BINARY - R-134A	SCS 032-0048
12	103930-13-702	EA	SERVICE VALVE W/O C.P.	050-152
13	103930-17-702	EA	GASKET OR SAE 015 #10 33-781	SCS 045-0127
14	103930-20-700	EA	VALVE EXPANSION BLOCK (2 TON)	034-0032
15	103930-20-702	EA	ROD F/BLEND AIR DOOR	073-0039
16	103930-20-703	EA	DOOR - BLEND AIR	071-0212
17	103930-20-704	EA	ROD - DOOR - RECIRCULATING	073-0018
18	103930-20-705	EA	DOOR PANEL - RECIRCULATING	071-0213
19	103930-20-706	EA	CLIP - RETAINER	022-0057
20	103930-20-707	EA	BLOWER HOUSING	062-0145
21	103930-20-708	EA	CLIP F/ MOTOR SHAFT	022-0001
22	103930-21-700	EA	HOSE ASM. - #6	085-0139
23	103930-21-701	EA	HOSE ASM. - #10	085-0140
24	110279-01-703	EA	HOSE - VENT - MOTOR BLOWER	SCS 70510034
25	110279-01-712	EA	HEATER FITTING	
26	113245-01-707	EA	GASKET	045-0126
	007281-01-000	EA	HOSE - FLEXIBLE PVC - 2.5"ID X 50' - ATCOFLEX	A-182-355
	072341-06-700	EA	SWITCH - 4 SPEED - FAN	ARA 0883502
	094831-01-709	EA	CLAMPS - ROD - 3/16" - MOTIVAIR	SCS ZGG14431
	103930-02-701	EA	VALVE - CONTROL HEAD	SCS 034-0015
	103930-02-702	EA	DECAL - FAN SWITCH	SCS 058-0008
	103930-02-703	EA	HARNESS - WIRE CONTROL	SCS 036-0048
	103930-02-704	EA	HARNESS - VACUUM CONTROL	SCS 036-0049
	103930-02-705	EA	CABLE - CONTROL - BOWDEN	SCS 074-0011
	103930-02-706	EA	CLIP - CABLE - CONTROL	SCS 022-0017
	103930-02-707	EA	RELAY	SCS 031-0001
	103930-02-710	EA	CANISTER - VACUUM	SCS 054-0002
	103930-02-711	EA	VALVE - WATER	SCS 034-00114
	103930-02-712	EA	CONTROL PANEL - A/C & HEAT - BLACK FACING	
	103930-04-000	EA	CONTROL/ PLENUM SET	SCS 093-00037
	103930-05-000	EA	MANUAL - OWNERS - HEATER - A/C	SCS 057-0049
	103930-17-000	EA	HOSE KIT - #10 GM - SANDEN COMP	SCS 093-00076
	103930-17-700	EA	FITTING - PAD COMP. SUCTION SAN	050-0131
	103930-17-701	EA	FITTING - #10.90 W/FERRULE/1342CP	050-0132
	103930-17-703	EA	GASKET - SEAL,SANDEW COMP33-76	045-0142
	103930-17-704	EA	HOSE ASSY - #10	085-0113
	024990-05-000	EA	4" DIAMETER OUTLET - W/ SWIVEL DEFLECTORS	
	103016-01-000	EA	PLENUM - TRANSITION	
	103017-01-000	EA	PLENUM - DEFROSTER	
	103558-01-03A	EA	VENT - DEFROSTER - ABS WILLOW	
	103796-01-01A	EA	LOUVER ASM - A/C CARY PROD BLACK	
	056402-05-000	EA	BRACKET - HEATER VENT - ROUND - W/ BEND - BLACK	
	077075-01-000	EA	GASKET - INSTRUMENT PANEL TO DEFROSTER PLENUM - .6" X 11.3"	
	077075-03-000	EA	GASKET - INSTRUMENT TO DEFROSTER PLENUM - SPL	

HEATING & AIR CONDITIONING GROUP (CONTINUED)

AUTOMOTIVE AIR CONDITIONING (CHEVY)

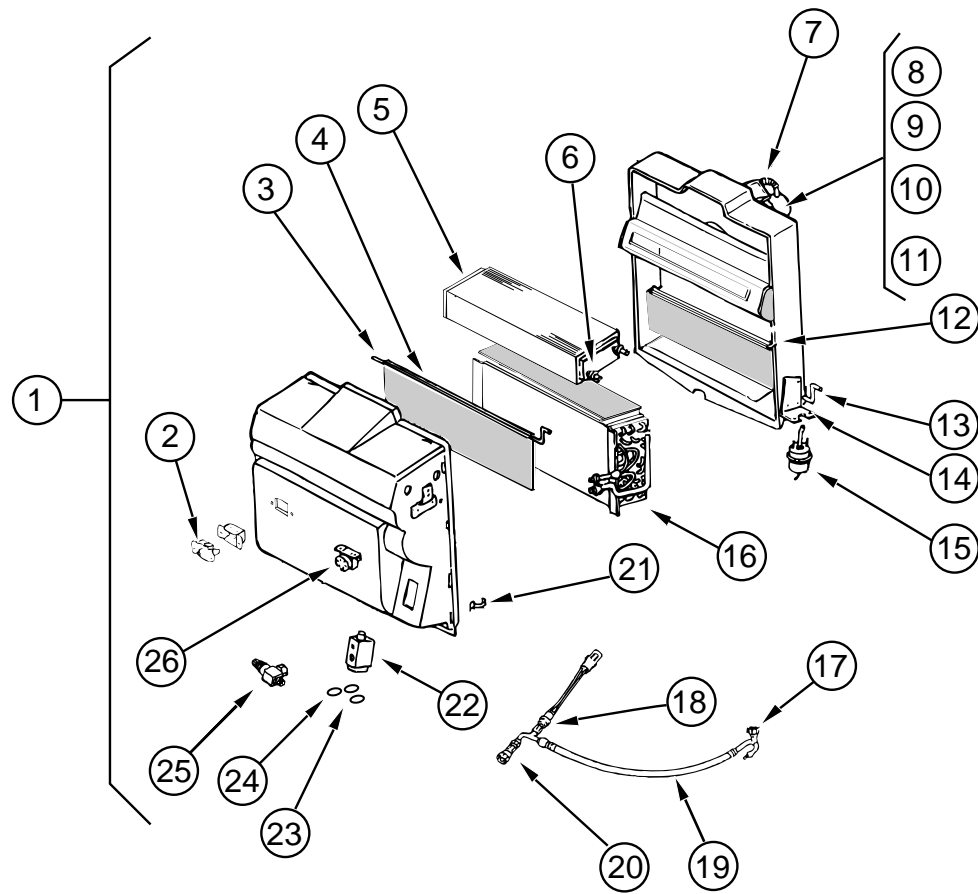

KEY	PART NUMBER	U/M	DESCRIPTION	VENDOR NO.
1	103930-20-000	EA	EVAPORATOR/ HEATER ASSEMBLY	SCS 090-00084
2	103930-01-710	EA	RESISTOR - FUSED	SCS 035-0006
3	103930-20-702	EA	ROD F/BLEND AIR DOOR	073-0039
4	103930-20-703	EA	DOOR - BLEND AIR	071-0212
5	103930-01-703	EA	COIL - HEATER	SCS 042-0010
6	110279-01-712	EA	HEATER FITTING	
7	110279-01-703	EA	HOSE - VENT - MOTOR BLOWER	SCS 70510034
8	103930-01-717	EA	WHEEL - CLOCKWISE	SCS 062-0010
9	103930-01-720	EA	MOTOR	SCS 030-0004
10	103930-20-707	EA	BLOWER HOUSING	062-0145
11	103930-20-708	EA	CLIP F/ MOTOR SHAFT	022-0001
12	103930-20-705	EA	DOOR PANEL - RECIRCULATING	071-0213
13	103930-20-704	EA	ROD - DOOR - RECIRCULATING	073-0018
14	103930-01-708	EA	BRACKET - VACUUM MOTOR	SCS 070-0113
15	103930-02-708	EA	MOTOR - VACUUM SERVO - A/C	SCS 030-0002
16	103930-01-704	EA	COIL EVAPORATOR	041-0017
17	103930-12-708	EA	SWITCH - BINARY - R-134A	SCS 032-0048
18	103930-01-716	EA	SWITCH - PRESSURE - FAN	SCS 032-0036
19	103930-20-701	EA	HOSE ASM. - #6 GM	085-0138
20	103930-12-709	EA	FITTING - QUICK CONNECT	SCS 050-0120
21	103930-20-706	EA	CLIP - RETAINER	022-0057
22	103930-20-700	EA	VALVE EXPANSION BLOCK (2 TON)	034-0032
23	103930-17-702	EA	GASKET OR SAE 015 #10 33-781	SCS 045-0127
24	113245-01-707	EA	GASKET	045-0126
25	103930-20-709	EA	SERVICE VALVE W/O C.P.	050-0159
26	103930-01-711	EA	THERMOSTAT	SCS 033-0003
	007281-01-000	EA	HOSE - FLEXIBLE PVC - 2.5"ID X 50' - ATCOFLEX	A-182-355
	072341-06-700	EA	SWITCH - 4 SPEED - FAN	ARA 0883502
	094831-01-709	EA	CLAMPS - ROD - 3/16" - MOTIVAIR	SCS ZGG14431
	103930-02-701	EA	VALVE - CONTROL HEAD	SCS 034-0015
	103930-02-702	EA	DECAL - FAN SWITCH	SCS 058-0008
	103930-02-703	EA	HARNESS - WIRE CONTROL	SCS 036-0048
	103930-02-704	EA	HARNESS - VACUUM CONTROL	SCS 036-0049
	103930-02-705	EA	CABLE - CONTROL - BOWDEN	SCS 074-0011
	103930-02-706	EA	CLIP - CABLE - CONTROL	SCS 022-0017
	103930-02-707	EA	RELAY	SCS 031-0001
	103930-02-710	EA	CANISTER - VACUUM	SCS 054-0002
	103930-02-711	EA	VALVE - WATER	SCS 034-00114
	103930-02-712	EA	CONTROL PANEL - A/C & HEAT - BLACK FACING	
	103930-04-000	EA	CONTROL/ PLENUM SET	SCS 093-00037
	103930-05-000	EA	MANUAL - OWNERS - HEATER - A/C	SCS 057-0049
	024990-05-000	EA	4" DIAMETER OUTLET - W/ SWIVEL DEFLECTORS	
	103016-01-000	EA	PLENUM - TRANSITION	
	103017-01-000	EA	PLENUM - DEFROSTER	
	103558-01-03A	EA	VENT - DEFROSTER - ABS WILLOW	
	103796-01-01A	EA	LOUVER ASM - A/C CARY PROD BLACK	
	056402-05-000	EA	BRACKET - HEATER VENT - ROUND - W/ BEND - BLACK	
	077075-01-000	EA	GASKET - INSTRUMENT PANEL TO DEFROSTER PLENUM - .6" X 11.3"	
	077075-03-000	EA	GASKET - INSTRUMENT TO DEFROSTER PLENUM - SPL	

INTERIOR FINISH GROUP

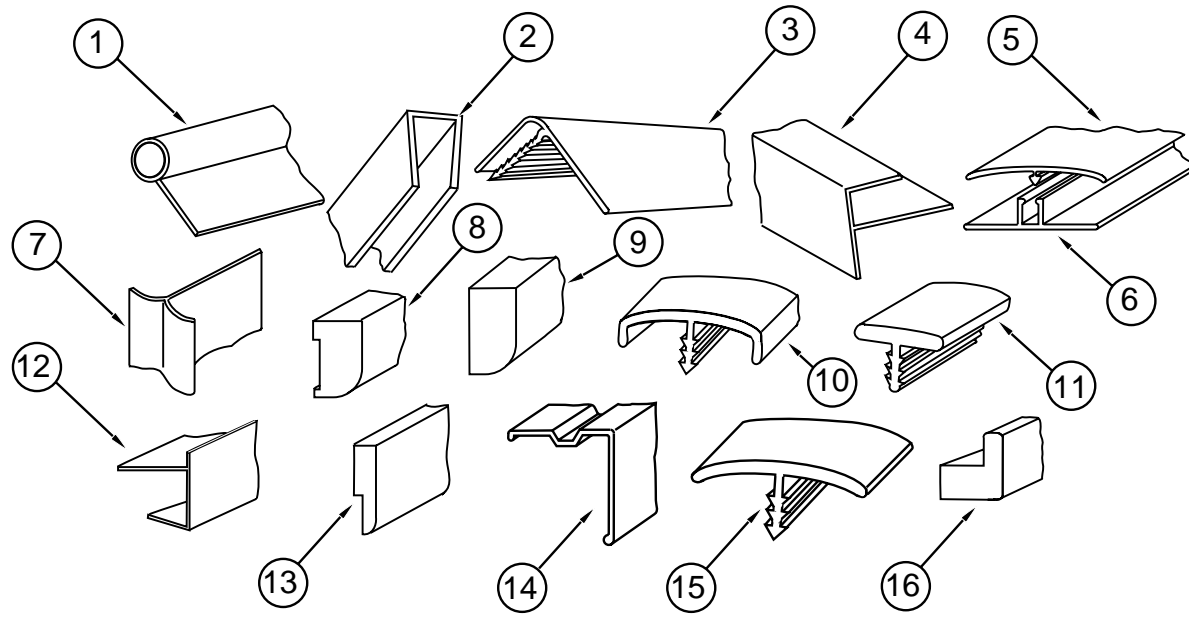

INTERIOR TRIM & MOLDINGS

KEY	PART NUMBER	U/M DESCRIPTION
1	009767-12-000	FT MOLDING - SIDEWALL TO CEILING/CABINET - WELTING - OFF WHITE
2	009778-12-000	FT U CHANNEL - PLASTIC - 1" WIDE X 8' - WOODGRAIN
2	070504-23-000	FT EXTRUSION - U CHANNEL - 22.56 - COUNTRY FOREST
2	070504-28-000	FT EXTRUSION - U CHANNEL - 1.65 - PICKLED ASH
2	070504-29-000	FT EXTRUSION - U CHANNEL - 20.70 - PICKLED ASH
3	009809-21-000	EA MOLDING - CORNER - OUTSIDE - 1" - PLASTIC - WOODGRAIN
3	009809-23-000	EA MOLDING - CORNER - OUTSIDE - 1" - PLASTIC - IVORY
4	009812-22-000	EA MOLDING - CORNER - OUTSIDE - .5" X 7' - PLASTIC - BROWN
5	086229-15-000	EA BATTEN - CEILING - 1" - MODERN IVORY
6	086229-16-000	EA RETAINER - BATTEN - 3/4"
7	022992-11-000	FT MOLDING - REVERSE COVE - T-SHAPED - VINYL - IVORY
8	100041-01-000	EA MOLDING - VINYL WRAPPED - .7" X 1.57" X 84.02" - RAMBLING OAK
8	100041-02-000	EA MOLDING - VINYL WRAPPED - .7" X 2.5" X 84" - RAMBLING OAK
9	100818-01-02A	EA MOLDING - VINYL WRAPPED - 1.65" X .4" X 7' - RAMBLING OAK
10	083620-07-000	FT MOLDING - T - END CAP EDGE - W/EDGE LIPS - .75" - THOR PECAN
10	083620-10-000	FT MOLDING - T - W/ EDGE LIPS - 3/4" - PICKLED ASH
11	104676-01-01A	FT MOLDING - T - RIGID - 5/16" - GOLD
12	103186-01-01A	FT MOLDING - EDGE - SHELF - .78" WIDE - PLASTIC - RAMBLING OAK
12	103186-02-01A	FT MOLDING - EDGE - SHELF - 1.3" WIDE - PLASTIC - RAMBLING OAK
13	105004-01-02A	EA MOLDING - VINYL WRAP - RAMBLING OAK
	076325-25-000	FT MOLDING - EDGE BAND - LOUNGE TABLE - RAMBLING OAK
	076325-65-000	FT MOLDING - EDGE BAND - 1 5/16" WIDE - PEPPERMINT (F11)
	076325-39-000	FT MOLDING - EDGE BAND - 1 5/16" WIDE - NEUTRAL (F12)
	076325-66-000	FT MOLDING - EDGE BAND - RECESSED SINK EDGE & SINK COVER - PEPPERMINT (F11)
	076325-40-000	FT MOLDING - EDGE BAND - RECESSED SINK EDGE & SINK COVER - NEUTRAL (F12)
	076325-34-000	FT MOLDING - EDGE BAND - EXTERIOR ENTERTAINMENT CENTER - ORCHID
14	093873-01-01A	EA TRIM - CARPET - L-ANGLE - 1.1" X 1.3" X 12' - VINYL - GRAY
15	105709-01-000	FT MOLDING - T - 1" - MODERN IVORY
16	100819-01-02A	EA MOLDING - VINYL WRAPPED - L-SHAPED - 1.5" X 1.5" X 7' - OAK
	100040-01-000	EA LUMBER - VINYL WRAPPED - .71" X 1.5" X 8' - RAMBLING OAK
	100040-01-000	EA LUMBER - VINYL WRAPPED - .71" X 1.5" X 8' - RAMBLING OAK
	100040-03-000	EA LUMBER - VINYL WRAPPED - .71" X 2" X 8' - RAMBLING OAK
	100040-06-000	EA LUMBER - VINYL WRAPPED - RAMBLING OAK
	100040-07-000	EA LUMBER - VINYL WRAPPED - RAMBLING OAK
	109332-02-01A	FT TRIM - J - MIRROR - BRASS
	112198-01-000	FT MOLDING-J - CRILA PLASTICS

INTERIOR FINISH GROUP (CONTINUED)

BATT STRIPS

KEY	PART NUMBER	U/M DESCRIPTION
	088263-B3-000	EA BATT STRIP - MAIN WALL - MEADOW (F11)
	088263-A9-000	EA BATT STRIP - MAIN WALL - GLOW (F12)
	069733-80-000	EA BATT STRIP - WOODGRAIN - 8' - WINNI OAK
	088263-78-000	EA BATT STRIP - SHOWER - 8' - OFF WHITE
	085284-A4-000	FT STRIP - TAPE - MAIN WALL - MEADOW (F11)
	085284-A1-000	FT STRIP - TAPE - MAIN WALL - GLOW (F12)
	085284-67-000	FT STRIP - TAPE - 541 WINNI OAK
	085284-76-000	FT STRIP - TAPE - WET BATH - ANTIQUE WHITE
	086229-04-000	EA BATTEN - 1" WIDE - IVORY
	086229-15-000	EA BATTEN - CEILING - 1" - MODERN IVORY
	086229-16-000	EA RETAINER - BATTEN - 3/4"

PANELING & PLASTIC LAMINATE

KEY	PART NUMBER	U/M DESCRIPTION
	088272-D6-000	SF PANELING - MAIN WALL - ALLURE-MEADOW (F11)
	088272-D2-000	SF PANELING - MAIN WALL - GLOW (F12)
	088272-98-000	SF PANELING - SHOWER - OFF WHITE - 4' X 7'
	074497-21-000	SF PANELING - WOODGRAIN - 4' X 8'
	000885-56-000	SF PARTICLE BOARD - VINYL 1 SIDE - 3/8" X 48" X 96" - WINNI OAK
	000885-61-000	SF PARTICLE BOARD - VINYL 2 SIDES - 3/4" X 48" X 96" - WINNI OAK
	074498-34-000	SF LAMINATE - PLASTIC - 5' X 8'
	074498-67-000	SF LAMINATE - PLASTIC - ORCHID MIST
	074498-73-000	SF LAMINATE - PLASTIC - PEPPERMINT (F11)
	074498-71-000	SF LAMINATE - PLASTIC - NEUTRAL (F12)
	095688-01-000	SF VENEER - FLAT LUANA - 48" X 96"

CARPET, PADS & FLOOR MATS

KEY	PART NUMBER	U/M DESCRIPTION
	096060-A2-000	SY CARPET - 12' ROLL - NEW MEADOW (F11)
	096060-99-000	SY CARPET - 12' ROLL - PARCHMENT (F12)
	093486-01-000	SY CARPET - COMPARTMENT - 54" WIDE - DARK GRAY
	075233-01-000	SY PAD - CARPET - 3/8" X 6' ROLL
	047034-06-000	SF PLASTIC - CARPET - 2' WIDE - CLEAR POLY
	105924-01-F11	EA MAT - FLOOR - DRIVERS COMPARTMENT - 18" X 27"
	105924-01-F12	EA MAT - FLOOR - DRIVERS COMPARTMENT - 18" X 27"

FIRE EXTINGUISHER, DETECTORS & WALL CLOCK

KEY	PART NUMBER	U/M DESCRIPTION
	094499-01-000	EA EXTINGUISHER - FIRE - DRY W/ MOUNTING BRACKET - 10 BC - US
	094499-02-000	EA EXTINGUISHER - FIRE - DRY - 1A10BC - CANADIAN
	094499-01-700	EA BRACKET - MOUNTING - W/ PLASTIC STRAP - FIRE EXTINGUISHER
	072852-01-000	EA DETECTOR - SMOKE - W/ 9 VOLT BATTERY - US
	072852-02-000	EA DETECTOR - SMOKE - W/ 9 VOLT BATTERY - CANADIAN
	112320-01-000	EA DETECTOR - CO GAS - MODEL 9B-I - COSTAR 940000000
	112320-02-000	EA BATTERY/ SENSOR - CO GAS - COSTAR 940001000
	100793-02-01A	EA CLOCK - WALL - 11" DIAMETER - BOLDEN 9988

INTERIOR FINISH GROUP (CONTINUED)

CABINET HARDWARE

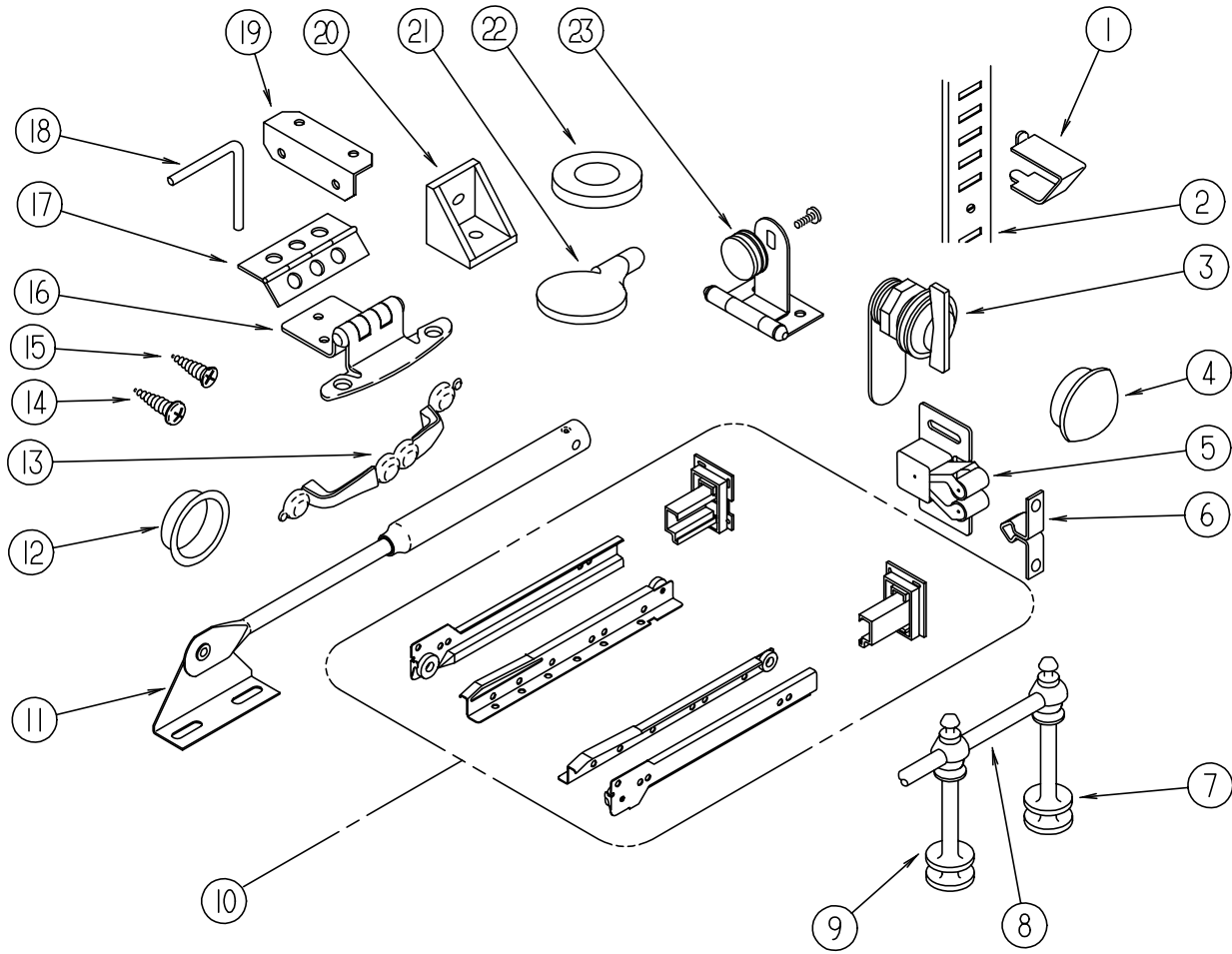

KEY	PART NUMBER	U/M DESCRIPTION
10	114031-01-700	EA DRAWER SLIDE KIT - 12" - W/ BACKSOCKETS - ADJUSTABLE
10	114031-13-700	EA DRAWER SLIDE KIT - 18" - W/ BACKSOCKETS - ADJUSTABLE
10	114031-17-700	EA DRAWER SLIDE KIT - 20" - W/ BACKSOCKETS - ADJUSTABLE
10	114031-21-700	EA DRAWER SLIDE KIT - 22" - W/ BACKSOCKETS - ADJUSTABLE
11	074493-02-000	EA SUPPORT - PISTON SPRING - CABINET DOOR
12	098410-01-01A	EA PULL - FINGER - OVAL - BRASS
13	111765-01-000	EA DOOR PULL - CABINET - BRASS
14	000G68-06-10G	EA SCREW - PHILLIPS - OVAL HEAD - 6-18 X 5/8" - ANTIQUE BRASS
15	000G13-06-10G	EA SCREW - PHILLIPS - FLAT HEAD - 6-20 X 5/8" - ANTIQUE BRASS
16	108138-01-000	EA HINGE - DOOR - CABINET - BURNISHED BRASS
17	009059-02-000	EA HINGE - DOOR - 2" X 2.7" - BRASS
18	108487-02-01A	EA PROP ROD - OVERHEAD GLASS DOOR SUPPORT - BLACK
	108486-01-01A	EA BRACKET - PROP ROD - OVERHEAD - BLACK
	039984-01-000	EA CAP - VINYL - PROP ROD - BLACK
19	016604-03-000	EA BRACE - CABINET - ANGLE - 2.5" - METAL - BEIGE
19	016604-05-000	EA BRACE - CABINET - ANGLE - 2.5" - METAL - OFF WHITE
20	065740-01-000	EA BRACE - CABINET CORNER - PLASTIC
21	101766-01-000	EA PIN - SUPPORT - GLASS DOOR
22	100707-01-000	EA SPACER - DOOR - GLASS - PLASTIC
23	100711-01-01A	EA HINGE - DOOR - GLASS
	009063-01-000	EA HINGE - CONTINUOUS - 1 1/2" X 72" - UNPAINTED
	009066-01-000	EA HINGE - ALUMINUM - W/O HOLES - 1 1/16" X 6" - UNPAINTED
	004354-01-000	EA BUMPER - RUBBER - .5" DIAMETER - BROWN
	042438-01-000	EA DOWEL - WOOD - CLOTHES ROD - 1" DIAMETER X 4'
	009112-01-000	EA FLANGE - ROD - 1" - COTHES ROD - PLASTIC - OFF WHITE
	016604-01-000	EA BRACE - CABINET - ANGLE - 2.5" - METAL - UNPAINTED
	016604-05-000	EA BRACE - CABINET - L ANGLE - 2.5" - METAL - OFF WHITE
	041389-25-000	EA HINGE - PIANO - 1.5" X 1397 - MILL FINISH

KEY	PART NUMBER	U/M DESCRIPTION
1	098979-01-000	EA CLIP - ADJUSTABLE SHELF
2	098980-01-000	EA PILASTER - ADJUSTABLE SHELF - 18" LONG
2	098980-02-000	EA PILASTER - ADJUSTABLE SHELF - 12" LONG
2	098980-06-000	EA PILASTER - ADJUSTABLE SHELF - 24" LONG
3	100710-01-01A	EA LOCK - GLASS DOOR - TWIST TYPE - BRASS
	101272-01-000	EA CATCH - DOOR - GLASS
4	042356-01-000	EA PLUG - MAHOGANY - 3/8" DIAMETER - WOOD
4	074045-01-000	EA PLUG - OAK - 1/2" DIAMETER
5	093586-06-000	EA CATCH - SPRING - ROLLER - FASTEC C411-AC
6	093586-05-000	EA STRIKE - SPRING - STEEL - FASTEC S411-AC
7	084070-02-000	EA POST - END - 2.4" - BRASS
8	084071-04-000	EA ROD - 11.9" - BRASS
8	084071-15-000	EA ROD - 8.27" - BRASS
9	084070-01-000	EA POST - CENTER - 2.4" - BRASS

LABELS GROUP

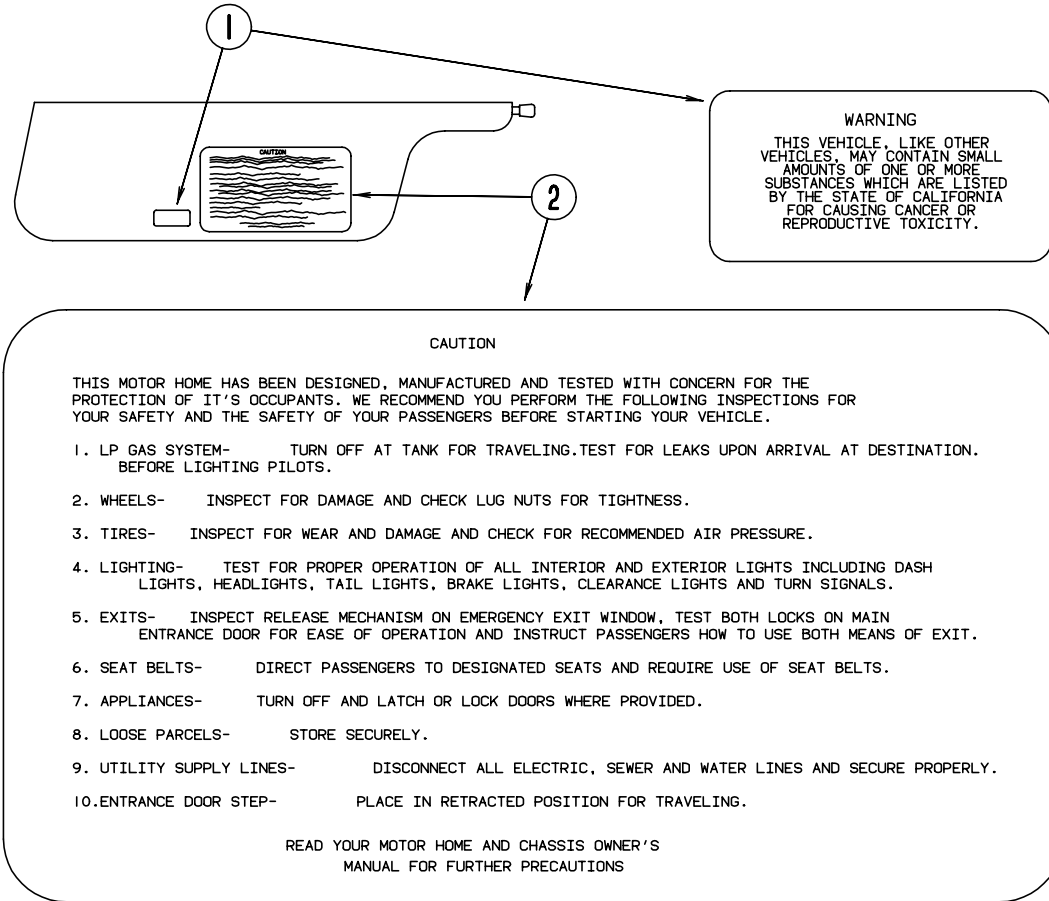

KEY	PART NUMBER	U/M DESCRIPTION
1	099689-01-000	EA LABEL - WARNING - CANCER/TOXICITY
2	056259-01-000	EA LABEL - SAFETY CHECK LIST

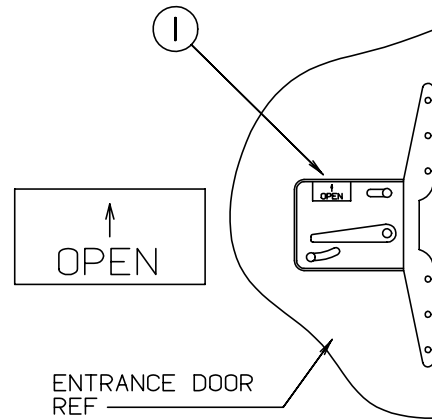

KEY	PART NUMBER	U/M DESCRIPTION
1	040944-01-000	EA LABEL - ENTRANCE DOOR - "OPEN"

LABELS GROUP (CONTINUED)

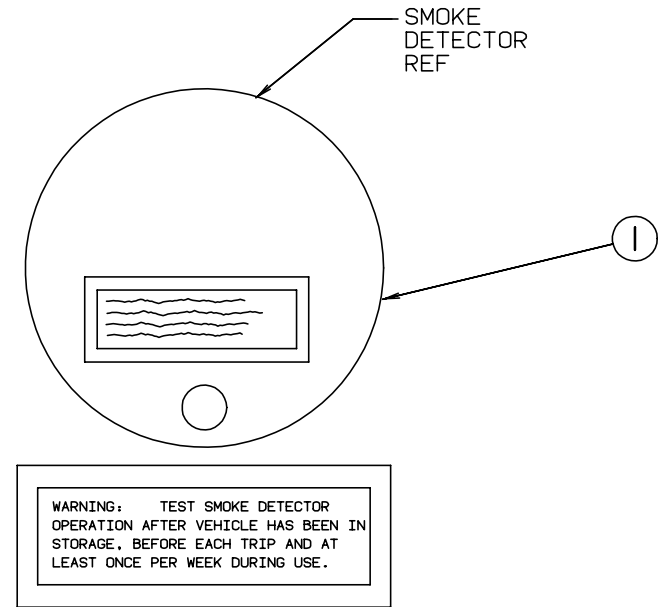

KEY	PART NUMBER	U/M DESCRIPTION
1	077956-01-000	EA LABEL - WARNING - SMOKE DETECTOR

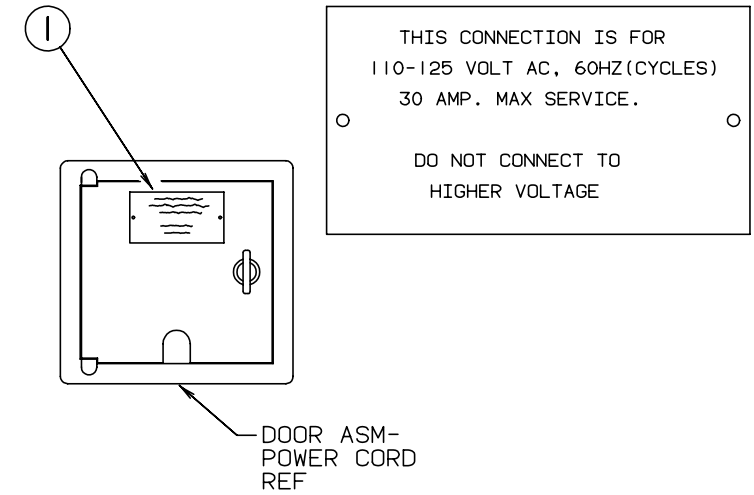

KEY	PART NUMBER	U/M DESCRIPTION
1	006062-01-000	EA TAG - ELECTRIC - 110V CONNECTION

LABELS GROUP (CONTINUED)

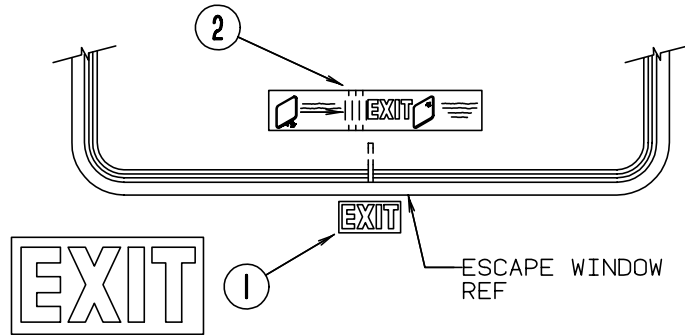
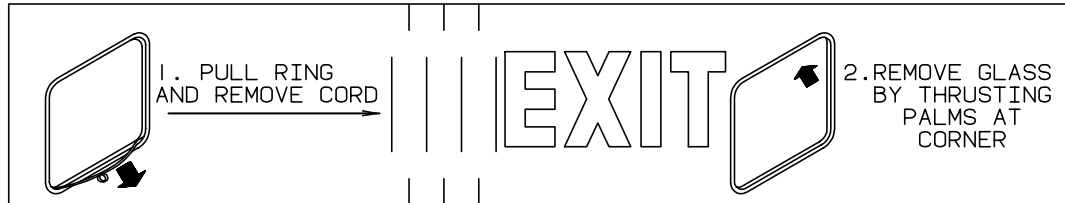

KEY	PART NUMBER	U/M DESCRIPTION
1	107571-01-000	EA LABEL - EXIT/ESCAPE WINDOW
2	039290-01-000	EA LABEL - EXIT WARNING

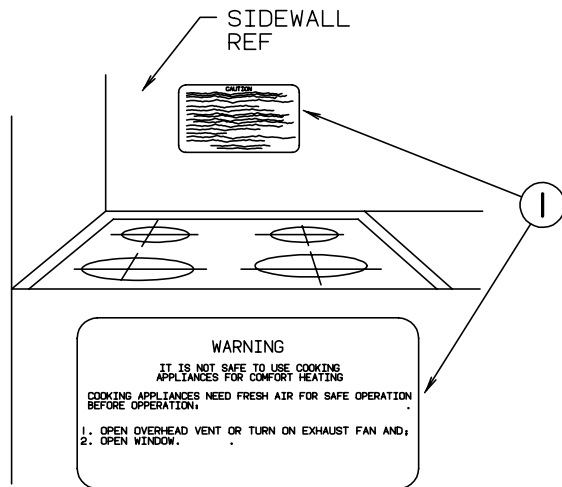

KEY	PART NUMBER	U/M DESCRIPTION
1	050225-01-000	EA LABEL - WARNING - STOVE VENT - US
1	050222-01-000	EA LABEL - WARNING - STOVE VENT - CSA

LABELS GROUP (CONTINUED)

CAUTION	TO HELP AVOID PERSONAL INJURY DURING REMOVAL OF FUEL FILLER CAP, SLOWLY LOOSEN CAP 1/2 TURN TO ALLOW ANY FUEL PRESSURE TO BE RELIEVED BEFORE TURNING CAP FURTHER.
FUEL SPRAY MAY CAUSE PERSONAL INJURY	STOP ADDING FUEL AFTER FIRST SHUTOFF BY AUTOMATIC NOZZLE WHEN TANK IS NEARLY FULL. DO NOT OVERFILL FUEL TANK. SEE OWNERS MANUAL FOR ADDITIONAL INFORMATION.
	PRINTED IN U.S.A. MLC PT NO 15611763

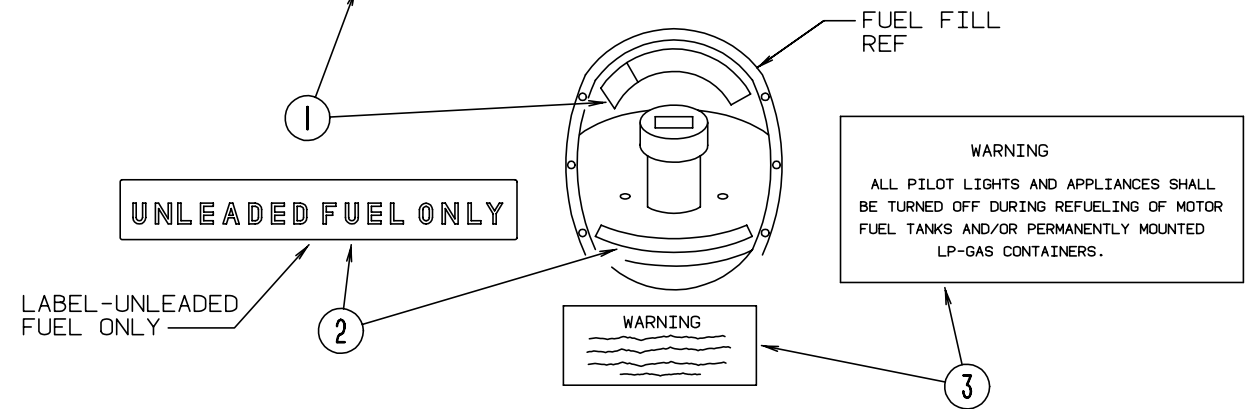

KEY	PART NUMBER	U/M DESCRIPTION
1	087207-05-000	EA LABEL - FUEL CAP REMOVAL
2	062043-01-000	EA LABEL - FUEL - UNLEADED
3	006040-01-000	EA TAG - GAS REFUELING WARNING
3	006040-02-000	EA TAG - GAS REFUELING WARNING (CANADIAN)

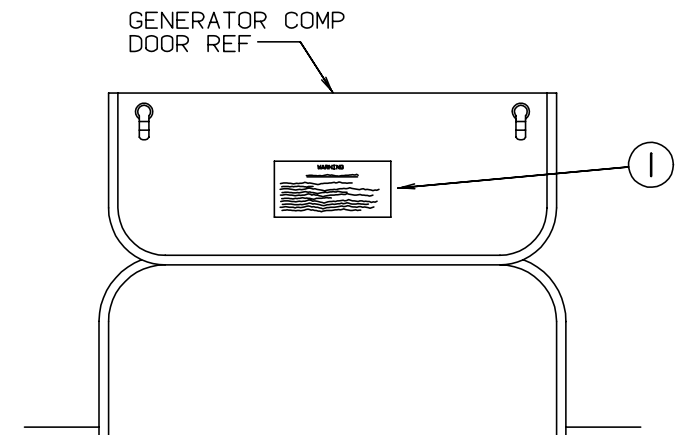

WARNING

WHEN ADDING A GENERATOR SET:

HIGH VOLTAGE-USE EXTREME CAUTION WHEN WORKING ON ELECTRICAL COMPONENTS.
HAVE ALL ELECTRICAL INSTALLATION PERFORMED BY A QUALIFIED LICENSED ELECTRICIAN-FOLLOW ALL STATE AND LOCAL CODES.
ONLY INSTALL GENERATOR SET APPROVED FOR R.V. APPLICATION. HAVE INSTALLED BY QUALIFIED TECHNICIAN.
TO AVOID HEAT BUILD-UP AND TO GUARANTEE AN ADEQUATE AIR SUPPLY TO THE GENERATOR CARBURETOR, FOLLOW INSTALLATION INSTRUCTIONS.
GENERATOR ENGINE EXHAUST GASES ARE TOXIC AND MUST NOT TERMINATE UNDER THE VEHICLE-DISCHARGE EXHAUST AWAY FROM VEHICLE.

KEY	PART NUMBER	U/M DESCRIPTION
1	077510-01-000	EA LABEL - GENERATOR PREP

LABELS GROUP (CONTINUED)

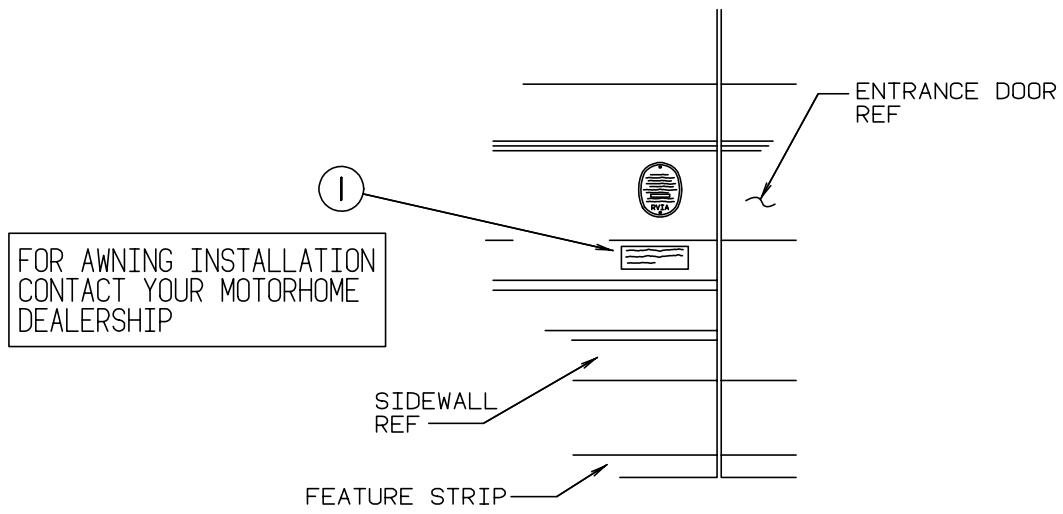

KEY	PART NUMBER	U/M DESCRIPTION
1	099509-01-000	EA LABEL - AWNING INSTALLATION

LABELS GROUP (CONTINUED)

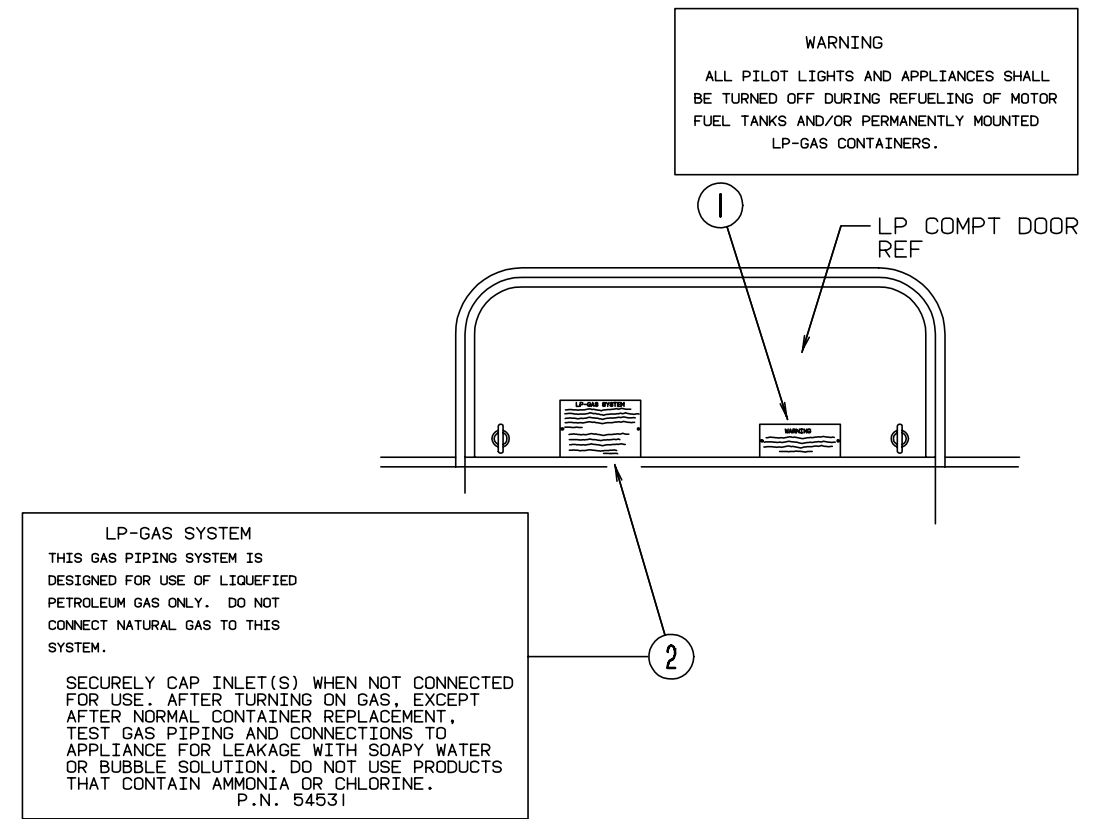

KEY	PART NUMBER	U/M DESCRIPTION
1	006040-01-000	EA TAG - GAS REFUELING WARNING
1	006040-02-000	EA TAG - GAS REFUELING WARNING (CANADIAN)
2	054531-01-000	EA LABEL - LP GAS ONLY
2	023769-01-000	EA LABEL - WARNING-LPG (CANADIAN)

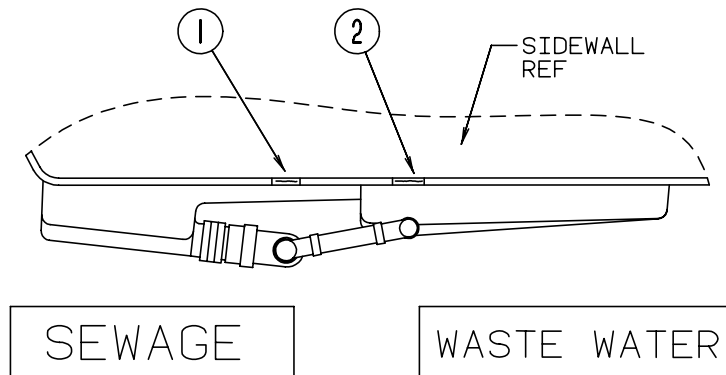

KEY	PART NUMBER	U/M DESCRIPTION
1	006187-01-000	EA LABEL - SEWAGE
2	006188-01-000	EA LABEL - WASTE WATER

LABELS GROUP (CONTINUED)

MISCELLANEOUS LABELS

KEY	PART NUMBER	U/M DESCRIPTION
	094675-01-000	EA LABEL - EXTERIOR LIGHT - SERVICE
	073998-01-000	EA LABEL - LPG ODOR WARNING
	079966-01-000	EA LABEL - WARNING - STOWED - MOTION
	091224-02-000	EA LABEL - TRAILER LIGHTING
	091243-01-000	EA LABEL - A/C COVER - "AIR CONDITIONING CIRCUIT. ETC."
	098379-04-000	EA LABEL - ELECTRICAL BOX SIDE
	098641-01-000	EA LABEL - FUEL - UNLEADED - DASH
	104678-01-000	EA LABEL - CB PREP
	111104-01-000	EA LABEL - HITCH - READ MANUAL
	111537-04-000	EA LABEL - FUSES
	087236-01-000	EA LABEL - CABLE -INPUT
	112518-01-000	EA LABEL - HANG TAG -CO DETECTOR
	111802-01-000	EA LABEL - CFC WARNING

LP GROUP

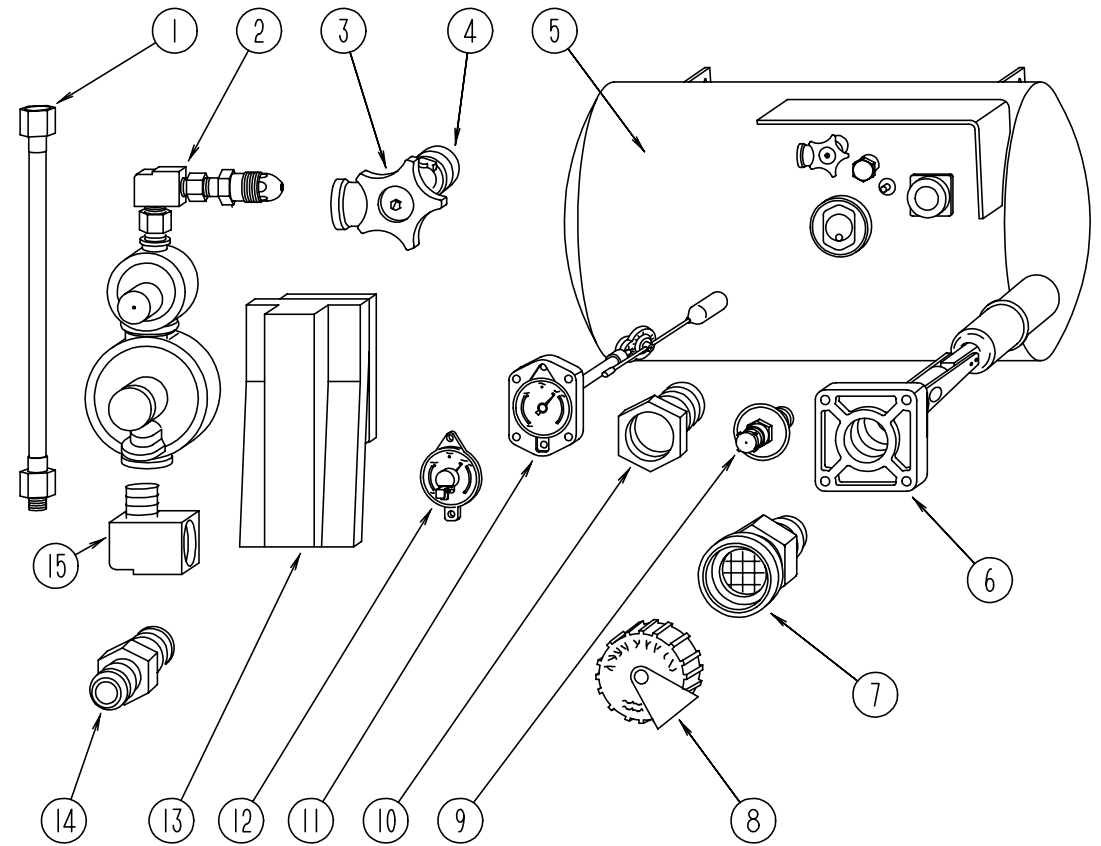

LP TANK & COMPONENTS

KEY	PART NUMBER	U/M DESCRIPTION
1	045703-05-000	EA HOSE - LP - 3/8" ID X 28" - 3/8" MPT X 1/2" F SWIVEL - US
1	045703-06-000	EA HOSE - LP - 3/8" ID X 28" - 3/8" MPT X 1/2" F SWIVEL - CANADA
2	106150-01-000	EA REGULATOR - TWO STAGE
3	040421-01-708	EA HANDWHEEL - VAPOR RELIEF VALVE - BRUNNER G-1015-A
4	040421-01-712	EA VALVE - SERVICE W/HANDWHEEL
5	088253-03-000	EA TANK - LP - 100 LB - 16"D X 36" - SPL
6	040421-01-711	EA VALVE - 80% W/FLOAT - PLATE - BOLTS & GASKET - BRUNNER
7	040421-01-701	EA VALVE - SHORT LP FILLER W/YELLOW CAP - BRUNNER 75478
8	040421-01-702	EA CAP - LP FILLER VALVE - PLASTIC - YELLOW - BRUNNER G-1014-A
9	040421-01-700	EA GAUGE - LIQUID LEVEL - 20% LP - BRUNNER G-1013
10	040421-01-713	EA PRESSURE RELIEF VALVE
11	088253-01-700	EA L.P. FLOAT GAUGE - 4 MACHINE SCREW STYLE
12	040440-02-000	EA TRANSMITTER - DIAL - 90 OHM
13	105658-01-000	EA COMPARTMENT - LP REGULATOR
14	010323-01-000	EA ADAPTER - BRASS - 3/8" F X 1/2" MPT

LOUNGE GROUP

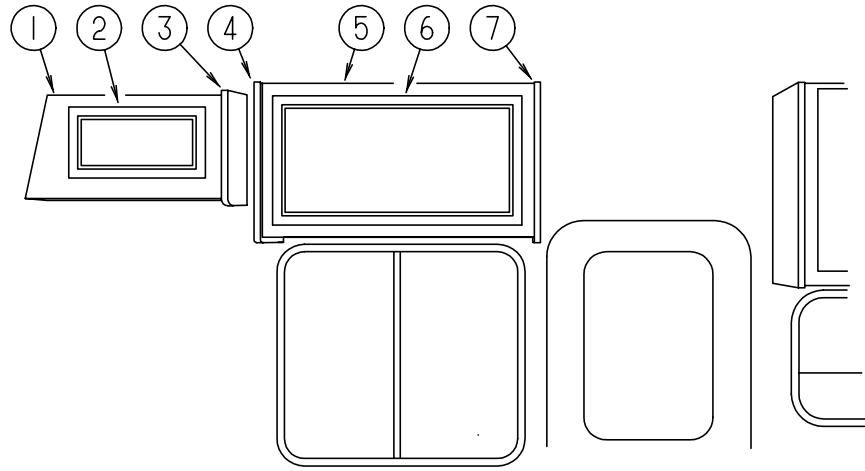

FRONT OVERHEAD CABINET (PASSENGER SIDE)

KEY	PART NUMBER	U/M	DESCRIPTION
1	M06838-01-F11	EA	CABINET ASM. - FRONT OVERHEAD - PASSENGER SIDE
1	M06838-01-F12	EA	CABINET ASM. - FRONT OVERHEAD - PASSENGER SIDE
2	M06803-04-E07	EA	DOOR ASM - RAIL - W/O HARDWARE
3	103128-08-F11	EA	END CAP ASM. (FRONT OVERHEAD)
4	103128-07-F11	EA	END CAP ASM. - LEFT HAND
5	M06838-08-F11	EA	CABINET ASM. - OVERHEAD
6	M06833-30-E10	EA	DOOR ASM - W/O HARDWARE
7	103128-10-F11	EA	END CAP ASM. - RIGHT HAND

LOUNGE GROUP (CONTINUED)

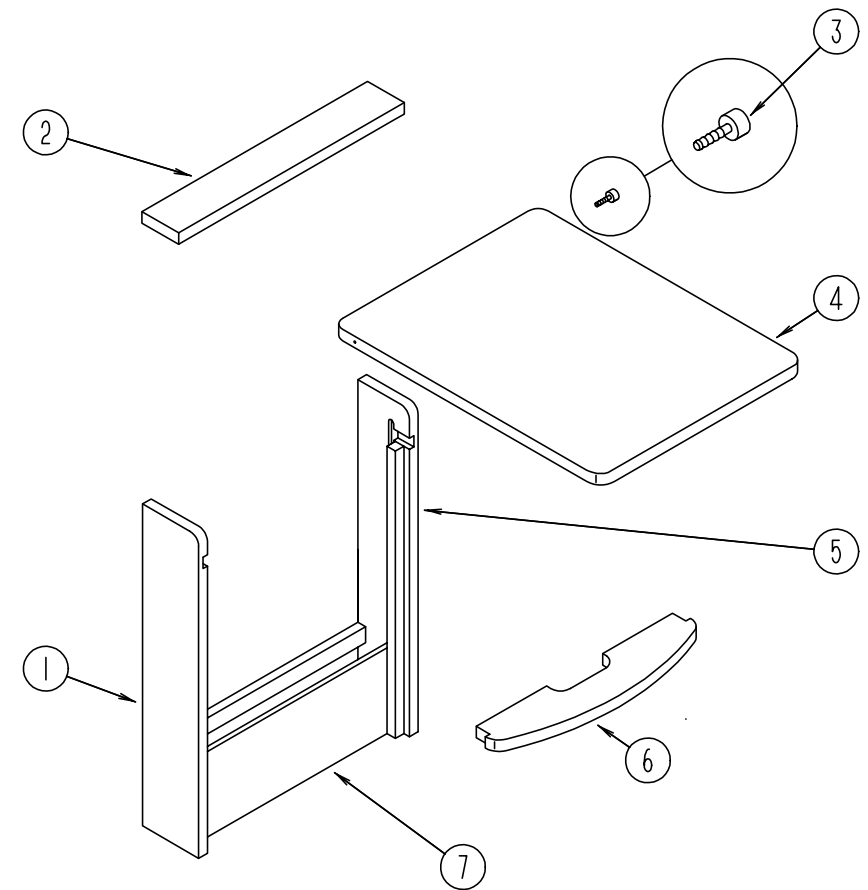

PULLOUT TABLE

KEY	PART NUMBER	U/M	DESCRIPTION
	M96873-01-E07	EA	CABINET ASM. - TABLE - W/O PULLOUT TOP
1	096873-14-B87	EA	SIDE END - TABLE - 28.7" X 5.7" - LEFT SIDE
2	096873-15-B87	EA	SHELF - SUPPORT - OVER PULL OUT TABLE TOP
3	079921-01-000	EA	NYLON ROLLER W/SHAFT
4	096873-11-E01	EA	PULLOUT TOP
5	096873-13-B87	EA	SIDE END - TABLE - 28.7" X 5.7" - RIGHT SIDE
6	096873-12-B87	EA	SHELF - SUPPORT - UNDER PULL OUT TABLE TOP
7	096873-16-B87	EA	PANEL - TABLE - FRONT BOTTOM - 18.1" X 6.7"
	080736-01-000	EA	PULL - RECESSED - 1.25" X 4" - OAK

LOUNGE GROUP (CONTINUED)

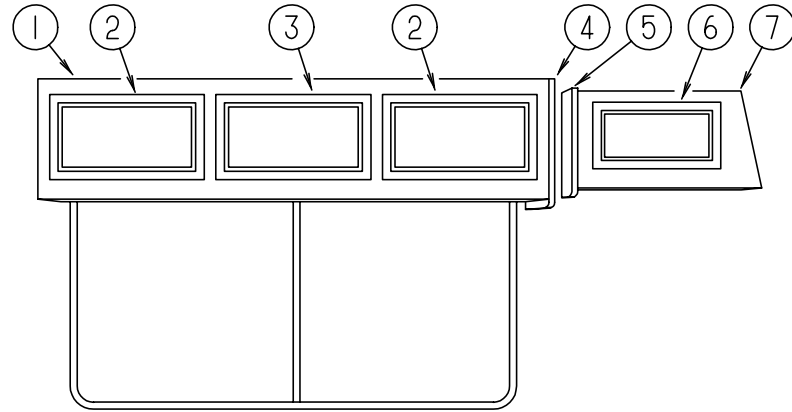

FRONT OVERHEAD CABINET (DRIVER SIDE)

KEY	PART NUMBER	U/M	DESCRIPTION
1	M06838-07-F11	EA	CABINET ASM.
2	M06803-03-E10	EA	DOOR ASM. - RAIL - W/O HARDWARE - W/ MIRROR - 400 X 520 MM
2	108536-03-04A	EA	MIRROR - CABINET DOOR - 317 X 437 MM
3	M06803-13-E10	EA	DOOR ASM. - RAIL - W/O HARDWARE - W/ MIRROR - 400 X 710 MM
3	108536-04-04A	EA	MIRROR - CABINET DOOR - 317 X 627 MM
4	103128-01-F11	EA	END CAP ASM. - RIGHT HAND
5	103128-09-F11	EA	END CAP ASM. (FRONT OVERHEAD)
6	M06803-04-E07	EA	DOOR ASM - W/O HARDWARE - 255 X 485 MM
7	M06839-02-F11	EA	CABINET ASM. - FRONT OVERHEAD - DRIVER SIDE
7	M06839-02-F12	EA	CABINET ASM. - FRONT OVERHEAD - DRIVER SIDE

LOUNGE GROUP (CONTINUED)

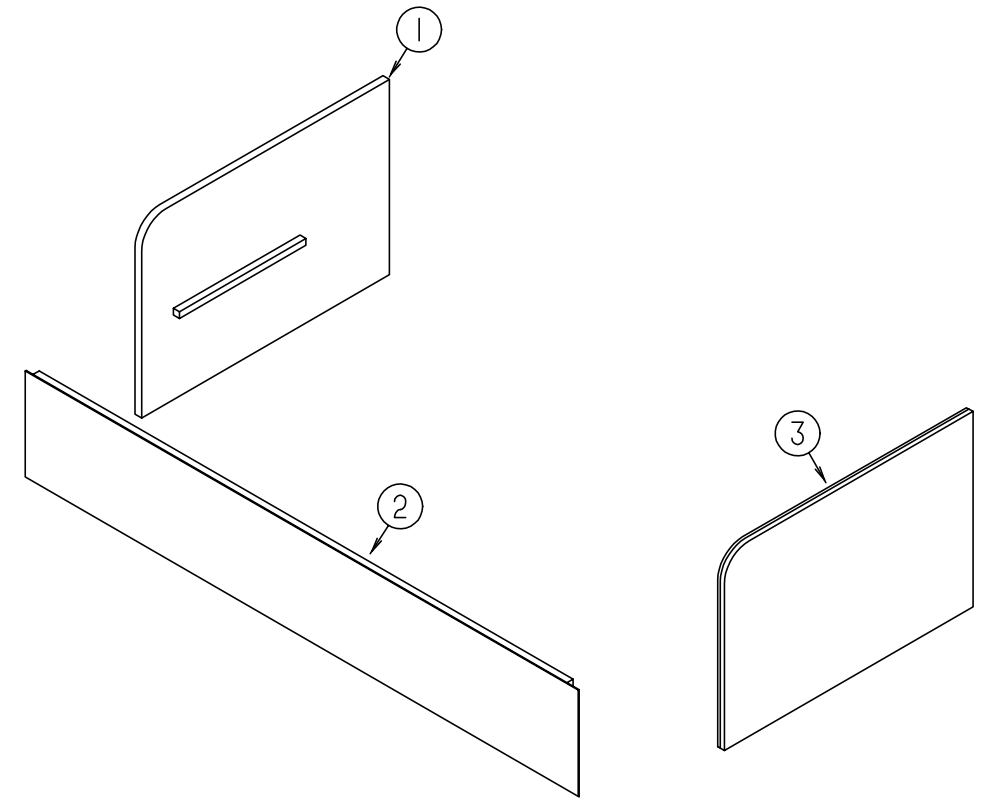

COUCH CABINET

KEY	PART NUMBER	U/M	DESCRIPTION
1	M04187-36-F11	EA	CABINET - COUCH - RIGHT HAND - W/ FABRIC
1	M04187-36-E33	EA	CABINET - COUCH - RIGHT HAND - W/ FABRIC (F12)
2	M04187-37-F11	EA	CABINET - COUCH - FRONT - W/ FABRIC
2	M04187-37-F12	EA	CABINET - COUCH - FRONT - W/ FABRIC
3	M04187-34-F11	EA	CABINET - COUCH - LEFT HAND - W/ FABRIC
3	M04187-34-E33	EA	CABINET - COUCH - LEFT HAND - W/ FABRIC (F12)
	083125-07-000	EA	BRACE - ANGLE - COUCH - OFF WHITE

SEALANTS & FASTENERS GROUP**ADHESIVE AND BOLTS**

KEY	PART NUMBER	U/M DESCRIPTION
	004020-01-000	QT ADHESIVE - ABS CEMENT - QUART
	081377-01-700	EA ADHESIVE - CYANOACRYLATE - 10 GRAM TUBE
	004006-04-700	EA ADHESIVE - PIERCE - 1 GAL - J9270-X-1
	087211-01-000	GL ADHESIVE - PROMOTER
	004005-02-000	EA ADHESIVE - SWIFTS - 1 GAL - W1333
	099039-01-000	EA ADHESIVE - WEATHERSTRIP - 8 OZ.
	053766-02-000	EA BEDDING COMPOUND - TUBE - WHITE
	102333-01-02A	EA BOLT - CARRIAGE - 7/16 - 14
	051387-06-000	EA BOLT - CARRIAGE - W/O HOLE - 5/16-18 X 9.5 ZN
	000C12-08-24B	EA BOLT - HEX - 1/2-13 X 1 1/2 - ZN 5
	000C12-05-16B	EA BOLT - HEX - 5/16-18 X 1 - ZINC 5
	000C12-10-24B	EA BOLT - HEX - 5/8-11 X 1 1/2 ZN - 5
	000C12-07-20B	EA BOLT - HEX - 7/16 - 14 X 1 1/4" - ZN5
	000C13-07-48B	EA BOLT - HEX - 7/16 - 20 X 3 - ZN 5
	000C26-04-10B	EA BOLT - HEX - SER FLG - 1/4-20 X 5/8 ZINC
	000C26-05-20B	EA BOLT - HEX - SER FLG 5/16-18 X 1 1/4" - ZINC
	000C12-05-24B	EA BOLT - HEX - 5/16-18 X 11/2 ZN 5

CLAMPS - GROMMETS AND FASTENERS

KEY	PART NUMBER	U/M DESCRIPTION
	010495-01-000	EA CLAMP - CABLE - 9/16"
	010497-06-000	EA CLAMP - CLOSED - 11/16" ID
	010497-03-000	EA CLAMP - CLOSED - 1" ID - CUSHIONED
	010499-01-000	EA CLAMP - CLOSED - 3/8" ID
	010497-01-000	EA CLAMP - CLOSED - 5/8"ID
	010497-08-000	EA CLAMP - CLOSED - .125"
	075148-02-000	EA CLAMP - GROUNDING - BRONZE SCREWS
	062401-02-000	EA CLAMP - HOSE - WORMGEAR - 1.56" - 2.5"
	062401-10-000	EA CLAMP - HOSE - WORMGEAR 1.06"- 2"
	073194-02-000	EA CLAMP - HOSE - WORMGEAR 32-50 MM
	062401-07-000	EA CLAMP - HOSE - WORMGEAR 5"- 7"
	062401-06-000	EA CLAMP - HOSE - WORMGEAR .22"-.62"
	062401-01-000	EA CLAMP - HOSE - WORMGEAR .25"- 1"
	062401-04-000	EA CLAMP - HOSE - WORMGEAR .69"- 1.25"
	062401-03-000	EA CLAMP - HOSE - WORMGEAR - .22"- 1"
	083609-01-000	EA CLAMP - WIRE -DUAL - EQUAL 5/8" DIAMETER
	094362-02-000	EA CLIP - CHRISTMAS TREE - FLAT HEAD
	077953-01-000	EA GROMMET - EDGE LINER - FITS 1"
	023942-01-000	EA GROMMET - RUBBER - 2" OD
	071015-21-000	EA GROMMET - .50"ID - FITS .19" MATERIAL - RUBBER - SPLIT
	009066-01-000	EA HINGE - ALUMINUM - NO HOLES - 11/16" X 72" - UNPAINTED
	056134-02-000	EA HOLDER - RING - 1.5" ID PIPE SIZE - STEEL
	092321-01-000	FT INSULATION - FIBERGLASS - W/ALUMINUM FOIL
	077955-01-000	EA J CLIP - VINYL COATED - 3/8" USED IN WIRING TO CLEARANCE LIGHTS
	008401-01-000	EA STRAP - CONDUIT - 3/4" - 1 HOLE - GALVANIZED STEEL
	016604-01-000	EA BRACE - CABINET - ANGLED METAL - 2.5"

NUTS & RIVETS

KEY	PART NUMBER	U/M DESCRIPTION
	072893-01-000	EA NUTSERT - M5 X 0 - 8
	077049-01-000	EA NUT - ACORN - 10-32 ALUMINUM
	095094-01-000	EA NUT - ACORN - 1/4 - 20 ALUMINUM
	000D14-05-00B	EA NUT - HEX - 5/16-18 - ZN 5
	000D34-04-00B	EA NUT - HEX - LK 1/4 - 20 ZN
	000D39-04-00B	EA NUT - HEX - SER FLG LK 1/4 - 20 ZN
	000D39-08-00B	EA NUT - HEX - SER FLG LK - 1/2-13 ZN
	000D39-06-00B	EA NUT - HEX - SER FLG LK - 3/8-16 ZN
	000D39-05-00B	EA NUT - HEX - SER FLG LK - 5/16 - 18 ZN
	000D24-10-00B	EA NUT - HEX - SF/LK - 10-32 ZN
	000D34-06-00B	EA NUT - HEX LK-3/8-16 GRADE C ZN
	075467-01-000	EA NUT - INVERTED FLARE - 1/4"
	088497-02-000	EA NUT - INVERTED FLARE - 1/4"
	063253-07-000	EA NUT - J - #8A .120- .130 PNL THK

SEALANTS & FASTENERS GROUP (CONTINUED)**NUTS & RIVETS (CONTINUED)**

KEY	PART NUMBER	U/M DESCRIPTION
	044364-02-000	EA NUT - SPEED - FLAT - ROUND
	040921-06-000	EA NUT - SPEED - U TYPE - NO. 8
	040921-04-000	EA NUT - SPEED - U TYPE - NO. 8
	040921-05-000	EA NUT - SPEED - U TYPE - NO.8
	044364-01-000	EA NUT - SPEED -FLAT
	064081-01-000	EA NUT - WING - 3/8" X 16 THREAD
	084884-01-000	EA PLUG - BRASS - 3/8"
	000H16-04-06R	EA RIVET - POP - AL 1/8 X .313-.375
	069592-02-000	EA RIVET - T (POP) 1/4 X .093-.156
	063729-04-000	EA RIVNUT - 10-32 UNF - .010-.080
	063729-01-000	EA RIVNUT - 1/4 X 20 UNC - .030-.125

SCREWS

KEY	PART NUMBER	U/M DESCRIPTION
	000G67-10-24B	EA SCREW - 10-12 X 1 1/2 PPH - ZN
	000G67-10-16P	EA SCREW - 10-12 X 1 PPH - DARK BROWN
	000G67-10-16B	EA SCREW - 10-12 X 1 PPH - ZN
	000G67-10-08B	EA SCREW - 10-12 X 1/2 PPH ZN
	000G67-10-08R	EA SCREW - 10-12 X 1/2 PPH - BEIGE - TYPE A
	000G67-10-12B	EA SCREW - 10-12 X 3/4 - PPH ZN
	000G67-10-10B	EA SCREW - 10-12 X 5/8 PPH ZN - TYPE A
	000G67-10-10R	EA SCREW - 10-12 X 5/8 PPH - TYPE A - BEIGE
	000G67-10-12P	EA SCREW - 10-12 X .75 PPH - DARK BROWN
	049465-01-000	EA SCREW - 10-16 W/WASHER PTH - DARK BROWN
	049465-04-000	EA SCREW - 10-16 X 1 PTH W/WASHER - BEIGE
	000G11-10-16B	EA SCREW - 10-16 X 1 - PPH ZN
	000G11-10-12R	EA SCREW - 10-16 X 3/4 PPH - BEIGE
	000G11-10-12D	EA SCREW - 10-16 X 3/4 PPH - BLACK
	000G68-06-10G	EA SCREW - 6-18 X 5/8 POH - ANTIQUE BRASS
	076790-01-000	EA SCREW - 6-20 X 1 1/4 PPH - BLACK
	000G13-06-16R	EA SCREW - 6-20 X 1 PFH - BEIGE
	000G13-06-08B	EA SCREW - 6-20 X 1/2 PFH ZN
	000G13-06-10G	EA SCREW - 6-20 X 5/8 PFH - ANTIQUE BRASS
	000G11-06-10B	EA SCREW - 6-20 X 5/8 PPH ZN
	000G11-06-10J	EA SCREW - 6-20 X 5/8 PPH - BRASS
	000G11-07-08B	EA SCREW - 7-19 X 1/2 PPH - ZN
	000G13-07-12B	EA SCREW - 7-19 X 3/4 PFH ZN
	000G13-08-16B	EA SCREW - 8-18 X 1 PFH - ZN
	000G11-08-08T	EA SCREW - 8-18 X 1/2 PPH
	000G11-08-08B	EA SCREW - 8-18 X 1/2 PPH ZN
	000G11-08-12B	EA SCREW - 8-18 X 3/4 PPH ZN
	000G11-08-12R	EA SCREW - 8-18 X 3/4 PPH - BEIGE
	000G11-08-12D	EA SCREW - 8-18 X 3/4 PPH - BLACK
	000G55-08-12W	EA SCREW - 8-18 X.75 - SF/DT - PWH
	000G11-08-16R	EA SCREW - 8-18 X 1.00 PPH - BEIGE
	000G67-10-32B	EA SCREW - 10-12 X 2 PPH ZN
	000G67-10-12R	EA SCREW - 10-12 X .75 PPH BEIGE
	000G67-10-120	EA SCREW - 10-12 X .75 PPH TAN
	049465-03-000	EA SCREW - 10-16 X 1 POH W/WASHER
	000G11-10-12S	EA SCREW - 10-16 X.75 PPH OFF WHITE
	000G54-04-20B	EA SCREW - 1/4-20 X 11/4 PTH TYP 23
	000G57-05-16J	EA SCREW - 5-20 X 1 PFH BRASS
	000G12-06-08T	EA SCREW - 6-20 X .50 POH - BLACK
	000G13-06-16J	EA SCREW - 6-20 X 1.00 PFH BRASS
	000G11-08-12P	EA SCREW - 8- 18 X .75.DARK BROWN
	085318-01-000	EA SCREW - 8-08B X 1/2 -CRIMPTITE HD
	000G67-08-32B	EA SCREW - 8-15 X 2 PPH ZN
	000G12-08-16S	EA SCREW - 8-18 X 1" POH - OFF WHITE•
	000G11-08-16S	EA SCREW - 8-18 X 1.00 PPH OFF WHITE
	009439-07-000	EA SCREW - 8-32 X 1 1/4 POH -BLACK
	087721-01-000	EA SCREW - FLAT HEAD - TAPPING - 1/4 X 1 1/4 LG ZN
	086763-01-000	EA SCREW - MACH - 10 - 32 X 1/4 PTH
	000G19-10-08B	EA SCREW - MACH - 10-32 X 1/2 PPH ZN
	000G19-10-10B	EA SCREW - MACH - 10-32 X 5/8 - PPH - ZINC

SEALANTS & FASTENERS GROUP (CONTINUED)

SCREWS (CONTINUED)

KEY	PART NUMBER	U/M DESCRIPTION
	000G50-04-12B	EA SCREW - MACHINE - 1/4-20 X 3/4 PPH ZN
	081908-01-000	EA SCREW - MACHINE - 6-32 X .62 W/ NYLOCK
	089371-01-000	EA SCREW - MACHINE - 8-32 X 3 5/16.ZN
	000G19-10-20B	EA SCREW - MACHINE - 10-32 X 1 1/14 PPH ZINK
	000G18-08-16B	EA SCREW - MACHINE - 8-32 X 1 - PPH ZN
	075908-01-000	EA SCREW - MACHINE - 10-32 X .56PTH(SEMS)
	000G53-04-06B	EA SCREW - MACHINE - 1/4-20 X 3/8 PPH 2N
	000G18-08-22B	EA SCREW - MACHINE - 8-32 X 1 3/8 PPH ZN
	000G39-10-20B	EA SCREW - SF/DR - 10-16 X 1 1/4 PPH ZN
	000G39-10-12R	EA SCREW - SF/DR - 10-16 X 3/4 PPH - BEIGE
	000G39-10-12D	EA SCREW - SF/DR - 10-16 X 3/4 PPH - BLACK
	000G39-06-16T	EA SCREW - SF/DR - 6-20 X 1 PPH - BLACK
	000G39-06-10T	EA SCREW - SF/DR - 6-20 X 5/8 PPH - BLACK
	000G39-08-24B	EA SCREW - SF/DR - 8-18 X 1 1/2 PPH ZN
	000G39-08-16E	EA SCREW - SF/DR - 8-18 X 1 PPH CHROME
	000G39-08-16B	EA SCREW - SF/DR - 8-18 X 1 PPH ZN
	000G39-08-16T	EA SCREW - SF/DR - 8-18 X 1 PPH - BLACK
	000G55-08-162	EA SCREW - SF/DR - 8-18 X 1.00 - BEIGE
	000G39-08-08B	EA SCREW - SF/DR - 8-18 X 1/2 PPH ZN
	000G39-08-32B	EA SCREW - SF/DR - 8-18 X 2 PPH - ZINC
	000G39-08-12B	EA SCREW - SF/DR - 8-18 X 3/4 PPH ZN
	000G39-08-12T	EA SCREW - SF/DR - 8-18 X 3/4 PPH - BLACK
	000G39-08-06B	EA SCREW - SF/DR - 8-18 X 3/8 PPH ZN
	000G60-10-28T	EA SCREW - SF/DR -10-16 X 1.75
	000G39-08-16R	EA SCREW - SF/DR - 8-18 X 1.00 PPH BEIGE
	000G39-08-08R	EA SCREW - SF/DT - 8-18 X 1/2 PPH
	079382-01-000	EA SCREW - SOCKET - 8-18 X 1" - BLACK

SEALERS

KEY	PART NUMBER	U/M DESCRIPTION
	106205 01 000	EA SEALER - PUMPABLE
	069640-02-000	FT SEALER - RIBBON - 1/2" X 1/8"- INCREMENTS OF 30'
	069640-09-000	FT SEALER - RIBBON - 1/32" X 2 1/2"
	069640-01-000	FT SEALER - RIBBON - 1/4" DIAMETER - INCREMENTS OF 20'
	069640-03-000	FT SEALER - RIBBON - 3/4" X 1/8" - INCREMENTS OF 60'
	069640-06-000	FT SEALER - RIBBON - 5/16" DIAMETER - INCREMENTS OF 25'
	091255-03-000	FT SEAL - FOAM - 1/4 X 3/16 ROLL
	091255-01-000	FT SEAL - FOAM - 3.2MM X 4.8MM
	090340-01-000	FT SEAL - FOAM - CLOSED CELL - 1/4" X 1/2" X 50'
	053752-01-000	GL SEAM SEALER - 5 GAL -ALUMINUM
	034552-04-000	EA SILICONE - TUBE - 300 ML - BEIGE - W/ O NOZZLE
	034552-02-000	EA SILICONE - TUBE - 300 ML - CLEAR - W/ O NOZZLE
	900390-03-000	EA NOZZLE -SILICONE TUBE

SEALANTS & FASTENERS GROUP (CONTINUED)

TAPES AND TIES

KEY	PART NUMBER	U/M DESCRIPTION
	100028-01-000	FT TAPE - ADHESIVE - .031" X .75" WIDE
	004363-01-000	FT TAPE - ADHESIVE FOAM - 1 SIDE - 3/16" X 1/2" - GRAY
	093071-01-000	FT TAPE - BONDING - DOUBLE SIDED - 1/64" X 2"
	093071-01-000	FT TAPE - BONDING - DOUBLE SIDED - 1/64" X 2"
	076322-03-000	FT TAPE - FOAM - DOUBLE COATED - .045" X .5"
	088244-01-000	FT TAPE - FOAM - VINYL COATED - 2" WIDE - INCREMENTS OF 108 FT
	009200-01-000	EA TAPE - FURNACE - 1 1/2"
	087691-01-000	EA TAPE - MASKING - WEATHER RESISTANT
	008343-02-000	EA TIE - WIRE - 14"
	008343-01-000	EA TIE - WIRE - 6"

WASHERS

KEY	PART NUMBER	U/M DESCRIPTION
	077071-01-000	EA WASHER - FENDER - 3/16" ID X 1" OD
	000E13-14-00B	EA WASHER - FLAT - 1/4" WIDE ZN
	000E13-11-00B	EA WASHER - FLAT - 3/16" WIDE ZN
	000E13-17-00B	EA WASHER - FLAT - 3/8 AR ZN

WATER & SEWAGE GROUP

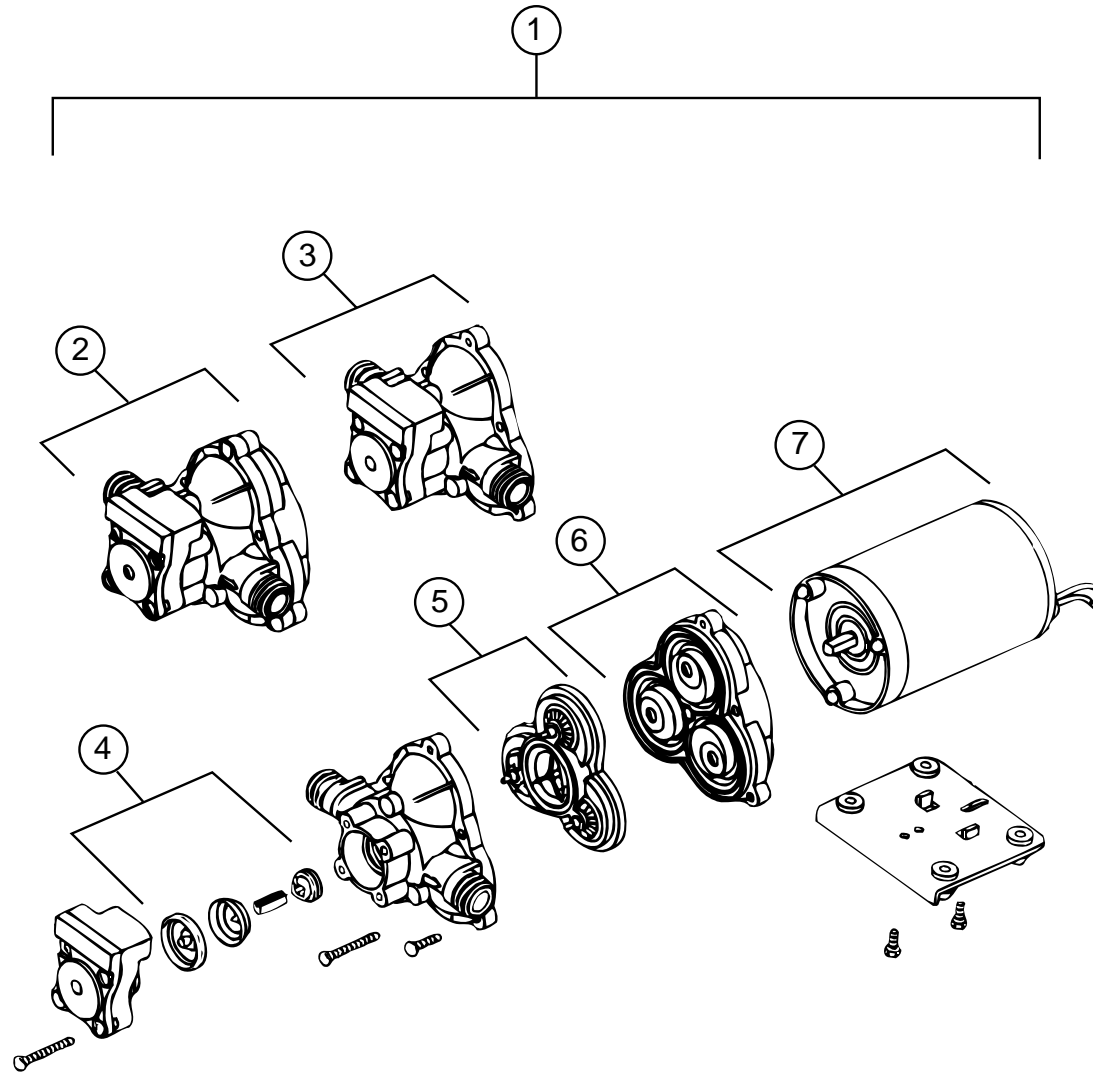

WATER PUMP (SHURFLO)

KEY	PART NUMBER	U/M DESCRIPTION	SHURFLO VENDOR NO.
1	098607-01-000	EA PUMP - WATER - W/.5"MPT FITTING - FLOW 2.8 GPM - UL	
2	098607-01-700	EA PUMPHEAD - REPLACEMENT	94-236-08
3	098607-01-706	EA UPPER HOUSING/ SWITCH KIT	94-231-20
4	098607-01-705	EA CHECK VALVE - KIT	94-237-00
5	098607-01-703	EA VALVE ASM	94-232-00
6	098607-01-702	EA DRIVE/ DIAPHRAGM - KIT	94-238-04
7	098607-01-707	EA MOTOR/ BASEPLATE REPLACEMENT	94-235-03

WATER & SEWAGE GROUP (CONTINUED)

FRESH WATER TANK

KEY	PART NUMBER	U/M DESCRIPTION
	117005-01-000	EA TANK ASM - WATER - 50 GAL - W/O FITTINGS
	117005-02-000	EA TANK ASM - WATER - 50 GAL - W/ FITTINGS
	116881-01-000	EA TANK ASM - WATER - 48 GAL (W/ NOTCHED CORNER) - W/O FITTINGS
	116881-02-000	EA TANK ASM - WATER - 48 GAL (W/ NOTCHED CORNER) - W/ FITTINGS
	042989-05-000	EA FITTING - SPINWELD - PLASTIC 1/2FPT
	042989-03-000	EA FITTING - SPINWELD - PLASTIC - 1 1/4" FPT
	049032-01-000	EA PATCH - SPINWELD - 3/8" - PLASTIC
	039861-01-000	EA SENDING UNIT W/SCREW - WASHER
	091208-01-000	EA WASHER - RUBBER - .06" X .75" X .5"
	077954-02-000	EA FILTER - WATER TANK - SCREEN IN TANK

EXTERIOR SHOWER COMPONENTS

KEY	PART NUMBER	U/M DESCRIPTION
	103092-01-000	EA SHOWER HEAD - W/60" HOSE (US)
	103092-02-000	EA SHOWER HEAD - W/HOSE (CSA)
	104044-01-000	EA BRACKET - SUPPORT - FAUCET
	103092-01-700	EA BRACKET (FOR SHOWER HEAD) CLEAR
	103092-01-701	EA BRACKET (FOR SHOWER HEAD) BONE
	075241-05-000	EA FAUCET - SHOWER - BONE

WATER SYSTEM COMPONENTS

KEY	PART NUMBER	U/M DESCRIPTION
	701069-01-000	EA WATER PURIFICATION SYSTEM
	701069-03-700	EA CARTRIDGE - WATER FILTER - AC - EVERPURE 9601-11
	039800-04-000	FT TUBING - POLYBUTYL - 1/4" OD X 20FT
	039800-02-000	FT TUBING - POLYBUTYL - 5/8" OD X 20FT
	010219-01-000	EA ELBOW - 1 1/4" MPT X 1 1/4" BARB - WATER FILL - PLASTIC
	039798-01-000	EA TEE - 1/2" MPT X 1/2" MPT X 1/2" MPT - PLASTIC
	101814-01-000	EA COUPLING - FEMALE - 1/2" X 1/2" FPT
	M06993-02-000	EA INSULATION - WATER TANK
	110915-01-01A	EA FILL - WATER - CITY - CHROME - KEVCO 64713
	103798-01-000	EA CONNECTOR - 1/4"OD X 3/8"MPT
	110438-01-000	EA VALVE - CHECK - BRASS

WATER SYSTEM COMPONENTS (FLAIR-IT)

KEY	PART NUMBER	U/M DESCRIPTION	FLAIR-IT VENDOR NO.
	114427-01-000	EA CAP - 1/2P	02860
	114427-02-000	EA PLUG - 1/2P	02863
	114428-01-000	EA TEE - 1/2P X 1/2P X 1/2P	02820
	114428-02-000	EA TEE - SWIVEL - 1/2P X 1/2P X 1/2FPT	02821
	114428-03-000	EA TEE - 1/2P X 1/2P X 1/2MPT	02822
	114429-01-000	EA ELBOW - 1/2P X 1/2P	02800
	114429-02-000	EA ELBOW - 1/2P X 1/2MPT	02803
	114429-03-000	EA ELBOW - SWIVEL - 1/2P X 1/2FPT	02816
	114429-04-000	EA ELBOW - 1/2P X 3/8MPT	02810
	114429-05-000	EA ELBOW - 1/2P X 3/4MPT	02812
	114429-06-000	EA ELBOW - SWIVEL - 1/2P X 3/4FPT	02811
	114430-01-000	EA ADAPTER - 1/2P X 1/2P	02840
	114430-02-000	EA ADAPTER - SWIVEL - 1/2P X 1/2FPT	02873
	114430-03-000	EA ADAPTER - 1/2P X 1/2MPT	02842
	114431-01-000	EA VALVE - LINE DRAIN 1/2P	02914
	114431-02-000	EA VALVE - 1/2P - BYPASS	02910
	114431-03-000	EA VALVE - 1/2P X 1/2P	02884
	114431-04-000	EA VALVE - STOP - 1/2P X 1/2P	02880

WATER & SEWAGE GROUP (CONTINUED)

DRAINAGE SYSTEM

KEY	PART NUMBER	U/M	DESCRIPTION
1	092303-01-000	EA	STRAINER - SINK
2	079968-01-000	EA	VENT - MECHANICAL TRAP ARM - ANTI-SIPHON - 2" DIA X 7.3"
3	010008-01-000	EA	ELBOW - 90 DEGREE - 1/4 BEND - 1 1/2" HUB X HUB - EXTRA LONG TURN
4	061607-01-000	EA	GROMMET - HOLDING TANK - 1 1/2" NPS
	010115-01-000	EA	COUPLING - 1 1/2" HUB X HUB - PLASTIC
5	104352-01-000	EA	TANK - HOLDING - 50 GAL
6	010006-01-000	EA	ELBOW - 45 DEGREE - 1/8 BEND - 1 1/2" HUB X HUB
7	010051-01-000	EA	ELBOW - 45 DEGREE STREET- 1/8 BEND - 1 1/2" S X H - PLASTIC
8	112789-01-000	EA	TANK - HOLDING - 46 GAL
9	063641-01-000	EA	FLANGE - CLOSET - 4" X 3"
10	061607-02-000	EA	GROMMET - HOLDING TANK - 3" NPS
11	107538-01-000	EA	P-TRAP - 1 1/4 - PLASTIC (US)
11	011071-01-000	EA	P-TRAP - 1 1/2 - PLASTIC (CSA) (GALLEY)
11	011066-01-000	EA	P-TRAP - 1 1/2 - PLASTIC (CSA) (BATH)
12	078406-01-000	EA	COUPLER - RUBBER - W/ CLAMPS - 3" X 3"
13	041056-01-000	EA	ELBOW - STREET - 1/4" BEND - 3" X 90° XLT
14	070916-01-000	EA	VALVE ASM - DUAL DUMP - W/CAP - 3" X 1 1/2"
	070916-01-700	EA	VALVE ONLY - 3"
	070916-01-701	EA	VALVE ONLY - 1 1/2"
	062415-01-000	EA	SEWER CAP - 3"
15	062422-01-000	EA	ADAPTER - OFFSET REDUCER - 3" X 1 1/2"
16	010071-01-000	EA	TEE - SANITARY - 1 1/2" HUB X HUB X HUB
17	011069-03-000	EA	TAILPIECE - SHOWER/ TUB - 1 1/2" X 1 3/4" - PLASTIC (US)
17	011069-02-000	EA	TAILPIECE - TUB/ SHOWER - 1 1/2" X 1 1/4" X 4" - BRASS (CSA)
	066440-01-000	EA	STRAINER - SHOWER - W/RUBBER WASHER
	066436-01-000	EA	NUT - SLIP - TAILPIECE - 1.5"
18	034250-01-000	EA	ELBOW - 90 DEGREE - 1/4 BEND - 1 1/2" HUB X HUB - LONG TURN
19	010073-01-000	EA	WYE - 45 DEGREE - 1 1/2" HUB X HUB X HUB
20	096927-01-701	EA	TAILPIECE - BATH SINK
21	109571-01-000	EA	ADAPTER - P-TRAP - 1 1/2" P X 1 1/4" MPT
22	011091-02-000	EA	CONTINUOUS WASTE - DOUBLE SINK - 1 1/4" (US)
22	011091-03-000	EA	CONTINUOUS WASTE - DOUBLE SINK - 1 1/4" (CSA)
	010201-01-000	EA	HOSE - SEWER - 3" ID X 8'
	062416-01-000	EA	ADAPTER - SEWER HOSE TO 3" PIPE

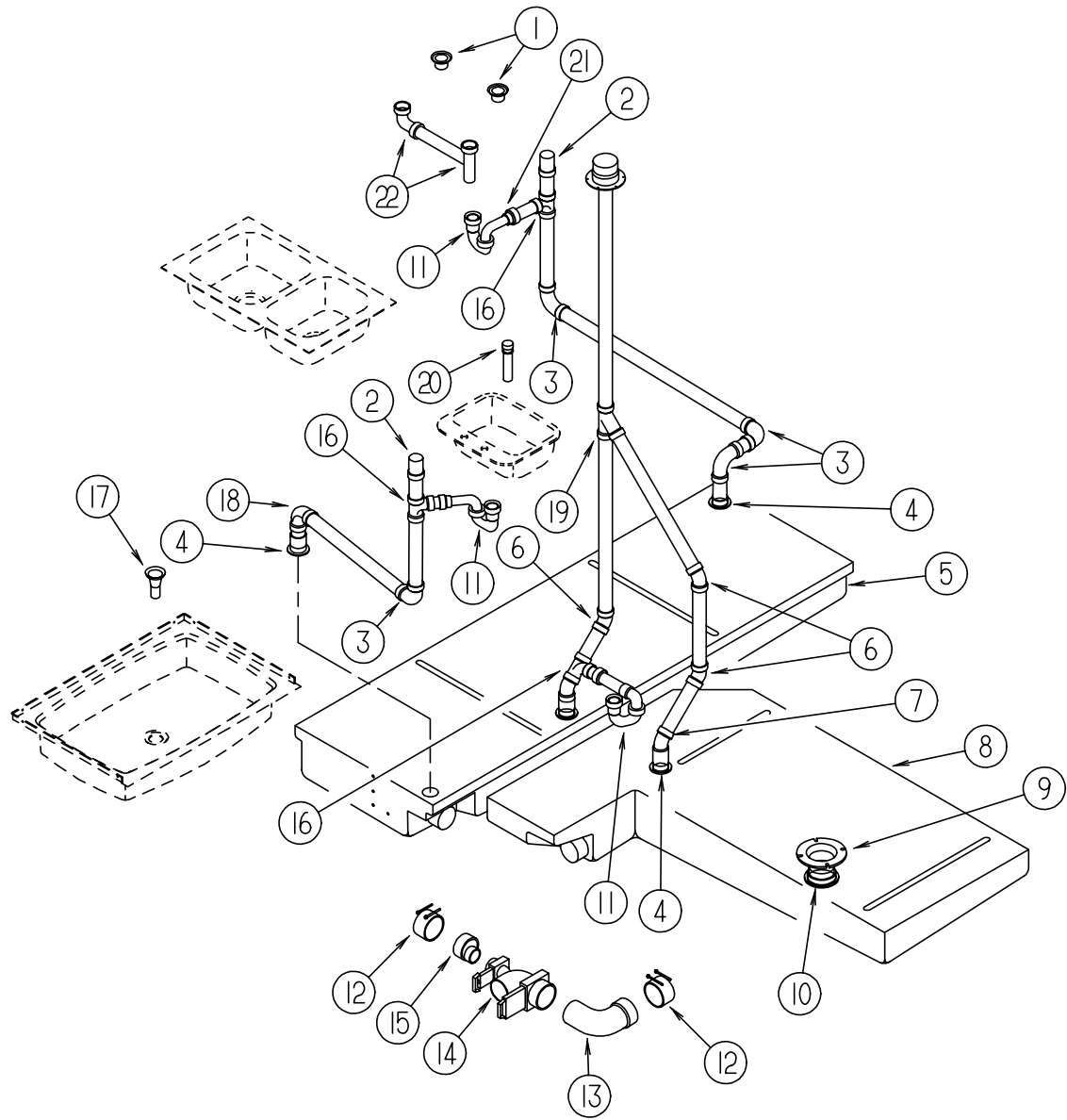

WATER & SEWAGE GROUP (CONTINUED)

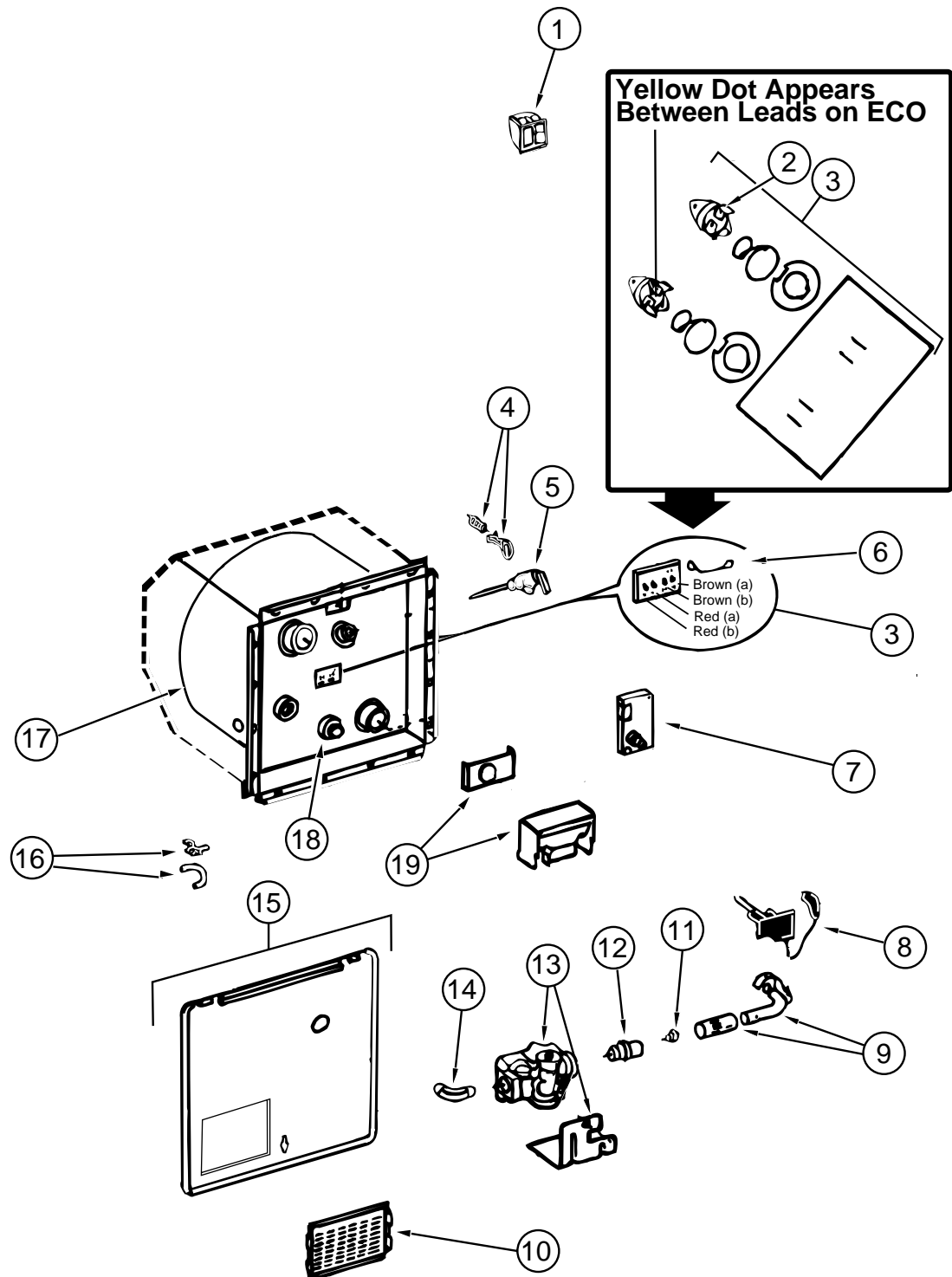

WATER HEATER W/MOTOR AID ATWOOD (GH6-7E)

KEY	PART NUMBER	U/M DESCRIPTION	ATWOOD VENDOR NO.
	051393-01-000	EA WATER HEATER - W/ MOTOR AID - PILOTLESS IGNITION	
1	051393-01-701	EA SWITCH PACKAGE	91959
2	051391-04-701	EA THERMOSTAT 12 VDC-120 PRESET	91470
3	051393-01-721	EA ECO & THERMOSTAT ASM - FRONT MOUNT - 140°	91447
4	051391-01-705	EA FASTENER - CAMLOC	92609
5	051391-01-704	EA VALVE - RELIEF - 1/2" FITTING	91604
6	051393-01-723	EA SWITCH - ENERGY CUT-OFF	93866
7	051393-01-724	EA CIRCUIT BOARD - W/ SPADE TERMINAL	93867
8	051393-01-725	EA ELECTRODE - SINGLE SPADE CONNECTION	93868
9	051391-04-703	EA BURNER - MAIN	91638
10	051391-01-717	EA GRILLE	92640
11	051391-01-710	EA ORIFICE - MAIN BURNER	92742
12	051391-03-700	EA ORIFICE HOLDER	91563
13	051393-01-726	EA SOLENOID VALVE & BRACKET	93870
14	051391-01-714	EA ELBOW - 45 DEGREE - 3/8"F X 3/8"MPT	91044
15	052009-01-000	EA DOOR - WATER HEATER - OFF WHITE	
16	051391-01-700	EA HINGE KIT - W/CLIP	92568 & 92559
17	051393-03-701	EA TANK - INNER	91642
18	051391-01-715	EA DRAIN PLUG	91857
19	051391-04-706	EA FLUE & GASKET	92787
	116424-01-000	EA PROTECTOR - ROUND VINYL - WATER HEATER LATCH	

WATER HEATER W/MOTOR AID ATWOOD (G6A-7E)

KEY	PART NUMBER	U/M DESCRIPTION	ATWOOD VENDOR NO.
	051391-03-000	EA WATER HEATER - W/ ELECTRIC IGNITION	
1	051393-01-701	EA SWITCH PACKAGE	91959
2	051391-04-701	EA THERMOSTAT 12 VDC-120 PRESET	91470
3	051393-01-721	EA ECO & THERMOSTAT ASM - FRONT MOUNT - 140°	91447
4	051391-01-705	EA FASTENER - CAMLOC	92609
5	051391-01-704	EA VALVE - RELIEF - 1/2" FITTING	91604
6	051393-01-723	EA SWITCH - ENERGY CUT-OFF	93866
7	051393-01-724	EA CIRCUIT BOARD - W/ SPADE TERMINAL	93867
8	051393-01-725	EA ELECTRODE - SINGLE SPADE CONNECTION	93868
9	051391-04-703	EA BURNER - MAIN	91638
10	051391-01-717	EA GRILLE	92640
11	051391-01-710	EA ORIFICE - MAIN BURNER	92742
12	051391-03-700	EA ORIFICE HOLDER	91563
13	051393-01-726	EA SOLENOID VALVE & BRACKET	93870
14	051391-01-714	EA ELBOW - 45 DEGREE - 3/8"F X 3/8"MPT	91044
15	052009-01-000	EA DOOR - WATER HEATER - OFF WHITE	
16	051391-01-700	EA HINGE KIT - W/CLIP	92568 & 92559
17	051391-04-706	EA TANK - INNER	91641
18	051391-01-715	EA DRAIN PLUG	91857
19	051391-04-706	EA FLUE & GASKET	92787
	116424-01-000	EA PROTECTOR - ROUND VINYL - WATER HEATER LATCH	

WINDOW, VENT & EXTERIOR DOOR GROUP

WINDOWS & VENTS

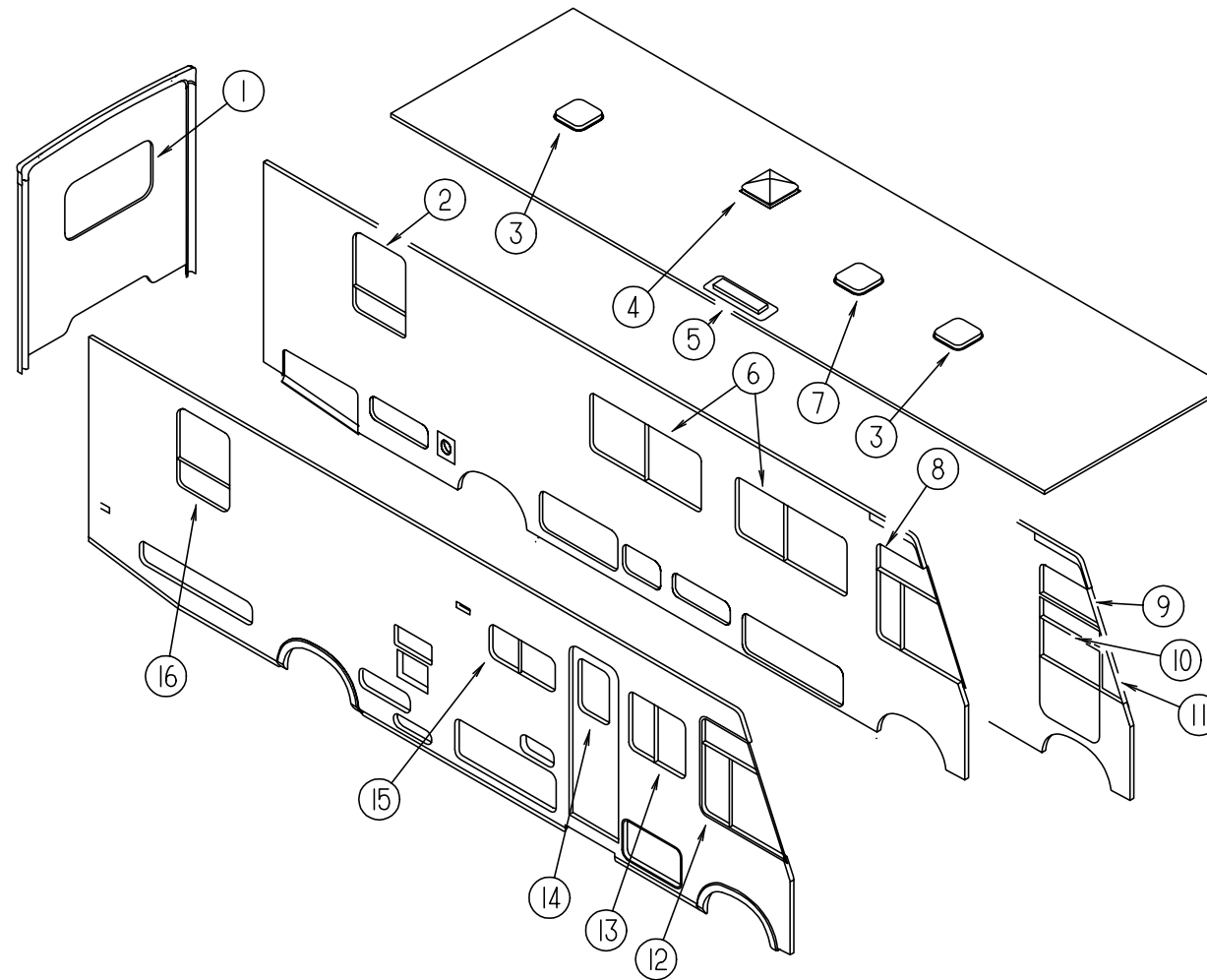

KEY	PART NUMBER	U/M DESCRIPTION
1	113502-01-01A	EA WINDOW ASM. - ESCAPE - THERMO - W/ INSIDE FRAME (KING OR QUEEN BED)
1	113733-07-01A	EA WINDOW ASM. - STATIONARY - THERMO - W/ INSIDE FRAME (TWIN BED)
1	078528-06-E10	EA WINDOW ASM. - ESCAPE - W/O INSIDE FRAME (KING OR QUEEN BED)
1	078528-13-F11	EA WINDOW ASM. - ESCAPE - W/O INSIDE FRAME (TWIN BED)
2	112898-08-01A	EA WINDOW ASM. - SLIDER - THERMO - W/ INSIDE FRAME (KING OR QUEEN BED)
2	112898-09-01A	EA WINDOW ASM. - ESCAPE SLIDER - THERMO - W/ INSIDE FRAME (TWIN BED)
2	112463-01-01A	EA WINDOW ASM. - TORQUE - TIPOUT (KING OR QUEEN BED)
3	110051-02-01A	EA VENT - ROOF - NON POWERED
4	110051-04-01A	EA VENT - ROOF - POWERED (US)
4	110051-06-01A	EA VENT - ROOF - POWERED (CSA)
5	084073-03-000	EA REFRIGERATOR ROOF VENT (OFF-WHITE)
6	112795-15-01A	EA WINDOW ASM. - SLIDER - THERMO INSULATED - W/ INSIDE FRAME (OPTION)
6	098647-22-01A	EA WINDOW ASM. - SLIDER - W/ INSIDE FRAME (OFF-WHITE)
7	084079-14-000	EA VENT - ROOF - POWERED (US)
7	084079-15-000	EA VENT - ROOF - POWERED (CSA)
8	113501-01-01A	EA WINDOW ASM. - CAB - THERMO INSULATED - W/ INSIDE FRAME (OPTION)
8	103658-07-01A	EA WINDOW ASM. - CAB - DRIVER SIDE

KEY	PART NUMBER	U/M DESCRIPTION
9	116000-02-01A	EA WINDOW ASM. - VISTA - THERMO INSULATED - W/ INSIDE FRAME (OPTION)
9	106467-03-01A	EA WINDOW ASM. - VISTA - DRIVER SIDE
10	106469-01-704	EA WINDOW - DRIVER DOOR - ROLL-UP GLASS ASM. - W/ BRACKET
11	115999-02-01A	EA WINDOW ASM. - FRONT SLANT - THERMO INSULATED - DRIVER SIDE (OPTION)
11	106468-02-01A	EA WINDOW ASM. - FRONT SLANT- DRIVER SIDE
12	113501-02-01A	EA WINDOW ASM. - CAB - THERMO INSULATED - W/ INSIDE FRAME (OPTION)
12	103658-08-01A	EA WINDOW ASM. - CAB - PASSENGER SIDE
13	112795-18-01A	EA WINDOW ASM. - SLIDER - THERMO INSULATED - W/ INSIDE FRAME (OPTION)
13	098647-25-01A	EA WINDOW ASM. - SLIDER - W/ INSIDE FRAME (OFF-WHITE)
14	113733-01-01A	EA WINDOW ASM. - THERMO INSULATED - W/ INSIDE FRAME (OPTION)
14	117053-02-F36	EA WINDOW ASM. - ENTRANCE DOOR - W/O INSIDE FRAME (FRONT DOOR)
15	112795-19-01A	EA WINDOW ASM. - SLIDER - THERMO INSULATED - W/ INSIDE FRAME (OPTION)
15	098647-33-01A	EA WINDOW ASM. - SLIDER - W/ INSIDE FRAME (OFF-WHITE)
16	112898-08-01A	EA WINDOW ASM. - SLIDER - THERMO INSULATED - W/ INSIDE FRAME (OPTION)
16	112463-01-01A	EA WINDOW ASM. - TORQUE - TIPOUT

WINDOW, VENT & EXTERIOR DOOR GROUP (CONTINUED)

SINGLE SLIDER WINDOW (EXCEL) (PASSENGER SIDE, LOUNGE)

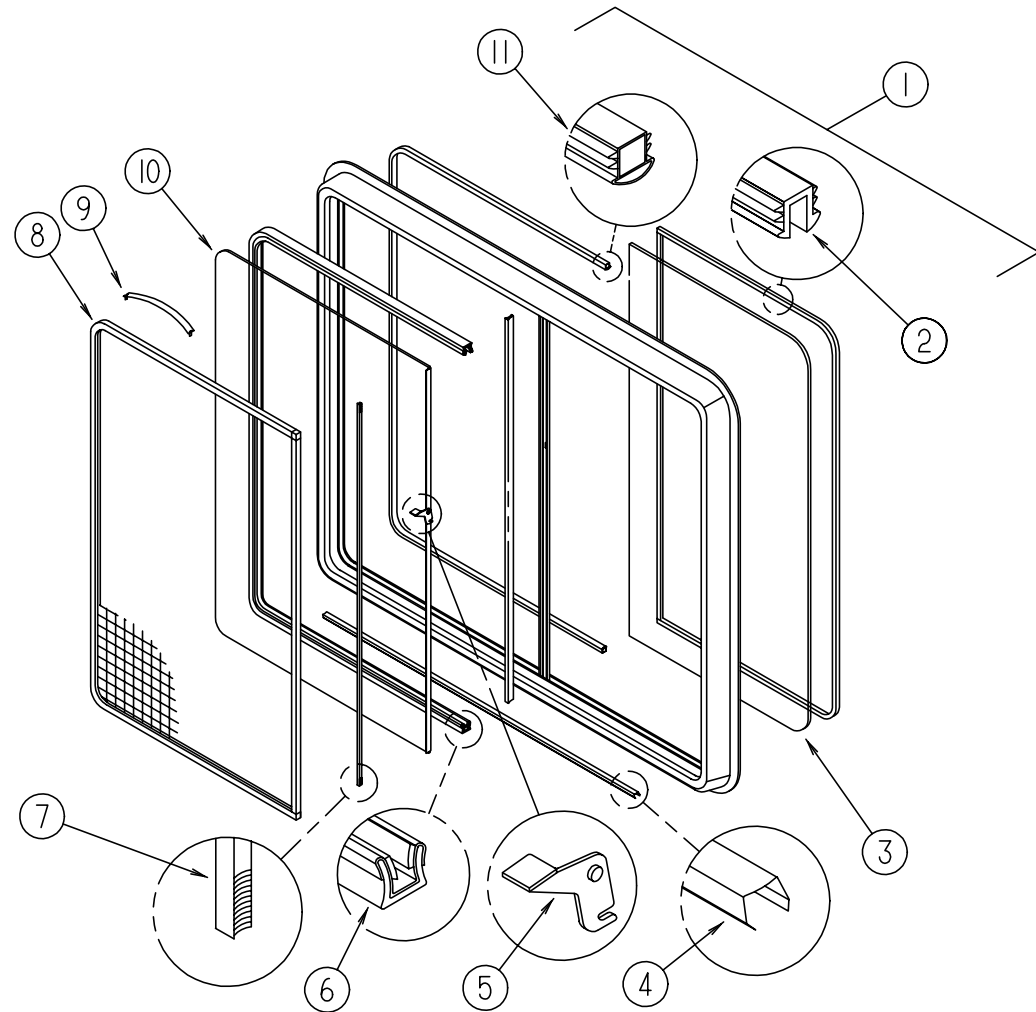

KEY	PART NUMBER	U/M DESCRIPTION	VENDOR NO.
	098647-25-01A	EA WINDOW ASM - SLIDER - W/ INSIDE FRAME	H286-G2W66R
1	098647-25-700	EA WINDOW ASM - SLIDER - W/O INSIDE FRAME	H286-G2R
	098647-25-701	EA FRAME - INSIDE (OFF WHITE)	W28666
2	100322-01-703	FT GLAZING STRIP	132-010723
3	098647-25-702	EA GLASS - STATIONARY	106-017657
4	098644-01-710	FT TRACK - SCREEN SPACER - 12' LENGTH	132-017135
5	098644-01-700	EA LATCH - REPAIR KIT	B801-CK
6	098644-01-708	FT CHANNEL - PIERCED RUN	122-016543
7	098644-01-711	FT WEATHERSTRIP - SCREEN - BLACK	171-016965
8	098647-25-704	EA SCREEN ASM. - W/ SPRINGS & WEATHERSTRIP	410-019065
9	098644-01-713	EA SPRING - SCREEN FRAME (CLIP)	226-016966
10	098647-25-703	EA GLASS - SLIDING - W/ SASH & LATCH	H286-G9
11	098644-01-706	FT WEATHERSTRIP	171-010668
	098644-01-716	FT PLUG - FILLER	132-014470
	098644-01-717	FT SPLINE - SCREEN	132-004716

SINGLE SLIDER WINDOW (EXCEL) (GALLEY)

KEY	PART NUMBER	U/M DESCRIPTION	VENDOR NO.
	098647-33-01A	EA WINDOW ASM - SLIDER - W/ INSIDE FRAME	H425-G2W66R
1	098647-33-700	EA WINDOW ASM - SLIDER - W/O INSIDE FRAME	H425-G2R
	098647-33-701	EA FRAME - INSIDE (OFF WHITE)	CW2966
2	100322-01-703	FT GLAZING STRIP	132-010723
3	098647-33-702	EA GLASS - STATIONARY	106-019297
4	098644-01-710	FT TRACK - SCREEN SPACER - 12' LENGTH	132-017135
5	098644-01-700	EA LATCH - REPAIR KIT	B801-CK
6	098644-01-708	FT CHANNEL - PIERCED RUN	122-016543
7	098644-01-711	FT WEATHERSTRIP - SCREEN - BLACK	171-016965
8	098647-33-704	EA SCREEN ASM. - W/ SPRINGS & WEATHERSTRIP	410-019134

SINGLE SLIDER WINDOW (EXCEL) (DRIVER SIDE, DINETTE & LOUNGE)

KEY	PART NUMBER	U/M DESCRIPTION	VENDOR NO.
	098647-22-01A	EA WINDOW ASM - SLIDER - W/ INSIDE FRAME	H287-G2W66L
1	098647-22-700	EA WINDOW ASM - SLIDER - W/O INSIDE FRAME	H287-G2L
	098647-23-702	EA FRAME - INSIDE (OFF WHITE)	W28766
2	100322-01-703	FT GLAZING STRIP	132-010723
3	098647-23-703	EA GLASS - STATIONARY	106-017622
4	098644-01-710	FT TRACK - SCREEN SPACER - 12' LENGTH	132-017135
5	098644-01-700	EA LATCH - REPAIR KIT	B801-CK
6	098644-01-708	FT CHANNEL - PIERCED RUN	122-016543
7	098644-01-711	FT WEATHERSTRIP - SCREEN - BLACK	171-016965
8	098647-23-704	EA SCREEN ASM. - W/ SPRINGS & WEATHERSTRIP	410-019066
9	098644-01-713	EA SPRING - SCREEN FRAME (CLIP)	226-016966
10	098647-23-700	EA GLASS - SLIDING - W/ SASH & LATCH	H287-G9
11	098644-01-706	FT WEATHERSTRIP	171-010668
	098644-01-716	FT PLUG - FILLER	132-014470
	098644-01-717	FT SPLINE - SCREEN	132-004716

WINDOW, VENT & EXTERIOR DOOR GROUP (CONTINUED)

BEDROOM WINDOW (EXCEL TIPOUT) (KING OR QUEEN BED)

KEY	PART NUMBER	U/M DESCRIPTION	EXCEL VENDOR NO.
	112463-01-01A	EA WINDOW ASM - TORQUE - TIPOUT	CH81-G2W59
	100322-01-703	FT STRIP - GLAZING,BUTYL EXCEL	132-010723
	112463-01-700	EA GLASS - STATIONARY 62 % GP	106-018807
	112463-01-701	EA WINDOW W/O TRIM	CH81-G2
	112463-01-702	EA TRIM	CW8159
	112463-01-703	EA VENT ASSEMBLY	CH81-G9
	112463-01-704	EA OPERATOR & BAR ASSEMBLY	CH78-18
	112463-01-705	EA SCREEN ASSEMBLY	410-018811

WINDOW, VENT & EXTERIOR DOOR GROUP (CONTINUED)

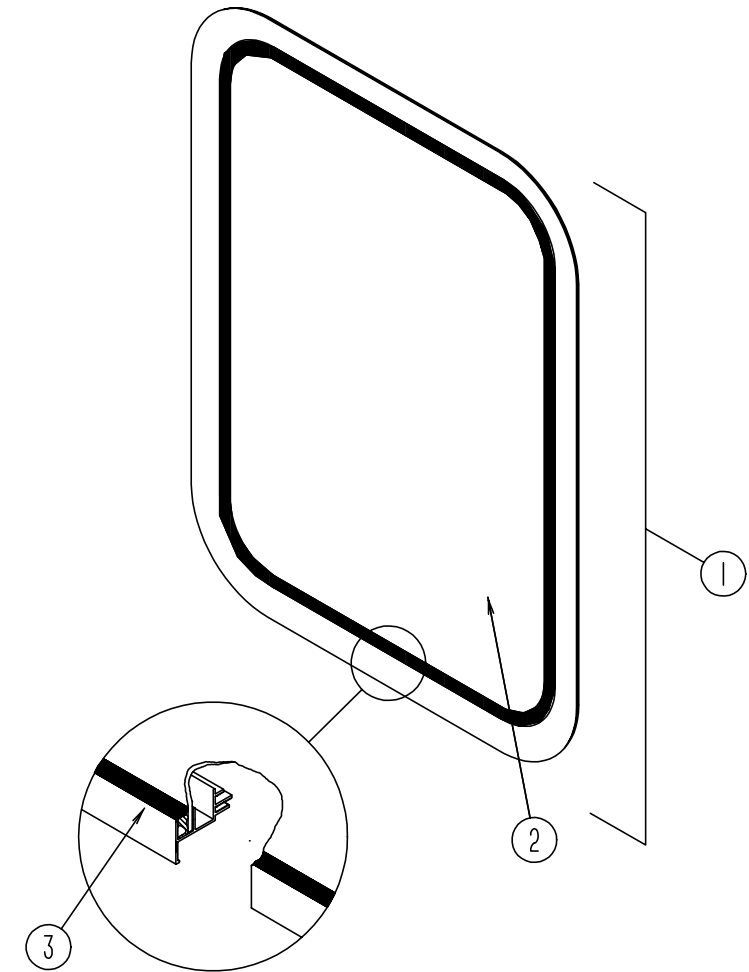

ENTRY DOOR WINDOW

KEY	PART NUMBER	U/M DESCRIPTION
1	079733-15-F04	EA WINDOW ASM. - ENTRANCE DOOR - W/O INSIDE FRAME
	067609-38-000	EA INSIDE FRAME - OFF WHITE
2	002181-24-000	EA GLASS - PICTURE 687.4 X 449.4
3	087561-01-000	FT SEAL - GLASS - EXTERIOR - .5" WIDE - VINYL - BLACK

WINDOW, VENT & EXTERIOR DOOR GROUP (CONTINUED)

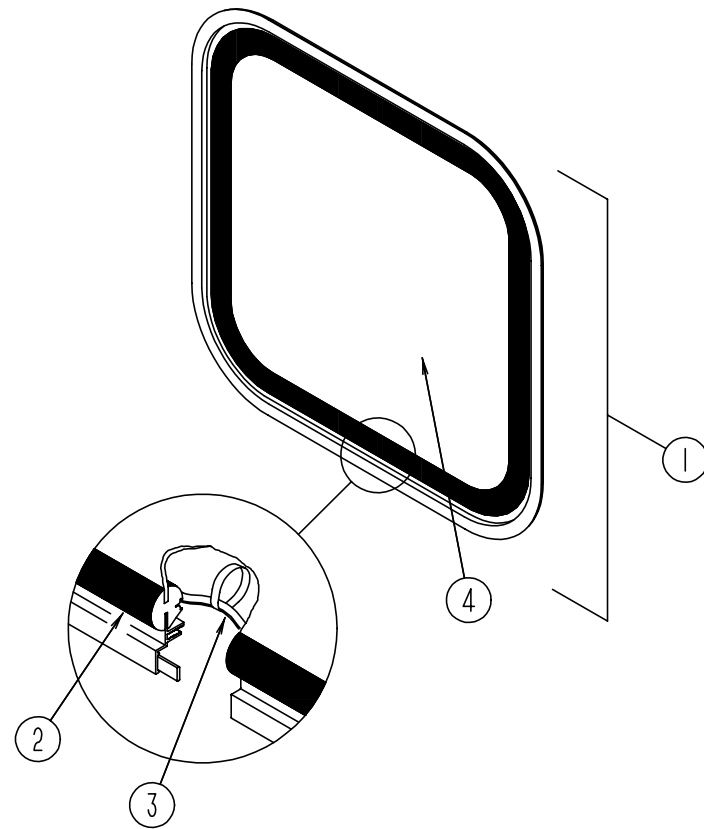

BACKWALL ESCAPE WINDOW (KING OR QUEEN BED)

KEY	PART NUMBER	U/M DESCRIPTION
1	078528-06-E10	EA WINDOW - ESCAPE - 24.75" X 48.75" - W/O INSIDE FRAME
	074816-08-000	EA INSIDE FRAME - OFF WHITE
2	002282-09-000	EA WEATHERSTRIP - .125" VULCANIZED - 130.53" LONG - BLACK
3	002285-01-000	FT FILLER - WEATHER STRIP RUBBER - BLACK
4	076337-12-000	EA GLASS - WINDOW

BACKWALL ESCAPE WINDOW (TWIN BED)

KEY	PART NUMBER	U/M DESCRIPTION
1	078528-13-F11	EA WINDOW - ESCAPE - W/O INSIDE FRAME
	074816-15-000	EA INSIDE FRAME - OFF WHITE
2	002282-13-000	EA WEATHERSTRIP - .125" VULCANIZED - BLACK
3	002285-01-000	FT FILLER - WEATHER STRIP RUBBER - BLACK
4	076337-18-000	EA GLASS - WINDOW

WINDOW, VENT & EXTERIOR DOOR GROUP (CONTINUED)

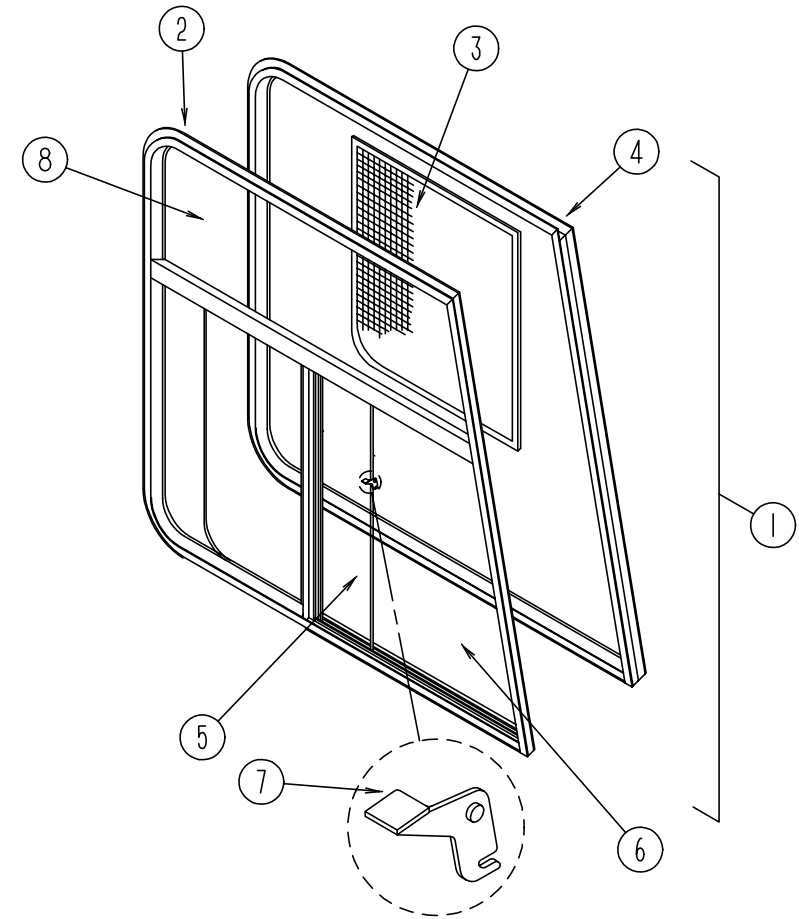

FRONT CAB WINDOWS (EXCEL)

KEY	PART NUMBER	U/M DESCRIPTION
1	103658-07-01A	EA WINDOW ASM. - CAB - W/ INSIDE FRAME - DRIVER SIDE
1	103658-08-01A	EA WINDOW ASM. - CAB - W/ INSIDE FRAME - PASSENGER SIDE
2	103658-08-700	EA WINDOW ASM. - SLIDER - W/O INSIDE FRAME - PASSENGER SIDE
2	103658-07-704	EA WINDOW ASM. - SLIDER - W/O INSIDE FRAME - DRIVER SIDE
3	103658-01-700	EA SCREEN ASM. - WINDOW - DRIVER SIDE
3	103658-02-700	EA SCREEN ASM. - WINDOW - PASSENGER SIDE
	098644-01-717	FT SCREEN SPLINE
	098644-01-713	EA SCREEN CLIPS (METAL)(BLACK)
	098644-01-710	FT TRACK - SPACER - FOR SCREEN 12'
	098644-01-711	FT WEATHERSTRIP - SCREEN - BLACK
4	103658-08-701	EA INSIDE FRAME - PASSENGER SIDE
4	103658-07-700	EA INSIDE FRAME - DRIVER SIDE
5	103658-01-703	EA GLASS - SLIDING - W/SASH & LATCH - DRIVER SIDE
5	103658-02-701	EA GLASS - SLIDING - W/SASH & LATCH - PASSENGER SIDE
6	103658-01-702	EA GLASS - STATIONARY - BOTTOM - DRIVER OR PASSENGER SIDE
7	098644-01-700	EA LATCH - REPAIR KIT
8	103658-07-701	EA GLASS - STATIONARY - TOP - DRIVER OR PASSENGER SIDE
	098644-01-708	FT CHANNEL - PIERCED RUN
	098644-01-706	FT WEATHERSTRIP - GLASS
	098644-01-716	FT PLUG - FILLER

WINDOW, VENT & EXTERIOR DOOR GROUP (CONTINUED)

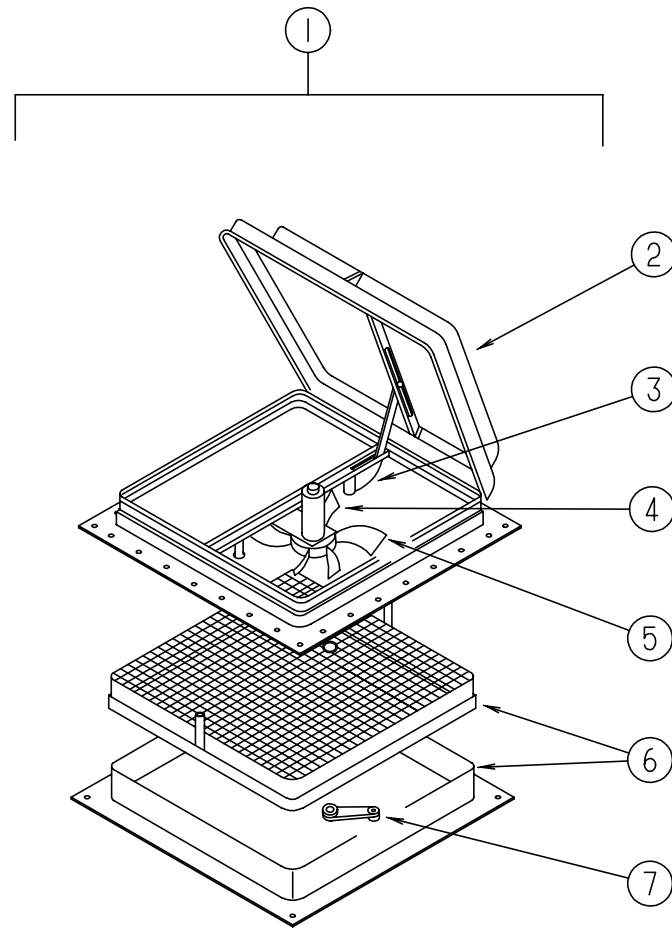

POWERED ROOF VENT (US) (JENSEN)

KEY	PART NUMBER	U/M DESCRIPTION	VENDOR NO.
1	110051-04-01A	EA VENT ASM. - ROOF - POWERED	7797
2	064470-01-700	EA COVER - ROOF VENT	7291
3	110051-01-702	EA GEAR - LIFT-ARM ASM.	RP-1000B
4	048648-01-000	EA MOTOR - 12V NONVENTED 1/8 SHAFT	42-472-01
5	048649-01-000	EA FAN - PLASTIC - 6 IN - 6 BLADED	RP-10002B
6	110051-01-704	EA SCREEN & FRAME	29-688-03
7	110051-01-703	EA CRANK HANDLE	RP-1031-B

POWERED ROOF VENT (CANADIAN) (JENSEN)

KEY	PART NUMBER	U/M DESCRIPTION	VENDOR NO.
1	110051-06-01A	EA VENT ASM. - ROOF - POWERED	C7797
2	064470-01-700	EA COVER - ROOF VENT	7291
3	110051-01-702	EA GEAR - LIFT-ARM ASM.	RP-1000B
4	048648-01-000	EA MOTOR - 12V NONVENTED 1/8 SHAFT	42-472-01
5	048649-01-000	EA FAN - PLASTIC - 6 IN - 6 BLADED	RP-10002B
6	110051-01-704	EA SCREEN & FRAME	29-688-03
7	110051-01-703	EA CRANK HANDLE	RP-1031-B

WINDOW, VENT & EXTERIOR DOOR GROUP (CONTINUED)

NON POWERED ROOF VENT (JENSEN)

KEY	PART NUMBER	U/M DESCRIPTION	VENDOR NO.
	110051-02-01A	EA ROOF VENT - W/ SCREEN	7727
	064470-01-700	EA COVER - ROOF VENT	7291
	110051-01-702	EA GEAR - LIFT-ARM ASM.	RP-1000B
	110051-01-703	EA CRANK HANDLE	RP-1031-B
	110051-01-704	EA SCREEN & FRAME	29-688-03

POWERED ROOF VENT (FANTASTIC) (US)

KEY	PART NUMBER	U/M DESCRIPTION	VENDOR NO.
	084079-14-000	EA VENT - EXHAUST - POWERED - OFF WHITE	1020K-19
	084079-01-700	EA VENT COVER	1030-80
	084079-01-701	EA SCREEN ASM. - OFF WHITE	101105
	084079-01-702	EA ARM LIFT ASSEMBLY - MANUAL	1140K-00
	084079-01-703	EA KNOB - LIFT - W/ EXTENTION & SCREW	1122.05
	084079-01-707	EA SWITCH - SAFETY	1031-05
	084079-01-709	EA SWITCH - MAIN POWER - 3 SPEED	2040-80
	084079-07-700	EA GARNISH - INTERIOR - 4" - OFF WHITE	4017K-09
	084079-11-700	EA MOTOR, BRACKET, & FAN BLADE KIT	1010K-81
	084079-11-702	EA BASE - MAIN W/ DOME SWITCH	

POWERED ROOF VENT (FANTASTIC) (CSA)

KEY	PART NUMBER	U/M DESCRIPTION	VENDOR NO.
	084079-15-000	EA VENT - EXHAUST - POWERED - OFF WHITE	1020K-19
	084079-01-700	EA VENT COVER	1030-80
	084079-01-701	EA SCREEN ASM. - OFF WHITE	101105
	084079-01-702	EA ARM LIFT ASSEMBLY - MANUAL	1140K-00
	084079-01-703	EA KNOB - LIFT - W/ EXTENTION & SCREW	1122.05
	084079-01-707	EA SWITCH - SAFETY	1031-05
	084079-01-709	EA SWITCH - MAIN POWER - 3 SPEED	2040-80
	084079-07-700	EA GARNISH - INTERIOR - 4" - OFF WHITE	4017K-09
	084079-11-700	EA MOTOR, BRACKET, & FAN BLADE KIT	1010K-81
	084079-11-702	EA BASE - MAIN W/ DOME SWITCH	

ROOF VENTS

KEY	PART NUMBER	U/M DESCRIPTION
	083558-03-000	EA VENT COVER - PLUMBING PIPE - ROOF
	084073-03-000	EA COVER - ROOF VENT - NORCOLD REFRIGERATOR - OFF WHITE
	084073-04-000	EA BASE - ROOF VENT - NORCOLD REFRIGERATOR - BLACK

SIDEWALL VENTS

KEY	PART NUMBER	U/M DESCRIPTION
	084616-01-000	EA SHROUD - RANGE HOOD VENT - OFF WHITE
	084878-09-000	EA VENT - RANGE HOOD - SHORT - LVS

WINDOW, VENT & EXTERIOR DOOR GROUP (CONTINUED)

EXTERIOR DOORS

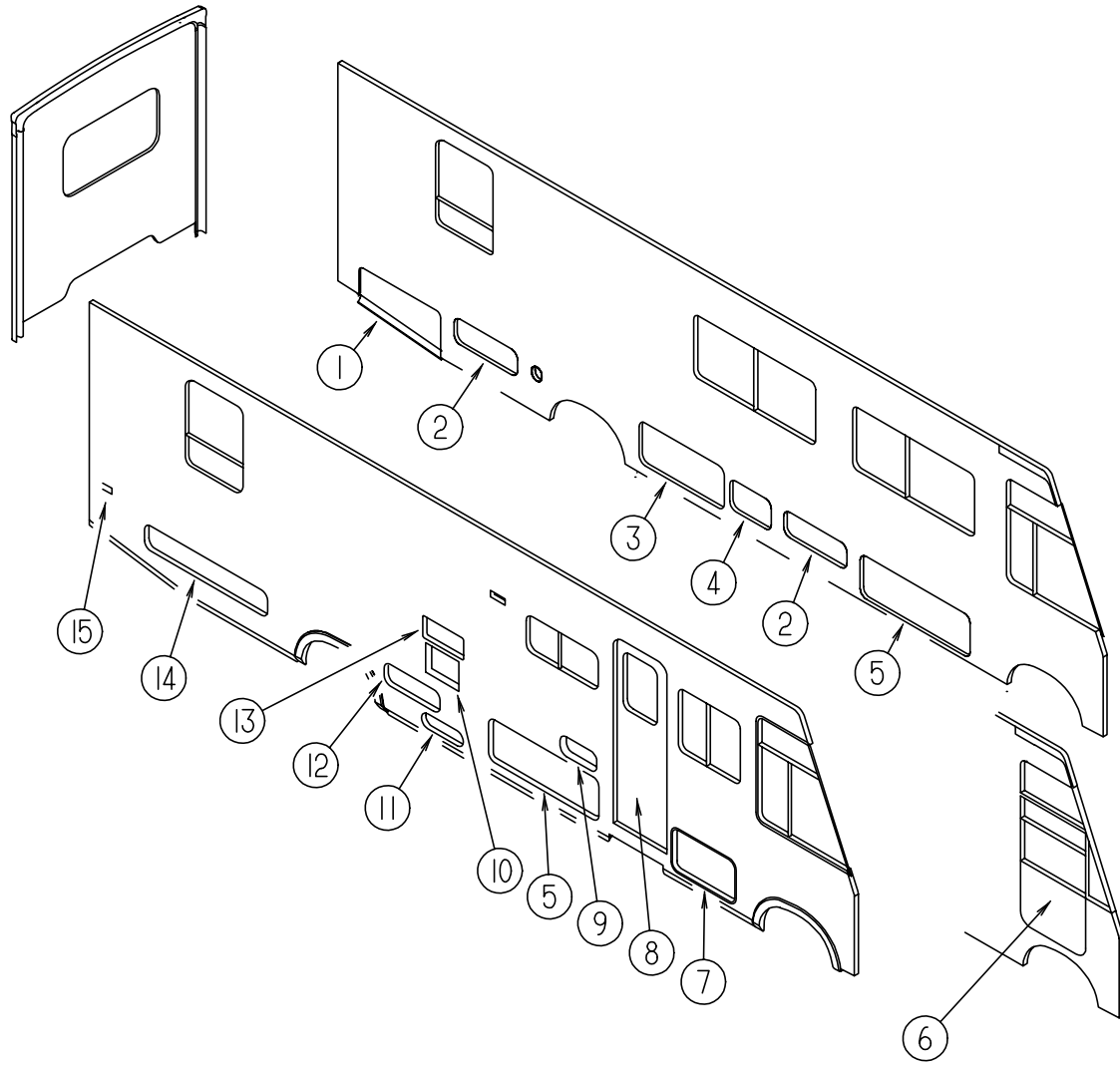

KEY	PART NUMBER	U/M DESCRIPTION
1	111012-06-F11	EA DOOR ASM - GENERATOR
2	111013-18-F11	EA DOOR ASM - ACCESS
3	111013-21-F11	EA DOOR ASM - (WATER DUMP VALVES & EXTERIOR SHOWER)
4	098668-12-000	EA DOOR ASM - FURNACE - EXTERIOR
5	111013-17-F11	EA DOOR ASM - STORAGE
6	106469-07-01A	EA DOOR ASM. - DRIVERS - BLACK - V130-01L
7	111013-16-F11	EA DOOR ASM - STORAGE
8	115108-02-F11	EA DOOR - ENTRANCE - W/ SCREEN - W/O WINDOW
8	115108-02-F12	EA DOOR - ENTRANCE - W/ SCREEN - W/O WINDOW
9	111017-01-F11	EA DOOR ASM - ACCESS - EXTERIOR RADIO
10	052009-04-000	EA DOOR - WATER HEATER - BUFF
11	111009-01-F11	EA DOOR - LP COMPARTMENT - 16.9" X 5.4" - ALUMINUM
12	111017-03-E10	EA DOOR ASM - STORAGE
13	084103-06-000	EA DOOR - REFRIGERATOR - VENTED - JAMB - BUFF
13	084104-06-000	EA JAMB - REFRIGERATOR - BUFF
14	111013-19-F11	EA DOOR ASM - STORAGE
15	081240-12-000	EA DOOR - WATER FILL - LOCKABLE W/O LOCK - 4" X 4 5/8" - BUFF

WINDOW, VENT & EXTERIOR DOOR GROUP (CONTINUED)

DRIVER DOOR (EXCEL) (V130-01L)

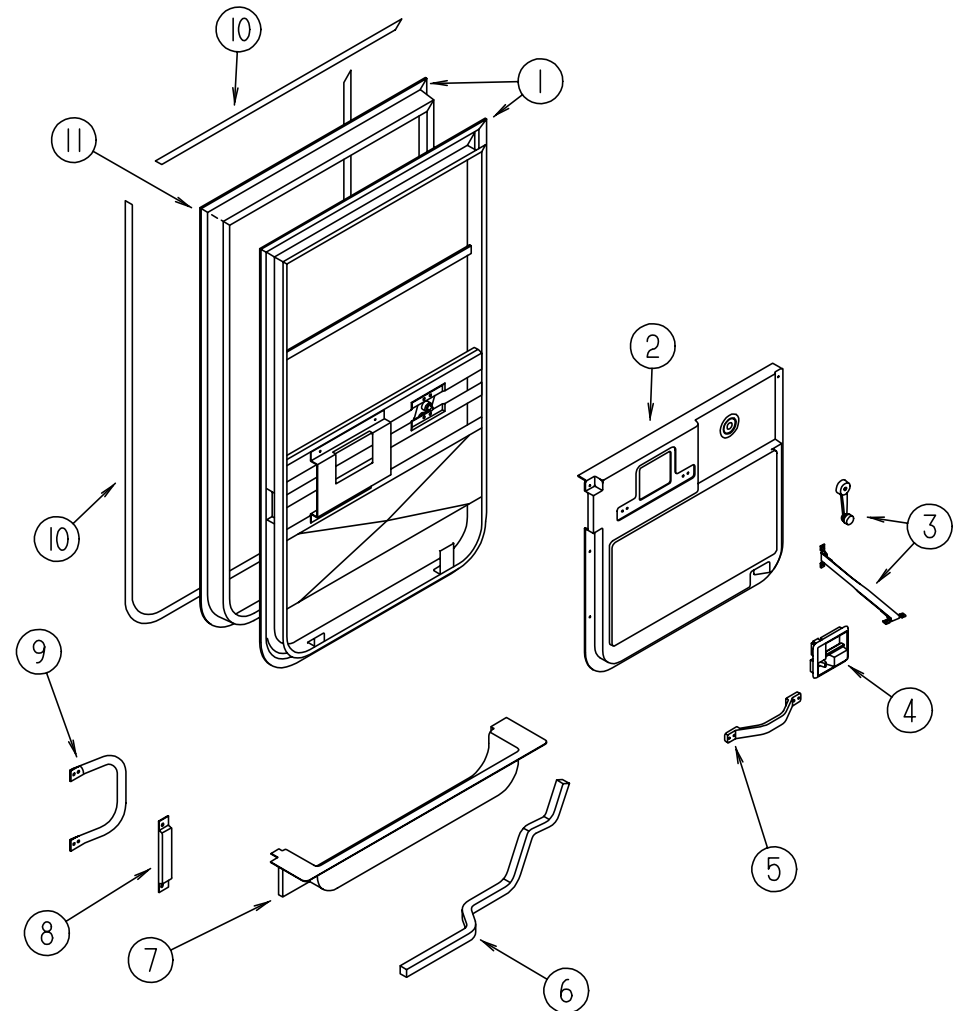
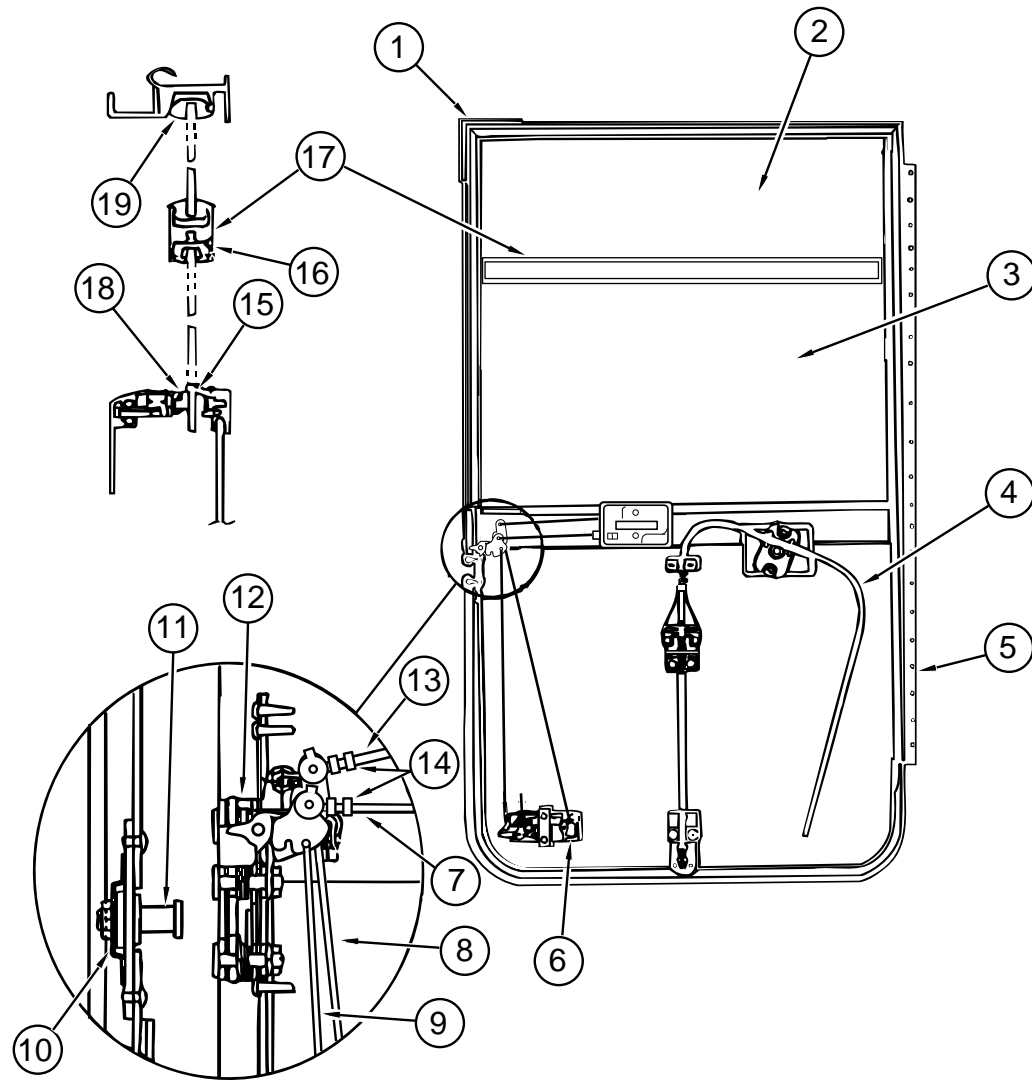

KEY	PART NUMBER	U/M DESCRIPTION	VENDOR NO.
1	106469-01-702	EA DOOR SEAL	122-040984
2	106469-02-702	EA GLASS-STATIONARY	106-041104
3	106469-01-704	EA GLASS ASM - ROLL-UP W/ BRACKET	V103-65L
4	106469-02-701	EA REGULATOR ASSEMBLY	V108-90L
5	106469-05-702	EA HINGE - 42"	211-041194
6	106469-04-700	EA PADDLE ASM. W/ COLLAR	248-041237
7	106469-04-711	EA LOCK ROD, HORIZONTAL	203-041137
8	106469-05-703	EA LATCH ROD (VERTICAL) ADJ.	203-041239
9	106469-05-705	EA LOCK ROD (VERTICAL) ADJ.	203-041279
10	106469-04-704	EA CAGED NUT ASSEMBLY (STRIKER)	248-041151
11	106469-04-703	EA STRIKER BOLT (W/ WASHER)	248-041152
12	106469-05-706	EA ROTARY LATCH & LINKAGE	248-041150
13	106469-04-705	EA LATCH ROD-HORIZONTAL	203-041139
14	106469-04-714	EA ROD CLIP R.H.	248-041153
	106469-04-713	EA ROD CLIP L.H.	248-041154
15	106469-02-703	EA BELT WEATHERSTRIP (EXT) WDO.	V047-57
16	106469-01-705	FT RUN - CHANNEL	122-010850
17	106469-01-719	EA MULLION RAIL	V103-84
18	106469-01-709	FT WEATHERSTRIP - FUZZY	171-040630
19	106469-02-705	EA HORIZONTAL GLAZING VINYL	V108-87
	106469-04-701	EA TUMBLER & KEYS (TRI-MARK)	248-041179
	106469-04-702	EA KEYS (BLANK)	248-041180

KEY	PART NUMBER	U/M DESCRIPTION	VENDOR NO.
1	106469-07-01A	EA DOOR ASM. - DRIVERS - BLACK	
2	114973-01-01A	EA PANEL - DRIVER DOOR - INNER - LIGHT GRAY - PLASTIC	
3	106469-02-704	EA PARTS BAG (WINDOW HANDLE & CHECK STRAP)	V068-16
4	106469-04-712	EA INNER HANDLE HRDWE. L. H.	248-041148
5	110604-01-01A	EA HANDLE - ASSIST - DRIVERS DOOR	
6	063977-12-000	EA STEP - DRIVER DOOR - LEFT - PAINTED	
6	063977-11-000	EA STEP - DRIVER DOOR - LEFT - UNPAINTED	
7	107818-01-03A	EA TRIM - STEP - DRIVERS DOOR - PLASTIC - GRAY	
	106746-01-000	EA PANEL - STEEL - STEPWELL	
	106747-01-000	EA PANEL - STEEL - STEPWELL - END RH	
	106747-02-000	EA PANEL - STEEL - STEPWELL - END LH	
	102569-02-000	EA MAT - ANTI SLIP - LOWER	
8	108654-01-01A	EA COVER - STRIKE - DRIVERS DOOR - BLACK	
9	108832-01-02A	EA HANDLE - ASSIST - DRIVERS DOOR - METAL - OFF WHITE	
	108833-01-01A	EA COVER - HANDLE - ASSIST - OFF WHITE	
10	109235-01-01A	FT COVER - SCREW - MATTE BLACK - DAWN	132-081046
11	106469-07-700	EA MOUNTING FRAME ASM.	V130-30L
	108129-02-02A	EA GARNISH - DRIVERS DOOR - FRONT - BLACK	
	108107-01-02A	EA GARNISH - DRIVERS DOOR - TOP - BLACK	
	108108-02-02A	EA GARNISH - DRIVERS DOOR - REAR UPPER - BLACK	
	108897-02-01A	EA GARNISH - DRIVERS DOOR - REAR LOWER - BLACK	
	P01713-01-000	EA SWITCH - PUSH BUTTON - IN DOOR JAMB - METAL CHROME	
	076725-06-000	EA COVER - ACCESS - DOOR JAMB PUSH BUTTON - BLACK	

WINDOW, VENT & EXTERIOR DOOR GROUP (CONTINUED)

BRIGGS & STRATTON LOCKS & COMPONENTS

NOTE:
 WHEN ORDERING THE LOCK CASE, THE KEY CODE MUST MATCH THE LAST DIGIT OF THE VEHICLE'S SERIAL NUMBER AND PART NUMBER; WHEN ORDERING THE KEYS, THE THIRD DIGIT OF THE KEY CODE MUST MATCH THE LAST DIGIT OF THE VEHICLE'S SERIAL NUMBER AND PART NUMBER

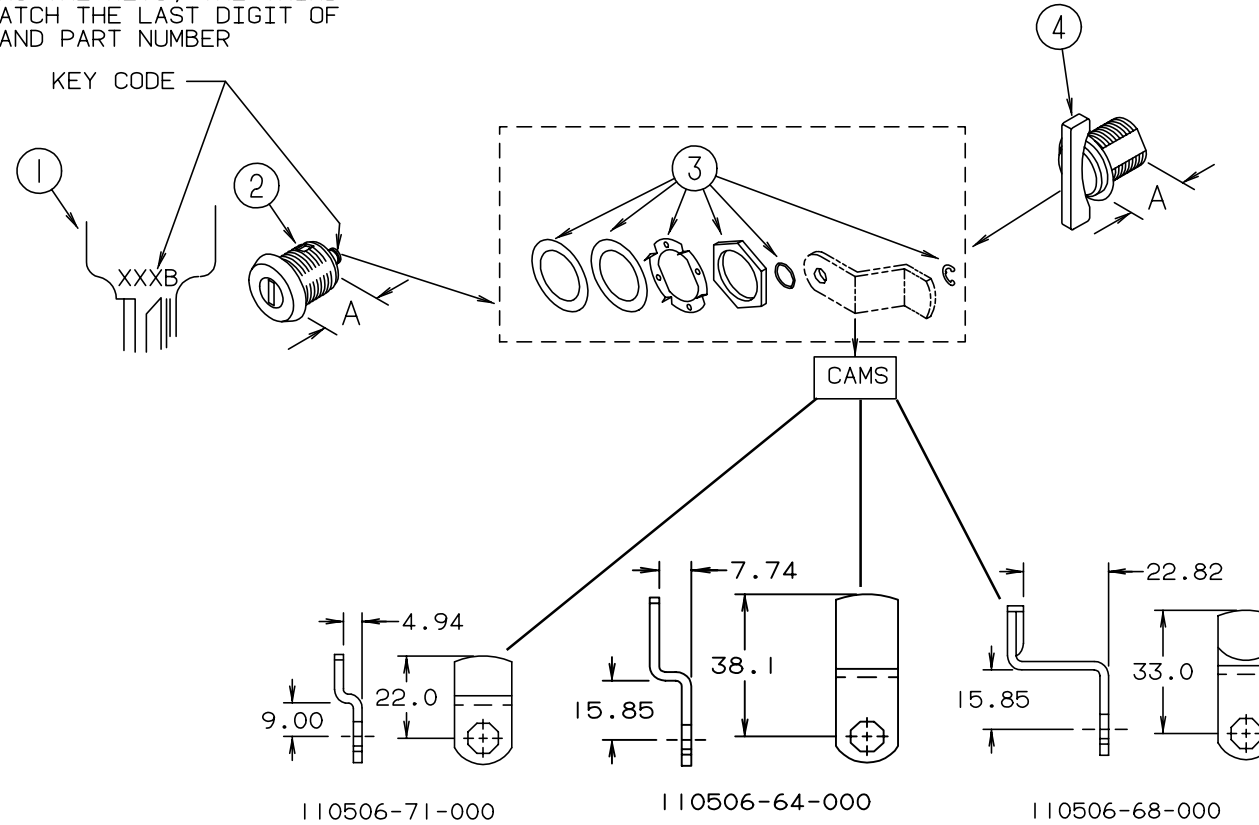

KEY	PART NUMBER	U/M	DESCRIPTION	VENDOR NO.
1	110506-59-000	EA	KEYS - SET OF TWO	596720
2	110506-52-000	EA	CASE - LOCK - A= 17 MM	702370
2	110506-53-000	EA	CASE - LOCK - A= 25 MM	702380
1	110506-59-001	EA	KEYS - SET OF TWO	596721
2	110506-52-001	EA	CASE - LOCK - A= 17 MM	702371
2	110506-53-001	EA	CASE - LOCK - A= 25 MM	702381
1	110506-59-002	EA	KEYS - SET OF TWO	596722
2	110506-52-002	EA	CASE - LOCK - A= 17 MM	702372
2	110506-53-002	EA	CASE - LOCK - A= 25 MM	702382
1	110506-59-003	EA	KEYS - SET OF TWO	596723
2	110506-52-003	EA	CASE - LOCK - A= 17 MM	702373
2	110506-53-003	EA	CASE - LOCK - A= 25 MM	702383
1	110506-59-004	EA	KEYS - SET OF TWO	596724
2	110506-52-004	EA	CASE - LOCK - A= 17 MM	702374
2	110506-53-004	EA	CASE - LOCK - A= 25 MM	702384
1	110506-59-005	EA	KEYS - SET OF TWO	596725
2	110506-52-005	EA	CASE - LOCK - A= 17 MM	702375
2	110506-53-005	EA	CASE - LOCK - A= 25 MM	702385

KEY	PART NUMBER	U/M	DESCRIPTION	VENDOR NO.
1	110506-59-006	EA	KEYS - SET OF TWO	596726
2	110506-52-006	EA	CASE - LOCK - A= 17 MM	702376
2	110506-53-006	EA	CASE - LOCK - A= 25 MM	702386
1	110506-59-007	EA	KEYS - SET OF TWO	596727
2	110506-52-007	EA	CASE - LOCK - A= 17 MM	702377
2	110506-53-007	EA	CASE - LOCK - A= 25 MM	702387
1	110506-59-008	EA	KEYS - SET OF TWO	596728
2	110506-52-008	EA	CASE - LOCK - A= 17 MM	702378
2	110506-53-008	EA	CASE - LOCK - A= 25 MM	702388
1	110506-59-009	EA	KEYS - SET OF TWO	596729
2	110506-52-009	EA	CASE - LOCK - A= 17 MM	702379
2	110506-53-009	EA	CASE - LOCK - A= 25 MM	702389
3	110506-40-700	EA	HARDWARE KIT	
4	110506-50-000	EA	CASE - TWIST LOCK - A= 17 MM	596952
4	110506-51-000	EA	CASE - TWIST LOCK - A= 25 MM	596669
	110506-40-000	EA	CLIP-E - LOCK ASM.	93981
	110506-64-000	EA	CAM - LOCK	322280
	110506-68-000	EA	CAM - LOCK	322284
	110506-71-000	EA	CAM - LOCK	322287
	110506-59-701	EA	KEY BLANK - GOLD	

WINDOW - VENT & EXTERIOR DOOR GROUP (CONTINUED)

ENTRY DOOR W/O WINDOW

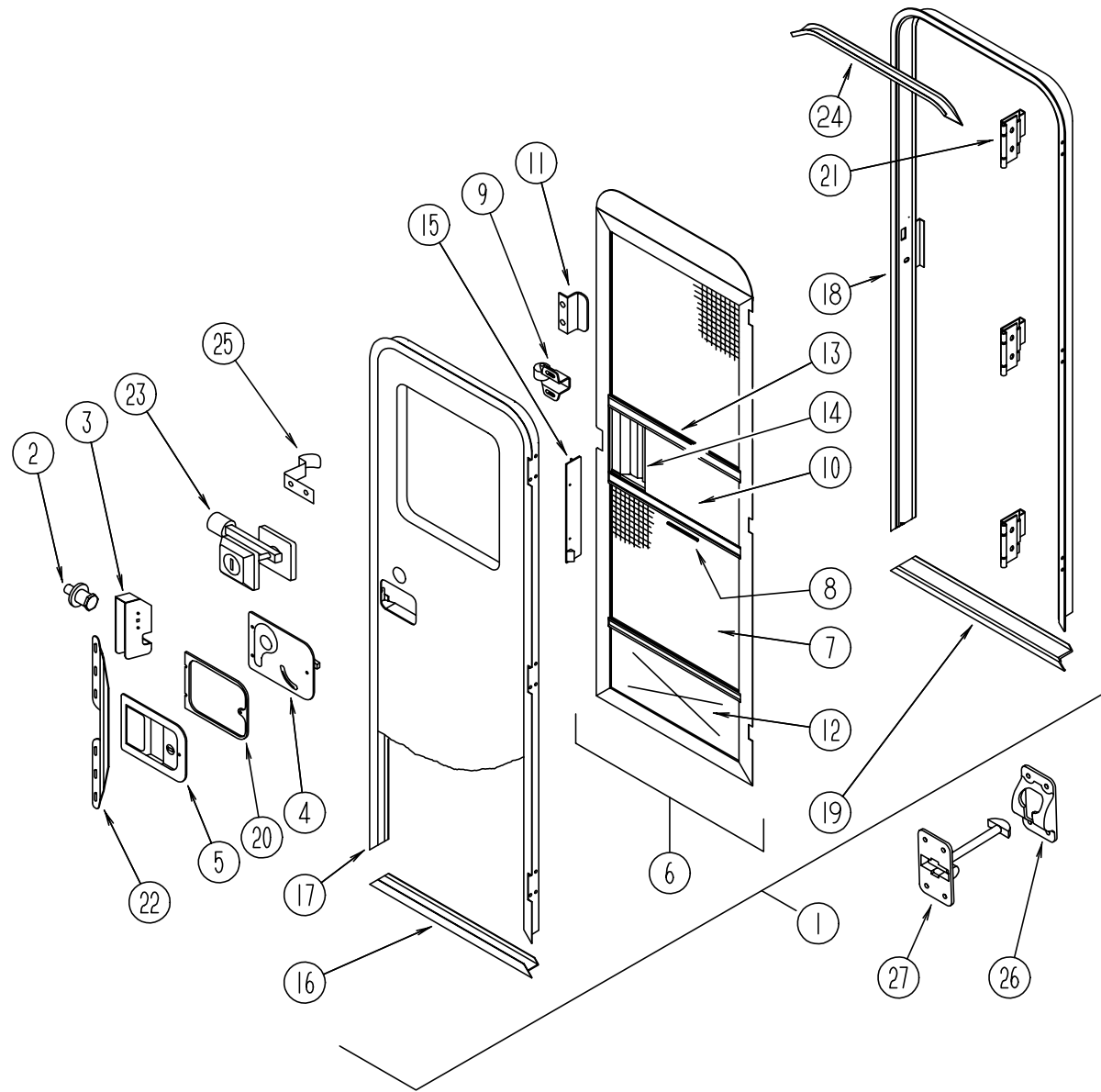

KEY	PART NUMBER	U/M	DESCRIPTION
1	115108-02-F11	EA	DOOR - ENTRANCE - W/ SCREEN - W/O WINDOW
1	115108-02-F12	EA	DOOR - ENTRANCE - W/ SCREEN - W/O WINDOW
2	039539-01-000	EA	STRIKE - LOCK - ENTRY DOOR - ROUND W/THREADED WASHER
	077461-03-000	EA	COVER - STRIKE - ENTRY DOOR - 6.5" X 2.5" - PLASTIC - OFF WHITE
3	039540-01-000	EA	LATCH MECHANISM - HOOK - ENTRY DOOR - INTERIOR
	039715-01-000	EA	NUT - SERT - 1/4" DIAMETER - 20 THREADS
4	039979-04-000	EA	COVER - INTERIOR LATCH - W/TRIP ARM - RIGHT - BLACK
	039984-01-000	EA	CAP - ROUND - VINYL - .28" ID X .62" LONG - BLACK
	041546-05-000	EA	BRACKET - DOOR ANGLE - 5" X 1.9" - METAL - OFF WHITE
5	045017-11-000	EA	LATCH - ENTRY DOOR - MECHANISM W/LOCK & KEY - BLACK
	045017-11-701	EA	KEY - BLANK - ROUND TOP - SILVER - TRI/ MARK
	058806-03-000	EA	PLUG - TAPERED - PLASTIC - 1.06" DIAMETER - RED
	063729-04-000	EA	RIVNUT - 10-32 UNF - .010-.080
	072893-01-000	EA	NUT-SERT - M5 X 0 8
	075671-04-000	FT	SEAL - SPONGE - LAZY T SHAPE - W/ADHESIVE STRIPE - .5" WIDE
6	079012-05-B10	EA	DOOR - SCREEN - ENTRANCE DOOR
7	002293-02-000	SF	SCREENING - WINDOW/DOOR - 26" - CHARCOAL
8	002294-01-000	FT	SPLINE - SCREENING - .135" X .138" - BLACK
9	109403-01-000	EA	CATCH - SINGLE ROLLER - SCREEN DOOR
10	016454-01-000	EA	INSERT - CENTER - LEATHER GRAIN ALUMINUM - UNPAINTMCD
	001014-01-013	EA	SHEET - ALUMINUM - LEATHER GRAIN - 10.25" X 16.31" - UNPAINTED
11	050712-04-000	EA	HANDLE - SCREEN DOOR - ALUMINUM - OFF WHITE
12	078552-03-000	EA	KICK PANEL - SCREEN DOOR - LOWER INSERT - UNPAINTED
	078595-01-000	EA	TOP PLATE - SCREEN DOOR - CURVED TOP - 4.7" X 25.35"
13	078777-01-000	EA	CHANNEL - SLIDE - SCREEN DOOR CENTER SLIDER COVER
14	079086-02-000	EA	SLIDER - SCREEN DOOR - OFF WHITE
15	079087-02-000	EA	STRIKE - SLIDER - W/ LIP FOR ELBOW CATCH - 1.5" X 8.6" - OFF WHITE
16	089748-09-000	EA	FRAME - BOTTOM - ENTRY DOOR - 24.8" LONG - BUFF
	090340-02-000	FT	SEAL - FOAM - CLOSED CELL - 3/8" X 1/2" X 50'
17	095276-03-05A	EA	FRAME - ENTRANCE DOOR - BUFF
18	095277-04-05A	EA	JAMB - ENTRANCE DOOR - BUFF
19	051049-01-000	EA	JAMB - BOTTOM - ENTRY DOOR - 25.9" - UNPAINTED
20	096810-01-01A	EA	PLATE - LATCH - ENTRY DOOR - PLASTIC - BLACK
21	106719-01-01A	EA	HINGE - ENTRANCE DOOR - MILL FINISH
22	098173-01-04A	EA	STIFFENER - ENTRY DOOR - SUPPORTS LATCH/STRIKE AREA - UNPAINTED
	100128-02-000	FT	SEAL - FOAM - ADHESIVE BACK - .37" W X .37" THICK
23	101145-01-01A	EA	DEADBOLT - ENTRY DOOR - W/2 KEYS W/O BACK SET BOLT OR SCREWS
	101145-01-04A	EA	DEADBOLT - ENTRY DOOR - BUFF/BLACK
	101147-01-000	EA	BOLT - SECURITY - 4.12" BACKSET
	102524-01-000	EA	BUMPER - RUBBER - FLAT - BLACK
	040944-01-000	EA	LABEL - ENTRANCE DOOR - "OPEN"
24	044582-33-000	EA	CAP - DRIP - DOOR JAMB MOUNTED -
	115222-02-01A	EA	GARNISH - RADIUS - ENTRANCE DOOR - OFF WHITE
25	100412-01-000	EA	CATCH - SCREEN DOOR - THUMB CLIP
26	104099-02-01A	EA	CATCH - DOOR HOLDER - RETAINER - OFF WHITE
27	104099-01-01A	EA	CATCH - DOOR HOLDER - STRIKE - OFF WHITE
	009126-02-000	EA	HANDLE - ASSIST - ENTRANCE DOOR - BLACK
	093673-01-01A	FT	TRIM - ENTRANCE DOOR - 1.4" WIDE X 8' LONG - OFF WHITE PLASTIC

WINDOW, VENT & EXTERIOR DOOR GROUP (CONTINUED)

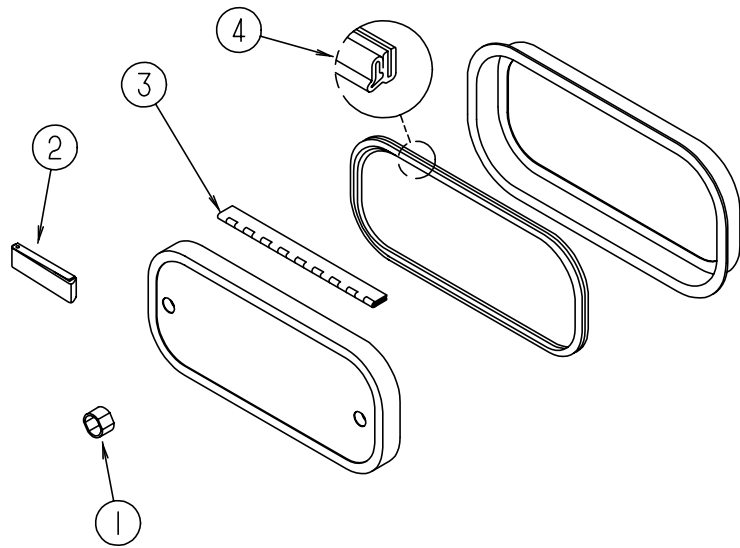

EXTERIOR DOORS

KEY	PART NUMBER	U/M DESCRIPTION
1	107997-51-001	EA SPACER - .86" X .6" - ALUMINUM
2	102768-01-000	EA HOLDER - COMPARTMENT/ ENTRY DOOR - METAL - MILL FINISH
3	081801-02-000	EA HINGE - PIANO - 2" X 96" - ALUMINUM
4	064075-07-000	FT SEAL - BULB - W/ WIRED U CHANNEL - .3" X .5" CHANNEL - BLACK
	096217-55-001	EA U-CHANNEL - 17.5' - OFF WHITE
	096217-55-006	EA U-CHANNEL - 17.5' - BRIGHT WHITE

WINDSHIELD & WIPER GROUP

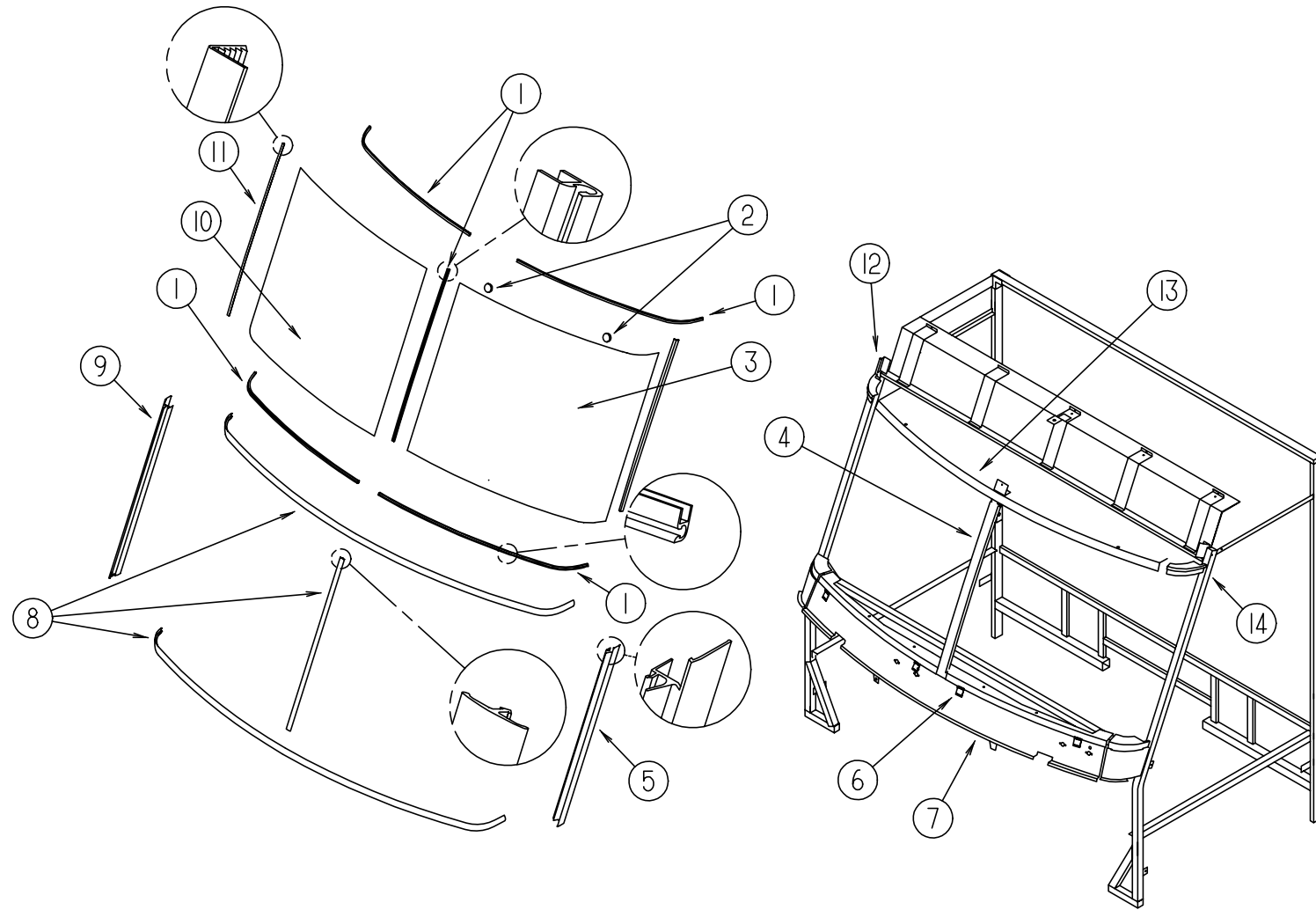

WINDSHIELD MOLDINGS & GLASS

KEY	PART NUMBER	U/M DESCRIPTION
1	110268-01-000	EA CARRIER - REVEAL - 1280 MM
2	081914-01-000	EA BUMPER - RUBBER - ROUND - .43" DIAMETER - BLACK
3	114432-02-000	EA GLASS - WINDSHIELD - DRIVER SIDE
4	075710-01-000	EA FRAME - WINDSHIELD - CENTER DIVIDER - INNER
5	103107-04-01A	EA TRIM - WINDSHIELD - DRIVER SIDE - BLACK
6	104449-01-000	EA BRACKET - WINDSHIELD SUPPORT
7	077847-05-000	EA SUPPORT - WINDSHIELD - LOWER - W/O BRACKETS
	077847-03-000	EA SUPPORT - WINDSHIELD - END - PASSENGER SIDE
	077847-04-000	EA SUPPORT - WINDSHIELD - END - DRIVER SIDE
8	102936-01-000	FT MOLDING - REVEAL - WINDSHIELD
9	103107-03-01A	EA TRIM - WINDSHIELD - PASSENGER SIDE - BLACK
10	114432-01-000	EA GLASS - WINDSHIELD - PASSENGER SIDE
11	098788-03-000	EA CHANNEL - REVEAL - 48.9" WINDSHIELD
12	077922-03-000	EA HEADER WINDSHIELD END - PASSENGER SIDE
	114583-01-01B	EA HEADER - WINDSHIELD - FILLER - UPPER - MILL

WINDSHIELD & WIPER GROUP (CONTINUED)

WINDSHIELD WIPER ASM

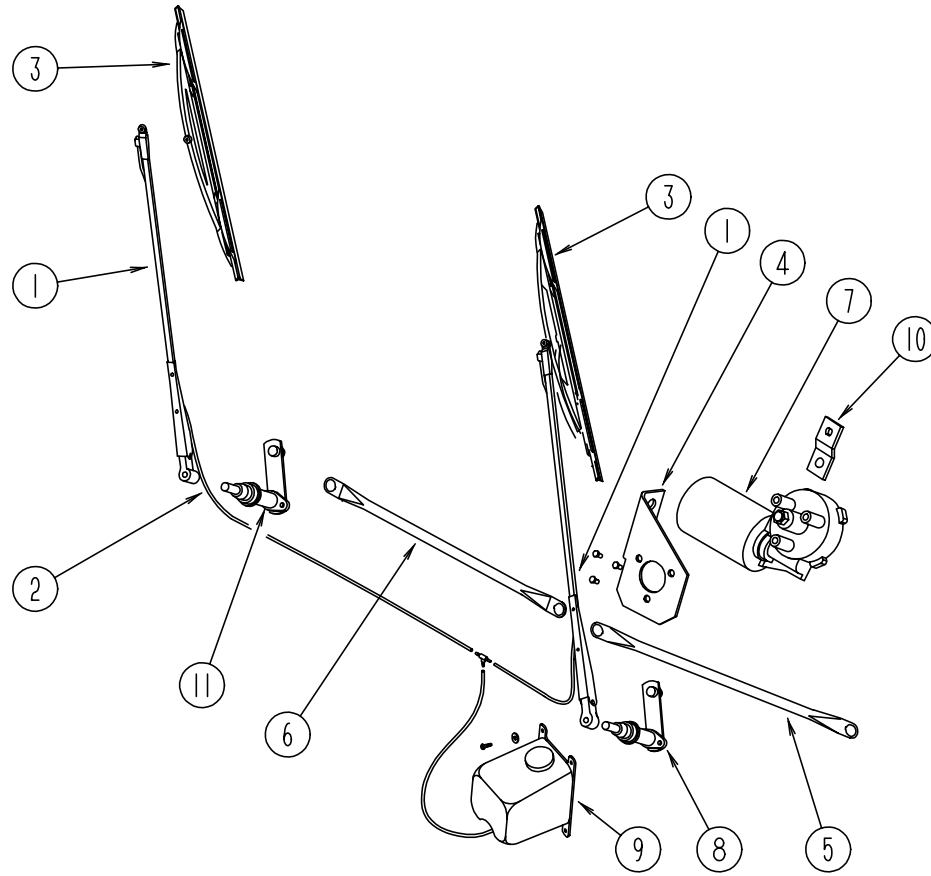

KEY	PART NUMBER	U/M	DESCRIPTION
1	103671-01-000	EA	ARM - WIPER - 24"
2	096931-01-700	FT	HOSE
3	095964-01-000	EA	BLADE - WIPER - WINDSHIELD - 24"
	095964-01-700	EA	BLADE - REFILL 24" (PAIR)
4	104549-01-000	EA	BRACKET ASM - WIPER MOTOR
5	103672-01-000	EA	LINK ASM - CONNECTING - 21.85" - DRIVER SIDE
			FROM: 00-00-00 THRU: 02-16-95
5	117008-01-000	EA	LINK ASM - CONNECTING - 21.85" - DRIVER SIDE
			FROM: 02-17-95 THRU: 99-99-99
6	103672-02-000	EA	LINK ASM - CONNECTING - 21.85" - PASSENGER SIDE
			FROM: 00-00-00 THRU: 02-16-95
6	117008-02-000	EA	LINK ASM - CONNECTING - 21.85" - PASSENGER SIDE
			FROM: 02-17-95 THRU: 99-99-99
7	104346-02-000	EA	WIPER MOTOR (CHEVY)
7	104346-03-000	EA	WIPER MOTOR (FORD)
	110178-01-000	EA	HOUSING - WIPER MOTOR
8	096505-06-000	EA	PIVOT & SHAFT ASM - WIPER - DRIVER SIDE
9	056000-04-000	EA	WINDSHIELD WASHER - BOTTLE & PUMP
	056000-01-700	EA	VACUUM HOSE 7/64 - 5/32
	096931-01-701	EA	NOZZLE & HARDWARE KIT, INCLUDES NOZZLE, NUT, SHORT THREAD SCREW, LONG THREAD SCREW, AND PLASTIC CAP
			FROM: 00-00-00 THRU: 04-02-95
9	117766-02-000	EA	WASHER ASM - WINDSHIELD WIPER - MCCORD 600328
			FROM: 04-03-95 THRU: 99-99-99
	110605-01-000	EA	TEE - PLAS - BARBED 1/8 X 1/8 X 3/16 BAYLOCK 3799721
			FROM: 04-03-95 THRU: 99-99-99
	117765-01-000	EA	CONNECTOR - 5/32-1/4-3/8 WINDSHIELD WASHER DANA - WEATHERHD
			FROM: 04-03-95 THRU: 99-99-99
10	104347-01-000	EA	ARM - DRIVE - WIPER MOTOR - 1.54"
11	096505-05-000	EA	PIVOT & SHAFT ASM - WIPER - PASSENGER SIDE
	110742-01-000	EA	WIPER GASKET
	067188-01-000	EA	STUD - WIPER CRANK
	096505-02-703	EA	CAP - NUT (ACORN) HD W/.687 BARREL