

**1995
WCF31RQ**

F04

F05

F06

F07

F14

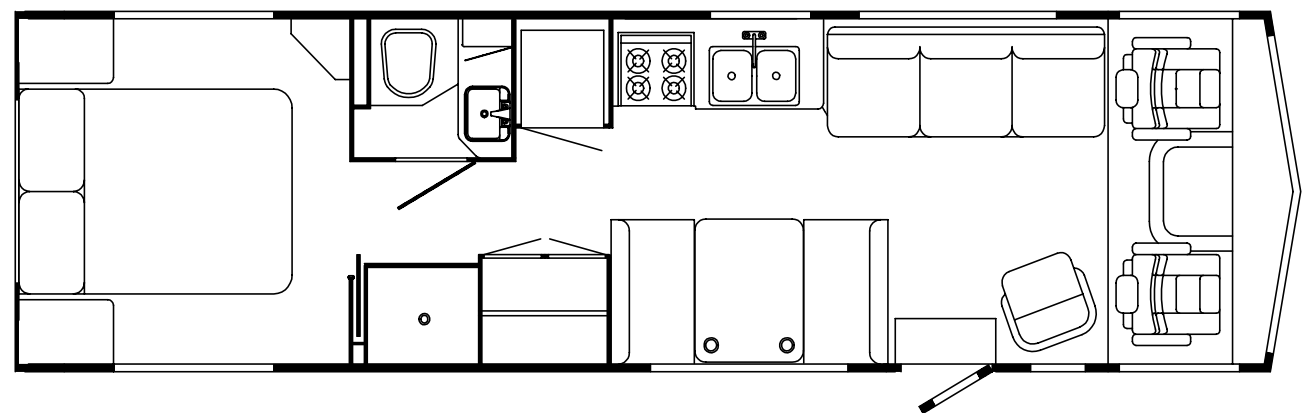
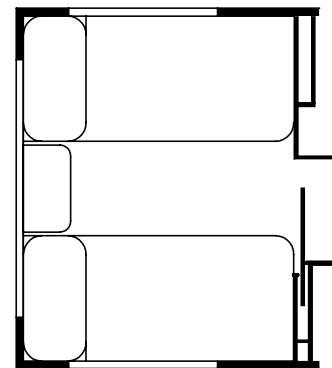
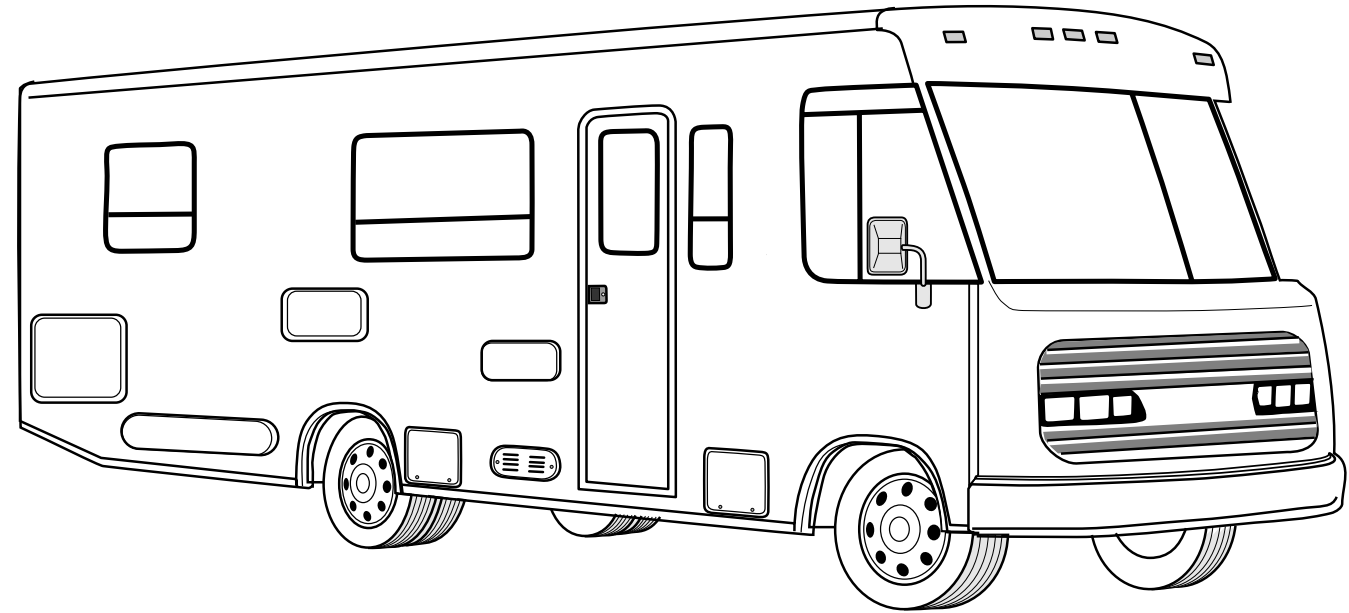

**ACCESSORIES GROUP
OPERATOR MANUAL**

KEY	PART NUMBER	U/M DESCRIPTION
	054185-C5-000	EA MANUAL, OPERATOR 95 BRAVE - F-SERIES
	092318-01-000	EA BINDER - 3 RING, MOTOR HOME MANUAL
	092319-01-000	EA POCKET PAGE - RING BINDER, PLASTIC
	113921-01-000	DW TOP LEVEL DRAWING-F, 1995

**AUDIO VIDEO GROUP
PATIO ENTERTAINMENT CENTER**

KEY	PART NUMBER	U/M DESCRIPTION
	077069-02-000	EA CABLE-ANTENNA, RADIO - EXTENSION 96" - ARA 6700667
	087683-02-000	EA RADIO-AM/FM STEREO CASSETTE - AUDIOVOX P-1A
	090944-01-000	EA ANTENNA-RADIO, 16" RUBBER
	108847-01-000	EA BRACKET-ANTENNA GROUND
	109889-02-000	EA ANTENNA-SHAFT EXTENDER 2" - MAGNADYNE RV71EX2
	110469-01-000	EA SPEAKER - 4 X 6 OVAL, COAXIAL - MAGNADYNE F46XB-12
	110470-01-01A	EA GRILLE-SPEAKER, OVAL 4 X 6 BLK - MAGNADYNE G46WI

RADIO SYSTEM & ANTENNA

KEY	PART NUMBER	U/M DESCRIPTION
	116148-01-000	EA RADIO-AM/FM STEREO, CD PLAYER - CLARION 5633CD
	110267-03-000	EA RADIO-AM/FM STEREO, AUDIOVOX IM-400
	077069-02-000	EA CABLE-ANTENNA, RADIO - EXTENSION 96" - ARA 6700667
	090944-01-000	EA ANTENNA-RADIO, 16" RUBBER
	081059-02-000	EA WIRE ASM - 9-PIN, RADIO - AUDIOVOX 112B-1761
	089340-02-000	EA GRILLE-SPEAKER, 6.5" SQUARE
	089340-03-000	EA SPACER-GRILLE, 6.5" SQUARE - TAN - MAGNADYNE G514
	094097-01-000	EA SPEAKER-RADIO, W/O GRILLE - 5.25" DIA - AUDIOVOX 110C3030
	110469-01-000	EA SPEAKER - 4" X 6", OVAL - MAGNADYNE F46XB-12
	110470-01-01A	EA GRILLE-SPEAKER, OVAL - 4" X 6" - BLACK - MAGNADYNE G46WI

CB ANTENNA

KEY	PART NUMBER	U/M DESCRIPTION
	105248-01-000	EA ANTENNA-CB, ADVANCE 8604

TV, VCR & COMPONENTS

KEY	PART NUMBER	U/M DESCRIPTION
	098447-07-000	EA TV - 13", COLOR W/JACK - U.S. - MAGNAVOX RR1342C
	098447-07-700	EA REMOTE-TV, MAGNAVOX RR1342C
	098447-08-000	EA TV - 13", COLOR W/REMOTE - CANADIAN - MAGNAVOX XR1333C FROM: 00-00-00 THRU: 10-09-94
	098447-12-000	EA TV - 13", COLOR W/JACK - CANADIAN - MAGNAVOX 13XNC15 FROM: 10-10-94 THRU: 99-99-99
	098447-08-700	EA REMOTE-TV, MAGNAVOX XR1333C
	098446-06-000	EA VCR-VHS CABLE READY -REMOTE - MAGNAVOX VR9210
	098446-06-700	EA REMOTE F/MODEL #9210 ONLY
	092310-02-000	EA TV-COLOR, 9" - AC/DC - W/REMOTE - MAGNAVOX RD0945
	092310-02-700	EA REMOTE-TV, MAGNAVOX RD0945
	086757-03-000	EA CONTROL CENTER-SWITCH, VCR/TV - MAGNADYNE VCS-6
	086777-05-000	EA PLATE-WALL, ANTENNA 1 OUTPUT IVORY - WINEGARD RV-0921
	093214-01-02A	EA GRILL-SPEAKER, 4" BROWN
	098819-01-000	EA SPEAKER - 2 WATT, 8 OHM - 4"
	099717-01-000	EA TIEDOWN-TV, STRAP ON FEMALE END IS 22.8" LONG
	099717-02-000	EA TIEDOWN-TV, STRAP ON FEMALE END IS 28.7" LONG
	076319-09-000	EA WALLPLATE-CABLE RECEPTACLE, TV - SINGLE - BROWN
	076319-08-000	EA WALLPLATE-CABLE RECEPTACLE, TV - SINGLE - IVORY
	086777-01-000	EA WALLPLATE-TV CABLE, W/ANTENNA SWITCH - IVORY
	086777-03-000	EA PLATE-WALL, CABLE - W/TV ANTENNA SWITCH & BOOSTER - IVORY
	076319-12-000	EA CONNECTOR-COAXIAL, ONE PIECE
	082134-01-000	EA ADAPTER-TV, CABLE TO CABLE - WINEGARD F-81M
	086756-01-000	EA SPLITTER-TV, 2 WAY
	076319-03-000	FT CABLE-COAXIAL, 75 OHM
	076319-06-000	EA ADAPTOR-CABLE ROOF PLATE, WINEGARD RPJ-1

AUDIO VIDEO GROUP (CONTINUED)

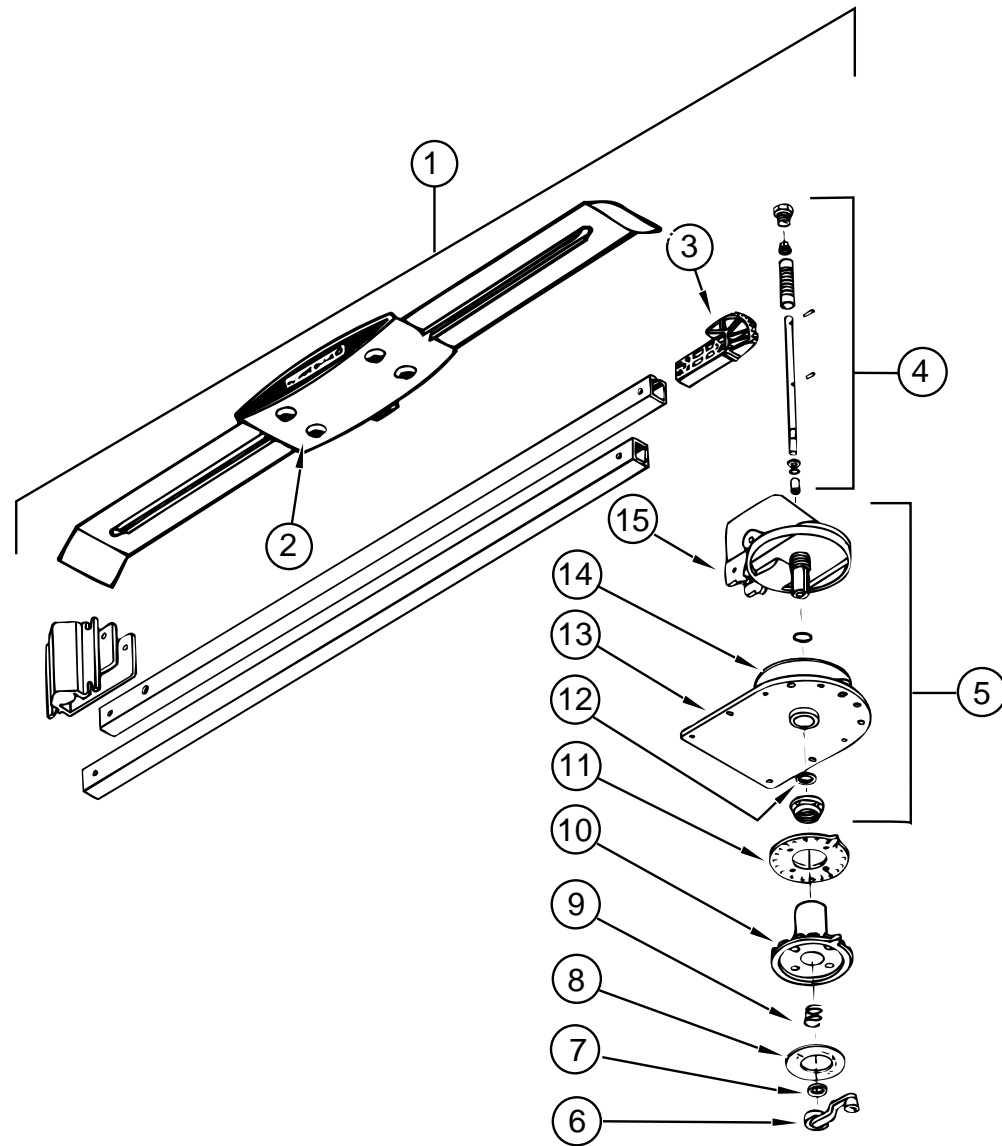

TV ANTENNA

KEY	PART NUMBER	U/M DESCRIPTION
1	076319-01-000	EA ANTENNA-TV, ROOF MOUNT - 44.5" MAST - RVA W02
2	076319-01-700	EA HEAD-ANTENNA, AMPLIFIED - WINEGARD# RVSA U/V
3	076319-01-701	EA GEAR-ELEVATING, PLASTIC - WINEGARD# 2200046
4	076319-01-702	EA SHAFT ASM-ELEVATING, WINEGARD# RVP-400A
5	076319-01-711	EA BASE & LIFT ASM - 2762802
6	076319-01-706	EA CRANK-ELEVATING, W/SET SCREW - WINEGARD# 5755100
7	076319-01-705	EA GROMMET-NYLON, 7/8"ID - WINEGARD# 3200658
8	076319-01-708	EA CRANK COVER DECAL, WINEGARD# 5413002
9	076319-01-707	EA SPRING-HANDLE, WINEGARD# 5160800
10	076319-01-709	EA PLATE-DIRECTIONAL, FOR HEAD - WINEGARD #3200644
11	076319-01-712	EA PLATE-CEILING, WINEGARD# 3200608
12	076319-01-704	EA BEARING-NYLON, 1.25"OD - WINEGARD# 3200657
13	076319-01-713	EA PLATE-BASE, WINEGARD# 3100523
14	076319-01-703	EA BEARING-NYLON, 5"OD - WINEGARD# 3200656
15	076319-01-714	EA HOUSING, ROTATING GEAR - 2200049

BATH GROUP

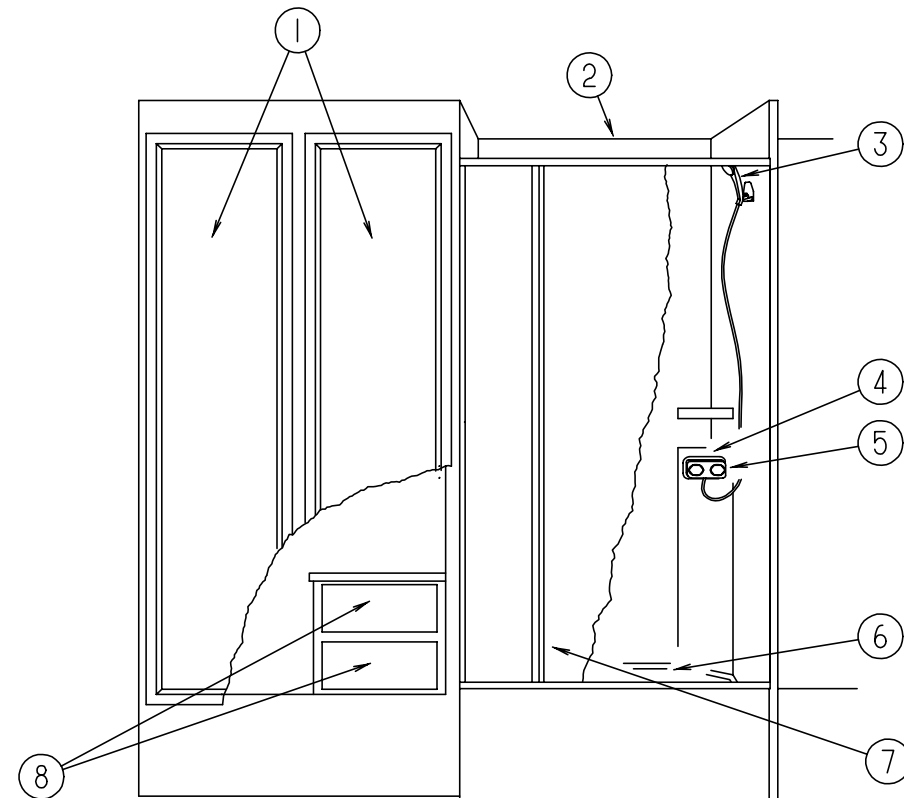

BATHROOM CABINET & COMPONENTS

KEY	PART NUMBER	U/M DESCRIPTION
1	M06803-11-E07	EA DOOR ASM-W/O HARDWARE - 410 X 1660 (FO4,FO5,F06.F07)
1	M06803-11-F14	EA DOOR ASM-W/O HARDWARE - 410 X 1660 (F14)
2	101805-01-01A	EA SURROUND-SHOWER, OFF WHITE
3	103092-02-000	EA SHOWER HEAD-W/HOSE, CANADIAN
3	103092-01-000	EA SHOWER HEAD-W/60" HOSE , US
	103092-01-700	EA BRACKET ONLY-CLEAR FOR SHOWER
	103092-01-701	EA BRACKET ONLY-BONE FOR SHOWER
4	075606-01-000	EA PANEL-FAUCET BACK, SHOWER - 5" X 9" - PLASTIC
5	075241-05-000	EA FAUCET-SHOWER, BONE
6	M02429-09-000	EA PAN-SHOWER
	066436-01-000	EA NUT-SLIP, TAILPIECE - 1.5"
	066440-01-000	EA STRAINER-SHOWER, W/RUBBER WASHER
	011069-02-000	EA TAILPIECE-TUB/SHOWER, 1 1/2" X 1 1/4" X 4" - BRASS
7	089318-01-000	EA DOOR-SHOWER, HINGED - W/GOLD FRAME - PLASTIC - 29.8" WIDE
	089318-02-000	EA JAMB-EXPANDER
	057671-01-000	EA COVER-SCREW, #8 - PLASTIC - OFF WHITE
	089318-01-700	EA STRAP F/SHOWER DOOR
	089318-01-701	EA VINYL SWEEP
	089318-01-702	EA BUSHING W/ARM
	089318-01-703	EA STRIKE-JAMB, W/MAGNETIC STRIP
	092574-01-703	EA GOLD DOOR PULL - COASTAL 8149G
	092574-01-704	EA SCREW-GOLD, #6 3/8 - COASTAL 638G
	092574-01-705	EA MAGNETIC STRIP - 56.9" - COASTAL 98-41
	092574-01-707	EA PIVOT BUSHING - 18712B
8	P11023-03-E07	EA DRAWER COMPLETE-SLIDE

BATH GROUP (CONTINUED)
BATHROOM CABINET & COMPONENTS (CONTINUED)

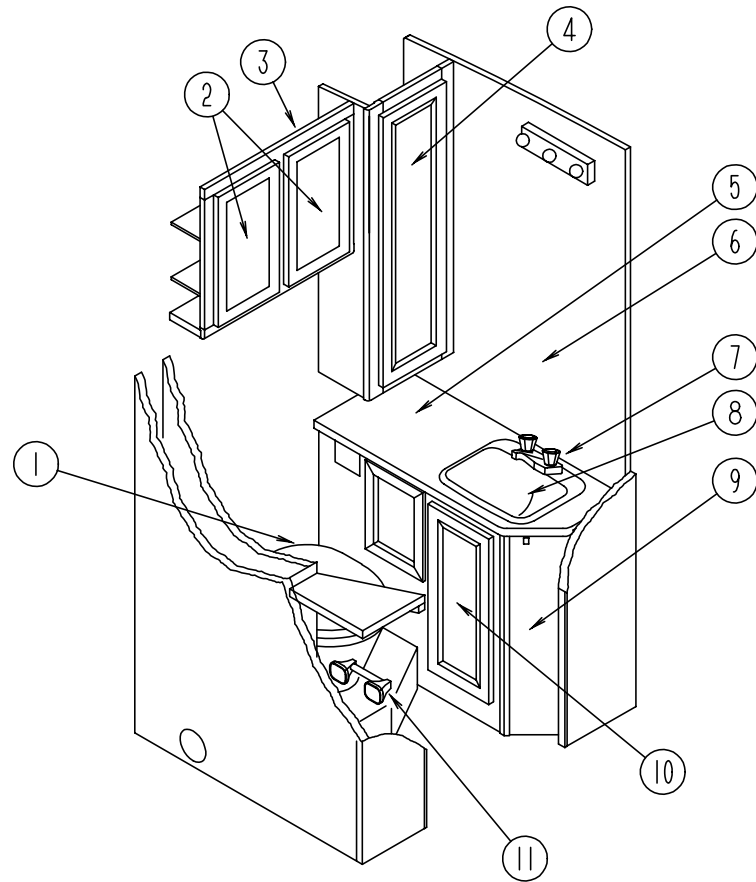

KEY	PART NUMBER	U/M DESCRIPTION
1	067487-02-000	EA TOILET-12.37", IVORY - FOOT FLUSH - THETFORD
	063740-01-700	EA LEVER-WATER, THETFORD 12514
	063740-01-706	EA BOLT PACKAGE-CLOSET, THETFORD 12524
	063740-01-710	EA LINK, THETFORD 12513
	063740-01-713	EA SEAL-BALL VALVE TO BOWL, THETFORD 12502
	063740-01-714	EA VALVE ASM-WATER, THETFORD 12492
	063740-01-717	EA TUBE-FLUSH, TOILET - THETFORD 12509
	063740-02-700	EA SEAT & COVER, PARCHMENT - THETFORD 20829
	116644-01-000	EA FLANGE-CLOSET, TOILET - 4" X 3" - US
	024676-02-000	EA FLANGE-CLOSET, 4" X 3" - ABS - CANADIAN
2	M06803-06-E07	EA DOOR-W/O HARDWARE - 285 X 500MM (F04,F05,F06,F07)
2	M06803-06-F14	EA DOOR-W/O HARDWARE - 285 X 500MM
3	111760-01-F04	EA CABINET ASM-LINEN
4	M06803-10-E07	EA DOOR-W/O HARDWARE - 275 X 925MM (F04,F05,F06,F07)
4	M06803-H5-F14	EA DOOR-W/O HARDWARE - 275 X 925MM
5	106300-11-E28	EA COUNTERTOP ASM (F04,F07)
5	106300-11-F05	EA COUNTERTOP ASM
5	106300-11-F06	EA COUNTERTOP ASM
5	106300-16-F14	EA COUNTERTOP ASM
6	058331-51-000	EA MIRROR-GLASS,SAFETY - 660 X 1016MM
7	075240-06-000	EA FAUCET-LAVATORY, BONE
	091253-01-000	EA GASKET-FAUCET, LAVATORY/GALLEY
8	096927-01-01A	EA SINK-LAVATORY, RECTANGULAR - PLASTIC - BONE
	096927-01-700	EA SINK-STOPPER
	096927-01-701	EA TAILPIECE-SINK
9	P06300-01-E28	EA CABINET ASM-LAVATORY, W/O DOORS OR HARDWARE (F04,F07)
9	P06300-01-F05	EA CABINET ASM-LAVATORY, W/O DOORS OR HARDWARE
9	P06300-01-F06	EA CABINET ASM-LAVATORY, W/O DOORS OR HARDWARE
9	P06300-02-F14	EA CABINET ASM-LAVATORY, W/O DOORS OR HARDWARE
10	M06803-12-E07	EA DOOR-W/O HARDWARE - 285 X 500MM (F04,F05,F06,F07)
10	M06803-06-F14	EA DOOR-W/O HARDWARE - 285 X 500MM
11	075452-02-000	EA HOLDER-TOILET TISSUE, BRASS
	075453-02-000	EA BAR-TOWEL, 18" BRASS
	100357-01-000	EA ROD-TOWEL, BRASS W/ENDS BENT FOR BACK OF BATH DOOR
	102089-13-E07	EA WOOD RAIL - TOWEL RACK - RIGHT SIDE - 26" LONG
	102089-14-E07	EA WOOD RAIL - TOWEL RACK - LEFT SIDE - 26" LONG
	M87868-10-F04	EA DOOR-CABINET BATH (F04,F06,F07)
	M87868-10-E07	EA DOOR-CABINET BATH (F05)
	094485-03-01A	EA KNOB-DOOR, BRASS - THUNADER L132PB
	102920-01-01A	EA HINGE-DOOR, SPRING LOADED - BRASS
	104013-02-D35	EA DOOR ASM-SLIDING
	103874-01-000	EA HANGER-SLIDING DOOR
	103868-02-01A	EA TRACK-DOOR,1234,O/W

BEDROOM GROUP
QUEEN BEDROOM CABINETS

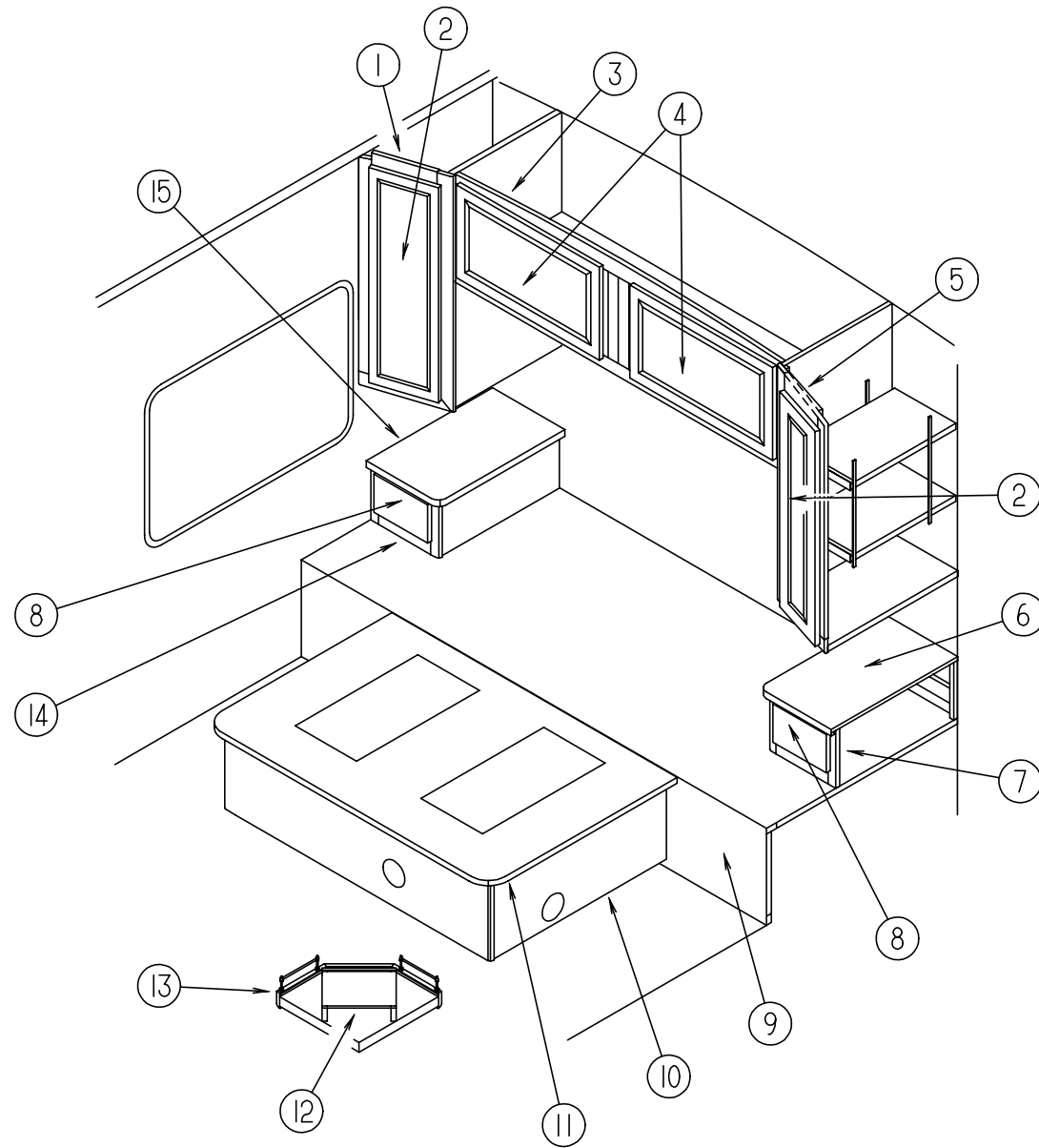

KEY	PART NUMBER	U/M	DESCRIPTION
1	110625-01-F04	EA	CABINET-SHIRT CLOSET, W/O DOOR OR HARDWARE
	009112-01-000	EA	FLANGE-1" ROD, CLOTHES - PLASTIC - OFF WHITE
	042438-01-000	EA	DOWEL-WOOD, CLOTHES ROD - 1" DIAMETER X 4'
2	M06803-10-E07	EA	DOOR-W/O HARDWARE - 275 MM X 925 MM (F04,F05,F06,F07)
2	M06803-H5-F14	EA	DOOR-W/O HARDWARE - 275 MM X 925 MM
3	M06852-01-E10	EA	CABINET-OVERHEAD, W/O DOORS OR HARDWARE - EUROPEAN OPTION (F04,F05,F06,F07)
3	M06852-01-F14	EA	CABINET-OVERHEAD, W/O DOORS OR HARDWARE - EUROPEAN OPTION
3	106523-01-E07	EA	CABINET-OVERHEAD, W/O DOORS OR HARDWARE
4	M06803-82-E10	EA	DOOR-W/O HARDWARE W/O MIRROR - 400 MM X 710 MM - EUROPEAN OPTION (F04,F05,F06,F07)
4	M06803-82-F14	EA	DOOR-W/O HARDWARE W/O MIRROR - 400 MM X 710 MM - EUROPEAN OPTION
4	M06803-13-E07	EA	DOOR-W/O HARDWARE W/MIRROR - 400 MM X 710 MM (F04,F05,F06,F07)
4	M06803-13-F14	EA	DOOR-W/O HARDWARE W/MIRROR - 400 MM X 710 MM
5	110625-02-F04	EA	CABINET-SHIRT CLOSET, W/O DOOR OR HARDWARE
	009112-01-000	EA	FLANGE-1" ROD, CLOTHES - PLASTIC - OFF WHITE
	042438-01-000	EA	DOWEL-WOOD, CLOTHES ROD - 1" DIAMETER X 4'
6	110626-12-E28	EA	COUNTERTOP-NIGHTSTAND (F04)
6	110626-12-F05	EA	COUNTERTOP-NIGHTSTAND
6	110626-12-F06	EA	COUNTERTOP-NIGHTSTAND
6	110626-12-F24	EA	COUNTERTOP-NIGHTSTAND (F07)
6	110626-12-F14	EA	COUNTERTOP-NIGHTSTAND
7	P10626-02-E28	EA	CABINET-NIGHTSTAND W/COUNTERTOP (F04)
7	P10626-02-F05	EA	CABINET-NIGHTSTAND W/COUNTERTOP
7	P10626-02-F06	EA	CABINET-NIGHTSTAND W/COUNTERTOP
7	P10626-02-F04	EA	CABINET-NIGHTSTAND W/COUNTERTOP (F07)
7	P10626-02-F14	EA	CABINET-NIGHTSTAND W/COUNTERTOP
8	M05971-56-F04	EA	DRAWER-CABINET, W/O HARDWARE - 155 MM X 290 MM FACE SIZE (F04,F05,F06,F07)
8	M05971-56-F14	EA	DRAWER-CABINET, W/O HARDWARE - 155 MM X 290 MM FACE SIZE
9	P10624-01-000	EA	CABINET-COMPARTMENT, W/O CARPET OR TOP
10	P10623-01-F04	EA	CABINET-QUEEN BED W/O TOP
11	M05706-05-000	EA	TOP-QUEEN BED CABINET
12	111236-15-E07	EA	WEDGE-TV
13	111236-01-E07	EA	SHELF ASM-TV, W/BRASS RAILING & WEDGE - 420 MM X 410 MM
	105219-01-E07	EA	SHELF ASM-W/BRASS RAILING - 273 MM X 274 MM
	084070-02-000	EA	POST-END, 2.4" - BRASS
	084071-15-000	EA	ROD-BRASS, 210 MM LONG
	058331-17-000	EA	MIRROR-GLASS, SAFETY - 8.75" X 12.5"
	105004-01-01A	EA	MOLDING-MIRROR, VINYL WRAPPED - OAK
14	P10626-01-E28	EA	CABINET-NIGHTSTAND W/COUNTERTOP (F04)
14	P10626-01-F05	EA	CABINET-NIGHTSTAND W/COUNTERTOP
14	P10626-01-F06	EA	CABINET-NIGHTSTAND W/COUNTERTOP
14	P10626-01-F04	EA	CABINET-NIGHTSTAND W/COUNTERTOP (F07)
14	P10626-01-F14	EA	CABINET-NIGHTSTAND W/COUNTERTOP
15	110626-11-E28	EA	COUNTERTOP-NIGHTSTAND (F04)
15	110626-11-F05	EA	COUNTERTOP-NIGHTSTAND
15	110626-11-F06	EA	COUNTERTOP-NIGHTSTAND
15	110626-11-F24	EA	COUNTERTOP-NIGHTSTAND (F07)
15	110626-11-F14	EA	COUNTERTOP-NIGHTSTAND

BEDROOM GROUP (CONTINUED)

TWIN BEDROOM CABINETS

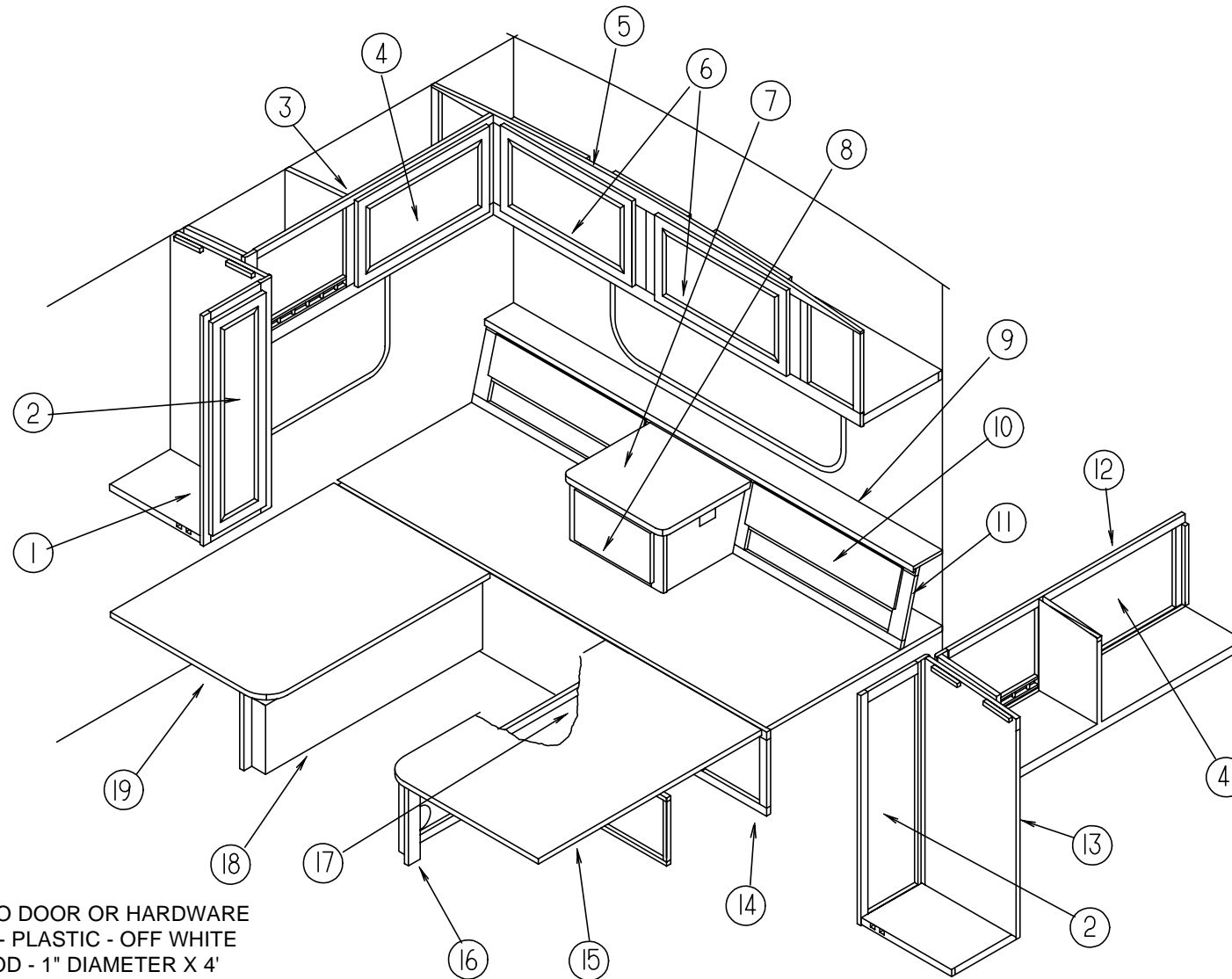

KEY	PART NUMBER	U/M DESCRIPTION
1	110946-01-E07	EA CABINET-SHIRT CLOSET, W/O DOOR OR HARDWARE
	009112-01-000	EA FLANGE - 1" ROD, CLOTHES - PLASTIC - OFF WHITE
	042438-01-000	EA DOWEL-WOOD, CLOTHES ROD - 1" DIAMETER X 4'
2	M06803-15-E07	EA DOOR-W/O HARDWARE - 305 MM X 1015 MM (F04,F05,F06,F07)
2	M06803-F3-F14	EA DOOR-W/O HARDWARE - 305 MM X 1015 MM
3	111185-01-F04	EA CABINET-OVERHEAD, W/O DOOR OR HARDWARE
	111775-01-01A	EA RAIL-DECORATIVE, 1830 MM - OAK
	058331-A5-000	EA MIRROR-GLASS, SAFETY - 396 MM X 516 MM
4	M06803-02-E07	EA DOOR-W/O HARDWARE - 400 MM X 710 MM (F04,F05,F06,F07)
4	M06803-02-F14	EA DOOR-W/O HARDWARE - 400 MM X 710 MM
5	111239-01-E07	EA CABINET-OVERHEAD, W/O DOORS OR HARDWARE
6	M06803-02-E07	EA DOOR-W/O HARDWARE W/O MIRROR - 400 MM X 710 MM - EUROPEAN OPTION (F04,F05,F06,F07)
6	M06803-02-F14	EA DOOR-W/O HARDWARE - 400 MM X 710 MM
6	M06803-13-E07	EA DOOR-W/O HARDWARE W/MIRROR - 400 MM X 710 MM (F04,F05,F06,F07)
6	M06803-13-F14	EA DOOR-W/O HARDWARE W/MIRROR - 400 MM X 710 MM
7	110826-13-E08	EA COUNTERTOP-NIGHTSTAND CABINET (F04)
7	110826-13-F05	EA COUNTERTOP-NIGHTSTAND CABINET
7	110826-13-F06	EA COUNTERTOP-NIGHTSTAND CABINET
7	110826-13-F24	EA COUNTERTOP-NIGHTSTAND CABINET (F07)
7	110826-13-F14	EA COUNTERTOP-NIGHTSTAND CABINET
8	M05971-59-E07	EA DRAWER-CABINET, W/O HARDWARE - 235 MM X 410 MM FACE SIZE (F04,F05,F06,F07)
8	M05971-59-F14	EA DRAWER-CABINET, W/O HARDWARE - 235 MM X 410 MM FACE SIZE
9	110826-11-E08	EA COUNTERTOP-NIGHTSTAND CABINET (F04)
9	110826-11-F05	EA COUNTERTOP-NIGHTSTAND CABINET
9	110826-11-F06	EA COUNTERTOP-NIGHTSTAND CABINET
9	110826-11-F24	EA COUNTERTOP-NIGHTSTAND CABINET (F07)
9	110826-11-F14	EA COUNTERTOP-NIGHTSTAND CABINET

KEY	PART NUMBER	U/M DESCRIPTION
10	110826-12-E08	EA DOOR-W/O HARDWARE - FABRIC COVERED - 176 MM X 802 MM - EITHER SIDE (F04)
10	110826-12-F05	EA DOOR-W/O HARDWARE - FABRIC COVERED - 176 MM X 802 MM - EITHER SIDE
10	110826-12-F06	EA DOOR-W/O HARDWARE - FABRIC COVERED - 176 MM X 802 MM - EITHER SIDE
10	110826-12-F27	EA DOOR-W/O HARDWARE - FABRIC COVERED - 176 MM X 802 MM - EITHER SIDE (F07)
10	110826-12-F14	EA DOOR-W/O HARDWARE - FABRIC COVERED - 176 MM X 802 MM - EITHER SIDE
11	110826-01-F04	EA CABINET-NIGHTSTAND, W/COUNTERTOPS - W/O DOORS OR DRAWER
11	110826-01-F05	EA CABINET-NIGHTSTAND, W/COUNTERTOPS - W/O DOORS OR DRAWER
11	110826-01-F06	EA CABINET-NIGHTSTAND, W/COUNTERTOPS - W/O DOORS OR DRAWER
11	110826-01-F27	EA CABINET-NIGHTSTAND, W/COUNTERTOPS - W/O DOORS OR DRAWER (F07)
11	110826-01-F14	EA CABINET-NIGHTSTAND, W/COUNTERTOPS - W/O DOORS OR DRAWER
12	111186-01-E07	EA CABINET-OVERHEAD, W/O DOOR OR HARDWARE
	111775-01-01A	EA RAIL-DECORATIVE, 1830 MM - OAK
	058331-A5-000	EA MIRROR-GLASS, SAFETY - 396 MM X 516 MM
13	110947-01-E07	EA CABINET-SHIRT CLOSET, W/O DOOR OR HARDWARE - DRIVER SIDE
	009112-01-000	EA FLANGE-1" ROD, CLOTHES - PLASTIC - OFF WHITE
	042438-01-000	EA DOWEL-WOOD, CLOTHES ROD - 1" DIAMETER X 4'
14	P10877-01-000	EA CABINET-COMPARTMENT, W/O TOP OR CARPET
15	M04170-05-000	EA TOP-TWIN BED
16	P11184-01-E07	EA CABINET-TWIN BED W/O TOP
17	M06803-68-E07	EA DOOR-W/O HARDWARE - 305 MM X 555 MM - DRIVER SIDE TWIN BED CABINET (F04,F05,F06,F07)
17	M06803-68-F14	EA DOOR-W/O HARDWARE - 305 MM X 555 MM - DRIVER SIDE TWIN BED CABINET
18	P10828-01-E07	EA CABINET-TWIN BED W/O TOP
19	M04170-04-000	EA TOP-TWIN BED, PASSENGER SIDE

BEDROOM GROUP (CONTINUED)

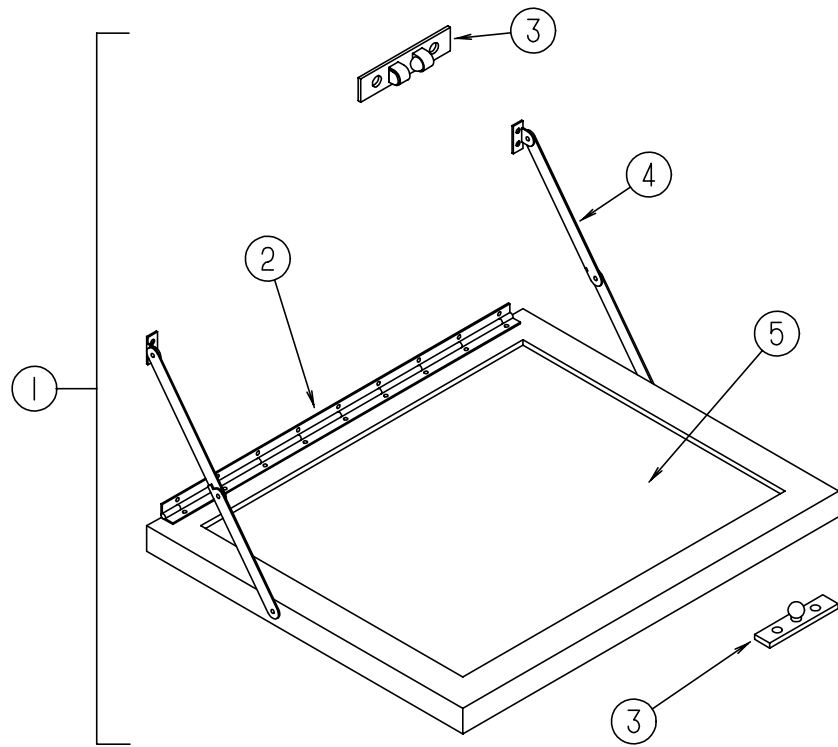

TV STAND

KEY	PART NUMBER	U/M DESCRIPTION
1	084357-02-E07	EA STAND-FOLD DOWN, TV - W/MIRROR
2	084413-01-000	EA HINGE-CONTINUOUS, W/HOLES
3	084451-01-000	EA CATCH-TV SHELF, BRASS
4	084412-01-000	EA SUPPORT-HINGED (PAIR)
5	084356-08-000	EA INSERT-TV STAND, W/SUPPORT HINGE - METAL - OFF WHITE
5	058331-14-000	EA MIRROR-GLASS, SAFETY - 14" X 12.7"

BEDROOM GROUP (CONTINUED)

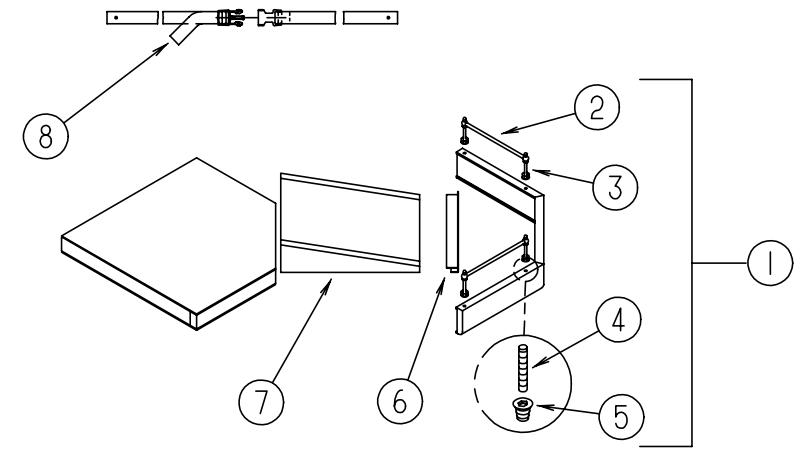

TV SHELVES

KEY	PART NUMBER	U/M DESCRIPTION
1	111236-01-E07	EA SHELF ASM-TV, W/BRASS RAILING & WEDGE - 420 MM X 410 MM
2	084071-15-000	EA ROD-BRASS, 210 MM LONG
3	084070-02-000	EA POST-END, 2.4" - BRASS
4	105247-01-000	EA NUT-INSERT, 8-32 THREAD X .394" LONG - STAFST PRODUCTS
5	105246-01-000	EA POST-ANCHOR
6	103186-01-01A	FT MOLDING-EDGE, SHELF - .78" WIDE - PLASTIC - RAMBLING OAK
7	111236-15-E07	EA WEDGE-TV
8	099717-01-000	EA TIEDOWN-TV, STRAP ON FEMALE END IS 22.8" LONG

CHASSIS GROUP

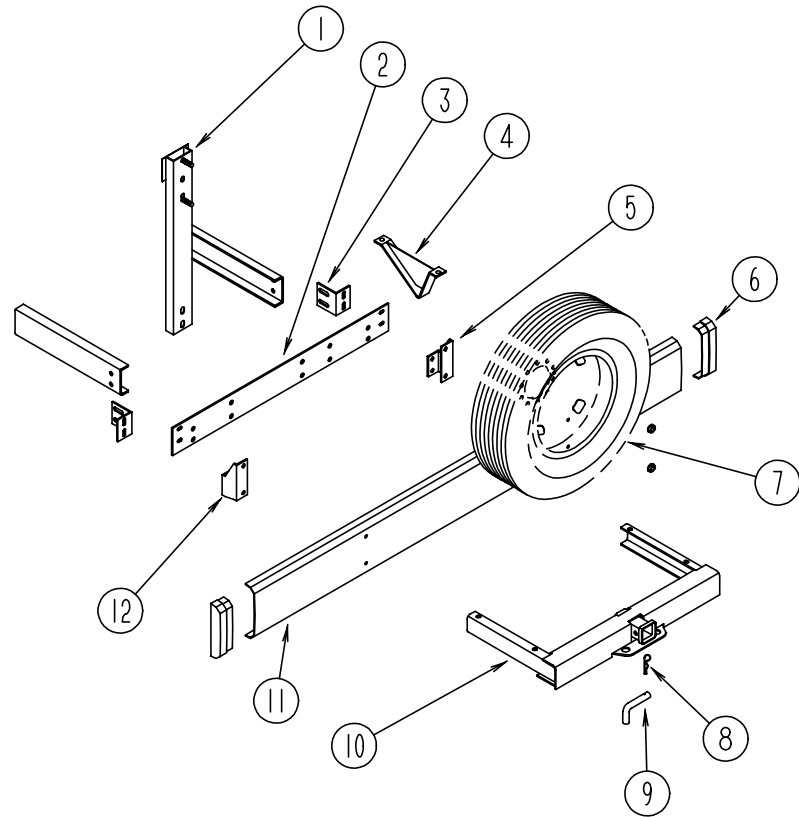

REAR BUMPER, TRAILER HITCH & COMPONENTS

KEY	PART NUMBER	U/M	DESCRIPTION
1	102944-01-000	EA	BRACKET ASM-TIRE CARRIER
1	102944-02-000	EA	BRACKET ASM-TIRE CARRIER, FORD OPTION
2	078678-02-000	EA	PLATE-MOUNTING, BUMPER - REAR
3	078668-01-000	EA	SUPPORT ANGLE-BUMPER, REAR
4	083376-01-000	EA	SKID PLATE
5	102945-03-000	EA	BRACKET ASM-BUMPER, REAR
6	103228-01-05A	EA	CAP-END, BUMPER - REAR - DRIVER OR PASSENGER SIDE
7	083425-10-000	EA	TIRE-LT215/85R16, LRE XCH4 - MICHELIN XCH4 ORBL - FORD OPTION
7	007324-04-000	EA	TIRE - 8R19.5 LRD, MICHELIN XZA - CHEVY
	051377-01-000	EA	STEM-VALVE, TR 500
	051377-05-000	EA	STEM-VALVE, EATON VS-938 F53-92 - FORD OPTION
	095853-02-000	EA	WHEEL-STEEL, 16" X 6K - F2TA-1015-NA - ACCURIDE 28513-7 - FORD OPTION
8	034513-01-000	EA	PIN-HITCH - 3/16" WIRE
9	034512-01-000	EA	PIN-LOCKING-DRAWBAR
10	107707-01-000	EA	HITCH ASM W/O DRAWBAR
11	103099-01-02A	EA	BUMPER-REAR, OFF WHITE
12	102945-04-000	EA	BRACKET ASM-BUMPER, REAR
	113589-02-000	EA	CONNECTOR-SOCKET, TRAILER - GENERAL 433601
	113589-01-000	EA	CONNECTOR-PLUG, TRAILER - GENERAL 433501

CHASSIS GROUP (CONTINUED)

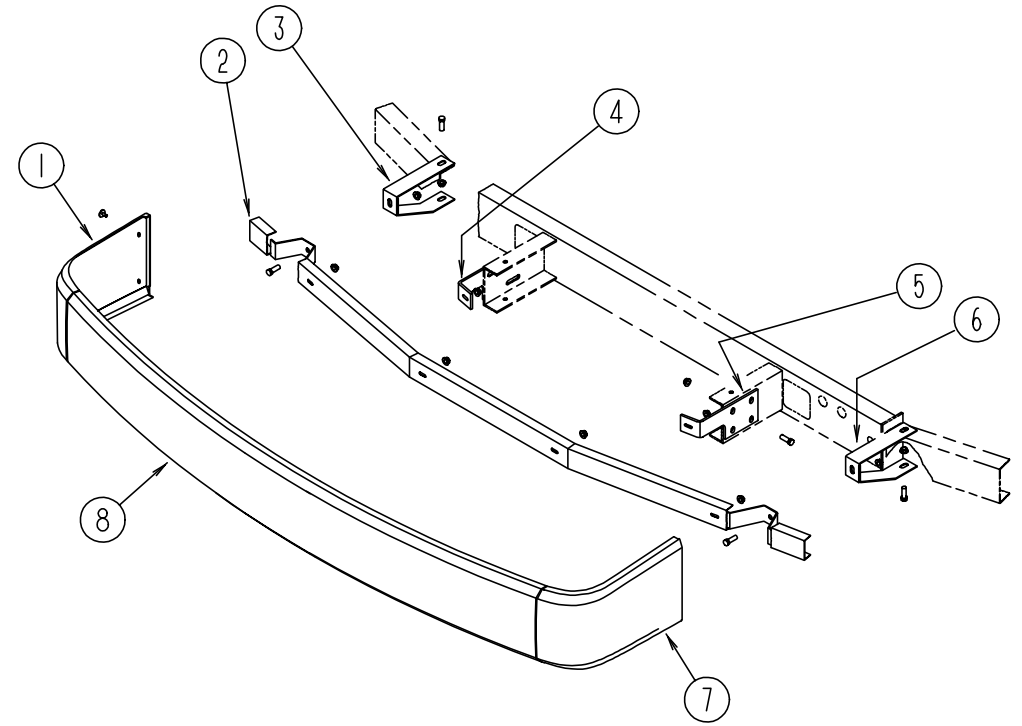

FRONT BUMPER

KEY	PART NUMBER	U/M	DESCRIPTION
1	103692-01-02A	EA	PANEL-FACIA, BUMPER - FRONT RIGHT - OFF WHITE
2	103512-01-000	EA	CHANNEL ASM-BUMPER
3	103497-01-000	EA	BRACE-BUMPER, FRONT
4	086140-03-000	EA	SUPPORT-FRONT BUMPER, PASSENGER SIDE - 9.1" X 4" - STEEL
5	086140-04-000	EA	SUPPORT-FRONT BUMPER, DRIVER SIDE - 9.1" X 4" - STEEL
6	103611-01-000	EA	BRACE-BUMPER, FRONT
7	103692-02-02A	EA	PANEL-FACIA, BUMPER - FRONT LEFT - OFF WHITE
8	103758-01-E07	EA	BUMPER ASM-FRONT, W/DRIVER & PASSENGER SIDE FACIA PANELS OFF WHITE

CHASSIS GROUP (CONTINUED)

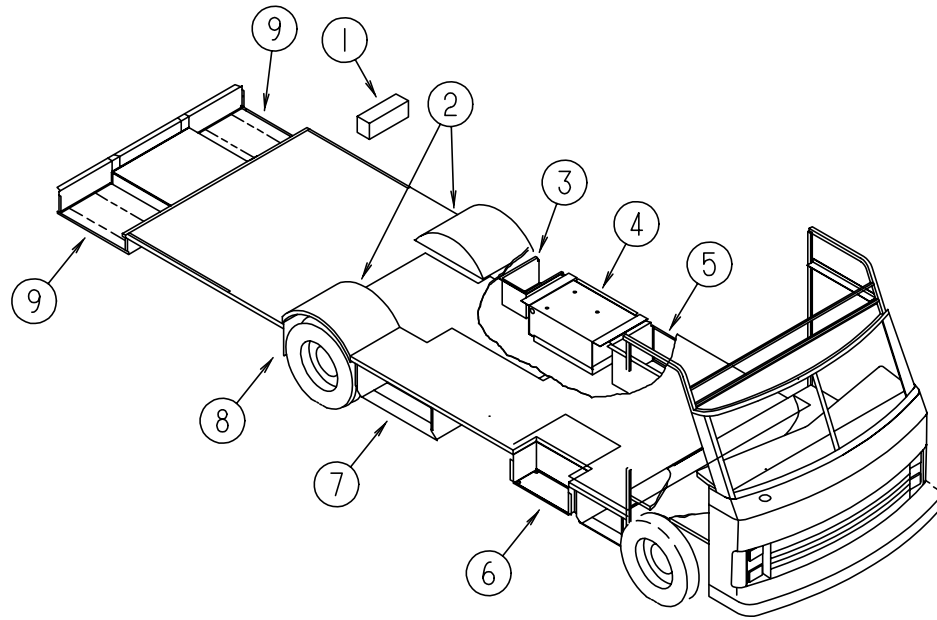

STORAGE COMPARTMENTS & WHEELWELLS

KEY	PART NUMBER	U/M	DESCRIPTION
1	085967-01-000	EA	COMPARTMENT-SEWER HOSE, 6" X 6.6" X 17.8" - PLASTIC
2	102921-01-000	EA	WHEELWELL - PLASTIC
3	102979-01-000	EA	BOX-POWER CORD
4	078137-04-000	EA	TRAY-COMPARTMENT, GENERATOR - 29.1" WIDE X 22.4" DEEP
5	103036-02-000	EA	COMPARTMENT ASM-STORAGE
6	077848-02-000	EA	STEP-PULLOUT
	077848-01-000	EA	STEP-PULLOUT, W/BRACKETS - BLACK
	091176-01-000	EA	SUPPORT-BASE-ENTRANCE STEP
7	103032-06-000	EA	COMPARTMENT ASM-STORAGE
8	017516-01-000	EA	FLAP-MUD, 14" X 18" - BLACK
	020167-04-000	EA	GUARD-DIRT
9	110820-01-000	EA	COMPARTMENT ASM-STORAGE
	065450-05-000	EA	TIEDOWN-BATTERY, 8.4" TUBE
	056748-01-000	EA	PLUG-CAP, 1.5" DIAMETER - BLACK
	061420-01-000	EA	PLUG-PLASTIC, 1.75" - BROWN
	105732-02-000	EA	TRAY ASM-GENERATOR

CHASSIS GROUP (CONTINUED)

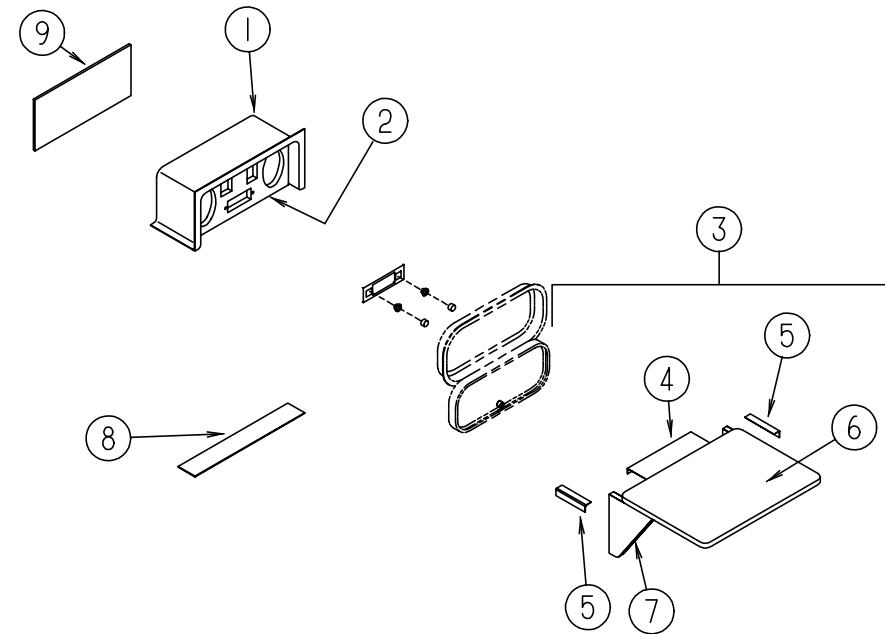

PATIO ENTERTAINMENT CENTER

KEY	PART NUMBER	U/M	DESCRIPTION
1	104897-03-01A	EA	BOX-ENTERTAINMENT CENTER - OFF WHITE
2	104899-01-C05	EA	PLATE-RADIO MOUNTING
3	105230-01-E01	EA	SHELF
4	105377-01-01A	EA	BRACKET-TABLE HANGER, OFF WHITE
5	105376-01-02A	EA	HINGE-CONTINUOUS, 2" X 140 MM - OFF WHITE
6	105230-11-E01	EA	SHELF
7	105230-12-E01	EA	SUPPORT-SHELF
8	104898-01-01A	EA	PLATE-PLASTIC, BOTTOM - 19.38" X 3.1" - OFF WHITE
9	104898-02-01A	EA	PLATE-PLASTIC, REAR - 16.1" X 6.3" - OFF WHITE

CHASSIS GROUP (CONTINUED)
CHASSIS MISCELLANEOUS

KEY	PART NUMBER	U/M DESCRIPTION
	070579-06-000	EA PLATE-ANCHOR, W/7/16 WELD NUT - 1.5" X 3.3"
	077001-01-000	EA ANGLE-MOUNTING, ROOF PANEL - V ANGLE - 3" X 2.4" X 1.5"
	103136-01-000	EA BRACKET-SUPPORT, UPPER - HINGE - RH
	103136-02-000	EA BRACKET-SUPPORT, UPPER - HINGE - LH
	110934-01-000	EA CONNECTOR-PLASTIC, BARB 5/16 KEVCO TC 7055
	113007-01-000	EA PIN-SPRING, .375 X 3.00 IN (FORD)
	083163-06-000	EA PUSHNUT-FLAT TYPE 3/8 STUD
	113875-01-000	EA HOSE-HUMP, 3" GRIFFITH HH3
	087234-01-000	EA NUT-JACK, 1/4 X 20THD,MOLLY ARDEN 8-L,JN BRASS MOUNTS LICENSE PLATES
	093719-01-000	EA HOSE-OIL FILL, PREFORMED 90 DEGREE BEND
	076310-01-000	EA SHEET-RUBBER, RADIATOR BAFFLE - .12" X 15" X 62" - BLACK
	098443-03-000	EA SUPPORT-SHIELD, EXHAUST - 1.5" X 29.2" - STEEL - PRIMED
	075307-03-000	EA SHIELD-HEAT, LP
	101544-01-000	EA SHIELD-HEAT, EXHAUST - 19.7" X 28.9" - STEEL

FRONT SHOCKS

KEY	PART NUMBER	U/M DESCRIPTION
	104993-01-000	EA SHOCK ABSORBER-GAS, P30 FRONT - BILSTEIN B46-1173

TIRE COVERS

KEY	PART NUMBER	U/M DESCRIPTION
	117213-01-000	EA COVER-TIRE, 32" - BRAVE - FORD OPTION
	117213-02-000	EA COVER-TIRE, 34" - BRAVE - CHEVY
	108163-02-01A	EA COVER ASM-TIRE, 19.5" CHEVY - CHROME - EXTERIOR TRIM OPTION
	108560-03-01A	EA INSERT-TIRE COVER, 19.5" CHEVY - OFF WHITE - EXTERIOR TRIM OPTION
	108163-01-01A	EA COVER ASM-TIRE, 16" FORD - CHROME - EXTERIOR TRIM OPTION
	108560-02-01A	EA INSERT-TIRE COVER, 16" CHEVY - OFF WHITE - EXTERIOR TRIM OPTION

ELECTRIC STEP

KEY	PART NUMBER	U/M DESCRIPTION
	075723-02-000	EA SPACER-SWITCH, W/HOLE - .2" X .9" X 2" - METAL - OFF WHITE
	094708-01-01A	EA STEP-ENTRY DOOR, ELECTRIC - SINGLE - KWIKEE 2813
	094707-02-700	EA MOTOR REPLACEMENT KIT - MODELS 32 & 28 - KWIKEE 9520
	094707-02-702	EA GEAR KIT - KWIKEE 9525
	094707-02-703	EA PARTS KIT, (BEARINGS & PINS) - KWIKEE 9530
	094707-02-704	EA CONNECTOR KIT-MOTOR, KWIKEE 9537
	094707-02-705	EA CONTROL UNIT, (ORANGE) - KWIKEE 9513
	094708-02-700	EA CONVERSION KIT 28 SERIES - 9570 KWIKEE
	094708-03-700	EA LINKAGE ASM F/28 SERIES - 9522
	P01713-01-000	EA SWITCH ASM-ELECTIC STEP W/SEAL
	113285-01-01A	EA SEAL-STEP, SWITCH - BLACK

CHASSIS GROUP (CONTINUED)
19.5" CHEVY STAINLESS STEEL WHEEL LINERS

KEY	PART NUMBER	U/M DESCRIPTION
	091209-01-000	EA LINER-WHEEL, 19.5" - STAINLESS STEEL - SET OF 4 - KAPER 1954-ION
	091209-01-700	EA LINER-WHEEL, 19.5" FRONT - 10 LUG - CHEVY P-30
	091209-01-701	EA LINER-WHEEL, 19.5" REAR-10 LUG-CHEVY P-30 SINGLE
	091209-01-702	EA COVER-AXLE, 19.5" FRONT - 10 LUG - CHEVY P-30
	091209-01-703	EA COVER-AXLE, 19.5" REAR - 10 LUG - CHEVY P-30
	091209-01-704	EA COVER-LUG NUT
	095012-03-000	EA EXTENSION-VALVE STEM, DUAL WHEEL
	095012-04-000	EA STABILIZER-VALVE STEM EXTENSION, DICOR AG-STA-2
	077030-02-000	EA EXTENSION-VALVE STEM, 1.25"

16" FORD CHROME WHEEL LINERS

KEY	PART NUMBER	U/M DESCRIPTION
	091209-08-000	EA LINER-WHEEL, SET OF 4 - 16" - CHROME - KAPER II 1604-10FOL
	091209-08-700	EA LINER-WHEEL, 16" FRONT - W/AXLE COVER - 10 LUG
	091209-08-701	EA LINER-WHEEL, 16" REAR - 10 LUG
	091209-08-702	EA COVER-AXLE, 16" REAR - 10 LUG
	091209-08-703	EA LUG NUT COVER
	091209-08-704	EA FRONT SIMULATOR
	091209-08-705	EA REAR SIMULATOR
	091209-08-706	EA FLAT NUT .500, 9/16 STUD
	091209-01-704	EA COVER-LUG NUT W/O FLANGE
	091209-11-702	EA JAMB NUT (LONG) REAR
	095012-03-000	EA EXTENSION-VALVE STEM, DUAL WHEEL
	095012-04-000	EA STABILIZER-VALVE STEM EXTENSION, DICOR AG-STA-2
	077030-02-000	EA EXTENSION-VALVE STEM, 1.25"

16" FORD WHEEL COVERS

KEY	PART NUMBER	U/M DESCRIPTION
	098532-01-000	EA COVER-WHEEL, FORD - 16" - SET OF 4 - DICOR SH-SD-16
	098532-01-700	EA COVER-LUG NUT, FORD - CHROME - DICOR SP-FM-CLN
	098532-01-701	EA COVER-WHEEL, FORD - 16"

19.5" CHEVY WHEEL COVERS

KEY	PART NUMBER	U/M DESCRIPTION
	109443-01-000	EA WHEEL-COVER 4/SET 19.5 W/HDW DICOR SHAG95
	109443-01-700	EA WHEEL-COVER 19.5 F&R SHAG95 DICOR
	109443-01-701	EA SET-BRACKET, 1 FRONT WHEEL SHAG95-FBS DICOR
	109443-01-702	EA SET-BRACKET, 1 REAR WHEEL SHAG95-RBS DICOR
	109443-01-703	EA CAP-CENTER, HUB - DICOR SP-AUCAP

LUG WRENCH & LEVERAGE BAR

KEY	PART NUMBER	U/M DESCRIPTION
	080208-01-000	EA LUG WRENCH, 1.06 X 1.00
	080208-02-000	EA BAR-LEVERAGE, LUG WRENCH

CHASSIS GROUP (CONTINUED)
EXHAUST SYSTEM (FORD)

KEY	PART NUMBER	U/M	DESCRIPTION
1	094918-03-000	EA	CLAMP-EXHAUST, 2.5"
2	101544-01-000	EA	SHIELD-HEAT, EXHAUST - 19.7" X 28.9" - STEEL
3	101544-06-000	EA	SHIELD-HEAT, EXHAUST, FORD

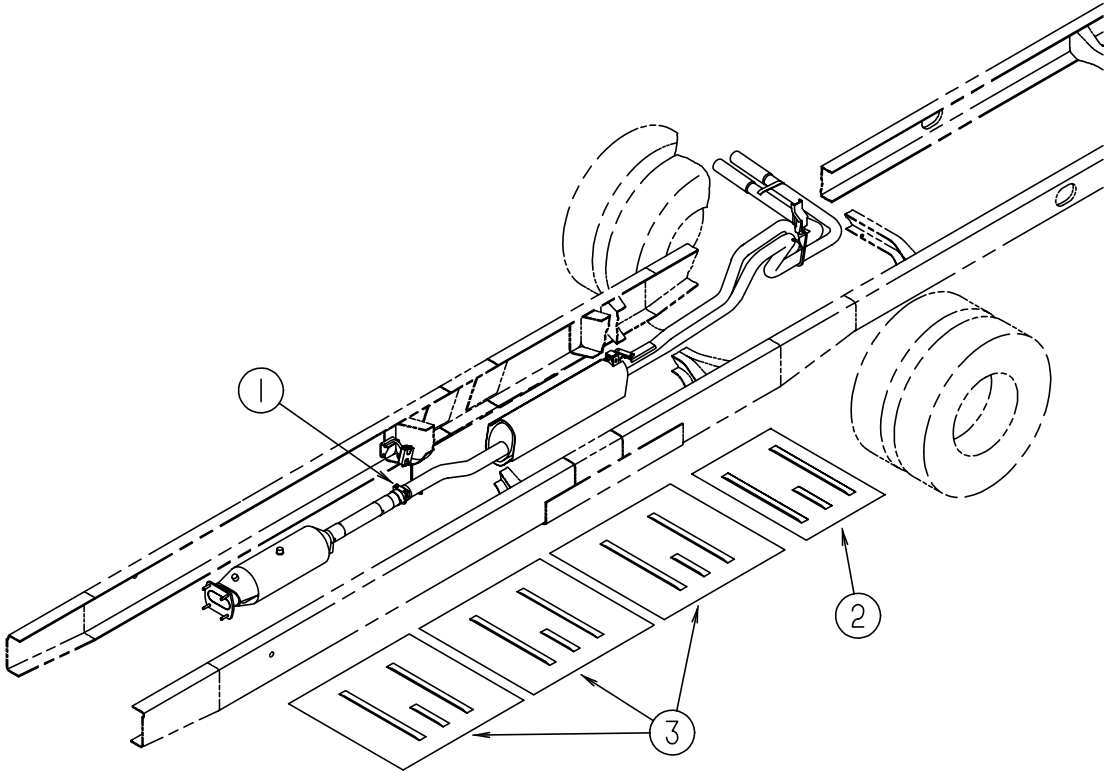

CHASSIS GROUP (CONTINUED)

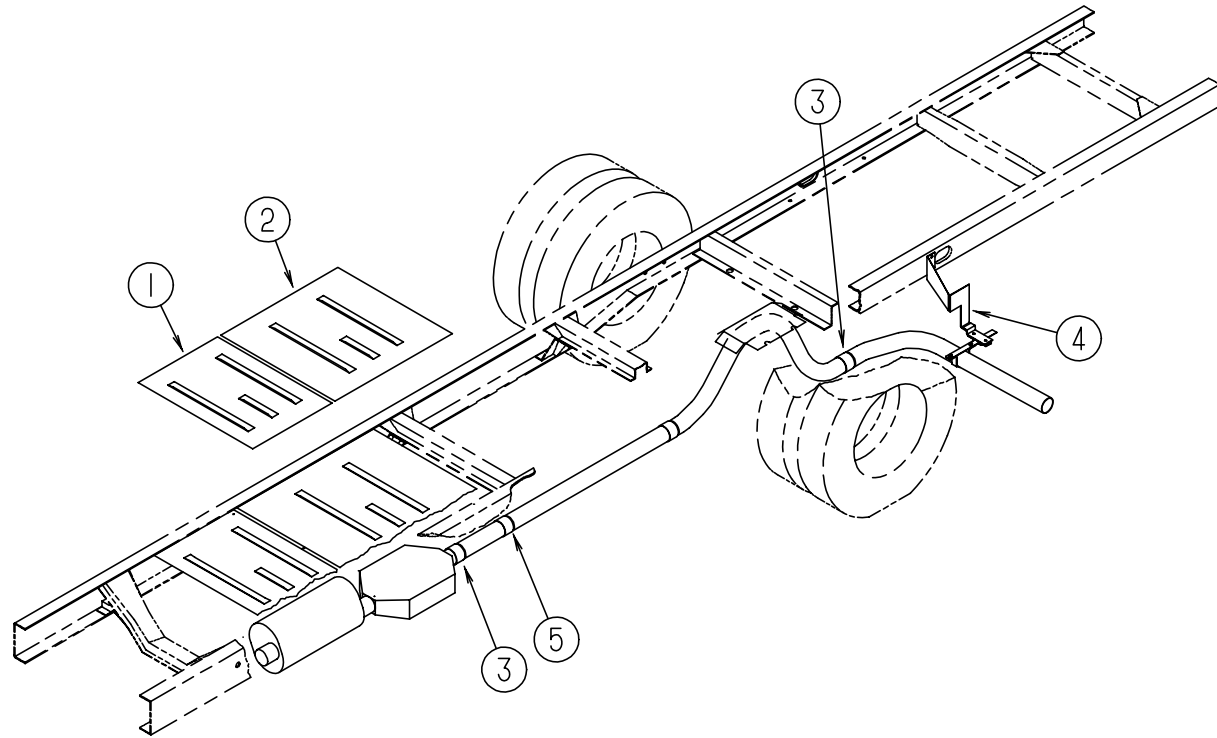

EXHAUST SYSTEM (CHEVY)

KEY	PART NUMBER	U/M DESCRIPTION
1	101544-01-000	EA SHIELD-HEAT, EXHAUST - 19.7" X 28.9" - STEEL
2	101544-02-000	EA SHIELD-HEAT, EXHAUST - 30" X 28.9" - STEEL
3	094918-01-000	EA CLAMP-EXHAUST, 3" - GUILLOTINE STYLE
4	098833-02-000	EA BRACKET-EXHAUST, HANGER
5	098762-05-000	EA EXTENSION-EXHAUST, STRAIGHT - 3" OD X 7.9" LONG - SST
	110236-01-000	EA PIPE-EXHAUST, EXTENSION
	081918-01-000	EA EXTENSION-EXHAUST, 2.25"OD X 9.44" - STAINLESS STEEL
	M98762-05-000	EA PIPE-EXHAUST, STRAIGHT 3"

CHASSIS GROUP (CONTINUED)

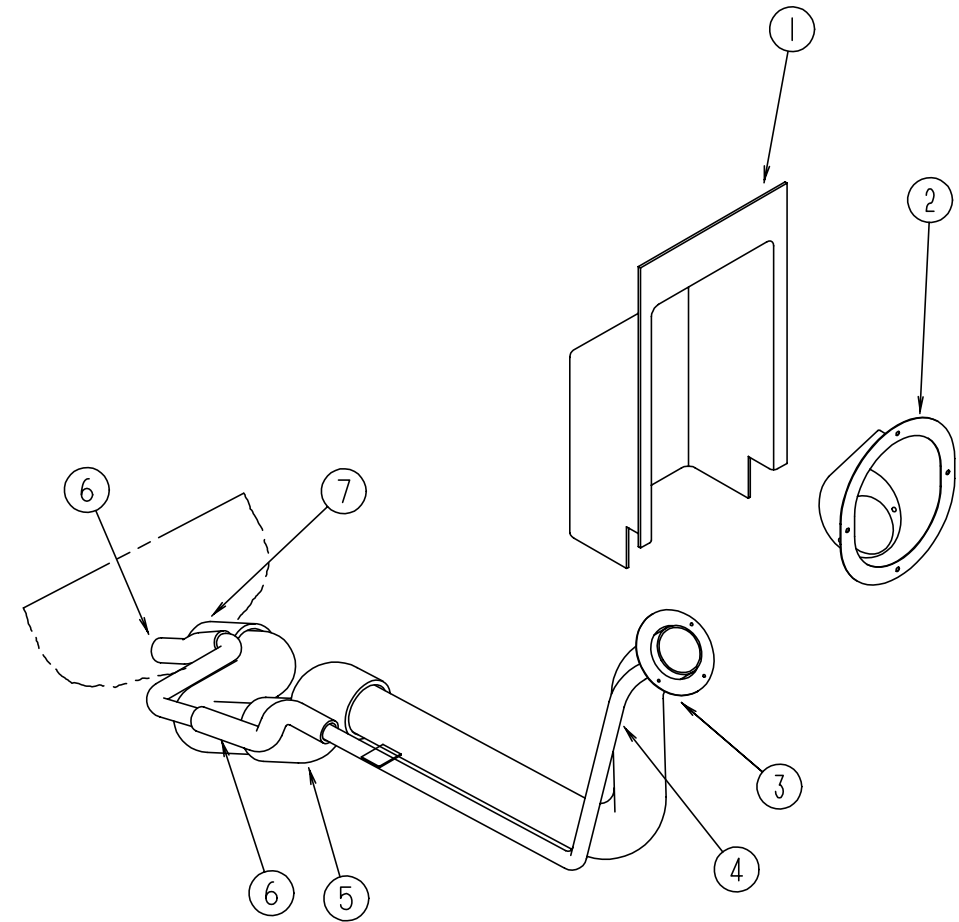

FUEL SYSTEM (FORD)

KEY	PART NUMBER	U/M DESCRIPTION
1	072447-04-000	EA SHROUD-FUEL FILL, UPPER - PLASTIC
2	095854-01-02A	EA SHROUD-FUEL FILL, OFF WHITE
3	078200-01-000	EA GASKET-FUEL FILL, 3.5"OD X 2"ID
4	095606-01-000	EA NECK-FUEL FILL, W/CHECK VALVE - L-SHAPED - 18.2" LONG
5	100156-01-000	EA HOSE-FUEL FILL, 8.3" LONG W/2" ID
6	066732-03-000	FT HOSE-FUEL FILL, .75" ID
7	007111-02-000	EA HOSE-FUEL FILL, 2.00 ID - IN 3FT LENGTHS
	007063-01-000	FT HOSE-GAS 1/4"ID X 1/2"OD
	084884-01-000	EA PLUG-BRASS, 3/8"
	080081-01-000	EA STRAP-MOUNTING, FUEL LINE - 2" X 32"

CHASSIS GROUP (CONTINUED)

CURTAIN & CUSHION GROUP NOTICE

IN ORDER TO ASSIST OUR PARTS SALES DEPT. IN PROVIDING INTERIOR SOFTGOODS ITEMS, PLEASE INCLUDE THE SERIAL NUMBER AND THE COLOR CODE NUMBER FROM THE VEHICLE CERTIFICATION LABEL WHEN ORDERING. THIS LABEL IS LOCATED ON THE LEFT SIDEWALL AT THE END OF THE DASH (A-BODY), OR ON THE DRIVER'S DOOR LATCH PLATE (C-BODY).

AN EXAMPLE OF A COLOR CODE NUMBER IS B07, WHICH DESIGNATES AN OVERALL COLOR SCHEME OF A PARTICULAR UNIT. THE COLOR LISTED AFTER THE ITEM DESCRIPTION ON THE MICROFICHE, INDICATES THE OVERALL UNIT COLOR. ORDER THE ITEM YOU DESIRE ACCORDING TO UNIT COLOR CODE.

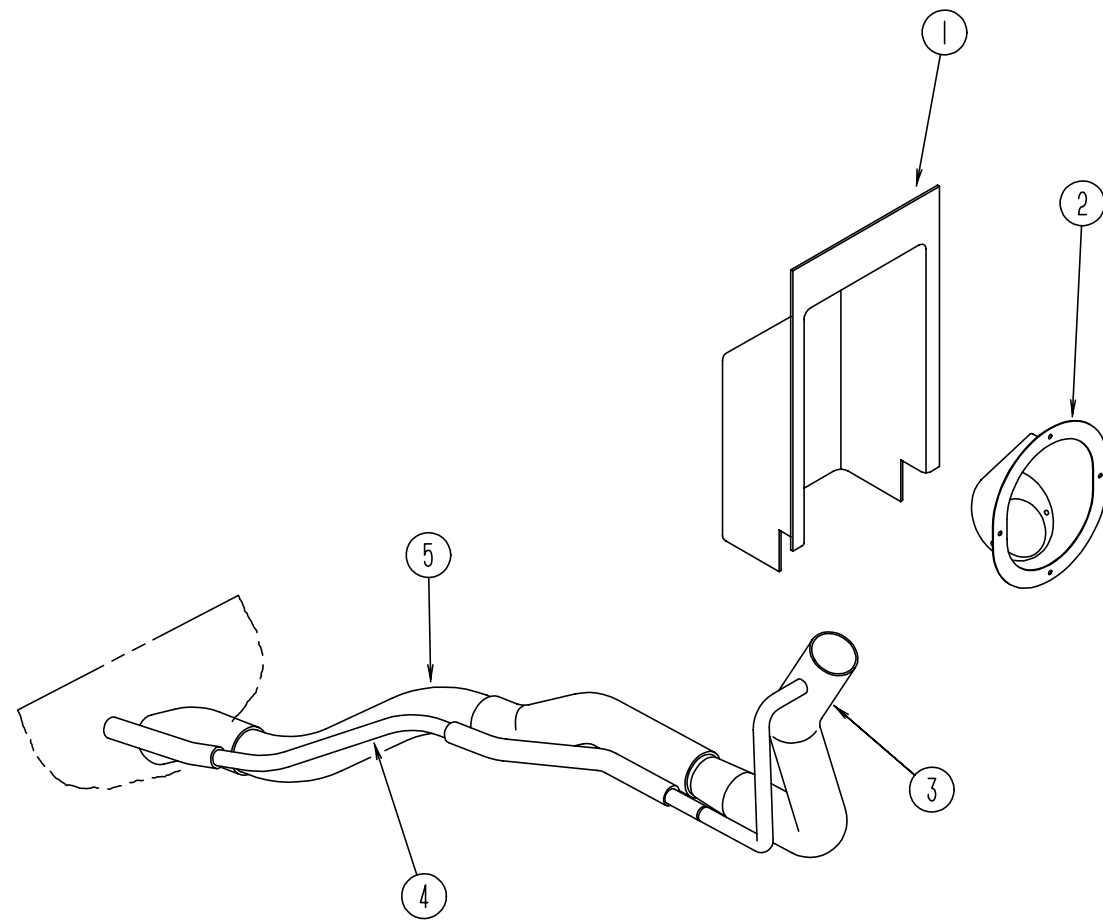

FUEL SYSTEM (CHEVY)

KEY	PART NUMBER	U/M	DESCRIPTION
1	072447-04-000	EA	SHROUD-FUEL FILL, UPPER - PLASTIC
2	095854-01-02A	EA	SHROUD-FUEL FILL, OFF WHITE
3	078200-01-000	EA	GASKET-FUEL FILL, 3.5"OD X 2"ID
4	098804-01-000	EA	PIPE-VENT, FUEL FILL - 12" LONG
5	098805-01-000	EA	PIPE-FUEL, FUEL FILL - 11.4" LONG
	084884-01-000	EA	PLUG-BRASS, 3/8"
	007063-01-000	FT	HOSE-GAS 1/4"ID X 1/2"OD
	044317-01-000	EA	HOSE-FUEL, 3/8" ID - DIESEL OPTION

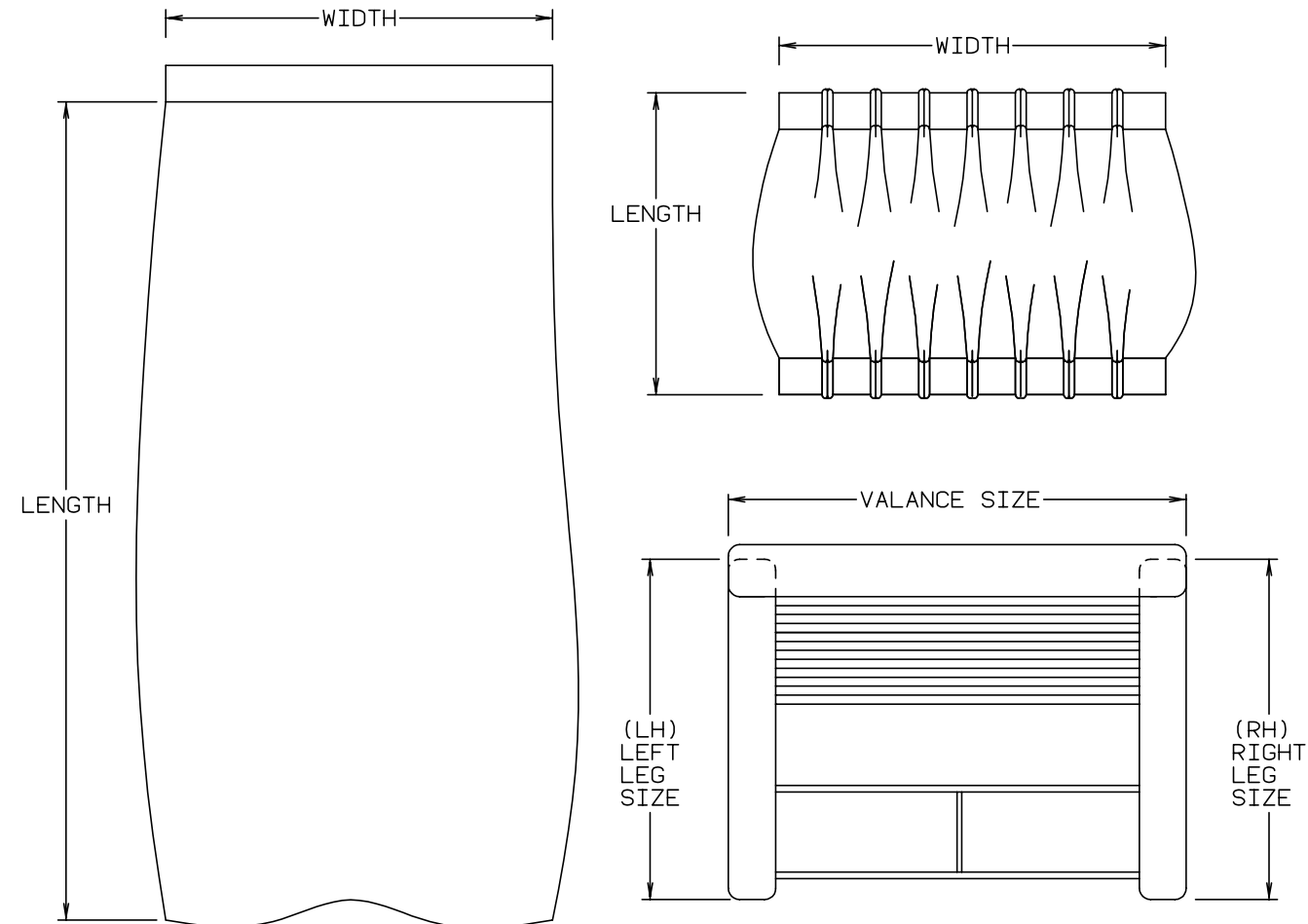

NOTE : USE THIS ILLUSTRATION WHEN DETERMINING LENGTH AND WIDTH MEASUREMENTS FOR CURTAINS. YOU WILL NOTE THE WIDTH MEASUREMENT IS TAKEN ON THE TOP OF THE CURTAIN WITH THE CURTAIN FULLY EXTENDED. THE LENGTH MEASUREMENT IS TAKEN FROM TOP TO BOTTOM. LEFT AND RIGHT WINDOW LEGS ARE DETERMINED WHEN FACING THE WINDOW.

CURTAIN & CUSHION GROUP (CONTINUED)
WINDOW TREATMENT

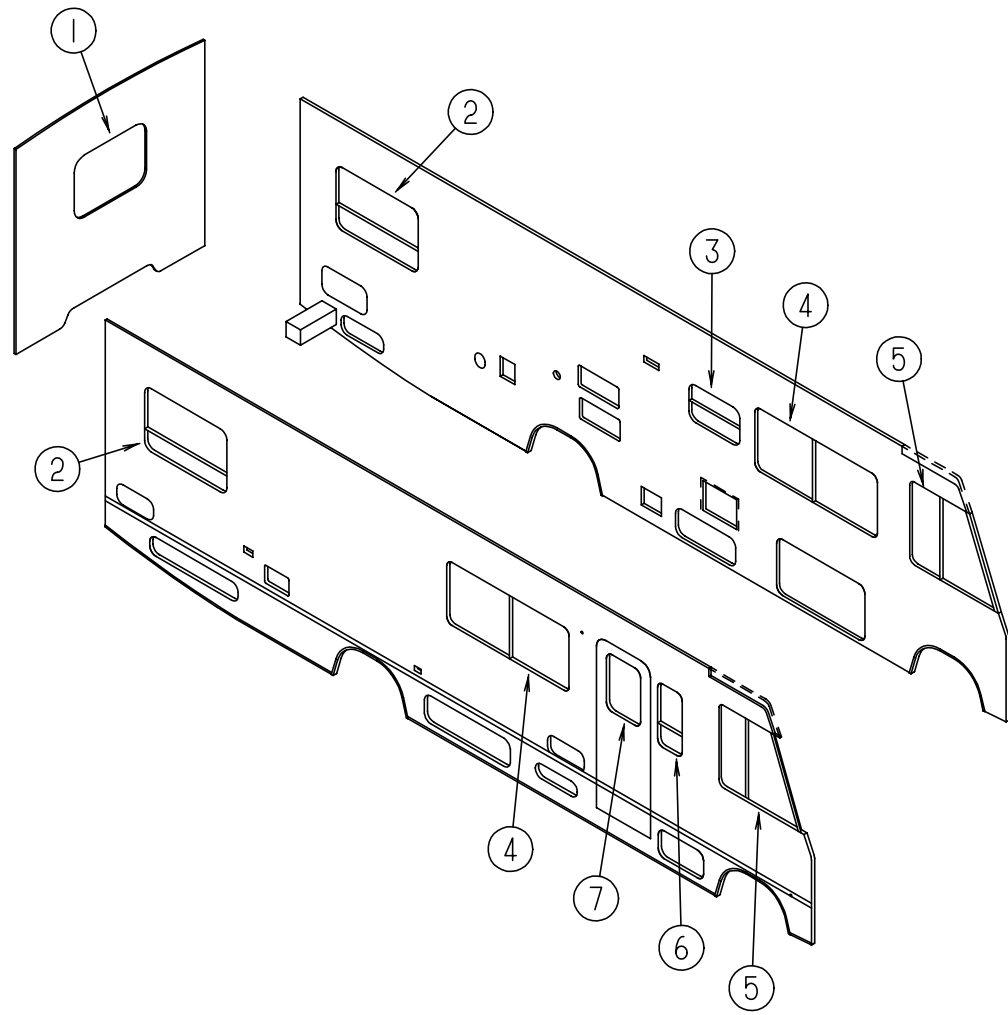

KEY	PART NUMBER	U/M	DESCRIPTION
1	114781-01-F04	EA	VALANCE ASM-SAHARA, 52" - W/O HEADER
1	114781-01-F05	EA	VALANCE ASM-SAHARA, 52" - W/O HEADER
1	114781-01-F06	EA	VALANCE ASM-SAHARA, 52" - W/O HEADER
1	114993-01-F27	EA	VALANCE ASM, 52" - TAILOR (F07)
1	115929-01-F29	EA	VALANCE ASM, 52" - CATALINA (F14)
1	112986-02-F04	EA	CURTAIN - 29.5 X 9, PENCIL PLEAT TOP, POCKET BOTTOM FROM: 00-00-00 THRU: 07-24-94
1	112986-04-F04	EA	CURTAIN - 29.5 X 6, PENCIL PLEAT TOP, POCKET BOTTOM FROM: 07-25-94 THRU: 99-99-99
1	112986-02-F05	EA	CURTAIN - 29.5 X 9, PENCIL PLEAT TOP, POCKET BOTTOM FROM: 00-00-00 THRU: 07-24-94
1	112986-04-F05	EA	CURTAIN - 29.5 X 6, PENCIL PLEAT TOP, POCKET BOTTOM FROM: 07-25-94 THRU: 99-99-99
1	112986-02-F06	EA	CURTAIN - 29.5 X 9, PENCIL PLEAT TOP, POCKET BOTTOM FROM: 00-00-00 THRU: 07-24-94
1	112986-04-F06	EA	CURTAIN - 29.5 X 6, PENCIL PLEAT TOP, POCKET BOTTOM FROM: 07-25-94 THRU: 99-99-99
1	112986-04-F27	EA	CURTAIN - 29.5 X 6, PENCIL PLEAT TOP, POCKET BOTTOM (F07)
1	093475-55-04A	EA	BLIND-MINI, 48 X 28 DROP (F04,F06) FROM: 00-00-00 THRU: 07-24-94
1	093475-68-08A	EA	BLIND-MINI, 48 X 27 DROP (F04,F06) FROM: 07-25-94 THRU: 99-99-99
1	093475-55-03A	EA	BLIND-MINI, 48 X 28 DROP (F05) FROM: 00-00-00 THRU: 07-24-94
1	093475-68-07A	EA	BLIND-MINI, 48 X 27 DROP (F05) FROM: 07-25-94 THRU: 99-99-99
1	093475-68-08A	EA	BLIND-MINI, 48 X 27 DROP (F07)
1	111910-19-F29	EA	BLIND-MINI, 50 X 28 DROP (F14)
2	114781-02-F04	EA	VALANCE ASM-SAHARA, 44" - W/HEADER
2	114781-02-F05	EA	VALANCE ASM-SAHARA, 44" - W/HEADER
2	114781-02-F06	EA	VALANCE ASM-SAHARA, 44" - W/HEADER
2	114993-02-F27	EA	VALANCE ASM, 44" - TAILOR (F07)
2	115929-04-F29	EA	VALANCE ASM, 44" - CATALINA (F14)
2	112986-03-F04	EA	CURTAIN - 31.5 X 9, PENCIL PLEAT TOP, POCKET BOTTOM FROM: 00-00-00 THRU: 07-24-94
2	112986-05-F04	EA	CURTAIN - 31.5 X 6, PENCIL PLEAT TOP, POCKET BOTTOM FROM: 07-25-94 THRU: 99-99-99
2	112986-03-F05	EA	CURTAIN - 31.5 X 9, PENCIL PLEAT TOP, POCKET BOTTOM FROM: 00-00-00 THRU: 07-24-94
2	112986-05-F05	EA	CURTAIN - 31.5 X 6, PENCIL PLEAT TOP, POCKET BOTTOM FROM: 07-25-94 THRU: 99-99-99
2	112986-03-F06	EA	CURTAIN - 31.5 X 9, PENCIL PLEAT TOP, POCKET BOTTOM FROM: 00-00-00 THRU: 07-24-94
2	112986-05-F06	EA	CURTAIN - 31.5 X 6, PENCIL PLEAT TOP, POCKET BOTTOM FROM: 07-25-94 THRU: 99-99-99
2	112986-05-F27	EA	CURTAIN - 31.5 X 9, PENCIL PLEAT TOP, POCKET BOTTOM (F07)
2	114781-03-F04	EA	VALANCE ASM-SAHARA, 44" - W/O HEADER - TWIN BED OPTION
2	114781-03-F05	EA	VALANCE ASM-SAHARA, 44" - W/O HEADER - TWIN BED OPTION
2	114781-03-F06	EA	VALANCE ASM-SAHARA, 44" - W/O HEADER - TWIN BED OPTION
2	114993-03-F07	EA	VALANCE ASM-SAHARA, 44" - W/O HEADER - TWIN BED OPTION
2	115929-06-F29	EA	VALANCE ASM-CATALINA, 44" - TWIN BED OPTION (F14)
2	093475-99-03A	EA	BLIND-MINI, 41 X 28.5 DROP (F04,F06,F07)
2	093475-99-02A	EA	BLIND-MINI, 41 X 28.5 DROP (F05)
2	111910-25-F14	EA	BLIND-MINI, 41 X 28.5 DROP (F14)
2	093475-41-09A	EA	BLIND-MINI, 39 X 26 DROP (F04,F06,F07) - TWIN BED OPTION
2	093475-41-08A	EA	BLIND-MINI, 39 X 26 DROP (F05) - TWIN BED OPTION
2	111910-25-F14	EA	BLIND-MINI, 41 X 28.5 DROP (F14) - TWIN BED OPTION

CURTAIN & CUSHION GROUP (CONTINUED)
WINDOW TREATMENT (CONTINUED)

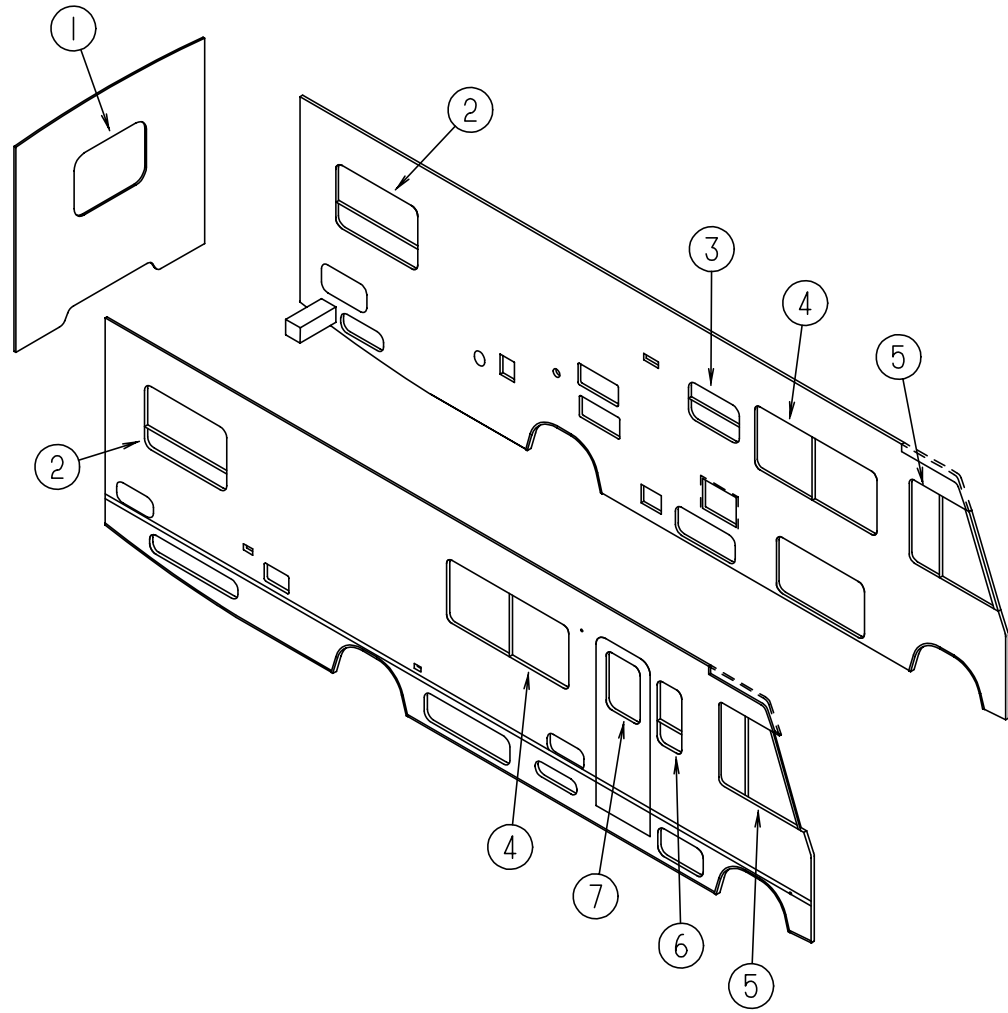

KEY	PART NUMBER	U/M	DESCRIPTION
3	109041-20-02A	EA	BLIND-MINI, 31 X 18 DROP (F04,F06,F07,F14)
3	109041-20-01A	EA	BLIND-MINI, 31 X 18 DROP (F05)
3	109353-07-02A	EA	BLIND-SLAT, 31" (F04,F06,F07,F14)
3	109353-07-01A	EA	BLIND-SLAT, 31" (F05)
3	109353-04-000	EA	CLIP-VALANCE SLAT MOUNTING, CLEAR PLASTIC - PAR
4	105923-19-F04	EA	VALANCE - 63.5" RODEWAY W/BRASS WELT
4	105923-19-F05	EA	VALANCE - 63.5" RODEWAY W/BRASS WELT
4	105923-19-F06	EA	VALANCE - 63.5" RODEWAY W/BRASS WELT
4	105923-36-F07	EA	VALANCE - 63.5" RODEWAY W/BRASS WELT
4	113637-10-F14	EA	VALANCE - 63.5" ROSEANNE W/BRASS WELT
4	109234-29-E08	EA	LEG-RH., 27" - PLAIN - W/O HOLE (F04)
4	109234-29-F05	EA	LEG-RH., 27" - PLAIN - W/O HOLE
4	109234-29-F06	EA	LEG-RH., 27" - PLAIN - W/O HOLE (F06,F14)
4	109234-31-F07	EA	LEG-RH., 27" - PLAIN - W/O HOLE
4	109234-30-E08	EA	LEG-LH., 27" - PLAIN - W/O HOLE (F04)
4	109234-30-F05	EA	LEG-LH., 27" - PLAIN - W/O HOLE
4	109234-30-F06	EA	LEG-LH., 27" - PLAIN - W/O HOLE (F06,F14)
4	109234-32-F07	EA	LEG-LH., 27" - PLAIN - W/O HOLE
4	093475-76-06A	EA	BLIND-MINI, 60 X 28.5 DROP (F04,F06,F07)
4	093475-76-05A	EA	BLIND-MINI, 60 X 28.5 DROP (F05)
4	109802-10-E05	EA	BLIND-MINI, 60 X 28.5 DROP (F14)
5	101668-30-D09	EA	CURTAIN - 38 X 80 TAPE TOP, RH (F04,F06,F07)
5	101668-30-D10	EA	CURTAIN - 38 X 80 TAPE TOP, RH (F05)
5	101668-30-E90	EA	CURTAIN - 38 X 80 TAPE TOP, RH (F14)
5	101668-31-D09	EA	CURTAIN - 38 X 80 TAPE TOP, LH (F04,F06,F07)
5	101668-31-D10	EA	CURTAIN - 38 X 80 TAPE TOP, LH (F05)
5	101668-31-E90	EA	CURTAIN - 38 X 80 TAPE TOP, LH (F14)
5	101668-32-D09	EA	CURTAIN ASM - 40 X 40, TAPE TOP - BUNK OPTION (F04,F06,F07)
5	101668-32-D10	EA	CURTAIN ASM - 40 X 40, TAPE TOP - BUNK OPTION (F05)
5	101668-32-E90	EA	CURTAIN ASM - 40 X 40, TAPE TOP - BUNK OPTION (F14)
5	101668-33-D09	EA	CURTAIN ASM - 38 X 125, TAPE TOP - BUNK OPTION (F04,F06,F07)
5	101668-33-D10	EA	CURTAIN ASM - 38 X 125, TAPE TOP - BUNK OPTION (F05)
5	101668-33-E90	EA	CURTAIN ASM - 38 X 125, TAPE TOP - BUNK OPTION (F14)
5	073260-42-D09	EA	TIEBACK ASM - 6 X 18 (F04,F06,F07)
5	073260-42-D10	EA	TIEBACK ASM - 6 X 18 (F05)
5	073260-42-C18	EA	TIEBACK ASM - 6 X 18 (F14)
6	105923-30-F04	EA	VALANCE - 17", RODEWAY, W/O INSERT
6	105923-30-F05	EA	VALANCE - 17", RODEWAY, W/O INSERT
6	105923-30-F06	EA	VALANCE - 17", RODEWAY, W/O INSERT
6	105923-39-F07	EA	VALANCE - 17", RODEWAY, W/O INSERT
6	113637-11-F14	EA	VALANCE - 17", ROSEANNE W/BRASS WELT
6	109041-30-02A	EA	BLIND-MINI, 15.5 X 33 (F04,F06,F07)
6	109041-30-01A	EA	BLIND-MINI, 15.5 X 33 (F05)
6	109802-41-F14	EA	BLIND-MINI, 15.5 X 33
7	113268-10-F04	EA	VALANCE - 33.75", FLAT W/O INSERT
7	113268-10-F05	EA	VALANCE - 33.75", FLAT W/O INSERT
7	113268-10-F06	EA	VALANCE - 33.75", FLAT W/O INSERT
7	113268-10-F07	EA	VALANCE - 33.75", FLAT W/O INSERT
7	113268-10-F29	EA	VALANCE - 33.75", FLAT W/O INSERT (F14)
7	084755-57-E07	EA	SHADE ASM-PULL, 27.25 - W/O TRIM

CURTAIN & CUSHION GROUP (CONTINUED)

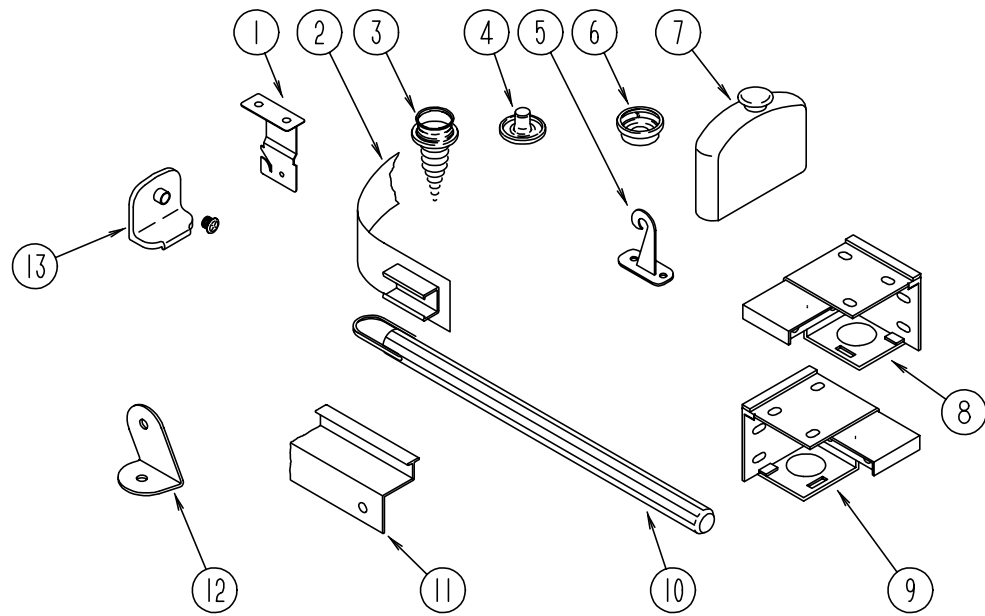

CURTAIN, BLIND HARDWARE & TRACKS

KEY	PART NUMBER	U/M DESCRIPTION
1	084434-01-000	EA BRACKET-MOUNTING, ROLLER SHADE - 1 3/8"
2	101031-01-000	YD TAPE-GLIDE, CURTAIN - 4.25" SPACING
3	029130-01-000	EA SCREW-SNAP SOCKET, #8 PH X 5/8"
3	029130-03-000	EA SCREW-SNAP SOCKET, #8 PH X 1"
4	029155-01-000	EA CAP-SNAP, 5/32" O.D. OF PIN
5	109441-01-000	EA HOLD DOWN-BLIND, HOOK
6	029156-01-000	EA SOCKET-SNAP, 9/16" O.D.
7	093475-01-701	EA END CAP-BLIND, W/STUD
8	083170-01-000	EA BRACKET-BLIND, LEFT SIDE WHEN FACING WINDOW
9	083170-02-000	EA BRACKET-BLIND, RIGHT SIDE WHEN FACING WINDOW
10	093475-01-700	EA WAND-BLIND, W/METAL CLIP - 8" LONG
11	105450-01-01A	EA TRACK-CURTAIN, 30.8" LONG - ALUMINUM - OFF WHITE
12	099205-02-02A	EA BRACKET-WRAPAROUND O/W
13	106544-01-000	EA PULL-SHADE,BRASS
	106544-01-001	EA SCREW-BRASS,SHADE
	046867-01-000	EA GROMMET-BRASS - 7/16" ID X 1" OD
	048394-02-000	YD VELCRO TAPE-HOOK, ADHESIVE BACK - .75" WIDE - BEIGE
	075943-09-000	EA BRACE-VALANCE,O/WHT 8.00 IN
	088792-01-000	YD VELCRO-HOOK, .75" WIDE - BEIGE
	088792-02-000	YD VELCRO TAPE-LOOP, ADHESIVE BACKED - .75" WIDE - BEIGE
	089522-02-000	EA PANEL-LEG, TWO SIDED 31.5" LONG - PLASTIC - BLACK LEFT SIDE
	096843-01-000	EA SPRING-REWIND, ROLLER SHADE
	101589-02-C05	EA TRACK ASM-CURTAIN,WRAPAROUND
	105324-01-01A	EA TRACK-CURTAIN, WRAPAROUND O/W
	105324-02-01A	EA TRACK-CURTAIN, WRAPAROUND - PASSENGER SIDE - OFF WHITE
	105324-03-01A	EA TRACK-CURTAIN, WRAPAROUND - DRIVER SIDE - OFF WHITE
	086276-01-000	EA TAPE-DOUBLE SIDED, 1/2"
	056003-01-000	EA BRACKET-DRAPERY RETAINING, FRONT - METAL
	056003-02-000	EA BRACKET-DRAPERY RETAINING, REAR - METAL
	109441-02-000	EA HOLD DOWN-SPACER

CURTAIN & CUSHION GROUP (CONTINUED)

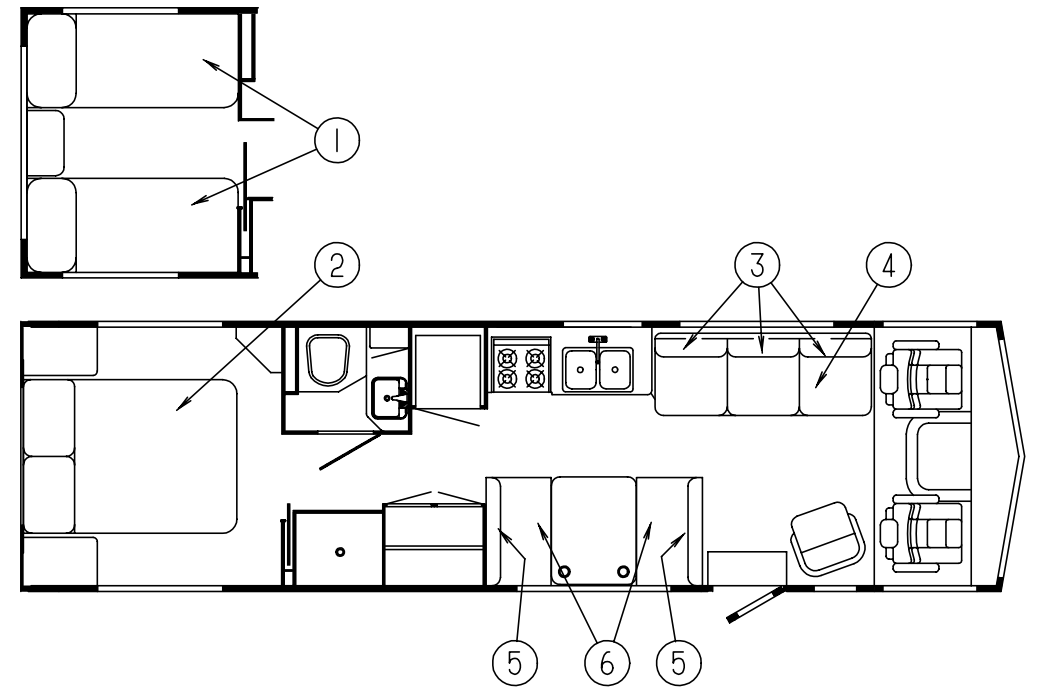

TWIN MATTRESS & BEDSPREAD

KEY	PART NUMBER	U/M DESCRIPTION
1	101123-07-000	EA MATTRESS COMPLETE-FOAM 32 X 79
1	P01123-07-000	EA COVER-MATTRESS, 32 X 79 - FOAM
1	085365-17-E08	EA BEDSPREAD - 33 X 80, THROW W/ROUND CORNER (F04)
1	085365-17-E30	EA BEDSPREAD - 33 X 80, THROW W/ROUND CORNER (F05)
1	085365-17-F06	EA BEDSPREAD - 33 X 80, THROW W/ROUND CORNER
1	085365-17-F27	EA BEDSPREAD - 33 X 80, THROW W/ROUND CORNER (F07)
1	085365-17-F32	EA BEDSPREAD - 33 X 80, THROW W/ROUND CORNER (F14)
	111862-03-F04	EA PILLOW - 15 X 15 ACCENT W/.5"MAIN
	111862-03-F05	EA PILLOW - 15 X 15 ACCENT W/.5"MAIN
	111862-03-F06	EA PILLOW - 15 X 15 ACCENT W/.5"MAIN
	111862-03-F27	EA PILLOW - 15 X 15 ACCENT W/.5"MAIN (F07)
	111862-04-F32	EA PILLOW - 15 X 15 ACCENT W/.5"MAIN (F14)

QUEEN MATTRESS & BEDSPREAD

KEY	PART NUMBER	U/M DESCRIPTION
2	101123-08-000	EA MATTRESS COMPLETE-FOAM 60 X 75
2	P01123-08-000	EA COVER-MATTRESS, 60 X 75 - FOAM
2	085365-19-E08	EA BEDSPREAD - 60 THROW, W/1" GATHERED WELT (F04)
2	085365-19-F05	EA BEDSPREAD - 60 THROW, W/1" GATHERED WELT
2	085365-19-F06	EA BEDSPREAD - 60 THROW, W/1" GATHERED WELT
2	085365-19-F27	EA BEDSPREAD - 60 THROW, W/1" GATHERED WELT (F07)
2	085365-19-F32	EA BEDSPREAD - 60 THROW, W/1" GATHERED WELT (F14)
	111863-01-E08	EA PILLOW SHAM - 1/2" GATHERED WELT (F04)
	111863-01-F05	EA PILLOW SHAM - 1/2" GATHERED WELT
	111863-01-F06	EA PILLOW SHAM - 1/2" GATHERED WELT
	111863-01-F27	EA PILLOW SHAM - 1/2" GATHERED WELT (F07)
	102161-22-F32	EA PILLOW SHAM - 1/2" GATHERED WELT (F14)

CURTAIN & CUSHION GROUP (CONTINUED)

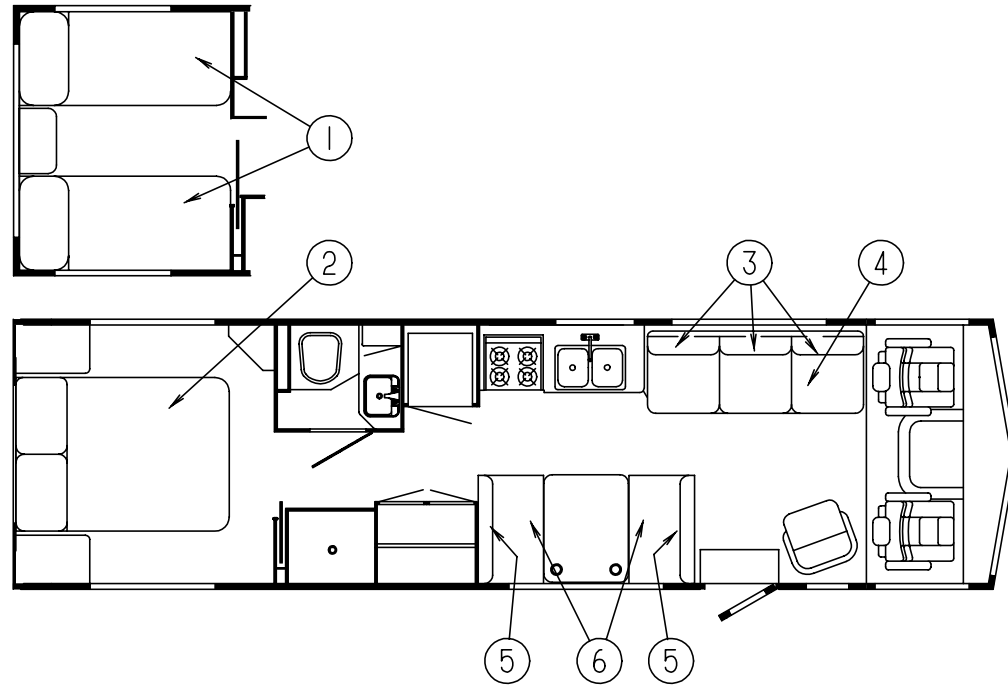

COUCH

KEY	PART NUMBER	U/M DESCRIPTION
3	111319-01-E08	EA BED ASM-JACK KNIFE BACK,KNIFE EDGE, 74 (F04)
3	111319-01-F05	EA BED ASM-JACK KNIFE BACK,KNIFE EDGE, 74
3	111319-01-F06	EA BED ASM-JACK KNIFE BACK,KNIFE EDGE, 74
3	111319-01-FA6	EA BED ASM-JACK KNIFE BACK,KNIFE EDGE, 74 (F06) FROM: 00-00-00 THRU: 09-18-94
3	111319-05-F07	EA BED ASM-JACK KNIFE BACK,KNIFE EDGE, 74 FROM: 09-19-94 THRU: 99-99-99
3	112104-01-F29	EA BED ASM-JACK KNIFE BACK,KNIFE EDGE, 74 (F14)
3	P11319-01-E08	EA COVER-BED, JACK KNIFE KNIFE EDGE BACK, 74 (F04)
3	P11319-01-F05	EA COVER-BED, JACK KNIFE KNIFE EDGE BACK, 74
3	P11319-01-F06	EA COVER-BED, JACK KNIFE KNIFE EDGE BACK, 74
3	P11319-01-FA6	EA COVER-BED, JACK KNIFE KNIFE EDGE BACK, 74 (F06) FROM: 00-00-00 THRU: 09-18-94
3	P11319-05-F07	EA COVER-BED, JACK KNIFE KNIFE EDGE BACK, 74 FROM: 09-19-94 THRU: 99-99-99
3	P12104-01-F29	EA COVER-BED, JACK KNIFE KNIFE EDGE BACK, 74 (F14)
4	100032-43-E08	EA BED-JACK KNIFE, SEAT - 74" TUCK - W/O ARMS (F04)
4	100032-43-F05	EA BED-JACK KNIFE, SEAT - 74" TUCK - W/O ARMS
4	100032-43-F06	EA BED-JACK KNIFE, SEAT - 74" TUCK - W/O ARMS
4	100032-43-FA6	EA BED-JACK KNIFE, SEAT - 74" TUCK - W/O ARMS (F06) FROM: 00-00-00 THRU: 09-18-94
4	100032-49-F07	EA BED-JACK KNIFE, SEAT - 74" TUCK - W/O ARMS FROM: 09-19-94 THRU: 99-99-99
4	100032-49-F07	EA BED-JACK KNIFE, SEAT - 74" TUCK - W/O ARMS
4	100032-43-F29	EA BED-JACK KNIFE, SEAT - 74" TUCK - W/O ARMS (F14)
4	P00032-43-E08	EA COVER-JACK KNIFE SEAT, 74" TUCK - W/O ARM (F04)
4	P00032-43-F05	EA COVER-JACK KNIFE SEAT, 74" TUCK - W/O ARM
4	P00032-43-F06	EA COVER-JACK KNIFE SEAT, 74" TUCK - W/O ARM
4	P00032-43-FA6	EA COVER-JACK KNIFE SEAT, 74" TUCK - W/O ARM (F06) FROM: 00-00-00 THRU: 09-18-94
4	P00032-49-F07	EA COVER-JACK KNIFE SEAT, 74" TUCK - W/O ARM FROM: 09-19-94 THRU: 99-99-99
4	P00032-43-F29	EA COVER-JACK KNIFE SEAT, 74" TUCK - W/O ARM (F14)
	101085-04-000	EA FRAME-SEAT, 74.75"
	101085-06-000	EA FRAME-BASE, 74.75"
	101085-10-000	EA FRAME - 74.5 X 16 BACK FRAME JACKKNIFE

**CURTAIN & CUSHION GROUP (CONTINUED)
COUCH (CONTINUED)**

KEY	PART NUMBER	U/M DESCRIPTION
	111637-02-F04	EA PILLOW ASM - 22 X 22, KNIFE EDGE W/WELT
	111637-02-F05	EA PILLOW ASM - 22 X 22, KNIFE EDGE W/WELT
	111637-02-F06	EA PILLOW ASM - 22 X 22, KNIFE EDGE W/WELT
	111637-02-F07	EA PILLOW ASM - 22 X 22, KNIFE EDGE W/WELT
	111637-02-F32	EA PILLOW ASM - 22 X 22, KNIFE EDGE W/WELT (F14)

NOTE: COUCH FRONT AND SIDE PANELS ARE FOUND IN THE LOUNGE GROUP

DINETTE CUSHIONS

KEY	PART NUMBER	U/M DESCRIPTION
5	111897-04-F04	EA CUSHION - 13.5 X 38 X 5 CLUB BACK
5	111897-04-F05	EA CUSHION - 13.5 X 38 X 5 CLUB BACK
5	111897-04-F06	EA CUSHION - 13.5 X 38 X 5 CLUB BACK
5	111897-08-F07	EA CUSHION - 13.5 X 38 X 5 CLUB BACK
5	111897-04-F14	EA CUSHION - 13.5 X 38 X 5 CLUB BACK
5	P11897-04-F04	EA COVER - 13.5 X 38 X 5 CLUB BACK
5	P11897-04-F05	EA COVER - 13.5 X 38 X 5 CLUB BACK
5	P11897-04-F06	EA COVER - 13.5 X 38 X 5 CLUB BACK
5	P11897-08-F07	EA COVER - 13.5 X 38 X 5 CLUB BACK
5	P11897-04-F14	EA COVER - 13.5 X 38 X 5 CLUB BACK
5	078155-01-000	EA STRAP-SNAP, BACKREST CUSHION
6	088927-87-E08	EA CUSHION - 23 X 38 X 5, DINETTE SEAT (F04)
6	088927-87-F05	EA CUSHION - 23 X 38 X 5, DINETTE SEAT
6	088927-87-F06	EA CUSHION - 23 X 38 X 5, DINETTE SEAT
6	105603-03-F07	EA CUSHION - 23 X 38 X 5, DINETTE SEAT
6	088927-87-F32	EA CUSHION - 23 X 38 X 5, DINETTE SEAT (F14)
6	M88927-87-E08	EA COVER - 23 X 38 X 5, DINETTE SEAT (F04)
6	M88927-87-F05	EA COVER - 23 X 38 X 5, DINETTE SEAT
6	M88927-87-F06	EA COVER - 23 X 38 X 5, DINETTE SEAT
6	P05603-03-F07	EA COVER - 23 X 38 X 5, DINETTE SEAT
6	M88927-87-F32	EA COVER - 23 X 38 X 5, DINETTE SEAT (F14)

BUNK CUSHION

KEY	PART NUMBER	U/M DESCRIPTION
	081717-03-E07	EA BED ASM-BUNK, FRONT
	079145-06-000	EA CUSHION-BUNK, 30" X 77" X 4"
	M79145-06-000	EA COVER-CUSHION, BUNK
	102695-08-000	YD TAPE-CARPET BIND, #481 BROWN
	102695-11-000	YD TAPE-CART BIND, MATTRESS - 3/4" WIDE - LIGHT TAN
	102695-12-000	YD TAPE-CART BIND,#474 LIGHT TAN - ESHCO 1 1/4"

CURTAIN & CUSHION GROUP (CONTINUED)

DRIVER & PASSENGER BUCKET SEATS

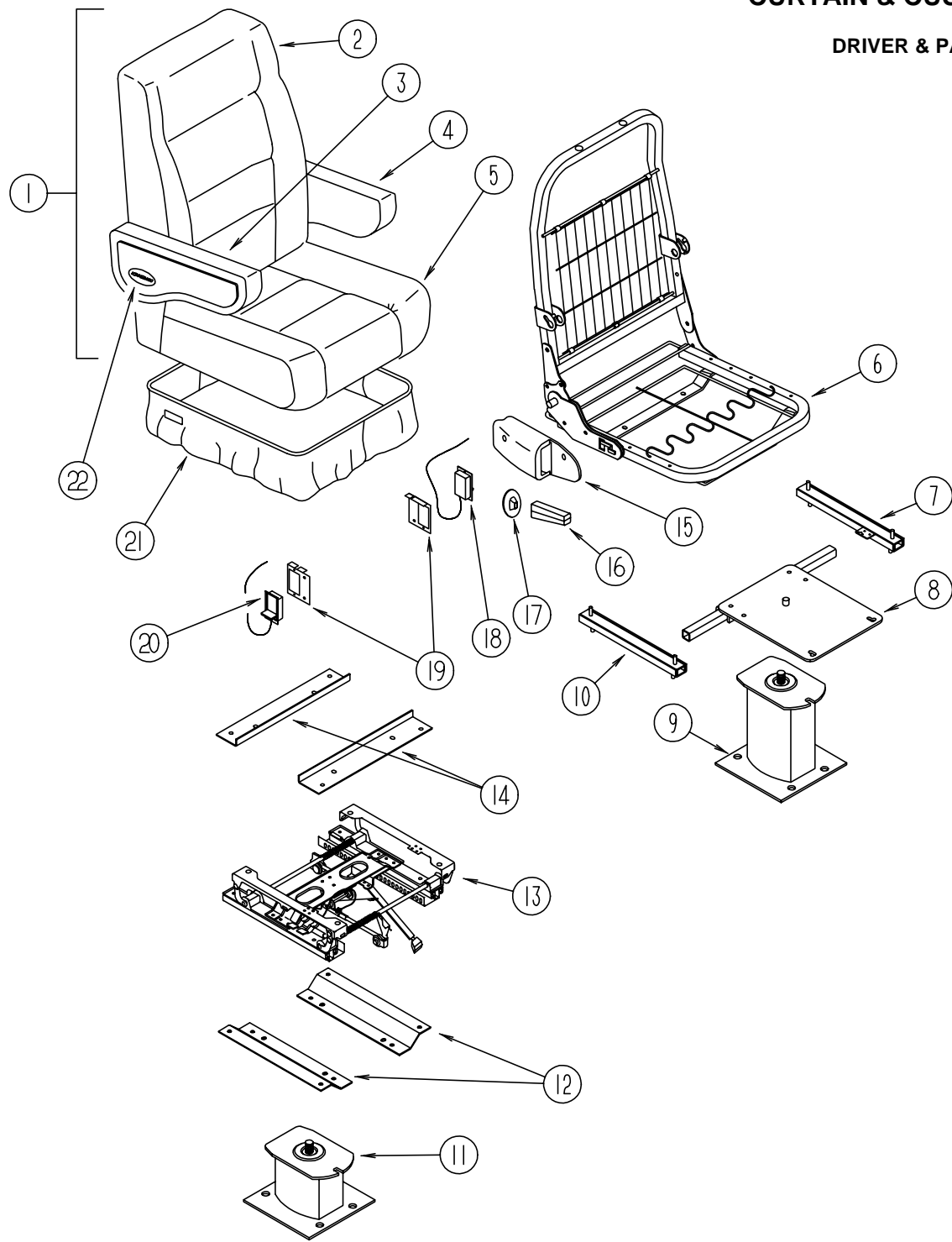

KEY	PART NUMBER	U/M DESCRIPTION
3	111320-03-F06	EA ARMREST-RIGHT, BUCKET SEAT (F06,F07,F14)
	P11320-03-E08	EA COVER-ARMREST, RIGHT (F04)
	P11320-03-F05	EA COVER-ARMREST, RIGHT (F05)
	P11320-03-F06	EA COVER-ARMREST, RIGHT (F06,F07,F14)
4	111320-04-E08	EA ARMREST-LEFT, BUCKET SEAT (F04)
4	111320-04-F05	EA ARMREST-LEFT, BUCKET SEAT (F05)
4	111320-04-F06	EA ARMREST-LEFT, BUCKET SEAT (F06,F07,F14)
	P11320-04-E08	EA COVER-ARMREST, LEFT (F04)
	P11320-04-F05	EA COVER-ARMREST, LEFT (F05)
	P11320-04-F06	EA COVER-ARMREST, LEFT (F06,F07,F14)
5	M05962-06-F04	EA COVER-SEAT, BUCKET SEAT
5	M05962-06-F05	EA COVER-SEAT, BUCKET SEAT
5	M05962-04-F29	EA COVER-SEAT, BUCKET SEAT (F06,F07,F14)
6	M80906-11-000	EA FRAME-SEAT, BACK & SPRING
7	069246-05-000	EA ADJUSTER-BUCKET SEAT W/LOCK, FORWARD & BACK
		FROM: 00-00-00 THRU: 10-16-94
	069246-05-700	EA SPRING-ADJUSTER, FOR REMOTE
		FROM: 00-00-00 THRU: 10-16-94
	069246-05-701	EA CLIP-CABLE, FOR REMOTE
		FROM: 00-00-00 THRU: 10-16-94
7	069246-14-000	EA ADJUSTER-BUCKET SEAT W/LOCK & BLUE SPRING, FORWARD & BACK
		FROM: 10-17-94 THRU: 99-99-99
	069246-99-000	EA SPRING-BUCKET SEAT ADJUSTER, BLUE
		FROM: 10-17-94 THRU: 99-99-99
	117125-01-02B	EA BRACKET-CABLE MOUNT, ADJUSTER W/LOCK - STEEL - E-COAT
		FROM: 10-17-94 THRU: 99-99-99
8	107921-05-000	EA PLATE-TOP, W/SEAT BELT BAR
9	107921-01-000	EA PLATE-SUB, FLOOR MOUNTED PEDESTAL - W/9.75" EXTENSION
	107921-06-000	EA BEARING KIT-SEAT SWIVEL
10	069246-02-000	EA ADJUSTER-SLIDE, FORWARD AND BACK
		FROM: 00-00-00 THRU: 10-16-94
10	069246-15-000	EA ADJUSTER-SLIDE, FORWARD AND BACK
		FROM: 10-17-94 THRU: 99-99-99
11	107921-07-000	EA BASE-FLOOR MOUNTED PEDESTAL, 4.5" - MANUAL SEAT OPTION
		FROM: 00-00-00 THRU: 09-18-94
11	107921-14-000	EA BASE-FLOOR MOUNTED PEDESTAL, 5.75" - MANUAL SEAT OPTION
		FROM: 09-19-94 THRU: 99-99-99
12	116215-03-000	EA PLATE-LOWER, MANUAL - 6-WAY - ATWOOD 83835 - MANUAL SEAT OPTION
13	116215-01-000	EA SEAT-MANUAL, 6-WAY - DRIVER - ATWOOD 83805 - MANUAL SEAT OPTION
14	116215-02-000	EA PLATE-UPPER, MANUAL - 6-WAY - ATWOOD 85118 - MANUAL SEAT OPTION
15	080730-09-000	EA SHIELD-RECLINER HANDLE
16	080730-08-000	EA HANDLE-RECLINER, BLACK
17	080730-11-000	EA SHIELD-RUBBER BOOT
18	089368-04-000	EA CABLE-SLIDE, W/SWITCH
		FROM: 00-00-00 THRU: 10-16-94
18	108049-01-000	EA CABLE W/SWITCH - 28", F/FLEXSTEEL PEDESTAL
		FROM: 10-17-94 THRU: 99-99-99
	108049-02-000	EA CLIP-CABLE, PEDESTAL
		FROM: 10-17-94 THRU: 99-99-99
19	097683-03-000	EA BRACKET-REMOTE, SIDE MOUNT - SINGLE
20	108049-01-000	EA CABLE W/SWITCH - 28", F/FLEXSTEEL PEDESTAL
	108049-02-000	EA CLIP-CABLE, PEDESTAL
21	071126-43-E08	EA SKIRT-BUCKET SEAT (F04)
21	071126-43-F05	EA SKIRT-BUCKET SEAT (F05)
21	071126-43-F06	EA SKIRT-BUCKET SEAT (F06,F07,F14)
21	071126-54-F04	EA SKIRT-BUCKET SEAT (F04) - MANUAL SEAT OPTION
21	071126-54-F05	EA SKIRT-BUCKET SEAT (F05) - MANUAL SEAT OPTION
21	071126-54-F06	EA SKIRT-BUCKET SEAT (F06,F07,F14) - MANUAL SEAT OPTION
22	111169-01-000	EA PLATE-BACK, ARMREST
22	111169-02-000	EA INSERT-ARMREST, OVAL DECAL - WINNEBAGO
	007221-01-000	EA SPACER-SEAT, ADJUSTER
	089323-01-000	FT STRIP-POLYENTHYLENE, J-CHANNEL - FLEX-O-LATORS
	114889-01-000	EA STOP BAR-UNIVERSAL, SHROCK

KEY	PART NUMBER	U/M DESCRIPTION
1	112103-04-F04	EA SEAT-BUCKET, W/ARMRESTS - W/O SKIRT
1	112103-04-F05	EA SEAT-BUCKET, W/ARMRESTS - W/O SKIRT
1	112103-04-F06	EA SEAT-BUCKET, W/ARMRESTS - W/O SKIRT (F06,F07,F14)
1	112103-06-F04	EA SEAT-BUCKET, W/ARMRESTS - W/O SKIRT - MANUAL SEAT OPTION
1	112103-06-F05	EA SEAT-BUCKET, W/ARMRESTS - W/O SKIRT - MANUAL SEAT OPTION
1	112103-06-F06	EA SEAT-BUCKET, W/ARMRESTS - W/O SKIRT - MANUAL SEAT OPTION (F06,F07,F14)
2	M05962-09-F04	EA COVER-BACK, BUCKET SEAT
2	M05962-09-F05	EA COVER-BACK, BUCKET SEAT
2	M05962-09-F06	EA COVER-BACK, BUCKET SEAT (F06,F07,F14)
3	111320-03-E08	EA ARMREST-RIGHT, BUCKET SEAT (F04)
3	111320-03-F05	EA ARMREST-RIGHT, BUCKET SEAT (F05)

CURTAIN & CUSHION GROUP (CONTINUED)

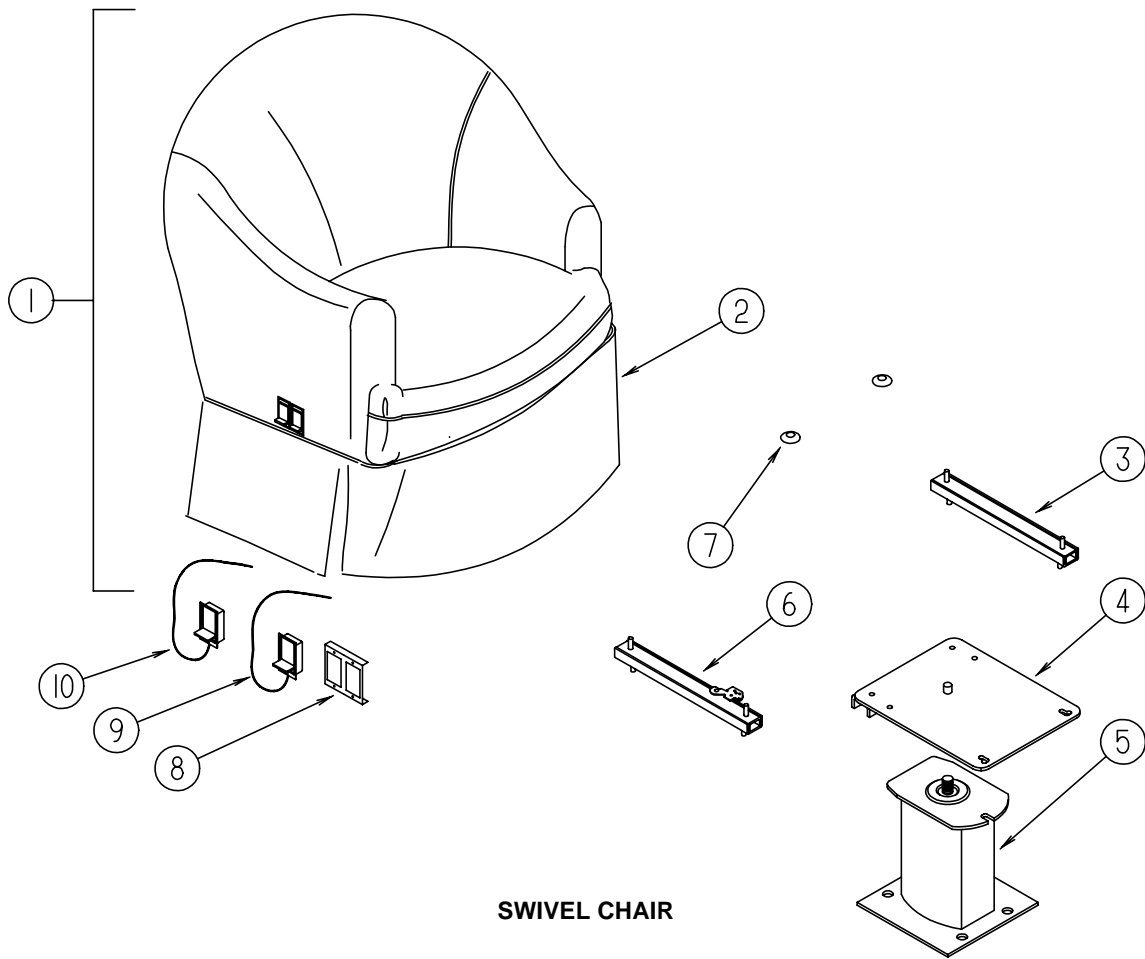

SWIVEL CHAIR

KEY	PART NUMBER	U/M DESCRIPTION
1	107957-01-F04	EA CHAIR-SWIVEL, W/O SKIRT
1	107957-01-F05	EA CHAIR-SWIVEL, W/O SKIRT
1	107957-01-E28	EA CHAIR-SWIVEL, W/O SKIRT (F06)
1	107957-04-F07	EA CHAIR-SWIVEL, W/O SKIRT
1	116016-01-F32	EA CHAIR-SWIVEL, RECLINER (F14)
	P07957-01-F04	EA COVER-SWIVEL CHAIR
	P07957-01-F05	EA COVER-SWIVEL CHAIR
	P07957-01-E28	EA COVER-SWIVEL CHAIR (F06)
	P07957-04-F07	EA COVER-SWIVEL CHAIR
	P16016-01-F32	EA COVER-SWIVEL CHAIR, RECLINER (F14)
2	107977-01-F04	EA SKIRT-SWIVEL CHAIR
2	107977-01-F05	EA SKIRT-SWIVEL CHAIR
2	107977-01-E28	EA SKIRT-SWIVEL CHAIR (F06)
2	107977-01-F07	EA SKIRT-SWIVEL CHAIR
3	069246-06-000	EA ADJUSTER-SWIVEL CHAIR, FORWARD & BACK
4	107921-08-000	EA PLATE-TOP, W/O SEAT BELT BAR
	107921-06-000	EA BEARING KIT-SEAT SWIVEL
5	107921-01-000	EA PLATE-SUB, FLOOR MOUNTED PEDESTAL - W/9.75" EXTENSION
6	069246-08-000	EA ADJUSTER-SWIVEL CHAIR, REMOTE - FORWARD & BACK
7	007221-01-000	EA SPACER-SEAT, ADJUSTER
8	097683-02-000	EA BRACKET-MOUNT, REMOTE
9	108049-01-000	EA CABLE W/SWITCH - 28", F/FLEXSTEEL PEDESTAL
	108049-02-000	EA CLIP-CABLE, PEDESTAL
10	089368-04-000	EA CABLE-SLIDE, W/SWITCH

CURTAIN & CUSHION GROUP (CONTINUED)
BUTTON, TRIM, ASSIST HANDLE & SEAT BELT

KEY	PART NUMBER	U/M DESCRIPTION
	070578-02-B29	EA BUTTON-SCREW, STUD - #30 - VINYL
	070578-11-B18	EA BUTTON-SCREW, STUD - #30 - VINYL
	079349-04-E08	YD WELT ASM-NARROW, ACCENT (F04)
	079349-04-F05	YD WELT ASM-NARROW, ACCENT
	079349-04-E22	YD WELT ASM-NARROW, ACCENT (F06,F07,F14)
	057759-01-000	EA WASHER BRACKET-SEAT BELT, 4" DIAMETER
	007021-01-000	EA BELT-SEAT, 2" X 90" - BLACK
	056271-02-000	EA BELT-SEAT, 2" X 72" - BLACK
	069178-02-000	EA BRACKET-MOUNTING, ASSIST HANDLE - L ANGLE - W/HOLES - STEEL
	053552-02-AA8	EA HANDLE-ASSIST, INTERIOR - ENTRY DOOR - VINYL - OFF WHITE
	057534-01-000	EA TIEBACK/TIEDOWN-BED/CURTAIN/DOOR, 6" - PLASTIC - CLEAR

FABRICS

KEY	PART NUMBER	U/M DESCRIPTION
	079680-07-000	YD FABRIC-VINYL, 54" WIDE - BEIGE
	087272-03-000	YD DRAPERY LINING-54" IVORY, ROCKLAND MILLS
	089351-03-000	YD VINYL-CEILING, DIAMOND DESIGN - 54" WIDE
	103907-01-01A	YD FABRIC-VINYL, 54" WIDE - OFF WHITE
	096008-85-000	YD FABRIC-UPHOLSTERY/CURTAIN, PLAIN VELOUR - 54" WIDE
	106569-02-04A	EA VINYL-LAMINATE CAMBRIDGE BIS, 1/4" X 16" X 96
	108446-35-000	YD FABRIC-UPHOLSTERY, COLLISION - SESAME - JOAN FABRICS - MAIN (F04)
	108446-A6-000	YD FABRIC-UPHOLSTERY, CAPE COD - 685 - MAIN (F05)
	108446-A7-000	YD FABRIC-UPHOLSTERY, DECO - JASPER - MAIN (F06)
	108446-D9-000	YD FABRIC-UPHOLSTERY, GRECO - JASPER - MAIN (F06)
	108446-D2-000	YD FABRIC-UPHOLSTERY, DOBLIN/CONFETTI - 9435 - MAIN (F07)
	108446-C8-000	YD FABRIC-UPHOLSTERY, CANASTA STONE - MAIN (F14)
	104233-59-000	YD FABRIC-UPHOLSTERY, 325 CASHMERE - ALBANY 1418 - PLAIN ACCENT (F04)
	108446-A9-000	YD FABRIC-UPHOLSTERY, PREMEIR 685 - PLAIN ACCENT (F05)
	108446-55-000	YD FABRIC-UPHOLSTERY, ALBANY - 350 WHEAT - PLAIN ACCENT (F06,F07)
	108446-A5-000	YD FABRIC-UPHOLSTERY, FUSION - HAZEL - JOAN FABRICS - PATTERN ACCENT (F04)
	108446-B0-000	YD FABRIC-UPHOLSTERY, HARBOR - 685 MARINE - PATTERN ACCENT (F05)
	108446-57-000	YD FABRIC-UPHOLSTERY, CELTIC - CASHMERE - PATTERN ACCENT (F06)
	108446-D6-000	YD FABRIC-UPHOLSTERY, MASTERCRAFT - PATTERN ACCENT (F07)
	105745-28-000	YD FABRIC-BEDSPREAD, SAHARA - SAUTERNE - AMETEX - MAIN (F04)
	105745-65-000	YD FABRIC-BEDSPREAD, CITEAUX - WINDSOR - MAIN (F05)
	105745-83-000	YD FABRIC-BEDSPREAD, MACON - ONYX - MAIN (F06)
	105745-96-000	YD FABRIC-BEDSPREAD, RICHLOOM/HERALD SQUARE - WEDGEWOOD - MAIN (F07)
	105745-93-000	YD FABRIC-BEDSPREAD, DOVER-F SUNTAN - MAIN (F14)
	105745-63-000	YD FABRIC-BEDSPREAD, RADIANCE - TOAST - ACCENT (F04,F06)
	105745-64-000	YD FABRIC-BEDSPREAD, RADIANCE - SLATE - ACCENT (F05)
	105745-97-000	YD FABRIC-BEDSPREAD, RICHLOOM/FRANK - MULTI - ACCENT (F07)
	105745-92-000	YD FABRIC-BEDSPREAD, DANIELLE-F SUNTAN - ACCENT (F14)
	072333-90-000	YD FABRIC-CURTAIN, 54" WIDE - TAN (F04,F06,F07)
	072333-82-000	YD FABRIC-CURTAIN, 54" WIDE - BEIGE (F05)

DINETTE GROUP

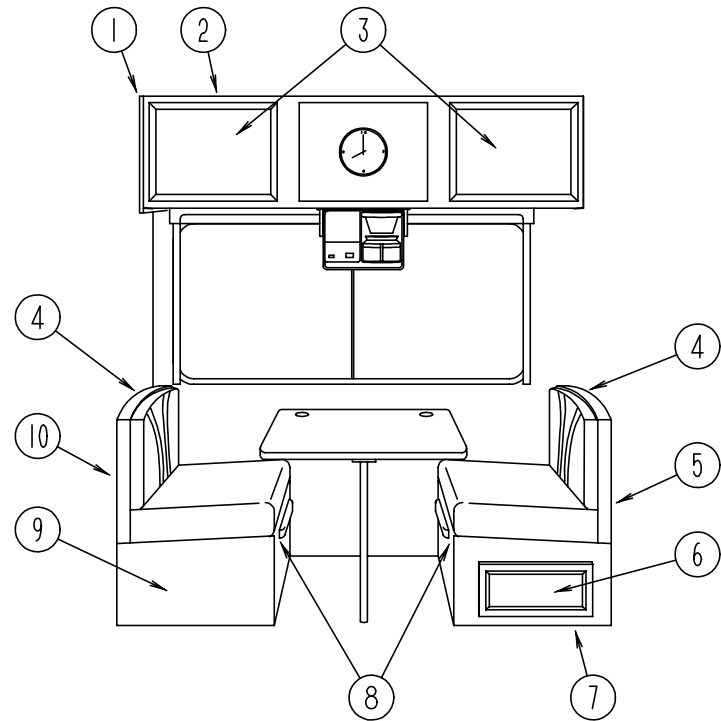

DINETTE CABINETRY

KEY	PART NUMBER	U/M DESCRIPTION
1	103128-02-E10	EA END CAP ASM, OVERHEAD
2	113881-01-F04	EA CABINET ASM-OVHD DINETTE
2	113881-01-F05	EA CABINET ASM-OVHD DINETTE
2	113881-01-F06	EA CABINET ASM-OVHD DINETTE
2	113881-01-F07	EA CABINET ASM-OVHD DINETTE
2	113881-01-F14	EA CABINET ASM-OVHD DINETTE
3	M06803-02-E07	EA DOOR ASM-W/O HARDWARE - 400 X 710 (F04,F05,F06,F07)
3	M06803-82-F14	EA DOOR ASM-W/O HARDWARE - 400 X 710 (F14)
4	104787-01-E08	EA PAD ASM-DINETTE (F04,F07)
4	104787-01-F05	EA PAD ASM-DINETTE
4	104787-01-F06	EA PAD ASM-DINETTE
4	104787-03-F06	EA PAD ASM-DINETTE (F14)
5	M04174-68-F04	EA CABINET-SEATBACK RH
6	M06803-07-E07	EA DOOR ASM-W/O HARDWARE - 255 X 485 (F04,F05,F06,F07)
6	M06803-07-F14	EA DOOR ASM-W/O HARDWARE - 255 X 485 (F14)
7	M04175-68-F04	EA CABINET-SEATBASE RH
8	081295-01-AA8	EA SUPPORT-BED, DINETTE, 712 LG
9	M04175-69-F04	EA CABINET-SEATBASE LH
10	M04174-69-F04	EA CABINET-SEATBACK LH

DINETTE GROUP (CONTINUED)

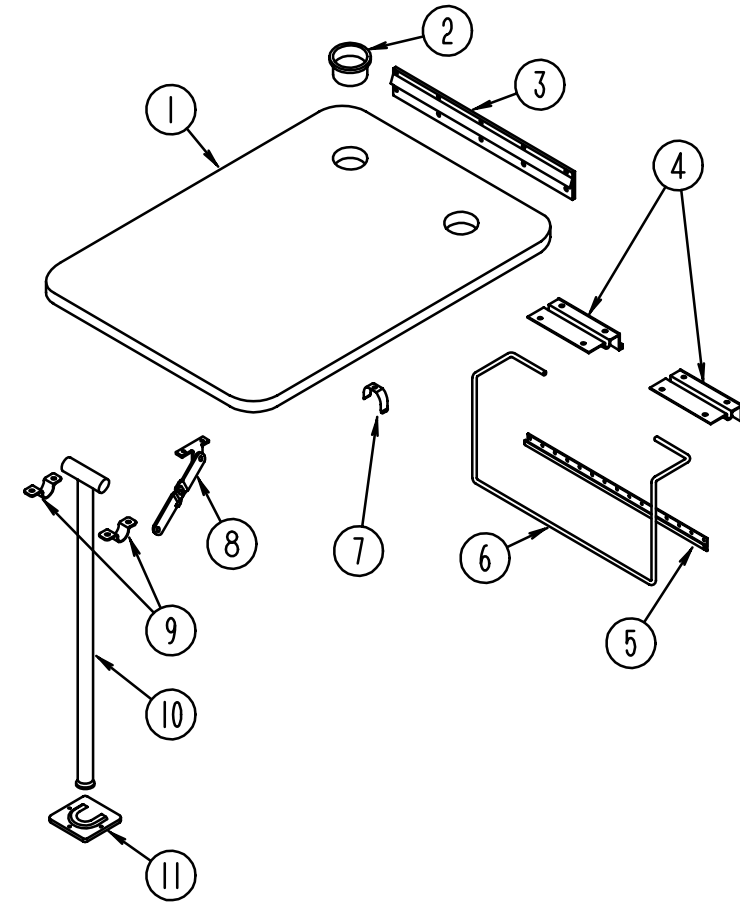

DINETTE TABLE

KEY	PART NUMBER	U/M DESCRIPTION
1	M81299-06-E08	EA TABLE-DINETTE, W/O EDGE BAND OR HARDWARE (F04)
1	M81299-06-F05	EA TABLE-DINETTE, W/O EDGE BAND OR HARDWARE
1	M81299-06-F06	EA TABLE-DINETTE, W/O EDGE BAND OR HARDWARE
1	M81299-06-E28	EA TABLE-DINETTE, W/O EDGE BAND OR HARDWARE (F07)
1	M81299-06-F14	EA TABLE-DINETTE, W/O EDGE BAND OR HARDWARE
2	064781-06-000	EA HOLDER-CUP, TWO STEP - OFF WHITE
3	053200-12-000	EA SUPPORT-TABLE, 23.5" - BEIGE
4	088410-02-000	EA BRACKET-LIFT, TABLE MOUNTED - OFF WHITE
5	024281-14-000	EA BRACKET-LIFT ROD, LOWER WALL MOUNTED - 22.12" - OFF WHITE
6	024275-12-000	EA ROD-TABLE LIFT, OFF WHITE
7	024283-01-000	EA CLIP-LEG, 1" X 1.125" OD - BLACK
8	024282-01-000	EA BRACE-TABLE LEG, HINGED
9	064050-05-000	EA HINGE-TABLE LEG, OFF WHITE
10	024276-23-000	EA LEG-TABLE, METAL - OFF WHITE
11	049493-12-000	EA CATCH-LEG, FLOOR MOUNTED - 2.5" X 2.7" - METAL - OFF WHITE
11	049493-11-700	EA CATCH-LEG, FLOOR MOUNTED - 2.5" X 2.7" - METAL - E-COAT

DRIVERS COMPARTMENT GROUP
DRIVERS COMPARTMENT - UPPER

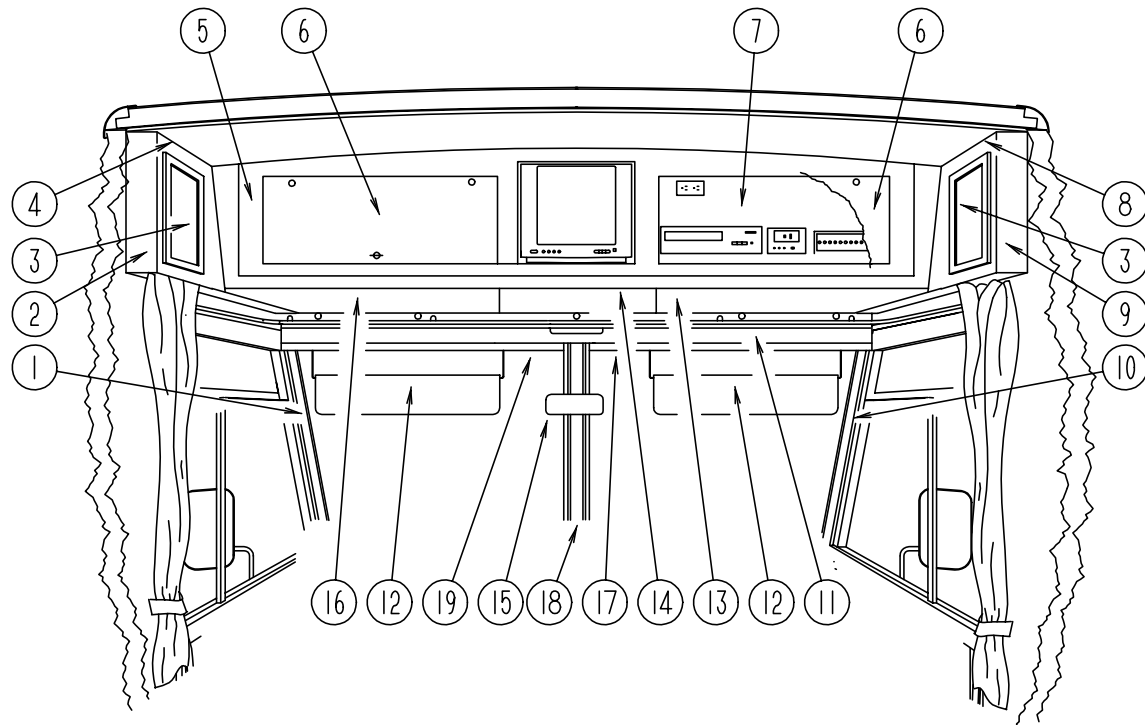

KEY	PART NUMBER	U/M	DESCRIPTION
1	103931-02-01A	EA	COVER-INNER, A-PILLAR - DRIVERS
2	103128-09-E10	EA	CAP-END, FRONT OVERHEAD, DRIVERS SIDE (F04,F05,F06,F07)
2	103128-09-F31	EA	CAP-END, FRONT OVERHEAD, DRIVERS SIDE (F14)
3	M06803-04-E07	EA	DOOR-CABINET, W/O HARDWARE - 255 MM X 485 MM (F04,F05,F06,F07)
3	M06803-04-F14	EA	DOOR-CABINET, W/O HARDWARE - 255 MM X 485 MM
4	109561-02-F04	EA	CABINET-FRONT OVERHEAD W/O DOOR, DRIVERS SIDE (F04,F14)
4	109561-02-F05	EA	CABINET-FRONT OVERHEAD W/O DOOR, DRIVERS SIDE
4	109561-02-F06	EA	CABINET-FRONT OVERHEAD W/O DOOR, DRIVERS SIDE
4	109561-02-F07	EA	CABINET-FRONT OVERHEAD W/O DOOR, DRIVERS SIDE
	P09561-02-E07	EA	BOTTOM-VINYL COVERED, FRONT OVERHEAD - DRIVERS SIDE
	104289-02-C05	EA	PAD-VINYL COVERED, 30.3" X 9.6" - ANGLED - DRIVERS SIDE
5	M05893-01-E07	EA	FACE-TV CABINET W/O DOORS, FRONT OVERHEAD
	106699-01-01A	EA	BRACKET-L-ANGLE, TV CABINET FACE - 5.1" LONG - OFF WHITE STEEL
	108911-01-E07	EA	TRIM-TV, 15.3" X 13.9" - WOOD
	100676-02-000	EA	STAND-VCR, STEEL
6	100708-06-000	EA	DOOR-GLASS, TV CABINET - W/O HARDWARE - 9.68" X 28.42"
	100710-01-01A	EA	LOCK-TWIST TYPE
	100711-01-01A	EA	HINGE-DOOR, GLASS
	100707-01-000	EA	SPACER
	101272-01-000	EA	CATCH-GLASS DOOR
	101766-01-000	EA	PIN-SUPPORT, GLASS DOOR
7	103040-01-C05	EA	PANEL-HEADLINER FRONT OVERHEAD - PADDED - STANDARD
7	103040-02-C05	EA	PANEL-HEADLINER FRONT OVERHEAD - PADDED - TV OPTION
7	103040-03-C05	EA	PANEL-HEADLINER FRONT OVERHEAD - PADDED - TV/VCR/EUROPEAN OPTIONS
7	103040-04-C05	EA	PANEL-HEADLINER FRONT OVERHEAD - PADDED - TV/VCR/INVERTER OPTION
7	103040-05-C05	EA	PANEL-HEADLINER FRONT OVERHEAD - PADDED - TV/INVERTER OPTION
8	114188-01-F04	EA	CABINET-FRONT OVERHEAD W/O DOOR, PASSENGERS SIDE
8	114188-01-F05	EA	CABINET-FRONT OVERHEAD W/O DOOR, PASSENGERS SIDE
8	114188-01-F06	EA	CABINET-FRONT OVERHEAD W/O DOOR, PASSENGERS SIDE
8	114188-01-F07	EA	CABINET-FRONT OVERHEAD W/O DOOR, PASSENGERS SIDE
8	114188-01-F14	EA	CABINET-FRONT OVERHEAD W/O DOOR, PASSENGERS SIDE
9	103128-08-E10	EA	CAP-END, FRONT OVERHEAD, PASSENGERS SIDE
	P09561-01-E07	EA	BOTTOM-VINYL COVERED, FRONT OVERHEAD - PASSENGERS SIDE
	104289-01-C05	EA	PAD-VINYL COVERED, 30.3" X 9.6" - ANGLED - DRIVERS SIDE
10	103931-01-01A	EA	COVER-INNER, A-PILLAR - PASSENGERS
11	078811-05-C07	EA	PANEL-HEADER W/RECEPTACLE CUTOUTS - 90.2" LONG - VINYL COVERED
12	082286-18-F04	EA	SUNVISOR-DRIVER OR PASSENGER - W/O POCKET
	102377-01-000	EA	BRACKET-SUNVISOR, 1 PIECE - STEEL
	007211-01-000	EA	HINGE-SUNVISOR
	074012-01-000	EA	CLIP-SUNVISOR, SQUARE PINCH-ON
13	P03077-02-C05	EA	SHELF-CABINET, PASSENGERS SIDE - VINYL COVERED
14	P04415-01-C05	EA	SHELF-TV CABINET, VINYL COVERED
	100628-02-000	EA	SHELF ASM-TV, STEEL
	101150-01-000	EA	SUPPORT-SHELF, TV - PASSENGER SIDE - STEEL
	101150-02-000	EA	SUPPORT-SHELF, TV - DRIVER SIDE - STEEL
	104417-01-E07	EA	CABINET-BLANKET (STANDARD CABINET)
15	040714-01-000	EA	MIRROR-REAR VIEW, W/ARM MOUNT & SET SCREW - GM# 911722
	067490-01-000	EA	BUTTON-MIRROR, REAR VIEW - STANK S927H
16	P03077-01-C05	EA	SHELF-CABINET, DRIVERS SIDE - VINYL COVERED
17	078579-07-000	EA	TRIM - WINDSHIELD - UPPER INNER - RIGHT - OFF WHITE
18	079765-07-000	EA	TRIM - WINDSHIELD - CENTER INNER - OFF WHITE
19	078579-08-000	EA	TRIM - WINDSHIELD - UPPER INNER - LEFT - OFF WHITE

DRIVERS COMPARTMENT GROUP (CONTINUED)
DRIVERS COMPARTMENT - LOWER

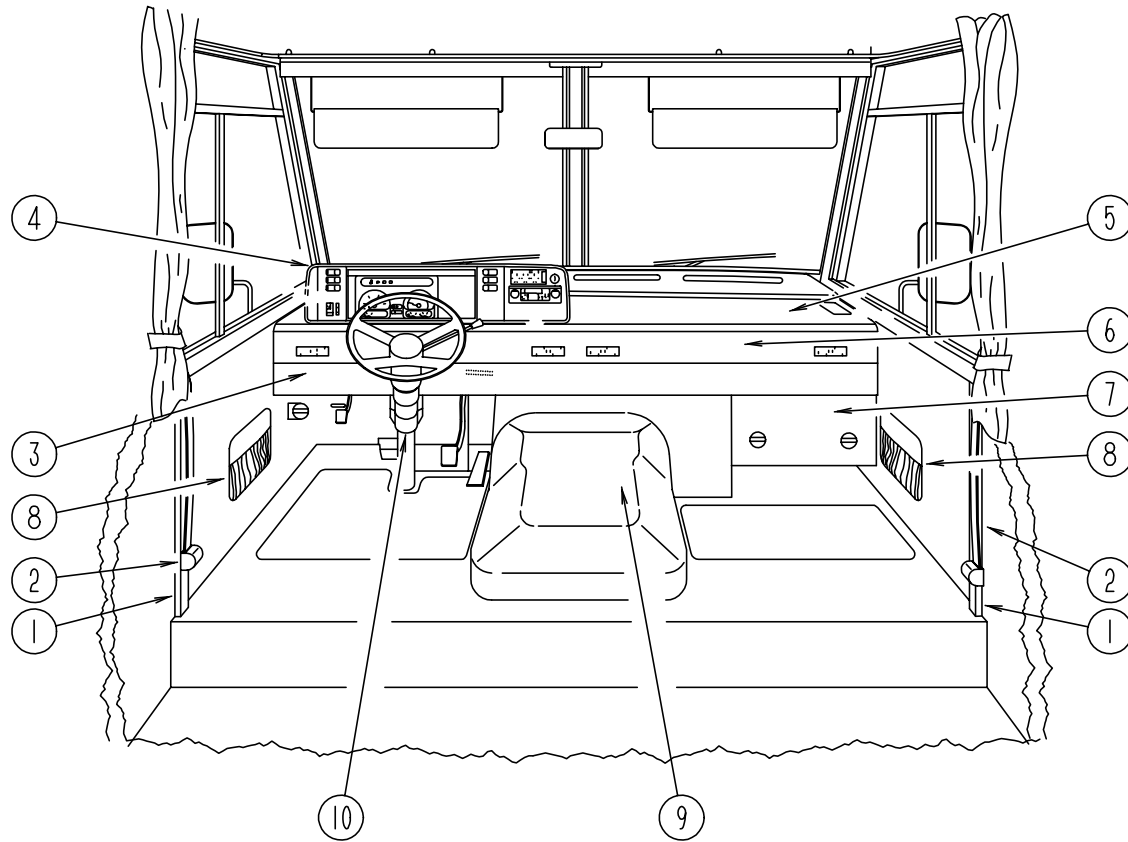

KEY	PART NUMBER	U/M	DESCRIPTION
1	024700-44-000	EA	COVER-SIDEWALL ROLL BAR, OFF WHITE - 53"
1	024700-45-000	EA	COVER-SIDEWALL ROLL BAR, OFF WHITE - 12.8"
2	091990-04-01A	EA	SEAT BELT-SHOULDER HARNESS - DRIVERS/PASSENGERS - BLACK
	091990-01-700	EA	BOLT COVER
	109146-01-000	EA	BOLT-SHOULDER, SEAT BELT
	103961-01-01A	EA	COVER-BRACKET, SEATBELT - OFF WHITE
	103961-02-01A	EA	COVER-BRACKET, SEATBELT - OFF WHITE - DRIVER DOOR OPTION
3	103812-01-05A	EA	TRIM-DASH, LOWER
4	111499-01-04A	EA	POD-INSTRUMENT PANEL
5	P03817-10-000	EA	DASH ASM, W/O VINYL - FORD
5	P03817-11-000	EA	DASH ASM, W/O VINYL - CHEVY
	105927-02-000	EA	PANEL-DASH TOP, STEEL
6	104354-04-02A	EA	APPLIQUE-LOWER DASH, 2300 MM LONG - CHEVY
6	104354-05-02A	EA	APPLIQUE-LOWER DASH, 2300 MM LONG - FORD
7	095757-03-F04	EA	COVER-HEATER W/CARPET (F04,F07,F14)
7	095757-03-F05	EA	COVER-HEATER W/CARPET
7	095757-03-F06	EA	COVER-HEATER W/CARPET
8	086120-01-F04	EA	PAD-MAP POCKET, 12" X 16"
8	086120-01-F05	EA	PAD-MAP POCKET, 12" X 16"
8	086120-01-F06	EA	PAD-MAP POCKET, 12" X 16" (F14)
8	086120-01-E07	EA	PAD-MAP POCKET, 12" X 16" (F07)
9	097552-01-000	EA	COVER-MOTOR, W/O CARPET
			FROM: 00-00-00 THRU: 09-18-94
9	114512-01-01A	EA	COVER-MOTOR, W/O CARPET (6.5 DIESEL OPTION)
			FROM: 00-00-00 THRU: 09-18-94
	075564-01-000	EA	BRACKET-MOUNTING, MOTOR COVER
			FROM: 00-00-00 THRU: 09-18-94
9	115840-01-01A	EA	COVER-MOTOR, W/O CARPET - GAS OR 6.5 DIESEL OPTION
			FROM: 09-19-94 THRU: 99-99-99
	115850-01-02A	EA	RETAINER-LATCH, MOTOR COVER - GAS OR 6.5 DIESEL OPTION
			FROM: 09-19-94 THRU: 99-99-99
	116581-01-000	EA	LATCH-MOTOR COVER - SOUTHCO 2710074088 - GAS OR 6.5 DIESEL OPTION
			FROM: 09-19-94 THRU: 99-99-99
	116833-01-02B	EA	WRENCH-HEX, MOTOR COVER - E-COAT - GAS OR 6.5 DIESEL OPTION
			FROM: 09-19-94 THRU: 99-99-99
	113828-02-01A	EA	TRIM-MOTOR COVER, MILL
			FROM: 00-00-00 THRU: 09-18-94
	114519-01-E07	EA	TRIM-MOTOR COVER (6.5 DIESEL OPTION)
			FROM: 00-00-00 THRU: 09-18-94
	115860-01-01A	EA	TRIM-MOTOR COVER - GAS OR 6.5 DIESEL OPTION
			FROM: 09-19-94 THRU: 99-99-99
	039623-01-000	FT	SEAL-MOTOR COVER, RUBBER BULB TYPE - BLACK
	111618-01-E10	EA	TRAY ASM-BEVERAGE
	111618-13-E07	EA	LID-BEVERAGE TRAY ASM
	046886-03-000	EA	ASHTRAY-CHROME, W/COVER
10	103498-06-000	EA	BOOT-STEERING COLUMN, BLACK VINYL
	111521-01-04A	EA	COVER-STEERING COLUMN, BLACK
	112634-01-01A	EA	TRIM-STEERING COLUMN, RH BLK
	112634-02-01A	EA	TRIM-STEERING COLUMN, LH BLK

DRIVERS COMPARTMENT GROUP (CONTINUED)
DASH, GAUGES & SWITCHES (CHEVY)

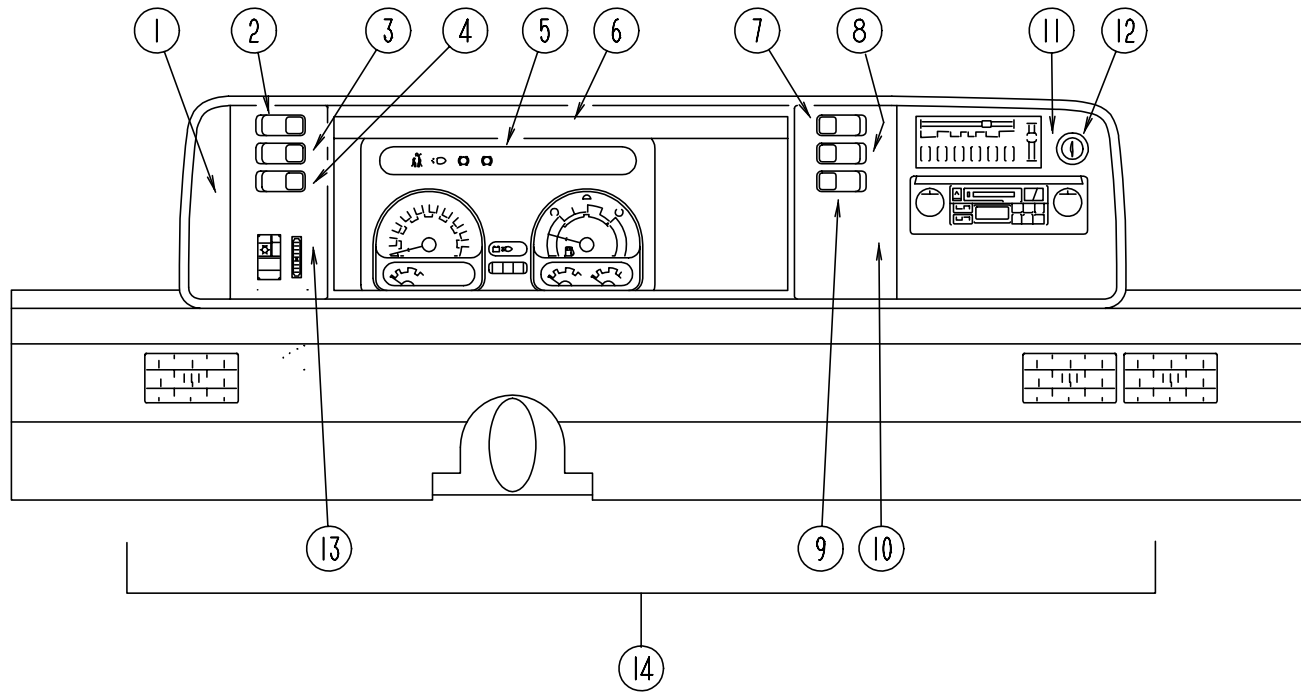

KEY	PART NUMBER	U/M	DESCRIPTION
1	104056-01-01A	EA	APPLIQUE-BEZEL
2	108356-02-01A	EA	COVER-SWITCH W/DIMPLES, CARLING VVAZC00 BLA
2	108357-05-000	EA	SWITCH-ROCKER, SPDT ON/NONE/ON - RADIO POWER - CARLING V4D1000B-0
3	108356-02-01A	EA	COVER-SWITCH W/DIMPLES, CARLING VVAZC00 BLA
3	108357-09-000	EA	SWITCH-ROCKER, SPDT ON/NONE/MOM - DUAL BATTERY - CARLING V5D1000B-0
4	108356-02-01A	EA	COVER-SWITCH W/DIMPLES, CARLING VVAZC00 BLA
4	108357-06-000	EA	SWITCH-ROCKER, DPDT MOM/OFF/MOM - CARLING VLD1000B-0 BATTERY DISCONNECT SWITCH OPTION
4	096241-03-000	EA	SWITCH-BLANK
5	094796-07-000	EA	CLUSTER-INSTRUMENT PANEL, KILOMETERS - GM #16167145 (GAS)
5	094796-08-000	EA	CLUSTER-INSTRUMENT PANEL, KILOMETERS - GM #16164645 (DIESEL)
6	103662-01-01A	EA	BEZEL-INSTRUMENT PANEL
7	108356-04-01A	EA	COVER-SWITCH W/DIMPLES & LENS, CARLING VVAGC00
7	108357-10-000	EA	SWITCH-ROCKER, SPDT MOM/OFF/MOM - LIGHTED - CARLING V8D1160B-0 GENERATOR OPTION
7	096241-03-000	EA	SWITCH-BLANK
8	108356-02-01A	EA	COVER-SWITCH W/DIMPLES, CARLING VVAZC00 BLA
8	108357-03-000	EA	SWITCH-ROCKER, SPDT ON/OFF/ON - CARLING V6D1000B-0 REAR HEATER OPTION
8	096241-03-000	EA	SWITCH-BLANK
9	096241-03-000	EA	SWITCH-BLANK
10	104056-21-01A	EA	APPLIQUE-BEZEL
11	104056-06-01A	EA	APPLIQUE-BEZEL
12	089294-01-000	EA	LIGHTER ASM-CIGARETTE - CASCO C213275
13	104056-22-01A	EA	APPLIQUE-BEZEL
14	M05946-17-F04	EA	DASH POD ASM-CHEVY
	100138-01-000	EA	MODULE-DAYTIME RUNNING LIGHT - CANADIAN
	077031-01-000	EA	FILM-BLACK, 1" X 1.75"
	077031-02-000	EA	FILM-AMBER, 1" X 1.75"
	077031-03-000	EA	FILM-WHITE, .75" X 1"
	103603-01-000	EA	BULB-12V NO.74 0.12A WEDGE
	105615-01-000	FT	FILM-PROTECTIVE CLEAR
	077539-01-000	EA	BRACKET-MOUNTING, DASH PANEL - L/SHAPED - 2.5" X 1" X 1.5"
	062901-02-000	EA	FUSE - 5 AMPS, AUTOMOTIVE
	062901-05-000	EA	FUSE - 15 AMPS, AUTOMOTIVE
	062901-07-000	EA	FUSE - 25 AMPS, AUTOMOTIVE

DRIVERS COMPARTMENT GROUP (CONTINUED)

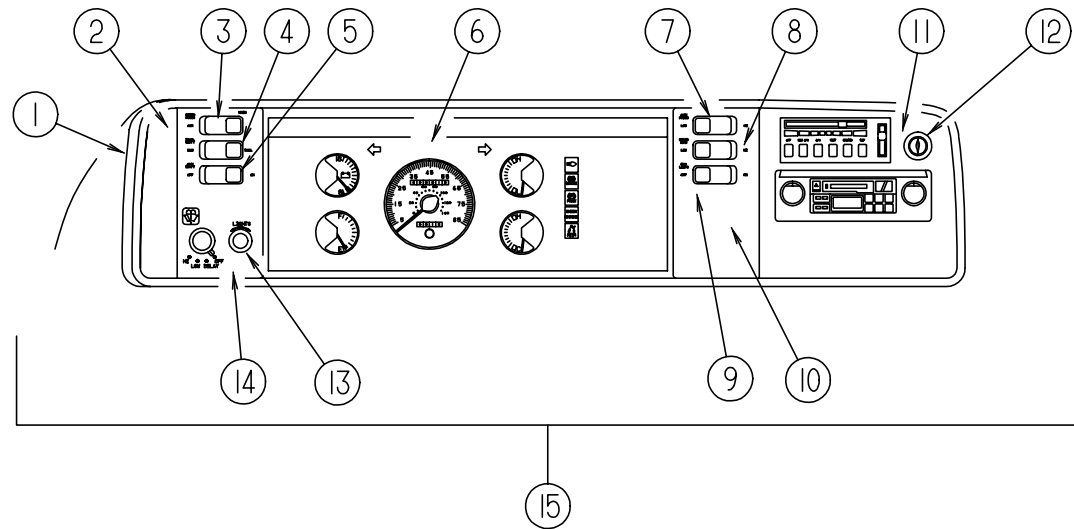

DASH, GAUGES & SWITCHES (FORD)

KEY	PART NUMBER	U/M	DESCRIPTION
1	103662-04-01A	EA	BEZEL-INSTRUMENT PANEL
2	104056-01-01A	EA	APPLIQUE-BEZEL
3	108356-02-01A	EA	COVER-SWITCH W/DIMPLES, CARLING VVAZC00 BLA
3	108357-05-000	EA	SWITCH-ROCKER, SPDT ON/NONE/ON - RADIO POWER - CARLING V4D1000B-0
4	108356-02-01A	EA	COVER-SWITCH W/DIMPLES, CARLING VVAZC00 BLA
4	108357-09-000	EA	SWITCH-ROCKER, SPDT ON/NONE/MOM - DUAL BATTERY - CARLING V5D1000B-0
5	108356-02-01A	EA	COVER-SWITCH W/DIMPLES, CARLING VVAZC00 BLA
5	108357-06-000	EA	SWITCH-ROCKER, DPDT MOM/OFF/MOM - CARLING VLD1000B-0 BATTERY DISCONNECT SWITCH OPTION
5	096241-03-000	EA	SWITCH-BLANK
6	094794-04-000	EA	CLUSTER-INSTRUMENT PANEL, KILOMETERS - FORD F3TD-10849-BA
7	108356-04-01A	EA	COVER-SWITCH W/DIMPLES & LENS, CARLING VVAGC00
7	108357-10-000	EA	SWITCH-ROCKER, SPDT MOM/OFF/MOM - LIGHTED - CARLING V8D1160B-0 GENERATOR OPTION
7	096241-03-000	EA	SWITCH-BLANK
8	108356-02-01A	EA	COVER-SWITCH W/DIMPLES, CARLING VVAZC00 BLA
8	108357-03-000	EA	SWITCH-ROCKER, SPDT ON/OFF/ON - CARLING V6D1000B-0 REAR HEATER OPTION
8	096241-03-000	EA	SWITCH-BLANK
9	096241-03-000	EA	SWITCH-BLANK
10	104056-21-01A	EA	APPLIQUE-BEZEL
11	104056-06-01A	EA	APPLIQUE-BEZEL
12	089294-01-000	EA	LIGHTER ASM-CIGARETTE - CASCO C213275
13	096674-01-000	EA	NUT-HEADLAMP KNOB, BLACK
13	096675-01-000	EA	KNOB - HEADLAMP - W/SHAFT
14	104056-24-01A	EA	APPLIQUE-BEZEL
15	M05946-18-F04	EA	DASH POD ASM-FORD
	100138-01-000	EA	MODULE-DAYTIME RUNNING LIGHT - CANADIAN
	111915-03-000	EA	WIRE ASM-DAY RUN LAMPS, FUSE - CANADIAN
	103603-01-000	EA	BULB-12V NO.74 0.12A WEDGE
	077031-01-000	EA	FILM-BLACK, 1" X 1.75"
	077031-03-000	EA	FILM-WHITE, .75" X 1"
	105615-01-000	FT	FILM-PROTECTIVE CLEAR
	111904-01-000	EA	INDICATOR ASM-TRANSMISSION - FORD F2US-7B053

DRIVERS COMPARTMENT GROUP (CONTINUED)

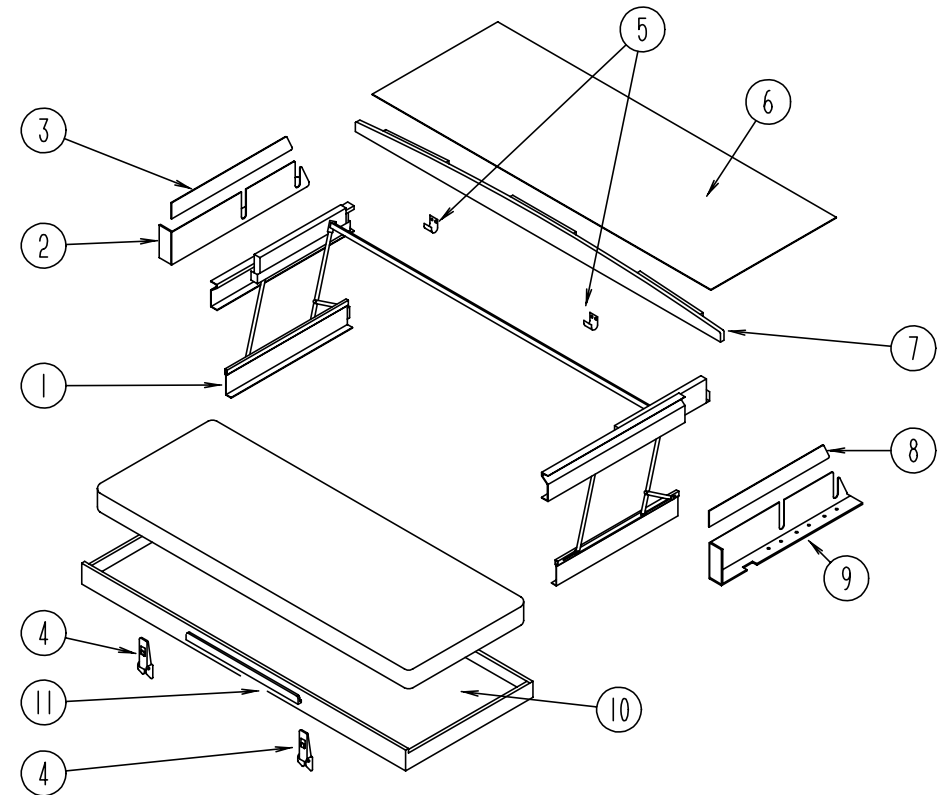

FRONT BUNK

KEY	PART NUMBER	U/M	DESCRIPTION
1	076760-02-000	EA	BUNK HARDWARE (COMPLETE)
	076760-02-700	EA	SPRING-GAS-BUNK HARDWARE
2	101499-06-C05	EA	PANEL ASM.- BOTTOM DRIVERS - PADDED - USED W/BUNK
3	101497-08-C05	EA	PANEL ASM.- UPPER DRIVERS - PADDED - USED W/BUNK
4	042541-04-000	EA	LATCH-W/O STRIKE, BRASS
5	042541-05-000	EA	STRIKE-BRASS
6	103040-06-C05	EA	PANEL-HEADLINER FRONT OVERHEAD - PADDED - USED W/BUNK
7	P03199-01-C05	EA	BOARD ASM-TRIM, BUNK - CEILING MOUNTED
8	101497-07-C05	EA	PANEL ASM.- UPPER PASSENGERS - PADDED - USED W/BUNK
9	101499-05-C05	EA	PANEL ASM.- BOTTOM PASSENGERS - PADDED - USED W/BUNK
10	081717-03-E07	EA	BED ASM-BUNK, FRONT
11	094658-01-E07	EA	HANDLE-BUNK, OAK

ELECTRICAL GROUP
EXTERIOR LIGHTS

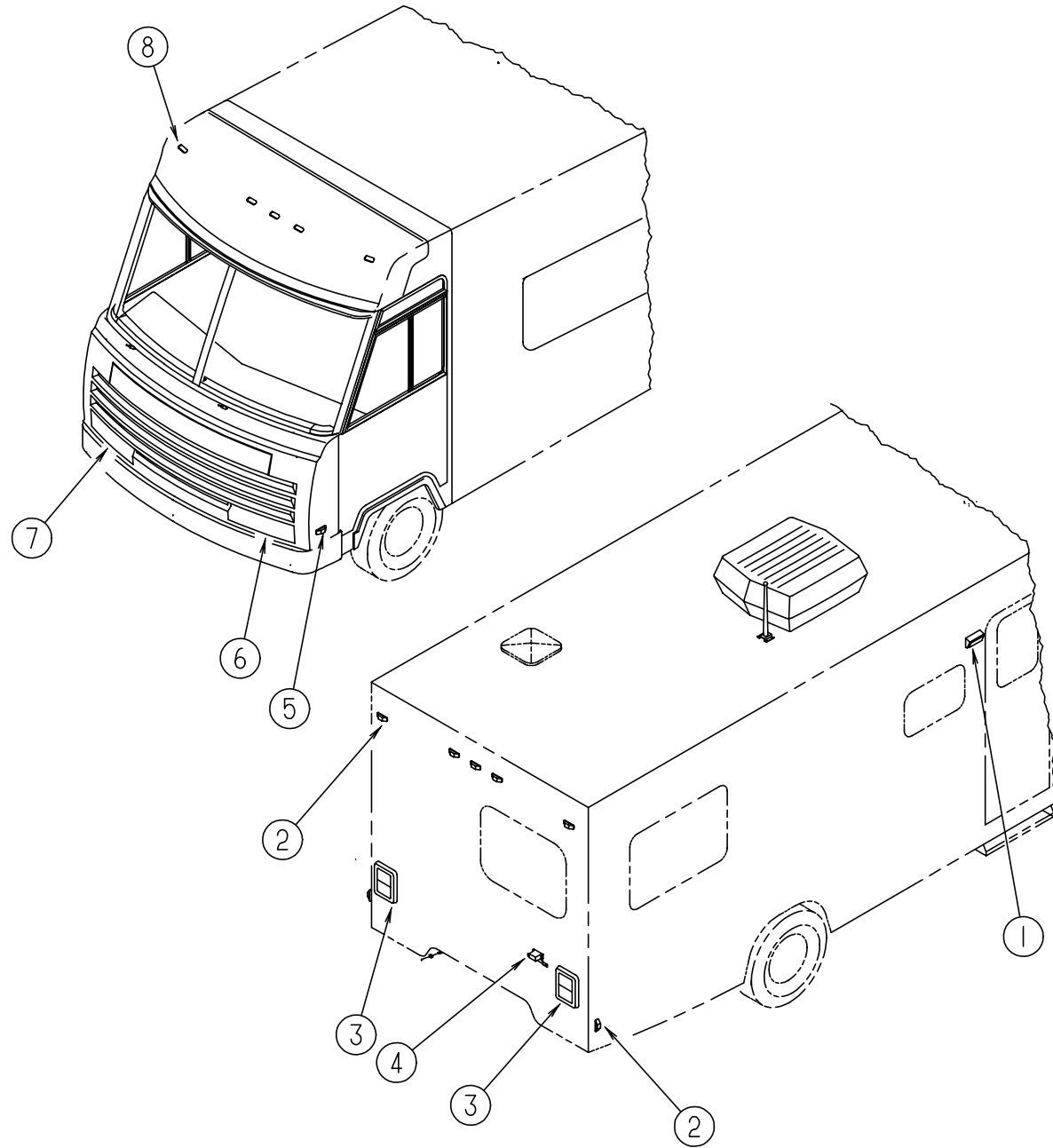

KEY	PART NUMBER	U/M	DESCRIPTION
1	097917-01-01A	EA	LIGHT-PORCH, ENTRY DOOR - OFF WHITE
	008215-01-000	EA	BULB - 12V, #1003 - .94 AMP
	097917-01-700	EA	LENS-LIGHT, PORCH
2	111102-01-000	EA	LAMP-MARKER, BASE - TRIPLEX 117XAS
2	111102-03-000	EA	LENS-MARKER LAMP, RED - TRIPLEX 117R
	036196-01-000	EA	BULB - 12V, #194 - .27 AMP - BAYONETTE
3	081638-01-000	EA	TAILLIGHT-DOUBLE, W/BLACK TRIM - DRIVER OR PASSENGER SIDE
	037934-01-000	EA	BULB - 12V, #1156 - 2.1 AMP - CLEAR GLASS
	037935-01-000	EA	BULB - 12V, #1157 OR #2057 - 2.1 AMP - CLEAR GLASS
	081638-01-700	EA	LENS-TAILLIGHT, RED - BARGMAN 30-84-010
	081638-01-701	EA	LENS-TAILLIGHT, W/BACKUP - BARGMAN 30-84-700
	103355-01-01A	EA	POD-TAILLIGHT, OFF WHITE
4	066432-02-000	EA	LIGHT-LICENSE, BLACK
	066432-03-000	EA	BRACKET-LICENSE PLATE - BARGMAN 30-60-030
5	111102-01-000	EA	LAMP-MARKER, BASE - TRIPLEX 117XAS
5	111102-02-000	EA	LENS-MARKER LAMP, AMBER - TRIPLEX 118A
	036196-01-000	EA	BULB - 12V, #194 - .27 AMP - BAYONETTE
6	049186-01-000	EA	HEADLAMP CAPSULE-DRIVER, HIGH/LOW BEAM - RECTANGULAR
	049188-01-000	EA	HEADLAMP CAPSULE-DRIVER, HIGH BEAM - RECTANGULAR
7	049185-01-000	EA	HEADLAMP CAPSULE-PASSENGER, HIGH/LOW BEAM - RECTANGULAR
	049187-01-000	EA	HEADLAMP CAPSULE-PASSENGER, HIGH BEAM - RECTANGULAR
	P03783-01-000	EA	WIRE ASM-HEADLAMP
	049359-01-000	EA	SPRING-RETAINER, HEADLAMP - GM 496096
	110750-01-000	EA	SCREW-ADJUSTING, HEADLAMP
	110783-01-01A	EA	BRACKET-HEADLAMP, QUAD - PASSENGER - UNPAINTED
	110783-02-01A	EA	BRACKET-HEADLAMP, QUAD - DRIVER - UNPAINTED
	089292-01-000	EA	LIGHT-TURN, DRIVER OR PASSENGER - W/AMBER LENS
	037935-01-000	EA	BULB - 12V, #1157 OR #2057 - 2.1 AMP - CLEAR GLASS
8	102520-01-000	EA	LIGHT-CLEARANCE, W/O SOCKET CONNECTIONS - AMBER
	036196-01-000	EA	BULB - 12V, #194 - .27 AMP - BAYONETTE
	102540-01-000	EA	SEAL-SCREW, ROUND - RUBBER
	102541-01-000	EA	GASKET-CLEARANCE LIGHT
	102582-01-000	EA	BRACKET-LIGHT, CLEARANCE - L-SHAPED METAL - 2.2" X 4.7"
	112823-01-000	EA	SPLICE-REDUCER, 16-14 TO 18-22 - ETC BA-631X
	067789-02-000	EA	SOCKET-LAMP

ELECTRICAL GROUP (CONTINUED)

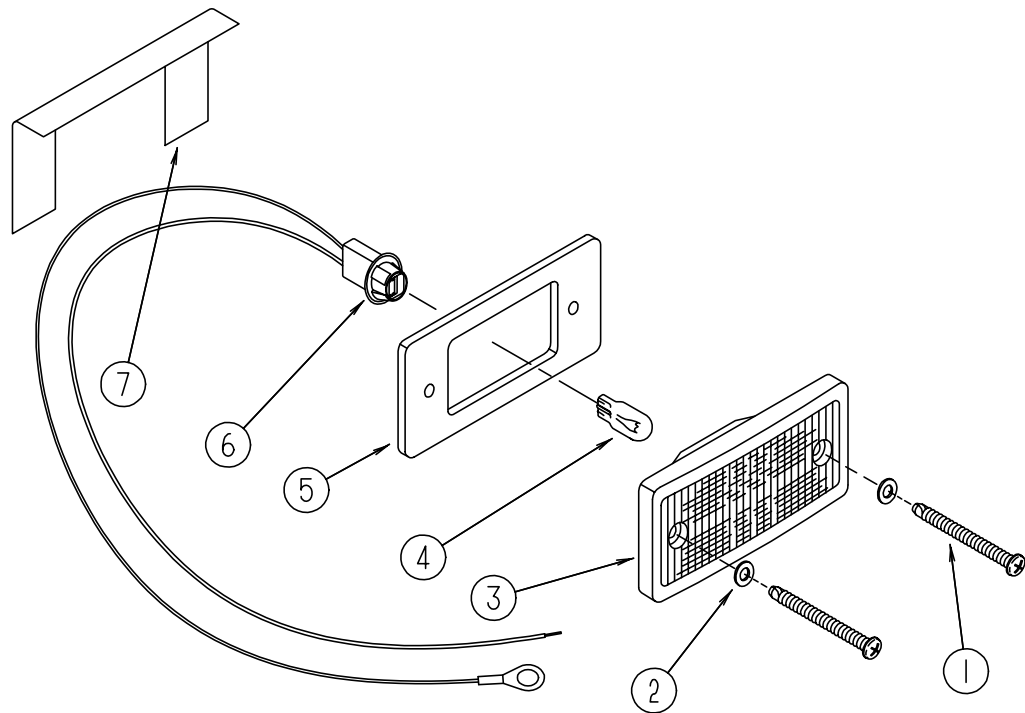

EXTERIOR CLEARANCE LIGHTS

KEY	PART NUMBER	U/M DESCRIPTION
1	000G39-08-24B	EA SCREW, SELF DRIVING
2	102540-01-000	EA SEAL-SCREW, ROUND - RUBBER
3	102520-01-000	EA LIGHT-CLEARANCE, W/O SOCKET CONNECTIONS - AMBER
4	036196-01-000	EA BULB - #1194 - CLEARANCE LIGHT
5	102541-01-000	EA GASKET-CLEARANCE LIGHT
6	067789-02-000	EA SOCKET ASM.-CAB MARKER
7	102582-01-000	EA BRACKET-LIGHT, CLEARANCE - L-SHAPED METAL - 2.2" X 4.7"

ELECTRICAL GROUP (CONTINUED) INTERIOR LIGHTS

KEY	PART NUMBER	U/M DESCRIPTION
	098024-01-01A	EA LIGHT-DOME, 1 BULB - US - IVORY
	008218-01-000	EA BULB-DOME LIGHT, 12V - NUMBER 1141
	098024-01-700	EA LENS-DOME LIGHT
	061424-01-000	EA LIGHT-AISLE, 12V - RECTANGULAR
	008103-01-000	EA BULB-DASH/AISLE LIGHT, #53 - 12 V - .12 AMP
	065201-09-000	EA SHADE-LAMP, FABRIC - PARCHMENT
	065202-22-000	EA LAMP-WALL,BRASS (US/CANADIAN) (F04,F05,F06,F07)
	065202-25-000	EA LAMP-WALL,BRASS (CANADIAN) (F14)
	065202-24-000	EA LAMP-WALL,BRASS (US) (F14)
		FROM: 00-00-00 THRU: 11-13-94
	065202-26-000	EA LAMP-WALL,BRASS (US) (F14)
		FROM: 11-14-94 THRU: 99-99-99
	067479-01-000	EA BULB - 12V, NUMBER 1076
	086280-01-000	EA LIGHT-SURFACE MOUNT, 12V - JENSEN 1236
	086280-01-700	EA BULB - 12 VOLT, 6 WATT
	098024-01-01A	EA LIGHT-DOME, 1 BULB - US - IVORY
	008218-01-000	EA BULB-DOME LIGHT, 12V - NUMBER 1141
	098024-01-700	EA LENS-DOME LIGHT
	098024-03-01A	EA LIGHT-DOME, 2 BULB - IVORY
	008218-01-000	EA BULB-DOME LIGHT, 12V - NUMBER 1141
	098024-01-700	EA LENS-DOME LIGHT
	110235-01-01A	EA LIGHT-MAKE UP,3 BULB PANLESS
	081633-01-700	EA BULB-MAKE UP LIGHT, JENSEN

FUSES & CIRCUIT BREAKERS

KEY	PART NUMBER	U/M DESCRIPTION
	008234-01-000	EA FUSE - 12V, 10 AMP
	062037-01-000	EA HOUSING-AUTO FUSE, NATURAL
	062037-02-000	EA HOUSING-AUTO FUSE, GREEN
	062037-03-000	EA HOUSING-AUTO FUSE, BLACK
	062037-04-000	EA HOUSING-AUTO FUSE, BLUE
	062037-05-000	EA HOUSING-AUTO FUSE, GRAY
	062037-06-000	EA HOUSING-AUTO FUSE, BROWN
	062901-02-000	EA FUSE - 5 AMPS, AUTOMOTIVE
	062901-05-000	EA FUSE - 15 AMPS, AUTOMOTIVE
	062901-07-000	EA FUSE-AUTOMOTIVE, 25 AMPS
	062901-08-000	EA FUSE - 30 AMPS,AUTOMOTIVE
	083209-01-000	EA CIRCUIT BREAKER - 15 AMP, 120V - BW G-15 - CANADIAN
	083209-02-000	EA CIRCUIT BREAKER - 15/15AMP, 120V - BW H-15/15
	083209-03-000	EA CIRCUIT BREAKER - 15/20AMP, 120V - BW O-15/20
	083209-04-000	EA CIRCUIT BREAKER - 30A, 120V - BW L-30
	083209-05-000	EA CIRCUIT BREAKER - 20A, 120V - BW J-20
	083209-06-000	EA CIRCUIT BREAKER - 30/15 AMP, 120V - BW D-30/15
	093655-03-000	EA CIRCUIT BREAKER - 40A, 12V - USD 17440-4E03A2A
	097611-01-000	EA CIRCUIT BREAKER - 10A, 12V - VB3-A10-F57
	106655-02-000	EA TERMINAL-FUSE BLOCK, 10-12AWG PACKARD 12020400
	106656-01-000	EA FUSE BLOCK - 4 CAVITY AUTOFUSE PACKARD 12004943
	108669-01-000	EA HOUSING-AUTO FUSE HOLDER, PACKARD 12010105

ELECTRICAL GROUP (CONTINUED)
TERMINALS

KEY	PART NUMBER	U/M	DESCRIPTION
	008326-01-000	EA	TERMINAL-RING, 16/14 WIRE - 3/8" STUD
	008328-01-000	EA	TERMINAL-RING, 12/10 WIRE - #10 STUD FIT
	008331-01-000	EA	TERMINAL-RING,TONGUE - #4 WIRE - 3/8" STUD - COPPER
	008348-01-000	EA	TERMINAL-RING, 3/8" STUD - #2 WIRE
	047443-01-000	EA	TERMINAL - .250 RECEPTACLE FIT, INSULATED - 16/14 AWG
	062036-01-000	EA	TERMINAL-PACK-CON,12/10 AWG PACKARD 12033817
	062036-02-000	EA	TERMINAL-PACK-CON, 16/14 AWG
	035416-04-000	EA	TERMINAL-RING #10 STUD FIT, INSULATED BARREL #16/14
	106655-01-000	EA	TERMINAL-FUSE BLOCK,14-16 AWG - PACKARD 12020321
	113306-01-000	EA	TERMINAL-FEMALE, METRI-PACK - PACKARD12048451
	113307-01-000	EA	TERMINAL-FEMALE, METRI-PACK - PACKARD12048074
	104100-03-000	EA	TERMINAL - 75 AMP - AMP 53880-4 LOOSE

ELECTRIC BOXES & CORDS

KEY	PART NUMBER	U/M	DESCRIPTION
	008052-01-000	EA	CORD-POWER, 10/3 - 30 AMP - 25' - CANADIAN
	008054-01-000	EA	CORD-POWER, 10/3 - 30 AMP - 25'
	008289-01-000	EA	BOX-ELECTRIC, STEEL - 1/2" AND 3/4" KNOCKOUTS - 4" X 4"
	008289-02-000	EA	BOX-ELECTRICAL, 4" X 4" - 1/2" & 3/4" KNOCKOUTS - CANADIAN
	008294-01-000	EA	COVER-ELECTRICAL BOX, BLANK/STEEL - 4" X 4" - GRAY
	008294-02-000	EA	COVER-ELECTRICAL BOX, BLANK STEEL - 4" X 4" - CANADIAN
	069238-01-000	EA	COVER-ELECTRICAL BOX, W/HOLE - 4" X 4" - GRAY USED WITH 30 AMP RECEPTACLE
	074890-01-000	EA	BOX-EXTENSION, STEEL - OPEN SIDES - 4" X 4" X 1 1/2"
	074897-01-000	EA	COVER-ELECTRIC BOX, 1 LARGE & 2 SMALL HOLES - 4" X 4"
	091910-01-000	EA	BOX-ELECTRIC, 3.75" X 3.5" X 1.75" - PLASTIC
	091910-02-000	EA	BOX-ELECTRICAL, PLASTIC - 57 X 88MM

ELECTRICAL GROUP (CONTINUED)
WIRE ASSEMBLIES

KEY	PART NUMBER	U/M	DESCRIPTION
	073328-B4-000	EA	CABLE ASSEMBLY-BATTERY, W/TERMINALS
	096449-01-000	EA	WIRE ASSEMBLY-WATER TANK TO MONITOR PANEL
	097618-01-000	EA	WIRE ASM-MONITOR PANEL, W/3 WIRES & ORANGE RESISTOR- LVS ORANGE RESISTOR W/3 (ORANGE-GREEN-BLUE) WIRES
	102636-01-000	EA	WIRE ASM-CLEARANCE LAMPS
	103328-06-000	EA	WIRE ASM-PUMP,EXTERIOR SHOWER
	111448-01-000	EA	WIRE ASM-INSTRUMENT PANEL, MAIN (GM)
	111915-01-000	EA	WIRE ASM-DAY RUN LAMPS, FUSE - GM
	111915-03-000	EA	WIRE ASM-DAY RUN LAMPS, FUSE - FORD
	P03783-01-000	EA	WIRE ASM-HEADLAMP (GM)
	P03783-02-000	EA	WIRE ASM-HEADLAMP(FORD)

CONDUIT

KEY	PART NUMBER	U/M	DESCRIPTION
	041953-01-000	FT	CONDUIT-CONVOLUTE SLIT, .5"ID
	041953-03-000	FT	CONDUIT-CONVOLUTE SLIT, 1" ID (CLOTHES ROD COVER)
	041953-05-000	FT	CONDUIT-CONVOLUTE SOLID, .62" ID
	041953-06-000	FT	CONDUIT-CONVOLUTE, SLIT .375"ID
	041953-07-000	FT	CONDUIT-CONVOLUTE, SLIT - .25" ID
	041953-08-000	FT	CONDUIT-CONVOLUTE, SLIT,1.50"ID
	041953-09-000	FT	CONDUIT-CONVOLUTE, SLIT .50"ID
	041953-10-000	FT	CONDUIT-CONVOLUTE, SLIT - .75" ID
	041953-11-000	FT	CONDUIT-CONVOLUTE, SLIT- 1.06" ID
	041953-12-000	FT	CONDUIT-CONVOLUTE, NON SLIT 1.1" ID

CONVERTER & INVERTER

KEY	PART NUMBER	U/M	DESCRIPTION
	083208-02-000	EA	CONVERTER-POWER, 45A - 120V/12V - BW 6345
	099048-01-000	EA	INVERTER - 100 WATT

ELECTRICAL GROUP (CONTINUED)
RECEPTACLES

KEY	PART NUMBER	U/M	DESCRIPTION
	024924-02-000	EA	RECEPTACLE-POWER CORD, W/PARTIAL PLATE
	058707-01-000	EA	RECEPTACLE-ELECTRIC, SINGLE - BROWN
	058708-01-000	EA	RECEPTACLE-ELECTRIC, DOUBLE - BROWN
	058708-02-000	EA	RECEPTACLE-ELECTRIC, DOUBLE - IVORY
	084076-02-000	EA	RECEPTACLE-GFI, 15A - 125V - BROWN
	091927-01-000	EA	COVER-RECEPTACLE, DOUBLE - IVORY
	102568-01-E90	EA	SPACER-RECEPTACLE, SIDEWALL
	112822-01-01A	EA	RECEPTACLE-DUPLEX, IVORY - WIRECON WDRU15IV
	112824-01-02A	EA	COVER-EXTERIOR DUPLEX RECEPTACLE, O/W - P&S 3780-SC-CW

SWITCHES

KEY	PART NUMBER	U/M	DESCRIPTION
	054250-01-000	EA	COVER-ANGLED, W/O HOLE - 3.6" X 4.5" - PLASTIC - BEIGE ELECTRICAL PLATE SUPPORT W/O HOLES
	054250-04-000	EA	COVER-ANGLED, W/O HOLE - 3.6" X 4.5" - PLASTIC - OFF WHITE ELECTRICAL PLATE SUPPORT
	073626-04-000	EA	COVER-ELECTRIC, 10.4" X 7.8" - BEIGE PLASTIC
	075723-01-000	EA	SPACER-SWITCH, W/O HOLE - .2" X .9" X 2" - METAL - OFF WHITE
	075723-02-000	EA	SPACER-SWITCH, W/HOLE - .2" X .9" X 2" - METAL - OFF WHITE FOR ELECTRIC STEP DOOR JAMB SWITCH
	079364-01-000	EA	SWITCH-ON/OFF ROCKER, 2 PRONGS - BROWN
	079364-03-000	EA	SWITCH-ON/OFF ROCKER, 3 PRONGS - BROWN
	095188-01-01A	EA	SPACER-SWITCH, 2.3" X 3.4" - PLASTIC - DARK BROWN
	095188-02-01A	EA	SPACER-SWITCH, 2.3" X 4.1" - PLASTIC - DARK BROWN
	098351-01-01A	EA	PLATE-SWITCH, 1 GANG - POLISHED BRASS - JENSEN
	098351-02-01A	EA	PLATE-SWITCH, 2 GANG - POLISHED BRASS - JENSEN
	098351-05-01A	EA	PLATE-SWITCH, 3 GANG - POLISH BRASS - JENSEN
	098351-06-01A	EA	PLATE-SWITCH, 2 GANG W/LABEL - JENSEN - POLISHED BRASS
	108355-01-000	EA	HOUSING-SWITCH CARLING VCH
	108356-01-01A	EA	COVER-SWITCH W/GROOVES, CARLING VVCZC00 BLA
	108356-02-01A	EA	COVER-SWITCH W/DIMPLES, CARLING VVAZC00 BLA
	108356-04-01A	EA	COVER-SWITCH W/DIMPLES & LENS, CARLING VVAGC00
	108357-03-000	EA	SWITCH-ROCKER, SPDT ON/OFF/ON - CARLING V6D1000B-0
	108357-05-000	EA	SWITCH-ROCKER, SPDT ON/NONE/ON - CARLING V4D1000B-0
	108357-06-000	EA	SWITCH-ROCKER, DPDT MOM/OFF/MOM - CARLING VLD1000B-0
	108357-08-000	EA	SWITCH-ROCKER, DPDT ON/NONE/ON - CARLING VDD1S00C-0
	108357-09-000	EA	SWITCH-ROCKER, SPDT ON/NONE/MOM - CARLING V5D1000B-0
	108357-10-000	EA	SWITCH-ROCKER, SPDT MOM/OFF/MOM - CARLING V8D1160B-0 LIGHTED

ELECTRICAL GROUP (CONTINUED)
HOUSINGS, CONNECTORS & MISCELLANOUS

KEY	PART NUMBER	U/M	DESCRIPTION
	088473-01-000	EA	HOUSING-PIN, 12 CAVITY - AMP 1-480708-0
	088473-03-000	EA	HOUSING-PIN, 9 CAVITY - AMP 1-480706-0
	088473-06-000	EA	HOUSING-PIN, 6 CAVITY - AMP 1-480704-0
	088473-08-000	EA	HOUSING-PIN, 4 CAVITY - AMP 1-480702-0
	088473-09-000	EA	HOUSING-PIN, 3 CAVITY - AMP 1-480700-0
	088473-10-000	EA	HOUSING-PIN, 2 CAVITY - AMP 1-480698-0
	088474-01-000	EA	HOUSING-SOCKET, 12 CAVITY - AMP 1-480709-0
	088474-02-000	EA	HOUSING-SOCKET, 12 CAVITY - AMP 1-480711-0
	088474-03-000	EA	HOUSING-SOCKET, 9 CAVITY - AMP 1-480707-0
	088474-06-000	EA	HOUSING-SOCKET, 6 CAVITY - AMP 1-480705-0
	088474-07-000	EA	HOUSING-SOCKET, 5 CAVITY - AMP 1-480764-0
	088474-08-000	EA	HOUSING-SOCKET, 4 CAVITY - AMP 1-480703-0
	088474-09-000	EA	HOUSING-SOCKET, 3 CAVITY - AMP 1-480701-0
	088474-10-000	EA	HOUSING-SOCKET, 2 CAVITY - AMP 1-480699-0
	101571-01-000	EA	HOUSING - 2 POSITION, MALE
	104100-01-000	EA	HOUSING - 1 POSITION, 75 AMP - AMP 53884-1
	106006-01-000	EA	HOUSING - 1 POSITION, FEMALE - PACKARD 12015952
	063910-01-000	EA	HOUSING-RELAY, BOSCH 3 334 485 008
	113468-01-000	EA	HOUSING - 2 POSITION, FEMALE - 56-SERIES - PACKARD 02965981 USED ON WIPER/WASHER WIRE ASM
	007949-01-000	EA	TAB-HOUSING, 1 POSITION
	007940-01-000	EA	RECEPTACLE-SLIDE, 16 TO 12 AWG - FEMALE END
	080015-02-000	EA	RECEPTACLE-FLAG, .185 - 16/14 GA - AMP 3
	008311-01-000	EA	CONNECTOR-WIRE NUT, INSULATED - RED
	008312-01-000	EA	CONNECTOR-WIRE NUT, INSULATED - BLUE
	008314-01-000	EA	CONNECTOR-WIRE NUT, INSULATED - GRAY
	008355-01-000	EA	CONNECTOR-CABLE CLAMPING, 3/4"
	008356-01-000	EA	CONNECTOR-PLASTIC, 3/8" AVG
	008398-01-000	EA	CONNECTOR - 1/2" X 90 DEGREE, FLEX CONDUIT - UL AND CSA
	082740-01-000	EA	CONNECTOR-PLASTIC BODY, FOR 2 MALE SPADES
	082741-01-000	EA	CONNECTOR BODY - 2 CONNECTOR MALE
	058028-01-000	EA	CONNECTOR-ELECTRICAL PIGTAIL, NYLON - CLEAR
	088475-01-000	EA	PIN-CONNECTOR, 14 TO 20 AWG
	088475-02-000	EA	PIN-CONNECTOR, 10 TO 12 AWG
	088476-01-000	EA	SOCKET-CONNECTOR, BRASS - PRE-TIN
	088476-02-000	EA	SOCKET-CONNECTOR, 12-10 GA - PHOS. BRZ - PRE-TIN
	103608-01-000	EA	SOCKET-WEDGE BASE W/LEADS - JKL 2944-6 OR EQUIVLANT
	036346-02-000	EA	BUSHING-STEEL 3/4MPT X 318FPT
	077479-01-000	EA	BOOT-BATTERY TERMINAL, DOUBLE CABLE
	077479-02-000	EA	BOOT-BATTERY TERMINAL, SINGLE CABLE
	087225-01-000	FT	SLEEVING - 1/2", TYPE H - VARFLEX
	087225-02-000	FT	SLEEVING - 5/8", TYPE H - VARFLEX VARGLAS
	103987-02-000	EA	SEAL-SOLENOID ACCESS
	104100-03-000	EA	TERMINAL - 75 AMP - AMP 53880-4 LOOSE
	106655-01-000	EA	TERMINAL-FUSE BLOCK, 14-16AWG - PACKARD 12020321
	007093-01-000	EA	FLASHER-SIGNAL, STAT
	008188-01-000	EA	SOLENOID- 3 POST, BATTERY CHANGE OVER
	067789-02-000	EA	SOCKET-LAMP
	086233-01-000	EA	STUD-ISOLATED, 3/8" X 7/8" LONG
	086273-01-000	EA	RELAY-BATTERY DISCONNECT

EXTERIOR BODY GROUP
EXTERIOR BODY PANELS AND TRIM

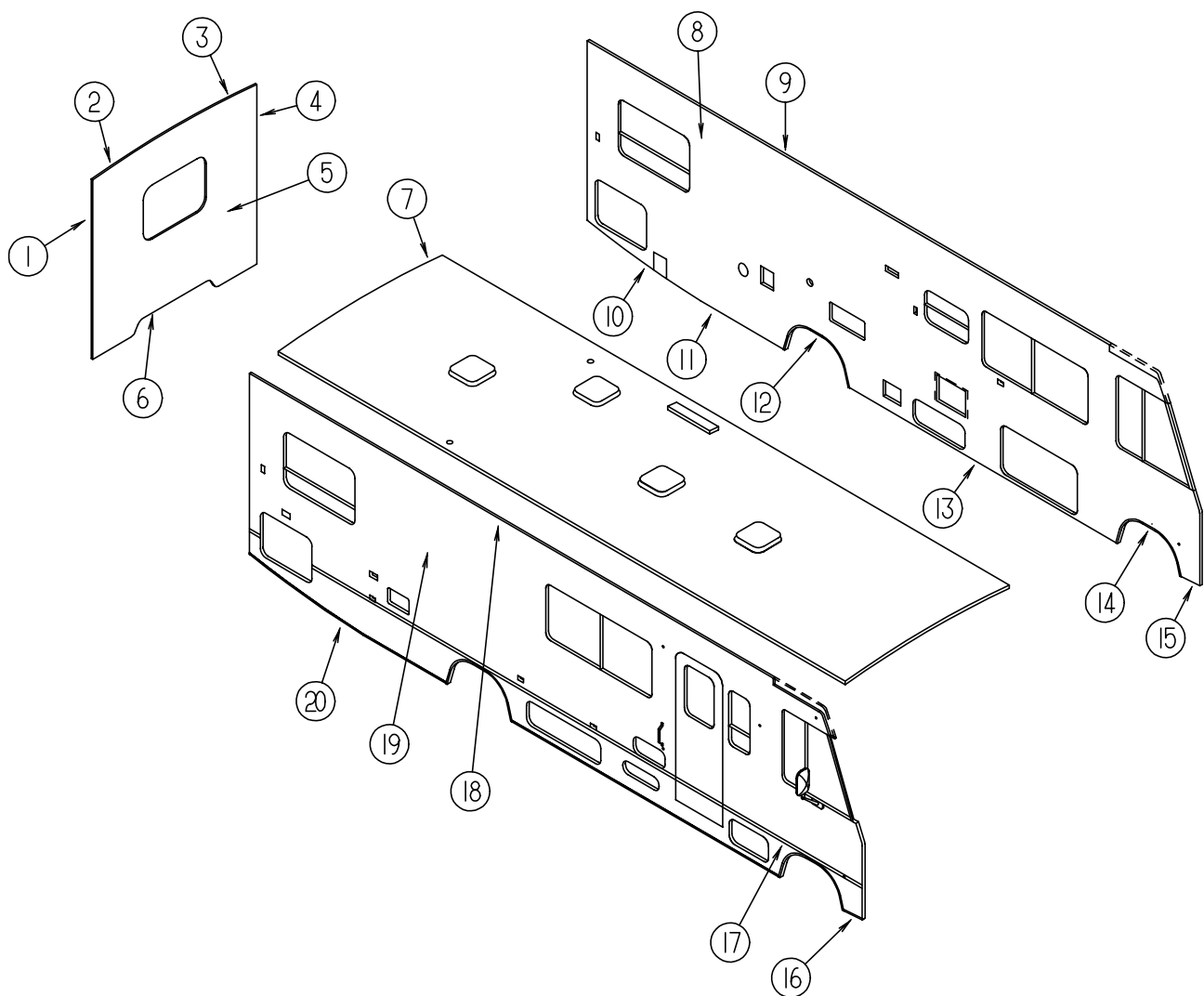

KEY	PART NUMBER	U/M	DESCRIPTION
1	103598-01-700	EA	TRIM-BACKWALL, SIDE, RIGHT - PRIMED
1	104033-01-01A	EA	TRIM-J, BACKWALL, RIGHT - OFF WHITE
2	103599-01-01A	EA	TRIM-BACKWALL, TOP, RIGHT - OFF WHITE
3	103600-01-01A	EA	TRIM-BACKWALL, TOP, LEFT - OFF WHITE
4	103598-02-700	EA	TRIM-BACKWALL, SIDE, LEFT - PRIMED
4	104033-02-01A	EA	TRIM-J, BACKWALL, LEFT - OFF WHITE
5	M05703-16-F04	EA	BACKWALL ASM W/QUEEN BED FORD
5	M05703-16-F05	EA	BACKWALL ASM W/QUEEN BED FORD
5	M05703-16-F06	EA	BACKWALL ASM W/QUEEN BED FORD
5	M05703-16-F07	EA	BACKWALL ASM W/QUEEN BED FORD
5	M05703-16-F14	EA	BACKWALL ASM W/QUEEN BED FORD

KEY	PART NUMBER	U/M	DESCRIPTION
5	M05703-14-F04	EA	BACKWALL ASM W/QUEEN BED GM
5	M05703-14-F05	EA	BACKWALL ASM W/QUEEN BED GM
5	M05703-14-F06	EA	BACKWALL ASM W/QUEEN BED GM
5	M05703-14-F07	EA	BACKWALL ASM W/QUEEN BED GM
5	M05703-14-F14	EA	BACKWALL ASM W/QUEEN BED GM
5	M05703-17-F04	EA	BACKWALL ASM W/TWIN BED FORD
5	M05703-17-F05	EA	BACKWALL ASM W/TWIN BED FORD
5	M05703-17-F06	EA	BACKWALL ASM W/TWIN BED FORD
5	M05703-17-F07	EA	BACKWALL ASM W/TWIN BED FORD
5	M05703-17-F14	EA	BACKWALL ASM W/TWIN BED FORD
5	M05703-15-F04	EA	BACKWALL ASM W/TWIN BED GM
5	M05703-15-F05	EA	BACKWALL ASM W/TWIN BED GM
5	M05703-15-F06	EA	BACKWALL ASM W/TWIN BED GM
5	M05703-15-F07	EA	BACKWALL ASM W/TWIN BED GM
5	M05703-15-F14	EA	BACKWALL ASM W/TWIN BED GM
6	050406-15-000	EA	TRIM-BACKWALL, LOWER - OFF WHITE
7	M05702-08-E07	EA	ROOF ASM W/TWIN
7	M05702-07-E07	EA	ROOF ASM W/QUEEN
8	M05705-31-F04	EA	SIDEWALL ASM-LH W/TWIN
8	M05705-31-F05	EA	SIDEWALL ASM-LH W/TWIN
8	M05705-31-F06	EA	SIDEWALL ASM-LH W/TWIN
8	M05705-31-F07	EA	SIDEWALL ASM-LH W/TWIN
8	M05705-31-F14	EA	SIDEWALL ASM-LH W/TWIN
8	M05705-37-F14	EA	SIDEWALL ASM-LH W/TWIN - DRIVERS DOOR OPTION
8	M05705-30-F04	EA	SIDEWALL ASM-LH W/QUEEN
8	M05705-30-F05	EA	SIDEWALL ASM-LH W/QUEEN
8	M05705-30-F06	EA	SIDEWALL ASM-LH W/QUEEN
8	M05705-30-F07	EA	SIDEWALL ASM-LH W/QUEEN
8	M05705-30-F14	EA	SIDEWALL ASM-LH W/QUEEN
8	M05705-36-F14	EA	SIDEWALL ASM-LH W/QUEEN - DRIVERS DOOR OPTION
9	103801-02-01A	EA	TRIM-ROOF, W/O DRILLED HOLES - OFF WHITE
10	111108-01-01A	EA	TRIM-SIDEWALL, BOTTOM, REAR - OFF WHITE
11	108038-10-01A	EA	TRIM-SIDEWALL, BOTTOM, REAR - OFF WHITE
12	108070-01-01A	EA	TRIM-WHEELWELL, REAR - OFF WHITE
13	108039-03-01A	EA	TRIM-SIDEWALL, BOTTOM, CENTER - OFF WHITE
14	108069-02-01A	EA	TRIM-WHEELWELL, FRONT - OFF WHITE
15	108109-01-01A	EA	TRIM-SIDEWALL, LOW, FRONT - DRIVER OR PASSENGER - OFF WHITE
16	108109-01-01A	EA	TRIM-SIDEWALL, LOW, FRONT - DRIVER OR PASSENGER - OFF WHITE
17	108688-01-01A	EA	FEATURE STRIP-W/HOLES - OFF WHITE
	002444-04-002	EA	STRIP-FEATURE, W/O INSERT - 15' LONG - OFF WHITE
	108651-01-01A	EA	END CAP-FEATURE STRIP
	001030-02-003	EA	INSERT-FEATURE STRIP, 17' LONG - OFF WHITE
18	103802-02-01A	EA	RAIL-AWNING, W/O DRILLED HOLES - OFF WHITE
19	M05704-30-F04	EA	SIDEWALL ASM-RH W/QUEEN
19	M05704-30-F05	EA	SIDEWALL ASM-RH W/QUEEN
19	M05704-30-F06	EA	SIDEWALL ASM-RH W/QUEEN
19	M05704-30-F07	EA	SIDEWALL ASM-RH W/QUEEN
19	M05704-30-F14	EA	SIDEWALL ASM-RH W/QUEEN
19	M05704-31-F04	EA	SIDEWALL ASM-RH W/TWIN
19	M05704-31-F05	EA	SIDEWALL ASM-RH W/TWIN
19	M05704-31-F06	EA	SIDEWALL ASM-RH W/TWIN
19	M05704-31-F07	EA	SIDEWALL ASM-RH W/TWIN
19	M05704-31-F14	EA	SIDEWALL ASM-RH W/TWIN
20	108038-02-01A	EA	TRIM-SIDEWALL, BOTTOM, REAR - OFF WHITE
	058267-01-000	FT	CHANNEL-STEEL, W/HOLES - SIDEWALL STIFFENER - 2" X 20'
	002754-01-001	EA	ANGLE-EXTRUDED, .75" X .75" X 18' - MILL ALUMINUM
	086180-55-001	EA	U-CHANNEL-EXTRUDED, 1.7" X 16' - OFF WHITE - SERRATED
	086754-03-000	EA	CAP-JOINT, ROOF TO SIDEWALL TRIM - 2" X 1.25" - OFF WHITE
	002726-01-001	EA	GARNISH-U-CHANNEL, 1.38" X 19' - SERRATED - MILL ALUMINUM
	089922-24-000	EA	TRIM-FIBERGLASS, PANEL - OFF WHITE
	093673-01-01A	FT	TRIM-ENTRANCE DOOR, 1.3" WIDE - OFF WHITE
	103814-01-000	EA	BRACKET-TRIM ATTACHMENT

EXTERIOR BODY GROUP (CONTINUED)

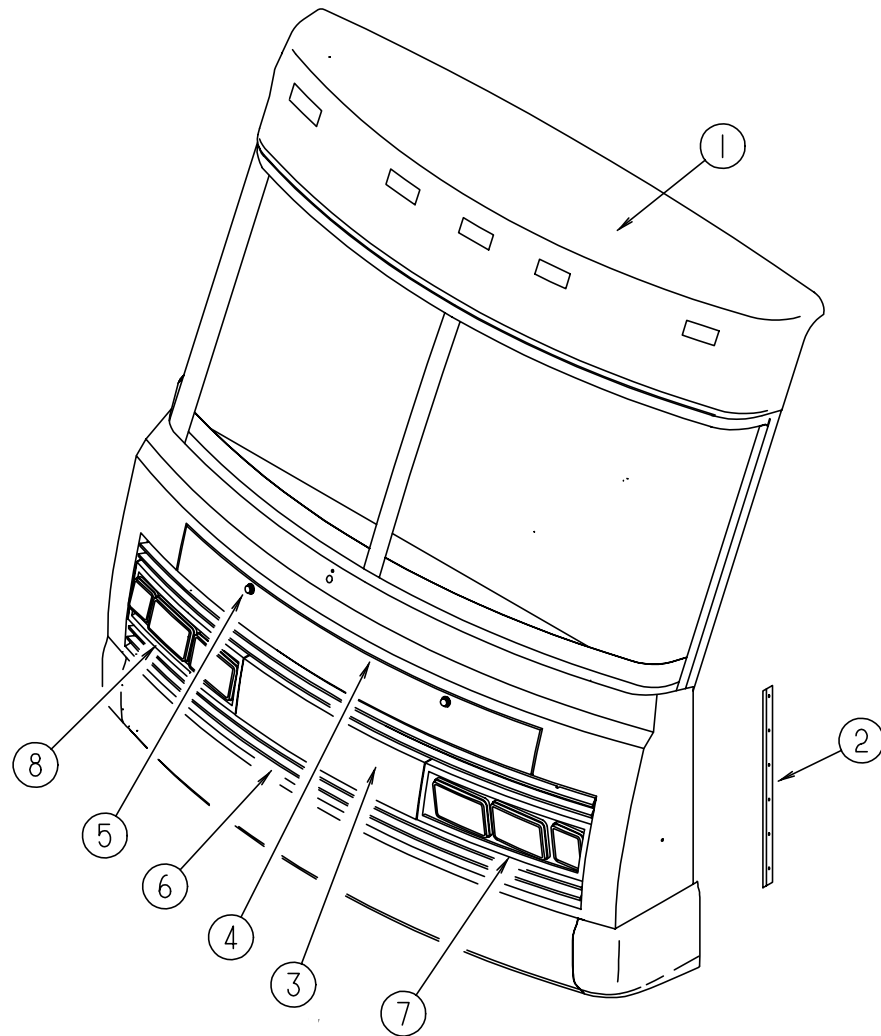

FRONT END COMPONENTS

KEY	PART NUMBER	U/M DESCRIPTION
1	M05145-05-E07	EA CAP ASM-FRONT, OFF WHITE
2	089922-24-000	EA TRIM-FRONT END/SIDEWALL, DRIVER OR PASSENGER SIDE - OFF WHITE
3	103485-01-02A	EA FRONT END ASM-W/GRILLE ASM, W/O HOOD OR HOOD HINGES - OFF WHITE
4	103478-02-E07	EA PANEL ASM-HOOD
	058786-01-000	EA BOLT-ADJUSTING, HOOD - W/BLACK PAD - .31" #18 X 2"
5	102330-02-000	EA LOCK-SINGLE HOLE, VISE ACTION - SOUTHCOE 3-56-715-5
	102328-01-000	EA KEY-BARREL, NICKEL PLATED - SOUTHCOE 3-26-715-19
	104584-03-000	EA BRACKET ASM-HOOD HINGE, BODY - RIGHT
	104584-04-000	EA BRACKET ASM-HOOD HINGE, BODY - LEFT
	105095-01-000	EA LINK ASM-HINGE, HOOD - INNER RIGHT
	105095-02-000	EA LINK ASM-HINGE, HOOD - INNER LEFT
	104582-02-000	EA LINK ASM-HINGE, HOOD - OUTER
6	110598-01-E07	EA GRILLE ASSEMBLY - 4 BAR
7	103617-02-02A	EA BEZEL-HEADLIGHT, DRIVER SIDE - OFF WHITE
8	103617-01-02A	EA BEZEL-HEADLIGHT, PASSENGER SIDE - OFF WHITE
	110690-01-D18	EA PLATE ASM-HEADLAMP, QUAD - PASSENGER - BLACK - STEEL
	110692-01-01A	EA PLATE-HEADLAMP, QUAD - PASSENGER - UNPAINTED - STEEL
	110690-02-D18	EA PLATE ASM-HEADLAMP, QUAD - DRIVER - BLACK - STEEL
	110692-02-01A	EA PLATE-HEADLAMP, QUAD - DRIVER - UNPAINTED - STEEL
	110691-01-01A	EA BRACKET-SPRING, HEADLAMP - DRIVER OR PASSENGER SIDE - UNPAINTED

EXTERIOR BODY GROUP (CONTINUED)
FIBERGLASS, STYROFOAM, ALUMINUM & INSULATION

KEY	PART NUMBER	U/M DESCRIPTION
	076054-F3-000	EA FIBERGLASS SHEET 2438 X 2438 - OFF WHITE
	076054-H2-000	EA FIBERGLASS SHEET 2438 X 9030 - OFF WHITE
	077517-24-000	EA SHEET-FIBERGLASS, FLAT - 48" X 96" - OFF WHITE
	083574-03-000	SF STYROFOAM - 3/4" X 48" X 96"
	083574-02-000	SF STYROFOAM, DOW TYPE SM - 1.5" X 24" X 90.5" - INCREMENTS OF 15 SF
	000870-06-000	SF STYROFOAM-1.34" X 48" X 96" - PLANED - INCREMENTS OF 32 SF
	044487-01-002	EA AL - .019" X 96" X 432" COIL MILL
	044487-01-001	EA ALUMINUM SHEET - .019" X 96" X 360" - MILL FINISH
	108535-01-701	EA FIBERGLASS PEBBLE 6" X 34" - OFF WHITE
	108535-01-704	EA FIBERGLASS PEBBLE 104" X 348" - OFF WHITE
	072878-01-000	EA INSULATION-SOUND BARRIER PAD, .058" X 33" X 58"
	065747-01-000	SF INSULATION-MICROFOAM, .5" THICK X 72" X 112'
	105077-01-000	EA FOAM-COVE, ROOF
	105077-03-000	EA FOAM-PLUG, SIDEWALL TUBE - WISCONSIN EPS

ASSIST HANDLE

KEY	PART NUMBER	U/M DESCRIPTION
	009126-02-000	EA HANDLE-ASSIST, ENTRY DOOR - BLACK
	069726-02-000	EA BUMPER - .88" DIA X .40", BLACK

EXTERIOR BODY GROUP (CONTINUED)

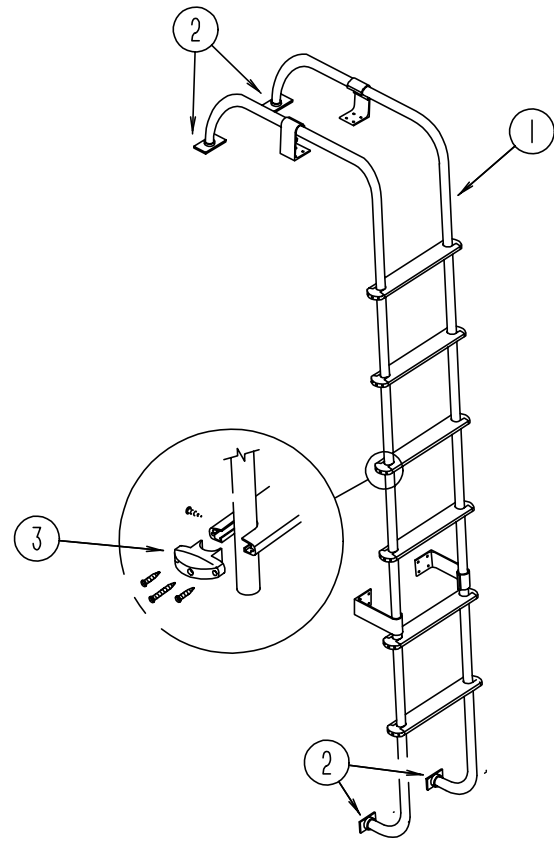

LADDER

KEY	PART NUMBER	U/M DESCRIPTION
1	102953-09-F04	EA LADDER ASM
2	067165-01-000	EA MOUNTING BRACKET-LADDER, LOWER
3	076980-02-000	EA END CAP-STEP, BLACK

EXTERIOR BODY GROUP (CONTINUED)

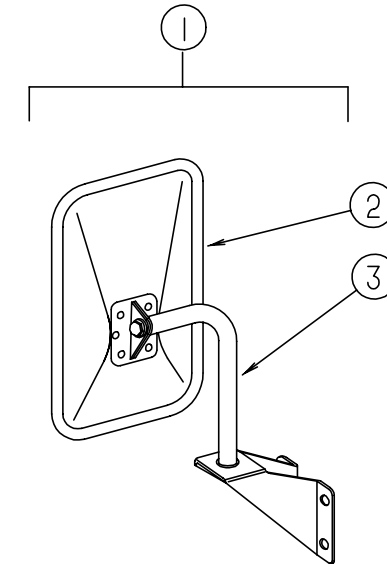

EXTERIOR MIRROR

KEY	PART NUMBER	U/M DESCRIPTION
1	105076-01-702	EA MIRROR ASM-LOW MOUNT RH/LH (FLAT) 713196 1 ONLY W/BRACKET
2	105076-01-703	EA MIRROR HEAD ONLY(FLAT BLK) 709275-8
	049347-01-700	EA GLASS-EXTERIOR MIRROR, 7.5" X 10.5"
3	105076-01-704	EA ARM Q780521-9
	105439-01-000	EA MIRROR-AUX,CONVEX STICK-ON VELVAC 723068-6

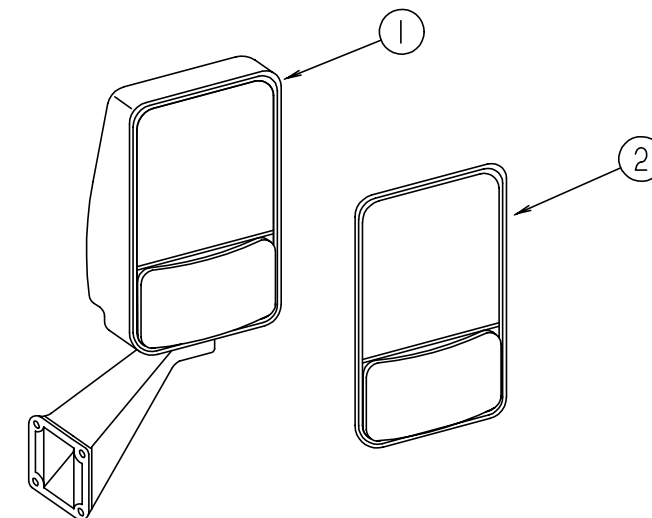

EXTERIOR MIRROR

KEY	PART NUMBER	U/M DESCRIPTION
1	106015-09-01A	EA MIRROR ASM-EXTERIOR GLASS RIGHT - VELVAC 713126 BLACK
1	106015-10-01A	EA MIRROR ASM-EXTERIOR ADJUST GLASS LEFT - VELVAC 713125 BLACK
2	106015-01-703	EA MIRROR KIT (BEZEL W/MIRRORS) PASSENGER SIDE
2	106015-02-702	EA MIRROR KIT (BEZEL W/MIRRORS) DRIVER SIDE

EXTERIOR BODY GROUP (CONTINUED)
DECALS, FILM STRIPES & PAINT

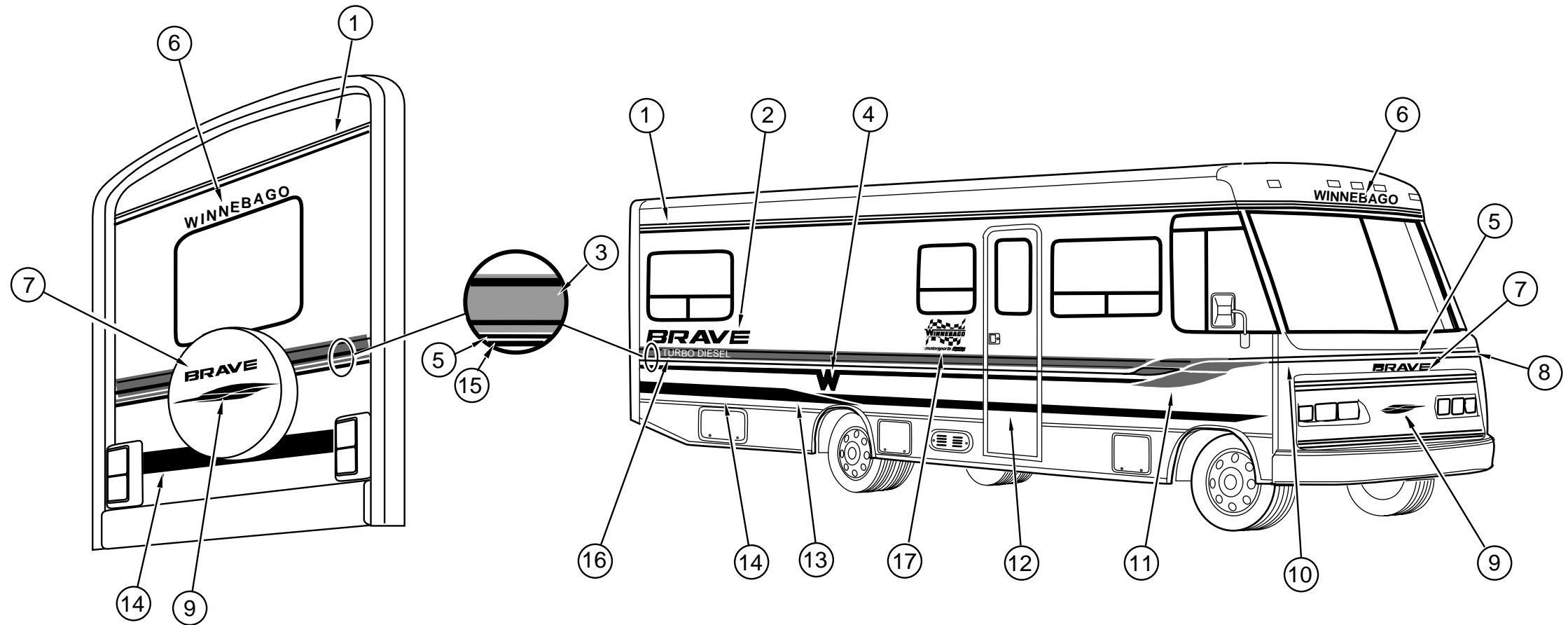

KEY	PART NUMBER	U/M	DESCRIPTION
1	094443-26-01A	FT	FILM-MULTISTRIPE, 3 STRIPES - 63.5 MM - DARK PURPLE/SHALE BLUE/MEDIUM BLUE
2	115642-01-01A	EA	DECAL-BRAVE, LARGE - DARK PURPLE/SHALE BLUE/MEDIUM BLUE
3	094433-08-01A	FT	FILM-OVERLAY, 101.6 MM - MEDIUM BLUE/DARK PURPLE/SHALE BLUE
4	115641-01-01A	EA	DECAL-LOGO, W - DARK PURPLE
5	093681-36-02A	FT	FILM-SINGLE STRIPE, 25.4 MM - SHALE BLUE
6	110206-02-01A	EA	DECAL-WINNEBAGO, SHALE BLUE
7	115642-02-01A	EA	DECAL-BRAVE, SMALL - DARK PURPLE/SHALE BLUE/MEDIUM BLUE
8	115643-02-01A	EA	DECAL-FRONT, CORNER - LH - SHALE BLUE
9	115645-03-01A	EA	DECAL-SWEEP, SMALL - SHALE BLUE/DARK PURPLE
10	115643-01-01A	EA	DECAL-FRONT, CORNER - RH - SHALE BLUE
11	115645-01-01A	EA	DECAL-SWEEPS, RH - SHALE BLUE/DARK PURPLE
11	115645-02-01A	EA	DECAL-SWEEPS, LH - SHALE BLUE/DARK PURPLE
12	093681-44-01A	FT	FILM-SINGLE STRIPE, 63.5 MM - MEDIUM BLUE
13	115644-01-01A	EA	DECAL-RADIUS, RH - SHALE BLUE/DARK PURPLE/MEDIUM BLUE
13	115644-02-01A	EA	DECAL-RADIUS, LH - SHALE BLUE/DARK PURPLE/MEDIUM BLUE
14	115640-01-01A	FT	FILM-OVERLAY, 152.4 MM - SHALE BLUE/DARK PURPLE/MEDIUM BLUE
15	093681-40-03A	FT	FILM-SINGLE STRIPE, 50.8 MM - DARK PURPLE
16	111318-03-01A	EA	DECAL-TURBO DIESEL, OFF WHITE
17	116515-10-01A	EA	DECAL-MOTORSPORTS
	041561-03-000	EA	PAINT - 16 OZ SPRAY, OFF WHITE - ACRYLIC ENAMEL
	106315-06-000	FT	POLYETHYLENE FILM TAPE - 4" - SHORE PAPER 30LD23

DUPONT COLOR CODES

OFF WHITE #L8723

EXTERIOR BODY GROUP (CONTINUED)

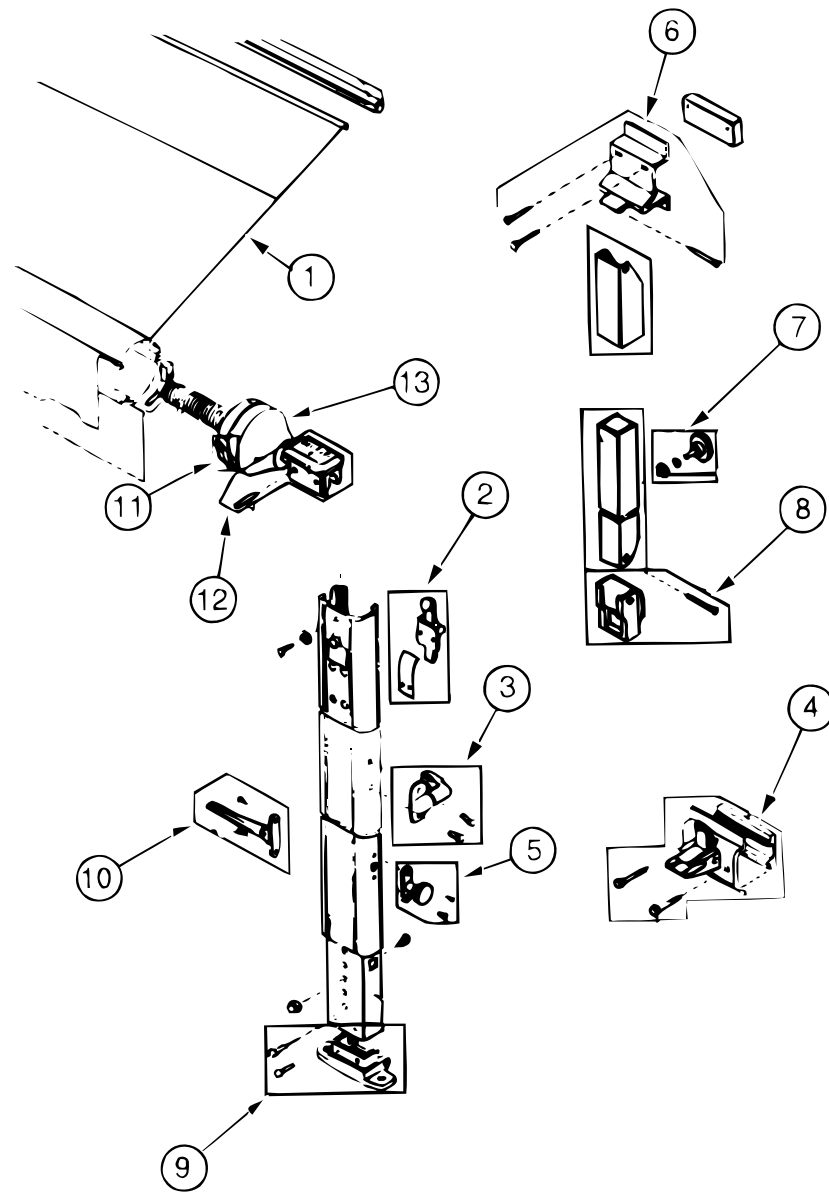

AWNING (FAULKNER)

KEY	PART NUMBER	U/M DESCRIPTION
1	110634-01-03A	EA AWNING-ROLLER ASM, 18'
	110634-02-02A	EA AWNING-HARDWARE KIT, OFF WHITE
	111037-01-01A	EA SPACER-AWNING, UPPER BLACK
	111038-01-01A	EA SPACER-AWNING, LOWER BLACK
2	110634-01-700	EA RAFTER LOCKING MECH KIT - 7605-0001
3	110634-01-701	EA SAFETY & LATCH KIT - 7509-0001
4	110634-01-702	EA BOTTOM BRACKET KIT - 7512-0001
5	110634-01-703	EA HEIGHT LOCK HANDLE KIT - 7510-0001
6	110634-01-704	EA UPPER BRACKET KIT W/BOLTS - 7505-0001
7	110634-01-705	EA ULTRA RAFTER KNOB KIT - 7522-0001
8	110634-01-706	EA RAFTER SLIDE KIT
9	110634-01-707	EA GROUND BRACKET KIT - 7511-0001
10	110634-01-708	EA LIFT HANDLES W/RIVETS - 7000-0001
11	110634-01-709	EA RATCHET HANDLE KIT - 7507-0001
12	110634-01-710	EA ARM CAP KIT - 7503-0001
13	110634-01-711	EA FRONT SPRING ASM - 6598-0001
13	110634-01-712	EA REAR SPRING ASM - 6599-0001
13	110634-01-713	EA REAR END CAP KIT - 7504-0001

GALLEY GROUP

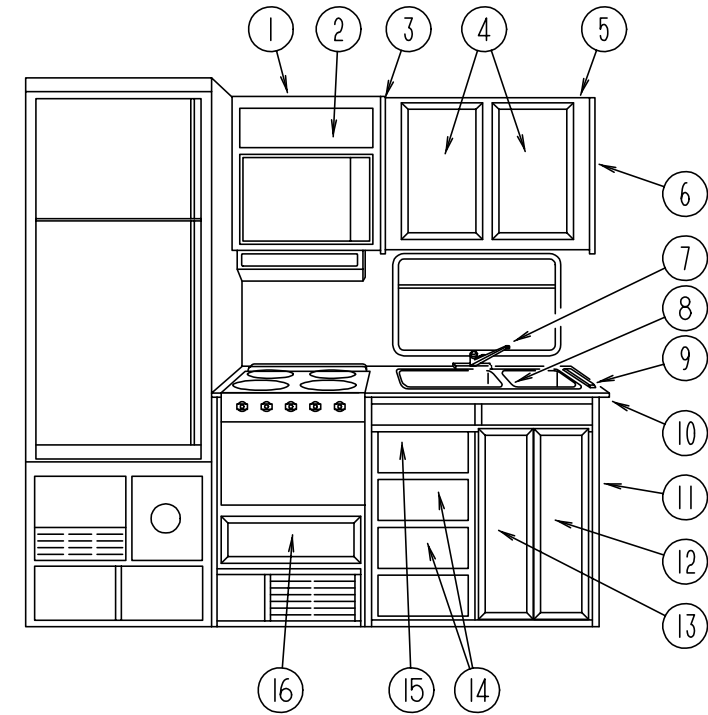

GALLEY CABINETRY

KEY	PART NUMBER	U/M DESCRIPTION
1	114390-01-F04	EA CABINET ASM-MICROWAVE OVERHEAD (F04,F05,F06,F07)
1	114390-01-F14	EA CABINET ASM-MICROWAVE OVERHEAD
2	M05992-11-E07	EA DOOR-CABINET, W/O HARDWARE - 180 X 555MM (F04,F05,F06,F07)
2	M05992-11-F14	EA DOOR-CABINET, W/O HARDWARE - 180 X 555MM
3	081320-16-E10	EA CAP-END, OVERHEAD
4	M06803-05-E07	EA DOOR-CABINET, W/O HARDWARE - 365 X 555MM
5	103276-01-E07	EA CABINET ASM-OVERHEAD,GALLEY
6	081320-17-B25	EA CAP ASM-END,OVERHEAD
7	103243-01-000	EA FAUCET-GALLEY,DUAL CONTROL 8 IN CENTERSET
8	110654-01-000	EA SINK-SST,DOUBLE/SMALL BASIN - DAYTON FR2917
	092303-01-000	EA STRAINER-SINK
	108464-04-E08	EA COVER ASM-SINK (F04,F07)
	108464-04-E38	EA COVER ASM-SINK (F05)
	108464-04-E31	EA COVER ASM-SINK (F06)
	108464-04-E32	EA COVER ASM-SINK (F14)
9	098335-02-E28	EA RAIL-GALLEY,565 (F04,F07)
9	098335-02-E04	EA RAIL-GALLEY,565 (F05)
9	098335-02-E31	EA RAIL-GALLEY,565 (F06)
9	098335-02-E32	EA RAIL-GALLEY,565 (F14)
10	111181-13-E08	EA COUNTERTOP ASM (F04,F07)
10	111181-13-F05	EA COUNTERTOP ASM
10	111181-13-F06	EA COUNTERTOP ASM
10	111181-18-F14	EA COUNTERTOP ASM
11	P11181-01-F04	EA CABINET ASM-GALLEY (F04,F07)
11	P11181-01-F05	EA CABINET ASM-GALLEY
11	P11181-01-F06	EA CABINET ASM-GALLEY
11	P11181-03-F14	EA CABINET ASM-GALLEY
12	M06803-08-E07	EA DOOR-CABINET, W/O HARDWARE - 230 X 675MM (F04,F05,F06,F07)
12	M06803-08-F14	EA DOOR-CABINET, W/O HARDWARE - 230 X 675MM
13	M06803-09-E07	EA DOOR-CABINET, W/O HARDWARE - 230 X 675MM (F04,F05,F06,F07)
13	M06803-09-F14	EA DOOR-CABINET, W/O HARDWARE - 230 X 675MM
14	M05971-11-E07	EA DRAWER-CABINET, W/O HARDWARE (F04,F05,F06,F07)
14	M05971-11-F14	EA DRAWER-CABINET, W/O HARDWARE
15	M05971-83-E07	EA DRAWER-CABINET, W/O HARDWARE (F04,F05,F06,F07)
15	M05971-83-F14	EA DRAWER-CABINET, W/O HARDWARE
16	M05971-50-E07	EA DRAWER-CABINET, W/O HARDWARE (F04,F05,F06,F07)
16	M05971-50-F14	EA DRAWER-CABINET, W/O HARDWARE
	103445-01-01A	EA HOLDER-PAPER TOWEL - PLASTIC - ALMOND
	090329-01-000	FT SEAL-T, REFRIGERATOR CABINET - .6" WIDE TOP X 2" TAIL

GALLEY GROUP (CONTINUED)
RANGE HOOD (CANADIAN)

KEY	PART NUMBER	U/M	DESCRIPTION
	100258-17-01A	EA	HOOD-RANGE, W/O MONITOR PANEL - VENTLINE - CANADIAN
	090973-01-700	EA	MOTOR - LVS CA508-1
	090973-01-702	EA	BLADE-FAN, LVS VA183-1
	092696-01-709	EA	BULB - 912, VENTLINE VA415
	092696-01-710	EA	SOCKET-LIGHT, VENTLINE CB267-2
	096983-01-700	EA	SWITCH-ON/OFF, VENTLINE 108
	096983-01-702	EA	SWITCH-TWO WAY MOMENTARY, VENTLINE 112
	096983-01-707	EA	FILTER-GREASE, 8" X 8" - LVS CC246
	092696-02-701	EA	LENS-LAMP, VENTLINE CC179
	100258-01-700	EA	HOOD-NOSE LABEL, CC428
	100258-10-01A	EA	METER-HOUR, VENTLINE 150

RANGE HOOD

KEY	PART NUMBER	U/M	DESCRIPTION
	100258-18-01A	EA	HOOD-RANGE 22W W/O MONITOR PANEL - VENTLINE - US TPS5007NAD
	090973-01-700	EA	MOTOR - LVS CA508-1
	090973-01-702	EA	BLADE-FAN, LVS VA183-1
	092696-01-709	EA	BULB - 912, VENTLINE VA415
	092696-01-710	EA	SOCKET-LIGHT, VENTLINE CB267-2
	096983-01-700	EA	SWITCH-ON/OFF, VENTLINE 108
	096983-01-702	EA	SWITCH-TWO WAY MOMENTARY, VENTLINE 112
	096983-01-707	EA	FILTER-GREASE, 8" X 8" - LVS CC246
	092696-02-701	EA	LENS-LAMP, VENTLINE CC179
	100258-01-700	EA	HOOD-NOSE LABEL, CC428
	100258-10-01A	EA	METER-HOUR, VENTLINE 150
	100258-16-01A	EA	HOOD-RANGE, W/O MONITOR PANEL - VENTLINE - US TCS5008NAD
	090973-01-700	EA	MOTOR - LVS CA508-1
	090973-01-702	EA	BLADE-FAN, LVS VA183-1
	092696-01-709	EA	BULB - 912, VENTLINE VA415
	092696-01-710	EA	SOCKET-LIGHT, VENTLINE CB267-2
	096983-01-700	EA	SWITCH-ON/OFF, VENTLINE 108
	096983-01-702	EA	SWITCH-TWO WAY MOMENTARY, VENTLINE 112
	096983-01-707	EA	FILTER-GREASE, 8" X 8" - LVS CC246
	092696-02-701	EA	LENS-LAMP, VENTLINE CC179
	100258-01-700	EA	HOOD-NOSE LABEL, CC428
	100258-10-01A	EA	METER-HOUR, VENTLINE 150
	102765-03-01A	EA	PANEL-MONITOR, W/PLUG - FOR 2 TANKS & WATER HEATER - LVS

MICROWAVE OVEN

KEY	PART NUMBER	U/M	DESCRIPTION
	091269-05-000	EA	OVEN-MICROWAVE, DM15H-14B
	094745-01-01A	EA	TRIM-MICROWAVE, LOWER - BLACK
	094774-01-01A	EA	TRIM-MICROWAVE, EITHER SIDE - .5" X 14.8" - METAL - BLACK
	115303-01-000	EA	OVEN-MICROWAVE - MCD-DM15K-7B
	115401-01-01A	EA	TRIM-MICROWAVE, BLACK
	094750-07-000	EA	BRACKET-MICROWAVE, 89 DEGREE - STEEL

COFFEE MAKER

KEY	PART NUMBER	U/M	DESCRIPTION
	103799-01-02A	EA	COFFEE MAKER - GRAY - BLACK & DECKER - W/GLASS POT
	104610-01-000	EA	STRAP ASM-COFFEE MAKER

GALLEY GROUP (CONTINUED)
REFRIGERATOR & LEVEL

KEY	PART NUMBER	U/M	DESCRIPTION
	104138-05-01A	EA	REFRIGERATOR SMALL DOUBLE DOOR 2-WAY - NORCOLD 6162 LH BL
	075217-01-734	EA	FUSE - 3 AMP, NORCOLD# 61538822
	075217-01-738	EA	SWITCH-HUMIDITY, NORCOLD 61525922
	084879-03-700	EA	COOLING UNIT - HORIZONTAL BURNER, NORCOLD# 61687237
	084880-01-705	EA	ORIFICE - NORCOLD# 614522
	084880-01-713	EA	CONNECTOR-MALE, INLET FITTING - NORCOLD# 615256
	084880-01-718	EA	VALVE-GAS, NORCOLD 61551822
	084880-01-720	EA	SPRING (FOR DOOR HANDLE) NORCOLD 61558822
	084880-01-722	EA	CRISPER COVER - NORCOLD 615641
	084880-01-726	EA	HINGE BRACKET (CTR HINGE), NORCOLD 61566523
	084880-01-731	EA	HINGE PIN, NORCOLD 61578123
	084880-01-732	EA	LATCH, NORCOLD 61578522
	084880-01-734	EA	BRACKET-HINGE, TOP RH - BOTTOM LH - BROWN NORCOLD 61580837
	084880-01-735	EA	HINGE BRKT, TOP LH-BTM RH BRN - NORCOLD 61580937
	084880-01-739	EA	END CAP (SPRING CATCH) BRN NORCOLD 61593722
	084880-01-740	EA	END CAP (STOP CATCH) NORCOLD 61593830
	084880-01-746	EA	CABLE, NORCOLD 61571522
	084880-01-747	EA	PLUG-HOLE, NORCOLD 61582022
	084880-01-749	EA	HINGE BUSHING - NORCOLD 615807
	084880-01-753	EA	THERMISTER 78" - NORCOLD 61693822
	084880-01-760	EA	CLIP (THERMISTER) NORCOLD 61689122
	084880-01-761	EA	END CAP (SPRING CATCH) BLACK NORCOLD 61593730
	084880-02-700	EA	LOWER FLANGE 8663 & 8683, NORCOLD 61622123
	084880-03-702	EA	HINGE PIN TOP/BTM FEMALE NORCOLD 61580630
	084880-03-705	EA	BRACKET F/INTERIOR REFRIGERATOR LIGHT - NORCOLD 61629722
	084880-03-706	EA	LAMP (BULB) - NORCOLD 61628922
	084880-03-707	EA	COVER F/LAMP OR BULB - NORCOLD 61627922
	088248-01-706	EA	BURNER-HORIZONTAL, NORCOLD 61588122
	088248-01-707	EA	ELECTRODE-SENSOR, (HORIZONTAL), NORCOLD# 61573322
	088248-01-709	EA	HEATER-AC, (HORIZONTAL) - NORCOLD# 615627
	088248-01-710	EA	HEATER-DC, (HORIZONTAL) - 3 WAY - NORCOLD# 615628
	094038-01-700	EA	GASKET-LOWER, GRAY - NORCOLD 61567930
	094038-01-701	EA	LINER-DOOR, LOWER - BROWN/WHITE - NORCOLD 61581937-B
	094038-01-702	EA	LINER-DOOR, LOWER - BLACK/WHITE - NORCOLD 61581938-B
	094038-01-703	EA	HANDLE-DOOR, LOWER - BROWN - NORCOLD 61650137
	094038-01-704	EA	HANDLE-DOOR, LOWER - BLACK - NORCOLD 61650138
	094039-01-702	EA	GASKET (GRAY) UPPER - NORCOLD 61567830
	094039-01-703	EA	PLATE-HINGE, LH - BROWN - NORCOLD 61631422
	094039-01-704	EA	PLATE-HINGE, BLACK - NORCOLD 61631430
	094039-01-706	EA	UPPER DOOR LINER (WHITE) BLK - NORCOLD 61581838-B
	094039-01-708	EA	HANDLE-DOOR, UPPER - BLACK - NORCOLD 61650038
	094039-01-709	EA	PLATE-HINGE, TOP RH - LH BOTTOM - BROWN - NORCOLD 61631322
	094039-01-710	EA	PLATE-HINGE, BLACK - NORCOLD 61631330
	094039-01-722	EA	HOLE PLUG (BLK) HINGE HOLES - NORCOLD 61582030
	094039-01-723	EA	HINGE BRKT, TOP RH-BTM LH BLK - NORCOLD 61580838
	094039-01-724	EA	BRACKET-HINGE, TOP LH - BOTTOM RH - BLK - NORCOLD 61580938
	094039-01-725	EA	HINGE PIN (BLACK)(MALE) - NORCOLD 61578130
	094039-01-726	EA	SHELF-FREEZER EVAPORATOR, NORCOLD 615236
	094039-01-730	EA	HINGE PIN SHAFT(BLK) CENTER HGE - NORCOLD 61566730
	094039-01-732	EA	FRONT COVER(BLK) BTM TRIM - NORCOLD 61622130
	094039-01-733	EA	WIRE SHELF, GRAY (MIDDLE) - NORCOLD 61563822
	094039-01-734	EA	WIRE SHELF, GRAY (TOP) W/RISER - NORCOLD 61563722
	094039-01-735	EA	INSIDE DRIP TRAY (WHITE) NORCOLD 61572830
	094039-01-736	EA	SWITCH-LIGHT, BLACK - NORCOLD 615810
	094039-01-739	EA	SHELF (CUTOUT) NORCOLD 61646722
	094039-04-700	EA	PRINTED CIRCUIT BOARD-2 WAY, NORCOLD# 61647322
	094039-04-701	EA	EYEBROW (SHELL) 2 WAY - NORCOLD 61669822
	094039-04-702	EA	POWER SUPPLY (2 WAY) - NORCOLD 61647422
	104137-02-700	EA	MODULE-CONTROL, CHANNEL - NORCOLD 61717037
	104137-06-700	EA	EYEBROW SHELL (2-WAY) NORCOLD 61726622
	104137-06-702	EA	RACK-JUICE (WHITE) NORCOLD 61580525

GALLEY GROUP (CONTINUED)
REFRIGERATOR & LEVEL (CONTINUED)

KEY	PART NUMBER	U/M	DESCRIPTION
	104137-06-703	EA	BIN-DOOR SHELF (WHITE) NORCOLD 61564025
	104137-06-706	EA	WIRE SHELF (SHORT) NORCOLD 61718222
	104137-06-707	EA	CRISPER (WHITE) NORCOLD 61571325
	104137-06-709	EA	VALVE SHUT-OFF-MANUAL ASM NORCOLD 61694922
	104137-06-710	EA	PRESSURE TAP NORCOLD 61594422
	104137-06-711	EA	FUSE 5 AMP NORCOLD 61611622
	104137-06-712	EA	FITTING-GAS TUBE CONNECTION NORCOLD 61692722
	104137-06-713	EA	ORFICE GASKET NORCOLD 61475122
	104137-06-714	EA	BURNER ASSEMBLY (5-SLOT) NORCOLD 61705222
	104137-06-715	EA	SPARK/SENSE ELECTRODE(SINGLE) NORCOLD 61692222
	104138-04-701	EA	FOAMED CAB ASM (BLK W/WHITE) NORCOLD 61725038
	054450-01-000	EA	LEVEL-REFRIGERATOR
	065225-02-000	EA	PLATE-TIEDOWN, REFRIGERATOR
	103251-02-01A	EA	INSERT-ACRYLIC, 19.53 X 16.6 (F14)
	103251-03-01A	EA	INSERT-ACRYLIC, 19.53 X 32.20 (F14)

RANGE

KEY	PART NUMBER	U/M	DESCRIPTION
	112881-01-01A	EA	RANGE-16" 3 BURNER ALMOND - MAGIC CHEF 16RA-3B FROM: 00-00-00 THRU: 06-19-94
	055282-04-700	EA	PANEL-OVEN DOOR, ALMOND - MAGIC CHEF 50-26577-2A
	102020-01-700	EA	SHELF-OVEN, MAGIC CHEF - 7801-P027-60
	102020-01-701	EA	HANDLE-DOOR, MAGIC CHEF - 7701P092-60
	102020-01-709	EA	BUMPER-GRATE, MAGIC CHEF 8007P018-60
	102020-01-711	EA	GRATE-TOP, MAGIC CHEF 7518P012-60
	102020-01-722	EA	VALVE-TOP BURNER, MAGIC CHEF 7502P095-60
	102020-01-724	EA	BUMPER-MAIN TOP, MAGIC CHEF 8003P008-60
	102022-01-708	EA	REGULATOR PRESSURE 1/4IN 1/2 OUT 7510P041-60
	112881-01-700	EA	TOP, MAIN-ALMOND 2001F110-84
	112881-01-701	EA	MANIFOLD PANEL 2616F091-70
	112881-01-702	EA	VALVE-MERCURY (SAFETY VALVE) 7501-P121-60
	112881-01-703	EA	VALVE-TOP BURNER HI-OUTPUT 7502P180-60
	112881-01-704	EA	KNOB-THERMOSTAT 7731P067-60
	112881-01-705	EA	KNOB-TOP BURNER 7733P072-60
	112881-01-706	EA	THERMOSTAT 12400026
	112881-01-707	EA	TRIM-FLAT (LEFT) (BLK) 3608W035-70
	112881-01-708	EA	TRIM-FLAT (RIGHT) (BLK) 3608W036-70
	112881-01-709	EA	PIPE-MANIFOLD 7513P097-60
	112881-01-710	EA	OVEN PILOT 7505P202-60
	112881-01-711	EA	OVEN BURNER 3404W025045
	112881-01-03A	EA	RANGE-16" 3 BURNER ALMOND - MAGIC CHEF FROM: 06-20-94 THRU: 99-99-99
	055282-04-700	EA	PANEL OVEN DOOR ALMOND
	102020-01-700	EA	SHELF-OVEN
	102020-01-701	EA	HANDLE, DOOR
	102020-01-709	EA	BUMPER, GRATE
	102020-01-711	EA	GRATE, TOP
	102020-01-722	EA	VALVE, TOP BURNER
	102020-01-724	EA	BUMPER, MAIN TOP
	102022-01-708	EA	REGULATOR PRESSURE 1/4IN 1/2 OUT
	112881-01-700	EA	TOP, MAIN-ALMOND
	112881-01-701	EA	MANIFOLD PANEL
	112881-01-702	EA	VALVE-MERCURY (SAFETY VALVE)
	112881-01-703	EA	VALVE-TOP BURNER HI-OUTPUT
	112881-01-704	EA	KNOB-THERMOSTAT
	112881-01-705	EA	KNOB-TOP BURNER
	112881-01-706	EA	THERMOSTAT
	112881-01-707	EA	TRIM-FLAT (LEFT) (BLK)
	112881-01-708	EA	TRIM-FLAT (RIGHT) (BLK)
	112881-01-709	EA	PIPE-MANIFOLD
	112881-01-710	EA	OVEN PILOT
	112881-01-711	EA	OVEN BURNER
	112881-01-713	EA	DOOR-OVEN-TEXTURED

GENERATOR GROUP
5.0 KW EMERALD PLUS EXPORT

KEY	PART NUMBER	U/M	DESCRIPTION
	100975-03-000	EA	GENERATOR - 5.0 KW EMERALD PLUS - ONAN NHE-FN/29236G WITH ONAN TRAY #403-2218
	007131-01-000	EA	HANGER-TAILPIPE, 6 SLOTS
	079654-05-000	EA	PIPE-EXHAUST, ANGLED - W/FLANGE - 2" ID - ONAN# 154-2539
	082272-01-000	EA	MUFFLER-GENERATOR
	094059-01-000	EA	SPACER-GENERATOR, ONAN
	105732-02-000	EA	TRAY ASM-GENERATOR
	105958-03-000	EA	PIPE-EXHAUST,GENERATOR
	007125-03-000	EA	CLAMP-MUFFLER - 1.5" DIA.
	007125-04-000	EA	CLAMP-MUFFLER - 1.1" DIA.

4,000 WATT ONAN EMERALD PLUS

KEY	PART NUMBER	U/M	DESCRIPTION
	100974-01-000	EA	GENERATOR - 4,000 WATT EMERALD PLUS, ONAN BGE-FA/26100G
	007067-01-000	SF	INSULATION-FIBERGLASS, 1" THICK X 4' - INCREMENTS OF 4 SF
	007125-03-000	EA	CLAMP-MUFFLER, 1.5" DIA
	007125-04-000	EA	CLAMP-MUFFLER, 1.1" DIA
	079654-05-000	EA	PIPE-EXHAUST, ANGLED - W/FLANGE - 2" ID - ONAN# 154-2539
	082272-01-000	EA	MUFFLER-GENERATOR, ONAN
	094059-01-000	EA	SPACER-GENERATOR, ONAN
	105732-02-000	EA	TRAY ASM-GENERATOR
	106602-01-000	EA	PIPE-EXHAUST, GENERATOR
	106607-01-000	EA	ANGLE-SUPPORT, EXHAUST

4.0 KW EMERALD PLUS EXPORT

KEY	PART NUMBER	U/M	DESCRIPTION
	100974-04-000	EA	GENERATOR - 4.0KW EMERALD PLUS ONAN BGE-FN/29236G WITH ONAN TRAY #403-2218
	007131-01-000	EA	HANGER-TAILPIPE, 6 SLOTS
	079654-05-000	EA	PIPE-EXHAUST, ANGLED - W/FLANGE - 2" ID - ONAN# 154-2539
	082272-01-000	EA	MUFFLER-GENERATOR
	094059-01-000	EA	SPACER-GENERATOR, ONAN
	105732-02-000	EA	TRAY ASM-GENERATOR
	105958-03-000	EA	PIPE-EXHAUST,GENERATOR
	007067-01-000	SF	INSULATION-FIBERGLASS, 1" THICK X 4' - INCREMENTS OF 4 SF
	007125-01-000	EA	CLAMP-MUFFLER - 1.62" DIA.
	007125-03-000	EA	CLAMP-MUFFLER - 1.5" DIA.
	007125-04-000	EA	CLAMP-MUFFLER - 1.1" DIA.
	093511-01-000	EA	VAPOR KIT-LP, GENERATOR

4.0 KW EMERALD PLUS

KEY	PART NUMBER	U/M	DESCRIPTION
	100974-01-000	EA	GENERATOR - 4.0KW EMERALD PLUS, ONAN BGE-FA/26100G
	007067-01-000	SF	INSULATION-FIBERGLASS, 1" THICK X 4' - INCREMENTS OF 4 SF
	079654-05-000	EA	PIPE-EXHAUST, ANGLED - W/FLANGE - 2" ID - ONAN# 154-2539
	082272-01-000	EA	MUFFLER-GENERATOR
	094059-01-000	EA	SPACER-GENERATOR, ONAN
	105732-02-000	EA	TRAY ASM-GENERATOR
	105958-03-000	EA	PIPE-EXHAUST,GENERATOR
	007125-04-000	EA	CLAMP-MUFFLER - 1.1" DIA.

GENERATOR GROUP (CONTINUED)
6.5 KW EMERALD PLUS

KEY	PART NUMBER	U/M DESCRIPTION
	100975-01-000	EA GENERATOR - 6.5KW EMERALD PLUS, ONAN NHE-FA/26100G WITH ONAN TRAY #403-2218
	007067-01-000	SF INSULATION-FIBERGLASS, 1" THICK X 4' - INCREMENTS OF 4 SF
	079654-05-000	EA PIPE-EXHAUST, ANGLED - W/FLANGE - 2" ID - ONAN# 154-2539
	082272-01-000	EA MUFFLER-GENERATOR
	094059-01-000	EA SPACER-GENERATOR, ONAN
	105732-02-000	EA TRAY ASM-GENERATOR
	105958-03-000	EA PIPE-EXHAUST,GENERATOR
	007125-03-000	EA CLAMP-MUFFLER - 1.5" DIA.
	007125-04-000	EA CLAMP-MUFFLER - 1.1" DIA.
	007131-01-000	EA HANGER-TAILPIPE, 6 SLOTS

5000W KOHLER LOW PROFILE

KEY	PART NUMBER	U/M DESCRIPTION
	105524-01-000	EA GENERATOR - 5KW LOW PROFILE KOHLER 5CKM21
	007067-01-000	SF INSULATION-FIBERGLASS, 1" THICK X 4' - INCREMENTS OF 4 SF
	105526-01-000	EA ARRESTER-SPARK, KOHLER 278621
	105527-01-000	EA PIPE-EXHAUST ADAPTER, KOHLER 278524
	105530-01-000	EA MUFFLER-SIDE EXHAUST W/O SPARK KOHLER 278733
	105602-01-000	EA GASKET-EXHAUST, KOHLER-278320
	105732-02-000	EA TRAY ASM-GENERATOR
	105958-03-000	EA PIPE-EXHAUST,GENERATOR
	007125-03-000	EA CLAMP-MUFFLER - 1.5" DIA.
	007125-04-000	EA CLAMP-MUFFLER - 1.1" DIA.

7.0KW KOHLER LOW PROFILE

KEY	PART NUMBER	U/M DESCRIPTION
	105525-01-000	EA GENERATOR - 7.0KW - LOW PROFILE - KOHLER 7CKM21
	007067-01-000	SF INSULATION-FIBERGLASS, 1" THICK X 4' - INCREMENTS OF 4 SF
	094059-01-000	EA SPACER-GENERATOR, ONAN
	105526-01-000	EA ARRESTER-SPARK, KOHLER 278621
	105527-02-000	EA PIPE-EXHAUST ADAPTER, KOHLER-278979
	105530-01-000	EA MUFFLER-SIDE EXHAUST W/O SPARK KOHLER 278733
	105602-01-000	EA GASKET-EXHAUST, KOHLER-278320
	105732-02-000	EA TRAY ASM-GENERATOR
	105958-03-000	EA PIPE-EXHAUST,GENERATOR
	007125-03-000	EA CLAMP-MUFFLER - 1.5" DIA.
	007125-04-000	EA CLAMP-MUFFLER - 1.1" DIA.

5 KW EMERALD PLUS

KEY	PART NUMBER	U/M DESCRIPTION
	109303-01-000	EA GENERATOR - 5KW EMERALD PLUS - ONAN WITH ONAN TRAY #403-2727
	007067-01-000	SF INSULATION-FIBERGLASS, 1" THICK X 4' - INCREMENTS OF 4 SF
	007125-04-000	EA CLAMP-MUFFLER, 1.1" DIA
	079654-05-000	EA PIPE-EXHAUST, ANGLED - W/FLANGE - 2" ID - ONAN# 154-2539
	082272-01-000	EA MUFFLER-GENERATOR
	094059-01-000	EA SPACER-GENERATOR, ONAN
	105732-02-000	EA TRAY ASM-GENERATOR
	105958-03-000	EA PIPE-EXHAUST,GENERATOR

HEATING & AIR CONDITIONING GROUP
30,000 BTU SUBURBAN FURNACE & WALL THERMOSTAT

KEY	PART NUMBER	U/M DESCRIPTION
	098668-20-000	EA FURNACE - 30,000 BTU, SUBURBAN SF-30 2273
	069634-01-733	EA RELAY, TIME DELAY 20 & 30 BTU, SUBURBAN 231202
	075695-01-709	EA MICRO SWITCH (FOR MODELS 30 & 34S) - SUBURBAN#230509
	090039-01-709	EA GASKET-COVER, OBSERVATION HOLE
	092300-01-704	EA GASKET-ELECTRODE, SUBURBAN 070163
	092300-02-701	EA ORFICE, MAIN BURNER - SUBURBAN 180214
	093365-01-000	EA THERMOSTAT-WALL, FURNACE - SUBURBAN 0160902
	098668-01-700	EA CABINET FRONT, SUBURBAN 101242
	098668-01-701	EA CABINET ASM, SUBURBAN 101299
	098668-01-704	EA VALVE, SUBURBAN 160938
	098668-01-705	EA SWITCH-LIMIT, SUBURBAN 231630
	098668-01-706	EA WHEEL-COMBUSTION AIR, SUBURBAN 350122
	098668-01-707	EA VENT CAP & EXHAUST TUBE ASM, SUBURBAN 260193
	098668-01-708	EA BLOWER ASM (COMBUSTION AIR), SUBURBAN 390441
	098668-01-709	EA MOTOR ASM.-FOR SF-25, SF-30 - SUBURBAN 231706
	098668-01-710	EA BLOWER ASM (ROOM AIR), SUBURBAN 390440
	098668-01-711	EA WHEEL, ROOM AIR - SUBURBAN 350123
	098668-01-712	EA BOARD-MODULE, SUBURBAN 231741
	098668-01-713	EA INTAKE VENT TUBE ASM 051044
	098668-01-714	EA GAS VALVE FOR SF MODELS S.N.#921401821 AND UP
	098668-01-715	EA ELECTRODE ASM. (SGL PROBE) F/SF MODELS S.N.#921401821 & UP
	098668-02-700	EA BURNER ASM COMPLETE (SF-30/SF35), SUBURBAN 010745
	069636-02-000	EA CONNECTOR-DUCT, 4" ID - SUBURBAN 050715
	009198-01-000	FT DUCT-HEAT, FLEXIBLE - 4" ID X 25 FT
	009200-01-000	EA TAPE-FURNACE, 1 1/2"
	098668-06-000	EA DOOR-ACCESS, FURNACE - OFF WHITE - SUBURBAN 520574
	056464-04-000	EA REGISTER-HEAT, 4" DIAMETER - W/DAMPER - PLASTIC - SAND
	056464-05-000	EA REGISTER-PLASTIC W/O DAMPER - 4" DIAMETER - GOLDEN
	093614-01-01A	EA GRILLE-RETURN AIR, FURNACE - 15.6" X 7.6" - BROWN

HEATING & AIR CONDITIONING GROUP (CONTINUED)
35,000 BTU SUBURBAN FURNACE

KEY	PART NUMBER	U/M DESCRIPTION
	098668-21-000	EA FURNACE - 35,000 BTU, SUBURBAN SF-35 2274
	069634-01-720	EA ORIFICE-MAIN BURNER, SUBURBAN# 0180222
	074466-01-702	EA RELAY-TIME DELAY, SUBURBAN# 230625
	075695-01-709	EA MICRO SWITCH (FOR MODELS 30 & 34S) - SUBURBAN#230509
	093365-01-000	EA THERMOSTAT-WALL, FURNACE - SUBURBAN 0160902
	098668-01-700	EA CABINET FRONT, SUBURBAN 101242
	098668-01-706	EA WHEEL-COMBUSTION AIR, SUBURBAN 350122
	098668-01-707	EA VENT CAP & EXHAUST TUBE ASM, SUBURBAN 260193
	098668-01-708	EA BLOWER ASM (COMBUSTION AIR), SUBURBAN 390441
	098668-01-709	EA MOTOR ASM.-FOR SF-25, SF-30 - SUBURBAN 231706
	098668-01-710	EA BLOWER ASM (ROOM AIR), SUBURBAN 390440
	098668-01-711	EA WHEEL, ROOM AIR - SUBURBAN 350123
	098668-01-712	EA BOARD-MODULE, SUBURBAN 231741
	098668-01-713	EA INTAKE VENT TUBE ASM 051044
	098668-02-700	EA BURNER ASM COMPLETE (SF-30/SF35), SUBURBAN 010745
	098668-03-700	EA MOTOR ASM-SF-35, SUBURBAN# 231707
	101990-01-714	EA MICROSCHWITCH GASKET, SUBURBAN 230877
	009198-01-000	FT DUCT-HEAT, FLEXIBLE - 4" ID X 25 FT
	009200-01-000	EA TAPE-FURNACE, 1 1/2"
	069636-02-000	EA CONNECTOR-DUCT, 4" ID - SUBURBAN 050715

REAR HEATER & WATER HEATER W/MOTOR AID

KEY	PART NUMBER	U/M DESCRIPTION
	009198-01-000	FT DUCT-HEAT, FLEXIBLE - 4" ID - INCREMENTS OF 25'
	009200-01-000	EA TAPE-FURNACE, 1 1/2"
	023146-01-000	EA CLAMP-SCREW TYPE - 4"
	069636-02-000	EA CONNECTOR-DUCT, 4" ID
	007076-01-000	EA HOSE-FLEXIBLE PVC - 2" ID - INCREMENTS OF 50'
	007108-01-000	FT HOSE-HEATER, 5/8" ID
	008042-01-000	FT TUBING-VINYL, .65" ID
	056464-04-000	EA REGISTER-W/DAMPER, 4" DIAMETER - PLASTIC - SAND
	056464-05-000	EA REGISTER-W/O DAMPER, 4" DIAMETER - PLASTIC - GOLDEN
	061673-01-000	EA BRACKET-MOTOR AID TUBES, 4" X 1.5" - STEEL
	088753-01-000	FT TUBE-ALUMINIZED STEEL, 5/8" - 18 GAUGE
	079059-01-000	EA HOSE - 90 DEGREE, 5/8" ID X 4" X 36"
	079059-02-000	EA HOSE - 90 DEGREE, .61"ID X 4" X 6"
	079059-03-000	EA HOSE - 90 DEGREE, .61"ID X 4" X 18"
	010227-01-000	EA TEE-BARB, 5/8" OR 3/4" HOSE - PLASTIC

EVANS REAR HEATER

KEY	PART NUMBER	U/M DESCRIPTION
	084405-01-000	EA HEATER ASM-REAR, DUCTED - W/MOTOR AID - EVANS
	084405-01-700	EA HEATER CORE-EVANS# FT200229
	084405-01-701	EA FAN BLADES-EVANS# HV029931
	084405-01-702	EA MOTOR ASM - 12 V, EVANS# 200146

HEATING & AIR CONDITIONING GROUP (CONTINUED)

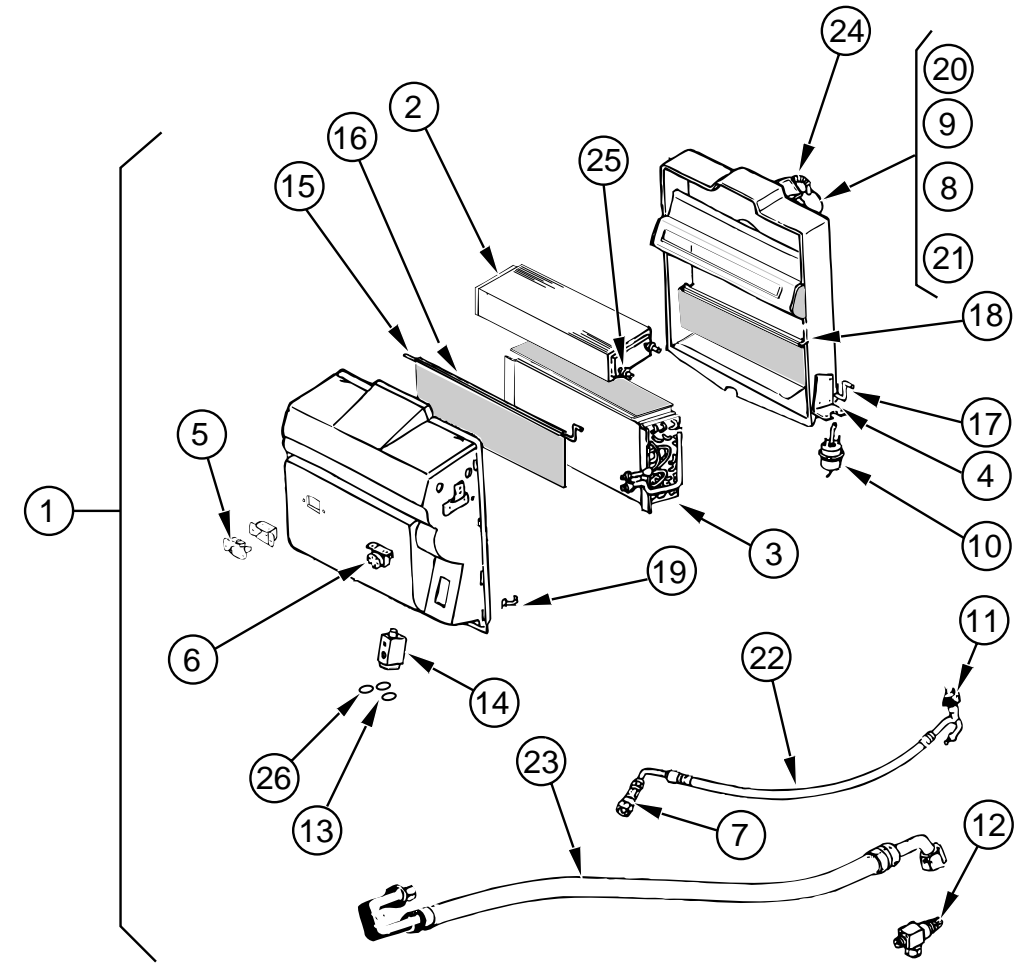

EVAPORATOR/HEATER ASSEMBLY - FORD GAS CHASSIS

KEY	PART NUMBER	U/M DESCRIPTION
1	103930-21-000	EA EVAPORATOR/HEATER ASSEMBLY - SCS 090-00084
2	103930-01-703	EA COIL-HEATER, SCS 042-0010
3	103930-01-704	EA COIL EVAPORATOR, SCS 041-0017
4	103930-01-708	EA BRACKET-VACUUM MOTOR, SCS 070-0113
5	103930-01-710	EA RESISTOR-FUSED, SCS 035-0006
6	103930-01-711	EA THERMOSTAT, SCS 033-0003
7	103930-01-713	EA FITTING-QUICK CONNECT, #4 - SCS 050-003
8	103930-01-717	EA WHEEL-CLOCK-WISE, SCS 062-0010
9	103930-01-720	EA MOTOR, SCS 030-0004
10	103930-02-708	EA MOTOR-VACUUM SERVO, A/C - SCS 030-0002
11	103930-12-708	EA SWITCH-BINARY, R-134A - SCS 032-0048
12	103930-13-702	EA SERVICE VALVE - SCS 050-152
13	103930-17-702	EA GASKET OR SAE 015 #10 33-781, SCS 045-0127
14	103930-20-700	EA VALVE-EXPANSION BLOCK, 2 TON - SCS 034-0032
15	103930-20-702	EA ROD-AIR BLEND DOOR, SCS 073-0039
16	103930-20-703	EA DOOR-AIR BLEND, SCS 071-0212
17	103930-20-704	EA ROD-RECIRCULATING DOOR, SCS 073-0018
18	103930-20-705	EA DOOR-RECIRCULATING, SCS 071-0213
19	103930-20-706	EA CLIP-RETAINER, SCS 022-0057
20	103930-20-707	EA HOUSING-BLOWER, SCS 062-0145
21	103930-20-708	EA CLIP F/MOTOR SHAFT, SCS 022-0001
22	103930-21-700	EA HOSE #6 - FORD - SCS 085-0139
23	103930-21-701	EA HOSE #10 - FORD - SCS 085-0140
24	110279-01-703	EA HOSE-VENT, BLOWER MOTOR, SCS 051-0034
25	110279-01-712	EA FITTING-HEATER, SCS 050-0076
26	113245-01-707	EA GASKET #8, SCS 045-0126

HEATING & AIR CONDITIONING GROUP (CONTINUED)

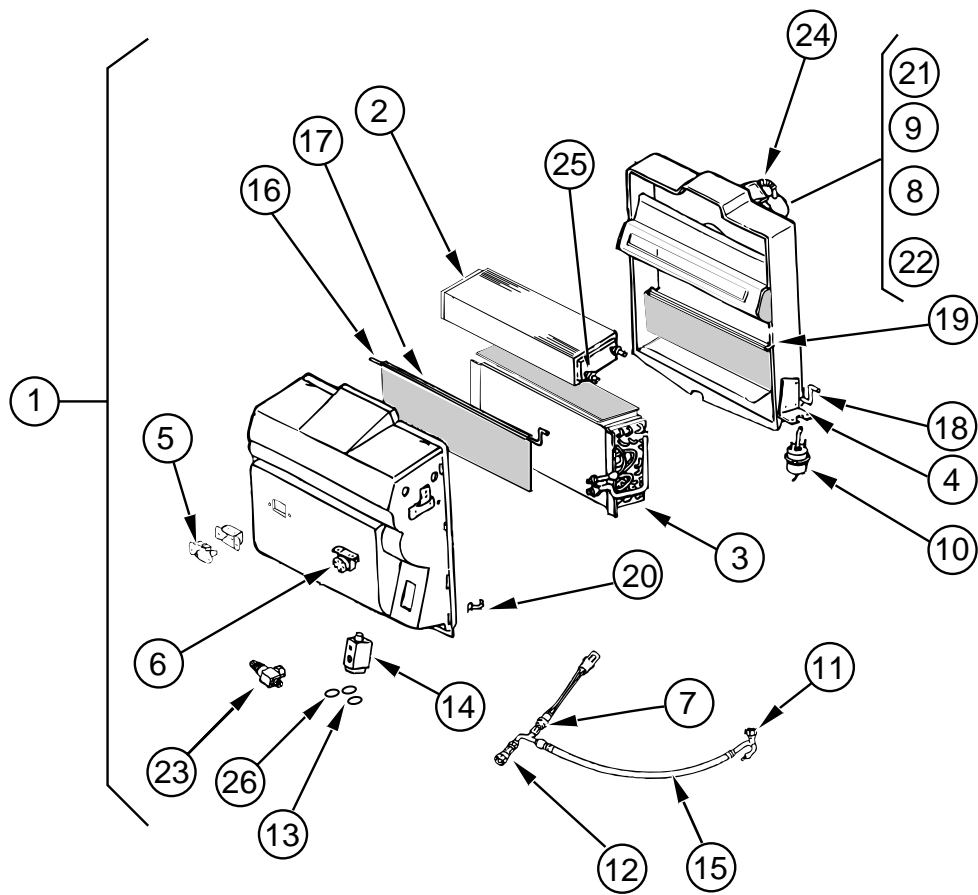

EVAPORATOR/HEATER ASSEMBLY - CHEVY GAS & DIESEL CHASSIS

KEY	PART NUMBER	U/M DESCRIPTION
1	103930-20-000	EA EVAPORATOR/HEATER ASSEMBLY - SCS 090-00083
2	103930-01-703	EA COIL-HEATER, SCS 042-0010
3	103930-01-704	EA COIL EVAPORATOR, SCS 041-0017
4	103930-01-708	EA BRACKET-VACUUM MOTOR, SCS 070-0113
5	103930-01-710	EA RESISTOR-FUSED, SCS 035-0006
6	103930-01-711	EA THERMOSTAT, SCS 033-0003
7	103930-01-716	EA SWITCH-PRESSURE, FAN - SCS 032-0036
8	103930-01-717	EA WHEEL-CLOCK-WISE, SCS 062-0010
9	103930-01-720	EA MOTOR, SCS 030-0004
10	103930-02-708	EA MOTOR-VACUUM SERVO, A/C - SCS 030-0002
11	103930-12-708	EA SWITCH-BINARY, R-134A - SCS 032-0048
12	103930-12-709	EA FITTING-QUICK CONNECT - SCS 050-0120
13	103930-17-702	EA GASKET OR SAE 015 #10 33-781, SCS 045-0127
14	103930-20-700	EA VALVE-EXPANSION BLOCK, 2 TON - SCS 034-0032
15	103930-20-701	EA HOSE ASM - #6, SCS 085-0138
16	103930-20-702	EA ROD-AIR BLEND DOOR, SCS 073-0039
17	103930-20-703	EA DOOR-AIR BLEND, SCS 071-0212
18	103930-20-704	EA ROD-RECIRCULATING DOOR, SCS 073-0018
19	103930-20-705	EA DOOR-RECIRCULATING, SCS 071-0213
20	103930-20-706	EA CLIP-RETAINER, SCS 022-0057
21	103930-20-707	EA HOUSING-BLOWER, SCS 062-0145
22	103930-20-708	EA CLIP F/MOTOR SHAFT, SCS 022-0001
23	103930-20-709	EA SERVICE VALVE - SCS 050-159
24	110279-01-703	EA MOTOR-BLOWER, SCS 051-0034
25	110279-01-712	EA FITTING-HEATER, SCS 050-0076
26	113245-01-707	EA GASKET #8, SCS 045-0126

HEATING & AIR CONDITIONING GROUP (CONTINUED) CONTROL/PLENUM

KEY	PART NUMBER	U/M DESCRIPTION
	103930-04-000	EA CONTROL/PLENUM SET SCS 093-00037
	072341-06-700	EA SWITCH - 4 SPEED, FAN - ARA 0883502
	094831-01-709	EA CLAMPS-ROD, 3/16" - MOTIVAIR/SCS ZGG14431
	103930-02-700	EA PANEL-CONTROL, SCS 032-0018
	103930-02-701	EA VALVE-CONTROL HEAD, SCS 034-0015
	103930-02-702	EA DECAL-FAN SWITCH, SCS 058-0008
	103930-02-703	EA HARNESS-WIRE CONTROL, SCS 036-0048
	103930-02-704	EA HARNESS-VACUUM CONTROL, SCS 036-0049
	103930-02-705	EA CABLE-CONTROL, BOWDEN - SCS 074-0011 SHEATH LENGTH IS 84 1/4" - CABLE LENGTH IS 89" LONG
	103930-02-706	EA CLIP-CABLE, CONTROL - SCS 022-0017
	103930-02-707	EA RELAY, SCS 031-0001
	103930-02-708	EA MOTOR-VACUUM SERVO, A/C - SCS 030-0002
	103930-02-710	EA CANISTER-VACUUM, SCS 054-0002
	103930-02-711	EA VALVE-WATER, SCS 034-00114

HOSE KITS

KEY	PART NUMBER	U/M DESCRIPTION
	103930-18-000	EA HOSE KIT #10 GM-HARRISON COM SCS 093-00077
	103930-17-701	EA FTG #10.90 W/FERRULE/1342CP 050-0132
	103930-17-702	EA GASKET OR SAE 015 #10 33-781, SCS 045-0127
	103930-17-703	EA GASKET-SEAL,SANDEW COMP33-76 045-0142
	103930-18-700	EA FTG,PAD,COMP SUCTION (HARRIS 050-00133
	103930-18-701	EA HOSE ASSY #10 085-0114
	103930-18-702	EA GASKET SEAL HARRISON 045-0143
	110279-01-708	EA HOSE, REFG. BARRIER#10SAEJ51 051-0008
	103930-17-000	EA HOSE KIT #10 GM-SANDEN COMP SCS 093-00076
	103930-01-708	EA BRACKET-VACUUM MOTOR, SCS 070-0113
	103930-17-700	EA FTG. PAD COMP. SUCTION SAN 050-0131
	103930-17-701	EA FTG #10.90 W/FERRULE/1342CP 050-0132
	103930-17-702	EA GASKET OR SAE 015 #10 33-781, SCS 045-0127
	103930-17-703	EA GASKET-SEAL,SANDEW COMP33-76 045-0142
	103930-17-704	EA HOSE ASSY #10 085-0113

AUTOMOTIVE HEATER MISCELLANEOUS

KEY	PART NUMBER	U/M DESCRIPTION
	007281-01-000	EA HOSE-FLEXIBLE PVC, 2.5"ID X 50' - ATCOFLEX A-182-355
	024990-05-000	EA 4" DIAMETER OUTLET W/SWIVEL DEFLECTORS
	056402-05-000	EA BRACKET-HEATER VENT, ROUND - W/BEND - BLACK
	077075-01-000	EA GASKET-INSTRUMENT PANEL TO DEFROSTER PLENUM - .6" X 11.3"
	077075-03-000	EA GASKET-NSTRUMENT PANEL TO DEFROSTER PLENUM,SPL
	103016-01-000	EA PLENUM-TRANSITION
	103017-01-000	EA PLENUM-DEFROSTER
	103558-01-05A	EA VENT-DEFROST,ABS CAMB BISQUE
	103796-01-01A	EA LOUVER ASM-A/C CARY PROD BLK, 268-3B,100-2-4-8
	097494-02-000	EA TEE-BRASS, BARB - 3/8 X 5/32 X 3/8 - PARKER 224-8-8-4
	103930-05-000	EA MANUAL-OWNERS, HEATER-A/C - SCS 057-0049
	103930-20-700	EA VALVE EXP. BLOCK (2 TON) 034-0032
	103930-20-701	EA HOSE ASSY #6 WINN GM 085-0138

ROOF A/C COVER

KEY	PART NUMBER	U/M DESCRIPTION
	092633-02-02A	EA COVER-BLANK, ROOF A/C - 5.1" X 5.1" - PLASTIC - OFF WHITE
	022756-03-000	EA COVER-A/C, OFF WHITE - PLASTIC
	022756-02-000	EA COVER-PROTECTIVE, 5.5" ENDS X 8.2" - PLASTIC - OFF WHITE

HEATING & AIR CONDITIONING GROUP (CONTINUED)
13,500 BTU COLEMAN ROOF A/C & CEILING ASSEMBLY

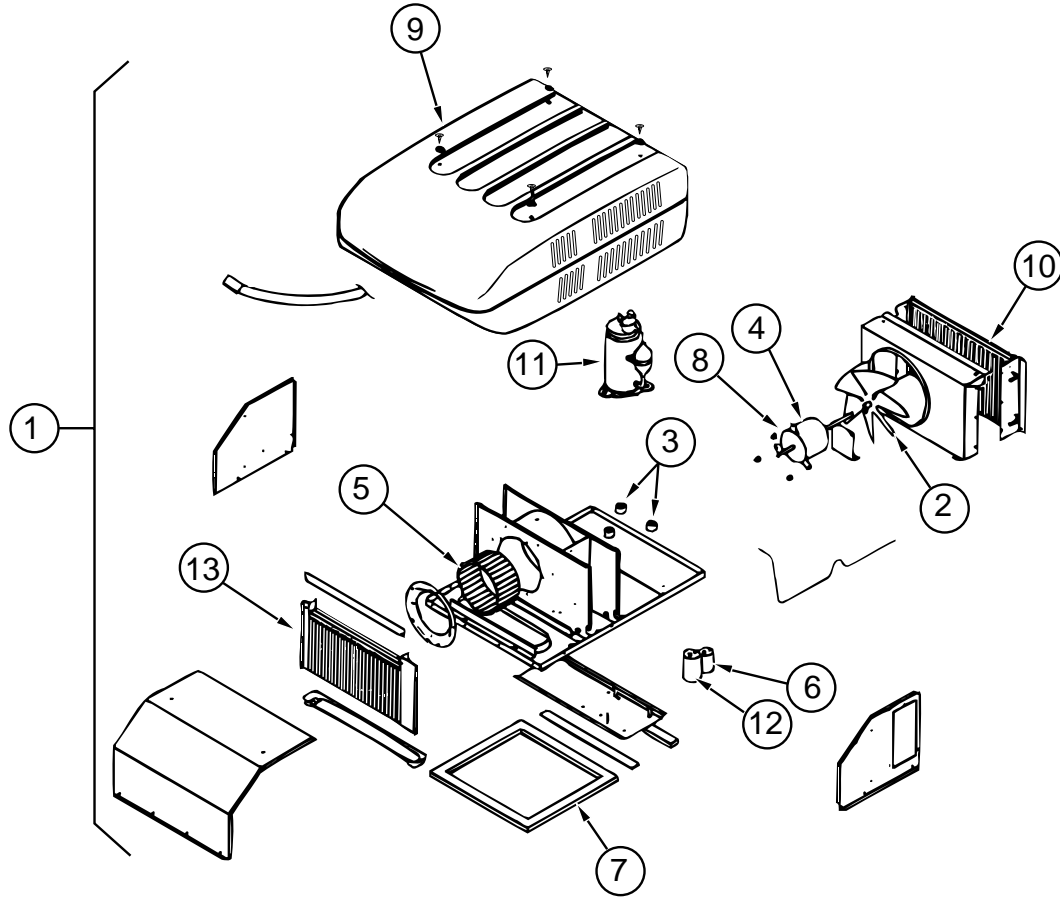

KEY	PART NUMBER	U/M	DESCRIPTION
1	108889-01-01A	EA	A/C-ROOF, 13,500 TSR HO IVORY - COLEMAN 7333-887
2	093763-01-712	EA	FAN BLADE-CONDENSER, COLEMAN 6733-3221
3	105620-01-706	EA	FOOT PACKAGE-COMPRESSOR, 3 PER PACKAGE - COLEMAN 6759-3081
4	108889-01-705	EA	MOTOR-115V, 60HZ - COLEMAN 1468-3049
5	108889-01-706	EA	IMPELLOR - COLEMAN 1472-1041
6	108889-01-708	EA	CAPACITOR-FAN, (7.5MFD.370U) - COLEMAN 1499-5461
	108889-01-710	EA	FILLER PAD-COND AIR SEAL - COLEMAN 6759A3971
7	108889-01-711	EA	GASKET PACKAGE - COLEMAN 6792-3301
8	108889-01-715	EA	MOTOR MOUNT & SHAFT SEAL KIT - COLEMAN 6792-3361
9	108889-01-701	EA	SHROUD-(IVORY/IVORY), W/O LOGO - COLEMAN 6759-4601
10	108889-01-703	EA	CONDENSER COIL - COLEMAN 1452-1301
11	105620-01-704	EA	COMPRESSOR, RH & LH - COLEMAN 1450-2009
12	108889-01-707	EA	CAPACITOR-RUN, COMPRESSOR-25MFD/370 - COLEMAN 1499-5661
	091225-01-709	EA	RELAY-START, COLEMAN 1497-4131
13	108889-01-709	EA	EVAPORATOR COIL - COLEMAN 1452-1311
	108889-01-714	EA	DISCHARGE LINE ASSEMBLY - COLEMAN 6792-531
	108889-01-712	EA	REDUCER-SUCTION LINE, (3/8" X 1/2") - COLEMAN 1215-2161
	108889-01-713	EA	SUCTION LINE, (3/8" OD X .032" WALL) - COLEMAN 6792-130
	091225-01-710	EA	CAPACITOR-START, COLEMAN 1497-0881
	093306-01-701	EA	DECAL PACKAGE-LEFT & RIGHT - COLEMAN 6798B3591
	108889-01-704	EA	OVERLOAD - COLEMAN 6749-3541
	102289-01-000	EA	SPRING-SCREW, ROOF A/C GASKET - COLEMAN 6757-150
	108891-01-01A	EA	CEILING ASM-A/C COOL TSR HO - COLEMAN 7330-714 IV
	042204-01-709	EA	THERMOSTAT-IN 64 OUT 58, COLEMAN 6701-3401
	063903-01-702	EA	LOUVER-COLEMAN 6703A5191
	073742-01-701	EA	SELECTOR SWITCH (5 TERMINAL), COLEMAN 6759-3251
	073742-01-702	EA	DECAL COOL ONLY, COLEMAN 6759C3431
	076303-01-707	EA	FILTER - 6" X 14 3/4" X 1/2", 12 PER PKG - COLEMAN 6703A3151
	081606-01-712	EA	CEILING SHROUD (IVORY), COLEMAN 6769-5061
	091225-01-713	EA	KNOB (2 PER PACKAGE), COLEMAN 6701-3351
	091225-01-717	EA	DECAL (THERMOSTAT) COOL ONLY, COLEMAN 6799A3441
	093766-02-701	EA	DECAL-LEFT SIDE, COLEMAN 6799-3971
	108891-01-700	EA	SINGLE PARTS PACKAGE, COLEMAN 6792-5991
	108891-01-701	EA	RETAINER CLIPS F/FILTER, COLEMAN 6799-3141

HEATING & AIR CONDITIONING GROUP (CONTINUED)
13,500 BTU COLEMAN ROOF A/C & CEILING ASSEMBLY - EUROPEAN

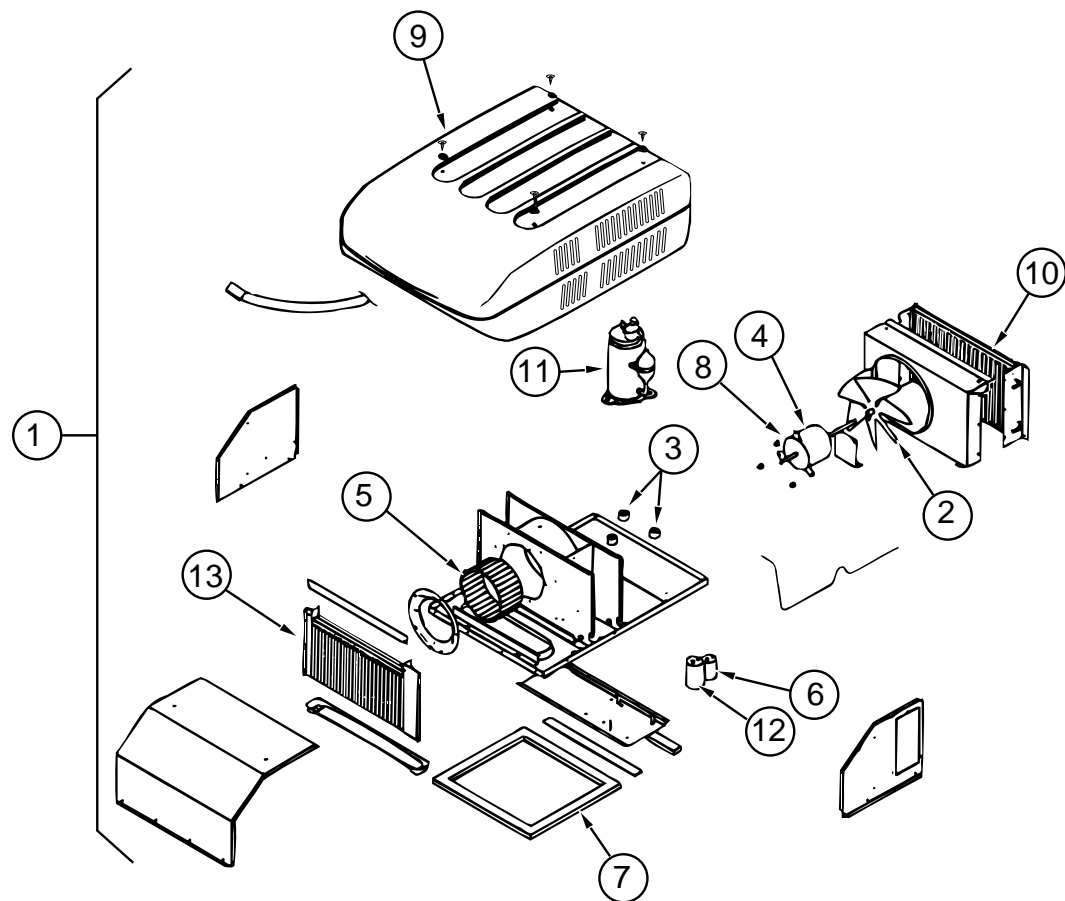

KEY	PART NUMBER	U/M DESCRIPTION
1	108889-02-01A	EA A/C-ROOF, 13,500 TSR 220 IVORY - COLEMAN 7373-597
2	093763-01-712	EA FAN BLADE-CONDENSER, COLEMAN 6733-3221
3	105620-01-706	EA FOOT PACKAGE-COMPRESSOR, 3 PER PACKAGE - COLEMAN 6759-3081
4	108889-01-705	EA MOTOR-115V, 60HZ - COLEMAN 1468-3049
5	108889-01-706	EA IMPELLOR - COLEMAN 1472-1041
6	108889-01-708	EA CAPACITOR-FAN, (7.5MFD.370U) - COLEMAN 1499-5461
	108889-01-710	EA FILLER PAD-COND AIR SEAL - COLEMAN 6759A3971
7	108889-01-711	EA GASKET PACKAGE - COLEMAN 6792-3301
8	108889-01-715	EA MOTOR MOUNT & SHAFT SEAL KIT - COLEMAN 6792-3361
9	108889-01-701	EA SHROUD-(IVORY/IVORY), W/O LOGO - COLEMAN 6759-4601
10	108889-01-703	EA CONDENSER COIL - COLEMAN 1452-1301
11	105620-01-704	EA COMPRESSOR, RH & LH - COLEMAN 1450-2009
12	108889-01-707	EA CAPACITOR-RUN, COMPRESSOR-25MFD/370 - COLEMAN 1499-5661
	091225-01-709	EA RELAY-START, COLEMAN 1497-4131
13	108889-01-709	EA EVAPORATOR COIL - COLEMAN 1452-1311
	108889-01-714	EA DISCHARGE LINE ASSEMBLY - COLEMAN 6792-531
	108889-01-712	EA REDUCER-SUCTION LINE, (3/8" X 1/2") - COLEMAN 1215-2161
	108889-01-713	EA SUCTION LINE, (3/8" OD X .032" WALL) - COLEMAN 6792-130
	091225-01-710	EA CAPACITOR-START, COLEMAN 1497-0881
	093306-01-701	EA DECAL PACKAGE-LEFT & RIGHT - COLEMAN 6798B3591
	108889-01-704	EA OVERLOAD - COLEMAN 6749-3541
	102289-01-000	EA SPRING-SCREW, ROOF A/C GASKET - COLEMAN 6757-150
	108891-01-01A	EA CEILING ASM-A/C COOL TSR HO - COLEMAN 7330-714 IV
	042204-01-709	EA THERMOSTAT-IN 64-OUT 58, COLEMAN 6701-3401
	073742-01-701	EA SELECTOR SWITCH (5 TERMINAL), COLEMAN 6759-3251
	073742-01-702	EA DECAL COOL ONLY, COLEMAN 6759C3431
	076303-01-707	EA FILTER - 6" X 14 3/4" X 1/2", 12 PER PKG - COLEMAN 6703A3151
	081606-01-712	EA CEILING SHROUD (IVORY), COLEMAN 6769-5061
	091225-01-713	EA KNOB (2 PER PACKAGE), COLEMAN 6701-3351
	091225-01-717	EA DECAL (THERMOSTAT) COOL ONLY, COLEMAN 6799A3441
	093766-02-701	EA DECAL-LEFT SIDE, COLEMAN 6799-3971
	108891-01-700	EA SINGLE PARTS PACKAGE (KNOBS & NUTS) COLEMAN 6792-5991
	108891-01-701	EA RETAINER CLIPS F/FILTER (6 PER) COLEMAN 6799-3141

**INTERIOR FINISH GROUP
MOLDINGS & TRIMS**

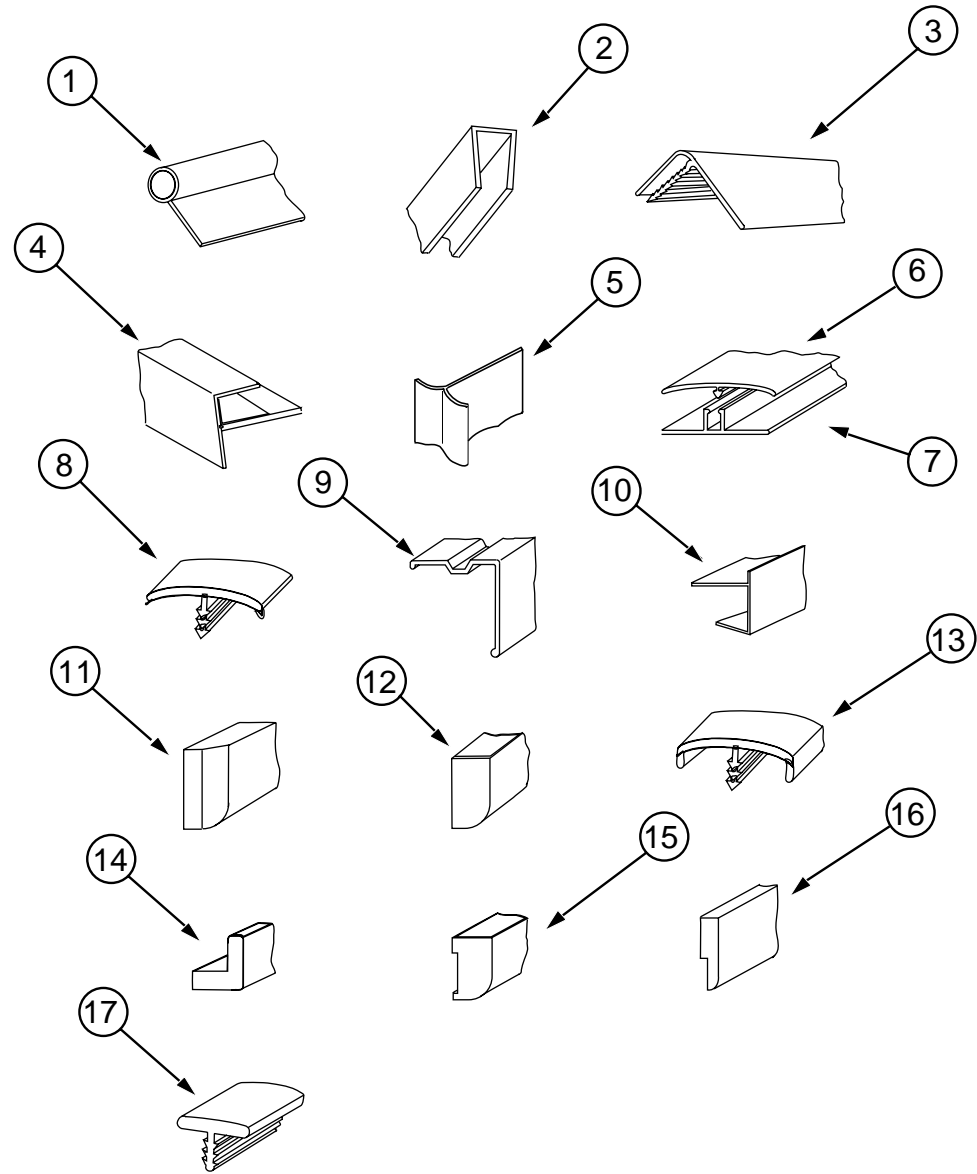

KEY	PART NUMBER	U/M	DESCRIPTION
1	009767-12-000	FT	MOLDING-SIDEWALL TO CEILING/CABINET - WELTING - OFF WHITE
2	009778-12-000	FT	U CHANNEL-PLASTIC, 1" WIDE X 8' INCREMENTS - WOODGRAIN
2	070504-01-000	FT	U-CHANNEL-PLASTIC, .065" WIDE - LIGHT BROWN - INCREMENTS OF 8'
2	070504-18-000	FT	U-CHANNEL-PLASTIC, .065" WIDE - IVORY - INCREMENTS OF 8'
2	070504-19-000	FT	U-CHANNEL-PLASTIC, .815" WIDE - BROWN - INCREMENTS OF 8'
2	070504-20-000	FT	U-CHANNEL-PLASTIC, .815" WIDE - THOR PECAN - INCREMENTS OF 8'
3	009809-21-000	EA	MOLDING-CORNER, OUTSIDE - 1" - PLASTIC - WOODGRAIN
3	009809-23-000	EA	MOLDING-CORNER, OUTSIDE - 1" - PLASTIC - IVORY
4	009812-22-000	EA	MOLDING-CORNER, OUTSIDE - .5" X 7' - PLASTIC - BROWN
5	022992-11-000	FT	MOLDING-REVERSE COVE, T-SHAPED - VINYL - IVORY
6	086229-04-000	EA	BATTEN-CEILING, 1" WIDE - IVORY - 7.6'
7	086229-01-000	EA	RETAINER-BATTEN, CEILING - .75" WIDE - 7.6'
8	105709-01-000	FT	T-MOLDING-1", MODERN IVORY
9	093873-01-01A	EA	TRIM-CARPET, L-ANGLE - 1.1" X 1.3" X 12' - VINYL - GRAY
10	103186-01-01A	FT	MOLDING-EDGE, SHELF - .78" WIDE - PLASTIC - RAMBLING OAK
10	103186-02-01A	FT	MOLDING-EDGE, SHELF - 1.3" WIDE - PLASTIC - RAMBLING OAK
11	100659-01-E01	EA	MOLDING-TRIM, VINYL FLOOR
12	100818-01-02A	EA	MOLDING-VINYL WRAPPED, 1.65" X .4" X 7' - RAMBLING OAK
13	083620-07-000	FT	MOLDING-T, END CAP EDGE - W/EDGE LIPS - .75" - THOR PECAN
14	100819-01-02A	EA	MOLDING-VINYL WRAPPED, L-SHAPED, 1.5" X 1.5" X 7' - OAK
15	100041-01-000	EA	MOLDING-VINYL WRAPPED, .7" X 1.57" X 84.02" - RAMBLING OAK
15	100041-02-000	EA	MOLDING-VINYL WRAPPED, .7" X 2.5" X 84" - RAMBLING OAK
16	105004-01-02A	EA	MOLDING-VINYL WRAP, RAMBLING OAK
17	104676-01-01A	FT	T-MOLDING, 5/16 RIGID - GOLD
	112198-01-000	FT	MOLDING-#90227 J-MOLDING CRILA PLASTICS
	109736-01-01A	FT	T-MOLDING, 1" BRASS/BLACK
	070504-23-000	FT	EXTRUSION-U CHANNEL, 22.56 - COUNTRY FOREST

INTERIOR FINISH GROUP (CONTINUED)
BATT STRIPS

KEY	PART NUMBER	U/M DESCRIPTION
	085284-76-000	FT BATT STRIP-SHOWER, ADHESIVE BACKED - OFF WHITE
	069733-80-000	EA BATT STRIP-WOODGRAIN, 8' - WINNI OAK
	088263-78-000	EA BATT STRIP-SHOWER, 8' - OFF WHITE
	079653-09-000	EA BATT STRIP-KERFED, WOODGRAIN
	088263-96-000	EA BATT STRIP-DECORATIVE, 8' LONG (F04) (MAIN WALL & BATH & GALLEY)
	088263-A1-000	EA BATT STRIP-DECORATIVE, W/FLOWERS - 8' LONG (F05) (MAIN WALL,BATH & GALLEY)
	088263-B2-000	EA BATT STRIP-DECORATIVE, 8' LONG (F06) (MAIN WALL & BATH & GALLEY)
	088263-B8-000	EA BATT STRIP-DECORATIVE, 8' LONG (F07) (MAIN WALL & BATH & GALLEY)
	085284-67-000	FT BATT STRIP-WOODGRAIN, ADHESIVE BACKED - WINNI OAK
	085284-86-000	FT BATT STRIP-DECORATIVE, ADHESIVE BACKED (F04) (MAIN WALL & BATH & GALLEY)
	085284-98-000	FT BATT STRIP-DECORATIVE, ADHESIVE BACKED (F05) (MAIN WALL & BATH & GALLEY)
	085284-A3-000	FT BATT STRIP-DECORATIVE, ADHESIVE BACKED (F06) (MAIN WALL & BATH & GALLEY)
	085284-B1-000	FT BATT STRIP-DECORATIVE, ADHESIVE BACKED (F07) (MAIN WALL & BATH & GALLEY)
	085284-61-000	FT BATT STRIP-DECORATIVE, ADHESIVE BACKED (F14) (MAIN WALL & BATH & GALLEY)
	088263-73-000	FT BATT STRIP-DECORATIVE, ADHESIVE BACKED (F14)

LUMBER

KEY	PART NUMBER	U/M DESCRIPTION
	100040-01-000	EA LUMBER-VINYL WRAPPED, .71" X 1.5" X 8' - RAMBLING OAK
	100040-03-000	EA LUMBER-VINYL WRAPPED, .71" X 2" X 8' - RAMBLING OAK
	100040-06-000	EA LUMBER-VINYL WRAPPED, 766 RAMBLING OAK
	100040-07-000	EA LUMBER-VINYL WRAPPED, 766 RAMBLING OAK

PLASTIC LAMINATE

KEY	PART NUMBER	U/M DESCRIPTION
	074498-54-000	SF LAMINATE-PLASTIC, SAND - 5' X 8' - INCREMENTS OF 40 SF (F04,F07)
	074498-62-000	SF LAMINATE-PLASTIC, GRAY FINESSE - 5' X 8' - INCREMENTS OF 40 SF (F05)
	074498-61-000	SF LAMINATE-PLASTIC, NEUTRA - 5' X 8' - INCREMENTS OF 40 SF (F06)
	074498-72-000	SF LAMINATE-PLASTIC, PEBBLE SANTOS - 5' X 8' - INCREMENTS OF 40 SF (F14)
	074498-67-000	SF LAMINATE-PLASTIC, ORCHID MIST - 5' X 8' - INCREMENTS OF 40SF (PATIO ENTERTAINMENT CENTER TABLE)
	074498-34-000	SF LAMINATE-PLASTIC, RAMBLING OAK - 5' X 8' - INCREMENTS OF 40 SF
	076325-25-000	FT MOLDING-EDGE BAND, RAMBLING OAK
	076325-44-000	FT MOLDING-EDGE BAND, 1032 SAND - .876" X .024" X 600" (F04,F07) (INSIDE OF RECESSED SINK)
	076325-43-000	FT MOLDING-EDGE BAND, 1035 CLOUD - .876" X .024" X 600" (F05) (INSIDE OF RECESSED SINK)
	076325-54-000	FT MOLDING-EDGE BAND, 1049 NEUTRA - .875 "X .024" X 600" (F06) (INSIDE OF RECESSED SINK)
	076325-37-000	FT MOLDING-EDGE BAND, 1136 - .875 "X .024" X 600" (F14) (INSIDE OF RECESSED SINK)
	076325-34-000	FT MOLDING-EDGE BAND, 1233 ORCHID MIST - 1 5/16" X .030" X 600" (PATIO ENTERTAINMENT CENTER TABLE)
	076325-47-000	FT MOLDING-EDGE BAND, 1032 SAND - 1 5/16" X .030" X 600" (F04,F07)
	076325-46-000	FT MOLDING-EDGE BAND, 1035 CLOUD - 1 5/16" X .030" X 600" (F05)
	076325-53-000	FT MOLDING-EDGE BAND, 1049 NEUTRA - 1 5/16" X .030" X 600" (F06)

INTERIOR FINISH GROUP (CONTINUED)
DETECTORS, FIRE EXTINGUISHER & CLOCK

KEY	PART NUMBER	U/M DESCRIPTION
	072852-01-000	EA DETECTOR-SMOKE, W/9 VOLT BATTERY
	072852-02-000	EA DETECTOR-SMOKE, W/9 VOLT BATTERY - CANADIAN
	094499-01-000	EA EXTINGUISHER-FIRE, DRY W/MOUNTING BRACKET - 10 BC
	094499-01-700	EA BRACKET-MOUNTING, W/PLASTIC STRAP - FIRE EXTINGUISHER
	094499-02-000	EA EXTINGUISHER-FIRE, DRY - 1A10BC - CANADIAN
	100793-02-01A	EA CLOCK-WALL, 11" DIAMETER - BOLDEN 9988
	112320-01-000	EA DETECTOR-CO GAS, MODEL 9B-I - COSTAR 940000000
	112320-02-000	EA BATTERY/SENSOR-CO GAS, COSTAR 940001000

ANTISLIP & FLOOR MATS

KEY	PART NUMBER	U/M DESCRIPTION
	091261-01-000	FT SLIPNOT-ANTISLIP, 1' WIDE (100' ROLL)
	105924-01-F04	EA MAT-FLOOR 18 X 27 (F14)
	105924-01-F05	EA MAT-FLOOR 18 X 27
	105924-01-F06	EA MAT-FLOOR 18 X 27
	105924-01-F07	EA MAT-FLOOR 18 X 27

CARPET

KEY	PART NUMBER	U/M DESCRIPTION
	075233-01-000	SY PAD-CARPET, 3/8" X 6' ROLL
	093486-01-000	SY CARPET-COMPARTMENT, 54" WIDE - DARK GRAY
	096060-95-000	SY CARPET - 12' ROLL, INCREMENTS OF 4 SY (F04,F07,F14)
	096060-97-000	SY CARPET - 12' ROLL, INCREMENTS OF 4 SY (F05)
	096060-98-000	SY CARPET - 12' ROLL, INCREMENTS OF 4 SY (F06)

PANELING & PLYWOOD

KEY	PART NUMBER	U/M DESCRIPTION
	074497-21-000	SF PANELING-WOODGRAIN, 4' X 8' - INCREMENTS OF 32 SF
	088272-98-000	SF PANELING-SHOWER, OFF WHITE - 4' X 7' - INCREMENTS OF 28 SF
	088272-B8-000	SF PANELING-DECORATIVE, 4' X 7' - INCREMENTS OF 28 SF (F04) (MAIN WALL & BATH)
	088272-C9-000	SF PANELING-DECORATIVE, W/FLOWERS - 4' X 7' - INCREMENTS OF 28 SF (F05) (MAIN WALL & BATH)
	088272-D5-000	SF PANELING-DECORATIVE, 4' X 7' - INCREMENTS OF 28 SF (F06) (MAIN WALL & BATH)
	088272-E0-000	SF PANELING-DECORATIVE, 4' X 7' - INCREMENTS OF 28 SF (F07) (MAIN WALL & BATH)
	088272-93-000	SF PANELING-DECORATIVE, 4' X 7' - INCREMENTS OF 28 SF (F14) (MAIN WALL & BATH)
	095688-01-000	SF VENEER-FLAT LUANA, 4' X 8' - INCREMENTS OF 32 SF

INTERIOR FINISH GROUP (CONTINUED)
CABINET HARDWARE

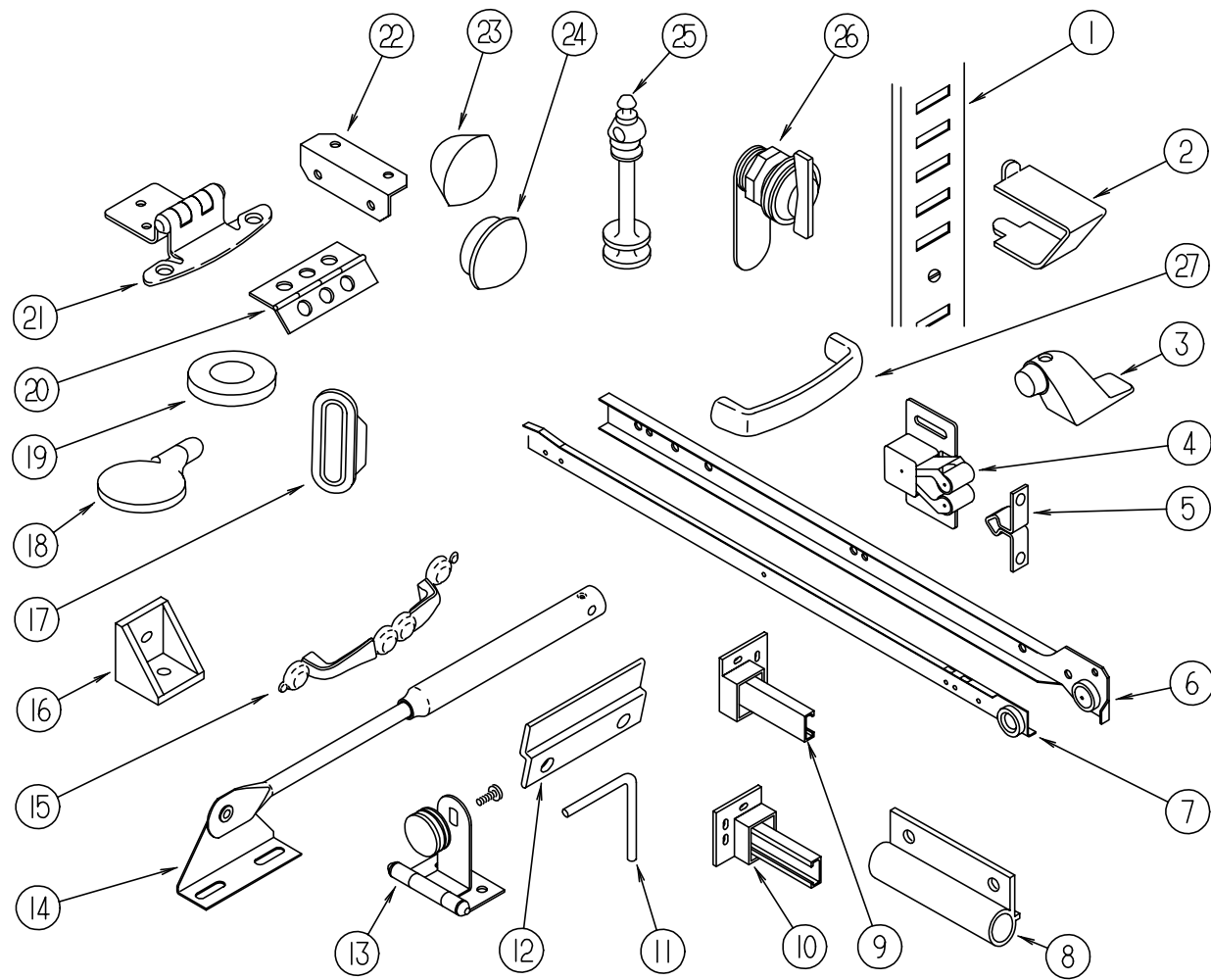

KEY	PART NUMBER	U/M	DESCRIPTION	
1	098979-01-000	EA	CLIP-ADJUSTABLE SHELF	
2	098980-01-000	EA	PILASTER-ADJUSTABLE SHELF, 18" LONG WOODGRAIN APPEARANCE	
3	103257-01-000	EA	STOP-DOOR	
4	093586-03-000	EA	CATCH-SPRING, ROLLER	
5	093586-04-000	EA	STRIKE-SPRING STEEL	
6	114031-13-000	EA	SLIDE-DRAWER, 18" LEFT CABINET	HOUCK 7200-RV-1
6	114031-14-000	EA	SLIDE-DRAWER, 18" RIGHT CABINET	HOUCK 7200-RV-2
6	114031-21-000	EA	SLIDE-DRAWER, 22" LEFT CABINET	HOUCK 7200-RV-1
6	114031-22-000	EA	SLIDE-DRAWER, 22" RIGHT CABINET	HOUCK 7200-RV-2
7	114031-15-000	EA	SLIDE-DRAWER, 18" LEFT DRAWER	HOUCK 7200-RV-3
7	114031-16-000	EA	SLIDE-DRAWER, 18" RIGHT DRAWER	HOUCK 7200-RV-4
7	114031-23-000	EA	SLIDE-DRAWER, 22" LEFT DRAWER	HOUCK 7200-RV-3
7	114031-24-000	EA	SLIDE-DRAWER, 22" RIGHT DRAWER	HOUCK 7200-RV-4
8	108486-01-01A	EA	BRACKET-PROP ROD, OVHD - BLACK	
9	114045-01-000	EA	BACKSOCKET-ADJUSTABLE, LEFT	HOUCK 751-1
10	114045-02-000	EA	BACKSOCKET-ADJUSTABLE, RIGHT	HOUCK 751-2
11	108487-02-01A	EA	SUPPORT-PROP ROD,OVHD - BLACK	
12	101272-01-000	EA	CATCH-DOOR, GLASS	
13	100711-01-01A	EA	HINGE-DOOR, GLASS	
14	074493-02-000	EA	SUPPORT-PISTON SPRING, CABINET DOOR	
15	111765-01-000	EA	PULL-CABINET, BRASS - AMEROCK D1390-3 (F04,F05,F06,F07)	
16	065740-01-000	EA	BRACE-CABINET CORNER, PLASTIC	
17	098410-01-01A	EA	PULL-FINGER, OVAL - BRASS	
18	101766-01-000	EA	PIN-SUPPORT, GLASS DOOR	
19	100707-01-000	EA	SPACER-DOOR, GLASS - .8" DIA - .3" HOLE - PLASTIC	
20	009059-02-000	EA	HINGE-DOOR, 2" X 2.7" - BRASS	
21	108138-01-000	EA	HINGE-DOOR, CABINET - BURNISHED BRASS	
22	016604-01-000	EA	BRACE-CABINET, ANGLE - 2.5" - METAL - UNPAINTED	
22	016604-03-000	EA	BRACE-CABINET, ANGLE - 2.5" - METAL - BEIGE	
22	016604-05-000	EA	BRACE-CABINET, L ANGLE - 2.5" - METAL - OFF WHITE	
23	042356-01-000	EA	PLUG-BUTTON, MAHOGANY - 3/8" DIAMETER - WOOD	
24	074045-07-000	EA	PLUG-WOOD, 1/2"	
25	084070-02-000	EA	POST-END, 2.4" - BRASS	
26	100710-01-01A	EA	LOCK-GLASS DOOR, TWIST TYPE - BRASS	
27	111093-01-000	EA	PULL-CABINET, BRASS - CM1940AU (F14)	
	000G13-06-10G	EA	SCREW - 6-20 X 5/8 PFH, ANTIQUE BRASS	
	004354-01-000	EA	BUMPER-RUBBER, .5" DIA - BROWN	
	009112-01-000	EA	FLANGE-ROD, 1" - COTHES ROD - PLASTIC - OFF WHITE	
	023320-01-000	EA	PAD-FELT, 3/8" DIAMETER - BROWN	
	042438-01-000	EA	DOWEL-WOOD, CLOTHES ROD - 1" DIAMETER X 4'	
	042541-04-000	EA	LATCH-BRASS, W/O STRIKE - HASP TYPE - BRASS BRASS STRIKE #04254105000	
	076790-01-000	EA	SCREW, 6-20 X 1 1/4 PPH - BLACK	
	084451-01-000	EA	CATCH-TV SHELF, BRASS	
	098980-02-000	EA	PILASTER-ADJUSTABLE SHELF, 12" LONG WOODGRAIN APPEARANCE	
	103874-01-000	EA	HANGER-SLIDING DOOR	
	111866-01-01A	EA	BRACE-SEAT, ANGLE	

LABELS GROUP

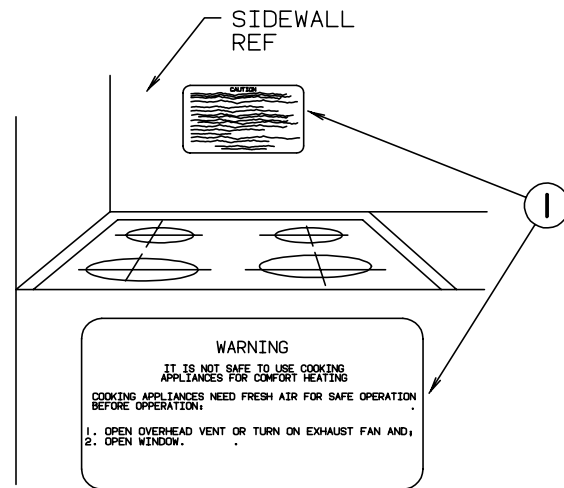

KEY	PART NUMBER	U/M DESCRIPTION
1	050225-01-000	EA LABEL-WARNING, STOVE VENT - US
1	050222-01-000	EA LABEL-WARNING, STOVE VENT - CANADIAN

LABELS GROUP (CONTINUED)

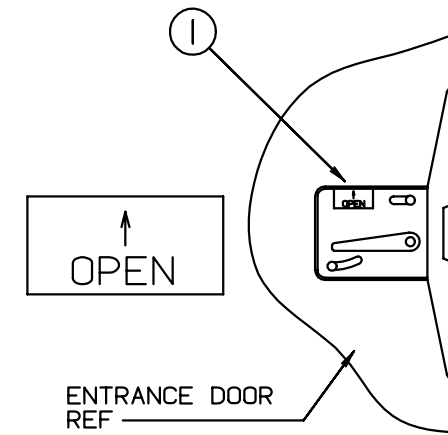

KEY	PART NUMBER	U/M DESCRIPTION
1	040944-01-000	EA LABEL-ENTRANCE DOOR, "OPEN"

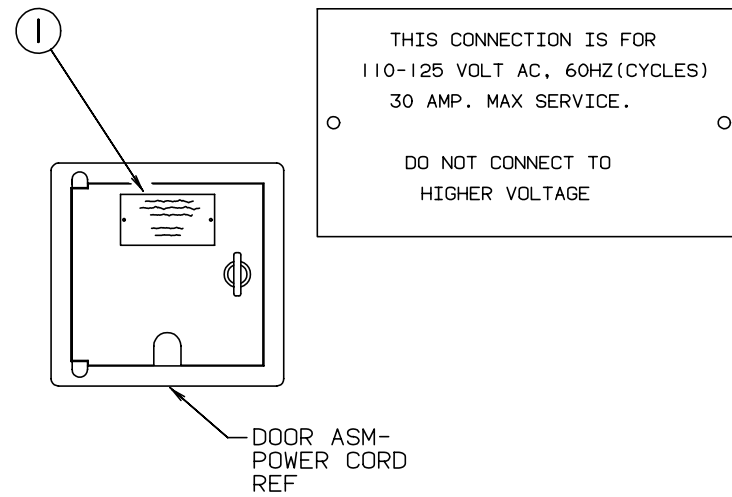

KEY	PART NUMBER	U/M DESCRIPTION
1	006062-01-000	EA TAG-ELECTRIC, 110V CONNECTION

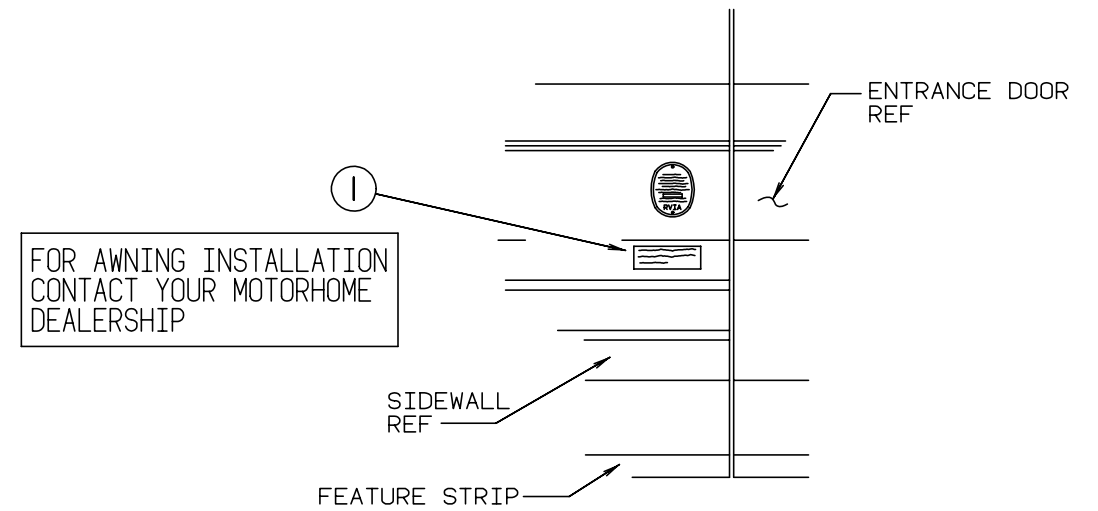

KEY	PART NUMBER	U/M DESCRIPTION
1	099509-01-000	EA LABEL-AWNING INSTALLATION

LABELS GROUP (CONTINUED)

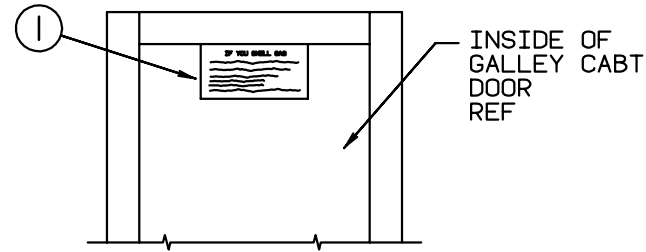

IF YOU SMELL GAS

1. EXTINGUISH ANY OPEN FLAME, PILOT LIGHTS AND ALL SMOKING MATERIALS.
2. SHUT OFF THE GAS SUPPLY AT THE TANK VALVE(OR GAS SUPPLY CONNECTION.
3. OPEN DOORS AND OTHER VENTILATING OPENINGS.
4. DO NOT TOUCH ELECTRICAL SWITCHES.
5. LEAVE THE AREA UNTIL ODOR CLEARS.
6. HAVE THE GAS SYSTEM CHECKED AND LEAKAGE SOURCE CORRECTED BEFORE USING AGAIN.

KEY	PART NUMBER	U/M DESCRIPTION
1	073998-01-000	EA LABEL-LPG ODOR WARNING

LABELS GROUP (CONTINUED)

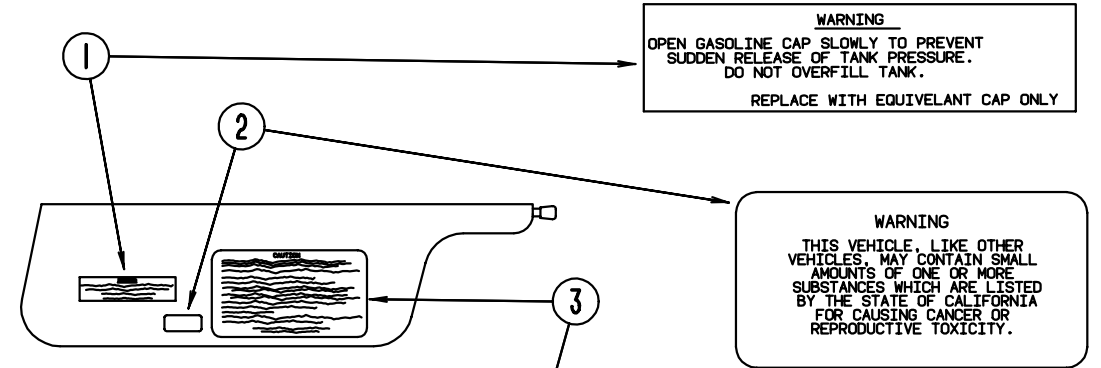

WARNING
OPEN GASOLINE CAP SLOWLY TO PREVENT SUDDEN RELEASE OF TANK PRESSURE. DO NOT OVERFILL TANK.
REPLACE WITH EQUIVELANT CAP ONLY

WARNING
THIS VEHICLE, LIKE OTHER VEHICLES, MAY CONTAIN SMALL AMOUNTS OF ONE OR MORE SUBSTANCES WHICH ARE LISTED BY THE STATE OF CALIFORNIA FOR CAUSING CANCER OR REPRODUCTIVE TOXICITY.

CAUTION

THIS MOTOR HOME HAS BEEN DESIGNED, MANUFACTURED AND TESTED WITH CONCERN FOR THE PROTECTION OF IT'S OCCUPANTS. WE RECOMMEND YOU PERFORM THE FOLLOWING INSPECTIONS FOR YOUR SAFETY AND THE SAFETY OF YOUR PASSENGERS BEFORE STARTING YOUR VEHICLE.

1. LP GAS SYSTEM- TURN OFF AT TANK FOR TRAVELING. TEST FOR LEAKS UPON ARRIVAL AT DESTINATION. BEFORE LIGHTING PILOTS.
2. WHEELS- INSPECT FOR DAMAGE AND CHECK LUG NUTS FOR TIGHTNESS.
3. TIRES- INSPECT FOR WEAR AND DAMAGE AND CHECK FOR RECOMMENDED AIR PRESSURE.
4. LIGHTING- TEST FOR PROPER OPERATION OF ALL INTERIOR AND EXTERIOR LIGHTS INCLUDING DASH LIGHTS, HEADLIGHTS, TAIL LIGHTS, BRAKE LIGHTS, CLEARANCE LIGHTS AND TURN SIGNALS.
5. EXITS- INSPECT RELEASE MECHANISM ON EMERGENCY EXIT WINDOW, TEST BOTH LOCKS ON MAIN ENTRANCE DOOR FOR EASE OF OPERATION AND INSTRUCT PASSENGERS HOW TO USE BOTH MEANS OF EXIT.
6. SEAT BELTS- DIRECT PASSENGERS TO DESIGNATED SEATS AND REQUIRE USE OF SEAT BELTS.
7. APPLIANCES- TURN OFF AND LATCH OR LOCK DOORS WHERE PROVIDED.
8. LOOSE PARCELS- STORE SECURELY.
9. UTILITY SUPPLY LINES- DISCONNECT ALL ELECTRIC, SEWER AND WATER LINES AND SECURE PROPERLY.
10. ENTRANCE DOOR STEP- PLACE IN RETRACTED POSITION FOR TRAVELING.

READ YOUR MOTOR HOME AND CHASSIS OWNER'S MANUAL FOR FURTHER PRECAUTIONS

KEY	PART NUMBER	U/M DESCRIPTION
1	087207-05-000	EA LABEL-FUEL CAP REMOVAL
2	099689-01-000	EA LABEL-WARNING, CANCER/TOXICITY
3	056259-01-000	EA LABEL-SAFETY CHECK LIST

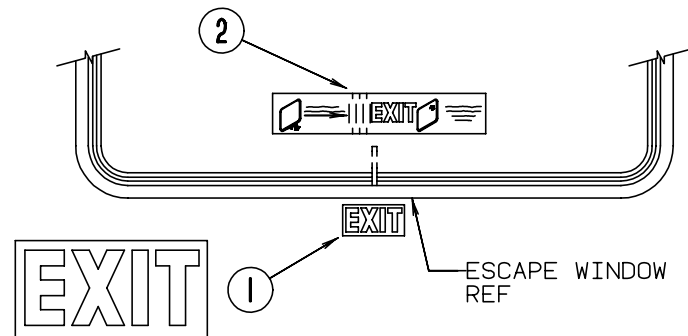
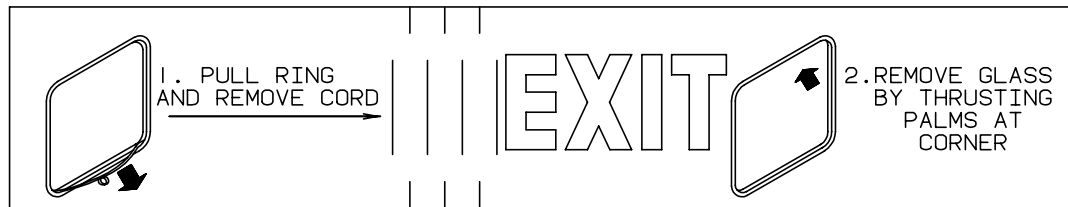

KEY	PART NUMBER	U/M DESCRIPTION
1	039290-01-000	EA LABEL-WARNING, EXIT
2	107571-01-000	EA LABEL-ESCAPE EXIT, WINDOW

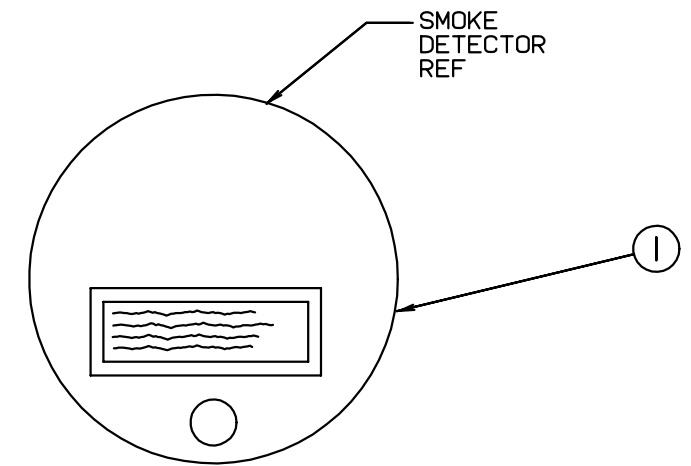

WARNING: TEST SMOKE DETECTOR OPERATION AFTER VEHICLE HAS BEEN IN STORAGE. BEFORE EACH TRIP AND AT LEAST ONCE PER WEEK DURING USE.

KEY	PART NUMBER	U/M DESCRIPTION
1	077956-01-000	EA LABEL-WARNING, SMOKE DETECTOR

LABELS GROUP (CONTINUED)

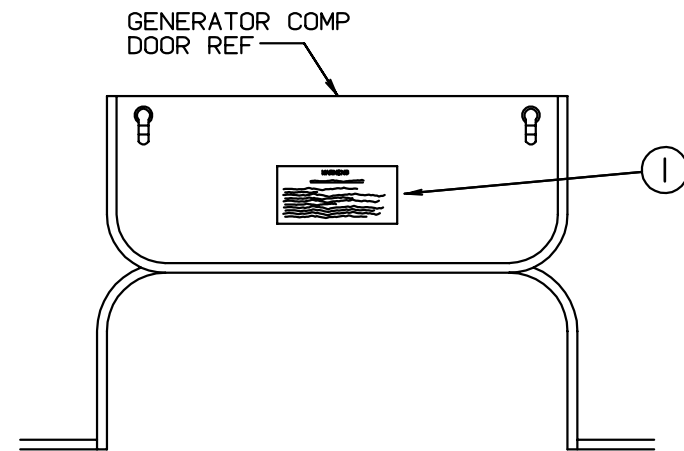

WARNING

WHEN ADDING A GENERATOR SET:

HIGH VOLTAGE-USE EXTREME CAUTION WHEN WORKING ON ELECTRICAL COMPONENTS.
 HAVE ALL ELECTRICAL INSTALLATION PERFORMED BY A QUALIFIED LICENSED ELECTRICIAN-FOLLOW ALL STATE AND LOCAL CODES.
 ONLY INSTALL GENERATOR SET APPROVED FOR R.V. APPLICATION. HAVE INSTALLED BY QUALIFIED TECHNICIAN.
 TO AVOID HEAT BUILD-UP AND TO GUARANTEE AN ADEQUATE AIR SUPPLY TO THE GENERATOR CARBURETOR, FOLLOW INSTALLATION INSTRUCTIONS.
 GENERATOR ENGINE EXHAUST GASES ARE TOXIC AND MUST NOT TERMINATE UNDER THE VEHICLE-DISCHARGE EXHAUST AWAY FROM VEHICLE.

KEY	PART NUMBER	U/M DESCRIPTION
1	077510-01-000	EA LABEL-GENERATOR PREP

LABELS GROUP (CONTINUED)
MISCELLANEOUS LABELS

KEY	PART NUMBER	U/M DESCRIPTION
	068383-01-000	EA LABEL-DIESEL FUEL, GM 557005
	074983-01-000	EA LABEL-SWITCH, A/C SELECTOR FOR FRONT OR REAR
	091224-02-000	EA LABEL-TRAILER LIGHTING
	091243-01-000	EA LABEL-A/C COVER, "AIR CONDITIONING CIRCUIT. ETC."
	098379-04-000	EA LABEL-ELECTRICAL BOX, SIDE
	098641-01-000	EA LABEL-FUEL, UNLEADED - DASH
	104678-01-000	EA LABEL-CB PREP
	111537-04-000	EA LABEL-FUSES
	111802-01-000	EA LABEL-CFC WARNING
	093236-01-000	EA LABEL-CIRCUIT BREAKER, MAIN
	093237-01-000	EA LABEL-CIRCUIT BREAKER, FRONT - BATTERY CONDITION/RADIO
	093237-03-000	EA LABEL-CIRCUIT BREAKER, FRONT - POWER SEAT (LIFT)
	093237-06-000	EA LABEL-CIRCUIT BREAKER, FRONT - REAR PANEL
	093237-07-000	EA LABEL-CIRCUIT BREAKER, FRONT - REAR PNL/CONV
	093237-09-000	EA LABEL-CIRCUIT BREAKER, FRONT - INVERTER

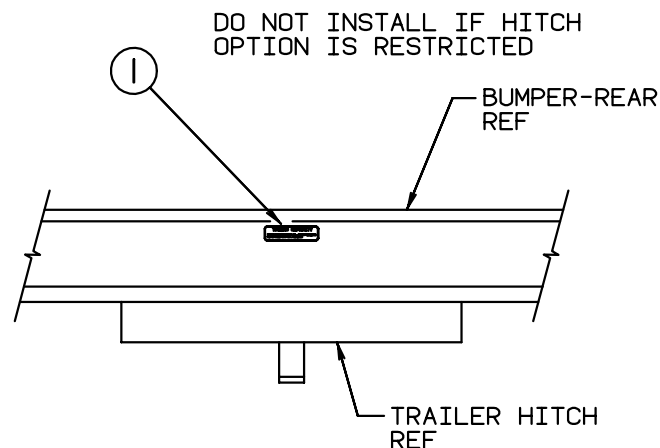

TOWING CAPACITY

TOWED VEHICLE 3500 LB. GROSS MAXIMUM
 HITCH BALL 200 LB. MAXIMUM

KEY	PART NUMBER	U/M DESCRIPTION
1	111104-01-000	EA LABEL-HITCH,READ MANUAL

LABELS GROUP (CONTINUED)

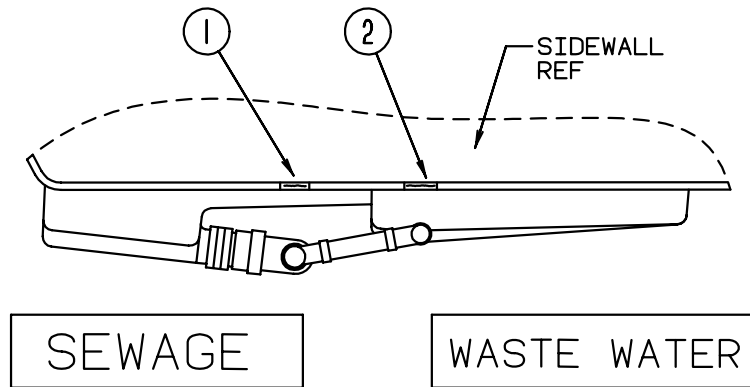

KEY	PART NUMBER	U/M DESCRIPTION
1	006187-01-000	EA LABEL-SEWAGE
2	006188-01-000	EA LABEL-WASTE WATER

LABELS GROUP (CONTINUED)

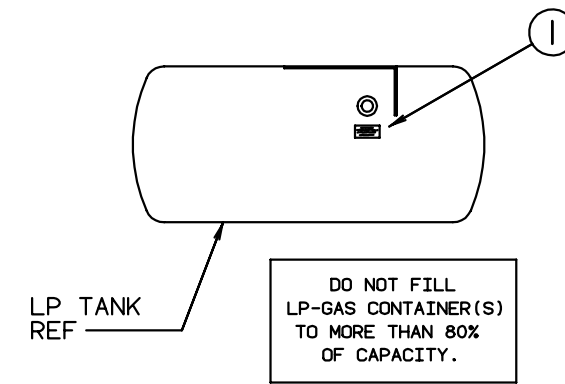

KEY	PART NUMBER	U/M DESCRIPTION
1	079965-01-000	EA LABEL-LPG 80 CAPACITY

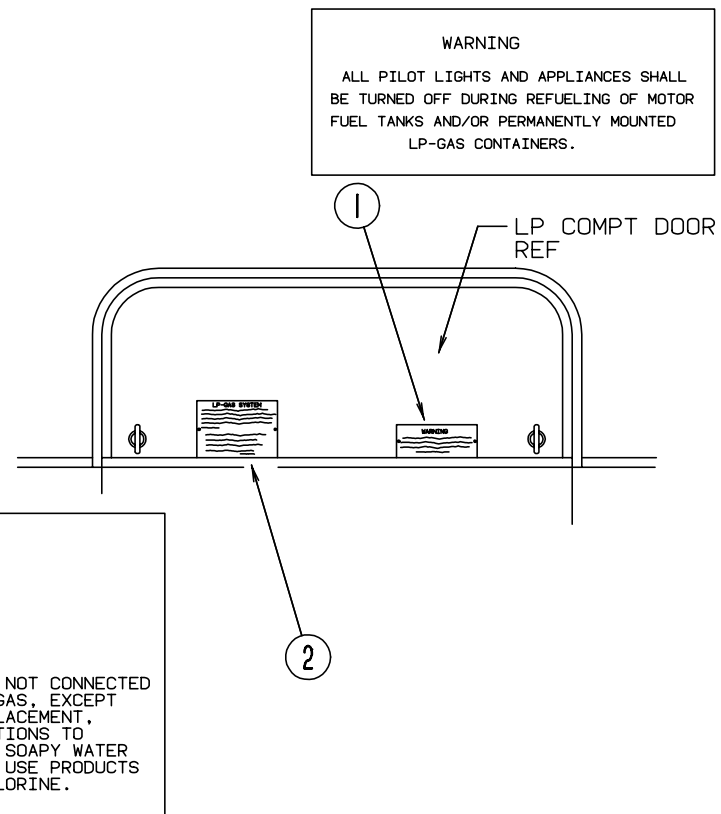

KEY	PART NUMBER	U/M DESCRIPTION
1	006040-01-000	EA TAG-GAS REFUELING WARNING
1	006040-02-000	EA TAG-GAS REFUEL WARNING, CANADIAN
2	054531-01-000	EA LABEL-LP GAS ONLY
2	023769-01-000	EA LABEL-WARNING, LPG - CANADIAN

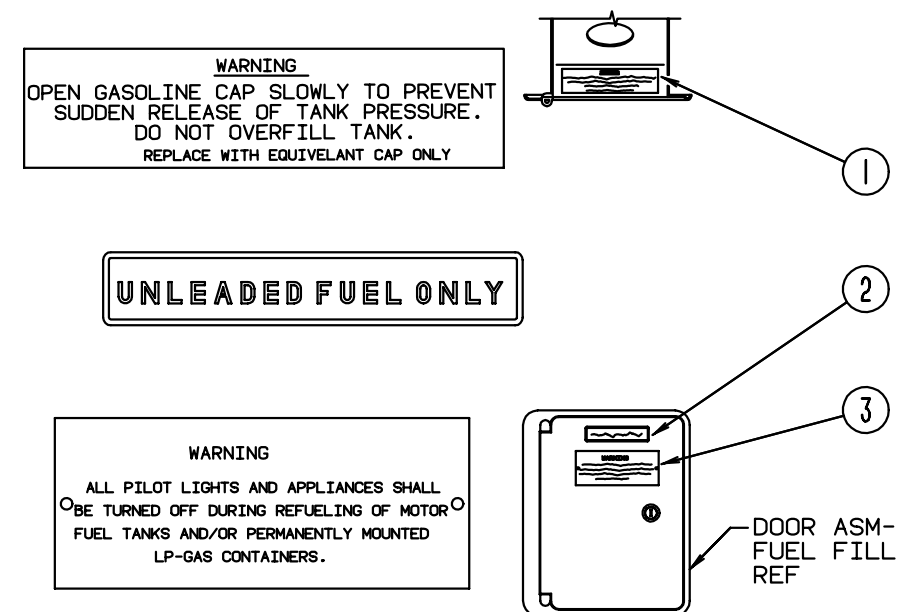

KEY	PART NUMBER	U/M DESCRIPTION
1	087207-05-000	EA LABEL-FUEL CAP REMOVAL
2	062043-01-000	EA LABEL-FUEL, UNLEADED
3	006040-01-000	EA TAG-GAS REFUELING WARNING
3	006040-02-000	EA TAG-GAS REFUEL WARNING, CANADIAN

LP GROUP

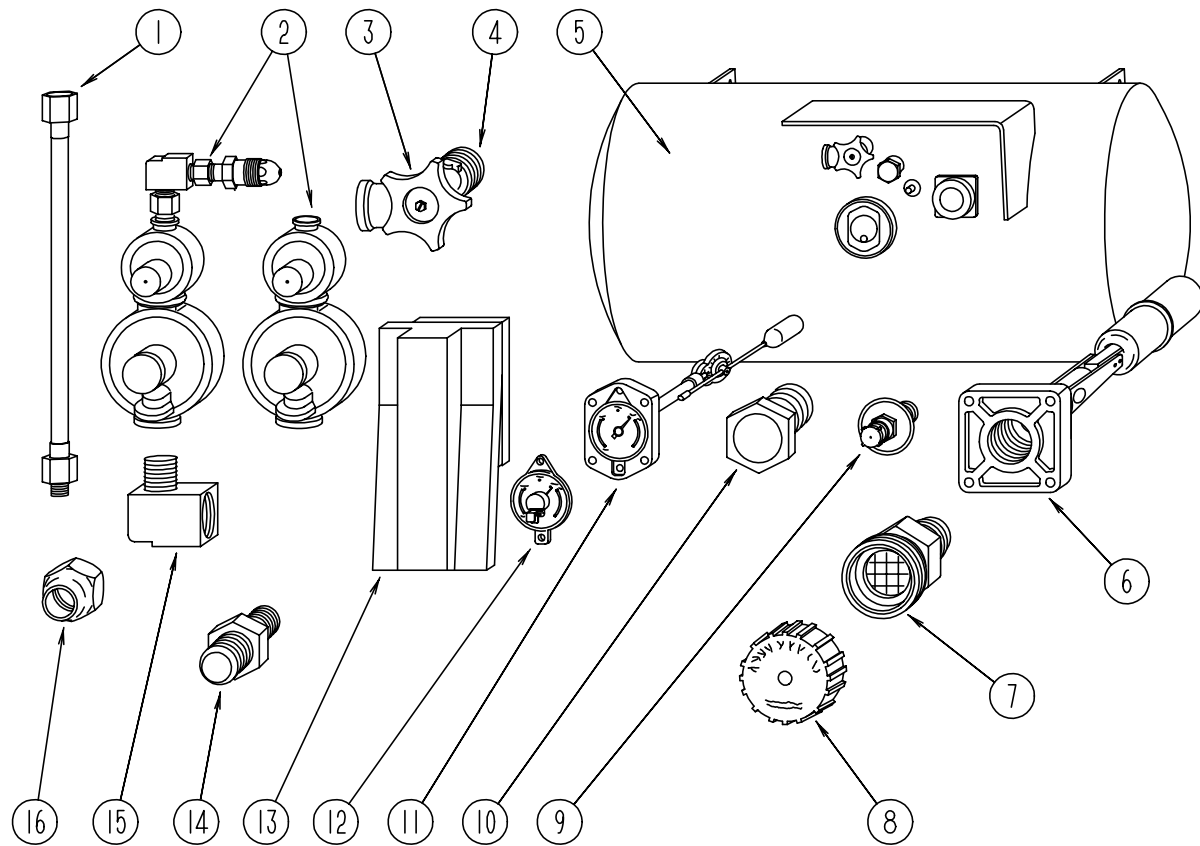

LP TANK & COMPONENTS

KEY	PART NUMBER	U/M	DESCRIPTION
1	045703-01-000	EA	HOSE-LP, 3/8" ID X 24" - 3/8" MPT X 1/2" F SWIVEL - US
1	045703-02-000	EA	HOSE-LP, 3/8" ID X 24" - 3/8" MPT X 1/2" F SWIVEL - CANADIAN
1	045703-03-000	EA	HOSE-LP, 3/8" ID X 18" - 3/8" MPT X 1/2" F SWIVEL - EXPORT LP GENERATOR
2	106150-01-000	EA	REGULATOR-TWO STAGE
2	106150-02-000	EA	REGULATOR-TWO STAGE - EUROPEAN EXPORT OPTION
3	040421-01-708	EA	HANDWHEEL-VAPOR RELIEF VALVE, BRUNNER G-1015-A
4	040421-01-712	EA	VALVE-SERVICE W/O VAPOR RELIEF, 29000853
5	088253-03-000	EA	TANK-LP, 100 LB - 16" X 36" LONG
6	040421-01-711	EA	VALVE - 80% W/FLOAT, PLATE, BOLTS & GASKET - BRUNNER
7	040421-01-701	EA	VALVE-SHORT LP FILLER W/YELLOW CAP - BRUNNER 75478
8	040421-01-702	EA	CAP-LP FILLER VALVE, PLASTIC - YELLOW - BRUNNER G-1014-A
9	040421-01-700	EA	GAUGE-LIQUID LEVEL, 20% LP - BRUNNER G-1013
10	040421-01-713	EA	PRESSURE RELIEF VALVE
11	040421-01-707	EA	GAUGE-FLOAT W/VISIBLE DIAL - BRUNNER MA-9 6244-4
12	040440-02-000	EA	TRANSMITTER-DIAL, 90 OHM
13	105658-01-000	EA	COMPARTMENT-LP REGULATOR
14	010329-01-000	EA	ADAPTER-BRASS, 1/2" F X 1/2" MPT
14	010323-01-000	EA	ADAPTER-BRASS, 3/8" F X 1/2" MPT
15	065318-02-000	EA	ELBOW - 90 DEGREE, 3/8" MPT TO 3/8" FPT
16	010377-02-000	EA	NUT-BRASS, 3/8 FEMALE - FORGED
	024250-01-000	EA	ADAPTER-BRASS, 3/8" F X 1/2" FPT
	036346-01-000	EA	BUSHING-STEEL, 3/4" MPT X 1/2" FPT - EUROPEAN EXPORT OPTION
	008042-01-000	FT	TUBING-VINYL, .65" ID
	074458-01-000	EA	ELBOW - 3/8" M FL X 3/8" F FL SWIVEL - ANCHOR BRASS A800
	095624-01-000	EA	ELBOW - 90 DEGREE, 1/4" FPT X 1/4" FPT - BRASS
	010380-02-000	EA	NUT-BRASS, 1/2" FEMALE - FORGED
	103613-01-000	EA	DETECTOR-LP GAS

LOUNGE GROUP

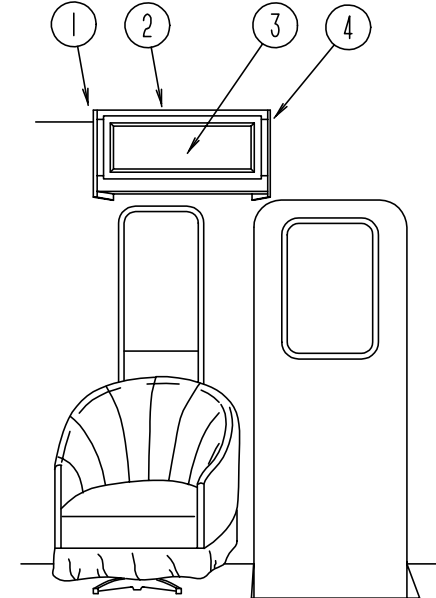

PASSENGER SIDE LOUNGE BUNK OPTION

KEY	PART NUMBER	U/M	DESCRIPTION
1	103128-09-E10	EA	CAP ASM-END, OVHD - LH (F04,F05,F06,F07)
1	103128-09-F31	EA	CAP ASM-END, OVHD - LH (F14)
2	114189-01-F04	EA	CABINET ASM-OVERHEAD (F04,F05,F06,F07)
2	114189-01-F14	EA	CABINET ASM-OVERHEAD
3	M06803-04-E07	EA	DOOR-CABINET, W/O HARDWARE - 255 MM X 485 MM (F04,F05,F06,F07)
3	M06803-07-F14	EA	DOOR-CABINET, W/O HARDWARE - 255 MM X 485 MM
4	103128-08-E10	EA	CAP ASM-END, OVHD - RH
	104006-01-C05	EA	LID-ENTRANCE STEP COMPARTMENT, W/O CARPET
	101222-01-01A	EA	BRACKET-CATCH, LID - BEIGE

LOUNGE GROUP (CONTINUED)
DRIVERS SIDE LOUNGE

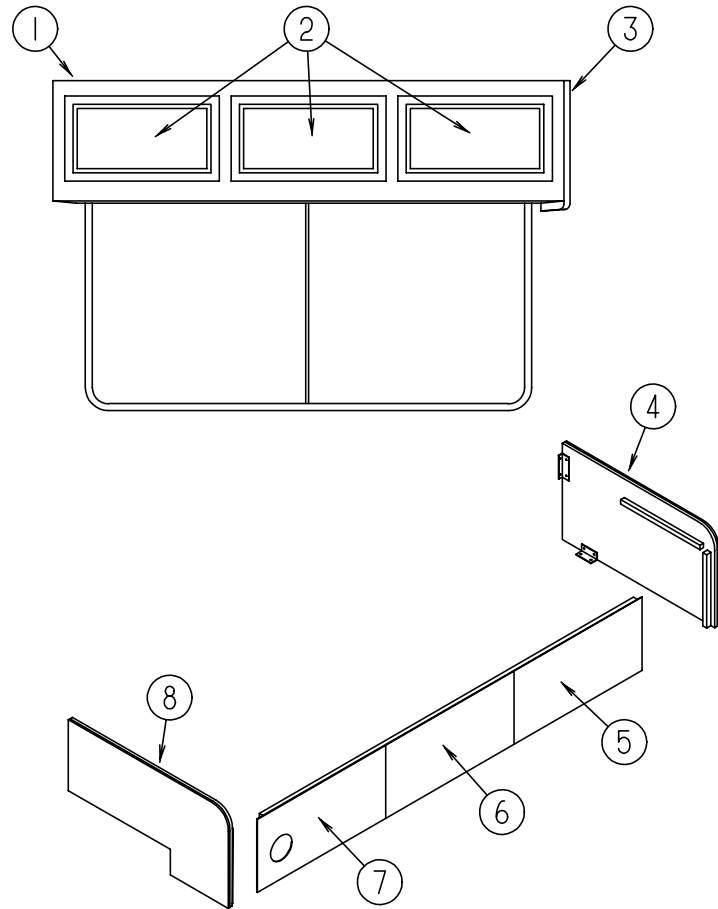

KEY	PART NUMBER	U/M	DESCRIPTION
1	M05974-03-F04	EA	CABINET ASM-OVERHEAD, FRONT - LEFT (F04,F06,F07)
1	M05974-03-F07	EA	CABINET ASM-OVERHEAD, FRONT - LEFT (F05)
1	M05974-03-F14	EA	CABINET ASM-OVERHEAD, FRONT - LEFT
2	M06803-03-E07	EA	DOOR ASM. W/DECORATIVE MIRROR INSERT - 400 X 520 (F04,F07,F14)
2	M06803-03-F04	EA	DOOR ASM. W/DECORATIVE MIRROR INSERT - 400 X 520 (F05)
2	M06803-03-F14	EA	DOOR ASM. W/DECORATIVE MIRROR INSERT - 400 X 520
3	103128-01-E10	EA	CAP ASM-END, OVERHEAD (F04,F06,F07)
3	103128-01-F31	EA	CAP ASM-END, OVERHEAD (F05,F14)
4	M04187-44-E08	EA	PANEL-COUCH CABINET - FABRIC COVERED (F04)
4	M04187-44-F05	EA	PANEL-COUCH CABINET - FABRIC COVERED
4	M04187-44-F06	EA	PANEL-COUCH CABINET - FABRIC COVERED
4	M04187-44-F27	EA	PANEL-COUCH CABINET - FABRIC COVERED (F07)
4	M04187-44-F14	EA	PANEL-COUCH CABINET - FABRIC COVERED
5	M04187-47-E08	EA	PANEL-COUCH CABINET - FABRIC COVERED (F04)
5	M04187-47-F05	EA	PANEL-COUCH CABINET - FABRIC COVERED
5	M04187-47-F06	EA	PANEL-COUCH CABINET - FABRIC COVERED
5	M04187-47-F27	EA	PANEL-COUCH CABINET - FABRIC COVERED (F07)
5	M04187-47-F14	EA	PANEL-COUCH CABINET - FABRIC COVERED
6	M04187-46-E08	EA	PANEL-COUCH CABINET - FABRIC COVERED (F04)
6	M04187-46-F05	EA	PANEL-COUCH CABINET - FABRIC COVERED
6	M04187-46-F06	EA	PANEL-COUCH CABINET - FABRIC COVERED
6	M04187-46-F27	EA	PANEL-COUCH CABINET - FABRIC COVERED (F07)
6	M04187-46-F14	EA	PANEL-COUCH CABINET - FABRIC COVERED
7	M04187-45-E08	EA	PANEL-COUCH CABINET - FABRIC COVERED (F04)
7	M04187-45-F05	EA	PANEL-COUCH CABINET - FABRIC COVERED
7	M04187-45-F06	EA	PANEL-COUCH CABINET - FABRIC COVERED
7	M04187-45-F27	EA	PANEL-COUCH CABINET - FABRIC COVERED (F07)
7	M04187-45-F14	EA	PANEL-COUCH CABINET - FABRIC COVERED
8	M04187-43-E08	EA	PANEL-COUCH CABINET - FABRIC COVERED (F04)
8	M04187-43-F05	EA	PANEL-COUCH CABINET - FABRIC COVERED
8	M04187-43-F06	EA	PANEL-COUCH CABINET - FABRIC COVERED
8	M04187-43-F27	EA	PANEL-COUCH CABINET - FABRIC COVERED (F07)
8	M04187-43-F14	EA	PANEL-COUCH CABINET - FABRIC COVERED
	105947-01-000	EA	BRACKET-HOLD DOWN,COUCH - CSA UNITS
	083125-05-000	EA	BRACE-ANGLE, COUCH - 2.5" - BEIGE

SEALANTS & FASTENERS GROUP

SEALANTS & ADHESIVE

KEY	PART NUMBER	U/M DESCRIPTION
	002707-02-000	FT TAPE-SEALER, 5/16" X 1/2" - INCREMENTS OF 50 FT
	034552-02-000	EA SILICONE-TUBE, 300 ML - CLEAR
	034552-06-000	EA SILICONE-TUBE, 300 ML - OFF WHITE
	053766-02-000	EA BEDDING COMPOUND-TUBE, WHITE SCHNEE# 5522
	053766-06-000	EA BEDDING COMPOUND-TUBE, CLEAR
	053766-08-000	EA BEDDING COMPOUND-TUBE, GRAY - SCHNEE# 5522
	062917-03-000	EA ADHESIVE-LOCTITE 242
	063642-01-000	FT TAPE-ADHESIVE, 10 MM X 1.5" WIDE X 180'
	069640-03-000	FT SEALER-RIBBON, 3/4" X 1/8" - INCREMENTS OF 60'
	069640-07-000	FT SEALER-RIBBON, 2" X 3/32" - INCREMENTS OF 30' OR 45'
	069640-09-000	FT SEALER-RIBBON, 1/32" X 2 1/2" - INCREMENTS OF 80'
	069640-11-000	FT SEALER-TAPE, 3/16" X 3/8", BLACK - MANUS
	069640-13-000	FT SEALER-TAPE, 3/32" X 2" BLACK - MANUS
	069640-14-000	FT SEALER-TAPE, 1/16" X 1" GRAY - MANUS
	072889-01-000	EA SEALANT-URETHANE, BLACK - 1/10 - ESSEX 552.2
	076314-02-000	FT TAPE-CARPET SEAM, HEAT-BOND - 4" WIDE
	076322-01-000	FT TAPE-FOAM, DOUBLE COATED ADHESIVE BACKED - .75" X 216'
	076322-02-000	FT TAPE-FOAM, DOUBLE COATED ADHESIVE BACKED - 1" X 108'
	076322-05-000	FT TAPE-FOAM, DOUBLE COATED - .025" X 1.5" X 108'
	076322-07-000	FT TAPE-FOAM, DOUBLE COATED - .045" X .50"
	110274-01-000	FT TAPE-FOAM, DOUBLE COATED - .045" X 1.0"
	087211-01-000	GL PROMOTER-ADHESIVE
	102352-01-000	EA SEALER-PUMPABLE, BLACK - COLORIMETRIC MS101
	106206-01-000	EA SEALER-PUMPABLE
	108716-01-000	EA SILICONE-TUBE, OFF WHITE - SELF LEVELING - CSL 510
	900390-01-000	EA TIP - 2 1/2" X 1/8" ORIFICE, ELLSWORTH#TS216
	900390-03-000	EA NOZZLES-SILICONE TUBE, CSL# D10
	114311-01-000	GL ADHESIVE-GLUE
	091255-01-000	FT SEAL-FOAM, 3.2MM X 4.8MM

BOLTS, NUTS & WASHERS

KEY	PART NUMBER	U/M DESCRIPTION
	000C12-05-12B	EA BOLT-HEX, 5/16-18 X 3/4 ZN 5
	000C12-05-16B	EA BOLT-HEX, 5/16-18 X 1 - ZINC 5
	000C12-06-16B	EA BOLT-HEX, 3/8-16 X 1LG,ZN 5
	000C12-07-20B	EA BOLT-HEX, 7/16 - 14 X 1 1/4" - ZN5
	000C12-08-24B	EA BOLT-HEX, 1/2-13 X 1 1/2 - ZN 5
	000C12-09-20B	EA BOLT-HEX, 9/16-12 X 1 1/4,ZN 5
	000C12-10-24B	EA BOLT-HEX, 5/8-11 X 1 1/2 ZN - 5
	000C13-07-48B	EA BOLT-HEX, 7/16 - 20 X 3 - ZN 5
	000C18-05-40A	EA BOLT-ELEV, 5/16"-18 X 2 1/2" PL
	000C26-04-14B	EA BOLT-HEX, SER FLG - 1/4-20 X 7/8 ZINC
	000C26-04-10B	EA BOLT-HEX, SER FLG - 1/4-20 X 5/8 ZINC
	000C26-05-12B	EA BOLT-HEX, SER FLG 5/16-18 X 3/4 ZN
	000C26-06-28B	EA BOLT-HEX, SER FLG 3/8-16 X 13/4 ZN
	000C26-06-12B	EA BOLT-HEX, SER FLG 3/8-16 X 3/4 ZN
	000C27-10-32B	EA BOLT-CARR 5/8-11 X 2.00
	000D14-04-00B	EA NUT-HEX, 1/4-20 ZN
	000D24-10-00B	EA NUT-HEX, SF/LK - 10-32 ZN
	000D29-09-00B	EA NUT-HEX SELFLOCK 9/16-12 ZN
	000D34-06-00B	EA NUT-HEX, LK - 3/8 - 16 GRADE C ZN - PREVAILING TORQUE
	000D39-04-00B	EA NUT-HEX, SER FLG LK 1/4 - 20 ZN
	000D39-05-00B	EA NUT-HEX, SER FLG LK - 5/16 - 18 ZN
	000D39-06-00B	EA NUT-HEX, SER FLG LK - 3/8-16 ZN
	000D39-08-00B	EA NUT-HEX, SER FLG LK - 1/2-13 ZN
	000D44-07-00B	EA NUT-HEX, SER FLG LK - 7/16-20 ZN
	000D46-04-00A	EA NUT-HEX, WELD - 1/4-20 - PLAIN
	087234-01-000	EA NUT-JACK, 1/4 X 20THD - MOLLY
	041322-01-000	EA WASHER-FL, 15/32ID X 2 3/8OD - FOR SEAT BELT MOUNT
	058716-02-000	EA WASHER-FLAT NYLON, .406 X .750 X .060
	000E11-07-00B	EA WASHER-LK - 7/16 MED SPLIT ZN

SEALANTS & FASTENERS GROUP (CONTINUED)

BOLTS, NUTS & WASHERS (CONTINUED)

KEY	PART NUMBER	U/M DESCRIPTION
	000E13-14-00B	EA WASHER-FL, 1/4" WIDE ZN
	000E13-18-00B	EA WASHER-FLARE, 3/8" WIDE ZN
	000E13-20-00B	EA WASHER-FL, 7/16" WIDE - ZN
	000E13-21-00B	EA WASHER-FL - W/2 NAR ZN
	000E14-10-00B	EA WASHER-LK - NO 10 EXT TOOTH - ZN
	000G45-05-16B	EA BOLT-LAG 5/16 - 9 X 1 ZN
	040921-03-000	EA NUT-SPEED, U TYPE - NO 10
	040921-04-000	EA NUT-SPEED, U TYPE - NO. 8 - .59" LENGTH X .44" WIDTH
	044364-02-000	EA NUT-SPEED, FLAT - ROUND
	044533-01-000	EA WASHER-PLASTIC, 1 3/8"OD - FOR BUTTONS
	051387-06-000	EA BOLT-CARRIAGE, W/O HOLE - 5/16-18 X 9.5 ZN
	063253-07-000	EA NUT-J, #8A .120- .130 PNL THK
	077071-01-000	EA WASHER-FENDER, 3/16" ID X 1" OD
	095094-01-000	EA NUT-ACORN, 1/4 - 20 ALUMINUM
	102333-01-02A	EA BOLT-CARRIAGE, 7/16 - 14 SST CAP O/W BUMPER BOLT
	104369-01-000	EA NUT-HEX,HEAVY,5/8-11 UNC
	105247-01-000	EA INSERT NUT 8-32 THD X .394LG - STAFEST PRODUCTS
	106649-01-000	EA WASHER-SEALING,GALVANIZED - 5/8 ID
	106649-02-000	EA WASHER-SEALING,GALVANIZED - 9/16 ID

SCREWS

KEY	PART NUMBER	U/M DESCRIPTION
	000G11-06-06B	EA SCREW, 6-20 X 3/8 PPH ZN
	000G11-06-10J	EA SCREW, 6-20 X 5/8 PPH - BRASS
	000G11-06-10B	EA SCREW, 6-20 X 5/8 PPH ZN
	000G11-07-08B	EA SCREW, 7-19 X 1/2 PPH - ZN
	000G11-08-06B	EA SCREW, 8-18 X 3/8 PPH ZN
	000G11-08-12S	EA SCREW, 8-18 X 3/4 PPH - OFF WHITE
	000G11-08-12P	EA SCREW, 8-18 X .75 PPH - DARK BROWN
	000G11-08-12D	EA SCREW, 8-18 X 3/4 PPH - BLACK
	000G11-08-12B	EA SCREW, 8-18 X 3/4 PPH ZN
	000G11-08-08B	EA SCREW, 8-18 X 1/2 PPH - ZN
	000G11-10-16B	EA SCREW, 10-16 X 1 - PPH ZN
	000G11-10-12S	EA SCREW-10-16 X .75 PPH OFF WHT
	000G11-10-12D	EA SCREW, 10-16 X 3/4 PPH - BLACK
	000G11-10-40B	EA SCREW, 10 - 16 X 2 1/2 PPH CAD - 34927-01-000
	000G12-06-08T	EA SCREW, 6-20 X .50 POH - BLACK
	000G12-08-16S	EA SCREW, 8-18 X 1.00 POH - OFF WHITE
	000G13-06-08B	EA SCREW, 6-20 X 1/2 PFH ZN
	000G13-06-16J	EA SCREW, 6-20 X 1.00 PFH - BRASS
	000G13-06-08G	EA SCREW, 6-20 X 1/2 PFH - ANTIQUE BRASS
	000G13-07-12B	EA SCREW, 7-19 X 3/4 PFH ZN
	000G18-08-22B	EA SCREW-MACHINE, 8-32 X 1 3/8 PPH ZN
	000G19-10-20B	EA SCREW-MACHINE, 10-32 X 1 1/14 PPH ZINK
	000G19-10-08B	EA SCREW-MACHINE, 10-32 X 1/2 PPH ZN
	000G32-10-06B	EA SCREW-10-32 X 3/8" - PPH - ZINC
	000G39-06-16T	EA SCREW-SF/DR, 6-20 X 1 PPH - BLACK
	000G39-06-10T	EA SCREW-SF/DR, 6-20 X 5/8 PPH - BLACK
	000G39-08-08B	EA SCREW-SF/DR, 8-18 X 1/2 PPH ZN
	000G39-08-06B	EA SCREW-SF/DR, 8-18 X 3/8 PPH ZN
	000G39-08-12B	EA SCREW-SF/DR, 8-18 X 3/4 PPH ZN
	000G39-08-08T	EA SCREW-SF/DR, 8-18 X .50 PPH BLACK
	000G39-08-08S	EA SCREW-SF/DR, 8-18 X 1/2 PPH - OFF WHITE
	000G39-08-08R	EA SCREW-SF/DR, 8-18 X 1/2 PPH - BEIGE
	000G39-08-32B	EA SCREW-SF/DR, 8-18 X 2 PPH - ZINC
	000G39-08-16T	EA SCREW-SF/DR, 8-18 X 1 PPH - BLACK
	000G39-08-16S	EA SCREW-SF/DR, 8-18 X 1.00 PPH, OFF WHITE
	000G39-08-16B	EA SCREW-SF/DR, 8-18 X 1 PPH ZN
	000G39-08-12T	EA SCREW-SF/DR, 8-18 X 3/4 PPH - BLACK

SEALANTS & FASTENERS GROUP (CONTINUED)

SCREWS (CONTINUED)

KEY	PART NUMBER	U/M	DESCRIPTION
	000G39-10-129	EA	SCREW-SF/DR, 10-16 X 3/4 PPH - FLUOROCARBON SILVER
	000G39-10-12D	EA	SCREW-SF/DR, 10-16 X 3/4 PPH - BLACK
	000G39-10-10B	EA	SCREW-SF/DR, 10-16 X .625 ZN
	000G39-10-209	EA	SCREW-SF/DR,10-16X1.25 PPH FLUOROCARBON SILVER FROM: 08-13-93 THRU: 99-99-99
	000G39-10-20B	EA	SCREW-SF/DR, 10-16 X 1 1/4 PPH ZN
	000G42-04-12B	EA	SCREW-SF/DR 1/4-14 X 3/4HWH ZN
	000G43-06-24B	EA	SCREW-MACHINE, 6-32" X 1 1/2" ZN
	000G46-08-24T	EA	SCREW-MACHINE, 8-32-1.50 IN PFH - BLACK
	000G50-04-12B	EA	SCREW-MACH, 1/4-20 X 3/4 PPH ZN
	000G53-04-06B	EA	SCREW-MACHINE, 1/4-20 X 3/8 PPH ZN - UNDERCUT HEAD
	000G54-04-20B	EA	SCREW, 1/4-20 X 1 1/4 PTH - TYPE 23 - ZINC PLATED
	000G56-12-48B	EA	SCREW-WOOD, 12 - 11 X 3 POH - SPECIAL HARDENED
	000G60-08-164	EA	SCREW-SF/DR, 8-18 X 1.00 POH ASH GRAY
	000G60-10-28T	EA	SCREW-SF/DR, 10-16 X 1.75 - BLACK
	000G67-10-36T	EA	SCREW-10-12 X 2.25PPHBLACK STALGARD FROM: 12-15-93 THRU: 99-99-99
	000G67-10-24B	EA	SCREW, 10-12 X 1 1/2 PPH - ZN
	000G67-10-20D	EA	SCREW, 10-12 X 1 1/4 PPH - BLACK
	000G67-10-16B	EA	SCREW, 10-12 X 1 PPH - ZN
	000G67-10-120	EA	SCREW, 10-12 X .75" PPH - TAN
	000G67-10-12B	EA	SCREW, 10-12 X 3/4" PPH - ZN
	000G67-10-10D	EA	SCREW, 10-12 X 5/8 PPH - BLACK - TYPE A
	000G67-10-10B	EA	SCREW, 10-12 X 5/8 PPH ZN - TYPE A
	000G67-10-08R	EA	SCREW, 10-12 X 1/2 PPH - BEIGE - TYPE A
	000G67-10-08B	EA	SCREW, 10-12 X 1/2 PPH ZN
	000G68-06-10G	EA	SCREW, 6-18 X 5/8 POH - ANTIQUE BRASS
	049465-01-000	EA	SCREW, 10-16 W/WASHER PTH - DARK BROWN
	049465-03-000	EA	SCREW, 10-16 X 1 POH W/WASHER - OFF WHITE
	049465-04-000	EA	SCREW, 10-16 X 1 PTH W/WASHER - BEIGE
	049465-05-000	EA	SCREW, 10-16 X 1 PTH W/WASHER - GRAY
	075908-01-000	EA	SCREW-MACHINE, 10-32 X .56 PTH - ZINC EXTERNAL TOOTH
	101289-01-01A	EA	SCREW-MACHINE, 8-32 X 4 - POH - BRASS - FOR EXTENDED KNOB
	101289-01-01A	EA	SCREW-MACHINE, 8-32 X 4 - POH - BRASS - FOR EXTENDED KNOB

SEALANTS & FASTENERS GROUP (CONTINUED)

CLAMPS

KEY	PART NUMBER	U/M	DESCRIPTION
	007161-01-000	EA	CLAMP-HOSE, SPRING TYPE - 1/2"
	010495-01-000	EA	CLAMP-CABLE, 9/16"
	010497-01-000	EA	CLAMP-CLOSED, 5/8" ID
	010497-03-000	EA	CLAMP-CLOSED, 1" ID - CUSHIONED
	010497-05-000	EA	CLAMP-CLOSED, 1/2" ID
	010499-01-000	EA	CLAMP-CLOSED, 3/8" ID
	062401-01-000	EA	CLAMP-HOSE, WORMGEAR .25" - 1"
	062401-02-000	EA	CLAMP-HOSE, WORMGEAR, 1.56" - 2.5"
	062401-04-000	EA	CLAMP-HOSE, WORMGEAR .69"- 1.25"
	062401-06-000	EA	CLAMP-HOSE, WORMGEAR .22"-.62"
	062401-11-000	EA	CLAMP-HOSE, WORMGEAR 3.56"- 4.5"
	075148-02-000	EA	CLAMP-GROUNDING, BRONZE SCREWS
	083609-01-000	EA	CLAMP-WIRE, DUAL EQUAL - 5/8" DIAMETER
	083610-01-000	EA	CLAMP-WIRE, DUAL - UNEQUAL DIAMETERS - .75" & 1.25"

RIVETS, GROMMETS & MISCELLANEOUS

KEY	PART NUMBER	U/M	DESCRIPTION
	000H16-04-06R	EA	RIVET-POP, AL 1/8 X .313-.375
	008380-01-000	EA	GROMMET-RUBBER, 5/8" HOLE X 1 1/2" DIA - BLACK
	016188-03-000	EA	GROMMET-L/P LINE, 3/8" HOLE X 2 1/2" LONG - RUBBER
	016188-05-000	EA	GROMMET-L/P LINE, 3/8" HOLE X 1 1/4" LONG - RUBBER
	023942-01-000	EA	GROMMET-RUBBER, 2" OD
	056134-02-000	EA	HOLDER-RING, 1.8" DIAMETER - METAL
	077955-01-000	EA	CLIP-J,VINYL COATED, 3/8"
	080211-03-000	EA	CLIP-MOUNTING, (XMAS TREE) - DECORATIVE PADS
	080734-02-000	EA	CLIP-WIRE, NYLON
	094362-02-000	EA	CLIP-CHRISTMAS TREE, FLAT HEAD - .5" X .95"
	099637-01-000	EA	GROMMET-RUBBER, .37" X .94" DIAMETER - BLACK
	008343-01-000	EA	TIE-WIRE, 6"
	008343-02-000	EA	TIE-WIRE, 14"
	029094-04-000	YD	VELCRO TAPE-LOOP, 1" WIDE - BLACK
	029096-03-000	YD	VELCRO TAPE-HOOK, 1" WIDE - BLACK
	029096-04-000	YD	TAPE-HOOK, VELCRO - 1" WIDE - BLACK
	085774-01-000	FT	FASTENER-DUAL HOOK, 1" WIDE - ADHESIVE BACK - BLACK
	085774-02-000	FT	FASTENER-DUAL LOOP, 1" WIDE - ADHESIVE BACK - BLACK
	086285-01-000	EA	SPACER-NYLON, .5" OD X .257" ID
	081211-05-000	EA	PLUG-PLASTIC, .188 DIA - NATURAL
	108046-02-000	EA	CABLE TIE-SCREW MOUNT 15" - DENNISON 10035

WATER & SEWAGE GROUP
WATER HEATER W/ELECTRIC IGNITION

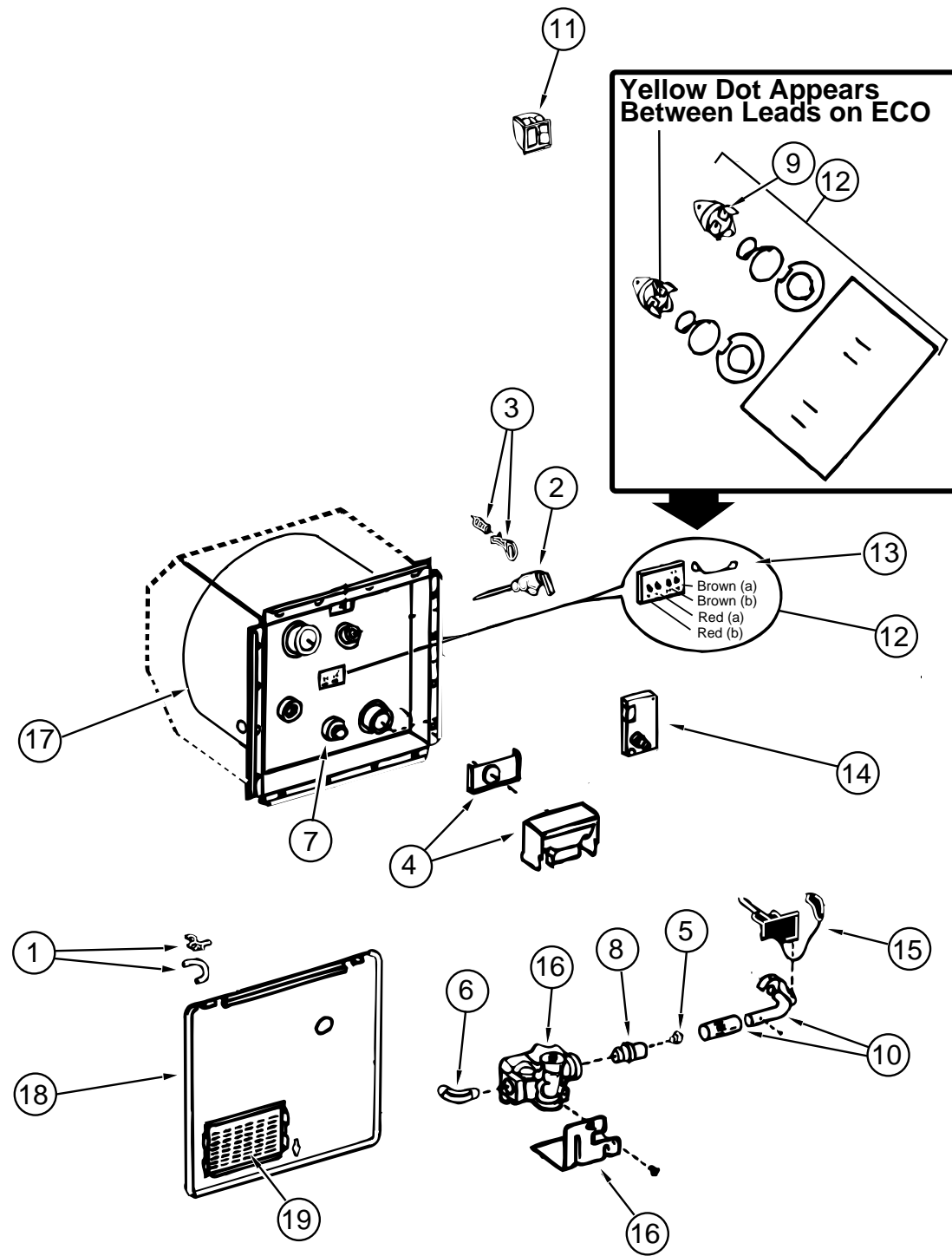

KEY	PART NUMBER	U/M	DESCRIPTION
	051391-03-000	EA	HEATER-WATER, W/ELECTRIC IGNITION - ATWOOD G6A-7E
1	051391-01-700	EA	HINGE KIT-W/CLIP, ATWOOD# 92568 & 92559
2	051391-01-704	EA	VALVE-RELIEF, 1/2" FITTING - ATWOOD# 91604
3	051391-01-705	EA	FASTENER-CAMLOC, ATWOOD# 92609
4	051391-01-706	EA	FLUE & GASKET
5	051391-01-710	EA	ORIFICE-MAIN BURNER, ATWOOD# 92742
6	051391-01-714	EA	ELBOW - 45 DEGREE, 3/8" F X 3/8" MPT - ATWOOD 91044
7	051391-01-715	EA	DRAIN PLUG, ATWOOD# 91561
8	051391-03-700	EA	ORIFICE HOLDER-ATWOOD# 91563
9	051391-04-701	EA	THERMOSTAT 12 VDC-120 PRESET, FRONT MOUNT ONLY - ATWOOD# 91470
10	051391-04-703	EA	BURNER-MAIN, 3E ONLY - ATWOOD# 91638
11	097967-01-000	EA	SWITCH-WATER HEATER, REMOTE W/LIGHT - ATWOOD# 91959
12	051393-01-721	EA	ECO & THERMOSTAT ASM-FRONT MOUNT, 140 DEGREE - ATWOOD# 91447
13	051393-01-723	EA	SWITCH-THERMAL CUT-OFF 2/PKG, ATWOOD# 93866
14	051393-01-724	EA	CIRCUIT BOARD-SPADE TERMINAL, ATWOOD# 93867
15	051393-01-725	EA	ELECTRODE-SINGLE SPADE CONNECT - ATWOOD 93868
16	051393-01-726	EA	SOLENOID VALVE AND BRACKET - ATWOOD# 93870
17	051391-04-706	EA	TANK-INNER, G6A-4E & 6E - FRONT MOUNT - ATWOOD# 91641
18	052009-06-000	EA	DOOR-WATER HEATER, BRIGHT WHITE
19	051391-01-717	EA	GRILL ONLY
	116424-01-000	EA	PROTECTOR-WATER HEATER LATCH - ATWOOD 92611

WATER & SEWAGE GROUP (CONTINUED)
WATER HEATER W/MOTOR AID

KEY	PART NUMBER	U/M	DESCRIPTION
	051393-01-000	EA	WATER HEATER-W/MOTOR AID, PILOTLESS IGNITION - ATWOOD GH6-7E
1	051391-01-700	EA	HINGE KIT-W/CLIP, ATWOOD # 92568 & 92559
2	051391-01-704	EA	VALVE-RELIEF, 1/2" FITTING - ATWOOD# 91604
3	051391-01-705	EA	FASTENER-CAMLOC, ATWOOD# 92609
4	051391-01-706	EA	FLUE & GASKET
5	051391-01-710	EA	ORIFICE-MAIN BURNER, ATWOOD# 92742
6	051391-01-714	EA	ELBOW - 45 DEGREE, 3/8"F X 3/8"MPT - ATWOOD 91044
7	051391-01-715	EA	DRAIN PLUG, ATWOOD# 91561
8	051391-03-700	EA	ORIFICE HOLDER-ATWOOD# 91563
9	051391-04-701	EA	THERMOSTAT 12 VDC-120 PRESET, FRONT MOUNT ONLY - ATWOOD# 91470
10	051391-04-703	EA	BURNER-MAIN, 3E ONLY - ATWOOD# 91638
11	097967-01-000	EA	SWITCH-WATER HEATER, REMOTE W/LIGHT - ATWOOD 91959
12	051393-01-721	EA	ECO & THERMOSTAT ASM-FRONT MOUNT, 140 DEGREE - ATWOOD# 91447
13	051393-01-723	EA	SWITCH-THERMAL CUT-OFF 2/PKG, ATWOOD# 93866
14	051393-01-724	EA	CIRCUIT BOARD-SPADE TERMINAL, ATWOOD# 93867
15	051393-01-725	EA	ELECTRODE-SINGLE SPADE CONNECT - ATWOOD 93868
16	051393-01-726	EA	SOLENOID VALVE AND BRACKET - ATWOOD# 93870
17	051393-03-701	EA	TANK-INNER - ATWOOD# 91642
18	052009-06-000	EA	DOOR-WATER HEATER, BRIGHT WHITE
19	051391-01-717	EA	GRILL ONLY
	116424-01-000	EA	PROTECTOR-WATER HEATER LATCH - ATWOOD 92611
	0MD75C-10-000	EA	NUT-HEX FLG,M10X1.5 CAD PREV CLASS 10
	114430-03-000	EA	ADAPTER-1/2" P X 1/2" MPT - FLAIR-IT 02842
	101814-01-000	EA	COUPLING-FEMALE, 1/2" X 1/2" FPT W/COMP. SLEEVE - GRAY
	110438-01-000	EA	VALVE-CHECK, BRASS - G784

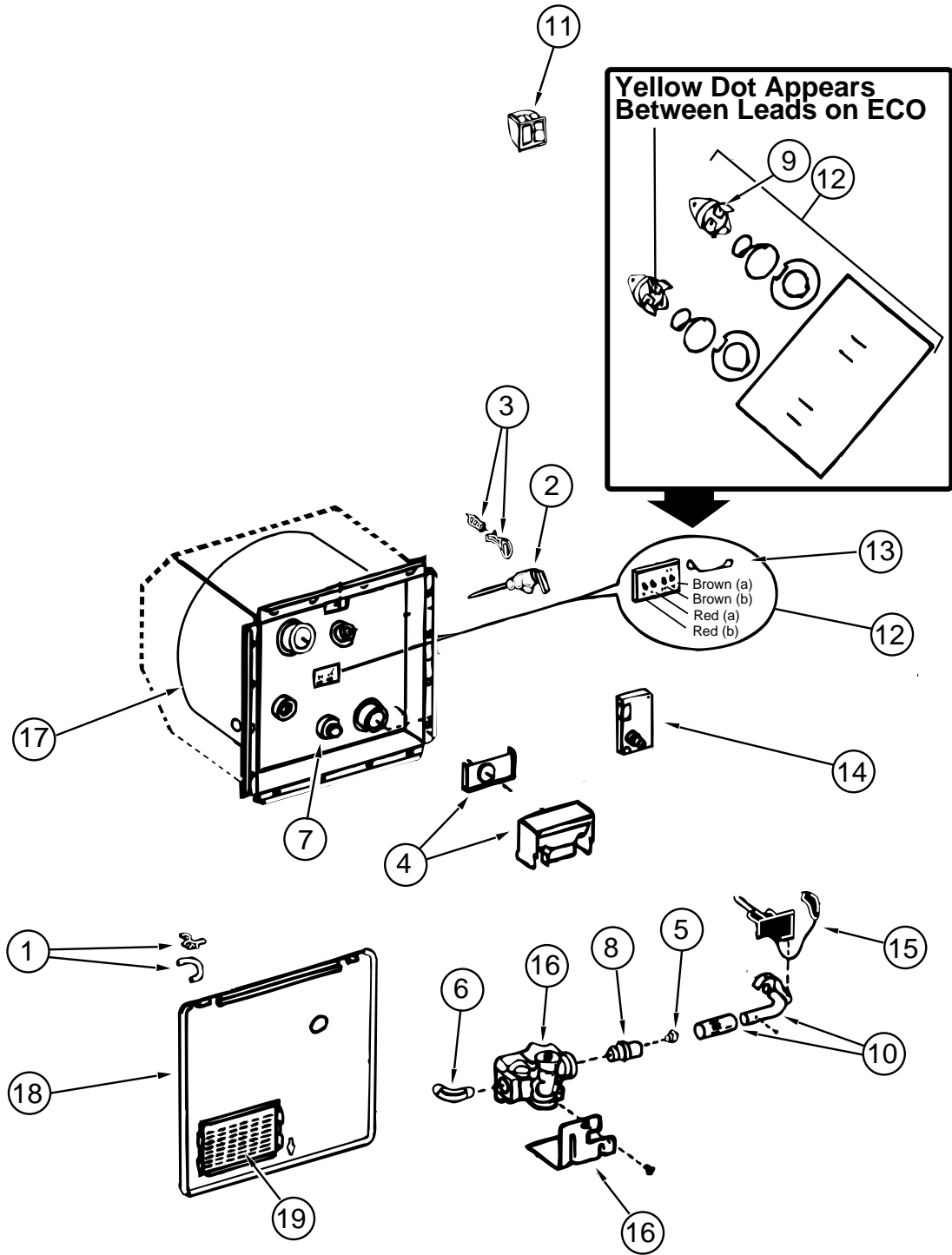

WATER & SEWAGE GROUP (CONTINUED)
EUROPEAN EXPORT WATER HEATER

KEY	PART NUMBER	U/M DESCRIPTION
	111129-01-000	EA WATER HEATER-ELECTRIC IGNITION GAS/220V ELECTRIC - ATWOOD9472ICH66E
	111129-01-700	EA WALL SWITCH PACKAGE - ATWOOD# 91208
	111129-01-701	EA PRESSURE/DRAIN VALVE 2 BAR - ATWOOD# 91190
	111129-01-702	EA PRESSURE DRAIN VALVE 3.5 BAR - ATWOOD# 91210
	111129-01-703	EA THERMOSTAT (60 DEGREE)ECO(82 DEGREE)KIT - ATWOOD# 91191
	111129-01-704	EA IGNITION BOARD - ATWOOD# 91194
	111129-01-705	EA GAS PRESSURE REGULATOR W/NO.10 - ATWOOD# 91198
	111129-01-706	EA MAIN BURNER ORFICE W/FITTING - ATWOOD# 91017
	111129-01-707	EA MAIN BURNER KIT - ATWOOD# 91204
	111129-01-708	EA SPARK/PROBE IGNITION KIT - ATWOOD# 91196
	111129-01-709	EA FLUE ASSEMBLY - ATWOOD# 91045
	111129-01-710	EA ACCESS DOOR, W/LOCK - ATWOOD# 91203
	111129-01-711	EA CORNER BRACKETS (SET OF 4) - ATWOOD# 91928
	111129-01-712	EA HARDWARE KIT, W/LOCK - ATWOOD# 91193
	111129-01-713	EA TANK INNER ICH6-6E - ATWOOD# 91188
	111129-01-714	EA THERMOSTAT-ELECTRIC, 220V - ATWOOD# 91207
	111129-01-715	EA RELAY,220 V/12 VDC - ATWOOD# 91206
	111129-01-716	EA HEATING ELEMENT 220V/500WATT - ATWOOD# 91081
	111129-01-717	EA BUSHING-STRAIN RELIEF - ATWOOD# 91372
	112176-01-000	FT TUBING-VINYL, REINFORCED - 1/2" ID - KEVCO
	112177-01-000	EA ADAPTER-BRASS, 1/2" MPT X 1/2" BARB - KEVCO

WATER PUMP

KEY	PART NUMBER	U/M DESCRIPTION
	098607-01-000	EA PUMP-WATER, W/.5"MPT FITTING - FLOW 2.8 GPM - UL
	098607-01-700	EA PUMPHEAD-REPLACEMENT, SHURFLO# 94-236-08
	098607-01-701	EA DRIVE ASM, SHURFLO# 94-234-03
	098607-01-702	EA DIAPHRAGM-KIT, SHURFLO# 94-233-10
	098607-01-703	EA VALVE ASM, SHURFLO# 94-232-00
	098607-01-706	EA SWITCH ASM-COMPLETE, SHURFLO# 94-230-00
	098607-01-705	EA CHECK VALVE-KIT, SHURFLO# 94-237-00
	098607-01-707	EA MOTOR/BASEPLATE REPLACEMENT, SHURFLO# 94-234-03

WATER HEATER BYPASS

KEY	PART NUMBER	U/M DESCRIPTION
	099729-01-000	EA BYPASS KIT-WATER HEATER, COMPLETE W/VALVE & TUBING
	099729-01-700	EA VALVE ONLY CHECK PLASTIC
	099729-02-000	EA BYPASS KIT-WATER HEATER (CANADIAN)
	099729-02-700	EA VALVE ONLY CHECK BRASS (CANADIAN)
	103259-01-000	EA BRACKET-BYPASS, WATER HEATER

WATER TANK

KEY	PART NUMBER	U/M DESCRIPTION
	110622-03-000	EA TANK ASM-WATER 55 GAL - W/FITTINGS
	110622-01-000	EA TANK-WATER BASE, 55 GAL - W/O FITTINGS
	110622-02-000	EA TANK ASM-WATER 50 GAL - W/FITTINGS
	110622-01-000	EA TANK-WATER BASE, 50 GAL - W/O FITTINGS
	039861-01-000	EA SENDING UNIT-W/SCREW, WASHER, WELL NUT & TERMINAL RING
	010224-01-000	EA ADAPTER-HOSE TO PIPE, 3/8" MPT X 3/8" BARB - PLASTIC BLACK
	042989-03-000	EA FITTING-WATER TANK, SPINWELD - 1 1/4"NPT - PLASTIC - WHITE
	042989-04-000	EA FITTING-WATER TANK, SPINWELD - 3/8" FPT - PLASTIC - WHITE
	042989-05-000	EA FITTING-WATER TANK, SPINWELD - 1/2" FPT - PLASTIC - WHITE
	044927-01-000	EA ADAPTER-HOSE TO PIPE, 1 1/4"MPT X 1 1/4"BARB-BLACK PLASTIC
	049032-01-000	EA PATCH-SPINWELD, 3/8" - PLASTIC
	052955-01-000	EA TEE-1/2"F X 1/2"F X 1/2"MPT - PLASTIC
	074462-02-000	FT TUBING-VINYL, 3/8" ID - CLEAR - INCREMENTS OF 20'
	077954-02-000	EA FILTER-WATER TANK, SCREEN IN TANK
	079381-01-000	FT TUBING-SMOOTH FLEXIBLE, 1 1/4" ID - INCREMENTS OF 20'

WATER & SEWAGE GROUP (CONTINUED)
EXTERIOR SHOWER KIT

KEY	PART NUMBER	U/M DESCRIPTION
	046128-01-000	EA VALVE-DRAIN, PLASTIC - 1/2" FPT
	052959-02-000	EA CONNECTOR, 1/2" F X 1/2" MPT - PLASTIC - GRAY
	057457-01-000	EA ELBOW-UNION, 1/2" X 1/2" FLARE
	065120-01-000	EA ELBOW-SWIVEL, 1/2" FPT X 1/2" FLARE - PLASTIC - GRAY
	052957-02-000	EA ELBOW-MALE, 1/2" F X 1/2" MPT - PLASTIC - GRAY
	103173-03-705	EA LABEL
	103173-03-706	EA SHOWER HEAD,HOSE,BRACKET
	103173-03-707	EA FAUCET-SHOWER W/ADAPT
	103173-03-708	EA STEM & BONNET (SETS)

WATER SYSTEM

KEY	PART NUMBER	U/M DESCRIPTION
	114427-01-000	EA CAP-1/2P - FLAIR-IT 02860
	114427-02-000	EA PLUG-1/2P - FLAIR-IT 02863
	114428-01-000	EA TEE-1/2P X 1/2P X 1/2P - FLAIR-IT 02820
	114428-02-000	EA TEE-SWIVEL - 1/2P X 1/2P X 1/2FPT - FLAIR-IT 02821
	114428-03-000	EA TEE-1/2P X 1/2P X 1/2MPT - FLAIR-IT 02822
	114429-01-000	EA ELBOW-1/2P X 1/2P - FLAIR-IT 02800
	114429-02-000	EA ELBOW-1/2P X 1/2MPT - FLAIR-IT 02803
	114429-03-000	EA ELBOW-SWIVEL - 1/2P X 1/2FPT - FLAIR-IT 02816
	114429-04-000	EA ELBOW-1/2P X 3/8MPT - FLAIR-IT 02810
	114429-05-000	EA ELBOW-1/2P X 3/4MPT - FLAIR-IT 02812
	114429-06-000	EA ELBOW-SWIVEL - 1/2P X 3/4FPT - FLAIR-IT 02811
	114430-01-000	EA ADAPTER-1/2P X 1/2P - FLAIR-IT 02840
	114430-02-000	EA ADAPTER-SWIVEL - 1/2P X 1/2FPT - FLAIR-IT 02873
	114430-03-000	EA ADAPTER-1/2P X 1/2MPT - FLAIR-IT 02842
	114431-01-000	EA VALVE-LINE DRAIN 1/2P - FLAIR-IT 02914
	114431-02-000	EA VALVE-1/2P - BYPASS - FLAIR-IT 02910
	114431-03-000	EA VALVE-1/2P X 1/2P - FLAIR-IT 02884
	114431-04-000	EA VALVE-STOP - 1/2P X 1/2P - FLAIR-IT 02880
	039800-02-000	FT TUBING-POLYBUTYL, 5/8" OD - INCREMENTS OF 20' - BLACK
	110915-01-01A	EA FILL-WATER, CITY - CHROME - KEVCO 64713
	010219-01-000	EA ELBOW-1 1/4" MPT X 1 1/4" BARB, WATER FILL - PLASTIC
	035539-01-000	EA ELBOW-PLASTIC, 3/8"MPT X 3/8"BARB
	052956-01-000	EA TEE-1/2" F X 1/2" MPT X 1/2" F - PLASTIC
	052957-01-000	EA ELBOW-PLASTIC, 1/2" F X 3/8" MPT
	039808-03-000	EA ELBOW-1/2" MPT X 1/2" MPT, PLASTIC - KEVCO 17296
	101814-01-000	EA COUPLING-FEMALE, 1/2" X 1/2" FPT W/COMP. SLEEVE - GRAY
	046128-01-000	EA VALVE-DRAIN, PLASTIC - 1/2" FPT
	039800-01-000	FT TUBING-POLYBUTYL, 1/2" OD - INCREMENTS OF 20' - BLACK
	052952-01-000	EA NUT-PLASTIC, 1/2" F X 1/2" TUBE - GRAY
	052952-02-000	EA NUT-PLASTIC, 5/8" FLARE
	052958-01-000	EA TEE, 1/2" F X 1/2" F X 1/2" F - PLASTIC - GRAY
	113698-01-000	EA VALVE-LINE DRAIN,1/2F X 1/2F PLASTIC-WATER
	055290-01-000	EA ELBOW-5/8"F X 1/2"MPT
	057457-02-000	EA ELBOW-UNION, 5/8" X 5/8" FL - WATER
	079317-01-000	EA ADAPTER-SWIVEL, 1/2" TUBE X 1/2" FPT - PLASTIC - GRAY
	106258-01-000	EA CAP-INSERTABLE, 1/2" FLARE
	091208-01-000	EA WASHER-RUBBER, .06" X .75" X .5"

WATER & SEWAGE GROUP (CONTINUED)
DRAINAGE SYSTEM

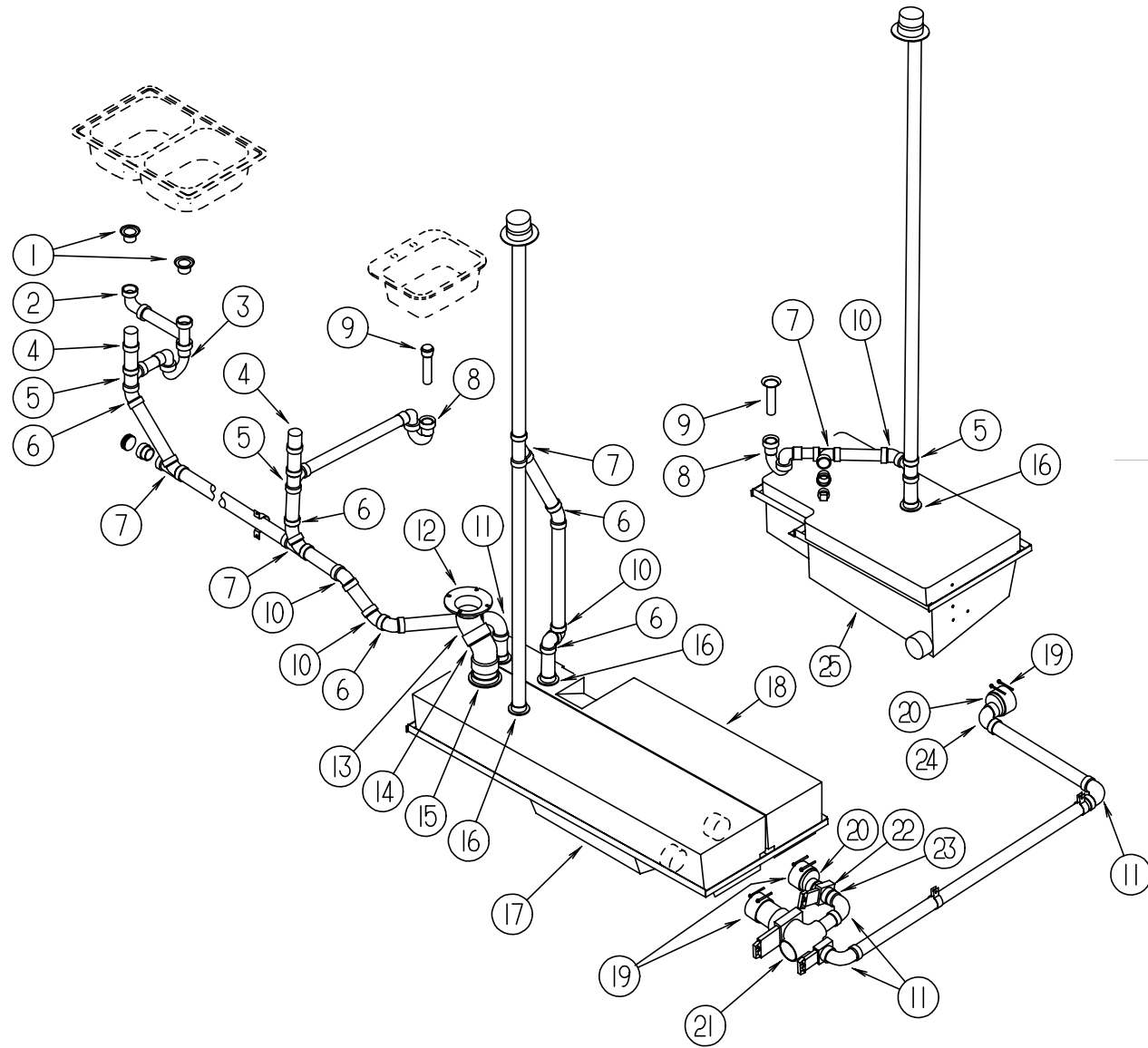

KEY	PART NUMBER	U/M	DESCRIPTION
1	092303-01-000	EA	STRAINER-SINK
2	011091-02-000	EA	PIPE-DRAIN, DOUBLE SINK - BAFFLE TEE - 1 1/2" - US ONE PIPE W/TEE TO DRAIN BOTH SIDES OF SINK
2	011091-03-000	EA	PIPE-DRAIN, W/SEALS - DOUBLE SINK - EXTENDS 9" TO 16" - CANADIAN
3	107538-01-000	EA	P-TRAP-PLASTIC, 1 1/4" W/EXT ARM - US
3	109571-01-000	EA	P-TRAP ADAPTER-1 1/2" P X 1 1/4" MPT - US
3	011071-01-000	EA	P-TRAP-PLASTIC, 1 1/2" - PLASTIC - CANADIAN
3	107537-01-000	EA	P-TRAP ADAPTER-1 1/4" SLIP - CANADIAN
4	079968-01-000	EA	VENT-MECHANICAL TRAP ARM, ANTI-SIPHON - 2" DIA X 7.3" - PLASTIC
5	010071-01-000	EA	TEE-SANITARY, 1 1/2" HUB X HUB X HUB - PLASTIC - BLACK
6	010051-01-000	EA	ELBOW - 45 DEGREE BEND, 1 1/2" SPIGOT AND HUB - PLASTIC - BLACK
7	010073-01-000	EA	WYE - 45 DEGREE, 1 1/2" HUB X HUB X HUB - PLASTIC - BLACK
	010122-01-000	EA	BUSHING-REDUCER, 1 1/2" SMTH X 1 1/4" THD - PLASTIC - BLACK
	010166-01-000	EA	PLUG-THREADED, 1 1/4" DIAMETER - PLASTIC - BLACK
8	107538-01-000	EA	P-TRAP-PLASTIC, 1 1/4" W/EXT ARM - US
8	011066-02-000	EA	P-TRAP-1 1/4" HUB X SLIP JOINT, W/UNION - ABS - CANADIAN
9	011069-02-000	EA	TAILPIECE-TUB/SHOWER, 1 1/2" X 1 1/4" X 4" - BRASS
10	010006-01-000	EA	ELBOW - 45 DEGREE, 1/8 BEND - 1 1/2" HUB X HUB - BLACK PLASTIC
11	010008-01-000	EA	ELBOW - 90 DEGREE, 1/4 BEND - 1 1/2" HUB X HUB - BLACK PLASTIC
	061607-01-000	EA	GROMMET-HOLDING TANK, 1 1/2" NPS
12	024676-02-000	EA	FLANGE-CLOSET, 4" X 3" - ABS - CANADIAN
12	063641-01-000	EA	FLANGE-CLOSET, 4" X 3" - US
13	010061-01-000	EA	ELBOW - 45 DEGREE, STREET - 1/8 BEND - 3" S X H - PLASTIC
14	010024-01-000	EA	ELBOW-PLASTIC, 1/8 BD - 3 X 45 - H X H
15	061607-02-000	EA	GROMMET-HOLDING TANK, 3" NPS
16	061607-01-000	EA	GROMMET-HOLDING TANK, 1 1/2" NPS
17	081149-01-000	EA	TANK-HOLDING, 29 GALLON - 59.25" X 13.4" X 15.5"
18	081185-01-000	EA	TANK-HOLDING, 20 GALLON - 59.25" X 11.4" X 13.8"
19	078406-01-000	EA	COUPLER-RUBBER, W/CLAMPS - 3" X 3"
20	062422-01-000	EA	ADAPTER-OFFSET REDUCER, 3" X 1 1/2" - PLASTIC - BLACK
21	082696-01-000	EA	VALVE-WASTE, DRAINAGE - 3"
22	062421-01-000	EA	VALVE-DUMP, W/HANDLE - 1 1/2" - PLASTIC - BLACK
	088770-01-000	EA	STANDOFF-THREADED, 3/8" X 1 1/4"
	088771-01-000	EA	ROD-THREADED, .25" DIAMETER X 7.25" LONG
23	010115-01-000	EA	COUPLING-1 1/2" HUB X HUB, PLASTIC
24	033761-01-000	EA	ELBOW-TURN, 1/4 BEND X 1.5"HUB X 1.5"SPIGOT - BLK PLASTIC
25	076574-01-000	EA	TANK-HOLDING, 25 GALLON - 37.2" X 20" X 12.6"
	010201-01-000	EA	HOSE-SEWER, 3" ID X 8'
	062416-01-000	EA	ADAPTER-SEWER HOSE TO 3" PIPE

WINDOW, VENT & EXTERIOR DOOR GROUP
EXTERIOR WINDOWS

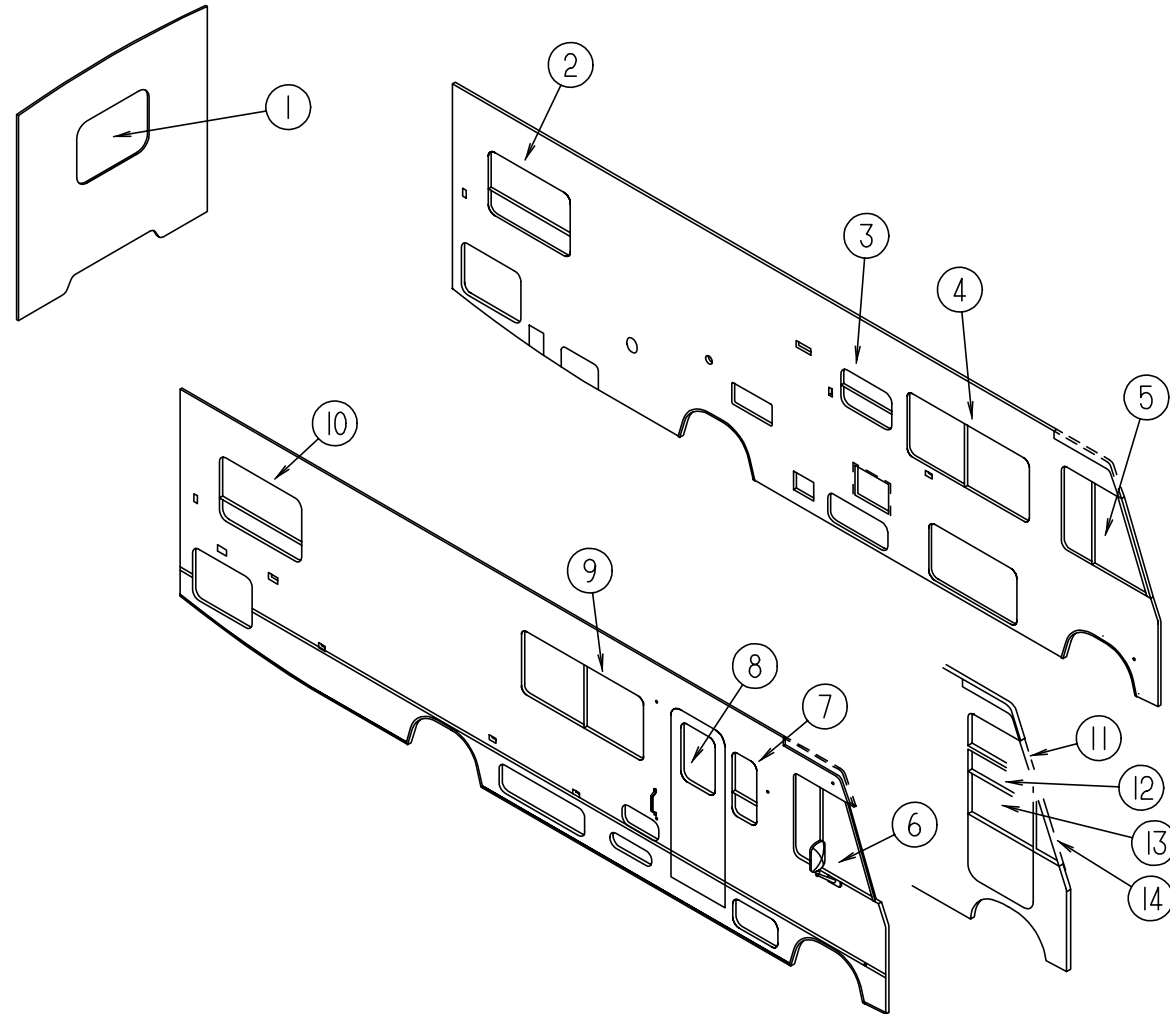

KEY	PART NUMBER	U/M	DESCRIPTION
1	078528-06-E10	EA	WINDOW ASM-ESCAPE
1	113502-01-01A	EA	WINDOW ASM- REAR ESCAPE BLK/OW - THERMOPANE
2	113500-01-01A	EA	WINDOW ASM-TIPOUT, DOUBLE - BLK/OW
2	112795-23-01A	EA	WINDOW ASM-SLIDER, HORIZONTAL - THERMOPANE - DRIVER SIDE
3	098647-34-01A	EA	WINDOW ASM-SLIDER, HORIZONTAL
3	112795-20-01A	EA	WINDOW ASM-SLIDER, HORIZONTAL - THERMOPANE
4	098647-22-01A	EA	WINDOW ASM-SLIDER, HORIZONTAL BLK/OW
4	112795-15-01A	EA	WINDOW ASM-SLIDER, HORIZONTAL - THERMOPANE
5	103658-09-01A	EA	WINDOW ASM-CAB DRIVER
5	113501-03-01A	EA	WINDOW ASM-CAB DRIVER - THERMOPANE
6	103658-10-01A	EA	WINDOW ASM-CAB, PASSENGER
6	113501-04-01A	EA	WINDOW ASM-CAB, PASSENGER - THERMOPANE
7	098644-07-01A	EA	WINDOW ASM-SINGLE RAISE BLK/OW
7	112898-04-01A	EA	WINDOW ASM-SLIDER, VERTICAL - THERMOPANE
8	079733-15-F04	EA	WINDOW-ENTRY DOOR, PICTURE
8	113733-01-01A	EA	WINDOW ASM-STATIONARY, THERMOPANE
9	098647-22-01A	EA	WINDOW ASM-SLIDER, HORIZONTAL BLK/OW
9	112795-15-01A	EA	WINDOW ASM-SLIDER, HORIZONTAL - THERMOPANE
10	113500-01-01A	EA	WINDOW ASM-TIPOUT, DOUBLE - BLK/OW
10	112795-21-01A	EA	WINDOW ASM-SLIDER, HORIZONTAL - THERMOPANE - PASSENGER SIDE
11	106467-02-01A	EA	WINDOW-VISTA, DRIVER SIDE
12	106469-02-702	EA	WINDOW-DRIVER DOOR, STATIONARY GLASS
13	106469-01-704	EA	WINDOW-DRIVER DOOR, ROLL-UP GLASS ASM. - W/BRACKET
14	106468-02-01A	EA	WINDOW-FRONT SLANT

WINDOW, VENT & EXTERIOR DOOR GROUP (CONTINUED)
EXTERIOR DOORS & VENTS

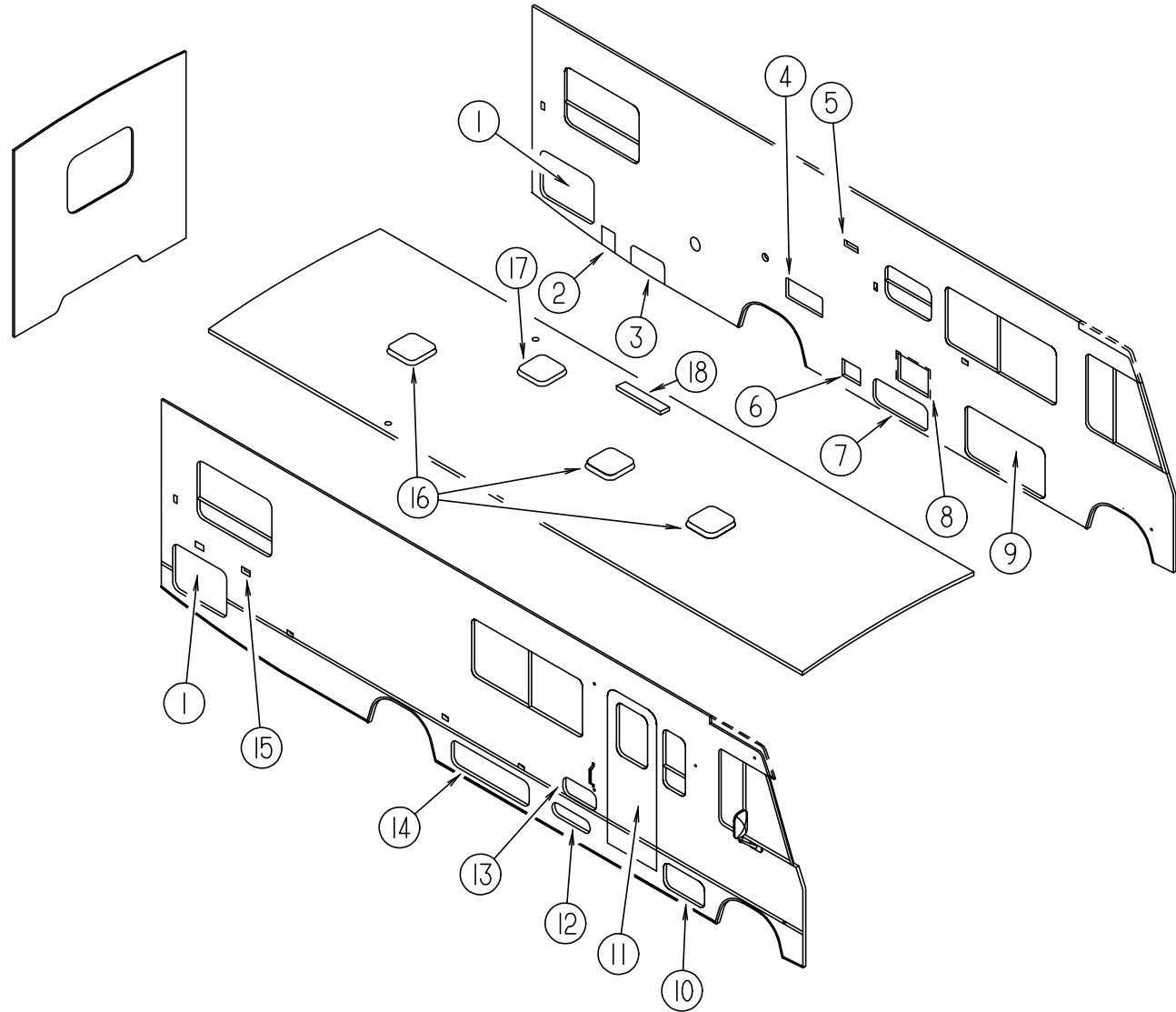

KEY	PART NUMBER	U/M	DESCRIPTION
1	111013-36-E07	EA	DOOR ASM-STORAGE
2	052423-01-000	EA	DOOR-ACCESS, 6.6" X 6.3" - PLASTIC - OFF WHITE
	052424-01-000	EA	JAMB-DOOR, 8" X 7.7" - PLASTIC - OFF WHITE
3	111012-02-E07	EA	DOOR ASM-STORAGE (F04,F05,F06,F07)
3	111012-02-F14	EA	DOOR ASM-STORAGE
4	084103-03-000	EA	DOOR-REFRIGERATOR, VENTED - W/O JAMB - OFF WHITE
	084104-03-000	EA	JAMB-DOOR, REFRIGERATOR - OFF WHITE
	084104-01-700	EA	LOCK-MALE, FASTENER - REFRIGERATOR DOOR
	084104-01-701	EA	LOCK-FEMALE, FASTENER - REFRIGERATOR DOOR
5	084616-01-000	EA	SHROUD-RANGE HOOD VENT, OFF WHITE
	084878-09-000	EA	VENT-RANGE HOOD, SHORT - LVS
6	088794-01-000	EA	DOOR-POWER CORD, W/HATCH - OFF WHITE
7	111018-01-E07	EA	DOOR ASM-GENERATOR (F04,F05,F06,F07)
7	111018-01-F14	EA	DOOR ASM-GENERATOR
8	052009-01-000	EA	DOOR-WATER HEATER, OFF WHITE - ATWOOD 5576-27
9	111013-09-E07	EA	DOOR ASM-STORAGE
10	111013-04-E07	EA	DOOR ASM-STORAGE (F04,F05,F06,F07)
10	111013-04-F14	EA	DOOR ASM-STORAGE
11	M06977-01-F04	EA	DOOR-ENTRY W/SCREEN DOOR - W/O WINDOW
11	M06977-01-F05	EA	DOOR-ENTRY W/SCREEN DOOR - W/O WINDOW
11	M06977-01-F06	EA	DOOR-ENTRY W/SCREEN DOOR - W/O WINDOW
11	M06977-01-F07	EA	DOOR-ENTRY W/SCREEN DOOR - W/O WINDOW
11	115108-01-F14	EA	DOOR-ENTRY W/SCREEN DOOR - W/O WINDOW
			FROM: 00-00-00 THRU: 10-23-94
11	115108-05-F14	EA	DOOR-ENTRY W/SCREEN DOOR - W/O WINDOW
			FROM: 10-24-94 THRU: 99-99-99
12	111009-01-E01	EA	DOOR-COMPARTMENT, LP - 16.9" X 5.4" - ALUMINUM - OFF WHITE
			(F04,F05,F06,F07)
12	111009-01-F14	EA	DOOR-COMPARTMENT, LP - 16.9" X 5.4" - ALUMINUM - SHALE BLUE
13	111017-01-E07	EA	DOOR-STORAGE (F04,F05,F06,F07)
13	111017-01-F14	EA	DOOR-STORAGE
14	111013-13-E07	EA	DOOR ASM-STORAGE (F04,F05,F06,F07)
14	111013-13-F14	EA	DOOR ASM-STORAGE
15	081240-11-000	EA	FILL-WATER, LOCKABLE W/O LOCK - OFF WHITE
	110506-02-000	EA	LOCK-KEYED, 13.64 MM - BRIGGS & STRATTON
16	110051-01-01A	EA	VENT-ROOF, NONPOWERED - 2" ROOF - JENSEN 7724 WHE
17	110051-03-01A	EA	VENT-ROOF, POWERED - 2" ROOF - JENSEN 7757 WHE - US
17	110051-05-01A	EA	VENT-ROOF, POWERED - 2" ROOF - JENSEN C7757 WHE - CANADIAN
18	084073-03-000	EA	COVER-ROOF VENT, REFRIGERATOR - OFF WHITE - NORCOLD
	084073-04-000	EA	BASE-ROOF VENT, REFRIGERATOR - BLACK - NORCOLD

WINDOW, VENT & EXTERIOR DOOR GROUP (CONTINUED)
ENTRY DOOR

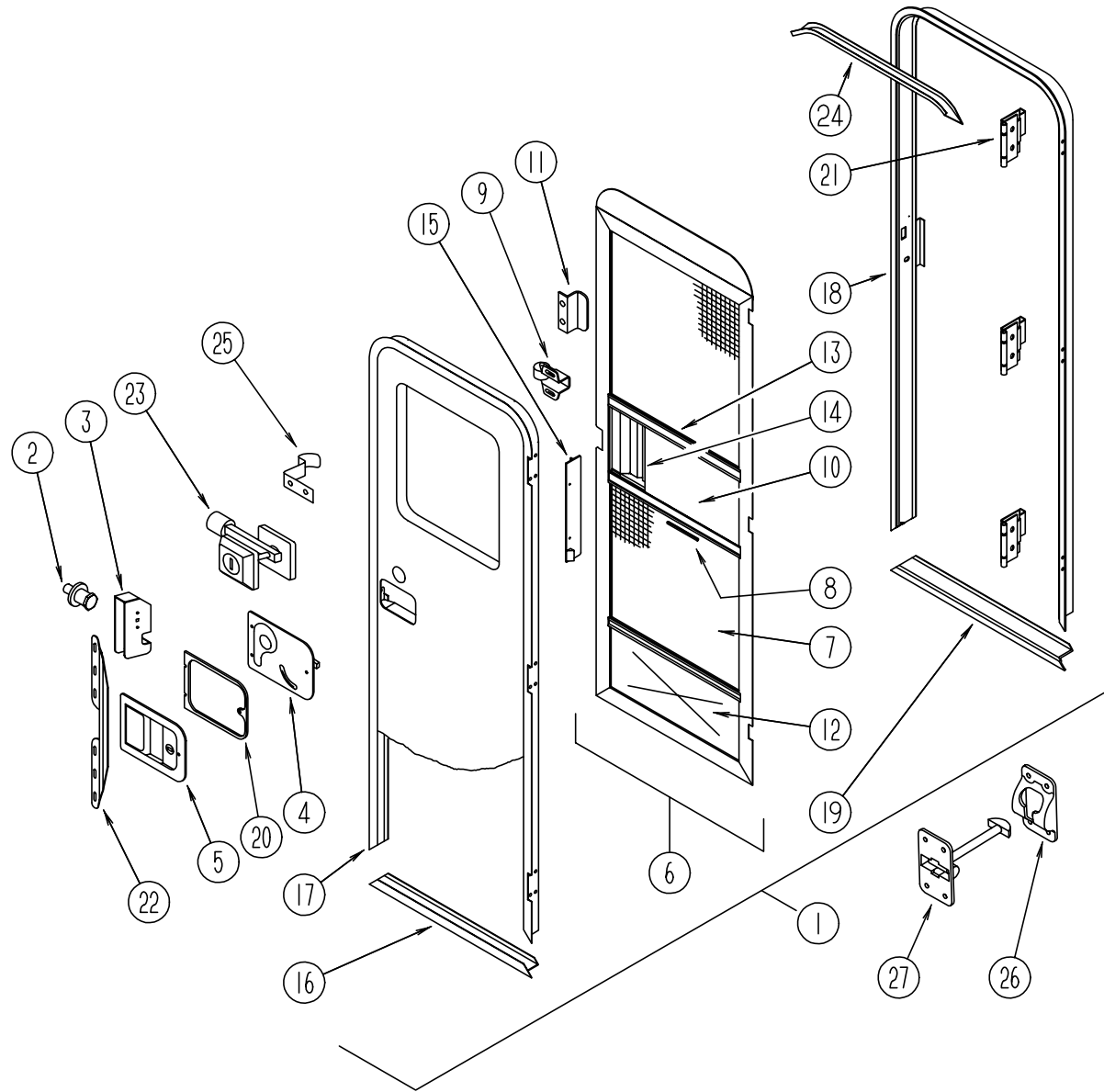

KEY	PART NUMBER	U/M DESCRIPTION
2	039539-01-000	EA STRIKE-LOCK, ENTRY DOOR - ROUND W/THREADED WASHER
3	039540-01-000	EA LATCH MECHANISM-HOOK, ENTRY DOOR - INTERIOR
	039715-01-000	EA NUT-SERT, 1/4" DIAMETER - 20 THREADS
4	039979-04-000	EA COVER-INTERIOR LATCH, W/TRIP ARM - RIGHT - BLACK
	039984-01-000	EA CAP-ROUND, VINYL - .28" ID X .62" LONG - BLACK
	041546-05-000	EA BRACKET-DOOR ANGLE, 5" X 1.9" - OFF WHITE - METAL
5	045017-11-000	EA LATCH-ENTRY DOOR, MECHANISM W/LOCK & KEY - BLACK
	045017-11-701	EA KEY BLANK
	063729-04-000	EA RIVNUT, 10-32 UNF - .010-.080
	058806-03-000	EA PLUG-TAPERED, PLASTIC - 1.06" DIAMETER - RED
	075671-04-000	FT SEAL-SPONGE, LAZY T SHAPE - W/ADHESIVE STRIPE - .5" WIDE
6	079012-09-F15	EA DOOR-SCREEN
7	002293-02-000	SF SCREENING-WINDOW/DOOR, 26" - CHARCOAL
8	002294-01-000	FT SPLINE-SCREENING, .135" X .138" - BLACK
9	109403-01-000	EA CATCH-ASM-SINGLE ROLLER
10	016454-01-000	EA INSERT-CENTER, LEATHER GRAIN ALUMINUM - UNPAINTED
10	001014-01-013	EA INSERT-CENTER, 10.25" X 16.31" - UNPAINTED
11	050712-04-000	EA HANDLE-SCREEN DOOR, ALUMINUM - OFF WHITE
12	078552-03-000	EA KICK PANEL-SCREEN DOOR, LOWER INSERT - UNPAINTED
	078595-01-000	EA TOP PLATE-SCREEN DOOR, CURVED TOP - 4.7" X 25.35"
13	078777-01-000	EA CHANNEL-SLIDE, SCREEN DOOR CENTER SLIDER COVER
14	079086-02-000	EA SLIDER-SCREEN DOOR, OFF WHITE
15	079087-02-000	EA STRIKE-SLIDER, W/LIP FOR ELBOW CATCH - 1.5" X 8.6" - OFF WHITE
	081914-01-000	EA BUMPER-RUBBER, ROUND - .43" DIAMETER - BLACK
	104692-01-000	FT SEAL - 3/4" X 3/4", ADHESIVE BACK
16	089748-01-000	EA FRAME-BOTTOM, ENTRY DOOR - 24.8" LONG - OFF WHITE
17	095276-07-01A	EA FRAME-ENTRY DOOR, W/O BOTTOM - OFF WHITE
18	095277-08-01A	EA JAMB-ENTRY DOOR, W/BOTTOM - OFF WHITE
		FROM: 00-00-00 THRU: 10-23-94
18	095277-09-01A	EA JAMB-ENTRY DOOR, W/BOTTOM - OFF WHITE
		FROM: 10-24-94 THRU: 99-99-99
19	051049-01-000	EA JAMB-BOTTOM, ENTRY DOOR - 25.9" - UNPAINTED
20	096810-01-01A	EA PLATE-LATCH, ENTRY DOOR - PLASTIC - BLACK
21	106719-01-01A	EA HINGE-ENTRY DOOR, UNPAINTED
22	098173-01-04A	EA STIFFENER-ENTRY DOOR, SUPPORTS LATCH/STRIKE AREA - UNPAINTED
	100128-02-000	FT SEAL-FOAM, ADHESIVE BACK - .37" WIDE X .37" THICK - SCREEN DOOR
23	101145-01-01A	EA DEADBOLT-ENTRY DOOR, W/2 KEYS W/O BACK SET BOLT OR SCREWS
	095229-01-700	EA KEY BLANK FOR DEADBOLT
	101147-01-000	EA BOLT-SECURITY, 4.12" BACKSET
	102524-01-000	EA BUMPER-RUBBER, FLAT - BLACK
24	044582-02-000	EA CAP-DRIP, ENTRY DOOR - JAMB MOUNTED - ALUMINUM - OFF WHITE
	115222-01-01A	EA GARNISH-RADIUS, ENTRY DOOR - OFF WHITE
	077461-03-000	EA COVER-STRIKE, ENTRY DOOR - 6.5" X 2.5" - PLASTIC - WHITE
	091876-01-000	EA RETAINER-DOOR, 1.9" X .8" - METAL
25	100412-01-000	EA CATCH-SCREEN DOOR, THUMB CLIP W/BLACK PLASTIC CAP
26	104099-02-01A	EA CATCH-DOOR HOLDER, RETAINER - OFF WHITE
27	104099-01-01A	EA CATCH-DOOR HOLDER, STRIKE - OFF WHITE
	009126-02-000	EA HANDLE-ASSIST, ENTRY DOOR - BLACK

KEY	PART NUMBER	U/M DESCRIPTION
1	115108-01-F04	EA DOOR-ENTRY W/SCREEN DOOR & JAMB - W/O WINDOW
		FROM: 00-00-00 THRU: 10-23-94
1	115108-01-F05	EA DOOR-ENTRY W/SCREEN DOOR & JAMB - W/O WINDOW
		FROM: 00-00-00 THRU: 10-23-94
1	115108-01-F06	EA DOOR-ENTRY W/SCREEN DOOR & JAMB - W/O WINDOW
		FROM: 00-00-00 THRU: 10-23-94
1	115108-01-F07	EA DOOR-ENTRY W/SCREEN DOOR & JAMB - W/O WINDOW
		FROM: 00-00-00 THRU: 10-23-94
1	115108-01-F14	EA DOOR-ENTRY W/SCREEN DOOR & JAMB - W/O WINDOW
		FROM: 00-00-00 THRU: 10-23-94
1	115108-05-F04	EA DOOR-ENTRY W/SCREEN DOOR & JAMB - W/O WINDOW
		FROM: 10-24-94 THRU: 99-99-99
1	115108-05-F05	EA DOOR-ENTRY W/SCREEN DOOR & JAMB - W/O WINDOW
		FROM: 10-24-94 THRU: 99-99-99
1	115108-05-F06	EA DOOR-ENTRY W/SCREEN DOOR & JAMB - W/O WINDOW
		FROM: 10-24-94 THRU: 99-99-99
1	115108-05-F07	EA DOOR-ENTRY W/SCREEN DOOR & JAMB - W/O WINDOW
		FROM: 10-24-94 THRU: 99-99-99
1	115108-05-F14	EA DOOR-ENTRY W/SCREEN DOOR & JAMB - W/O WINDOW
		FROM: 10-24-94 THRU: 99-99-99

WINDOW, VENT & EXTERIOR DOOR GROUP (CONTINUED)
DRIVERS DOOR (FROM: 00-00-00 THRU: 11-13-94)

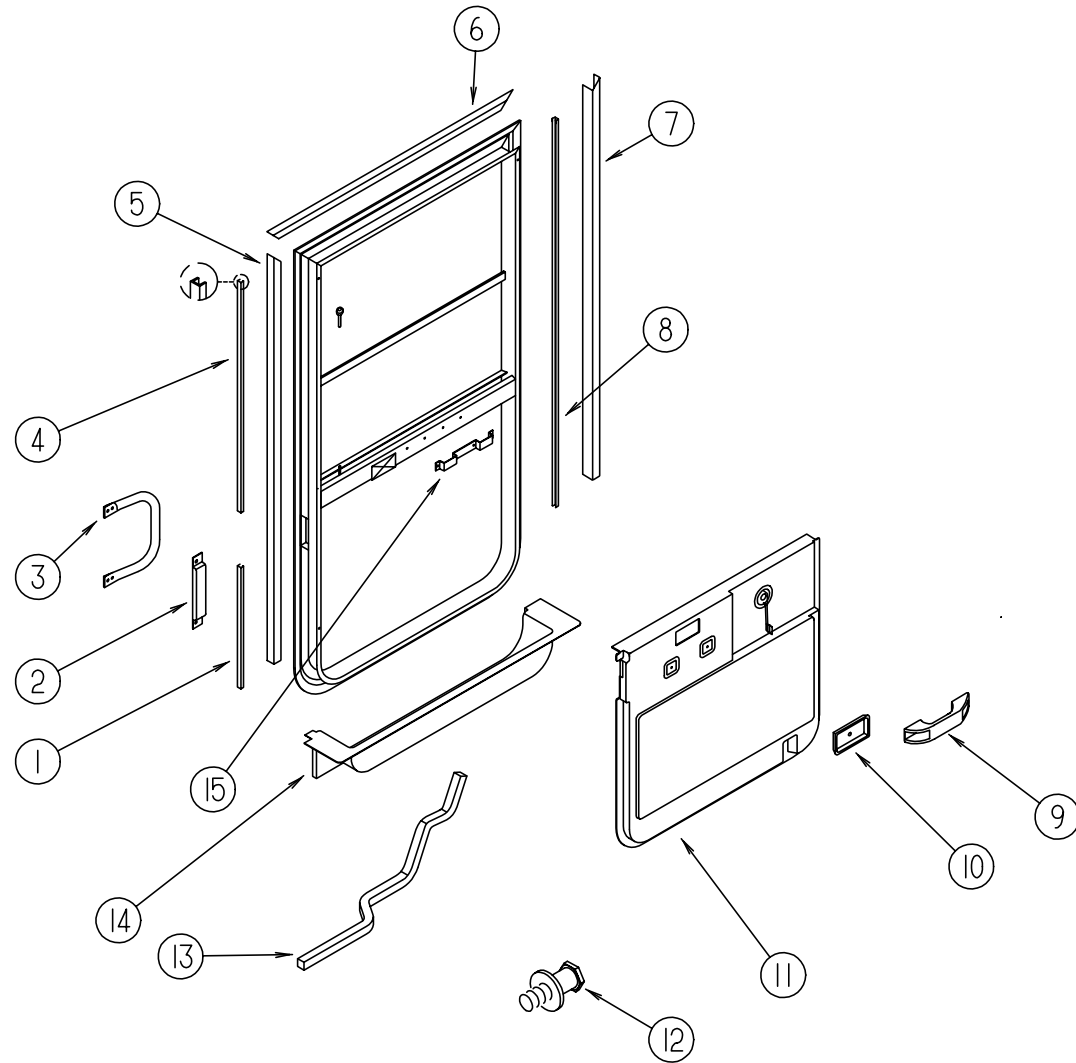

KEY	PART NUMBER	U/M DESCRIPTION
	106469-02-01A	EA DOOR - DRIVERS - BLACK - EXCEL V108-01L
1	108642-03-01A	EA TRIM - DOOR - DRIVERS - BLACK
2	108654-01-01A	EA COVER - STRIKE - DRIVERS DOOR - BLACK
3	108832-01-02A	EA HANDLE - ASSIST - DRIVERS DOOR - METAL - OFF WHITE
3	108832-01-01A	EA HANDLE - ASSIST - DRIVERS DOOR - METAL - MILL FINISHED
3	108833-01-01A	EA COVER - HANDLE - ASSIST - OFF WHITE
4	108642-05-01A	EA TRIM - DOOR - DRIVERS - BLACK
5	108129-02-02A	EA GARNISH - DRIVERS DOOR - BLACK
6	108107-01-02A	EA GARNISH - DRIVERS DOOR - BLACK
7	108108-02-02A	EA GARNISH - DRIVERS DOOR - BLACK
8	108642-04-01A	EA TRIM - DOOR - DRIVERS - BLACK
9	102710-01-01A	EA HANDLE - ASSIST - DRIVERS DOOR - 6.6" LONG - BLACK
10	106469-01-707	EA BEZEL - LATCH - INTERIOR (SUPPLIED W/DRIVERS DOOR) - EXCEL 130-081310
11	111816-01-04A	EA PANEL - DRIVER DOOR - INNER - BISQUE - PLASTIC
12	106469-01-715	EA STRIKER ASSEMBLY - (SUPPLIED W/DRIVERS DOOR) - EXCEL 248-081003
13	063977-12-000	EA STEP - DRIVER DOOR - LEFT - PAINTED BLACK
13	063977-11-000	EA STEP - DRIVER DOOR - LEFT - UNPAINTED
14	107818-01-06A	EA TRIM - STEP - DRIVERS DOOR - PLASTIC - BISQUE
14	102569-02-000	EA MAT-ANTISLIP, 4" X 22"
15	108533-01-000	EA BRACKET - HANDLE - MOUNT
	108897-01-01A	EA GARNISH - DOOR - DRIVERS - U-CHANNEL - BLACK
	109378-01-000	EA STRAP - CHECK - DRIVERS DOOR - BLACK
	109235-01-01A	FT COVER - SCREW - MAT BLACK
	109235-01-03A	FT COVER - SCREW - OFF WHITE

WINDOW, VENT & EXTERIOR DOOR GROUP (CONTINUED)
DRIVERS DOOR (FROM: 11-14-94 THRU: 99-99-99) (CONTINUED)

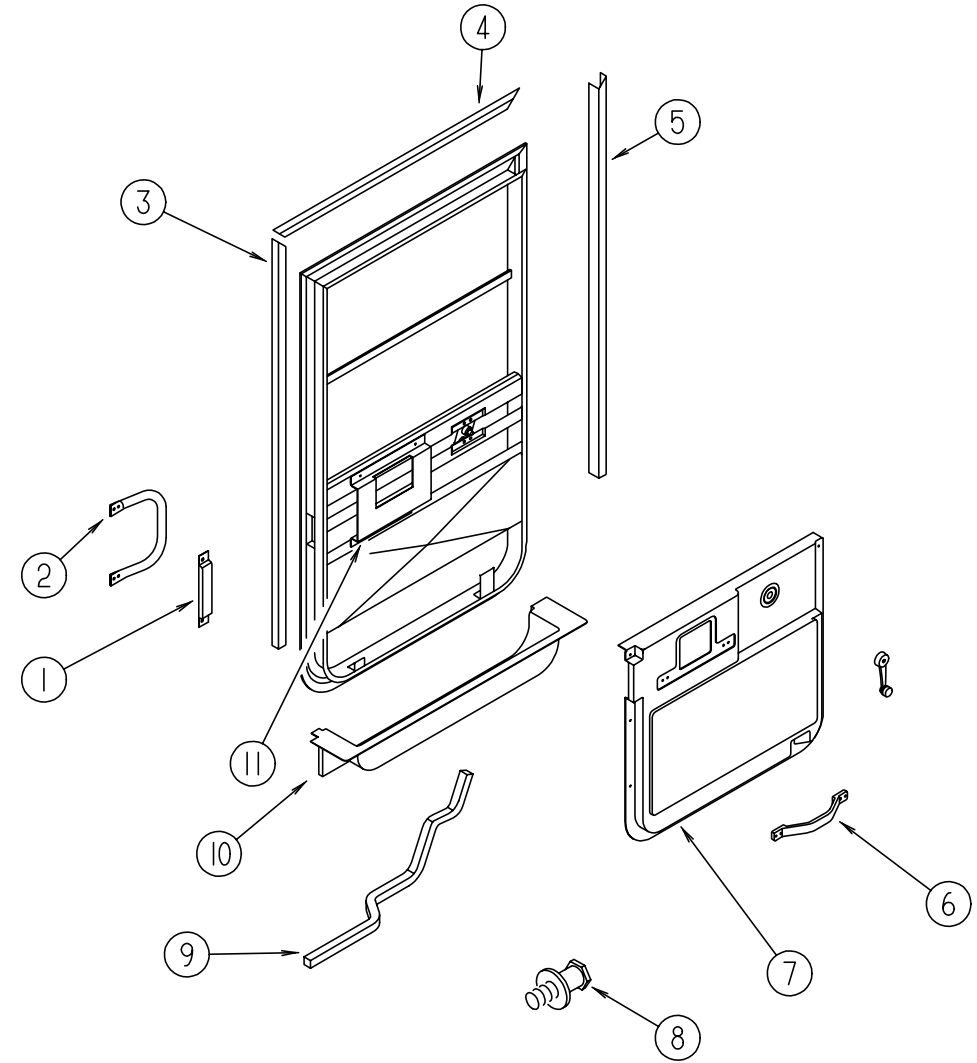

KEY	PART NUMBER	U/M DESCRIPTION
	106469-07-01A	EA DOOR - DRIVERS - BLACK - EXCEL V130-01L
1	108654-01-01A	EA COVER - STRIKE - DRIVERS DOOR - BLACK
2	108832-01-02A	EA HANDLE - ASSIST - DRIVERS DOOR - METAL - OFF WHITE
2	108832-01-01A	EA HANDLE - ASSIST - DRIVERS DOOR - METAL - MILL FINISHED
	108833-01-01A	EA COVER - HANDLE - ASSIST - OFF WHITE
3	108129-02-02A	EA GARNISH - DRIVERS DOOR - BLACK
4	108107-01-02A	EA GARNISH - DRIVERS DOOR - BLACK
5	108108-04-02A	EA GARNISH - DRIVERS DOOR - BLACK
6	110604-01-01A	EA HANDLE - ASSIST - DRIVERS DOOR - 10.8" LONG - BLACK
7	114973-01-03A	EA PANEL - DRIVER DOOR - INNER - BISQUE - PLASTIC
8	106469-01-715	EA STRIKER ASSEMBLY - (SUPPLIED W/DRIVERS DOOR) - EXCEL 248-081003
9	063977-12-000	EA STEP - DRIVER DOOR - LEFT - PAINTED BLACK
9	063977-11-000	EA STEP - DRIVER DOOR - LEFT - UNPAINTED
10	107818-01-06A	EA TRIM - STEP - DRIVERS DOOR - PLASTIC - BISQUE
	102569-02-000	EA MAT-ANTISLIP, 4" X 22"
11	115051-01-01B	EA BRACKET - HANDLE - MOUNT
	108897-01-01A	EA GARNISH - DOOR - DRIVERS - U-CHANNEL - BLACK
	109378-01-000	EA STRAP - CHECK - DRIVERS DOOR - BLACK
	064219-01-000	EA RETAINER-CHECK STRAP, DRIVERS DOOR - BLACK
	109235-01-01A	FT COVER - SCREW - MAT BLACK
	109235-01-03A	FT COVER - SCREW - OFF WHITE

WINDOW, VENT & EXTERIOR DOOR GROUP (CONTINUED)
 DRIVERS DOOR (FROM: 00-00-00 THRU: 11-13-94) (CONTINUED)

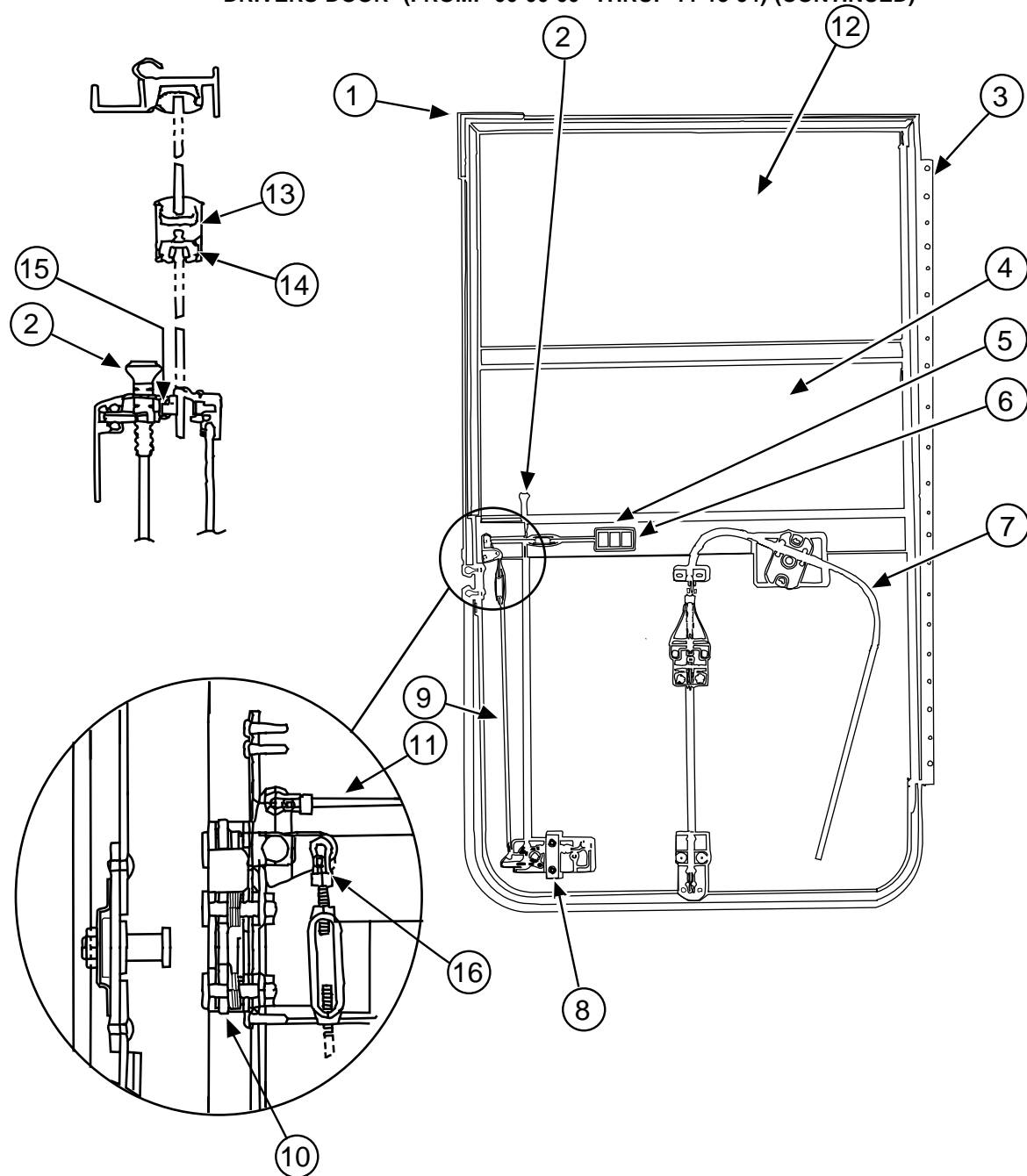

KEY	PART NUMBER	U/M	DESCRIPTION
1	106469-01-702	EA	DOOR SEAL, EXCEL 122-040984
2	106469-01-708	EA	BUTTON-LOCK, BLACK PLASTIC, EXCEL 130-081313
3	106469-01-716	EA	HINGE - 21", EXCEL 211-080807
4	106469-01-704	EA	ROLL-UP GLASS ASM W/BRACKET, EXCEL V103-65L
5	106469-01-707	EA	BEZEL-LATCH, INTERIOR - BLACK PLASTIC - EXCEL 130-081310
6	106469-01-717	EA	HANDLE-INTERIOR, EXCEL 248-081308
7	106469-02-701	EA	REGULATOR ASSEMBLY, EXCEL V108-90L
8	106469-01-711	EA	HANDLE-EXTERIOR, EXCEL 410-081036
	106469-01-701	EA	TUMBLER & 2 KEYS, EXCEL 248-040557
	106469-01-718	EA	KEY-BLANK (2), EXCEL 248-040558
9	106469-01-712	EA	LATCH ROD ASSEMBLY, VERTICAL - EXCEL V103-49
10	106469-01-710	EA	LATCH-ROTARY, EXCEL 248-081311
11	106469-01-714	EA	LATCH-ROD, HORIZONTAL - EXCEL 203-081015
12	106469-02-702	EA	GLASS-STATIONARY, EXCEL 106-041104
13	106469-01-719	EA	MULLION RAIL, EXCEL V103-84
14	106469-01-705	FT	RUN-CHANNEL, EXCEL 122-010850
15	106469-01-709	FT	WEATHERSTRIP-FUZZY, EXCEL 171-040630
16	106469-01-706	EA	FASTENER-ROD END, EXCEL 130-040593

WINDOW, VENT & EXTERIOR DOOR GROUP (CONTINUED)
 DRIVERS DOOR (FROM: 11-14-94 THRU: 99-99-99) (CONTINUED)

KEY	PART NUMBER	U/M	DESCRIPTION
	106469-02-700	EA	JAMB-DRIVER DOOR, EXCEL V108-30L
	106469-02-703	EA	BELT-WEATHERSTRIP, EXTERIOR WINDOW - EXCELV047-57
	106469-01-704	EA	ROLL-UP GLASS ASM W/BRACKET, EXCEL V103-65L
	106469-02-702	EA	GLASS-STATIONARY, EXCEL 106-041104

WINDOW, VENT & EXTERIOR DOOR GROUP (CONTINUED)

LOCKS & EXTERIOR DOOR COMPONENTS

NOTE:
WHEN ORDERING THE LOCK CASE, THE KEY CODE MUST MATCH THE LAST DIGIT OF THE VEHICLE'S SERIAL NUMBER AND PART NUMBER; WHEN ORDERING THE KEYS, THE THIRD DIGIT OF THE KEY CODE MUST MATCH THE LAST DIGIT OF THE VEHICLE'S SERIAL NUMBER AND PART NUMBER

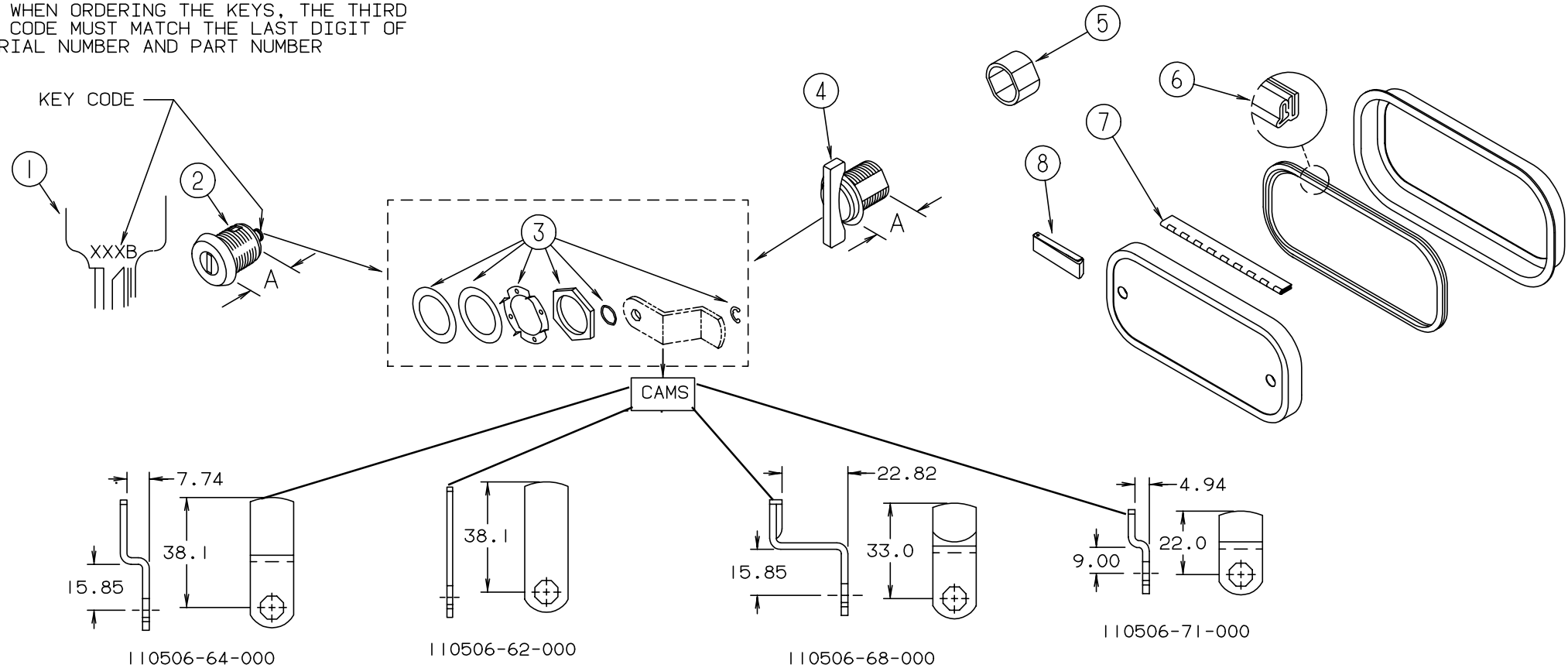

KEY	PART NUMBER	U/M	DESCRIPTION
1	110506-59-000	EA	KEYS - SET OF TWO - BRIGGS & STRATTON 596720
2	110506-52-000	EA	CASE - LOCK - A= 17 MM - BRIGGS & STRATTON 702370
2	110506-53-000	EA	CASE - LOCK - A= 25 MM - BRIGGS & STRATTON 702380
1	110506-59-001	EA	KEYS - SET OF TWO - BRIGGS & STRATTON 596721
2	110506-52-001	EA	CASE - LOCK - A= 17 MM - BRIGGS & STRATTON 702371
2	110506-53-001	EA	CASE - LOCK - A= 25 MM - BRIGGS & STRATTON 702381
1	110506-59-002	EA	KEYS - SET OF TWO - BRIGGS & STRATTON 596722
2	110506-52-002	EA	CASE - LOCK - A= 17 MM - BRIGGS & STRATTON 702372
2	110506-53-002	EA	CASE - LOCK - A= 25 MM - BRIGGS & STRATTON 702382
1	110506-59-003	EA	KEYS - SET OF TWO - BRIGGS & STRATTON 596723
2	110506-52-003	EA	CASE - LOCK - A= 17 MM - BRIGGS & STRATTON 702373
2	110506-53-003	EA	CASE - LOCK - A= 25 MM - BRIGGS & STRATTON 702383
1	110506-59-004	EA	KEYS - SET OF TWO - BRIGGS & STRATTON 596724
2	110506-52-004	EA	CASE - LOCK - A= 17 MM - BRIGGS & STRATTON 702374
2	110506-53-004	EA	CASE - LOCK - A= 25 MM - BRIGGS & STRATTON 702384
1	110506-59-005	EA	KEYS - SET OF TWO - BRIGGS & STRATTON 596725
2	110506-52-005	EA	CASE - LOCK - A= 17 MM - BRIGGS & STRATTON 702375
2	110506-53-005	EA	CASE - LOCK - A= 25 MM - BRIGGS & STRATTON 702385
1	110506-59-006	EA	KEYS - SET OF TWO - BRIGGS & STRATTON 596726
2	110506-52-006	EA	CASE - LOCK - A= 17 MM - BRIGGS & STRATTON 702376
2	110506-53-006	EA	CASE - LOCK - A= 25 MM - BRIGGS & STRATTON 702386
1	110506-59-007	EA	KEYS - SET OF TWO - BRIGGS & STRATTON 596727
2	110506-52-007	EA	CASE - LOCK - A= 17 MM - BRIGGS & STRATTON 702377
2	110506-53-007	EA	CASE - LOCK - A= 25 MM - BRIGGS & STRATTON 702387

KEY	PART NUMBER	U/M	DESCRIPTION
1	110506-59-008	EA	KEYS - SET OF TWO - BRIGGS & STRATTON 596728
2	110506-52-008	EA	CASE - LOCK - A= 17 MM - BRIGGS & STRATTON 702378
2	110506-53-008	EA	CASE - LOCK - A= 25 MM - BRIGGS & STRATTON 702388
1	110506-59-009	EA	KEYS - SET OF TWO - BRIGGS & STRATTON 596729
2	110506-52-009	EA	CASE - LOCK - A= 17 MM - BRIGGS & STRATTON 702379
2	110506-53-009	EA	CASE - LOCK - A= 25 MM - BRIGGS & STRATTON 702389
3	110506-40-700	EA	HARDWARE KIT
	110506-59-701	EA	KEY BLANK
4	110506-08-000	EA	LOCK - TWIST TYPE - BRIGGS & STRATTON (A= 17 MM)
4	110506-13-000	EA	LOCK - TWIST TYPE - BRIGGS & STRATTON (A= 25 MM)
5	107997-51-001	EA	SPACER - .86" X .6" - ALUMINUM
6	064075-07-000	FT	SEAL - BULB - W/ WIRED U CHANNEL - .3" X .5" CHANNEL - BLACK
7	081801-02-000	EA	HINGE - PIANO - 2" X 96" - ALUMINUM - OFF WHITE
8	102768-01-000	EA	HOLDER - COMPARTMENT/ ENTRY DOOR - METAL - MILL FINISH
	081914-01-000	EA	BUMPER - RUBBER - ROUND - .43" DIAMETER - BLACK
	104692-01-000	FT	SEAL - 3/4" X 3/4" - ADHESIVE BACK
	091876-01-000	EA	RETAINER - DOOR - 1.9" X .8" - METAL

WINDOW, VENT & EXTERIOR DOOR GROUP (CONTINUED)
POWERED ROOF VENT

KEY	PART NUMBER	U/M DESCRIPTION
	110051-03-01A	EA VENT-ROOF, POWERED - 2" ROOF - JENSEN 7757 WHE
	048648-01-000	EA MOTOR-ROOF VENT, 1/8 SHAFT - 12V - JENSEN
	048649-01-000	EA FAN-ROOF VENT, 6 BLADES - 6" - JENSEN
	064470-01-700	EA COVER-ROOF VENT, JENSEN 7291
	110051-01-701	EA GARNISH W/SCREEN & FRAME-2", JENSEN 29-800-01
	110051-01-702	EA LIFT ASM-VENT LID W/O CRANK, JENSEN RP-1000B
	110051-01-703	EA CRANK, JENSEN RP-1031-B

NONPOWERED ROOF VENT

KEY	PART NUMBER	U/M DESCRIPTION
	110051-01-01A	EA VENT-ROOF, NONPOWERED - 2" ROOF - JENSEN 7724 WHE
	064470-01-700	EA COVER-ROOF VENT, JENSEN 7291
	110051-01-701	EA GARNISH W/SCREEN & FRAME-2", JENSEN 29-800-01
	110051-01-702	EA LIFT ASM-VENT LID W/O CRANK, JENSEN RP-1000B
	110051-01-703	EA CRANK, JENSEN RP-1031-B

VENTS, SHROUDS & ROOF COVERS

KEY	PART NUMBER	U/M DESCRIPTION
	083558-03-000	EA VENT-PLUMBING PIPE ROOF W/COVER - OFF WHITE
	084616-01-000	EA SHROUD-RANGE HOOD VENT, PLASTIC - OFF WHITE
	084878-09-000	EA VENT-RANGE HOOD, SHORT - LVS
	084073-03-000	EA COVER-ROOF VENT, REFRIGERATOR - OFF WHITE - NORCOLD
	084073-04-000	EA BASE-ROOF VENT, REFRIGERATOR - BLACK - NORCOLD
	105028-01-000	EA FLASHING ASM-VENT, REFRIGERATOR

WINDOW, VENT & EXTERIOR DOOR GROUP (CONTINUED)

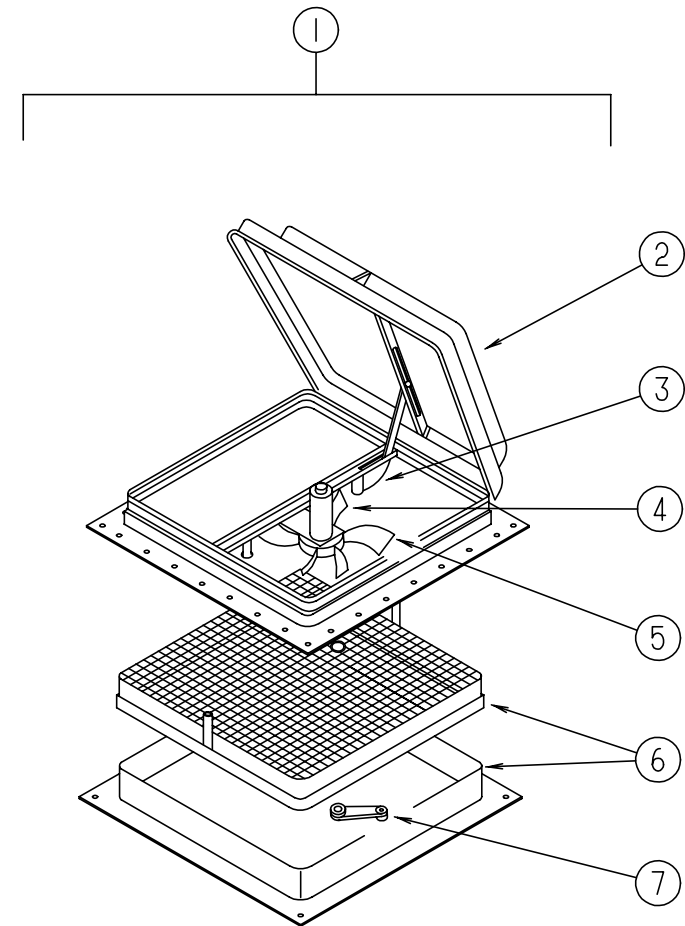

POWERED ROOF VENT - JENSEN - CANADIAN

KEY	PART NUMBER	U/M DESCRIPTION
1	110051-05-01A	EA VENT-ROOF, POWERED - 2" ROOF - CSA - JENSEN C7757 WHE
2	064470-01-700	EA COVER-ROOF VENT, JENSEN 7291
3	110051-01-702	EA LIFT ASM-VENT LID W/O CRANK, JENSEN RP-1000B
4	048648-01-000	EA MOTOR-ROOF VENT, 1/8 SHAFT - 12V
5	048649-01-000	EA FAN-ROOF VENT, 6 BLADES - 6"
6	110051-01-701	EA GARNISH W/SCREEN & FRAME-2", JENSEN 29-800-01
7	110051-01-703	EA CRANK HANDLE-ROOF VENT, JENSEN RP-1031-B

WINDOW, VENT & EXTERIOR DOOR GROUP (CONTINUED)

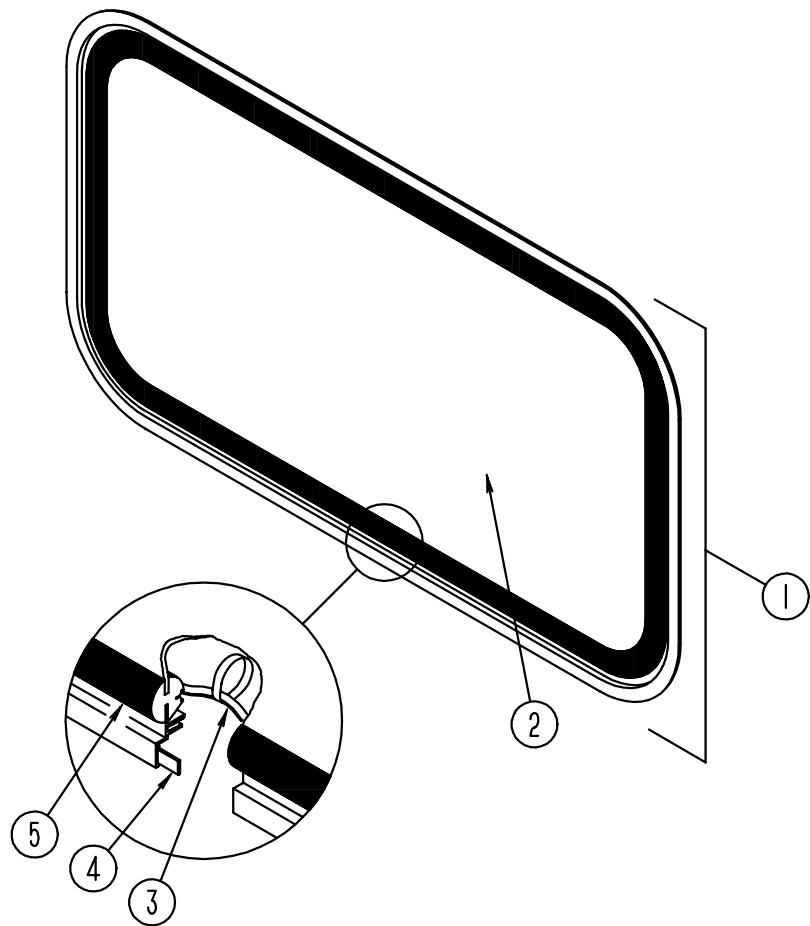

BACKWALL ESCAPE WINDOW

KEY	PART NUMBER	U/M	DESCRIPTION
	074816-11-000	EA	FRAME-WINDOW, INSIDE - ESCAPE - OFF WHITE
1	078528-06-E10	EA	WINDOW-ESCAPE, BACKWALL - W/O INSIDE FRAME
2	076337-12-000	EA	GLASS-WINDOW, 1157.4 X 548.1
3	002285-01-000	FT	FILLER-WEATHER STRIP, RUBBER - BLACK
	077066-01-702	EA	RED POLY.005 X .500" X 150' ROLL
4	069640-10-000	FT	SEALER-RIBBON, 1/32" X 1 1/2" INCREMENTS OF 90'
5	002282-09-000	EA	WEATHERSTRIP-WINDOW, .125" X 130.53 - VULCANIZED - BLACK

WINDOW, VENT & EXTERIOR DOOR GROUP (CONTINUED)

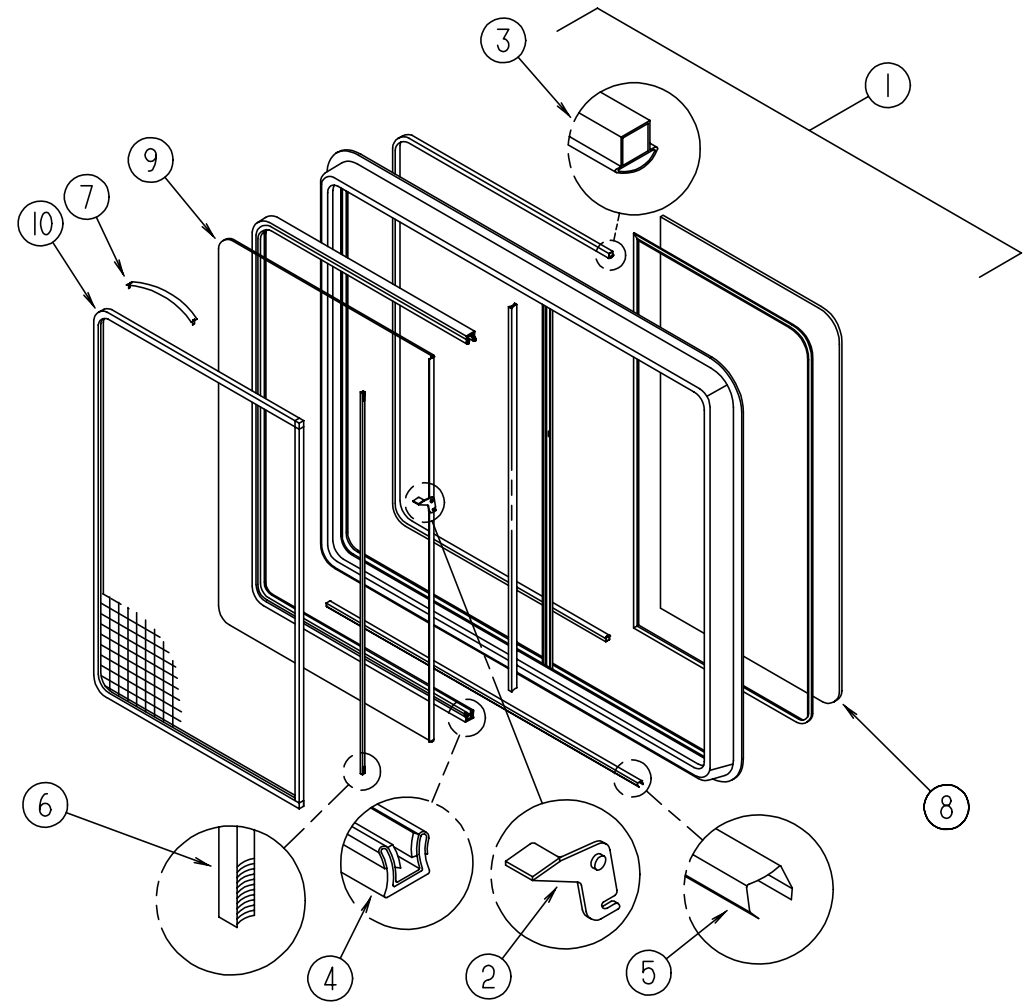

DRIVER SIDE LOUNGE & DINETTE SLIDING WINDOW

KEY	PART NUMBER	U/M	DESCRIPTION
1	098647-22-01A	EA	WINDOW ASM-SLIDER, HORIZONTAL BLK/OW
	098647-22-700	EA	WINDOW ASM-SLIDER, W/O TRIM
	098647-23-702	EA	TRIM
2	098644-01-700	EA	LATCH REPAIR KIT
3	098644-01-706	FT	WEATHERSTRIP EXCEL 171-010668
4	098644-01-708	FT	CHANNEL-PIERCED RUN EXCEL 122-016543
5	098644-01-710	FT	TRACK-SCREEN SPACER 12' LENGTH - EXCEL M401-31
6	098644-01-711	FT	WEATHERSTRIP-SCREEN BLACK - EXCEL 171-016965
7	098644-01-713	EA	SPRING-SCREEN FRAME (CLIP) PLASTIC - BLACK - EXCEL 226-016966
8	098647-23-703	EA	GLASS-STATIONARY, EXCEL 106-017622
9	098647-23-700	EA	GLASS-SLIDING, W/SASH & LATCH - EXCEL H287-G9
10	098647-23-704	EA	SCREEN ASSEMBLY, EXCEL 410-019066
	098644-01-716	FT	PLUG-FILLER, EXCEL 132-014470
	098644-01-717	FT	SPLINE-SCREEN MFG, EXCEL 32-004716

WINDOW, VENT & EXTERIOR DOOR GROUP (CONTINUED)
DRIVER & PASSENGER SIDE BEDROOM WINDOW

KEY	PART NUMBER	U/M	DESCRIPTION
	113500-01-01A	EA	WINDOW ASM-TIPOUT, DOUBLE - BLK/OW
	113500-01-701	EA	WINDOW W/O TRIM
	113500-01-700	EA	SCREEN ASM. (RH & LH) W/SPRING
	113500-01-702	EA	TRIM
	113500-01-703	EA	TOP GLASS-STATIONARY
	113500-01-704	EA	UPPER VENT GLASS ASSEMBLY
	113500-01-705	EA	LOWER VENT GLASS ASSEMBLY
	113500-01-706	EA	OPERATOR & BAR ASSEMBLY

DRIVER SIDE BEDROOM THERMOPANE WINDOW

KEY	PART NUMBER	U/M	DESCRIPTION
	112795-23-01A	EA	WINDOW ASM-SLIDER, HORIZONTAL - THERMOPANE - DRIVER SIDE
	112795-23-700	EA	WINDOW W/O TRIM
	098647-29-701	EA	TRIM
	098647-29-704	EA	SCREEN ASSEMBLY
	112795-01-700	EA	LATCH ASSEMBLY (BLK)
	112795-01-701	FT	SLIDE-STOP
	112795-01-702	FT	FILLER PLUG
	112795-01-703	FT	RUN CHANNEL
	112795-01-704	FT	VINYL-GLAZING
	112795-21-701	EA	GLASS-STATIONARY
	112795-21-702	EA	SLIDE ASSEMBLY

DRIVER SIDE GALLY WINDOW

KEY	PART NUMBER	U/M	DESCRIPTION
	098647-34-01A	EA	WINDOW ASM-SLIDER, HORIZONTAL
	098647-34-700	EA	WINDOW W/O TRIM
	098644-01-700	EA	LATCH REPAIR KIT (BLACK)
	098644-01-706	FT	WEATHERSTRIP-GLASS
	098644-01-708	FT	CHANNEL-RUN, PIERCED - GLASS
	098644-01-710	FT	TRACK-SPACER, FOR SCREEN 12'
	098644-01-711	FT	WEATHERSTRIP-SCREEN, BLACK
	098644-01-713	EA	SCREEN CLIPS (METAL) (BLK)
	098644-01-716	FT	PLUG-FILLER
	098644-01-717	FT	SPLINE-SCREEN
	098647-33-701	EA	TRIM
	098647-33-702	EA	GLASS-STATIONARY
	098647-33-703	EA	GLASS SLIDE ASSEMBLY
	098647-33-704	EA	SCREEN ASSEMBLY

DRIVER SIDE GALLY THERMOPANE WINDOW

KEY	PART NUMBER	U/M	DESCRIPTION
	112795-20-01A	EA	WINDOW ASM-SLIDER, HORIZONTAL - THERMOPANE
	098647-31-701	EA	TRIM
	098647-31-704	EA	SCREEN ASSEMBLY
	112795-01-700	EA	LATCH ASSEMBLY (BLK)
	112795-01-701	FT	SLIDE-STOP
	112795-01-702	FT	FILLER PLUG
	112795-01-703	FT	RUN CHANNEL
	112795-01-704	FT	VINYL-GLAZING

WINDOW, VENT & EXTERIOR DOOR GROUP (CONTINUED)
DRIVER SIDE LOUNGE & DINETTE THERMOPANE WINDOW

KEY	PART NUMBER	U/M	DESCRIPTION
	112795-15-01A	EA	WINDOW ASM-SLIDER, HORIZONTAL - THERMOPANE
	112795-15-700	EA	WINDOW W/O TRIM
	098647-23-702	EA	TRIM
	098647-23-704	EA	SCREEN ASSEMBLY
	112795-01-700	EA	LATCH ASSEMBLY (BLK)
	112795-01-701	FT	SLIDE-STOP
	112795-01-702	FT	FILLER PLUG
	112795-01-703	FT	RUN CHANNEL
	112795-01-704	FT	VINYL-GLAZING
	112795-15-701	EA	GLASS-STATIONARY
	112795-15-702	EA	SLIDE ASSEMBLY

DRIVER SIDE CAB WINDOW

KEY	PART NUMBER	U/M	DESCRIPTION
	103658-09-01A	EA	WINDOW ASM-CAB DRIVER
	103658-09-701	EA	WINDOW W/O TRIM
	098644-01-700	EA	LATCH REPAIR KIT (BLACK)
	098644-01-706	FT	WEATHERSTRIP-GLASS
	098644-01-708	FT	CHANNEL-RUN, PIERCED - GLASS
	098644-01-710	FT	TRACK-SPACER, FOR SCREEN 12'
	098644-01-711	FT	WEATHERSTRIP-SCREEN, BLACK
	098644-01-713	EA	SCREEN CLIPS (METAL) (BLK)
	098644-01-716	FT	PLUG-FILLER
	098644-01-717	FT	SPLINE-SCREEN MFG
	103658-09-700	EA	GLASS-STATIONARY (RH & LH)
	103658-09-702	EA	TRIM-LEFT
	103658-09-704	EA	SLIDE ASSEMBLY
	103658-09-705	EA	SCREEN ASSEMBLY

DRIVER SIDE CAB WINDOW - THERMOPANE

KEY	PART NUMBER	U/M	DESCRIPTION
	113501-03-01A	EA	WINDOW ASM-CAB DRIVER - THERMOPANE
	113501-03-700	EA	WINDOW W/O TRIM
	103658-09-702	EA	TRIM-LEFT
	103658-09-705	EA	SCREEN ASSEMBLY
	113501-03-701	EA	GLASS-STATIONARY
	113501-03-702	EA	GLASS-SLIDE ASSEMBLY

PASSENGER SIDE CAB WINDOW

KEY	PART NUMBER	U/M	DESCRIPTION
	103658-10-01A	EA	WINDOW ASM-CAB, PASSENGER
	103658-10-700	EA	WINDOW W/O TRIM
	098644-01-700	EA	LATCH REPAIR KIT (BLACK)
	098644-01-706	FT	WEATHERSTRIP-GLASS
	098644-01-708	FT	CHANNEL-RUN, PIERCED - GLASS
	098644-01-710	FT	TRACK-SPACER, FOR SCREEN 12'
	098644-01-711	FT	WEATHERSTRIP-SCREEN, BLACK
	098644-01-713	EA	SCREEN CLIPS (METAL) (BLK)
	098644-01-716	FT	PLUG-FILLER
	098644-01-717	FT	SPLINE-SCREEN MFG
	103658-09-700	EA	GLASS-STATIONARY (RH & LH)
	103658-10-701	EA	TRIM-RIGHT
	103658-10-703	EA	SLIDE ASSEMBLY
	103658-10-704	EA	SCREEN ASSEMBLY

WINDOW, VENT & EXTERIOR DOOR GROUP (CONTINUED)**PASSENGER SIDE CAB THERMOPANE WINDOW**

KEY	PART NUMBER	U/M	DESCRIPTION
	113501-04-01A	EA	WINDOW ASM-CAB, PASSENGER - THERMOPANE
	113501-04-700	EA	WINDOW W/O TRIM
	103658-10-701	EA	TRIM-RIGHT
	103658-10-704	EA	SCREEN ASSEMBLY
	113501-04-701	EA	GLASS-STATIONARY
	113501-04-702	EA	GLASS-SLIDE ASSEMBLY

PASSENGER SIDE LOUNGE WINDOW

KEY	PART NUMBER	U/M	DESCRIPTION
	098644-07-01A	EA	WINDOW ASM-SINGLE RAISE BLK/OW
	098644-07-700	EA	WINDOW W/O TRIM
	098644-01-700	EA	LATCH REPAIR KIT (BLACK)
	098644-01-706	FT	WEATHERSTRIP-GLASS
	098644-01-708	FT	CHANNEL-RUN, PIERCED - GLASS
	098644-01-710	FT	TRACK-SPACER, FOR SCREEN 12'
	098644-01-711	FT	WEATHERSTRIP-SCREEN, BLACK
	098644-01-713	EA	SCREEN CLIPS (METAL) (BLK)
	098644-01-716	FT	PLUG-FILLER
	098644-01-717	FT	SPLINE-SCREEN MFG
	098644-07-701	EA	TRIM
	098644-07-702	EA	GLASS-STATIONARY
	098644-07-703	EA	SLIDE ASSEMBLY
	098644-07-704	EA	SCREEN ASSEMBLY

PASSENGER SIDE LOUNGE THERMOPANE WINDOW

KEY	PART NUMBER	U/M	DESCRIPTION
	112898-04-01A	EA	WINDOW ASM-SLIDER, VERTICAL - THERMOPANE
	112898-04-700	EA	WINDOW W/O TRIM
	098644-07-701	EA	TRIM
	098644-07-704	EA	SCREEN ASSEMBLY
	112898-04-701	EA	GLASS-STATIONARY
	112898-04-702	EA	SLIDE ASSEMBLY

ENTRY DOOR WINDOW

KEY	PART NUMBER	U/M	DESCRIPTION
	079733-15-F04	EA	WINDOW-ENTRY DOOR, PICTURE
	000H13-04-07B	EA	RIVET-SEMITUB-STL 1/8 X .219
	002181-22-000	EA	GLASS-PICTURE 687.4 X 449.4
	004012-02-000	QT	ADHESIVE-3M 4475 (QUART)
	053752-08-000	GL	SEAM SEALER-5 GAL, BLACK
	075201-02-000	GL	SEALANT-ACRYLIC, BLACK
	087561-01-000	FT	EXTR-VINYL SEAL, TIPOUT/SLIDE
	090907-51-002	EA	EXTR-STRAP

ENTRY DOOR THERMOPANE WINDOW

KEY	PART NUMBER	U/M	DESCRIPTION
	113733-01-01A	EA	WINDOW ASM-STATIONARY, THERMOPANE
	113733-01-700	EA	WINDOW ASM. W/O TRIM
	113733-01-701	EA	TRIM (W)
	113733-01-702	EA	GLASS-STATIONARY

WINDOW, VENT & EXTERIOR DOOR GROUP (CONTINUED)**DRIVER & PASSENGER SIDE BEDROOM WINDOW**

KEY	PART NUMBER	U/M	DESCRIPTION
	113500-01-01A	EA	WINDOW ASM-TIPOUT, DOUBLE - BLK/OW
	113500-01-701	EA	WINDOW W/O TRIM
	113500-01-700	EA	SCREEN ASM. (RH & LH) W/SPRING
	113500-01-702	EA	TRIM
	113500-01-703	EA	TOP GLASS-STATIONARY
	113500-01-704	EA	UPPER VENT GLASS ASSEMBLY
	113500-01-705	EA	LOWER VENT GLASS ASSEMBLY
	113500-01-706	EA	OPERATOR & BAR ASSEMBLY

PASSENGER SIDE BEDROOM THERMOPANE WINDOW

KEY	PART NUMBER	U/M	DESCRIPTION
	112795-21-01A	EA	WINDOW ASM-SLIDER, HORIZONTAL - THERMOPANE - PASSENGER SIDE
	112795-21-700	EA	WINDOW W/O TRIM
	098647-29-701	EA	TRIM
	098647-29-704	EA	SCREEN ASSEMBLY
	112795-01-700	EA	LATCH ASSEMBLY (BLK)
	112795-01-701	FT	SLIDE-STOP
	112795-01-702	FT	FILLER PLUG
	112795-01-703	FT	RUN CHANNEL
	112795-01-704	FT	VINYL-GLAZING
	112795-21-701	EA	GLASS-STATIONARY
	112795-21-702	EA	SLIDE ASSEMBLY

REAR ESCAPE THERMOPANE WINDOW

KEY	PART NUMBER	U/M	DESCRIPTION
	113502-01-01A	EA	WINDOW ASM-REAR ESCAPE BLK/OW - THERMOPANE
	113502-06-700	EA	WINDO W/O TRIM
	113502-06-701	EA	TRIM
	113502-06-702	EA	GLASS-STATIONARY (RH & LH)
	113502-06-703	EA	GLASS- STATIONARY (CENTER)
	112898-06-704	EA	LOCK-HANDLE CAM RED RH
	112898-06-705	EA	LOCK-HANDLE CAM RED LH

WINDSHIELD & WIPER GROUP

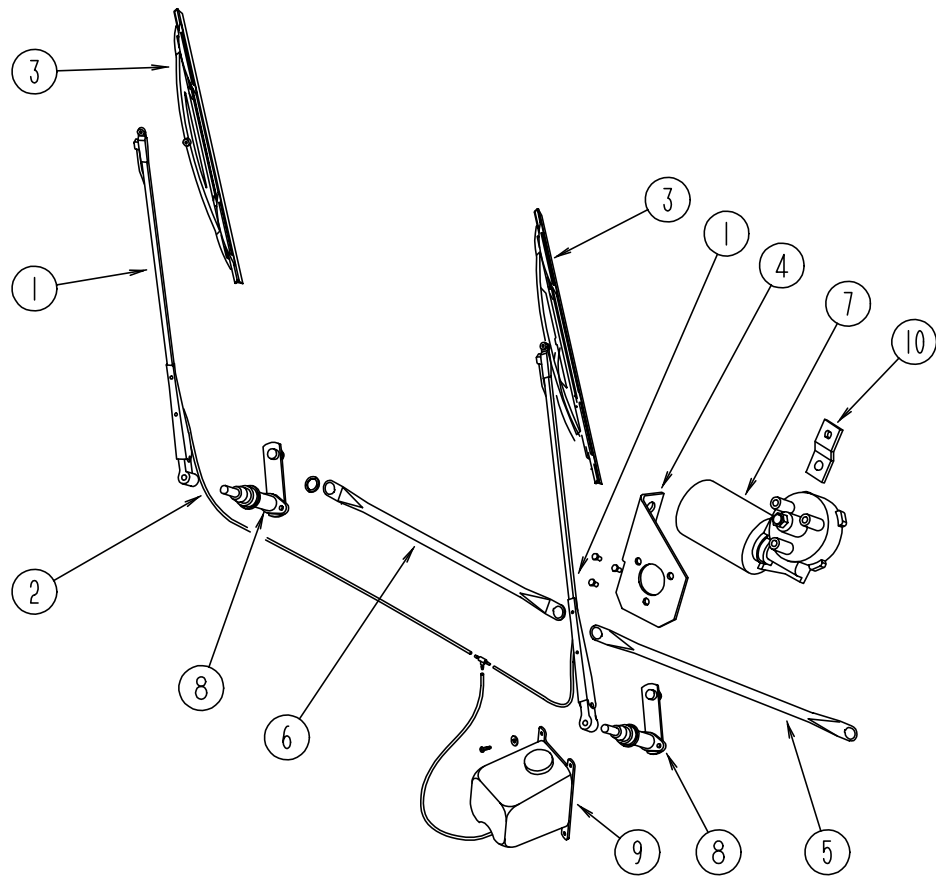

WIPER COMPONENTS

KEY	PART NUMBER	U/M	DESCRIPTION
1	103671-01-000	EA	ARM-WIPER, PANTOGRAPH - 24"
	096931-01-700	FT	HOSE-WIPER, TO BLADE
	096931-01-701	EA	NOZZLE-HARDWARE KIT, INCLUDES NOZZEL, NUT, SHORT THREAD SCREW, LONG THREAD SCREW, AND PLASTIC CAP
2	045794-01-000	FT	HOSE-WASHER, WINDSHIELD - 5/32" ID - BLACK
3	095964-01-000	EA	BLADE-WIPER, 24"
	095964-01-700	EA	REFILL-WIPER BLADE, 24" - PAIR
4	104549-01-000	EA	BRACKET ASSEMBLY-WIPER MOTOR
5	103672-01-000	EA	LINK ASM - CONNECTING - DRIVERS
6	103672-02-000	EA	LINK ASM - CONNECTING - PASSENGERS
7	104346-02-000	EA	MOTOR-WIPER, CHEVY
7	104346-03-000	EA	MOTOR-WIPER, FORD
8	096505-05-000	EA	PIVOT & SHAFT ASM-WIPER, PASSENGER WINDSHIELD
8	096505-06-000	EA	PIVOT & SHAFT ASM-WIPER, DRIVER WINDSHIELD
	096526-01-000	EA	SCREW-HEX, 1/4 - 28
9	056000-04-000	EA	WASHER-WINDSHIELD, BOTTLE & PUMP
9	110605-01-000	EA	TEE-PLASTIC, BARBED - 1/8 X 1/8 X 3/16
			FROM: 00-00-00 THRU: 04-02-95
			FROM: 04-03-95 THRU: 99-99-99
9	117765-01-000	EA	CONNECTOR- 5/32 - 1/4 - 3/8 WINDSHIELD WAHER
			FROM: 04-03-95 THRU: 99-99-99
9	117766-02-000	EA	RESERVOIR/PUMP ASM
			FROM: 04-03-95 THRU: 99-99-99
10	104347-01-000	EA	ARM-DRIVE, WIPER MOTOR - 1.54"
	056000-01-700	FT	VACUUM HOSE 7/64 - 5/32
	061603-01-000	EA	GROMMET-SNAP, 3/16 ID - 3/8 HOLE - PLASTIC - BLACK
	067188-01-000	EA	STUD-CRANK, WIPER
	110742-01-000	EA	GASKET-WIPER
	110178-01-000	EA	HOUSING-WIPER MOTOR - UT6237440-EC25WJ

WINDSHIELD & WIPER GROUP (CONTINUED)

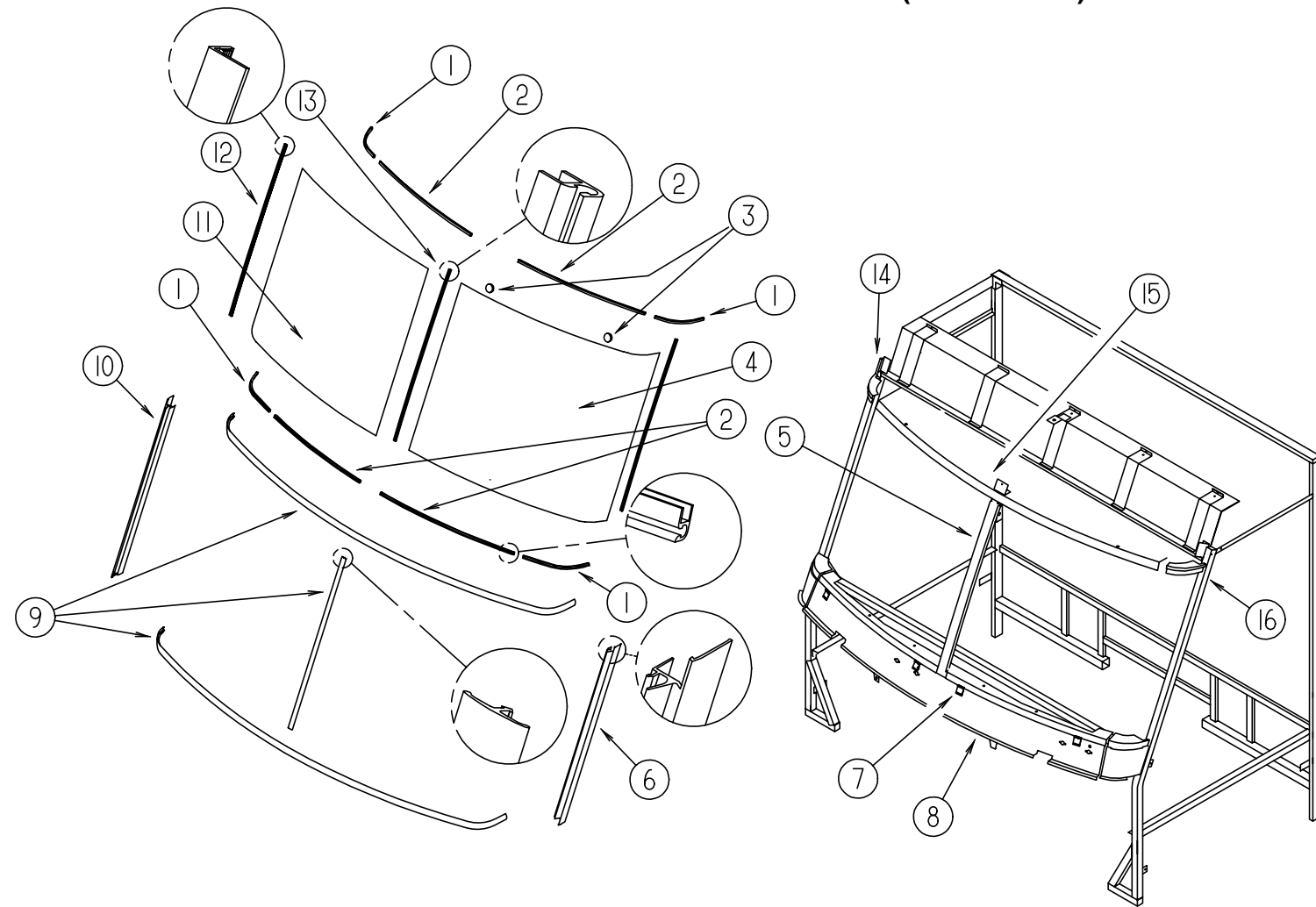

WINDSHIELD MOLDINGS & GLASS

KEY	PART NUMBER	U/M	DESCRIPTION
1	102935-08-000	EA	CARRIER-REVEAL, 2" - WINDSHIELD
2	110268-01-000	EA	CARRIER-REVEAL, 50.4" - WINDSHIELD
3	081914-01-000	EA	BUMPER-RUBBER, ROUND - .43" DIAMETER - BLACK
4	088793-04-000	EA	GLASS-WINDSHIELD, DRIVER
5	075710-03-000	EA	FRAME-WINDSHIELD, CENTER DIVIDER - INNER
6	103107-02-01A	EA	TRIM-WINDSHIELD, DRIVER SIDE - BLACK
7	104449-01-000	EA	BRACKET-WINDSHIELD SUPPORT
8	077847-02-000	EA	SUPPORT-WINDSHIELD, LOWER - W/O BRACKETS
9	102936-01-000	FT	MOLDING - REVEAL - WINDSHIELD
10	103107-01-01A	EA	TRIM - WINDSHIELD - PASSENGER SIDE - BLACK
11	088793-03-000	EA	GLASS-WINDSHIELD, PASSENGER
12	098788-06-000	EA	CHANNEL - 49" PCV, DRIVER OR PASSENGER SIDE
13	110268-02-000	EA	CARRIER-REVEAL, 38" - WINDSHIELD
14	077922-03-000	EA	HEADER WINDSHIELD END - RIGHT - STEEL
15	077922-05-000	EA	HEADER WINDSHIELD - CENTER - STEEL
16	077922-04-000	EA	HEADER WINDSHIELD END - LEFT - STEEL