

**1995  
ICG34RA**

**F31**

**F32**

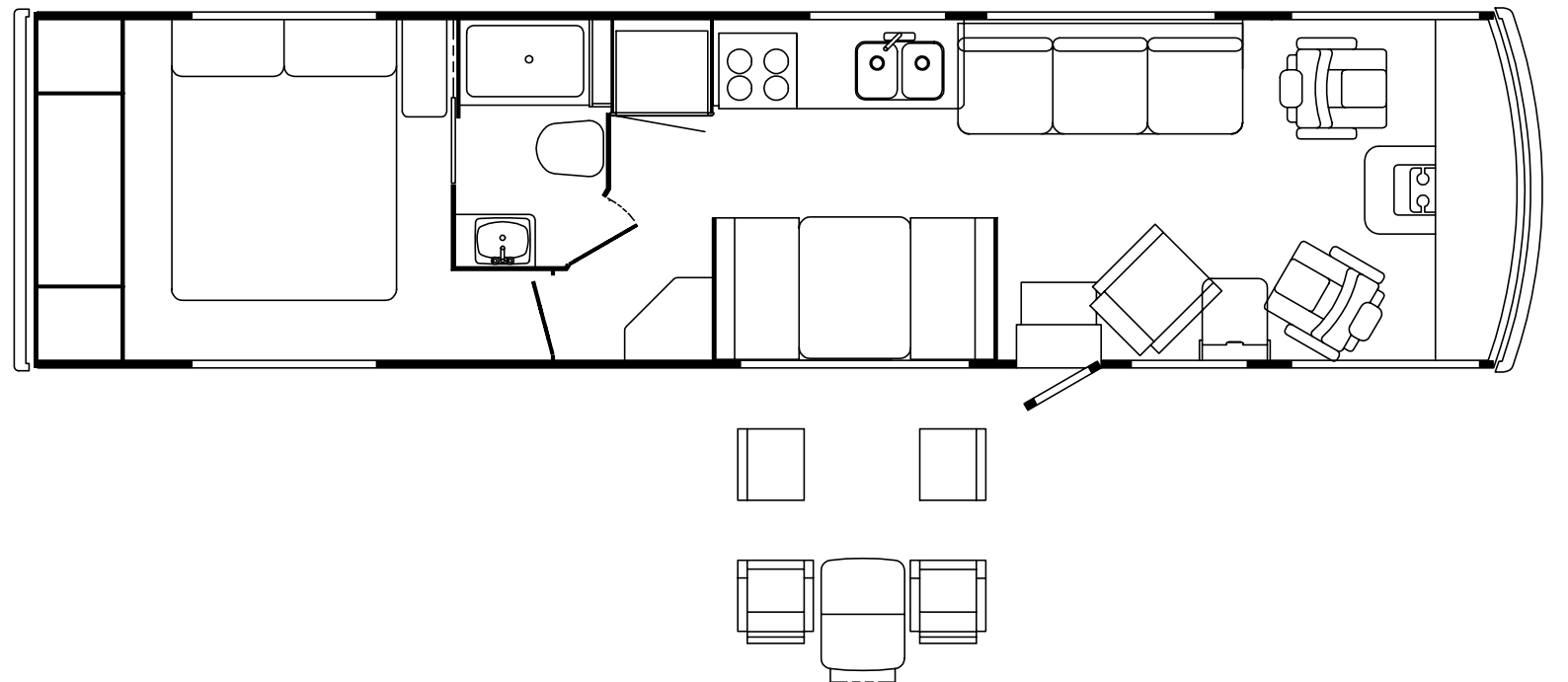
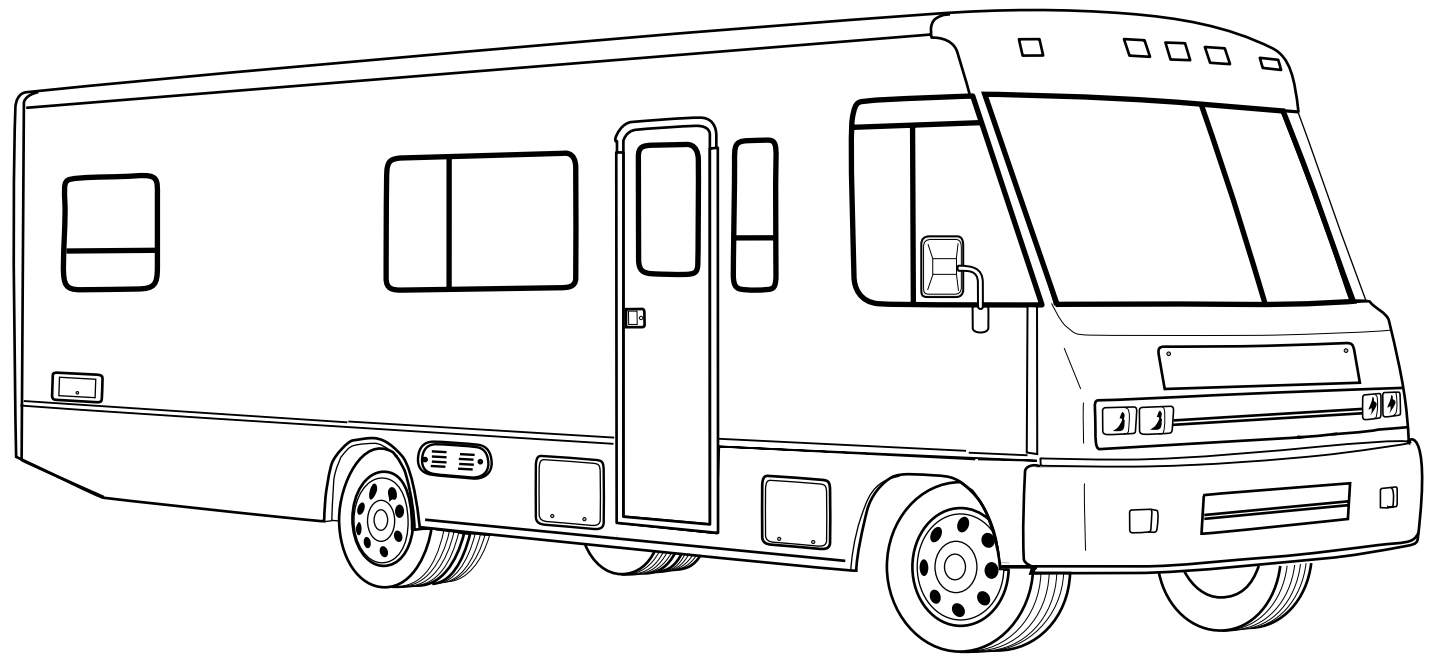

## ACCESSORIES GROUP

### OPERATOR MANUAL

KEY	PART NUMBER	U/M DESCRIPTION
	054185-D3-000	EA MANUAL - OPERATOR 95 SUNCRUISER - G-SERIES
	092318-01-000	EA BINDER - 3 RING - MOTOR HOME MANUAL
	092319-01-000	EA POCKET PAGE - 3 RING BINDER - PLASTIC
	114399-01-000	EA TOP LEVEL DRAWING NUMBER

## AUDIO VIDEO GROUP

### RADIO SYSTEMS & ANTENNA

KEY	PART NUMBER	U/M DESCRIPTION
	087683-03-000	EA RADIO - AM/ FM STEREO CASSETTE AUDIOVOX RS-100
	110267-03-000	EA RADIO - AM/ FM STEREO CD COMPACT AUDIOVOX IM-400
	116148-01-000	EA RADIO - AM/ FM STEREO - CD PLAYER CLARION 5633CD
	077069-02-000	EA CABLE - ANTENNA - RADIO - EXTENSION 96" - ARA 6700667
	110469-01-000	EA SPEAKER - OVAL - 4" X 6" - BLACK
	110470-01-01A	EA GRILLE - SPEAKER - OVAL - 4" X 6" - BLACK
	081059-02-000	EA WIRE ASM - 9-PIN - RADIO - AUDIOVOX 112B-1761
	105248-01-000	EA ANTENNA - CB - ADVANCE 8604
	090944-01-000	EA ANTENNA - RADIO - 16" RUBBER
	108847-01-000	EA BRACKET - ANTENNA GROUND
	115916-01-01B	EA BRACKET - ANTENNA MOUNT
	074979-08-000	EA SHIELD - SPEAKER - BACK - MOLDED PLASTIC - LIGHT OAK
	089340-02-000	EA GRILLE - SPEAKER - 6.5" SQUARE
	089340-03-000	EA SPACER - GRILLE - 6.5" SQUARE - TAN - MAGNADYNE G514
	094097-01-000	EA SPEAKER - RADIO - W/O GRILLE - 5.25" DIA - AUDIOVOX 110C3030

### REAR MONITOR SYSTEM

KEY	PART NUMBER	U/M DESCRIPTION
	093040-05-000	EA TELEVISION SYSTEM - REAR VIEW 7" - SONY YM-RVF7AM
	093040-04-700	EA CAMERA - W/BRACKET & WIRING - REAR VIEW - SSC-520AM
	093040-05-700	EA MONITOR - 7" W/POWER HARNESS - SSM721AM
	093040-06-000	EA WIRE ASM. - MONITOR - SONY SM-HRN7
	093041-01-000	EA CABLE - MONITOR/ CAMERA - INTERNAL USE
	093041-02-000	EA CABLE - MONITOR/ CAMERA - EXTERNAL USE
	093041-03-000	EA CABLE - MONITOR/ CAMERA - SONY UK121A
	096717-03-000	EA WIRE ASM. - REAR MONITOR - UPPER
	108885-01-000	EA WIRE ASM. - INSTRUMENT PANEL - REAR MONITOR (CHEVY)

### PATIO ENTERTAINMENT CENTER

KEY	PART NUMBER	U/M DESCRIPTION
	110469-01-000	EA SPEAKER - OVAL - 4" X 6" - BLACK
	110470-01-01A	EA GRILLE - SPEAKER - OVAL - 4" X 6" - BLACK
	077069-02-000	EA CABLE - ANTENNA - RADIO - EXTENSION 96" - ARA 6700667
	087683-03-000	EA RADIO - AM/ FM STEREO W/ CASSETTE - AUDIOVOX
	090944-01-000	EA ANTENNA - RADIO - 16" RUBBER
	108847-01-000	EA BRACKET - ANTENNA GROUND
	109889-02-000	EA ANTENNA - 2" SHAFT EXTENDER - MAGNADYNE RV71EX2

# AUDIO VIDEO GROUP (CONTINUED)

## TV ANTENNA

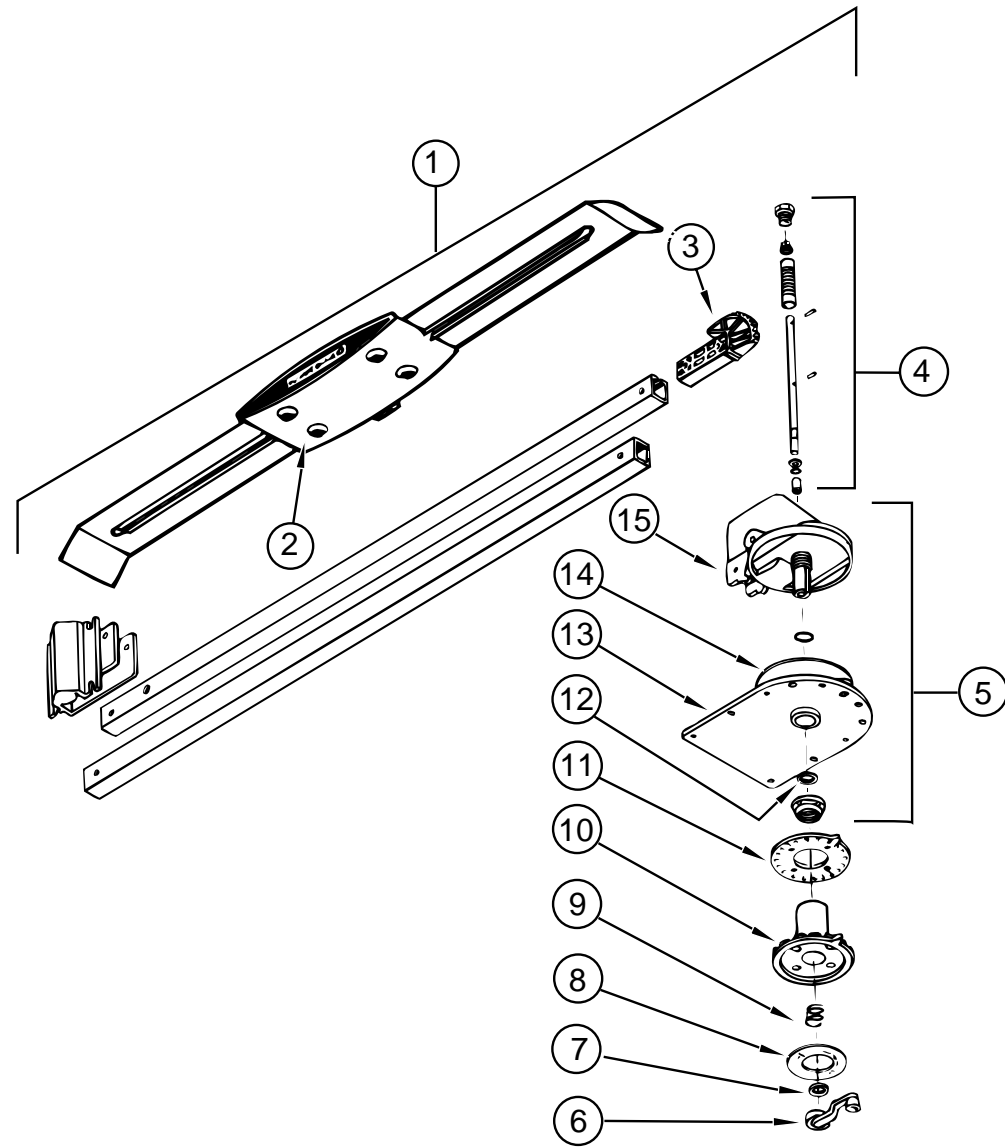

KEY	PART NUMBER	U/M	DESCRIPTION
1	076319-18-000	EA	ANTENNA - TV - ROOF MOUNT
2	076319-01-700	EA	HEAD - ANTENNA - AMPLIFIED - WINEGARD - RVSA U/V
3	076319-01-701	EA	GEAR - ELEVATING - PLASTIC - WINEGARD - 2200046
4	076319-01-702	EA	SHAFT ASM - ELEVATING - WINEGARD - RVP-400A
5	076319-01-711	EA	BASE & LIFT ASM - WINEGARD - 2762802
6	076319-01-706	EA	CRANK - ELEVATING - W/ SET SCREW - WINEGARD - 5755100
7	076319-01-705	EA	BEARING - NYLON - 7/8"ID - WINEGARD - 3200658
8	076319-01-708	EA	CRANK COVER DECAL - WINEGARD - 5413002
9	076319-01-707	EA	SPRING - HANDLE - WINEGARD - 5160822
10	076319-01-709	EA	PLATE - DIRECTIONAL - FOR HEAD - WINEGARD - 3200644
11	076319-01-712	EA	CEILING PLATE - WINEGARD - 3200608
12	076319-01-704	EA	BEARING - NYLON - 1.5"OD - WINEGARD - 3200657
13	076319-01-713	EA	BASE PLATE - WINEGARD - 3100523
14	076319-01-703	EA	BEARING - NYLON - 5"OD - WINEGARD - 3200656
15	076319-01-714	EA	HOUSING - ROTATING GEAR 2200049

## AUDIO VIDEO GROUP (CONTINUED)

### TV - VCR SYSTEMS

KEY	PART NUMBER	U/M	DESCRIPTION
	082134-01-000	EA	ADAPTER - TV - CABLE TO CABLE - WINEGARD F-81M
	086756-01-000	EA	SPLITTER - TV - 2 WAY
	076319-03-000	FT	CABLE - COAXIAL - 75 OHM
	076319-12-000	EA	CONNECTOR - COAXIAL - ONE PIECE
	086757-03-000	EA	CONTROL CENTER - SWITCH - VCR/TV - MAGNADYNE VCS-6
	098446-06-000	EA	VCR - VHS - CABLE READY - REMOTE - MAGNAVOX VR9210 FROM: 00-00-00 THRU: 09-30-94
	098446-06-700	EA	REMOTE F/ MODEL #9210 - 0974584
	098446-07-000	EA	VCR - VHS - CABLE READY - REMOTE MAGNAVOX VR9320 FROM: 10-01-94 THRU: 99-99-99
	113684-01-000	EA	TV - 19" COLOR UL AND CSA - AUDIOVOX AVT-1975
	113684-01-700	EA	REMOTE - 8822345
	092310-02-000	EA	TV - COLOR - 9"- AC/ DC - W/ REMOTE - MAGNAVOX RD0945 (REAR TV)
	092310-02-700	EA	REMOTE - F/ TV MAGNAVOX RD0945 - 0822334
	098819-01-000	EA	SPEAKER - 2 WATT - 8 OHM - 4"
	093214-01-02A	EA	GRILL - SPEAKER - 4" BROWN
	099717-02-000	EA	TIEDOWN - TV STRAP - 28.7" LONG
	109889-04-000	EA	EXTENDER - SHAFT - ANTENNA 3" MAGNADYNE RV71EX3
	082136-01-000	EA	JAM NUT - HEX 3/8-32 - WINEGARD
	076319-08-000	EA	WALLPLATE - CABLE RECEPTACLE - TV - SINGLE - IVORY
	076319-09-000	EA	WALLPLATE - CABLE RECEPTACLE - TV - SINGLE - BROWN
	086777-01-000	EA	WALLPLATE - TV CABLE - W/ ANTENNA SWITCH - IVORY
	086777-03-000	EA	WALLPLATE - CABLE - W/ TV ANTENNA SWITCH & BOOSTER - IVORY
	086757-03-000	EA	CONTROL CENTER - SWITCH - VCR/ TV - MAGNADYNE VCS-6

## BATH GROUP

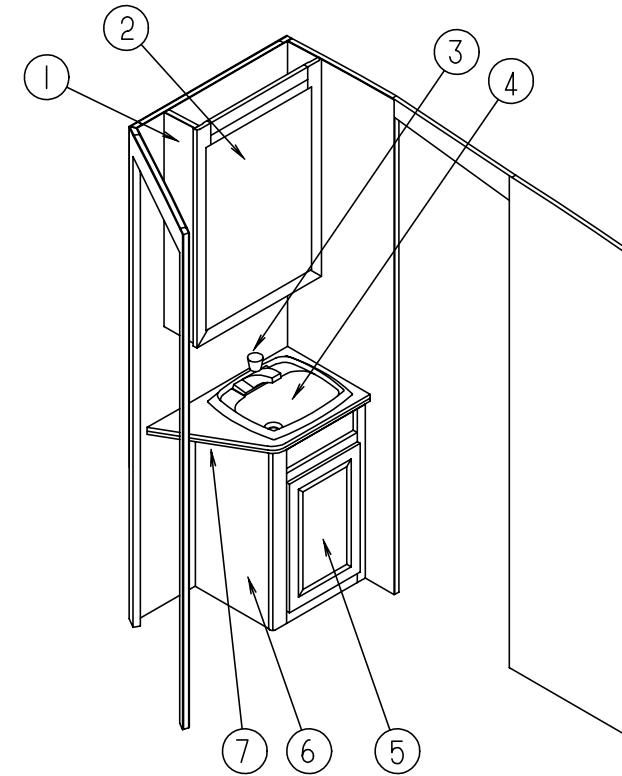

### BATH CABINETS & PRIVACY DOOR

KEY	PART NUMBER	U/M	DESCRIPTION
1	P04650-01-C27	EA	CABINET ASM - MEDICINE
2	115237-01-E10	EA	DOOR ASM - MIRROR - MEDICINE CABINET
	075454-02-000	EA	RING - TOWEL - W/ MOUNTING HARDWARE - BRASS
3	075240-06-000	EA	FAUCET - LAVATORY - BONE
	091253-01-000	EA	GASKET - FAUCET
4	096927-01-01A	EA	SINK - LAVATORY - RECTANGULAR - PLASTIC - BONE
	096927-01-700	EA	SINK STOPPER
	096927-01-701	EA	TAILPIECE - SINK
5	M05993-37-F31	EA	DOOR ASM - W/O HARDWARE - LAVATORY 295 X 555
6	P04634-01-F31	EA	CABINET ASM - LAVATORY
6	P04634-01-F32	EA	CABINET ASM - LAVATORY
7	104634-11-F31	EA	COUNTERTOP ASM
7	104634-11-F32	EA	COUNTERTOP ASM
	104013-04-F31	EA	DOOR ASM - SLIDING (REAR BATH)
	104013-04-F32	EA	DOOR ASM - SLIDING (REAR BATH)
	103874-01-000	EA	HANGER - SLIDING DOOR
	064467-01-000	EA	GUIDE - POCKET - SLIDING DOOR - WALL MOUNTED
	075452-02-000	EA	HOLDER - TOILET TISSUE - BRASS
	100494-02-E33	EA	DOOR ASM - BATH (FRONT BATH)
	009151-01-000	EA	GUARD - WARP - CABINET/ PRIVACY DOOR - 48"
	058335-02-000	EA	LATCH - BATH DOOR (FRONT BATH) BROWN PLASTIC
	100357-01-000	EA	ROD - TOWEL - BRASS W/ENDS BENT FOR BACK OF BATH DOOR
	102089-11-E10	EA	MOUNT-TOWEL ROD RIGHT SIDE - 53.5" LONG - WOOD
	102089-12-E10	EA	MOUNT-TOWEL ROD LEFT SIDE - 53.5" LONG - WOOD
	104014-02-F31	EA	DOOR ASM - BATH (SIDE AISLE)
	080728-01-000	EA	HANDLE - PULL - TABLE TOP - 1.3" X 4.4" - PLASTIC - BROWN
	102920-01-01A	EA	HINGE - DOOR - SPRING LOADED - BRASS

## BATH GROUP (CONTINUED)

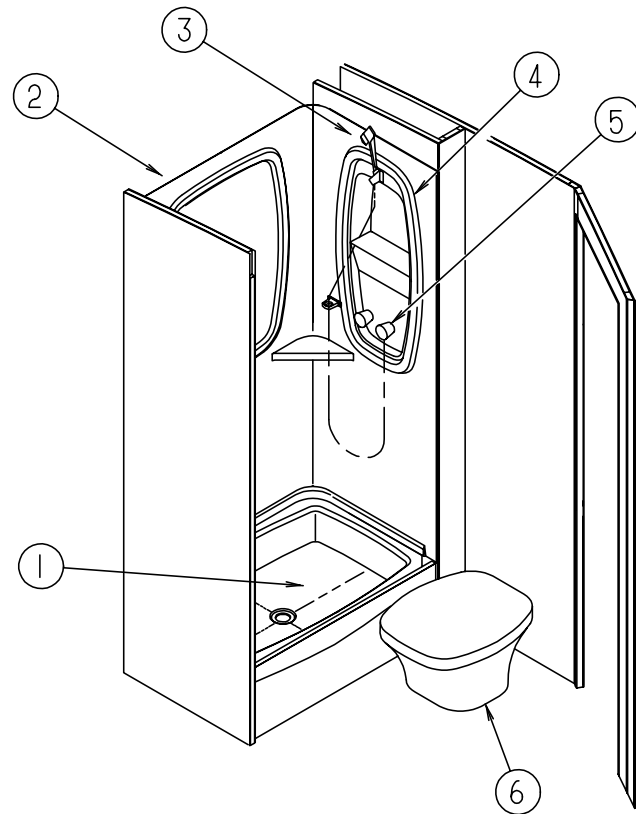

### SHOWER COMPONENTS

KEY	PART NUMBER	U/M	DESCRIPTION
1	M02630-22-C07	EA	SHOWER PAN ASM
	066440-01-000	EA	STRAINER - SHOWER - W/ RUBBER WASHER
	069735-01-000	EA	WASHER - STRAINER TO TAILPIECE PLASTIC - 1.5"
2	104464-01-01A	EA	SURROUND - SHOWER - OFF WHITE
3	103092-01-000	EA	SHOWER HEAD - W/60" HOSE
	103092-02-000	EA	SHOWER HEAD - W/ HOSE
	103092-01-700	EA	BRACKET ONLY - CLEAR - F/ SHOWER HEAD
	011048-03-700	EA	BRACKET ONLY (BONE) F/ SHOW HEAD
	057671-01-000	EA	COVER - SCREW - #8 - PLASTIC - OFF WHITE
4	104462-01-01A	EA	CADDY - SHOWER - OFF WHITE
5	075241-05-000	EA	FAUCET - SHOWER - BONE
	113714-02-01A	EA	RETAINER - SHELF - SHOWER OFF WHITE
6	085330-06-000	EA	TOILET - CHINA -STD W/ SPRAYER SEALAND 591003 - BONE

## BATH GROUP (CONTINUED)

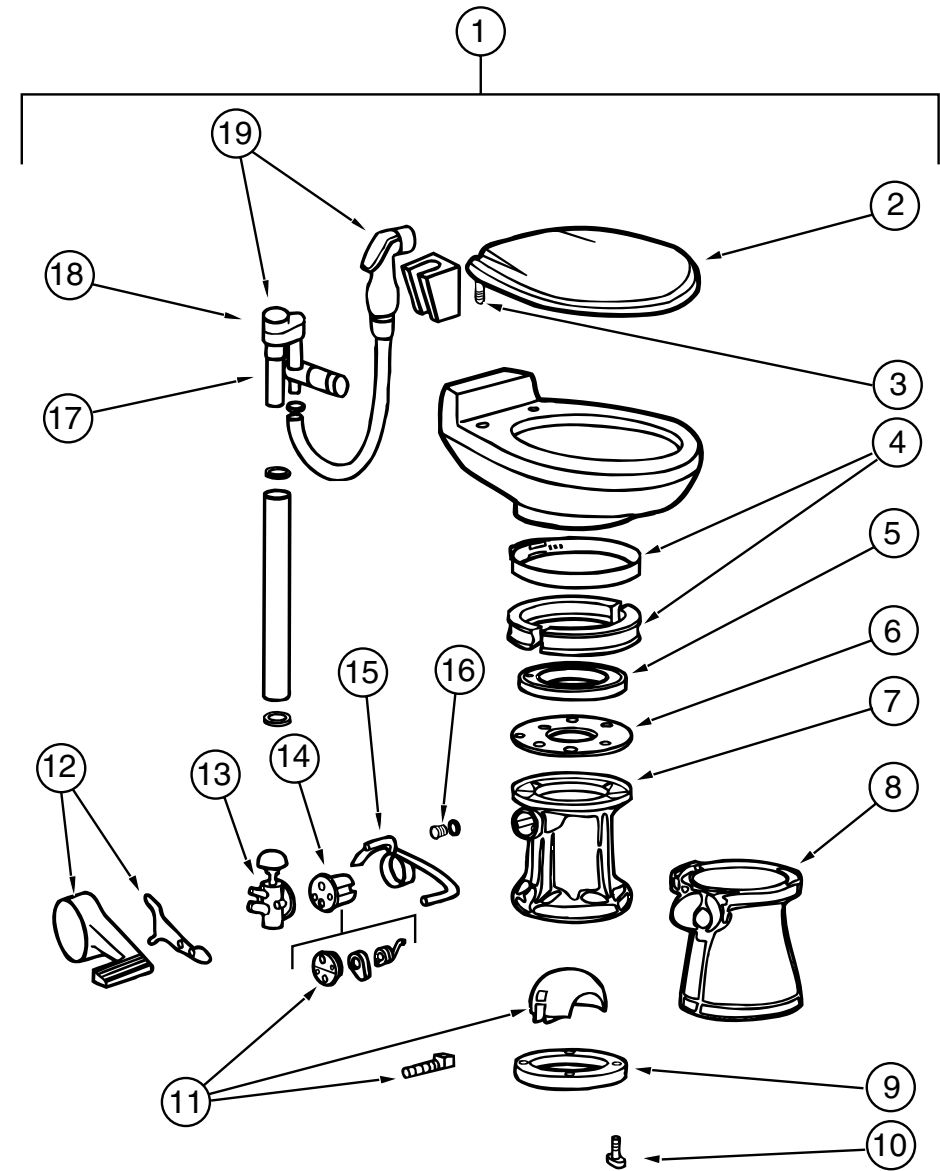

### TOILET (SEALAND)

KEY	PART NUMBER	U/M	DESCRIPTION
1	085330-06-000	EA	TOILET-CHINA - STANDARD W/ SPRAYER 591003 (BONE) MODEL 910 W/SPRAY
2	085330-06-700	EA	SEAT ASSEMBLY (BONE) 340591
3	085330-06-702	EA	HINGE HARDWARE (BONE) SET - 342131
4	085330-01-703	EA	RING & HALF CLAMPS ASM (BONE) 385310048
5	085330-01-704	EA	TEFLON & RUBBER SEALS - 385316140
6	085330-01-705	EA	SUPPORT - SEAL - PLASTIC - 390346405
7	085330-02-700	EA	BASE ASM - 310121
8	085330-02-702	EA	PEDESTAL COVER KIT (BONE) 510 - 310112
9	085330-01-714	EA	SEAL - FLANGE - FLOOR - 390343892
10	085330-01-717	EA	BOLT MOUNTING PACKAGE - 385310064
	085330-01-718	EA	SEAL & BOLT MOUNTING PACKAGE - 385310063
11	085330-01-706	EA	BALL - SHAFT & CARTRIDGE - 385318162
12	085330-02-703	EA	PEDAL COVER KIT (BONE) NEW STYLE - 310115
13	085330-01-709	EA	VALVE - WATER - 385314349
14	085330-01-707	EA	CARTRIDGE - SPRING - 381236096
15	085330-06-703	EA	FLUSH LEVER - 340873
16	085330-01-710	EA	PLUG - DRAIN - & CAP - W/ SEAL - 385316142
17	085330-06-701	EA	VALVE W/ DIVERTER (VACUUM BREAKER) 230335
18	085330-06-704	EA	VACUUM BREAKER KIT - 316906
19	085330-04-706	EA	BREAKER - VACUUM - W/ HAND SPRAY - 385319055

## BEDROOM GROUP

### BEDROOM CABINETS

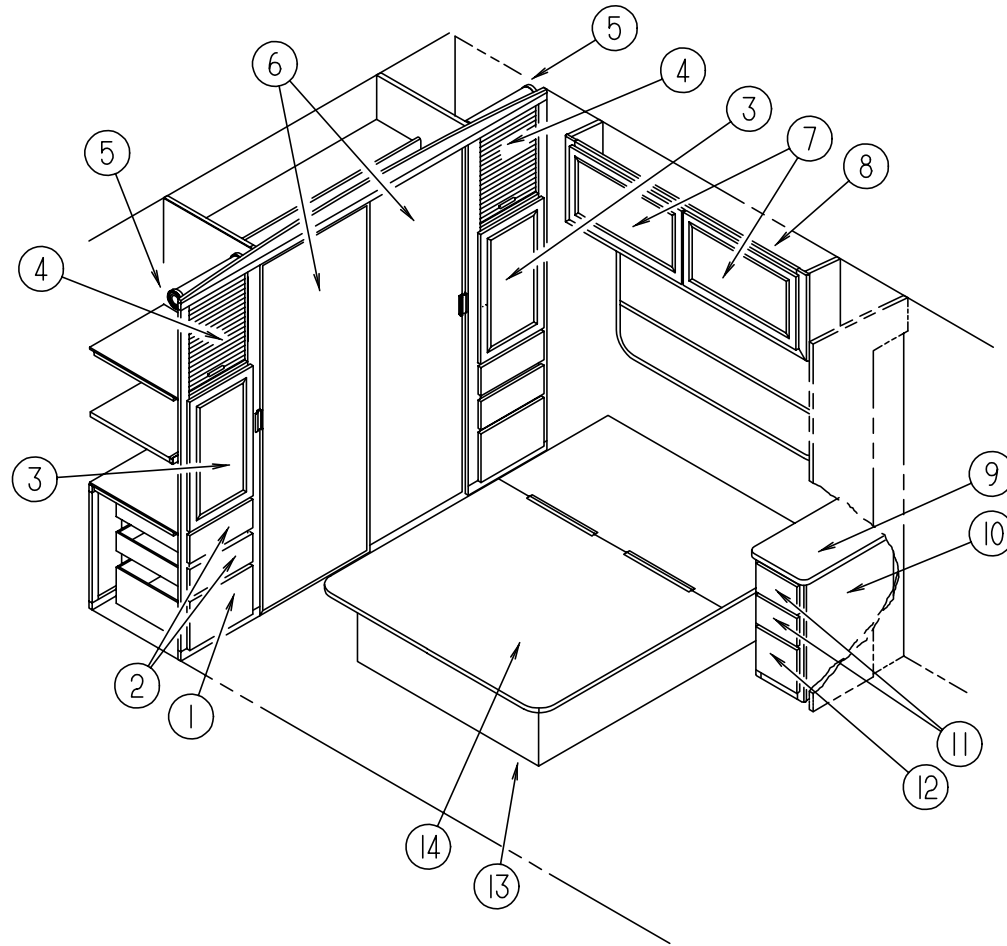

KEY	PART NUMBER	U/M	DESCRIPTION
1	M05970-98-E01	EA	DRAWER ASM.
2	M05970-99-E30	EA	DRAWER ASM.
3	M05993-48-F31	EA	DOOR ASM - W/O HARDWARE - 400 X 710
4	108221-20-E10	EA	DOOR TAMBOUR
	057882-04-000	SF	TAMBOUR - FOR DOORS
	M97191-01-E37	EA	HANDLE - DOOR - TAMBOUR
5	097141-02-700	EA	TRACK - SPIRAL - TAMBOUR DOOR KIT (1 LEFT & 1 RIGHT)
6	107403-02-E10	EA	DOOR COMPLETE - WARDROBE - MIRRORED
			FROM: 00-00-00 THRU: 08-28-94
6	114149-01-F31	EA	DOOR COMPLETE - WARDROBE - MIRRORED
			FROM: 08-29-94 THRU: 99-99-99
6	058331-81-000	EA	MIRROR - GLASS - SAFETY - 673MM X 1913MM
			FROM: 00-00-00 THRU: 08-28-94
6	058331-C3-000	EA	MIRROR - GLASS - SAFETY - 653MM X 1898MM
			FROM: 08-29-94 THRU: 99-99-99
6	107387-02-01A	EA	RAIL - DOOR - BY-PASS 635
6	107389-02-01A	EA	TRACK - TOP - BY-PASS 1320
6	107390-01-000	EA	HANGER - CORNER CONNECTION
6	107391-01-000	EA	GUIDE BOTTOM - BY-PASS
7	M05993-48-F31	EA	DOOR ASM - W/O HARDWARE - 400 X 710
8	M06839-10-F31	EA	CABINET ASM - OVERHEAD - REAR - LH
9	104639-11-F31	EA	COUNTERTOP ASM
9	104639-11-F32	EA	COUNTERTOP ASM
10	104639-01-F31	EA	CABINET ASM. - NIGHTSTAND
10	104639-01-F32	EA	CABINET ASM. - NIGHTSTAND
11	M05970-97-E30	EA	DRAWER ASM. - SLIDE - UPPER
12	M05970-71-E30	EA	DRAWER ASM. - SLIDE - LOWER
13	P09476-01-E10	EA	CABINET ASM - BED - QUEEN
	091261-01-000	FT	BACKING - NON-SKID - 12" X 100' - QUEEN BED
14	M05905-02-D12	EA	TOP ASM. - BED - QUEEN
	057460-04-000	EA	SPRING - GAS
	089025-01-000	EA	SUPPORT - SPRING-TO BED - ANGLE 1.5" X 11.8" LONG - STEEL

### CHASSIS GROUP

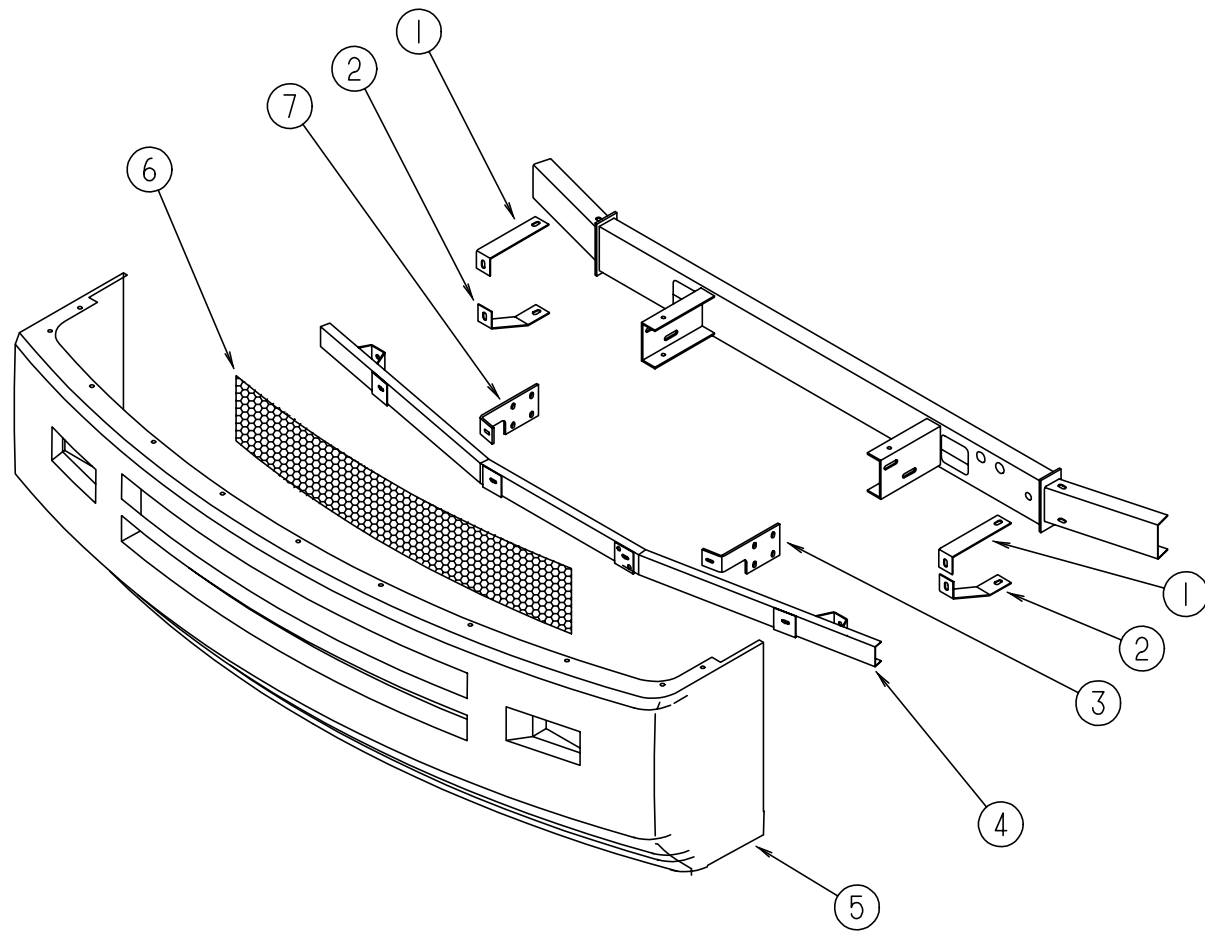

### FRONT BUMPER

KEY	PART NUMBER	U/M DESCRIPTION
1	103497-01-000	EA BRACE - BUMPER - FRONT - UPPER
2	103611-01-000	EA BRACE - BUMPER - FRONT - LOWER
3	086140-04-000	EA SUPPORT - FRONT BUMPER - DRIVER SIDE - 9.1" X 4" - STEEL
4	103512-01-000	EA CHANNEL ASM - BUMPER
5	111077-01-E10	EA BUMPER PANNEL ASM - FRONT
6	104318 02 C07	EA GRILL ASM.
7	086140-03-000	EA SUPPORT - FRONT BUMPER - PASSENGER SIDE - 9.1" X 4" - STEEL

### CHASSIS GROUP (CONTINUED)

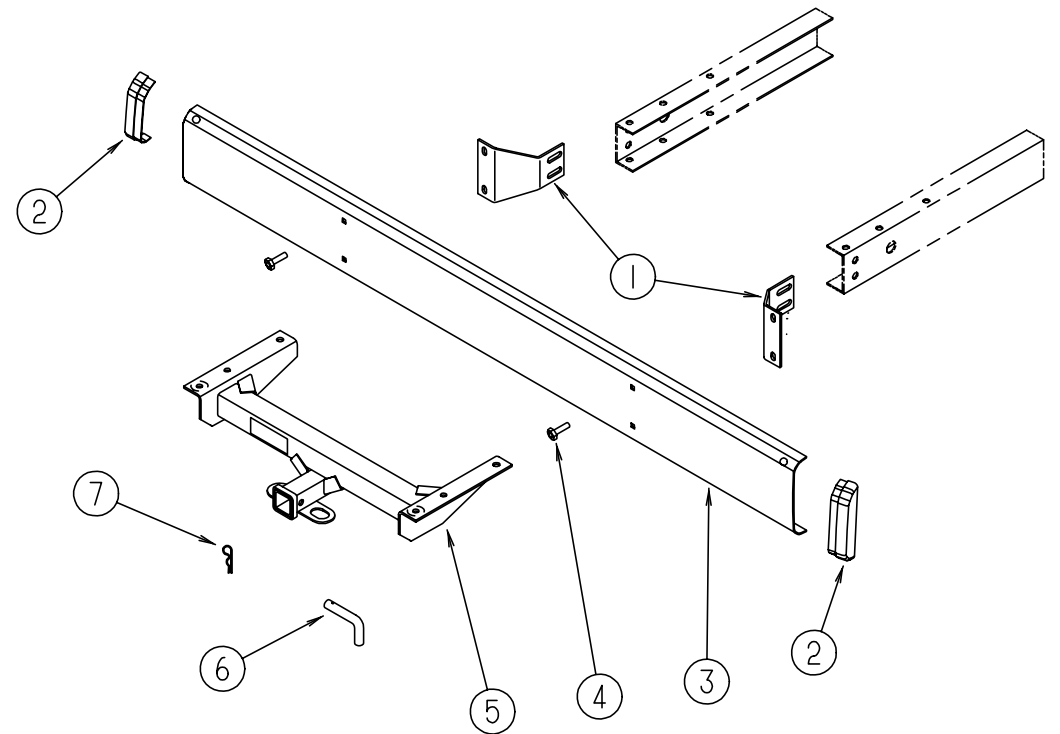

### REAR BUMPER

KEY	PART NUMBER	U/M DESCRIPTION
1	104418-07-000	EA ANGLE - SUPPORT - BUMPER REAR
2	103228-01-05A	EA END CAP - BUMPER REAR - BLACK
3	103099-01-02A	EA REAR BUMPER - OFF WHITE
4	102333-01-02A	EA BOLT - 7/16"
5	107707-01-000	EA HITCH ASM - CLASS II
6	034512-01-000	EA PIN
7	034513-01-000	EA PIN - 3/16" WIRE
	113589-01-000	EA CONNECTOR - PLUG - TRAILER
	113589-02-000	EA CONNECTOR - SOCKET - TRAILER

## CHASSIS GROUP (CONTINUED)

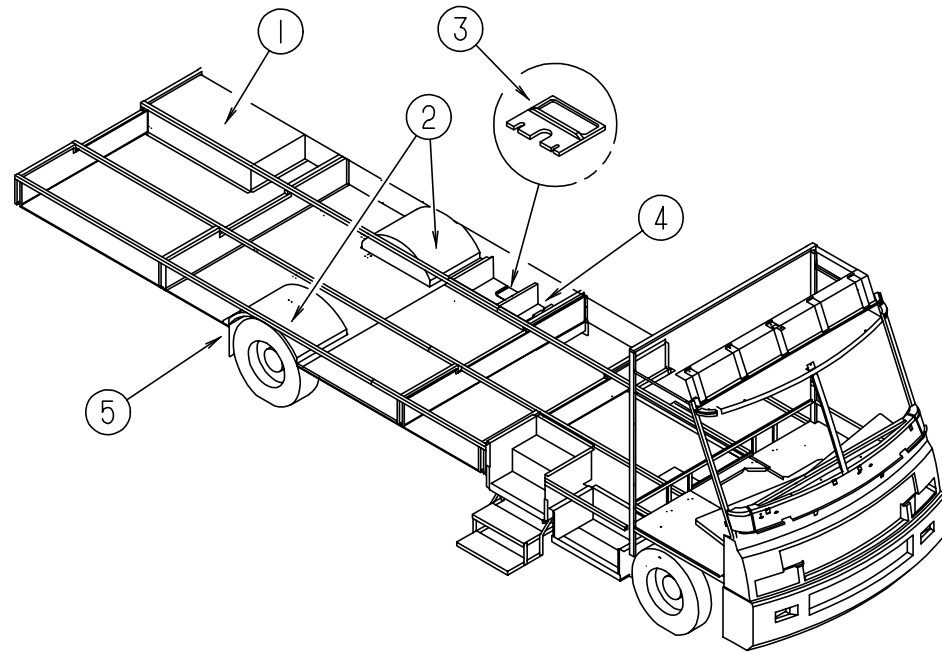

### COMPARTMENTS & TRAYS

KEY	PART NUMBER	U/M DESCRIPTION
1	094657-02-000	EA TRAY - GENERATOR - 22.5" X 30.4" X 6.9" W/ANGLE & NUTS
2	055374-01-000	EA REAR WHEELWELL - PLASTIC
3	M06991-03-F36	EA HATCH ASM - W/ FOAM
	114677-01-01A	EA RETAINER - HATCH - SEWER HOSE
4	114679-01-01A	EA COMPARTMENT-STORAGE
5	020167-05-000	EA GUARD - DIRT
5	017516-01-000	EA FLAP - MUD - 14" X 18" - BLACK
	093287-09-01A	EA NET - CARGO - 254 MM X 1510 MM
	065450-05-000	EA TIEDOWN - BATTERY - 8.4" TUBE

## CHASSIS GROUP (CONTINUED)

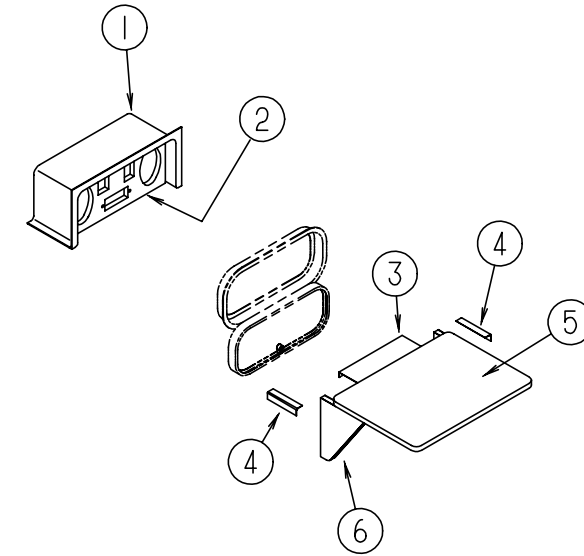

### COMPARTMENT (ENTERTAINMENT CENTER)

KEY	PART NUMBER	U/M DESCRIPTION
1	104897-01-01A	EA BOX - ENTERTAINMENT CENTER - OFF WHITE
2	104899-01-C05	EA PLATE - RADIO MOUNTING
3	105377-01-01A	EA BRACKET - TABLE HANGER OFF WHITE
4	105376-01-02A	EA HINGE - CONTINUED - 2"X140MM OFF WHITE
5	105230-11-	



# CHASSIS GROUP (CONTINUED)

## EXHAUST SYSTEM (FORD)

KEY	PART NUMBER	U/M DESCRIPTION
1	075307-03-000	EA SHIELD - HEAT - LP
2	096055-05-000	EA SUPPORT - EXHAUST PIPE
3	095190-01-000	EA HANGER ASM - EXHAUST
4	102117-06-000	EA HANGER ASM -TAILPIPE
5	098762-12-000	EA PIPE -EXHAUST -STRAIGHT -2.25 IN
	007125-07-000	EA CLAMP - MUFFLER - 2.50" DIAMETER
6	007125-05-000	EA CLAMP - MUFFLER - 2" DIAMETER
7	101544-01-000	EA SHIELD - EXHAUST
8	101544-06-000	EA SHIELD - EXHAUST

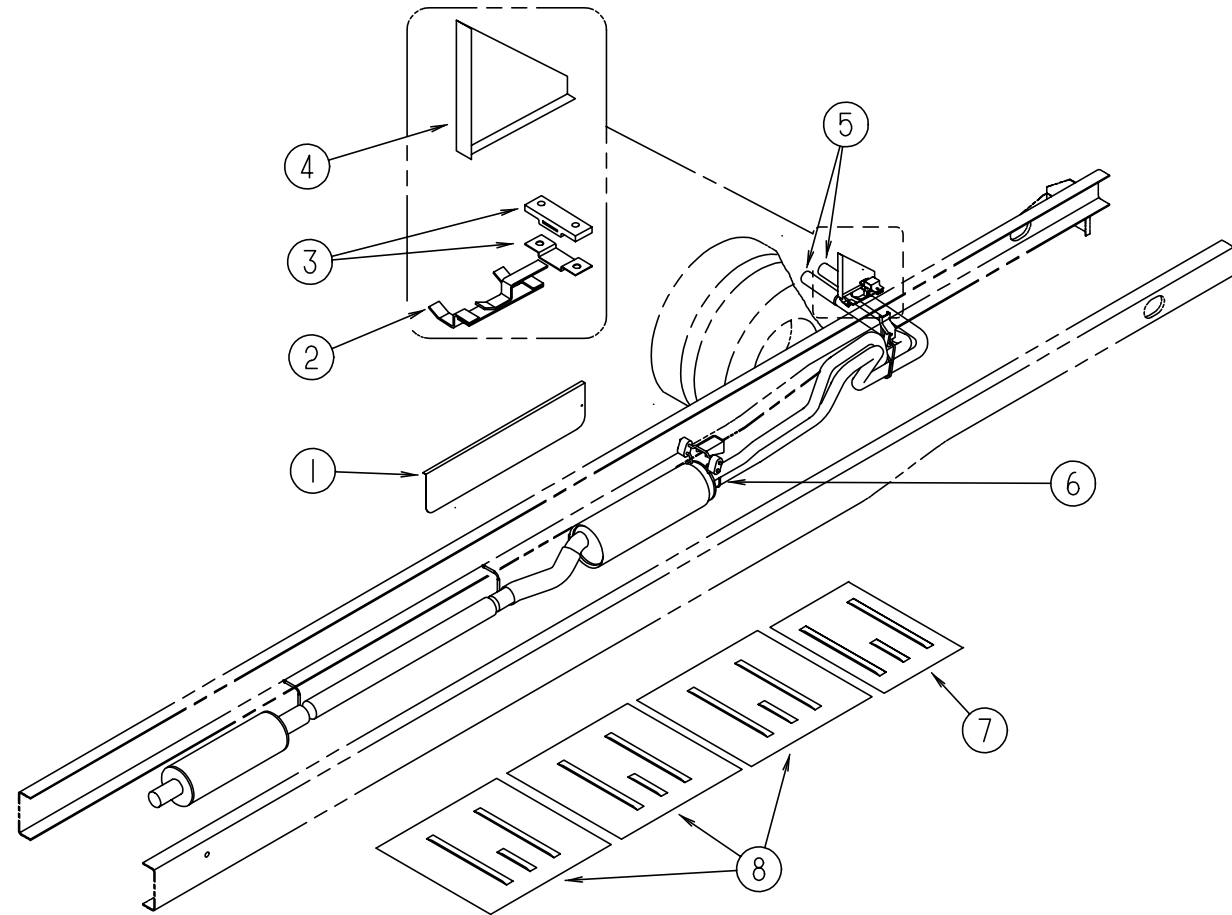

### CHASSIS GROUP (CONTINUED)

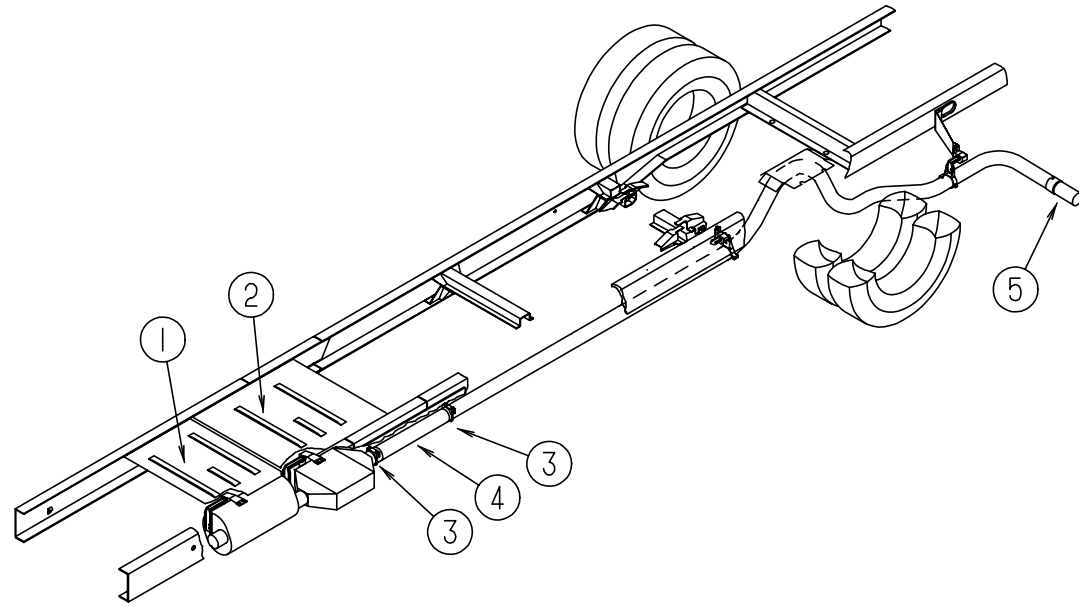

EXHAUST SYSTEM (CHEVY)

KEY	PART NUMBER	U/M DESCRIPTION
1	101544-01-000	EA SHIELD - HEAT - EXHAUST - 19.7" X 28.9" - STEEL
2	101544-02-000	EA SHIELD - HEAT - EXHAUST - 30" X 28.9" - STEEL
3	094918-01-000	EA CLAMP - EXHAUST - 3"
4	098762-06-000	EA PIPE - EXHAUST - STRAIGHT - 3.0" X 22"
5	098762-05-000	EA PIPE - EXHAUST EXTENSION - STRAIGHT - 3.0" X 9"

### CHASSIS GROUP (CONTINUED)

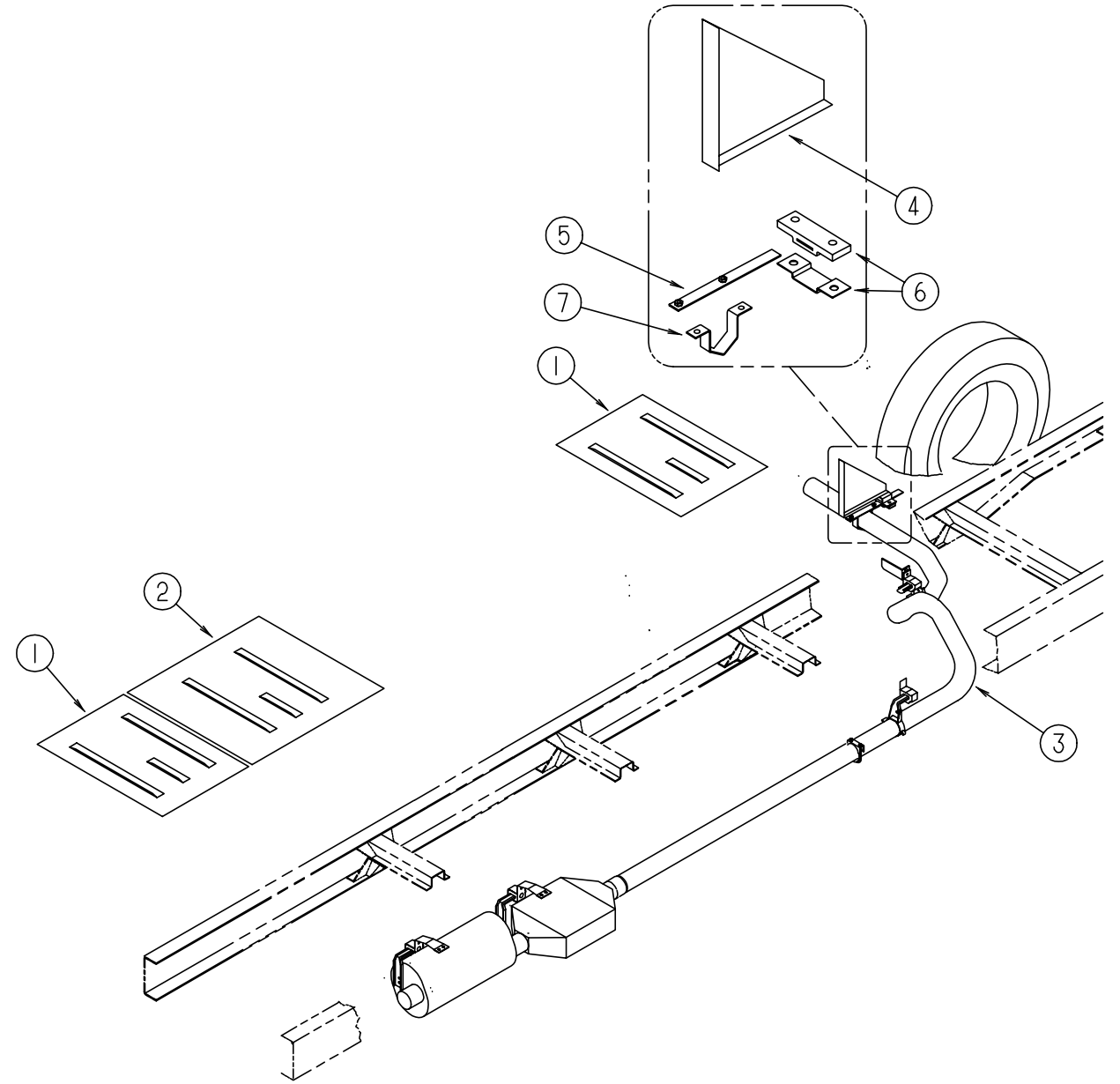

EXHAUST SYSTEM (CHEVY W/ LEVELING JACKS)

KEY	PART NUMBER	U/M DESCRIPTION
1	101544-01-000	EA SHIELD - HEAT - EXHAUST - 19.7" X 28.9" - STEEL
2	101544-02-000	EA SHIELD - HEAT - EXHAUST - 30" X 28.9" - STEEL
3	107754-01-000	EA PIPE - EXHAUST - TAIL - STAINLESS STEEL
4	102117-02-000	EA HANGER - TAILPIPE - STEEL
5	095523-11-000	EA BRACKET - EXHAUST - UPPER W/ WELDNUTS - STEEL
6	095190-01-000	EA HANGER - EXHAUST - 4" X 1.4"
7	095223-03-000	EA BRACKET - EXHAUST - LOWER - STEEL

### CHASSIS GROUP (CONTINUED)

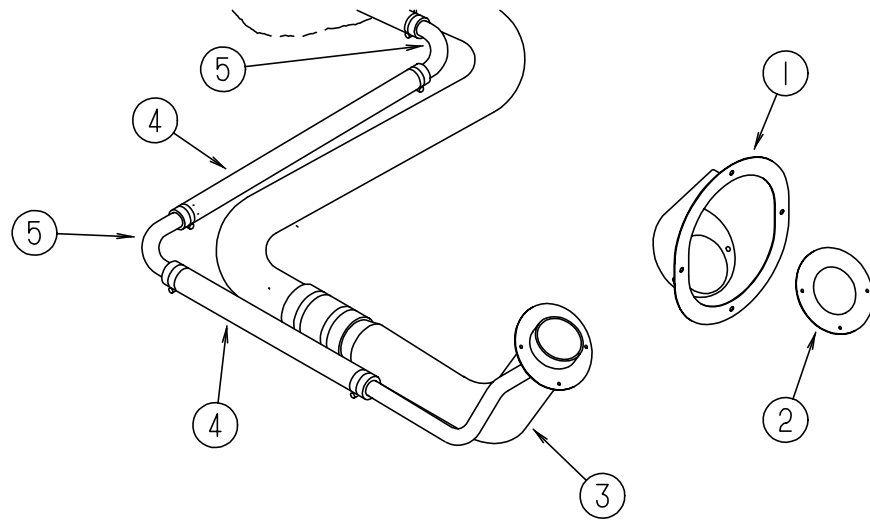

### FUEL SYSTEM (FORD)

KEY	PART NUMBER	U/M DESCRIPTION
1	095854-01-01A	EA SHROUD - FUEL FILL
2	078200-01-000	EA GASKET - FUEL FILL - 3.5"OD X 2"ID
3	087256-07-000	EA NECK ASM - FUEL FILL
4	066732-01-000	FT HOSE - FUEL FILL - .62" ID
5	098806-01-000	EA PIPE - FILL VENT - 90 DEGREE BEND - .625" OD - STEEL
	007063-01-000	FT HOSE - GAS 1/4"ID X 1/2"OD
	084884-01-000	EA PLUG - BRASS - 3/8"
	007111-02-000	EA HOSE - FUEL FILL - 2" ID - IN 3FT LENGTHS

### CHASSIS GROUP (CONTINUED)

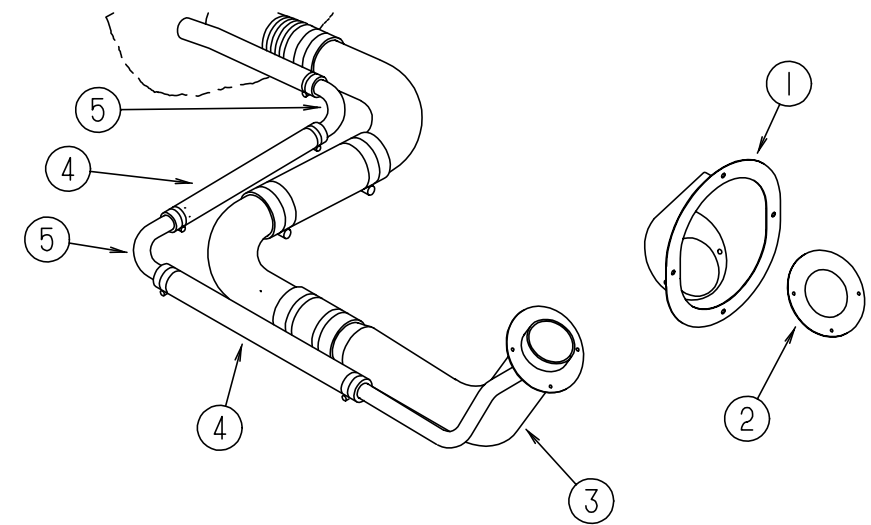

### FUEL SYSTEM (CHEVY)

KEY	PART NUMBER	U/M DESCRIPTION
1	095854-01-01A	EA SHROUD - FUEL FILL
2	078200-01-000	EA GASKET - FUEL FILL - 3.5"OD X 2"ID
3	087256-06-000	EA NECK ASM. - FUEL FILL
4	066732-01-000	FT HOSE - FUEL FILL - .62" ID
5	098806-01-000	EA PIPE - FILL VENT - 90 DEGREE BEND - .625" OD - STEEL
6	098779-01-000	EA COUPLER - FUEL LINE M14 X 1.5-6H - GM 15550219
7	098758-02-000	EA FUEL LINE ASM - RETURN - 5/16 - 508 LONG
8	098759-02-000	EA FUEL LINE ASM - SUPPLY - 3/8 - 508 LONG
9	098779-02-000	EA COUPLER - FUEL LINE M16 X 1.5-6H
10	074800-18-000	EA TUBE - EXTENSION - MAIN FUEL - 208 TO 228 LONG
11	007063-01-000	FT HOSE - GAS 1/4"ID X 1/2"OD
	098807-01-000	EA PIPE - FUEL FILL - 90 DEGREE BEND - 6.6" - 1 3/4" OD - STEEL
	075466-01-000	EA UNION - INVERTED FLARE TUBE - 1/4"
	084884-01-000	EA PLUG - BRASS - 3/8"

## CHASSIS GROUP (CONTINUED)

### TIRE & WHEEL HARDWARE (FORD)

KEY	PART NUMBER	U/M DESCRIPTION
	077030-02-000	EA EXTENSION - VALVE STEM - 1.25"
	091209-08-000	EA WHEEL LINER SET W/FRONT HUB COVER 16" (SET OF 4)
	091209-08-700	EA LINER - WHEEL - 16" FRONT W/AXLE COVER - 10 LUG
	091209-08-701	EA LINER - WHEEL - 16" REAR - 10 LUG
	091209-08-702	EA COVER - AXLE - 16" REAR
	091209-01-704	EA LUG NUT COVER (WHEEL LINER)
	091209-11-702	EA JAMB NUT (LONG) REAR WHEEL
	091209-08-704	EA FRONT SIMULATOR
	091209-08-705	EA REAR SIMULATOR
	091209-08-706	EA FLAT NUT .500 - 9/16 STUD
	095012-03-000	EA EXTENSION - VALVE STEM - DUAL WHEEL
	095012-04-000	EA STABILIZER - VALVE EXTENSION
	M00080-60-000	EA FORD TIRE & WHEEL
	051377-05-000	EA VALVE STEM ASM - VS938
	083425-05-000	EA TIRE - MICHELIN - LT235/85R16 LRE - XPS RIB
	095853-02-000	EA WHEEL - STEEL - 16" X 6K - F2TA- 1015 - NA
	098532-01-000	EA COVER - WHEEL - FORD - 16" - SET OF 4
	098532-01-700	EA COVER - LUG NUT - CHROME
	098532-01-701	EA COVER - WHEEL - 16"

### TIRE & WHEEL HARDWARE (CHEVY)

KEY	PART NUMBER	U/M DESCRIPTION
	091209-01-000	EA LINER - WHEEL - 19.5" - SST - SET OF 4 - KAPER 1954-ION
	091209-01-700	EA LINER - WHEEL - 19.5" FRONT - 10 LUG - CHEVY P-30
	091209-01-701	EA LINER - WHEEL - 19.5" REAR - 10 LUG - CHEVY P-30
	091209-01-702	EA COVER - AXLE - 19.5" FRONT - 10 LUG - CHEVY P-30
	091209-01-703	EA COVER - AXLE - 19.5" REAR - 10 LUG - CHEVY P-30
	091209-01-704	EA COVER - LUG NUT
	077030-02-000	EA EXTENSION - VALVE STEM - 1.25"
	095012-03-000	EA EXTENSION - VALVE STEM - DUAL WHEEL
	095012-04-000	EA STABILIZER - VALVE EXTENSION - DICOR AG-STA-2
	109443-01-000	EA WHEEL - COVER 4/SET 19.5 W/HDW
	109443-01-700	EA WHEEL - COVER 19.5 - FRONT & REAR - SHAG95 LONLY DICOR
	109443-01-701	EA SET - BRACKET - 1 FRONT WHEEL - SHAG95-FBS DICOR
	109443-01-702	EA SET - BRACKET - 1 REAR WHEEL - SHAG95-RBS DICOR
	109443-01-703	EA CAP - CENTER - HUB DICOR
	109443 01 704	EA PUSH NUT - V160GM-PNT
	M00080-38-000	EA TIRE & VALVE STEM
	007324-03-000	EA TIRE - 8R19.8 LRF - MICHELIN XZA
	051377-01-000	EA STEM - VALVE - TR 500
	080208-01-000	EA LUG WRENCH - 1.06 X 1.00
	080208-02-000	EA BAR - LEVERAGE - LUG WRENCH

## CHASSIS GROUP (CONTINUED)

### HYDRAULIC LEVELING SYSTEM (CHEVY,FORD)

KEY	PART NUMBER	U/M DESCRIPTION
	100532-08-000	EA LEVELING SYSTEM - HYDRAULIC - JOYSTICK HWH AP0758
	100532-01-704	EA SWITCH - MERCURY F/ 6K & 9K JACK RAP1010
	100532-01-705	EA SPRING KIT - 9K JACK R1171
	100532-02-700	EA 6K TALL JACK ASM RAP7164
	100532-02-701	EA SPRING KIT - 6K JACK R6824
	100532-02-704	EA ACTIVATOR CABLE - 6K JACK RAP7194
	100532-02-705	EA PUMP/ RESERVOIR ASM - MONARCH RAP8178
	100532-03-710	EA SENSING UNIT 21' MTA RAP6798
	100532-03-715	EA CAP - BREATHER RAP7876
	100532-08-700	EA POWER UNIT ASM. RAP0595
	100532-08-701	EA BI-AXIS CONTROL - 200 SYSTEM RAP0612
	100532-08-702	EA VALVE - BI-AXIS RAP9589
	100532-08-703	EA PANEL ASM. - 200 BI - AXIS SYS. RAP9755
	100532-08-704	EA JACK ASM. - 9K TALL 200 SYS. RAP7002
	100532-09-707	EA ACTUATOR ASM. - 9K - REAR JACKS RAP0547
	100532-09-709	EA ACTUATOR ASM. - 6K - FRONT JACKS RAP0448
	100532-09-710	EA SOLENOID - 4 POST INT. DUTY RAP0533
	100533-05-000	EA BRACKETS - FRONT LEVELING JACKS - HWH AP7107 (GM)
	100533-06-000	EA BRACKETS - FRONT LEVELING JACKS - HWH AP7160 (FORD)
	100534 12 000	EA BRACKETS - REAR LEVELING JACKS - HWH AP0921 (GM)
	100534-06-000	EA BRACKETS - REAR LEVELING JACKS - HWH# AP6957 (FORD )
	100536-10-000	EA HOSE KIT - HWH #AP0012
	107890-01-000	EA ELBOW - STEEL 90D 1/4 X 37D FLARE PARKER 4-C6X-S
	112236-01-E10	EA BEZEL - MONITOR - UNDER DASH - LEFT SIDE

### DRIVESHAFT & BRAKE LINE

KEY	PART NUMBER	U/M DESCRIPTION
	088498-01-000	EA UNION - INVERTED FLARE - BRASS - 3/16 - 3/8 - 24 THREAD - BRAKE LINE
	074833-01-000	EA SPACER - BEARING - DRIVESHAFT - 2" X 8" X .5" THICK
	074833-04-000	EA SPACER - BEARING - DRIVESHAFT - 8" X 2" - STEEL
	075302-09-000	EA DRIVESHAFT ASM. - YOKE/ YOKE - 50"
	075302-25-000	EA DRIVESHAFT ASM. - BAL.PR-20/21
	075302-20-000	EA DRIVESHAFT ASM. - YOKE/ BRG/ SPLINE
	075302-21-000	EA DRIVESHAFT ASM. - SLIP - YOKE/ YOKE
	107212-01-000	EA CROSSMEMBER ASM. - BREARING SUPPORT CHEVY 228 3 SHAFT
	088497-02-000	EA NUT - INVERTED FLARE - 1/4"
	085771-03-000	EA NUT - HEX - FL. PREV. TORQUE - GRADE G DRIVE SHAFT

### STEP ASSEMBLIES & PANELS

KEY	PART NUMBER	U/M DESCRIPTION
	094707-01-01A	EA STEP - DOUBLE - ELECTRIC - KWIKEE 3218
	094707-02-700	EA MOTOR REPLACEMENT KIT - MODELS 32 & 28 - KWIKEE 9520
	094707-02-701	EA LINKAGE ASM - MODEL 32 - KWIKEE 9523
	094707-02-702	EA GEAR KIT - KWIKEE 9525
	094707-02-703	EA PARTS KIT (BEARINGS & PINS) - KWIKEE 9530
	094707-02-704	EA CONNECTOR KIT - MOTOR - KWIKEE 9537
	094707-02-705	EA CONTROL UNIT (ORANGE) - KWIKEE 9513
	P01713 01 000	EA SWITCH ASM - ELECT STEP W/ SEAL
	116995 01 000	EA SWITCH/ MAGNET - STEP - ELECTRIC FROM: 00-00-00 THRU: 10-23-94 FROM: 10-24-94 THRU: 99-99-99
	113285-01-01A	EA SEAL - STEP - SWITCH - BLACK
	094707-02-707	EA NON -SKID TREAD - BLACK. 6" X 21"

### SHOCK ABSORBER (CHEVY)

KEY	PART NUMBER	U/M DESCRIPTION
	104993-01-000	EA SHOCK ABSORBER - GAS - P30 FRONT

## CURTAIN & CUSHION GROUP

### NOTICE

IN ORDER TO ASSIST OUR PARTS SALES DEPT. IN PROVIDING INTERIOR SOFTGOODS ITEMS, PLEASE INCLUDE THE SERIAL NUMBER AND THE COLOR CODE NUMBER FROM THE VEHICLE CERTIFICATION LABEL WHEN ORDERING. THIS LABEL IS LOCATED ON THE LEFT SIDEWALL AT THE END OF THE DASH (A-BODY), OR ON THE DRIVER'S DOOR LATCH PLATE (C-BODY).

AN EXAMPLE OF A COLOR CODE NUMBER IS B07, WHICH DESIGNATES AN OVERALL COLOR SCHEME OF A PARTICULAR UNIT. THE COLOR LISTED AFTER THE ITEM DESCRIPTION ON THE MICROFICHE, INDICATES THE OVERALL UNIT COLOR. ORDER THE ITEM YOU DESIRE ACCORDING TO UNIT COLOR CODE.

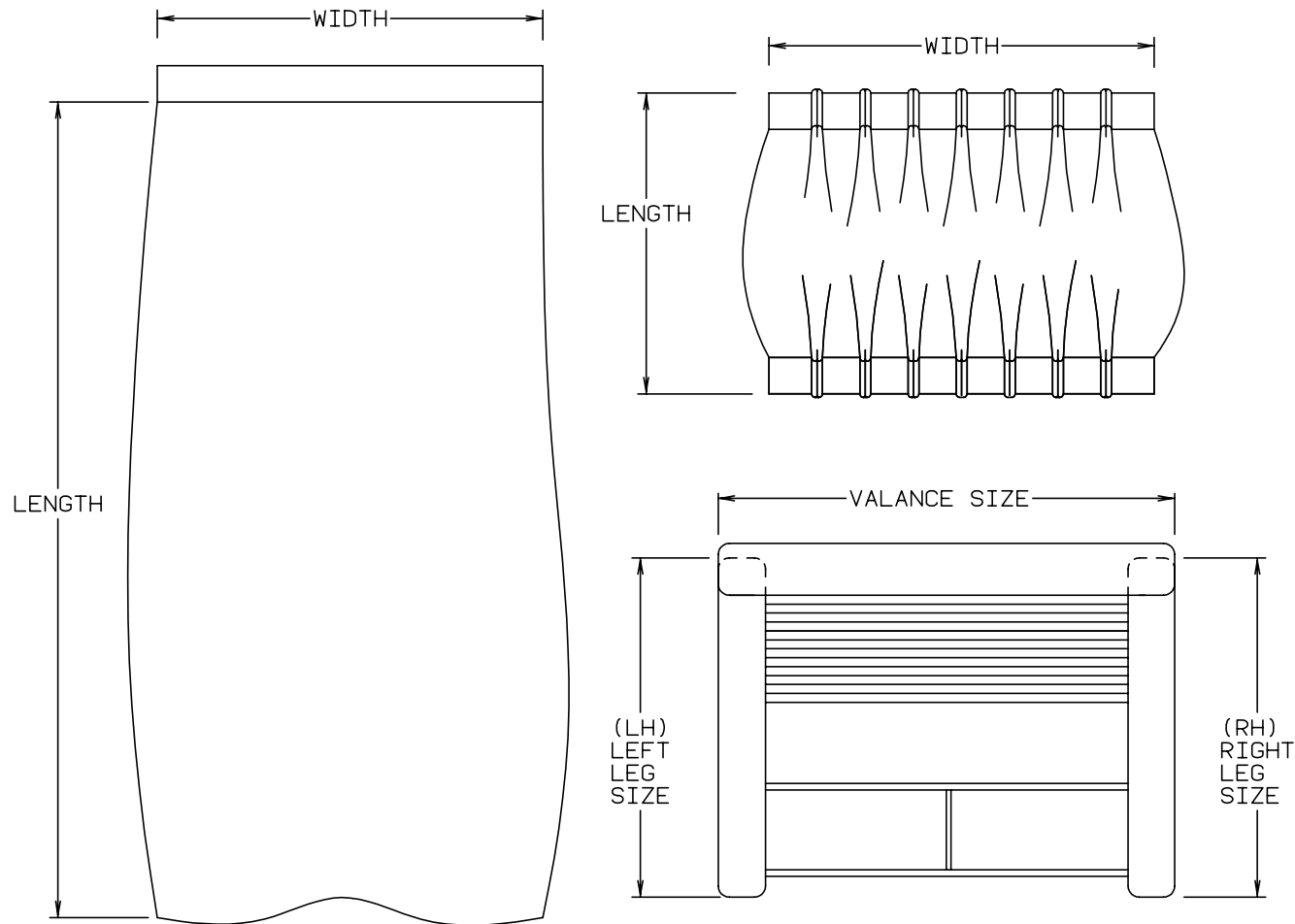

NOTE: USE THIS ILLUSTRATION WHEN DETERMINING LENGTH AND WIDTH MEASUREMENTS FOR CURTAINS. YOU WILL NOTE THE WIDTH MEASUREMENT IS TAKEN ON THE TOP OF THE CURTAIN WITH THE CURTAIN FULLY EXTENDED. THE LENGTH MEASUREMENT IS TAKEN FROM TOP TO BOTTOM. LEFT AND RIGHT WINDOW LEGS ARE DETERMINED WHEN FACING THE WINDOW.

## CURTAIN & CUSHION GROUP (CONTINUED)

### FABRIC & TRIMS

KEY	PART NUMBER	U/M DESCRIPTION
	072333-85-000	YD FABRIC - CURTAIN - MUSHROOM
	087272 03 000	YD DRAPERY - LINING - 54" IVORY
	079680-07-000	YD FABRIC - VINYL- 54" WIDE - BEIGE
	103907-01-01A	YD FABRIC - VINYL- 54" WIDE - OFF WHITE
	075244-07-000	YD FABRIC - VINYL - SHOWER CURTAIN - EGGPLANT (F31)
	075244-03-000	YD FABRIC - VINYL - SHOWER CURTAIN - ALMOND (F32)
	105745-88-000	YD FABRIC - BEDSPREAD - MAIN - TARA (F31)
	105745-93-000	YD FABRIC - BEDSPREAD - MAIN - SUNTAN (F32)
	105745-87-000	YD FABRIC - BEDSPREAD - ACCENT - RADIANCE/ ORCHID (F31)
	105745-92-000	YD FABRIC - BEDSPREAD - ACCENT - CHRIS STONE (F32)
	108446-C9-000	YD FABRIC - UPHOLSTERY - PLAIN ACCENT (BUCKET SEAT) (F31)
	108446-55-000	YD FABRIC - UPHOLSTERY - PLAIN ACCENT (BUCKET SEAT) (F32)
	108446-D0-000	YD FABRIC - UPHOLSTERY - PATTERN ACCENT (MAP POCKET) (F31)
	108446-76-000	YD FABRIC - UPHOLSTERY - PATTERN ACCENT (MAP POCKET) (F32)
	108446-C7-000	YD FABRIC - UPHOLSTERY - MAIN (DINETTE SEAT) (F31)
	108446-C8-000	YD FABRIC - UPHOLSTERY - MAIN (DINETTE SEAT) (F32)
	089351-03-000	YD VINYL - CEILING - DIAMOND DESIGN - 54" WIDE

### ASSIST HANDLE & BUTTONS

KEY	PART NUMBER	U/M DESCRIPTION
	057759-01-000	EA WASHER BRACKET - SEAT BELT - 4" DIAMETER
	069178-02-000	EA BRACKET - MOUNTING - ASSIST HANDLE - L ANGLE - W/ HOLES - STEEL
	000C16-07-16B	EA BOLT - CARRIAGE - ASSIST HANDLE - 7/16" - 14 X 1" ZN
	000D20-07-00B	EA NUT - ACORN - ASSIST HANDLE - 7/16" X 14 ZN
	053552-02-AA8	EA HANDLE - ASSIST - INTERIOR - ENTRY DOOR - VINYL - OFF WHITE
	070578-02-B29	EA BUTTON - SCREW - STUD - #30 - VINYL

## CURTAIN & CUSHION GROUP (CONTINUED)

### CURTAINS & WINDOW TREATMENT

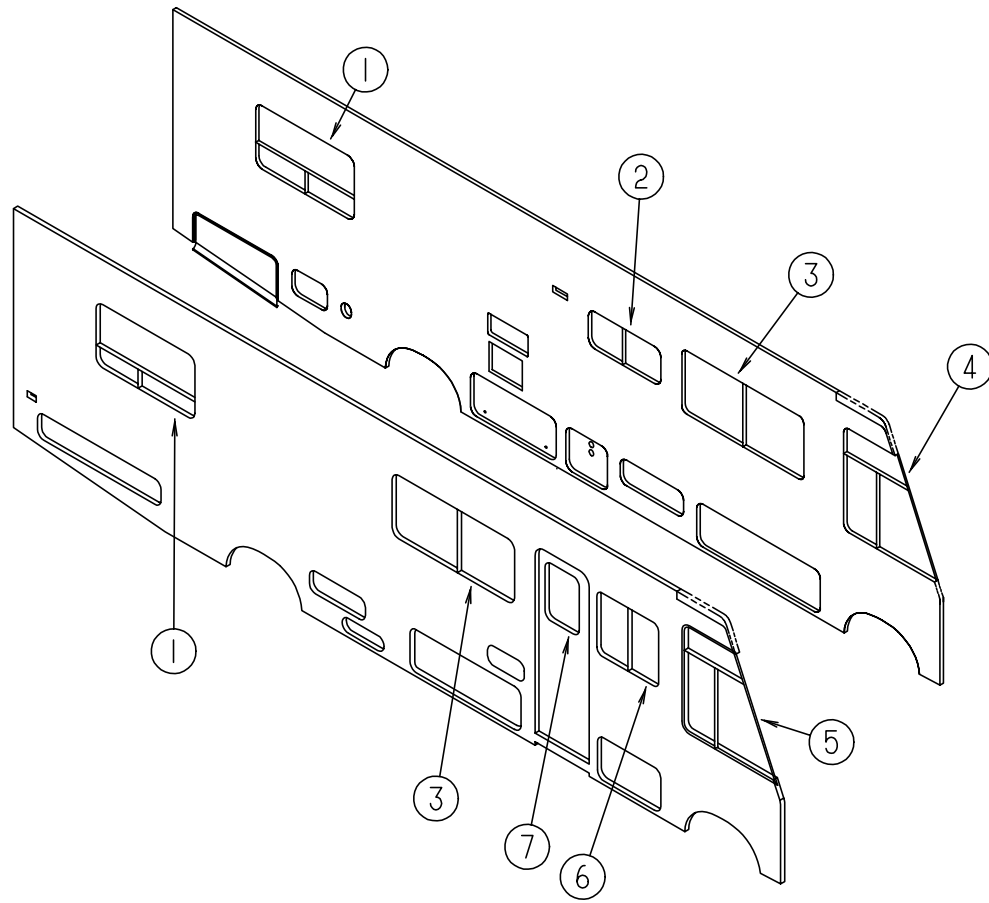

KEY	PART NUMBER	U/M	DESCRIPTION
1	115811-03-F31	EA	VALANCE ASM. - 52" - 3 SIDED - LAMBREQUIN
1	115811-03-F32	EA	VALANCE ASM. - 52" - 3 SIDED - LAMBREQUIN
1	111910-24-F31	EA	BLIND - PLEATED - 49" X 28.5"
1	111910-24-F32	EA	BLIND - PLEATED - 49" X 28.5"
2	109041-20-01A	EA	MINI BLIND - 31" X 18" - SILVER (F31)
2	109041-20-02A	EA	MINI BLIND - 31" X 18" - BEIGE (F32)
2	109353-07-01A	EA	BLIND SLAT - 31" - SILVER (F31)
2	109353-07-02A	EA	BLIND SLAT - 31" - BEIGE (F32)
3	115811-01-F31	EA	VALANCE ASM. - 63" - 3 SIDED - LAMBREQUIN
3	115811-01-F32	EA	VALANCE ASM. - 63" - 3 SIDED - LAMBREQUIN
3	109802-38-F31	EA	BLIND - PLEATED - 60" X 30"
3	109802-38-F32	EA	BLIND - PLEATED - 60" X 30"
4	101668-46-E91	EA	CURTAIN ASM. - 48" X 80" - DRIVER SIDE - TAPE TOP
4	073260-42-C18	EA	TIEBACK ASM. - 6" X 18"
5	101668-45-E91	EA	CURTAIN ASM. - 48" X 80" - PASSENGER SIDE - TAPE TOP
5	073260-42-C18	EA	TIEBACK ASM. - 6" X 18"
6	115811-07-F31	EA	VALANCE ASM. - 33" - 3 SIDED - LAMBREQUIN
6	115811-07-F32	EA	VALANCE ASM. - 33" - 3 SIDED - LAMBREQUIN
6	109802-39-F31	EA	BLIND - PLEATED - 30" X 30"
6	109802-39-F32	EA	BLIND - PLEATED - 30" X 30"
7	084755-57-E07	EA	PULL SHADE - 27.25"
7	115811-11-F31	EA	VALANCE ASM. - 31"
7	115811-11-F32	EA	VALANCE ASM. - 31"

## CURTAIN & CUSHION GROUP (CONTINUED)

### BUCKET SEAT

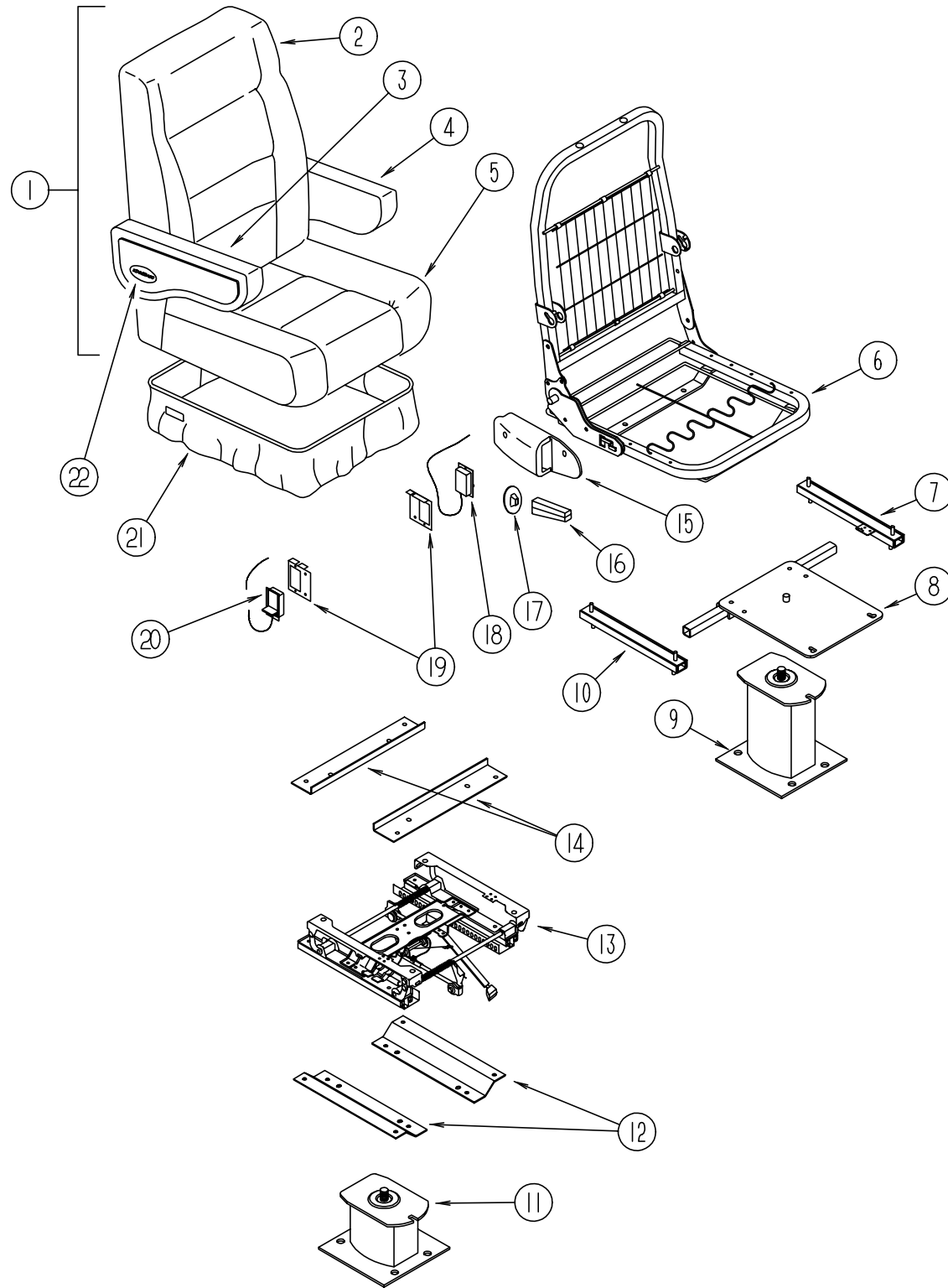

KEY	PART NUMBER	U/M	DESCRIPTION
1	111855-03-F31	EA	WINDSOR MANUAL RECLINER - W/ EXECUTIVE ARMRESTS
1	111855-03-F32	EA	WINDSOR MANUAL RECLINER - W/ EXECUTIVE ARMRESTS
2	M05962-03-F31	EA	COVER ASM. - BACK - WINDSOR
2	M05962-03-F32	EA	COVER ASM. - BACK - WINDSOR
3	111320-03-F31	EA	ARMREST ASM. - RIGHT HAND
3	111320-03-F06	EA	ARMREST ASM. - RIGHT HAND (F32)
3	P11320-03-F31	EA	COVER ASM. - ARMREST W/ PAD - RIGHT HAND
3	P11320-03-F06	EA	COVER ASM. - ARMREST W/ PAD - RIGHT HAND (F32)
4	111320-04-F31	EA	ARMREST ASM. - LEFT HAND
4	111320-04-F06	EA	ARMREST ASM. - LEFT HAND (F32)
4	P11320-04-F31	EA	COVER ASM. - ARMREST W/ PAD - LEFT HAND
4	P11320-04-F06	EA	COVER ASM. - ARMREST W/ PAD - LEFT HAND (F32)
5	M05962-04-F31	EA	COVER ASM. - SEAT - WINDSOR
5	M05962-04-F32	EA	COVER ASM. - SEAT - WINDSOR
6	M80906-11-000	EA	FRAME - SEAT - BACK & SPRING
7	069246-05-000	EA	ADJUSTER SIDE - W/ LOCK - FORWARD & BACK
			FROM: 00-00-00 THRU: 10-16-94
	069246-05-700	EA	SPRING - ADJUSTER - FOR REMOTE
			FROM: 00-00-00 THRU: 10-16-94
7	069246-14-000	EA	ADJUSTER SIDE - W/ LOCK - FORWARD & BACK
			FROM: 10-17-94 THRU: 99-99-99
	069246-99-000	EA	SPRING - ADJUSTER - FOR REMOTE - LIGHT BLUE
			FROM: 10-17-94 THRU: 99-99-99
	117125 01 02B	EA	BRACKET - CABLE HOLDER - STEEL
			FROM: 10-17-94 THRU: 99-99-99
	069246-05-701	EA	CLIP - CABLE - FOR REMOTE
8	107921-05-000	EA	TOP PLATE - PEDESTAL - W/ SEATBELT BAR
9	107921-01-000	EA	FLOOR MOUNTED PEDESTAL - W/ 9.75" EXTENSION
	107921-06-000	EA	BEARING KIT - PEDESTAL
10	069246-02-000	EA	ADJUSTER SIDE - W/O LOCK - FORWARD & BACK
			FROM: 00-00-00 THRU: 10-16-94
10	069246-15-000	EA	ADJUSTER SIDE - W/O LOCK - FORWARD & BACK
			FROM: 10-17-94 THRU: 99-99-99
11	107921-03-000	EA	FLOOR MOUNTED PEDESTAL - W/ 4.5" EXTENSION
			FROM: 00-00-00 THRU: 09-18-94
11	107921-14-000	EA	FLOOR MOUNTED PEDESTAL - W/ 5.75" EXTENSION
			FROM: 09-19-94 THRU: 99-99-99
12	116215-03-000	EA	LOWER PLATE - 6 WAY MANUAL CONTROL
13	116215-01-000	EA	6 WAY MANUAL CONTROL
14	116215-02-000	EA	UPPER PLATE - 6 WAY MANUAL CONTROL
15	080730-09-000	EA	SHIELD - RECLINER HANDLE
	080730-10-000	EA	SCREW - RECLINER HANDLE SHIELD
16	080730-08-000	EA	HANDLE - RECLINER - BLACK
17	080730-11-000	EA	SHIELD - RUBBER BOOT
18	108049-01-000	EA	REMOTE & CABLE - 28"
19	097683-03-000	EA	BRACKET - REMOTE - SIDE MOUNT - SINGLE
20	108049-01-000	EA	REMOTE & CABLE - 28"
	108049-02-000	EA	CABLE CLIP
21	071126-43-F31	EA	SKIRT ASM - SINGLE - 10.5" - W/ OPEN BACK
21	071126-43-F06	EA	SKIRT ASM - SINGLE - 10.5" - W/ OPEN BACK (F32)
21	071126-54-F31	EA	SKIRT ASM - SINGLE - 10.5" - W/ OPEN BACK (W/ 6 WAY MANUAL CONTROL)
21	071126-54-F32	EA	SKIRT ASM - SINGLE - 10.5" - W/ OPEN BACK (W/ 6 WAY MANUAL CONTROL)
22	111169-01-000	EA	BACK PLATE - ITASCA EMBLEM
22	111169-05-000	EA	EMBLEM - "ITASCA"

## CURTAIN & CUSHION GROUP (CONTINUED)

### SWIVEL CHAIR (RECLINER)

KEY	PART NUMBER	U/M	DESCRIPTION
1	116016-01-F31	EA	SWIVEL CHAIR - RECLINER
1	116016-01-F32	EA	SWIVEL CHAIR - RECLINER
1	P16016-01-F31	EA	COVER ASM. - SWIVEL CHAIR - RECLINER
1	P16016-01-F32	EA	COVER ASM. - SWIVEL CHAIR - RECLINER
2	085187-08-F31	EA	SKIRT ASM.
2	085187-08-F32	EA	SKIRT ASM.
3	097683-03-000	EA	BRACKET - REMOTE - SIDE MOUNT
4	089368-04-000	EA	REMOTE & CABLE - ADJUSTER SLIDE
	069246-05-701	EA	CLIP - CABLE - FOR REMOTE
5	069246-08-000	EA	ADJUSTER SLIDE - W/ LOCKING ARM
			FROM: 00-00-00 THRU: 10-16-94
5	069246-12-000	EA	ADJUSTER SLIDE - W/ LOCKING ARM
			FROM: 10-17-94 THRU: 99-99-99
	108049-02-000	EA	CLIP - PEDESTAL CABLE
	069246-05-700	EA	SPRING - ADJUSTER - FOR REMOTE
6	107921-08-000	EA	TOP PLATE - PEDESTAL - W/O SEATBELT BAR
7	107921-01-000	EA	FLOOR MOUNTED PEDESTAL - W/9.75" EXTENSION
8	108445-02-000	EA	SUB PLATE - FLOOR MOUNTED PEDESTAL
	107921-06-000	EA	BEARING KIT - PEDESTAL
9	069246-06-000	EA	ADJUSTER SLIDE - W/O LOCKING ARM
			FROM: 00-00-00 THRU: 10-16-94
9	069246-13-000	EA	ADJUSTER SLIDE - W/O LOCKING ARM
			FROM: 10-17-94 THRU: 99-99-99
10	007221-01-000	EA	SPACER - SEAT ADJUSTER
11	097683-02-000	EA	BRACKET - REMOTE - SIDE MOUNT
12	089368-05-000	EA	REMOTE & CABLE - RECLINE
13	108049-01-000	EA	REMOTE & CABLE - SWIVEL
	108049-02-000	EA	CLIP - PEDESTAL CABLE
	057759-01-000	EA	WASHER BRACKET - SEAT BELT - 4" DIAMETER
	007021-01-000	EA	SEAT BELT - 2" X 90" - BLACK

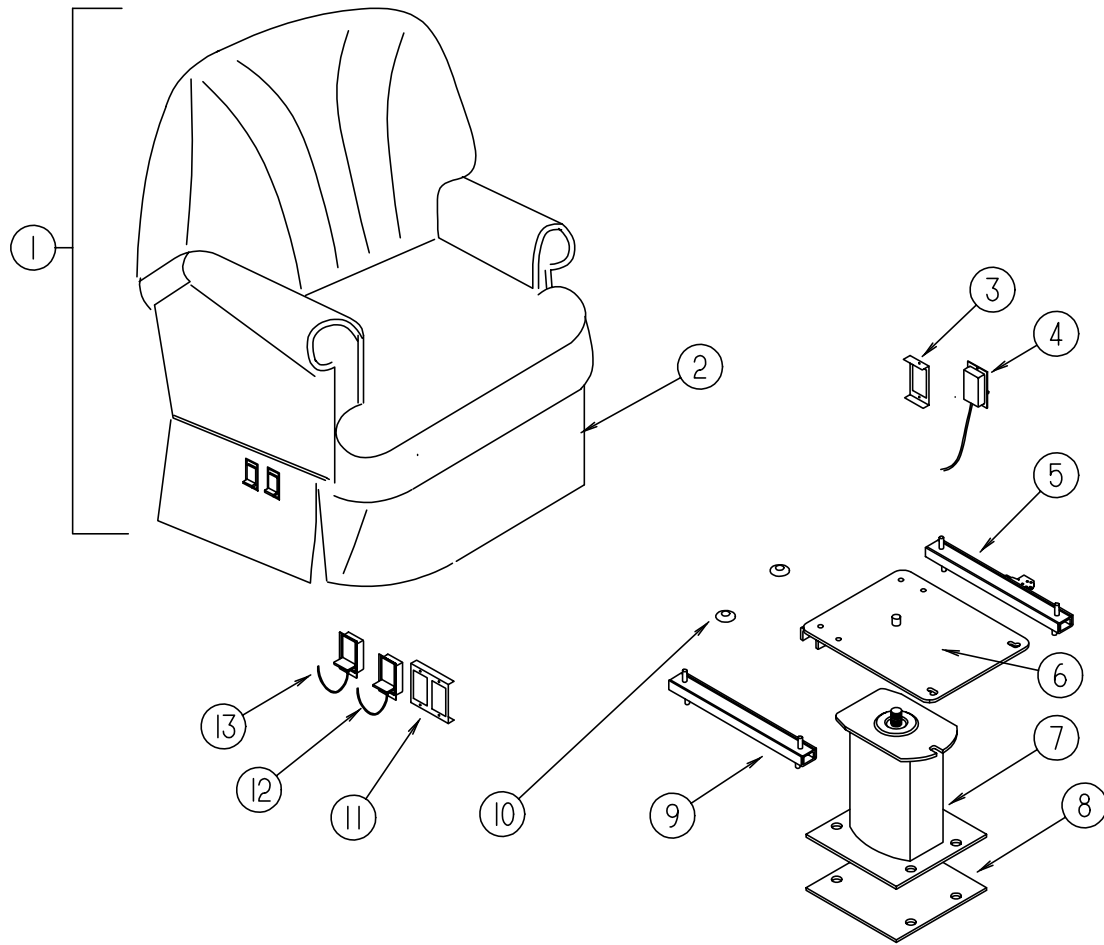



**CURTAIN & CUSHION GROUP (CONTINUED)**

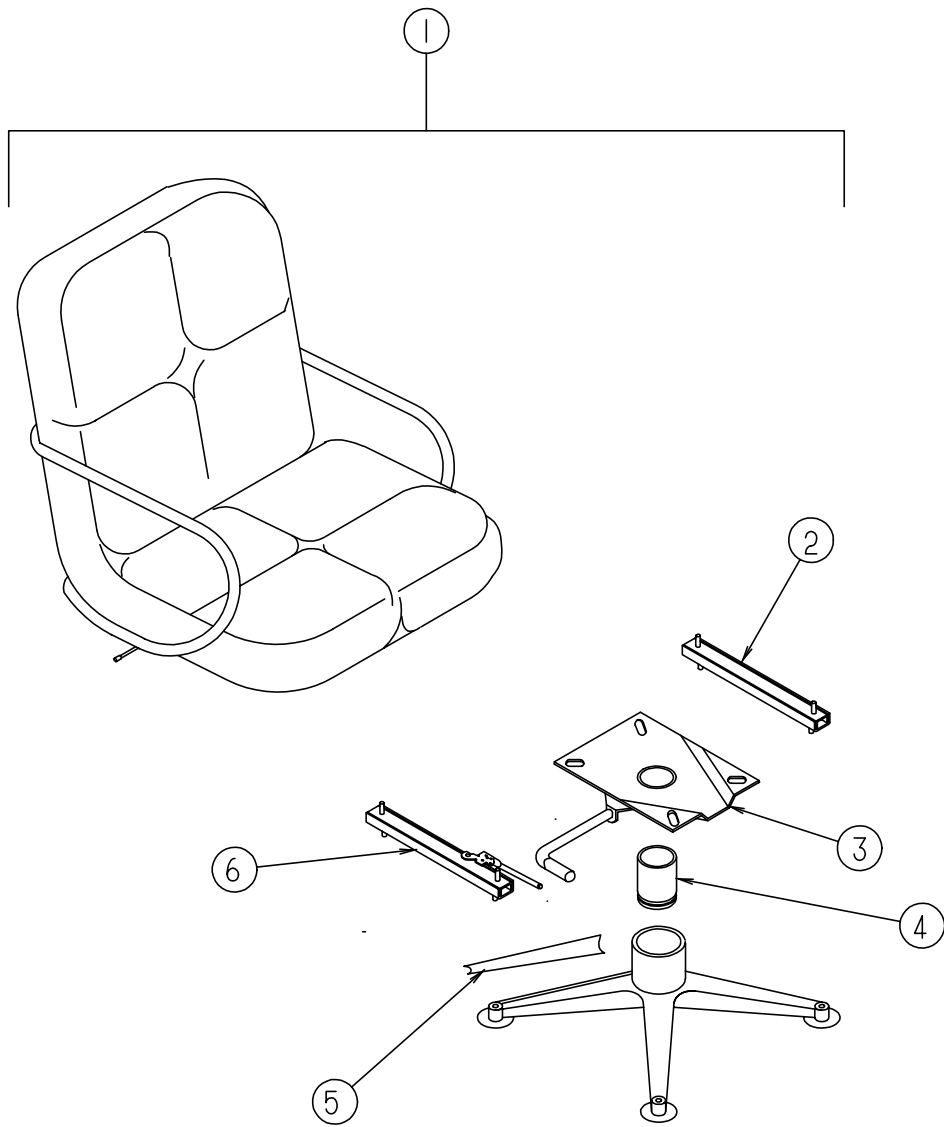

**CHROME CRAFT CHAIRS**

KEY	PART NUMBER	U/M DESCRIPTION
1	109379-02-F31	EA CHAIR ASM - CHROME CRAFT II
1	109379-02-F32	EA CHAIR ASM - CHROME CRAFT II
	105799-01-004	EA BOLT - SEAT - CHAIR #723634-1
2	069246-06-000	EA ADJUSTER SLIDE - SWIVEL CHAIR - W/O LOCK - FORWARD & BACK
3	088245-03-000	EA TOP PLATE - SWIVEL W/O TILT - W/LOCK
4	105799-01-006	EA STEM UPRIGHT - LOCKOUT
5	105799-01-003	EA LEG - WOOD COVER BASE (CHAIR)
6	069246-08-000	EA ADJUSTER SLIDE - SWIVEL CHAIR - W/LOCKING ARM - FORWARD & BACK

**CURTAIN & CUSHION GROUP (CONTINUED)**

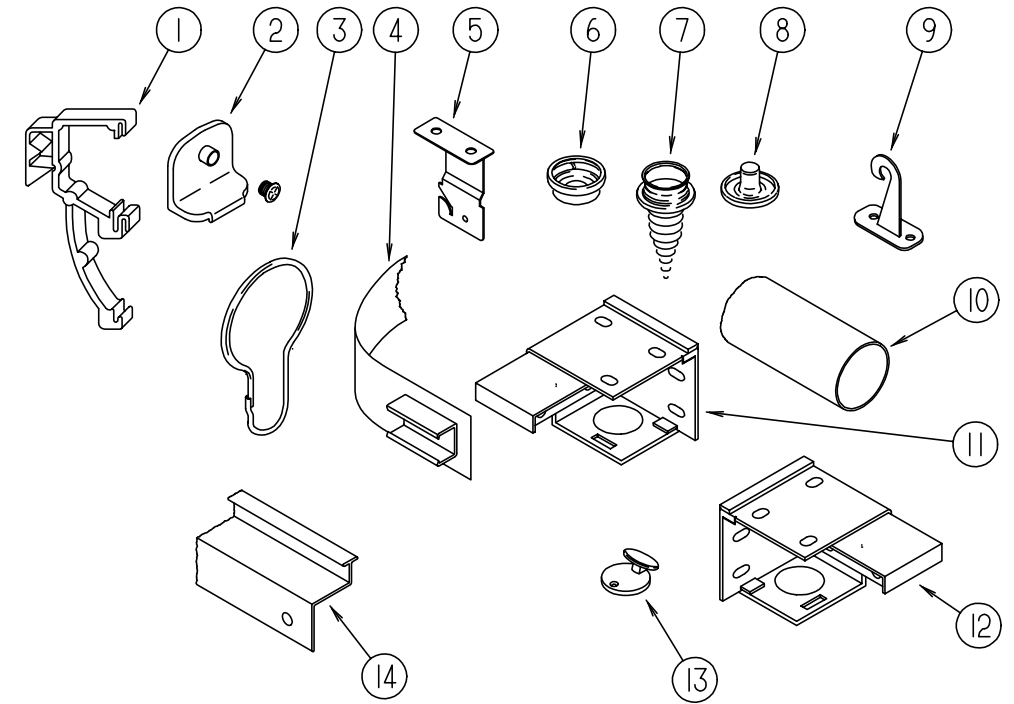

**CURTAIN & BLIND HARDWARE**

KEY	PART NUMBER	U/M DESCRIPTION
1	109353-04-000	EA CLIP - VALANCE SLAT MOUNTING - CLEAR PLASTIC - PAR
2	106544-01-000	EA SHADE PULL - BRASS
	106544-01-001	EA SCREW - SHADE PULL - BRASS
3	009136-02-000	EA HANGER - RING - PIN TYPE - CURTAIN - BRASS
4	101031-01-000	YD TAPE - GLIDE - CURTAIN - 4.25" SPACING
5	084434-01-000	EA BRACKET - MOUNTING - ROLLER SHADE - 1 3/8"
	096843-01-000	EA SPRING - REWIND - ROLLER SHADE
6	029156-01-000	EA SOCKET - SNAP - 9/16" O.D
7	029130-01-000	EA SCREW - SNAP SOCKET - 8 PH X 5/8"
8	029155-01-000	EA CAP - SNAP - 5/32" O.D. OF PIN
	046867-01-000	EA GROMMET - BRASS - 7/16" ID X 1" OD
9	109441-01-000	EA HOLD DOWN - BLIND, HOOK
10	102075-06-01A	EA SHOWER ROD
	009136-02-000	EA BRASS SHOWER RINGS
	009112-01-000	EA FLANGE - SHOWER ROD
11	083170-02-000	EA BRACKET - BLIND - LEFT SIDE
12	083170-01-000	EA BRACKET - BLIND - RIGHT SIDE
13	102555-01-000	EA CLEAT - CORD - BLIND - OFF WHITE
14	114641 01 01A	EA TRACK - WRAPAROUND CURTAIN - OFF WHITE (PASSENGER SIDE)
14	114641 02 01A	EA TRACK - WRAPAROUND CURTAIN - OFF WHITE (DRIVER SIDE)
	048394-02-000	YD VELCRO TAPE - HOOK - ADHESIVE BACK - .75" WIDE - BEIGE
	088792-02-000	YD VELCRO TAPE - LOOP - ADHESIVE BACKED - .75" WIDE - BEIGE
	068716-01-001	EA BRACKET - 90 DEGREE L-ANGLE - 192" - EXTRUDED ALUMINUM
	075943-01-000	EA BRACE - WINDOW VALANCE - 1" X 1.5" X 20" - ALUMINUM - BEIGE
	094896-02-000	EA GROMMET - CORD - PLEATED BLIND - NYLON - GRAY
	094907-02-000	EA END CAP - TOP - PLEATED BLIND - PLASTIC - GRAY
	094907-04-000	EA END CAP - BOTTOM - PULL TYPE SPECIALITY WINDOW
	097564-01-000	EA T-HANDLE - EZ LIFT SHADE
	097565-01-000	EA BRACKET - MOUNTING - PLEATED BLIND
	097591-01-000	EA SPRING - EXTENSION - PLEATED BLIND
	097592-01-000	EA SPOOL - CORD - ELEVATED BLIND HOLDUP - CLEAR PLASTIC
	097593-11-000	FT CORD - .9MM 633 CORNFLOWER
	103986-01-000	FT TRIM - VALANCE - U-CHANNEL - .75" WIDE - BRASS

## CURTAIN & CUSHION GROUP (CONTINUED)

### CONTINENTAL SOFA BED

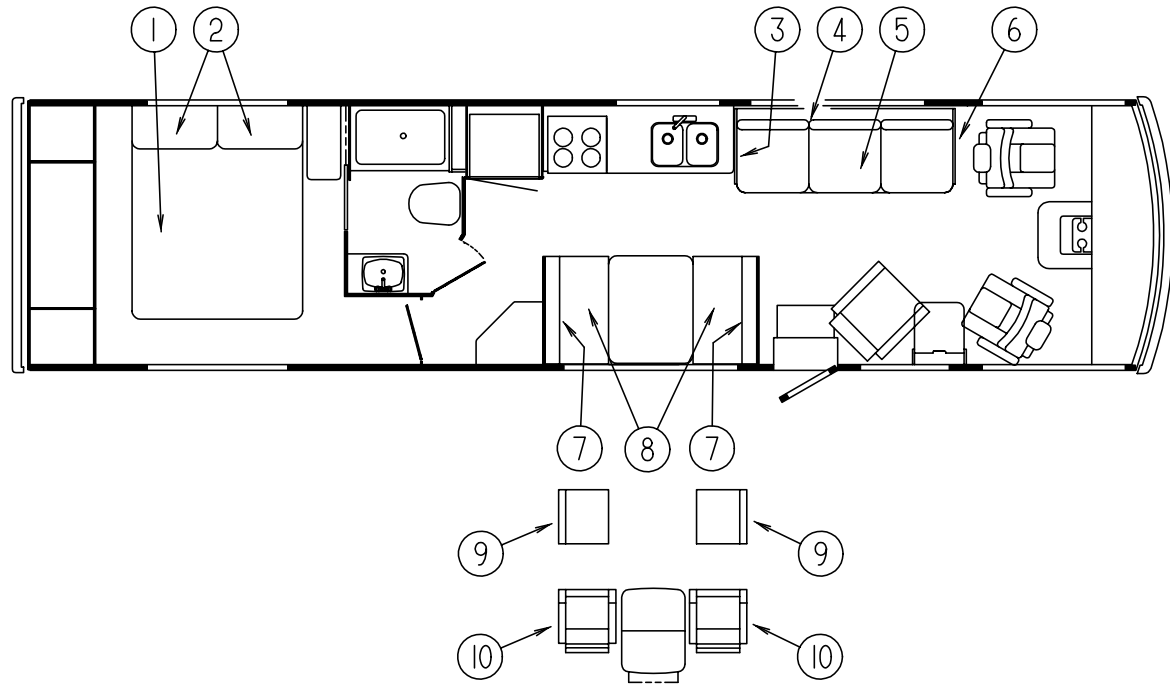

### QUEEN BED

KEY	PART NUMBER	U/M DESCRIPTION
1	098176-04-000	EA MATTRESS - QUEEN - INNERSPRING - 60" X 75" - SEALY
1	085365-21-F31	EA BEDSPREAD W/ 1" GATHERED WELT - 60" X 75"
1	085365-22-F32	EA BEDSPREAD W/ 1" GATHERED WELT - 60" X 75"
2	102161-22-F31	EA PILLOW SHAM - W/ 1/2" GATHERED WELT
2	102161-22-F32	EA PILLOW SHAM - W/ 1/2" GATHERED WELT
	111862-04-F31	EA PILLOW ASM - 15" X 15" W/ 1/2" GATHERED WELT
	111862-04-F32	EA PILLOW ASM - 15" X 15" W/ 1/2" GATHERED WELT

KEY	PART NUMBER	U/M DESCRIPTION
3	111905-03-F31	EA ARMREST ASM - RIGHT HAND
3	111905-03-F32	EA ARMREST ASM - RIGHT HAND
3	P11905-03-F31	EA COVER - ARMREST - RIGHT HAND
3	P11905-03-F32	EA COVER - ARMREST - RIGHT HAND
4	111877-01-F31	EA CUSHION - SOFA BED - BACK (2 USED)
4	111877-01-F32	EA CUSHION - SOFA BED - BACK (2 USED)
4	P11877-01-F31	EA COVER - SOFA BED - BACK
4	P11877-01-F32	EA COVER - SOFA BED - BACK
5	104652-03-F31	EA SOFA BED - 70" (W/O BACK CUSHIONS)
5	104652-03-F32	EA SOFA BED - 70" (W/O BACK CUSHIONS)
5	P04652-03-F31	EA COVER - SOFA BED - SEAT
5	P04652-03-F32	EA COVER - SOFA BED - SEAT
6	111905-02-F31	EA ARMREST ASM - LEFT HAND
6	111905-02-F32	EA ARMREST ASM - LEFT HAND
6	P11905-02-F31	EA COVER - ARMREST - LEFT HAND
6	P11905-02-F32	EA COVER - ARMREST - LEFT HAND
	105433-01-000	EA FRAME - SEAT - 70"
	111637-02-F31	EA PILLOW ASM - 22" X 22" W/ WELT
	111637-02-F32	EA PILLOW ASM - 22" X 22" W/ WELT

### DINETTE CUSHIONS

KEY	PART NUMBER	U/M DESCRIPTION
7	111880-01-F31	EA CUSHION ASM. - CHANNEL STYLE BACK - W/ STRAP - 13.5" X 38" X 5"
7	111880-01-F32	EA CUSHION ASM. - CHANNEL STYLE BACK - W/ STRAP - 13.5" X 38" X 5"
7	P11880-01-F31	EA COVER - CHANNEL STYLE BACK - W/ STRAP
7	P11880-01-F32	EA COVER - CHANNEL STYLE BACK - W/ STRAP
8	088927-87-F31	EA CUSHION ASM. - 23" X 38" X 5" - DINETTE SEAT
8	088927-87-F32	EA CUSHION ASM. - 23" X 38" X 5" - DINETTE SEAT
8	M88927-87-F31	EA COVER - CUSHION - 23" X 38" X 5" - DINETTE SEAT
8	M88927-87-F32	EA COVER - CUSHION - 23" X 38" X 5" - DINETTE SEAT

### DINETTE OPTION

KEY	PART NUMBER	U/M DESCRIPTION
9	101604-01-01A	EA CHAIR - FOLDING - DINETTE - OAK
10	109379-02-F31	EA CHAIR ASM - CHROME CRAFT II
10	109379-02-F32	EA CHAIR ASM - CHROME CRAFT II

# DINETTE GROUP

## DINETTE & OVERHEAD CABINERY

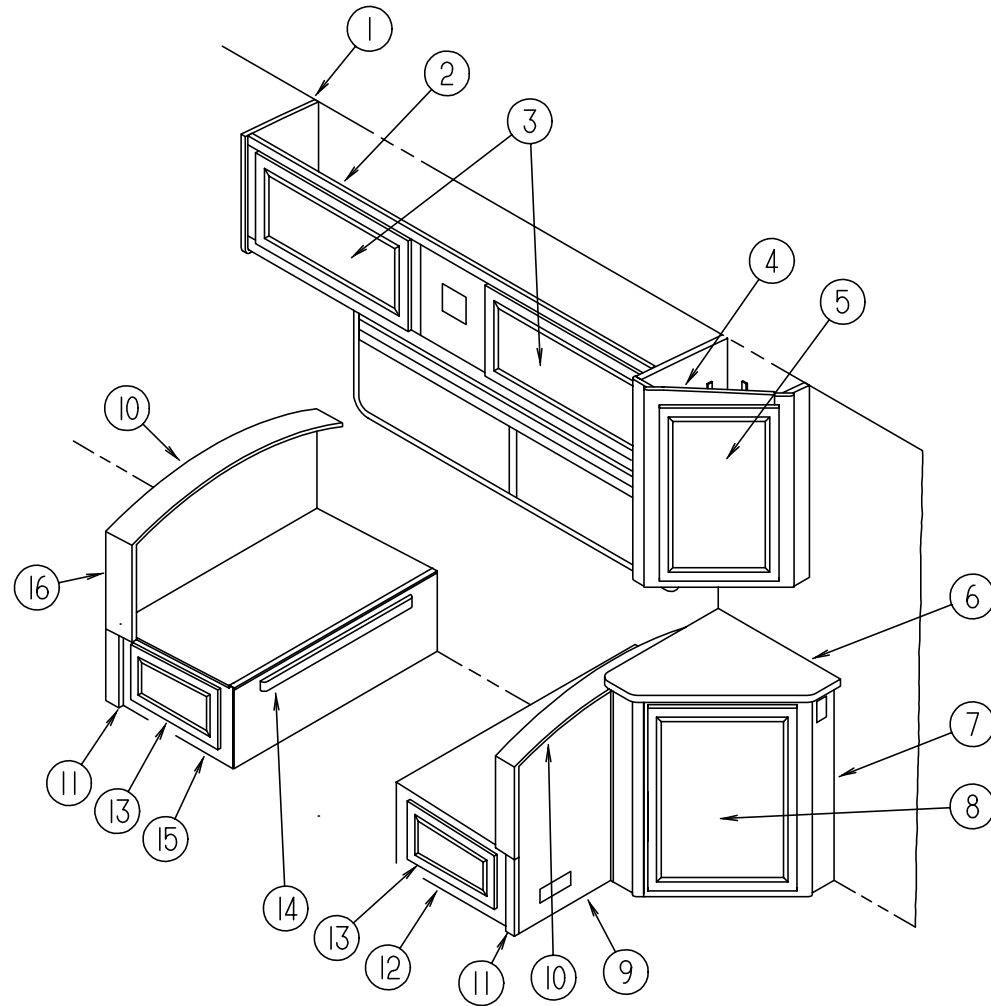

KEY	PART NUMBER	U/M	DESCRIPTION
1	103128-02-E10	EA	CAP ASM - END - DINETTE OVERHEAD
2	M06839-09-F31	EA	CABINET ASM. - DINETTE OVERHEAD - W/O DOORS OR HARDWARE
2	M06839-09-F32	EA	CABINET ASM. - DINETTE OVERHEAD - W/O DOORS OR HARDWARE
3	M05993-16-E30	EA	DOOR ASM - DINETTE OVERHEAD - W/O HARDWARE
4	P04636-01-E10	EA	CABINET ASM - HUTCH - UPPER
5	M05993-70-E30	EA	DOOR ASM - UPPER HUTCH - W/O HARDWARE
6	104635-11-F31	EA	COUNTERTOP ASM - HUTCH
6	104635-11-F32	EA	COUNTERTOP ASM - HUTCH
7	104635-01-F31	EA	CABINET ASM - HUTCH - LOWER
7	104635-01-F32	EA	CABINET ASM - HUTCH - LOWER
	104635-12-E10	EA	SHELF ASM - HUTCH - LOWER
8	M05993-71-E30	EA	DOOR ASM - LOWER HUTCH - W/O HARDWARE
9	M04174-63-E10	EA	CABINET-SEATBACK RIGHT
10	104787-03-F31	EA	PAD ASM. - DINETTE
10	104787-03-E31	EA	PAD ASM. - DINETTE (F32)
11	111338-10-F31	EA	PAD ASM. - DINETTE
11	111338-10-E31	EA	PAD ASM. - DINETTE (F32)
12	M04175-63-E10	EA	CABINET - SEATBASE RIGHT
13	M05970-35-E30	EA	DRAWER ASM. - W/O HARDWARE
14	081295-01-AA8	EA	SUPPORT - BED - DINETTE - 712 LONG
15	M04175-62-E10	EA	CABINET - SEATBASE LEFT
16	M04174-62-E10	EA	CABINET - SEATBACK LEFT
	113405-12-F11	EA	SEATBOARD (F31)
	113405-12-F32	EA	SEATBOARD

### DINETTE GROUP (CONTINUED)

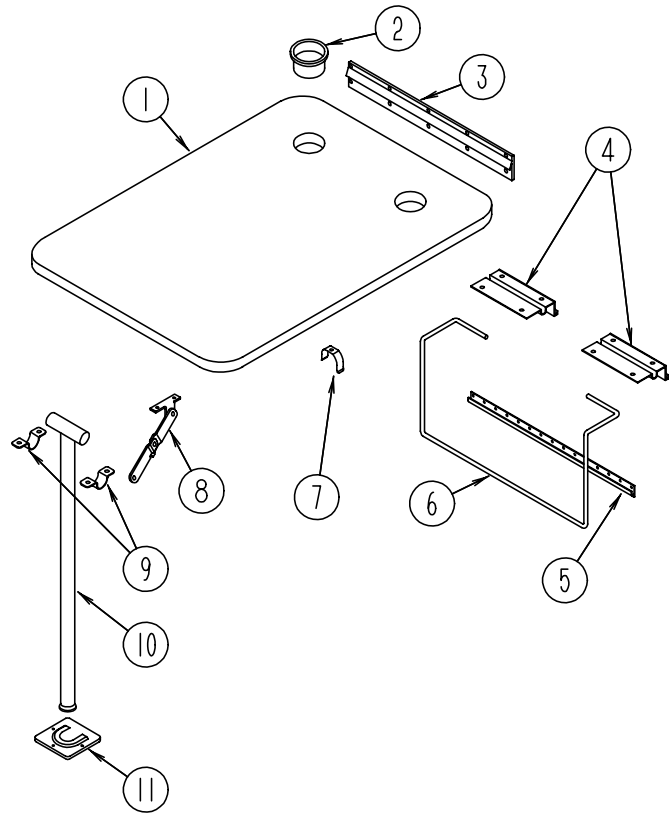

### DINETTE TABLE

KEY	PART NUMBER	U/M DESCRIPTION
1	M02115-09-E04	EA DINETTE TABLE (F31)
1	M02115-09-F32	EA DINETTE TABLE
2	064781-06-000	EA CUP HOLDER - 2 STEP
3	053200-12-000	EA BRACKET - TABLE SUPPORT - UPPER WALL MOUNTED - 23.5" - OFF WHITE
4	088410-02-000	EA BRACKET - TABLE MOUNTED - OFF WHITE
5	024281-14-000	EA BRACKET - LIFT ROD - LOWER WALL MOUNTED - 22.12" - OFF WHITE
6	024275-12-000	EA ROD - TABLE LIFT - 8" X 23.5" - OFF WHITE
7	024283-01-000	EA CLIP - LEG - 1" - 1.125" OD - BLACK
8	024282-01-000	EA BRACE - TABLE LEG - HINGED
9	064050-05-000	EA CLAMP - SADDLE - LEG HINGE - OFF WHITE
10	024276-23-000	EA TABLE LEG - METAL - OFF WHITE
11	049493-12-000	EA LEG CATCH - FLOOR MOUNTED - 2.5" X 2.7" - METAL - E-COAT

### DINETTE GROUP (CONTINUED)

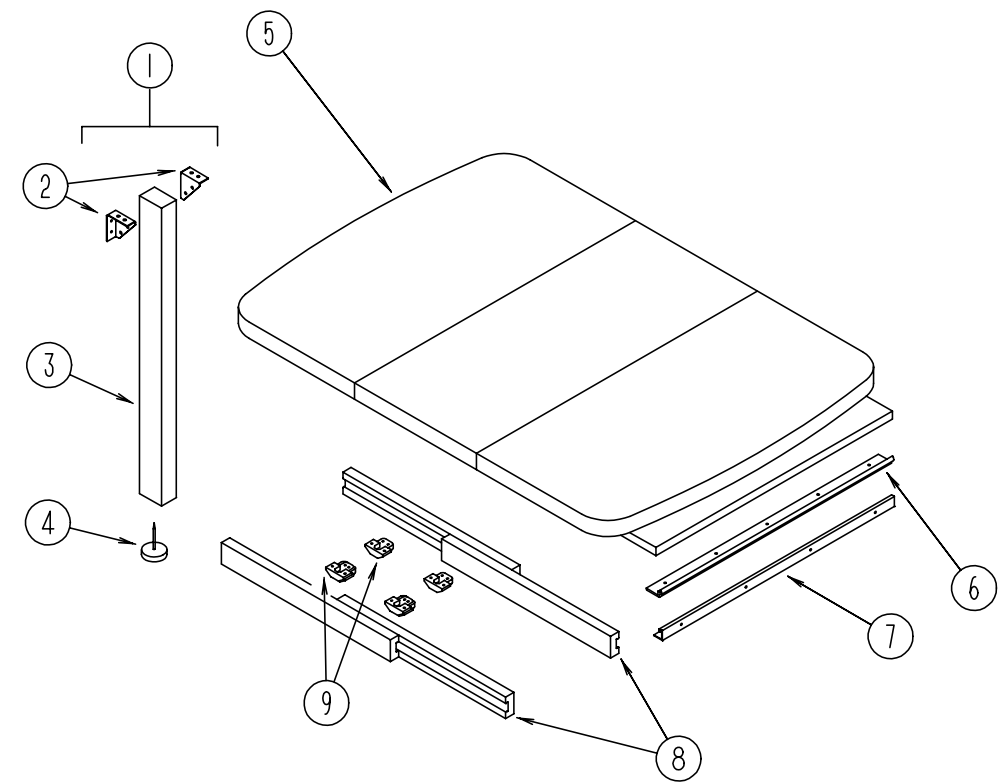

### DINETTE TABLE (SLIDE)

KEY	PART NUMBER	U/M DESCRIPTION
1	092708-10-E30	EA LEG ASM - TABLE
2	102810-01-02A	EA BRACE - TABLE LEG - OFF WHITE
3	092707-08-05A	EA LEG MOLDING - OAK - RAMBLING ASH
4	102194-01-000	EA GUIDE - PLASTIC
5	P02056-06-E30	EA TABLE ASM. - W/ DROP LEAF
6	102201-02-02A	EA SUPPORT - HINGE CATCH - OFF WHITE
7	102200-02-02A	EA SUPPORT - HINGE LOCK - OFF WHITE
8	110749-01-000	EA SLIDE - TABLE - 19 3/4 LONG
9	009050-02-000	EA LEVELER - TABLE TOP - FEMALE & MALE ENDS W/4 SCREWS - PLASTIC

# DRIVERS COMPARTMENT GROUP

## UPPER & LOWER DRIVER COMPARTMENT

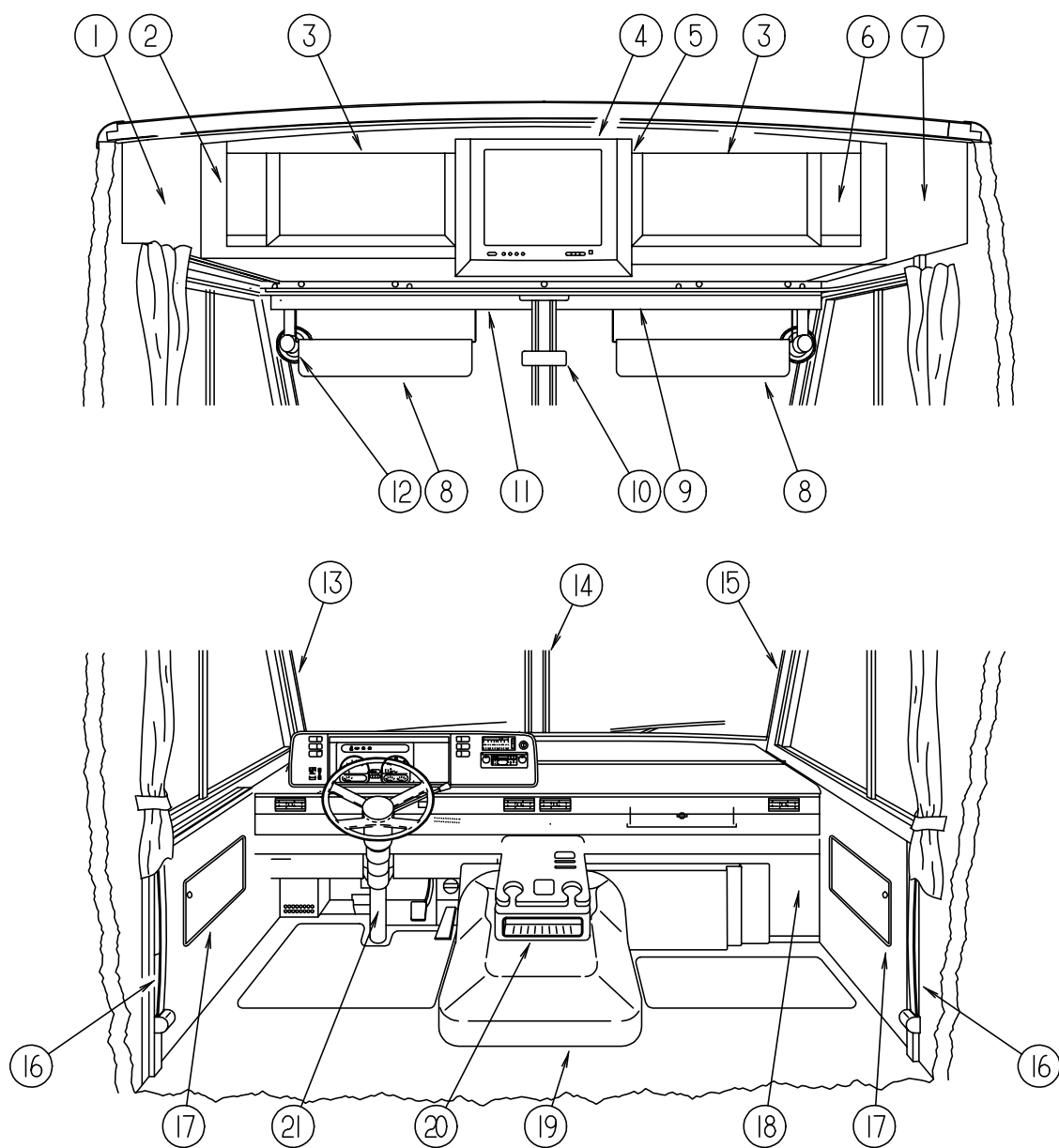

KEY	PART NUMBER	U/M DESCRIPTION	
1	104289-04-D12	EA PANEL - SIDE - DRIVER OVERHEAD VINYL	
	106699-01-01A	EA BRACKET - CABINET - OVERHEAD TV - OFF WHITE	
2	114612-02-E10	EA CABINET ASM - FACE - DRIVER OVERHEAD - 19 TV	
	P03077-03-E10	EA SHELF - BASE - CABINET - DRIVER OVERHEAD	
	114661-06-E10	EA PANEL ASM - LINER DRIVER OVERHEAD 19" TV	
	078811-08-E10	EA PANEL - TRIM - HEADER - LOWER - 19" TV - BETWEEN OVERHEAD AND W/S TRIM	
3	108353-02-000	FT SEAL - FOAM - 1/4 X 5/8.ADH BACK - 19" TV	
	100708-12-000	EA DOOR - GLASS - 19" TV CABINET	
	100710-01-01A	EA LOCK ASM - TWIST TYPE BRASS	
	100711-01-01A	EA HINGE - DOOR - GLASS	
	100707- 01-000	EA SPACER - DOOR - GLASS - .8" DIA - .3" HOLE - PLASTIC	
	101272-01-000	EA CATCH-GLASS DOOR - OVHD TV	
	101766-01-000	EA PIN - SUPPORT - GLASS DOOR	
	100676-02-000	EA STAND - VCR	
	4	M05993-C5-E30	EA DOOR ASM. - FOR 19" TV OVERHEAD
	5	116791-01-F31	EA CABINET ASM - FRAME - 19" TV
114615-02-F31		EA COVER ASM - 19" TV - WITH VINYL	
6	114612-01-E10	EA CABINET ASM - FACE - PASSENGER OVERHEAD - 19" TV	
	P03077-04-E10	EA SHELF - BASE - CABINET - PASSENGER OVERHEAD	
	114661-01-E10	EA PANEL ASM - LINER PASSENGER OVERHEAD W/O 19" TV	
	114661-03-E10	EA PANEL ASM - LINER PASSENGER OVERHEAD W/ 19" TV	
7	104289-03-D12	EA PANEL - SIDE - PASSENGER OVERHEAD VINYL	
8	082286-19-D12	EA SUNVISOR ASM	
	007211-01-000	EA HINGE - SUNVISOR - 25.5" X 1.5" - METAL	
	074012-01-000	EA CLIP - SUNVISOR - SQUARE - PINCH ON	
	102377-01-000	EA BRACKET SUNVISOR - 1 PIECE - STEEL	
	046886-03-000	EA ASHTRAY - CHROME - W/ COVER	
	024700-44-000	EA COVER - ROLL BAR - OFF WHITE 53"	
	024700-46-000	EA COVER - ROLL BAR - OFF WHITE 21.2"	
	024700-47-000	EA COVER - SIDEWALL ROLL BAR - OFF WHITE - 18.9"	
	024700-48-000	EA COVER - SIDEWALL ROLL BAR - OFF WHITE - 25"	
	103961-01-01A	EA COVER - BRACKET - SEATBELT - OFF WHITE	
	103961-02-01A	EA COVER - BRACKET - SEATBELT - OFF WHITE (W/DRIVER DOOR)	
	R77030-53-447	EA FLAT WASHER	
	9	078579-09-000	EA TRIM - WINDSHIELD - UPPER INNER - RH - LIGHT GRAY
10	040714-01-000	EA MIRROR - REAR VIEW - W/ARM MOUNT & SET SCREW	
	067490-01-000	EA BUTTON - MIRROR - REAR VIEW	
11	078579-10-000	EA TRIM - WINDSHIELD - UPPER INNER - LH - LIGHT GRAY	
12	036420-02-000	EA FAN - DEFROSTER - 2 SPEED - 6" DIAMETER	
13	103931-04-02A	EA INTERIOR COVER - A-PILLAR - DRIVER SIDE - LIGHT GRAY	
14	079765-10-000	EA TRIM - WINDSHIELD - CENTER - LIGHT GRAY	
15	103931-03-02A	EA INTERIOR COVER - A-PILLAR - PASSENGER SIDE - LIGHT GRAY	
16	091990-04-01A	EA SEAT BELT & SHOULDER HARNESS - DRIVER/ PASSENGER SIDE	
	109146-01-000	EA BOLT - SHOULDER - SEAT BELT	
17	086120-01-F31	EA PAD - MAP POCKET - 12" X 16"	
	086120-01-F32	EA PAD - MAP POCKET - 12" X 16"	
18	095757-03-F31	EA COVER ASM - HEATER	
	095757-03-F04	EA COVER ASM - HEATER (F32)	
19	097552-01-000	EA MOTOR COVER - W/O CARPET	
	113828-02-01A	EA TRIM - MOTOR COVER - MILL	
	075564-01-000	EA BRACKET - MOUNTING - MOTOR COVER	
	039623-01-000	FT SEAL - MOTOR COVER - RUBBER BULB TYPE - BLACK	
20	111618-01-E10	EA BEVERAGE TRAY ASM.	
	111618-13-E07	EA LID ASM.	
21	103498-06-000	EA BOOT - COLUMN - UNIVERSAL	
	111521-01-04A	EA COVER - STEERING COLUMN - BLACK (FORD)	
	112634-01-01A	EA TRIM - STEERING COLUMN - RH BLACK (FORD)	
	112634-02-01A	EA TRIM - STEERING COLUMN - LH BACKL (FORD)	

## DRIVERS COMPARTMENT GROUP (CONTINUED)

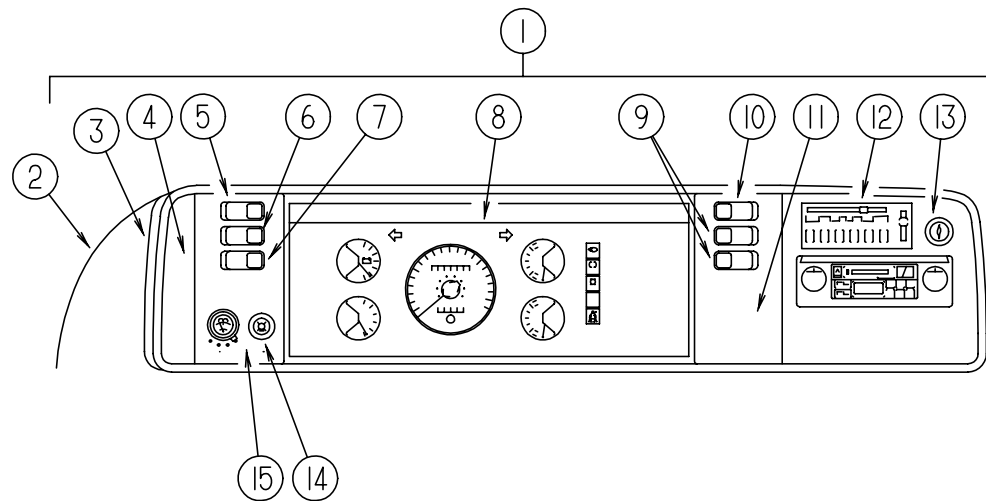

DASH, GAUGES & SWITCHES (FORD)

KEY	PART NUMBER	U/M	DESCRIPTION
1	M05946-16-F31	EA	DASH POD ASM.
2	111499-01-02A	EA	POD - INSTRUMENT PANEL - GRAY
3	103662-04-01A	EA	BEZEL - INSTRUMENT PANEL
4	104056-01-03A	EA	APPLIQUE - BEZEL - LEFT - DRESS UP
5	108357-05-000	EA	SWITCH - ROCKER - SPDT ON/ NONE/ ON
5	108356-02-01A	EA	SWITCH COVER - W/ DIMPLES - CARLING VVAZC00 BLA
6	108357-09-000	EA	SWITCH - ROCKER - SPDT ON/ NONE/ MOM
6	108356-02-01A	EA	SWITCH COVER - W/ DIMPLES - CARLING VVAZC00 BLA
7	108357-06-000	EA	SWITCH - ROCKER - DPDT MOM/ OFF/ MOM
7	108356-02-01A	EA	SWITCH COVER - W/ DIMPLES - CARLING VVAZC00 BLA
8	094794-03-000	EA	CLUSTER - INSTRUMENT PANEL- MILES (US)
8	094794-04-000	EA	CLUSTER - INSTRUMENT PANEL- KILOMETER (CSA)
9	108357-03-000	EA	SWITCH - ROCKER - SPDT ON/ OFF/ ON
9	108356-02-01A	EA	SWITCH COVER - W/ DIMPLES - CARLING VVAZC00 BLA
10	108357-10-000	EA	SWITCH - ROCKER - SPDT MOM/ OFF/ MOM
10	108356-04-01A	EA	SWITCH COVER - W/ DIMPLES & LENS - CARLING VVAGC00
	096241-03-000	EA	SWITCH - BLANK
11	104056-21-01A	EA	APPLIQUE - BEZEL - SWITCH RIGHT
12	104056-06-03A	EA	APPLIQUE - BEZEL - RIGHT DRESS UP
13	089294-01-000	EA	LIGHTER ASM. - CIGARETTE
14	096675-01-000	EA	KNOB - HEADLAMP SWITCH - W/SHAFT
	096674-01-000	EA	NUT - HEADLAMP SWITCH - BLACK
15	104056-24-01A	EA	APPLIQUE - BEZEL - SWITCH LEFT
	P03817-10-000	EA	DASH ASM - LOWER - W/O VINYL
	106569-02-02A	EA	PADDED VINYL - LAMINATE MADRID - GRAY - 1/4" X 16" X 96" - 2LB
	100138-01-000	EA	MODULE - DAYTIME RUNNING LIGHT (CSA)
	077031-01-000	EA	FILM - BLACK - 1" X 1.75"
	077031-03-000	EA	FILM - WHITE .75" X 1"
	104354-01-02A	EA	APPLIQUE - LOWER DASH - FORD
	105927-02-000	EA	PANEL ASM - DASH - TOP - W/STUD
	111904-01-000	EA	INDICATOR ASM - TRANSMISSION
	112235-01-02A	EA	BEZEL - MONITOR - LEVELING JACK - GRAY
	117306-01-F31	EA	TRIM - DASH - LOWER - RIGHT HAND - GRAY

## DRIVERS COMPARTMENT GROUP (CONTINUED)

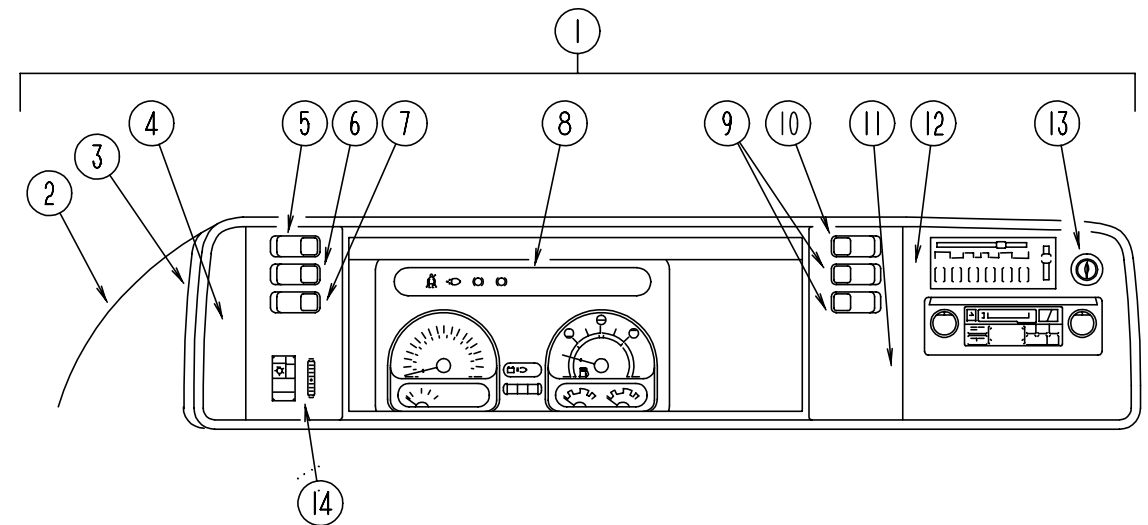

DASH, GAUGES & SWITCHES (CHEVY)

KEY	PART NUMBER	U/M	DESCRIPTION
1	M05946-15-F31	EA	DASH POD ASM.
2	111499-01-02A	EA	POD - INSTRUMENT PANEL - GRAY
3	103662-01-01A	EA	BEZEL - INSTRUMENT PANEL
4	104056-01-03A	EA	APPLIQUE - BEZEL - LEFT - DRESS UP
5	108357-05-000	EA	SWITCH - ROCKER - SPDT ON/ NONE/ ON
5	108356-02-01A	EA	SWITCH COVER - W/ DIMPLES - CARLING VVAZC00 BLA
6	108357-09-000	EA	SWITCH - ROCKER - SPDT ON/ NONE/ MOM
6	108356-02-01A	EA	SWITCH COVER - W/ DIMPLES - CARLING VVAZC00 BLA
7	108357-06-000	EA	SWITCH - ROCKER - DPDT MOM/ OFF/ MOM
7	108356-02-01A	EA	SWITCH COVER - W/ DIMPLES - CARLING VVAZC00 BLA
8	094796-07-000	EA	CLUSTER - INSTRUMENT PANEL - KILOMETER (CSA)
9	108357-03-000	EA	SWITCH - ROCKER - SPDT ON/ OFF/ ON
9	108356-02-01A	EA	SWITCH COVER - W/ DIMPLES - CARLING VVAZC00 BLA
10	108357-10-000	EA	SWITCH - ROCKER - SPDT MOM/ OFF/ MOM
10	108356-04-01A	EA	SWITCH COVER - W/ DIMPLES & LENS - CARLING VVAGC00
	096241-03-000	EA	SWITCH - BLANK
11	104056-21-01A	EA	APPLIQUE - BEZEL - SWITCH RIGHT
12	104056-06-03A	EA	APPLIQUE - BEZEL - RIGHT DRESS UP
13	089294-01-000	EA	LIGHTER ASM. - CIGARETTE
14	104056-22-01A	EA	APPLIQUE - BEZEL - SWITCH LEFT
	P03817-11-000	EA	DASH ASM - LOWER - W/O VINYL
	106569-02-02A	EA	PADDED VINYL - LAMINATE MADRID - GRAY - 1/4" X 16" X 96" - 2LB
	077031-01-000	EA	FILM - BLACK - 1" X 1.75"
	077031-03-000	EA	FILM - WHITE .75" X 1"
	105615-01-000	FT	FILM - PROTECTIVE - CLEAR
	103812-06-02A	EA	TRIM - DASH - LOWER - GRAY
	104354-01-02A	EA	APPLIQUE - LOWER DASH
	100138-01-000	EA	MODULE - DAYTIME RUNNING LIGHT (CSA)
	105927-02-000	EA	PANEL ASM - DASH - TOP - W/STUD
	077539-01-000	EA	BRACKET - MOUNTING - DASH PANEL - L/ SHAPED
	112235-01-02A	EA	BEZEL - MONITOR - LEVELING JACK - GRAY

## ELECTRICAL GROUP

### EXTERIOR LIGHTS

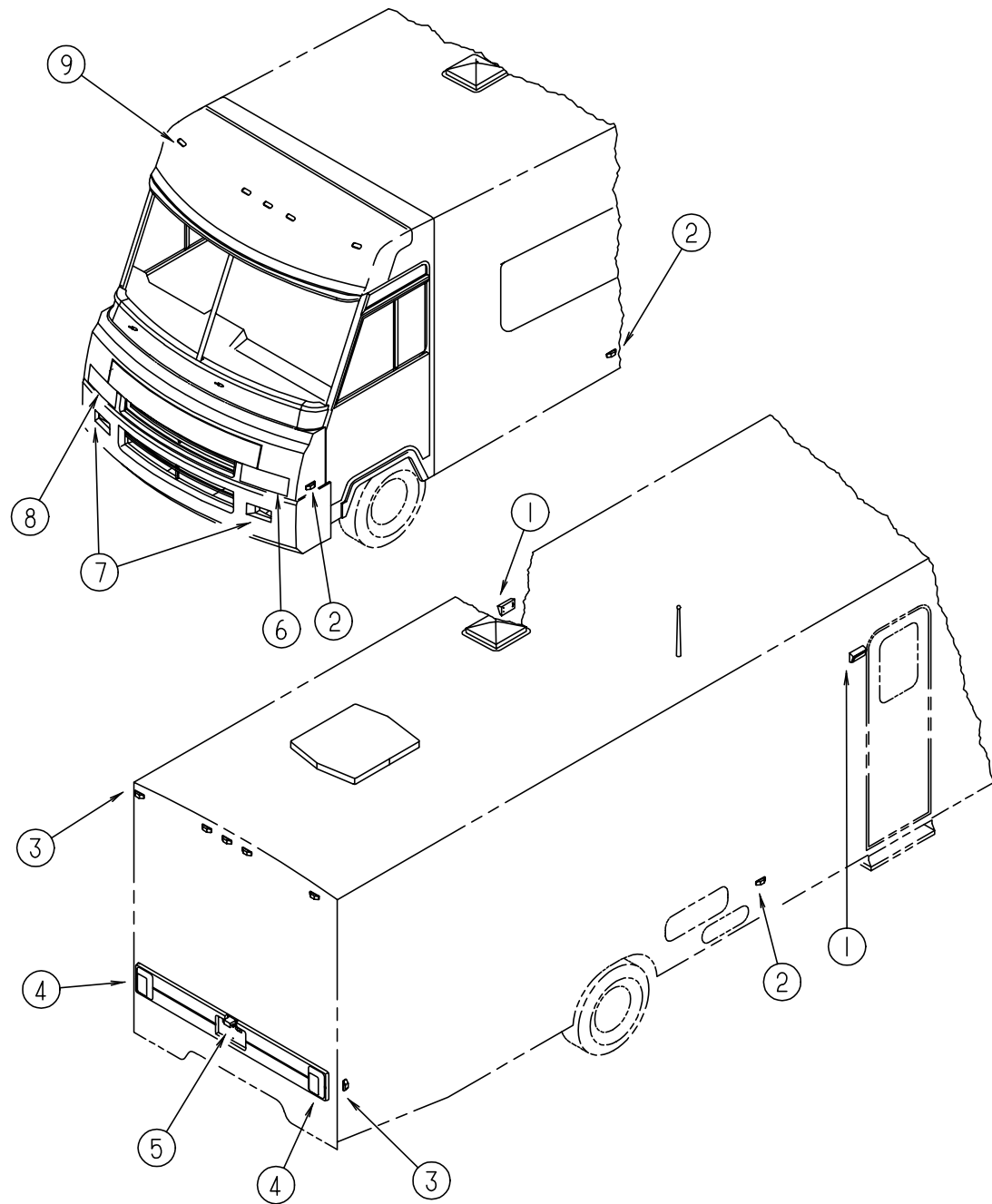

KEY	PART NUMBER	U/M DESCRIPTION
1	097917-01-01A	EA LIGHT - PORCH - ENTRY DOOR - OFF WHITE
1	008215-01-000	EA BULB
1	097917-01-700	EA LENS - LIGHT - PORCH
2	111102-01-000	EA LAMP - MARKER - BASE - TRIPLEX - 117XAS
2	036196-01-000	EA BULB
2	111102-02-000	EA LENS - MARKER LAMP - AMBER - TRIPLEX - 118A
2	112823-01-000	EA SPLICE - REDUCER
3	111102-01-000	EA LAMP - MARKER - BASE - TRIPLEX - 117XAS
3	036196-01-000	EA BULB
3	111102-03-000	EA LENS - MARKER LAMP - RED - TRIPLEX - 117R
3	112823-01-000	EA SPLICE - REDUCER
4	081638-01-000	EA TAIL LIGHT - DOUBLE - W/ BLACK TRIM - DRIVER & PASSENGER SIDE
4	081638-01-700	EA LENS - TAIL LIGHT - RED
4	081638-01-701	EA LENS - TAIL LIGHT - W/BACKUP
4	037934-01-000	EA BULB #1156 (BACK UP & TURN SIGNAL)
4	037935-01-000	EA BULB #2057 OR #1157 (BRAKE LIGHT)
5	066432-02-000	EA LIGHT ASM. - LICENSE PLATE
5	066432-03-000	EA BRACKET - LICENSE PLATE
6	049186-01-000	EA HEADLAMP CAPSULE - DRIVER SIDE - HIGH/ LOW BEAM
6	049188-01-000	EA HEADLAMP CAPSULE - DRIVER SIDE - HIGH BEAM
7	084901-01-000	EA LAMP - PARK/ TURN - GM # 916558 (BULB #2057)
8	049185-01-000	EA HEADLAMP CAPSULE - PASSENGER SIDE - HIGH/ LOW BEAM
8	049187-01-000	EA HEADLAMP CAPSULE - PASSENGER SIDE - HIGH BEAM
	050030-02-000	EA HOUSING - HEADLAMP WIRING - HIGH BEAM
	063749-01-000	EA HOUSING - HEADLAMP WIRING - LOW BEAM
	049359-01-000	EA SPRING - RETAINER - HEADLAMP
	110750-01-000	EA SCREW - ADJUSTING - HEADLAMP
	103624-01-000	EA PLATE - BLINDER - HEADLIGHT
9	102520-01-000	EA CLEARANCE LIGHT ASM. - W/O SOCKET CONNECTIONS - AMBER
9	036196-01-000	EA BULB
9	102540-01-000	EA SEAL - SCREW - ROUND - RUBBER
9	102541-01-000	EA GASKET - CLEARANCE LIGHT
9	067789-02-000	EA SOCKET - LAMP - PACKARD 8919426
9	088474-09-000	EA HOUSING - SOCKET - 3 CAVITY - AMP 1-480701-0
9	088476-01-000	EA SOCKET - CONNECTOR - BRASS - PRE-TIN

### INTERIOR LIGHTS

KEY	PART NUMBER	U/M DESCRIPTION
	098024-01-01A	EA DOME LIGHT - 1 BULB - US - IVORY
	098024-03-01A	EA DOME LIGHT - 2 BULB - IVORY
	008218-01-000	EA BULB - DOME LIGHT
	098024-01-700	EA LENS - DOME LIGHT
	061424-01-000	EA LIGHT - AISLE - 12V - RECTANGULAR
	008103-01-000	EA BULB - AISLE
	065202-30-000	EA LAMP - WALL - BRASS - US
	067479-01-000	EA BULB - 12 VOLT - #1076
	065202-31-000	EA LAMP - WALL - BRASS - CSA
	065201-09-000	EA SHADE - LAMP - FABRIC - PARCHMENT
	110235-01-01A	EA LIGHT - MAKE UP - 3 BULB - PANLESS
	081633-01-700	EA BULB - MAKE-UP
	086280-01-000	EA LIGHT - SURFACE MOUNT - 12V - JENSEN 1236
	086280-01-700	EA BULB - SURFACE MOUNT - 12 VOLT - 6 WATT
	087694-01-000	EA LIGHT - WARDROBE/CLOSET - W/SWITCH
	087694-01-700	EA BULB - GE561 - WARDROBE/ CLOSET
	093575-06-01A	EA LIGHT - CEILING W/ FLUTED GLASS
	093575-07-01A	EA LIGHT - CEILING W/ FLUTED GLASS

## ELECTRICAL GROUP (CONTINUED)

### ELECTRIC COMPONENTS

KEY	PART NUMBER	U/M DESCRIPTION
	008326-01-000	EA TERMINAL - RING - 16/14 WIRE - 3/8" STUD
	008328-01-000	EA TERMINAL - RING - 12/10 WIRE - #10 STUD FIT
	008331-01-000	EA TERMINAL - RING - TONGUE - #4 WIRE - 3/8" STUD - COPPER
	008348-01-000	EA TERMINAL - RING - 3/8" STUD - #2 WIRE
	035416-04-000	EA TERMINAL - RING #10 STUD FITTING - INSULATED BARREL #16/14
	047443-01-000	EA TERMINAL - .250 RECEPTACLE FITTING - INSULATED - 16/14 AWG
	062036-02-000	EA TERMINAL - PACK - CONNECTOR - 16/14 AWG
	104100-03-000	EA TERMINAL - 75 AMP AMP 53880-4 LOOSE
	106655-02-000	EA TERMINAL - FUSE BLOCK - 10-12AWG
	113306-01-000	EA TERMINAL - FEMALE - METRI-PACK
	113307-01-000	EA TERMINAL - FEMALE - METRI-PACK
	103603-01-000	EA BULB - 12V NO.74 0.12A WEDGE
	008218-01-000	EA BULB - DOME LIGHT - 12V - NUMBER 1141
	067479-01-000	EA BULB - 12V - NUMBER 1076
	103608-01-000	EA SOCKET - WEDGE BASE W/ LEADS
	077479-01-000	EA BOOT - BATTERY TERMINAL - DOUBLE CABLE
	077479-02-000	EA BOOT - BATTERY TERMINAL - SINGLE CABLE
	086233-01-000	EA STUD - ISOLATED - 3/8" X 7/8" LONG
	086273-01-000	EA RELAY - BATTERY DISCONNECT
	087949-01-000	EA BUSS BAR - 2 POSITION - .6" X 1.5" - ALUMINUM
	087949-02-000	EA BUSS BAR - 3 POSITION - 90 WIV
	007093-01-000	EA FLASHER - SIGNAL - STAT
	008188-01-000	EA SOLENOID - 3 POST - BATTERY CHANGE OVER
	075723-02-000	EA SPACER - SWITCH - W/HOLE - .2" X .9" X 2" - METAL - OFF WHITE FOR ELECTRIC STEP DOOR JAMB SWITCH
	095188-01-01A	EA SPACER - SWITCH - 2.3" X 3.4" - PLASTIC - DARK BROWN
	102568-01-E90	EA SPACER - RECEPTACLE - SIDEWALL
	103987-02-000	EA SEAL - SOLENOID ACCESS
	063910-01-000	EA HOUSING - RELAY - BOSCH 3 334 485 008
	063912-02-000	EA RELAY - CANISTER - SPDT - BOSCH 0332204101
	115504-01-000	EA PANEL - SOLAR 10 WATT
	115505-01-000	EA MONITOR - SOLAR CHARGER
	087225-01-000	FT SLEEVING - 1/2" - TYPE H
	087225-02-000	FT SLEEVING - 5/8" - TYPE H

### CONVERTER & LOAD CENTER

KEY	PART NUMBER	U/M DESCRIPTION
	109677-01-000	EA LOAD CENTER - 120V - 40A WESCO TT120 FLGNM
	113132-01-000	EA LOAD CENTER - 120/ 240V - 60A WESCO 2460SGNM
	083208-02-000	EA CONVERTER - POWER - 45A - 120V/12V - BW 6345
	099048-01-000	EA INVERTER - 100 WATT

## ELECTRICAL GROUP (CONTINUED)

### ELECTRICAL HOUSINGS

KEY	PART NUMBER	U/M DESCRIPTION
	088473-01-000	EA PIN HOUSING - 12 POSITION
	088473-02-000	EA PIN HOUSING - 15 POSITION
	088473-03-000	EA PIN HOUSING - 9 POSITION
	088473-05-000	EA PIN HOUSING - 6 POSITION (SINGLE ROW)
	088473-06-000	EA PIN HOUSING - 6 POSITION (TWO ROWS OF THREE)
	088473-08-000	EA PIN HOUSING - 4 POSITION
	088473-09-000	EA PIN HOUSING - 3 POSITION (SINGLE ROW)
	088473-10-000	EA PIN HOUSING - 2 POSITION
	088474-01-000	EA HOUSING - SOCKET - 12 POSITIONS
	088474-02-000	EA HOUSING - SOCKET - 15 POSITION (3 ROWS OF 5)
	088474-03-000	EA HOUSING - SOCKET - 9 POSITION
	088474-06-000	EA HOUSING - SOCKET - 6 POSITION (2 ROWS OF THREE)
	088474-07-000	EA HOUSING - SOCKET - 5 POSITION
	088474-08-000	EA HOUSING - SOCKET - 4 POSITION (SINGLE ROW)
	088474-09-000	EA HOUSING - SOCKET - 3 POSITION
	088474-10-000	EA HOUSING - SOCKET - 2 POSITION
	101571-01-000	EA HOUSING - 2 POSITION - MALE
	104100-01-000	EA HOUSING - 1 POSITION - 75 AMP - AMP 53884-1
	106006-01-000	EA HOUSING - 1 POSITION - FEMALE - PACKARD 12015952
	113468-01-000	EA HOUSING - 2 POSITION - FEMALE (WIPER/WASHER WIRE ASM)
	108355-01-000	EA HOUSING - SWITCH - CARLING VCH

### ROCKER SWITCHES (DASH)

KEY	PART NUMBER	U/M DESCRIPTION
	108357-03-000	EA SWITCH - ROCKER - SPDT ON/ OFF/ ON 3 TERM. CARLING - V6D1000B-0
	108356-02-01A	EA SWITCH COVER W/ 2 DIMPLES - CARLING - CCAZC00
	108357-05-000	EA SWITCH - ROCKER - SPDT ON/ NONE/ ON 3 TERM. CARLING - V4D1000B-0
	108356-02-01A	EA SWITCH COVER W/ 2 DIMPLES - CARLING - CCAZC00
	108357-06-000	EA SWITCH - ROCKER - DPDT MOM/ OFF/ MOM 6 TERM. CARLING - VLD1000B-0
	108356-02-01A	EA SWITCH COVER W/ 2 DIMPLES - CARLING - CCAZC00
	108357-09-000	EA SWITCH - ROCKER - SPDT ON/ NONE/ MOM 3 TERM. CARLING - V5D1000B-0
	108356-02-01A	EA SWITCH COVER W/ 2 DIMPLES - CARLING - CCAZC00
	108357-10-000	EA SWITCH - ROCKER - SPDT MOM/ ON LIGHTED-5 TERM (3 SWITCH/ 2 LIGHT)
	108356-04-01A	EA SWITCH COVER W/ DIMPLES - LIGHTED - CARLING - VVAGC00
	096241-03-000	EA SWITCH - BLANK
	077942-01-000	EA SWITCH - DUMMY - BLACK



## ELECTRICAL GROUP (CONTINUED)

### SWITCHES, RECEPTACLES & COVERS

KEY	PART NUMBER	U/M DESCRIPTION
	108357-05-000	EA SWITCH - ROCKER - SPDT ON/ NONE/ ON
	108356-02-01A	EA SWITCH COVER - W/ DIMPLES - CARLING VVAZC00 BLA
	108357-09-000	EA SWITCH - ROCKER - SPDT ON/ NONE/ MOM
	108356-02-01A	EA SWITCH COVER - W/ DIMPLES - CARLING VVAZC00 BLA
	108357-06-000	EA SWITCH - ROCKER - DPDT MOM/ OFF/ MOM
	108356-02-01A	EA SWITCH COVER - W/ DIMPLES - CARLING VVAZC00 BLA
	108357-03-000	EA SWITCH - ROCKER - SPDT ON/ OFF/ ON
	108356-02-01A	EA SWITCH COVER - W/ DIMPLES - CARLING VVAZC00 BLA
	108357-10-000	EA SWITCH - ROCKER - SPDT MOM/ OFF/ MOM
	108356-04-01A	EA SWITCH COVER - W/ DIMPLES & LENS - CARLING VVAGC00
	096241-03-000	EA SWITCH - BLANK
	077942-01-000	EA SWITCH - DUMMY - BLACK
	079364-01-000	EA SWITCH - ON/OFF - ROCKER - 2 PRONGS - BROWN
	079364-03-000	EA SWITCH - ON/OFF - ROCKER - 3 PRONGS - BROWN
	098351-01-01A	EA PLATE - SWITCH - 1 GANG - POLISHED BRASS
	098351-02-01A	EA PLATE - SWITCH - 2 GANG - POLISHED BRASS
	098351-05-01A	EA PLATE - SWITCH - 3 GANG - POLISH BRASS - JENSEN
	080015-02-000	EA RECEPTACLE - FLAG - .185 - 16/14 GA - AMP 3
	084076-02-000	EA RECEPTACLE - GFI - 15A - 125V - BROWN
	058707-01-000	EA RECEPTACLE - ELECTRIC - SINGLE - BROWN
	058707-02-000	EA RECEPTACLE - BLANK - JUNCTION WIRECON
	058708-01-000	EA RECEPTACLE - ELECTRIC - DOUBLE - BROWN
	058708-02-000	EA RECEPTACLE - ELECTRIC - DOUBLE - IVORY
	007940-01-000	EA RECEPTACLE - SLIDE - 16 TO 12 AWG - FEMALE END
	007954-01-000	EA RECEPTACLE - HSG - 6 POSITION
	024924-02-000	EA RECEPTACLE - POWER CORD - W/PARTIAL PLATE
	091927-01-000	EA COVER - RECEPTACLE - DOUBLE - IVORY
	102568-01-E90	EA SPACER - RECEPTACLE - SIDEWALL
	112822-01-01A	EA RECEPTACLE - DUPLEX - IVORY
	112824-01-02A	EA COVER - EXTERIOR DUPLEX RECEPTACLE - OFF WHITE

### ELECTRICAL WIRING & BOXES

KEY	PART NUMBER	U/M DESCRIPTION
	008052-01-000	EA CORD - POWER - 10/3 - 30 AMP - 25' - CANADIAN
	008054-01-000	EA CORD - POWER - 10/3 - 30 AMP - 25'
	008289-01-000	EA BOX - ELECTRIC - STEEL - 1/2" AND 3/4" KNOCKOUTS - 4" X 4"
	008289-02-000	EA BOX - ELECTRICAL - 4" X 4" - 1/2" & 3/4" KNOCKOUTS - CANADIAN
	074890-01-000	EA BOX - EXTENSION - STEEL - OPEN SIDES - 4" X 4" X 1 1/2"
	091910-01-000	EA BOX - ELECTRIC - 3.75" X 3.5" X 1.75" - PLASTIC
	091910-02-000	EA BOX - ELECTRIC - 57 X 88 MM - PLASTIC
	008294-01-000	EA COVER - ELECTRICAL BOX - BLANK/STEEL - 4" X 4" - GRAY
	008294-02-000	EA COVER - ELECTRICAL BOX - BLANK STEEL - 4" X 4" - CANADIAN
	074897-01-000	EA COVER - ELECTRIC BOX - 1 LARGE & 2 SMALL HOLES - 4" X 4"
	069238-01-000	EA COVER - ELECTRICAL BOX - W/HOLE - 4" X 4" - GRAY USED WITH 30 AMP RECEPTACLE
	111510-01-000	EA DOOR - ELECTRICAL BOX - FRONT
	108304-01-000	EA WIRE ASM. - AUX FANS
	090986-01-000	EA WIRE ASM - ELECTRIC STEP
	096449-01-000	EA WIRE ASSEMBLY - WATER TANK TO MONITOR PANEL
	097618-01-000	EA WIRE ASM - MONITOR PANEL - W/ 3 WIRES & ORANGE RESISTOR - LVS ORANGE RESISTOR W/3 (ORANGE-GREEN-BLUE) WIRES
	108303-01-000	EA WIRE ASM - REAR AUTO HEATER
	111915-03-000	EA WIRE ASM - DAY RUN LAMPS - FUSE - FORD
	111915-01-000	EA WIRE ASM - DAY RUN LAMPS - FUSE (GM)
	P03784-02-000	EA WIRE ASM. - HEADLAMP(FORD)
	P03784-01-000	EA WIRE ASM. - HEADLAMP(GM)
	073328-B4-000	EA CABLE ASSEMBLY - BATTERY - W/TERMINALS

## ELECTRICAL GROUP (CONTINUED)

### ELECTRICAL CONNECTORS & CONDUIT

KEY	PART NUMBER	U/M DESCRIPTION
	041953-01-000	FT CONDUIT - CONVOLUTE - SLIT - .5"ID
	041953-03-000	FT CONDUIT - CONVOLUTE - SLIT - 1" ID (CLOTHES ROD COVER)
	041953-05-000	FT CONDUIT - CONVOLUTE - SOLID - .62" ID
	041953-06-000	FT CONDUIT - CONVOLUTE - SLIT .375"ID
	041953-07-000	FT CONDUIT - CONVOLUTE - SLIT - .25" ID
	041953-08-000	FT CONDUIT - CONVOLUTE - SLIT - 1.50"ID
	041953-09-000	FT CONDUIT - CONVOLUTE - SLIT .50"ID
	041953-10-000	FT CONDUIT - CONVOLUTE - SLIT - .75" ID
	041953-11-000	FT CONDUIT - CONVOLUTE - SLIT - 1.06" ID
	041953-12-000	FT CONDUIT - CONVOLUTE - NON SLIT 1.1" ID
	008311-01-000	EA CONNECTOR - WIRE NUT - INSULATED - RED
	008312-01-000	EA CONNECTOR - WIRE NUT - INSULATED - BLUE
	008314-01-000	EA CONNECTOR - WIRE NUT - INSULATED - GRAY
	008355-01-000	EA CONNECTOR - CABLE CLAMPING - 3/4"
	008356-01-000	EA CONNECTOR - PLASTIC - 3/8" AVG
	082741-01-000	EA CONNECTOR - BODY - 2 CONNECTOR - MALE
	058028-01-000	EA CONNECTOR - ELECTRICAL PIGTAIL - NYLON - CLEAR
	041480-01-000	EA CONNECTOR - STRAIGHT - 1/2" FLEX CONDUIT
	088475-01-000	EA PIN-CONNECTOR - 14 TO 20 AWG
	088476-01-000	EA SOCKET - CONNECTOR - BRASS - PRE - TIN
	088476-02-000	EA SOCKET - CONNECTOR - 12-10 GA - PHOS. BRZ - PRE - TIN

### CIRCUIT BREAKERS & FUSES

KEY	PART NUMBER	U/M DESCRIPTION
	097611-01-000	EA CIRCUIT BREAKER - 6AMP - ATC - BLACK
	093655-03-000	EA CIRCUIT BREAKER - 40 AMP USD 17440-4E03A2A
	083209-02-000	EA CIRCUIT BREAKER - 15/15AMP - 120V - BW H - 15/15
	083209-03-000	EA CIRCUIT BREAKER - 15/20AMP - 120V - BW - 0-15/20
	083209-04-000	EA CIRCUIT BREAKER - 30A - 120V - BW L - 30
	083209-06-000	EA CIRCUIT BREAKER - 30/15 AMP - 120V - BW D - 30/15
	083209-07-000	EA CIRCUIT BREAKER - 20/20A - 120V - BW K - 20/20
	083209-08-000	EA CIRCUIT BREAKER - BLANK - BW
	062901-02-000	EA FUSE - 5 AMP - AUTOMOTIVE
	062901-05-000	EA FUSE - 15 AMPS - AUTOMOTIVE
	062901-07-000	EA FUSE - AUTOMOTIVE - 25 AMPS
	062901-08-000	EA FUSE - 30 AMPS - AUTOMOTIVE
	106656-01-000	EA FUSE BLOCK - 4 CAVITY AUTOFUSE
	108669-01-000	EA HOUSING - AUTO FUSE HOLDER
	062037-01-000	EA HOUSING - AUTO FUSE - NATURAL
	062037-03-000	EA HOUSING - AUTO FUSE - BLACK
	062037-04-000	EA HOUSING - AUTO FUSE - BLUE
	062037-06-000	EA HOUSING - AUTO FUSE - BROWN

# EXTERIOR BODY GROUP

## EXTERIOR BODY PANELS & TRIM

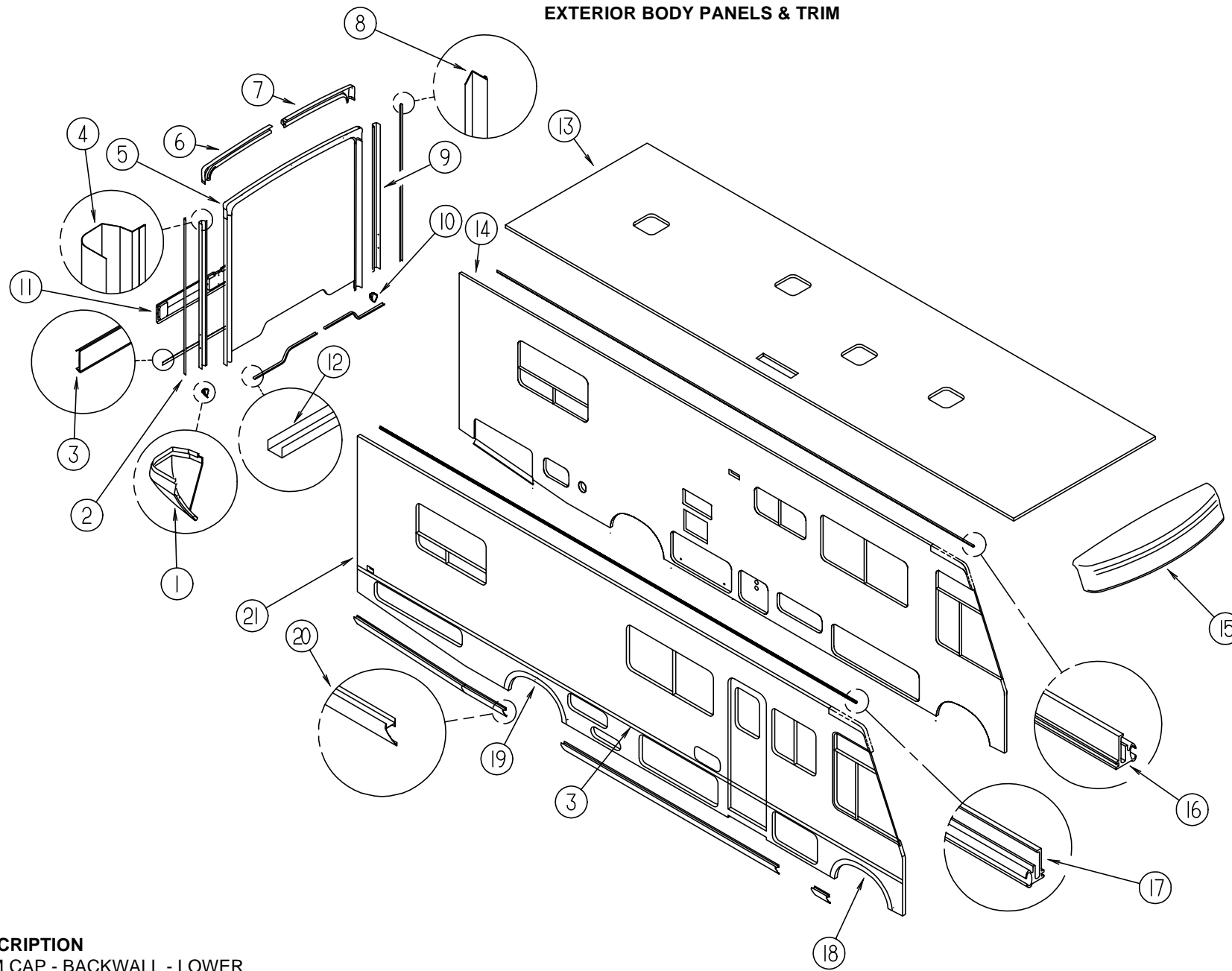

KEY	PART NUMBER	U/M DESCRIPTION
1	115848-01-01A	EA TRIM CAP - BACKWALL - LOWER
2	104033-05-01A	EA TRIM - J - BUFF
3	108688-01-01A	EA FEATURE STRIP - W/HOLES - OFF WHITE
	105312-01-03A	FT INSERT - FEATURE STRIP
	108651-01-01A	EA END CAP - FEATURE STRIP
4	114874-01-03B	EA TRIM - BACKWALL - OFF WHITE (PASSENGER SIDE)
5	M06972-03-F31	EA BACKWALL ASM
5	M06972-03-F32	EA BACKWALL ASM
6	114872-01-01A	EA TRIM - BACKWALL - TOP - OFF WHITE (PASSENGER SIDE)
7	114873-01-01A	EA TRIM - BACKWALL - TOP - OFF WHITE (DRIVER SIDE)
8	104033-04-01A	EA TRIM - J - OFF WHITE (DRIVER SIDE)
9	114874-02-03B	EA TRIM - BACKWALL - OFF WHITE (DRIVER SIDE)
10	115848-02-01A	EA TRIM CAP - BACKWALL - LOWER
11	106125-02-F31	EA TRIM ASM - BACKWALL
12	050406-15-000	EA TRIM - BACKWALL - LOWER LEFT OR RIGHT SIDE - OFF WHITE
13	P15903-01-F31	EA ROOF ASM.
14	M07450-01-F31	EA SIDEWALL ASM (DRIVER SIDE) (W/O DRIVER DOOR)
14	M07450-01-F32	EA SIDEWALL ASM (DRIVER SIDE) (W/O DRIVER DOOR)
14	M07450-02-F31	EA SIDEWALL ASM (DRIVER SIDE) (W/ DRIVER DOOR)
14	M07450-02-F32	EA SIDEWALL ASM (DRIVER SIDE) (W/ DRIVER DOOR)

KEY	PART NUMBER	U/M DESCRIPTION
15	M07435-01-F31	EA CAP ASM - FRONT - W/O TRIM - OFF WHITE
16	103801-01-01A	EA TRIM - ROOF - OFF WHITE
17	103802-02-01A	EA RAIL - AWNING - OFF WHITE
18	104068-01-05A	EA TRIM - WHEELWELL - FRONT - (PASSENGER SIDE)
	104068-02-05A	EA TRIM - WHEELWELL - FRONT - (DRIVER SIDE W/O DRIVER DOOR)
	104068-03-01A	EA TRIM - WHEELWELL - FRONT - (DRIVER SIDE W/ DRIVER DOOR)
19	104070-01-05A	EA TRIM - WHEELWELL - REAR (DRIVER OR PASSENGER SIDE)
20	109140-55-002	EA TRIM - WHEELWELL - REAR (DRIVER OR PASSENGER SIDE)
21	M07449-01-F31	EA SIDEWALL ASM (PASSENGER SIDE)
21	M07449-01-F32	EA SIDEWALL ASM (PASSENGER SIDE)

**EXTERIOR BODY GROUP (CONTINUED)**

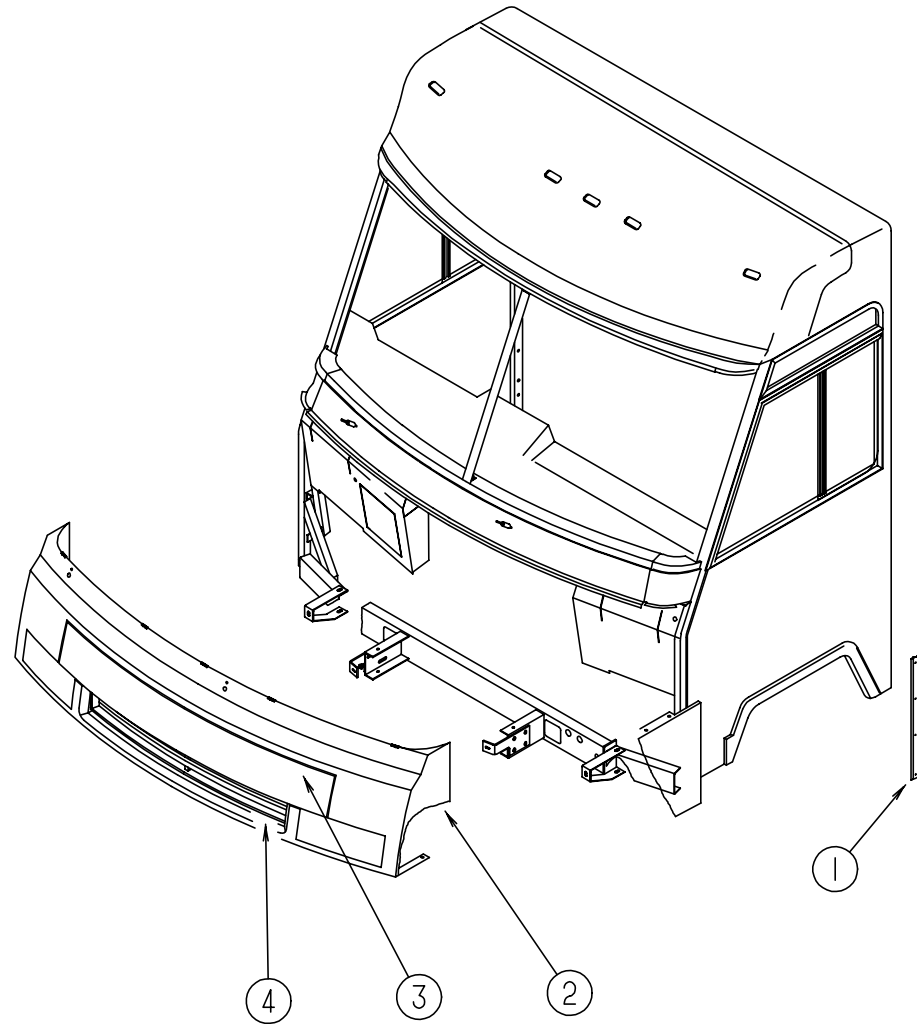

**FRONT END ASM**

KEY	PART NUMBER	U/M DESCRIPTION
1	089922-09-000	EA TRIM - FIBERGLASS - OFF WHITE
2	111068-01-03A	EA PANEL - FRONT - LOWER - OFF WHITE
3	104645-01-E30	EA PANEL ASM. - HOOD - OFF WHITE
4	104318-01-C07	EA GRILLE ASM. - MESH - FACIA
	058786-01-000	EA BOLT - ADJUSTING - HOOD - W/ BLACK PAD - 5/16" #18 X 2"
	058786-02-000	EA BOLT - ADJUSTING - HOOD - W/ BLACK PAD - 5/16" #18 X 1.25"
	104582-02-000	EA LINK ASM. - HINGE - HOOD - OUTER
	104584-03-000	EA BRACKET ASM. - HOOD HINGE BODY - PASSENGER SIDE
	104584-04-000	EA BRACKET ASM. - HOOD HINGE BODY - DRIVER SIDE
	105095-01-000	EA LINK ASM. - HINGE - HOOD - INNER - PASSENGER SIDE
	105095-02-000	EA LINK ASM. - HINGE - HOOD - INNER - DRIVER SIDE
	102330 02 000	EA HOOD LOCK - SINGLE HOLE - VISE ACTION
	102328-01-000	EA BARREL KEY - HOOD LOCK
	110690-02-D18	EA PLATE - HEADLAMP - QUAD - LH
	110692-02-01A	EA PLATE - HEADLAMP - QUAD - LH - MILL
	110783-02-01A	EA BRACKET - HEADLAMP - QUAD - LH - MILL
	110782-01-000	EA ANGLE - SUPPORT - HEADLAMP
	110690-01-D18	EA PLATE - HEADLAMP - QUAD - RH
	110692-01-01A	EA PLATE - HEADLAMP - QUAD - RH - MILL
	110783-01-01A	EA BRACKET - HEADLAMP - QUAD - RH - MILL
	110782-01-000	EA ANGLE - SUPPORT - HEADLAMP
	110691-01-01A	EA BRACKET-SPRING - HEADLAMP - MILL

**EXTERIOR BODY GROUP (CONTINUED)**

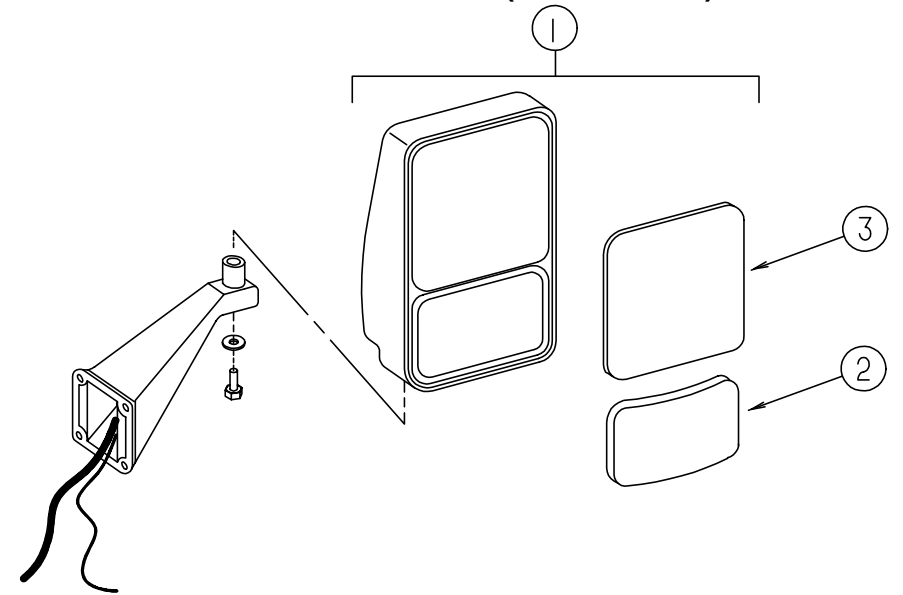

**EXTERIOR MIRROR OPTION (REMOTE & HEAT)**

KEY	PART NUMBER	U/M DESCRIPTION
1	106015-05-01A	EA MIRROR ASM - EXTERIOR REMOTE & HEAT - PASSENGER SIDE
1	106015-06-01A	EA MIRROR ASM - EXTERIOR REMOTE & HEAT - DRIVER SIDE
2	086261-02-700	EA CONVEX REPLACEMENT - INNER HOUSING & BEZEL - DRIVER SIDE
2	086261-01-703	EA CONVEX REPLACEMENT - INNER HOUSING & BEZEL - PASSENGER SIDE
3	086261-01-702	EA GLASS - FLAT - HEATED - W/ BEZEL
	087695-01-000	EA SWITCH - HEATER - EXTERIOR MIRROR
	088246-01-000	EA SWITCH - REMOTE - EXT. MIRROR - SQUARE PUSH
	086261-02-701	EA KIT - EXTERIOR. MIRROR - W/BEZEL - FLAT & CONVEX GLASS - DRIVER SIDE KIT INCLUDES: BEZEL - CONVEX GLASS - HEATED FLAT GLASS FOR CURRENT AND OLD STYLE MIRROR
	086261-01-704	EA KIT - EXTERIOR. MIRROR - W/BEZEL - FLAT & CONVEX GLASS - PASSENGER SIDE KIT INCLUDES: BEZEL - CONVEX GLASS - HEATED FLAT GLASS FOR CURRENT AND OLD STYLE MIRROR

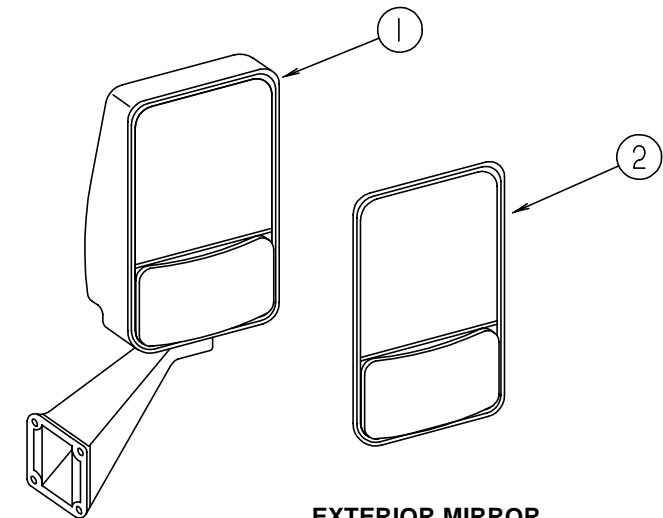

**EXTERIOR MIRROR**

KEY	PART NUMBER	U/M DESCRIPTION
1	106015-09-01A	EA MIRROR ASM - PASSENGER SIDE
1	106015-10-01A	EA MIRROR ASM - DRIVER SIDE
2	106015-01-703	EA MIRROR KIT (BEZEL W/MIRRORS) PASSENGER SIDE
2	106015-02-702	EA MIRROR KIT (BEZEL W/MIRRORS) DRIVER SIDE

## EXTERIOR BODY GROUP (CONTINUED)

### DECALS, FILM STRIPES & PAINT

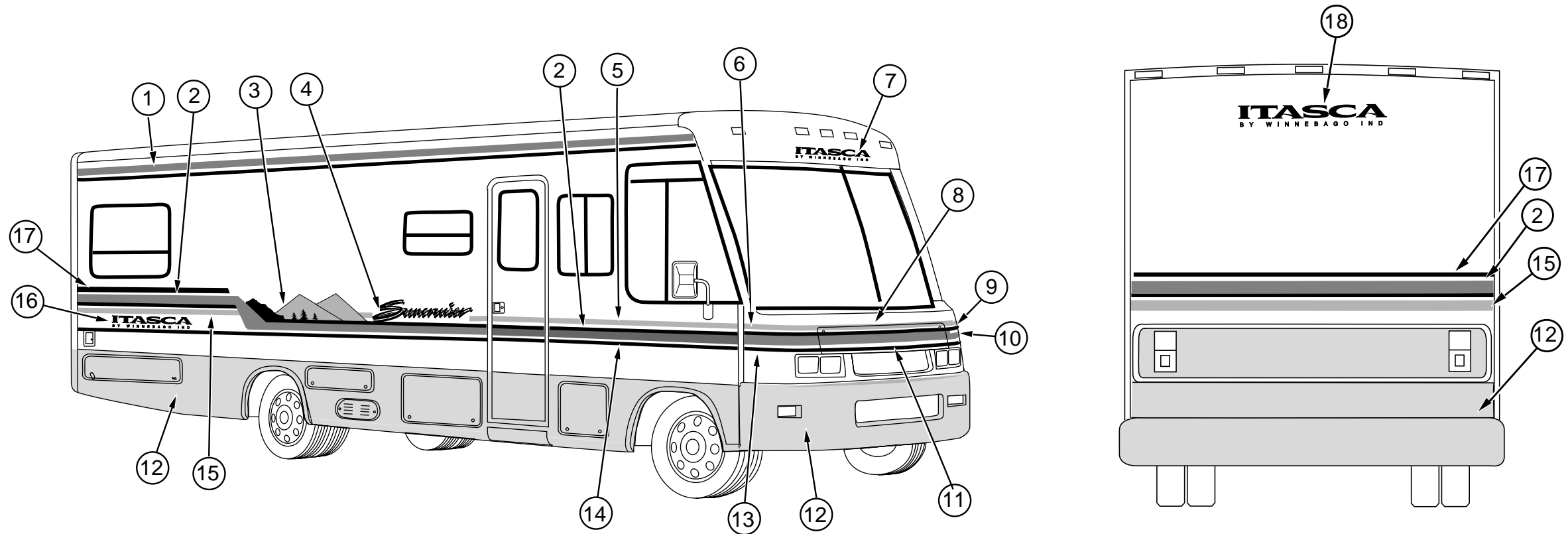

KEY	PART NUMBER	U/M DESCRIPTION
1	105781-29-01A	FT FILM - MULTISTRIPE 95.3 MM X 150' MEDIUM AQUA/ TROPICAL BLUE
2	105781-28-01A	FT FILM - MULTISTRIPE 95.3 MM X 150' TROPICAL BLUE/ MEDIUM AQUA
3	111308-01-01A	EA DECAL - SCENE - PASS. SIDE - ORANGE/ LIGHT RUTILE/ TROPICAL BLUE/ MED AQUA
3	111308-02-01A	EA DECAL - SCENE - DRIVER SIDE - ORANGE/ LIGHT RUTILE/ TROPICAL BLUE/ MED AQUA
4	111307-01-01A	EA DECAL "SUNCRUISER" OFF WHITE/ TROPICAL BLUE
5	107385-11-03A	FT FILM - 31.8 MM X 150 FT - MEDIUM TITANIUM
6	111310-01-01A	EA DECAL - CORNER - FRONT - UPPER - PASSENGER SIDE - MEDIUM TITANIUM
7	111306-02-01A	EA DECAL - LOGO "ITASCA, BY WINNEBAGO IND." TROPICAL BLUE/ OFF WHITE/ TROPICAL BLUE
8	107385-17-01A	FT FILM - 33.3 MM X 150 FT - MEDIUM TITANIUM
9	111310-02-01A	EA DECAL - CORNER - FRONT - UPPER - DRIVER SIDE - MEDIUM TITANIUM
10	111309-02-01A	EA DECAL - CORNER - FRONT - LOWER - DRIVER SIDE - TROPICAL BLUE/ MEDIUM AQUA
11	111302-01-01A	EA DECAL - HOOD - TROPICAL BLUE/ MEDIUM AQUA
12	N / P	PAINT - MEDIUM TITANIUM METALIC (DUPONT C9284)
13	111309-01-01A	EA DECAL - CORNER - FRONT - LOWER - PASSENGER SIDE - TROPICAL BLUE/ MEDIUM AQUA
14	107385-09-02A	FT FILM - 38.1 MM X 150 FT - TROPICAL BLUE
15	107385-02-05A	FT FILM - 50.8 MM X 150 FT - MEDIUM TITANIUM
16	111303-02-01A	EA DECAL - LOGO "ITASCA, BY WINNEBAGO IND." TROPICAL BLUE/ OFF WHITE/ TROPICAL BLUE
17	107385-02-06A	FT FILM - 50.8 MM X 150 FT - LIGHT RUTILE
18	111303-03-01A	EA DECAL - LOGO "ITASCA, BY WINNEBAGO IND." TROPICAL BLUE

#### DUPONT PAINT COLOR CODES

OFF WHITE	DUPONT L8723
MEDIUM TITANIUM	DUPONT C9284
LIGHT RUTILE	DUPONT G9859K
MEDIUM AQUA	DUPONT F0739
TROPICAL BLUE	DUPONT G9841
ORANGE	DUPONT F0750

## EXTERIOR BODY GROUP (CONTINUED)

### STYROFOAM & FIBERGLASS SHEETING

KEY	PART NUMBER	U/M DESCRIPTION
	083574-06-000	SF STYROFOAM - 1.3 /4" X 48" X 96" - PLANED
	000870-08-000	SF STYROFOAM - .75" X 48" X 96" - PLANED
	083574-03-000	SF STYROFOAM - 3/4" X 48" X 96"
	083574-05-000	SF STYROFOAM - 2.0" X 48" X 96"
	065747-01-000	SF INSULATION - MICROFOAM - .5" X 72" X 112' ROLL
	083574-02-000	SF STYROFOAM - DOW TYPE SM - 1.5" X 24" X 90.5" (15 SF)
	076054-F3-000	EA FIBERGLASS SHEET 2438 X 2438 - OFF WHITE
	077517-24-000	EA SHEET - FIBERGLASS - FLAT - 48" X 96" - OFF WHITE
	076054-H1-000	EA OFF/ WHITE FIBERGLASS SHEET - 96" X 102"
	108535-02-701	EA OFF/ WHITE FIBERGLASS SHEET - 104" X 396" (ROOF)
	076054-F7-000	EA FIBERGLASS SHEET 2590 X 9785 - OFF WHITE
	105077-03-000	EA FOAM - PLUG - SIDEWALL TUBE
	105077-04-000	EA FOAM - ROOF COVE - 8'
	105077-05-000	EA FOAM - ENDCAP - ROOF COVE

### EXTERIOR BODY HARDWARE

KEY	PART NUMBER	U/M DESCRIPTION
	002726-01-001	EA GARNISH - U-CHANNEL - 1.38" X 19' - SERRATED - MILL ALUMINUM
	002754-01-001	EA ANGLE - EXTRUDED - .75" X .75" X 18' - MILL ALUMINUM
	033381-17-001	FT STEEL - TUBE 16GA 1.5 X 1.5 X 288.00 HOT FORMED ASTM A50
	044487-01-000	LB AL - 019 X 96.00 X COIL MILL FINISH WT .353LB/SF ORDER #044487-01-001 - .19" X 96" X 300" #044487-01-002 - .019" X 96" X 432"
	055278-01-001	FT TUBING - STEEL - .75" X 1.5" X 288" REPLACE WITH 055278-51-259 WHICH IS 12.5'LONG
	058267-01-000	FT CHANNEL - STEEL - W/ HOLES - SIDEWALL STIFFENER - 2" X 20'
	068716-01-001	EA BRACE - 90 DEGREE L-ANGLE - 192" - EXTRUDED ALUMINUM
	089297-01-000	SF PLYWOOD - LUAN - OVERLAY GRADE - 4' X 8'

## EXTERIOR BODY GROUP (CONTINUED)

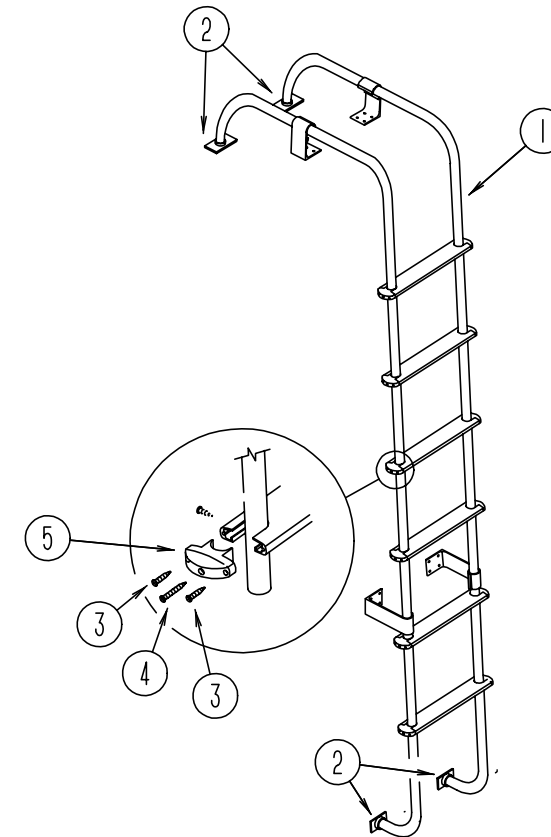

### LADDER

KEY	PART NUMBER	U/M DESCRIPTION
1	102953-11-F31	EA LADDER ASM
2	067165-01-000	EA MOUNTING BRACKET - LADDER - LOWER
3	000G39-06-10T	EA SCREW-SF/ DR - 6 - 20 X 5/8 PPH - BLACK
4	000G68-10-36T	EA SCREW - 10 - 12 X 2.25 POH BLACK
5	076980-02-000	EA END CAP - STEP - BLACK
	038327-01-000	FT TAPE - ANTI SLIP - 2" X 60FT

## EXTERIOR BODY GROUP (CONTINUED)

EXTERIOR AWNING (FROM: 00-00-00 THRU: 08-25-94 )

KEY	PART NUMBER	U/M DESCRIPTION
	110634-02-02A	EA AWNING - HARDWARE KIT - OFF WHITE
	110634-07-02A	EA AWNING - ROLLER ASM - 19'
	110634-01-700	EA RAFTER LOCKING MECHANICAL KIT - 7605-0001
	110634-01-701	EA SAFETY & LATCH KIT - 7509-0001
	110634-01-702	EA BOTTOM BRACKET KIT - 7512-0001
	110634-01-703	EA HEIGHT LOCK HANDLE KIT - 7510-0001
	110634-01-704	EA UPPER BRACKET KIT W/BOLTS - 7505-0001
	110634-01-705	EA ULTRA RAFTER KNOB KIT - 7522-0001
	110634-01-706	EA RAFTER SLIDE KIT
	110634-01-707	EA GROUND BRACKET KIT - 7511-0001
	110634-01-708	EA LIFT HANDLES W/ RIVETS - 7000-0001
	110634-01-709	EA RATCHET HANDLE KIT - 7507-0001
	110634-01-710	EA ARM CAP KIT - 7503-0001
	110634-01-711	EA FRONT SPRING ASM - 6598-0001
	110634-01-712	EA REAR SPRING ASM - 6599-0001
	110634-01-713	EA REAR END CAP KIT - 7504-0001
	110634-05-01A	EA AWNING - CRADLE SUPPORT
	110634-06-01A	EA AWNING - CENTER RAFTER ASM
	111037-01-01A	EA SPACER - AWNING - UPPER BLACK
	111038-01-01A	EA SPACER - AWNING - LOWER BLACK

## EXTERIOR BODY GROUP (CONTINUED)

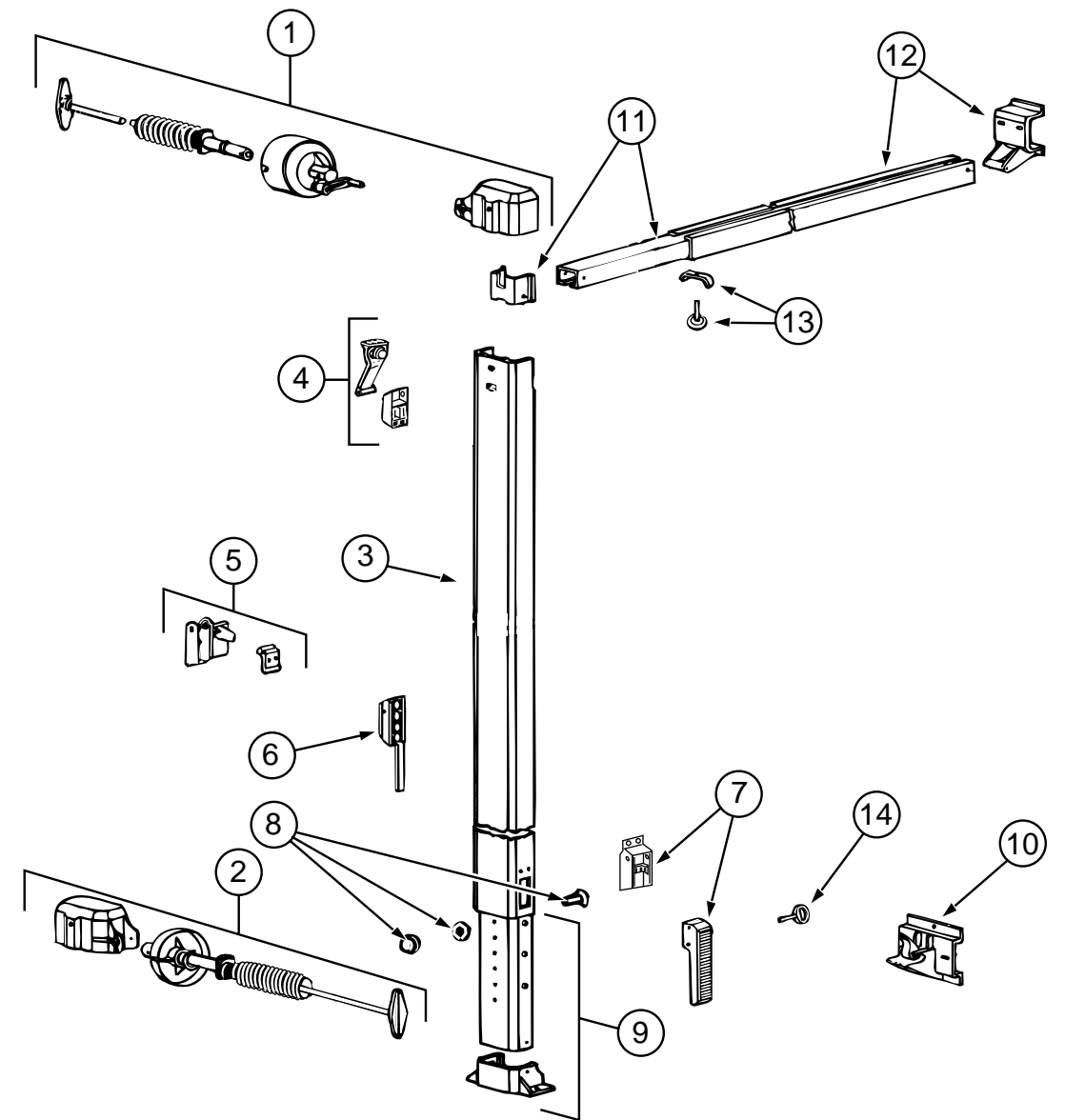

EXTERIOR AWNING (FROM: 08-26-94 THRU: 99-99-99)

KEY	PART NUMBER	U/M DESCRIPTION
	116059-04-01A	EA AWNING - ROLLER ASM - 19' - CAREFREE TEAL - VINYL
1	116059-01-700	EA FRONT SPRING & BRAKE ASSEM. - 249001AC
2	116059-01-701	EA REAR SPRING ASSEM. - 249020AC
3	116059-01-702	EA UPPER ARM ASM. - FRONT 66" - 249528C
	116059-01-703	EA UPPER ARM ASM. - REAR 66" - 249529C
4	116059-01-704	EA UPPER SLIDER ASM. - 249040C
5	116059-01-705	EA ARM STORAGE LOCK ASM. - 249060C
6	116059-01-706	EA BRAKE CONTROL - 249070C
7	116059-01-707	EA HANDLE ASM. - 249080C
8	116059-01-708	EA STOP BOLT - W/ NUT & WASHER - 011131C
9	116059-01-709	EA LOWER ARM ASM. - FRONT. 56" - 249600C
	116059-01-710	EA LOWER ARM ASM. - REAR 56" - 249601C
10	116059-01-711	EA BOTTOM BRKT - ASM. - 012411-001C
11	116059-01-712	EA LOWER BRACE ASM. - COMP. 50" - 249140C
12	116059-01-713	EA UPPER BRACE ASM. - COMP. 50" - 249159C
13	116059-01-714	EA BLACK LOCKING KNOB - W/ CLAMP - 249105C
14	116059-01-717	EA HANDLE LOCK PIN - 040279C
	116059-01-715	EA DOOR ROLLER - 060063C
	116059-01-716	EA NUTSERT TOOL KIT - 905007C

## GALLEY GROUP

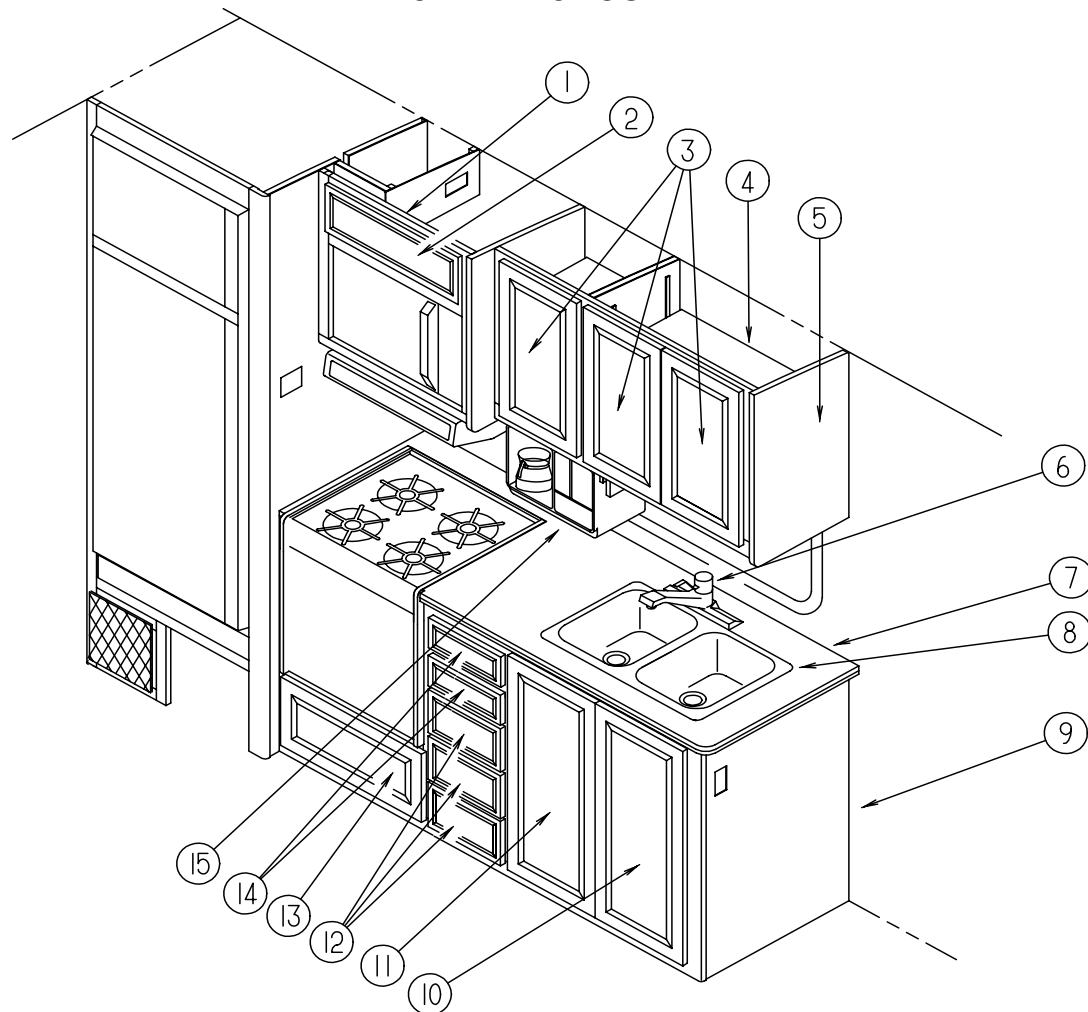

**GALLEY CABINETRY & FIXTURES**

KEY	PART NUMBER	U/M	DESCRIPTION
1	114390-01-F04	EA	CABINET ASM - MICROWAVE OVERHEAD
	116592-01-F11	EA	CABINET ASM - A/C SWITCH
2	M05993-11-F31	EA	DOOR ASM - RAIL - W/O HARDWARE 240 X 555
3	M05993-14-E30	EA	DOOR ASM - W/O HARDWARE - 305 X 555
4	P04372-02-C27	EA	CABINET ASM - OVERHEAD - GALLEY
5	081319-17-C27	EA	END CAP ASM. - OVERHEAD - GALLEY
6	104114-02-01A	EA	FAUCET - GALLEY - SINGLE CONTROL
7	116628-12-F31	EA	COUNTERTOP ASM.
7	116628-12-F32	EA	COUNTERTOP ASM.
	108464-04-E38	EA	COVER - SINK (F31)
	108464-04-F32	EA	COVER - SINK
8	110654-01-000	EA	SINK - STAINLESS STEEL LARGE/ SMALL BASIN - DOUBLE
	092303-01-000	EA	STRAINER - SINK
9	116628-01-F31	EA	GALLEY CABINET ASM. - W/ COUNTERTOP
9	116628-01-F32	EA	GALLEY CABINET ASM. - W/ COUNTERTOP
10	M05993-19-E30	EA	DOOR ASM - W/O HARDWARE 0345 X 0770
11	M05993-18-E30	EA	DOOR ASM - W/O HARDWARE 0345 X 0770
12	M05970-11-E01	EA	DRAWER ASM. - W/O HARDWARE
13	M05970-A1-E30	EA	DRAWER ASM. - W/O HARDWARE
14	M05970-68-E30	EA	DRAWER ASM. - W/O HARDWARE
15	103799-01-02A	EA	COFFEE MAKER - GRAY
	103799-01-700	EA	CARAFE GLASS POT
	103799-01-701	EA	BRACKETS - WHITE PAIR - COFFEE MAKER
	104610-01-000	EA	STRAP ASM - COFFEE MAKER
	090329-01-000	FT	T-SEAL - REFRIGERATOR CABINET - .6" WIDE TOP X 2" TAIL

## GALLEY GROUP (CONTINUED)

### REFRIGERATOR (NORCOLD 6182)

KEY	PART NUMBER	U/M	DESCRIPTION
	104137-07-01A	EA	REFRIGERATOR - LARGE DBL DOOR 2-WAY
	093646-01-000	EA	BRACKET ASM - TIEDOWN - REFRIGERATOR
	093646-02-000	EA	BRACKET ASM - TIEDOWN - REFRIGERATOR
	075217-01-734	EA	FUSE - 3 AMP61538822
	075217-01-738	EA	SWITCH - HUMIDITY61525922
	084880-01-705	EA	ORIFICE - 614522
	084880-01-718	EA	VALVE - GAS - 61551822
	084880-01-720	EA	SPRING (FOR DOOR HANDLE) - 61558822
	084880-01-722	EA	CRISPER COVER - 615641
	084880-01-732	EA	LATCH - 61578522
	084880-01-740	EA	END CAP (STOP CATCH) - 61593830
	084880-01-746	EA	CABLE - 61571522
	084880-01-749	EA	HINGE BUSHING - 615807
	084880-01-753	EA	THERMISTER 78" - 61693822
	084880-01-760	EA	CLIP (THERMISTER) - 61689122
	084880-01-761	EA	END CAP (SPRING CATCH) BLACK - 61593730
	084880-03-701	EA	COOLING UNIT (HORIZ BURNER) - 61687337
	084880-03-702	EA	HINGE PIN TOP/BTM FEMALE - 61580630
	088248-01-709	EA	HEATER - AC (HORIZONTAL) - 615627
	088248-01-710	EA	HEATER - DC (HORIZONTAL) 3 WAY - 615628
	094039-01-702	EA	GASKET (GRAY) UPPER - 61567830
	094039-01-704	EA	PLATE - HINGE - BLACK - 61631430
	094039-01-706	EA	UPPER DOOR LINER (WHITE) BLACK - 61581838-B
	094039-01-708	EA	DOOR HANDLE ASM - UPPER - BLACK - 61650038
	094039-01-710	EA	PLATE - HINGE - BLACK - 61631330
	094039-01-713	EA	DOOR GASKET (LOWER) GRAY - 61568030
	094039-01-715	EA	LOWER DOOR LINER (BLACK/WHITE) - 61581738-B
	094039-01-717	EA	DOOR HANDLE ASM - LOWER (BLACK) - 61649938
	094039-01-722	EA	HOLE PLUG (BLACK) HINGE HOLES - 61582030
	094039-01-723	EA	HINGE BRACKET - TOP RH - BOTTOM - LH - BLACK - 61580838
	094039-01-724	EA	HINGE BRACKET - TOP LH - BOTTOM - RH - BLACK - 61580938
	094039-01-725	EA	HINGE PIN (BLACK)(MALE) - 61578130
	094039-01-730	EA	HINGE PIN SHAFT (BLACK) CENTER HINGE - 61566730
	094039-01-732	EA	FRONT COVER (BLACK) BOTTOM TRIM - 61622130
	094039-01-733	EA	WIRE SHELF (MIDDLE) - 61563822
	094039-01-735	EA	INSIDE DRIP TRAY (WHITE) - 61572830
	094039-01-739	EA	SHELF (CUTOUT) - 61646722
	094039-04-700	EA	PRINTED CIRCUIT BOARD - 2 WAY - 1647322
	094039-04-702	EA	POWER SUPPLY (2 WAY) - 61647422
	104137-02-700	EA	MODULE - CONTROL - CHANNEL - 61717037
	104137-06-700	EA	EYEBROW SHELL (2-WAY) - 61726622
	104137-06-702	EA	RACK - JUICE (WHITE) - 61580525
	104137-06-703	EA	BIN - DOOR SHELF (WHITE) - 61564025
	104137-06-706	EA	WIRE SHELF (SHORT) - 61718222
	104137-06-707	EA	CRISPER (WHITE) - 61571325
	104137-06-708	EA	FOAMED CAB ASM (BLACK W/WHITE) - 61725138
	104137-06-709	EA	VALVE SHUT - OFF - MANUAL ASM - 61694922
	104137-06-710	EA	PRESSURE TAP - 61594422
	104137-06-711	EA	FUSE 5 AMP - 61611622
	104137-06-712	EA	FITTING - GAS TUBE CONNECTION - 61692722
	104137-06-713	EA	ORFICE GASKET - 61475122
	104137-06-714	EA	BURNER ASSEMBLY (5-SLOT) - 61705222
	104137-06-715	EA	SPARK/ SENSE ELECTRODE (SINGLE) - 61692222
	104137-08-01A	EA	LIGHT KIT - REFRIGERATOR - 61771022
	104137-09-01A	EA	FREEZER - SHELF - 61710622
	054450-01-000	EA	LEVEL - REFRIGERATOR
	065225-02-000	EA	PLATE - TIEDOWN - REFRIGERATOR

**GALLEY GROUP (CONTINUED)**

**WEDGEWOOD RANGE, 4 BURNER (BLACK) 21"**

KEY	PART NUMBER	U/M	DESCRIPTION
	107323-01-01A	EA	RANGE - 21" 4 - BURNER BLACK
	107314-01-01A	EA	RANGE COVER - BIFOLD 21" BLACK
	105458-03-000	EA	BRACKET - TIEDOWN - STOVE - RIGHT
	105458-04-000	EA	BRACKET - TIEDOWN - STOVE - LEFT
	101593-01-703	EA	KNOB - BURNER - 53000
	106689-01-701	EA	SPARK - IGNITOR ASM - HIGH OUTPUT - 53078
	106689-01-702	EA	PIEZO PUSH BUTTON - 52279
	106689-01-703	EA	VALVE - HIGH OUTPUT - 53047
	106689-01-704	EA	REGULATOR W/EXTREME PRESSURE - 52154
	106689-01-705	EA	VALVE - BURNER - 52123
	107246-01-700	EA	RANGE TOP (BLACK) - 53083
	107246-01-701	EA	GRATE - 53050
	107323-01-700	EA	RANGE TOP - 53513
	107323-01-702	EA	TRIM LEFT - 53023
	107323-01-703	EA	TRIM RIGHT - 53024
	107323-01-704	EA	MANIFOLD COVER - 53556
	107323-01-705	EA	TRIM VENT - 53525
	107323-01-706	EA	TRIM BOTTOM - 53526
	107323-01-707	EA	INSERT BLACKGLASS - W/O HOLE - 53426
	107323-01-708	EA	HANDLE ROD - W/O HOLE - 53085
	107323-01-709	EA	HANDLE END CAP - W/O HOLE - 53424
	107323-01-710	EA	GRATE CLIP - 53301
	107323-01-711	EA	RUBBER GRATE CUSHION - 53008
	107246-01-703	EA	THERMOSTAT ROBERT SHAW - 52122
	107323-01-713	EA	BLACKGLASS INSERT - W/HOLE - 53426
	107323-01-714	EA	HANDLE FOR W/HOLE GLASS - 51112
	107323-01-715	EA	SAFETY VALVE (HARPER WYMAN) 51136
	107323-01-716	EA	GRATE CLIP - GREEN - 50005

**MICROWAVE OVEN**

KEY	PART NUMBER	U/M	DESCRIPTION
	115303-01-000	EA	OVEN - MICROWAVE
	098916-14-01A	EA	BRACE - MICROWAVE CABINET - LEFT
	098916-15-01A	EA	BRACE - MICROWAVE CABINET - RIGHT
	115401-01-01A	EA	TRIM - MICROWAVE - BLACK
	094756-02-01A	EA	BRACKET - MICROWAVE - 6.1" LONG X 3.9" WIDE - STEEL - TAN
	094756-01-02A	EA	BRACKET - ANGLE - W/ HOLES - MILL

**GALLEY GROUP (CONTINUED)**

**RANGE HOOD , W/O HOUR METER - VENTLINE, TCS 5008-NBCLG (CANADIAN)**

KEY	PART NUMBER	U/M	DESCRIPTION	VENDOR NO.
	100258-17-04A	EA	HOOD - RANGE - W/O MONITOR PANEL	
	090973-01-700	EA	MOTOR - LVS	CA508-1
	090973-01-702	EA	BLADE - FAN - LVS	VA183-1
	092696-01-709	EA	BULB - 912	VA415
	092696-01-710	EA	SOCKET - LIGHT	CB267-2
	096983-01-700	EA	SWITCH - ON/OFF	108
	096983-01-702	EA	SWITCH - TWO WAY MOMENTARY	112
	096983-01-707	EA	FILTER - GREASE - 8" X 8" - LVS	CC246
	092696-02-701	EA	LENS - LAMP	CC179
	100258-01-700	EA	HOOD NOSE LABEL	CC428
	100258-10-01A	EA	GAUGE - HOUR METER W/ SWITCH - SCREW ON	150
	100258-10-701	EA	GAUGE - HOUR METER - CLIP ON	72367

**RANGE HOOD , W/O HOUR METER - VENTLINE, TCS-5008-NBDG (USA)**

KEY	PART NUMBER	U/M	DESCRIPTION	VENDOR NO.
	100258-16-04A	EA	HOOD - RANGE - W/O MONITOR PANEL	
	090973-01-700	EA	MOTOR - LVS	CA508-1
	090973-01-702	EA	BLADE - FAN - LVS	VA183-1
	092696-01-709	EA	BULB - 912	VA415
	092696-01-710	EA	SOCKET - LIGHT	CB267-2
	096983-01-700	EA	SWITCH - ON/OFF	108
	096983-01-702	EA	SWITCH - TWO WAY MOMENTARY	112
	096983-01-707	EA	FILTER - GREASE - 8" X 8" - LVS	CC246
	092696-02-701	EA	LENS - LAMP	CC179
	100258-01-700	EA	HOOD NOSE LABEL	CC428

**RANGE HOOD , W/HOUR METER - VENTLINE, TPS-5009-SBDLG (USA)**

KEY	PART NUMBER	U/M	DESCRIPTION	VENDOR NO.
	100258-18-03A	EA	HOOD - RANGE 22W W/O MONITOR PANEL	
	090973-01-700	EA	MOTOR - LVS	CA508-1
	090973-01-702	EA	BLADE - FAN - LVS	VA183-1
	092696-01-709	EA	BULB - 912	VA415
	092696-01-710	EA	SOCKET - LIGHT	CB267-2
	096983-01-700	EA	SWITCH - ON/OFF	108
	096983-01-702	EA	SWITCH - TWO WAY MOMENTARY	112
	096983-01-707	EA	FILTER - GREASE - 8" X 8" - LVS	CC246
	092696-02-701	EA	LENS - LAMP	CC179
	100258-01-700	EA	HOOD NOSE LABEL	CC428
	100258-10-01A	EA	GAUGE - HOUR METER W/ SWITCH - SCREW ON	150
	100258-10-701	EA	GAUGE - HOUR METER - CLIP ON	72367

**MONITOR PANEL (2 WATER TANKS & WATER HEATER)**

KEY	PART NUMBER	U/M	DESCRIPTION
	102765-04-01A	EA	PANEL - MONITOR - W/PLUG - FOR 2 TANKS & WATER HEATER - LVS



## GENERATOR GROUP

### ONAN GENERATOR, 5.0 KW EMERALD PLUS (US, CSA)

KEY	PART NUMBER	U/M DESCRIPTION
	109303-01-000	EA GENERATOR - 5.0 KW EMERALD PLUS
	007125-03-000	EA CLAMP - MUFFLER - 1.5" DIA
	007125-04-000	EA CLAMP - MUFFLER - 1.1" DIA
	082272-01-000	EA MUFFLER
	079654-05-000	EA PIPE - EXHAUST - ANGLED - W/ FLANGE - 2" ID - ONAN# 154-2539
	105958-03-000	EA PIPE - EXHAUST - 90° TURN
	094059-01-000	EA SPACER

### ONAN GENERATOR, 6.5 KW EMERALD PLUS (NHE-FA/26100G) (US, CSA)

KEY	PART NUMBER	U/M DESCRIPTION
	100975-01-000	EA GENERATOR - 6.5 KW EMERALD PLUS
	105958-03-000	EA PIPE - EXHAUST - GENERATOR
	007125-03-000	EA CLAMP - MUFFLER - 1.5" DIA
	007125-04-000	EA CLAMP - MUFFLER - 1.1" DIA
	079654-05-000	EA PIPE - EXHAUST - ANGLED - W/FLANGE - 2" ID - ONAN# 154-2539
	082272-01-000	EA MUFFLER
	094059-01-000	EA SPACER

### ONAN GENERATOR, 5.0 KW EMERALD PLUS (NHE-FN/29236G) (EXPORT)

KEY	PART NUMBER	U/M DESCRIPTION
	100975-03-000	EA GENERATOR - 5.0 KW EMERALD PLUS
	007125-03-000	EA CLAMP - MUFFLER - 1.5" DIA
	007131-01-000	EA HANGER - TAILPIPE - 6 SLOTS
	083151-01-000	EA MUFFLER
	094059-01-000	EA SPACER

### ONAN GENERATOR, 3.5 KW EMERALD PLUS (BGE-FN/29236G) (EXPORT)

KEY	PART NUMBER	U/M DESCRIPTION
	100974-04-000	EA GENERATOR - 4.0 KW EMERALD PLUS
	105958-03-000	EA PIPE - EXHAUST - GENERATOR
	007125-03-000	EA CLAMP - MUFFLER - 1.5" DIA
	007125-04-000	EA CLAMP - MUFFLER - 1.1" DIA
	079654-05-000	EA PIPE - EXHAUST - ANGLED - W/ FLANGE - 2" ID - ONAN# 154-2539
	082272-01-000	EA MUFFLER
	094059-01-000	EA SPACER

## HEATING & AIR CONDITIONING GROUP

### COLEMAN ROOF AIR 13,500 BTU (EXPORT)

KEY	PART NUMBER	U/M DESCRIPTION
	056464-06-000	EA REGISTER - HEAT/A/C - ROUND W/O DAMPER - 4" - PLAS - OFF WHITE
	102289-01-000	EA SPRING - SCREW - ROOF A/C GASKET - 6757-150
	108889-02-01A	EA A/C - ROOF - 13 - 500 TSR 220 IVORY - 7373-597
	063903-01-700	EA SHROUD - 6759-4601
	093306-01-701	EA DECAL PKG - LEFT & RIGHT - 6798B3591
	093763-01-712	EA FAN BLADE - CONDENSER - 6733-3221
	105620-01-705	EA PROTECTOR - OVERLOAD - RH & LH - 6759-3791
	105620-01-706	EA FOOT PKG - COMPRESSOR - 3 PER PKG - 6759-3081
	108889-01-703	EA CONDENSER COIL - 1452A1301
	108889-01-706	EA IMPELLOR - 1472-1041
	108889-01-707	EA RUN CAPACITOR(COMP-25MFD/370 - 1499-5661
	108889-01-708	EA FAN CAPACITOR(7.5MFD.370U) - 1499-5461
	108889-01-709	EA EVAPORATOR COIL - 1452A1311
	108889-01-710	EA FILLER PAD - COND AIR SEAL - 6759A3971
	108889-01-711	EA GASKET PKG - 6792-3301
	108889-01-713	EA SUCTION LINE (3/8OD X .032 WALL) - 6792-130
	108889-01-714	EA DISCHARGE LINE ASSY - 6792-531
	108889-01-715	EA MOTOR MOUNT & SHAFT SEAL KIT - 6792-3361
	108889-02-700	EA COMPRESSOR (TECUMSEH) - 1452-2029
	108889-02-701	EA MOTOR - 1468-3059
	108889-02-702	EA CAPACITOR (START) 1497-0891
	108889-02-703	EA RELAY (START) 1497-4141
	108892-01-01A	EA CEILING ASM - A/C DUCTED - 7330-730 IV
	108892-01-700	EA PLUG ASSEMBLY - 7330-540
	108892-01-701	EA TERMINAL BOARD - 7330-3201
	108892-01-702	EA PIC. BOARD - 7330-3211
	108892-01-703	EA FILTER - 6798A3761
	108892-01-704	EA GRILLE (PLASTIC) - 6798-3041
	108892-01-705	EA SMALL PARTS PKG - 7330A6101
	102289-01-000	EA SPRING - SCREW - ROOF A/C GASKET - 6757-150

# HEATING & AIR CONDITIONING GROUP (CONTINUED)

## COLEMAN ROOF AIR 13,500 BTU (US, CSA)

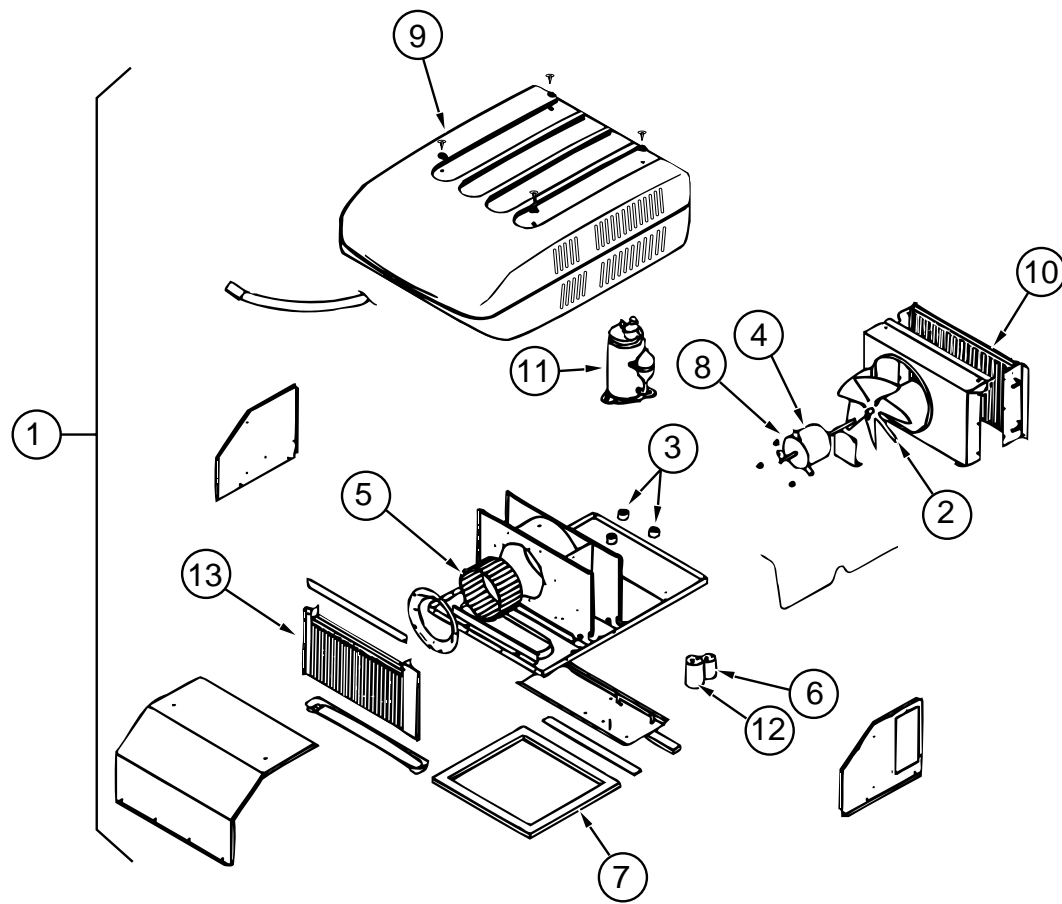

KEY	PART NUMBER	U/M	DESCRIPTION
1	108889-01-01A	EA	A/C-ROOF - 13,500 TSR HO IVORY - 7333-887
2	093763-01-712	EA	FAN BLADE - CONDENSER - 6733-3221
3	105620-01-706	EA	FOOT PKG - COMPRESSOR - 3 PER PKG - 6759-3081
4	108889-01-705	EA	MOTOR (115 - 60HZ) 1468-3049
5	108889-01-706	EA	IMPELLOR - 1472-1041
6	108889-01-708	EA	FAN CAPACITOR (7.5MFD.370U) 1499-5461
7	108889-01-711	EA	GASKET PKG - 6792-3301
8	108889-01-715	EA	MOTOR MOUNT & SHAFT SEAL KIT - 6792-3361
9	063903-01-700	EA	SHROUD (IVORY/ IVORY) LESS/ LOGO - 6759-4601
10	108889-01-703	EA	CONDENSER COIL - 1452A1301
11	105620-01-704	EA	COMPRESSOR - RH & LH - 1450-2009
	108889-01-704	EA	OVERLOAD (MRA#98693) 6749-3541
12	108889-01-707	EA	RUN CAPACITOR (COMP-25MFD/370) 1499-5661
13	108889-01-709	EA	EVAPORATOR COIL - 1452A1311
	108889-01-710	EA	FILLER PAD - COND AIR SEAL - 6759A3971
	108889-01-712	EA	SUCTION LINE REDUCER(3/8 X 1/2) 1215-2161
	108889-01-713	EA	SUCTION LINE (3/8OD X .032 WALL - 6792-130
	108889-01-714	EA	DISCHARGE LINE ASM - 6792-531
	108892-01-01A	EA	CEILING ASM - A/C DUCTED - 7330-730 IV
	108892-01-700	EA	PLUG ASSEMBLY - 7330-540
	108892-01-701	EA	TERMINAL BOARD - 7330-3201
	108892-01-702	EA	PIC. BOARD - 7330-3211
	108892-01-703	EA	FILTER - 6798A3761
	108892-01-704	EA	GRILLE (PLASTIC) - 6798-3041
	091225-01-709	EA	START RELAY - 1497-4131
	091225-01-710	EA	START CAPACITOR - 1497-0881
	093306-01-701	EA	DECAL PKG - LEFT & RIGHT - 6798B3591
	108892-01-705	EA	SMALL PARTS PKG - 7330A6101
	108893-01-01A	EA	THERMOSTAT - A/C & FURNACE BGE - 6799B6951
	108893-02-01A	EA	LABEL - THERMOSTAT A/C ONLY - 6798-391 BK
	110403-01-F31	EA	SPACER ASM - RETURN AIR - OAK
	073937-03-000	EA	SWITCH - ROTARY SELECTOR - 3 DECK - A/C - CA20-USA892
	088238-01-000	EA	COVER - SWITCH - A/C SELECTOR - FRONT TO REAR A/C
	103930-20-702	EA	ROD F/ BLEND AIR DOOR - 073-0039
	103930-20-703	EA	DOOR - BLEND AIR - 071-0212
	103930-20-704	EA	ROD-DOOR - RECIRCULATING - 073-0018
	103930-20-705	EA	DOOR PANEL - RECIRCULATING - 071-0213
	103930-20-706	EA	CLIP - RETAINER - 022-0057
	103930-20-707	EA	BLOWER HOUSING - 062-0145
	103930-20-708	EA	CLIP F/ MOTOR SHAFT - 022-0001
	103930-20-709	EA	SERVICE VALVE - 050-0159
	022756-03-000	EA	COVER - A/C PLASTIC - OFF WHITE
	022756-02-000	EA	COVER - PROTECTIVE - 5.5" ENDS X 8.2" - PLASTIC - OFF WHITE
	088238-02-000	EA	COVER - SWITCH - A/C SELECTOR FOR FRONT OR REAR
	092633-02-02A	EA	COVER - BLANK - ROOF A/C - 5.1" X 5.1" - PLASTIC - OFF WHITE

# HEATING & AIR CONDITIONING GROUP (CONTINUED)

## FURNACE HEATER SYSTEM

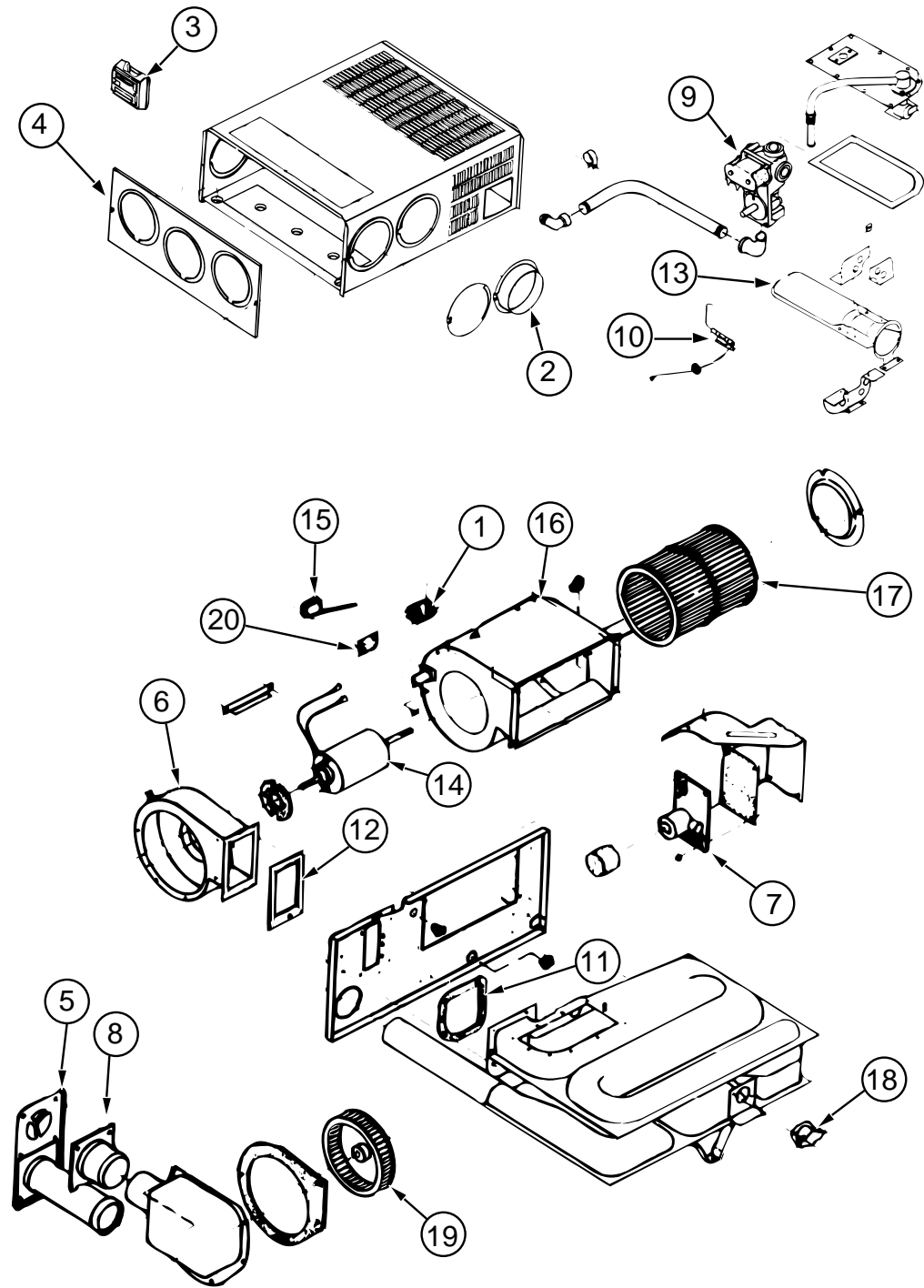

KEY	PART NUMBER	U/M DESCRIPTION
	009198-01-000	FT DUCT - HEAT - FLEXIBLE - 4" ID X 25 FT
	098668-22-000	EA FURNACE - 40,000 BTU - SUBURBAN SF-42 2275
1	074466-01-702	EA RELAY - TIME DELAY - SUBURBAN 230625
2	075696-02-703	EA COLLAR - DUCT - SUBURBAN 050715
3	115764-01-01A	EA THERMOSTAT - FURNACE -SUBURBAN REP'L BY 115764-01
4	098668-01-700	EA CABINET FRONT - SUBURBAN 101242
5	098668-01-707	EA VENT CAP & EXHAUST TUBE ASM - SUBURBAN 260193
6	098668-01-708	EA BLOWER ASM (COMBUSTION AIR) - SUBURBAN 390441
7	098668-01-712	EA BOARD - MODULE - SUBURBAN 231741
8	098668-01-713	EA INTAKE VENT TUBE ASM 051248
9	098668-01-714	EA GAS VALVE FOR SF MODELS S.N. 921401821 AND UP
10	098668-01-715	EA ELECTRODE ASM. (SGL PROBE) F/SF MODELS S.N. 921401821 & UP
11	098668-01-716	EA GASKET FIREWALL(CHAMBER SIDE) 070808
12	098668-01-717	EA GASKET FIREWALL(BLOWER SIDE) 070809
	098668-11-700	EA ORFICE - MAIN BURNER SF-42F 180216
13	098668-11-701	EA BURNER ASM COMP (SF-42F) 010799
14	098668-11-702	EA MOTOR ASM COMP (SF-42F) 232212
15	098668-11-703	EA SWITCH - SAIL(ASM)(SF-42F) 232216
16	098668-11-704	EA BLOWER ASM ROOM AIR(SF-42F) 390698
17	098668-01-711	EA WHEEL - ROOM AIR - SUBURBAN 350123
18	098668-11-706	EA LIMIT SWITCH(SF42 & SF42F) 232217
19	098668-22-702	EA WHEEL COMB. AIR 350183
20	101990-01-714	EA MICROSWITCH GASKET - SUBURBAN 230877
	092777-01-000	EA ADAPTER - DUCT - 4"
	098668-13-000	EA GASKET - FIBERGLASS - .5" X 16.37" X 17.56" - SUBURBAN 070977
	094600-01-02A	EA REGISTER - HEAT - W/O DAMPER - 3.6" X 11.2" - BROWN
	098668-14-000	EA GASKET - FIBERGLASS - .5" X 18" X 18" - SUBURBAN 070976
	098668-06-000	EA DOOR - ACCESS - FURNACE - OFF WHITE - SUBURBAN 520574
	115764-01-01A	EA THERMOSTAT - FURNACE *SUBURBAN 160902
	093614-02-01A	EA GRILL - RETURN AIR - BROWN *92 G-SERIES
	093614-03-01A	EA GRILL - RETURN AIR -BROWN *D & W 170 14X8 BR

## HEATING & AIR CONDITIONING GROUP (CONTINUED)

### AUTOMOTIVE AIR CONDITIONING (FORD)

KEY	PART NUMBER	U/M DESCRIPTION
	007281-01-000	EA HOSE - FLEXIBLE PVC - 2.5"ID X 50' - ATCOFLEX A-182-355
	056402-05-000	EA BRACKET - HEATER VENT - ROUND - W/BEND - BLACK
	077075-01-000	EA GASKET - INSTRUMENT PANEL TO DEFROSTER PLENUM - .6" X 11.3"
	077075-03-000	EA GASKET - INSTRUMENT PANEL TO DEFROSTER PLENUM - SPL
	072341-06-700	EA SWITCH - 4 SPEED - FAN - ARA 0883502
	024990-05-000	EA 4" DIAMETER OUTLET - W/ SWIVEL DEFLECTORS
	103016-01-000	EA PLENUM - TRANSITION
	103017-01-000	EA PLENUM - DEFROSTER
	103558-01-02A	EA VENT - DEFROSTER - ABS LIGHT GRAY
	103796-01-01A	EA LOUVER ASM - A/C CARY PROD BLACK
	103930-21-000	EA EVAPORATOR/HEATER ASSEMBLY - SCS 090-00084
	110279-01-703	EA HOSE - VENT - MOTOR BLOWER - SCS70510034
	110279-01-712	EA HEATER FITTING
	113245-01-707	EA GASKET - 045-0126
	094831-01-709	EA CLAMPS - ROD - 3/16" - MOTIVAIR - SCS ZGG14431
	103930-01-703	EA COIL - HEATER - SCS 042-0010
	103930-01-704	EA COIL EVAPORATOR - 041-0017
	103930-01-708	EA BRACKET - VACUUM MOTOR - SCS 070-0113
	103930-01-710	EA RESISTOR - FUSED - SCS 035-0006
	103930-01-711	EA THERMOSTAT - SCS 033-0003
	103930-01-713	EA FITTING - QUICK CONNECT - #4 - SCS 050-003
	103930-01-717	EA WHEEL - CLOCKWISE - SCS 062-0010
	103930-01-720	EA MOTOR - SCS 030-0004
	103930-02-700	EA PANEL - CONTROL - W/O FACE DECAL - SCS #032-0018
	103930-02-701	EA VALVE - CONTROL HEAD - SCS 034-0015
	103930-02-702	EA DECAL - FAN SWITCH - SCS 058-0008
	103930-02-703	EA HARNESS - WIRE CONTROL - SCS 036-0048
	103930-02-704	EA HARNESS - VACUUM CONTROL - SCS 036-0049
	103930-02-705	EA CABLE - CONTROL - BOWDEN - SCS 074-0011
	103930-02-706	EA CLIP - CABLE - CONTROL - SCS 022-0017
	103930-02-707	EA RELAY - SCS 031-0001
	103930-02-708	EA MOTOR - VACUUM SERVO - A/C - SCS 030-0002
	103930-02-710	EA CANISTER - VACUUM - SCS 054-0002
	103930-02-711	EA VALVE - WATER - SCS 034-00114
	103930-01-708	EA BRACKET - VACUUM MOTOR - SCS 070-0113
	103930-12-708	EA SWITCH - BINARY - R-134A - SCS 032-0048
	103930-13-702	EA SERVICE VALVE W/O C.P. - 050-152
	103930-17-000	EA HOSE KIT #10 SANDEN COMP - SCS 093-00076
	103930-17-700	EA FTG. PAD COMP. SUCTION SAN - 050-0131
	103930-17-701	EA FTG #10.90 W/ FERRULE/ 1342CP - 050-0132
	103930-17-702	EA GASKET OR SAE 015 #10 33-781 - SCS 045-0127
	103930-17-703	EA GASKET - SEAL - SANDEW COMP 33-76 - 045-0142
	103930-17-704	EA HOSE ASM. - #10 - 085-0113
	103930-20-700	EA VALVE EXP. BLOCK (2 TON) - 034-0032
	103930-21-700	EA HOSE ASM. - #6 WINN FORD - 085-0139
	103930-21-701	EA HOSE ASM. - #10 WINN FORD - 085-0140

## HEATING & AIR CONDITIONING GROUP (CONTINUED)

### AUTOMOTIVE AIR CONDITIONING (CHEVY)

KEY	PART NUMBER	U/M DESCRIPTION
	007281-01-000	EA HOSE - FLEXIBLE PVC - 2.5"ID X 50' - ATCOFLEX A-182-355
	056402-05-000	EA BRACKET - HEATER VENT - ROUND - W/ BEND - BLACK
	077075-01-000	EA GASKET - INSTRUMENT PANEL TO DEFROSTER PLENUM - .6" X 11.3"
	072341-06-700	EA SWITCH - 4 SPEED - FAN - ARA 0883502
	077075-03-000	EA GASKET - INSTRUMENT PANEL TO DEFROSTER PLENUM
	024990-05-000	EA 4" DIAMETER OUTLET - W/ SWIVEL DEFLECTORS
	103016-01-000	EA PLENUM - TRANSITION
	103017-01-000	EA PLENUM - DEFROSTER
	103558-01-02A	EA VENT - DEFROSTER - ABS LIGHT GRAY
	103796-01-01A	EA LOUVER ASM - A/C CARY PROD BLACK
	103930-20-000	EA EVAPORATOR/ HEATER CHEV R134A BLOCK - SCS 090-00083
	103930-01-703	EA COIL - HEATER - SCS 042-0010
	103930-01-704	EA COIL EVAPORATOR - 041-0017
	103930-01-708	EA BRACKET - VACUUM MOTOR - SCS 070-0113
	103930-01-710	EA RESISTOR - FUSED - SCS 035-0006
	103930-01-711	EA THERMOSTAT - SCS 033-0003
	103930-01-716	EA SWITCH - PRESSURE - FAN - SCS 032-0029
	103930-01-717	EA WHEEL - CLOCKWISE - SCS 062-0010
	103930-01-720	EA MOTOR - SCS 030-0004
	103930-02-700	EA PANEL - CONTROL - SCS 032-0018
	103930-02-701	EA VALVE - CONTROL HEAD - SCS 034-0015
	103930-02-702	EA DECAL - FAN SWITCH - SCS 058-0008
	103930-02-703	EA HARNESS - WIRE CONTROL - SCS 036-0048
	103930-02-704	EA HARNESS - VACUUM CONTROLSCS 036-0049
	103930-02-705	EA CABLE - CONTROL - BOWDEN - SCS 074-0011
	103930-02-706	EA SHEATH LENGTH IS 84 1/4" - CABLE LENGTH IS 89" LONG
	103930-02-706	EA CLIP - CABLE - CONTROL - SCS 022-0017
	103930-02-707	EA RELAY - SCS 031-0001
	103930-02-708	EA MOTOR - VACUUM SERVO - A/C - SCS 030-0002
	103930-02-710	EA CANISTER - VACUUM - SCS 054-0002
	103930-02-711	EA VALVE - WATER - SCS 034-00114
	103930-12-708	EA SWITCH - BINARY - R-134A - SCS 032-0048
	103930-12-709	EA FITTING - QUICK CONNECT - SCS 050-0120
	103930-17-702	EA GASKET OR SAE 015 #10 33-781 - SCS 045-0127
	110279-01-703	EA HOSE - VENT - MOTOR BLOWER - SCS 051-0034
	103930-05-000	EA MANUAL - OWNERS - HEATER-A/C - SCS 057-0049
	103930-20-700	EA VALVE - EXPANSION - BLOCK (2 TON) - 034-0032
	103930-20-701	EA HOSE ASM. - #6 WINN GM - 085-0138
	110279-01-712	EA HEATER FITTING - 050-0076

**HEATING & AIR CONDITIONING GROUP (CONTINUED)**

**REAR HEATER W/MOTOR AID (EVANS)**

KEY	PART NUMBER	U/M DESCRIPTION
	084405-01-000	EA HEATER ASM - REAR - DUCTED - W/MOTOR AID
	084405-01-700	EA HEATER CORE - FT200229
	084405-01-701	EA FAN BLADES - HV029931
	084405-01-702	EA MOTOR ASM - 12 V - 200146
	061673-01-000	EA BRACKET - MOTOR AID TUBES - 4" X 1.5" - STEEL
	088753-01-000	FT TUBE - ALUMINIZED STEEL - 5/8" - 18 GAUGE
	007076-01-000	EA HOSE - FLEXIBLE PVC - 2" ID X 50'
	007108-01-000	FT HOSE - HEATER, 5/8" ID - HI-TEMP - ESE-M2D192-A
	079059-01-000	EA HOSE - 90 DEGREE - 5/8" ID X 4" X 36"
	079059-02-000	EA HOSE - 90 DEGREE - .61" ID X 4" X 6"
	079059-03-000	EA HOSE - 90 DEGREE - .61" ID X 4" X 18"

**INTERIOR FINISH GROUP**

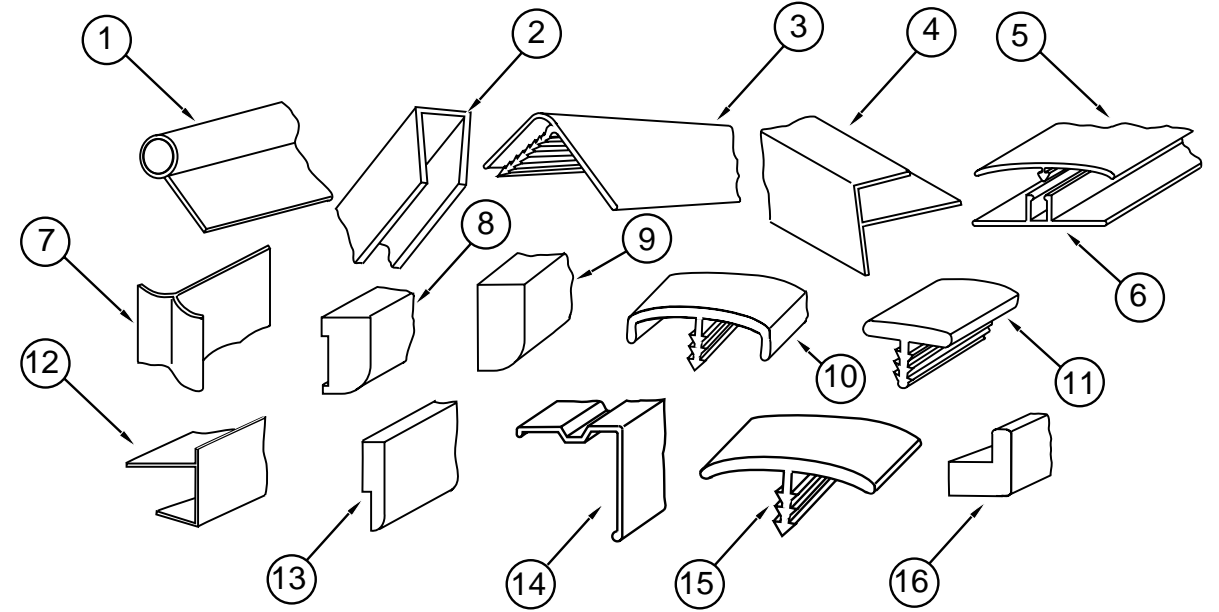

**INTERIOR TRIM, BATT STRIPS & MOLDINGS**

KEY	PART NUMBER	U/M DESCRIPTION
1	009767-12-000	FT MOLDING - SIDEWALL TO CEILING/ CABINET - WELTING - OFF WHITE
2	009778-16-000	FT U-CHANNEL - 1" - PICKLED ASH
2	070504-19-000	FT EXTRUSION - U CHANNEL - .815" WIDE - BROWN - 8'
2	070504-23-000	FT EXTRUSION - U CHANNEL - 22.56 - COUNTRY FOREST
2	070504-29-000	FT EXTRUSION - U CHANNEL - 20.70 - PICKLED ASH
3	009809-21-000	EA MOLDING - CORNER - OUTSIDE - 1" - PLASTIC - WOODGRAIN
3	009809-23-000	EA MOLDING - CORNER - OUTSIDE - 1" - PLASTIC - IVORY
4	009812-22-000	EA MOLDING - CORNER - OUTSIDE - .5" X 7' - PLASTIC - BROWN
5	086229-13-000	EA BATTEN - CEILING - 1" WIDE - IVORY - 7.6'
6	086229-01-000	EA RETAINER - BATTEN - CEILING - .75" WIDE - 7.6'
7	022992-11-000	FT MOLDING - REVERSE COVE - T-SHAPED - VINYL - IVORY
8	100041-01-000	EA MOLDING - VINYL WRAPPED - .7" X 1.57" X 84.02" - RAMBLING OAK
8	100041-02-000	EA MOLDING - VINYL WRAPPED - .7" X 2.5" X 84" - RAMBLING OAK
9	100818-01-02A	EA MOLDING - VINYL WRAP - TRIM - RAMBLING OAK
10	083620-07-000	FT T-MOLDING - 3/4 END CAP EDGE - W/ EDGE LIPS - THOR PECAN
10	083620-10-000	FT T-MOLDING - 3/4 W/ EDGE LIPS - PICKLED ASH
11	104676-01-01A	FT T-MOLDING - 5/16 RIGID - GOLD
12	103186-02-02A	FT MOLDING - PLASTIC - SHELF EDGING - 1.3" WIDE - PLASTIC - REGAL OAK
12	103186-01-01A	FT MOLDING - PLASTIC - SHELF EDGING - .78" - RAMBLING OAK
13	105004-01-02A	EA MOLDING - VINYL WRAP - RAMBLING OAK
	076325-25-000	FT MOLDING - EDGE BAND - 1 5/16" WIDE - RAMBLING OAK
	076325-31-000	FT MOLDING - EDGE BAND - RAMBLING OAK .93 X .024 X 600'
	076325-46-000	FT MOLDING - EDGE BAND - 1035 CLOUD - 15/16 X .030 X 600
	076325-47-000	FT MOLDING - EDGE BAND - 1032 SAND - 15/16 X .030 X 600
	076325-34-000	FT MOLDING - EDGE BAND - 1233 ORCHID MIST - 15/16 X .030 X 600 (PATIO TABLE)
14	093873-01-01A	EA TRIM - CARPET - L-ANGLE - 1.1" X 1.3" X 12' - VINYL - GRAY
15	105709-01-000	FT T-MOLDING - 1" - MODERN IVORY
16	100819-01-02A	EA MOLDING - VINYL WRAP - L-SHAPED, 1.5" X 1.5" X 7' - OAK
	085284-76-000	FT STRIP-TAPE - ADHESIVE - SHOWER - TRAVERTINE - ANTIQUE WHITE
	085284-67-000	FT STRIP-TAPE - ADHESIVE - 541 - RAMBLING OAK PLUSWOOD
	085284-A4-000	FT STRIP-TAPE - ADHESIVE - ALLURE MEADOW (MAIN WALL) (F31)
	085284-61-000	FT STRIP-TAPE - ADHESIVE - FAUX STRIPE (MAIN WALL) (F32)
	069733-80-000	EA BATT STRIP - 8' - RAMBLING OAK
	088263-78-000	EA BATT STRIP - SHOWER - TRAVERTINE - ANTIQUE WHITE
	088263-B3-000	EA BATT STRIP - ALLURE MEADOW (MAIN WALL) (F31)
	088263-73-000	EA BATT STRIP - FAUX STRIPE (MAIN WALL) (F32)
	100040-01-000	EA LUMBER - VINYL WRAPPED - .71" X 1.5" X 8' - RAMBLING OAK
	100040-03-000	EA LUMBER - VINYL WRAPPED - .71" X 2" X 8' - RAMBLING OAK
	100040-06-000	EA LUMBER - VINYL WRAPPED - RAMBLING OAK
	100040-07-000	EA LUMBER - VINYL WRAPPED - RAMBLING OAK

# INTERIOR FINISH GROUP (CONTINUED)

## CABINET HARDWARE

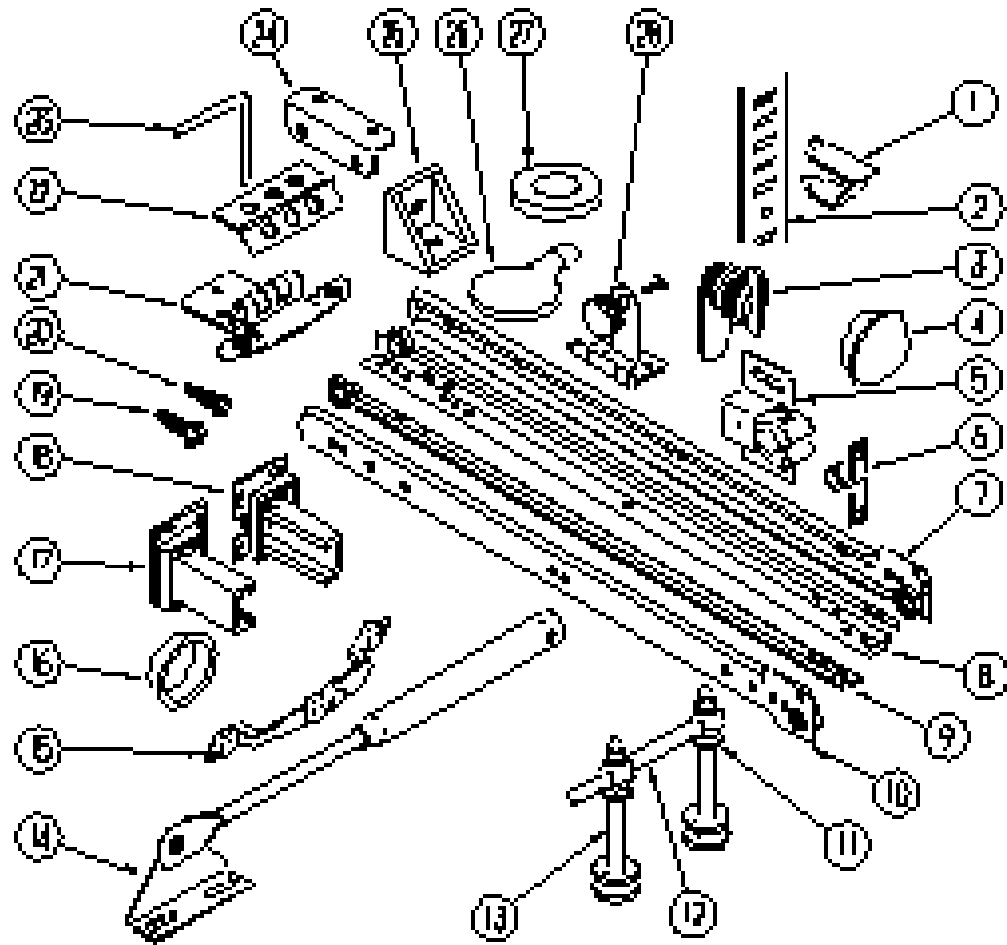

KEY	PART NUMBER	U/M DESCRIPTION
1	098979-01-000	EA CLIP - ADJUSTABLE SHELF
2	098980-01-000	EA PILASTER - ADJUSTABLE SHELF - 18" LONG
2	098980-02-000	EA PILASTER - ADJUSTABLE SHELF - 12" LONG
2	098980-06-000	EA PILASTER - ADJUSTABLE SHELF - 24" LONG
3	100710-01-01A	EA LOCK - GLASS DOOR - TWIST TYPE - BRASS
	101272-01-000	EA CATCH - DOOR - GLASS
4	042356-01-000	EA PLUG - MAHOGANY - 3/8" DIAMETER - WOOD
4	074045-01-000	EA PLUG - OAK - 1/2" DIAMETER
5	093586-01-000	EA CATCH - SPRING - ROLLER
6	093586-02-000	EA STRIKE - SPRING STEEL
7	114031-02-000	EA SLIDE - DRAWER - 12" - CABINET - RIGHT SIDE
7	114031-14-000	EA SLIDE - DRAWER - 18" - CABINET - RIGHT SIDE
7	114031-18-000	EA SLIDE - DRAWER - 20" - CABINET - RIGHT SIDE
7	114031-22-000	EA SLIDE - DRAWER - 22" - CABINET - RIGHT SIDE
8	114031-04-000	EA SLIDE - DRAWER - 12" - RIGHT SIDE
8	114031-16-000	EA SLIDE - DRAWER - 18" - RIGHT SIDE
8	114031-20-000	EA SLIDE - DRAWER - 20" - RIGHT SIDE
8	114031-24-000	EA SLIDE - DRAWER - 22" - RIGHT SIDE
9	114031-03-000	EA SLIDE - DRAWER - 12" - LEFT SIDE
9	114031-15-000	EA SLIDE - DRAWER - 18" - LEFT SIDE
9	114031-19-000	EA SLIDE - DRAWER - 20" - LEFT SIDE
9	114031-23-000	EA SLIDE - DRAWER - 22" - LEFT SIDE
10	114031-01-000	EA SLIDE - DRAWER - 12" - CABINET - LEFT SIDE
10	114031-13-000	EA SLIDE - DRAWER - 18" - CABINET - LEFT SIDE
10	114031-17-000	EA SLIDE - DRAWER - 20" - CABINET - LEFT SIDE
10	114031-21-000	EA SLIDE - DRAWER - 22" - CABINET - LEFT SIDE
11	084070-02-000	EA POST - END - 2.4" - BRASS
12	084071-04-000	EA ROD - BRASS - 11.9"
12	084071-15-000	EA ROD - BRASS - 8.27"
13	084070-01-000	EA POST - CENTER - 2.4" - BRASS
14	074493-02-000	EA SUPPORT - PISTON SPRING - CABINET DOOR
15	111765-01-000	EA CABINET DOOR PULL - BRASS
16	098410-01-01A	EA PULL - FINGER - OVAL - BRASS
17	114045-01-000	EA BACKSOCKET - ADJUSTABLE - LEFT
18	114045-02-000	EA BACKSOCKET - ADJUSTABLE - RIGHT
19	000G68-06-10G	EA SCREW - 6-18 X 5/8" - PHILLIP OVAL HEAD - ANTIQUE BRASS
20	000G13-06-10G	EA SCREW - 6-20 X 5/8" - PHILLIP FLAT HEAD - ANTIQUE BRASS
21	108138-01-000	EA HINGE - DOOR - CABINET - BURNISHED BRASS
22	009059-02-000	EA HINGE - DOOR - 2" X 2.7" - BRASS
23	108487-02-01A	EA PROP ROD - OVERHEAD GLASS DOOR SUPPORT - BLACK
	108486-01-01A	EA BRACKET - PROP ROD - OVHD - BLACK
	039984 01 000	EA CAP - VINYL - BLACK (PROP ROD)
24	016604-03-000	EA BRACE - CABINET - ANGLE - 2.5" - METAL - BEIGE
25	065740-01-000	EA BRACE - CABINET CORNER - PLASTIC
26	101766-01-000	EA PIN - SUPPORT - GLASS DOOR
27	100707-01-000	EA SPACER - DOOR - GLASS - PLASTIC
28	100711-01-01A	EA HINGE - DOOR - GLASS
	P02786-04-E10	EA HANDRAIL - ENTRANCE DOOR
	099682-01-01A	EA BRACKET - MOUNTING - HAND RAIL - BRASS
	009063-01-000	EA HINGE - CONTINUOUS - 1 1/2" X 72" - UNPAINTED
	009066-01-000	EA HINGE - ALUMINUM - NO HOLES - 1 1/16" X 6' - UNPAINTED
	004354-01-000	EA BUMPER - RUBBER - .5" DIA - BROWN

## INTERIOR FINISH GROUP (CONTINUED)

### PANELING, PLASTIC LAMINATE & CARPET

KEY	PART NUMBER	U/M	DESCRIPTION
	074497-21-000	SF	PANELING - 541 WINNI OAK
	074498-34-000	SF	LAMINATE - PLASTIC - RAMBLING OAK - 5' X 8' (40 SF) (PULLOUT TABLE)
	074498-62-000	SF	LAMINATE - PLASTIC - GRAY FINESSE - 5' X 8' (40 SF) (F31)
	074498-72-000	SF	LAMINATE - PLASTIC - PEBBLE SANTOS - 5' X 8' (40 SF) (F32)
	074498-67-000	SF	LAMINATE - PLASTIC - ORCHID MIST - 5' X 8' (40 SF) (PATIO TABLE)
	088272-D6-000	SF	PANELING - ALLURE MEADOW (MAIN WALL) (F31)
	088272-93-000	SF	PANELING - FAUX STRIPE (MAIN WALL) (F32)
	088272-98-000	SF	PANELING - SHOWER - OFF WHITE - 4' X 7' (28 SF)
	089297-01-000	SF	PLYWOOD - LUAN - OVERLAY GRADE - 4' X 8' (32 SF)
	089351-03-000	YD	VINYL - CEILING - DIAMOND DESIGN - 54" WIDE
	096060-A7-000	SY	CARPET - 12' ROLL - LAVENDAR GRAY(MINIMUM 4 SY) (F31)
	096060-95-000	SY	CARPET - 12' ROLL - DOESKIN (MINIMUM 4 SY) (F32)
	093486-01-000	SY	CARPET - (COMPARTMENT - 54" WIDE - DARK GRAY
	075233-01-000	SY	PAD - CARPET - 3/8" X 6' ROLL
	075233-05-000	SY	PAD - CARPET - 3/8" X 4' ROLL
	075233-06-000	SY	PAD - CARPET - 3/8" X 2' ROLL
	047034-02-000	SF	PLASTIC - CARPET - 4' WIDE - CLEAR POLY
	105924-01-F31	EA	MAT - FLOOR 18 X 27 (DRIVERS COMPARTMENT)
	105924-01-F32	EA	MAT - FLOOR 18 X 27 (DRIVERS COMPARTMENT)

### FIRE EXTINGUISHER, DETECTORS & WALL CLOCK

KEY	PART NUMBER	U/M	DESCRIPTION
	072852-01-000	EA	DETECTOR - SMOKE - W/9 VOLT BATTERY
	072852-02-000	EA	DETECTOR - SMOKE - W/9 VOLT BATTERY - CANADIAN
	112320-01-000	EA	DETECTOR (CO GAS) MODEL 9B-I - COSTAR 940000000
	112320-02-000	EA	BATTERY/ SENSOR (CO GAS) COSTAR 940001000
	094499-01-000	EA	FIRE EXTINGUISHER - DRY W/MOUNTING BRACKET - 10 BC
	094499-01-700	EA	BRACKET - MOUNTING - W/PLASTIC STRAP - FIRE EXTINGUISHER
	094499-02-000	EA	FIRE EXTINGUISHER - DRY - 1A10BC - CANADIAN
	100793-02-01A	EA	WALL CLOCK - 11" DIAMETER - BOLDEN 9988

## LABELS GROUP

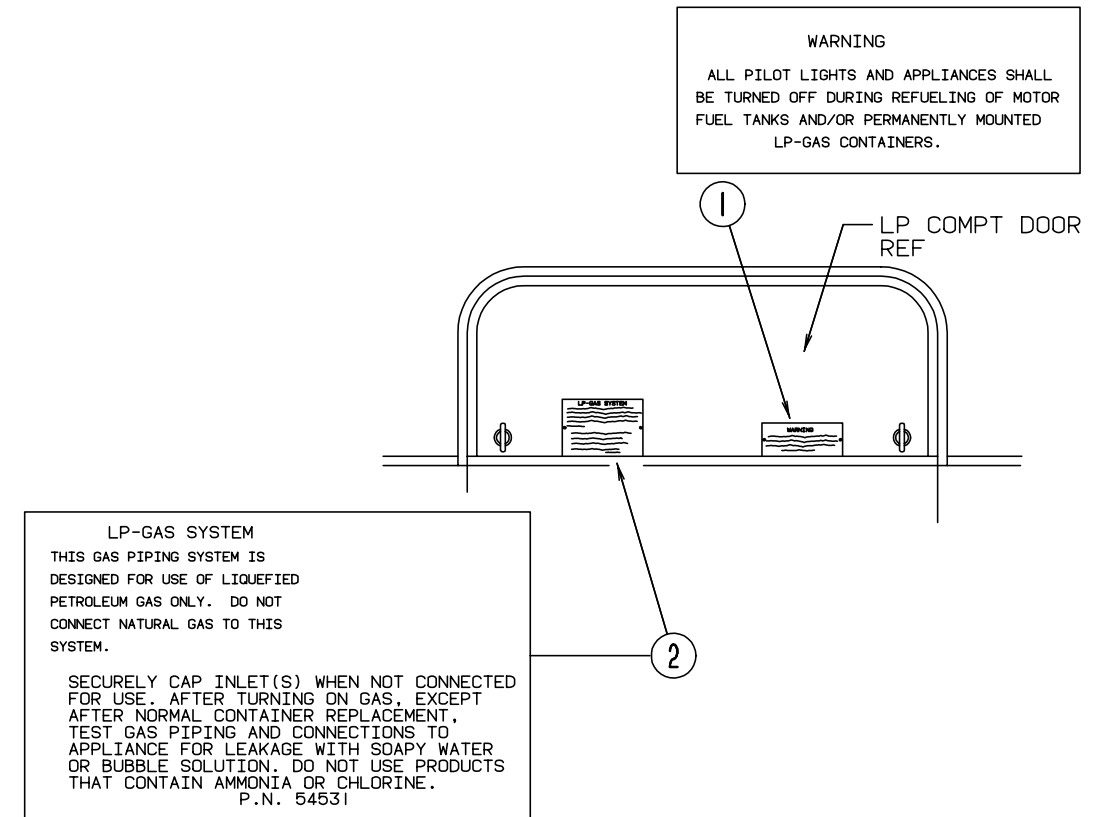

KEY	PART NUMBER	U/M	DESCRIPTION
1	006040-01-000	EA	TAG - GAS REFUELING WARNING
1	006040-02-000	EA	TAG - GAS REFUELING WARNING (CANADIAN)
2	054531-01-000	EA	LABEL - LP GAS ONLY
2	023769-01-000	EA	LABEL - WARNING-LPG (CANADIAN)

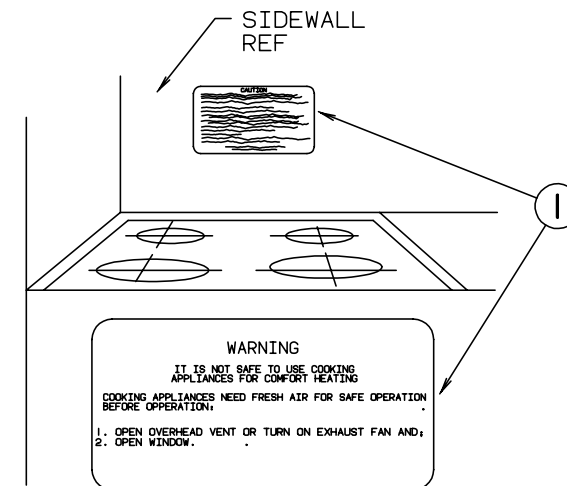

KEY	PART NUMBER	U/M	DESCRIPTION
1	050225-01-000	EA	LABEL - WARNING - STOVE VENT - US
1	050222-01-000	EA	LABEL - WARNING - STOVE VENT - CSA

**LABELS GROUP (CONTINUED)**

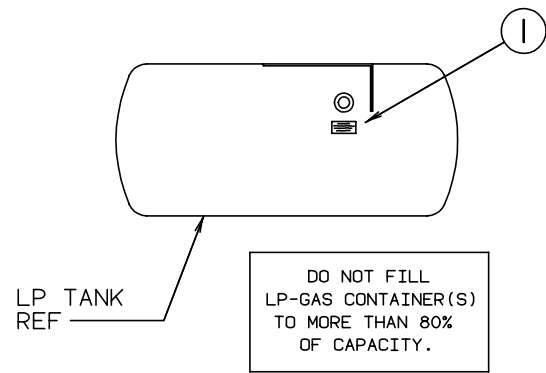

KEY	PART NUMBER	U/M DESCRIPTION
1	079965-01-000	EA LABEL - LPG - 80% CAPACITY

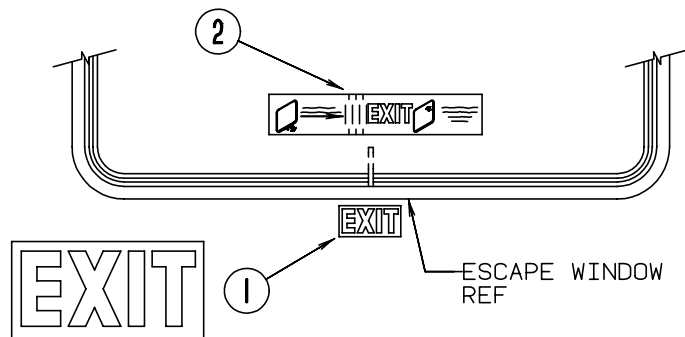
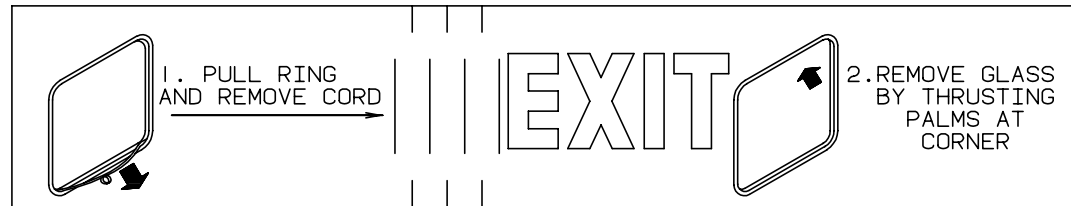

KEY	PART NUMBER	U/M DESCRIPTION
1	107571-01-000	EA LABEL - EXIT/ESCAPE WINDOW
2	039290-01-000	EA LABEL - EXIT WARNING

**LABELS GROUP (CONTINUED)**

<b>CAUTION</b>	TO HELP AVOID PERSONAL INJURY DURING REMOVAL OF FUEL FILLER CAP, SLOWLY LOOSEN CAP 1/2 TURN TO ALLOW ANY FUEL PRESSURE TO BE RELIEVED BEFORE TURNING CAP FURTHER.
<b>FUEL SPRAY MAY CAUSE PERSONAL INJURY</b>	STOP ADDING FUEL AFTER FIRST SHUTOFF BY AUTOMATIC NOZZLE WHEN TANK IS NEARLY FULL. DO NOT OVERFILL FUEL TANK. SEE OWNERS MANUAL FOR ADDITIONAL INFORMATION.
	PRINTED IN U.S.A. <span style="float: right;">MLC PT NO 15611763</span>

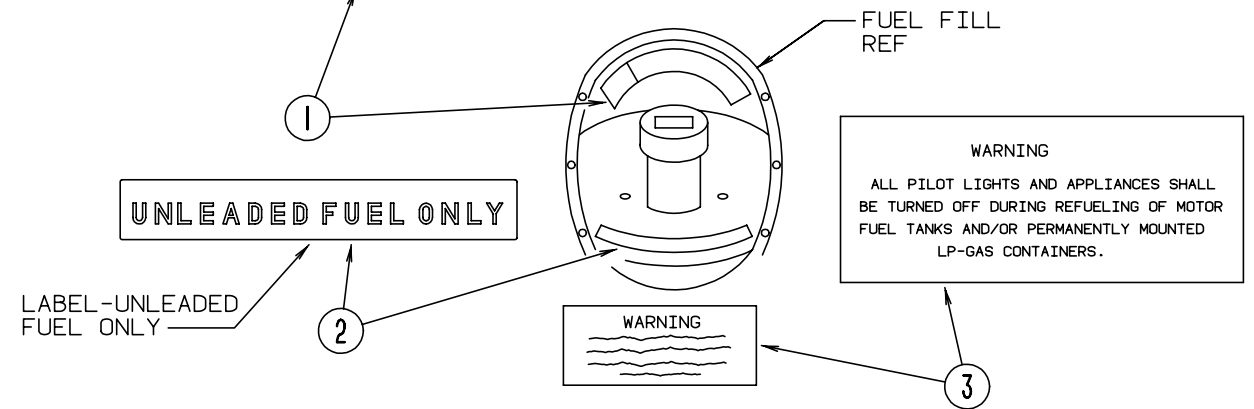

KEY	PART NUMBER	U/M DESCRIPTION
1	087207-05-000	EA LABEL - FUEL CAP REMOVAL
2	062043-01-000	EA LABEL - FUEL - UNLEADED
3	006040-01-000	EA TAG - GAS REFUELING WARNING
3	006040-02-000	EA TAG - GAS REFUELING WARNING (CANADIAN)

GENERATOR COMP  
DOOR REF

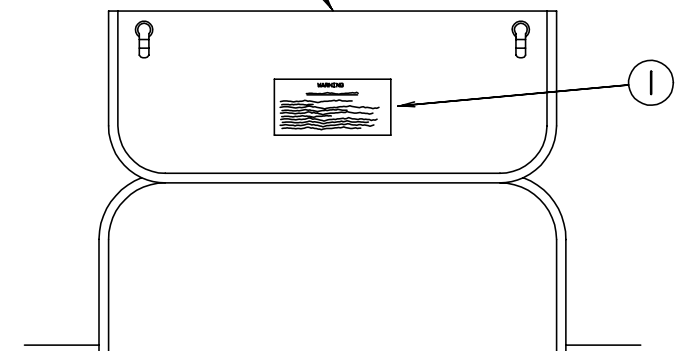

**WARNING**

WHEN ADDING A GENERATOR SET:

HIGH VOLTAGE-USE EXTREME CAUTION WHEN WORKING ON ELECTRICAL COMPONENTS. HAVE ALL ELECTRICAL INSTALLATION PERFORMED BY A QUALIFIED LICENSED ELECTRICIAN-FOLLOW ALL STATE AND LOCAL CODES. ONLY INSTALL GENERATOR SET APPROVED FOR R.V. APPLICATION. HAVE INSTALLED BY QUALIFIED TECHNICIAN. TO AVOID HEAT BUILD-UP AND TO GUARANTEE AN ADEQUATE AIR SUPPLY TO THE GENERATOR CARBURETOR, FOLLOW INSTALLATION INSTRUCTIONS. GENERATOR ENGINE EXHAUST GASES ARE TOXIC AND MUST NOT TERMINATE UNDER THE VEHICLE-DISCHARGE EXHAUST AWAY FROM VEHICLE.

KEY	PART NUMBER	U/M DESCRIPTION
1	077510-01-000	EA LABEL - GENERATOR PREP



**LABELS GROUP (CONTINUED)**

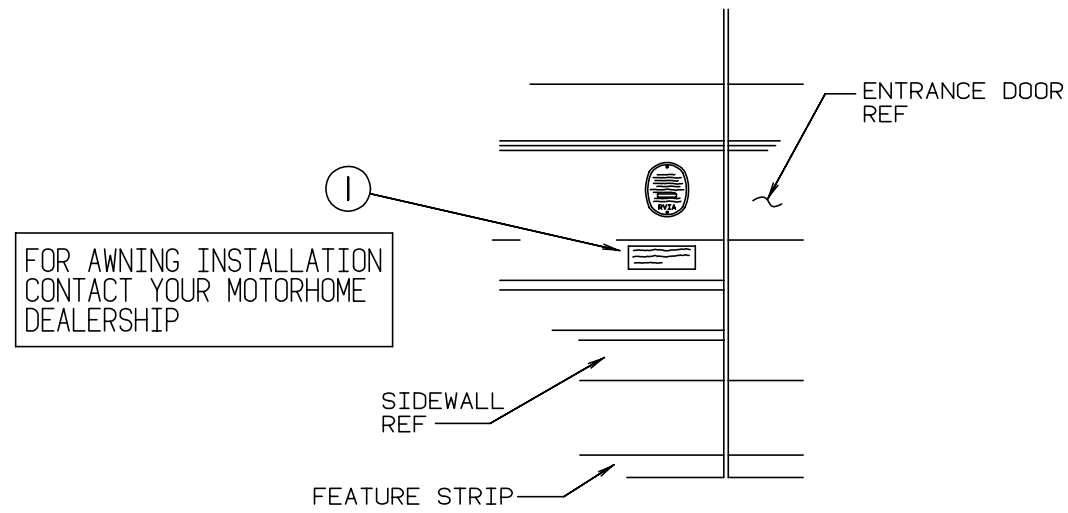

KEY	PART NUMBER	U/M DESCRIPTION
1	099509-01-000	EA LABEL - AWNING INSTALLATION

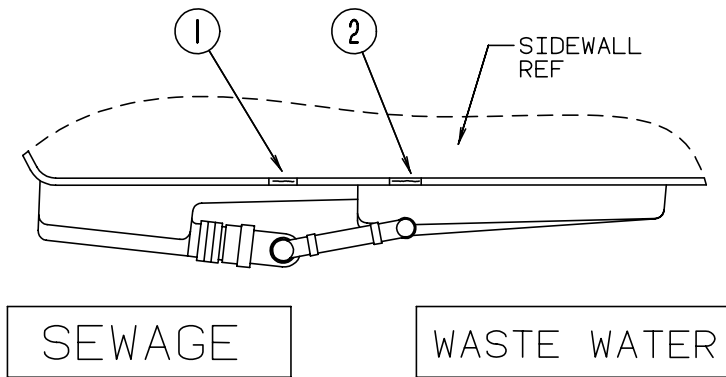

KEY	PART NUMBER	U/M DESCRIPTION
1	006187-01-000	EA LABEL - SEWAGE
2	006188-01-000	EA LABEL - WASTE WATER

**LABELS GROUP (CONTINUED)**

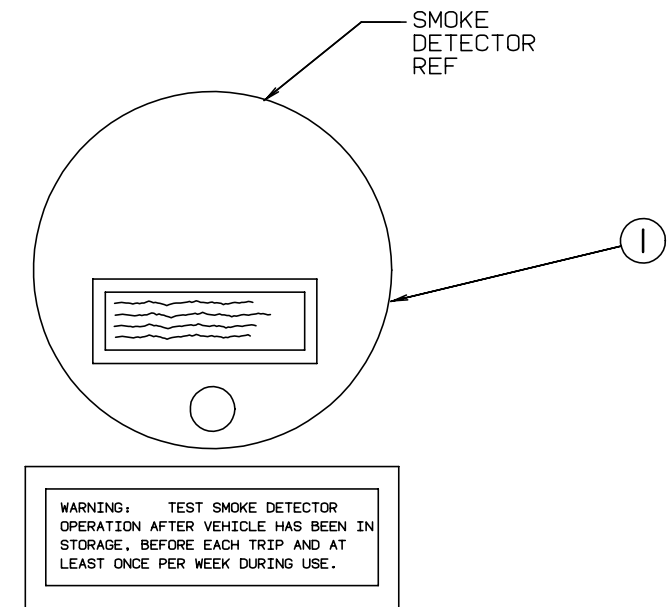

KEY	PART NUMBER	U/M DESCRIPTION
1	077956-01-000	EA LABEL - WARNING - SMOKE DETECTOR

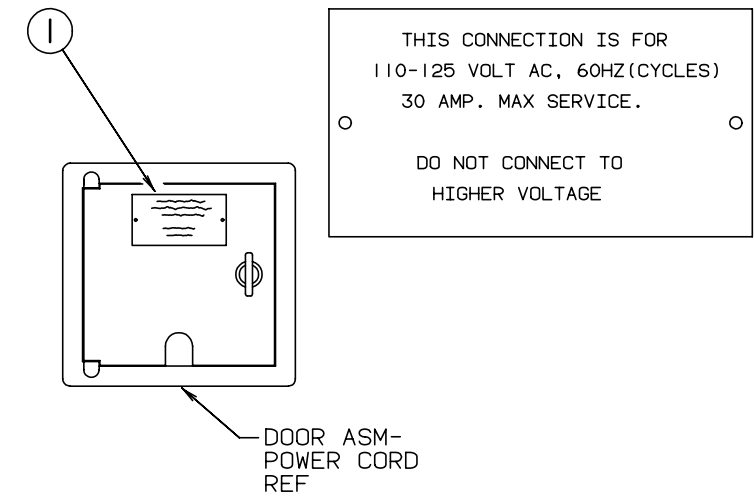

KEY	PART NUMBER	U/M DESCRIPTION
1	006062-01-000	EA TAG - ELECTRIC - 110V CONNECTION

## LABELS GROUP (CONTINUED)

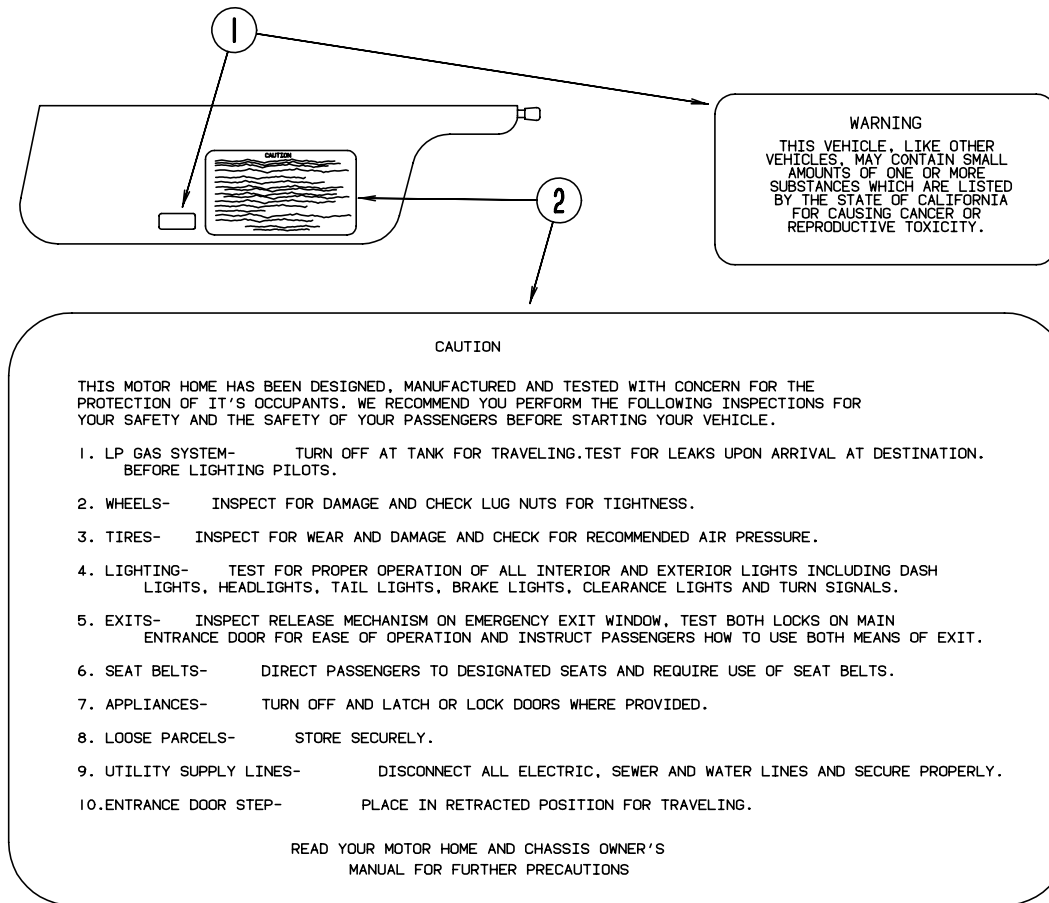

## LABELS GROUP (CONTINUED)

### MISCELLANEOUS LABELS

KEY	PART NUMBER	U/M DESCRIPTION
	050222-01-000	EA LABEL - STOVE VENT - CANADIAN
	094675-01-000	EA LABEL - EXTERIOR LIGHT - SERVICE
	073998-01-000	EA LABEL - LPG ODOR WARNING
	079966-01-000	EA LABEL - WARNING - STOWED - MOTION
	091224-02-000	EA LABEL - TRAILER LIGHTING
	091243-01-000	EA LABEL - A/C COVER - "AIR CONDITIONING CIRCUIT. ETC."
	098379-04-000	EA LABEL - ELECTRICAL BOX SIDE
	098641-01-000	EA LABEL - FUEL - UNLEADED - DASH
	104678-01-000	EA LABEL - CB PREP
	111104-01-000	EA LABEL - HITCH - READ MANUAL
	111537-01-000	EA LABEL - FUSES
	111537-05-000	EA LABEL - SLIDEOUT CONTROLS
	111802-01-000	EA LABEL - CFC WARNING

KEY	PART NUMBER	U/M DESCRIPTION
1	099689-01-000	EA LABEL - WARNING - CANCER/TOXICITY
2	056259-01-000	EA LABEL - SAFETY CHECK LIST

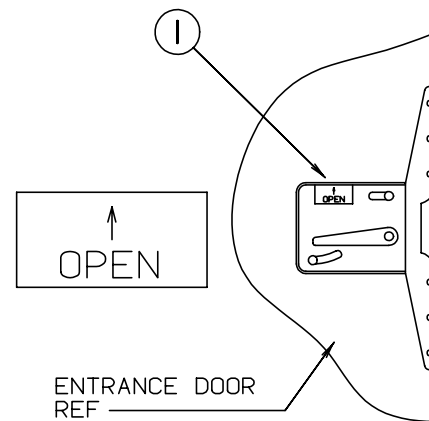

KEY	PART NUMBER	U/M DESCRIPTION
1	040944-01-000	EA LABEL - ENTRANCE DOOR - "OPEN"

## LP GROUP

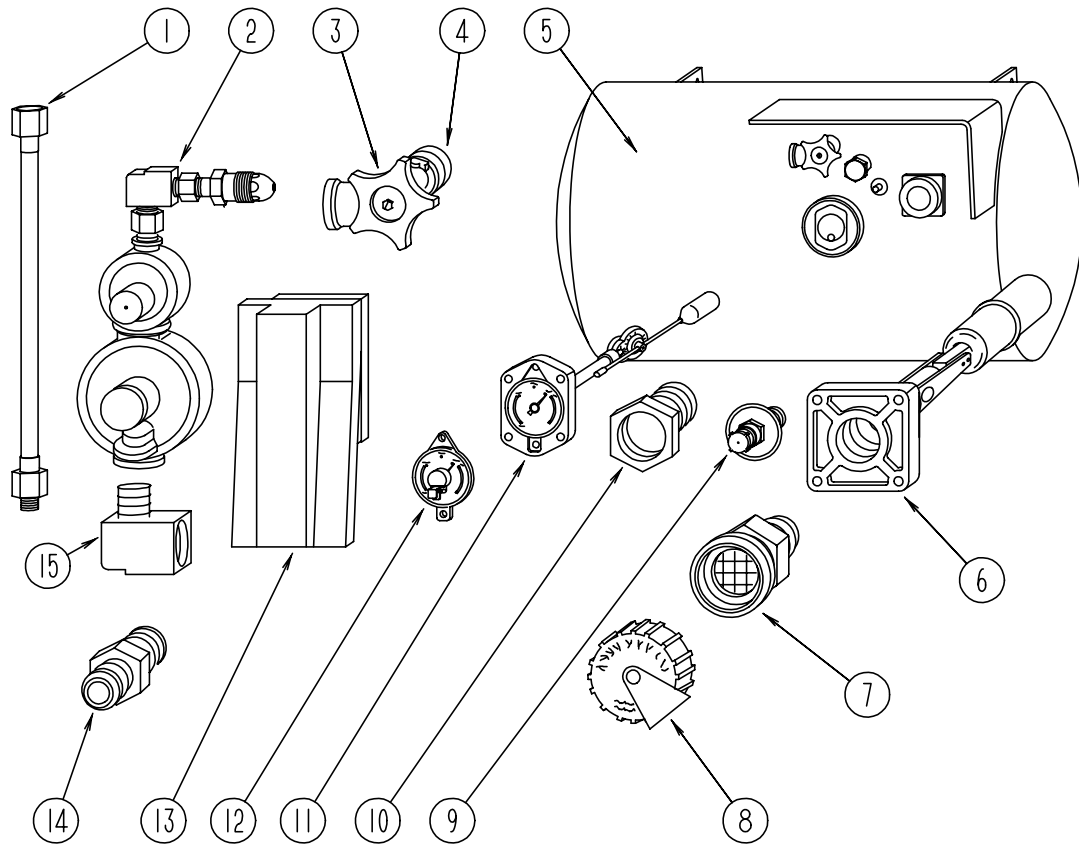

## LP TANK & COMPONENTS

KEY	PART NUMBER	U/M	DESCRIPTION
1	045703-05-000	EA	HOSE - LP - 3/8" ID X 28" - 3/8" MPT X 1/2" F SWIVEL - US
1	045703-06-000	EA	HOSE - LP - 3/8" ID X 28" - 3/8" MPT X 1/2" F SWIVEL - CANADA
2	106150-01-000	EA	REGULATOR - TWO STAGE
3	040421-01-708	EA	HANDWHEEL - VAPOR RELIEF VALVE - BRUNNER G-1015-A
4	040421-01-712	EA	VALVE - SERVICE W/HANDWHEEL
5	088253-03-000	EA	TANK - LP - 100 LB - 16"D X 36" - SPL
6	040421-01-711	EA	VALVE - 80% W/FLOAT - PLATE - BOLTS & GASKET - BRUNNER
7	040421-01-701	EA	VALVE - SHORT LP FILLER W/YELLOW CAP - BRUNNER 75478
8	040421-01-702	EA	CAP - LP FILLER VALVE - PLASTIC - YELLOW - BRUNNER G-1014-A
9	040421-01-700	EA	GAUGE - LIQUID LEVEL - 20% LP - BRUNNER G-1013
10	040421-01-713	EA	PRESSURE RELIEF VALVE
11	088253-01-700	EA	L.P. FLOAT GAUGE - 4 MACHINE SCREW STYLE
12	040440-02-000	EA	TRANSMITTER - DIAL - 90 OHM
13	105658-01-000	EA	COMPARTMENT - LP REGULATOR
14	010252-01-000	EA	ELBOW - BRASS - 90 DEGREE - 3/8" F X 1/2" MPT
	010265-01-000	EA	ELBOW - BRASS - 90 DEGREE - 3/8" F X 1/2" FPT
15	065318-01-000	EA	ELBOW - 90 DEGREE - 1/4" MPT TO 1/4" FPT
	103613-01-000	EA	DETECTOR - LP GAS

## LOUNGE GROUP

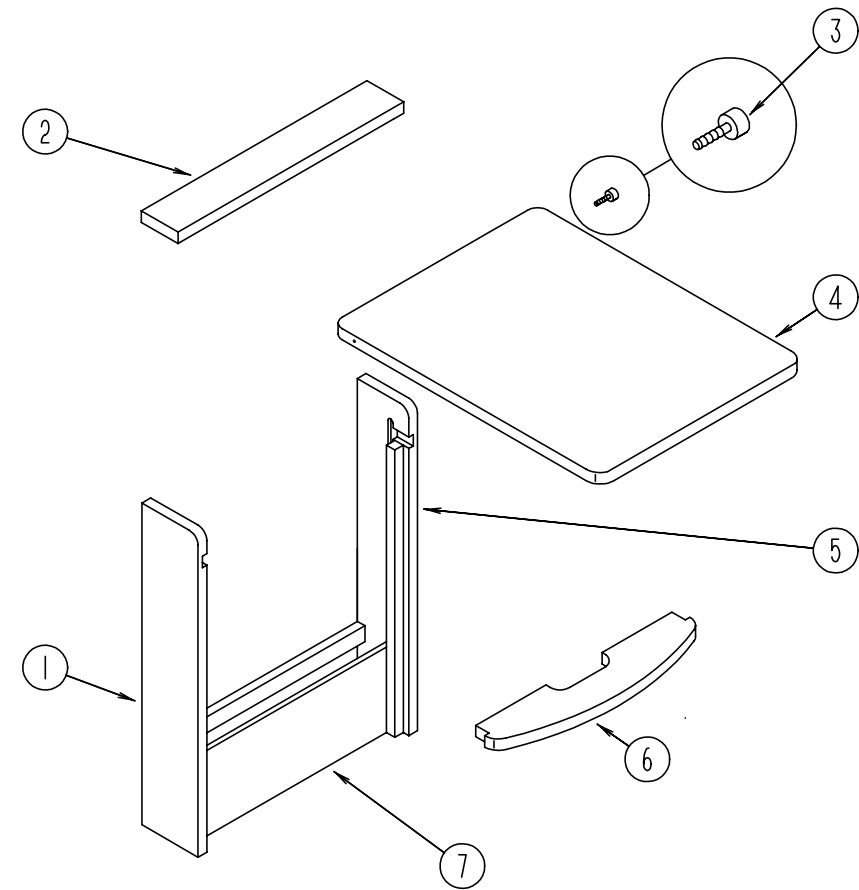

## PULLOUT TABLE

KEY	PART NUMBER	U/M	DESCRIPTION
	M96873-01-E07	EA	CABINET ASM. - TABLE - W/O PULLOUT TOP
1	096873-14-B87	EA	SIDE END - TABLE - 28.7" X 5.7" - LEFT SIDE
2	096873-15-B87	EA	SHELF - SUPPORT - OVER PULL OUT TABLE TOP
3	079921-01-000	EA	NYLON ROLLER W/SHAFT
4	096873-11-E01	EA	PULLOUT TOP
5	096873-13-B87	EA	SIDE END - TABLE - 28.7" X 5.7" - RIGHT SIDE
6	096873-12-B87	EA	SHELF - SUPPORT - UNDER PULL OUT TABLE TOP
7	096873-16-B87	EA	PANEL - TABLE - FRONT BOTTOM - 18.1" X 6.7"
	080736-01-000	EA	PULL - RECESSED - 1.25" X 4" - OAK

**LOUNGE GROUP (CONTINUED)**

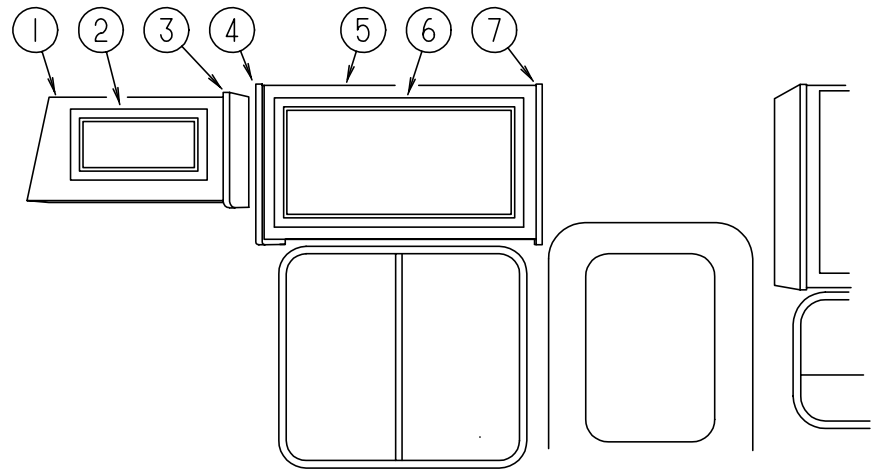

**FRONT OVERHEAD CABINET (PASSENGER SIDE)**

KEY	PART NUMBER	U/M	DESCRIPTION
1	M06839-01-F31	EA	CABINET ASM. - FRONT OVERHEAD - PASSENGER SIDE
1	M06839-01-F32	EA	CABINET ASM. - FRONT OVERHEAD - PASSENGER SIDE
2	M05993-13-E30	EA	DOOR ASM - RAIL - W/O HARDWARE
3	103128-08-E10	EA	END CAP ASM. (FRONT OVERHEAD)
4	103128-07-F31	EA	END CAP ASM. - LEFT HAND
5	M06839-08-F31	EA	CABINET ASM. - OVERHEAD
6	M05993-16-E30	EA	DOOR ASM - W/O HARDWARE
7	103128-10-F31	EA	END CAP ASM. - RIGHT HAND
	104414-12-F31	EA	SHELF ASM.

**LOUNGE GROUP (CONTINUED)**

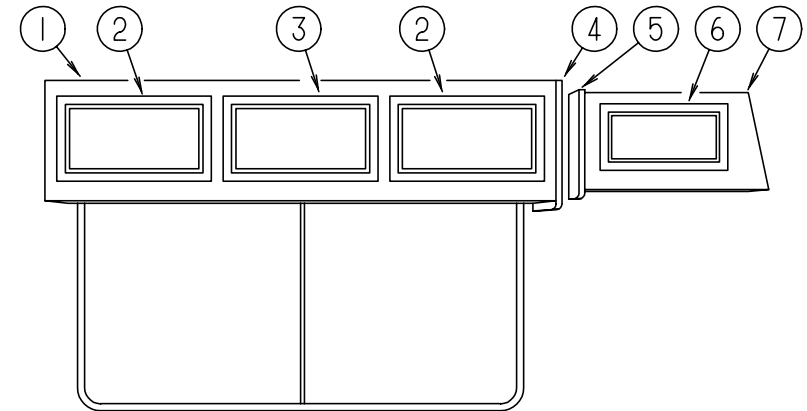

**FRONT OVERHEAD CABINET (DRIVER SIDE)**

KEY	PART NUMBER	U/M	DESCRIPTION
1	M06839-07-E30	EA	CABINET ASM. - OVERHEAD - DRIVER SIDE
2	M05993-21-E30	EA	DOOR ASM. - RAIL - W/O HARDWARE - W/ MIRROR
2	108536-06-04A	EA	MIRROR - CABINET DOOR
3	M05993-22-E30	EA	DOOR ASM. - RAIL - W/O HARDWARE - W/ MIRROR
3	108536-05-04A	EA	MIRROR - CABINET DOOR
4	103128-01-E10	EA	END CAP ASM. - RIGHT HAND
5	103128-09-E10	EA	END CAP ASM. (FRONT OVERHEAD)
6	M05993-13-E30	EA	DOOR ASM - W/O HARDWARE
7	M06839-02-F31	EA	CABINET ASM. - FRONT OVERHEAD - DRIVER SIDE
7	M06839-02-F32	EA	CABINET ASM. - FRONT OVERHEAD - DRIVER SIDE

**SEALANTS & FASTENERS GROUP**

**ADHESIVE AND BOLTS**

KEY	PART NUMBER	U/M DESCRIPTION
	004020-01-000	QT ADHESIVE - ABS CEMENT - QUART
	081377-01-700	EA ADHESIVE - CYANOACRYLATE - 10 GRAM TUBE
	004006-04-700	EA ADHESIVE - PIERCE - 1 GAL - J9270-X-1
	087211-01-000	GL ADHESIVE - PROMOTER
	004005-02-000	EA ADHESIVE - SWIFTS - 1 GAL - W1333
	099039-01-000	EA ADHESIVE - WEATHERSTRIP - 8 OZ.
	053766-02-000	EA BEDDING COMPOUND - TUBE - WHITE
	102333-01-02A	EA BOLT - CARRIAGE - 7/16 - 14
	051387-06-000	EA BOLT - CARRIAGE - W/O HOLE - 5/16-18 X 9.5 ZN
	000C12-08-24B	EA BOLT - HEX - 1/2-13 X 1 1/2 - ZN 5
	000C12-05-16B	EA BOLT - HEX - 5/16-18 X 1 - ZINC 5
	000C12-10-24B	EA BOLT - HEX - 5/8-11 X 1 1/2 ZN - 5
	000C12-07-20B	EA BOLT - HEX - 7/16 - 14 X 1 1/4" - ZN5
	000C13-07-48B	EA BOLT - HEX - 7/16 - 20 X 3 - ZN 5
	000C26-04-10B	EA BOLT - HEX - SER FLG - 1/4-20 X 5/8 ZINC
	000C26-05-20B	EA BOLT - HEX - SER FLG 5/16-18 X 1 1/4" - ZINC
	000C12-05-24B	EA BOLT - HEX - 5/16-18 X 11/2 ZN 5

**CLAMPS - GROMMETS AND FASTENERS**

KEY	PART NUMBER	U/M DESCRIPTION
	010495-01-000	EA CLAMP - CABLE - 9/16"
	010497-06-000	EA CLAMP - CLOSED - 11/16" ID
	010497-03-000	EA CLAMP - CLOSED - 1" ID - CUSHIONED
	010499-01-000	EA CLAMP - CLOSED - 3/8" ID
	010497-01-000	EA CLAMP - CLOSED - 5/8"ID
	010497-08-000	EA CLAMP - CLOSED - .125"
	075148-02-000	EA CLAMP - GROUNDING - BRONZE SCREWS
	062401-02-000	EA CLAMP - HOSE - WORMGEAR - 1.56" - 2.5"
	062401-10-000	EA CLAMP - HOSE - WORMGEAR 1.06"- 2"
	073194-02-000	EA CLAMP - HOSE - WORMGEAR 32-50 MM
	062401-07-000	EA CLAMP - HOSE - WORMGEAR 5"- 7"
	062401-06-000	EA CLAMP - HOSE - WORMGEAR .22"-.62"
	062401-01-000	EA CLAMP - HOSE - WORMGEAR .25"- 1"
	062401-04-000	EA CLAMP - HOSE - WORMGEAR .69"- 1.25"
	062401-03-000	EA CLAMP - HOSE - WORMGEAR - .22"- 1"
	083609-01-000	EA CLAMP - WIRE -DUAL - EQUAL 5/8" DIAMETER
	094362-02-000	EA CLIP - CHRISTMAS TREE - FLAT HEAD
	077953-01-000	EA GROMMET - EDGE LINER - FITS 1"
	023942-01-000	EA GROMMET - RUBBER - 2" OD
	071015-21-000	EA GROMMET - .50"ID - FITS .19" MATERIAL - RUBBER - SPLIT
	009066-01-000	EA HINGE - ALUMINUM - NO HOLES - 11/16" X 72" - UNPAINTED
	056134-02-000	EA HOLDER - RING - 1.5" ID PIPE SIZE - STEEL
	092321-01-000	FT INSULATION - FIBERGLASS - W/ALUMINUM FOIL
	077955-01-000	EA J CLIP - VINYL COATED - 3/8" USED IN WIRING TO CLEARANCE LIGHTS
	008401-01-000	EA STRAP - CONDUIT - 3/4" - 1 HOLE - GALVANIZED STEEL
	016604-01-000	EA BRACE - CABINET - ANGLED METAL - 2.5"

**NUTS & RIVETS**

KEY	PART NUMBER	U/M DESCRIPTION
	072893-01-000	EA NUTSERT - M5 X 0 - 8
	077049-01-000	EA NUT - ACORN - 10-32 ALUMINUM
	095094-01-000	EA NUT - ACORN - 1/4 - 20 ALUMINUM
	000D14-05-00B	EA NUT - HEX - 5/16-18 - ZN 5
	000D34-04-00B	EA NUT - HEX - LK 1/4 - 20 ZN
	000D39-04-00B	EA NUT - HEX - SER FLG LK 1/4 - 20 ZN
	000D39-08-00B	EA NUT - HEX - SER FLG LK - 1/2-13 ZN
	000D39-06-00B	EA NUT - HEX - SER FLG LK - 3/8-16 ZN
	000D39-05-00B	EA NUT - HEX - SER FLG LK - 5/16 - 18 ZN
	000D24-10-00B	EA NUT - HEX - SF/LK - 10-32 ZN
	000D34-06-00B	EA NUT - HEX LK-3/8-16 GRADE C ZN
	075467-01-000	EA NUT - INVERTED FLARE - 1/4"
	088497-02-000	EA NUT - INVERTED FLARE - 1/4"
	063253-07-000	EA NUT - J - #8A .120- .130 PNL THK

**SEALANTS & FASTENERS GROUP (CONTINUED)**

**NUTS & RIVETS (CONTINUED)**

KEY	PART NUMBER	U/M DESCRIPTION
	044364-02-000	EA NUT - SPEED - FLAT - ROUND
	040921-06-000	EA NUT - SPEED - U TYPE - NO. 8
	040921-04-000	EA NUT - SPEED - U TYPE - NO. 8
	040921-05-000	EA NUT - SPEED - U TYPE - NO.8
	044364-01-000	EA NUT - SPEED -FLAT
	064081-01-000	EA NUT - WING - 3/8" X 16 THREAD
	084884-01-000	EA PLUG - BRASS - 3/8"
	000H16-04-06R	EA RIVET - POP - AL 1/8 X .313-.375
	069592-02-000	EA RIVET - T (POP) 1/4 X .093-.156
	063729-04-000	EA RIVNUT - 10-32 UNF - .010-.080
	063729-01-000	EA RIVNUT - 1/4 X 20 UNC - .030-.125

**SCREWS**

KEY	PART NUMBER	U/M DESCRIPTION
	000G67-10-24B	EA SCREW - 10-12 X 1 1/2 PPH - ZN
	000G67-10-16P	EA SCREW - 10-12 X 1 PPH - DARK BROWN
	000G67-10-16B	EA SCREW - 10-12 X 1 PPH - ZN
	000G67-10-08B	EA SCREW - 10-12 X 1/2 PPH ZN
	000G67-10-08R	EA SCREW - 10-12 X 1/2 PPH - BEIGE - TYPE A
	000G67-10-12B	EA SCREW - 10-12 X 3/4 - PPH ZN
	000G67-10-10B	EA SCREW - 10-12 X 5/8 PPH ZN - TYPE A
	000G67-10-10R	EA SCREW - 10-12 X 5/8 PPH - TYPE A - BEIGE
	000G67-10-12P	EA SCREW - 10-12 X .75 PPH - DARK BROWN
	049465-01-000	EA SCREW - 10-16 W/WASHER PTH - DARK BROWN
	049465-04-000	EA SCREW - 10-16 X 1 PTH W/WASHER - BEIGE
	000G11-10-16B	EA SCREW - 10-16 X 1 - PPH ZN
	000G11-10-12R	EA SCREW - 10-16 X 3/4 PPH - BEIGE
	000G11-10-12D	EA SCREW - 10-16 X 3/4 PPH - BLACK
	000G68-06-10G	EA SCREW - 6-18 X 5/8 POH - ANTIQUE BRASS
	076790-01-000	EA SCREW - 6-20 X 1 1/4 PPH - BLACK
	000G13-06-16R	EA SCREW - 6-20 X 1 PFH - BEIGE
	000G13-06-08B	EA SCREW - 6-20 X 1/2 PFH ZN
	000G13-06-10G	EA SCREW - 6-20 X 5/8 PFH - ANTIQUE BRASS
	000G11-06-10B	EA SCREW - 6-20 X 5/8 PPH ZN
	000G11-06-10J	EA SCREW - 6-20 X 5/8 PPH - BRASS
	000G11-07-08B	EA SCREW - 7-19 X 1/2 PPH - ZN
	000G13-07-12B	EA SCREW - 7-19 X 3/4 PFH ZN
	000G13-08-16B	EA SCREW - 8-18 X 1 PFH - ZN
	000G11-08-08T	EA SCREW - 8-18 X 1/2 PPH
	000G11-08-08B	EA SCREW - 8-18 X 1/2 PPH ZN
	000G11-08-12B	EA SCREW - 8-18 X 3/4 PPH ZN
	000G11-08-12R	EA SCREW - 8-18 X 3/4 PPH - BEIGE
	000G11-08-12D	EA SCREW - 8-18 X 3/4 PPH - BLACK
	000G55-08-12W	EA SCREW - 8-18 X.75 - SF/DT - PWH
	000G11-08-16R	EA SCREW - 8-18 X 1.00 PPH - BEIGE
	000G67-10-32B	EA SCREW - 10-12 X 2 PPH ZN
	000G67-10-12R	EA SCREW - 10-12 X .75 PPH BEIGE
	000G67-10-120	EA SCREW - 10-12 X .75 PPH TAN
	049465-03-000	EA SCREW - 10-16 X 1 POH W/WASHER
	000G11-10-12S	EA SCREW - 10-16 X.75 PPH OFF WHITE
	000G54-04-20B	EA SCREW - 1/4-20 X 1 1/4 PTH TYP 23
	000G57-05-16J	EA SCREW - 5-20 X 1 PFH BRASS
	000G12-06-08T	EA SCREW - 6-20 X .50 POH - BLACK
	000G13-06-16J	EA SCREW - 6-20 X 1.00 PFH BRASS
	000G11-08-12P	EA SCREW - 8- 18 X .75.DARK BROWN
	085318-01-000	EA SCREW - 8-08B X 1/2 -CRIMPTITE HD
	000G67-08-32B	EA SCREW - 8-15 X 2 PPH ZN
	000G12-08-16S	EA SCREW - 8-18 X 1" POH - OFF WHITE•
	000G11-08-16S	EA SCREW - 8-18 X 1.00 PPH OFF WHITE
	009439-07-000	EA SCREW - 8-32 X 1 1/4 POH -BLACK
	087721-01-000	EA SCREW - FLAT HEAD - TAPPING - 1/4 X 1 1/4 LG ZN
	086763-01-000	EA SCREW - MACH - 10 - 32 X 1/4 PTH
	000G19-10-08B	EA SCREW - MACH - 10-32 X 1/2 PPH ZN
	000G19-10-10B	EA SCREW - MACH - 10-32 X 5/8 - PPH - ZINC

**SEALANTS & FASTENERS GROUP (CONTINUED)**

**SCREWS (CONTINUED)**

KEY	PART NUMBER	U/M DESCRIPTION
	000G50-04-12B	EA SCREW - MACHINE - 1/4-20 X 3/4 PPH ZN
	081908-01-000	EA SCREW - MACHINE - 6-32 X .62 W/ NYLOCK
	089371-01-000	EA SCREW - MACHINE - 8-32 X 3 5/16.ZN
	000G19-10-20B	EA SCREW - MACHINE - 10-32 X 1 1/14 PPH ZINK
	000G18-08-16B	EA SCREW - MACHINE - 8-32 X 1 - PPH ZN
	075908-01-000	EA SCREW - MACHINE - 10-32 X .56PTH(SEMS)
	000G53-04-06B	EA SCREW - MACHINE - 1/4-20 X 3/8 PPH 2N
	000G18-08-22B	EA SCREW - MACHINE - 8-32 X 1 3/8 PPH ZN
	000G39-10-20B	EA SCREW - SF/DR - 10-16 X 1 1/4 PPH ZN
	000G39-10-12R	EA SCREW - SF/DR - 10-16 X 3/4 PPH - BEIGE
	000G39-10-12D	EA SCREW - SF/DR - 10-16 X 3/4 PPH - BLACK
	000G39-06-16T	EA SCREW - SF/DR - 6-20 X 1 PPH - BLACK
	000G39-06-10T	EA SCREW - SF/DR - 6-20 X 5/8 PPH - BLACK
	000G39-08-24B	EA SCREW - SF/DR - 8-18 X 1 1/2 PPH ZN
	000G39-08-16E	EA SCREW - SF/DR - 8-18 X 1 PPH CHROME
	000G39-08-16B	EA SCREW - SF/DR - 8-18 X 1 PPH ZN
	000G39-08-16T	EA SCREW - SF/DR - 8-18 X 1 PPH - BLACK
	000G55-08-162	EA SCREW - SF/DR - 8-18 X 1.00 - BEIGE
	000G39-08-08B	EA SCREW - SF/DR - 8-18 X 1/2 PPH ZN
	000G39-08-32B	EA SCREW - SF/DR - 8-18 X 2 PPH - ZINC
	000G39-08-12B	EA SCREW - SF/DR - 8-18 X 3/4 PPH ZN
	000G39-08-12T	EA SCREW - SF/DR - 8-18 X 3/4 PPH - BLACK
	000G39-08-06B	EA SCREW - SF/DR - 8-18 X 3/8 PPH ZN
	000G60-10-28T	EA SCREW - SF/DR -10-16 X 1.75
	000G39-08-16R	EA SCREW - SF/DR - 8-18 X 1.00 PPH BEIGE
	000G39-08-08R	EA SCREW - SF/DT - 8-18 X 1/2 PPH
	079382-01-000	EA SCREW - SOCKET - 8-18 X 1" - BLACK

**SEALERS**

KEY	PART NUMBER	U/M DESCRIPTION
	106205 01 000	EA SEALER - PUMPABLE
	069640-02-000	FT SEALER - RIBBON - 1/2" X 1/8"- INCREMENTS OF 30'
	069640-09-000	FT SEALER - RIBBON - 1/32" X 2 1/2"
	069640-01-000	FT SEALER - RIBBON - 1/4" DIAMETER - INCREMENTS OF 20'
	069640-03-000	FT SEALER - RIBBON - 3/4" X 1/8" - INCREMENTS OF 60'
	069640-06-000	FT SEALER - RIBBON - 5/16" DIAMETER - INCREMENTS OF 25'
	091255-03-000	FT SEAL - FOAM - 1/4 X 3/16 ROLL
	091255-01-000	FT SEAL - FOAM - 3.2MM X 4.8MM
	090340-01-000	FT SEAL - FOAM - CLOSED CELL - 1/4" X 1/2" X 50'
	053752-01-000	GL SEAM SEALER - 5 GAL -ALUMINUM
	034552-04-000	EA SILICONE - TUBE - 300 ML - BEIGE - W/ O NOZZLE
	034552-02-000	EA SILICONE - TUBE - 300 ML - CLEAR - W/ O NOZZLE
	900390-03-000	EA NOZZLE -SILICONE TUBE

**SEALANTS & FASTENERS GROUP (CONTINUED)**

**TAPES AND TIES**

KEY	PART NUMBER	U/M DESCRIPTION
	100028-01-000	FT TAPE - ADHESIVE - .031" X .75" WIDE
	004363-01-000	FT TAPE - ADHESIVE FOAM - 1 SIDE - 3/16" X 1/2" - GRAY
	093071-01-000	FT TAPE - BONDING - DOUBLE SIDED - 1/64" X 2"
	093071-01-000	FT TAPE - BONDING - DOUBLE SIDED - 1/64" X 2"
	076322-03-000	FT TAPE - FOAM - DOUBLE COATED - .045" X .5"
	088244-01-000	FT TAPE - FOAM - VINYL COATED - 2" WIDE - INCREMENTS OF 108 FT
	009200-01-000	EA TAPE - FURNACE - 1 1/2"
	087691-01-000	EA TAPE - MASKING - WEATHER RESISTANT
	008343-02-000	EA TIE - WIRE - 14"
	008343-01-000	EA TIE - WIRE - 6"

**WASHERS**

KEY	PART NUMBER	U/M DESCRIPTION
	077071-01-000	EA WASHER - FENDER - 3/16" ID X 1" OD
	000E13-14-00B	EA WASHER - FLAT - 1/4" WIDE ZN
	000E13-11-00B	EA WASHER - FLAT - 3/16" WIDE ZN
	000E13-17-00B	EA WASHER - FLAT - 3/8 AR ZN

## WATER & SEWAGE GROUP

### WATER PUMP (SHURFLOW)

KEY	PART NUMBER	U/M DESCRIPTION
	098607-01-000	EA PUMP - WATER - W/.5"MPT FITTING - FLOW 2.8 GPM - UL
	098607-01-700	EA PUMPHEAD - REPLACEMENT - 94-236-08
	098607-01-701	EA DRIVE ASM - 94-234-03
	098607-01-702	EA DIAPHRAGM - KIT - 94-233-10
	098607-01-703	EA VALVE ASM - 94-232-00
	098607-01-704	EA HOUSING - UPPER - 94-231-01
	098607-01-705	EA CHECK VALVE - KIT - 94-237-00
	098607-01-706	EA UPPER HOUSING/SWITCH KIT - 94-230-00
	098607-01-707	EA MOTOR/ BASEPLATE REPLACEMENT - 94-234-03

### WATER SYSTEM COMPONENTS

KEY	PART NUMBER	U/M DESCRIPTION
	079381-01-000	FT TUBING - SMOOTH FLEXIBLE - 1.38" ID
	039800-02-000	FT TUBING - POLYBUTYL - 5/8" OD
	010219-01-000	EA ELBOW - 1 1/4" MPT X 1 1/4" BARB - WATER FILL - PLASTIC
	039798-01-000	EA TEE - 1/2" MPT X 1/2" MPT X 1/2" MPT - PLASTIC
	101814-01-000	EA COUPLING - FEMALE - 1/2" X 1/2" FPT
	110915-01-01A	EA WATER FILL - CITY - CHROME - KEVCO 64713

### WATER SYSTEM COMPONENTS (FLAIR-IT)

KEY	PART NUMBER	U/M DESCRIPTION
	114427-01-000	EA CAP - 1/2P - 02860
	114427-02-000	EA PLUG - 1/2P - 02863
	114428-01-000	EA TEE - 1/2P X 1/2P X 1/2P - 02820
	114428-02-000	EA TEE - SWIVEL - 1/2P X 1/2P X 1/2FPT - 02821
	114428-03-000	EA TEE - 1/2P X 1/2P X 1/2MPT - 02822
	114429-01-000	EA ELBOW - 1/2P X 1/2P - 02800
	114429-02-000	EA ELBOW - 1/2P X 1/2MPT - 02803
	114429-03-000	EA ELBOW - SWIVEL - 1/2P X 1/2FPT - 02816
	114429-04-000	EA ELBOW - 1/2P X 3/8MPT - 02810
	114429-05-000	EA ELBOW - 1/2P X 3/4MPT - 02812
	114429-06-000	EA ELBOW - SWIVEL - 1/2P X 3/4FPT - 02811
	114430-01-000	EA ADAPTER - 1/2P X 1/2P - 02840
	114430-02-000	EA ADAPTER - SWIVEL - 1/2P X 1/2FPT - 02873
	114430-03-000	EA ADAPTER - 1/2P X 1/2MPT - 02842
	114431-01-000	EA VALVE - LINE DRAIN 1/2P - 02914
	114431-02-000	EA VALVE - 1/2P - BYPASS - 02910
	114431-03-000	EA VALVE - 1/2P X 1/2P - 02884
	114431-04-000	EA VALVE - STOP - 1/2P X 1/2P - 02880

## WATER & SEWAGE GROUP (CONTINUED)

### FRESH WATER TANK

KEY	PART NUMBER	U/M DESCRIPTION
	104363-04-000	EA TANK ASM - WATER - 100 GAL
	042989-05-000	EA FITTING - SPINWELD - PLASTIC 1/2FPT
	042989-03-000	EA FITTING - SPINWELD - PLASTIC - 11/4" FPT
	049032-01-000	EA PATCH - SPINWELD - 3/8" - PLASTIC
	039861-01-000	EA SENDING UNIT W/SCREW - WASHER
	091208-01-000	EA WASHER - RUBBER - .06" X .75" X .5"
	077954-02-000	EA FILTER - WATER TANK - SCREEN IN TANK

### EXTERIOR SHOWER COMPONENTS

KEY	PART NUMBER	U/M DESCRIPTION
	103092-01-000	EA SHOWER HEAD - W/60" HOSE (US)
	103092-02-000	EA SHOWER HEAD - W/HOSE (CSA)
	104044-01-000	EA BRACKET - SUPPORT - FAUCET
	103092-01-700	EA BRACKET (FOR SHOWER HEAD) CLEAR
	103092-01-701	EA BRACKET (FOR SHOWER HEAD) BONE
	075241-05-000	EA FAUCET - SHOWER - BONE

# WATER & SEWAGE GROUP (CONTINUED)

## DRAINAGE SYSTEM

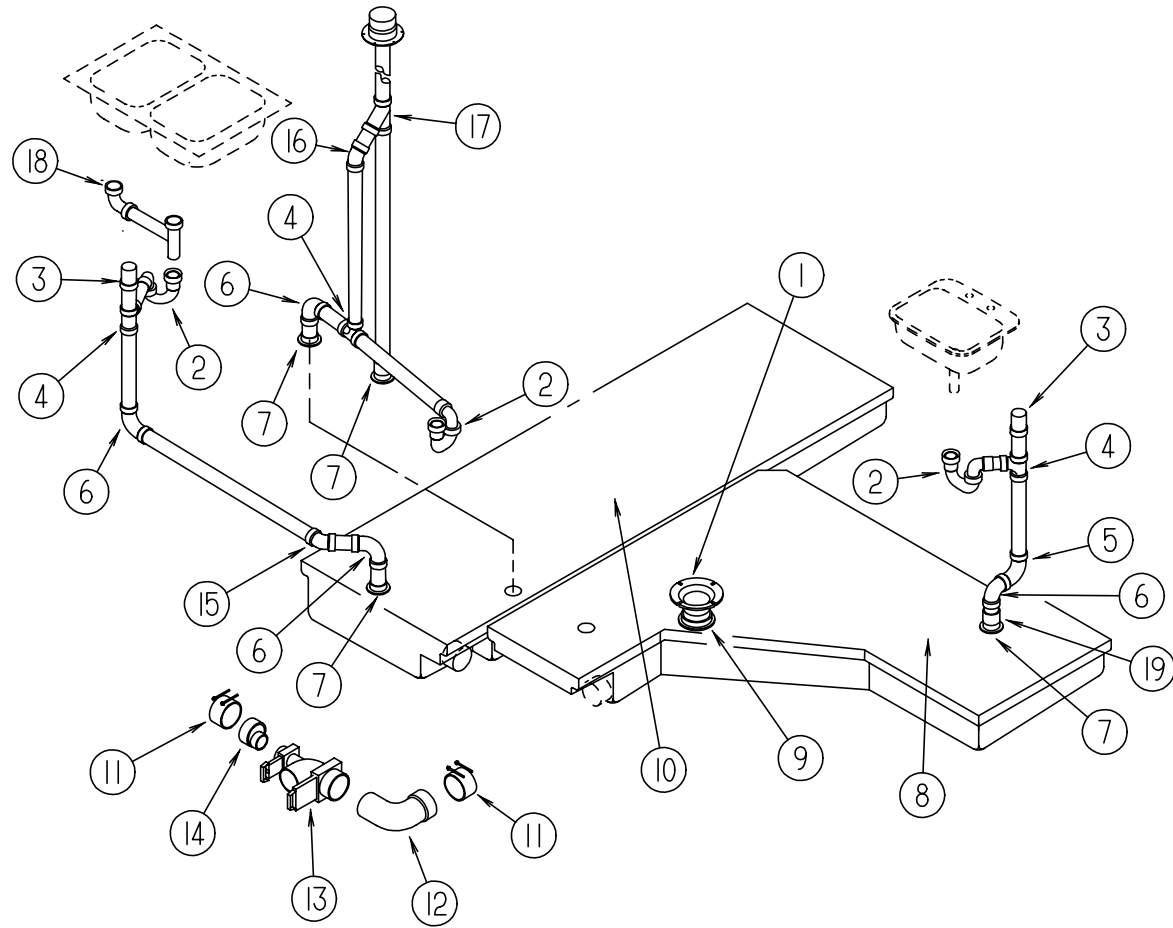

KEY	PART NUMBER	U/M	DESCRIPTION
1	063641-01-000	EA	FLANGE - CLOSET - 4" X 3"
2	107537-01-000	EA	P-TRAP ADAPTER - 1 1/4" SLIP
2	107538-01-000	EA	P-TRAP - PLASTIC - 1 1/4" W/ EXTENTION ARM
	061607-01-000	EA	GROMMET - HOLDING TANK - 1 1/2" NPS
3	079968-01-000	EA	VENT - MECHANICAL TRAP ARM - ANTI-SIPHON - 2" DIA. X 7.3" - PLASTIC
4	010071-01-000	EA	TEE - SANITARY - 1 1/2" HUB X HUB X HUB
5	010009-01-000	EA	ELBOW - 90 ° - 1/4 BEND - 1 1/2" - PLASTIC
6	010008-01-000	EA	ELBOW - 90 ° - 1/4 BEND - 1 1/2" HUB X HUB - BLACK PLASTIC
7	061607-01-000	EA	GROMMET - HOLDING TANK - 1 1/2" NPS
8	104350-04-000	EA	TANK - HOLDING - 69 GAL (BLACK)
9	061607-02-000	EA	GROMMET - HOLDING TANK - 3" NPS
10	104352-05-000	EA	TANK - HOLDING - 50 GAL (GRAY)
11	078406-01-000	EA	COUPLER - RUBBER - W/ CLAMPS - 3" X 3"
12	041956-01-000	EA	ELBOW - STREET - 1/4" BEND - 3" X 90° XLT
13	070916-01-000	EA	VALVE - DUAL DUMP - W/ CAP - 3" X 1 1/2" - PLASTIC - BLACK
	070916-01-700	EA	VALVE ONLY - 3"
	070916-01-701	EA	VALVE ONLY - 1 1/2"
14	062422-01-000	EA	ADAPTER - OFFSET REDUCER - 3" X 1 1/2" - PLASTIC - BLACK
	010201-01-000	EA	HOSE - SEWER - 3" ID X 8 FEET
	062416-01-000	EA	ADAPTER - SEWER HOSE TO 3" PIPE
	062416-01-000	EA	ADAPTER - SEWER HOSE TO 3" PIPE
15	010006-01-000	EA	ELBOW - 45°- 1/8 BEND - 1 1/2" HUB X HUB - BLACK PLASTIC
16	010051-01-000	EA	ELBOW - 45° BEND - 1 1/2" SPIGOT AND HUB - PLASTIC - BLACK
17	010073-01-000	EA	WYE - 45 DEGREE - 1 1/2" HUB X HUB X HUB - PLASTIC - BLACK
18	011091-03-000	EA	PIPE - DRAIN - W/SEALS - DOUBLE SINK - EXTENDS 9" TO 16"
18	011091-02-000	EA	PIPE - DRAIN - DOUBLE SINK - BAFFLE TEE - 1 1/2"
19	010115-01-000	EA	COUPLING - 1 1/2" HUB X HUB - PLASTIC



## WATER & SEWAGE GROUP (CONTINUED)

### WATER HEATER W/MOTOR AID ATWOOD (GH6-7E)

KEY	PART NUMBER	U/M DESCRIPTION
	051393-01-000	EA WATER HEATER - W/MOTOR AID - PILOTLESS IGNITION
1	051393-01-701	EA SWITCH PACKAGE - 91959
2	051391-04-701	EA THERMOSTAT 12 VDC-120 PRESET - 91470
3	051393-01-721	EA ECO & THERMOSTAT ASM - FRONT MOUNT - 140° - 91447
4	051391-01-705	EA FASTENER - CAMLOC - 92609
5	051391-01-704	EA VALVE - RELIEF - 1/2" FITTING - 91604
6	051393-01-723	EA SWITCH - ENERGY CUT-OFF - 93866
7	051393-01-724	EA CIRCUIT BOARD - W/ SPADE TERMINAL - 93867
8	051393-01-725	EA ELECTRODE - SINGLE SPADE CONNECTION - 93868
9	051391-04-703	EA BURNER - MAIN - 91638
10	051391-01-717	EA GRILL - 92640
11	051391-01-710	EA ORIFICE - MAIN BURNER - 92742
12	051391-03-700	EA ORIFICE HOLDER - 91563
13	051393-01-726	EA SOLENOID VALVE & BRACKET - 93870
14	051391-01-714	EA ELBOW - 45 DEGREE - 3/8" F X 3/8" MPT - 91044
15	052009-01-000	EA DOOR - WATER HEATER - OFF WHITE
16	051391-01-700	EA HINGE KIT - W/CLIP - 92568 & 92559
17	051393-03-701	EA TANK - INNER - 91642
18	051391-01-715	EA DRAIN PLUG - 91857
19	051391-04-706	EA FLUE & GASKET - 92787
	116424-01-000	EA PROTECTOR - ROUND VINYL - WATER HEATER LATCH

### WATER HEATER W/MOTOR AID ATWOOD (G6A-7E)

KEY	PART NUMBER	U/M DESCRIPTION
	051391-03-000	EA WATER HEATER - W/ ELECTRIC IGNITION
1	051393-01-701	EA SWITCH PACKAGE - 91959
2	051391-04-701	EA THERMOSTAT 12 VDC-120 PRESET - 91470
3	051393-01-721	EA ECO & THERMOSTAT ASM - FRONT MOUNT - 140° - 91447
4	051391-01-705	EA FASTENER - CAMLOC - 92609
5	051391-01-704	EA VALVE - RELIEF - 1/2" FITTING - 91604
6	051393-01-723	EA SWITCH - ENERGY CUT-OFF - 93866
7	051393-01-724	EA CIRCUIT BOARD - W/ SPADE TERMINAL - 93867
8	051393-01-725	EA ELECTRODE - SINGLE SPADE CONNECTION - 93868
9	051391-04-703	EA BURNER - MAIN - 91638
10	051391-01-717	EA GRILL - 92640
11	051391-01-710	EA ORIFICE - MAIN BURNER - 92742
12	051391-03-700	EA ORIFICE HOLDER - 91563
13	051393-01-726	EA SOLENOID VALVE & BRACKET - 93870
14	051391-01-714	EA ELBOW - 45 DEGREE - 3/8" F X 3/8" MPT - 91044
15	052009-01-000	EA DOOR - WATER HEATER - OFF WHITE
16	051391-01-700	EA HINGE KIT - W/CLIP - 92568 & 92559
17	051391-04-706	EA TANK - INNER - 91641
18	051391-01-715	EA DRAIN PLUG - 91857
19	051391-04-706	EA FLUE & GASKET - 92787
	116424-01-000	EA PROTECTOR - ROUND VINYL - WATER HEATER LATCH

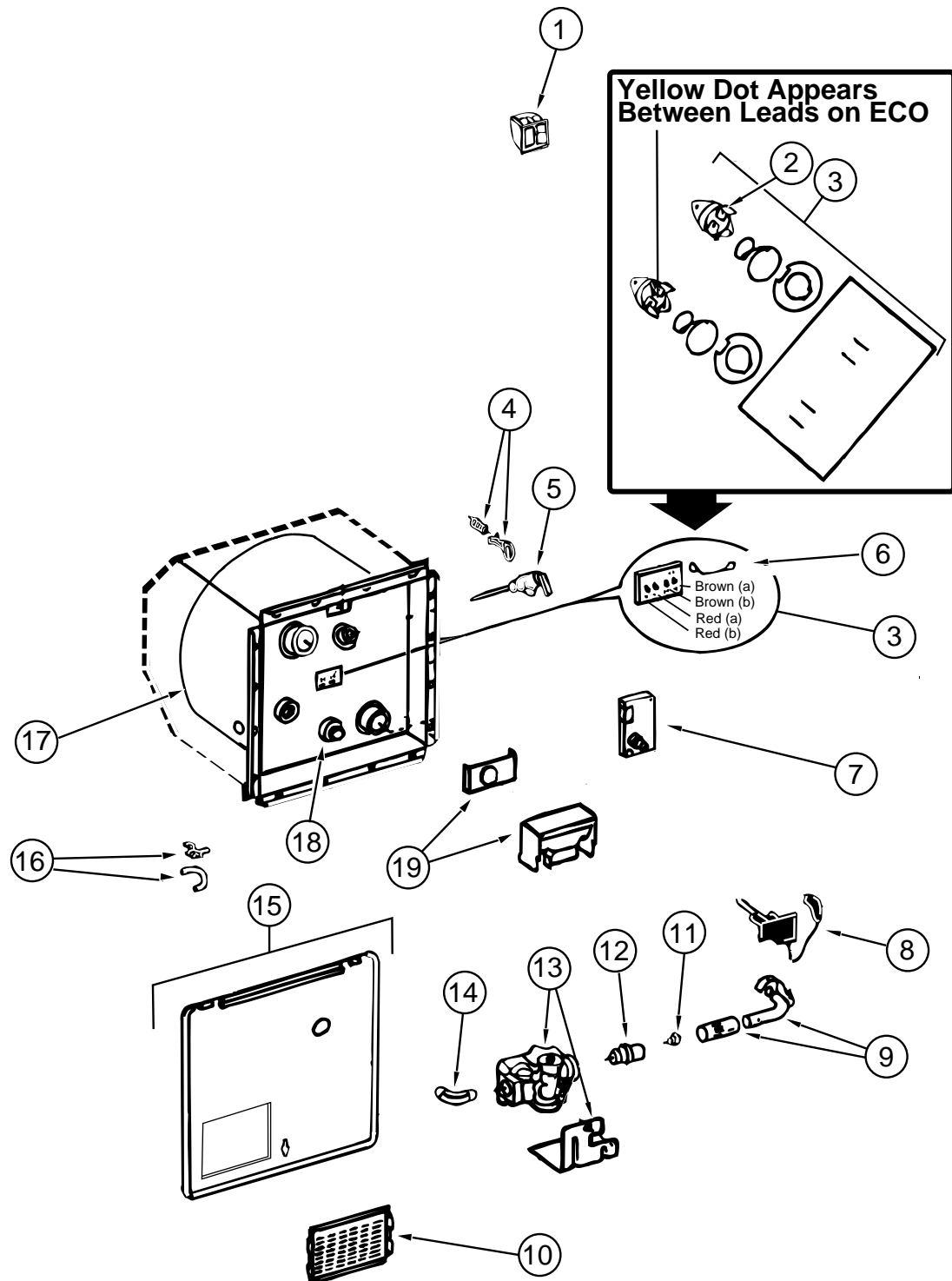

# WINDOW, VENT & EXTERIOR DOOR GROUP

## WINDOWS & VENTS

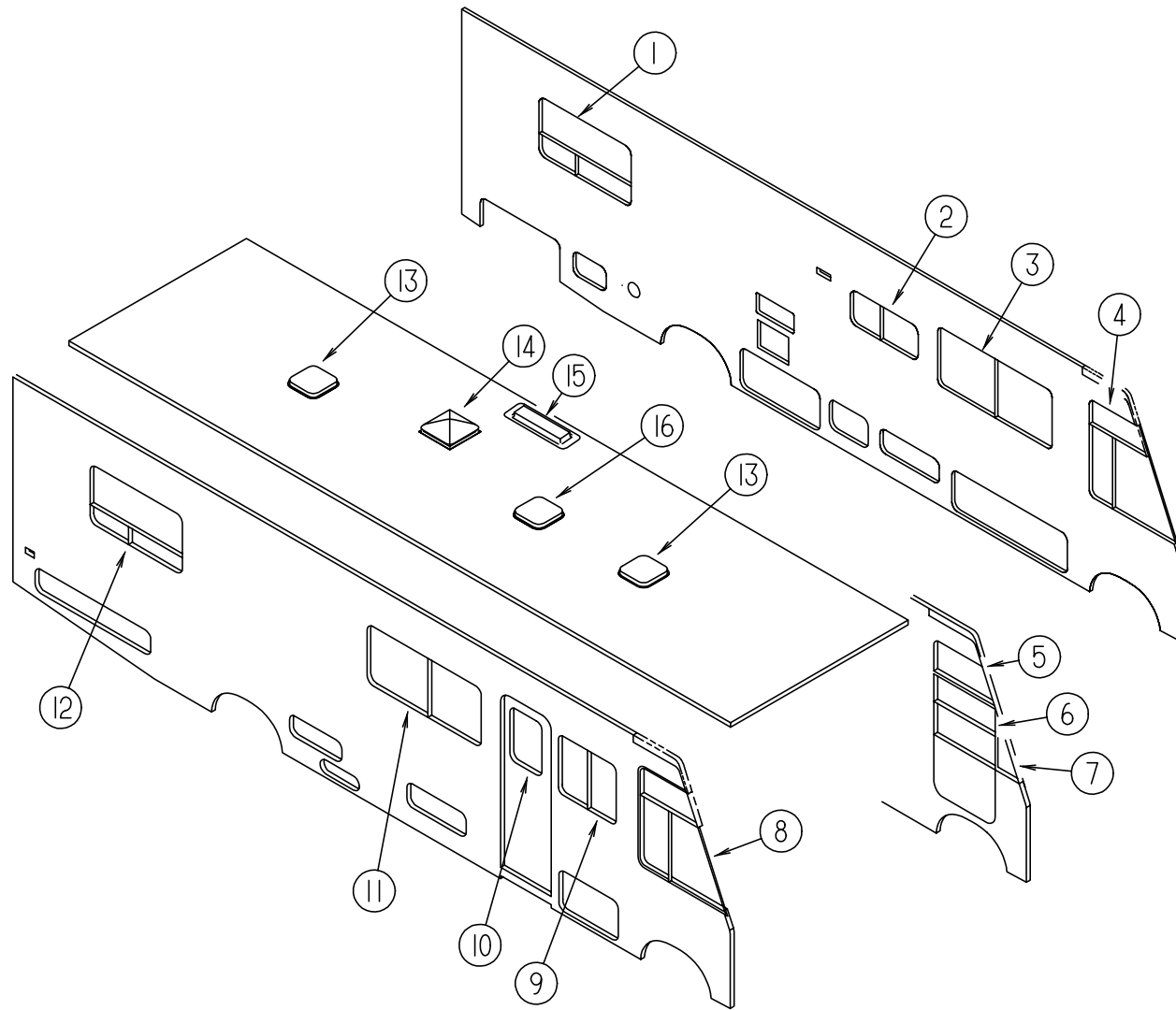

KEY	PART NUMBER	U/M DESCRIPTION
1	104691-14-01A	EA WINDOW ASM. - TIPOUT ESCAPE
1	112795 24 01A	EA WINDOW ASM. - ESCAPE - THERMO INSULATED - W/ INSIDE FRAME (OPTION)
2	098647-34-01A	EA WINDOW ASM. - SLIDER - W/ INSIDE TRIM (OFF-WHITE)
2	112795-20-01A	EA WINDOW ASM. - SLIDER - THERMO INSULATED - W/ INSIDE FRAME (OPTION)
3	098647-22-01A	EA WINDOW ASM. - SLIDER - W/ INSIDE TRIM (OFF-WHITE)
3	112795-15-01A	EA WINDOW ASM. - SLIDER - THERMO INSULATED - W/ INSIDE FRAME (OPTION)
4	103658-07-01A	EA WINDOW ASM. - CAB - DRIVER SIDE
4	113501-01-01A	EA WINDOW ASM. - CAB - THERMO INSULATED - W/ INSIDE FRAME (OPTION)
5	106467-03-01A	EA WINDOW ASM. - VISTA - DRIVER SIDE
5	116000-02-01A	EA WINDOW ASM. - VISTA - THERMO INSULATED - W/ INSIDE FRAME (OPTION)
6	106469-01-704	EA WINDOW - DRIVER DOOR - ROLL-UP GLASS ASM. - W/ BRACKET
7	106468-02-01A	EA WINDOW ASM. - FRONT SLANT- DRIVER SIDE
7	115999-02-01A	EA WINDOW ASM. - FRONT SLANT - THERMO INSULATED - DRIVER SIDE (OPTION)
8	103658-08-01A	EA WINDOW ASM. - CAB - PASSENGER SIDE
8	113501-02-01A	EA WINDOW ASM. - SLIDER - THERMO INSULATED - W/ INSIDE FRAME (OPTION)
9	098647-25-01A	EA WINDOW ASM. - SLIDER - W/ INSIDE TRIM (OFF-WHITE)
9	112795-18-01A	EA WINDOW ASM. - SLIDER - THERMO INSULATED - W/ INSIDE FRAME (OPTION)
10	079733-15-F04	EA WINDOW ASM. - ENTRANCE DOOR - W/O INSIDE FRAME
10	113733 01 01A	EA WINDOW ASM. - STATIONARY - THERMO INSULATED - W/ INSIDE FRAME (OPTION)
11	098647-23-01A	EA WINDOW ASM. - SLIDER - W/ INSIDE TRIM (OFF-WHITE)
11	112795-16-01A	EA WINDOW ASM. - SLIDER - THERMO INSULATED - W/ INSIDE FRAME (OPTION)
12	104691-13-01A	EA WINDOW ASM. - TIPOUT OFF WHITE
12	112795-22-01A	EA WINDOW ASM. - SLIDER - THERMO INSULATED - W/ INSIDE FRAME (OPTION)
13	110051-02-01A	EA VENT - ROOF - NON POWERED
14	110051-04-01A	EA VENT - ROOF - POWERED
15	084073-03-000	EA REFRIGERATOR ROOF VENT - OFF WHITE
16	084079-14-000	EA VENT - EXHAUST - POWERED - OFF WHITE (US)
16	084079-15-000	EA VENT - EXHAUST - POWERED - OFF WHITE (CSA)

## WINDOW, VENT & EXTERIOR DOOR GROUP (CONTINUED)

### SINGLE SLIDER WINDOW (EXCEL) (PASSENGER SIDE, LOUNGE)

KEY	PART NUMBER	U/M	DESCRIPTION
	098647-25-01A	EA	WINDOW ASM - SLIDER - W/ INSIDE FRAME (OFF WHITE)
1	098647-25-700	EA	WINDOW ASM - SLIDER - W/O INSIDE FRAME
	098647-25-701	EA	FRAME - INSIDE (OFF WHITE)
2	098647-25-702	EA	GLASS - STATIONARY
3	098644-01-710	FT	TRACK - SCREEN SPACER - 12' LENGTH
4	098644-01-700	EA	LATCH - REPAIR KIT
5	098644-01-708	FT	CHANNEL - PIERCED RUN
6	098644-01-711	FT	WEATHERSTRIP - SCREEN - BLACK
7	098647-25-704	EA	SCREEN ASM. - W/ SPRINGS & WEATHERSTRIP
8	098644-01-713	EA	SPRING - SCREEN FRAME (CLIP)
9	098647-25-703	EA	GLASS - SLIDING - W/ SASH & LATCH
10	098644-01-706	FT	WEATHERSTRIP
	098644-01-716	FT	PLUG - FILLER
	098644-01-717	FT	SPLINE - SCREEN

### SINGLE SLIDER WINDOW (EXCEL) (GALLEY)

KEY	PART NUMBER	U/M	DESCRIPTION
	098647-34-01A	EA	WINDOW ASM - SLIDER - W/ INSIDE FRAME (OFF WHITE)
1	098647-34-700	EA	WINDOW ASM - SLIDER - W/O INSIDE FRAME
	098647-33-701	EA	FRAME - INSIDE (OFF WHITE)
2	098647-33-702	EA	GLASS - STATIONARY
3	098644-01-710	FT	TRACK - SCREEN SPACER - 12' LENGTH
4	098644-01-700	EA	LATCH - REPAIR KIT
5	098644-01-708	FT	CHANNEL - PIERCED RUN
6	098644-01-711	FT	WEATHERSTRIP - SCREEN - BLACK
7	098647-33-704	EA	SCREEN ASM. - W/ SPRINGS & WEATHERSTRIP
8	098644-01-713	EA	SPRING - SCREEN FRAME (CLIP)

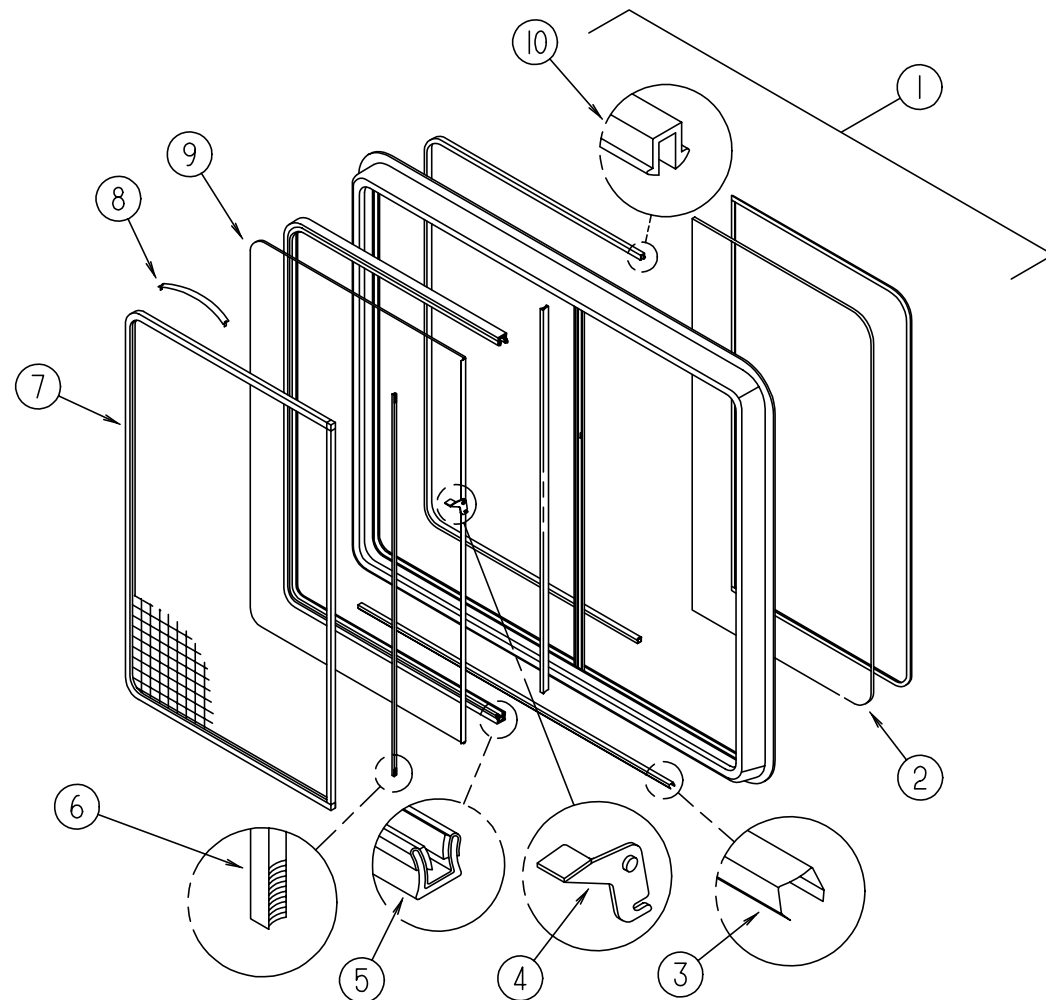

### SINGLE SLIDER WINDOW (EXCEL) (LOUNGE)

KEY	PART NUMBER	U/M	DESCRIPTION
	098647-22-01A	EA	WINDOW ASM - SLIDER - W/ INSIDE FRAME (OFF WHITE)
1	098647-22-700	EA	WINDOW ASM - SLIDER - W/O INSIDE FRAME
	098647-23-702	EA	FRAME - INSIDE (OFF WHITE)
2	098647-23-703	EA	GLASS - STATIONARY
3	098644-01-710	FT	TRACK - SCREEN SPACER - 12' LENGTH
4	098644-01-700	EA	LATCH - REPAIR KIT
5	098644-01-708	FT	CHANNEL - PIERCED RUN
6	098644-01-711	FT	WEATHERSTRIP - SCREEN - BLACK
7	098647-23-704	EA	SCREEN ASM. - W/ SPRINGS & WEATHERSTRIP
8	098644-01-713	EA	SPRING - SCREEN FRAME (CLIP)
9	098647-23-700	EA	GLASS - SLIDING - W/ SASH & LATCH
10	098644-01-706	FT	WEATHERSTRIP
	098644-01-716	FT	PLUG - FILLER
	098644-01-717	FT	SPLINE - SCREEN

**WINDOW, VENT & EXTERIOR DOOR GROUP (CONTINUED)**

**BEDROOM WINDOW (ESCAPE) (DRIVER SIDE)**

KEY	PART NUMBER	U/M	DESCRIPTION
	104691-14-01A	EA	WINDOW ASM. - DOUBLE TIPOUT- EXCEL - W/ INSIDE FRAME
	104691-14-700	EA	WINDOW W/O TRIM - CH88-G2
	104691-14-701	EA	TRIM - CW8859
	104691-14-702	EA	GLASS-STATIONARY - 106-019117
	104691-14-703	EA	VENT ASSEMBLY - CH88-G9
	104691-14-704	EA	OPERATOR & BAR ASSEMBLY - CH88-18
	104691-14-705	EA	SCREEN ASSEMBLY - 410-019120

**BEDROOM WINDOW (PASSENGER SIDE)**

KEY	PART NUMBER	U/M	DESCRIPTION
	104691-13-01A	EA	WINDOW ASM. - DOUBLE TIPOUT- EXCEL - W/ INSIDE FRAME
	104691-13-700	EA	WINDOW W/O TRIM - CH37-G2
	104691-13-701	EA	TRIM - W30359
	104691-13-702	EA	GLASS - STATIONARY - 106-017670
	104691-13-703	EA	VENT ASSEMBLY - CH37-G9
	104691-13-704	EA	OPERATOR & BAR ASSEMBLY - CH36-18
	104691-13-705	EA	SCREEN ASSEMBLY - 410-017763

**WINDOW, VENT & EXTERIOR DOOR GROUP (CONTINUED)**

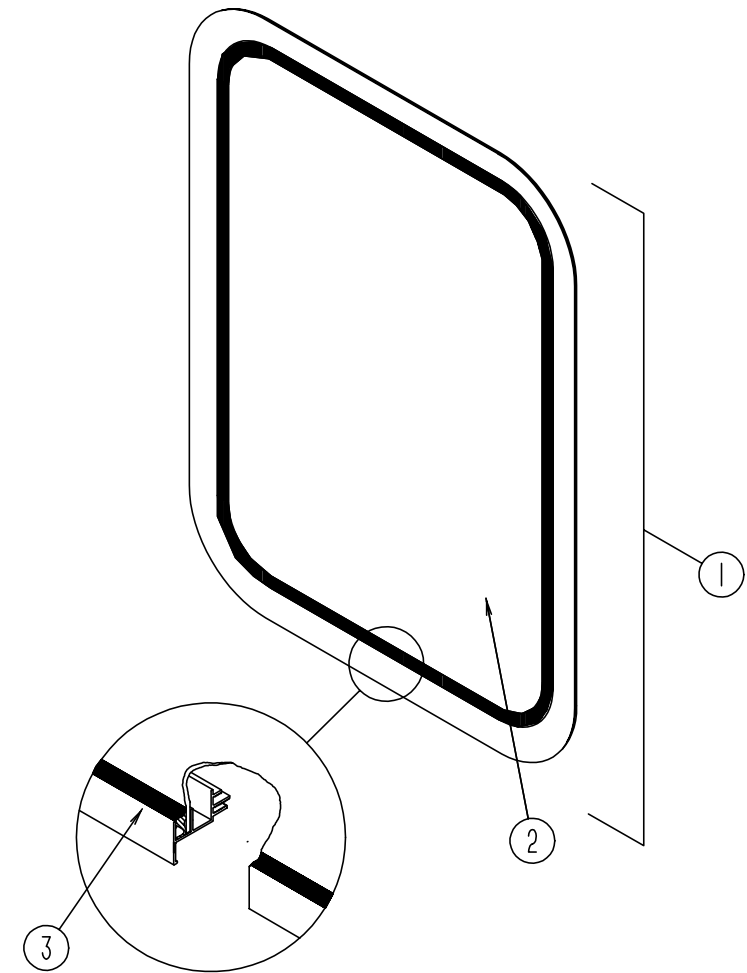

**ENTRY DOOR**

KEY	PART NUMBER	U/M	DESCRIPTION
1	079733-15-F04	EA	WINDOW ASM. - ENTRANCE DOOR - W/O INSIDE FRAME
	067609-38-000	EA	INSIDE FRAME - OFF WHITE
2	002181-24-000	EA	GLASS - PICTURE 687.4 X 449.4
3	087561-01-000	FT	SEAL - GLASS - EXTERIOR - .5" WIDE - VINYL - BLACK

## WINDOW, VENT & EXTERIOR DOOR GROUP (CONTINUED)

### FRONT CAB WINDOWS (EXCEL)

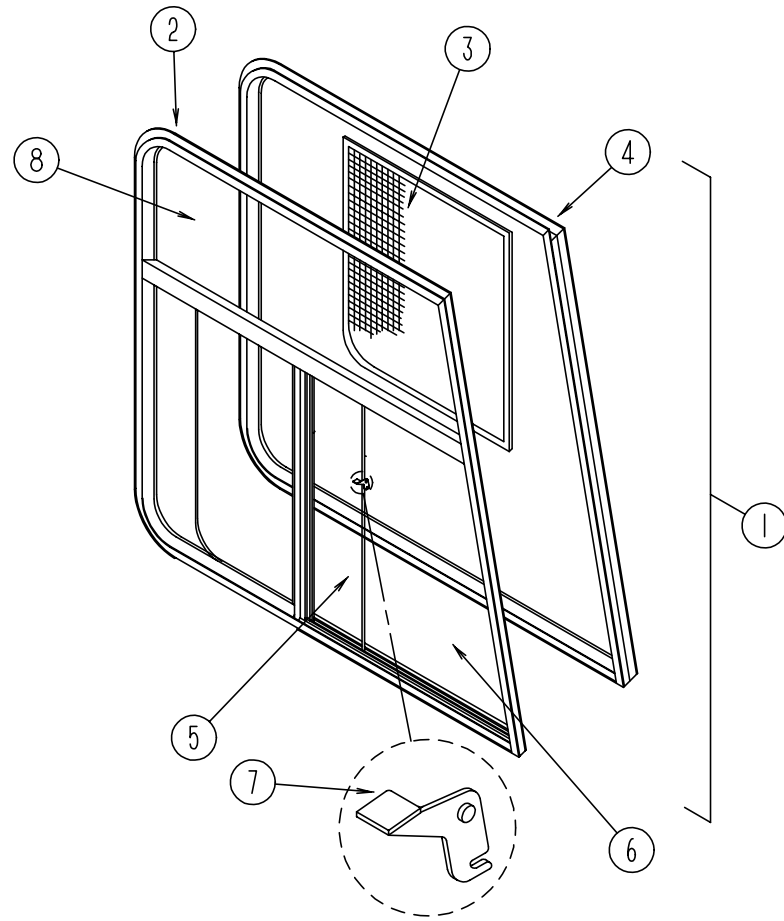

KEY	PART NUMBER	U/M	DESCRIPTION
1	103658-07-01A	EA	WINDOW ASM. - CAB - W/ INSIDE FRAME - DRIVER SIDE
1	103658-08-01A	EA	WINDOW ASM. - CAB - W/ INSIDE FRAME - PASSENGER SIDE
2	103658-08-700	EA	WINDOW ASM. - SLIDER - W/O INSIDE FRAME - PASSENGER SIDE
2	103658-07-704	EA	WINDOW ASM. - SLIDER - W/O INSIDE FRAME - DRIVER SIDE
3	103658-01-700	EA	SCREEN ASM. - WINDOW - DRIVER SIDE
3	103658-02-700	EA	SCREEN ASM. - WINDOW - PASSENGER SIDE
	098644-01-717	FT	SCREEN SPLINE
	098644-01-713	EA	SCREEN CLIPS (METAL)(BLACK)
	098644-01-710	FT	TRACK - SPACER - FOR SCREEN 12'
	098644-01-711	FT	WEATHERSTRIP - SCREEN - BLACK
4	103658-08-701	EA	INSIDE FRAME - PASSENGER SIDE
4	103658-07-700	EA	INSIDE FRAME - DRIVER SIDE
5	103658-01-703	EA	GLASS - SLIDING - W/SASH & LATCH - DRIVER SIDE
5	103658-02-701	EA	GLASS - SLIDING - W/SASH & LATCH - PASSENGER SIDE
6	103658-01-702	EA	GLASS - STATIONARY - BOTTOM - DRIVER OR PASSENGER SIDE
7	098644-01-700	EA	LATCH - REPAIR KIT
8	103658-07-701	EA	GLASS - STATIONARY - TOP - DRIVER OR PASSENGER SIDE
	098644-01-708	FT	CHANNEL - PIERCED RUN
	098644-01-706	FT	WEATHERSTRIP - GLASS
	098644-01-716	FT	PLUG - FILLER

**WINDOW, VENT & EXTERIOR DOOR GROUP (CONTINUED)**

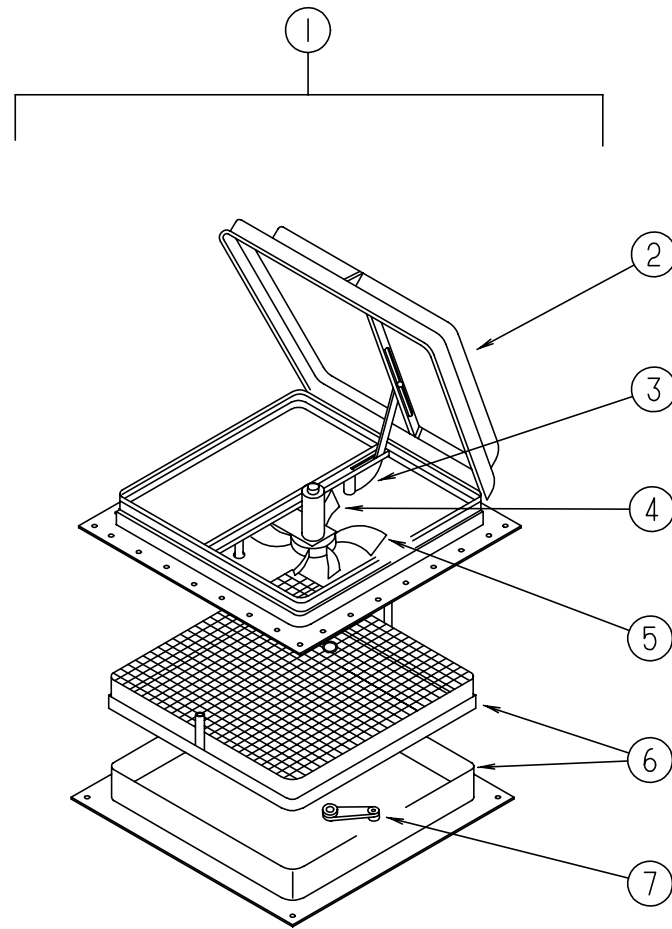

**POWERED ROOF VENT (US)**

KEY	PART NUMBER	U/M DESCRIPTION
1	110051-04-01A	EA VENT ASM. - ROOF - POWERED
2	064470-01-700	EA COVER - ROOF VENT
3	110051-01-702	EA GEAR-ARM-LIFT ASM.
4	048648-01-000	EA MOTOR - 12V NONVENTED 1/8 SHAFT
5	048649-01-000	EA FAN - PLASTIC - 6 IN - 6 BLADED
6	110051-01-704	EA W/ SCREEN & FRAME
7	110051-01-703	EA CRANK HANDLE

**POWERED ROOF VENT (CANADIAN)**

KEY	PART NUMBER	U/M DESCRIPTION
1	110051-06-01A	EA VENT ASM. - ROOF - POWERED
2	064470-01-700	EA COVER - ROOF VENT
3	110051-01-702	EA GEAR-ARM-LIFT ASM.
4	048648-01-000	EA MOTOR - 12V NONVENTED 1/8 SHAFT
5	048649-01-000	EA FAN - PLASTIC - 6 IN - 6 BLADED
6	110051-01-704	EA W/ SCREEN & FRAME
7	110051-01-703	EA CRANK HANDLE

**WINDOW, VENT & EXTERIOR DOOR GROUP (CONTINUED)**

**NON POWERED ROOF VENT**

KEY	PART NUMBER	U/M DESCRIPTION
	110051-02-01A	EA ROOF VENT - W/SCREEN
	064470-01-700	EA COVER - ROOF VENT
	110051-01-702	EA GEAR-ARM-LIFT ASM.
	110051-01-703	EA CRANK HANDLE - ROOF VENT
	110051-01-704	EA SCREEN & FRAME ASM.

**POWERED ROOF VENT (FANTASTIC) (US)**

KEY	PART NUMBER	U/M DESCRIPTION
	084079-14-000	EA VENT - EXHAUST - POWERED - OFF WHITE
	084079-01-700	EA VENT COVER - 1020-19
	084079-01-701	EA SCREEN ASM. - WHITE - 1030-80
	084079-01-703	EA CRANK - EXTERIOR - 1060-09
	084079-01-704	EA BLADE - FAN - 1070-00
	084079-01-705	EA MOTOR - 1080-00
	084079-01-707	EA SWITCH - SAFETY - 1120-00
	084079-01-709	EA SWITCH - ON & OFF - MAIN POWER - 1100-00
	084079-01-711	EA H-MOLDING - MOTOR MOUNT - PLASTIC
	084079-01-712	EA GARNISH - INTERIOR - 1 7/8" - OFF WHITE

**POWERED ROOF VENT (FANTASTIC) (CSA)**

KEY	PART NUMBER	U/M DESCRIPTION
	084079-15-000	EA VENT - EXHAUST - POWERED - OFF WHITE
	084079-01-700	EA VENT COVER - 1020-19
	084079-01-701	EA SCREEN ASM. - OFF WHITE - 1030-80
	084079-01-703	EA CRANK - EXTERIOR - 1060-09
	084079-01-704	EA BLADE - FAN - 1070-00
	084079-01-705	EA MOTOR - 1080-00
	084079-01-707	EA SWITCH - SAFETY - 1120-00
	084079-01-709	EA SWITCH - ON & OFF - MAIN POWER - 1100-00
	084079-01-711	EA H-MOLDING - MOTOR MOUNT - PLASTIC
	084079-01-712	EA GARNISH - INTERIOR - 1 7/8" - OFF WHITE

**ROOF VENTS**

KEY	PART NUMBER	U/M DESCRIPTION
	083558-03-000	EA VENT COVER - PLUMBING PIPE - ROOF
	084073-03-000	EA COVER - ROOF VENT - NORCOLD REFRIGERATOR - OFF WHITE
	084073-04-000	EA BASE - ROOF VENT - NORCOLD REFRIGERATOR - BLACK

**SIDEWALL VENTS**

KEY	PART NUMBER	U/M DESCRIPTION
	084616-01-000	EA SHROUD - RANGE HOOD VENT - OFF WHITE
	084878-09-000	EA VENT - RANGE HOOD - SHORT - LVS

## WINDOW, VENT & EXTERIOR DOOR GROUP (CONTINUED)

### EXTERIOR DOORS

KEY	PART NUMBER	U/M	DESCRIPTION
1	111012-06-F31	EA	DOOR ASM - GENERATOR
2	111013-18-E30	EA	DOOR ASM - ACCESS
3	052009-01-000	EA	DOOR - WATER HEATER - OFF WHITE
4	084103-03-000	EA	DOOR - REFRIGERATOR - VENTED - JAMB - OFF WHITE
4	084104-03-000	EA	JAMB - REFRIGERATOR - OFF WHITE
5	111013-21-E30	EA	DOOR ASM - STORAGE
6	098668-06-000	EA	DOOR ASM - FURNACE - EXTERIOR
7	111013-18-E30	EA	DOOR ASM - STORAGE
8	111013-17-E30	EA	DOOR ASM - STORAGE
9	106469-02-01A	EA	DOOR ASM - DRIVERS - BLACK
10	111013-16-E30	EA	DOOR ASM - STORAGE
11	115108-02-F31	EA	DOOR - ENTRY - W/ SCREEN DOOR - W/O WINDOW
11	115108-02-F32	EA	DOOR - ENTRY - W/ SCREEN DOOR - W/O WINDOW
12	111017-01-F31	EA	DOOR ASM - ACCESS - EXTERIOR RADIO
13	111009-01-E30	EA	DOOR - LP COMPARTMENT - 16.9" X 5.4" - ALUMINUM
14	111013-20-E30	EA	DOOR ASM - ACCESS
15	111013-19-E30	EA	DOOR ASM - ACCESS - EXTERIOR SHOWER
16	081240-11-000	EA	DOOR - WATER FILL - LOCKABLE W/O LOCK - 4" X 4 5/8" - OFF WHITE

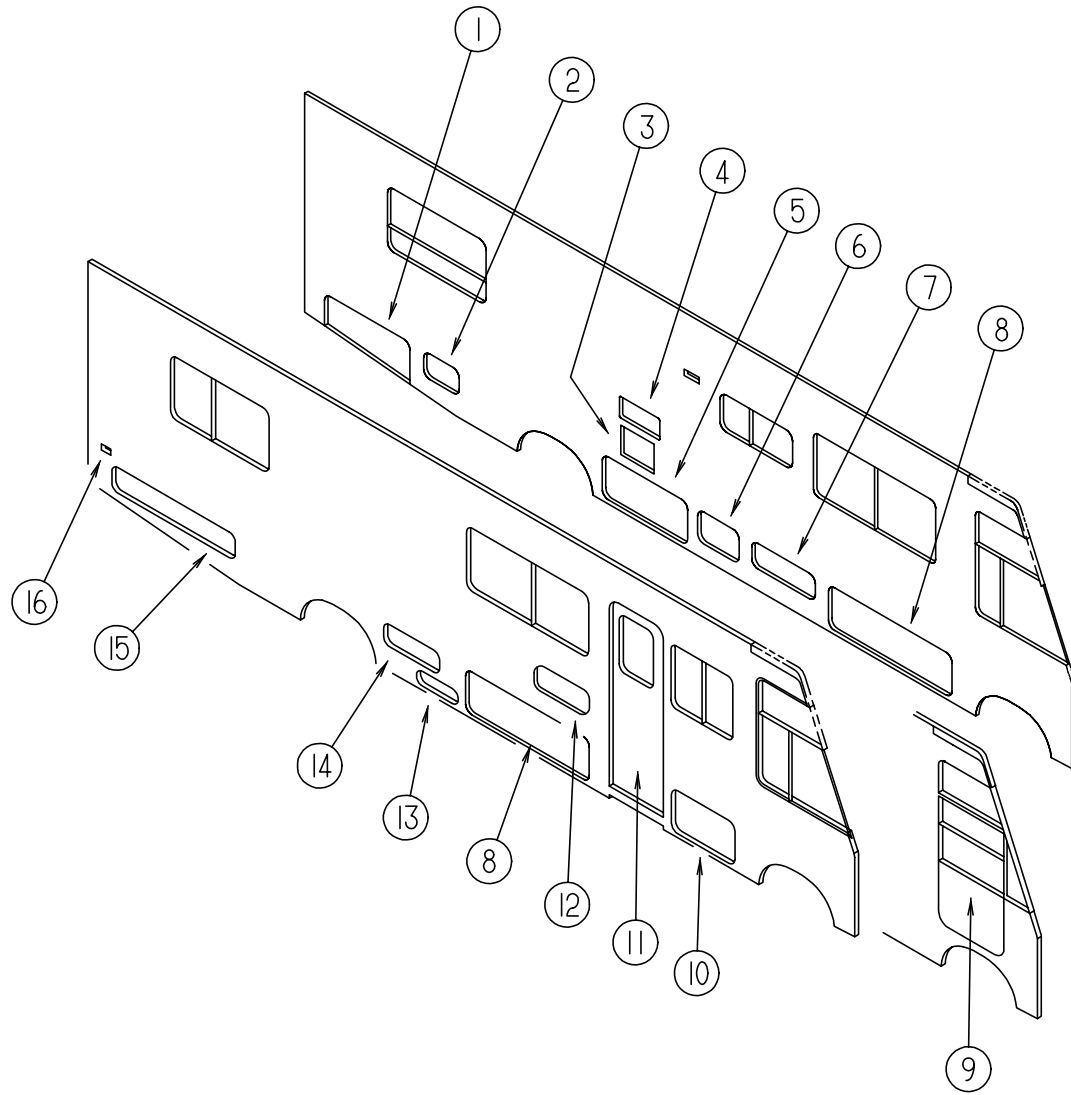

**WINDOW, VENT & EXTERIOR DOOR GROUP (CONTINUED)**

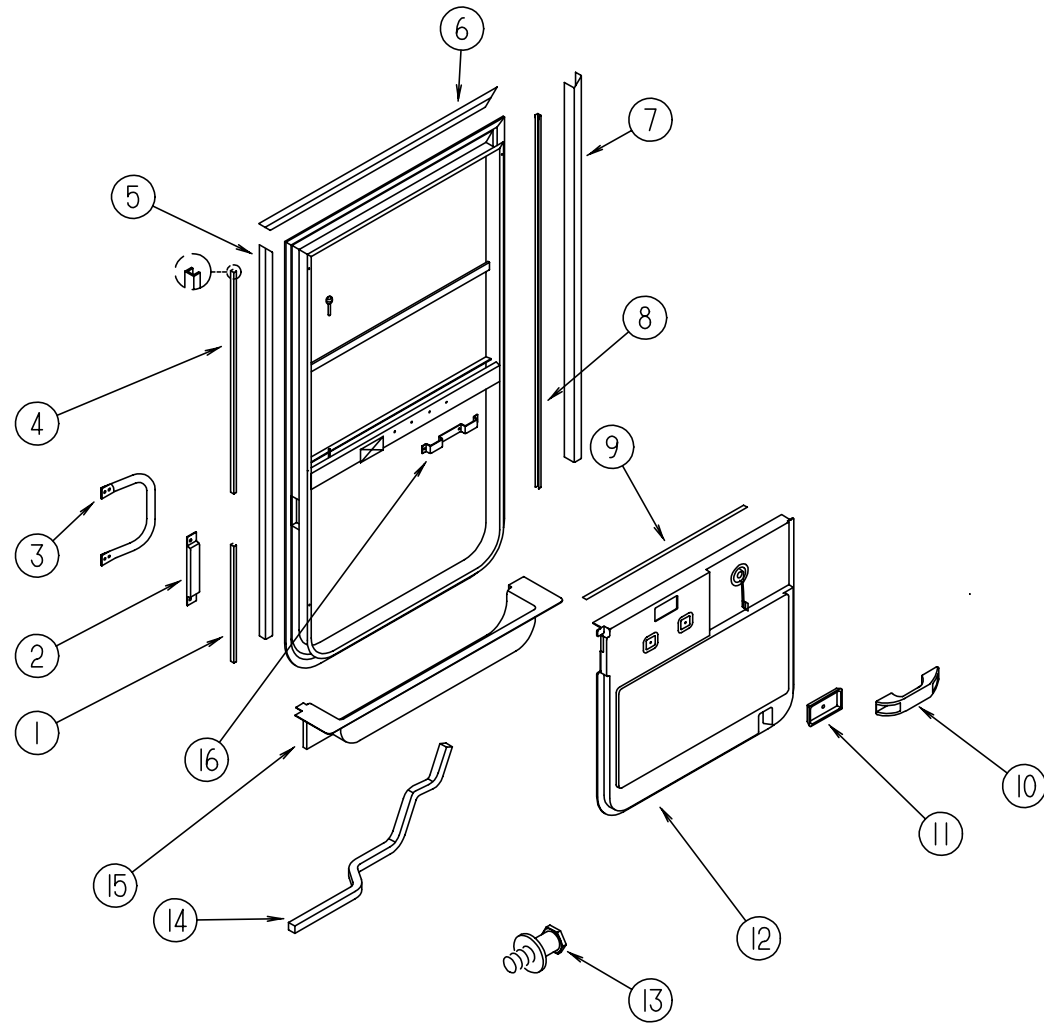

**DRIVER DOOR (EXCEL) (FROM: 00-00-00 THRU: 11-13-94)**

KEY	PART NUMBER	U/M DESCRIPTION
	106469-02-01A	EA DOOR - DRIVERS - BLACK - V108-01L
1	108642-03-01A	EA TRIM - DOOR - DRIVERS - BLACK
2	108654-01-01A	EA COVER - STRIKE - DRIVERS DOOR - BLACK
3	108832-01-02A	EA HANDLE - ASSIST - DRIVERS DOOR - METAL - OFF WHITE
3	108832-01-01A	EA HANDLE - ASSIST - DRIVERS DOOR - METAL - MILL FINISHED
	108833-01-01A	EA COVER - HANDLE - ASSIST - OFF WHITE
4	108642-05-01A	EA TRIM - DOOR - DRIVERS - BLACK
5	108129-02-02A	EA GARNISH - DRIVERS DOOR - BLACK
6	108107-01-02A	EA GARNISH - DRIVERS DOOR - BLACK
7	108108-02-02A	EA GARNISH - DRIVERS DOOR - BLACK
8	108642-04-01A	EA TRIM - DOOR - DRIVERS - BLACK
9	109644-01-000	FT TRIM - EDGE - RUBBER
10	102710-01-01A	EA HANDLE - ASSIST - DRIVERS DOOR - 6.6" LONG - BLACK
11	106469-01-707	EA BEZEL - LATCH - INTERIOR (SUPPLIED W/DRIVERS DOOR) 130-081310
12	111816-01-01A	EA PANEL - DRIVER DOOR - INNER - OFF WHITE - PLASTIC
13	106469-01-715	EA STRIKER ASSEMBLY - (SUPPLIED W/DRIVERS DOOR) 248-081003
14	063977-12-000	EA STEP - DRIVER DOOR - LEFT - PAINTED
14	063977-11-000	EA STEP - DRIVER DOOR - LEFT - UNPAINTED
15	107818-01-03A	EA TRIM - STEP - DRIVERS DOOR - PLASTIC - GRAY
16	108533-01-000	EA BRACKET - HANDLE - MOUNT
	102569-02-000	EA MAT - ANTI SLIP - LOWER
	041250 01 000	EA SWITCH - PUSH BUTTON - IN DOOR JAMB - METAL CHROME
	108897-01-01A	EA GARNISH - DOOR - DRIVERS - U-CHANNEL - BLACK
	109378-01-000	EA STRAP - CHECK - DRIVERS DOOR - BLACK
	109235-01-01A	FT COVER - SCREW - MAT BLACK - DAWN 132-081046
	109235-01-03A	FT COVER - SCREW - OFF WHITE - DAWN

**WINDOW, VENT & EXTERIOR DOOR GROUP (CONTINUED)**

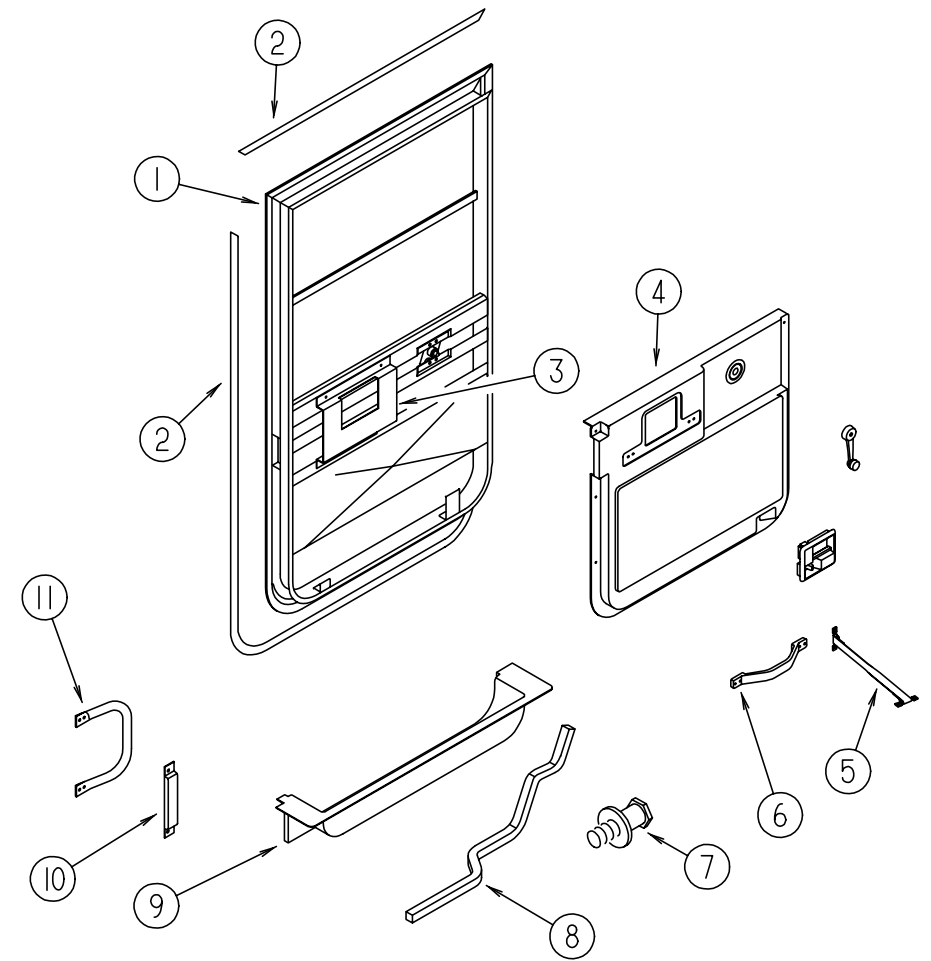

**DRIVER DOOR (EXCEL) (FROM: 11-14-94 THRU: 99-99-99)**

KEY	PART NUMBER	U/M DESCRIPTION
1	106469-07-01A	EA DOOR - DRIVERS - BLACK - V130-01L
2	109235-01-01A	FT COVER - SCREW - MAT BLACK - DAWN 132-081046
3	115051-01-01B	EA CHANNEL - HAT - MILL
4	114973-01-01A	EA PANEL - DRIVER DOOR - INNER - LIGHT GRAY - PLASTIC
5	109378-01-000	EA STRAP - CHECK - DRIVERS DOOR - BLACK
	064219-01-000	EA RETAINER - CHECK STRAP - DRIVERS DOOR - BLACK
6	110604-01-01A	EA HANDLE - ASSIST - DRIVERS DOOR
7	106469-01-715	EA STRIKER ASSEMBLY - (SUPPLIED W/ DRIVERS DOOR) 248-081003
8	063977-12-000	EA STEP - DRIVER DOOR - LEFT - PAINTED
8	063977-11-000	EA STEP - DRIVER DOOR - LEFT - UNPAINTED
9	107818-01-03A	EA TRIM - STEP - DRIVERS DOOR - PLASTIC - GRAY
	102569-02-000	EA MAT - ANTI SLIP - LOWER
10	108654-01-01A	EA COVER - STRIKE - DRIVERS DOOR - BLACK
11	108832-01-02A	EA HANDLE - ASSIST - DRIVERS DOOR - METAL - OFF WHITE
11	108832-01-01A	EA HANDLE - ASSIST - DRIVERS DOOR - METAL - MILL FINISHED
	108833-01-01A	EA COVER - HANDLE - ASSIST - OFF WHITE
	041250-01-000	EA SWITCH - PUSH BUTTON - IN DOOR JAMB - METAL CHROME



**WINDOW, VENT & EXTERIOR DOOR GROUP (CONTINUED)**

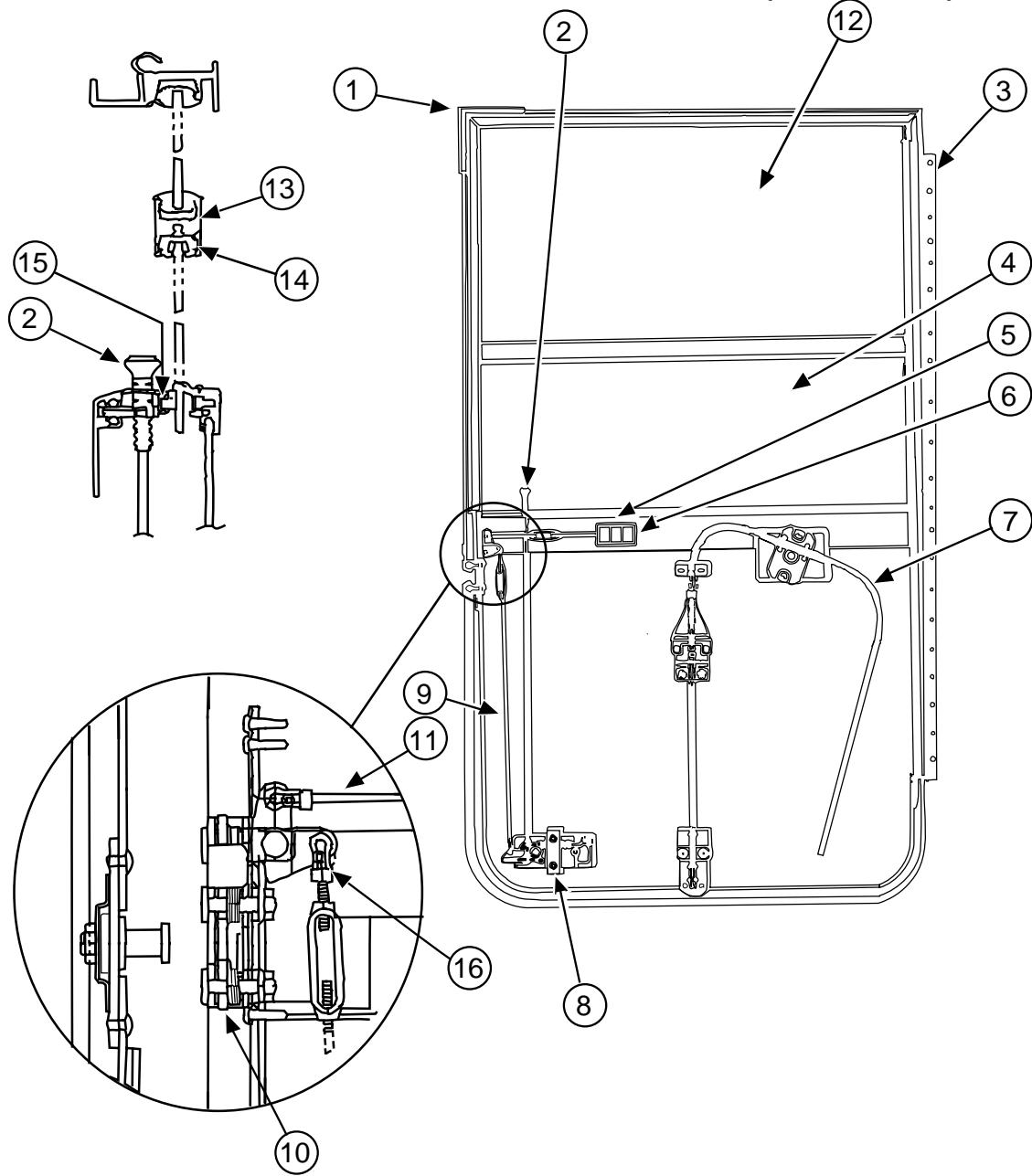

**DRIVER DOOR (EXCEL) (FROM: 00-00-00 THRU: 11-13-94)**

KEY	PART NUMBER	U/M DESCRIPTION
1	106469-01-702	EA DOOR SEAL - 122-040984
2	106469-01-708	EA BUTTON - LOCK - BLACK PLASTIC - 130-081313
3	106469-01-716	EA HINGE - 21" - 211080807
4	106469-01-704	EA GLASS ASM - ROLL-UP W/ BRACKET - V103-65L
5	106469-01-707	EA BEZEL - LATCH - INTERIOR - BLACK PLASTIC - 130-08131
6	106469-01-717	EA HANDLE - INTERIOR - 248-081308
7	106469-02-701	EA REGULATOR ASSEMBLY - V108-90L
8	106469-01-711	EA HANDLE - EXTERIOR - 410-081036
	106469-01-701	EA TUMBLER & 2 KEYS - 248-040557
	106469-01-718	EA KEY - BLANK (2) - 248-040558
9	106469-01-712	EA LATCH ROD ASSEMBLY - VERTICAL - V103-49
10	106469-01-710	EA LATCH - ROTARY - 248-081311
11	106469-01-714	EA LATCH - ROD - HORIZONTAL - 203-081015
12	106469-02-702	EA GLASS-STATIONARY - 106-041104
13	106469-01-719	EA MULLION RAIL - V103-84
14	106469-01-705	FT RUN - CHANNEL - 122-010850
15	106469-01-709	FT WEATHERSTRIP - FUZZY - 171-040630
16	106469-01-706	EA FASTENER - ROD END - 130-040593
	106469-02-700	EA JAMB - DRIVER DOOR - V108-30L

**WINDOW, VENT & EXTERIOR DOOR GROUP (CONTINUED)**

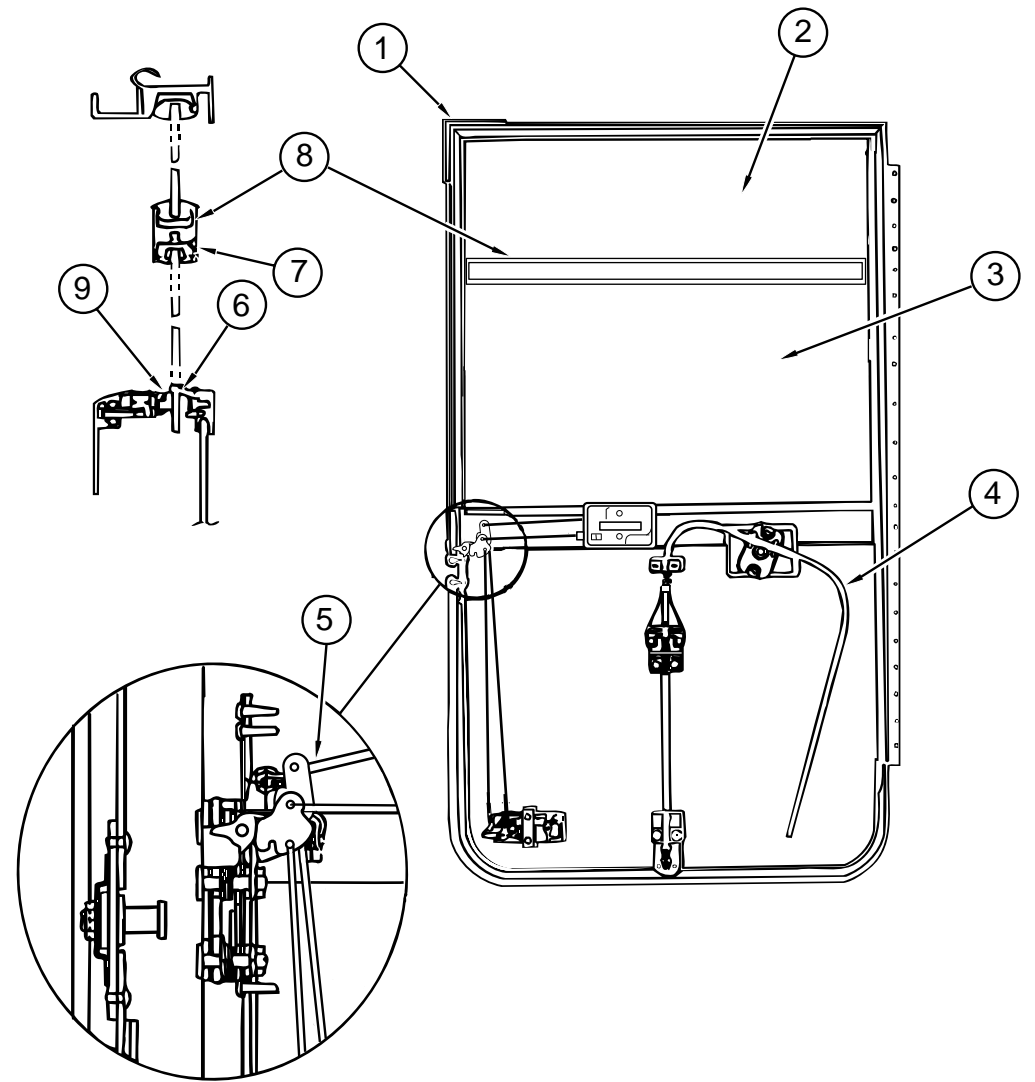

**DRIVER DOOR (EXCEL) (FROM: 11-14-94 THRU: 99-99-99)**

KEY	PART NUMBER	U/M DESCRIPTION
1	106469-01-702	EA DOOR SEAL - 122-040984
2	106469-02-702	EA GLASS-STATIONARY - 106-041104
3	106469-01-704	EA GLASS ASM - ROLL-UP W/ BRACKET - V103-65L
4	106469-02-701	EA REGULATOR ASSEMBLY - V108-90L
5	106469-01-706	EA FASTENER - ROD END - 130-040593
6	106469-01-709	FT BELT - WEATHERSTRIP - VO47-57
7	106469-01-705	FT RUN - CHANNEL - 122-010850
8	106469-01-719	EA MULLION RAIL - V103-84
9	106469-01-709	FT WEATHERSTRIP - FUZZY - 171-040630
	106469-02-700	EA JAMB - DRIVER DOOR - V108-30L

# WINDOW, VENT & EXTERIOR DOOR GROUP (CONTINUED)

## BRIGGS & STRATTON LOCKS & COMPONENTS

NOTE:  
 WHEN ORDERING THE LOCK CASE, THE KEY CODE MUST MATCH THE LAST DIGIT OF THE VEHICLE'S SERIAL NUMBER AND PART NUMBER; WHEN ORDERING THE KEYS, THE THIRD DIGIT OF THE KEY CODE MUST MATCH THE LAST DIGIT OF THE VEHICLE'S SERIAL NUMBER AND PART NUMBER

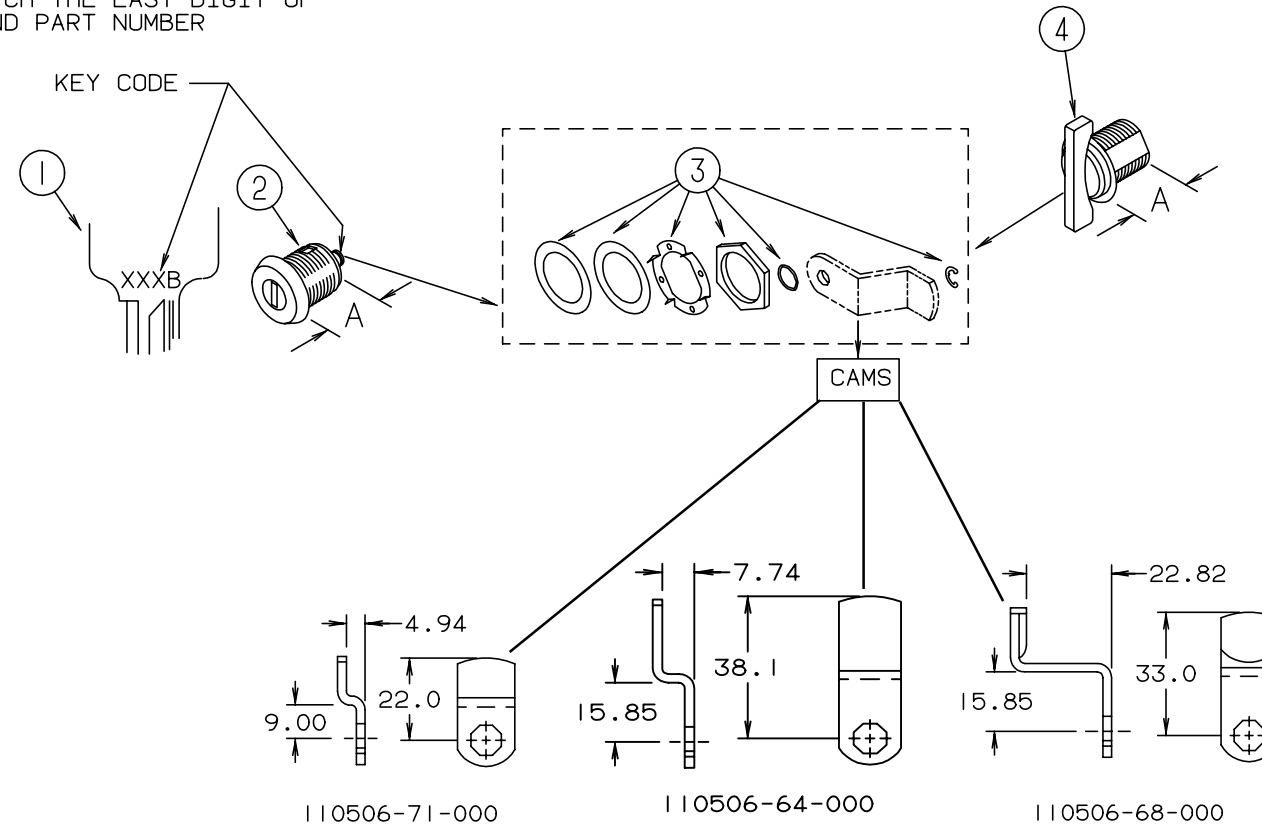

KEY	PART NUMBER	U/M	DESCRIPTION
1	110506-59-000	EA	KEYS - SET OF TWO - 596720
2	110506-52-000	EA	CASE - LOCK - A= 17 MM - 702370
2	110506-53-000	EA	CASE - LOCK - A= 25 MM - 702380
1	110506-59-001	EA	KEYS - SET OF TWO - 596721
2	110506-52-001	EA	CASE - LOCK - A= 17 MM - 702371
2	110506-53-001	EA	CASE - LOCK - A= 25 MM - 702381
1	110506-59-002	EA	KEYS - SET OF TWO - 596722
2	110506-52-002	EA	CASE - LOCK - A= 17 MM - 702372
2	110506-53-002	EA	CASE - LOCK - A= 25 MM - 702382
1	110506-59-003	EA	KEYS - SET OF TWO - 596723
2	110506-52-003	EA	CASE - LOCK - A= 17 MM - 702373
2	110506-53-003	EA	CASE - LOCK - A= 25 MM - 702383
1	110506-59-004	EA	KEYS - SET OF TWO - 596724
2	110506-52-004	EA	CASE - LOCK - A= 17 MM - 702374
2	110506-53-004	EA	CASE - LOCK - A= 25 MM - 702384
1	110506-59-005	EA	KEYS - SET OF TWO - 596725
2	110506-52-005	EA	CASE - LOCK - A= 17 MM - 702375
2	110506-53-005	EA	CASE - LOCK - A= 25 MM - 702385
1	110506-59-006	EA	KEYS - SET OF TWO - 596726
2	110506-52-006	EA	CASE - LOCK - A= 17 MM - 702376
2	110506-53-006	EA	CASE - LOCK - A= 25 MM - 702386

KEY	PART NUMBER	U/M	DESCRIPTION
1	110506-59-007	EA	KEYS - SET OF TWO - 596727
2	110506-52-007	EA	CASE - LOCK - A= 17 MM - 702377
2	110506-53-007	EA	CASE - LOCK - A= 25 MM - 702387
1	110506-59-008	EA	KEYS - SET OF TWO - 596728
2	110506-52-008	EA	CASE - LOCK - A= 17 MM - 702378
2	110506-53-008	EA	CASE - LOCK - A= 25 MM - 702388
1	110506-59-009	EA	KEYS - SET OF TWO - 596729
2	110506-52-009	EA	CASE - LOCK - A= 17 MM - 702379
2	110506-53-009	EA	CASE - LOCK - A= 25 MM - 702389
3	110506-40-700	EA	HARDWARE KIT
4	110506-50-000	EA	CASE - TWIST LOCK - A= 17 MM - 596952
4	110506-51-000	EA	CASE - TWIST LOCK - A= 25 MM - 596669
	110506-40-000	EA	CLIP-E - LOCK ASM. - 93981
	110506-64-000	EA	CAM - LOCK - 322280
	110506-68-000	EA	CAM - LOCK - 322284
	110506-71-000	EA	CAM - LOCK - 322287
	110506-59-701	EA	KEY BLANK - GOLD

## WINDOW, VENT & EXTERIOR DOOR GROUP (CONTINUED)

### ENTRY DOOR W/O WINDOW

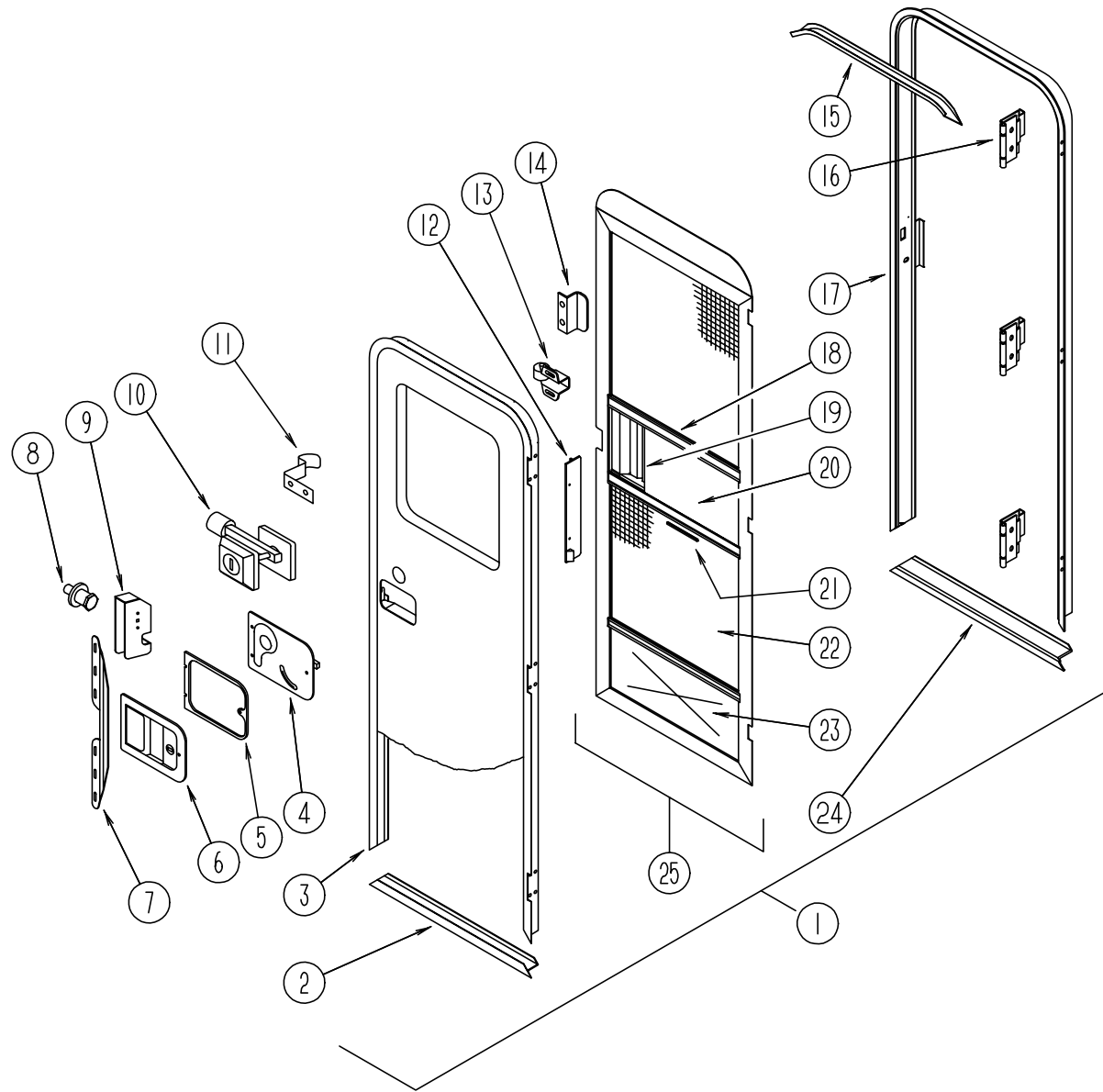

KEY	PART NUMBER	U/M	DESCRIPTION
1	115108-02-F31	EA	DOOR - ENTRY - W/O WINDOW - W/ SCREEN DOOR
1	115108-02-F32	EA	DOOR - ENTRY - W/O WINDOW - W/ SCREEN DOOR
	041546-05-000	EA	BRACKET - DOOR ANGLE - 5" X 1.9" - OFF WHITE - METAL
	115222-02-01A	EA	GARNISH - RADIUS - ENTRY DOOR - OFF WHITE
2	089748-01-000	EA	FRAME - BOTTOM ENTRY DOOR - OFF WHITE
3	095276-03-01A	EA	FRAME - ENTRY DOOR - W/O BOTTOM - OFF WHITE
4	039979-04-000	EA	COVER - INTERIOR LATCH - W/TRIP ARM - RIGHT - BLACK
5	096810-01-01A	EA	SPACER - DOOR LOCK - PLASTIC - BLACK
6	045017-11-000	EA	LATCH - PADDLE - MECHANISM W/LOCK CYLINDER & KEY - BLACK
	045017-11-701	EA	KEY BLANK
7	098173-01-04A	EA	STIFFENER - ENTRY DOOR - SUPPORTS LATCH/ STRIKE AREA - MILL
8	039539-01-000	EA	STRIKE - ENTRANCE DOOR LOCK
	077461-03-000	EA	COVER - STRIKE - ENTRY DOOR - 6.5" X 2.5" - PLASTIC - OFF WHITE
9	039540-01-000	EA	LATCH MECHANISM - HOOK - ENTRY DOOR - INTERIOR
	039715-01-000	EA	NUT - SERT - 1/4" DIAMETER - 20 THREADS
	039984-01-000	EA	CAP - ROUND - VINYL - .28" ID X .62" LONG - BLACK
	040944-01-000	EA	LABEL - ENTRANCE DOOR - "OPEN"
10	101145-01-01A	EA	DEADBOLT - ENTRY DOOR - BLACK
	095229-01-700	EA	KEY ONLY - BLANK
	101147-01-000	EA	BOLT - SECURITY - 4.12" BACKSET
	102524-01-000	EA	BUMPER - RUBBER - FLAT - BLACK
11	100412-01-000	EA	CATCH - SCREEN DOOR - THUMB CLIP
12	079087-02-000	EA	STRIKE - SLIDER - W/LIP FOR ELBOW CATCH - 1.5" X 8.6" - OFF WHITE
13	109403-01-000	EA	CATCH - SCREEN DOOR ROLLER
	063729-04-000	EA	RIVNUT - 10-32 UNF - .010-.080
	072893-01-000	EA	NUTSERT - M5 X 0 - 8
	075671-04-000	FT	SEAL - SPONGE - LAZY-T SHAPE - W/ ADHESIVE STRIPE - .5" WIDE
	100128-01-000	FT	SEAL - PILE - ADHESIVE BACK - GRAY
14	050712-04-000	EA	HANDLE - SCREEN DOOR - OFF WHITE
15	044582-02-000	EA	CAP - DRIP - ENTRY DOOR - ALUMINUM - OFF WHITE
16	097724-01-02A	EA	HINGE - ENTRY DOOR - OFF WHITE
17	095277-04-01A	EA	JAMB ASM - ENTRANCE DOOR - OFF WHITE
18	078777-01-000	EA	CHANNEL - SLIDE - SCREEN DOOR CENTER SLIDER COVER
19	079086-02-000	EA	SLIDER - SCREEN DOOR - OFF WHITE
	078595-01-000	EA	TOP PLATE - SCREEN DOOR - CURVED TOP - 4.7" X 25.35"
20	016454-01-000	EA	INSERT - SCREEN DOOR - CENTER - LEATHER GRAIN ALUMINUM
21	002294-01-000	FT	SPLINE - SCREENING - .135" X .138" - BLACK
22	002293-02-000	SF	SCREENING - 26" - CHARCOAL
23	078552-03-000	EA	KICK PANEL - SCREEN DOOR - LOWER INSERT - UNPAINTED
24	051049-01-000	EA	JAMB BOTTOM - ENTRY DOOR - 25.9" - UNPAINTED
25	079012-05-B10	EA	DOOR - SCREEN
	100128-02-000	FT	SEAL - SCREEN DOOR

**WINDOW, VENT & EXTERIOR DOOR GROUP (CONTINUED)**

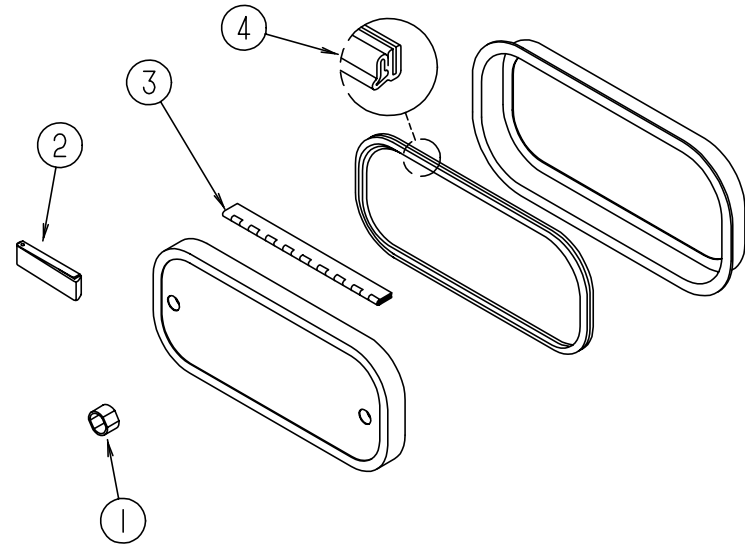

**EXTERIOR COMPARTMENT DOORS**

KEY	PART NUMBER	U/M DESCRIPTION
1	107997-51-001	EA SPACER - .86" X .6" - ALUMINUM
2	102768-01-000	EA HOLDER - COMPARTMENT/ ENTRY DOOR - METAL - MILL FINISH
3	081801-02-000	EA HINGE - PIANO - 2" X 96" - ALUMINUM
4	064075-07-000	FT SEAL - BULB - W/ WIRED U CHANNEL - .3" X .5" CHANNEL - BLACK
	096217-55-001	EA U-CHANNEL - 17.5' - OFF WHITE
	096217-55-006	EA U-CHANNEL - 17.5' - BRIGHT WHITE

**WINDSHIELD & WIPER GROUP**

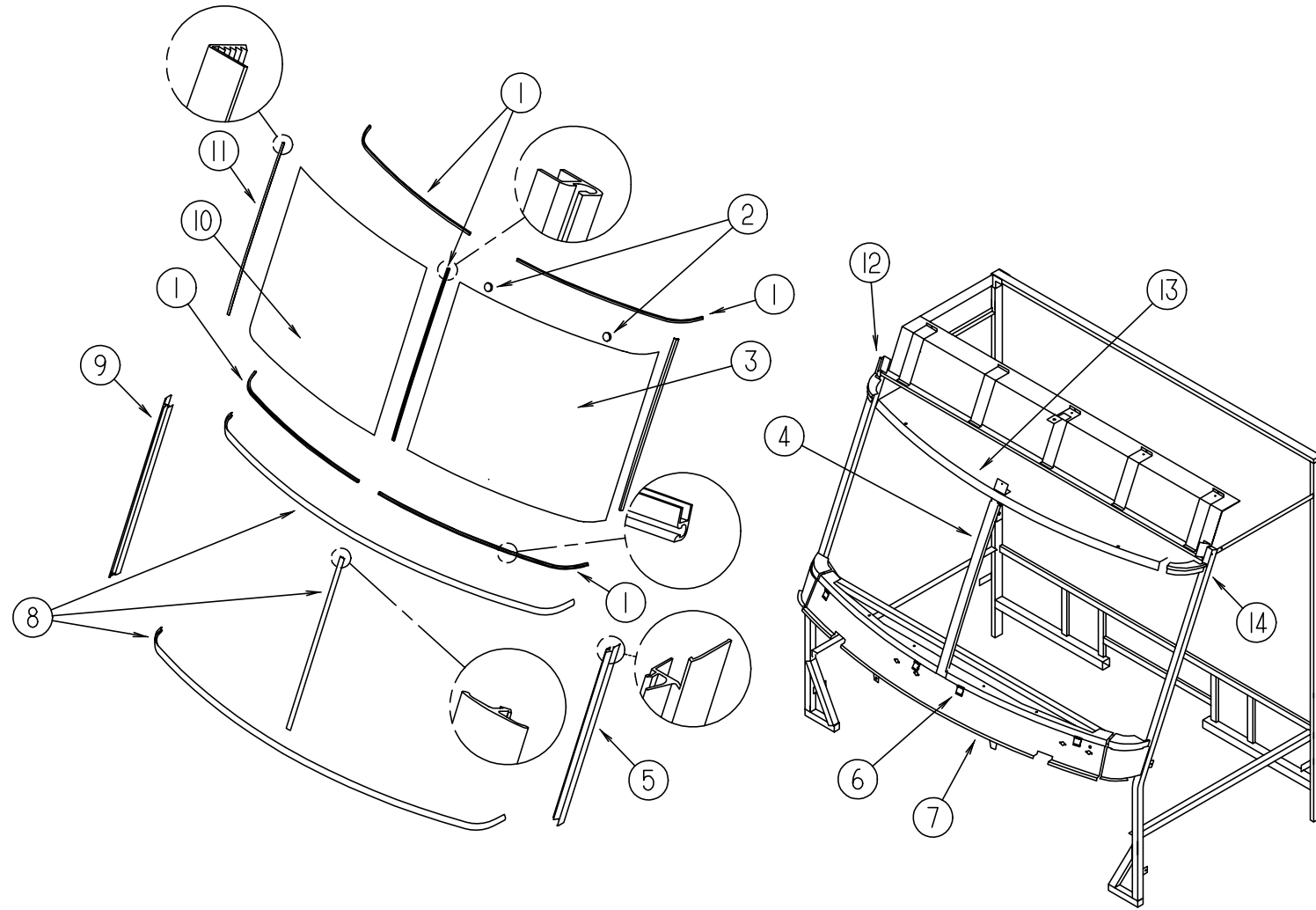

**WINDSHIELD MOLDINGS & GLASS**

KEY	PART NUMBER	U/M DESCRIPTION
1	110268-01-000	EA CARRIER - REVEAL - 1280 MM
2	081914-01-000	EA BUMPER - RUBBER - ROUND - .43" DIAMETER - BLACK
3	103788-02-000	EA GLASS - WINDSHIELD - DRIVER SIDE
4	075710-01-000	EA FRAME - WINDSHIELD - CENTER DIVIDER - INNER
5	103107-04-01A	EA TRIM - WINDSHIELD - DRIVER SIDE - BLACK
6	104449-01-000	EA BRACKET - WINDSHIELD SUPPORT
7	077847-02-000	EA SUPPORT - WINDSHIELD - LOWER - W/O BRACKETS
8	102936-01-000	FT MOLDING - REVEAL - WINDSHIELD
9	103107-03-01A	EA TRIM - WINDSHIELD - PASSENGER SIDE - BLACK
10	103788-01-000	EA GLASS - WINDSHIELD - PASSENGER SIDE
11	098788-06-000	EA CARRIER - REVEAL - 48.9" WINDSHIELD
12	077922-03-000	EA HEADER WINDSHIELD END - PASSENGER SIDE
13	077922-05-000	EA HEADER WINDSHIELD - CENTER
14	077922-04-000	EA HEADER WINDSHIELD END - DRIVER SIDE

### WINDSHIELD & WIPER GROUP (CONTINUED)

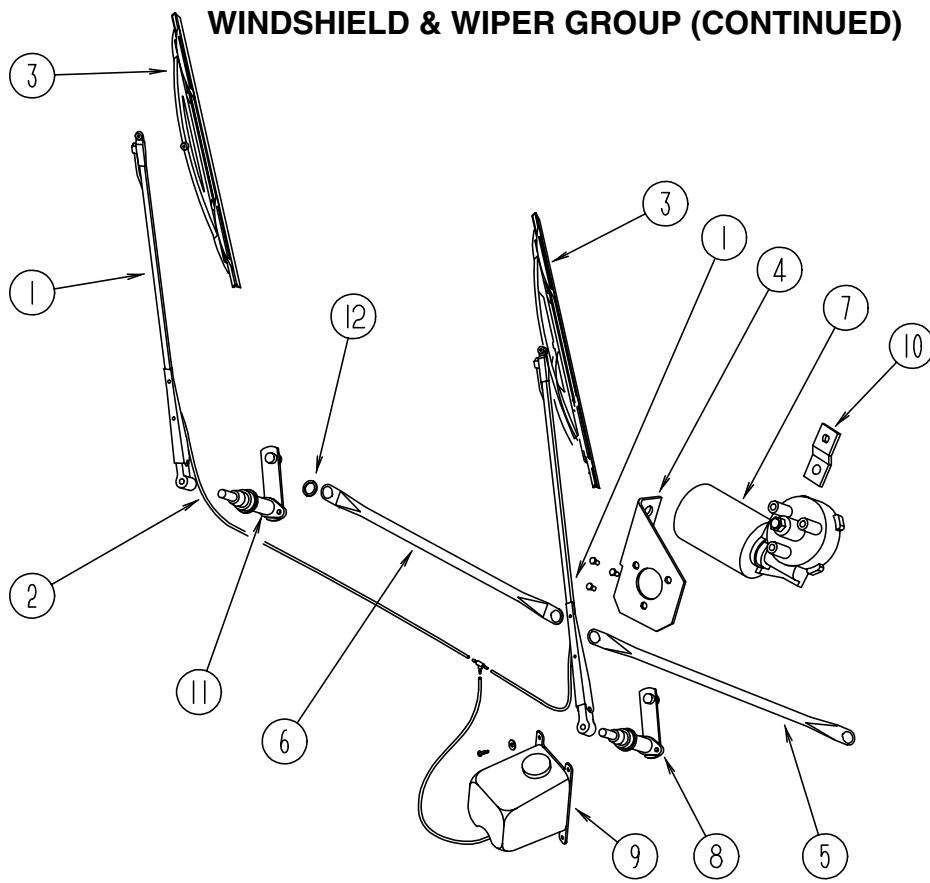

WINDSHIELD WIPER ASM (CHEVY)

KEY	PART NUMBER	U/M DESCRIPTION
1	103671-01-000	EA ARM - WIPER - 24"
2	096931-01-700	FT HOSE
3	095964-01-000	EA BLADE - WIPER - WINDSHIELD - 24"
	095964-01-700	EA BLADE - REFILL 24" (PAIR)
4	104549-01-000	EA BRACKET ASM - WIPER MOTOR
5	103672-01-000	EA LINK ASM - CONNECTING - 21.85" - DRIVER SIDE FROM: 00-00-00 THRU: 12-04-94
5	117008-01-000	EA LINK ASM - CONNECTING - 21.85" - DRIVER SIDE FROM: 12-05-94 THRU: 99-99-99
6	103672-02-000	EA LINK ASM - CONNECTING - 21.85" - PASSENGER SIDE FROM: 00-00-00 THRU: 12-04-94
6	117008-02-000	EA LINK ASM - CONNECTING - 21.85" - PASSENGER SIDE FROM: 12-05-94 THRU: 99-99-99
6	096526-01-000	EA SCREW-HEX 1/4-28 UNF FROM: 00-00-00 THRU: 01-23-95
7	104346-07-000	EA WIPER MOTOR
	110178-01-000	EA HOUSING - WIPER MOTOR
8	096505-06-000	EA PIVOT & SHAFT ASM - WIPER - DRIVER SIDE
9	056000-04-000	EA WINDSHIELD WASHER - BOTTLE & PUMP
	096931-01-701	EA NOZZLE & HARDWARE KIT, INCLUDES NOZZEL, NUT, SHORT THREAD SCREW, LONG THREAD SCREW, AND PLASTIC CAP FROM: 00-00-00 THRU: 04-02-95
9	117766-02-000	EA WASHER ASM - WINDSHIELD WIPER - MCCORD 600328 FROM: 04-03-95 THRU: 99-99-99
	110605-01-000	EA TEE - PLAS - BARBED 1/8 X 1/8 X 3/16 BAYLOCK 3799721 FROM: 04-03-95 THRU: 99-99-99
9	117765-01-000	EA CONNECTOR - 5/32-1/4-3/8 WINDSHIELD WASHER DANA - WEATHERHD FROM: 04-03-95 THRU: 99-99-99
10	104347-01-000	EA ARM - DRIVE - WIPER MOTOR - 1.54"
11	096505-05-000	EA PIVOT & SHAFT ASM - WIPER - PASSENGER SIDE
12	067193-05-000	EA GROMMET BUSHING - CONTROL ARM
	061603-01-000	EA GROMMET - SNAP - 3/16"ID - 3/8" HOLE - PLASTIC - BLACK
	110742-01-000	EA WIPER GASKET
	067188-01-000	EA STUD - WIPER CRANK
	067193-05-000	EA TOOL KIT - GROMMET BUSHING

### WINDSHIELD & WIPER GROUP (CONTINUED)

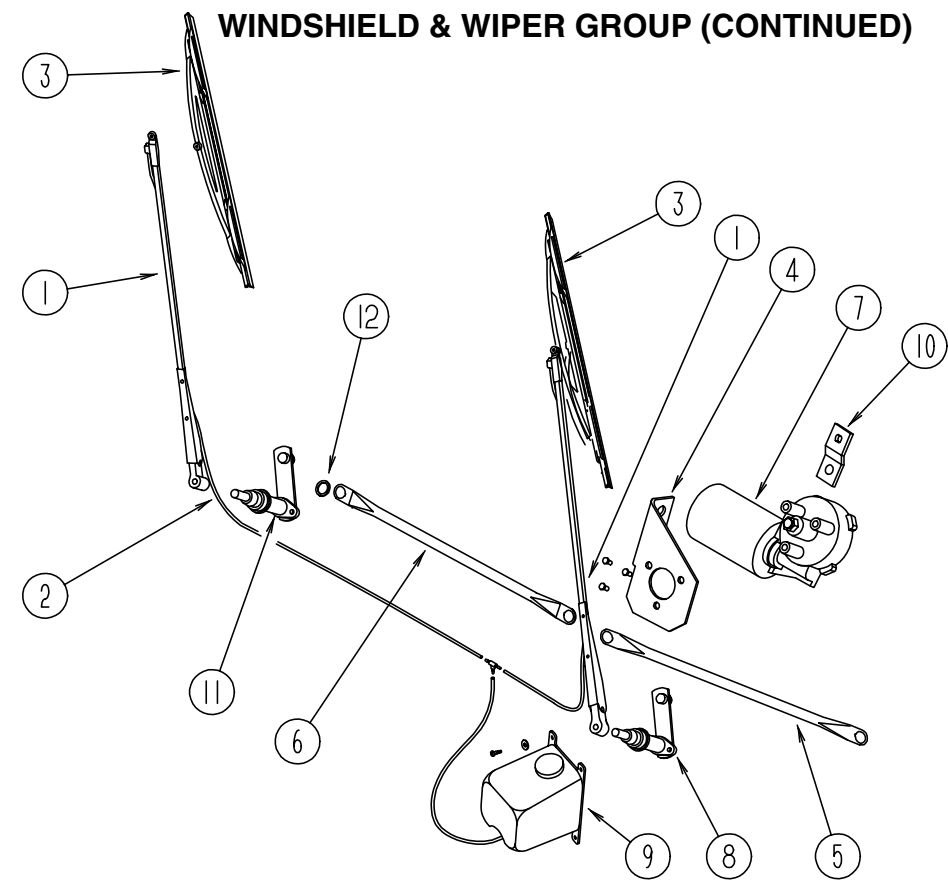

WINDSHIELD WIPER ASM (FORD)

KEY	PART NUMBER	U/M DESCRIPTION
1	103671-01-000	EA ARM - WIPER - 24"
2	096931-01-700	FT HOSE
3	095964-01-000	EA BLADE - WIPER - WINDSHIELD - 24"
	095964-01-700	EA BLADE - REFILL 24" (PAIR)
4	104549-01-000	EA BRACKET ASM - WIPER MOTOR
5	103672-01-000	EA LINK ASM - CONNECTING - 21.85" - DRIVER SIDE FROM: 00-00-00 THRU: 12-04-94
5	117008-01-000	EA LINK ASM - CONNECTING - 21.85" - DRIVER SIDE FROM: 12-05-94 THRU: 99-99-99
6	103672-02-000	EA LINK ASM - CONNECTING - 21.85" - PASSENGER SIDE FROM: 00-00-00 THRU: 12-04-94
6	117008-02-000	EA LINK ASM - CONNECTING - 21.85" - PASSENGER SIDE FROM: 12-05-94 THRU: 99-99-99
6	096526-01-000	EA SCREW-HEX 1/4-28 UNF FROM: 00-00-00 THRU: 01-23-95
7	104355-04-000	EA WIPER MOTOR - W/ DRIVE ASM
	110178-01-000	EA HOUSING - WIPER MOTOR
8	096505-06-000	EA PIVOT & SHAFT ASM - WIPER - DRIVER SIDE
9	056000-04-000	EA WINDSHIELD WASHER - BOTTLE & PUMP
	096931-01-701	EA NOZZLE & HARDWARE KIT, INCLUDES NOZZEL, NUT, SHORT THREAD SCREW, LONG THREAD SCREW, AND PLASTIC CAP FROM: 00-00-00 THRU: 04-02-95
9	117766-02-000	EA WASHER ASM - WINDSHIELD WIPER - MCCORD 600328 FROM: 04-03-95 THRU: 99-99-99
	110605-01-000	EA TEE - PLAS - BARBED 1/8 X 1/8 X 3/16 BAYLOCK 3799721 FROM: 04-03-95 THRU: 99-99-99
9	117765-01-000	EA CONNECTOR - 5/32-1/4-3/8 WINDSHIELD WASHER DANA - WEATHERHD FROM: 04-03-95 THRU: 99-99-99
10	104347-01-000	EA ARM - DRIVE - WIPER MOTOR - 1.54"
11	096505-05-000	EA PIVOT & SHAFT ASM - WIPER - PASSENGER SIDE
12	067193-05-000	EA GROMMET BUSHING - CONTROL ARM
	061603-01-000	EA GROMMET - SNAP - 3/16"ID - 3/8" HOLE - PLASTIC - BLACK
	110742-01-000	EA WIPER GASKET
	067188-01-000	EA STUD - WIPER CRANK
	067193-05-000	EA TOOL KIT - GROMMET BUSHING