

**1995
ICF33RQ**

F24

F25

F26

F27

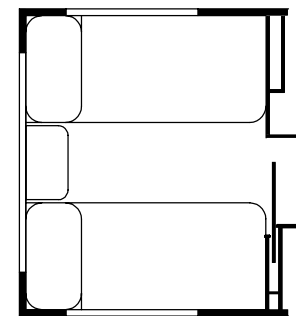
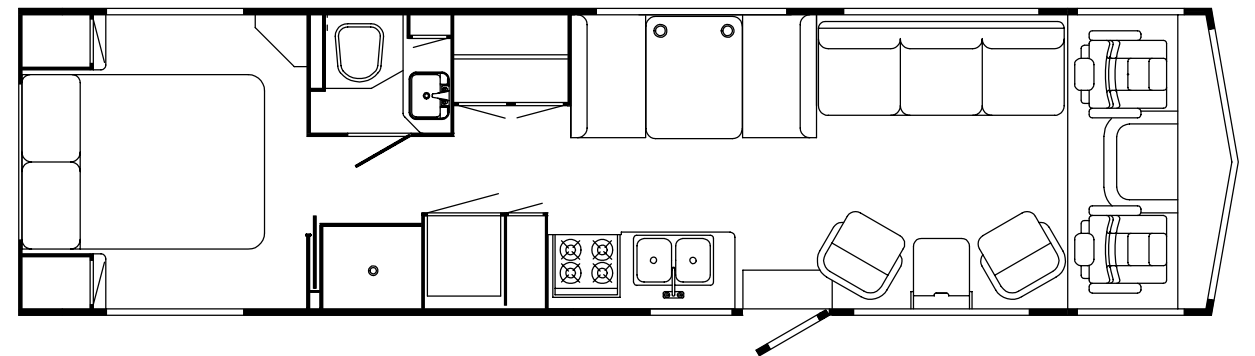
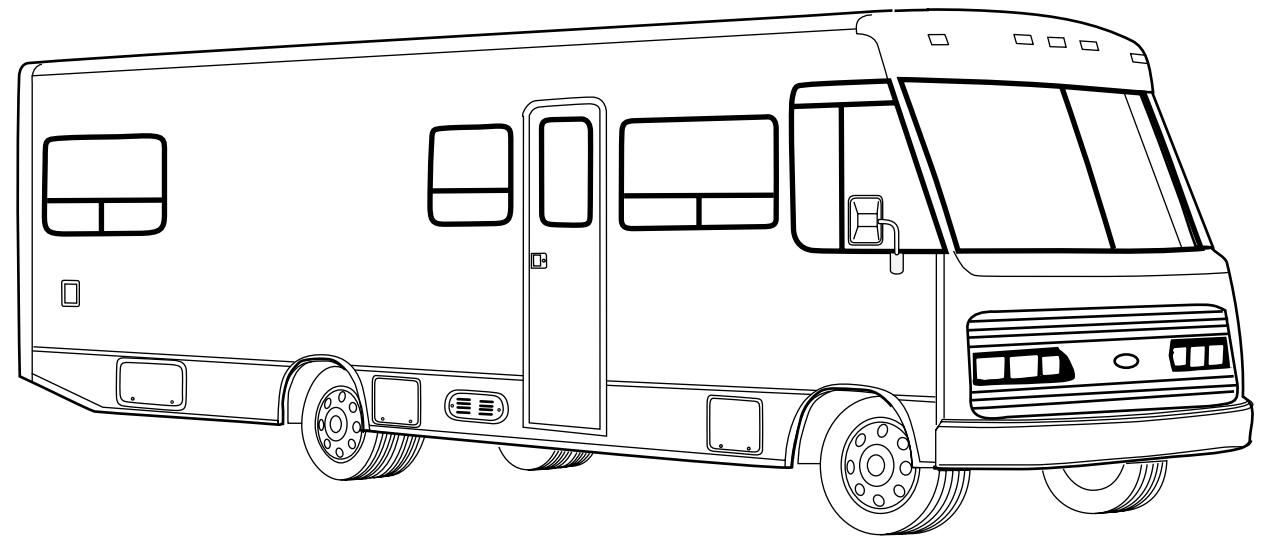

**ACCESSORIES GROUP
OPERATOR MANUAL**

KEY	PART NUMBER	U/M DESCRIPTION
	054185-D2-000	EA MANUAL-OPERATOR 95 SUNRISE - F-SERIES
	092318-01-000	EA BINDER - 3 RING, MOTOR HOME MANUAL
	092319-01-000	EA POCKET PAGE - 3 RING BINDER, PLASTIC
	112106-01-000	DW TOP LEVEL DRAWING-F, 1995

**AUDIO VIDEO GROUP
PATIO ENTERTAINMENT CENTER**

KEY	PART NUMBER	U/M DESCRIPTION
	077069-02-000	EA CABLE-ANTENNA, RADIO - EXTENSION 96" - ARA 6700667
	087683-03-000	EA RADIO-AM/FM STEREO CASSETTE - AUDIOVOX RS-100
	090944-01-000	EA ANTENNA-RADIO, 16" RUBBER
	108847-01-000	EA BRACKET-ANTENNA GROUND
	104498-01-000	EA BRACKET-ANTENNA MOUNT
	109889-02-000	EA ANTENNA-SHAFT EXTENDER 2" - MAGNADYNE RV71EX2
	110469-01-000	EA SPEAKER - 4 X 6 OVAL, COAXIAL - MAGNADYNE F46XB-12
	110470-01-01A	EA GRILLE-SPEAKER, OVAL 4 X 6 BLK - MAGNADYNE G46WI

RADIO SYSTEM & ANTENNA

KEY	PART NUMBER	U/M DESCRIPTION
	116148-01-000	EA RADIO-AM/FM STEREO, CD PLAYER - CLARION 5633CD
	110267-03-000	EA RADIO-AM/FM STEREO, AUDIOVOX IM-400
	077069-02-000	EA CABLE-ANTENNA, RADIO - EXTENSION 96" - ARA 6700667
	090944-01-000	EA ANTENNA-RADIO, 16" RUBBER
	081059-02-000	EA WIRE ASM - 9-PIN, RADIO - AUDIOVOX 112B-1761
	089340-02-000	EA GRILLE-SPEAKER, 6.5" SQUARE
	089340-03-000	EA SPACER-GRILLE, 6.5" SQUARE - TAN - MAGNADYNE G514
	094097-01-000	EA SPEAKER-RADIO, W/O GRILLE - 5.25" DIA - AUDIOVOX 110C3030
	110469-01-000	EA SPEAKER - 4" X 6", OVAL - MAGNADYNE F46XB-12
	110470-01-01A	EA GRILLE-SPEAKER, OVAL - 4" X 6" - BLACK - MAGNADYNE G46WI

CB ANTENNA

KEY	PART NUMBER	U/M DESCRIPTION
	105248-01-000	EA ANTENNA-CB, ADVANCE 8604

AUDIO VIDEO GROUP (CONTINUED)
TV, VCR & COMPONENTS

KEY	PART NUMBER	U/M DESCRIPTION
	098447-11-000	EA TV - 13", COLOR W/JACK - U.S. - MAGNAVOX RR1342C
	098447-11-700	EA REMOTE-TV, MAGNAVOX 8822336
	098447-08-000	EA TV - 13", COLOR W/REMOTE - CANADIAN - MAGNAVOX XR1333C FROM: 00-00-00 THRU: 10-09-94
	098447-12-000	EA TV - 13", COLOR W/JACK - CANADIAN - MAGNAVOX 13XNC15 FROM: 10-10-94 THRU: 99-99-99
	098447-08-700	EA REMOTE-TV, MAGNAVOX XR1333C
	098446-06-000	EA VCR-VHS CABLE READY -REMOTE - MAGNAVOX VR9210 FROM: 00-00-00 THRU: 10-02-94
	098446-06-700	EA REMOTE F/MODEL #9210 ONLY
	098446-07-000	EA VCR-VHS CABLE READY -REMOTE - MAGNAVOX VR9320 FROM: 10-03-94 THRU: 99-99-99
	098446-07-700	EA REMOTE F/MODEL #9320 ONLY
	092310-02-000	EA TV-COLOR, 9" - AC/DC - W/REMOTE - MAGNAVOX RD0945
	092310-02-700	EA REMOTE-TV, MAGNAVOX RD0945
	086757-03-000	EA CONTROL CENTER-SWITCH, VCR/TV - MAGNADYNE VCS-6
	093214-01-02A	EA PLATE-WALL,ANTENNA 1 OUTPUT IVORY - WINEGARD RV-0921
	093214-01-02A	EA GRILL-SPEAKER, 4" BROWN
	098819-01-000	EA SPEAKER - 2 WATT, 8 OHM - 4"
	099717-01-000	EA TIEDOWN-TV, STRAP ON FEMALE END IS 22.8" LONG
	099717-02-000	EA TIEDOWN-TV, STRAP ON FEMALE END IS 28.7" LONG
	076319-09-000	EA WALLPLATE-CABLE RECEPTACLE, TV - SINGLE - BROWN
	076319-08-000	EA WALLPLATE-CABLE RECEPTACLE, TV - SINGLE - IVORY
	086777-01-000	EA WALLPLATE-TV CABLE, W/ANTENNA SWITCH - IVORY
	086777-03-000	EA PLATE-WALL, CABLE - W/TV ANTENNA SWITCH & BOOSTER - IVORY
	076319-12-000	EA CONNECTOR-COAXIAL, ONE PIECE
	082134-01-000	EA ADAPTER-TV, CABLE TO CABLE - WINEGARD F-81M
	086756-01-000	EA SPLITTER-TV, 2 WAY
	076319-03-000	FT CABLE-COAXIAL, 75 OHM
	076319-06-000	EA ADAPTOR-CABLE ROOF PLATE, WINEGARD RPJ-1

AUDIO VIDEO GROUP (CONTINUED)

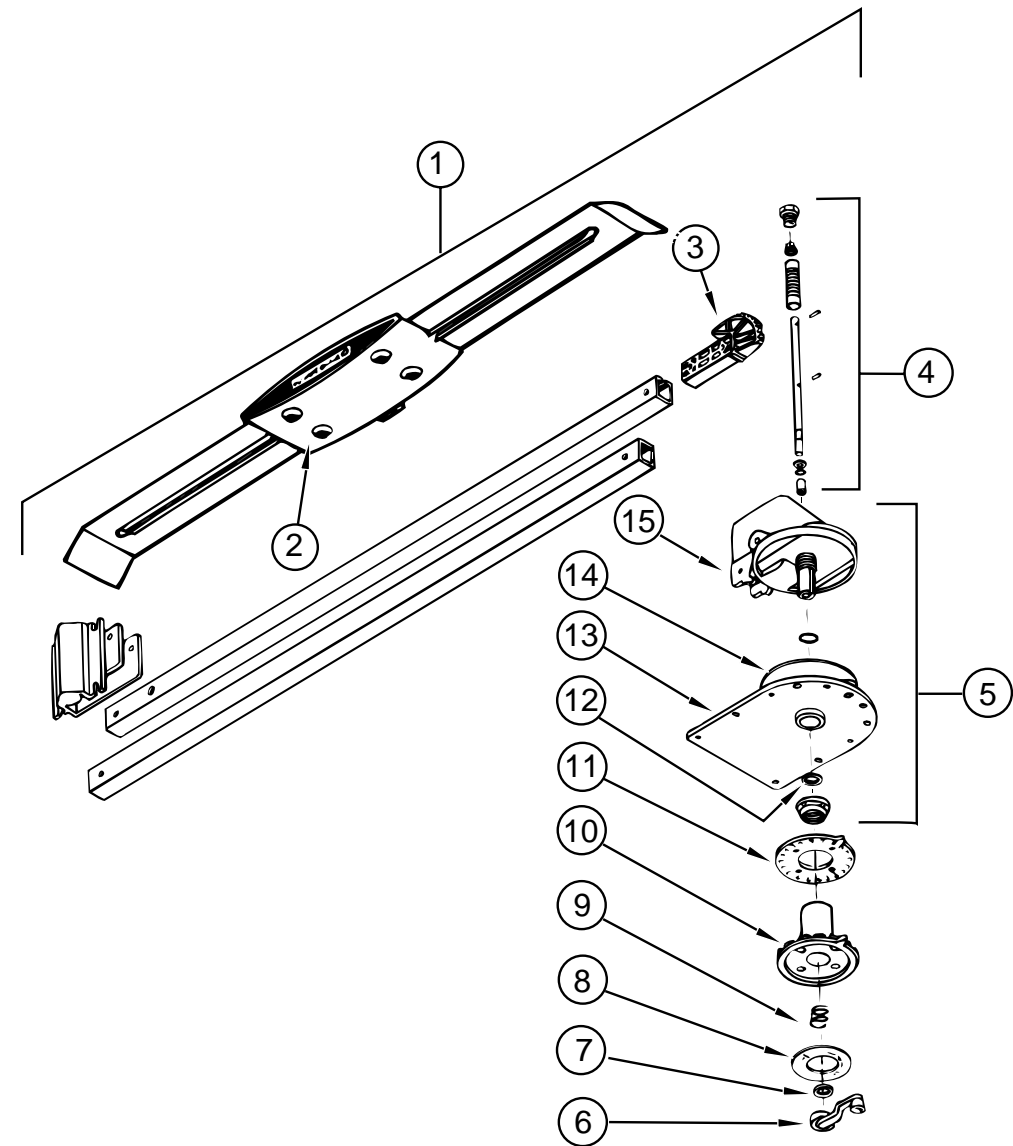

TV ANTENNA

KEY	PART NUMBER	U/M DESCRIPTION
1	076319-01-000	EA ANTENNA-TV, ROOF MOUNT - 44.5" MAST - RVA W02
2	076319-01-700	EA HEAD-ANTENNA, AMPLIFIED - WINEGARD# RVSA U/V
3	076319-01-701	EA GEAR-ELEVATING, PLASTIC - WINEGARD# 2200046
4	076319-01-702	EA SHAFT ASM-ELEVATING, WINEGARD# RVP-400A
5	076319-01-711	EA BASE & LIFT ASM - 2762802
6	076319-01-706	EA CRANK-ELEVATING, W/SET SCREW - WINEGARD# 5755100
7	076319-01-705	EA GROMMET-NYLON, 7/8"ID - WINEGARD# 3200658
8	076319-01-708	EA CRANK COVER DECAL, WINEGARD# 5413002
9	076319-01-707	EA SPRING-HANDLE, WINEGARD# 5160800
10	076319-01-709	EA PLATE-DIRECTIONAL, FOR HEAD - WINEGARD #3200644
11	076319-01-712	EA PLATE-CEILING, WINEGARD# 3200608
12	076319-01-704	EA BEARING-NYLON, 1.25"OD - WINEGARD# 3200657
13	076319-01-713	EA PLATE-BASE, WINEGARD# 3100523
14	076319-01-703	EA BEARING-NYLON, 5"OD - WINEGARD# 3200656
15	076319-01-714	EA HOUSING, ROTATING GEAR - 2200049

BATH GROUP
BATHROOM CABINET & COMPONENTS

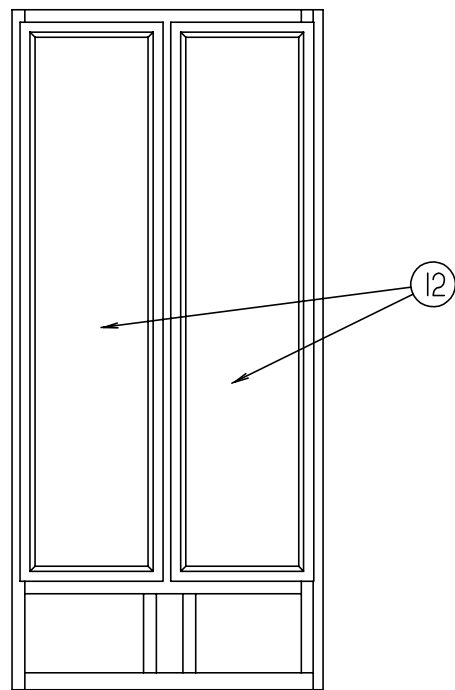
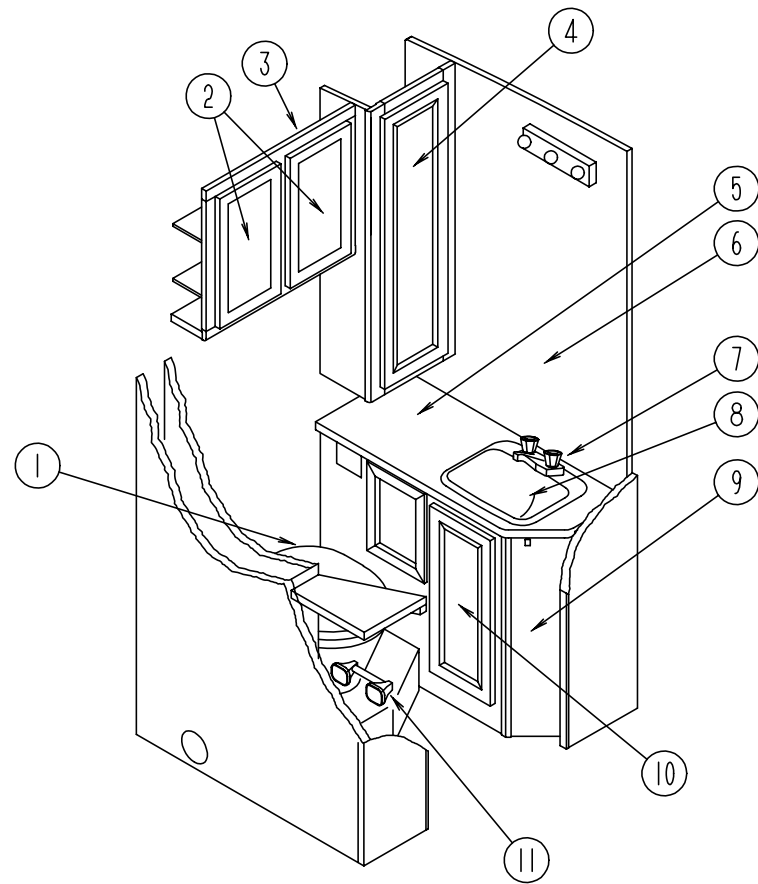

KEY	PART NUMBER	U/M	DESCRIPTION	
1	067487-02-000	EA	TOILET-12.37", IVORY - FOOT FLUSH - THETFORD	
	063740-01-700	EA	LEVER-WATER, THETFORD 12514	
	063740-01-706	EA	BOLT PACKAGE-CLOSET, THETFORD 12524	
	063740-01-710	EA	LINK, THETFORD 12513	
	063740-01-713	EA	SEAL-BALL VALVE TO BOWL, THETFORD 12502	
	063740-01-714	EA	VALVE ASM-WATER, THETFORD 12492	
	063740-01-717	EA	TUBE-FLUSH, TOILET - THETFORD 12509	
	063740-02-700	EA	SEAT & COVER, PARCHMENT - THETFORD 20829	
	063641-01-000	EA	FLANGE-CLOSET, TOILET - 4" X 3" - US	
	024676-02-000	EA	FLANGE-CLOSET, 4" X 3" - ABS - CANADIAN	
	2	M06803-06-E07	EA	DOOR-W/O HARDWARE - 285 X 500
3		111178-01-E07	EA	CABINET ASM-LINEN
		M06803-10-E07	EA	DOOR-W/O HARDWARE - 275 X 925
5		100013-11-E08	EA	COUNTERTOP ASM (F24,F27)
		100013-11-F05	EA	COUNTERTOP ASM (F25)
5		100013-11-F26	EA	COUNTERTOP ASM (F26)
		6	058331-51-000	EA
7			075240-06-000	EA
		8	091253-01-000	EA
096927-01-01A			EA	SINK-LAVATORY, RECTANGULAR - PLASTIC - BONE
096927-01-700			EA	SINK-STOPPER
9	096927-01-701	EA	TAILPIECE-SINK	
	P00013-01-F04	EA	CABINET ASM-LAVATORY, W/O DOORS OR HARDWARE (F24,F27)	
	P00013-01-F05	EA	CABINET ASM-LAVATORY, W/O DOORS OR HARDWARE (F25)	
9	P00013-01-F26	EA	CABINET ASM-LAVATORY, W/O DOORS OR HARDWARE (F26)	
	10	M06803-70-E07	EA	DOOR-W/O HARDWARE - 275 X 605
11		075452-02-000	EA	HOLDER-TOILET TISSUE, BRASS
	075453-02-000	EA	BAR-TOWEL, 18" BRASS	
	100357-01-000	EA	ROD-TOWEL, BRASS W/ENDS BENT FOR BACK OF BATH DOOR	
	102089-13-E07	EA	WOOD RAIL - TOWEL RACK - RIGHT SIDE - 26" LONG	
	102089-14-E07	EA	WOOD RAIL - TOWEL RACK - LEFT SIDE - 26" LONG	
	M87868-10-F04	EA	DOOR-CABINET BATH	
12	094485-03-01A	EA	KNOB-DOOR,BRASS - THUNADER L132PB	
	102920-01-01A	EA	HINGE-DOOR, SPRING LOADED - BRASS	
	104013-02-D35	EA	DOOR ASM-SLIDING	
	103874-01-000	EA	HANGER-SLIDING DOOR	
	M06803-11-E07	EA	DOOR-W/O HARDWARE - 410 X 1660	

BATH GROUP (CONTINUED)
SHOWER & COMPONENTS

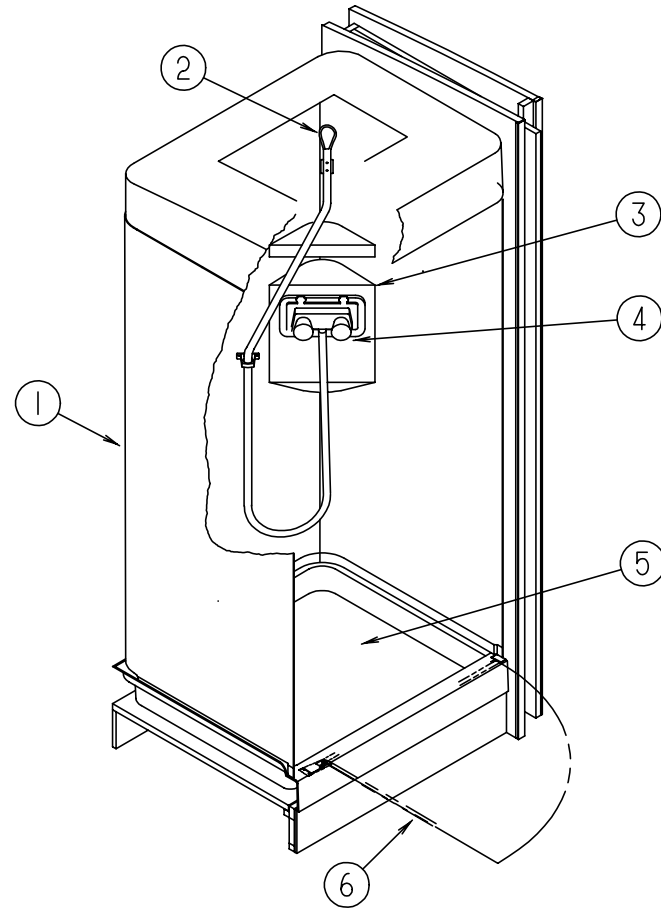

KEY	PART NUMBER	U/ M DESCRIPTION
1	101805-01-01A	EA SURROUND-SHOWER OFF WHITE
2	103092-02-000	EA SHOWER HEAD-W/HOSE - CANADIAN
	103092-01-000	EA SHOWER HEAD-W/60" HOSE - US
	103092-01-700	EA BRACKET ONLY-CLEAR, F/SHOWER HEAD - 2328028
	103092-01-701	EA BRACKET ONLY-BONE, F/SHOWER HEAD - 2328029
	093527-02-000	EA BRACKET-SQUEEGEE/SHOWER HEAD
3	075606-01-000	EA PANEL-FAUCET BACK, SHOWER - 5" X 9" - PLASTIC
4	075241-05-000	EA FAUCET-SHOWER, BONE
5	M02429-07-000	EA PAN-SHOWER
	066436-01-000	EA NUT-SLIP, TAILPIECE - 1.5"
	066440-01-000	EA STRAINER-SHOWER, W/RUBBER WASHER
	089318-01-000	EA DOOR-SHOWER, HINGED - W/GOLD FRAME - PLASTIC - 29.8" WIDE
	089318-02-000	EA JAMB-EXPANDER
	089318-01-700	EA STRAP F/SHOWER DOOR
	089318-01-701	EA VINYL SWEEP
	089318-01-702	EA BUSHING W/ARM
	089318-01-703	EA STRIKE-JAMB W/MAGNETIC STRIP
	092574-01-703	EA GOLD DOOR PULL
	092574-01-704	EA SCREW-GOLD, #6 3/8 - COASTAL 638G
092574-01-705	EA MAGNETIC STRIP - 56.9" - COASTAL 98-41	
092574-01-707	EA PIVOT BUSHING - 18712B	
057671-01-000	EA COVER-SCREW, #8 - PLASTIC - OFF WHITE	
113714-02-01A	EA RETAINER-SHELF, SHOWER O/W	

BEDROOM GROUP
QUEEN BEDROOM CABINETS

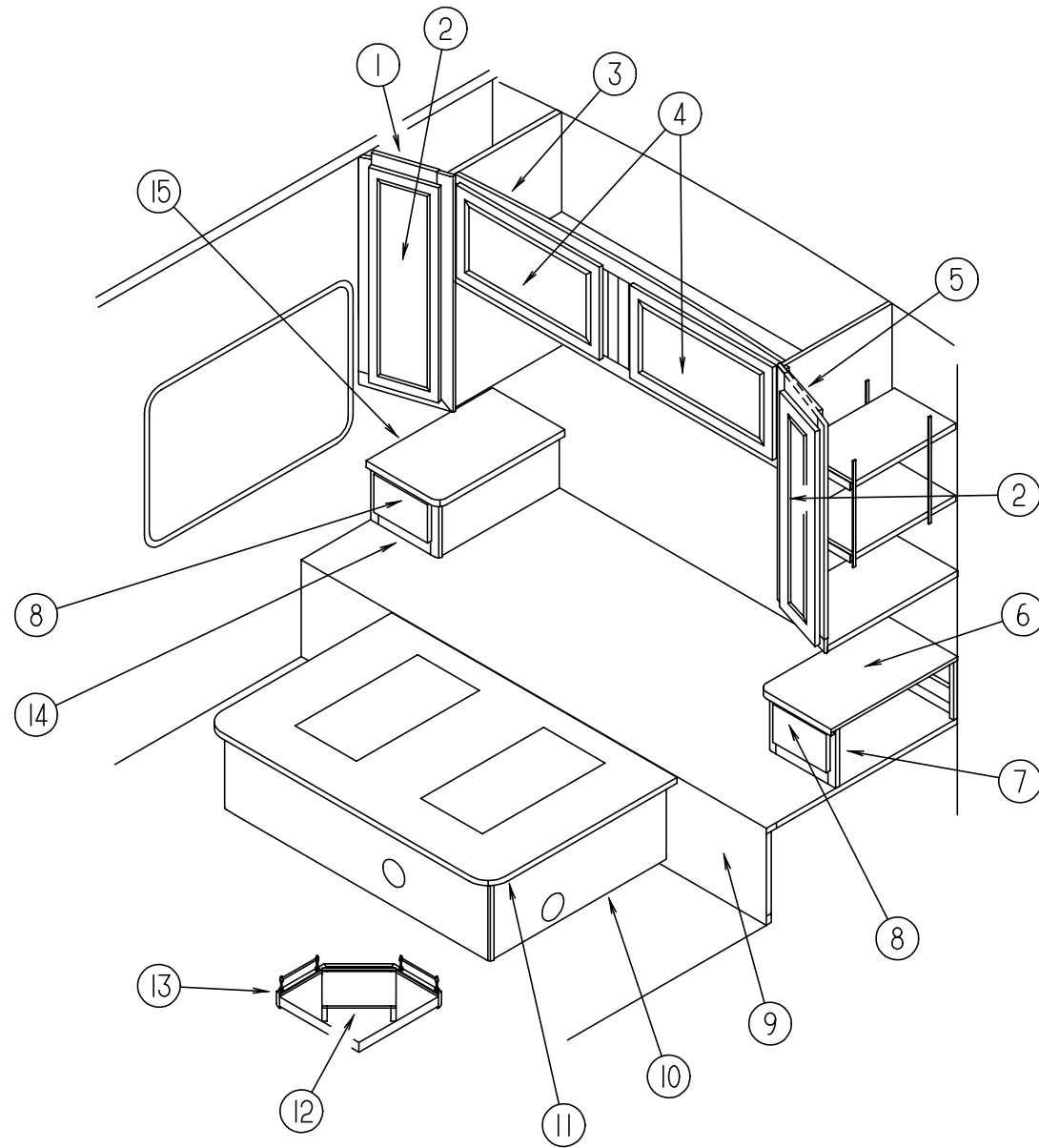

KEY	PART NUMBER	U/M	DESCRIPTION
1	110625-01-F04	EA	CABINET-SHIRT CLOSET, W/O DOOR OR HARDWARE
	009112-01-000	EA	FLANGE-1" ROD, CLOTHES - PLASTIC - OFF WHITE
	042438-01-000	EA	DOWEL-WOOD, CLOTHES ROD - 1" DIAMETER X 4'
2	M06803-10-E07	EA	DOOR-W/O HARDWARE - 275 MM X 925 MM
3	M06852-01-E10	EA	CABINET-OVERHEAD, W/O DOORS OR HARDWARE - EUROPEAN OPTION
3	106523-01-E07	EA	CABINET-OVERHEAD, W/O DOORS OR HARDWARE
4	M06803-82-E10	EA	DOOR-W/O HARDWARE W/O MIRROR - 400 MM X 710 MM - EUROPEAN OPTION
4	M06803-13-E07	EA	DOOR-W/O HARDWARE W/MIRROR - 400 MM X 710 MM
	108536-04-08A	EA	MIRROR-GLASS GALAXY FLOWER - 317 X 627
5	110625-02-F04	EA	CABINET-SHIRT CLOSET, W/O DOOR OR HARDWARE
	009112-01-000	EA	FLANGE-1" ROD, CLOTHES - PLASTIC - OFF WHITE
	042438-01-000	EA	DOWEL-WOOD, CLOTHES ROD - 1" DIAMETER X 4'
6	110626-12-F24	EA	COUNTERTOP-NIGHTSTAND (F24,F27)
6	110626-12-F05	EA	COUNTERTOP-NIGHTSTAND (F25)
6	110626-12-F26	EA	COUNTERTOP-NIGHTSTAND
7	P10626-02-F04	EA	CABINET-NIGHTSTAND W/COUNTERTOP (F24,F27)
7	P10626-02-F05	EA	CABINET-NIGHTSTAND W/COUNTERTOP (F25)
7	P10626-02-F26	EA	CABINET-NIGHTSTAND W/COUNTERTOP
8	M05971-56-E07	EA	DRAWER-CABINET, W/O HARDWARE - 155 MM X 290 MM FACE SIZE
9	P10624-01-000	EA	CABINET-COMPARTMENT, W/O CARPET OR TOP
10	P10623-01-F04	EA	CABINET-QUEEN BED W/O TOP
11	M05706-05-000	EA	TOP-QUEEN BED CABINET
12	111236-15-E07	EA	WEDGE-TV
13	111236-01-E07	EA	SHELF ASM-TV, W/BRASS RAILING & WEDGE - 420 MM X 410 MM
	105219-01-E07	EA	SHELF ASM-W/BRASS RAILING - 273 MM X 274 MM
	084070-02-000	EA	POST-END, 2.4" - BRASS
	084071-15-000	EA	ROD-BRASS, 210 MM LONG
	058331-17-000	EA	MIRROR-GLASS, SAFETY - 8.75" X 12.5"
	105004-01-01A	EA	MOLDING-MIRROR, VINYL WRAPPED - OAK
14	P10626-01-F04	EA	CABINET-NIGHTSTAND W/COUNTERTOP (F24,F27)
14	P10626-01-F05	EA	CABINET-NIGHTSTAND W/COUNTERTOP (F25)
14	P10626-01-F26	EA	CABINET-NIGHTSTAND W/COUNTERTOP
15	110626-11-F24	EA	COUNTERTOP-NIGHTSTAND (F24,F27)
15	110626-11-F05	EA	COUNTERTOP-NIGHTSTAND (F25)
15	110626-11-F26	EA	COUNTERTOP-NIGHTSTAND

BEDROOM GROUP (CONTINUED)
TWIN BEDROOM CABINETS

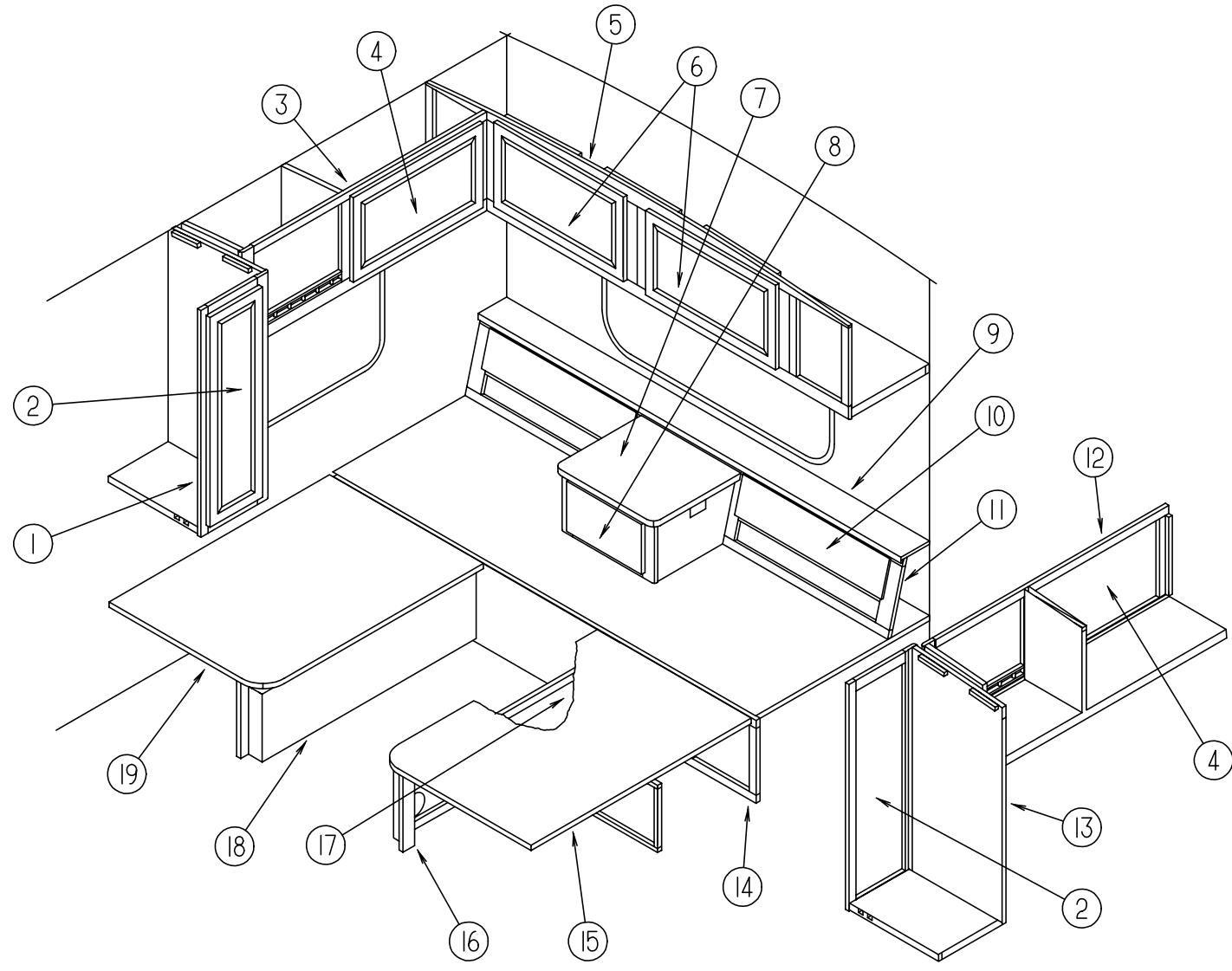

KEY	PART NUMBER	U/M	DESCRIPTION
1	110946-01-E07	EA	CABINET-SHIRT CLOSET, W/O DOOR OR HARDWARE
	009112-01-000	EA	FLANGE-1" ROD, CLOTHES - PLASTIC - OFF WHITE
	042438-01-000	EA	DOWEL-WOOD, CLOTHES ROD - 1" DIAMETER X 4'
2	M06803-15-E07	EA	DOOR-W/O HARDWARE - 305 MM X 1015 MM
3	111185-01-F04	EA	CABINET-OVERHEAD, W/O DOOR OR HARDWARE
	111775-01-01A	EA	RAIL-DECORATIVE, 1830 MM - OAK
	058331-A5-000	EA	MIRROR-GLASS, SAFETY - 396 MM X 516 MM
4	M06803-02-E07	EA	DOOR-W/O HARDWARE - 400 MM X 710 MM
5	111239-01-E07	EA	CABINET-OVERHEAD, W/O DOORS OR HARDWARE
6	M06803-02-E07	EA	DOOR-W/O HARDWARE - 400 MM X 710 MM
6	M06803-13-E07	EA	DOOR-W/O HARDWARE W/MIRROR - 400 MM X 710 MM
	108536-04-08A	EA	MIRROR-GLASS GALAXY FLOWER - 317 X 627
7	110826-13-F24	EA	COUNTERTOP-NIGHTSTAND CABINET (F24,F27)
7	110826-13-F05	EA	COUNTERTOP-NIGHTSTAND CABINET (F25)
7	110826-13-F06	EA	COUNTERTOP-NIGHTSTAND CABINET (F26)
8	M05971-59-E07	EA	DRAWER-CABINET, W/O HARDWARE - 235 MM X 410 MM FACE SIZE

KEY	PART NUMBER	U/M	DESCRIPTION
9	110826-11-F24	EA	COUNTERTOP-NIGHTSTAND CABINET (F24,F27)
9	110826-11-F05	EA	COUNTERTOP-NIGHTSTAND CABINET (F25)
9	110826-11-E90	EA	COUNTERTOP-NIGHTSTAND CABINET (F26)
10	110826-12-F24	EA	DOOR-W/O HARDWARE - FABRIC COVERED - 176 MM X 802 MM - EITHER SIDE
10	110826-12-F25	EA	DOOR-W/O HARDWARE - FABRIC COVERED - 176 MM X 802 MM - EITHER SIDE
10	110826-12-F26	EA	DOOR-W/O HARDWARE - FABRIC COVERED - 176 MM X 802 MM - EITHER SIDE
10	110826-12-F27	EA	DOOR-W/O HARDWARE - FABRIC COVERED - 176 MM X 802 MM - EITHER SIDE
11	110826-01-F24	EA	CABINET-NIGHTSTAND, W/COUNTERTOPS - W/O DOORS OR DRAWER
11	110826-01-F25	EA	CABINET-NIGHTSTAND, W/COUNTERTOPS - W/O DOORS OR DRAWER
11	110826-01-F26	EA	CABINET-NIGHTSTAND, W/COUNTERTOPS - W/O DOORS OR DRAWER
11	110826-01-F27	EA	CABINET-NIGHTSTAND, W/COUNTERTOPS - W/O DOORS OR DRAWER
12	111186-01-E07	EA	CABINET-OVERHEAD, W/O DOOR OR HARDWARE
	111775-01-01A	EA	RAIL-DECORATIVE, 1830 MM - OAK
	058331-A5-000	EA	MIRROR-GLASS, SAFETY - 396 MM X 516 MM
13	110947-01-E07	EA	CABINET-SHIRT CLOSET, W/O DOOR OR HARDWARE - DRIVER SIDE
	009112-01-000	EA	FLANGE-1" ROD, CLOTHES - PLASTIC - OFF WHITE
	042438-01-000	EA	DOWEL-WOOD, CLOTHES ROD - 1" DIAMETER X 4'
14	P10877-01-000	EA	CABINET-COMPARTMENT, W/O TOP OR CARPET
15	M04170-05-000	EA	TOP-TWIN BED
16	P11184-01-E07	EA	CABINET-TWIN BED W/O TOP
17	M06803-68-E07	EA	DOOR-W/O HARDWARE - 305 MM X 555 MM - DRIVER SIDE TWIN BED CABINET
18	P10828-01-E07	EA	CABINET-TWIN BED W/O TOP
19	M04170-04-000	EA	TOP-TWIN BED, PASSENGER SIDE

BEDROOM GROUP (CONTINUED)

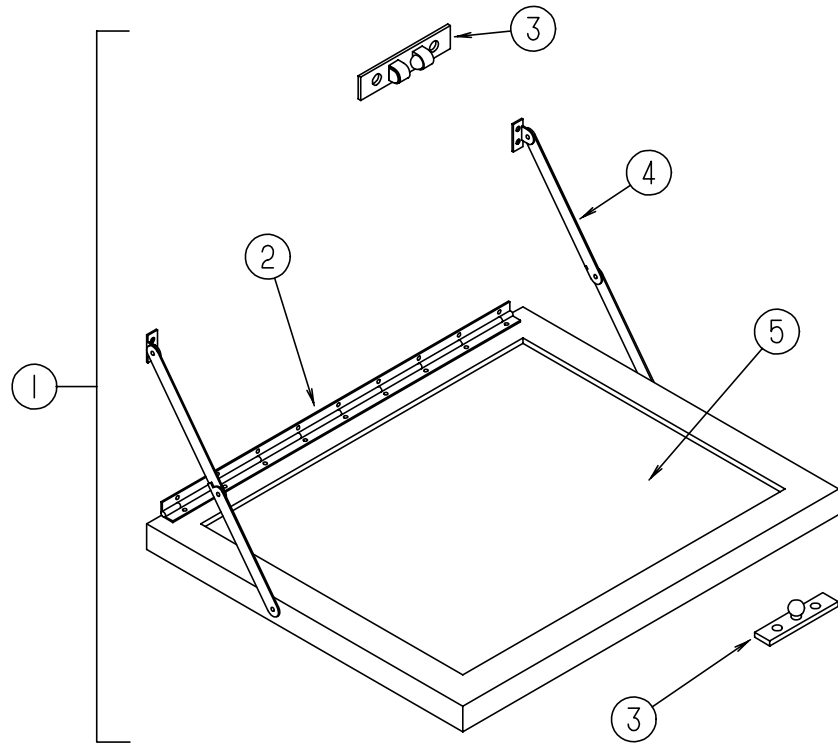

TV STAND

KEY	PART NUMBER	U/M	DESCRIPTION
1	084357-02-E07	EA	STAND-FOLD DOWN, TV - W/MIRROR
2	084413-01-000	EA	HINGE-CONTINUOUS, W/HOLES
3	084451-01-000	EA	CATCH-TV SHELF, BRASS
4	084412-01-000	EA	SUPPORT-HINGED (PAIR)
5	084356-08-000	EA	INSERT-TV STAND, W/SUPPORT HINGE - METAL - OFF WHITE
5	058331-14-000	EA	MIRROR-GLASS, SAFETY - 14" X 12.7"

BEDROOM GROUP (CONTINUED)

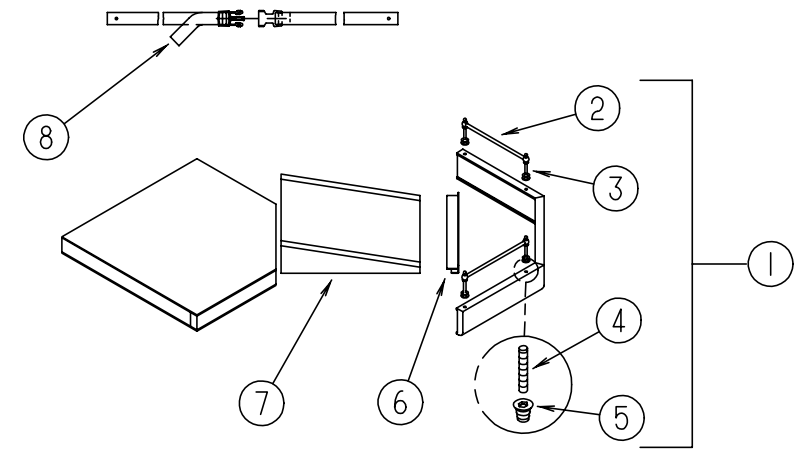

TV SHELVES

KEY	PART NUMBER	U/M	DESCRIPTION
1	111236-01-E07	EA	SHELF ASM-TV, W/BRASS RAILING & WEDGE - 420 MM X 410 MM
2	084071-15-000	EA	ROD-BRASS, 210 MM LONG
3	084070-02-000	EA	POST-END, 2.4" - BRASS
4	105246-01-000	EA	POST-ANCHOR
5	105247-01-000	EA	NUT-INSERT, 8-32 THREAD X .394" LONG - STAFEST PRODUCTS
6	103186-01-01A	FT	MOLDING-EDGE, SHELF - .78" WIDE - PLASTIC - RAMBLING OAK
7	111236-15-E07	EA	WEDGE-TV
8	099717-01-000	EA	TIEDOWN-TV, STRAP ON FEMALE END IS 22.8" LONG

CHASSIS GROUP

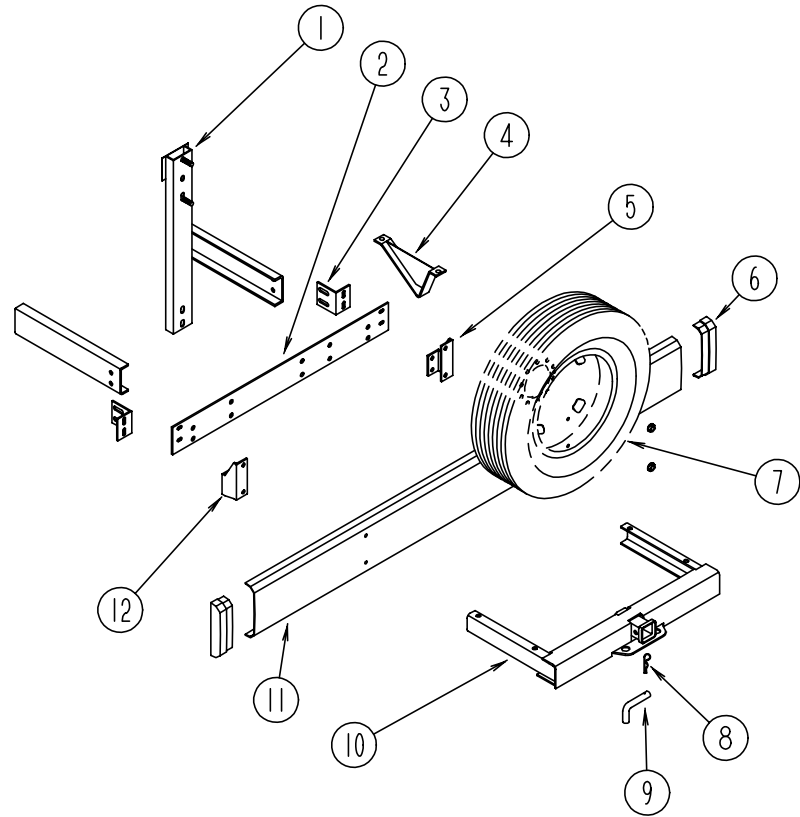

REAR BUMPER, TRAILER HITCH & COMPONENTS

KEY	PART NUMBER	U/M	DESCRIPTION
1	102944-01-000	EA	BRACKET ASM-TIRE CARRIER
1	102944-02-000	EA	BRACKET ASM-TIRE CARRIER, FORD OPTION
2	078678-02-000	EA	PLATE-MOUNTING, BUMPER - REAR
3	078668-01-000	EA	SUPPORT ANGLE-BUMPER, REAR
4	083376-01-000	EA	SKID PLATE
5	102945-03-000	EA	BRACKET ASM-BUMPER, REAR
6	103228-01-06A	EA	CAP-END, BUMPER - REAR - DRIVER OR PASSENGER SIDE
7	083425-10-000	EA	TIRE-LT215/85R16, LRE XCH4 - MICHELIN XCH4 ORBL - FORD OPTION
7	007324-04-000	EA	TIRE - 8R19.5 LRD, MICHELIN XZA - CHEVY
	051377-01-000	EA	STEM-VALVE, TR 500
	051377-05-000	EA	STEM-VALVE, EATON VS-938 F53-92 - FORD OPTION
	095853-02-000	EA	WHEEL-STEEL, 16" X 6K - F2TA-1015-NA - ACCURIDE 28513-7 - FORD OPTION
8	034513-01-000	EA	PIN-HITCH - 3/16" WIRE
9	034512-01-000	EA	PIN-LOCKING-DRAWBAR
10	107707-01-000	EA	HITCH ASM W/O DRAWBAR
11	103099-01-06A	EA	BUMPER-REAR, BRIGHT WHITE
12	102945-04-000	EA	BRACKET ASM-BUMPER, REAR
	113589-02-000	EA	CONNECTOR-SOCKET, TRAILER - GENERAL 433601
	113589-01-000	EA	CONNECTOR-PLUG, TRAILER - GENERAL 433501

CHASSIS GROUP (CONTINUED)

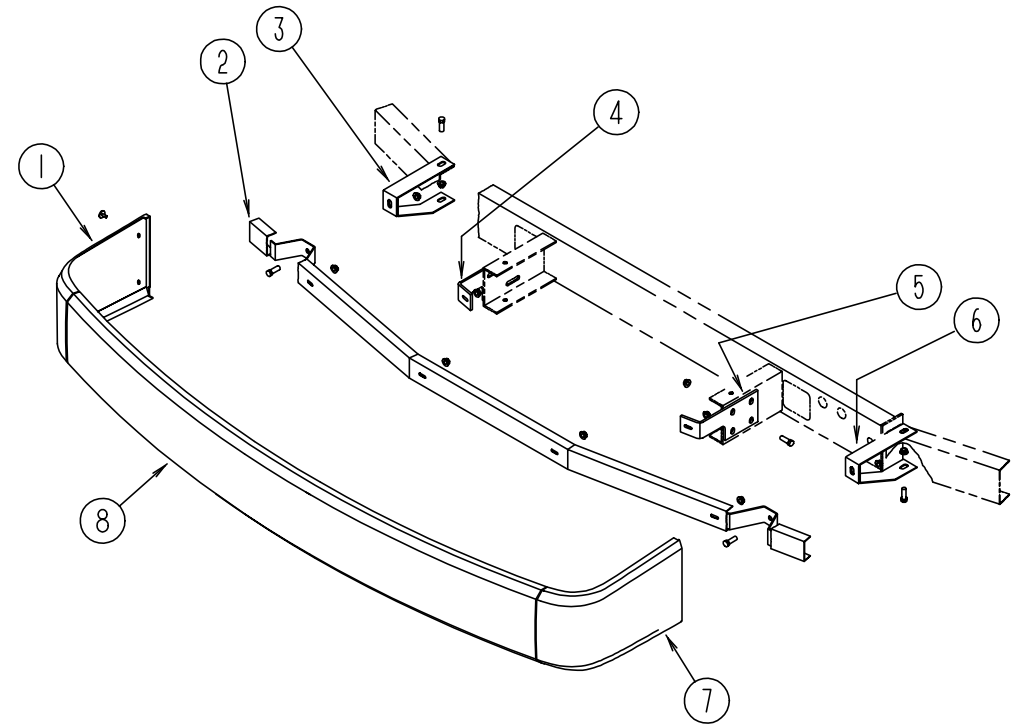

FRONT BUMPER

KEY	PART NUMBER	U/M	DESCRIPTION
1	103692-01-04A	EA	PANEL-FACIA, BUMPER - FRONT RIGHT - BRIGHT WHITE
2	103512-01-000	EA	CHANNEL ASM-BUMPER
3	103497-01-000	EA	BRACE-BUMPER, FRONT
4	086140-03-000	EA	SUPPORT-FRONT BUMPER, PASSENGER SIDE - 9.1" X 4" - STEEL
5	086140-04-000	EA	SUPPORT-FRONT BUMPER, DRIVER SIDE - 9.1" X 4" - STEEL
6	103611-01-000	EA	BRACE-BUMPER, FRONT
7	103692-02-04A	EA	PANEL-FACIA, BUMPER - FRONT LEFT - BRIGHT WHITE
8	103693-01-04A	EA	PANEL-FACIA, BUMPER - CENTER - BRIGHT WHITE
8	103758-01-F24	EA	BUMPER ASM-FRONT, W/DRIVER & PASSENGER SIDE FACIA PANELS BRIGHT WHITE

CHASSIS GROUP (CONTINUED)

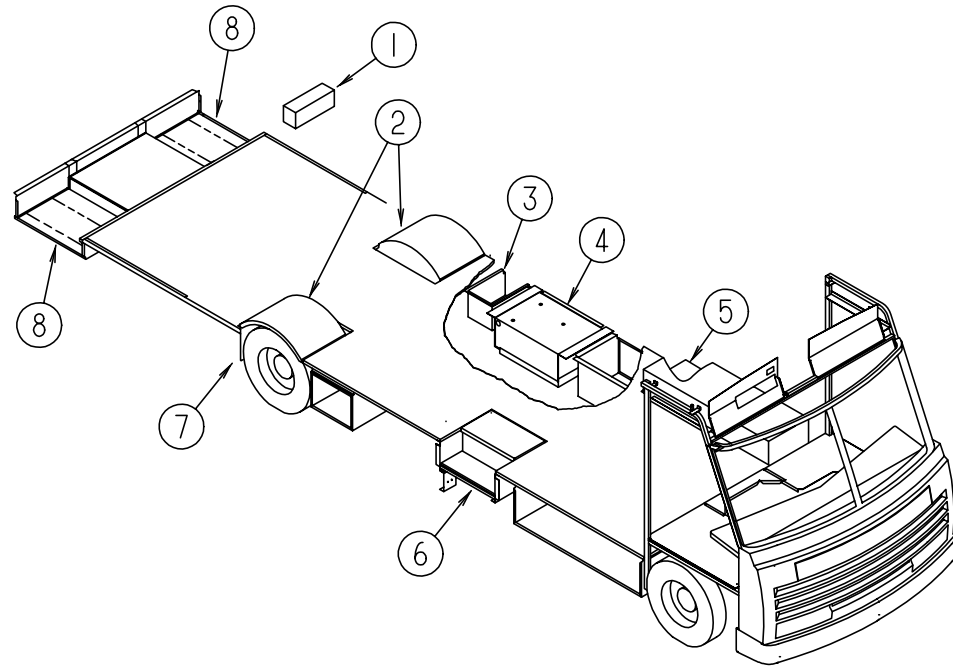

STORAGE COMPARTMENTS & WHEELWELLS

KEY	PART NUMBER	U/MDESCRIPTION
1	085967-01-000	EA COMPARTMENT-SEWER HOSE, 6" X 6.6" X 17.8" - PLASTIC
2	102921-01-000	EA WHEELWELL - PLASTIC
3	102979-01-000	EA BOX-POWER CORD
4	078137-04-000	EA TRAY-COMPARTMENT, GENERATOR - 29.1" WIDE X 22.4" DEEP
5	103036-02-000	EA COMPARTMENT ASM-STORAGE
6	077848-02-000	EA STEP-PULLOUT
	091176-01-000	EA SUPPORT-BASE-ENTRANCE STEP
6	094708-01-01A	EA STEP-ENTRY DOOR, ELECTRIC - SINGLE - KWIKEE 2813
7	017516-01-000	EA FLAP-MUD, 14" X 18" - BLACK
	020167-04-000	EA GUARD DIRT
8	110820-01-000	EA COMPARTMENT ASM-STORAGE

CHASSIS GROUP (CONTINUED) CHASSIS MISCELLANEOUS

KEY	PART NUMBER	U/MDESCRIPTION
	070579-06-000	EA PLATE-ANCHOR, W/7/16 WELD NUT - 1.5" X 3.3"
	077001-01-000	EA ANGLE-MOUNTING, ROOF PANEL - V ANGLE - 3" X 2.4" X 1.5"
	103136-01-000	EA BRACKET-SUPPORT,UPPER,HINGE,RH
	103136-02-000	EA BRACKET-SUPPORT,UPPER,HINGE,LH
	110934-01-000	EA CONNECTOR-PLAS,BARB 5/16 - KEVCO TC 7055
	113007-01-000	EA PIN-SPRING,.375 X 3.00 IN (FORD)
	087234-01-000	EA NUT-JACK,1/4 X 20 THD,MOLLY ARDEN 8-L,JN BRASS MOUNTS LICENSE PLATES
	093719-01-000	EA HOSE-OIL FILL, PREFORMED 90 DEGREE BEND
	076310-01-000	EA SHEET-RUBBER, RADIATOR BAFFLE - .12" X 15" X 62" - BLACK
	098443-03-000	EA SUPPORT-SHIELD, EXHAUST - 1.5" X 29.2" - STEEL - PRIMED
	075307-03-000	EA SHIELD-HEAT,LP
	101544-01-000	EA SHIELD-HEAT, EXHAUST - 19.7" X 28.9" - STEEL
	085000-01-000	EA SHIELD-A/C, 6.8" X 3.1" - STEEL
	065450-05-000	EA TIEDOWN-BATTERY, 8.4" TUBE
	087475-02-000	EA BRACKET-TIE DOWN, BATTERY - 13.5" X 1.3"
	090604-06-000	EA TRAY-BATTERY, AUTO - W/TWO HEX NUTS - FORD
	115361-01-01A	EA PLUG-PLASTIC, CAPLUG NO.W5

FRONT SHOCKS

KEY	PART NUMBER	U/MDESCRIPTION
	104993-01-000	EA SHOCK ABSORBER-GAS, P30 FRONT - BILSTEIN B46-1173

TIRE COVERS

KEY	PART NUMBER	U/MDESCRIPTION
	104408-09-E27	EA COVER-TIRE, 32" - SUNRISE - FORD OPTION
	104408-10-F24	EA COVER-TIRE, 34" - SUNRISE - CHEVY
	108163-02-01A	EA COVER ASM-TIRE, 19.5" CHEVY - CHROME - EXTERIOR TRIM OPTION

CHASSIS GROUP (CONTINUED)
19.5" CHEVY STAINLESS STEEL WHEEL LINERS

KEY	PART NUMBER	U/M DESCRIPTION
	091209-01-000	EA LINER-WHEEL, 19.5" - STAINLESS STEEL - SET OF 4 - KAPER 1954-ION
	091209-01-700	EA LINER-WHEEL, 19.5" FRONT - 10 LUG - CHEVY P-30
	091209-01-701	EA LINER-WHEEL, 19.5" REAR-10 LUG-CHEVY P-30 SINGLE
	091209-01-702	EA COVER-AXLE, 19.5" FRONT - 10 LUG - CHEVY P-30
	091209-01-703	EA COVER-AXLE, 19.5" REAR - 10 LUG - CHEVY P-30
	091209-01-704	EA COVER-LUG NUT
	095012-03-000	EA EXTENSION-VALVE STEM, DUAL WHEEL
	095012-04-000	EA STABILIZER-VALVE STEM EXTENSION, DICOR AG-STA-2

16" FORD CHROME WHEEL LINERS

KEY	PART NUMBER	U/M DESCRIPTION
	091209-08-000	EA LINER-WHEEL, SET OF 4 - 16" - CHROME - KAPER II 1604-10FOL
	091209-08-700	EA LINER-WHEEL, 16" FRONT - W/AXLE COVER - 10 LUG
	091209-08-701	EA LINER-WHEEL, 16" REAR - 10 LUG
	091209-08-702	EA COVER-AXLE, 16" REAR - 10 LUG
	091209-08-704	EA FRONT SIMULATOR
	091209-08-705	EA REAR SIMULATOR
	091209-08-706	EA FLAT NUT .500, 9/16 STUD
	091209-01-704	EA COVER-LUG NUT
	091209-11-702	EA JAMB NUT (LONG) REAR
	095012-03-000	EA EXTENSION-VALVE STEM, DUAL WHEEL
	095012-04-000	EA STABILIZER-VALVE STEM EXTENSION, DICOR AG-STA-2

16" FORD WHEEL COVERS

KEY	PART NUMBER	U/M DESCRIPTION
	098532-01-000	EA COVER-WHEEL, FORD - 16" - SET OF 4 - DICOR SH-SD-16
	098532-01-700	EA COVER-LUG NUT, FORD - CHROME - DICOR SP-FM-CLN
	098532-01-701	EA COVER-WHEEL, FORD - 16"

19.5" CHEVY WHEEL COVERS

KEY	PART NUMBER	U/M DESCRIPTION
	109443-01-000	EA WHEEL-COVER 4/SET 19.5 W/HDW DICOR SHAG95
	109443-01-700	EA WHEEL-COVER 19.5 - DICOR
	109443-01-701	EA SET-BRACKET, 1 FRONT WHEEL SHAG95-FBS DICOR
	109443-01-702	EA SET-BRACKET, 1 REAR WHEEL SHAG95-RBS DICOR
	109443-01-703	EA CAP-CENTER, HUB - DICOR SP-AUCAP

CHEVY LUG WRENCH & LEVERAGE BAR

KEY	PART NUMBER	U/M DESCRIPTION
	080208-01-000	EA LUG WRENCH, 1.06 X 1.00
	080208-02-000	EA BAR-LEVERAGE, LUG WRENCH

CHASSIS GROUP (CONTINUED)

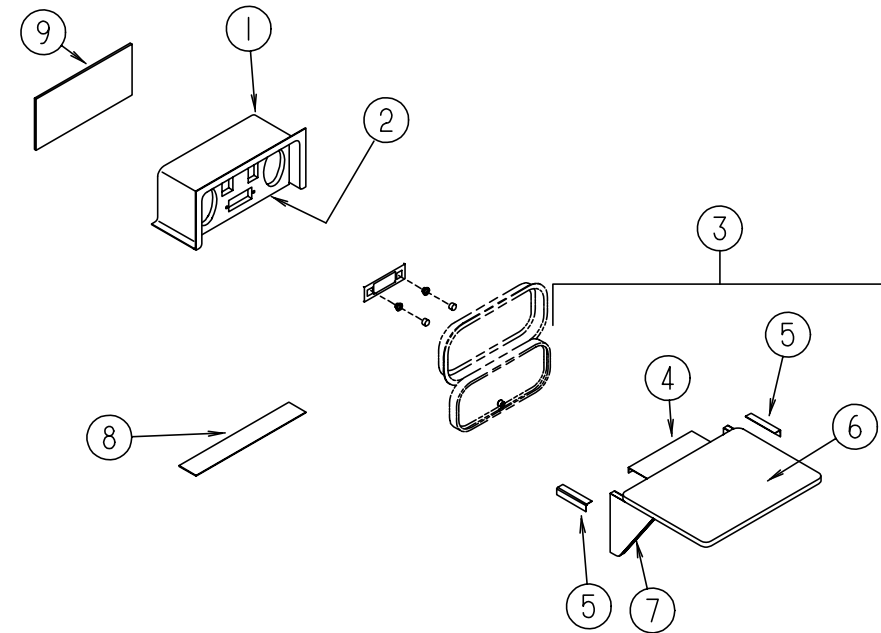

PATIO ENTERTAINMENT CENTER

KEY	PART NUMBER	U/M DESCRIPTION
1	104897-03-01A	EA BOX-ENTERTAINMENT CENTER - OFF WHITE
1	104897-03-02A	EA BOX-ENTERTAINMENT CENTER - BRIGHT WHITE
2	104899-01-C05	EA PLATE-RADIO MOUNTING
3	105230-01-E01	EA SHELF
4	105377-01-01A	EA BRACKET-TABLE HANGER, OFF WHITE
5	105376-01-02A	EA HINGE-CONTINUOUS, 2" X 140 MM - OFF WHITE
6	105230-11-E01	EA SHELF
7	105230-12-E01	EA SUPPORT-SHELF
8	104898-01-01A	EA PLATE-PLASTIC, BOTTOM - 19.38" X 3.1" - OFF WHITE
8	104898-01-02A	EA PLATE-PLASTIC, BOTTOM - 19.38" X 3.1" - BRIGHT WHITE
9	104898-02-01A	EA PLATE-PLASTIC, REAR - 16.1" X 6.3" - OFF WHITE
9	104898-02-02A	EA PLATE-PLASTIC, REAR - 16.1" X 6.3" - BRIGHT WHITE

CHASSIS GROUP (CONTINUED)

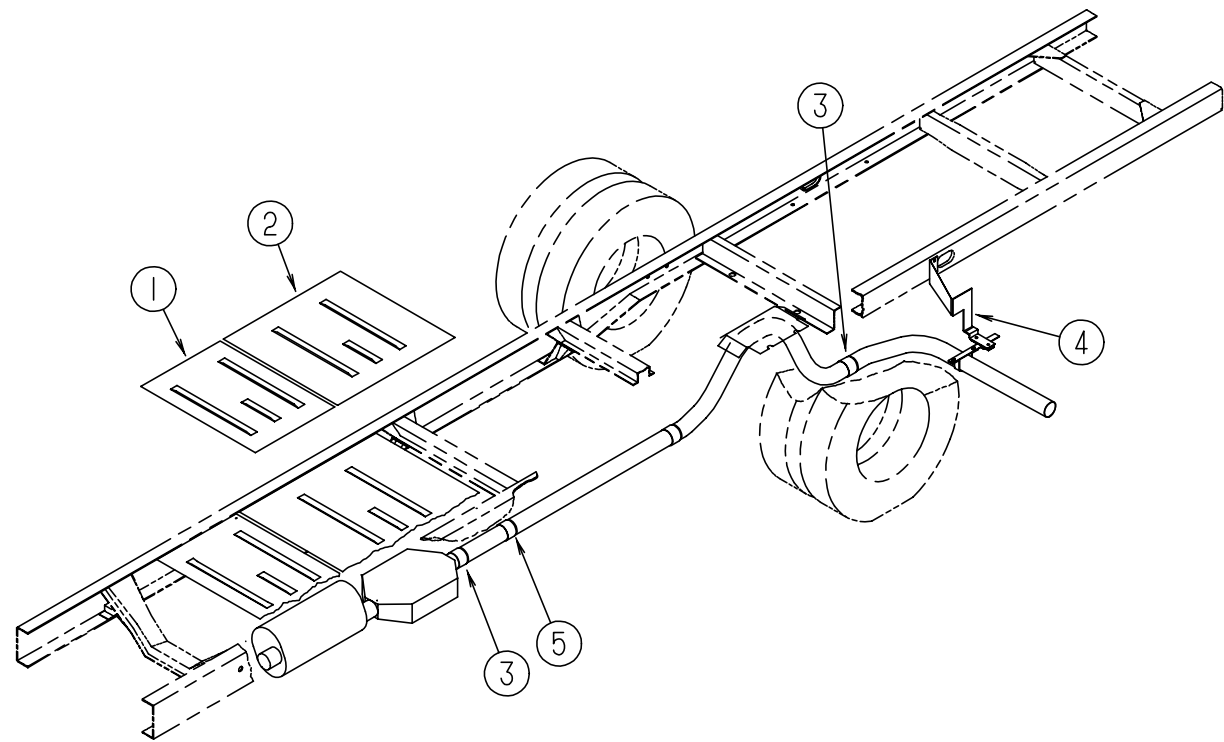

EXHAUST SYSTEM (CHEVY)

KEY	PART NUMBER	U/M	DESCRIPTION
1	101544-01-000	EA	SHIELD-HEAT, EXHAUST - 19.7" X 28.9" - STEEL
2	101544-02-000	EA	SHIELD-HEAT, EXHAUST - 30" X 28.9" - STEEL
3	094918-01-000	EA	CLAMP-EXHAUST, 3" - GUILLOTINE STYLE
4	098833-02-000	EA	BRACKET-EXHAUST,HANGER
5	098762-05-000	EA	EXTENSION-EXHAUST, STRAIGHT - 3" OD X 7.9" LONG - SST
	110236-01-000	EA	PIPE-EXHAUST,EXTENSION
	081918-01-000	EA	EXTENSION-EXHAUST, 2.25" OD X 9.44" - STAINLESS STEEL

CHASSIS GROUP (CONTINUED)

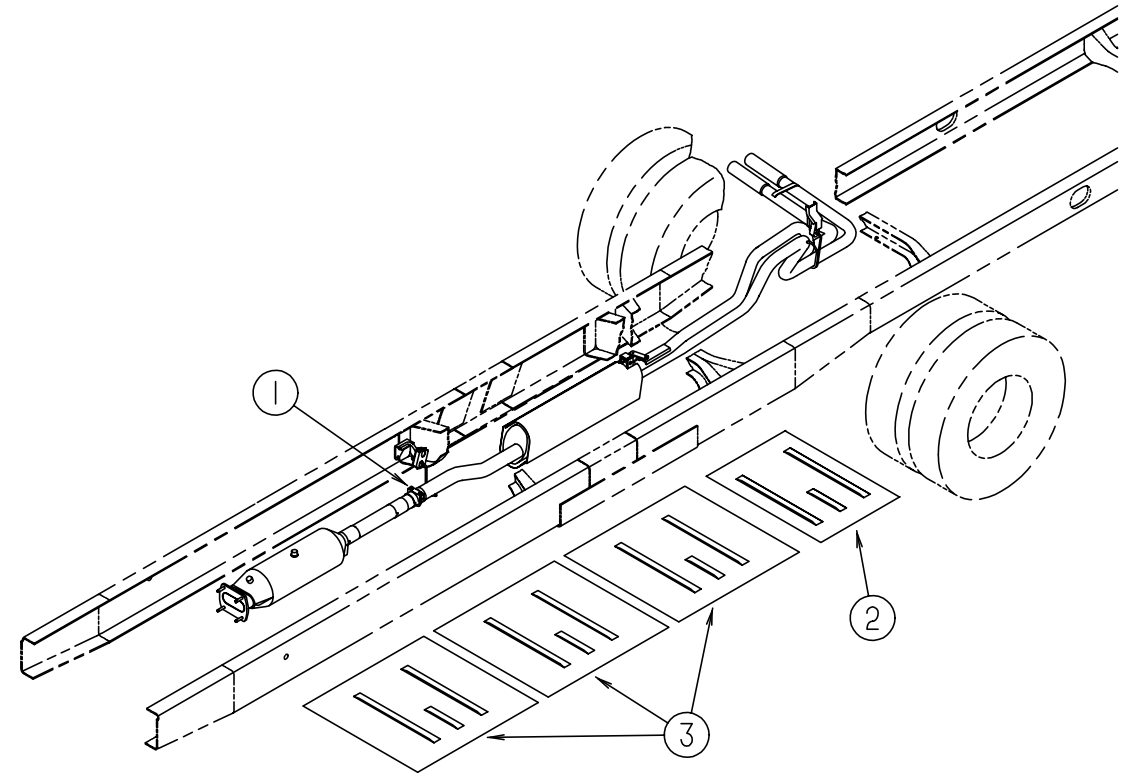

EXHAUST SYSTEM (FORD)

KEY	PART NUMBER	U/M	DESCRIPTION
1	094918-03-000	EA	CLAMP-EXHAUST, 2.5"
2	101544-01-000	EA	SHIELD-HEAT, EXHAUST - 19.7" X 28.9" - STEEL
3	101544-06-000	EA	SHIELD-HEAT, EXHAUST, FORD

CHASSIS GROUP (CONTINUED)

CHASSIS GROUP (CONTINUED)

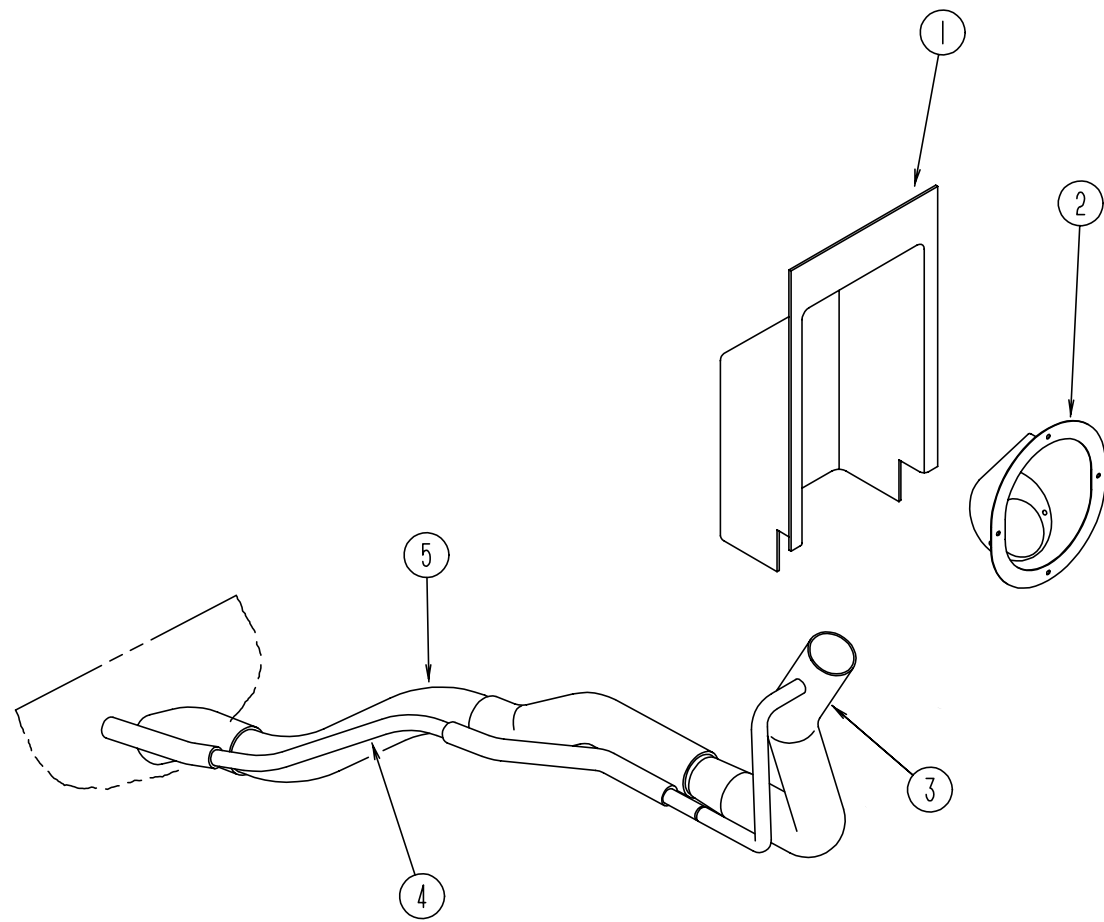

FUEL SYSTEM (CHEVY)

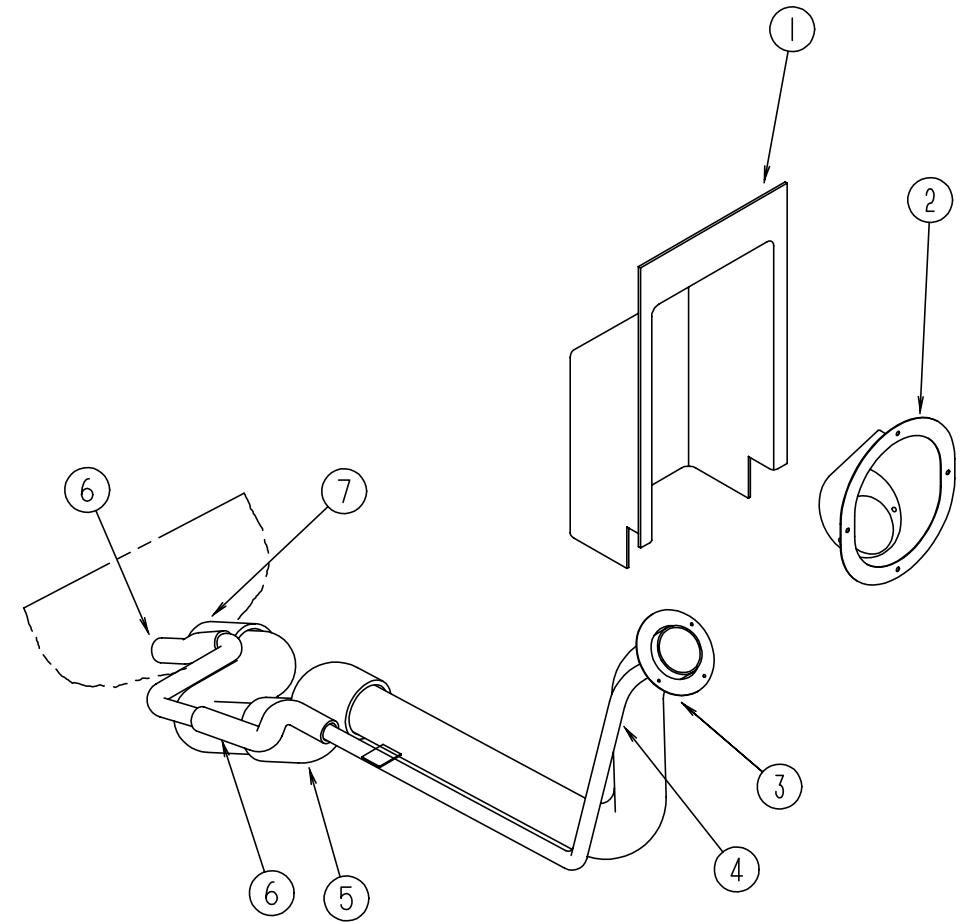

FUEL SYSTEM (FORD)

KEY	PART NUMBER	U/M	DESCRIPTION
1	072447-04-000	EA	SHROUD-FUEL FILL, UPPER - PLASTIC
2	095854-01-04A	EA	SHROUD-FUEL FILL, BRIGHT WHITE
3	078200-01-000	EA	GASKET-FUEL FILL, 3.5"OD X 2"ID
4	098804-01-000	EA	PIPE-VENT, FUEL FILL - 12" LONG
5	098805-01-000	EA	PIPE-FUEL, FUEL FILL - 11.4" LONG
	084884-01-000	EA	PLUG-BRASS, 3/8"
	007063-01-000	FT	HOSE-GAS 1/4"ID X 1/2"OD
	044317-01-000	EA	HOSE-FUEL, 3/8" ID - DIESEL OPTION

KEY	PART NUMBER	U/M	DESCRIPTION
1	072447-04-000	EA	SHROUD-FUEL FILL, UPPER - PLASTIC
2	095854-01-04A	EA	SHROUD-FUEL FILL, BRIGHT WHITE
3	078200-01-000	EA	GASKET-FUEL FILL, 3.5"OD X 2"ID
4	095606-01-000	EA	NECK-FUEL FILL, W/CHECK VALVE - L-SHAPED - 18.2" LONG
5	100156-01-000	EA	HOSE-FUEL FILL, 8.3" LONG W/2" ID
6	066732-03-000	FT	HOSE-FUEL FILL, .75" ID
7	007111-02-000	EA	HOSE-FUEL FILL, 2.00 ID - IN 3FT LENGTHS
	007063-01-000	FT	HOSE-GAS 1/4"ID X 1/2"OD
	084884-01-000	EA	PLUG-BRASS, 3/8"
	080081-01-000	EA	STRAP-MOUNTING, FUEL LINE - 2" X 32"

CURTAIN & CUSHION GROUP NOTICE

IN ORDER TO ASSIST OUR PARTS SALES DEPT. IN PROVIDING INTERIOR SOFTGOODS ITEMS, PLEASE INCLUDE THE SERIAL NUMBER AND THE COLOR CODE NUMBER FROM THE VEHICLE CERTIFICATION LABEL WHEN ORDERING. THIS LABEL IS LOCATED ON THE LEFT SIDEWALL AT THE END OF THE DASH (A-BODY), OR ON THE DRIVER'S DOOR LATCH PLATE (C-BODY).

AN EXAMPLE OF A COLOR CODE NUMBER IS B07, WHICH DESIGNATES AN OVERALL COLOR SCHEME OF A PARTICULAR UNIT. THE COLOR LISTED AFTER THE ITEM DESCRIPTION ON THE MICROFICHE, INDICATES THE OVERALL UNIT COLOR. ORDER THE ITEM YOU DESIRE ACCORDING TO UNIT COLOR CODE.

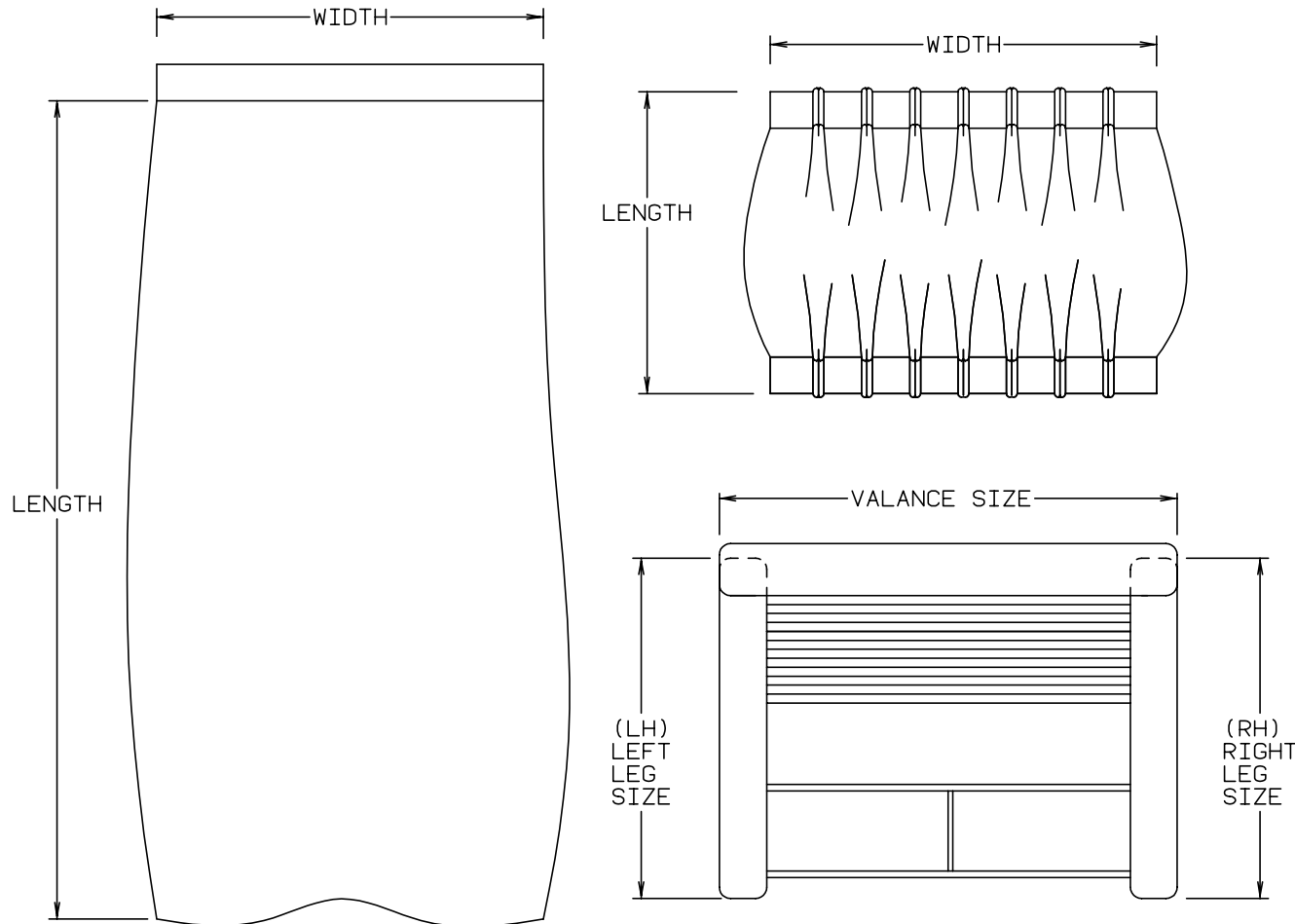

NOTE: USE THIS ILLUSTRATION WHEN DETERMINING LENGTH AND WIDTH MEASUREMENTS FOR CURTAINS. YOU WILL NOTE THE WIDTH MEASUREMENT IS TAKEN ON THE TOP OF THE CURTAIN WITH THE CURTAIN FULLY EXTENDED. THE LENGTH MEASUREMENT IS TAKEN FROM TOP TO BOTTOM. LEFT AND RIGHT WINDOW LEGS ARE DETERMINED WHEN FACING THE WINDOW.

CURTAIN & CUSHION GROUP (CONTINUED)

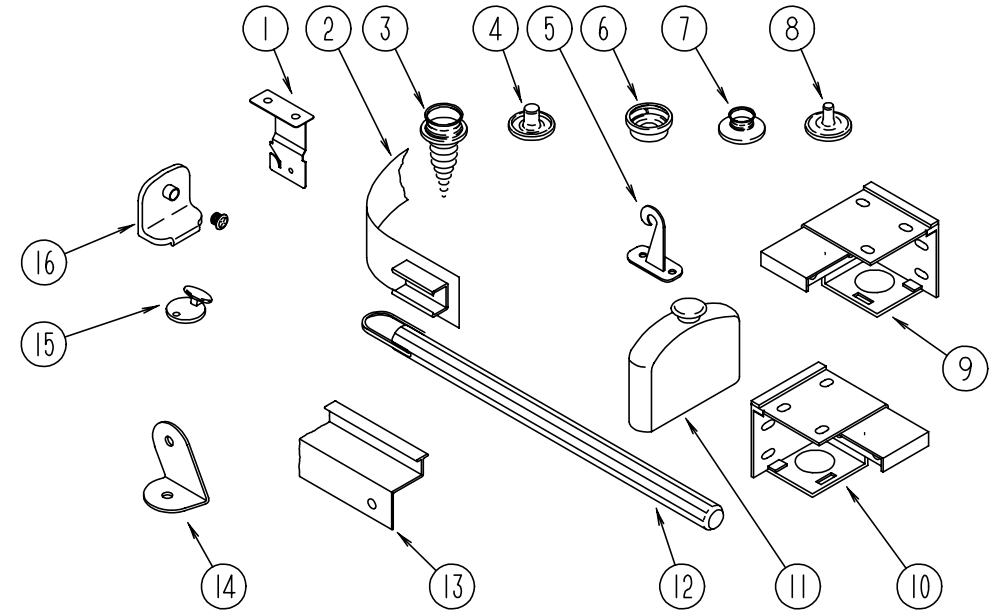

CURTAIN, BLIND HARDWARE & TRACKS

KEY	PART NUMBER	U/M	DESCRIPTION
1	084434-01-000	EA	BRACKET-MOUNTING, ROLLER SHADE - 1 3/8"
2	101031-01-000	YD	TAPE-GLIDE, CURTAIN - 4.25" SPACING
3	029130-01-000	EA	SCREW-SNAP SOCKET, #8 PH X 5/8"
3	029130-03-000	EA	SCREW-SNAP SOCKET, #8 PH X 1"
4	029155-01-000	EA	CAP-SNAP, 5/32" O.D. OF PIN
4	029155-02-000	EA	CAP-SNAP, 7/64" O.D. OF PIN
5	109441-01-000	EA	HOLD DOWN-BLIND, HOOK
6	029156-01-000	EA	SOCKET-SNAP, 9/16" O.D.
6	029156-02-000	EA	SOCKET-SNAP, 27/64" O.D.
7	029092-01-000	EA	STUD-SNAP, NICKEL
8	029093-01-000	EA	EYELET-SNAP, NICKEL
9	083170-01-000	EA	BRACKET-BLIND, LEFT SIDE WHEN FACING WINDOW
10	083170-02-000	EA	BRACKET-BLIND, RIGHT SIDE WHEN FACING WINDOW
11	093475-01-701	EA	END CAP-BLIND, W/STUD
12	093475-01-700	EA	WAND-BLIND, W/METAL CLIP - 8" LONG
13	101589-02-C05	EA	TRACK ASM W/BRKTS-CURTAIN, RIGHT HAND - OFF WHITE - 10'
13	105450-01-01A	EA	TRACK-CURTAIN, LEFT HAND WRAPAROUND - OFF WHITE - 30.8" LONG
13	114641-03-E10	EA	TRACK ASM-CURTAIN, RIGHT HAND WRAPAROUND - O/W - 6.95' - TV OPTIONS
13	114641-04-E10	EA	TRACK ASM-CURTAIN, LEFT HAND WRAPAROUND - O/W - 6.95' - TV OPTIONS
14	099205-02-02A	EA	BRACKET-WRAPAROUND CURTAIN TRACK, OFF WHITE
15	102555-01-000	EA	CLEAT-BLIND CORD - CLEAR PLASTIC
16	106544-01-000	EA	PULL-SHADE, BRASS
16	106544-01-001	EA	SCREW-SHADE PULL, BRASS
	056003-01-000	EA	BRACKET-RETAIN, CURTAIN - RH
	056003-02-000	EA	BRACKET-RETAIN, CURTAIN - LH
	083125-07-000	EA	BRACE-L-SHAPED W/HOLES, 64 MM X 35 MM X 19 MM - ALUMINUM - OFF WHITE
	048394-02-000	YD	VELCRO TAPE-HOOK, ADHESIVE BACK - .75" WIDE - BEIGE
	088792-01-000	YD	VELCRO-HOOK, .75" WIDE - BEIGE
	088792-02-000	YD	VELCRO TAPE-LOOP, ADHESIVE BACKED - .75" WIDE - BEIGE
	068716-01-001	EA	BRACE - 90 DEGREE L-ANGLE, 192" - EXTRUDED ALUMINUM
	075943-06-000	EA	BRACE-L-SHAPED - 8" LONG - ALUMINUM - BEIGE
	105648-01-02A	EA	BRACE-VALANCE, ANGLE - 1.5" X 1.5" X 14" - OFF WHITE

CURTAIN & CUSHION GROUP (CONTINUED)
WINDOW TREATMENT

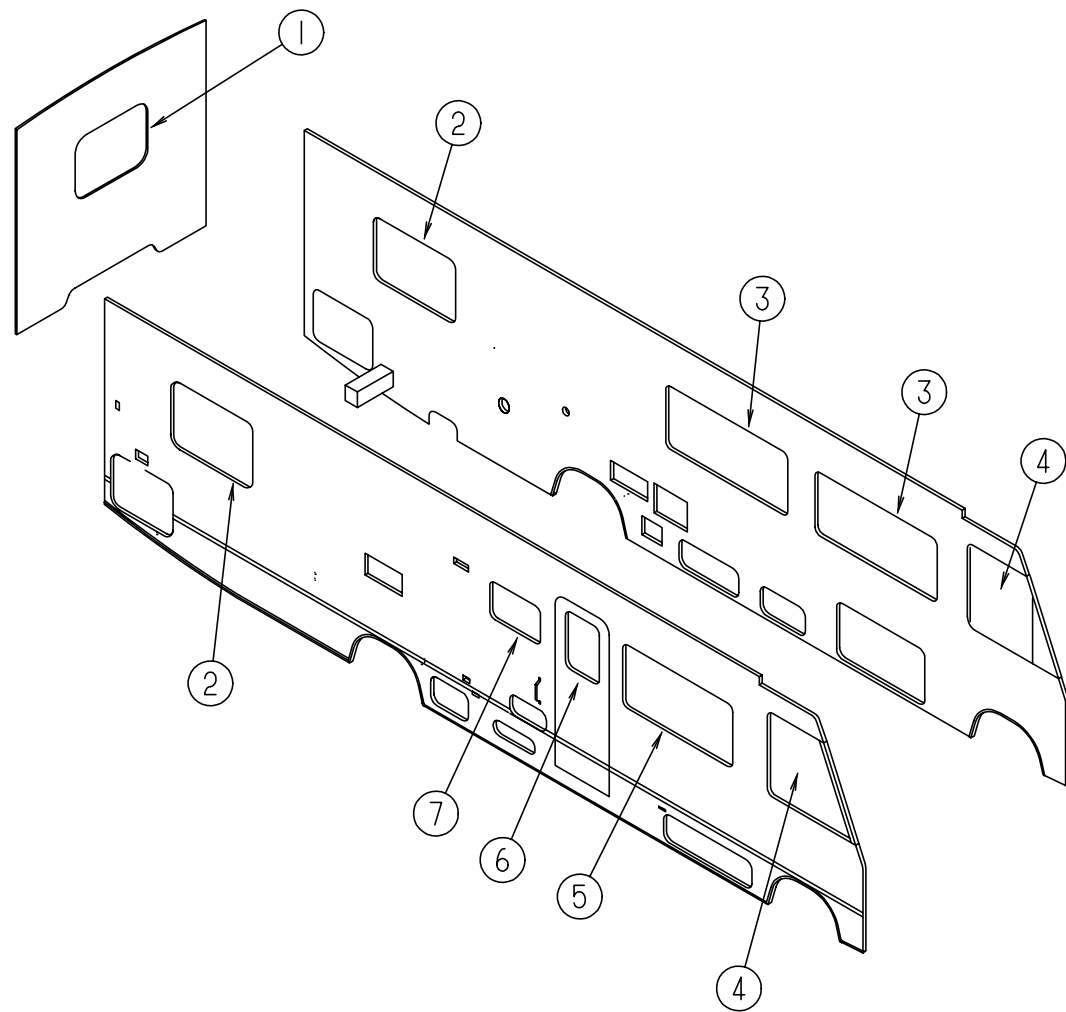

KEY	PART NUMBER	U/M DESCRIPTION
1	114993-01-F24	EA VALANCE ASM- 52" - TAILOR
1	114993-01-F25	EA VALANCE ASM- 52" - TAILOR
1	114993-01-F26	EA VALANCE ASM- 52" - TAILOR
1	114993-01-F27	EA VALANCE ASM- 52" - TAILOR
1	112986-04-F24	EA CURTAIN - 29.5 X 6, PENCIL PLEAT TOP, POCKET BOTTOM
1	112986-04-F25	EA CURTAIN - 29.5 X 6, PENCIL PLEAT TOP, POCKET BOTTOM
1	112986-04-F26	EA CURTAIN - 29.5 X 6, PENCIL PLEAT TOP, POCKET BOTTOM
1	112986-04-F27	EA CURTAIN - 29.5 X 6, PENCIL PLEAT TOP, POCKET BOTTOM
1	093475-55-04A	EA BLIND-MINI, 48 X 28 DROP (F24,F26,F27)
1	093475-68-08A	EA BLIND-MINI, 48 X 27 DROP (F24,F26,F27)
		FROM: 00-00-00 THRU: 07-24-94
1	093475-55-03A	EA BLIND-MINI, 48 X 28 DROP (F25)
		FROM: 07-25-94 THRU: 99-99-99
1	093475-68-07A	EA BLIND-MINI, 48 X 27 DROP (F25)
		FROM: 00-00-00 THRU: 07-24-94
		FROM: 07-25-94 THRU: 99-99-99

KEY	PART NUMBER	U/M DESCRIPTION
2	114993-02-F24	EA VALANCE ASM- 44" - TAILOR
2	114993-02-F25	EA VALANCE ASM- 44" - TAILOR
2	114993-02-F26	EA VALANCE ASM- 44" - TAILOR
2	114993-02-F27	EA VALANCE ASM- 44" - TAILOR
2	112986-05-F24	EA CURTAIN - 31.5 X 6, PENCIL PLEAT TOP, POCKET BOTTOM
2	112986-05-F25	EA CURTAIN - 31.5 X 6, PENCIL PLEAT TOP, POCKET BOTTOM
2	112986-05-F26	EA CURTAIN - 31.5 X 6, PENCIL PLEAT TOP, POCKET BOTTOM
2	112986-05-F27	EA CURTAIN - 31.5 X 6, PENCIL PLEAT TOP, POCKET BOTTOM
2	093475-99-03A	EA BLIND-MINI, 41 X 28.5 DROP (F24,F27)
2	093475-99-02A	EA BLIND-MINI, 41 X 28.5 DROP (F25,F26)
2	093475-41-09A	EA BLIND-MINI, 39 X 26 DROP - TWIN BED OPTION (F24,F27)
2	093475-41-08A	EA BLIND-MINI, 39 X 26 DROP - TWIN BED OPTION (F25,F26)
2	112986-04-F24	EA CURTAIN - 29.5 X 6, PENCIL PLEAT TOP, POCKET BOTTOM - TWIN BED OPTION
2	112986-04-F25	EA CURTAIN - 29.5 X 6, PENCIL PLEAT TOP, POCKET BOTTOM - TWIN BED OPTION
2	112986-04-F26	EA CURTAIN - 29.5 X 6, PENCIL PLEAT TOP, POCKET BOTTOM - TWIN BED OPTION
2	112986-04-F27	EA CURTAIN - 29.5 X 6, PENCIL PLEAT TOP, POCKET BOTTOM - TWIN BED OPTION
3	111650-09-F24	EA VALANCE ASM - 63.5" UNITY (F24,F27)
3	111650-12-F25	EA VALANCE ASM - 63.5" UNITY
3	111650-12-F26	EA VALANCE ASM - 63.5" UNITY
3	109234-29-F24	EA LEG-RH., 27" - PLAIN - W/O HOLE
3	109234-29-E04	EA LEG-RH., 27" - PLAIN - W/O HOLE (F25)
3	109234-29-F26	EA LEG-RH., 27" - PLAIN - W/O HOLE
3	109234-31-F27	EA LEG-RH., 27" - PLAIN - W/O HOLE
3	109234-30-F24	EA LEG-LH., 27" - PLAIN - W/O HOLE
3	109234-30-E04	EA LEG-LH., 27" - PLAIN - W/O HOLE (F25)
3	109234-30-F26	EA LEG-LH., 27" - PLAIN - W/O HOLE
3	109234-32-F27	EA LEG-LH., 27" - PLAIN - W/O HOLE
3	093475-76-06A	EA BLIND-MINI, 60 X 28.5 DROP (F24,F27)
3	093475-76-05A	EA BLIND-MINI, 60 X 28.5 DROP (F25,F26)
4	101668-30-D09	EA CURTAIN - 38 X 80 TAPE TOP, RH (F24,F27)
4	101668-30-D10	EA CURTAIN - 38 X 80 TAPE TOP, RH (F25,F26)
4	101668-31-D09	EA CURTAIN - 38 X 80 TAPE TOP, LH (F24,F27)
4	101668-31-D10	EA CURTAIN - 38 X 80 TAPE TOP, LH (F25,F26)
4	101668-32-D09	EA CURTAIN ASM - 40 X 40, TAPE TOP - BUNK OPTION (F24,F27)
4	101668-32-D10	EA CURTAIN ASM - 40 X 40, TAPE TOP - BUNK OPTION (F25,F26)
4	101668-33-D09	EA CURTAIN ASM - 38 X 125, TAPE TOP - BUNK OPTION (F24,F27)
4	101668-33-D10	EA CURTAIN ASM - 38 X 125, TAPE TOP - BUNK OPTION (F25,F26)
4	073260-42-D09	EA TIEBACK ASM - 6 X 18 (F24,F27)
4	073260-42-D10	EA TIEBACK ASM - 6 X 18 (F25,F26)
5	111650-11-F24	EA VALANCE - 57.5" UNITY, W/WELT
5	111650-13-F25	EA VALANCE - 57.5" UNITY, W/WELT
5	111650-13-F26	EA VALANCE - 57.5" UNITY, W/WELT
5	105923-33-F27	EA VALANCE - 57.5" RODEWAY, W/O INSERT
5	109234-31-F27	EA LEG-RH., 27" - PLAIN - W/O HOLE
5	109234-32-F27	EA LEG-LH., 27" - PLAIN - W/O HOLE
5	109041-28-02A	EA BLIND-MINI, 54 X 28.5 DROP (F24,F27)
5	109041-28-01A	EA BLIND-MINI, 54 X 28.5 DROP (F25,F26)
6	113268-06-F24	EA VALANCE-FLAT, 33.75" W/WELT (F24,F27)
6	113268-07-F25	EA VALANCE-FLAT, 33.75" W/WELT
6	113268-07-F26	EA VALANCE-FLAT, 33.75" W/WELT
6	113268-11-F27	EA VALANCE-FLAT, 33.75" W/WELT
6	084755-68-F04	EA SHADE ASM-PULL, 30.75 - W/O TRIM
7	109041-20-02A	EA BLIND-MINI, 31 X 18 DROP (F24,F27)
7	109041-20-01A	EA BLIND-MINI, 31 X 18 DROP (F25,F26)
7	109353-07-02A	EA BLIND-SLAT, 31" (F24,F27)
7	109353-07-01A	EA BLIND-SLAT, 31" (F25,F26)
7	109353-04-000	EA CLIP-VALANCE SLAT MOUNTING, CLEAR PLASTIC - PAR

CURTAIN & CUSHION GROUP (CONTINUED)

DINETTE CUSHIONS

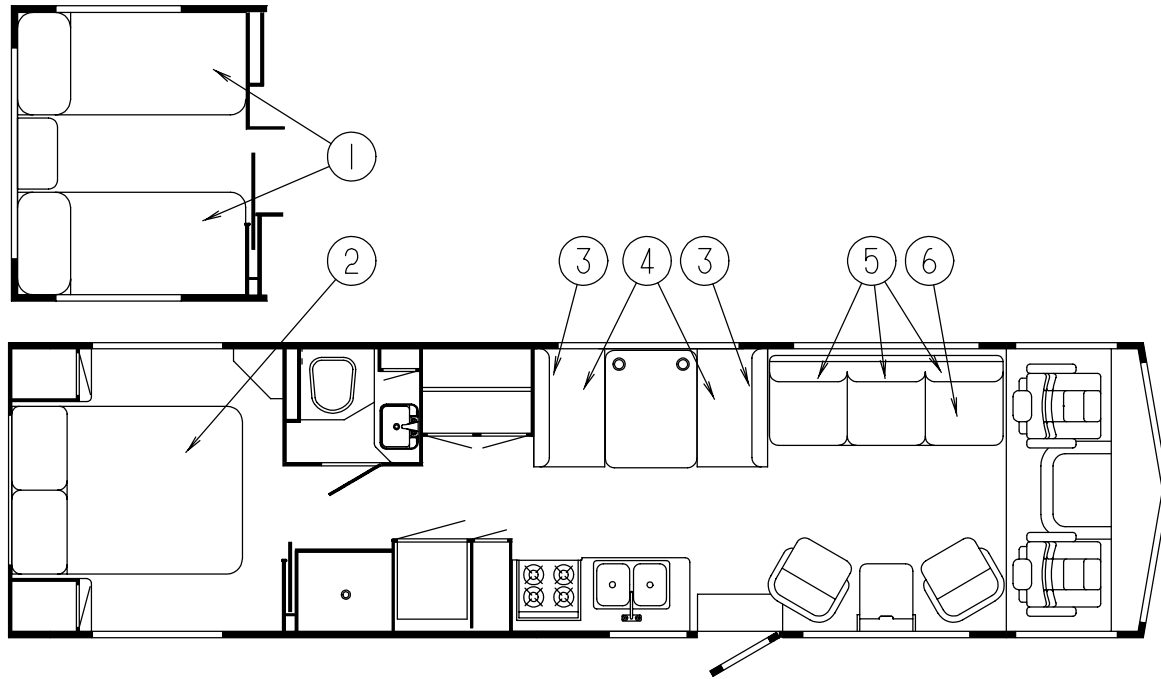

TWIN MATTRESS & BEDSPREAD

KEY	PART NUMBER	U/M	DESCRIPTION
1	098176-10-000	EA	MATTRESS-INNERSPRING, 32 X 79.5
1	085365-17-E28	EA	BEDSPREAD - 33 X 80, THROW W/ROUND CORNER (F24)
1	085365-17-F25	EA	BEDSPREAD - 33 X 80, THROW W/ROUND CORNER
1	085365-17-F26	EA	BEDSPREAD - 33 X 80, THROW W/ROUND CORNER
1	085365-17-F27	EA	BEDSPREAD - 33 X 80, THROW W/ROUND CORNER
	111862-03-F24	EA	PILLOW - 15 X 15 ACCENT W/.5"MAIN
	111862-03-F25	EA	PILLOW - 15 X 15 ACCENT W/.5"MAIN
	111862-03-F26	EA	PILLOW - 15 X 15 ACCENT W/.5"MAIN
	111862-03-F27	EA	PILLOW - 15 X 15 ACCENT W/.5"MAIN

QUEEN MATTRESS & BEDSPREAD

KEY	PART NUMBER	U/M	DESCRIPTION
2	098176-04-000	EA	MATTRESS-QUEEN, INNERSPRING - 59" X 74" - SEALY
2	085365-19-F24	EA	BEDSPREAD - 60 THROW, W/1" GATHERED WELT
2	085365-19-F25	EA	BEDSPREAD - 60 THROW, W/1" GATHERED WELT
2	085365-19-F26	EA	BEDSPREAD - 60 THROW, W/1" GATHERED WELT
2	085365-19-F27	EA	BEDSPREAD - 60 THROW, W/1" GATHERED WELT
2	102161-22-F24	EA	SHAM ASM-W/1/2" GATHERED WELT
2	102161-22-F25	EA	SHAM ASM-W/1/2" GATHERED WELT
2	102161-22-F26	EA	SHAM ASM-W/1/2" GATHERED WELT
2	102161-22-F27	EA	SHAM ASM-W/1/2" GATHERED WELT
	111862-03-F24	EA	PILLOW - 15 X 15 ACCENT W/.5"MAIN
	111862-03-F25	EA	PILLOW - 15 X 15 ACCENT W/.5"MAIN
	111862-03-F26	EA	PILLOW - 15 X 15 ACCENT W/.5"MAIN
	111862-03-F27	EA	PILLOW - 15 X 15 ACCENT W/.5"MAIN

KEY	PART NUMBER	U/M	DESCRIPTION
3	111880-01-F24	EA	CUSHION - 13.5 X 38 X 5 BACK
3	111880-01-F25	EA	CUSHION - 13.5 X 38 X 5 BACK
3	111880-01-F26	EA	CUSHION - 13.5 X 38 X 5 BACK
3	111897-08-F27	EA	CUSHION - 13.5 X 38 X 5 BACK
3	P11880-01-F24	EA	COVER - 13.5 X 38 X 5 BACK
3	P11880-01-F25	EA	COVER - 13.5 X 38 X 5 BACK
3	P11880-01-F26	EA	COVER - 13.5 X 38 X 5 BACK
3	P11897-08-F27	EA	COVER - 13.5 X 38 X 5 CLUB BACK
3	078155-01-000	EA	STRAP-SNAP, BACKREST CUSHION
4	088927-87-E28	EA	CUSHION - 23 X 38 X 5, DINETTE SEAT (F24)
4	088927-87-F25	EA	CUSHION - 23 X 38 X 5, DINETTE SEAT
4	088927-87-F26	EA	CUSHION - 23 X 38 X 5, DINETTE SEAT
4	105603-03-F27	EA	CUSHION - 23 X 38 X 5, DINETTE SEAT
4	M88927-87-E28	EA	COVER - 23 X 38 X 5, DINETTE SEAT (F24)
4	M88927-87-F25	EA	COVER - 23 X 38 X 5, DINETTE SEAT
4	M88927-87-F26	EA	COVER - 23 X 38 X 5, DINETTE SEAT
4	P05603-03-F27	EA	COVER - 23 X 38 X 5, DINETTE SEAT
5	P11319-01-F27	EA	COVER-BED,JACK KNIFE KNIFE EDGE BACK,74
5	112104-01-F24	EA	BED ASM-JACK KNIFE BACK,KNIFE EDGE,74
5	112104-01-F25	EA	BED ASM-JACK KNIFE BACK,KNIFE EDGE,74
5	112104-01-F26	EA	BED ASM-JACK KNIFE BACK,KNIFE EDGE,74
5	111319-01-F27	EA	BED ASM-JACK KNIFE BACK,KNIFE EDGE,74
5	P12104-01-F24	EA	COVER-BED,JACK KNIFE KNIFE EDGE BACK,74
5	P12104-01-F25	EA	COVER-BED,JACK KNIFE KNIFE EDGE BACK,74
5	P12104-01-F26	EA	COVER-BED,JACK KNIFE KNIFE EDGE BACK,74
6	100032-43-F26	EA	BED-JACK KNIFE, SEAT - 74" TUCK - W/O ARMS
6	100032-43-E28	EA	BED-JACK KNIFE, SEAT - 74" TUCK - W/O ARMS (F24)
6	100032-43-F27	EA	BED-JACK KNIFE, SEAT - 74" TUCK - W/O ARMS
6	P00032-43-E28	EA	COVER-JACK KNIFE SEAT,74" TUCK - W/O ARM (F24)
6	P00032-43-F25	EA	COVER-JACK KNIFE SEAT,74" TUCK - W/O ARM
6	P00032-43-F26	EA	COVER-JACK KNIFE SEAT,74" TUCK - W/O ARM
6	100032-43-F25	EA	BED-JACK KNIFE, SEAT - 74" TUCK - W/O ARMS
	101085-04-000	EA	FRAME-SEAT, 74.75"
	081717-03-E07	EA	BED ASM-BUNK, FRONT
	079145-06-000	EA	CUSHION-BUNK, 30" X 77" X 4"
	M79145-06-000	EA	COVER-CUSHION, BUNK
	102695-08-000	YD	TAPE-CARPET BIND, #481 BROWN
	102695-11-000	YD	TAPE-CART BIND, MATTRESS - 3/4" WIDE - LIGHT TAN
	102695-12-000	YD	TAPE-CART BIND, #474 LIGHT TAN - ESHCO 1 1/4"
	101085-06-000	EA	FRAME-BASE, 74.75"
	101085-10-000	EA	FRAME - 74.5 X 16 BACK FRAME JACKKNIFE

CURTAIN & CUSHION GROUP (CONTINUED)

DRIVER & PASSENGER BUCKET SEATS

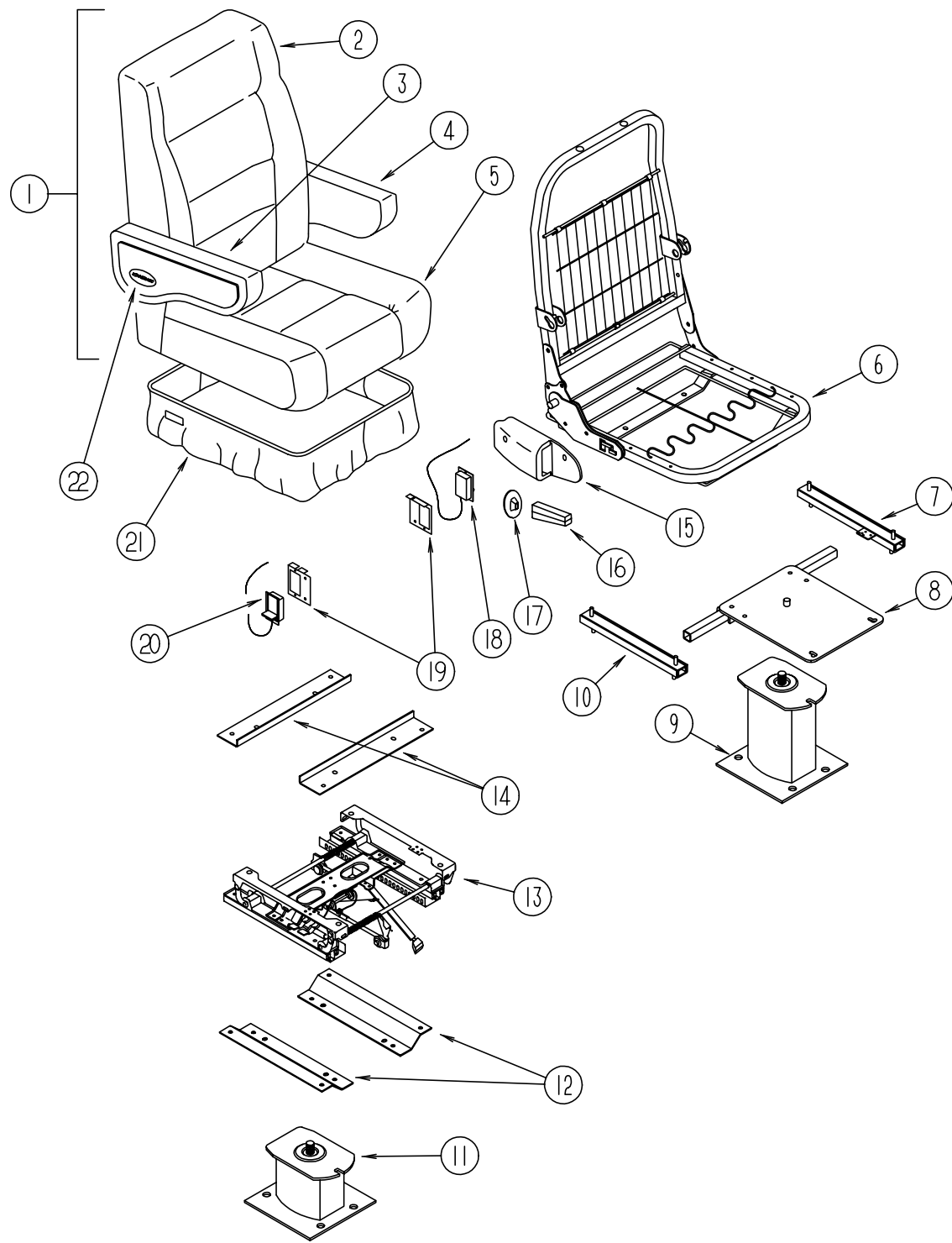

KEY	PART NUMBER	U/M	DESCRIPTION
1	112103-05-F24	EA	SEAT-BUCKET, W/ARMRESTS - W/O SKIRT
1	112103-05-F25	EA	SEAT-BUCKET, W/ARMRESTS - W/O SKIRT
1	112103-05-F26	EA	SEAT-BUCKET, W/ARMRESTS - W/O SKIRT
1	112103-05-F27	EA	SEAT-BUCKET, W/ARMRESTS - W/O SKIRT
1	112103-07-F24	EA	SEAT-BUCKET, W/ARMRESTS - W/O SKIRT - MANUAL SEAT OPTION
1	112103-07-F25	EA	SEAT-BUCKET, W/ARMRESTS - W/O SKIRT - MANUAL SEAT OPTION
1	112103-07-F26	EA	SEAT-BUCKET, W/ARMRESTS - W/O SKIRT - MANUAL SEAT OPTION
1	112103-07-F27	EA	SEAT-BUCKET, W/ARMRESTS - W/O SKIRT - MANUAL SEAT OPTION
2	M05962-12-F24	EA	COVER-BACK, BUCKET SEAT
2	M05962-12-F25	EA	COVER-BACK, BUCKET SEAT
2	M05962-12-F26	EA	COVER-BACK, BUCKET SEAT
2	M05962-12-F27	EA	COVER-BACK, BUCKET SEAT
3	111320-03-F24	EA	ARMREST-RIGHT, BUCKET SEAT
3	111320-03-E04	EA	ARMREST-RIGHT, BUCKET SEAT (F25)
3	111320-03-E25	EA	ARMREST-RIGHT, BUCKET SEAT (F26)
3	111320-03-F06	EA	ARMREST-RIGHT, BUCKET SEAT (F27)
	P11320-03-F24	EA	COVER-ARMREST, RIGHT
	P11320-03-E04	EA	COVER-ARMREST, RIGHT (F25)
	P11320-03-E25	EA	COVER-ARMREST, RIGHT (F26)
	P11320-03-F06	EA	COVER-ARMREST, RIGHT (F27)
4	111320-04-F24	EA	ARMREST-LEFT, BUCKET SEAT
4	111320-04-E04	EA	ARMREST-LEFT, BUCKET SEAT (F25)
4	111320-04-E25	EA	ARMREST-LEFT, BUCKET SEAT (F26)
4	111320-04-F06	EA	ARMREST-LEFT, BUCKET SEAT (F27)
	P11320-04-F24	EA	COVER-ARMREST, LEFT
	P11320-04-E04	EA	COVER-ARMREST, LEFT (F25)
	P11320-04-E25	EA	COVER-ARMREST, LEFT (F26)
	P11320-04-F06	EA	COVER-ARMREST, LEFT (F27)
5	M05962-06-F24	EA	COVER-SEAT, BUCKET SEAT
5	M05962-06-F25	EA	COVER-SEAT, BUCKET SEAT
5	M05962-06-F26	EA	COVER-SEAT, BUCKET SEAT
5	M05962-06-F06	EA	COVER-SEAT, BUCKET SEAT (F27)
6	M80906-11-000	EA	FRAME-SEAT, BACK & SPRING
7	069246-02-000	EA	ADJUSTER-SLIDE, FORWARD & BACK
8	107921-05-000	EA	PLATE-TOP, W/SEAT BELT BAR
9	107921-01-000	EA	PLATE-SUB, FLOOR MOUNTED PEDESTAL - W/9.75" EXTENSION
	107921-06-000	EA	BEARING KIT-SEAT SWIVEL
10	069246-05-000	EA	ADJUSTER-BUCKET SEAT W/LOCK, FORWARD AND BACK
	069246-05-700	EA	SPRING-ADJUSTER, FOR REMOTE
	069246-05-701	EA	CLIP-CABLE, FOR REMOTE
11	107921-07-000	EA	BASE-FLOOR MOUNTED PEDESTAL, 4.5" - MANUAL SEAT OPTION
12	116215-03-000	EA	PLATE-LOWER, MANUAL - 6 - WAY - ATWOOD 83835 - MANUAL SEAT OPTION
13	116215-01-000	EA	SEAT-MANUAL, 6 - WAY - DRIVER - ATWOOD 83805 - MANUAL SEAT OPTION
14	116215-02-000	EA	PLATE-UPPER, MANUAL - 6 - WAY - ATWOOD 85118 - MANUAL SEAT OPTION
15	080730-09-000	EA	SHIELD-RECLINER HANDLE
16	080730-08-000	EA	HANDLE-RECLINER, BLACK
17	080730-11-000	EA	SHIELD-RUBBER BOOT
18	089368-04-000	EA	CABLE-SLIDE, W/SWITCH
19	097683-03-000	EA	BRACKET-REMOTE, SIDE MOUNT - SINGLE
20	108049-01-000	EA	CABLE W/SWITCH - 28", F/FLEXSTEEL PEDESTAL
	108049-02-000	EA	CLIP-CABLE, PEDESTAL
21	071126-43-F24	EA	SKIRT-BUCKET SEAT
21	071126-43-F25	EA	SKIRT-BUCKET SEAT
21	071126-43-E34	EA	SKIRT-BUCKET SEAT (F26)
21	071126-43-F06	EA	SKIRT-BUCKET SEAT (F27)
21	071126-54-F24	EA	SKIRT-BUCKET SEAT - MANUAL SEAT OPTION
21	071126-54-F25	EA	SKIRT-BUCKET SEAT - MANUAL SEAT OPTION
21	071126-54-F26	EA	SKIRT-BUCKET SEAT - MANUAL SEAT OPTION
21	071126-54-F27	EA	SKIRT-BUCKET SEAT - MANUAL SEAT OPTION
22	111169-01-000	EA	PLATE-BACK, ARMREST
22	111169-03-000	EA	INSERT-ARMREST, OVAL DECAL - ITASCA
	007221-01-000	EA	SPACER-SEAT, ADJUSTER
	007221-01-000	EA	SPACER-SEAT, ADJUSTER
	089323-01-000	FT	STRIP-POLYENTHYLENE, J-CHANNEL - FLEX-O-LATORS
	114889-01-000	EA	STOP BAR-UNIVERSAL, SHROCK

CURTAIN & CUSHION GROUP (CONTINUED)

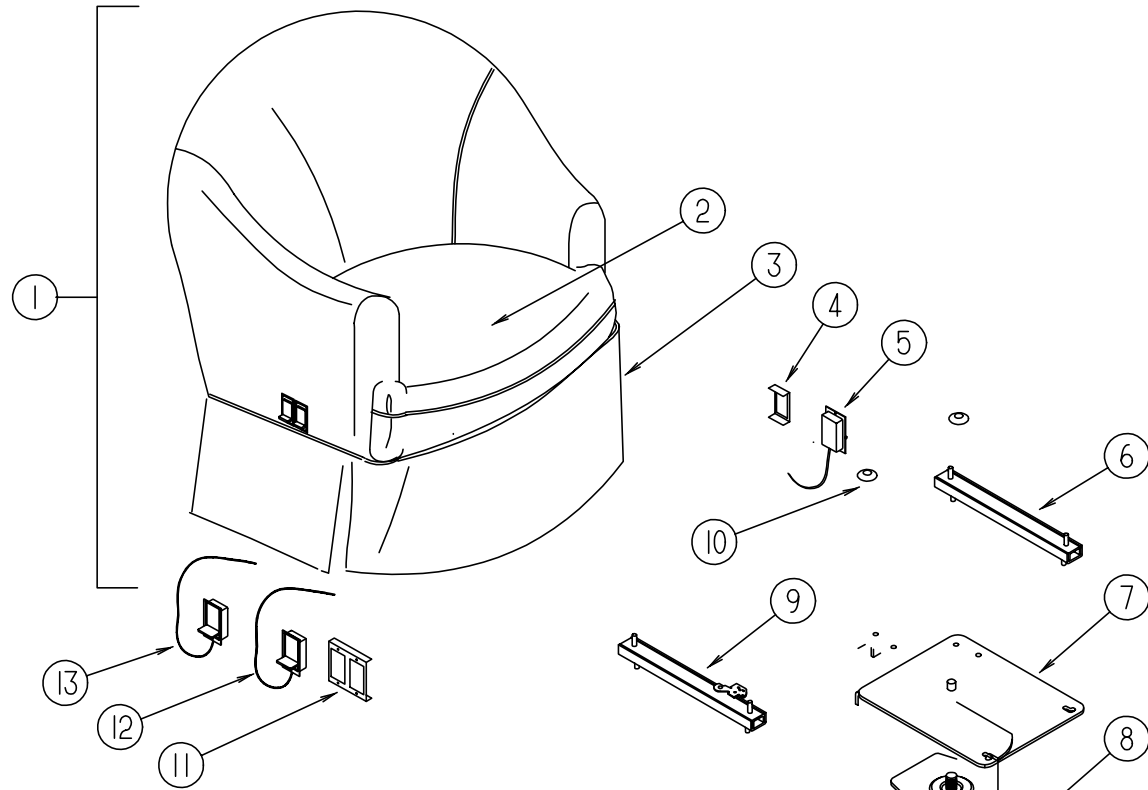

SWIVEL CHAIR

KEY	PART NUMBER	U/M	DESCRIPTION
1	116016-01-F24	EA	CHAIR-SWIVEL, W/O SKIRT
1	116016-01-F25	EA	CHAIR-SWIVEL, W/O SKIRT
1	116016-01-F26	EA	CHAIR-SWIVEL, W/O SKIRT
1	116016-02-F27	EA	CHAIR-SWIVEL, W/O SKIRT
	P16016-01-F24	EA	COVER-SWIVEL CHAIR
	P16016-01-F25	EA	COVER-SWIVEL CHAIR
	P16016-01-F26	EA	COVER-SWIVEL CHAIR
	P16016-02-F27	EA	COVER-SWIVEL CHAIR
2	116016-10-F24	EA	CUSHION-SEAT, SWIVEL CHAIR
2	116016-10-F25	EA	CUSHION-SEAT, SWIVEL CHAIR
2	116016-10-F26	EA	CUSHION-SEAT, SWIVEL CHAIR
	P16016-10-F24	EA	COVER-SEAT, SWIVEL CHAIR
	P16016-10-F25	EA	COVER-SEAT, SWIVEL CHAIR
	P16016-10-F26	EA	COVER-SEAT, SWIVEL CHAIR
3	085187-05-F24	EA	SKIRT-SWIVEL CHAIR
3	085187-05-F25	EA	SKIRT-SWIVEL CHAIR
3	085187-05-F26	EA	SKIRT-SWIVEL CHAIR
3	085187-07-F27	EA	SKIRT-SWIVEL CHAIR
4	097683-03-000	EA	BRACKET-MOUNT, REMOTE - SINGLE
5	089368-04-000	EA	CABLE-W/SWITCH, SLIDE
			FROM: 00-00-00 THRU: 11-13-94
5	108049-03-000	EA	CABLE-W/SWITCH, 20" - Z - END CABLE - SLIDE
			FROM: 11-14-94 THRU: 99-99-99
6	069246-06-000	EA	ADJUSTER-SWIVEL CHAIR, FORWARD & BACK
			FROM: 00-00-00 THRU: 10-16-94
6	069246-13-000	EA	ADJUSTER-SWIVEL CHAIR, FORWARD & BACK
			FROM: 10-17-94 THRU: 99-99-99
7	107921-08-000	EA	PLATE-TOP, W/O SEAT BELT BAR
	107921-06-000	EA	BEARING KIT-SEAT SWIVEL
8	107921-01-000	EA	PLATE-SUB, FLOOR MOUNTED PEDESTAL - W/9.75" EXTENSION
9	069246-08-000	EA	ADJUSTER-SWIVEL CHAIR W/LOCK, REMOTE - FORWARD & BACK
			FROM: 00-00-00 THRU: 10-16-94

CURTAIN & CUSHION GROUP (CONTINUED)

SWIVEL CHAIR (CONTINUED)

KEY	PART NUMBER	U/M	DESCRIPTION
9	069246-12-000	EA	ADJUSTER-SWIVEL CHAIR W/LOCK, REMOTE - FORWARD & BACK
			FROM: 10-17-94 THRU: 99-99-99
	117125-01-02B	EA	BRACKET-CABLE MOUNT, ADJUSTER W/LOCK - STEEL - E-COAT
			FROM: 10-17-94 THRU: 99-99-99
	069246-99-000	EA	SPRING-BUCKET SEAT ADJUSTER, BLUE
			FROM: 10-17-94 THRU: 99-99-99
10	007221-01-000	EA	SPACER-SEAT, ADJUSTER
11	097683-02-000	EA	BRACKET-MOUNT, REMOTE
12	089368-05-000	EA	CABLE W/SWITCH, RECLINE
13	108049-01-000	EA	CABLE W/SWITCH - 28", SWIVEL
			FROM: 00-00-00 THRU: 11-13-94
13	108049-03-000	EA	CABLE W/SWITCH, 20" - Z - END CABLE - SWIVEL
			FROM: 11-14-94 THRU: 99-99-99
	108049-02-000	EA	CLIP-CABLE, PEDESTAL
	108445-02-000	EA	PLATE ASM-PEDESTAL, SEAT - 230 MM X 157 MM - W/WELDNUTS

BUTTON, TRIM, ASSIST HANDLE & SEAT BELT

KEY	PART NUMBER	U/M	DESCRIPTION
	070578-02-B29	EA	BUTTON-SCREW, STUD - #30 - VINYL
	079349-04-F24	YD	WELT ASM-NARROW,ACCENT
	079349-04-E04	YD	WELT ASM-NARROW,ACCENT (F25)
	079349-04-E26	YD	WELT ASM-NARROW,ACCENT (F26)
	079349-04-E22	YD	WELT ASM-NARROW,ACCENT (F27)
	057759-01-000	EA	WASHER BRACKET-SEAT BELT, 4" DIAMETER
	007021-01-000	EA	BELT-SEAT, 2" X 90" - BLACK
	056271-02-000	EA	BELT-SEAT, 2" X 72" - BLACK
	069178-02-000	EA	BRACKET-MOUNTING, ASSIST HANDLE - L ANGLE - W/HOLES - STEEL
	053552-02-AA8	EA	HANDLE-ASSIST, INTERIOR - ENTRY DOOR - VINYL - OFF WHITE
	057534-01-000	EA	TIEBACK/TIEDOWN-BED/CURTAIN/DOOR, 6" - PLASTIC - CLEAR

FABRICS

KEY	PART NUMBER	U/M	DESCRIPTION
	079680-07-000	YD	FABRIC-VINYL, 54" WIDE - BEIGE
	087272-03-000	YD	DRAPERY LINING - 54" IVORY, ROCKLAND MILLS
	089351-03-000	YD	VINYL-CEILING, DIAMOND DESIGN - 54" WIDE
	103907-01-01A	YD	FABRIC-VINYL, 54" WIDE - OFF WHITE
	108446-46-000	YD	FABRIC-UPHOLSTERY, QUAKER/MONTE CARLO - ROSEQUARTZ - MAIN (F24)
	108446-B1-000	YD	FABRIC-UPHOLSTERY, COLLINS & AIKMAN/FIGI - 965 - BLUE - MAIN (F25)
	108446-B2-000	YD	FABRIC-UPHOLSTERY, COLLINS & AIKMAN/GYPSY - 767 - GREEN - MAIN (F26)
	108446-D2-000	YD	FABRIC-UPHOLSTERY, DOBLIN/CONFETTI - 9435 - MAIN (F27)
	104233-14-000	YD	FABRIC-UPHOLSTERY, JOAN/STARLIGHT - COCOA - PLAIN ACCENT (F24)
	098428-30-000	YD	FABRIC-UPHOLSTERY, COLLINS & AIKMAN/PHOENIX - 965 - PLAIN ACCENT (F25)
	098428-33-000	YD	FABRIC-UPHOLSTERY, COLLINS & AIKMAN/PHOENIX - 767 - PLAIN ACCENT (F26)
	108446-55-000	YD	FABRIC-UPHOLSTERY, LAFRANCE/ALBANY - 350 WHEAT - PLAIN ACCENT (F27)
	108446-57-000	YD	FABRIC-UPHOLSTERY, JOAN/CELTIC - CASHMERE - PATTERN ACCENT (F24)
	098428-30-000	YD	FABRIC-UPHOLSTERY, COLLINS & AIKMAN/PHOENIX - 965 - PATTERN ACCENT (F25)
	098428-33-000	YD	FABRIC-UPHOLSTERY, COLLINS & AIKMAN/PHOENIX - 767 - PATTERN ACCENT (F26)
	108446-D3-000	YD	FABRIC-UPHOLSTERY, MASTERCRAFT/HAPPY DAYS -001 - PATTERN ACCENT (F27) DINETTE CUSHIONS & THROW PILLOWS
	108446-D4-000	YD	FABRIC-UPHOLSTERY, MASTERCRAFT/ONE GREAT PLATE - 001 PATTERN ACCENT (F27) LOUNGE AREA WINDOW VALANCES
	105745-43-000	YD	FABRIC-BEDSPREAD, RICHLOOM/MONTURA - NATURAL - MAIN (F24)
	105745-91-000	YD	FABRIC-BEDSPREAD, DI LEWIS STUDIOS/KLEE - GALAXY - MAIN (F25)
	105745-84-000	YD	FABRIC-BEDSPREAD, LANSCOT-ARLEN/SEQUE - HAZE - MAIN (F26)
	105745-96-000	YD	FABRIC-BEDSPREAD,RICHLOOM/HERALD SQUARE - WEDGEWOOD - MAIN (F27)
	105745-63-000	YD	FABRIC-BEDSPREAD, RADIANCE - TOAST - ACCENT (F24)
	105745-61-000	YD	FABRIC-BEDSPREAD, RADIANCE - NORWEGIAN - ACCENT (F25)
	105745-45-000	YD	FABRIC-BEDSPREAD, RADIANCE - GREEN - ACCENT (F26)
	105745-97-000	YD	FABRIC-BEDSPREAD, RICHLOOM/FRANK - MULTI - ACCENT (F27)
	072333-90-000	YD	FABRIC-CURTAIN, 54" WIDE - TAN (F24,F27)
	072333-82-000	YD	FABRIC-CURTAIN, 54" WIDE - BEIGE (F25,F26)

DINETTE GROUP

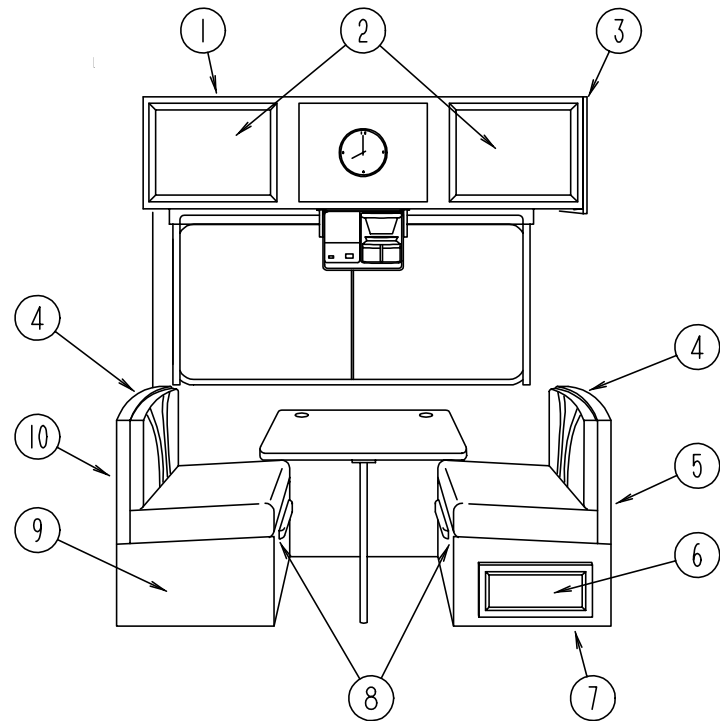

DINETTE CABINETRY

KEY	PART NUMBER	U/M	DESCRIPTION
1	113882-01-F06	EA	CABINET ASM-OVHD DINETTE (F24)
1	113882-01-F25	EA	CABINET ASM-OVHD DINETTE
1	113882-01-F26	EA	CABINET ASM-OVHD DINETTE
1	113882-01-F27	EA	CABINET ASM-OVHD DINETTE
2	M06803-02-E07	EA	DOOR ASM-W/O HARDWARE - 400 X 710
3	103128-01-E10	EA	END CAP ASM, OVERHEAD
4	104787-01-F24	EA	PAD ASM-DINETTE
4	104787-01-E04	EA	PAD ASM-DINETTE (F25)
4	104787-01-F26	EA	PAD ASM-DINETTE
4	104787-01-F06	EA	PAD ASM-DINETTE (F27)
5	M04174-42-E07	EA	CABINET-SEATBACK RH
6	M06803-07-E07	EA	DOOR ASM-W/O HARDWARE - 255 X 485
7	M04175-42-E07	EA	CABINET-SEATBASE RH
8	081295-01-AA8	EA	SUPPORT-BED, DINETTE, 712 LG
9	M04175-24-E07	EA	CABINET-SEATBASE LH
10	M04174-24-E07	EA	CABINET-SEATBACK LH

DINETTE GROUP (CONTINUED)

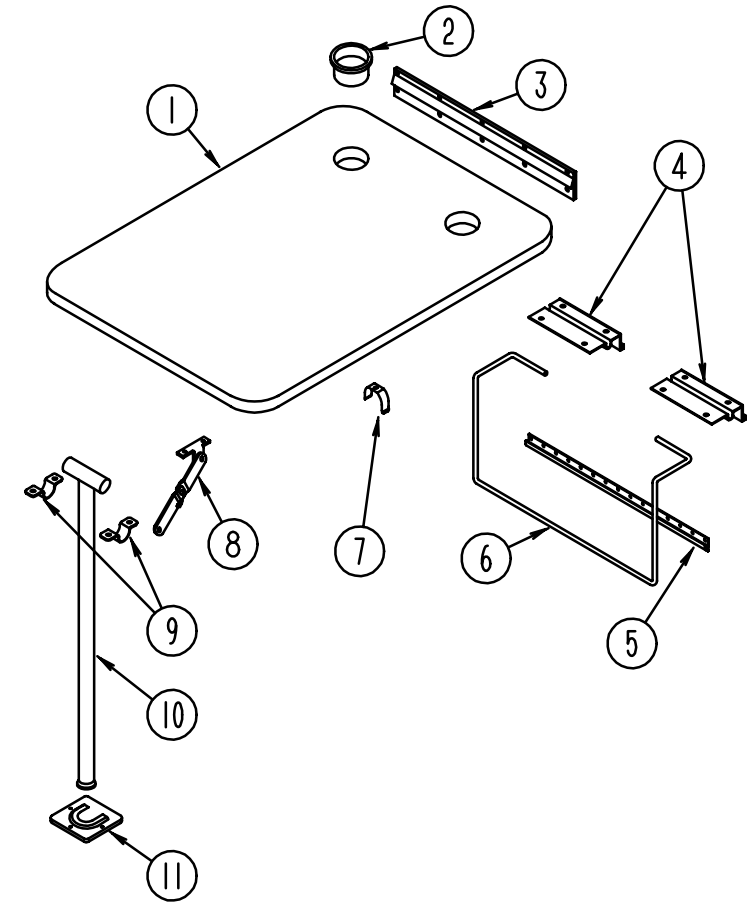

DINETTE TABLE

KEY	PART NUMBER	U/M	DESCRIPTION
1	M81299-09-E08	EA	TABLE-DINETTE, W/O EDGE BAND OR HARDWARE (F24)
1	M81299-09-E13	EA	TABLE-DINETTE, W/O EDGE BAND OR HARDWARE (F25)
1	M81299-09-E94	EA	TABLE-DINETTE, W/O EDGE BAND OR HARDWARE (F26)
1	M81299-09-E01	EA	TABLE-DINETTE, W/O EDGE BAND OR HARDWARE (F27)
2	064781-06-000	EA	HOLDER-CUP, TWO STEP - OFF WHITE
3	053200-12-000	EA	SUPPORT-TABLE, 23.5" - BEIGE
4	088410-02-000	EA	BRACKET-LIFT, TABLE MOUNTED - OFF WHITE
5	024281-14-000	EA	BRACKET-LIFT ROD, LOWER WALL MOUNTED - 22.12" - OFF WHITE
6	024275-12-000	EA	ROD-TABLE LIFT, OFF WHITE
7	024283-01-000	EA	CLIP-LEG, 1" X 1.125" OD - BLACK
8	024282-01-000	EA	BRACE-TABLE LEG, HINGED
9	064050-05-000	EA	HINGE-TABLE LEG, OFF WHITE
10	024276-24-000	EA	LEG-TABLE, METAL - OFF WHITE
11	049493-12-000	EA	CATCH-LEG, FLOOR MOUNTED - 2.5" X 2.7" - METAL - OFF WHITE
11	049493-11-700	EA	CATCH-LEG, FLOOR MOUNTED - 2.5" X 2.7" - METAL - E-COAT

DRIVERS COMPARTMENT GROUP
DRIVERS COMPARTMENT - UPPER

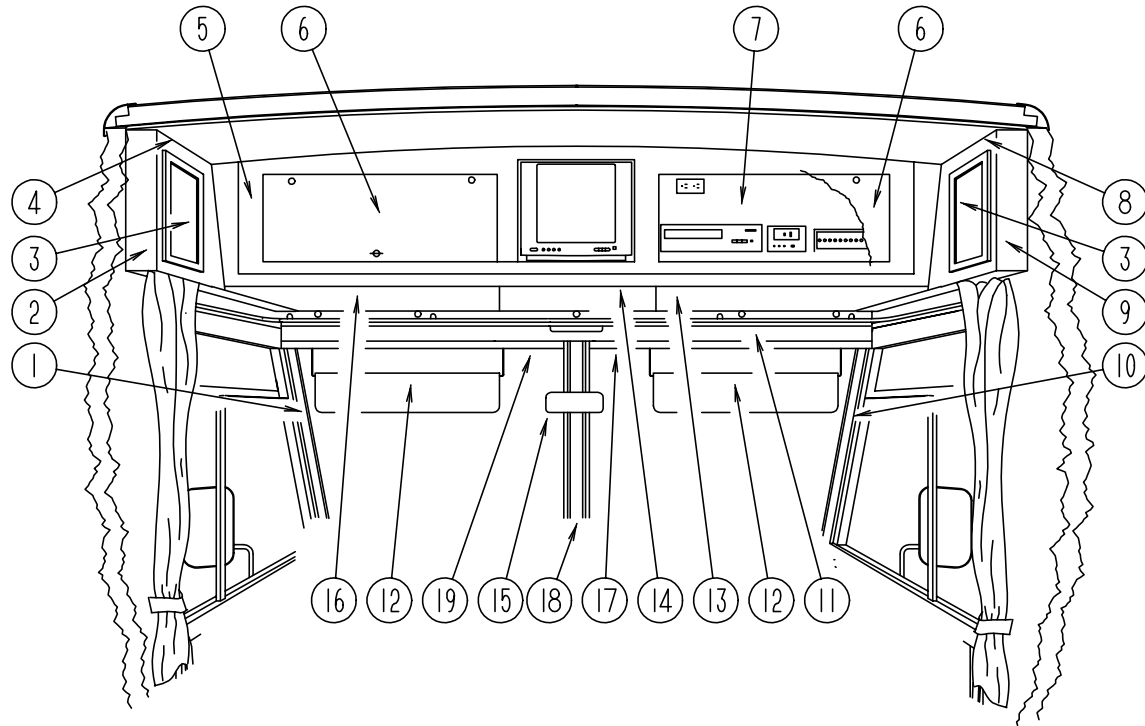

KEY	PART NUMBER	U/M	DESCRIPTION
1	103931-02-02A	EA	COVER-INNER, A-PILLAR - DRIVERS
2	103128-09-E10	EA	CAP-END, FRONT OVERHEAD, DRIVERS SIDE
3	M06803-04-E07	EA	DOOR-CABINET, W/O HARDWARE - 255 MM X 485 MM
4	109561-02-F06	EA	CABINET-FRONT OVERHEAD W/O DOOR, DRIVERS SIDE
	P09561-02-E07	EA	BOTTOM-VINYL COVERED, FRONT OVERHEAD - DRIVERS SIDE
	104289-02-F24	EA	PAD-VINYL COVERED, 30.3" X 9.6" - ANGLED - DRIVERS SIDE
5	M05893-01-E07	EA	FACE-TV CABINET W/O DOORS, FRONT OVERHEAD
	106699-01-01A	EA	BRACKET-L-ANGLE, TV CABINET FACE - 5.1" LONG - OFF WHITE STEEL
	108911-01-F04	EA	TRIM-TV, 15.3" X 13.9" - WOOD
	100676-02-000	EA	STAND-VCR, STEEL
6	100708-06-000	EA	DOOR-GLASS, TV CABINET - W/O HARDWARE - 9.68" X 28.42"
	100710-01-01A	EA	LOCK-TWIST TYPE
	100711-01-01A	EA	HINGE-DOOR, GLASS
	100707-01-000	EA	SPACER
	101272-01-000	EA	CATCH-GLASS DOOR
	101766-01-000	EA	PIN-SUPPORT, GLASS DOOR
7	103040-01-C05	EA	PANEL-HEADLINER FRONT OVERHEAD - PADDED - STANDARD
7	103040-02-C05	EA	PANEL-HEADLINER FRONT OVERHEAD - PADDED - TV OPTION
7	103040-03-C05	EA	PANEL-HEADLINER FRONT OVERHEAD - PADDED - TV/VCR/EUROPEAN OPTIONS
7	103040-04-C05	EA	PANEL-HEADLINER FRONT OVERHEAD - PADDED - TV/VCR/INVERTER OPTION
7	103040-05-C05	EA	PANEL-HEADLINER FRONT OVERHEAD - PADDED - TV/INVERTER OPTION
8	114188-01-F06	EA	CABINET-FRONT OVERHEAD W/O DOOR, PASSENGERS SIDE (F24)
8	114188-01-F25	EA	CABINET-FRONT OVERHEAD W/O DOOR, PASSENGERS SIDE
8	114188-01-F26	EA	CABINET-FRONT OVERHEAD W/O DOOR, PASSENGERS SIDE
8	114188-01-F27	EA	CABINET-FRONT OVERHEAD W/O DOOR, PASSENGERS SIDE
9	103128-08-E10	EA	CAP-END, FRONT OVERHEAD, PASSENGERS SIDE
	P09561-01-E07	EA	BOTTOM-VINYL COVERED, FRONT OVERHEAD - PASSENGERS SIDE
	104289-01-F24	EA	PAD-VINYL COVERED, 30.3" X 9.6" - ANGLED - DRIVERS SIDE
10	103931-01-02A	EA	COVER-INNER, A-PILLAR - PASSENGERS
11	078811-05-C07	EA	PANEL-HEADER W/RECEPTACLE CUTOUTS - 90.2" LONG - VINYL COVERED
12	082286-18-F04	EA	SUNVISOR-DRIVER OR PASSENGER - W/O POCKET
	102377-01-000	EA	BRACKET-SUNVISOR, 1 PIECE - STEEL
	007211-01-000	EA	HINGE-SUNVISOR
	074012-01-000	EA	CLIP-SUNVISOR, SQUARE PINCH-ON
13	P03077-02-C05	EA	SHELF-CABINET, PASSENGERS SIDE - VINYL COVERED
14	P04415-01-C05	EA	SHELF-TV CABINET, VINYL COVERED
	100628-02-000	EA	SHELF ASM-TV, STEEL
	101150-01-000	EA	SUPPORT-SHELF, TV - PASSENGER SIDE - STEEL
	101150-02-000	EA	SUPPORT-SHELF, TV - DRIVER SIDE - STEEL
	104417-01-E07	EA	CABINET-BLANKET (STANDARD CABINET)
15	040714-01-000	EA	MIRROR-REAR VIEW, W/ARM MOUNT & SET SCREW - GM# 911722
	067490-01-000	EA	BUTTON-MIRROR, REAR VIEW - STANK S927H
16	P03077-01-C05	EA	SHELF-CABINET, DRIVERS SIDE - VINYL COVERED
17	078579-09-000	EA	TRIM - WINDSHIELD - UPPER INNER - RIGHT - LIGHT GRAY
18	079765-08-000	EA	TRIM - WINDSHIELD - CENTER INNER - LIGHT GRAY
19	078579-10-000	EA	TRIM - WINDSHIELD - UPPER INNER - LEFT - LIGHT GRAY

DRIVERS COMPARTMENT GROUP (CONTINUED)
DRIVERS COMPARTMENT - LOWER

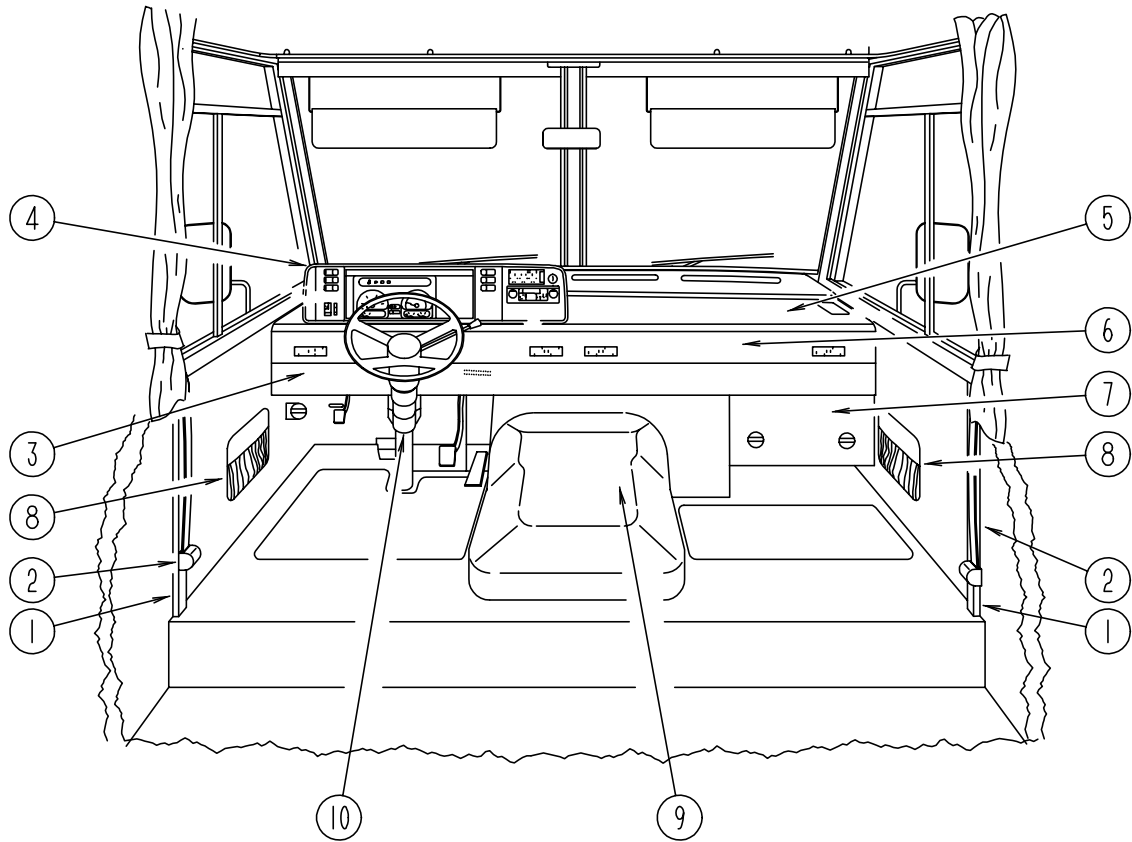

KEY	PART NUMBER	U/M DESCRIPTION
1	024700-44-000	EA COVER-SIDEWALL ROLL BAR, OFF WHITE - 53"
1	024700-45-000	EA COVER-SIDEWALL ROLL BAR, OFF WHITE - 12.8"
2	091990-04-01A	EA SEAT BELT-SHOULDER HARNESS - DRIVERS/PASSENGERS - BLACK
	091990-01-700	EA BOLT COVER
	109146-01-000	EA BOLT-SHOULDER, SEAT BELT
	103961-01-01A	EA COVER-BRACKET, SEATBELT - OFF WHITE
	103961-02-01A	EA COVER-BRACKET, SEATBELT - OFF WHITE - DRIVER DOOR OPTION
3	103812-01-02A	EA TRIM-DASH, LOWER
4	111499-01-02A	EA POD-INSTRUMENT PANEL
5	P03817-10-000	EA DASH ASM, W/O VINYL - FORD
5	P03817-11-000	EA DASH ASM, W/O VINYL - CHEVY
	105927-02-000	EA PANEL-DASH TOP, STEEL
6	104354-04-03A	EA APPLIQUE-LOWER DASH, 2300 MM LONG - CHEVY
6	104354-05-03A	EA APPLIQUE-LOWER DASH, 2300 MM LONG - FORD
7	095757-03-F04	EA COVER-HEATER W/CARPET (F24,F27)
7	095757-03-F25	EA COVER-HEATER W/CARPET
7	095757-03-F26	EA COVER-HEATER W/CARPET
8	086120-01-F24	EA PAD-MAP POCKET, 12" X 16" (F24,F27)
8	086120-01-F25	EA PAD-MAP POCKET, 12" X 16"
8	086120-01-F26	EA PAD-MAP POCKET, 12" X 16"
9	097552-01-000	EA COVER-MOTOR, W/O CARPET
		FROM: 00-00-00 THRU: 09-18-94
9	114512-01-01A	EA COVER-MOTOR, W/O CARPET (6.5 DIESEL OPTION)
		FROM: 00-00-00 THRU: 09-18-94
	075564-01-000	EA BRACKET-MOUNTING, MOTOR COVER
		FROM: 00-00-00 THRU: 09-18-94
9	115840-01-01A	EA COVER-MOTOR, W/O CARPET - GAS OR 6.5 DIESEL OPTION
		FROM: 09-19-94 THRU: 99-99-99
	115850-01-02A	EA RETAINER-LATCH, MOTOR COVER - GAS OR 6.5 DIESEL OPTION
		FROM: 09-19-94 THRU: 99-99-99
	116581-01-000	EA LATCH-MOTOR COVER - SOUTHCO 2710074088 - GAS OR 6.5 DIESEL OPTION
		FROM: 09-19-94 THRU: 99-99-99
	116833-01-02B	EA WRENCH-HEX, MOTOR COVER - E-COAT - GAS OR 6.5 DIESEL OPTION
		FROM: 09-19-94 THRU: 99-99-99
	113828-02-01A	EA TRIM-MOTOR COVER, MILL
		FROM: 00-00-00 THRU: 09-18-94
	114519-01-E07	EA TRIM-MOTOR COVER (6.5 DIESEL OPTION)
		FROM: 00-00-00 THRU: 09-18-94
	115860-01-01A	EA TRIM-MOTOR COVER - GAS OR 6.5 DIESEL OPTION
		FROM: 09-19-94 THRU: 99-99-99
	039623-01-000	FT SEAL-MOTOR COVER, RUBBER BULB TYPE - BLACK
	111618-01-E10	EA TRAY ASM-BEVERAGE
	111618-13-E07	EA LID-BEVERAGE TRAY ASM
	046886-03-000	EA ASHTRAY-CHROME, W/COVER
10	103498-06-000	EA BOOT-STEERING COLUMN, BLACK VINYL
	111521-01-04A	EA COVER-STEERING COLUMN, BLACK
	112634-01-01A	EA TRIM-STEERING COLUMN, RH BLK
	112634-02-01A	EA TRIM-STEERING COLUMN, LH BLK

DRIVERS COMPARTMENT GROUP (CONTINUED)

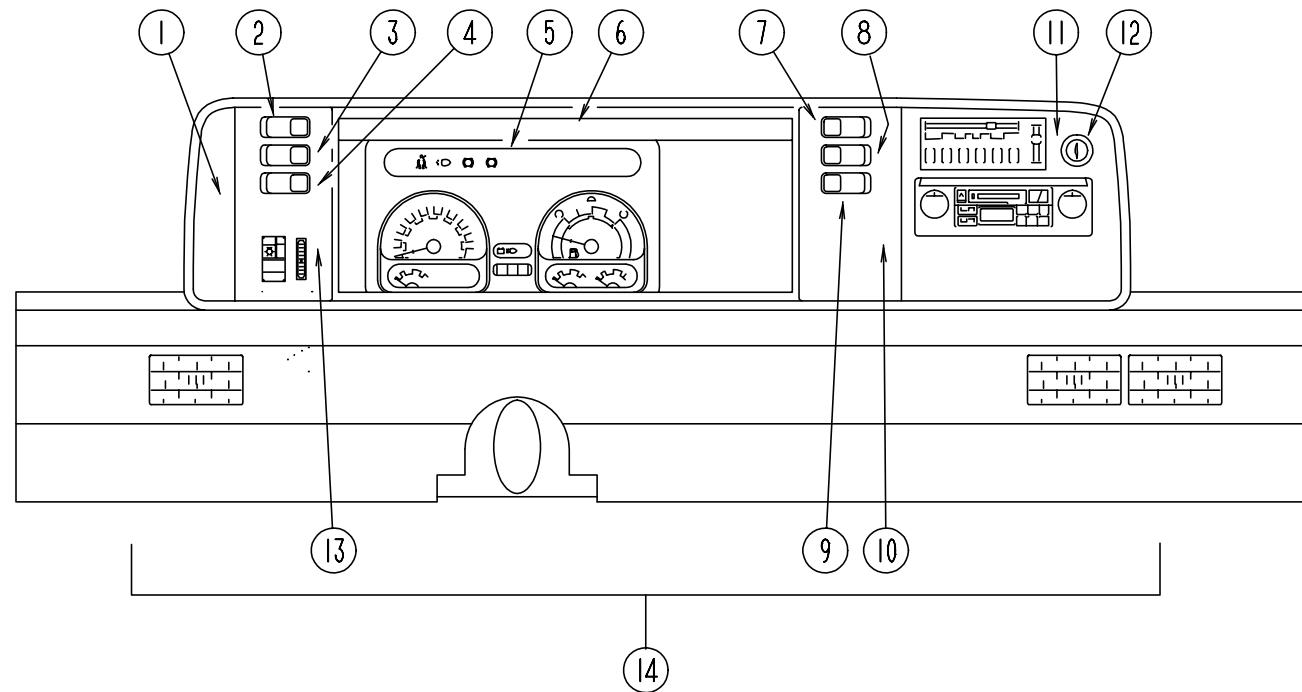

INSTRUMENT CLUSTER (CHEVY)

KEY	PART NUMBER	U/M	DESCRIPTION
1	104056-01-01A	EA	APPLIQUE-BEZEL
2	108356-02-01A	EA	COVER-SWITCH W/DIMPLES, CARLING VVAZC00 BLA
2	108357-05-000	EA	SWITCH-ROCKER, SPDT ON/NONE/ON - RADIO POWER - CARLING V4D1000B-0
3	108356-02-01A	EA	COVER-SWITCH W/DIMPLES, CARLING VVAZC00 BLA
3	108357-09-000	EA	SWITCH-ROCKER, SPDT ON/NONE/MOM - DUAL BATTERY - CARLING V5D1000B-0
4	108356-02-01A	EA	COVER-SWITCH W/DIMPLES, CARLING VVAZC00 BLA
4	108357-06-000	EA	SWITCH-ROCKER, DPDT MOM/OFF/MOM - CARLING VLD1000B-0 BATTERY DISCONNECT SWITCH OPTION
4	096241-03-000	EA	SWITCH-BLANK
5	094796-07-000	EA	CLUSTER-INSTRUMENT PANEL, KILOMETERS - GM #16167145 (GAS)
5	094796-08-000	EA	CLUSTER-INSTRUMENT PANEL, KILOMETERS - GM #16164645 (DIESEL)
6	103662-01-01A	EA	BEZEL-INSTRUMENT PANEL
7	108356-04-01A	EA	COVER-SWITCH W/DIMPLES & LENS, CARLING VVAGC00
7	108357-10-000	EA	SWITCH-ROCKER, SPDT MOM/OFF/MOM - LIGHTED - CARLING V8D1160B-0 GENERATOR OPTION
7	096241-03-000	EA	SWITCH-BLANK
8	108356-02-01A	EA	COVER-SWITCH W/DIMPLES, CARLING VVAZC00 BLA
8	108357-03-000	EA	SWITCH-ROCKER, SPDT ON/OFF/ON - CARLING V6D1000B-0 REAR HEATER OPTION
8	096241-03-000	EA	SWITCH-BLANK
9	096241-03-000	EA	SWITCH-BLANK
10	104056-21-01A	EA	APPLIQUE-BEZEL
11	104056-06-01A	EA	APPLIQUE-BEZEL
12	089294-01-000	EA	LIGHTER ASM-CIGARETTE - CASCO C213275
13	104056-22-01A	EA	APPLIQUE-BEZEL
14	M05946-17-F24	EA	DASH POD ASM-CHEVY
	100138-01-000	EA	MODULE-DAYTIME RUNNING LIGHT - CANADIAN
	077031-01-000	EA	FILM-BLACK, 1" X 1.75"
	077031-02-000	EA	FILM-AMBER, 1" X 1.75"
	077031-03-000	EA	FILM-WHITE, .75" X 1"
	103603-01-000	EA	BULB-12V NO.74 0.12A WEDGE
	105615-01-000	FT	FILM-PROTECTIVE CLEAR
	077539-01-000	EA	BRACKET-MOUNTING, DASH PANEL - L/SHAPED - 2.5" X 1" X 1.5"
	062901-02-000	EA	FUSE - 5 AMPS, AUTOMOTIVE
	062901-05-000	EA	FUSE - 15 AMPS, AUTOMOTIVE
	062901-07-000	EA	FUSE - 25 AMPS, AUTOMOTIVE

DRIVERS COMPARTMENT GROUP (CONTINUED)

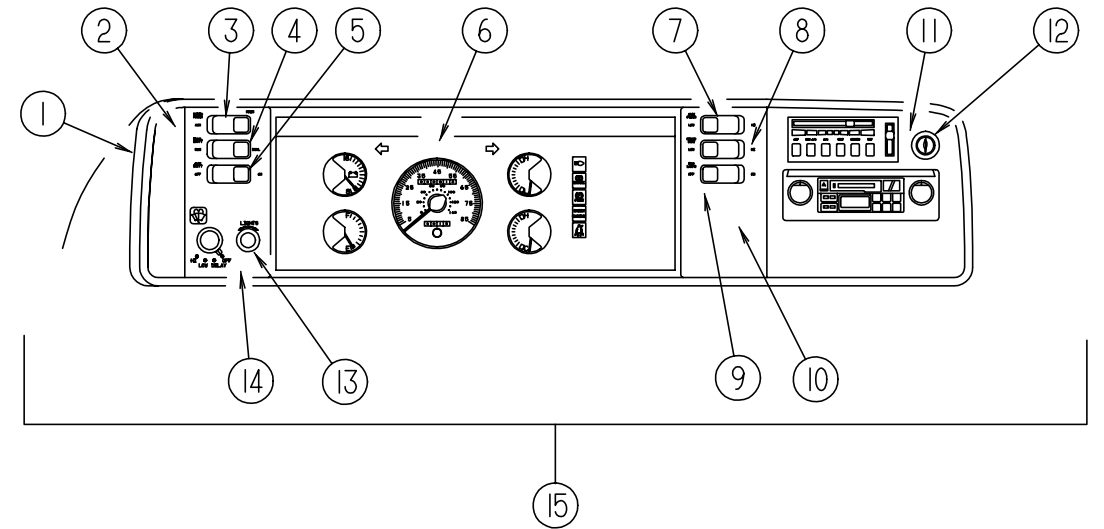

DASH, GAUGES & SWITCHES (FORD)

KEY	PART NUMBER	U/M	DESCRIPTION
1	103662-04-01A	EA	BEZEL-INSTRUMENT PANEL
2	104056-01-01A	EA	APPLIQUE-BEZEL
3	108356-02-01A	EA	COVER-SWITCH W/DIMPLES, CARLING VVAZC00 BLA
3	108357-05-000	EA	SWITCH-ROCKER, SPDT ON/NONE/ON - RADIO POWER - CARLING V4D1000B-0
4	108356-02-01A	EA	COVER-SWITCH W/DIMPLES, CARLING VVAZC00 BLA
4	108357-09-000	EA	SWITCH-ROCKER, SPDT ON/NONE/MOM - DUAL BATTERY - CARLING V5D1000B-0
5	108356-02-01A	EA	COVER-SWITCH W/DIMPLES, CARLING VVAZC00 BLA
5	108357-06-000	EA	SWITCH-ROCKER, DPDT MOM/OFF/MOM - CARLING VLD1000B-0 BATTERY DISCONNECT SWITCH OPTION
5	096241-03-000	EA	SWITCH-BLANK
6	094794-04-000	EA	CLUSTER-INSTRUMENT PANEL, KILOMETERS - FORD F3TD-10849-BA
7	108356-04-01A	EA	COVER-SWITCH W/DIMPLES & LENS, CARLING VVAGC00
7	108357-10-000	EA	SWITCH-ROCKER, SPDT MOM/OFF/MOM - LIGHTED - CARLING V8D1160B-0 GENERATOR OPTION
7	096241-03-000	EA	SWITCH-BLANK
8	108356-02-01A	EA	COVER-SWITCH W/DIMPLES, CARLING VVAZC00 BLA
8	108357-03-000	EA	SWITCH-ROCKER, SPDT ON/OFF/ON - CARLING V6D1000B-0 REAR HEATER OPTION
8	096241-03-000	EA	SWITCH-BLANK
9	096241-03-000	EA	SWITCH-BLANK
10	104056-21-01A	EA	APPLIQUE-BEZEL
11	104056-06-01A	EA	APPLIQUE-BEZEL
12	089294-01-000	EA	LIGHTER ASM-CIGARETTE - CASCO C213275
13	096674-01-000	EA	NUT-HEADLAMP KNOB, BLACK
13	096675-01-000	EA	KNOB - HEADLAMP - W/SHAFT
14	104056-24-01A	EA	APPLIQUE-BEZEL
15	M05946-18-F24	EA	DASH POD ASM-FORD
	100138-01-000	EA	MODULE-DAYTIME RUNNING LIGHT - CANADIAN
	111915-03-000	EA	WIRE ASM-DAY RUN LAMPS, FUSE - CANADIAN
	103603-01-000	EA	BULB - 12V NO.74 0.12A WEDGE
	077031-01-000	EA	FILM-BLACK, 1" X 1.75"
	077031-03-000	EA	FILM-WHITE, .75" X 1"
	105615-01-000	FT	FILM-PROTECTIVE CLEAR
	111904-01-000	EA	INDICATOR ASM-TRANSMISSION - FORD F2US-7B053

DRIVERS COMPARTMENT GROUP (CONTINUED)
FRONT BUNK

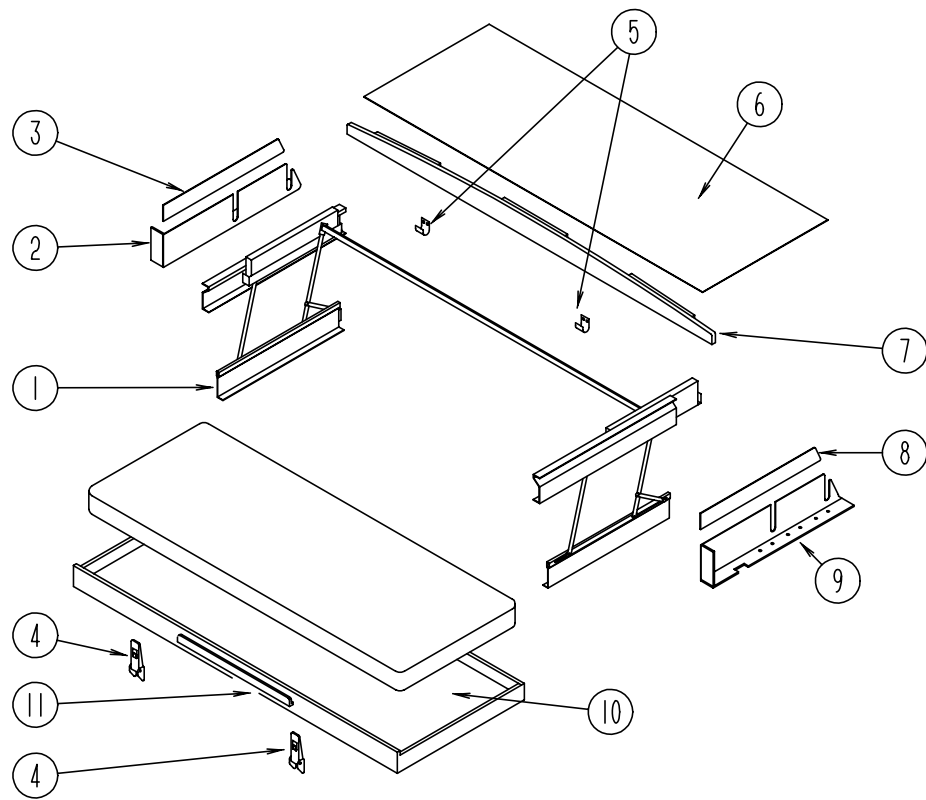

KEY	PART NUMBER	U/MDESCRIPTION
1	076760-02-000	EA BUNK HARDWARE (COMPLETE)
	076760-02-700	EA SPRING-GAS-BUNK HARDWARE
2	101499-06-F24	EA PANEL ASM.- BOTTOM DRIVERS - PADDED - USED W/BUNK (F24,F27)
2	101499-06-C05	EA PANEL ASM.- BOTTOM DRIVERS - PADDED - USED W/BUNK (F25,F26)
3	101497-08-F24	EA PANEL ASM.- UPPER DRIVERS - PADDED - USED W/BUNK (F24,F27)
3	101497-08-C05	EA PANEL ASM.- UPPER DRIVERS - PADDED - USED W/BUNK (F25,F26)
4	042541-04-000	EA LATCH-W/O STRIKE, BRASS
5	042541-05-000	EA STRIKE-BRASS
6	103040-06-F24	EA PANEL-HEADLINER FRONT OVERHEAD - PADDED - USED W/BUNK (F24,F27)
6	103040-06-C05	EA PANEL-HEADLINER FRONT OVERHEAD - PADDED - USED W/BUNK (F25,F26)
7	P03199-01-C05	EA BOARD ASM-TRIM, BUNK - CEILING MOUNTED
8	101497-07-F24	EA PANEL ASM.- UPPER PASSENGERS - PADDED - USED W/BUNK (F24,F27)
8	101497-07-C05	EA PANEL ASM.- UPPER PASSENGERS - PADDED - USED W/BUNK (F25,F26)
9	101499-05-F24	EA PANEL ASM.- BOTTOM PASSENGERS - PADDED - USED W/BUNK (F24,F27)
9	101499-05-C05	EA PANEL ASM.- BOTTOM PASSENGERS - PADDED - USED W/BUNK (F25,F26)
10	081717-03-E07	EA BED ASM-BUNK, FRONT
11	094658-01-E07	EA HANDLE-BUNK, OAK

ELECTRICAL GROUP
EXTERIOR LIGHTS

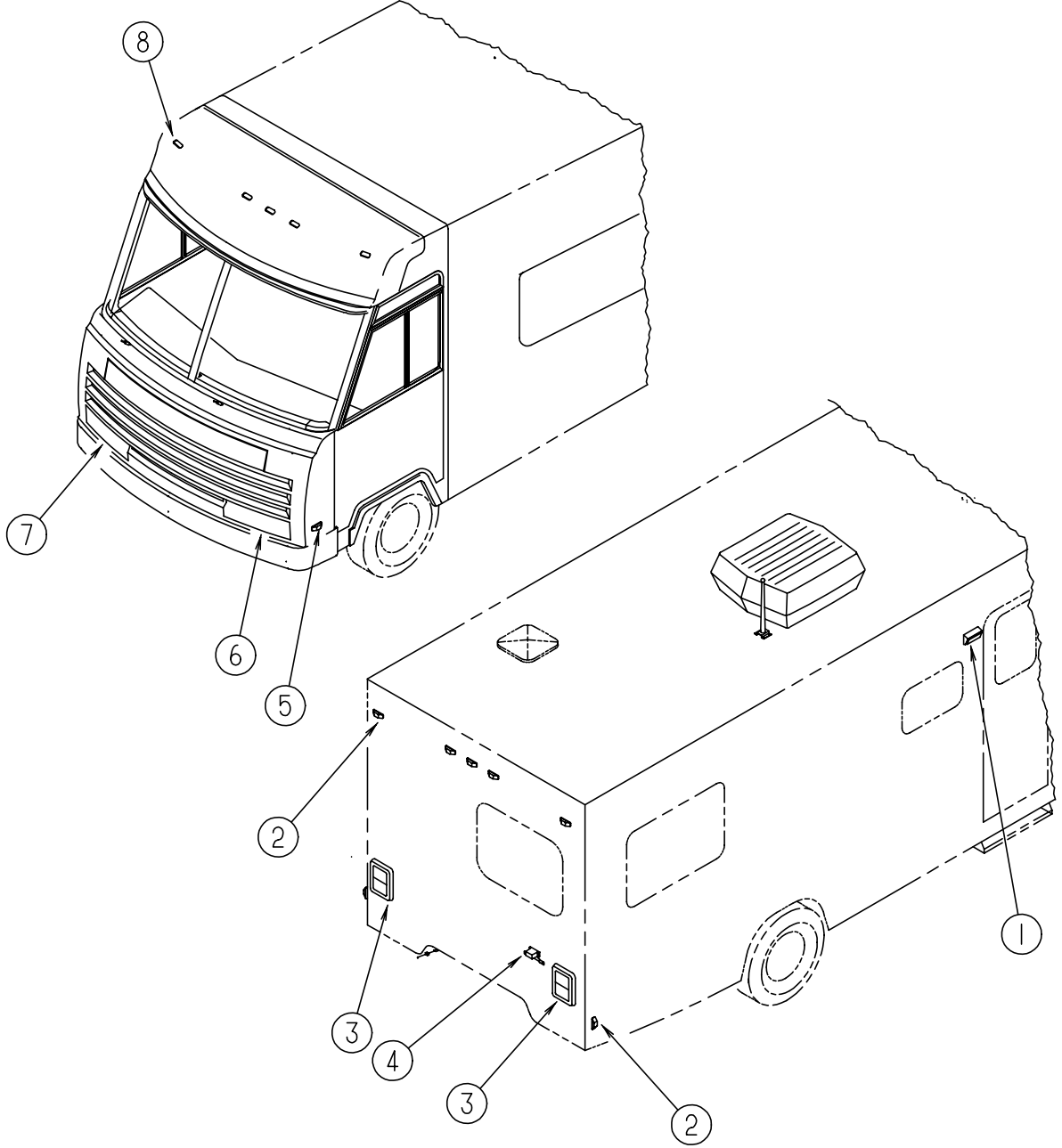

KEY	PART NUMBER	U/M	DESCRIPTION
1	097917-01-06A	EA	LIGHT-PORCH, ENTRY DOOR - BRIGHT WHITE
	008215-01-000	EA	BULB - 12V, #1003 - .94 AMP
	097917-01-700	EA	LENS-LIGHT, PORCH
2	111102-01-000	EA	LAMP-MARKER, BASE - TRIPLEX 117XAS
2	111102-03-000	EA	LENS-MARKER LAMP, RED - TRIPLEX 117R
	036196-01-000	EA	BULB - 12V, #194 - .27 AMP - BAYONETTE
3	081638-01-000	EA	TAILLIGHT-DOUBLE, W/BLACK TRIM - DRIVER OR PASSENGER SIDE
	037934-01-000	EA	BULB - 12V, #1156 - 2.1 AMP - CLEAR GLASS
	037935-01-000	EA	BULB - 12V, #1157 OR #2057 - 2.1 AMP - CLEAR GLASS
	081638-01-700	EA	LENS-TAILLIGHT, RED - BARGMAN 30-84-010
	081638-01-701	EA	LENS-TAILLIGHT, W/BACKUP - BARGMAN 30-84-700
	103355-01-03A	EA	POD-TAILLIGHT, ASH GRAY
	103355-01-05A	EA	POD-TAILLIGHT, BRIGHT WHITE
4	066432-02-000	EA	LIGHT-LICENSE, BLACK
	066432-03-000	EA	BRACKET-LICENSE PLATE - BARGMAN 30-60-030
5	111102-01-000	EA	LAMP-MARKER, BASE - TRIPLEX 117XAS
5	111102-02-000	EA	LENS-MARKER LAMP, AMBER - TRIPLEX 118A
	036196-01-000	EA	BULB - 12V, #194 - .27 AMP - BAYONETTE
6	049186-01-000	EA	HEADLAMP CAPSULE-DRIVER, HIGH/LOW BEAM - RECTANGULAR
	049188-01-000	EA	HEADLAMP CAPSULE-DRIVER, HIGH BEAM - RECTANGULAR
7	049185-01-000	EA	HEADLAMP CAPSULE-PASSENGER, HIGH/LOW BEAM - RECTANGULAR
	049187-01-000	EA	HEADLAMP CAPSULE-PASSENGER, HIGH BEAM - RECTANGULAR
	P03783-01-000	EA	WIRE ASM-HEADLAMP
	049359-01-000	EA	SPRING-RETAINER, HEADLAMP - GM 496096
	110750-01-000	EA	SCREW-ADJUSTING, HEADLAMP
	110783-01-01A	EA	BRACKET-HEADLAMP, QUAD - PASSENGER - UNPAINTED
	110783-02-01A	EA	BRACKET-HEADLAMP, QUAD - DRIVER - UNPAINTED
	089292-01-000	EA	LIGHT-TURN, DRIVER OR PASSENGER - W/AMBER LENS
	037935-01-000	EA	BULB - 12V, #1157 OR #2057 - 2.1 AMP - CLEAR GLASS

ELECTRICAL GROUP (CONTINUED)

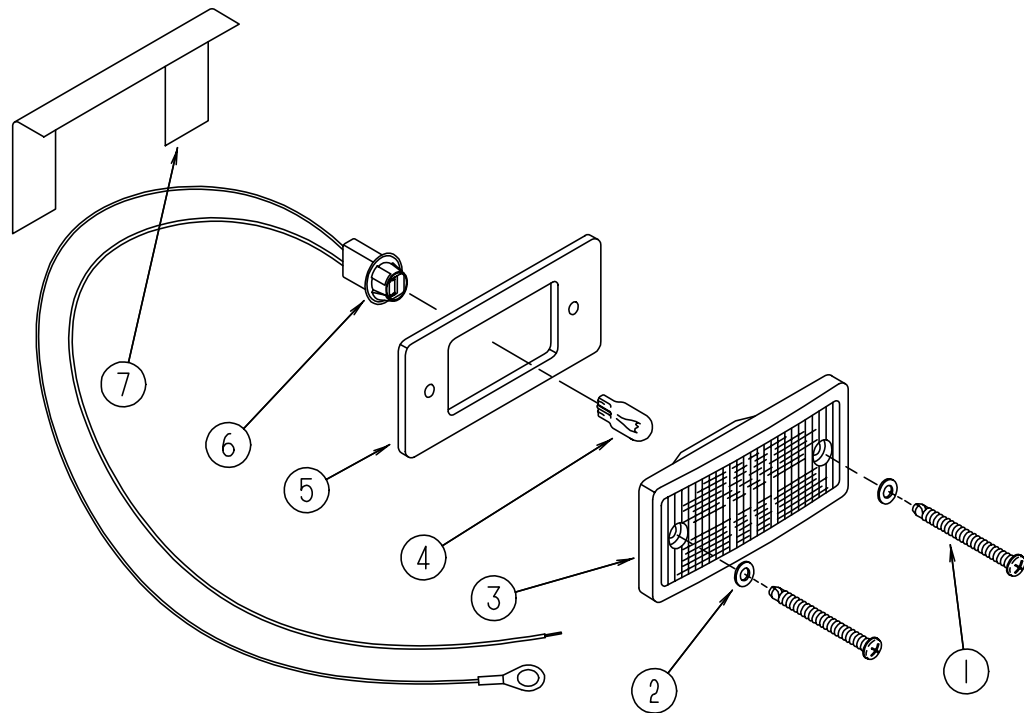

EXTERIOR CLEARANCE LIGHTS

KEY	PART NUMBER	U/M DESCRIPTION
1	000G39-08-24B	EA SCREW, SELF DRIVING
2	102540-01-000	EA SEAL-SCREW, ROUND - RUBBER
3	102520-01-000	EA LIGHT-CLEARANCE, W/O SOCKET CONNECTIONS - AMBER
4	036196-01-000	EA BULB - #1194 - CLEARANCE LIGHT
5	102541-01-000	EA GASKET-CLEARANCE LIGHT
6	067789-02-000	EA SOCKET ASM.-CAB MARKER
7	102582-01-000	EA BRACKET-LIGHT, CLEARANCE - L-SHAPED METAL - 2.2" X 4.7"

ELECTRICAL GROUP (CONTINUED) INTERIOR LIGHTS

KEY	PART NUMBER	U/M DESCRIPTION
	065202-29-000	EA LAMP-WALL,BRASS (CANADIAN)
	098024-01-01A	EA LIGHT-DOME, 1 BULB - US - IVORY
	008218-01-000	EA BULB-DOME LIGHT, 12V - NUMBER 1141
	098024-01-700	EA LENS-DOME LIGHT
	061424-01-000	EA LIGHT-AISLE, 12V - RECTANGULAR
	008103-01-000	EA BULB-DASH/AISLE LIGHT, #53 - 12 V - .12 AMP
	065201-09-000	EA SHADE-LAMP, FABRIC - PARCHMENT
	065202-28-000	EA LAMP-WALL,BRASS (US)
	067479-01-000	EA BULB - 12V, NUMBER 1076
	086280-01-000	EA LIGHT-SURFACE MOUNT, 12V - JENSEN 1236
	086280-01-700	EA BULB - 12 VOLT, 6 WATT
	098024-01-01A	EA LIGHT-DOME, 1 BULB - US - IVORY
	008218-01-000	EA BULB-DOME LIGHT, 12V - NUMBER 1141
	098024-01-700	EA LENS-DOME LIGHT
	098024-03-01A	EA LIGHT-DOME, 2 BULB - IVORY
	008218-01-000	EA BULB-DOME LIGHT, 12V - NUMBER 1141
	098024-01-700	EA LENS-DOME LIGHT
	110235-01-01A	EA LIGHT-MAKE UP,3 BULB PANLESS
	081633-01-700	EA BULB-MAKE UP LIGHT, JENSEN

FUSES & CIRCUIT BREAKERS

KEY	PART NUMBER	U/M DESCRIPTION
	008234-01-000	EA FUSE - 12V, 10 AMP
	062037-01-000	EA HOUSING-AUTO FUSE, NATURAL
	062037-02-000	EA HOUSING-AUTO FUSE, GREEN
	062037-03-000	EA HOUSING-AUTO FUSE, BLACK
	062037-04-000	EA HOUSING-AUTO FUSE, BLUE
	062037-05-000	EA HOUSING-AUTO FUSE, GRAY
	062037-06-000	EA HOUSING-AUTO FUSE, BROWN
	062901-02-000	EA FUSE - 5 AMPS, AUTOMOTIVE
	062901-05-000	EA FUSE - 15 AMPS, AUTOMOTIVE
	062901-07-000	EA FUSE-AUTOMOTIVE, 25 AMPS
	062901-08-000	EA FUSE - 30 AMPS,AUTOMOTIVE
	083209-01-000	EA CIRCUIT BREAKER - 15 AMP, 120V - BW G-15 - CANADIAN
	083209-02-000	EA CIRCUIT BREAKER - 15/15AMP, 120V - BW H-15/15
	083209-03-000	EA CIRCUIT BREAKER - 15/20AMP, 120V - BW 0-15/20
	083209-04-000	EA CIRCUIT BREAKER - 30A, 120V - BW L-30
	083209-05-000	EA CIRCUIT BREAKER - 20A, 120V - BW J-20
	083209-06-000	EA CIRCUIT BREAKER - 30/15 AMP, 120V - BW D-30/15
	093655-03-000	EA CIRCUIT BREAKER - 40A, 12V - USD 17440-4E03A2A
	097611-01-000	EA CIRCUIT BREAKER - 10A, 12V - VB3-A10-F57
	106655-02-000	EA TERMINAL-FUSE BLOCK,10-12AWG PACKARD 12020400
	106656-01-000	EA FUSE BLOCK - 4 CAVITY AUTOFUSE PACKARD 12004943
	108669-01-000	EA HOUSING-AUTO FUSE HOLDER, PACKARD 12010105

CONVERTER & INVERTER

KEY	PART NUMBER	U/M DESCRIPTION
	083208-02-000	EA CONVERTER-POWER, 45A - 120V/12V - BW 6345
	099048-01-000	EA INVERTER-100 WATT

ELECTRICAL GROUP (CONTINUED)
RECEPTACLES

KEY	PART NUMBER	U/M DESCRIPTION
	024924-02-000	EA RECEPTACLE-POWER CORD, W/PARTIAL PLATE
	058707-01-000	EA RECEPTACLE-ELECTRIC, SINGLE - BROWN
	058707-02-000	EA RECEPTACLE-BLANK, JUNCTION - WIRECON WDJ20BR
	058708-01-000	EA RECEPTACLE-ELECTRIC, DOUBLE - BROWN
	058708-02-000	EA RECEPTACLE-ELECTRIC, DOUBLE - IVORY
	084076-02-000	EA RECEPTACLE-GFI, 15A - 125V - BROWN
	091927-01-000	EA COVER-RECEPTACLE, DOUBLE - IVORY
	102568-01-E90	EA SPACER-RECEPTACLE, SIDEWALL
	112822-01-01A	EA RECEPTACLE-DUPLEX, IVORY - WIRECON WDRU15IV
	112824-01-02A	EA COVER-EXTERIOR DUPLEX RECEPTACLE, O/W - P&S 3780-SC-CW
	007940-01-000	EA RECEPTACLE-SLIDE, 16 TO 12 AWG - FEMALE END
	080015-02-000	EA RECEPTACLE-FLAG, .185 - 16/14 GA - AMP 3
	007954-01-000	EA RECEPTACLE-HSG- 6 POSITION

SWITCHES

KEY	PART NUMBER	U/M DESCRIPTION
	054250-01-000	EA COVER-ANGLED, W/O HOLE - 3.6" X 4.5" - PLASTIC - BEIGE ELECTRICAL PLATE SUPPORT W/O HOLES
	054250-04-000	EA COVER-ANGLED, W/O HOLE - 3.6" X 4.5" - PLASTIC - OFF WHITE ELECTRICAL PLATE SUPPORT
	073626-04-000	EA COVER-ELECTRIC, 10.4" X 7.8" - BEIGE PLASTIC
	075723-01-000	EA SPACER-SWITCH, W/O HOLE - .2" X.9"X 2" - METAL - OFF WHITE
	075723-02-000	EA SPACER-SWITCH, W/HOLE - .2" X .9" X 2" - METAL - OFF WHITE FOR ELECTRIC STEP DOOR JAMB SWITCH
	079364-01-000	EA SWITCH-ON/OFF ROCKER, 2 PRONGS - BROWN
	079364-03-000	EA SWITCH-ON/OFF ROCKER, 3 PRONGS - BROWN
	095188-01-01A	EA SPACER-SWITCH, 2.3" X 3.4" - PLASTIC - DARK BROWN
	095188-02-01A	EA SPACER-SWITCH, 2.3" X 4.1" - PLASTIC - DARK BROWN
	098351-01-01A	EA PLATE-SWITCH, 1 GANG - POLISHED BRASS - JENSEN
	098351-02-01A	EA PLATE-SWITCH, 2 GANG - POLISHED BRASS - JENSEN
	098351-05-01A	EA PLATE-SWITCH, 3 GANG - POLISH BRASS - JENSEN
	098351-06-01A	EA PLATE-SWITCH, 2 GANG W/LABEL - JENSEN - POLISHED BRASS
	108355-01-000	EA HOUSING-SWITCH CARLING VCH
	108356-01-01A	EA COVER-SWITCH W/GROOVES, CARLING VVCZC00 BLA
	108356-02-01A	EA COVER-SWITCH W/DIMPLES, CARLING VVAZC00 BLA
	108356-04-01A	EA COVER-SWITCH W/DIMPLES & LENS, CARLING VVAGC00
	108357-03-000	EA SWITCH-ROCKER, SPDT ON/OFF/ON - CARLING V6D1000B-0
	108357-05-000	EA SWITCH-ROCKER, SPDT ON/NONE/ON - CARLING V4D1000B-0
	108357-06-000	EA SWITCH-ROCKER, DPDT MOM/OFF/MOM - CARLING VLD1000B-0
	108357-08-000	EA SWITCH-ROCKER, DPDT ON/NONE/ON - CARLING VDD1S00C-0
	108357-09-000	EA SWITCH-ROCKER, SPDT ON/NONE/MOM - CARLING V5D1000B-0
	108357-10-000	EA SWITCH-ROCKER, SPDT MOM/OFF/MOM - CARLING V8D1160B-0 LIGHTED

ELECTRIC BOXES & CORDS

KEY	PART NUMBER	U/M DESCRIPTION
	008052-01-000	EA CORD-POWER, 10/3 - 30 AMP - 25' - CANADIAN
	008054-01-000	EA CORD-POWER, 10/3 - 30 AMP - 25'
	008289-01-000	EA BOX-ELECTRIC, STEEL - 1/2" AND 3/4" KNOCKOUTS - 4" X 4"
	008289-02-000	EA BOX-ELECTRICAL, 4" X 4" - 1/2" & 3/4" KNOCKOUTS - CANADIAN
	008294-01-000	EA COVER-ELECTRICAL BOX, BLANK/STEEL - 4" X 4" - GRAY
	008294-02-000	EA COVER-ELECTRICAL BOX, BLANK STEEL - 4" X 4" - CANADIAN
	069238-01-000	EA COVER-ELECTRICAL BOX, W/HOLE - 4" X 4" - GRAY USED WITH 30 AMP RECEPTACLE
	074890-01-000	EA BOX-EXTENSION, STEEL - OPEN SIDES - 4" X 4" X 1 1/2"
	074897-01-000	EA COVER-ELECTRIC BOX, 1 LARGE & 2 SMALL HOLES - 4" X 4"
	091910-01-000	EA BOX-ELECTRIC, 3.75" X 3.5" X 1.75" - PLASTIC
	091910-02-000	EA BOX-ELECTRICAL, PLASTIC - 57 X 88MM
	111510-01-000	EA DOOR-ELECTRICAL BOX, FRONT

ELECTRICAL GROUP (CONTINUED)
WIRE ASSEMBLIES

KEY	PART NUMBER	U/M DESCRIPTION
	073328-B4-000	EA CABLE ASSEMBLY-BATTERY, W/TERMINALS
	096449-01-000	EA WIRE ASSEMBLY-WATER TANK TO MONITOR PANEL
	097618-01-000	EA WIRE ASM-MONITOR PANEL, W/3 WIRES & ORANGE RESISTOR- LVS ORANGE RESISTOR W/3 (ORANGE-GREEN-BLUE) WIRES
	102636-01-000	EA WIRE ASM-CLEARANCE LAMPS
	103328-06-000	EA WIRE ASM-PUMP,EXT SHOWER
	111448-01-000	EA WIRE ASM-IP,MAIN(GM)
	111915-01-000	EA WIRE ASM-DAY RUN LAMPS,FUSE,GM
	111915-03-000	EA WIRE ASM-DAY RUN LAMPS,FUSE,FORD
	P03783-01-000	EA WIRE ASM-HEADLAMP(GM)
	P03783-02-000	EA WIRE ASM-HEADLAMP(FORD)

CONDUIT

KEY	PART NUMBER	U/M DESCRIPTION
	041953-01-000	FT CONDUIT-CONVOLUTE SLIT, .5"ID
	041953-03-000	FT CONDUIT-CONVOLUTE SLIT, 1" ID (CLOTHES ROD COVER)
	041953-05-000	FT CONDUIT-CONVOLUTE SOLID, .62" ID
	041953-06-000	FT CONDUIT-CONVOLUTE, SLIT .375"ID
	041953-07-000	FT CONDUIT-CONVOLUTE, SLIT - .25" ID
	041953-08-000	FT CONDUIT-CONVOLUTE, SLIT,1.50"ID
	041953-09-000	FT CONDUIT-CONVOLUTE, SLIT .50"ID
	041953-10-000	FT CONDUIT-CONVOLUTE, SLIT - .75" ID
	041953-11-000	FT CONDUIT-CONVOLUTE, SLIT- 1.06" ID
	041953-12-000	FT CONDUIT-CONVOLUTE, NON SLIT 1.1" ID

HOUSINGS

KEY	PART NUMBER	U/M DESCRIPTION
	007949-01-000	EA TAB-HOUSING, 1 POSITION
	088473-02-000	EA HOUSING-PIN, 15 CAVITY - AMP 1-480710-0
	088473-03-000	EA HOUSING-PIN, 9 CAVITY - AMP 1-480706-0
	088473-05-000	EA HOUSING-PIN, 6 CAVITY - AMP 640585-1
	088473-06-000	EA HOUSING-PIN, 6 CAVITY - AMP 1-480704-0
	088473-08-000	EA HOUSING-PIN, 4 CAVITY - AMP 1-480702-0
	088473-09-000	EA HOUSING-PIN, 3 CAVITY - AMP 1-480700-0
	088473-10-000	EA HOUSING-PIN, 2 CAVITY - AMP 1-480698-0
	088474-01-000	EA HOUSING-SOCKET, 12 CAVITY - AMP 1-480709-0
	088474-02-000	EA HOUSING-SOCKET, 12 CAVITY - AMP 1-480711-0
	088474-03-000	EA HOUSING-SOCKET, 9 CAVITY - AMP 1-480707-0
	088474-06-000	EA HOUSING-SOCKET, 6 CAVITY - AMP 1-480705-0
	088474-07-000	EA HOUSING-SOCKET, 5 CAVITY - AMP 1-480764-0
	088474-08-000	EA HOUSING-SOCKET, 4 CAVITY - AMP 1-480703-0
	088474-09-000	EA HOUSING-SOCKET, 3 CAVITY - AMP 1-480701-0
	088474-10-000	EA HOUSING-SOCKET, 2 CAVITY - AMP 1-480699-0
	100690-01-000	EA HOUSING-5 PIN, WEATHER PACK
	101571-01-000	EA HOUSING-2 POSITION, MALE
	104100-01-000	EA HOUSING-1 POSITION, 75 AMP AMP 53884-1
	106006-01-000	EA HOUSING-1 POSITION, FEMALE - PACKARD 12015952

ELECTRICAL GROUP (CONTINUED)
TERMINALS

KEY	PART NUMBER	U/M DESCRIPTION
	008326-01-000	EA TERMINAL-RING, 16/14 WIRE - 3/8" STUD
	008328-01-000	EA TERMINAL-RING, 12/10 WIRE - #10 STUD FIT
	008331-01-000	EA TERMINAL-RING, TONGUE - #4 WIRE - 3/8" STUD - COPPER
	008348-01-000	EA TERMINAL-RING, 3/8" STUD - #2 WIRE
	035416-04-000	EA TERMINAL-RING #10 STUD FIT, INSULATED BARREL #16/14
	047443-01-000	EA TERMINAL - .250 RECEPTACLE FIT, INSULATED - 16/14 AWG
	062036-01-000	EA TERMINAL-PACK-CON, 12/10 AWG PACKARD 12033817
	062036-02-000	EA TERMINAL-PACK-CON, 16/14 AWG
	104100-02-000	EA TERMINAL - 75 AMP AMP 53880-2 STRIP
	104100-03-000	EA TERMINAL - 75 AMP AMP 53880-4 LOOSE
	106655-01-000	EA TERMINAL-FUSE BLOCK, 14-16AWG PACKARD 12020321
	113306-01-000	EA TERMINAL-FEMALE, METRI-PACK PACKARD12048451
	113307-01-000	EA TERMINAL-FEMALE, METRI-PACK PACKARD12048074
	077479-01-000	EA BOOT-BATTERY TERMINAL, DOUBLE CABLE
	077479-02-000	EA BOOT-BATTERY TERMINAL, SINGLE CABLE

CONNECTORS

KEY	PART NUMBER	U/M DESCRIPTION
	008311-01-000	EA CONNECTOR-WIRE NUT, INSULATED - RED
	008312-01-000	EA CONNECTOR-WIRE NUT, INSULATED - BLUE
	008314-01-000	EA CONNECTOR-WIRE NUT, INSULATED - GRAY
	008355-01-000	EA CONNECTOR-CABLE CLAMPING, 3/4"
	008356-01-000	EA CONNECTOR-PLASTIC, 3/8" AVG
	008398-01-000	EA CONNECTOR - 1/2" X 90 DEGREE, FLEX CONDUIT - UL AND CSA
	041480-01-000	EA CONNECTOR-STRAIGHT, 1/2" FLEX CONDUIT
	058028-01-000	EA CONNECTOR-ELECTRICAL PIGTAIL, NYLON - CLEAR
	082740-01-000	EA CONNECTOR-PLASTIC BODY, FOR 2 MALE SPADES
	082741-01-000	EA CONNECTOR BODY - 2 CONNECTOR MALE SERV ELEC 2P-FYL
	087225-01-000	FT SLEEVING - 1/2", TYPE H VARFLEX
	088475-01-000	EA PIN-CONNECTOR, 14 TO 20 AWG
	088475-02-000	EA PIN-CONNECTOR, 10 TO 12 AWG
	088476-01-000	EA SOCKET-CONNECTOR, BRASS - PRE-TIN
	088476-02-000	EA SOCKET-CONNECTOR, 12-10 GA - PHOS. BRZ - PRE-TIN
	098261-02-000	EA SOCKET-CONNECTOR, WEATHERPACK PACKARD 12010182
	098262-01-000	EA SEAL-CONNECTOR, WEATHER PACK PACKARD 12010293
	098265-02-000	EA PIN-CONNECTOR, WEATHER PACK PACKARD12089305

ELECTRICAL MISCELLANEOUS

KEY	PART NUMBER	U/M DESCRIPTION
	007093-01-000	EA FLASHER-SIGNAL, STAT
	008188-01-000	EA SOLENOID - 3 POST, BATTERY CHANGE OVER
	063910-01-000	EA HOUSING-RELAY, BOSCH 3 334 485 008
	067789-02-000	EA SOCKET-LAMP
	086233-01-000	EA STUD-ISOLATED, 3/8" X 7/8" LONG
	086273-01-000	EA RELAY-BATTERY DISCONNECT
	103608-01-000	EA SOCKET-WEDGE BASE W/LEADS JKL 2944-6
	103987-02-000	EA SEAL-SOLENOID ACCESS

EXTERIOR BODY GROUP

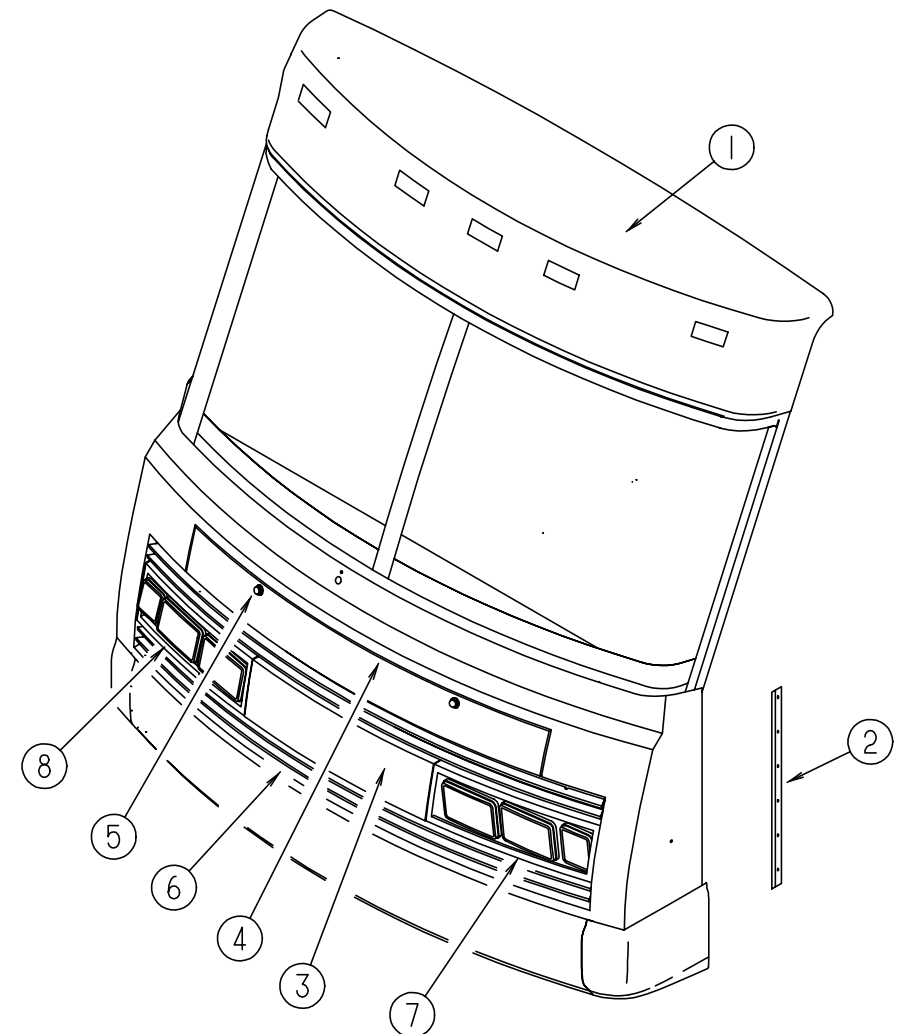

FRONT END COMPONENTS

KEY	PART NUMBER	U/M DESCRIPTION
1	M05145-05-F24	EA CAP ASM-FRONT, BRIGHT WHITE
2	089922-27-000	EA TRIM-FRONT END/SIDEWALL, DRIVER OR PASSENGER SIDE - BRIGHT WHITE
3	103485-01-04A	EA FRONT END ASM-W/GRILLE ASM, W/O HOOD OR HOOD HINGES - BRIGHT WHITE
4	103478-02-F24	EA PANEL ASM-HOOD - BRIGHT WHITE
	058786-01-000	EA BOLT-ADJUSTING, HOOD - W/BLACK PAD - .31" #18 X 2"
5	102330-02-000	EA LOCK-SINGLE HOLE, VISE ACTION - SOUTHCOE 3-56-715-5
	102328-01-000	EA KEY-BARREL, NICKEL PLATED - SOUTHCOE 3-26-715-19
	104584-03-000	EA BRACKET ASM-HOOD HINGE, BODY - RIGHT
	104584-04-000	EA BRACKET ASM-HOOD HINGE, BODY - LEFT
	105095-01-000	EA LINK ASM-HINGE, HOOD - INNER RIGHT
	105095-02-000	EA LINK ASM-HINGE, HOOD - INNER LEFT
	104582-02-000	EA LINK ASM-HINGE, HOOD - OUTER
6	110598-01-E07	EA GRILLE ASSEMBLY - 4 BAR
7	103617-02-04A	EA BEZEL-HEADLIGHT, DRIVER SIDE - BRIGHT WHITE
8	103617-01-04A	EA BEZEL-HEADLIGHT, PASSENGER SIDE - BRIGHT WHITE
	110690-01-D18	EA PLATE ASM-HEADLAMP, QUAD - PASSENGER - BLACK - STEEL
	110692-01-01A	EA PLATE-HEADLAMP, QUAD - PASSENGER - UNPAINTED - STEEL
	110690-02-D18	EA PLATE ASM-HEADLAMP, QUAD - DRIVER - BLACK - STEEL
	110692-02-01A	EA PLATE-HEADLAMP, QUAD - DRIVER - UNPAINTED - STEEL
	110691-01-01A	EA BRACKET-SPRING, HEADLAMP - DRIVER OR PASSENGER SIDE - UNPAINTED

EXTERIOR BODY GROUP (CONTINUED)
EXTERIOR BODY PANELS AND TRIM

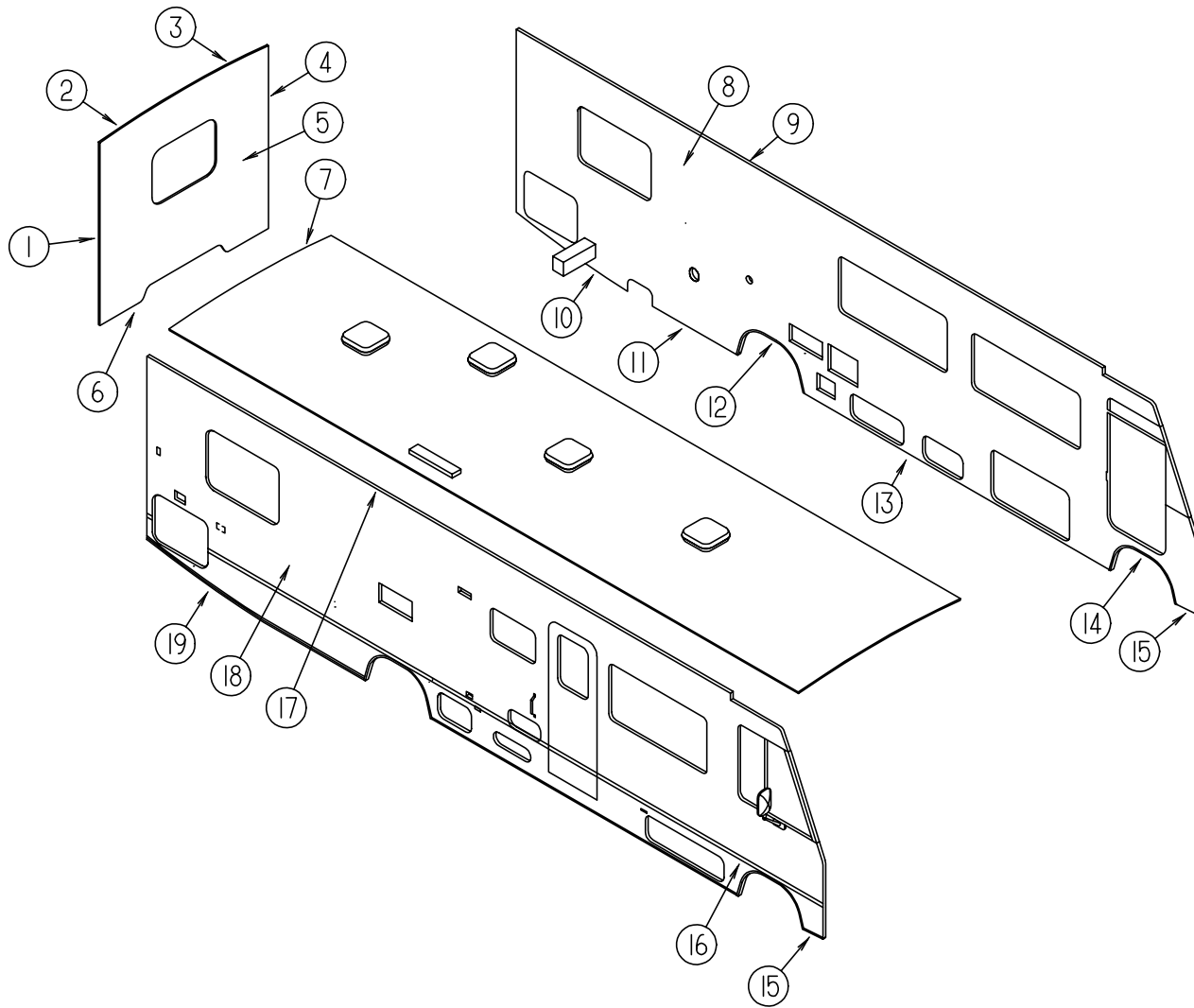

KEY	PART NUMBER	U/M DESCRIPTION
1	103598-01-700	EA TRIM-BACKWALL, SIDE, RIGHT - PRIMED
1	104033-01-05A	EA TRIM-J, BACKWALL, RIGHT - BRIGHT WHITE
2	103599-01-05A	EA TRIM-BACKWALL, TOP, RIGHT - BRIGHT WHITE
3	103600-01-05A	EA TRIM-BACKWALL, TOP, LEFT - BRIGHT WHITE
4	103598-02-700	EA TRIM-BACKWALL, SIDE, LEFT - PRIMED
4	103598-02-05A	EA TRIM-BACKWALL, SIDE, LEFT - BRIGHT WHITE
4	104033-02-05A	EA TRIM-J, BACKWALL, LEFT - BRIGHT WHITE
5	M07419-01-F24	EA BACKWALL ASM W/QUEEN BED GM
5	M07419-01-F25	EA BACKWALL ASM W/QUEEN BED GM
5	M07419-01-F26	EA BACKWALL ASM W/QUEEN BED GM
5	M07419-01-F27	EA BACKWALL ASM W/QUEEN BED GM
5	M07419-02-F24	EA BACKWALL ASM W/TWIN BED GM
5	M07419-02-F25	EA BACKWALL ASM W/TWIN BED GM
5	M07419-02-F26	EA BACKWALL ASM W/TWIN BED GM
5	M07419-02-F27	EA BACKWALL ASM W/TWIN BED GM
5	M07419-03-F24	EA BACKWALL ASM W/QUEEN BED FORD
5	M07419-03-F25	EA BACKWALL ASM W/QUEEN BED FORD
5	M07419-03-F26	EA BACKWALL ASM W/QUEEN BED FORD
5	M07419-03-F27	EA BACKWALL ASM W/QUEEN BED FORD
5	M07419-04-F24	EA BACKWALL ASM W/TWIN BED FORD
5	M07419-04-F25	EA BACKWALL ASM W/TWIN BED FORD
5	M07419-04-F26	EA BACKWALL ASM W/TWIN BED FORD
5	M07419-04-F27	EA BACKWALL ASM W/TWIN BED FORD

KEY	PART NUMBER	U/M DESCRIPTION
6	050406-21-000	EA TRIM-BACKWALL, LOWER - BRIGHT WHITE
7	M05702-09-F24	EA ROOF ASM QUEEN BED
7	M05702-10-F24	EA ROOF ASM TWIN BED
8	M05735-07-F24	EA SIDEWALL ASM-LH QUEEN BED
8	M05735-07-F25	EA SIDEWALL ASM-LH QUEEN BED
8	M05735-07-F26	EA SIDEWALL ASM-LH QUEEN BED
8	M05735-07-F27	EA SIDEWALL ASM-LH QUEEN BED
8	M05735-08-F24	EA SIDEWALL ASM-LH TWIN BED
8	M05735-08-F25	EA SIDEWALL ASM-LH TWIN BED
8	M05735-08-F26	EA SIDEWALL ASM-LH TWIN BED
8	M05735-08-F27	EA SIDEWALL ASM-LH TWIN BED
9	103801-02-05A	EA TRIM-ROOF, W/O DRILLED HOLES - BRIGHT WHITE
10	111108-02-03A	EA TRIM-SIDEWALL, LOWER BRIGHT WHITE
11	108038-11-03A	EA TRIM-SIDEWALL, BOTTOM, REAR BRIGHT WHITE
12	108070-01-04A	EA TRIM-WHEELWELL, REAR - BRIGHT WHITE - DRIVER OR PASSENGER
13	108039-04-04A	EA TRIM-SIDEWALL, BOTTOM, CENTER - BRIGHT WHITE
14	108069-02-03A	EA TRIM-WHEELWELL, FRONT - BRIGHT WHITE - DRIVER OR PASSENGER
15	108109-01-04A	EA TRIM-SIDEWALL, LOW, FRONT - DRIVER OR PASSENGER - BRIGHT WHITE
16	108688-01-03A	EA STRIP-FEATURE BRIGHT WHITE
	108651-01-01A	EA CAP-FEATURE STRIP MILL
	001030-02-003	EA INSERT-FEATURE STRIP, 17' LONG - OFF WHITE
17	103802-02-05A	EA RAIL-AWNING, W/O DRILLED HOLES - BRIGHT WHITE
18	M05734-07-F24	EA SIDEWALL ASM-RH QUEEN BED
18	M05734-07-F25	EA SIDEWALL ASM-RH QUEEN BED
18	M05734-07-F26	EA SIDEWALL ASM-RH QUEEN BED
18	M05734-07-F27	EA SIDEWALL ASM-RH QUEEN BED
18	M05734-08-F24	EA SIDEWALL ASM-RH TWIN BED
18	M05734-08-F25	EA SIDEWALL ASM-RH TWIN BED
18	M05734-08-F26	EA SIDEWALL ASM-RH TWIN BED
18	M05734-08-F27	EA SIDEWALL ASM-RH TWIN BED
19	108038-13-03A	EA TRIM-SIDEWALL, BOTTOM, REAR BRIGHT WHITE
	086180-55-015	EA U-CHANNEL-EXTRUDED, 1.7" X 16' - OFF WHITE - SERRATED
		FROM: 00-00-00 THRU: 10-25-94
	116800-55-005	EA U-CHANNEL, OFF WHITE - 4877MM
		FROM: 10-26-94 THRU: 99-99-99
	086754-03-000	EA CAP-JOINT, ROOF TO SIDEWALL TRIM - 2" X 1.25" - OFF WHITE
	002726-01-001	EA GARNISH-U-CHANNEL, 1.38" X 19' - SERRATED - MILL ALUMINUM
	089922-27-000	EA TRIM-FIBERGLASS, PANEL - BRIGHT WHITE
	093673-01-01A	FT TRIM-ENTRANCE DOOR, 1.3" WIDE - OFF WHITE
	103814-01-000	EA BRACKET-TRIM ATTACHMENT

EXTERIOR BODY GROUP (CONTINUED)

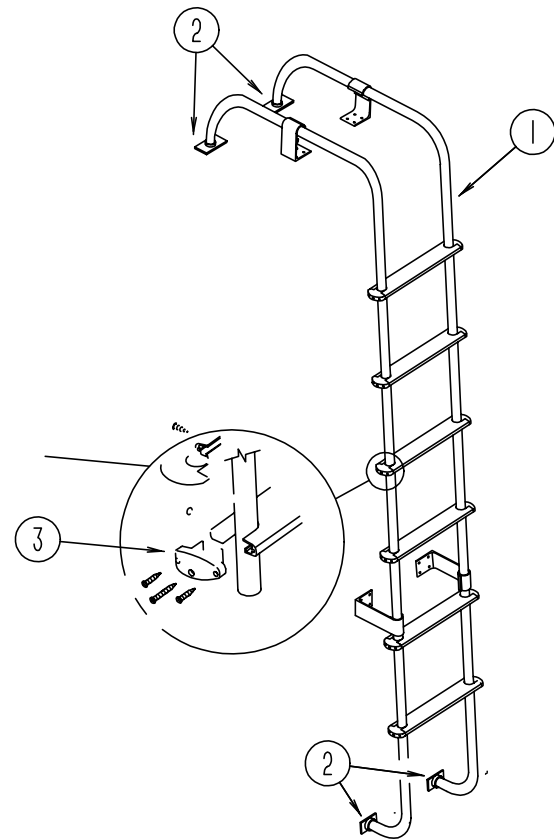

LADDER

KEY	PART NUMBER	U/M DESCRIPTION
1	102953-09-F04	EA LADDER ASM
2	067165-01-000	EA MOUNTING BRACKET-LADDER, LOWER
3	076980-02-000	EA END CAP-STEP, BLACK

EXTERIOR BODY GROUP (CONTINUED)

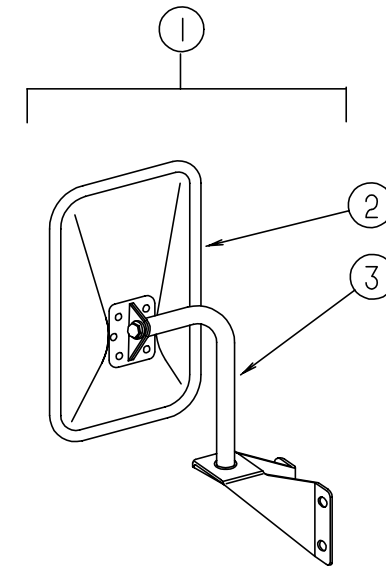

EXTERIOR MIRROR

KEY	PART NUMBER	U/M DESCRIPTION
1	105076-01-702	EA MIRROR ASM-LOW MOUNT RH/LH (FLAT) 713196 1 ONLY W/BRACKET
2	105076-01-703	EA MIRROR HEAD ONLY (FLAT BLK) 709275-8
	049347-01-700	EA GLASS-EXTERIOR MIRROR, 7.5" X 10.5"
3	105076-01-704	EA ARM Q780521-9
	105439-01-000	EA MIRROR-AUX, CONVEX STICK-ON VELVAC 723068-6

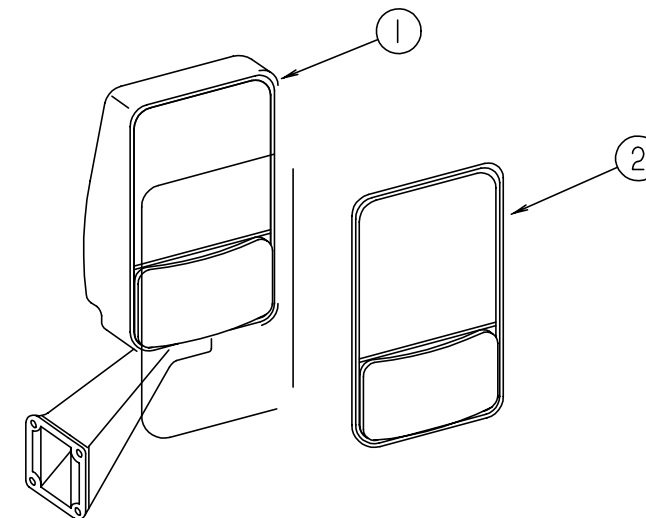

EXTERIOR MIRROR

KEY	PART NUMBER	U/M DESCRIPTION
1	106015-09-01A	EA MIRROR ASM-EXTERIOR GLASS RIGHT - VELVAC 713126 BLACK
1	106015-10-01A	EA MIRROR ASM-EXTERIOR ADJUST GLASS LEFT - VELVAC 713125 BLACK
2	106015-01-703	EA MIRROR KIT (BEZEL W/MIRRORS) PASSENGER SIDE
2	106015-02-702	EA MIRROR KIT (BEZEL W/MIRRORS) DRIVER SIDE

EXTERIOR BODY GROUP (CONTINUED)
DECALS, FILM STRIPES & PAINT

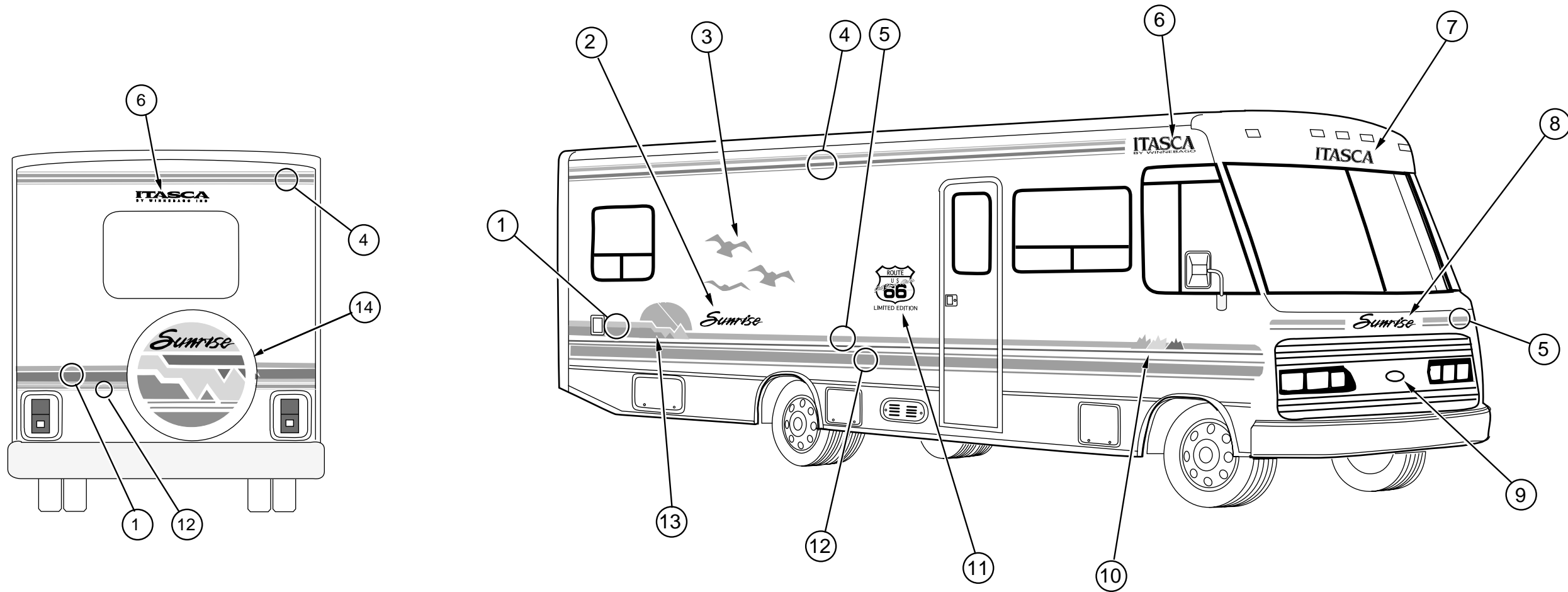

KEY	PART NUMBER	U/M	DESCRIPTION
1	094423-05-02A	EA	FILM-OVERLAY, MULTISTRIPE, AQUA/REGGAE BLUE/REGGAE BLUE
2	110193-01-02A	EA	DECAL-SUNRISE, AQUA/W/REGGAE BLUE SHADOW
3	110192-01-02A	EA	DECAL-BIRDS, REGGAE BLUE/AQUA
4	093689-15-02A	FT	FILM-MULTISTRIPE, 101.6 MM X 150' - AQUA/AQUA/REGGAE BLUE/REGGAE BLUE
5	105781-02-10A	FT	FILM-MULTISTRIPE, 63.5 MM X 150' - AQUA/AQUA
6	111588-03-09A	EA	DECAL-LOGO, ITASCA - LARGE - REGGAE BLUE/BRIGHT WHITE/REGGAE BLUE
6	114698-01-01A	EA	DECAL-LOGO, "BY WINNEBAGO" - REGGAE BLUE
7	111588-04-06A	EA	DECAL-LOGO, ITASCA - SMALL - REGGAE BLUE/BRIGHT WHITE/REGGAE BLUE
8	110193-02-02A	EA	DECAL-SUNRISE, SMALL - AQUA/REGGAE BLUE
9	088772-03-000	EA	MEDALLION-HOOD, I - BLACK/CHROME
10	110190-01-02A	EA	DECAL-MOUNTAINS, RH - REGGAE BLUE/MAGENTA/AQUA
10	110190-02-02A	EA	DECAL-MOUNTAINS, LH - REGGAE BLUE/MAGENTA/AQUA
11	116404-01-01A	EA	DECAL-ROUTE 66, FROSTY JACK/WARM SILVER
12	094443-20-02A	FT	FILM-MULTISTRIPE, 146.1 MM X 150' REGGAE BLUE/REGGAE BLUE/REGGAE BLUE
13	113951-01-01A	EA	DECAL-SUN, RH - MAGENTA/AQUA/REGGAE BLUE
13	113951-02-01A	EA	DECAL-SUN, LH - MAGENTA/AQUA/REGGAE BLUE
14	114653-01-01A	EA	DECAL-COVER, TIRE - SPARE - MAGENTA/AQUA/REGGAE BLUE
	041561-03-000	EA	PAINT-LOW BAKE, OFF WHITE
	044486-03-000	EA	PAINT-LOW BAKE, BEIGE
	106315-06-000	FT	POLYETHYLENE FILM TAPE 4" SHORE PAPER 30LD23
	099399-23-700	EA	PAINT-BRIGHT WHITE, DUPONT B8951U

EXTERIOR BODY GROUP (CONTINUED)

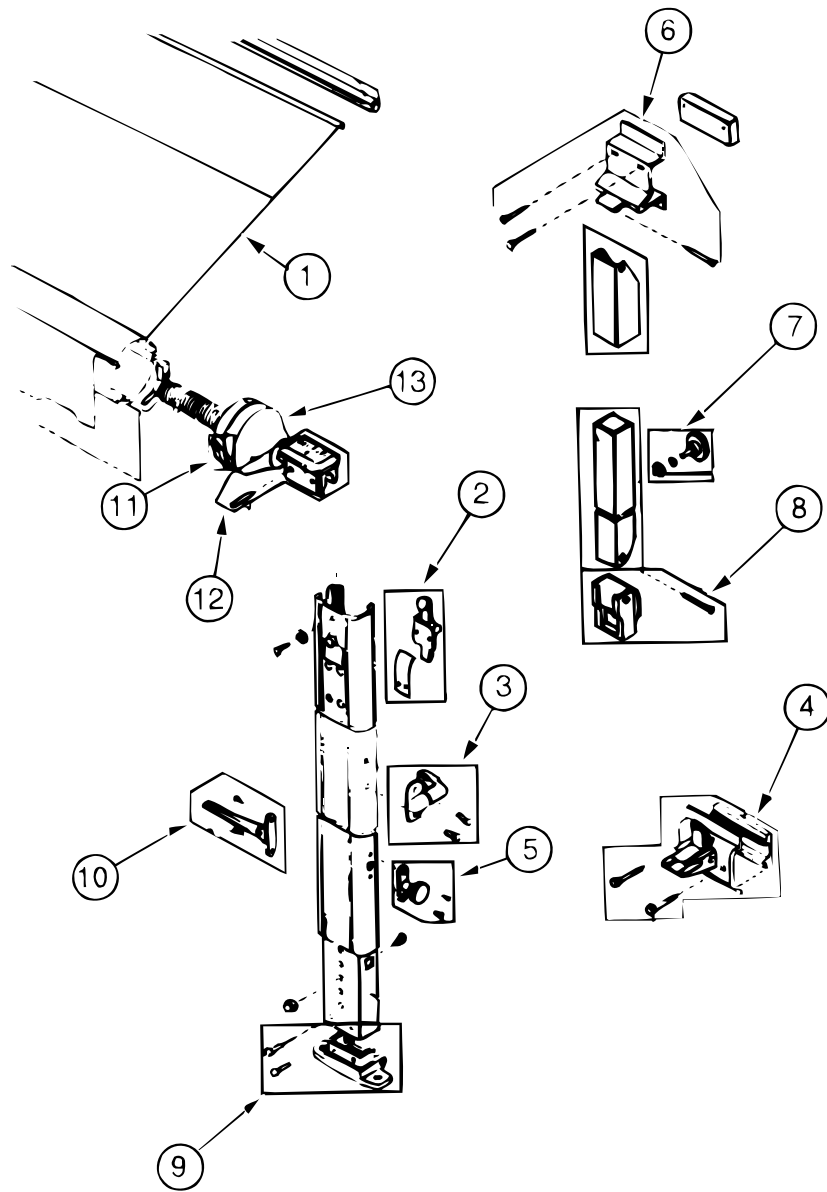

AWNING (FAULKNER)

KEY	PART NUMBER	U/M DESCRIPTION
1	110634-01-10A	EA AWNING-ROLLER ASM, 18'
	110634-02-04A	EA AWNING-HARDWARE KIT, BRIGHT WHITE
	111037-01-01A	EA SPACER-AWNING, UPPER BLACK
	111038-01-01A	EA SPACER-AWNING, LOWER BLACK
2	110634-01-700	EA RAFTER LOCKING MECHICAL KIT - 7605-0001
3	110634-01-701	EA SAFETY & LATCH KIT - 7509-0001
4	110634-01-702	EA BOTTOM BRACKET KIT - 7512-0001
5	110634-01-703	EA HEIGHT LOCK HANDLE KIT - 7510-0001
6	110634-01-704	EA UPPER BRACKET KIT W/BOLTS - 7505-0001
7	110634-01-705	EA ULTRA RAFTER KNOB KIT - 7522-0001
8	110634-01-706	EA RAFTER SLIDE KIT
9	110634-01-707	EA GROUND BRACKET KIT - 7511-0001
10	110634-01-708	EA LIFT HANDLES W/RIVETS - 7000-0001
11	110634-01-709	EA RATCHET HANDLE KIT - 7507-0001
12	110634-01-710	EA ARM CAP KIT - 7503-0001
13	110634-01-711	EA FRONT SPRING ASM - 6598-0001
13	110634-01-712	EA REAR SPRING ASM - 6599-0001
13	110634-01-713	EA REAR END CAP KIT - 7504-0001
	110634-01-714	EA STAKE (4 PER BAG) - 5208-0001
	110634-01-715	EA PULL DOWN WAND - 7604-0001

EXTERIOR BODY GROUP (CONTINUED)
FIBERGLASS, STYROFOAM, ALUMINUM & INSULATION

KEY	PART NUMBER	U/M DESCRIPTION
	002726-01-001	EA GARNISH-U-CHANNEL, 1.38" X 19' - SERRATED - MILL ALUMINUM
	002754-01-001	EA ANGLE-EXTRUDED, .75" X .75" X 18' - MILL ALUMINUM
	044487-01-001	LB AL - .019 X 96.00 X 300'
	044487-01-001	LB AL - .019 X 96.00 X 432'
	044487-51-001	EA AL - .019 X 0758 X 0317 MILL
	055278-51-259	FT TUBING-STEEL, .75" X 1.5" X 12.5' LONG
	065747-01-000	SF INSULATION-MICROFOAM, .5" THICK X 72" X 112' ROLL
	068716-01-001	EA BRACE - 90 DEGREE L-ANGLE, 192" - EXTRUDED ALUMINUM
	076054-M8-001	EA FIBERGLASS SHEET 48 X 96", BRIGHT WHITE
	076054-M8-000	EA FIBERGLASS SHEET 2438 X 2438, BRIGHT WHITE
		FROM: 00-00-00 THRU: 09-30-94
	076054-P4-000	EA FIBERGLASS-SHEET 2438 X 2463, BRIGHT WHITE
		FROM: 10-01-94 THRU: 99-99-99
	076054-N2-000	EA FIBERGLASS SHEET 2438 X 9737, BRIGHT WHITE
	077517-62-000	EA FIBERGLASS-SHEET, 48 X 96 - BRIGHT WHITE,FLAT
	083574-02-000	SF STYROFOAM, DOW TYPE SM - 1.5" X 24" X 90.5" - INCREMENTS OF 15 SF
		FROM: 00-00-00 THRU: 09-30-94
	083574-03-000	SF STYROFOAM - 3/4" X 48" X 96"
	089297-01-000	SF PLYWOOD-LUAN, OVERLAY GRADE - 4' X 8'
	100619-01-000	BF FOAM-EXPANDED POLYSTYRENE, 48" X 96" X 1.34"
	100619-04-000	BF FOAM-EXPANDED POLYSTYRENE, EPS 48" X 96" X .5
	100619-05-000	BF FOAM-EXPANDED POLYSTYRENE, 48" X 96" X .75"
	105077-01-000	EA FOAM-COVE, ROOF
	105077-03-000	EA FOAM-PLUG, SIDEWALL TUBE - WISCONSIN EPS
	108535-01-04A	SF FIBERGLASS PEBBLE 104" X 500' BRIGHT WHITE

ASSIST HANDLE

KEY	PART NUMBER	U/M DESCRIPTION
	009126-02-000	EA HANDLE-ASSIST, ENTRY DOOR - BLACK
	069726-02-000	EA BUMPER - .88" DIA X .40", BLACK

GALLEY GROUP
GALLEY CABINETS

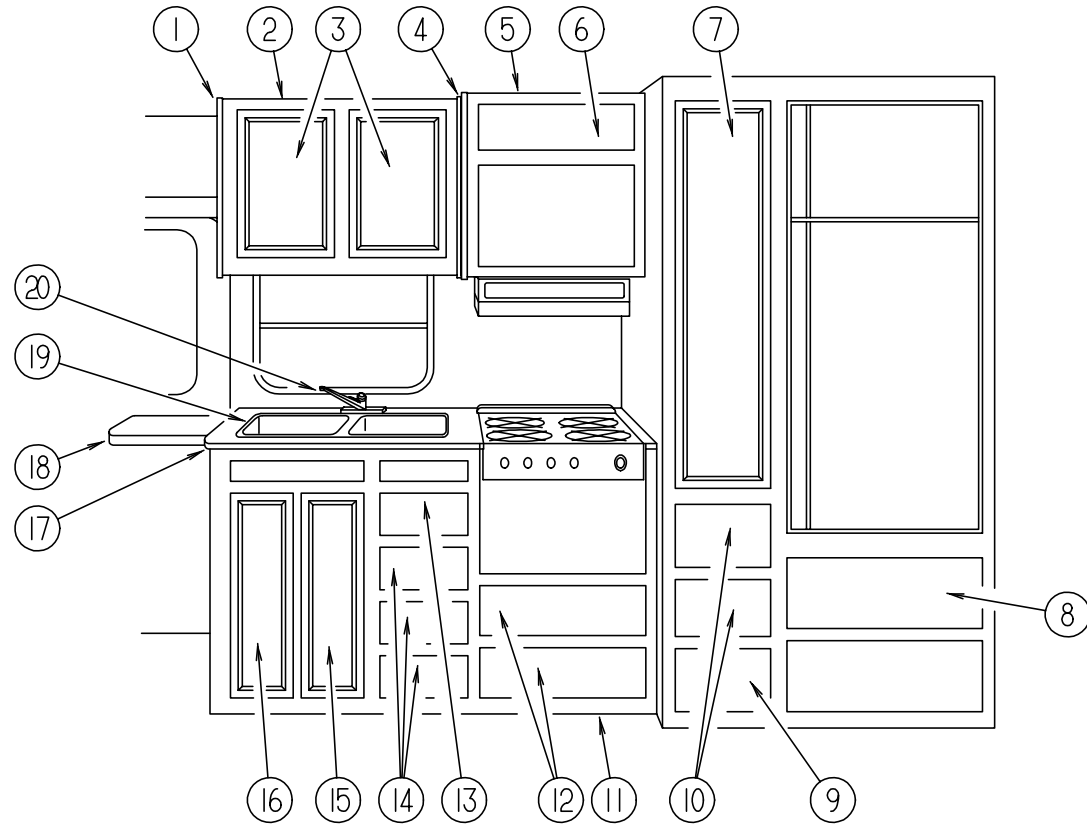

KEY	PART NUMBER	U/M	DESCRIPTION
1	081320-20-B25	EA	CAP-END, CABINET - FRONT
2	103276-02-E07	EA	CABINET ASM-OVERHEAD,GALLEY
3	M06803-05-E07	EA	DOOR-CABINET, W/O HARDWARE - 365 X 555
4	081320-14-E10	EA	CAP-END, CABINET - FRONT
			FROM: 00-00-00 THRU: 08-02-94
4	081320-16-E10	EA	CAP-END, CABINET - FRONT
			FROM: 08-03-94 THRU: 99-99-99
5	114390-05-F04	EA	CABINET ASM-MICROWAVE OVERHEAD
			FROM: 00-00-00 THRU: 08-02-94
5	114390-02-F04	EA	CABINET ASM-MICROWAVE OVERHEAD
			FROM: 08-03-94 THRU: 99-99-99
6	M05992-11-E07	EA	DOOR-CABINET, W/O HARDWARE - 180 X 555
7	M06803-40-E07	EA	DOOR-CABINET, W/O HARDWARE - 305 X 1220
8	M05971-55-E07	EA	DRAWER COMPLETE-SLIDE, OGEE
9	M05971-54-E07	EA	DRAWER COMPLETE-SLIDE, OGEE
10	M05971-39-E07	EA	DRAWER COMPLETE-SLIDE, OGEE
11	M07426-01-F24	EA	CABINET ASM-GALLEY (F24,F27)
11	M07426-01-F25	EA	CABINET ASM-GALLEY
11	M07426-01-F26	EA	CABINET ASM-GALLEY
12	M05971-50-E07	EA	DRAWER COMPLETE-SLIDE, OGEE
13	M05971-82-E07	EA	DRAWER COMPLETE-SLIDE, OGEE
14	M05971-11-E07	EA	DRAWER COMPLETE-SLIDE, OGEE
15	M06803-08-E07	EA	DOOR-CABINET, W/O HARDWARE - 230 X 675
16	M06803-09-E07	EA	DOOR-CABINET, W/O HARDWARE - 230 X 675
17	111243-11-E08	EA	COUNTERTOP ASM (F24,F27)
17	111243-11-F05	EA	COUNTERTOP ASM (F25)
17	111243-11-E90	EA	COUNTERTOP ASM (F26)
18	080812-04-E08	EA	EXTENSION ASM-GALLEY (F24,F27)
18	080812-04-F05	EA	EXTENSION ASM-GALLEY (F25)
18	080812-04-E90	EA	EXTENSION ASM-GALLEY (F26)
19	110654-01-000	EA	SINK-SST, DOUBLE - LARGE/SMALL BASIN
	092303-01-000	EA	STRAINER-SINK
	108464-04-E08	EA	COVER ASM-SINK (F24,F27)
	108464-04-E38	EA	COVER ASM-SINK (F25)
	108464-04-E90	EA	COVER ASM-SINK (F26)
20	104114-02-01A	EA	FAUCET-GALLY, SINGLE CONTROL - 8" CHROME
	103635-01-000	EA	FAUCET-GALLEY, SINGLE CONTROL - DRINKING WATER
	090329-01-000	FT	SEAL-T, REFRIGERATOR CABINET - .6" WIDE TOP X 2" TAIL

GALLEY GROUP (CONTINUED)
RANGE HOOD (CANADIAN)

KEY	PART NUMBER	U/M	DESCRIPTION
	100258-17-01A	EA	HOOD-RANGE, W/O MONITOR PANEL - VENTLINE - CANADIAN FROM: 00-00-00 THRU: 09-25-94
	090973-01-700	EA	MOTOR - LVS CA508-1
	090973-01-702	EA	BLADE-FAN, LVS VA183-1
	092696-01-709	EA	BULB - 912, VENTLINE VA415
	092696-01-710	EA	SOCKET-LIGHT, VENTLINE CB267-2
	096983-01-700	EA	SWITCH-ON/OFF, VENTLINE 108
	096983-01-702	EA	SWITCH-TWO WAY MOMENTARY, VENTLINE 112
	096983-01-707	EA	FILTER-GREASE, 8" X 8" - LVS CC246
	092696-02-701	EA	LENS-LAMP, VENTLINE CC179
	100258-01-700	EA	HOOD-NOSE LABEL, CC428
	100258-10-01A	EA	METER-HOUR, VENTLINE 150
	100258-17-03A	EA	HOOD-RANGE, W/O MONITOR PANEL - VENTLINE - CANADIAN FROM: 09-26-94 THRU: 99-99-99
	090973-01-700	EA	MOTOR - LVS CA508-1
	090973-01-702	EA	BLADE-FAN, LVS VA183-1
	092696-01-709	EA	BULB - 912, VENTLINE VA415
	092696-01-710	EA	SOCKET-LIGHT, VENTLINE CB267-2
	096983-01-700	EA	SWITCH-ON/OFF, VENTLINE 108
	096983-01-702	EA	SWITCH-TWO WAY MOMENTARY, VENTLINE 112
	096983-01-707	EA	FILTER-GREASE, 8" X 8" - LVS CC246
	092696-02-701	EA	LENS-LAMP, VENTLINE CC179
	100258-01-700	EA	HOOD-NOSE LABEL, CC428
	100258-10-01A	EA	METER-HOUR, VENTLINE 150

RANGE HOOD

KEY	PART NUMBER	U/M	DESCRIPTION
	100258-18-01A	EA	HOOD-RANGE 22W W/O MONITOR PANEL - VENTLINE - US TPS5007NAD FROM: 00-00-00 THRU: 07-31-94
	090973-01-700	EA	MOTOR - LVS CA508-1
	090973-01-702	EA	BLADE-FAN, LVS VA183-1
	092696-01-709	EA	BULB - 912, VENTLINE VA415
	092696-01-710	EA	SOCKET-LIGHT, VENTLINE CB267-2
	096983-01-700	EA	SWITCH-ON/OFF, VENTLINE 108
	096983-01-702	EA	SWITCH-TWO WAY MOMENTARY, VENTLINE 112
	096983-01-707	EA	FILTER-GREASE, 8" X 8" - LVS CC246
	092696-02-701	EA	LENS-LAMP, VENTLINE CC179
	100258-01-700	EA	HOOD-NOSE LABEL, CC428
	100258-10-01A	EA	METER-HOUR, VENTLINE 150
	100258-18-02A	EA	HOOD-RANGE 22W W/O MONITOR PANEL - VENTLINE - US TPS5009SADLG FROM: 08-01-94 THRU: 99-99-99
	090973-01-700	EA	MOTOR - LVS CA508-1
	090973-01-702	EA	BLADE-FAN, LVS VA183-1
	092696-01-709	EA	BULB - 912, VENTLINE VA415
	092696-01-710	EA	SOCKET-LIGHT, VENTLINE CB267-2
	096983-01-700	EA	SWITCH-ON/OFF, VENTLINE 108
	096983-01-702	EA	SWITCH-TWO WAY MOMENTARY, VENTLINE 112
	096983-01-707	EA	FILTER-GREASE, 8" X 8" - LVS CC246
	092696-02-701	EA	LENS-LAMP, VENTLINE CC179
	100258-01-700	EA	HOOD-NOSE LABEL, CC428
	100258-10-01A	EA	METER-HOUR, VENTLINE 150

GALLEY GROUP (CONTINUED)
RANGE HOOD (CONTINUED)

KEY	PART NUMBER	U/M	DESCRIPTION
	100258-16-01A	EA	HOOD-RANGE, W/O MONITOR PANEL - VENTLINE - US TCS5008NAD FROM: 00-00-00 THRU: 11-06-94
	090973-01-700	EA	MOTOR - LVS CA508-1
	090973-01-702	EA	BLADE-FAN, LVS VA183-1
	092696-01-709	EA	BULB - 912, VENTLINE VA415
	092696-01-710	EA	SOCKET-LIGHT, VENTLINE CB267-2
	096983-01-700	EA	SWITCH-ON/OFF, VENTLINE 108
	096983-01-702	EA	SWITCH-TWO WAY MOMENTARY, VENTLINE 112
	096983-01-707	EA	FILTER-GREASE, 8" X 8" - LVS CC246
	092696-02-701	EA	LENS-LAMP, VENTLINE CC179
	100258-01-700	EA	HOOD-NOSE LABEL, CC428
	100258-10-01A	EA	METER-HOUR, VENTLINE 150
	102765-03-01A	EA	PANEL-MONITOR, W/PLUG - FOR 2 TANKS & WATER HEATER - LVS
	100258-16-03A	EA	HOOD-RANGE, W/O MONITOR PANEL - VENTLINE - US TCS5008NADLG FROM: 11-07-94 THRU: 99-99-99
	090973-01-700	EA	MOTOR - LVS CA508-1
	090973-01-702	EA	BLADE-FAN, LVS VA183-1
	092696-01-709	EA	BULB - 912, VENTLINE VA415
	092696-01-710	EA	SOCKET-LIGHT, VENTLINE CB267-2
	096983-01-700	EA	SWITCH-ON/OFF, VENTLINE 108
	096983-01-702	EA	SWITCH-TWO WAY MOMENTARY, VENTLINE 112
	096983-01-707	EA	FILTER-GREASE, 8" X 8" - LVS CC246
	092696-02-701	EA	LENS-LAMP, VENTLINE CC179
	100258-01-700	EA	HOOD-NOSE LABEL, CC428
	100258-10-01A	EA	METER-HOUR, VENTLINE 150
	102765-03-01A	EA	PANEL-MONITOR, W/PLUG - FOR 2 TANKS & WATER HEATER - LVS

MONITOR PANEL

KEY	PART NUMBER	U/M	DESCRIPTION
	102765-04-01A	EA	PANEL-MONITOR, W/PLUG - FOR 2 TANKS & WATER HEATER - LVS
	075470-01-703	EA	SWITCH-ON/MOMENTARY, JENSEN AND VENTLINE
	096983-01-700	EA	SWITCH-ON/OFF, VENTLINE 108
	102765-04-700	EA	CIRCUIT BOARD, LVS 5076-11

MICROWAVE OVEN

KEY	PART NUMBER	U/M	DESCRIPTION
	091269-05-000	EA	OVEN-MICROWAVE, DM15H-14B FROM: 00-00-00 THRU: 08-02-94
	115303-01-000	EA	OVEN-MICROWAVE, MCD-DM15K-7B FROM: 08-03-94 THRU: 99-99-99
	094745-01-01A	EA	TRIM-MICROWAVE, LOWER - BLACK FROM: 00-00-00 THRU: 08-02-94
	115401-01-01A	EA	TRIM-MICROWAVE, LOWER - BLACK FROM: 08-03-94 THRU: 99-99-99
	094774-03-01A	EA	TRIM-MICROWAVE, EITHER SIDE - 1.5" X 14.8" - METAL - BLACK
	094750-01-000	EA	BRACKET-MICROWAVE, 90 DEGREE - STEEL
	098916-03-01A	EA	BRACE-MICROWAVE CABINET, LEFT - 9.4" X 7.5" - STEEL FROM: 00-00-00 THRU: 07-28-94
	098916-04-01A	EA	BRACE-MICROWAVE CABINET, RIGHT - 9.4" X 7.5" - STEEL FROM: 00-00-00 THRU: 07-28-94
	098916-14-01A	EA	BRACE-MICROWAVE CABINET, LEFT - STEEL FROM: 07-29-94 THRU: 99-99-99
	098916-15-01A	EA	BRACE-MICROWAVE CABINET, RIGHT - STEEL FROM: 07-29-94 THRU: 99-99-99

GALLEY GROUP (CONTINUED)
REFRIGERATOR

KEY	PART NUMBER	U/M DESCRIPTION
	104138-04-01A	EA REFRIGERATOR SMALL DOUBLE DOOR 2-WAY - NORCOLD 6162 RH BL
	075217-01-734	EA FUSE - 3 AMP, NORCOLD# 61538822
	075217-01-738	EA SWITCH-HUMIDITY, NORCOLD 61525922
	084879-03-700	EA COOLING UNIT - HORIZONTAL BURNER, NORCOLD# 61687237
	084880-01-705	EA ORIFICE - NORCOLD# 614522
	084880-01-715	EA VALVE-SHUT OFF, MANUAL - NORCOLD# 61697922
	084880-01-718	EA VALVE-GAS, NORCOLD 61551822
	084880-01-720	EA SPRING (FOR DOOR HANDLE) NORCOLD 61558822
	084880-01-722	EA CRISPER COVER - NORCOLD 615641
	084880-01-726	EA HINGE BRACKET (CTR HINGE), NORCOLD 61566523
	084880-01-731	EA HINGE PIN, NORCOLD 61578123
	084880-01-732	EA LATCH, NORCOLD 61578522
	084880-01-734	EA BRACKET-HINGE, TOP RH - BOTTOM LH - BROWN NORCOLD 61580837
	084880-01-735	EA HINGE BRACKET ,TOP LH-BOTTOM RH BRN - NORCOLD 61580937
	084880-01-739	EA END CAP (SPRING CATCH) BRN NORCOLD 61593722
	084880-01-740	EA END CAP (STOP CATCH) NORCOLD 61593830
	084880-01-746	EA CABLE, NORCOLD 61571522
	084880-01-747	EA PLUG-HOLE, NORCOLD 61582022
	084880-01-749	EA HINGE BUSHING - NORCOLD 615807
	084880-01-753	EA THERMISTER 78" - NORCOLD 61693822
	084880-01-760	EA CLIP (THERMISTER) NORCOLD 61689122
	084880-01-761	EA END CAP (SPRING CATCH) BLACK NORCOLD 61593730
	084880-02-700	EA LOWER FLANGE 8663 & 8683, NORCOLD 61622123
	084880-03-702	EA HINGE PIN TOP/BOTTOM FEMALE NORCOLD 61580630
	084880-03-705	EA BRACKET F/INTERIOR REFRIGERATOR LIGHT - NORCOLD 61629722
	084880-03-706	EA LAMP (BULB) - NORCOLD 61628922
	084880-03-707	EA COVER F/LAMP OR BULB - NORCOLD 61627922
	088248-01-706	EA BURNER-HORIZONTAL, NORCOLD 61588122
	088248-01-707	EA ELECTRODE-SENSOR, (HORIZONTAL), NORCOLD# 61573322
	088248-01-709	EA HEATER-AC, (HORIZONTAL) - NORCOLD# 615627
	088248-01-710	EA HEATER-DC, (HORIZONTAL) - 3 WAY - NORCOLD# 615628
	094038-01-700	EA GASKET-LOWER, GRAY - NORCOLD 61567930
	094038-01-701	EA LINER-DOOR, LOWER - BROWN/WHITE - NORCOLD 61581937-B
	094038-01-702	EA LINER-DOOR, LOWER - BLACK/WHITE - NORCOLD 61581938-B
	094038-01-703	EA HANDLE-DOOR, LOWER - BROWN - NORCOLD 61650137
	094038-01-704	EA HANDLE-DOOR, LOWER - BLACK - NORCOLD 61650138
	094039-01-702	EA GASKET (GRAY) UPPER - NORCOLD 61567830
	094039-01-703	EA PLATE-HINGE, LH - BROWN - NORCOLD 61631422
	094039-01-704	EA PLATE-HINGE, BLACK - NORCOLD 61631430
	094039-01-706	EA UPPER DOOR LINER (WHITE) BLK - NORCOLD 61581838-B
	094039-01-708	EA HANDLE-DOOR, UPPER - BLACK - NORCOLD 61650038
	094039-01-709	EA PLATE-HINGE, TOP RH - LH BOTTOM - BROWN - NORCOLD 61631322
	094039-01-710	EA PLATE-HINGE, BLACK - NORCOLD 61631330
	094039-01-722	EA HOLE PLUG (BLK) HINGE HOLES - NORCOLD 61582030
	094039-01-723	EA HINGE BRACKET, TOP RH-BOTTOM LH BLK - NORCOLD 61580838
	094039-01-724	EA BRACKET-HINGE, TOP LH - BOTTOM RH - BLK - NORCOLD 61580938
	094039-01-725	EA HINGE PIN (BLACK)(MALE) - NORCOLD 61578130
	094039-01-726	EA SHELF-FREEZER EVAPORATOR, NORCOLD 615236
	094039-01-730	EA HINGE PIN SHAFT(BLK) CENTER HINGE - NORCOLD 61566730
	094039-01-732	EA FRONT COVER(BLK) BOTTOM TRIM - NORCOLD 61622130
	094039-01-733	EA WIRE SHELF (MIDDLE) - NORCOLD 61563822
	094039-01-734	EA WIRE SHELF (TOP) W/RISER - NORCOLD 61563722
	094039-01-735	EA INSIDE DRIP TRAY (WHITE) NORCOLD 61572830
	094039-01-736	EA SWITCH-LIGHT, BLACK - NORCOLD 615810
	094039-01-739	EA SHELF (CUTOUT) NORCOLD 61646722
	094039-04-700	EA PRINTED CIRCUIT BOARD-2 WAY, NORCOLD# 61647322
	094039-04-701	EA EYEBROW (SHELL) 2 WAY - NORCOLD 61669822
	094039-04-702	EA POWER SUPPLY (2 WAY) - NORCOLD 61647422
	104137-02-700	EA MODULE-CONTROL, CHANNEL - NORCOLD 61717037

GALLEY GROUP (CONTINUED)
REFRIGERATOR (CONTINUED)

KEY	PART NUMBER	U/M DESCRIPTION
	104137-06-700	EA EYEBROW SHELL (2-WAY) - NORCOLD 61726622
	104137-06-702	EA RACK-JUICE (WHITE) - NORCOLD 61580525
	104137-06-703	EA BIN-DOOR SHELF (WHITE) - NORCOLD 61564025
	104137-06-706	EA WIRE SHELF (SHORT) - NORCOLD 61718222
	104137-06-707	EA CRISPER (WHITE) - NORCOLD 61571325
	104137-06-709	EA VALVE SHUT-OFF-MANUAL ASM - NORCOLD 61694922
	104137-06-710	EA PRESSURE TAP - NORCOLD 61594422
	104137-06-711	EA FUSE 5 AMP - NORCOLD 61611622
	104137-06-712	EA FITTING-GAS TUBE CONNECTION - NORCOLD 61692722
	104137-06-713	EA ORFICE GASKET - NORCOLD 61475122
	104137-06-714	EA BURNER ASSEMBLY (5-SLOT) - NORCOLD 61705222
	104137-06-715	EA SPARK/SENSE ELECTRODE(SINGLE) - NORCOLD 61692222
	104138-04-701	EA FOAMED CAB ASM (BLK W/WHITE) - NORCOLD 61725038
	054450-01-000	EA LEVEL-REFRIGERATOR

COFFEE MAKER

KEY	PART NUMBER	U/M DESCRIPTION
	103799-01-02A	EA COFFEE MAKER - GRAY - BLACK & DECKER - W/GLASS POT
	104610-01-000	EA STRAP ASM-COFFEE MAKER
	103799-01-700	EA CARAFE GLASS POT
	103799-01-701	EA BRACKETS, WHITE PAIR

RANGE

KEY	PART NUMBER	U/M DESCRIPTION
	112881-01-03A	EA RANGE-16" 3 BURNER ALMOND - MAGIC CHEF
	055282-04-700	EA PANEL OVEN DOOR ALMOND
	102020-01-700	EA SHELF-OVEN
	102020-01-701	EA HANDLE, DOOR
	102020-01-709	EA BUMPER, GRATE
	102020-01-711	EA GRATE, TOP
	102020-01-722	EA VALVE, TOP BURNER
	102020-01-724	EA BUMPER, MAIN TOP
	102022-01-708	EA REGULATOR PRESSURE 1/4 IN 1/2 OUT
	112881-01-700	EA TOP, MAIN-ALMOND
	112881-01-701	EA MANIFOLD PANEL
	112881-01-702	EA VALVE-MERCURY (SAFETY VALVE)
	112881-01-703	EA VALVE-TOP BURNER HI-OUTPUT
	112881-01-704	EA KNOB-THERMOSTAT
	112881-01-705	EA KNOB-TOP BURNER
	112881-01-706	EA THERMOSTAT
	112881-01-707	EA TRIM-FLAT (LEFT) (BLK)
	112881-01-708	EA TRIM-FLAT (RIGHT) (BLK)
	112881-01-709	EA PIPE-MANIFOLD
	112881-01-710	EA OVEN PILOT
	112881-01-711	EA OVEN BURNER
	112881-01-713	EA DOOR-OVEN-TEXTURED

**GENERATOR GROUP
5.0 KW EMERALD PLUS EXPORT**

KEY	PART NUMBER	U/M DESCRIPTION
	100975-03-000	EA GENERATOR - 5.0 KW EMERALD PLUS - ONAN NHE-FN/29236G WITH ONAN TRAY #403-2218
	007131-01-000	EA HANGER-TAILPIPE, 6 SLOTS
	079654-05-000	EA PIPE-EXHAUST, ANGLED - W/FLANGE - 2" ID - ONAN# 154-2539
	082272-01-000	EA MUFFLER-GENERATOR
	094059-01-000	EA SPACER-GENERATOR, ONAN
	105732-02-000	EA TRAY ASM-GENERATOR
	105958-03-000	EA PIPE-EXHAUST,GENERATOR
	007125-03-000	EA CLAMP-MUFFLER - 1.5" DIA.
	007125-04-000	EA CLAMP-MUFFLER - 1.1" DIA.

4,000 WATT ONAN EMERALD PLUS

KEY	PART NUMBER	U/M DESCRIPTION
	100974-01-000	EA GENERATOR - 4,000 WATT EMERALD PLUS, ONAN BGE-FA/26100G
	007067-01-000	SF INSULATION-FIBERGLASS, 1" THICK X 4' - INCREMENTS OF 4 SF
	007125-03-000	EA CLAMP-MUFFLER, 1.5" DIA
	007125-04-000	EA CLAMP-MUFFLER, 1.1" DIA
	079654-05-000	EA PIPE-EXHAUST, ANGLED - W/FLANGE - 2" ID - ONAN# 154-2539
	081364-03-000	EA MUFFLER-GENERATOR, ONAN
	094059-01-000	EA SPACER-GENERATOR, ONAN
	105732-02-000	EA TRAY ASM-GENERATOR
	106602-01-000	EA PIPE-EXHAUST, GENERATOR
	106607-01-000	EA ANGLE-SUPPORT, EXHAUST

4.0 KW EMERALD PLUS EXPORT

KEY	PART NUMBER	U/M DESCRIPTION
	100974-04-000	EA GENERATOR - 4.0KW EMERALD PLUS ONAN BGE-FN/29236G WITH ONAN TRAY #403-2218
	007131-01-000	EA HANGER-TAILPIPE, 6 SLOTS
	079654-05-000	EA PIPE-EXHAUST, ANGLED - W/FLANGE - 2" ID - ONAN# 154-2539
	082272-01-000	EA MUFFLER-GENERATOR
	094059-01-000	EA SPACER-GENERATOR, ONAN
	105732-02-000	EA TRAY ASM-GENERATOR
	105958-03-000	EA PIPE-EXHAUST,GENERATOR
	007067-01-000	SF INSULATION-FIBERGLASS, 1" THICK X 4' - INCREMENTS OF 4 SF
	007125-01-000	EA CLAMP-MUFFLER - 1.62" DIA.
	007125-03-000	EA CLAMP-MUFFLER - 1.5" DIA.
	007125-04-000	EA CLAMP-MUFFLER - 1.1" DIA.
	093511-01-000	EA VAPOR KIT-LP, GENERATOR

**GENERATOR GROUP (CONTINUED)
6.5 KW EMERALD PLUS**

KEY	PART NUMBER	U/M DESCRIPTION
	100975-01-000	EA GENERATOR - 6.5KW EMERALD PLUS, ONAN NHE-FA/26100G WITH ONAN TRAY #403-2218
	007067-01-000	SF INSULATION-FIBERGLASS, 1" THICK X 4' - INCREMENTS OF 4 SF
	079654-05-000	EA PIPE-EXHAUST, ANGLED - W/FLANGE - 2" ID - ONAN# 154-2539
	082272-01-000	EA MUFFLER-GENERATOR
	094059-01-000	EA SPACER-GENERATOR, ONAN
	105732-02-000	EA TRAY ASM-GENERATOR
	105958-03-000	EA PIPE-EXHAUST,GENERATOR
	007125-03-000	EA CLAMP-MUFFLER - 1.5" DIA.
	007125-04-000	EA CLAMP-MUFFLER - 1.1" DIA.
	007131-01-000	EA HANGER-TAILPIPE, 6 SLOTS

5000W KOHLER LOW PROFILE

KEY	PART NUMBER	U/M DESCRIPTION
	105524-01-000	EA GENERATOR - 5KW LOW PROFILE KOHLER 5CKM21
	007067-01-000	SF INSULATION-FIBERGLASS, 1" THICK X 4' - INCREMENTS OF 4 SF
	105526-01-000	EA ARRESTER-SPARK, KOHLER 278621
	105527-01-000	EA PIPE-EXHAUST ADAPTER, KOHLER 278524
	105530-01-000	EA MUFFLER-SIDE EXHAUST W/O SPARK KOHLER 278733
	105602-01-000	EA GASKET-EXHAUST, KOHLER-278320
	105732-02-000	EA TRAY ASM-GENERATOR
	105958-03-000	EA PIPE-EXHAUST,GENERATOR
	007125-03-000	EA CLAMP-MUFFLER - 1.5" DIA.
	007125-04-000	EA CLAMP-MUFFLER - 1.1" DIA.

7.0KW KOHLER LOW PROFILE

KEY	PART NUMBER	U/M DESCRIPTION
	105525-01-000	EA GENERATOR - 7.0KW - LOW PROFILE - KOHLER 7CKM21
	007067-01-000	SF INSULATION-FIBERGLASS, 1" THICK X 4' - INCREMENTS OF 4 SF
	094059-01-000	EA SPACER-GENERATOR, ONAN
	105526-01-000	EA ARRESTER-SPARK, KOHLER 278621
	105527-02-000	EA PIPE-EXHAUST ADAPTER, KOHLER-278979
	105530-01-000	EA MUFFLER-SIDE EXHAUST W/O SPARK KOHLER 278733
	105602-01-000	EA GASKET-EXHAUST, KOHLER-278320
	105732-02-000	EA TRAY ASM-GENERATOR
	105958-03-000	EA PIPE-EXHAUST,GENERATOR
	007125-03-000	EA CLAMP-MUFFLER - 1.5" DIA.
	007125-04-000	EA CLAMP-MUFFLER - 1.1" DIA.

5 KW EMERALD PLUS

KEY	PART NUMBER	U/M DESCRIPTION
	109303-01-000	EA GENERATOR - 5KW EMERALD PLUS - ONAN WITH ONAN TRAY #403-2727
	007067-01-000	SF INSULATION-FIBERGLASS, 1" THICK X 4' - INCREMENTS OF 4 SF
	007125-04-000	EA CLAMP-MUFFLER, 1.1" DIA
	079654-05-000	EA PIPE-EXHAUST, ANGLED - W/FLANGE - 2" ID - ONAN# 154-2539
	082272-01-000	EA MUFFLER-GENERATOR
	094059-01-000	EA SPACER-GENERATOR, ONAN
	105732-02-000	EA TRAY ASM-GENERATOR
	105958-03-000	EA PIPE-EXHAUST, GENERATOR

**HEATING & AIR CONDITIONING GROUP
30,000 BTU SUBURBAN FURNACE**

KEY	PART NUMBER	U/M DESCRIPTION
	098668-20-000	EA FURNACE-30,000 BTU SUBURBAN SF-30 2273
	074466-01-702	EA RELAY-TIME DELAY, SUBURBAN# 230625
	075696-02-703	EA COLLAR-DUCT, SUBURBAN #050715
	092300-02-701	EA ORFICE, MAIN BURNER - SUBURBAN 180214
	115764-01-01A	EA THERMOSTAT-FURNACE, SUBURBAN REP'L BY 115764-01
	098668-01-700	EA CABINET FRONT, SUBURBAN 101242
	098668-01-706	EA WHEEL-COMBUSTION AIR, SUBURBAN 350122
	098668-01-707	EA VENT CAP & EXHAUST TUBE ASM, SUBURBAN 260193
	098668-01-708	EA BLOWER ASM (COMBUSTION AIR), SUBURBAN 390441
	098668-01-709	EA MOTOR ASM.-FOR SF-25, SF-30 - SUBURBAN 231706
	098668-01-710	EA BLOWER ASM (ROOM AIR), SUBURBAN 390440
	098668-01-711	EA WHEEL,ROOM AIR - SUBURBAN 350123
	098668-01-712	EA BOARD-MODULE, SUBURBAN 231741
	098668-01-713	EA INTAKE VENT TUBE ASM 051248
	098668-01-714	EA GAS VALVE FOR SF MODELS S.N.#921401821 AND UP
	098668-01-715	EA ELECTRODE ASM. (SGL PROBE) F/SF MODELS S.N.#921401821 & UP
	098668-01-716	EA GASKET FIREWALL(CHAMBER SIDE 070808
	098668-01-717	EA GASKET FIREWALL(BLOWER SIDE) 070809
	098668-02-700	EA BURNER ASM COMPLETE (SF-30/SF35), SUBURBAN 010745
	098668-21-700	EA MICROSWITCH, W/O FLAG 3 1/4" 232261
	098668-21-701	EA LIMIT SWITCH 231799
	101990-01-714	EA MICROSWITCH GASKET, SUBURBAN 230877
	098668-23-000	EA DOOR-ACCESS, FURNACE, BRIGHT WHITE SUBURBAN 520574
	115764-01-01A	EA THERMOSTAT-FURNACE - SUBURBAN 160902
	056464-04-000	EA REGISTER-HEAT, 4" DIAMETER - W/DAMPER - PLASTIC - SAND
	056464-05-000	EA REGISTER-PLASTIC W/O DAMPER - 4" DIAMETER - GOLDEN
	093614-01-01A	EA GRILLE-RETURN AIR, FURNACE - 15.6" X 7.6" - BROWN

**HEATING & AIR CONDITIONING GROUP (CONTINUED)
35,000 BTU SUBURBAN FURNACE**

KEY	PART NUMBER	U/M DESCRIPTION
	098668-21-000	EA FURNACE-35,000 BTU SUBURBAN SF-35 2274
	069634-01-720	EA ORIFICE-MAIN BURNER, SUBURBAN# 0180222
	074466-01-702	EA RELAY-TIME DELAY, SUBURBAN# 230625
	075696-02-703	EA COLLAR-DUCT, SUBURBAN #050715
	115764-01-01A	EA THERMOSTAT-FURNACE,SUBURBAN REP'L BY 115764-01
	098668-01-700	EA CABINET FRONT, SUBURBAN 101242
	098668-01-706	EA WHEEL-COMBUSTION AIR, SUBURBAN 350122
	098668-01-707	EA VENT CAP & EXHAUST TUBE ASM, SUBURBAN 260193
	098668-01-708	EA BLOWER ASM (COMBUSTION AIR), SUBURBAN 390441
	098668-01-710	EA BLOWER ASM (ROOM AIR), SUBURBAN 390440
	098668-01-711	EA WHEEL,ROOM AIR - SUBURBAN 350123
	098668-01-712	EA BOARD-MODULE, SUBURBAN 231741
	098668-01-713	EA INTAKE VENT TUBE ASM 051248
	098668-01-714	EA GAS VALVE FOR SF MODELS S.N.#921401821 AND UP
	098668-01-715	EA ELECTRODE ASM. (SGL PROBE) F/SF MODELS S.N.#921401821 & UP
	098668-01-716	EA GASKET FIREWALL(CHAMBER SIDE 070808
	098668-01-717	EA GASKET FIREWALL(BLOWER SIDE) 070809
	098668-02-700	EA BURNER ASM COMPLETE (SF-30/SF35), SUBURBAN 010745
	098668-03-700	EA MOTOR ASM-SF-35, SUBURBAN# 231707
	098668-21-700	EA MICROSWITCH, W/O FLAG 3 1/4" 232261
	101990-01-714	EA MICROSWITCH GASKET, SUBURBAN 230877
	009198-01-000	FT DUCT-HEAT, FLEXIBLE - 4" ID X 25 FT
	009200-01-000	EA TAPE-FURNACE, 1 1/2"
	069636-02-000	EA CONNECTOR-DUCT, 4" ID - SUBURBAN 050715
	056464-05-000	EA REGISTER-PLASTIC W/O DAMPER - 4" DIAMETER - GOLDEN

MISCELLANOUS COMPONENTS FOR REAR HEATER & WATER HEATER W/MOTOR AID

KEY	PART NUMBER	U/M DESCRIPTION
	009198-01-000	FT DUCT-HEAT, FLEXIBLE - 4" ID - INCREMENTS OF 25'
	009200-01-000	EA TAPE-FURNACE, 1 1/2"
	023146-01-000	EA CLAMP-SCREW TYPE - 4"
	069636-02-000	EA CONNECTOR-DUCT, 4" ID
	007076-01-000	EA HOSE-FLEXIBLE PVC - 2" ID - INCREMENTS OF 50'
	007108-01-000	FT HOSE-HEATER, 5/8" ID
	008042-01-000	FT TUBING-VINYL, .65" ID
	056464-04-000	EA REGISTER-W/DAMPER, 4" DIAMETER - PLASTIC - SAND
	056464-05-000	EA REGISTER-W/O DAMPER, 4" DIAMETER - PLASTIC - GOLDEN
	061673-01-000	EA BRACKET-MOTOR AID TUBES, 4" X 1.5" - STEEL
	088753-01-000	FT TUBE-ALUMINIZED STEEL, 5/8" - 18 GAUGE
	079059-01-000	EA HOSE - 90 DEGREE, 5/8" ID X 4" X 36"
	079059-02-000	EA HOSE - 90 DEGREE, .61"ID X 4" X 6"
	079059-03-000	EA HOSE - 90 DEGREE, .61"ID X 4" X 18"
	010227-01-000	EA TEE-BARB, 5/8" OR 3/4" HOSE - PLASTIC

EVANS REAR HEATER

KEY	PART NUMBER	U/M DESCRIPTION
	084405-01-000	EA HEATER ASM-REAR, DUCTED - W/MOTOR AID - EVANS
	084405-01-700	EA HEATER CORE-EVANS# FT200229
	084405-01-701	EA FAN BLADES-EVANS# HV029931
	084405-01-702	EA MOTOR ASM - 12 V, EVANS# 200146

HEATING & AIR CONDITIONING GROUP (CONTINUED)

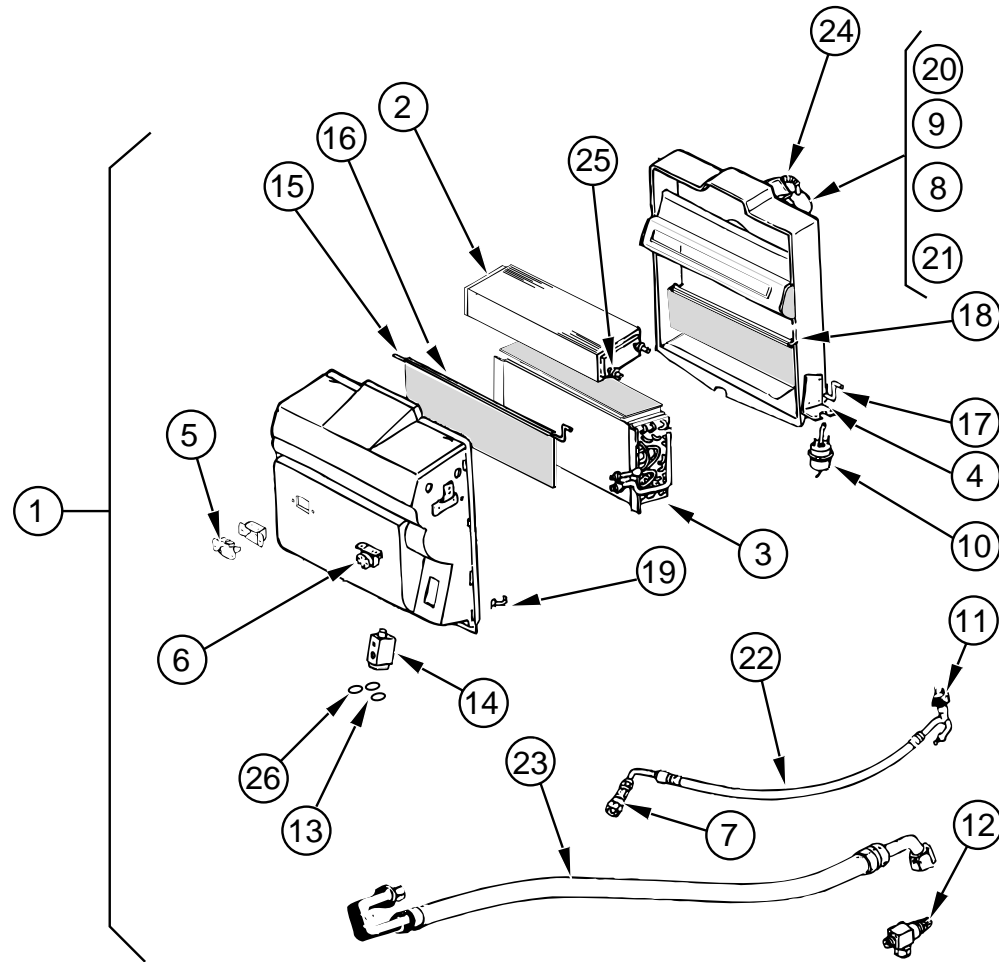

EVAPORATOR/HEATER ASSEMBLY - FORD GAS CHASSIS

KEY	PART NUMBER	U/M	DESCRIPTION
1	103930-21-000	EA	EVAPORATOR/HEATER ASSEMBLY - SCS 090-00084
2	103930-01-703	EA	COIL-HEATER, SCS 042-0010
3	103930-01-704	EA	COIL EVAPORATOR, SCS 041-0017
4	103930-01-708	EA	BRACKET-VACUUM MOTOR, SCS 070-0113
5	103930-01-710	EA	RESISTOR-FUSED, SCS 035-0006
6	103930-01-711	EA	THERMOSTAT, SCS 033-0003
7	103930-01-713	EA	FITTING-QUICK CONNECT, #4 - SCS 050-003
8	103930-01-717	EA	WHEEL-CLOCK-WISE, SCS 062-0010
9	103930-01-720	EA	MOTOR, SCS 030-0004
10	103930-02-708	EA	MOTOR-VACUUM SERVO, A/C - SCS 030-0002
11	103930-12-708	EA	SWITCH-BINARY, R-134A - SCS 032-0048
12	103930-13-702	EA	SERVICE VALVE - SCS 050-152
13	103930-17-702	EA	GASKET OR SAE 015 #10 33-781, SCS 045-0127
14	103930-20-700	EA	VALVE-EXPANSION BLOCK, 2 TON - SCS 034-0032
15	103930-20-702	EA	ROD-AIR BLEND DOOR, SCS 073-0039
16	103930-20-703	EA	DOOR-AIR BLEND, SCS 071-0212
17	103930-20-704	EA	ROD-RECIRCULATING DOOR, SCS 073-0018
18	103930-20-705	EA	DOOR-RECIRCULATING, SCS 071-0213
19	103930-20-706	EA	CLIP-RETAINER, SCS 022-0057
20	103930-20-707	EA	HOUSING-BLOWER, SCS 062-0145
21	103930-20-708	EA	CLIP F/MOTOR SHAFT, SCS 022-0001
22	103930-21-700	EA	HOSE #6 - FORD - SCS 085-0139
23	103930-21-701	EA	HOSE #10 - FORD - SCS 085-0140
24	110279-01-703	EA	HOSE-VENT, BLOWER MOTOR, SCS 051-0034
25	110279-01-712	EA	FITTING-HEATER, SCS 050-0076
26	113245-01-707	EA	GASKET #8, SCS 045-0126

HEATING & AIR CONDITIONING GROUP (CONTINUED)

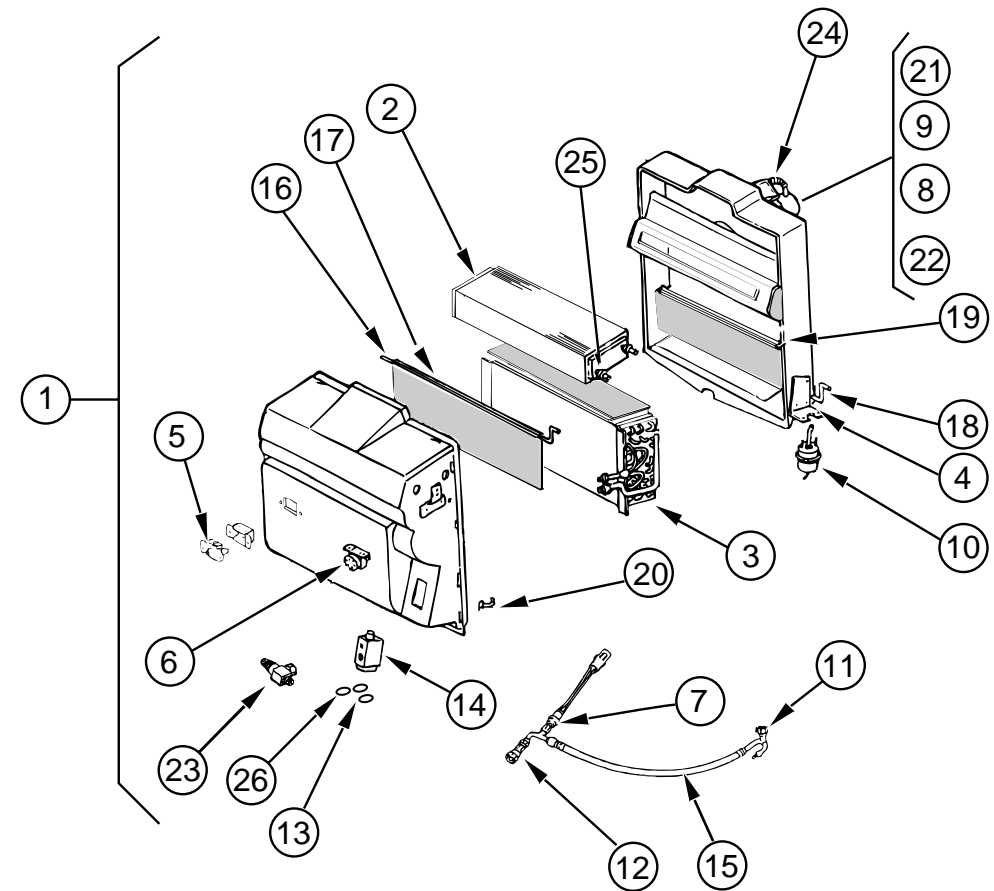

EVAPORATOR/HEATER ASSEMBLY - CHEVY GAS & DIESEL CHASSIS

KEY	PART NUMBER	U/M	DESCRIPTION
1	103930-20-000	EA	EVAPORATOR/HEATER ASSEMBLY - SCS 090-00083
2	103930-01-703	EA	COIL-HEATER, SCS 042-0010
3	103930-01-704	EA	COIL EVAPORATOR, SCS 041-0017
4	103930-01-708	EA	BRACKET-VACUUM MOTOR, SCS 070-0113
5	103930-01-710	EA	RESISTOR-FUSED, SCS 035-0006
6	103930-01-711	EA	THERMOSTAT, SCS 033-0003
7	103930-01-716	EA	SWITCH-PRESSURE, FAN - SCS 032-0036
8	103930-01-717	EA	WHEEL-CLOCK-WISE, SCS 062-0010
9	103930-01-720	EA	MOTOR, SCS 030-0004
10	103930-02-708	EA	MOTOR-VACUUM SERVO, A/C - SCS 030-0002
11	103930-12-708	EA	SWITCH-BINARY, R-134A - SCS 032-0048
12	103930-12-709	EA	FITTING-QUICK CONNECT - SCS 050-0120
13	103930-17-702	EA	GASKET OR SAE 015 #10 33-781, SCS 045-0127
14	103930-20-700	EA	VALVE-EXPANSION BLOCK, 2 TON - SCS 034-0032
15	103930-20-701	EA	HOSE ASM - #6, SCS 085-0138
16	103930-20-702	EA	ROD-AIR BLEND DOOR, SCS 073-0039
17	103930-20-703	EA	DOOR-AIR BLEND, SCS 071-0212
18	103930-20-704	EA	ROD-RECIRCULATING DOOR, SCS 073-0018
19	103930-20-705	EA	DOOR-RECIRCULATING, SCS 071-0213
20	103930-20-706	EA	CLIP-RETAINER, SCS 022-0057
21	103930-20-707	EA	HOUSING-BLOWER, SCS 062-0145
22	103930-20-708	EA	CLIP F/MOTOR SHAFT, SCS 022-0001
23	103930-20-709	EA	SERVICE VALVE - SCS 050-159
24	110279-01-703	EA	MOTOR-BLOWER, SCS 051-0034
25	110279-01-712	EA	FITTING-HEATER, SCS 050-0076
26	113245-01-707	EA	GASKET #8, SCS 045-0126

HEATING & AIR CONDITIONING GROUP (CONTINUED)

CONTROL/PLENUM

KEY	PART NUMBER	U/M	DESCRIPTION
	103930-04-000	EA	CONTROL/PLENUM SET SCS 093-00037
	072341-06-700	EA	SWITCH - 4 SPEED, FAN - ARA 0883502
	094831-01-709	EA	CLAMPS-ROD, 3/16" - MOTIVAIR/SCS ZGG14431
	103930-02-700	EA	PANEL-CONTROL, SCS 032-0018
	103930-02-701	EA	VALVE-CONTROL HEAD, SCS 034-0015
	103930-02-702	EA	DECAL-FAN SWITCH, SCS 058-0008
	103930-02-703	EA	HARNESS-WIRE CONTROL, SCS 036-0048
	103930-02-704	EA	HARNESS-VACUUM CONTROL, SCS 036-0049
	103930-02-705	EA	CABLE-CONTROL, BOWDEN - SCS 074-0011 SHEATH LENGTH IS 84 1/4" - CABLE LENGTH IS 89" LONG
	103930-02-706	EA	CLIP-CABLE, CONTROL - SCS 022-0017
	103930-02-707	EA	RELAY, SCS 031-0001
	103930-02-708	EA	MOTOR-VACUUM SERVO, A/C - SCS 030-0002
	103930-02-710	EA	CANISTER-VACUUM, SCS 054-0002
	103930-02-711	EA	VALVE-WATER, SCS 034-00114

HOSE KITS

KEY	PART NUMBER	U/M	DESCRIPTION
	103930-18-000	EA	HOSE KIT #10 GM-HARRISON COM SCS 093-00077
	103930-17-701	EA	FTG #10.90 W/FERRULE/1342CP 050-0132
	103930-17-702	EA	GASKET OR SAE 015 #10 33-781, SCS 045-0127
	103930-17-703	EA	GASKET-SEAL,SANDEW COMP33-76 045-0142
	103930-18-700	EA	FTG,PAD,COMP SUCTION (HARRIS 050-00133
	103930-18-701	EA	HOSE ASSY #10 085-0114
	103930-18-702	EA	GASKET SEAL HARRISON 045-0143
	110279-01-708	EA	HOSE, REFRIGERATOR BARRIER#10SAEJ51 051-0008
	103930-17-000	EA	HOSE KIT #10 GM-SANDEN COMP SCS 093-00076
	103930-01-708	EA	BRACKET-VACUUM MOTOR, SCS 070-0113
	103930-17-700	EA	FTG. PAD COMP. SUCTION SAN 050-0131
	103930-17-701	EA	FTG #10.90 W/FERRULE/1342CP 050-0132
	103930-17-702	EA	GASKET OR SAE 015 #10 33-781, SCS 045-0127
	103930-17-703	EA	GASKET-SEAL,SANDEW COMP33-76 045-0142
	103930-17-704	EA	HOSE ASSY #10 085-0113

AUTOMOTIVE HEATER MISCELLANEOUS

KEY	PART NUMBER	U/M	DESCRIPTION
	007281-01-000	EA	HOSE-FLEXIBLE PVC, 2.5"ID X 50' - ATCOFLEX A-182-355
	024990-05-000	EA	4" DIAMETER OUTLET W/SWIVEL DEFLECTORS
	056402-05-000	EA	BRACKET-HEATER VENT, ROUND - W/BEND - BLACK
	077075-01-000	EA	GASKET-INSTRUMENT PANEL TO DEFROSTER PLENUM - .6" X 11.3"
	077075-03-000	EA	GASKET-NSTRUMENT PANEL TO DEFROSTER PLENUM,SPL
	103016-01-000	EA	PLENUM-TRANSITION
	103017-01-000	EA	PLENUM-DEFROSTER
	103558-01-02A	EA	VENT-DEFROST,ABS LIGHT GRAY
	103796-01-01A	EA	LOUVER ASM-A/C CARY PROD BLK, 268-3B,100-2-4-8
	097494-02-000	EA	TEE-BRASS, BARB - 3/8 X 5/32 X 3/8 - PARKER 224-8-8-4
	103930-05-000	EA	MANUAL-OWNERS, HEATER-A/C - SCS 057-0049
	103930-20-700	EA	VALVE EXP. BLOCK (2 TON) 034-0032
	103930-20-701	EA	HOSE ASSY #6 WINN GM 085-0138

ROOF A/C COVER

KEY	PART NUMBER	U/M	DESCRIPTION
	092633-02-02A	EA	COVER-BLANK, ROOF A/C - 5.1" X 5.1" - PLASTIC - OFF WHITE
	022756-03-000	EA	COVER-A/C, OFF WHITE - PLASTIC
	022756-02-000	EA	COVER-PROTECTIVE, 5.5" ENDS X 8.2" - PLASTIC - OFF WHITE

HEATING & AIR CONDITIONING GROUP (CONTINUED)

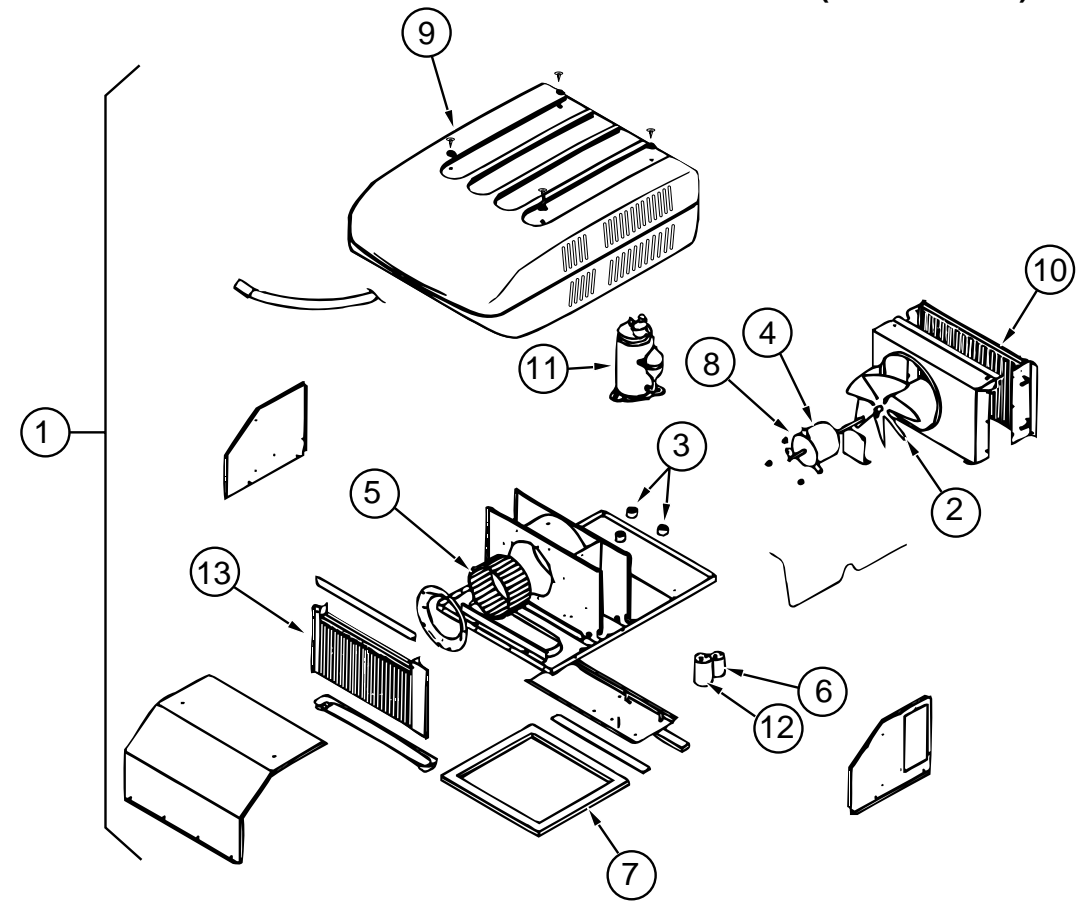

13,500 BTU COLEMAN ROOF A/C & CEILING ASSEMBLY

KEY	PART NUMBER	U/M	DESCRIPTION
	108889-01-05A	EA	A/C-ROOF, 13,500 TSR HO BRIGHT WHITE - COLEMAN 7333
	093763-01-712	EA	FAN BLADE-CONDENSER, COLEMAN 6733-3221
	105620-01-706	EA	FOOT PACKAGE-COMPRESSOR, 3 PER PACKAGE - COLEMAN 6759-3081
	108889-01-705	EA	MOTOR - 115V, 60HZ - COLEMAN 1468-3049
	108889-01-706	EA	IMPELLOR - COLEMAN 1472-1041
	108889-01-708	EA	CAPACITOR-FAN, (7.5MFD.370U) - COLEMAN 1499-5461
	108889-01-710	EA	FILLER PAD-COND AIR SEAL - COLEMAN 6759A3971
	108889-01-711	EA	GASKET PACKAGE - COLEMAN 6792-3301
	108889-01-715	EA	MOTOR MOUNT & SHAFT SEAL KIT - COLEMAN 6792-3361
	108889-05-700	EA	SHROUD-(BRIGHT WHITE), W/O LOGO - COLEMAN 7333-4601
	108889-01-703	EA	CONDENSER COIL - COLEMAN 1452-1301
	105620-01-704	EA	COMPRESSOR, RH & LH - COLEMAN 1450-2009
	108889-01-707	EA	CAPACITOR-RUN, COMPRESSOR-25MFD/370 - COLEMAN 1499-5661
	091225-01-709	EA	RELAY-START, COLEMAN 1497-4131
	108889-01-709	EA	EVAPORATOR COIL - COLEMAN 1452-1311
	108889-01-714	EA	DISCHARGE LINE ASSEMBLY - COLEMAN 6792-531
	108889-01-712	EA	REDUCER-SUCTION LINE, (3/8" X 1/2") - COLEMAN 1215-2161
	108889-01-713	EA	SUCTION LINE, (3/8" OD X .032" WALL - COLEMAN 6792-130
	091225-01-710	EA	CAPACITOR-START, COLEMAN 1497-0881
	093306-01-701	EA	DECAL PACKAGE-LEFT & RIGHT - COLEMAN 6798B3591
	108889-01-704	EA	OVERLOAD - COLEMAN 6749-3541
	102289-01-000	EA	SPRING-SCREW, ROOF A/C GASKET - COLEMAN 6757-150

CEILING ASSEMBLY 13,500 BTU A/C

KEY	PART NUMBER	U/M	DESCRIPTION
	108891-01-01A	EA	CEILING ASM-A/C COOL TSR HO - COLEMAN 7330-714 IV
	042204-01-709	EA	THERMOSTAT-IN 64 OUT 58, COLEMAN 6701-3401
	063903-01-702	EA	LOUVER-COLEMAN 6703A5191
	073742-01-701	EA	SELECTOR SWITCH (5 TERMINAL), COLEMAN 6759-3251
	073742-01-702	EA	DECAL COOL ONLY, COLEMAN 6759C3431
	076303-01-707	EA	FILTER - 6" X 14 3/4" X 1/2", 12 PER PKG - COLEMAN 6703A3151
	081606-01-712	EA	CEILING SHROUD (IVORY), COLEMAN 6769-5061
	091225-01-713	EA	KNOB (2 PER PACKAGE), COLEMAN 6701-3351
	091225-01-717	EA	DECAL (THERMOSTAT) COOL ONLY, COLEMAN 6799A3441
	093766-02-701	EA	DECAL-LEFT SIDE, COLEMAN 6799-3971
	108891-01-700	EA	SINGLE PARTS PACKAGE, COLEMAN 6792-5991
	108891-01-701	EA	RETAINER CLIPS F/FILTER, COLEMAN 6799-3141

HEATING & AIR CONDITIONING GROUP (CONTINUED)
13,500 BTU COLEMAN ROOF A/C & CEILING ASSEMBLY - EUROPEAN

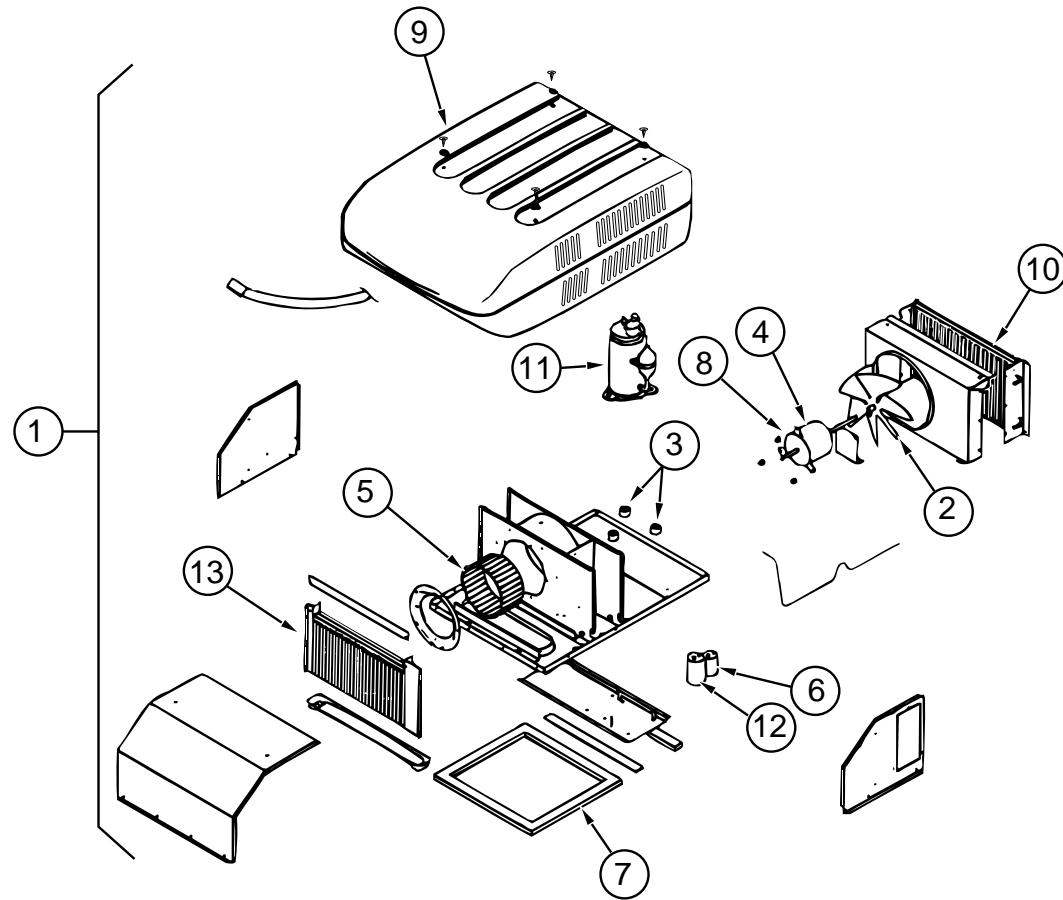

KEY	PART NUMBER	U/M	DESCRIPTION
1	108889-02-03A	EA	A/C-ROOF, 13,500 TSR 220 BRIGHT WHITE - COLEMAN 7373A891
2	093763-01-712	EA	FAN BLADE-CONDENSER, COLEMAN 6733-3221
3	105620-01-706	EA	FOOT PACKAGE-COMPRESSOR, 3 PER PACKAGE - COLEMAN 6759-3081
4	108889-01-705	EA	MOTOR-115V, 60HZ - COLEMAN 1468-3049
5	108889-01-706	EA	IMPELLOR - COLEMAN 1472-1041
6	108889-01-708	EA	CAPACITOR-FAN, (7.5MFD.370U) - COLEMAN 1499-5461
	108889-01-710	EA	FILLER PAD-COND AIR SEAL - COLEMAN 6759A3971
7	108889-01-711	EA	GASKET PACKAGE - COLEMAN 6792-3301
8	108889-01-715	EA	MOTOR MOUNT & SHAFT SEAL KIT - COLEMAN 6792-3361
9	108889-05-700	EA	SHROUD-(BRIGHT WHITE), W/O LOGO - COLEMAN 7333-4601
10	108889-01-703	EA	CONDENSER COIL - COLEMAN 1452-1301
11	105620-01-704	EA	COMPRESSOR, RH & LH - COLEMAN 1450-2009
12	108889-01-707	EA	CAPACITOR-RUN, COMPRESSOR-25MFD/370 - COLEMAN 1499-5661
	091225-01-709	EA	RELAY-START, COLEMAN 1497-4131
13	108889-01-709	EA	EVAPORATOR COIL - COLEMAN 1452-1311
	108889-01-714	EA	DISCHARGE LINE ASSEMBLY - COLEMAN 6792-531
	108889-01-712	EA	REDUCER-SUCTION LINE, (3/8" X 1/2") - COLEMAN 1215-2161
	108889-01-713	EA	SUCTION LINE, (3/8" OD X .032" WALL) - COLEMAN 6792-130
	091225-01-710	EA	CAPACITOR-START, COLEMAN 1497-0881
	093306-01-701	EA	DECAL PACKAGE-LEFT & RIGHT - COLEMAN 6798B3591
	108889-01-704	EA	OVERLOAD - COLEMAN 6749-3541
	102289-01-000	EA	SPRING-SCREW, ROOF A/C GASKET - COLEMAN 6757-150
	108891-01-01A	EA	CEILING ASM-A/C COOL TSR HO - COLEMAN 7330-714 IV
	042204-01-709	EA	THERMOSTAT-IN 64-OUT 58, COLEMAN 6701-3401
	073742-01-701	EA	SELECTOR SWITCH (5 TERMINAL), COLEMAN 6759-3251
	073742-01-702	EA	DECAL COOL ONLY, COLEMAN 6759C3431
	076303-01-707	EA	FILTER - 6" X 14 3/4" X 1/2", 12 PER PKG - COLEMAN 6703A3151
	081606-01-712	EA	CEILING SHROUD (IVORY), COLEMAN 6769-5061
	091225-01-713	EA	KNOB (2 PER PACKAGE), COLEMAN 6701-3351

HEATING & AIR CONDITIONING GROUP (CONTINUED)
14,800 BTU COLEMAN ROOF A/C & CEILING ASSEMBLY

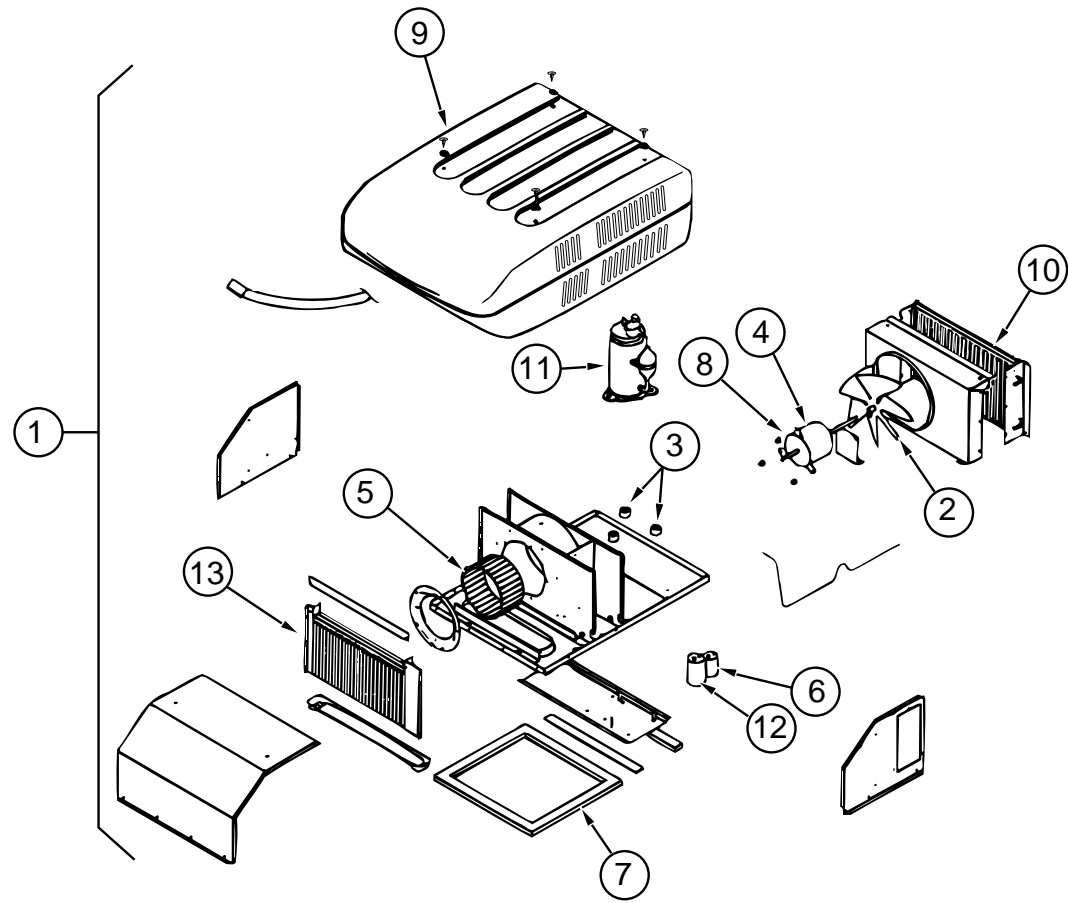

KEY	PART NUMBER	U/M DESCRIPTION
1	115219-01-03A	EA A/C-ROOF, 14,800 MACH 15 BRIGHT WHITE - COLEMAN 7335B896
2	093763-01-712	EA FAN BLADE-CONDENSER, COLEMAN 6733-3221
3	105620-01-706	EA FOOT PACKAGE-COMPRESSOR, 3 PER PACKAGE - COLEMAN 6759-3081
4	108889-01-705	EA MOTOR-115V, 60HZ - COLEMAN 1468-3049
5	108889-01-706	EA IMPELLOR - COLEMAN 1472-1041
6	108889-01-708	EA CAPACITOR-FAN, (7.5MFD.370U) - COLEMAN 1499-5461
	108889-01-710	EA FILLER PAD-COND AIR SEAL - COLEMAN 6759A3971
7	108889-01-711	EA GASKET PACKAGE - COLEMAN 6792-3301
8	108889-01-715	EA MOTOR MOUNT & SHAFT SEAL KIT - COLEMAN 6792-3361
9	108889-05-700	EA SHROUD-(BRIGHT WHITE), W/O LOGO - COLEMAN 7333-4601
10	108889-01-703	EA CONDENSER COIL - COLEMAN 1452-1301
11	105620-01-704	EA COMPRESSOR, RH & LH - COLEMAN 1450-2009
12	108889-01-707	EA CAPACITOR-RUN, COMPRESSOR-25MFD/370 - COLEMAN 1499-5661
	091225-01-709	EA RELAY-START, COLEMAN 1497-4131
13	108889-01-709	EA EVAPORATOR COIL - COLEMAN 1452-1311
	108889-01-714	EA DISCHARGE LINE ASSEMBLY - COLEMAN 6792-531
	108889-01-712	EA REDUCER-SUCTION LINE, (3/8" X 1/2") - COLEMAN 1215-2161
	108889-01-713	EA SUCTION LINE, (3/8" OD X .032" WALL) - COLEMAN 6792-130
	091225-01-710	EA CAPACITOR-START, COLEMAN 1497-0881
	093306-01-701	EA DECAL PACKAGE-LEFT & RIGHT - COLEMAN 6798B3591
	108889-01-704	EA OVERLOAD - COLEMAN 6749-3541
	102289-01-000	EA SPRING-SCREW, ROOF A/C GASKET - COLEMAN 6757-150
	108891-01-01A	EA CEILING ASM-A/C COOL TSR HO - COLEMAN 7330-714 IV
	042204-01-709	EA THERMOSTAT-IN 64-OUT 58, COLEMAN 6701-3401
	073742-01-701	EA SELECTOR SWITCH (5 TERMINAL), COLEMAN 6759-3251
	073742-01-702	EA DECAL COOL ONLY, COLEMAN 6759C3431
	076303-01-707	EA FILTER - 6" X 14 3/4" X 1/2", 12 PER PKG - COLEMAN 6703A3151
	081606-01-712	EA CEILING SHROUD (IVORY), COLEMAN 6769-5061
	091225-01-713	EA KNOB (2 PER PACKAGE), COLEMAN 6701-3351
	091225-01-717	EA DECAL (THERMOSTAT) COOL ONLY, COLEMAN 6799A3441
	093766-02-701	EA DECAL-LEFT SIDE, COLEMAN 6799-3971
	108891-01-700	EA SINGLE PARTS PACKAGE (KNOBS & NUTS) COLEMAN 6792-5991
	108891-01-701	EA RETAINER CLIPS F/FILTER (6 PER) COLEMAN 6799-3141

**INTERIOR FINISH GROUP
MOLDINGS & TRIMS**

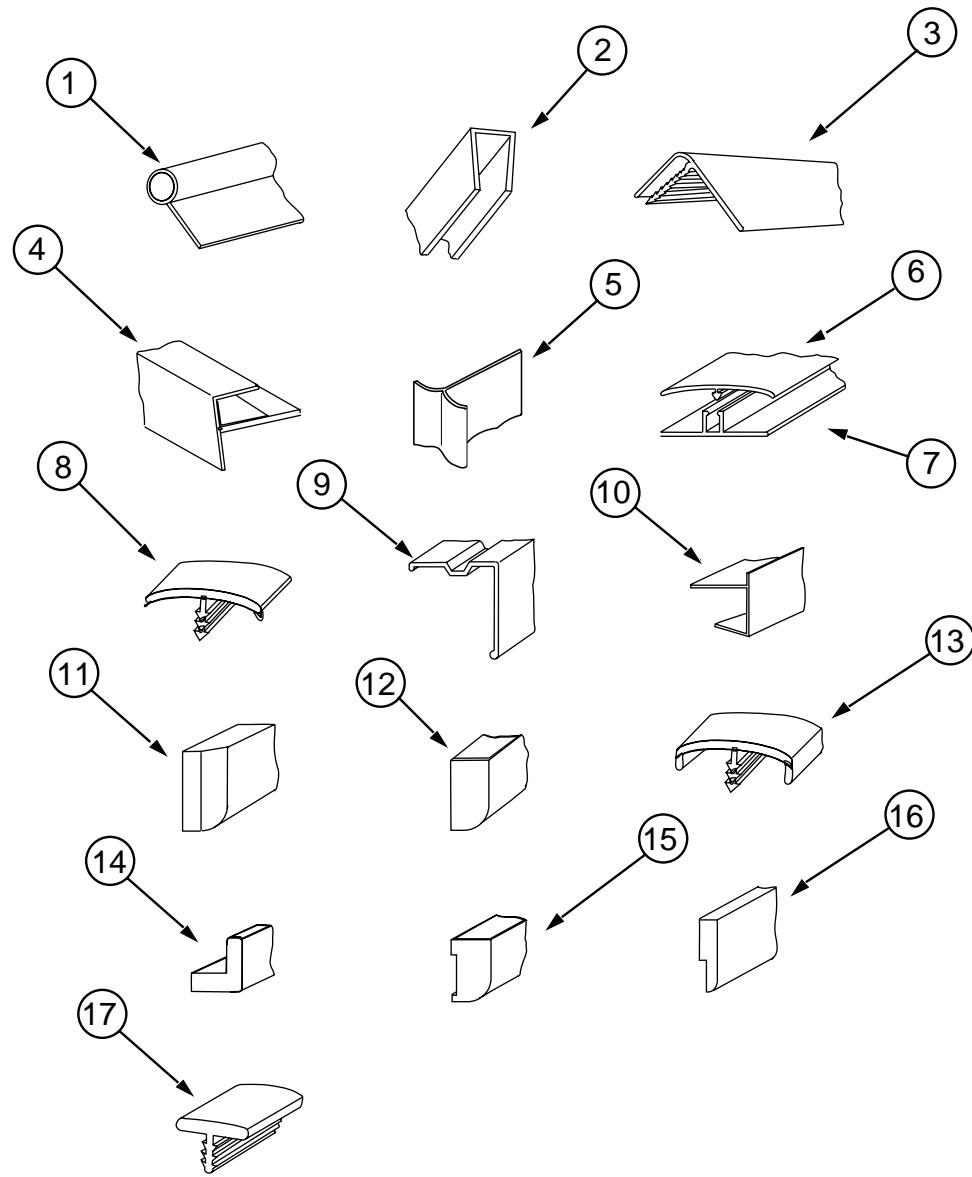

KEY	PART NUMBER	U/M DESCRIPTION
1	009767-12-000	FT MOLDING-SIDEWALL TO CEILING/CABINET - WELTING - OFF WHITE
2	009778-12-000	FT U CHANNEL-PLASTIC, 1" WIDE X 8' INCREMENTS - WOODGRAIN
2	070504-01-000	FT U-CHANNEL-PLASTIC, .065" WIDE - LIGHT BROWN - INCREMENTS OF 8'
2	070504-18-000	FT U-CHANNEL-PLASTIC, .065" WIDE - IVORY - INCREMENTS OF 8'
2	070504-19-000	FT U-CHANNEL-PLASTIC, .815" WIDE - BROWN - INCREMENTS OF 8'
2	070504-20-000	FT U-CHANNEL-PLASTIC, .815" WIDE - THOR PECAN - INCREMENTS OF 8'
3	009809-21-000	EA MOLDING-CORNER, OUTSIDE - 1" - PLASTIC - WOODGRAIN
3	009809-23-000	EA MOLDING-CORNER, OUTSIDE - 1" - PLASTIC - IVORY
4	009812-22-000	EA MOLDING-CORNER, OUTSIDE - .5" X 7' - PLASTIC - BROWN
5	022992-11-000	FT MOLDING-REVERSE COVE, T-SHAPED - VINYL - IVORY
6	086229-04-000	EA BATTEN-CEILING, 1" WIDE - IVORY - 7.6'
7	086229-01-000	EA RETAINER-BATTEN, CEILING - .75" WIDE - 7.6'
8	105709-01-000	FT T-MOLDING - 1", MODERN IVORY
9	093873-01-01A	EA TRIM-CARPET, L-ANGLE - 1.1" X 1.3" X 12' - VINYL - GRAY
10	103186-01-01A	FT MOLDING-EDGE, SHELF - .78" WIDE - PLASTIC - RAMBLING OAK
10	103186-02-01A	FT MOLDING-EDGE, SHELF - 1.3" WIDE - PLASTIC - RAMBLING OAK
11	100659-01-E01	EA MOLDING-TRIM, VINYL FLOOR
12	100818-01-02A	EA MOLDING-VINYL WRAPPED, 1.65" X .4" X 7' - RAMBLING OAK
13	083620-07-000	FT MOLDING-T, END CAP EDGE - W/EDGE LIPS - .75" - THOR PECAN
14	100819-01-02A	EA MOLDING-VINYL WRAPPED, L-SHAPED, 1.5" X 1.5" X 7' - OAK
15	100041-01-000	EA MOLDING-VINYL WRAPPED, .7" X 1.57" X 84.02" - RAMBLING OAK
15	100041-02-000	EA MOLDING-VINYL WRAPPED, .7" X 2.5" X 84" - RAMBLING OAK
16	105004-01-02A	EA MOLDING-VINYL WRAP, RAMBLING OAK
17	104676-01-01A	FT T-MOLDING, 5/16 RIGID - GOLD
	112198-01-000	FT MOLDING - #90227 J-MOLDING CRILA PLASTICS
	109736-01-01A	FT T-MOLDING, 1" BRASS/BLACK
	070504-23-000	FT EXTRUSION-U CHANNEL, 22.56 - COUNTRY FOREST

INTERIOR FINISH GROUP (CONTINUED)
BATT STRIPS

KEY	PART NUMBER	U/M DESCRIPTION
	085284-76-000	FT BATT STRIP-SHOWER, ADHESIVE BACKED - OFF WHITE
	069733-80-000	EA BATT STRIP-WOODGRAIN, 8' - WINNI OAK
	088263-78-000	EA BATT STRIP-SHOWER, 8' - OFF WHITE
	079653-09-000	EA BATT STRIP-KERFED, WOODGRAIN
	088263-96-000	EA BATT STRIP-DECORATIVE, 8' LONG (F24) (MAIN WALL & BATH & GALLEY)
	088263-B5-000	EA BATT STRIP-DECORATIVE, PASTEL - 8' LONG (F25) (MAIN WALL & BATH & GALLEY)
	088263-B7-000	EA BATT STRIP-DECORATIVE, 8' LONG (F26) (MAIN WALL & BATH & GALLEY)
	088263-B8-000	EA BATT STRIP-DECORATIVE, 8' LONG (F27) (MAIN WALL & BATH & GALLEY)
	085284-67-000	FT BATT STRIP-WOODGRAIN, ADHESIVE BACKED - WINNI OAK
	085284-86-000	FT BATT STRIP-DECORATIVE, ADHESIVE BACKED (F24) (MAIN WALL & BATH & GALLEY)
	085284-A6-000	FT BATT STRIP-DECORATIVE, ADHESIVE BACKED (F25) (MAIN WALL & BATH & GALLEY)
	085284-A9-000	FT BATT STRIP-DECORATIVE, ADHESIVE BACKED (F26) (MAIN WALL & BATH & GALLEY)
	085284-B1-000	FT BATT STRIP-DECORATIVE, ADHESIVE BACKED (F27) (MAIN WALL & BATH & GALLEY)

LUMBER

KEY	PART NUMBER	U/M DESCRIPTION
	100040-01-000	EA LUMBER-VINYL WRAPPED, .71" X 1.5" X 8' - RAMBLING OAK
	100040-03-000	EA LUMBER-VINYL WRAPPED, .71" X 2" X 8' - RAMBLING OAK
	100040-06-000	EA LUMBER-VINYL WRAPPED, 766 RAMBLING OAK
	100040-07-000	EA LUMBER-VINYL WRAPPED ALL AROUND, 766 RAMBLING OAK

PLASTIC LAMINATE

KEY	PART NUMBER	U/M DESCRIPTION
	074498-54-000	SF LAMINATE-PLASTIC, SAND - 5' X 8' - INCREMENTS OF 40 SF (F24,F27)
	074498-62-000	SF LAMINATE-PLASTIC, GRAY FINESSE - 5' X 8' - INCREMENTS OF 40 SF (F25)
	074498-50-000	SF LAMINATE-PLASTIC, ALPINE ESSENCE - 5' X 8' - INCREMENTS OF 40 SF (F26)
	074498-67-000	SF LAMINATE-PLASTIC, ORCHID MIST - 5' X 8' - INCREMENTS OF 40SF (PATIO ENTERTAINMENT CENTER TABLE)
	074498-34-000	SF LAMINATE-PLASTIC, RAMBLING OAK - 5' X 8' - INCREMENTS OF 40 SF
	076325-25-000	FT MOLDING-EDGEBAND, RAMBLING OAK
	076325-44-000	FT MOLDING-EDGEBAND, 1032 SAND - .876" X .024" X 600" (F24,F27) (INSIDE OF RECESSED SINK)
	076325-43-000	FT MOLDING-EDGEBAND, 1035 CLOUD - .876" X .024" X 600" (F25) (INSIDE OF RECESSED SINK)
	076325-56-000	FT MOLDING-EDGEBAND, 1233 ALPINE - .875 "X .024" X 600" (F26) (INSIDE OF RECESSED SINK)
	076325-34-000	FT MOLDING-EDGEBAND, 1233 ORCHID MIST - 1 5/16" X .030" X 600" (PATIO ENTERTAINMENT CENTER TABLE)
	076325-47-000	FT MOLDING-EDGEBAND, 1032 SAND - 1 5/16" X .030" X 600" (F24,F27)
	076325-46-000	FT MOLDING-EDGEBAND, 1035 CLOUD - 1 5/16" X .030" X 600" (F25)
	076325-57-000	FT MOLDING-EDGEBAND, 1233 ALPINE - 1 5/16" X .030" X 600" (F26)

INTERIOR FINISH GROUP (CONTINUED)
DETECTORS, FIRE EXTINGUISHER & CLOCK

KEY	PART NUMBER	U/M DESCRIPTION
	072852-01-000	EA DETECTOR-SMOKE, W/9 VOLT BATTERY
	072852-02-000	EA DETECTOR-SMOKE, W/9 VOLT BATTERY - CANADIAN
	094499-01-000	EA EXTINGUISHER-FIRE, DRY W/MOUNTING BRACKET - 10 BC
	094499-01-700	EA BRACKET-MOUNTING, W/PLASTIC STRAP - FIRE EXTINGUISHER
	094499-02-000	EA EXTINGUISHER-FIRE, DRY - 1A10BC - CANADIAN
	100793-02-01A	EA CLOCK-WALL, 11" DIAMETER - BOLDEN 9988
	112320-01-000	EA DETECTOR-CO GAS, MODEL 9B-I - COSTAR 940000000
	112320-02-000	EA BATTERY/SENSOR-CO GAS, COSTAR 940001000

ANTISLIP & FLOOR MATS

KEY	PART NUMBER	U/M DESCRIPTION
	091261-01-000	FT SLIPNOT-ANTISLIP, 1' WIDE (100' ROLL)
	105924-01-F24	EA MAT-FLOOR 18 X 27 (F24,F27)
	105924-01-F25	EA MAT-FLOOR 18 X 27
	105924-01-F26	EA MAT-FLOOR 18 X 27

CARPET & VINYL FLOORCOVERING

KEY	PART NUMBER	U/M DESCRIPTION
	075233-01-000	SY PAD-CARPET, 3/8" X 6' ROLL
	093486-01-000	SY CARPET-COMPARTMENT, 54" WIDE - DARK GRAY
	096060-95-000	SY CARPET-12' ROLL, INCREMENTS OF 4 SY (F24,F27)
	096060-A8-000	SY CARPET-12' ROLL, INCREMENTS OF 4 SY (F25)
	096060-A2-000	SY CARPET-12' ROLL, INCREMENTS OF 4 SY (F26)
	042720-12-000	SY VINYL FLOORCOVERING

PANELING & PLYWOOD

KEY	PART NUMBER	U/M DESCRIPTION
	074497-21-000	SF PANELING-WOODGRAIN, 4' X 8' - INCREMENTS OF 32 SF
	088272-98-000	SF PANELING-SHOWER, OFF WHITE - 4' X 7' - INCREMENTS OF 28 SF
	088272-B8-000	SF PANELING-DECORATIVE, 4' X 7' - INCREMENTS OF 28 SF (F24) (MAIN WALL & BATH)
	088272-D8-000	SF PANELING-DECORATIVE, 4' X 7' - INCREMENTS OF 28 SF (F25) (MAIN WALL & BATH)
	088272-D9-000	SF PANELING-DECORATIVE, 4' X 7' - INCREMENTS OF 28 SF (F26) (MAIN WALL & BATH)
	088272-E0-000	SF PANELING-DECORATIVE, 4' X 7' - INCREMENTS OF 28 SF (F27) (MAIN WALL & BATH)
	095688-01-000	SF VENEER-FLAT LUANA, 4' X 8' - INCREMENTS OF 32 SF
	089351-03-000	SF VINYL HEADLINER

INTERIOR FINISH GROUP (CONTINUED)
CABINET HARDWARE

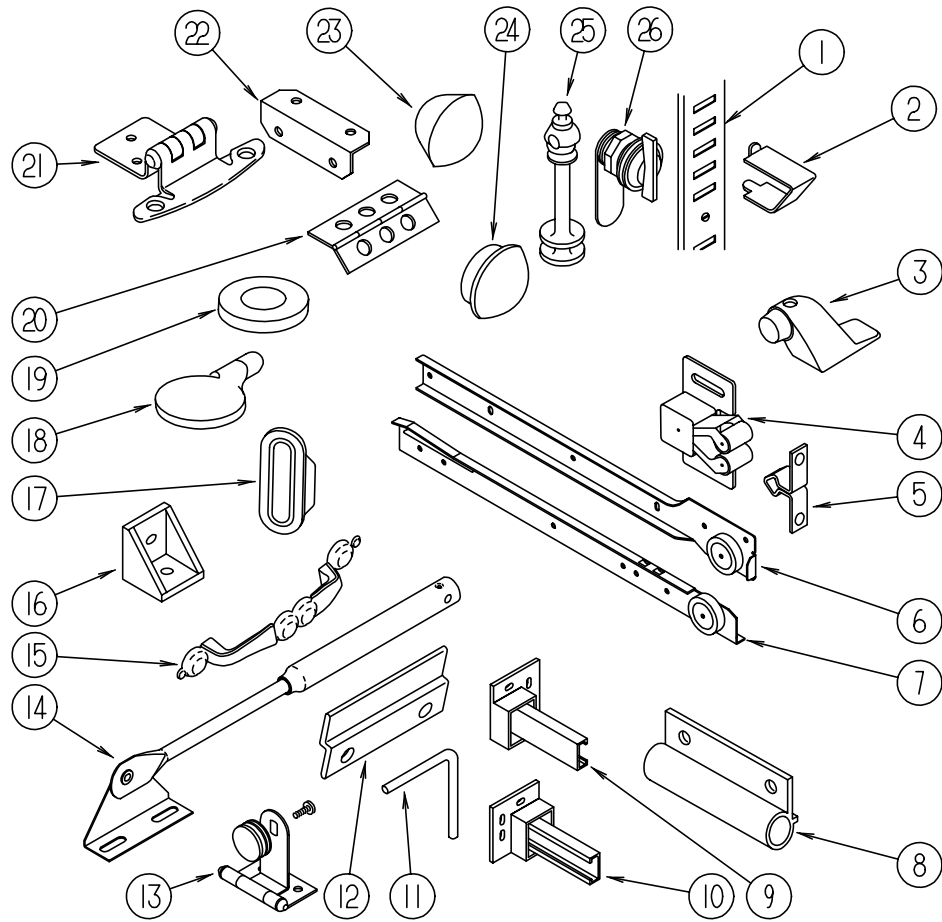

KEY	PART NUMBER	U/M	DESCRIPTION
1	098980-01-000	EA	PILASTER-ADJUSTABLE SHELF, 18" LONG WOODGRAIN APPEARANCE
1	098980-02-000	EA	PILASTER-ADJUSTABLE SHELF, 12" LONG WOODGRAIN APPEARANCE
2	098979-01-000	EA	CLIP-ADJUSTABLE SHELF
3	103257-01-000	EA	STOP-DOOR
4	093586-03-000	EA	CATCH-SPRING, ROLLER
5	093586-04-000	EA	STRIKE-SPRING STEEL
6	114031-13-000	EA	SLIDE-DRAWER, 18" LEFT CABINET HOUCK 7200-RV-1
6	114031-14-000	EA	SLIDE-DRAWER, 18" RIGHT CABINET HOUCK 7200-RV-2
6	114031-21-000	EA	SLIDE-DRAWER, 22" LEFT CABINET HOUCK 7200-RV-1
6	114031-22-000	EA	SLIDE-DRAWER, 22" RIGHT CABINET HOUCK 7200-RV-2
7	114031-15-000	EA	SLIDE-DRAWER, 18" LEFT DRAWER HOUCK 7200-RV-3
7	114031-16-000	EA	SLIDE-DRAWER, 18" RIGHT DRAWER HOUCK 7200-RV-4
7	114031-23-000	EA	SLIDE-DRAWER, 22" LEFT DRAWER HOUCK 7200-RV-3
7	114031-24-000	EA	SLIDE-DRAWER, 22" RIGHT DRAWER HOUCK 7200-RV-4
8	108486-01-01A	EA	BRACKET-PROP ROD, OVHD - BLACK
9	114045-01-000	EA	BACKSOCKET-ADJUSTABLE, LEFT HOUCK 751-1
10	114045-02-000	EA	BACKSOCKET-ADJUSTABLE, RIGHT HOUCK 751-2
11	108487-02-01A	EA	SUPPORT-PROP ROD,OVHD - BLACK
12	101272-01-000	EA	CATCH-DOOR, GLASS
13	100711-01-01A	EA	HINGE-DOOR, GLASS
14	074493-02-000	EA	SUPPORT-PISTON SPRING, CABINET DOOR
15	111765-01-000	EA	PULL-CABINET, BRASS - AMEROCK D1390-3
16	065740-01-000	EA	BRACE-CABINET CORNER, PLASTIC
17	098410-01-01A	EA	PULL-FINGER, OVAL - BRASS
18	101766-01-000	EA	PIN-SUPPORT, GLASS DOOR
19	100707-01-000	EA	SPACER-DOOR, GLASS - .8" DIA - .3" HOLE - PLASTIC
20	009059-02-000	EA	HINGE-DOOR, 2" X 2.7" - BRASS
21	108138-01-000	EA	HINGE-DOOR, CABINET - BURNISHED BRASS
22	016604-01-000	EA	BRACE-CABINET, ANGLE - 2.5" - METAL - UNPAINTED
22	016604-03-000	EA	BRACE-CABINET, ANGLE - 2.5" - METAL - BEIGE
22	016604-05-000	EA	BRACE-CABINET, L ANGLE - 2.5" - METAL - OFF WHITE
23	042356-01-000	EA	PLUG-BUTTON, MAHOGANY - 3/8" DIAMETER - WOOD
24	074045-07-000	EA	PLUG-WOOD, 1/2"
25	084070-02-000	EA	POST-END, 2.4" - BRASS
26	100710-01-01A	EA	LOCK-GLASS DOOR, TWIST TYPE - BRASS
	000G13-06-10G	EA	SCREW - 6-20 X 5/8 PFH, ANTIQUE BRASS
	004354-01-000	EA	BUMPER-RUBBER, .5" DIA - BROWN
	009112-01-000	EA	FLANGE-ROD, 1" - COTHES ROD - PLASTIC - OFF WHITE
	023320-01-000	EA	PAD-FELT, 3/8" DIAMETER - BROWN
	042438-01-000	EA	DOWEL-WOOD, CLOTHES ROD - 1" DIAMETER X 4'
	042541-04-000	EA	LATCH-BRASS, W/O STRIKE - HASP TYPE - BRASS BRASS STRIKE #04254105000
	076790-01-000	EA	SCREW, 6-20 X 1 1/4 PPH - BLACK
	084451-01-000	EA	CATCH-TV SHELF, BRASS
	098980-02-000	EA	PILASTER-ADJUSTABLE SHELF, 12" LONG WOODGRAIN APPEARANCE
	103874-01-000	EA	HANGER-SLIDING DOOR
	111866-01-01A	EA	BRACE-SEAT, ANGLE

LABELS GROUP

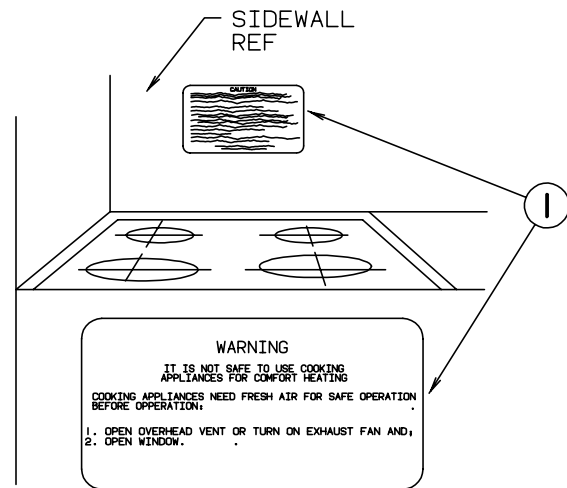

KEY	PART NUMBER	U/M	DESCRIPTION
1	050225-01-000	EA	LABEL-WARNING, STOVE VENT - US
1	050222-01-000	EA	LABEL-WARNING, STOVE VENT - CANADIAN

LABELS GROUP (CONTINUED)

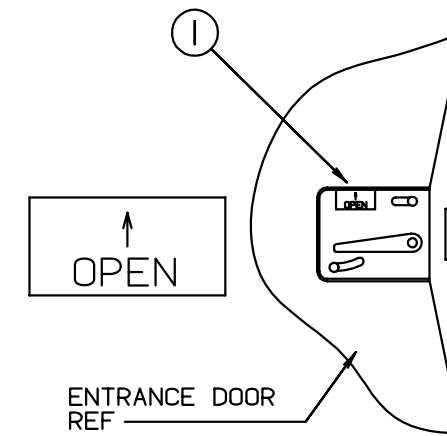

KEY	PART NUMBER	U/M	DESCRIPTION
1	040944-01-000	EA	LABEL-ENTRANCE DOOR, "OPEN"

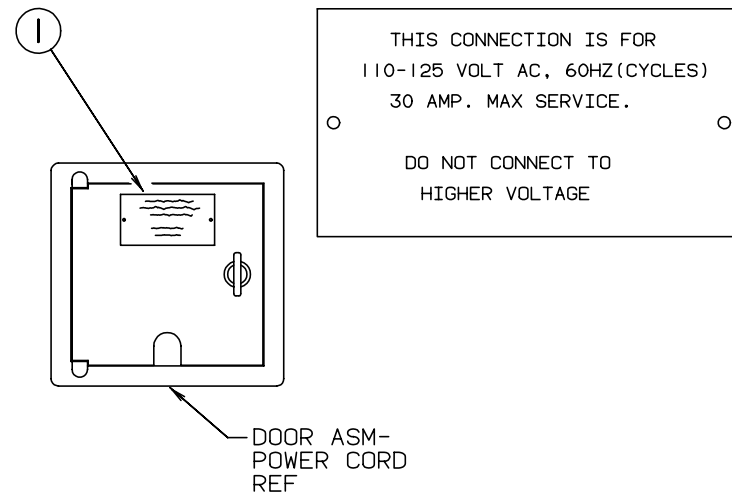

KEY	PART NUMBER	U/M	DESCRIPTION
1	006062-01-000	EA	TAG-ELECTRIC, 110V CONNECTION

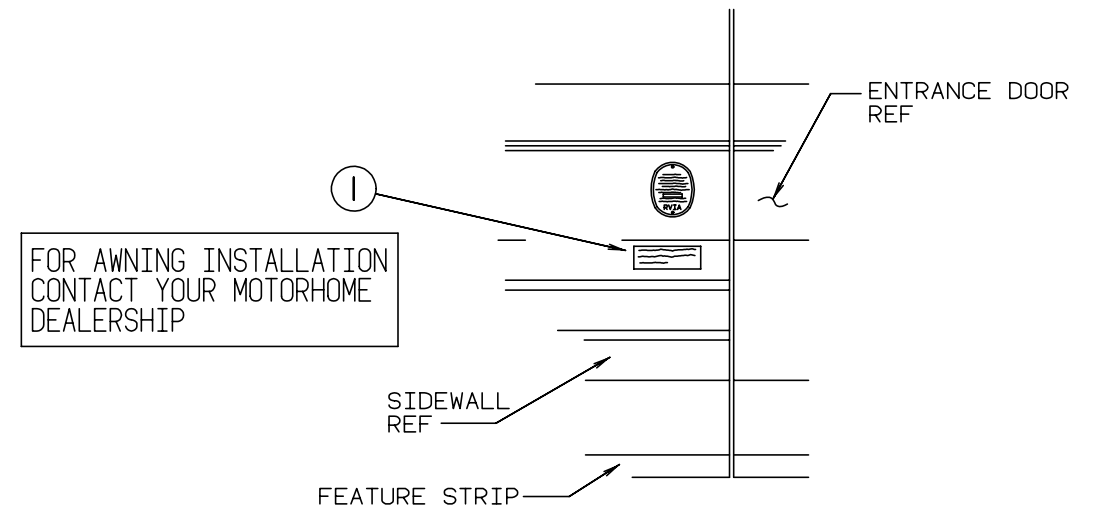

KEY	PART NUMBER	U/M	DESCRIPTION
1	099509-01-000	EA	LABEL-AWNING INSTALLATION

LABELS GROUP (CONTINUED)

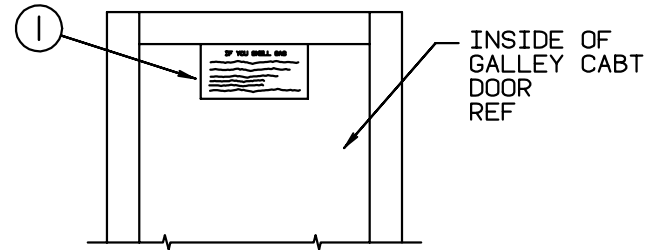

IF YOU SMELL GAS

1. EXTINGUISH ANY OPEN FLAME, PILOT LIGHTS AND ALL SMOKING MATERIALS.
2. SHUT OFF THE GAS SUPPLY AT THE TANK VALVE(OR GAS SUPPLY CONNECTION.
3. OPEN DOORS AND OTHER VENTILATING OPENINGS.
4. DO NOT TOUCH ELECTRICAL SWITCHES.
5. LEAVE THE AREA UNTIL ODOR CLEARS.
6. HAVE THE GAS SYSTEM CHECKED AND LEAKAGE SOURCE CORRECTED BEFORE USING AGAIN.

KEY	PART NUMBER	U/M	DESCRIPTION
1	073998-01-000	EA	LABEL-LPG ODOR WARNING

LABELS GROUP (CONTINUED)

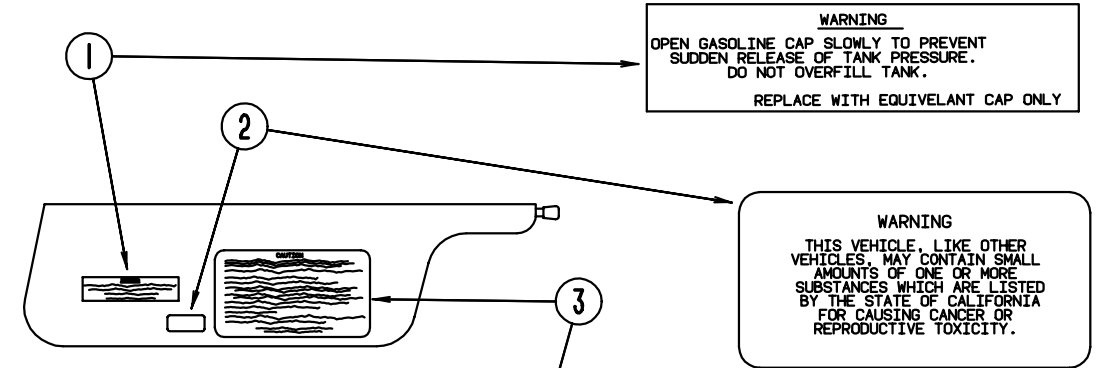

WARNING
 OPEN GASOLINE CAP SLOWLY TO PREVENT SUDDEN RELEASE OF TANK PRESSURE. DO NOT OVERFILL TANK.
 REPLACE WITH EQUIVELANT CAP ONLY

WARNING
 THIS VEHICLE, LIKE OTHER VEHICLES, MAY CONTAIN SMALL AMOUNTS OF ONE OR MORE SUBSTANCES WHICH ARE LISTED BY THE STATE OF CALIFORNIA FOR CAUSING CANCER OR REPRODUCTIVE TOXICITY.

CAUTION

THIS MOTOR HOME HAS BEEN DESIGNED, MANUFACTURED AND TESTED WITH CONCERN FOR THE PROTECTION OF IT'S OCCUPANTS. WE RECOMMEND YOU PERFORM THE FOLLOWING INSPECTIONS FOR YOUR SAFETY AND THE SAFETY OF YOUR PASSENGERS BEFORE STARTING YOUR VEHICLE.

1. LP GAS SYSTEM- TURN OFF AT TANK FOR TRAVELING. TEST FOR LEAKS UPON ARRIVAL AT DESTINATION. BEFORE LIGHTING PILOTS.
2. WHEELS- INSPECT FOR DAMAGE AND CHECK LUG NUTS FOR TIGHTNESS.
3. TIRES- INSPECT FOR WEAR AND DAMAGE AND CHECK FOR RECOMMENDED AIR PRESSURE.
4. LIGHTING- TEST FOR PROPER OPERATION OF ALL INTERIOR AND EXTERIOR LIGHTS INCLUDING DASH LIGHTS, HEADLIGHTS, TAIL LIGHTS, BRAKE LIGHTS, CLEARANCE LIGHTS AND TURN SIGNALS.
5. EXITS- INSPECT RELEASE MECHANISM ON EMERGENCY EXIT WINDOW, TEST BOTH LOCKS ON MAIN ENTRANCE DOOR FOR EASE OF OPERATION AND INSTRUCT PASSENGERS HOW TO USE BOTH MEANS OF EXIT.
6. SEAT BELTS- DIRECT PASSENGERS TO DESIGNATED SEATS AND REQUIRE USE OF SEAT BELTS.
7. APPLIANCES- TURN OFF AND LATCH OR LOCK DOORS WHERE PROVIDED.
8. LOOSE PARCELS- STORE SECURELY.
9. UTILITY SUPPLY LINES- DISCONNECT ALL ELECTRIC, SEWER AND WATER LINES AND SECURE PROPERLY.
10. ENTRANCE DOOR STEP- PLACE IN RETRACTED POSITION FOR TRAVELING.

READ YOUR MOTOR HOME AND CHASSIS OWNER'S MANUAL FOR FURTHER PRECAUTIONS

KEY	PART NUMBER	U/M	DESCRIPTION
1	087207-05-000	EA	LABEL-FUEL CAP REMOVAL
2	099689-01-000	EA	LABEL-WARNING, CANCER/TOXICITY
3	056259-01-000	EA	LABEL-SAFETY CHECK LIST

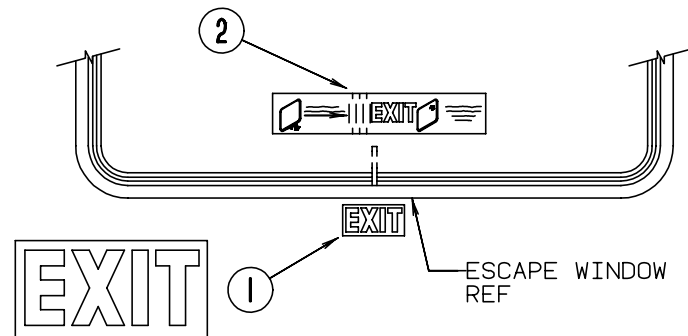

KEY	PART NUMBER	U/M	DESCRIPTION
1	039290-01-000	EA	LABEL-WARNING, EXIT
2	107571-01-000	EA	LABEL-ESCAPE EXIT, WINDOW

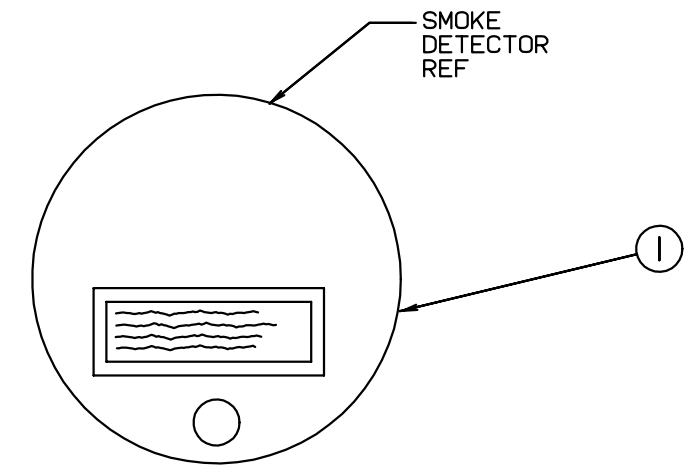

WARNING: TEST SMOKE DETECTOR OPERATION AFTER VEHICLE HAS BEEN IN STORAGE. BEFORE EACH TRIP AND AT LEAST ONCE PER WEEK DURING USE.

KEY	PART NUMBER	U/M	DESCRIPTION
1	077956-01-000	EA	LABEL-WARNING, SMOKE DETECTOR

LABELS GROUP (CONTINUED)

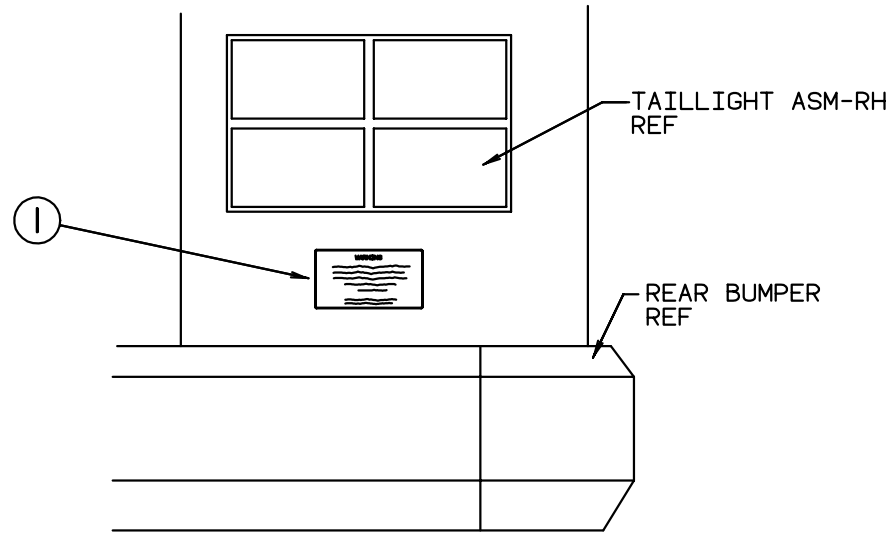

WARNING

DO NOT EXCEED THE VEHICLE WEIGHT RATINGS
OR LOADING RECOMMENDATIONS (E.G., GROSS
VEHICLE, GROSS AXLE, GROSS COMBINED) OF
THE CHASSIS MANUFACTURER OR
WINNEBAGO IND.

REFER TO YOUR OWNERS MANUAL,
BEFORE LOADING OR TOWING.

KEY PART NUMBER U/M DESCRIPTION
1 075220-01-000 EA LABEL-WARNING, EXTERIOR LOAD

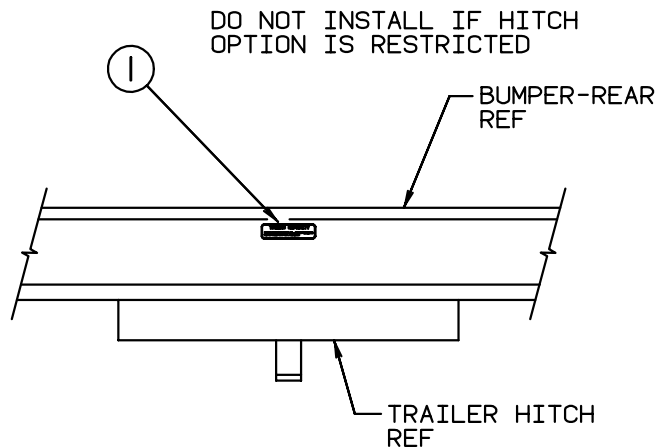

TOWING CAPACITY

TOWED VEHICLE 3500 LB. GROSS MAXIMUM
HITCH BALL 200 LB. MAXIMUM

KEY PART NUMBER U/M DESCRIPTION
1 075221-03-000 EA LABEL-TRAILER HITCH

LABELS GROUP (CONTINUED)

WARNING DISCONNECT BATTERIES BEFORE
CONNECTING EXTERNAL CHARGING EQUIPMENT.

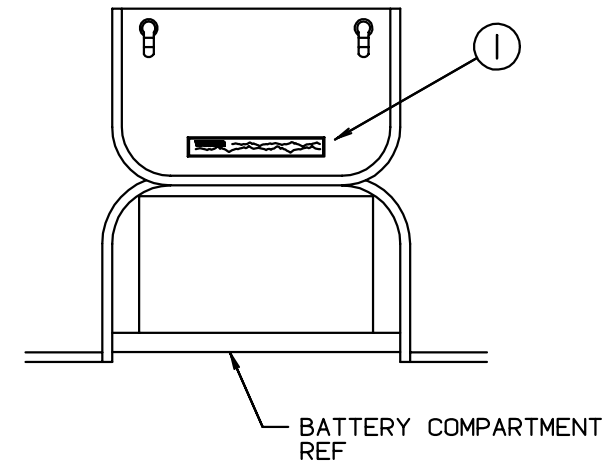

KEY PART NUMBER U/M DESCRIPTION
1 065748-01-000 EA LABEL-CAUTION, BATTERY CHARGING

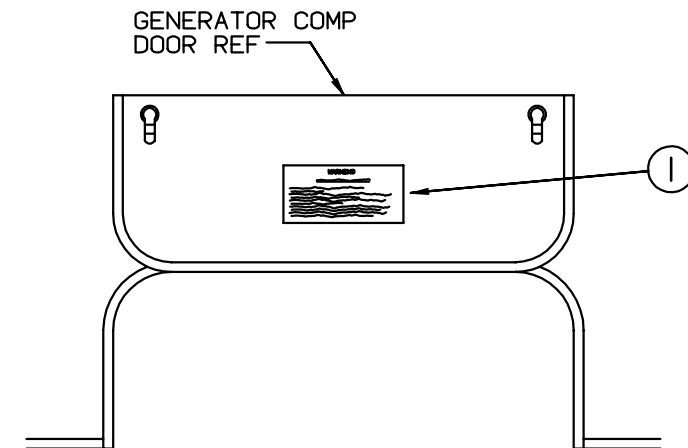

WARNING

WHEN ADDING A GENERATOR SET:

HIGH VOLTAGE-USE EXTREME CAUTION WHEN WORKING ON
ELECTRICAL COMPONENTS.
HAVE ALL ELECTRICAL INSTALLATION PERFORMED BY A QUALIFIED LICENSED
ELECTRICIAN-FOLLOW ALL STATE AND LOCAL CODES.
ONLY INSTALL GENERATOR SET APPROVED FOR R.V. APPLICATION. HAVE
INSTALLED BY QUALIFIED TECHNICIAN.
TO AVOID HEAT BUILD-UP AND TO GUARANTEE AN ADEQUATE AIR SUPPLY TO
THE GENERATOR CARBURETOR, FOLLOW INSTALLATION INSTRUCTIONS.
GENERATOR ENGINE EXHAUST GASES ARE TOXIC AND MUST NOT TERMINATE
UNDER THE VEHICLE-DISCHARGE EXHAUST AWAY FROM VEHICLE.

KEY PART NUMBER U/M DESCRIPTION
1 077510-01-000 EA LABEL-GENERATOR PREP

LABELS GROUP (CONTINUED)

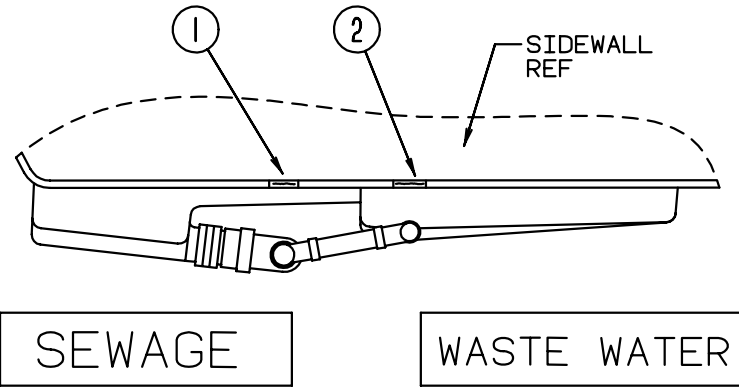

KEY	PART NUMBER	U/M	DESCRIPTION
1	006187-01-000	EA	LABEL-SEWAGE
2	006188-01-000	EA	LABEL-WASTE WATER

LABELS GROUP (CONTINUED)

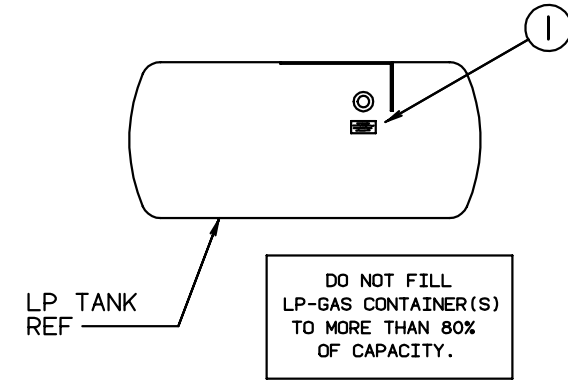

KEY	PART NUMBER	U/M	DESCRIPTION
1	079965-01-000	EA	LABEL-LPG 80 CAPACITY

WARNING
 ALL PILOT LIGHTS AND APPLIANCES SHALL BE TURNED OFF DURING REFUELING OF MOTOR FUEL TANKS AND/OR PERMANENTLY MOUNTED LP-GAS CONTAINERS.

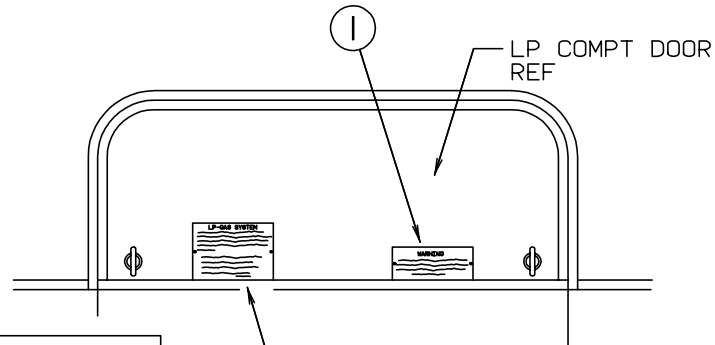

LP-GAS SYSTEM
 THIS GAS PIPING SYSTEM IS DESIGNED FOR USE OF LIQUEFIED PETROLEUM GAS ONLY. DO NOT CONNECT NATURAL GAS TO THIS SYSTEM.
 SECURELY CAP INLET(S) WHEN NOT CONNECTED FOR USE. AFTER TURNING ON GAS, EXCEPT AFTER NORMAL CONTAINER REPLACEMENT, TEST GAS PIPING AND CONNECTIONS TO APPLIANCE FOR LEAKAGE WITH SOAPY WATER OR BUBBLE SOLUTION. DO NOT USE PRODUCTS THAT CONTAIN AMMONIA OR CHLORINE.
 P.N. 54531

KEY	PART NUMBER	U/M	DESCRIPTION
1	006040-01-000	EA	TAG-GAS REFUELING WARNING
1	006040-02-000	EA	TAG-GAS REFUEL WARNING, CANADIAN
2	054531-01-000	EA	LABEL-LP GAS ONLY
2	023769-01-000	EA	LABEL-WARNING, LPG - CANADIAN

WARNING
 OPEN GASOLINE CAP SLOWLY TO PREVENT SUDDEN RELEASE OF TANK PRESSURE. DO NOT OVERFILL TANK.
 REPLACE WITH EQUIVELANT CAP ONLY

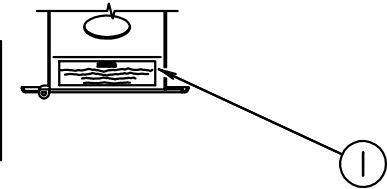

UNLEADED FUEL ONLY

WARNING
 ALL PILOT LIGHTS AND APPLIANCES SHALL BE TURNED OFF DURING REFUELING OF MOTOR FUEL TANKS AND/OR PERMANENTLY MOUNTED LP-GAS CONTAINERS.

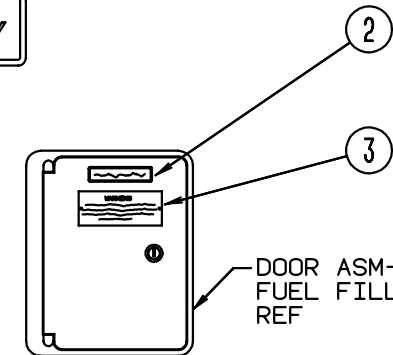

KEY	PART NUMBER	U/M	DESCRIPTION	MISCELLANEOUS LABELS
1	087207-05-000	EA	LABEL-FUEL CAP REMOVAL	
2	062043-01-000	EA	LABEL-FUEL, UNLEADED	
3	006040-01-000	EA	TAG-GAS REFUELING WARNING	
3	006040-02-000	EA	TAG-GAS REFUEL WARNING, CANADIAN	
	091224-02-000	EA	LABEL-TRAILER LIGHTING	
	061606-01-000	EA	LABEL-OVERLAY, VEHICLE CERTIFICATION - ADHESIVE BACKED	
	074983-01-000	EA	LABEL-SWITCH, A/C SELECTOR FOR FRONT OR REAR	
	091243-01-000	EA	LABEL-A/C COVER, "AIR CONDITIONING CIRCUIT. ETC."	
	098379-03-000	EA	LABEL-ELECTRICAL BOX,FRONT	
	098641-01-000	EA	LABEL-FUEL, UNLEADED - DASH	
	104678-01-000	EA	LABEL-CB PREP	
	111104-01-000	EA	LABEL-HITCH,READ MANUAL	
	111537-01-000	EA	LABEL-FUSES	

LP GROUP

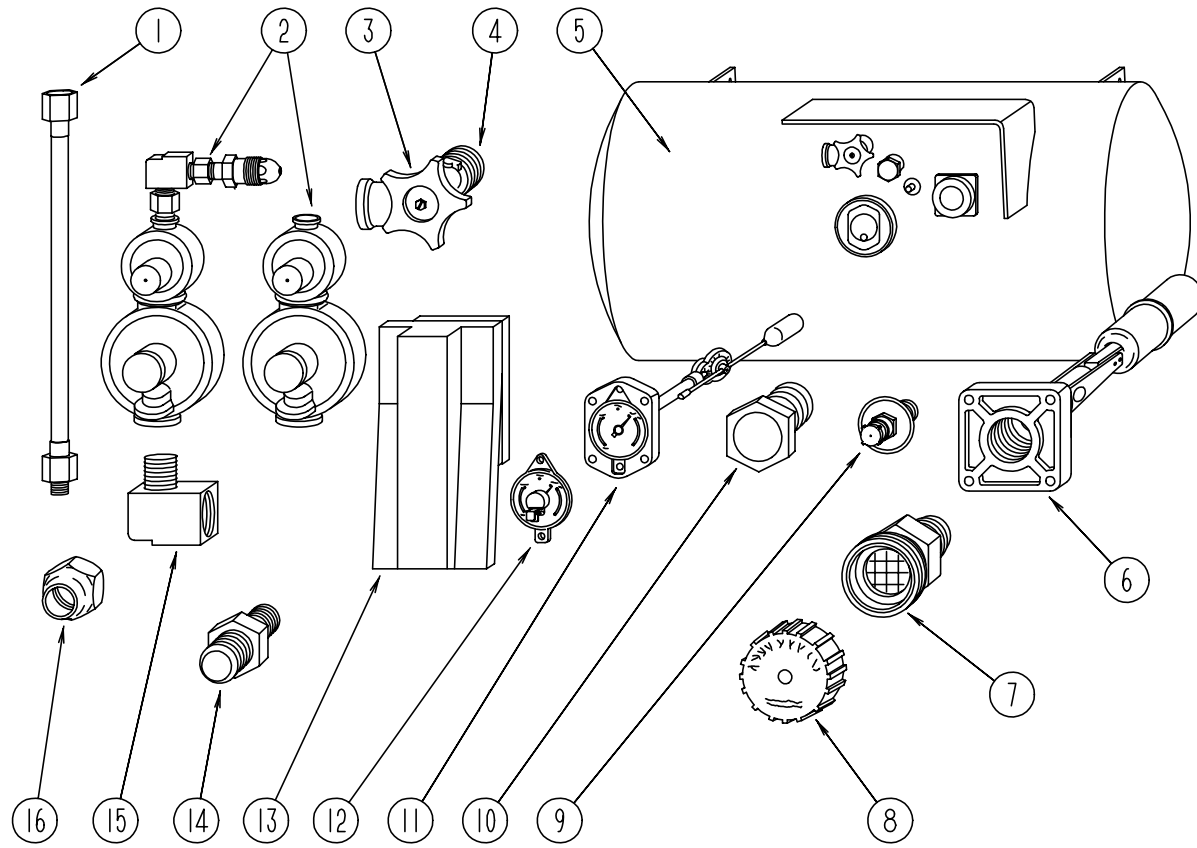

LP TANK & COMPONENTS

KEY	PART NUMBER	U/M	DESCRIPTION
1	045703-01-000	EA	HOSE-LP, 3/8" ID X 24" - 3/8" MPT X 1/2" F SWIVEL - US
1	045703-02-000	EA	HOSE-LP, 3/8" ID X 24" - 3/8" MPT X 1/2" F SWIVEL - CANADIAN
1	045703-03-000	EA	HOSE-LP, 3/8" ID X 18" - 3/8" MPT X 1/2" F SWIVEL - EXPORT LP GENERATOR
2	106150-01-000	EA	REGULATOR-TWO STAGE
2	106150-02-000	EA	REGULATOR-TWO STAGE - EUROPEAN EXPORT OPTION
3	040421-01-708	EA	HANDWHEEL-VAPOR RELIEF VALVE, BRUNNER G-1015-A
4	040421-01-712	EA	VALVE-SERVICE W/O VAPOR RELIEF, 29000853
5	088253-03-000	EA	TANK-LP, 100 LB - 16" X 36" LONG
6	040421-01-711	EA	VALVE - 80% W/FLOAT, PLATE, BOLTS & GASKET - BRUNNER
7	040421-01-701	EA	VALVE-SHORT LP FILLER W/YELLOW CAP - BRUNNER 75478
8	040421-01-702	EA	CAP-LP FILLER VALVE, PLASTIC - YELLOW - BRUNNER G-1014-A
9	040421-01-700	EA	GAUGE-LIQUID LEVEL, 20% LP - BRUNNER G-1013
10	040421-01-713	EA	PRESSURE RELIEF VALVE
11	040421-01-707	EA	GAUGE-FLOAT W/VISIBLE DIAL - BRUNNER MA-9 6244-4
12	040440-02-000	EA	TRANSMITTER-DIAL, 90 OHM
13	105658-01-000	EA	COMPARTMENT-LP REGULATOR
14	010329-01-000	EA	ADAPTER-BRASS, 1/2" F X 1/2" MPT
14	010323-01-000	EA	ADAPTER-BRASS, 3/8" F X 1/2" MPT
15	065318-02-000	EA	ELBOW - 90 DEGREE, 3/8" MPT TO 3/8" FPT
16	010377-02-000	EA	NUT-BRASS, 3/8 FEMALE - FORGED
	024250-01-000	EA	ADAPTER-BRASS, 3/8" F X 1/2" FPT
	036346-01-000	EA	BUSHING-STEEL, 3/4" MPT X 1/2" FPT - EUROPEAN EXPORT OPTION
	008042-01-000	FT	TUBING-VINYL, .65" ID
	074458-01-000	EA	ELBOW - 3/8" M FL X 3/8" F FL SWIVEL - ANCHOR BRASS A800
	095624-01-000	EA	ELBOW - 90 DEGREE, 1/4" FPT X 1/4" FPT - BRASS
	010380-02-000	EA	NUT-BRASS, 1/2" FEMALE - FORGED
	103613-01-000	EA	DETECTOR-LP GAS

LOUNGE GROUP

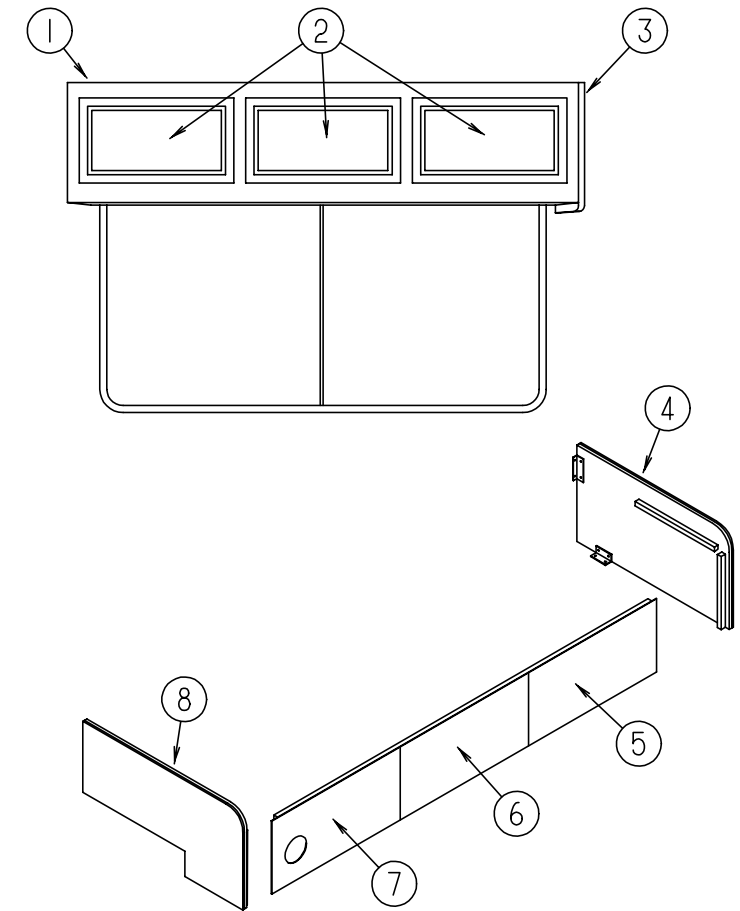

DRIVERS SIDE LOUNGE

KEY	PART NUMBER	U/M	DESCRIPTION
1	106524-01-F04	EA	CABINET ASM-OVERHEAD, FRONT, LEFT
2	M06803-03-F04	EA	DOOR ASM. W/DECORATIVE MIRROR INSERT - 400 X 520
3	103128-01-E10	EA	CAP ASM-END, OVERHEAD
4	M04187-44-E28	EA	PANEL-COUCH CABINET - FABRIC COVERED (F24)
4	M04187-44-F25	EA	PANEL-COUCH CABINET - FABRIC COVERED
4	M04187-44-F26	EA	PANEL-COUCH CABINET - FABRIC COVERED
4	M04187-44-F27	EA	PANEL-COUCH CABINET - FABRIC COVERED
5	M04187-47-E28	EA	PANEL-COUCH CABINET - FABRIC COVERED (F24)
5	M04187-47-F25	EA	PANEL-COUCH CABINET - FABRIC COVERED
5	M04187-47-F26	EA	PANEL-COUCH CABINET - FABRIC COVERED
5	M04187-47-F27	EA	PANEL-COUCH CABINET - FABRIC COVERED
6	M04187-46-E28	EA	PANEL-COUCH CABINET - FABRIC COVERED (F24)
6	M04187-46-F25	EA	PANEL-COUCH CABINET - FABRIC COVERED
6	M04187-46-F26	EA	PANEL-COUCH CABINET - FABRIC COVERED
6	M04187-46-F27	EA	PANEL-COUCH CABINET - FABRIC COVERED
7	M04187-45-E28	EA	PANEL-COUCH CABINET - FABRIC COVERED (F24)
7	M04187-45-F25	EA	PANEL-COUCH CABINET - FABRIC COVERED

LOUNGE GROUP (CONTINUED)

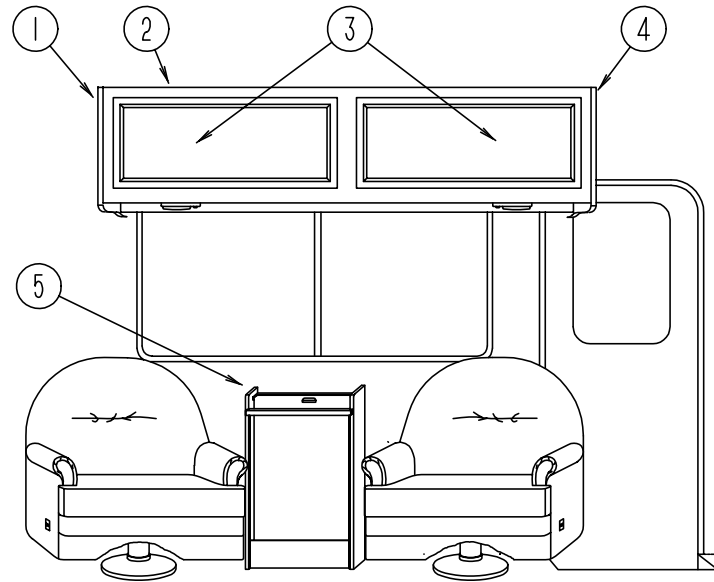

PASSENGER SIDE LOUNGE

KEY	PART NUMBER	U/M	DESCRIPTION
1	103128-02-E10	EA	CAP ASM-END, OVERHEAD
2	106483-01-F04	EA	CABINET ASM-OVERHEAD, FRONT, RIGHT (F24)
2	106483-01-E07	EA	CABINET ASM-OVERHEAD, FRONT, RIGHT (F25,F26)
2	106483-01-F24	EA	CABINET ASM-OVERHEAD, FRONT, RIGHT (F27)
3	M06803-02-E07	EA	DOOR ASM-W/O HARDWARE - 400 X 710
4	103128-01-E10	EA	CAP ASM-END, OVERHEAD
5	M96873-01-E07	EA	TABLE ASM-PULLOUT
	104006-01-C05	EA	LID-ENTRANCE STEP COMPARTMENT, W/O CARPET
	101222-01-02A	EA	BRACKET-CATCH, LID - O/W
	107941-01-02A	EA	SUPPORT-LID, ENTRANCE STEP - O/W

LOUNGE GROUP (CONTINUED)

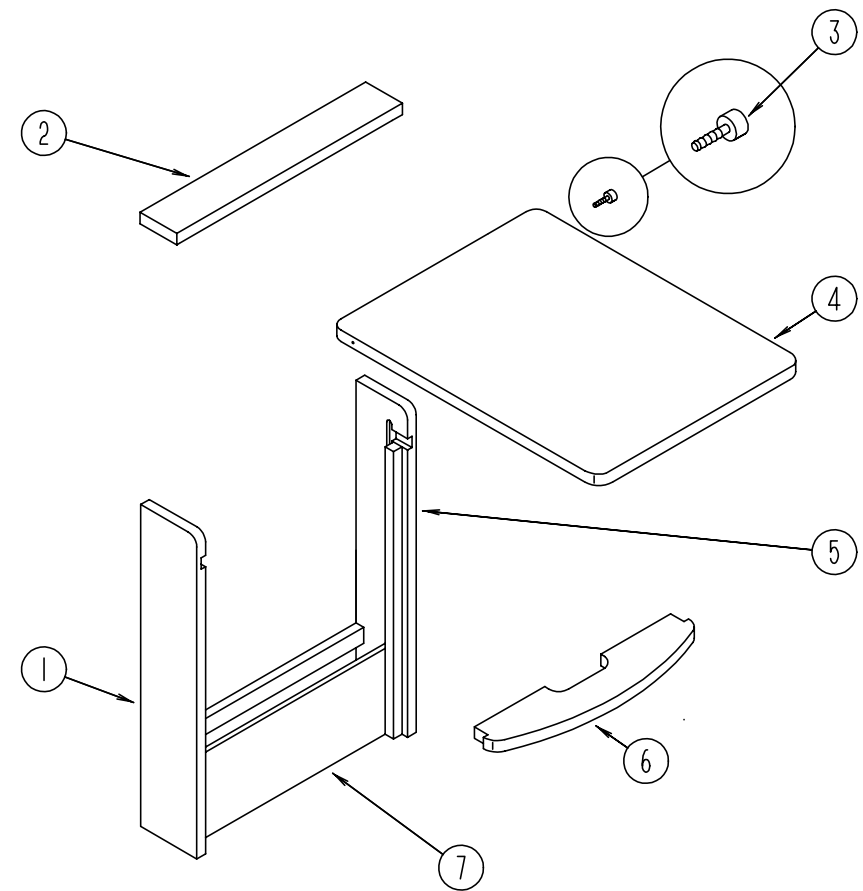

PULLOUT TABLE

KEY	PART NUMBER	U/M	DESCRIPTION
	M96873-01-E07	EA	CABINET ASM. - TABLE - W/O PULLOUT TOP
1	096873-14-B87	EA	SIDE END - TABLE - 28.7" X 5.7" - LEFT SIDE
2	096873-15-B87	EA	SHELF - SUPPORT - OVER PULL OUT TABLE TOP
3	079921-01-000	EA	NYLON ROLLER W/SHAFT
4	096873-11-E13	EA	PULLOUT TOP
5	096873-13-B87	EA	SIDE END - TABLE - 28.7" X 5.7" - RIGHT SIDE
6	096873-12-B87	EA	SHELF - SUPPORT - UNDER PULL OUT TABLE TOP
7	096873-16-B87	EA	PANEL - TABLE - FRONT BOTTOM - 18.1" X 6.7"
	080736-01-000	EA	PULL - RECESSED - 1.25" X 4" - OAK

SEALANTS & FASTENERS GROUP
SEALANTS & ADHESIVE

KEY	PART NUMBER	U/M DESCRIPTION
	002707-02-000	FT TAPE-SEALER, 5/16" X 1/2" - INCREMENTS OF 50 FT
	063642-01-000	FT TAPE-ADHESIVE, 10 MM X 1.5" WIDE X 180'
	076314-02-000	FT TAPE-CARPET SEAM, HEAT-BOND - 4" WIDE
	076322-01-000	FT TAPE-FOAM, DOUBLE COATED ADHESIVE BACKED - .75" X 216'
	076322-02-000	FT TAPE-FOAM, DOUBLE COATED ADHESIVE BACKED - 1" X 108'
	076322-05-000	FT TAPE-FOAM, DOUBLE COATED - .025" X 1.5" X 108'
	076322-07-000	FT TAPE-FOAM, DOUBLE COATED - .045" X .50"
	034552-02-000	EA SILICONE-TUBE, 300 ML - CLEAR
	034552-06-000	EA SILICONE-TUBE, 300 ML - OFF WHITE
	108716-01-000	EA SILICONE-TUBE, OFF WHITE - SELF LEVELING - CSL 510
	900390-01-000	EA TIP-2 1/2" X 1/8" ORIFICE, ELLSWORTH#TS216
	900390-03-000	EA NOZZLES-SILICONE TUBE, CSL# D10
	053766-02-000	EA BEDDING COMPOUND-TUBE, WHITE SCHNEE# 5522
	053766-06-000	EA BEDDING COMPOUND-TUBE, CLEAR
	053766-15-000	EA BEDDING COMPOUND-TUBE, BRIGHT WHITE
	062917-03-000	EA ADHESIVE-LOCTITE 242 LOCTITE 242,SIDE 41
	069640-01-000	FT SEALER-RIBBON, 1/4" DIAMETER - INCREMENTS OF 30'
	069640-03-000	FT SEALER-RIBBON, 3/4" X 1/8" - INCREMENTS OF 60'
	069640-09-000	FT SEALER-RIBBON, 1/32" X 2 1/2" - INCREMENTS OF 80'
	069640-11-000	FT SEALER-TAPE, 3/16" X 3/8", BLACK - MANUS
	069640-13-000	FT SEALER-TAPE, 3/32" X 2" BLACK MANUS
	069640-14-000	FT SEALER-TAPE, 1/16" X 1" GRAY MANUS
	072889-01-000	EA SEALANT-URETHANE, BLACK - 1/10 - ESSEX 552.2
	072889-01-000	EA SEALANT-URETHANE, BLACK (TUBE) - MANUS 75AM
		FROM: 01-19-94 THRU: 99-99-99
	087211-01-000	GL PROMOTER-ADHESIVE
	102352-01-000	EA SEALER-PUMPABLE, BLACK - COLORIMETRIC MS101
	091255-01-000	FT SEAL-FOAM, 3.2MM X 4.8MM
	106206-01-000	EA SEALER PUMPABLE, MANUS 30A - BLACK
	114311-01-000	GL ADHESIVE-GLUE

BOLTS, NUTS & WASHERS

KEY	PART NUMBER	U/M DESCRIPTION
	000C12-05-12B	EA BOLT-HEX, 5/16-18 X 3/4 ZN 5
	000C12-05-16B	EA BOLT-HEX, 5/16-18 X 1 - ZINC 5
	000C12-06-16B	EA BOLT-HEX, 3/8-16 X 1LG,ZN 5
	000C12-07-20B	EA BOLT-HEX, 7/16 - 14 X 1 1/4" - ZN5
	000C12-08-24B	EA BOLT-HEX, 1/2-13 X 1 1/2 - ZN 5
	000C12-09-20B	EA BOLT-HEX, 9/16-12 X 1 1/4,ZN 5
	000C12-10-24B	EA BOLT-HEX, 5/8-11 X 1 1/2 ZN - 5
	000C13-07-48B	EA BOLT-HEX, 7/16 - 20 X 3 - ZN 5
	000C18-05-40A	EA BOLT-ELEV, 5/16"-18 X 2 1/2" PL
	000C26-04-10B	EA BOLT-HEX, SER FLG - 1/4-20 X 5/8 ZINC
	000C26-05-12B	EA BOLT-HEX-SER FLG 5/16-18 X 3/4 ZN
	000C26-06-28B	EA BOLT-HEX-SER FLG 3/8-16 X 13/4 ZN
	000C27-10-32B	EA BOLT-CARR 5/8-11 X 2.00
	000G45-05-16B	EA BOLT-LAG 5/16 - 9 X 1 ZN
	051387-06-000	EA BOLT-CARRIAGE, W/O HOLE - 5/16-18 X 9.5 ZN
	102333-01-02A	EA BOLT-CARRIAGE, 7/16 - 14 SST CAP O/W BUMPER BOLT
	104369-01-000	EA NUT-HEX,HEAVY, 5/8-11 UNC SPARE TIRE
	105247-01-000	EA INSERT NUT 8-32 THD X .394LG STAFAST PRODUCTS
	063253-07-000	EA NUT-J, #8A .120- .130 PNL THK
	040921-03-000	EA NUT-SPEED, U TYPE - NO 10
	040921-04-000	EA NUT-SPEED, U TYPE - NO. 8 - .59" LENGTH X .44" WIDTH
	044364-02-000	EA NUT-SPEED, FLAT - ROUND
	000D24-10-00B	EA NUT-HEX, SF/LK - 10-32 ZN
	000D29-09-00B	EA NUT-HEX SELFLOCK 9/16-12 ZN
	000D34-06-00B	EA NUT-HEX, LK - 3/8 - 16 GRADE C ZN - PREVAILING TORQUE
	000D39-04-00B	EA NUT-HEX, SER FLG LK 1/4 - 20 ZN
	000D39-05-00B	EA NUT-HEX, SER FLG LK - 5/16 - 18 ZN
	000D39-06-00B	EA NUT-HEX, SER FLG LK - 3/8-16 ZN

SEALANTS & FASTENERS GROUP (CONTINUED)
BOLTS, NUTS & WASHERS (CONTINUED)

KEY	PART NUMBER	U/M DESCRIPTION
	044533-01-000	EA WASHER-PLASTIC, 1 3/8" OD - FOR BUTTONS
	077071-01-000	EA WASHER-FENDER, 3/16" ID X 1" OD
	106649-01-000	EA WASHER-SEALING,GALVANIZED
	106649-02-000	EA WASHER-SEALING,GALVANIZED
	000D39-08-00B	EA NUT-HEX, SER FLG LK - 1/2-13 ZN
	000D44-07-00B	EA NUT-HEX, SER FLG LK - 7/16-20 ZN
	000E11-07-00B	EA WASHER-LK-7/16 MED SPLIT ZN 05114-01-000
	000E13-14-00B	EA WASHER-FL, 1/4" WIDE ZN
	000E13-20-00B	EA WASHER-FL, 7/16" WIDE - ZN
	000E13-21-00B	EA WASHER-FL - W/2 NAR ZN
	000E14-10-00B	EA WASHER-LK - NO 10 EXT TOOTH - ZN

SCREWS

KEY	PART NUMBER	U/M DESCRIPTION
	000G11-06-10J	EA SCREW, 6-20 X 5/8 PPH - BRASS
	000G11-06-10B	EA SCREW, 6-20 X 5/8 PPH ZN
	000G11-06-06B	EA SCREW, 6-20 X 3/8 PPH ZN
	000G11-07-08B	EA SCREW, 7-19 X 1/2 PPH - ZN
	000G11-08-12B	EA SCREW, 8-18 X 3/4 PPH ZN
	000G11-08-08B	EA SCREW, 8-18 X 1/2 PPH - ZN
	000G11-08-06B	EA SCREW, 8-18 X 3/8 PPH ZN
	000G11-08-12T	EA SCREW, 8-18 X 3/4 PPH - BLACK
	000G11-08-12S	EA SCREW, 8-18 X 3/4 PPH - OFF WHITE
	000G11-08-12P	EA SCREW, 8-18 X .75 PPH - DARK BROWN
	000G11-08-12D	EA SCREW, 8-18 X 3/4 PPH - BLACK
	000G11-10-40B	EA SCREW-10 - 16 X 2 1/2 PPH CAD - 34927-01-000
	000G11-10-16B	EA SCREW, 10-16 X 1 - PPH ZN
	000G11-10-12S	EA SCREW, 10-16 X .75 PPH OFF WHT
	000G11-10-12D	EA SCREW, 10-16 X 3/4 PPH - BLACK
	000G12-06-08T	EA SCREW, 6-20 X .50 POH - BLACK
	000G12-08-16S	EA SCREW, 8-18 X 1.00 POH - OFF WHITE
	000G13-06-08G	EA SCREW, 6-20 X 1/2 PFH - ANTIQUE BRASS
	000G13-06-08B	EA SCREW, 6-20 X 1/2 PFH ZN
	000G13-06-16J	EA SCREW, 6-20 X 1.00 PFH - BRASS
	000G18-08-22B	EA SCREW-MACH, 8-32 X 1 3/8 PPH ZN
	000G19-10-08B	EA SCREW-MACHINE, 10-32 X 1/2 PPH ZN
	000G19-10-20B	EA SCREW-MACHINE, 10-32 X 1 1/14 PPH ZINK
	000G19-10-12B	EA SCREW-MACH, 10-32 TPI X .75
	000G32-10-06B	EA SCREW, 10-32 X 3/8" - PPH - ZINC
	000G39-06-10T	EA SCREW-SF/DR, 6-20 X 5/8 PPH - BLACK
	000G39-06-16T	EA SCREW-SF/DR, 6-20 X 1 PPH - BLACK
	000G39-08-08R	EA SCREW-SF/DR, 8-18 X 1/2 PPH - BEIGE
	000G39-08-08B	EA SCREW-SF/DR, 8-18 X 1/2 PPH ZN
	000G39-08-06B	EA SCREW-SF/DR, 8-18 X 3/8 PPH ZN
	000G39-08-12T	EA SCREW-SF/DR, 8-18 X 3/4 PPH - BLACK
	000G39-08-12B	EA SCREW-SF/DR, 8-18 X 3/4 PPH ZN
	000G39-08-08T	EA SCREW-SF/DR, 8-18 X .50 PPH BLACK
	000G39-08-08S	EA SCREW-SF/DR, 8-18 X 1/2 PPH - OFF WHITE
	000G39-08-32B	EA SCREW-SF/DR, 8-18 X 2 PPH - ZINC
	000G39-08-16T	EA SCREW-SF/DR, 8-18 X 1 PPH - BLACK
	000G39-08-16S	EA SCREW-SF/DR, 8-18 X 1.00 PPH, OFF WHITE
	000G39-08-16B	EA SCREW-SF/DR, 8-18 X 1 PPH ZN
	000G39-10-209	EA SCREW-SF/DR, 10-16 X 1.25 PPH FLUOROCARBON SILVER

SEALANTS & FASTENERS GROUP (CONTINUED)
SCREWS (CONTINUED)

KEY	PART NUMBER	U/M DESCRIPTION
	000G39-10-20B	EA SCREW-SF/DR, 10-16 X 1 1/4 PPH ZN
	000G39-10-129	EA SCREW-SF/DR, 10-16 X 3/4 PPH - FLUOROCARBON SILVER
	000G39-10-12D	EA SCREW-SF/DR, 10-16 X 3/4 PPH - BLACK
	000G42-04-12B	EA SCREW-SF/DR 1/4-14 X 3/4HWH ZN
	000G43-06-24B	EA SCREW-MACHINE, 6-32" X 1 1/2" ZN
	000G46-08-24T	EA SCREW-MACHINE, 8-32-1.50 IN PFH - BLACK
	000G50-04-12B	EA SCREW-MACH, 1/4-20 X 3/4 PPH ZN
	000G52-08-18B	EA SCREW-MACH, 8-32 X 11/8 PTH ZN
	000G53-04-06B	EA SCREW-MACHINE, 1/4-20 X 3/8 PPH ZN - UNDERCUT HEAD
	000G54-04-20B	EA SCREW, 1/4-20 X 1 1/4 PTH - TYPE 23 - ZINC PLATED
	000G56-12-48B	EA SCREW-WOOD, 12 - 11 X 3 POH - SPECIAL HARDENED
	000G60-08-164	EA SCREW-SF/DR, 8-18 X 1.00 POH ASH GRAY
	000G60-10-28T	EA SCREW-SF/DR, 10-16 X 1.75 - BLACK
	000G67-10-08B	EA SCREW, 10-12 X 1/2 PPH ZN
	000G67-10-36T	EA SCREW-10-12 X 2.25PPHBLACK STALGARD
	000G67-10-24B	EA SCREW, 10-12 X 1 1/2 PPH - ZN
	000G67-10-20D	EA SCREW, 10-12 X 1 1/4 PPH - BLACK
	000G67-10-16B	EA SCREW, 10-12 X 1 PPH - ZN
	000G67-10-120	EA SCREW, 10-12 X .75" PPH - TAN
	000G67-10-12B	EA SCREW, 10-12 X 3/4" PPH - ZN
	000G67-10-10D	EA SCREW, 10-12 X 5/8 PPH - BLACK - TYPE A
	000G67-10-10B	EA SCREW, 10-12 X 5/8 PPH ZN - TYPE A
	000G67-10-08R	EA SCREW, 10-12 X 1/2 PPH - BEIGE - TYPE A
	000G68-06-10G	EA SCREW, 6-18 X 5/8 POH - ANTIQUE BRASS
	049465-01-000	EA SCREW, 10-16 W/WASHER PTH - DARK BROWN
	049465-03-000	EA SCREW, 10-16 X 1 POH W/WASHER - OFF WHITE
	049465-04-000	EA SCREW, 10-16 X 1 PTH W/WASHER - BEIGE
	049465-05-000	EA SCREW, 10-16 X 1 PTH W/WASHER - GRAY
	075908-01-000	EA SCREW-MACHINE, 10-32 X .56 PTH - ZINC EXTERNAL TOOTH

SEALANTS & FASTENERS GROUP (CONTINUED)
CLAMPS, RIVETS & GROMMETS

KEY	PART NUMBER	U/M DESCRIPTION
	000H14-06-14R	EA RIVET-MANDREL BLIND, 3/16"
	007161-01-000	EA CLAMP-HOSE, SPRING TYPE - 1/2"
	010495-01-000	EA CLAMP-CABLE, 9/16"
	010497-01-000	EA CLAMP-CLOSED, 5/8" ID
	010497-01-000	EA CLAMP-CLOSED, 5/8" ID
	010497-03-000	EA CLAMP-CLOSED, 1" ID - CUSHIONED
	010497-04-000	EA CLAMP-CLOSED, 1.62 ID ADEL,945-2717
	010499-01-000	EA CLAMP-CLOSED, 3/8" ID
	062401-01-000	EA CLAMP-HOSE, WORMGEAR .25" - 1"
	062401-02-000	EA CLAMP-HOSE, WORMGEAR, 1.56" - 2.5"
	062401-03-000	EA CLAMP-HOSE, WORMGEAR - .22" - 1"
	062401-04-000	EA CLAMP-HOSE, WORMGEAR .69"- 1.25"
	062401-06-000	EA CLAMP-HOSE, WORMGEAR .22"- .62"
	062401-11-000	EA CLAMP-HOSE, WORMGEAR 3.56"- 4.5"
	075148-02-000	EA CLAMP-GROUNDING, BRONZE SCREWS
	083609-01-000	EA CLAMP-WIRE, DUAL EQUAL - 5/8" DIAMETER
	083610-01-000	EA CLAMP-WIRE, DUAL UNEQUAL DIAMETERS - .75" & 1.25"
	083610-02-000	EA CLAMP-WIRE, DUAL UNEQUAL DIA
	016188-03-000	EA GROMMET-L/P LINE, 3/8" HOLE X 2 1/2" LONG - RUBBER
	016188-05-000	EA GROMMET-L/P LINE, 3/8" HOLE X 1 1/4" LONG - RUBBER
	023942-01-000	EA GROMMET-RUBBER, 2" OD
	099637-01-000	EA GROMMET-RUBBER, .37" X .94" DIAMETER - BLACK
	056134-02-000	EA HOLDER-RING, 1.8" DIAMETER - METAL
	077955-01-000	EA CLIP-J, VINYL COATED, 3/8"
	080211-03-000	EA CLIP-MOUNTING, (XMAS TREE) - DECORATIVE PADS
	080734-02-000	EA CLIP-WIRE, NYLON
	094362-02-000	EA CLIP-CHRISTMAS TREE, FLAT HEAD - .5" X .95"

SEALANTS & FASTENERS MISCELLANEOUS

KEY	PART NUMBER	U/M DESCRIPTION
	008343-01-000	EA TIE-WIRE, 6"
	008343-02-000	EA TIE-WIRE, 14"
	029094-04-000	YD VELCRO TAPE-LOOP, 1" WIDE - BLACK
	029096-03-000	YD VELCRO TAPE-HOOK, 1" WIDE - BLACK
	029096-04-000	YD TAPE-HOOK, VELCRO - 1" WIDE - BLACK
	085774-01-000	FT FASTENER-DUAL HOOK, 1" WIDE - ADHESIVE BACK - BLACK
	085774-02-000	FT FASTENER-DUAL LOOP, 1" WIDE - ADHESIVE BACK - BLACK
	086285-01-000	EA SPACER-NYLON, .5" OD X .257" ID
	108046-02-000	EA CABLE TIE-SCREW MOUNT 15" DENNISON 10035

WATER & SEWAGE GROUP
WATER HEATER W/ELECTRIC IGNITION

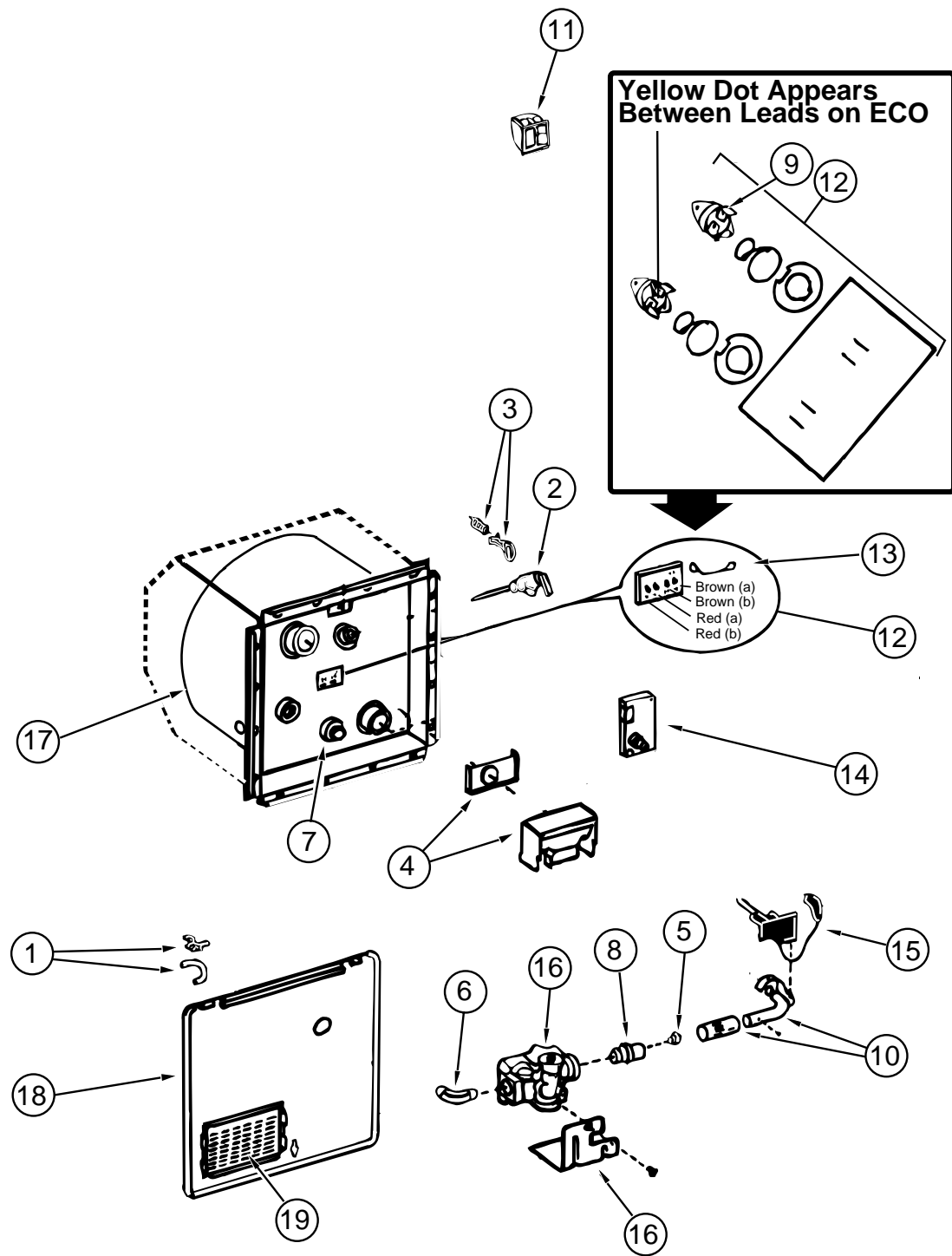

KEY	PART NUMBER	U/M DESCRIPTION
	051391-03-000	EA HEATER-WATER, W/ELECTRIC IGNITION - ATWOOD G6A-7E
1	051391-01-700	EA HINGE KIT-W/CLIP, ATWOOD# 92568 & 92559
2	051391-01-704	EA VALVE-RELIEF, 1/2" FITTING - ATWOOD# 91604
3	051391-01-705	EA FASTENER-CAMLOC, ATWOOD# 92609
4	051391-01-706	EA FLUE & GASKET
5	051391-01-710	EA ORIFICE-MAIN BURNER, ATWOOD# 92742
6	051391-01-714	EA ELBOW - 45 DEGREE, 3/8"F X 3/8"MPT - ATWOOD 91044
7	051391-01-715	EA DRAIN PLUG, ATWOOD# 91561
8	051391-03-700	EA ORIFICE HOLDER-ATWOOD# 91563
9	051391-04-701	EA THERMOSTAT 12 VDC-120 PRESET, FRONT MOUNT ONLY - ATWOOD# 91470
10	051391-04-703	EA BURNER-MAIN, 3E ONLY - ATWOOD# 91638
11	097967-01-000	EA SWITCH-WATER HEATER, REMOTE W/LIGHT - ATWOOD# 91959
12	051393-01-721	EA ECO & THERMOSTAT ASM-FRONT MOUNT, 140 DEGREE - ATWOOD# 91447
13	051393-01-723	EA SWITCH-THERMAL CUT-OFF 2/PKG, ATWOOD# 93866
14	051393-01-724	EA CIRCUIT BOARD-SPADE TERMINAL, ATWOOD# 93867
15	051393-01-725	EA ELECTRODE-SINGLE SPADE CONNECT - ATWOOD 93868
16	051393-01-726	EA SOLENOID VALVE AND BRACKET - ATWOOD# 93870
17	051391-04-706	EA TANK-INNER, G6A-4E & 6E - FRONT MOUNT - ATWOOD# 91641
18	052009-06-000	EA DOOR-WATER HEATER, BRIGHT WHITE
19	051391-01-717	EA GRILL ONLY
	116424-01-000	EA PROTECTOR-WATER HEATER LATCH - ATWOOD 92611

WATER & SEWAGE GROUP (CONTINUED)
WATER HEATER W/MOTOR AID

KEY	PART NUMBER	U/M DESCRIPTION
	051393-01-000	EA WATER HEATER-W/MOTOR AID, PILOTLESS IGNITION - ATWOOD GH6-7E
1	051391-01-700	EA HINGE KIT-W/CLIP, ATWOOD # 92568 & 92559
2	051391-01-704	EA VALVE-RELIEF, 1/2" FITTING - ATWOOD# 91604
3	051391-01-705	EA FASTENER-CAMLOC, ATWOOD# 92609
4	051391-01-706	EA FLUE & GASKET
5	051391-01-710	EA ORIFICE-MAIN BURNER, ATWOOD# 92742
6	051391-01-714	EA ELBOW - 45 DEGREE, 3/8"F X 3/8"MPT - ATWOOD 91044
7	051391-01-715	EA DRAIN PLUG, ATWOOD# 91561
8	051391-03-700	EA ORIFICE HOLDER-ATWOOD# 91563
9	051391-04-701	EA THERMOSTAT 12 VDC-120 PRESET, FRONT MOUNT ONLY - ATWOOD# 91470
10	051391-04-703	EA BURNER-MAIN, 3E ONLY - ATWOOD# 91638
11	097967-01-000	EA SWITCH-WATER HEATER, REMOTE W/LIGHT - ATWOOD 91959
12	051393-01-721	EA ECO & THERMOSTAT ASM-FRONT MOUNT, 140 DEGREE - ATWOOD# 91447
13	051393-01-723	EA SWITCH-THERMAL CUT-OFF 2/PKG, ATWOOD# 93866
14	051393-01-724	EA CIRCUIT BOARD-SPADE TERMINAL, ATWOOD# 93867
15	051393-01-725	EA ELECTRODE-SINGLE SPADE CONNECT - ATWOOD 93868
16	051393-01-726	EA SOLENOID VALVE AND BRACKET - ATWOOD# 93870
17	051393-03-701	EA TANK-INNER - ATWOOD# 91642
18	052009-06-000	EA DOOR-WATER HEATER, BRIGHT WHITE
19	051391-01-717	EA GRILL ONLY
	116424-01-000	EA PROTECTOR-WATER HEATER LATCH - ATWOOD 92611
	0MD75C-10-000	EA NUT-HEX FLG,M10X1.5 CAD PREV CLASS 10
	114430-03-000	EA ADAPTER-1/2" P X 1/2" MPT - FLAIR-IT 02842
	101814-01-000	EA COUPLING-FEMALE, 1/2" X 1/2" FPT W/COMP. SLEEVE - GRAY
	110438-01-000	EA VALVE-CHECK, BRASS - G784

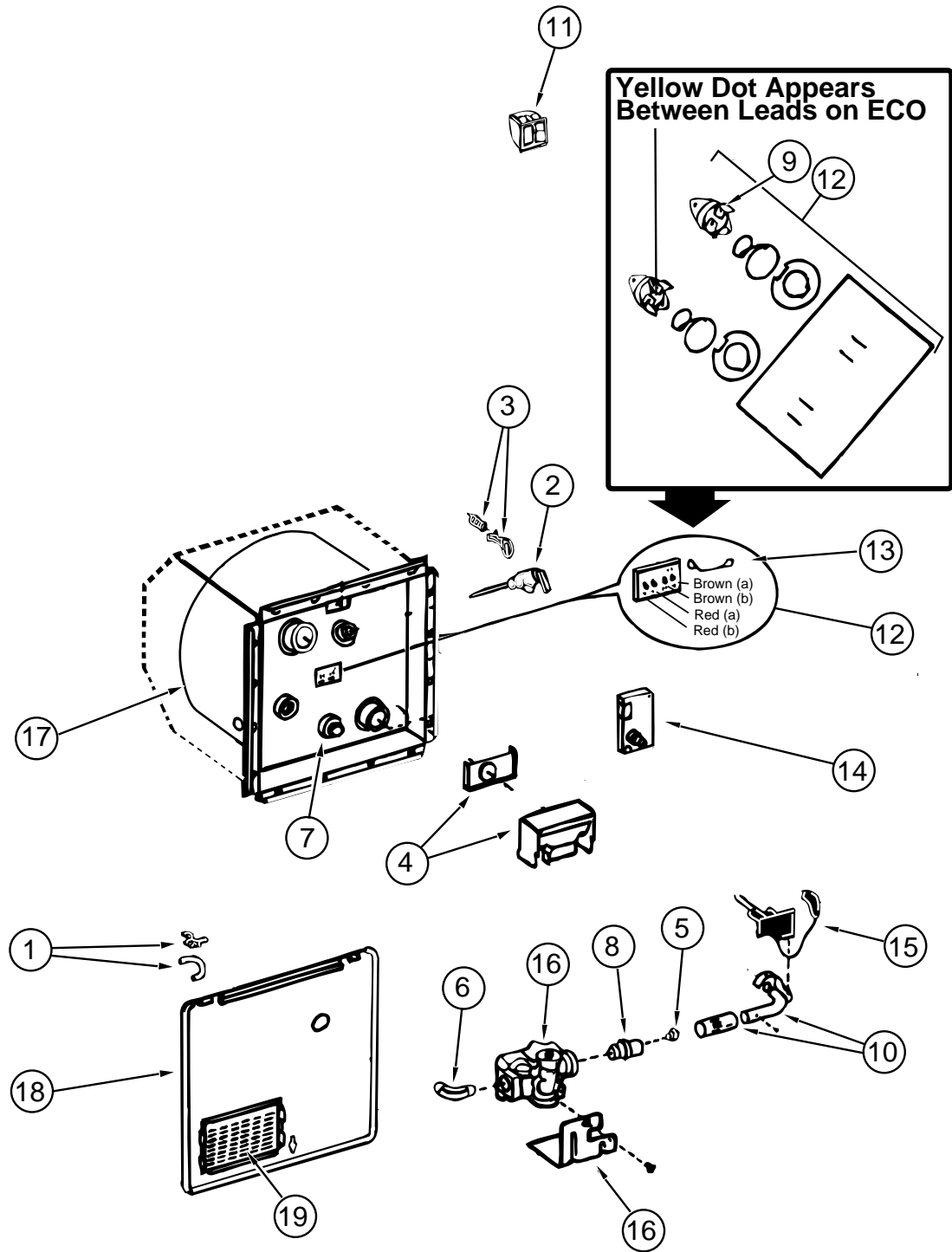

WATER & SEWAGE GROUP (CONTINUED)
WATER PUMP

KEY	PART NUMBER	U/M DESCRIPTION
	098607-01-000	EA PUMP-WATER, W/.5"MPT FITTING - FLOW 2.8 GPM - UL
	098607-01-700	EA PUMPHEAD-REPLACEMENT, SHURFLO# 94-236-08
	098607-01-701	EA DRIVE ASM, SHURFLO# 94-234-03
	098607-01-702	EA DIAPHRAGM-KIT, SHURFLO# 94-233-10
	098607-01-703	EA VALVE ASM, SHURFLO# 94-232-00
	098607-01-706	EA SWITCH ASM-COMPLETE, SHURFLO# 94-230-00
	098607-01-705	EA CHECK VALVE-KIT, SHURFLO# 94-237-00
	098607-01-707	EA MOTOR/BASEPLATE REPLACEMENT, SHURFLO# 94-234-03

WATER HEATER BYPASS

KEY	PART NUMBER	U/M DESCRIPTION
	099729-01-000	EA BYPASS KIT-WATER HEATER, COMPLETE W/VALVE & TUBING
	099729-01-700	EA VALVE ONLY CHECK PLASTIC
	099729-02-000	EA BYPASS KIT-WATER HEATER (CANADIAN)
	099729-02-700	EA VALVE ONLY CHECK BRASS (CANADIAN)

WATER TANK

KEY	PART NUMBER	U/M DESCRIPTION
	110622-03-000	EA TANK ASM-WATER, 55 GAL - W/FITTINGS (QUEEN BED)
	110622-01-000	EA TANK-WATER, 55 GAL - W/O FITTINGS (QUEEN BED)
	110622-02-000	EA TANK ASM-WATER, 50 GAL - W/FITTINGS (TWIN BED)
	110622-01-000	EA TANK-WATER, 50 GAL - W/O FITTINGS (TWIN BED)
	039861-01-000	EA SENDING UNIT-W/SCREW, WASHER, WELL NUT & TERMINAL RING
	010224-01-000	EA ADAPTER-HOSE TO PIPE, 3/8" MPT X 3/8" BARB - PLASTIC BLACK
	042989-03-000	EA FITTING-WATER TANK, SPINWELD - 1 1/4"NPT - PLASTIC - WHITE
	042989-04-000	EA FITTING-WATER TANK, SPINWELD - 3/8" FPT - PLASTIC - WHITE
	042989-05-000	EA FITTING-WATER TANK, SPINWELD - 1/2" FPT - PLASTIC - WHITE
	044927-01-000	EA ADAPTER-HOSE TO PIPE, 1 1/4"MPT X 1 1/4"BARB-BLACK PLASTIC
	049032-01-000	EA PATCH-SPINWELD, 3/8" - PLASTIC
	052955-01-000	EA TEE-1/2"F X 1/2"F X 1/2"MPT - PLASTIC
	074462-02-000	FT TUBING-VINYL, 3/8" ID - CLEAR - INCREMENTS OF 20'
	077954-02-000	EA FILTER-WATER TANK, SCREEN IN TANK
	079381-01-000	FT TUBING-SMOOTH FLEXIBLE, 1 1/4" ID - INCREMENTS OF 20'
	096449-01-000	EA WIRE ASSEMBLY-WATER TANK TO MONITOR PANEL
	077954-02-000	EA FILTER-WATER TANK, SCREEN IN TANK
	052952-01-000	EA NUT-PLASTIC, 1/2" F X 1/2" TUBE - GRAY

EXTERIOR SHOWER KIT

KEY	PART NUMBER	U/M DESCRIPTION
	046128-01-000	EA VALVE-DRAIN, PLASTIC - 1/2" FPT
	052959-02-000	EA CONNECTOR, 1/2" F X 1/2" MPT - PLASTIC - GRAY
	057457-01-000	EA ELBOW-UNION, 1/2" X 1/2" FLARE
	065120-01-000	EA ELBOW-SWIVEL, 1/2" FPT X 1/2" FLARE - PLASTIC - GRAY
	114429-03-000	EA ELBOW-MALE, 1/2" P X 1/2" FPT - PLASTIC - GRAY
	075241-05-000	EA FAUCET-SHOWER CONTROL, BONE
	103092-01-000	EA SHOWER HEAD-W/60" HOSE
	114293-01-01A	EA PAN-DRIP, EXTERIOR O/W
	111039-02-000	EA BRACKET-FAUCET

WATER & SEWAGE GROUP (CONTINUED)
WATER SYSTEM (FROM: 00-00-00 THRU: 04-18-94)

KEY	PART NUMBER	U/M DESCRIPTION
	103259-01-000	EA BRACKET-BYPASS, WATER HEATER
	039800-01-000	FT TUBING-POLYBUTYL, 1/2" OD - INCREMENTS OF 20' - BLACK
	039800-02-000	FT TUBING-POLYBUTYL, 5/8" OD - INCREMENTS OF 20' - BLACK
	052952-01-000	EA NUT-PLASTIC, 1/2" F X 1/2" TUBE - GRAY
	052952-02-000	EA NUT-PLASTIC, 5/8" FLARE
	052958-01-000	EA TEE, 1/2" F X 1/2" F X 1/2" F - PLASTIC - GRAY
	052959-02-000	EA CONNECTOR, 1/2" F X 1/2" MPT - PLASTIC - GRAY
	052960-01-000	EA DRAIN VALVE-IN LINE, HEADER - 1/2" F X 1/2" F - GRAY PLASTIC
	052960-03-000	EA DRAIN VALVE-IN LINE, HEADER - 5/8"F X 5/8"F - PLASTIC
	055290-01-000	EA ELBOW - 5/8"F X 1/2"MPT
	079317-01-000	EA ADAPTER-SWIVEL, 1/2" TUBE X 1/2" FPT - PLASTIC - GRAY
	110915-01-01A	EA FILL-WATER, CITY - CHROME
	087659-01-700	EA FILL-WATER STRAP & CAP ONLY
	098417-01-000	EA CONNECTOR - 5/8"F X 1/2"MPT, PLASTIC - KEVCO
	101814-01-000	EA COUPLING-FEMALE, 1/2" X 1/2" FPT
	106258-01-000	EA CAP-INSERTABLE, 1/2" FLARE
	091208-01-000	EA WASHER-RUBBER, .06" X .75" X .5"
	057973-01-000	EA TEE-PLASTIC, 1/2"F X 1/2"F X 5/8"F - WATER
	010219-01-000	EA ELBOW - 1 1/4" MPT X 1 1/4" BARB, WATER FILL - PLASTIC
	035539-01-000	EA ELBOW-PLASTIC, 3/8"MPT X 3/8"BARB
	039808-03-000	EA ELBOW-PLASTIC, 1/2MPT X 1/2MPT KEVCO 17296

WATER SYSTEM (FLAIR-IT) (FROM: 04-18-94 THRU: 99-99-99)

KEY	PART NUMBER	U/M DESCRIPTION
	114427-01-000	EA CAP-1/2P - FLAIR-IT 02860
	114427-02-000	EA PLUG-1/2P - FLAIR-IT 02863
	114428-01-000	EA TEE-1/2P X 1/2P X 1/2P - FLAIR-IT 02820
	114428-02-000	EA TEE-SWIVEL - 1/2P X 1/2P X 1/2FPT - FLAIR-IT 02821
	114428-03-000	EA TEE-1/2P X 1/2P X 1/2MPT - FLAIR-IT 02822
	114429-01-000	EA ELBOW-1/2P X 1/2P - FLAIR-IT 02800
	114429-02-000	EA ELBOW-1/2P X 1/2MPT - FLAIR-IT 02803
	114429-03-000	EA ELBOW-SWIVEL - 1/2P X 1/2FPT - FLAIR-IT 02816
	114429-04-000	EA ELBOW-1/2P X 3/8MPT - FLAIR-IT 02810
	114429-05-000	EA ELBOW-1/2P X 3/4MPT - FLAIR-IT 02812
	114429-06-000	EA ELBOW-SWIVEL - 1/2P X 3/4FPT - FLAIR-IT 02811
	114430-01-000	EA ADAPTER-1/2P X 1/2P - FLAIR-IT 02840
	114430-02-000	EA ADAPTER-SWIVEL - 1/2P X 1/2FPT - FLAIR-IT 02873
	114430-03-000	EA ADAPTER-1/2P X 1/2MPT - FLAIR-IT 02842
	114431-01-000	EA VALVE-LINE DRAIN 1/2P - FLAIR-IT 02914
	114431-02-000	EA VALVE-1/2P - BYPASS - FLAIR-IT 02910
	114431-03-000	EA VALVE-1/2P X 1/2P - FLAIR-IT 02884
	114431-04-000	EA VALVE-STOP - 1/2P X 1/2P - FLAIR-IT 02880
	039800-02-000	FT TUBING-POLYBUTYL, 5/8" OD - INCREMENTS OF 20' - BLACK
	110915-01-01A	EA FILL-WATER, CITY - CHROME - KEVCO 64713

WATER & SEWAGE GROUP (CONTINUED)
DRAINAGE SYSTEM

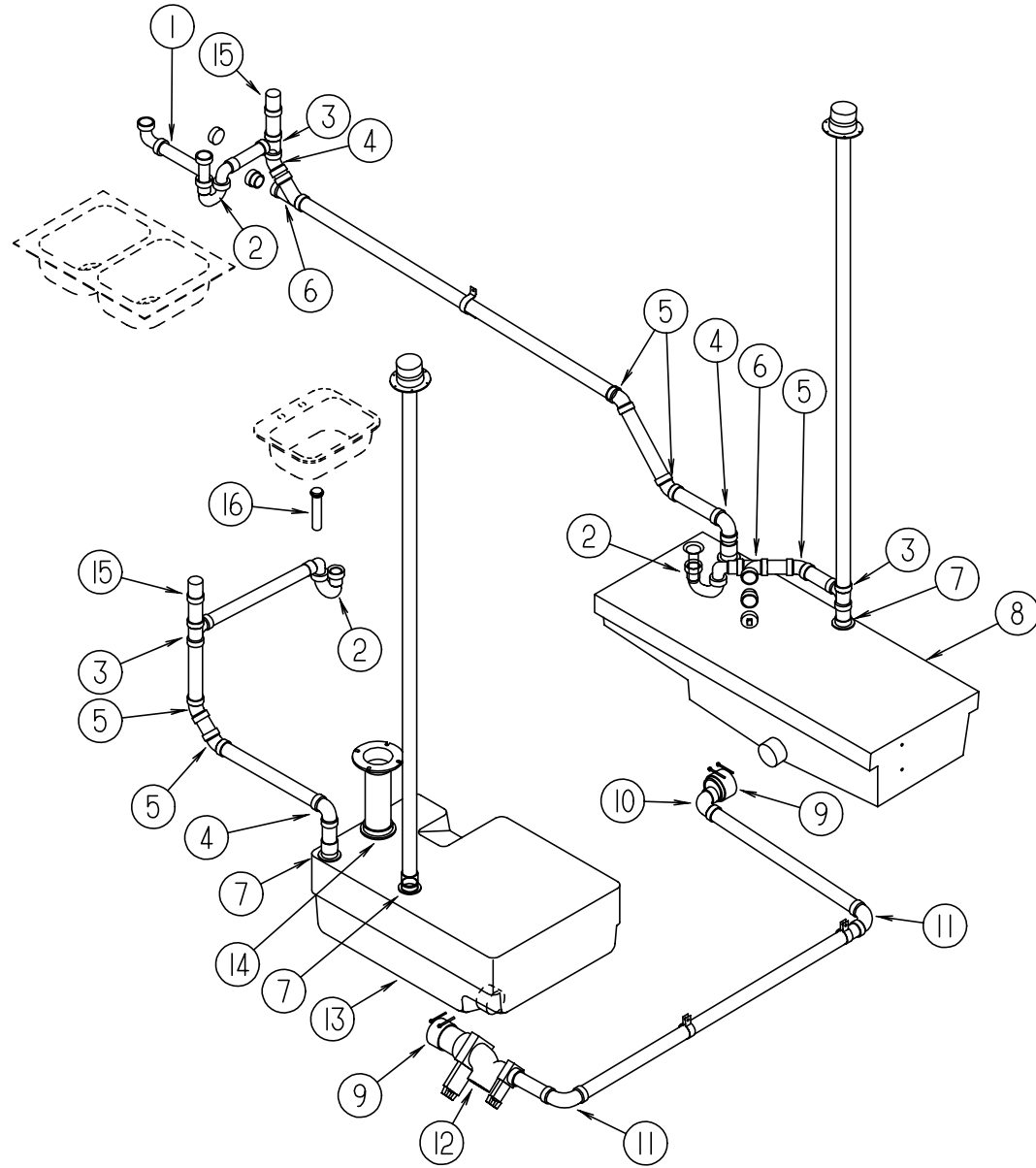

KEY	PART NUMBER	U/M	DESCRIPTION
1	011091-03-000	EA	PIPE-DRAIN, W/SEALS - DOUBLE SINK - EXTENDS 9" TO 16" - CANADIAN
1	011091-02-000	EA	PIPE-DRAIN, DOUBLE SINK - BAFFLE TEE - 1 1/2"
2	107538-01-000	EA	P-TRAP-PLASTIC, 1 1/4" W/EXT ARM
2	011071-01-000	EA	P-TRAP, 1 1/2" - PLASTIC - CANADIAN
	109571-01-000	EA	ADAPTER-P TRAP, 1 1/2" P X 1 1/4" MPT
3	010071-01-000	EA	TEE-SANITARY, 1 1/2" HUB X HUB X HUB - PLASTIC - BLACK
4	034250-01-000	EA	ELBOW - 90 DEGREE, LONG TURN - 1 1/2" HUB X HUB - ABS
5	010006-01-000	EA	ELBOW - 45 DEGREE, 1/8 BEND - 1 1/2" HUB X HUB - BLACK PLASTIC
6	010073-01-000	EA	WYE - 45 DEGREE, 1 1/2" HUB X HUB X HUB - PLASTIC - BLACK
	010166-01-000	EA	PLUG-THREADED, 1 1/4" DIAMETER - PLASTIC - BLACK
	062422-01-000	EA	ADAPTER-OFFSET REDUCER, 3" X 1 1/2" - PLASTIC - BLACK
7	061607-01-000	EA	GROMMET-HOLDING TANK, 1 1/2" NPS
7	010115-01-000	EA	COUPLING - 1 1/2" HUB X HUB, PLASTIC
8	061805-01-000	EA	TANK-HOLDING W/O GROMMETS - 40 GALLONS
9	078406-01-000	EA	COUPLER-RUBBER, W/CLAMPS - 3" X 3"
10	033761-01-000	EA	ELBOW-TURN, 1/4 BEND X 1.5"HUB X 1.5"SPIGOT - BLK PLASTIC
11	010008-01-000	EA	ELBOW - 90 DEGREE, 1/4 BEND - 1 1/2" HUB X HUB - BLACK PLASTIC
12	070916-01-000	EA	VALVE-DUAL DUMP, W/CAP - 3" X 1 1/2" - PLASTIC - BLACK
	070916-01-700	EA	VALVE ONLY, 3"
	070916-01-701	EA	VALVE ONLY, 1 1/2"
	062421-01-000	EA	VALVE-DUMP, W/HANDLE - 1 1/2" - PLASTIC - BLACK
13	106598-01-000	EA	TANK-HOLDING W/O GROMMETS - 44 GALLONS
14	061607-02-000	EA	GROMMET-HOLDING TANK, 3" NPS
15	079968-01-000	EA	VENT-MECHANICAL TRAP ARM, ANTI-SIPHON - 2" DIA X 7.3" - PLASTIC
16	011069-02-000	EA	TAILPIECE-TUB/SHOWER, 1 1/2" X 1 1/4" X 4" - BRASS
	010201-01-000	EA	HOSE-SEWER, 3" ID X 8'
	024676-02-000	EA	FLANGE-CLOSET, 4" X 3" - ABS - CANADIAN
	024676-01-000	EA	FLANGE-CLOSET, TOILET - 4" X 3" - RED
			FROM: 00-00-00 THRU: 08-24-94
	116644-01-000	EA	FLANGE-CLOSET, TOILET - 4" X 3" - RED
			FROM: 08-25-94 THRU: 99-99-99
	062416-01-000	EA	ADAPTER-SEWER HOSE TO 3" PIPE
	088770-01-000	EA	STANDOFF-THREADED, 3/8" X 1 1/4"

WINDOW, VENT & EXTERIOR DOOR GROUP
EXTERIOR WINDOWS & VENTS

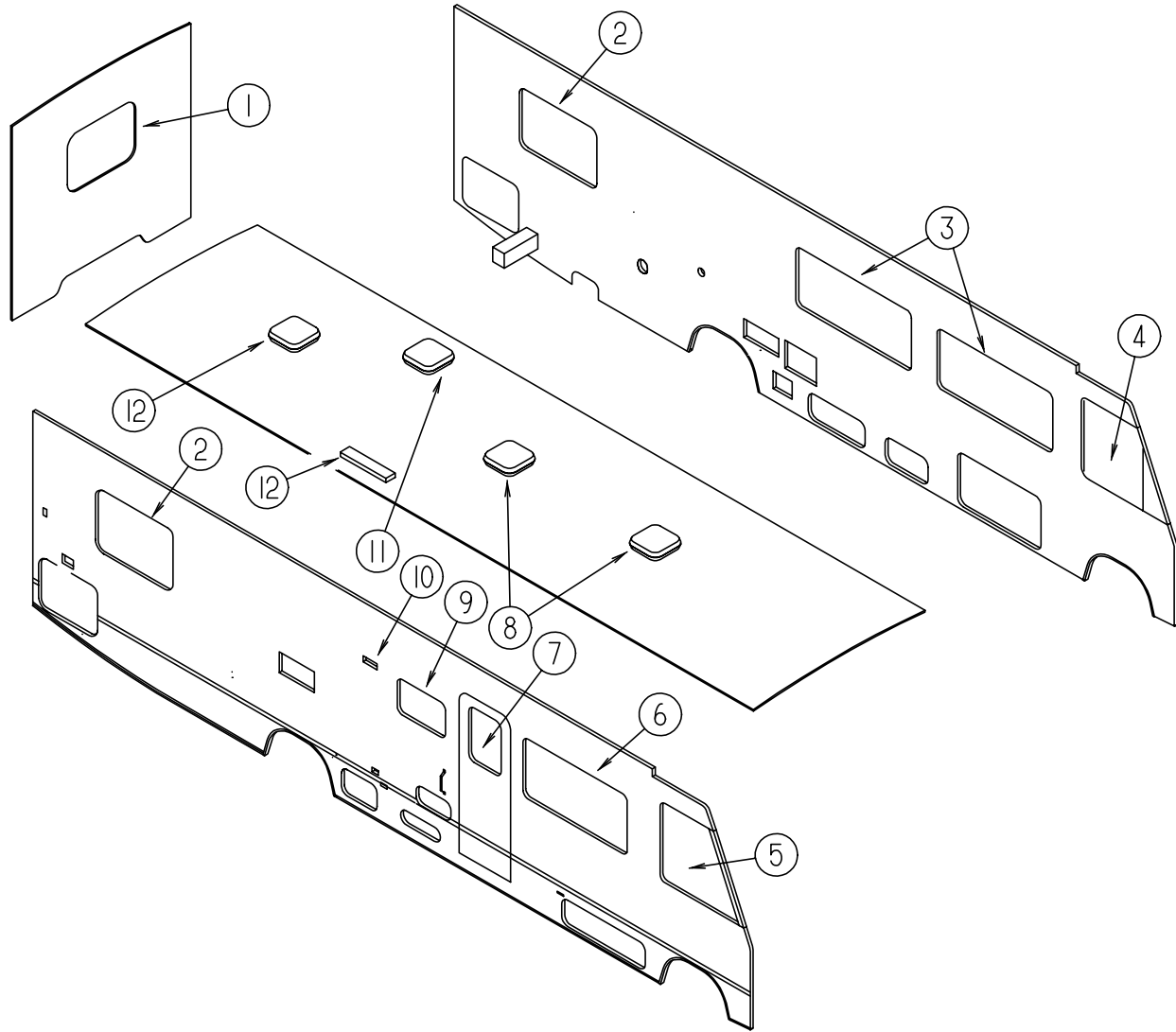

KEY	PART NUMBER	U/M	DESCRIPTION
1	078528-06-E10	EA	WINDOW ASM-ESCAPE
1	113502-01-01A	EA	WINDOW ASM- REAR ESCAPE BLK/OW - THERMOPANE
2	113500-01-01A	EA	WINDOW ASM-TIPOUT, DOUBLE - BLK/OW
2	112795-23-01A	EA	WINDOW ASM-SLIDER, HORIZONTAL - THERMOPANE - DRIVER SIDE
2	112795-21-01A	EA	WINDOW ASM-SLIDER, HORIZONTAL - THERMOPANE - PASSENGER SIDE
3	098647-22-01A	EA	WINDOW ASM-SLIDER, HORIZONTAL BLK/OW
3	112795-15-01A	EA	WINDOW ASM-SLIDER, HORIZONTAL - THERMOPANE
4	103658-09-01A	EA	WINDOW ASM-CAB DRIVER
4	113501-03-01A	EA	WINDOW ASM-CAB DRIVER - THERMOPANE
5	103658-10-01A	EA	WINDOW ASM-CAB, PASSENGER
5	113501-04-01A	EA	WINDOW ASM-CAB, PASSENGER - THERMOPANE
6	098647-24-01A	EA	WINDOW ASM- SLIDER, HORIZONTAL - BLK/OW
6	112795-17-01A	EA	WINDOW ASM-SLIDER, HORIZONTAL - THERMOPANE
7	079733-15-F04	EA	WINDOW-ENTRY DOOR, PICTURE
7	113733-01-01A	EA	WINDOW ASM-STATIONARY, THERMOPANE
8	110051-01-01A	EA	VENT-ROOF, NONPOWERED - 2" ROOF - JENSEN 7724 WHE
9	098647-33-01A	EA	WINDOW ASM-SLIDER, HORIZONTAL
9	112795-19-01A	EA	WINDOW ASM-SLIDER, HORIZONTAL - THERMOPANE
10	084616-01-000	EA	SHROUD-RANGE HOOD VENT, OFF WHITE
	084878-09-000	EA	VENT-RANGE HOOD, SHORT - LVS
11	110051-03-01A	EA	VENT-ROOF, POWERED - 2" ROOF - JENSEN 7757 WHE - US
11	110051-05-01A	EA	VENT-ROOF, POWERED - 2" ROOF - JENSEN C7757 WHE - CANADIAN
12	084073-07-000	EA	COVER-ROOF VENT, REFRIGERATOR - BRIGHT WHITE - NORCOLD
	084073-04-000	EA	BASE-ROOF VENT, REFRIGERATOR - BLACK - NORCOLD

WINDOW, VENT & EXTERIOR DOOR GROUP (CONTINUED)

EXTERIOR DOORS

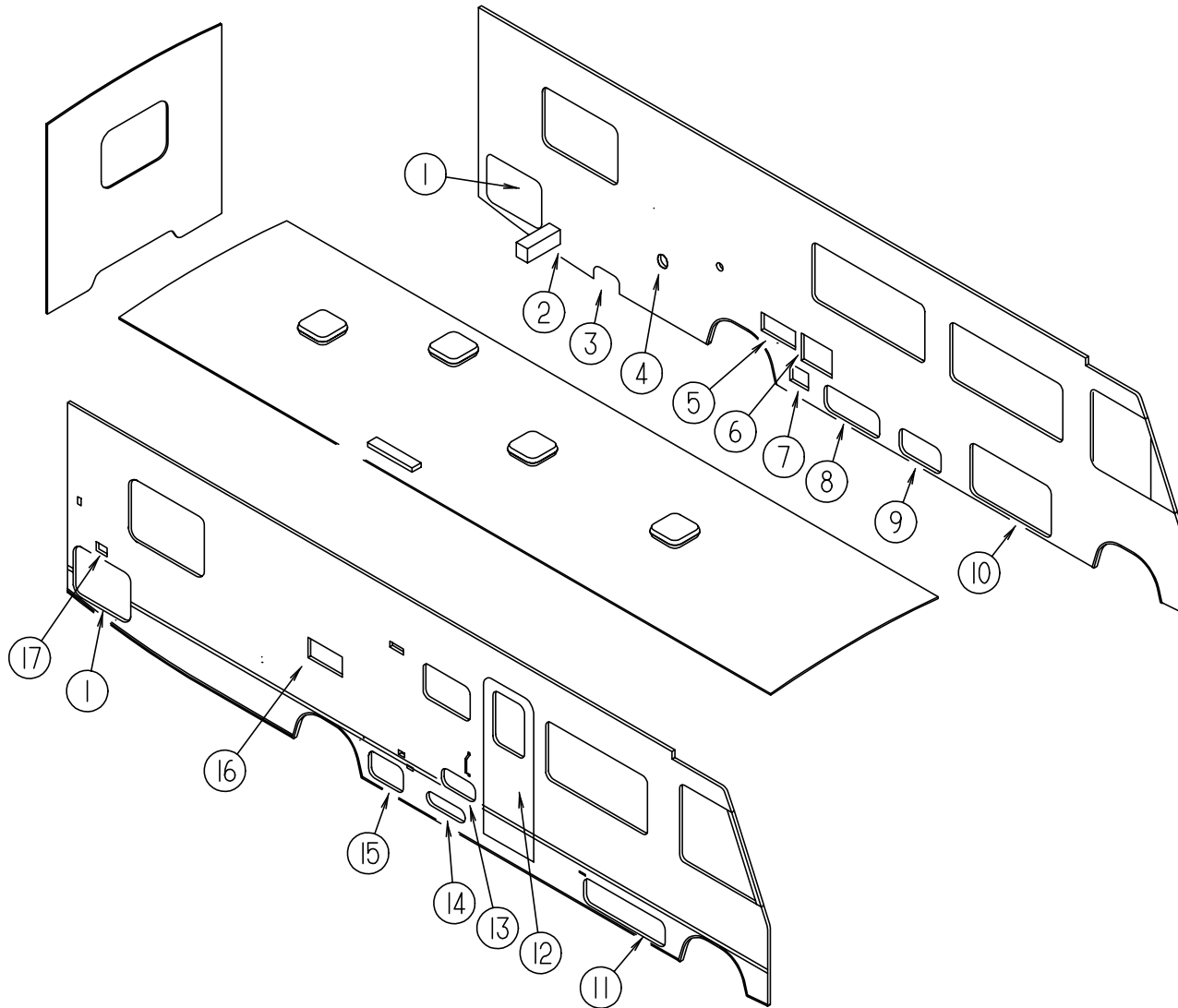

KEY	PART NUMBER	U/M DESCRIPTION
1	111013-36-F24	EA DOOR ASM-STORAGE
2	052423-07-000	EA DOOR-ACCESS, 6.6" X 6.3" - PLASTIC - BRIGHT WHITE
	052424-06-000	EA JAMB-DOOR, 8" X 7.7" - PLASTIC - BRIGHT WHITE
3	111012-03-F24	EA DOOR ASM-STORAGE
4	110915-01-01A	EA FILL-WATER, CITY - CHROME
5	098668-23-000	EA DOOR-ACCESS, FURNACE, BRIGHT WHITE SUBURBAN 520574
6	052009-06-000	EA DOOR-WATER HEATER, BRIGHT WHITE - ATWOOD
7	088794-06-000	EA DOOR-POWER CORD, W/HATCH - BRIGHT WHITE
8	111018-01-F24	EA DOOR ASM-GENERATOR
9	111013-04-F24	EA DOOR ASM-STORAGE
10	111013-09-F24	EA DOOR ASM-STORAGE
11	111013-14-F24	EA DOOR ASM-STORAGE
12	115108-01-FC4	EA DOOR-ENTRY W/SCREEN DOOR - W/O WINDOW (F24,F25,F26)
		FROM: 00-00-00 THRU: 10-23-94
12	115108-05-F24	EA DOOR-ENTRY W/SCREEN DOOR - W/O WINDOW
		FROM: 10-24-94 THRU: 99-99-99
12	115108-05-F25	EA DOOR-ENTRY W/SCREEN DOOR - W/O WINDOW
		FROM: 10-24-94 THRU: 99-99-99
12	115108-05-F26	EA DOOR-ENTRY W/SCREEN DOOR - W/O WINDOW
		FROM: 10-24-94 THRU: 99-99-99
12	115108-01-FC7	EA DOOR-ENTRY W/SCREEN DOOR - W/O WINDOW (F27)
		FROM: 00-00-00 THRU: 10-23-94
12	115108-01-F27	EA DOOR-ENTRY W/SCREEN DOOR - W/O WINDOW
		FROM: 10-24-94 THRU: 99-99-99
13	111017-01-F24	EA DOOR-STORAGE
14	111009-01-F24	EA DOOR-COMPARTMENT, LP - 16.9" X 5.4" - ALUMINUM - BRIGHT WHITE
15	111013-05-F24	EA DOOR ASM-STORAGE
16	084103-08-000	EA DOOR-REFRIGERATOR, VENTED - W/O JAMB - BRIGHT WHITE
	084104-08-000	EA JAMB-DOOR, REFRIGERATOR - BRIGHT WHITE
	084104-01-700	EA LOCK-MALE, FASTENER - REFRIGERATOR DOOR
	084104-01-701	EA LOCK-FEMALE, FASTENER - REFRIGERATOR DOOR
17	081240-16-000	EA FILL-WATER, LOCKABLE W/O LOCK - BRIGHT WHITE

WINDOW, VENT & EXTERIOR DOOR GROUP (CONTINUED)
ENTRANCE DOOR

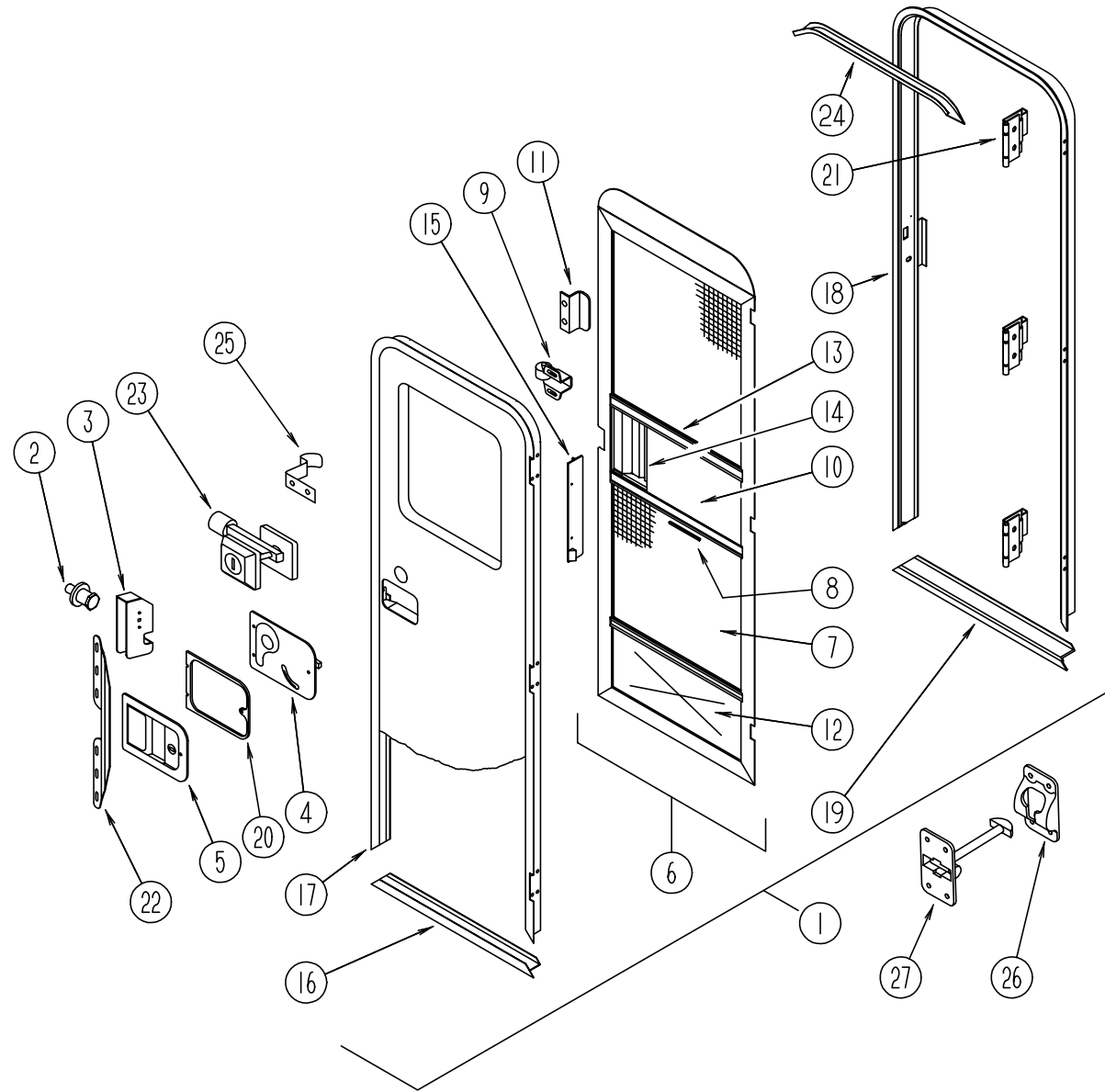

KEY	PART NUMBER	U/M	DESCRIPTION
5	045017-11-000	EA	LATCH-ENTRY DOOR, MECHANISM W/LOCK & KEY - BLACK
	045017-11-701	EA	KEY BLANK
	058025-02-000	EA	CLIP-ROLLER LATCH CATCH, SCREEN DOOR
	063729-01-000	EA	RIVNUT, 1/4 X 20 UNC - .030-.125
	063729-04-000	EA	RIVNUT, 10-32 UNF - .010-.080
	072893-01-000	EA	NUTSERT-M5 X 0, 8
	075671-04-000	FT	SEAL-SPONGE, LAZY T SHAPE - W/ADHESIVE STRIPE - .5" WIDE
6	079012-09-F15	EA	DOOR-SCREEN
	100128-02-000	FT	SEAL-FOAM, ADHESIVE BACK - SCREEN DOOR - GRAY
7	002293-02-000	SF	SCREENING-WINDOW/DOOR, 26" - CHARCOAL
8	002294-01-000	FT	SPLINE-SCREENING, .135" X .138" - BLACK
	002748-01-000	EA	CORNER KEY-DOOR
9	109403-01-000	EA	CATCH-ASM-SINGLE ROLLER
10	016454-01-000	EA	INSERT-CENTER, LEATHER GRAIN ALUMINUM - UNPAINTED
10	001014-01-013	EA	INSERT-CENTER, 10.25" X 16.31" - UNPAINTED
11	050712-04-000	EA	HANDLE-SCREEN DOOR, ALUMINUM - OFF WHITE
12	078552-03-000	EA	KICK PANEL-SCREEN DOOR, LOWER INSERT - UNPAINTED
	078595-01-000	EA	TOP PLATE-SCREEN DOOR, CURVED TOP - 4.7" X 25.35"
13	078777-01-000	EA	CHANNEL-SLIDE, SCREEN DOOR CENTER SLIDER COVER
14	079086-02-000	EA	SLIDER-SCREEN DOOR, OFF WHITE
15	079087-02-000	EA	STRIKE-SLIDER, W/LIP FOR ELBOW CATCH - 1.5" X 8.6" - OFF WHITE
16	089748-21-000	EA	FRAME-BOTTOM, ENTRY DOOR - 24.8" LONG - BRIGHT WHITE
	090340-01-000	FT	SEAL-FOAM, CLOSED CELL - 1/4" X 1/2" X 50'
17	095276-07-03A	EA	FRAME-ENTRY DOOR, W/O BOTTOM - BRIGHT WHITE
18	095277-08-03A	EA	JAMB-ENTRY DOOR, W/BOTTOM - BRIGHT WHITE
19	051049-01-000	EA	JAMB-BOTTOM, ENTRY DOOR - 25.9" - UNPAINTED
20	096810-01-01A	EA	PLATE-LATCH, ENTRY DOOR - PLASTIC - BLACK
21	106719-01-01A	EA	HINGE-ENTRY DOOR, UNPAINTED
	076725-02-000	EA	COVER-HINGE, ENTRY DOOR - 6" X 3.2" - PLASTIC - OFF WHITE
22	098173-01-04A	EA	STIFFENER-ENTRY DOOR, SUPPORTS LATCH/STRIKE AREA - UNPAINTED
	100128-02-000	FT	SEAL-PILE, ADHESIVE BACK - SCREEN DOOR - GRAY
23	101145-01-01A	EA	DEADBOLT-ENTRY DOOR, W/2 KEYS W/O BACK SET BOLT OR SCREWS
	095229-01-700	EA	KEY BLANK FOR DEADBOLT
	101147-01-000	EA	BOLT-SECURITY, 4.12" BACKSET
	102524-01-000	EA	BUMPER-RUBBER, FLAT - BLACK
24	044582-44-000	EA	CAP-DRIP, ENTRY DOOR - JAMB MOUNTED - ALUMINUM - BRIGHT WHITE
	115222-01-01A	EA	GARNISH-RADIUS, ENTRY DOOR - OFF WHITE
	077461-03-000	EA	COVER-STRIKE, ENTRY DOOR - 6.5" X 2.5" - PLASTIC - WHITE
	091876-01-000	EA	RETAINER-DOOR, 1.9" X .8" - METAL
25	100412-01-000	EA	CATCH-SCREEN DOOR, THUMB CLIP W/BLACK PLASTIC CAP
26	104099-01-01A	EA	CATCH-DOOR HOLDER, STRIKE - OFF WHITE
27	104099-02-01A	EA	CATCH-DOOR HOLDER, RETAINER - OFF WHITE
	009126-02-000	EA	HANDLE-ASSIST, ENTRY DOOR - BLACK
	102248-01-000	EA	SHIM-DOOR

KEY	PART NUMBER	U/M	DESCRIPTION
1	115108-01-FC4	EA	DOOR-ENTRY W/SCREEN DOOR - W/O WINDOW (F24,F25,F26) FROM: 00-00-00 THRU: 10-23-94
1	115108-05-F24	EA	DOOR-ENTRY W/SCREEN DOOR - W/O WINDOW FROM: 10-24-94 THRU: 99-99-99
1	115108-05-F25	EA	DOOR-ENTRY W/SCREEN DOOR - W/O WINDOW FROM: 10-24-94 THRU: 99-99-99
1	115108-05-F26	EA	DOOR-ENTRY W/SCREEN DOOR - W/O WINDOW FROM: 10-24-94 THRU: 99-99-99
1	115108-01-FC7	EA	DOOR-ENTRY W/SCREEN DOOR - W/O WINDOW (F27) FROM: 00-00-00 THRU: 10-23-94
1	115108-01-F27	EA	DOOR-ENTRY W/SCREEN DOOR - W/O WINDOW FROM: 10-24-94 THRU: 99-99-99
2	039539-01-000	EA	STRIKE-LOCK, ENTRY DOOR - ROUND W/THREADED WASHER
3	039540-01-000	EA	LATCH MECHANISM-HOOK, ENTRY DOOR - INTERIOR
	039715-01-000	EA	NUT-SERT, 1/4" DIAMETER - 20 THREADS
4	039979-04-000	EA	COVER-INTERIOR LATCH, W/TRIP ARM - RIGHT - BLACK
	039984-01-000	EA	CAP-ROUND, VINYL - .28" ID X .62" LONG - BLACK
	041546-03-000	EA	BRACKET-DOOR ANGLE, 5" X 1.9" - BEIGE - METAL

WINDOW, VENT & EXTERIOR DOOR GROUP (CONTINUED)

BRIGGS & STRATTON LOCKS & EXTERIOR DOOR COMPONENTS

NOTE:

WHEN ORDERING THE LOCK CASE, THE KEY CODE MUST MATCH THE LAST DIGIT OF THE VEHICLE'S SERIAL NUMBER AND PART NUMBER; WHEN ORDERING THE KEYS, THE THIRD DIGIT OF THE KEY CODE MUST MATCH THE LAST DIGIT OF THE VEHICLE'S SERIAL NUMBER AND PART NUMBER

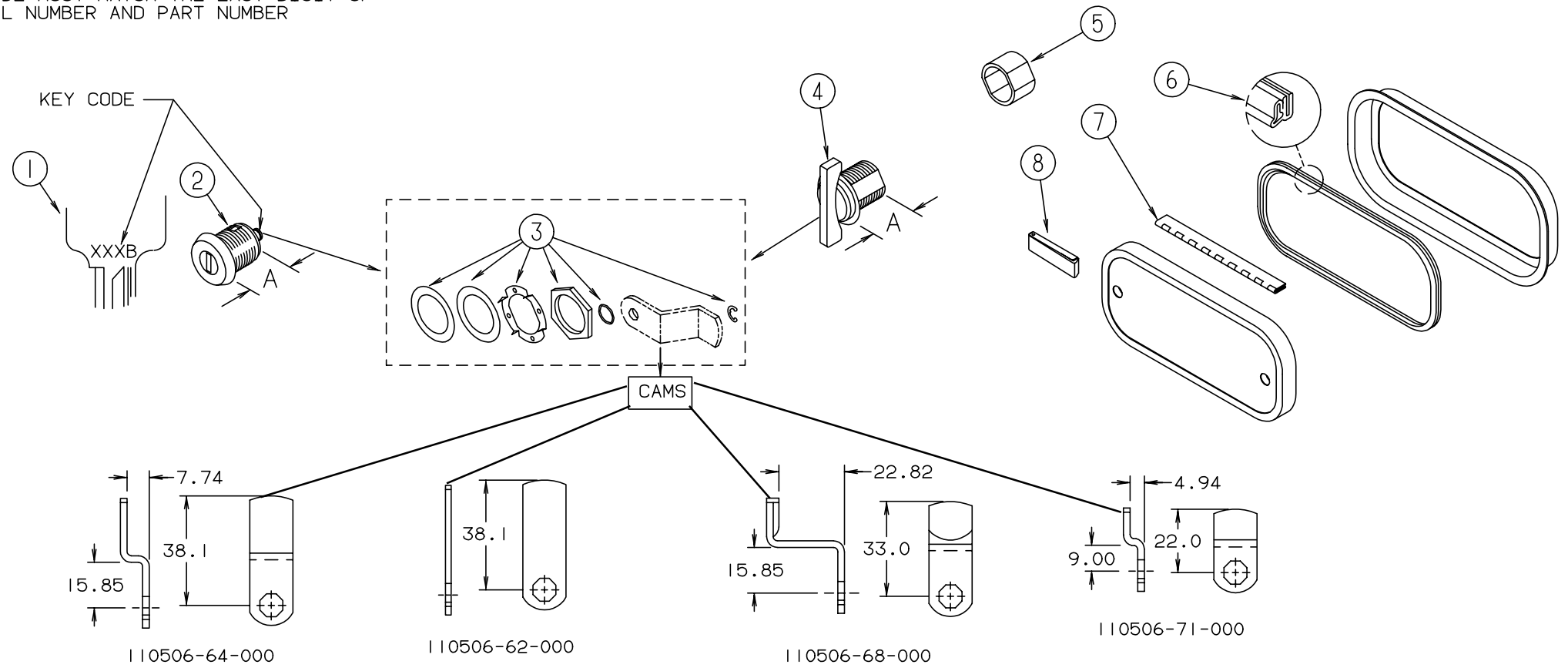

KEY	PART NUMBER	U/M DESCRIPTION
1	110506-59-000	EA KEYS - SET OF TWO - 596720
2	110506-52-000	EA CASE - LOCK - A= 17 MM - 702370
2	110506-53-000	EA CASE - LOCK - A= 25 MM - 702380
1	110506-59-001	EA KEYS - SET OF TWO - 596721
2	110506-52-001	EA CASE - LOCK - A= 17 MM - 702371
2	110506-53-001	EA CASE - LOCK - A= 25 MM - 702381
1	110506-59-002	EA KEYS - SET OF TWO - 596722
2	110506-52-002	EA CASE - LOCK - A= 17 MM - 702372
2	110506-53-002	EA CASE - LOCK - A= 25 MM - 702382
1	110506-59-003	EA KEYS - SET OF TWO - 596723
2	110506-52-003	EA CASE - LOCK - A= 17 MM - 702373
2	110506-53-003	EA CASE - LOCK - A= 25 MM - 702383
1	110506-59-004	EA KEYS - SET OF TWO - 596724
2	110506-52-004	EA CASE - LOCK - A= 17 MM - 702374
2	110506-53-004	EA CASE - LOCK - A= 25 MM - 702384
1	110506-59-005	EA KEYS - SET OF TWO - 596725
2	110506-52-005	EA CASE - LOCK - A= 17 MM - 702375
2	110506-53-005	EA CASE - LOCK - A= 25 MM - 702385

KEY	PART NUMBER	U/M DESCRIPTION
1	110506-59-006	EA KEYS - SET OF TWO - 596726
2	110506-52-006	EA CASE - LOCK - A= 17 MM - 702376
2	110506-53-006	EA CASE - LOCK - A= 25 MM - 702386
1	110506-59-007	EA KEYS - SET OF TWO - 596727
2	110506-52-007	EA CASE - LOCK - A= 17 MM - 702377
2	110506-53-007	EA CASE - LOCK - A= 25 MM - 702387
1	110506-59-008	EA KEYS - SET OF TWO - 596728
2	110506-52-008	EA CASE - LOCK - A= 17 MM - 702378
2	110506-53-008	EA CASE - LOCK - A= 25 MM - 702388
1	110506-59-009	EA KEYS - SET OF TWO - 596729
2	110506-52-009	EA CASE - LOCK - A= 17 MM - 702379
2	110506-53-009	EA CASE - LOCK - A= 25 MM - 702389
3	110506-40-700	EA HARDWARE KIT
	110506-59-701	EA KEY BLANK
4	110506-08-000	EA LOCK - TWIST TYPE - (A= 17 MM)
4	110506-13-000	EA LOCK - TWIST TYPE - (A= 25 MM)
5	107997-51-001	EA SPACER - .86" X .6" - ALUMINUM
6	064075-07-000	FT SEAL - BULB - W/ WIRED U CHANNEL - .3" X .5" CHANNEL - BLACK
7	081801-02-000	EA HINGE - PIANO - 2" X 96" - ALUMINUM - OFF WHITE
8	102768-01-000	EA HOLDER - COMPARTMENT/ ENTRY DOOR - METAL - MILL FINISH
	081914-01-000	EA BUMPER - RUBBER - ROUND - .43" DIAMETER - BLACK
	104692-01-000	FT SEAL - 3/4" X 3/4" - ADHESIVE BACK
	091876-01-000	EA RETAINER - DOOR - 1.9" X .8" - METAL

WINDOW, VENT & EXTERIOR DOOR GROUP (CONTINUED)
POWERED ROOF VENT

KEY	PART NUMBER	U/M DESCRIPTION
	110051-03-01A	EA VENT-ROOF, POWERED - 2" ROOF - JENSEN 7757 WHE
	048648-01-000	EA MOTOR-ROOF VENT, 1/8 SHAFT - 12V - JENSEN
	048649-01-000	EA FAN-ROOF VENT, 6 BLADES - 6" - JENSEN
	064470-01-700	EA COVER-ROOF VENT, JENSEN 7291
	110051-01-701	EA GARNISH W/SCREEN & FRAME-2", JENSEN 29-800-01
	110051-01-702	EA LIFT ASM-VENT LID W/O CRANK, JENSEN RP-1000B
	110051-01-703	EA CRANK, JENSEN RP-1031-B

NONPOWERED ROOF VENT

KEY	PART NUMBER	U/M DESCRIPTION
	110051-01-01A	EA VENT-ROOF, NONPOWERED - 2" ROOF - JENSEN 7724 WHE
	064470-01-700	EA COVER-ROOF VENT, JENSEN 7291
	110051-01-701	EA GARNISH W/SCREEN & FRAME-2", JENSEN 29-800-01
	110051-01-702	EA LIFT ASM-VENT LID W/O CRANK, JENSEN RP-1000B
	110051-01-703	EA CRANK, JENSEN RP-1031-B

VENTS, SHROUDS & ROOF COVERS

KEY	PART NUMBER	U/M DESCRIPTION
	083558-07-000	EA VENT-PLUMBING PIPE ROOF W/COVER - BRIGHT WHITE
	084616-07-000	EA SHROUD-RANGE HOOD VENT, PLASTIC - BRIGHT WHITE
	084878-09-000	EA VENT-RANGE HOOD, SHORT - LVS
	084073-07-000	EA COVER-ROOF VENT, REFRIGERATOR - BRIGHT WHITE - NORCOLD
	084073-04-000	EA BASE-ROOF VENT, REFRIGERATOR - BLACK - NORCOLD
	105028-01-000	EA FLASHING ASM-VENT, REFRIGERATOR

WINDOW, VENT & EXTERIOR DOOR GROUP (CONTINUED)

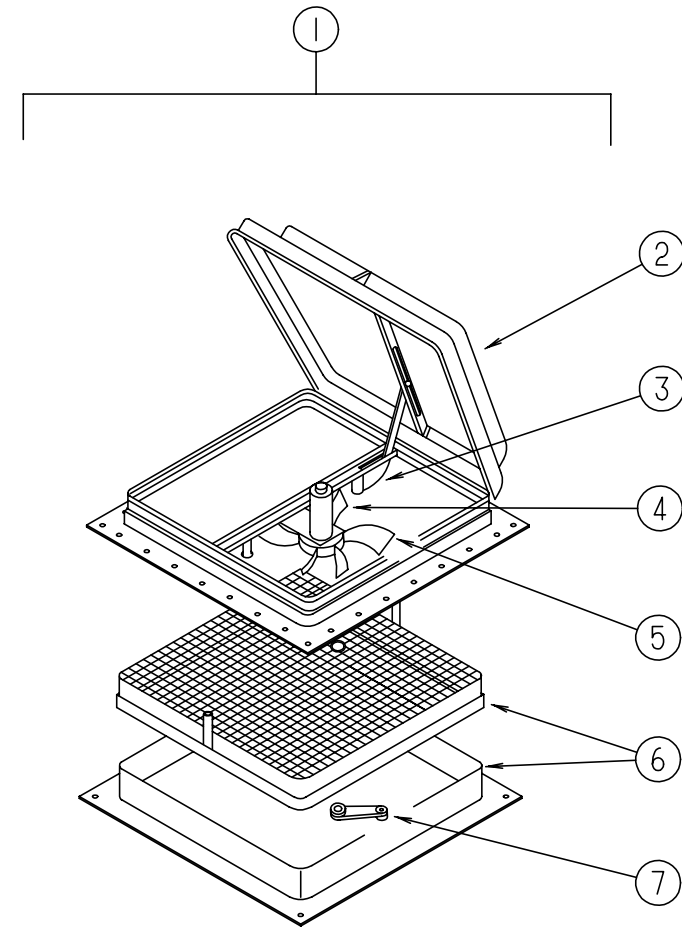

POWERED ROOF VENT - JENSEN - CANADIAN

KEY	PART NUMBER	U/M DESCRIPTION
1	110051-05-01A	EA VENT-ROOF, POWERED - 2" ROOF - CSA - JENSEN C7757 WHE
2	064470-01-700	EA COVER-ROOF VENT, JENSEN 7291
3	110051-01-702	EA LIFT ASM-VENT LID W/O CRANK, JENSEN RP-1000B
4	048648-01-000	EA MOTOR-ROOF VENT, 1/8 SHAFT - 12V
5	048649-01-000	EA FAN-ROOF VENT, 6 BLADES - 6"
6	110051-01-701	EA GARNISH W/SCREEN & FRAME-2", JENSEN 29-800-01
7	110051-01-703	EA CRANK HANDLE-ROOF VENT, JENSEN RP-1031-B

WINDOW, VENT & EXTERIOR DOOR GROUP (CONTINUED)
DRIVER & PASSENGER SIDE BEDROOM WINDOW

KEY	PART NUMBER	U/M	DESCRIPTION
	113500-01-01A	EA	WINDOW ASM-TIPOUT, DOUBLE - BLK/OW
	113500-01-700	EA	SCREEN ASM. (RH & LH) W/SPRING
	113500-01-701	EA	WINDOW W/O TRIM
	113500-01-702	EA	TRIM
	113500-01-703	EA	TOP GLASS-STATIONARY
	113500-01-704	EA	UPPER VENT GLASS ASSEMBLY
	113500-01-705	EA	LOWER VENT GLASS ASSEMBLY
	113500-01-706	EA	OPERATOR & BAR ASSEMBLY

DRIVER SIDE BEDROOM THERMOPANE WINDOW

KEY	PART NUMBER	U/M	DESCRIPTION
	112795-23-01A	EA	WINDOW ASM-SLIDER, HORIZONTAL - THERMOPANE - DRIVER SIDE
	098647-29-701	EA	TRIM
	098647-29-704	EA	SCREEN ASSEMBLY
	112795-01-700	EA	LATCH ASSEMBLY (BLK)
	112795-01-701	FT	SLIDE-STOP
	112795-01-702	FT	FILLER PLUG
	112795-01-703	FT	RUN CHANNEL
	112795-01-704	FT	VINYL-GLAZING
	112795-21-701	EA	GLASS-STATIONARY
	112795-21-702	EA	SLIDE ASSEMBLY
	112795-23-700	EA	WINDOW W/O TRIM

DRIVER SIDE DINETTE & LOUNGE WINDOW

KEY	PART NUMBER	U/M	DESCRIPTION
	098647-22-01A	EA	WINDOW ASM-SLIDER, HORIZONTAL BLK/OW
	098644-01-700	EA	LATCH REPAIR KIT (BLACK)
	098644-01-706	FT	WEATHERSTRIP-GLASS
	098644-01-708	FT	CHANNEL-RUN, PIERCED - GLASS
	098644-01-710	FT	TRACK-SPACER, FOR SCREEN 12'
	098644-01-711	FT	WEATHERSTRIP-SCREEN, BLACK
	098644-01-713	EA	SCREEN CLIPS (METAL)(BLK)
	098644-01-716	FT	PLUG-FILLER
	098644-01-717	FT	SPLINE-SCREEN MFG
	098647-22-700	EA	WINDOW W/O TRIM
	098647-23-700	EA	GLASS SLIDING, W/SASH & LATCH
	098647-23-702	EA	TRIM
	098647-23-703	EA	GLASS-STATIONARY
	098647-23-704	EA	SCREEN W/SPRING & WEATHERSTRIP

DRIVER SIDE DINETTE & LOUNGE THERMOPANE WINDOW

KEY	PART NUMBER	U/M	DESCRIPTION
	112795-15-01A	EA	WINDOW ASM-SLIDER, HORIZONTAL - THERMOPANE
	098647-23-702	EA	TRIM
	098647-23-704	EA	SCREEN W/SPRING & WEATHERSTRIP
	112795-01-700	EA	LATCH ASSY. (BLK)
	112795-01-701	FT	SLIDE-STOP
	112795-01-702	FT	FILLER PLUG
	112795-01-703	FT	RUN CHANNEL
	112795-01-704	FT	VINYL-GLAZING
	112795-15-700	EA	WINDOW W/O TRIM
	112795-15-701	EA	GLASS-STATIONARY
	112795-15-702	EA	GLASS-SLIDING, W/SASH & LATCH

WINDOW, VENT & EXTERIOR DOOR GROUP (CONTINUED)
DRIVER SIDE CAB WINDOW

KEY	PART NUMBER	U/M	DESCRIPTION
	103658-09-01A	EA	WINDOW ASM-CAB DRIVER
	098644-01-700	EA	LATCH REPAIR KIT (BLACK)
	098644-01-706	FT	WEATHERSTRIP-GLASS
	098644-01-708	FT	CHANNEL-RUN, PIERCED - GLASS
	098644-01-710	FT	TRACK-SPACER, FOR SCREEN 12'
	098644-01-711	FT	WEATHERSTRIP-SCREEN, BLACK
	098644-01-713	EA	SCREEN CLIPS (METAL) (BLK)
	098644-01-716	FT	PLUG-FILLER
	098644-01-717	FT	SPLINE-SCREEN MFG
	103658-09-700	EA	GLASS-STATIONARY (RH & LH)
	103658-09-701	EA	WINDOW W/O TRIM
	103658-09-702	EA	TRIM-LEFT
	103658-09-704	EA	SLIDE ASSEMBLY
	103658-09-705	EA	SCREEN ASSEMBLY

DRIVER SIDE CAB WINDOW - THERMOPANE

KEY	PART NUMBER	U/M	DESCRIPTION
	113501-03-01A	EA	WINDOW ASM-CAB DRIVER - THERMOPANE
	103658-09-702	EA	TRIM-LEFT
	103658-09-705	EA	SCREEN ASSEMBLY
	113501-03-700	EA	WINDOW W/O TRIM
	113501-03-701	EA	GLASS-STATIONARY
	113501-03-702	EA	GLASS-SLIDE ASSEMBLY

PASSENGER SIDE CAB WINDOW

KEY	PART NUMBER	U/M	DESCRIPTION
	103658-10-01A	EA	WINDOW ASM-CAB, PASSENGER
	098644-01-700	EA	LATCH REPAIR KIT (BLACK)
	098644-01-706	FT	WEATHERSTRIP-GLASS
	098644-01-708	FT	CHANNEL-RUN, PIERCED - GLASS
	098644-01-710	FT	TRACK-SPACER, FOR SCREEN 12'
	098644-01-711	FT	WEATHERSTRIP-SCREEN, BLACK
	098644-01-713	EA	SCREEN CLIPS (METAL) (BLK)
	098644-01-716	FT	PLUG-FILLER
	098644-01-717	FT	SPLINE-SCREEN MFG
	103658-09-700	EA	GLASS-STATIONARY (RH & LH)
	103658-10-700	EA	WINDOW W/O TRIM
	103658-10-701	EA	TRIM-RIGHT
	103658-10-703	EA	SLIDE ASSEMBLY
	103658-10-704	EA	SCREEN ASSEMBLY

PASSENGER SIDE CAB THERMOPANE WINDOW

KEY	PART NUMBER	U/M	DESCRIPTION
	113501-04-01A	EA	WINDOW ASM-CAB, PASSENGER - THERMOPANE
	103658-10-701	EA	TRIM-RIGHT
	103658-10-704	EA	SCREEN ASSEMBLY
	113501-04-700	EA	WINDOW W/O TRIM
	113501-04-701	EA	GLASS-STATIONARY
	113501-04-702	EA	GLASS-SLIDE ASSEMBLY

WINDOW, VENT & EXTERIOR DOOR GROUP (CONTINUED)

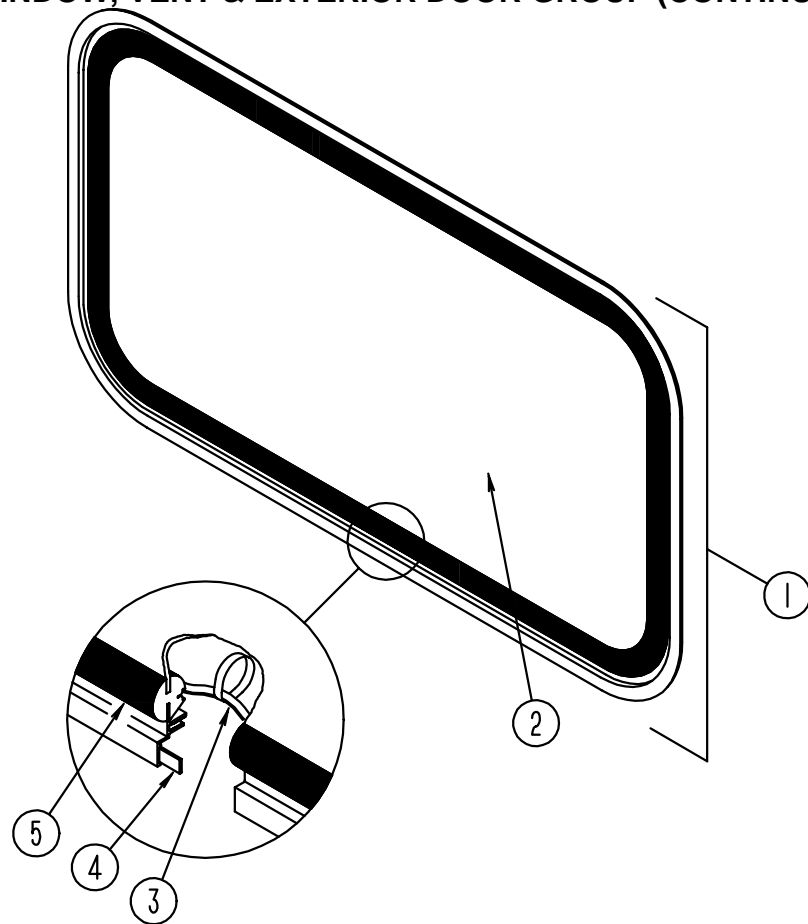

BACKWALL ESCAPE WINDOW

KEY	PART NUMBER	U/M DESCRIPTION
	074816-11-000	EA FRAME-WINDOW, INSIDE - ESCAPE - OFF WHITE
1	078528-06-E10	EA WINDOW-ESCAPE, BACKWALL - W/O INSIDE FRAME
2	076337-12-000	EA GLASS-WINDOW, 1157.4 X 548.1
3	002285-01-000	FT FILLER-WEATHER STRIP, RUBBER - BLACK
	077066-01-702	EA RED POLY.005 X .500" X 150' ROLL
4	069640-10-000	FT SEALER-RIBBON, 1/32" X 1 1/2" INCREMENTS OF 90'
5	002282-09-000	EA WEATHERSTRIP-WINDOW, .125" X 130.53 - VULCANIZED - BLACK

PASSENGER SIDE LOUNGE WINDOW

KEY	PART NUMBER	U/M DESCRIPTION
	098647-24-01A	EA WINDOW ASM-SLIDER, HORIZONTAL - BLK/OW
	098644-01-700	EA LATCH REPAIR KIT (BLACK)
	098644-01-706	FT WEATHERSTRIP-GLASS
	098644-01-708	FT CHANNEL-RUN, PIERCED - GLASS
	098644-01-710	FT TRACK-SPACER, FOR SCREEN 12'
	098644-01-711	FT WEATHERSTRIP-SCREEN, BLACK
	098644-01-713	EA SCREEN CLIPS (METAL)(BLK)
	098644-01-716	FT PLUG-FILLER
	098644-01-717	FT SPLINE-SCREEN MFG
	098647-24-700	EA WINDOW W/O TRIM
	098647-35-701	EA GLASS-STATIONARY
	098647-35-702	EA GLASS-SLIDING, W/SASH & LATCH
	098647-36-701	EA TRIM
	098647-36-704	EA SCREEN W/SPRING & WEATHERSTRIP

WINDOW, VENT & EXTERIOR DOOR GROUP (CONTINUED)

ENTRY DOOR WINDOW

KEY	PART NUMBER	U/M DESCRIPTION
	079733-15-F04	EA WINDOW-ENTRY DOOR, PICTURE
	000H13-04-07B	EA RIVET-SEMITUB-STL 1/8 X .219
	002181-22-000	EA GLASS-PICTURE 687.4 X 449.4
	004012-02-000	QT ADHESIVE - 3M 4475 (QUART)
	053752-08-000	GL SEAM SEALER - 5 GAL,BLACK
	075201-02-000	GL SEALANT-ACRYLIC, BLACK
	087561-01-000	FT EXTR-VINYL SEAL, TIPOUT/SLIDE
	090907-51-002	EA EXTR-STRAP

ENTRY DOOR THERMOPANE WINDOW

KEY	PART NUMBER	U/M DESCRIPTION
	113733-01-01A	EA WINDOW ASM-STATIONARY, THERMOPANE
	113733-01-700	EA WINDOW ASM. W/O TRIM
	113733-01-701	EA TRIM
	113733-01-702	EA GLASS-STATIONARY

PASSENGER SIDE LOUNGE THERMOPANE WINDOW

KEY	PART NUMBER	U/M DESCRIPTION
	112795-17-01A	EA WINDOW ASM-SLIDER, HORIZONTAL - THERMOPANE
	112795-01-700	EA LATCH ASSY. (BLK)
	112795-01-701	FT SLIDE-STOP
	112795-01-702	FT FILLER PLUG
	112795-01-703	FT RUN CHANNEL
	112795-01-704	FT VINYL-GLAZING

PASSENGER SIDE GALLEY WINDOW

KEY	PART NUMBER	U/M DESCRIPTION
	098647-33-01A	EA WINDOW ASM-SLIDER, HORIZONTAL
	098644-01-700	EA LATCH REPAIR KIT (BLACK)
	098644-01-706	FT WEATHERSTRIP-GLASS
	098644-01-708	FT CHANNEL-RUN, PIERCED - GLASS
	098644-01-710	FT TRACK-SPACER, FOR SCREEN 12'
	098644-01-711	FT WEATHERSTRIP-SCREEN, BLACK
	098644-01-713	EA SCREEN CLIPS (METAL) (BLK)
	098644-01-716	FT PLUG-FILLER
	098644-01-717	FT SPLINE-SCREEN
	098647-33-701	EA TRIM
	098647-33-702	EA GLASS-STATIONARY
	098647-33-703	EA GLASS SLIDE ASSEMBLY
	098647-33-704	EA SCREEN ASSEMBLY
	098647-33-700	EA WINDOW W/O TRIM

PASSENGER SIDE GALLEY THERMOPANE WINDOW

KEY	PART NUMBER	U/M DESCRIPTION
	112795-19-01A	EA WINDOW ASM-SLIDER, HORIZONTAL - THERMOPANE
	098647-31-701	EA TRIM
	098647-31-704	EA SCREEN ASSEMBLY
	112795-01-700	EA LATCH ASSEMBLY (BLK)
	112795-01-701	FT SLIDE-STOP
	112795-01-702	FT FILLER PLUG
	112795-01-703	FT RUN CHANNEL
	112795-01-704	FT VINYL-GLAZING
	112795-19-700	EA WINDOW W/O TRIM
	112795-19-701	EA GLASS-STATIONARY
	112795-19-702	EA GLASS-SLIDING, W/SASH & LATCH

WINDOW, VENT & EXTERIOR DOOR GROUP (CONTINUED)
DRIVER & PASSENGER SIDE BEDROOM WINDOW

KEY	PART NUMBER	U/M	DESCRIPTION
	113500-01-01A	EA	WINDOW ASM-TIPOUT, DOUBLE - BLK/OW
	113500-01-700	EA	SCREEN ASM. (RH & LH) W/SPRING
	113500-01-701	EA	WINDOW W/O TRIM
	113500-01-702	EA	TRIM
	113500-01-703	EA	TOP GLASS-STATIONARY
	113500-01-704	EA	UPPER VENT GLASS ASSEMBLY
	113500-01-705	EA	LOWER VENT GLASS ASSEMBLY
	113500-01-706	EA	OPERATOR & BAR ASSEMBLY

PASSENGER SIDE BEDROOM THERMOPANE WINDOW

KEY	PART NUMBER	U/M	DESCRIPTION
	112795-21-01A	EA	WINDOW ASM-SLIDER, HORIZONTAL - THERMOPANE - PASSENGER SIDE
	098647-29-701	EA	TRIM
	098647-29-704	EA	SCREEN ASSEMBLY
	112795-01-700	EA	LATCH ASSEMBLY (BLK)
	112795-01-701	FT	SLIDE-STOP
	112795-01-702	FT	FILLER PLUG
	112795-01-703	FT	RUN CHANNEL
	112795-01-704	FT	VINYL-GLAZING
	112795-21-700	EA	WINDOW W/O TRIM
	112795-21-701	EA	GLASS-STATIONARY
	112795-21-702	EA	SLIDE ASSEMBLY

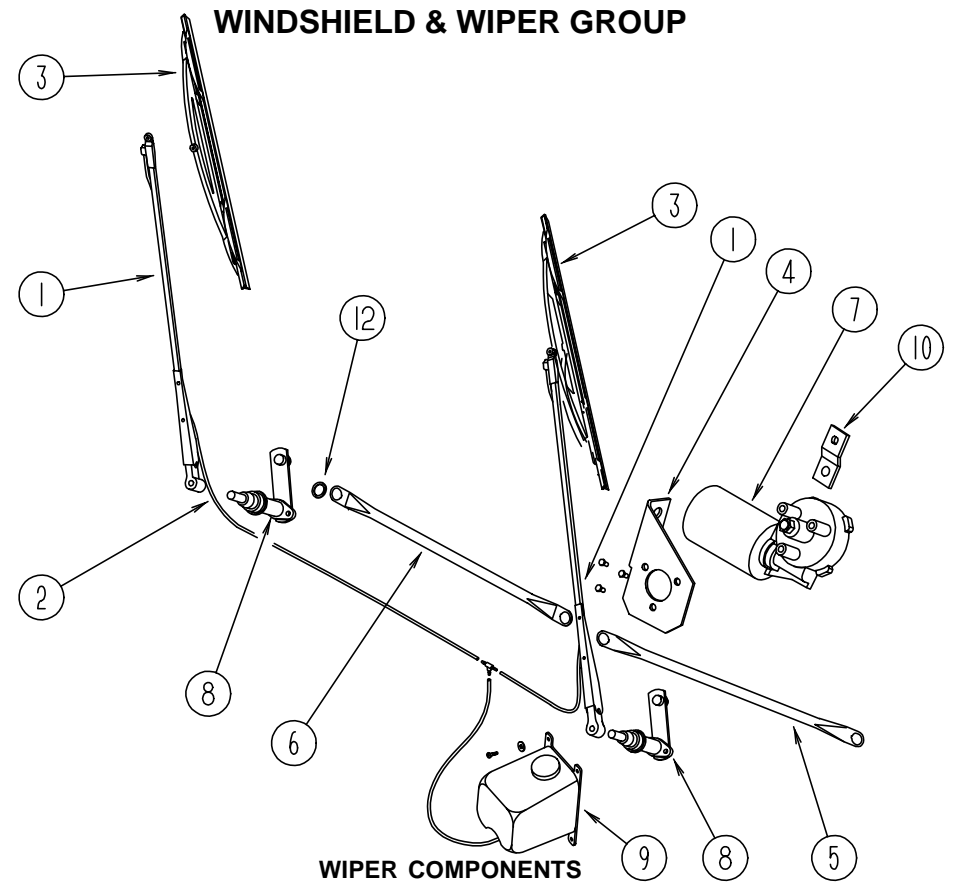

KEY	PART NUMBER	U/M	DESCRIPTION
1	103671-01-000	EA	ARM-WIPER, PANTOGRAPH - 24"
	096931-01-700	FT	HOSE-WIPER, TO BLADE
	096931-01-701	EA	NOZZLE-HARDWARE KIT, INCLUDES NOZZEL, NUT, SHORT THREAD SCREW, LONG THREAD SCREW, AND PLASTIC CAP
2	045794-01-000	FT	HOSE-WASHER, WINDSHIELD - 5/32" ID - BLACK
3	095964-01-000	EA	BLADE-WIPER, 24"
	095964-01-700	EA	REFILL-WIPER BLADE, 24" - PAIR
4	104549-01-000	EA	BRACKET ASSEMBLY-WIPER MOTOR
4	103726-01-000	EA	BRACKET-WIPER, MOTOR
5	103672-01-000	EA	LINK ASM - CONNECTING - DRIVERS
			FROM: 00-00-00 THRU: 01-23-95
5	117008-01-000	EA	LINK ASM - CONNECTING - DRIVERS
			FROM: 01-24-95 THRU: 99-99-99
6	103672-02-000	EA	LINK ASM - CONNECTING - PASSENGERS
			FROM: 00-00-00 THRU: 01-23-95
6	117008-02-000	EA	LINK ASM - CONNECTING - PASSENGERS
			FROM: 01-24-95 THRU: 99-99-99
7	104346-02-000	EA	MOTOR-WIPER, CHEVY
7	104346-03-000	EA	MOTOR-WIPER, FORD
8	096505-05-000	EA	PIVOT & SHAFT ASM-WIPER, PASSENGER WINDSHIELD
8	096505-06-000	EA	PIVOT & SHAFT ASM-WIPER, DRIVER WINDSHIELD
	096526-01-000	EA	SCREW-HEX, 1/4 - 28
9	056000-04-000	EA	WASHER-WINDSHIELD, BOTTLE & PUMP
			FROM: 00-00-00 THRU: 04-02-95
9	110605-01-000	EA	TEE-PLASTIC, BARBED - 1/8 X 1/8 X 3/16
			FROM: 04-03-95 THRU: 99-99-99
9	117765-01-000	EA	CONNECTOR- 5/32 - 1/4 - 3/8 WINDSHIELD WAHER
			FROM: 04-03-95 THRU: 99-99-99
9	117766-02-000	EA	RESERVOIR/PUMP ASM
			FROM: 04-03-95 THRU: 99-99-99
10	104347-01-000	EA	ARM-DRIVE, WIPER MOTOR - 1.54"
	056000-01-700	FT	VACUUM HOSE 7/64 - 5/32
	061603-01-000	EA	GROMMET-SNAP, 3/16 ID - 3/8 HOLE - PLASTIC - BLACK
	067188-01-000	EA	STUD-CRANK, WIPER
	110742-01-000	EA	GASKET-WIPER
	110178-01-000	EA	HOUSING-WIPER MOTOR - UT6237440-EC25WJ

WINDSHIELD & WIPER GROUP (CONTINUED)
WINDSHIELD MOLDINGS & GLASS

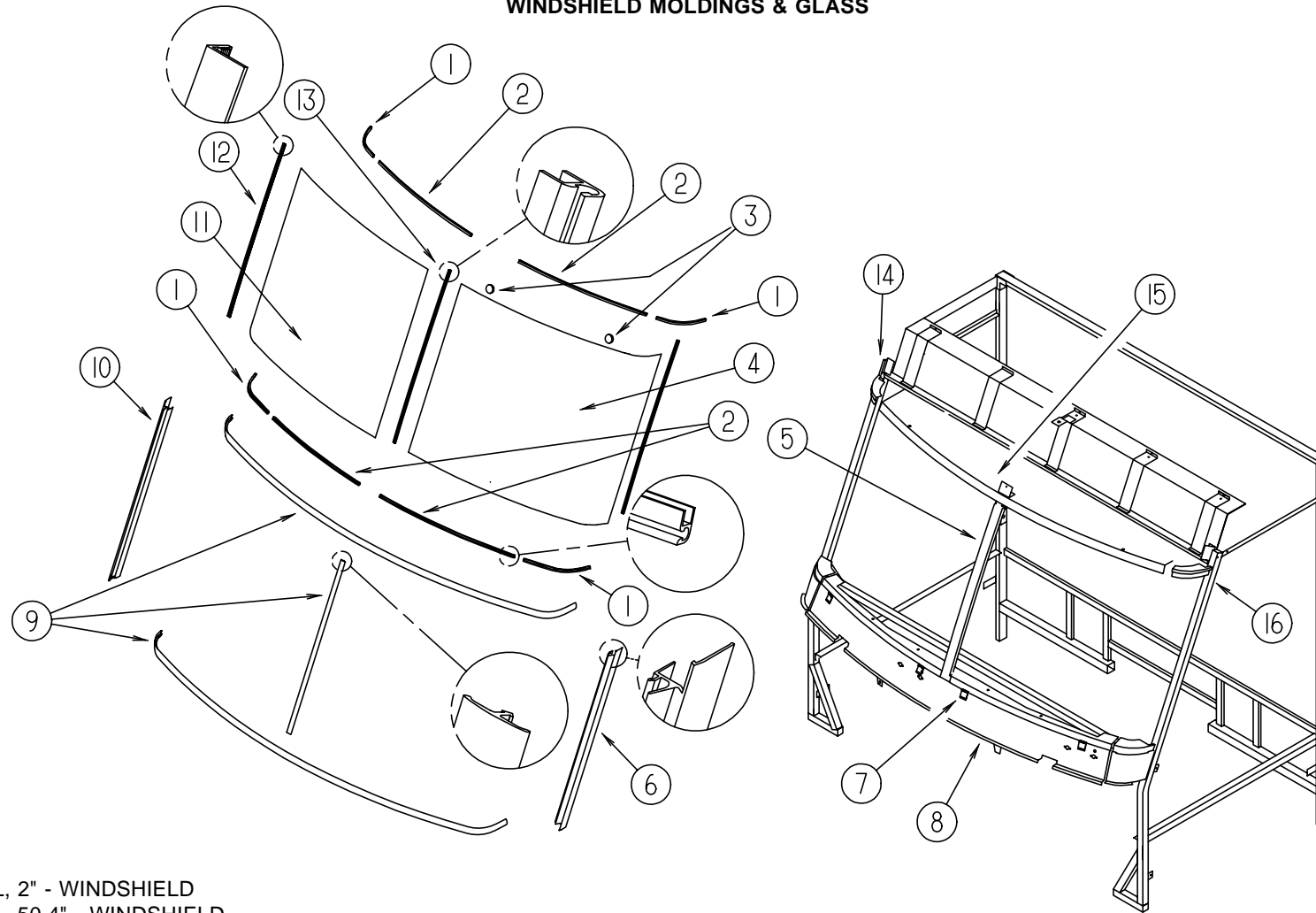

KEY	PART NUMBER	U/M	DESCRIPTION
1	102935-08-000	EA	CARRIER-REVEAL, 2" - WINDSHIELD
2	110268-01-000	EA	CARRIER-REVEAL, 50.4" - WINDSHIELD
3	081914-01-000	EA	BUMPER-RUBBER, ROUND - .43" DIAMETER - BLACK
4	088793-04-000	EA	GLASS-WINDSHIELD, DRIVER
5	075710-03-000	EA	FRAME-WINDSHIELD, CENTER DIVIDER - INNER
6	103107-02-01A	EA	TRIM-WINDSHIELD, DRIVER SIDE - BLACK
7	104449-01-000	EA	BRACKET-WINDSHIELD SUPPORT
8	077847-02-000	EA	SUPPORT-WINDSHIELD, LOWER - W/O BRACKETS
9	102936-01-000	FT	MOLDING - REVEAL - WINDSHIELD
10	103107-01-01A	EA	TRIM - WINDSHIELD - PASSENGER SIDE - BLACK
11	088793-03-000	EA	GLASS-WINDSHIELD, PASSENGER
12	098788-06-000	EA	CHANNEL - 49" PCV, DRIVER OR PASSENGER SIDE
13	110268-02-000	EA	CARRIER-REVEAL, 38" - WINDSHIELD
14	077922-03-000	EA	HEADER WINDSHIELD END - RIGHT - STEEL
15	077922-05-000	EA	HEADER WINDSHIELD - CENTER - STEEL
16	077922-04-000	EA	HEADER WINDSHIELD END - LEFT - STEEL