

1995 ICF27RQ

F24

F25

F26

F27

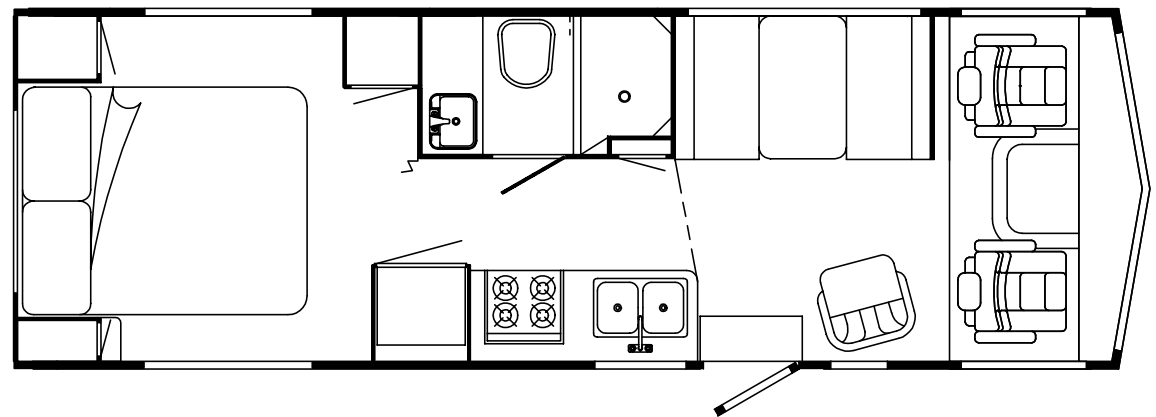
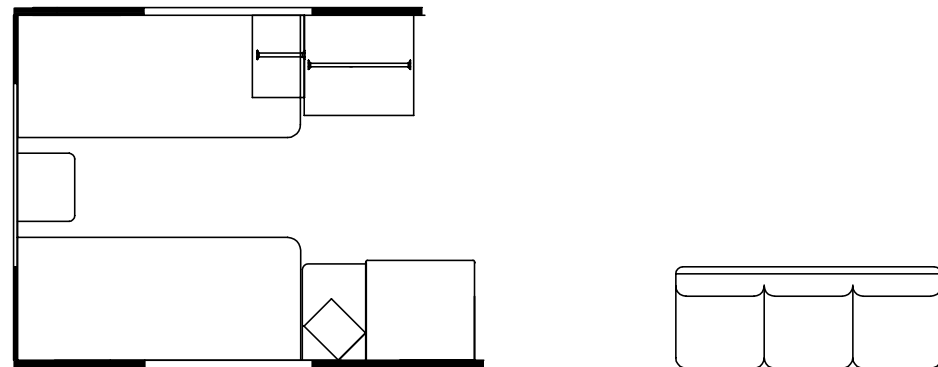
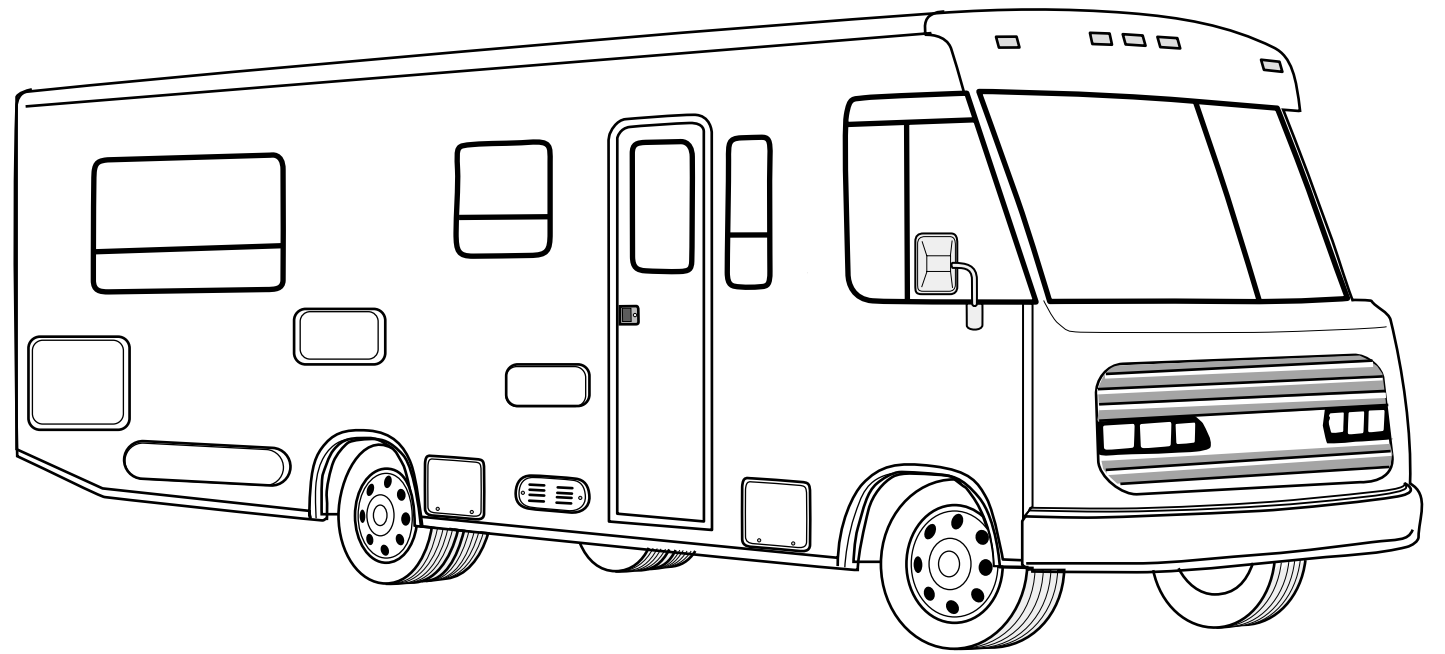

ACCESSORIES GROUP

OPERATOR MANUAL

KEY	PART NUMBER	U/M DESCRIPTION
	054185-D2-000	EA MANUAL-OPERATOR, 95 SUNRISE - F-SERIES
	092318-01-000	EA BINDER - 3 RING, MOTOR HOME MANUAL
	092319-01-000	EA POCKET PAGE - 3 RING BINDER, PLASTIC
	112106-01-000	DW TOP LEVEL-F, 1994

AUDIO VIDEO GROUP

PATIO ENTERTAINMENT CENTER

KEY	PART NUMBER	U/M DESCRIPTION
	110469-01-000	EA SPEAKER - 4" X 6", OVAL - MAGNADYNE F46XB-12
	110470-01-01A	EA GRILLE-SPEAKER, OVAL - 4" X 6" - BLACK - MAGNADYNE G46WI
	087683-03-000	EA RADIO-AM/FM STEREO W/CASSETTE - AUDIOVOX RS-100
	108847-01-000	EA BRACKET-ANTENNA GROUND

RADIO SYSTEM & ANTENNA

KEY	PART NUMBER	U/M DESCRIPTION
	116148-01-000	EA RADIO-AM/FM STEREO, CD PLAYER - CLARION 5633CD
	110267-03-000	EA RADIO-AM/FM STEREO, AUDIOVOX IM-400
	077069-02-000	EA CABLE-ANTENNA, RADIO - EXTENSION 96" - ARA 6700667
	090944-01-000	EA ANTENNA-RADIO, 16" RUBBER
	109889-02-000	EA EXTENDER-SHAFT, ANTENNA 2" - MAGNADYNE RV71EX2
	081059-02-000	EA WIRE ASM - 9-PIN, RADIO - AUDIOVOX 112B-1761
	089340-02-000	EA GRILLE-SPEAKER, 6.5" SQUARE
	089340-03-000	EA SPACER-GRILLE, 6.5" SQUARE - TAN - MAGNADYNE G514
	094097-01-000	EA SPEAKER-RADIO, W/O GRILLE - 5.25" DIA - AUDIOVOX 110C3030
	110469-01-000	EA SPEAKER - 4" X 6", OVAL - MAGNADYNE F46XB-12
	110470-01-01A	EA GRILLE-SPEAKER, OVAL - 4" X 6" - BLACK - MAGNADYNE G46WI

CB ANTENNA

KEY	PART NUMBER	U/M DESCRIPTION
	105248-01-000	EA ANTENNA-CB, ADVANCE 8604

AUDIO VIDEO GROUP (CONTINUED)

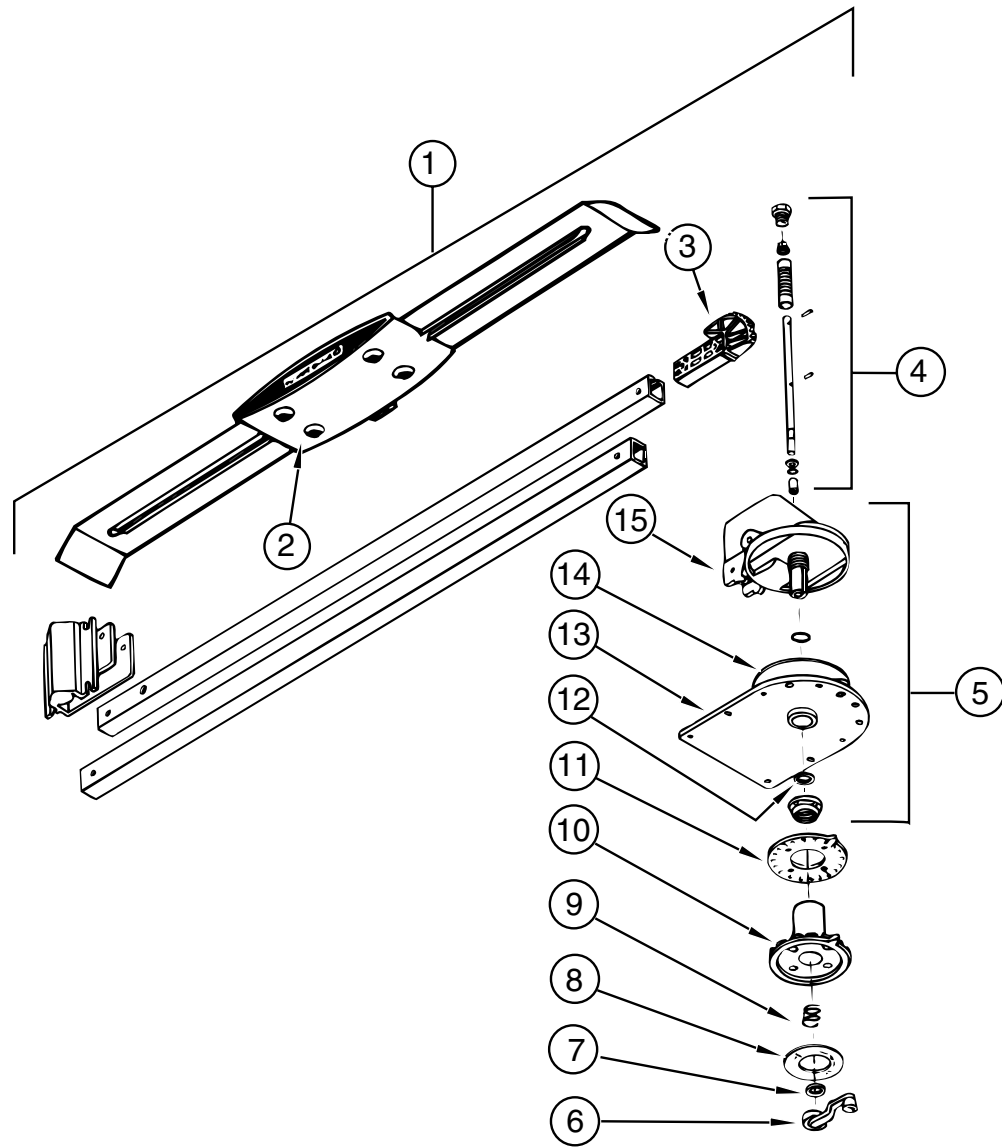

TV ANTENNA

KEY	PART NUMBER	U/M DESCRIPTION	VENDOR NO.
1	076319-01-000	EA ANTENNA-TV, ROOF MOUNT - 44.5" MAST	RVA W02
2	076319-01-700	EA HEAD-ANTENNA, AMPLIFIED	RVSA U/V
3	076319-01-701	EA GEAR-ELEVATING, PLASTIC	2200046
4	076319-01-702	EA SHAFT ASM-ELEVATING	RVP-400A
5	076319-01-711	EA BASE & LIFT ASM	2762802
6	076319-01-706	EA CRANK-ELEVATING, W/SET SCREW	5755100
7	076319-01-705	EA GROMMET-NYLON, 7/8"ID	3200658
8	076319-01-708	EA CRANK COVER DECAL	5413002
9	076319-01-707	EA SPRING-HANDLE	5160800
10	076319-01-709	EA PLATE-DIRECTIONAL, FOR HEAD	3200644
11	076319-01-712	EA PLATE-CEILING	3200608
12	076319-01-704	EA BEARING-NYLON, 1.25"OD	3200657
13	076319-01-713	EA PLATE-BASE	3100523
14	076319-01-703	EA BEARING-NYLON, 5"OD	3200656
15	076319-01-714	EA HOUSING, ROTATING GEAR	2200049

AUDIO VIDEO GROUP (CONTINUED)

TV, VCR & CONTROL CENTER

KEY	PART NUMBER	U/M DESCRIPTION	VENDOR NO.
	098447-11-000	EA TV - 13", COLOR W/JACK - U.S. - MAGNAVOX 13PRC10	
	098447-11-700	EA REMOTE-TV, MAGNAVOX	13PRC10
	098447-08-000	EA TV - 13", COLOR W/REMOTE - CANADIAN - MAGNAVOX XR1333C	
		FROM: 00-00-00 THRU: 10-09-94	
	098447-08-700	EA REMOTE-TV, MAGNAVOX	XR1333C
	098447-12-000	EA TV - 13", COLOR W/JACK - CANADIAN - MAGNAVOX 13XNC15	
		FROM: 10-10-94 THRU: 99-99-99	
	098447-11-700	EA REMOTE-TV, MAGNAVOX	13PRC10 OR13XNC15
	098446-06-000	EA VCR-VHS CABLE READY -REMOTE - MAGNAVOX VR9210	
		FROM: 00-00-00 THRU: 09-12-94	
	098446-06-700	EA REMOTE F/MODEL 9210 ONLY	
	098446-07-000	EA VCR-VHS CABLE READY -REMOTE - MAGNAVOX VR9320	
		FROM: 09-13-94 THRU: 99-99-99	
	092310-02-000	EA TV-COLOR, 9" - AC/DC - W/REMOTE - MAGNAVOX RD0945	
	092310-02-700	EA REMOTE-TV, MAGNAVOX	RD0945
	086757-03-000	EA CONTROL CENTER-SWITCH, VCR/TV - MAGNADYNE VCS-6	
	086777-05-000	EA PLATE-WALL,ANTENNA 1 OUTPUT IVORY - WINEGARD RV-0921	
	093214-01-02A	EA GRILL-SPEAKER, 4" BROWN	
	098819-01-000	EA SPEAKER - 2 WATT, 8 OHM - 4"	
	099717-01-000	EA TIEDOWN-TV, STRAP ON FEMALE END IS 22.8" LONG	
	099717-02-000	EA TIEDOWN-TV, STRAP ON FEMALE END IS 28.7" LONG	
	076319-09-000	EA WALLPLATE-CABLE RECEPTACLE, TV - SINGLE - BROWN	
	076319-08-000	EA WALLPLATE-CABLE RECEPTACLE, TV - SINGLE - IVORY	
	086777-01-000	EA WALLPLATE-TV CABLE, W/ANTENNA SWITCH - IVORY	
	086777-03-000	EA PLATE-WALL, CABLE - W/TV ANTENNA SWITCH & BOOSTER - IVORY	
	076319-12-000	EA CONNECTOR-COAXIAL, ONE PIECE	
	082134-01-000	EA ADAPTER-TV, CABLE TO CABLE - WINEGARD F-81M	
	086756-01-000	EA SPLITTER-TV, 2 WAY	
	076319-03-000	FT CABLE-COAXIAL, 75 OHM	
	076319-06-000	EA ADAPTOR-CABLE ROOF PLATE, WINEGARD RPJ-1	

BATH GROUP

BATHROOM CABINET & COMPONENTS

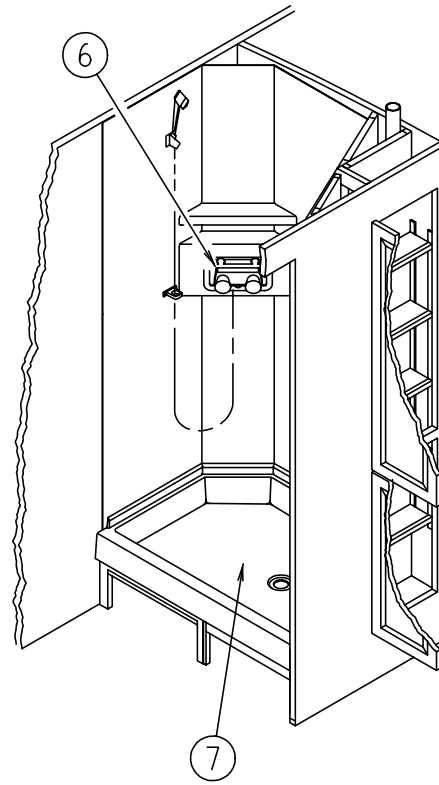
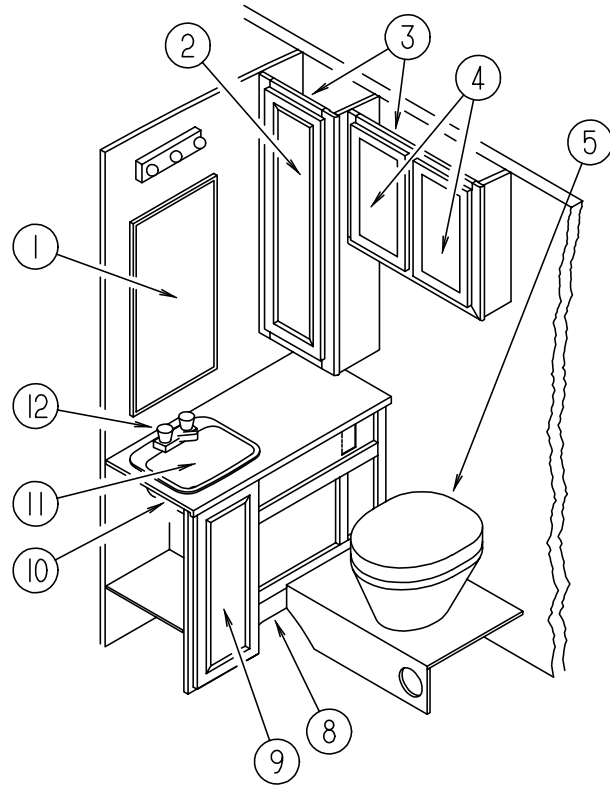

KEY	PART NUMBER	U/M	DESCRIPTION
1	058331-51-000	EA	MIRROR-GLASS, SAFETY - 660 MM X 1016 MM
	105004-01-02A	EA	MOLDING-VINYL WRAPPED, MIRROR - 1" X 8' - OAK
2	M06803-10-E07	EA	DOOR-W/O HARDWARE - 275 MM X 925 MM
3	111760-01-F04	EA	CABINET-MEDICINE/STORAGE, W/O DOORS OR HARDWARE
4	M06803-06-E07	EA	DOOR-W/O HARDWARE, W/MIRROR - 285 MM X 500 MM
5	067487-02-000	EA	TOILET-12.37", IVORY - FOOT FLUSH - THETFORD
	063740-01-700	EA	LEVER-WATER, THETFORD 12514
	063740-01-706	EA	BOLT PACKAGE-CLOSET, THETFORD 12524
	063740-01-710	EA	LINK, THETFORD 12513
	063740-01-713	EA	SEAL-BALL VALVE TO BOWL, THETFORD 12502
	063740-01-714	EA	VALVE ASM-WATER, THETFORD 12492
	063740-01-717	EA	TUBE-FLUSH, TOILET - THETFORD 12509
	063740-02-700	EA	SEAT & COVER, PARCHMENT - THETFORD 20829
	075241-05-000	EA	FAUCET-SHOWER, BONE
	075606-01-000	EA	PANEL-FAUCET BACK, SHOWER - 5" X 9" - PLASTIC
	103092-01-000	EA	SHOWER HEAD-W/60" HOSE - US
	103092-02-000	EA	SHOWER HEAD-W/60" HOSE - CANADIAN
6	103092-01-700	EA	BRACKET ONLY-CLEAR, F/SHOWER HEAD - 2328028
	103092-01-701	EA	BRACKET ONLY-BONE, F/SHOWER HEAD - 2328029
	M02429-09-000	EA	PAN-SHOWER, OFF WHITE
	066436-01-000	EA	NUT-SLIP, TAILPIECE - 1.5"
	011069-02-000	EA	TAILPIECE-TUB/SHOWER, 1 1/2" X 1 1/4" X 4" - BRASS
	066440-01-000	EA	STRAINER-SHOWER, W/RUBBER WASHER
	069735-01-000	EA	WASHER-STRAINER TO TAILPIECE PLASTIC, 1.5"
	057671-01-000	EA	COVER-SCREW, #8 - PLASTIC - OFF WHITE
	112693-01-01A	EA	SURROUND-SHOWER, ONE PIECE - OFF WHITE
	101447-01-000	EA	CLIP-U TYPE, TINNEMAN
	P07842-01-E08	EA	CABINET-LAVATORY W/COUNTERTOP (F24,F27)
	P07842-01-F05	EA	CABINET-LAVATORY W/COUNTERTOP (F25)
P07842-01-F06	EA	CABINET-LAVATORY W/COUNTERTOP (F26)	
8	P07842-01-F05	EA	CABINET-LAVATORY W/COUNTERTOP (F25)
	P07842-01-F06	EA	CABINET-LAVATORY W/COUNTERTOP (F26)
9	M06803-61-E10	EA	DOOR-W/O HARDWARE - 290 MM X 715 MM
10	107842-11-E08	EA	COUNTERTOP-LAVATORY CABINET (F24,F27)
	107842-11-F05	EA	COUNTERTOP-LAVATORY CABINET (F25)
10	107842-11-F06	EA	COUNTERTOP-LAVATORY CABINET (F26)
11	096927-01-01A	EA	SINK-LAVATORY, RECTANGULAR - PLASTIC - BONE
	096927-01-700	EA	SINK-STOPPER
	096927-01-701	EA	TAILPIECE-SINK
12	075240-06-000	EA	FAUCET-LAVATORY, BONE
	091253-01-000	EA	GASKET-FAUCET, LAVATORY/GALLEY
	M87868-13-E10	EA	DOOR-BATH CABINET, W/O HARDWARE - 1859 MM X 523 MM
	100357-01-000	EA	ROD-TOWEL, BRASS W/ENDS BENT FOR BACK OF BATH DOOR
	102089-13-E07	EA	WOOD RAIL - TOWEL RACK - RIGHT SIDE - 26" LONG
	102089-14-E07	EA	WOOD RAIL - TOWEL RACK - LEFT SIDE - 26" LONG
	094485-03-01A	EA	KNOB-DOOR W/LOCK, BRASS - THUNADER L132PB
	103194-01-000	EA	STOP-DOOR, BATH
	075453-02-000	EA	BAR-TOWEL, 18" BRASS
	075452-02-000	EA	HOLDER-TOILET TISSUE, BRASS
	M04145-11-E07	EA	BATH DOOR W/JAMB

BEDROOM GROUP

QUEEN BEDROOM CABINETS

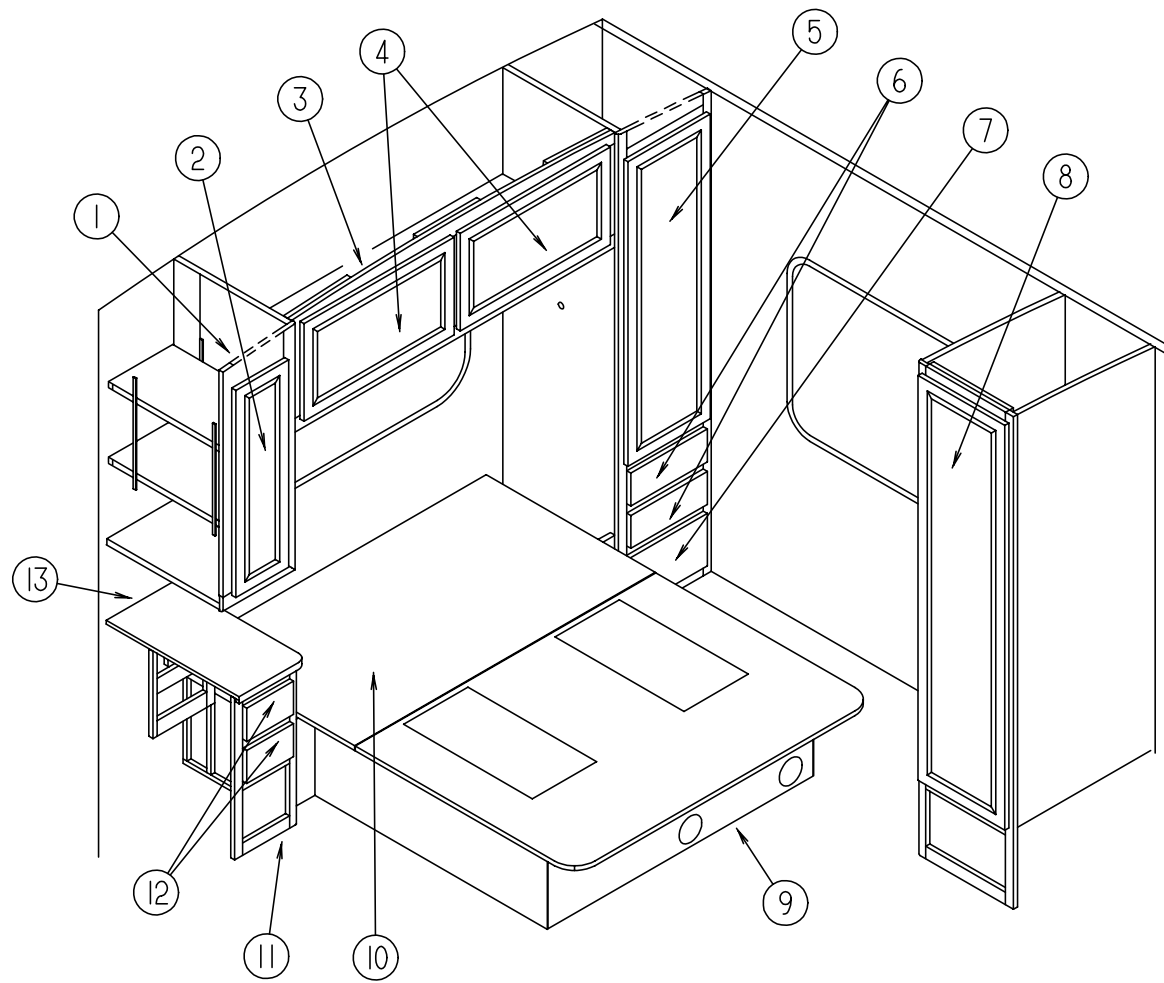

KEY	PART NUMBER	U/M	DESCRIPTION	VENDOR NO.
	111236-01-E07	EA	SHELF ASM-TV, W/BRASS RAILING & WEDGE - 420 MM X 410 MM	
	105219-01-E07	EA	SHELF ASM-W/BRASS RAILING - 273 MM X 274 MM	
	084070-02-000	EA	POST-END, 2.4" - BRASS	
	084071-15-000	EA	ROD-BRASS, 210 MM LONG	
	058331-17-000	EA	MIRROR-GLASS, SAFETY - 8.75" X 12.5"	
	105004-01-01A	EA	MOLDING-MIRROR, VINYL WRAPPED - OAK	
1	106521-01-E07	EA	CABINET-SHIRT CLOSET, W/O DOOR OR HARDWARE	
2	M06803-84-E07	EA	DOOR-W/O HARDWARE - 250 MM X 850 MM	
3	107832-01-E07	EA	CABINET-OVERHEAD, W/O DOORS OR HARDWARE	
4	M06803-02-E07	EA	DOOR-W/O HARDWARE W/O MIRROR - 400 MM X 710 MM - EUROPEAN OPTION	
4	M06803-13-E07	EA	DOOR-W/O HARDWARE W/MIRROR - 400 MM X 710 MM	
5	M06803-45-E07	EA	DOOR-W/O HARDWARE - 390 MM X 1250 MM	
6	M05971-84-E07	EA	DRAWER-CABINET, W/O HARDWARE - 155 MM X 390 MM FACE SIZE	
7	M05971-85-E07	EA	DRAWER-CABINET, W/O HARDWARE - 235 MM X 390 MM FACE SIZE	
8	M06803-11-E07	EA	DOOR-W/O HARDWARE - 410 MM X 1660 MM	
	009112-01-000	EA	FLANGE-1" ROD, CLOTHES - PLASTIC - OFF WHITE	
	042438-01-000	EA	DOWEL-WOOD, CLOTHES ROD - 1" DIAMETER X 4'	
9	P10623-01-F04	EA	CABINET-QUEEN BED W/O TOP	
	M05706-05-000	EA	TOP-QUEEN BED CABINET	
10	P11375-01-F04	EA	CABINET-COMPARTMENT, W/O CARPET OR TOP	
	M05706-07-000	EA	TOP-COMPARTMENT CABINET	
11	P11376-01-E08	EA	CABINET-NIGHTSTAND W/COUNTERTOP (F24,F27)	
11	P11376-01-F05	EA	CABINET-NIGHTSTAND W/COUNTERTOP (F25)	
11	P11376-01-F06	EA	CABINET-NIGHTSTAND W/COUNTERTOP (F26)	
12	M05971-86-E07	EA	DRAWER-CABINET, W/O HARDWARE - 155 MM X 250 MM FACE SIZE	
13	111376-11-E08	EA	COUNTERTOP-NIGHTSTAND (F24,F27)	
13	111376-11-F05	EA	COUNTERTOP-NIGHTSTAND (F25)	
13	111376-11-F06	EA	COUNTERTOP-NIGHTSTAND (F26)	
	042488-10-000	EA	DOOR-FOLDING, FABRIC - 37" X 75" - OFF WHITE	
	080224-01-703	EA	LATCH & CATCH ASSEMBLY-ALMOND -	DE00020AL
	080224-01-705	EA	CATCH ONLY-DOOR JAMB-ALMOND -	DE25020AL

BEDROOM GROUP (CONTINUED)

TWIN BEDROOM CABINERY

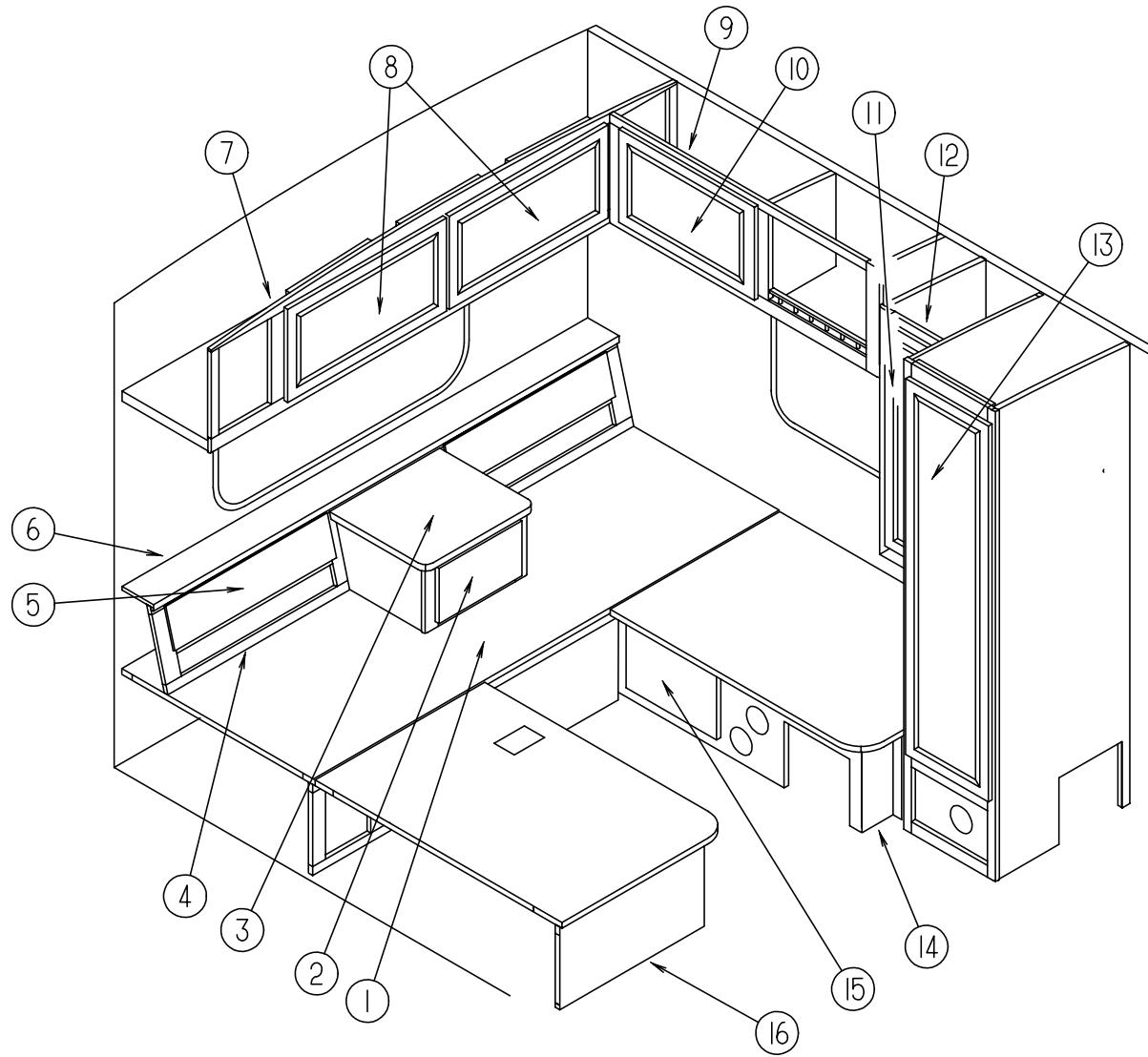

KEY	PART NUMBER	U/M DESCRIPTION	VENDOR NO.
1	P11377-01-000	EA CABINET-COMPARTMENT, W/O CARPET	
2	M05971-59-E07	EA DRAWER-CABINET, W/O HARDWARE - 235 MM X 410 MM FACE SIZE	
3	110826-13-F24	EA COUNTERTOP-NIGHTSTAND CABINET (F24,F27)	
3	110826-13-F05	EA COUNTERTOP-NIGHTSTAND CABINET (F25)	
3	110826-13-E90	EA COUNTERTOP-NIGHTSTAND CABINET (F26)	
4	110826-01-F24	EA CABINET-NIGHTSTAND, W/COUNTERTOPS - W/O DOORS OR DRAWER	
4	110826-01-F25	EA CABINET-NIGHTSTAND, W/COUNTERTOPS - W/O DOORS OR DRAWER	
4	110826-01-F26	EA CABINET-NIGHTSTAND, W/COUNTERTOPS - W/O DOORS OR DRAWER	
4	110826-01-F27	EA CABINET-NIGHTSTAND, W/COUNTERTOPS - W/O DOORS OR DRAWER	
5	110826-12-E24	EA DOOR-W/O HARDWARE - FABRIC COVERED - 176 MM X 802 MM - EITHER SIDE	
5	110826-12-F25	EA DOOR-W/O HARDWARE - FABRIC COVERED - 176 MM X 802 MM - EITHER SIDE	
5	110826-12-F26	EA DOOR-W/O HARDWARE - FABRIC COVERED - 176 MM X 802 MM - EITHER SIDE	
5	110826-12-F27	EA DOOR-W/O HARDWARE - FABRIC COVERED - 176 MM X 802 MM - EITHER SIDE	
6	110826-11-F24	EA COUNTERTOP-NIGHTSTAND CABINET (F24,F27)	
6	110826-11-F05	EA COUNTERTOP-NIGHTSTAND CABINET (F25)	
6	110826-11-E90	EA COUNTERTOP-NIGHTSTAND CABINET (F26)	
7	111239-01-E07	EA CABINET-OVERHEAD, W/O DOORS OR HARDWARE	
8	M06803-02-E07	EA DOOR-W/O HARDWARE W/O MIRROR - 400 MM X 710 MM - EUROPEAN OPTION	
8	M06803-13-E07	EA DOOR-W/O HARDWARE W/MIRROR - 400 MM X 710 MM	
9	111186-01-E07	EA CABINET-OVERHEAD, W/O DOOR OR HARDWARE - DRIVER SIDE	
	111185-01-F04	EA CABINET-OVERHEAD, W/O DOOR OR HARDWARE - PASS SIDE (NOT SHOWN)	
	111775-01-01A	EA RAIL-DECORATIVE, 1830 MM - OAK	
	058331-A5-000	EA MIRROR-GLASS, SAFETY - 396 MM X 516 MM	
10	M06803-02-E07	EA DOOR-W/O HARDWARE - 400 MM X 710 MM - DRIVER OR PASS SIDE	
11	M06803-15-E07	EA DOOR-W/O HARDWARE - 305 MM X 1015 MM - DRIVER OR PASS SIDE	
12	111379-01-E07	EA CABINET-SHIRT CLOSET, W/O DOOR OR HARDWARE - DRIVER SIDE	
	111761-01-E07	EA CABINET-SHIRT CLOSET, W/O DOOR OR HARDWARE - PASS SIDE (NOT SHOWN)	
13	M06803-11-E07	EA DOOR-W/O HARDWARE - 410 MM X 1660 MM	
	009112-01-000	EA FLANGE-1" ROD, CLOTHES - PLASTIC - OFF WHITE	
	042438-01-000	EA DOWEL-WOOD, CLOTHES ROD - 1" DIAMETER X 4'	
14	P11378-01-F04	EA CABINET-TWIN BED W/O TOP, DRIVER SIDE	
	M05138-11-000	EA TOP-TWIN BED, DRIVER SIDE	
15	M06803-25-E07	EA DOOR-W/O HARDWARE - 305 MM X 475 MM	
16	P11762-01-F04	EA CABINET-TWIN BED W/O TOP, PASSENGER SIDE	
	M05138-12-000	EA TOP-TWIN BED, PASSENGER SIDE	
	042488-10-000	EA DOOR-FOLDING, FABRIC - 37" X 75" - OFF WHITE	
	080224-01-703	EA LATCH & CATCH ASSEMBLY-ALMOND -	DE00020AL
	080224-01-705	EA CATCH ONLY-DOOR JAMB-ALMOND -	DE25020AL

BEDROOM GROUP (CONTINUED)

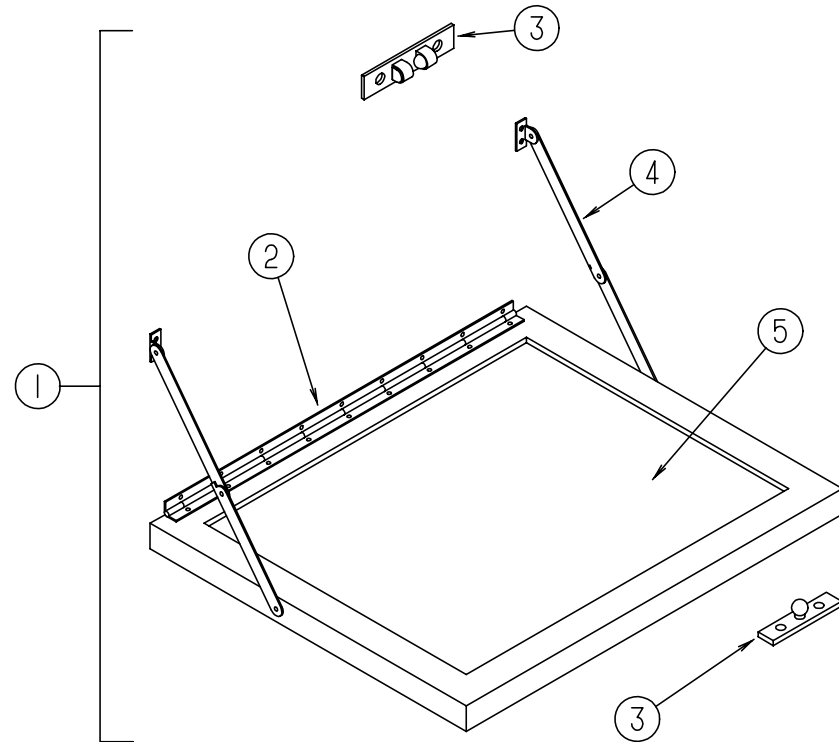

TV STAND

KEY	PART NUMBER	U/M DESCRIPTION
1	084357-02-E07	EA STAND-FOLD DOWN, TV - W/MIRROR
2	084413-01-000	EA HINGE-CONTINUOUS, W/HOLES
3	084451-01-000	EA CATCH-TV SHELF, BRASS
4	084412-01-000	EA SUPPORT-HINGED (PAIR)
5	084356-08-000	EA INSERT-TV STAND, W/SUPPORT HINGE - METAL - OFF WHITE
5	058331-14-000	EA MIRROR-GLASS, SAFETY - 14" X 12.7"

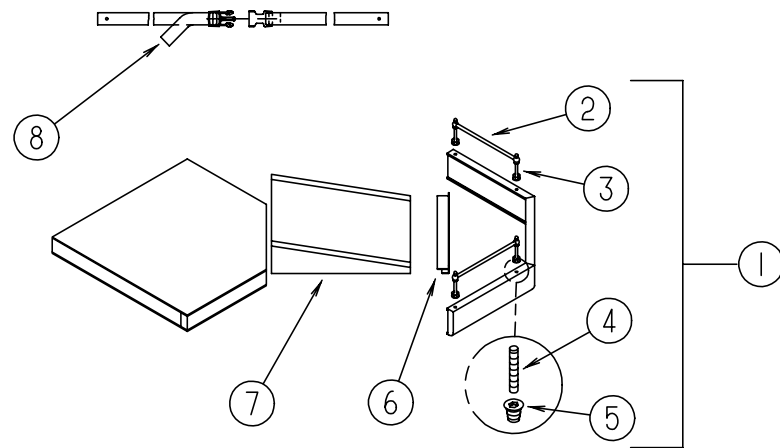

TV SHELVES

KEY	PART NUMBER	U/M DESCRIPTION
1	111236-01-E07	EA SHELF ASM-TV, W/BRASS RAILING & WEDGE - 420 MM X 410 MM
2	084071-15-000	EA ROD-BRASS, 210 MM LONG
3	084070-02-000	EA POST-END, 2.4" - BRASS
4	105247-01-000	EA NUT-INSERT, 8-32 THREAD X .394" LONG - STAFEST PRODUCTS
5	105246-01-000	EA POST-ANCHOR
6	103186-01-01A	FT MOLDING-EDGE, SHELF - .78" WIDE - PLASTIC - RAMBLING OAK
7	111236-15-E07	EA WEDGE-TV
8	099717-01-000	EA TIEDOWN-TV, STRAP ON FEMALE END IS 22.8" LONG

CHASSIS GROUP

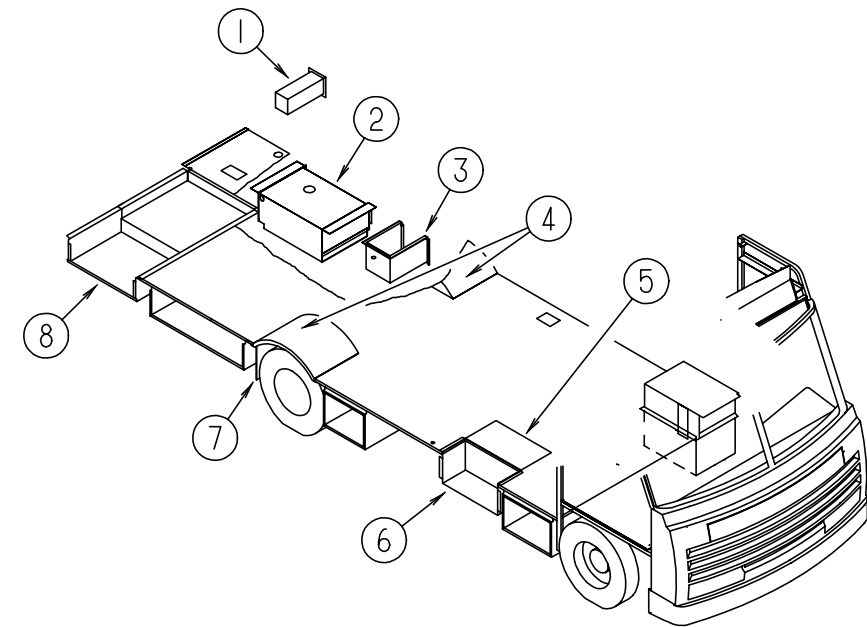

COMPARTMENTS & WHEELWELLS

KEY	PART NUMBER	U/M DESCRIPTION
1	085967-01-000	EA COMPARTMENT-SEWER HOSE, 6" X 6.6" X 17.8" - PLASTIC
2	078137-04-000	EA TRAY-COMPARTMENT, 29.1" WIDE X 22.4" DEEP
3	102979-01-000	EA BOX-POWER CORD
4	102921-01-000	EA WHEELWELL-PLASTIC
5	104006-01-C05	EA LID-ENTRANCE STEP COMPARTMENT, W/O CARPET
	101222-01-01A	EA BRACKET-CATCH, LID - BEIGE
	042541-04-000	EA LATCH-BRASS, W/O STRIKE - HASP TYPE - BRASS
6	077848-02-000	EA STEP-PULLOUT
	091176-01-000	EA SUPPORT-BASE-ENTRANCE STEP
	056746-01-000	EA PLUG-CAP, 1" DIAMETER
	056748-01-000	EA PLUG-CAP, 1.5" DIAMETER - BLACK
7	017516-01-000	EA FLAP-MUD, 14" X 18" - BLACK
	020167-03-000	EA GUARD-DIRT
8	110820-01-000	EA COMPARTMENT ASM STORAGE

CHASSIS GROUP (CONTINUED)

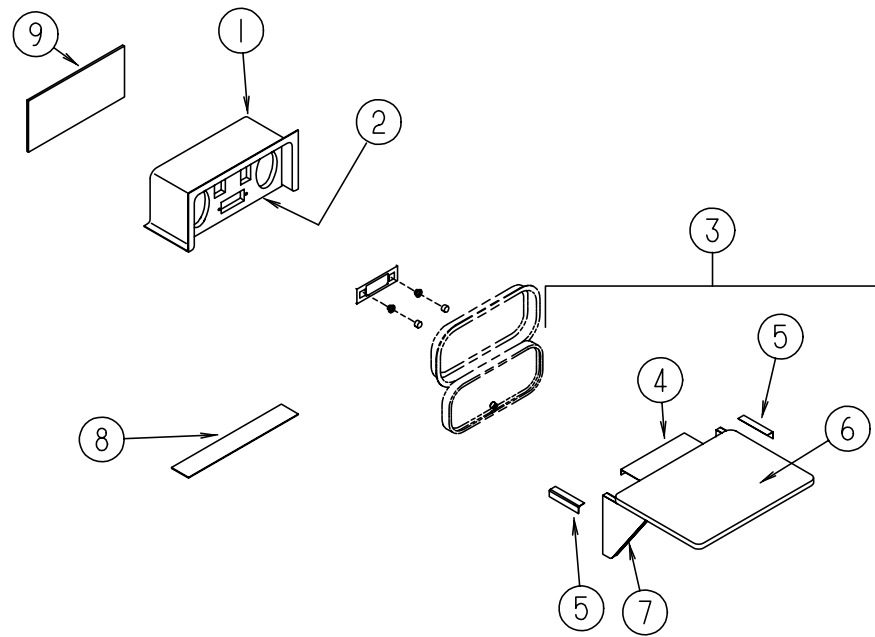

PATIO ENTERTAINMENT CENTER

KEY	PART NUMBER	U/M DESCRIPTION
1	104897-03-02A	EA BOX-ENTERTAINMENT CENTER - BRIGHT WHITE
2	104899-01-C05	EA PLATE-RADIO MOUNTING
3	105230-01-E01	EA SHELF
4	105377-01-01A	EA BRACKET-TABLE HANGER, OFF WHITE
5	105376-01-02A	EA HINGE-CONTINUOUS, 2" X 140 MM - OFF WHITE
6	105230-11-E01	EA SHELF
7	105230-12-E01	EA SUPPORT-SHELF
8	104898-01-02A	EA PLATE-PLASTIC, BOTTOM - 19.38" X 3.1" - BRIGHT WHITE
9	104898-02-02A	EA PLATE-PLASTIC, REAR - 16.1" X 6.3" - BRIGHT WHITE

CHASSIS GROUP (CONTINUED)

16" CHEVY STAINLESS STEEL WHEEL LINERS

KEY	PART NUMBER	U/M DESCRIPTION
	091209-05-000	EA LINER-WHEEL, SET OF 4 - 16" - STAINLESS STEEL
	091209-03-702	EA COVER-AXLE, FRONT - 8 LUG - FORD & CHEVY
	091209-03-703	EA COVER-AXLE, REAR - 8 LUG - FORD & CHEVY
	091209-03-704	EA RING-SNAP, FRONT OR REAR - 8 LUG - FORD & CHEVY
	091209-05-700	EA LINER-WHEEL, 16" FRONT - W/AXLE COVER & 8 LUG - CHEVY/FORD
	091209-05-701	EA LINER-WHEEL, 16" REAR - W/AXLE COVER & 8 LUG - CHEVY/FORD
	095012-03-000	EA EXTENSION-VALVE STEM, DUAL WHEEL
	095012-04-000	EA STABILIZER-VALVE STEM EXTENSION, DICOR AG-STA-2
	077030-02-000	EA EXTENSION-VALVE STEM, 1.25"

16" CHEVY WHEEL COVERS

KEY	PART NUMBER	U/M DESCRIPTION
	109443-05-000	EA COVER-WHEEL, 16" - SET OF 4 - DICOR SHFM16
	109443-05-700	EA COVER-WHEEL, 16" - DICOR SHFM16-CVR
	109443-05-001	EA COVER-LUG NUT, PLATED ABS - DICOR SP-FM-LNC

ELECTRIC ENTRY STEP

KEY	PART NUMBER	U/M DESCRIPTION	VENDOR NO.
	P01713-01-000	EA SWITCH ASSEMBLY - SEALED - STEP AND DOOR SWITCH	
	113285-01-01A	EA SEAL-SWITCH, STEP - BLACK - LUNDELL	
	094708-01-01A	EA STEP-ENTRY DOOR, ELECTRIC - SINGLE - KWIKEE 2813	
	094707-02-700	EA MOTOR REPLACEMENT KIT - MODELS 32 & 28 - KWIKEE	9520
	094707-02-702	EA GEAR KIT - KWIKEE	9525
	094707-02-703	EA PARTS KIT, (BEARINGS & PINS) - KWIKEE	9530
	094707-02-704	EA CONNECTOR KIT-MOTOR, KWIKEE	9537
	094707-02-705	EA CONTROL UNIT, (ORANGE) - KWIKEE	9513
	094708-02-700	EA CONVERSION KIT 28 SERIES - KWIKEE	9570
	094708-03-700	EA LINKAGE ASM F/28 SERIES - KWIKEE	9522

LUG WRENCH & LEVERAGE BAR

KEY	PART NUMBER	U/M DESCRIPTION
	080208-01-000	EA LUG WRENCH, 1.06 X 1.00
	080208-02-000	EA LEVERAGE BAR-LUG WRENCH

CHASSIS GROUP (CONTINUED)

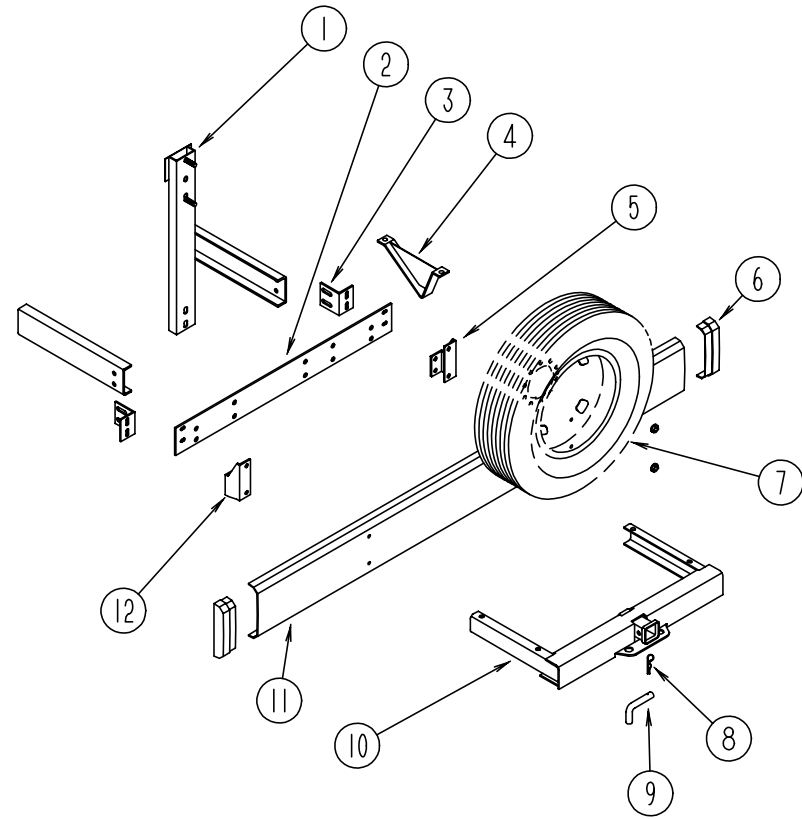

REAR BUMPER, TRAILER HITCH & COMPONENTS

KEY	PART NUMBER	U/M	DESCRIPTION
1	102944-01-000	EA	BRACKET ASM-TIRE CARRIER
1	102944-02-000	EA	BRACKET ASM-TIRE CARRIER, FORD OPTION
2	078678-02-000	EA	PLATE-MOUNTING, BUMPER - REAR
3	078668-01-000	EA	SUPPORT ANGLE-BUMPER, REAR
4	083376-01-000	EA	SKID PLATE
5	102945-03-000	EA	BRACKET ASM-BUMPER, REAR
6	103228-01-06A	EA	CAP-END, BUMPER - REAR - DRIVER OR PASSENGER SIDE
7	083425-10-000	EA	TIRE-LT215/85R16, LRE XCH4 - MICHELIN XCH4 ORBL - FORD OPTION
7	007324-04-000	EA	TIRE - 8R19.5 LRD, MICHELIN XZA - CHEVY
	051377-01-000	EA	STEM-VALVE, TR 500
	051377-05-000	EA	STEM-VALVE, EATON VS-938 F53-92 - FORD OPTION
	095853-02-000	EA	WHEEL-STEEL, 16" X 6K - F2TA-1015-NA - ACCURIDE 28513-7 - FORD OPTION
8	034513-01-000	EA	PIN-HITCH - 3/16" WIRE
9	034512-01-000	EA	PIN-LOCKING-DRAWBAR
10	107707-01-000	EA	HITCH ASM W/O DRAWBAR
11	103099-01-06A	EA	BUMPER-REAR, BRIGHT WHITE
12	102945-04-000	EA	BRACKET ASM-BUMPER, REAR
	113589-02-000	EA	CONNECTOR-SOCKET, TRAILER - GENERAL 433601
	113589-01-000	EA	CONNECTOR-PLUG, TRAILER - GENERAL 433501

CHASSIS GROUP (CONTINUED)

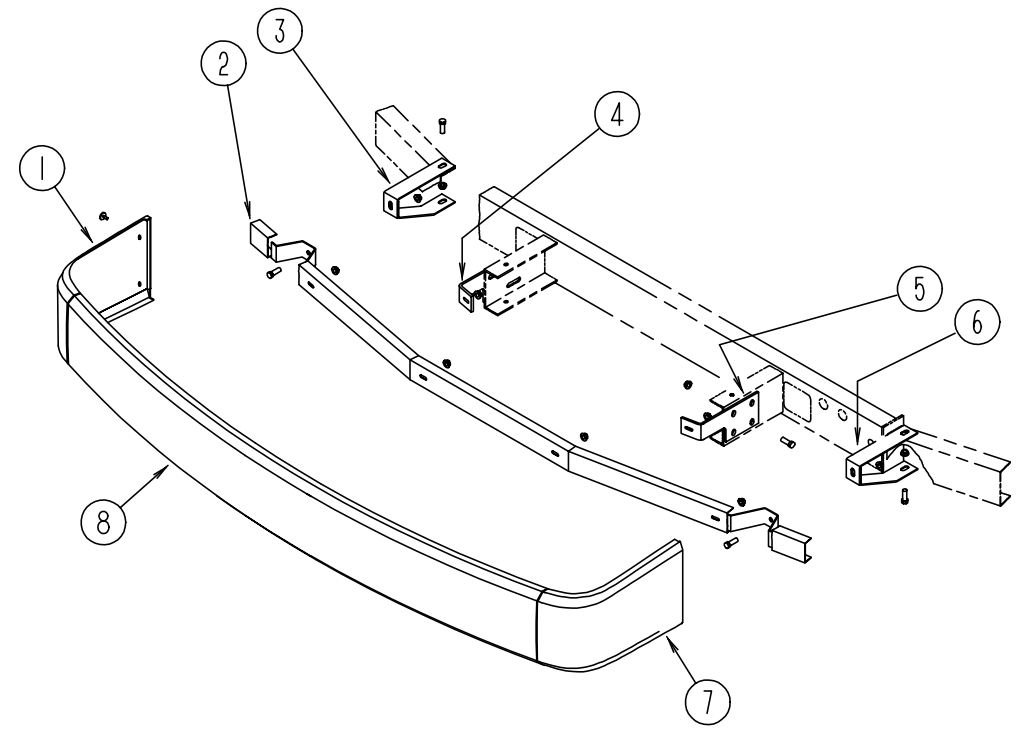

FRONT BUMPER

KEY	PART NUMBER	U/M	DESCRIPTION
1	103692-01-04A	EA	PANEL-FACIA, BUMPER - FRONT RIGHT - BRIGHT WHITE
2	103512-01-000	EA	CHANNEL ASM-BUMPER
3	103497-01-000	EA	BRACE-BUMPER, FRONT
4	086140-03-000	EA	SUPPORT-FRONT BUMPER, PASSENGER SIDE - 9.1" X 4" - STEEL
5	086140-04-000	EA	SUPPORT-FRONT BUMPER, DRIVER SIDE - 9.1" X 4" - STEEL
6	103611-01-000	EA	BRACE-BUMPER, FRONT
7	103692-02-04A	EA	PANEL-FACIA, BUMPER - FRONT LEFT - BRIGHT WHITE
8	103693-01-04A	EA	PANEL-FACIA, BUMPER - CENTER - BRIGHT WHITE
8	103758-01-F24	EA	BUMPER ASM-FRONT, W/DRIVER & PASSENGER SIDE FACIA PANELS BRIGHT WHITE

CHASSIS GROUP (CONTINUED)

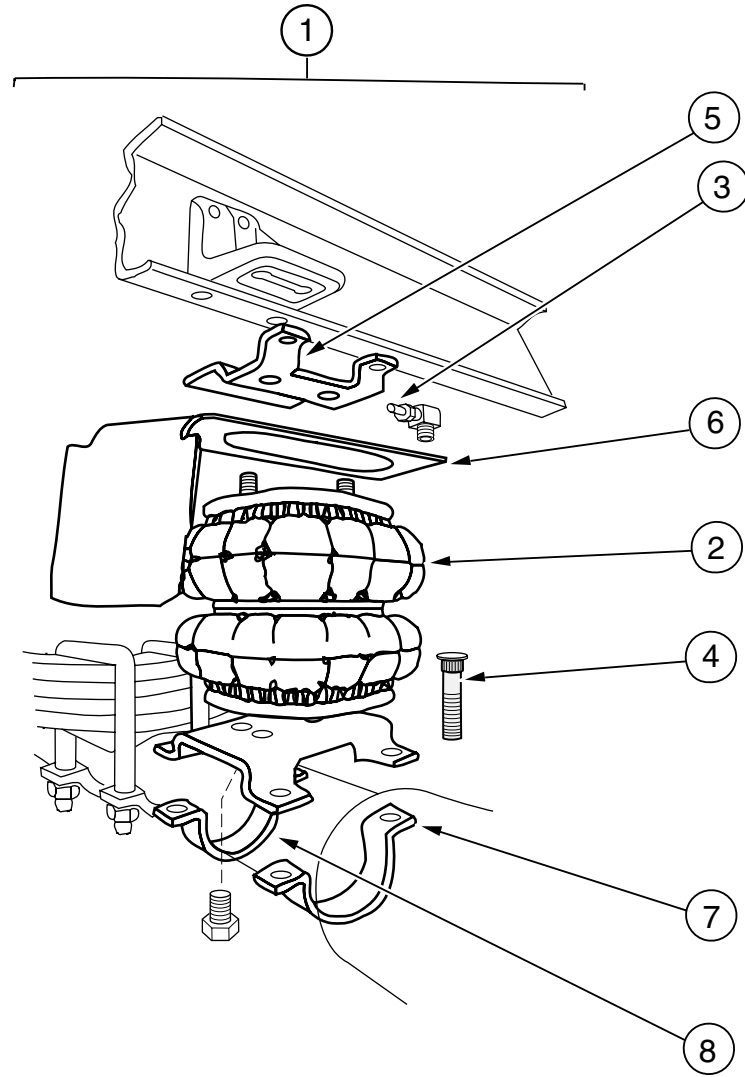

REAR AXLE AIRSPRINGS

KEY	PART NUMBER	U/M DESCRIPTION	VENDOR NO.
1	084086-04-000	EA AIRSPRING-BELLOWS, REAR AXLE - FIRESTONE# MHA224 - GAS ENGINE	W217602064
2	084086-04-702	EA AIR BAG-ONLY, FIRESTONE#	21-0938
3	084086-01-701	EA TUBING-DOT 1/4" X 18' - FIRESTONE#	21-0829
4	084086-01-702	EA BOLT-RIBBED NECK, 3/8"-24 X 2.5" FIRESTONE#	21-0899
	084086-01-705	EA TUBING PROTECTORS, FIRESTONE#	21-0150
5	084086-01-706	EA BRACKET-UPPER TO FRAME, FIRESTONE#	21-5042
6	084086-01-711	EA HEAT SHIELD-224 DOS SYSTEM, FIRESTONE#	21-1163
7	084086-01-713	EA AXLE STRAP BRACKET, AXLE TUBE - 3 USED - FIRESTONE#	21-5038
8	084086-01-714	EA AXLE STRAP BRACKET, DIFFERENTIAL - 1 USED - FIRESTONE#	
	084086-04-700	EA BRACKET, LOWER DRIVERS SIDE	
	084086-04-701	EA BRACKET, LOWER PASSENGER SIDE	

CHASSIS GROUP (CONTINUED)

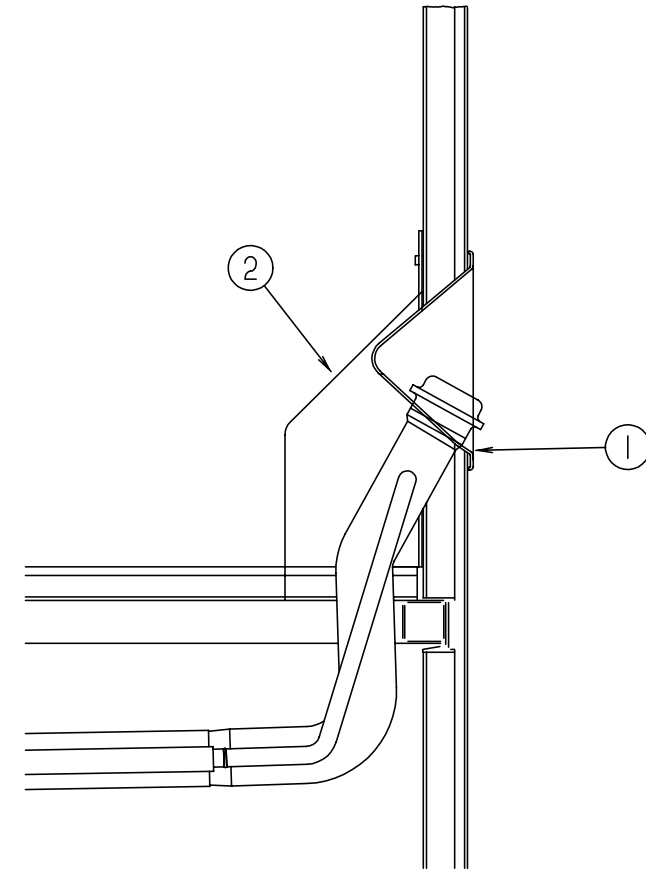

FUEL SYSTEM

KEY	PART NUMBER	U/M DESCRIPTION
1	095854-01-04A	EA SHROUD-FUEL FILL, BRIGHT WHITE
2	072447-04-000	EA SHROUD-FUEL FILL, UPPER - PLASTIC
	007063-01-000	FT HOSE-GAS 1/4"ID X 1/2"OD
	084884-01-000	EA PLUG-BRASS, 3/8"
	044317-01-000	FT HOSE-FUEL, 3/8" ID - DIESEL ONLY
	087269-01-000	EA TEE-1/4" X 1/4" X 1/4", BRASS

CHASSIS GROUP (CONTINUED)

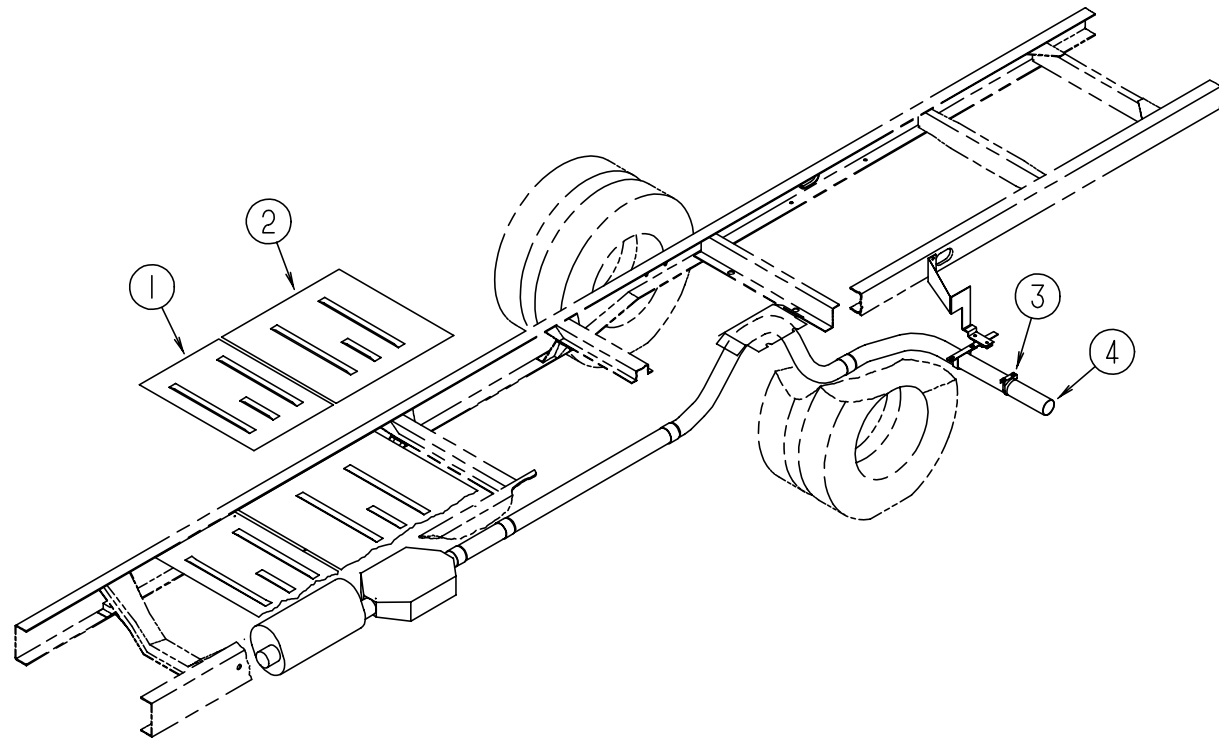

EXHAUST SYSTEM - GAS

KEY	PART NUMBER	U/M	DESCRIPTION
1	101544-01-000	EA	SHIELD-HEAT, EXHAUST - 19.7" X 28.9" - STEEL
2	101544-02-000	EA	SHIELD-HEAT, EXHAUST - 30" X 28.9" - STEEL
3	094918-01-000	EA	CLAMP-EXHAUST, 3" - GUILLOTINE STYLE
4	098762-05-000	EA	EXTENSION-EXHAUST, STRAIGHT - 3" OD X 7.9" LONG - STAINLESS STEEL
	053322-10-000	EA	SHIELD-HEAT, EXHAUST - 48" X 7.5" - STEEL

CHASSIS GROUP (CONTINUED)

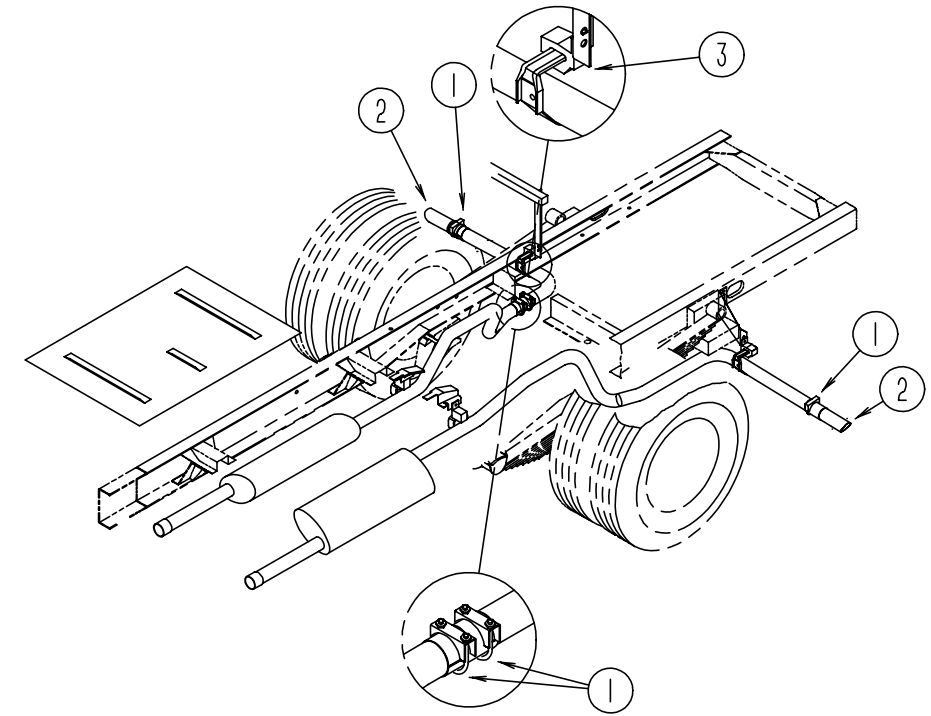

EXHAUST SYSTEM - DIESEL

KEY	PART NUMBER	U/M	DESCRIPTION
1	094918-03-000	EA	CLAMP-EXHAUST, 2.5"
2	081918-01-000	EA	EXTENSION-EXHAUST, STRAIGHT - 2.25" OD X 9.44" - STAINLESS STEEL
3	098833-01-000	EA	BRACKET-EXHAUST, HANGER - L ANGLE - 1.7" X 13.3" - STEEL

CHASSIS GROUP (CONTINUED)

FRONT SHOCKS

KEY	PART NUMBER	U/M DESCRIPTION
	104993-01-000	EA SHOCK ABSORBER-GAS, P30 FRONT - BILSTEIN B46-1173

TIRE COVERS

KEY	PART NUMBER	U/M DESCRIPTION
	117213-03-000	EA COVER-TIRE, 32" - SUNRISE - FORD OPTION
	117213-04-000	EA COVER-TIRE, 34" - SUNRISE - CHEVY
	108163-02-01A	EA COVER ASM-TIRE, 19.5" CHEVY - CHROME - EXTERIOR TRIM OPTION
	108560-03-03A	EA INSERT-TIRE COVER, 19.5" CHEVY - BRIGHT WHITE - EXTERIOR TRIM OPTION
	108163-01-01A	EA COVER ASM-TIRE, 16" FORD - CHROME - EXTERIOR TRIM OPTION
	108560-02-03A	EA INSERT-TIRE COVER, 16" CHEVY - BRIGHT WHITE - EXTERIOR TRIM OPTION

CHASSIS MISCELLANEOUS

KEY	PART NUMBER	U/M DESCRIPTION
	055278-51-259	FT TUBING-STEEL, .75" X 1.5" X 12.5"
	008042-01-000	FT TUBING-VINYL, .65" ID
	065450-05-000	EA TIEDOWN-BATTERY, 8.4" TUBE - STEEL
	075307-03-000	EA SHIELD-HEAT, LP - DIESEL OPTION
	093719-01-000	EA HOSE-OIL FILL, PREFORMED 90 DEGREE BEND - DIESEL OPTION
	077001-01-000	EA ANGLE-MOUNTING, ROOF PANEL - V ANGLE - 3" X 2.4" X 1.5"
	070579-06-000	EA PLATE-ANCHOR, W/7/16 WELD NUT - 1.5" X 3.3"
	103136-01-000	EA BRACKET-SUPPORT, UPPER HINGE - RIGHT
	103136-02-000	EA BRACKET-SUPPORT, UPPER HINGE - LEFT
	076310-01-000	EA BAFFLE-RADIATOR, .12" X 15" X 62" - RUBBER
	096630-01-000	EA BOTTLE-OVERFLOW, RADIATOR - GM 14042454

CURTAIN & CUSHION GROUP

NOTICE

IN ORDER TO ASSIST OUR PARTS SALES DEPT. IN PROVIDING INTERIOR SOFTGOODS ITEMS, PLEASE INCLUDE THE SERIAL NUMBER AND THE COLOR CODE NUMBER FROM THE VEHICLE CERTIFICATION LABEL WHEN ORDERING. THIS LABEL IS LOCATED ON THE LEFT SIDEWALL AT THE END OF THE DASH (A-BODY), OR ON THE DRIVER'S DOOR LATCH PLATE (C-BODY).

AN EXAMPLE OF A COLOR CODE NUMBER IS B07, WHICH DESIGNATES AN OVERALL COLOR SCHEME OF A PARTICULAR UNIT. THE COLOR LISTED AFTER THE ITEM DESCRIPTION ON THE MICROFICHE, INDICATES THE OVERALL UNIT COLOR. ORDER THE ITEM YOU DESIRE ACCORDING TO UNIT COLOR CODE.

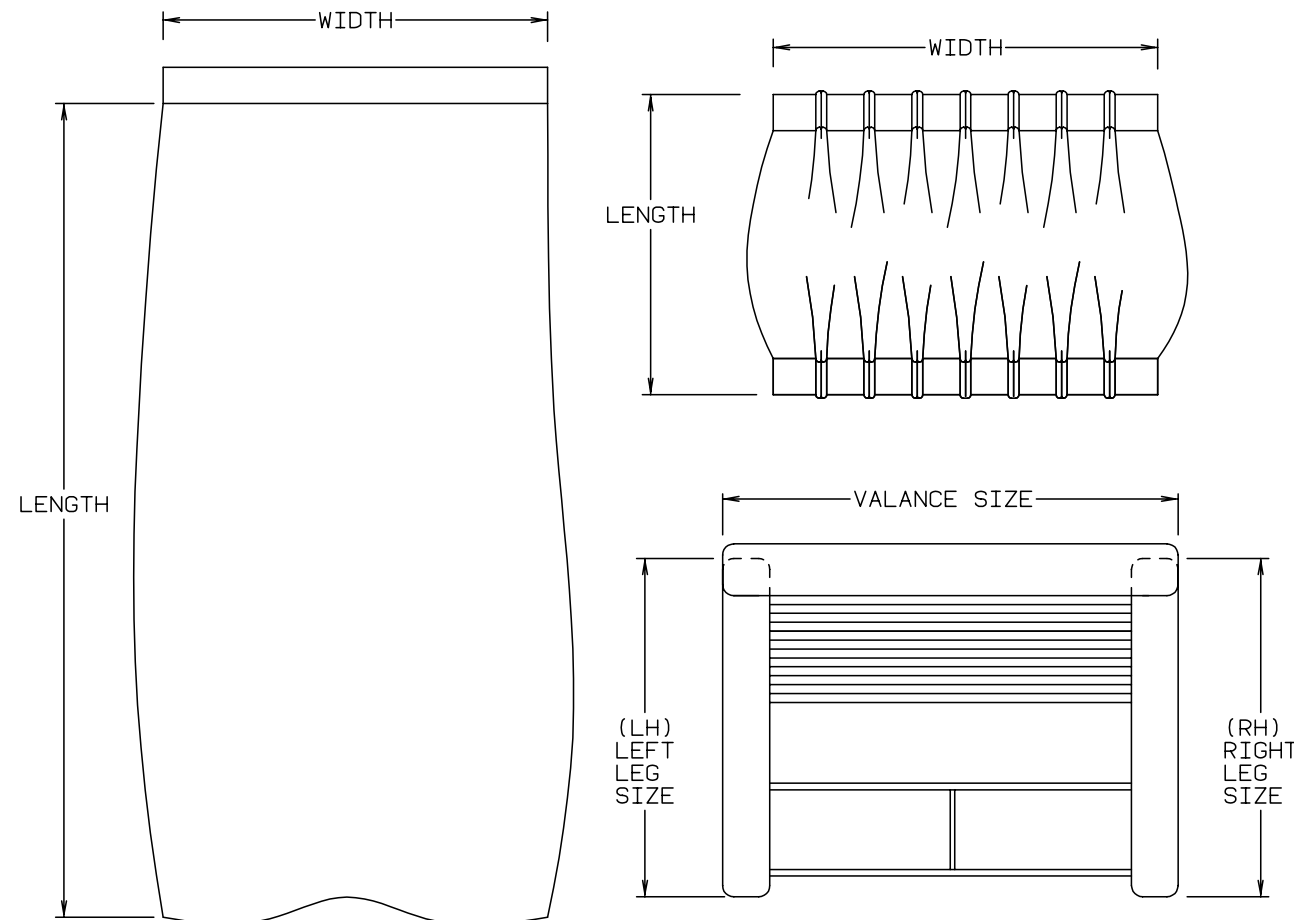

NOTE: USE THIS ILLUSTRATION WHEN DETERMINING LENGTH AND WIDTH MEASUREMENTS FOR CURTAINS. YOU WILL NOTE THE WIDTH MEASUREMENT IS TAKEN ON THE TOP OF THE CURTAIN WITH THE CURTAIN FULLY EXTENDED. THE LENGTH MEASUREMENT IS TAKEN FROM TOP TO BOTTOM. LEFT AND RIGHT WINDOW LEGS ARE DETERMINED WHEN FACING THE WINDOW.

CURTAIN & CUSHION GROUP (CONTINUED)

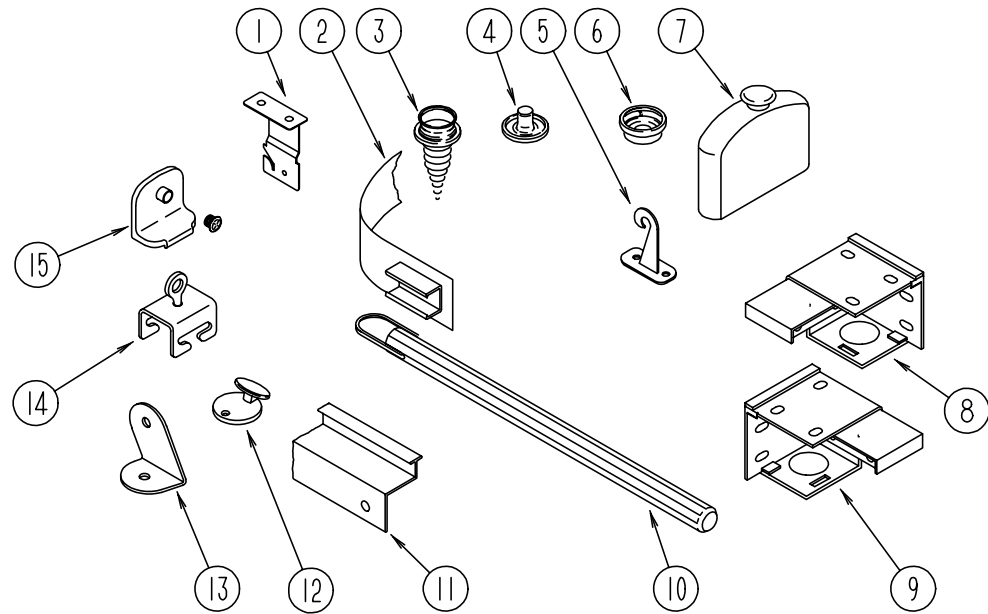

CURTAIN, BLIND HARDWARE & TRACKS

KEY	PART NUMBER	U/M DESCRIPTION
1	084434-01-000	EA BRACKET-MOUNTING, ROLLER SHADE - 1 3/8"
2	101031-01-000	YD TAPE-GLIDE, CURTAIN - 4.25" SPACING
3	029130-01-000	EA SCREW-SNAP SOCKET, #8 PH X 5/8"
3	029130-03-000	EA SCREW-SNAP SOCKET, #8 PH X 1"
4	029155-01-000	EA CAP-SNAP, 5/32" O.D. OF PIN
5	109441-01-000	EA HOLD DOWN-BLIND, HOOK
6	029156-01-000	EA SOCKET-SNAP, 9/16" O.D.
7	093475-01-701	EA END CAP-BLIND, W/STUD
8	083170-01-000	EA BRACKET-BLIND, LEFT SIDE WHEN FACING WINDOW
9	083170-02-000	EA BRACKET-BLIND, RIGHT SIDE WHEN FACING WINDOW
10	093475-01-700	EA WAND-BLIND, W/METAL CLIP - 8" LONG
11	105450-01-01A	EA TRACK-CURTAIN, 30.8" LONG - ALUMINUM - OFF WHITE
12	102555-01-000	EA CLEAT-CORD, BLIND - OFF WHITE
13	099205-02-02A	EA BRACKET-WRAPAROUND O/W
14	009702-01-000	EA END-STOP-CURTAIN CARRIER, L ROD
15	106544-01-000	EA PULL-SHADE, BRASS
	106544-01-001	EA SCREW-BRASS, SHADE
	046867-01-000	EA GROMMET-BRASS - 7/16" ID X 1" OD
	048394-02-000	YD VELCRO TAPE-HOOK, ADHESIVE BACK - .75" WIDE - BEIGE
	075943-09-000	EA BRACE-VALANCE, O/WHT 8.00 IN
	088792-01-000	YD VELCRO-HOOK, .75" WIDE - BEIGE
	088792-02-000	YD VELCRO TAPE-LOOP, ADHESIVE BACKED - .75" WIDE - BEIGE
	089522-02-000	EA PANEL-LEG, TWO SIDED 31.5" LONG - PLASTIC - BLACK LEFT SIDE
	096843-01-000	EA SPRING-REWIND, ROLLER SHADE
	101589-02-C05	EA TRACK ASM-CURTAIN, WRAPAROUND
	105324-01-01A	EA TRACK-CURTAIN, WRAPAROUND O/W
	105324-02-01A	EA TRACK-CURTAIN, WRAPAROUND - PASSENGER SIDE - OFF WHITE
	105324-03-01A	EA TRACK-CURTAIN, WRAPAROUND - DRIVER SIDE - OFF WHITE
	086276-01-000	EA TAPE-DOUBLE SIDED, 1/2"
	009136-02-000	EA HANGER-RING, PIN TYPE - CURTAIN - BRASS
	009700-04-002	EA TRACK, L-SHAPED 195.2" - OFF WHITE
	056003-04-000	EA BRACKET-RETAIN, 1.5 X 6" RH. - SHROCK
	056003-05-000	EA BRACKET-RETAIN, 1.5 X 6" LH. - SHROCK
	075943-01-000	EA BRACE-WINDOW VALANCE, 1" X 1.5" X 20" - ALUMINUM - BEIGE
	099205-02-02A	EA BRACKET-WRAPAROUND O/W

CURTAIN & CUSHION GROUP (CONTINUED)

BUTTON, TRIM, ASSIST HANDLE & SEAT BELT

KEY	PART NUMBER	U/M DESCRIPTION
	070578-02-B29	EA BUTTON-SCREW, STUD - #30 - VINYL
	079349-04-F24	YD WELT ASM-NARROW, ACCENT
	079349-04-E04	YD WELT ASM-NARROW, ACCENT (F25)
	079349-04-E26	YD WELT ASM-NARROW, ACCENT (F26)
	079349-04-E22	YD WELT ASM-NARROW, ACCENT (F27)
	057759-01-000	EA WASHER BRACKET-SEAT BELT, 4" DIAMETER
	007021-01-000	EA BELT-SEAT, 2" X 90" - BLACK
	056271-02-000	EA BELT-SEAT, 2" X 72" - BLACK
	069178-02-000	EA BRACKET-MOUNTING, ASSIST HANDLE - L ANGLE - W/HOLES - STEEL
	053552-02-AA8	EA HANDLE-ASSIST, INTERIOR - ENTRY DOOR - VINYL - OFF WHITE
	057534-01-000	EA TIEBACK/TIEDOWN-BED/CURTAIN/DOOR, 6" - PLASTIC - CLEAR

FABRICS

KEY	PART NUMBER	U/M DESCRIPTION
	079680-07-000	YD FABRIC-VINYL, 54" WIDE - BEIGE
	087272-03-000	YD DRAPERY LINING-54" IVORY, ROCKLAND MILLS
	089351-03-000	YD VINYL-CEILING, DIAMOND DESIGN - 54" WIDE
	103907-01-01A	YD FABRIC-VINYL, 54" WIDE - OFF WHITE
	108446-46-000	YD FABRIC-UPR, QUAKER/MONTE CARLO - ROSEQUARTZ - MAIN (F24)
	108446-B1-000	YD FABRIC-UPR, COLLINS & AIKMAN/FIGI - 965 - BLUE - MAIN (F25)
	108446-B2-000	YD FABRIC-UPR, COLLINS & AIKMAN/GYPSY - 767 - GREEN - MAIN (F26)
	108446-D2-000	YD FABRIC-UPR, DOBLIN/CONFETTI - 9435 - MAIN (F27)
	104233-14-000	YD FABRIC-UPR, JOAN/STARLIGHT - COCOA - PLAIN ACCENT (F24)
	098428-30-000	YD FABRIC-UPR, COLLINS & AIKMAN/PHOENIX - 965 - PLAIN ACCENT (F25)
	098428-33-000	YD FABRIC-UPR, COLLINS & AIKMAN/PHOENIX - 767 - PLAIN ACCENT (F26)
	108446-55-000	YD FABRIC-UPR, LAFRANCE/ALBANY - 350 WHEAT - PLAIN ACCENT (F27)
	108446-57-000	YD FABRIC-UPR, JOAN/CELTIC - CASHMERE - PATTERN ACCENT (F24)
	098428-30-000	YD FABRIC-UPR, COLLINS & AIKMAN/PHOENIX - 965 - PATTERN ACCENT (F25)
	098428-33-000	YD FABRIC-UPR, COLLINS & AIKMAN/PHOENIX - 767 - PATTERN ACCENT (F26)
	108446-D3-000	YD FABRIC-UPR, MASTERCRAFT/HAPPY DAYS -001 - PATTERN ACCENT (F27)
		DINETTE CUSHIONS & THROW PILLOWS
	108446-D4-000	YD FABRIC-UPR, MASTERCRAFT/ONE GREAT PLATE - 001 PATTERN ACCENT (F27) LOUNGE AREA WINDOW VALANCES
	105745-43-000	YD FABRIC-BEDSPREAD, RICHLOOM/MONTURA - NATURAL - MAIN (F24)
	105745-91-000	YD FABRIC-BEDSPREAD, DI LEWIS STUDIOS/KLEE - GALAXY - MAIN (F25)
	105745-84-000	YD FABRIC-BEDSPREAD, LANSCOT-ARLEN/SEQUE - HAZE - MAIN (F26)
	105745-96-000	YD FABRIC-BEDSPREAD, RICHLOOM/HERALD SQUARE - WEDGEWOOD - MAIN (F27)
	105745-63-000	YD FABRIC-BEDSPREAD, RADIANCE - TOAST - ACCENT (F24)
	105745-61-000	YD FABRIC-BEDSPREAD, RADIANCE - NORWEGIAN - ACCENT (F25)
	105745-45-000	YD FABRIC-BEDSPREAD, RADIANCE - GREEN - ACCENT (F26)
	105745-97-000	YD FABRIC-BEDSPREAD, RICHLOOM/FRANK - MULTI - ACCENT (F27)
	072333-90-000	YD FABRIC-CURTAIN, 54" WIDE - TAN (F24, F27)
	072333-82-000	YD FABRIC-CURTAIN, 54" WIDE - BEIGE (F25, F26)

CURTAIN & CUSHION GROUP (CONTINUED)

WINDOW TREATMENT

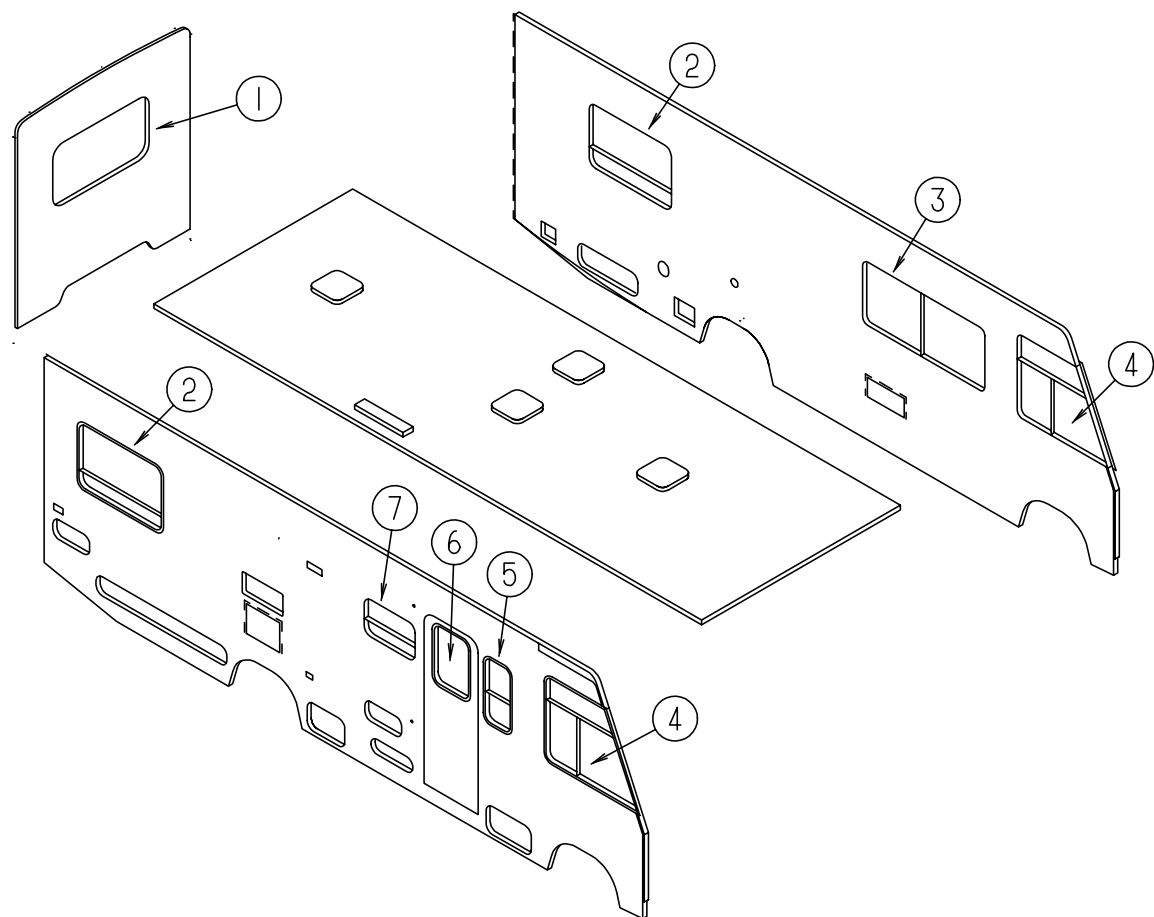

KEY	PART NUMBER	U/M	DESCRIPTION
1	114993-01-F24	EA	VALANCE ASM - 52" TAILOR
1	114993-01-F25	EA	VALANCE ASM - 52" TAILOR
1	114993-01-F26	EA	VALANCE ASM - 52" TAILOR
1	114993-01-F27	EA	VALANCE ASM - 52" TAILOR
1	112986-04-F24	EA	CURTAIN - 29.5 X 6, PENCIL PLEAT TOP, POCKET BOTTOM
1	112986-04-F25	EA	CURTAIN - 29.5 X 6, PENCIL PLEAT TOP, POCKET BOTTOM
1	112986-04-F26	EA	CURTAIN - 29.5 X 6, PENCIL PLEAT TOP, POCKET BOTTOM
1	112986-04-F27	EA	CURTAIN - 29.5 X 6, PENCIL PLEAT TOP, POCKET BOTTOM
1	093475-55-04A	EA	BLIND-MINI, 48 X 28 DROP (F24)
1	093475-68-08A	EA	BLIND-MINI, 48 X 27 DROP (F24)
			FROM: 00-00-00 THRU: 07-24-94
1	093475-55-03A	EA	BLIND-MINI, 48 X 28 DROP (F25,F26)
			FROM: 07-25-94 THRU: 99-99-99
1	093475-68-07A	EA	BLIND-MINI, 48 X 27 DROP (F25,F26)
			FROM: 00-00-00 THRU: 07-24-94
			FROM: 07-25-94 THRU: 99-99-99
1	093475-68-08A	EA	BLIND-MINI, 48 X 27 DROP (F27)
2	114993-02-F24	EA	VALANCE ASM, 44" - TAILOR
2	114993-02-F25	EA	VALANCE ASM, 44" - TAILOR
2	114993-02-F26	EA	VALANCE ASM, 44" - TAILOR
2	114993-02-F27	EA	VALANCE ASM, 44" - TAILOR
2	112986-05-F24	EA	CURTAIN - 31.5 X 6, PENCIL PLEAT TOP, POCKET BOTTOM
2	112986-05-F25	EA	CURTAIN - 31.5 X 6, PENCIL PLEAT TOP, POCKET BOTTOM
2	112986-05-F26	EA	CURTAIN - 31.5 X 6, PENCIL PLEAT TOP, POCKET BOTTOM
2	112986-05-F27	EA	CURTAIN - 31.5 X 6, PENCIL PLEAT TOP, POCKET BOTTOM
2	114993-03-F24	EA	VALANCE ASM - 44", TAILOR - TWIN BED OPTION
2	114993-03-F25	EA	VALANCE ASM - 44", TAILOR - TWIN BED OPTION
2	114993-03-F26	EA	VALANCE ASM - 44", TAILOR - TWIN BED OPTION
2	114993-03-F27	EA	VALANCE ASM - 44", TAILOR - TWIN BED OPTION

KEY	PART NUMBER	U/M	DESCRIPTION
2	093475-99-03A	EA	BLIND-MINI, 41 X 28.5 DROP (F24,F27)
2	093475-99-02A	EA	BLIND-MINI, 41 X 28.5 DROP (F25,F26)
2	093475-41-09A	EA	BLIND-MINI, 39 X 26 DROP - TWIN BED OPTION (F24,F27)
2	093475-41-08A	EA	BLIND-MINI, 39 X 26 DROP - TWIN BED OPTION (F25,F26)
3	111650-11-F24	EA	VALANCE - 57.5" UNITY
3	111650-13-F25	EA	VALANCE - 57.5" UNITY
3	111650-13-F26	EA	VALANCE - 57.5" UNITY
3	105923-33-F27	EA	VALANCE - 57.5" RODEWAY, W/O INSERT
3	109234-29-F24	EA	LEG-RH., 27" - PLAIN - W/O HOLE
3	109234-29-E04	EA	LEG-RH., 27" - PLAIN - W/O HOLE (F25)
3	109234-29-F26	EA	LEG-RH., 27" - PLAIN - W/O HOLE
3	109234-31-F27	EA	LEG-RH., 27" - PLAIN - W/O HOLE
3	109234-30-F24	EA	LEG-LH., 27" - PLAIN - W/O HOLE
3	109234-30-E04	EA	LEG-LH., 27" - PLAIN - W/O HOLE (F25)
3	109234-30-F26	EA	LEG-LH., 27" - PLAIN - W/O HOLE
3	109234-32-F27	EA	LEG-LH., 27" - PLAIN - W/O HOLE
3	109041-28-02A	EA	BLIND-MINI, 54 X 28.5 DROP (F24,F27)
3	109041-28-01A	EA	BLIND-MINI, 54 X 28.5 DROP (F25,F26)
4	101668-30-D09	EA	CURTAIN - 38 X 80 TAPE TOP, RH (F24,F27)
4	101668-30-D10	EA	CURTAIN - 38 X 80 TAPE TOP, RH (F25,F26)
4	101668-31-D09	EA	CURTAIN - 38 X 80 TAPE TOP, LH (F24,F27)
4	101668-31-D10	EA	CURTAIN - 38 X 80 TAPE TOP, LH (F25,F26)
4	101668-32-D09	EA	CURTAIN ASM - 40 X 40, TAPE TOP - BUNK OPTION (F24,F27)
4	101668-32-D10	EA	CURTAIN ASM - 40 X 40, TAPE TOP - BUNK OPTION (F25,F26)
4	101668-33-D09	EA	CURTAIN ASM - 38 X 125, TAPE TOP - BUNK OPTION (F24,F27)
4	101668-33-D10	EA	CURTAIN ASM - 38 X 125, TAPE TOP - BUNK OPTION (F25,F26)
4	073260-42-D09	EA	TIEBACK ASM - 6 X 18 (F24,F27)
4	073260-42-D10	EA	TIEBACK ASM - 6 X 18 (F25,F26)
5	111650-16-F24	EA	VALANCE - 17", UNITY
5	111650-15-F25	EA	VALANCE - 17", UNITY
5	111650-15-F26	EA	VALANCE - 17", UNITY
5	105923-32-F27	EA	VALANCE - 17", RODEWAY, W/O INSERT
5	109041-15-03A	EA	BLIND-MINI, 14.5 X 32 (F24,F27)
5	109041-15-01A	EA	BLIND-MINI, 14.5 X 32 (F25,F26)
6	113268-08-F24	EA	VALANCE-FLAT, 31.25" - W/WELT
6	113268-09-F25	EA	VALANCE-FLAT, 31.25" - W/WELT
6	113268-09-F26	EA	VALANCE-FLAT, 31.25" - W/WELT
6	113268-13-F27	EA	VALANCE-FLAT, 31.25"
6	084755-57-E07	EA	SHADE ASM-PULL-27.25, W/O TRIM
7	109041-20-02A	EA	BLIND-MINI, 31 X 18 DROP (F24,F27)
7	109041-20-01A	EA	BLIND-MINI, 31 X 18 DROP (F25,F26)
7	109353-07-02A	EA	BLIND-SLAT, 31" (F24,F27)
7	109353-07-01A	EA	BLIND-SLAT, 31" (F25,F26)
7	109353-04-000	EA	CLIP-VALANCE SLAT MOUNTING, CLEAR PLASTIC - PAR
	084481-25-E08	EA	CURTAIN ASM-SHOWER, 67 X 38 (F24)
	084481-25-D12	EA	CURTAIN ASM-SHOWER, 67 X 38 (F25)
	084481-25-D35	EA	CURTAIN ASM-SHOWER, 67 X 38 (F26)
	084481-25-E10	EA	CURTAIN ASM-SHOWER, 67 X 38 (F27)
	073260-54-E08	EA	TIEBACK ASM - 3 X 16 (F24)
	073260-54-C30	EA	TIEBACK ASM - 3 X 16 (F25)
	073260-54-C10	EA	TIEBACK ASM - 3 X 16 (F26)
	073260-54-E01	EA	TIEBACK ASM - 3 X 16 (F27)

CURTAIN & CUSHION GROUP (CONTINUED)

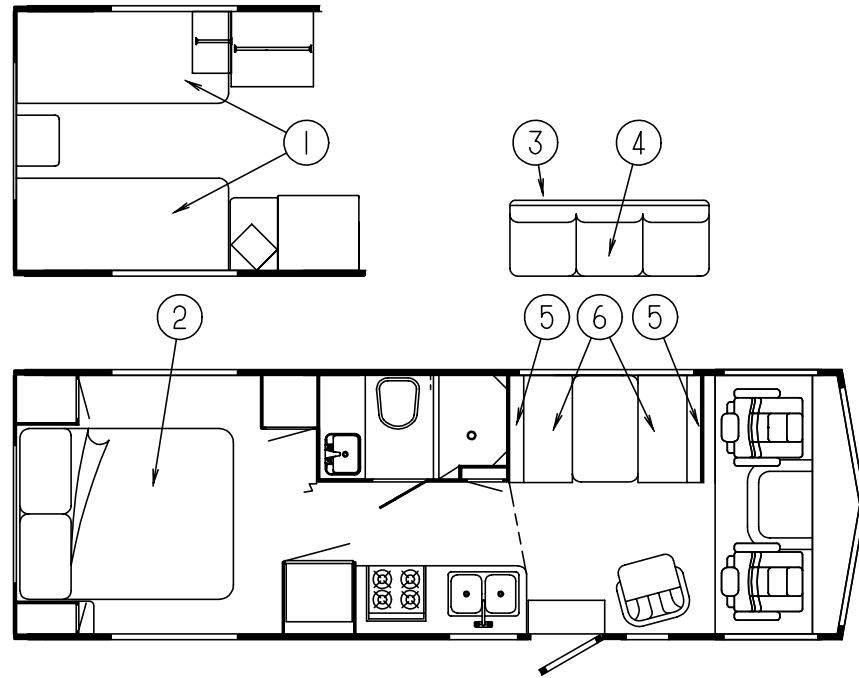

TWIN MATTRESSES, BEDSPREADS & PILLOW SHAMS

KEY	PART NUMBER	U/M DESCRIPTION
1	101123-02-000	EA MATTRESS COMPLETE-FOAM 32 X 74
1	P01123-02-000	EA COVER-MATTRESS, 32 X 79 - FOAM
1	085365-07-E28	EA BEDSPREAD - 33 X 80, THROW W/ROUND CORNER (F24)
1	085365-07-F25	EA BEDSPREAD - 33 X 80, THROW W/ROUND CORNER
1	085365-07-F26	EA BEDSPREAD - 33 X 80, THROW W/ROUND CORNER
1	085365-07-F27	EA BEDSPREAD - 33 X 80, THROW W/ROUND CORNER
	111862-03-F24	EA PILLOW - 15 X 15 ACCENT W/.5"MAIN
	111862-03-F25	EA PILLOW - 15 X 15 ACCENT W/.5"MAIN
	111862-03-F26	EA PILLOW - 15 X 15 ACCENT W/.5"MAIN
	111862-03-F27	EA PILLOW - 15 X 15 ACCENT W/.5"MAIN

QUEEN MATTRESS, BEDSPREAD & PILLOW SHAMS

KEY	PART NUMBER	U/M DESCRIPTION
2	101123-08-000	EA MATTRESS COMPLETE-FOAM 60 X 75
2	P01123-08-000	EA COVER-MATTRESS, 60 X 75 - FOAM
2	085365-19-F24	EA BEDSPREAD - 60 THROW, W/1" GATHERED WELT
2	085365-19-F25	EA BEDSPREAD - 60 THROW, W/1" GATHERED WELT
2	085365-19-F26	EA BEDSPREAD - 60 THROW, W/1" GATHERED WELT
2	085365-19-F27	EA BEDSPREAD - 60 THROW, W/1" GATHERED WELT
	102161-22-F24	EA SHAM ASM-W/1/2" GATHERED WELT
	102161-22-F25	EA SHAM ASM-W/1/2" GATHERED WELT
	102161-22-F26	EA SHAM ASM-W/1/2" GATHERED WELT
	102161-22-F27	EA SHAM ASM-W/1/2" GATHERED WELT
	111862-03-F24	EA PILLOW - 15 X 15 ACCENT W/.5"MAIN
	111862-03-F25	EA PILLOW - 15 X 15 ACCENT W/.5"MAIN
	111862-03-F26	EA PILLOW - 15 X 15 ACCENT W/.5"MAIN
	111862-03-F27	EA PILLOW - 15 X 15 ACCENT W/.5"MAIN

CURTAIN & CUSHION GROUP (CONTINUED)

COUCH

KEY	PART NUMBER	U/M DESCRIPTION
3	112104-02-F24	EA BED ASM-JACK KNIFE BACK, KNIFE EDGE, 66.5" W/O ARMS
3	112104-02-F25	EA BED ASM-JACK KNIFE BACK, KNIFE EDGE, 66.5" W/O ARMS
3	112104-02-F26	EA BED ASM-JACK KNIFE BACK, KNIFE EDGE, 66.5" W/O ARMS
3	111319-03-F27	EA BED ASM-JACK KNIFE BACK, KNIFE EDGE, 66.5" W/O ARMS
3	P12104-02-F24	EA COVER-BED, JACK KNIFE KNIFE EDGE BACK
3	P12104-02-F25	EA COVER-BED, JACK KNIFE KNIFE EDGE BACK
3	P12104-02-F26	EA COVER-BED, JACK KNIFE KNIFE EDGE BACK
3	P11319-03-F27	EA COVER-BED, JACK KNIFE KNIFE EDGE BACK
	101085-09-000	EA FRAME-BACK, 66.5"
4	100032-37-F01	EA BED-JACK KNIFE, SEAT - 66.5" TUCK - W/O ARMS (F24)
4	100032-37-F25	EA BED-JACK KNIFE, SEAT - 66.5" TUCK - W/O ARMS
4	100032-37-F26	EA BED-JACK KNIFE, SEAT - 66.5" TUCK - W/O ARMS
4	100032-37-F27	EA BED-JACK KNIFE, SEAT - 66.5" TUCK - W/O ARMS
4	P00032-37-F01	EA COVER-JACK KNIFE SEAT, 66.5" TUCK - W/O ARM (F24)
4	P00032-37-F25	EA COVER-JACK KNIFE SEAT, 66.5" TUCK - W/O ARM
4	P00032-37-F26	EA COVER-JACK KNIFE SEAT, 66.5" TUCK - W/O ARM
4	P00032-37-F27	EA COVER-JACK KNIFE SEAT, 66.5" TUCK - W/O ARM
	101085-01-000	EA FRAME-SEAT, 66.5"
	101085-03-000	EA FRAME-BASE, 66.5"
	111637-02-F24	EA PILLOW ASM - 22 X 22, KNIFE EDGE W/WELT
	111637-02-E04	EA PILLOW ASM - 22 X 22, KNIFE EDGE W/WELT (F25)
	111637-02-F26	EA PILLOW ASM - 22 X 22, KNIFE EDGE W/WELT
	111637-02-F27	EA PILLOW ASM - 22 X 22, KNIFE EDGE W/WELT

NOTE: COUCH FRONT AND SIDE PANELS ARE FOUND IN LOUNGE GROUP

DINETTE CUSHIONS

KEY	PART NUMBER	U/M DESCRIPTION
5	111880-01-F24	EA CUSHION - 13.5 X 38 X 5 CHANNEL BACK
5	111880-01-F25	EA CUSHION - 13.5 X 38 X 5 CHANNEL BACK
5	111880-01-F26	EA CUSHION - 13.5 X 38 X 5 CHANNEL BACK
5	111897-08-F27	EA CUSHION - 13.5 X 38 X 5 CLUB BACK
5	P11880-01-F24	EA COVER - 13.5 X 38 X 5 CLUB BACK
5	P11880-01-F25	EA COVER - 13.5 X 38 X 5 CLUB BACK
5	P11880-01-F26	EA COVER - 13.5 X 38 X 5 CLUB BACK
5	P11897-08-F27	EA COVER - 13.5 X 38 X 5 CLUB BACK
5	078155-01-000	EA STRAP-SNAP, BACKREST CUSHION
6	088927-86-E28	EA CUSHION - 21 X 38 X 5, DINETTE SEAT (F24)
6	088927-86-F25	EA CUSHION - 21 X 38 X 5, DINETTE SEAT
6	088927-86-F26	EA CUSHION - 21 X 38 X 5, DINETTE SEAT
6	105603-18-F27	EA CUSHION - 21 X 38 X 5, DINETTE SEAT
6	M88927-86-E28	EA COVER - 21 X 38 X 5, DINETTE SEAT (F24)
6	M88927-86-F25	EA COVER - 21 X 38 X 5, DINETTE SEAT
6	M88927-86-F26	EA COVER - 21 X 38 X 5, DINETTE SEAT
6	P05603-18-F27	EA COVER - 21 X 38 X 5, DINETTE SEAT

BUNK CUSHION

KEY	PART NUMBER	U/M DESCRIPTION
	079145-06-000	EA CUSHION-BUNK, 30" X 77" X 4"
	M79145-06-000	EA COVER-CUSHION, BUNK

CURTAIN & CUSHION GROUP (CONTINUED)

DRIVER & PASSENGER BUCKET SEATS

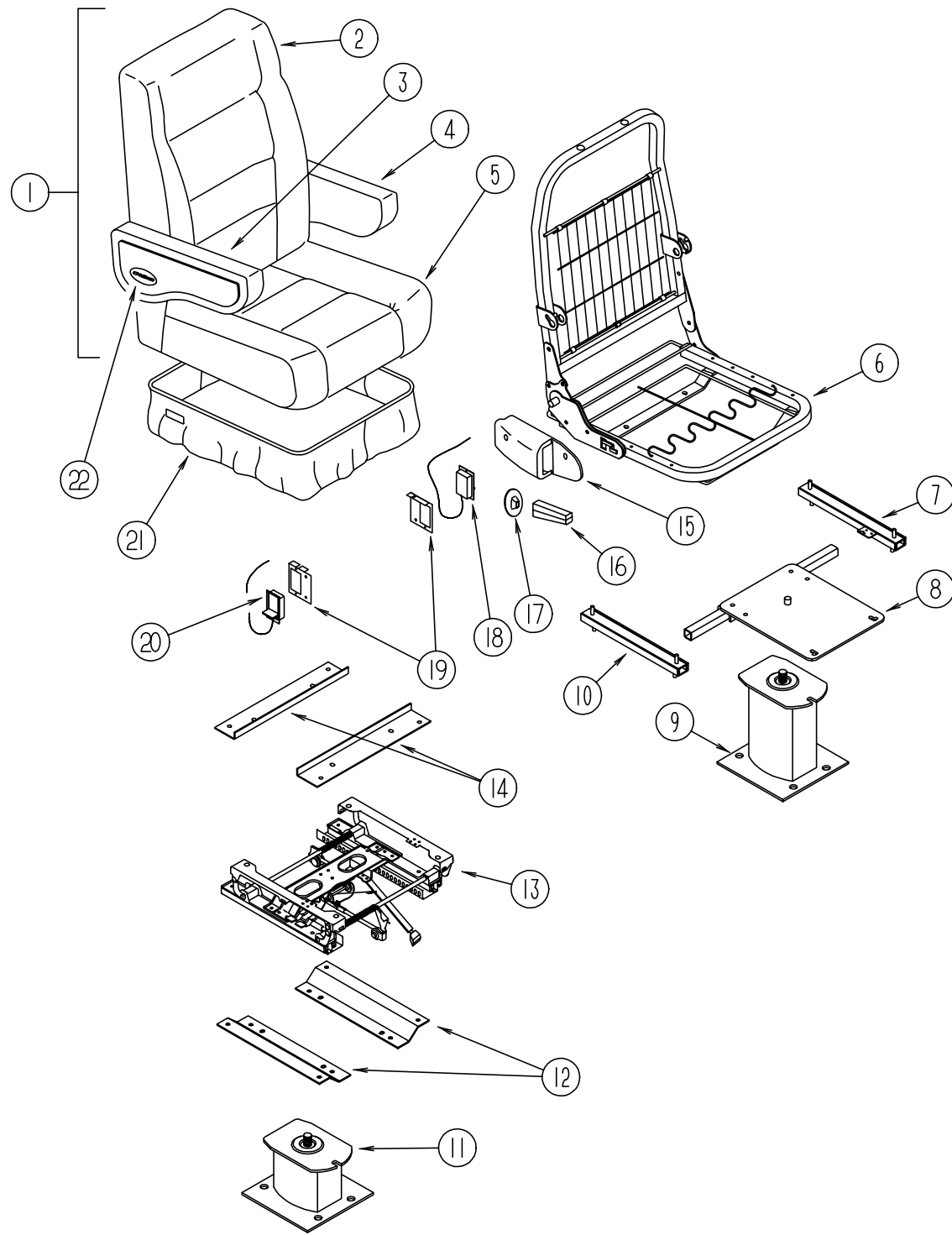

KEY	PART NUMBER	U/M	DESCRIPTION
1	112103-05-F24	EA	SEAT-BUCKET, W/ARMRESTS - W/O SKIRT
1	112103-05-F25	EA	SEAT-BUCKET, W/ARMRESTS - W/O SKIRT
1	112103-05-F26	EA	SEAT-BUCKET, W/ARMRESTS - W/O SKIRT
1	112103-05-F27	EA	SEAT-BUCKET, W/ARMRESTS - W/O SKIRT
1	112103-07-F24	EA	SEAT-BUCKET, W/ARMRESTS - W/O SKIRT - MANUAL SEAT OPTION
1	112103-07-F25	EA	SEAT-BUCKET, W/ARMRESTS - W/O SKIRT - MANUAL SEAT OPTION
1	112103-07-F26	EA	SEAT-BUCKET, W/ARMRESTS - W/O SKIRT - MANUAL SEAT OPTION
1	112103-07-F27	EA	SEAT-BUCKET, W/ARMRESTS - W/O SKIRT - MANUAL SEAT OPTION
2	M05962-12-F24	EA	COVER-BACK, BUCKET SEAT
2	M05962-12-F25	EA	COVER-BACK, BUCKET SEAT
2	M05962-12-F26	EA	COVER-BACK, BUCKET SEAT
2	M05962-12-F27	EA	COVER-BACK, BUCKET SEAT
3	111320-03-F24	EA	ARMREST-RIGHT, BUCKET SEAT
3	111320-03-E04	EA	ARMREST-RIGHT, BUCKET SEAT (F25)
3	111320-03-E25	EA	ARMREST-RIGHT, BUCKET SEAT (F26)
3	111320-03-F06	EA	ARMREST-RIGHT, BUCKET SEAT (F27)
	P11320-03-F24	EA	COVER-ARMREST, RIGHT
	P11320-03-E04	EA	COVER-ARMREST, RIGHT (F25)
	P11320-03-E25	EA	COVER-ARMREST, RIGHT (F26)
	P11320-03-F06	EA	COVER-ARMREST, RIGHT (F27)
4	111320-04-F24	EA	ARMREST-LEFT, BUCKET SEAT
4	111320-04-E04	EA	ARMREST-LEFT, BUCKET SEAT (F25)
4	111320-04-E25	EA	ARMREST-LEFT, BUCKET SEAT (F26)
4	111320-04-F06	EA	ARMREST-LEFT, BUCKET SEAT (F27)
	P11320-04-F24	EA	COVER-ARMREST, LEFT
	P11320-04-E04	EA	COVER-ARMREST, LEFT (F25)
	P11320-04-E25	EA	COVER-ARMREST, LEFT (F26)
	P11320-04-F06	EA	COVER-ARMREST, LEFT (F27)
5	M05962-06-F24	EA	COVER-SEAT, BUCKET SEAT
5	M05962-06-F25	EA	COVER-SEAT, BUCKET SEAT
5	M05962-06-F26	EA	COVER-SEAT, BUCKET SEAT
5	M05962-06-F06	EA	COVER-SEAT, BUCKET SEAT (F27)
6	M80906-11-000	EA	FRAME-SEAT, BACK & SPRING
7	069246-02-000	EA	ADJUSTER-SLIDE, FORWARD & BACK
8	107921-05-000	EA	PLATE-TOP, W/SEAT BELT BAR
9	107921-01-000	EA	PLATE-SUB, FLOOR MOUNTED PEDESTAL - W/9.75" EXTENSION
	107921-06-000	EA	BEARING KIT-SEAT SWIVEL
10	069246-05-000	EA	ADJUSTER-BUCKET SEAT W/LOCK, FORWARD AND BACK
	069246-05-700	EA	SPRING-ADJUSTER, FOR REMOTE
	069246-05-701	EA	CLIP-CABLE, FOR REMOTE
11	107921-07-000	EA	BASE-FLOOR MOUNTED PEDESTAL, 4.5" - MANUAL SEAT OPTION
12	116215-03-000	EA	PLATE-LOWER, MANUAL - 6 - WAY - ATWOOD 83835 - MANUAL SEAT OPTION
13	116215-01-000	EA	SEAT-MANUAL, 6 - WAY - DRIVER - ATWOOD 83805 - MANUAL SEAT OPTION
14	116215-02-000	EA	PLATE-UPPER, MANUAL - 6 - WAY - ATWOOD 85118 - MANUAL SEAT OPTION
15	080730-09-000	EA	SHIELD-RECLINER HANDLE
16	080730-08-000	EA	HANDLE-RECLINER, BLACK
17	080730-11-000	EA	SHIELD-RUBBER BOOT
18	089368-04-000	EA	CABLE-SLIDE, W/SWITCH
19	097683-03-000	EA	BRACKET-REMOTE, SIDE MOUNT - SINGLE
20	108049-01-000	EA	CABLE W/SWITCH - 28", F/FLEXSTEEL PEDESTAL
	108049-02-000	EA	CLIP-CABLE, PEDESTAL
21	071126-43-F24	EA	SKIRT-BUCKET SEAT
21	071126-43-F25	EA	SKIRT-BUCKET SEAT
21	071126-43-E34	EA	SKIRT-BUCKET SEAT (F26)
21	071126-43-F06	EA	SKIRT-BUCKET SEAT (F27)
21	071126-54-F24	EA	SKIRT-BUCKET SEAT - MANUAL SEAT OPTION
21	071126-54-F25	EA	SKIRT-BUCKET SEAT - MANUAL SEAT OPTION
21	071126-54-F26	EA	SKIRT-BUCKET SEAT - MANUAL SEAT OPTION
21	071126-54-F27	EA	SKIRT-BUCKET SEAT - MANUAL SEAT OPTION
22	111169-01-000	EA	PLATE-BACK, ARMREST
22	111169-03-000	EA	INSERT-ARMREST, OVAL DECAL - ITASCA
	007221-01-000	EA	SPACER-SEAT, ADJUSTER
	089323-01-000	FT	STRIP-POLYENTHYLENE, J-CHANNEL - FLEX-O-LATORS
	114889-01-000	EA	STOP BAR-UNIVERSAL, SHROCK

CURTAIN AND CUSHION GROUP (CONTINUED)

SWIVEL CHAIR

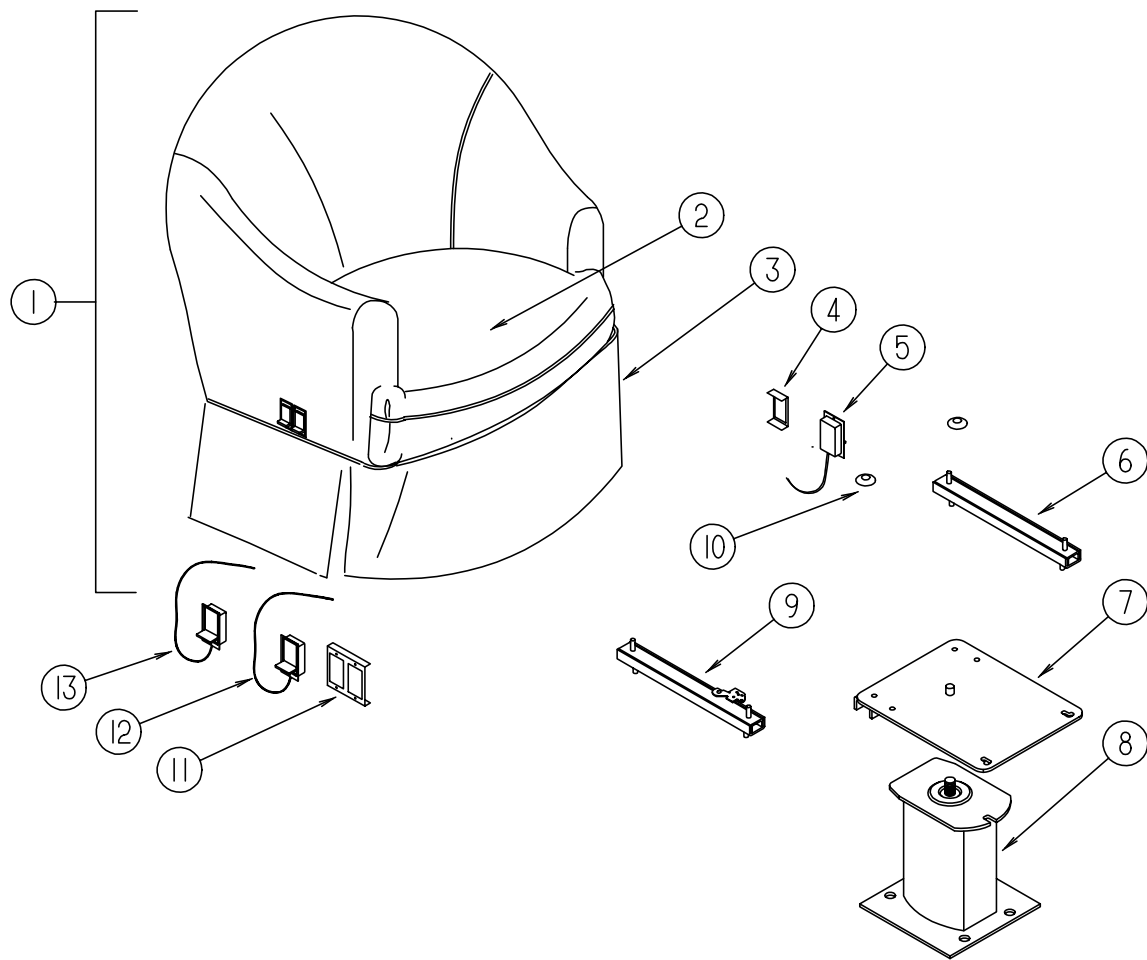

KEY	PART NUMBER	U/M	DESCRIPTION
1	116016-01-F24	EA	CHAIR-SWIVEL, W/O SKIRT
1	116016-01-F25	EA	CHAIR-SWIVEL, W/O SKIRT
1	116016-01-F26	EA	CHAIR-SWIVEL, W/O SKIRT
1	116016-02-F27	EA	CHAIR-SWIVEL, W/O SKIRT
	P16016-01-F24	EA	COVER-SWIVEL CHAIR
	P16016-01-F25	EA	COVER-SWIVEL CHAIR
	P16016-01-F26	EA	COVER-SWIVEL CHAIR
	P16016-02-F27	EA	COVER-SWIVEL CHAIR
2	116016-10-F24	EA	CUSHION-SEAT, SWIVEL CHAIR
2	116016-10-F25	EA	CUSHION-SEAT, SWIVEL CHAIR
2	116016-10-F26	EA	CUSHION-SEAT, SWIVEL CHAIR
	P16016-10-F24	EA	COVER-SEAT, SWIVEL CHAIR
	P16016-10-F25	EA	COVER-SEAT, SWIVEL CHAIR
	P16016-10-F26	EA	COVER-SEAT, SWIVEL CHAIR
3	085187-05-F24	EA	SKIRT-SWIVEL CHAIR
3	085187-05-F25	EA	SKIRT-SWIVEL CHAIR
3	085187-05-F26	EA	SKIRT-SWIVEL CHAIR
3	085187-07-F27	EA	SKIRT-SWIVEL CHAIR
4	097683-03-000	EA	BRACKET-MOUNT, REMOTE - SINGLE
5	089368-04-000	EA	CABLE-W/SWITCH, SLIDE
			FROM: 00-00-00 THRU: 11-13-94
5	108049-03-000	EA	CABLE-W/SWITCH, 20" - Z - END CABLE - SLIDE
			FROM: 11-14-94 THRU: 99-99-99
6	069246-06-000	EA	ADJUSTER-SWIVEL CHAIR, FORWARD & BACK
			FROM: 00-00-00 THRU: 10-16-94
6	069246-13-000	EA	ADJUSTER-SWIVEL CHAIR, FORWARD & BACK
			FROM: 10-17-94 THRU: 99-99-99
7	107921-08-000	EA	PLATE-TOP, W/O SEAT BELT BAR
	107921-06-000	EA	BEARING KIT-SEAT SWIVEL
8	107921-01-000	EA	PLATE-SUB, FLOOR MOUNTED PEDESTAL - W/9.75" EXTENSION
9	069246-08-000	EA	ADJUSTER-SWIVEL CHAIR W/LOCK, REMOTE - FORWARD & BACK
			FROM: 00-00-00 THRU: 10-16-94
9	069246-12-000	EA	ADJUSTER-SWIVEL CHAIR W/LOCK, REMOTE - FORWARD & BACK
			FROM: 10-17-94 THRU: 99-99-99
	117125-01-02B	EA	BRACKET-CABLE MOUNT, ADJUSTER W/LOCK - STEEL - E-COAT
			FROM: 10-17-94 THRU: 99-99-99
	069246-99-000	EA	SPRING-BUCKET SEAT ADJUSTER, BLUE
			FROM: 10-17-94 THRU: 99-99-99
10	007221-01-000	EA	SPACER-SEAT, ADJUSTER
11	097683-02-000	EA	BRACKET-MOUNT, REMOTE
12	089368-05-000	EA	CABLE W/SWITCH, RECLINE
13	108049-01-000	EA	CABLE W/SWITCH - 28", SWIVEL
			FROM: 00-00-00 THRU: 11-13-94
13	108049-03-000	EA	CABLE W/SWITCH, 20" - Z - END CABLE - SWIVEL
			FROM: 11-14-94 THRU: 99-99-99
	108049-02-000	EA	CLIP-CABLE, PEDESTAL
	108445-02-000	EA	PLATE ASM-PEDESTAL, SEAT - 230 MM X 157 MM - W/WELDNUTS

DINETTE GROUP

DINETTE CABINETRY

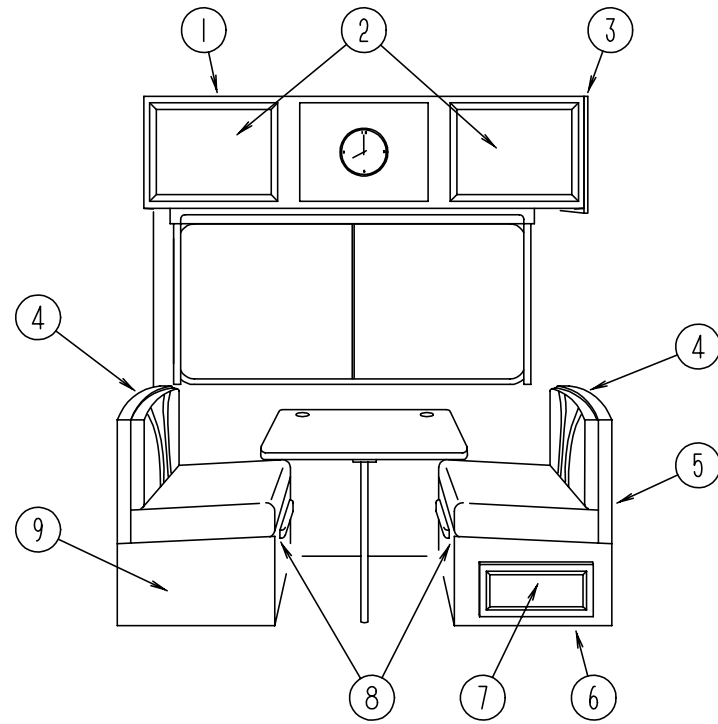

KEY	PART NUMBER	U/M DESCRIPTION
1	113879-01-F24	EA CABINET-OVERHEAD, W/O DOORS
1	113879-01-F25	EA CABINET-OVERHEAD, W/O DOORS
1	113879-01-F26	EA CABINET-OVERHEAD, W/O DOORS
1	113879-01-F27	EA CABINET-OVERHEAD, W/O DOORS
2	M06803-03-F04	EA DOOR-CABINET, W/O HARDWARE - 400 MM X 520 MM
2	M06803-41-E10	EA DOOR-CABINET, W/O HARDWARE - 400 MM X 520 MM (DECORATIVE DOOR)
	108536-04-08A	EA MIRROR-GLASS GALAXY FLOWER
3	103128-01-E10	EA CAP-END, OVERHEAD CABINET - FRONT
4	104787-03-F24	EA PAD-DINETTE
4	104787-03-F25	EA PAD-DINETTE
4	104787-03-F26	EA PAD-DINETTE
4	104787-01-F06	EA PAD-DINETTE (F27)
5	M04174-40-E07	EA CABINET-SEATBACK, FRONT
6	M04175-40-E07	EA CABINET-SEATBASE, FRONT - W/O DOOR
7	M06803-04-E07	EA DOOR-CABINET, W/O HARDWARE - 255 MM X 485 MM
8	081295-01-AA8	EA SUPPORT-BED, DINETTE, 28" LONG - WOOD
9	M04175-16-E01	EA CABINET-SEATBASE, REAR
	058331-48-000	EA MIRROR-GLASS, SAFETY - 502 MM X 554 MM
	105004-01-02A	EA MOLDING-MIRROR, VINYL WRAPPED - OAK

DINETTE GROUP (CONTINUED)

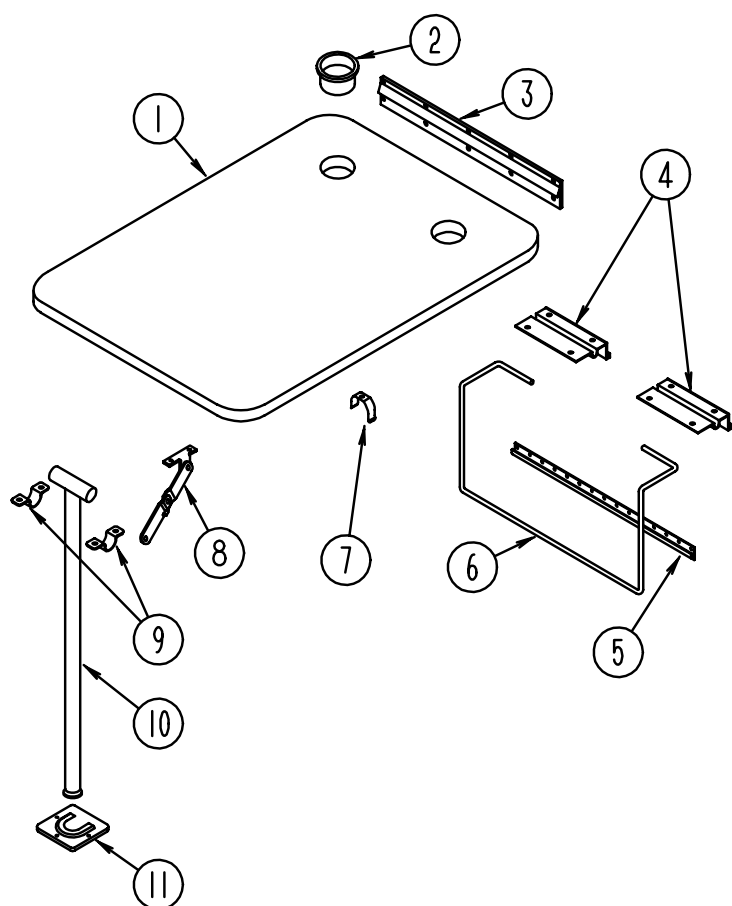

DINETTE TABLE

KEY	PART NUMBER	U/M DESCRIPTION
1	M81299-06-E08	EA TABLE-DINETTE, W/O EDGE BAND OR HARDWARE (F24)
1	M81299-06-F05	EA TABLE-DINETTE, W/O EDGE BAND OR HARDWARE (F25)
1	M81299-06-F26	EA TABLE-DINETTE, W/O EDGE BAND OR HARDWARE
1	M81299-06-E28	EA TABLE-DINETTE, W/O EDGE BAND OR HARDWARE (F27)
2	064781-06-000	EA HOLDER-CUP, TWO STEP - OFF WHITE
3	053200-12-000	EA SUPPORT-TABLE, 23.5" - BEIGE
4	088410-02-000	EA BRACKET-LIFT, TABLE MOUNTED - OFF WHITE
5	024281-14-000	EA BRACKET-LIFT ROD, LOWER WALL MOUNTED - 22.12" - OFF WHITE
6	024275-12-000	EA ROD-TABLE LIFT, OFF WHITE
7	024283-01-000	EA CLIP-LEG, 1" X 1.125" OD - BLACK
8	024282-01-000	EA BRACE-TABLE LEG, HINGED
9	064050-05-000	EA HINGE-TABLE LEG, OFF WHITE
10	024276-23-000	EA LEG-TABLE, METAL - OFF WHITE
11	049493-12-000	EA CATCH-LEG, FLOOR MOUNTED - 2.5" X 2.7" - METAL - OFF WHITE
11	049493-11-700	EA CATCH-LEG, FLOOR MOUNTED - 2.5" X 2.7" - METAL - E-COAT

DRIVERS COMPARTMENT GROUP

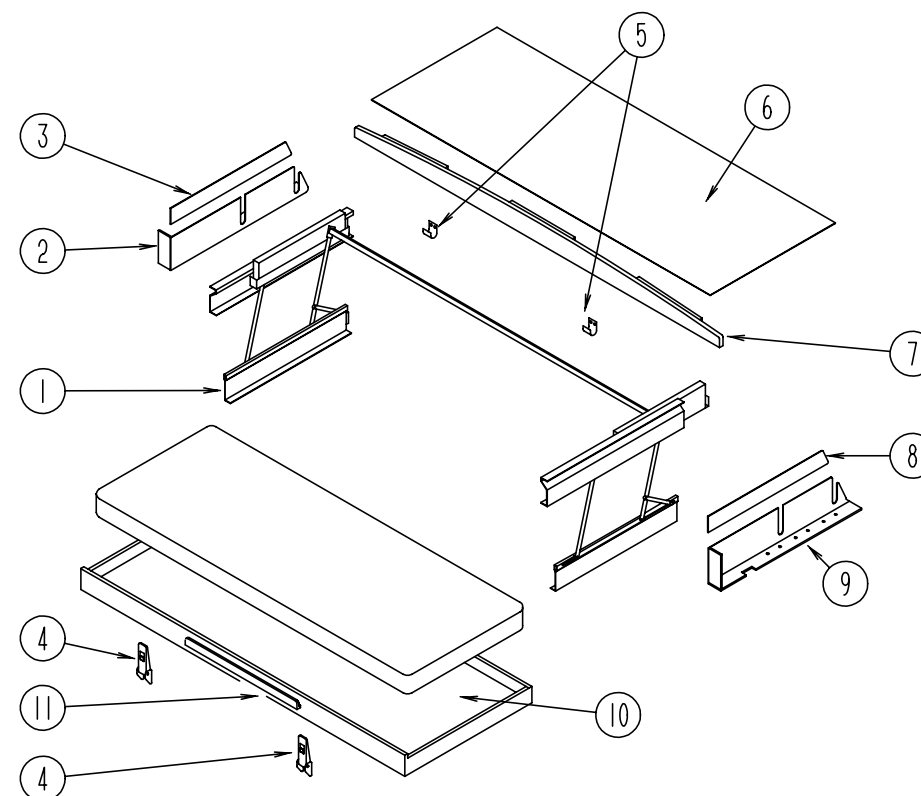

FRONT BUNK-SINGLE

KEY	PART NUMBER	U/M DESCRIPTION
1	076760-02-000	EA BUNK HARDWARE (COMPLETE)
	076760-02-700	EA SPRING-GAS-BUNK HARDWARE
2	101499-06-F24	EA PANEL ASM.- BOTTOM DRIVERS - PADDED - USED W/BUNK (F24,F27)
2	101499-06-C05	EA PANEL ASM.- BOTTOM DRIVERS - PADDED - USED W/BUNK (F25,F26)
3	101497-08-F24	EA PANEL ASM.- UPPER DRIVERS - PADDED - USED W/BUNK (F24,F27)
3	101497-08-C05	EA PANEL ASM.- UPPER DRIVERS - PADDED - USED W/BUNK (F25,F26)
4	042541-04-000	EA LATCH-W/O STRIKE, BRASS
5	042541-05-000	EA STRIKE-BRASS
6	103040-06-F24	EA PANEL-HEADLINER FRONT OVERHEAD - PADDED - USED W/BUNK (F24,F27)
6	103040-06-C05	EA PANEL-HEADLINER FRONT OVERHEAD - PADDED - USED W/BUNK (F25,F26)
7	P03199-01-C05	EA BOARD ASM-TRIM, BUNK - CEILING MOUNTED
8	101497-07-F24	EA PANEL ASM.- UPPER PASSENGERS - PADDED - USED W/BUNK (F24,F27)
8	101497-07-C05	EA PANEL ASM.- UPPER PASSENGERS - PADDED - USED W/BUNK (F25,F26)
9	101499-05-F24	EA PANEL ASM.- BOTTOM PASSENGERS - PADDED - USED W/BUNK (F24,F27)
9	101499-05-C05	EA PANEL ASM.- BOTTOM PASSENGERS - PADDED - USED W/BUNK (F25,F26)
10	081717-03-E07	EA BED ASM-BUNK, FRONT
11	094658-01-E07	EA HANDLE-BUNK, OAK

DRIVERS COMPARTMENT GROUP (CONTINUED)

DRIVERS COMPARTMENT - UPPER

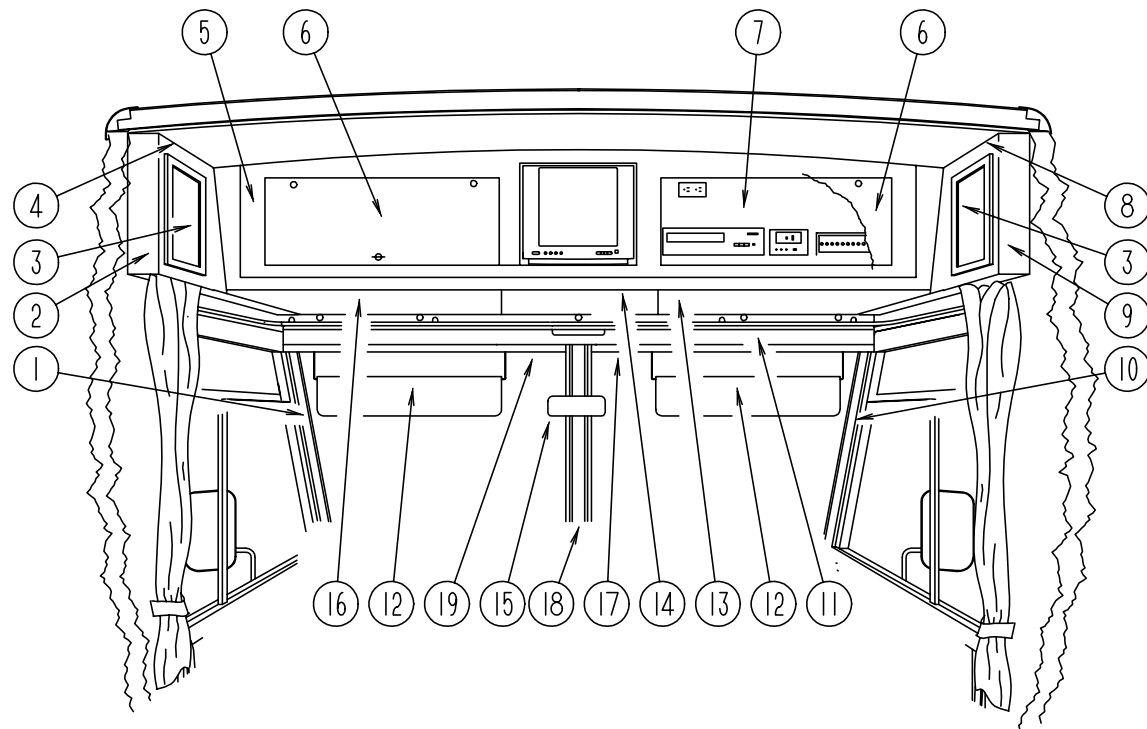

KEY	PART NUMBER	U/M DESCRIPTION
1	103931-02-02A	EA COVER-INNER, A-PILLAR - DRIVERS
2	103128-09-E10	EA CAP-END, FRONT OVERHEAD, DRIVERS SIDE
3	M06803-04-E07	EA DOOR-CABINET, W/O HARDWARE - 255 MM X 485 MM
4	109561-02-F06	EA CABINET-FRONT OVERHEAD W/O DOOR, DRIVERS SIDE (F24)
4	109561-02-F25	EA CABINET-FRONT OVERHEAD W/O DOOR, DRIVERS SIDE
4	109561-02-F26	EA CABINET-FRONT OVERHEAD W/O DOOR, DRIVERS SIDE
4	109561-02-F27	EA CABINET-FRONT OVERHEAD W/O DOOR, DRIVERS SIDE
	P09561-02-E07	EA BOTTOM-VINYL COVERED, FRONT OVERHEAD - DRIVERS SIDE
	104289-02-F24	EA PAD-VINYL COVERED, 30.3" X 9.6" - ANGLED - DRIVERS SIDE
5	M05893-01-E07	EA FACE-TV CABINET W/O DOORS, FRONT OVERHEAD
	106699-01-01A	EA BRACKET-L-ANGLE, TV CABINET FACE - 5.1" LONG - OFF WHITE STEEL
	108911-01-F04	EA TRIM-TV, 15.3" X 13.9" - WOOD
	100676-02-000	EA STAND-VCR, STEEL
6	100708-06-000	EA DOOR-GLASS, TV CABINET - W/O HARDWARE - 9.68" X 28.42"
	100710-01-01A	EA LOCK-TWIST TYPE
	100711-01-01A	EA HINGE-DOOR, GLASS
	100707-01-000	EA SPACER
	101272-01-000	EA CATCH-GLASS DOOR
	101766-01-000	EA PIN-SUPPORT, GLASS DOOR
7	103040-01-C05	EA PANEL-HEADLINER FRONT OVERHEAD - PADDED - STANDARD
7	103040-02-C05	EA PANEL-HEADLINER FRONT OVERHEAD - PADDED - TV OPTION
7	103040-03-C05	EA PANEL-HEADLINER FRONT OVERHEAD - PADDED - TV/VCR/EUROPEAN OPTIONS
7	103040-04-C05	EA PANEL-HEADLINER FRONT OVERHEAD - PADDED - TV/VCR/INVERTER OPTION
7	103040-05-C05	EA PANEL-HEADLINER FRONT OVERHEAD - PADDED - TV/INVERTER OPTION
8	114188-01-F06	EA CABINET-FRONT OVERHEAD W/O DOOR, PASSENGERS SIDE (F24)
8	114188-01-F25	EA CABINET-FRONT OVERHEAD W/O DOOR, PASSENGERS SIDE
8	114188-01-F26	EA CABINET-FRONT OVERHEAD W/O DOOR, PASSENGERS SIDE
8	114188-01-F27	EA CABINET-FRONT OVERHEAD W/O DOOR, PASSENGERS SIDE
9	103128-08-E10	EA CAP-END, FRONT OVERHEAD, PASSENGERS SIDE
	P09561-01-E07	EA BOTTOM-VINYL COVERED, FRONT OVERHEAD - PASSENGERS SIDE
	104289-01-F24	EA PAD-VINYL COVERED, 30.3" X 9.6" - ANGLED - DRIVERS SIDE
10	103931-01-02A	EA COVER-INNER, A-PILLAR - PASSENGERS
11	078811-05-C07	EA PANEL-HEADER W/RECEPTACLE CUTOUPS - 90.2" LONG - VINYL COVERED
12	082286-18-F04	EA SUNVISOR-DRIVER OR PASSENGER - W/O POCKET
	102377-01-000	EA BRACKET-SUNVISOR, 1 PIECE - STEEL
	007211-01-000	EA HINGE-SUNVISOR
	074012-01-000	EA CLIP-SUNVISOR, SQUARE PINCH-ON
13	P03077-02-C05	EA SHELF-CABINET, PASSENGERS SIDE - VINYL COVERED
14	P04415-01-C05	EA SHELF-TV CABINET, VINYL COVERED
	100628-02-000	EA SHELF ASM-TV, STEEL
	101150-01-000	EA SUPPORT-SHELF, TV - PASSENGER SIDE - STEEL
	101150-02-000	EA SUPPORT-SHELF, TV - DRIVER SIDE - STEEL
	104417-01-E07	EA CABINET-BLANKET (STANDARD CABINET)
15	040714-01-000	EA MIRROR-REAR VIEW, W/ARM MOUNT & SET SCREW - GM# 911722
	067490-01-000	EA BUTTON-MIRROR, REAR VIEW - STANK S927H
16	P03077-01-C05	EA SHELF-CABINET, DRIVERS SIDE - VINYL COVERED
17	078579-09-000	EA TRIM - WINDSHIELD - UPPER INNER - RIGHT - LIGHT GRAY
18	079765-08-000	EA TRIM - WINDSHIELD - CENTER INNER - LIGHT GRAY
19	078579-10-000	EA TRIM - WINDSHIELD - UPPER INNER - LEFT - LIGHT GRAY

DRIVERS COMPARTMENT GROUP (CONTINUED)

DRIVERS COMPARTMENT - LOWER

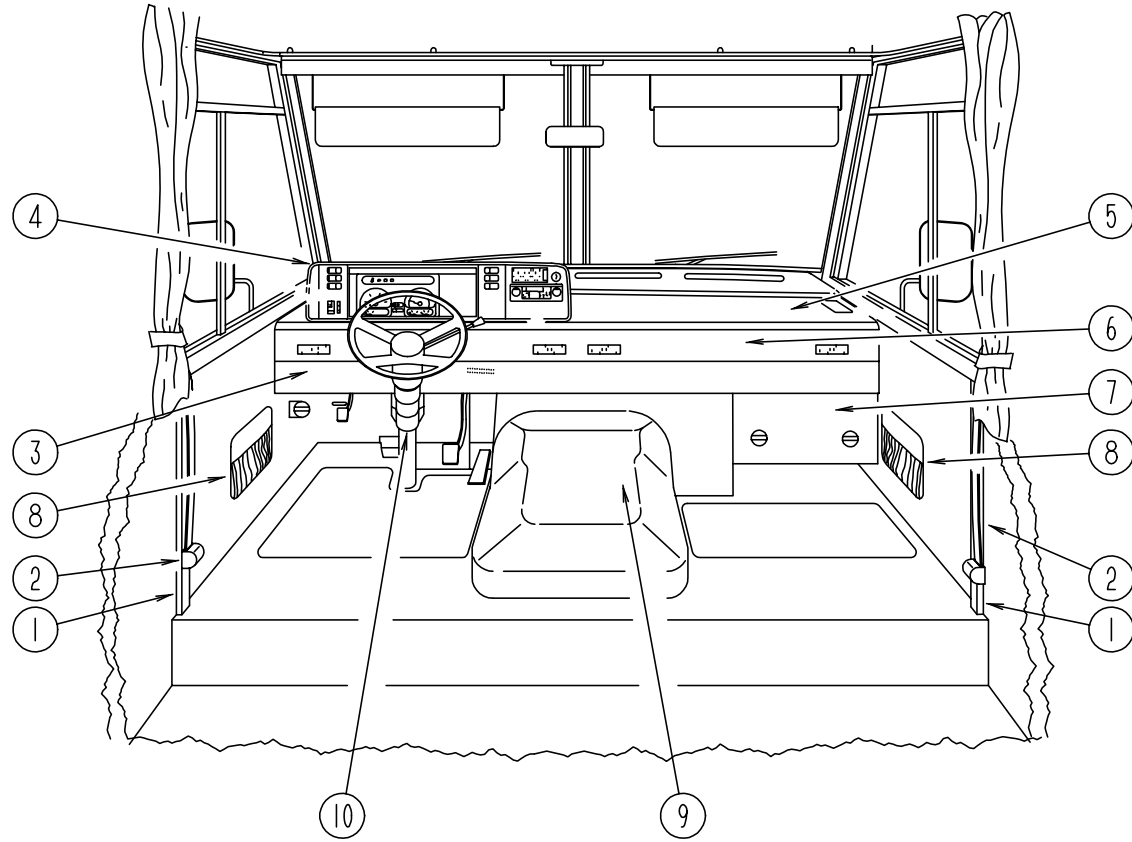

KEY	PART NUMBER	U/M	DESCRIPTION
1	024700-44-000	EA	COVER-SIDEWALL ROLL BAR, OFF WHITE - 53"
1	024700-45-000	EA	COVER-SIDEWALL ROLL BAR, OFF WHITE - 12.8"
2	091990-04-01A	EA	SEAT BELT-SHOULDER HARNESS - DRIVERS/PASSENGERS - BLACK
	091990-01-700	EA	BOLT COVER
	109146-01-000	EA	BOLT-SHOULDER, SEAT BELT
	103961-01-01A	EA	COVER-BRACKET, SEATBELT - OFF WHITE
	103961-02-01A	EA	COVER-BRACKET, SEATBELT - OFF WHITE - DRIVER DOOR OPTION
3	103812-01-02A	EA	TRIM-DASH, LOWER
4	111499-01-02A	EA	POD-INSTRUMENT PANEL
5	P03817-10-000	EA	DASH ASM, W/O VINYL - FORD
5	P03817-11-000	EA	DASH ASM, W/O VINYL - CHEVY
	105927-02-000	EA	PANEL-DASH TOP, STEEL
6	104354-04-03A	EA	APPLIQUE-LOWER DASH, 2300 MM LONG - CHEVY
6	104354-05-03A	EA	APPLIQUE-LOWER DASH, 2300 MM LONG - FORD
7	095757-03-F04	EA	COVER-HEATER W/CARPET (F24,F27)
7	095757-03-F25	EA	COVER-HEATER W/CARPET
7	095757-03-F26	EA	COVER-HEATER W/CARPET
8	086120-01-F24	EA	PAD-MAP POCKET, 12" X 16" (F24,F27)
8	086120-01-F25	EA	PAD-MAP POCKET, 12" X 16"
8	086120-01-F26	EA	PAD-MAP POCKET, 12" X 16"
9	097552-01-000	EA	COVER-MOTOR, W/O CARPET
			FROM: 00-00-00 THRU: 09-18-94
9	114512-01-01A	EA	COVER-MOTOR, W/O CARPET (6.5 DIESEL OPTION)
			FROM: 00-00-00 THRU: 09-18-94
	075564-01-000	EA	BRACKET-MOUNTING, MOTOR COVER
			FROM: 00-00-00 THRU: 09-18-94
9	115840-01-01A	EA	COVER-MOTOR, W/O CARPET - GAS OR 6.5 DIESEL OPTION
			FROM: 09-19-94 THRU: 99-99-99
	115850-01-02A	EA	RETAINER-LATCH, MOTOR COVER - GAS OR 6.5 DIESEL OPTION
			FROM: 09-19-94 THRU: 99-99-99
	116581-01-000	EA	LATCH-MOTOR COVER - SOUTHCO 2710074088 - GAS OR 6.5 DIESEL OPTION
			FROM: 09-19-94 THRU: 99-99-99
	116833-01-02B	EA	WRENCH-HEX, MOTOR COVER - E-COAT - GAS OR 6.5 DIESEL OPTION
			FROM: 09-19-94 THRU: 99-99-99
	113828-02-01A	EA	TRIM-MOTOR COVER, MILL
			FROM: 00-00-00 THRU: 09-18-94
	114519-01-E07	EA	TRIM-MOTOR COVER (6.5 DIESEL OPTION)
			FROM: 00-00-00 THRU: 09-18-94
	115860-01-01A	EA	TRIM-MOTOR COVER - GAS OR 6.5 DIESEL OPTION
			FROM: 09-19-94 THRU: 99-99-99
	039623-01-000	FT	SEAL-MOTOR COVER, RUBBER BULB TYPE - BLACK
	111618-01-E10	EA	TRAY ASM-BEVERAGE
	111618-13-E07	EA	LID-BEVERAGE TRAY ASM
	046886-03-000	EA	ASHTRAY-CHROME, W/COVER
10	103498-06-000	EA	BOOT-STEERING COLUMN, BLACK VINYL
	111521-01-04A	EA	COVER-STEERING COLUMN, BLACK
	112634-01-01A	EA	TRIM-STEERING COLUMN, RH BLK
	112634-02-01A	EA	TRIM-STEERING COLUMN, LH BLK

DRIVERS COMPARTMENT GROUP (CONTINUED)

INSTRUMENT CLUSTER (CHEVY)

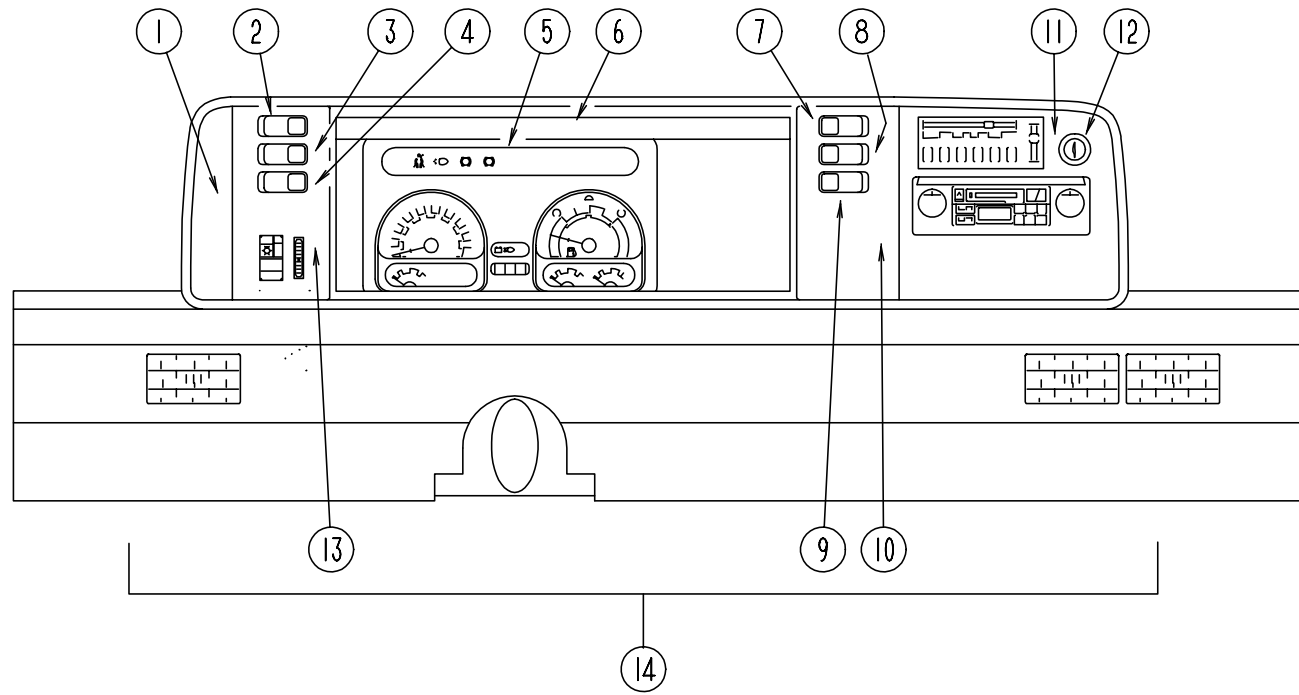

KEY	PART NUMBER	U/M DESCRIPTION
1	104056-01-01A	EA APPLIQUE-BEZEL
2	108356-02-01A	EA COVER-SWITCH W/DIMPLES, CARLING VVAZC00 BLA
2	108357-05-000	EA SWITCH-ROCKER, SPDT ON/NONE/ON - RADIO POWER - CARLING V4D1000B-0
3	108356-02-01A	EA COVER-SWITCH W/DIMPLES, CARLING VVAZC00 BLA
3	108357-09-000	EA SWITCH-ROCKER, SPDT ON/NONE/MOM - DUAL BATTERY - CARLING V5D1000B-0
4	108356-02-01A	EA COVER-SWITCH W/DIMPLES, CARLING VVAZC00 BLA
4	108357-06-000	EA SWITCH-ROCKER, DPDT MOM/OFF/MOM - CARLING VLD1000B-0 BATTERY DISCONNECT SWITCH OPTION
4	096241-03-000	EA SWITCH-BLANK
5	094796-07-000	EA CLUSTER-INSTRUMENT PANEL, KILOMETERS - GM #16167145 (GAS)
5	094796-08-000	EA CLUSTER-INSTRUMENT PANEL, KILOMETERS - GM #16164645 (DIESEL)
6	103662-01-01A	EA BEZEL-INSTRUMENT PANEL
7	108356-04-01A	EA COVER-SWITCH W/DIMPLES & LENS, CARLING VVAGC00
7	108357-10-000	EA SWITCH-ROCKER, SPDT MOM/OFF/MOM - LIGHTED - CARLING V8D1160B-0 GENERATOR OPTION
7	096241-03-000	EA SWITCH-BLANK
8	108356-02-01A	EA COVER-SWITCH W/DIMPLES, CARLING VVAZC00 BLA
8	108357-03-000	EA SWITCH-ROCKER, SPDT ON/OFF/ON - CARLING V6D1000B-0 REAR HEATER OPTION
8	096241-03-000	EA SWITCH-BLANK
9	096241-03-000	EA SWITCH-BLANK
10	104056-21-01A	EA APPLIQUE-BEZEL
11	104056-06-01A	EA APPLIQUE-BEZEL
12	089294-01-000	EA LIGHTER ASM-CIGARETTE - CASCO C213275
13	104056-22-01A	EA APPLIQUE-BEZEL
14	M05946-17-F24	EA DASH POD ASM-CHEVY
	100138-01-000	EA MODULE-DAYTIME RUNNING LIGHT - CANADIAN
	077031-01-000	EA FILM-BLACK, 1" X 1.75"
	077031-02-000	EA FILM-AMBER, 1" X 1.75"
	077031-03-000	EA FILM-WHITE, .75" X 1"
	103603-01-000	EA BULB-12V NO.74 0.12A WEDGE
	105615-01-000	FT FILM-PROTECTIVE CLEAR
	077539-01-000	EA BRACKET-MOUNTING, DASH PANEL - L/SHAPED - 2.5" X 1" X 1.5"
	062901-02-000	EA FUSE - 5 AMPS, AUTOMOTIVE
	062901-05-000	EA FUSE - 15 AMPS, AUTOMOTIVE
	062901-07-000	EA FUSE - 25 AMPS, AUTOMOTIVE

ELECTRICAL GROUP**INTERIOR LIGHTS**

KEY	PART NUMBER	U/M DESCRIPTION
	065202-29-000	EA LAMP-WALL,BRASS (CANADIAN)
	098024-01-01A	EA LIGHT-DOME, 1 BULB - US - IVORY
	008218-01-000	EA BULB-DOME LIGHT, 12V - NUMBER 1141
	098024-01-700	EA LENS-DOME LIGHT
	061424-01-000	EA LIGHT-AISLE, 12V - RECTANGULAR
	008103-01-000	EA BULB-DASH/AISLE LIGHT, #53 - 12 V - .12 AMP
	065201-09-000	EA SHADE-LAMP, FABRIC - PARCHMENT
	065202-28-000	EA LAMP-WALL,BRASS (US)
	067479-01-000	EA BULB - 12V, NUMBER 1076
	086280-01-000	EA LIGHT-SURFACE MOUNT, 12V - JENSEN 1236
	086280-01-700	EA BULB - 12 VOLT, 6 WATT
	098024-01-01A	EA LIGHT-DOME, 1 BULB - US - IVORY
	008218-01-000	EA BULB-DOME LIGHT, 12V - NUMBER 1141
	098024-01-700	EA LENS-DOME LIGHT
	098024-03-01A	EA LIGHT-DOME, 2 BULB - IVORY
	008218-01-000	EA BULB-DOME LIGHT, 12V - NUMBER 1141
	098024-01-700	EA LENS-DOME LIGHT
	110235-01-01A	EA LIGHT-MAKE UP,3 BULB PANLESS
	081633-01-700	EA BULB-MAKE UP LIGHT, JENSEN

FUSES & CIRCUIT BREAKERS

KEY	PART NUMBER	U/M DESCRIPTION
	062037-01-000	EA HOUSING-AUTO FUSE, NATURAL
	062037-03-000	EA HOUSING-AUTO FUSE, BLACK
	062037-04-000	EA HOUSING-AUTO FUSE, BLUE
	062037-06-000	EA HOUSING-AUTO FUSE, BROWN
	062901-02-000	EA FUSE - 5 AMPS, AUTOMOTIVE
	062901-05-000	EA FUSE - 15 AMPS, AUTOMOTIVE
	062901-07-000	EA FUSE-AUTOMOTIVE, 25 AMPS
	083209-01-000	EA CIRCUIT BREAKER - 15 AMP, 120V - BW G-15 - CANADIAN
	083209-02-000	EA CIRCUIT BREAKER - 15/15AMP, 120V - BW H-15/15
	083209-03-000	EA CIRCUIT BREAKER - 15/20AMP, 120V - BW 0-15/20
	083209-04-000	EA CIRCUIT BREAKER - 30A, 120V - BW L-30
	083209-06-000	EA CIRCUIT BREAKER - 30/15 AMP, 120V - BW D-30/15
	083209-07-000	EA CIRCUIT BREAKER - 20/20A, 120V - BW K-20/20
	093655-03-000	EA CIRCUIT BREAKER - 40A, 12V - USD 17440-4E03A2A
	097611-01-000	EA CIRCUIT BREAKER - 10A, 12V - VB3-A10-F57
	106655-02-000	EA TERMINAL-FUSE BLOCK, 10-12AWG PACKARD 12020400
	106656-01-000	EA FUSE BLOCK - 4 CAVITY AUTOFUSE PACKARD 12004943
	108669-01-000	EA HOUSING-AUTO FUSE HOLDER, PACKARD 12010105

CONDUIT

KEY	PART NUMBER	U/M DESCRIPTION
	041953-01-000	FT CONDUIT-CONVOLUTE SLIT, .5"ID
	041953-03-000	FT CONDUIT-CONVOLUTE SLIT, 1" ID (CLOTHES ROD COVER)
	041953-05-000	FT CONDUIT-CONVOLUTE SOLID, .62" ID
	041953-06-000	FT CONDUIT-CONVOLUTE,SLIT .375"ID
	041953-07-000	FT CONDUIT-CONVOLUTE, SLIT - .25" ID
	041953-08-000	FT CONDUIT-CONVOLUTE,SLIT,1.50"ID
	041953-09-000	FT CONDUIT-CONVOLUTE,SLIT .50"ID
	041953-10-000	FT CONDUIT-CONVOLUTE, SLIT - .75" ID
	041953-11-000	FT CONDUIT-CONVOLUTE, SLIT- 1.06" ID
	041953-12-000	FT CONDUIT-CONVOLUTE, NON SLIT 1.1" ID

POWER CORDS

KEY	PART NUMBER	U/M DESCRIPTION
	008052-01-000	EA CORD-POWER, 10/3 - 30 AMP - 25' - CANADIAN
	008054-01-000	EA CORD-POWER, 10/3 - 30 AMP - 25' - US

ELECTRICAL GROUP (CONTINUED)**CONNECTORS**

KEY	PART NUMBER	U/M DESCRIPTION
	008311-01-000	EA CONNECTOR-WIRE NUT, INSULATED - RED
	008312-01-000	EA CONNECTOR-WIRE NUT, INSULATED - BLUE
	008314-01-000	EA CONNECTOR-WIRE NUT, INSULATED - GRAY
	008355-01-000	EA CONNECTOR-CABLE CLAMPING, 3/4"
	008356-01-000	EA CONNECTOR-PLASTIC, 3/8" AVG
	008398-01-000	EA CONNECTOR - 1/2" X 90 DEGREE, FLEX CONDUIT - UL AND CSA
	041480-01-000	EA CONNECTOR-STRAIGHT, 1/2" FLEX CONDUIT
	082740-01-000	EA CONNECTOR-PLASTIC BODY, FOR 2 MALE SPADES
	082741-01-000	EA CONNECTOR BODY - 2 CONNECTOR - MALE - SERV ELEC 2P-FYL
	058028-01-000	EA CONNECTOR-ELECTRICAL PIGTAIL, NYLON - CLEAR
	007940-01-000	EA RECEPTACLE-SLIDE, 16 TO 12 AWG - FEMALE END
	080015-02-000	EA RECEPTACLE-FLAG, .185 - 16/14 GA - AMP 3

RECEPTACLES, RECEPTACLE PLATES & SPACER

KEY	PART NUMBER	U/M DESCRIPTION
	091927-01-000	EA COVER-RECEPTACLE, DOUBLE - IVORY
	102568-01-E90	EA SPACER-RECEPTACLE, BETWEEN SIDEWALL & PLATE - WOOD
	024924-02-000	EA RECEPTACLE-POWER CORD, W/PARTIAL PLATE
	058707-01-000	EA RECEPTACLE-ELECTRIC, SINGLE - BROWN
	058707-02-000	EA RECEPTACLE-BLANK, JUNCTION - WIRECON WDJ20BR
	058708-01-000	EA RECEPTACLE-ELECTRIC, DOUBLE - BROWN
	058708-02-000	EA RECEPTACLE-ELECTRIC, DOUBLE - IVORY
	084076-02-000	EA RECEPTACLE-GFI, 15A - 125V - BROWN
	112824-01-02A	EA COVER-EXTERIOR RECEPTACLE, OFF WHITE - P&S 3780-SC-CW
	112822-01-01A	EA RECEPTACLE-EXTERIOR, DUPLEX - IVORY - WIRECON WDRU15IV
	007940-01-000	EA RECEPTACLE-SLIDE, 16 TO 12 AWG - FEMALE END
	007954-01-000	EA RECEPTACLE-HSG - 6 POSITION
	080015-02-000	EA RECEPTACLE-FLAG, .185 - 16/14 GA - AMP 3

TERMINALS

KEY	PART NUMBER	U/M DESCRIPTION
	008326-01-000	EA TERMINAL-RING, 16/14 WIRE - 3/8" STUD
	008328-01-000	EA TERMINAL-RING, 12/10 WIRE - #10 STUD FIT
	008331-01-000	EA TERMINAL-RING,TONGUE - #4 WIRE - 3/8" STUD - COPPER
	008348-01-000	EA TERMINAL-RING, 3/8" STUD - #2 WIRE
	035416-04-000	EA TERMINAL-RING #10 STUD FIT, INSULATED BARREL #16/14
	047443-01-000	EA TERMINAL - .250 RECEPTACLE FIT, INSULATED - 16/14 AWG
	062036-01-000	EA TERMINAL-PACK-CON, 12/10 AWG
	062036-02-000	EA TERMINAL-PACK-CON, 16/14 AWG
	104100-02-000	EA TERMINAL - 75 AMP - AMP 53880-2 STRIP
	104100-03-000	EA TERMINAL - 75 AMP - AMP 53880-4 LOOSE
	106655-01-000	EA TERMINAL-FUSE BLOCK,14-16AWG PACKARD 12020321
	113306-01-000	EA TERMINAL-FEMALE, METRI-PACK - PACKARD 12048451
	113307-01-000	EA TERMINAL-FEMALE, METRI-PACK - PACKARD 12048074

WIRE ASSEMBLIES

KEY	PART NUMBER	U/M DESCRIPTION
	073328-B4-000	EA CABLE ASSEMBLY-BATTERY, W/TERMINALS
	096449-01-000	EA WIRE ASSEMBLY-WATER TANK TO MONITOR PANEL
	097618-01-000	EA WIRE ASM-MONITOR PANEL, W/3 WIRES & ORANGE RESISTOR- LVS ORANGE RESISTOR W/3 (ORANGE-GREEN-BLUE) WIRES
	102636-01-000	EA WIRE ASM-CLEARANCE LAMPS
	103328-06-000	EA WIRE ASM-PUMP, EXTERIOR SHOWER
	111448-01-000	EA WIRE ASM-INSTRUMENT PANEL ,MAIN (GM)
	111915-01-000	EA WIRE ASM-DAY RUN LAMPS, FUSE - GM
	P03783-01-000	EA WIRE ASM-HEADLAMP (GM)

ELECTRICAL GROUP (CONTINUED)**HOUSINGS, PINS & SOCKETS**

KEY	PART NUMBER	U/M	DESCRIPTION
	007949-01-000	EA	TAB-HOUSING, 1 POSITION
	063910-01-000	EA	HOUSING-RELAY, BOSCH 3 334 485 008
	088473-01-000	EA	HOUSING-PIN, 4 ROWS OF 3
	088473-03-000	EA	HOUSING-PIN, 9 POSITION
	088473-05-000	EA	HOUSING-PIN, 6 POSITION (SINGLE ROW)
	088473-06-000	EA	HOUSING-PIN, 6 POSITION (TWO ROWS OF THREE)
	088473-08-000	EA	HOUSING-PIN, 4 POSITION
	088473-09-000	EA	HOUSING-PIN, 3 POSITION (SINGLE ROW)
	088473-10-000	EA	HOUSING-PIN, 2 POSITION
	088474-01-000	EA	HOUSING-SOCKET, 12 POSITIONS
	088474-02-000	EA	HOUSING-SOCKET, 12 CAVITY - AMP 1-480711-0
	088474-03-000	EA	HOUSING-SOCKET, 9 POSITION
	088474-06-000	EA	SOCKET-HOUSING, 6 POSITION (2 ROWS OF THREE)
	088474-07-000	EA	HOUSING-SOCKET, 5 CAVITY - AMP 1-480764-0
	088474-08-000	EA	SOCKET-HOUSING, 4 POSITION (SINGLE ROW)
	088474-09-000	EA	HOUSING-SOCKET, 3 POSITION
	088474-10-000	EA	HOUSING-SOCKET, 2 POSITION
	088475-01-000	EA	PIN-CONNECTOR, 14 TO 20 AWG
	088475-02-000	EA	PIN-CONNECTOR, 10 TO 12 AWG
	104100-01-000	EA	HOUSING - 1 POSITION, 75 AMP AMP 53884-1
	101571-01-000	EA	HOUSING - 2 POSITION, MALE
	106006-01-000	EA	HOUSING - 1 POSITION, FEMALE - PACKARD 12015952
	108355-01-000	EA	HOUSING-SWITCH, CARLING VCH
	113468-01-000	EA	HOUSING - 2 POSITION, FEMALE - 56 SERIES - PACKARD 02965981

CONVERTER & INVERTER

KEY	PART NUMBER	U/M	DESCRIPTION
	083208-02-000	EA	CONVERTER-POWER, 45A - 120V/12V - BW 6345
	099048-01-000	EA	INVERTER-100 WATT

SWITCHES, SWITCH PLATES & SPACERS

KEY	PART NUMBER	U/M	DESCRIPTION
	054250-04-000	EA	COVER-ANGLED, W/O HOLE - 3.6" X 4.5" - PLASTIC - OFF WHITE ELECTRICAL PLATE SUPPORT
	075723-01-000	EA	SPACER-SWITCH, W/O HOLE - .2" X .9" X 2" - METAL - OFF WHITE
	075723-02-000	EA	SPACER-SWITCH, W/HOLE - .2" X .9" X 2" - METAL - OFF WHITE FOR ELECTRIC STEP DOOR JAMB SWITCH
	079364-01-000	EA	SWITCH-ON/OFF ROCKER, 2 PRONGS - BROWN
	079364-03-000	EA	SWITCH-ON/OFF ROCKER, 3 PRONGS - BROWN
	095188-01-01A	EA	SPACER-SWITCH, 2.3" X 3.4" - PLASTIC - DARK BROWN
	095188-02-01A	EA	SPACER-SWITCH, 2.3" X 4.1" - PLASTIC - DARK BROWN
	096241-03-000	EA	SWITCH-BLANK
	098351-01-01A	EA	PLATE-SWITCH, 1 GANG - POLISHED BRASS - JENSEN
	098351-05-01A	EA	PLATE-SWITCH, 3 GANG - POLISH BRASS - W/LABEL - JENSEN
	098351-06-01A	EA	PLATE-SWITCH, 2 GANG W/LABEL - JENSEN - POLISHED BRASS
	108355-01-000	EA	HOUSING-SWITCH CARLING VCH
	108356-01-01A	EA	COVER-SWITCH W/GROOVES, CARLING VVCZC00 BLA
	108356-02-01A	EA	COVER-SWITCH W/DIMPLES, CARLING VVAZC00 BLA
	108356-04-01A	EA	COVER-SWITCH W/DIMPLES & LENS, CARLING VVAGC00
	108357-05-000	EA	SWITCH-ROCKER, SPDT ON/NONE/ON - CARLING V4D1000B-0
	108357-08-000	EA	SWITCH-ROCKER, DPDT ON/NONE/ON - CARLING VDD1S00C-0
	108357-10-000	EA	SWITCH-ROCKER, SPDT MOM/OFF/MOM - CARLING V8D1160B-0 LIGHTED

ELECTRICAL GROUP (CONTINUED)**ELECTRIC BOXES & COVERS**

KEY	PART NUMBER	U/M	DESCRIPTION
	008289-01-000	EA	BOX-ELECTRIC, STEEL - 1/2" AND 3/4" KNOCKOUTS - 4" X 4" - US
	008289-02-000	EA	BOX-ELECTRICAL, 4" X 4" - 1/2" & 3/4" KNOCKOUTS - CANADIAN
	058049-01-000	EA	BOX-ELECTRIC SWITCH, 2" X 3" X 2.25"
	091910-01-000	EA	BOX-ELECTRIC, 3.75" X 3.5" X 1.75" - PLASTIC
	091910-02-000	EA	BOX-ELECTRICAL, PLASTIC - 57 MM X 88 MM
	008294-01-000	EA	COVER-ELECTRICAL BOX, BLANK/STEEL - 4" X 4" - GRAY
	008294-02-000	EA	COVER-ELECTRICAL BOX, BLANK STEEL - 4" X 4" - CANADIAN
	054250-04-000	EA	COVER-ANGLED, W/O HOLE - 3.6" X 4.5" - PLASTIC - OFF WHITE ELECTRICAL PLATE SUPPORT
	069238-01-000	EA	COVER-ELECTRICAL BOX, W/HOLE - 4" X 4" - GRAY USED WITH 30 AMP RECEPTACLE

MISCELLANEOUS ELECTRICAL COMPONENTS

KEY	PART NUMBER	U/M	DESCRIPTION
	007093-01-000	EA	FLASHER-SIGNAL, STAT
	008188-01-000	EA	SOLENOID - 3 POST, BATTERY CHANGE OVER
	086233-01-000	EA	STUD-ISOLATED, 3/8" X 7/8" LONG
	086273-01-000	EA	RELAY-BATTERY DISCONNECT
	088476-01-000	EA	SOCKET-CONNECTOR, BRASS - PRE-TIN
	088476-02-000	EA	SOCKET-CONNECTOR, 12-10 GA - PHOSPHATE BRONZE - PRE-TIN
	103608-01-000	EA	SOCKET-WEDGE BASE W/LEADS, JKL 2944-6 OR EQUIVALENT
	103987-02-000	EA	SEAL-SOLENOID ACCESS
	087225-01-000	FT	SLEEVING - 1/2", TYPE H - VARFLEX
	087225-02-000	FT	SLEEVING - 5/8", TYPE H - VARFLEX VARGLAS
	073328-B4-000	EA	CABLE ASSEMBLY-BATTERY, W/TERMINALS
	088751-01-000	FT	CABLE-BATTERY, 1/0 AWG, STRANDED, RED
	077479-01-000	EA	BOOT-BATTERY TERMINAL, DOUBLE CABLE
	077479-02-000	EA	BOOT-BATTERY TERMINAL, SINGLE CABLE
	036346-02-000	EA	BUSHING-STEEL 3/4MPT X 318FPT

ELECTRICAL GROUP (CONTINUED)

EXTERIOR LIGHTS

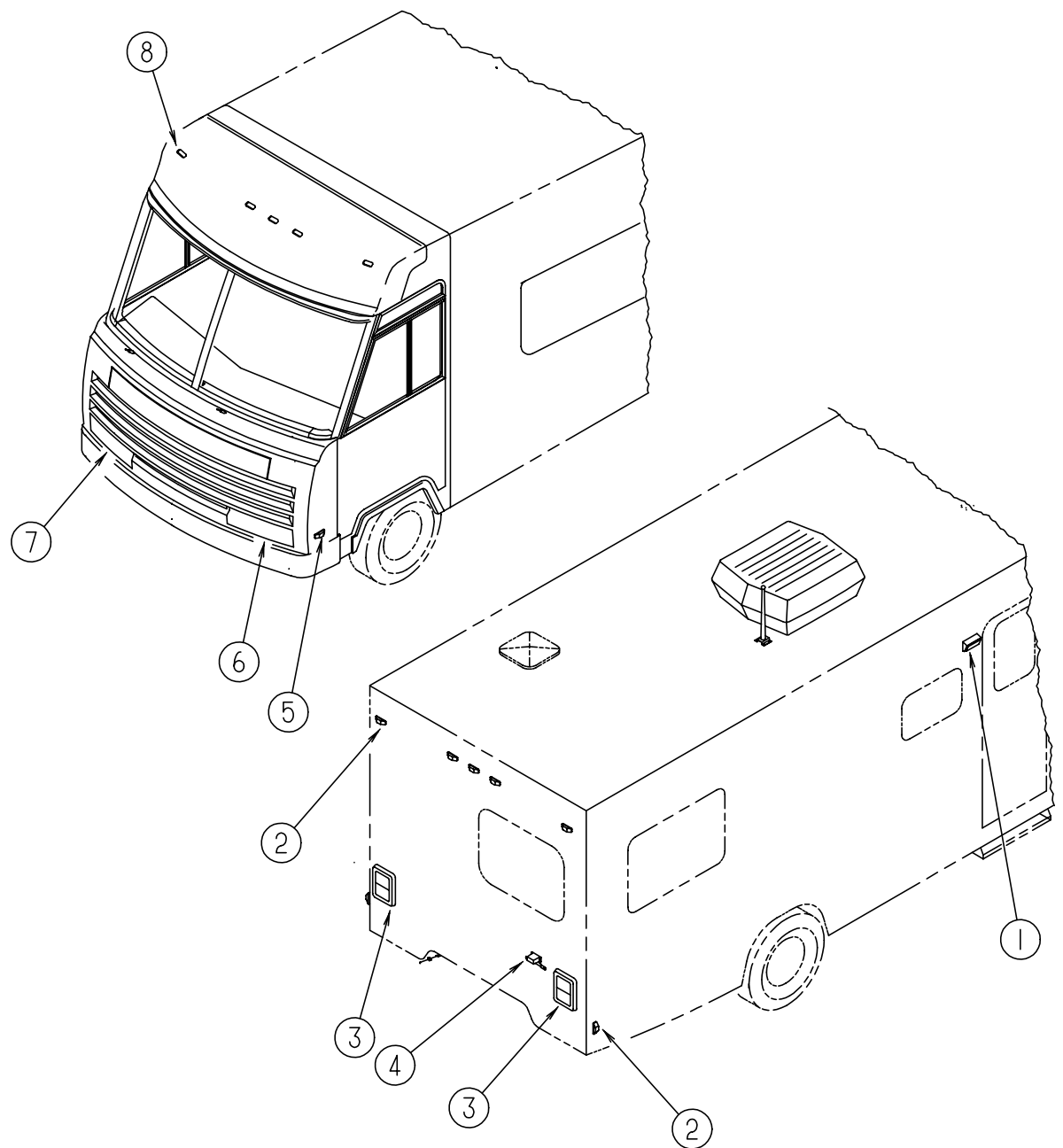

KEY	PART NUMBER	U/M DESCRIPTION
1	097917-01-06A	EA LIGHT-PORCH, ENTRY DOOR - BRIGHT WHITE
	008215-01-000	EA BULB - 12V, #1003 - .94 AMP
	097917-01-700	EA LENS-LIGHT, PORCH
2	111102-01-000	EA LAMP-MARKER, BASE - TRIPLEX 117XAS
	111102-03-000	EA LENS-MARKER LAMP, RED - TRIPLEX 117R
3	036196-01-000	EA BULB - 12V, #194 - .27 AMP - BAYONETTE
	081638-01-000	EA TAILLIGHT-DOUBLE, W/BLACK TRIM - DRIVER OR PASSENGER SIDE
	037934-01-000	EA BULB - 12V, #1156 - 2.1 AMP - CLEAR GLASS
	037935-01-000	EA BULB - 12V, #1157 OR #2057 - 2.1 AMP - CLEAR GLASS
	081638-01-700	EA LENS-TAILLIGHT, RED - BARGMAN 30-84-010
	081638-01-701	EA LENS-TAILLIGHT, W/BACKUP - BARGMAN 30-84-700
	103355-01-03A	EA POD-TAILLIGHT, ASH GRAY
	103355-01-05A	EA POD-TAILLIGHT, BRIGHT WHITE
4	066432-02-000	EA LIGHT-LICENSE, BLACK
	066432-03-000	EA BRACKET-LICENSE PLATE - BARGMAN 30-60-030
5	111102-01-000	EA LAMP-MARKER, BASE - TRIPLEX 117XAS
	111102-02-000	EA LENS-MARKER LAMP, AMBER - TRIPLEX 118A
6	036196-01-000	EA BULB - 12V, #194 - .27 AMP - BAYONETTE
	049186-01-000	EA HEADLAMP CAPSULE-DRIVER, HIGH/LOW BEAM - RECTANGULAR
7	049188-01-000	EA HEADLAMP CAPSULE-DRIVER, HIGH BEAM - RECTANGULAR
	049185-01-000	EA HEADLAMP CAPSULE-PASSENGER, HIGH/LOW BEAM - RECTANGULAR
	049187-01-000	EA HEADLAMP CAPSULE-PASSENGER, HIGH BEAM - RECTANGULAR
	P03783-01-000	EA WIRE ASM-HEADLAMP
	049359-01-000	EA SPRING-RETAINER, HEADLAMP - GM 496096
8	110750-01-000	EA SCREW-ADJUSTING, HEADLAMP
	110783-01-01A	EA BRACKET-HEADLAMP, QUAD - PASSENGER - UNPAINTED
	110783-02-01A	EA BRACKET-HEADLAMP, QUAD - DRIVER - UNPAINTED
	089292-01-000	EA LIGHT-TURN, DRIVER OR PASSENGER - W/AMBER LENS
	037935-01-000	EA BULB - 12V, #1157 OR #2057 - 2.1 AMP - CLEAR GLASS
	102520-01-000	EA LIGHT-CLEARANCE, W/O SOCKET CONNECTIONS - AMBER
	036196-01-000	EA BULB - 12V, #194 - .27 AMP - BAYONETTE
	102540-01-000	EA SEAL-SCREW, ROUND - RUBBER
	102541-01-000	EA GASKET-CLEARANCE LIGHT
	102582-01-000	EA BRACKET-LIGHT, CLEARANCE - L-SHAPED METAL - 2.2" X 4.7"
112823-01-000	EA SPLICE-REDUCER, 16-14 TO 18-22 - ETC BA-631X	
067789-02-000	EA SOCKET-LAMP	

EXTERIOR BODY GROUP

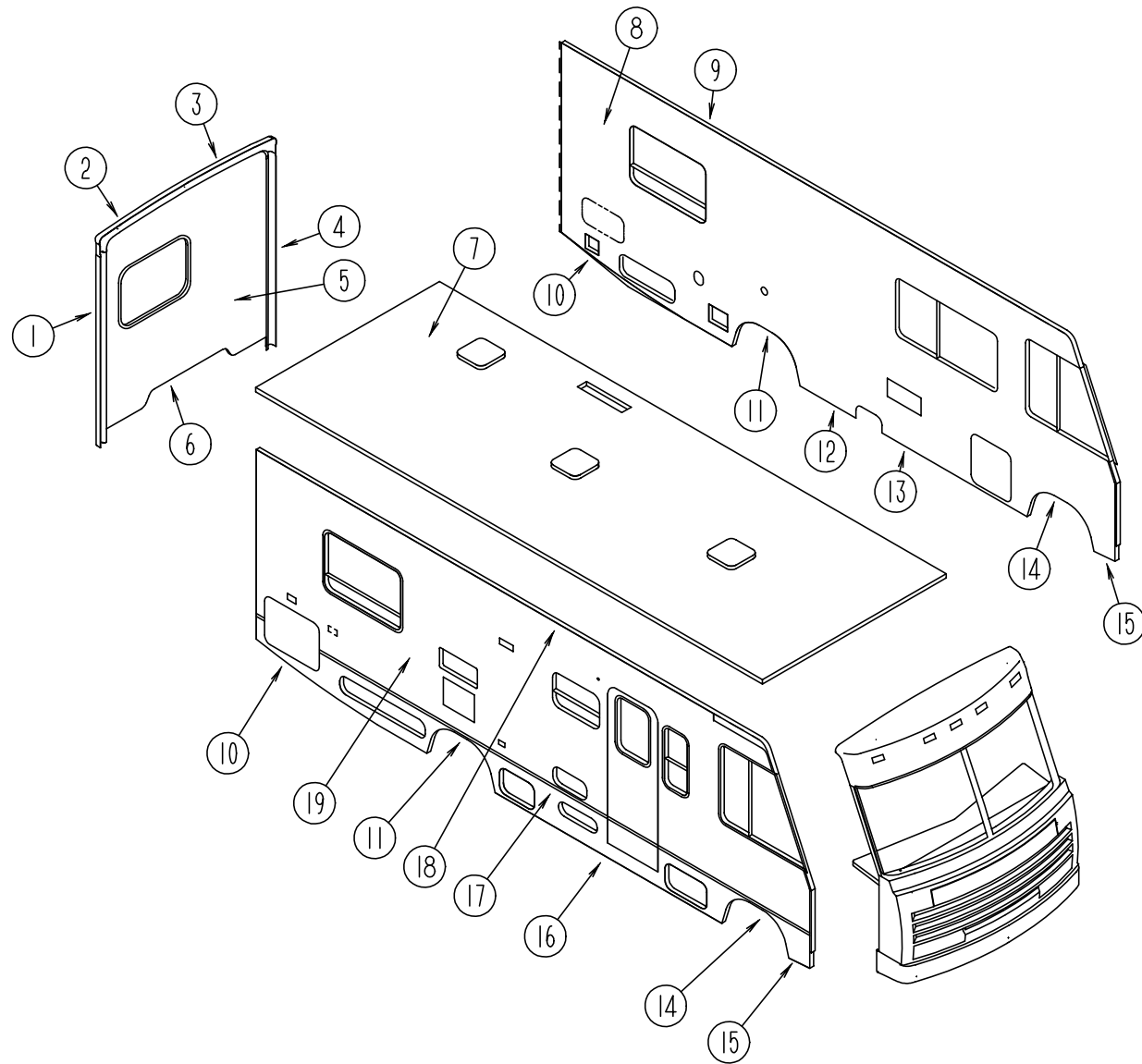

EXTERIOR BODY PANELS AND TRIM

KEY	PART NUMBER	U/M DESCRIPTION
1	103598-01-700	EA TRIM-BACKWALL SIDE, RIGHT - PRIMED
1	104033-01-05A	EA TRIM-J, BACKWALL - RIGHT - BRIGHT WHITE - ALUMINUM
2	103599-01-05A	EA TRIM-BACKWALL, TOP W/O CLEARANCE LIGHTS - RH - BRIGHT WHITE - PLASTIC
3	103600-01-05A	EA TRIM-BACKWALL, TOP W/O CLEARANCE LIGHTS - LH - BRIGHT WHITE - PLASTIC
4	103598-02-700	EA TRIM-BACKWALL SIDE, LEFT - PRIMED
4	104033-02-05A	EA TRIM-J, BACKWALL - LEFT - BRIGHT WHITE - ALUMINUM
5	M07419-05-F24	EA BACKWALL-W/O WINDOW, LIGHTS, OR DECALS - QUEEN BED
5	M07419-05-F25	EA BACKWALL-W/O WINDOW, LIGHTS, OR DECALS - QUEEN BED
5	M07419-05-F26	EA BACKWALL-W/O WINDOW, LIGHTS, OR DECALS - QUEEN BED
5	M07419-05-F27	EA BACKWALL-W/O WINDOW, LIGHTS, OR DECALS - QUEEN BED
5	M07419-06-F24	EA BACKWALL-W/O WINDOW, LIGHTS, OR DECALS - TWIN BEDS OPTION
5	M07419-06-F25	EA BACKWALL-W/O WINDOW, LIGHTS, OR DECALS - TWIN BEDS OPTION
5	M07419-06-F26	EA BACKWALL-W/O WINDOW, LIGHTS, OR DECALS - TWIN BEDS OPTION
5	M07419-06-F27	EA BACKWALL-W/O WINDOW, LIGHTS, OR DECALS - TWIN BEDS OPTION
6	050406-21-000	EA TRIM-BACKWALL, LOWER - DRIVER OR PASS SIDE - BRIGHT WHITE - ALUMINUM
7	M05702-11-F24	EA ROOF-W/O VENTS - QUEEN BED
7	M05702-12-F24	EA ROOF-W/O VENTS - TWIN BEDS OPTION
8	M07418-11-F24	EA SIDEWALL ASM-DRIVER SIDE, W/O DOORS OR WINDOWS - QUEEN BED
8	M07418-11-F25	EA SIDEWALL ASM-DRIVER SIDE, W/O DOORS OR WINDOWS - QUEEN BED
8	M07418-11-F26	EA SIDEWALL ASM-DRIVER SIDE, W/O DOORS OR WINDOWS - QUEEN BED
8	M07418-11-F27	EA SIDEWALL ASM-DRIVER SIDE, W/O DOORS OR WINDOWS - QUEEN BED

EXTERIOR BODY GROUP (CONTINUED)

EXTERIOR BODY PANELS AND TRIM (CONTINUED)

KEY	PART NUMBER	U/M DESCRIPTION
8	M07418-12-F24	EA SIDEWALL ASM-DRIVER SIDE, W/O DOORS OR WINDOWS - TWIN BEDS OPTION
8	M07418-12-F25	EA SIDEWALL ASM-DRIVER SIDE, W/O DOORS OR WINDOWS - TWIN BEDS OPTION
8	M07418-12-F26	EA SIDEWALL ASM-DRIVER SIDE, W/O DOORS OR WINDOWS - TWIN BEDS OPTION
8	M07418-12-F27	EA SIDEWALL ASM-DRIVER SIDE, W/O DOORS OR WINDOWS - TWIN BEDS OPTION
9	103801-02-05A	EA TRIM-ROOF, 16' LONG - W/O DRILLED HOLES - DRIVER SIDE - BRIGHT WHITE
10	108038-01-04A	EA TRIM-SIDEWALL, BOTTOM - REAR - DRIVER OR PASSENGER - BRIGHT WHITE
11	108070-01-04A	EA TRIM-WHEELWELL, REAR - DRIVER OR PASSENGER - BRIGHT WHITE
12	108038-15-03A	EA TRIM-SIDEWALL, BOTTOM - DRIVER SIDE - BRIGHT WHITE
13	108038-14-03A	EA TRIM-SIDEWALL, BOTTOM - DRIVER SIDE - BRIGHT WHITE
14	108069-02-03A	EA TRIM-WHEELWELL, FRONT - DRIVER OR PASSENGER - BRIGHT WHITE
15	108109-01-04A	EA TRIM-SIDEWALL, BOTTOM - FRONT - DRIVER OR PASSENGER - BRIGHT WHITE
	086180-55-015	EA U-CHANNEL-SERRATED, 1.7" X 16' - BRIGHT WHITE
16	108039-01-04A	EA TRIM-SIDEWALL, BOTTOM - CENTER - PASSENGER SIDE - BRIGHT WHITE
17	108688-01-03A	EA STRIP-FEATURE, W/O INSERT - 15' LONG - BRIGHT WHITE
	108651-01-01A	EA END CAP-FEATURE STRIP
	105312-01-07A	FT INSERT-TRIM, VINYL - BRIGHT WHITE
18	103802-02-05A	EA RAIL-AWNING, 16' LONG - W/O DRILLED HOLES - PASS SIDE - BRIGHT WHITE
19	M07418-09-F24	EA SIDEWALL ASM-PASSENGER SIDE, W/O DOORS OR WINDOWS - QUEEN BED
19	M07418-09-F25	EA SIDEWALL ASM-PASSENGER SIDE, W/O DOORS OR WINDOWS - QUEEN BED
19	M07418-09-F26	EA SIDEWALL ASM-PASSENGER SIDE, W/O DOORS OR WINDOWS - QUEEN BED
19	M07418-09-F27	EA SIDEWALL ASM-PASSENGER SIDE, W/O DOORS OR WINDOWS - QUEEN BED
19	M07418-10-F24	EA SIDEWALL ASM-PASSENGER SIDE, W/O DOORS OR WINDOWS - TWIN BEDS
19	M07418-10-F25	EA SIDEWALL ASM-PASSENGER SIDE, W/O DOORS OR WINDOWS - TWIN BEDS
19	M07418-10-F26	EA SIDEWALL ASM-PASSENGER SIDE, W/O DOORS OR WINDOWS - TWIN BEDS
19	M07418-10-F27	EA SIDEWALL ASM-PASSENGER SIDE, W/O DOORS OR WINDOWS - TWIN BEDS
	002754-01-001	EA ANGLE-EXTRUDED, .75" X .75" X 18' - MILL ALUMINUM
	055278-51-259	FT TUBING-STEEL, .75" X 1.5" X 12.5' LONG
	002726-01-001	EA GARNISH-U-CHANNEL, 1.38" X 19' - SERRATED - MILL ALUMINUM
	069726-02-000	EA BUMPER - .88" DIAMETER X .40", BLACK

FIBERGLASS, STYROFOAM & PLYWOOD

KEY	PART NUMBER	U/M DESCRIPTION
	076054-M9-000	EA FIBERGLASS SHEET-FLAT, 2438 MM X 7660 MM - BRIGHT WHITE
	076054-M8-000	EA FIBERGLASS SHEET-FLAT, 2438 MM X 2438 MM - BRIGHT WHITE
		FROM: 00-00-00 THRU: 09-30-94
	076054-P4-000	EA FIBERGLASS SHEET-FLAT, 2438 MM X 2463 MM - BRIGHT WHITE
		FROM: 10-01-94 THRU: 99-99-99
	076054-M8-001	EA FIBERGLASS SHEET-48" X 96" - BRIGHT WHITE
	077517-62-000	EA FIBERGLASS SHEET-FLAT, 48" X 96" - BRIGHT WHITE
	108535-01-707	EA FIBERGLASS-PEBBLED, 6" X 33' - BRIGHT WHITE
	083574-02-000	SF STYROFOAM, DOW TYPE SM - 1.5" X 24" X 90.5" - INCREMENTS OF 15 SF
	083574-03-000	SF STYROFOAM - 3/4" X 48" X 96" - INCREMENTS OF 32 SF
	000870-08-000	SF STYROFOAM - .75" X 48" X 96" - INCREMENTS OF 32 SF
	089297-01-000	SF PLYWOOD-LUAN, OVERLAY GRADE - 4' X 8'
	105077-01-000	EA FOAM-COVE, ROOF
	105077-03-000	EA FOAM-PLUG, SIDEWALL TUBE - WISCONSIN EPS

EXTERIOR BODY GROUP (CONTINUED)

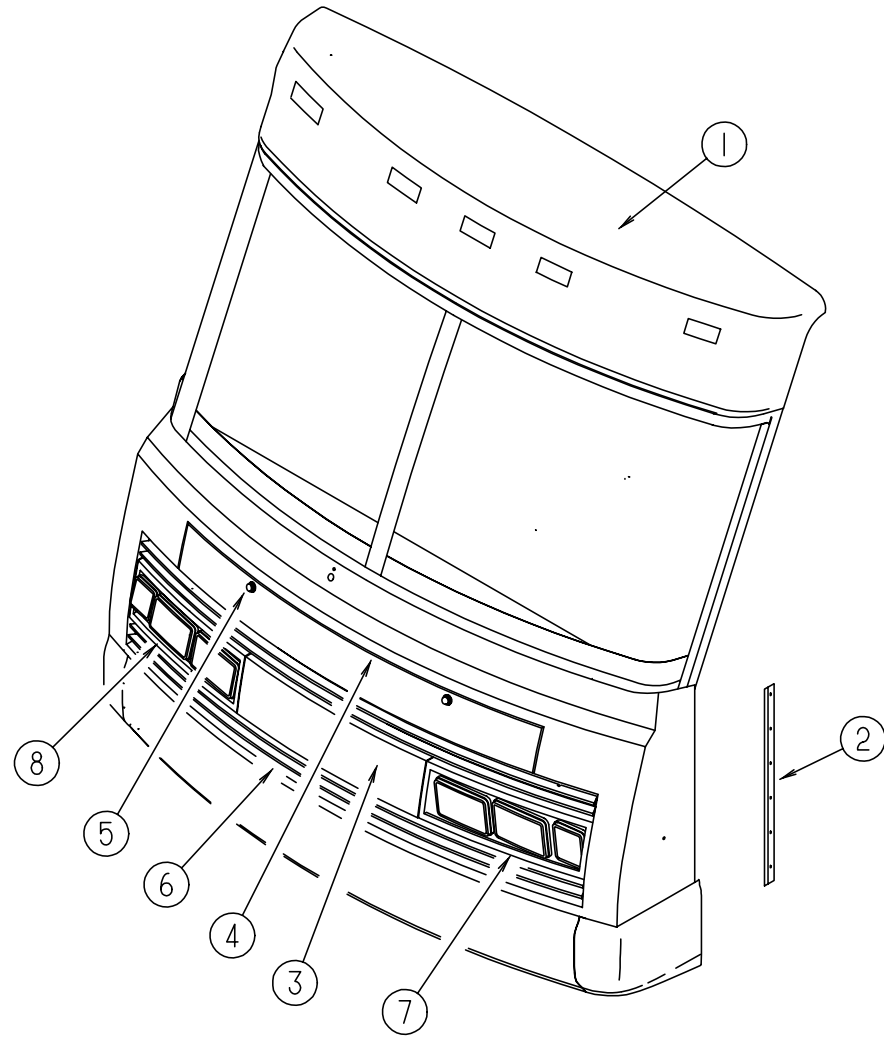

FRONT END COMPONENTS & BUMPER

KEY	PART NUMBER	U/M	DESCRIPTION
1	M05145-05-F24	EA	CAP ASM-FRONT, BRIGHT WHITE
2	089922-27-000	EA	TRIM-FRONT END/SIDEWALL, DRIVER OR PASSENGER SIDE - BRIGHT WHITE
3	103485-01-04A	EA	FRONT END ASM-W/GRILLE ASM, W/O HOOD OR HOOD HINGES - BRIGHT WHITE
4	103478-02-F24	EA	PANEL ASM-HOOD
	058786-01-000	EA	BOLT-ADJUSTING, HOOD - W/BLACK PAD - .31" #18 X 2"
5	102330-02-000	EA	LOCK-SINGLE HOLE, VISE ACTION - SOUTHCOE 3-56-715-5
	102328-01-000	EA	KEY-BARREL, NICKEL PLATED - SOUTHCOE 3-26-715-19
	104584-03-000	EA	BRACKET ASM-HOOD HINGE, BODY - RIGHT
	104584-04-000	EA	BRACKET ASM-HOOD HINGE, BODY - LEFT
	105095-01-000	EA	LINK ASM-HINGE, HOOD - INNER RIGHT
	105095-02-000	EA	LINK ASM-HINGE, HOOD - INNER LEFT
	104582-02-000	EA	LINK ASM-HINGE, HOOD - OUTER
6	110598-01-E07	EA	GRILLE ASSEMBLY-4 BAR
7	103617-02-04A	EA	BEZEL-HEADLIGHT, DRIVER SIDE - BRIGHT WHITE
8	103617-01-04A	EA	BEZEL-HEADLIGHT, PASSENGER SIDE - BRIGHT WHITE
	110690-01-D18	EA	PLATE ASM-HEADLAMP, QUAD - PASSENGER - BLACK - STEEL
	110692-01-01A	EA	PLATE-HEADLAMP, QUAD - PASSENGER - UNPAINTED - STEEL
	110690-02-D18	EA	PLATE ASM-HEADLAMP, QUAD - DRIVER - BLACK - STEEL
	110692-02-01A	EA	PLATE-HEADLAMP, QUAD - DRIVER - UNPAINTED - STEEL
	110691-01-01A	EA	BRACKET-SPRING, HEADLAMP - DRIVER OR PASSENGER SIDE - UNPAINTED

EXTERIOR BODY GROUP (CONTINUED)

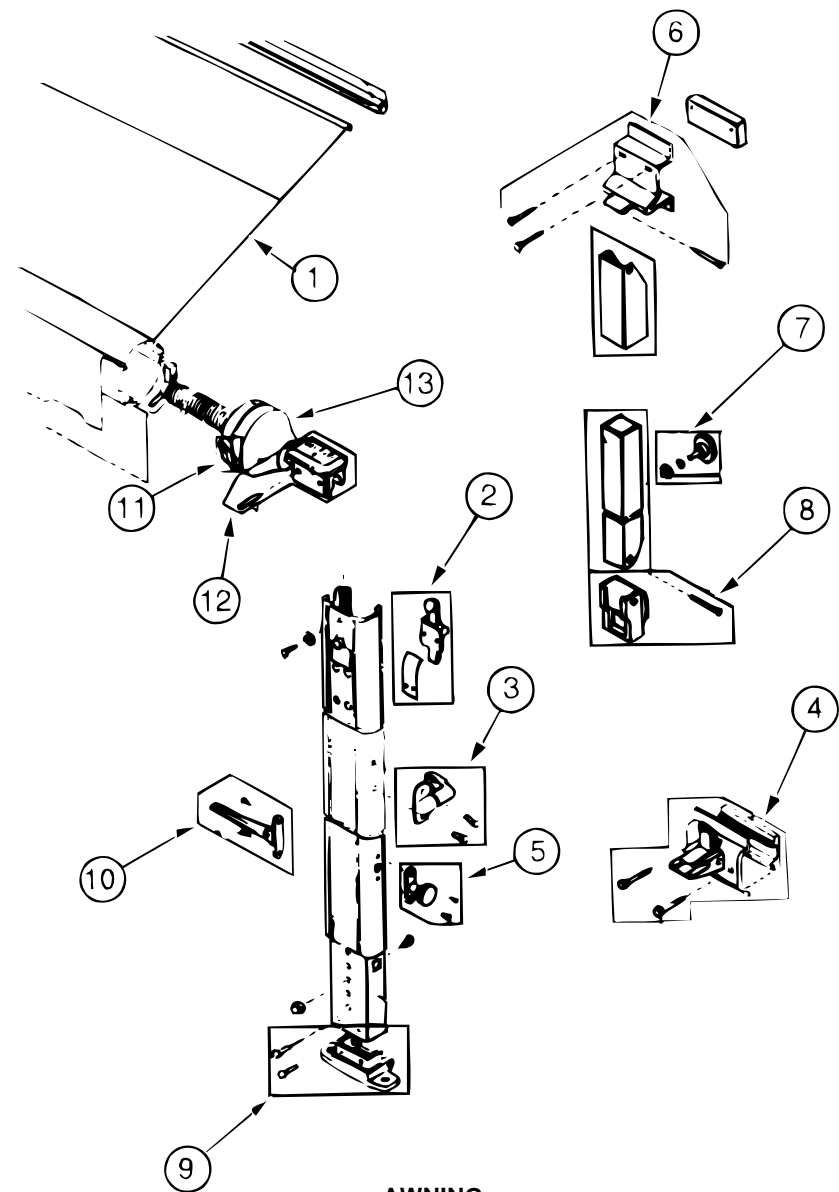

AWNING

KEY	PART NUMBER	U/M	DESCRIPTION	VENDOR NO.
1	110634-08-04A	EA	AWNING-ROLLER ASM, 14'	
	110634-02-04A	EA	AWNING-HARDWARE KIT, BRIGHT WHITE	
	111037-01-01A	EA	SPACER-AWNING, UPPER BLACK	
	111038-01-01A	EA	SPACER-AWNING, LOWER BLACK	
2	110634-01-700	EA	RAFTER LOCKING MECH KIT -	7605-0001
3	110634-01-701	EA	SAFETY & LATCH KIT -	7509-0001
4	110634-01-702	EA	BOTTOM BRACKET KIT -	7512-0001
5	110634-01-703	EA	HEIGHT LOCK HANDLE KIT -	7510-0001
6	110634-01-704	EA	UPPER BRACKET KIT W/BOLTS -	7505-0001
7	110634-01-705	EA	ULTRA RAFTER KNOB KIT -	7522-0001
8	110634-01-706	EA	RAFTER SLIDE KIT	
9	110634-01-707	EA	GROUND BRACKET KIT -	7511-0001
10	110634-01-708	EA	LIFT HANDLES W/RIVETS -	7000-0001
11	110634-01-709	EA	RATCHET HANDLE KIT -	7507-0001
12	110634-01-710	EA	ARM CAP KIT -	7503-0001
13	110634-01-711	EA	FRONT SPRING ASM -	6598-0001
13	110634-01-712	EA	REAR SPRING ASM -	6599-0001
13	110634-01-713	EA	REAR END CAP KIT -	7504-0001

EXTERIOR BODY GROUP (CONTINUED)

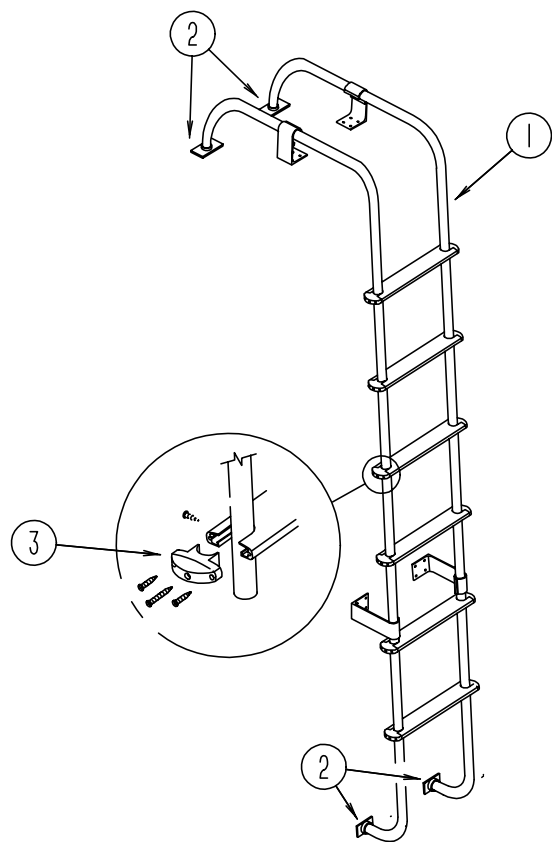

LADDER

KEY	PART NUMBER	U/M DESCRIPTION
1	102953-09-F04	EA LADDER ASM
2	067165-01-000	EA MOUNTING BRACKET-LADDER, LOWER
3	076980-02-000	EA END CAP-STEP, BLACK

EXTERIOR BODY GROUP (CONTINUED)

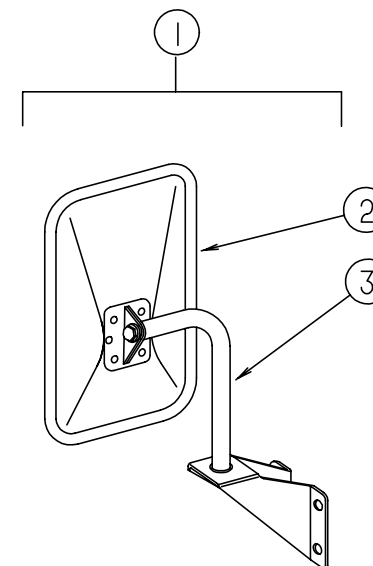

EXTERIOR MIRROR

KEY	PART NUMBER	U/M DESCRIPTION	VENDOR NO.
1	105076-01-702	EA MIRROR ASM-LOW MOUNT, DRIVER OR PASSENGER SIDE	713196
2	105076-01-703	EA MIRROR HEAD ONLY-FLAT BLACK	709275-8
	049347-01-700	EA GLASS ONLY-EXTERIOR MIRROR, 7.5" X 10.5"	702081
3	105076-01-704	EA ARM	Q780521-9
	105439-01-000	EA MIRROR-CONVEX, STICK-ON	723068-6

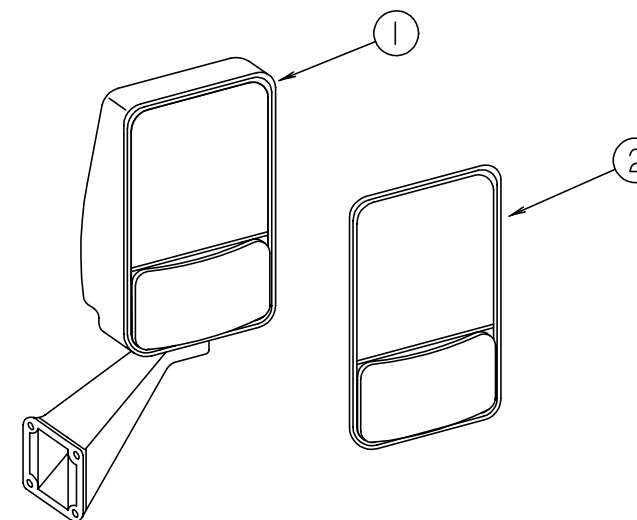

OPTIONAL EXTERIOR MIRRORS

KEY	PART NUMBER	U/M DESCRIPTION
1	106015-09-01A	EA MIRROR ASM-PASSENGER SIDE, VELVAC 713126 BLACK
1	106015-10-01A	EA MIRROR ASM-DRIVER SIDE, VELVAC 713125 BLACK
2	106015-01-703	EA KIT-BEZEL & MIRRORS, PASSENGER SIDE
2	106015-02-702	EA KIT-BEZEL & MIRRORS, DRIVER SIDE

EXTERIOR BODY GROUP (CONTINUED)

DECALS, FILM STRIPES & PAINT

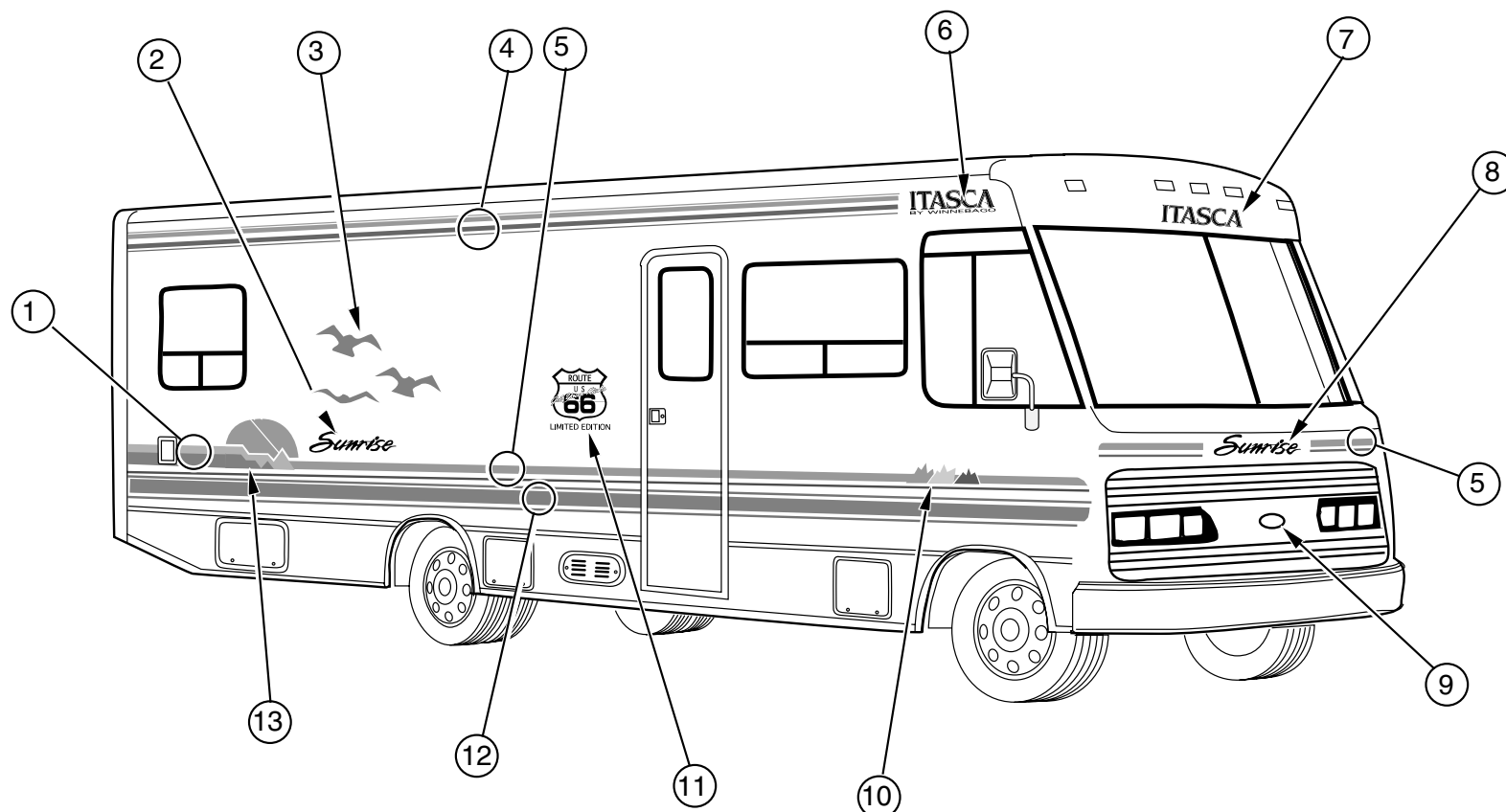
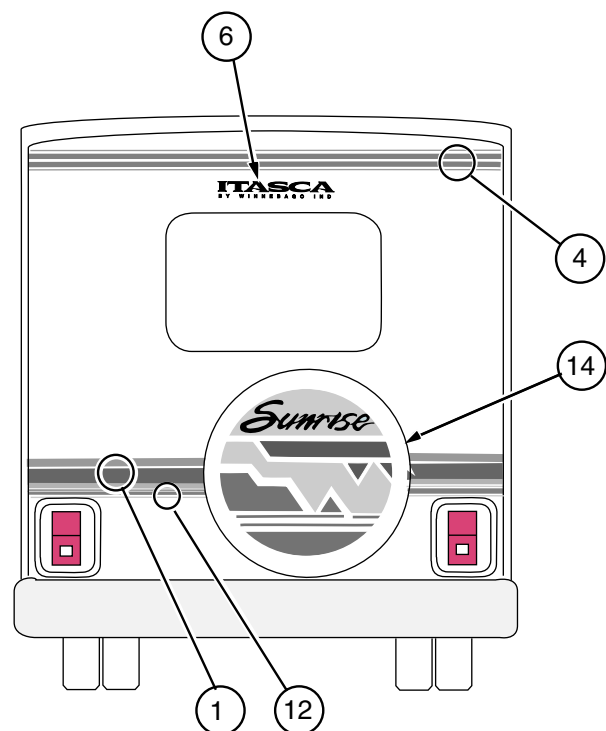

KEY	PART NUMBER	U/M	DESCRIPTION	VENDOR NO.
1	094423-05-02A	EA	FILM-OVERLAY, MULTISTRIPE, AQUA/REGGAE BLUE/REGGAE BLUE	
2	110193-01-02A	EA	DECAL-SUNRISE, AQUA/W/REGGAE BLUE SHADOW	
3	110192-01-02A	EA	DECAL-BIRDS, REGGAE BLUE/AQUA	
4	093689-15-02A	FT	FILM-MULTISTRIPE, 101.6 MM X 150' - AQUA/AQUA/REGGAE BLUE/REGGAE BLUE	
5	105781-02-10A	FT	FILM-MULTISTRIPE, 63.5 MM X 150' - AQUA/AQUA	
6	111588-03-09A	EA	DECAL-LOGO, ITASCA - LG - REGGAE BLUE/BRIGHT WHITE/REGGAE BLUE	
6	111588-03-01A	EA	DECAL-LOGO, ITASCA - LG - REGGAE BLUE/ASH GRAY/REGGAE BLUE	
6	114698-01-01A	EA	DECAL-LOGO, "BY WINNEBAGO" - REGGAE BLUE	
7	111588-04-01A	EA	DECAL-LOGO, ITASCA - SML - REGGAE BLUE/ASH GRAY/REGGAE BLUE	
7	111588-04-06A	EA	DECAL-LOGO, ITASCA - SML - REGGAE BLUE/BRIGHT WHITE/REGGAE BLUE	
8	110193-02-02A	EA	DECAL-SUNRISE, SML - AQUA/REGGAE BLUE	
9	088772-03-000	EA	MEDALLION-HOOD, I - BLACK/CHROME	
10	110190-01-02A	EA	DECAL-MOUNTAINS, RH - REGGAE BLUE/MAGENTA/AQUA	
10	110190-02-02A	EA	DECAL-MOUNTAINS, LH - REGGAE BLUE/MAGENTA/AQUA	
11	116404-01-01A	EA	DECAL-ROUTE 66, FROSTY JACK/WARM SILVER	
12	094443-20-02A	FT	FILM-MULTISTRIPE, 146.1 MM X 150' REGGAE BLUE/REGGAE BLUE/REGGAE BLUE	
13	113951-01-01A	EA	DECAL-SUN, RH - MAGENTA/AQUA/REGGAE BLUE	
13	113951-02-01A	EA	DECAL-SUN, LH - MAGENTA/AQUA/REGGAE BLUE	
14	114653-01-01A	EA	DECAL-COVER, TIRE - SPARE - MAGENTA/AQUA/REGGAE BLUE	
	041561-03-000	EA	PAINT-LOW BAKE, OFF WHITE	
	044486-03-000	EA	PAINT-LOW BAKE, BEIGE	
	106315-06-000	FT	POLYETHYLENE FILM TAPE 4" SHORE PAPER 30LD23	
	099399-23-700	EA	PAINT-BRIGHT WHITE	B8951U

GALLEY GROUP

GALLEY CABINETRY

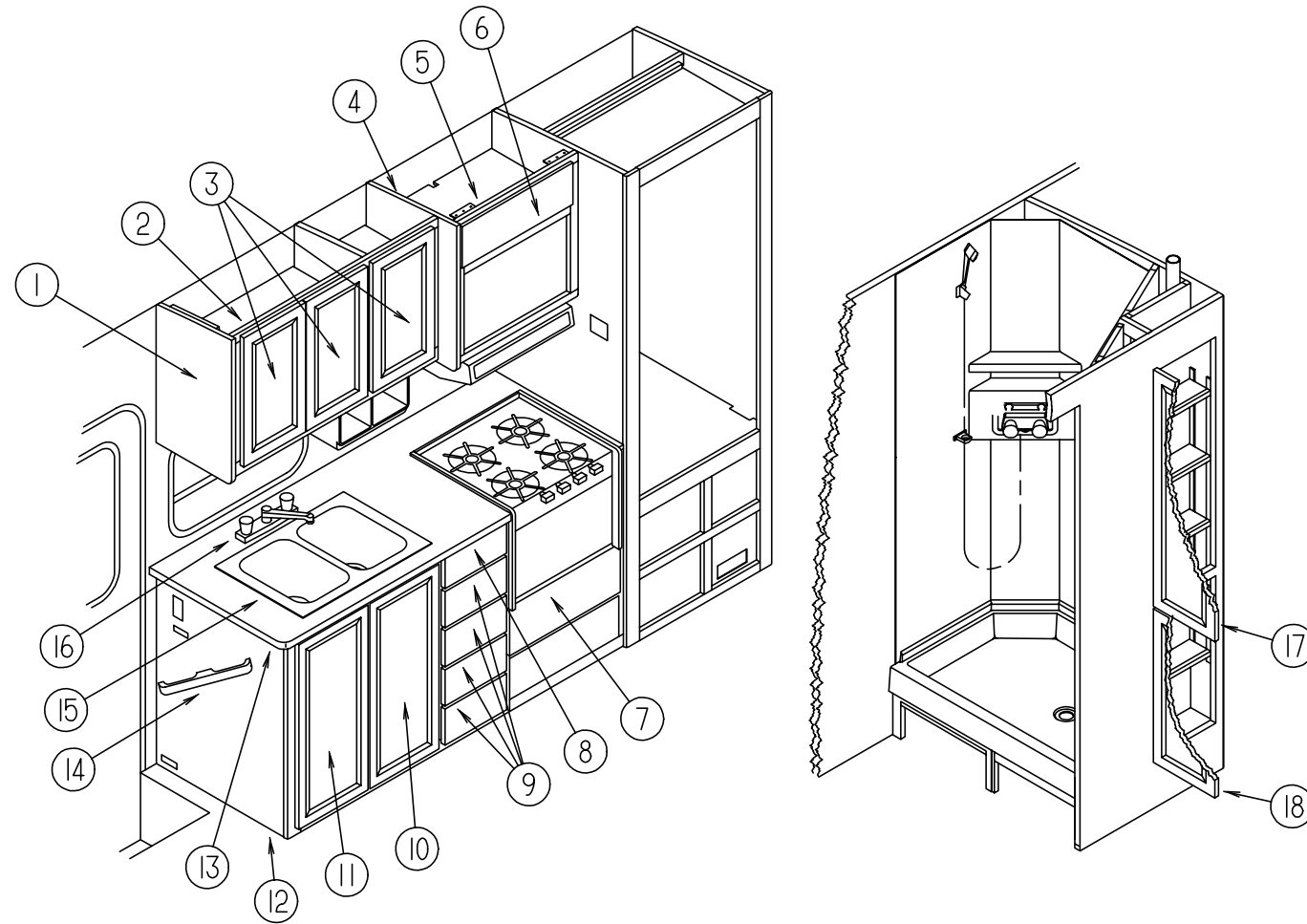

KEY	PART NUMBER	U/M DESCRIPTION
1	081319-17-C27	EA CAP-END, OVERHEAD - FRONT
2	P07838-01-E07	EA CABINET-OVERHEAD, W/O DOOR
3	M06803-58-E07	EA DOOR-CABINET, W/O HARDWARE - 305 MM X 555 MM
4	081320-14-E10	EA CAP-END, OVERHEAD - FRONT
5	114390-02-F04	EA CABINET-OVERHEAD, W/O DOORS
6	M05992-11-E07	EA DOOR-CABINET, W/O HARDWARE - 180 MM X 555 MM
7	M05971-50-E07	EA DRAWER-CABINET, W/O HARDWARE - 180 MM X 560 MM FACE SIZE
8	M05971-68-E10	EA DRAWER-CABINET, W/O HARDWARE - 105 MM X 310 MM FACE SIZE
9	M05971-11-E07	EA DRAWER-CABINET, W/O HARDWARE - 155 MM X 310 MM FACE SIZE
10	M06803-32-E10	EA DOOR-CABINET, W/O HARDWARE - 345 MM X 770 MM
11	M06803-33-E10	EA DOOR-CABINET, W/O HARDWARE - 345 MM X 770 MM
12	M07426-05-F24	EA CABINET-GALLEY, W/COUNTERTOP - W/O DOORS OR DRAWERS (F24,F27)
12	M07426-05-F25	EA CABINET-GALLEY, W/COUNTERTOP - W/O DOORS OR DRAWERS
12	M07426-05-F26	EA CABINET-GALLEY, W/COUNTERTOP - W/O DOORS OR DRAWERS
13	111374-11-F04	EA COUNTERTOP-GALLEY CABINET (F24,F27)
13	111374-11-F05	EA COUNTERTOP-GALLEY CABINET (F25)
13	111374-11-F26	EA COUNTERTOP-GALLEY CABINET

KEY	PART NUMBER	U/M DESCRIPTION
14	091257-08-000	EA HANDLE-ASSIST, ENTRY DOOR - WOOD - FINISHED
14	091257-02-000	EA HANDLE-ASSIST, ENTRY DOOR - WOOD - UNFINISHED
15	110654-01-000	EA SINK-DOUBLE, LARGE/SMALL BASINS - SST - DAYTON FR2917
	092303-01-000	EA STRAINER-SINK
	108464-04-E08	EA COVER-SINK (F24,F27)
	108464-04-E38	EA COVER-SINK (F25)
	108464-04-E90	EA COVER-SINK (F26)
16	103243-01-000	EA FAUCET-GALLEY, DUAL CONTROL - 8"
	091253-01-000	EA GASKET-FAUCET, LAVATORY/GALLEY
17	M06803-15-E07	EA DOOR-CABINET, W/O HARDWARE - 305 MM X 1015 MM
18	M06803-59-E07	EA DOOR-CABINET, W/O HARDWARE - 305 MM X 660 MM
	090329-01-000	FT SEAL-T, REFRIGERATOR CABINET - .6" WIDE TOP X 2" TAIL
	008380-01-000	EA GROMMET-RUBBER, 5/8" HOLE X 1 1/2" DIAMETER - BLACK

GALLEY GROUP (CONTINUED)

**RANGE HOOD - CANADIAN
FROM: 00-00-00 THRU: 09-25-94**

KEY	PART NUMBER	U/M DESCRIPTION	VENDOR NO.
	100258-17-01A	EA HOOD-RANGE, W/O MONITOR PANEL - VENTLINE - CANADIAN	
	090973-01-700	EA MOTOR -	LVS CA508-1
	090973-01-702	EA BLADE-FAN,	LVS VA183-1
	092696-01-709	EA BULB - 912, VENTLINE	VA415
	092696-01-710	EA SOCKET-LIGHT, VENTLINE	CB267-2
	096983-01-700	EA SWITCH-ON/OFF, VENTLINE	108
	096983-01-702	EA SWITCH-TWO WAY MOMENTARY, VENTLINE	112
	096983-01-707	EA FILTER-GREASE, 8" X 8" -	LVS CC246
	092696-02-701	EA LENS-LAMP, VENTLINE	CC179
	100258-01-700	EA HOOD-NOSE LABEL,	CC428
	100258-10-01A	EA METER-HOUR, VENTLINE	150

**RANGE HOOD - CANADIAN
FROM: 09-26-94 THRU: 99-99-99**

KEY	PART NUMBER	U/M DESCRIPTION	VENDOR NO.
	100258-17-03A	EA HOOD-RANGE W/O MONITOR PANEL - VENTLINE TCS-5008-NACLG	
	090973-01-700	EA MOTOR -	LVS CA508-1
	090973-01-702	EA BLADE-FAN,	LVS VA183-1
	092696-01-709	EA BULB - 912, VENTLINE	VA415
	092696-01-710	EA SOCKET-LIGHT, VENTLINE	CB267-2
	092696-02-701	EA LENS-LAMP,	LVS CC179
	096983-01-700	EA SWITCH-ON/OFF, VENTLINE	108
	096983-01-702	EA SWITCH-TWO WAY MOMENTARY, VENTLINE	112
	096983-01-707	EA FILTER-GREASE, 8" X 8" -	LVS CC246
	100258-01-700	EA HOOD-NOSE LABEL,	CC428

**RANGE HOODS - US
FROM: 00-00-00 THRU: 07-31-94**

KEY	PART NUMBER	U/M DESCRIPTION	VENDOR NO.
	100258-18-01A	EA HOOD-RANGE, W/O MONITOR PANEL - VENTLINE - US TPS5007NAD	
	090973-01-700	EA MOTOR -	LVS CA508-1
	090973-01-702	EA BLADE-FAN,	LVS VA183-1
	092696-01-709	EA BULB - 912, VENTLINE	VA415
	092696-01-710	EA SOCKET-LIGHT, VENTLINE	CB267-2
	096983-01-700	EA SWITCH-ON/OFF, VENTLINE	108
	096983-01-702	EA SWITCH-TWO WAY MOMENTARY, VENTLINE	112
	096983-01-707	EA FILTER-GREASE, 8" X 8" -	LVS CC246
	092696-02-701	EA LENS-LAMP, VENTLINE	CC179
	100258-01-700	EA HOOD-NOSE LABEL,	CC428
	100258-10-01A	EA METER-HOUR, VENTLINE	150

**RANGE HOODS - US
FROM: 08-01-94 THRU: 99-99-99**

KEY	PART NUMBER	U/M DESCRIPTION	VENDOR NO.
	100258-18-02A	EA HOOD-RANGE W/O MONITOR PANEL -VENTLINE TPS-5009-SADLG	
	090973-01-700	EA MOTOR -	LVS CA508-1
	090973-01-702	EA BLADE-FAN,	LVS VA183-1
	092696-01-709	EA BULB - 912, VENTLINE	VA415
	092696-01-710	EA SOCKET-LIGHT, VENTLINE	CB267-2
	092696-02-701	EA LENS-LAMP,	LVS CC179
	096983-01-700	EA SWITCH-ON/OFF, VENTLINE	108
	096983-01-702	EA SWITCH-TWO WAY MOMENTARY, VENTLINE	112
	096983-01-707	EA FILTER-GREASE, 8" X 8" -	LVS CC246
	100258-01-700	EA HOOD-NOSE LABEL,	CC428
	100258-10-01A	EA METER-HOUR, W/SWITCH VENTLINE	150

GALLEY GROUP (CONTINUED)

**RANGE HOODS - US
FROM: 00-00-00 THRU: 08-21-94**

KEY	PART NUMBER	U/M DESCRIPTION	VENDOR NO.
	100258-16-01A	EA HOOD-RANGE, W/O MONITOR PANEL - VENTLINE - US TCS5008NAD - STANDARD	
	090973-01-700	EA MOTOR -	LVS CA508-1
	090973-01-702	EA BLADE-FAN,	LVS VA183-1
	092696-01-709	EA BULB - 912, VENTLINE	VA415
	092696-01-710	EA SOCKET-LIGHT, VENTLINE	CB267-2
	096983-01-700	EA SWITCH-ON/OFF, VENTLINE	108
	096983-01-702	EA SWITCH-TWO WAY MOMENTARY, VENTLINE	112
	096983-01-707	EA FILTER-GREASE, 8" X 8" -	LVS CC246
	092696-02-701	EA LENS-LAMP, VENTLINE	CC179
	100258-01-700	EA HOOD-NOSE LABEL,	CC428

**RANGE HOODS - US
FROM: 08-22-94 THRU: 99-99-99**

KEY	PART NUMBER	U/M DESCRIPTION	VENDOR NO.
	100258-16-03A	EA HOOD-RANGE W/O MONITOR PANEL - VENTLINE TCS-5008-NADLG	
	090973-01-700	EA MOTOR -	LVS CA508-1
	090973-01-702	EA BLADE-FAN,	LVS VA183-1
	092696-01-709	EA BULB - 912, VENTLINE	VA415
	092696-01-710	EA SOCKET-LIGHT, VENTLINE	CB267-2
	092696-02-701	EA LENS-LAMP,	LVS CC179
	096983-01-700	EA SWITCH-ON/OFF, VENTLINE	108
	096983-01-702	EA SWITCH-TWO WAY MOMENTARY, VENTLINE	112
	096983-01-707	EA FILTER-GREASE, 8" X 8" -	LVS CC246
	100258-01-700	EA HOOD-NOSE LABEL,	CC428

GALLEY GROUP (CONTINUED)

REFRIGERATOR & LEVEL

KEY	PART NUMBER	U/M	DESCRIPTION	VENDOR NO.
	104138-04-01A	EA	REFRIGERATOR-DOUBLE DOOR, 2-WAY	6162 RH BL
	064472-01-702	EA	COMBINED THERMOSTAT	614376
	075217-01-734	EA	FUSE - 3 AMP	61538822
	075217-01-738	EA	SWITCH-HUMIDITY	61525922
	084879-03-700	EA	COOLING UNIT - HORIZONTAL BURNER	61687237
	084880-01-705	EA	ORIFICE	614522
	084880-01-715	EA	VALVE-SHUT OFF, MANUAL	61697922
	084880-01-718	EA	VALVE-GAS	61551822
	084880-01-720	EA	SPRING (FOR DOOR HANDLE)	61558822
	084880-01-722	EA	CRISPER COVER	615641
	084880-01-726	EA	HINGE BRACKET (CENTER HINGE)	61566523
	084880-01-731	EA	HINGE PIN	61578123
	084880-01-732	EA	LATCH	61578522
	084880-01-734	EA	BRACKET-HINGE, TOP RH - BOTTOM LH - BROWN	61580837
	084880-01-735	EA	HINGE BRACKET, TOP LH-BOTTOM RH BROWN	61580937
	084880-01-739	EA	END CAP (SPRING CATCH) BROWN	61593722
	084880-01-740	EA	END CAP (STOP CATCH)	61593830
	084880-01-746	EA	CABLE	61571522
	084880-01-747	EA	PLUG-HOLE	61582022
	084880-01-749	EA	HINGE BUSHING	615807
	084880-01-753	EA	THERMISTER 78"	61693822
	084880-01-760	EA	CLIP (THERMISTER)	61689122
	084880-01-761	EA	END CAP (SPRING CATCH) BLACK	61593730
	084880-02-700	EA	LOWER FLANGE 8663 & 8683	61622123
	084880-03-702	EA	HINGE PIN TOP/BOTTOM FEMALE	61580630
	084880-03-705	EA	BRACKET F/INTERIOR REFRIGERATOR LIGHT	61629722
	084880-03-706	EA	LAMP (BULB)	61628922
	084880-03-707	EA	COVER F/LAMP OR BULB	61627922
	088248-01-706	EA	BURNER-HORIZONTAL	61588122
	088248-01-707	EA	ELECTRODE-SENSOR, (HORIZONTAL)	61573322
	088248-01-709	EA	HEATER-AC, (HORIZONTAL)	615627
	088248-01-710	EA	HEATER-DC, (HORIZONTAL) - 3 WAY	615628
	094038-01-700	EA	GASKET-LOWER, GRAY	61567930
	094038-01-701	EA	LINER-DOOR, LOWER - BROWN/WHITE	61581937-B
	094038-01-702	EA	LINER-DOOR, LOWER - BLACK/WHITE	61581938-B
	094038-01-703	EA	HANDLE-DOOR, LOWER - BROWN	61650137
	094038-01-704	EA	HANDLE-DOOR, LOWER - BLACK	61650138
	094039-01-702	EA	GASKET (GRAY) UPPER	61567830
	094039-01-703	EA	PLATE-HINGE, LH - BROWN	61631422
	094039-01-704	EA	PLATE-HINGE, BLACK	61631430
	094039-01-706	EA	UPPER DOOR LINER (WHITE) BLACK	61581838-B
	094039-01-708	EA	HANDLE-DOOR, UPPER - BLACK	61650038
	094039-01-709	EA	PLATE-HINGE, TOP RH - LH BOTTOM - BROWN	61631322
	094039-01-710	EA	PLATE-HINGE, TOP RH - LH BOTTOM - BLACK	61631330
	094039-01-722	EA	HOLE PLUG, (BLACK) HINGE HOLES	61582030
	094039-01-723	EA	HINGE BRACKET, TOP RH - BOTTOM LH - BLACK	61580838
	094039-01-724	EA	BRACKET-HINGE, TOP LH - BOTTOM RH - BLACK	61580938
	094039-01-725	EA	HINGE PIN, (BLACK) (MALE)	61578130
	094039-01-726	EA	SHELF-FREEZER EVAPORATOR	615236

GALLEY GROUP (CONTINUED)

REFRIGERATOR & LEVEL (CONTINUED)

KEY	PART NUMBER	U/M	DESCRIPTION	VENDOR NO.
	094039-01-728	EA	HINGE BRACKET-CENTER HINGE, BLACK	615236
	094039-01-730	EA	HINGE PIN SHAFT, (BLACK) CENTER HINGE	61566730
	094039-01-732	EA	FRONT COVER, (BLACK) BOTTOM TRIM	61622130
	094039-01-733	EA	WIRE SHELF, (MIDDLE)	61563822
	094039-01-734	EA	WIRE SHELF, (TOP) W/RISER	61563722
	094039-01-735	EA	INSIDE DRIP TRAY, (WHITE)	61572830
	094039-01-736	EA	SWITCH-LIGHT, BLACK	615810
	094039-01-739	EA	SHELF, (CUTOFF)	61646722
	094039-04-700	EA	BOARD-PRINTED CIRCUIT, 2 WAY	61647322
	094039-04-701	EA	EYEBROW, (SHELL) 2 WAY	61669822
	094039-04-702	EA	POWER SUPPLY, (2 WAY)	61647422
	104137-02-700	EA	MODULE-CONTROL, CHANNEL	61717037
	104137-06-700	EA	EYEBROW SHELL, (2-WAY)	61726622
	104137-06-701	EA	HANDLE, UPPER DOOR W/DECAL	61666722
	104137-06-702	EA	RACK-JUICE, (WHITE)	61580525
	104137-06-703	EA	BIN-DOOR SHELF, (WHITE)	61564025
	104137-06-706	EA	WIRE SHELF, (SHORT)	61718222
	104137-06-707	EA	CRISPER, (WHITE)	61571325
	104137-06-709	EA	VALVE, SHUT-OFF-MANUAL ASM	61694922
	104137-06-710	EA	PRESSURE TAP	61594422
	104137-06-711	EA	FUSE, 5 AMP	61611622
	104137-06-712	EA	FITTING-GAS TUBE CONNECTION	61692722
	104137-06-713	EA	ORFICE GASKET	61475122
	104137-06-714	EA	BURNER ASSEMBLY, (5-SLOT)	61705222
	104137-06-715	EA	SPARK/SENSE ELECTRODE, (SINGLE)	61692222
	104138-04-701	EA	FOAMED CABINET ASSEMBLY, BLACK W/WHITE	61725038
	054450-01-000	EA	LEVEL-REFRIGERATOR	

GALLEY GROUP (CONTINUED)

MONITOR PANEL

KEY	PART NUMBER	U/M DESCRIPTION	VENDOR NO.
	102765-04-01A	EA PANEL-MONITOR, W/PLUG - FOR 2 TANKS & WATER HEATER - LVS	
	102765-04-700	EA CIRCUIT BOARD	LVS 5076-11

MICROWAVE OVEN

KEY	PART NUMBER	U/M DESCRIPTION
	115303-01-000	EA OVEN-MICROWAVE, MAGIC CHEF - MODEL DM15K-7B
	115401-01-01A	EA TRIM-MICROWAVE, BLACK
	098916-03-01A	EA BRACE-MICROWAVE CABINET, LEFT - 9.4" X 7.5" - STEEL
	098916-04-01A	EA BRACE-MICROWAVE CABINET, RIGHT - 9.4" X 7.5" - STEEL
	094750-07-000	EA BRACKET-MICROWAVE, 89 DEGREE - STEEL

COFFEE MAKER

KEY	PART NUMBER	U/M DESCRIPTION
	103799-01-02A	EA COFFEE MAKER - GRAY - BLACK & DECKER W/GLASS POT
	104610-01-000	EA STRAP-COFFEE MAKER

GALLEY GROUP (CONTINUED)

RANGE
FROM: 00-00-00 THRU: 06-19-94

KEY	PART NUMBER	U/M DESCRIPTION	VENDOR NO.
	112881-01-01A	EA RANGE-16" 3 BURNER ALMOND - MAGIC CHEF	16RA-3B
	055282-04-700	EA PANEL-OVEN DOOR, ALMOND - MAGIC CHEF	50-26577-2A
	102020-01-700	EA SHELF-OVEN, MAGIC CHEF -	7801-P027-60
	102020-01-701	EA HANDLE-DOOR, MAGIC CHEF -	7701P092-60
	102020-01-709	EA BUMPER-GRATE, MAGIC CHEF	8007P018-60
	102020-01-711	EA GRATE-TOP, MAGIC CHEF	7518P012-60
	102020-01-722	EA VALVE-TOP BURNER, MAGIC CHEF	7502P095-60
	102020-01-724	EA BUMPER-MAIN TOP, MAGIC CHEF	8003P008-60
	102022-01-708	EA REGULATOR PRESSURE 1/4IN 1/2 OUT	7510P041-60
	112881-01-700	EA TOP, MAIN-ALMOND	2001F110-84
	112881-01-701	EA MANIFOLD PANEL	2616F091-70
	112881-01-702	EA VALVE-MERCURY (SAFETY VALVE)	7501-P121-60
	112881-01-703	EA VALVE-TOP BURNER HI-OUTPUT	7502P180-60
	112881-01-704	EA KNOB-THERMOSTAT	7731P067-60
	112881-01-705	EA KNOB-TOP BURNER	7733P072-60
	112881-01-706	EA THERMOSTAT	12400026
	112881-01-707	EA TRIM-FLAT (LEFT) (BLK)	3608W035-70
	112881-01-708	EA TRIM-FLAT (RIGHT) (BLK)	3608W036-70
	112881-01-709	EA PIPE-MANIFOLD	7513P097-60
	112881-01-710	EA OVEN PILOT	7505P202-60
	112881-01-711	EA OVEN BURNER	3404W025045

RANGE
FROM: 06-20-94 THRU: 99-99-99

KEY	PART NUMBER	U/M DESCRIPTION
	112881-01-03A	EA RANGE-16" 3 BURNER ALMOND - MAGIC CHEF
	055282-04-700	EA PANEL OVEN DOOR ALMOND
	102020-01-700	EA SHELF-OVEN
	102020-01-701	EA HANDLE, DOOR
	102020-01-709	EA BUMPER, GRATE
	102020-01-711	EA GRATE, TOP
	102020-01-722	EA VALVE, TOP BURNER
	102020-01-724	EA BUMPER, MAIN TOP
	102022-01-708	EA REGULATOR PRESSURE 1/4IN 1/2 OUT
	112881-01-700	EA TOP, MAIN-ALMOND
	112881-01-701	EA MANIFOLD PANEL
	112881-01-702	EA VALVE-MERCURY (SAFETY VALVE)
	112881-01-703	EA VALVE-TOP BURNER HI-OUTPUT
	112881-01-704	EA KNOB-THERMOSTAT
	112881-01-705	EA KNOB-TOP BURNER
	112881-01-706	EA THERMOSTAT
	112881-01-707	EA TRIM-FLAT (LEFT) (BLK)
	112881-01-708	EA TRIM-FLAT (RIGHT) (BLK)
	112881-01-709	EA PIPE-MANIFOLD
	112881-01-710	EA OVEN PILOT
	112881-01-711	EA OVEN BURNER
	112881-01-713	EA DOOR-OVEN-TEXTURED

GENERATOR GROUP

4,000 WATT ONAN EMERALD PLUS - 220 VOLT - LP - EXPORT

KEY	PART NUMBER	U/M	DESCRIPTION
	100974-04-000	EA	GENERATOR - 4,000 WATT EMERALD PLUS - ONAN BGE-FN/29236G
	007067-01-000	SF	INSULATION-FIBERGLASS, 1" THICK X 4' - INCREMENTS OF 4 SF
	007125-01-000	EA	CLAMP-MUFFLER, 1.62 DIAMETER
	007125-03-000	EA	CLAMP-MUFFLER, 1.5" DIA
	007125-04-000	EA	CLAMP-MUFFLER, 1.1" DIA
	007131-01-000	EA	HANGER-TAILPIPE, 6 SLOTS
	079654-05-000	EA	PIPE-EXHAUST, ANGLED - W/FLANGE - 2" ID - ONAN# 154-2539
	082272-01-000	EA	MUFFLER-GENERATOR
	093511-01-000	EA	VAPOR KIT-LP, GENERATOR
	094059-01-000	EA	SPACER-GENERATOR, ONAN
	105732-02-000	EA	TRAY ASM-GENERATOR
	105958-03-000	EA	PIPE-EXHAUST, GENERATOR

4,000 WATT ONAN EMERALD PLUS - 110 VOLT - LP - EXPORT

KEY	PART NUMBER	U/M	DESCRIPTION
	100974-01-000	EA	GENERATOR - 4,000 WATT EMERALD PLUS, ONAN BGE-FA/26100G
	093511-01-000	EA	VAPOR KIT-LP, GENERATOR
	007125-01-000	EA	CLAMP-MUFFLER, 1.62 DIAMETER
	007125-03-000	EA	CLAMP-MUFFLER - 1.5" DIA
	007125-04-000	EA	CLAMP-MUFFLER, 1.1" DIA
	007131-01-000	EA	HANGER-TAILPIPE, 6 SLOTS
	079654-05-000	EA	PIPE-EXHAUST, ANGLED - W/FLANGE - 2" ID - ONAN# 154-2539
	082272-01-000	EA	MUFFLER-GENERATOR
	094059-01-000	EA	SPACER-GENERATOR, ONAN
	105732-02-000	EA	TRAY ASM-GENERATOR
	105958-03-000	EA	PIPE-EXHAUST, GENERATOR
	007067-01-000	SF	INSULATION-FIBERGLASS, 1" THICK X 4' - INCREMENTS OF 4 SF

GENERATOR GROUP (CONTINUED)

4,000 WATT ONAN EMERALD PLUS - 220 VOLT - GAS - EXPORT

KEY	PART NUMBER	U/M	DESCRIPTION
	100974-04-000	EA	GENERATOR - 4,000 WATT EMERALD PLUS - ONAN BGE-FN/29236G
	007067-01-000	SF	INSULATION-FIBERGLASS, 1" THICK X 4' - INCREMENTS OF 4 SF
	007125-03-000	EA	CLAMP-MUFFLER, 1.5" DIA
	007125-04-000	EA	CLAMP-MUFFLER, 1.1" DIA
	007131-01-000	EA	HANGER-TAILPIPE, 6 SLOTS
	079654-05-000	EA	PIPE-EXHAUST, ANGLED - W/FLANGE - 2" ID - ONAN# 154-2539
	082272-01-000	EA	MUFFLER-GENERATOR
	094059-01-000	EA	SPACER-GENERATOR, ONAN
	105732-02-000	EA	TRAY ASM-GENERATOR
	105958-03-000	EA	PIPE-EXHAUST, GENERATOR

4,000 WATT ONAN EMERALD PLUS - US

KEY	PART NUMBER	U/M	DESCRIPTION
	100974-01-000	EA	GENERATOR - 4,000 WATT EMERALD PLUS, ONAN BGE-FA/26100G
	007067-01-000	SF	INSULATION-FIBERGLASS, 1" THICK X 4' - INCREMENTS OF 4 SF
	007125-04-000	EA	CLAMP-MUFFLER, 1.1" DIA
	079654-05-000	EA	PIPE-EXHAUST, ANGLED - W/FLANGE - 2" ID - ONAN# 154-2539
	082272-01-000	EA	MUFFLER-GENERATOR
	094059-01-000	EA	SPACER-GENERATOR, ONAN
	105732-02-000	EA	TRAY ASM-GENERATOR
	105958-03-000	EA	PIPE-EXHAUST, GENERATOR

MICROLITE GENERATOR

KEY	PART NUMBER	U/M	DESCRIPTION
	109982-04-000	EA	GENERATOR - 3.6 MICROLITE, LP
	109982-03-000	EA	GENERATOR - 4.0 MICROLITE
	007125-03-000	EA	CLAMP-MUFFLER, 1.5" DIA
	007125-04-000	EA	CLAMP-MUFFLER, 1.1" DIA
	079654-05-000	EA	PIPE-EXHAUST, ANGLED - W/FLANGE - 2" ID - ONAN# 154-2539
	082272-01-000	EA	MUFFLER-GENERATOR
	114070-02-02B	EA	SUPPORT ASM.- GENERATOR - CENTER
	114071-02-02B	EA	SUPPORT ASM.- GENERATOR - RIGHT

HEATING & AIR CONDITIONING GROUP

30,000 BTU SUBURBAN FURNACE & WALL THERMOSTAT

KEY	PART NUMBER	U/M DESCRIPTION	VENDOR NO.
	098668-20-000	EA FURNACE - 30,000 BTU, SUBURBAN SF-30 2273	
	093365-01-000	EA THERMOSTAT - WALL, FURNACE - SUBURBAN 160902	
	098668-01-700	EA CABINET-FRONT	101242
	098668-01-701	EA CABINET ASSEMBLY	101299
	098668-01-702	EA ELECTRODE	231740
	098668-01-703	EA BURNER ASSEMBLY COMPLETE - (SF-25)	101299
	098668-01-704	EA VALVE, (JOHNSON)	160938
	098668-01-705	EA SWITCH-LIMIT	231630
	098668-01-706	EA WHEEL-COMBUSTION AIR	350122
	098668-01-707	EA VENT ASSEMBLY-CAP AND TUBE	260193
	098668-01-708	EA BLOWER ASSEMBLY-COMBUSTION AIR	390441
	098668-01-709	EA MOTOR ASSEMBLY-F/SF-25, SF-30	231706
	098668-01-710	EA BLOWER ASSEMBLY-ROOM AIR	390440
	098668-01-711	EA WHEEL-ROOM AIR	350123
	098668-01-712	EA BOARD-MODULE	231741
	098668-01-713	EA INTAKE VENT TUBE ASSEMBLY	051044
	098668-01-714	EA VALVE-GAS, (WHITE ROGERS)	161070
	098668-01-715	EA ELECTRODE ASSEMBLY-SINGLE PROBE	232166
	069634-01-733	EA RELAY-TIME DELAY, 20,000 BTU & 30,000 BTU	231202
	075695-01-709	EA MICROSWITCH ASM F/30 & 34S	230509
	092300-02-701	EA ORIFICE-(MAIN BURNER)	180214
	098668-02-700	EA BURNER ASSEMBLY COMPLETE - (SF-30/SF35)	010745
	090039-01-709	EA GASKET-OBSERVATION HOLE COVER	070367
	092300-01-704	EA GASKET-ELECTRODE	070163
	098668-06-000	EA DOOR-ACCESS, FURNACE - OFF WHITE - SUBURBAN 520574	
	093614-01-01A	EA GRILLE-RETURN AIR, FURNACE - 15.6" X 7.6" - BROWN	

25,000 BTU SUBURBAN FURNACE & WALL THERMOSTAT

KEY	PART NUMBER	U/M DESCRIPTION	VENDOR NO.
	098668-19-000	EA FURNACE - 25,000 BTU, SUBURBAN SF-25 2272	
	069634-01-733	EA RELAY, TIME DELAY 20 & 30 BTU	231202
	075695-01-709	EA MICRO SWITCH (FOR MODELS 30 & 34S)	230509
	090039-01-703	EA ORFICE-MAIN BURNER	180193
	090039-01-709	EA GASKET-COVER, OBSERVATION HOLE	
	092300-01-704	EA GASKET-ELECTRODE	070163
	093365-01-000	EA THERMOSTAT-WALL, FURNACE - SUBURBAN 0160902	
	098668-01-700	EA CABINET FRONT	101242
	098668-01-701	EA CABINET ASM	101299
	098668-01-702	EA ELECTRODE	231740
	098668-01-703	EA BURNER ASSEMBLY COMPLETE - (SF-25)	101299
	098668-01-704	EA VALVE	160938
	098668-01-705	EA SWITCH-LIMIT	231630
	098668-01-706	EA WHEEL-COMBUSTION AIR	350122
	098668-01-707	EA VENT CAP & EXHAUST TUBE ASM	260193
	098668-01-708	EA BLOWER ASM (COMBUSTION AIR)	390441
	098668-01-709	EA MOTOR ASM.-FOR SF-25, SF-30	231706
	098668-01-710	EA BLOWER ASM (ROOM AIR)	390440
	098668-01-711	EA WHEEL, ROOM AIR	350123
	098668-01-712	EA BOARD-MODULE	231741
	098668-01-713	EA INTAKE VENT TUBE ASM	051044
	098668-01-714	EA GAS VALVE (WHITE ROGERS)	161070
	098668-01-715	EA ELECTRODE ASM (SINGLE PROBE)	232166
	098668-06-000	EA DOOR-ACCESS, FURNACE - OFF WHITE - SUBURBAN 520574	
	093614-01-01A	EA GRILLE-RETURN AIR, FURNACE - 15.6" X 7.6" - BROWN	
	069636-02-000	EA CONNECTOR-DUCT, 4" ID - SUBURBAN 050715	

HEATING & AIR CONDITIONING GROUP (CONTINUED)

REAR HEATER & WATER HEATER W/MOTOR AID

KEY	PART NUMBER	U/M DESCRIPTION
	009198-01-000	FT DUCT-HEAT, FLEXIBLE - 4" ID - INCREMENTS OF 25'
	009200-01-000	EA TAPE-FURNACE, 1 1/2"
	023146-01-000	EA CLAMP-SCREW TYPE - 4"
	069636-02-000	EA CONNECTOR-DUCT, 4" ID
	007108-01-000	FT HOSE-HEATER, 5/8" ID
	008042-01-000	FT TUBING-VINYL, .65" ID
	056464-04-000	EA REGISTER-W/DAMPER, 4" DIAMETER - PLASTIC - SAND
	056464-05-000	EA REGISTER-W/O DAMPER, 4" DIAMETER - PLASTIC - GOLDEN
	061673-01-000	EA BRACKET-MOTOR AID TUBES, 4" X 1.5" - STEEL
	088753-01-000	FT TUBE-ALUMINIZED STEEL, 5/8" - 18 GAUGE
	079059-01-000	EA HOSE - 90 DEGREE, 5/8" ID X 4" X 36"
	079059-13-000	EA HOSE - 90 DEGREE, .61" ID X 4" X 48"
	083081-01-000	EA HOSE-FORMED, 90 DEGREES - 5/8" ID
	010227-01-000	EA TEE-BARB, 5/8" OR 3/4" HOSE - PLASTIC

EVANS REAR HEATER

KEY	PART NUMBER	U/M DESCRIPTION	VENDOR NO.
	084405-01-000	EA HEATER ASM-REAR, DUCTED - W/MOTOR AID - EVANS	
	084405-01-700	EA HEATER CORE	FT200229
	084405-01-701	EA FAN BLADES	HV029931
	084405-01-702	EA MOTOR ASM - 12 V	200146

HEATING & AIR CONDITIONING GROUP (CONTINUED)

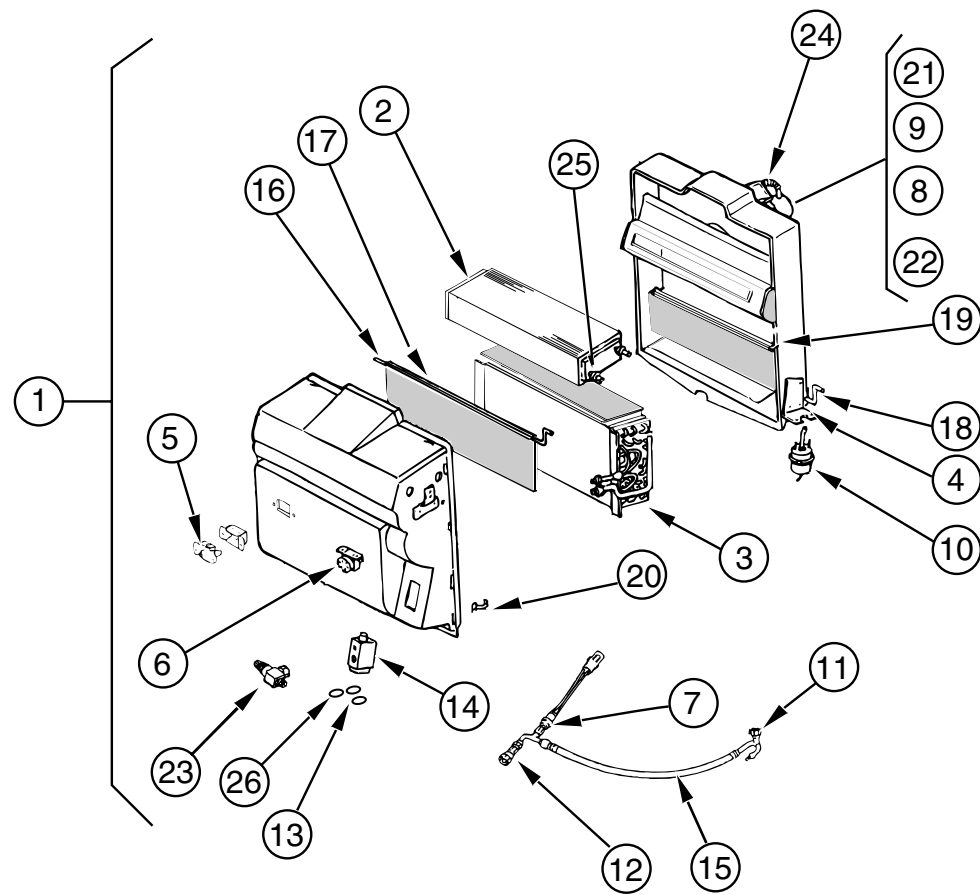

EVAPORATOR/HEATER ASSEMBLY - CHEVY GAS & DIESEL CHASSIS

KEY	PART NUMBER	U/M DESCRIPTION	VENDOR NO.
1	103930-20-000	EA EVAPORATOR/HEATER ASSEMBLY	090-00083
2	103930-01-703	EA COIL-HEATER	042-0010
3	103930-01-704	EA COIL EVAPORATOR	041-0017
4	103930-01-708	EA BRACKET-VACUUM MOTOR	070-0113
5	103930-01-710	EA RESISTOR-FUSED	035-0006
6	103930-01-711	EA THERMOSTAT	033-0003
7	103930-01-716	EA SWITCH-PRESSURE, FAN	032-0036
8	103930-01-717	EA WHEEL-CLOCK-WISE	062-0010
9	103930-01-720	EA MOTOR	030-0004
10	103930-02-708	EA MOTOR-VACUUM SERVO, A/C	030-0002
11	103930-12-708	EA SWITCH-BINARY, R-134A	032-0048
12	103930-12-709	EA FITTING-QUICK CONNECT	050-0120
13	103930-17-702	EA GASKET OR SAE 015 #10 33-781	045-0127
14	103930-20-700	EA VALVE-EXPANSION BLOCK, 2 TON	034-0032
15	103930-20-701	EA HOSE ASM - #6	085-0138
16	103930-20-702	EA ROD-AIR BLEND DOOR	073-0039
17	103930-20-703	EA DOOR-AIR BLEND	071-0212
18	103930-20-704	EA ROD-RECIRCULATING DOOR	073-0018
19	103930-20-705	EA DOOR-RECIRCULATING	071-0213
20	103930-20-706	EA CLIP-RETAINER	022-0057
21	103930-20-707	EA HOUSING-BLOWER	062-0145
22	103930-20-708	EA CLIP F/MOTOR SHAFT	022-0001
23	103930-20-709	EA SERVICE VALVE	050-159
24	110279-01-703	EA MOTOR-BLOWER	051-0034
25	110279-01-712	EA FITTING-HEATER	050-0076
26	113245-01-707	EA GASKET #8	045-0126

HEATING & AIR CONDITIONING GROUP (CONTINUED)

CONTROL/PLENUM

KEY	PART NUMBER	U/M DESCRIPTION	VENDOR NO.
	103930-04-000	EA CONTROL/PLENUM SET SCS 093-00037	
	072341-06-700	EA SWITCH - 4 SPEED, FAN - ARA 0883502	
	094831-01-709	EA CLAMPS-ROD, 3/16" - MOTIVAIR/SCS ZGG14431	
	103930-02-700	EA PANEL-CONTROL, SCS 032-0018	
	103930-02-701	EA VALVE-CONTROL HEAD, SCS 034-0015	
	103930-02-702	EA DECAL-FAN SWITCH, SCS 058-0008	
	103930-02-703	EA HARNESS-WIRE CONTROL, SCS 036-0048	
	103930-02-704	EA HARNESS-VACUUM CONTROL, SCS 036-0049	
	103930-02-705	EA CABLE-CONTROL, BOWDEN - SCS 074-0011 SHEATH LENGTH IS 84 1/4" - CABLE LENGTH IS 89" LONG	
	103930-02-706	EA CLIP-CABLE, CONTROL - SCS 022-0017	
	103930-02-707	EA RELAY, SCS 031-0001	
	103930-02-708	EA MOTOR-VACUUM SERVO, A/C - SCS 030-0002	
	103930-02-710	EA CANISTER-VACUUM, SCS 054-0002	
	103930-02-711	EA VALVE-WATER, SCS 034-00114	

HOSE KITS

KEY	PART NUMBER	U/M DESCRIPTION	VENDOR NO.
	103930-18-000	EA HOSE KIT #10 GM-HARRISON COM 093-00077	
	103930-17-701	EA FTG #10.90 W/FERRULE/1342CP	050-0132
	103930-17-702	EA GASKET OR SAE 015 #10 33-781,	045-0127
	103930-17-703	EA GASKET-SEAL,SANDEW COMP33-76	045-0142
	103930-18-700	EA FTG,PAD,COMP SUCTION	050-00133
	103930-18-701	EA HOSE ASSY #10	085-0114
	103930-18-702	EA GASKET SEAL HARRISON	045-0143
	110279-01-708	EA HOSE, REFG. BARRIER#10SAEJ51	051-0008
	103930-17-000	EA HOSE KIT #10 GM-SANDEN COMP	093-00076
	103930-01-708	EA BRACKET-VACUUM MOTOR,	070-0113
	103930-17-700	EA FTG. PAD COMP. SUCTION SAN	050-0131
	103930-17-701	EA FTG #10.90 W/FERRULE/1342CP	050-0132
	103930-17-702	EA GASKET OR SAE 015 #10 33-781	045-0127
	103930-17-703	EA GASKET-SEAL,SANDEW COMP33-76	045-0142
	103930-17-704	EA HOSE ASSY #10	085-0113

AUTOMOTIVE HEATER MISCELLANEOUS

KEY	PART NUMBER	U/M DESCRIPTION	VENDOR NO.
	007281-01-000	EA HOSE-FLEXIBLE PVC, 2.5"ID X 50' - ATCOFLEX A-182-355	
	024990-05-000	EA 4" DIAMETER OUTLET W/SWIVEL DEFLECTORS	
	056402-05-000	EA BRACKET-HEATER VENT, ROUND - W/BEND - BLACK	
	077075-01-000	EA GASKET-INSTRUMENT PANEL TO DEFROSTER PLENUM - .6" X 11.3"	
	077075-03-000	EA GASKET-NSTRUMENT PANEL TO DEFROSTER PLENUM,SPL	
	103016-01-000	EA PLENUM-TRANSITION	
	103017-01-000	EA PLENUM-DEFROSTER	
	103558-01-05A	EA VENT-DEFROST,ABS CAMB BISQUE	
	103796-01-01A	EA LOUVER ASM-A/C CARY PROD BLK, 268-3B,100-2-4-8	
	097494-02-000	EA TEE-BRASS, BARB - 3/8 X 5/32 X 3/8 - PARKER 224-8-8-4	
	103930-05-000	EA MANUAL-OWNERS, HEATER-A/C - SCS 057-0049	
	103930-20-700	EA VALVE EXP. BLOCK (2 TON)	034-0032
	103930-20-701	EA HOSE ASSY #6 WINN GM	085-0138

ROOF A/C COVER

KEY	PART NUMBER	U/M DESCRIPTION
	092633-02-02A	EA COVER-BLANK, ROOF A/C - 5.1" X 5.1" - PLASTIC - OFF WHITE
	022756-03-000	EA COVER-A/C, OFF WHITE - PLASTIC
	022756-02-000	EA COVER-PROTECTIVE, 5.5" ENDS X 8.2" - PLASTIC - OFF WHITE

HEATING & AIR CONDITIONING GROUP (CONTINUED)

13,500 BTU COLEMAN ROOF A/C

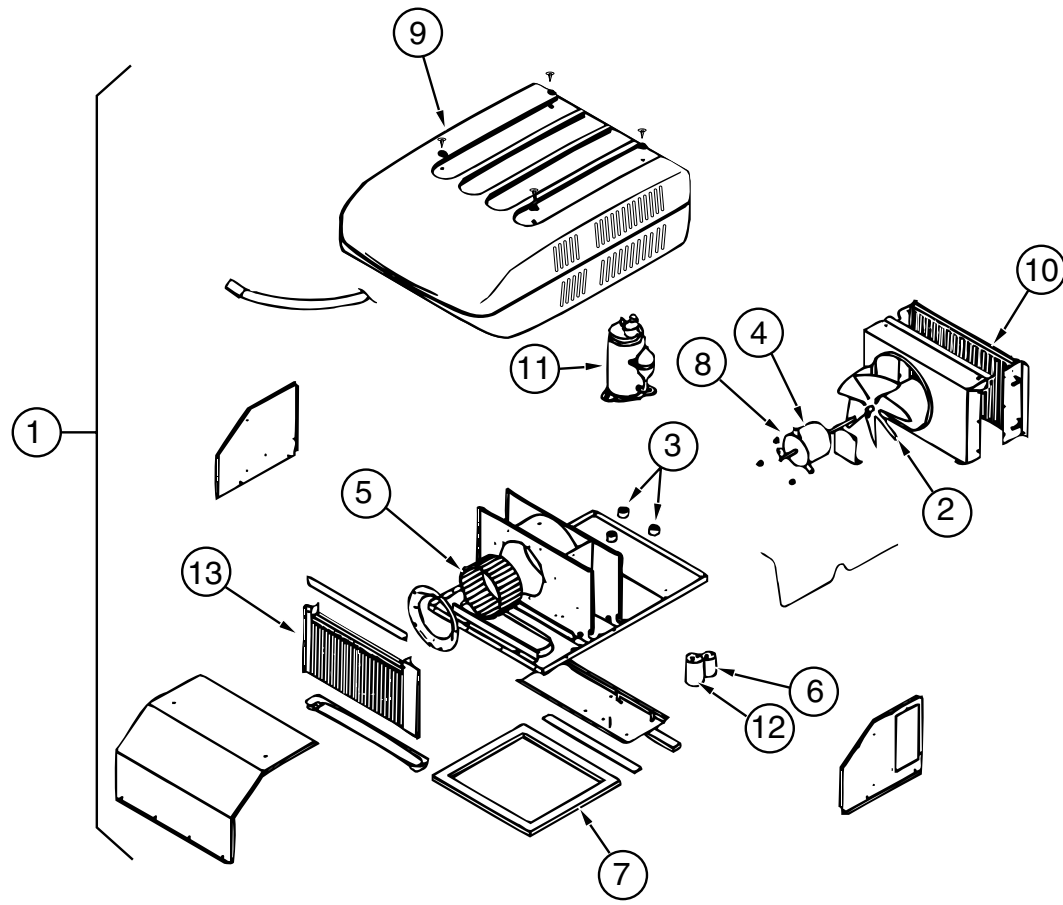

KEY	PART NUMBER	U/M DESCRIPTION	VENDOR NO.
1	108889-01-05A	EA A/C-ROOF, 13,500 TSR HO BRIGHT WHITE 7333	
2	093763-01-712	EA FAN BLADE-CONDENSER	6733-3221
3	105620-01-706	EA FOOT PACKAGE-COMPRESSOR, 3 PER PACKAGE	6759-3081
4	108889-01-705	EA MOTOR - 115V, 60HZ	1468-3049
5	108889-01-706	EA IMPELLOR	1472-1041
6	108889-01-708	EA CAPACITOR-FAN, (7.5MFD.370U)	1499-5461
	108889-01-710	EA FILLER PAD-COND AIR SEAL	6759A3971
7	108889-01-711	EA GASKET PACKAGE	6792-3301
8	108889-01-715	EA MOTOR MOUNT & SHAFT SEAL KIT	6792-3361
9	108889-01-700	EA SHROUD-(GRAY/GRAY), W/O LOGO	6759-6421
9	108889-05-700	EA SHROUD-(BRIGHT WHITE), W/O LOGO	7333-4601
10	108889-01-703	EA CONDENSER COIL	1452-1301
11	105620-01-704	EA COMPRESSOR, RH & LH	1450-2009
12	108889-01-707	EA CAPACITOR-RUN, COMPRESSOR-25MFD/370	1499-5661
	091225-01-709	EA RELAY-START	1497-4131
13	108889-01-709	EA EVAPORATOR COIL	1452-1311
	108889-01-714	EA DISCHARGE LINE ASSEMBLY	6792-531
	108889-01-712	EA REDUCER-SUCTION LINE, (3/8" X 1/2")	1215-2161
	108889-01-713	EA SUCTION LINE, (3/8" OD X .032" WALL	6792-130
	091225-01-710	EA CAPACITOR-START	1497-0881
	093306-01-701	EA DECAL PACKAGE-LEFT & RIGHT	6798B3591
	108889-01-704	EA OVERLOAD	6749-3541
	102289-01-000	EA SPRING-SCREW, ROOF A/C GASKET	6757-150

CEILING ASSEMBLY 13,500 BTU A/C

KEY	PART NUMBER	U/M DESCRIPTION	VENDOR NO.
	108891-01-01A	EA CEILING ASM-A/C COOL TSR HO - 7330-714 IV	
	042204-01-709	EA THERMOSTAT-IN 64 OUT 58	6701-3401
	063903-01-702	EA LOUVER-COLEMAN 6703A5191	
	073742-01-701	EA SELECTOR SWITCH (5 TERMINAL)	6759-3251
	073742-01-702	EA DECAL COOL ONLY	6759C3431
	076303-01-707	EA FILTER - 6" X 14 3/4" X 1/2", 12 PER PKG	6703A3151
	081606-01-712	EA CEILING SHROUD (IVORY)	6769-5061
	091225-01-713	EA KNOB (2 PER PACKAGE)	6701-3351
	091225-01-717	EA DECAL (THERMOSTAT) COOL ONLY	6799A3441
	093766-02-701	EA DECAL-LEFT SIDE	6799-3971
	108891-01-700	EA SINGLE PARTS PACKAGE	6792-5991
	108891-01-701	EA RETAINER CLIPS F/FILTER	6799-3141

INTERIOR FINISH GROUP

MOLDINGS & TRIMS

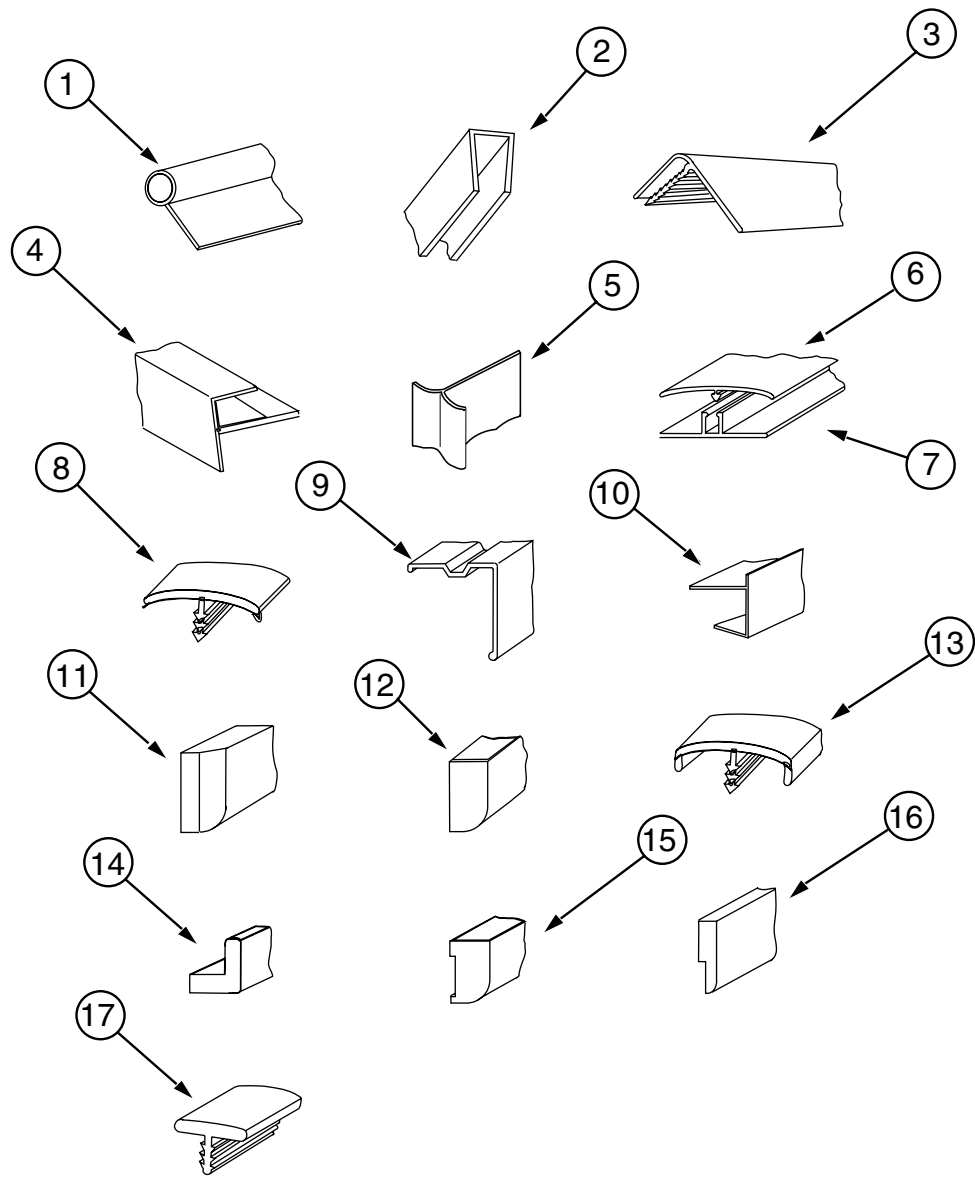

KEY	PART NUMBER	U/M DESCRIPTION
1	009767-12-000	FT MOLDING-SIDEWALL TO CEILING/CABINET - WELTING - OFF WHITE
2	009778-12-000	FT U CHANNEL-PLASTIC, 1" WIDE X 8' INCREMENTS - WOODGRAIN
2	070504-18-000	FT U-CHANNEL-PLASTIC, .065" WIDE - IVORY - INCREMENTS OF 8'
2	070504-19-000	FT U-CHANNEL-PLASTIC, .815" WIDE - BROWN - INCREMENTS OF 8'
3	009809-21-000	EA MOLDING-CORNER, OUTSIDE - 1" - PLASTIC - WOODGRAIN
4	009812-22-000	EA MOLDING-CORNER, OUTSIDE - .5" X 7' - PLASTIC - BROWN
5	022992-11-000	FT MOLDING-REVERSE COVE, T-SHAPED - VINYL - IVORY
6	086229-04-000	EA BATTEN-CEILING, 1" WIDE - IVORY - 7.6' EA
7	086229-01-000	EA RETAINER-BATTEN, CEILING - .75" WIDE - 7.6' EA
8	105709-01-000	FT T-MOLDING-1", MODERN IVORY
9	093873-01-01A	EA TRIM-CARPET, L-ANGLE - 1.1" X 1.3" X 12' - VINYL - GRAY
10	103186-01-01A	FT MOLDING-EDGE, SHELF - .78" WIDE - PLASTIC - RAMBLING OAK
10	103186-02-01A	FT MOLDING-EDGE, SHELF - 1.3" WIDE - PLASTIC - RAMBLING OAK
11	100659-01-E01	EA MOLDING-TRIM, VINYL FLOOR
12	100818-01-02A	EA MOLDING-VINYL WRAPPED, 1.65" X .4" X 7' - RAMBLING OAK
13	083620-07-000	FT MOLDING-T, END CAP EDGE - W/EDGE LIPS - .75" - THOR PECAN
14	100819-01-02A	EA MOLDING-VINYL WRAPPED, L-SHAPED, 1.5" X 1.5" X 7' - OAK
15	100041-01-000	EA MOLDING-VINYL WRAPPED, .7" X 1.57" X 84.02" - RAMBLING OAK
15	100041-02-000	EA MOLDING-VINYL WRAPPED, .7" X 2.5" X 84" - RAMBLING OAK
16	105004-01-02A	EA MOLDING-VINYL WRAP, RAMBLING OAK
17	104676-01-01A	FT T-MOLDING, 5/16 RIGID - GOLD
	112198-01-000	FT MOLDING-#90227 J-MOLDING CRILA PLASTICS

INTERIOR FINISH GROUP (CONTINUED)**BATT STRIPS**

KEY	PART NUMBER	U/M DESCRIPTION
	085284-76-000	FT BATT STRIP-SHOWER, ADHESIVE BACKED - OFF WHITE
	069733-80-000	EA BATT STRIP-WOODGRAIN, 8' - WINNI OAK
	088263-78-000	EA BATT STRIP-SHOWER, 8' - OFF WHITE
	079653-09-000	EA BATT STRIP-KERFED, WOODGRAIN
	088263-96-000	EA BATT STRIP-DECORATIVE, 8' LONG (F24) (MAIN WALL & BATH & GALLEY)
	088263-B5-000	EA BATT STRIP-DECORATIVE, PASTEL - 8' LONG (F25) (MAIN WALL & BATH & GALLEY)
	088263-B7-000	EA BATT STRIP-DECORATIVE, 8' LONG (F26) (MAIN WALL & BATH & GALLEY)
	088263-B8-000	EA BATT STRIP-DECORATIVE, 8' LONG (F27) (MAIN WALL & BATH & GALLEY)
	085284-67-000	FT BATT STRIP-WOODGRAIN, ADHESIVE BACKED - WINNI OAK
	085284-86-000	FT BATT STRIP-DECORATIVE, ADHESIVE BACKED (F24) (MAIN WALL & BATH & GALLEY)
	085284-A6-000	FT BATT STRIP-DECORATIVE, ADHESIVE BACKED (F25) (MAIN WALL & BATH & GALLEY)
	085284-A9-000	FT BATT STRIP-DECORATIVE, ADHESIVE BACKED (F26) (MAIN WALL & BATH & GALLEY)
	085284-B1-000	FT BATT STRIP-DECORATIVE, ADHESIVE BACKED (F27) (MAIN WALL & BATH & GALLEY)

LUMBER

KEY	PART NUMBER	U/M DESCRIPTION
	100040-01-000	EA LUMBER-VINYL WRAPPED, .71" X 1.5" X 8' - RAMBLING OAK
	100040-03-000	EA LUMBER-VINYL WRAPPED, .71" X 2" X 8' - RAMBLING OAK
	100040-06-000	EA LUMBER-VINYL WRAPPED, 766 RAMBLING OAK
	100040-07-000	EA LUMBER-VINYL WRAPPED, 766 RAMBLING OAK

PLASTIC LAMINATE

KEY	PART NUMBER	U/M DESCRIPTION
	074498-54-000	SF LAMINATE-PLASTIC, SAND - 5' X 8' - INCREMENTS OF 40 SF (F24,F27)
	074498-62-000	SF LAMINATE-PLASTIC, GRAY FINESSE - 5' X 8' - INCREMENTS OF 40 SF (F25)
	074498-50-000	SF LAMINATE-PLASTIC, ALPINE ESSENCE - 5' X 8' - INCREMENTS OF 40 SF (F26)
	074498-67-000	SF LAMINATE-PLASTIC, ORCHID MIST - 5' X 8' - INCREMENTS OF 40SF (PATIO ENTERTAINMENT CENTER TABLE)
	074498-34-000	SF LAMINATE-PLASTIC, RAMBLING OAK - 5' X 8' - INCREMENTS OF 40 SF
	076325-25-000	FT MOLDING-EDGE BAND, RAMBLING OAK
	076325-44-000	FT MOLDING-EDGE BAND, 1032 SAND - .876" X .024" X 600" (F24,F27) (INSIDE OF RECESSED SINK)
	076325-43-000	FT MOLDING-EDGE BAND, 1035 CLOUD - .876" X .024" X 600" (F25) (INSIDE OF RECESSED SINK)
	076325-56-000	FT MOLDING-EDGE BAND, 1233 ALPINE - .875 "X .024" X 600" (F26) (INSIDE OF RECESSED SINK)
	076325-34-000	FT MOLDING-EDGE BAND, 1233 ORCHID MIST - 1 5/16" X .030" X 600" (PATIO ENTERTAINMENT CENTER TABLE)
	076325-47-000	FT MOLDING-EDGE BAND, 1032 SAND - 1 5/16" X .030" X 600" (F24,F27)
	076325-46-000	FT MOLDING-EDGE BAND, 1035 CLOUD - 1 5/16" X .030" X 600" (F25)
	076325-57-000	FT MOLDING-EDGE BAND, 1233 ALPINE - 1 5/16" X .030" X 600" (F26)

PANELING & PLYWOOD

KEY	PART NUMBER	U/M DESCRIPTION
	074497-21-000	SF PANELING-WOODGRAIN, 4' X 8' - INCREMENTS OF 32 SF
	088272-98-000	SF PANELING-SHOWER, OFF WHITE - 4' X 7' - INCREMENTS OF 28 SF
	088272-B8-000	SF PANELING-DECORATIVE, 4' X 7' - INCREMENTS OF 28 SF (F24) (MAIN WALL & BATH)
	088272-D8-000	SF PANELING-DECORATIVE, 4' X 7' - INCREMENTS OF 28 SF (F25) (MAIN WALL & BATH)
	088272-D9-000	SF PANELING-DECORATIVE, 4' X 7' - INCREMENTS OF 28 SF (F26) (MAIN WALL & BATH)
	088272-E0-000	SF PANELING-DECORATIVE, 4' X 7' - INCREMENTS OF 28 SF (F27) (MAIN WALL & BATH)
	095688-01-000	SF VENEER-FLAT LUANA, 4' X 8' - INCREMENTS OF 32 SF
	089351-03-000	SF VINYL HEADLINER

INTERIOR FINISH GROUP (CONTINUED)**DETECTORS, FIRE EXTINGUISHER & CLOCK**

KEY	PART NUMBER	U/M DESCRIPTION
	072852-01-000	EA DETECTOR-SMOKE, W/9 VOLT BATTERY
	072852-02-000	EA DETECTOR-SMOKE, W/9 VOLT BATTERY - CANADIAN
	094499-01-000	EA EXTINGUISHER-FIRE, DRY W/MOUNTING BRACKET - 10 BC
	094499-01-700	EA BRACKET-MOUNTING, W/PLASTIC STRAP - FIRE EXTINGUISHER
	094499-02-000	EA EXTINGUISHER-FIRE, DRY - 1A10BC - CANADIAN
	100793-02-01A	EA CLOCK-WALL, 11" DIAMETER - BOLDEN 9988
	112320-01-000	EA DETECTOR-CO GAS, MODEL 9B-I - COSTAR 940000000
	112320-02-000	EA BATTERY/SENSOR-CO GAS, COSTAR 940001000

ANTISLIP & FLOOR MATS

KEY	PART NUMBER	U/M DESCRIPTION
	091261-01-000	FT SLIPNOT-ANTISLIP, 1' WIDE (100' ROLL)
	105924-01-F24	EA MAT-FLOOR 18 X 27 (F24,F27)
	105924-01-F25	EA MAT-FLOOR 18 X 27
	105924-01-F26	EA MAT-FLOOR 18 X 27

CARPET & VINYL FLOORCOVERING

KEY	PART NUMBER	U/M DESCRIPTION
	075233-01-000	SY PAD-CARPET, 3/8" X 6' ROLL
	093486-01-000	SY CARPET-COMPARTMENT, 54" WIDE - DARK GRAY
	096060-95-000	SY CARPET-12' ROLL, INCREMENTS OF 4 SY (F24,F27)
	096060-A8-000	SY CARPET-12' ROLL, INCREMENTS OF 4 SY (F25)
	096060-A2-000	SY CARPET-12' ROLL, INCREMENTS OF 4 SY (F26)
	042720-12-000	SY VINYL FLOORCOVERING

INTERIOR FINISH GROUP (CONTINUED)

CABINET HARDWARE

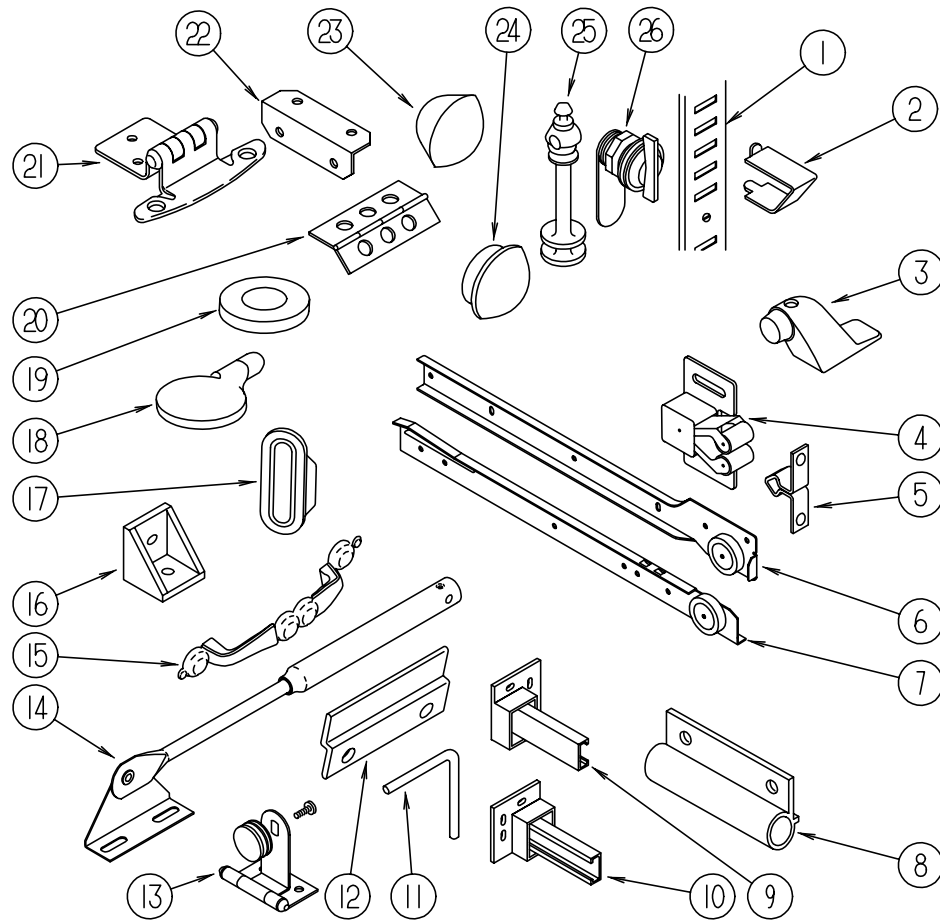

KEY	PART NUMBER	U/M DESCRIPTION
1	098979-01-000	EA CLIP-ADJUSTABLE SHELF
2	098980-01-000	EA PILASTER-ADJUSTABLE SHELF, 18" LONG WOODGRAIN APPEARANCE
2	098980-02-000	EA PILASTER-ADJUSTABLE SHELF, 12" LONG WOODGRAIN APPEARANCE
3	103257-01-000	EA STOP-DOOR
4	093586-03-000	EA CATCH-SPRING, ROLLER
5	093586-04-000	EA STRIKE-SPRING STEEL
6	114031-13-000	EA SLIDE-DRAWER, 18" LEFT CABINET HOUCK 7200-RV-1
6	114031-14-000	EA SLIDE-DRAWER, 18" RIGHT CABINET HOUCK 7200-RV-2
6	114031-21-000	EA SLIDE-DRAWER, 22" LEFT CABINET HOUCK 7200-RV-1
6	114031-22-000	EA SLIDE-DRAWER, 22" RIGHT CABINET HOUCK 7200-RV-2
7	114031-15-000	EA SLIDE-DRAWER, 18" LEFT DRAWER HOUCK 7200-RV-3
7	114031-16-000	EA SLIDE-DRAWER, 18" RIGHT DRAWER HOUCK 7200-RV-4
7	114031-23-000	EA SLIDE-DRAWER, 22" LEFT DRAWER HOUCK 7200-RV-3
7	114031-24-000	EA SLIDE-DRAWER, 22" RIGHT DRAWER HOUCK 7200-RV-4
8	108486-01-01A	EA BRACKET-PROP ROD, OVHD - BLACK
9	114045-01-000	EA BACKSOCKET-ADJUSTABLE, LEFT HOUCK 751-1
10	114045-02-000	EA BACKSOCKET-ADJUSTABLE, RIGHT HOUCK 751-2
11	108487-02-01A	EA SUPPORT-PROP ROD,OVHD - BLACK
12	101272-01-000	EA CATCH-DOOR, GLASS
13	100711-01-01A	EA HINGE-DOOR, GLASS
14	074493-02-000	EA SUPPORT-PISTON SPRING, CABINET DOOR
15	111765-01-000	EA PULL-CABINET, BRASS - AMEROCK D1390-3
16	065740-01-000	EA BRACE-CABINET CORNER, PLASTIC
17	098410-01-01A	EA PULL-FINGER, OVAL - BRASS
18	101766-01-000	EA PIN-SUPPORT, GLASS DOOR
19	100707-01-000	EA SPACER-DOOR, GLASS - .8" DIA - .3" HOLE - PLASTIC
20	009059-02-000	EA HINGE-DOOR, 2" X 2.7" - BRASS
21	108138-01-000	EA HINGE-DOOR, CABINET - BURNISHED BRASS
22	016604-01-000	EA BRACE-CABINET, ANGLE - 2.5" - METAL - UNPAINTED
22	016604-03-000	EA BRACE-CABINET, ANGLE - 2.5" - METAL - BEIGE
22	016604-05-000	EA BRACE-CABINET, L ANGLE - 2.5" - METAL - OFF WHITE
23	042356-01-000	EA PLUG-BUTTON, MAHOGANY - 3/8" DIAMETER - WOOD
24	074045-07-000	EA PLUG-WOOD, 1/2"
25	084070-02-000	EA POST-END, 2.4" - BRASS
26	100710-01-01A	EA LOCK-GLASS DOOR, TWIST TYPE - BRASS
	000G13-06-10G	EA SCREW - 6-20 X 5/8 PFH, ANTIQUE BRASS
	004354-01-000	EA BUMPER-RUBBER, .5" DIA - BROWN
	009112-01-000	EA FLANGE-ROD, 1" - COTHES ROD - PLASTIC - OFF WHITE
	023320-01-000	EA PAD-FELT, 3/8" DIAMETER - BROWN
	042438-01-000	EA DOWEL-WOOD, CLOTHES ROD - 1" DIAMETER X 4'
	042541-04-000	EA LATCH-BRASS, W/O STRIKE - HASP TYPE - BRASS BRASS STRIKE #04254105000
	076790-01-000	EA SCREW, 6-20 X 1 1/4 PPH - BLACK
	084451-01-000	EA CATCH-TV SHELF, BRASS
	098980-02-000	EA PILASTER-ADJUSTABLE SHELF, 12" LONG WOODGRAIN APPEARANCE
	103874-01-000	EA HANGER-SLIDING DOOR
	111866-01-01A	EA BRACE-SEAT, ANGLE

LABELS GROUP

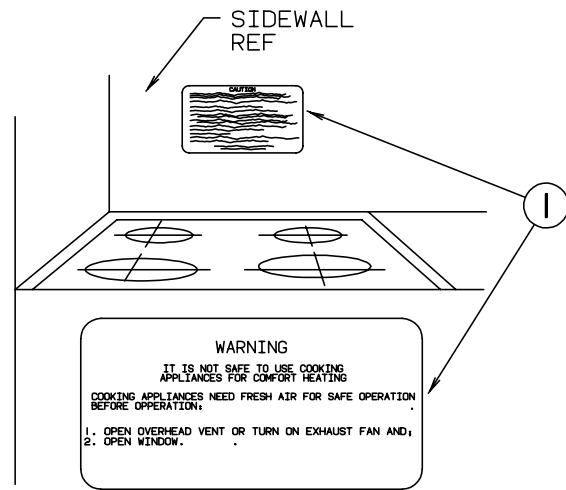

KEY	PART NUMBER	U/M DESCRIPTION
1	050225-01-000	EA LABEL-WARNING, STOVE VENT - US
1	050222-01-000	EA LABEL-WARNING, STOVE VENT - CANADIAN

LABELS GROUP (CONTINUED)

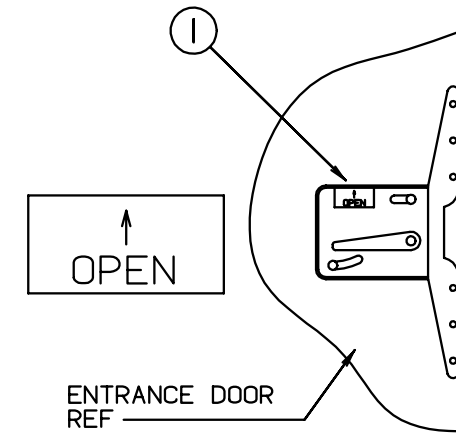

KEY	PART NUMBER	U/M DESCRIPTION
1	040944-01-000	EA LABEL-ENTRANCE DOOR, "OPEN"

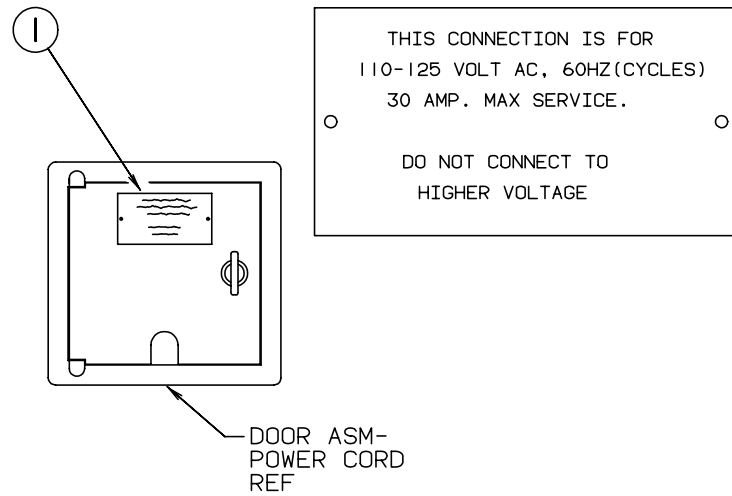

KEY	PART NUMBER	U/M DESCRIPTION
1	006062-01-000	EA TAG-ELECTRIC, 110V CONNECTION

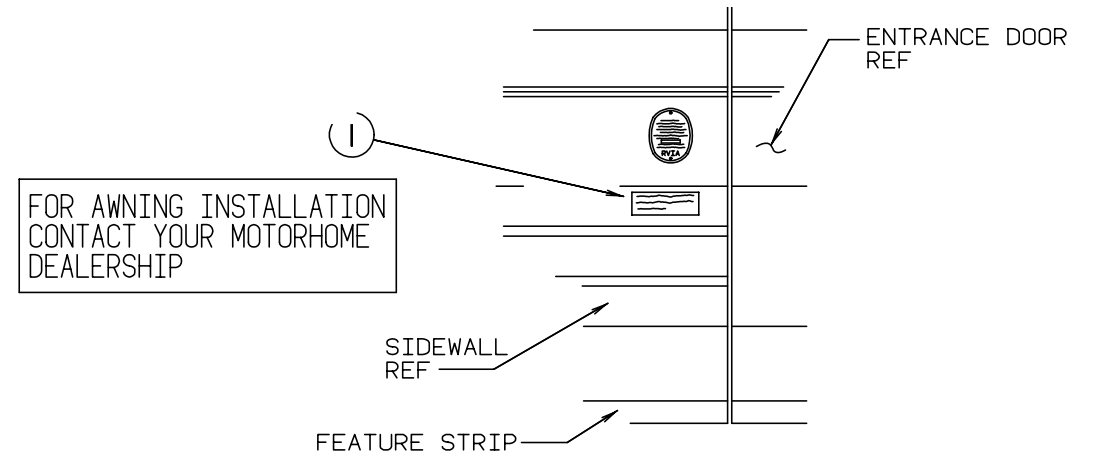

KEY	PART NUMBER	U/M DESCRIPTION
1	099509-01-000	EA LABEL-AWNING INSTALLATION

LABELS GROUP (CONTINUED)

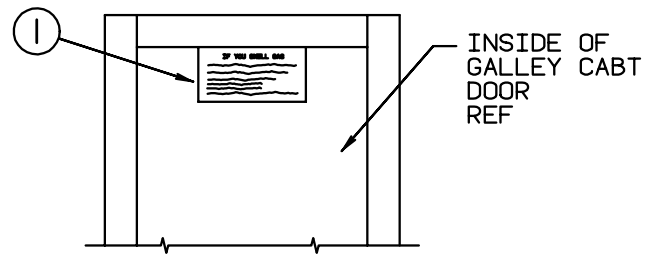

IF YOU SMELL GAS

1. EXTINGUISH ANY OPEN FLAME, PILOT LIGHTS AND ALL SMOKING MATERIALS.
2. SHUT OFF THE GAS SUPPLY AT THE TANK VALVE(OR GAS SUPPLY CONNECTION.
3. OPEN DOORS AND OTHER VENTILATING OPENINGS.
4. DO NOT TOUCH ELECTRICAL SWITCHES.
5. LEAVE THE AREA UNTIL ODOR CLEARS.
6. HAVE THE GAS SYSTEM CHECKED AND LEAKAGE SOURCE CORRECTED BEFORE USING AGAIN.

KEY	PART NUMBER	U/M DESCRIPTION
1	073998-01-000	EA LABEL-LPG ODOR WARNING

LABELS GROUP (CONTINUED)

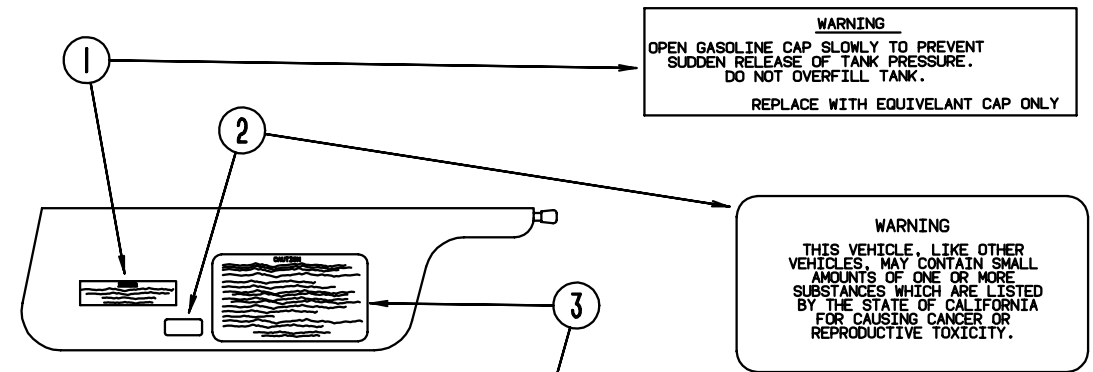

WARNING
OPEN GASOLINE CAP SLOWLY TO PREVENT SUDDEN RELEASE OF TANK PRESSURE. DO NOT OVERFILL TANK.
REPLACE WITH EQUIVELANT CAP ONLY

WARNING
THIS VEHICLE, LIKE OTHER VEHICLES, MAY CONTAIN SMALL AMOUNTS OF ONE OR MORE SUBSTANCES WHICH ARE LISTED BY THE STATE OF CALIFORNIA FOR CAUSING CANCER OR REPRODUCTIVE TOXICITY.

CAUTION

THIS MOTOR HOME HAS BEEN DESIGNED, MANUFACTURED AND TESTED WITH CONCERN FOR THE PROTECTION OF IT'S OCCUPANTS. WE RECOMMEND YOU PERFORM THE FOLLOWING INSPECTIONS FOR YOUR SAFETY AND THE SAFETY OF YOUR PASSENGERS BEFORE STARTING YOUR VEHICLE.

1. LP GAS SYSTEM- TURN OFF AT TANK FOR TRAVELING. TEST FOR LEAKS UPON ARRIVAL AT DESTINATION. BEFORE LIGHTING PILOTS.
2. WHEELS- INSPECT FOR DAMAGE AND CHECK LUG NUTS FOR TIGHTNESS.
3. TIRES- INSPECT FOR WEAR AND DAMAGE AND CHECK FOR RECOMMENDED AIR PRESSURE.
4. LIGHTING- TEST FOR PROPER OPERATION OF ALL INTERIOR AND EXTERIOR LIGHTS INCLUDING DASH LIGHTS, HEADLIGHTS, TAIL LIGHTS, BRAKE LIGHTS, CLEARANCE LIGHTS AND TURN SIGNALS.
5. EXITS- INSPECT RELEASE MECHANISM ON EMERGENCY EXIT WINDOW, TEST BOTH LOCKS ON MAIN ENTRANCE DOOR FOR EASE OF OPERATION AND INSTRUCT PASSENGERS HOW TO USE BOTH MEANS OF EXIT.
6. SEAT BELTS- DIRECT PASSENGERS TO DESIGNATED SEATS AND REQUIRE USE OF SEAT BELTS.
7. APPLIANCES- TURN OFF AND LATCH OR LOCK DOORS WHERE PROVIDED.
8. LOOSE PARCELS- STORE SECURELY.
9. UTILITY SUPPLY LINES- DISCONNECT ALL ELECTRIC, SEWER AND WATER LINES AND SECURE PROPERLY.
10. ENTRANCE DOOR STEP- PLACE IN RETRACTED POSITION FOR TRAVELING.

READ YOUR MOTOR HOME AND CHASSIS OWNER'S MANUAL FOR FURTHER PRECAUTIONS

KEY	PART NUMBER	U/M DESCRIPTION
1	087207-05-000	EA LABEL-FUEL CAP REMOVAL
2	099689-01-000	EA LABEL-WARNING, CANCER/TOXICITY
3	056259-01-000	EA LABEL-SAFETY CHECK LIST

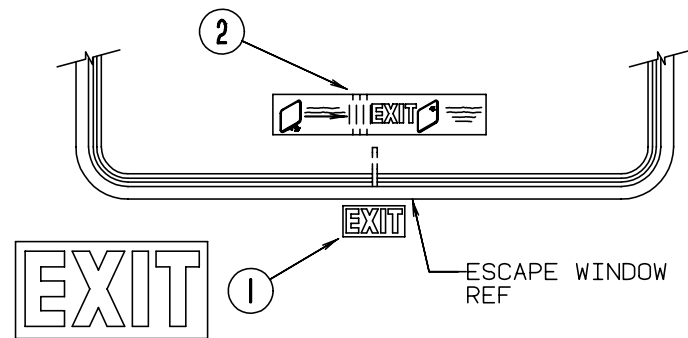

KEY	PART NUMBER	U/M DESCRIPTION
1	039290-01-000	EA LABEL-WARNING, EXIT
2	107571-01-000	EA LABEL-ESCAPE EXIT, WINDOW

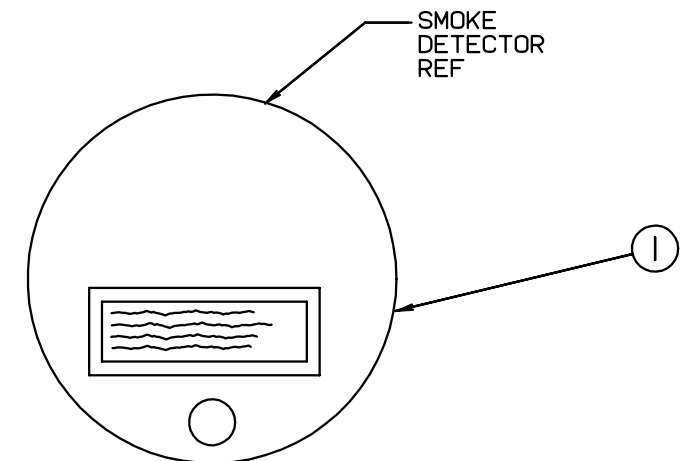

WARNING: TEST SMOKE DETECTOR OPERATION AFTER VEHICLE HAS BEEN IN STORAGE. BEFORE EACH TRIP AND AT LEAST ONCE PER WEEK DURING USE.

KEY	PART NUMBER	U/M DESCRIPTION
1	077956-01-000	EA LABEL-WARNING, SMOKE DETECTOR

LABELS GROUP (CONTINUED)

NOTE: TUNE ANTENNA PER MANUFACTURER'S DIRECTIONS. FAILURE TO COMPLY COULD RESULT IN DAMAGE TO CB.

CB POWER PROVISION
 RED +12 V
 BLACK GROUND
 COAX ANTENNA
 (SEE REVERSE ALSO)

KEY PART NUMBER U/M DESCRIPTION
 1 104678-01-000 EA LABEL-CB PREP

WARNING
 MUST BE STOWED
 IN LATCHED POSITION
 WHILE VEHICLE IS IN MOTION

KEY PART NUMBER U/M DESCRIPTION
 1 079966-01-000 EA LABEL-WARNING, STOWED, MOTION

DO NOT USE HITCH BEFORE
 READING OWNERS MANUAL REGARDING
 VEHICLE LOADING AND TOWING

KEY PART NUMBER U/M DESCRIPTION
 1 111104-01-000 EA LABEL-HITCH, READ MANUAL

WIRE IDENTITY :
 YELLOW - LEFT TURN LAMP
 GREEN - RIGHT TURN LAMP
 RED - BRAKE LAMP
 BROWN - RUNNING LAMP
 BLACK - BACKUP LAMP

KEY PART NUMBER U/M DESCRIPTION
 1 091224-02-000 EA LABEL-TRAILER LIGHTING

LABELS GROUP (CONTINUED)

WARNING DISCONNECT BATTERIES BEFORE
 CONNECTING EXTERNAL CHARGING EQUIPMENT.

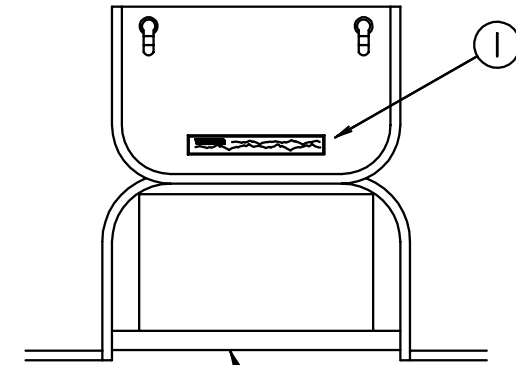

KEY PART NUMBER U/M DESCRIPTION
 1 065748-01-000 EA LABEL-CAUTION, BATTERY CHARGING

BATTERY COMPARTMENT
 REF

GENERATOR COMP
 DOOR REF

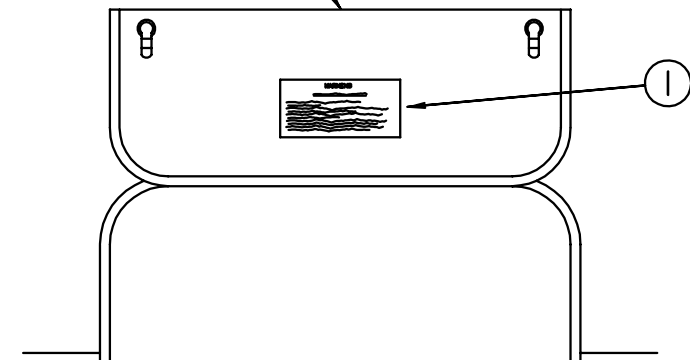

WARNING
 WHEN ADDING A GENERATOR SET:
 HIGH VOLTAGE-USE EXTREME CAUTION WHEN WORKING ON
 ELECTRICAL COMPONENTS.
 HAVE ALL ELECTRICAL INSTALLATION PERFORMED BY A QUALIFIED LICENSED
 ELECTRICIAN-FOLLOW ALL STATE AND LOCAL CODES.
 ONLY INSTALL GENERATOR SET APPROVED FOR R.V. APPLICATION. HAVE
 INSTALLED BY QUALIFIED TECHNICIAN.
 TO AVOID HEAT BUILD-UP AND TO GUARANTEE AN ADEQUATE AIR SUPPLY TO
 THE GENERATOR CARBURETOR, FOLLOW INSTALLATION INSTRUCTIONS.
 GENERATOR ENGINE EXHAUST GASES ARE TOXIC AND MUST NOT TERMINATE
 UNDER THE VEHICLE-DISCHARGE EXHAUST AWAY FROM VEHICLE.

KEY PART NUMBER U/M DESCRIPTION
 1 077510-01-000 EA LABEL-GENERATOR PREP

LABELS GROUP (CONTINUED)

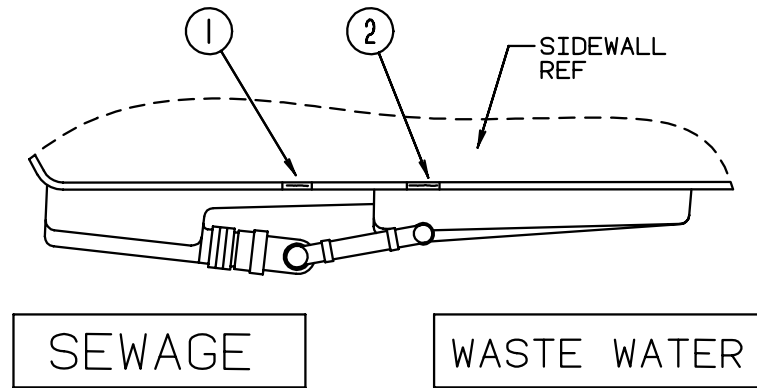

KEY	PART NUMBER	U/M DESCRIPTION
1	006187-01-000	EA LABEL-SEWAGE
2	006188-01-000	EA LABEL-WASTE WATER

LABELS GROUP (CONTINUED)

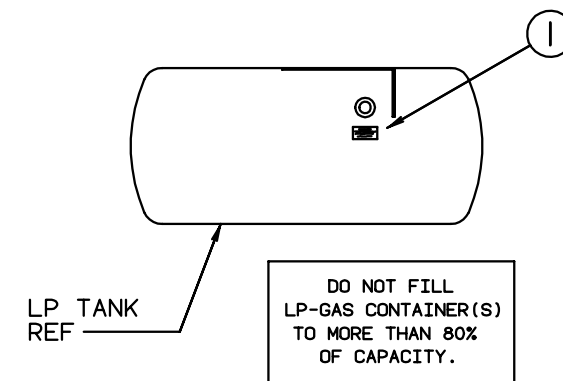

KEY	PART NUMBER	U/M DESCRIPTION
1	079965-01-000	EA LABEL-LPG, 80 LB CAPACITY

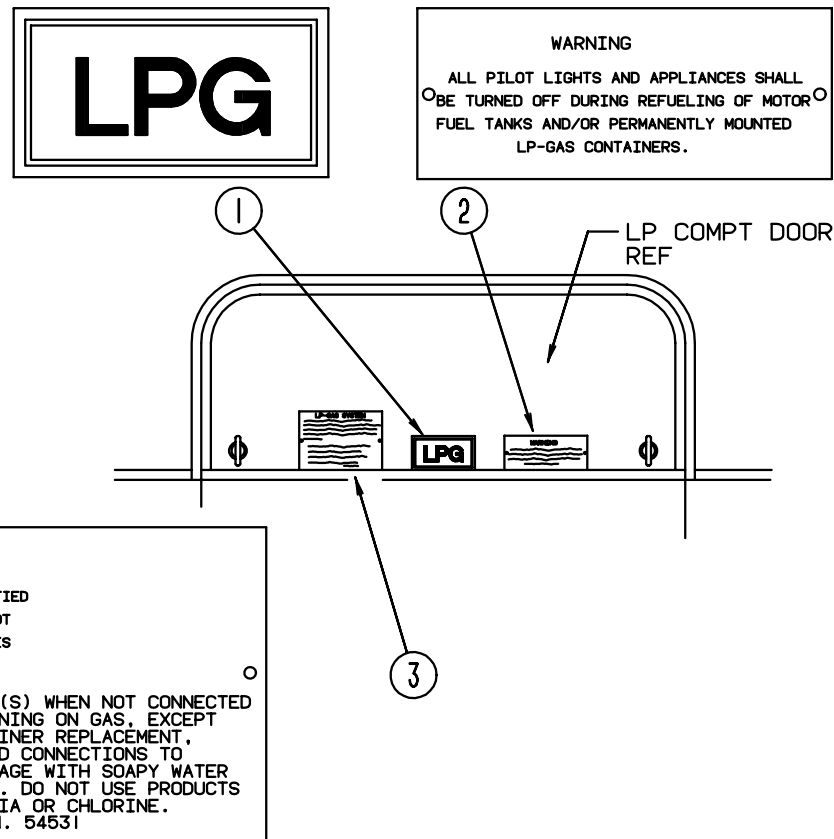

KEY	PART NUMBER	U/M DESCRIPTION
1	074559-01-000	EA DECAL-LOGO, LPG - RED - (CALIF CODE)
2	006040-01-000	EA TAG-GAS REFUELING WARNING
2	006040-02-000	EA TAG-GAS REFUEL WARNING, CANADIAN
3	054531-01-000	EA LABEL-LP GAS ONLY
3	023769-01-000	EA LABEL-WARNING, LPG - CANADIAN

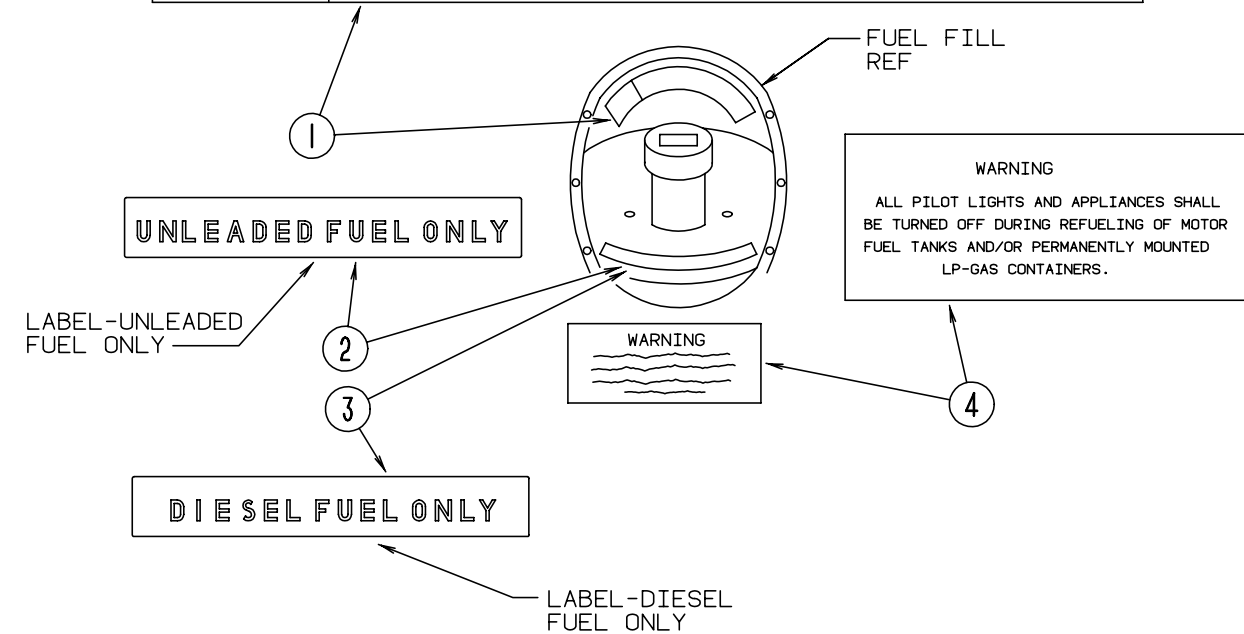
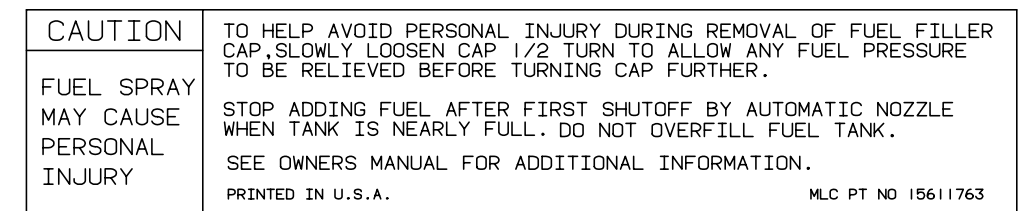

KEY	PART NUMBER	U/M DESCRIPTION
1	087207-05-000	EA LABEL-FUEL CAP REMOVAL
2	062043-01-000	EA LABEL-FUEL, UNLEADED
3	068383-01-000	EA LABEL-DIESEL FUEL
4	006040-01-000	EA TAG-GAS REFUELING WARNING
4	006040-02-000	EA TAG-GAS REFUEL WARNING, CANADIAN

LABELS GROUP (CONTINUED)

MISCELLANEOUS LABELS

KEY	PART NUMBER	U/M DESCRIPTION
	061606-01-000	EA LABEL-OVERLAY, VEHICLE CERTIFICATION - ADHESIVE BACKED
	090342-01-000	EA LABEL-VAPOR RELIEF
	061417-01-000	EA LABEL-FUEL, ON FUEL FILL DOOR
	006064-01-000	EA LABEL-SEAT W/O SEATBELT "NOT INTENDED FOR USE WHILE COACH IN MOTION"
	091243-01-000	EA LABEL-A/C COVER, "AIR CONDITIONING CIRCUIT. ETC."
	098641-01-000	EA LABEL-FUEL, UNLEADED - DASH
	111537-01-000	EA LABEL-FUSES
	111802-01-000	EA LABEL-CFC WARNING
	098379-04-000	EA LABEL-ELECTRICAL BOX, SIDE

LP GROUP

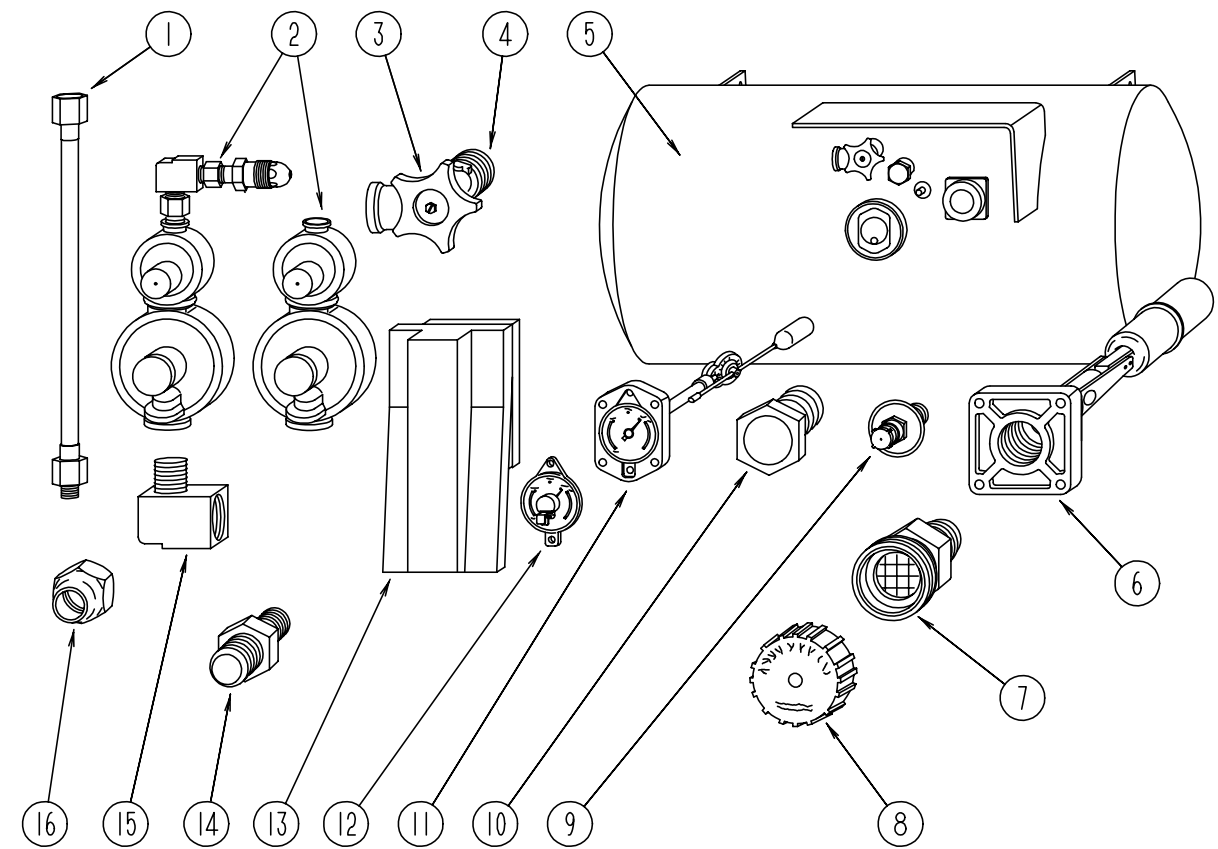

LP TANK & COMPONENTS

KEY	PART NUMBER	U/M DESCRIPTION	VENDOR NO.
1	045703-01-000	EA HOSE-LP, 3/8" ID X 24" - 3/8" MPT X 1/2" F SWIVEL - US	
1	045703-02-000	EA HOSE-LP, 3/8" ID X 24" - 3/8" MPT X 1/2" F SWIVEL - CANADIAN	
2	106150-01-000	EA REGULATOR-TWO STAGE	
2	106150-02-000	EA REGULATOR-TWO STAGE - EUROPEAN	
3	040421-01-708	EA HANDWHEEL-VAPOR RELIEF VALVE	G-1015-A
4	040421-01-712	EA VALVE-SERVICE W/O VAPOR RELIEF	29000853
5	097821-01-000	EA TANK-LP, 60 LB BRUNNER - 14" X 30"	
6	040421-01-711	EA VALVE-80% W/FLOAT, PLATE, BOLTS & GASKET	
7	040421-01-701	EA VALVE-SHORT LP FILLER W/YELLOW CAP	75478
8	040421-01-702	EA CAP-LP FILLER VALVE, PLASTIC - YELLOW	G-1014-A
9	040421-01-700	EA GAUGE-LIQUID LEVEL, 20% LP	G-1013
10	040421-01-713	EA PRESSURE RELIEF VALVE	
11	040421-01-707	EA GAUGE-FLOAT W/VISIBLE DIAL	MA-9 6244-4
12	040440-02-000	EA TRANSMITTER-DIAL, 90 OHM	
13	105658-01-000	EA COMPARTMENT-LP REGULATOR	
14	010329-01-000	EA ADAPTER-BRASS, 1/2" F X 1/2" MPT	
14	010323-01-000	EA ADAPTER-BRASS, 3/8" F X 1/2" MPT	
15	065318-02-000	EA ELBOW-90 DEGREE, 3/8" MPT TO 3/8" FPT	
16	010377-02-000	EA NUT-BRASS, 3/8" FEMALE - FORGED	
	024250-01-000	EA ADAPTER-BRASS, 3/8" F X 1/2" FPT	
	036346-01-000	EA BUSHING-STEEL, 3/4" MPT X 1/2" FPT - EXPORT OPTION	
	071391-02-000	EA NIPPLE-HEX, 1/4" PIPE - 3325X4 WEATHERHEAD - US	
	008042-01-000	FT TUBING-VINYL, .65" ID	
	095624-01-000	EA ELBOW-BRASS, 90 DEGREE - 1/4" FPT X 1/4" FPT - US	
	010380-02-000	EA NUT-BRASS, 1/2" FEMALE - FORGED	
	103613-01-000	EA DETECTOR-LP GAS	

LOUNGE GROUP

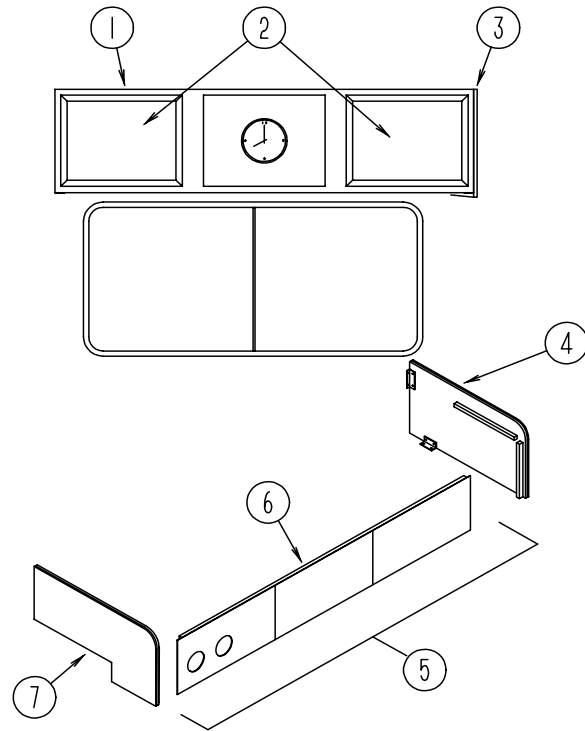

DRIVERS SIDE LOUNGE

KEY	PART NUMBER	U/M	DESCRIPTION
1	113879-01-F24	EA	CABINET-OVERHEAD, W/O DOORS
1	113879-01-F25	EA	CABINET-OVERHEAD, W/O DOORS
1	113879-01-F26	EA	CABINET-OVERHEAD, W/O DOORS
1	113879-01-F27	EA	CABINET-OVERHEAD, W/O DOORS
2	M06803-03-E07	EA	DOOR-CABINET, W/O HARDWARE - 400 MM X 520 MM
2	M06803-41-E10	EA	DOOR-CABINET, W/O HARDWARE - 400 MM X 520 MM (DECORATIVE DOOR)
	108536-03-08A	EA	MIRROR-GLASS GALAXY FLOWER
3	103128-01-E10	EA	CAP-END, OVERHEAD CABINET - FRONT
4	M04187-29-E28	EA	PANEL-COUCH CABINET - LEFT SIDE - FABRIC COVERED (F24)
4	M04187-29-F25	EA	PANEL-COUCH CABINET - LEFT SIDE - FABRIC COVERED
4	M04187-29-F26	EA	PANEL-COUCH CABINET - LEFT SIDE - FABRIC COVERED
4	M04187-29-F27	EA	PANEL-COUCH CABINET - LEFT SIDE - FABRIC COVERED
5	M04187-31-E28	EA	PANEL-COUCH CABINET - FRONT - W/DOOR - FABRIC COVERED (F24)
5	M04187-31-F25	EA	PANEL-COUCH CABINET - FRONT - W/DOOR - FABRIC COVERED
5	M04187-31-F26	EA	PANEL-COUCH CABINET - FRONT - W/DOOR - FABRIC COVERED
5	M04187-31-F27	EA	PANEL-COUCH CABINET - FRONT - W/DOOR - FABRIC COVERED
6	M04187-32-E28	EA	DOOR-CABINET, W/O HARDWARE - 11" X 21.6" - FABRIC COVERED (F24)
6	M04187-32-F25	EA	DOOR-CABINET, W/O HARDWARE - 11" X 21.6" - FABRIC COVERED
6	M04187-32-F26	EA	DOOR-CABINET, W/O HARDWARE - 11" X 21.6" - FABRIC COVERED
6	M04187-32-F27	EA	DOOR-CABINET, W/O HARDWARE - 11" X 21.6" - FABRIC COVERED
7	M04187-30-E28	EA	PANEL-COUCH CABINET - RIGHT SIDE - W/FABRIC (F24)
7	M04187-30-F25	EA	PANEL-COUCH CABINET - RIGHT SIDE - W/FABRIC
7	M04187-30-F26	EA	PANEL-COUCH CABINET - RIGHT SIDE - W/FABRIC
7	M04187-30-F27	EA	PANEL-COUCH CABINET - RIGHT SIDE - W/FABRIC
	105947-01-000	EA	BRACKET-HOLD DOWN, COUCH - CANADIAN
	082525-01-000	EA	BRACE-COUCH, FLOOR MOUNT - ANGLE 3" LONG - METAL
	083125-03-000	EA	BRACE-ANGLE, COUCH - 2.5" - TAN
	083125-05-000	EA	BRACE-ANGLE, COUCH - 2.5" - BEIGE
	081298-01-E01	EA	TABLE-LOUNGE, 432 MM X 610 MM - W/O HARDWARE (F24,F27)
	081298-01-E04	EA	TABLE-LOUNGE, 432 MM X 610 MM - W/O HARDWARE (F25)
	081298-01-F26	EA	TABLE-LOUNGE, 432 MM X 610 MM - W/O HARDWARE
	009040-02-000	EA	PEDESTAL TABLE LEG-27.5" X 2.25" DIA - CHROME
	041194-01-000	EA	BASE-TABLEMCW, FLUSH - FLOOR MOUNTED
	009040-03-000	EA	BASE-TABLE, RAISED - TABLE MOUNTED
	042438-02-000	EA	DOWEL-WOOD, 2" X 2"
	076840-02-000	EA	HOLD DOWN CORD-BUNGEE - 18"
	077968-01-000	EA	RETAINER-NYLON, .5" X 1.6"
	062046-01-000	EA	CLIP-LEG, PEDESTAL - 1.7" X 2.2" - DIA. FROM 2" TO 2.5"

LOUNGE GROUP (CONTINUED)

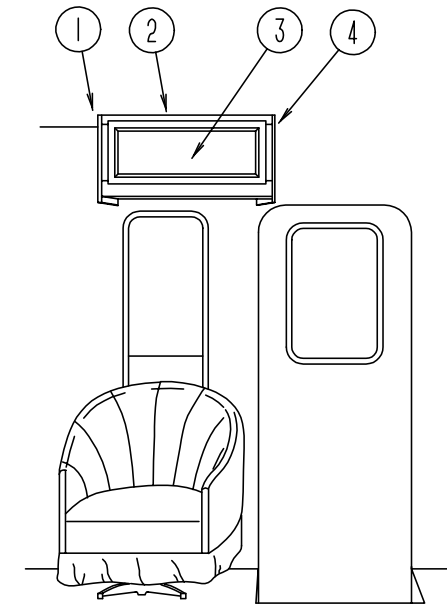

PASSENGER SIDE LOUNGE BUNK OPTION

KEY	PART NUMBER	U/M	DESCRIPTION
1	103128-09-E10	EA	CAP ASM-END, OVHD - LH
2	114189-01-F04	EA	CABINET ASM-OVERHEAD
3	M06803-04-E07	EA	DOOR-CABINET, W/O HARDWARE - 255 MM X 485 MM
4	103128-08-E10	EA	CAP ASM-END, OVHD - RH
	104006-01-C05	EA	LID-ENTRANCE STEP COMPARTMENT, W/O CARPET
	101222-01-02A	EA	BRACKET-CATCH, LID - O/WHT
	107941-01-02A	EA	SUPPORT-LID, ENTRANCE STEP O/WHT

SEALANTS & FASTENERS GROUP

SEALANTS & FASTENERS GROUP (CONTINUED)

SEALANTS & ADHESIVE

BOLTS, NUTS & WASHERS (CONTINUED)

KEY	PART NUMBER	U/M	DESCRIPTION
	002707-02-000	FT	TAPE-SEALER, 5/16" X 1/2" - INCREMENTS OF 50 FT
	034552-02-000	EA	SILICONE-TUBE, 300 ML - CLEAR
	034552-15-000	EA	SILICONE-TUBE, 300 ML - BRIGHT WHITE
	053766-02-000	EA	BEDDING COMPOUND-TUBE, WHITE SCHNEE# 5522
	053766-06-000	EA	BEDDING COMPOUND-TUBE, CLEAR
	053766-08-000	EA	BEDDING COMPOUND-TUBE, GRAY - SCHNEE# 5522
	062917-03-000	EA	ADHESIVE-LOCTITE 242
	063642-01-000	FT	TAPE-ADHESIVE, 10 MM X 1.5" WIDE X 180'
	069640-01-000	FT	SEALER-RIBBON, 1/4" DIAMETER - INCREMENTS OF 30'
	069640-02-000	FT	SEALER-RIBBON, 1/2" X 1/8" - INCREMENTS OF 60'
	069640-03-000	FT	SEALER-RIBBON, 3/4" X 1/8" - INCREMENTS OF 60'
	069640-07-000	FT	SEALER-RIBBON, 2" X 3/32" - INCREMENTS OF 30' OR 45'
	069640-09-000	FT	SEALER-RIBBON, 1/32" X 2 1/2" - INCREMENTS OF 80'
	069640-11-000	FT	SEALER-TAPE, 3/16" X 3/8", BLACK - MANUS
	069640-13-000	FT	SEALER-TAPE, 3/32" X 2" BLACK - MANUS
	069640-14-000	FT	SEALER-TAPE, 1/16" X 1" GRAY - MANUS
	072889-01-000	EA	SEALANT-URETHANE, BLACK - 1/10 - ESSEX 552.2
	072889-09-000	EA	SEALANT-URETHANE, BLACK - TUBE - MANUS 75AM
	076314-02-000	FT	TAPE-CARPET SEAM, HEAT-BOND - 4" WIDE
	076322-01-000	FT	TAPE-FOAM, DOUBLE COATED ADHESIVE BACKED - .75" X 216'
	076322-02-000	FT	TAPE-FOAM, DOUBLE COATED ADHESIVE BACKED - 1" X 108'
	076322-05-000	FT	TAPE-FOAM, DOUBLE COATED - .025" X 1.5" X 108'
	076322-07-000	FT	TAPE-FOAM, DOUBLE COATED - .045" X .50"
	110274-01-000	FT	TAPE-FOAM, DOUBLE COATED - .045" X 1.0"
	087211-01-000	GL	PROMOTER-ADHESIVE
	102352-01-000	EA	SEALER-PUMPABLE, BLACK - COLORIMETRIC MS101
	106206-01-000	EA	SEALER-PUMPABLE
	108716-01-000	EA	SILICONE-TUBE, OFF WHITE - SELF LEVELING - CSL 510
	900390-01-000	EA	TIP - 2 1/2" X 1/8" ORIFICE, ELLSWORTH#TS216
	900390-03-000	EA	NOZZLES-SILICONE TUBE, CSL# D10
	114311-01-000	GL	ADHESIVE-GLUE
	091255-01-000	FT	SEAL-FOAM, 3.2MM X 4.8MM

KEY	PART NUMBER	U/M	DESCRIPTION
	000E13-20-00B	EA	WASHER-FL, 7/16" WIDE - ZN
	000E13-21-00B	EA	WASHER-FL - W/2 NAR ZN
	000E14-10-00B	EA	WASHER-LK - NO 10 EXT TOOTH - ZN
	000G45-05-16B	EA	BOLT-LAG 5/16 - 9 X 1 ZN
	040921-04-000	EA	NUT-SPEED, U TYPE - NO. 8 - .59" LENGTH X .44" WIDTH
	044364-02-000	EA	NUT-SPEED, FLAT - ROUND
	051387-06-000	EA	WASHER-PLASTIC, 1 3/8"OD - FOR BUTTONS
	058716-02-000	EA	BOLT-CARRIAGE, W/O HOLE - 5/16-18 X 9.5 ZN
	063253-07-000	EA	WASHER-FLAT NYLON .406 X .750 X .060
	087234-01-000	EA	NUT-J, #8A .120- .130 PNL THK
		EA	NUT-JACK, 1/4 X 20 THD,MOLLY ARDEN 8-L,JN BRASS
			MOUNTS LICENSE PLATES
	102333-01-06A	EA	BOLT-CARRIAGE, 7/16 - 14 SST CAP BRIGHT WHITE BUMPER BOLT
	104369-01-000	EA	NUT-HEX,HEAVY,5/8-11 UNC SPARE TIRE INSTL
	105247-01-000	EA	INSERT NUT 8-32 THD X .394LG STAFASST PRODUCTS
	106649-01-000	EA	WASHER-SEALING,GALVANIZED 5/8 ID

BOLTS, NUTS & WASHERS

SCREWS

KEY	PART NUMBER	U/M	DESCRIPTION
	000C12-05-16B	EA	BOLT-HEX, 5/16 - 18 X 1 - ZINC 5
	000C12-05-64B	EA	BOLT-HEX, 5/16 - 18 X 4
	000C12-06-16B	EA	BOLT-HEX, 3/8 - 16 X 1LG,ZN 5
	000C12-07-20B	EA	BOLT-HEX, 7/16 - 14 X 1 1/4" - ZN5
	000C12-08-24B	EA	BOLT-HEX, 1/2 - 13 X 1 1/2 - ZN 5
	000C12-10-24B	EA	BOLT-HEX, 5/8 - 11 X 1 1/2 ZN - 5
	000C13-07-48B	EA	BOLT-HEX, 7/16 - 20 X 3 - ZN 5
	000C18-05-40A	EA	BOLT-ELEV, 5/16"-18 X 2 1/2" PL
	000C26-04-14B	EA	BOLT-HEX SERRATED FLANGE, 1/4 X 20 X 7/8 ZINC
	000C26-04-10B	EA	BOLT-HEX, SER FLG - 1/4 - 20 X 5/8 ZINC
	000C26-05-12B	EA	BOLT-HEX-SER FLG 5/16 - 18 X 3/4 ZN
	000C26-06-12B	EA	BOLT-HEX-SER FLG 3/8 - 16 X 3/4 ZN
	000C26-06-28B	EA	BOLT-HEX-SER FLG 3/8 - 16 X 13/4 ZN
	000C27-10-32B	EA	BOLT-CARR 5/8 - 11 X 2.00
	000D14-04-00B	EA	NUT-HEX, 1/4-20,ZN 5
	000D24-10-00B	EA	NUT-HEX, SF/LK - 10-32 ZN
	000D34-04-00B	EA	NUT-HEX, LK 1/4 - 20 ZN
	000D34-06-00B	EA	NUT-HEX, LK - 3/8 - 16 GRADE C ZN - PREVAILING TORQUE
	000D39-04-00B	EA	NUT-HEX, SER FLG LK 1/4 - 20 ZN
	000D39-05-00B	EA	NUT-HEX, SER FLG LK - 5/16 - 18 ZN
	000D39-06-00B	EA	NUT-HEX, SER FLG LK - 3/8-16 ZN
	000D39-08-00B	EA	NUT-HEX, SER FLG LK - 1/2-13 ZN
	000D44-07-00B	EA	NUT-HEX, SER FLG LK - 7/16-20 ZN
	000D46-04-00A	EA	NUT-HEX,WELD,1/4-20,PLAIN SHORT PILOT
	000E11-07-00B	EA	WASHER-LK - 7/16 MED SPLIT ZN
	000E13-18-00B	EA	WASHER-FL - 3/8 WIDE ZN

KEY	PART NUMBER	U/M	DESCRIPTION
	000G11-06-08B	EA	SCREW, 6 - 20 X 1/2 PPH ZINC
	000G11-06-06B	EA	SCREW, 6 - 20 X 3/8 PPH ZN
	000G11-06-10J	EA	SCREW, 6 - 20 X 5/8 PPH - BRASS
	000G11-06-10B	EA	SCREW, 6 - 20 X 5/8 PPH ZN
	000G11-07-08B	EA	SCREW, 7 - 19 X 1/2 PPH - ZN
	000G11-08-06B	EA	SCREW, 8 - 18 X 3/8 PPH ZN
	000G11-08-20B	EA	SCREW, 8 - 18 X 11/4 PPH ZN 05031-01-000
	000G11-08-16S	EA	SCREW, 8 - 18 X 1.00 PPH - OFF WHITE
	000G11-08-12T	EA	SCREW, 8 - 18 X 3/4 PPH - BLACK
	000G11-08-12S	EA	SCREW, 8 - 18 X 3/4 PPH - OFF WHITE
	000G11-08-12P	EA	SCREW, 8 - 18 X .75 PPH - DARK BROWN
	000G11-08-12D	EA	SCREW, 8 - 18 X 3/4 PPH - BLACK
	000G11-08-12B	EA	SCREW, 8 - 18 X 3/4 PPH ZN
	000G11-08-08B	EA	SCREW, 8 - 18 X 1/2 PPH - ZN
	000G11-10-40B	EA	SCREW, 10 - 16 X 2 1/2 PPH CAD - 34927-01-000
	000G11-10-16B	EA	SCREW, 10 - 16 X 1 - PPH ZN
	000G11-10-12S	EA	SCREW, 10 - 16 X .75 PPH OFF WHT
	000G11-10-12D	EA	SCREW, 10 - 16 X 3/4 PPH - BLACK
	000G12-08-16S	EA	SCREW, 8 - 18 X 1.00 POH - OFF WHITE
	000G13-06-16J	EA	SCREW, 6 - 20 X 1.00 PFH - BRASS
	000G13-06-08G	EA	SCREW, 6 - 20 X 1/2 PFH - ANTIQUE BRASS
	000G13-06-24J	EA	SCREW, 6 - 20 X 1.50 PFH BRASS
	000G18-08-22B	EA	SCREW-MACH, 8-32 X 1 3/8 PPH ZN
	000G19-10-20B	EA	SCREW-MACHINE, 10-32 X 1 1/14 PPH ZINK
	000G19-10-08B	EA	SCREW-MACHINE, 10-32 X 1/2 PPH ZN
	000G32-10-06B	EA	SCREW-10-32 X 3/8" - PPH - ZINC
	000G39-06-10T	EA	SCREW-SF/DR, 6-20 X 5/8 PPH - BLACK
	000G39-08-08B	EA	SCREW-SF/DR, 8-18 X 1/2 PPH ZN
	000G39-08-06B	EA	SCREW-SF/DR, 8-18 X 3/8 PPH ZN
	000G39-08-16B	EA	SCREW-SF/DR, 8-18 X 1 PPH ZN
	000G39-08-12T	EA	SCREW-SF/DR, 8-18 X 3/4 PPH - BLACK
	000G39-08-12B	EA	SCREW-SF/DR, 8-18 X 3/4 PPH ZN
	000G39-08-08S	EA	SCREW-SF/DR, 8-18 X 1/2 PPH - OFF WHITE
	000G39-08-32B	EA	SCREW-SF/DR, 8-18 X 2 PPH - ZINC
	000G39-08-16T	EA	SCREW-SF/DR, 8-18 X 1 PPH - BLACK
	000G39-08-16S	EA	SCREW-SF/DR, 8-18 X 1.00 PPH, OFF WHITE
	000G39-10-12B	EA	SCREW-SF/DR,10-16 X .75 PPH ZN
	000G39-10-209	EA	SCREW-SF/DR,10-16 X 1.25 PPH FLUOROCARBON SILVER
	000G39-10-20B	EA	SCREW-SF/DR, 10-16 X 1 1/4 PPH ZN
	000G39-10-129	EA	SCREW-SF/DR, 10-16 X 3/4 PPH - FLUOROCARBON SILVER
	000G39-10-12D	EA	SCREW-SF/DR, 10-16 X 3/4 PPH - BLACK
	000G43-06-24B	EA	SCREW-MACHINE, 6-32" X 1 1/2" ZN

SEALANTS & FASTENERS GROUP (CONTINUED)**SCREWS (CONTINUED)**

KEY	PART NUMBER	U/M	DESCRIPTION
	000G46-08-24T	EA	SCREW-MACHINE, 8-32-1.50 IN PFH - BLACK
	000G50-04-08B	EA	SCREW-MACH, 1/4-20 X 1/2 PTH 2N
	000G50-04-12B	EA	SCREW-MACH, 1/4-20 X 3/4 PPH ZN
	000G52-08-18B	EA	SCREW-MACH, 8-32 X 1 1/8 PTH ZN
	000G53-04-06B	EA	SCREW-MACHINE, 1/4-20 X 3/8 PPH ZN - UNDERCUT HEAD
	000G54-04-20B	EA	SCREW, 1/4-20 X 1 1/4 PTH - TYPE 23 - ZINC PLATED
	000G56-12-48B	EA	SCREW-WOOD, 12 - 11 X 3 POH - SPECIAL HARDENED
	000G57-05-16J	EA	SCREW, 5-20 X 1 PFH - BRASS
	000G60-10-28T	EA	SCREW-SF/DR, 10-16 X 1.75 - BLACK
	000G67-10-08B	EA	SCREW, 10-12 X 1/2 PPH ZN
	000G67-10-36T	EA	SCREW-10-12 X 2.25 PPH BLACK STALGARD
	000G67-10-24B	EA	SCREW, 10-12 X 1 1/2 PPH - ZN
	000G67-10-20D	EA	SCREW, 10-12 X 1 1/4 PPH - BLACK
	000G67-10-16B	EA	SCREW, 10-12 X 1 PPH - ZN
	000G67-10-120	EA	SCREW, 10-12 X .75" PPH - TAN
	000G67-10-12P	EA	SCREW, 10-12 X .75" - PPH - DARK BROWN
	000G67-10-12B	EA	SCREW, 10-12 X 3/4" PPH - ZN
	000G67-10-10S	EA	SCREW, 10-12 X 5/8" - PPH - OFF WHITE
	000G67-10-10D	EA	SCREW, 10-12 X 5/8 PPH - BLACK - TYPE A
	000G67-10-10B	EA	SCREW, 10-12 X 5/8 PPH ZN - TYPE A
	000G68-06-10G	EA	SCREW, 6-18 X 5/8 POH - ANTIQUE BRASS
	049465-01-000	EA	SCREW, 10-16 W/WASHER PTH - DARK BROWN
	049465-03-000	EA	SCREW, 10-16 X 1 POH W/WASHER - OFF WHITE
	049465-04-000	EA	SCREW, 10-16 X 1 PTH W/WASHER - BEIGE
	049465-05-000	EA	SCREW, 10-16 X 1 PTH W/WASHER - GRAY
	075908-01-000	EA	SCREW-MACHINE, 10-32 X .56 PTH - ZINC EXTERNAL TOOTH
	101618-01-000	EA	SCREW-1/4-20 X 3/4 HEX/TAPPING STALGARD TYPE F

CLAMPS, CLIPS & GROMMETS

KEY	PART NUMBER	U/M	DESCRIPTION
	007161-01-000	EA	CLAMP-HOSE, SPRING TYPE - 1/2"
	008380-01-000	EA	GROMMET-RUBBER, 5/8" HOLE X 1 1/2" DIAMETER - BLACK
	010495-01-000	EA	CLAMP-CABLE, 9/16"
	010497-01-000	EA	CLAMP-CLOSED, 5/8" ID
	010497-03-000	EA	CLAMP-CLOSED, 1" ID - CUSHIONED
	010497-04-000	EA	CLAMP-CLOSED, 1.62 ID ADEL,945-2717
	010497-05-000	EA	CLAMP-CLOSED, 1/2" ID
	010499-01-000	EA	CLAMP-CLOSED, 3/8" ID
	016188-03-000	EA	GROMMET-L/P LINE, 3/8" HOLE X 2 1/2" LONG - RUBBER
	016188-05-000	EA	GROMMET-L/P LINE, 3/8" HOLE X 1 1/4" LONG - RUBBER
	023942-01-000	EA	GROMMET-RUBBER, 2" OD
	062401-01-000	EA	CLAMP-HOSE, WORMGEAR .25" - 1"
	062401-04-000	EA	CLAMP-HOSE, WORMGEAR .69"- 1.25"
	062401-06-000	EA	CLAMP-HOSE, WORMGEAR .22"-.62"
	062401-11-000	EA	CLAMP-HOSE, WORMGEAR 3.56"- 4.5"
	075148-02-000	EA	CLAMP-GROUNDING, BRONZE SCREWS
	077955-01-000	EA	CLIP-J,VINYL COATED, 3/8"
	080211-03-000	EA	CLIP-MOUNTING, (XMAS TREE) - DECORATIVE PADS
	080734-02-000	EA	CLIP-WIRE, NYLON
	083609-01-000	EA	CLAMP-WIRE, DUAL EQUAL - 5/8" DIAMETER
	083610-01-000	EA	CLAMP-WIRE, DUAL - UNEQUAL DIAMETERS - .75" & 1.25"
	094362-02-000	EA	CLIP-CHRISTMAS TREE, FLAT HEAD - .5" X .95"
	099637-01-000	EA	GROMMET-RUBBER, .37" X .94" DIAMETER - BLACK
	101447-01-000	EA	CLIP-U TYPE, TINNERMAN HOLDS SHOWER SURROUND TOGETHER

SEALANTS & FASTENERS GROUP (CONTINUED)**MISCELANOUS FASTENERS**

KEY	PART NUMBER	U/M	DESCRIPTION
	008343-01-000	EA	TIE-WIRE, 6"
	008343-02-000	EA	TIE-WIRE, 14"
	029094-04-000	YD	VELCRO TAPE-LOOP, 1" WIDE - BLACK
	029096-03-000	YD	VELCRO TAPE-HOOK, 1" WIDE - BLACK
	029096-04-000	YD	TAPE-HOOK, VELCRO - 1" WIDE - BLACK
	081211-05-000	EA	PLUG-PLASTIC, .188 DIA - NATURAL
	085774-01-000	FT	FASTENER-DUAL HOOK, 1" WIDE - ADHESIVE BACK - BLACK
	085774-02-000	FT	FASTENER-DUAL LOOP, 1" WIDE - ADHESIVE BACK - BLACK
	086285-01-000	EA	SPACER-NYLON, .5" OD X .257" ID
	108046-02-000	EA	CABLE TIE-SCREW MOUNT 15" DENNISON 10035

WATER & SEWAGE GROUP

WATER HEATER W/MOTOR AID

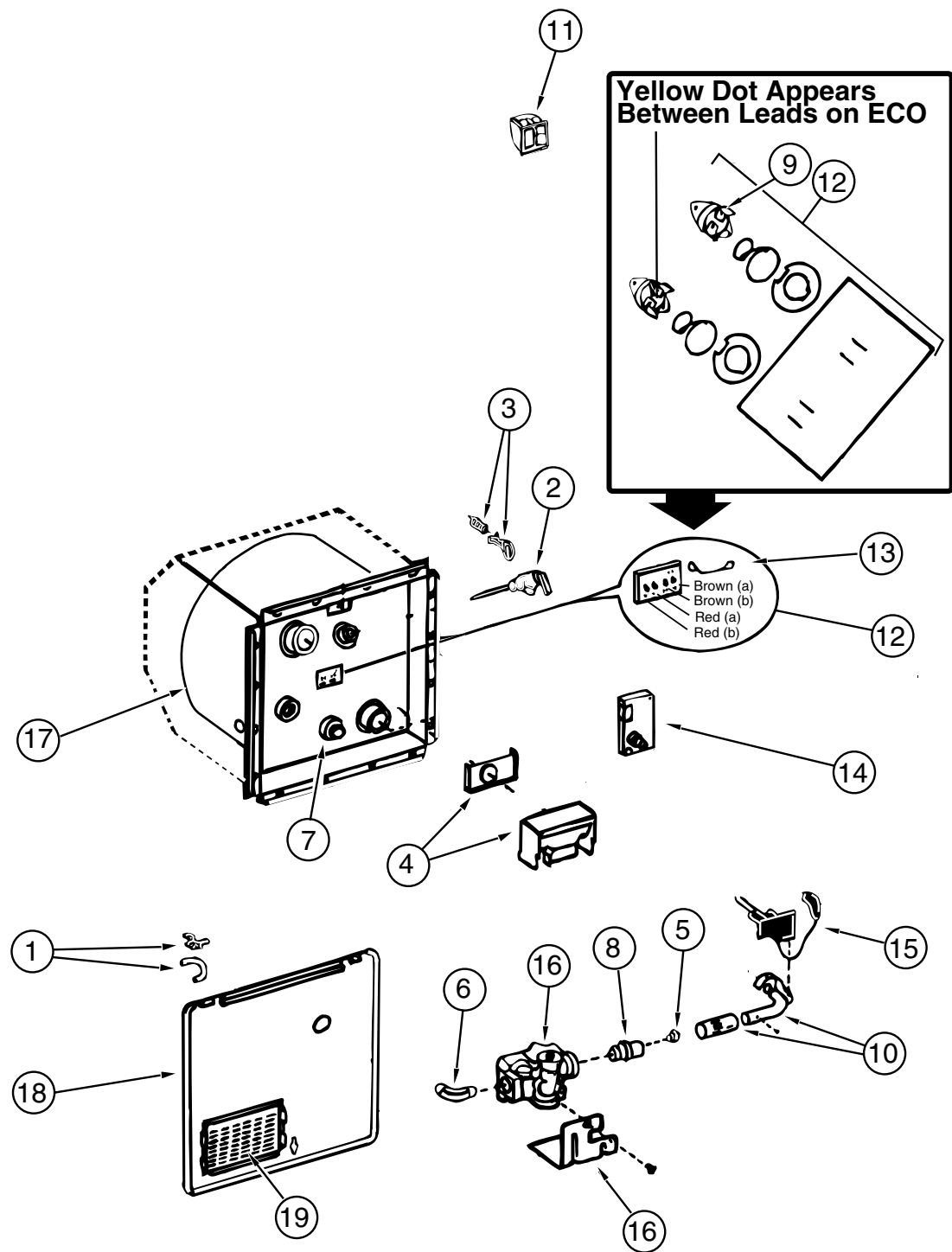

KEY	PART NUMBER	U/M DESCRIPTION	VENDOR NO.
	051393-01-000	EA WATER HEATER-W/MOTOR AID, PILOTLESS IGNITION - ATWOOD GH6-7E	
1	051391-01-700	EA HINGE KIT-W/CLIP	92568 & 92559
2	051391-01-704	EA VALVE-RELIEF, 1/2" FITTING	91604
3	051391-01-705	EA FASTENER-CAMLOC	92609
4	051391-01-706	EA FLUE & GASKET	
5	051391-01-710	EA ORIFICE-MAIN BURNER	92742
6	051391-01-714	EA ELBOW - 45 DEGREE, 3/8"F X 3/8"MPT	91044
7	051391-01-715	EA DRAIN PLUG	91561
8	051391-03-700	EA ORIFICE HOLDER	91563
9	051391-04-701	EA THERMOSTAT 12 VDC-120 PRESET, FRONT MOUNT ONLY	91470
10	051391-04-703	EA BURNER-MAIN, 3E ONLY	91638
11	097967-01-000	EA SWITCH-WATER HEATER, REMOTE W/LIGHT	91959
12	051393-01-721	EA ECO & THERMOSTAT ASM-FRONT MOUNT, 140 DEGREE	91447
13	051393-01-723	EA SWITCH-THERMAL CUT-OFF 2/PKG	93866
14	051393-01-724	EA CIRCUIT BOARD-SPADE TERMINAL	93867
15	051393-01-725	EA ELECTRODE-SINGLE SPADE CONNECT	93868
16	051393-01-726	EA SOLENOID VALVE AND BRACKET	93870
17	051393-03-701	EA TANK-INNER	91642
18	052009-06-000	EA DOOR-WATER HEATER, BRIGHT WHITE	
19	051391-01-717	EA GRILL ONLY	
	116424-01-000	EA PROTECTOR-WATER HEATER LATCH 92611	
	0MD75C-10-000	EA NUT-HEX FLG,M10X1.5 CAD PREV CLASS 10	
	114430-03-000	EA ADAPTER-1/2" P X 1/2" MPT 02842	
	101814-01-000	EA COUPLING-FEMALE, 1/2" X 1/2" FPT W/COMP. SLEEVE - GRAY	
	110438-01-000	EA VALVE-CHECK, BRASS - G784	

WATER & SEWAGE GROUP (CONTINUED)

WATER HEATER W/ELECTRIC IGNITION

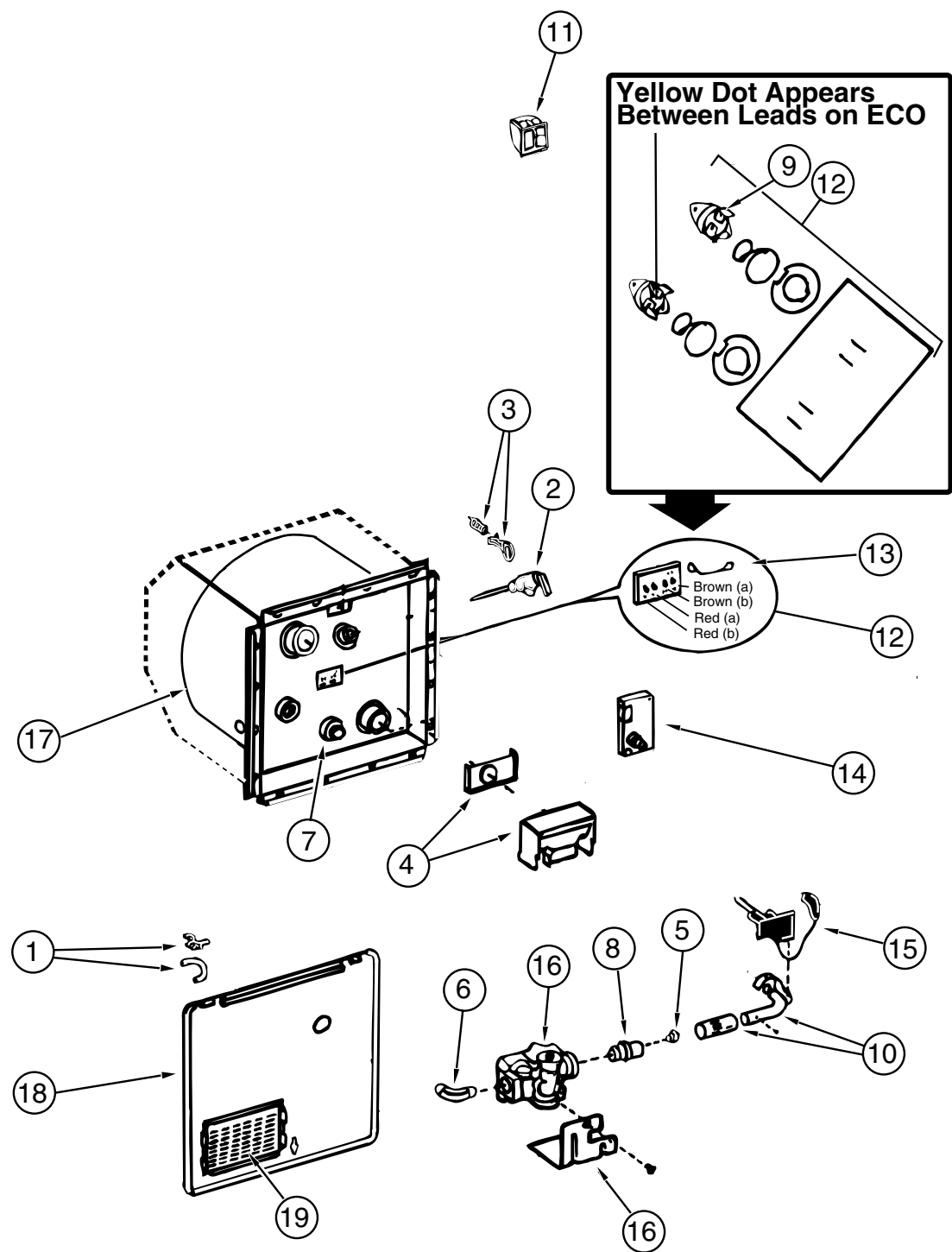

KEY	PART NUMBER	U/M DESCRIPTION	VENDOR NO.
	051391-03-000	EA HEATER-WATER, W/ELECTRIC IGNITION - ATWOOD G6A-7E	
1	051391-01-700	EA HINGE KIT-W/CLIP	92568 & 92559
2	051391-01-704	EA VALVE-RELIEF, 1/2" FITTING	91604
3	051391-01-705	EA FASTENER-CAMLOC	92609
4	051391-01-706	EA FLUE & GASKET	
5	051391-01-710	EA ORIFICE-MAIN BURNER	92742
6	051391-01-714	EA ELBOW - 45 DEGREE, 3/8"F X 3/8"MPT	91044
7	051391-01-715	EA DRAIN PLUG	91561
8	051391-03-700	EA ORIFICE HOLDER	91563
9	051391-04-701	EA THERMOSTAT 12 VDC-120 PRESET, FRONT MOUNT ONLY	91470
10	051391-04-703	EA BURNER-MAIN, 3E ONLY	91638
11	097967-01-000	EA SWITCH-WATER HEATER, REMOTE W/LIGHT	91959
12	051393-01-721	EA ECO & THERMOSTAT ASM-FRONT MOUNT, 140 DEGREE	91447
13	051393-01-723	EA SWITCH-THERMAL CUT-OFF 2/PKG	93866
14	051393-01-724	EA CIRCUIT BOARD-SPADE TERMINAL	93867
15	051393-01-725	EA ELECTRODE-SINGLE SPADE CONNECT	93868
16	051393-01-726	EA SOLENOID VALVE AND BRACKET	93870
17	051391-04-706	EA TANK-INNER, G6A-4E & 6E - FRONT MOUNT	91641
18	052009-06-000	EA DOOR-WATER HEATER, BRIGHT WHITE	
19	051391-01-717	EA GRILL ONLY	
	116424-01-000	EA PROTECTOR-WATER HEATER LATCH - ATWOOD 92611	

WATER & SEWAGE GROUP (CONTINUED)

WATER PUMP

KEY	PART NUMBER	U/M DESCRIPTION	VENDOR NO.
	098607-01-000	EA PUMP-WATER, W/.5"MPT FITTING - FLOW 2.8 GPM - UL	
	098607-01-700	EA PUMPHEAD-REPLACEMENT	94-236-08
	098607-01-701	EA DRIVE ASM	94-234-03
	098607-01-702	EA DIAPHRAGM-KIT	94-233-10
	098607-01-703	EA VALVE ASM	94-232-00
	098607-01-705	EA CHECK VALVE-KIT	94-237-00
	098607-01-706	EA SWITCH ASM-COMPLETE	94-230-00
	098607-01-707	EA MOTOR/BASEPLATE REPLACEMENT	94-234-03

WATER HEATER BYPASS

KEY	PART NUMBER	U/M DESCRIPTION	VENDOR NO.
	099729-01-000	EA BYPASS KIT-WATER HEATER, COMPLETE W/VALVE & TUBING - US	
	099729-01-700	EA VALVE ONLY-CHECK, PLASTIC	PCV-100
	099729-02-000	EA BYPASS KIT-WATER HEATER, COMPLETE W/VALVE & TUBING - CANADIAN	
	099729-02-700	EA VALVE ONLY-CHECK, BRASS	BCV-100
	103259-01-000	EA BRACKET-BYPASS, WATER HEATER	
	039798-01-000	EA TEE - 1/2" MPT X 1/2" MPT X 1/2" MPT, PLASTIC	
	052956-01-000	EA TEE - 1/2" F X 1/2" MPT X 1/2" F, PLASTIC	
	093217-01-000	EA TEE-SWIVEL, 1/2" - PLASTIC	

WATER TANK QUEEN BED

KEY	PART NUMBER	U/M DESCRIPTION	VENDOR NO.
	110622-02-000	EA TANK ASSEMBLY-WATER 1066 MM X 724 MM X 340 MM - W/FITTINGS	
	110622-01-000	EA TANK-WATER, 1066 MM X 724 MM X 340 MM - W/O FITTINGS	
	039861-01-000	EA SENDING UNIT-W/SCREW, WASHER, WELL NUT & TERMINAL RING	
	010224-01-000	EA ADAPTER-HOSE TO PIPE, 3/8" MPT X 3/8" BARB - BLACK PLASTIC	
	042989-03-000	EA FITTING-WATER TANK, SPINWELD - 1 1/4"NPT - PLASTIC - WHITE	
	042989-04-000	EA FITTING-WATER TANK, SPINWELD - 3/8" FPT - PLASTIC - WHITE	
	042989-05-000	EA FITTING-WATER TANK, SPINWELD - 1/2" FPT - PLASTIC - WHITE	
	049032-01-000	EA PATCH-SPINWELD, 3/8" - PLASTIC	
	044927-01-000	EA ADAPTER-HOSE TO PIPE, 1 1/4"MPT X 1 1/4"BARB-BLACK PLASTIC	
	052957-02-000	EA ELBOW-MALE, 1/2" F X 1/2" MPT - PLASTIC - GRAY	
	052958-01-000	EA TEE, 1/2" F X 1/2" F X 1/2" F - PLASTIC - GRAY	
	055290-01-000	EA ELBOW - 5/8" F X 1/2" MPT	
	074462-02-000	FT TUBING-VINYL, 3/8" ID X 20' - CLEAR	
	077954-02-000	EA FILTER-WATER TANK, SCREEN IN TANK	
	079381-01-000	FT TUBING-SMOOTH FLEXIBLE, 1 1/4" ID X 20'	
	096449-01-000	EA WIRE ASSEMBLY-WATER TANK TO MONITOR PANEL	

WATER TANK TWIN BED

KEY	PART NUMBER	U/M DESCRIPTION	VENDOR NO.
	110622-03-000	EA TANK ASSEMBLY-WATER 1066 MM X 724 MM X 340 MM - W/FITTINGS	
	110622-01-000	EA TANK-WATER, 1066 MM X 724 MM X 340 MM - W/O FITTINGS	
	039861-01-000	EA SENDING UNIT-W/SCREW, WASHER, WELL NUT & TERMINAL RING	
	010219-01-000	EA ELBOW-1 1/4" MPT X 1 1/4" BARB, WATER FILL - PLASTIC	
	010224-01-000	EA ADAPTER-HOSE TO PIPE, 3/8" MPT X 3/8" BARB - BLACK PLASTIC	
	042989-03-000	EA FITTING-WATER TANK, SPINWELD - 1 1/4"NPT - PLASTIC - WHITE	
	042989-04-000	EA FITTING-WATER TANK, SPINWELD - 3/8" FPT - PLASTIC - WHITE	
	042989-05-000	EA FITTING-WATER TANK, SPINWELD - 1/2" FPT - PLASTIC - WHITE	
	049032-01-000	EA PATCH-SPINWELD, 3/8" - PLASTIC	
	052959-02-000	EA CONNECTOR, 1/2" F X 1/2" MPT - PLASTIC - GRAY	
	074462-02-000	FT TUBING-VINYL, 3/8" ID X 20' - CLEAR	
	077954-02-000	EA FILTER-WATER TANK, SCREEN IN TANK	
	079381-01-000	FT TUBING-SMOOTH FLEXIBLE, 1 1/4" ID X 20'	
	096449-01-000	EA WIRE ASSEMBLY-WATER TANK TO MONITOR PANEL	

WATER & SEWAGE GROUP (CONTINUED)

WATER SYSTEM

KEY	PART NUMBER	U/M DESCRIPTION	VENDOR NO.
	039800-01-000	FT TUBING-POLYBUTYL, 1/2" OD - INCREMENTS OF 20' - BLACK	
	039800-02-000	FT TUBING-POLYBUTYL, 5/8" OD - INCREMENTS OF 20' - BLACK	
	052952-01-000	EA NUT-PLASTIC, 1/2" F X 1/2" TUBE - GRAY	
	052952-02-000	EA NUT-PLASTIC, 5/8" FLARE	
	052957-02-000	EA ELBOW-MALE, 1/2" F X 1/2" MPT - PLASTIC - GRAY	
	052958-01-000	EA TEE, 1/2" F X 1/2" F X 1/2" F - PLASTIC - GRAY	
	052960-01-000	EA DRAIN VALVE-IN LINE, HEADER - 1/2" F X 1/2" F - GRAY PLASTIC	
	052960-03-000	EA DRAIN VALVE-IN LINE, HEADER - 5/8" F X 5/8" F - PLASTIC	
	055290-01-000	EA ELBOW - 5/8" F X 1/2" MPT	
	057457-01-000	EA ELBOW-UNION, 1/2" X 1/2" FLARE	
	079317-01-000	EA ADAPTER-SWIVEL, 1/2" TUBE X 1/2" FPT - PLASTIC - GRAY	
	101814-01-000	EA COUPLING-FEMALE, 1/2" X 1/2" FPT	
	110915-01-01A	EA FILL-WATER, CITY - KEVCO 64713	
	035539-01-000	EA ELBOW-PLASTIC, 3/8" MPT X 3/8" BARB	
	114430-03-000	EA ADAPTER - 1/2P X 1/2MPT FLAIR-IT 02842	
	039798-01-000	EA TEE - 1/2" MPT X 1/2" MPT X 1/2" MPT, PLASTIC	
	093217-01-000	EA TEE-SWIVEL, 1/2" - PLASTIC	
	039808-03-000	EA ELBOW - 1/2" MPT X 1/2" MPT, PLASTIC - KEVCO 17296	
	052957-01-000	EA ELBOW-PLASTIC, 1/2" F X 3/8" MPT	
	114429-03-000	EA ELBOW-SWIVEL, 1/2P X 1/2FPT FLAIR-IT 02816	
	039861-01-000	EA SENDING UNIT-W/SCREW, WASHER, WELL NUT & TERMINAL RING	
	010224-01-000	EA ADAPTER-HOSE TO PIPE, 3/8" MPT X 3/8"	
	044927-01-000	EA ADAPTER-HOSE TO PIPE, 1 1/4"MPT X 1 1/4"BARB-BLACK PLASTIC	
	074462-02-000	FT TUBING-VINYL, 3/8" ID - CLEAR	
	077954-02-000	EA FILTER-WATER TANK, SCREEN IN TANK	
	079381-01-000	FT TUBING-SMOOTH FLEXIBLE, 1 1/4" ID X 20'	
	110622-02-000	EA TANK ASM-WATER	
	114427-01-000	EA CAP - 1/2P FLAIR-IT 02860	
	114428-01-000	EA TEE - 1/2P X 1/2P X 1/2P FLAIR-IT 02820	
	114428-02-000	EA TEE-SWIVEL, 1/2P X 1/2P X 1/2FPT FLAIR-IT 02821	
	114429-01-000	EA ELBOW - 1/2P X 1/2P FLAIR-IT 02800	
	114429-02-000	EA ELBOW - 1/2P X 1/2MPT FLAIR-IT 02803	
	114429-03-000	EA ELBOW-SWIVEL, 1/2P X 1/2FPT FLAIR-IT 02816	
	114430-02-000	EA ADAPTER-SWIVEL, 1/2P X 1/2FPT FLAIR-IT -02873	
	114430-03-000	EA ADAPTER - 1/2P X 1/2MPT FLAIR-IT 02842	
	114431-01-000	EA VALVE-LINE DRAIN 1/2P FLAIR-IT 02914	

EXTERIOR SHOWER

KEY	PART NUMBER	U/M DESCRIPTION	VENDOR NO.
	046128-01-000	EA VALVE-DRAIN, PLASTIC - 1/2" FPT	
	052959-02-000	EA CONNECTOR, 1/2" F X 1/2" MPT - PLASTIC - GRAY	
	065120-01-000	EA ELBOW-SWIVEL, 1/2" FPT X 1/2" FLARE - PLASTIC - GRAY	
	075241-05-000	EA FAUCET-SHOWER, BONE	
	103092-01-000	EA SHOWER HEAD-W/60" HOSE - US	
	103092-02-000	EA SHOWER HEAD-W/60" HOSE - CANADIAN	
	103092-01-700	EA BRACKET ONLY-CLEAR, F/SHOWER HEAD	2328028
	103092-01-701	EA BRACKET ONLY-BONE, F/SHOWER HEAD	2328029
	108356-02-01A	EA COVER-SWITCH W/DIMPLES, CARLING VVAZC00 BLA	
	108357-08-000	EA SWITCH-ROCKER, DPDT ON/NONE/ON - CARLING VDD1S00C-0	
	114293-01-01A	EA PAN-DRIP, EXTERIOR O/W	

WATER & SEWAGE GROUP (CONTINUED)

DRAINAGE SYSTEM

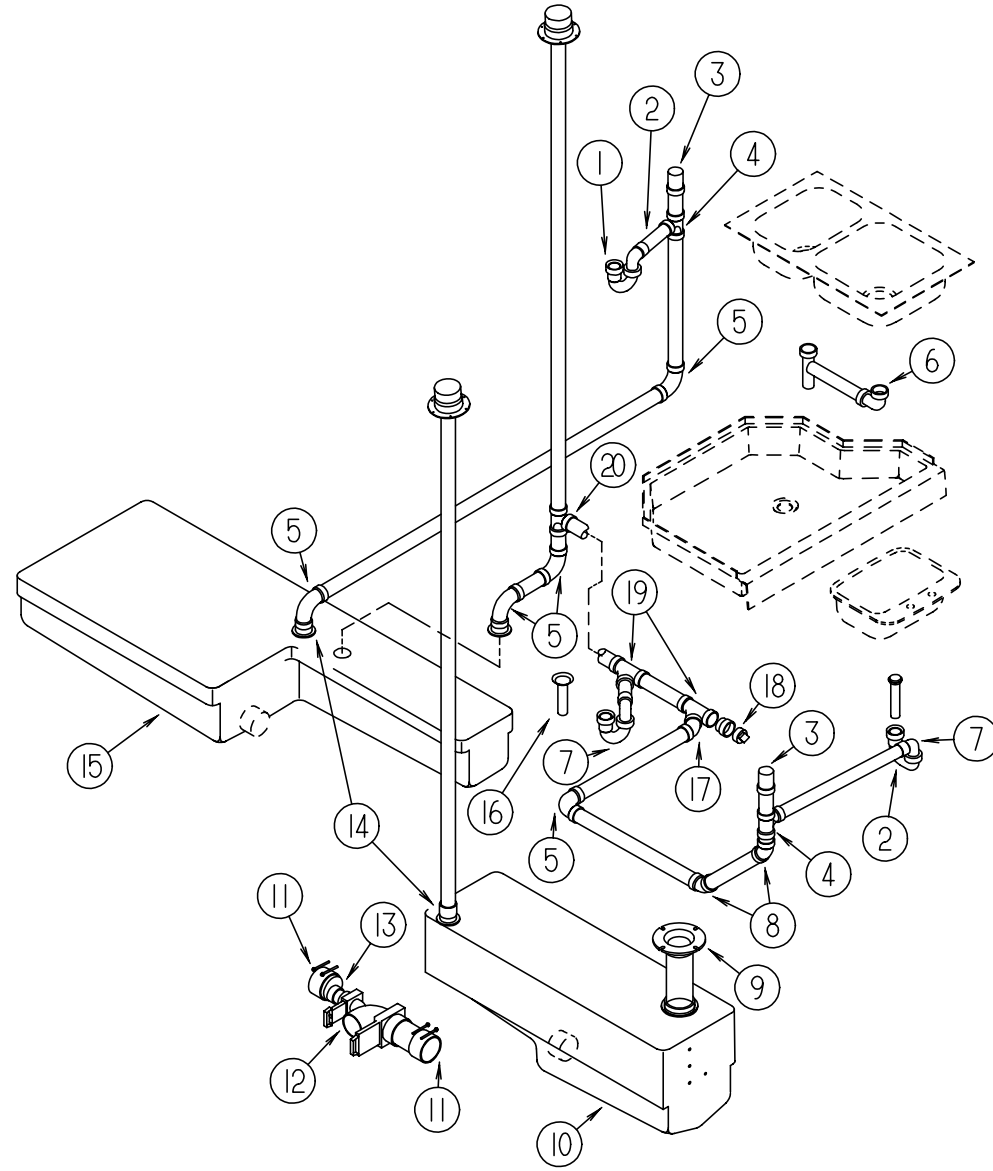

KEY	PART NUMBER	U/M	DESCRIPTION
1	011071-01-000	EA	P TRAP-PLASTIC, 1 1/2" - CANADIAN
1	107538-01-000	EA	P TRAP-PLASTIC, 1 1/4" W/EXT ARM - US
2	109571-01-000	EA	ADAPTER-P TRAP, 1 1/2" P X 1 1/4" MPT
3	079968-01-000	EA	VENT-MECHANICAL TRAP ARM, ANTI-SIPHON - 2" DIA X 7.3" - PLASTIC
4	010071-01-000	EA	TEE-SANITARY, 1 1/2" HUB X HUB X HUB - PLASTIC - BLACK
5	010008-01-000	EA	ELBOW - 90 DEGREE, 1/4 BEND - 1 1/2" HUB X HUB - BLACK PLASTIC
6	011091-02-000	EA	PIPE-DRAIN, DOUBLE SINK - BAFFLE TEE - 1 1/2" - US ONE PIPE W/TEE TO DRAIN BOTH SIDES OF SINK
6	011091-03-000	EA	PIPE-DRAIN, W/SEALS - DOUBLE SINK - EXTENDS 9" TO 16" - CANADIAN
7	107538-01-000	EA	P TRAP-PLASTIC, 1 1/4" W/EXT ARM - US
7	011066-03-700	EA	P TRAP KIT-PLASTIC, 1 1/2" X 1 1/2" - CANADIAN
7	010121-01-000	EA	BUSHING-REDUCER, 1 1/2" SMOOTH X 1 1/4"HUB - BLACK PLASTIC - CANADIAN
7	011066-03-701	EA	P TRAP-PLASTIC - CANADIAN
7	011066-03-702	EA	ADAPTER-P TRAP, 1 1/2" - CANADIAN
8	010006-01-000	EA	ELBOW - 45 DEGREE, 1/8 BEND - 1 1/2" HUB X HUB - BLACK PLASTIC
9	024676-01-000	EA	FLANGE-CLOSET, TOILET - 4" X 3" - RED - US
9	024676-02-000	EA	FLANGE-CLOSET, 4" X 3" - ABS - CANADIAN
10	106986-01-000	EA	TANK-HOLDING, 30 GALLON - 1144 MM X 354 MM X 426 MM
	061607-01-000	EA	GROMMET-HOLDING TANK, 1 1/2" NPS
	061607-02-000	EA	GROMMET-HOLDING TANK, 3" NPS
	039861-01-000	EA	SENDING UNIT-W/SCREW, WASHER, WELL NUT & TERMINAL RING
11	078406-01-000	EA	COUPLER-RUBBER, W/CLAMPS - 3" X 3"
12	070916-01-000	EA	VALVE-DUAL DUMP, W/CAP - 3" X 1 1/2" - PLASTIC - BLACK
	070916-01-700	EA	VALVE ONLY, 3"
	070916-01-701	EA	VALVE ONLY, 1 1/2"
	010201-01-000	EA	HOSE-SEWER, 3" ID X 8'
	062416-01-000	EA	ADAPTER-SEWER HOSE TO 3" PIPE
	062415-01-000	EA	CAP-SEWER 3" DIAMETER
	062415-01-700	EA	STRING SEWER CAP
13	062422-01-000	EA	ADAPTER-OFFSET REDUCER, 3" X 1 1/2" - PLASTIC - BLACK
14	010115-01-000	EA	COUPLING - 1 1/2" HUB X HUB, PLASTIC
15	106976-01-000	EA	TANK-HOLDING, 40 GALLON - 1746 MM X 632 MM X 245 MM
	061607-01-000	EA	GROMMET-HOLDING TANK, 1 1/2" NPS
	039861-01-000	EA	SENDING UNIT-W/SCREW, WASHER, WELL NUT & TERMINAL RING
16	011069-02-000	EA	TAILPIECE-TUB/SHOWER, 1 1/2" X 1 1/4" X 4" - BRASS
17	010051-01-000	EA	ELBOW - 45 DEGREE BEND, 1 1/2" SPIGOT AND HUB - PLASTIC - BLACK
18	010122-01-000	EA	BUSHING-REDUCER, 1 1/2" SMOOTH X 1 1/4" THREAD - PLASTIC - BLACK
18	010166-01-000	EA	PLUG-THREADED, 1 1/4" DIAMETER - PLASTIC - BLACK
19	010073-01-000	EA	WYE - 45 DEGREE, 1 1/2" HUB X HUB X HUB - PLASTIC - BLACK
20	010071-01-000	EA	TEE-SANITARY, 1 1/2" HUB X HUB X HUB - PLASTIC - BLACK

WINDOW, VENT & EXTERIOR DOOR GROUP

WINDOWS

KEY	PART NUMBER	U/M	DESCRIPTION
1	078528-06-E10	EA	WINDOW ASM-ESCAPE
1	113502-01-01A	EA	WINDOW ASM-REAR ESCAPE BLK/OW - THERMOPANE
2	113500-01-01A	EA	WINDOW ASM-TIPOUT, DOUBLE - BLK/OW
2	112795-23-01A	EA	WINDOW ASM-SLIDER, HORIZONTAL - THERMOPANE - DRIVER SIDE
2	112795-21-01A	EA	WINDOW ASM-SLIDER, HORIZONTAL - THERMOPANE - PASSENGER SIDE
3	098647-35-01A	EA	WINDOW ASM-SLIDER, HORIZONTAL
3	112795-35-01A	EA	WINDOW ASM-SLIDER, HORIZONTAL - THERMOPANE
4	103658-09-01A	EA	WINDOW ASM-CAB DRIVER
4	113501-03-01A	EA	WINDOW ASM-CAB DRIVER - THERMOPANE
5	103658-10-01A	EA	WINDOW ASM-CAB, PASSENGER
5	113501-04-01A	EA	WINDOW ASM-CAB, PASSENGER - THERMOPANE
6	098644-07-01A	EA	WINDOW ASM-SINGLE RAISE BLK/OW
6	112898-04-01A	EA	WINDOW ASM-SLIDER, VERTICAL - THERMOPANE
7	079733-15-F04	EA	WINDOW-ENTRY DOOR, PICTURE
7	113733-01-01A	EA	WINDOW ASM-STATIONARY, THERMOPANE
8	098647-33-01A	EA	WINDOW ASM-SLIDER, HORIZONTAL
8	112795-19-01A	EA	WINDOW ASM-SLIDER, HORIZONTAL - THERMOPANE

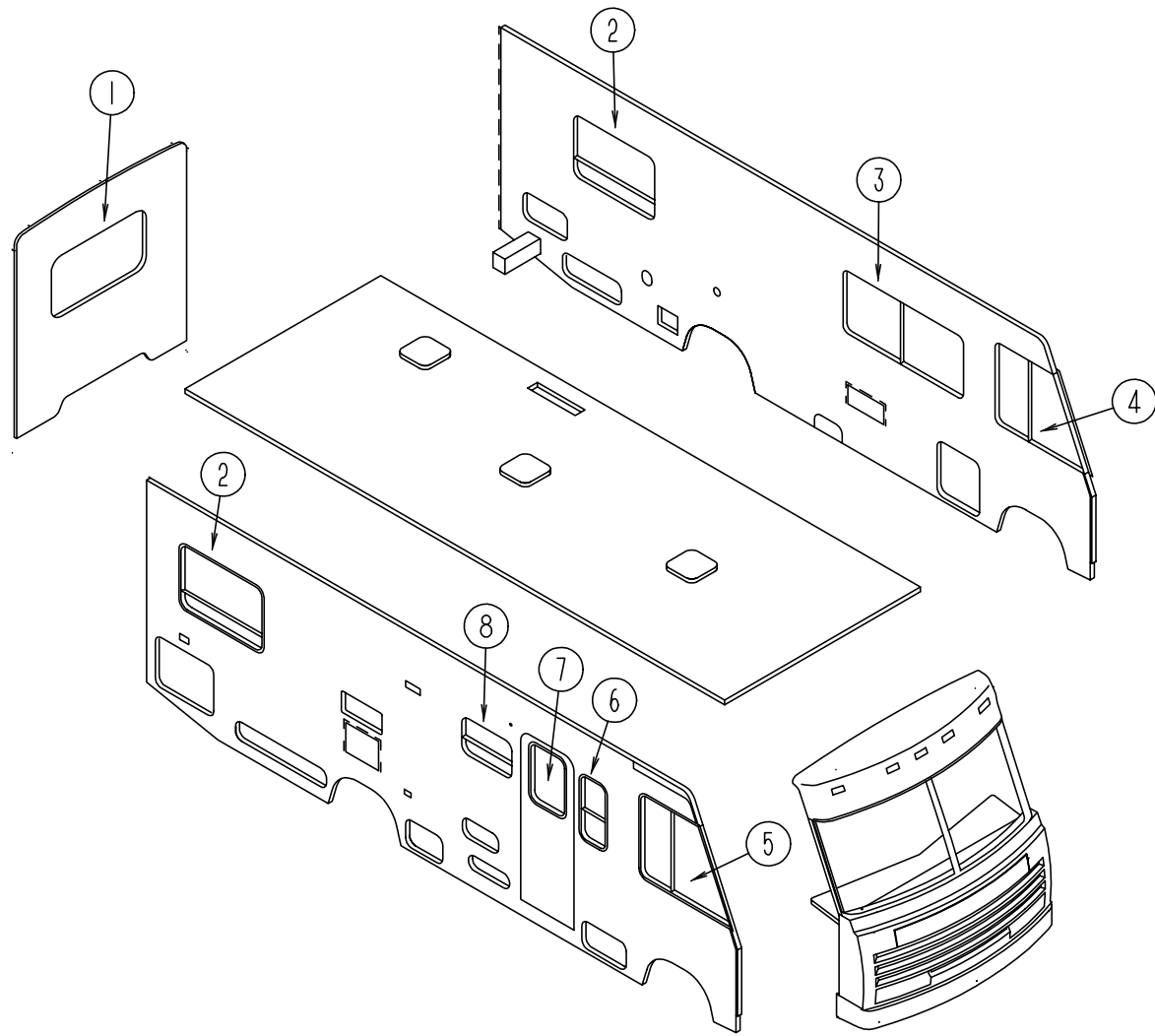

WINDOW, VENT & EXTERIOR DOOR GROUP (CONTINUED)

DOORS

KEY	PART NUMBER	U/M DESCRIPTION
1	052423-07-000	EA DOOR-ACCESS, 6.6" X 6.3" - PLASTIC - BRIGHT WHITE - SEWER HOSE DOOR
1	052424-06-000	EA JAMB-DOOR, 8" X 7.7" - PLASTIC - BRIGHT WHITE - SEWER HOSE DOOR
2	111013-04-F24	EA DOOR-STORAGE, 22.1" X 11.6" - BRIGHT WHITE - TWIN BEDS OPTION
3	111018-02-F24	EA DOOR-GENERATOR/STORAGE, 29.4" X 9.8" - BRIGHT WHITE
4	088794-06-000	EA DOOR-POWER CORD, W/HATCH - BRIGHT WHITE
5	111012-05-F24	EA DOOR-STORAGE, 336 MM X 163 MM - BRIGHT WHITE
6	111013-07-F24	EA DOOR-STORAGE, 538 MM X 573 MM - BRIGHT WHITE
7	111013-04-F24	EA DOOR-STORAGE, 22.1" X 11.6" - BRIGHT WHITE
8	M06977-09-F24	EA DOOR-ENTRANCE, W/SCREEN - W/O WINDOW - BRIGHT WHITE
8	M06977-09-F25	EA DOOR-ENTRANCE, W/SCREEN - W/O WINDOW - BRIGHT WHITE
8	M06977-09-F26	EA DOOR-ENTRANCE, W/SCREEN - W/O WINDOW - BRIGHT WHITE
8	M06977-09-F27	EA DOOR-ENTRANCE, W/SCREEN - W/O WINDOW - BRIGHT WHITE
9	111009-01-F24	EA DOOR-COMPARTMENT, LP - 16.9" X 5.4" - ALUMINUM - BRIGHT WHITE
10	111017-01-F24	EA DOOR-PATIO ENTERTAINMENT CENTER, 17.8" X 8.1" - BRIGHT WHITE
11	111013-05-F24	EA DOOR-STORAGE, 18.4" X 11.6" - BRIGHT WHITE
12	052009-06-000	EA DOOR-WATER HEATER, BRIGHT WHITE - ATWOOD
13	084103-08-000	EA DOOR-REFRIGERATOR, VENTED - W/O JAMB - BRIGHT WHITE
13	084104-08-000	EA JAMB-DOOR, REFRIGERATOR - BRIGHT WHITE
	084104-01-700	EA LOCK-MALE, FASTENER - REFRIGERATOR DOOR
	084104-01-701	EA LOCK-FEMALE, FASTENER - REFRIGERATOR DOOR
14	111013-44-F24	EA DOOR-STORAGE, BRIGHT WHITE
15	111013-36-F24	EA DOOR-STORAGE, 741 MM X 551 MM - BRIGHT WHITE
16	081240-16-000	EA DOOR-WATER FILL, LOCKABLE W/O LOCK, 4" X 4 5/8" - BRIGHT WHITE

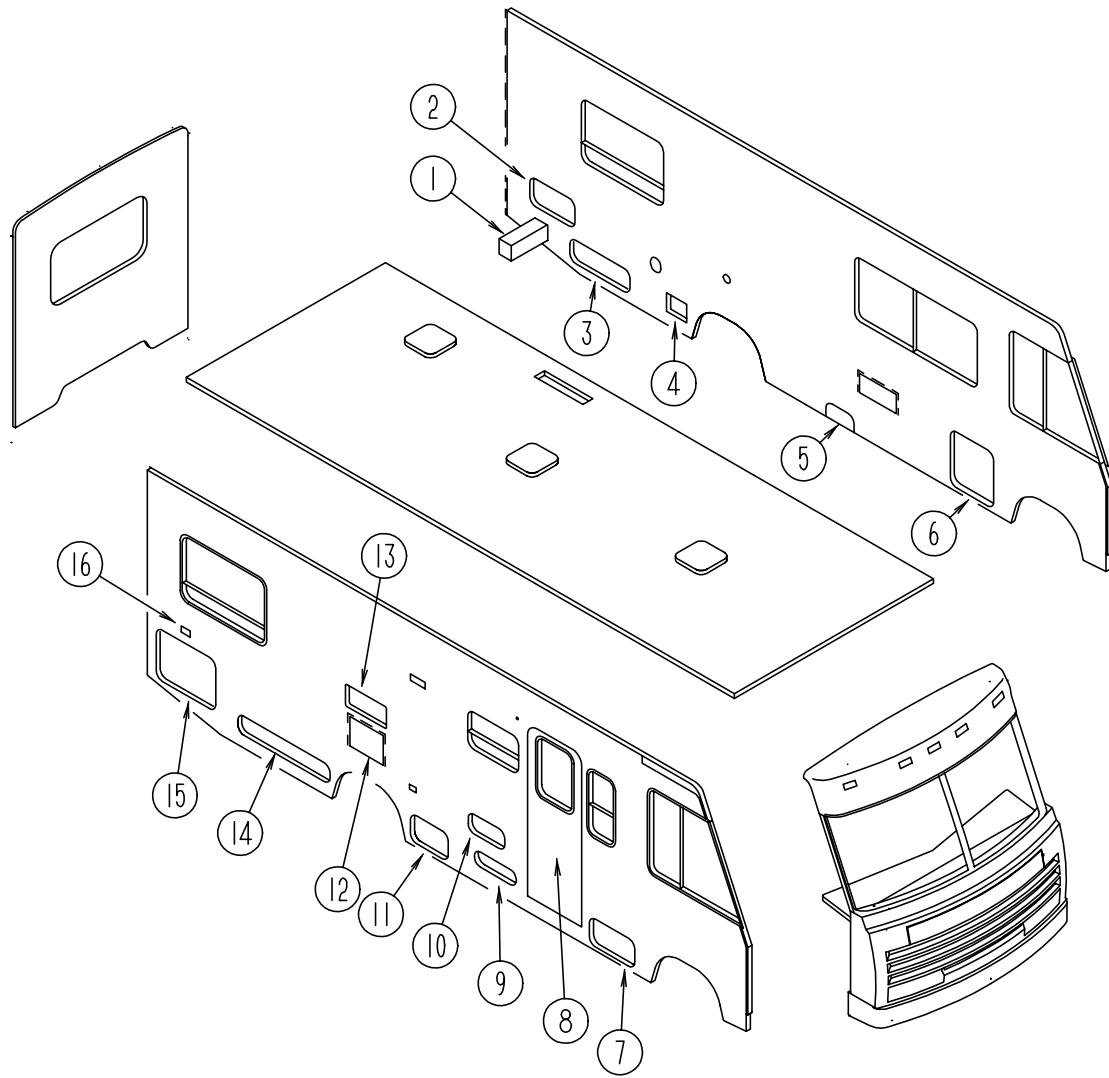

WINDOW, VENT & EXTERIOR DOOR GROUP (CONTINUED)

ENTRANCE DOOR

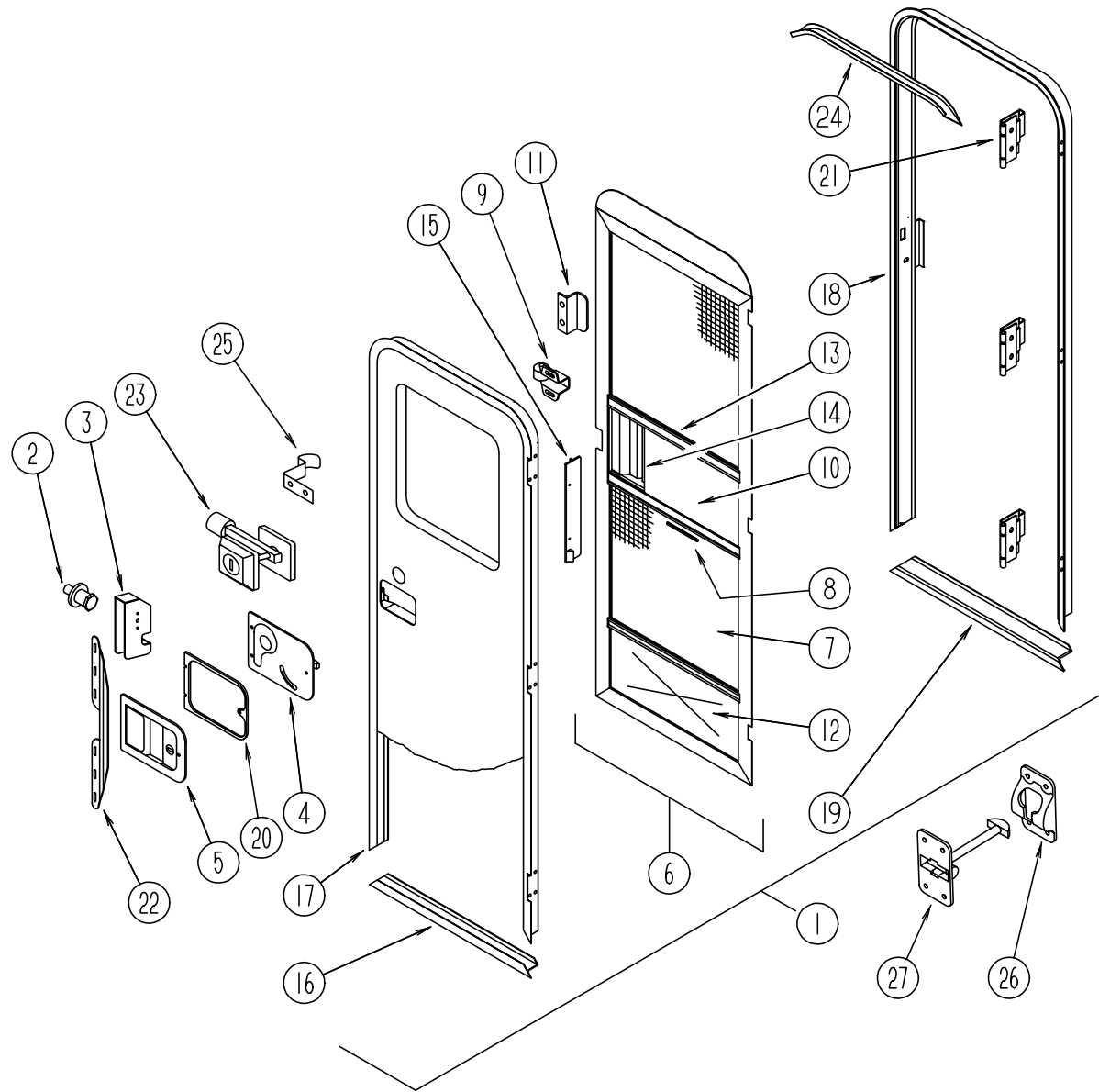

KEY	PART NUMBER	U/M	DESCRIPTION
1	M06977-09-F24	EA	DOOR-ENTRANCE, W/SCREEN - W/O WINDOW - BRIGHT WHITE
1	M06977-09-F25	EA	DOOR-ENTRANCE, W/SCREEN - W/O WINDOW - BRIGHT WHITE
1	M06977-09-F26	EA	DOOR-ENTRANCE, W/SCREEN - W/O WINDOW - BRIGHT WHITE
1	M06977-09-F27	EA	DOOR-ENTRANCE, W/SCREEN - W/O WINDOW - BRIGHT WHITE
2	039539-01-000	EA	STRIKE-LOCK, ENTRY DOOR - ROUND W/THREADED WASHER
3	039540-01-000	EA	LATCH MECHANISM-HOOK, ENTRY DOOR - INTERIOR
	039715-01-000	EA	NUT-SERT, 1/4" DIAMETER - 20 THREADS
4	039979-04-000	EA	COVER-INTERIOR LATCH, W/TRIP ARM - RIGHT - BLACK
	039984-01-000	EA	CAP-ROUND, VINYL - .28" ID X .62" LONG - BLACK
	041546-03-000	EA	BRACKET-DOOR ANGLE, 5" X 1.9" - BEIGE - METAL
5	045017-11-000	EA	LATCH-ENTRY DOOR, MECHANISM W/LOCK & KEY - BLACK
	045017-11-701	EA	KEY BLANK
	058025-02-000	EA	CLIP-ROLLER LATCH CATCH, SCREEN DOOR
	063729-01-000	EA	RIVNUT, 1/4 X 20 UNC - .030-.125
	063729-04-000	EA	RIVNUT, 10-32 UNF - .010-.080
	072893-01-000	EA	NUTSERT-M5 X 0, 8
	075671-04-000	FT	SEAL-SPONGE, LAZY T SHAPE - W/ADHESIVE STRIPE - .5" WIDE
6	079012-09-F15	EA	DOOR-SCREEN
	100128-02-000	FT	SEAL-FOAM, ADHESIVE BACK - SCREEN DOOR - GRAY
7	002293-02-000	SF	SCREENING-WINDOW/DOOR, 26" - CHARCOAL
8	002294-01-000	FT	SPLINE-SCREENING, .135" X .138" - BLACK
	002748-01-000	EA	CORNER KEY-DOOR
9	109403-01-000	EA	CATCH-ASM-SINGLE ROLLER
10	016454-01-000	EA	INSERT-CENTER, LEATHER GRAIN ALUMINUM - UNPAINTED
10	001014-01-013	EA	INSERT-CENTER, 10.25" X 16.31" - UNPAINTED
11	050712-04-000	EA	HANDLE-SCREEN DOOR, ALUMINUM - OFF WHITE
12	078552-03-000	EA	KICK PANEL-SCREEN DOOR, LOWER INSERT - UNPAINTED
	078595-01-000	EA	TOP PLATE-SCREEN DOOR, CURVED TOP - 4.7" X 25.35"
13	078777-01-000	EA	CHANNEL-SLIDE, SCREEN DOOR CENTER SLIDER COVER
14	079086-02-000	EA	SLIDER-SCREEN DOOR, OFF WHITE
15	079087-02-000	EA	STRIKE-SLIDER, W/LIP FOR ELBOW CATCH - 1.5" X 8.6" - OFF WHITE
16	089748-07-000	EA	FRAME-BOTTOM, ENTRY DOOR - 24.8" LONG - ASH GRAY
16	089748-21-000	EA	FRAME-BOTTOM, ENTRY DOOR - 24.8" LONG - BRIGHT WHITE
	090340-01-000	FT	SEAL-FOAM, CLOSED CELL - 1/4" X 1/2" X 50'
17	095276-07-03A	EA	FRAME-ENTRY DOOR, W/O BOTTOM - BRIGHT WHITE
18	095277-08-03A	EA	JAMB-ENTRY DOOR, W/BOTTOM - BRIGHT WHITE
19	051049-01-000	EA	JAMB-BOTTOM, ENTRY DOOR - 25.9" - UNPAINTED
20	096810-01-01A	EA	PLATE-LATCH, ENTRY DOOR - PLASTIC - BLACK
21	106719-01-01A	EA	HINGE-ENTRY DOOR, UNPAINTED
	076725-02-000	EA	COVER-HINGE, ENTRY DOOR - 6" X 3.2" - PLASTIC - OFF WHITE
22	098173-01-04A	EA	STIFFENER-ENTRY DOOR, SUPPORTS LATCH/STRIKE AREA - UNPAINTED
23	101145-01-01A	EA	DEADBOLT-ENTRY DOOR, W/2 KEYS W/O BACK SET BOLT OR SCREWS
	095229-01-700	EA	KEY BLANK FOR DEADBOLT
	101147-01-000	EA	BOLT-SECURITY, 4.12" BACKSET
	102524-01-000	EA	BUMPER-RUBBER, FLAT - BLACK
24	044582-44-000	EA	CAP-DRIP, ENTRY DOOR - JAMB MOUNTED - ALUMINUM - BRIGHT WHITE
	115222-01-01A	EA	GARNISH-RADIUS, ENTRY DOOR - OFF WHITE
	077461-03-000	EA	COVER-STRIKE, ENTRY DOOR - 6.5" X 2.5" - PLASTIC - WHITE
	091876-01-000	EA	RETAINER-DOOR, 1.9" X .8" - METAL
25	100412-01-000	EA	CATCH-SCREEN DOOR, THUMB CLIP W/BLACK PLASTIC CAP
26	104099-01-01A	EA	CATCH-DOOR HOLDER, STRIKE - OFF WHITE
27	104099-02-01A	EA	CATCH-DOOR HOLDER, RETAINER - OFF WHITE
	009126-02-000	EA	HANDLE-ASSIST, ENTRY DOOR - BLACK
	102248-01-000	EA	SHIM-DOOR

WINDOW, VENT & EXTERIOR DOOR GROUP (CONTINUED)

LOCKS & EXTERIOR DOOR COMPONENTS

NOTE:
WHEN ORDERING THE LOCK CASE, THE KEY CODE MUST MATCH THE LAST DIGIT OF THE VEHICLE'S SERIAL NUMBER AND PART NUMBER; WHEN ORDERING THE KEYS, THE THIRD DIGIT OF THE KEY CODE MUST MATCH THE LAST DIGIT OF THE VEHICLE'S SERIAL NUMBER AND PART NUMBER

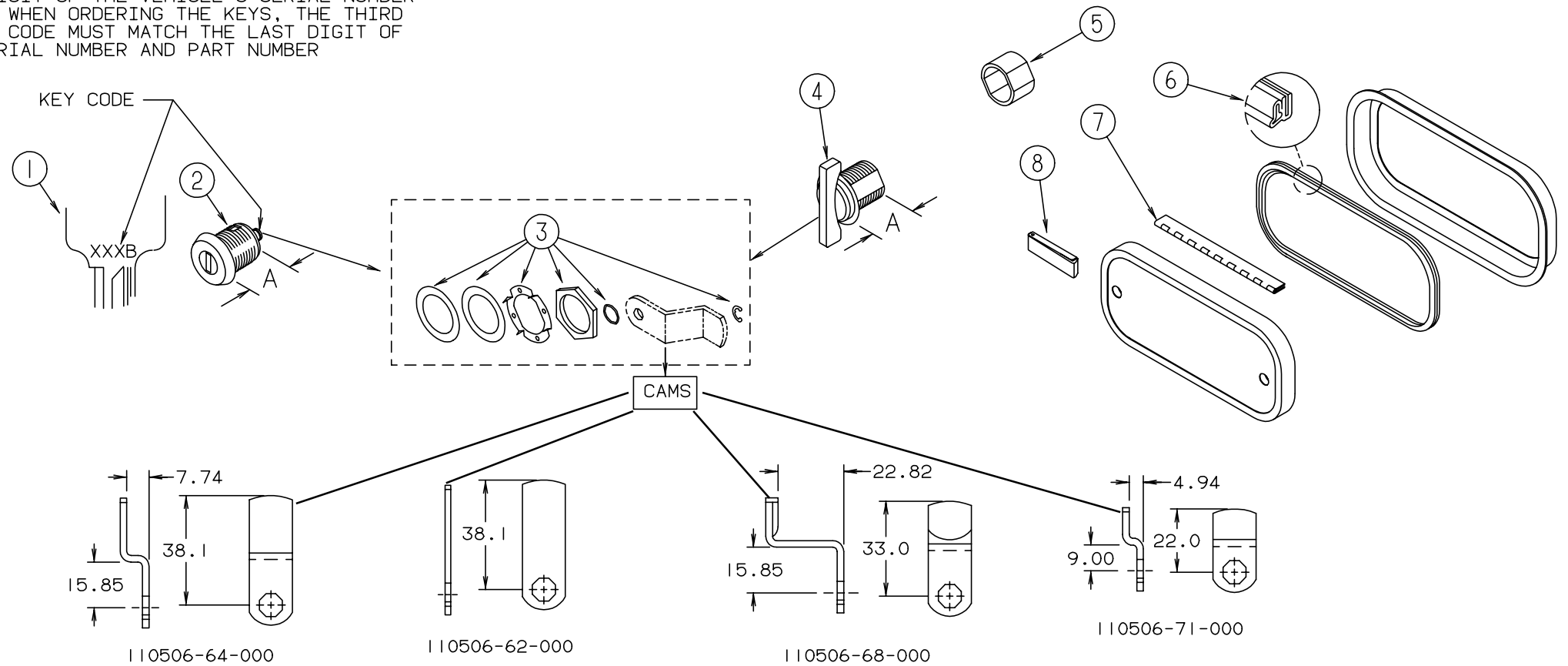

KEY	PART NUMBER	U/M DESCRIPTION
1	110506-59-000	EA KEYS - SET OF TWO - BRIGGS & STRATTON 596720
2	110506-52-000	EA CASE - LOCK - A= 17 MM - BRIGGS & STRATTON 702370
2	110506-53-000	EA CASE - LOCK - A= 25 MM - BRIGGS & STRATTON 702380
1	110506-59-001	EA KEYS - SET OF TWO - BRIGGS & STRATTON 596721
2	110506-52-001	EA CASE - LOCK - A= 17 MM - BRIGGS & STRATTON 702371
2	110506-53-001	EA CASE - LOCK - A= 25 MM - BRIGGS & STRATTON 702381
1	110506-59-002	EA KEYS - SET OF TWO - BRIGGS & STRATTON 596722
2	110506-52-002	EA CASE - LOCK - A= 17 MM - BRIGGS & STRATTON 702372
2	110506-53-002	EA CASE - LOCK - A= 25 MM - BRIGGS & STRATTON 702382
1	110506-59-003	EA KEYS - SET OF TWO - BRIGGS & STRATTON 596723
2	110506-52-003	EA CASE - LOCK - A= 17 MM - BRIGGS & STRATTON 702373
2	110506-53-003	EA CASE - LOCK - A= 25 MM - BRIGGS & STRATTON 702383
1	110506-59-004	EA KEYS - SET OF TWO - BRIGGS & STRATTON 596724
2	110506-52-004	EA CASE - LOCK - A= 17 MM - BRIGGS & STRATTON 702374
2	110506-53-004	EA CASE - LOCK - A= 25 MM - BRIGGS & STRATTON 702384
1	110506-59-005	EA KEYS - SET OF TWO - BRIGGS & STRATTON 596725
2	110506-52-005	EA CASE - LOCK - A= 17 MM - BRIGGS & STRATTON 702375
2	110506-53-005	EA CASE - LOCK - A= 25 MM - BRIGGS & STRATTON 702385
1	110506-59-006	EA KEYS - SET OF TWO - BRIGGS & STRATTON 596726
2	110506-52-006	EA CASE - LOCK - A= 17 MM - BRIGGS & STRATTON 702376
2	110506-53-006	EA CASE - LOCK - A= 25 MM - BRIGGS & STRATTON 702386
1	110506-59-007	EA KEYS - SET OF TWO - BRIGGS & STRATTON 596727
2	110506-52-007	EA CASE - LOCK - A= 17 MM - BRIGGS & STRATTON 702377
2	110506-53-007	EA CASE - LOCK - A= 25 MM - BRIGGS & STRATTON 702387

KEY	PART NUMBER	U/M DESCRIPTION
1	110506-59-008	EA KEYS - SET OF TWO - BRIGGS & STRATTON 596728
2	110506-52-008	EA CASE - LOCK - A= 17 MM - BRIGGS & STRATTON 702378
2	110506-53-008	EA CASE - LOCK - A= 25 MM - BRIGGS & STRATTON 702388
1	110506-59-009	EA KEYS - SET OF TWO - BRIGGS & STRATTON 596729
2	110506-52-009	EA CASE - LOCK - A= 17 MM - BRIGGS & STRATTON 702379
2	110506-53-009	EA CASE - LOCK - A= 25 MM - BRIGGS & STRATTON 702389
3	110506-40-700	EA HARDWARE KIT
	110506-59-701	EA KEY BLANK
4	110506-08-000	EA LOCK - TWIST TYPE - BRIGGS & STRATTON (A= 17 MM)
4	110506-13-000	EA LOCK - TWIST TYPE - BRIGGS & STRATTON (A= 25 MM)
5	107997-51-001	EA SPACER - .86" X .6" - ALUMINUM
6	064075-07-000	FT SEAL - BULB - W/ WIRED U CHANNEL - .3" X .5" CHANNEL - BLACK
7	081801-02-000	EA HINGE - PIANO - 2" X 96" - ALUMINUM - OFF WHITE
8	102768-01-000	EA HOLDER - COMPARTMENT/ ENTRY DOOR - METAL - MILL FINISH
	081914-01-000	EA BUMPER - RUBBER - ROUND - .43" DIAMETER - BLACK
	104692-01-000	FT SEAL - 3/4" X 3/4" - ADHESIVE BACK
	091876-01-000	EA RETAINER - DOOR - 1.9" X .8" - METAL

WINDOW, VENT & EXTERIOR DOOR GROUP (CONTINUED)

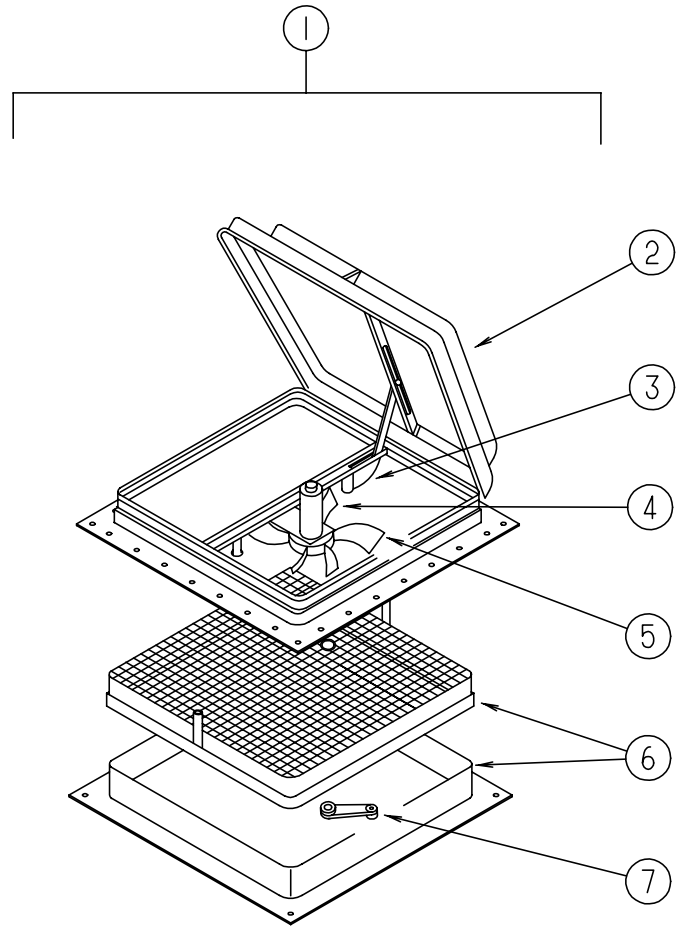

POWERED ROOF VENT - JENSEN - CANADIAN

KEY	PART NUMBER	U/M DESCRIPTION	VENDOR NO.
1	110051-05-01A	EA VENT-ROOF, POWERED - 2" ROOF - CSA - JENSEN C7757 WHE	
2	064470-01-700	EA COVER-ROOF VENT	7291
3	110051-01-702	EA LIFT ASM-VENT LID W/O CRANK	RP-1000B
4	048648-01-000	EA MOTOR-ROOF VENT, 1/8 SHAFT - 12V	
5	048649-01-000	EA FAN-ROOF VENT, 6 BLADES - 6"	
6	110051-01-701	EA GARNISH W/SCREEN & FRAME-2"	29-800-01
7	110051-01-703	EA CRANK HANDLE-ROOF VENT	RP-1031-B

WINDOW, VENT & EXTERIOR DOOR GROUP (CONTINUED)

POWERED ROOF VENT

KEY	PART NUMBER	U/M DESCRIPTION	VENDOR NO.
	110051-03-01A	EA VENT-ROOF, POWERED - 2" ROOF - JENSEN 7757 WHE	
	048648-01-000	EA MOTOR-ROOF VENT, 1/8 SHAFT - 12V - JENSEN	
	048649-01-000	EA FAN-ROOF VENT, 6 BLADES - 6" - JENSEN	
	064470-01-700	EA COVER-ROOF VENT	7291
	110051-01-701	EA GARNISH W/SCREEN & FRAME-2"	29-800-01
	110051-01-702	EA LIFT ASM-VENT LID W/O CRANK	RP-1000B
	110051-01-703	EA CRANK	RP-1031-B

NONPOWERED ROOF VENT

KEY	PART NUMBER	U/M DESCRIPTION	VENDOR NO.
	110051-01-01A	EA VENT-ROOF, NONPOWERED - 2" ROOF - JENSEN 7724 WHE	
	064470-01-700	EA COVER-ROOF VENT	7291
	110051-01-701	EA GARNISH W/SCREEN & FRAME-2"	29-800-01
	110051-01-702	EA LIFT ASM-VENT LID W/O CRANK	RP-1000B
	110051-01-703	EA CRANK	RP-1031-B

VENTS, SHROUDS & ROOF COVERS

KEY	PART NUMBER	U/M DESCRIPTION
	083558-07-000	EA VENT-PLUMBING PIPE ROOF W/COVER - BRIGHT WHITE
	084616-07-000	EA SHROUD-RANGE HOOD VENT, PLASTIC - BRIGHT WHITE
	084878-09-000	EA VENT-RANGE HOOD, SHORT - LVS
	084073-07-000	EA COVER-ROOF VENT, REFRIGERATOR - BRIGHT WHITE - NORCOLD
	084073-04-000	EA BASE-ROOF VENT, REFRIGERATOR - BLACK - NORCOLD
	105028-01-000	EA FLASHING ASM-VENT, REFRIGERATOR

WINDOW, VENT & EXTERIOR DOOR GROUP (CONTINUED)

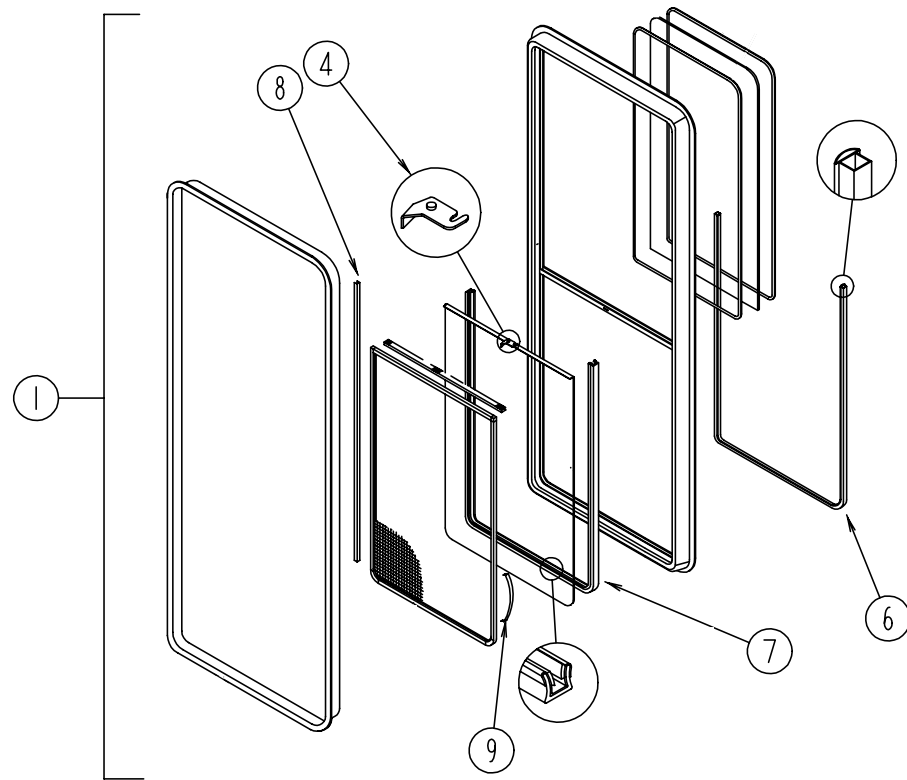

PASSENGER SIDE SWIVEL CHAIR WINDOW

KEY	PART NUMBER	U/M	DESCRIPTION	VENDOR NO.
1	098644-07-01A	EA	WINDOW ASM-SINGLE RAISE B/OW - EXCEL H170-G2W66	
4	098644-01-700	EA	LATCH-REPAIR KIT	B801-CK
6	098644-01-706	FT	WEATHERSTRIP	171-010668
7	098644-01-708	FT	CHANNEL-PIERCED RUN	122-016543
8	098644-01-710	FT	TRACK-SCREEN SPACER	EXCEL M401-31
	098644-01-711	FT	WEATHERSTRIP-SCREEN	EXCEL 171-016965
9	098644-01-713	EA	SPRING-SCREEN FRAME (CLIP), PLASTIC - BLACK	
	098644-01-716	FT	PLUG-FILLER	132-014470
	098644-01-717	FT	SPLINE-SCREEN	132-004716

WINDOW, VENT & EXTERIOR DOOR GROUP (CONTINUED)

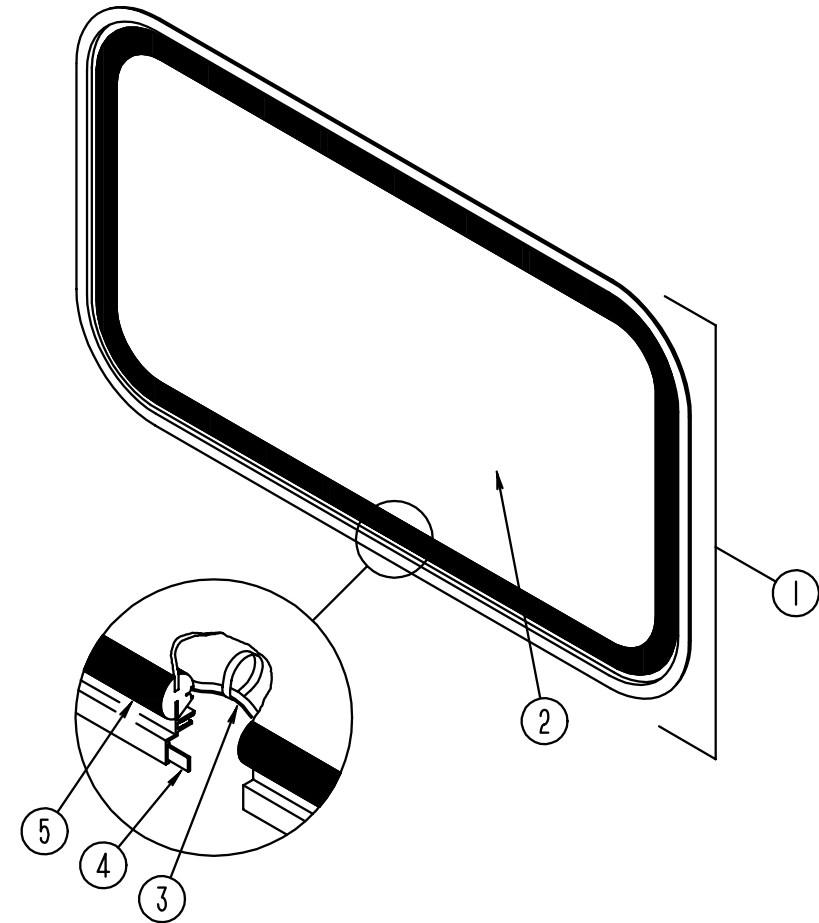

BACKWALL ESCAPE WINDOW

KEY	PART NUMBER	U/M	DESCRIPTION
	074816-11-000	EA	FRAME-WINDOW, INSIDE - ESCAPE - OFF WHITE
1	078528-06-E10	EA	WINDOW-ESCAPE, BACKWALL - W/O INSIDE FRAME
2	076337-12-000	EA	GLASS-WINDOW, 1157.4 X 548.1
3	002285-01-000	FT	FILLER-WEATHER STRIP, RUBBER - BLACK
	077066-01-702	EA	RED POLY.005 X .500" X 150' ROLL
4	069640-10-000	FT	SEALER-RIBBON, 1/32" X 1 1/2" INCREMENTS OF 90'
5	002282-09-000	EA	WEATHERSTRIP-WINDOW, .125" X 130.53 - VULCANIZED - BLACK

WINDOW, VENT & EXTERIOR DOOR GROUP (CONTINUED)

DRIVER & PASSENGER SIDE BEDROOM WINDOW

KEY	PART NUMBER	U/M DESCRIPTION
	113500-01-01A	EA WINDOW ASM-TIPOUT, DOUBLE - BLK/OW
	113500-01-700	EA SCREEN ASM. (RH & LH) W/SPRING
	113500-01-701	EA WINDOW W/O TRIM
	113500-01-702	EA TRIM
	113500-01-703	EA TOP GLASS-STATIONARY
	113500-01-704	EA UPPER VENT GLASS ASSEMBLY
	113500-01-705	EA LOWER VENT GLASS ASSEMBLY
	113500-01-706	EA OPERATOR & BAR ASSEMBLY

DRIVER SIDE BEDROOM THERMOPANE WINDOW

KEY	PART NUMBER	U/M DESCRIPTION
	112795-23-01A	EA WINDOW ASM-SLIDER, HORIZONTAL - THERMOPANE - DRIVER SIDE
	098647-29-701	EA TRIM
	098647-29-704	EA SCREEN ASSEMBLY
	112795-01-700	EA LATCH ASSEMBLY (BLK)
	112795-01-701	FT SLIDE-STOP
	112795-01-702	FT FILLER PLUG
	112795-01-703	FT RUN CHANNEL
	112795-01-704	FT VINYL-GLAZING
	112795-21-701	EA GLASS-STATIONARY
	112795-21-702	EA SLIDE ASSEMBLY
	112795-23-700	EA WINDOW W/O TRIM

PASSENGER SIDE BEDROOM THERMOPANE WINDOW

KEY	PART NUMBER	U/M DESCRIPTION
	112795-21-01A	EA WINDOW ASM-SLIDER, HORIZONTAL - THERMOPANE - PASSENGER SIDE
	098647-29-701	EA TRIM
	098647-29-704	EA SCREEN ASSEMBLY
	112795-01-700	EA LATCH ASSEMBLY (BLK)
	112795-01-701	FT SLIDE-STOP
	112795-01-702	FT FILLER PLUG
	112795-01-703	FT RUN CHANNEL
	112795-01-704	FT VINYL-GLAZING
	112795-21-700	EA WINDOW W/O TRIM
	112795-21-701	EA GLASS-STATIONARY
	112795-21-702	EA SLIDE ASSEMBLY

DRIVER SIDE DINETTE WINDOW

KEY	PART NUMBER	U/M DESCRIPTION
	098647-35-01A	EA WINDOW ASM-SLIDER, HORIZONTAL
	098644-01-700	EA LATCH REPAIR KIT (BLACK)
	098644-01-706	FT WEATHERSTRIP-GLASS
	098644-01-708	FT CHANNEL-RUN, PIERCED - GLASS
	098644-01-710	FT TRACK-SPACER, FOR SCREEN 12'
	098644-01-711	FT WEATHERSTRIP-SCREEN, BLACK
	098644-01-713	EA SCREEN CLIPS (METAL) (BLK)
	098644-01-716	FT PLUG-FILLER
	098644-01-717	FT SPLINE-SCREEN
	098647-36-701	EA TRIM
	098647-35-701	EA GLASS-STATIONARY
	098647-35-702	EA GLASS SLIDE ASSEMBLY
	098647-36-704	EA SCREEN ASSEMBLY
	098647-35-700	EA WINDOW W/O TRIM

WINDOW, VENT & EXTERIOR DOOR GROUP (CONTINUED)

DRIVER SIDE DINETTE THERMOPANE WINDOW

KEY	PART NUMBER	U/M DESCRIPTION
	112795-35-01A	EA WINDOW ASM-SLIDER, HORIZONTAL - THERMOPANE
	112795-01-700	EA LATCH ASSEMBLY (BLK)
	112795-01-701	FT SLIDE-STOP
	112795-01-702	FT FILLER PLUG
	112795-01-703	FT RUN CHANNEL
	112795-01-704	FT VINYL-GLAZING

DRIVER SIDE CAB WINDOW

KEY	PART NUMBER	U/M DESCRIPTION
	103658-09-01A	EA WINDOW ASM-CAB DRIVER
	098644-01-700	EA LATCH REPAIR KIT (BLACK)
	098644-01-706	FT WEATHERSTRIP-GLASS
	098644-01-708	FT CHANNEL-RUN, PIERCED - GLASS
	098644-01-710	FT TRACK-SPACER, FOR SCREEN 12'
	098644-01-711	FT WEATHERSTRIP-SCREEN, BLACK
	098644-01-713	EA SCREEN CLIPS (METAL) (BLK)
	098644-01-716	FT PLUG-FILLER
	098644-01-717	FT SPLINE-SCREEN MFG
	103658-09-700	EA GLASS-STATIONARY (RH & LH)
	103658-09-701	EA WINDOW W/O TRIM
	103658-09-702	EA TRIM-LEFT
	103658-09-704	EA SLIDE ASSEMBLY
	103658-09-705	EA SCREEN ASSEMBLY

DRIVER SIDE CAB WINDOW - THERMOPANE

KEY	PART NUMBER	U/M DESCRIPTION
	113501-03-01A	EA WINDOW ASM-CAB DRIVER - THERMOPANE
	103658-09-702	EA TRIM-LEFT
	103658-09-705	EA SCREEN ASSEMBLY
	113501-03-700	EA WINDOW W/O TRIM
	113501-03-701	EA GLASS-STATIONARY
	113501-03-702	EA GLASS-SLIDE ASSEMBLY

PASSENGER SIDE CAB WINDOW

KEY	PART NUMBER	U/M DESCRIPTION
	103658-10-01A	EA WINDOW ASM-CAB, PASSENGER
	098644-01-700	EA LATCH REPAIR KIT (BLACK)
	098644-01-706	FT WEATHERSTRIP-GLASS
	098644-01-708	FT CHANNEL-RUN, PIERCED - GLASS
	098644-01-710	FT TRACK-SPACER, FOR SCREEN 12'
	098644-01-711	FT WEATHERSTRIP-SCREEN, BLACK
	098644-01-713	EA SCREEN CLIPS (METAL) (BLK)
	098644-01-716	FT PLUG-FILLER
	098644-01-717	FT SPLINE-SCREEN MFG
	103658-09-700	EA GLASS-STATIONARY (RH & LH)
	103658-10-700	EA WINDOW W/O TRIM
	103658-10-701	EA TRIM-RIGHT
	103658-10-703	EA SLIDE ASSEMBLY
	103658-10-704	EA SCREEN ASSEMBLY

WINDOW, VENT & EXTERIOR DOOR GROUP (CONTINUED)**PASSENGER SIDE CAB THERMOPANE WINDOW**

KEY	PART NUMBER	U/M	DESCRIPTION
	113501-04-01A	EA	WINDOW ASM-CAB, PASSENGER - THERMOPANE
	103658-10-701	EA	TRIM-RIGHT
	103658-10-704	EA	SCREEN ASSEMBLY
	113501-04-700	EA	WINDOW W/O TRIM
	113501-04-701	EA	GLASS-STATIONARY
	113501-04-702	EA	GLASS-SLIDE ASSEMBLY

PASSENGER SIDE LOUNGE WINDOW

KEY	PART NUMBER	U/M	DESCRIPTION
	098644-07-01A	EA	WINDOW ASM-SINGLE RAISE BLK/OW
	098644-01-700	EA	LATCH REPAIR KIT (BLACK)
	098644-01-706	FT	WEATHERSTRIP-GLASS
	098644-01-708	FT	CHANNEL-RUN, PIERCED - GLASS
	098644-01-710	FT	TRACK-SPACER, FOR SCREEN 12'
	098644-01-711	FT	WEATHERSTRIP-SCREEN, BLACK
	098644-01-713	EA	SCREEN CLIPS (METAL) (BLK)
	098644-01-716	FT	PLUG-FILLER
	098644-01-717	FT	SPLINE-SCREEN MFG
	098644-07-700	EA	WINDOW W/O TRIM
	098644-07-701	EA	TRIM
	098644-07-702	EA	GLASS-STATIONARY
	098644-07-703	EA	SLIDE ASSEMBLY
	098644-07-704	EA	SCREEN ASSEMBLY

PASSENGER SIDE LOUNGE THERMOPANE WINDOW

KEY	PART NUMBER	U/M	DESCRIPTION
	112898-04-01A	EA	WINDOW ASM-SLIDER, VERTICAL - THERMOPANE
	098644-07-701	EA	TRIM
	098644-07-704	EA	SCREEN ASSEMBLY
	112898-04-700	EA	WINDOW W/O TRIM
	112898-04-701	EA	GLASS-STATIONARY
	112898-04-702	EA	SLIDE ASSEMBLY

ENTRY DOOR WINDOW

KEY	PART NUMBER	U/M	DESCRIPTION
	079733-15-F04	EA	WINDOW-ENTRY DOOR, PICTURE
	000H13-04-07B	EA	RIVET-SEMITUB-STL 1/8 X .219
	002181-22-000	EA	GLASS-PICTURE 687.4 X 449.4
	004012-02-000	QT	ADHESIVE - 3M 4475 (QUART)
	053752-08-000	GL	SEAM SEALER - 5 GAL, BLACK
	075201-02-000	GL	SEALANT-ACRYLIC, BLACK
	087561-01-000	FT	EXTR-VINYL SEAL, TIPOUT/SLIDE
	090907-51-002	EA	EXTR-STRAP

ENTRY DOOR THERMOPANE WINDOW

KEY	PART NUMBER	U/M	DESCRIPTION
	113733-01-01A	EA	WINDOW ASM-STATIONARY, THERMOPANE
	113733-01-700	EA	WINDOW ASM. W/O TRIM
	113733-01-701	EA	TRIM (W)
	113733-01-702	EA	GLASS-STATIONARY

WINDOW, VENT & EXTERIOR DOOR GROUP (CONTINUED)**PASSENGER SIDE GALLY WINDOW**

KEY	PART NUMBER	U/M	DESCRIPTION
	098647-34-01A	EA	WINDOW ASM-SLIDER, HORIZONTAL
	098644-01-700	EA	LATCH REPAIR KIT (BLACK)
	098644-01-706	FT	WEATHERSTRIP-GLASS
	098644-01-708	FT	CHANNEL-RUN, PIERCED - GLASS
	098644-01-710	FT	TRACK-SPACER, FOR SCREEN 12'
	098644-01-711	FT	WEATHERSTRIP-SCREEN, BLACK
	098644-01-713	EA	SCREEN CLIPS (METAL) (BLK)
	098644-01-716	FT	PLUG-FILLER
	098644-01-717	FT	SPLINE-SCREEN
	098647-33-701	EA	TRIM
	098647-33-702	EA	GLASS-STATIONARY
	098647-33-703	EA	GLASS SLIDE ASSEMBLY
	098647-33-704	EA	SCREEN ASSEMBLY
	098647-33-700	EA	WINDOW W/O TRIM

DRIVER SIDE GALLY THERMOPANE WINDOW

KEY	PART NUMBER	U/M	DESCRIPTION
	112795-19-01A	EA	WINDOW ASM-SLIDER, HORIZONTAL - THERMOPANE
	098647-31-701	EA	TRIM
	098647-31-704	EA	SCREEN ASSEMBLY
	112795-01-700	EA	LATCH ASSEMBLY (BLK)
	112795-01-701	FT	SLIDE-STOP
	112795-01-702	FT	FILLER PLUG
	112795-01-703	FT	RUN CHANNEL
	112795-01-704	FT	VINYL-GLAZING
	112795-19-700	EA	WINDOW W/O TRIM
	112795-19-701	EA	GLASS-STATIONARY
	112795-19-702	EA	SLIDE ASSEMBLY

REAR ESCAPE THERMOPANE WINDOW

KEY	PART NUMBER	U/M	DESCRIPTION
	113502-01-01A	EA	WINDOW ASM-REAR ESCAPE BLK/OW - THERMOPANE
	113502-06-700	EA	WINDO W/O TRIM
	113502-06-701	EA	TRIM
	113502-06-702	EA	GLASS-STATIONARY (RH & LH)
	113502-06-703	EA	GLASS- STATIONARY (CENTER)
	112898-06-704	EA	LOCK-HANDLE CAM RED RH
	112898-06-705	EA	LOCK-HANDLE CAM RED LH

WINDSHIELD & WIPER GROUP

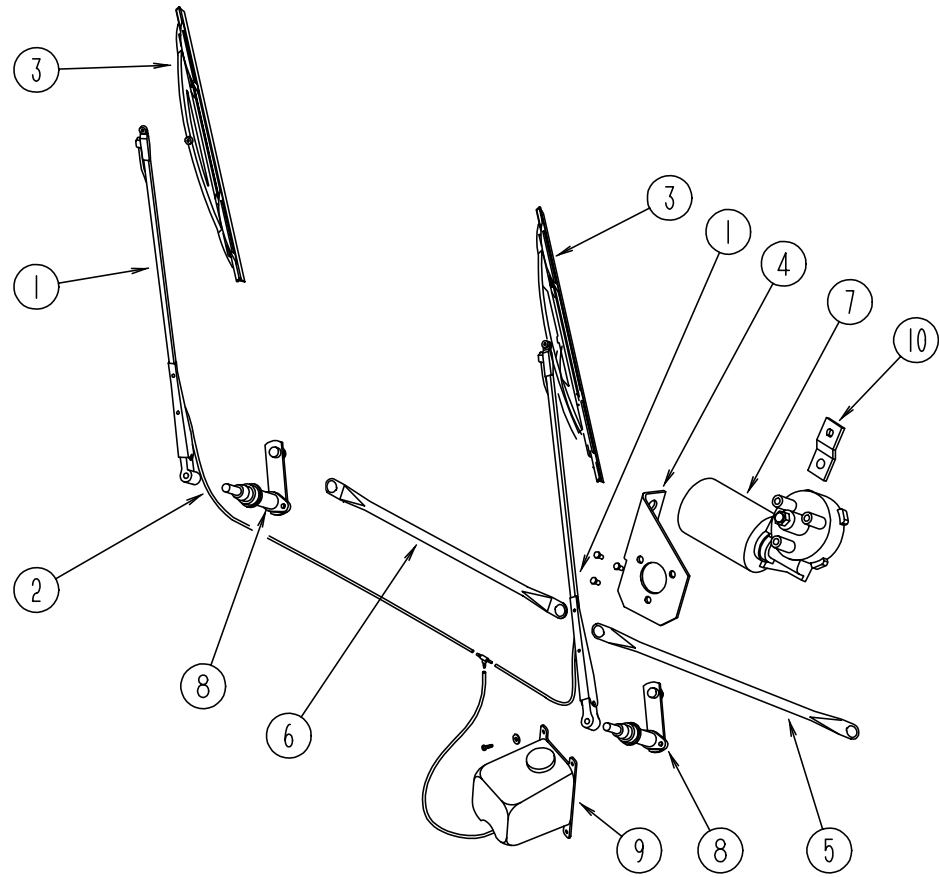

WIPER COMPONENTS

KEY	PART NUMBER	U/M	DESCRIPTION
1	103671-01-000	EA	ARM-WIPER, PANTOGRAPH - 24"
	096931-01-700	FT	HOSE-WIPER, TO BLADE
	096931-01-701	EA	NOZZLE-HARDWARE KIT, INCLUDES NOZZEL, NUT, SHORT THREAD SCREW, LONG THREAD SCREW, AND PLASTIC CAP
2	045794-01-000	FT	HOSE-WASHER, WINDSHIELD - 5/32" ID - BLACK
3	095964-01-000	EA	BLADE-WIPER, 24"
	095964-01-700	EA	REFILL-WIPER BLADE, 24" - PAIR
4	104549-01-000	EA	BRACKET ASSEMBLY-WIPER MOTOR
4	103726-01-000	EA	BRACKET-WIPER, MOTOR
5	103672-01-000	EA	LINK ASM - CONNECTING - DRIVERS
6	103672-02-000	EA	LINK ASM - CONNECTING - PASSENGERS
7	104346-02-000	EA	MOTOR-WIPER, CHEVY
7	104346-03-000	EA	MOTOR-WIPER, FORD
8	096505-05-000	EA	PIVOT & SHAFT ASM-WIPER, PASSENGER WINDSHIELD
8	096505-06-000	EA	PIVOT & SHAFT ASM-WIPER, DRIVER WINDSHIELD
	096526-01-000	EA	SCREW-HEX, 1/4 - 28
9	056000-04-000	EA	WASHER-WINDSHIELD, BOTTLE & PUMP
			FROM: 00-00-00 THRU: 04-02-95
9	110605-01-000	EA	TEE-PLASTIC, BARBED - 1/8 X 1/8 X 3/16
			FROM: 04-03-95 THRU: 99-99-99
9	117765-01-000	EA	CONNECTOR- 5/32 - 1/4 - 3/8 WINDSHIELD WAHER
			FROM: 04-03-95 THRU: 99-99-99
9	117766-02-000	EA	RESERVOIR/PUMP ASM
			FROM: 04-03-95 THRU: 99-99-99
10	104347-01-000	EA	ARM-DRIVE, WIPER MOTOR - 1.54"
	056000-01-700	FT	VACUUM HOSE 7/64 - 5/32
	061603-01-000	EA	GROMMET-SNAP, 3/16 ID - 3/8 HOLE - PLASTIC - BLACK
	067188-01-000	EA	STUD-CRANK, WIPER
	110742-01-000	EA	GASKET-WIPER
	110178-01-000	EA	HOUSING-WIPER MOTOR - UT6237440-EC25WJ

WINDSHIELD & WIPER GROUP (CONTINUED)

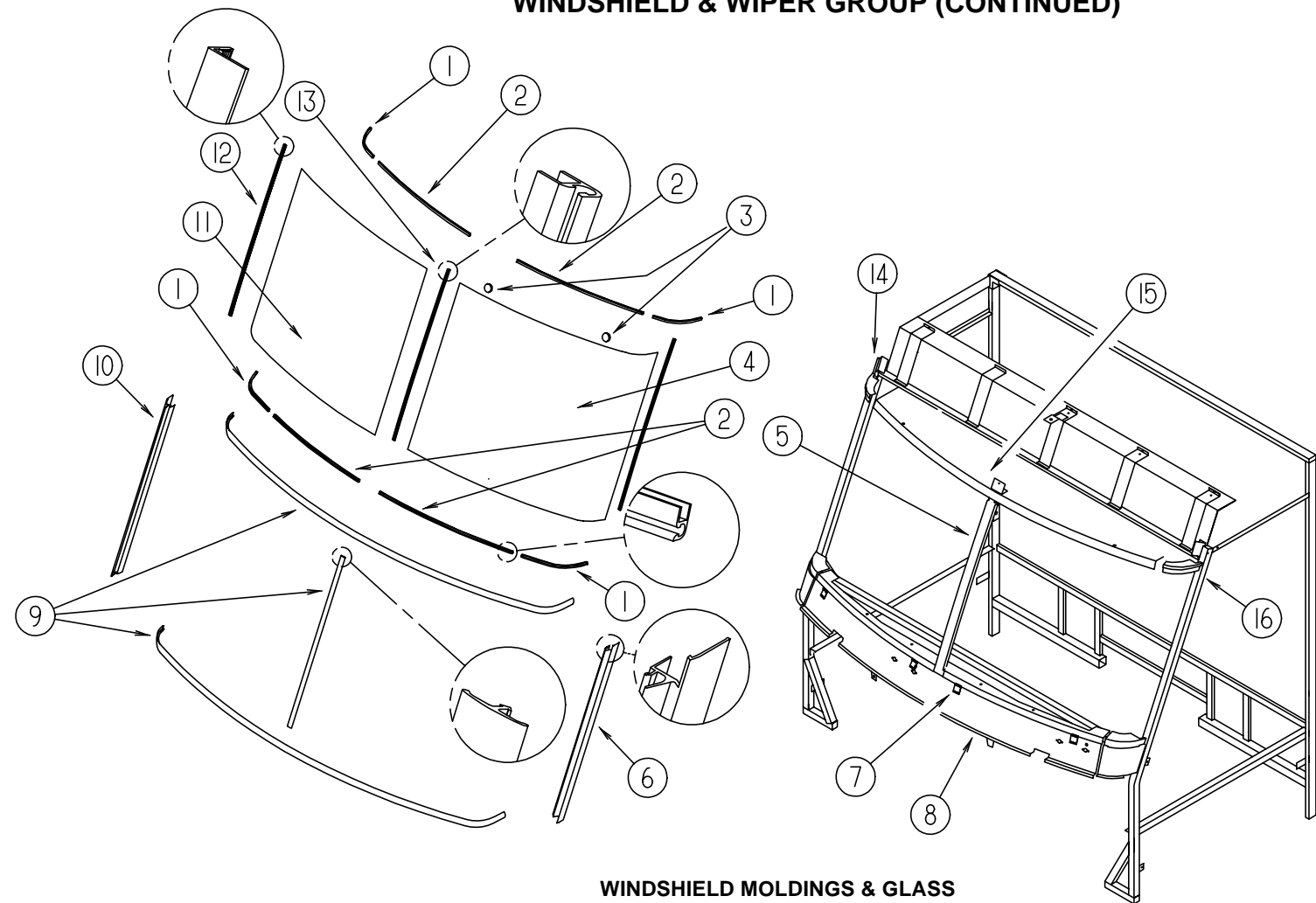

WINDSHIELD MOLDINGS & GLASS

KEY	PART NUMBER	U/M	DESCRIPTION
1	102935-08-000	EA	CARRIER-REVEAL, 2" - WINDSHIELD
2	110268-01-000	EA	CARRIER-REVEAL, 50.4" - WINDSHIELD
3	081914-01-000	EA	BUMPER-RUBBER, ROUND - .43" DIAMETER - BLACK
4	088793-04-000	EA	GLASS-WINDSHIELD, DRIVER
5	075710-03-000	EA	FRAME-WINDSHIELD, CENTER DIVIDER - INNER
6	103107-02-01A	EA	TRIM-WINDSHIELD, DRIVER SIDE - BLACK
7	104449-01-000	EA	BRACKET-WINDSHIELD SUPPORT
8	077847-02-000	EA	SUPPORT-WINDSHIELD, LOWER - W/O BRACKETS
9	102936-01-000	FT	MOLDING - REVEAL - WINDSHIELD
10	103107-01-01A	EA	TRIM - WINDSHIELD - PASSENGER SIDE - BLACK
11	088793-03-000	EA	GLASS-WINDSHIELD, PASSENGER
12	098788-06-000	EA	CHANNEL - 49" PCV, DRIVER OR PASSENGER SIDE
13	110268-02-000	EA	CARRIER-REVEAL, 38" - WINDSHIELD
14	077922-03-000	EA	HEADER WINDSHIELD END - RIGHT - STEEL
15	077922-05-000	EA	HEADER WINDSHIELD - CENTER - STEEL
16	077922-04-000	EA	HEADER WINDSHIELD END - LEFT - STEEL