

**1995
IF327RC**

F15

F16

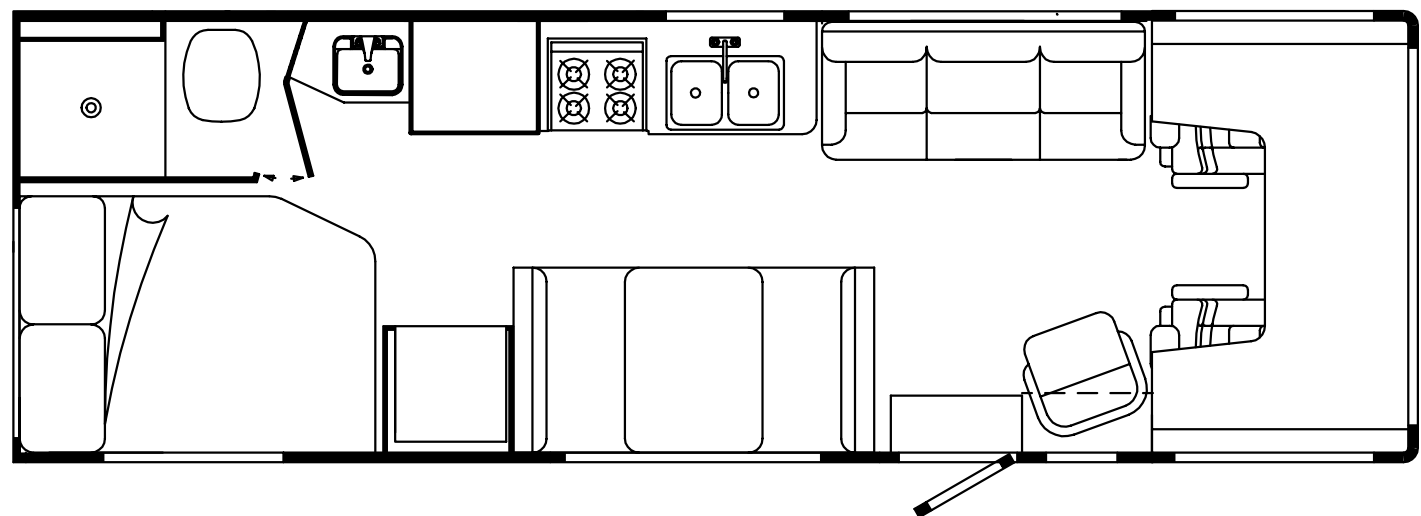
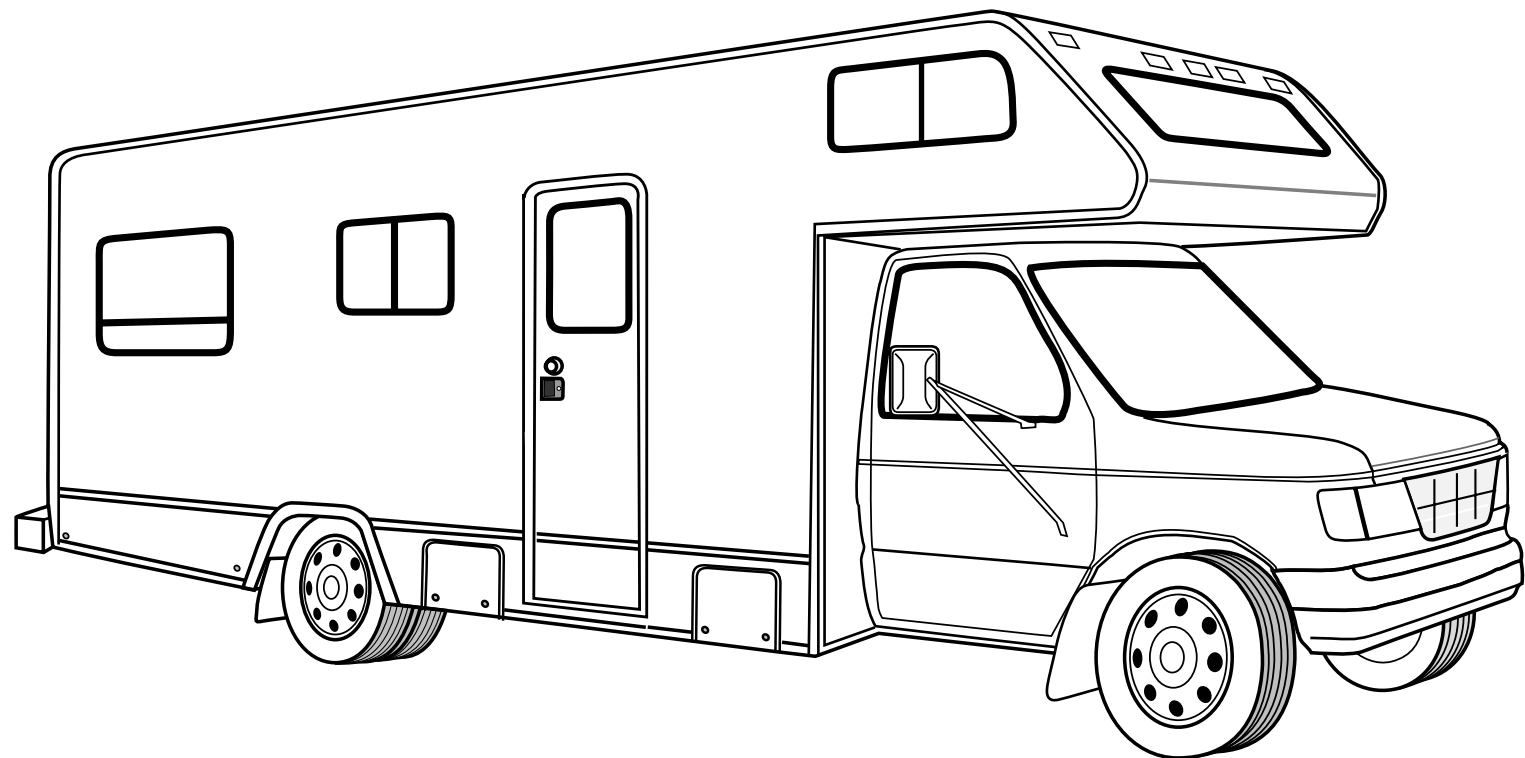

**ACCESSORIES GROUP
OPERATORS MANUAL**

KEY	PART NUMBER	U/M	DESCRIPTION
	054185-C8-000	EA	MANUAL-OPERATOR, 1995 SPIRIT 300 SERIES
	092318-01-000	EA	BINDER - 3 RING, MOTOR HOME MANUAL
	092319-01-000	EA	POCKET PAGE - 3 RING BINDER, PLASTIC
	114284-01-000	DW	TOP LEVEL DRAWINGS - C BODY, 1995

AUDIO VIDEO GROUP

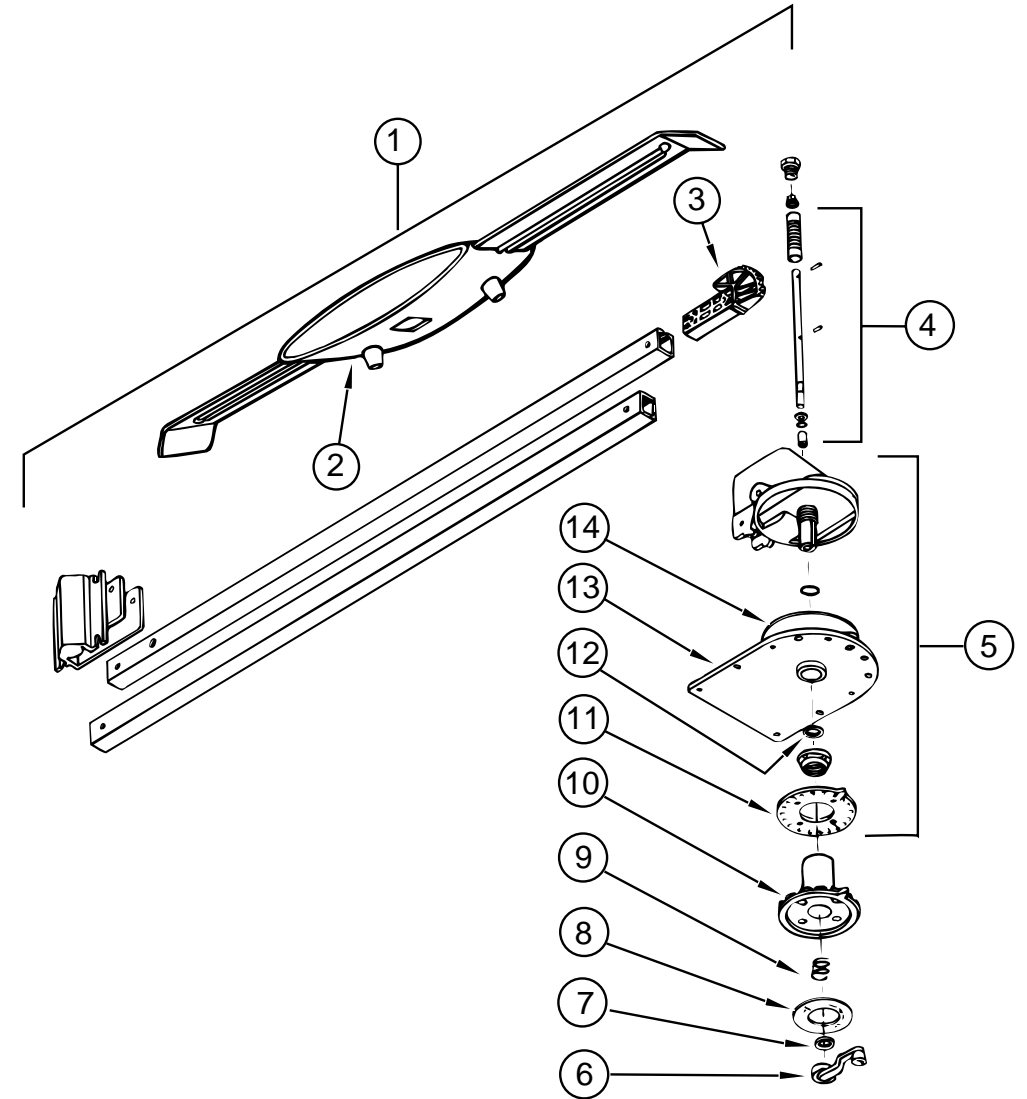

TV ANTENNA

KEY	PART NUMBER	U/M	DESCRIPTION
1	076319-01-000	EA	ANTENNA-TV, ROOF MOUNT - 44.5" MAST - RVA W02
2	076319-01-700	EA	HEAD-ANTENNA, AMPLIFIED - WINEGARD #RVSA U/V
3	076319-01-701	EA	GEAR-ELEVATING, PLASTIC - WINEGARD #2200046
4	076319-01-702	EA	SHAFT ASM-ELEVATING, WINEGARD #RVP-400A
5	076319-01-711	EA	BASE & LIFT ASM, WINEGARD #2762802
6	076319-01-706	EA	CRANK-ELEVATING, W/SET SCREW - WINEGARD #5755100
7	076319-01-705	EA	BEARING-NYLON, 7/8" ID - WINEGARD #3200658
8	076319-01-708	EA	DECAL-CRANK, WINEGARD #5413002
9	076319-01-707	EA	SPRING-HANDLE, WINEGARD #5160800
10	076319-01-709	EA	PLATE-DIRECTIONAL, FOR HEAD - WINEGARD #3200644
11	076319-01-712	EA	PLATE-CEILING, WINEGARD #3200608
12	076319-01-704	EA	BEARING-NYLON, 1.25" OD - WINEGARD #3200657
13	076319-01-713	EA	PLATE-BASE, WINEGARD #3100523
14	076319-01-703	EA	BEARING-NYLON, 5" OD - WINEGARD #3200656

AUDIO VIDEO GROUP (CONTINUED)
RADIO SPEAKER

KEY	PART NUMBER	U/M	DESCRIPTION
	074979-01-000	EA	SHIELD-SPEAKER, BACK - MOLDED PLASTIC - 8" X 9" - BEIGE
	111177-01-01A	EA	GRILLE-SPEAKER, OVAL - 5" X 7" - GRAY - MAGNADYNE SB68
	108137-01-000	EA	PLUG-ANTENNA HOLE, WARD PRODUCTS

TV INSTALLATION COMPONENTS

KEY	PART NUMBER	U/M	DESCRIPTION
	076319-03-000	FT	CABLE-COAXIAL, 75 OHM
	076319-12-000	EA	CONNECTOR-COAXIAL, ONE PIECE
	076319-06-000	EA	ADAPTOR-CABLE ROOF PLATE, WINEGARD RPJ-1
	082134-01-000	EA	ADAPTER-TV, CABLE TO CABLE - WINEGARD F-81M
	082136-01-000	EA	NUT-HEX JAM 3/8-32, WINEGARD
	086777-02-000	EA	WALLPLATE-TV CABLE, W/ANTENNA SWITCH - BROWN

BATH GROUP

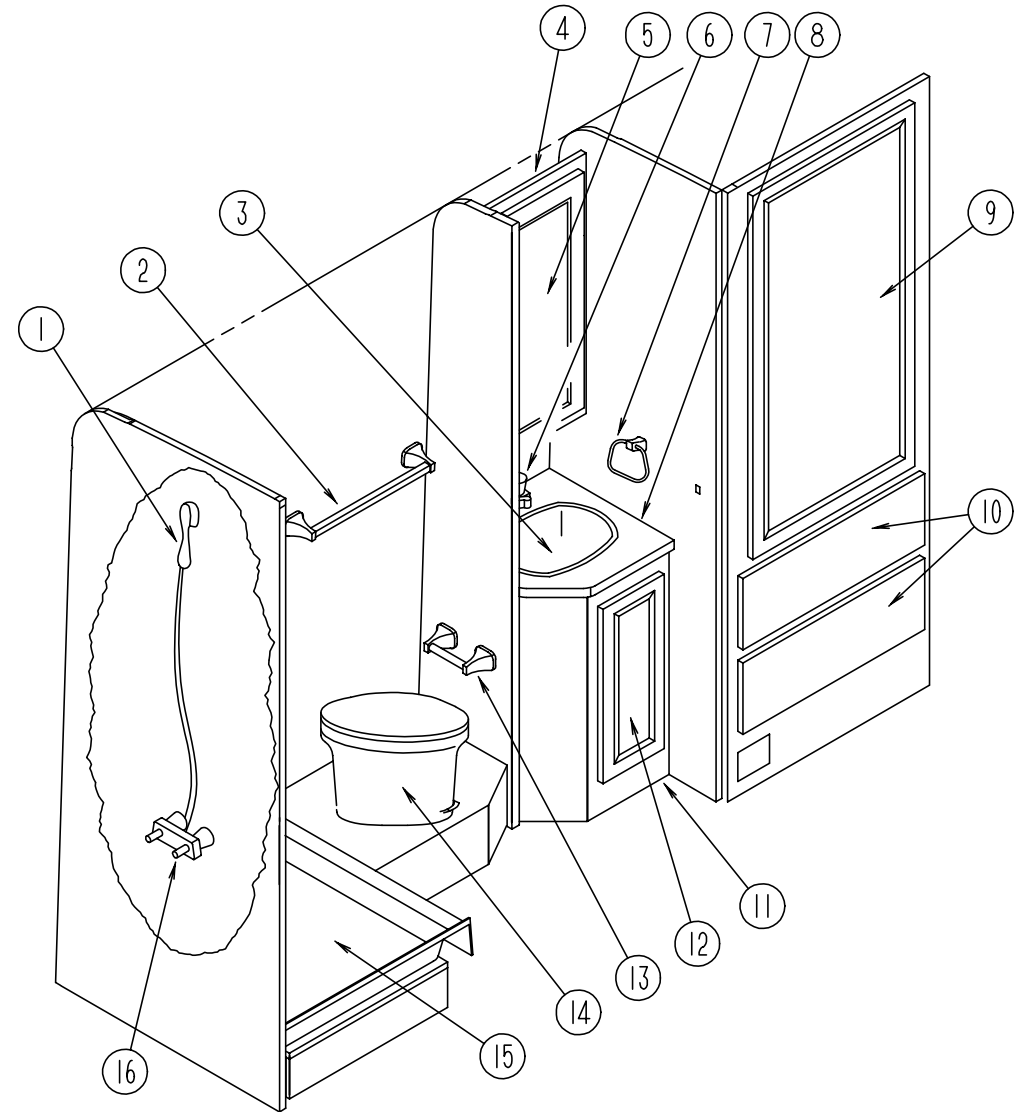

BATHROOM CABINETS & FIXTURES

KEY	PART NUMBER	U/M	DESCRIPTION
1	103092-01-000	EA	HEAD-SHOWER, W/60" HOSE - U.S.
1	103092-02-000	EA	HEAD-SHOWER, W/60" HOSE - CANADIAN
	103092-01-700	EA	BRACKET-SHOWER HEAD, CLEAR
	103092-01-701	EA	BRACKET-SHOWER HEAD, BONE
2	075453-02-000	EA	BAR-TOWEL, 18" - BRASS
3	096927-01-01A	EA	SINK-LAVATORY, RECTANGULAR - PLASTIC - BONE
	096927-01-700	EA	STOPPER-SINK
	096927-01-701	EA	TAILPIECE-SINK
4	102821-02-C43	EA	CABINET-MEDICINE, W/O DOOR & HARDWARE
5	115237-01-F15	EA	DOOR-CABINET - MIRRORED - W/O HARDWARE - 395MM X 750MM
6	075240-06-000	EA	FAUCET-LAVATORY, BONE
7	075454-02-000	EA	RING-TOWEL, W/MOUNTING HARDWARE - BRASS
8	105643-11-F15	EA	COUNTERTOP-CABINET, LAVATORY
9	110140-53-F15	EA	DOOR-CABINET, W/O HARDWARE - 525MM X 1220MM
10	M05970-K5-F15	EA	DRAWER COMPLETE-SLIDE

BATH GROUP (CONTINUED)
BATHROOM CABINETS & FIXTURES (CONTINUED)

KEY	PART NUMBER	U/M	DESCRIPTION
	009112-01-000	EA	FLANGE-1" ROD, CLOTHES - PLASTIC - OFF WHITE
	042438-01-000	EA	DOWEL-WOOD, CLOTHES ROD - 1" X 4' LONG
11	M05684-01-F15	EA	CABINET-LAVATORY - W/O DOOR & HARDWARE
12	110140-09-E01	EA	DOOR-CABINET, W/O HARDWARE - 340MM X 555MM
13	075452-02-000	EA	HOLDER-TOILET TISSUE, BRASS
14	067487-01-000	EA	TOILET - 12.37", IVORY - HAND FLUSH - THETFORD 150110
15	M02429-06-000	EA	PAN-SHOWER, OFF WHITE
	057671-01-000	EA	COVER-SCREW, #8 - PLASTIC - OFF WHITE
	066436-01-000	EA	NUT-SLIP, TAILPIECE - 1.5"
	066440-01-000	EA	STRAINER-SHOWER, W/RUBBER WASHER
	069735-01-000	EA	WASHER-STRAINER TO TAILPIECE, PLASTIC - 1.5"
	011069-02-000	EA	TAILPIECE-TUB/SHOWER, 1 1/2" X 1 1/4" X 4" - BRASS
16	075241-05-000	EA	FAUCET-SHOWER, BONE
	075606-01-000	EA	PANEL-FAUCET BACK, SHOWER - 5" X 9" - PLASTIC

TOILET & COMPONENTS

KEY	PART NUMBER	U/M	DESCRIPTION
	067487-01-000	EA	TOILET - 12.37", IVORY - HAND FLUSH - THETFORD 150110
	063740-01-700	EA	LEVER-WATER, THETFORD 12514
	063740-01-701	EA	LEVER-FLUSH, THETFORD 12515
	063740-01-706	EA	BOLT PACKAGE-CLOSET, THETFORD 12524
	063740-01-710	EA	LINK-THETFORD 12513
	063740-01-711	EA	SPRING-RETURN LEVER, THETFORD 12523
	063740-01-713	EA	SEAL-BALL VALVE TO BOWL, THETFORD 12502
	063740-01-714	EA	VALVE ASSEMBLY-WATER, THETFORD 12492
	063740-01-716	EA	SEAT & COVER-THETFORD 15017
	063740-01-717	EA	TUBE-FLUSH, TOILET - 12509 THETFORD

BATH PRIVACY DOOR

KEY	PART NUMBER	U/M	DESCRIPTION
	100494-08-F15	EA	DOOR-PRIVACY, BATH, W/O HARDWARE - 526MM X 1896MM
	009151-01-000	EA	GUARD-WARP, CABINET/PRIVACY DOOR - 48"
	058335-02-000	EA	LATCH-SHOWER/BATH DOOR, W/O LOCK - PLASTIC - BROWN

BEDROOM GROUP

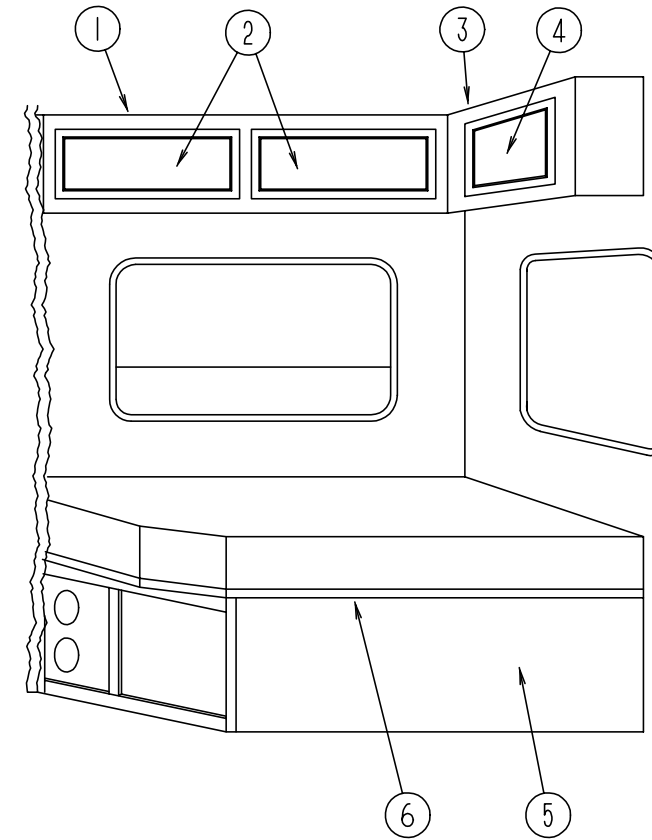

BEDROOM CABINETS

KEY	PART NUMBER	U/M	DESCRIPTION
1	115622-01-F15	EA	CABINET-OVERHEAD, W/O DOORS OR HARDWARE
2	110140-18-E01	EA	DOOR-CABINET, W/O HARDWARE - 400MM X 710MM
3	115621-01-F15	EA	CABINET-OVERHEAD, REAR - W/O DOORS OR HARDWARE
4	110140-18-E01	EA	DOOR-CABINET, W/O HARDWARE - 400MM X 710MM
4	110140-21-F15	EA	DOOR-CABINET, W/MIRROR - W/O HARDWARE - 400MM X 710MM
	108536-04-08A	EA	MIRROR-GLASS, GALAXY FLOWER
5	P05802-01-C43	EA	CABINET-DOUBLE BED, W/O CABINET TOPS
	106230-01-C43	EA	DIVIDER-CABINET, DOUBLE BED
6	M05689-02-000	EA	TOP-CABINET, DOUBLE BED - DRIVER SIDE
6	M05689-01-F15	EA	TOP-CABINET, DOUBLE BED - PASSENGER SIDE
	089076-03-000	EA	SUPPORT-BED, H-CHANNEL - 1.96" X 72.7" - ALUMINUM - BEIGE

CHASSIS GROUP

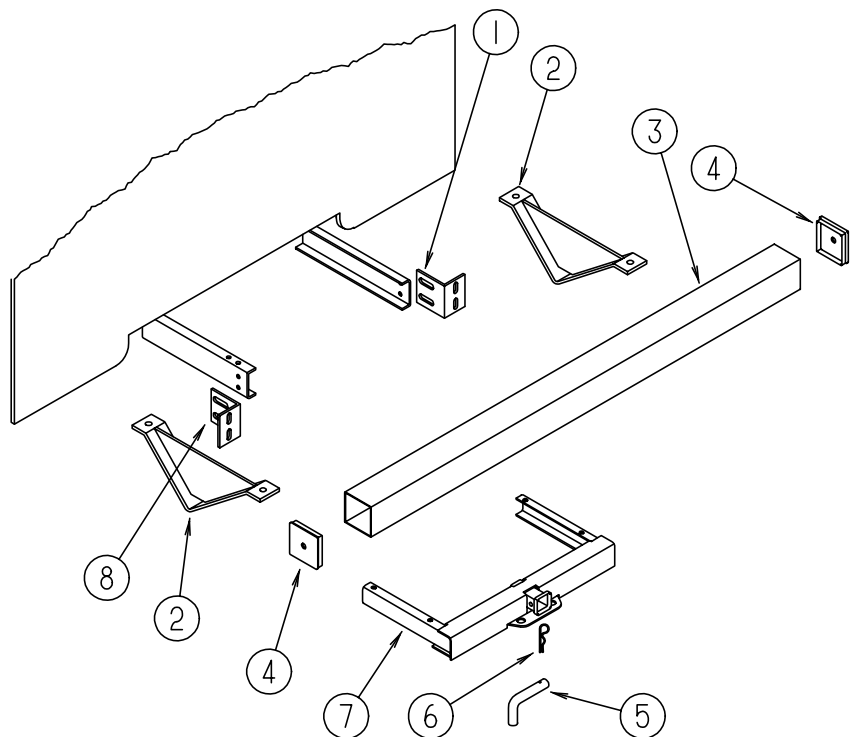

CHASSIS GROUP (CONTINUED)

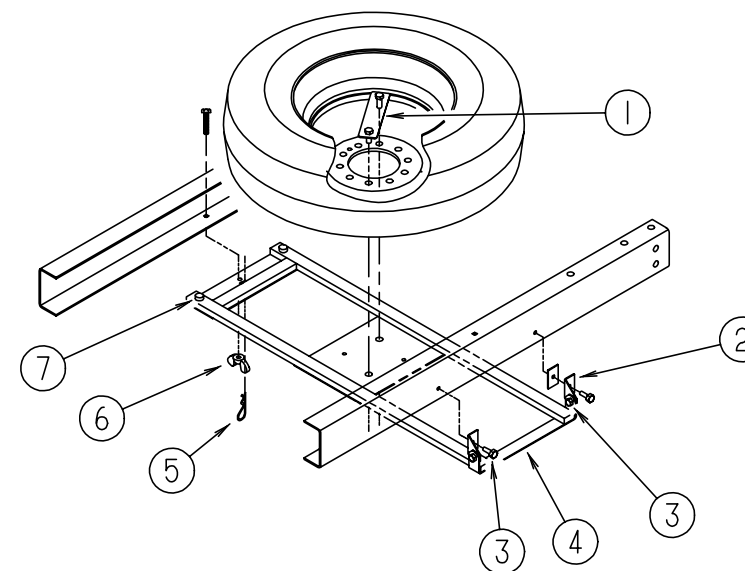

REAR BUMPER & HITCH

KEY	PART NUMBER	U/M	DESCRIPTION
1	104420-01-000	EA	SUPPORT-ANGLE, REAR BUMPER - RIGHT
2	083376-01-000	EA	PLATE-SKID, 13.2" X 6" X 2" - STEEL
3	103422-02-02A	EA	BUMPER-SQUARE, ALUMINUM - BRIGHT WHITE
4	039779-01-000	EA	CAP-BUMPER, RUBBER - 4" X 4" - BLACK
5	034512-01-000	EA	PIN-LOCKING, DRAWBAR
6	034513-01-000	EA	PIN-HITCH, 3/16" WIRE
7	077617-08-000	EA	HITCH-TRAILER, W/O DRAWBAR - 41.1" WIDE - STEEL - BLACK
8	104420-02-000	EA	SUPPORT-ANGLE, REAR BUMPER - LEFT
	097744-02-000	EA	HOUSING-TRAILER PIN, 48"
	097745-01-000	EA	HOUSING-RECEPTACLE, TRAILER - 12" WIRE LENGTH
	113589-02-000	EA	CONNECTOR-SOCKET, TRAILER - GENERAL 433601
	113589-01-000	EA	CONNECTOR-PLUG, TRAILER - GENERAL 433501
	113634-01-000	EA	WIRE ASSEMBLY-TRAILER, ADAPTER

SPARE TIRE INSTALLATION

KEY	PART NUMBER	U/M	DESCRIPTION
1	116338-02-02B	EA	BRACKET-CLAMP, SPARE TIRE - E-COAT
	000D39-08-00B	EA	NUT-HEX-SERRATED FLANGE LOCK, 1/2-13 - ZINC
2	116349-02-02B	EA	BRACKET-HINGE, SPARE TIRE - E-COAT
3	000C26-06-12B	EA	BOLT-HEX-SERRATED FLANGE, 3/8-16X3/4
	000D39-06-00B	EA	NUT-HEX-SERRATED FLANGE LOCK, 3/8-16 - ZINC
	000E13-17-00B	EA	WASHER-FLARE, 3/8 AR - ZINC
4	116348-02-02B	EA	CRADLE ASSEMBLY-SPARE TIRE, E-COAT
5	034513-01-000	EA	PIN-HITCH, 3/16 WIRE
6	064081-03-000	EA	NUT-WING, 3/8-16 - W/WELD NUT
7	069726-02-000	EA	BUMPER - .88 DIAMETER - 40 - BLACK
	080208-01-000	EA	LUG WRENCH, 1.06 X 1.00
	080208-02-000	EA	BAR-LEVERAGE, LUG WRENCH
	112358-01-000	EA	WRENCH-LUG, 7/8 - L-SHAPE FORD F2UA-17035-CA

CHASSIS GROUP (CONTINUED)

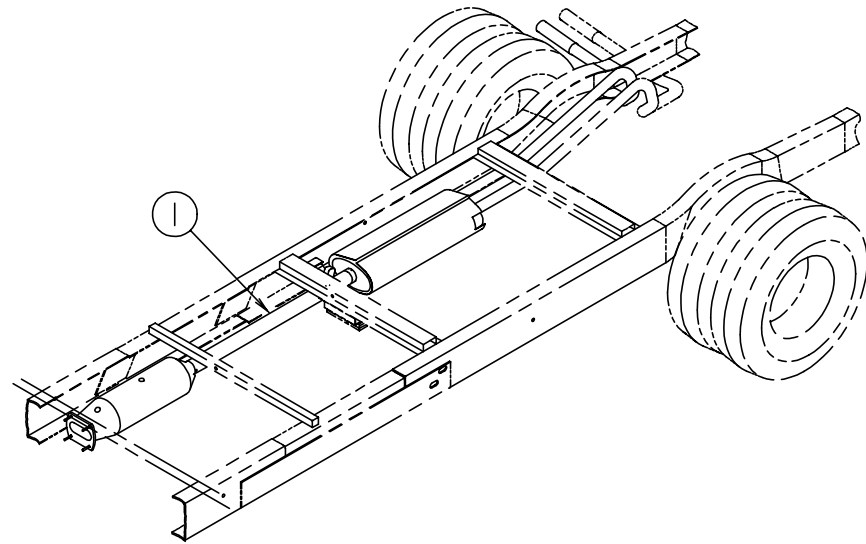

EXHAUST SYSTEM COMPONENTS

KEY	PART NUMBER	U/M	DESCRIPTION
	091182-03-000	EA	SHIELD-HEAT
1	096753-04-000	EA	PIPE-EXHAUST, SINGLE EXHAUST
	094918-03-000	EA	CLAMP-EXHAUST, 2.5" - GUILLOTINE STYLE
1	111478-01-000	EA	PIPE-EXHAUST, DUAL EXHAUST
	094918-06-000	EA	CLAMP-EXHAUST, 3" - HEAVY DUTY - HECO 24698

CHASSIS GROUP (CONTINUED)

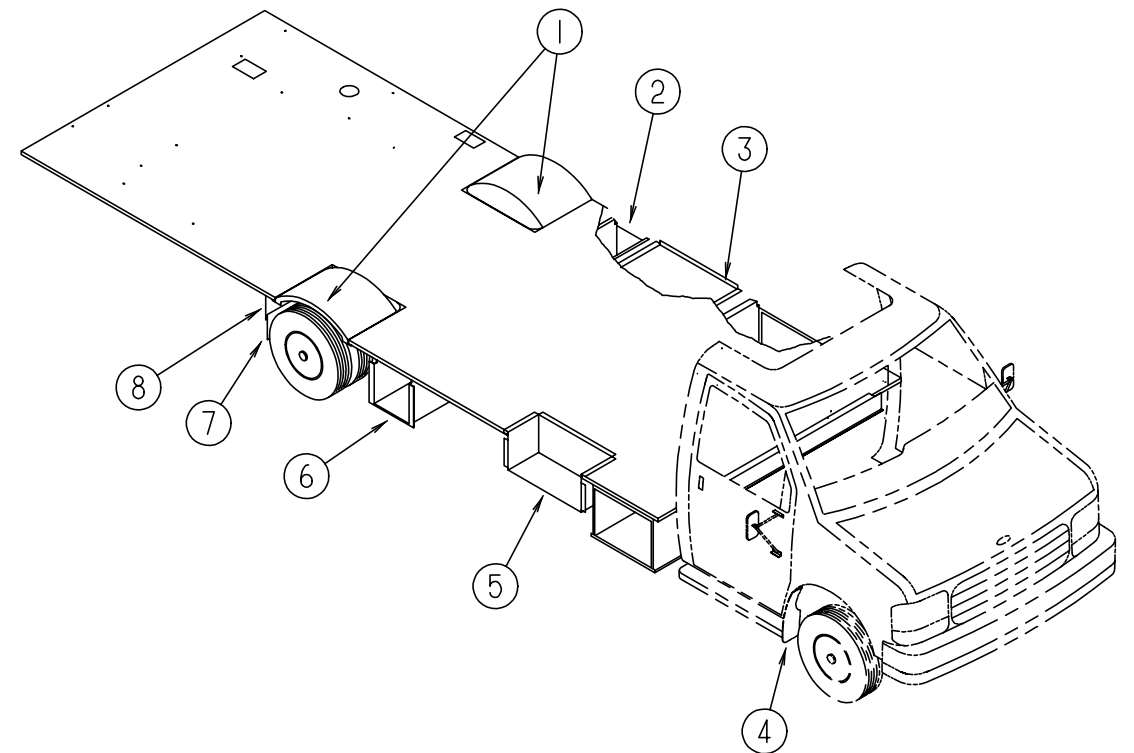

MISCELLANEOUS CHASSIS COMPONENTS

KEY	PART NUMBER	U/M	DESCRIPTION
1	102782-01-000	EA	WHEELWELL-PLASTIC
2	102979-01-000	EA	BOX-POWER CORD
	115361-01-01A	EA	PLUG-PLASTIC
3	114394-01-02B	EA	COMPARTMENT ASM-GENERATOR, E-COAT
	061420-01-000	EA	PLUG-PLASTIC, 1.75" - BROWN
	114070-02-02B	EA	SUPPORT ASM-GENERATOR, E-COAT
	114071-02-02B	EA	SUPPORT ASM-GENERATOR, RT - E-COAT
4	072884-27-703	EA	MUD FLAPS-PAIR, W/HOLES 99171
5	077848-02-000	EA	STEP-PULLOUT
	076241-13-000	EA	SUPPORT-STEP, ENTRANCE DOOR
	091176-01-000	EA	SUPPORT-BASE, ENTRANCE STEP
6	105203-01-000	EA	COMPARTMENT-BATTERY
	084993-01-000	EA	STRAP ASSEMBLY-BATTERY, WEBBING & BUCKLE - 1100MM X 1" WIDE
	084993-02-000	EA	STRAP ASSEMBLY-BATTERY, WEBBING & BUCKLE - 1400MM X 1" WIDE
7	017516-01-000	EA	FLAP-MUD, 14" X 18" - BLACK - REAR
8	045731-04-000	EA	GUARD-ROCK
			FROM: 00-00-00 THRU: 09-25-94
8	045731-06-000	EA	GUARD-ROCK
			FROM: 09-26-94 THRU: 99-99-99
	056748-01-000	EA	PLUG-CAP, 1.5" DIAMETER - BLACK

CHASSIS GROUP (CONTINUED)

WHEEL LINERS

KEY	PART NUMBER	U/M	DESCRIPTION
	110435-02-000	EA	LINER-WHEEL, SET 4 - DICOR V160F2
	110435-02-700	EA	LINER-WHEEL, FRONT V160F2-FWC
	110435-02-701	EA	LINER-WHEEL, REAR V160F2-RWC
	110435-02-702	EA	STUD EXTENSION V160SD-STX
	110435-02-703	EA	NUT-JAMB V160SD-JNT
	110435-02-704	EA	LUG NUT COVER V160F0-LNC
	110435-02-705	EA	TOOL-JAMB NUT, INSTALLATION V160F0-TOL

WHEEL COVERS

KEY	PART NUMBER	U/M	DESCRIPTION
	109443-05-000	EA	WHEEL COVER - 4/SET, 16" STAINLESS STEEL - DICOR SHFM16
	109443-05-700	EA	COVER WHEEL - 16" SHFM16-CVR
	109443-05-701	EA	LUG NUT COVER - ABS (PLATED) SP-FM-LNC

TIRE & WHEEL

KEY	PART NUMBER	U/M	DESCRIPTION
	083425-09-000	EA	TIRE-LT225/75R16 LRD - MICHELIN XCH4
	083617-03-000	EA	WHEEL-STEEL - 16.0X6 - ACCURIDE 28618
	095012-03-000	EA	EXTENSION-VALVE STEM - DUAL WHEEL
	112358-01-000	EA	WRENCH-LUG, 7/8 - L-SHAPE FORD F2UA-17035-CA

DRIVESHAFT & FLARE UNION

KEY	PART NUMBER	U/M	DESCRIPTION
	103653-06-000	EA	DRIVESHAFT ASM-BALANCED PAIR, 188" WHEELBASE (158) (DIESEL)
	103653-15-000	EA	DRIVESHAFT ASM-BALANCED PAIR, 188" WHEELBASE (158)
	074833-01-000	EA	SPACER-BEARING, DRIVESHAFT - 2" X 8" X .5" THICK
	085771-03-000	EA	NUT-HEX, TORQUE - GRADE G DRIVE SHAFT
	088498-01-000	EA	UNION-INVERTED FLARE, BRASS - 3/16 - 3/8 - 24 THD - BRAKE LINE

CHASSIS GROUP (CONTINUED)

FUEL SYSTEM COMPONENTS

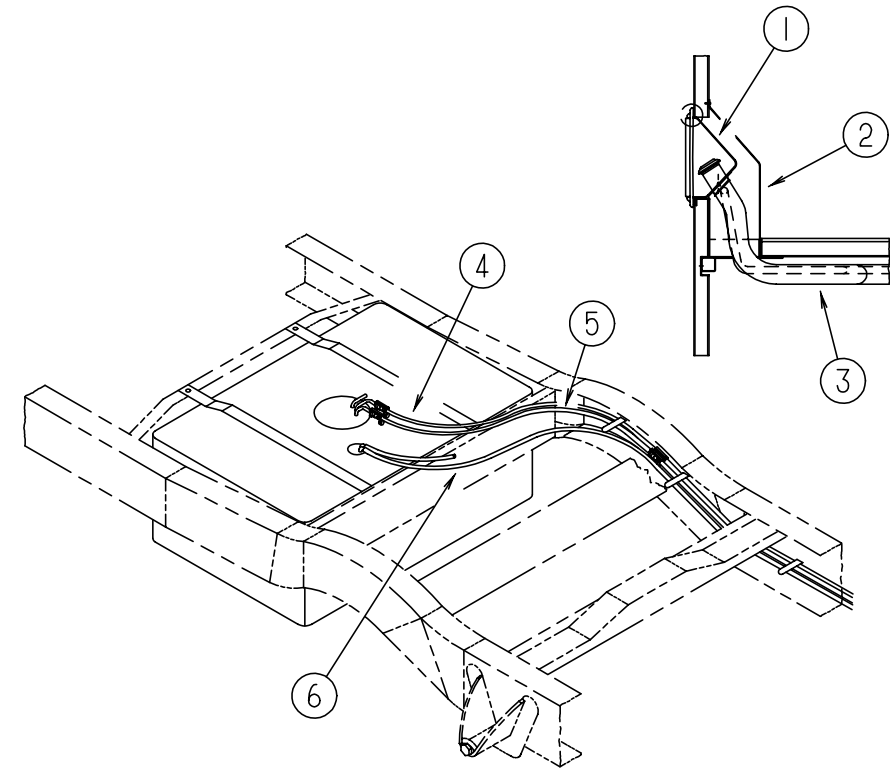

FUEL SYSTEM COMPONENTS

KEY	PART NUMBER	U/M	DESCRIPTION
1	095854-01-04A	EA	SHROUD-FUEL FILL, PLASTIC - BRIGHT WHITE
2	078040-06-000	EA	SHROUD-FUEL FILL, UPPER - PLASTIC
3	106413-01-000	EA	NECK-FUEL FILL, MAIN - GAS
3	106413-02-000	EA	NECK-FUEL FILL, MAIN - DIESEL
	078200-01-000	EA	GASKET-FUEL FILL, 3.5" OD X 2" ID
4	106389-01-000	EA	FUEL LINE ASM-FORD, 3/8 HP
5	106388-01-000	EA	FUEL LINE ASM-FORD, 5/16 HP
	007063-01-000	FT	HOSE-GAS, 1/4" ID X 1/2" OD
6	044317-01-000	FT	HOSE-FUEL, 3/8" ID
	084884-01-000	EA	PLUG-BRASS, 3/8"

CURTAIN & CUSHION GROUP

NOTICE

IN ORDER TO ASSIST OUR PARTS SALES DEPT. IN PROVIDING INTERIOR SOFTWARE ITEMS, PLEASE INCLUDE THE SERIAL NUMBER AND THE COLOR CODE NUMBER FROM THE VEHICLE CERTIFICATION LABEL WHEN ORDERING. THIS LABEL IS LOCATED ON THE LEFT SIDEWALL AT THE END OF THE DASH (A-BODY), OR ON THE DRIVER'S DOOR LATCH PLATE (C-BODY).

AN EXAMPLE OF A COLOR CODE NUMBER IS B07, WHICH DESIGNATES AN OVERALL COLOR SCHEME OF A PARTICULAR UNIT. THE COLOR LISTED AFTER THE ITEM DESCRIPTION ON THE MICROFICHE, INDICATES THE OVERALL UNIT COLOR. ORDER THE ITEM YOU DESIRE ACCORDING TO UNIT COLOR CODE.

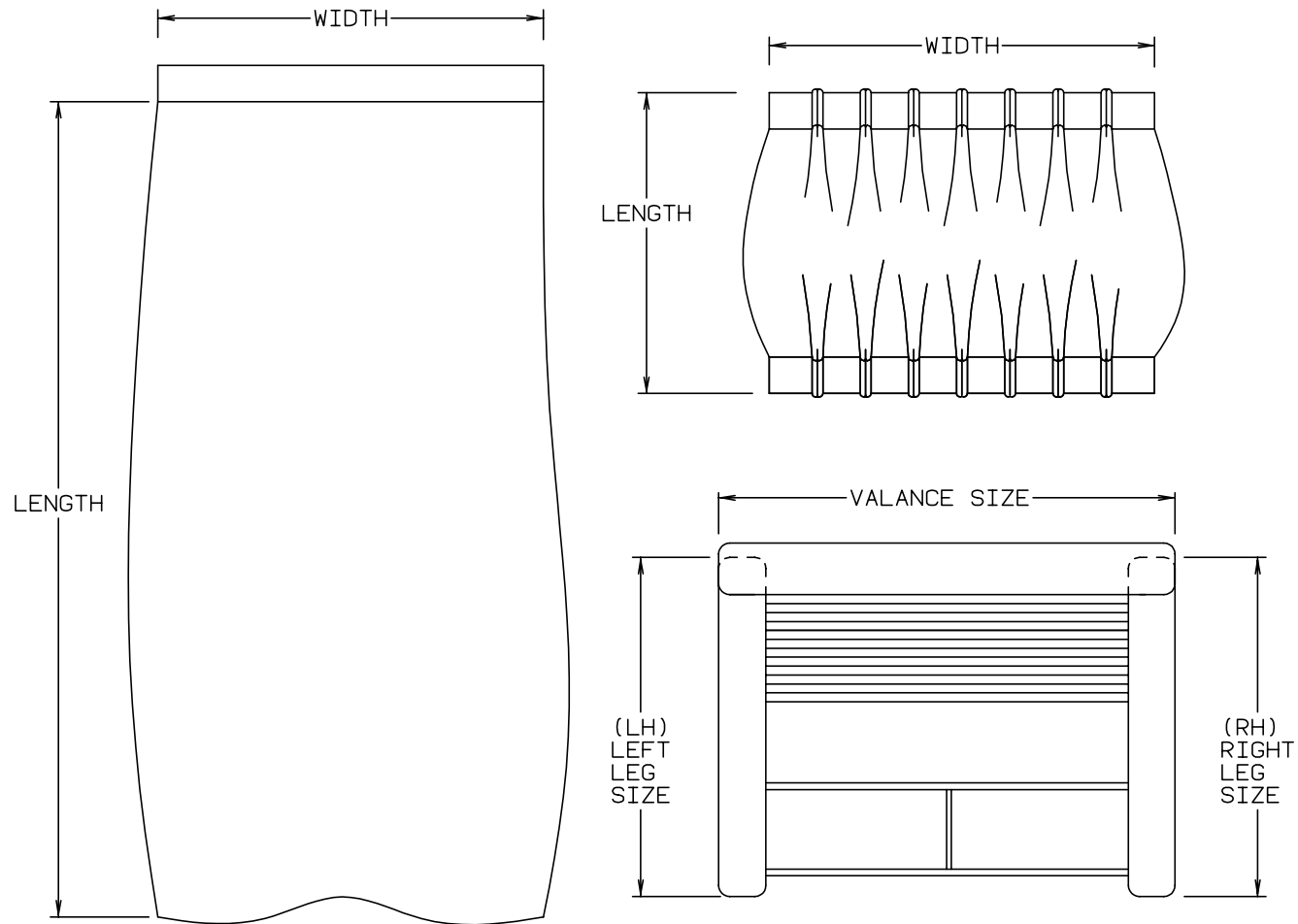

NOTE: USE THIS ILLUSTRATION WHEN DETERMINING LENGTH AND WIDTH MEASUREMENTS FOR CURTAINS. YOU WILL NOTE THE WIDTH MEASUREMENT IS TAKEN ON THE TOP OF THE CURTAIN WITH THE CURTAIN FULLY EXTENDED. THE LENGTH MEASUREMENT IS TAKEN FROM TOP TO BOTTOM. LEFT AND RIGHT WINDOW LEGS ARE DETERMINED WHEN FACING THE WINDOW.

CURTAIN & CUSHION GROUP (CONTINUED)

FABRICS

KEY	PART NUMBER	U/M DESCRIPTION
	087272-03-000	YD DRAPERY LINING-54" - IVORY
	105745-64-000	YD FABRIC-BEDSPREAD, DRAPERY & PRIVACY CURTAIN - SLATE (F15)
	105745-62-000	YD FABRIC-BEDSPREAD, DRAPERY & PRIVACY CURTAIN - LILAC (F16)
	105745-85-000	YD FABRIC-BEDSPREAD, MAIN - OPAL (F15)
	105745-86-000	YD FABRIC-BEDSPREAD, MAIN - DUSK (F16)
	108446-B3-000	YD FABRIC-UPHOLSTERY, MAIN - GULF (F15)
	108446-B8-000	YD FABRIC-UPHOLSTERY, MAIN - IVORY (F16)
	108446-49-000	YD FABRIC-UPHOLSTERY, PLAIN ACCENT - TWILIGHT (F15)
	108446-B4-000	YD FABRIC-UPHOLSTERY, PLAIN ACCENT - SMOKE (F16)
	108446-B5-000	YD FABRIC-UPHOLSTERY, PATTERN ACCENT - GULF (F15)
	108446-B6-000	YD FABRIC-UPHOLSTERY, PATTERN ACCENT - IVORY (F16)
	079680-01-000	YD FABRIC-VINYL, 54" WIDE - BEIGE
	103907-01-01A	YD FABRIC-VINYL, 54" WIDE - OFF WHITE

WELTING & BUTTONS

KEY	PART NUMBER	U/M DESCRIPTION
	079349-04-E27	YD WELTING-FABRIC (F15)
	079349-04-F16	YD WELTING-FABRIC (F16)
	070578-11-B18	EA BUTTON-SNAP TOP - #30 - VINYL - OFF WHITE

ASSIST HANDLE & SEATBELTS

KEY	PART NUMBER	U/M DESCRIPTION
	053552-02-AA8	EA HANDLE-ASSIST, INTERIOR - ENTRY DOOR - VINYL - OFF WHITE
	069178-02-000	EA BRACKET-MOUNTING, ASSIST HANDLE - L ANGLE - W/HOLES - STEEL
	000C16-07-16B	EA BOLT-CARRIAGE, ASSIST HANDLE - 7/16" - 14 X 1" - ZINC
	000D20-07-00B	EA NUT-ACORN - ASSIST HANDLE - 7/16" X 14 - ZINC
	057759-01-000	EA WASHER BRACKET-SEAT BELT, 4" DIAMETER
	007021-01-000	EA BELT-SEAT, 2" X 90" - BLACK
	056271-01-000	EA BELT-SEAT, 2" X 102" - BLACK

CURTAIN & CUSHION GROUP (CONTINUED)

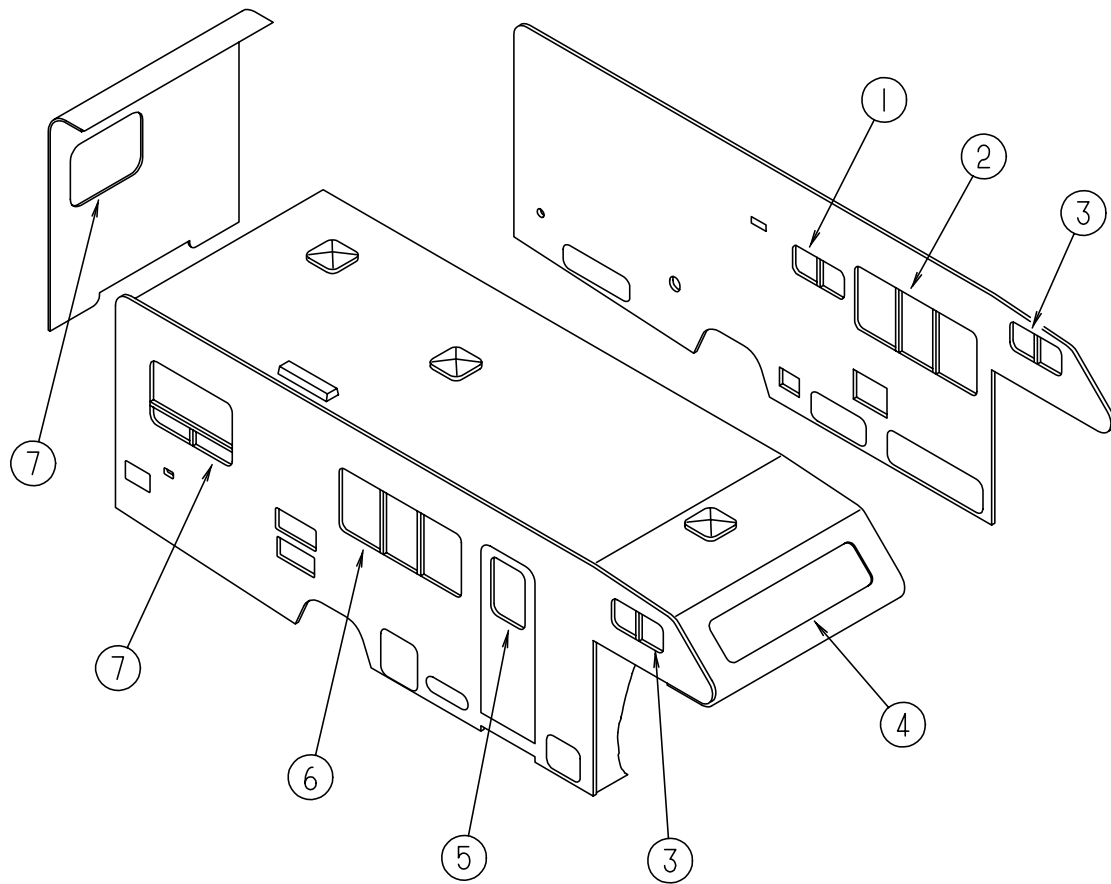

CURTAINS & WINDOW TREATMENT

KEY	PART NUMBER	U/M	DESCRIPTION
1	109041-20-01A	EA	BLIND-MINI, 31" X 18" DROP - PURE SILVER
	109353-07-01A	EA	VALANCE-BLIND, 31" SLAT - PURE SILVER
	109353-04-000	EA	CLIP-VALANCE SLAT MOUNTING, CLEAR PLASTIC
2	105923-24-F15	EA	VALANCE-WINDOW, RODEWAY - 63.5" - W/1" INSERT
2	105923-24-F16	EA	VALANCE-WINDOW, RODEWAY - 63.5" - W/1" INSERT
2	076892-21-FB1	EA	CURTAIN-WINDOW, PLAIN HEM TOP & BOTTOM - 30" X 15" (F15)
2	076892-21-FC1	EA	CURTAIN-WINDOW, PLAIN HEM TOP & BOTTOM - 30" X 15" (F16)
2	084755-76-F15	EA	SHADE-PULL, 62.25" - W/O TRIM
3	101034-45-F15	EA	CURTAIN-WINDOW, DARTED TAPE TOP - W/LINING - 20" X 34" - RH
3	101034-45-F16	EA	CURTAIN-WINDOW, DARTED TAPE TOP - W/LINING - 20" X 34" - RH
3	101034-46-F15	EA	CURTAIN-WINDOW, DARTED TAPE TOP - W/LINING - 20" X 34" - LH
3	101034-46-F16	EA	CURTAIN-WINDOW, DARTED TAPE TOP - W/LINING - 20" X 34" - LH
4	101034-33-F15	EA	CURTAIN-WINDOW, DART TAPE TOP & BOTTOM - 21" X 60" - RIGHT
4	101034-33-F16	EA	CURTAIN-WINDOW, DART TAPE TOP & BOTTOM - 21" X 60" - RIGHT
4	101034-34-F15	EA	CURTAIN-WINDOW, DART TAPE TOP & BOTTOM - 21" X 60" - LEFT
4	101034-34-F16	EA	CURTAIN-WINDOW, DART TAPE TOP & BOTTOM - 21" X 60" - LEFT

CURTAIN & CUSHION GROUP (CONTINUED)

CURTAINS & WINDOW TREATMENT (CONTINUED)

KEY	PART NUMBER	U/M	DESCRIPTION
5	105923-28-F15	EA	VALANCE-DOOR, RODEWAY - 29" - W/1" INSERT
5	105923-28-F16	EA	VALANCE-DOOR, RODEWAY - 29" - W/1" INSERT
5	084755-57-E07	EA	SHADE-PULL, 27.25"
6	105923-24-F15	EA	VALANCE-WINDOW, RODEWAY - 63.5" - W/1" INSERT
6	105923-24-F16	EA	VALANCE-WINDOW, RODEWAY - 63.5" - W/1" INSERT
6	076892-21-F15	EA	CURTAIN-WINDOW, PLAIN HEM TOP & BOTTOM - 31" X 15"
6	076892-21-F16	EA	CURTAIN-WINDOW, PLAIN HEM TOP & BOTTOM - 31" X 15"
6	084755-76-F15	EA	SHADE-PULL, 62.25" - W/O TRIM
7	104657-02-F15	EA	VALANCE-WINDOW, GEORGETOWN - 52" - W/O HEADER
7	104657-02-F16	EA	VALANCE-WINDOW, GEORGETOWN - 52" - W/O HEADER
7	101668-42-F15	EA	CURTAIN-WINDOW, TAPE TOP - 32" X 35"
7	101668-42-F16	EA	CURTAIN-WINDOW, TAPE TOP - 32" X 35"
7	084755-92-F15	EA	SHADE-PULL, 50.25"

PRIVACY CURTAINS

KEY	PART NUMBER	U/M	DESCRIPTION
	076892-20-F15	EA	CURTAIN-BUNK PRIVACY, SNAP TOP - PLAIN - W/LINING - 50" X 78"
	076892-20-F16	EA	CURTAIN-BUNK PRIVACY, SNAP TOP - PLAIN - W/LINING - 50" X 78"
	101668-39-F15	EA	CURTAIN-BUNK PRIVACY, TAPE TOP - W/LINING - 35" X 50" - RIGHT
	101668-40-F15	EA	CURTAIN-BUNK PRIVACY, TAPE TOP - W/LINING - 35" X 50" - LEFT
	101668-39-F16	EA	CURTAIN-BUNK PRIVACY, TAPE TOP - W/LINING - 35" X 50" - RIGHT
	101668-40-F16	EA	CURTAIN-BUNK PRIVACY, TAPE TOP - W/LINING - 35" X 50" - LEFT
	101668-48-F15	EA	CURTAIN-BEDROOM PRIVACY, TAPE TOP - W/LINING - 70" X 60"
	101668-48-F16	EA	CURTAIN-BEDROOM PRIVACY, TAPE TOP - W/LINING - 70" X 60"

SHOWER CURTAINS

KEY	PART NUMBER	U/M	DESCRIPTION
	084481-19-B88	EA	CURTAIN-SHOWER, 69" X 42" (F15)
	084481-19-D05	EA	CURTAIN-SHOWER, 69" X 42" (F16)

CURTAIN TIEBACKS

KEY	PART NUMBER	U/M	DESCRIPTION
	073260-25-F15	EA	TIEBACK-BEDROOM CURTAIN, 3" X 18"
	073260-25-F16	EA	TIEBACK-BEDROOM CURTAIN, 3" X 18"
	073260-23-F15	EA	TIEBACK-BUNK PRIVACY CURTAIN, 3" X 18"
	073260-23-F16	EA	TIEBACK-BUNK PRIVACY CURTAIN, 3" X 18"
	073260-54-C30	EA	TIEBACK-SHOWER CURTAIN, 3" X 16" (F15)
	073260-54-D36	EA	TIEBACK-SHOWER CURTAIN, 3" X 16" (F16)
	073260-59-F15	EA	TIEBACK-BEDROOM PRIVACY CURTAIN, 4" X 15"
	073260-59-F16	EA	TIEBACK-BEDROOM PRIVACY CURTAIN, 4" X 15"
	057534-01-000	EA	TIEBACK/TIEDOWN-BED/CURTAIN/DOOR - 6" - PLASTIC - CLEAR
	057534-06-000	EA	TIEBACK/TIEDOWN-VINYL, 6" - BEIGE

CURTAIN & CUSHION GROUP (CONTINUED)

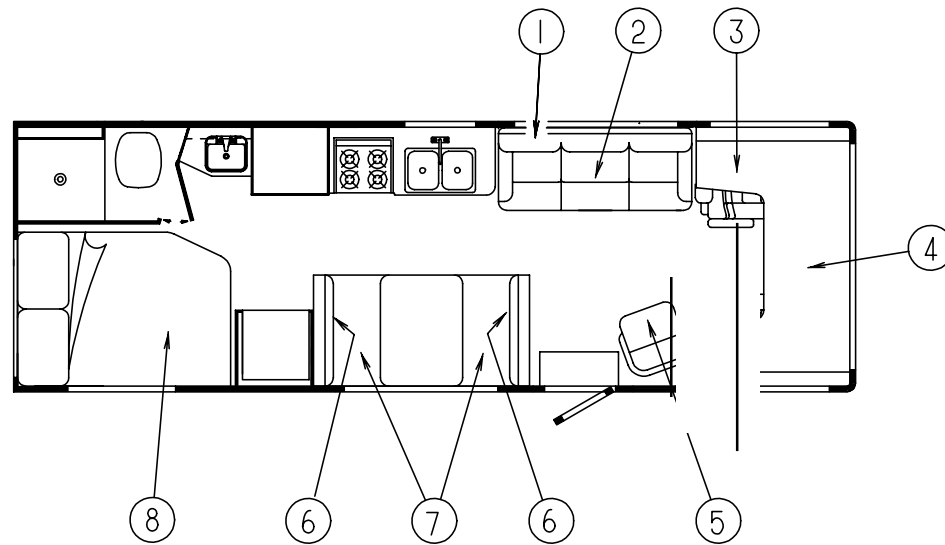

COUCH

KEY	PART NUMBER	U/M DESCRIPTION
1	100032-44-F15	EA BACKREST-COUCH, 66.5"
1	100032-44-F16	EA BACKREST-COUCH, 66.5"
	P00032-44-F15	EA COVER-BACKREST, 66.5"
	P00032-44-F16	EA COVER-BACKREST, 66.5"
	101085-09-000	EA FRAME-BACK, COUCH - 66.5" X 16"
2	100032-37-F15	EA SEAT-COUCH, W/O BACKREST - 66.5"
2	100032-37-F16	EA SEAT-COUCH, W/O BACKREST - 66.5"
	P00032-37-F15	EA COVER-SEAT, COUCH - 66.5"
	P00032-37-F16	EA COVER-SEAT, COUCH - 66.5"
	101085-01-000	EA FRAME-SEAT, COUCH - 66.5"
	101085-03-000	EA FRAME-BASE, COUCH - 66.5"
	105947-01-000	EA BRACKET-HOLD DOWN, COUCH - CANADIAN

NOTE: COUCH FRONT AND SIDE PANELS ARE FOUND IN LOUNGE GROUP

BUNK CUSHIONS

KEY	PART NUMBER	U/M DESCRIPTION
3	105573-12-F15	EA CUSHION-OVERHEAD, REAR - 27" X 23" X 80" X 4"
3	105573-12-F16	EA CUSHION-OVERHEAD, REAR - 27" X 23" X 80" X 4"
	P05573-12-F15	EA COVER-CUSHION, REAR - 27" X 23" X 80" X 4"
	P05573-12-F16	EA COVER-CUSHION, REAR - 27" X 23" X 80" X 4"
4	105573-11-F15	EA CUSHION-OVERHEAD, FRONT - DOUBLE ANGLED - 32.5" X 80" X 4"
4	105573-11-F16	EA CUSHION-OVERHEAD, FRONT - DOUBLE ANGLED - 32.5" X 80" X 4"
	P05573-11-F15	EA COVER-CUSHION, FRONT - DOUBLE ANGLED - 32.5" X 80" X 4"
	P05573-11-F16	EA COVER-CUSHION, FRONT - DOUBLE ANGLED - 32.5" X 80" X 4"

CURTAIN & CUSHION GROUP (CONTINUED)

CHAIR - SEIRRA

KEY	PART NUMBER	U/M DESCRIPTION
5	115470-01-F15	EA CHAIR-SEIRRA, W/SKIRT
5	115470-01-F16	EA CHAIR-SEIRRA, W/SKIRT

DINETTE CUSHIONS

KEY	PART NUMBER	U/M DESCRIPTION
6	116134-01-FB1	EA CUSHION-BACKREST, 13.5" X 37.5" X 5" (F15)
6	116134-01-FC1	EA CUSHION-BACKREST, 13.5" X 37.5" X 5" (F16)
	P16134-01-FB1	EA COVER-CUSHION, BACKREST - 13.5" X 37.5" X 5" (F15)
	P16134-01-FC1	EA COVER-CUSHION, BACKREST - 13.5" X 37.5" X 5" (F16)
	078155-01-000	EA STRAP-SNAP, BACKREST CUSHION
7	088927-87-F15	EA CUSHION-SEATBASE, 23" X 38" X 5"
7	088927-87-F16	EA CUSHION-SEATBASE, 23" X 38" X 5"
	M88927-87-F15	EA COVER-CUSHION, SEATBASE - 23" X 38" X 5"
	M88927-87-F16	EA COVER-CUSHION, SEATBASE - 23" X 38" X 5"

DOUBLE BEDSPREAD, PILLOW & MATTRESS

KEY	PART NUMBER	U/M DESCRIPTION
8	085365-27-F15	EA BEDSPREAD-THROW, W/ROUNDED CORNER - 54"
8	085365-27-F16	EA BEDSPREAD-THROW, W/ROUNDED CORNER - 54"
	102161-25-F15	EA PILLOW SHAM-W/4" RUFFLE
	102161-25-F16	EA PILLOW SHAM-W/4" RUFFLE
	101123-16-000	EA MATTRESS-FOAM, 54" X 74" - CUT CORNER
	P01123-16-000	EA COVER-MATTRESS, 54" X 74" - CUT CORNER

CURTAIN & CUSHION GROUP (CONTINUED)

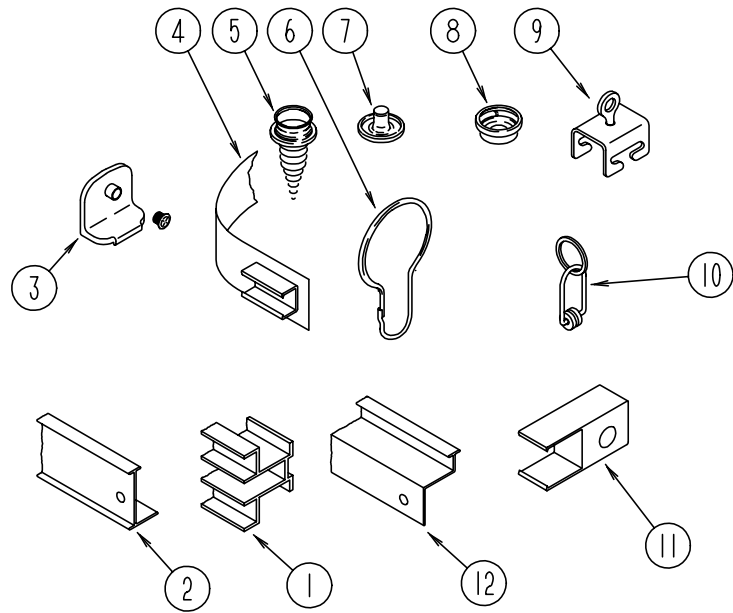

CURTAIN HARDWARE

KEY	PART NUMBER	U/M	DESCRIPTION
1	101033-03-000	FT	TRACK-WALL, WHITE
2	092464-05-01A	EA	TRACK-SHOWER, CURVED - OFF WHITE
	009700-04-002	EA	TRACK, L-SHAPED - 195.2" - OFF WHITE
3	106544-01-000	EA	PULL-SHADE, BRASS
	106544-01-001	EA	SCREW-BRASS, SHADE
4	101031-01-000	YD	TAPE-GLIDE, CURTAIN - 4.25" SPACING
5	029130-01-000	EA	SCREW-SNAP SOCKET, #8 PH X 5/8"
6	009136-02-000	EA	HANGER-RING, PIN TYPE - CURTAIN - BRASS
7	029155-01-000	EA	CAP-SNAP, 5/32" OD OF PIN
8	029156-01-000	EA	SOCKET-SNAP, 9/16" OD
9	009701-01-000	EA	CARRIER-CURTAIN, L ROD
10	009702-01-000	EA	END STOP-CURTAIN CARRIER, L ROD
11	101033-02-000	EA	END CAP-TRACK, CLEAR
12	105450-02-01A	EA	TRACK-CURTAIN, 48" LONG - ALUMINUM - OFF WHITE
12	105450-06-01A	EA	TRACK-CURTAIN, 88" LONG - ALUMINUM - OFF WHITE
12	105450-09-01A	EA	TRACK-CURTAIN, GEORGETOWN VALANCE - 55.5" LONG - ALUM-OFFWHITE
	046867-01-000	EA	GROMMET-BRASS - 7/16" ID X 1" OD
	048394-02-000	YD	VELCRO TAPE-HOOK, ADHESIVE BACK - .75" WIDE - BEIGE
	075943-01-000	EA	BRACE-WINDOW VALANCE, 1" X 1.5" X 20" - ALUMINUM - BEIGE
	068716-01-001	EA	BRACE - 90 DEGREE L-ANGLE, 192" - EXTRUDED ALUMINUM
	084432-06-000	FT	SLAT-ROLLER SHADE, PLASTIC
	084433-05-000	EA	SHADE-ROLLER, 72.25"
	084434-01-000	EA	BRACKET-MOUNTING, ROLLER SHADE - 1 3/8"
	086276-01-000	EA	TAPE-DOUBLE SIDED, 1/2"
	088792-01-000	YD	VELCRO-HOOK, .75" WIDE - BEIGE
	088792-02-000	YD	VELCRO TAPE-LOOP, ADHESIVE BACKED - .75" WIDE - BEIGE
	096843-01-000	EA	SPRING-REWIND, ROLLER SHADE
	056003-04-000	EA	BRACKET-DRAPERY RETAINING, FRONT - 1.5" EXTENSION - METAL
	056003-05-000	EA	BRACKET-DRAPERY RETAINING, REAR - 1.5" EXTENSION - METAL
	083170-01-000	EA	BRACKET-BLIND, LEFT SIDE WHEN FACING WINDOW
	083170-02-000	EA	BRACKET-BLIND, RIGHT SIDE WHEN FACING WINDOW
	109441-01-000	EA	HOLD DOWN-BLIND, HOOK

CURTAIN & CUSHION GROUP (CONTINUED)

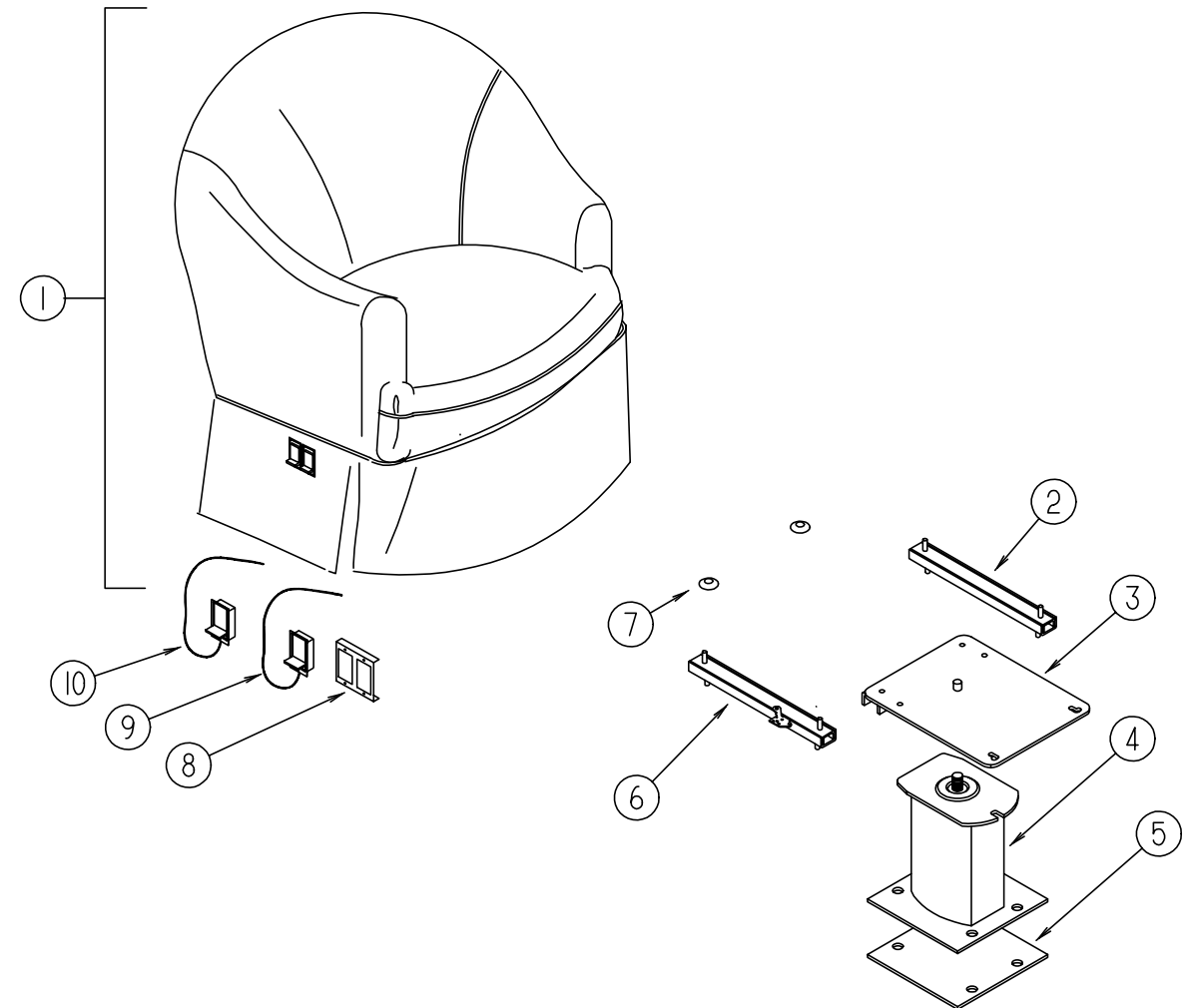

SWIVEL CHAIR

KEY	PART NUMBER	U/M	DESCRIPTION
1	115470-01-F15	EA	CHAIR-SEIRRA, W/SKIRT
1	115470-01-F16	EA	CHAIR-SEIRRA, W/SKIRT
	P15470-01-F15	EA	COVER-CHAIR, SEIRRA
	P15470-01-F16	EA	COVER-CHAIR, SEIRRA
2	069246-06-000	EA	ADJUSTER-SWIVEL CHAIR, MANUAL - FORWARD & BACK
3	107921-08-000	EA	TOP PLATE-W/O SEAT BELT BAR, FLEXSTEEL 2759PDTP
	107921-06-000	EA	BEARING KIT-FLEXSTEEL
4	107921-01-000	EA	BASE-PEDESTAL, W/9.75" EXTENSION - FLEXSTEEL 3060 MSPD
5	108445-02-000	EA	SUB-PLATE, PEDESTAL - FLOOR MOUNTED
6	069246-08-000	EA	ADJUSTER-SWIVEL CHAIR, FORWARD & BACK - REMOTE - SCHROCK
7	007221-01-000	EA	SPACER-SEAT ADJUSTER
8	097683-02-000	EA	BRACKET- MOUNT, REMOTE
9	108049-01-000	EA	CABLE-SWIVEL, W/SWITCH - 28" - FLEXSTEEL PED 23602
	108049-02-000	EA	CLIP-CABLE, PEDESTAL - FLEXSTEEL 2592-CA
10	089368-04-000	EA	CABLE-SLIDE, W/SWITCH

CURTAIN & CUSHION GROUP (CONTINUED)

DRIVER & PASSENGER BUCKET SEAT

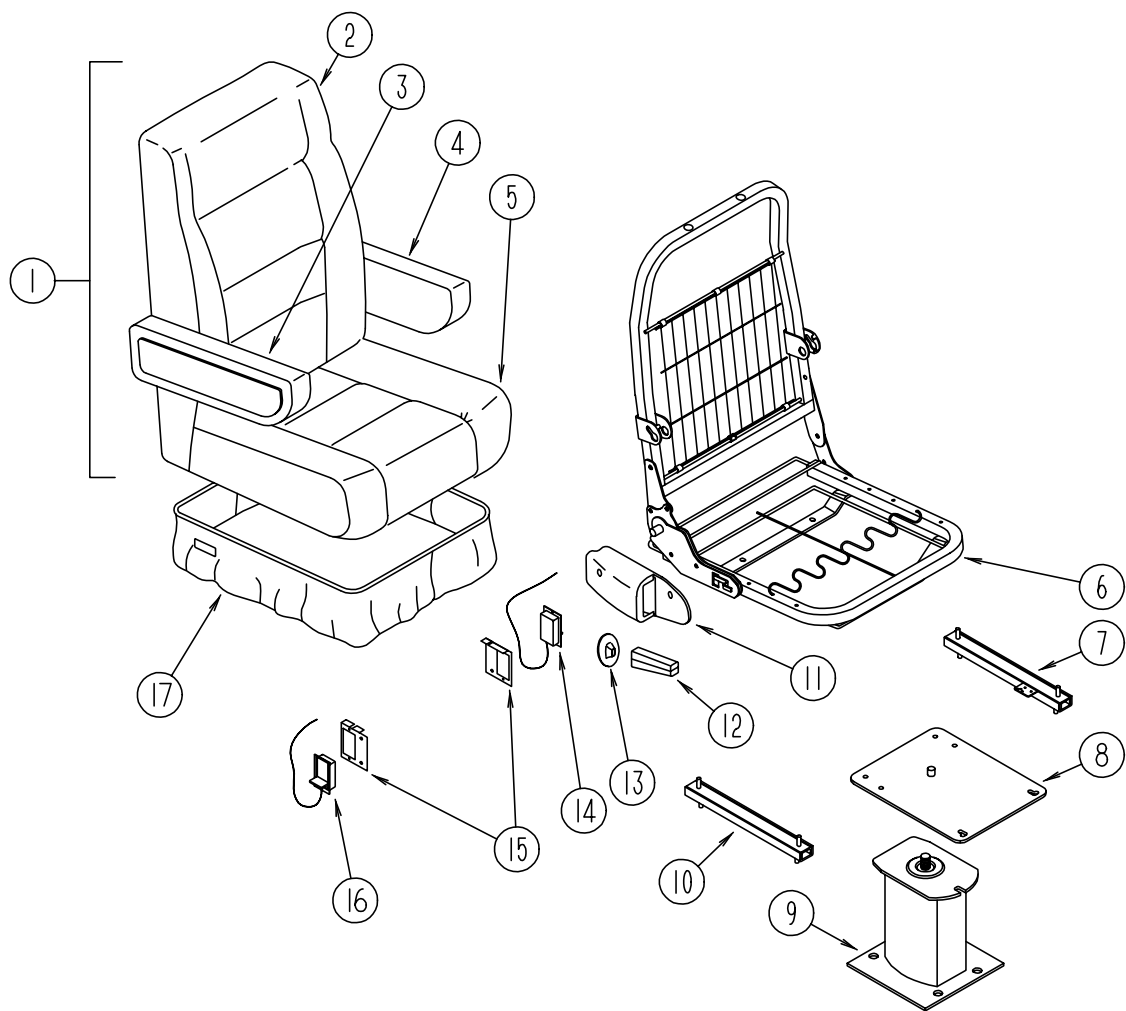

KEY	PART NUMBER	U/M	DESCRIPTION
1	110148-04-F15	EA	SEAT-ECONOMIZER II RECLINER, W/ECONO ARMS
1	110148-04-F16	EA	SEAT-ECONOMIZER II RECLINER, W/ECONO ARMS
2	M05962-17-F15	EA	COVER-BACK, ECONOMIZER II
2	M05962-17-F16	EA	COVER-BACK, ECONOMIZER II
	089323-01-000	FT	STRIP-POLYENTHYLENE, J-CHANNEL FLEX-O-LATORS
3	115520-01-FB1	EA	ARMREST-RH, ECONO W/O SEWLINES (F15)
3	115520-01-FC1	EA	ARMREST-RH, ECONO W/O SEWLINES (F16)
	P15520-01-FB1	EA	COVER-ARMREST, RH (F15)
	P15520-01-FC1	EA	COVER-ARMREST, RH (F16)
	081268-01-000	EA	ROD & CHANNEL-ARMREST, RIGHT - METAL
	081361-01-000	EA	ROD-ARMREST, METAL - RIGHT OR LEFT HAND
4	115520-02-FB1	EA	ARMREST-LH, ECONO W/O SEWLINES (F15)
4	115520-02-FC1	EA	ARMREST-LH, ECONO W/O SEWLINES (F16)
	P15520-02-FB1	EA	COVER-ARMREST, LH (F15)
	P15520-02-FC1	EA	COVER-ARMREST, LH (F16)
	081268-02-000	EA	ROD & CHANNEL-ARMREST, LEFT - METAL
	081361-01-000	EA	ROD-ARMREST, METAL - RIGHT OR LEFT HAND
5	M05962-18-F15	EA	COVER-SEAT, ECONOMIZER II
5	M05962-18-F16	EA	COVER-SEAT, ECONOMIZER II
6	M80906-11-000	EA	FRAME ASM-SEAT, BACK & SPRING
7	069246-05-000	EA	ADJUSTER-SEAT/CHAIR, W/REMOTE - FORWARD & BACK
	069246-05-700	EA	SPRING-ADJUSTER, FOR REMOTE
	069246-05-701	EA	CLIP-CABLE, FOR REMOTE
	114889-01-000	EA	STOP BAR-UNIVERSAL, SEAT ADJUSTER - SHROCK
8	107921-08-000	EA	TOP PLATE-W/O SEAT BELT BAR FLEXSTEEL 2759PDTP
	069585-27-000	EA	PEDESTAL-UPPER, W/RECLINE LEVER - STEEL
9	107921-09-000	EA	PEDESTAL ASM-SEAT FORD FLEXSTEEL 3067-PDMB
	107921-06-000	EA	BEARING KIT-PEDESTAL, FLEXSTEEL
10	069246-02-000	EA	ADJUSTER-SEAT/CHAIR, W/O LOCK - FORWARD & BACK
	114889-01-000	EA	STOP BAR-UNIVERSAL, SEAT ADJUSTER - SHROCK
11	080730-09-000	EA	SHIELD-FLEXSTEEL
12	080730-08-000	EA	HANDLE-30179907 KEIPER
13	080730-11-000	EA	SHIELD-RUBBER BOOT FLEXSTEEL
14	089368-04-000	EA	CABLE-SWIVEL/SLIDE, W/SWITCH
15	097683-03-000	EA	BRACKET-REMOTE, SIDE MOUNT - SINGLE
16	108049-01-000	EA	CABLE W/SWITCH - 28", FLEXSTEEL PEDESTAL
	108049-02-000	EA	CLIP-CABLE, PEDESTAL
17	071126-42-F15	EA	SKIRT - 7", W/SLIT - OPEN BACK CORNERS
17	071126-42-F16	EA	SKIRT - 7", W/SLIT - OPEN BACK CORNERS

DINETTE GROUP

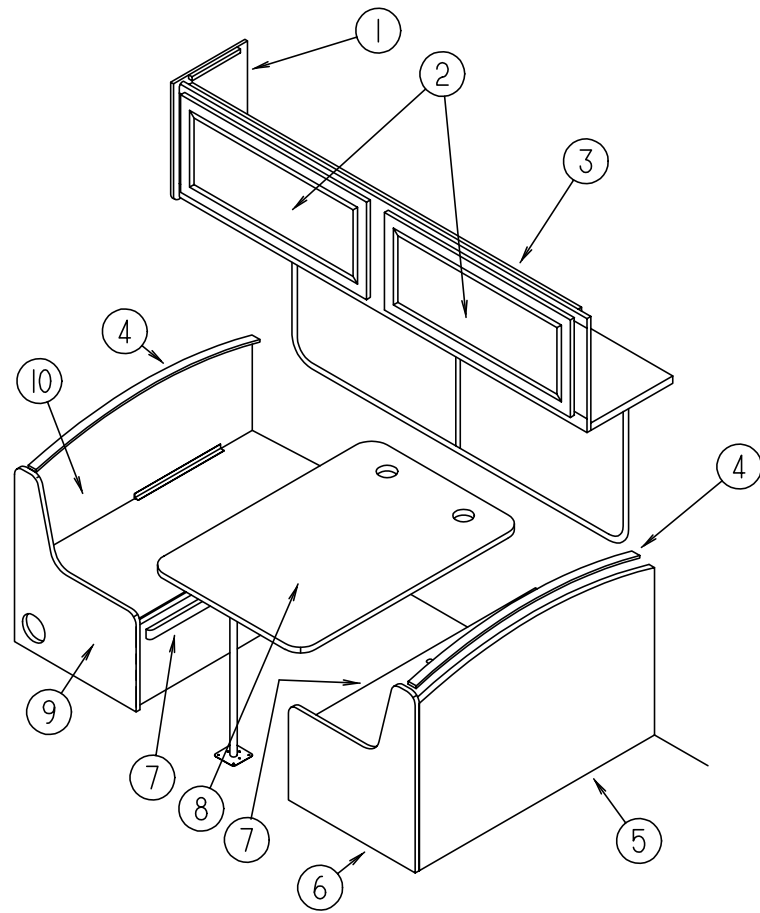

DINETTE CABINETS, PADS & TABLE

KEY	PART NUMBER	U/M	DESCRIPTION
1	109908-16-F15	EA	END CAP-CABINET
2	110140-05-EB1	EA	DOOR-CABINET, W/O HARDWARE - 365MM X 850MM
3	115623-01-F15	EA	CABINET-OVERHEAD, DINETTE - W/O DOORS OR HARDWARE
4	111338-09-F15	EA	PAD-DINETTE
4	111338-09-F16	EA	PAD-DINETTE
5	M06884-08-F15	EA	CABINET-SEATBACK, RH
6	M06885-20-F15	EA	CABINET-SEATBASE, RH
	081518-13-EB1	EA	SEAT-DINETTE
	112368-47-F15	EA	END CAP ASSEMBLY-DINETTE
7	081295-01-AA8	EA	SUPPORT-BED, DINETTE
8	M02115-09-F15	EA	TABLE-DINETTE, W/O HARDWARE
9	M06885-21-F15	EA	CABINET-SEATBASE, LH
	081518-13-EB1	EA	SEAT-DINETTE
	112368-44-F15	EA	END CAP ASSEMBLY-DINETTE
10	M06884-09-F15	EA	CABINET-SEATBACK, LH

DINETTE GROUP (CONTINUED)

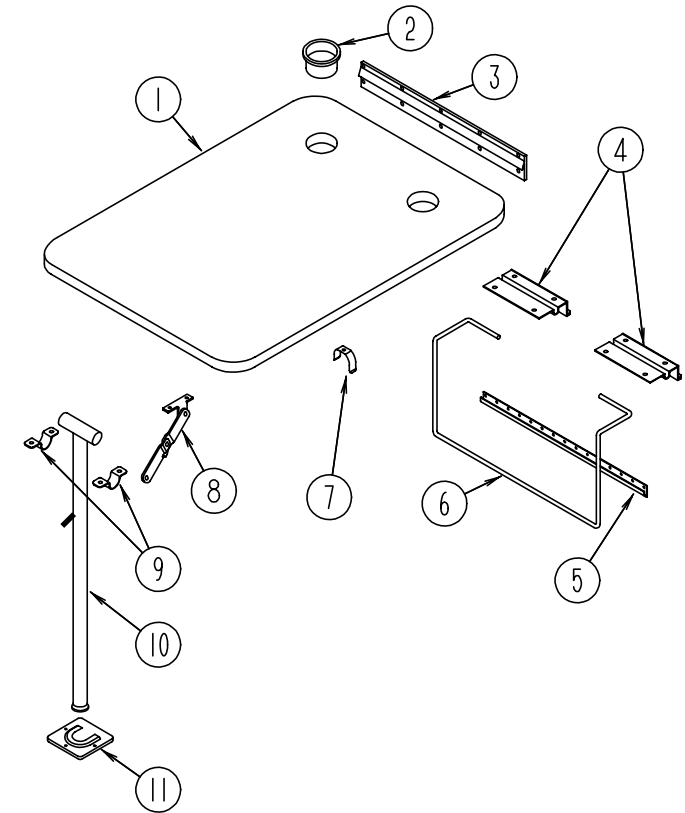

DINETTE TABLE & HARDWARE

KEY	PART NUMBER	U/M	DESCRIPTION
1	M02115-09-F15	EA	TABLE-DINETTE, W/O HARDWARE
2	064781-06-000	EA	HOLDER-CUP, TWO STAGE - OFF WHITE
3	053200-12-000	EA	BRACKET-TABLE SUPPORT - UPPER WALL MOUNTED - 23.5" - OFF WHITE
4	088410-02-000	EA	BRACKET-LIFT, TABLE MOUNTED - OFF WHITE
5	024281-14-000	EA	BRACKET-LIFT ROD, LOWER WALL MOUNTED - 22.12" - OFF WHITE
6	024275-12-000	EA	ROD-TABLE LIFT, OFF WHITE
7	024283-01-000	EA	CLIP-LEG, 1" X 1.125" OD - BLACK
8	024282-01-000	EA	BRACE-TABLE LEG, HINGED
9	064050-05-000	EA	HINGE-TABLE LEG, OFF WHITE
10	024276-23-000	EA	LEG-TABLE, METAL - OFF WHITE
11	049493-11-700	EA	CATCH-LEG, FLOOR MOUNTED - 2.5" X 2.7" - METAL - E-COAT
	049493-12-000	EA	CATCH-TABLE LEG, OFF WHITE

DRIVERS COMPARTMENT GROUP
DRIVERS COMPARTMENT

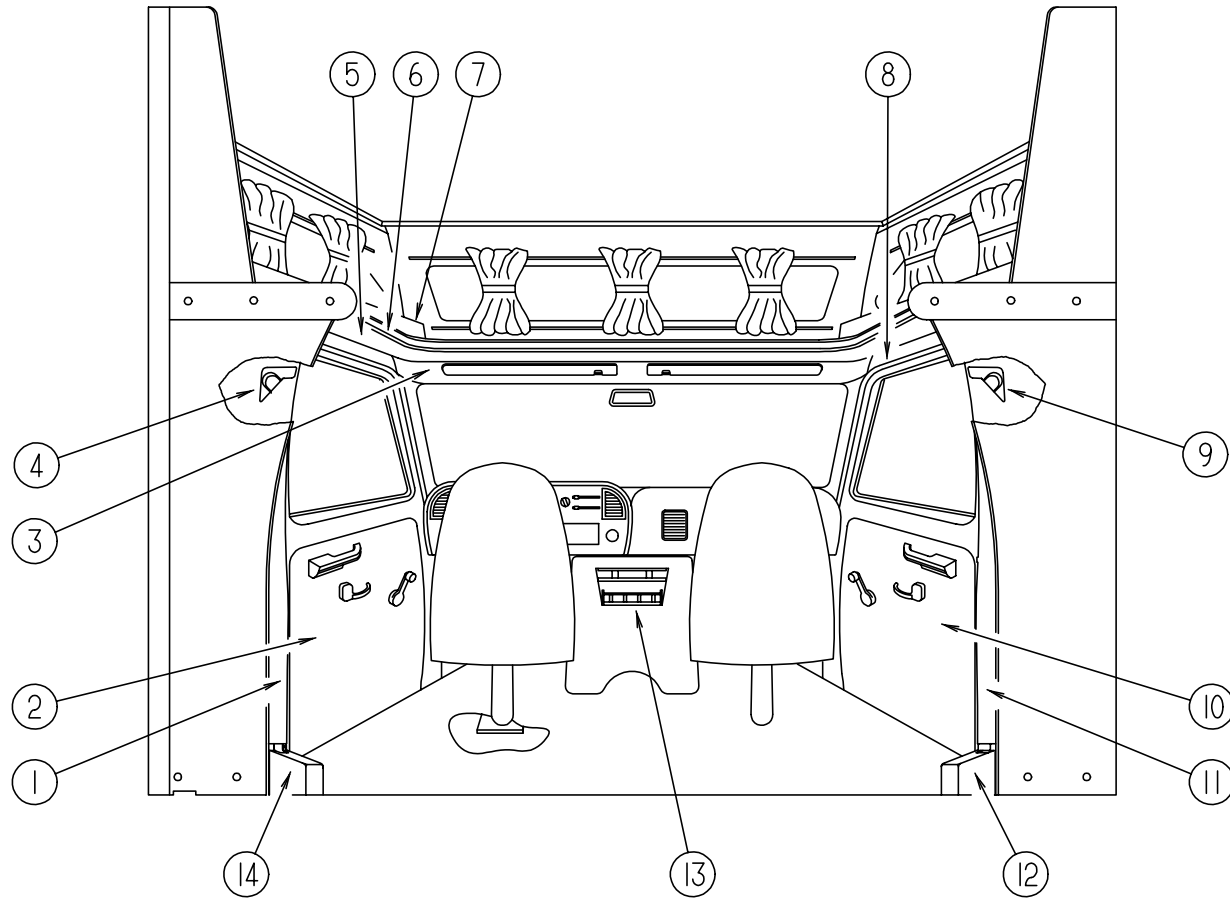

KEY	PART NUMBER	U/M	DESCRIPTION
1	106446-02-C03	EA	TRIM ASSEMBLY-CAB, B-PILLAR - LEFT HAND
	106445-02-C03	EA	TRIM ASSEMBLY-WINGWALL WRAP, BETWEEN CAB STEEL & B PILLAR TRIM
2	106432-02-F15	EA	PANEL ASSEMBLY-DOOR, INNER - LEFT HAND
2	106432-02-F16	EA	PANEL ASSEMBLY-DOOR, INNER - LEFT HAND
3	106448-01-C03	EA	HEADLINER-VINYL COVERED, FRONT - OFF WHITE
4	115038-02-01A	EA	COVER-SEAT BELT, UPPER - LH - OFF WHITE
5	106447-02-C03	EA	TRIM ASSEMBLY-CAB DOOR, UPPER - LEFT
6	079800-07-000	EA	TRIM-SLEEPERBOARD, INNER - OFF WHITE
	080742-03-000	FT	INSERT-TRIM, SLEEPER BOARD - VINYL - OFF WHITE
7	109894-01-F15	EA	CABINET ASSEMBLY-HAMPER, FRONT
8	106447-01-C03	EA	TRIM ASSEMBLY-CAB DOOR, UPPER - RIGHT
9	115038-01-01A	EA	COVER-SEAT BELT, UPPER - RH - OFF WHITE
10	106432-01-F15	EA	PANEL ASSEMBLY-DOOR, INNER - RIGHT HAND
10	106432-01-F16	EA	PANEL ASSEMBLY-DOOR, INNER - RIGHT HAND
11	106446-01-C03	EA	TRIM ASSEMBLY-CAB, B-PILLAR - RIGHT
	106445-01-C03	EA	TRIM ASSEMBLY-WINGWALL WRAP, BETWEEN CAB STEEL & B PILLAR TRIM
12	106431-01-01A	EA	COVER-SEATBELT RECOIL, RIGHT - OFF WHITE
13	112185-01-E93	EA	TRAY ASSEMBLY-BEVERAGE
	046886-03-000	EA	ASHTRAY-CHROME, W/COVER
	069885-23-F15	EA	COVER-MOTOR, W/POCKET - FORD
	069885-23-F16	EA	COVER-MOTOR, W/POCKET - FORD
14	106431-02-01A	EA	COVER-SEATBELT RECOIL - LEFT - OFF WHITE

INSTRUMENT CLUSTERS

KEY	PART NUMBER	U/M	DESCRIPTION
	094795-06-000	EA	CLUSTER-INSTRUMENT PANEL, KM - GAS/DIESEL - FORD F4UZ-10849-B
	100138-01-000	EA	MODULE-DAYTIME RUNNING LIGHT

ELECTRICAL GROUP

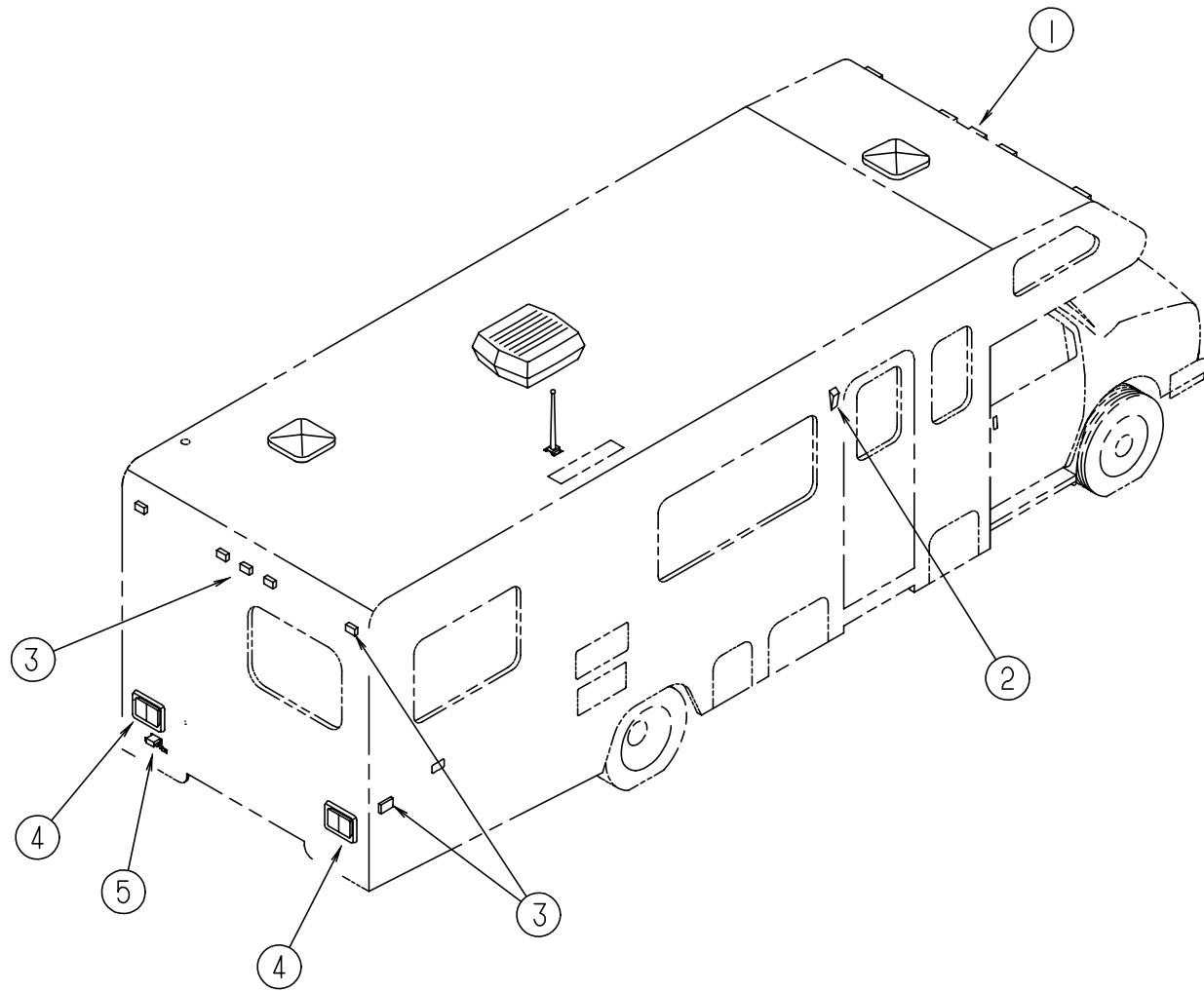

EXTERIOR LIGHTS

KEY	PART NUMBER	U/M	DESCRIPTION
1	111102-02-000	EA	LENS-MARKER LAMP, AMBER - TRIPLEX 118A
	111102-01-000	EA	LAMP-MARKER, BASE - TRIPLEX 117XAS
	091983-01-000	EA	GASKET-CLEARANCE/SIDEMARKER LIGHT
	036196-01-000	EA	BULB - 12V, #194 - .27AMP - BAYONETTE
	112823-01-000	EA	SPLICE-REDUCER, 16-14T018-22 ETC BA-631X
2	097917-01-06A	EA	LIGHT-PORCH, ENTRY DOOR - BRIGHT WHITE
	008215-01-000	EA	BULB - 12V, #1003 - .94AMP
	097917-01-700	EA	LENS-LIGHT, PORCH
3	111102-03-000	EA	LENS-MARKER LAMP, RED - TRIPLEX 117R
	111102-01-000	EA	LAMP-MARKER, BASE - TRIPLEX 117XAS
	091983-01-000	EA	GASKET-CLEARANCE/SIDEMARKER LIGHT
	036196-01-000	EA	BULB - 12V, #194 - .27AMP - BAYONETTE
	112823-01-000	EA	SPLICE-REDUCER, 16-14T018-22 ETC BA-631X
4	103355-01-05A	EA	POD-TAILLIGHT, BRIGHT WHITE
	081638-01-000	EA	TAILLIGHT-DOUBLE, W/BLACK TRIM - DRIVER & PASSENGER SIDE
	037934-01-000	EA	BULB - 12V, #1156 - 2.1AMP - CLEAR GLASS - BACK UP & TURN SIGNAL BULB
	037935-01-000	EA	BULB - 12V, #1157 OR #2057 - 2.1AMP - CLEAR GLASS - BRAKE LIGHT
	081638-01-700	EA	LENS-TAILLIGHT, RED - BARGMAN 30-84-010
	081638-01-701	EA	LENS-TAILLIGHT, W/BACKUP - BARGMAN 30-84-700
5	066432-02-000	EA	LIGHT-LICENSE PLATE
	066432-03-000	EA	BRACKET-LICENSE PLATE LIGHT

ELECTRICAL GROUP (CONTINUED)

INTERIOR LIGHTS

KEY	PART NUMBER	U/M	DESCRIPTION
	098024-01-01A	EA	LIGHT-DOME, 1 BULB - US - IVORY
	008218-01-000	EA	BULB-DOME LIGHT, 12V - NUMBER 1141
	098024-01-700	EA	LENS-DOME LIGHT
	098024-03-01A	EA	LIGHT-DOME, 2 BULB - IVORY
	008218-01-000	EA	BULB-DOME LIGHT, 12V - NUMBER 1141
	098024-01-700	EA	LENS-DOME LIGHT

SWITCHES & RECEPTACLES

KEY	PART NUMBER	U/M	DESCRIPTION
	079364-01-000	EA	SWITCH-ON/OFF ROCKER, 2 PRONGS - BROWN
	095188-01-01A	EA	SPACER-SWITCH, 2.3" X 3.4" - PLASTIC - DARK BROWN
	075723-01-000	EA	SPACER-SWITCH, W/O HOLE - .2" X .9" X 2" - METAL - OFF WHITE
	098351-01-01A	EA	PLATE-SWITCH, 1 GANG - POLISHED BRASS - JENSEN
	098351-06-01A	EA	PLATE-SWITCH, 2 GANG W/LABEL - POLISHED BRASS - JENSEN
	081994-06-000	EA	PLATE-SWITCH, AUXILIARY START - FORD
	108356-07-01A	EA	ACTUATOR-SWITCH DIMPLE II - CARLING VVAZCXX-XWB
	024924-02-000	EA	RECEPTACLE-POWER CORD, W/PARTIAL PLATE
	058707-01-000	EA	RECEPTACLE-ELECTRIC, SINGLE - BROWN
	058707-02-000	EA	RECEPTACLE-BLANK, JUNCTION WIRECON WDJ20BR
	058708-01-000	EA	RECEPTACLE-ELECTRIC, DOUBLE - BROWN
	058708-02-000	EA	RECEPTACLE-ELECTRIC, DOUBLE - IVORY
	084076-01-000	EA	RECEPTACLE-GFI, 15A - 125V - IVORY
	112822-01-01A	EA	RECEPTACLE-DUPLEX, IVORY - WIRECON WDRU15IV
	097734-01-01A	EA	EXTENSION-RECEPTACLE, 3.2" X 5" X .7" - PLASTIC - IVORY
	102568-01-E90	EA	SPACER-RECEPTACLE, SIDEWALL
	112824-01-02A	EA	COVER-EXTERIOR DUPLEX RECEPTACLE, OFF WHITE - P&S 3780-SC-CW

POWER CONVERTER

KEY	PART NUMBER	U/M	DESCRIPTION
	083208-01-000	EA	CONVERTER-POWER - 32A - 120V/12V - BW 6332

WIRING ASSEMBLIES

KEY	PART NUMBER	U/M	DESCRIPTION
	096449-01-000	EA	WIRE ASSEMBLY-WATER TANK TO MONITOR PANEL
	097618-01-000	EA	WIRE ASSEMBLY-MONITOR PANEL, W/3 WIRES & ORANGE RESISTOR- LVS ORANGE RESISTOR W/3 (ORANGE-GREEN-BLUE) WIRES
	106851-01-000	EA	WIRE ASSEMBLY-DAY RUN LAMP, FUSE

ELECTRICAL GROUP (CONTINUED)
FUSES & CIRCUIT BREAKERS

KEY	PART NUMBER	U/M	DESCRIPTION
	008235-01-000	EA	FUSE-AUTOMOTIVE, 12V - 15AMP
	062901-02-000	EA	FUSE - 5 AMPS, AUTOMOTIVE
	062901-05-000	EA	FUSE - 15 AMPS, AUTOMOTIVE
	083209-02-000	EA	CIRCUIT BREAKER - 15/15 AMP, 120V - BW H-15/15
	083209-03-000	EA	CIRCUIT BREAKER - 15/20 AMP, 120V - BW 0-15/20
	083209-04-000	EA	CIRCUIT BREAKER - 30A, 120V - BW L-30
	083209-05-000	EA	CIRCUIT BREAKER - 20A, 120V - BW J-20
	083209-06-000	EA	CIRCUIT BREAKER - 30/15 AMP, 120V - BW D-30/15
	093654-01-000	EA	CIRCUIT BREAKER - 6A, 12V - USD 17406-4E12A2A
	093655-02-000	EA	CIRCUIT BREAKER - 30A, 12V - USD 17430-4E03A2A
	100341-01-000	EA	FUSE HOLDER-IN LINE TYPE, WESCO 8931-92020

ELECTRIC BOXES, COVERS & POWER CORDS

KEY	PART NUMBER	U/M	DESCRIPTION
	008052-01-000	EA	CORD-POWER, 10/3 - 30 AMP - 25' - CANADIAN
	008054-01-000	EA	CORD-POWER, 10/3 - 30 AMP - 25'
	008289-01-000	EA	BOX-ELECTRIC, STEEL - 1/2" AND 3/4" KNOCKOUTS - 4" X 4"
	008289-02-000	EA	BOX-ELECTRICAL, 4" X 4" - 1/2" & 3/4" KNOCKOUTS - CANADIAN
	008294-01-000	EA	COVER-ELECTRICAL BOX, BLANK STEEL - 4" X 4" - GRAY
	008294-02-000	EA	COVER-ELECTRICAL BOX, BLANK STEEL - 4" X 4" - CANADIAN
	069238-01-000	EA	COVER-ELECTRICAL BOX, W/HOLE - 4" X 4" - GRAY USED WITH 30 AMP RECEPTACLE
	091910-01-000	EA	BOX-ELECTRIC, 3.75" X 3.5" X 1.75" - PLASTIC
	091910-02-000	EA	BOX-ELECTRIC, PLASTIC - 57 X 88MM
	093603-01-000	EA	BOX-ELECTRIC, 4" X 2 1/8" X 2 1/8" - STEEL
	107165-01-01A	EA	BOX-CIRCUIT BREAKER MOUNT, 14.6" X 4" - BLACK PLASTIC

CONDUIT

KEY	PART NUMBER	U/M	DESCRIPTION
	041953-01-000	FT	CONDUIT-CONVOLUTE, SLIT - .5" ID
	041953-02-000	FT	CONDUIT-CONVOLUTE, SLIT - .625" ID
	041953-03-000	FT	CONDUIT-CONVOLUTE, SLIT - 1" ID (CLOTHES ROD COVER)
	041953-05-000	FT	CONDUIT-CONVOLUTE, SOLID - .62" ID
	041953-06-000	FT	CONDUIT-CONVOLUTE, SLIT - .375" ID
	041953-07-000	FT	CONDUIT-CONVOLUTE, SLIT - .25" ID
	041953-08-000	FT	CONDUIT-CONVOLUTE, SLIT - 1.50" ID
	041953-09-000	FT	CONDUIT-CONVOLUTE, SLIT - .50" ID
	041953-10-000	FT	CONDUIT-CONVOLUTE, SLIT - .75" ID
	041953-11-000	FT	CONDUIT-CONVOLUTE, SLIT - 1.06" ID
	041953-12-000	FT	CONDUIT-CONVOLUTE, NON SLIT 1.1" ID

ELECTRICAL GROUP (CONTINUED)
CONNECTORS, HOUSINGS, & TERMINALS

KEY	PART NUMBER	U/M	DESCRIPTION
	008311-01-000	EA	CONNECTOR-WIRE NUT, INSULATED - RED
	008314-01-000	EA	CONNECTOR-WIRE NUT, INSULATED - GRAY
	008355-01-000	EA	CONNECTOR-CABLE CLAMPING, 3/4"
	008356-01-000	EA	CONNECTOR-PLASTIC, 3/8" AVG
	041480-01-000	EA	CONNECTOR-STRAIGHT, 1/2" FLEX CONDUIT
	058028-01-000	EA	CONNECTOR-ELECTRICAL PIGTAIL, NYLON - CLEAR
	088475-01-000	EA	PIN-CONNECTOR, 14 TO 20 AWG
	088476-01-000	EA	SOCKET-CONNECTOR, BRASS - PRE-TIN
	088476-02-000	EA	SOCKET-CONNECTOR, 12-10 GA - PHOS. BRZ - PRE-TIN
	077479-01-000	EA	BOOT-BATTERY TERMINAL, DOUBLE CABLE
	077479-02-000	EA	BOOT-BATTERY TERMINAL, SINGLE CABLE
	080015-02-000	EA	RECEPTACLE-FLAG, .185 - 16/14 GA - AMP 3
	080015-03-000	EA	RECEPTACLE-FLAG, .250 - 14/16 GA
	007940-01-000	EA	RECEPTACLE-SLIDE, 16 TO 12 AWG - FEMALE END
	087949-01-000	EA	BUSS BAR - 2 POSITION, .6' X 1.5" - ALUMINUM
	088473-05-000	EA	HOUSING-PIN, 6 CAVITY - AMP 640585-1
	088473-06-000	EA	HOUSING-PIN, 6 CAVITY - AMP 1-480704-0
	088473-08-000	EA	HOUSING-PIN, 4 CAVITY - AMP 1-480702-0
	088473-09-000	EA	HOUSING-PIN, 3 CAVITY - AMP 1-480700-0
	088473-10-000	EA	HOUSING-PIN, 2 CAVITY - AMP 1-480698-0
	088474-06-000	EA	HOUSING-SOCKET, 6 CAVITY - AMP 1-480705-0
	088474-07-000	EA	HOUSING-SOCKET, 5 CAVITY - AMP 1-480764-0
	088474-08-000	EA	HOUSING-SOCKET, 4 CAVITY - AMP 1-480703-0
	088474-09-000	EA	HOUSING-SOCKET, 3 CAVITY - AMP 1-480701-0
	088474-10-000	EA	HOUSING-SOCKET, 2 CAVITY - AMP 1-480699-0
	063910-01-000	EA	HOUSING-RELAY, BOSCH 3 334 485 008
	035416-04-000	EA	TERMINAL-RING, #10 STUD FIT, INSULATED BARREL #16/14
	008326-01-000	EA	TERMINAL-RING, 16/14 WIRE - 3/8" STUD
	008328-01-000	EA	TERMINAL-RING, 12/10 WIRE - #10 STUD FIT
	008331-01-000	EA	TERMINAL-RING, TONGUE - #4 WIRE - 3/8" STUD - COPPER
	008348-01-000	EA	TERMINAL-RING, 3/8" STUD - #2 WIRE
	047443-01-000	EA	TERMINAL - .250 RECEPTACLE FIT, INSULATED - 16/14 AWG
	008188-01-000	EA	SOLENOID - 3 POST, BATTERY CHANGE OVER
	112823-01-000	EA	SPLICE-REDUCER 16-14T018-22 ETC BA-631X

EXTERIOR BODY GROUP

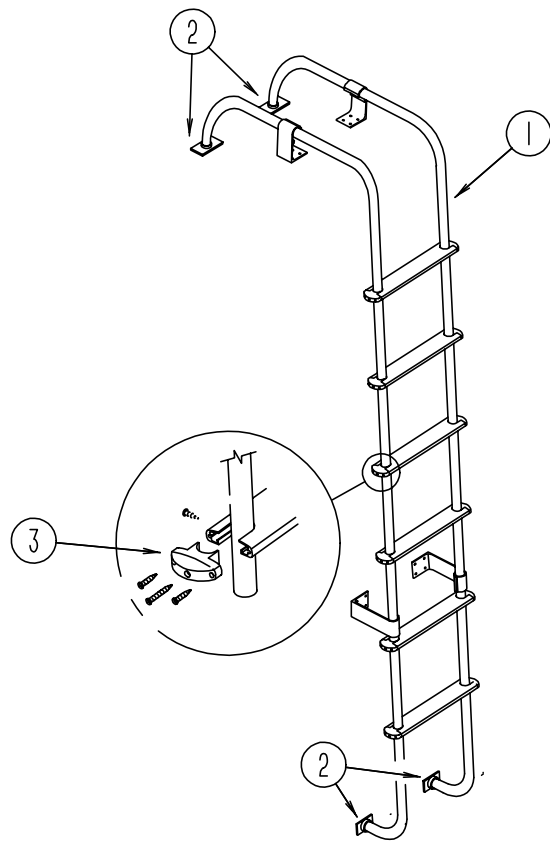

LADDER

KEY	PART NUMBER	U/M	DESCRIPTION
1	102953-10-F15	EA	LADDER ASM
2	067165-01-000	EA	MOUNTING BRACKET-LADDER, LOWER
3	076980-02-000	EA	END CAP-STEP, BLACK
	000G39-06-10T	EA	SCREW-SF/DR - 6-20 X 5/8 PPH - BLACK
	000G68-10-36T	EA	SCREW - 10-12 X 2.25 POH - BLACK

EXTERIOR BODY GROUP (CONTINUED)

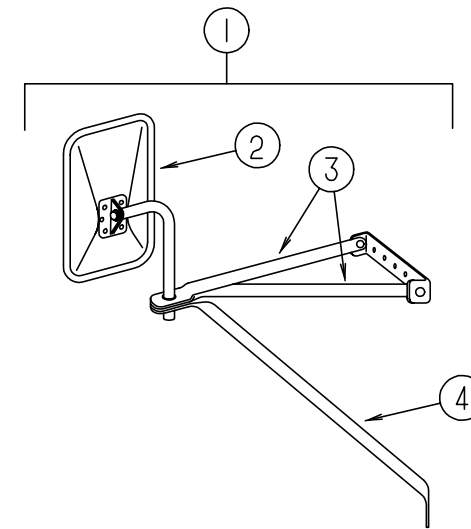

EXTERIOR MIRRORS

KEY	PART NUMBER	U/M	DESCRIPTION
1	106860-01-02A	EA	MIRROR-EXTERIOR, LOW MOUNT - BRIGHT WHITE
2	106860-01-707	EA	MIRROR-HEAD, EXTERIOR - BRIGHT WHITE
3	106860-01-708	EA	ARM-MIRROR - BRIGHT WHITE
4	106860-01-709	EA	BRACE LOWER FORWARD - DRIVER - BRIGHT WHITE
4	106860-01-710	EA	BRACE LOWER FORWARD - PASSENGER - BRIGHT WHITE
	106860-01-702	EA	HARDWARE PACKAGE
	106860-01-711	EA	MIRROR ASSEMBLY-LEFT SIDE COMPLETE - BRIGHT WHITE
	106860-01-706	EA	MIRROR ASSEMBLY-RIGHT SIDE COMPLETE - BRIGHT WHITE
	106860-01-712	EA	MIRROR-AUXILIARY, CONVEX - STICK-ON - VELVAC 723068-6

EXTERIOR BODY GROUP (CONTINUED)
EXTERIOR BODY PANELS

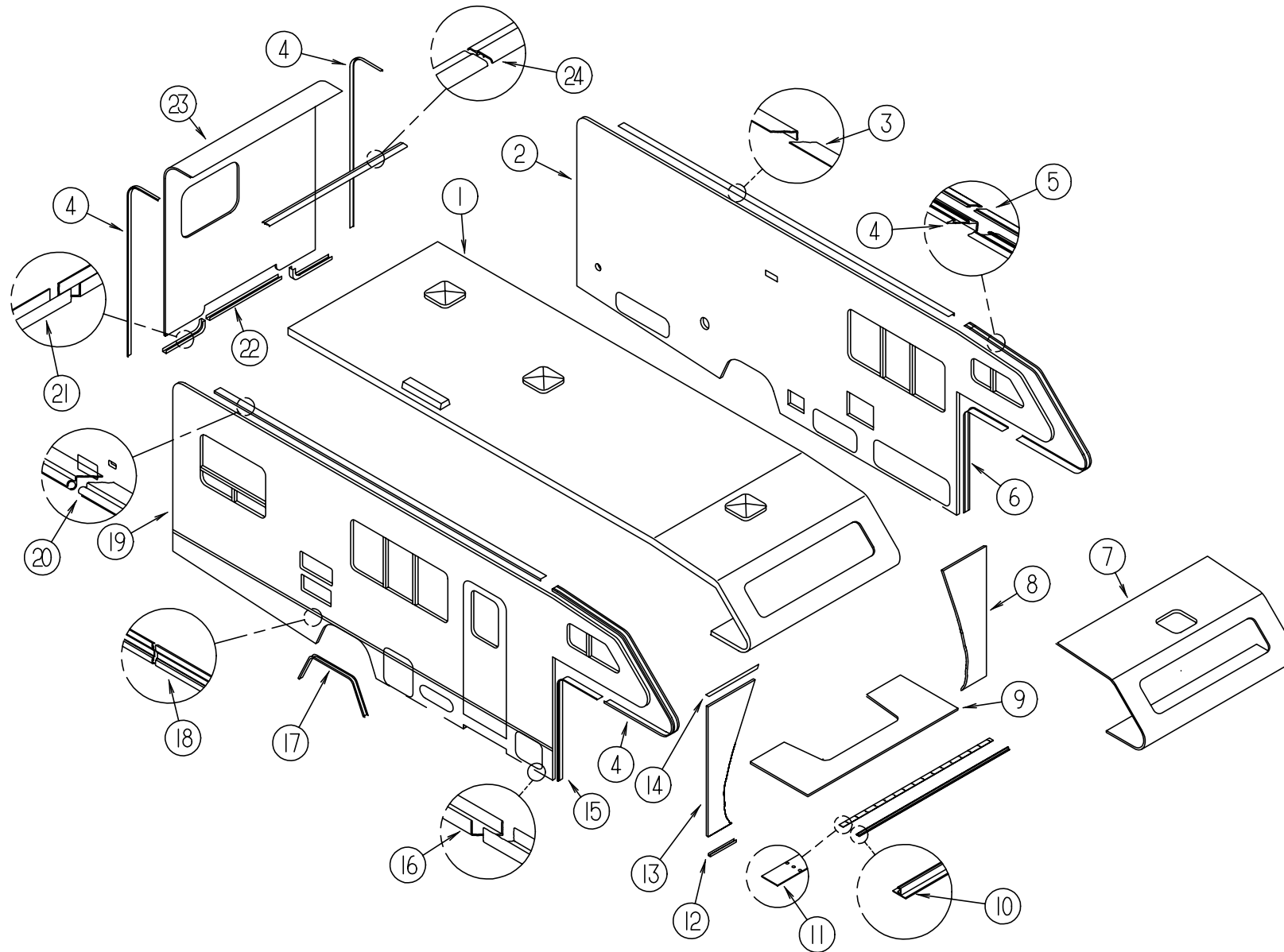

KEY	PART NUMBER	U/M	DESCRIPTION
1	M07401-02-F15	EA	ROOF-W/BASES, W/O VENTS - BRIGHT WHITE
2	M07421-06-F15	EA	SIDEWALL-LEFT, W/O WINDOWS OR LIGHTS - BRIGHT WHITE
3	096864-01-02A	EA	TRIM-CONTOUR, ROOF TO SIDEWALL - 120" - BRIGHT WHITE
4	096854-01-02A	EA	TRIM-CONTOUR, W/O VINYL INSERT - 108" - BRIGHT WHITE
5	105312-01-07A	FT	INSERT-TRIM, VINYL - BRIGHT WHITE
6	104479-06-02A	EA	TRIM-CONTOUR, FRONT - BRIGHT WHITE
7	M76177-01-700	EA	CAP-FRONT, OVERHEAD CAB TO FIRST SEAM OF ROOF - OFF WHITE
8	109659-04-D04	EA	WINGWALL-DRIVER SIDE, BRIGHT WHITE
9	M07422-01-F15	EA	SLEEPERBOARD ASSEMBLY - BRIGHT WHITE
10	100086-02-02A	EA	TRIM-SLEEPERBOARD, 2" X 90.7" - BRIGHT WHITE
11	100085-03-01A	EA	TRIM-SLEEPERBOARD, FLAT - 2.5" X 87.5" - OFF WHITE
12	002365-03-006	EA	U CHANNEL-EXTRUDED, 1.00 X 192.00 6063T5 - BRIGHT WHITE
13	M07423-05-F15	EA	WINGWALL-PASSENGER SIDE, BRIGHT WHITE
14	022992-14-000	EA	MOLDING-REVERSE COVE, T-SHAPED - VINYL - BRIGHT WHITE
15	104479-05-02A	EA	TRIM-CONTOUR, FRONT - BRIGHT WHITE
16	098072-55-003	EA	TRIM-SIDEWALL, LOWER - 48775 MM - BRIGHT WHITE
	105025-09-F16	EA	TRIM-SIDEWALL, UNDER ENTRANCE DOOR - BRIGHT WHITE

KEY	PART NUMBER	U/M	DESCRIPTION
17	105100-02-02A	EA	TRIM-WHEELWELL, BRIGHT WHITE
18	108688-01-03A	EA	STRIP-FEATURE, BRIGHT WHITE
	105312-01-07A	EA	INSERT-FEATURE STRIP, 17' LONG - VINYL - BRIGHT WHITE
	108651-01-01A	EA	CAP-FEATURE STRIP, MILL FINISH
19	M07421-07-F15	EA	SIDEWALL-RIGHT, W/O WINDOWS, LIGHTS OR DOORS - BRIGHT WHITE
	098072-55-003	EA	TRIM-SIDEWALL, LOWER, 4877 MM - BRIGHT WHITE
	064675-54-003	EA	STEEL-ANGLE ROOF JOINT, 1220 MM - OFF WHITE
20	099583-55-003	EA	RAIL-AWNING, 10' - BRIGHT WHITE
21	103334-02-02A	EA	TRIM-BACKWALL, LOWER - LEFT OR RIGHT - BRIGHT WHITE
22	103335-02-02A	EA	TRIM-BACKWALL, LOWER - BRIGHT WHITE
23	M07414-03-F15	EA	BACKWALL-BRIGHT WHITE
24	078580-01-000	EA	TRIM-ROOF TO BACKWALL/FRONT CAP, MILL FINISH

EXTERIOR BODY GROUP (CONTINUED)
DECALS, STRIPES & PAINT

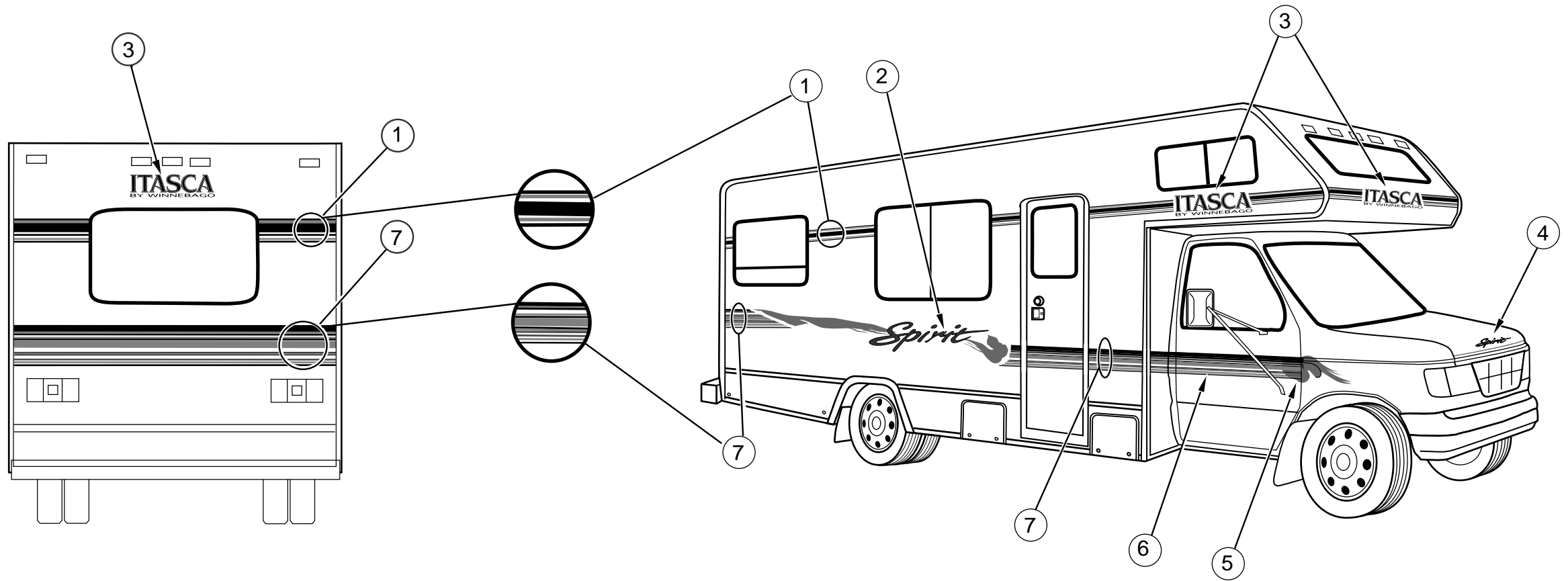

KEY	PART NUMBER	U/M	DESCRIPTION
1	115129-01-01A	FT	FILM-OVERLAY, 69.9MM - ROYAL PURPLE/PLUM BAY/REGGAE BLUE
2	115131-01-01A	EA	DECAL-SPIRIT, W/SPLASH - RH - REGGAE/PURPLE/PLUM BAY
2	115131-02-01A	EA	DECAL-SPIRIT, W/SPLASH - LH - REGGAE/PURPLE/PLUM BAY
3	115172-01-01A	EA	DECAL-LOGO, ITASCA - W/BY WINN - PLUM BAY/REGGAE
4	115130-01-01A	EA	DECAL-LOGO, SPIRIT - REGGAE BLUE
5	115132-01-01A	EA	DECAL-SPLASH, RH - REGGAE/PLUM BAY/PURPLE
5	115132-02-01A	EA	DECAL-SPLASH, LH - REGGAE/PLUM BAY/PURPLE
6	116030-01-01A	EA	DECAL-DOOR, RH - REGGAE/PLUM BAY/PURPLE
7	115128-01-01A	FT	FILM-OVERLAY, 190.5MM - REGGAE BLUE/PLUM BAY/ROYAL PURPLE

DUPONT COLOR CODES

041561-03-000	EA	PAINT-16OZ SPRAY, OFF WHITE - ACRYLIC ENAMEL - REF: 72897-01
---------------	----	--

EXTERIOR BODY GROUP (CONTINUED)
RUNNING BOARDS

KEY	PART NUMBER	U/M	DESCRIPTION
	072884-27-000	EA	RUNNING BOARD-FORD 39.00 KEM K12 15539
	072884-27-700	EA	BRACKET SET - 12", FORD RB2BRK/M
	072884-27-701	EA	39" UNIVERSAL RUNNING BOARD ONLY-DRIVERS OR PASSENGER
	072884-27-702	FT	TAPE-TREAD RB9202
	072884-27-703	EA	MUD FLAPS-PAIR, W/HOLES 99171
	072884-27-704	EA	END CAPS-PAIR 99148

FIBERGLASS, ALUMINUM, STYROFOAM & CHANNEL

KEY	PART NUMBER	U/M	DESCRIPTION
	076054-M8-000	EA	SHEET-FIBERGLASS, 2438 X 2438 - BRIGHT WHITE FROM: 00-00-00 THRU: 09-30-94
	076054-P4-000	EA	SHEET-FIBERGLASS, 2438 X 2463 - BRIGHT WHITE FROM: 10-01-94 THRU: 99-99-99
	076054-M8-001	EA	SHEET-FIBERGLASS, 48 X 96 - BRIGHT WHITE
	076054-N5-000	EA	SHEET-FIBERGLASS, 2590 X 7970 - BRIGHT WHITE
	076054-N9-000	EA	SHEET-FIBERGLASS, 2438 X 2591 - BRIGHT WHITE
	076054-P9-000	EA	SHEET-FIBERGLASS, 950 X 2591 - BRIGHT WHITE
	076054-R1-000	EA	SHEET-FIBERGLASS, 609 X 1674 - BRIGHT WHITE
	044487-01-001	EA	ALUMINUM SHEET - .019" X 96" X 360" - MILL FINISH
	044487-01-002	EA	ALUMINUM SHEET - .019" X 96" X 432" - MILL FINISH
	000870-08-000	SF	STYROFOAM - .75" X 48" X 96" - PLANED
	000870-06-000	SF	STYROFOAM - 1.34" X 48" X 96" - PLANED
	083574-03-000	SF	STYROFOAM - 75" X 48" X 96"
	002726-01-001	EA	GARNISH-U CHANNEL, 1.38" X 19' - SERRATED - MILL ALUMINUM
	002754-01-001	EA	ANGLE-EXTRUDED, .75" X .75" X 18' - MILL ALUMINUM
	055278-51-259	EA	TUBING-STEEL, .75" X 1.5" X 12.5'
	068716-01-001	EA	BRACE - 90 DEGREE L-ANGLE, 192" - EXTRUDED ALUMINUM

EXTERIOR BODY GROUP (CONTINUED)

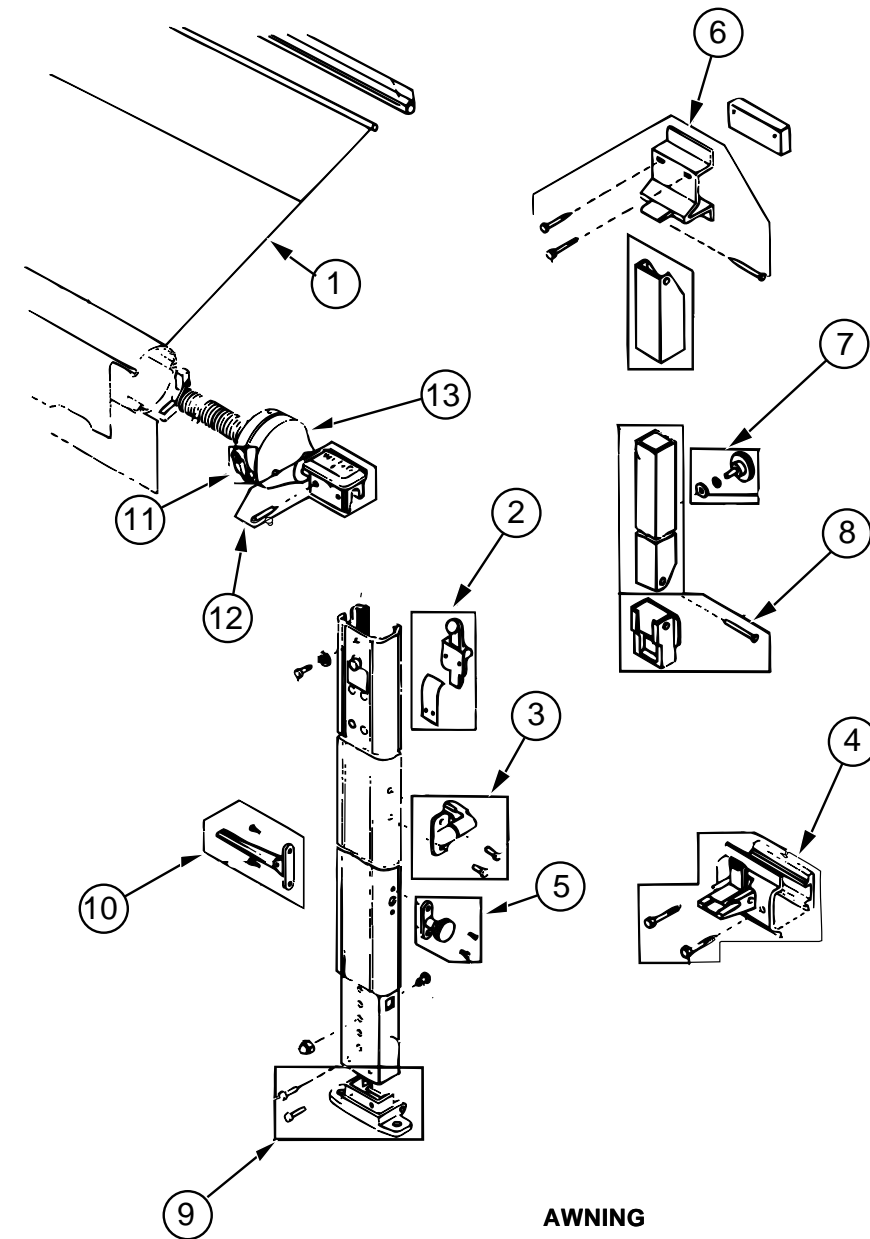

AWNING

KEY	PART NUMBER	U/M	DESCRIPTION
1	110634-08-06A	EA	AWNING-ROLLER ASSEMBLY, 14'
	110634-02-04A	EA	AWNING-HARDWARE KIT, BRIGHT WHITE
	111037-01-01A	EA	SPACER-AWNING, UPPER - BLACK
	111038-01-01A	EA	SPACER-AWNING, LOWER - BLACK
2	110634-01-700	EA	KIT-RAFTER LOCKING MECHANISM 7605-0001
3	110634-01-701	EA	KIT-SAFETY & LATCH 7509-0001
4	110634-01-702	EA	KIT-BOTTOM BRACKET 7512-0001
5	110634-01-703	EA	KIT-HEIGHT LOCK HANDLE 7510-0001
6	110634-01-704	EA	KIT-UPPER BRACKET, W/BOLTS 7505-0001
7	110634-01-705	EA	KIT-ULTRA RAFTER KNOB 7522-0001
8	110634-01-706	EA	KIT-RAFTER SLIDE
9	110634-01-707	EA	KIT-GROUND BRACKET 7511-0001
10	110634-01-708	EA	LIFT HANDLES-W/RIVETS 7000-0001
11	110634-01-709	EA	KIT-RATCHET HANDLE 7507-0001
12	110634-01-710	EA	KIT-ARM CAP 7503-0001
13	110634-01-711	EA	SPRING ASSEMBLY-FRONT 6598-0001
13	110634-01-712	EA	SPRING ASSEMBLY-REAR 6599-0001
13	110634-01-713	EA	KIT-REAR END CAP 7504-0001

GALLEY GROUP

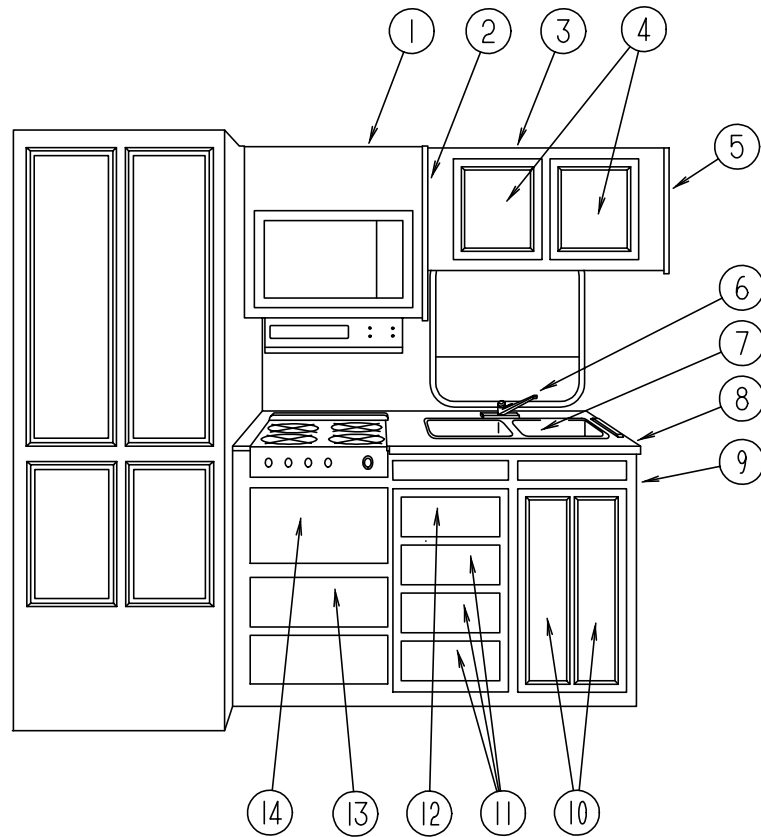

GALLEY CABINETS & FIXTURES

KEY	PART NUMBER	U/M	DESCRIPTION
1	114009-01-F15	EA	CABINET-OVERHEAD, MICROWAVE
2	109908-13-F15	EA	END CAP-CABINET, MICROWAVE
3	115526-01-F15	EA	CABINET-OVERHEAD GALLEY, W/O DOORS OR HARDWARE
4	110140-10-F15	EA	DOOR-CABINET, W/O HARDWARE - 365MM X 555MM
5	109908-14-F15	EA	END CAP-CABINET, OVERHEAD
6	103243-01-000	EA	FAUCET-GALLEY, DUAL CONTROL - W/8 INCH CENTERSET
7	104113-01-000	EA	SINK-DOUBLE, STAINLESS STEEL
	092303-01-000	EA	STRAINER-SINK
	103610-01-F15	EA	COVER -SINK
	008380-01-000	EA	GROMMET-RUBBER, 5/8" HOLE X 1 1/2" DIAMETER - BLACK
8	115625-11-F15	EA	COUNTERTOP-GALLEY
	098335-02-F15	EA	RAIL-GALLEY
9	P15625-01-F15	EA	CABINET-GALLEY, W/RANGE TOP - W/O DOORS OR HARDWARE
9	M07460-01-F15	EA	CABINET-GALLEY, W/OVEN - W/O DOORS OR HARDWARE
10	110140-46-E01	EA	DOOR-CABINET, W/O HARDWARE - 230MM X 675MM
11	M05970-K8-F15	EA	DRAWER-CABINET, W/O HARDWARE
12	M05970-K7-F15	EA	DRAWER-CABINET, W/O HARDWARE
13	M05970-K6-F15	EA	DRAWER-CABINET, W/O HARDWARE
14	110140-06-EB1	EA	DOOR-CABINET, W/O HARDWARE - 280MM X 555MM
	090329-01-000	FT	SEAL-T, REFRIGERATOR CABINET, .6" WIDE TOP X 2" TAIL
	115527-13-000	EA	SHELF-REFRIGERATOR CABINET

GALLEY GROUP (CONTINUED)

RANGE HOOD W/O MONITOR PANEL - U.S. (W/HOUR METER W/SWITCH)

KEY	PART NUMBER	U/M	DESCRIPTION
	100258-18-02A	EA	HOOD-RANGE, W/O MONITOR PANEL - TEXTURED - VENTLINE U.S. TPS5009SADL
	090973-01-700	EA	MOTOR - LVS CA508-1
	090973-01-702	EA	BLADE-FAN, LVS VA183-1
	092696-02-701	EA	LENS-LAMP, LVS CC179-2
	092696-01-709	EA	BULB - 912, VENTLINE VA415
	092696-01-710	EA	SOCKET-LIGHT, VENTLINE CB267-2
	096983-01-700	EA	SWITCH-ON/OFF, VENTLINE 108
	096983-01-702	EA	SWITCH-TWO WAY MOMENTARY, VENTLINE 112
	096983-01-707	EA	FILTER-GREASE, 8" X 8" - LVS CC246
	100258-01-700	EA	HOOD-NOSE LABEL, CC428
	100258-10-01A	EA	METER-HOUR, W/SWITCH VENTLINE 150

RANGE HOOD W/O MONITOR PANEL - U.S.

KEY	PART NUMBER	U/M	DESCRIPTION
	100258-16-03A	EA	HOOD-RANGE, W/O MONITOR PANEL -TEXTURED - U.S. - VENTLINE TCS5008NADL
	090973-01-700	EA	MOTOR - LVS CA508-1
	090973-01-702	EA	BLADE-FAN, LVS VA183-1
	092696-02-701	EA	LENS-LAMP, LVS CC179-2
	092696-01-709	EA	BULB - 912, VENTLINE VA415
	092696-01-710	EA	SOCKET-LIGHT, VENTLINE CB267-2
	096983-01-700	EA	SWITCH-ON/OFF, VENTLINE 108
	096983-01-702	EA	SWITCH-TWO WAY MOMENTARY, VENTLINE 112
	096983-01-707	EA	FILTER-GREASE, 8" X 8" - LVS CC246
	100258-01-700	EA	HOOD-NOSE LABEL, CC428

RANGE HOOD W/O MONITOR PANEL - CANADIAN

KEY	PART NUMBER	U/M	DESCRIPTION
	100258-17-03A	EA	HOOD-RANGE, W/O MONITOR PANEL - TEXTURED - VENTLINE - CANADIAN
	090973-01-700	EA	MOTOR - LVS CA508-1
	090973-01-702	EA	BLADE-FAN, LVS VA183-1
	092696-02-701	EA	LENS-LAMP, LVS CC179-2
	092696-01-709	EA	BULB - 912, VENTLINE VA415
	092696-01-710	EA	SOCKET-LIGHT, VENTLINE CB267-2
	096983-01-700	EA	SWITCH-ON/OFF, VENTLINE 108
	096983-01-702	EA	SWITCH-TWO WAY MOMENTARY, VENTLINE 112
	096983-01-707	EA	FILTER-GREASE, 8" X 8" - LVS CC246
	100258-01-700	EA	HOOD-NOSE LABEL, CC428

MONITOR PANEL

KEY	PART NUMBER	U/M	DESCRIPTION
	102765-04-01A	EA	PANEL-MONITOR, W/PLUG - FOR 2 TANKS & WATER HEATER - LVS
	075470-01-703	EA	SWITCH-ON/MOMENTARY, JENSEN AND VENTLINE
	096983-01-700	EA	SWITCH-ON/OFF, VENTLINE 108
	102765-04-700	EA	CIRCUIT BOARD-LVS 5076-11

GALLEY GROUP (CONTINUED)
REFRIGERATOR

KEY	PART NUMBER	U/M	DESCRIPTION
	104138-04-01A	EA	REFRIGERATOR, SMALL DOUBLE DOOR - 2-WAY - RH - BLACK - NORCOLD 6162
	075217-01-734	EA	FUSE - 3 AMP, NORCOLD 61538822
	075217-01-738	EA	SWITCH-HUMIDITY, NORCOLD 61525922
	084879-03-700	EA	COOLING UNIT-HORIZONTAL BURNER, NORCOLD 61687237
	084880-01-705	EA	ORIFICE-NORCOLD 614522
	104137-06-709	EA	VALVE-SHUT OFF, MANUAL - NORCOLD 61697922
	084880-01-718	EA	VALVE-GAS, NORCOLD 61551822
	084880-01-720	EA	SPRING-DOOR HANDLE, NORCOLD 61558822
	084880-01-722	EA	COVER-CRISPER, NORCOLD 615641
	084880-01-726	EA	HINGE BRACKET-CENTER HINGE, NORCOLD 61566523
	084880-01-731	EA	HINGE PIN, NORCOLD 61578123
	084880-01-732	EA	LATCH-NORCOLD 61578522
	084880-01-734	EA	BRACKET-HINGE, TOP RH - BOTTOM LH - BROWN - NORCOLD 61580837
	084880-01-735	EA	HINGE BRACKET, TOP LH - BOTTOM RH - BROWN - NORCOLD 61580937
	084880-01-739	EA	END CAP-SPRING CATCH, BROWN - NORCOLD 61593722
	084880-01-740	EA	END CAP-STOP CATCH, NORCOLD 61593830
	084880-01-746	EA	CABLE-NORCOLD 61571522
	084880-01-747	EA	PLUG-HOLE, NORCOLD 61582022
	084880-01-749	EA	BUSHING-HINGE, NORCOLD 615807
	084880-01-753	EA	THERMISTER 78" - NORCOLD 61693822
	084880-01-760	EA	CLIP-THERMISTER, NORCOLD 61689122
	084880-01-761	EA	END CAP-SPRING CATCH, BLACK - NORCOLD 61593730
	084880-02-700	EA	LOWER FLANGE 8663 & 8683, NORCOLD 61622123
	084880-03-702	EA	HINGE PIN-TOP/BOTTOM FEMALE, NORCOLD 61580630
	084880-03-705	EA	BRACKET-INTERIOR REFRIGERATOR LIGHT, NORCOLD 61629722
	084880-03-706	EA	LAMP-BULB, NORCOLD 61628922
	084880-03-707	EA	COVER-LAMP OR BULB, NORCOLD 61627922
	088248-01-706	EA	BURNER-HORIZONTAL, NORCOLD 61588122
	088248-01-707	EA	ELECTRODE-SENSOR, HORIZONTAL - NORCOLD 61573322
	088248-01-709	EA	HEATER-AC, HORIZONTAL - NORCOLD 615627
	088248-01-710	EA	HEATER-DC, HORIZONTAL - 3 WAY - NORCOLD 615628
	094038-01-700	EA	GASKET-LOWER, GRAY, NORCOLD 61567930
	094038-01-701	EA	LINER-DOOR, LOWER - BROWN/WHITE - NORCOLD 61581937-B
	094038-01-702	EA	LINER-DOOR, LOWER - BLACK/WHITE - NORCOLD 61581938-B
	094038-01-703	EA	HANDLE-DOOR, LOWER - BROWN - NORCOLD 61650137
	094038-01-704	EA	HANDLE-DOOR, LOWER - BLACK - NORCOLD 61650138
	094039-01-702	EA	GASKET-UPPER, GRAY - NORCOLD 61567830
	094039-01-703	EA	PLATE-HINGE, LH - BROWN - NORCOLD 61631422
	094039-01-704	EA	PLATE-HINGE, BLACK - NORCOLD 61631430
	094039-01-706	EA	UPPER DOOR LINER, WHITE/BLACK - NORCOLD 61581838-B
	094039-01-708	EA	HANDLE-DOOR, UPPER - BLACK - NORCOLD 61650038
	094039-01-709	EA	PLATE-HINGE, TOP RH - LH BOTTOM - BROWN - NORCOLD 61631322
	094039-01-710	EA	PLATE-HINGE, BLACK - NORCOLD 61631330
	094039-01-722	EA	HOLE PLUG-BLACK HINGE HOLES, NORCOLD 61582030
	094039-01-723	EA	BRACKET-HINGE, TOP RH - BOTTOM LH - BLACK - NORCOLD 61580838
	094039-01-724	EA	BRACKET-HINGE, TOP LH - BOTTOM RH - BLACK - NORCOLD 61580938
	094039-01-725	EA	HINGE PIN-MALE, BLACK - NORCOLD 61578130
	094039-01-726	EA	SHELF-FREEZER EVAPORATOR, NORCOLD 615236
	094039-01-730	EA	HINGE PIN SHAFT-CENTER HINGE, BLACK - NORCOLD 61566730
	094039-01-732	EA	COVER-FRONT, BLACK BOTTOM TRIM - NORCOLD 61622130
	094039-01-733	EA	WIRE SHELF-MIDDLE, NORCOLD 61563822
	094039-01-734	EA	WIRE SHELF-TOP W/RISER, NORCOLD 61563722
	094039-01-735	EA	DRIP TRAY-INSIDE, WHITE - NORCOLD 61572830
	094039-01-736	EA	SWITCH-LIGHT, BLACK - NORCOLD 615810
	094039-01-739	EA	SHELF-CUTOFF, NORCOLD 61646722

GALLEY GROUP (CONTINUED)
REFRIGERATOR (CONTINUED)

KEY	PART NUMBER	U/M	DESCRIPTION
	094039-04-700	EA	PRINTED CIRCUIT BOARD - 2 WAY, NORCOLD 61647322
	094039-04-701	EA	EYEBROW-SHELL, 2 WAY - NORCOLD 61669822
	094039-04-702	EA	POWER SUPPLY - 2 WAY, NORCOLD 61647422
	104137-02-700	EA	MODULE-CONTROL, CHANNEL - NORCOLD 61717037
	104137-06-700	EA	EYEBROW SHELL - 2-WAY, NORCOLD 61726622
	104137-06-702	EA	RACK-JUICE, WHITE - NORCOLD 61580525
	104137-06-703	EA	BIN-DOOR SHELF, WHITE - NORCOLD 61564025
	104137-06-706	EA	WIRE SHELF-SHORT, NORCOLD 61718222
	104137-06-707	EA	CRISPER-WHITE, NORCOLD 61571325
	104137-06-710	EA	PRESSURE TAP, NORCOLD 61594422
	104137-06-711	EA	FUSE - 5 AMP, NORCOLD 61611622
	104137-06-712	EA	FITTING-GAS TUBE CONNECTION, NORCOLD 61692722
	104137-06-713	EA	GASKET-ORFICE, NORCOLD 61475122
	104137-06-714	EA	BURNER ASSEMBLY - 5-SLOT, NORCOLD 61705222
	104137-06-715	EA	SPARK/SENSE ELECTRODE-SINGLE, NORCOLD 61692222
	104138-04-701	EA	FOAMED CABINET ASSEMBLY-BLACK W/WHITE, NORCOLD 61725038
	054450-01-000	EA	LEVEL-REFRIGERATOR
	065225-02-000	EA	PLATE-TIEDOWN, REFRIGERATOR
	093646-01-000	EA	BRACKET-TIEDOWN, REFRIGERATOR
	093646-02-000	EA	BRACKET-TIEDOWN, REFRIGERATOR

MICROWAVE OVEN

KEY	PART NUMBER	U/M	DESCRIPTION
	115303-01-000	EA	OVEN-MICROWAVE MCD-DM15K-7B
	115401-01-01A	EA	TRIM-MICROWAVE, BLACK
	098916-08-01A	EA	BRACE-MICROWAVE CABINET, LEFT - STEEL
	098916-09-01A	EA	BRACE-MICROWAVE CABINET, RIGHT - STEEL
	094750-07-000	EA	BRACKET-MICROWAVE, 89 DEGREE

GALLEY GROUP (CONTINUED)**RANGE W/O OVEN**

KEY	PART NUMBER	U/M	DESCRIPTION
	114030-01-01A	EA	RANGE - 3 BURNER, W/O OVEN - ALMOND - MAGIC CHEF 85RA-3B
	102019-01-705	EA	TRIM-REAR, BLACK #3608F009-70
	102022-01-708	EA	REGULATOR-PRESSURE, 1/4 IN-1/2 OUT #7510P041-60
	102020-01-709	EA	BUMPER-GRATE #8007-P020-60
	102020-01-710	EA	FILTER-PILOT #7507P046-60
	102020-01-711	EA	GRATE-TOP #7518P012-60
	102020-01-721	EA	VALVE-SHUT OFF #7506P096-60
	102020-01-722	EA	VALVE-TOP BURNER #7502P181-60
	102020-01-724	EA	BUMPER-MAIN TOP #8003P008-60
	112881-01-700	EA	TOP-MAIN, ALMOND #2001F110-84
	112881-01-703	EA	VALVE-TOP BURNER, HI-OUTPUT #7502P180-60
	112881-01-705	EA	KNOB-TOP BURNER #7733P072-60
	112881-01-709	EA	PIPE-MANIFOLD #7513P097-60
	114030-01-700	EA	PILOT-BURNER #7505P147-60
	114030-01-701	EA	PANEL-MANIFOLD #2616F078-70
	114030-01-702	EA	TRIM-RIGHT, BLACK #3608W040-70
	114030-01-703	EA	TRIM-LEFT, BLACK #3608W039-70
	081587-03-000	EA	BRACKET-TIEDOWN, RANGE - RH
	081587-04-000	EA	BRACKET-TIEDOWN, RANGE - LH
	063752-01-000	EA	SHROUD-RANGE, 18.5" X 20.6" X 16.2" - METAL - OFF WHITE

RANGE W/OVEN

KEY	PART NUMBER	U/M	DESCRIPTION
	112881-01-03A	EA	RANGE-16", 3 BURNER - ALMOND - BLACK TEXTURED DOOR, M'CHEF 16RA-3B49
	055282-04-700	EA	PANEL-OVEN DOOR, ALMOND 2401F079-74
	102020-01-700	EA	SHELF-OVEN 7801-P027-60
	102020-01-701	EA	HANDLE-DOOR 7701P092-60
	102020-01-709	EA	BUMPER-GRATE 8007-P020-60
	102020-01-711	EA	GRATE-TOP 7518P012-60
	102020-01-722	EA	VALVE-TOP BURNER 7502P181-60
	102020-01-724	EA	BUMPER-MAIN TOP 8003P008-60
	102022-01-708	EA	REGULATOR-PRESSURE, 1/4 IN-1/2 OUT 7510P041-60
	112881-01-700	EA	TOP-MAIN, ALMOND 2001F110-84
	112881-01-701	EA	MANIFOLD PANEL 2616F091-70
	112881-01-702	EA	VALVE-MERCURY, SAFETY VALVE 7501-P121-60
	112881-01-703	EA	VALVE-TOP BURNER, HI-OUTPUT 7502P180-60
	112881-01-704	EA	KNOB-THERMOSTAT 7731P067-60
	112881-01-705	EA	KNOB-TOP BURNER 7733P072-60
	112881-01-706	EA	THERMOSTAT 12400026
	112881-01-707	EA	TRIM-FLAT, LEFT - BLACK 3608W035-70
	112881-01-708	EA	TRIM-FLAT, RIGHT - BLACK 3608W036-70
	112881-01-709	EA	PIPE-MANIFOLD 7513P097-60
	112881-01-710	EA	PILOT-OVEN 7505P202-60
	112881-01-711	EA	BURNER-OVEN 3404W025045
	112881-01-713	EA	DOOR-OVEN, TEXTURED 2401F079-70
	105458-03-000	EA	BRACKET-TIEDOWN, STOVE
	105458-04-000	EA	BRACKET-TIEDOWN, STOVE

GENERATOR GROUP**3.3 KW ONAN GENERATOR - LP**

KEY	PART NUMBER	U/M	DESCRIPTION
	109982-05-000	EA	GENERATOR - 3.3 MICROLITE, ONAN KY-FR/26119 B
	007125-04-000	EA	CLAMP-MUFFLER, 1.1" DIAMETER
	105958-10-000	EA	PIPE-EXHAUST, GENERATOR
	007067-01-000	SF	INSULATION-FIBERGLASS, 1" THICK X 4' - INCREMENTS OF 4 SF

4.0 KW ONAN GENERATOR

KEY	PART NUMBER	U/M	DESCRIPTION
	109982-03-000	EA	GENERATOR - 4.0 MICROLITE, ONAN KY-FA/26100 B
	105958-10-000	EA	PIPE-EXHAUST, GENERATOR
	007125-04-000	EA	CLAMP-MUFFLER, 1.1" DIAMETER
	007067-01-000	SF	INSULATION-FIBERGLASS, 1" THICK X 4' - INCREMENTS OF 4 SF

3.6 KW ONAN GENERATOR - LP

KEY	PART NUMBER	U/M	DESCRIPTION
	109982-04-000	EA	GENERATOR - 3.6 MICROLITE, ONAN KY-FA/26120 B
	007125-04-000	EA	CLAMP-MUFFLER, 1.12" DIAMETER
	105958-10-000	EA	PIPE-EXHAUST, GENERATOR
	007067-01-000	SF	INSULATION-FIBERGLASS, 1" THICK X 4' - INCREMENTS OF 4 SF

HEATING & AIR CONDITIONING GROUP

ROOF A/C - 13,500 BTU

KEY	PART NUMBER	U/M	DESCRIPTION
1	108889-01-05A	EA	A/C-ROOF, 13,500 TSR HO - BRIGHT WHITE - COLEMAN 7333
2	093763-01-712	EA	FAN BLADE-CONDENSER, COLEMAN 6733-3221
3	105620-01-706	EA	FOOT PACKAGE-COMPRESSOR, 3 PER PKG- COLEMAN 6759-3081
4	108889-01-705	EA	MOTOR - 115, 60HZ) 1468-3049
5	108889-01-706	EA	IMPELLOR 1472-1041
6	108889-01-708	EA	CAPACITOR-FAN, (7.5MFD.370U) - COLEMAN 1499-5461
	108889-01-710	EA	FILLER PAD-CONDENSOR AIR SEAL 6759A3971
7	108889-01-711	EA	GASKET PACKAGE 6792-3301
8	108889-01-715	EA	MOTOR MOUNT & SHAFT SEAL KIT 6792-3361
9	108889-05-700	EA	SHROUD-A/C, LESS LOGO - 7333-4601 - BRIGHT WHITE
10	108889-01-703	EA	CONDENSER COIL 1452A1301
11	105620-01-704	EA	COMPRESSOR, RH & LH - COLEMAN 1450-2009
12	108889-01-707	EA	RUN CAPACITOR-COMPRESSOR, 25MFD/370 1499-5661
	091225-01-709	EA	START RELAY, COLEMAN 1497-4131
13	108889-01-709	EA	EVAPORATOR COIL 1452A1311
	108889-01-712	EA	SUCTION LINE REDUCER - 3/8 X 1/2 1215-2161
	108889-01-713	EA	SUCTION LINE - 3/8 OD X .032 WALL 6792-130
	108889-01-714	EA	DISCHARGE LINE ASSEMBLY 6792-531
	102289-01-000	EA	SPRING-SCREW, ROOF A/C GASKET - COLEMAN 6757-150
	091225-01-710	EA	START CAPACITOR, COLEMAN 1497-0881
	093306-01-701	EA	DECAL PACKAGE, LEFT & RIGHT - COLEMAN 6798B3591
	108889-01-704	EA	OVERLOAD (MRA#98693) 6749-3541

ROOF A/C-13,500 BTU-EUROPE

KEY	PART NUMBER	U/M	DESCRIPTION
1	108889-02-03A	EA	A/C-ROOF, 13,500 TSR 220 - BRIGHT WHITE - COLEMAN 7373
2	093763-01-712	EA	FAN BLADE-CONDENSER, COLEMAN# 6733-3221
3	105620-01-706	EA	FOOT PACKAGE-COMPRESSOR, 3 PER PKG- COLEMAN 6759-3081
4	108889-02-701	EA	MOTOR 1468-3059
5	108889-01-706	EA	IMPELLOR 1472-1041
6	108889-01-708	EA	CAPACITOR-FAN, (7.5MFD.370U) - COLEMAN 1499-5461
	108889-01-710	EA	FILLER PAD-CONDENSOR AIR SEAL 6759A3971
7	108889-01-711	EA	GASKET PACKAGE 6792-3301
8	108889-01-715	EA	MOTOR MOUNT & SHAFT SEAL KIT 6792-3361
9	108889-05-700	EA	SHROUD-A/C, LESS LOGO - 7333-4601 - BRIGHT WHITE
10	108889-01-703	EA	CONDENSER COIL 1452A1301
11	108889-02-700	EA	COMPRESSOR-TECUMSEH 1452-2029
12	108889-01-707	EA	RUN CAPACITOR-COMPRESSOR, 25MFD/370 1499-5661
	108889-02-703	EA	RELAY-START 1497-4141
13	108889-01-709	EA	EVAPORATOR COIL 1452A1311
	093306-01-701	EA	DECAL PACKAGE, LEFT & RIGHT - COLEMAN 6798B3591
	105620-01-705	EA	PROTECTOR-OVERLOAD, RH & LH - COLEMAN 6759-3791
	108889-01-713	EA	SUCTION LINE, 3/8 OD X .032 WALL 6792-130
	108889-01-714	EA	DISCHARGE LINE ASSEMBLY 6792-531
	108889-02-702	EA	CAPACITOR-START 1497-0891

CEILING A/C

KEY	PART NUMBER	U/M	DESCRIPTION
	108891-01-01A	EA	CEILING ASSEMBLY-A/C COOL TSR HO - COLEMAN 7330-714 IV
	042204-01-709	EA	THERMOSTAT-IN 64 OUT 58, COLEMAN 6701-3401
	063903-01-702	EA	LOUVER-COLEMAN 6703A5191
	073742-01-701	EA	SELECTOR SWITCH - 5 TERMINAL, COLEMAN 6759-3251
	073742-01-702	EA	DECAL COOL ONLY, COLEMAN 6759C3431
	081606-01-712	EA	CEILING SHROUD-IVORY, COLEMAN 6769-5061
	091225-01-713	EA	KNOB - 2 PER PACKAGE, COLEMAN 6701-3351
	091225-01-717	EA	DECAL-THERMOSTAT, COOL ONLY - COLEMAN 6799A3441
	093766-02-701	EA	DECAL-LEFT SIDE, COLEMAN 6799-3971
	108891-01-700	EA	SINGLE PARTS PACKAGE-KNOBS & NUTS, COLEMAN 6792-5991
	108891-01-701	EA	RETAINER CLIPS-FILTER, 6 PER - COLEMAN 6799-3141
	076303-01-717	EA	FILTER -(EACH = 1)
	084077-03-000	EA	COVER-BLANK, ROOF A/C - 5.2" X 3.5" - IVORY

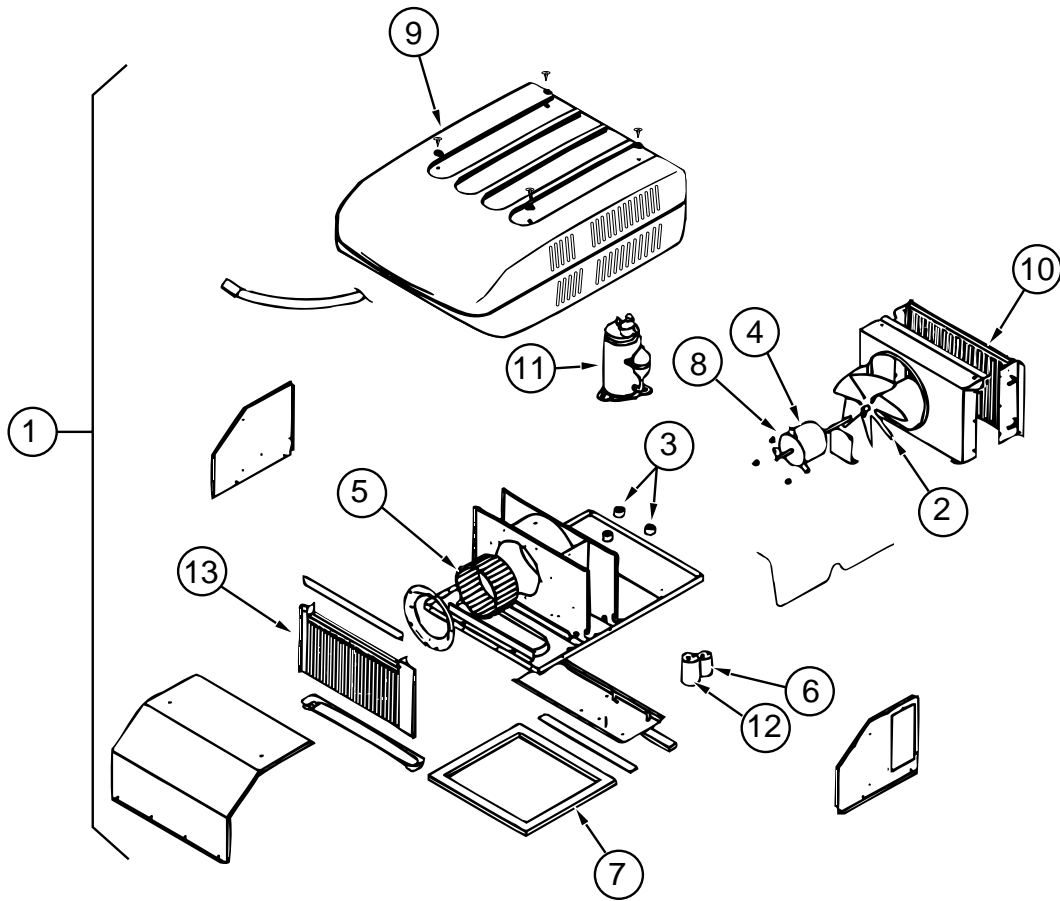

HEATING & AIR CONDITIONING GROUP (CONTINUED)
FURNACE AND COMPONENTS

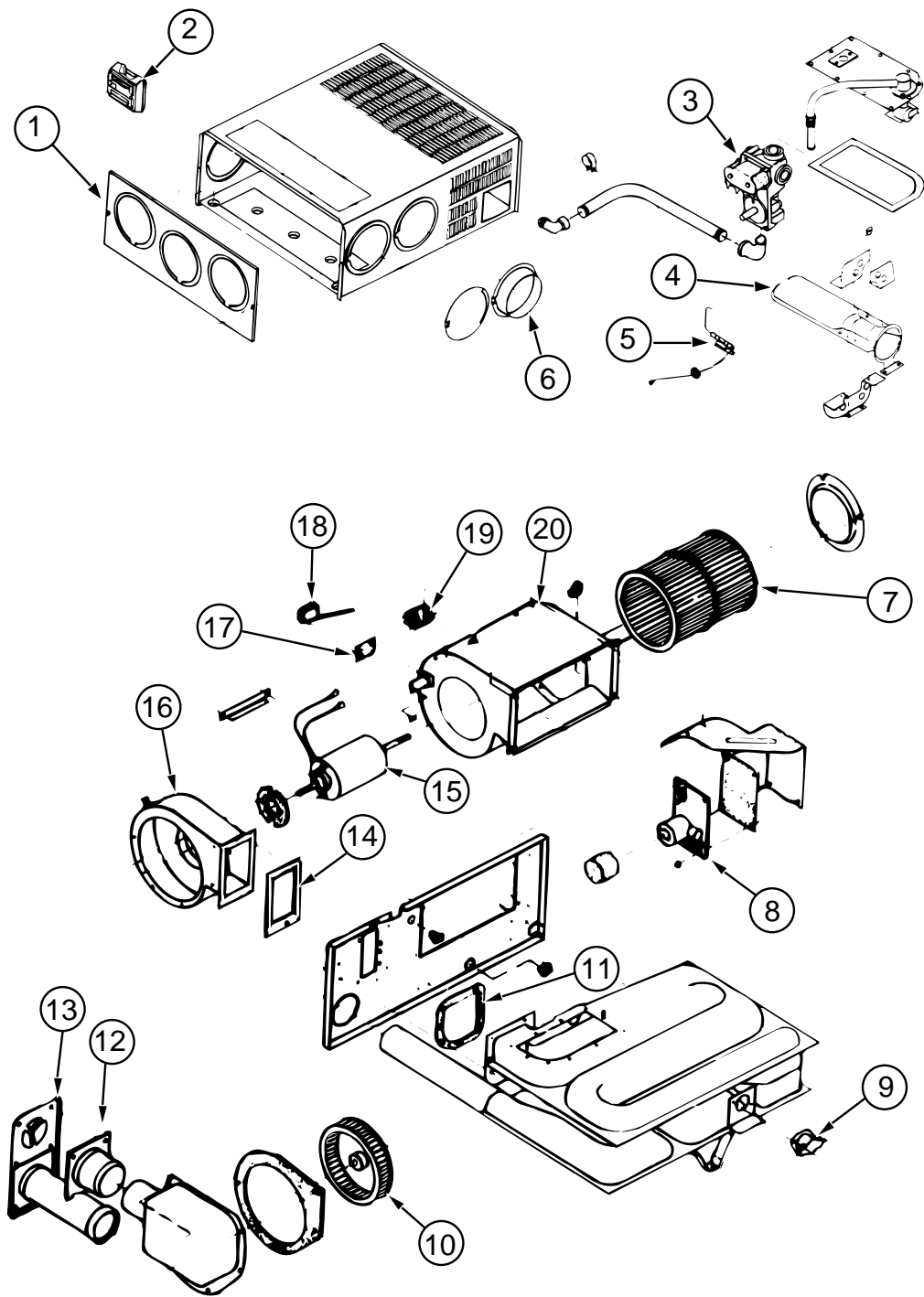

KEY	PART NUMBER	U/M	DESCRIPTION
	098668-19-000	EA	FURNACE - 25,000 BTU SUBURBAN SF-25 2272
1	098668-01-700	EA	CABINET FRONT, SUBURBAN 101242
2	093365-01-000	EA	THERMOSTAT-WALL, FURNACE - SUBURBAN 0160902
3	098668-01-714	EA	GAS VALVE FOR SF MODELS S.N. #921401821 AND UP
4	090039-01-703	EA	ORFICE-MAIN BURNER, SUBURBAN 180193
5	098668-01-715	EA	ELECTRODE-SINGLE PROBE, FOR SF MODELS S.N. #921401821 & UP
6	075696-02-703	EA	COLLAR-DUCT, SUBURBAN #050715
7	098668-01-711	EA	WHEEL-ROOM AIR, SUBURBAN 350123
8	098668-01-712	EA	BOARD-MODULE, SUBURBAN 231741
9	098668-01-705	EA	SWITCH-LIMIT, SUBURBAN 231630
10	098668-01-706	EA	WHEEL-COMBUSTION AIR, SUBURBAN 350122
11	098668-01-716	EA	GASKET FIREWALL(CHAMBER SIDE 070808
12	098668-01-713	EA	TUBE ASSEMBLY-INTAKE VENT 051044
13	098668-01-707	EA	VENT CAP & EXHAUST TUBE ASM, SUBURBAN 260193
14	090039-01-709	EA	GASKET-COVER, OBSERVATION HOLE
15	098668-01-709	EA	MOTOR-FOR SF-25, SF-30 - SUBURBAN 231706
16	098668-01-708	EA	BLOWER-COMBUSTION AIR, SUBURBAN 390441
17	101990-01-714	EA	MICROSWITCH GASKET, SUBURBAN 230877
18	098668-01-715	EA	ELECTRODE ASM. (SGL PROBE) F/SF MODELS S.N.#921401821 & UP
19	069634-01-733	EA	RELAY-TIME DELAY, 20 & 30 BTU, SUBURBAN 231202
20	098668-01-710	EA	BLOWER-ROOM AIR, SUBURBAN 390440
	098668-01-701	EA	CABINET-SUBURBAN 101299
	098668-23-000	EA	DOOR-ACCESS, FURNACE - BRIGHT WHITE- SUBURBAN
	056464-05-000	EA	REGISTER-PLASTIC W/O DAMPER - 4" DIAMETER - GOLDEN
	009198-01-000	FT	DUCT-HEAT, FLEXIBLE - 4" ID X 25 FT
	009200-01-000	EA	TAPE-FURNACE, 1 1/2"
	069636-02-000	EA	CONNECTOR-DUCT, 4" ID - SUBURBAN 050715

INTERIOR FINISH GROUP
MOLDINGS & TRIMS

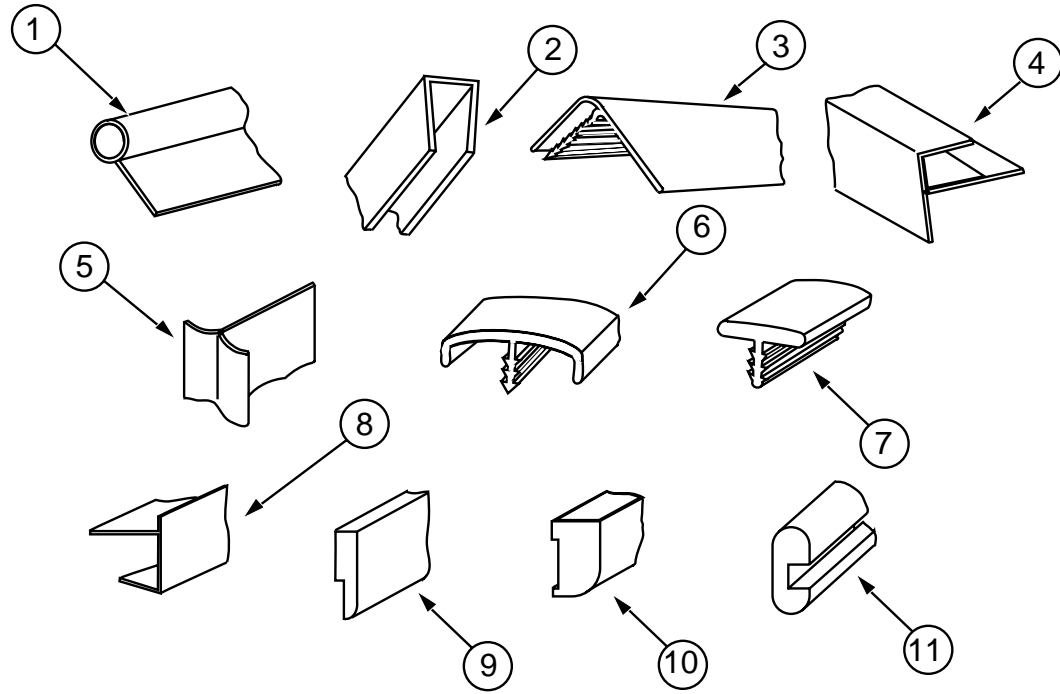

KEY	PART NUMBER	U/M	DESCRIPTION
1	009767-12-000	FT	MOLDING-SIDEWALL TO CEILING/CABINET - WELTING - OFF WHITE
2	009778-12-000	FT	U-CHANNEL, PLASTIC - 1" WIDE X 8' - WOODGRAIN
2	009778-20-000	FT	U-CHANNEL, 1" X 55", MODERN IVORY
2	070504-19-000	FT	U-CHANNEL, PLASTIC, .815" WIDE - BROWN
2	070504-23-000	FT	U-CHANNEL, 22.56 - COUNTRY FOREST
3	009809-21-000	EA	MOLDING-CORNER, OUTSIDE - 1" - PLASTIC - WOODGRAIN
3	009809-23-000	EA	MOLDING-CORNER, OUTSIDE - 1" - PLASTIC - IVORY
4	009812-22-000	EA	MOLDING-CORNER, OUTSIDE - .5" X 7' - PLASTIC - BROWN
4	009812-24-000	EA	MOLDING-PLASTIC, OUTSIDE CORNER - .50" - IVORY
5	022992-01-000	FT	MOLDING-REVERSE COVE, T-SHAPED - VINYL - WHITE
5	022992-11-000	FT	MOLDING-REVERSE COVE, T-SHAPED - VINYL - IVORY
6	083620-07-000	FT	MOLDING-T, END CAP EDGE - W/EDGE LIPS - .75" - THOR PECAN
6	083620-09-000	FT	T-MOLDING, 3/4 W/EDGE LIPS - MODERN IVORY
6	104676-02-01A	FT	T-MOLDING - 1/2" X 7'
7	104676-01-01A	FT	T-MOLDING, 5/16 - RIGID - GOLD
8	103186-01-01A	FT	MOLDING-EDGE, SHELF - .78" WIDE - PLASTIC - RAMBLING OAK
9	105004-01-02A	EA	MOLDING-VINYL WRAPPED, RAMBLING OAK
10	100041-01-000	EA	MOLDING-VINYL WRAPPED, .7" X 1.57" X 84.02" - RAMBLING OAK
10	100041-02-000	EA	MOLDING-VINYL WRAPPED, .7" X 2.5" X 84" - RAMBLING OAK
11	081294-02-000	EA	MOLDING-SHELF, NOTCHED WOOD - 8' LONG
	076325-31-000	FT	MOLDING EDGE BAND, RAMBLING OAK
	076325-34-000	FT	MOLDING-EDGE BAND, 1 5/16" WIDE
	076325-35-000	FT	MOLDING EDGE BAND, ORCHID
	100040-01-000	EA	LUMBER-VINYL WRAPPED, .71" X 1.5" X 8' - RAMBLING OAK
	100040-03-000	EA	LUMBER-VINYL WRAPPED, .71" X 2" X 8' - RAMBLING OAK
	100040-06-000	EA	LUMBER-VINYL WRAPPED, RAMBLING OAK

INTERIOR FINISH GROUP (CONTINUED)

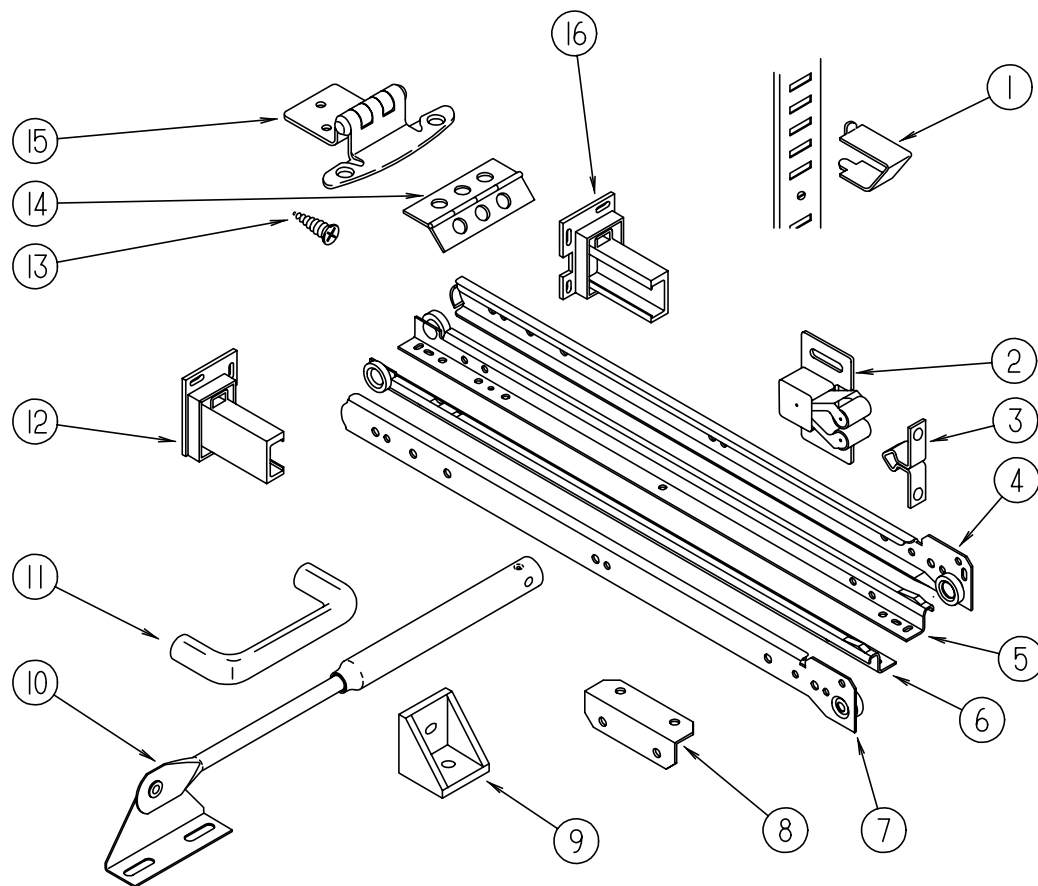

CABINET & TABLE HARDWARE

KEY	PART NUMBER	U/M	DESCRIPTION
1	098979-01-000	EA	CLIP-ADJUSTABLE SHELF
2	093586-01-000	EA	CATCH-SPRING, ROLLER GM INTERNATIONAL
3	093586-02-000	EA	STRIKE-SPRING, STEEL GM INTERNATIONAL
4	114031-02-000	EA	SLIDE-DRAWER, CABINET MOUNTED - RIGHT SIDE - 12"
4	114031-10-000	EA	SLIDE-DRAWER, CABINET MOUNTED - RIGHT SIDE - 16"
4	114031-14-000	EA	SLIDE-DRAWER, CABINET MOUNTED - RIGHT SIDE - 18"
5	114031-04-000	EA	SLIDE-DRAWER, DRAWER MOUNTED - RIGHT SIDE - 12"
5	114031-12-000	EA	SLIDE-DRAWER, DRAWER MOUNTED - RIGHT SIDE - 16"
5	114031-16-000	EA	SLIDE-DRAWER, DRAWER MOUNTED - RIGHT SIDE - 18"
6	114031-03-000	EA	SLIDE-DRAWER, DRAWER MOUNTED - LEFT SIDE - 12"
6	114031-11-000	EA	SLIDE-DRAWER, DRAWER MOUNTED - LEFT SIDE - 16"
6	114031-15-000	EA	SLIDE-DRAWER, DRAWER MOUNTED - LEFT SIDE - 18"
7	114031-01-000	EA	SLIDE-DRAWER, CABINET MOUNTED - LEFT SIDE - 12"
7	114031-09-000	EA	SLIDE-DRAWER, CABINET MOUNTED - LEFT SIDE - 16"
7	114031-13-000	EA	SLIDE-DRAWER, CABINET MOUNTED - LEFT SIDE - 18"
8	016604-01-000	EA	BRACE-CABINET, ANGLE - 2.5" - METAL - UNPAINTED
8	016604-03-000	EA	BRACE-CABINET, ANGLE - 2.5" - METAL - BEIGE
8	016604-05-000	EA	BRACE-CABINET, L ANGLE - 2.5" - METAL - OFF WHITE
9	065740-01-000	EA	BRACE-CABINET CORNER, PLASTIC
10	074493-02-000	EA	SUPPORT-PISTON SPRING, CABINET DOOR
11	112146-01-000	EA	PULL-CABINET, BRASS - AMEROCK D-1180-3
12	114045-01-000	EA	BACKSOCKET-ADJUSTABLE, LEFT - HOUCK 751-1
13	000G13-06-08G	EA	SCREW - 6-20 X 5/8 PFH - ANTIQUE BRASS
14	009059-01-000	EA	HINGE-DOOR, 2" X 1.4" - BRASS
15	108138-01-000	EA	HINGE-DOOR, CABINET - BURNISHED BRASS
16	114045-02-000	EA	BACKSOCKET-ADJUSTABLE, RIGHT - HOUCK 751-2
	009063-01-000	EA	HINGE-CONTINUOUS, 1 1/2" X 72" - UNPAINTED

INTERIOR FINISH GROUP (CONTINUED)

CABINET & TABLE HARDWARE (CONTINUED)

KEY	PART NUMBER	U/M	DESCRIPTION
	076790-01-000	EA	SCREW - 6-20 X 1 1/4 PPH - BLACK
	004354-01-000	EA	BUMPER-RUBBER, .5" DIAMETER - BROWN
	023320-01-000	EA	PAD-FELT, 3/8" DIAMETER - BROWN
	042356-01-000	EA	PLUG-BUTTON, MAHOGANY - 3/8" DIAMETER - WOOD
	009112-01-000	EA	FLANGE - 1" CLOTHES ROD - PLASTIC - OFF WHITE
	000G13-06-10G	EA	SCREW - 6-20 X 5/8 PFH - ANTIQUE BRASS
	042438-01-000	EA	DOWEL-WOOD, CLOTHES ROD - 1" DIAMETER X 4'
	042438-02-000	EA	DOWEL-WOOD, 2" X 2"
	047034-06-000	EA	POLY-CLEAR, ROLL SIZE - 2FT
	105037-01-000	EA	FASTENER-WOOD, CORNER - METAL - .5" X .5"

BATT STRIPS

KEY	PART NUMBER	U/M	DESCRIPTION
	088263-B4-000	EA	BATT STRIP, MAIN WALL - SILVERADO
	088263-B6-000	EA	BATT STRIP, CEILING - PEARL
	088263-78-000	EA	BATT STRIP-SHOWER, OFF WHITE
	069733-80-000	EA	BATT STRIP-WOODGRAIN, WINNIE OAK
	085284-A5-000	FT	STRIP-TAPE, MAIN WALL - SILVERADO
	085284-A7-000	FT	STRIP-TAPE, CEILING - PEARL
	085284-67-000	FT	STRIP-TAPE, WINNIE OAK
	085284-76-000	FT	STRIP-TAPE, SHOWER - ADHESIVE BACKED - OFF WHITE
	086229-01-000	EA	RETAINER-BATTEN, CEILING - .75" WIDE - 7.6'
	086229-04-000	EA	BATTEN-CEILING, 1" WIDE - IVORY - 7.6'

PANELING, LAMINATES & PLASTIC

KEY	PART NUMBER	U/M	DESCRIPTION
	074497-19-000	SF	PANELING-CEILING, 4' X 8' - INCREMENTS OF 32 SF
	074497-21-000	SF	PANELING-WOODGRAIN, 4' X 8' - INCREMENTS OF 32 SF
	088272-D7-000	SF	PANELING-MAIN WALL, SILVERADO
	088272-98-000	SF	PANELING-SHOWER, OFF WHITE - 4' X 7' - INC OF 28 SQ FT
	074498-67-000	SF	LAMINATE-PLASTIC, ORCHID MIST
	093743-02-01A	SF	PLASTIC-ABS, 20" WIDE ROLL - OFF WHITE
	093743-03-01A	SF	PLASTIC-ABS, 10.8" WIDE - OFF WHITE
	089297-01-000	SF	PLYWOOD-LUAN, OVERLAY GRADE - 4' X 8' - INC OF 32 SF
	000885-61-000	SF	PARTICLE BOARD - 3/4" X 48" X 96" - WINNI OAK - VINYL 2 SIDES

FIRE EXTINGUISHERS & DETECTORS

KEY	PART NUMBER	U/M	DESCRIPTION
	094499-02-000	EA	EXTINGUISHER-FIRE, DRY - 1A10BC - CANADIAN
	094499-01-000	EA	EXTINGUISHER-FIRE, DRY W/MOUNTING BRACKET - 10 BC
	094499-01-700	EA	BRACKET-MOUNTING, W/PLASTIC STRAP - FIRE EXTINGUISHER
	072852-01-000	EA	DETECTOR-SMOKE, W/9 VOLT BATTERY - US
	072852-02-000	EA	DETECTOR-SMOKE, W/9 VOLT BATTERY - CANADIAN
	112320-01-000	EA	DETECTOR-CO GAS, MODEL 9B-1 - COSTAR 940000000
	112320-02-000	EA	BATTERY/SENSOR-CO GAS, COSTAR 940001000

CARPETING

KEY	PART NUMBER	U/M	DESCRIPTION
	096060-97-000	SY	CARPET-LAPIS (F15)
	096060-A1-000	SY	CARPET-ARTIC GRAY (F16)
	093486-01-000	SY	CARPET-COMPARTMENT, 54" WIDE - DARK GRAY
	047034-02-000	SF	PLASTIC-CARPET, 4"WIDE - CLEAR POLY
	085746-01-000	SF	TRIM-J, CARPET - 1.2" X .5" ANGLE - 10' LONG - PVC - BEIGE

FLOOR MATS

KEY	PART NUMBER	U/M	DESCRIPTION
	106884-01-000	EA	MAT-FLOOR - PASSENGER - "W" - FORD
	106884-02-000	EA	MAT-FLOOR - DRIVER - "W" - FORD
	081075-03-000	EA	MAT-FLOOR, ENTRANCE - WINNEBAGO - PLASTICOLOR - GRAY

LABELS GROUP

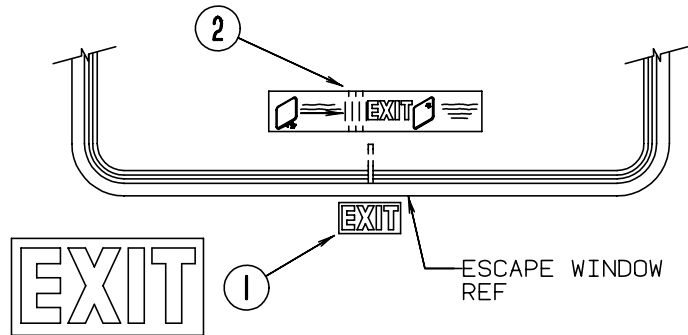
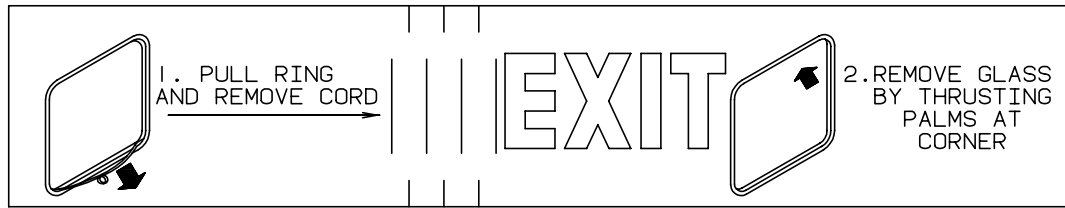

KEY	PART NUMBER	U/M	DESCRIPTION
1	039290-01-000	EA	LABEL-WARNING-EXIT
2	107571-01-000	EA	LABEL-EXIT-ESCAPE WINDOW

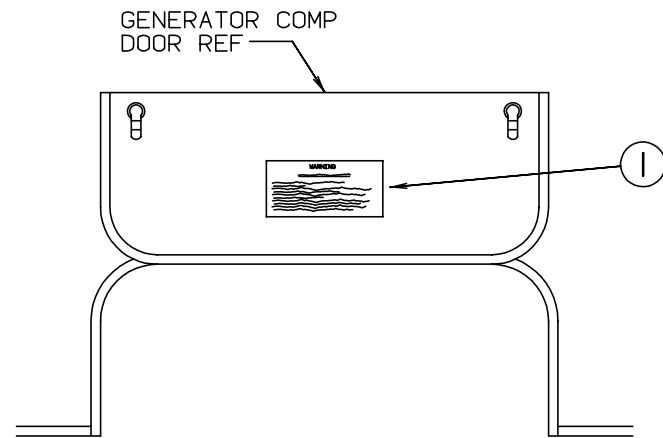

WARNING

WHEN ADDING A GENERATOR SET:

HIGH VOLTAGE-USE EXTREME CAUTION WHEN WORKING ON ELECTRICAL COMPONENTS.
 HAVE ALL ELECTRICAL INSTALLATION PERFORMED BY A QUALIFIED LICENSED ELECTRICIAN-FOLLOW ALL STATE AND LOCAL CODES.
 ONLY INSTALL GENERATOR SET APPROVED FOR R.V. APPLICATION. HAVE INSTALLED BY QUALIFIED TECHNICIAN.
 TO AVOID HEAT BUILD-UP AND TO GUARANTEE AN ADEQUATE AIR SUPPLY TO THE GENERATOR CARBURETOR, FOLLOW INSTALLATION INSTRUCTIONS.
 GENERATOR ENGINE EXHAUST GASES ARE TOXIC AND MUST NOT TERMINATE UNDER THE VEHICLE-DISCHARGE EXHAUST AWAY FROM VEHICLE.

KEY	PART NUMBER	U/M	DESCRIPTION
1	077510-01-000	EA	LABEL-GENERATOR PREP

LABELS GROUP (CONTINUED)

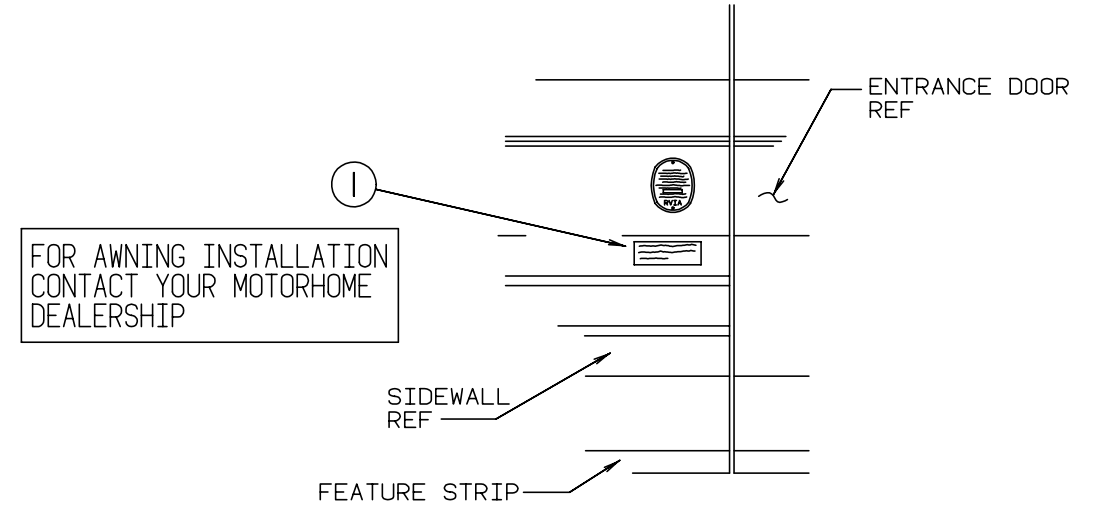

KEY	PART NUMBER	U/M	DESCRIPTION
1	099509-01-000	EA	LABEL-AWNING INSTALLATION

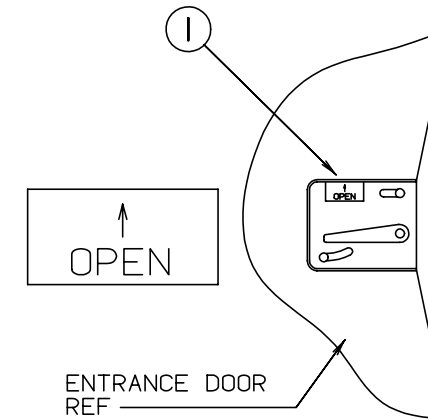

KEY	PART NUMBER	U/M	DESCRIPTION
1	040944-01-000	EA	LABEL-ENTRANCE DOOR - "OPEN"

LABELS GROUP (CONTINUED)

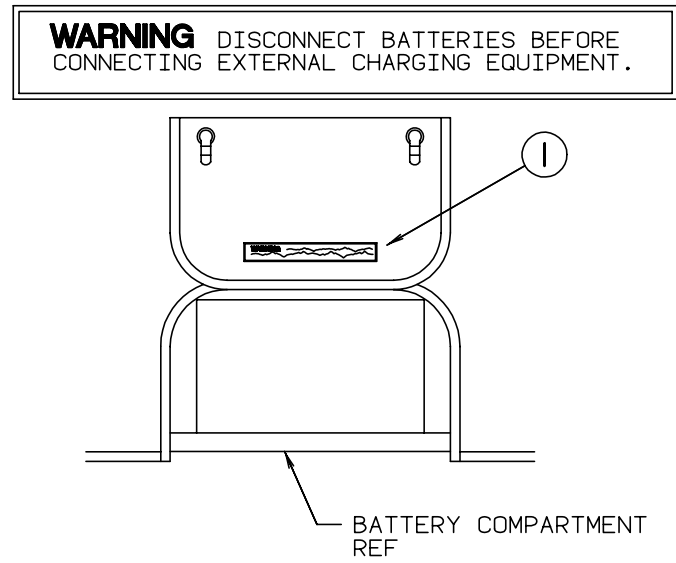

KEY	PART NUMBER	U/M	DESCRIPTION
1	065748-01-000	EA	LABEL-CAUTION-BATTERY CHARGING

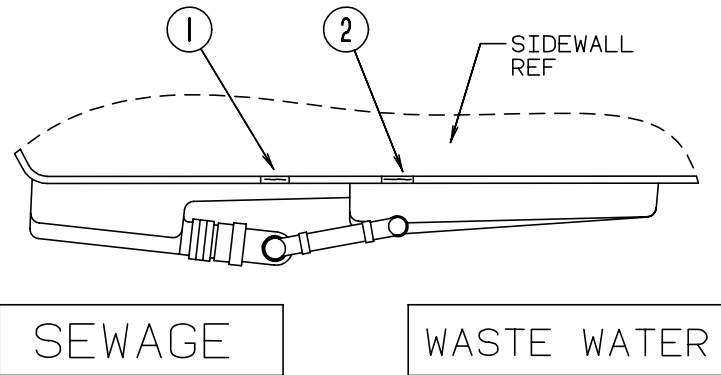

KEY	PART NUMBER	U/M	DESCRIPTION
1	006187-01-000	EA	LABEL-SEWAGE
2	006188-01-000	EA	LABEL-WASTE WATER

MISCELLANEOUS LABELS

KEY	PART NUMBER	U/M	DESCRIPTION
	104236-01-000	EA	LABEL-GENERATOR CIRCUIT
	006064-01-000	EA	LABEL-SEAT W/O SEATBELT (US)
	006064-02-000	EA	LABEL-SEAT W/O SEATBELT (CSA)
			NOT INTENDED FOR USE WHILE COACH IN MOTION
	091224-02-000	EA	LABEL-TRAILER LIGHTING
	091243-01-000	EA	LABEL-A/C COVER - "AIR CONDITIONING CIRCUIT. ETC."
	091243-02-000	EA	LABEL-COVER - "MICROWAVE CIRCUIT. ETC."
	093236-08-000	EA	LABEL-CIRCUIT BREAKER
	098641-01-000	EA	LABEL-FUEL - UNLEADED - DASH
	073998-01-000	EA	LABEL-LPG ODOR WARNING
	087236-01-000	EA	LABEL-CABLE - INPUT
	061417-01-000	EA	LABEL-FUEL - ON FUEL FILL DOOR
	006040-01-000	EA	TAG-GAS REFUELING WARNING (US)
	006040-02-000	EA	TAG-GAS REFUEL WARNING (CANADIAN)

LABELS GROUP (CONTINUED)

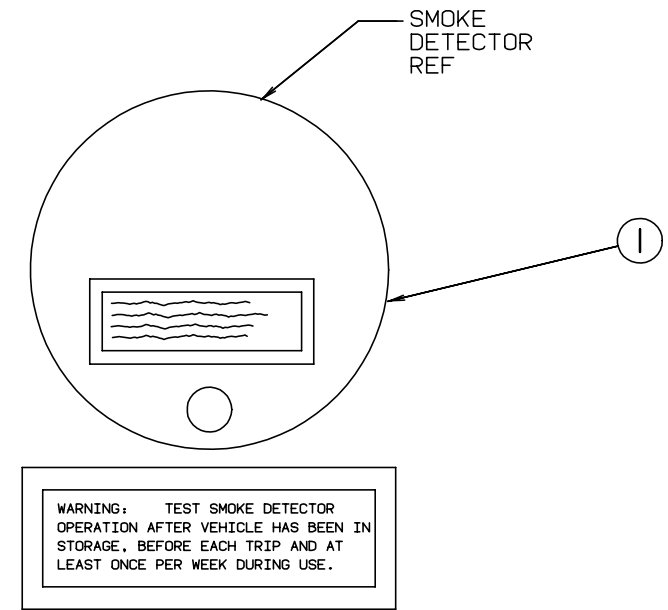

KEY	PART NUMBER	U/M	DESCRIPTION
1	077956-01-000	EA	LABEL-WARNING-SMOKE DETECTOR

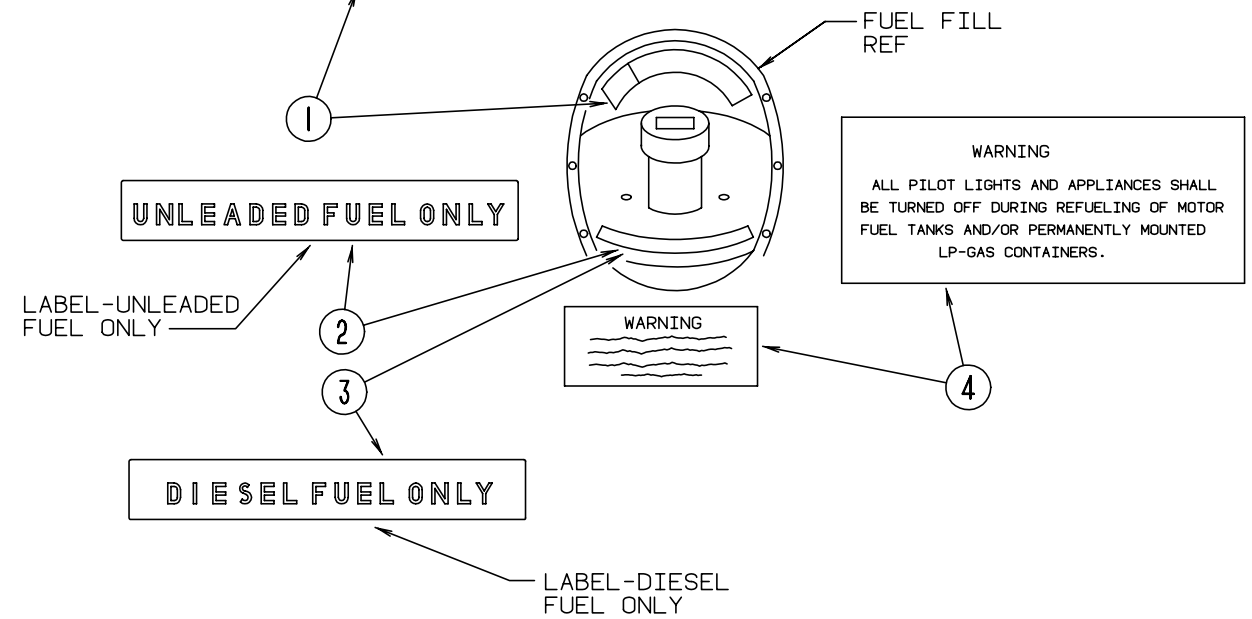
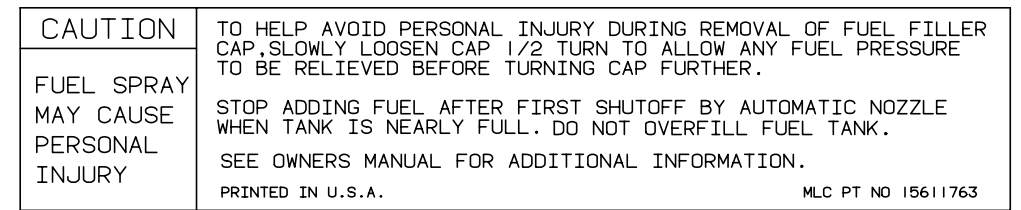

KEY	PART NUMBER	U/M	DESCRIPTION
1	087207-05-000	EA	LABEL-FUEL CAP REMOVAL
	087207-06-000	EA	LABEL-GAS OVERFILL
2			CHASSIS SUPPLIED
3			CHASSIS SUPPLIED
4	006040-01-000	EA	REFUEL WARNING - USA
4	006040-02-000	EA	REFUEL WARNING - CSA

LABELS GROUP (CONTINUED)

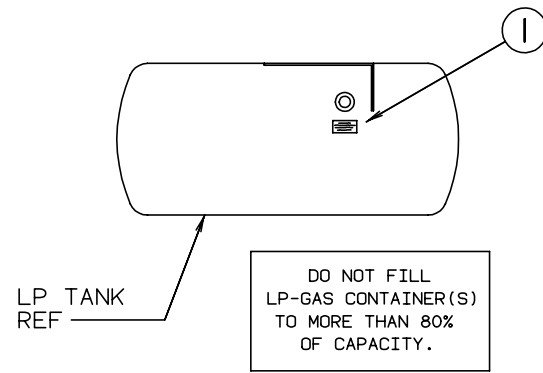

KEY	PART NUMBER	U/M DESCRIPTION
1	079965-01-000	EA LABEL-LPG - 80% CAPACITY

LABELS GROUP (CONTINUED)

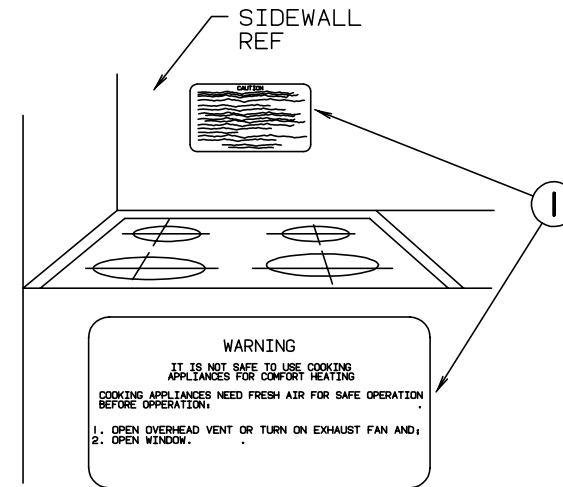

KEY	PART NUMBER	U/M DESCRIPTION
1	050225-01-000	EA LABEL-WARNING-STOVE VENT - US

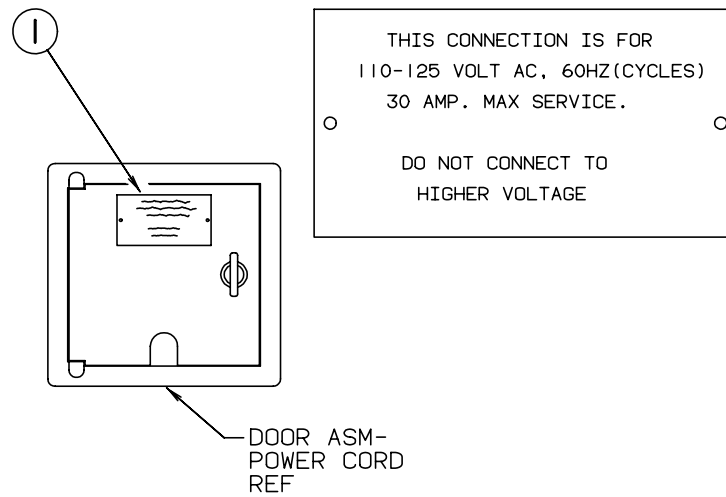

KEY	PART NUMBER	U/M DESCRIPTION
1	006062-01-000	EA TAG-ELECTRIC-110V CONNECTION

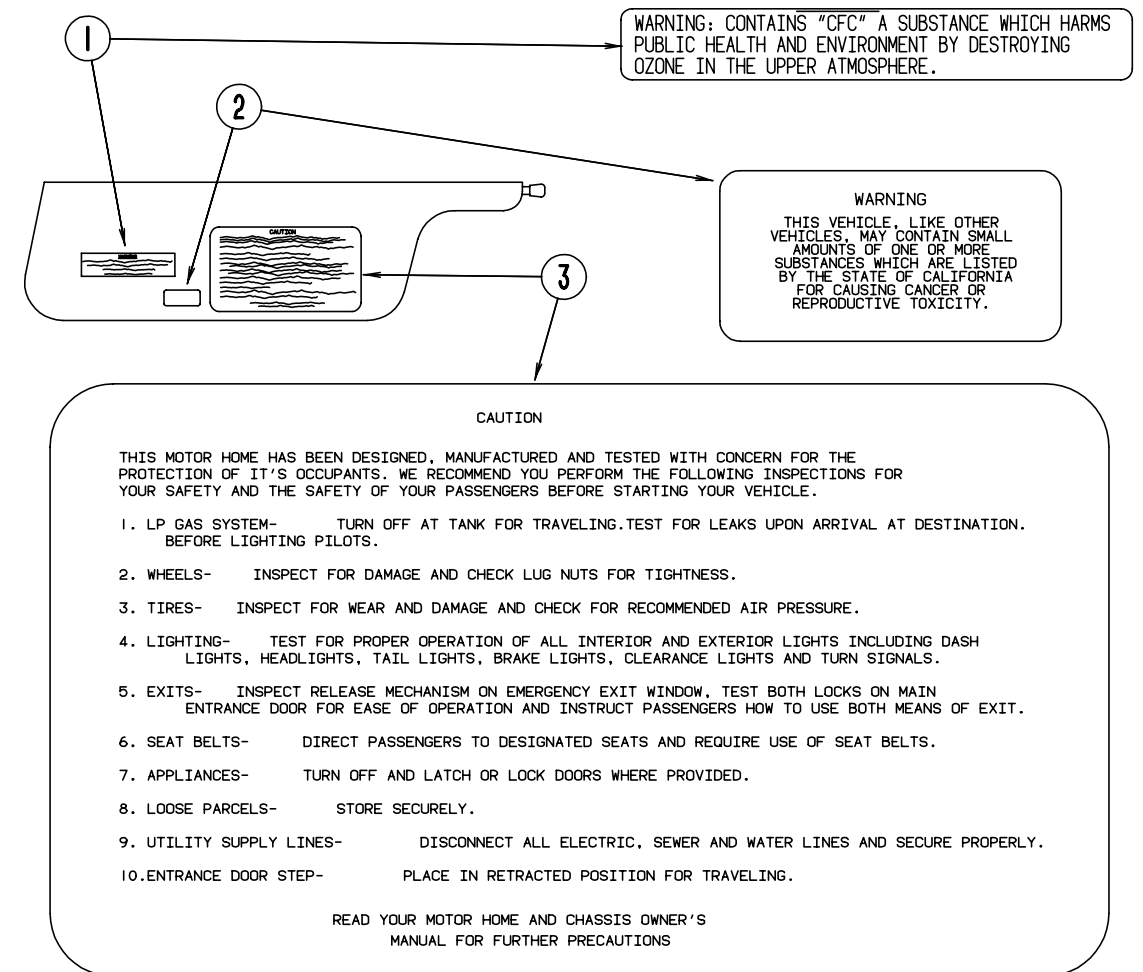

KEY	PART NUMBER	U/M DESCRIPTION
1	111802-01-000	EA LABEL-CFC WARNING
2	099689-01-000	EA LABEL-WARNING-CANCER/TOXICITY
3	056259-01-000	EA LABEL-SAFETY CHECK LIST

LP GROUP
LP SYSTEM

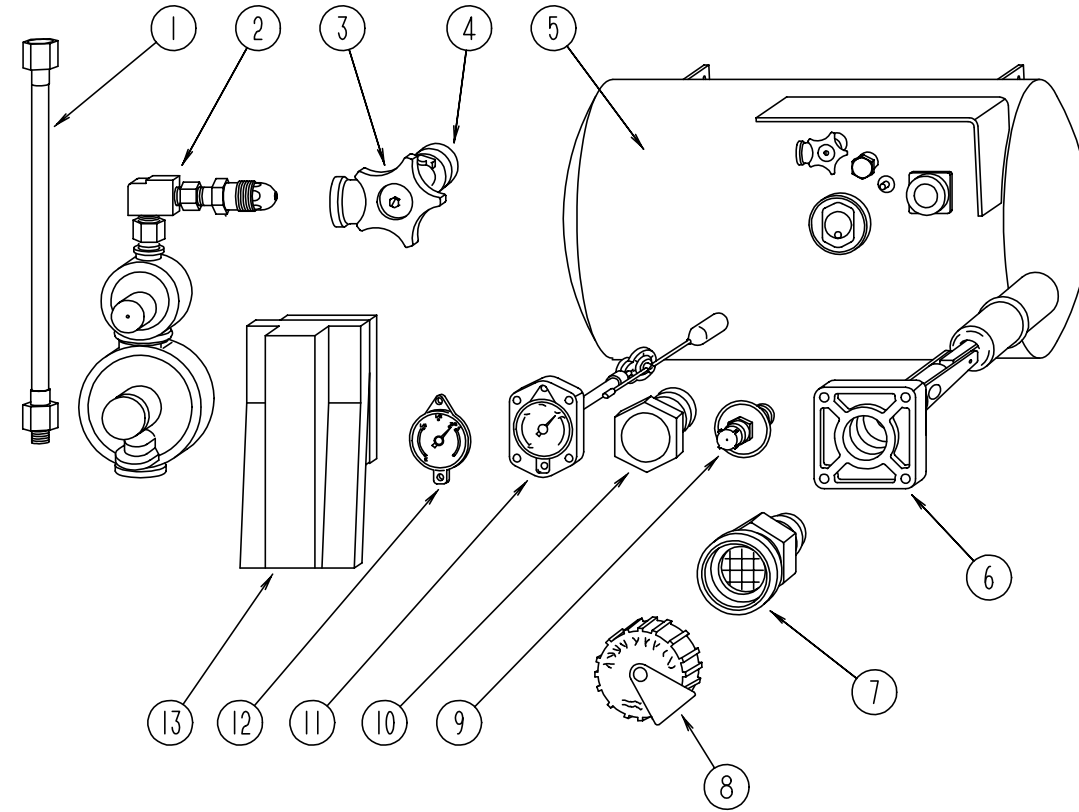

KEY	PART NUMBER	U/M	DESCRIPTION
1	045703-01-000	EA	HOSE-LP, 3/8" ID X 24" - 3/8" MPT X 1/2" F SWIVEL (U.S.)
1	045703-02-000	EA	HOSE-LP, 3/8" ID X 24" - 3/8" MPT X 1/2" F SWIVEL (CANADA)
2	106150-01-000	EA	REGULATOR-TWO STAGE, M'BRASS 293-303
3	040421-01-708	EA	HANDWHEEL-SERVICE VALVE, BRUNNER G-1015-A
4	040421-01-712	EA	VALVE-SERVICE W/O VAPOR RELIEF - 29000853
5	080450-01-000	EA	TANK-LP, 42 LB - 13" DIAMETER X 24" LONG
6	040421-01-711	EA	VALVE - 80% W/FLOAT, PLATE, BOLTS & GASKET - BRUNNER
7	040421-01-701	EA	VALVE-SHORT, LP FILLER W/YELLOW CAP - BRUNNER 75478
8	040421-01-702	EA	CAP-LP FILLER VALVE, PLASTIC - YELLOW - BRUNNER G-1014-A
9	040421-01-700	EA	VALVE-LIQUID LEVEL, 20% LP - BRUNNER G-1013
10	040421-01-713	EA	VALVE-VAPOR ONLY, 29000587
11	074142-01-700	EA	FLOAT GAUGE-SCREW ON - MACHINE 13C-SCR
12	040440-02-000	EA	TRANSMITTER-DIAL, 0-90 OHM - USED W/MONITOR PANEL
12	040421-01-706	EA	DIAL-LP TANK VOLUME, VISIBLE FACE (USE W/MONITOR PANEL)
13	105658-01-000	EA	COMPARTMENT-LP REGULATOR

KEY	PART NUMBER	U/M	DESCRIPTION
	010323-01-000	EA	ADAPTER-BRASS, 3/8" F X 1/2" MPT
	010377-02-000	EA	NUT-BRASS, 3/8" FEMALE - FORGED
	065318-02-000	EA	ELBOW - 90 DEGREE, 3/8" MPT TO 3/8" FPT
	095624-01-000	EA	ELBOW - 90 DEGREE, 1/4" FPT X 1/4" FPT - BRASS
	035340-01-000	EA	ELBOW - 3/8" MPT X 1/2" F, BRASS
	010252-01-000	EA	ELBOW-BRASS, 90 DEGREE 3/8" F X 1/2" MPT
	071391-02-000	EA	NIPPLE-HEX , 1/4" PIPE - 3325 X 4 WEATHERHEAD
	075148-02-000	EA	CLAMP-GROUNDING, BRONZE SCREWS
	083609-01-000	EA	CLAMP-WIRE, DUAL EQUAL - 5/8" DIAMETER
	103613-01-000	EA	DETECTOR-LEAK, LP GAS

LOUNGE GROUP

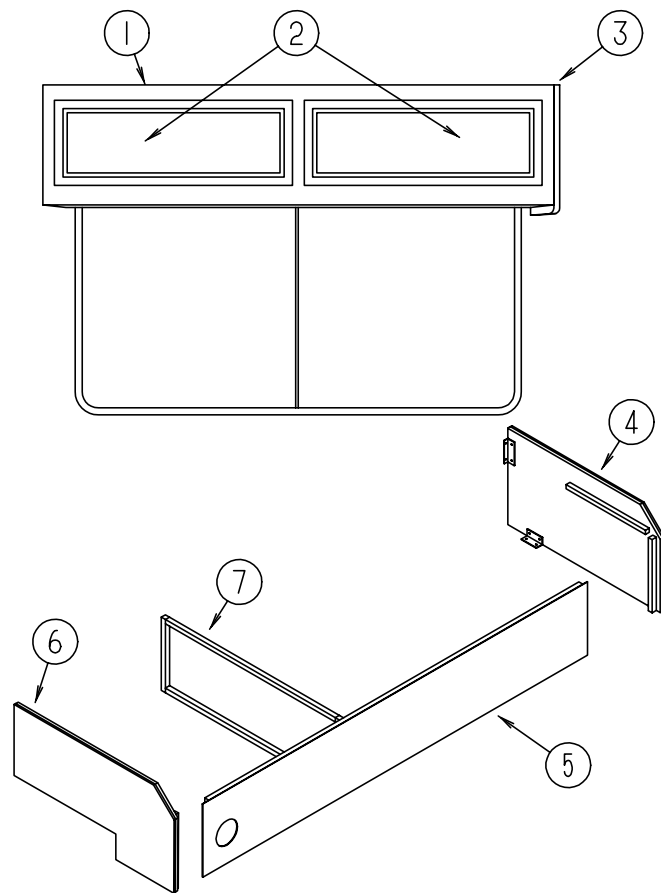

DRIVER SIDE LOUNGE CABINETS

KEY	PART NUMBER	U/M	DESCRIPTION
1	115624-01-F15	EA	CABINET-OVERHEAD, W/O DOORS & HARDWARE
2	110140-32-F15	EA	DOOR-CABINET, W/O HARDWARE - 320MM X 715MM
2	110140-38-E01	EA	DOOR-CABINET, W/MIRROR - W/O HARDWARE - 320MM X 715MM
	058331-76-000	EA	MIRROR-SAFETY, GLASS - 222MM X 657MM
3	109908-15-F15	EA	END CAP-CABINET, OVERHEAD
4	M06963-05-F15	EA	CABINET-COUCH, END SECTION - W/FABRIC
4	M06963-05-F16	EA	CABINET-COUCH, END SECTION - W/FABRIC
5	M06963-06-F15	EA	CABINET-COUCH FACE, W/FABRIC
5	M06963-06-F16	EA	CABINET-COUCH FACE, W/FABRIC
6	M06963-07-F15	EA	CABINET-COUCH, END SECTION - W/FABRIC
6	M06963-07-F16	EA	CABINET-COUCH, END SECTION - W/FABRIC
7	M06963-08-F15	EA	CABINET-COUCH
	083125-05-000	EA	BRACE-ANGLE, COUCH - BEIGE - 2.5"
	105947-01-000	EA	BRACKET-HOLD DOWN, COUCH - CANADIAN OPTION

LOUNGE GROUP (CONTINUED)

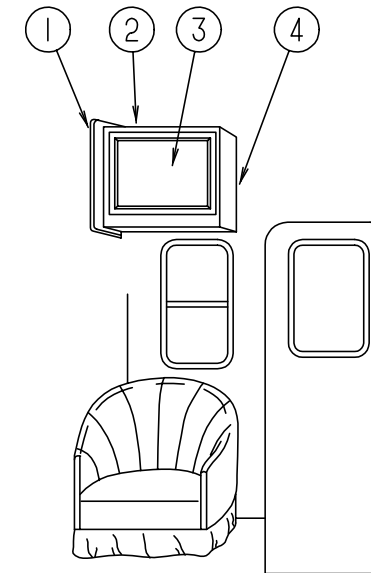

PASSENGER SIDE LOUNGE CABINETS

KEY	PART NUMBER	U/M	DESCRIPTION
1	109908-16-F15	EA	END CAP-CABINET, OVERHEAD
2	115459-01-F15	EA	CABINET-OVERHEAD, W/O DOOR OR HARDWARE
3	110140-66-F15	EA	DOOR-CABINET, W/O HARDWARE - 365MM X 455MM
4	109908-15-F15	EA	END CAP-CABINET, OVERHEAD

**SEALANTS & FASTENERS GROUP
ADHESIVES AND SEALERS**

KEY	PART NUMBER	U/M DESCRIPTION
	114311-01-000	GL ADHESIVE-GLUE, #72-7843 NATL STARC
	087211-01-000	GL PROMOTER-ADHESIVE
	102352-01-000	EA SEALER-PUMPABLE, BLACK - COLORIMETRIC MS101
	072889-09-000	EA SEALANT-URETHANE, TUBE - BLACK MANUS 75AM
	053766-02-000	EA BEDDING COMPOUND-TUBE, WHITE SCHNEE# 5522
	053766-08-000	EA BEDDING COMPOUND-TUBE, GRAY - SCHNEE# 5522
	069640-01-000	FT SEALER-RIBBON, 1/4" DIAMETER - INCREMENTS OF 30'
	069640-02-000	FT SEALER-RIBBON, 1/2" X 1/8"- INCREMENTS OF 60'
	069640-03-000	FT SEALER-RIBBON, 3/4" X 1/8" - INCREMENTS OF 60'
	069640-14-000	FT SEALER-TAPE, 1/16" X 1" - GRAY MANUS
	069640-10-000	FT SEALER-RIBBON, 1/32" X 1 1/2" INCREMENTS OF 90'
	069640-11-000	FT SEALER-TAPE, 3/16" X 3/8" - BLACK - MANUS
	091255-02-000	FT SEAL-ADHESIVE BACKED FOAM, .18" THICK X 1.5" WIDE
	063642-01-000	FT TAPE-ADHESIVE, 10 MM X 1.5" WIDE X 180'
	002707-02-000	FT TAPE-SEALER, 5/16" X 1/2" - INCREMENTS OF 50 FT
	076314-02-000	FT TAPE-CARPET SEAM, HEAT-BOND - 4" WIDE
	076322-01-000	FT TAPE-FOAM, DOUBLE COATED ADHESIVE BACKED - .75" X 216'
	076322-05-000	FT TAPE-FOAM, DOUBLE COATED - .025" X 1.5" X 108'
	076322-07-000	FT TAPE-FOAM, DOUBLE COATED - .045" X .50" NORT V2000
	108716-01-000	EA SILICONE-TUBE, OFF WHITE - SELF LEVELING - CSL 510
	034552-02-000	EA SILICONE-TUBE, 300 ML - CLEAR
	034552-06-000	EA SILICONE-TUBE, 300 ML - OFF WHITE
	034552-15-000	EA SILICONE-TUBE, 300 ML - BRIGHT WHITE
	900390-01-000	EA TIP - 2 1/2" X 1/8" ORIFICE, ELLSWORTH #TS216
	900390-03-000	EA NOZZLES-SILICONE TUBE, CSL# D10
	085774-01-000	FT FASTENER-DUAL HOOK, 1" WIDE - ADHESIVE BACK - BLACK
	085774-02-000	FT FASTENER-DUAL LOOP, 1" WIDE - ADHESIVE BACK - BLACK

WASHERS

KEY	PART NUMBER	U/M DESCRIPTION
	000E11-07-00B	EA WASHER-LOCK - 7/16 MED SPLIT - ZINC 05114-01-000
	000E13-14-00B	EA WASHER-FLARE, 1/4" WIDE - ZINC
	000E13-17-00B	EA WASHER-FLARE, 3/8" AR - ZINC
	000E13-18-00B	EA WASHER-FLARE, 3/8 WIDE - ZINC 05113-01-000
	000E13-20-00B	EA WASHER-FLARE, 7/16" WIDE - ZINC
	000E13-21-00B	EA WASHER-FLARE, W/2 NAR - ZINC
	000E14-10-00B	EA WASHER-LOCK, NO 10 EXT TOOTH - ZINC
	041322-01-000	EA WASHER-FLARE, 15/32" ID X 2 3/8" OD - FOR SEAT BELT MOUNT
	044533-01-000	EA WASHER-PLASTIC, 1 3/8" OD - FOR BUTTONS

BOLTS

KEY	PART NUMBER	U/M DESCRIPTION
	000G45-05-16B	EA BOLT-LAG, 5/16 - 9 X 1 - ZINC
	0MC31K-08-020	EA BOLT-HEX, SERRATED FLANGE - M8 X 020
	000C12-05-16B	EA BOLT-HEX, 5/16 - 18 X 1 - ZINC 5
	000C12-06-32B	EA BOLT-HEX, 3/8 - 16 X 2 LAG - ZINC 5
	000C12-06-16B	EA BOLT-HEX, 3/8 - 16 X 1 LAG - ZINC 5
	000C12-07-24B	EA BOLT-HEX, 7/16 - 14 X 1.50 - ZINC 5 MC-90
	000C12-08-24B	EA BOLT-HEX, 1/2 - 13 X 1 1/2 - ZINC 5
	000C12-10-24B	EA BOLT-HEX, 5/8 - 11 X 1 1/2 - ZINC 5
	000C13-07-48B	EA BOLT-HEX, 7/16 - 20 X 3 - ZINC 5
	000C18-05-40A	EA BOLT-ELEV, 5/16" - 18 X 2 1/2" PL
	000C18-06-48B	EA BOLT-ELEV, 3/8 - 16 X 3 - ZINC - GDE 5
	000C26-04-14B	EA BOLT-HEX, SERRATED FLANGE - 1/4 X 20 X 7/8 - ZINC
	000C26-04-10B	EA BOLT-HEX, SERRATED FLANGE - 1/4 - 20 X 5/8 - ZINC
	000C26-05-12B	EA BOLT-HEX, SERRATED FLANGE - 5/16 - 18 X 3/4 - ZINC
	000C26-06-12B	EA BOLT-HEX, SERRATED FLANGE - 3/8 - 16 X 3/4 - ZINC
	051387-06-000	EA BOLT-CARRIAGE, W/O HOLE - 5/16 - 18 X 9.5 - ZINC

**SEALANTS & FASTENERS GROUP (CONTINUED)
NUTS AND RIVETS**

KEY	PART NUMBER	U/M DESCRIPTION
	000D24-10-00B	EA NUT-HEX, SELFLOCK - 10 - 32 - ZINC
	000D29-06-00B	EA NUT-HEX, W/NYLON LOCK - 3/8 - 16 - ZINC
	104369-01-000	EA NUT-HEX, HEAVY - 5/8 - 11 UNC SPARE TIRE
	000D39-04-00B	EA NUT-HEX, SERRATED FLANGE LOCK - 1/4 - 20 - ZINC
	000D39-05-00B	EA NUT-HEX, SERRATED FLANGE LOCK - 5/16 - 18 - ZINC
	000D39-06-00B	EA NUT-HEX, SERRATED FLANGE LOCK - 3/8 - 16 - ZINC
	000D39-08-00B	EA NUT-HEX, SERRATED FLANGE LOCK - 1/2 - 13 - ZINC
	000D44-07-00B	EA NUT-HEX, SERRATED FLANGE LOCK - 7/16 - 20 - ZINC
	000D46-04-00A	EA NUT-HEX, WELD - 1/4 - 20 - PLAIN SHORT PILOT
	044364-02-000	EA NUT-SPEED, FLAT - ROUND
	000H16-04-06R	EA RIVET-POP, AL 1/8 X .313 - .375

CLAMPS AND TIES

KEY	PART NUMBER	U/M DESCRIPTION
	007161-01-000	EA CLAMP-HOSE, SPRING TYPE - 1/2"
	010495-01-000	EA CLAMP-CABLE, 9/16"
	010497-01-000	EA CLAMP-CLOSED, 5/8" ID
	010499-01-000	EA CLAMP-CLOSED, 3/8" ID
	062401-02-000	EA CLAMP-HOSE, WORMGEAR - 1.56" - 2.5"
	062401-01-000	EA CLAMP-HOSE, WORMGEAR - .25" - 1"
	062401-06-000	EA CLAMP-HOSE, WORMGEAR - .22" - .62"
	062401-11-000	EA CLAMP-HOSE, WORMGEAR - 3.56" - 4.5"
	075148-02-000	EA CLAMP-GROUNDING, BRONZE SCREWS
	083609-01-000	EA CLAMP-WIRE, DUAL - EQUAL - 5/8" DIAMETER
	083610-01-000	EA CLAMP-WIRE, DUAL - UNEQUAL DIAMETERS - .75" & 1.25"
	083610-02-000	EA CLAMP-WIRE, DUAL - UNEQUAL DIAMETERS
	080211-05-000	EA CLIP-XMAS TREE, 36MM FASNAP 09-280297
	080734-02-000	EA CLIP-WIRE, NYLON
	091952-01-000	EA CLIPPER-GRIPPER, 1"
	056134-01-000	EA HOLDER-RING, 3.6" DIAMETER - METAL
	056134-02-000	EA HOLDER-RING, 1.8" DIAMETER - METAL
	008343-01-000	EA TIE-WIRE, 6"
	108046-01-000	EA CABLE TIE-SCREW MOUNT 8" DENNISON 08415
	108046-02-000	EA CABLE TIE-SCREW MOUNT 15" DENNISON 10035

GROMMETS

KEY	PART NUMBER	U/M DESCRIPTION
	008380-01-000	EA GROMMET-RUBBER, 5/8" HOLE X 1 1/2" DIAMETER - BLACK
	071015-11-000	EA GROMMET - 1.00 ID, FITS .12 MATERIAL - MINOR RUBBER Z-306
	016188-05-000	EA GROMMET-L P LINE, 3/8" HOLE X 1 1/4" LONG - RUBBER
	023942-01-000	EA GROMMET-RUBBER, 2" OD
	077953-01-000	EA GROMMET-EDGE LINER, FITS 1"
	071015-26-000	EA GROMMET-RUBBER, 1.5" ID X 2.12" OD W/.06" GROOVE - BLACK

SEALANTS & FASTENERS GROUP (CONTINUED)

SCREWS

KEY	PART NUMBER	U/M DESCRIPTION
	000G11-06-06B	EA SCREW, 6 - 20 X 3/8 PPH - ZINC
	000G11-06-10J	EA SCREW, 6 - 20 X 5/8 PPH - BRASS
	000G11-06-08B	EA SCREW, 6 - 20 X 1/2 PPH - ZINC
	000G11-07-08B	EA SCREW, 7 - 19 X 1/2 PPH - ZINC
	000G11-08-06B	EA SCREW, 8 - 18 X 3/8 PPH - ZINC
	000G11-08-20B	EA SCREW, 8 - 18 X 11/4 PPH - ZINC 05031-01-000
	000G11-08-16S	EA SCREW, 8 - 18 X 1.00 PPH - OFF WHITE
	000G11-08-12T	EA SCREW, 8 - 18 X 3/4 PPH - BLACK
	000G11-08-12S	EA SCREW, 8 - 18 X 3/4 PPH - OFF WHITE
	0G1108-12-170	EA SCREW, 8 - 18 X 3/4 PPH - BRIGHT WHITE
	000G11-08-12P	EA SCREW, 8 - 18 X .75 PPH - DARK BROWN
	000G11-08-12E	EA SCREW, 8 - 18 X .75 PPH - CHROME ES0025.4
	000G11-08-12B	EA SCREW, 8 - 18 X 3/4 PPH - ZINC
	000G11-08-08B	EA SCREW, 8 - 18 X 1/2 PPH - ZINC
	000G11-10-12S	EA SCREW, 10 - 16 X .75 PPH - OFF WHITE
	000G12-08-12S	EA SCREW, 8 - 18 X 3/4 POH - OFF WHITE
	000G13-06-08B	EA SCREW, 6 - 20 X 1/2 PFH - ZINC
	000G13-07-12B	EA SCREW, 7 - 19 X 3/4 PFH - ZINC
	000G13-08-10B	EA SCREW, 8 - 18 X 5/8 PFH - ZINC 90 CW922FV
	000G32-10-06B	EA SCREW, 10 - 32 X 3/8" - PPH - ZINC
	000G39-06-10T	EA SCREW-SF/DR, 6 -20 X 5/8 PPH - BLACK
	000G39-06-08B	EA SCREW-DR, 6 -18 X 1/2 - ZINC
	000G39-08-24B	EA SCREW-SF/DR, 8 - 18 X 1 1/2 PPH - ZINC
	000G39-08-16S	EA SCREW-SF/DR, 8 - 18 X 1.00 PPH - OFF WHITE
	0G3908-16-170	EA SCREW-SF/DR, 8 - 18 X 1.00 PPH - BRIGHT WHITE
	000G39-08-16B	EA SCREW-SF/DR, 8 - 18 X 1 PPH - ZINC
	000G39-08-12B	EA SCREW-SF/DR, 8 - 18 X 3/4 PPH - ZINC
	000G39-08-08S	EA SCREW-SF/DR, 8 - 18 X 1/2 PPH - OFF WHITE
	0G3908-08-170	EA SCREW-SF/DR, 8 - 18 X 1/2 PPH - BRIGHT WHITE
	000G39-08-08B	EA SCREW-SF/DR, 8 - 18 X 1/2 PPH - ZINC
	000G39-10-12D	EA SCREW-SF/DR, 10 - 16 X 3/4 PPH - BLACK
	000G39-10-12B	EA SCREW-SF/DR, 10 - 16 X .75 PPH - ZINC
	000G39-10-20B	EA SCREW-SF/DR, 10 - 16 X 1 1/4 PPH - ZINC
	000G39-10-12R	EA SCREW-SF/DR, 10 - 16 X 3/4 PPH - BEIGE
	000G39-12-12E	EA SCREW-SF/DR, 12 - 14 X 3/4 PPH - CHROME
	000G42-04-12B	EA SCREW-SF/DR 1/4 -14 X 3/4 HWH - ZINC
	000G42-04-16B	EA SCREW-SF/DR, 1/4 -14 X 1 HWH - ZINC
	000G46-08-24T	EA SCREW-MACHINE, 8 -3 2 - 1.50 IN PFH - BLACK
	000G50-04-12B	EA SCREW-MACHINE, 1/4 -20 X 3/4 PPH - ZINC
	000G52-08-18B	EA SCREW-MACHINE, 8 - 32 X 11/8 PTH - ZINC
	000G53-04-06B	EA SCREW-MACHINE, 1/4 - 20 X 3/8 PPH - ZINC - UNDERCUT HEAD
	000G54-04-20B	EA SCREW, 1/4 - 20 X 1 1/4 PTH - TYPE 23 - ZINC PLATED
	000G56-12-48B	EA SCREW-WOOD, 12 - 11 X 3 POH - SPECIAL HARDENED

SEALANTS & FASTENERS GROUP (CONTINUED)

SCREWS (CONTINUED)

KEY	PART NUMBER	U/M DESCRIPTION
	000G60-10-28T	EA SCREW-SF/DR, 10 - 16 X 1.75 - BLACK
	000G67-10-10B	EA SCREW, 10 - 12 X 5/8 PPH - ZINC - TYPE A
	000G67-10-08R	EA SCREW, 10 - 12 X 1/2 PPH - BEIGE - TYPE A
	000G67-10-08B	EA SCREW, 10 - 12 X 1/2 PPH - ZINC
	000G67-10-12R	EA SCREW, 10 - 12 X .75 PPH - BEIGE
	000G67-10-12P	EA SCREW, 10 - 12 X .75" - PPH - DARK BROWN
	000G67-10-12B	EA SCREW, 10 - 12 X 3/4" PPH - ZINC
	000G67-10-10S	EA SCREW, 10 - 12 X 5/8" - PPH - OFF WHITE
	000G67-10-36T	EA SCREW, 10 - 12 X 2.25 PPH - BLACK STALGARD
	000G67-10-32B	EA SCREW, 10 - 12 X 2 PPH - ZINC
	000G67-10-24B	EA SCREW, 10 - 12 X 1 1/2 PPH - ZINC
	000G67-10-20D	EA SCREW, 10 - 12 X 1 1/4 PPH - BLACK
	000G67-10-16P	EA SCREW, 10 - 12 X 1 PPH - DARK BROWN
	000G67-10-16B	EA SCREW, 10 - 12 X 1 PPH - ZINC
	000G67-10-120	EA SCREW, 10 - 12 X .75" PPH - TAN
	000G68-06-10G	EA SCREW, 6 - 18 X 5/8 POH - ANTIQUE BRASS
	000G13-07-10H	EA SCREW, 7 - 19 X 5/8 PFH - BLACK
	0G6710-08-170	EA SCREW, 10 - 12 X 1/2 PPH - BRIGHT WHITE
	049465-04-000	EA SCREW, 10 - 16 X 1 PTH - W/WASHER - BEIGE
	075908-01-000	EA SCREW-MACHINE, 10 - 32 X .56 PTH - ZINC - EXTERNAL TOOTH
	087721-01-000	EA SCREW-FLAT HEAD, TAPPING - 1/4" X 1 1/4" LAG - ZINC
	101618-01-000	EA SCREW, 1/4 - 20 X 3/4 HEX/TAPPING STALGARD TYPE F

**WATER & SEWAGE GROUP
WATER HEATER W/ELECTRIC IGNITION**

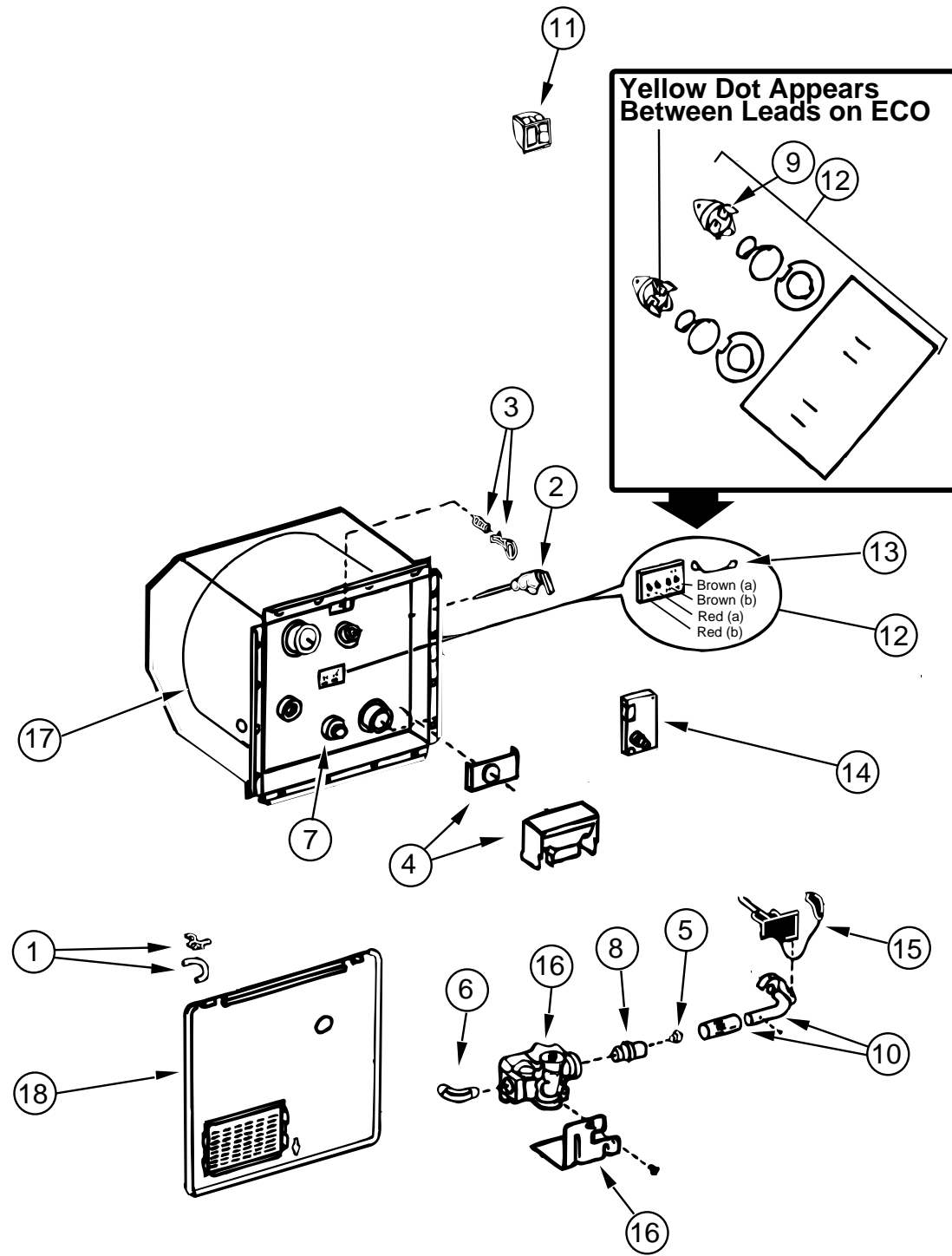

KEY	PART NUMBER	U/M	DESCRIPTION
	051391-03-A00	EA	HEATER-WATER, W/ELECTRIC IGNITION - ATWOOD G6A-7E
1	051391-01-700	EA	HINGE KIT-W/CLIP, ATWOOD 92568 & 92559
2	051391-01-704	EA	VALVE-RELIEF, 1/2" FITTING - ATWOOD 91604
3	051391-01-705	EA	FASTENER-CAMLOC, ATWOOD 92609
4	051391-04-707	EA	KIT-GRILLE, FLUE, & GASKET - ATWOOD 90960
5	051391-01-710	EA	ORIFICE-MAIN BURNER, ATWOOD 92742
6	051391-01-714	EA	ELBOW-45 DEGREE, 3/8"F X 3/8"MPT - ATWOOD 91044
7	051391-01-715	EA	DRAIN PLUG, ATWOOD 91561
8	051391-03-700	EA	ORFICE-HOLDER, ATWOOD 91563
9	051391-04-701	EA	THERMOSTAT 12 VDC-120 PRESET, ATWOOD 91470
10	051391-04-703	EA	BURNER-MAIN, ATWOOD# 91638
11	097967-01-000	EA	SWITCH-WATER HEATER, REMOTE W/LIGHT - ATWOOD 91959
12	051393-01-721	EA	ECO & THERMOSTAT ASM-FRONT MOUNT, 140 DEGREE - ATWOOD 91447
13	051393-01-723	EA	SWITCH-THERMAL-CUT OFF 2/PKG ATWOOD 93866
14	051393-01-724	EA	CIRCUIT BOARD-SPADE TERMINAL, ELECTRONIC IGNITION -ATWOOD 93867
15	051393-01-725	EA	ELECTRODE-SINGLE SPADE CONNECTION, SPARK PROBE - 93868
16	051393-01-726	EA	SOLENOID VALVE AND BRACKET 93870-WHITE-ROGERS
17	051391-04-706	EA	TANK-INNER, G6A-4E & 6E - FRONT MOUNT - ATWOOD 91641
18	052009-06-000	EA	DOOR-WATER HEATER, BRIGHT WHITE - ATWOOD

WATER & SEWAGE GROUP (CONTINUED)

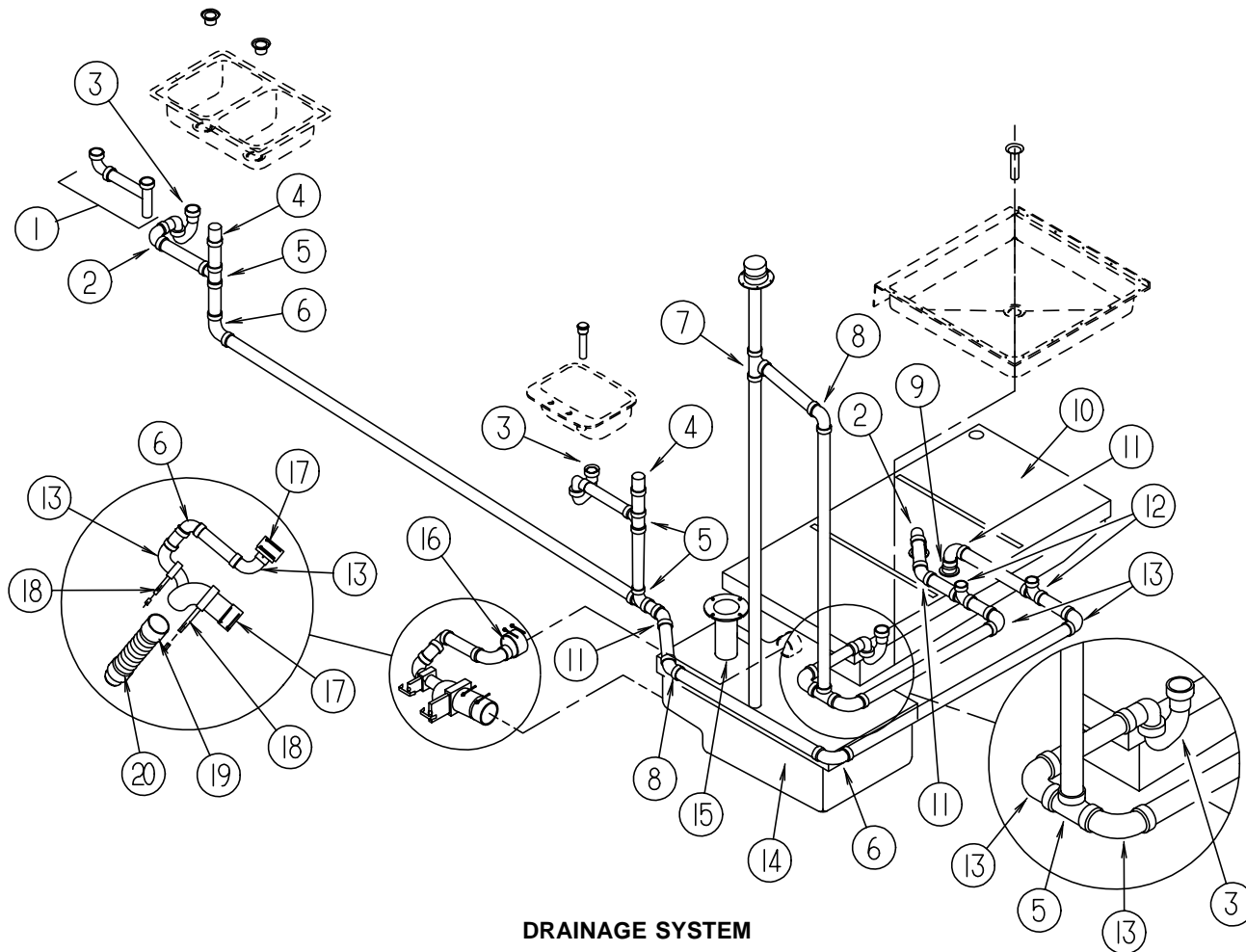

DRAINAGE SYSTEM

KEY	PART NUMBER	U/M DESCRIPTION
1	011091-02-000	EA PIPE-DRAIN, DOUBLE SINK - BAFFLE TEE - 1 1/2" - U.S.
1	011091-03-000	EA PIPE-DRAIN, W/SEALS - DOUBLE SINK - EXTENDS 9" TO 16" CANADIAN
2	034250-01-000	EA ELBOW - 90 DEGREE, LONG TURN - 1 1/2" HUB X HUB - ABS
3	107538-01-000	EA P TRAP-PLASTIC, 1 1/4" - W/EXT ARM - U.S.
3	011066-03-700	EA P TRAP KIT - 1 1/4" HUB X SLIP JOINT - W/UNION - ABS - CANADIAN
	010121-01-000	EA BUSHING-REDUCER, 1 1/2" SMOOTH X 1 1/4" HUB - BLACK PLASTIC
	109571-01-000	EA ADAPTER - P TRAP, 1 1/2" P X 1 1/4" MPT
4	079968-01-000	EA VENT-MECHANICAL TRAP ARM, ANTI-SIPHON - 2" DIAMETER X 7.3" - PLASTIC
5	010071-01-000	EA TEE-SANITARY, 1 1/2" X 1 1/2" X 1 1/4" H - PLASTIC - BLACK PLASTIC
6	010008-01-000	EA ELBOW - 90 DEGREE, 1/4 BEND - 1 1/2" HUB X HUB - BLACK PLASTIC
7	010073-01-000	EA WYE - 45 DEGREE, 1 1/2" HUB X HUB X HUB - BLACK PLASTIC
8	010006-01-000	EA ELBOW - 45 DEGREE, 1/8 BEND - 1 1/2" HUB X HUB - BLACK PLASTIC
9	061607-01-000	EA GROMMET-HOLDING TANK, 1 1/2" NPS
10	102762-03-000	EA TANK-HOLDING, 40 GALLON - WASTE WATER
11	010051-01-000	EA ELBOW - 45 DEGREE BEND, 1 1/2" SPIGOT AND HUB - BLACK PLASTIC
12	010071-01-000	EA TEE-SANITARY, 1 1/2" X 1 1/2" X 1 1/4" H - BLACK PLASTIC
	010166-01-000	EA PLUG-THREADED, 1 1/4" DIAMETER - BLACK PLASTIC
	050787-01-000	EA ADAPTER-CLEANOUT
13	033761-01-000	EA ELBOW-TURN, 1/4" BEND X 1.5" HUB X 1.5" SPIGOT - BLACK PLASTIC
14	102762-01-000	EA TANK-HOLDING, 42 GALLON - 57.4" X 8.4" X 29" - SEWAGE
	010115-01-000	EA COUPLING - 1 1/2" HUB X HUB - PLASTIC
	061607-01-000	EA GROMMET-HOLDING TANK, 1 1/2" NPS
15	061607-02-000	EA GROMMET-HOLDING TANK, 3" NPS
	024676-01-000	EA FLANGE-CLOSET, TOILET - 4" X 3" - RED
	024676-02-000	EA FLANGE-CLOSET, 4" X 3" - ABS - CANADIAN
16	062422-01-000	EA ADAPTER-OFFSET REDUCER, 3" X 1 1/2" - BLACK PLASTIC

WATER & SEWAGE GROUP (CONTINUED) DRAINAGE SYSTEM (CONTINUED)

KEY	PART NUMBER	U/M DESCRIPTION
17	078406-01-000	EA COUPLER-RUBBER, W/CLAMPS - 3" X 3"
18	070916-01-000	EA VALVE-DUAL DUMP, W/CAP - 3" X 1 1/2" - BLACK PLASTIC
	070916-01-700	EA VALVE ONLY - 3"
	070916-01-701	EA VALVE ONLY - 1 1/2"
19	062416-01-000	EA ADAPTER-SEWER HOSE TO 3" PIPE
20	010201-01-000	EA HOSE-SEWER, 3" ID X 8'
	010123-01-000	EA BUSHING - 2" X 1 1/2" HUB - PLASTIC

FRESH WATER TANK

KEY	PART NUMBER	U/M DESCRIPTION
	064214-08-000	EA TANK-WATER, 31 GALLONS - W/FITTINGS
	064214-01-000	EA TANK-WATER, 31 GALLONS - W/O FITTINGS - 24" X 12.75" X 30"
	039861-01-000	EA SENDING UNIT-W/SCREW, WASHER, WELL NUT & TERMINAL RING
	042989-03-000	EA FITTING-WATER TANK, SPINWELD - 1 1/4" NPT - PLASTIC - WHITE
	042989-04-000	EA FITTING-WATER TANK, SPINWELD - 3/8" FPT - PLASTIC - WHITE
	042989-05-000	EA FITTING-WATER TANK, SPINWELD - 1/2" FPT - PLASTIC - WHITE
	049032-01-000	EA PATCH-SPINWELD, 3/8" - PLASTIC

WATER SYSTEM

KEY	PART NUMBER	U/M DESCRIPTION
	010224-01-000	EA ADAPTER-HOSE TO PIPE, 3/8" MPT X 3/8" BARB - BLACK PLASTIC
	044927-01-000	EA ADAPTER-HOSE TO PIPE, 1 1/4" MPT X 1 1/4" BARB - BLACK PLASTIC
	074462-02-000	FT TUBING-VINYL, 3/8" ID - CLEAR
	079381-01-000	FT TUBING-SMOOTH FLEXIBLE, 1 1/4" ID X 20'
	039800-02-000	FT TUBING-POLYBUTYL, 5/8" OD - INCREMENTS OF 20' - BLACK
	101814-01-000	EA COUPLING-FEMALE, 1/2" X 1/2" FPT W/COMPRESSION SLEEVE - GRAY
	110915-01-01A	EA FILL-WATER, CITY - CHROME - KEVCO 64713
	091208-01-000	EA WASHER-RUBBER, .06" X .75" X .5"
	114428-01-000	EA TEE - 1/2 P X 1/2 P X 1/2 P FLAIR-IT 02820
	114429-01-000	EA ELBOW - 1/2 P X 1/2 P FLAIR-IT 02800
	114429-02-000	EA ELBOW - 1/2 P X 1/2 MPT FLAIR-IT 02803
	114429-03-000	EA ELBOW-SWIVEL, 1/2 P X 1/2 FPT FLAIR-IT 02816
	114430-02-000	EA ADAPTER-SWIVEL, 1/2 P X 1/2 FPT FLAIR-IT -02873
	114430-03-000	EA ADAPTER - 1/2 P X 1/2 MPT FLAIR-IT 02842
	114431-01-000	EA VALVE-LINE DRAIN, 1/2 P FLAIR-IT 02914
	114431-04-000	EA VALVE-STOP, 1/2 P X 1/2 P FLAIR-IT 02880
	114427-01-000	EA CAP - 1/2 P FLAIR-IT 02860

WATER PUMP

KEY	PART NUMBER	U/M DESCRIPTION
	098607-01-000	EA PUMP-WATER, W/.5" MPT FITTING - FLOW 2.8 GPM - UL
	098607-01-700	EA PUMPHEAD-REPLACEMENT, SHURFLO #94-236-08
	098607-01-701	EA DRIVE ASSEMBLY, SHURFLO #94-234-03
	098607-01-702	EA DIAPHRAGM-KIT, SHURFLO #94-233-10
	098607-01-703	EA VALVE ASM, SHURFLO #94-232-00
	098607-01-706	EA SWITCH ASSEMBLY-COMPLETE, SHURFLO #94-230-00
	098607-01-705	EA CHECK VALVE-KIT, SHURFLO #94-237-00
	098607-01-706	EA SWITCH ASSEMBLY-COMPLETE, SHURFLO #94-230-00
	098607-01-707	EA MOTOR/BASEPLATE REPLACEMENT, SHURFLO #94-234-03

WINDOW, VENT & EXTERIOR DOOR GROUP

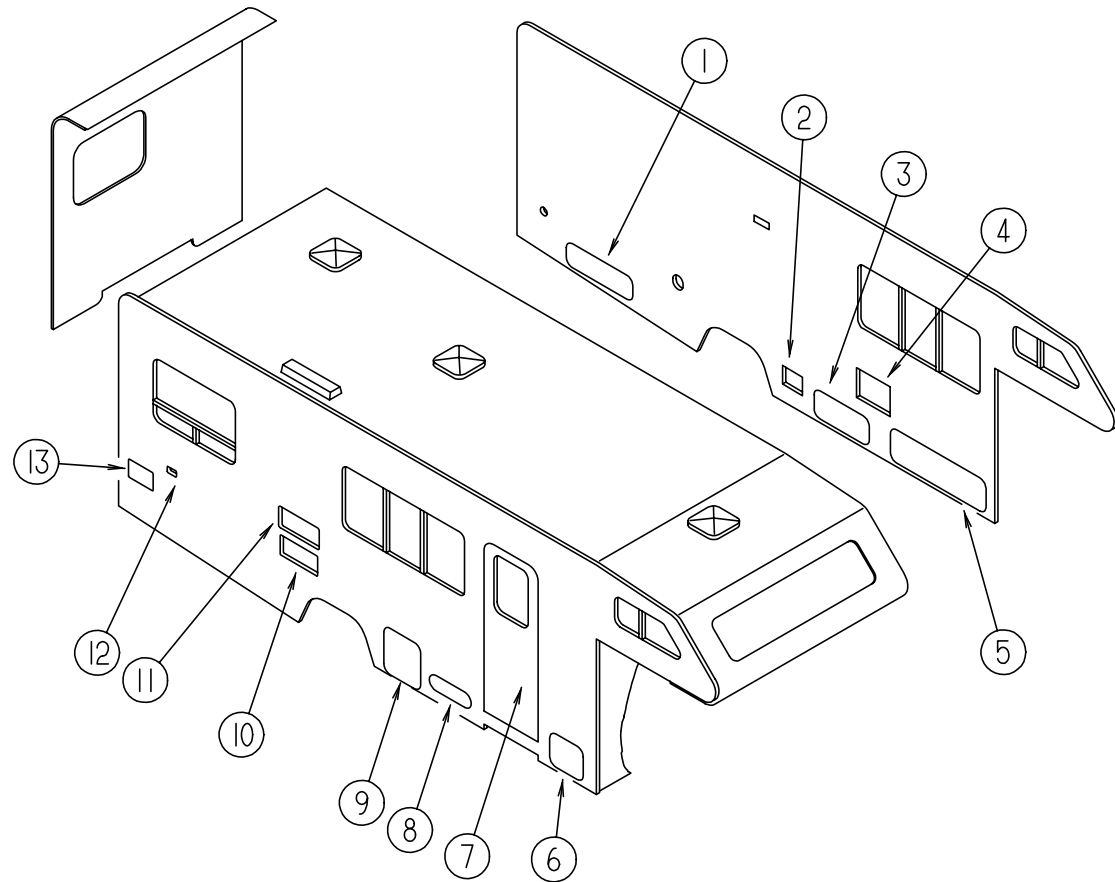

EXTERIOR DOORS

KEY	PART NUMBER	U/M	DESCRIPTION
1	104558-20-F16	EA	DOOR-STORAGE, BRIGHT WHITE
2	088794-06-000	EA	DOOR-POWER CORD, W/HATCH - 11" X 9.2" - BRIGHT WHITE
3	104558-12-F16	EA	DOOR-STORAGE, BRIGHT WHITE
4	052009-06-000	EA	DOOR-WATER HEATER, BRIGHT WHITE - ATWOOD
5	104558-13-F16	EA	DOOR-STORAGE, BRIGHT WHITE
6	104558-19-F16	EA	DOOR-STORAGE, BRIGHT WHITE
7	115108-01-F15	EA	DOOR-ENTRANCE, W/SCREEN - W/O WINDOW - BRIGHT WHITE
8	111009-01-F24	EA	DOOR-COMPARTMENT, LP - 16.9" X 5.4" - ALUMINUM - BRIGHT WHITE
9	104558-14-F16	EA	DOOR-STORAGE, BRIGHT WHITE
10	098668-23-000	EA	DOOR-ACCESS, FURNACE - BRIGHT WHITE - SUBURBAN
11	084103-08-000	EA	DOOR-REFRIGERATOR, VENTED - W/O JAMB - BRIGHT WHITE
	084104-08-000	EA	JAMB-DOOR, REFRIGERATOR - BRIGHT WHITE
	084104-01-700	EA	LOCK-MALE, FASTENER - REFRIGERATOR DOOR
	084104-01-701	EA	LOCK-FEMALE, FASTENER - REFRIGERATOR DOOR
12	081240-16-000	EA	FILL-WATER, LOCKABLE - W/O LOCK - BRIGHT WHITE
13	104558-18-F16	EA	DOOR-STORAGE, BRIGHT WHITE

WINDOW, VENT & EXTERIOR DOOR GROUP (CONTINUED)

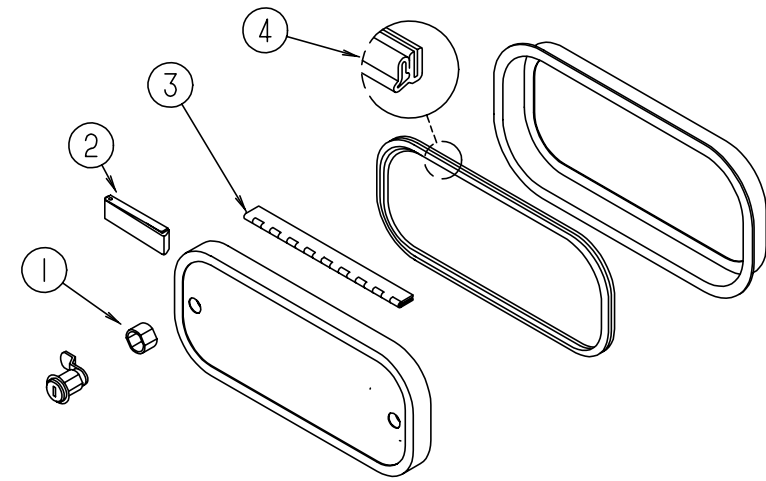

EXTERIOR DOOR HARDWARE

KEY	PART NUMBER	U/M	DESCRIPTION
1	107997-51-001	EA	SPACER - .86" X .6", ALUMINUM
2	102768-01-000	EA	HOLDER-COMPARTMENT/ENTRY DOOR, METAL - MILL FINISH
3	081801-V3-000	EA	HINGE - 2" X 96", BRIGHT WHITE
3	081801-05-000	EA	HINGE - 2" X 96", BRIGHT WHITE
	009065-01-000	EA	HINGE-ALUMINUM, 1 1/2" X 96" - UNPAINTED
4	064075-07-000	FT	SEAL-BULB, W/WIRED U CHANNEL - .3" X .5" CHANNEL - BLACK
	106850-01-000	FT	SEAL-E, 11 X 19 - SPONGE RUBBER
	002707-02-000	FT	SEAL - 5/16" X 1/2"
	096217-55-006	EA	U-CHANNEL, 5353 MM - BRIGHT WHITE
	091876-01-000	EA	RETAINER-DOOR, 1.9" X .8" - METAL
	116424-01-000	EA	PROTECTOR-WATER HEATER LATCH - ATWOOD 92611

WINDOW, VENT & EXTERIOR DOOR GROUP (CONTINUED)
ENTRANCE DOOR

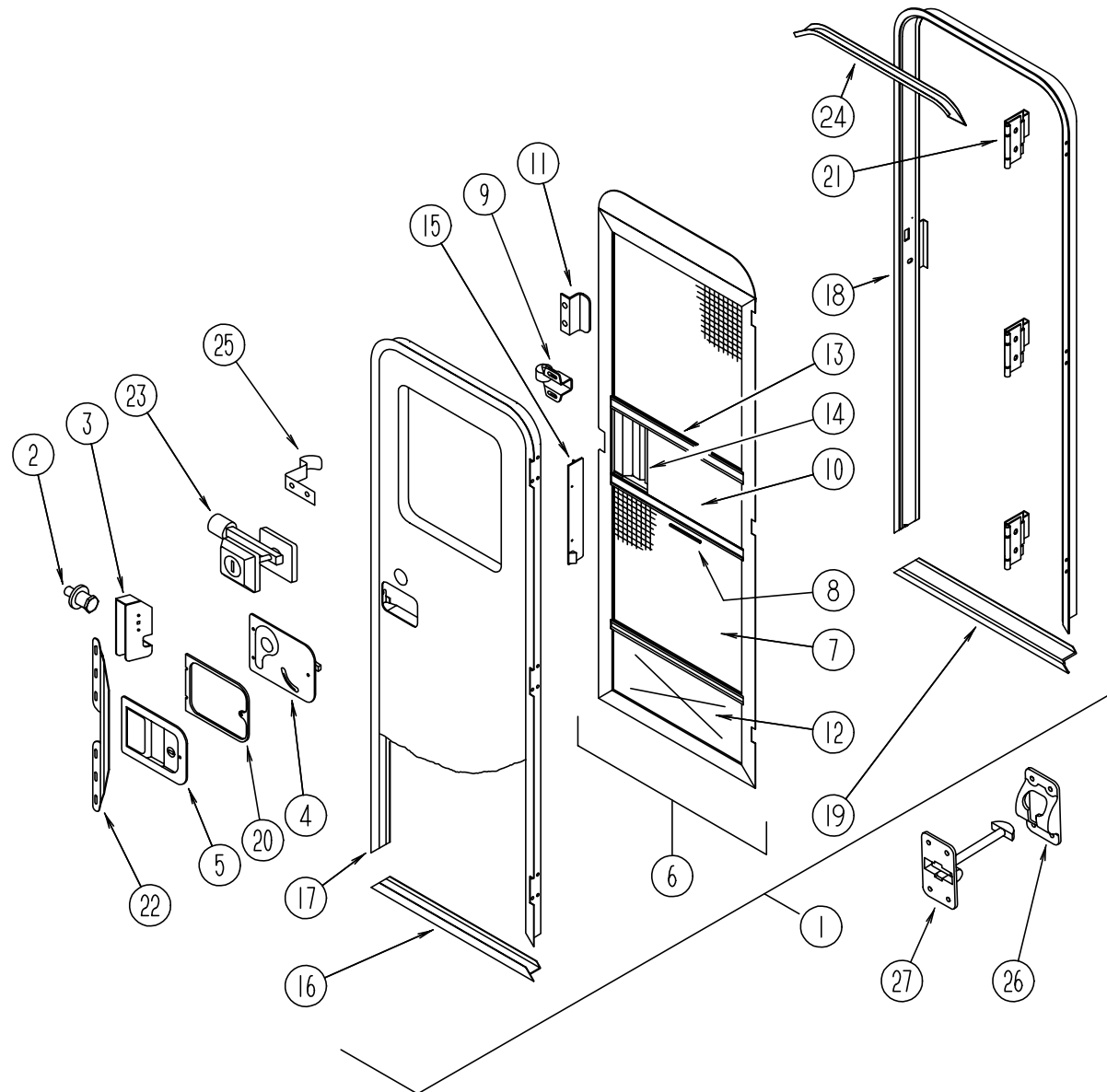

KEY	PART NUMBER	U/M	DESCRIPTION
1	115108-01-F15	EA	DOOR-ENTRANCE, W/SCREEN - W/O WINDOW - BRIGHT WHITE
2	039539-01-000	EA	STRIKE-LOCK, ENTRY DOOR - ROUND W/THREADED WASHER
3	039540-01-000	EA	LATCH MECHANISM-HOOK, ENTRY DOOR - INTERIOR
	039715-01-000	EA	NUT-SERT, 1/4" DIAMETER - 20 THREADS
4	039979-04-000	EA	COVER-INTERIOR LATCH, W/TRIP ARM - RIGHT - BLACK
	039984-01-000	EA	CAP-ROUND, VINYL - .28" ID X .62" LONG - BLACK
	041546-05-000	EA	BRACKET-DOOR ANGLE, 5" X 1.9" - METAL - OFF WHITE
5	045017-11-000	EA	LATCH-ENTRY DOOR, MECHANISM W/LOCK & KEY - BLACK
	045017-11-701	EA	KEY-BLANK, ROUND TOP - SILVER - TRI/MARK
	058806-03-000	EA	PLUG-TAPERED, PLASTIC - 1.06" DIAMETER - RED
	063729-04-000	EA	RIVNUT, 10-32 UNF - .010-.080
	072893-01-000	EA	NUTSERT - M5 X 0 8
	075671-04-000	FT	SEAL-SPONGE, LAZY T SHAPE - W/ADHESIVE STRIPE - .5" WIDE
6	079012-09-F15	EA	DOOR-SCREEN - OFF WHITE
			FROM: 00-00-00 THRU: 09-18-94
6	079012-09-F24	EA	DOOR-SCREEN - BRIGHT WHITE
			FROM: 09-19-94 THRU: 99-99-99
7	002293-02-000	SF	SCREENING-WINDOW/DOOR, 26" - CHARCOAL
8	002294-01-000	FT	SPLINE-SCREENING, .135" X .138" - BLACK
9	100412-01-000	EA	CATCH-SCREEN DOOR
10	001014-01-013	EA	INSERT-CENTER, 10.25" X 16.31" - UNPAINTED
10	016454-01-000	EA	INSERT-CENTER, LEATHER GRAIN ALUMINUM - UNPAINTED
11	050712-04-000	EA	HANDLE-SCREEN DOOR, ALUMINUM - OFF WHITE
			FROM: 00-00-00 THRU: 09-18-94
11	050712-06-000	EA	HANDLE-SCREEN DOOR, ALUMINUM - BRIGHT WHITE
			FROM: 09-19-94 THRU: 99-99-99
12	078552-03-000	EA	KICK PANEL-SCREEN DOOR, LOWER INSERT - UNPAINTED
	078595-01-000	EA	TOP PLATE-SCREEN DOOR, CURVED TOP - 4.7" X 25.35"
13	078777-01-000	EA	CHANNEL-SLIDE, SCREEN DOOR CENTER SLIDER COVER
14	079086-02-000	EA	SLIDER-SCREEN DOOR, OFF WHITE
			FROM: 00-00-00 THRU: 09-18-94
14	079086-03-000	EA	SLIDER-SCREEN DOOR, OFF WHITE
			FROM: 09-19-94 THRU: 99-99-99
15	079087-02-000	EA	STRIKE-SLIDER, W/LIP FOR ELBOW CATCH - 1.5" X 8.6" - OFF WHITE
			FROM: 00-00-00 THRU: 09-18-94
15	079087-02-000	EA	STRIKE-SLIDER, W/LIP FOR ELBOW CATCH - 1.5" X 8.6" - BRIGHT WHITE
			FROM: 09-19-94 THRU: 99-99-99
16	089748-21-000	EA	FRAME-BOTTOM, ENTRY DOOR - 24.8" LONG - BRIGHT WHITE
	090340-01-000	FT	SEAL-FOAM, CLOSED CELL - 1/4" X 1/2" X 50'
17	095276-07-03A	EA	FRAME-ENTRANCE DOOR, BRIGHT WHITE
18	095277-08-03A	EA	JAMB-ENTRANCE DOOR, BRIGHT WHITE
19	051049-01-000	EA	JAMB-BOTTOM, ENTRANCE DOOR - 25.9" - UNPAINTED
20	096810-01-01A	EA	PLATE-LATCH, ENTRANCE DOOR - PLASTIC - BLACK
21	106719-01-01A	EA	HINGE-ENTRANCE DOOR, MILL FINISH
22	098173-01-04A	EA	STIFFENER-ENTRY DOOR, SUPPORTS LATCH/STRIKE AREA - UNFINISHED
	100128-02-000	FT	SEAL-FOAM, ADHESIVE BACK - SCREEN DOOR - GRAY
23	101145-01-01A	EA	DEADBOLT-ENTRANCE DOOR, W/2 KEYS W/O BACK SET BOLT OR SCREWS
	095229-01-700	EA	KEY-BLANK
	101147-01-000	EA	BOLT-SECURITY, 4.12" BACKSET
	102524-01-000	EA	BUMPER-RUBBER, FLAT - BLACK
24	044582-44-000	EA	CAP-DRIP, DOOR JAMB MOUNTED - BRIGHT WHITE
	115222-04-02A	EA	GARNISH-RADIUS, ENTRANCE DOOR - BRIGHT WHITE
25	109403-01-000	EA	CATCH-SINGLE ROLLER, SCREEN DOOR
26	104099-02-04A	EA	CATCH-DOOR HOLDER, RETAINER - BRIGHT WHITE
27	104099-01-04A	EA	CATCH-DOOR HOLDER, STRIKE - BRIGHT WHITE
	009126-02-000	EA	HANDLE-ASSIST, ENTRANCE DOOR - BLACK
	112160-01-000	FT	SEAL-D SECTION, 6 X 10 - FOAM RUBBER - BLACK

WINDOW, VENT & EXTERIOR DOOR GROUP (CONTINUED)

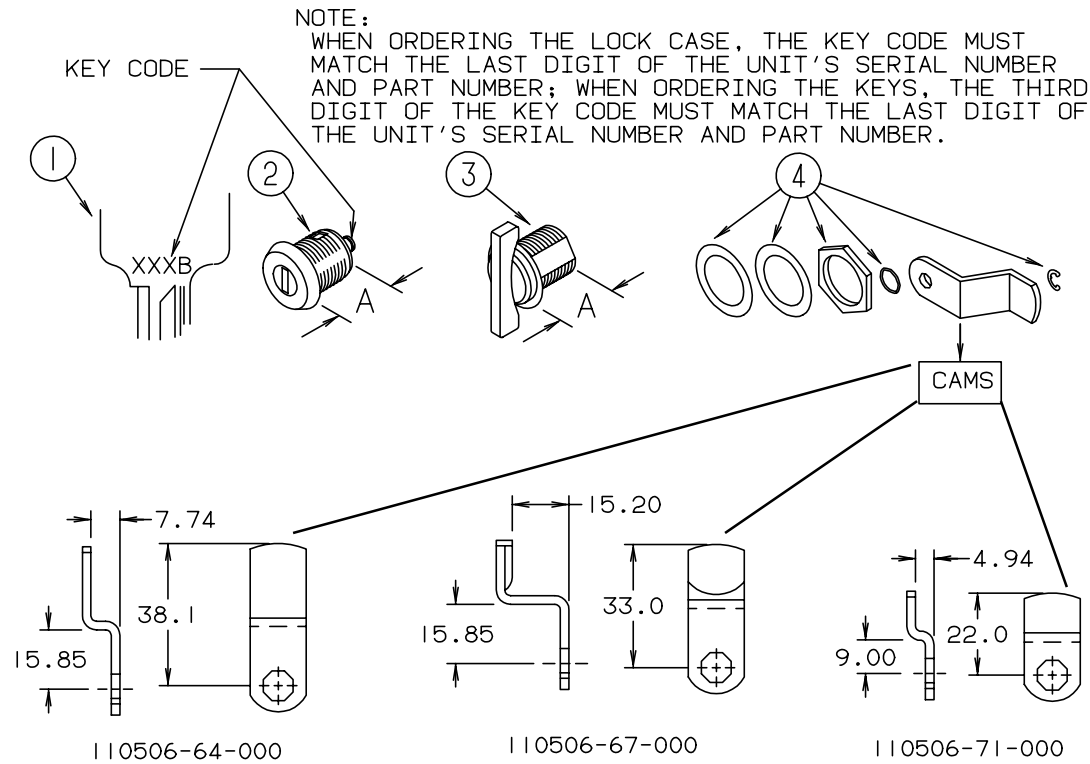

KEY, TWIST LOCKS & COMPONENTS

KEY	PART NUMBER	U/M	DESCRIPTION
1	110506-59-000	EA	KEY-SET OF TWO, BRIGGS & STRATTON 596720
	110506-59-701	EA	KEY-BLANK, GOLD
	110506-59-001	EA	KEY-SET OF TWO, BRIGGS & STRATTON 596721
	110506-59-002	EA	KEY-SET OF TWO, BRIGGS & STRATTON 596722
	110506-59-003	EA	KEY-SET OF TWO, BRIGGS & STRATTON 596723
	110506-59-004	EA	KEY-SET OF TWO, BRIGGS & STRATTON 596724
	110506-59-005	EA	KEY-SET OF TWO, BRIGGS & STRATTON 596725
	110506-59-006	EA	KEY-SET OF TWO, BRIGGS & STRATTON 596726
	110506-59-007	EA	KEY-SET OF TWO, BRIGGS & STRATTON 596727
110506-59-008	EA	KEY-SET OF TWO, BRIGGS & STRATTON 596728	
110506-59-009	EA	KEY-SET OF TWO, BRIGGS & STRATTON 596729	
2	110506-52-000	EA	CASE-LOCK, A=17 MM - BRIGGS & STRATTON 702370
	110506-52-001	EA	CASE-LOCK, A=17 MM - BRIGGS & STRATTON 702371
	110506-52-002	EA	CASE-LOCK, A=17 MM - BRIGGS & STRATTON 702372
	110506-52-003	EA	CASE-LOCK, A=17 MM - BRIGGS & STRATTON 702373
	110506-52-004	EA	CASE-LOCK, A=17 MM - BRIGGS & STRATTON 702374
	110506-52-005	EA	CASE-LOCK, A=17 MM - BRIGGS & STRATTON 702375
	110506-52-006	EA	CASE-LOCK, A=17 MM - BRIGGS & STRATTON 702376
	110506-52-007	EA	CASE-LOCK, A=17 MM - BRIGGS & STRATTON 702377
	110506-52-008	EA	CASE-LOCK, A=17 MM - BRIGGS & STRATTON 702378
110506-52-009	EA	CASE-LOCK, A=17 MM - BRIGGS & STRATTON 702379	
2	110506-53-000	EA	CASE-LOCK, A=25 MM - BRIGGS & STRATTON 702380
	110506-53-001	EA	CASE-LOCK, A=25 MM - BRIGGS & STRATTON 702381
	110506-53-002	EA	CASE-LOCK, A=25 MM - BRIGGS & STRATTON 702382
	110506-53-003	EA	CASE-LOCK, A=25 MM - BRIGGS & STRATTON 702383
	110506-53-004	EA	CASE-LOCK, A=25 MM - BRIGGS & STRATTON 702384
	110506-53-005	EA	CASE-LOCK, A=25 MM - BRIGGS & STRATTON 702385
	110506-53-006	EA	CASE-LOCK, A=25 MM - BRIGGS & STRATTON 702386
	110506-53-007	EA	CASE-LOCK, A=25 MM - BRIGGS & STRATTON 702387
	110506-53-008	EA	CASE-LOCK, A=25 MM - BRIGGS & STRATTON 702388
110506-53-009	EA	CASE-LOCK, A=25 MM - BRIGGS & STRATTON 702389	
3	110506-51-000	EA	CASE-TWIST LOCK, 25 MM - BRIGGS & STRATTON 596669
3	110506-50-000	EA	CASE-TWIST LOCK, 17 MM - BRIGGS & STRATTON 596932
4	110506-40-700	EA	HDWE KIT-NUT, E-RING, FLAT & SPUR WASHER, SPRING WASHER GASKET

WINDOW, VENT & EXTERIOR DOOR GROUP (CONTINUED)

POWERED ROOF VENT - U.S.

KEY	PART NUMBER	U/M	DESCRIPTION
	110051-03-01A	EA	VENT-ROOF, POWERED - 2" ROOF - JENSEN 7757 WHE
	048648-01-000	EA	MOTOR-12V, NONVENTED - 1/8" SHAFT
	048649-01-000	EA	FAN-PLASTIC, 6 IN-6 BLADED
	064470-01-700	EA	COVER-ROOF VENT
	110051-01-700	EA	SCREEN & FRAME 2"
	110051-01-702	EA	HAND CRANK & OPERATOR ASSEMBLY
	110051-01-703	EA	HANDLE-CRANK

POWERED ROOF VENT - CANADIAN.

KEY	PART NUMBER	U/M	DESCRIPTION
	110051-05-01A	EA	VENT-ROOF, POWERED - 2" ROOF - JENSEN 7757 WHE
	048648-01-000	EA	MOTOR-12V, NONVENTED - 1/8" SHAFT
	048649-01-000	EA	FAN-PLASTIC, 6 IN-6 BLADED
	064470-01-700	EA	COVER-ROOF VENT
	110051-01-700	EA	SCREEN & FRAME 2"
	110051-01-702	EA	HAND CRANK & OPERATOR ASSEMBLY
	110051-01-703	EA	HANDLE-CRANK

NONPOWERED ROOF VENT

KEY	PART NUMBER	U/M	DESCRIPTION
	110051-01-01A	EA	VENT-ROOF, NONPOWERED - 2" ROOF - JENSEN 7724 WHE
	064470-01-700	EA	COVER-ROOF VENT, JENSEN 7291
	110051-01-701	EA	GARNISH W/SCREEN & FRAME - 2", JENSEN 29-800-01 FITS 1" AND 2" THICK ROOFS
	110051-01-702	EA	LIFT-VENT LID W/O CRANK, JENSEN RP-1000B
	110051-01-703	EA	CRANK HANDLE-ROOF VENT, JENSEN RP-1031-B

VENTS, SHROUDS AND ROOF COVERS

KEY	PART NUMBER	U/M	DESCRIPTION
	084073-07-000	EA	COVER-ROOF VENT, REFRIGERATOR - BRIGHT WHITE - NORCOLD
	084073-04-000	EA	BASE-ROOF VENT, REFRIGERATOR - BLACK - NORCOLD
	084616-07-000	EA	SHROUD-RANGE HOOD VENT, BRIGHT WHITE
	084878-09-000	EA	VENT-RANGE HOOD - SHORT, LVS - OFF WHITE
	083558-07-000	EA	VENT-PLUMBING PIPE ROOF W/COVER, BRIGHT WHITE

WINDOW, VENT & EXTERIOR DOOR GROUP (CONTINUED)

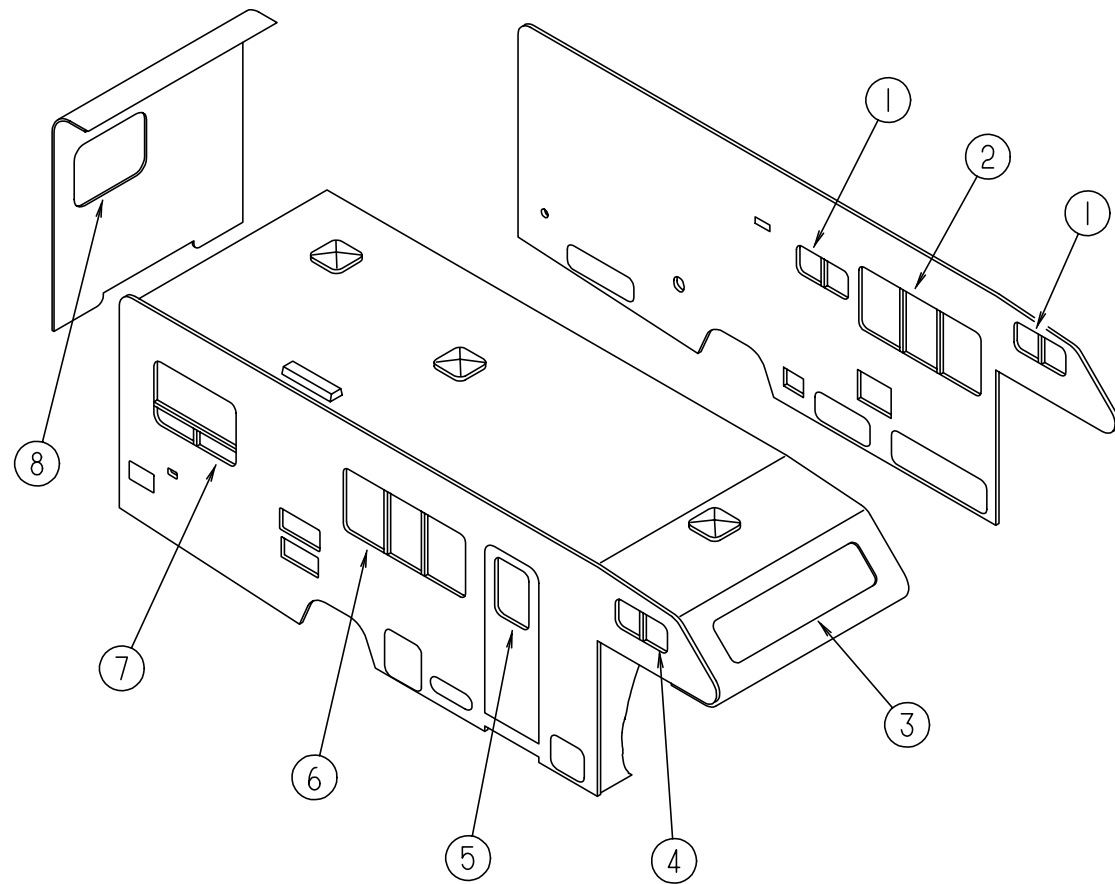

WINDOWS

KEY	PART NUMBER	U/M DESCRIPTION
1	098647-32-01A	EA WINDOW-SLIDER, HORIZONTAL - CLEAR - EXCEL H425-C1W66L
1	112795-20-01A	EA WINDOW-SLIDER, HORIZONTAL - THERMO - EXCEL DC29-G2W66L
2	098647-28-01A	EA WINDOW-SLIDER, HORIZONTAL - CLEAR - EXCEL H287-C1W66L
2	112795-15-01A	EA WINDOW-SLIDER, HORIZONTAL - THERMO - EXCEL DH287-G2W66L
3	103313-01-B05	EA WINDOW-PICTURE, W/O INSIDE FRAME
3	115630-01-01A	EA WINDOW-PICTURE, EXCEL DH438-G2W59
4	098647-31-01A	EA WINDOW-SLIDER, HORIZONTAL - CLEAR - EXCEL H425-C1W66R
4	112795-19-01A	EA WINDOW-SLIDER, HORIZONTAL - THERMO - EXCEL DC29-G2W66R
5	079733-17-F15	EA WINDOW-ENTRY DOOR
5	113733-01-01A	EA WINDOW-ENTRY DOOR, THERMO - EXCEL DH416-G2W66
6	098647-27-01A	EA WINDOW-SLIDER, HORIZONTAL - CLEAR - EXCEL H287-C1W66R
6	112795-16-01A	EA WINDOW-SLIDER, HORIZONTAL - THERMO - EXCEL DH287-G2W66R
7	098647-38-01A	EA WINDOW-SLIDER, HORIZONTAL - CLEAR - EXCEL H320-C1W66R
7	112795-22-01A	EA WINDOW-SLIDER, HORIZONTAL - THERMO - EXCEL DC48-G2W66R
8	078528-07-F15	EA WINDOW-ESCAPE, CLEAR
8	113502-01-01A	EA WINDOW-ESCAPE, THERMO - BLACK/OFF WHITE - EXCEL DH153-G2W66

WINDOW, VENT & EXTERIOR DOOR GROUP (CONTINUED)

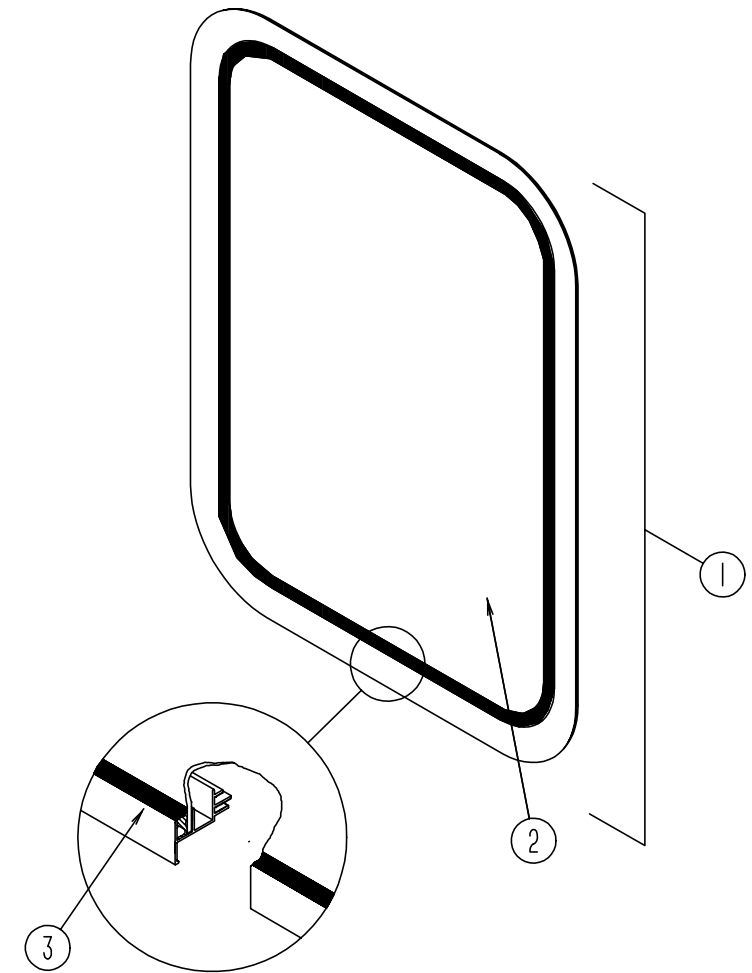

ENTRANCE DOOR WINDOW

KEY	PART NUMBER	U/M DESCRIPTION
	067609-38-000	EA FRAME-INSIDE WINDOW, OFF WHITE FROM: 00-00-00 THRU: 09-18-94
	067609-39-000	EA FRAME-INSIDE WINDOW, BRIGHT WHITE FROM: 09-19-94 THRU: 99-99-99
1	079733-17-F15	EA WINDOW-ENTRY DOOR, W/O INSIDE FRAME
2	002181-24-000	EA GLASS-PICTURE, 687.4 X 449.4 - CLEAR 90%
3	087561-01-000	FT SEAL-GLASS, EXTERIOR - .5" WIDE - VINYL - BLACK

ENTRY DOOR WINDOW - THERMO

KEY	PART NUMBER	U/M DESCRIPTION
	113733-01-01A	EA WINDOW-ENTRY DOOR, THERMO - W/O INSIDE FRAME
	113733-01-700	EA WINDOW-W/O TRIM
	113733-01-701	EA TRIM (W)
	113733-01-702	EA GLASS-STATIONARY

WINDOW, VENT & EXTERIOR DOOR GROUP (CONTINUED)

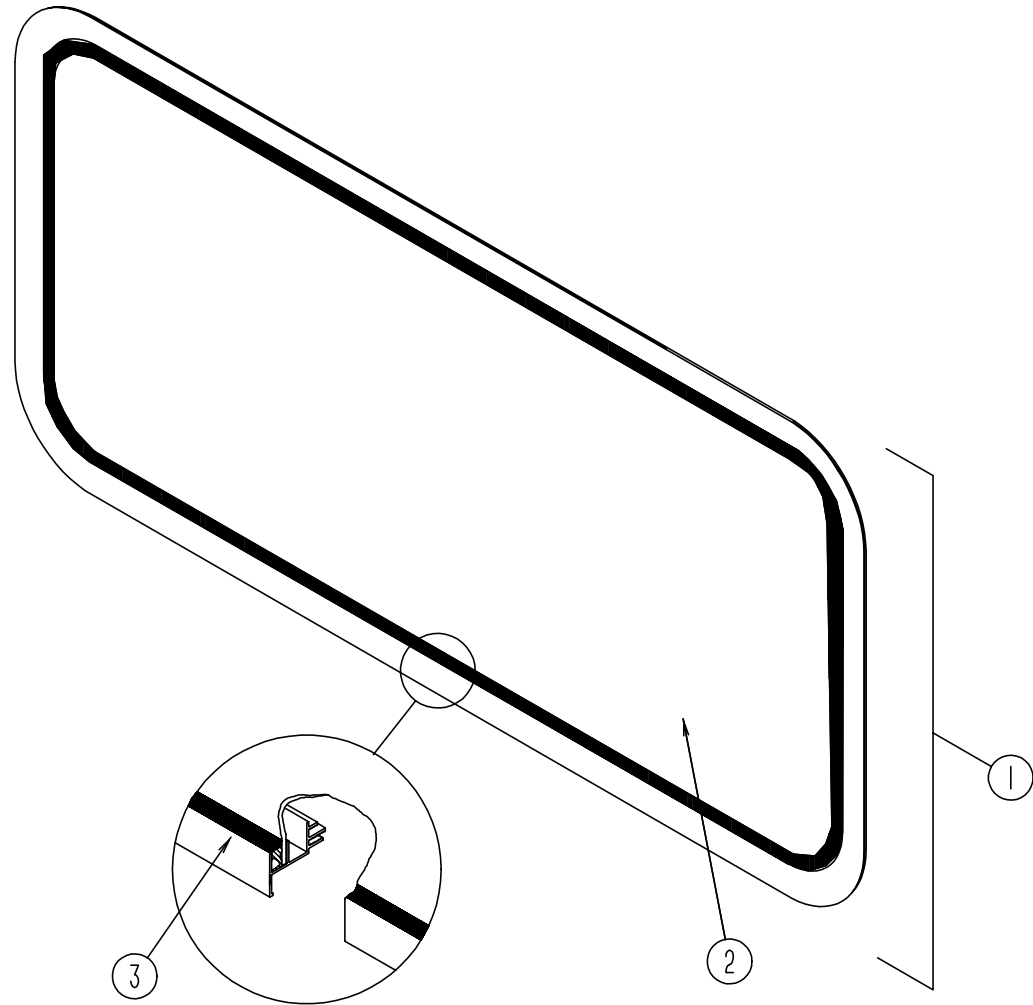

FRONT OVERHEAD BUNK WINDOW

KEY	PART NUMBER	U/M	DESCRIPTION
	067609-33-000	EA	FRAME-INSIDE WINDOW, OFF WHITE
1	103313-01-B05	EA	WINDOW-PICTURE, W/O INSIDE FRAME
2	002181-15-000	EA	GLASS-PICTURE, GRAY 31%
3	099154-01-000	FT	CHANNEL-GLAZING, STATIONARY GLASS - .62" X .45" - BLACK

WINDOW, VENT & EXTERIOR DOOR GROUP (CONTINUED)

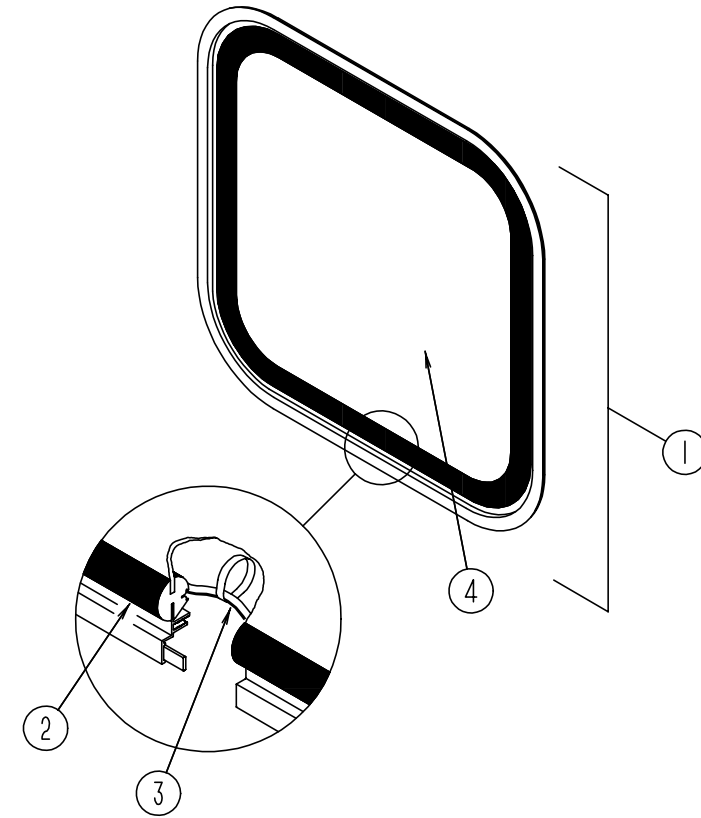

BACKWALL ESCAPE WINDOW

KEY	PART NUMBER	U/M	DESCRIPTION
	074816-11-000	EA	FRAME-INSIDE, ESCAPE - OFF WHITE
1	078528-07-F15	EA	WINDOW-ESCAPE, CLEAR
2	002282-09-000	EA	WEATHERSTRIP - .125" X 130.53", BLACK
	077066-01-702	EA	TAPE ASM-ESCAPE, WINDOW
3	002285-01-000	FT	FILLER-WEATHER STRIP, RUBBER - BLACK
4	076337-13-000	EA	GLASS-EGRESS, 1157MM X 548MM - CLEAR

WINDOW, VENT & EXTERIOR DOOR GROUP (CONTINUED)
EXCEL SLIDER WINDOWS

KEY	PART NUMBER	U/M	DESCRIPTION
	098647-27-01A	EA	WINDOW-SLIDER, HORIZONTAL - CLEAR - EXCEL H287-C1W66R
	098647-28-01A	EA	WINDOW-SLIDER, HORIZONTAL - CLEAR - EXCEL H287-C1W66L
	098647-31-01A	EA	WINDOW-SLIDER, HORIZONTAL - CLEAR - EXCEL H425-C1W66R
	098647-32-01A	EA	WINDOW-SLIDER, HORIZONTAL - CLEAR - EXCEL H425-C1W66L
	098647-38-01A	EA	WINDOW-SLIDER, HORIZONTAL - CLEAR - EXCEL H320-C1W66R
	098644-01-700	EA	LATCH-REPAIR KIT, EXCEL B801-CK
	098644-01-706	FT	WEATHERSTRIP, EXCEL 171-010668
	098644-01-708	FT	CHANNEL-PIERCED RUN, EXCEL 122-016543
	098644-01-710	FT	TRACK-SCREEN SPACER, 12' LENGTH - EXCEL M401-31
	098644-01-711	FT	WEATHERSTRIP-SCREEN, BLACK - EXCEL 171-016965
	098644-01-713	EA	SPRING-SCREEN FRAME (CLIP), PLASTIC - BLACK EXCEL 226-016966
	098644-01-716	FT	PLUG-FILLER, EXCEL 132-014470
	098644-01-717	FT	SPLINE-SCREEN, EXCEL 132-004716

EXCEL SLIDER WINDOWS - OVERHEAD BUNK - PASSENGER SIDE

KEY	PART NUMBER	U/M	DESCRIPTION
	098647-31-01A	EA	WINDOW-SLIDER, HORIZONTAL - CLEAR - EXCEL H425-C1W66R
	098644-01-700	EA	LATCH-REPAIR KIT, EXCEL B801-CK
	098644-01-706	FT	WEATHERSTRIP, EXCEL 171-010668
	098644-01-708	FT	CHANNEL-PIERCED RUN, EXCEL 122-016543
	098644-01-710	FT	TRACK-SCREEN SPACER, 12' LENGTH - EXCEL M401-31
	098644-01-711	FT	WEATHERSTRIP-SCREEN, BLACK - EXCEL 171-016965
	098644-01-713	EA	SPRING-SCREEN FRAME (CLIP), PLASTIC - BLACK EXCEL 226-016966
	098644-01-716	FT	PLUG-FILLER, EXCEL 132-014470
	098644-01-717	FT	SPLINE-SCREEN, EXCEL 132-004716
	098647-31-700	EA	WINDOW-W/O TRIM, EXCEL H425-C1R
	098647-31-701	EA	TRIM-WINDOW, EXCEL CW2966
	098647-31-702	EA	GLASS-STATIONARY, EXCEL 096-019299
	098647-31-703	EA	SLIDE ASSEMBLY-WINDOW EXCEL H425-C8
	098647-31-704	EA	SCREEN ASSEMBLY - EXCEL 410-019128

EXCEL SLIDER WINDOWS - OVERHEAD BUNK OR GALLEY - DRIVER SIDE

KEY	PART NUMBER	U/M	DESCRIPTION
	098647-32-01A	EA	WINDOW-SLIDER, HORIZONTAL - CLEAR - EXCEL H425-C1W66L
	098644-01-700	EA	LATCH-REPAIR KIT, EXCEL B801-CK
	098644-01-706	FT	WEATHERSTRIP, EXCEL 171-010668
	098644-01-708	FT	CHANNEL-PIERCED RUN, EXCEL 122-016543
	098644-01-710	FT	TRACK-SCREEN SPACER, 12' LENGTH - EXCEL M401-31
	098644-01-711	FT	WEATHERSTRIP-SCREEN, BLACK - EXCEL 171-016965
	098644-01-713	EA	SPRING-SCREEN FRAME (CLIP), PLASTIC - BLACK EXCEL 226-016966
	098644-01-716	FT	PLUG-FILLER, EXCEL 132-014470
	098644-01-717	FT	SPLINE-SCREEN, EXCEL 132-004716
	098647-31-700	EA	WINDOW-W/O TRIM, EXCEL H425-C1R
	098647-31-701	EA	TRIM-WINDOW, EXCEL CW2966
	098647-31-702	EA	GLASS-STATIONARY, EXCEL 096-019299
	098647-31-703	EA	SLIDE ASSEMBLY-WINDOW EXCEL H425-C8
	098647-31-704	EA	SCREEN ASSEMBLY - EXCEL 410-019128

WINDOW, VENT & EXTERIOR DOOR GROUP (CONTINUED)
EXCEL SLIDER WINDOWS - THERMO - LOUNGE

KEY	PART NUMBER	U/M	DESCRIPTION
	112795-15-01A	EA	WINDOW-SLIDER, HORIZONTAL - THERMO - EXCEL DH287-G2W66L
	098647-23-702	EA	TRIM-WINDOW, EXCEL W28766
	098647-23-704	EA	SCREEN ASSEMBLY, EXCEL 410-019066
	112795-15-700	EA	WINDOW-W/O TRIM, EXCEL DH287-G2L
	112795-15-701	EA	GLASS-STATIONARY, EXCEL 390-019045
	112795-15-702	EA	SLIDE ASSEMBLY-WINDOW, EXCEL DH287-G9

EXCEL SLIDER WINDOWS - THERMO - DINETTE

KEY	PART NUMBER	U/M	DESCRIPTION
	112795-16-01A	EA	WINDOW-SLIDER, HORIZONTAL - THERMO - EXCEL DH287-G2W66R
	098647-23-702	EA	TRIM-WINDOW, EXCEL W28766
	098647-23-704	EA	SCREEN ASSEMBLY, EXCEL 410-019066
	112795-16-700	EA	WINDOW W/O TRIM, EXCEL DH287-G2R
	112795-15-701	EA	GLASS-STATIONARY, EXCEL 390-019045
	112795-15-702	EA	SLIDE ASSEMBLY-WINDOW, EXCEL DH287-G9

EXCEL SLIDER WINDOWS - THERMO - OVERHEAD BUNK - PASSENGER SIDE

KEY	PART NUMBER	U/M	DESCRIPTION
	112795-19-01A	EA	WINDOW-SLIDER, HORIZONTAL - THERMO - EXCEL DC29-G2W66R
	098647-31-701	EA	TRIM-WINDOW, EXCEL CW2966
	098647-31-704	EA	SCREEN ASSEMBLY, EXCEL 410-019128
	112795-19-700	EA	WINDOW W/O TRIM, EXCEL DC29-G2R
	112795-19-701	EA	GLASS-STATIONARY, EXCEL 390-019134
	112795-19-702	EA	SLIDE ASSEMBLY, EXCEL DC29-G9

EXCEL SLIDER WINDOWS - THERMO - OVERHEAD BUNK OR GALLEY - DRIVER SIDE

KEY	PART NUMBER	U/M	DESCRIPTION
	112795-20-01A	EA	WINDOW-SLIDER, HORIZONTAL - THERMO - EXCEL DC29-G2W66L
	098647-31-701	EA	TRIM-WINDOW, EXCEL CW2966
	098647-31-701	EA	TRIM-WINDOW, EXCEL CW2966
	112795-19-701	EA	GLASS-STATIONARY, EXCEL 390-019134
	112795-19-702	EA	SLIDE ASSEMBLY, EXCEL DC29-G9
	112795-20-700	EA	WINDOW W/O TRIM, EXCEL DC29-G2L