

**1993 ITASCA
TABLE OF CONTENTS**

INTRODUCTION	A-01 - A-02
ABBREVIATIONS	A-03
ALPHABETICAL INDEX	A-04 - A-08
ICG32RQ	A-07 - E-16

**1993
ICG32RQ
D35
D36**

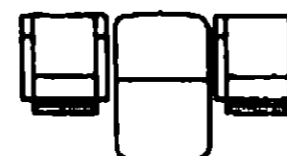
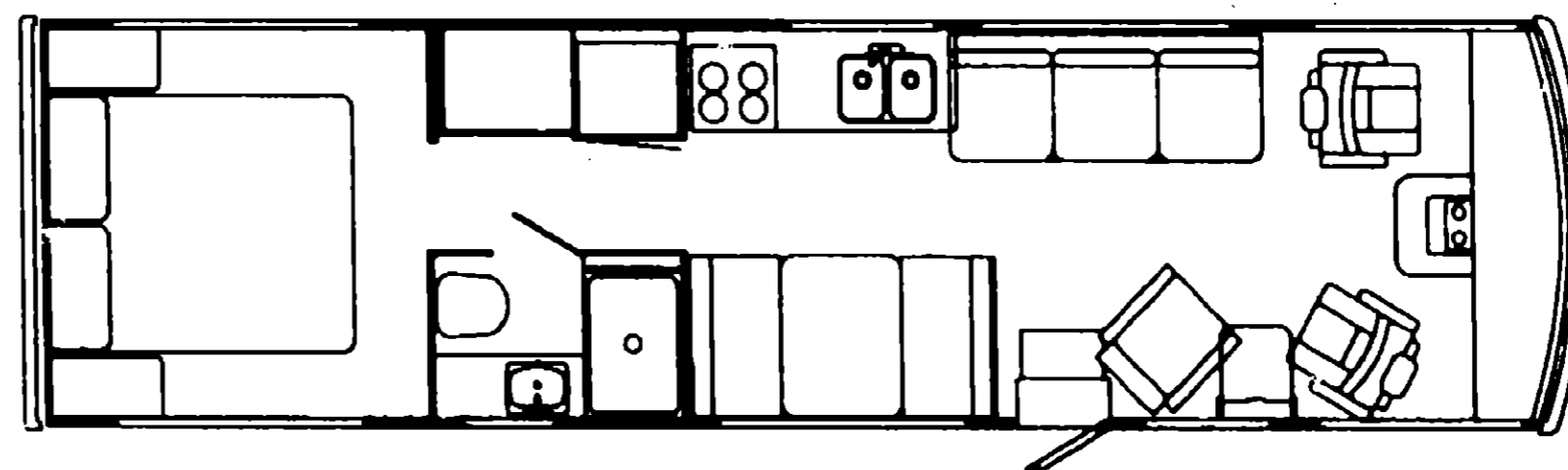
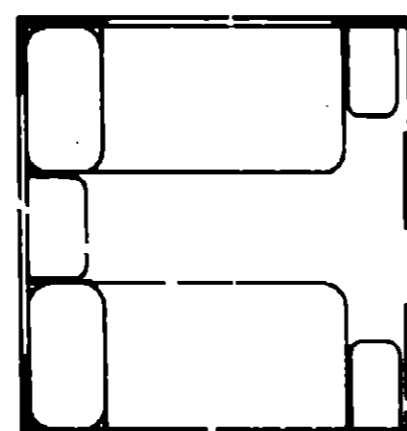
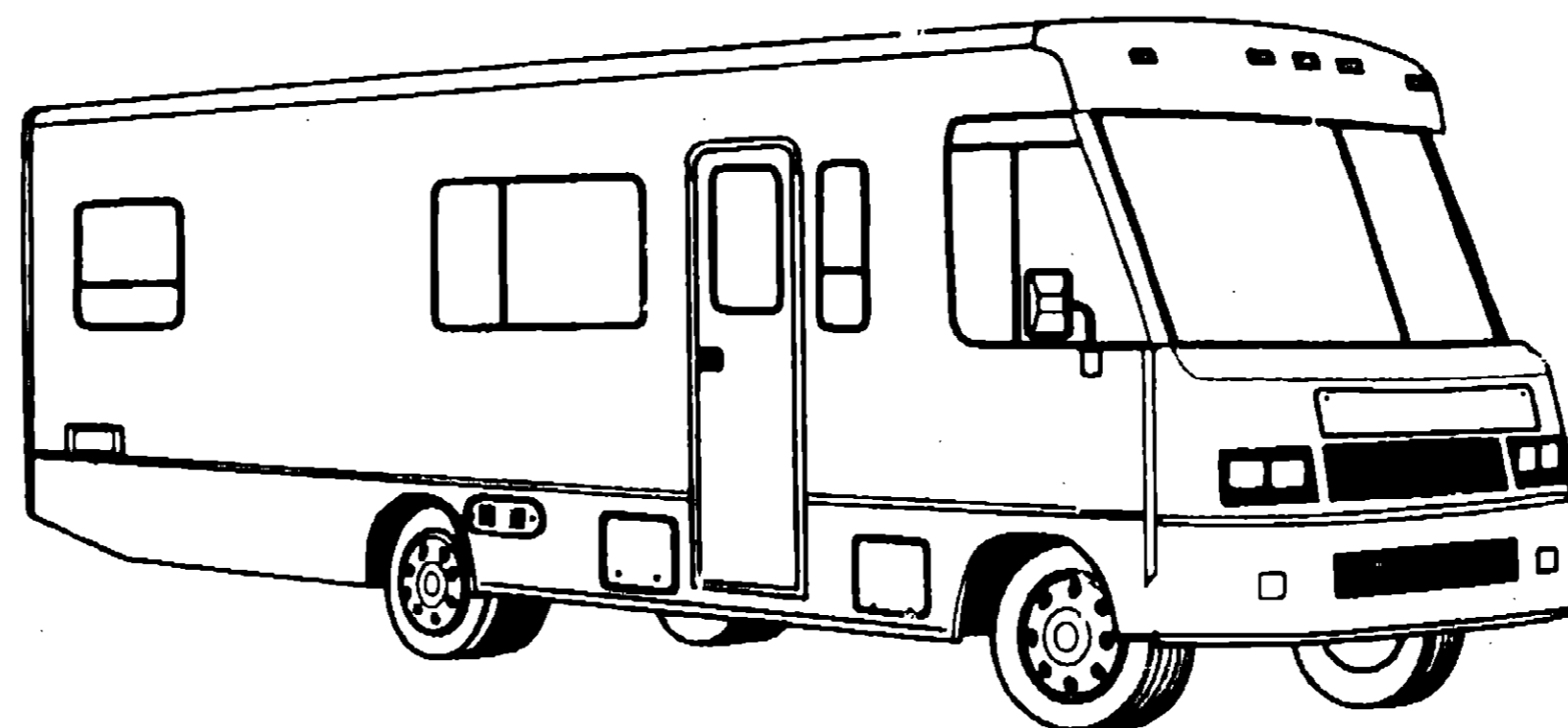

1993 ICG32RQ INDEX

FLOOR PLAN	A-07 - A-08
ACCESSORIES	A-09
AUDIO VIDEO	A-10 - A-11
BATH	A-12 - A-14
BEDROOM	A-15 - A-16
CHASSIS	A-17 - B-06
CURTAIN & CUSHION	B-07 - B-17
DINETTE	B-18 - B-20
DRIVERS COMPARTMENT	B-21 - B-24
ELECTRICAL	C-01 - C-06
EXTERIOR BODY	C-07 - C-14
GALLEY	C-15 - C-18
GENERATOR	C-19 - C-20
HEATING & A/C	C-21 - C-24
INTERIOR FINISH	D-01 - D-04
LABELS	D-05 - D-12
LP	D-13
LOUNGE	D-14 - D-16
SEALANTS & FASTENERS	D-17 - D-19
WATER & SEWAGE	D-20 - D-23
WINDOW, VENT & EXTERIOR DOOR	D-24 - E-14
WINDSHIELD & WIPER	E-15 - E-16

ACCESSORIES GROUP

OPERATOR MANUAL

KEY	PART NUMBER	U/M DESCRIPTION
	064186-53-000	EA MANUAL - OPERATOR 93 SUNCRUISER - G-SERIES
	092318-01-000	EA BINDER - 3 RING - MOTOR HOME MANUAL
	092319-01-000	EA POCKET PAGE - 3 RING BINDER - PLASTIC
	108753-01-000	EA TOP LEVEL DRAWING NUMBER

AUDIO VIDEO GROUP

RADIO SYSTEMS & ANTENNA

KEY	PART NUMBER	U/M DESCRIPTION
	077089-C2-000	EA CABLE - ANTENNA - RADIO - EXTENSION 96' - ARA 8700667
	073741-03-000	EA SPEAKER - OVAL - 4" X 6" - BLACK
	110469-01-000	EA SPEAKER - OVAL - 4" X 6" - BLACK
	073741-04-000	EA GRILLE - SPEAKER - OVAL - 4" X 6" - BLACK
	110470-01-01A	EA GRILLE - SPEAKER - OVAL - 4" X 6" - BLACK
	081059-02-000	EA WIRE ASM - 9-PIN - RADIO - AUDIOVOX 112B-1761
	104089-01-000	EA RADIO - AM/FM STEREO - CASSETTE DIN AUDIOVOX IM-DXF
	110267-01-000	EA RADIO-AM/FM STEREO, AUDIOVOX IM-200
	105248-01-000	EA ANTENNA - CB - ADVANCE 8604
	097621-02-000	EA MOUNTING KIT - RADIO - AUDIOVOX WMK - AB02
	090862-01-000	EA BRACKET - HAT - ANTENNA - 3 1" X 3 9" - STEEL - BLACK
	074979-03-000	EA SHIELD - SPEAKER - BACK - MOLDED PLASTIC - LIGHT OAK
	077063-02-000	EA CABLE - ANTENNA - RADIO - EXTENSION 96"
	090914-01-000	EA ANTENNA - RADIO - 16" RUBBER
	089340-02-000	EA GRILLE - SPEAKER - 6.5" SQUARE
	089340-03-000	EA SPACER - GRILLE - 6.5" SQUARE - TAN - MAGNADYNE G514
	094097-01-000	EA SPEAKER - RADIO - W/O GRILLE - 5 25" DIA - AUDIOVOX 110C3030

REAR MONITOR SYSTEM

KEY	PART NUMBER	U/M DESCRIPTION
	105249-01-000	EA TELEVISION CAMERA - REAR VIEW - AUDIOVOX 405 10
	105249-02-000	EA MONITOR - TV SYSTEM - REAR VIEW - AUDIOVOX AOM-55
	105249-03-000	EA CABLE - TV SYSTEM - REAR VIEW - AUDIOVOX OCA-20
	092881-01-000	EA WIRE - INSTRUMENT PANEL - REAR VIEW MONITOR
	105304-01-000	EA WIRE ASM - REAR MONITOR - UPPER

PATIO ENTERTAINMENT CENTER

KEY	PART NUMBER	U/M DESCRIPTION
	073741-03-000	EA SPEAKER - OVAL - 4" X 6" - BLACK
	110469-01-000	EA SPEAKER - OVAL - 4" X 6" - BLACK
	073741-04-000	EA GRILLE - SPEAKER - OVAL - 4" X 6" - BLACK
	110470-01-01A	EA GRILLE - SPEAKER - OVAL - 4" X 6" - BLACK
	077069-02-000	EA CABLE - ANTENNA - RADIO - EXTENSION 96" - ARA 6700667
	087683-01-000	EA RADIO - AM/FM STEREO W/CASSETTE AUDIOVOX 144D1559
	090944-01-000	EA ANTENNA - RADIO - 16" RUBBER

**1993 ITASCA
TABLE OF CONTENTS**

INTRODUCTION	A-01 - A-02
ABBREVIATIONS	A-03
ALPHABETICAL INDEX	A-04 - A-06
ICG32RQ	A-07 - E-16

1993 ICG32RQ INDEX

FLOOR PLAN	A-07 - A-08
ACCESSORIES	A-09
AUDIO VIDEO	A-10 - A-11
BATH	A-12 - A-14
BEDROOM	A-15 - A-16
CHASSIS	A-17 - B-06
CURTAIN & CUSHION	B-07 - B-17
DINETTE	B-18 - B-20
DRIVERS COMPARTMENT	B-21 - B-24
ELECTRICAL	C-01 - C-06
EXTERIOR BODY	C-07 - C-14
GALLEY	C-15 - C-18
GENERATOR	C-19 - C-20
HEATING & A/C	C-21 - C-24
INTERIOR FINISH	D-01 - D-04
LABELS	D-05 - D-12
LP	D-13
LOUNGE	D-14 - D-16
SEALANTS & FASTENERS	D-17 - D-19
WATER & SEWAGE	D-20 - D-23
WINDOW, VENT & EXTERIOR DOOR	D-24 - E-14
WINDSHIELD & WIPER	E-15 - E-16

AUDIO VIDEO GROUP (CONTINUED)

TV - VCR SYSTEMS & ANTENNA

KEY	PART NUMBER	U/M	DESCRIPTION
	062134-01-000	EA	ADAPTER - TV - CABLE TO CABLE - WINEGARD F-81M
	066756-01-000	EA	SPLITTER - TV - 2 WAY
	076319-03-000	FT	CABLE - COAXIAL - 75 OHM
	076319-12-000	EA	CONNECTOR - COAXIAL - ONE PIECE
	066757-03-000	EA	CONTROL CENTER - SWITCH - VCR/TV - MAGNADYNE VCS-6
	098446-03-000	EA	VCR-VHS - CABLE READY - REMOTE - MAGNAVOX VR9010 FROM 00-00-00 THRU 10-04-92
	098446-03-700	EA	REMOTE F/MODEL #9010
	098446-04-000	EA	VCR-VHS - CABLE READY - REMOTE - MAGNAVOX VR9110 FROM 10-05-92 THRU 99-99-99
	098446-04-700	EA	REMOTE F/MODEL #9110
	098447-03-000	EA	TV - 13" - COLOR W/REMOTE - U.S. - MAGNAVOX RR1337
	098447-04-000	EA	TV - 13" - COLOR W/REMOTE - CANADIAN - MAGNAVOX RR1330W
	098447-03-700	EA	REMOTE FOR TV-13"
	098819-01-000	EA	SPEAKER - 2 WATT - 8 OHM - 4"
	093214-01-02A	EA	GRILL - SPEAKER, 4" BROWN
	099717-02-000	EA	TIEDOWN - TV - STRAP ON FEMALE END IS 28 7" LONG
	099717-01-000	EA	TIEDOWN - TV - STRAP ON FEMALE END IS 22 8" LONG
	092310-02-000	EA	TV - COLOR - 9" - AC/DC - W/REMOTE - MAGNAVOX RD0945
	092310-02-700	EA	REMOTE F/TV 0822334
	076319-01-000	EA	ANTENNA - TV - ROOF MOUNT - 44.5' MAST FVA W02
	076319-01-700	EA	HEAD - ANTENNA - AMPLIFIED - WINEGARD RVSA U/V
	076319-01-701	EA	GEAR - ELEVATING - PLASTIC - WINEGARD 2200046
	076319-01-702	EA	SHAFT ASM - ELEVATING - WINEGARD RVP-400A
	076319-01-703	EA	BEARING - NYLON - 5"OD - WINEGARD 3200656
	076319-01-705	EA	GROMMET - NYLON - 7/8"ID - WINEGARD 3200658
	076319-01-706	EA	CRANK - ELEVATING - W/SET SCREW 5755100
	076319-01-707	EA	SPRING - HANDLE - WINEGARD 5160600
	076319-01-709	EA	PLATE - DIRECTIONAL - FOR HEAD - WINEGARD 3200644
	076319-01-706	EA	CRANK - ELEVATING - W/SET SCREW - WINEGARD 5755100
	076319-08-000	EA	WALLPLATE - CABLE RECEPTACLE - TV - SINGLE - IVORY
	076319-09-000	EA	WALLPLATE - CABLE RECEPTACLE - TV - SINGLE - BROWN
	082136-01-000	EA	NUT - HEX JAM 3/8-32 WINEGARD
	086777-01-000	EA	WALLPLATE - TV CABLE - W/ANTENNA SWITCH - IVORY
	086777-03-000	EA	WALLPLATE - TV CABLE - W/TV ANTENNA SWITCH & BOOSTER - IVORY FROM 00-00-00 THRU 04-14-93
	086777-05-000	EA	WALLPLATE - IVORY - ANTENNA 1 OUTPUT - WINEGARD RV-0921 FROM 04-15-93 THRU 99-99-99

BATH GROUP

**1993 ITASCA
TABLE OF CONTENTS**

INTRODUCTION	A-01 - A-02
ABBREVIATIONS	A-03
ALPHABETICAL INDEX	A-04 - A-06
ICG32RQ	A-07 - E-16

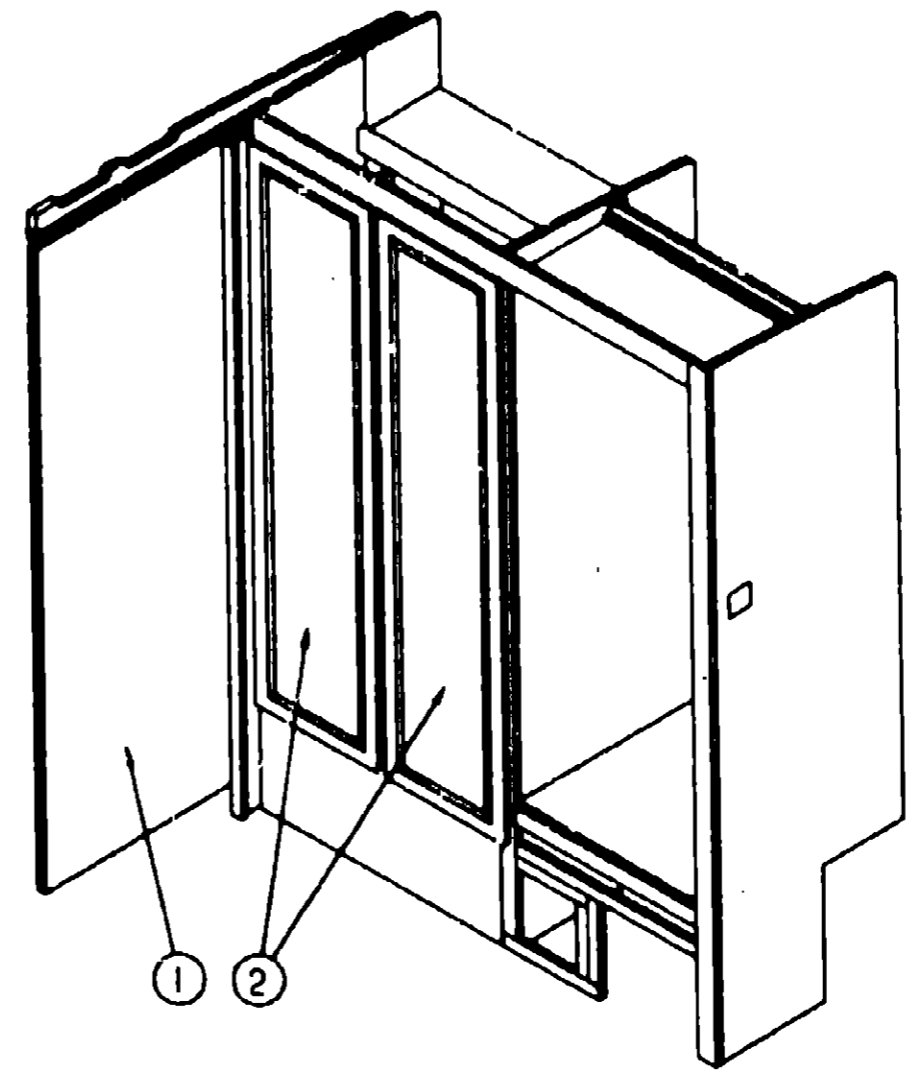

WARDROBE CABINETS & PRIVACY DOOR

KEY	PART NUMBER	U/M	DESCRIPTION
1	104013-03-D35	EA	DOOR ASM - SLIDING
	103874-01-000	EA	HANGER - SLIDING DOOR
	103868-03-01A	EA	TRACK - SLIDING DOOR - O/W
	103908-03-C27	EA	HEADER - DOOR
2	P04536-15-D35	EA	DOOR ASM - W/O HARDWARE

1993 ICG32RQ INDEX

FLOOR PLAN	A-07 - A-08
ACCESSORIES	A-09
AUDIO VIDEO	A-10 - A-11
BATH	A-12 - A-14
BEDROOM	A-15 - A-16
CHASSIS	A-17 - B-06
CURTAIN & CUSHION	B-07 - B-17
DINETTE	B-18 - B-20
DRIVERS COMPARTMENT	B-21 - B-24
ELECTRICAL	C-01 - C-06
EXTERIOR BODY	C-07 - C-14
GALLEY	C-15 - C-18
GENERATOR	C-19 - C-20
HEATING & A/C	C-21 - C-24
INTERIOR FINISH	D-01 - D-04
LABELS	D-05 - D-12
LP	D-13
LOUNGE	D-14 - D-16
SEALANTS & FASTENERS	D-17 - D-19
WATER & SEWAGE	D-20 - D-23
WINDOW, VENT &	
EXTERIOR DOOR	D-24 - E-14
WINDSHIELD & W/PER	E-15 - E-16

BATH GROUP (CONTINUED)
BATH CABINETS

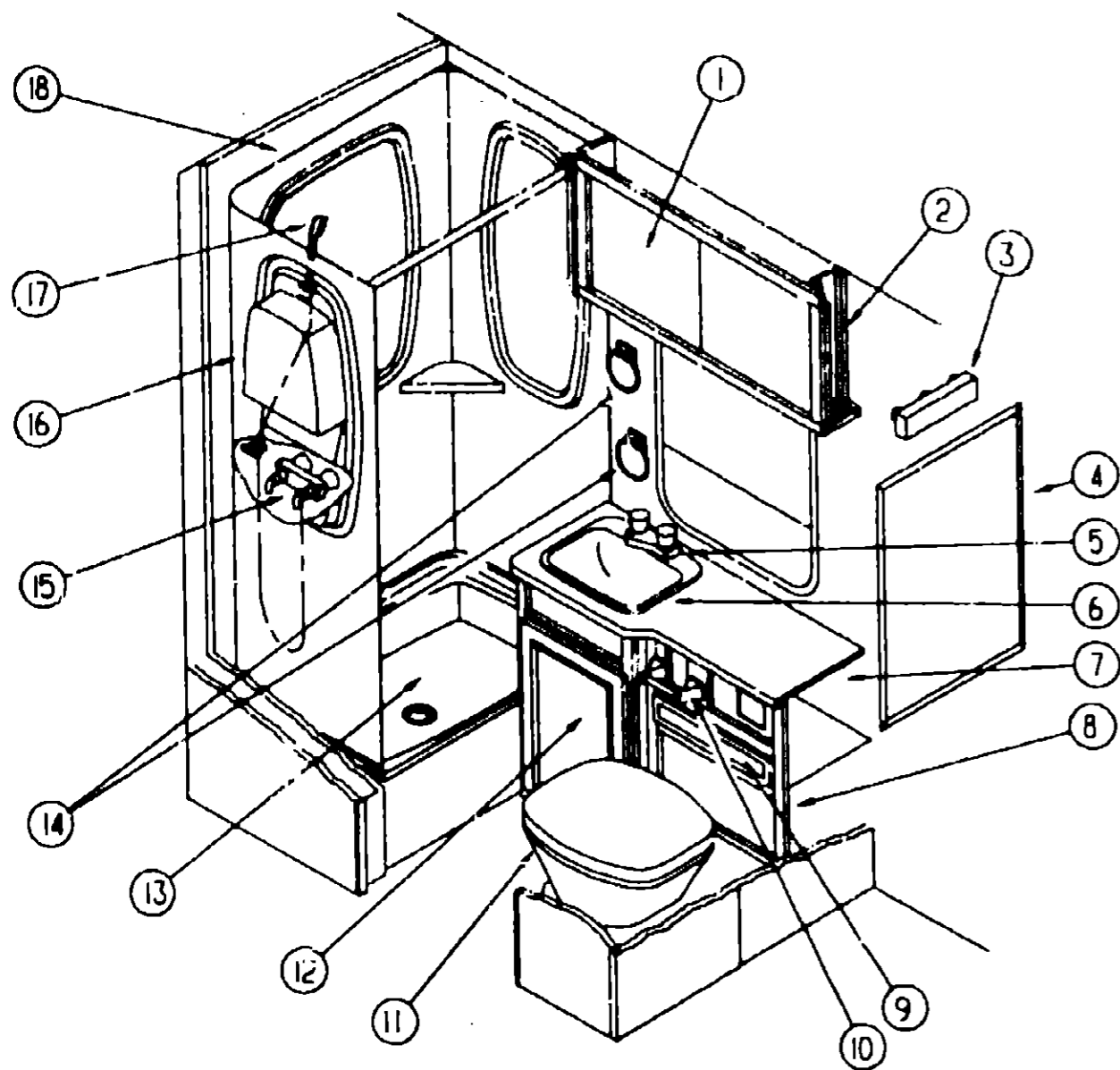

KEY	PART NUMBER	U/M	DESCRIPTION
1	101040-03-000	EA	MIRROR - GLASS - FINGER PULL - 364 2 X 445 0 MM
	042077-01-000	FT	CHANNEL - U - WINDOW GLASS OR CABINET DOOR RUN - 3/16"
2	104460-02-C27	EA	CABINET ASM - MEDICINE
3	110235-01-01A	EA	LIGHT - 3 BULB
4	058331-51-000	EA	MIRROR - SAFETY GLASS - 660X10'6MM
5	075240-06-000	EA	FAUCET - LAVATORY - BONE
	091253-01-000	EA	GASKET - FAUCET - LAVATORY/GALLEY
6	056927-01-01A	EA	SINK - LAVATORY - RECTANGULAR - PLASTIC - BONE
	096927-01-700	EA	SINK - STOPPER
	096927-01-701	EA	TAILPIECE - SINK
7	104459-14-D35	EA	COUNTERTOP ASM
7	104459-14-D36	EA	COUNTERTOP ASM
8	P04459-02-D35	EA	CABINET ASM - LAVATORY
8	P04459-02-D36	EA	CABINET ASM - LAVATORY
9	P07104-95-D35	EA	DRAWER ASM - W/O HARDWARE
10	075452-02-000	EA	HOLDER - TOILET TISSUE - BRASS
11	039341-03-000	EA	TOILET - STARLITE - HIGH - THETFORD PARCHMENT
	039341-02-703	EA	PLUG - HOLE - IVORY - THETFORD 03895-10
	039341-02-705	EA	MOUNTING PACKAGE - THETFORD 08975 A M
	039341-02-707	EA	PIN - HINGE - TOILET 12986
	039341-03-700	EA	COVER - TOILET - PARCHMENT 20923
	039341-03-701	EA	RING - SEAT - TOILET - PARCHMENT 1656457
	064076-01-701	EA	MECHANISM - FLUSHING 14622 IVORY STARLIGHT
12	P03702-F0-D35	EA	DOOR ASM - W/O HARDWARE
13	M02630-22-C07	EA	SHOWER PAN ASM
	066440-01-000	EA	STRAINER - SHOWER - W/RUBBER WASHER
	069735-01-000	EA	WASHER - STRAINER TO TAILPIECE PLASTIC - 1 5"
	066436-01-000	EA	SLIP NUT - TAILPIECE - 1 5"
14	075454-02-000	EA	RING - TOWEL - W/MOUNTING HARDWARE - BRASS
	100494-02-C27	EA	DOOR ASM - BATH - 75 2" X 23 9"
	009151-01-000	EA	GUARD - WARP - CABINET/PRIVACY DOOR - 48"
	100357-01-000	EA	ROD - TOWEL - BRASS W/ENDS BENT FOR BACK OF BATH DOOR
	102089-11-803	EA	MOUNT - ROD - RIGHT SIDE - FOR TOWEL RODS - 53 5" LONG - WOOD
	102089-12-803	EA	MOUNT - ROD - LEFT SIDE - FOR TOWEL RODS - 53 5" LONG - WOOD
	106017-02-D35	EA	SHELF ASM - BATH
	106017-02-D36	EA	SHELF ASM - BATH
15	075241-05-000	EA	FAUCET - SHOWER - BONE
16	104462-01-01A	EA	CADDY - SHOWER - OFF WHITE
17	103092-01-000	EA	SHOWER HEAD - W/60" HOSE
17	103092-02-000	EA	SHOWER HEAD - W/60" HOSE (CSA)
	103092-01-700	EA	BRACKET ONLY - CLEAR - F/SHOWER HEAD
	103092-01-701	EA	BRACKET ONLY (BONE) F/SHOWER HEAD
18	104464-02-01A	EA	SURROUND - SHOWER - OFF WHITE
	057671-01-000	EA	COVER - SCREW - #8 - PLASTIC - OFF WHITE

1983 ITASCA
TABLE OF CONTENTS

INTRODUCTION	A-01 - A-02
ABBREVIATIONS	A-03
ALPHABETICAL INDEX	A-04 - A-06
ICG32RQ	A-07 - E-16

1983 ICG32RQ INDEX

FLOOR PLAN	A-07 - A-08
ACCESSORIES	A-09
AUDIO VIDEO	A-10 - A-11
BATH	A-12 - A-14
BEDROOM	A-15 - A-16
CHASSIS	A-17 - B-06
CURTAIN & CUSHION	B-07 - B-17
DINETTE	B-18 - B-21
DRIVERS COMPARTMENT	B-21 - B-24
ELECTRICAL	C-01 - C-06
EXTERIOR BODY	C-07 - C-14
GALLEY	C-15 - C-18
GENERATOR	C-19 - C-20
HEATING & A/C	C-21 - C-24
INTERIOR FINISH	D-01 - D-04
LABELS	D-05 - D-12
LP	D-13
LOUNGE	D-14 - D-16
SEALANTS & FASTENERS	D-17 - D-19
WATER & SEWAGE	D-20 - D-23
WINDOW, VENT &	
EXTERIOR DOOR	D-24 - E-14
WINDSHIELD & W/PER	E-15 - E-16

BEDROOM GROUP

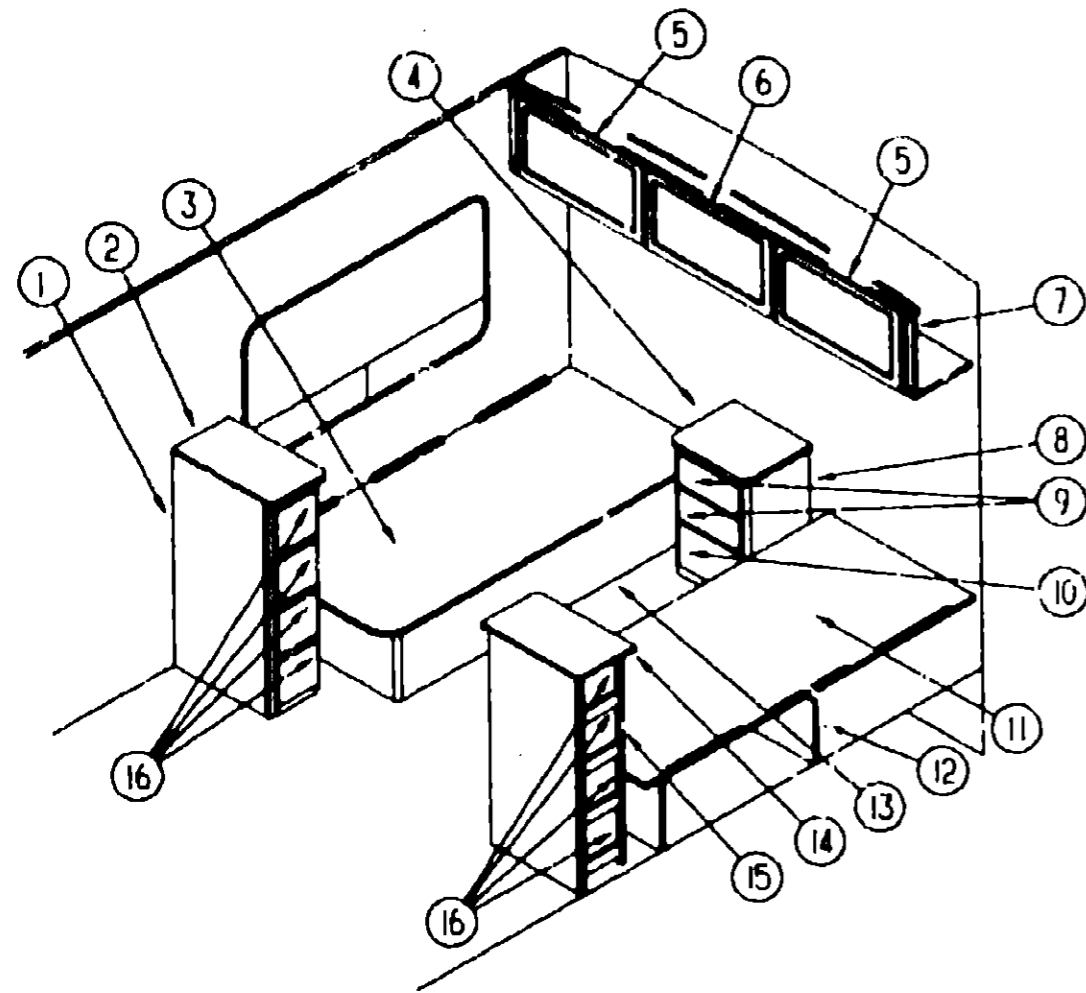

TWIN BEDROOM

KEY	PART NUMBER	U/M DESCRIPTION
1	107563-01-D35	EA CABINET ASM - CHEST - W/COUNTERTOP - PASSENGER SIDE
1	107563-01-D36	EA CABINET ASM - CHEST - W/COUNTERTOP - PASSENGER SIDE
2	107563-11-D35	EA COUNTERTOP ASM.
2	107563-11-D36	EA COUNTERTOP ASM.
3	M05193-02-C07	EA CABINET ASM - TWIN BED TOP - PASSENGER SIDE
4	104507-11-D12	EA COUNTERTOP ASM. (D35)
4	104507-11-D36	EA COUNTERTOP ASM.
5	P03702-12-D35	EA DOOR ASM - W/O HARDWARE
6	P03702-65-D35	EA DOOR ASM - W/O HARDWARE
7	M05160-16-D35	EA CABINET ASM - OVER HEAD
8	104507-01-D35	EA CABINET ASM - NIGHTSTAND
9	104507-01-D36	EA CABINET ASM - NIGHTSTAND
9	P07104-77-D35	EA DRAWER ASM - W/O HARDWARE
10	P07104-79-D35	EA DRAWER ASM - W/O HARDWARE
11	M05194-02-C07	EA CABINET ASM - TWIN BED TOP - DRIVER SIDE
12	M05197-04-C07	EA CABINET - TWIN BED BASE - DRIVER SIDE
13	M05197-03-C07	EA CABINET ASM - TWIN BED BASE - PASSENGER SIDE
14	107562-11-D35	EA COUNTERTOP ASM.
14	107562-11-D36	EA COUNTERTOP ASM.
15	107562-01-D35	EA CABINET ASM - CHEST - W/COUNTERTOP - DRIVER SIDE
15	107562-01-D36	EA CABINET ASM - CHEST - W/COUNTERTOP - DRIVER SIDE
16	P07104 75 D36	EA DRAWER ASM - W/O HARDWARE

BEDROOM GROUP (CONTINUED)

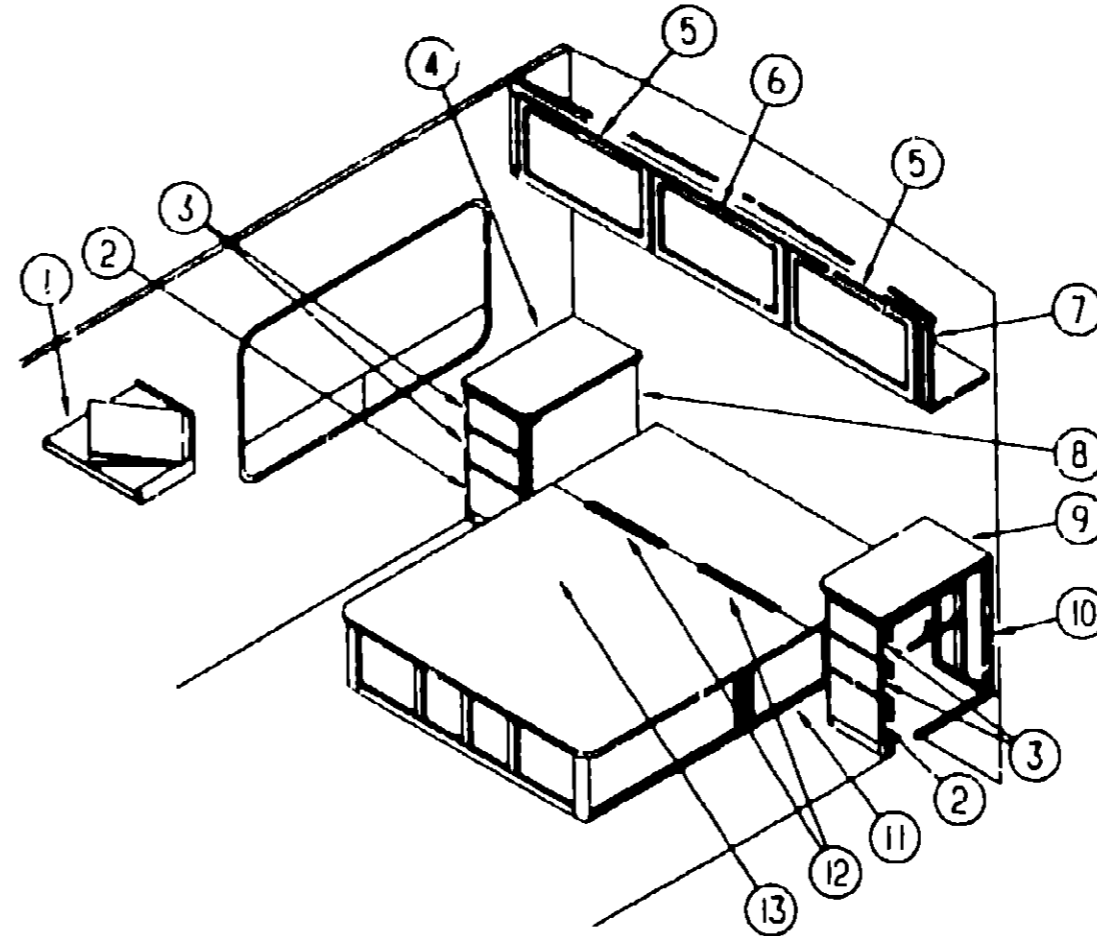

QUEEN BEDROOM

KEY	PART NUMBER	U/M DESCRIPTION
1	104826-01-C27	EA SHELF ASM - TV
2	P07104-99-D35	EA DRAWER ASM - CABINET - W/O HARDWARE
3	P07104-97-D35	EA DRAWER ASM - CABINET - W/O HARDWARE
4	104361-11-D12	EA COUNTERTOP ASM. (D35)
4	104361-11-D36	EA COUNTERTOP ASM.
5	P03702-12-D35	EA DOOR ASM - W/O HARDWARE
6	P03702-65-D35	EA DOOR ASM - W/O HARDWARE
7	M05160-16-D35	EA CABINET ASM - OVER HEAD
8	104361-01-D35	EA CABINET ASM - W/COUNTERTOP - NIGHTSTAND
8	104361-01-D36	EA CABINET ASM - W/COUNTERTOP - NIGHTSTAND
9	104362-11-D32	EA COUNTERTOP ASM. (D35)
9	104362-11-D36	EA COUNTERTOP ASM.
10	104362-01-D35	EA CABINET ASM - W/COUNTERTOP - NIGHTSTAND
10	104362-01-D36	EA CABINET ASM - W/COUNTERTOP - NIGHTSTAND
11	P09478-01-D35	EA CABINET ASM - QUEEN BED
12	041389-11-000	EA HINGE - PIANO - BEIGE 55.0°
13	M05905-04-D12	EA CABINET ASM - QUEEN BED TOP
	107540-01-000	EA BRACKET - 90 DEGREE - GAS SPRING
	107541-01-000	EA BRACKET - FLAT - GAS SPRING

**1993 ITASCA
TABLE OF CONTENTS**

INTRODUCTION	A-01 - A-02
ABBREVIATIONS	A-03
ALPHABETICAL INDEX	A-04 - A-06
ICG32RQ	A-07 - E-16

1993 ICG32RQ INDEX

FLOOR PLAN	A-07 - A-08
ACCESSORIES	A-09
AUDIO VIDEO	A-10 - A-11
BATH	A-12 - A-14
BEDROOM	A-15 - A-16
CHASSIS	A-17 - B-06
CURTAINS & CUSHION	B-07 - B-17
DINETTE	B-18 - B-20
DRIVERS COMPARTMENT	B-21 - B-24
ELECTRICAL	C-01 - C-06
EXTERIOR BODY	C-07 - C-14
GALLEY	C-15 - C-18
GENERATOR	C-19 - C-20
HEATING & AC	C-21 - C-24
INTERIOR FINISH	D-01 - D-04
LABELS	D-05 - D-12
LP	D-13
LOUNGE	D-14 - D-16
SEALANTS & FASTENERS	D-17 - D-19
WATER & SEWAGE	D-20 - D-23
WINDOW, VENT & EXTERIOR DOOR	D-24 - E-14
WINDSHIELD & WIPER	E-15 - E-16

CHASSIS GROUP

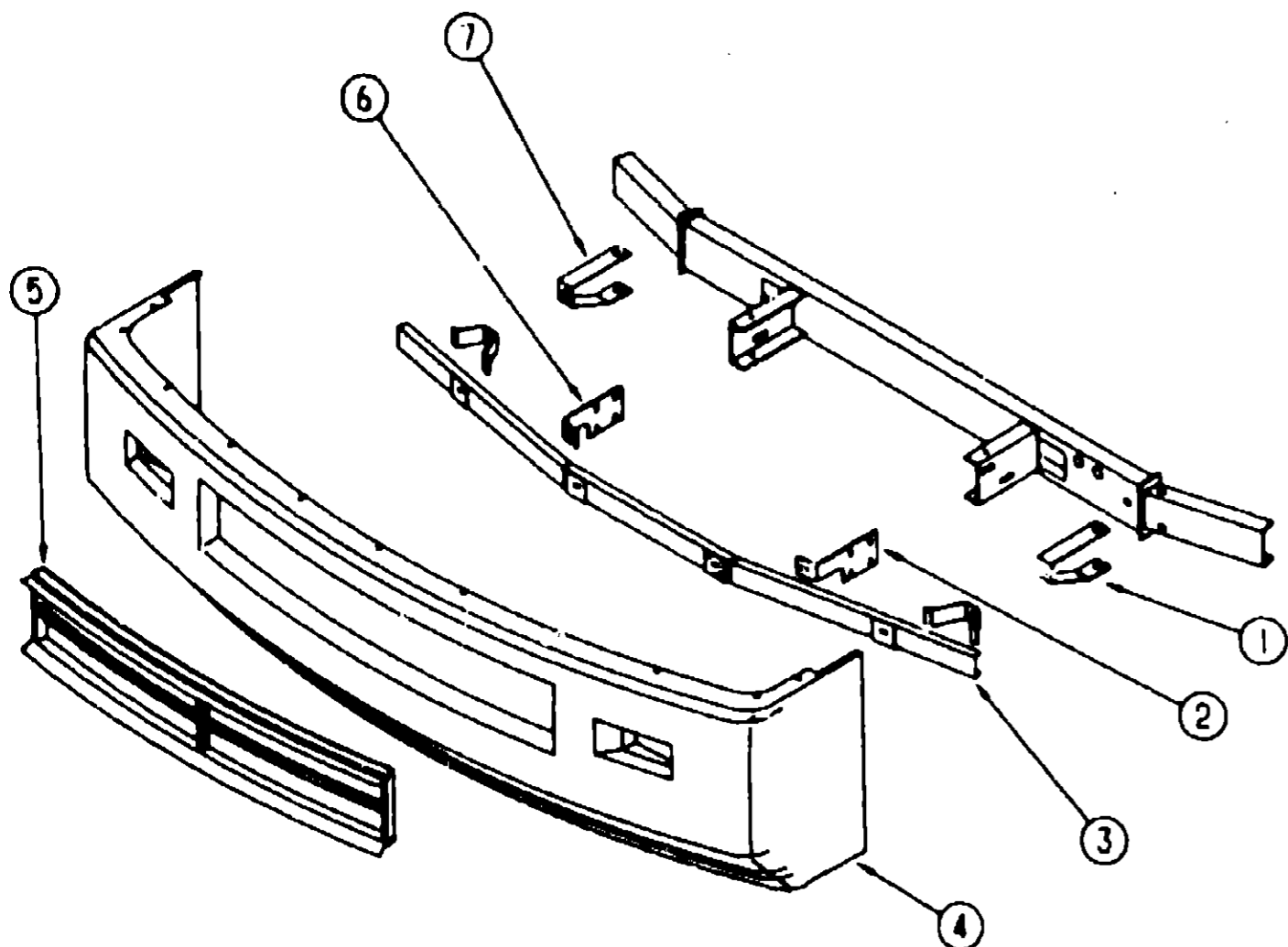

FRONT BUMPER

KEY	PART NUMBER	U/M DESCRIPTION
1	103611-01-000	EA BRACE - BUMPER - FRONT
2	086140-04-000	EA SUPPORT - FRONT BUMPER - DRIVER SIDE - 9 1" X 4" - STEEL
3	103512-01-000	EA CHANNEL ASM - BUMPER
4	104661-01-D12	EA BUMPER PANEL ASM - FRONT
5	104318-02-C07	EA GRILL ASM.
6	086140-03-000	EA SUPPORT - FRONT BUMPER - PASSENGER SIDE - 9 1" X 4" - STEEL
7	103497-01-000	EA BRACE - BUMPER - FRONT
	106065-01-06A	EA TRIM - BUMPER END CAP - DRIVER/PASSENGER SIDE

CHASSIS GROUP (CONTINUED)

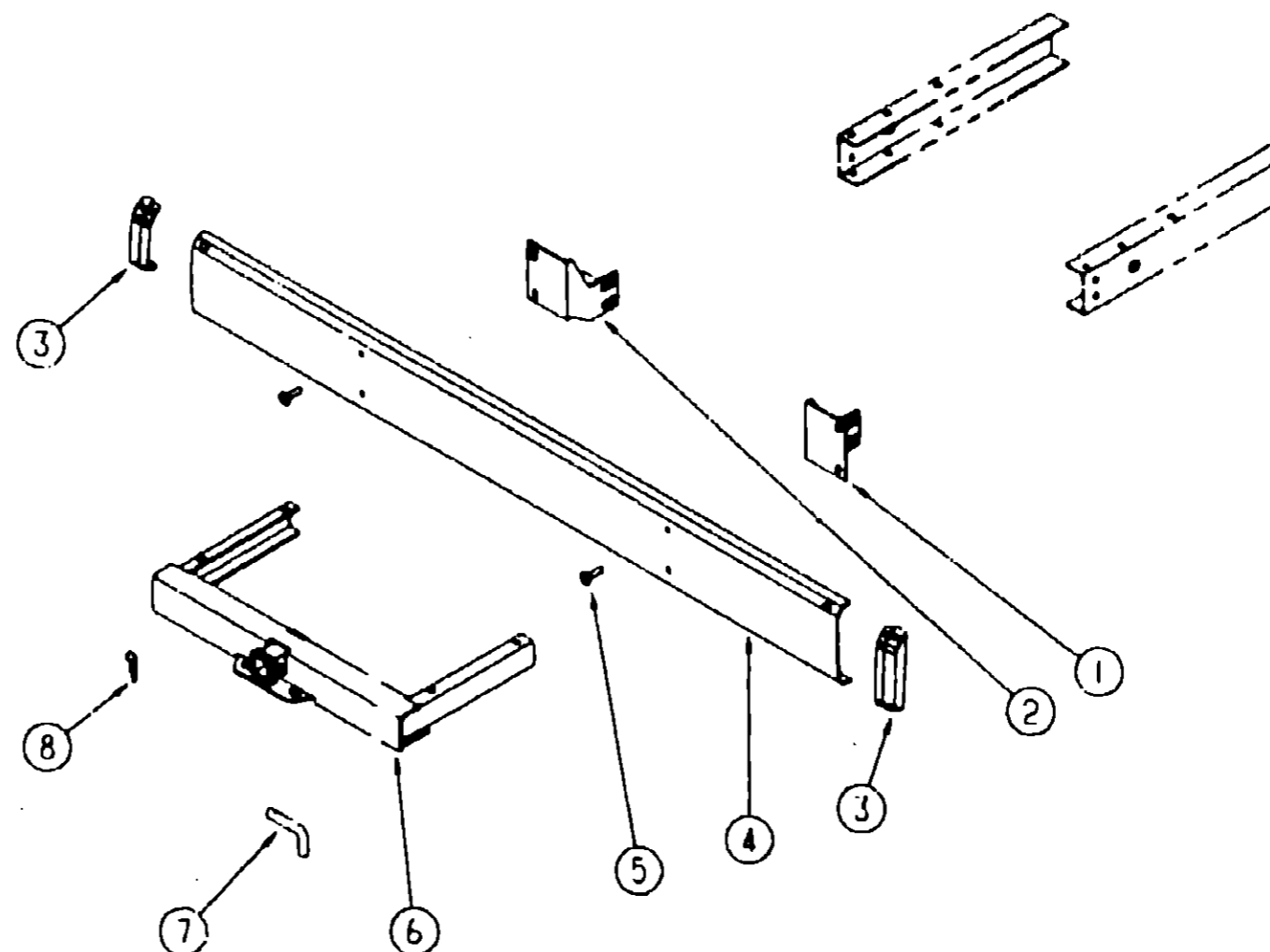

REAR BUMPER

KEY	PART NUMBER	U/M DESCRIPTION
1	104418-01-000	EA ANGLE - SUPPORT - BUMPER REAR
2	104418-02-000	EA ANGLE - SUPPORT - BUMPER REAR
3	103228-01-05A	EA END CAP - BUMPER REAR - BLACK
4	103099-01-04A	EA REAR BUMPER - ASH GRAY
5	102333-01-02A	EA BOLT - 7/16"
6	077617-01-000	EA HITCH ASM
7	034512-01-000	EA PIN
8	034513-01-000	EA PIN - 3/16" WIRE

**1993 ITASCA
TABLE OF CONTENTS**

INTRODUCTION	A-01 - A-02
ABBREVIATIONS	A-03
ALPHABETICAL INDEX	A-04 - A-06
ICG32RQ	A-07 - E-16

1993 ICG32RQ INDEX

FLOOR PLAN	A-07 - A-08
ACCESSORIES	A-09
AUDIO VIDEO	A-10 - A-11
BATH	A-12 - A-14
BEDROOM	A-15 - A-16
CHASSIS	A-17 - B-06
CURTAIN & CUSHION	B-07 - B-17
DINETTE	B-18 - B-20
DRIVERS COMPARTMENT	B-21 - B-24
ELECTRICAL	C-01 - C-06
EXTERIOR BODY	C-07 - C-14
GALLEY	C-15 - C-18
GENERATOR	C-19 - C-20
HEATING & A/C	C-21 - C-24
INTERIOR FINISH	D-01 - D-04
LABELS	D-05 - D-12
LP	D-13
LOUNGE	D-14 - D-16
SEALANTS & FASTENERS	D-17 - D-19
WATER & SEWAGE	D-20 - D-23
WINDOW, VENT &	
EXTERIOR DOOR	D-24 - E-14
WINDSHIELD & WIPER	E-15 - E-16

CHASSIS GROUP (CONTINUED)

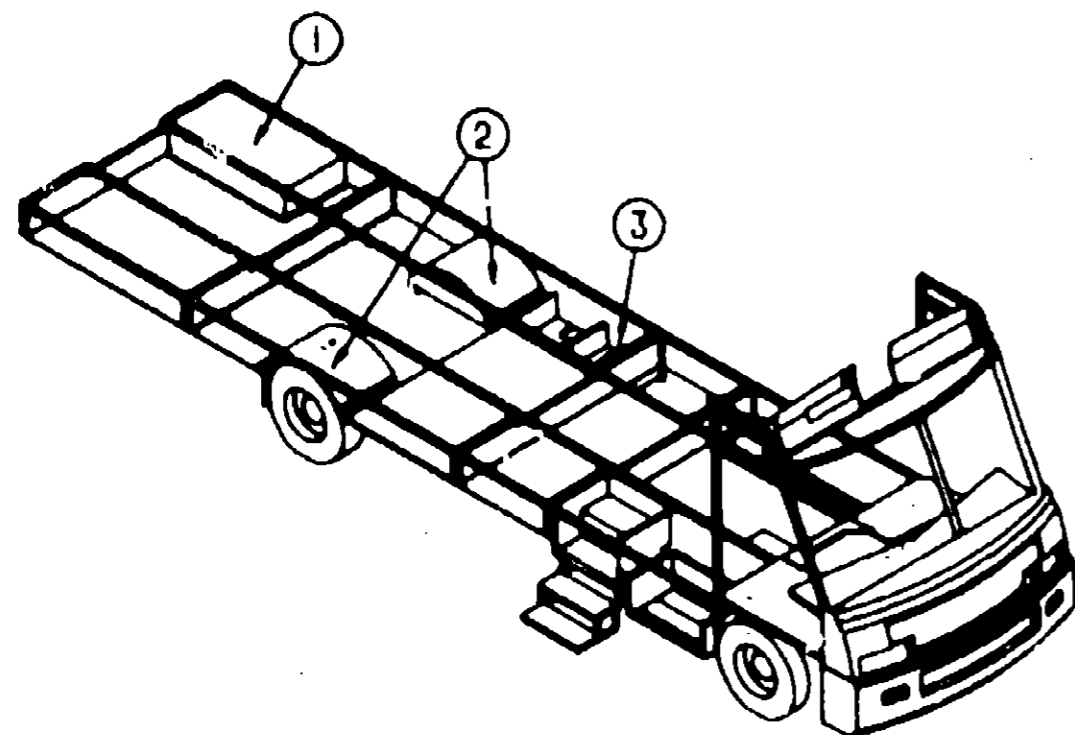

COMPARTMENTS & TRAYS

KEY	PART NUMBER	U/M DESCRIPTION
1	094657-02-000	EA TRAY - GENERATOR - 22.5' X 30.4' X 6.9' W/ANGLE & NUTS
2	055374-01-000	EA REAR WHEELWELL - PLASTIC
3	104742-01-007	EA STORAGE COMPARTMENT ASM
	092887-01-000	EA HATCH - COMPARTMENT - SEWER HOSE - 6"
	092887-03-000	EA CAP - TWIST HATCH - SEWER HOSE - 4" ID - BEIGE
	092887-04-000	EA CHAIN - TWIST CAP - 9"
	093287-03-01A	EA NET - CARGO
	065450-05-000	EA TIEDOWN-BATTERY - 8.4' TUBE
	017516-01-000	EA FLAP - MUD - 14" X 18" - BLACK
	020187-05-000	EA GUARD - DIRT

HYDRAULIC LEVELING SYSTEM & GAS SHOCKS (CHEVY)

KEY	PART NUMBER	U/M DESCRIPTION
	100532-02-000	EA LEVELING SYSTEM - HYDRAULIC HWH AP8156
	100533-05-000	EA BRACKETS - FRONT LEVELING JACK HWH AP7107
	100534-05-000	EA BRACKETS - REAR - LEVELING JACKS HWH AP6656
	100534-08-000	EA BRACKETS - REAR LEVELING JACK HWH AP0215
	100534-10-000	EA BRACKETS - REAR LEVELING JACK HWH AP0216
	100536-12-000	EA HOSE KIT - HWH AP0014

GAS SHOCKS (CHEVY)

KEY	PART NUMBER	U/M DESCRIPTION
	104983-01-000	EA SHOCK ABSORBER - GAS - P30 FRONT BILSTEIN B46-1173
	100332-01-000	EA PLATE - VALVE - AIR SPRING

HYDRAULIC LEVELING SYSTEM (FORD)

KEY	PART NUMBER	U/M DESCRIPTION
	100532-02-000	EA LEVELING SYSTEM - HYDRAULIC AP8156
	100533-08-000	EA BRACKETS - FRONT LEVELING JACK AP7160
	100534-08-000	EA BRACKETS - REAR LEVELING JACK AP6957
	100536-12-000	EA HOSE KIT AP0014

CHASSIS GROUP (CONTINUED)

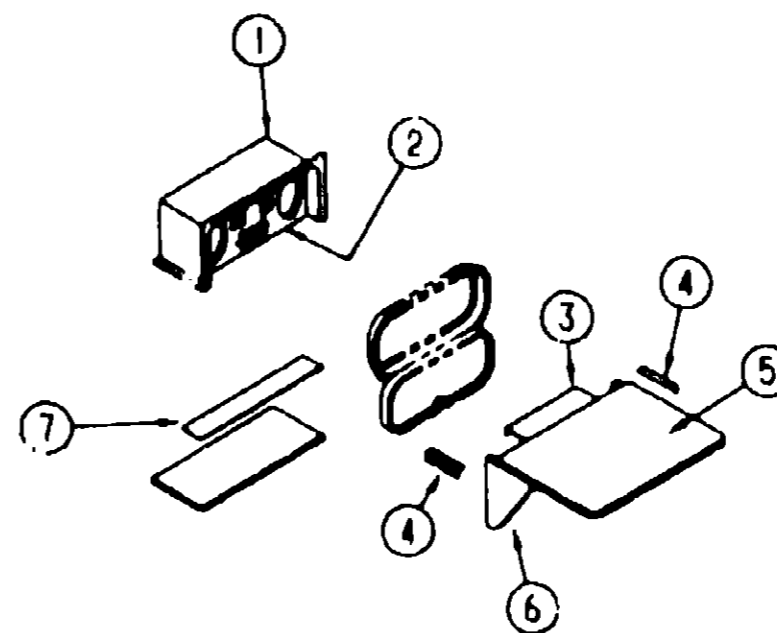

COMPARTMENT (ENTERTAINMENT CENTER)

KEY	PART NUMBER	U/M DESCRIPTION
1	104897-01-01A	EA BOX - ENTERTAINMENT CENTER - OFF WHITE (US)
1	104897-03-01A	EA BOX - ENTERTAINMENT CENTER - OFF WHITE (CSA)
2	104899-01-004	EA PLATE - RADIO MOUNTING
3	105377-01-01A	EA BRACKET - TABLE HANGER OFF WHITE
4	105376-01-02A	EA HINGE - CONTINUED - 2"X140MM OFF WHITE
5	105230-11-D05	EA SHELF ASM
6	105230-12-D09	EA SUPPORT ASM
	105230-01-D09	EA SHELF & SUPPORT ASM
7	104898-01-01A	EA PLATE - PLASTIC BOTTOM - OFF WHITE (CSA)
7	104898-02-01A	EA PLATE - PLASTIC BOTTOM - OFF WHITE (US)

STEP ASSEMBLIES

KEY	PART NUMBER	U/M DESCRIPTION
	094707-01-01A	EA STEP - DC'BLE - ELECTRIC KWIKEE 3218
	041250-01-000	EA SWITCH - PUSH BUTTON - IN DOOR JAMB - METAL - CHROME
	094707-02-700	EA MOTOR REPLACEMENT KIT - MODELS 32 & 28 KWIKEE 9520
	094707-02-701	EA LINKAGE ASM - MODEL 32 KWIKEE 9523
	094707-02-702	EA GEAR KIT KWIKEE 9525
	094707-02-703	EA PARTS KIT (BEARINGS & PINS) KWIKEE 9530
	094707-02-704	EA CONNECTOR KIT - MOTOR KWIKEE 9537
	094707-02-705	EA CONTROL UNIT (ORANGE) KWIKEE 9513
	077848-01-000	EA STEP-PULLOUT - WBRACKETS - BLACK

**1993 ITASCA
TABLE OF CONTENTS**

INTRODUCTION	A-01 - A-02
ABBREVIATIONS	A-03
ALPHABETICAL INDEX	A-04 - A-06
ICG32RO	A-07 - E-16

1993 ICG32RO INDEX

FLOOR PLAN	A-07 - A-08
ACCESSORIES	A-09
AUDIO VIDEO	A-10 - A-11
BATH	A-12 - A-14
BEDROOM	A-15 - A-16
CHASSIS	A-17 - B-06
CURTAIN & CUSHION	B-07 - B-17
DINETTE	B-18 - B-20
DRIVERS COMPARTMENT	B-21 - B-24
ELECTRICAL	C-01 - C-06
EXTERIOR BODY	C-07 - C-14
GALLEY	C-15 - C-18
GENERATOR	C-19 - C-20
HEATING & A/C	C-21 - C-24
INTERIOR FINISH	D-01 - D-04
LABELS	D-05 - D-12
LP	D-13
LOUNGE	D-14 - D-16
SEALANTS & FASTENERS	D-17 - D-19
WATER & SEWAGE	D-20 - D-23
WINDOW, VENT & EXTERIOR DOOR	D-24 - E-14
WINDSHIELD & WIPER	E-15 - E-16

CHASSIS GROUP (CONTINUED)

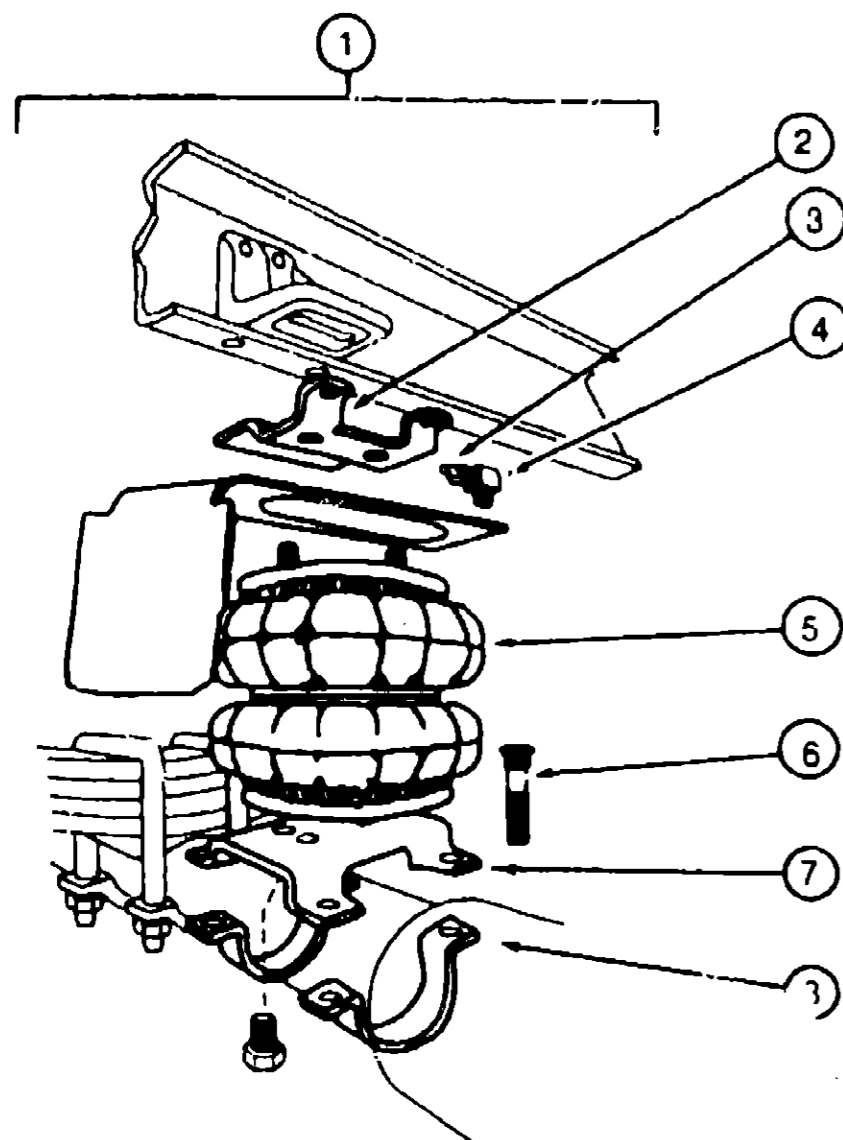

REAR AXLE AIRSPRING, CHEVY (FIRESTONE) (FROM: 00-00-00 THRU: 10-02-92)

KEY	PART NUMBER	U/M	DESCRIPTION	
1	084086-01-000	EA	BELLOW AIRSPRING ASM - REAR AXLE	WBA-89 OE
2	084086-01-706	EA	BRACKET - UPPER TO FRAME	21-0150
3	084086-01-701	EA	TUBING - DOT 1/4" X 18'	21-0938
4	084086-01-704	EA	CONNECTOR - ELBOW	21-0935
5	084086-01-700	EA	BELLOWS - AIRSPRING - AIR BAG ONLY	W21-760-0335
6	084086-01-702	EA	BOLT - RIBBED NECK - 3/8" X 2 5/8"	21-0829
7	084086-01-707	EA	BRACKET - LOWER - TOP	21-1162
8	084086-01-713	EA	BRACKET - AXLE STRAP	21-1163
	100332-01-000	EA	PLATE - VALVE - AIR SPRING	
	084086-01-708	EA	AIRLINE SERVICE KIT	W21-760-2012
	084086-01-709	EA	SHIELD - HEAT - 224 CR SYSTEM	21-1004
	084086-01-703	EA	VALVE - INFLATING - DOT 1/4" TUBING	21-0931
	084086-01-705	EA	PROTECTORS - TUBING	21-0899

CHASSIS GROUP (CONTINUED)

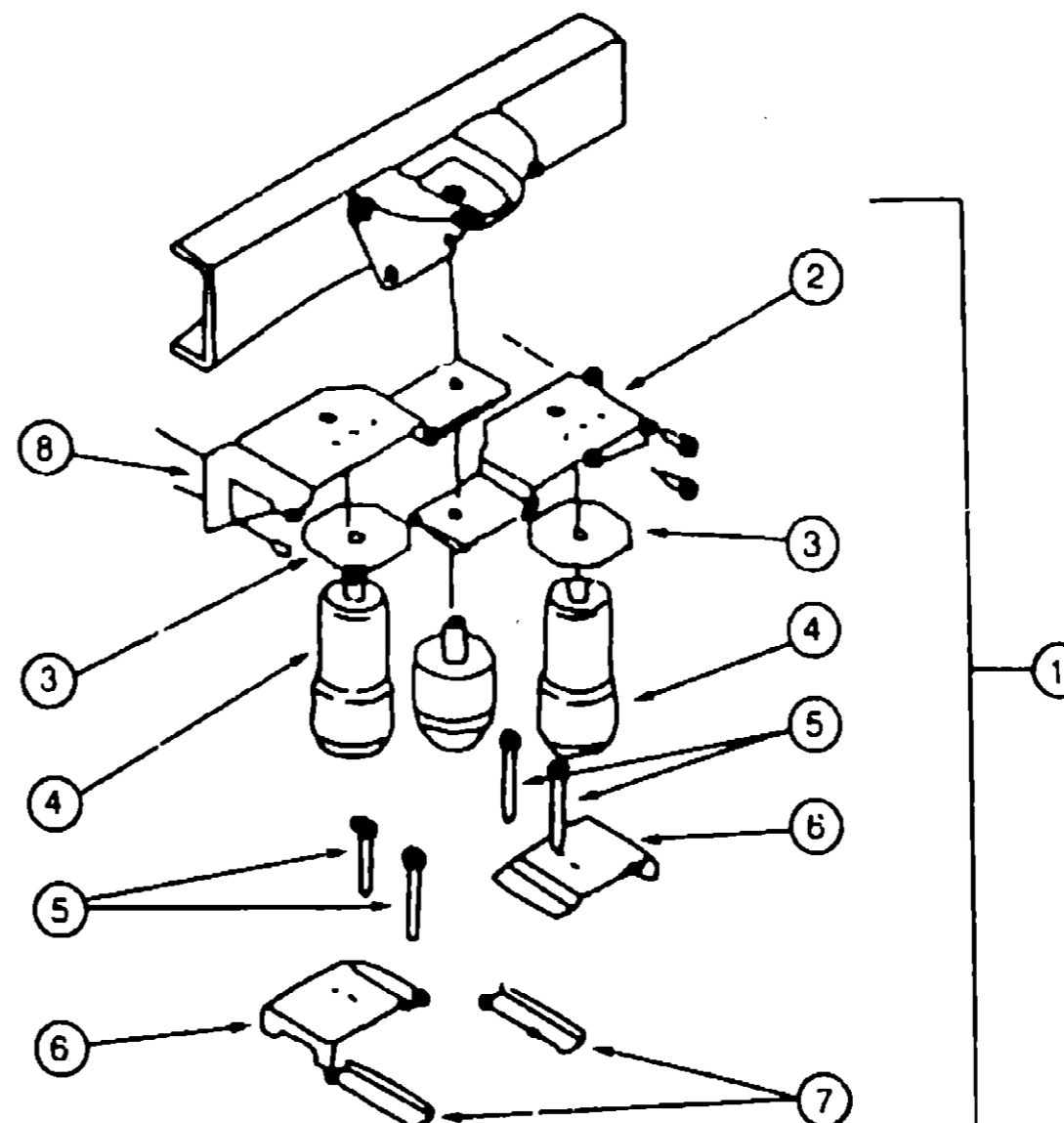

REAR AXLE AIRSPRING, CHEVY (RIDE RITE) (FROM: 10-03-92 THRU: 99-99-99)

KEY	PART NUMBER	U/M	DESCRIPTION	
1	084086-05-000	EA	AIRSPRING - RIDE RITE KIT	W217602075
2	084086-05-701	EA	UPPER BRACKET "A"	5097
3	084086-05-707	EA	SUPPORT PLATE	5099
4	084086-05-700	EA	BELLOWS ONLY (AIR BAG)	7012
5	084086-05-705	EA	CARRIAGE BOLT 3/8" 16X4 1/2"	21-0899
6	084086-05-703	EA	LOWER BRACKET	5098
7	084086-05-704	EA	BRACKET CLAMP	5086
8	084086-05-702	EA	UPPER BRACKET "B"	5096
	084086-05-706	EA	INFLATION VALVE	3032
	084086-01-701	EA	TUBING - DOT 1/4" X 18'	21-0938
	084086-05-708	EA	AIR LINE FITTING - BRASS TEE	21-3052

**1993 ITASCA
TABLE OF CONTENTS**

INTRODUCTION	A-01 - A-02
ABBREVIATIONS	A-03
ALPHABETICAL INDEX	A-04 - A-06
ICG32RQ	A-07 - E-16

1993 ICG32RQ INDEX

FLOOR PLAN	A-07 - A-08
ACCESSORIES	A-09
AUDIO VIDEO	A-10 - A-11
BATH	A-12 - A-14
BEDROOM	A-15 - A-16
CHASSIS	A-17 - B-06
CURTAIN & CUSHION	B-07 - B-17
DINETTE	B-18 - B-20
DRIVERS COMPARTMENT	B-21 - B-24
ELECTRICAL	C-01 - C-06
EXTERIOR BODY	C-07 - C-14
GALLEY	C-15 - C-18
GENERATOR	C-19 - C-20
HEATING & A/C	C-21 - C-24
INTERIOR FINISH	D-01 - D-04
LABELS	D-05 - D-12
LP	D-13
LOUNGE	D-14 - D-16
SEALANTS & FASTENERS	D-17 - D-19
WATER & SEWAGE	D-20 - D-23
WINDOW, VENT & EXTERIOR DOOR	D-24 - E-14
WINDSHIELD & WIPER	E-15 - E-16

CHASSIS GROUP (CONTINUED)

EXHAUST SYSTEM (FORD)

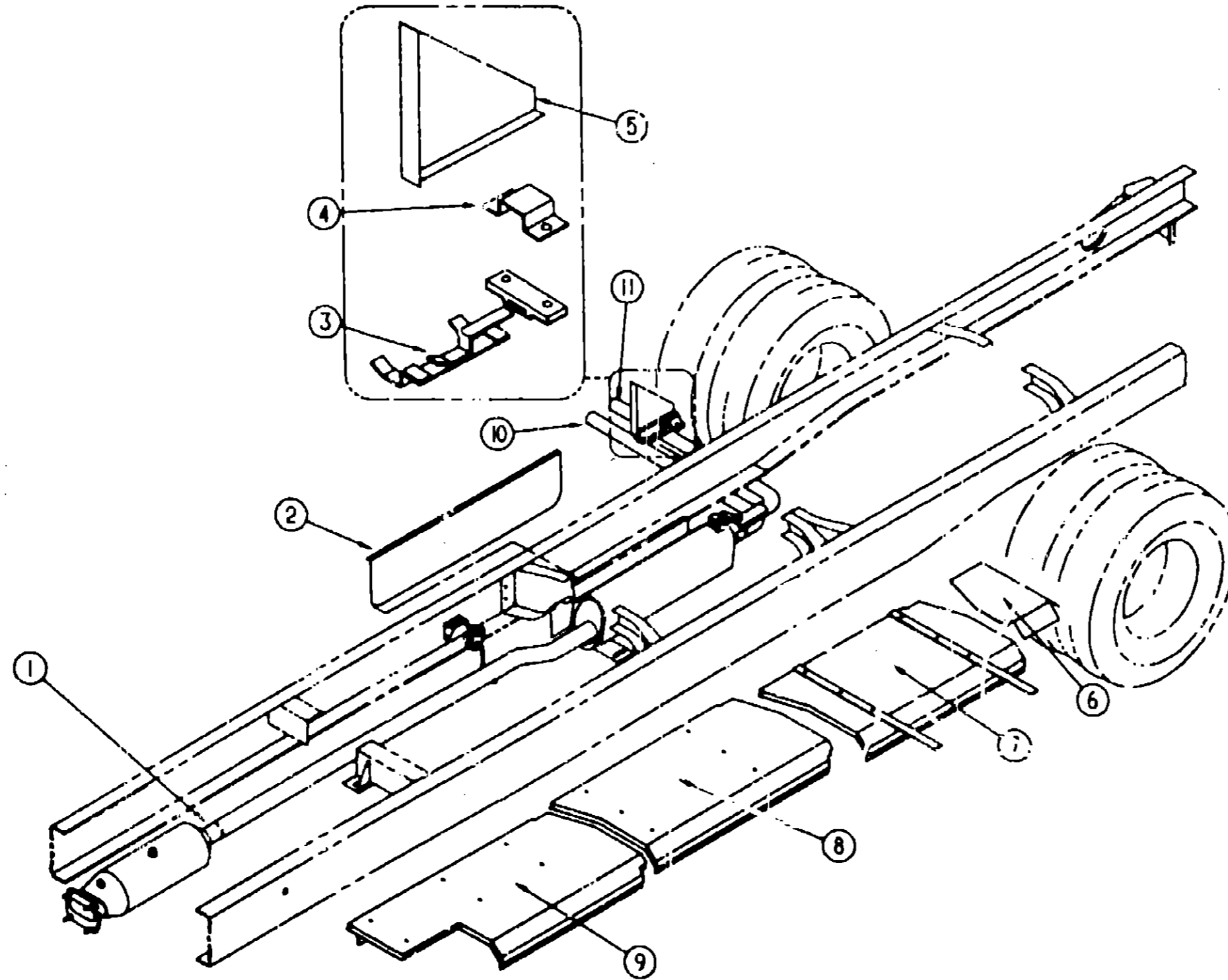

1993 ITASCA
TABLE OF CONTENTS

INTRODUCTION	A-01 - A-02
ABBREVIATIONS	A-03
ALPHABETICAL INDEX	A-04 - A-05
ICG32RQ	A-07 - E-16

1993 ICG32RQ INDEX

FLOOR PLAN	A-07 - A-08
ACCESSORIES	A-09
AUDIO VIDEO	A-10 - A-11
BATH	A-12 - A-14
BEDROOM	A-15 - A-16
CHASSIS	A-17 - B-06
CURTAIN & CUSHION	B-07 - B-17
DINETTE	B-18 - B-20
DRIVERS COMPARTMENT	B-21 - B-24
ELECTRICAL	C-01 - C-06
EXTERIOR BODY	C-07 - C-14
GALLEY	C-15 - C-18
GENERATOR	C-19 - C-20
HEATING & A/C	C-21 - C-24
INTERIOR FINISH	D-01 - D-04
LABELS	D-05 - D-12
LP	D-13
LOUNGE	D-14 - D-16
SEALANTS & FASTENERS	D-17 - D-19
WATER & SEWAGE	D-20 - D-23
WINDOW, VENT & EXTERIOR DOOR	D-24 - E-14
WINDSHIELD & WIPER	E-15 - E-16

KEY	PART NUMBER	U/M DESCRIPTION
1	094918-03-000	EA CLAMP - EXHAUST PIPE - 2.5"
	108084-01-000	EA PIPE - EXHAUST - STRAIGHT - FORD - 2.5 ID X 5"
2	075307-03-000	EA SHIELD - HEAT - LP
3	107887-01-000	EA HANGER ASM - EXHAUST
	007125-07-000	EA CLAMP - MUFFLER - 2.5" DIAMETER
4	095190-01-000	EA HANGER - EXHAUST - 4" X 1.4"
5	102117-03-000	EA HANGER ASM-TAILPIPE
6	099430-01-000	EA SHIELD - EXHAUST - REAR - 14" X 19.1" - FROM EDGE TO BEND
7	098795-06-000	EA SHIELD - EXHAUST 15.67" X 35.39"
8	098795-03-000	EA SHIELD - EXHAUST - GALVANIZED STEEL
9	098798-01-000	EA SHIELD - EXHAUST - CONVERTER
10	107755-01-000	EA TAIL PIPE - EXHAUST
11	107755-02-000	EA TAIL PIPE - EXHAUST
	098054-01-000	EA SUPPORT - EXHAUST PIPE - BENT - 2.6" X .8" - STEEL
	098443-03-000	EA SUPPORT - SHIELD - EXHAUST - 1.5" X 29.2" - STEEL - PRIMED

CHASSIS GROUP (CONTINUED)

EXHAUST SYSTEM (CHEVY)

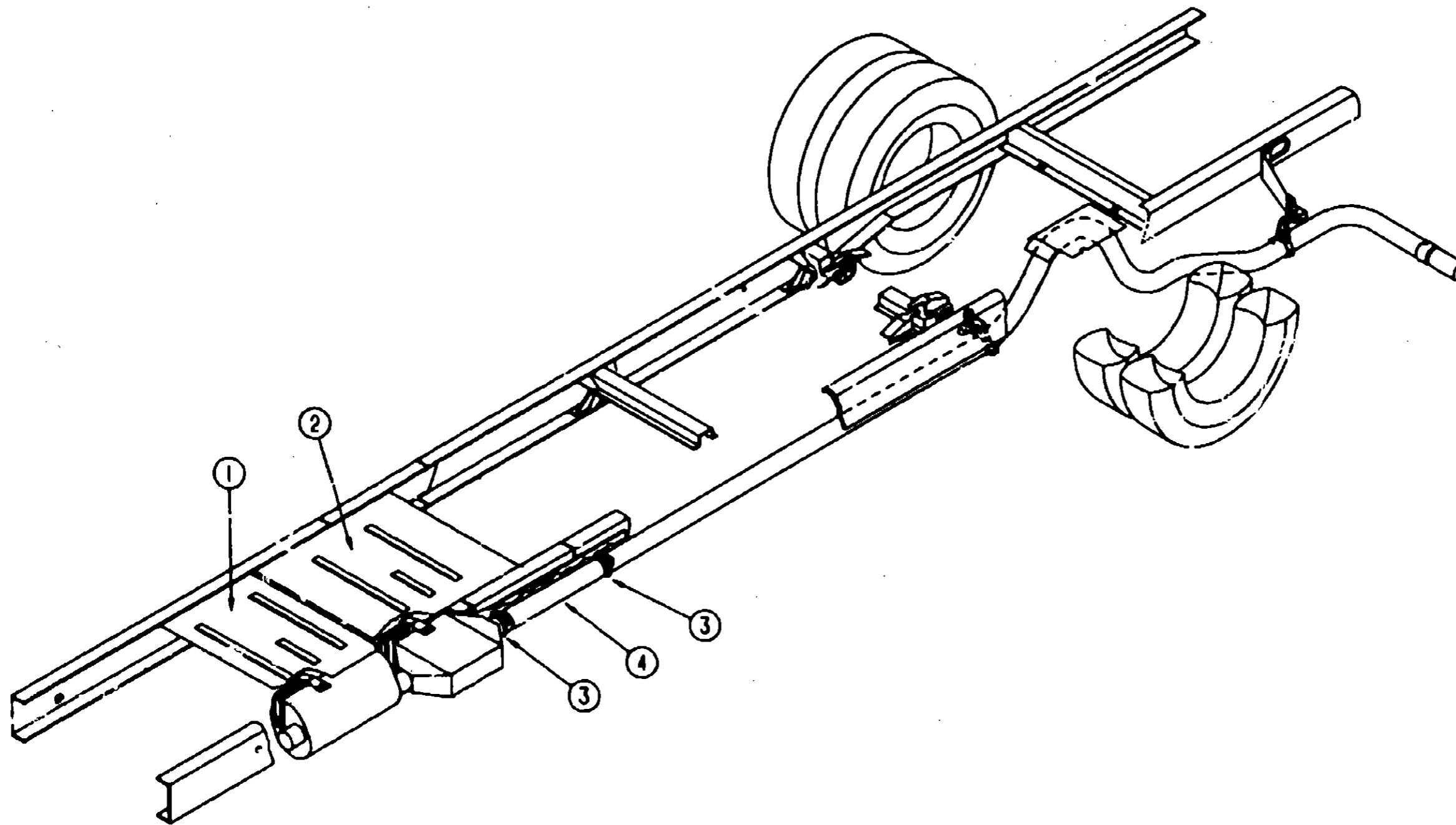

1983 ITASCA TABLE OF CONTENTS

INTRODUCTION	A-01 - A-02
ABBREVIATIONS	A-03
ALPHABETICAL INDEX	A-04 - A-06
ICG32RQ	A-07 - E-16

1983 ICG32RQ INDEX

FLOOR PLAN	A-07 - A-08
ACCESSORIES	A-09
AUDIO VIDEO	A-10 - A-11
BATH	A-12 - A-14
BEDROOM	A-15 - A-16
CHASSIS	A-17 - B-06
CURTAIN & CUSHION	B-07 - B-17
DINETTE	B-18 - B-20
DRIVERS COMPARTMENT	B-21 - B-24
ELECTRICAL	C-01 - C-06
EXTERIOR BODY	C-07 - C-14
GALLEY	C-15 - C-18
GENERATOR	C-19 - C-20
HEATING & A/C	C-21 - C-24
INTERIOR FINISH	D-01 - D-04
LABELS	D-05 - D-12
LP	D-13
LOUNGE	D-14 - D-16
SEALANTS & FASTENERS	D-17 - D-19
WATER & SEWAGE	D-20 - D-23
WINDOW, VENT &	
EXTERIOR DOOR	D-24 - E-14
WINDSHIELD & WIPER	F-15 - E-16

KEY	PART NUMBER	U/M DESCRIPTION
1	101544-01-000	EA SHIELD - HEAT - EXHAUST - 19.7" X 28.9" - STEEL
2	101544-02-000	EA SHIELD - HEAT - EXHAUST - 3.1" X 28.9" - STEEL
3	094918-01-000	EA CLAMP - EXHAUST - 3"
4	098762-05-000	EA PIPE - EXHAUST - STRAIGHT 3.0" X 7.9" LONG - S&T

CHASSIS GROUP (CONTINUED)

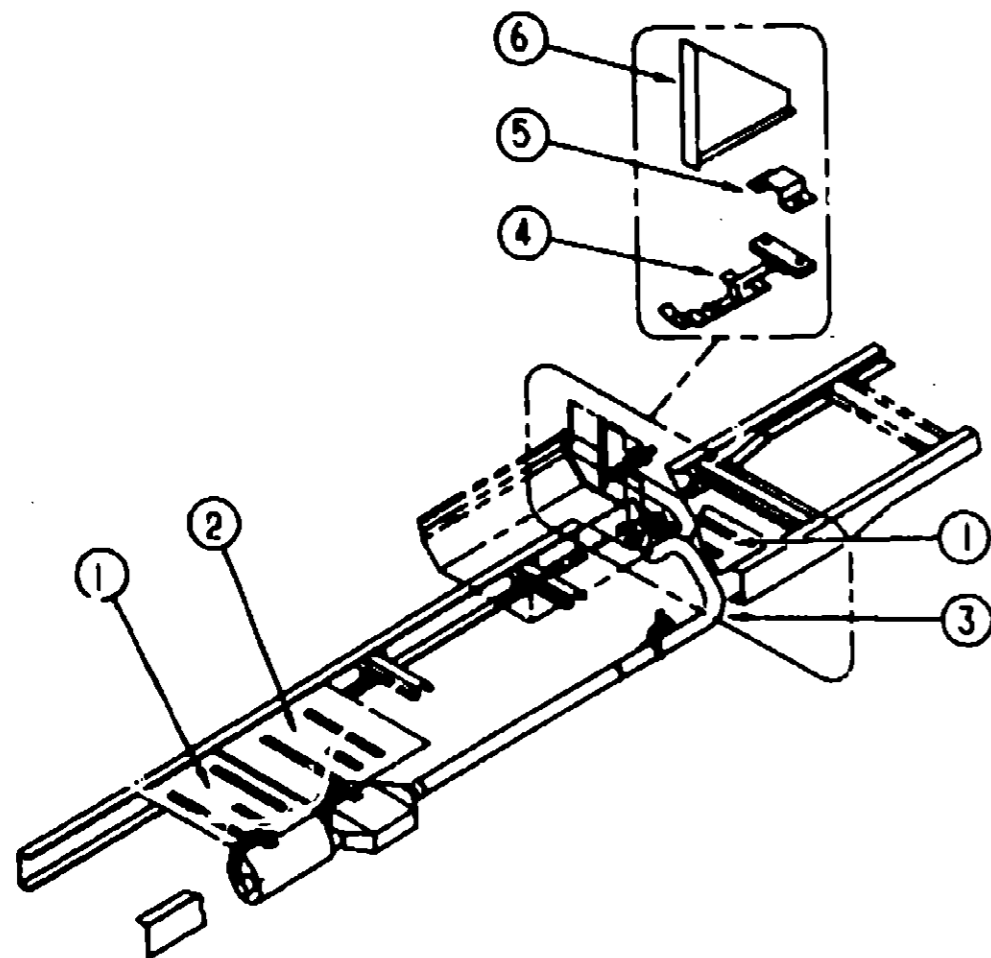

EXHAUST SYSTEM (CHEVY)

KEY	PART NUMBER	U/M DESCRIPTION
1	101544-01-000	EA SHIELD - HEAT - EXHAUST - 19.7" X 28.5" - STEEL
2	101544-02-000	EA SHIELD - HEAT - EXHAUST - 30" X 28.9" - STEEL
3	107754-01-000	EA PIPE - EXHAUST - TAIL
	094918-01-000	EA CLAMP - EXHAUST - 3"
	095223-03-000	EA BRACKET - LOWER
4	107887-01-000	EA HANGER ASM - EXHAUST
5	095190-01-000	EA HANGER - EXHAUST - 4" X 1.4"
6	102117-02-000	EA HANGER ASM - TAILPIPE

CHASSIS GROUP (CONTINUED)

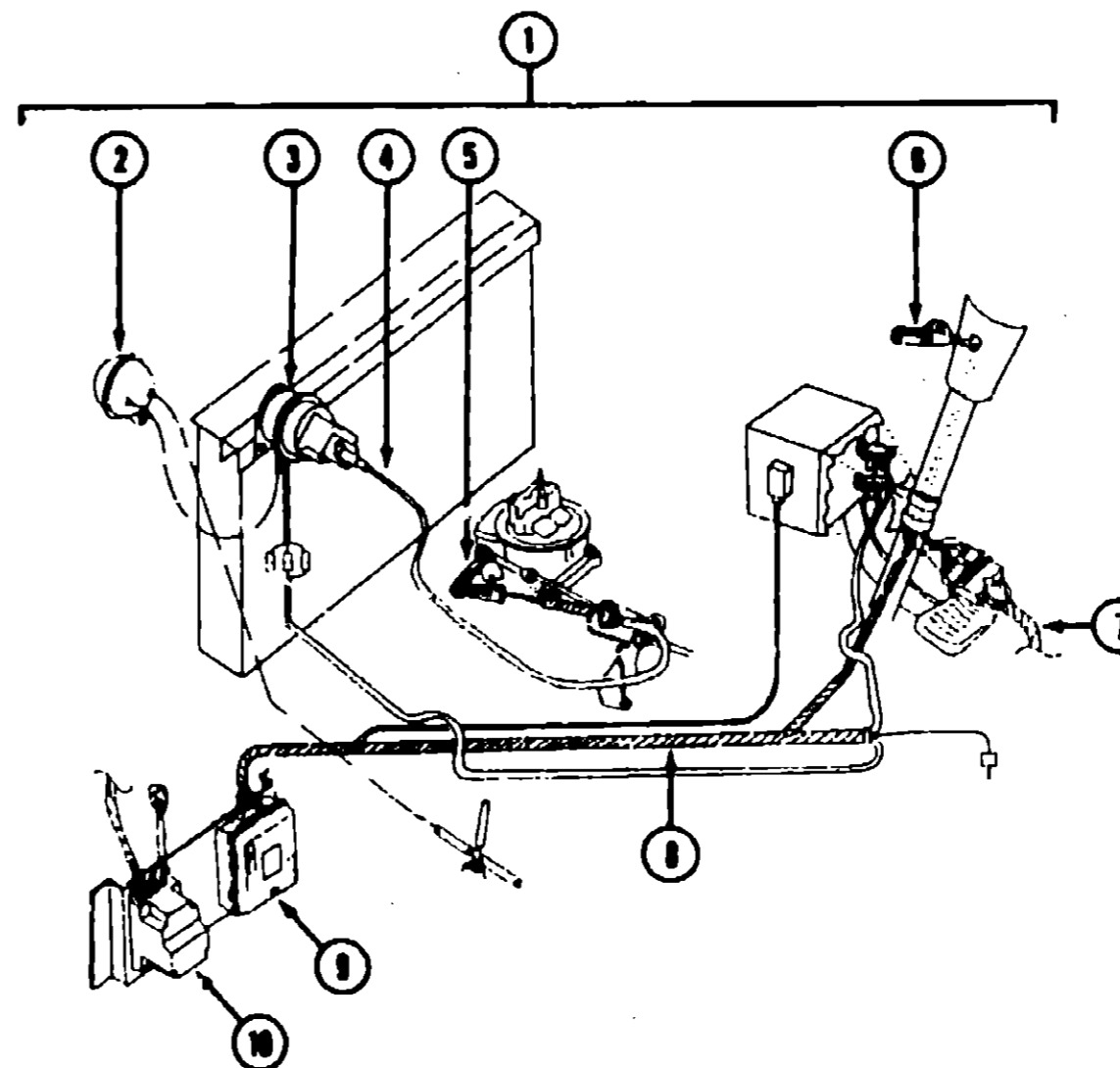

SPEED CONTROL (CHEVY)

KEY	PART NUMBER	U/M DESCRIPTION	DANA PART NUMBER
1	102362-01-000	EA SPEED CONTROL	DANA 59L-111010B
			FROM: 00-00-00 THRU: 10-01-92
			DANA 59L-111022-B
			FROM: 10-02-92 THRU: 99-99-99
1	102362-04-000	EA SPEED CONTROL	DANA 59C-02249
2	094369-01-705	EA VACUUM RESERVOIR	DANA 53D-11116-R
3	094369-01-706	EA SERVO	DANA 59C-03001
4	102362-01-700	EA SERVO CABLE	DANA 59A-02979
5	102362-01-706	EA THROTTLE STUD	DANA 53D-08X63-F
6	102362-01-707	EA SWITCH & LEVER - CONTROL	DANA 59C-02973
7	102362-01-703	EA HARNESS - PIVOT SW T() WIPER CONTROL	DANA 59D-02975
8	102362-01-704	EA HARNESS - MAIN WIRING	DANA 57C-08X13-R
9	102362-01-701	EA REGULATOR - ELECTRONIC	DANA 86C-00061
10	091907-01-702	EA WIPER CONTROL MODULE	DANA 59C-02291
	094863-01-704	EA HOUSING - 4 PIN	DANA 59A-02821
	102362-01-705	EA CLIP - THROTTLE RETAINER	

1993 ITASCA
TABLE OF CONTENTS

INTRODUCTION	A-01 - A-02
ABBREVIATIONS	A-03
ALPHABETICAL INDEX	A-04 - A-06
ICG32RQ	A-07 - E-16

1993 ICG32RQ INDEX

FLOOR PLAN	A-07 - A-08
ACCESSORIES	A-09
AUDIO VIDEO	A-10 - A-11
BATH	A-12 - A-14
BEDROOM	A-15 - A-16
CHASSIS	A-17 - B-06
CURTAIN & CUSHION	B-07 - B-17
DINETTE	B-18 - B-20
DRIVERS COMPARTMENT	B-21 - B-24
ELECTRICAL	C-01 - C-06
EXTERIOR BODY	C-07 - C-14
GALLEY	C-15 - C-18
GENERATOR	C-19 - C-20
HEATING & A/C	C-21 - C-24
INTERIOR FINISH	D-01 - D-04
LABELS	D-05 - D-12
LP	D-13
LOUNGE	D-14 - D-16
SEALANTS & FASTENERS	D-17 - D-19
WATER & SEWAGE	D-20 - D-23
WINDOW, VENT & EXTERIOR DOOR	D-24 - E-14
WINDSHIELD & WIPER	E-15 - E-16

CHASSIS GROUP (CONTINUED)

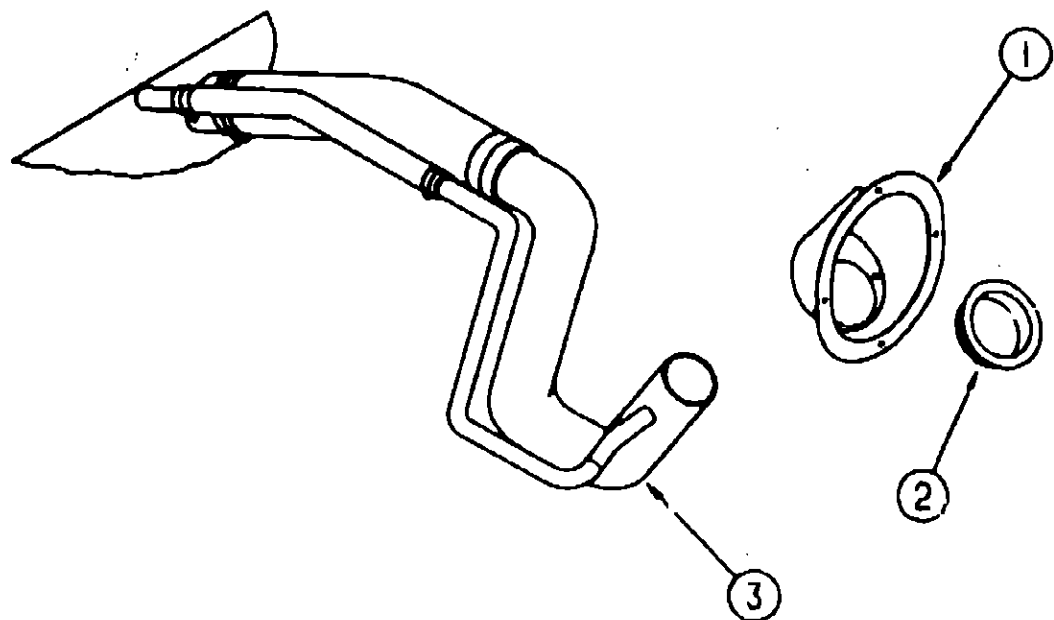

FUEL SYSTEM (FORD)

KEY	PART NUMBER	U/M DESCRIPTION
1	102951-01-04A	EA SHROUD - FUEL FILL - ASH GRAY
2	078200-01-000	EA GASKET - FUEL FILL - 3.5"OD X 2"ID
3	095607-01-000	EA NECK ASM - FUEL FILL
	007083-01-000	FT HOSE - GAS 1/4"ID X 1/2"OD
	075466-01-000	EA UNION - INVERTED FLARE TUBE - 1/4"
	075487-01-000	EA NUT - INVERTED FLARE - 1/4"
	084884-01-000	EA PLUG - BRASS - 3/8"

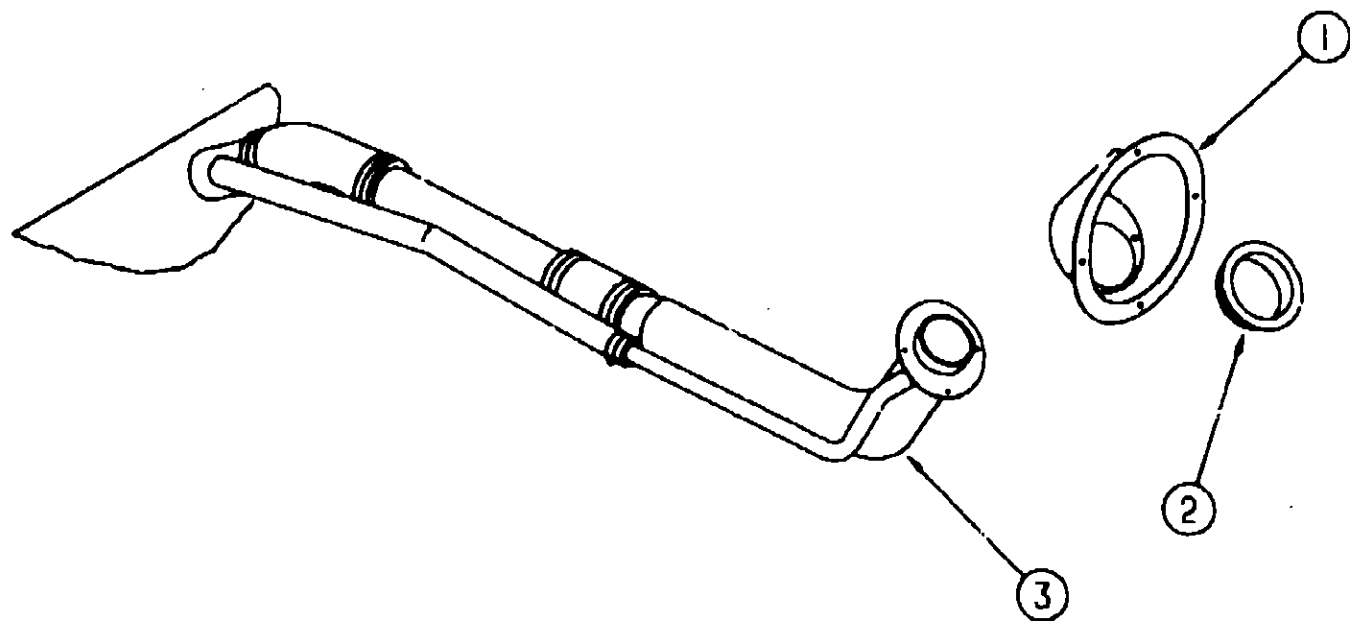

FUEL SYSTEM (CHEVY)

KEY	PART NUMBER	U/M DESCRIPTION
1	102951-01-02A	EA SHROUD - FUEL FILL - ASH GRAY
2	078200-01-000	EA GASKET - FUEL FILL - 3.5"OD X 2"ID
3	087258-02-000	EA NECK ASM - FUEL FILL
	007083-01-000	FT HOSE - GAS 1/4"ID X 1/2"OD
	075466-01-000	EA UNION - INVERTED FLARE TUBE - 1/4"
	084884-01-000	EA PLUG - BRASS - 3/8"

CHASSIS GROUP (CONTINUED)

TIRE & WHEEL HARDWARE (FORD)

KEY	PART NUMBER	U/M DESCRIPTION
	077030-02-000	EA EXTENSION-VALVE STEM - 1.25"
	091209-08-000	EA WHEEL LINER SET W/FRONT HUB COVER 16" (SET OF 4)
	091209-08-700	EA LINER - WHEEL - FRONT - 16" KAPER
	091209-08-701	EA LINER - WHEEL - REAR - 16" KAPER
	091209-06-702	EA COVER - AXLE - FRONT - 16" KAPER
	091209-06-703	EA COVER - AXLE - REAR - 16" KAPER
	091209-06-704	EA COVER - LUG NUT - 16" KAPER
	091209-08-700	EA LINER - WHEEL - 16" FRONT W/AXLE COVER - 10 LUG
	091209-08-701	EA LINER - WHEEL - 16" REAR - 10 LUG
	091209-08-702	EA COVER - AXLE - 16" REAR
	091209-01-704	EA COVER - LUG NUT
	095012-03-000	EA EXTENSION - VALVE STEM - DUAL WHEEL
	095012-04-000	EA STABILIZER - VALVE EXTENSION
	051377-05-000	EA VALVE STEM ASM. - VS938
	083425-02-000	EA TIRE - MICHELIN - LT235/85R16 LRE
	083425-05-000	EA TIRE - MICHELIN - LT235/85R16 LRE - XPS RIB
	095853-01-000	EA WHEEL - STEEL - 16"X 6K - E8TZ - 1015 - A
	098532-01-000	EA COVER - WHEEL - FORD - 16" - SET OF 4
	098532-01-700	EA COVER - LUG NUT - CHROME
	098532-01-701	EA COVER - WHEEL - 16"
	091209-10-704	EA JAM NUT

TIRE & WHEEL HARDWARE (CHEVY)

KEY	PART NUMBER	U/M DESCRIPTION
	091209-01-000	EA LINER - WHEEL - 19.5" - SST - SET OF 4 - KAPER 1954-10N
	091209-01-700	EA LINER - WHEEL - 19.5" FRONT - 10 LUG - CHEVY P-30
	091209-01-701	EA LINER - WHEEL - 19.5" REAR - 10 LUG - CHEVY P-30
	091209-01-702	EA COVER - AXLE - 19.5" FRONT - 10 LUG - CHEVY P-30
	091209-01-703	EA COVER - AXLE - 19.5" REAR - 10 LUG - CHEVY P-30
	091209-01-704	EA COVER - LUG NUT
	077030-02-000	EA EXTENSION - VALVE STEM - 1.25"
	095012-03-000	EA EXTENSION - VALVE STEM - DUAL WHEEL
	095012-04-000	EA STABILIZER - VALVE EXTENSION - DICOR AG-STA-2
	109443-01-000	EA WHEEL - COVER 4/SET 19.5 W/HDW
	109443-01-700	EA WHEEL - COVER 19.5 - 1EA = 1 ONLY - FRONT & REAR - SHAG95 LONLY DICOR
	109443-01-701	EA SET - BRACKET - 1 FRONT WHEEL - SHAG95-FBS DICOR
	109443-01-702	EA SET - BRACKET - 1 REAR WHEEL - SHAG95-RBS DICOR
	109443-01-703	EA CAP - CENTER - HUB - DICORE
	007324-04-000	EA TIRE - 8R19.5 LRD - MICHELIN XZA
	051377-01-000	EA STEM - VALVE - TR 500
	091209-10-704	EA JAM NUT

**1993 ITASCA
TABLE OF CONTENTS**

INTRODUCTION	A-01 - A-02
ABBREVIATIONS	A-03
ALPHABETICAL INDEX	A-04 - A-06
ICG32RQ	A-07 - E-16

1993 ICG32RQ INDEX

FLOOR PLAN	A-07 - A-08
ACCESSORIES	A-09
AUDIO VIDEO	A-10 - A-11
BATH	A-12 - A-14
BEDROOM	A-15 - A-16
CHASSIS	A-17 - B-06
CURTAIN & CUSHION	B-07 - B-17
DINETTE	B-18 - B-20
DRIVERS COMPARTMENT	B-21 - B-24
ELECTRICAL	C-01 - C-08
EXTERIOR BODY	C-07 - C-14
GALLEY	C-15 - C-18
GENERATOR	C-19 - C-20
HEATING & A/C	C-21 - C-24
INTERIOR FINISH	D-01 - D-04
LABELS	D-05 - D-12
LP	D-13
LOUNGE	D-14 - D-16
SEALANTS & FASTENERS	D-17 - D-19
WATER & SEWAGE	D-20 - D-23
WINDOW, VENT & EXTERIOR DOOR	D-24 - E-14
WINDSHIELD & WIPEH	E-15 - E-16

CURTAIN & CUSHION GROUP

NOTICE

IN ORDER TO ASSIST OUR PARTS SALES DEPT. IN PROVIDING INTERIOR SOFTGOODS ITEMS, PLEASE INCLUDE THE SERIAL NUMBER AND THE COLOR CODE NUMBER FROM THE VEHICLE CERTIFICATION LABEL WHEN ORDERING. THIS LABEL IS LOCATED ON THE LEFT SIDEWALL AT THE END OF THE DASH (A-BODY), OR ON THE DRIVER'S DOOR LATCH PLATE (C-BODY).

AN EXAMPLE OF A COLOR CODE NUMBER IS B07, WHICH DESIGNATES AN OVERALL COLOR SCHEME OF A PARTICULAR UNIT. THE COLOR LISTED AFTER THE ITEM DESCRIPTION ON THE MICROFICHE, INDICATES THE OVERALL UNIT COLOR. ORDER THE ITEM YOU DESIRE ACCORDING TO UNIT COLOR CODE.

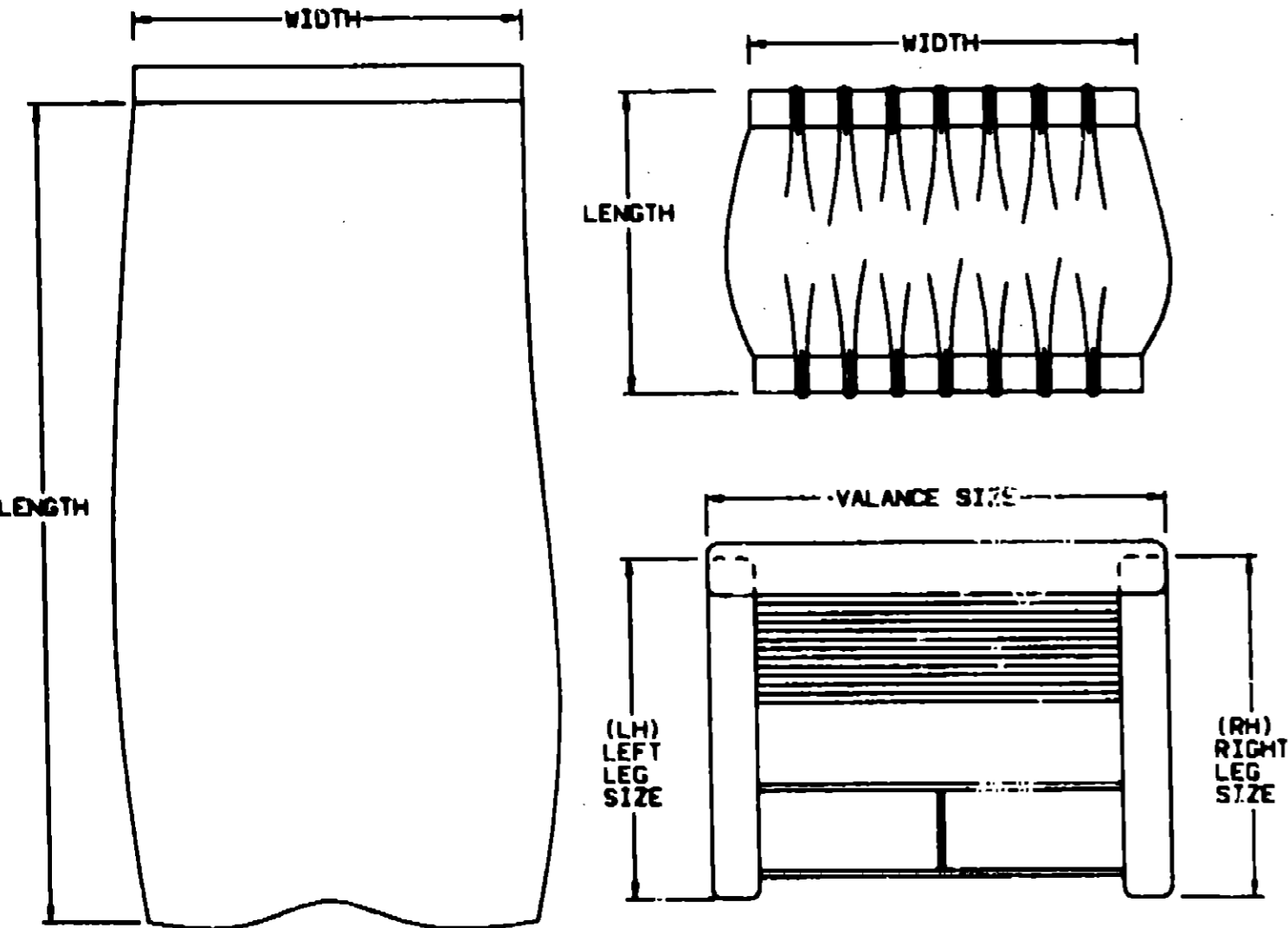

NOTE: USE THIS ILLUSTRATION WHEN DETERMINING LENGTH AND WIDTH MEASUREMENTS FOR CURTAINS. YOU WILL NOTE THE WIDTH MEASUREMENT IS TAKEN ON THE TOP OF THE CURTAIN WITH THE CURTAIN FULLY EXTENDED. THE LENGTH MEASUREMENT IS TAKEN FROM TOP TO BOTTOM. LEFT AND RIGHT WINDOW LEGS ARE DETERMINED WHEN FACING THE WINDOW.

CURTAIN & CUSHION GROUP (CONTINUED)

FABRIC & TRIMS

KEY	PART NUMBER	U/M DESCRIPTION
	072333-82-000	YD FABRIC - CURTAIN - 54" WIDE - BEIGE
	072333-88-000	YD FABRIC - DRAPERY - GALAXY ANTIQUE
	075244-06-000	YD FABRIC - VINYL - SHOWER CURTAIN - 72" WIDE - TEAL (D35)
	075244-07-000	YD FABRIC - VINYL - SHOWER CURTAIN - 72" WIDE - EGGPLANT (D36)
	089351-03-000	YD VINYL - CEILING - DIAMOND DESIGN - 54" WIDE
	103907-01-01A	YD FABRIC - VINYL - 54" WIDE - OFF WHITE
	103907-01-02A	YD VINYL - EXPANDED MADRID GRAY - 26 OZ. 54" X ROLL
	079680-07-000	YD FABRIC - VINYL - 54" WIDE - BEIGE
	079349-01-804	YD WELT ASM - ACCENT (D35)
	079349-01-D38	YD WELT ASM - ACCENT
	079349-01-D28	YD WELT ASM - NARROW - ACCENT (D35)
	079349-04-D36	YD WELT ASM - NARROW - ACCENT
	105745-19-000	YD FABRIC - BEDSPREAD - MAIN - JILLIAN - WOODROSE (D35)
	105745-22-000	YD FABRIC - BEDSPREAD - MAIN - PRINCETON - 25 MOONSTONE (D36)
	088273-66-000	YD FABRIC - BEDSPREAD - ACCENT - MECHELLE - GREEN MIST (D35)
	105745-13-000	YD FABRIC - BEDSPREAD - ACCENT - MECHELLE - BERRY (D36)
	104233-30-000	YD FABRIC - UPHOLSTERY - PLAIN ACCENT (BUCKET SEAT) (D35)
	104233-90-000	YD FABRIC - UPHOLSTERY - PLAIN ACCENT (BUCKET SEAT) (D36)
	104233-84-000	YD FABRIC - UPHOLSTERY - PATTERN ACCENT (MAP POCKET) (D35)
	104233-89-000	YD FABRIC - UPHOLSTERY - PATTERN ACCENT (MAP POCKET) (D36)
	104233-83-000	YD FABRIC - UPHOLSTERY - MAIN (DINETTE SEAT) (D35)
	096008-66-000	YD FABRIC - UPHOLSTERY - MAIN (DINETTE SEAT) (D36)
	057534-01-000	EA TIEBACK/TIEDOWN - BED/CURTAIN/DOOR - 6" - PLASTIC - CLEAR
	087272-01-000	YD DRAPERY LINING - 48" - IVORY
	087272-03-000	YD DRAPERY LINING - 54" - IVORY - ROCKLAND MILLS
	084415-45-000	YD BRAID TRIM - CURTAIN - TEAL (D35)
	084415-49-000	YD BRAID TRIM - CURTAIN - PLUM (D36)

FROM: 00-00-00 THRU: 09-30-92

FROM: 10-01-92 THRU: 99-99-99

1993 ITASCA TABLE OF CONTENTS

INTRODUCTION	A-01 - A-02
ABBREVIATIONS	A-03
ALPHABETICAL INDEX	A-04 - A-08
ICG32RQ	A-07 - E-18

1993 ICG32RQ INDEX

FLOOR PLAN	A-07 - A-08
ACCESSORIES	A-09
AUDIO VIDEO	A-10 - A-11
BATH	A-12 - A-14
BEDROOM	A-15 - A-16
CHASSIS	A-17 - B-06
CURTAIN & CUSHION	B-07 - B-17
DINETTE	B-18 - B-20
DRIVERS COMPARTMENT	B-21 - B-24
ELECTRICAL	C-01 - C-06
EXTERIOR BODY	C-07 - C-14
GALLEY	C-15 - C-18
GENERATOR	C-19 - C-20
HEATING & A/C	C-21 - C-24
INTERIOR FINISH	D-01 - D-04
LABELS	D-05 - D-12
LP	D-13
LOUNGE	D-14 - D-16
SEALANTS & FASTENERS	D-17 - D-19
WATER & SEWAGE	D-20 - D-23
WINDOW, VENT & EXTERIOR DOOR	D-24 - E-14
WINDSHIELD & WIPER	E-15 - E-18

CURTAIN & CUSHION GROUP (CONTINUED)

CURTAINS & WINDOW TREATMENT

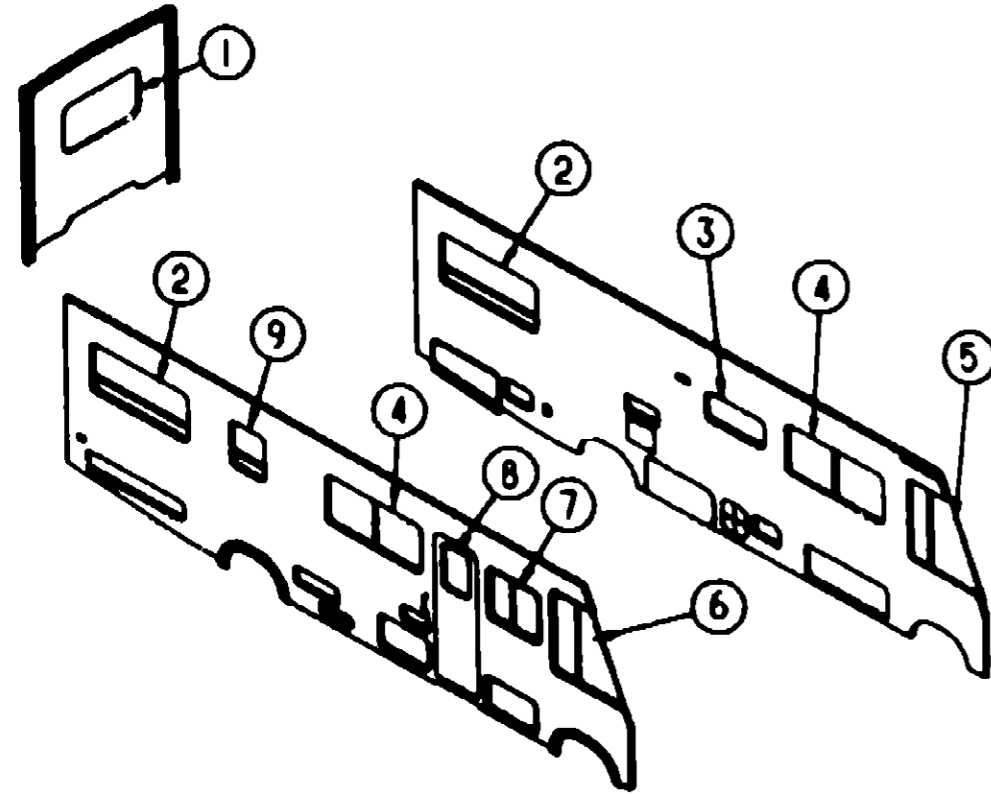

KEY	PART NUMBER	U/M DESCRIPTION
1	107788-07-D35	EA VALANCE ASM - 53" TWIST
1	107788-07-D36	EA VALANCE ASM - 53" TWIST
1	093475-95-01A	EA BLIND - MINI - 47.5" X 29" DROP
1	100281-82-D35	EA LEG - RIGHT - PLAIN - NO HOLE
1	100281-17-D36	EA LEG - RIGHT - PLAIN - NO HOLE
1	100281-83-D35	EA LEG - LEFT - PLAIN - NO HOLE
1	100281-18-D36	EA LEG - LEFT - PLAIN - NO HOLE
2	107788-12-D35	EA VALANCE ASM - 50" TWIST
2	107788-12-D36	EA VALANCE ASM - 58" TWIST
2	109041-05-01A	EA BLIND - MINI - 51" X 33" DROP
2	109234-01-D35	EA LEG - RIGHT - 31.5" - PLAIN - W/HOLE
2	100281-19-D36	EA LEG - RIGHT - 31.5" - PLAIN - W/HOLE
2	109234-02-D35	EA LEG - LEFT - 31.5" - PLAIN - W/HOLE
2	100281-20-D36	EA LEG - LEFT - 31.5" - PLAIN - W/HOLE
3	093475-88-04A	EA MINI BLIND - 38"X18 5" DROP
4	105906-01-04A	EA BLIND - WOVEN WOOD - 64"X31" (D35)
4	105906-03-04A	EA BLIND - WOVEN WOOD - 64"X31" (D36)
5	101668-35-D12	EA CURTAIN ASM - 48"X80" - DRIVER SIDE - TAPE TOP (D35)
5	101668-35-D36	EA CURTAIN ASM - 48"X80" - DRIVER SIDE - TAPE TOP
6	101668-34-D12	EA CURTAIN ASM - 48"X80" - PASSENGER SIDE - TAPE TOP (D35)
6	101668-34-D36	EA CURTAIN ASM - 48"X80" - PASSENGER SIDE - TAPE TOP
6	073280-42-D10	EA TIEBACK ASM - 6"X18" (D35)
6	073280-42-D36	EA TIEBACK ASM - 6"X18"
7	105906-02-03A	EA BLIND - WOVEN WOOD - 34"X31" (D35)
7	105906-04-04A	EA BLIND - WOVEN WOOD - 34"X31" (D36)
8	084755-57-DA4	EA PULL SHADE ASM - 27 25"
8	084755-57-DA5	EA PULL SHADE ASM - 27 25"
9	093475-87-04A	EA MINI BLIND - 24"X29" DROP
	084481-25-D35	EA CURTAIN ASM - SHOWER - 67" X 38"
	084481-25-D36	EA CURTAIN ASM - SHOWER - 67" X 38"

FROM: 00-00-00 THRU: 01-03-93

FROM: 01-04-93 THRU: 99-99-99

1993 ITASCA TABLE OF CONTENTS

INTRODUCTION	A-01 - A-02
ABBREVIATIONS	A-03
ALPHABETICAL INDEX	A-04 - A-06
ICG32RQ	A-07 - E-16

1993 ICG32RQ INDEX

FLOOR PLAN	A-07 - A-08
ACCESSORIES	A-09
AUDIO VIDEO	A-10 - A-11
BATH	A-12 - A-14
BEDROOM	A-15 - A-16
CHASSIS	A-17 - B-06
CURTAIN & CUSHION	B-07 - B-17
DINETTE	E-18 - B-20
DRIVERS COMPARTMENT	B-21 - B-24
ELECTRICAL	C-01 - C-05
EXTERIOR BODY	C-07 - C-14
GALLEY	C-15 - C-18
GENERATOR	C-19 - C-20
HEATING & A/C	C-21 - C-24
INTERIOR FINISH	D-01 - D-04
LABELS	D-05 - D-12
LP	D-13
LOUNGE	D-14 - D-16
SEALANTS & FASTENERS	D-17 - D-19
WATER & SEWAGE	D-20 - D-23
WINDOW, VENT &	
EXTERIOR DOOR	D-24 - E-14
WINDSHIELD & WIPER	E-15 - E-16

CURTAIN & CUSHION GROUP (CONTINUED)

BUCKET SEAT

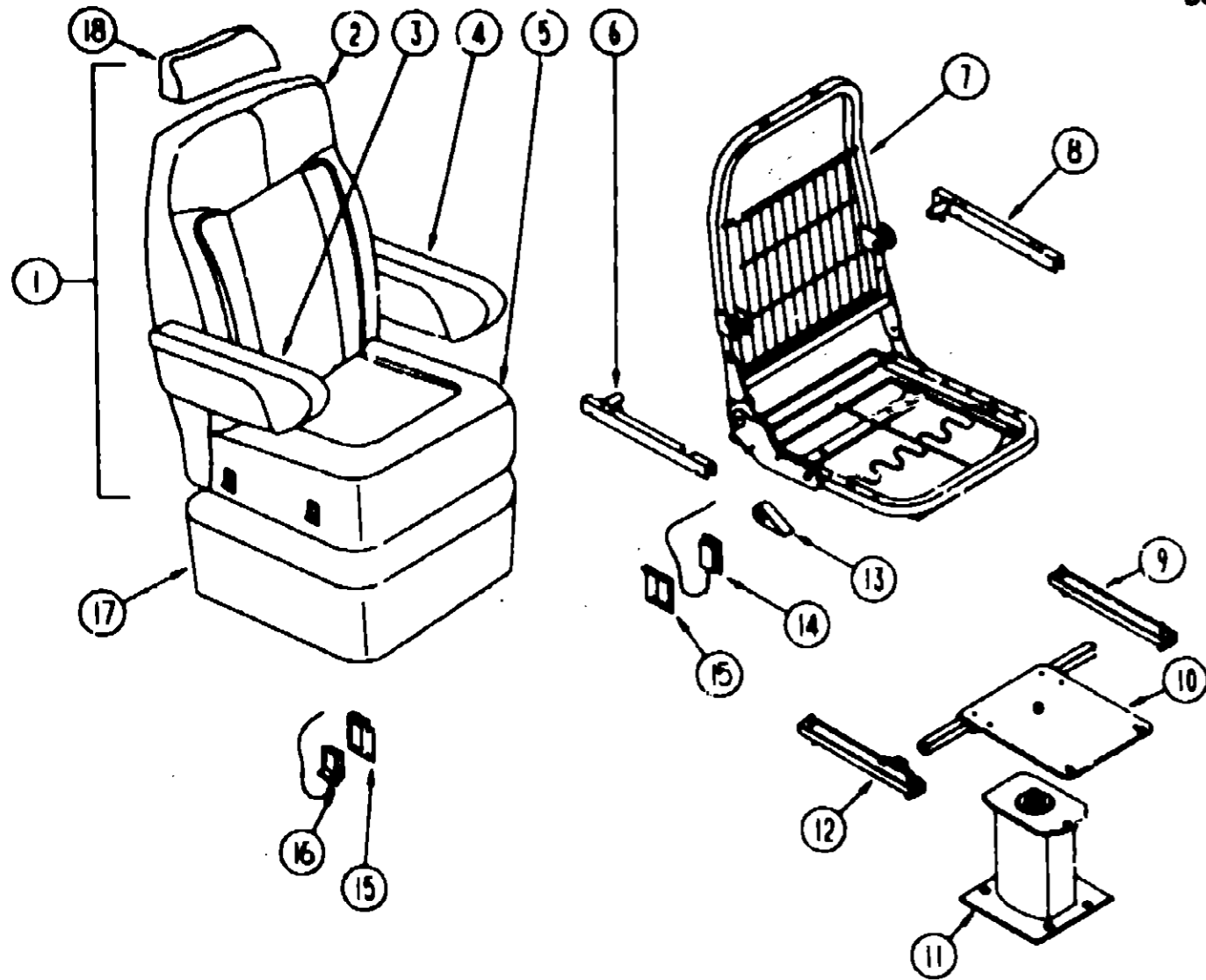

KEY	PART NUMBER	U/M DESCRIPTION
1	083450-39-D35	EA SEAT - ROYALE - W/HEAD & ARMREST (MANUAL RECLINE)
1	083450-42-D38	EA SEAT - ROYALE - W/HEAD & ARMREST (MANUAL RECLINE)
2	M03445-82-D35	EA COVER ASM. - BACK - ROYALE
2	M03445-86-D36	EA COVER ASM. - BACK - ROYALE
3	080243-49-D11	EA ARMREST ASM. - RIGHT HAND (D35)
3	080243-49-D36	EA ARMREST ASM. - RIGHT HAND
3	M80243-49-D11	EA COVER ASM. - ARM - RIGHT HAND (D35)
3	M80243-49-D36	EA COVER ASM. - ARM - RIGHT HAND
4	080243-50-D11	EA ARMREST ASM. - LEFT HAND (D35)
4	080243-50-D36	EA ARMREST ASM. - LEFT HAND
4	M80243-50-D11	EA COVER ASM. - ARM - LEFT HAND (D35)
4	M80243-50-D36	EA COVER ASM. - ARM - LEFT HAND
5	M03445-83-D35	EA COVER ASM. - SEAT
5	M03445-87-D36	EA COVER ASM. - SEAT
6	081268-01-000	EA ROD & CHANNEL - ARMREST - RIGHT - METAL
7	M30936-07-000	EA FRAME - SEAT - BACK & SPRING
8	081268-02-000	EA ROD & CHANNEL - ARMREST - LEFT - METAL
9	069246-02-000	EA ADJUSTER - W/O LOCK - FORWARD & BACK
10	107921-05-000	EA TOP PLATE - PEDESTAL - W/SEATBELT BAR
11	107921-01-000	EA SUB PLATE - FLOOR MOUNTED PEDESTAL - W/9.75" EXTENSION
	107921-08-000	EA BEARING KIT - PEDESTAL
12	069246-05-000	EA ADJUSTER - W/LOCK - FORWARD & BACK
	069246-05-700	EA SPRING - ADJUSTER - FOR REMOTE
	069246-05-701	EA CLIP - CABLE - FOR REMOTE
13	080730-03-700	EA HANDLE KIT - RECLINER
	080730-04-000	EA SCREW - RECLINER HANDLE
	039369-08-000	FA SHIELD - CABLE - REMOTE RECLINER
14	089368-04-000	EA CABLE - SWIVEL/SIDE - W/SWITCH
15	097683-03-000	EA BRACKET - REMOTE - SIDE MOUNT - SINGLE
16	108049-01-000	EA CABLE - 28" - FLEXSTEEL PED
	108049-02-000	EA CABLE CLIP
17	071126-36-D35	EA SKIRT ASM. - SINGLE - 10.5" - W/SLIT
17	071126-36-D36	EA SKIRT ASM. - SINGLE - 10.5" - W/SLIT
18	085268-01-D35	EA HEADREST ASM
18	085268-01-D36	EA HEADREST ASM
18	085268-03-D36	EA HEADREST ASM - W/MONOGRAM
18	M85268-01-D35	EA COVER ASM. - HEADREST
18	M85268-01-D36	EA COVER ASM. - HEADREST
18	M85268-03-D36	EA COVER ASM. - HEADREST - W/MONOGRAM

1993 ITASCA TABLE OF CONTENTS

INTRODUCTION	A-01 - A-02
ABBREVIATIONS	A-03
ALPHABETICAL INDEX	A-04 - A-06
ICG32RQ	A-07 - E-16

1993 ICG32RQ INDEX

FLOOR PLAN	A-07 - A-08
ACCESSORIES	A-09
AUDIO VIDEO	A-10 - A-11
BATH	A-12 - A-14
BEDROOM	A-15 - A-16
CHASSIS	A-17 - B-06
CURTAIN & CUSHION	B-07 - B-17
DINETTE	B-18 - B-20
DRIVERS COMPARTMENT	B-21 - B-24
ELECTRICAL	C-01 - C-06
EXTERIOR BODY	C-07 - C-14
GALLEY	C-15 - C-18
GENERATOR	C-19 - C-20
HEATING & A/C	C-21 - C-24
INTERIOR FINISH	D-01 - D-04
LABELS	D-05 - D-12
LP	D-13
LOUNGE	D-14 - D-16
SEALANTS & FASTENERS	D-17 - D-19
WATER & SEWAGE	D-20 - D-23
WINDOW, VENT & EXTERIOR DOOR	D-24 - E-14
WINDSHIELD & WIPER	E-15 - E-16

CURTAIN & CUSHION GROUP (CONTINUED)

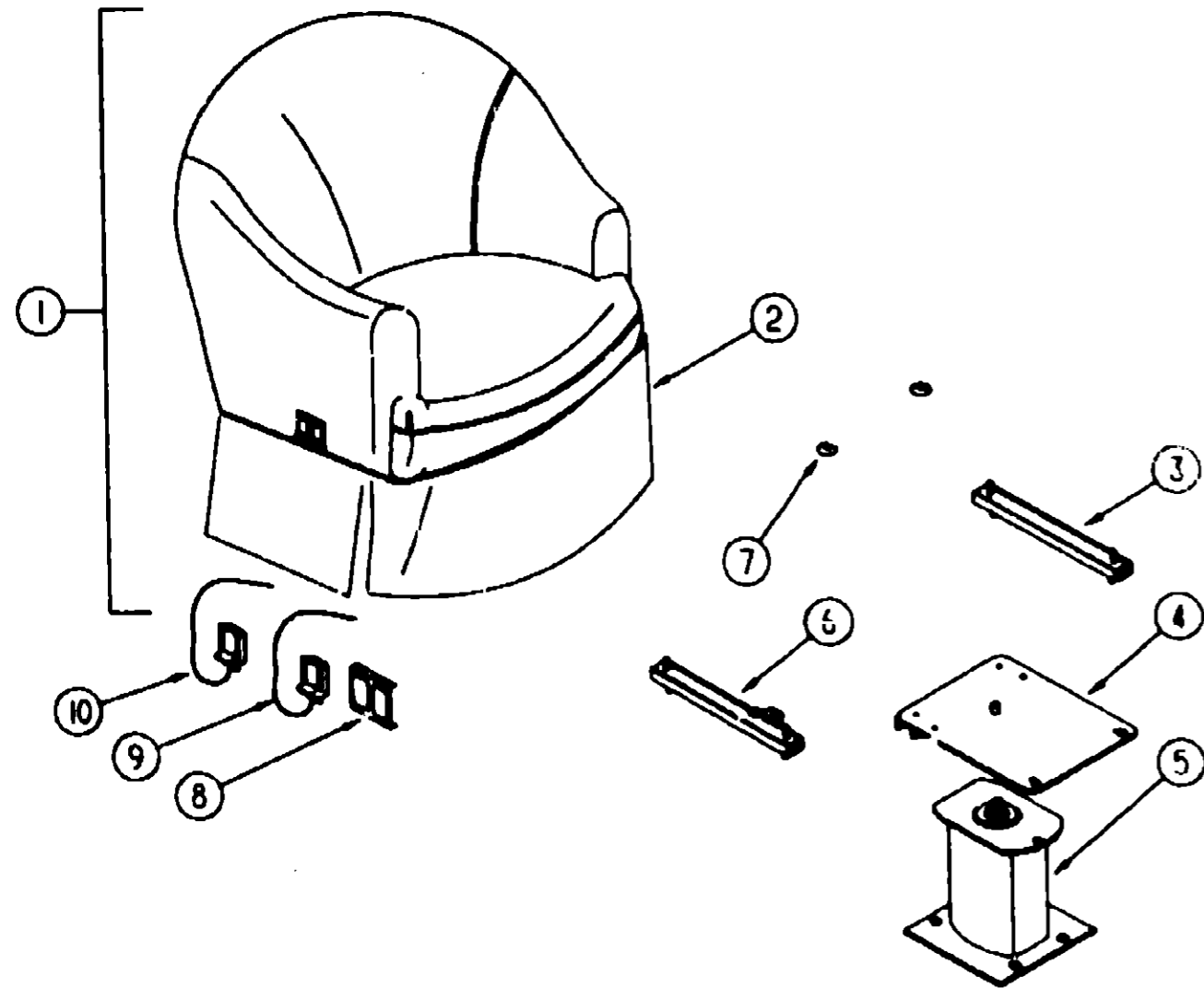

SWIVEL CHAIR

KEY	PART NUMBER	U/M DESCRIPTION
1	106331-02-D35	EA CHAIR - FAN RECLINER
1	106331-02-D36	EA CHAIR - FAN RECLINER
1	P06331-02-D35	EA COVER ASM. - FAN RECLINER
1	P06331-02-D36	EA COVER ASM. - FAN RECLINER
2	085187-05-D35	EA SKIRT ASM.
2	085187-05-D36	EA SKIRT ASM.
3	069246-02-000	EA ADJUSTER - SWIVEL CHAIR - FORWARD & BACK
4	107921-08-000	EA TOP PLATE - PEDESTAL - W/O SEATBELT BAR
5	107921-01-000	EA SUB PLATE - FLOOR MOUNTED PEDESTAL - W/9.75" EXTENSION
	107921-08-000	EA BEARING KIT - PEDESTAL
6	069246-06-000	EA ADJUSTER - SWIVEL CHAIR - W/LOCKING ARM - FORWARD & BACK
	069246-05-700	EA SPRING - ADJUSTER - FOR REMOTE
	069246-05-701	EA CLIP - CABLE - FOR REMOTE
7	007721-01-000	EA SPACER - SEAT - ADJUSTER (4 USED)
8	097983-02-000	EA BRACKET - REMOTE - SIDE MOUNT
9	108049-01-000	EA CABLE - 26" - FLEXSTEEL PEDESTAL
	108049-02-000	EA CLIP - PEDESTAL CABLE
10	069388-04-000	EA CABLE - SWIVEL/SLIDE - W/SWITCH
	067759-01-000	EA WASHER BRACKET - SEAT BELT - 4" DIAMETER
	007021-01-000	EA SEAT BELT - 2" X 90" - BLACK

CURTAIN & CUSHION GROUP (CONTINUED)

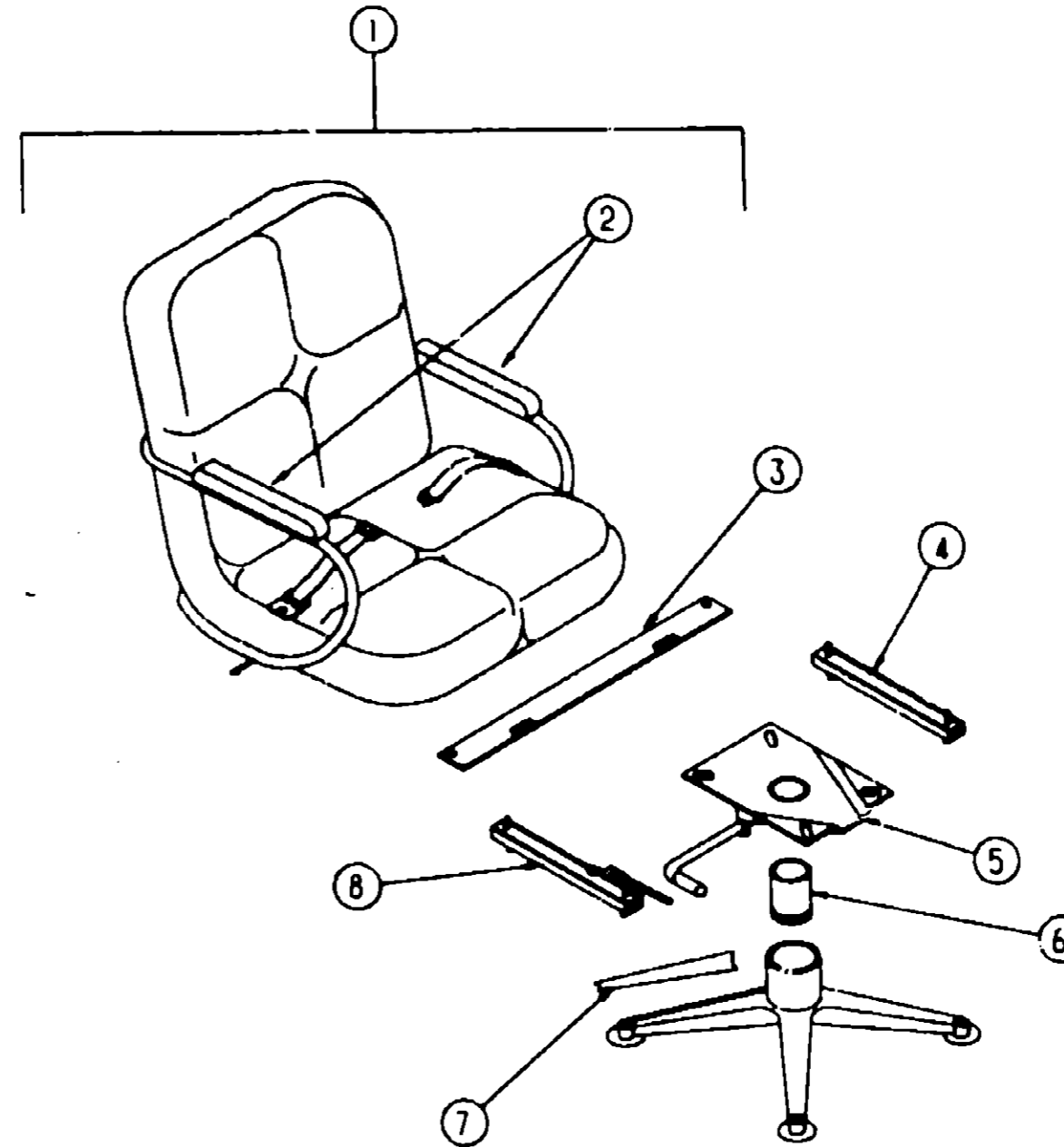

CHROME CRAFT CHAIR

KEY	PART NUMBER	U/M DESCRIPTION
1	109379-02-D35	EA CHAIR ASM - CHROME CRAFT II
1	109379-02-D36	EA CHAIR ASM - CHROME CRAFT II
	105799-13-000	EA CHAIR ASM - CHROME CRAFT W/O FABRIC (D35)
	105799-14-000	EA CHAIR ASM - CHROME CRAFT W/O FABRIC (D36)
	105799-01-004	EA BOLT - SEAT - CHAIR #723634-1
2	105799-01-700	EA WOOD ARM PADS FOR C57-855-BN
3	069705-02-000	EA BAR - SEAT BELT - 2.5" X 12.75"
4	069246-06-000	EA ADJUSTER - SWIVEL CHAIR - MANUAL - FORWARD & BACK
5	105799-01-001	EA TOP PLATE - SWIVEL CHAIR
5	068245-03-000	EA TOP PLATE - SWIVEL W/O TILT - W/LOCK
6	105799-01-002	EA UPRIGHT - CHAIR
6	105799-01-006	EA STEM UPRIGHT - LOCKOUT
7	105799-01-003	EA LEG - WOOD COVER BASE (CHAIR)
8	069246-07-000	EA ADJUSTER - SWIVEL CHAIR - W/LOCKING ARM - FORWARD & BACK

**1993 ITASCA
TABLE OF CONTENTS**

INTRODUCTION	A-01 - A-02
ABBREVIATIONS	A-03
ALPHABETICAL INDEX	A-04 - A-06
ICG32HQ	A-07 - E-18

1993 ICG32HQ INDEX

FLOOR PLAN	A-07 - A-08
ACCESSORIES	A-09
AUDIO VIDEO	A-10 - A-11
BATH	A-12 - A-14
BEDROOM	A-15 - A-16
CHASSIS	A-17 - B-08
CURTAIN & CUSHION	B-07 - B-17
DINETTE	B-18 - B-20
DRIVERS COMPARTMENT	B-21 - B-24
ELECTRICAL	C-01 - C-06
EXTERIOR BODY	C-07 - C-14
GALLEY	C-15 - C-18
GENERATOR	C-19 - C-20
HEATING & A/C	C-21 - C-24
INTERIOR FINISH	D-01 - D-04
LABELS	D-05 - D-12
LP	D-13
LOUNGE	D-14 - D-16
SEALANTS & FASTENERS	D-17 - D-19
WATER & SEWAGE	D-20 - D-23
WINDOW, VENT & EXTERIOR DOOR	D-24 - E-14
WINDSHIELD & WIPER	E-15 - E-16

CURTAIN & CUSHION GROUP (CONTINUED)

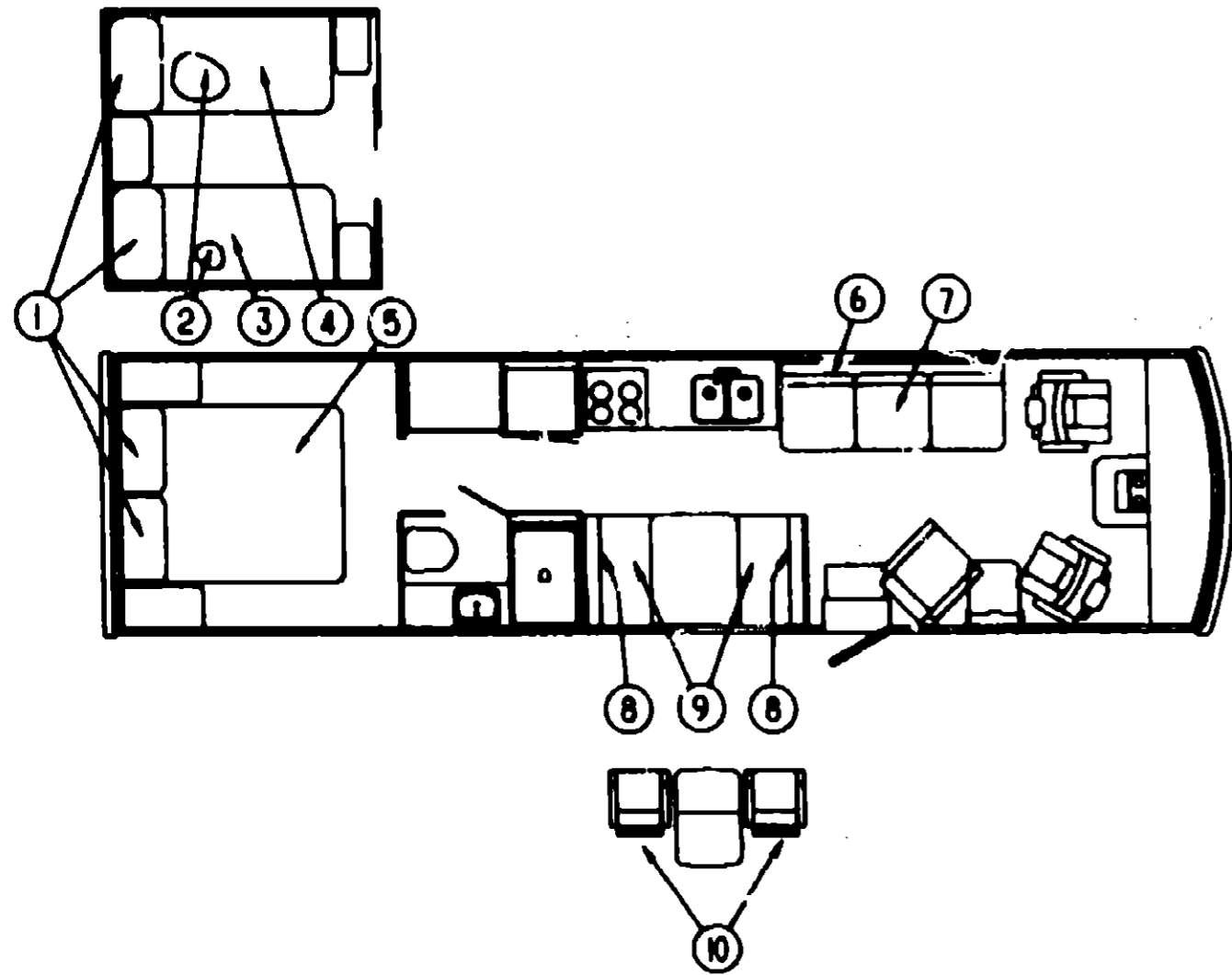

QUEEN & TWIN BEDS

KEY	PART NUMBER	U/M DESCRIPTION
1	102161-09-D35	EA PILLOW SHAM - W/4" RUFFLE
1	102161-13-D36	EA PILLOW SHAM - W/4" RUFFLE
2	098176-10-000	EA MATTRESS - TWIN - INNERSPRING - 32"X79.5" - SEALY
3	083986-17-D35	EA BEDSPREAD ASM - 33" X 80" (PASSENGER SIDE)
3	083986-17-D36	EA BEDSPREAD ASM - 33" X 80" (PASSENGER SIDE)
4	083986-18-D35	EA BEDSPREAD ASM - 33" X 80" (DRIVER SIDE)
4	083986-18-D36	EA BEDSPREAD ASM - 33" X 80" (DRIVER SIDE)
5	098176-04-000	EA MATTRESS - QUEEN - INNERSPRING - 59" X 74" - SEALY
5	092371-24-D35	EA BEDSPREAD ASM - 80" X 75" FITTED W/6" RUFFLE
5	092371-24-D36	EA BEDSPREAD ASM - 80" X 75" FITTED W/6" RUFFLE
	104259-01-C06	EA PILLOW ASM - 15" X 15" W/RUFFLE (D35)
	104259-04-D36	EA PILLOW ASM - 15" X 15" W/RUFFLE

SOFA BED

KEY	PART NUMBER	U/M DESCRIPTION	
6	101175-04-D35	EA CUSHION - FAN - SOFA BACK - W/ ARM - RIGHT HAND	
6	101175-04-D36	EA CUSHION - FAN - SOFA BACK - W/ARM - RIGHT HAND	
6	P01175-04-D35	EA COVER - FAN - SOFA BACK - W/ARM - RIGHT HAND	
6	P01175-04-D36	EA COVER - FAN - SOFA BACK - W/ARM - RIGHT HAND	
6	101175-05-D35	EA CUSHION - FAN - SOFA BACK - W/ARM - LEFT HAND	
6	101175-05-D36	EA CUSHION - FAN - SOFA BACK - W/ARM - LEFT HAND	
6	P01175-05-D35	EA COVER - FAN - SOFA BACK - W/ARM - LEFT HAND	
8	P01175-05-D36	EA COVER - FAN - SOFA BACK - W/ARM - LEFT HAND	
6	101175-06-D35	EA CUSHION - FAN - SOFA BACK - CENTER	
6	101175-06-D36	EA CUSHION - FAN - SOFA BACK - CENTER	
6	P01175-06-D35	EA COVER - FAN - SOFA BACK - CENTER	
6	P01175-06-D36	EA COVER - FAN - SOFA BACK - CENTER	
7	089007-05-D35	EA SOFA BED - SEAT - W/SKIRT	FROM: 00-00-00 THRU: 09-13-92
7	089007-05-D36	EA SOFA BED - SEAT - W/SKIRT	FROM: 00-00-00 THRU: 09-13-92
7	089007-06-D35	EA SOFA BED - SEAT - W/SKIRT	FROM: 09-14-92 THRU: 99-99-99
7	089007-06-D36	EA SOFA BED - SEAT - W/SKIRT	FROM: 09-14-92 THRU: 99-99-99
7	M89007-05-D35	EA COVER - SOFA BED - SEAT - W/SKIRT	FROM: 00-00-00 THRU: 09-13-92
7	M89007-05-D36	EA COVER - SOFA BED - SEAT - W/SKIRT	FROM: 00-00-00 THRU: 09-13-92
7	M89007-06-D35	EA COVER - SOFA BED - SEAT - W/SKIRT	FROM: 09-14-92 THRU: 99-99-99
7	M89007-06-D36	EA COVER - SOFA BED - SEAT - W/SKIRT	FROM: 09-14-92 THRU: 99-99-99
	103669-06-D28	EA PILLOW ASM - 15" X 15" THROW (D35)	
	103669-06-D36	EA PILLOW ASM - 15" X 15" THROW	
	079386-01-000	EA FRAME - COUCH	

DINETTE CUSHIONS

KEY	PART NUMBER	U/M DESCRIPTION
8	104146-01-D35	EA CUSHION - FAN VICTORIAN - W/STRAP - 13.5"X38"X5"
8	104146-01-D36	EA CUSHION - FAN VICTORIAN - W/STRAP - 13.5"X38"X5"
8	P04146-01-D35	EA COVER - VICTORIAN TUCK BACK - W/STRAP
8	P04146-01-D36	EA COVER - VICTORIAN TUCK BACK - W/STRAP
9	088927-87-D28	EA CUSHION - 23"X38"X5" - DINETTE SEAT (D35)
9	088927-87-B09	EA CUSHION - 23"X38"X5" - DINETTE SEAT (D36)
9	M88927-87-D28	EA COVER - 23"X38"X5" - DINETTE SEAT (D35)
9	M88927-87-B09	EA COVER - 23"X38"X5" - DINETTE SEAT (D36)

DINETTE OPTION

KEY	PART NUMBER	U/M DESCRIPTION
10	109379-02-D35	EA CHAIR ASM - CHROMECHAFT II
10	109379-02-D36	EA CHAIR ASM - CHROMECHAFT II

**1993 ITASCA
TABLE OF CONTENTS**

INTRODUCTION	A-01 - A-02
ABBREVIATIONS	A-03
ALPHABETICAL INDEX	A-04 - A-06
ICG32RQ	A-07 - E-16

1993 ICG32RQ INDEX

FLOOR PLAN	A-07 - A-08
ACCESSORIES	A-09
AUDIO VIDEO	A-10 - A-11
BATH	A-12 - A-14
BEDROOM	A-15 - A-16
CHASSIS	A-17 - B-06
CURTAIN & CUSHION	B-07 - B-17
DINETTE	B-18 - B-20
DRIVERS COMPARTMENT	B-21 - B-24
ELECTRICAL	C-01 - C-06
EXTERIOR BODY	C-07 - C-14
GALLEY	C-15 - C-18
GENERATOR	C-19 - C-20
HEATING & A/C	C-21 - C-24
INTERIOR FINISH	D-01 - D-04
LABELS	D-05 - D-12
LP	D-13
LOUNGE	D-14 - D-16
SEALANTS & FASTENERS	D-17 - D-19
WATER & SEWAGE	D-20 - D-23
WINDOW, VENT & EXTERIOR DOOR	D-24 - E-14
WINDSHIELD & WIPER	E-15 - E-16

CURTAIN & CUSHION GROUP (CONTINUED)

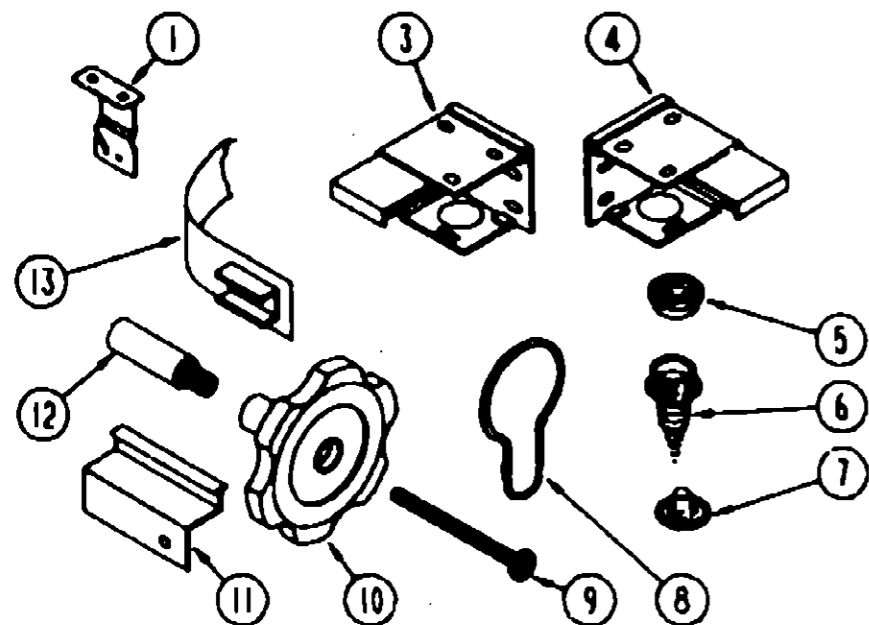

CURTAIN & BLIND HARDWARE

KEY	PART NUMBER	U/M DESCRIPTION
1	084434-01-000	EA BRACKET - MOUNTING - ROLLER SHADE - 1 3/8"
	008843-01-000	EA SPRING - REWIND - ROLLER SHADE
	108544-01-000	EA SHADE PULL - BRASS
	087253-01-000	EA SHADE PULL - PLASTIC - CLEAR
	109441-01-000	EA HOLD DOWN HOOK - BLIND
3	083170-01-000	EA BRACKET - BLIND - LEFT SIDE
4	083170-02-000	EA BRACKET - BLIND - RIGHT SIDE
5	029158-01-000	EA SOCKET - SNAP - 9/16" O.D.
6	029130-01-000	EA SCREW - SNAP SOCKET - 8 PH X 5/8"
7	029155-01-000	EA CAP - SNAP - 5/32" O.D. OF PIN
8	009138-02-000	EA HANGER - RING - PIN TYPE - CURTAIN - BRASS
	039175-01-000	EA ROD - CAFE - CURTAIN - EXTENDS 48" TO 84"
	039175-02-000	EA BRACKET - CURTAIN ROD - EXTENDING CAFE
	039175-05-000	EA BRACKET - CURTAIN ROD - CENTER CAFE
	048887-01-000	EA GROMMET - BRASS - 7/16" ID X 1" OD
9	009439-07-000	EA SCREW - 8-32 X 1 1/4" PH - BLACK
10	009439-05-000	EA WINDOW KNOB - BLACK
11	105324-02-01A	EA TRACK - WRAPAROUND CURTAIN - OFF WHITE (PASSENGER SIDE)
11	105324-03-01A	EA TRACK - WRAPAROUND CURTAIN - OFF WHITE (DRIVER SIDE)
12	009439-08-000	EA EXTENSION - WINDOW CONTROL
	C18394-02-000	YD VELCRO TAPE - HOOK - ADHESIVE BACK - 75" WIDE - BEIGE
	088792-02-000	YD VELCRO TAPE - LOOP - ADHESIVE BACKED - 75" WIDE - BEIGE
	088716-01-001	EA BRACKET - 90 DEGREE L-ANGLE - 192" - EXTRUDED ALUMINUM
	075943-01-000	EA BRACKET - ANGLE - WHOLES - 1" X 1 1/2" X 20" - ALUMINUM - BEIGE
	084432-08-000	FT SLAT - ROLLER SHADE - PLASTIC
13	101031-01-000	YD TAPE - GLIDE - CURTAIN - 4 25" SPACING
	102075-08-01A	EA SHOWER ROD
	009112-01-000	EA FLANGE - SHOWER ROD
	093475-01-700	EA WAND - BLIND - W/METAL CLIP - 8" LONG

ASSIST HANDLE & BUTTONS

KEY	PART NUMBER	U/M DESCRIPTION
	089178-02-000	EA BRACKET - MOUNTING - ASSIST HANDLE - L ANGLE - W/HOLES
	000C18-07-188	EA BOLT - CARRIAGE - ASSIST HANDLE - 7/16" - 14 X 1" ZN
	000D20-07-008	EA NUT - ACORN - ASSIST HANDLE - 7/16" X 14 ZN
	063552-02-AA8	EA HANDLE - ASSIST - INTERIOR - ENTRY DOOR - VINYL - OFF WHITE
	070578-04-Y05	EA BUTTON - SNAP TOP - #30 - VINYL - BEIGE

DINETTE GROUP

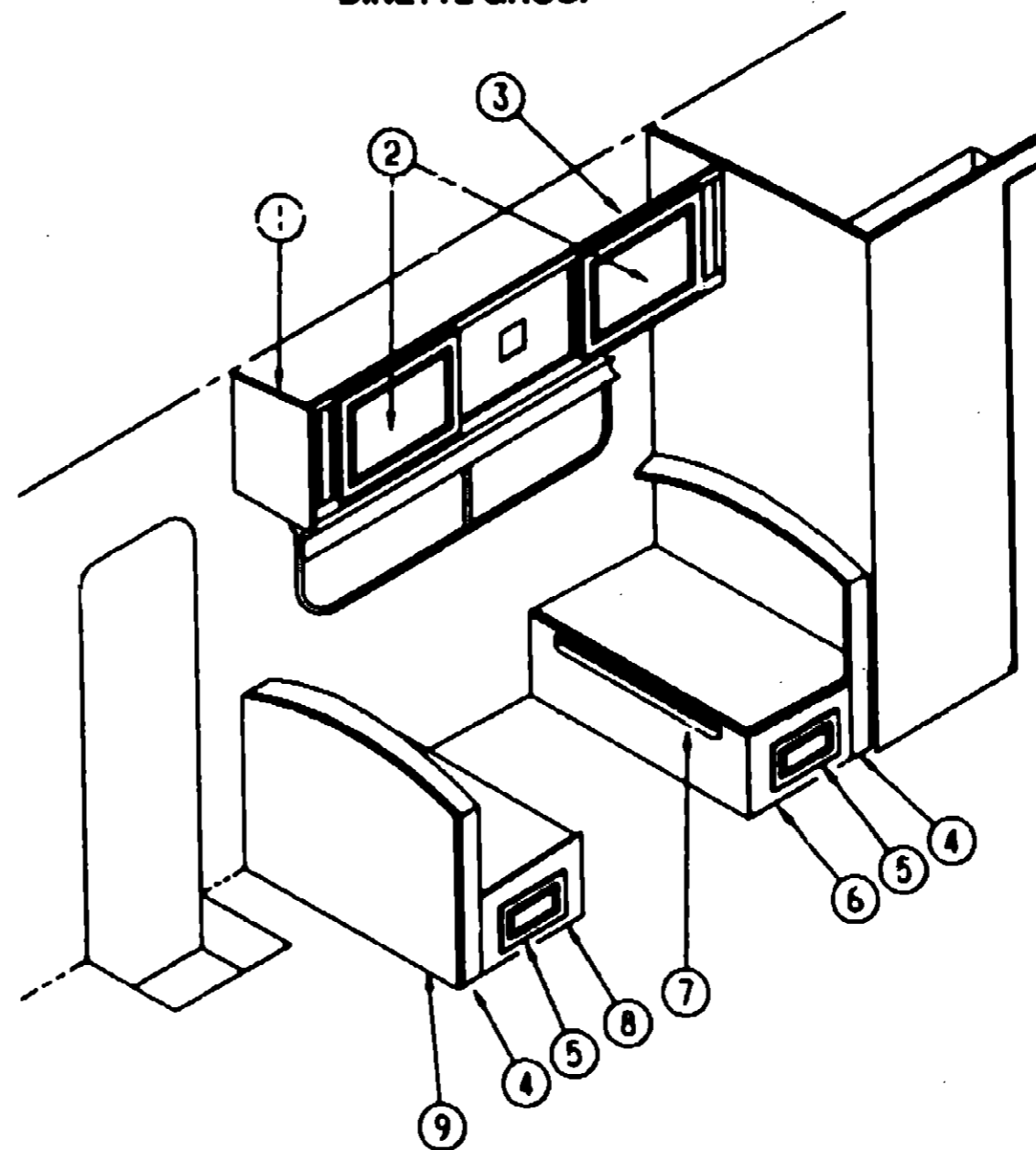

DINETTE & OVERHEAD CABINERY

KEY	PART NUMBER	U/M DESCRIPTION
1	103128-02-C27	EA END CAP ASM. - LEFT HAND
2	P03702-A5-D35	EA DOOR ASM - W/O HARDWARE
3	M05160-28-D35	EA CABINET - DINETTE OVERHEAD
3	M05160-28-D36	EA CABINET - DINETTE OVERHEAD
4	104787-01-D11	EA PAD ASM - DINETTE (D35)
4	104787-01-D36	EA PAD ASM - DINETTE
5	F07104-13-D35	EA DRAWER ASM. - W/O HARDWARE
6	M04175-35-D35	EA CABINET - SEATBASE - RIGHT HAND
7	081295-01-AA8	EA BED SUPPORT - DINETTE
8	M04175-36-D35	EA CABINET - SEATBASE - LEFT HAND
9	M04174-33-D35	EA CABINET - SEATBACK - LEFT HAND
	081518-01-B27	EA SEAT TOP - DINETTE

**1993 ITASCA
TABLE OF CONTENTS**

INTRODUCTION	A-01 - A-02
ABBREVIATIONS	A-03
ALPHABETICAL INDEX	A-04 - A-06
ICG32RQ	A-07 - E-18

1993 ICG32RQ INDEX

FLOOR PLAN	A-07 - A-08
ACCESSORIES	A-09
AUDIO VIDEO	A-10 - A-11
BATH	A-12 - A-14
BEDROOM	A-15 - A-16
CHASSIS	A-17 - B-06
CURTAIN & CUSHION	B-07 - B-17
DINETTE	B-18 - B-20
DRIVERS COMPARTMENT	B-21 - B-24
ELECTRICAL	C-01 - C-06
EXTERIOR BODY	C-07 - C-14
GALLEY	C-15 - C-18
GENERATOR	C-19 - C-20
HEATING & A/C	C-21 - C-24
INTERIOR FINISH	D-01 - D-04
LABELS	D-05 - D-12
LP	D-13
LOUNGE	D-14 - D-17
SEALANTS & FASTENERS	D-17 - D-19
WATER & SEWAGE	D-20 - D-23
WINDOW, VENT & EXTERIOR DOOR	D-24 - E-14
WINDSHIELD & WIPER	E-15 - E-18

DINETTE GROUP (CONTINUED)

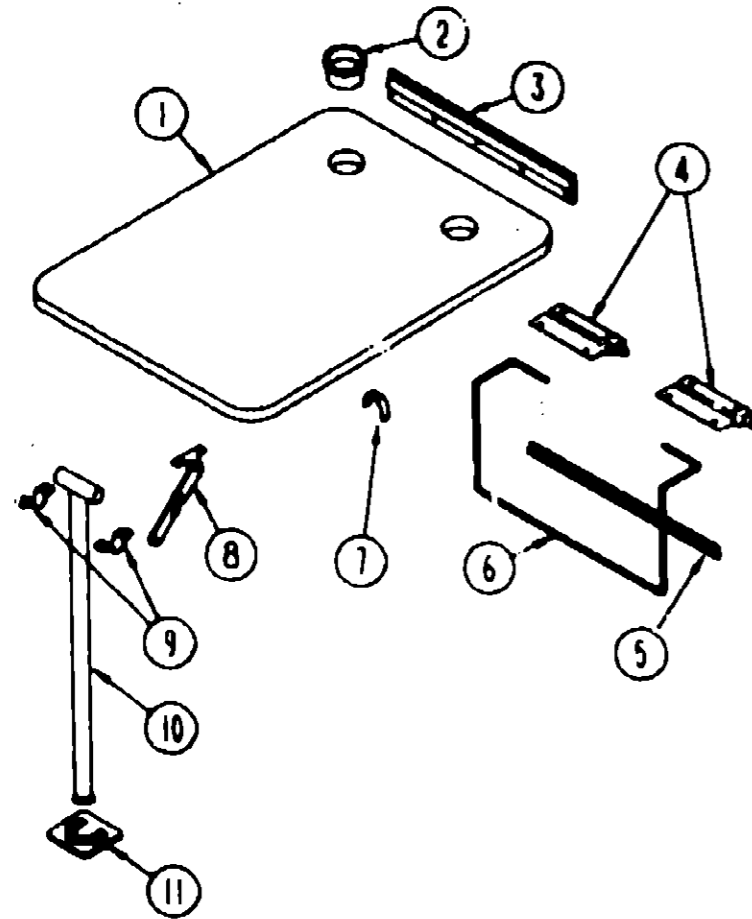

DINETTE TABLE ASM.

KEY	PART NUMBER	U/M DESCRIPTION
1	M02115-09-D32	EA DINETTE TABLE (D35)
1	M02115-09-D36	EA DINETTE TABLE
2	064781-06-000	EA CUP HOLDER 2 STEP
3	053200-12-000	EA BRACKET - TABLE SUPPORT - UPPER WALL MOUNTED - 23 5" - OFF WHITE
4	088410-02-000	EA BRACKET - TABLE MOUNTED - OFF WHITE
5	024281-14-000	EA BRACKET - LIFT ROD - LOWER WALL MOUNTED - 22 12" - OFF WHITE
6	024275-12-000	EA ROD - TABLE LIFT - 8" X 23 5" - OFF WHITE
7	024283-01-000	EA CLIP - LEG - 1" - 1.125" OD - BLACK
8	024282-01-000	EA BRACE - TABLE LEG - HINGED
9	064050-05-000	EA CLAMP - SADDLE - LEG HINGE - OFF WHITE
10	024278-23-000	EA TABLE LEG - METAL - OFF WHITE
11	049493-11-700	EA LEG CATCH - FLOOR MOUNTED - 2 5" X 2 7" - METAL - E-COAT

DINETTE GROUP (CONTINUED)

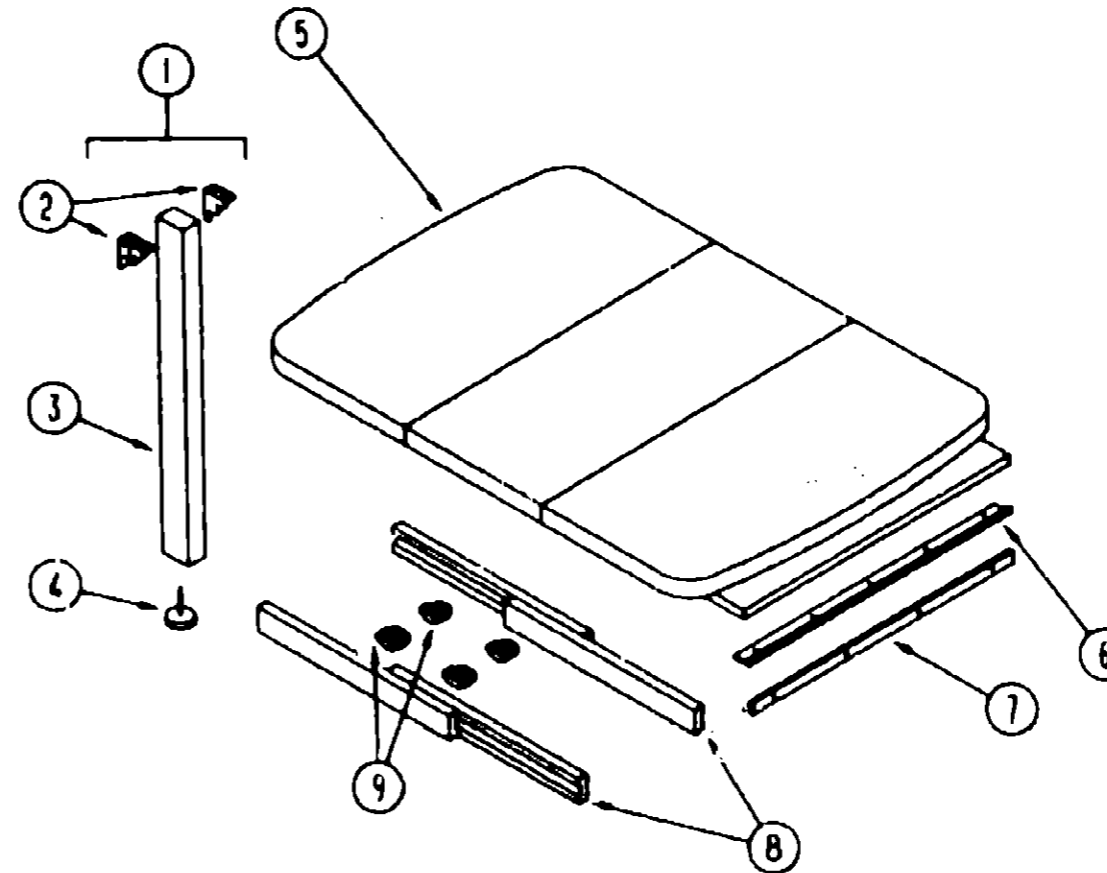

DINETTE TABLE ASM.

KEY	PART NUMBER	U/M DESCRIPTION
1	092708-10-D35	EA LEG ASM - TABLE
2	102810-01-02A	EA BRACE - TABLE LEG - OFF WHITE
3	092707-08-01A	EA LEG MOLDING - RAMBLING OAK
4	102194-01-000	EA GUIDE - PLASTIC
5	P02056-06-D35	EA TABLE ASM - W/DROP LEAF
6	102201-02-02A	EA SUPPORT - HINGE CATCH - OFF WHITE
7	102200-02-02A	EA SUPPORT - HINGE LOCK - OFF WHITE
8	009210-01-000	EA SLIDE - TABLE - 18" TO 50" - METAL
8	108490-01-000	EA SLIDE - TABLE - 19 LONG FROM 00-00-00 THRU 11-30-92
8	110749-01-000	EA SLIDE - TABLE - 19 3/4 LONG FROM 12-01-92 THRU 03-21-93
9	009050-02-000	EA LEVELER - TABLE TOP - FEMALE & MALE ENDS W/4 SCREWS - PLASTIC FROM 03-22-93 THRU 99-99-99

**1993 ITASCA
TABLE OF CONTENTS**

INTRODUCTION	A-01 - A-02
ABBREVIATIONS	A-03
ALPHABETICAL INDEX	A-04 - A-06
ICG32RO	A-07 - E-16

1993 ICG32RO INDEX

FLOOR PLAN	A-07 - A-08
ACCESSORIES	A-09
AUDIO VIDEO	A-10 - A-11
BATH	A-12 - A-14
BEDROOM	A-15 - A-16
CHASSIS	A-17 - B-08
CURTAIN & CUSHION	B-07 - B-17
DINETTE	B-18 - B-20
DRIVERS COMPARTMENT	B-21 - B-24
ELECTRICAL	C-01 - C-06
EXTERIOR BODY	C-07 - C-14
GALLEY	C-15 - C-18
GENERATOR	C-19 - C-20
HEATING & A/C	C-21 - C-24
INTERIOR FINISH	D-01 - D-04
LABELS	D-05 - D-12
LP	D-13
LOUNGE	D-14 - D-16
SEALANTS & FASTENERS	D-17 - D-19
WATER & SEWAGE	D-20 - D-23
WINDOW, VENT & EXTERIOR DOOR	D-24 - E-14
WINDSHIELD & W/PER	E-15 - E-16

DRIVERS COMPARTMENT GROUP

UPPER & LOWER DRIVER COMPARTMENT

KEY	PART NUMBER	U.S. DESCRIPTION
1	M05893-01-C27	EA CABINET ASM - FACE - OVHD - (W/TV)
1	M05893-02-C27	EA CABINET ASM - FACE - OVHD - (W/O TV)
2	100708-06-000	EA DOOR - GLASS - TV CABINET 246 X 722
	100710-01-01A	EA LOCK - GLASS DOOR - TWIST TYPE - BRASS
	100711-01-01A	EA HINGE - DOOR - GLASS
	101222-01-01A	EA BRACKET - CATCH - LID - BEIGE
	101272-C1-000	EA CATCH - DOOR - GLASS
	101766-01-000	EA PIN - SUPPORT - GLASS DOOR
	100707-01-000	EA SPACER - DOOR - GLASS - 8" DIA - 3" HOLE - PLASTIC
3	108911-01-D35	EA CABINET ASM - FRAME - TV
4	082286-19-D12	EA SUNVISOR ASM
	007211-01-000	EA HINGE - SUNVISOR - 25.5" X 1.5" - METAL
	074012-01-000	EA CLIP - SUNVISOR - SQUARE - PINCH ON
	102377-01-000	EA BRACKET SUNVISOR - 1 PIECE - STEEL
	046886-03-000	EA ASHTRAY - CHROME - W/COVER
	024700-44-000	EA COVER - SIDEWALL ROLL BAR - OFF WHITE 53"
	024700-46-000	EA COVER - SIDEWALL ROLL BAR - OFF WHITE 21.2"
	103961-01-01A	EA COVER - BRACKET - SEATBELT - OFF WHITE
	R77030-53-447	EA FLAT WASHER
5	040714-01-000	EA MIRROR - REAR VIEW
	075710-01-000	EA FRAME - WINDSHIELD - CENTER DIVIDER - INNER
	077922-03-000	EA HEADER WINDSHIELD END - RIGHT
	077922-04-000	EA HEADER WINDSHIELD END - LEFT
	077922-05-000	EA HEADER WINDSHIELD - CENTER
6	036420-02-000	EA FAN - DEFROSTER - 2 SPEED - 6" DIAMETER
7	078579-10-000	EA TRIM - WINDSHIELD - UPPER INNER - LH LIGHT GRAY
8	078579-09-000	EA TRIM - WINDSHIELD - UPPER INNER - RH LIGHT GRAY
9	103931-04-02A	EA INTERIOR COVER - A-PILLAR - LEFT HAND - GRAY
10	079765-10-000	EA TRIM - WINDSHIELD - CENTER - LIGHT GRAY
11	103931-03-02A	EA INTERIOR COVER - A-PILLAR - RIGHT HAND - GRAY
12	091990-01-01A	EA SEAT BELT & SHOULDER HARNESS - DRIVER/PASSENGER SIDE
	109145-01-000	EA BOLT - SHOULDER - SEAT BELT
13	097552-01-000	EA MOTOR COVER - W/O CARPET
	092406-01-000	EA TRIM - MOTOR COVER - ALUMINUM
	075564-01-000	EA BRACKET - MOUNTING - MOTOR COVER
	039623-01-000	FT SEAL - MOTOR COVER - RUBBER BULB TYPE - BLACK
14	107854-01-D35	EA BEVERAGE TRAY ASM
	M04032-01-B29	EA DOWEL - WOOD - STAINED - 1" X 1.75" (BEVERAGE TRAY)
	P07854-12-D35	EA TRAY ASM - W/STAIN
	P07854-13-D35	EA SIDE W/STAIN
15	103498-06-000	EA FOOT - COLUMN - UNIVERSAL
	100628-02-000	EA SHELF ASM - TV
	100676-02-000	EA STAND - VCR
	101150-01-000	EA SUPPORT - SHELF - TV - PASSENGER SIDE - STEEL
	101150-02-000	EA SUPPORT - SHELF - TV - DRIVER SIDE - STEEL
	103040-01-C05	EA PANEL - LINER - OVERHEAD TV - W/O TV
	103040-03-C05	EA PANEL - LINER - OVERHEAD TV - W/TV
	P03077-01-C05	EA SHELF - BASE - CABINET - LEFT HAND - VINYL
	P03077-02-C05	EA SHELF - BASE - CABINET - RIGHT HAND - VINYL
	P04415-01-C05	EA SHELF ASM - TV CABINET - VINYL
	101497-22-D12	EA PANEL ASM - END CAP - UPPER RIGHT HAND - TV
	101497-23-D12	EA PANEL ASM - END CAP - UPPER LEFT HAND - TV
	101499-07-C07	EA PANEL ASM - END CAP - BOTTOM RIGHT HAND
	101499-08-C07	EA PANEL ASM - END CAP - BOTTOM LEFT HAND
	106899-01-01A	EA BRACKET - CABINET - OVERHEAD TV - OFF WHITE
	104289-03-D12	EA PANEL - SIDE - OVERHEAD TV - RIGHT HAND
	104289-04-D12	EA PANEL - SIDE - OVERHEAD TV - LEFT HAND

1993 ITASCA TABLE OF CONTENTS

INTRODUCTION	A-01 - A-02
ABBREVIATIONS	A-03
ALPHABETICAL INDEX	A-04 - A-06
ICG32RQ	A-07 - E-16

1993 ICG32RQ INDEX

FLOOR PLAN	A-07 - A-08
ACCESSORIES	A-09
AUDIO VIDEO	A-10 - A-11
BATH	A-12 - A-14
BEDROOM	A-15 - A-16
CHASSIS	A-17 - B-06
CURTAIN & CUSHION	B-07 - E-17
DINETTE	B-18 - B-20
DRIVERS COMPARTMENT	B-21 - B-24
ELECTRICAL	C-01 - C-06
EXTERIOR BODY	C-07 - C-14
GALLEY	C-15 - C-18
GENERATOR	C-19 - C-20
HEATING & A/C	C-21 - C-24
INTERIOR FINISH	D-01 - D-04
LABELS	D-05 - D-12
LP	D-13
LOUNGE	D-14 - D-16
SEALANTS & FASTENERS	D-17 - D-19
WATER & SEWAGE	D-20 - D-23
WINDOW, VENT & EXTERIOR DOOR	D-24 - E-14
WINDSHIELD & WIPER	E-15 - E-16

DRIVERS COMPARTMENT GROUP (CONTINUED)

DRIVERS COMPARTMENT GROUP (CONTINUED)

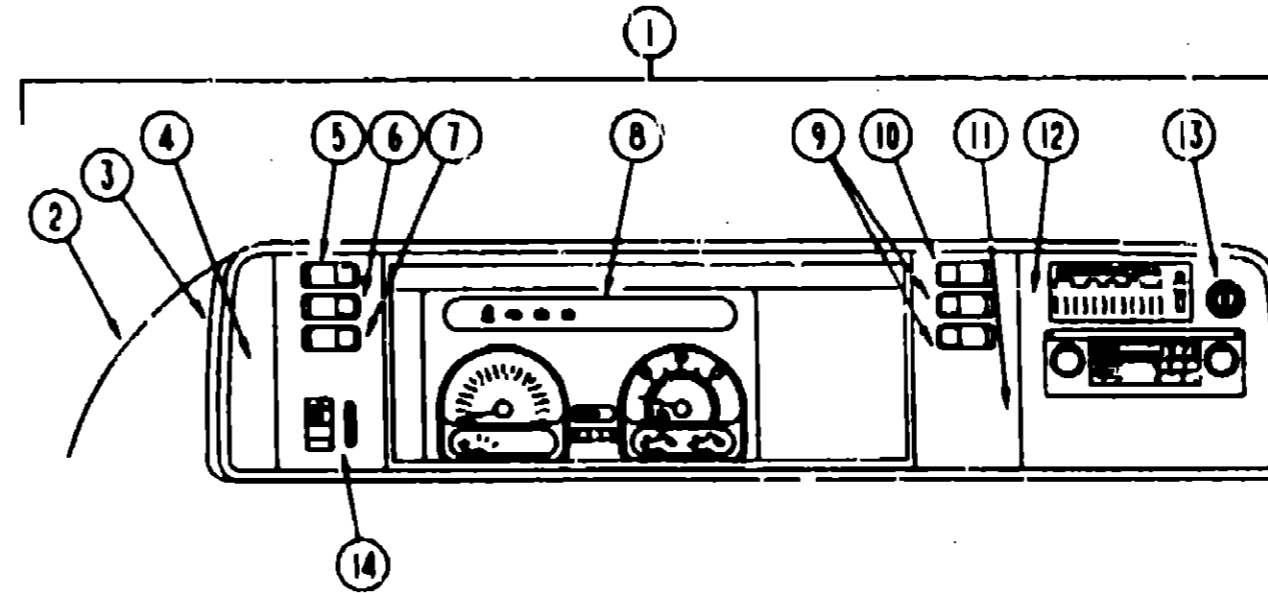
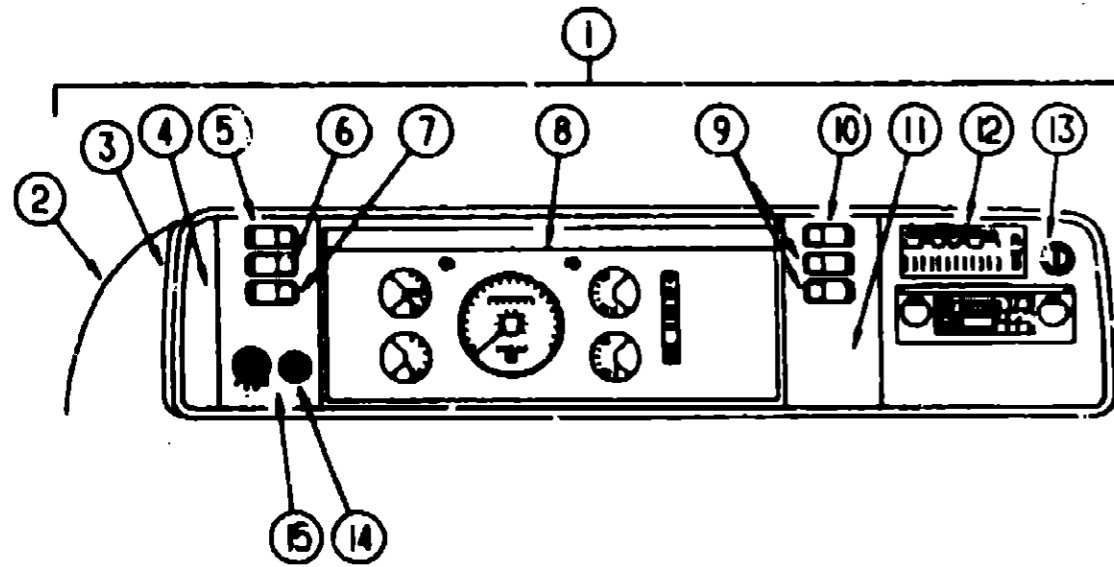

1993 ITASCA
TABLE OF CONTENTS

INTRODUCTION	A-01 - A-02
ABBREVIATIONS	A-03
ALPHABETICAL INDEX	A-04 - A-06
ICG32RQ	A-07 - E-16

DASH, GAUGES & SWITCHES (FORD)

DASH, GAUGES & SWITCHES (CHEVY)

KEY	PART NUMBER	U/M DESCRIPTION
1	M05946-05-035	EA DASH POD ASM.
2	103666-01-02A	EA POD - INSTRUMENT PANEL - GRAY
3	103662-02-01A	EA BEZEL - INSTRUMENT PANEL
4	104056-01-03A	EA APPLIQUE - BEZEL - LEFT - DRESS UP
5	108357-05-000	EA SWITCH - ROCKER - SPDT ON/NONE/ON
6	108357-04-000	EA SWITCH - ROCKER - SPDT ON/OFF/MOM
7	108357-06-000	EA SWITCH - ROCKER - DPDT MOM/OFF/MOM
8	094794-03-000	EA CLUSTER - INSTRUMENT - KILOMETER (CSA)
9	108357-03-000	EA SWITCH - ROCKER - SPDT ON/OFF/ON
10	108357-10-000	EA SWITCH - ROCKER - SPDT MOM/OFF/MOM
11	104056-05-01A	EA APPLIQUE - BEZEL SWITCH RIGHT - 3 SW FROM: 00-00-00 THRU 12-13-92
11	104056-04-01A	EA APPLIQUE - BEZEL - SWITCH RIGHT - BLANK FROM: 00-00-00 THRU 12-13-92
11	104056-21-01A	EA APPLIQUE - BEZEL - SWITCH RIGHT FROM: 12-14-92 THRU 99-99-99
12	104056-06-03A	EA APPLIQUE - BEZEL - RIGHT DRESS UP
13	089294-01-000	EA LIGHTER ASM - CIGARETTE
14	096675-01-000	EA KNOB - HEADLAMP - W/SHAFT
15	104056-03-01A	EA APPLIQUE - BEZEL - SWITCH LEFT
	P03817-01-000	EA DASH ASM - LOWER - W/O VINYL
	108569-02-02A	EA PADDED VINYL - LAMINATE MADRID - GRAY - 1/4"X16"X96" - 2LB
	100138-01-000	EA MODULE - DAYTIME RUNNING LIGHT
	077031-01-000	EA FILM - BLACK - 1" X 1.75"
	077031-03-000	EA FILM - WHITE .75" X 1"
	103812-02-02A	EA TRIM - DASH - LOWER - FORD - GRAY
	104354-01-02A	EA APPLIQUE - LOWER DASH

KEY	PART NUMBER	U/M DESCRIPTION
1	M05946-04-D35	EA DASH POD ASM.
2	103666-01-02A	EA POD - INSTRUMENT PANEL - GRAY
3	103662-01-01A	EA BEZEL - INSTRUMENT PANEL
4	104056-01-03A	EA APPLIQUE - BEZEL - LEFT - DRESS UP
5	108357-05-000	EA SWITCH - ROCKER - SPDT ON/NONE/ON
6	108357-04-000	EA SWITCH - ROCKER - SPDT ON/OFF/MOM
7	108357-06-000	EA SWITCH - ROCKER - DPDT MOM/OFF/MOM
8	094796-05-000	EA CLUSTER - INSTRUMENT PANEL - KILOMETERS - GAS (CSA)
9	108357-03-000	EA SWITCH - ROCKER - SPST ON/OFF/ON
10	108357-10-000	EA SWITCH - ROCKER - SPDT MOM/OFF/MOM
11	104056-05-01A	EA APPLIQUE - BEZEL SWITCH RIGHT - 3 SW FROM: 00-00-00 THRU 12-13-92
11	104056-04-01A	EA APPLIQUE - BEZEL - SWITCH RIGHT - BLANK FROM: 00-00-00 THRU 12-13-92
11	104056-21-01A	EA APPLIQUE - BEZEL - SWITCH RIGHT FROM: 12-14-92 THRU 99-99-99
12	104056-06-03A	EA APPLIQUE - BEZEL - RIGHT DRESS UP
13	089294-01-000	EA LIGHTER ASM - CIGARETTE
14	104056-02-01A	EA APPLIQUE - BEZEL - SWITCH LEFT
	P03817-01-000	EA DASH ASM - LOWER - W/O VINYL
	106569-02-01A	EA PADDED VINYL - LAMINATE MADRID - OFF WHITE - 1/4"X16"X96" - 2LB
	100138-01-000	EA MODULE - DAYTIME RUNNING LIGHT
	077031-01-000	EA FILM - BLACK - 1" X 1.75"
	077031-03-000	EA FILM - WHITE .75" X 1"
	103812-01-02A	EA TRIM - DASH - LOWER - GM - GRAY
	104354-01-02A	EA APPLIQUE - LOWER DASH

1993 ICG32RQ INDEX

FLOOR PLAN	A-07 - A-08
ACCESSORIES	A-09
AUDIO VIDEO	A-10 - A-11
BATH	A-12 - A-14
BEDROOM	A-15 - A-18
CHASSIS	A-17 - B-08
CURTAIN & CUSHION	B-07 - B-17
DINETTE	B-18 - B-20
DRIVERS COMPARTMENT	B-21 - B-24
ELECTRICAL	C-01 - C-06
EXTERIOR BODY	C-07 - C-14
GALLEY	C-18
GENERATOR	C-19 - C-20
HEATING & A/C	C-21 - C-24
INTERIOR FINISH	D-01 - D-04
LABELS	D-05 - D-10
LP	D-13
LOUNGE	D-14 - D-16
SEALANTS & FASTENERS	D-17 - D-19
WATER & SEWAGE	D-20 - D-23
WINDOW, VENT &	
EXTERIOR DOOR	D-24 - E-14
WINDSHIELD & WIPER	E-15 - E-16

ELECTRICAL GROUP

EXTERIOR LIGHTS

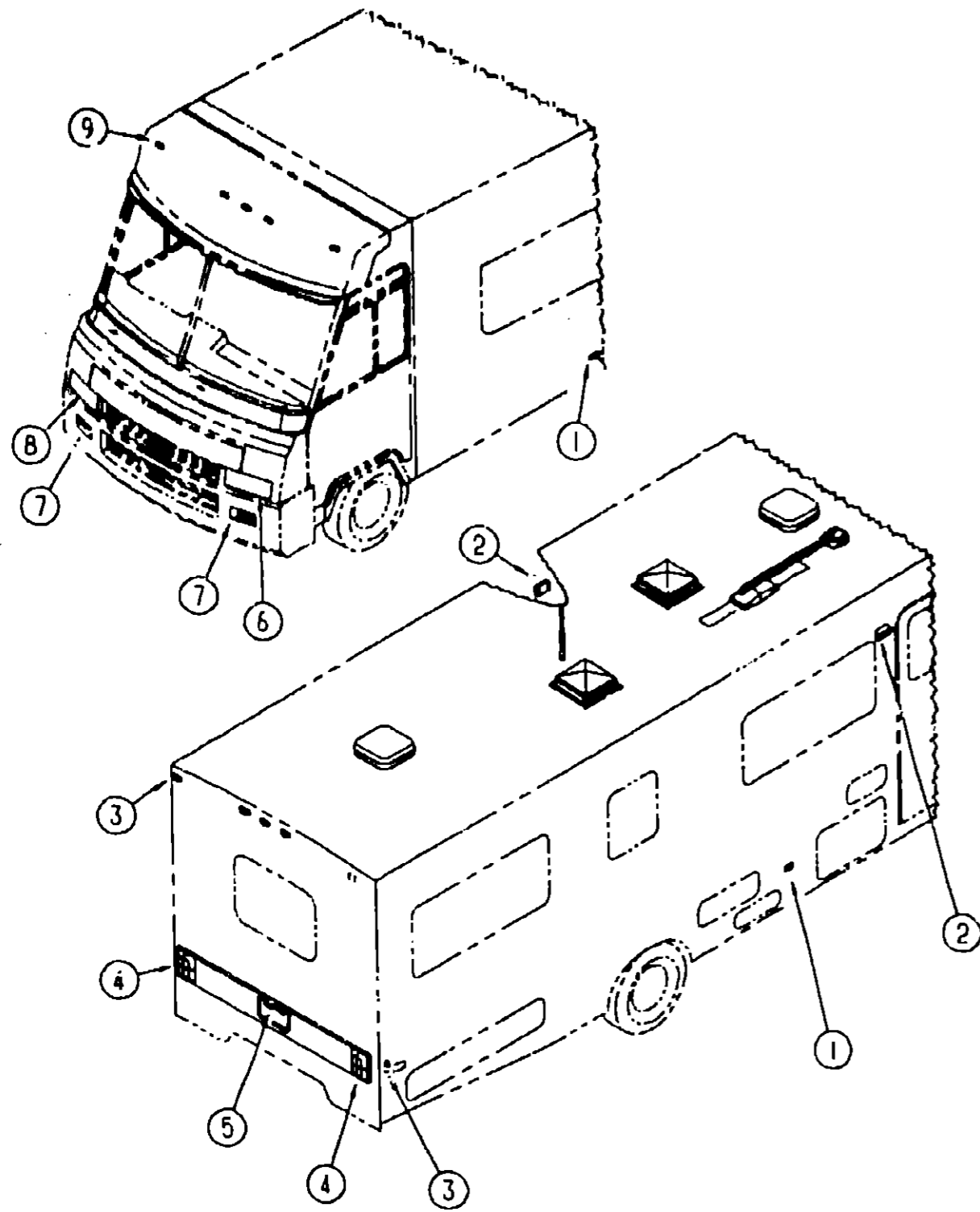

KEY	PART NUMBER	U/M DESCRIPTION
1	062648-02-000	EA LIGHT-CLEARANCE - AMBER
2	097917-01-03A	EA LIGHT - PORCH - ENTRY DOOR - GRAY
	008215-01-000	EA BULB
2	097917-01-700	EA LENS - LIGHT - PORCH
3	062648-01-000	EA LIGHT - CLEARANCE - RED
4	081638-01-000	EA TAIL LIGHT - DOUBLE - W/BLACK TRIM - DRIVER & PASSENGER SIDE
4	081638-01-700	EA LENS - TAIL LIGHT - RED
4	081638-01-701	EA LENS - TAIL LIGHT - W/BACKUP
	037934-01-000	EA BULB #1156 (BACK UP & TURN SIGNAL)
	037935-01-000	EA BULB #2057 OR #1157 (BRAKE LIGHT)
5	066432-02-000	EA LIGHT ASM - LICENSE PLATE
5	066432-03-000	EA BRACKET - LICENSE PLATE
6	049188-02-000	EA HEADLAMP CAPSULE - DRIVER SIDE - HIGH/LOW BEAM - W/BLACK RETAINER
6	049188-02-000	EA HEADLAMP CAPSULE - DRIVER SIDE - HIGH BEAM - W/BLACK RETAINER
7	084901-01-000	EA LAMP-PARK/TURN, GM # 916558 (BULB #2057)
8	049187-02-000	EA HEADLAMP CAPSULE - PASSENGER SIDE - HIGH BEAM - W/BLACK RETAINER
8	049185-02-000	EA HEADLAMP CAPSULE - PASSENGER SIDE - HIGH/LOW BEAM - W/BLACK RETAINER
	050030-02-000	EA HOUSING - HEADLAMP WIRING - HIGH BEAM
	063749-01-000	EA HOUSING - HEADLAMP WIRING - LOW BEAM
	049359-01-000	EA SPRING - RETAINER - HEADLAMP
	073308-01-000	EA SCREW - ADJUSTING - HEADLAMP
	096674-01-000	EA NUT - HEADLAMP - BLACK
9	102520-01-000	EA CLEARANCE LIGHT ASM - CLEARANCE - W/O SOCKET CONNECTIONS - AMBER
	036196-01-000	EA BULB
	067789-02-000	EA SOCKET ASM
	102540-01-000	EA SEAL - SCREW - ROUND - RUBBER
	102541-01-000	EA GASKET - CLEARANCE LIGHT

INTERIOR LIGHTS

KEY	PART NUMBER	U/M DESCRIPTION
	098024-01-01A	EA DOME LIGHT - 1 BULB - US - IVORY
	098024-03-01A	EA DOME LIGHT - 2 BULB - IVORY
	008218-01-000	EA BULB - DOME LIGHT
	098024-01-700	EA LENS - DOME LIGHT
	061424-01-000	EA LIGHT - AISLE - 12V - RECTANGULAR
	008103-01-000	EA BULB - AISLE
	065202-17-000	EA LAMP - WALL - BRASS - US
	065202-18-000	EA LAMP - WALL - BRASS - CSA
	065202-14-700	EA BRASS FINIAL (NEW STYLE)
	083978-01-000	EA WASHER - MOUNTING - LAMP
	065201-09-000	EA SHADE - LAMP - FABRIC - PARCHMENT
	082169-01-000	EA LIGHT - MAKE-UP - 3 BULB
		FROM: 00-00-00 THRU: 12-13-92
	110235-01-01A	EA LIGHT - MAKE UP - 3 BULB - PANLESS
		FROM: 12-14-92 THRU: 99-99-99
	081633-01-700	EA BULB - MAKE-UP
	086280-01-000	EA LIGHT - SURFACE MOUNT - 12V - JENSEN 1236
	086280-01-700	EA BULB - SURFACE MOUNT - 12 VOLT - 6 WATT
	087694-01-000	EA LIGHT - WARDROBE/CLOSET - W/SWITCH
	087694-01-700	EA BULB - GE561 - WARDROBE/CLOSET

1993 ITASCA TABLE OF CONTENTS

INTRODUCTION	A-01 - A-02
ABBREVIATIONS	A-03
ALPHABETICAL INDEX	A-04 - A-08
ICG32RQ	A-07 - E-16

1993 ICG32RQ INDEX

FLOOR PLAN	A-07 - A-08
ACCESSORIES	A-09
AUDIO VIDEO	A-10 - A-11
BATH	A-12 - A-14
BEDROOM	A-15 - A-16
CHASSIS	A-17 - B-06
CURTAIN & CUSHION	B-07 - B-17
DINETTE	B-18 - B-20
DRIVERS COMPARTMENT	B-21 - B-24
ELECTRICAL	C-01 - C-06
EXTERIOR BODY	C-07 - C-14
GALLEY	C-15 - C-18
GENERATOR	C-19 - C-20
HEATING & A/C	C-21 - C-24
INTERIOR FINISH	D-01 - D-04
LABELS	D-05 - D-12
LP	D-13
LOUNGE	D-14 - D-16
SEALANTS & FASTENERS	D-17 - D-19
WATER & SEWAGE	D-20 - D-23
WINDOW, VENT & EXTERIOR DOOR	D-24 - E-14
WINDSHIELD & WIPER	E-15 - E-16

ELECTRICAL GROUP (CONTINUED)

ELECTRIC COMPONENTS

KEY	PART NUMBER	U/M DESCRIPTION
	007083-01-000	EA FLASHER - SIGNAL - STAT
	007942-01-000	EA TAB - WIRE - 18 TO 14 AWG
	008188-01-000	EA SOLENOID - 3 POST - BATTERY CHANGE COVER
	095188-01-01A	EA SPACER - SWITCH - 2.3" X 3.4" - PLASTIC - DARK BROWN
	008328-01-000	EA TERMINAL - RING - 18/14 WIRE - 3/8" STUD
	008328-01-000	EA TERMINAL - RING - 12/10 WIRE - #10 STUD FIT
	008331-01-000	EA TERMINAL - RING - TONGUE - #4 WIRE - 3/8" STUD - COPPER
	008348-01-000	EA TERMINAL - RING - 3/8" STUD - #2 WIRE
	035416-04-000	EA TERMINAL - RING #10 STUD FITTING - INSULATED BARREL #18/14
	047443-01-000	EA TERMINAL - .250 RECP. FITTING - INSULATED - 18/14 AWG
	047443-02-000	EA TERMINAL - .250 RECP. FITTING - INSULATED - 12/10 AWG
	082036-02-000	EA TERMINAL - PACK - CONNECTOR - 18/14 AWG
	104100-03-000	EA TERMINAL - 75 AMP AMP 53880-4 LOOSE
	103603-01-000	EA BULB - 12V NO.74 0 12A WEDGE GE 22-25 OR EQUIV
	008215-01-000	EA BULB - 12V - #1003 - 94AMP
	008218-01-000	EA BULB - DOME LIGHT - 12V - NUMBER 1141
	035196-01-000	EA BULB - 12V - #194 - 27AMP - BAYONETTE
	067479-01-000	EA BULB - 12V - NUMBER 1076
	067789-02-000	EA SOCKET - LAMP
	103608-01-000	EA SOCKET - WEDGE BASE W/LEADS JKL 2944-6 OR EQUIV
	075723-01-000	EA BLOCK - SWITCH - SPACER W/O HOLE
	095188-01-01A	EA SPACER - SWITCH - 2.3" X 3.4" - PLASTIC - DARK BROWN
	075723-02-000	EA SPACER - SWITCH - W/HOLE - 2" X .9" X 2" - METAL - OFF WHITE FOR ELECTRIC STEP DOOR JAMB SWITCH
	077479-01-000	EA BOOT - BATTERY TERMINAL - DOUBLE CABLE
	077479-02-000	EA BOOT - BATTERY TERMINAL - SINGLE CABLE
	086233-01-000	EA STUD - ISOLATED - 3/8" X 7/8" LONG
	086273-01-000	EA RELAY - BATTERY DISCONNECT
	087949-01-000	EA BUSS BAR - 2 POSITION - 6" X 1.5" - ALUMINUM
	087949-02-000	EA BUSS BAR - 3 POS. 90 WIV
	090971-01-000	EA SPLICE - CABLE - 110V
	100341-01-000	EA FUSE HOLDER - IN LINE TYPE WESCO 8931-92020
	102568-01-B10	EA SPACER - RECEPTACLE - BETWEEN SIDEWALL & PLATE - WOOD
	092492-06-000	EA SEAL - ELECTRICAL BOX
	103873-01-000	EA SEAL - ELECTRICAL BOX/BULKHEAD ALFA III(215X215)
	103987-01-000	EA SEAL - SOLENOID ACCESS

CONVERTER & LOAD CENTER

KEY	PART NUMBER	U/M DESCRIPTION
	094809-01-000	EA LOAD CENTER - 240V - 125A - TPL412CT FROM: 00-00-00 THRU: 09-08-92
	109677-01-000	EA LOAD CENTER - 120V - 40A WESCO TT120 FLGNM FROM: 09-09-92 THRU: 99-99-99
	083208-02-000	EA CONVERTER - POWER - 45A - 120V/12V - BW 6345
	099048-01-C00	EA INVERTER - 100 WATT

ELECTRICAL GROUP (CONTINUED)

ELECTRICAL HOUSINGS

KEY	PART NUMBER	U/M DESCRIPTION
	088473-01-000	EA PIN HOUSING - 4 ROWS OF 3
	088473-02-000	EA PIN HOUSING - 15 POSITION
	088473-03-000	EA PIN HOUSING - 9 POSITION
	088473-05-000	EA PIN HOUSING - 6 POSITION (SINGLE ROW)
	088473-06-000	EA PIN HOUSING - 6 POSITION (TWO ROWS OF THREE)
	088473-08-000	EA PIN HOUSING - 4 POSITION
	088473-09-000	EA PIN HOUSING - 3 POSITION (SINGLE ROW)
	088473-10-000	EA PIN HOUSING - 2 POSITION
	088474-01-000	EA HOUSING - SOCKET - 12 POSITIONS
	088474-02-000	EA HOUSING - SOCKET - 15 POSITION (3 RCWS OF 5)
	088474-03-000	EA HOUSING - SOCKET - 9 POSITION
	088474-06-000	EA HOUSING - SOCKET - 6 POSITION (2 ROWS OF THREE)
	088474-07-000	EA HOUSING - SOCKET - 5 CAVITY - AMP 1-480764-0
	088474-08-000	EA HOUSING - SOCKET - 4 POSITION (SINGLE ROW)
	088474-09-000	EA HOUSING - SOCKET - 3 POSITION
	088474-10-000	EA HOUSING - SOCKET - 2 POSITION
	063910-01-000	EA HOUSING - RELAY - BOSCH 3 334 485 008
	050030-02-000	EA HOUSING - HEADLAMP WIRING - HIGH BEAM
	101571-01-000	EA HOUSING - 2 POSITION - MALE
	104100-01-000	EA HOUSING - 1 POSITION - 75 AMP - AMP 53884-1
	106006-01-000	EA HOUSING - 1 POSITION - FEMALE - PACKARD 12015952
	108355-01-000	EA HOUSING - SWITCH - CARLING VCH
	007949-01-000	EA TAB - HOUSING - 1 POSITION

**1993 ITASCA
TABLE OF CONTENTS**

INTRODUCTION	A-01 - A-02
ABBREVIATIONS	A-03
ALPHABETICAL INDEX	A-04 - A-06
ICG32RQ	A-07 - E-18

1993 ICG32RQ INDEX

FLOOR PLAN	A-07 - A-08
ACCESSORIES	A-09
AUDIO VIDEO	A-10 - A-11
BATH	A-12 - A-14
BEDROOM	A-15 - A-16
CHASSIS	A-17 - B-06
CURTAIN & CUSHION	B-07 - B-17
DINETTE	B-18 - B-20
DRIVERS COMPARTMENT	B-21 - B-24
ELECTRICAL	C-01 - C-06
EXTERIOR BODY	C-07 - C-14
GALLEY	C-15 - C-18
GENERATOR	C-19 - C-20
HEATING & A/C	C-21 - C-24
INTERIOR FINISH	D-01 - D-04
LABELS	D-05 - D-12
LP	D-13
LOUNGE	D-14 - D-16
SEALANTS & FASTENERS	D-17 - D-19
WATER & SEWAGE	D-20 - D-23
WINDOW, VENT & EXTERIOR DOOR	D-24 - E-14
WINDSHIELD & WIPER	E-15 - E-16

ELECTRICAL GROUP (CONTINUED)

SWITCHES, RECEPTACLES & COVERS

KEY	PART NUMBER	U/M	DESCRIPTION
	088241-03-000	EA	SWITCH - BLANK
	079384-01-000	EA	SWITCH - ON/OFF - ROCKER - 2 PRONGS - BROWN
	079384-03-000	EA	SWITCH - ON/OFF - ROCKER - 3 PRONGS - BROWN
	108367-08-000	EA	SWITCH - ROCKER - DPDT/ON/NONE/ON CARLING VDD1500C-0
	087734-01-01A	EA	EXTENSION - RECEPTACLE - 3.2" X 5" X 7" - PLASTIC - IVORY
	088351-01-01A	EA	PLATE - SWITCH - 1 GANG - POLISHED BRASS
	088361-02-01A	EA	PLATE - SWITCH - 2 GANG - POLISHED BRASS
	088361-04-01A	EA	PLATE - SWITCH - GENERATOR/DOOR LOCK - POLISH BRASS - JENSEN
	088361-05-01A	EA	PLATE - SWITCH - 3 GANG - POLISH BRASS - JENSEN
	080015-02-000	EA	RECEPTACLE - FLAG - 185 - 18/14 GA - AMP 3
	084076-02-000	EA	RECEPTACLE - CFI - 15A - 125V - BROWN
	058707-01-000	EA	RECEPTACLE - ELECTRIC - SINGLE - BROWN
	058707-02-000	EA	RECEPTACLE - PLANK - JUNCTION WIRECON
	058708-01-000	EA	RECEPTACLE - ELECTRIC - DOUBLE - BROWN
	058708-02-000	EA	RECEPTACLE - ELECTRIC - DOUBLE - IVORY
	007940-01-000	EA	RECEPTACLE - SLIDE - 16 TO 12 AWG - FEMALE END
	024924-02-000	EA	RECEPTACLE - POWER CORD - W/PARTIAL PLATE
	075736-02-000	EA	COVER - EXTERIOR RECEPTACLE - OFF WHITE
	088238-01-000	EA	COVER - SWITCH - A/C SELECTOR - FRONT TO REAR A/C
	088238-02-000	EA	COVER - SWITCH - A/C SELECTOR FOR FRONT OR REAR

ELECTRICAL WIRING & BOXES

KEY	PART NUMBER	U/M	DESCRIPTION
	008052-01-000	EA	CORD - POWER - 10/3 - 30 AMP - 25' - CANADIAN
	053054-01-000	EA	CORD - POWER - 10/3 - 30 AMP - 25'
	008288-01-000	EA	BOX - PLASTIC ELECTRICAL - 3" X 3 1/2"
	008288-02-000	EA	BOX - ELECTRIC - PLASTIC - 3.94" X 3.13" X 1.81"
	008289-01-000	EA	BOX - ELECTRIC - STEEL - 1/2" AND 3/4" KNOCKOUTS - 4" X 4"
	008289-02-000	EA	BOX - ELECTRICAL - 4" X 4" - 1/2" & 3/4" KNOCKOUTS - CANADIAN
	074890-01-000	EA	BOX - EXTENSION - STEEL - OPEN SIDES - 4" X 4" X 1 1/2"
	058049-01-000	EA	BOX - ELECTRIC SWITCH - 2" X 3" X 2 25"
	091910-01-000	EA	BOX - ELECTRIC - 3.75" X 3.5" X 1.75" - PLASTIC
	104677-01-000	EA	BOX - ELECTRICAL - CIRCUIT BREAKER - BRYANT 2-4-50FLG
	091927-01-000	EA	COVER - RECEPTACLE - DOUBLE - IVORY
	008294-01-000	EA	COVER - ELECTRICAL BOX - BLANK/STEEL - 4" X 4" - GRAY
	008294-02-000	EA	COVER - ELECTRICAL BOX - BLANK STEEL - 4" X 4" - CANADIAN
	074897-01-000	EA	COVER - ELECTRIC BOX - 1 LARGE & 2 SMALL HOLES - 4" X 4"
	069238-01-000	EA	COVER - ELECTRICAL BOX - W/HOLE - 4" X 4" - GRAY USED WITH 30 AMP RECEPTACLE
	084077-02-000	EA	PLATE - COVER - RECEPTACLE - GFI - BROWN
	104016-01-000	EA	WIRE ASM - AUX FANS
	102036-01-000	EA	WIRE ASM - CLEARANCE LAMPS
	094831-08-000	EA	WIRE ASM - AC COMPRESSOR ADAPTER - SCS 036-0054
	P03784-02-000	EA	WIRE ASM - HEADLAMP(FORD)
	P03784-01-000	EA	WIRE ASM - HEADLAMP(GM)
	088751-01-000	FT	CABLE - BATTERY - 1/0 AWG - 5 STRANDED - RED
	073328-B4-000	EA	CABLE ASSEMBLY - BATTERY - W/TERMINALS

ELECTRICAL GROUP (CONTINUED)

ELECTRICAL CONNECTORS & CONDUIT

KEY	PART NUMBER	U/M	DESCRIPTION
	041983-01-000	FT	CONDUIT - CONVOLUTE - SLIT - 5/8" ID
	041953-03-000	FT	CONDUIT - CONVOLUTE - SLIT - 1" ID (CLOTHES ROD COVER)
	041953-05-000	FT	CONDUIT - CONVOLUTE - SOLID - 82" ID
	041953-06-000	FT	CONDUIT - CONVOLUTE - SLIT 3/5" ID
	041953-07-000	FT	CONDUIT - CONVOLUTE - SLIT - 25" ID
	041953-08-000	FT	CONDUIT - CONVOLUTE - SLIT - 1.50" ID
	041953-09-000	FT	CONDUIT - CONVOLUTE - SLIT 50" ID
	041953-10-000	FT	CONDUIT - CONVOLUTE - SLIT - 75" ID
	041953-11-000	FT	CONDUIT - CONVOLUTE - SLIT - 1 06" ID
	041953-12-000	FT	CONDUIT - CONVOLUTE - NON SLIT 1 1" ID
	008311-01-000	EA	CONNECTOR - WIRE NUT - INSULATED - RED
	008312-01-000	EA	CONNECTOR - WIRE NUT - INSULATED - BLUE
	008314-01-000	EA	CONNECTOR - WIRE NUT - INSULATED - GRAY
	008355-01-000	EA	CONNECTOR - CABLE CLAMPING - 3/4"
	008356-01-000	EA	CONNECTOR - PLASTIC - 3/8" AVG
	058028-01-000	EA	CONNECTOR - ELECTRICAL PIGTAIL - NYLON - CLEAR
	041480-01-000	EA	CONNECTOR - STRAIGHT - 1/2" FLEX CONDUIT
	082740-01-000	EA	CONNECTOR - PLASTIC BODY - FOR 2 MALE SPADES
	088475-01-000	EA	PIN-CONNECTOR - 14 TO 20 AWG KEY
	088476-01-000	EA	SOCKET - CONNECTOR - BRASS - PRE - TIN
	088476-02-000	EA	SOCKET - CONNECTOR - 12-10 GA - PHOS BRZ - PRE - TIN

CIRCUIT BREAKERS & FUSES

KEY	PART NUMBER	U/M	DESCRIPTION
	097611-01-000	EA	CIRCUIT BREAKER - 6AMP - ATC - BLACK
	093654-01-000	EA	CIRCUIT BREAKER - 6 AMP - HOUSE CONTROL PANEL
	093654-02-000	EA	CIRCUIT BREAKER - 15 AMP
	093655-01-000	EA	CIRCUIT BREAKER - 25 AMP
	093655-02-000	EA	CIRCUIT BREAKER - 30 AMP - HOUSE CONTROL PANEL
	093655-03-000	EA	CIRCUIT BREAKER - 40 AMP USD 17440-4E03A2A
	094810-01-000	EA	CIRCUIT BREAKER - DOUBLE 30 AMP - GE THQ12130
	094811-01-000	EA	CIRCUIT BREAKER - DOUBLE 20 AMP - GE THQ12120
	083209-02-000	EA	CIRCUIT BREAKER - 15/15AMP - 120V - BW H - 15/15
	083209-03-000	EA	CIRCUIT BREAKER - 15/20AMP - 120V - BW - 0-15/20
	083209-04-000	EA	CIRCUIT BREAKER - 30A - 120V - BW L - 30
	083209-06-000	EA	CIRCUIT BREAKER - 30/15 AMP - 120V - BW D - 30/15
	083209-07-000	EA	CIRCUIT BREAKER - 20/20A - 120V - BW K - 20/20
	083209-08-000	EA	CIRCUIT BREAKER - BLANK - BW
	062901-02-000	EA	FUSE - 5 AMP - AUTOMOTIVE
	062901-05-000	EA	FUSE - 15 AMPS - AUTOMOTIVE
	062901-07-000	EA	FUSE - AUTOMOTIVE - 25 AMPS
	008235-01-000	EA	FUSE - AUTOMOTIVE - 12V - 15AMP
	062037-01-000	EA	HOUSING - AUTO FUSE - NATURAL
	062037-02-000	EA	HOUSING - AUTO FUSE - GREEN
	062037-03-000	EA	HOUSING - AUTO FUSE - BLACK
	062037-04-000	EA	HOUSING - AUTO FUSE - BLUE
	062037-05-000	EA	HOUSING - AUTO FUSE - GRAY
	062037-06-000	EA	HOUSING - AUTO FUSE - BROWN

**1993 ITASCA
TABLE OF CONTENTS**

INTRODUCTION	A-01 - A-02
ABBREVIATIONS	A-03
ALPHABETICAL INDEX	A-04 - A-08
ICG32RQ	A-07 - E-18

1993 ICG32RQ INDEX

FLOOR PLAN	A-07 - A-08
ACCESSORIES	A-09
AUDIO VIDEO	A-10 - A-11
BATH	A-12 - A-14
BEDROOM	A-15 - A-16
CHASSIS	A-17 - B-06
CURTAIN & CUSHION	B-07 - B-17
DINETTE	B-18 - B-20
DRIVERS COMPARTMENT	B-21 - B-24
ELECTRICAL	C-01 - C-06
EXTERIOR BODY	C-07 - C-14
GALLEY	C-15 - C-18
GENERATOR	C-19 - C-20
HEATING & A/C	C-21 - C-24
INTERIOR FINISH	D-01 - D-04
LABELS	D-05 - D-12
LP	D-13
LOUNGE	D-14 - D-16
SEALANTS & FASTENERS	D-17 - D-19
WATER & SEWAGE	D-20 - D-23
WINDOW, VENT &	
EXTERIOR DOOR	E-24 - E-14
WINDSHIELD & WIPER	E-15 - E-16

**EXTERIOR BODY GROUP
EXTERIOR BODY PANELS & TRIM**

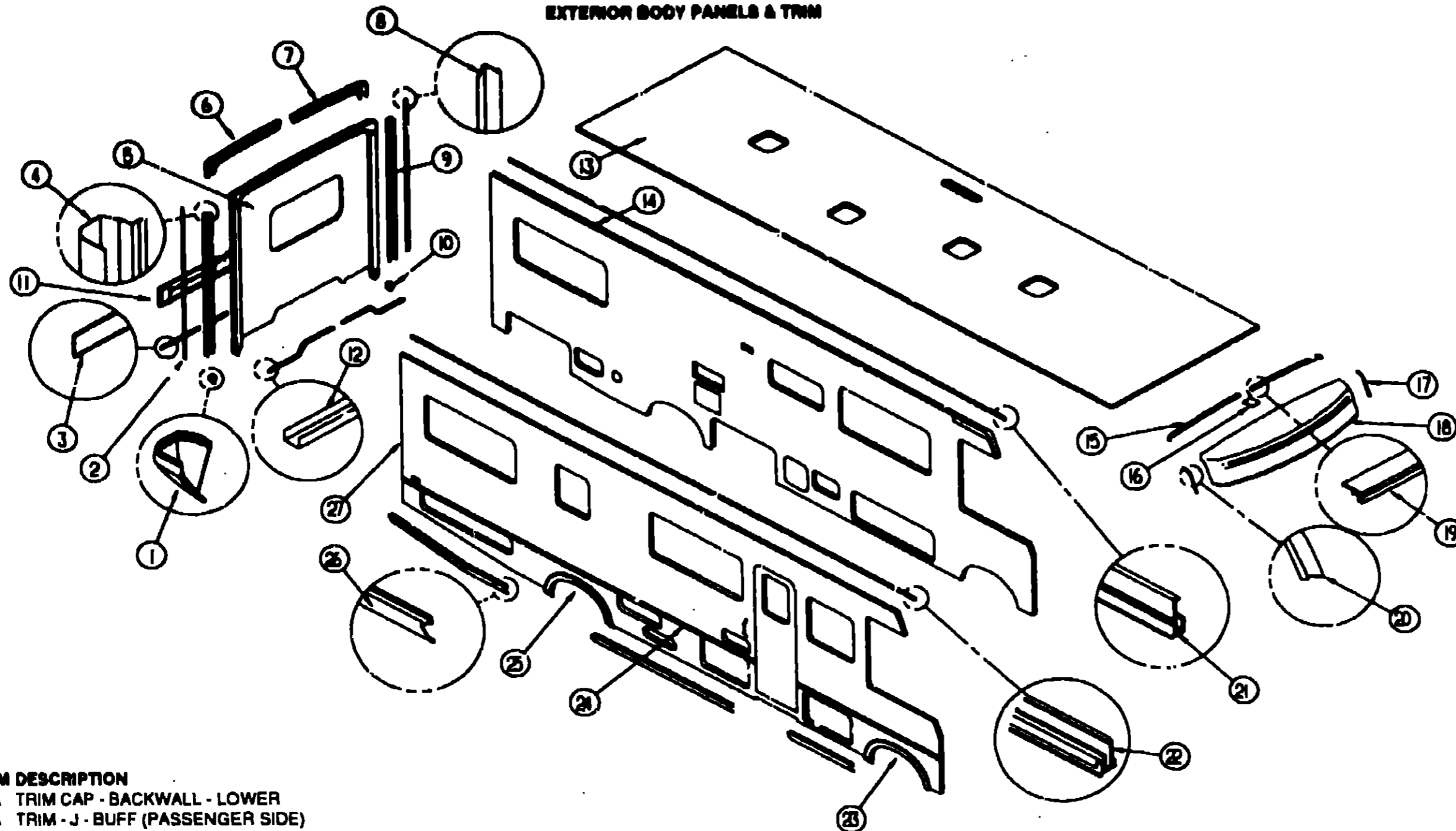

**1993 ITASC/A
TABLE OF CONTENTS**

INTRODUCTION	A-01 - A-02
ABBREVIATIONS	A-03
ALPHABETICAL INDEX	A-04 - A-08
ICG32RQ	A-07 - E-18

1993 ICG32RQ INDEX

FLOOR PLAN	A-07 - A-08
ACCESSORIES	A-09
AUDIO VIDEO	A-10 - A-11
BATH	A-12 - A-14
BEDROOM	A-15 - A-16
CHASSIS	A-17 - B-06
CURTAIN & CUSHION	B-07 - B-17
DINETTE	B-18 - B-20
DRIVERS COMPARTMENT	B-21 - B-24
ELECTRICAL	C-01 - C-06
EXTERIOR BODY	C-07 - C-14
GALLEY	C-15 - C-18
GENERATOR	C-19 - C-20
HEATING & A/C	C-21 - C-24
INTERIOR FINISH	D-01 - D-04
LABELS	D-05 - D-12
LP	D-13
LOUNGE	D-14 - D-16
SEALANTS & FASTENERS	D-17 - D-19
WATER & SEWAGE	D-20 - D-23
WINDOW, VENT & EXTERIOR DOOR	D-24 - E-14
WINDSHIELD & WIPER	E-15 - E-16

KEY	PART NUMBER	U/M DESCRIPTION
1	105167-03-01A	EA TRIM CAP - BACKWALL - LOWER
2	104033-03-03A	EA TRIM - J - BUFF (PASSENGER SIDE)
3	093673-01-04A	EA MOLDING - PLASTIC - GRAY
4	103598-03-04A	EA TRIM - BACKWALL - SIDE - GRAY (PASSENGER SIDE)
5	M05191-20-D35	EA BACKWALL ASM - TWIN BED (CHEVY)
5	M05191-20-D36	EA BACKWALL ASM - TWIN BED (CHEVY)
5	M05191-16-D35	EA BACKWALL ASM - QUEEN BED (CHEVY)
5	M05191-16-D36	EA BACKWALL ASM - QUEEN BED (CHEVY)
5	M05192-13-D35	EA BACKWALL ASM - QUEEN BED (FORD)
5	M05192-13-D36	EA BACKWALL ASM - QUEEN BED (FORD)
5	M05192-16-D35	EA BACKWALL ASM - TWIN BED (FORD)
5	M05192-16-D36	EA BACKWALL ASM - TWIN BED (FORD)
6	103599-01-03A	EA TRIM - BACKWALL - TOP - GRAY (PASSENGER SIDE)
7	103600-01-03A	EA TRIM - BACKWALL - TOP - LEFT GRAY
8	104033-04-03A	EA TRIM - J - BUFF (DRIVER SIDE)
9	103598-04-04A	EA TRIM - BACKWALL - SIDE - GRAY (DRIVER SIDE)
10	105167-04-01A	EA TRIM CAP - BACKWALL - LOWER
11	106125-01-D35	EA TRIM ASM - BACKWALL
12	050406-17-000	EA TRIM - BACKWALL - LOWER LEFT OR RIGHT SIDE - GRAY
13	P04811-01-D35	EA ROOF ASM
14	M05664-02-D35	EA SIDEWALL ASM - TWIN BED (DRIVER SIDE)
14	M05664-02-D36	EA SIDEWALL ASM - TWIN BED (DRIVER SIDE)
14	M05664-01-D35	EA SIDEWALL ASM - QUEEN BED (DRIVER SIDE)
14	M05664-01-D36	EA SIDEWALL ASM - QUEEN BED (DRIVER SIDE)
15	103815-02-04A	EA TRIM - FRONT CAP/ROOF - GRAY (PASSENGER SIDE)
16	088754-08-000	EA CAP - JOINT - GRAY
17	103816-04-03A	EA TRIM - FRONT CAP/SIDEWALL - GRAY (DRIVER SIDE)
18	103785-01-03A	EA CAP ASM - FRONT - GRAY

KEY	PART NUMBER	U/M DESCRIPTION
19	103815-03-04A	EA TRIM - FRONT CAP/ROOF - GRAY (DRIVER SIDE)
20	103816-01-03A	EA TRIM - FRONT CAP/SIDEWALL - GRAY (PASSENGER SIDE)
21	103801-01-03A	EA TRIM - ROOF - GRAY
22	103802-01-03A	EA RAIL - AWNING - GRAY
23	104068-01-03A	EA TRIM - WHEELWELL - FRONT - (PASSENGER SIDE)
	104068-02-03A	EA TRIM - WHEELWELL - FRONT - (DRIVER SIDE)
24	059576-05-000	EA FEATURE STRIP - WHOLES - OFF WHITE FROM 00-00-00 THRU: 03-28-93
24	108688-01-02A	EA FEATURE STRIP - WHOLES - OFF WHITE FROM 03-29-93 THRU: 99-99-99
	001030-02-004	EA INSERT - FEATURE STRIP - 17' LONG - OFF WHITE FROM 00-00-00 THRU 03-28-93
	105312-01-04A	FT INSERT - FEATURE STRIP - PEARL FAWN FROM 03-29-93 THRU: 99-99-93
	009731-01-000	EA END CAP - FEATURE STRIP FROM: 00-00-00 THRU: 03-28-93
	108651-01-01A	EA END CAP - FEATURE STRIP FROM: 03-29-93 THRU: 99-99-99
25	104070-01-03A	EA TRIM - WHEELWELL - REAR - GRAY (DRIVER OR PASSENGER SIDE)
26	079407-05-004	EA ROCKER PANEL 192"
27	M05843-02-D35	EA SIDEWALL ASM - TWIN BED (PASSENGER SIDE)
27	M05843-02-D36	EA SIDEWALL ASM - TWIN BED (PASSENGER SIDE)
27	M05843-01-D35	EA SIDEWALL ASM - QUEEN BED (PASSENGER SIDE)
27	M05843-01-D36	EA SIDEWALL ASM - QUEEN BED (PASSENGER SIDE)

EXTERIOR BODY GROUP (CONTINUED)

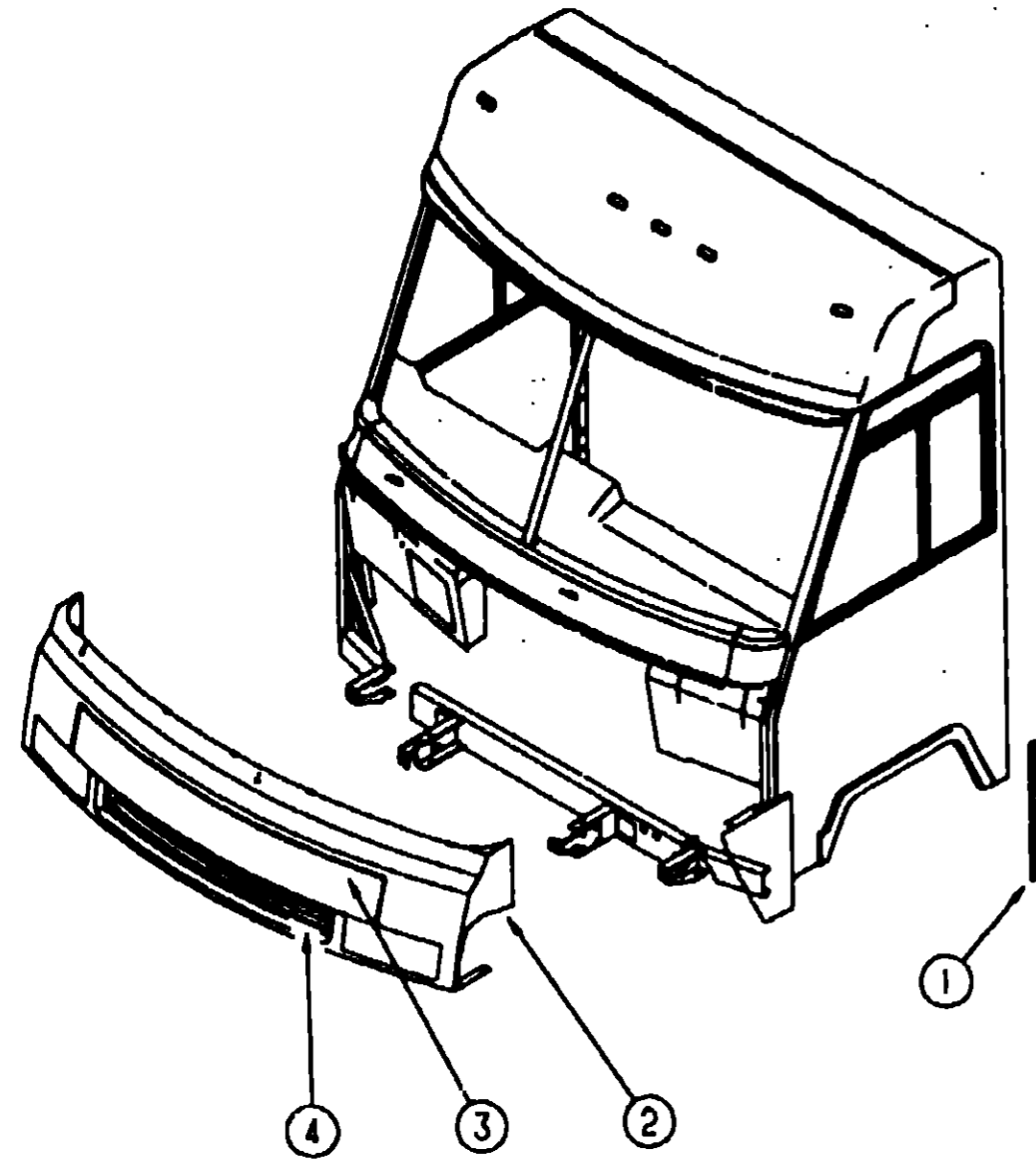

FRONT END ASM

KEY	PART NUMBER	U/M DESCRIPTION
1	089922-22-000	EA TRIM - FIBERGLASS - ASH GRAY
2	104062-01-03A	EA PANEL - FRONT - LOWER - ASH GRAY
3	104845-01-D35	EA PANEL ASM - HOOD - ASH GRAY
4	104318-01-C07	EA GRILLE ASM. - MESH - FACIA
	058786-01-000	EA BOLT - ADJUSTING - HOOD - W/BLACK PAD - 5/16" #18 X 2"
	058786-02-000	EA BOLT - ADJUSTING - HOOD - W/BLACK PAD - 5/16" #18 X 1 25"
	104582-02-000	EA LINK ASM. - HINGE - HOOD - OUTER
	104584-03-000	EA BRACKET ASM. - HOOD HINGE BODY - PASSENGER SIDE
	104584-04-000	EA BRACKET ASM. - HOOD HINGE BODY - DRIVER SIDE
	102330-02-000	EA LATCH - SINGLE HOLE - VISE ACTION
	105095-01-000	EA LINK ASM - HINGE - HOOD - INNER - PASSENGER SIDE
	105095-02-000	EA LINK ASM - HINGE - HOOD - INNER - DRIVER SIDE
	105096-02-000	EA TUBE - TIMING - HOOD HINGE

EXTERIOR BODY GROUP (CONTINUED)

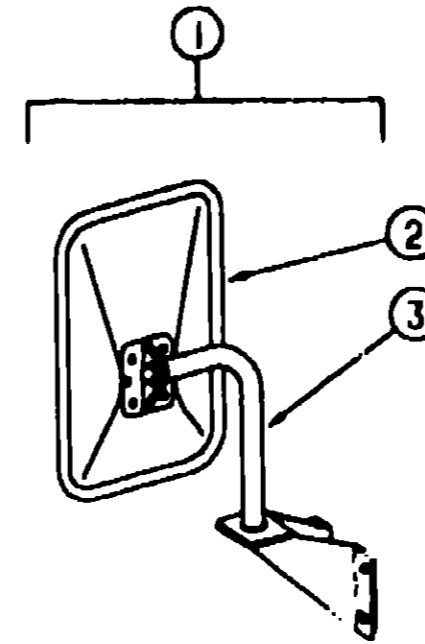

EXTERIOR MIRROR

KEY	PART NUMBER	U/M DESCRIPTION
1	105076-01-702	EA MIRROR ASM - DRIVER & PASSENGER SIDE
2	105076-01-703	EA MIRROR HEAD ONLY - DRIVER & PASSENGER SIDE
3	105076-01-704	EA ARM - DRIVER & PASSENGER SIDE
	105439-01-000	EA MIRROR - AUX - CONVEX STICK-ON
	049347-01-700	EA MIRROR - FLAT GLASS

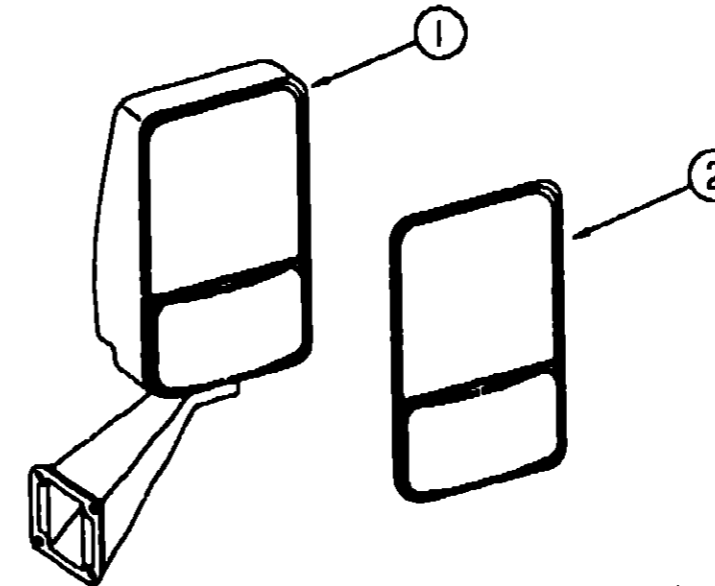

EXTERIOR MIRROR OPTION

KEY	PART NUMBER	U/M DESCRIPTION
1	106015-09-01A	EA MIRROR ASM - PASSENGER SIDE
1	106015-10-01A	EA MIRROR ASM - DRIVER SIDE
2	106015-01-703	EA MIRROR KIT (BEZEL W/MIRRORS) PASSENGER SIDE
2	106015-02-702	EA MIRROR KIT (BEZEL W/MIRRORS) DRIVER SIDE

**1993 ITASCA
TABLE OF CONTENTS**

INTRODUCTION	A-01 - A-02
ABBREVIATIONS	A-03
ALPHABETICAL INDEX	A-04 - A-08
ICG32RQ	A-07 - E-18

1993 ICG32RQ INDEX

FLOOR PLAN	A-07 - A-08
ACCESSORIES	A-09
AUDIO VIDEO	A-10 - A-11
BATH	A-12 - A-14
BEDROOM	A-15 - A-16
CHASSIS	A-17 - B-06
CURTAIN & CUSHION	B-07 - B-17
CINETTE	B-18 - B-20
DRIVERS COMPARTMENT	B-21 - B-24
ELECTRICAL	C-01 - C-06
EXTERIOR BODY	C-07 - C-14
GALLEY	C-15 - C-18
GENERATOR	C-19 - C-20
HEATING & A/C	C-21 - C-24
INTERIOR FINISH	D-01 - D-04
LABELS	D-05 - D-12
LP	D-13
LOUNGE	D-14 - D-16
SEALANTS & FASTENERS	D-17 - D-19
WATER & SEWAGE	D-20 - D-23
WINDOW, VENT &	
EXTERIOR DOOR	D-24 - E-14
WINDSHIELD & W/PER	E-15 - E-16

EXTERIOR BODY GROUP (CONTINUED)
DECALS, FILM STRIPES & PAINT

1993 ITASCA
TABLE OF CONTENTS

INTRODUCTION	A-01 - A-02
ABBREVIATIONS	A-03
ALPHABETICAL INDEX	A-04 - A-06
ICG32RQ	A-07 - E-16

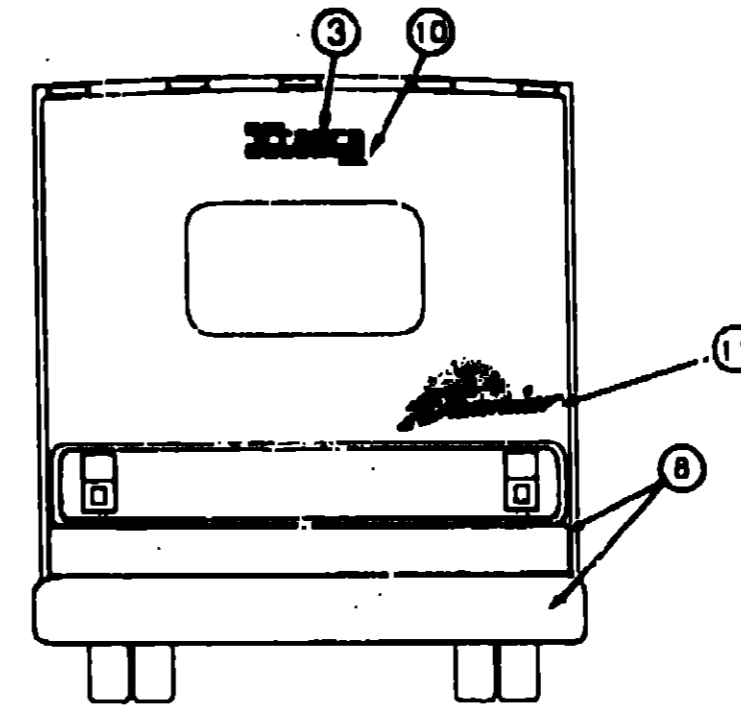
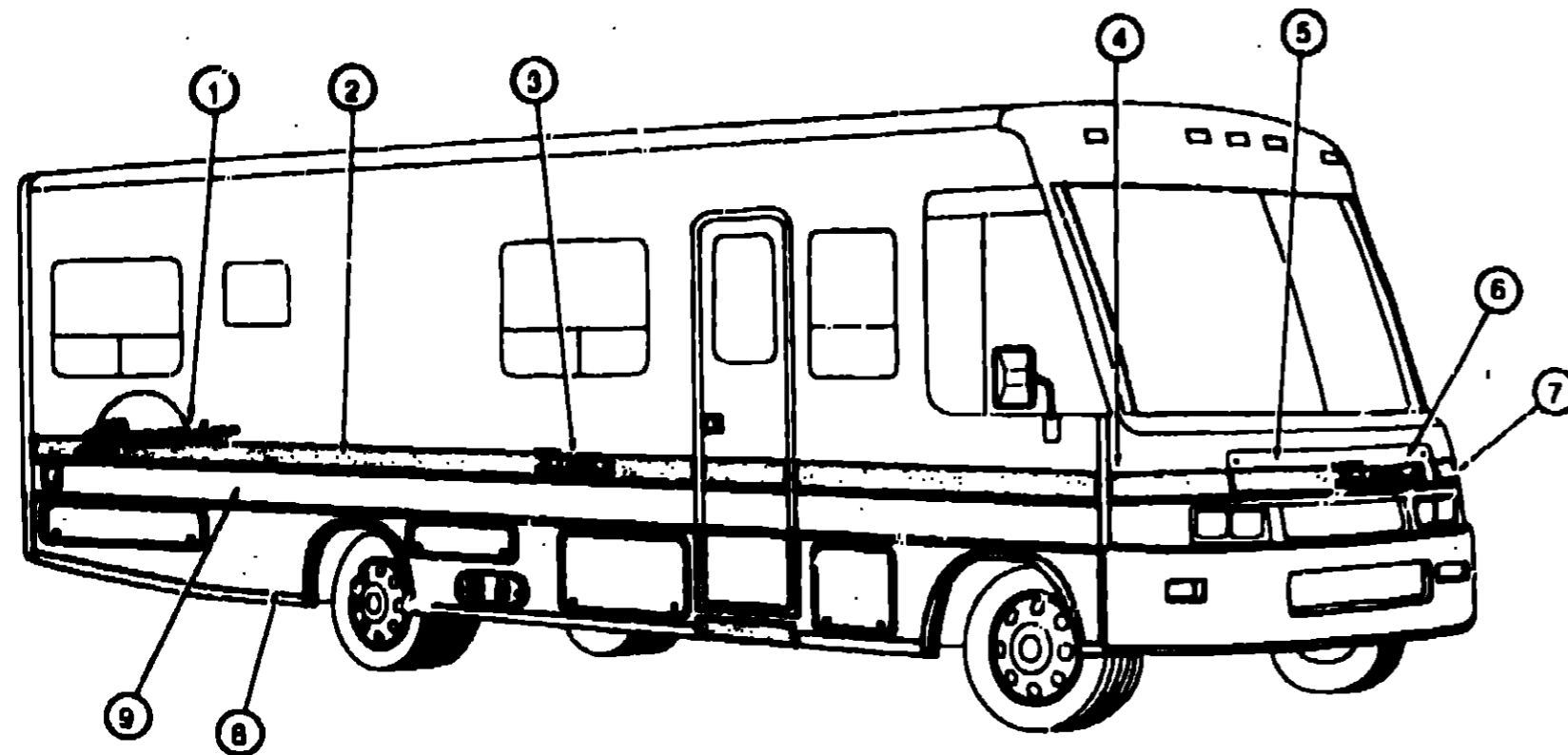

1993 ICG32RQ INDEX

FLOOR PLAN	A-07 - A-08
ACCESSORIES	A-09
AUDIO VIDEO	A-10 - A-11
BATH	A-12 - A-14
BEDROOM	A-15 - A-16
CHASSIS	A-17 - B-06
CURTAIN & CUSHION	B-07 - B-17
DINETTE	B-18 - B-20
DRIVERS COMPARTMENT	B-21 - B-24
ELECTRICAL	C-01 - C-06
EXTERIOR BODY	C-07 - C-14
GALLEY	C-15 - C-18
GENERATOR	C-19 - C-20
HEATING & A/C	C-21 - C-24
INTERIOR FINISH	D-01 - D-04
LABELS	D-05 - D-12
LP	D-13
LOUNGE	D-14 - D-16
SEALANTS & FASTENERS	D-17 - D-19
WATER & SEWAGE	D-20 - D-23
WINDOW, VENT &	
EXTERIOR DOOR	D-24 - E-14
WINDSHIELD & WIPER	E-15 - E-16

KEY	PART NUMBER	U/M	DESCRIPTION
1	108222-01-01A	EA	DECAL - SUNCRUISER - LARGE
2	094422-03-01A	FT	FILM - OVERLAY - MULTISTRIPE 139
3	078852-24-000	EA	DECAL - LOGO - ITASCA 6 50
4	108224-01-01A	EA	DECAL - CORNER - RH
5	108223-01-01A	EA	DECAL - HOOD
6	078852-25-000	EA	DECAL - LOGO - ITASCA 5 00
7	108224-02-01A	EA	DECAL - CORNER - LH
8	N/P		PAINT - GREY METALLIC (DUPONT H9283J)
9	107385-05-02A	FT	FILM-9 5MM X 150FT
10	084075-01-000	EA	DECAL - "BY WINNEBAGO INDUSTRIES" - BLACK
11	108222-02-01A	EA	DECAL - SUNCRUISER - SMALL

DUPONT PAINT COLOR CODES

SEAMIST BLUE METALLIC	G9845
ASH GRAY	L8730
FIESTA RED	G9836

EXTERIOR BODY GROUP (CONTINUED)

STYROFOAM & FIBERGLASS SHEETING

KEY	PART NUMBER	U/M	DESCRIPTION
	083674-03-000	SF	STYROFOAM - 3/4" X 48" X 96"
	000870-06-000	SF	STYROFOAM - 8" X 24" X 96" (16 SF)
	000470-03-000	SF	STYROFOAM - 1 3/4" X 48" X 96" (32 SF)
	083674-02-000	SF	STYROFOAM - DOW TYPE 5M - 1 1/2" X 24" X 96" (15 SF)
	078064-J1-000	EA	FIBERGLASS SHEET 2438 X 2438 - ASH GRAY
	077517-60-000	EA	SHEET - FIBERGLASS - FLAT - 48" X 96" - ASH GRAY
	078064-J6-000	EA	FIBERGLASS SHEET 2500 X 9785 - ASH GRAY
	086747-01-000	SF	INSULATION - MICROFOAM - 5"

EXTERIOR BODY GROUP (CONTINUED)

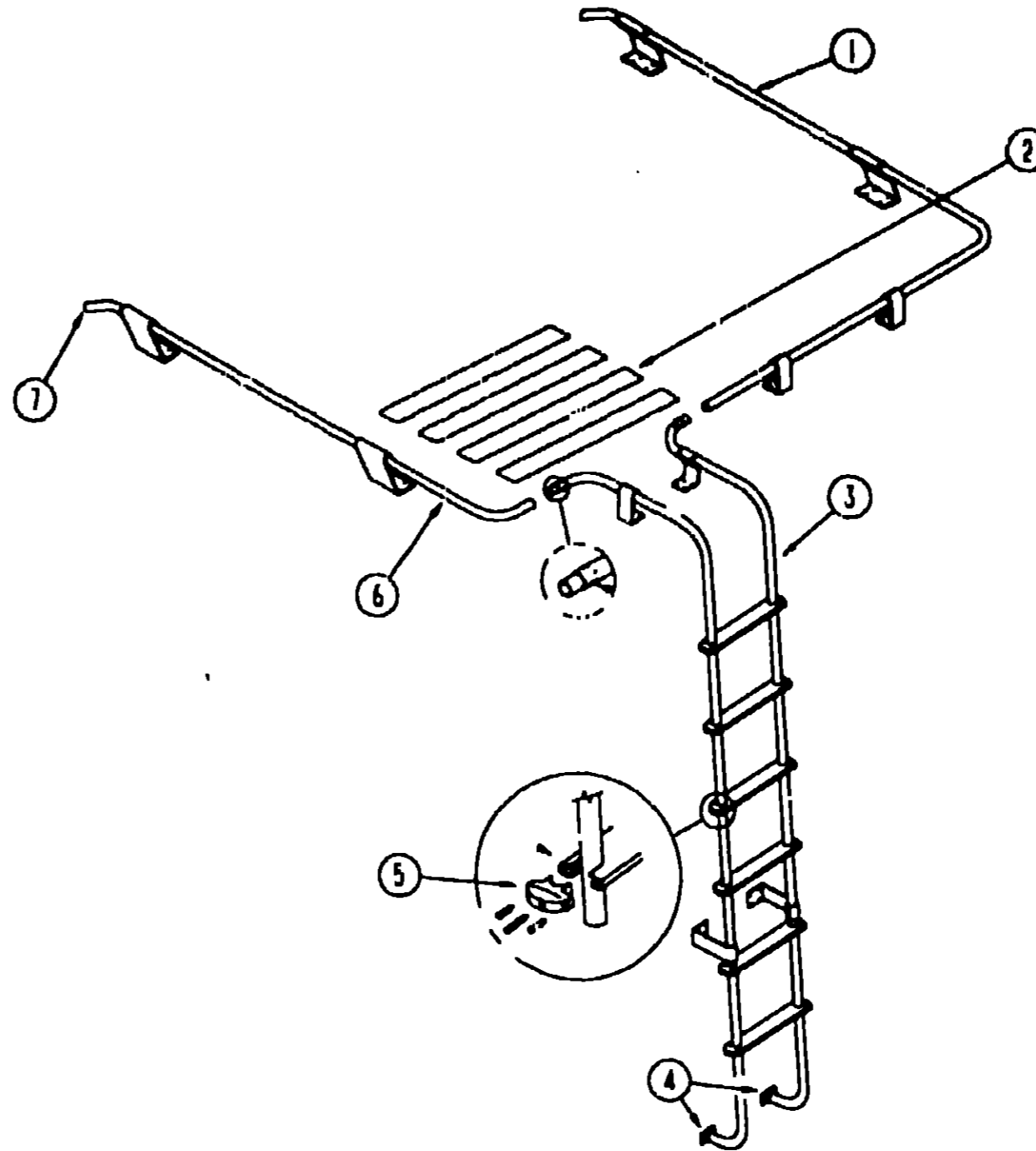

RACK & LADDER

KEY	PART NUMBER	U/M	DESCRIPTION
1	107438-05-C07	EA	RACK ASM. (PASSENGER SIDE)
2	038327-02-000	FT	TAPE - ANTI SLIP - 2" X 60FT
3	102953-03-C07	EA	LADDER ASM.
4	067165-01-000	EA	MOUNTING BRACKET - LADDER - LOWER
5	076960-02-000	EA	END CAP - STEP - BLACK
6	107438-06-C07	EA	RACK ASM. (DRIVER SIDE)
7	081114-01-000	EA	PLUG - ROUND - RACK & LADDER ENDS - PLASTIC - 1" DIA

**1993 ITASCA
TABLE OF CONTENTS**

INTRODUCTION	A-01 - A-02
ABBREVIATIONS	A-03
ALPHABETICAL INDEX	A-04 - A-08
ICG32RQ	A-07 - E-16

1993 ICG32RQ INDEX

FLOOR PLAN	A-07 - A-08
ACCESSORIES	A-09
AUDIO VIDEO	A-10 - A-11
BATH	A-12 - A-14
BEDROOM	A-15 - A-16
CHASSIS	A-17 - B-06
CURTAIN & CUSHION	B-07 - B-17
DINETTE	B-18 - B-20
DRIVERS COMPARTMENT	B-21 - B-24
ELECTRICAL	C-01 - C-06
EXTERIOR BODY	C-07 - C-14
GALLEY	C-15 - C-18
GENERATOR	C-19 - C-20
HEATING & A/C	C-21 - C-24
INTERIOR FINISH	D-01 - D-04
LABELS	D-05 - D-12
LP	D-13
LOUNGE	D-14 - D-16
SEALANTS & FASTENERS	D-17 - D-19
WATER & SEWAGE	D-20 - D-23
WINDOW, VENT & EXTERIOR DOOR	D-24 - E-14
WINDSHIELD & W/PER	E-15 - E-16

GALLEY GROUP

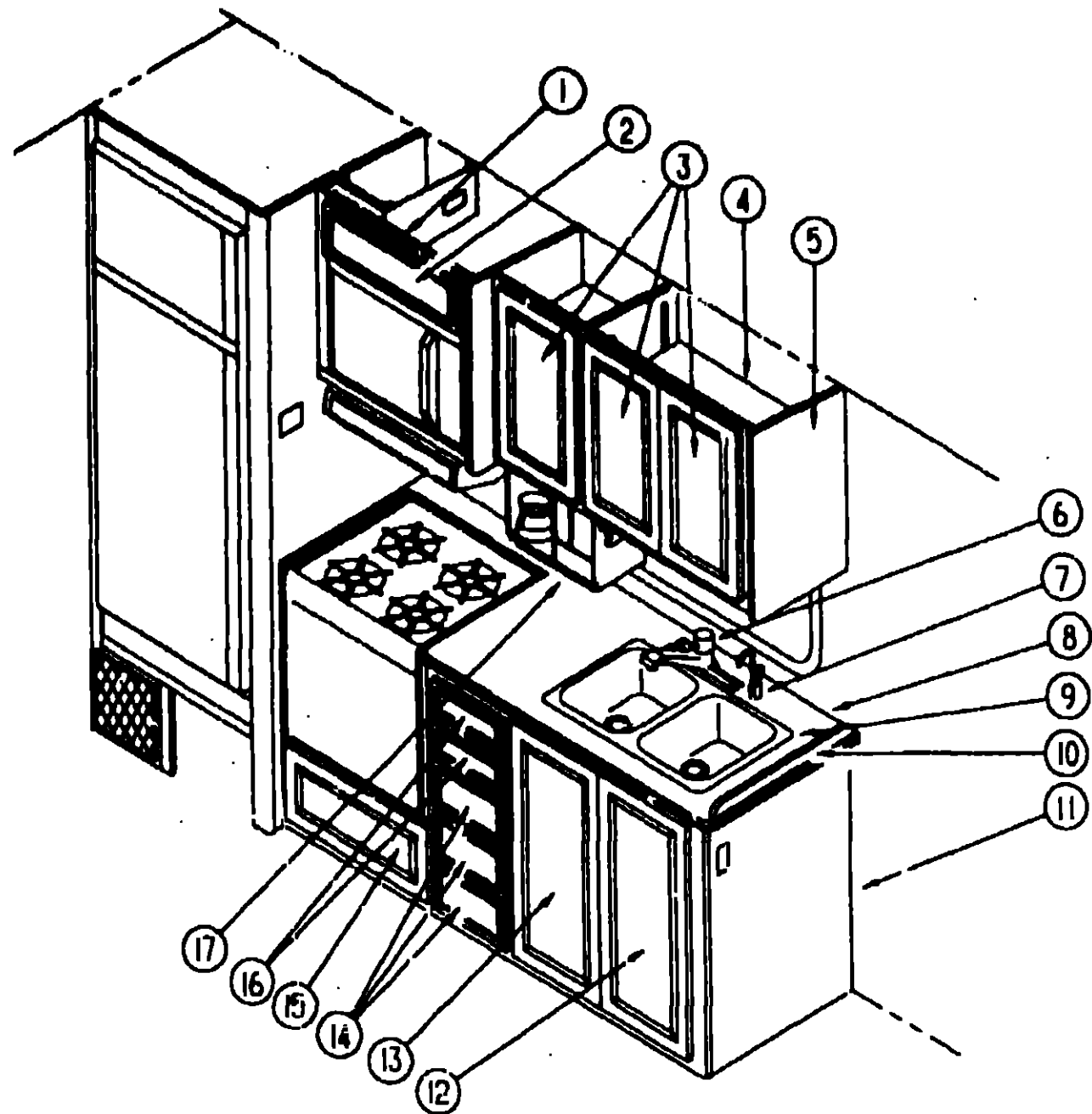

GALLEY CABINETHY & FIXTURES

KEY	PART NUMBER	U/M DESCRIPTION
1	M05019-80-D35	EA CABINET ASM - MICROWAVE OVHD
	104879-01-C27	EA CABINET ASM - AC SWITCH
2	P03702-E8-D35	EA DOOR ASM - RAIL - W/O HARDWARE
3	P03702-82-D35	EA DOOR ASM - W/O HARDWARE
4	P04855-01-C27	EA CABINET ASM - OVERHEAD - GALLEY
5	081319-17-C27	EA END CAP ASM - OVERHEAD - GALLEY
6	104114-01-01A	EA FAUCET - GALLEY - SINGLE CONTROL
7	103635-01-000	EA FAUCET - SINGLE CONTROL - EVERPURE 5435-00
8	104856-12-D35	EA COUNTERTOP ASM.
	104856-12-D35	EA COUNTERTOP ASM.
	103614-01-000	EA CUTTING BOARD
	104113-01-000	EA SINK - STAINLES STEEL - DOUBLE
	092303-01-000	EA STRAINER - SINK
10	098335-02-D35	EA RAIL - GALLEY - 22.3"
10	098335-02-D36	EA RAIL - GALLEY - 22.3"
11	M05635-04-D35	EA GALLEY CABINET ASM
11	M05635-04-D36	EA GALLEY CABINET ASM

GALLEY GROUP (CONTINUED)

GALLEY CABINETHY & FIXTURES (CONTINUED)

KEY	PART NUMBER	U/M DESCRIPTION
12	P03702-A8-D35	EA DOOR ASM - W/O HARDWARE
13	P03702-A7-D35	EA DOOR ASM - W/O HARDWARE
14	P07104-93-D35	EA DRAWER ASM - W/O HARDWARE
15	P07104-89-D35	EA DRAWER ASM - W/O HARDWARE
16	P07104-91-D35	EA DRAWER ASM - W/O HARDWARE
17	103799-01-02A	EA COFFEE MAKER GRAY
	104810-01-000	EA STRAP ASM - COFFEE MAKER
	103445-01-01A	EA HOLDER-PAPER TOWEL - PLASTIC - ALMOND
	090329-01-000	FT T-SEAL - REFRIGERATOR CABINET - 6" WIDE TOP X 2" TAIL

WEDGEWOOD RANGE, 4 BURNER (BLACK) 21"

KEY	PART NUMBER	U/M DESCRIPTION	
	107323-01-01A	EA RANGE - 21" 4 - BURNER BLACK	
	107314-01-01A	EA RANGE COVER - BIFOLD 21" BLACK	
	101593-01-703	EA KNOR - BURNER	53000
	106689-01-701	EA SPARK - IGNITOR ASM - HIGH OUTPUT	53078
	106689-01-702	EA PIEZO PUSH BUTTON	52279
	106689-01-703	EA VALVE - HIGH OUTPUT	53047
	106689-01-704	EA REGULATOR W/EXTREME PRESSURE	52154
	106689-01-705	EA VALVE - BURNER	52123
	107246-01-700	EA RANGE TOP (BLACK)	53083
	107246-01-701	EA GRATE	53050
	107323-01-700	EA RANGE TOP	53513
	107323-01-702	EA TRIM LEFT	53023
	107323-01-703	EA TRIM RIGHT	53024
	107323-01-704	EA MANIFOLD COVER	53556
	107323-01-705	EA TRIM VENT	53525
	107323-01-706	EA TRIM BOTTOM	53526
	107323-01-707	EA INSERT BLACKGLASS - W/O HOLE	53426
	107323-01-708	EA HANDLE ROD - W/O HOLE	53085
	107323-01-709	EA HANDLE END CAP - W/O HOLE	53424
	107323-01-710	EA GRATE CLIP	53301
	107323-01-711	EA RUBBER GRATE CUSHION	53000
	107246-01-703	EA THERMOSTAT ROBERT SHAW	52123
	107323-01-713	EA BLACKGLASS INSERT - W/HOLE	53425
	107323-01-714	EA HANDLE FOR W/HOLE GLASS	51112

1993 ITASCA TABLE OF CONTENTS

INTRODUCTION	A-01 - A-02
ABBREVIATIONS	A-03
ALPHABETICAL INDEX	A-04 - A-06
ICG32RQ	A-07 - E-18

1993 ICG32RQ INDEX

FLOOR PLAN	A-07 - A-08
ACCESSORIES	A-09
AUDIO VIDEO	A-10 - A-11
BATH	A-12 - A-14
BEDROOM	A-15 - A-16
CHASSIS	A-17 - B-06
CURTAIN & CUSHION	B-07 - B-17
DINETTE	B-18 - B-20
DRIVERS COMPARTMENT	B-21 - B-24
ELECTRICAL	C-01 - C-06
EXTERIOR BODY	C-07 - C-14
GALLEY	C-15 - C-18
GENERATOR	C-19 - C-20
HEATING & A/C	C-21 - C-24
INTERIOR FINISH	D-01 - D-04
LABELS	D-05 - D-12
LP	D-13
LOUNGE	D-14 - D-16
SEALANTS & FASTENERS	D-17 - D-19
WATER & SEWAGE	D-20 - D-23
WINDOW, VENT & EXTERIOR DOOR	D-24 - E-14
WINDSHIELD & WIPER	E-15 - E-16

GALLEY GROUP (CONTINUED)

REFRIGERATOR (NORCOLD 6162)

KEY	PART NUMBER	U/M DESCRIPTION	
	104137-07-01A	EA REFRIGERATOR - LARGE DBL. DOOR 2-WAY	
	083848-01-000	EA BRACKET ASM - TIEDOWN - REFRIGERATOR	
	083848-02-000	EA BRACKET ASM - TIEDOWN - REFRIGERATOR	
	075217-01-734	EA FUSE - 3 AMP	61538822
	075217-01-738	EA SWITCH - HUMIDITY	61525822
	084880-01-705	EA ORIFICE	614522
	084880-01-718	EA VALVE - GAS	61551822
	084880-01-722	EA CRISPER COVER	615841
	084880-01-732	EA LATCH	61578522
	084880-01-740	EA END CAP (STOP CATCH)	61593830
	084880-01-748	EA CABLE	61571522
	084880-01-749	EA HINGE BUSHING	615807
	084880-01-753	EA THERMISTER 78°	61693822
	084880-01-751	EA END CAP (SPRING CATCH) BLACK	61593730
	084880-03-701	EA COOLING UNIT (HORIZ BURNER)	61687337
	084880-03-702	EA HINGE PIN TOP/BTM FEMALE	61580630
	088248-01-709	EA HEATER - AC (HORIZONTAL)	615627
	088248-01-710	EA HEATER - DC (HORIZONTAL) 3 WAY	615628
	094039-01-702	EA GASKET (GRAY) UPPER	61567830
	094039-01-704	EA PLATE - HINGE - BLACK	61631430
	094039-01-705	EA UPPER DOOR LINER (WHITE) BLACK	61581838-B
	094039-01-708	EA HANDLE - DOOR - UPPER - BLACK	61650038
	094039-01-710	EA PLATE - HINGE - BLACK	61631330
	094039-01-713	EA DOOR GASKET (LOWER) GRAY	61568030
	094039-01-715	EA LOWER DOOR LINER (BLACK/WHITE)	61581738-B
	094039-01-717	EA LOWER DOOR HANDLE ASSY (BLACK)	61649838
	094039-01-722	EA HOLE PLUG (BLACK) HINGE HOLES	61582030
	094039-01-723	EA HINGE BRACKET - TOP RH - BOTTOM - LH - BLACK	61580838
	094039-01-724	EA HINGE BRACKET - TOP LH - BOTTOM - RH - BLACK	61580938
	094039-01-725	EA HINGE PIN (BLACK)(MALE)	61578130
	094039-01-730	EA HINGE PIN SHAFT (BLACK) CENTER RANGE	61566730
	094039-01-732	EA FRONT COVER (BLACK) BOTTOM TRIM	61622130
	094039-01-733	EA WIRE SHELF (MIDDLE)	61563822
	094039-01-735	EA INSIDE DRIP TRAY (WHITE)	61572830
	094039-01-739	EA SHELF (CUTOUT)	61646722
	094039-04-700	EA PRINTED CIRCUIT BOARD - 2 WAY	1647322
	094039-04-702	EA POWER SUPPLY (2 WAY)	61647422
	104137-02-700	EA MODULE - CONTROL - CHANNEL	61717037
	104137-06-700	EA EYEBROW SHELL (2-WAY)	61726622
	104137-06-701	EA HANDLE - UPPER DOOR W/DECAL	61666722
	104137-06-702	EA RACK - JUICE (WHITE)	61580525
	104137-06-703	EA BIN - DRYER SHELF (WHITE)	61564025
	104137-06-705	EA HANDLE - LOWER DOOR W/DECAL	61666622
	104137-06-706	EA WIRE SHELF (SHORT)	61718222
	104137-06-707	EA CRISPER (WHITE)	61571325
	104137-06-708	EA FOAMED CAB ASM (BLACK W/WHITE)	61725138
	104137-06-709	EA VALVE SHUT OFF - MANUAL ASM	61694922
	104137-06-710	EA PRESSURE TAP	61594422
	104137-06-711	EA FUSE 5 AMP	61611622
	104137-06-712	EA FITTING - GAS TUBE CONNECTION	61692722
	104137-06-713	EA ORIFICE GASKET	61475122
	104137-06-714	EA BURNER ASSEMBLY (5-SLOT)	61705222
	104137-06-715	EA SPARK/SENSE ELECTRODE (SINGLE)	61692222

GALLEY GROUP (CONTINUED)

MICROWAVE OVEN

KEY	PART NUMBER	U/M DESCRIPTION
	081289-08-000	EA OVEN - MICROWAVE
	088918-03-01A	EA BRACE - MICROWAVE CABINET - LEFT - 8 1/4" X 7 5/8" - STEEL
	088918-04-01A	EA BRACE - MICROWAVE CABINET - RIGHT - 8 1/4" X 7 5/8" - STEEL
	094745-01-01A	EA TRIM - MICROWAVE - LOWER - BLACK
	094774-03-01A	EA TRIM - MICROWAVE - EITHER SIDE - 1 5/8" X 14 8/16" - METAL - BLACK
	094750-01-000	EA BRACKET - MICROWAVE - 90 DEGREE - STEEL
	094756-02-01A	EA BRACKET - MICROWAVE - 8 1" LONG X 3 9/16" WIDE - STEEL - TAN

RANGE HOOD , W/O HOUR METER - VENTLINE (CANADIAN)

KEY	PART NUMBER	U/M DESCRIPTION
	100258-17-01A	EA HOOD - RANGE 22W - W/O MONITOR PANEL
	090973-01-700	EA MOTOR - LVS CA508-1
	090973-01-702	EA BLADE - FAN - LVS VA183-1
	092696-01-709	EA BULB - 912 VA415
	092696-01-710	EA SOCKET - LIGHT CB267-2
	096983-01-700	EA SWITCH - ON/OFF 108
	096983-01-707	EA FILTER - GREASE - 8" X 8" - LVS CC246
	092696-02-701	EA LENS - LAMP CC179
	100258-01-700	EA HOOD NOSE LABEL CC428

RANGE HOOD , W/O HOUR METER - VENTLINE (USA)

KEY	PART NUMBER	U/M DESCRIPTION
	100258-18-01A	EA HOOD - RANGE 22W - W/O MONITOR PANEL
	090973-01-700	EA MOTOR - LVS CA508-1
	090973-01-702	EA BLADE - FAN - LVS VA183-1
	092696-01-709	EA BULB - 912 VA415
	092696-01-710	EA SOCKET - LIGHT CB267-2
	096983-01-700	EA SWITCH - ON/OFF 108
	096983-01-707	EA FILTER - GREASE - 8" X 8" - LVS CC246
	092696-02-701	EA LENS - LAMP CC179
	100258-01-700	EA HOOD NOSE LABEL CC428

RANGE HOOD , W/HOUR METER - VENTLINE (USA)

KEY	PART NUMBER	U/M DESCRIPTION
	100258-18-01A	EA HOOD - RANGE 22W W/O MONITOR PANEL
	090973-01-700	EA MOTOR - LVS CA508-1
	090973-01-702	EA BLADE-FAN - LVS VA183-1
	092696-01-709	EA BULB - 912 VA415
	092696-01-710	EA SOCKET - LIGHT CB267-2
	096983-01-700	EA SWITCH - ON/OFF 108
	096983-01-702	EA SWITCH - TWO WAY MOMENTARY 112
	096983-01-707	EA FILTER - GREASE - 8" X 8" - LVS CC246
	092696-02-701	EA LENS - LAMP CC179
	100258-01-700	EA HOOD NOSE LABEL CC428
	100258-10-01A	EA METER-HOUR 150

MONITOR PANEL (2 WATER TANKS & WATER HEATER)

KEY	PART NUMBER	U/M DESCRIPTION
	102765-04-01A	EA PANEL - MONITOR - W/PLUG - FOR 2 TANKS & WATER HEATER - LVS
	102765-04-700	EA CIRCUIT BOARD - H-T(2) - 5076-11

**1993 ITASCA
TABLE OF CONTENTS**

INTRODUCTION	A-01 - A-02
ABBREVIATIONS	A-03
ALPHABETICAL INDEX	A-04 - A-08
ICG32RQ	A-07 - E-18

1993 ICG32RQ INDEX

FLOOR PLAN	A-07 - A-08
ACCESSORIES	A-09
AUDIO VIDEO	A-10 - A-11
BATH	A-12 - A-14
BEDROOM	A-15 - A-16
CHASSIS	A-17 - B-06
CURTAIN & CUSHION	B-07 - B-17
DINETTE	B-18 - B-20
DRIVERS COMPARTMENT	B-21 - B-24
ELECTRICAL	C-01 - C-06
EXTERIOR BODY	C-07 - C-14
GALLEY	C-15 - C-18
GENERATOR	C-19 - C-20
HEATING & A/C	C-21 - C-24
INTERIOR FINISH	D-01 - D-04
LABELS	D-05 - D-12
LP	D-13
LCUNGE	D-14 - D-16
SEALANTS & FASTENERS	D-17 - D-19
WATER & SEWAGE	D-20 - D-23
WINDOW, VENT & EXTERIOR DOOR	D-24 - E-14
WINDSHIELD & WIPER	E-15 - E-16

GENERATOR GROUP

KOHLER GENERATOR, 4.0KW LOW PROFILE (4CKM21) (US,CSA)

KEY	PART NUMBER	U/M DESCRIPTION
	105623-01-000	EA GENERATOR - 4.0 KW LOW PROFILE
	105626-01-000	EA ARRESTER - SPARK
	105627-01-000	EA PIPE - EXHAUST ADAPTER
	105630-01-000	EA MUFFLER - SIDE EXHAUST W/O SPARK ARRESTER
	105602-01-000	EA GASKET-EXHAUST
	105958-03-000	EA PIPE - EXHAUST - GENERATOR
	024976-01-000	EA SWITCH - GENERATOR - W/O CIRCUIT BOARD
	007125-03-000	EA CLAMP - MUFFLER - 1.5" DIA
	007125-04-000	EA CLAMP - MUFFLER - 1.1" DIA

ONAN GENERATOR, 4.0KW EMERALD PLUS (US,CSA) (BEIGE-FA/281000)

KEY	PART NUMBER	U/M DESCRIPTION
	100974-01-000	EA GENERATOR - 4.0 KW EMERALD PLUS
	105958-03-000	EA PIPE - EXHAUST - GENERATOR
	024976-01-000	EA SWITCH - GENERATOR - W/O CIRCUIT BOARD
	079654-05-000	EA PIPE - EXHAUST - ANGLED - W/FLANGE - 2" ID - ONAN# 154-2539
	007125-03-000	EA CLAMP - MUFFLER - 1.5" DIA
	007125-04-000	EA CLAMP - MUFFLER - 1.1" DIA
	082272-01-000	EA MUFFLER
	094059-01-000	EA SPACER

ONAN GENERATOR, 5.0KW EMERALD PLUS (US,CSA)

KEY	PART NUMBER	U/M DESCRIPTION
	109303-01-000	EA GENERATOR - 5.0 KW EMERALD PLUS
	024976-01-000	EA SWITCH - GENERATOR - W/O CIRCUIT BOARD
	007125-03-000	EA CLAMP - MUFFLER - 1.5" DIA
	007125-04-000	EA CLAMP - MUFFLER - 1.1" DIA
	082272-01-000	EA MUFFLER
	105958-03-000	EA PIPE - EXHAUST - GENERATOR
	079654-05-000	EA PIPE - EXHAUST - ANGLED - W/FLANGE - 2" ID - ONAN# 154-2539
	094059-01-000	EA SPACER

KOHLER GENERATOR, 5.0 KW LOW PROFILE (US,CSA) (5CKM21)

KEY	PART NUMBER	U/M DESCRIPTION
	105524-01-000	EA GENERATOR - 5.0 KW LOW PROFILE
	105526-01-000	EA ARRESTER - SPARK
	105527-01-000	EA PIPE - EXHAUST ADAPTER
	105530-01-000	EA MUFFLER - SIDE EXHAUST W/O SPARK
	105602-01-000	EA GASKET - EXHAUST
	105958-03-000	EA PIPE - EXHAUST - GENERATOR
	024976-01-000	EA SWITCH-GENERATOR - W/O CIRCUIT BOARD
	007125-03-000	EA CLAMP - MUFFLER - 1.5" DIA
	007125-04-000	EA CLAMP - MUFFLER - 1.1" DIA

GENERATOR GROUP (CONTINUED)

ONAN GENERATOR, 3.5 KW EMERALD PLUS (BGE-FN/283800) (EXPORT)

KEY	PART NUMBER	U/M DESCRIPTION
	100974-04-000	EA GENERATOR - 4.0 KW EMERALD PLUS
	105958-03-000	EA PIPE - EXHAUST - GENERATOR
	024976-01-000	EA SWITCH - GENERATOR - W/O CIRCUIT BOARD
	007125-03-000	EA CLAMP - MUFFLER - 1.5" DIA
	007125-04-000	EA CLAMP - MUFFLER - 1.1" DIA
	079654-05-000	EA PIPE - EXHAUST - ANGLED - W/FLANGE - 2" ID - ONAN# 154-2539
	082272-01-000	EA MUFFLER
	094059-01-000	EA SPACER

ONAN GENERATOR, 6.5 KW EMERALD PLUS (US,CSA) (NHE-FA/281000)

KEY	PART NUMBER	U/M DESCRIPTION
	100975-01-000	EA GENERATOR - 6.5 KW EMERALD PLUS
	105958-03-000	EA PIPE - EXHAUST - GENERATOR
	024976-01-000	EA SWITCH - GENERATOR - W/O CIRCUIT BOARD
	007125-03-000	EA CLAMP - MUFFLER - 1.5" DIA
	007125-04-000	EA CLAMP - MUFFLER - 1.1" DIA
	079654-05-000	EA PIPE - EXHAUST - ANGLED - W/FLANGE - 2" ID - ONAN# 154-2539
	082272-01-000	EA MUFFLER
	094059-01-000	EA SPACER

KOHLER GENERATOR, 7.0 KW LOW PROFILE (US,CSA) (7CKM21)

KEY	PART NUMBER	U/M DESCRIPTION	
	105525-01-000	EA GENERATOR - 7.0 KW - LOW PROFILE	KOHLER 7CKM21
	105526-01-000	EA ARRESTER - SPARK	KOHLER 278621
	105527-02-000	EA PIPE - EXHAUST ADAPTER	KOHLER 278979
	105530-01-000	EA MUFFLER - SIDE EXHAUST - W/O SPARK	KOHLER 278733
	105602-01-000	EA GASKET - EXHAUST	KOHLER 278320
	105958-03-000	EA PIPE - EXHAUST - GENERATOR	
	024976-01-000	EA SWITCH - GENERATOR - W/O CIRCUIT BOARD	
	007125-03-000	EA CLAMP - MUFFLER - 1.5" DIA	
	007125-04-000	EA CLAMP - MUFFLER - 1.1" DIA	

ONAN GENERATOR, 7.0 KW MARQUIS (US,CSA) (NHM-IR/281000)

KEY	PART NUMBER	U/M DESCRIPTION
	105559-01-000	EA GENERATOR - 7 KW MARQUIS
	106234-01-000	EA PIPE - EXHAUST - GENERATOR
	106235-01-000	EA ADAPTOR - EXHAUST - GENERATOR
	024976-01-000	EA SWITCH - GENERATOR - W/O CIRCUIT BOARD
	007125-03-000	EA CLAMP - MUFFLER - 1.5" DIA

**1993 ITABCA
TABLE OF CONTENTS**

INTRODUCTION	A-01 - A-02
ABBREVIATIONS	A-03
ALPHABETICAL INDEX	A-04 - A-06
ICG32RQ	A-07 - E-16

1993 ICG32RQ INDEX

FLOOR PLAN	A-07 - A-08
ACCESSORIES	A-09
AUDIO VIDEO	A-10 - A-11
BATH	A-12 - A-14
BEDROOM	A-15 - A-16
CHASSIS	A-17 - B-06
CURTAIN & CUSHION	B-07 - B-17
DINETTE	B-18 - B-20
DRIVERS COMPARTMENT	B-21 - B-24
ELECTRICAL	C-01 - C-06
EXTERIOR BODY	C-07 - C-14
GALLEY	C-15 - C-18
GENERATOR	C-19 - C-20
HEATING & A/C	C-21 - C-24
INTERIOR FINISH	D-01 - D-04
LABELS	D-05 - D-12
LP	D-13
LOUNGE	D-14 - D-16
SEALANTS & FASTENERS	D-17 - D-19
WATER & SEWAGE	D-20 - D-23
WINDOW, VENT &	
EXTERIOR DOOR	D-24 - E-14
WINDSHIELD & WIPER	E-15 - E-16

HEATING & AIR CONDITIONING GROUP

AUTOMOTIVE AIR CONDITIONING

KEY	PART NUMBER	UOM DESCRIPTION
	086000-01-000	EA SHIELD - AC - 6.8" X 3 1" - STEEL
	007075-01-000	EA HOSE - FLEXIBLE PVC - 2" ID - 50'
	007281-01-000	EA HOSE - FLEXIBLE PVC - 2 5/8" ID X 50' - ATCOFLEX A-182-355
	024980-05-000	EA OUTLET - DEFROSTER - W/SWIVEL - 2IN BLACK
	058402-06-000	EA BRACKET - HEATER VENT - ROUND - WBEND - BLACK
	077075-01-000	EA GASKET - INSTRUMENT PANEL TO DEFROSTER PLENUM - 6" X 11 1/2"
	077075-03-000	EA GASKET - INSTRUMENT PANEL TO DEFROSTER PLENUM - SPL
	094831-08-000	EA WIRE ASSEMBLY - AC COMPRESSOR ADAPTER SCS 036-0054
	103016-01-000	EA PLENUM - TRANSITION
	103017-01-000	EA PLENUM - DEFROSTER
	103558-01-02A	EA VENT - DEFROSTER - ABS - GRAY
	103798-01-01A	EA LOUVER ASM - AC CARY PROD - BLACK
	064831-08-709	EA CLAMPS - ROD - 3/16 - MOTIVEAIR SCS CGG14431
	088227-02-701	EA BRACKET - BOWDEN CABLE MOUNTING ARA 0409417
	103930-01-000	EA EVAPORATOR/HEATER ASSEMBLY SCS 090-0041
	094831-01-724	EA O-RING - #4 - MOTIVEAIR SCS ZGG14561
	103930-01-700	EA ROD - AIR BLEND DOOR SCS 073-0017
	103930-01-701	EA PANEL - DOOR - FOR AIR BLEND SCS 071-0123
	103930-01-702	EA GASKET - DOOR - FOR AIR BLEND SCS 045-0080
	103930-01-703	EA COIL - HEATER SCS 042-0010
	103930-01-705	EA VALVE - EXPANSION BLOCK SCS 034-0019
	103930-01-706	EA GASKET - O-RING - #8 SCS 045-0011
	103930-01-707	EA GASKET - O-RING - #10 SCS 045-0012
	103930-01-708	EA BRACKET - VACUUM MOTOR SCS 070-0113
	103930-01-710	EA RESISTOR - FUSED SCS 035-0006
	103930-01-711	EA THERMOSTAT SCS 033-0003
	103930-01-712	EA GASKET - O-RING SCS 045-0010
	103930-01-713	EA FITTING - QUICK CONNECT - #4 SCS 050-003
	103930-01-714	EA FITTING - SERVICE VALVE - #10 SCS 050-0031
	103930-01-715	EA SWITCH - BINARY SCS 032-0030
	103930-01-716	EA SWITCH - PRESSURE - FAN SCS 032-0029
	103930-01-717	EA WHEEL - CLOCK - WISE SCS 062-0010
	103930-01-718	EA HOSE #6 SCS 051-0036
	103930-01-719	EA HOSE - #10 SCS 051-0017
	103930-01-720	EA MOTOR SCS 030-0004
	103930-01-721	EA GASKET O-RING #12 SCS 045-0062
	103930-04-000	EA CONTROL/PLENUM SET SCS 093-00037
	103930-02-700	EA PANEL - CONTROL SCS 032-0018
	103930-02-701	EA VALVE - CONTROL HEAD SCS 034-0015
	103930-02-702	EA DECAL - WINNEBAGO "N" SCS 058-0008
	103930-02-703	EA HARNESS - WIRE CONTROL SCS 036-0048
	103930-02-704	EA HARNESS - VACUUM CONTROL SCS 036-0049
	103930-02-705	EA CABLE - CONTROL - BOWDEN SCS 074-0011
	103930-02-706	EA CLIP - CABLE - CONTROL SCS 022-0017
	103930-02-707	EA RELAY SCS 031-0001
	103930-02-708	EA MOTOR - VACUUM SERVO - AC SCS 030-0002
	103930-02-710	EA CANISTER - VACUUM SCS 054-0002
	103930-02-711	EA VALVE - WATER SCS 034-0114
	103930-05-000	EA MANUAL - OWNERS - HEATER - AC SCS 057-0049

HEATING & AIR CONDITIONING GROUP (CONTINUED)

FURNACE & HEATER SYSTEMS

KEY	PART NUMBER	UOM DESCRIPTION
	007108-01-000	FT HOSE - HEATER - 5/8" ID - HI-TEMP (FORD)
	081873-01-000	EA BRACKET - MOTOR AID TUBES - 4" X 1 1/2" - STEEL
	088753-01-000	FT TUBE - ALUMINIZED STEEL - 5/8" - 18 GAUGE
	009198-01-000	FT DUCT - HEAT - FLEXIBLE - 4" ID X 25 FT
	009200-01-000	EA TAPE - FURNACE - 1 1/2"
	089838-02-000	EA CONNECTOR - DUCT - 4" ID SUBURBAN 050715
	079059-01-000	EA HOSE - 90 DEGREE - 5/8" ID X 4' X 36"
	079059-02-000	EA HOSE - 90 DEGREE - 6 1/8" ID X 4' X 6"
	083081-01-000	EA HOSE - FORMED - 90 DEGREES - 5/8" ID
	084405-01-000	EA HEATER ASM - REAR - DUCTED - W/MOTOR AID EVANS
	084405-01-700	EA HEATER CORE EVANS# FT200229
	084405-01-701	EA FAN BLADES EVANS# HVU29931
	084405-01-702	EA MOTOR ASM - 12 V EVANS# 200146
	094600-01-02A	EA REGISTER - HEAT - W/O DAMPER - 3 6" X 11 2" - BROWN
	007108-02-000	FT HOSE - HEATER - 3/4" ID - HI-TEMP (FORD)
	008042-01-000	FT TUBING - VINYL - 65" ID
	092777-01-000	EA ADAPTER - DUCT - 4"
	092300-04-000	EA GASKET - FIBERGLASS
	092300-06-000	EA FURNACE - 34,000 BTU SUBURBAN NT34BW
	069634-01-706	EA MODULE BOARD SUBURBAN 231427
	069634-01-712	EA GASKET - MANIFOLD SUBURBAN 070408
	069634-01-716	EA VALVE - MANUAL SHUTOFF SUBURBAN 160740
	069634-01-720	EA ORIFICE - MAIN BURNER SUBURBAN 0180222
	069634-01-729	EA VALVE - GAS - JOHNSON SUBURBAN 160832
	069634-01-732	EA GASKET - BURNER ACCESS DOOR SUBURBAN 076398
	069634-01-733	EA RELAY - TIME DELAY 20&30 BTU SUBURBAN 231202
	075695-01-709	EA MICRO SWITCH (FOR MODELS 30 & 34S) SUBURBAN 230509
	075696-01-700	EA MOTOR ASM SUBURBAN 231208
	075696-02-709	EA DISC - GLASS SUBURBAN 310026
	075696-02-727	EA BRACKET - MOTOR MOUNT SUBURBAN 062138
	075696-02-728	EA GASKET - CROSSOVER TUBE SUBURBAN 070385
	092300-01-700	EA CABINET SUBURBAN X101176
	092300-01-701	EA CABINET FRONT SUBURBAN 101172
	092300-01-704	EA GASKET - ELECTRODE SUBURBAN 070163
	092300-01-705	EA ELECTRODE SUBURBAN 230956
	092300-01-706	EA DOOR - BURNER ACCESS SUBURBAN 030523
	092300-01-708	EA SWITCH LIMIT SUBURBAN 231440
	092300-01-711	EA VENT CAP ASSEMBLY SUBURBAN X260179
	092300-01-712	EA BURNER ASM SUBURBAN X010701
	092300-01-715	EA MANIFOLD ASSEMBLY SUBURBAN 171034
	092300-01-717	EA WIRE ASSEMBLY (POWER SUPPLY) SUBURBAN X231428
	092300-01-718	EA ELBOW 90° SUBURBAN 170374
	092300-01-720	EA WHEEL - ROOM AIR SUBURBAN 350113
	092300-01-721	EA BLOWER HOUSING ASSEMBLY SUBURBAN 390283
	092300-01-724	EA GASKET - MOTOR MOUNT SUBURBAN 070384
	092300-01-726	EA WHEEL - COMBUSTION AIR SUBURBAN 350110
	092300-01-727	EA GASKET - COMBUSTION AIR HOUSING SUBURBAN 070386
	092300-01-728	EA HOUSING - COMBUSTION AIR (OUTSIDE) SUBURBAN 390424
	092300-02-700	EA COMBUSTION CHAMBER ASM 30&34 BW SUBURBAN X021015
	092300-03-702	EA HOUSING - COMBUSTION AIR ASM NT - 34BW SUBURBAN X390417
	093365-01-000	EA THERMOSTAT - WALL - FURNACE SUBURBAN 0160902
	092300-09-000	EA FACE - FRONT - FURNACE SUBURBAN 520607
	092300-08-000	EA VENT KIT - FURNACE - STRAIGHT SUBURBAN 520608
	093365-01-000	EA THERMOSTAT - WALL - FURNACE SUBURBAN 0160902
	093614-02-01A	EA GRILLE - RETURN AIR - FURNACE - 9 7" X 9 7" - BROWN
	093614-01-01A	EA GRILLE - RETURN AIR - FURNACE - 15 6" X 7 6" - BROWN
	058464-05-000	EA REGISTER - PLASTIC W/O DAMPER - 4" DIAMETER - GOLDEN
	094600-01-02A	EA HEAT REGISTER - W/O DAMPER - 3 6" X 11 2" - BROWN

1993 ITASCA TABLE OF CONTENTS

INTRODUCTION	A01 - A02
ABBREVIATIONS	A03
ALPHABETICAL INDEX	A04 - A06
ICG32RQ	A07 - E-16

1993 ICG32RQ INDEX

FLOOR PLAN	A-07 - A-08
ACCESSORIES	A-09
AUDIO VIDEO	A-10 - A-11
BATH:	A-12 - A-14
BEDROOM	A-15 - A-16
CHASSIS	A-17 - B-06
CURTAIN & CUSHION	B-07 - B-17
DINETTE	B-18 - B-20
DRIVERS COMPARTMENT	B-21 - B-24
ELECTRICAL	C-01 - C-06
EXTERIOR BODY	C-07 - C-14
GALLEY	C-15 - C-18
GENERATOR	C-19 - C-20
HEATING & A/C	C-21 - C-24
INTERIOR FINISH	D-01 - D-04
LABELS	D-05 - D-12
LP	D-13
LOUNGE	D-14 - D-16
SEALANTS & FASTENERS	D-17 - D-19
WATER & SEWAGE	D-20 - D-23
WINDOW, VENT & EXTERIOR DOOR	D-24 - E-14
WINDSHIELD & WIPER	E-15 - E-16

HEATING & AIR CONDITIONING GROUP (CONTINUED)

COLEMAN ROOF AIR 13,200 BTU (US, CBA)

KEY	PART NUMBER	U/M DESCRIPTION	
	108890-01-02A	EA A/C-ROOF - 13,200 TSR HO GRAY	7333-892
	091225-01-709	EA START RELAY	1497-4131
	091225-01-710	EA START CAPACITOR	1497-0881
	093306-01-701	EA DECAL PKG - LEFT & RIGHT	679883591
	093306-01-712	EA COMPRESSOR	6707C3579
	105620-01-704	EA COMPRESSOR - RH & LH	1450-2009
	105620-01-708	EA FOOT PKG-COMPRESSOR - 3 PER PACKAGE	6759-3081
	108890-01-700	EA SHROUD (GREY/GREY) LESS LOGO	6759-6421
	108890-01-703	EA CONDENSER COIL	1452-1301
	108890-01-704	EA OVERLOAD (MRA#98893)	6759-6421
	108890-01-705	EA MOTOR (115 - 60HZ)	1468-3049
	108890-01-708	EA IMPELLOR	1472-1041
	108890-01-707	EA RUN CAPACITOR(COMP-25MFD/370	1499-5661
	108890-01-708	EA FAN CAPACITOR(7 5MFD 370U)	1499-5461
	108890-01-709	EA EVAPORATOR COIL	1452-1311
	108890-01-710	EA FILLER PAD-COND AIR SEAL	6759A3971
	108890-01-711	EA GASKET PACKAGE	6792-3301
	108890-01-712	EA SUCTION LINE REDUCER(3/8X1/2	1215-2161
	108890-01-713	EA SUCTION LINE(3/8ODX 032 VJALL	6792-130
	108890-01-714	EA DISCHARGE LINE ASSY	6792-531
	108890-01-715	EA MOTOR MOUNT & SHAFT SEAL KIT	6792-3361
	108891-01-01A	EA CEILING ASM-A/C COOL TSR HO	7330-714 IV
	042204-01-709	EA THERMOSTAT - IN 64 OUT 58	6701-3401
	073742-01-701	EA SELECTOR SWITCH (5 TERMINAL)	6759-3251
	073742-01-702	EA DECAL COOL ONLY	6759C3431
	076303-01-707	EA FILTER-6" X 14 3/4" X 1/2" - 12 PER PACKAGE	6703A3151
	081606-01-712	EA CEILING SHROUD (IVORY)	6769-5061
	091225-01-713	EA KNOB (2 PER PACKAGE)	6701-3351
	091225-01-717	EA DECAL (THERMOSTAT) COOL ONLY	6799A3441
	093766-02-701	EA DECAL - LEFT SIDE	6799-3971
	108891-01-700	EA SINGLE PARTS PACKAGE (KNOBS & NUTS)	6792-5991
	108891-01-701	EA RETAINER CLIPS F/FILTER (6 PER PACKAGE)	6799-3141
	102289-01-000	EA SPRING - SCREW - ROOF A/C GASKET	6757-150

HEATING & AIR CONDITIONING GROUP (CONTINUED)

COLEMAN ROOF AIR 11,000 BTU (US, CBA) (FROM: 00-00-00 THRU: 11-18-92)

KEY	PART NUMBER	U/M DESCRIPTION	
	105850-01-03A	EA A/C - ROOF - 11,000 BTU - GRAY	67573802
	037848-01-714	EA PACKAGE - GASKET	6759-3281
	076303-01-712	EA MOTOR	6707A3119
	091225-01-709	EA START RELAY	1497-4131
	093306-01-701	EA DECAL PKG - LEFT & RIGHT	679883591
	093306-01-707	EA START CAPACITOR, 47 - 56 MFD - 250	62503421
	093766-01-703	EA IMPELLOR - 7" DIA X 2 8" WIDE	6759-3271
	093763-01-704	EA CAPACITOR - FAN	1499-3461
	093763-01-708	EA CONDENSER COIL	1452-1251
	093763-01-712	EA FAN BLADE - CONDENSER	6733-3221
	105850-01-700	EA COMPRESSOR (TEC #AK144AT-02L)	6757-3679
	105850-01-701	EA COMPRESSOR RUN CAPACITOR	6743-4681
	105850-01-702	EA EVAPORATOR COIL	1452-1362
	105850-01-703	EA OVERLOAD (CRA2718-250)	
	108890-01-700	EA SHROUD (GREY/GREY)LESS LOGO	6759-6421

COLEMAN ROOF AIR 11,000 BTU (US, CBA) (FROM: 11-18-92 THRU: 11-01-98)

KEY	PART NUMBER	U/M DESCRIPTION	
	108890-01-02A	EA A/C - ROOF - 11,000 TSR HO - GREY	7332-892
	108891-01-01A	EA CEILING ASM - A/C COOL TSR HO	7330-714 IV
	042204-01-709	EA THERMOSTAT - IN 64 OUT 58	6701-3401
	073742-01-701	EA SELECTOR SWITCH (5 TERMINAL)	6759-3251
	073742-01-702	EA DECAL COOL ONLY	6759C3431
	076303-01-707	EA FILTER - 6" X 14 3/4" X 1/2" (12 PER PACKAGE)	6703A3151
	081606-01-712	EA CEILING SHROUD (IVORY)	6769-5061
	091225-01-713	EA KNOB (2 PER PACKAGE)	6701-3351
	091225-01-717	EA DECAL (THERMOSTAT) COOL ONLY	6799A3441
	093766-02-701	EA DECAL - LEFT SIDE	6799-3971
	108891-01-700	EA SINGLE PARTS PACKAGE (KNOBS & NUTS)	6792-5991
	108891-01-701	EA RETAINER CLIPS F/FILTER (6 PER PACKAGE)	6799-3141
	102289-01-000	EA SPRING - SCREW - ROOF A/C GASKET	6757-150

**1993 ITASCA
TABLE OF CONTENTS**

INTRODUCTION	A-01 - A-02
ABBREVIATIONS	A-03
ALPHABETICAL INDEX	A-04 - A-06
ICG32RQ	A-07 - E-18

1993 ICG32RQ INDEX

FLOOR PLAN	A-07 - A-08
ACCESSORIES	A-09
AUDIO VIDEO	A-10 - A-11
BATH	A-12 - A-14
BEDROOM	A-15 - A-16
CHASSIS	A-17 - B-06
CURTAIN & CUSHION	B-07 - B-17
DINETTE	B-18 - E-20
DRIVERS COMPARTMENT	B-21 - B-24
ELECTRICAL	C-01 - C-06
EXTERIOR BODY	C-07 - C-14
GALLEY	C-15 - C-18
GENERATOR	C-19 - C-20
HEATING & A/C	C-21 - C-24
INTERIOR FINISH	D-01 - D-04
LABELS	D-05 - D-12
LP	D-13
LOUNGE	D-14 - D-16
SEALANTS & FASTENERS	D-17 - D-19
WATER & SEWAGE	D-20 - D-23
WINDOW, VENT &	
EXTERIOR DOOR	D-24 - E-14
WINDSHIELD & WIPER	E-15 - E-16

INTERIOR FINISH GROUP

INTERIOR TRIM, BATT STRIPS & MOLDINGS

KEY	PART NUMBER	U/M DESCRIPTION
	009767-10-000	FT WELTING - CABINET TO WALL - MAHOGANY
	009767-12-000	FT MOLDING - SIDEWALL TO CEILING/CABINET - WELTING - OFF WHITE
	009778-12-000	FT U CHANNEL - PLASTIC - 1" WIDE X 8" - WOODGRAIN
	009809-21-000	EA MOLDING - CORNER - OUTSIDE - 1" - PLASTIC - WOODGRAIN
	009809-25-000	EA MOLDING - CORNER - OUTSIDE - 1" - PLASTIC - OFF WHITE
	009812-22-000	EA MOLDING - CORNER - OUTSIDE - .5" X 7" - PLASTIC - BROWN
	009812-24-000	EA MOLDING - PLASTIC - OUTSIDE CORNER - .5" - IVORY
	022992-11-000	FT MOLDING - REVERSE COVE - T-SHAPED - VINYL - IVORY
	069733-80-000	EA BATT STRIP - WOODGRAIN - 8" - WINNI OAK
	070504-01-000	FT U-CHANNEL - PLASTIC - .065" WIDE - LIGHT BROWN - 8"
	070504-19-000	FT U-CHANNEL - PLASTIC - .815" WIDE - BROWN - 8"
	070504-21-000	FT U-CHANNEL - PLASTIC - .735" WIDE - COUNTRY FOREST - 8"
	070504-23-000	FT EXTRUSION - U CHANNEL - .875 - COUNTRY FOREST
	072368-02-000	EA TRIM - VINYL - EDGE - BLACK
	075249-01-000	EA RAILING - OAK - 72" - UNFINISHED
	076325-25-000	FT MOLDING - EDGEBAND - 1 5/16" WIDE - RAMBLING OAK
	076325-31-000	FT MOLDING - EDGEBAND - RAMBLING OAK - .93 X .024 X 600'
	076325-37-000	FT MOLDING - EDGEBAND - 1136 - 1-5/16X.030X600
	076325-39-000	FT MOLDING - EDGEBAND - 1527 - 1-5/16X.030X600 (D36)
	076325-40-000	FT MOLDING - EDGEBAND - 1527 - .875X.024X600 (D35)
	078323-06-B25	EA MOLDING - WALL CAP - LIPS BOTH SIDES - WOOD - 6 6" LONG
	078811-05-C07	EA PANEL - TRIM - HEADER - LOWER
	083620-07-000	FT MOLDING - T - END CAP EDGE - WEDGE LIPS - .75" - THOR PECAN
	085284-55-000	FT BATT STRIP - TAPE - GLORIA - PASTEL DECOR (BATHROOM & GALLEY) (D35)
	085284-75-000	FT BATT STRIP - TAPE - MONIQUE - BLUE STONE (BATHROOM & GALLEY) (D36)
	085284-56-000	FT BATT STRIP - TAPE - POMPEII - PASTEL DECOR (MAIN WALL) (D35)
	085284-74-000	FT BATT STRIP - TAPE - BARCELONA - BLUE STONE (MAIN WALL) (D36)
	085284-67-000	FT STRIP - TAPE - 541 WINNI OAK - PLUSWOOD
	086229-01-000	EA RETAINER - BATTEN - CEILING - .75" WIDE - 7.6'
	086229-04-000	EA BATTEN - CEILING - 1" WIDE - IVORY - 7.6'
	088263-67-000	EA BATT - STRIP - POMPEII - PASTEL DECOR (MAIN WALL) (D35)
	088263-86-000	EA BATT - STRIP - BARCELONA - BLUE STONE (MAIN WALL) (D36)
	088263-68-000	EA BATT - STRIP - GLORIA - PASTEL DECOR (BATHROOM & GALLEY) (D35)
	088263-85-000	EA BATT - STRIP - MONIQUE - BLUE STONE (BATHROOM & GALLEY) (D36)
	093873-01-01A	EA TRIM - CARPET - L - ANGLE - 1.1" X 1.3" X 12" - VINYL - GRAY
	100040-01-000	EA LUMBER - VINYL WRAPPED - 1.5" X 8" - 766 RAMBLING OAK
	100040-03-000	EA LUMBER - VINYL WRAPPED - 2" X 8" - 766 RAMBLING OAK
	100040-06-000	EA LUMBER - VINYL WRAPPED - 3" X 8" - RAMBLING OAK
	100040-07-000	EA LUMBER - VINYL WRAPPED (ALL AROUND) 3" X 8" - RAMBLING OAK
	100041-01-000	EA MOLDING - VINYL WRAPPED - 7" X 1.57" X 84.02" - RAMBLING OAK
	100041-02-000	EA MOLDING - VINYL WRAPPED - 7" X 2.5" X 84" - RAMBLING OAK
	100182-10-B29	EA TRIM-CHAIR RAIL - WALL - 2 5" X 8" EA - WOOD
	104008-01-C05	EA LID - ENTRANCE STEP
	105004-01-02A	EA MOLDING - VINYL WRAP - RAMBLING OAK
	105709-01-000	FT T-MOLDING - 1" - MODERN IVORY

INTERIOR FINISH GROUP (CONTINUED)

PANELING, PLASTIC LAMINATE & CARPET

KEY	PART NUMBER	U/M DESCRIPTION
	074497-21-000	SF PANELING - WOODGRAIN - WINNI OAK - 4' X 8' (32 SF)
	074498-34-000	SF LAMINATE - PLASTIC - 5' X 8' - RAMBLING OAK (40 SF)
	074498-45-000	SF LAMINATE - PLASTIC - 5' X 8' (40 SF) (D35)
	074498-42-000	SF LAMINATE - PLASTIC - 5' X 8' (40 SF) (D36)
	083618-02-000	SF PLYWOOD - OAK - 1 SIDE FINISHED - 3/16" X 4' X 8' (32 SF)
	088272-88-000	SF PANELING - GLORIA PASTEL (BATH & GALLEY) (D35)
	088272-A6-000	SF PANELING - MONIQUE - BLUE STONE (BATH & GALLEY) (D36)
	088272-89-000	SF PANELING - POMPEII - PASTEL (BEDROOM & DINETTE) (D35)
	088272-A7-000	SF PANELING - BARCELONA - BLUE STONE (BEDROOM & DINETTE) (D36)
	088272-98-000	SF PANELING - SHOWER - OFF WHITE - 4' X 7' (28 SF)
	089297-01-000	SF PLYWOOD - LUAN - OVERLAY GRADE - 4' X 8' (32 SF)
	089351-03-000	YD VINYL - CEILING - DIAMOND DESIGN - 54" WIDE
	095688-01-000	SF VENEER - FLAT LUANA 48 X 96
	095233-01-000	SY PAD - CARPET - 3/8" X 6' ROLL
	096060-42-000	SY CARPET - 12' ROLL - TEAL (MINIMUM 4 SY) (D35)
	096060-21-000	SY CARPET - 12' ROLL - PALE ORCHID (MINIMUM 4 SY) (D36)
	093486-01-000	SY CARPET - COMPARTMENT - 54" WIDE - DARK GRAY
	047034-02-000	SF PLASTIC - CARPET - 4" WIDE - CLEAR POLY
	098531-01-000	SF PLYWOOD - RED OAK - 1/2"
	105924-01-D11	EA MAT - FLOOR 18X27 (D35)
	105924-01-C25	EA MAT - FLOOR 18X27 (D36)

FIRE EXTINGUISHER, SMOKE DETECTOR & WALL CLOCK

KEY	PART NUMBER	U/M DESCRIPTION
	072852-01-000	EA DETECTOR - SMOKE - W/9 VOLT BATTERY
	072852-02-000	EA DETECTOR - SMOKE - W/9 VOLT BATTERY - CANADIAN
	094498-01-000	EA EXTINGUISHER - FIRE - DRY W/MOUNTING BRACKET - 10 BC
	094499-01-700	EA BRACKET - MOUNTING - W/PLASTIC STRAP - FIRE EXTINGUISHER
	094499-02-000	EA EXTINGUISHER - FIRE - DRY - 1A10BC - CANADIAN
	104764 01 01A	EA CLOCK - WALL SPARTUS 5616-42
		FROM 00-00-00 THRU: 04-20-93
	101333-01-000	EA BACKPLATE - CLOCK - 6" X 6" - PLASTIC - BLACK
		FROM 00-00-00 THRU: 04-20-93
	100793-02-01A	EA CLOCK-WALL - 11" DIAMETER - BOLDEN 9988
		FROM 04-21-93 THRU 99-99-99

MIRRORS

KEY	PART NUMBER	U/M DESCRIPTION
	058331-51-000	EA MIRROR - SAFETY GLASS - 660X1016MM
	110252-01-000	EA MIRROR - SAFETY GLASS - 364 2 X 445 0MM
	104755-05-000	EA MIRROR - DECORATIVE GLASS - 317MM X 627MM

**1993 ITASCA
TABLE OF CONTENTS**

INTRODUCTION	A-01 - A-02
ABBREVIATIONS	A-03
ALPHABETICAL INDEX	A-04 - A-06
ICG32RQ	A-07 - E-16

1993 ICG32RQ INDEX

FLOOR PLAN	A-07 - A-08
ACCESSORIES	A-09
AUDIO VIDEO	A-10 - A-11
BATH	A-12 - A-14
BEDROOM	A-15 - A-16
CHASSIS	A-17 - B-06
CURTAIN & CUSHION	B-07 - B-17
DINETTE	B-18 - B-20
DRIVERS COMPARTMENT	B-21 - B-24
ELECTRICAL	C-01 - C-06
EXTERIOR BODY	C-07 - C-14
GALLEY	C-15 - C-16
GENERATOR	C-19 - C-20
HEATING & A/C	C-21 - C-24
INTERIOR FINISH	D-01 - D-04
LABELS	D-05 - D-12
LP	D-13
LOUNGE	D-14 - D-18
SEALANTS & FASTENERS	D-17 - D-19
WATER & SEWAGE	D-20 - D-23
WINDOW, VENT &	
EXTERIOR DOOR	D-24 - E-14
WINDSHIELD & W/PER	E-15 - E-16

INTERIOR FINISH GROUP (CONTINUED)

CABINET HARDWARE

KEY	PART NUMBER	U/M DESCRIPTION
8	106913-04-000	EA SLIDE - DRAWER - 12" - RIGHT SIDE
8	106913-08-000	EA SLIDE - DRAWER - 18" - RIGHT SIDE
8	106913-20-000	EA SLIDE - DRAWER - 22" - RIGHT SIDE
8	106913-24-000	EA SLIDE - DRAWER - 24" - RIGHT SIDE
9	106913-03-000	EA SLIDE - DRAWER - 12" - LEFT SIDE
9	106913-07-000	EA SLIDE - DRAWER - 18" - LEFT SIDE
9	106913-19-000	EA SLIDE - DRAWER - 22" - LEFT SIDE
9	106913-23-000	EA SLIDE - DRAWER - 24" - LEFT SIDE
10	106913-01-000	EA SLIDE - DRAWER - 12" - CABINET - LEFT SIDE
10	106913-05-000	EA SLIDE - DRAWER - 18" - CABINET - LEFT SIDE
10	106913-17-000	EA SLIDE - DRAWER - 22" - CABINET - LEFT SIDE
10	106913-21-000	EA SLIDE - DRAWER - 24" - CABINET - LEFT SIDE
11	084070-02-000	EA POST - END - 2.4" - BRASS
12	084071-04-000	EA ROD - BRASS - 11.9"
12	084071-15-000	EA ROD - BRASS - 8.27"
13	084070-01-000	EA POST - CENTER - 2.4" - BRASS
14	107539-01-000	EA SPRING - GAS - 20" BLADE END - SPRING LIFT
15	074493-02-000	EA SUPPORT - PISTON SPRING - CABINET DOOR
16	096645-01-000	EA PULL - CABINET - BRASS - TWIST - 1.1" X 3.4"
		FROM 00-00-00 THRU 02-04-93
16	109747-01-000	EA PULL - CABINET - BRASS
		FROM 02-05-93 THRU 99-99-99
17	081376-01-000	EA BACKPLATE - DOOR PULL - OVAL - BRASS - 8" X 4.25"
18	098410-01-01A	EA PULL - FINGER - OVAL - BRASS
19	107030-01-000	EA BACK SOCKET - LEFT SIDE
20	000G68-06-10G	EA SCREW - 6-18 X 5/8" - PHILLIP OVAL HEAD - ANTIQUE BRASS
21	000G13-06-08G	EA SCREW - 6-20 X 5" - PHILLIP FLAT HEAD - ANTIQUE BRASS
22	108138-01-000	EA HINGE - DOOR - CABINET - BURNISHED BRASS
23	009059-02-000	EA HINGE - DOOR - 2" X 2.7" - BRASS
24	107030-02-000	EA BACK SOCKET - RIGHT SIDE
25	100711-01-01A	EA HINGE - DOOR - GLASS
	105037-02-000	EA FASTENER - WOOD - CORNER - METAL - 5" X 6"
	P02788-04-D12	EA HANDRAIL ASM - ENTRANCE DOOR
	099682-01-01A	EA BRACKET - MOUNTING - HAND RAIL - BRASS
	009063-01-000	EA HINGE - CONTINUOUS - 1 1/2" X 72" - UNPAINTED
	009066-01-000	EA HINGE - ALUMINUM - NO HOLES - 1 1/16" X 6" - UNPAINTED
	103130-01-000	EA HOOK - CUP - BRASS - 1.25"
	103868-03-01A	EA TRACK - DOOR - 1250 - OFF WHITE
	105847-06-C05	EA KEY RING HOLDER
	004354-01-000	EA BUMPER - RUBBER - 5" DIA - BROWN
	016604-03-000	EA BRACE - CABINET - ANGLE - 2.5" - METAL - BEIGE
	023320-01-000	EA PAD - FELT - 3/8" DIAMETER - BROWN
	058335-02-000	EA LATCH - SHOWER/BATH DOOR - W/O LOCK - PLASTIC - BROWN
	065740-01-000	EA BRACE - CABINET CORNER - PLASTIC
	076790-01-000	EA SCREW - 6-20 X 1 1/4 PPH - BLACK
	079921-01-000	EA ROLLER - NYLON - W/STEEL SHAFT - BARBED
	R77006-13-498	EA GUIDE - BOLT
	009112-01-000	EA FLANGE - 1" ROD - CLOTHES - PLASTIC - OFF WHITE
	042438-01-000	EA DOWEL - WOOD - CLOTHES ROD - 1" DIAMETER X 4"
	042438-06-000	EA DOWEL - WOOD - 1.5" X 26" - OAK
	101222-01-01A	EA BRACKET - CATCH - LID - BEIGE
	101766-01-000	EA PIN - SUPPORT - GLASS DOOR
	103936-01-01A	EA KNOB - MIRROR - 1" X 1" - ACRYLIC - CLEAR

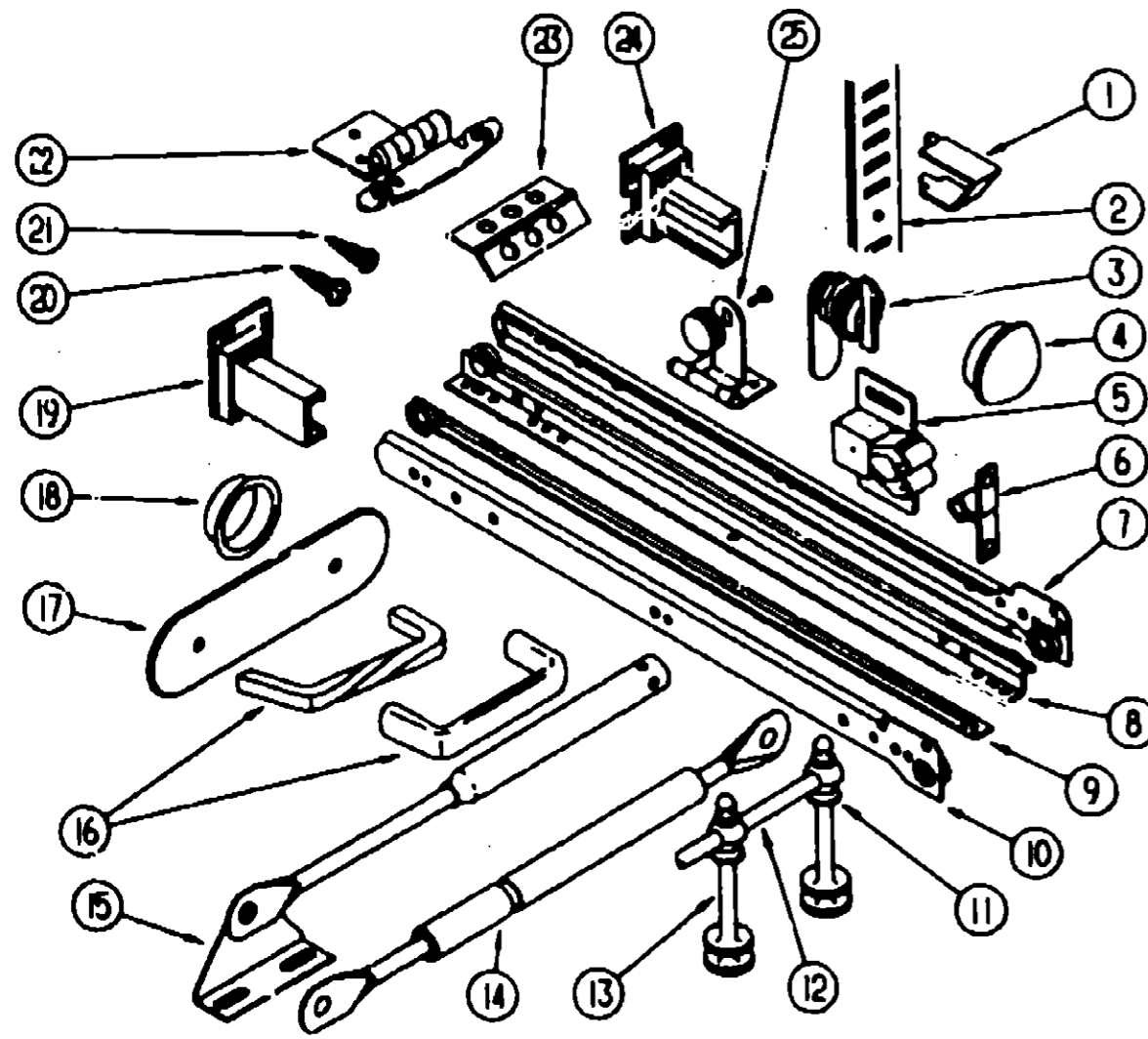

1993 ITASCA TABLE OF CONTENTS

INTRODUCTION	A-01 - A-02
ABBREVIATIONS	A-03
ALPHABETICAL INDEX	A-04 - A-06
ICG32RQ	A-07 - E-16

1993 ICG32RQ INDEX

FLOOR PLAN	A-07 - A-08
ACCESSORIES	A-09
AUDIO VIDEO	A-10 - A-11
BATH	A-12 - A-14
BEDROOM	A-15 - A-16
CHASSIS	A-17 - B-06
CURTAIN & CUSHION	B-07 - B-17
DINETTE	B-18 - B-20
DRIVERS COMPARTMENT	B-21 - B-24
ELECTRICAL	C-01 - C-06
EXTERIOR BODY	C-07 - C-14
GALLEY	C-15 - C-18
GENERATOR	C-19 - C-20
HEATING & A/C	C-21 - C-24
INTERIOR FINISH	D-01 - D-04
LABELS	D-05 - D-12
LP	D-13
LOUNGE	D-14 - D-16
SEALANTS & FASTENERS	D-17 - D-19
WATER & SEWAGE	D-20 - D-23
WINDOW, VENT &	
EXTERIOR DOOR	D-24 - E-14
WINDSHIELD & WIPER	E-15 - E-16

KEY	PART NUMBER	U/M DESCRIPTION
1	098979-01-000	EA CLIP - ADJUSTABLE SHELF
2	098980-01-000	EA PILASTER - ADJUSTABLE SHELF - 18" LONG
2	098980-02-000	EA PILASTER - ADJUSTABLE SHELF - 12" LONG
3	100710-01-01A	EA LOCK - GLASS DOOR - TWIST TYPE - BRASS
	101272-01-000	EA CATCH - DOOR - GLASS
4	042356-01-000	EA PLUG - MAHOGANY - 3/8" DIAMETER - WOOD
4	074045-01-000	EA PLUG - OAK - 1/2" DIAMETER
5	093588-03-000	EA CATCH - SPRING - ROLLER
6	093586-04-000	EA STRIKE - SPRING STEEL
	101766-01-000	EA PIN - SUPPORT - GLASS DOOR
7	106913-02-000	EA SLIDE - DRAWER - 12" - CABINET - RIGHT SIDE
7	106913-06-000	EA SLIDE - DRAWER - 18" - CABINET - RIGHT SIDE
7	106913-18-000	EA SLIDE - DRAWER - 22" - CABINET - RIGHT SIDE
7	106913-22-000	EA SLIDE - DRAWER - 24" - CABINET - RIGHT SIDE

LABELS GROUP

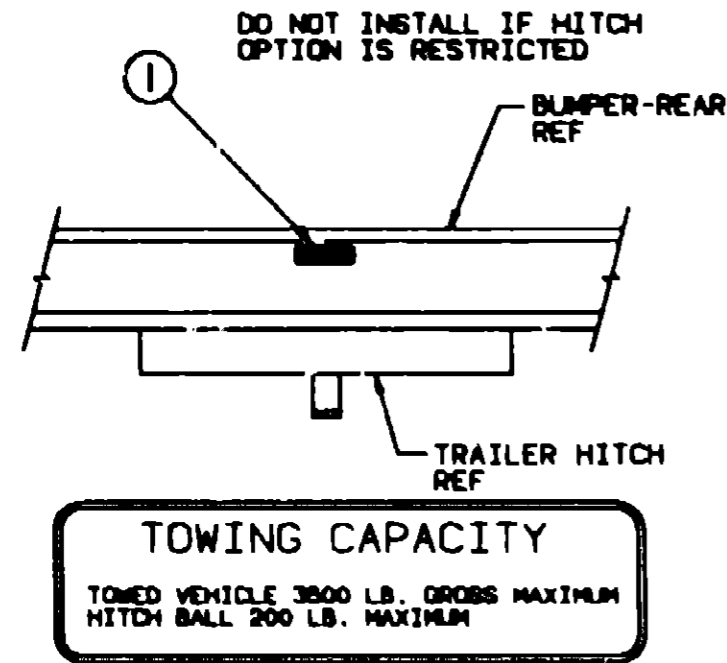

KEY	PART NUMBER	U/M DESCRIPTION
1	075221-03-000	EA LABEL - TRAILER HITCH
	111104-01-000	EA LABEL - HITCH - READ MANUAL

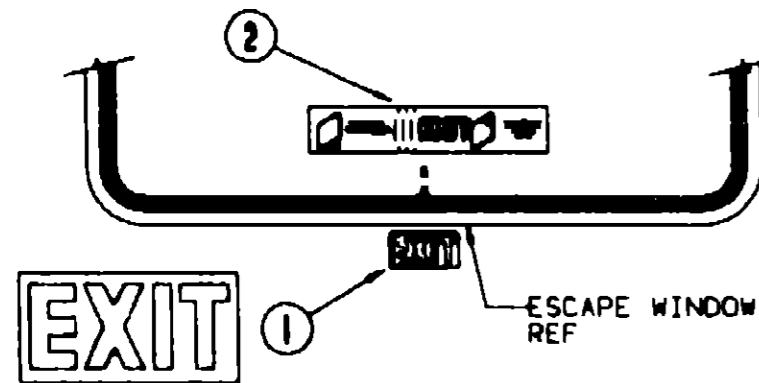

KEY	PART NUMBER	U/M DESCRIPTION
1	107571-01-000	EA LABEL - EXIT/ESCAPE WINDOW
2	039290-01-000	EA LABEL - EXIT WARNING

LABELS GROUP (CONTINUED)

CAUTION
FUEL SPRAY MAY CAUSE PERSONAL INJURY
 TO HELP AVOID PERSONAL INJURY DURING REMOVAL OF FUEL FILLER CAP, SLOWLY LOOSEN CAP 1/2 TURN TO ALLOW ANY FUEL PRESSURE TO BE RELIEVED BEFORE TURNING CAP FURTHER.
 STOP ADDING FUEL AFTER FIRST SHUTOFF BY AUTOMATIC NOZZLE WHEN TANK IS NEARLY FULL. DO NOT OVERFILL FUEL TANK.
 SEE OWNERS MANUAL FOR ADDITIONAL INFORMATION.
 PRINTED IN U.S.A. NLC PT NO 15-1153

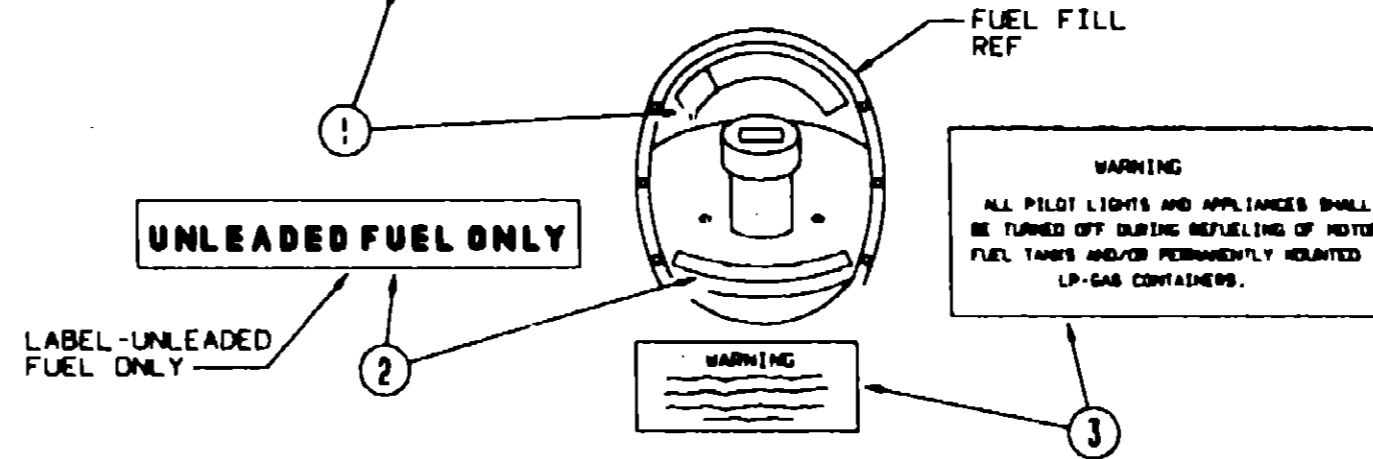

KEY	PART NUMBER	U/M DESCRIPTION
1	087207-05-000	EA LABEL - FUEL CAP REMOVAL
2	062043-01-000	EA LABEL - FUEL - UNLEADED
3	006040-01-000	EA TAG - GAS REFUELING WARNING
3	006040-02-000	EA TAG - GAS REFUELING WARNING (CANADIAN)

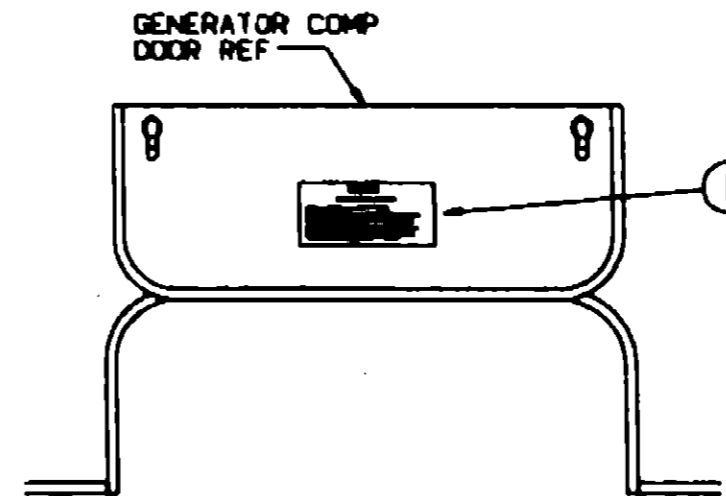

KEY	PART NUMBER	U/M DESCRIPTION
1	077510-01-000	EA LABEL - GENERATOR PREP

1993 ITASCA TABLE OF CONTENTS

INTRODUCTION	A-01 - A-02
ABBREVIATIONS	A-03
ALPHABETICAL INDEX	A-04 - A-06
ICG32RQ	A-07 - E-16

1993 ICG32RQ INDEX

FLOOR PLAN	A-07 - A-08
ACCESSORIES	A-09
AUDIO VIDEO	A-10 - A-11
BATH	A-12 - A-14
BEDROOM	A-15 - A-16
CHASSIS	A-17 - B-06
CURTAIN & CUSHION	B-07 - B-17
DINETTE	B-18 - B-20
DRIVERS COMPARTMENT	B-21 - B-24
ELECTRICAL	C-01 - C-06
EXTERIOR BODY	C-07 - C-14
GALLEY	C-15 - C-18
GENERATOR	C-19 - C-20
HEATING & A/C	C-21 - C-24
INTERIOR FINISH	D-01 - D-04
LABELS	D-05 - D-12
LP	D-13
LOUNGE	D-14 - D-16
SEALANTS & FASTENERS	D-17 - D-19
WATER & SEWAGE	D-20 - D-23
WINDOW, VENT & EXTERIOR DOOR	D-24 E-14
WINDSHIELD & WIPER	E-15 E-16

LABELS GROUP (CONTINUED)

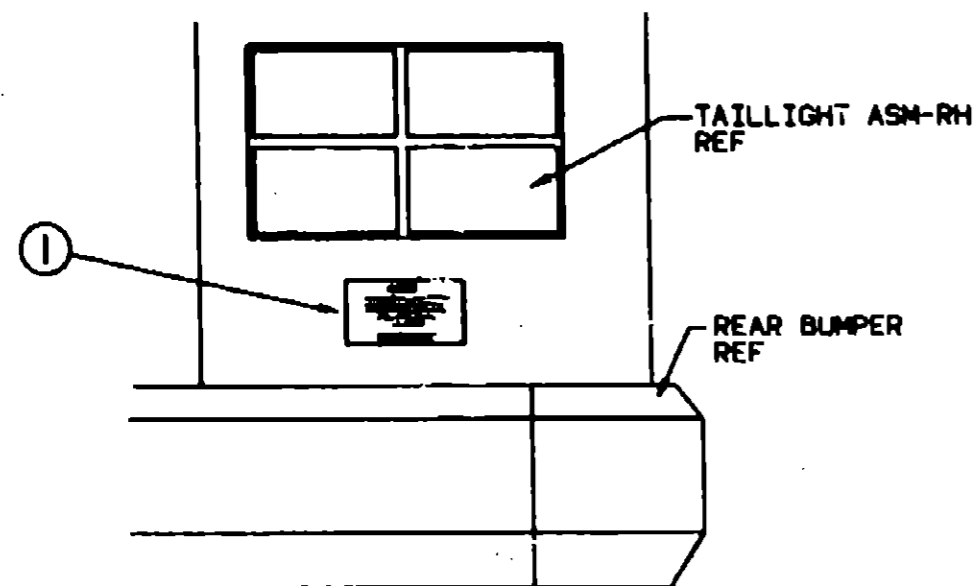

WARNING

DO NOT EXCEED THE VEHICLE WEIGHT RATINGS OR LOADING RECOMMENDATIONS (E.G., GROSS VEHICLE, GROSS AXLE, GROSS COMBINED) OF THE CHASSIS MANUFACTURER OR WINNEBAGO INC.

REFER TO YOUR OWNERS MANUAL, BEFORE LOADING OR TOWING.

KEY	PART NUMBER	U/M DESCRIPTION
1	075220-01-000	EA LABEL - WARNING - EXTERIOR LOAD

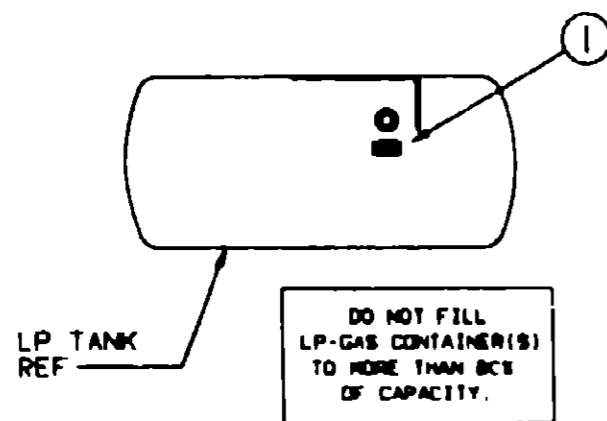

KEY	PART NUMBER	U/M DESCRIPTION
1	079265-01-000	EA LABEL - LPG - 80% CAPACITY

LABELS GROUP (CONTINUED)

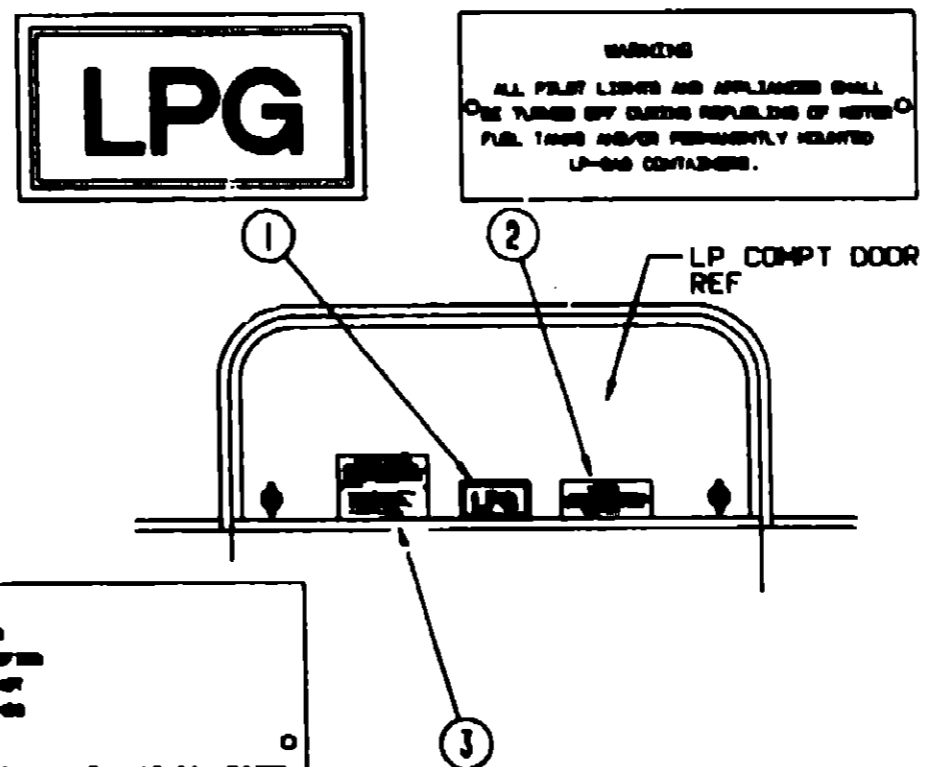

KEY	PART NUMBER	U/M DESCRIPTION
1	074559-01-000	EA DECAL - LOGO - LPG - RED - (CALIF CODE)
2	006040-01-000	EA TAG - GAS REFUELING WARNING
2	006040-02-000	EA TAG - GAS REFUELING WARNING (CANADIAN)
3	054531-01-000	EA LABEL - LP GAS ONLY
3	023769-01-000	EA LABEL - WARNING-LPG (CANADIAN)

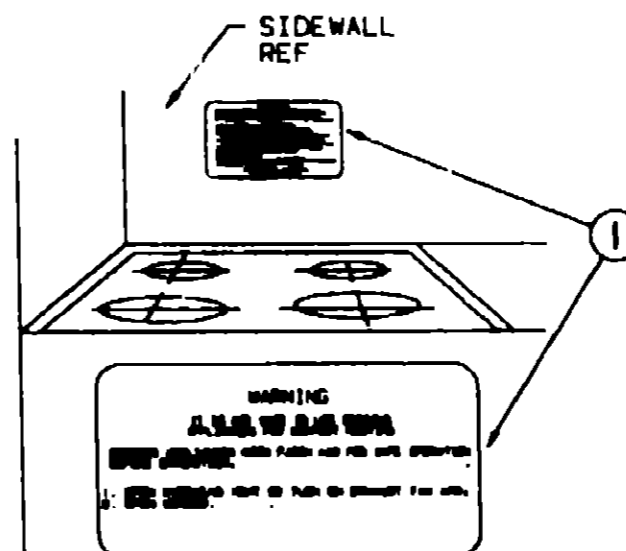

KEY	PART NUMBER	U/M DESCRIPTION
1	050225-01-000	EA LABEL - WARNING - STOVE VENT - US
1	050222-01-000	EA LABEL - WARNING - STOVE VENT - CSA

**1993 ITASCA
TABLE OF CONTENTS**

INTRODUCTION	A-01 - A-02
ABBREVIATIONS	A-03
ALPHABETICAL INDEX	A-04 - A-06
ICG32RQ	A-07 - E-16

1993 ICG32RQ INDEX

FLOOR PLAN	A-07 - A-08
ACCESSORIES	A-09
AUDIO VIDEO	A-10 - A-11
BATH	A-12 - A-14
BEDROOM	A-15 - A-16
CHASSIS	A-17 - B-06
CURTAIN & CUSHION	B-07 - B-17
DINETTE	B-18 - B-20
DRIVERS COMPARTMENT	B-21 - B-24
ELECTRICAL	C-01 - C-06
EXTERIOR BODY	C-07 - C-14
GALLEY	C-15 - C-18
GENERATOR	C-19 - C-20
HEATING & A/C	C-21 - C-24
INTERIOR FINISH	D-01 - D-04
LABELS	D-05 - D-12
LP	D-13
LOUNGE	D-14 - D-16
SEALANTS & FASTENERS	D-17 - D-19
WATER & SEWAGE	D-20 - D-23
WINDOW, VENT & EXTERIOR DOOR	D-24 - E-14
WINDSHIELD & WIPER	E-15 - E-16

LABELS GROUP (CONTINUED)

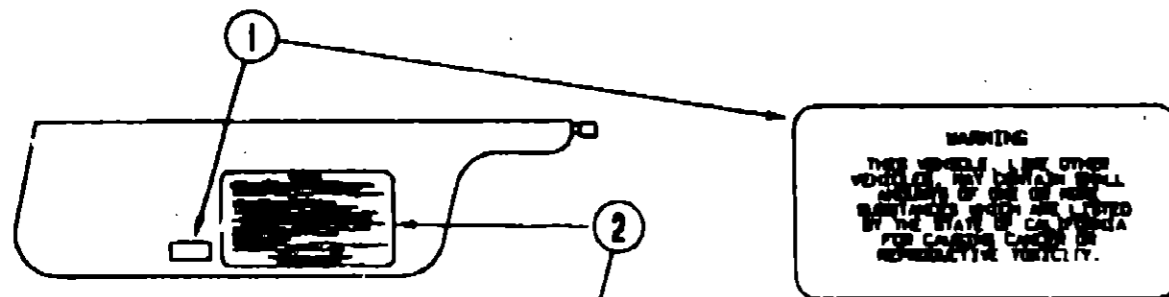

WARNING
 THIS VEHICLE LIES OTHER
 VEHICLES. THE DRIVER SHALL
 BE RESPONSIBLE FOR THE
 SAFETY OF THE PASSENGERS
 IN THE STATE OF CALIFORNIA
 FOR CAUSING DAMAGE TO
 NON-RECREATIVE VEHICLE.

CAUTION

THIS MOTOR HOME HAS BEEN DESIGNED, MANUFACTURED AND TESTED WITH CONCEPTS FOR THE PROTECTION OF ITS OCCUPANTS. WE RECOMMEND YOU PERFORM THE FOLLOWING INSPECTIONS FOR YOUR SAFETY AND THE SAFETY OF YOUR PASSENGERS BEFORE STARTING YOUR VEHICLE.

1. LP GAS SYSTEM- TURN OFF AT TANK FOR TRAVELING. TEST FOR LEAKS UPON ARRIVAL AT DESTINATION. BEFORE LEAVING PILOTS.
2. WHEELS- INSPECT FOR DAMAGE AND CHECK LUB NUTS FOR TIGHTNESS.
3. TIRES- INSPECT FOR WEAR AND DAMAGE AND CHECK FOR RECOMMENDED AIR PRESSURE.
4. LIGHTING- TEST FOR PROPER OPERATION OF ALL INTERIOR AND EXTERIOR LIGHTS INCLUDING DASH LIGHTS, HEADLIGHTS, TAIL LIGHTS, BRAKE LIGHTS, CLEARANCE LIGHTS AND TURN SIGNALS.
5. EXITS- INSPECT RELEASE MECHANISM ON EMERGENCY EXIT WINDOWS. TEST BOTH LOCKS ON MAIN ENTRANCE DOOR FOR EASE OF OPERATION AND INSTRUCT PASSENGERS HOW TO USE BOTH REARS OF EXIT.
6. SEAT BELTS- DIRECT PASSENGERS TO DESIGNATED SEATS AND REQUIRE USE OF SEAT BELTS.
7. APPLIANCES- TURN OFF AND LATCH OR LOCK COOKS WHERE PROVIDED.
8. LOOSE PARTS- STORE SECURELY.
9. UTILITY SUPPLY LINES- DISCONNECT ALL ELECTRIC, SEWER AND WATER LINES AND SECURE PROPERLY.
10. ENTRANCE DOOR STEP- PLACE IN RETRACTED POSITION FOR TRAVELING.

READ YOUR MOTOR HOME AND CHASSIS OWNER'S MANUAL FOR FURTHER PRECAUTIONS

KEY	PART NUMBER	U/M DESCRIPTION
1	090889-01-000	EA LABEL - WARNING - CANCER/TOXICITY
2	056255-01-000	EA LABEL - SAFETY CHECK LIST

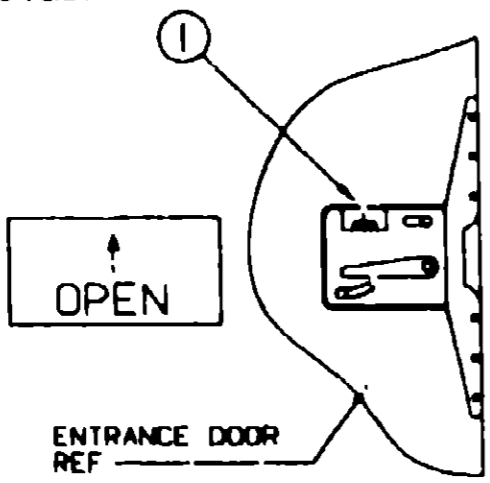

KEY	PART NUMBER	U/M DESCRIPTION
1	040944-01-000	EA LABEL - ENTRANCE DOOR - "OPEN"

LABELS GROUP (CONTINUED)

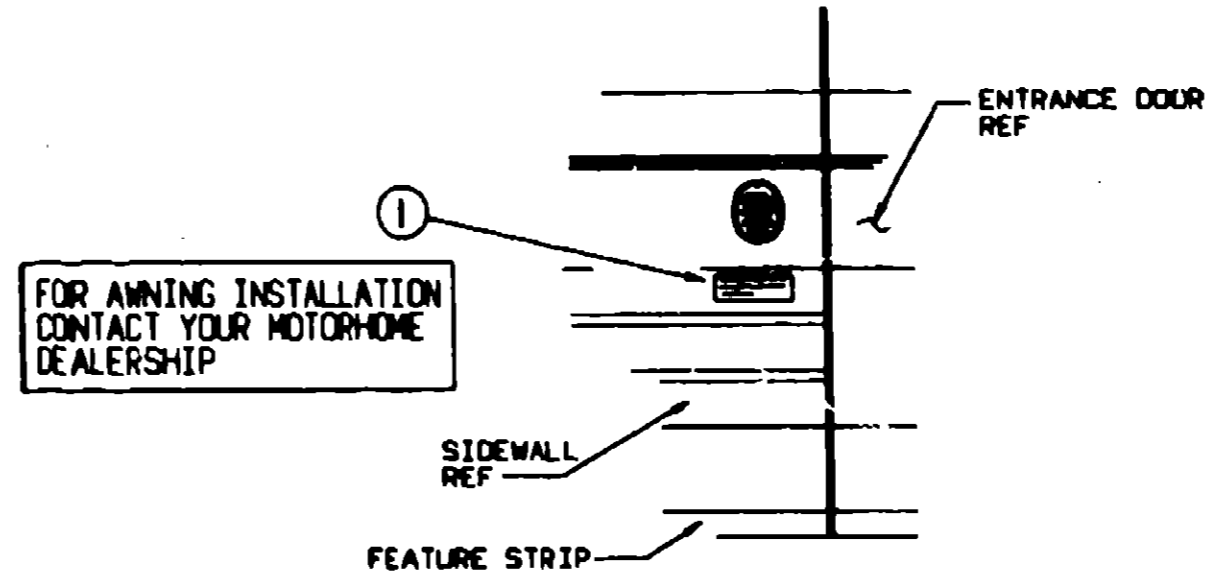

**FOR AWNING INSTALLATION
 CONTACT YOUR MOTORHOME
 DEALERSHIP**

KEY	PART NUMBER	U/M DESCRIPTION
1	099509-01-000	EA LABEL - AWNING INSTALLATION

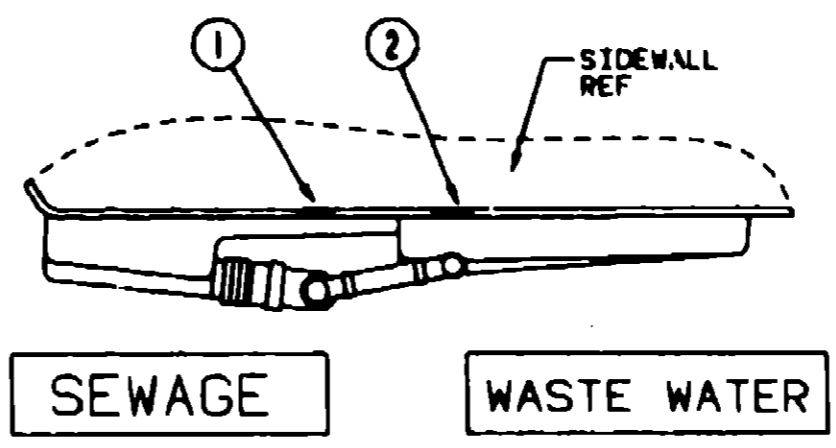

KEY	PART NUMBER	U/M DESCRIPTION
1	006187-01-000	EA LABEL - SEWAGE
2	006188-01-000	EA LABEL - WASTE WATER

**1993 ITASCA
 TABLE OF CONTENTS**

INTRODUCTION	A-01 - A-02
ABBREVIATIONS	A-03
ALPHABETICAL INDEX	A-04 - A-06
ICG32RQ	A-07 - E-16

1993 ICG32RQ INDEX

FLOOR PLAN	A-07 - A-08
ACCESSORIES	A-09
AUDIO VIDEO	A-10 - A-11
BATH	A-12 - A-14
BEDROOM	A-15 - A-16
CHASSIS	A-17 - B-03
CURTAIN & CUSHION	B-07 - B-17
DINETTE	B-18 - B-20
DRIVERS COMPARTMENT	B-21 - F-24
ELECTRICAL	C-01 - C-06
EXTERIOR BODY	C-07 - C-14
GALLEY	C-15 - C-18
GENERATOR	C-19 - C-20
HEATING & AC	C-21 - C-24
INTERIOR FINISH	D-01 - D-04
LABELS	D-05 - D-12
LP	D-13
LOUNGE	D-14 - D-16
SEALANTS & FASTENERS	D-17 - D-19
WATER & SEWAGE	D-20 - D-23
WINDOW, VENT & EXTERIOR DOOR	D-24 - E-14
WINDSHIELD & WIPER	E-15 - E-16

LABELS GROUP (CONTINUED)

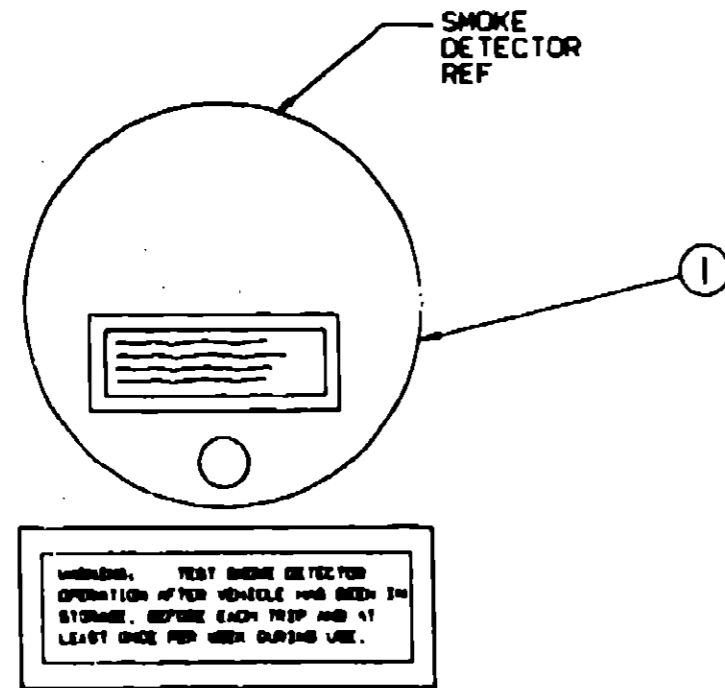

KEY	PART NUMBER	U/M DESCRIPTION
	061806-01-000	EA LABEL - OVERLAY - VEHICLE CERTIFICATION - ADHESIVE BACKED
	073998-01-000	EA LABEL - LPG ODOR WARNING
	074983-01-000	EA LABEL - SWITCH - A/C SELECTOR FOR FRONT OR REAR
	079986-01-000	EA LABEL - WARNING - STOWED - MOTION
	091224-02-000	EA LABEL - TRAILER LIGHTING
	091243-01-000	EA LABEL - A/C COVER - "AIR CONDITIONING CIRCUIT ETC."
	102257-01-000	EA LABEL - NO OCCUPANCY - US
	098379-03-000	EA LABEL - ELECTRICAL BOX - FRONT
	098379-04-000	EA LABEL - ELECTRICAL BOX - SIDE
	098641-01-000	EA LABEL - FUEL - UNLEADED - DASH
	104678-01-000	EA LABEL - CB PREP

LABELS GROUP (CONTINUED)

MISCELLANEOUS LABELS

**1993 ITASCA
TABLE OF CONTENTS**

INTRODUCTION	A-01 - A-02
ABBREVIATIONS	A-03
ALPHABETICAL INDEX	A-04 - A-06
ICG32RQ	A-07 - E-18

KEY	PART NUMBER	U/M DESCRIPTION
1	077956-01-000	EA LABEL - WARNING - SMOKE DETECTOR

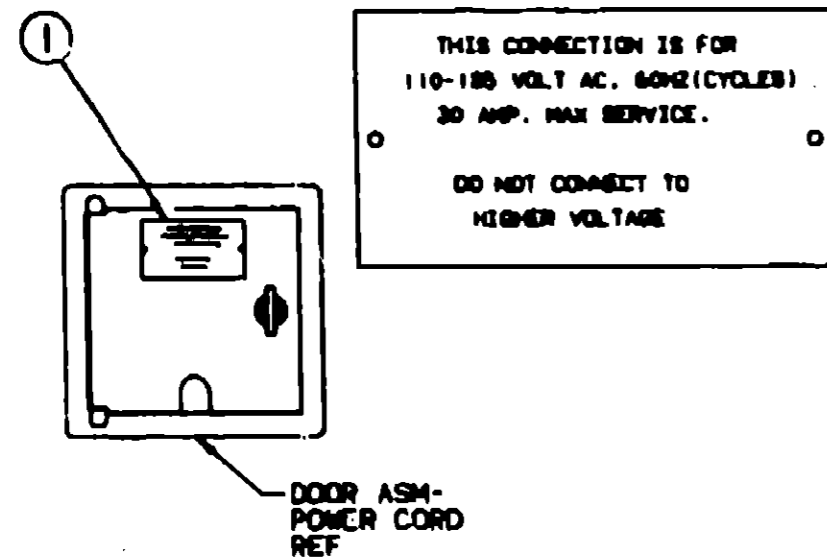

KEY	PART NUMBER	U/M DESCRIPTION
1	006082-01-000	EA TAG - ELECTRIC - 110V CONNECTION

1993 ICG32RQ INDEX

FLOOR PLAN	A-07 - A-08
ACCESSORIES	A-09
AUDIO VIDEO	A-10 - A-11
BATH	A-12 - A-14
BEDROOM	A-15 - A-16
CHASSIS	A-17 - B-06
CURTAIN & CUSHION	B-07 - B-17
DINETTE	B-18 - B-20
DRIVERS COMPARTMENT	B-21 - B-24
ELECTRICAL	C-01 - C-06
EXTERIOR BODY	C-07 - C-14
GALLEY	C-15 - C-18
GENERATOR	C-19 - C-20
HEATING & A/C	C-21 - C-24
INTERIOR FINISH	D-01 - D-04
LABELS	D-05 - D-12
LP	D-13
LOUNGE	D-14 - D-16
SEALANTS & FASTENERS	D-17 - D-19
WATER & SEWAGE	D-20 - D-23
WINDOW, VENT &	
EXTERIOR DOOR	D-24 - E-14
WINDSHIELD & WIPER	E-15 - E-16

LP GROUP

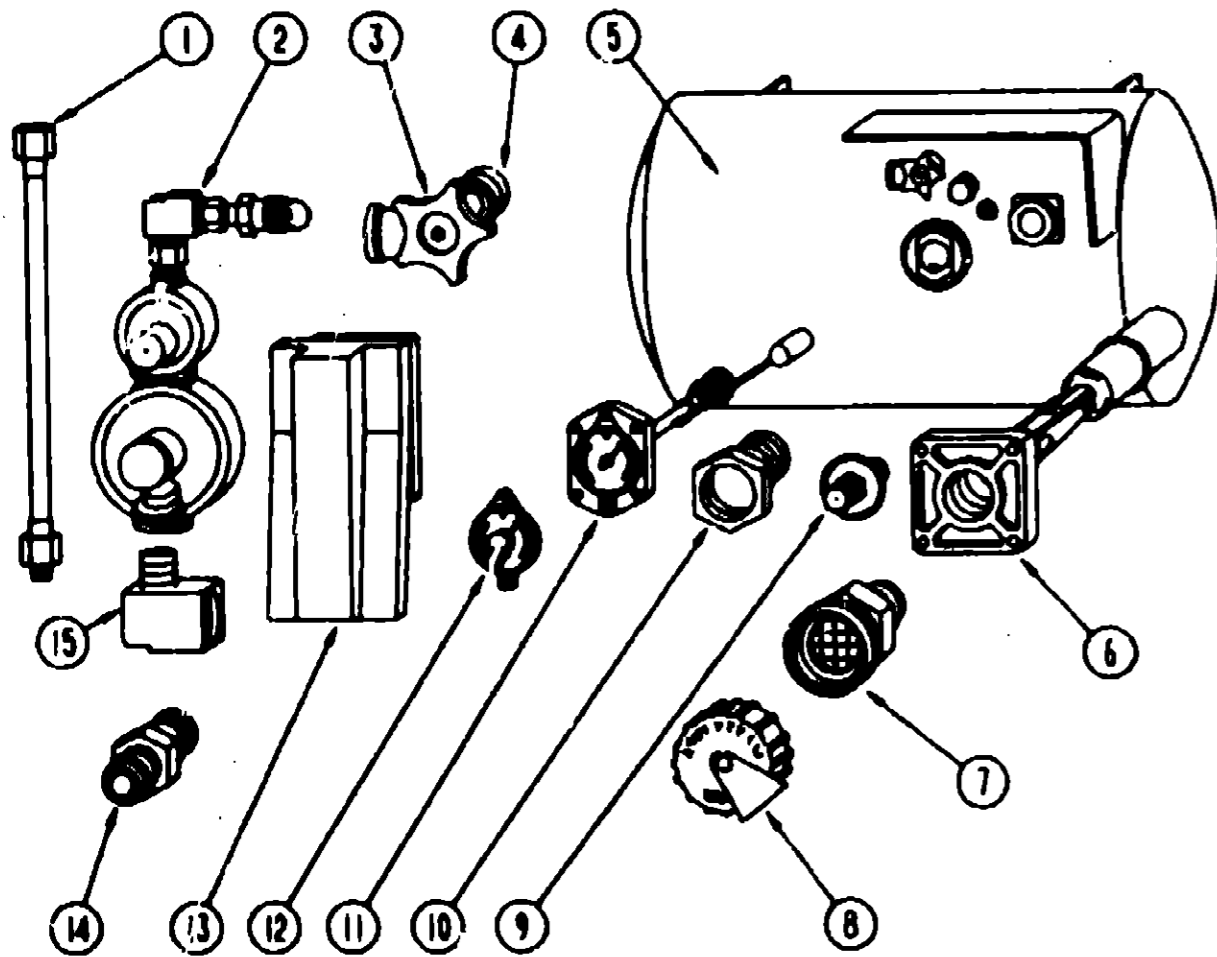

LP TANK & COMPONENTS

KEY	PART NUMBER	U/M	DESCRIPTION
1	045703-01-000	EA	HOSE - LP - 3/8" ID X 24' US - 3/8 MPT X 1/2 F SWIVEL
1	045703-02-000	EA	HOSE - LP - 3/8" ID X 24' - 3/8 MPT X 1/2 F SWIVEL - CANADA
2	108150-01-000	EA	REGULATOR - TWO STAGE
3	040421-01-708	EA	HANDWHEEL - VAPOR RELIEF VALVE - BRUNNER G-1015-A
4	040421-01-712	EA	VALVE - SERVICE W/HANDWHEEL
5	088253-03-000	EA	TANK - LP - 100 LB - 18" D X 36" - SPL
6	040421-01-711	EA	VALVE - 80% W/FLOAT - PLATE - BOLTS & GASKET - BRUNNER
7	040421-01-701	EA	VALVE - SHORT LP FILLER W/YELLOW CAP - BRUNNER 7547B
8	040421-01-702	EA	CAP - LP FILLER VALVE - PLASTIC - YELLOW - BRUNNER G-1014-A
9	040421-01-700	EA	GAUGE - LIQUID LEVEL - 20% LP - BRUNNER G-1013
10	040421-01-713	EA	PRESSURE RELIEF VALVE
11	040421-01-708	EA	GAUGE - FLOAT W/VISIBLE DIAL
12	040440-02-000	EA	TRANSMITTER - DIAL - 90 OHM
13	106858-01-000	EA	COMPARTMENT - LP REGULATOR
14	010323-01-000	EA	ADAPTER - BRASS - 3/8" F X 1/2" MPT
15	085318-02-000	EA	ELBOW - 90 DEGREE - 3/8" MPT TO 3/8" MPT
	010377-02-000	EA	NUT - BRASS - 3/8 FEMALE - FORGED
	093380-01-000	EA	COUPLER - 1/2" TO 3/8" BLACK PIPE
	010329-01-000	EA	ADAPTER - BRASS - 1/2" F X 1/2" MPT
	010285-01-000	EA	ELBOW - BRASS - 90 DEGREE - 3/8" F X 1/2" FPT
	086742-01-000	EA	TEE - 3/8" F X 3/8" F X 25" FPT - BRASS
	103813-01-000	EA	DETECTOR - LP GAS
	086741-01-000	EA	GAUGE - DIAPHRAGM PRESSURE - MARSHALLTOWN MFG

LOUNGE GROUP

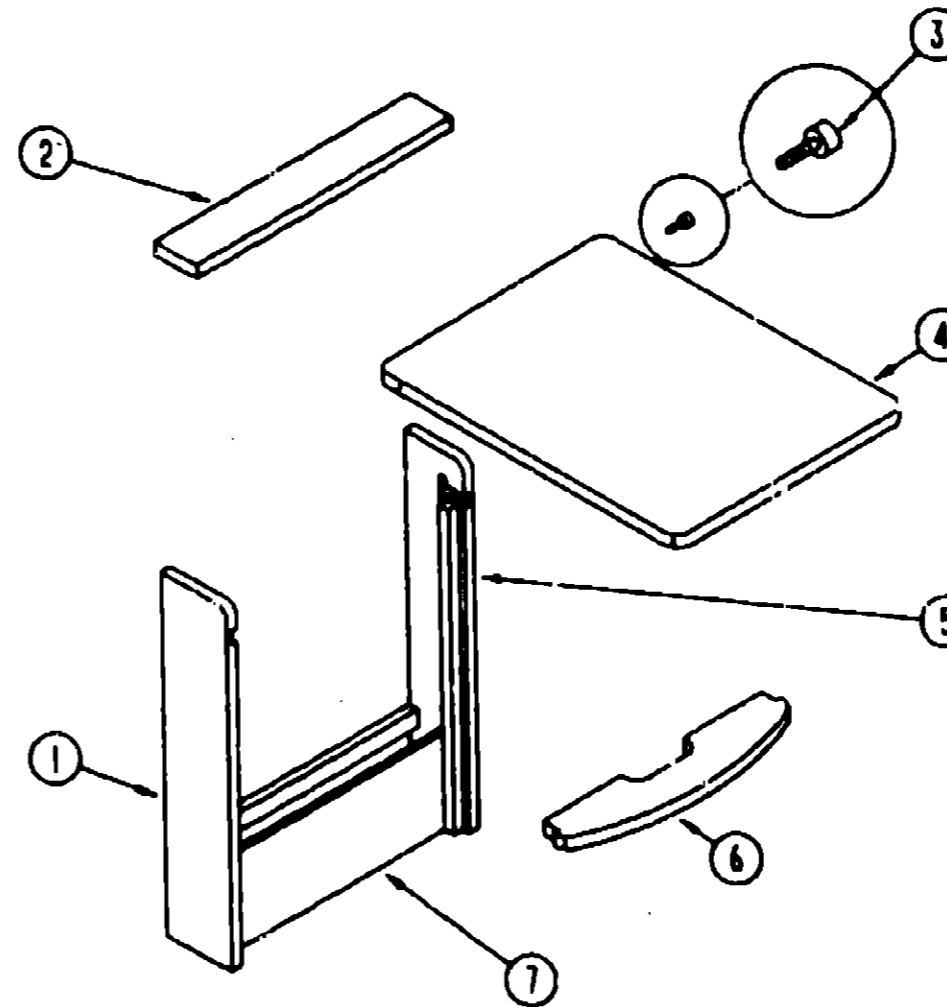

PULLOUT TABLE

KEY	PART NUMBER	U/M	DESCRIPTION
	M96873-01-B87	EA	CABINET ASM - TABLE - W/O PULLOUT TOP
1	096873-14-B87	EA	SIDE END - TABLE - 28.7" X 5.7" - LEFT SIDE
2	096873-15-B87	EA	SHELF - SUPPORT - OVER PULL OUT TABLE TOP
3	079921-01-000	EA	NYLON ROLLER W/SHAFT
4	096873-11-B27	EA	PULLOUT TOP
5	096873-13-B87	EA	SIDE END - TABLE - 28.7" X 5.7" - RIGHT SIDE
6	096873-12-B87	EA	SHELF - SUPPORT - UNDER PULL OUT TABLE TOP
7	096873-16-B87	EA	PANEL - TABLE - FRONT BOTTOM - 18.1" X 6.7"
	080736-01-000	EA	PULL - RECESSED - 1.25" X .4" - OAK

**1993 ITASCA
TABLE OF CONTENTS**

INTRODUCTION	A-01 - A-02
ABBREVIATIONS	A-03
ALPHABETICAL INDEX	A-04 - A-06
ICG32RQ	A-07 - E-16

1993 ICG32RQ INDEX

FLOOR PLAN	A-07 - A-08
ACCESSORIES	A-09
AUDIO VIDEO	A-10 - A-11
BATH	A-12 - A-14
BEDROOM	A-15 - A-16
CHASSIS	A-17 - B-06
CURTAIN & CUSHION	B-07 - B-17
DINETTE	B-18 - B-20
DRIVERS COMPARTMENT	B-21 - B-24
ELECTRICAL	C-01 - C-06
EXTERIOR BODY	C-07 - C-14
GALLEY	C-15 - C-18
GENERATOR	C-19 - C-20
HEATING & A/C	C-21 - C-24
INTERIOR FINISH	D-01 - D-04
LABELS	D-05 - D-12
LP	D-13
LOUNGE	D-14 - D-16
SEALANTS & FASTENERS	D-17 - D-19
WATER & SEWAGE	D-20 - D-23
WINDOW, VENT & EXTERIOR DOOR	D-24 - E-14
WINDSHIELD & WIPER	E-15 - E-16

LOUNGE GROUP (CONTINUED)

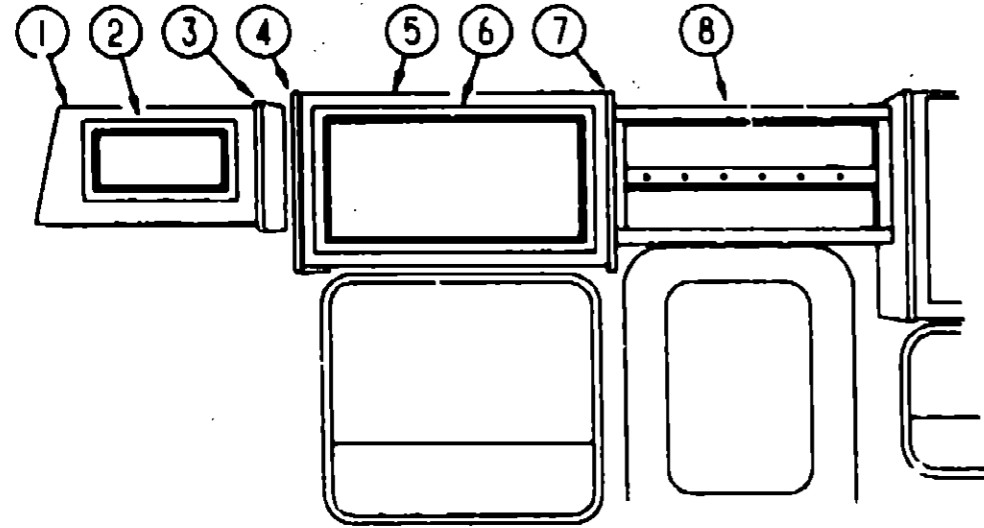

FRONT OVERHEAD CABINET (PASSENGER SIDE)

KEY	PART NUMBER	U/M DESCRIPTION
1	M05160-24-D35	EA CABINET ASM - FRONT OVERHEAD - PASSENGER SIDE FROM: 00-00-00 THRU: 08-16-92
1	M05160-24-D36	EA CABINET ASM - FRONT OVERHEAD - PASSENGER SIDE FROM: 00-00-00 THRU 08-16-92
1	M05899-01-D35	EA CABINET ASM - FRONT OVERHEAD - PASSENGER SIDE FROM: 08-17-92 THRU 99-99-99
1	M05899-01-D36	EA CABINET ASM - FRONT OVERHEAD - PASSENGER SIDE FROM: 08-17-92 THRU 99-99-99
2	P03702-33-D35	EA DOOR ASM - RAIL - W/O HARDWARE
3	103128-08-D35	EA END CAP ASM. (FRONT OVERHEAD) (D35,D36)
4	103128-02-C27	EA END CAP ASM. - LEFT HAND (D35,D36)
5	M05160-17-D35	EA CABINET ASM - OVERHEAD (D35,D36)
6	P03702-A5-D35	EA DOOR ASM - W/O HARDWARE (D35,D36)
7	103128-01-C27	EA END CAP ASM. - RIGHT HAND (D35,D36)
8	105916-11-D35	EA CABINET ASM - OVHD - KEY RACK
8	105916-11-D36	EA CABINET ASM - OVHD - KEY RACK

LOUNGE GROUP (CONTINUED)

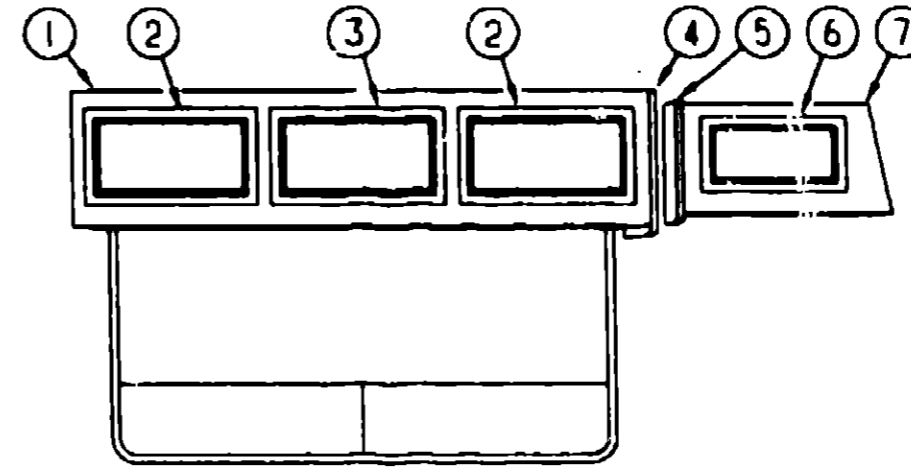

FRONT OVERHEAD CABINET (DRIVER SIDE)

KEY	PART NUMBER	U/M DESCRIPTION
1	M05160-15-D35	EA CABINET ASM (D35,D36)
2	M05908-04-D35	EA DOOR ASM - RAIL - W/O HARDWARE (D35,D36) FROM: 00-00-00 THRU 08-09-92
2	P03702-65-D35	EA DOOR ASM - RAIL - W/O HARDWARE (D35,D36) FROM: 08-17-92 THRU 99-99-99
3	M05908-05-D35	EA DOOR ASM - RAIL - W/O HARDWARE (D35,D36) FROM: 00-00-00 THRU 08-09-92
3	P03702-12-D35	EA DOOR ASM - RAIL - W/O HARDWARE (D35,D36) FROM: 08-10-92 THRU 99-99-99
4	103128-01-C27	EA END CAP ASM. - RIGHT HAND (D35,D36)
5	103128-08-D35	EA END CAP ASM (FRONT OVERHEAD) (D35,D36)
6	P03702-33-D35	EA DOOR ASM - W/O HARDWARE (D35,D36)
7	M05160-25-D35	EA CABINET ASM - FRONT OVERHEAD - DRIVER SIDE FROM: 00-00-00 THRU 08-16-92
7	M05160-25-D36	EA CABINET ASM - FRONT OVERHEAD - DRIVER SIDE FROM: 00-00-00 THRU 08-16-92
7	M05899-02-D35	EA CABINET ASM - FRONT OVERHEAD - DRIVER SIDE FROM: 08-17-92 THRU 99-99-99
7	M05899-02-D36	EA CABINET ASM - FRONT OVERHEAD - DRIVER SIDE FROM: 08-17-92 THRU 99-99-99

**1993 ITASCA
TABLE OF CONTENTS**

INTRODUCTION	A-01 - A-02
ABBREVIATIONS	A-03
ALPHABETICAL INDEX	A-04 - A-06
ICG32RQ	A-07 - E-16

1993 ICG32RQ INDEX

FLOOR PLAN	A-07 - A-08
ACCESSORIES	A-09
AUDIO VIDEO	A-10 - A-11
BATH	A-12 - A-14
BEDROOM	A-15 - A-16
CHASSIS	A-17 - B-06
CURTAIN & CUSHION	B-07 - B-17
DINETTE	B-18 - B-20
DRIVERS COMPARTMENT	B-21 - B-24
ELECTRICAL	C-01 - C-08
EXTERIOR BODY	C-07 - C-14
GALLEY	C-15 - C-18
GENERATOR	C-19 - C-20
HEATING & A/C	C-21 - C-24
INTERIOR FINISH	D-01 - D-04
LABELS	D-05 - D-12
LP	D-13
LOUNGE	D-14 - D-16
SEALANTS & FASTENERS	D-17 - D-19
WATER & SEWAGE	D-20 - D-23
WINDOW, VENT & EXTERIOR DOOR	D-24 - E-14
WINDSHIELD & WIPER	E-15 - E-16

SEALANTS & FASTENERS GROUP

ADHESIVE AND BOLTS

KEY	PART NUMBER	U/M DESCRIPTION
	004020-01-000	QT ADHESIVE - ABS CEMENT - QUART
	081377-01-700	EA ADHESIVE - CYANOACRYLATE - 10 GRAM TUBE
	004006-04-700	EA ADHESIVE - PIERCE - 1 GAL - J9270-X-1
	087211-01-000	GL ADHESIVE - PROMOTER
	004005-02-000	EA ADHESIVE - SWIFTS - 1 GAL - W1333
	099039-01-000	EA ADHESIVE - WEATHERSTRIP - 8 OZ
	053756-02-000	EA BEDDING COMPOUND - TUBE - WHITE
	005200-01-000	EA BOLT - BUMPER - ROUND HEAD - SQUARE NECK - W/SST CAP 7/16 - 14 X 1 1/4
	102333-01-01A	EA BOLT - CARRIAGE - 7/16 - 14 - STAINLESS STEEL CAP - BEIGE
	051387-06-000	EA BOLT - CARRIAGE - W/O HOLE - 5/16-18 X 9 5 ZN
	000C12-08-248	EA BOLT - HEX - 1/2-13 X 1 1/2 - ZN 5
	000C12-05-168	EA BOLT - HEX - 5/16-18 X 1 - ZINC 5
	000C12-10-248	EA BOLT - HEX - 5/8-11 X 1 1/2 ZN - 5
	000C12-07-208	EA BOLT - HEX - 7/16 - 14 X 1 1/4 - ZN5
	000C13-07-488	EA BOLT - HEX - 7/16 - 20 X 3 - ZN 5
	000C26-04-108	EA BOLT - HEX - SER FLG - 1/4-20 X 5/8 ZINC
	000C26-05-208	EA BOLT - HEX - SER FLG 5/16-18 X 1 1/4 - ZINC
	000C12-05-248	EA BOLT - HEX - 5/16-18X1 1/2 ZN 5

CLAMPS - GROMMETS AND FASTENERS

KEY	PART NUMBER	U/M DESCRIPTION
	010495-01-000	EA CLAMP - CABLE - 9/16"
	010497-06-000	EA CLAMP - CLOSED - 11/16" ID
	010497-03-000	EA CLAMP - CLOSED - 1" ID - CUSHIONED
	010499-01-000	EA CLAMP - CLOSED - 3/8" ID
	010497-01-000	EA CLAMP - CLOSED - 5/8" ID
	010497-08-000	EA CLAMP - CLOSED - .125"
	075148-02-000	EA CLAMP - GROUNDING - BRONZE SCREWS
	062401-02-000	EA CLAMP - HOSE - WORMGEAR - 1.56" - 2.5"
	062401-10-000	EA CLAMP - HOSE - WORMGEAR 1.06" - 2"
	073194-02-000	EA CLAMP - HOSE - WORMGEAR 32-50 MM
	062401-07-000	EA CLAMP - HOSE - WORMGEAR 5" - 7"
	062401-06-000	EA CLAMP - HOSE - WORMGEAR 22" - 62"
	062401-01-000	EA CLAMP - HOSE - WORMGEAR 25" - 1"
	062401-04-000	EA CLAMP - HOSE - WORMGEAR 69" - 1.25"
	062401-03-000	EA CLAMP - HOSE WORMGEAR - 22" - 1"
	083609-01-000	EA CLAMP - WIRE - DUAL - EQUAL 5/8" DIAMETER
	094362-02-000	EA CLIP - CHRISTMAS TREE - FLAT HEAD
	077953-01-000	EA GROMMET - EDGE LINER - FITS 1"
	023942-01-000	EA GROMMET - RUBBER - 2" OD
	071015-21-000	EA GROMMET - 50"ID - FITS 19" MATERIAL - RUBBER - SPLIT
	008086-01-000	EA HINGE - ALUMINUM - NO HOLES - 11/16" X 72" - UNPAINTED
	058134-02-000	EA HOLDER - RING - 1 5" ID PIPE SIZE - STEEL
	077955-01-000	EA J CLIP - VINYL COATED - 3/8" USED IN WIRING TO CLEARANCE LIGHTS
	008401-01-000	EA STRAP - CONDUIT - 3/4" - 1 HOLE - GALVANIZED STEEL
	016604-01-000	EA BRACE - CABINET - ANGLED METAL - 2 5"

NUTS

KEY	PART NUMBER	U/M DESCRIPTION
	072893-01-000	EA NUTSERT - M5 X 0 - 8
	077049-01-000	EA NUT - ACORN - 10-32 ALUMINUM
	095094-01-000	EA NUT - ACORN - 1/4 - 20 ALUMINUM
	000D14-05-008	EA NUT - HEX - 5/16-18 - ZN 5
	000D34-04-008	EA NUT - HEX - LK 1/4 - 20 ZN
	000D39-04-008	EA NUT - HEX - SER FLG LK 1/4 - 20 ZN
	000D39-08-008	EA NUT - HEX - SER FLG LK - 1/2-13 ZN
	000D39-06-008	EA NUT - HEX - SER FLG LK - 3/8-16 ZN
	000D39-05-008	EA NUT - HEX - SER FLG LK - 5/16 - 18 ZN
	000D44-07-008	EA NUT - HEX - SER FLG LK - 7/16-20 ZN
	000D24-10-008	EA NUT - HEX - SF/LK - 10-32 ZN
	000D34-08-008	EA NUT - HEX LK-3/8-16 GRADE C ZN
	075467-01-000	EA NUT - INVERTED FLARE - 1/4
	088497-02-000	EA NUT - INVERTED FLARE - 1/4
	083253-07-000	EA NUT - J - 8BA - 120 - 130 PNL THK
	044384-02-000	EA NUT - SPEED - FLAT - ROUND
	040921-08-000	EA NUT - SPEED - U TYPE - NO 8

SEALANTS & FASTENERS GROUP (CONTINUED)

NUTS (CONTINUED)

KEY	PART NUMBER	U/M DESCRIPTION
	040921-04-000	EA NUT - SPEED - U TYPE - NO 8
	040921-05-000	EA NUT - SPEED - U TYPE - NO 8
	044384-01-000	EA NUT - SPEED - FLAT
	064081-01-000	EA NUT - WING - 3/8" X 16 THREAD
	084884-01-000	EA PLUG - BRASS - 3/8"
	000H16-04-06R	EA RIVET - POP - AL 1/8 X 313-375
	069592-02-000	EA RIVET - T (POP) 1/4X 093-156
	063729-04-000	EA RIVNUT - 10-32 UNF - .010-080
	063729-01-000	EA RIVNUT - 1/4 X 20 UNC - 030-125

SCREWS

KEY	PART NUMBER	U/M DESCRIPTION
	000G67-10-248	EA SCREW - 10-12 X 1 1/2 PPH - ZN
	000G67-10-16P	EA SCREW - 10-12 X 1 PPH - DARK BROWN
	000G67-10-16B	EA SCREW - 10-12 X 1 PPH - ZN
	000G67-10-08B	EA SCREW - 10-12 X 1/2 PPH ZN
	000G67-10-08R	EA SCREW - 10-12 X 1/2 PPH - BEIGE - TYPE A
	000G67-10-12B	EA SCREW - 10-12 X 3/4 - PPH ZN
	000G67-10-10B	EA SCREW - 10-12 X 5/8 PPH ZN - TYPE A
	000G67-10-10R	EA SCREW - 10-12 X 5/8 PPH - TYPE A - BEIGE
	000G67-10-12P	EA SCREW - 10-12 X 75 PPH - DARK BROWN
	049465-01-000	EA SCREW - 10-16 W/WASHER PTH - DARK BROWN
	049465-04-000	EA SCREW - 10-16 X 1 PTH W/WASHER - BEIGE
	000G11-10-16B	EA SCREW - 10-16 X 1 - PPH ZN
	000G11-10-12R	EA SCREW - 10-16 X 3/4 PPH - BEIGE
	000G11-10-120	EA SCREW - 10-16 X 3/4 PPH - BLACK
	000G68-06-10G	EA SCREW - 6-18 X 5/8 POH - ANTIQUE BRASS
	076790-01-000	EA SCREW - 6-20 X 1 1/4 PPH - BLACK
	000G13-06-16R	EA SCREW - 6-20 X 1 PFH - BEIGE
	000G13-06-08B	EA SCREW - 6-20 X 1/2 PFH ZN
	000G13-06-10G	EA SCREW - 6-20 X 5/8 PFH - ANTIQUE BRASS
	000G11-06-10B	EA SCREW - 6-20 X 5/8 PPH ZN
	000G11-06-10J	EA SCREW - 6-20 X 5/8 PPH - BRASS
	000G11-07-08B	EA SCREW - 7-19 X 1/2 PPH - ZN
	000G13-07-12B	EA SCREW - 7-19 X 3/4 PFH ZN
	000G13-08-16B	EA SCREW - 8-18 X 1 PFH - ZN
	000G11-08-08T	EA SCREW - 8-18 X 1/2 PPH
	000G11-08-08B	EA SCREW - 8-18 X 1/2 PPH ZN
	000G11-08-12B	EA SCREW - 8-18 X 3/4 PPH ZN
	000G11-08-12R	EA SCREW - 8-18 X 3/4 PPH - BEIGE
	000G11-08-12D	EA SCREW - 8-18 X 3/4 PPH - BLACK
	000G11-08-16R	EA SCREW - 8-18X1.00 PPH - BEIGE
	000G67-10-32B	EA SCREW - NO. 10 - 12 X 2 PPH ZN
	000G55-08-12W	EA SCREW - SF/DT - 8-18X 75 PWH
	000G67-10-12R	EA SCREW - 10-12X 75 PPH BEIGE
	000G67-10-120	EA SCREW - 10-12X 75 PPH TAN
	049465-03-000	EA SCREW - 10-16X1 POH W/WASHER
	000G11-10-12S	EA SCREW - 10-16X 75 PPH OFF WHITE
	000G54-04-208	EA SCREW - 1/4-20X1 1/4 PTH TYP 23
	000G57-05-16J	EA SCREW - 5-20X1 PFH BRASS
	000G12-06-08T	EA SCREW - 6-20 X 50 POH - BLACK
	000G13-06-16J	EA SCREW - 6-20X1 00 PFH BRASS
	000G11-08-12P	EA SCREW - 8-18X 75 DARK BROWN
	085318-01-000	EA SCREW - 8-08BX 1/2 - CRIMPTITE HD
	000G67-08-32B	EA SCREW - 8-15X2 PPH ZN
	000G12-08-16S	EA SCREW - 8-18 X 1" POH - OFF WHITE
	000G11-08-16S	EA SCREW - 8-18X1.00 PPH OFF WHITE
	009439-07-000	EA SCREW - 8-32X1 1/4 POH - BLACK
	087721-01-000	EA SCREW - FLAT HEAD - TAPPING - 1/4 X 1 1/4 LG ZN
	088783-01-000	EA SCREW - MACH - 10 - 32 X 1/4 PTH
	000G19-10-08B	EA SCREW - MACH - 10-32 X 1/2 PPH ZN
	000G19-10-10B	EA SCREW - MACH - 10-32 X 5/8 - PPH - ZINC
	000G50-04-12B	EA SCREW - MACH - 1/4-20 X 3/4 PPH ZN
	081808-01-000	EA SCREW - MACH 6-32X 62 W/WYLOCK
	088371-01-000	EA SCREW - MACH 8-32X3 5/16 ZN
	000G19-10-20B	EA SCREW - MACHINE - 10-32 X 1 1/4 PPH ZINC

**1993 ITASCA
TABLE OF CONTENTS**

INTRODUCTION	A-01 - A-02
ABBREVIATIONS	A-03
ALPHABETICAL INDEX	A-04 - A-06
ICG32RQ	A-07 - E-16

1993 ICG32RQ INDEX

FLOOR PLAN	A-07 - A-08
ACCESSORIES	A-09
AUDIO VIDEO	A-10 - A-11
BATH	A-12 - A-14
BEDROOM	A-15 - A-18
CHASSIS	A-17 - B-06
CURTAIN & CUSHION	B-07 - B-17
DINETTE	B-18 - B-20
DRIVERS COMPARTMENT	B-21 - B-24
ELECTRICAL	C-01 - C-06
EXTERIOR BODY	C-07 - C-14
GALLEY	C-15 - C-18
GENERATOR	C-19 - C-20
HEATING & A/C	C-21 - C-24
INTERIOR FINISH	D-01 - D-04
LABELS	D-05 - D-12
LP	D-13
LOUNGE	D-14 - D-16
SEALANTS & FASTENERS	D-17 - D-19
WATER & SEWAGE	D-20 - D-23
WINDOW, VENT & EXTERIOR DOOR	D-24 - E-14
WINDSHIELD & WIPER	E-15 - E-16

SEALANTS & FASTENERS GROUP (CONTINUED)

SCREWS (CONTINUED)

KEY	PART NUMBER	U/M DESCRIPTION
	000G18-08-168	EA SCREW - MACHINE - 8 X 32 X 1 - PPH ZN
	075908-01-000	EA SCREW - MACH-10-32X.56PTH(SEMS
	000G53-04-068	EA SCREW - MACH-1/4-20X3/8 PPH ZN
	000G18-08-228	EA SCREW - MACH-8-32X1 3/8 PPH ZN
	000G39-10-208	EA SCREW - SF/DR - 10-16 X 1 1/4 PPH ZN
	000G39-10-12R	EA SCREW - SF/DR - 10-16 X 3/4 PPH - BEIGE
	000G39-10-12D	EA SCREW - SF/DR - 10-16 X 3/4 PPH - BLACK
	000G39-06-16T	EA SCREW - SF/DR - 6-20 X 1 PPH - BLACK
	000G39-06-10T	EA SCREW - SF/DR - 6-20 X 5/8 PPH - BLACK
	000G39-08-24B	EA SCREW - SF/DR - 8-18 X 1 1/2 PPH ZN
	000G39-08-16E	EA SCREW - SF/DR - 8-18 X 1 PPH CHROME
	000G39-08-16B	EA SCREW - SF/DR - 8-18 X 1 PPH ZN
	000G39-08-16T	EA SCREW - SF/DR - 8-18 X 1 PPH - BLACK
	000G55-08-16Z	EA SCREW - SF/DR - 8-18 X 1 00 - BEIGE
	000G39-08-08B	EA SCREW - SF/DR - 8-18 X 1/2 PPH ZN
	000G39-08-32B	EA SCREW - SF/DR - 8-18 X 2 PPH - ZINC
	000G39-08-12B	EA SCREW - SF/DR - 8-18 X 3/4 PPH ZN
	000G39-08-12T	EA SCREW - SF/DR - 8-18 X 3/4 PPH - BLACK
	000G39-08-06B	EA SCREW - SF/DR - 8-18 X 3/8 PPH ZN
	000G60-10-28T	EA SCREW - SF/DR - 10-16X1 75
	000G39-08-16R	EA SCREW - SF/DR - 8-18X1 00 PPH BEIGE
	000G39-08-08R	EA SCREW - SF/DT - 8-18X1/2 PPH
	079382-01-000	EA SCREW-SOCKET-8-18 X 1" - BLACK

SEALERS

KEY	PART NUMBER	U/M DESCRIPTION
	108205 01 000	EA SEALER - PUMPABLE
	069840-02-000	FT SEALER - RIBBON - 1/2" X 1/8" - 30'
	069840-09-000	FT SEALER - RIBBON - 1/32" X 2 1/2" X 60'
	069840-01-000	FT SEALER - RIBBON - 1/4" DIAMETER - 20'
	069840-03-000	FT SEALER - RIBBON - 3/4" X 1/8" - 60'
	069840-08-000	FT SEALER - RIBBON - 5/16" DIAMETER - OF 25'
	091255-03-000	FT SEAL - FOAM - 1/4 X 3/16 ROLL
	091255-01-000	FT SEAL - FOAM - 3 2MM X 4 8MM
	090340-01-000	FT SEAL - FOAM - CLOSED CELL - 1/4" X 1/2" X 50'
	034552-04-000	EA SILICONE - TUBE - 300 ML - W/O NOZZEL - BEIGE
	034552-02-000	EA SILICONE - TUBE - 300 ML - W/O NOZZEL CLEAR
	900390-03-000	EA TIP - 2 1/2" X 1/8" - ORIFICE
	900390-03-000	EA NOZZLE (SILICONE TUBE)

TAPES AND TIES

KEY	PART NUMBER	U/M DESCRIPTION
	100028-01-000	FT TAPE - ADHESIVE - .031" X .75" WIDE
	004383-01-000	FT TAPE - ADHESIVE FOAM - 1 SIDE - 3/16" X 1/2" - GRAY
	093071-01-000	FT TAPE - BONDING - DOUBLE SIDED - 1/64" X 2"
	093071-01-000	FT TAPE - BONDING - DOUBLE SIDED - 1/64" X 2"
	078322-03-000	FT TAPE - FOAM - DOUBLE COATED - .045" X 5"
	088244-01-000	FT TAPE - FOAM - VINYL COATED - 2" WIDE - INCREMENTS OF 108 FT
	009200-01-000	EA TAPE - FURNACE - 1 1/2"
	087591-01-000	EA TAPE - MASKING - WEATHER RESISTANT
	008343-02-000	EA TIE - WIRE - 14"
	008343-01-000	EA TIE - WIRE - 6"

WASHERS

KEY	PART NUMBER	U/M DESCRIPTION
	077071-01-000	EA WASHER - FENDER - 3/16" ID X 1" OD
	000E13-14-008	EA WASHER - FLAT - 1/4" WIDE ZN
	000E13-11-008	EA WASHER - FLAT - 3/16" WIDE ZN
	000E13-17-008	EA WASHER - FLAT - 3/8 AR ZN

WATER & SEWAGE GROUP

WATER PUMP (SHURFLOW)

KEY	PART NUMBER	U/M DESCRIPTION
	098607-01-000	EA PUMP - WATER - W/5" MPT FITTING - FLOW 2 8 GPM - UL
	098607-01-700	EA PUMP HEAD - REPLACEMENT 94-236-08
	098607-01-701	EA DRIVE ASM 94-234-03
	098607-01-702	EA DIAPHRAGM - KIT 94-233-10
	098607-01-703	EA VALVE ASM 94-232-00
	098607-01-704	EA HOUSING - UPPER 94-231-01
	098607-01-705	EA CHECK VALVE - KIT 94-237-00
	098607-01-706	EA UPPER HOUSING/SWITCH KIT 94-230-00
	098607-01-707	EA MOTOR/BASEPLATE REPLACEMENT 94-234-03

WATER HEATER W/MOTOR AID ATWOOD (GH6-3E, 4E, 6E)

KEY	PART NUMBER	U/M DESCRIPTION
	051393-01-000	EA WATER HEATER - W/MOTOR AID - PILOTLESS IGNITION
	051391-01-700	EA HINGE KIT - W/CLIP 92568 & 92559
	051391-01-704	EA VALVE - RELIEF - 1/2" FITTING 91604
	051391-01-705	EA FASTENER - CAMLOC 92609
	051391-01-706	EA GRILLE - EXHAUST 92787
	051391-01-708	EA BURNER - MAIN - 3E ONLY 92615
	051391-01-710	EA ORIFICE - MAIN BURNER 92742
	051391-01-714	EA ELBOW - 45 DEGREE - 3/8" F X 3/8" MPT 91044
	051391-01-715	EA DRAIN PLUG 91561
	051391-04-701	EA THERMOSTAT 12 VDC-120 PRESET 91470
	051391-04-704	EA TANK - INNER - FRONT MOUNT - GH6-4E & 6E 91642
	051393-01-700	EA TANK - INNER - 3E FRONT MOUNT 91023
	097967-01-000	EA SWITCH - WATER HEATER - REMOTE W/LIGHT 91959
	051393-01-702	EA SWITCH - ENERGY CUT-OFF 91951
	051393-01-703	EA THERMOSTAT - REAR MOUNT 91952
	051393-01-704	EA CIRCUIT BOARD - W/BLACK BOX 91420
	051393-01-705	EA ORIFICE HOLDER 91925
	051393-01-714	EA TANK - INNER (GH6-3E) - REAR MOUNT 91408
	051393-01-716	EA SPARK & PROBE ASM 91606
	051393-01-718	EA VALVE - DUAL SOLENOID 91605
	051393-01-721	EA ECO&THERMOSTAT ASM - FRONT MOUNT - 140° 91447
	099729-01-000	EA BYPASS KIT - WATER HEATER - COMPLETE W/VALVE & TUBING
	099729-01-700	EA VALVE ONLY CHECK PLASTIC (US)
	099729-02-000	EA BYPASS KIT - WATER HEATER - COMPLETE W/VALVE & TUBING
	099729-02-700	EA VALVE ONLY CHECK PLASTIC (CSA)

WATER HEATER W/O MOTOR AID ATWOOD (G6A-3E)

KEY	PART NUMBER	U/M DESCRIPTION
	051391-03-000	EA HEATER - WATER - W/ELECTRIC IGNITION
	051391-01-700	EA HINGE KIT - W/CLIP 92568 & 92559
	051391-01-704	EA VALVE - RELIEF - 1/2" FITTING 91604
	051391-01-705	EA FASTENER - CAMLOC 92609
	051391-01-706	EA GRILLE - EXHAUST 92787
	051391-01-708	EA BURNER - MAIN - 3E ONLY 92615
	051391-01-710	EA ORIFICE - MAIN BURNER 92742
	051391-01-715	EA DRAIN PLUG 91561
	051391-04-700	EA TANK - INNER (G6A-3E) - FRNT MT 91608
	051391-04-701	EA THERMOSTAT 12 VDC-120 PRESET 91470
	051391-04-706	EA TANK - INNER - FRONT MOUNT 91641
	097967-01-000	EA SWITCH - WATER HEATER - REMOTE W/LIGHT 91959
	051393-01-702	EA SWITCH - ENERGY CUT-OFF 91951
	051393-01-703	EA THERMOSTAT - REAR MOUNT 91952
	051393-01-704	EA CIRCUIT BOARD - W/BLACK BOX 91420
	051393-01-706	EA ORIFICE HOLDER 91925
	051393-01-716	EA SPARK & PROBE ASM 91606
	051393-01-718	EA VALVE - DUAL SOLENOID 91605
	051393-01-721	EA ECO&THERMOSTAT ASM - FRONT MOUNT - 140° 91447
	051393-03-700	EA TANK - INNER (G6A-3E) - REAR MOUNT 91408

**1993 ITASCA
TABLE OF CONTENTS**

INTRODUCTION	A-01 - A-02
ABBREVIATIONS	A-03
ALPHABETICAL INDEX	A-04 - A-06
ICG32RC	A-07 - E-16

1993 ICG32RC INDEX

FLOOR PLAN	A-07 - A-08
ACCESSORIES	A-09
AUDIO VIDEO	A-10 - A-11
BATH	A-12 - A-14
BEDROOM	A-15 - A-16
CHASSIS	A-17 - B-06
CURTAIN & CUSHION	B-07 - B-17
DINETTE	B-18 - B-20
DRIVERS COMPARTMENT	B-21 - B-24
ELECTRICAL	C-01 - C-06
EXTERIOR BODY	C-07 - C-14
GALLEY	C-15 - C-18
GENERATOR	C-19 - C-20
HEATING & A/C	C-21 - C-24
INTERIOR FINISH	D-01 - D-04
LABELS	D-05 - D-12
LP	D-13
LOUNGE	D-14 - D-16
SEALANTS & FASTENERS	D-17 - D-19
WATER & SEWAGE	D-20 - D-23
WINDOW, VENT &	
EXTERIOR DOOR	D-24 - E-14
WINDSHIELD & WIPER	E-15 - E-16

WATER & SEWAGE GROUP (CONTINUED)

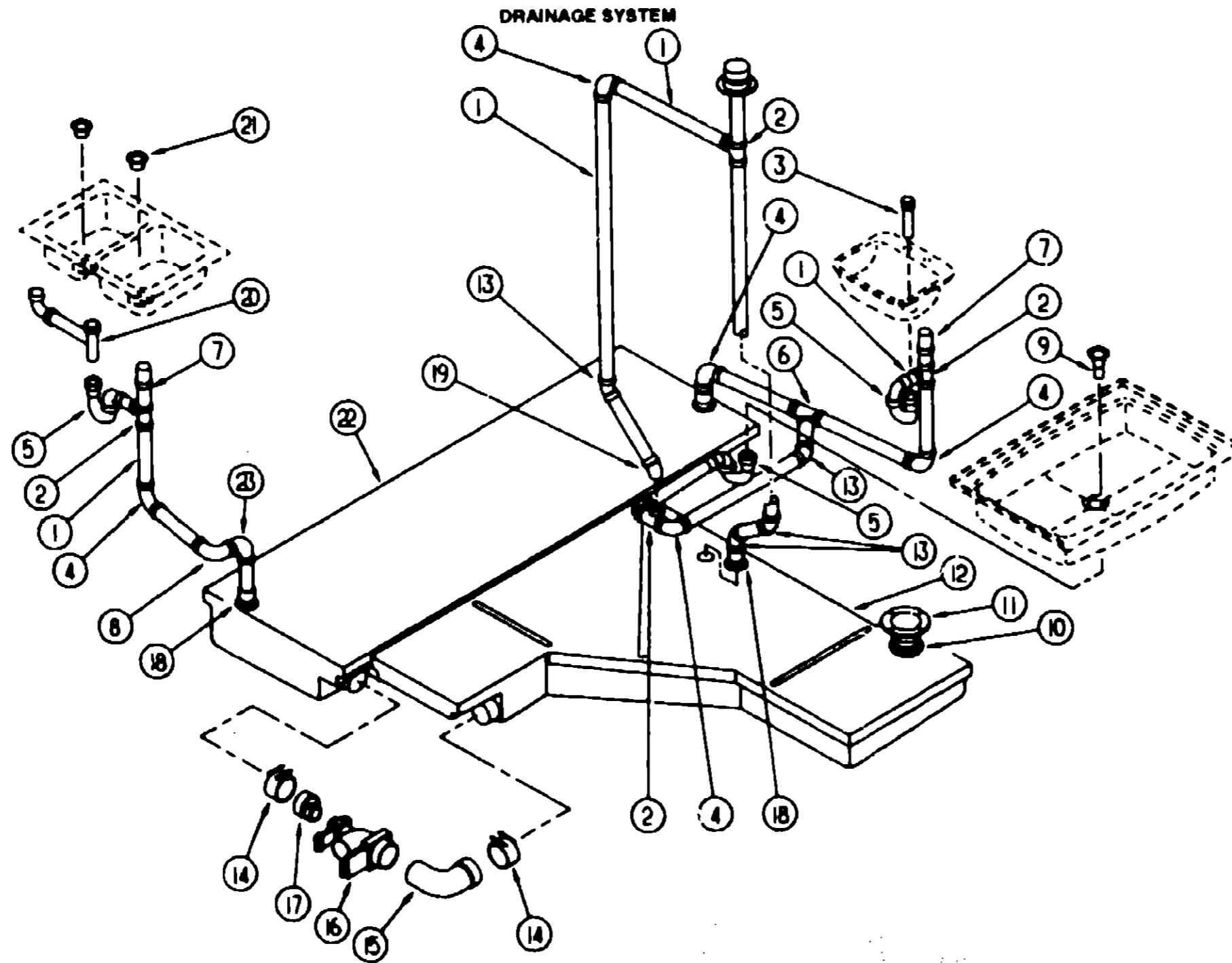

**1993 ITASCA
TABLE OF CONTENTS**

INTRODUCTION	A-01 - A-02
ABBREVIATIONS	A-03
ALPHABETICAL INDEX	A-04 - A-06
ICG32RQ	A-07 - E-16

1993 ICG32RQ INDEX

FLOOR PLAN	A-07 - A-08
ACCESSORIES	A-09
AUDIO VIDEO	A-10 - A-11
BATH	A-12 - A-14
BEDROOM	A-15 - A-16
CHASSIS	A-17 - B-06
CURTAIN & CUSHION	B-07 - B-17
DINETTE	B-18 - B-20
DRIVERS COMPARTMENT	B-21 - B-24
ELECTRICAL	C-01 - C-06
EXTERIOR BODY	C-07 - C-14
GALLEY	C-15 - C-18
GENERATOR	C-19 - C-20
HEATING & A/C	C-21 - C-24
INTERIOR FINISH	D-01 - D-04
LABELS	D-05 - D-12
I.P.	D-13
LOUNGE	D-14 - D-16
SEALANTS & FASTENERS	D-17 - D-19
WATER & SEWAGE	D-20 - D-23
WINDOW, VENT & EXTERIOR DOOR	D-24 - E-14
WINDSHIELD & WIPER	E-15 - E-16

KEY PART NUMBER	U/M	DESCRIPTION
1	N/P/N	FT PIPE - 1 1/2" - PLASTIC
2	010071-01-000	EA TEE - SANITARY - 1 1/2" HUB X HUB X HUB
3	096827-01-701	EA TAILPIECE - SINK
4	010008-01-000	EA ELBOW - 90 DEGREE - 1/4 BEND - 1 1/2" HUB X HUB
5	107538-01-000	EA P-TRAP - PLASTIC - 1 1/4" W/EXT ARM
	109571-01-000	EA ADAPTER - 1 1/2" H X 1 1/4" MPT
6	010073-01-000	EA WYE - 1 1/2" HUB X HUB X HUB
7	079988-01-000	EA VENT - MECH TRAP ARM - ANTI-SIPHON - 2" DIA X 7' 3"
8	033781-01-000	EA ELBOW - STREET - 90 DEGREE - 1/4 BEND - 1 1/2" HUB - LONG TURN
9	011089-03-000	EA TAILPIECE - SHOWER/TUB - 1 1/2" X 1 3/4" - PLASTIC (US)
9	011089-02-000	EA TAILPIECE - TUB/SHOWER - 1 1/2" X 1 1/4" X 4" - BRASS (CSA)
	086440-01-000	EA STRAINER - SHOWER - W/RUBBER WASHER
	086438-01-000	EA NUT - SLIP - TAILPIECE - 1 5"
10	081807-02-000	EA GROMMET - HOLDING TANK - 3" NPS
11	024876-01-000	EA FLANGE - CLOSET - 4" X 3"
12	104380-01-000	EA TANK - HOLDING - 69 GAL
13	010008-01-000	EA ELBOW - 45 DEGREE - 1/8 BEND - 1 1/2" HUB X HUB - BLACK PLASTIC
14	078408-01-000	EA COUPLER - RUBBER - W/CLAMPS - 3" X 3"
15	041988-01-000	EA ELBOW - STREET - 1/4" BEND - 3" X 90° XLT

KEY PART NUMBER	U/M	DESCRIPTION
16	070916-01-000	EA VALVE ASM - DUAL DUMP - W/CAP - 3" X 1 1/2"
	070916-01-700	EA VALVE ONLY - 3"
	070916-01-701	EA VALVE ONLY - 1 1/2"
17	062422-01-000	EA ADAPTER - OFFSET REDUCER - 3" X 1 1/2"
18	061607-01-000	EA GROMMET - HOLDING TANK - 1 1/2" NPS
18	010115-01-000	EA COUPLING - 1 1/2" HUB X HUB - PLASTIC
19	010051-01-000	EA ELBOW - 45 DEGREE BEND - 1 1/2" STREET - PLASTIC
20	011091-02-000	EA DRAIN PIPE - DRAIN - DOUBLE SINK - BAFFLE TEE - 1 1/2" (US)
20	011091-03-000	EA DRAIN PIPE - W/SEALS - DOUBLE SINK (CSA)
21	092303-01-000	EA STRAINER - SINK
22	104352-01-000	EA TANK - HOLDING - 50 GALLON
23	010009-01-000	EA ELBOW - 90 DEGREE - 1/4 BEND - 1 1/2" HUB X HUB - LONG TURN
	062418-01-000	EA ADAPTER - SEWER HOSE TO 3" PIPE
	103354-01-000	EA CONNECTOR - HOSE - SEWER
	010201-02-000	EA HOSE - SEWER - 3" ID X 20 FEET

WATER SYSTEM COMPONENTS

KEY	PART NUMBER	U/M DESCRIPTION
	039970-01-000	FT TUBING - POLYBUTYL - 1/2" OD - 20' - BLACK
	079331-01-000	FT TUBING - SMOOTH FLEXIBLE - 1 1/4" ID X 20'
	074452-02-000	FT TUBING - VINYL - 3/8" ID X 20' - CLEAR
	039900-02-000	FT TUBING - POLYBUTY - 5/8" OD - 20' - BLACK
	052952-01-000	EA NUT-PLASTIC - 1/2" F X 1/2" TUBE - GRAY
	052952-02-000	EA NUT-PLASTIC - 5/8" FLARE
	052957-01-000	EA ELBOW - PLASTIC - 1/2" F X 3/8" MPT
	052957-02-000	EA ELBOW - MALE - 1/2" F X 1/2" MPT - PLASTIC - GRAY
	052967-04-000	EA ELBOW - 5/8" F X 3/4" MPT
	035539-01-000	EA ELBOW - PLASTIC - 3/8" MPT X 3/8" BARB
	055290-01-000	EA ELBOW - 5/8" F X 1/2" MPT
	057457-01-000	EA ELBOW - UNION - 1/2" X 1/2" FLARE
	057457-02-000	EA ELBOW - UNION - 5/8" X 5/8" FLARE
	065120-01-000	EA ELBOW - SWIVEL - 1/2" FPT X 1/2" FLARE - PLASTIC - GRAY
	103259-01-000	EA BRACKET - BYPASS - WATER HEATER
	052960-01-000	EA DRAIN VALVE - IN LINE - HEADER - 1/2" F X 1/2" F - GRAY PLASTIC
	049032-01-000	EA PATCH - SPINWELD - 3/8" - PLASTIC
	106258-01-000	EA CAP - INSERTABLE 1/2 FLARE
	039798-01-000	EA TEE - 1/2" MPT X 1/2" MPT X 1/2" MPT - PLASTIC
	052955-01-000	EA TEE - WATER - 1/2" F X 1/2" F X 1/2" MPT - PLASTIC - GRAY
	052958-01-000	EA TEE - 1/2" F X 1/2" MPT X 1/2" F - PLASTIC
	052958-01-000	EA TEE - 1/2" F X 1/2" F X 1/2" F - PLASTIC - GRAY
	055295-01-000	EA TEE - 5/8" F X 1/2" MPT X 1/2" F - PLASTIC
	057973-01-000	EA TEE - PLASTIC - 1/2" F X 1/2" F X 5/8" F - WATER
	057974-01-000	EA TEE - 5/8" F X 1/2" F X 1/2" F - PLASTIC
	010227-01-000	EA TEE - PLAS - BARB 5/8" OR 3/4" HOSE
	079317-01-000	EA ADAPTER - SWIVEL - 1/2" TUBE X 1/2" FPT - PLASTIC - GRAY
	087869-06-000	EA FILL - WATER - CITY - BUFF
	101814-01-000	EA COUPLING - FEMALE - 1/2" X 1/2" FPT
	701069-03-700	EA CARTRIDGE - WATER FILTER - AC - EVERPURE 9601-11

FRESH WATER TANK - 100 GALLON

KEY	PART NUMBER	U/M DESCRIPTION
	104383-02-000	EA TANK ASM - WATER - 100 GAL
	042989-05-000	EA FITTING - SPINWELD - PLASTIC 1/2 FPT
	042989-04-000	EA FITTING - WATER TANK - SPINWELD - 3/8" FPT - PLASTIC - WHITE
	042989-03-000	EA FITTING - SPINWELD - PLASTIC - 1/4" FPT
	049032-01-000	EA PATCH - SPINWELD - 3/8" - PLASTIC
	031881-01-000	EA SENDING UNIT W/SCREW - WASHER
	091449-01-000	EA WIRE ASM - TANK - WATER
	077954-02-000	EA FILTER - WATER TANK - SCREEN IN TANK

EXTERIOR SHOWER COMPONENTS

KEY	PART NUMBER	U/M DESCRIPTION
	103092-01-000	EA SHOWER HEAD - W/60" HOSE (US)
	103092-02-000	EA SHOWER HEAD - W/HOSE (CSA)
	104044-01-000	EA BRACKET - SUPPORT - FAUCET
	103092-01-700	EA BRACKET (FOR SHOWER HEAD)
	075241-05-000	EA FAUCET - SHOWER - BONE
	103092-01-000	EA BRACKET ONLY (FOR SHOWER HEAD) (NONE)

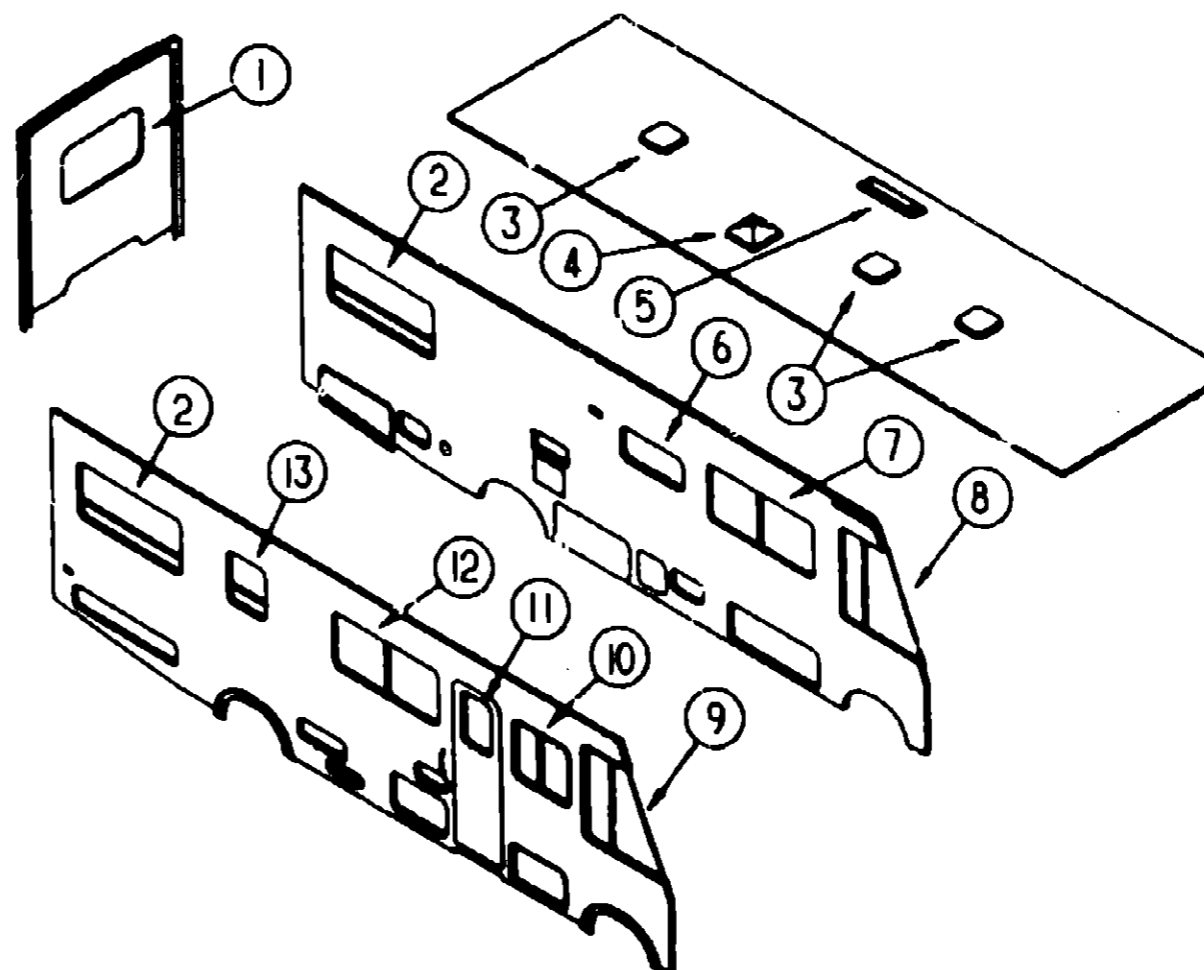

WINDOWS & VENTS

KEY	PART NUMBER	U/M DESCRIPTION
1	078528-03-Y12	EA WINDOW - ESCAPE - 27" X 48" - W/O INSIDE FRAME
2	092234-11-Y12	EA WINDOW - DOUBLE TIPOUT - W/O INSIDE FRAME
3	110051-01-01A	EA VENT - ROOF - NONPOWERED
4	110051-03-01A	EA VENT - ROOF - POWERED (US)
4	110051-05-01A	EA VENT - ROOF - POWERED (CSA)
5	084073-06-000	EA REFRIGERATOR ROOF VENT - ASH GRAY
6	092235-14-Y12	EA WINDOW - SINGLE TIPOUT - W/O INSIDE FRAME
7	098647-10-02A	EA WINDOW ASM - SLIDER - W/INSIDE FRAME (OFF-WHITE)
8	103658-07-01A	EA WINDOW ASM - CAB - DRIVER SIDE
9	103658-08-01A	EA WINDOW ASM - CAB - PASSENGER SIDE
10	098647-08-02A	EA WINDOW ASM - SLIDER - W/INSIDE FRAME (OFF-WHITE)
11	079733-12-D12	EA WINDOW ASM - ENTRANCE DOOR - W/O INSIDE FRAME
12	098647-09-02A	EA WINDOW ASM - SLIDER - W/INSIDE FRAME (OFF-WHITE)
13	092235-15-Y12	EA WINDOW - SINGLE TIPOUT (W/O INSIDE FRAME)

**1993 ITASCA
TABLE OF CONTENTS**

INTRODUCTION	A-01 - A-02
ABBREVIATIONS	A-03
ALPHABETICAL INDEX	A-04 - A-06
ICG32RQ	A-07 - E-16

1993 ICG32RQ INDEX

FLOOR PLAN	A-07 - A-08
ACCESSORIES	A-09
AUDIO VIDEO	A-10 - A-11
BATH	A-12 - A-14
BEDROOM	A-15 - A-16
CHASSIS	A-17 - B-06
CURTAIN & CUSHION	B-07 - B-17
DINETTE	B-18 - B-20
TRIVERS COMPARTMENT	B-21 - B-24
ELECTRICAL	C-01 - C-06
EXTERIOR BODY	C-07 - C-14
GALLEY	C-15 - C-18
GENERATOR	C-19 - C-20
HEATING & A/C	C-21 - C-24
INTERIOR FINISH	D-01 - D-04
LABELS	D-05 - D-12
LP	D-13
LOUNGE	D-14 - D-16
SEALANTS & FASTENERS	D-17 - D-19
WATER & SEWAGE	D-20 - D-23
WINDOW, VENT & EXTERIOR DOOR	D-24 - E-14
WINDSHIELD & WIPER	E-15 - E-16

WINDOW, VENT & EXTERIOR DOOR GROUP (CONTINUED)

BEDROOM WINDOW (DRIVER & PASSENGER SIDE)

KEY	PART NUMBER	U/M	DESCRIPTION
1	092234-11-Y12 090693-23-01A	EA	WINDOW ASM. - TIPOUT - DOUBLE (W/O INSIDE FRAME)
2	035302-02-000	EA	INSIDE FRAME - WINDOW - OFF WHITE (NOT INCLUDED IN WINDOW ASM.)
3	009439-06-000	EA	OPERATOR - TORQUE - TIPOUT WINDOW - LEFT
4	009439-05-000 009439-07-000	EA	EXTENSION - WINDOW CONTROL (NOT INCLUDED IN WINDOW ASM.)
5	083227-07-000	EA	WINDOW KNOB - BLACK (NOT INCLUDED IN WINDOW ASM.)
6	088816-51-001	EA	SCREW - WINDOW KNOB - BLACK (NOT INCLUDED IN WINDOW ASM.)
7	084068-21-000	EA	TUBE - TORQUE - WINDOW - RIGHT
8	100168-01-000	EA	TUBE - SLEEVE .02" ID X .035" OD X 1 2" LONG - ALUMINUM
9	100234-04-B07	EA	GLASS - TIPOUT - .11" X 9.25" X 26 4"
10	080218-03-000 100240-01-000 081377-01-700	EA	CLIP - SPRING - SCREEN
11	100234-03-B07	EA	SCREEN - DOUBLE TIPOUT WINDOW
12	086762-01-000	SF	SCREEN - FIBERGLASS - 12" WIDE
13	068927-03-000	FT	SPLINE - SCREEN - T-SHAPED
14	084473-01-000	EA	ADHESIVE - CYANOACRYLATE - 10 GRAM TUBE
15	086763-01-000	EA	SCREEN - DOUBLE TIPOUT WINDOW -
16	097578-01-000	EA	T-NUT 10-32
17	081649-01-000	EA	SEAL - WINDOW - RUBBER - ROUND - .80" DIA - BLACK
18	084453-02-000	EA	SEAL - RUBBER - TIPOUT WINDOW
19	089913-01-000	EA	SCREW - MACH - 10 - 32 X 1/4 PTH
20	084067-02-000	EA	LINKAGE - TIPOUT WINDOW
21	069640-11-000	EA	RING-SNAP - 7/32 SHAFT DIAMETER
22	035302-01-000	EA	WASHER - .060 X .50 X .135 - PLASTIC
23	038865-01-000	EA	HINGE - TIPOUT WINDOW - BLACK
24	080918-01-000	EA	SEAL - E SHAPED - SPONGE - TIPOUT WINDOW - 4" X 4" - BLACK
25	083228-07-000 080918-02-000 088803-01-01A 000G39-06-16T	EA	SEALER - TAPE - 3/16" X 3/8" BLACK
		EA	OPERATOR - TORQUE - TIPOUT WINDOW - RIGHT
		EA	TAPE - BUTYL - 31" X 31" X 148" LONG
		EA	SPRING - TORQUE TUBE - LEFT
		EA	TUBE - TORQUE - WINDOW - LEFT
		EA	SPRING - TORQUE TUBE - RIGHT
		EA	MULLION - VERTICAL - 9 5" LONG - ALUMINUM - BLACK
		EA	SCREW-SF/DR - 6-20 X 1 PPH - BLACK

1993 ITASCA TABLE OF CONTENTS

INTRODUCTION	A-01 - A-02
ABBREVIATIONS	A-03
ALPHABETICAL INDEX	A-04 - A-06
ICG32RQ	A-07 - E-16

1993 ICG32RQ INDEX

FLOOR PLAN	A-07 - A-08
ACCESSORIES	A-09
AUDIO VIDEO	A-10 - A-11
BATH	A-12 - A-14
BEDROOM	A-15 - A-16
CHASSIS	A-17 - B-06
CURTAIN & CUSHION	B-07 - B-17
DINETTE	B-18 - B-20
DRIVERS COMPARTMENT	B-21 - B-24
ELECTRICAL	C-01 - C-06
EXTERIOR BODY	C-07 - C-14
GALLEY	C-15 - C-18
GENERATOR	C-19 - C-20
HEATING & A/C	C-21 - C-24
INTERIOR FINISH	D-01 - D-04
LABELS	D-05 - D-12
LP	D-13
LOUNGE	D-14 - D-16
SEALANTS & FASTENERS	D-17 - D-19
WATER & SEWAGE	D-20 - D-23
WINDOW, VENT & EXTERIOR DOOR	D-24 - E-14
WINDSHIELD & WIPER	E-15 - E-16

WINDOW, VENT & EXTERIOR DOOR GROUP (CONTINUED)

GALLEY WINDOW

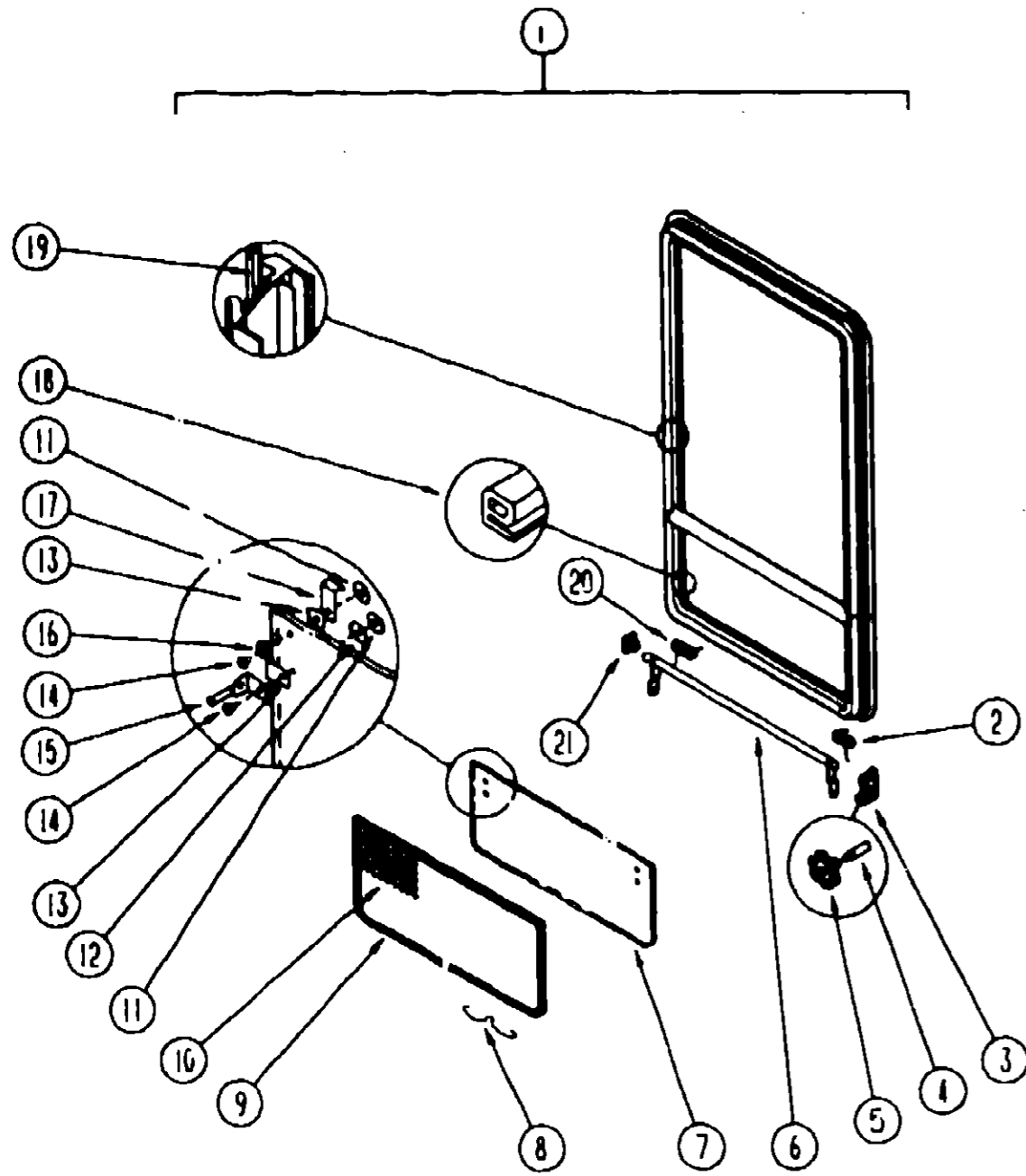

KEY	PART NUMBER	U/M DESCRIPTION
1	092235-14-Y12	EA WINDOW - TIPOUT (W/O INSIDE FRAME)
	090893-19-02A	EA INSIDE FRAME - WINDOW (NOT INCLUDED IN WINDOW ASM.) OFF WHITE
2	080918-02-000	EA SPRING - TORQUE TUBE - RIGHT
3	035302-02-000	EA OPERATOR - TORQUE - TIPOUT WINDOW - LEFT
4	009439-06-000	EA EXTENSION - WINDOW CONTROL (NOT INCLUDED IN WINDOW ASM.)
5	009439-05-000	EA WINDOW KNOB - BLACK (NOT INCLUDED IN WINDOW ASM.)
	009439-07-000	EA SCREW - 8-32 X 1 1/4 POH - BLACK (NOT INCLUDED IN WINDOW ASM.)
6	083150-15-000	EA TUBE ASM. - TORQUE - WINDOW
7	084068-24-000	EA GLASS-TIPOUT - 9 2" X 35 3"
8	100168-01-000	EA CLIP - SPRING - SCREEN
9	100235-07-807	EA SCREEN - SINGLE TIPOUT WINDOW
10	080218-03-000	SF SCREEN - FIBERGLASS - 12" WIDE
	100240-01-000	FT SPLINE - SCREEN - T-SHAPED
11	086762-01-000	EA T NUT 10-32
12	068927-03-000	EA SEAL - WINDOW - RUBBER - ROUND - 80" DIA - BLACK
13	084473-01-000	EA SEAL - RUBBER - TIPOUT WINDOW
14	086763-01-000	EA SCREW - MACH - 10 - 32 X 1/4 PTH
15	097578-01-000	EA LINKAGE - TIPOUT WINDOW
	081649-01-000	EA RING - SNAP - 7/32 SHAFT DIA.
16	084453-02-000	EA WASHER - .060 X .50 X .250 - PLASTIC
17	089913-01-000	EA HINGE - TIPOUT WINDOW - BLACK
18	084067-02-000	FT SEAL - E SHAPED - SPONGE - TIPOUT WINDOW - .4" X .4" - BLACK
19	069640-11-000	EA SEALER - TAPE - 3/16"X3/8" BLACK
20	080918-01-000	EA SPRING-TORQUE TUBE - LEFT
21	081354-01-000	EA SLEEVE - TORQUE TUBE - TIPOUT WINDOW - 1.3" X 1.2" X .7"

BATH WINDOW

KEY	PART NUMBER	U/M DESCRIPTION
1	092235-15-Y12	EA WINDOW - TIPOUT - (W/O INSIDE FRAME)
	090893-21-02A	EA INSIDE FRAME - WINDOW (NOT INCLUDED IN WINDOW ASM.) OFF WHITE
2	080918-02-000	EA SPRING-TORQUE TUBE - RIGHT
3	035302-02-000	EA OPERATOR - TORQUE - TIPOUT WINDOW - LEFT
4	009439-06-000	EA EXTENSION - WINDOW CONTROL (NOT INCLUDED IN WINDOW ASM.)
5	009439-05-000	EA WINDOW KNOB - BLACK (NOT INCLUDED IN WINDOW ASM.)
	009439-07-000	EA SCREW - 8-32 X 1 1/4 POH - BLACK (NOT INCLUDED IN WINDOW ASM.)
6	083150-16-000	EA TUBE ASM. - TORQUE - WINDOW
7	084068-14-000	EA GLASS-TIPOUT - 9 2" X 21 3"
8	100168-01-000	EA CLIP - SPRING - SCREEN
9	100235-08-807	EA SCREEN - SINGLE TIPOUT WINDOW
10	080218-03-000	SF SCREEN - FIBERGLASS - 12" WIDE
	100240-01-000	FT SPLINE - SCREEN - T-SHAPED
11	086762-01-000	EA T NUT 10-32
12	068927-03-000	EA SEAL - WINDOW - RUBBER - ROUND - 80" DIA - BLACK
13	084473-01-000	EA SEAL - RUBBER - TIPOUT WINDOW
14	086763-01-000	EA SCREW - MACH - 10 - 32 X 1/4 PTH
15	097578-01-000	EA LINKAGE - TIPOUT WINDOW
	081649-01-000	EA RING - SNAP - 7/32 SHAFT DIA.
16	084453-02-000	EA WASHER - .060 X .50 X .250 - PLASTIC
17	089913-01-000	EA HINGE - TIPOUT WINDOW - BLACK
18	084067-01-000	FT SEAL - E SHAPED - SPONGE - TIPOUT WINDOW - .4" X .4" - BLACK
19	069640-11-000	EA SEALER - TAPE - 3/16"X3/8" BLACK
20	080918-01-000	EA SPRING-TORQUE TUBE - LEFT
21	081354-01-000	EA SLEEVE - TORQUE TUBE - TIPOUT WINDOW - 1.3" X 1.2" X .7"

1993 ITASCA
TABLE OF CONTENTS

INTRODUCTION	A-01 - A-02
ABBREVIATIONS	A-03
ALPHABETICAL INDEX	A-04 - A-06
ICG32RQ	A-07 - E-18

1993 ICG32RQ INDEX

FLOOR PLAN	A-07 - A-08
ACCESSORIES	A-09
AUDIO VIDEO	A-10 - A-11
BATH	A-12 - A-14
BEDROOM	A-15 - A-16
CHASSIS	A-17 - B-06
CURTAIN & CUSHION	B-07 - B-17
DINETTE	B-18 - B-20
DRIVERS COMPARTMENT	B-21 - B-24
ELECTRICAL	C-01 - C-06
EXTERIOR BODY	C-07 - C-14
GALLEY	C-15 - C-18
GENERATOR	C-19 - C-20
HEATING & A/C	C-21 - C-24
INTERIOR FINISH	D-01 - D-04
LABELS	D-05 - D-12
LP	D-13
LOUNGE	D-14 - D-16
SEALANTS & FASTENERS	D-17 - D-19
WATER & SEWAGE	D-20 - D-23
WINDOW, VENT & EXTERIOR DOOR	D-24 - E-14
WINDSHIELD & WIPER	E-15 - E-16

WINDOW, VENT & EXTERIOR DOOR GROUP (CONTINUED)

SLIDER WINDOW (EXCEL) (PASSENGER SIDE, LOUNGE)

KEY	PART NUMBER	U/M DESCRIPTION
	098647-08-02A	EA WINDOW ASM - SLIDER - W/INSIDE FRAME (OFF WHITE)
	098647-08-704	EA FRAME - INSIDE (OFF WHITE)
1	098647-08-701	EA WINDOW ASM - SLIDER - W/O INSIDE FRAME
2	098644-01-705	FT GLAZING STRIP
3	098647-08-700	EA GLASS - STATIONARY
4	098644-01-710	FT TRACK - SCREEN SPACER - 12" LENGTH
5	098644-01-700	EA LATCH - REPAIR KIT
6	098644-01-708	FT CHANNEL - PIERCED RUN
7	098644-01-711	FT WEATHERSTRIP - SCREEN - BLACK
8	098647-08-706	EA SCREEN WSPRINGS & WEATHERSTRIP
9	098644-01-713	EA SPRING - SCREEN FRAME (CLIP)
10	098647-08-703	EA GLASS - SLIDING - W/SASH & LATCH
11	098644-01-706	FT WEATHERSTRIP
	098644-01-716	FT PLUG - FILLER
	098644-01-717	FT SPLINE - SCREEN

SLIDER WINDOW (EXCEL) (DRIVER SIDE, LOUNGE)

KEY	PART NUMBER	U/M DESCRIPTION
	098647-10-02A	EA WINDOW ASM - SLIDER - W/INSIDE FRAME (OFF WHITE)
	098647-09-704	EA FRAME - INSIDE (OFF WHITE)
1	098647-10-700	EA WINDOW ASM - SLIDER - W/O INSIDE FRAME
2	098644-01-705	FT GLAZING STRIP
3	098647-09-700	EA GLASS - STATIONARY
4	098644-01-710	FT TRACK - SCREEN SPACER - 12" LENGTH
5	098644-01-700	EA LATCH - REPAIR KIT
6	098644-01-708	FT CHANNEL - PIERCED RUN
7	098644-01-711	FT WEATHERSTRIP - SCREEN - BLACK
8	098647-09-705	EA SCREEN WSPRINGS & WEATHERSTRIP
9	098644-01-713	EA SPRING - SCREEN FRAME (CLIP)
10	098647-09-701	EA GLASS - SLIDING - W/SASH & LATCH
11	098644-01-706	FT WEATHERSTRIP
	098644-01-716	FT PLUG - FILLER
	098644-01-717	FT SPLINE - SCREEN

SLIDER WINDOW (EXCEL) (PASSENGER SIDE, DINETTE)

KEY	PART NUMBER	U/M DESCRIPTION
	098647-09-02A	EA WINDOW ASM - SLIDER - W/INSIDE FRAME (OFF WHITE)
	098647-09-704	EA FRAME - INSIDE (OFF WHITE)
1	098647-09-703	EA WINDOW ASM - SLIDER - W/O INSIDE FRAME
2	098644-01-705	FT GLAZING STRIP
3	098647-09-700	EA GLASS - STATIONARY
4	098644-01-710	FT TRACK - SCREEN SPACER - 12" LENGTH
5	098644-01-700	EA LATCH - REPAIR KIT
6	098644-01-708	FT CHANNEL - PIERCED RUN
7	098644-01-711	FT WEATHERSTRIP - SCREEN - BLACK
8	098647-09-705	EA SCREEN WSPRINGS & WEATHERSTRIP
9	098644-01-713	EA SPRING - SCREEN FRAME (CLIP)
10	098647-09-701	EA GLASS - SLIDING - W/SASH & LATCH
11	098644-01-706	FT WEATHERSTRIP
	098644-01-716	FT PLUG - FILLER
	098644-01-717	FT SPLINE - SCREEN

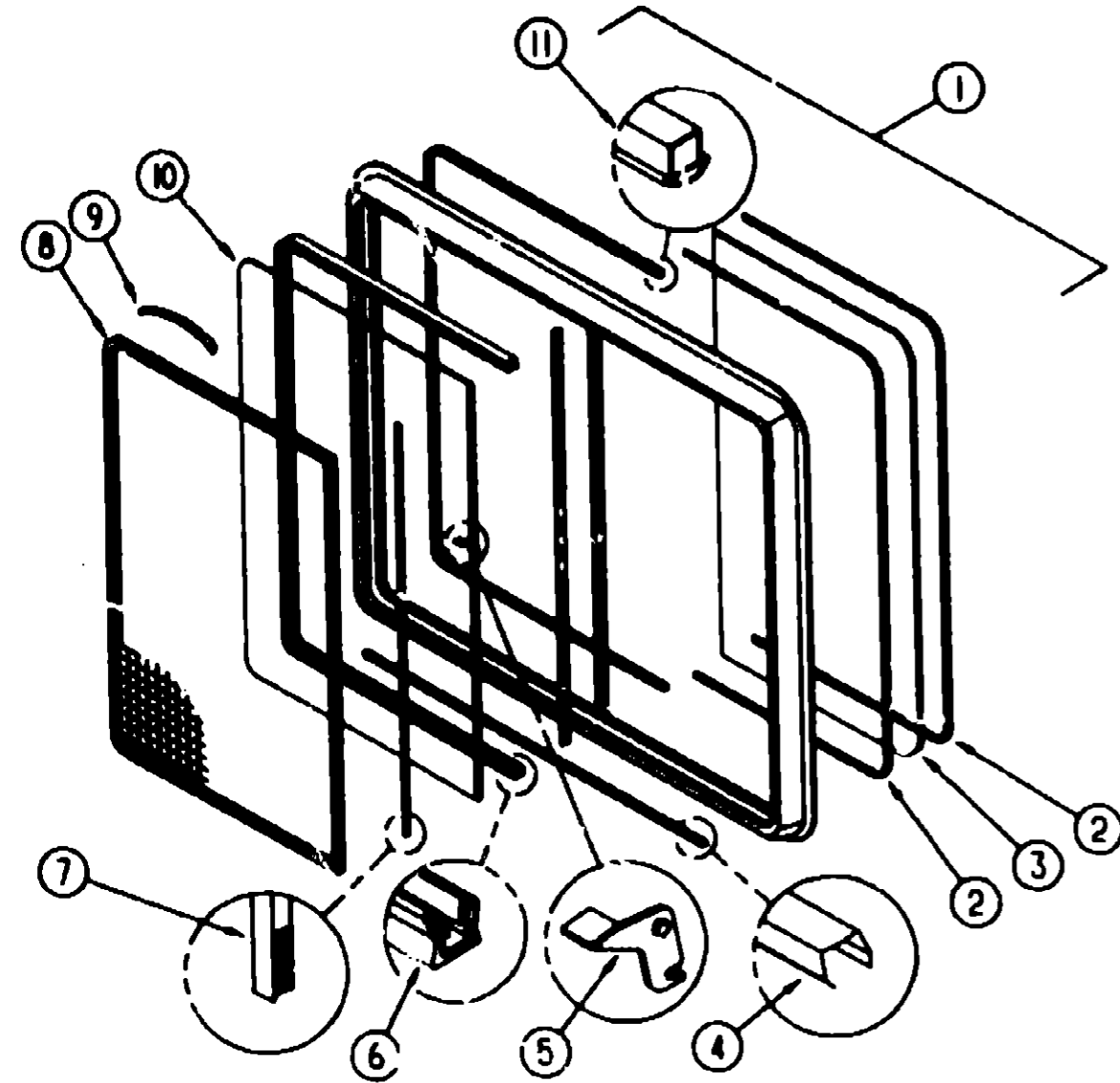

**1983 ITASCA
TABLE OF CONTENTS**

INTRODUCTION	A-01 - A-02
ABBREVIATIONS	A-03
ALPHABETICAL INDEX	A-04 - A-08
ICG32RQ	A-07 - E-18

1983 ICG32RQ INDEX

FLOOR PLAN	A-07 - A-08
ACCESSORIES	A-09
AUDIO VIDEO	A-10 - A-11
BATH	A-12 - A-14
BEDROOM	A-15 - A-16
CHASSIS	A-17 - B-06
CURTAIN & CUSHION	B-07 - B-17
DINETTE	B-18 - B-20
DRIVERS COMPARTMENT	B-21 - B-24
ELECTRICAL	C-01 - C-06
EXTERIOR BODY	C-07 - C-14
GALLEY	C-15 - C-18
GENERATOR	C-19 - C-20
HEATING & A/C	C-21 - C-24
INTERIOR FINISH	D-01 - D-04
LABELS	D-05 - D-12
LP	D-13
LOUNGE	D-14 - D-16
SEALANTS & FASTENERS	D-17 - D-19
WATER & SEWAGE	D-20 - D-23
WINDOW, VENT &	
EXTERIOR DOOR	D-24 - E-14
WINDSHIELD & W/PER	E-15 - E-16

1993 ITASCA
TABLE OF CONTENTS

INTRODUCTION	A-01 - A-02
ABBREVIATIONS	A-03
ALPHABETICAL INDEX	A-04 - A-08
ICG32RQ	A-07 - E-16

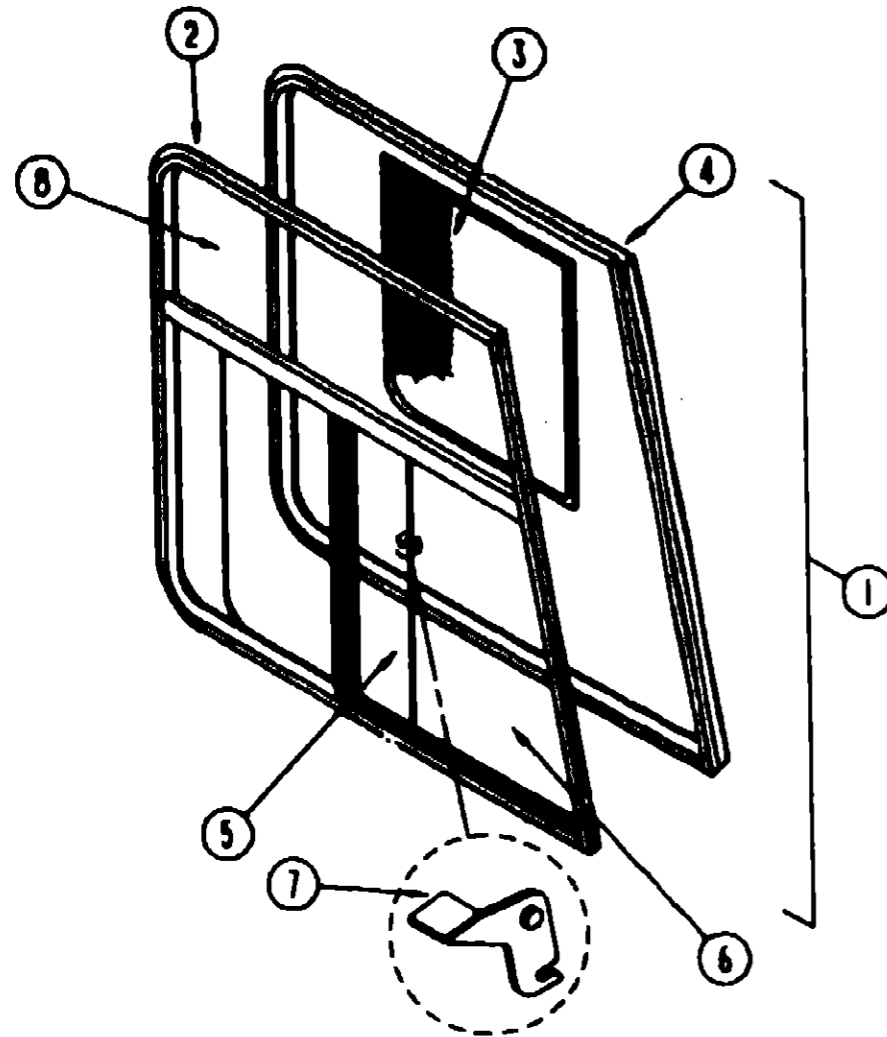

FRONT CAB WINDOWS (EXCEL)

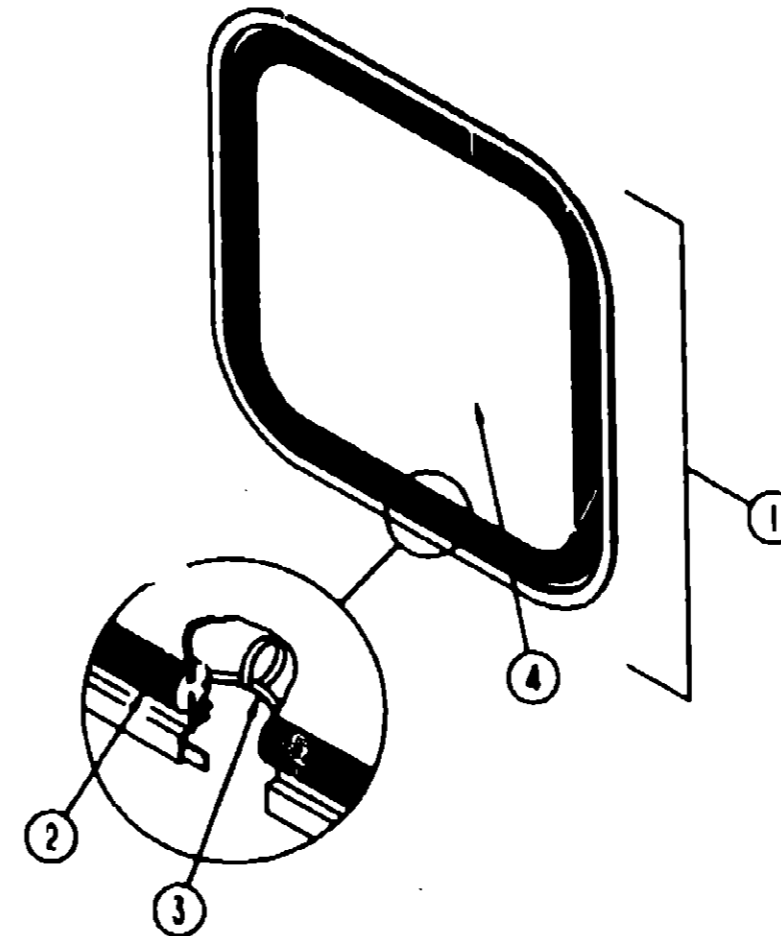

BACKWALL ESCAPE WINDOW

1993 ICG32RQ INDEX

FLOOR PLAN	A-07 - A-08
ACCESSORIES	A-09
AUDIO VIDEO	A-10 - A-11
BATH	A-12 - A-14
BEDROOM	A-15 - A-16
CHASSIS	A-17 - B-06
CURTAIN & CUSHION	B-07 - B-17
DINETTE	B-18 - B-20
DRIVERS COMPARTMENT	B-21 - B-24
ELECTRICAL	C-01 - C-06
EXTERIOR BODY	C-07 - C-14
GALLEY	C-15 - C-18
GENERATOR	C-19 - C-20
HEATING & A/C	C-21 - C-24
INTERIOR FINISH	D-01 - D-04
LABELS	D-05 - D-12
LP	D-13
LOUNGE	D-14 - D-16
SEALANTS & FASTENERS	D-17 - D-19
WATER & SEWAGE	D-20 - D-23
WINDOW, VENT & EXTERIOR DOOR	D-24 - E-14
WINDSHIELD & WIPER	E-15 - E-16

KEY	PART NUMBER	U/M	DESCRIPTION
1	103658-07-01A	EA	WINDOW ASM. - CAB - WINSIDE FRAME - DRIVER SIDE
1	103658-08-01A	EA	WINDOW ASM. - CAB - WINSIDE FRAME - PASSENGER SIDE
2	103658-08-700	EA	WINDOW ASM. - SLIDER - W/O INSIDE FRAME - PASSENGER SIDE
2	103658-07-704	EA	WINDOW ASM. - SLIDER - W/O INSIDE FRAME - DRIVER SIDE
3	103658-07-703	EA	SCREEN ASM. - WINDOW - DRIVER OR PASSENGER SIDE
	098644-01-717	FT	SCREEN SPLINE
	098644-01-713	EA	SCREEN CLIPS (METAL)(BLACK)
	098644-01-710	FT	TRACK - SPACER - FOR SCREEN 12"
	098644-01-711	FT	WEATHERSTRIP - SCREEN - BLACK
4	103658-08-701	EA	INSIDE FRAME - PASSENGER SIDE
4	103658-07-700	EA	INSIDE FRAME - DRIVER SIDE
5	103658-07-702	EA	GLASS - SLIDING - W/SASH & LATCH - DRIVER OR PASSENGER SIDE
6	103658-01-702	EA	GLASS - STATIONARY - BOTTOM - DRIVER OR PASSENGER SIDE
7	098644-01-700	EA	LATCH - REPAIR KIT
8	103658-07-701	EA	GLASS - STATIONARY - TOP - DRIVER OR PASSENGER SIDE
	098644-01-708	FT	CHANNEL - PIERCED RUN
	098644-01-706	FT	WEATHERSTRIP - GLASS
	098644-01-716	FT	PLUG - FILLER

KEY	PART NUMBER	U/M	DESCRIPTION
1	078528-03-Y12	EA	WINDOW - REAR ESCAPE
	074816-08-000	EA	FRAME - WINDOW INSIDE - OFF WHITE
2	002282-06-000	EA	WEATHERSTRIP - WINDOW 125" VULCANIZED - 79 1" LONG - BLACK
3	077066-01-702	EA	TAPE ASM - ESCAPE WINDOW
	002285-01-000	FT	FILLER - WEATHER STRIP RUBBER - BLACK
4	076337-08-000	EA	GLASS - WINDOW

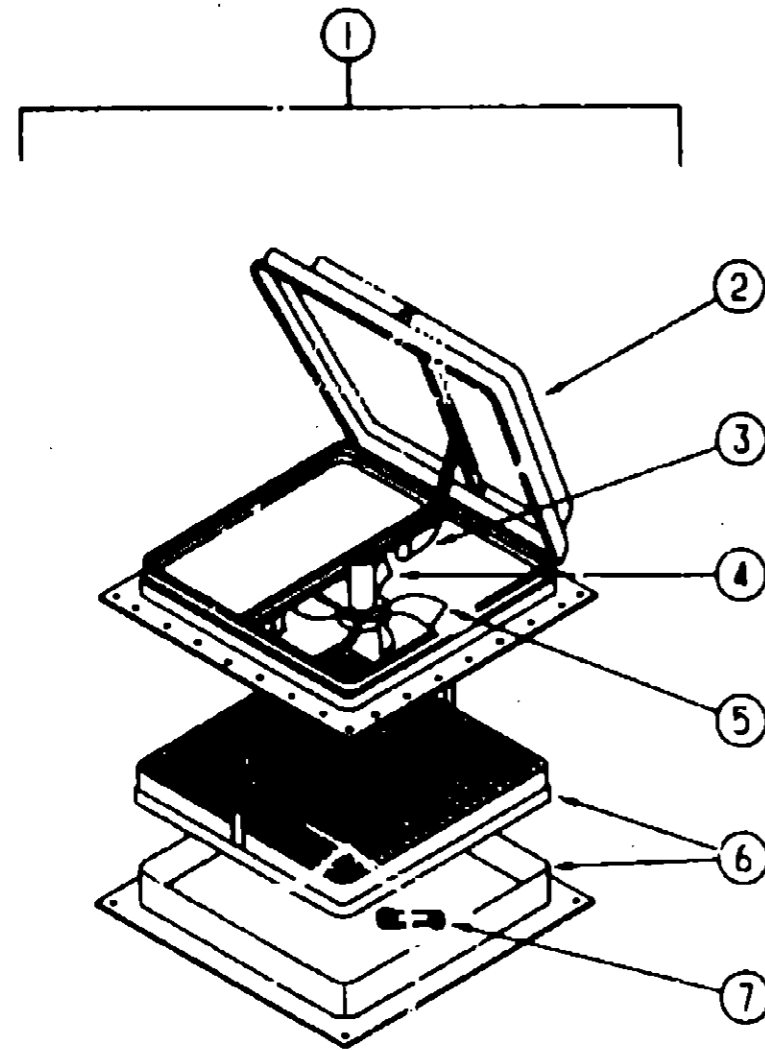

POWERED ROOF VENT (US)

KEY	PART NUMBER	U/M DESCRIPTION
1	110051-03-01A	EA VENT ASM. - ROOF - POWERED
2	064470-01-700	EA COVER - ROOF VENT
3	110051-01-702	EA HAND CRANK & OPERATOR ASM
4	048648-01-000	EA MOTOR - 12V NONVENTED 1/8 SHAFT
5	048649-01-000	EA FAN - PLASTIC - 6 IN - 6 BLADED
6	110051-01-701	EA GARNISH - W/SCREEN & FRAME
7	110051-01-703	EA CRANK HANDLE

POWERED ROOF VENT (CANADIAN)

KEY	PART NUMBER	U/M DESCRIPTION
1	110051-05-01A	EA VENT ASM. - ROOF - POWERED
2	064470-01-700	EA COVER - ROOF VENT
3	110051-01-702	EA HAND CRANK & OPERATOR ASM
4	048648-01-000	EA MOTOR - 12V NONVENTED 1/8 SHAFT
5	048649-01-000	EA FAN - PLASTIC - 6 IN - 6 BLADED
6	110051-01-701	EA GARNISH - W/SCREEN & FRAME
7	110051-01-703	EA CRANK HANDLE

NON POWERED ROOF VENT

KEY	PART NUMBER	U/M DESCRIPTION
	110051-01-01A	EA ROOF VENT - W/SCREEN
	064470-01-700	EA COVER - ROOF VENT
	110051-01-701	EA GARNISH - W/SCREEN & FRAME 2"
	110051-01-702	EA HAND CRANK & OPERATOR ASM
	110051-01-703	EA CRANK HANDLE - ROOF VENT

ROOF VENTS

KEY	PART NUMBER	U/M DESCRIPTION
	083558-05-000	EA VENT COVER - PLUMBING PIPE ROOF
	084073-08-000	EA COVER - ROOF VENT - NORCOLD REFRIGERATOR - ASH GRAY
	084073-04-000	EA BASE - ROOF VENT - NORCOLD REFRIGERATOR - BLACK

SIDEWALL VENT

KEY	PART NUMBER	U/M DESCRIPTION
	084616-05-000	EA SHROUD - RANGE HOOD VENT - ASH GRAY
	084878-09-000	EA VENT - RANGE HOOD - SHORT - LVS

1993 ITASCA
TABLE OF CONTENTS

INTRODUCTION	A-01 - A-02
ABBREVIATIONS	A-03
ALPHABETICAL INDEX	A-04 - A-08
ICQ32RQ	A-07 - E-18

1993 ICG32RQ INDEX

FLOOR PLAN	A-07 - A-08
ACCESSORIES	A-09
AUDIO VIDEO	A-10 - A-11
BATH	A-12 - A-14
BEDROOM	A-15 - A-16
CHASSIS	A-17 - B-08
CURTAIN & CUSHION	B-07 - B-17
DINETTE	B-18 - B-20
DRIVERS COMPARTMENT	B-21 - B-24
ELECTRICAL	C-01 - C-06
EXTERIOR BODY	C-07 - C-14
GALLEY	C-15 - C-18
GENERATOR	C-19 - C-20
HEATING & A/C	C-21 - C-24
INTERIOR FINISH	D-01 - D-04
LABELS	D-05 - D-12
LP	D-13
LOUNGE	D-14 - D-16
SEALANTS & FASTENERS	D-17 - D-19
WATER & SEWAGE	D-20 - D-23
WINDOW, VENT &	
EXTERIOR DOOR	D-24 - E-14
WINDSHIELD & WIPER	E-15 - E-16

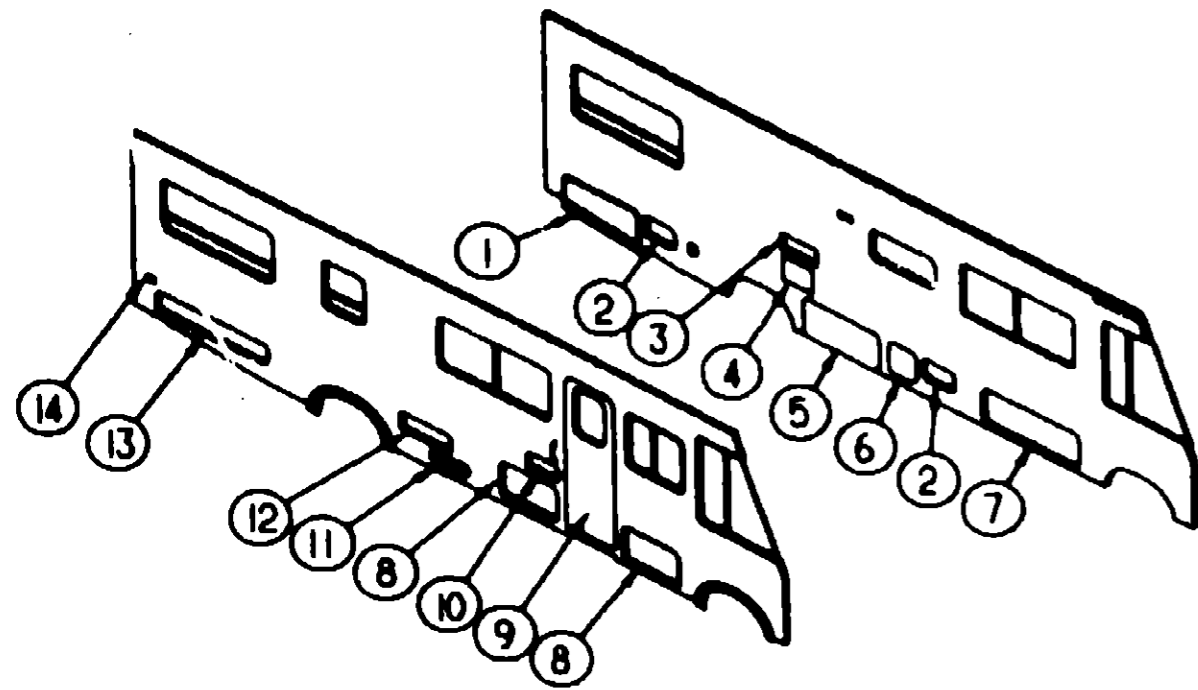

EXTERIOR DOORS

KEY	PART NUMBER	U/M DESCRIPTION
1	083284-06-D35	EA DOOR ASM - GENERATOR COMPARTMENT
2	079578-22-D35	EA DOOR ASM - STORAGE
3	084103-07-000	EA DOOR - REFRIGERATOR - VENTED - W/O JAMB - BUFF
3	084104-07-000	EA JAMB - REFRIGERATOR - BUFF
	084104-01-700	EA LOCK - MALE DZUS FASTENER (REFRIGERATOR VENT)
	084104-01-701	EA LOCK - FEMALE DZUS FASTENER (REFRIGERATOR VENT)
	052009-05-000	EA DOOR - WATER HEATER - BUFF
5	106987-18-D35	EA DOOR ASM - STORAGE
6	105084-01-D35	EA DOOR ASM - FURNACE - EXTERIOR
7	106987-14-D35	EA DOOR ASM - STORAGE
8	106987-13-D35	EA DOOR ASM - STORAGE
9	M01870-66-D35	EA DOOR - ENTRY - W/SCREEN DOOR
9	M01870-66-D36	EA DOOR - ENTRY - W/SCREEN DOOR
10	105118-01-D32	EA DOOR ASM - ACCESS - RADIO
11	078720-02-D35	EA DOOR - COMPARTMENT - LP - 16.9" X 5.4" - ALUMINUM
12	106987-17-D35	EA DOOR ASM - STORAGE
13	105987-16-D35	EA DOOR ASM - ACCESS - EXTERIOR SHOWER
14	081240-10-000	EA DOOR - WATER FILL - LOCKABLE - 4' X 4 5/8" - ASH GRAY

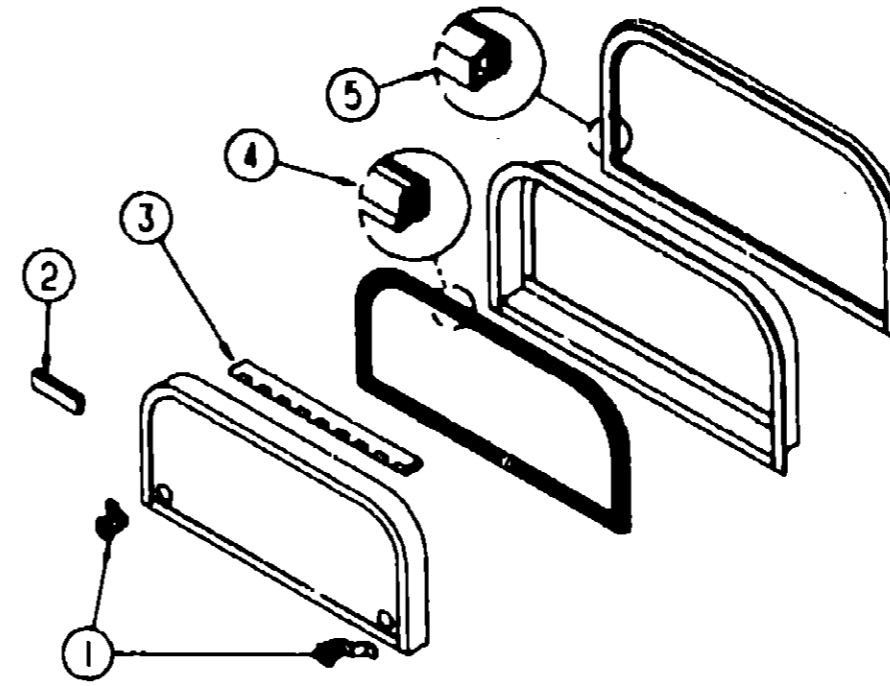

EXTERIOR DOOR HARDWARE

KEY	PART NUMBER	U/M DESCRIPTION
1	079366-04-000	EA LOCK - DOOR - KEY TYPE W/O KEYS - 1 9 OFF SET
	082684-01-700	EA KEY BLANK - COMPARTMENT DOOR LOCK
	102328-01-000	EA KEY - BARREL - NICKEL PLATED
1	079927-03-000	EA LOCK - TWIST TYPE - DOUBLE CAM - 2 10 OFF SET
2	102768-01-000	EA HOLDER - COMPARTMENT/ENTRY DOOR - METAL - MILL FINISH
3	081801-07-000	EA HINGE - 2" X 96" - DARK GRAY
4	064075-07-000	FT SEAL - BULB - W/WRED U CHANNEL - 3" X 5" CHANNEL - BLACK
5	081632-02-000	FT SEAL - BULB - DOOR - W/WIRE CARRIER - 8" WIDE - RUBBER - BLACK
	084104-01-700	EA LOCK - MALE - FASTENER - REFRIGERATOR DOOR
	084104-01-701	EA LOCK - FEMALE - FASTENER - REFRIGERATOR DOOR
	009126-02-000	EA HANDLE - ASSIST - ENTRY DOOR - BLACK

1993 ITASCA
TABLE OF CONTENTS

INTRODUCTION	A-01 - A-02
ABBREVIATIONS	A-03
ALPHABETICAL INDEX	A-04 - A-06
ICG32RQ	A-07 - E-18

1993 ICG32RQ INDEX

FLOOR PLAN	A-07 - A-08
ACCESSORIES	A-09
AUDIO VIDEO	A-10 - A-11
BATH	A-12 - A-14
BEDROOM	A-15 - A-16
CHASSIS	A-17 - B-06
CURTAIN & CUSHION	B-07 - B-17
DINETTE	B-18 - B-20
DRIVERS COMPARTMENT	B-21 - B-24
ELECTRICAL	C-01 - C-06
EXTERIOR BODY	C-07 - C-14
GALLEY	C-15 - C-18
GENERATOR	C-19 - C-20
HEATING & A/C	C-21 - C-24
INTERIOR FINISH	D-01 - D-04
LABELS	D-05 - D-12
LP	D-13
LOUNGE	D-14 - D-16
SEALANTS & FASTENERS	D-17 - D-19
WATER & SEWAGE	D-20 - D-23
WINDOW, VENT & EXTERIOR DOOR	D-24 - E-14
WINDSHIELD & W/PER	E-15 - E-16

WINDOW, VENT & EXTERIOR DOOR GROUP (CONTINUED)

ENTRANCE DOOR

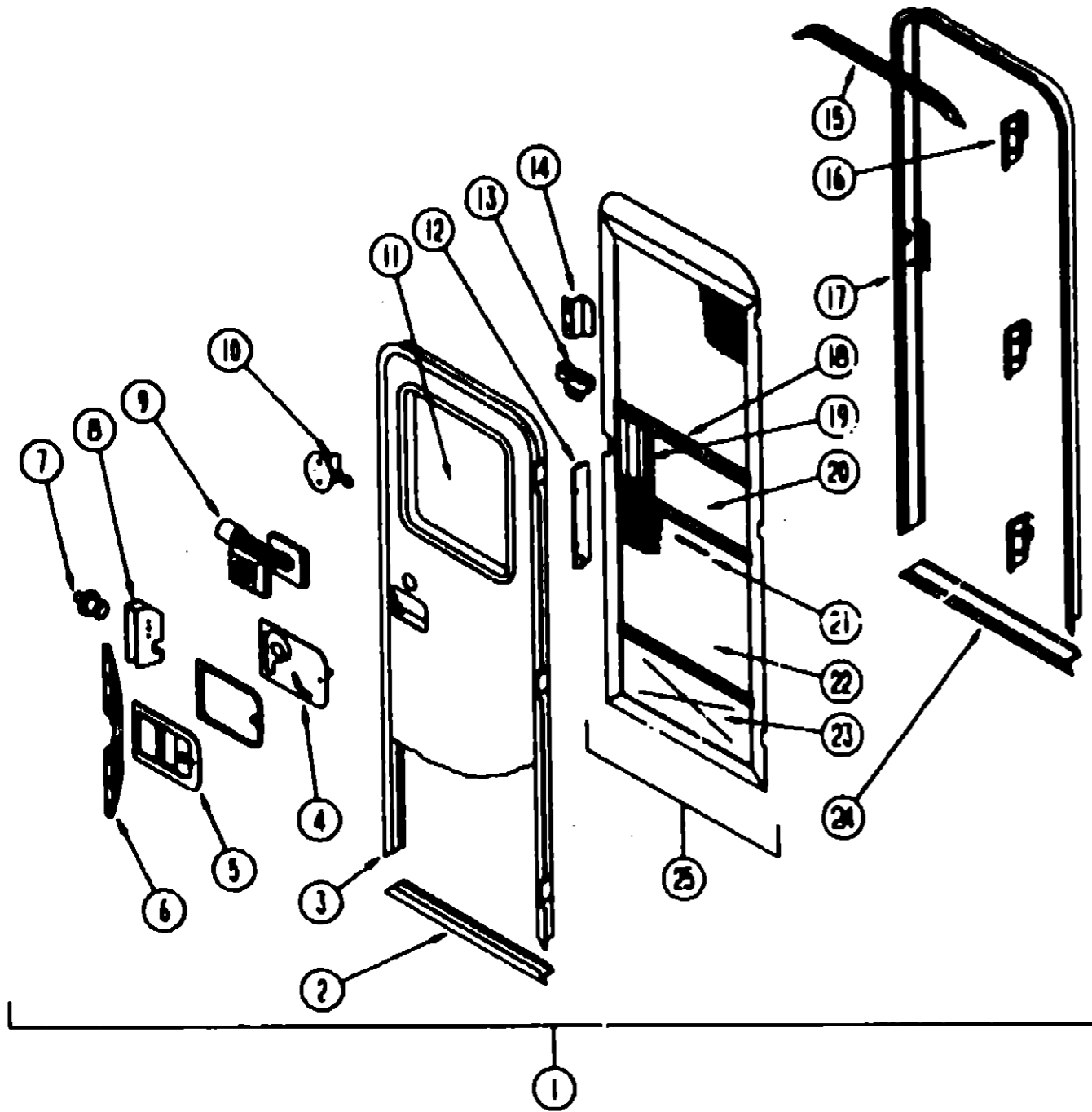

KEY	PART NUMBER	U/M DESCRIPTION
5	045017-11-000	EA LATCH - PADDLE - MECHANISM W/LOCK CYLINDER & KEY - BLACK
	045017-11-701	EA KEY BLANK
6	098173-01-04A	EA STIFFENER - ENTRY DOOR - SUPPORTS LATCH/STRIKE AREA - MILL
7	039539-01-000	EA STRIKE - ENTRANCE DOOR LOCK
	077481-03-000	EA COVER - STRIKE - ENTRY DOOR - 6 5" X 2 5" - PLASTIC - WHITE
8	039540-01-000	EA LATCH MECHANISM - HOOK - ENTRY DOOR - INTERIOR
	039715-01-000	EA NUT - SERT - 1/4" DIAMETER - 20 THREADS
	039984-01-000	EA CAP - ROUND - VINYL - 28" ID X 82" LONG - BLACK
	040944-01-000	EA LABEL - ENTRANCE DOOR - "OPEN"
	058808-01-000	EA PLUG - CAP - 1" DIAMETER
9	101145-01-01A	EA DEADBOLT - ENTRY DOOR - BLACK
	095229-01-700	EA KEY ONLY - BLANK
	101147-01-000	EA BOLT - SECURITY - 4 12" BACKSET
	081914-01-000	EA BUMPER - RUBBER - ROUND - BLACK
10	100412-01-000	EA CATCH - SCREEN DOOR
11	079733-12-D12	EA WINDOW - PICTURE - W/O INSIDE FRAME - 17" X 27"
	067609-35-000	EA FRAME - WINDOW - INSIDE PICTURE - OFF WHITE
	002181-19-000	EA GLASS - PICTURE WINDOW
	087561-01-000	FT VINYL SEAL - GLASS - EXTERIOR - BLACK
12	079087-02-000	EA STRIKE - SLIDER - W/LIP FOR ELBOW CATCH - 1 5" X 8 6" BEIGE
13	109403-01-000	EA CATCH - SCREEN DOOR ROLLER
	058025-02-000	EA CLIP - ROLLER LATCH CATCH
	063729-04-000	EA RIVNUT - 10-32 UNF - 010-080
	072893-01-000	EA NUTSERT - M5 X 0 - 6
	075671-04-000	FT SEAL - SPONGE - LAZY T SHAPE - W/ADHESIVE STRIPE - 5" WIDE
	100128-01-000	FT SEAL - PILE - ADHESIVE BACK - GRAY
	075908-01-000	EA SCREW - MACH - 10-32X.56PTH(SEMS
14	050712-04-000	EA HANDLE - SCREEN DOOR - OFF WHITE
15	044582-31-000	EA CAP - DRIP - ENTRY DOOR - ALUMINUM - ASH GRAY
16	097724-01-04A	EA HINGE - ENTRY DOOR - UNPAINTED
17	095277-04-04A	EA JAMB ASM - ENTRANCE DOOR - ASH GRAY
	079207-01-000	EA STRIKER - ROLLER CATCH - WELDED TO DOOR JAMB - 4" X 1 15"
18	078777-01-000	EA CHANNEL - SLIDE - SCREEN DOOR CENTER SLIDER COVER
19	079086-02-000	EA SLIDER - SCREEN DOOR - OFF WHITE
	078595-01-000	EA TOP PLATE - SCREEN DOOR - CURVED TOP - 4 7" X 25 35"
20	016454-01-000	EA INSERT - SCREEN DOOR - CENTER - LEATHER GRAIN ALUMINUM
21	002294-01-000	FT SPLINE - SCREENING - .135" X .138" - BLACK
22	002293-02-000	SF SCREENING - 26" - CHARCOAL
23	078552-03-000	EA KICK PANEL - SCREEN DOOR - LOWER INSERT - UNPAINTED
24	051049-01-000	EA JAMB BOTTOM - ENTRY DOOR - 25 9" - UNPAINTED
25	079012-05-B10	EA DOOR - SCREEN
	100128-01-000	FT SEAL - SCREEN DOOR
	085774-01-000	FT FASTENER - DUAL LOCK - 1" WIDE
	085774-02-000	FT FASTENER - DUAL LOCK - 1" WIDE
	090340-01-000	FT SEAL - FOAM - CLOSED CELL - 1/4" X 1/2" X 50'
	093145-01-000	EA SLEEVE - WIRE - 10" LONG - PLASTIC - BLACK
	093146-01-000	EA GROMMET - WIRE - 1.7" X 3.1" - OVAL SHAPED - PLASTIC - BLACK

1983 ITASCA
TABLE OF CONTENTS

INTRODUCTION	A-01 - A-02
ABBREVIATIONS	A-03
ALPHABETICAL INDEX	A-04 - A-06
ICG32RQ	A-07 - E-16

1983 ICG32RQ INDEX

FLOOR PLAN	A-07 - A-08
ACCESSORIES	A-09
AUDIO VIDEO	A-10 - A-11
BATH	A-12 - A-14
BEDROOM	A-15 - A-16
CHASSIS	A-17 - B-06
CURTAIN & CUSHION	B-07 - B-17
DINETTE	B-18 - B-20
DRIVERS COMPARTMENT	B-21 - B-24
ELECTRICAL	C-01 - C-06
EXTERIOR BODY	C-07 - C-14
GALLEY	C-15 - C-18
GENERATOR	C-19 - C-20
HEATING & AC	C-21 - C-24
INTERIOR FINISH	D-01 - D-04
LABELS	D-05 - D-12
LP	D-13
LOUNGE	D-14 - D-16
SEALANTS & FASTENERS	D-17 - D-19
WATER & SEWAGE	D-20 - D-23
WINDOW, VENT & EXTERIOR DOOR	D-24 - E-14
WINDSHIELD & WIPER	E-15 - E-16

KEY	PART NUMBER	U/M DESCRIPTION
1	M01870-86-D35	EA DOOR - ENTRY - W/SCREEN DOOR
1	M01870-86-D36	EA DOOR - ENTRY - W/SCREEN DOOR
	041546-03-000	EA BRACKET - DOOR ANGLE - 5" X 1.9" - BEIGE - METAL
	075839-14-000	EA GARNISH - RADIUS - ENTRY DOOR - OFF WHITE
	093673-01-04A	EA TRIM - ENTRANCE DOOR - 1.3" WIDE - ASH GRAY
2	089748-10-000	EA FRAME - BOTTOM ENTRY DOOR - ASH GRAY
3	095276-03-04A	EA FRAME - ENTRY DOOR - W/O BOTTOM - ASH GRAY
4	039979-04-000	EA COVER - INTERIOR LATCH - W/TRIP ARM - RIGHT - BLACK

WINDSHIELD & WIPER GROUP

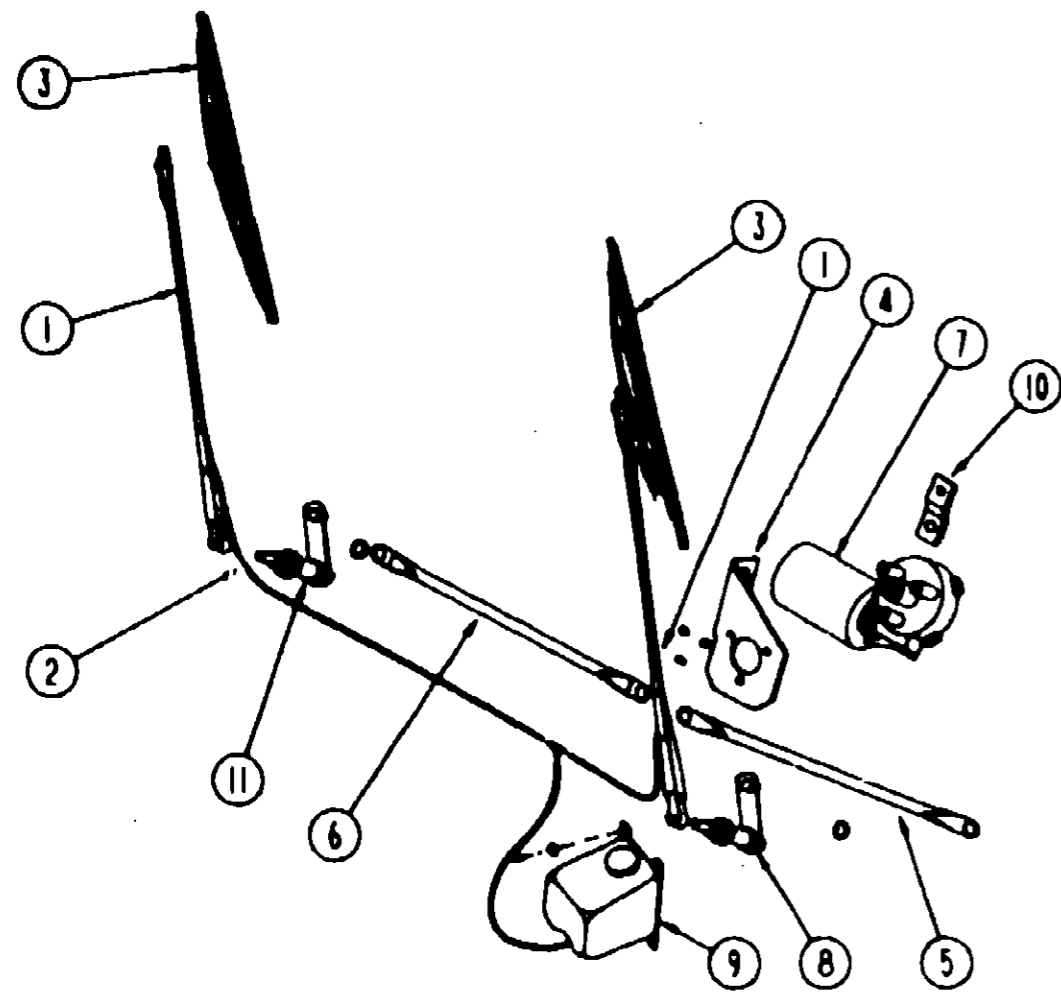

WINDSHIELD WIPER ASM

KEY	PART NUMBER	U/M DESCRIPTION
1	103671-01-000	EA ARM - WIPER - 24"
2	096931-01-700	FT HOSE
	096931-01-701	EA NOZZLE HARDWARE KIT
3	096984-01-000	EA BLADE - WIPER - WINDSHIELD - 24"
4	104549-01-000	EA BRACKET ASM - WIPER MOTOR
5	103672-01-000	EA LINK ASM - CONNECTING - 21.85° - DRIVER SIDE
6	103672-02-000	EA LINK ASM - CONNECTING - 21.85° - PASSENGER SIDE
7	104348-01-000	EA WIPER MOTOR
	104549-01-000	EA MOUNTING BRACKET - WIPER MOTOR
	110178-01-000	EA HOUSING - WIPER MOTOR
8	096505-02-000	EA PIVOT & SHAFT ASM - WIPER - DRIVER SIDE FROM: 00-00-00 THRU: 12-18-92
8	096505-06-000	EA PIVOT & SHAFT ASM - WIPER - DRIVER SIDE FROM: 12-19-92 THRU: 99-99-99
9	056000-02-000	EA WASHER - WINDSHIELD - BOTTLE & PUMP
	056000-01-700	FT HOSE - VACUUM - 7 / 64
10	104347-01-000	EA ARM - DRIVE - WIPER MOTOR - 1.54"
11	096505-03-000	EA PIVOT & SHAFT ASM - WIPER - PASSENGER SIDE FROM: 00-00-00 THRU: 04-20-93
11	096505-05-000	EA PIVOT & SHAFT ASM - WIPER - PASSENGER SIDE FROM: 04-21-93 THRU: 99-99-99
	110742-01-000	EA WIPER GASKET
	067188-01-000	EA STUD - WIPER CRANK

WINDSHIELD & WIPER GROUP (CONTINUED)

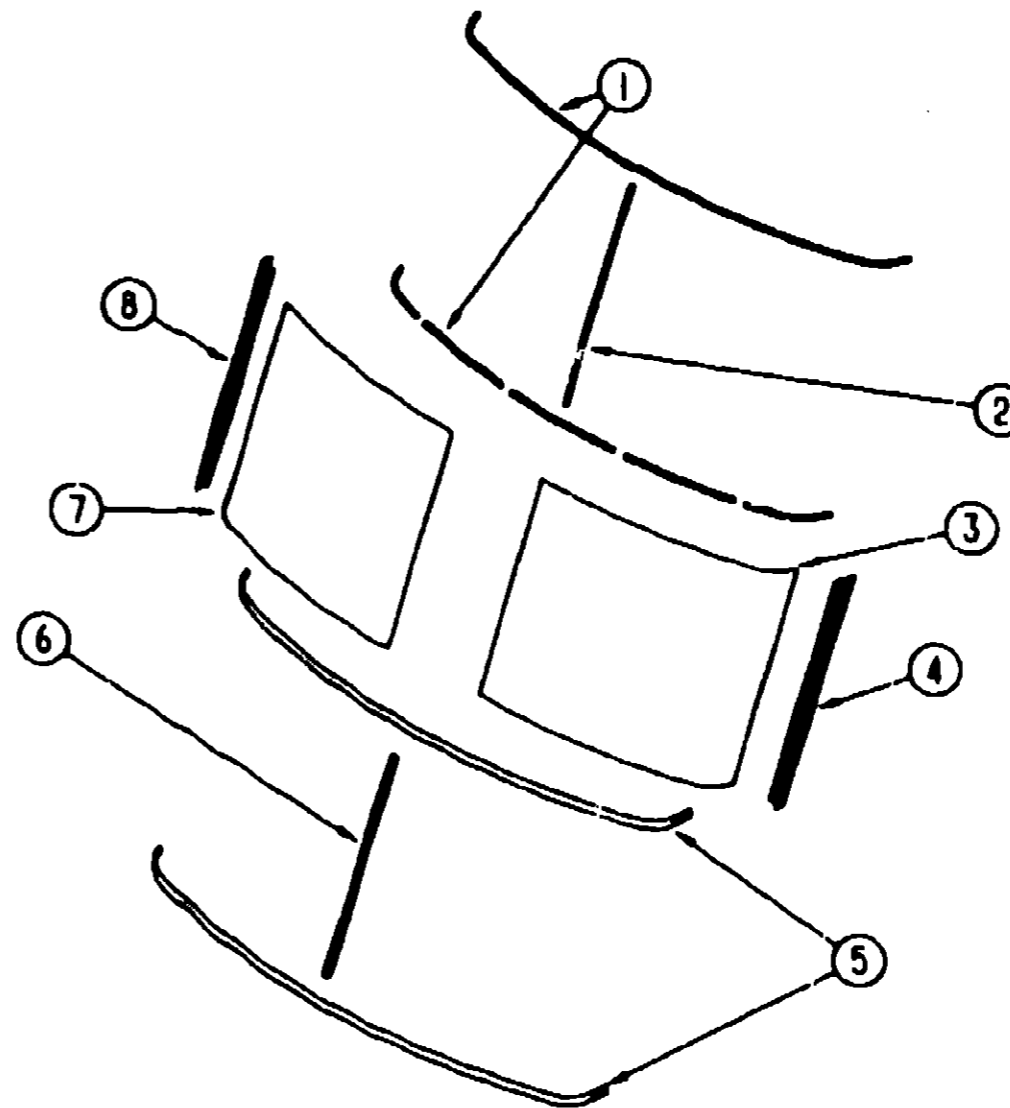

WINDSHIELD MOLDINGS & GLASS

KEY	PART NUMBER	U/M DESCRIPTION
1	102935-01-000	EA CARRIER - REVEAL - 50" - WINDSHIELD
1	110268-03-000	EA CARRIER - REVEAL - 47.2" - WINDSHIELD
		FROM: 00-00-00 THRU: 12-13-92
1	110268-05-000	EA CARRIER - REVEAL - 2" WINDSHIELD FROM: 12-14-92 THRU: 99-99-99
2	110268-07-000	EA CARRIER - REVEAL - 42.1" WINDSHIELD FROM: 12-14-92 THRU: 99-99-99
3	103788-02-000	EA GLASS - WINDSHIELD - DRIVER SIDE
4	103107-04-01A	EA TRIM - WINDSHIELD - DRIVER SIDE - BLACK
5	102936-01-000	FT MOLDING - REVEAL - WINDSHIELD
6	102936-01-000	FT MOLDING - REVEAL - WINDSHIELD - CENTER
7	103788-01-000	EA GLASS - WINDSHIELD - PASSENGER SIDE
8	103107-03-01A	EA TRIM - WINDSHIELD - PASSENGER SIDE - BLACK
	098788-06-000	EA CHANNEL - RIGID - 49
	075710-01-000	EA FRAME - WINDSHIELD - CENTER DIVIDER - INNER
	077847-02-000	EA SUPPORT - WINDSHIELD - LOWER - W/O BRACKETS
	104449-01-000	EA BRACKET - WINDSHIELD SUPPORT

**1993 ITASCA
TABLE OF CONTENTS**

INTRODUCTION	A-01 - A-02
ABBREVIATIONS	A-03
ALPHABETICAL INDEX	A-04 - A-08
ICG32RQ	A-07 - E-18

1993 ICG32RQ INDEX

FLOOR PLAN	A-07 - A-08
ACCESSORIES	A-09
AUDIO VIDEO	A-10 - A-11
BATH	A-12 - A-14
BEDROOM	A-15 - A-16
CHASSIS	A-17 - B-06
CURTAIN & CUSHION	B-07 - B-17
DINETTE	B-18 - B-20
DRIVERS COMPARTMENT	B-21 - B-24
ELECTRICAL	C-01 - C-06
EXTERIOR BODY	C-07 - C-14
GALLEY	C-15 - C-18
GENERATOR	C-19 - C-20
HEATING & A/C	C-21 - C-24
INTERIOR FINISH	D-01 - D-04
LABELS	D-05 - D-12
LP	D-13
LOUNGE	D-14 - D-16
SEALANTS & FASTENERS	D-17 - D-19
WATER & SEWAGE	D-20 - D-23
WINDOW, VENT & EXTERIOR DOOR	D-24 - E-14
WINDSHIELD & WIPER	E-15 - E-16