

1991 WCN28RT

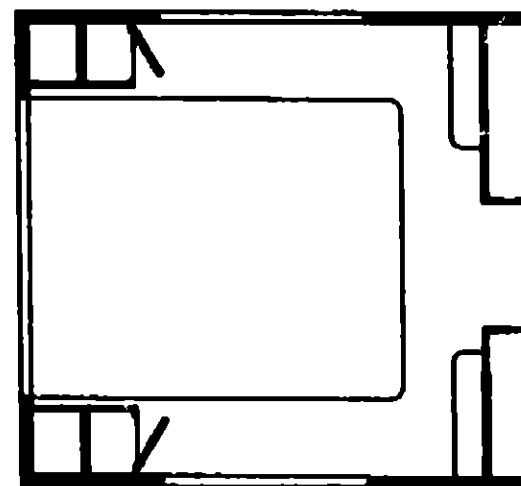
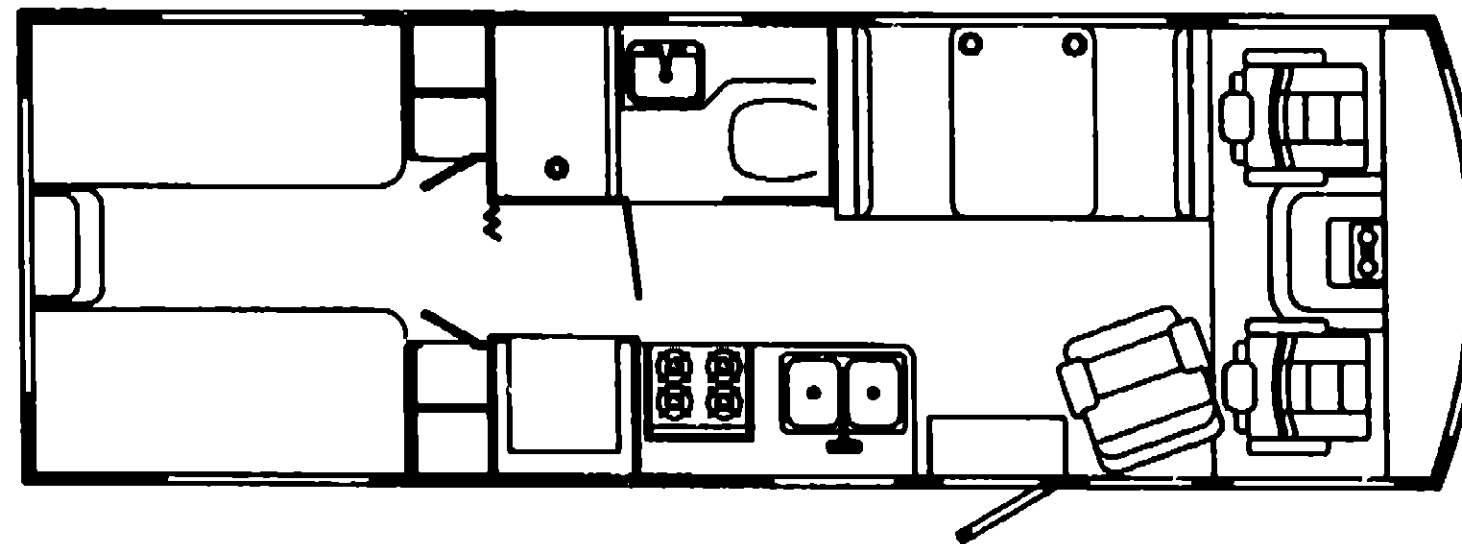
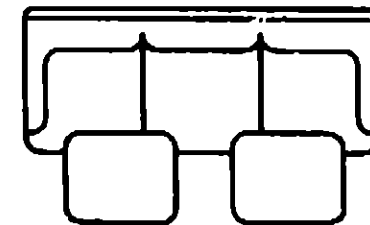
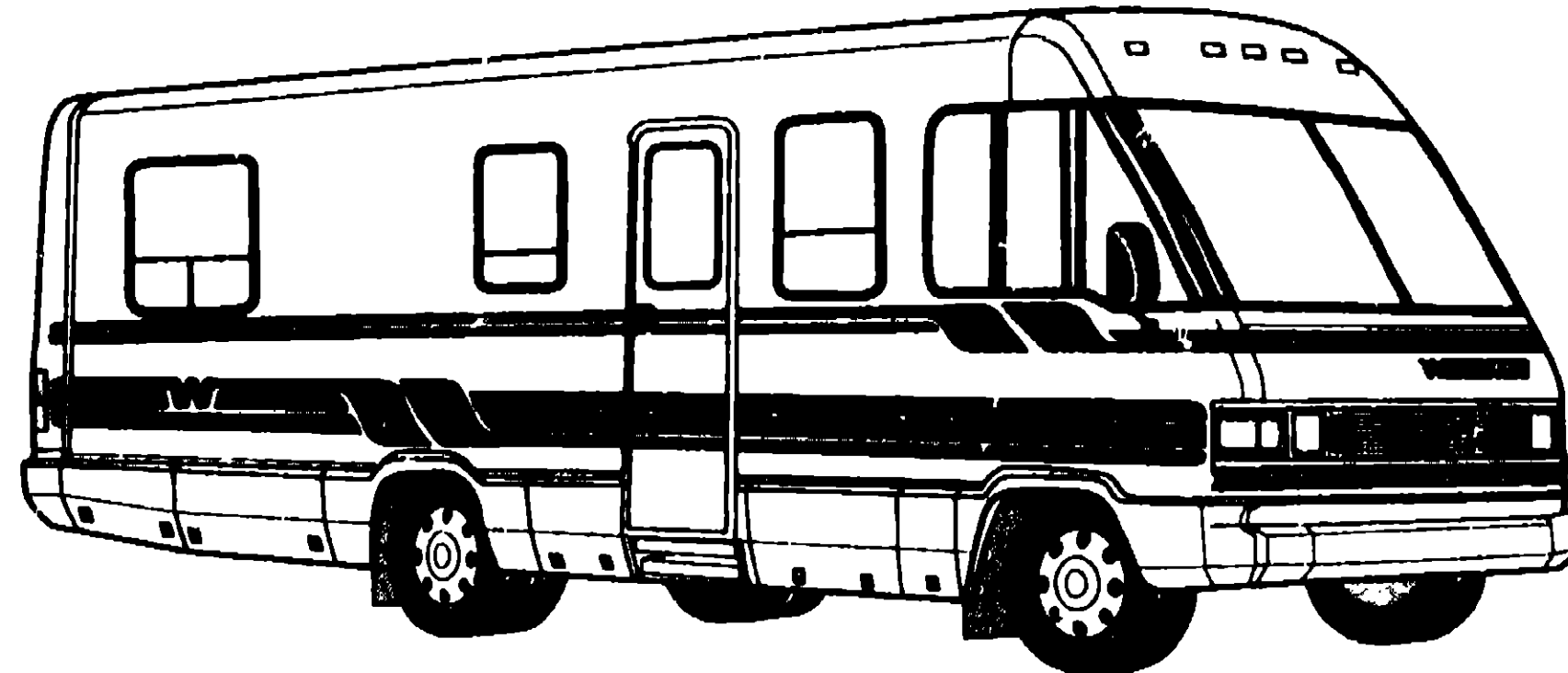

A-07

1991 WINNEBAGO TABLE OF CONTENTS

INTRODUCTION	A-01 - A-02
ABBREVIATIONS	A-03
ALPHABETICAL INDEX	A-04 - A-06
WCN28RT	A-07 - G-10
WCN32RQ	G-11 - L-20

1991 WCN28RT INDEX

FLOOR PLAN	A-07 - A-08
ACCESSORIES	A-09 - A-24
BATH	B-01 - B-04
BEDROOM	B-05 - B-08
CHASSIS	B-09 - C-06
C C & PAD	C-07 - C-18
DINETTE	C-19 - C-20
DRIVERS	C-21 - C-24
ELECTRICAL	D-01 - D-08
EXTERIOR BODY	D-09 - D-18
GALLEY	D-19 - E-02
HEATING & AC	E-03 - E-08
INTERIOR FINISH	E-09 - E-13
LABEL	E-14 - E-22
LP	E-23
LOUNGE	E-24 - F-01
SEALANTS & FASTENERS	F-02 - F-04
WATER & SEWAGE	F-05 - F-11
WINDOW, VENT AND EXTERIOR DOOR	F-12 - G-10

A-08

ACCESSORIES GROUP

DELUXE STEERING WHEEL OPTION L38P

KEY PART NUMBER	U/M	DESCRIPTION
080752-08-000	EA	HUB-ADAPTER, STEERING WHEEL
080752-08-000	EA	SCREW-CUSTOM STEERING WHEEL
080752-17-000	EA	WHEEL-STEERING WITH 2 HORN BUTTONS
		FROM: 00-00-00 THRU: 02-24-91
080752-15-000	EA	WHEEL-STEERING, W/4 SPOKES
		FROM: 02-25-91 THRU: 04-29-91
080752-17-000	EA	WHEEL-STEERING WITH 2 HORN BUTTONS
		FROM: 04-29-91 THRU: 99-99-99

ELECTRIC ENTRY STEP

KEY PART NUMBER	U/M	DESCRIPTION
094707-01-01A	EA	STEP-DOUBLE, ENTRANCE - ELECTRIC
094707-01-700	EA	CONTROL UNIT, KWIKEE 8310
		FROM: 00-00-00 THRU: 03-15-91
094707-02-705	EA	CONTROL UNIT, (ORANGE) - KWIKEE 9513
		FROM: 03-16-91 THRU: 99-99-99
088748-01-701	EA	MOTOR-ALL MODELS, KWIKEE 9035
		FROM: 00-00-00 THRU: 03-15-91
094707-02-700	EA	MOTOR REPLACEMENT KIT - MODELS 32 & 28 - KWIKEE 9520
		FROM: 03-16-91 THRU: 99-99-99
094707-02-704	EA	CONNECTOR KIT-MOTOR, KWIKEE 9537
		FROM: 03-16-91 THRU: 99-99-99
091201-01-700	EA	LINKAGE ASSEMBLY, KWIKEE 8289
		FROM: 00-00-00 THRU: 03-15-91
094707-02-701	EA	LINKAGE ASM - MODEL 32 - KWIKEE 9523
		FROM: 03-16-91 THRU: 99-99-99
088748-01-702	EA	GEAR-ALL MODELS, KWIKEE 9038
		FROM: 00-00-00 THRU: 03-15-91
094707-02-702	EA	GEAR KIT - KWIKEE 9525
		FROM: 03-16-91 THRU: 99-99-99
094707-02-703	EA	PARTS KIT, (BEARINGS & PINS) - KWIKEE 9530
		FROM: 03-16-91 THRU: 99-99-99
088748-01-703	EA	BRACKET, MOTOR BEARING, KWIKEE 7040
088748-01-705	EA	LIGHT-UNDER STEP, KWIKEE 9004
088748-01-706	EA	SWITCH-KILL, KWIKEE 9016
094707-01-701	EA	SWITCH-DOOR JAMB, PLASTIC - KWIKEE - 9316

STAINLESS STEEL WHEEL LINERS OPTION L83K - 19.5"

KEY PART NUMBER	U/M	DESCRIPTION
077030-02-000	EA	EXTENSION-VALVE STEM, 1.25"
091209-01-000	EA	LINER-WHEEL, SET OF 4 - 19.5" - GM - KAPER II
091209-01-700	EA	SIMULATOR-FRONT WHEEL EA-1
091209-01-701	EA	SIMULATOR-REAR WHEEL EA-1
091209-01-702	EA	COVER-FRONT AXLE
091209-01-703	EA	REAR AXLE COVER
091209-01-704	EA	COVER-LUG NUT
086012-01-000	EA	EXTENSION-VALVE STEM, DUAL WHEEL

OWNER MANUAL, BINDER & CASSETTE

KEY PART NUMBER	U/M	DESCRIPTION
054185-88-000	EA	MANUAL-OPERATORS, 1991 CHIEFTAIN
082318-01-000	EA	BINDER-3 RING, MOTOR HOME MANUAL
082319-01-000	EA	POCKET PAGE-3 RING BINDER, PLASTIC
088084-03-000	EA	CASSETTE-WINNEBAGO CHIEFTAIN
072852-01-000	EA	DETECTOR-SMOKE, W/9 VOLT BATTERY

AUXILIARY DEFROSTER FANS OPTION L364- W/SWITCH

KEY PART NUMBER	U/M	DESCRIPTION
097372-03-01A	EA	SWITCH-ON-OFF-ON
076788-01-000	EA	SOCKET-MINI BAYONET LAMP, DASH
088476-01-000	EA	SOCKET-CONNECTOR
000G39-08-24B	EA	SCREW-SF/DR, 8-18 X 1 1/2 PPH ZN
036420-02-000	EA	FAN-DEFROSTER, 2 SPEED - 6" DIAMETER

ACCESSORIES GROUP (CONTINUED)

EXTERIOR ACCESSORY PACKAGE OPTION L28E

KEY PART NUMBER	U/M	DESCRIPTION
091270-01-000	EA	HOSE-5/8", ON REEL - WATER - NON TOXIC - 50' - TORO
093300-01-000	EA	BOX-TOOL, W/TRAY - 16" X 7" X 7.5"

SQUEEGEE

KEY PART NUMBER	U/M	DESCRIPTION
091952-01-000	EA	CLIP-GRIPPER, 1"
		FROM: 00-00-00 THRU: 05-28-90
091952-02-000	EA	CLIP-GRIPPER, 3/4"
		FROM: 05-27-90 THRU: 99-99-99
091955-02-000	EA	SQUEEGEE-EXTENDED HANDLE
093527-01-000	EA	BRACKET-SQUEEGEE

AM/FM CASSETTE RADIO OPTION L57E - ELECTRONIC TUNE

KEY PART NUMBER	U/M	DESCRIPTION
097480-01-000	EA	RADIO-AM/FM STEREO/CASSETTE, SONY XR-300
		REPLACED BY 097480-02-000
		FROM: 00-00-00 THRU: 07-22-90
097480-02-000	EA	RADIO-AM/FM STEREO/CASSETTE, SONY XR-4147
		THIS RADIO REPLACES THE SONY XR-300 RADIO
		FROM: 07-23-90 THRU: 99-99-99
097820-03-000	EA	MOUNTING KIT-RADIO, SONY
		CLIPS, SCREWS, PLASTIC BRACKET, ETC.
097820-04-000	EA	BRACKET-FACE, RADIO - SONY - STEEL
100014-01-000	EA	TRAY-RADIO, SONY - STEEL
		RADIOS & RELATED ITEMS
073741-03-000	EA	SPEAKER-RADIO, OVAL - AUDIOVOX 110-2074 - 4" X 6"
094097-01-000	EA	SPEAKER-RADIO, W/O GRILLE - 5.25" DIA - AUDIOVOX 110C3030
098819-01-000	EA	SPEAKER-2 WATT, 8 OHM - 4"
093214-01-02A	EA	GRILL-SPEAKER, 4" BROWN
073741-04-000	EA	GRILLE-SPEAKER, OVAL - 4" X 6" - BLACK
099340-01-000	EA	GRILLE-SPEAKER, 6.5" SQUARE
		FROM: 00-00-00 THRU: 09-09-90
099340-02-000	EA	GRILLE-SPEAKER, 6.5" SQUARE
		FROM: 09-10-90 THRU: 99-99-99
074979-01-000	EA	COVER-SPEAKER, 6" X 6" - BEIGE
074979-01-000	EA	SHIELD-SPEAKER, BACK - MOLDED PLASTIC - BEIGE
097459-01-000	EA	RADIO-AM/FM STEREO, CASSETTE - AUDIOVOX MM-DXA
099998-01-000	EA	BRACKET-RADIO, AUDIOVOX
007821-01-000	EA	MOUNTING KIT-RADIO, AUDIOVOX WMK-AB01 - CHEVY

ANTENNA RADIO

KEY PART NUMBER	U/M	DESCRIPTION
090844-01-000	EA	ANTENNA-RADIO, 16" RUBBER
084073-01-000	EA	COVER-ROOF VENT, NORCOLD REFRIGERATOR - BEIGE
084073-04-000	EA	BASE-ROOF VENT, NORCOLD REFRIGERATOR - BLACK

ANTENNA T.V.

KEY PART NUMBER	U/M	DESCRIPTION
076319-01-000	EA	ANTENNA-TV, ROOF MOUNT - 44.5" MAST - RVA W02
076319-01-700	EA	HEAD-ANTENNA, AMPLIFIED - WINEGARD# RVSA UV
076319-01-701	EA	GEAR-ELEVATING, PLASTIC - WINEGARD# 2200046
076319-01-702	EA	SHAFT ASM-ELEVATING, WINEGARD# RVP-400A
076319-01-703	EA	BEARING-NYLON, 5"OD - WINEGARD# 3200656
076319-01-704	EA	BEARING-NYLON, 1.25"OD - WINEGARD# 3200657
076319-01-705	EA	GROMMET-NYLON, 7/8"ID - WINEGARD# 3200658
076319-01-706	EA	CRANK-ELEVATING, W/SET SCREW - WINEGARD# 5755100
076319-01-707	EA	SFRING-HANDLE, WINEGARD# 5160800
076319-06-000	EA	ADAPTER-CABLE ROOF PLATE, WINEGARD RPJ-1
076319-11-000	EA	ADAPTER-COAX WITH SPLITTER WINEGARD MSJ-6
082134-01-000	EA	ADAPTER-TV, CABLE TO CABLE - WINEGARD F-81M

**1991 WINNEBAGO
TABLE OF CONTENTS**

INTRODUCTION	A-01 - A-02
ABBREVIATIONS	A-03
ALPHABETICAL INDEX	A-04 - A-08
WCN28RT	A-07 - G-10
WCN32RC	G-11 - L-20

1991 WCN28RT INDEX

FLOOR PLAN	A-07 - A-08
ACCESSORIES	A-09 - A-24
BATH	B-01 - B-04
BEDROOM	B-05 - B-08
CHASSIS	B-09 - C-08
C C & PAD	C-07 - C-18
DINETTE	C-19 - C-20
DRIVERS	C-21 - C-24
ELECTRICAL	D-01 - D-08
EXTERIOR BODY	D-09 - D-16
GALLEY	D-19 - E-02
HEATING & A/C	E-03 - E-08
INTERIOR FINISH	E-09 - E-13
LABEL	E-14 - E-22
LP	E-23
LOUNGE	E-24 - F-01
SEALANTS & FASTENERS	F-02 - F-04
WATER & SEWAGE	F-05 - F-11
WINDOW, VENT AND EXTERIOR DOOR	F-12 - G-10

ACCESSORIES GROUP (CONTINUED)

TV AND VCR SWITCHING SYSTEM OPTION L42C - US & CANADIAN

KEY PART NUMBER	U/M	DESCRIPTION
058708-02-000	EA	RECEPTACLE-DOUBLE ELECTRIC, IVORY - US
085774-01-000	FT	FASTENER-DUAL HOOK, 1" WIDE - ADHESIVE BACK - BLACK
085774-02-000	FT	FASTENER-DUAL LOOP, 1" WIDE - ADHESIVE BACK - BLACK
086757-01-000	EA	CONTROL CENTER-SWITCH, VCR/TV - CHANNEL MASTER REPLACED BY 086757-02-000
		FROM: 00-00-00 THRU: 06-03-90
086757-02-000	EA	CONTROL CENTER-SWITCH, VCR/TV - XANTECH
		FROM: 06-04-90 THRU: 04-10-91
086757-03-000	EA	CONTROL CENTER-SWITCHING, MAGNADYNE VCR-8
		FROM: 04-11-91 THRU: 99-99-99
086777-03-000	EA	PLATE-WALL, ANTENNA/POWER, IVORY
076319-03-000	FT	CABLE-COAXIAL, 75 OHM
076319-12-000	EA	CONNECTOR-COAXIAL, ONE PIECE
076319-04-000	EA	CONNECTOR W/FERRULE
093214-01-02A	EA	GRILL-SPEAKER, 4" BROWN
086446-01-000	EA	VCR-VHS-CABLE READY - REMOTE - MAGNAVOX VR9815
		FROM: 00-00-00 THRU: 09-24-90
086446-02-000	EA	VCR-VHS, CABLE READY - REMOTE - MAGNAVOX VR9912
		FROM: 09-25-90 THRU: 99-99-99
086447-01-000	EA	TV-13", COLOR W/REMOTE - U.S. - MAGNAVOX RX4029WA
086447-01-700	EA	REMOTE
086447-02-000	EA	TV-13", COLOR W/REMOTE - CANADIAN - MAGNAVOX XK4029CH
086447-01-700	EA	REMOTE-TV, MAGNAVOX 0822338
086819-01-000	EA	SPEAKER-2 WATT, 8 OHM - 4" - US
069030-01-000	EA	WIRE-SPEAKER, TV
086475-01-000	EA	PIN-CONNECTOR
086476-01-000	EA	SOCKET-CONNECTOR
086637-01-000	EA	GROMMET
089717-01-000	EA	TIEDOWN-TV - STRAP ON FEMALE END IS 22.8" LONG
089717-02-000	EA	TIEDOWN, TV - STRAP ON FEMALE END IS 28.7" LONG
101150-01-000	EA	SUPPORT-SHELF, TV - PASSENGER SIDE - STEEL
101150-02-000	EA	SUPPORT-SHELF, TV - DRIVER SIDE - STEEL
100954-01-000	EA	SHELF-TV, STEEL

FRONT OVERHEAD TV OPTION L42Y - US & CANADIAN

KEY PART NUMBER	U/M	DESCRIPTION
058708-02-000	EA	RECEPTACLE-DOUBLE ELECTRIC, IVORY
085774-01-000	FT	FASTENER-DUAL HOOK, 1" WIDE - ADHESIVE BACK - BLACK
085774-02-000	FT	FASTENER-DUAL LOOP, 1" WIDE - ADHESIVE BACK - BLACK
086757-01-000	EA	SPLITTER-TV, 2 WAY
101150-01-000	EA	SUPPORT-SHELF, TV - PASSENGER SIDE - STEEL
101150-02-000	EA	SUPPORT-SHELF, TV - DRIVER SIDE - STEEL
100954-01-000	EA	SHELF-TV, STEEL
076319-03-000	FT	CABLE-COAXIAL, 75 OHM
076319-04-000	EA	CONNECTOR W/FERRULE
076319-12-000	EA	CONNECTOR-COAXIAL, ONE PIECE
093214-01-02A	EA	GRILL-SPEAKER, 4" BROWN
086447-01-000	EA	TV-13", COLOR W/REMOTE - U.S. - MAGNAVOX RX4029WA
086447-01-700	EA	REMOTE
086447-02-000	EA	TV-13", COLOR W/REMOTE - CANADIAN - MAGNAVOX XK4029CH
086447-01-700	EA	REMOTE-TV, MAGNAVOX 0822338
086819-01-000	EA	SPEAKER-2 WATT, 8 OHM - 4"
069030-01-000	EA	WIRE-SPEAKER, TV
086475-01-000	EA	PIN-CONNECTOR
086476-01-000	EA	SOCKET-CONNECTOR
086637-01-000	EA	GROMMET
089717-01-000	EA	TIEDOWN-TV
		STRAP ON FEMALE END IS 22.8" LONG
089717-02-000	EA	TIEDOWN, TV
		STRAP ON FEMALE END IS 28.7" LONG

ACCESSORIES GROUP (CONTINUED)

TV & VCR & RELATED ITEMS

KEY PART NUMBER	U/M	DESCRIPTION
086819-01-000	EA	SPEAKER-2 WATT, 8 OHM - 4"
093214-01-02A	EA	GRILL-SPEAKER, 4" BROWN
086757-01-000	EA	SPLITTER-TV, 2 WAY
086777-01-000	EA	PLATE-WALL, ANTENNA
		REAR VIEW TELEVISION OPTION L67Z - CHEVY & FORD
		KEY PART NUMBER
000G39-10-12D	EA	SCREW-SF/DR, 10-18 X 3/4 PPH - BLACK
093040-01-000	EA	TELEVISION SYSTEM-REAR VIEW, SONY TO ADD THIS OPTION TO A COACH ORDER 093040-02-000 SYSTEM & 093041-02-000 EXTERNAL CABLE
		FROM: 00-00-00 THRU: 01-06-91
093040-01-000	EA	TELEVISION SYSTEM-REAR VIEW, SONY
		FROM: 00-00-00 THRU: 01-06-91
093040-01-700	EA	CAMERA ONLY
093040-01-701	EA	MONITOR 6"W/BRACKET & WIRE HARNESS
093040-01-702	EA	CAMERA & HOUSING
093040-04-000	EA	TELEVISION SYSTEM-REAR VIEW, SONY YM-RVFIAM ALSO ORDER CABLES 093041-02-000 & WIRE 093040-03-000
		FROM: 01-07-91 THRU: 99-99-99
093041-01-000	EA	CABLE-MONITOR/CAMERA, INTERNAL USE
093041-02-000	EA	CABLE-MONITOR/CAMERA, EXTERNAL USE
093040-03-000	EA	WIRE-MONITOR, REAR VIEW TELEVISION - SONY SM-HRN1
092881-01-000	EA	WIRE-IP, REAR MONITOR - CHEVY

REAR VIEW TELEVISION OPTION L67Z - CHEVY & FORD

KEY PART NUMBER	U/M	DESCRIPTION
093040-01-000	EA	TELEVISION SYSTEM-REAR VIEW, SONY TO ADD THIS OPTION TO A COACH ORDER 093040-02-000 SYSTEM & 093041-02-000 EXTERNAL CABLE
		FROM: 00-00-00 THRU: 01-06-91
093040-01-700	EA	CAMERA ONLY
093040-01-701	EA	MONITOR 6"W/BRACKET & WIRE HARNESS
093040-01-702	EA	CAMERA & HOUSING
093040-04-000	EA	TELEVISION SYSTEM-REAR VIEW, SONY YM-RVFIAM ALSO ORDER CABLES 093041-02-000 & WIRE 093040-03-000
		FROM: 01-07-91 THRU: 99-99-99
093041-01-000	EA	CABLE-MONITOR/CAMERA, INTERNAL USE
093041-02-000	EA	CABLE-MONITOR/CAMERA, EXTERNAL USE
093040-03-000	EA	WIRE-MONITOR, REAR VIEW TELEVISION - SONY SM-HRN1
093071-01-000	FT	TAPE-BONDING, DOUBLE SIDED - 1/84" X 2"
		FROM: 00-00-00 THRU: 02-10-91
099288-01-000	EA	LENS-REAR, MONITOR SHROUD
		FROM: 00-00-00 THRU: 02-10-91
093957-02-02A	EA	SHROUD-TV, BLACK
		FROM: 00-00-00 THRU: 02-10-91
102903-01-04A	EA	SHROUD-CAMERA, OUTER - BLACK
		FROM: 02-11-91 THRU: 99-99-99
099305-01-000	EA	SPRING-COMPRESSION
		FROM: 00-00-00 THRU: 02-10-91
092881-01-000	EA	WIRE-INSTRUMENT PANEL, REAR MONITOR - CHEVY
094001-01-000	EA	CLAMP-CAMERA
		FROM: 00-00-00 THRU: 02-10-91
094002-01-000	EA	BRACKET-CAMERA
		FROM: 00-00-00 THRU: 02-10-91
099325-01-000	EA	BRACKET-CAMERA, ADJUSTABLE
		FROM: 00-00-00 THRU: 02-10-91
104311-01-000	EA	BRACKET-CAMERA, REAR
		FROM: 02-11-91 THRU: 99-99-99
100319-01-000	EA	RETAINER-LENS, CAMERA
		FROM: 00-00-00 THRU: 02-10-91

**1991 WINNEBAGO
TABLE OF CONTENTS**

INTRODUCTION	A-01 - A-02
ABBREVIATIONS	A-03
ALPHABETICAL INDEX	A-04 - A-06
WCN28RT	A-07 - G-10
WCN352RQ	G-11 - L-20

1991 WCN28RT INDEX

FLOOR PLAN	A-07 - A-08
ACCESSORIES	A-09 - A-24
BATH	B-01 - B-04
BEDROOM	B-05 - B-08
CHASSIS	B-09 - C-06
C C & PAD	C-07 - C-18
DINETTE	C-19 - C-20
DRIVERS	C-21 - C-24
ELECTRICAL	D-01 - D-08
EXTERIOR BODY	D-09 - D-18
GALLEY	D-19 - E-02
HEATING & AC	E-03 - E-08
INTERIOR FINISH	E-09 - E-13
LABEL	E-14 - E-22
I.P	E-23
LOUNGE	E-24 - F-01
SEALANTS & FASTENERS	F-02 - F-04
WATER & SEWAGE	F-05 - F-11
WINDOW, VENT AND EXTERIOR DOOR	F-12 - G-10

ACCESSORIES GROUP (CONTINUED)

DRIVER DOOR WITH POWER WINDOW AND MIRROR OPTION L28P

KEY PART NUMBER	U/M	DESCRIPTION
		STATIONARY WINDOW
086259-04-000	EA	MIRROR-REMOTE HEAT, W/ARM & MIRRORS - PRE-WIRED - PASSENGER
086259-04-700	EA	GLASS ONLY CONVEX HEATED RH
086259-04-701	EA	GLASS ONLY FLAT HEATED RH
086259-05-000	EA	MIRROR-REMOTE HEAT, W/ARM & MIRRORS - PRE-WIRED - DRIVER
086259-05-700	EA	GLASS ONLY CONVEX HEATED LH
086259-05-701	EA	GLASS ONLY FLAT HEATED LH
092880-01-000	EA	WIRE-INSTRUMENT PANEL, REMOTE MIRROR

**DRIVER DOOR W/POWERED WINDOW AND MIRROR OPTION L28P
TIPOUT WINDOW**

KEY PART NUMBER	U/M	DESCRIPTION
086259-04-000	EA	MIRROR-REMOTE HEAT, W/ARM & MIRRORS - PRE-WIRED - PASSENGER
086259-04-700	EA	GLASS ONLY CONVEX HEATED RH
086259-04-701	EA	GLASS ONLY FLAT HEATED RH
086259-05-000	EA	MIRROR-REMOTE HEAT, W/ARM & MIRRORS - PRE-WIRED - DRIVER
086259-05-700	EA	GLASS ONLY CONVEX HEATED LH
086259-05-701	EA	GLASS ONLY FLAT HEATED LH
092880-01-000	EA	WIRE-INSTRUMENT PANEL, REMOTE MIRROR

EXTERIOR MIRRORS

KEY PART NUMBER	U/M	DESCRIPTION
086280-01-000	EA	MIRROR-W/CONVEX, PASSENGER
086280-02-000	EA	MIRROR-W/CONVEX, DRIVER
086280-03-000	EA	ACCESSORY KIT-MIRROR, EXTENSION
086259-04-000	EA	MIRROR-REMOTE HEAT, W/ARM & MIRRORS - PRE-WIRED - PASSENGER
086259-04-700	EA	GLASS-MIRROR, HEATED CONVEX - PASSENGER SIDE
086259-04-701	EA	GLASS-MIRROR, HEATED FLAT - PASSENGER SIDE
086259-05-000	EA	MIRROR-REMOTE HEAT, W/ARM & MIRRORS - PRE-WIRED - DRIVER
086259-05-700	EA	GLASS-MIRROR, HEATED CONVEX - DRIVER SIDE
086259-05-701	EA	GLASS-MIRROR, HEATED FLAT - DRIVER SIDE
092880-01-000	EA	WIRE-INSTRUMENT PANEL, REMOTE MIRROR

AUXILIARY DEFROSTER FANS OPTION L38N - W/SWITCH

KEY PART NUMBER	U/M	DESCRIPTION
097372-03-01A	EA	SWITCH-ON-OFF-ON
000G39-08-24B	EA	SCREW-SF/DR, 8-18 X 1 1/2 PPH ZN
036420-02-000	EA	FAN-DEFROSTER, 2 SPEED - 6" DIAMETER

FIRE EXTINGUISHER

KEY PART NUMBER	U/M	DESCRIPTION
094499-02-000	EA	EXTINGUISHER-FIRE, DRY - 1A10BC - CANADIAN
094499-01-000	EA	EXTINGUISHER-FIRE, DRY W/MOUNTING BRACKET - 10 BC
094499-01-700	EA	BRACKET-MOUNTING, W/PLASTIC STRAP - FIRE EXTINGUISHER

ACCESSORIES GROUP (CONTINUED)

LP GENERATOR OPTION L33L- EXPORT

KEY PART NUMBER	U/M	DESCRIPTION
007125-03-000	EA	CLAMP-MUFFLER - 1.5" DIA
007125-04-000	EA	CLAMP-MUFFLER, 1.1" DIA
003289-01-000	EA	BOX-ELECTRIC, STEEL - 1/2" AND 3/4" KNOCKOUTS - 4" X 4"
008294-01-000	EA	COVER-ELECTRICAL BOX, STEEL/BLANK - 4" X 4" - GRAY
100974-05-000	EA	GENERATOR-4.0 KW EMERALD PLUS, ONAN BEIGE-FN
083152-04-000	EA	PIPE-EXHAUST, 1.3"OD X 4.9" TO BEND X 18.9" TO END
093511-01-000	EA	GENERATOR-VAPOR KIT, LP
093590-02-000	EA	MUFFLER-GENERATOR
008054-02-000	EA	CORD-POWER, 10-3 - 30AMP - 33'
008029-01-000	FT	WIRE-12/2, ROMEX - W/GROUND
008312-01-000	EA	CONNECTOR-WIRE NUT, INSULATED - BLUE
008314-01-000	EA	CONNECTOR-WIRE NUT, INSULATED - GRAY
008328-01-000	EA	TERMINAL-RING, 12/10 WIRE - #10 STUD FIT
008331-01-000	EA	TERMINAL-RING,TONGUE - #4 WIRE - 3/8" STUD - COPPER
008355-01-000	EA	CONNECTOR-CABLE CLAMPING, 3/4"
008356-01-000	EA	CONNECTOR-PLASTIC, 3/8" AVG
010497-01-000	EA	CLAMP-CLOSED, 5/8"ID
024924-02-000	EA	RECEPTACLE-POWER CORD, W/PARTIAL PLATE
041953-01-000	FT	CONDUIT-CONVOLUTED SLIT, .5"ID
087782-01-000	EA	CONVERTER-40 AMP, W/CHARGER - TRIAD TU-740-2
		FROM: 00-00-00 THRU: 07-29-90
089238-01-000	EA	COVER-ELECTRICAL BOX, W/HOLE - 4" X 4" - GRAY
		USED WITH 30 OR 50 AMP RECEPTACLE
083209-02-000	EA	CIRCUIT BREAKER-15/15AMP, 120V - BW H-15/15
083209-04-000	EA	CIRCUIT BREAKER-30A, 120V - BW L-30
		FROM: 06-29-90 THRU: 99-99-99
083209-05-000	EA	CIRCUIT BREAKER-20A, 120V - BW J-20
083209-08-000	EA	CIRCUIT BREAKER-30/15 AMP, 120V - BW D-30/15
		FROM: 00-00-00 THRU: 05-28-90
091213-01-000	EA	BOX-CIRCUIT BREAKER- W/KNOCKOUTS - 5.3" X 11.8" X 2.5"
095721-03-000	EA	LABEL-CONTROL CENTER, US
		FROM: 00-00-00 THRU: 07-08-90
000C28-04-10B	EA	BOLT-HEX, SER FLG - 1/4-20 X 5/8 ZINC
000D14-05-00B	EA	NUT-HEX, 5/16-16 - ZN 5
000D39-04-00B	EA	NUT-HEX, SER FLG LK 1/4 - 20 ZN
000D39-05-00B	EA	NUT-HEX, SER FLG LK - 5/16 - 18 ZN
000G39-08-08B	EA	SCREW-SF/DR, 8-18 X 1/2 PPH ZN
007125-03-000	EA	CLAMP-MUFFLER - 1.5" DIA
007131-01-000	EA	HANGER-TAILPIPE
008311-01-000	EA	CONNECTOR-WIRE NUT, INSULATED - RED
023942-01-000	EA	GROMMET-RUBBER, 2" OD

**1991 WINNEBAGO
TABLE OF CONTENTS**

INTRODUCTION	A-01 - A-02
ABBREVIATIONS	A-03
ALPHABETICAL INDEX	A-04 - A-08
WCN28RT	A-07 - G-10
WCN32RO	G-11 - L-20

1991 WCN28RT INDEX

FLOOR PLAN	A-07 - A-08
ACCESSORIES	A-09 - A-24
BATH	B-01 - B-04
BEDROOM	B-05 - B-08
CHASSIS	B-09 - C-08
C C & PAD	C-07 - C-18
DINETTE	C-19 - C-20
DRIVERS	C-21 - C-24
ELECTRICAL	D-01 - D-08
EXTERIOR BODY	D-09 - D-18
GALLEY	D-19 - E-02
HEATING & A/C	E-03 - E-08
INTERIOR FINISH	E-09 - E-13
LABEL	E-14 - E-22
LP	E-23
LOUNGE	E-24 - F-01
SEALANTS & FASTENERS	F-02 - F-04
WATER & SEWAGE	F-05 - F-11
WINDOW, VENT AND EXTERIOR DOOR	F-12 - G-10

ACCESSORIES GROUP (CONTINUED)

4.5 KW KOHLER GENERATOR OPTION L350 - US & CANADIAN

KEY PART NUMBER	U/M	DESCRIPTION
007125-03-000	EA	CLAMP-MUFFLER - 1.5" DIA
007125-04-000	EA	CLAMP-MUFFLER, 1.1" DIA
008289-01-000	EA	BOX-ELECTRIC, STEEL - 1/2" AND 3/4" KNOCKOUTS - 4" X 4"
008289-02-000	EA	BOX-ELECTRICAL, 4" X 4" - 1/2" & 3/4" KNOCKOUTS - CANADIAN
008294-01-000	EA	COVER-ELECTRICAL BOX, STEEL/BLANK - 4" X 4" - GRAY
008294-02-000	EA	COVER-ELECTRICAL BOX, BLANK STEEL - 4" X 4" - CANADIAN
083152-10-000	EA	PIPE-EXHAUST, 1.3"OD X 7.8" TO BEND X 22" TO END
093590-02-000	EA	MUFFLER-GENERATOR
093740-01-000	EA	GENERATOR-KOHLER, 4500KW - 4.5CKM21
008054-02-000	EA	CORD-POWER, 10-3 - 30AMP - 33'
008052-01-000	EA	CORD-POWER, 10/3 - 30 AMP - 25' - CANADIAN
008026-01-000	FT	WIRE-12/2, ROMEX - W/GROUND
008312-01-000	EA	CONNECTOR-WIRE NUT, INSULATED - BLUE
008314-01-000	EA	CONNECTOR-WIRE NUT, INSULATED - GRAY
008328-01-000	EA	TERMINAL-RING, 12/10 WIRE - #10 STUD FIT
008331-01-000	EA	TERMINAL-RING, TONGUE - #4 WIRE - 3/8" STUD - COPPER
008355-01-000	EA	CONNECTOR-CABLE CLAMPING, 3/4"
008356-01-000	EA	CONNECTOR-PLASTIC, 3/8" AVG
010497-01-000	EA	CLAMP-CLOSED, 5/8" ID
024924-02-000	EA	RECEPTACLE-POWER CORD, W/PARTIAL PLATE
041953-01-000	FT	CONDUIT-CONVOLUTED SLIT, 5" ID
087782-01-000	EA	CONVERTER-40 AMP, W/CHARGER - TRIAD TU-740-2 FROM: 00-00-00 THRU: 07-29-90
087782-02-000	EA	CONVERTER-40AMP, W/CHARGER - TRIAD TU-840-2 - CANADIAN FROM: 00-00-00 THRU: 07-29-90
089238-01-000	EA	COVER-ELECTRICAL BOX, W/HOLE - 4" X 4" - GRAY USED WITH 30 OR 50 AMP RECEPTACLE
083209-02-000	EA	CIRCUIT BREAKER-15/15AMP, 120V - BW H-15/15
083209-03-000	EA	CIRCUIT BREAKER-15/20AMP, 120V - BW - 0-15/20 - CANADIAN
083209-04-000	EA	CIRCUIT BREAKER-30A, 120V - BW L-30 FROM: 05-29-90 THRU: 99-99-99
083209-05-000	EA	CIRCUIT BREAKER-20A, 120V - BW J-20
083209-06-000	EA	CIRCUIT BREAKER-30/15 AMP, 120V - BW D-30/15
083210-02-000	EA	CIRCUIT BREAKER-GFI, 15A - 120V - BW U-15 - CANADIAN FROM: 00-00-00 THRU: 05-29-90
091213-01-000	EA	BOX-CIRCUIT BREAKER- W/KNOCKOUTS - 5.3" X 11.8" X 2.5"
093257-01-000	EA	BOX-ELECTRICAL, CIRCUIT BREAKER
095721-03-000	EA	LABEL-CONTROL CENTER, US FROM: 00-00-00 THRU: 07-08-90
008353-01-000	EA	CONNECTOR-CABLE CLAMPING, 3/8" - CANADIAN
024978-01-000	EA	SWITCH-GENERATOR, W/O CIRCUIT BOARD - CANADIAN
000C26-04-10B	EA	BOLT-HEX, SER FLG - 1/4-20 X 5/8 ZINC
000D14-05-00B	EA	NUT-HEX, 5/16-18 - ZN 5
000D39-04-00B	EA	NUT-HEX, SER FLG LK 1/4 - 20 ZN
000D39-05-00B	EA	NUT-HEX, SER FLG LK - 5/16 - 18 ZN
000G39-08-08B	EA	SCREW-SF/DR, 8-18 X 1/2 PPH ZN
007131-01-000	EA	HANGER-TAILPIPE
008311-01-000	EA	CONNECTOR-WIRE NUT, INSULATED - RED

ACCESSORIES GROUP (CONTINUED)

4.5 KW KOHLER GENERATOR OPTION L350- DIESEL - US & CANADIAN

KEY PART NUMBER	U/M	DESCRIPTION
045703-01-000	EA	HOSE-L/P, 3/8" ID X 24" US - 3/8 MPT X 1/2 F SWIVEL
045703-02-000	EA	HOSE-L/P, 3/8" ID X 24" - 3/8" MPT X 1/2" F SWIVEL - CANADA
085318-02-000	EA	ELBOW-90 DEGREE, 3/8" MPT TO 3/8" FPT
078301-01-000	EA	REGULATOR-TWO STAGE LPG, MARSHALL BRASS 280-00
081938-01-000	EA	COVER-COMPARTMENT - LP REGULATOR - BLACK
007125-03-000	EA	CLAMP-MUFFLER - 1.5" DIA
007125-04-000	EA	CLAMP-MUFFLER, 1.1" DIA
008294-01-000	EA	COVER-ELECTRICAL BOX, STEEL/BLANK - 4" X 4" - GRAY
008294-02-000	EA	COVER-ELECTRICAL BOX, BLANK STEEL - 4" X 4" - CANADIAN
083152-10-000	EA	PIPE-EXHAUST, 1.3"OD X 7.8" TO BEND X 22" TO END
093590-02-000	EA	MUFFLER-GENERATOR
093740-01-000	EA	GENERATOR-KOHLER, 4500KW - 4.5CKM21
008054-02-000	EA	CORD-POWER, 10-3 - 30AMP - 33'
008052-01-000	EA	CORD-POWER, 10/3 - 30 AMP - 25' - CANADIAN
008289-01-000	EA	BOX-ELECTRIC, STEEL - 1/2" AND 3/4" KNOCKOUTS - 4" X 4"
008289-02-000	EA	BOX-ELECTRICAL, 4" X 4" - 1/2" & 3/4" KNOCKOUTS - CANADIAN
008312-01-000	EA	CONNECTOR-WIRE NUT, INSULATED - BLUE
008314-01-000	EA	CONNECTOR-WIRE NUT, INSULATED - GRAY
008328-01-000	EA	TERMINAL-RING, 12/10 WIRE - #10 STUD FIT
008331-01-000	EA	TERMINAL-RING, TONGUE - #4 WIRE - 3/8" STUD - COPPER
008353-01-000	EA	CONNECTOR-CABLE CLAMPING, 3/8" - CANADIAN
008355-01-000	EA	CONNECTOR-CABLE CLAMPING, 3/4"
008356-01-000	EA	CONNECTOR-PLASTIC, 3/8" AVG
010497-01-000	EA	CLAMP-CLOSED, 5/8" ID
024924-02-000	EA	RECEPTACLE-POWER CORD, W/PARTIAL PLATE
041953-01-000	FT	CONDUIT-CONVOLUTED SLIT, 5" ID
087782-01-000	EA	CONVERTER-40 AMP, W/CHARGER - TRIAD TU-740-2 FROM: 00-00-00 THRU: 07-29-90
087782-02-000	EA	CONVERTER-40AMP, W/CHARGER - TRIAD TU-840-2 - CANADIAN FROM: 00-00-00 THRU: 07-29-90
089238-01-000	EA	COVER-ELECTRICAL BOX, W/HOLE - 4" X 4" - GRAY USED WITH 30 OR 50 AMP RECEPTACLE
083209-02-000	EA	CIRCUIT BREAKER-15/15AMP, 120V - BW H-15/15
083209-03-000	EA	CIRCUIT BREAKER-15/20AMP, 120V - BW - 0-15/20
083209-04-000	EA	CIRCUIT BREAKER-30A, 120V - BW L-30 FROM: 05-29-90 THRU: 99-99-99
083209-05-000	EA	CIRCUIT BREAKER-20A, 120V - BW J-20
083209-06-000	EA	CIRCUIT BREAKER-30/15 AMP, 120V - BW D-30/15
083210-02-000	EA	CIRCUIT BREAKER-GFI, 15A - 120V - BW U-15 - CANADIAN FROM: 00-00-00 THRU: 05-29-90
091213-01-000	EA	BOX-CIRCUIT BREAKER- W/KNOCKOUTS - 5.3" X 11.8" X 2.5"
093257-01-000	EA	BOX-ELECTRICAL, CIRCUIT BREAKER - CANADIAN
095721-03-000	EA	LABEL-CONTROL CENTER, US FROM: 00-00-00 THRU: 07-08-90
000C26-04-10B	EA	BOLT-HEX, SER FLG - 1/4-20 X 5/8 ZINC
000D14-05-00B	EA	NUT-HEX, 5/16-18 - ZN 5
000D39-04-00B	EA	NUT-HEX, SER FLG LK 1/4 - 20 ZN
000D39-05-00B	EA	NUT-HEX, SER FLG LK - 5/16 - 18 ZN
000G39-08-08B	EA	SCREW-SF/DR, 8-18 X 1/2 PPH ZN
007131-01-000	EA	HANGER-TAILPIPE
008311-01-000	EA	CONNECTOR-WIRE NUT, INSULATED - RED

1991 WINNEBAGO

TABLE OF CONTENTS

INTRODUCTION	A-01 - A-02
ABBREVIATIONS	A-03
ALPHABETICAL INDEX	A-04 - A-08
WCN28RT	A-07 - G-10
WCN32RQ	G-11 - L-20

1991 WCN28RT INDEX

FLOOR PLAN	A-07 - A-08
ACCESSORIES	A-09 - A-24
BATH	B-01 - B-04
BEDROOM	B-05 - B-08
CHASSIS	B-09 - C-06
C C & PAD	C-07 - C-18
DINETTE	C-19 - C-20
DRIVERS	C-21 - C-24
ELECTRICAL	D-01 - D-08
EXTERIOR BODY	D-09 - D-18
GALLEY	D-19 - E-02
HEATING & AC	E-03 - E-08
INTERIOR FINISH	E-09 - E-13
LABEL	E-14 - E-22
LP	E-23
LOUNGE	E-24 - F-01
SEALANTS & FASTENERS	F-02 - F-04
WATER & SEWAGE	F-05 - F-11
WINDOW, VENT AND EXTERIOR DOOR	F-12 - G-10

ACCESSORIES GROUP (CONTINUED)

3.5KW ONAN GENERATOR OPTION L383 - EXPORT

KEY PART NUMBER	U/M	DESCRIPTION
007125-03-000	EA	CLAMP-MUFFLER - 1.5" DIA
007125-04-000	EA	CLAMP-MUFFLER, 1.1" DIA
008289-01-000	EA	BOX-ELECTRIC, STEEL - 1/2" AND 3/4" KNOCKOUTS - 4" X 4"
008294-01-000	EA	COVER-ELECTRICAL BOX, STEEL/BLANK - 4" X 4" - GRAY
100974-06-000	EA	GENERATOR-4.0 KW EMERALD PLUS, ONAN BEIGE-FN
083152-04-000	EA	PIPE-EXHAUST, 1.3"OD X 4.9" TO BEND X 18.9" TO END
093590-02-000	EA	MUFFLER-GENERATOR
008054-01-000	EA	CORD-POWER, 10/3 WIRE - 30 AMP - 25'
008026-01-000	FT	WIRE-12/2, ROMEX - W/GROUND
008289-01-000	EA	BOX-ELECTRIC, STEEL - 1/2" AND 3/4" KNOCKOUTS - 4" X 4"
008311-01-000	EA	CONNECTOR-WIRE NUT, INSULATED - RED
008312-01-000	EA	CONNECTOR-WIRE NUT, INSULATED - BLUE
008314-01-000	EA	CONNECTOR-WIRE NUT, INSULATED - GRAY
008328-01-000	EA	TERMINAL-RING, 12/10 WIRE - #10 STUD FIT
008331-01-000	EA	TERMINAL-RING, TONGUE - #4 WIRE - 3/8" STUD - COPPER
008353-01-000	EA	CONNECTOR-CABLE CLAMPING, 3/8"
008355-01-000	EA	CONNECTOR-CABLE CLAMPING, 3/4"
008356-01-000	EA	CONNECTOR-PLASTIC, 3/8" AVG
010497-01-000	EA	CLAMP-CLOSED, 5/8" ID
016604-01-000	EA	BRACE-CABINET, ANGLED METAL - 2.5"
024924-02-000	EA	RECEPTACLE-POWER CORD, W/PARTIAL PLATE
041953-01-000	FT	CONDUIT-CONVOLUTED SLIT, .5" ID
092615-01-000	EA	CONVERTER-40 AMP, W/CHARGER - B-W 32400P FROM: 00-00-00 THRU: 05-28-90
067762-02-000	EA	CONVERTER-40AMP, W/CHARGER - TRIAD TU-840-2 FROM: 05-29-90 THRU: 07-29-90
089238-01-000	EA	COVER-ELECTRICAL BOX, W/HOLE - 4" X 4" - GRAY USED WITH 30 OR 50 AMP RECEPTACLE
073937-03-000	EA	SWITCH-ROTARY SELECTOR - 3 DECK - A/C - TK20-090804-001
073937-01-700	EA	KNOB-ROTARY SWITCH, A/C SELECTOR - 145749
074890-01-000	EA	BOX-EXTENSION, STEEL - OPEN SIDES - 4" X 4" X 1 1/2"
074897-01-000	EA	COVER-ELECTRIC BOX, 1 LARGE & 2 SMALL HOLES - 4" X 4"
008294-01-000	EA	COVER-ELECTRICAL BOX, STEEL/BLANK - 4" X 4" - GRAY
091213-01-000	EA	BOX-CIRCUIT BREAKER- W/KNOCKOUTS - 5.3" X 11.8" X 2.5"
000C26-04-10B	EA	BOLT-HEX, SER FLG - 1/4-20 X 5/8 ZINC
000D14-05-00B	EA	NUT-HEX, 5/16-18 - ZN 5
000D39-04-00B	EA	NUT-HEX, SER FLG LK 1/4 - 20 ZN
000D39-05-00B	EA	NUT-HEX, SER FLG LK - 5/16 - 18 ZN
000G39-08-08B	EA	SCREW-SF/DR, 8-18 X 1/2 PPH ZN
007131-01-000	EA	HANGER-TAILPIPE
024976-01-000	EA	SWITCH-GENERATOR, W/O CIRCUIT BOARD

ACCESSORIES GROUP (CONTINUED)

4.0KW ONAN GENERATOR OPTION L39E - U.S. & CANADIAN

KEY PART NUMBER	U/M	DESCRIPTION
007125-03-000	EA	CLAMP-MUFFLER - 1.5" DIA
007125-04-000	EA	CLAMP-MUFFLER, 1.1" DIA
008289-01-000	EA	BOX-ELECTRIC, STEEL - 1/2" AND 3/4" KNOCKOUTS - 4" X 4"
008294-01-000	EA	COVER-ELECTRICAL BOX, STEEL/BLANK - 4" X 4" - GRAY
008294-02-000	EA	COVER-ELECTRICAL BOX, BLANK STEEL - 4" X 4" - CANADIAN
079854-05-000	EA	PIPE-EXHAUST, ANGLED - W/FLANGE - EMERALD - ONAN# 154-2539
081384-03-000	EA	MUFFLER-GENERATOR, ONAN
083152-01-000	EA	PIPE-EXHAUST, 1.3"OD X 33.3" TO BEND X 28.7" TO END
083152-08-000	EA	PIPE-EXHAUST, 1.3"OD X 4.9" TO BEND X 55.1" TO END
100974-01-000	EA	GENERATOR-4.0KW EMERALD PLUS, ONAN BEIGE-FA/26100G
094059-01-000	EA	SPACER-GENERATOR, ONAN
055278-01-001	FT	TUBING-STEEL, .75" X 1.5" X 288"
094657-02-000	EA	TRAY-GENERATOR, 22.5" X 30.4" X 8.9"
094657-01-000	EA	TRAY-GENERATOR, 22.5" X 30.4" X 6.9"
008054-02-000	EA	CORD-POWER, 10-3 - 30AMP - 33'
008052-01-000	EA	CORD-POWER, 10/3 - 30 AMP - 25' - CANADIAN
008026-01-000	FT	WIRE-12/2, ROMEX - W/GROUND
008312-01-000	EA	CONNECTOR-WIRE NUT, INSULATED - BLUE
008314-01-000	EA	CONNECTOR-WIRE NUT, INSULATED - GRAY
008328-01-000	EA	TERMINAL-RING, 12/10 WIRE - #10 STUD FIT
008331-01-000	EA	TERMINAL-RING, TONGUE - #4 WIRE - 3/8" STUD - COPPER
008355-01-000	EA	CONNECTOR-CABLE CLAMPING, 3/4"
008356-01-000	EA	CONNECTOR-PLASTIC, 3/8" AVG
010497-01-000	EA	CLAMP-CLOSED, 5/8" ID
024924-02-000	EA	RECEPTACLE-POWER CORD, W/PARTIAL PLATE
041953-01-000	FT	CONDUIT-CONVOLUTED SLIT, .5" ID
067762-01-000	EA	CONVERTER-40 AMP, W/CHARGER - TRIAD TU-740-2 FROM: 00-00-00 THRU: 07-29-90
067762-02-000	EA	CONVERTER-40AMP, W/CHARGER - TRIAD TU-840-2 - CANADIAN FROM: 00-00-00 THRU: 07-29-90
089238-01-000	EA	COVER-ELECTRICAL BOX, W/HOLE - 4" X 4" - GRAY USED WITH 30 OR 50 AMP RECEPTACLE
083209-02-000	EA	CIRCUIT BREAKER-15/15AMP, 120V - BW H-15/15
083209-03-000	EA	CIRCUIT BREAKER-15/20AMP, 120V - BW - 0-15/20 - CANADIAN
083209-04-000	EA	CIRCUIT BREAKER-30A, 120V - BW L-30 FROM: 05-29-90 THRU: 99-99-99
083209-05-000	EA	CIRCUIT BREAKER-20A, 120V - BW J-20
083209-06-000	EA	CIRCUIT BREAKER-30/15 AMP, 120V - BW D-30/15
083210-02-000	EA	CIRCUIT BREAKER-GFI, 15A - 120V - PW U-15 - CANADIAN FROM: 00-00-00 THRU: 05-29-90
091213-01-000	EA	BOX-CIRCUIT BREAKER- W/KNOCKOUTS - 5.3" X 11.8" X 2.5"
093257-01-000	EA	BOX-ELECTRICAL, CIRCUIT BREAKER - CANADIAN
095721-03-000	EA	LABEL-CONTROL CENTER, US FROM: 00-00-00 THRU: 07-08-90
000C26-04-10B	EA	BOLT-HEX, SER FLG - 1/4-20 X 5/8 ZINC
000D14-05-00B	EA	NUT-HEX, 5/16-18 - ZN 5
000D39-04-00B	EA	NUT-HEX, SER FLG LK 1/4 - 20 ZN
000D39-05-00B	EA	NUT-HEX, SER FLG LK - 5/16 - 18 ZN
000G39-08-08B	EA	SCREW-SF/DR, 8-18 X 1/2 PPH ZN
007131-01-000	EA	HANGER-TAILPIPE
008311-01-000	EA	CONNECTOR-WIRE NUT, INSULATED - RED
008353-01-000	EA	CONNECTOR-CABLE CLAMPING, 3/8" - CANADIAN
024976-01-000	EA	SWITCH-GENERATOR, W/O CIRCUIT BOARD

**1991 WINNEBAGO
TABLE OF CONTENTS**

INTRODUCTION	A-01 - A-02
ABBREVIATIONS	A-03
ALPHABETICAL INDEX	A-04 - A-08
WCN28HT	A-07 - G-10
WCN32RO	G-11 - L-20

1991 WCN28RT INDEX

FLOOR PLAN	A-07 - A-08
ACCESSORIES	A-09 - A-24
BATH	B-01 - B-04
BEDROOM	B-05 - B-08
CHASSIS	B-09 - C-06
C C & PAD	C-07 - C-18
DINETTE	C-19 - C-20
DRIVERS	C-21 - C-24
ELECTRICAL	D-01 - D-08
EXTERIOR BODY	D-09 - D-18
GALLEY	D-19 - E-02
HEATING & A/C	E-03 - E-08
INTERIOR FINISH	E-09 - E-13
LABEL	E-14 - E-22
LP	E-23
LOUNGE	E-24 - F-01
SEALANTS & FASTENERS	F-02 - F-04
WATER & SEWAGE	F-05 - F-11
WINDOW, VENT AND EXTERIOR DOOR	F-12 - G-10

ACCESSORIES GROUP (CONTINUED)

GENERATOR-ONAN, 3.5 KW - EXPORT OPTION L383

KEY PART NUMBER	U/M	DESCRIPTION
007125-03-000	EA	CLAMP-MUFFLER - 1.5" DIA
007125-04-000	EA	CLAMP-MUFFLER, 1.1" DIA
008289-01-000	EA	BOX-ELECTRIC, STEEL - 1/2" AND 3/4" KNOCKOUTS - 4" X 4"
008294-01-000	EA	COVER-ELECTRICAL BOX, STEEL/BLANK - 4" X 4" - GRAY
100974-05-000	EA	GENERATOR-4.0 KW EMERALD PLUS, ONAN BEIGE-FN
083152-04-000	EA	PIPE-EXHAUST, 1.3"OD X 4.9" TO BEND X 18.9" TO END
083590-02-000	EA	MUFFLER-GENERATOR
008054-01-000	EA	CORD-POWER, 10/3 WIRE - 30 AMP - 25'
008026-01-000	FT	WIRE-12/2, ROMEX - W/GROUND
008289-01-000	EA	BOX-ELECTRIC, STEEL - 1/2" AND 3/4" KNOCKOUTS - 4" X 4"
008311-01-000	EA	CONNECTOR-WIRE NUT, INSULATED - RED
008312-01-000	EA	CONNECTOR-WIRE NUT, INSULATED - BLUE
008314-01-000	EA	CONNECTOR-WIRE NUT, INSULATED - GRAY
008328-01-000	EA	TERMINAL-RING, 12/10 WIRE - #10 STUD FIT
078331-01-000	EA	TERMINAL-RING, TONGUE - #4 WIRE - 3/8" STUD - COPPER
008353-01-000	EA	CONNECTOR-CABLE CLAMPING, 3/8"
008355-01-000	EA	CONNECTOR-CABLE CLAMPING, 3/4"
008356-01-000	EA	CONNECTOR-PLASTIC, 3/8" AVG
010497-01-000	EA	CLAMP-CLOSED, 5/8" ID
018804-01-000	EA	BRACE-CABINET, ANGLED METAL - 2.5"
024924-02-000	EA	RECEPTACLE-POWER CORD, W/PARTIAL PLATE
041953-01-000	FT	CONDUIT-CONVOLUTED SLIT, .5" ID
082815-01-000	EA	CONVERTER-40 AMP, W/CHARGER - B-W 32400P
		FROM: 00-00-00 THRU: 05-28-90
087782-02-000	EA	CONVERTER-40AMP, W/CHARGER - TRIAD TU-840-2
		FROM: 05-29-90 THRU: 07-23-90
089238-01-000	EA	COVER-ELECTRICAL BOX, W/HOLE - 4" X 4" - GRAY
		USED WITH 30 OR 50 AMP RECEPTACLE
073937-03-000	EA	SWITCH-ROTARY SELECTOR - 3 DECK - AC - TK20-080804-001
073937-01-700	EA	KNOB-ROTARY SWITCH, AC SELECTOR - 145749
074890-01-000	EA	BOX-EXTENSION, STEEL - OPEN SIDES - 4" X 4" X 1 1/2"
074897-01-000	EA	COVER-ELECTRIC BOX, 1 LARGE & 2 SMALL HOLES - 4" X 4"
008294-01-000	EA	COVER-ELECTRICAL BOX, STEEL/BLANK - 4" X 4" - GRAY
091213-01-000	EA	BOX-CIRCUIT BREAKER- W/KNOCKOUTS - 5.3" X 11.8" X 2.5"
000C26-04-10B	EA	BOLT-HEX, SER FLG - 1/4-20 X 5/8 ZINC
000D14-05-00B	EA	NUT-HEX, 5/16-18 - ZN 5
000D39-04-00B	EA	NUT-HEX, SER FLG LK 1/4 - 20 ZN
000D39-05-00B	EA	NUT-HEX, SER FLG LK - 5/16 - 18 ZN
000G39-08-08B	EA	SCREW-SF/DR, 8-18 X 1/2 PPH ZN
007131-01-000	EA	HANGER-TAILPIPE
024978-01-000	EA	SWITCH-GENERATOR, W/O CIRCUIT BOARD

ACCESSORIES GROUP (CONTINUED)

4.0KW ONAN GENERATOR OPTION L39E - U.S. & CANADIAN

KEY PART NUMBER	U/M	DESCRIPTION
007125-03-000	EA	CLAMP-MUFFLER - 1.5" DIA
007125-04-000	EA	CLAMP-MUFFLER, 1.1" DIA
008289-01-000	EA	BOX-ELECTRIC, STEEL - 1/2" AND 3/4" KNOCKOUTS - 4" X 4"
008289-02-000	EA	BOX-ELECTRICAL, 4" X 4" - 1/2" & 3/4" KNOCKOUTS - CANADIAN
008294-01-000	EA	COVER-ELECTRICAL BOX, STEEL/BLANK - 4" X 4" - GRAY
008294-02-000	EA	COVER-ELECTRICAL BOX, BLANK STEEL - 4" X 4" - CANADIAN
079854-05-000	EA	PIPE-EXHAUST, ANGLED - W/FLANGE - EMERALD - ONAN# 154-2539
081364-03-000	EA	MUFFLER-GENERATOR, ONAN
083152-01-000	EA	PIPE-EXHAUST, 1.3"OD X 33.3" TO BEND X 28.7" TO END
083152-08-000	EA	PIPE-EXHAUST, 1.3"OD X 4.9" TO BEND X 55.1" TO END
100974-01-000	EA	GENERATOR-4.0KW EMERALD PLUS, ONAN BEIGE-FA/28100G
094059-01-000	EA	SPACER-GENERATOR, ONAN
056278-01-001	FT	TUBING-STEEL, .75" X 1.5" X 288"
084857-02-000	EA	TRAY-GENERATOR, 22.5" X 30.4" X 8.9"
094857-01-000	EA	TRAY-GENERATOR, 22.5" X 30.4" X 8.9"
008054-02-000	EA	CORD-POWER, 10-3 - 30 AMP - 33'
008052-01-000	EA	CORD-POWER, 10/3 - 30 AMP - 25' - CANADIAN
008026-01-000	FT	WIRE-12/2, HOMEX - W/GROUND
008312-01-000	EA	CONNECTOR-WIRE NUT, INSULATED - BLUE
008314-01-000	EA	CONNECTOR-WIRE NUT, INSULATED - GRAY
008328-01-000	EA	TERMINAL-RING, 12/10 WIRE - #10 STUD FIT
008331-01-000	EA	TERMINAL-RING, TONGUE - #4 WIRE - 3/8" STUD - COPPER
008355-01-000	EA	CONNECTOR-CABLE CLAMPING, 3/4"
008356-01-000	EA	CONNECTOR-PLASTIC, 3/8" AVG
010497-01-000	EA	CLAMP-CLOSED, 5/8" ID
024924-02-000	EA	RECEPTACLE-POWER CORD, W/PARTIAL PLATE
041953-01-000	FT	CONDUIT-CONVOLUTED SLIT, .5" ID
087782-01-000	EA	CONVERTER-40 AMP, W/CHARGER - TRIAD TU-740-2
		FROM: 00-00-00 THRU: 07-29-90
087782-02-000	EA	CONVERTER-40AMP, W/CHARGER - TRIAD TU-840-2 - CANADIAN
		FROM: 00-00-00 THRU: 07-29-90
089238-01-000	EA	COVER-ELECTRICAL BOX, W/HOLE - 4" X 4" - GRAY
		USED WITH 30 OR 50 AMP RECEPTACLE
083209-02-000	EA	CIRCUIT BREAKER-15/15AMP, 120V - BW H-15/15
083209-03-000	EA	CIRCUIT BREAKER-15/20AMP, 120V - BW - 0-15/20 - CANADIAN
083209-04-000	EA	CIRCUIT BREAKER-30A, 120V - BW L-30
		FROM: 05-29-90 THRU: 99-99-99
083209-05-000	EA	CIRCUIT BREAKER-20A, 120V - BW J-20
083209-06-000	EA	CIRCUIT BREAKER-30/15 AMP, 120V - BW D-30/15
083210-02-000	EA	CIRCUIT BREAKER-GFI, 15A - 120V - BW U-15 - CANADIAN
		FROM: 00-00-00 THRU: 05-28-90
091213-01-000	EA	BOX-CIRCUIT BREAKER- W/KNOCKOUTS - 5.3" X 11.8" X 2.5"
083257-01-000	EA	BOX-ELECTRICAL, CIRCUIT BREAKER - CANADIAN
095721-03-000	EA	LABEL-CONTROL CENTER, US
		FROM: 00-00-00 THRU: 07-08-90
000C26-04-10B	EA	BOLT-HEX, SER FLG - 1/4-20 X 5/8 ZINC
000D14-05-00B	EA	NUT-HEX, 5/16-18 - ZN 5
000D39-04-00B	EA	NUT-HEX, SER FLG LK 1/4 - 20 ZN
000D39-05-00B	EA	NUT-HEX, SER FLG LK - 5/16 - 18 ZN
000G39-08-08B	EA	SCREW-SF/DR, 8-18 X 1/2 PPH ZN
007131-01-000	EA	HANGER-TAILPIPE
008311-01-000	EA	CONNECTOR-WIRE NUT, INSULATED - RED
008353-01-000	EA	CONNECTOR-CABLE CLAMPING, 3/8" - CANADIAN
024978-01-000	EA	SWITCH-GENERATOR, W/O CIRCUIT BOARD

**1991 WINNEBAGO
TABLE OF CONTENTS**

INTRODUCTION	A-01 - A-02
ABBREVIATIONS	A-03
ALPHABETICAL INDEX	A-04 - A-08
WCN28RT	A-07 - G-10
WCN32RQ	G 11 - L-20

1991 WCN28RT INDEX

FLOOR PLAN	A-07 - A-08
ACCESSORIES	A-09 - A-24
BATH	B-01 - B-04
BEDROOM	B-05 - B-08
CHASSIS	B-09 - C-06
C C & PAD	C-07 - C-18
DINETTE	C-19 - C-20
DRIVERS	C-21 - C-24
ELECTRICAL	D-01 - D-08
EXTERIOR BODY	D-09 - D-18
GALLEY	D-19 - E-02
HEATING & A/C	E-03 - E-08
INTERIOR FINISH	E-09 - E-13
LABEL	E-14 - E-22
LP	E-23
LOUNGE	E-24 - F-01
SEALANTS & FASTENERS	F-02 - F-04
WATER & SEWAGE	F-05 - F-11
WINDOW, VENT AND EXTERIOR DOOR	F-12 - G-10

ACCESSORIES GROUP (CONTINUED)

4.0KW ONAN GENERATOR OPTION L39E- DIESEL - US & CANADIAN

KEY PART NUMBER	U/M	DESCRIPTION
041703-01-000	EA	HOSE-LP, 3/8" ID X 24" US - 3/8 MPT X 1/2 F SWIVEL
041703-02-000	EA	HOSE-LP, 3/8" ID X 24" - 3/8" MPT X 1/2" F SWIVEL - CANADA
085318-02-000	EA	ELBOW-90 DEGREE, 3/8" MPT TO 3/8" FPT
078101-01-000	EA	REGULATOR-TWO STAGE I.P.G. MARSHALL BRASS 280-00
081136-01-000	EA	COVER-COMPARTMENT - LP REGULATOR - BLACK
007125-03-000	EA	CLAMP-MUFFLER - 1.5" DIA
007125-04-000	EA	CLAMP-MUFFLER, 1.1" DIA
008269-01-000	EA	BOX-ELECTRIC, STEEL - 1/2" AND 3/4" KNOCKOUTS - 4" X 4"
008269-02-000	EA	BOX-ELECTRICAL, 4" X 4" - 1/2" & 3/4" KNOCKOUTS - CANADIAN
008269-01-000	EA	COVER-ELECTRICAL BOX, STEEL/BLANK - 4" X 4" - GRAY
008294-02-000	EA	COVER-ELECTRICAL BOX, BLANK STEEL - 4" X 4" - CANADIAN
079854-05-000	EA	PIPE-EXHAUST, ANGLED - W/FLANGE - EMERALD - ONAN# 154-2539
081364-03-000	EA	MUFFLER-GENERATOR, ONAN
083152-01-000	EA	PIPE-EXHAUST, 1.3" OD X 33.3" TO BEND X 28.7" TO END
083152-06-000	EA	PIPE-EXHAUST, 1.3" OD X 4.9" TO BEND X 55.1" TO END
100974-01-000	EA	GENERATOR-4.0KW EMERALD PLUS, ONAN BEIGE-FA/28100G
094059-01-000	EA	SPACER-GENERATOR, ONAN
055278-01-001	FT	TUBING-STEEL, .75" X 1.5" X 288"
094657-02-000	EA	TRAY-GENERATOR, 22.5" X 30.4" X 6.9" W/ANGLE & NUTS
094657-01-000	EA	TRAY-GENERATOR, 22.5" X 30.4" X 6.9"
008054-02-000	EA	CORD-POWER, 10-3 - 30AMP - 33'
008052-01-000	EA	CORD-POWER, 10/3 - 30 AMP - 25' - CANADIAN
008028-01-000	FT	WIRE-12/2, ROMEX - W/GROUND
008312-01-000	EA	CONNECTOR-WIRE NUT, INSULATED - BLUE
008314-01-000	EA	CONNECTOR-WIRE NUT, INSULATED - GRAY
008328-01-000	EA	TERMINAL-RING, 12/10 WIRE - #10 STUD FIT
008331-01-000	EA	TERMINAL-RING, TONGUE - #4 WIRE - 3/8" STUD - COPPER
008355-01-000	EA	CONNECTOR-CABLE CLAMPING, 3/4"
008356-01-000	EA	CONNECTOR-PLASTIC, 3/8" AVG
010497-01-000	EA	CLAMP-CLOSED, 5/8" ID
024924-02-000	EA	RECEPTACLE-POWER CORD, W/PARTIAL PLATE
041953-01-000	FT	CONDUIT-CONVOLUTED SLIT, .5" ID
067762-01-000	EA	CONVERTER-40 AMP, W/CHARGER - TRIAD TU-740-2 FROM: 00-00-00 THRU: 07-29-90
067762-02-000	EA	CONVERTER-40AMP, W/CHARGER - TRIAD TU-840-2 - CANADIAN FROM: 00-00-00 THRU: 07-29-90
069238-01-000	EA	COVER-ELECTRICAL BOX, W/HOLE - 4" X 4" - GRAY USED WITH 30 OR 50 AMP RECEPTACLE
083209-02-000	EA	CIRCUIT BREAKER-15/15AMP, 120V - BW H-15/15
083209-03-000	EA	CIRCUIT BREAKER-15/20AMP, 120V - BW - 0-15/20
083209-04-000	EA	CIRCUIT BREAKER-30A, 120V - BW L-30 FROM: 05-29-90 THRU: 99-99-99
083209-05-000	EA	CIRCUIT BREAKER-20A, 120V - BW J-20
083209-06-000	EA	CIRCUIT BREAKER-30/15 AMP, 120V - BW D-30/15
083210-02-000	EA	CIRCUIT BREAKER-GFI, 15A - 120V - BW U-15 - CANADIAN FROM: 00-00-00 THRU: 05-28-90
091213-01-000	EA	BOX-CIRCUIT BREAKER- W/KNOCKOUTS - 5.3" X 11.8" X 2.5"
093257-01-000	EA	BOX-ELECTRICAL, CIRCUIT BREAKER - CANADIAN
095721-03-000	EA	LABEL-CONTROL CENTER, US FROM: 00-00-00 THRU: 07-08-90
000C28-04-10B	EA	BOLT-HEX, SER FLG - 1/4-20 X 5/8 ZINC
000D14-05-00B	EA	NUT-HEX, 5/16-18 - ZN 5
000D39-04-00B	EA	NUT-HEX, SER FLG LK 1/4 - 20 ZN
000D39-05-00B	EA	NUT-HEX, SER FLG LK - 5/16 - 18 ZN
0C0G39-08-08B	EA	SCREW-SF/DR, 8-18 X 1/2 PPH ZN
007125-03-000	EA	CLAMP-MUFFLER - 1.5" DIA
007131-01-000	EA	HANGER-TAILPIPE
008311-01-000	EA	CONNECTOR-WIRE NUT, INSULATED - RED
008353-01-000	EA	CONNECTOR-CABLE CLAMPING, 3/8" - CANADIAN
024978-01-000	EA	SWITCH-GENERATOR, W/O CIRCUIT BOARD

ACCESSORIES GROUP (CONTINUED)

4.0 KW ONAN GENERATOR OPTION

KEY PART NUMBER	U/M	DESCRIPTION
007125-03-000	EA	CLAMP-MUFFLER - 1.5" DIA
007125-04-000	EA	CLAMP-MUFFLER, 1.1" DIA
079854-05-000	EA	PIPE-EXHAUST, ANGLED - W/FLANGE - EMERALD - ONAN# 154-2539
081364-03-000	EA	MUFFLER-GENERATOR, ONAN
083152-01-000	EA	PIPE-EXHAUST, 1.3" OD X 33.3" TO BEND X 28.7" TO END
083152-06-000	EA	PIPE-EXHAUST, 1.3" OD X 4.9" TO BEND X 55.1" TO END
100974-01-000	EA	GENERATOR-4.0KW EMERALD PLUS, ONAN BEIGE-FA/28100G
094059-01-000	EA	SPACER-GENERATOR, ONAN
055278-01-001	FT	TUBING-STEEL, .75" X 1.5" X 288"
094657-02-000	EA	TRAY-GENERATOR, 22.5" X 30.4" X 6.9"
094657-01-000	EA	TRAY-GENERATOR, 22.5" X 30.4" X 6.9"
008054-02-000	EA	CORD-POWER, 10-3 - 30AMP - 33'
008052-01-000	EA	CORD-POWER, 10/3 - 30 AMP - 25' - CANADIAN
008028-01-000	FT	WIRE-12/2, ROMEX - W/GROUND
008328-01-000	EA	TERMINAL-RING, 12/10 WIRE - #10 STUD FIT
008331-01-000	EA	TERMINAL-RING, TONGUE - #4 WIRE - 3/8" STUD - COPPER
008355-01-000	EA	CONNECTOR-CABLE CLAMPING, 3/4"
008356-01-000	EA	CONNECTOR-PLASTIC, 3/8" AVG
010497-01-000	EA	CLAMP-CLOSED, 5/8" ID
024924-02-000	EA	RECEPTACLE-POWER CORD, W/PARTIAL PLATE
041953-01-000	FT	CONDUIT-CONVOLUTED SLIT, .5" ID
067762-01-000	EA	CONVERTER-40 AMP, W/CHARGER - TRIAD TU-740-2 FROM: 00-00-00 THRU: 07-29-90
067762-02-000	EA	CONVERTER-40AMP, W/CHARGER - TRIAD TU-840-2 - CANADIAN FROM: 00-00-00 THRU: 07-29-90
069238-01-000	EA	COVER-ELECTRICAL BOX, W/HOLE - 4" X 4" - GRAY USED WITH 30 OR 50 AMP RECEPTACLE
083209-02-000	EA	CIRCUIT BREAKER-15/15AMP, 120V - BW H-15/15
083209-03-000	EA	CIRCUIT BREAKER-15/20AMP, 120V - BW - 0-15/20 - CANADIAN
083209-04-000	EA	CIRCUIT BREAKER-30A, 120V - BW L-30 FROM: 05-29-90 THRU: 99-99-99
083209-05-000	EA	CIRCUIT BREAKER-20A, 120V - BW J-20
083209-06-000	EA	CIRCUIT BREAKER-30/15 AMP, 120V - BW D-30/15
083210-02-000	EA	CIRCUIT BREAKER-GFI, 15A - 120V - BW U-15 - CANADIAN FROM: 00-00-00 THRU: 05-28-90
095721-03-000	EA	LABEL-CONTROL CENTER, US FROM: 00-00-00 THRU: 07-08-90
007131-01-000	EA	HANGER-TAILPIPE
008311-01-000	EA	CONNECTOR-WIRE NUT, INSULATED - RED
008353-01-000	EA	CONNECTOR-CABLE CLAMPING, 3/8" - CANADIAN
024978-01-000	EA	SWITCH-GENERATOR, W/O CIRCUIT BOARD - JAPAN
008054-02-000	EA	CORD-POWER, 10-3 - 30AMP - 33'
008028-01-000	FT	WIRE-12/2, ROMEX - W/GROUND
010497-01-000	EA	CLAMP-CLOSED, 5/8" ID
024924-02-000	EA	RECEPTACLE-POWER CORD, W/PARTIAL PLATE
092615-01-000	EA	CONVERTER-40 AMP, W/CHARGER - B-W 32400P FROM: 00-00-00 THRU: 05-28-90
067762-01-000	EA	CONVERTER-40 AMP, W/CHARGER - TRIAD TU-740-2 FROM: 05-29-90 THRU: 07-29-90
091213-01-000	EA	BOX-CIRCUIT BREAKER- W/KNOCKOUTS - 5.3" X 11.8" X 2.5"
095721-03-000	EA	LABEL-CONTROL CENTER, US FROM: 00-00-00 THRU: 07-08-90
083152-05-000	EA	PIPE-EXHAUST, 1.3" OD X 4.9" TO BEND X 48" TO END

**1991 WINNEBAGO
TABLE OF CONTENTS**

INTRODUCTION	A-01 - A-02
ABBREVIATIONS	A-03
ALPHABETICAL INDEX	A-04 - A-06
WCN28RT	A-07 - G-10
WCN32RQ	G-11 - L-20

1991 WCN28RT INDEX

FLOOR PLAN	A-07 - A-08
ACCESSORIES	A-09 - A-24
BATH	B-01 - B-04
BEDROOM	B-05 - B-06
CHASSIS	B-09 - C-06
C C & PAD	C-07 - C-18
DINETTE	C-19 - C-20
DRIVERS	C-21 - C-24
ELECTRICAL	D-01 - D-06
EXTERIOR BODY	D-09 - D-18
GALLEY	D-19 - E-02
HEATING & A/C	E-03 - E-06
INTERIOR FINISH	E-09 - E-13
LABEL	E-14 - E-22
LP	E-23
LOUNGE	E-24 - F-01
SEALANTS & FASTENERS	F-02 - F-04
WATER & SEWAGE	F-05 - F-11
WINDOW, VENT AND EXTERIOR DOOR	F-12 - G-10

ACCESSORIES GROUP (CONTINUED)

LUGGAGE RACK & LADDER OPTION L35U

1991 WINNEBAGO

TABLE OF CONTENTS

INTRODUCTION	A-01 - A-02
ABBREVIATIONS	A-03
ALPHABETICAL INDEX	A-04 - A-08
WCN28RT	A-07 - G-10
WCN32RQ	G-11 - L-20

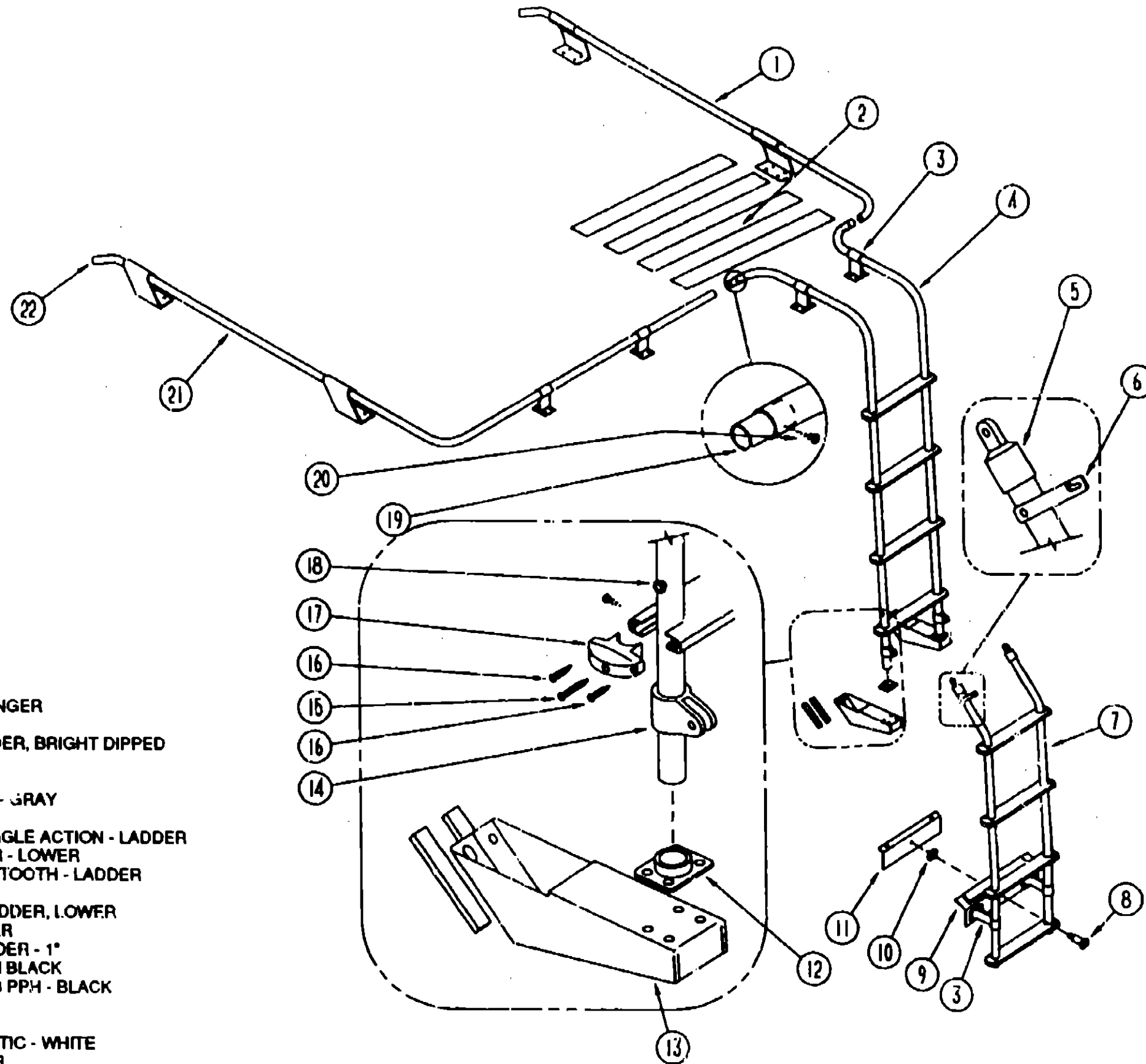

1991 WCN28RT INDEX

FLOOR PLAN	A-07 - A-08
ACCESSORIES	A-09 - A-24
BATH	B-01 - B-04
BEDROOM	B-05 - B-08
CHASSIS	B-09 - C-08
C & C & PAD	C-07 - C-18
DINETTE	C-19 - C-20
DRIVERS	C-21 - C-24
ELECTRICAL	D-01 - D-08
EXTERIOR BODY	D-09 - D-18
GALLEY	D-19 - E-02
HEATING & A/C	E-03 - E-08
INTERIOR FINISH	E-09 - E-13
LABEL	E-14 - E-22
LP	E-23
LOUNGE	E-24 - F-01
SEALANTS & FASTENERS	F-02 - F-04
WATER & SEWAGE	F-05 - F-11
WINDOW, VENT AND EXTERIOR DOOR	F-12 - G-10

KEY PART NUMBER	U/M	DESCRIPTION
1	EA	RACK-LUGGAGE, PASSENGER
2	EA	TAPE-ANTI SLIP, 2" X 60"
3	EA	STANDOFF-RACK & LADDER, BRIGHT DIPPED
4	EA	LADDER-UPPER
5	EA	CAP-TOP, 1 INCH
6	EA	LATCH-LADDER, LOWER - GRAY
7	EA	LADDER-LOWER
8	EA	PIN-QUICK RELEASE, SINGLE ACTION - LADDER
9	EA	PLATE-BUMPER, LADDER - LOWER
10	EA	SPRING GRIP-INTERNAL TOOTH - LADDER
11	EA	BRACKET-BUMPER PIN
12	EA	MOUNTING BRACKET-LADDER, LOWER
13	EA	FOOTING-LADDER, UPPER
14	EA	SLIDE-TOP, RACK & LADDER - 1"
15	EA	SCREW-10-12 X 2.25 POH BLACK
16	EA	SCREW-SF/DR, 6-20 X 5/8 PPH - BLACK
17	EA	END CAP-STEP, BLACK
17	EA	END CAP-STEP, BLACK
18	EA	BUSHING-FLANGE, PLASTIC - WHITE
21	EA	RACK-LUGGAGE, DRIVER
22	EA	PLUG-ROUND, RACK & LADDER ENDS - PLASTIC - 1" DIA.

BATH GROUP

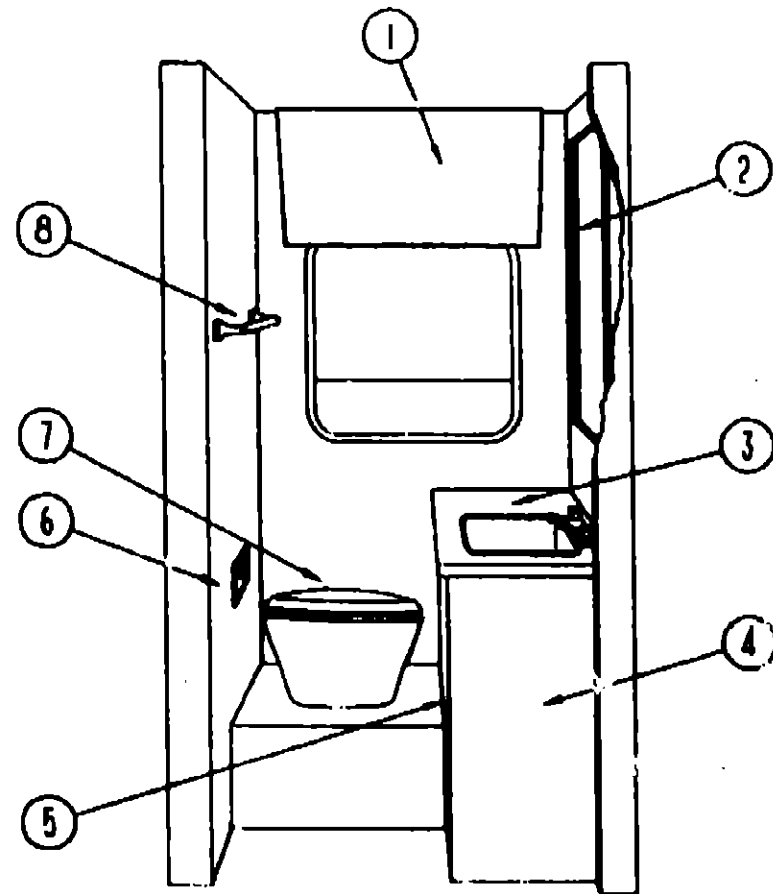

BATH CABINET

**BATH GROUP (CONTINUED)
BATH DOOR, TRIMS & TOWEL RACK**

KEY PART NUMBER	U/M DESCRIPTION
M87868-01-B07	EA DOOR-BATH, W/O HARDWARE - 71.7" X 19.1" FROM: 00-00-00 THRU: 06-21-90
M87868-03-B07	EA DOOR-BATH, W/O HARDWARE - 71.7" X 19.1" FROM: 06-22-90 THRU: 04-07-91
M87868-07-B07	EA DOOR ASM-BATH W/O LOCKSET FROM: 04-08-91 THRU: 99-99-99
081317-12-Y10	EA JAMB-DOOR, HINGED SIDE - W/O HOLE - 73.3" LONG FROM: 00-00-00 THRU: 09-16-90
081317-13-Y10	EA JAMB-DOOR, LATCH SIDE - W/HOLE - 73.3" LONG FROM: 00-00-00 THRU: 09-16-90
081318-02-Y10	EA JAMB-DOOR, TOP FROM: 00-00-00 THRU: 09-16-90
100357-01-000	EA ROD-TOWEL, BRASS W/ENDS BENT FOR BACK OF BATH DOOR
102089-13-B07	EA MOUNT-ROD, RIGHT SIDE - FOR TOWEL RODS - 26" LONG - WOOD
102089-14-B07	EA MOUNT-ROD, LEFT SIDE - FOR TOWEL RODS - 26" LONG - WOOD
074045-01-000	EA PLUG-OAK, 1/2" DIAMETER

**1991 WINNEBAGO
TABLE OF CONTENTS**

INTRODUCTION	A-01 - A-02
ABBREVIATIONS	A-03
ALPHABETICAL INDEX	A-04 - A-06
WCN28RT	A-07 - G-10
WCN32RQ	G-11 - L-20

1991 WCN28RT INDEX

FLOOR PLAN	A-07 - A-08
ACCESSORIES	A-09 - A-24
BATH	B-01 - B-04
BEDROOM	B-05 - B-08
CHASSIS	B-09 - C-06
C C & PAD	C-07 - C-18
DINETTE	C-19 - C-20
DRIVERS	C-21 - C-24
ELECTRICAL	D-01 - D-08
EXTERIOR BODY	D-09 - D-16
GALLEY	D-19 - E-02
HEATING & A/C	E-03 - E-08
INTERIOR FINISH	E-09 - E-13
LABEL	E-14 - E-22
LP	E-23
LOUNGE	E-24 - F-01
SEALANTS & FASTENERS	F-02 - F-04
WATER & SEWAGE	F-05 - F-11
WINDOW, VENT AND EXTERIOR DOOR	F-12 - G-10

KEY PART NUMBER	U/M DESCRIPTION
1 097520-01-B07	EA CABINET-MEDICINE, W/O DOORS OR HARDWARE FROM: 00-00-00 THRU: 07-08-90
1 102334-01-B07	EA CABINET-MEDICINE, W/O DOOR OR HARDWARE FROM: 07-09-90 THRU: 99-99-99
1 P00520-19-B07	EA DOOR-CABINET, W/O HARDWARE - 10" X 19"
M87519-01-B07	EA CABINET-LAVATORY, W/O DOORS OR HARDWARE FROM: 00-00-00 THRU: 07-08-90
P02335-01-B07	EA CABINET-LAVATORY, W/O DOORS OR HARDWARE FROM: 07-06-90 THRU: 99-99-99
097519-11-B07	EA CCOUNTERTOP-LAVATORY FROM: 00-00-00 THRU: 07-08-90
102335-11-B07	EA COUNTERTOP-LAVATORY FROM: 07-09-90 THRU: 99-99-99
075240-05-000	EA FAUCET-LAVATORY, BRASS
091253-01-000	EA GASKET-FAUCET, LAVATORY/GALLEY
098927-01-01A	EA SINK-LAVATORY, RECTANGULAR - PLASTIC - BONE
098927-01-700	EA SINK-STOPPER
098927-01-701	EA TAILPIECE-SINK
P00520-32-B13	EA DOOR-CABINET, W/O HARDWARE - 14.4" X 17.9"
P00520-B1-B07	EA DOOR-CABINET, W/O HARDWARE - 14.4" X 16.1" ADDED AFTER THIS DATE FROM: 02-04-91 THRU: 99-99-99
065278-01-000	EA HOLDER-TOILET PAPER, RECESSED - BRASS
095546-01-B07	EA CABINET-PIPE COVER
075453-02-000	EA BAR-TOWEL, 18" BRASS FROM: 00-00-00 THRU: 06-22-90
075454-02-000	EA RING-TOWEL, W/MOUNTING HARDWARE - BRASS

CANADA EXPORT OPTION L265

KEY PART NUMBER	U/M DESCRIPTION
011048-05-000	EA SHOWER HEAD-W/60" HOSE, W/O VACUUM BREAKER - CANADIAN
024676-02-000	EA FLANGE-CLOSET, 4" X 3" - ABS - CANADIAN
075240-06-000	EA FAUCET-LAVATORY, BONE

BATH GROUP (CONTINUED)

SHOWER STALL & TRIMS

KEY PART NUMBER	U/M DESCRIPTION
101249-01-01A	EA SURROUND-SHOWER, PASS. SIDE - PLASTIC - OFF/WHITE - W/O CORNER CADY FROM: 00-00-00 THRU: 06-29-90
101249-01-01A	EA SURROUND-SHOWER, DRIVER SIDE - PLASTIC - OFF/WHITE - W/CORNER CADY FROM: 00-00-00 THRU: 06-29-90
101249-01-01A	EA SURROUND-SHOWER, PASS. SIDE - PLASTIC - OFF/WHITE - W/O CORNER CADY FROM: 06-30-90 THRU: 99-99-99
101249-01-01A	EA SURROUND-SHOWER, DRIVER SIDE - PLASTIC - OFF/WHITE - W/CORNER CADY FROM: 06-30-90 THRU: 99-99-99
101250-01-01A	EA CAP-SHOWER, CEILING - PLASTIC - OFF WHITE
096204-02-01A	EA TRIM-J, .5" WIDTH EXPOSED - 1" X 52.1" LONG - ALUMINUM - OFF WHITE FROM: 07-18-90 THRU: 99-99-99
096204-03-01A	EA TRIM-J, .5" WIDTH EXPOSED - 1" X 58.9" - ALUMINUM - OFF WHITE FROM: 07-25-90 THRU: 99-99-99

SHOWER PAN & SCREW COVERS

KEY PART NUMBER	U/M DESCRIPTION
M02630-15-B07	EA PAN-SHOWER
086438-01-000	EA NUT-SLIP, TAILPIECE - 1.5"
086440-01-000	EA STRAINER W/PURBER WASHER
086640-08-000	FT SEALER-RIBBON, 5/16" DIAMETER - INCREMENTS OF 25'
086735-01-000	EA WASHER-STRAINER TO TAILPIECE PLASTIC, 1.5"
011089-02-000	EA TAILPIECE-TUB/SHOWER, 1 1/2" X 1 1/4" X 4" - BRASS
057871-01-000	EA COVER-SCREW, #8 - PLASTIC - OFF WHITE

SHOWER FAUCET, BACKPLATE & SHOWER HEAD

KEY PART NUMBER	U/M DESCRIPTION
075241-04-000	EA FAUCET-SHOWER, BRASS
075808-01-000	EA PANEL-FAUCET BACK, SHOWER - PLASTIC
011048-02-000	EA HEAD-SHOWER, W/SH HOSE

SHOWER CURTAIN, CURTAIN TRACK & HARDWARE

KEY PART NUMBER	U/M DESCRIPTION
084481-15-000	EA CURTAIN-GROMMET TOP, SHOWER - 62" X 36" - VINYL - ALMOND
048887-01-000	EA GROMMET-BRASS - 7/16" ID X 1" OD
009112-01-000	EA FLANGE-1" ROD, CLOTHES - PLASTIC - OFF WHITE
075680-02-000	EA ROD-CURTAIN, SHOWER - 27" TO 38" - ADJUSTABLE FROM: 00-00-00 THRU: 08-01-90
102075-02-01A	EA ROD-CURTAIN, SHOWER - 1" OD X 32.8" - OFF WHITE FROM: 08-02-90 THRU: 99-99-99
009138-01-000	EA HANGER-RING, PIN TYPE - CURTAIN - CHROME FROM: 00-00-00 THRU: 03-03-91
009138-02-000	EA HANGER-RING, PIN TYPE - CURTAIN - BRASS FROM: 03-04-91 THRU: 99-99-99

KEY PART NUMBER

064076-01-000
039341-02-704
039341-02-703
039341-01-700
039341-02-705
064076-01-701
067487-01-701
067487-01-702
024676-01-000

KEY PART NUMBER

083841-01-000
010117-01-000
085330-04-000
085330-04-700
085330-01-700
085330-04-702
085330-01-714
085330-01-709
085330-01-702
085330-04-703
085330-01-703
085330-01-704
085330-01-705
085330-01-708
085330-01-707
085330-01-710
085330-01-718
085330-04-705
085330-04-704
085330-04-706
085330-01-717
085330-01-718

BATH GROUP (CONTINUED)

TOILET & CLOSET FLANGE

U/M DESCRIPTION

EA TOILET-11.25" TALL, IVORY - THETFORD 50
EA SEAT & COVER SET-NEWSTYLE, THETFORD 08855
EA PLUG-HOLE, IVORY - THETFORD 03895-10
EA MECH-ASM-SH SL & SH GL & GH, THETFORD 15283
EA MOUNTING PACKAGE-THETFORD 08975
EA MECHANISM STARLIGHT IVORY, THETFORD 14822
EA WATER SAVER PACKAGE-THETFORD 08993
EA CLAMP-THETFORD 03752
EA FLANGE-CLOSET, TOILET - 4" X 3" - RED

PORCELAIN TOILET OPTION L43E

U/M DESCRIPTION

EA FLANGE-CLOSET, 4" X 3"
EA COUPLING-PLASTIC, 3" - HXH
EA TOILET-CHINA, SHORTY W/SPRAY - TRAVELER 510
EA BREAKER-VACUUM, FOR HANDSPRAY - SEALAND# 230325
EA RING & COVER-SEAT, SEALAND# 390340217
EA LEVER-FLUSH, SEALAND# 340825
EA SEAL-FLANGE, FLOOR - SEALAND# 390343892
EA VALVE-WATER, SEALAND# 385314349
EA TUBE-FLUSH, SEALAND# 385315002
EA COVER ASM-PEDAL, SEALAND# 310118
EA RING & HALF CLAMPS ASM-BONE, SEALAND# 385310048
EA TEFLON & RUBBER SEALS-SEALAND# 385316140
EA SUPPORT-SEAL, PLASTIC - SEALAND# 390346406
EA BALL, SHAFT, & CARTRIDGE, SEALAND# 385318162
EA CARTRIDGE-SPRING, SEALAND# 381238098
EA PLUG-DRAIN, & CAP - W/SEAL - SEALAND# 385318142
EA FLANGE-FLOOR, 3" MPT - SEALAND# 390346058
EA COVER ASM-PEDESTAL, SEALAND# 310109
EA BASE ASM-BONE, SEALAND# 310124
EA BREAKER-VACUUM, W/HAND SPRAY - SEALAND# 385319055
EA BOLT MOUNTING PACKAGE-SEALAND# 385310084
EA SEAL-BASE & MOUNTING HARDWARE, SEALAND# 385310083

1991 WINNEBAGO

TABLE OF CONTENTS

INTRODUCTION	A-01 - A-02
ABBREVIATIONS	A-03
ALPHABETICAL INDEX	A-04 - A-08
WCN28RT	A-07 - G-10
WCN32RQ	G-11 - L-20

1991 WCN28RT INDEX

FLOOR PLAN	A-07 - A-08
ACCESSORIES	A-09 - A-24
BATH	B-01 - B-04
BEDROOM	B-05 - B-08
CHASSIS	B-09 - C-06
C C & PAD	C-07 - C-18
DINETTE	C-19 - C-20
DRIVERS	C-21 - C-24
ELECTRICAL	D-01 - D-08
EXTERIOR BODY	D-09 - D-18
GALLEY	D-19 - E-02
HEATING & A/C	E-03 - E-08
INTERIOR FINISH	E-09 - E-13
LABEL	E-14 - E-22
LP	E-23
LOUNGE	E-24 - F-01
SEALANTS & FASTENERS	F-02 - F-04
WATER & SEWAGE	F-05 - F-11
WINDOW, VENT AND EXTERIOR DOOR	F-12 - G-10

BEDROOM GROUP

QUEEN BED CABINRY AND COMPONENTS

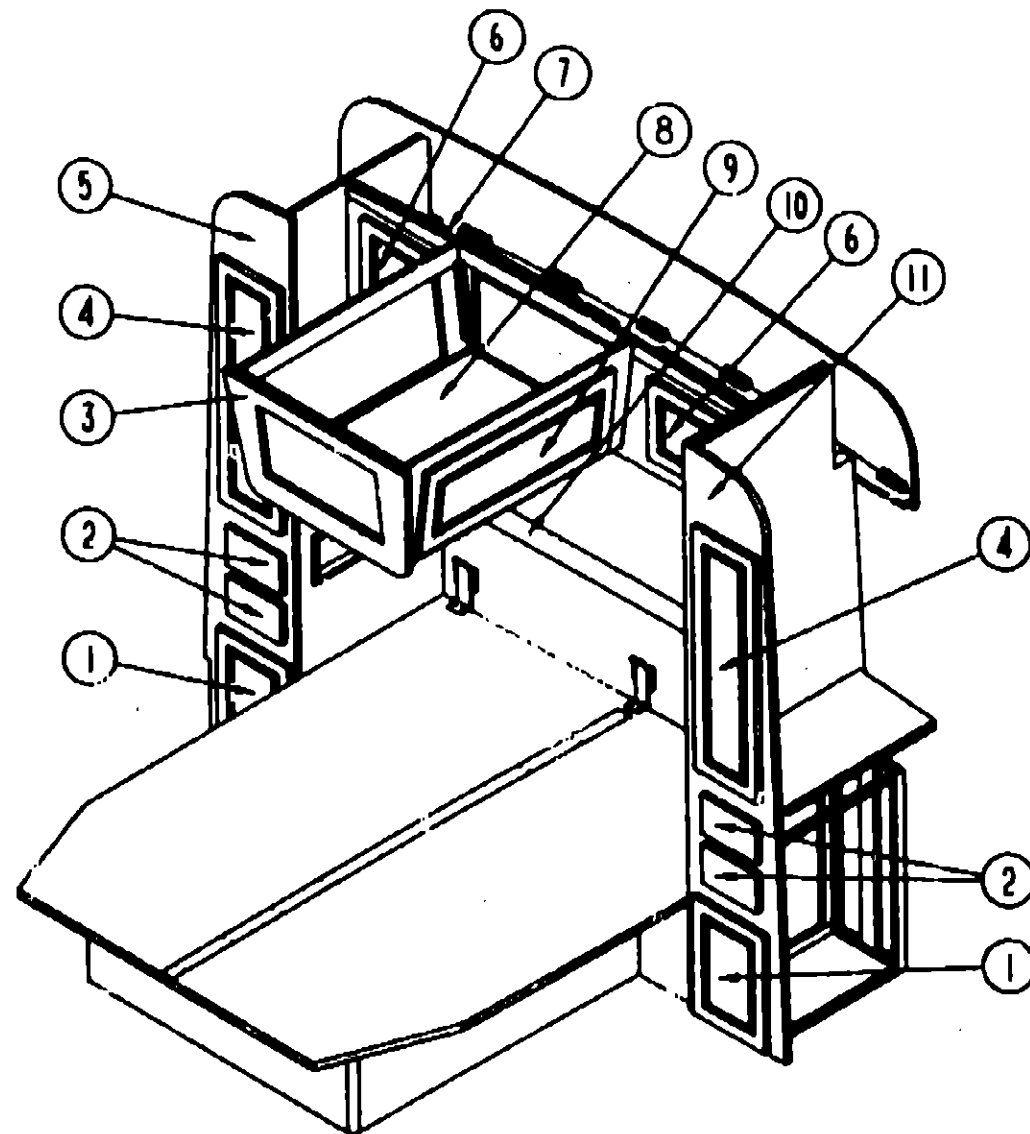

KEY PART NUMBER	U/M	DESCRIPTION
1 P00520-18-B07	EA	DOOR-CABINET, W/O HARDWARE - 11.4" X 18.1" - US
2 P00521-05-B07	EA	DRAWER-CABINET, W/O HARDWARE - 8.5" WIDE X 18.5" DEEP
2 P03397-28-B07	EA	DRAWER-CABINET, W/O HARDWARE - 8.4" WIDE X 18.5" DEEP
3 088599-01-B07	EA	END CAP-CABINET, OVERHEAD - CENTER ISLAND
4 P00520-14-B07	EA	DOOR-CABINET, W/O HARDWARE - 9.8" X 33.5"
5 M04163-03-B07	EA	CABINET-SHIRT CLOSET, W/O DOORS OR HARDWARE
041953-03-000	FT	CONDUIT-CONVOLUTED SLIT, 1" ID (CLOTHES ROD COVER)
009112-01-000	EA	FLANGE-1" ROD, CLOTHES - PLASTIC - OFF WHITE
042438-01-000	EA	DOWEL-WOOD, CLOTHES ROD - 1" DIAMETER X 4'
6 P00520-07-B07	EA	DOOR-CABINET, BACKWALL - W/O HARDWARE - 11" X 11"
7 M04156-01-B07	EA	CABINET-OVERHEAD, BACKWALL - W/O DOORS OR HARDWARE
082082-02-01A	EA	SHELF-CABINET, BACKWALL OVERHEAD
8 M04157-01-B07	EA	CABINET-OVERHEAD, BED ISLAND - W/O DOORS OR HARDWARE
9 P00520-08-B07	EA	DOOR-CABINET, W/O HARDWARE - 12" X 29.1"
10 082525-01-B07	EA	COUNTERTOP-BACKWALL
084791-01-Y12	EA	TRIM-CABINET TO BACKWALL COUNTERTOP - 1.5" X 4.25" - WOOD
11 082865-01-B07	EA	CABINET-SHIRT CLOSET, DRIVER SIDE - W/O DOORS OR HARDWARE
11 092865-02-B07	EA	CABINET-SHIRT CLOSET, W/O DOORS OR HARDWARE - CANADIAN

U/M	DESCRIPTION
EA	DOOR-CABINET, W/O HARDWARE - 11.4" X 18.1" - US
EA	DRAWER-CABINET, W/O HARDWARE - 8.5" WIDE X 18.5" DEEP
	FROM: 00-00-00 THRU: 01-08-91
EA	DRAWER-CABINET, W/O HARDWARE - 8.4" WIDE X 18.5" DEEP
	FROM: 01-07-91 THRU: 99-99-99
EA	END CAP-CABINET, OVERHEAD - CENTER ISLAND
EA	DOOR-CABINET, W/O HARDWARE - 9.8" X 33.5"
EA	CABINET-SHIRT CLOSET, W/O DOORS OR HARDWARE
FT	CONDUIT-CONVOLUTED SLIT, 1" ID (CLOTHES ROD COVER)
EA	FLANGE-1" ROD, CLOTHES - PLASTIC - OFF WHITE
EA	DOWEL-WOOD, CLOTHES ROD - 1" DIAMETER X 4'
EA	DOOR-CABINET, BACKWALL - W/O HARDWARE - 11" X 11"
EA	CABINET-OVERHEAD, BACKWALL - W/O DOORS OR HARDWARE
EA	SHELF-CABINET, BACKWALL OVERHEAD
EA	CABINET-OVERHEAD, BED ISLAND - W/O DOORS OR HARDWARE
EA	DOOR-CABINET, W/O HARDWARE - 12" X 29.1"
EA	COUNTERTOP-BACKWALL
EA	TRIM-CABINET TO BACKWALL COUNTERTOP - 1.5" X 4.25" - WOOD
EA	CABINET-SHIRT CLOSET, DRIVER SIDE - W/O DOORS OR HARDWARE
EA	CABINET-SHIRT CLOSET, W/O DOORS OR HARDWARE - CANADIAN

QUEEN BED CABINET

KEY PART NUMBER	U/M	DESCRIPTION
M92734-01-B07	EA	CABINET-QUEEN BED, W/O DOORS OR HARDWARE

DRIVER SIDE WHEELWELL CABINET

KEY PART NUMBER	U/M	DESCRIPTION
101104-01-B07	EA	CABINET-WHEELWELL, DRIVER SIDE
101104-11-B07	EA	COUNTERTOP-WHEELWELL CABINET, DRIVER SIDE

PASSENGER SIDE WHEELWELL CABINET

KEY PART NUMBER	U/M	DESCRIPTION
101105-01-B07	EA	CABINET-WHEELWELL, PASSENGER SIDE
101105-11-B07	EA	COUNTERTOP-WHEELWELL CABINET, PASSENGER SIDE

1991 WINNEBAGO TABLE OF CONTENTS

INTRODUCTION	A-01 - A-02
ABBREVIATIONS	A-03
ALPHABETICAL INDEX	A-04 - A-06
WCN28RT	A-07 - G-10
WCN32RQ	G-11 - L-20

1991 WCN28RT INDEX

FLOOR PLAN	A-07 - A-08
ACCESSORIES	A-09 - A-24
BATH	B-01 - B-04
BEDROOM	B-05 - B-08
CHASSIS	B-09 - C-08
C C & PAD	C-07 - C-18
DINETTE	C-19 - C-20
DRIVERS	C-21 - C-24
ELECTRICAL	D-01 - D-08
EXTERIOR BODY	D-09 - D-18
GALLEY	D-19 - E-02
HEATING & A/C	E-03 - E-08
INTERIOR FINISH	E-09 - E-13
LABE'L	E-14 - E-22
LP	E-23
LOUNGE	E-24 - F-01
SEALANTS & FASTENERS	F-02 - F-04
WATER & SEWAGE	F-05 - F-11
WINDOW, VENT AND EXTERIOR DOOR	F-12 - G-10

BEDROOM GROUP (CONTINUED)

TWIN BEDS CABINRY AND COMPONENTS

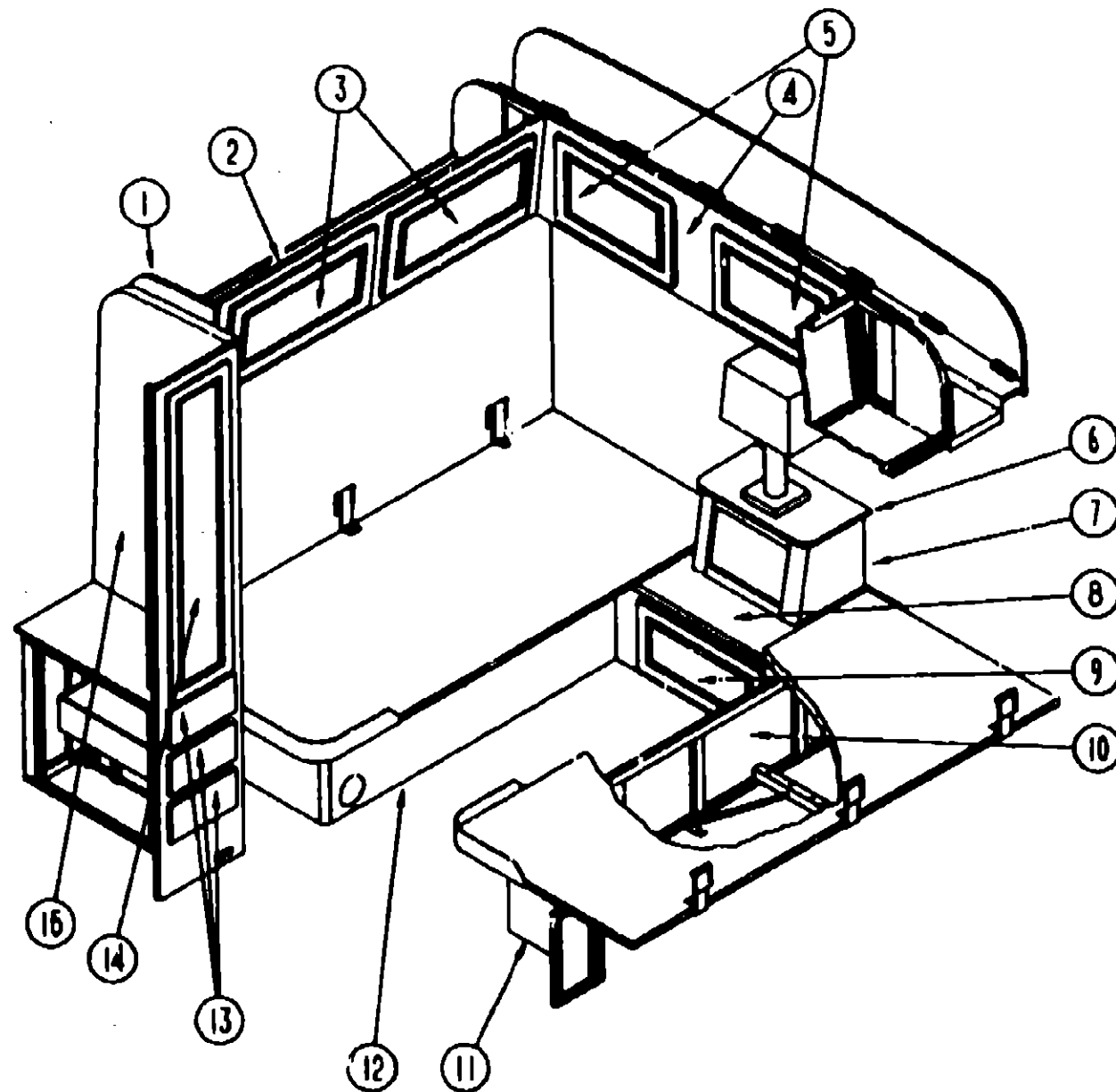

KEY PART NUMBER

1	092747-01-B07
2	M04153-04-B07
3	M04153-03-B07
4	M04155-02-B07
5	P00520-04-B07
6	092525-02-B07
7	098889-12-B07
8	098889-14-AB6
9	098889-01-B07
10	098889-11-B07
11	M82184-29-B07
12	067205-04-000
13	P00520-18-B07
14	067534-01-000
15	M93231-02-B07
16	M93231-01-B07
17	M92883-01-B07
18	P00521-08-B07
19	P03397-13-B10
20	P00520-15-B07
21	042439-01-000
22	011953-03-000
23	009112-01-000

KEY PART NUMBER

084357-01-W13
084358-03-000
084412-01-000
084451-01-000
084625-02-000
084413-01-000

KEY PART NUMBER

042408-08-000
084858-02-01A
009700-04-002
009701-01-000
009702-01-000
067534-01-000

U/M DESCRIPTION

EA	END CAP-CABINET, OVERHEAD
EA	CABINET-OVERHEAD, PASSENGER SIDE - W/O DOORS OR HARDWARE
EA	CABINET-OVERHEAD, DRIVERS SIDE - W/O DOORS OR HARDWARE
EA	DOOR-CABINET, W/O HARDWARE - 14.4" X 28.8"
EA	CABINET-OVERHEAD, W/O DOORS OR HARDWARE
EA	DOOR-CABINET, W/O HARDWARE - 13.4" X 21.9"
EA	COUNTERTOP-BACKWALL
EA	COUNTERTOP-NIGHTSTAND, UPPER
EA	DOOR-TAMBOUR, W/O HARDWARE - 11.8" X 15"
EA	CABINET-NIGHTSTAND, W/O DOORS OR HARDWARE
EA	COUNTERTOP-NIGHTSTAND, LOWER
EA	DRAWER-CABINET, W/O HARDWARE - 11" X 21.9"
EA	SUPPORT-BED, 20" - METAL - BEIGE
EA	DOOR-CABINET, W/O HARDWARE - 12.8" X 17.7"
EA	TIEBACK-CURTAIN, 6" - PLASTIC - CLEAR
EA	CABINET-TWIN BED, DRIVER SIDE - W/O DOORS OR HARDWARE
EA	CABINET-TWIN BED, DRIVER SIDE - W/O DOORS OR HARDWARE
EA	CABINET-TWIN BED, PASSENGER SIDE - W/O DOORS OR HARDWARE
EA	DRAWER-CABINET, W/O HARDWARE - 10.8" WIDE - 19.5" DEEP
EA	DRAWER-CABINET, W/O HARDWARE - 10.6" WIDE X 18.3" DEEP
	FROM: 00-00-00 THRU: 01-06-91
EA	DOOR-CABINET, W/O HARDWARE - 12" X 48"
EA	DOWEL-WOOD, CLOTHES ROD - 1" DIAMETER X 4'
FT	CONDUIT-CONVOLUTED SLIT, 1" ID (CLOTHES ROD COVER)
EA	FLANGE-1" ROD, CLOTHES - PLASTIC - OFF WHITE

TV STAND

U/M DESCRIPTION

EA	STAND-TV, W/MIRROR
EA	INSERT-TV STAND, METAL - TAN - OFF WHITE INSERT NO LONGER AVAILABLE
EA	SUPPORT-HINGED
EA	CATCH-TV SHELF, BRASS
EA	HINGE-ALUMINUM, W/HOLES - 17.2" - TAN
EA	OFF WHITE HING NO LONGER AVAILABLE
EA	HINGE-CONTINUOUS, ALUMINUM - 1" X 72" - W/HOLES

STANDARD COMPONENTS

PRIVACY DOOR, TRACK, HARDWARE & TIEBACK

U/M DESCRIPTION

EA	DOOR-FOLDING, PRIVACY - 75" X 27.5" - OAK WOOD
EA	TRACK-FOLDING DOOR/CURTAIN, 27.5" - OFF WHITE
EA	ROD-EXTRUDED, 196.5" - OFF WHITE
EA	CARRIER-SHOWER CURTAIN
EA	END STOP-CURTAIN CARRIER, SHOWER
EA	TIEBACK-CURTAIN, 6" - PLASTIC - CLEAR

1991 WINNEBAGO TABLE OF CONTENTS

INTRODUCTION	A-01 - A-02
ABBREVIATIONS	A-03
ALPHABETICAL INDEX	A-04 - A-06
WCN28RT	A-07 - G-10
WCN32RO	G-11 - L-20

1991 WCN28RT INDEX

FLOOR PLAN	A-07 - A-08
ACCESSORIES	A-09 - A-24
BATH	B-01 - B-04
BEDROOM	B-05 - B-08
CHASSIS	B-09 - C-05
C C & PAD	C-07 - C-18
DINETTE	C-19 - C-20
DRIVERS	C-21 - C-24
ELECTRICAL	D-01 - D-08
EXTERIOR BODY	D-09 - D-18
GALLEY	D-19 - E-02
HEATING & A/C	E-03 - E-08
INTERIOR FINISH	E-09 - E-13
LABEL	E-14 - E-22
LP	E-23
LOUNGE	E-24 - F-01
SEALANTS & FASTENERS	F-02 - F-04
WATER & SEWAGE	F-05 - F-11
WINDOW, VENT AND EXTERIOR DOOR	F-12 - G-10

CHASSIS GROUP

FORD CHASSIS COMPONENTS & FORD TIRE & WHEEL

KEY PART NUMBER	U/M DESCRIPTION
007125-07-000	EA CLAMP-MUFFLER, 2.50" DIAMETER
007125-11-000	EA CLAMP-MUFFLER, 2.75"
053322-12-000	EA SHIELD-HEAT, EXHAUST - 32" X 9"
080081-01-000	EA STRAP-MOUNTING, FUEL LINE - 2" X 32"
087475-02-000	EA BRACKET-TIE DOWN, BATTERY - 13.5" X 1.3"
083393-02-000	EA PANEL-COWL, PASSENGER
094918-03-000	EA CLAMP-EXHAUST, 2.5"
051377-01-000	EA STEM-VALVE
083425-02-000	EA TIRE-MICHELIN, LT235 / 85R16 LRE
085853-01-000	EA WHEEL-STEEL, 16" X 6K - E8TZ - 1015 - A - ACCURIDE 28375-12

FUEL NECK & HOSE

KEY PART NUMBER	U/M DESCRIPTION
095804-01-000	EA HOSE-FUEL FILL, FORMED 2" ID
044317-01-000	FT HOSE-FUEL, 3/8ID
095808-01-000	EA NECK-FUEL FILL, W/CHECK VALVE - L-SHAPED - 18.2" LONG
088753-01-000	FT TUBE-ALUMINIZED STEEL, 5/8" - 18 GAUGE
096054-01-000	EA SUPPORT-EXHAUST PIPE, BENT - 2.6" X .8" - STEEL
096087-01-000	EA BRACKET-STRAP, EXHAUST PIPE - W/CENTER BENT LIP - 13" X 5.

PARK BRAKE CABLE

KEY PART NUMBER	U/M DESCRIPTION
096351-01-000	EA CABLE-BRAKE, PARK - FORD CHASSIS

RADIATOR OVERFLOW BOTTLE

KEY PART NUMBER	U/M DESCRIPTION
096830-01-000	EA BOTTLE-OVERFLOW, RADIATOR - GM 14042454

EXHAUST COMPONENTS

KEY PART NUMBER	U/M DESCRIPTION
078310-01-000	EA BAFFLE-RADIATOR, .12" X 15" X 62" - RUBBER
095190-01-000	EA HANGOFF-EXHAUST, 4" X 1.4"
098795-01-000	EA SHIELD-EXHAUST, 41" X 19.9" - GALVANIZED STEEL
098795-02-000	EA SHIELD-EXHAUST
098795-05-000	EA SHIELD-EXHAUST, 52.3" X 19.9" - GALVANIZED STEEL
098798-01-000	EA SHIELD-EXHAUST, CONVERTOR
098798-04-000	EA SHIELD-EXHAUST, CONVERTER - 28.3" X 19.9" FROM: 00-00-00 THRU: 11-25-90
099344-01-000	EA PIPE-EXHAUST, FRONT - 40.7" LONG - FORD FROM: 02-15-91 THRU: 99-99-99 FORD PROVIDED PART PRIOR TO 11-89
098753-01-000	EA PIPE-EXHAUST, DOUBLE WALL - 24.8" FROM: 11-13-89 THRU: 04-30-90
100572-01-000	EA PIPE-EXHAUST, OFFSET - 15.2" LONG - 2.5"ID - FORD FROM: 00-00-00 THRU: 04-30-90
100800-01-000	EA PIPE-EXHAUST, REAR - 42" LONG - FORD FROM: 05-01-90 THRU: 99-99-99
100801-01-000	EA PIPE-EXHAUST, FRONT - 40.7" LONG - FORD FROM: 05-01-90 THRU: 99-99-99
096087-04-000	EA BRACKET-STRAP, EXHAUST PIPE - W/SIDE LIP & NUTS - 13" X 5.8" FROM: 05-01-90 THRU: 99-99-99 FORD PROVIDED PART PRIOR TO 11-89
096087-02-000	EA BRACKET-STRAP, EXHAUST PIPE - 5.8" X 13" - W/NUTS FROM: 11-13-89 THRU: 01-14-90
095818-01-000	EA SUPPORT-EXHAUST PIPE, 6.3" X 2" - STEEL - BLACK FROM: 01-15-90 THRU: 99-99-99
096055-02-000	EA SUPPORT-EXHAUST PIPE, 1" X 15.8" FROM: 00-00-00 THRU: 11-12-89 FORD PROVIDED PART PRIOR TO 11-89 FROM: 11-13-89 THRU: 99-99-99

CHASSIS GROUP CONTINUED

CANADIAN OPTION

KEY PART NUMBER	U/M DESCRIPTION
007131-01-000	EA HANGER-TAILPIPE
079059-02-000	EA HOSE-90 DEGREE, .81"ID X 4" X 6"
088753-01-000	FT TUBE-ALUMINIZED STEEL, 5/8" - 18 GAUGE
100138-01-000	EA MODULE-DAYTIME RUNNING LIGHT
100158-01-000	EA WIRE ASM-DAYTIME RUNNING LIGHTS
100159-01-000	EA WIRE ASM-DAYTIME RUNNING LIGHTS, W/FUSE
100138-01-000	EA MODULE-DAYTIME RUNNING LIGHT
100158-01-000	EA WIRE ASM-DAYTIME RUNNING LIGHTS

JETRIDE SUSPENSION W/PARK & LEVEL L80C - CHEVY

KEY PART NUMBER	U/M DESCRIPTION
000C12-05-188	EA BOLT-HEX, 5/16-18 X 1 - ZINC 5
000E13-17-008	EA WASHER-FLARE, 3/8" AR ZN
007125-11-000	EA CLAMP-MUFFLER, 2.75"
018379-02-000	EA STRAP-HANGER EXTENSION, 2" X 1" - STEEL
071374-03-000	EA FITTING-BULKHEAD, 1/4" X 1/4" MNPT
090436-03-000	EA SPRING-LEAF, SEMI - JET# 361
090436-05-000	EA VALVE-HEIGHT, PARK/LEVEL - JET# 358-359
090436-06-000	EA CONTROL-PARK/LEVEL, W/WIRING - JET# 340-384
090436-08-000	EA MOUNT-AIRSPRING, UPPER DRIVER - JET# 375
090436-09-000	EA MOUNT-AIRSPRING, UPPER PASSENGER - JET# 376
090436-34-000	EA WIRING-ELECTRONIC, JET #80712
090436-35-000	EA COMPRESSOR-TANK, W/O WIRING - JET# 60703
090436-36-000	EA MOUNT-SPRING, LH - UPPER ELT - CHEVY - JET# 60750
090436-37-000	EA MOUNT-SPRING, RH - UPPER ELT - CHEVY - JET# 60751
090436-10-000	EA MOUNT-SPRING/AXLE, LOWER DRIVER - JET# 373
090436-11-000	EA MOUNT-SPRING/AXLE, LOWER PASSENGER - JET# 374
090436-12-000	EA U-BOLT-FORWARD, STRAIGHT - 7/8" - JET# 351
090436-13-000	EA U-BOLT-REARWARD, BENT - 7/8" - JET# 351-1
090436-14-000	EA BAR-TRACK, W/PIVOT BOLTS & BRACKET - JET# 356-1
090436-16-000	EA BRACKET-BRAKE HOSE/AXLE MOUNT, P-30 CHASSIS - JET# 370
091250-01-000	EA BUSHING-SWAY BAR, 1.25" CUT - HELLWIG# PB 731
091250-02-000	EA BUSHING-SWAY BAR, 1.25" UN CUT - HELLWIG# PB 734
091250-03-000	EA BUSHING-SWAY BAR, 1.75" CUT - HELLWIG# PB 732
093237-04-000	EA LABEL-CIRCUIT BREAKER, FRONT - AIR BAG COMP

JETRIDE SUSPENSION- W/PARK & LEVEL L80C - FORD

KEY PART NUMBER	U/M DESCRIPTION
090436-07-000	EA COMPRESSOR-W/TANK & WIRING, JET# 345-1
290436-07-700	EA COMPRESSOR (ONLY)
090436-31-000	EA BAR-TRACK, W/BOLTS & BRACKETS - JET# 40358
090436-18-000	EA MOUNT-AIRSPRING, UPPER DRIVER - JET# 40375
090436-19-000	EA MOUNT-AIRSPRING, UPPER PASSENGER - JET# 40376
090436-20-000	EA MOUNT-SPRING/AXLE, LOWER DRIVER - JET# 40373
090436-21-000	EA MOUNT-SPRING/AXLE, LOWER PASSENGER - JET# 40374
090436-22-000	EA U-BOLT, 1-14 X 4" X 14" - W/NUTS - JET# 40351
090436-23-000	EA SPRING-LEAF, SEMI - FORD - JET# 40361
090436-25-000	EA U-BOLT, 1-14 X 4" X 15" - W/NUTS - JET# 40352
090436-26-000	EA BAR-STABILIZER, REAR - JET# 40358
090436-28-000	EA SHIELD-HEAT, FUEL TANK - JET# 40360
090436-29-000	EA BRACKET-BRAKE HOSE/FRAME, JET# 40382
090436-30-000	EA BRACKET-BRAKE HOSE/CALIPER, JET# 40384
090436-31-000	EA BAR-TRACK, W/BOLTS & BRACKETS - JET# 40358
090436-32-000	EA CONTROL-PARK/LEVEL, ELECTRIC - JET #80778
090436-34-000	EA WIRING-ELECTRONIC, JET #80712
090436-35-000	EA COMPRESSOR-TANK, W/O WIRING - JET# 60703
098753-02-000	EA PIPE-EXHAUST, FORD - 8.5" X 14.8"
100572-01-000	EA PIPE-EXHAUST, OFFSET - 15.2" LONG - 2.5"ID - FORD
100593-01-000	EA PIPE-EXHAUST, EXTENSION - FORD
100800-01-000	EA PIPE-EXHAUST, REAR - 42" LONG - FORD
100801-01-000	EA PIPE-EXHAUST, FRONT - 40.7" LONG - FORD

1991 WINNEBAGO

TABLE OF CONTENTS

INTRODUCTION	A-01 - A-02
ABBREVIATIONS	A-03
ALPHABETICAL INDEX	A-04 - A-08
WCN26RT	A-07 - G-10
WCN32RQ	G-11 - L-20

1991 WCN26RT INDEX

FLOOR PLAN	A-07 - A-08
ACCESSORIES	A-09 - A-24
BATH	B-01 - B-04
BEDROOM	B-05 - B-08
CHASSIS	B-09 - C-08
C C & PAD	C-07 - C-18
DNETTE	C-19 - C-20
DRIVERS	C-21 - C-24
ELECTRICAL	D-01 - D-08
EXTERIOR BODY	D-09 - D-18
GALLEY	D-19 - E-02
HEATING & A/C	E-03 - E-08
INTERIOR FINISH	E-09 - E-13
LABEL	E-14 - E-22
LP	E-23
LOUNGE	E-24 - F-01
SEALANTS & FASTENERS	F-02 - F-04
WATER & SEWAGE	F-05 - F-11
WINDOW, VENT AND EXTERIOR DOOR	F-12 - G-10

CHASSIS GROUP CONTINUED

JET RIDE SUSPENSION WITH PARK AND LEVEL OPTION L60C - FORD & CHEVY

KEY PART NUMBER	U/M	DESCRIPTION
090438-32-000	EA	CONTROL-PARK/LEVEL, ELECTRIC - JET #60778
101025-01-01A	EA	PANEL-DASH, LOWER - W/CUTOUTS - CHEVY - 11.9" LONG - BLACK
097372-04-01A	EA	SWITCH-MOMENTARY/OFF/MOMENTARY

STABILIZER SHOCKS OPTION L84A (FRONT ONLY)

KEY PART NUMBER	U/M	DESCRIPTION
079942-01-000	EA	SHOCK ABSORBER-STABILIZER, FRONT - 4-WAY

HYDRAULIC LEVELING JACKS OPTION L84H - CHEVY

KEY PART NUMBER	U/M	DESCRIPTION
100632-01-000	EA	LEVELING SYSTEM-HYDRAULIC, HWH# AP7371
100633-04-000	EA	BRACKETS-FRONT LEVELING JACK, HWH# AP7392
100634-05-000	EA	BRACKETS-REAR LEVELING JACKS, HWH# AP6656
100635-02-000	EA	BRACKET-PUMP, LEVELING JACK, HW# P8282
100636-03-000	EA	HOSE KIT-LEVELING JACKS, HWH# AP7374
098808-01-000	EA	SPACER-PEDESTAL, DRIVER

HYDRAULIC LEVELING JACKS OPTION L84H - FORD

KEY PART NUMBER	U/M	DESCRIPTION
100632-01-000	EA	LEVELING SYSTEM-HYDRAULIC, HWH# AP7371
098808-01-000	EA	SPACER-PEDESTAL, DRIVER
100633-02-000	EA	BRACKETS-FRONT LEVELING JACK, HWH# AP7390
100634-06-000	EA	BRACKETS-REAR LEVELING JACKS, HWH# AP6657
100635-02-000	EA	BRACKET-PUMP, LEVELING JACK, HWH# P8282
100636-03-000	EA	HOSE KIT-LEVELING JACKS, HWH# AP7374

MANUAL LEVELING JACKS OPTION L84L

KEY PART NUMBER	U/M	DESCRIPTION
099025-01-000	EA	STABILIZER-JACK, PASSENGER
099025-02-000	EA	STABILIZER-JACK, DRIVER
099116-01-000	EA	BRACKET-STABILIZER JACK, W/2 SQUARE TUBES
099841-02-000	EA	BRACKET-JACK, REAR
099842-01-000	EA	BRACKET-JACK, W/ANGLE BRACE
099842-02-000	EA	BRACKET-JACK, FRONT

CHASSIS GROUP CONTINUED

GENERATOR OPTION L05J - 5,000 WATT - EXPORT

KEY PART NUMBER	U/M	DESCRIPTION
007125-03-000	EA	CLAMP-MUFFLER - 1.5" DIA
007125-04-000	EA	CLAMP-MUFFLER, 1.1" DIA
008289-01-000	EA	BOX-ELECTRIC, STEEL - 1/2" AND 3/4" KNOCKOUTS - 4" X 4"
008294-01-000	EA	COVER-ELECTRICAL BOX, STEEL/BLANK - 4" X 4" - GRAY
079854-05-000	EA	PIPE-EXHAUST, ANGLED - W/FLANGE - EMERALD - ONAN 154-2539
100975-04-000	EA	GENERATOR-5KW, EMERALD, ONAN NHE/FN29237G
077353-09-000	EA	SHROUD-INSTRUMENT CLUSTER, BACK SHIELD - PLASTIC - BLACK NOT USED AFTER 7-01-90

FROM: 00-00-00 THRU: 07-01-90

083152-01-000	EA	PIPE-EXHAUST, GENERATOR - ONAN - 1.3" OD X 33.3" X 27.7"
083152-03-000	EA	PIPE-EXHAUST, GENERATOR - 1.37" OD X 4.92" X 11.8"
083152-08-000	EA	PIPE-EXHAUST, GENERATOR - ONAN - 1.3" OD X 4.9" X 55.1"
083590-04-000	EA	MUFFLER-GENERATOR
008054-01-000	EA	CORD-POWER, 10/3 WIRE - 30 PPH - 25'
000G11-08-088	EA	SCREW, 8-18 X 1/2 PPH ZN
000G11-10-188	EA	SCREW, 10-18 X 1 - PPH ZN
000G87-10-12B	EA	SCREW, 10-12 X 3/4 - PPH ZN
008028-01-000	FT	WIRE-12/2, ROMEX - W/GROUND
008311-01-000	EA	CONNECTOR-WIRE NUT, INSULATED - RED
008314-01-000	EA	CONNECTOR-WIRE NUT, INSULATED - GRAY
008329-01-000	EA	TERMINAL-RING, 12/10 WIRE - #10 STUD FIT
008331-01-000	EA	TERMINAL-RING, TONGUE - #4 WIRE - 3/8" STUD - COPPER
008353-01-000	EA	CONNECTOR-CABLE CLAMPING, 3/8"
008355-01-000	EA	CONNECTOR-CABLE CLAMPING, 3/4"
008358-01-000	EA	CONNECTOR-PLASTIC, 3/8" AVG
024924-02-000	EA	RECEPTACLE-POWER CORD, W/PARTIAL PLATE
041953-01-000	FT	CONDUIT-CONVOLUTE SLIT .50ID
089238-01-000	EA	COVER-ELECTRICAL BOX, W/HOLE - 4" X 4" - GRAY USED WITH 30 OR 50 AMP RECEPTACLE

073937-03-000	EA	SWITCH-ROTARY SELECTOR, 3 DECK - A/C - CA20-USA892
073937-01-700	EA	KNOB-ROTARY SWITCH-A/C SEL
074890-01-000	EA	BOX-EXTENSION, STEEL - OPEN SIDES - 4" X 4" X 1 1/2"
074897-01-000	EA	COVER-ELECTRIC BOX, 1 LARGE & 2 SMALL HOLES - 4" X 4"
091213-01-000	EA	BOX-CIRCUIT BREAKER - W/KNOCKOUTS - 5.3" X 11.8" X 2.5"
092615-01-000	EA	CONVERTER-40 AMP, W/CHARGER - B-W 32400P
094809-01-000	EA	LOAD CENTER-240 VOLT, 125 AMP
094810-01-000	EA	CIRCUIT BREAKER-DOUBLE 30 AMP, GE THQ12130
094811-01-000	EA	CIRCUIT BREAKER-DOUBLE 20 AMP, GE THQ12120
000C28-04-10B	EA	BOLT-HEX, SER FLG - 1/4-20 X 5/8 ZINC
000D14-06-00B	EA	NUT-HEX, 5/16-18 - ZN 5
000D39-04-00B	EA	NUT-HEX, SER FLG LK 1/4 - 20 ZN
000D39-06-00B	EA	NUT-HEX, SER FLG LK - 5/16 - 18 ZN
007131-01-000	EA	HANGER-TAILPIPE
024976-01-000	EA	SWITCH-GENERATOR, W/O CIRCUIT BOARD
041480-01-000	EA	CONNECTOR-STRAIGHT, 1/2" FLEX CONDUIT
088238-01-000	EA	COVER-A/C SELECTOR SWITCH FOR FRONT OR REAR
031035-01-000	EA	GAUGE-HOURMETER
077353-09-000	EA	SHROUD-INSTRUMENT PANEL CLUSTER, GENERATOR
081087-01-000	EA	LIGHT ASM-INDICATOR
097372-04-01A	EA	SWITCH-MOMENTARY-OFF-MOMENTARY

1991 INNEBAGO

TABLE OF CONTENTS

INTRODUCTION	A-01 - A-02
ABBREVIATIONS	A-03
ALPHABETICAL INDEX	A-04 - A-08
WCN28RT	A-07 - G-10
WCN32RQ	G-11 - L-20

1991 WCN28RT INDEX

FLOOR PLAN	A-07 - A-08
ACCESSORIES	A-09 - A-24
BATH	B-01 - B-04
BEDROOM	B-05 - B-08
CHASSIS	B-09 - C-06
C C & PAD	C-07 - C-18
DINETTE	C-19 - C-20
DRIVERS	C-21 - C-24
ELECTRICAL	D-01 - D-08
EXTERIOR BODY	D-09 - D-18
GALLEY	D-19 - E-02
HEATING & A/C	E-03 - E-08
INTERIOR FINISH	E-09 - E-13
LABEL	E-14 - E-22
LP	E-23
LOUNGE	E-24 - F-01
SEALANTS & FASTENERS	F-02 - F-04
WATER & SEWAGE	F-05 - F-11
WINDOW, VENT AND EXTERIOR DOOR	F-12 - G-10

CHASSIS GROUP CONTINUED
LP GENERATOR OPTION L33L - EXPORT

KEY PART NUMBER	U/M	DESCRIPTION
007125-03-000	EA	CLAMP-MUFFLER - 1.5 " DIA
007125-04-000	EA	CLAMP-MUFFLER, 1.1 " DIA
008289-01-000	EA	BOX-ELECTRIC, STEEL - 1/2 " AND 3/4 " KNOCKOUTS - 4 " X 4 "
008294-01-000	EA	COVER-ELECTRICAL BOX, STEEL/BLANK - 4 " X 4 " - GRAY
100974-05-000	EA	GENERATOR-4.0 KW EMERALD PLUS, ONAN BGE-FN
083152-04-000	EA	PIPE-EXHAUST, 1.3 "OD X 4.9 " TO BEND X 18.9 " TO END
093511-01-000	EA	GENERATOR-VAPOR KIT, LP
093590-02-000	EA	MUFFLER-GENERATOR
008054-02-000	EA	CORD-POWER, 10-3 - 30AMP - 33'
008026-01-000	FT	WIRE-12/2, ROMEX - W/GROUND
008312-01-000	EA	CONNECTOR-WIRE NUT, INSULATED - BLUE
008314-01-000	EA	CONNECTOR-WIRE NUT, INSULATED - GRAY
008328-01-000	EA	TERMINAL-RING, 12/10 WIRE - #10 STUD FIT
008331-01-000	EA	TERMINAL-RING, TONGUE - #4 WIRE - 3/8 " STUD - COPPER
008355-01-000	EA	CONNECTOR-CABLE CLAMPING, 3/4 "
008358-01-000	EA	CONNECTOR-PLASTIC, 3/8 " AVG
010497-01-000	EA	CLAMP-CLOSED, 5/8 "ID
024924-02-000	EA	RECEPTACLE-POWER CORD, W/PARTIAL PLATE
041953-01-000	FT	CONDUIT-CONVOLUTED SLIT, .5 "ID
067782-01-000	EA	CONVERTER-40 AMP, W/CHARGER - TRIAD TU-740-2
		FROM: 00-00-00 THRU: 07-29-90
069238-01-000	EA	COVER-ELECTRICAL BOX, W/HOLE - 4 " X 4 " - GRAY
		USED WITH 30 OR 50 AMP RECEPTACLE
083209-02-000	EA	CIRCUIT BREAKER-15/15AMP, 120V - BW H-15/15
083209-04-000	EA	CIRCUIT BREAKER-30A, 120V - BW L-30
		FROM: 05-29-90 THRU: 99-99-99
083209-05-000	EA	CIRCUIT BREAKER-20A, 120V - BW J-20
083209-08-000	EA	CIRCUIT BREAKER-30/15 AMP, 120V - BW D-30/15
		FROM: 00-00-00 THRU: 05-28-90
091213-01-000	EA	BOX-CIRCUIT BREAKER- W/KNOCKOUTS - 5.3 " X 11.8 " X 2.5 "
095721-03-000	EA	LABEL-CONTROL CENTER, US
		FROM: 00-00-00 THRU: 07-08-90
000C26-04-10B	EA	BOLT-HEX, SER FLG - 1/4-20 X 5/8 ZINC
000D14-05-00B	EA	NUT-HEX, 5/16-18 - ZN 5
000D39-04-00B	EA	NUT-HEX, SER FLG LK 1/4 - 20 ZN
000D39-05-00B	EA	NUT-HEX, SER FLG LK - 5/16 - 18 ZN
000G39-08-08B	EA	SCREW-SF/DR, 8-18 X 1/2 PPH ZN
007125-03-000	EA	CLAMP-MUFFLER - 1.5 " DIA
007131-01-000	EA	HANGER-TAILPIPE
008311-01-000	EA	CONNECTOR-WIRE NUT, INSULATED - RED
023942-01-000	EA	GROMMET-RUBBER, 2 " OD

CHASSIS GROUP CONTINUED
4.5 KW KOHLER GENERATOR OPTION L350 - US & CANADIAN

KEY PART NUMBER	U/M	DESCRIPTION
007125-03-000	EA	CLAMP-MUFFLER - 1.5 " DIA
007125-04-000	EA	CLAMP-MUFFLER, 1.1 " DIA
008289-01-000	EA	BOX-ELECTRIC, STEEL - 1/2 " AND 3/4 " KNOCKOUTS - 4 " X 4 "
008289-02-000	EA	BOX-ELECTRICAL, 4 " X 4 " - 1/2 " & 3/4 " KNOCKOUTS - CANADIAN
008294-01-000	EA	COVER-ELECTRICAL BOX, STEEL/BLANK - 4 " X 4 " - GRAY
008294-02-000	EA	COVER-ELECTRICAL BOX, BLANK STEEL - 4 " X 4 " - CANADIAN
083152-10-000	EA	PIPE-EXHAUST, 1.3 "OD X 7.8 " TO BEND X 22 " TO END
093590-02-000	EA	MUFFLER-GENERATOR
093740-01-000	EA	GENERATOR-KOHLER, 4500KW - 4.5CKM21
008054-02-000	EA	CORD-POWER, 10-3 - 30AMP - 33'
008052-01-000	EA	CORD-POWER, 10/3 - 30 AMP - 25' - CANADIAN
008026-01-000	FT	WIRE-12/2, ROMEX - W/GROUND
008312-01-000	EA	CONNECTOR-WIRE NUT, INSULATED - BLUE
008314-01-000	EA	CONNECTOR-WIRE NUT, INSULATED - GRAY
008328-01-000	EA	TERMINAL-RING, 12/10 WIRE - #10 STUD FIT
008331-01-000	EA	TERMINAL-RING, TONGUE - #4 WIRE - 3/8 " STUD - COPPER
008355-01-000	EA	CONNECTOR-CABLE CLAMPING, 3/4 "
008358-01-000	EA	CONNECTOR-PLASTIC, 3/8 " AVG
010497-01-000	EA	CLAMP-CLOSED, 5/8 "ID
024924-02-000	EA	RECEPTACLE-POWER CORD, W/PARTIAL PLATE
041953-01-000	FT	CONDUIT-CONVOLUTED SLIT, .5 "ID
067782-01-000	EA	CONVERTER-40 AMP, W/CHARGER - TRIAD TU-740-2
		FROM: 00-00-00 THRU: 07-29-90
067782-02-000	EA	CONVERTER-40AMP, W/CHARGER - TRIAD TU-840-2 - CANADIAN
		FROM: 00-00-00 THRU: 07-29-90
069238-01-000	EA	COVER-ELECTRICAL BOX, W/HOLE - 4 " X 4 " - GRAY
		USED WITH 30 OR 50 AMP RECEPTACLE
083209-02-000	EA	CIRCUIT BREAKER-15/15AMP, 120V - BW H-15/15
083209-03-000	EA	CIRCUIT BREAKER-15/20AMP, 120V - BW - 0-15/20 - CANADIAN
083209-04-000	EA	CIRCUIT BREAKER-30A, 120V - BW L-30
		FROM: 05-29-90 THRU: 99-99-99
083209-05-000	EA	CIRCUIT BREAKER-20A, 120V - BW J-20
083209-06-000	EA	CIRCUIT BREAKER-30/15 AMP, 120V - BW D-30/15
083210-02-000	EA	CIRCUIT BREAKER-GFI, 15A - 120V - BW U-15 - CANADIAN
		FROM: 00-00-00 THRU: 05-28-90
091213-01-000	EA	BOX-CIRCUIT BREAKER- W/KNOCKOUTS - 5.3 " X 11.8 " X 2.5 "
093257-01-000	EA	BOX-ELECTRICAL, CIRCUIT BREAKER
095721-03-000	EA	LABEL-CONTROL CENTER, US
		FROM: 00-00-00 THRU: 07-08-90
008353-01-000	EA	CONNECTOR-CABLE CLAMPING, 3/8 " - CANADIAN
024978-01-000	EA	SWITCH-GENERATOR, W/O CIRCUIT BOARD - CANADIAN
000C26-04-10B	EA	BOLT-HEX, SER FLG - 1/4-20 X 5/8 ZINC
000D14-05-00B	EA	NUT-HEX, 5/16-18 - ZN 5
000D39-04-00B	EA	NUT-HEX, SER FLG LK 1/4 - 20 ZN
000D39-05-00B	EA	NUT-HEX, SER FLG LK - 5/16 - 18 ZN
000G39-08-08B	EA	SCREW-SF/DR, 8-18 X 1/2 PPH ZN
007131-01-000	EA	HANGER-TAILPIPE
008311-01-000	EA	CONNECTOR-WIRE NUT, INSULATED - RED

1991 WINNEBAGO
TABLE OF CONTENTS

INTRODUCTION	A-01 - A-02
ABBREVIATIONS	A-03
ALPHABETICAL INDEX	A-04 - A-08
WCN28RT	A-07 - G-10
WCN329J	G-11 - L-20

1991 WCN28RT INDEX

FLOOR PLAN	A-07 - A-08
ACCESSORIES	A-09 - A-24
BATH	B-01 - B-04
BEDROOM	B-05 - B-08
CHASSIS	B-09 - C-06
C C & PAD	C-07 - C-18
DINETTE	C-19 - C-20
DRIVERS	C-21 - C-24
ELECTRICAL	D-01 - D-08
EXTERIOR BODY	D-09 - D-18
GALLEY	D-19 - E-02
HEATING & A/C	E-03 - E-08
INTERIOR FINISH	E-09 - E-13
LABEL	E-14 - E-22
LP	E-23
LOUNGE	E-24 - F-01
SEALANTS & FASTENERS	F-02 - F-04
WATER & SEWAGE	F-05 - F-11
WINDOW, VENT AND EXTERIOR DOOR	F-12 - G-10

CHASSIS GROUP CONTINUED

4.5 KW KOHLER GENERATOR OPTION L350 - DIESEL - US & CANADIAN

KEY PART NUMBER	U/M	DESCRIPTION
045703-01-000	EA	HOSE-LP, 3/8 "ID X 24 "US - 3/8 MPT X 1/2 F SWIVEL
045703-02-000	EA	HOSE-LP, 3/8 "ID X 24 " - 3/8 "MPT X 1/2 "F SWIVEL - CANADA
065318-02-000	EA	ELBOW-90 DEGREE, 3/8 "MPT TO 3/8 "FPT
078301-01-000	EA	REGULATOR-TWO STAGE LPG,MARSHALL BRASS 280-CO
081938-01-000	EA	COVER-COMPARTMENT - LP REGULATOR - BLACK
007125-03-000	EA	CLAMP-MUFFLER - 1.5 " DIA
007125-04-000	EA	CLAMP-MUFFLER, 1.1 " DIA
008294-01-000	EA	COVER-ELECTRICAL BOX, STEEL/BLANK - 4 " X 4 " - GRAY
008294-02-000	EA	COVER-ELECTRICAL BOX, BLANK STEEL - 4 " X 4 " - CANADIAN
083152-10-000	EA	PIPE-EXHAUST, 1.3 "OD X 7.8 " TO BEND X 22 " TO END
083590-02-000	EA	MUFFLER-GENERATOR
083740-01-000	EA	GENERATOR-KOHLER, 4500KW - 4.5CKM21
008054-02-000	EA	CORD-POWER, 10/3 - 30AMP - 33'
008052-01-000	EA	CORD-POWER, 10/3 - 30 AMP - 25' - CANADIAN
008289-01-000	EA	BOX-ELECTRIC, STEEL - 1/2 " AND 3/4 " KNOCKOUTS - 4 " X 4 "
008289-02-000	EA	BOX-ELECTRICAL, 4 " X 4 " - 1/2 " 3/4 " KNOCKOUTS - CANADIAN
008312-01-000	EA	CONNECTOR-WIRE NUT, INSULATED - BLUE
008312-01-000	EA	CONNECTOR-WIRE NUT, INSULATED - GRAY
008316-01-000	EA	TERMINAL-RING, 12/10 WIRE - #10 STUD FIT
008331-01-000	EA	TERMINAL-RING,TONGUE - #4 WIRE - 3/8 " STUD - COPPER
008353-01-000	EA	CONNECTOR-CABLE CLAMPING, 3/8 " - CANADIAN
008355-01-000	EA	CONNECTOR-CABLE CLAMPING, 3/4 "
008356-01-000	EA	CONNECTOR-PLASTIC, 3/8 " AVG
010497-01-000	EA	CLAMP-CLOSED, 5/8 "ID
024924-02-000	EA	RECEPTACLE-POWER CORD, W/PARTIAL PLATE
024976-01-000	EA	SWITCH-GENERATOR, W/O CIRCUIT BOARD - CANADIAN
041953-01-000	FT	CONDUIT-CONVOLUTED SLIT, .5 "ID
067782-01-000	EA	CONVERTER-40 AMP, W/CHARGER - TRIAD TU-740-2 FROM: 00-00-00 THRU: 07-29-90
067782-02-000	EA	CONVERTER-40AMP, W/CHARGER - TRIAD TU-840-2 - CANADIAN FROM: 00-00-00 THRU: 07-29-90
089238-01-000	EA	COVER-ELECTRICAL BOX, WHOLE - 4 " X 4 " - GRAY USED WITH 30 OR 50 AMP RECEPTACLE
083209-02-000	EA	CIRCUIT BREAKER-15/15AMP, 120V - BW H-15/15
083209-03-000	EA	CIRCUIT BREAKER-15/20AMP, 120V - BW O-15/20
083209-04-000	EA	CIRCUIT BREAKER-30A, 120V - BW L-30 FROM: 05-29-90 THRU: 09-99-99
083209-05-000	EA	CIRCUIT BREAKER-20A, 120V - BW J-20
083209-06-000	EA	CIRCUIT BREAKER-30/15 AMP, 120V - BW D-30/15
083210-02-000	EA	CIRCUIT BREAKER-GFI, 15A - 120V - BW U-15 - CANADIAN FROM: 00-00-00 THRU: 05-28-90
091213-01-000	EA	BOX-CIRCUIT BREAKER- W/KNOCKOUTS - 5.3 " X 11.8 " X 2.5 "
093257-01-000	EA	BOX-ELECTRICAL, CIRCUIT BREAKER - CANADIAN
095721-05-000	EA	LABEL-CONTROL CENTER, US FROM: 00-00-00 THRU: 07-08-90
000C26-04-10B	EA	BOLT-HEX, SER FLG - 1/4-20 X 5/8 ZINC
000D14-05-00B	EA	NUT-HEX, 5/16-18 - ZN 5
000D39-04-00B	EA	NUT-HEX, SER FLG LK 1/4 - 20 ZN
000D39-05-00B	EA	NUT-HEX, SER FLG LK - 5/16 - 18 ZN
000G39-08-08B	EA	SCREW-SF/DR, 8-18 X 1/2 PPH ZN
007131-01-000	EA	HANGER- TAILPIPE
008311-01-000	EA	CONNECTOR-WIRE NUT, INSULATED - RED

CHASSIS GROUP CONTINUED

3.5KW ONAN GENERATOR OPTION L383 - EXPORT

KEY PART NUMBER	U/M	DESCRIPTION
007125-03-000	EA	CLAMP-MUFFLER - 1.5" DIA
007125-04-000	EA	CLAMP-MUFFLER, 1.1" DIA
008289-01-000	EA	BOX-ELECTRIC, STEEL - 1/2" AND 3/4" KNOCKOUTS - 4" X 4"
008294-01-000	EA	COVER-ELECTRICAL BOX, STEEL/BLANK - 4" X 4" - GRAY
100974-05-000	EA	GENERATOR-4.0 KW EMERALD PLUS, ONAN BGE-FN
083152-04-000	EA	PIPE-EXHAUST, 1.3"OD X 4.9" TO BEND X 19.9" TO END
083590-02-000	EA	MUFFLER-GENERATOR
008054-01-000	EA	CORD-POWER, 10/3 WIRE - 30 AMP - 25'
008028-01-000	FT	WIRE-12/2, ROMEX - W/GROUND
008289-01-000	EA	BOX-ELECTRIC, STEEL - 1/2" AND 3/4 " KNOCKOUTS - 4" X 4"
008311-01-000	EA	CONNECTOR-WIRE NUT, INSULATED - RED
008312-01-000	EA	CONNECTOR-WIRE NUT, INSULATED - BLUE
008314-01-000	EA	CONNECTOR-WIRE NUT, INSULATED - GRAY
008328-01-000	EA	TERMINAL-RING, 12/10 WIRE - #10 STUD FIT
008331-01-000	EA	TERMINAL-RING,TONGUE - #4 WIRE - 3/8 " STUD - COPPER
008353-01-000	EA	CONNECTOR-CABLE CLAMPING, 3/8"
008355-01-000	EA	CONNECTOR-CABLE CLAMPING, 3/4"
008356-01-000	EA	CONNECTOR-PLASTIC, 3/8" AVG
010497-01-000	EA	CLAMP-CLOSED, 5/8"ID
018804-01-000	EA	BRACE-CABINET, ANGLED METAL - 2.5"
024924-02-000	EA	RECEPTACLE-POWER CORD, W/PARTIAL PLATE
041953-01-000	FT	CONDUIT-CONVOLUTED SLIT, .5 "ID
092815-01-000	EA	CONVERTER-40 AMP, W/CHARGER - B-W 32400P FROM: 00-00-00 THRU: 05-28-90
067782-02-000	EA	CONVERTER-40AMP, W/CHARGER - TRIAD TU-840-2 FROM: 05-29-90 THRU: 07-29-90
089238-01-000	EA	COVER-ELECTRICAL BOX, WHOLE - 4" X 4" - GRAY USED WITH 30 OR 50 AMP RECEPTACLE
073937-03-000	EA	SWITCH-ROTARY SELECTOR - 3 DECK - A/C - TK20-090804-001
073937-01-700	EA	KNOB-ROTARY SWITCH, A/C SELECTOR - 148749
074810-01-000	EA	BOX-EXTENSION, STEEL - OPEN SIDES - 4" X 4" X 1 1/2"
074997-01-000	EA	COVER-ELECTRIC BOX, 1 LARGE & 2 SMALL HOLES - 4 " X 4 "
008294-01-000	EA	COVER-ELECTRICAL BOX, STEEL/BLANK - 4" X 4" - GRAY
091213-01-000	EA	BOX-CIRCUIT BREAKER- W/KNOCKOUTS - 5.3" X 11.8" X 2.5"
000C26-04-10B	EA	BOLT-HEX, SER FLG - 1/4-20 X 5/8 ZINC
000D14-05-00B	EA	NUT-HEX, 5/16-18 - ZN 5
000D39-04-00B	EA	NUT-HEX, SER FLG LK 1/4 - 20 ZN
000D39-05-00B	EA	NUT-HEX, SER FLG LK - 5/16 - 18 ZN
000G39-08-08B	EA	SCREW-SF/DR, 8-18 X 1/2 PPH ZN
007131-01-000	EA	HANGER-TAILPIPE
024976-01-000	EA	SWITCH-GENERATOR, W/O CIRCUIT BOARD

1991 WINNEBAGO

TABLE OF CONTENTS

INTRODUCTION	A-01 - A-02
ABBREVIATIONS	A-03
ALPHABETICAL INDEX	A-04 - A-08
WLN28RT	A-07 - G-10
WCN32RQ	G-11 - L-20

1991 WCN28RT INDEX

FLOOR PLAN	A-07 - A-08
ACCESSORIES	A-09 - A-24
BATH	B-01 - B-04
BEDROOM	B-05 - B-08
CHASSIS	B-09 - C-08
C C & PAD	C-07 - C-18
DINETTE	C-19 - C-20
DRIVERS	C-21 - C-24
ELECTRICAL	D-01 - D-08
EXTERIOR BODY	D-09 - D-18
GALLEY	D-19 - E-02
HEATING & A/C	E-03 - E-08
INTERIOR FINISH	E-09 - E-13
LABEL	E-14 - E-22
LP	E-23
LOUNGE	E-24 - F-01
SEALANTS & FASTENERS	F-02 - F-04
WATER & SEWAGE	F-05 - F-11
WINDOW, VENT AND EXTERIOR DOOR	F-12 - G-10

CHASSIS GROUP CONTINUED

4.0KW ONAN GENERATOR OPTION L39E - U.S. & CANADIAN

KEY PART NUMBER	U/M DESCRIPTION
007125-03-000	EA CLAMP-MUFFLER - 1.5 " DIA
007125-04-000	EA CLAMP-MUFFLER, 1.1 " DIA
008289-01-000	EA BOX-ELECTRIC, STEEL - 1/2 " AND 3/4 " KNOCKOUTS - 4 " X 4 "
008289-02-000	EA BOX-ELECTRICAL, 4 " X 4 " - 1/2 " & 3/4 " KNOCKOUTS - CANADIAN
008294-01-000	EA COVER-ELECTRICAL BOX, STEEL/BLANK - 4 " X 4 " - GRAY
008294-02-000	EA COVER-ELECTRICAL BOX, BLANK STEEL - 4 " X 4 " - CANADIAN
079854-05-000	EA PIPE-EXHAUST, ANGLED - W/FLANGE - EMERALD - ONAN# 154-2539
081384-03-000	EA MUFFLER-GENERATOR, ONAN
083152-01-000	EA PIPE-EXHAUST, 1.3 " OD X 33.3 " TO BEND X 28.7 " TO END
083152-08-000	EA PIPE-EXHAUST, 1.3 " OD X 4.9 " TO BEND X 55.1 " TO END
100974-01-000	EA GENERATOR-4.0KW EMERALD PLUS, ONAN BGE-FA/28100G
094059-01-000	EA SPACER-GENERATOR, ONAN
055278-01-001	FT TUBING-STEEL, .75 " X 1.5 " X 288 "
094857-02-000	EA TRAY-GENERATOR, 22.5 " X 30.4 " X 6.9 "
094857-01-000	EA TRAY-GENERATOR, 22.5 " X 30.4 " X 6.9 "
008054-02-000	EA CORD-POWER, 10-3 - 30AMP - 33'
008052-01-000	EA CORD-POWER, 10/3 - 30 AMP - 25' - CANADIAN
008028-01-000	FT WIRE-12/2, ROMEX - W/GROUND
008312-01-000	EA CONNECTOR-WIRE NUT, INSULATED - BLUE
008314-01-000	EA CONNECTOR-WIRE NUT, INSULATED - GRAY
008328-01-000	EA TERMINAL-RING, 12/10 WIRE - #10 STUD FIT
008331-01-000	EA TERMINAL-RING, TONGUE - #4 WIRE - 3/8 " STUD - COPPER
008355-01-000	EA CONNECTOR-CABLE CLAMPING, 3/8 "
008356-01-000	EA CONNECTOR-PLASTIC, 3/8 " AVG
010497-01-000	EA CLAMP-CLOSED, 5/8 " ID
024924-02-000	EA RECEPTACLE-POWER CORD, W/PARTIAL PLATE
041953-01-000	FT CONDUIT-CONVOLUTED SLIT, .5 " ID
087782-01-000	EA CONVERTER-40 AMP, W/CHARGER - TRIAD TU-740-2 FROM: 00-00-00 THRU: 07-29-90
087782-02-000	EA CONVERTER-40AMP, W/CHARGER - TRIAD TU-840-2 - CANADIAN FROM: 00-00-00 THRU: 07-29-90
089238-01-000	EA COVER-ELECTRICAL BOX, W/HOLE - 4 " X 4 " - GRAY USED WITH 30 OR 50 AMP RECEPTACLE
083209-02-000	EA CIRCUIT BREAKER-15/15AMP, 120V - BW H-15/15
083209-03-000	EA CIRCUIT BREAKER-15/20AMP, 120V - BW - 0-15/20 - CANADIAN
083209-04-000	EA CIRCUIT BREAKER-30A, 120V - BW L-30 FROM: 05-29-90 THRU: 99-99-99
083209-05-000	EA CIRCUIT BREAKER-20A, 120V - BW J-20
083209-06-000	EA CIRCUIT BREAKER-30/15 AMP, 120V - BW D-30/15
083210-02-000	EA CIRCUIT BREAKER-GFI, 15A - 120V - BW U-15 - CANADIAN FROM: 00-00-00 THRU: 05-28-90
091213-01-000	EA BOX-CIRCUIT BREAKER - W/KNOCKOUTS - 5.3 " X 11.8 " X 2.5 "
093257-01-000	EA BOX-ELECTRICAL, CIRCUIT BREAKER - CANADIAN
095721-03-000	EA LABEL-CONTROL CENTER, US FROM: 00-00-00 THRU: 07-08-90
000C26-04-10B	EA BOLT-HEX, SER FLG - 1/4-20 X 5/8 ZINC
000D14-05-00B	EA NUT-HEX, 5/16-18 - ZN 5
000D39-04-00B	EA NUT-HEX, SER FLG LK 1/4 - 20 ZN
000D39-05-00B	EA NUT-HEX, SER FLG LK - 5/16 - 18 ZN
000G39-08-08B	EA SCREW-SF/DH, 8-18 X 1/2 PPH ZN
007131-01-000	EA HANGER-TAILPIPE
008311-01-000	EA CONNECTOR-WIRE NUT, INSULATED - RED
008353-01-000	EA CONNECTOR-CABLE CLAMPING, 3/8 " - CANADIAN
024976-01-000	EA SWITCH-GENERATOR, W/O CIRCUIT BOARD

CHASSIS GROUP CONTINUED

4.0KW ONAN GENERATOR OPTION L39E - DIESEL - US & CANADIAN

KEY PART NUMBER	U/M DESCRIPTION
045703-01-000	EA HOSE-L/P, 3/8 " ID X 24 " US - 3/8 MPT X 1/2 F SWIVEL
045703-02-000	EA HOSE-LP, 3/8 " ID X 24 " - 3/8 " MPT X 1/2 " F SWIVEL - CANADA
085318-02-000	EA ELBOW-90 DEGREE, 3/8 " MPT TO 3/8 " FPT
078301-01-000	EA REGULATOR-TWO STAGE LPG, MARSHALL BRASS 280-00
081938-01-000	EA COVER-COMPARTMENT - LP REGULATOR - BLACK
007125-03-000	EA CLAMP-MUFFLER - 1.5 " DIA
007125-04-000	EA CLAMP-MUFFLER, 1.1 " DIA
008289-01-000	EA BOX-ELECTRIC, STEEL - 1/2 " AND 3/4 " KNOCKOUTS - 4 " X 4 "
008289-02-000	EA BOX-ELECTRICAL, 4 " X 4 " - 1/2 " & 3/4 " KNOCKOUTS - CANADIAN
008294-01-000	EA COVER-ELECTRICAL BOX, STEEL/BLANK - 4 " X 4 " - GRAY
008294-02-000	EA COVER-ELECTRICAL BOX, BLANK STEEL - 4 " X 4 " - CANADIAN
079854-05-000	EA PIPE-EXHAUST, ANGLED - W/FLANGE - EMERALD - ONAN# 154-2539
081384-03-000	EA MUFFLER-GENERATOR, ONAN
083152-01-000	EA PIPE-EXHAUST, 1.3 " OD X 33.3 " TO BEND X 28.7 " TO END
083152-08-000	EA PIPE-EXHAUST, 1.3 " OD X 4.9 " TO BEND X 55.1 " TO END
100974-01-000	EA GENERATOR-4.0KW EMERALD PLUS, ONAN BGE-FA/28100G
094059-01-000	EA SPACER-GENERATOR, ONAN
055278-01-001	FT TUBING-STEEL, .75 " X 1.5 " X 288 "
094857-02-000	EA TRAY-GENERATOR, 22.5 " X 30.4 " X 6.9 " W/ANGLE & NUTS
094857-01-000	EA TRAY-GENERATOR, 22.5 " X 30.4 " X 6.9 "
008054-02-000	EA CORD-POWER, 10-3 - 30AMP - 33'
008052-01-000	EA CORD-POWER, 10/3 - 30 AMP - 25' - CANADIAN
008028-01-000	FT WIRE-12/2, ROMEX - W/GROUND
008312-01-000	EA CONNECTOR-WIRE NUT, INSULATED - BLUE
008314-01-000	EA CONNECTOR-WIRE NUT, INSULATED - GRAY
008328-01-000	EA TERMINAL-RING, 12/10 WIRE - #10 STUD FIT
008331-01-000	EA TERMINAL-RING, TONGUE - #4 WIRE - 3/8 " STUD - COPPER
008355-01-000	EA CONNECTOR-CABLE CLAMPING, 3/4 "
008356-01-000	EA CONNECTOR-PLASTIC, 3/8 " AVG
010497-01-000	EA CLAMP-CLOSED, 5/8 " ID
024924-02-000	EA RECEPTACLE-POWER CORD, W/PARTIAL PLATE
041953-01-000	FT CONDUIT-CONVOLUTED SLIT, .5 " ID
087782-01-000	EA CONVERTER-40 AMP, W/CHARGER - TRIAD TU-740-2 FROM: 00-00-00 THRU: 07-29-90
087782-02-000	EA CONVERTER-40AMP, W/CHARGER - TRIAD TU-840-2 - CANADIAN FROM: 00-00-00 THRU: 07-29-90
089238-01-000	EA COVER-ELECTRICAL BOX, W/HOLE - 4 " X 4 " - GRAY USED WITH 30 OR 50 AMP RECEPTACLE
083209-02-000	EA CIRCUIT BREAKER-15/15AMP, 120V - BW H-15/15
083209-03-000	EA CIRCUIT BREAKER-15/20AMP, 120V - BW - 0-15/20
083209-04-000	EA CIRCUIT BREAKER-30A, 120V - BW L-30 FROM: 05-29-90 THRU: 99-99-99
083209-05-000	EA CIRCUIT BREAKER-20A, 120V - BW J-20
083209-06-000	EA CIRCUIT BREAKER-30/15 AMP, 120V - BW D-30/15
083210-02-000	EA CIRCUIT BREAKER-GFI, 15A - 120V - BW U-15 - CANADIAN FROM: 00-00-00 THRU: 05-28-90
091213-01-000	EA BOX-CIRCUIT BREAKER - W/KNOCKOUTS - 5.3 " X 11.8 " X 2.5 "
093257-01-000	EA BOX-ELECTRICAL, CIRCUIT BREAKER - CANADIAN
095721-03-000	EA LABEL-CONTROL CENTER, US FROM: 00-00-00 THRU: 07-08-90
000C26-04-10B	EA BOLT-HEX, SER FLG - 1/4-20 X 5/8 ZINC
000D14-05-00B	EA NUT-HEX, 5/16-18 - ZN 5
000D39-04-00B	EA NUT-HEX, SER FLG LK 1/4 - 20 ZN
000D39-05-00B	EA NUT-HEX, SER FLG LK - 5/16 - 18 ZN
000G39-08-08B	EA SCREW-SF/DH, 8-18 X 1/2 PPH ZN
007131-01-000	EA HANGER-TAILPIPE
008311-01-000	EA CONNECTOR-WIRE NUT, INSULATED - RED
008353-01-000	EA CONNECTOR-CABLE CLAMPING, 3/8 " - CANADIAN
024976-01-000	EA SWITCH-GENERATOR, W/O CIRCUIT BOARD

**1991 WINNEBAGO
TABLE OF CONTENTS**

INTRODUCTION	A-01 - A-02
ABBREVIATIONS	A-03
ALPHABETICAL INDEX	A-04 - A-06
WCN28RT	A-07 - G-10
WCN32RQ	G-11 - L-20

1991 WCN28RT INDEX

FLOOR PLAN	A-07 - A-08
ACCESSORIES	A-09 - A-24
BATH	B-01 - B-04
BEDROOM	B-05 - B-08
CHASSIS	B-09 - C-08
C C & PAD	C-07 - C-18
DINETTE	C-19 - C-20
DRIVERS	C-21 - C-24
ELECTRICAL	D-01 - D-08
EXTERIOR BODY	D-09 - D-18
GALLEY	D-19 - E-02
HEATING & A/C	E-03 - E-08
INTERIOR FINISH	E-09 - E-13
LABEL	E-14 - E-22
LP	E-23
LOUNGE	E-24 - F-01
SEALANTS & FASTENERS	F-02 - F-04
WATER & SEWAGE	F-05 - F-11
WINDOW, VENT AND EXTERIOR DOOR	F-12 - G-10

CHASSIS GROUP CONTINUED

4.0 KW ONAN GENERATOR OPTION L39F - JAPAN

KEY PART NUMBER	U/M	DESCRIPTION
008054-02-000	EA	CORD-POWER, 10-3 - 30AMP - 3'
008026-01-000	FT	WIRE-12/2, ROMEX - W/GROUND
008289-01-000	EA	BOX-ELECTRIC, STEEL - 1/2 " AND 3/4 " KNOCKOUTS - 4 " X 4 "
008312-01-000	EA	CONNECTOR-WIRE NUT, INSULATED - BLUE
008314-01-000	EA	CONNECTOR-WIRE NUT, INSULATED - GRAY
008328-01-000	EA	TERMINAL-RING, 12/10 WIRE - #10 STUD FIT
008331-01-000	EA	TERMINAL-RING, TONGUE - #4 WIRE - 3/8 " STUD - COPPER
008355-01-000	EA	CONNECTOR-CABLE CLAMPING, 3/4 "
008366-01-000	EA	CONNECTOR-PLASTIC, 3/8 " AVG
010497-01-000	EA	CLAMP-CLOSED, 5/8 " ID
024024-02-000	EA	RECEPTACLE-POWER CORD, W/PARTIAL PLATE
041953-01-000	FT	CONDUIT-CONVOLUTED SLIT, .5 " ID
092815-01-000	EA	CONVERTER-40 AMP, W/CHARGER - B-W 32400P FROM: 00-00-00 THRU: 05-28-90
097782-01-000	EA	CONVERTER-40 AMP, W/CHARGER - TRIAD TU-740-2 FROM: 05-29-90 THRU: 07-29-90
099238-01-000	EA	COVER-ELECTRICAL BOX, WHOLE - 4 " X 4 " - GRAY USED WITH 30 OR 50 AMP RECEPTACLE
093209-02-000	EA	CIRCUIT BREAKER-15/15AMP, 120V - BW H-15/15
093209-04-000	EA	CIRCUIT BREAKER-30A, 120V - BW L-30 FROM: 05-29-90 THRU: 09-09-99
093209-05-000	EA	CIRCUIT BREAKER-20A, 120V - BW J-20
093209-08-000	EA	CIRCUIT BREAKER-30/15 AMP, 120V - BW D-30/15 FROM: 00-00-00 THRU: 05-28-90
091213-01-000	EA	BOX-CIRCUIT BREAKER - W/KNOCKOUTS - 5.3 " X 11.8 " X 2.5 "
095721-03-000	EA	LABEL-CONTROL CENTER, US FROM: 00-00-00 THRU: 07-01-90
007125-03-000	EA	CLAMP-MUFFLER - 1.5 " DIA
007125-04-000	EA	CLAMP-MUFFLER, 1.1 " DIA
008294-01-000	EA	COVER-ELECTRICAL BOX, STEEL/BLANK - 4 " X 4 " - GRAY
079864-05-000	EA	PIPE-EXHAUST, ANGLED - W/FLANGE - EMERALD - ONAN# 154-2738
081384-03-000	EA	MUFFLER-GENERATOR, ONAN
083152-06-000	EA	PIPE-EXHAUST, 1.3 " OD X 4.9 " TO BEND X 48 " TO END
094059-01-000	EA	SPACER-GENERATOR, ONAN
066278-01-001	FT	TUBING-STEEL, .75 " X 1.5 " X 288 "
094857-02-000	EA	TRAY-GENERATOR, 22.5 " X 30.4 " X 6.9 "
094857-01-000	EA	TRAY-GENERATOR, 22.5 " X 30.4 " X 6.9 "
000C26-04-108	EA	BOLT-HEX, SER FLG - 1/4-20 X 5/8 ZINC
000D14-05-008	EA	NUT-HEX, 5/16-18 - ZN 5
000D39-04-008	EA	NUT-HEX, SER FLG LK 1/4 - 20 ZN
000D39-05-008	EA	NUT-HEX, SER FLG LK - 5/16 - 18 ZN
000G39-08-088	EA	SCREW-SF/DR, 8-18 X 1/2 PPH ZN
007131-01-000	EA	HANGER-TAILPIPE
008311-01-000	EA	CONNECTOR-WIRE NUT, INSULATED - RED
024978-01-000	EA	SWITCH-GENERATOR, W/O CIRCUIT BOARD

CHASSIS GROUP CONTINUED

DIESEL EXPORT OPTION L05M

KEY PART NUMBER	U/M	DESCRIPTION
072878-01-000	EA	INSULATION-SOUND BARRIER PAD, 29.25 " X 40.19 "
000D39-05-008	EA	NUT-HEX, SER FLG LK - 5/16 - 18 ZN
007063-01-000	FT	HOSE-GAS 1/4 " ID X 1/2 " OD
062401-05-000	EA	CLAMP-HOSE, WORMGEAR - 2 " X 3 "
062401-08-000	EA	CLAMP-HOSE, WORMGEAR 4.08 " - 5.0 "
075467-01-000	EA	NUT-INVERTED FLARE, 1/4 "
088497-02-000	EA	NUT-INVERTED FLARE, 1/4 "
079860-01-000	EA	GROMMET-SEAL, VALVE - FUEL - FORD# E1FZ-9B078-B
079861-01-000	EA	VALVE-VENT, FUEL TANK - FORD# E7DZ-9B593-A
086254-01-000	EA	RETAINER-SENDER, FUEL
086255-01-000	EA	GASKET-SENDER, FUEL
088488-02-000	EA	STRAP-FUEL TANK, STEEL
092352-03-000	EA	TANK-FUEL, 60 GAL - 39.4 " X 27 " X 15.7 "
093719-01-000	EA	HOSE-OIL FULL, PREFORMED 90 DEGREE BEND
095189-01-000	EA	PIPE-EXHAUST, PASSENGER SIDE - 28.5 " LONG - 11.5 " TO BEND
095189-02-000	EA	PIPE-EXHAUST, DRIVER SIDE - 28.5 " LONG - 11.5 " TO BEND
095523-02-000	EA	BRACKET-EXHAUST, UPPER - STRAIGHT - W/NUTS

DIESEL CRUISE CONTROL

KEY PART NUMBER	U/M	DESCRIPTION
102382-02-000	EA	SPEED CONTROL-1991 CHEVY DIESEL, DANA 59L111020P
102382-01-701	EA	REGULATOR-ELECTRONIC, DANA 57C-08X13-R
102382-01-702	EA	MODULE-WIPER CONTROL, DANA 68D-00081
102382-01-703	EA	HARNES-PIVOT SW TO WIPER CONTROL, DANA 59C-02973
102382-01-704	EA	HARNES-MAIN WIRING, DANA 59D-02975
102382-01-707	EA	SWITCH & LEVER-CONTROL, DANA 53D-08X63-F
083212-01-705	EA	RELEASE VALVE ONLY, DANA# 59C-02297
094389-01-701	EA	SWITCH & LEVER ASM, DANA# 58D-11118-F
094389-01-708	EA	SERVO-DANA# 53D-11118-R
094389-02-700	EA	CABLE-SERVO, DIESEL - DANA# 59C-2282
094389-02-702	EA	EXTENSION-WIRE HARNES, DANA# 59C-02279
094863-01-704	EA	HOUSING-4 PIN, SPEED CONTROL - TOYOTA - DANA 59C-02291

DIESEL ENGINE OPTION L33N - US & EXPORT

KEY PART NUMBER	U/M	DESCRIPTION
072878-01-000	EA	INSULATION-SOUND BARRIER PAD, 29.25 " X 40.19 "
079860-01-000	EA	GROMMET-SEAL, VALVE - FUEL - FORD# E1FZ-9B078-B
079861-01-000	EA	VALVE-VENT, FUEL TANK - FORD# E7DZ-9B593-A
086254-01-000	EA	RETAINER-SENDER, FUEL
086255-01-000	EA	GASKET-SENDER, FUEL
088488-02-000	EA	STRAP-FUEL TANK, STEEL
092352-03-000	EA	TANK-FUEL, 60 GAL - 39.4 " X 27 " X 15.7 "
093719-01-000	EA	HOSE-OIL FULL, PREFORMED 90 DEGREE BEND
095189-01-000	EA	PIPE-EXHAUST, PASSENGER SIDE - 28.5 " LONG - 11.5 " TO BEND
095189-02-000	EA	PIPE-EXHAUST, DRIVER SIDE - 28.5 " LONG - 11.5 " TO BEND
095222-02-000	EA	BRACKET-EXHAUST, UPPER - W/BEND & NUTS, CHEVY PROVIDED PRIOR TO 12-89
095223-01-000	EA	BRACKET-EXHAUST, LOWER - U SHAPED
095523-02-000	EA	BRACKET-EXHAUST, UPPER - STRAIGHT - W/NUTS
102382-02-000	EA	SPEED CONTROL-1991 CHEVY DIESEL, DANA 59L111020P
102382-01-701	EA	REGULATOR-ELECTRONIC, DANA 57C-08X13-R
102382-01-702	EA	MODULE-WIPER CONTROL, DANA 68D-00081
102382-01-703	EA	HARNES-PIVOT SW TO WIPER CONTROL, DANA 59C-02973
102382-01-704	EA	HARNES-MAIN WIRING, DANA 59D-02975
102382-01-707	EA	SWITCH & LEVER-CONTROL, DANA 53D-08X63-F
083212-01-705	EA	RELEASE VALVE ONLY, DANA# 59C-02297
094389-01-701	EA	SWITCH & LEVER ASM, DANA# 58D-11118-F
094389-01-708	EA	SERVO-DANA# 53D-11118-R
094389-02-700	EA	CABLE-SERVO, DIESEL - DANA# 59C-2282
094389-02-702	EA	EXTENSION-WIRE HARNES, DANA# 59C-02279
094863-01-704	EA	HOUSING-4 PIN, SPEED CONTROL - TOYOTA - DANA 59C-02291

**1991 WINNEBAGO
TABLE OF CONTENTS**

INTRODUCTION	A-01 - A-02
ABBREVIATIONS	A-03
ALPHABETICAL INDEX	A-04 - A-08
WCN28RT	A-07 - G-10
WCN32RQ	G-11 - L-20

1991 WCN28RT INDEX

FLOOR PLAN	A-07 - A-08
ACCESSORIES	A-09 - A-24
BATH	B-01 - B-04
BEDROOM	B-05 - B-08
CHASSIS	B-09 - C-06
C C & PAD	C-07 - C-18
DINETTE	C-19 - C-20
DRIVERS	C-21 - C-24
ELECTRICAL	D-01 - D-06
EXTERIOR BODY	D-09 - D-18
GALLEY	D-19 - E-02
HEATING & A/C	E-03 - E-08
INTERIOR FINISH	E-09 - E-13
LABEL	E-14 - E-22
LP	E-23
LOUNGE	E-24 - F-01
SEALANTS & FASTENERS	F-02 - F-04
WATER & SEWAGE	F-05 - F-11
WINDOW, VENT AND EXTERIOR DOOR	F-12 - G-10

CHASSIS GROUP CONTINUED

SPEED CONTROL

KEY PART NUMBER	U/M	DESCRIPTION
094369-03-000	EA	SPEED CONTROL-SMART STICK, EFI - GAS - DANA# 59L-111298 USED ON 1990 CHASSIS WITH IGNITION SWITCH IN DASH - IF IGNITION SWITCH IS ON STEERING COLUMN USE 102362-01-000 FROM: 00-00-00 THRU: 04-04-91
094369-01-702	EA	REGULATOR ASM-ELECTRONIC, DANA# 57C-08X12-R
091900-01-702	EA	WIPER CONTROL MODULE-DANA# 68C-00081
094369-01-708	EA	SERVO-DANA# 53D-11116-R
083211-01-703	EA	SERVO CABLE ASM ONLY, DANA# 59C-02538
083212-01-704	EA	STOP LAMP/PIVOT RELEASE SWITCH, DANA# 59C-02543
089829-01-704	EA	SIGNAL GENERATOR ONLY ASM, DANA# 59L-08X221P
083212-04-701	EA	MAIN WIRING HARNESS, DANA# 59D-02570
094369-01-701	EA	SWITCH & LEVER ASM, DANA# 58D-11118-F
094369-01-704	EA	HEADLIGHT UPPER MODULE ASM-DANA# 63C-00001
059778-01-710	EA	TESTER CRUISE CONT.W/HARNESS, DANA# 58L-08X33-B
089829-01-706	EA	SIGNAL GENERATOR ONLY, DANA# 59D-02392-1
094369-01-705	EA	VACUUM RESERVOIR DANA# 59C-02249
083212-01-705	EA	RELEASE VALVE ONLY, DANA# 59C-02297
079972-01-707	EA	EXTENSION HARNESS ASM-SIGNAL GENERATOR, DANA# 69C-2378-1
102362-01-000	EA	SPEED CONTROL-1991 CHEVY, DANA 59L-111010B USED ON 1991 CHASSIS WITH IGNITION SWITCH ON STEERING COLUMN, IF SWITCH IS ON DASH USE 094369-03-000 FROM: 04-05-91 THRU: 99-99-99
102362-01-700	EA	CABLE-SERVO, CABLE ONLY - DANA 59C-03001
102362-01-701	EA	REGULATOR-ELECTRONIC, DANA 57C-08X13-R
102362-01-702	EA	MODULE-WIPER CONTROL, DANA 68D-00081
102362-01-703	EA	HARNESS-PIVOT SW TO WIPER CONTROL, DANA 59C-02973
102362-01-704	EA	HARNESS-MAIN WIRING, DANA 59D-02975
102362-01-705	EA	CLIP-THROTTLE RETAINER, DANA 59A-02821
102362-01-708	EA	STUD-THROTTLE, DANA 59A-02979
102362-01-707	EA	SWITCH & LEVER-CONTROL, DANA 53D-08X83-F
094369-01-708	EA	SERVO-DANA# 53D-11116-R
094883-01-704	EA	HOUSING-4 PIN, SPEED CONTROL - TOYOTA - DANA 59C-02291
094369-01-705	EA	VACUUM RESERVOIR-DANA# 59C-02249

LUG WRENCH, MUD FLAP, DIRTGUARD, SPARE TIRE & PLATE

KEY PART NUMBER	U/M	DESCRIPTION
080208-01-000	EA	LUG WRENCH, 1.08X1.00
080209-02-000	EA	LEVERAGE BAR-LUG WRENCH
017516-01-000	EA	FLAP-MUD, BLACK
020187-03-000	EA	DIRT GUARD-STEEL, FOR MUDFLAP
NOTE		RIM PROVIDED BY CHASSIS SUPPLIER
007324-04-000	EA	TIRE-8R19.5 LRD, MICHELIN XZA
051377-01-000	EA	STEM-VALVE
095989-02-000	EA	PLATE-SPARE TIRE, 3.9 " X 5.9 " - W/STUD

PARKING BRAKE

KEY PART NUMBER	U/M	DESCRIPTION
093074-01-000	EA	CABLE-PARK BRAKE, FOOT OPERATED FROM: 00-00-00 THRU: 04-04-91
093631-01-000	EA	LEVER-PARK BRAKE, FOOT OPERATED CHEVY PROVIDED AUTOMATIC PARK BRAKE AFTER 5-13-90 FROM: 00-00-00 THRU: 04-04-91
093802-01-000	EA	BRACKET-BRAKE, PARK FROM: 00-00-00 THRU: 03-11-90

BATTERY COMPONENTS

KEY PART NUMBER	U/M	DESCRIPTION
030804-03-000	EA	TRAY-BATTERY, AUTO - W/TWO HEX NUTS - CHEVY
051387-06-000	EA	BOLT-CARRIAGE, W/O HOLE - 5/16-18 X 9.5 ZN
015365-01-000	EA	PIN-TIRE CARRIER, CADMIUM PLATED
088751-01-000	FT	CABLE-BATTERY, 10 AWG, STRANDED, RED FROM: 07-02-90 THRU: 99-99-99

CHASSIS GROUP CONTINUED

FUEL SYSTEM

KEY PART NUMBER	U/M	DESCRIPTION
007083-01-000	FT	HOSE-GAS 1/4 "ID X 1/2 "OD
086732-01-000	FT	HOSE-FUEL FILL, .82 "ID
080081-01-000	EA	STRAP-MOUNTING, FUEL LINE - 2 " X 32 " FROM: 01-09-91 THRU: 99-99-99
079860-01-000	EA	GROMMET-SEAL, VALVE - FUEL - FORD# E1FZ-9B078-B
072447-04-000	EA	SHROUD-FUEL FILL, UPPER
083578-01-000	EA	BOOT-FUEL FILL
084235-01-000	EA	SUPPORT-FLANGE, FUEL FILL BOOT
098803-01-000	EA	PIPE-FUEL FILL, 90 DEGREE BEND - 13.2 " - 1 3/4 " OD - STEEL
098906-01-000	EA	PIPE-FILL VENT, 90 DEGREE BEND - 13.2 " - 1 3/4 " OD - STEEL
098807-01-000	EA	PIPE-FUEL FILL, 90 DEGREE BEND - 6.0 " - 1 3/4 " OD - STEEL

TIRE

KEY PART NUMBER	U/M	DESCRIPTION
107324-04-000	EA	TIRE-8R19.5 LRD, MICHELIN XZA
051377-01-000	EA	STEM-VALVE
M04019-01-000	EA	WHEELWELL-BRIDGE, E-COATED
007083-01-000	FT	HOSE-GAS 1/4"ID X 1/2"OD
040731-01-000	EA	NIPPLE-INLET MANIFOLD, GM 3832094
082401-03-000	EA	CLAMP-HOSE WORMGEAR, 22" - 1"
082401-05-000	EA	CLAMP-HOSE, WORMGEAR 2" - 3"
087797-01-000	FT	SPACER-STRAP, W/FOAM ADHESIVE - .31" X 1.5" - NEOPRENE
078785-02-000	EA	ELBOW-BRASS, 90 DEGREE - 3/4" FPT X 3/4" MPT
088753-01-000	FT	TUBE-ALUMINIZED STEEL, 5/8" - 18 GAUGE

ENTRY STEP BOX

KEY PART NUMBER	U/M	DESCRIPTION
088412-02-000	EA	TRIM-STEPBOX, ENTRY DOOR - TAN
088412-04-000	EA	TRIM-STEPBOX, ENTRY DOOR - BEIGE
092893-02-01A	EA	LINER-STEP BOX, ENTRANCE DOOR - 5 " - BLACK
M92065-01-000	EA	PANEL-ACCESS, STEP BOX - WHINGE
088254-01-000	EA	CATCH-MAGNETIC, 1.8 " X 7 "
009083-01-000	EA	HINGE-CONTINUOUS, 1 1/2 " X 72 "

STEP WELL ACCESS PANEL

KEY PART NUMBER	U/M	DESCRIPTION
M92065-01-000	EA	PANEL-ACCESS, STEP WELL - W/HINGE
009083-01-000	EA	HINGE-CONTINUOUS, 1 1/2 " X 72 "
088254-01-000	EA	CATCH-MAGNETIC, 1.8 " X 7 "

DRIVESHAFT

KEY PART NUMBER	U/M	DESCRIPTION
074833-01-000	EA	SPACER-BEARING, DRIVESHAFT - .5 " THICK
074833-02-000	EA	SPACER-BEARING, DRIVESHAFT - .187 " THICK
075302-12-000	EA	DRIVESHAFT-YOKE/SPLINE FROM: 00-00-00 THRU: 04-04-91
103913-01-000	EA	DRIVESHAFT-YOKE/SPLINE FROM: 04-05-91 THRU: 99-99-99
099009-01-000	EA	FRAME WELDMENT SHIELD-HEAT CONVERTER FROM: 00-00-00 THRU: 06-10-90
055278-01-001	FT	TUBING-STEEL, .75 " X 1.5 " X 288 "
M04019-01-000	EA	BRIDGE-WHEELWELL, E-COATED
093048-01-000	EA	PLATE-SKID, REAR BUMPER - V SHAPED

1991 WINNEBAGO

TABLE OF CONTENTS

INTRODUCTION	A-01 - A-02
ABBREVIATIONS	A-03
ALPHABETICAL INDEX	A-04 - A-06
WCN28RT	A-07 - G-10
WCN32RO	G-11 - L-20

1991 WCN28RT INDEX

FLOOR PLAN	A-07 - A-08
ACCESSORIES	A-09 - A-24
BATH	B-01 - B-04
BEDROOM	B-05 - B-08
CHASSIS	B-09 - C-08
C C & PAD	C-07 - C-18
DINETTE	C-19 - C-20
DRIVERS	C-21 - C-24
ELECTRICAL	D-01 - D-08
EXTERIOR BODY	D-09 - D-18
GALLEY	D-19 - E-02
HEATING & AC	E-03 - E-08
INTERIOR FINISH	E-09 - E-13
LABEL	E-14 - E-22
LP	E-23
LOUNGE	E-24 - F-01
SEALANTS & FASTENERS	F-02 - F-04
WATER & SEWAGE	F-05 - F-11
WINDOW, VENT AND EXTERIOR DOOR	F-12 - G-10

CHASSIS GROUP CONTINUED

EXHAUST COMPONENTS

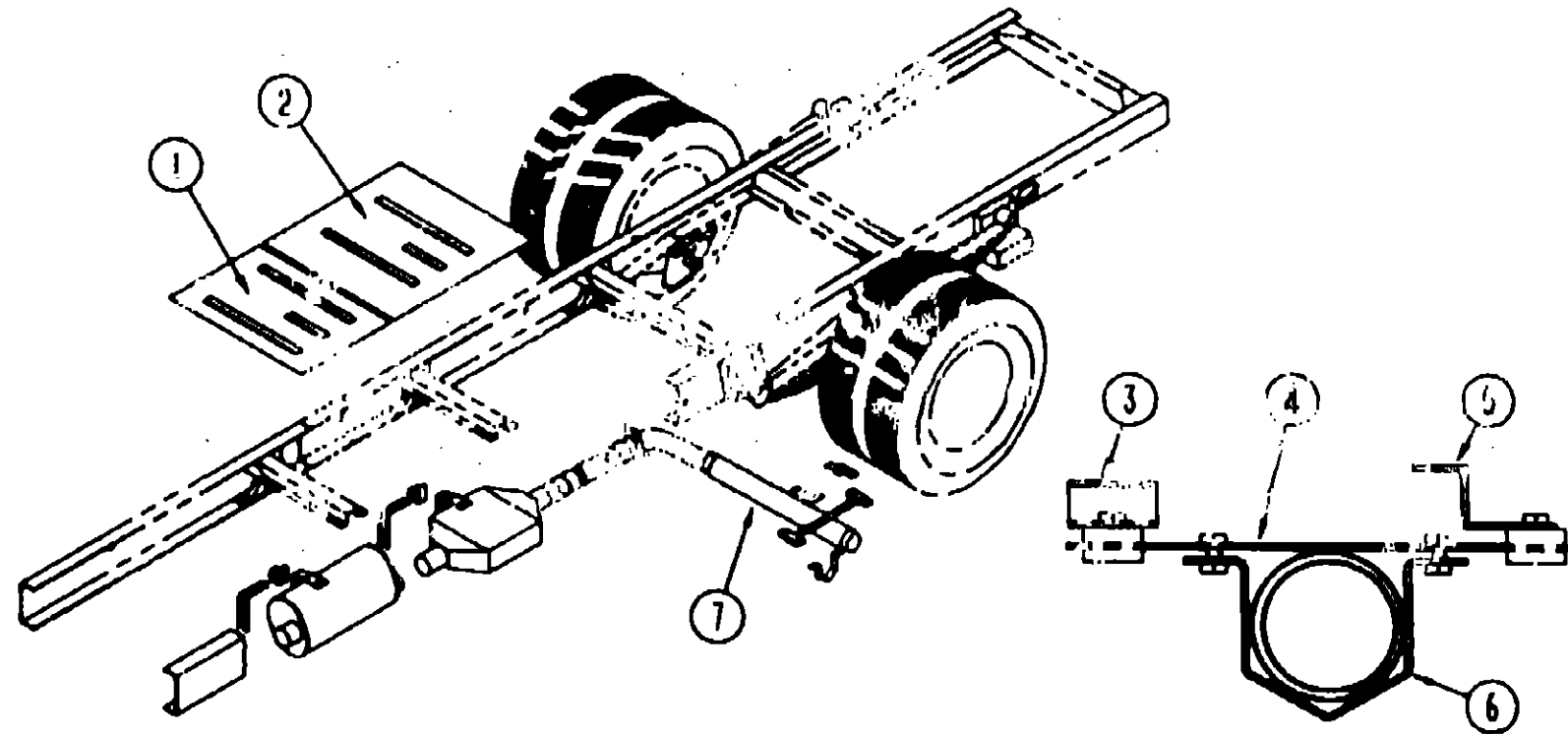

1991 WINNEBAGO TABLE OF CONTENTS

INTRODUCTION	A-01 - A-02
ABBREVIATIONS	A-03
ALPHABETICAL INDEX	A-04 - A-08
WCN28RT	A-07 - G-10
WCN28RQ	G-11 - L-A

1991 WCN28FT INDEX

FLOOR PLAN	A-07 - A-08
ACCESSORIES	A-09 - A-24
BATH	B-01 - B-04
BEDROOM	B-05 - B-08
CHASSIS	B-09 - C-06
C & PAD	C-07 - C-18
DINETTE	C-19 - C-20
DRIVERS	C-21 - C-24
ELECTRICAL	D-01 - D-08
EXTERIOR BODY	D-09 - D-18
GALLEY	D-19 - F-02
HEATING & A/C	E-03 - E-08
INTERIOR FINISH	E-09 - E-13
LABEL	E-14 - E-22
LP	E-23
LOUNGE	F-24 - F-01
SEALANTS & FASTENERS	F-02 - F-04
WATER & SEWAGE	F-05 - F-11
WINDOW, VENT AND EXTERIOR DOOR	F-12 - G-10

KEY PART NUMBER	U/M	DESCRIPTION
1 101544 01 000	EA	SHIELD-HEAT,EXHAUST
2 101544 02 000	EA	SHIELD-HEAT,EXHAUST
095523 04 000	EA	BRACKET ASM-EXHAUST,UPPER
4 095523-03-000	EA	BRACKET-EXHAUST,UPPER
5 095222-02-000	EA	BRACKET-EXHAUST, UPPER - W/BEND & NUTS - CHEVY PROVIDED PRIOR TO 12-89 FROM: 12-05-89 THRU: 99-99-99
6 095223-02-000	EA	BRACKET-EXHAUST, LOWER - STRAIGHT - W/NUTS - CHEVY PROVIDED PRIOR TO 12-89 FROM: 12-05-89 THRU: 99-99-99
7 098599-01-000	EA	PIPE-EXHAUST
095190-01-000	EA	HANGER-EXHAUST, 4" X 1.4" - CHEVY PROVIDED PRIOR TO 12-89 FROM: 12-05-89 THRU: 99-99-99
094918-01-000	EA	CLAMP-EXHAUST, 3" - GUILLOTINE STYLE

CHASSIS GROUP CONTINUED

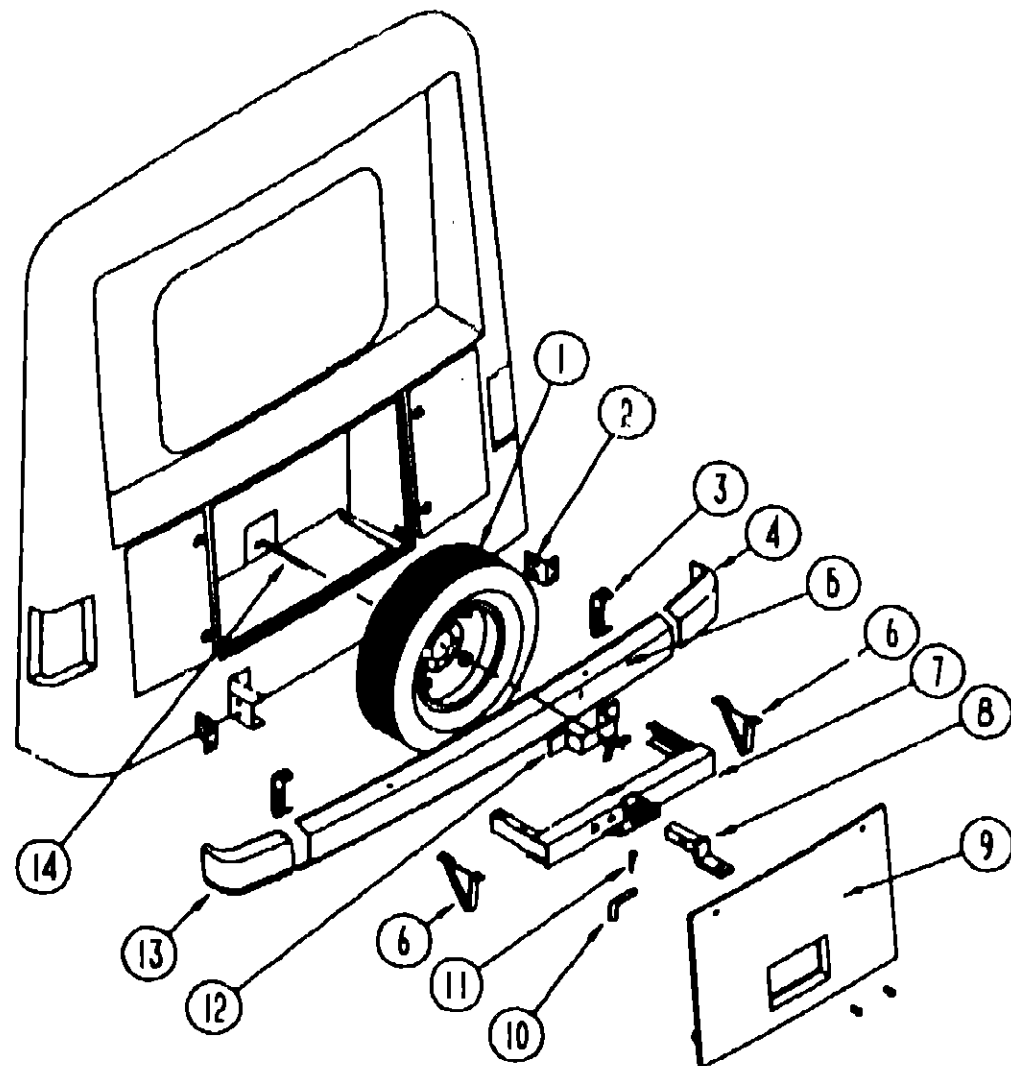

REAR BUMPER, END CAP & TRAILER TOWING HOUSINGS

KEY PART NUMBER	U/M DESCRIPTION
097744-02-000	EA HOUSING-TRAILER PIN, 48"
097746-01-000	EA HOUSING CAP-TRAILER PIN
097745-02-000	EA HOUSING-RECEPTACLE, TRAILER - 48" WIRE LENGTH
1 007324-04-000	EA TIRE-8R19.5 LRD, MICHELIN XZA
1 051377-01-000	EA STEM-VALVE
1 M04019-01-000	EA WHEELWELL-BRIDGE, E-COATED
2 076558-01-000	EA SUPPORT-L ANGLE, BUMPER - PASSENGER SIDE - 5" X 4.9"
2 076558-02-000	EA SUPPORT-L ANGLE, BUMPER - DRIVER SIDE - 5" X 4.9"
3 077855-01-000	EA BRACKET-BUMPER, REAR - BENT ENDS - 2" WIDE X 8" LONG
005200-01-000	EA BOLT-BUMPER, ROUND HEAD-SQUARE NECK- W/SST CAP 7/16-14 X 1 1/4
4 092250-01-01A	EA CAP-BUMPER END, REAR PASSENGER - PLASTIC - BEIGE
5 077851-08-000	EA BUMPER-REAR, UNFINISHED
6 093048-01-000	EA PLATE-SKID, REAR BUMPER - V SHAPE/L
7 077617-04-000	EA HITCH-W/O DRAWBAR
8 077613-01-000	EA DRAWBAR ONLY
9 092982-01-Y10	EA DOOR-SPARE TIRE, W/LOCKS - 26.8" X 41.3" - BEIGE
10 034512-01-000	EA PIN-LOCKING, DRAWBAR
11 034513-01-000	EA PIN-HITCH, 3/16" WIRE
12 077399 01 000	EA RETAINER-SPARE TIRE
064081-01-000	EA NUT-WING - SPARE TIRE
13 092250-02-01A	EA CAP-BUMPER END, REAR DRIVER - PLASTIC - BEIGE
097501-01-000	EA BRACKET-BACKWALL, ANGLED 2.2" X 39" LONG
14 095969-02-000	EA PLATE ASM-SPARE TIRE WITH RETAINING ROD

CHASSIS GROUP CONTINUED

FRONT BUMPER & END CAP

KEY PART NUMBER	U/M DESCRIPTION
091994-01-02A	EA BUMPER-FRONT, BEIGE
091994-01-01A	EA BUMPER-FRONT, UNFINISHED
005200-01-000	EA BOLT-BUMPER, ROUND HEAD-SQUARE NECK- W/SST CAP 7/16-14 X 1 1/4
077852-01-000	EA BRACKET-BUMPER, FRONT - 2 PER COACH - BENT 2" X 8"
093614-01-000	EA SUPPORT-BUMPER, FRONT - L ANGLE - 4" X 7"
081107-01-000	EA BRACKET-BUMPER PIN, ANGLE 2.8" X 7.8" - METAL - BLACK
091840-02-01A	EA CAP-BUMPER END, FRONT DRIVER - PLASTIC - BEIGE
091840-01-01A	EA CAP-BUMPER END, FRONT PASSENGER - PLASTIC - BEIGE

PLASTIC WHEELWELL

KEY PART NUMBER	U/M DESCRIPTION
095071-01-000	EA WHEELWELL-PLASTIC

COMPARTMENTS AND PROP RODS

KEY PART NUMBER	U/M DESCRIPTION
092284-05-000	EA COMPARTMENT, STORAGE/FURNACE - 52.6" X 24.3" - GALVANIZED
096381-01-000	EA COMPARTMENT-STORAGE, 75.3" X 24.3" - GALVANIZED
096381-05-000	EA COMPARTMENT-STORAGE, 37.2" X 24.3" - GALVANIZED
093836-08-000	EA COMPARTMENT-STORAGE, 41.7" X 19.9" - GALVANIZED
093836-08-000	EA COMPARTMENT-STORAGE, 43.3" X 19.1" - GALVANIZED
M03488-01-000	EA COMPARTMENT-STORAGE
092844-02-Y12	EA PROP ROD-COMPARTMENT DOOR, W/SPRING & BRACKET
092489-01-000	EA SPRING-#020-050 COMP
092839-01-000	EA BRACKET-DOOR PROP
093081-01-02A	EA STRIKER-DOOR, LUGGAGE, BLACK
079388-01-000	FT SEAL-ACCESS DOOR
081113-01-000	EA BUSHING-FLANGE, PLASTIC - WHITE
069329-01-000	EA CLIP-SPRING, 3/8"
008386-01-000	EA GROMMET-SNAP, 3/8"
094376-02-000	EA ROD-PROP, GENERATOR DOOR
094387-02-000	EA STRIKER-DOOR, GENERATOR
093305-01-01A	FT TRIM-EDGE, C-TYPE - WIRE CARRIER - .35" X .24" - VINYL
M03636-04-000	EA TRAY-COMPARTMENT, W/O HATCH - 63"
093834-04-000	EA COMPARTMENT-TANK, HOLDING - 63" X 27.8" - GALVANIZED
099008-01-02A	EA HATCH-COMPARTMENT, SEWER HOSE
091255-02-000	FT SEAL-ADHESIVE BACKED FOAM, 1.5" X .18"
094376-01-000	EA ROD-PROP, HOLDING TANK DOOR

EXTERIOR ACCESSORY PACKAGE OPTION L28E

KEY PART NUMBER	U/M DESCRIPTION
096765-01-000	EA RAIL-DRAWER

MISCELLANEOUS COMPONENTS

KEY PART NUMBER	U/M DESCRIPTION
010265-01-000	EA ELBOW-BRASS, 90 DEGREE - 3/8 "F X 1/2 "FPT
000E13-17-00B	EA WASHER-FLARE, 3/8 " AR ZN
024142-01-000	EA TEE-BARB, 3/16 " - PLASTIC
050207-01-000	EA TEE-BARB, 1/4 " - PLASTIC
075466-01-000	EA UNION-INVERTED FL TUBE, 1/4 " -
075467-01-000	EA NUT-INVERTED FLARE, 1/4 " -
088497-02-000	EA NUT-INVERTED FLARE, 1/4 " -
084884-01-000	EA PLUG-BRASS, 3/8 " -
071015-11-000	EA GROMMET-1.00 "ID, FITS .12 MATERIAL, RUBBER

1991 WINNEBAGO

TABLE OF CONTENTS

INTRODUCTION	A-01 - A-02
ABBREVIATIONS	A-03
ALPHABETICAL INDEX	A-04 - A-08
WCN28RT	A-07 - G-10
WCN32RQ	G-11 - L-20

1991 WCN28RT INDEX

FLOOR PLAN	A-07 - A-08
ACCESSORIES	A-09 - A-24
BATH	B-01 - B-04
BEDROOM	B-05 - B-08
CHASSIS	B-09 - C-06
C C & PAD	C-07 - C-18
DINETTE	C-19 - C-20
DRIVERS	C-21 - C-24
ELECTRICAL	D-01 - D-08
EXTERIOR BODY	D-09 - D-18
GALLEY	D-19 - E-02
HEATING & A/C	E-03 - E-08
INTERIOR FINISH	E-09 - E-13
LABEL	E-14 - E-22
LP	E-23
LOUNGE	E-24 - F-01
SEALANTS & FASTENERS	F-02 - F-04
WATER & SEWAGE	F-05 - F-11
WINDOW, VENT AND EXTERIOR DOOR	F-12 - G-10

CHASSIS GROUP CONTINUED

CANADA EXPORT OPTION L265

KEY PART NUMBER	U/M DESCRIPTION
100138-01-000	EA MODULE-DAYTIME RUNNING LIGHT
100158-01-000	EA WIRE ASM-DAYTIME RUNNING LIGHTS
100159-01-000	EA WIRE ASM-DAYTIME RUNNING LIGHTS, W/FUSE FROM: 00-00-00 THRU: 04-04-91
062037-01-000	EA HOUSING-AUTO FUSE, NATURAL
100159-08-000	EA WIRE ASM-DAYTIME RUNNING LIGHTS, W/FUSE FROM: 04-05-91 THRU: 99-99-99
062036-02-000 L27E	EA TERMINAL-PACK-CON, 16/14 AWG CANADIAN NATIONAL STANDARDS OPTION - CHEVY - GAS & DIESEL
100138-01-000	EA MODULE-DAYTIME RUNNING LIGHT
100158-01-000	EA WIRE ASM-DAYTIME RUNNING LIGHTS
100159-01-000	EA WIRE ASM-DAYTIME RUNNING LIGHTS, W/FUSE FROM: 00-00-00 THRU: 04-04-91
062037-01-000	EA HOUSING-AUTO FUSE, NATURAL
100159-08-000	EA WIRE ASM-DAYTIME RUNNING LIGHTS, W/FUSE FROM: 04-05-91 THRU: 99-99-99
062036-02-000	EA TERMINAL-PACK-CON, 16/14 AWG

JETRIDE SUSPENSION OPTION L60C- PARK & LEVEL

KEY PART NUMBER	U/M DESCRIPTION
000C12-04-12A	EA BOLT-HEX, 1/4-20X.75, PLAIN 5
000C12-08-32B	EA BOLT-HEX, 3/8-18X2LG, ZN 5
000C14-08-32B	EA BOLT-HEX, 3/8-18X2.00 GD 8
000C26-06-20B	EA BOLT-HEX, SER FLG 5/16 - 18 X 1 1/4 ZINC
000D34-08-00B	EA NUT-HEX, LK - 3/8 - 18 GRADE C ZN - PREVAILING TORQUE
000E13-17-00B	EA WASHER-FLARE, 3/8 " AR ZN
071374-03-000	EA FITTING-BULKHEAD, 1/4 " X 1/4 " MNPT
090436-03-000	EA SPRING-LEAF, SEMI - JET# 361
090436-10-000	EA MOUNT-SPRING/AXLE, LOWER DRIVER - JET# 373
090436-11-000	EA MOUNT-SPRING/AXLE, LOWER PASSENGER - JET# 374
090436-12-000	EA U-BOLT-FOREWARD, STRAIGHT - 7/8 " - JET# 351
090436-13-000	EA U-BOLT-REARWARD, BENT - 7/8 " - JET# 351-1
090436-14-000	EA BAR-TRACK, W/PIVOT BOLTS & BRACKET - JET# 356-1
090436-16-000	EA BRACKET-BRAKE HOSE/AXLE MOUNT, P-30 CHASSIS - JET# 370 FROM: 00-00-00 THRU: 07-17-90
090436-32-000	EA CONTROL-PARK/LEVEL, ELECTRIC - JET #60778 FROM: 00-00-00 THRU: 09-17-90
090436-34-000	EA WIRING-ELECTRONIC, JET #60712
090436-35-000	EA COMPRESSOR-TANK, W/O WIRING - JET# 60703
088753-01-000	FT TUBE-AJ, UMINIZED STEEL, 5/8 " - 18 GAUGE
091250-01-000	EA BUSHING-SWAY BAR, 1.25 " CUT - HELLWIG# PB 731
091250-02-000	EA BUSHING-SWAY BAR, 1.25 " UNCUT - HELLWIG# PB 734
091250-03-000	EA BUSHING-SWAY BAR, 1.75 " CUT - HELLWIG# PB 732

STAINLESS STEEL WHEEL LINERS OPTION L63K- 19.5"

KEY PART NUMBER	U/M DESCRIPTION
077030-02-000	EA EXTENSION-VALVE STEM, 1.25 "
091209-01-000	EA LINER-WHEEL, SET OF 4 - 19.5 " - GM - KAPER II
091209-01-700	EA SIMULATOR-FRONT WHEEL EA=1
091209-01-701	EA SIMULATOR-REAR WHEEL EA=1
091209-01-702	EA COVER-FRONT AXLE
091209-01-703	EA REAR AXLE COVER
091209-01-704	EA COVER-LUG NUT
095012-01-000	EA EXTENSION-VALVE STEM, DUAL WHEEL

STABILIZER SHOCKS OPTION L64A(FRONT ONLY)

KEY PART NUMBER	U/M DESCRIPTION
079942-01-000	EA SHOCK ABSORBER-STABILIZER, FRONT - 4-WAY SC3001

CHASSIS GROUP CONTINUED

HYDRAULIC LEVELING JACKS OPTION L64H- CHEVY

KEY PART NUMBER	U/M DESCRIPTION
096808-01-000	EA SPACER-PEDESTAL, DRIVER
100532-01-000	EA LEVELING SYSTEM-HYDRAULIC, HWH# AP7371
100533-04-000	EA BRACKETS-FRONT LEVELING JACK, HWH# AP7392
100534-05-000	EA BRACKETS-REAR LEVELING JACKS, HWH# AP6868
100535-02-000	EA BRACKET-PUMP, LEVELING JACK, HWH# P0282
100536-08-000	EA HOSE KIT-LEVELING JACKS, HWH# AP 7943

MANUAL LEVELING JACKS OPTION L64L

KEY PART NUMBER	U/M DESCRIPTION
099025-01-000	EA STABILIZER-JACK, PASSENGER
099025-02-000	EA STABILIZER-JACK, DRIVER
099118-01-000	EA BRACKET-STABILIZER JACK, W/2 SQUARE TUBES
099641-02-000	EA BRACKET-JACK, REAR
099642-01-000	EA BRACKET-JACK, W/ANGLE BRACE
099642-02-000	EA BRACKET-JACK, FRONT

TRAILER TOWING HOUSINGS

KEY PART NUMBER	U/M DESCRIPTION
097744-02-000	EA HOUSING-TRAILER PIN, 48 "
097746-01-000	EA HOUSING CAP-TRAILER PIN
097745-02-000	EA HOUSING-RECEPTACLE, TRAILER - 48 " WIRE LENGTH

ENGINE COMPARTMENT COMPONENTS

KEY PART NUMBER	U/M DESCRIPTION
093008-01-000	EA PANEL-COWL, DRIVER - STEEL
093393-01-000	EA PANEL-COWL, PASSENGER SIDE - STEEL
076310-01-000	EA BAFFLE-RADIATOR, .12 " X 15 " X 62 " - RUBBER
085000-01-000	EA SHIELD-A/C, 8.8 " X 3.1 " - STEEL
099100-01-000	EA CAP-BOTTLE, OVERFLOW - GM 14054390 FROM: 06-12-90 THRU: 99-99-99
096630-01-000	EA BOTTLE-OVERFLOW, RADIATOR - GM 14042454

SUSPENSION SYSTEM

KEY PART NUMBER	U/M DESCRIPTION
084086-01-000	EA AIRSPRING-BELLOWS, REAR AXLE - FIRESTONE# MHA224
084086-01-700	EA AIR BAG-ONLY, FIRESTONE# W21-760-0335
084086-01-701	EA TUBING-DOT 1/4 " X 18" - FIRESTONE# 21-0938
084086-01-703	EA INFLATING VALVE-DOT 1/4 " TUBING, FIRESTONE# 21-0931
084086-01-704	EA ELBOW CONNECTOR, FIRESTONE# 21-0935
084086-01-705	EA TUBING PROTECTORS, FIRESTONE# 21-0899
084086-01-706	EA BRACKET-UPPER TO FRAME, FIRESTONE# 21-0150
084086-01-707	EA BRACKET-LOWER, TOP - FIRESTONE# 21-1162
084086-01-708	EA AIRLINE SERVICE KIT, FIRESTONE# W21-760-2012
084086-01-709	EA HEAT SHIELD, FIRESTONE# 21-1004
084086-01-710	EA BOLT PACKAGE, FIRESTONE 2135823002
084086-01-711	EA HEAT SHIELD-224 DOS SYSTEM, FIRESTONE 21-5042
084086-01-712	EA BRACKET-LOWER DRIVERS 224DOS, FIRESTONE 21-5037
084086-01-713	EA AXLE STRAP BRACKET, FIRESTONE 21-1163
084086-01-714	EA AXLE STRAP BRACKET, FIRESTONE 21-5038
084086-03-000	EA BRACKET-AXLE, P30 CHASSIS - FIRESTONE# W21-760-2044 FROM: 04-05-91 THRU: 99-99-99

WHEEL COVERS

KEY PART NUMBER	U/M DESCRIPTION
083181-03-700	EA COVER-WHEEL, 19.5 - 1 ONLY
083181-12-000	EA RETAINER-4SET, 19.5 " - CHEVY - DEL-MET

1991 WINNEBAGO

TABLE OF CONTENTS

INTRODUCTION	A-01 - A-02
ABBREVIATIONS	A-03
ALPHABETICAL INDEX	A-04 - A-06
WCN28RT	A-07 - G-10
WCN32RO	G-11 - L-20

1991 WCN28RT INDEX

FLOOR PLAN	A-07 - A-08
ACCESSORIES	A-09 - A-24
BATH	B-01 - B-04
BEDROOM	B-05 - B-08
CHASSIS	B-09 - C-06
C C & PAD	C-07 - C-18
DINETTE	C-19 - C-20
DRIVERS	C-21 - C-24
ELECTRICAL	D-01 - D-08
EXTERIOR BODY	D-09 - D-18
GALLEY	D-19 - E-02
HEATING & A/C	E-03 - E-08
INTERIOR FINISH	E-09 - E-13
LABEL	E-14 - E-22
LP	E-23
LOUNGE	E-24 - F-01
SEALANTS & FASTENERS	F-02 - F-04
WATER & SEWAGE	F-05 - F-11
WINDOW, VENT AND EXTERIOR DOOR	F-12 - G-10

CHASSIS GROUP CONTINUED

STORAGE COMPARTMENTS & TRAYS

KEY PART NUMBER	U/M	DESCRIPTION
092252-01-000	EA	COMPARTMENT-SPARE TIRE
077384-01-000	EA	PLATE-PIN, LADDER - 1.6 " X 1.6 " - 4 SM HOLES-1 LRG HOLE
077385-01-000	EA	PIN-PIVOT - FOR 077384-01-000
077399-01-000	EA	RETAINER-SPARE TIRE, 2 " X 7.9 " - HOLE IN MIDDLE
064081-01-000	EA	NUT-WING, 3/8 " X 18 THREAD
096361-06-000	EA	COMPARTMENT-STORAGE, 39.6 " X 24.3 " - GALVANIZED
099122-01-000	EA	COMPARTMENT-STORAGE, 37.4 " X 15.8 " - GALVANIZED
093636-07-000	EA	COMPARTMENT-STORAGE, 34.2 " X 19.8 " - GALVANIZED
095389-01-000	EA	COMPARTMENT-STORAGE/FURNACE, 44.2 " X 19.6 " - GALVANIZED
093636-05-000	EA	COMPARTMENT-STORAGE, 19.1 " X 27.6 " - GALVANIZED
092844-02-Y12	EA	PROP ROD-COMPARTMENT DOOR, W/SPRING & BRACKET
092489-01-000	EA	SPRING-#020-000 COMP
092839-01-000	EA	BRACKET-DOOR PROP
039984-01-000	EA	CAP-ROUND, VINYL - .28 " ID X .82 " LONG - BLACK
093081-01-02A	EA	STRIKER-DOOR, LUGGAGE, BLACK
079368-01-000	FT	SEAL-ACCESS DOOR
093895-01-000	EA	TRAY-BATTERY, W/GUIDE & LATCH STRIKE
074994-01-000	EA	GUIDE-TRACK, BATTERY TRAY
051897-01-000	EA	BRACKET-BATTERY, TIE DOWN
051387-08-000	EA	BOLT-CARRIAGE, W/O HOLE - 5/16-18 X 9.5 ZN
086233-01-000	EA	STUD-ISOLATED, 3/8 " X 7/8 " LONG
093718-01-000	EA	PLATE-STRIKE, BATTERY/STORAGE COMPARTMENT
015385-01-000	EA	PIN-TIRE CARRIER, CADMIUM PLATED
M03636-06-000	EA	TRAY-HOLDING TANK, W/HATCH - 62.9 " WIDE FROM: 00-00-00 THRU: 10-21-90
M03636-08-000	EA	TRAY-COMPARTMENT, W/O HATCH - 83 " WIDE FROM: 10-22-90 THRU: 99-99-99
090804-03-000	EA	TRAY-BATTERY, AUTO - W/TWO HEX NUTS
089329-01-000	EA	CLIP-SPRING, 3/8 "
008386-01-000	EA	GROMMET-SNAP, 3/8 "
094376-02-000	EA	ROD-PROP, GENERATOR DOOR
094387-02-000	EA	STRIKER-DOOR, GENERATOR
094798-01-000	EA	SUPPORT-L ANGLE, DOOR STRIKER - 1.25 " X 31.7 " LONG - STEEL
069726-02-000	EA	BUMPER-.88 " DIA X .40 " , BLACK
093305-01-01A	FT	TRIM-EDGE, C-TYPE - WIRE CARRIER - .35 " X .24 " - VINYL

CHASSIS GROUP CONTINUED

ELECTRIC ENTRY STEP

KEY PART NUMBER	U/M	DESCRIPTION
094707-01-01A	EA	STEP-DOUBLE, ENTRANCE - ELECTRIC
094707-01-700	EA	CONTROL UNIT, KWIKEE 8310 FROM: 00-00-00 THRU: 03-15-91
094707-02-705	EA	CONTROL UNIT, (ORANGE) - KWIKEE 9513 FROM: 03-16-91 THRU: 99-99-99
088746-01-701	EA	MOTOR-ALL MODELS, KWIKEE 9035 FROM: 00-00-00 THRU: 03-15-91
094707-02-700	EA	MOTOR REPLACEMENT KIT - MODELS 32 & 28 - KWIKEE 9520 FROM: 03-16-91 THRU: 99-99-99
094707-02-704	EA	CONNECTOR KIT-MOTOR, KWIKEE 9637 FROM: 03-16-91 THRU: 99-99-99
091201-01-700	EA	LINKAGE ASSEMBLY, KWIKEE 8289 FROM: 00-00-00 THRU: 03-15-91
094707-02-701	EA	LINKAGE ASM - MODEL 32 - KWIKEE 9523 FROM: 03-16-91 THRU: 99-99-99
088746-01-702	EA	GEAR-ALL MODELS, KWIKEE 9038 FROM: 00-00-00 THRU: 03-15-91
094707-02-702	EA	GEAR KIT - KWIKEE 9525 FROM: 03-16-91 THRU: 99-99-99
094707-02-703	EA	PARTS KIT, (BEARINGS & PINS) - KWIKEE 9530 FROM: 03-16-91 THRU: 99-99-99
088746-01-703	EA	BRACKET, MOTOR BEARING, KWIKEE 7040
088746-01-705	EA	LIGHT-UNDER STEP, KWIKEE 9004
088746-01-706	EA	SWITCH-KILL, KWIKEE #016
094707-01-701	EA	SWITCH-DOOR JAMB, PLASTIC - KWIKEE - 931C

**1991 WINNEBAGO
TABLE OF CONTENTS**

INTRODUCTION	A-01 - A-02
ABBREVIATIONS	A-03
ALPHABETICAL INDEX	A-04 - A-08
WCN28RT	A-07 - G-10
WCN32RQ	G-11 - L-20

1991 WCN28RT INDEX

FLOOR PLAN	A-07 - A-08
ACCESSORIES	A-09 - A-24
BATH	B-01 - B-04
BEDROOM	B-05 - B-08
CHASSIS	B-09 - C-06
C C & PAD	C-07 - C-18
DINETTE	C-19 - C-20
DRIVERS	C-21 - C-24
ELECTRICAL	D-01 - D-08
EXTERIOR BODY	D-09 - D-18
GALLEY	D-19 - E-02
HEATING & AC	E-03 - E-08
INTERIOR FINISH	E-09 - E-13
LABEL	E-14 - E-22
LP	E-23
LOUNGE	E-24 - F-01
SEALANTS & FASTENERS	F-02 - F-04
WATER & SEWAGE	F-05 - F-11
WINDOW, VENT AND EXTERIOR DOOR	F-12 - G-10

CURTAIN, CUSHION & PAD GROUP

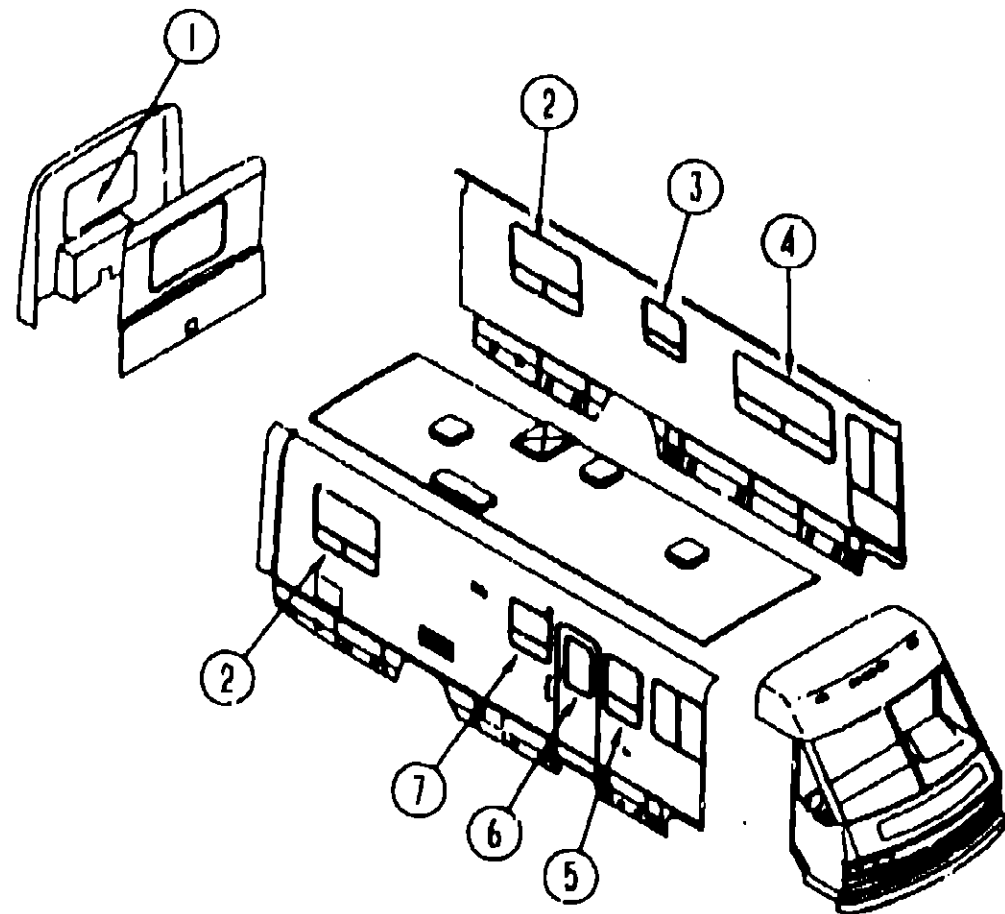

BACKWALL WINDOW TREATMENT

KEY PART NUMBER	U/M DESCRIPTION
1 100281-17-B07	EA LEG-WINDOW, DRIVER SIDE - B07 - CAMEO BLUE
1 100281-17-B08	EA LEG-WINDOW, DRIVER SIDE - B08 - AUTUMN LEAVES
1 100281-17-B09	EA LEG-WINDOW, DRIVER SIDE - B09 - WINTER FOREST
1 100281-17-B22	EA LEG-WINDOW, DRIVER SIDE - B22 - STORMY BLUE
1 100281-18-B07	EA LEG-WINDOW, PASS SIDE - B07 - CAMEO BLUE
1 100281-18-B08	EA LEG-WINDOW, PASS SIDE - B08 - AUTUMN LEAVES
1 100281-18-B09	EA LEG-WINDOW, PASS SIDE - B09 - WINTER FOREST
1 100281-18-B22	EA LEG-WINDOW, PASS SIDE - B22 - STORMY BLUE
1 096335-13-B08	EA BLIND-PLEATED, 45.5" X 33" DROP - B08 - AUTUMN LEAVES
1 096335-13-B09	EA BLIND-PLEATED, 45.5" X 33" DROP - B09 - WINTER FOREST
1 096335-13-AB6	EA BLIND-PLEATED, 45.5" X 33" DROP - CAMEO BLUE/STORMY BLUE B07/B22

DRIVER & PASSENGER SIDE WINDOW TREATMENT

KEY PART NUMBER	U/M DESCRIPTION
2 100281-19-B07	EA LEG-WINDOW, B07 - CAMEO BLUE REAR ON PASS SIDE - FRONT ON DRIVER SIDE
2 100281-19-B08	EA LEG-WINDOW, B08 - AUTUMN LEAVES REAR ON PASS SIDE - FRONT ON DRIVER SIDE
2 100281-19-B09	EA LEG-WINDOW, B09 - WINTER FOREST REAR ON PASS SIDE - FRONT ON DRIVER SIDE
2 100281-19-B22	EA LEG-WINDOW, B22 - STORMY BLUE REAR ON PASS SIDE - FRONT ON DRIVER SIDE
2 100281-20-B07	EA LEG-WINDOW, B07 - CAMEO BLUE FRONT ON PASS SIDE - REAR ON DRIVER SIDE
2 100281-20-B08	EA LEG-WINDOW, B08 - AUTUMN LEAVES FRONT ON PASS SIDE - REAR ON DRIVER SIDE
2 100281-20-B09	EA LEG-WINDOW, B09 - WINTER FOREST FRONT ON PASS SIDE - REAR ON DRIVER SIDE
2 100281-20-B22	EA LEG-WINDOW, B22 - STORMY BLUE FRONT ON PASS SIDE - REAR ON DRIVER SIDE
2 096335-43-B10	EA BLIND-PLEATED, 39.5" X 34" DROP - B07 - CAMEO BLUE
2 096335-43-B11	EA BLIND-PLEATED, 39.5" X 34" DROP - B08 - AUTUMN LEAVES
2 096335-43-B12	EA BLIND-PLEATED, 39.5" X 34" DROP - B09 - WINTER FOREST
2 096335-43-B07	EA BLIND-PLEATED, 39.5" X 34" DROP - B22 - STORMY BLUE

CURTAIN, CUSHION & PAD GROUP (CONTINUED)

BATH WINDOW TREATMENT

KEY PART NUMBER	U/M DESCRIPTION
3 093475-72-01A	EA BLIND-MINI, 13.5" X 28.5" DROP - BEIGE B07
3 093475-72-01A	EA BLIND-MINI, 13.5" X 28.5" DROP - BEIGE B08 FROM: 00-00-00 THRU: 01-13-91
3 093475-72-02A	EA BLIND-MINI, 13.5" X 28.5" DROP - BEIGE B08 FROM: 01-14-91 THRU: 99-99-99
3 093475-72-01A	EA BLIND-MINI, 13.5" X 28.5" DROP - BEIGE B09 FROM: 00-00-00 THRU: 01-13-91
3 093475-72-03A	EA BLIND-MINI, 13.5" X 28.5" DROP - SILVER B09 FROM: 01-14-91 THRU: 99-99-99
3 093475-72-01A	EA BLIND-MINI, 13.5" X 28.5" DROP - BEIGE B22 FROM: 00-00-00 THRU: 01-13-91
3 093475-72-03A	EA BLIND-MINI, 13.5" X 28.5" DROP - SILVER B22 FROM: 01-14-91 THRU: 99-99-99
3 101079-06-B07	EA LEG-WINDOW, 27.5" - FRONT - W/HOLE - B07/B22 CAMEO BLUE/STORMY BLUE
3 101079-06-B08	EA LEG-WINDOW, 27.5" - FRONT - W/HOLE - B08 - AUTUMN LEAVES
3 101079-06-B09	EA LEG-WINDOW, 27.5" - FRONT - W/HOLE - B09 - WINTER FOREST
3 101079-07-B07	EA LEG-WINDOW, 27.5" - REAR - W/O HOLE - B07/B22 CAMEO BLUE/STORMY BLUE
3 101079-07-B08	EA LEG-WINDOW, 27.5" - REAR - W/O HOLE - B08 - AUTUMN LEAVES
3 101079-07-B09	EA LEG-WINDOW, 27.5" - REAR - W/O HOLE - B09 - WINTER FOREST

DINETTE WINDOW TREATMENT

KEY PART NUMBER	U/M DESCRIPTION
4 101079-02-B13	EA LEG-WINDOW, 31.5" - FRONT - CAMEO BLUE/STORMY BLUE B07/B22
4 101079-02-B14	EA LEG-WINDOW, 31.5" - FRONT - B08 - AUTUMN LEAVES
4 101079-02-B15	EA LEG-WINDOW, 31.5" - FRONT - B09 - WINTER FOREST
4 101079-04-B07	EA LEG-WINDOW, 31.5" - REAR - CAMEO BLUE/STORMY BLUE B07/B22
4 101079-04-B14	EA LEG-WINDOW, 31.5" - REAR - B08 - AUTUMN LEAVES
4 101079-04-B15	EA LEG-WINDOW, 31.5" - REAR - B09 - WINTER FOREST
4 093475-63-01A	EA BLIND-MINI, 57.5" X 31.5" - BEIGE B07
4 093475-63-01A	EA BLIND-MINI, 57.5" X 31.5" - BEIGE B08 FROM: 00-00-00 THRU: 01-13-91
4 093475-63-03A	EA BLIND-MINI, 57.5" X 31.5" - BEIGE B08 FROM: 01-14-91 THRU: 99-99-99
4 093475-63-01A	EA BLIND-MINI, 57.5" X 31.5" - BEIGE B09 FROM: 00-00-00 THRU: 01-13-91
4 093475-63-04A	EA BLIND-MINI, 57.5" X 31.5" - SILVER B09 FROM: 01-14-91 THRU: 99-99-99
4 093475-63-01A	EA BLIND-MINI, 57.5" X 31.5" - BEIGE B22 FROM: 00-00-00 THRU: 01-13-91
4 093475-63-04A	EA BLIND-MINI, 57.5" X 31.5" - SILVER B22 FROM: 01-14-91 THRU: 99-99-99

PASSENGER SIDE WINDOW TREATMENT

KEY PART NUMBER	U/M DESCRIPTION
5 101079-02-B07	EA LEG-WINDOW, 31.5" - REAR - B07 - CAMEO BLUE
5 101079-02-B08	EA LEG-WINDOW, 31.5" - REAR - B08 - AUTUMN LEAVES
5 101079-02-B09	EA LEG-WINDOW, 31.5" - REAR - B09 - WINTER FOREST
5 101079-02-B13	EA LEG-WINDOW, 31.5" - REAR - B22 - STORMY BLUE
5 101079-05-B07	EA LEG-WINDOW, 31.5" - FRONT - B07 - CAMEO BLUE
5 101079-05-B08	EA LEG-WINDOW, 31.5" - FRONT - B08 - AUTUMN LEAVES
5 101079-05-B09	EA LEG-WINDOW, 31.5" - FRONT - B09 - WINTER FOREST
5 101079-05-B13	EA LEG-WINDOW, 31.5" - FRONT - B22 - STORMY BLUE
5 093475-22-08A	EA BLIND-MINI, 21" X 32" DROP - B07/B08/B09/B22 AFTER THIS DATE B07 WAS DISCONTINUED
5 093475-22-03A	EA BLIND-MINI, 21" X 32" DROP - B08 - AUTUMN LEAVES FROM: 00-00-00 THRU: 01-13-91
5 093475-22-10A	EA BLIND-MINI, 21" X 32" DROP - WINTER FOREST/STORMY BLUE - B09/B22 FROM: 01-14-91 THRU: 99-99-99

1991 WINNEBAGO

TABLE OF CONTENTS

INTRODUCTION	A-01 - A-02
ABBREVIATIONS	A-03
ALPHABETICAL INDEX	A-04 - A-06
WCN28RT	A-07 - G-10
WCN32RQ	G-11 - L-20

1991 WCN28RT INDEX

FLOOR PLAN	A-07 - A-08
ACCESSORIES	A-09 - A-24
BATH	B-01 - B-04
BEDROOM	B-05 - B-08
CHASSIS	B-09 - C-06
C C & PAD	C-07 - C-18
DINETTE	C-19 - C-20
DRIVERS	C-21 - C-24
ELECTRICAL	D-01 - D-08
EXTERIOR BODY	D-09 - D-18
GALLEY	D-19 - E-02
HEATING & A/C	E-03 - E-08
INTERIOR FINISH	E-09 - E-13
LABEL	E-14 - E-22
LP	E-23
LOUNGE	E-24 - F-01
SEALANTS & FASTENERS	F-02 - F-04
WATER & SEWAGE	F-05 - F-11
WINDOW, VENT AND EXTERIOR DOOR	F-12 - G-10

CURTAIN, CUSHION & PAD GROUP (CONTINUED)

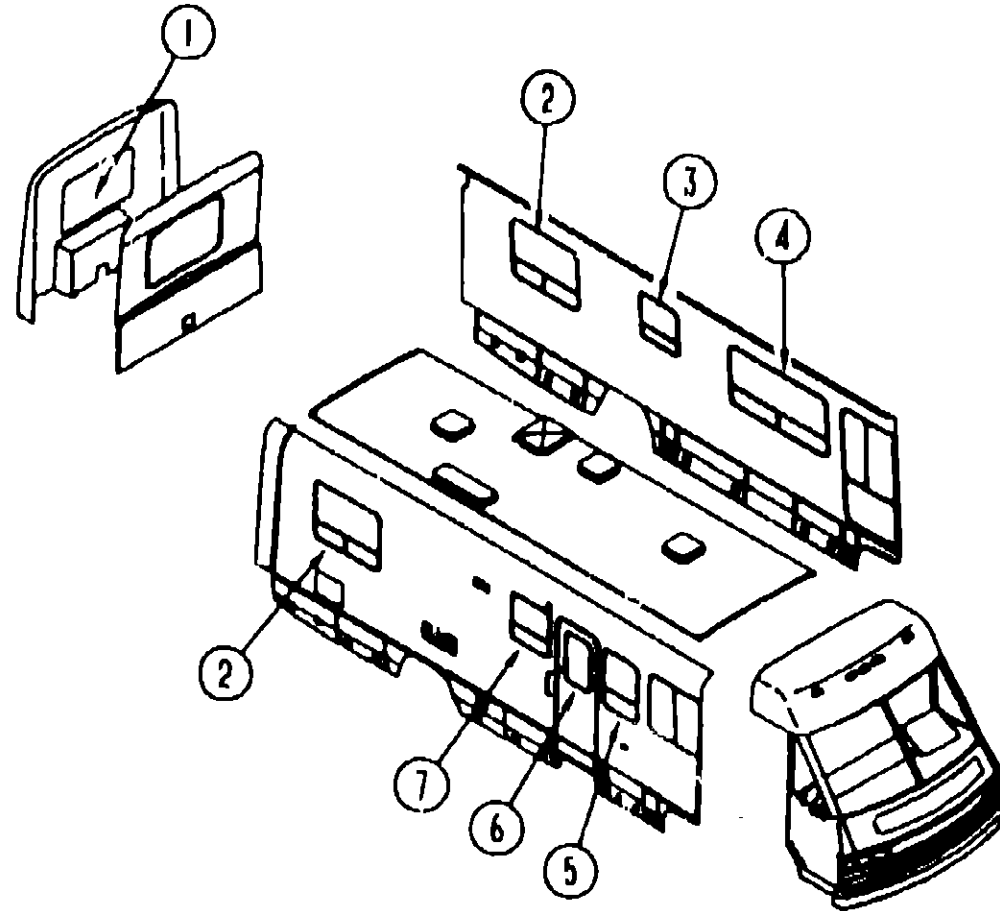

ENDRANCE DOOR WINDOW TREATMENT

KEY PART NUMBER	U/M DESCRIPTION
6 084755-57-B07	EA SHADE-PULL, 27.25"
6 101189-01-B07	EA VALANCE-WINDOW, 46" - B07 - CAMEO BLUE FROM: 00-00-00 THRU: 02-10-91
6 101189-01-B08	EA VALANCE-WINDOW, 46" - B08 - AUTUMN LEAVES FROM: 00-00-00 THRU: 02-10-91
6 101189-01-B09	EA VALANCE-WINDOW, 46" - B09 - WINTER FOREST FROM: 00-00-00 THRU: 02-10-91
6 101189-01-B22	EA VALANCE-WINDOW, 46" - B22 - STORMY BLUE FROM: 00-00-00 THRU: 02-10-91
6 104169-02-B07	EA VALANCE-WINDOW, 45" - B07 - CAMEO BLUE FROM: 02-11-91 THRU: 99-99-99
6 104169-02-B08	EA VALANCE-WINDOW, 45" - B08 - AUTUMN LEAVES FROM: 02-11-91 THRU: 99-99-99
6 104169-02-B09	EA VALANCE-WINDOW, 45" - B09 - WINTER FOREST FROM: 02-11-91 THRU: 99-99-99
6 104169-02-B22	EA VALANCE-WINDOW, 45" - B22 - STORMY BLUE FROM: 02-11-91 THRU: 99-99-99

GALLEY WINDOW TREATMENT

KEY PART NUMBER	U/M DESCRIPTION
7 093475-37-07A	EA BLIND-MINI, 28" X 21" DROP - BEIGE B07
7 093475-37-07A	EA BLIND-MINI, 28" X 21" DROP - BEIGE B08 FROM: 00-00-00 THRU: 01-13-91
7 093475-37-01A	EA BLIND-MINI, 28" X 21" DROP - BEIGE B08 FROM: 01-14-91 THRU: 99-99-99
7 093475-37-07A	EA BLIND-MINI, 28" X 21" DROP - BEIGE B09 FROM: 00-00-00 THRU: 01-13-91
7 093475-37-09A	EA BLIND-MINI, 28" X 21" DROP - SILVER B09 FROM: 01-14-91 THRU: 99-99-99
7 093475-37-07A	EA BLIND-MINI, 28" X 21" DROP - BEIGE B22 FROM: 00-00-00 THRU: 01-13-91
7 093475-37-09A	EA BLIND-MINI, 28" X 21" DROP - SILVER B22 FROM: 01-14-91 THRU: 99-99-99

CURTAIN, CUSHION & PAD GROUP (CONTINUED)

WINDSHIELD CURTAINS & TIEBACK

KEY PART NUMBER	U/M DESCRIPTION
097994-03-B07	EA CURTAIN-HOOK TOP, 34" X 75" - B07 - CAMEO BLUE FROM: 00-00-00 THRU: 10-04-90
097994-03-B10	EA CURTAIN-HOOK TOP, 34" X 75" - B07 - CAMEO BLUE FROM: 10-05-90 THRU: 12-18-90
097994-01-B07	EA CURTAIN-HOOK TOP, 36" X 78" - B07 - CAMEO BLUE FROM: 12-17-90 THRU: 99-99-99
097994-03-B07	EA CURTAIN-HOOK TOP, 34" X 75" - B08 - AUTUMN LEAVES FROM: 00-00-00 THRU: 12-18-90
097994-01-B18	EA CURTAIN-HOOK TOP, 36" X 78" - B08 - AUTUMN LEAVES FROM: 12-17-90 THRU: 99-99-99
097994-03-B09	EA CURTAIN-HOOK TOP, 34" X 75" - B09 - WINTER FOREST FROM: 00-00-00 THRU: 12-18-90
097994-01-B40	EA CURTAIN-HOOK TOP, 36" X 78" - B09 - WINTER FOREST FROM: 12-17-90 THRU: 99-99-99
097994-03-B07	EA CURTAIN-HOOK TOP, 34" X 75" - B22 - STORMY BLUE
073260-42-B07	EA TIEBACK-CURTAIN, 6" X 18" - B07 - CAMEO BLUE FROM: 00-00-00 THRU: 10-04-90
073260-42-B10	EA TIEBACK-CURTAIN, 6" X 18" - B07 - CAMEO BLUE FROM: 10-05-90 THRU: 99-99-99
073260-42-B07	EA TIEBACK-CURTAIN, 6" X 18" - B08 - AUTUMN LEAVES
073260-42-B09	EA TIEBACK-CURTAIN, 6" X 18" - B09 - WINTER FOREST
073260-42-B07	EA TIEBACK-CURTAIN, 6" X 18" - B22 - STORMY BLUE
102754-01-B09	EA CUSHION-SEAT, SWIVEL CHAIR - B09 - WINTER FOREST
P02754-01-B07	EA COVER-SEAT, SWIVEL CHAIR - CAMEO BLUE/STORMY BLUE - B07/B22
P02754-01-B08	EA COVER-SEAT, SWIVEL CHAIR - B08 - AUTUMN LEAVES
P02754-01-B09	EA COVER-SEAT, SWIVEL CHAIR - B09 - WINTER FOREST
P01178-25-B07	EA COVER-ARMREST, SWIVEL CHAIR - RH - CAMEO BLUE/STORMY BLUE - B07/B22
P01178-25-B08	EA COVER-ARMREST, SWIVEL CHAIR - RH - B08 - AUTUMN LEAVES
P01178-25-B09	EA COVER-ARMREST, SWIVEL CHAIR - RH - B09 - WINTER FOREST
P01178-26-B07	EA COVER-ARMREST, SWIVEL CHAIR - LH - CAMEO BLUE/STORMY BLUE - B07/B22
P01178-26-B08	EA COVER-ARMREST, SWIVEL CHAIR - LH - B08 - AUTUMN LEAVES
P01178-26-B09	EA COVER-ARMREST, SWIVEL CHAIR - LH - B09 - WINTER FOREST

SHOWER CURTAIN

KEY PART NUMBER	U/M DESCRIPTION
084481-15-000	EA CURTAIN-GROMMET TOP, SHOWER - 62" X 36" - VINYL - ALMOND

**1991 WINNEBAGO
TABLE OF CONTENTS**

INTRODUCTION	A-01 - A-02
ABBREVIATIONS	A-03
ALPHABETICAL INDEX	A-04 - A-08
WCN28RT	A-07 - G-10
WCN32RQ	G-11 - L-20

1991 WCN28RT INDEX

FLOOR PLAN	A-07 - A-08
ACCESSORIES	A-09 - A-24
BATH	B-01 - B-04
BEDROOM	B-05 - B-08
CHASSIS	B-09 - C-06
C C & PAD	C-07 - C-18
DINETTE	C-19 - C-20
DRIVERS	C-21 - C-24
ELECTRICAL	D-01 - D-08
EXTERIOR BODY	D-09 - D-18
GALLEY	D-19 - E-02
HEATING & A/C	E-03 - E-08
INTERIOR FINISH	E-09 - E-13
LABEL	E-14 - E-22
LP	E-23
LOUNGE	E-24 - F-01
SEALANTS & FASTENERS	F-02 - F-04
WATER & SEWAGE	F-05 - F-11
WINDOW, VENT AND EXTERIOR DOOR	F-12 - G-10

CURTAIN, CUSHION & PAD GROUP (CONTINUED)

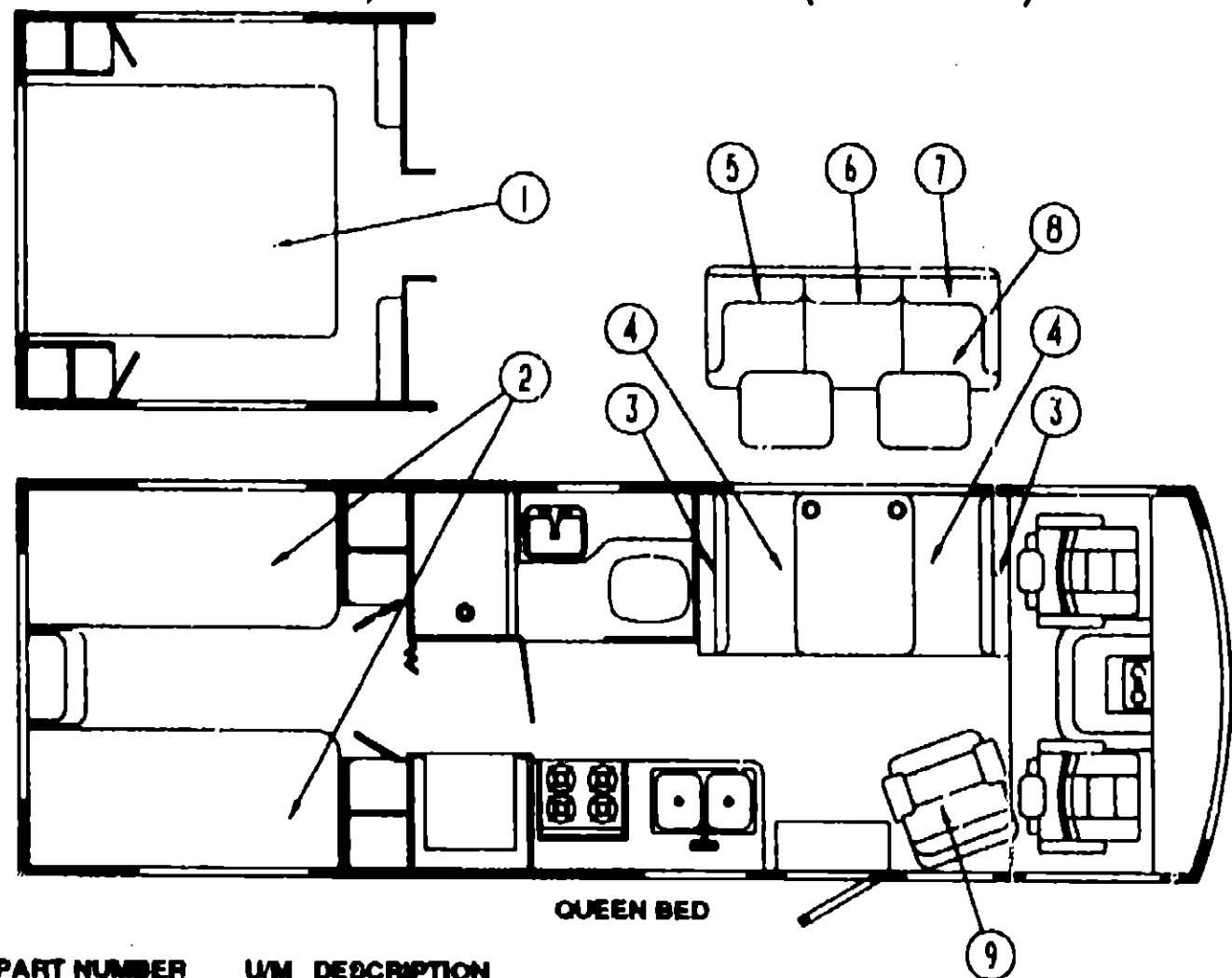

QUEEN BED

TWIN BED

KEY PART NUMBER	U/M DESCRIPTION
1 098176-04-000	EA MATTRESS-QUEEN, 59" X 74"
1 083986-04-B07	EA BEDSPREAD-QUEEN, 60" - B07 - CAMEO BLUE FROM: 00-00-00 THRU: 02-10-91
1 083986-04-B08	EA BEDSPREAD-QUEEN, 60" - B08 - AUTUMN LEAVES FROM: 00-00-00 THRU: 02-10-91
1 083986-04-B09	EA BEDSPREAD-QUEEN, 60" - B09 - WINTER FOREST FROM: 00-00-00 THRU: 02-10-91
1 083986-04-B22	EA BEDSPREAD-QUEEN, 60" - B22 - STORMY BLUE FROM: 00-00-00 THRU: 02-10-91
1 104170-02-B07	EA BEDSPREAD-QUEEN, 59" - B07 - CAMEO BLUE FROM: 02-11-91 THRU: 99-99-99
1 104170-02-B08	EA BEDSPREAD-QUEEN, 59" - B08 - AUTUMN LEAVES FROM: 02-11-91 THRU: 99-99-99
1 104170-02-B09	EA BEDSPREAD-QUEEN, 59" - B09 - WINTER FOREST FROM: 02-11-91 THRU: 99-99-99
1 104170-02-B22	EA BEDSPREAD-QUEEN, 59" - B22 - STORMY BLUE FROM: 02-11-91 THRU: 99-99-99
KEY PART NUMBER	U/M DESCRIPTION
2 098176-01-000	EA MATTRESS-TWIN, 32" X 74"
2 085365-07-B07	EA BEDSPREAD-TWIN, 33" - B07 - CAMEO BLUE FROM: 00-00-00 THRU: 02-10-91
2 085365-07-B08	EA BEDSPREAD-TWIN, 33" - B08 - AUTUMN LEAVES FROM: 00-00-00 THRU: 02-10-91
2 085365-07-B09	EA BEDSPREAD-TWIN, 33" - B09 - WINTER FOREST FROM: 00-00-00 THRU: 02-10-91
2 085365-07-B22	EA BEDSPREAD-TWIN, 33" - B22 - STORMY BLUE FROM: 00-00-00 THRU: 02-10-91
2 085365-13-B07	EA BEDSPREAD-TWIN, 33" - B07 - CAMEO BLUE FROM: 02-11-91 THRU: 99-99-99
2 085365-13-B08	EA BEDSPREAD-TWIN, 33" - B08 - AUTUMN LEAVES FROM: 02-11-91 THRU: 99-99-99
2 085365-13-B09	EA BEDSPREAD-TWIN, 33" - B09 - WINTER FOREST FROM: 02-11-91 THRU: 99-99-99
2 085365-13-B22	EA BEDSPREAD-TWIN, 33" - B22 - STORMY BLUE FROM: 02-11-91 THRU: 99-99-99

CURTAIN, CUSHION & PAD GROUP (CONTINUED)

PILLOW SHAMS TWIN & QUEEN BEDS

KEY PART NUMBER	U/M DESCRIPTION
02181-01-B07	EA SHAM-PILLOW, W/FOAM - B07 - CAMEO BLUE FROM: 00-00-00 THRU: 02-10-91
102181-01-B08	EA SHAM-PILLOW, W/FOAM - B08 - AUTUMN LEAVES FROM: 00-00-00 THRU: 02-10-91
102181-01-B09	EA SHAM-PILLOW, W/FOAM - B09 - WINTER FOREST FROM: 00-00-00 THRU: 02-10-91
102181-01-B22	EA SHAM-PILLOW, W/FOAM - B22 - STORMY BLUE FROM: 00-00-00 THRU: 02-10-91
081997-07-B10	EA SHAM-PILLOW, B07 - CAMEO BLUE
081997-07-B11	EA SHAM-PILLOW, B08 - AUTUMN LEAVES
081997-07-B12	EA SHAM-PILLOW, B08 - WINTER FOREST
081997-07-B22	EA SHAM-PILLOW, B22 - STORMY BLUE
102181-05-B07	EA SHAM-PILLOW, W/FOAM - B07 - CAMEO BLUE FROM: 02-11-91 THRU: 99-99-99
102181-05-B08	EA SHAM-PILLOW, W/FOAM - B08 - AUTUMN LEAVES FROM: 02-11-91 THRU: 99-99-99
102181-05-B09	EA SHAM-PILLOW, W/FOAM - B09 - WINTER FOREST FROM: 02-11-91 THRU: 99-99-99
102181-05-B22	EA SHAM-PILLOW, W/FOAM - B22 - STORMY BLUE FROM: 02-11-91 THRU: 99-99-99
101176-02-B07	EA SHAM-PILLOW, B07 - CAMEO BLUE
104176-02-B08	EA SHAM-PILLOW, B08 - AUTUMN LEAVES
104176-02-B09	EA SHAM-PILLOW, B09 - WINTER FOREST
104176-02-B22	EA SHAM-PILLOW, B22 - STORMY BLUE

BACKREST CUSHIONS

KEY PART NUMBER	U/M DESCRIPTION
3 088927-79-B07	EA CUSHION-BACKREST, 14.5" X 38" - B07 - CAMEO BLUE
3 088927-79-B08	EA CUSHION-BACKREST, 14.5" X 38" - B08 - AUTUMN LEAVES
3 088927-79-B09	EA CUSHION-BACKREST, 14.5" X 38" - B09 - WINTER FOREST
3 088927-79-B40	EA CUSHION-BACKREST, 14.5" X 38" - B22 - STORMY BLUE
3 M88927-79-B07	EA COVER-BACK, DINETTE - 14.5" X 38" - B07 - CAMEO BLUE
3 M88927-79-B08	EA COVER-BACK, DINETTE - 14.5" X 38" - B08 - AUTUMN LEAVES
3 M88927-79-B09	EA COVER-BACK, DINETTE - 14.5" X 38" - B09 - WINTER FOREST
3 M88927-79-B40	EA COVER-BACK, DINETTE - 14.5" X 38" - B22 - STORMY BLUE

SEAT CUSHIONS

KEY PART NUMBER	U/M DESCRIPTION
4 088927-87-B07	EA CUSHION-SEAT, DINETTE - 23" X 38" - B07 - CAMEO BLUE
4 088927-87-B08	EA CUSHION-SEAT, DINETTE - 23" X 38" - B08 - AUTUMN LEAVES
4 088927-87-B09	EA CUSHION-SEAT, DINETTE - 23" X 38" - B09 - WINTER FOREST
4 088927-87-B40	EA CUSHION-SEAT, DINETTE - 23" X 38" - B22 - STORMY BLUE
4 M88927-87-B07	EA COVER-SEAT, DINETTE - 23" X 38" - B07 - CAMEO BLUE
4 M88927-87-B08	EA COVER-SEAT, DINETTE - 23" X 38" - B08 - AUTUMN LEAVES
4 M88927-87-B09	EA COVER-SEAT, DINETTE - 23" X 38" - B09 - WINTER FOREST
4 M88927-87-B40	EA COVER-SEAT, DINETTE - 23" X 38" - B22 - STORMY BLUE
4 M89007-05-B09	EA COVER-SEAT, COUCH - B09 - WINTER FOREST
079386-01-000	EA FRAME-COUCH, CONTINENTAL

**1991 WINNEBAGO
TABLE OF CONTENTS**

INTRODUCTION	A-01 - A-02
ABBREVIATIONS	A-03
ALPHABETICAL INDEX	A-04 - A-08
WCN28RT	A-07 - G-10
WCN32RQ	G-11 - L-20

1991 WCN28RT INDEX

FLOOR PLAN	A-07 - A-08
ACCESSORIES	A-09 - A-24
BATH	B-01 - B-04
BEDROOM	B-05 - B-08
CHASSIS	B-09 - C-08
C C & PAD	C-07 - C-18
DINETTE	C-19 - C-20
DRIVERS	C-21 - C-24
ELECTRICAL	D-01 - D-08
EXTERIOR BODY	D-09 - D-18
GALLEY	D-19 - E-02
HEATING & A/C	E-03 - E-08
INTERIOR FINISH	E-09 - E-13
LABEL	E-14 - E-22
LP	E-23
LOUNGE	E-24 - F-01
SEALANTS & FASTENERS	F-02 - F-04
WATER & SEWAGE	F-05 - F-11
WINDOW, VENT AND EXTERIOR DOOR	F-12 - G-10

CURTAIN, CUSHION & PAD GROUP (CONTINUED)

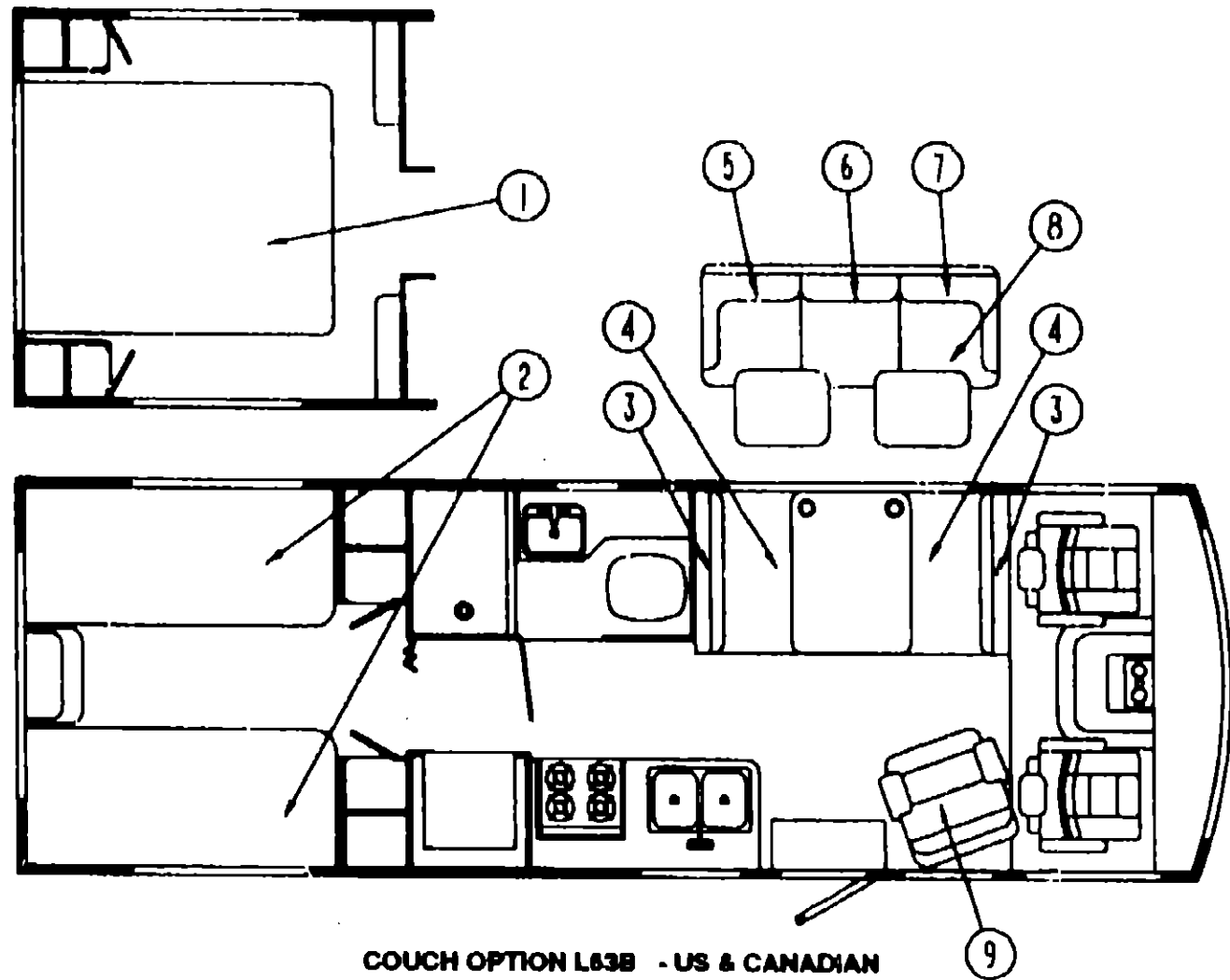

CURTAIN, CUSHION & PAD GROUP (CONTINUED)

PASSENGER SIDE SWIVEL CHAIR

KEY PART NUMBER	U/M DESCRIPTION
9 101178-01-B07	EA CHAIR-SWIVEL, W/O BASE OR SKIRT - CAMEO BLUE/STORMY BLUE - B07/B22
9 101178-01-B08	EA CHAIR-SWIVEL, W/O BASE OR SKIRT - B08 - AUTUMN LEAVES
9 101178-01-B09	EA CHAIR-SWIVEL, W/O BASE OR SKIRT - B09 - WINTER FOREST
P01178-01-B07	EA COVER-CHAIR, SWIVEL - CAMEO BLUE/STORMY BLUE - B07/B22
P01178-01-B08	EA COVER-CHAIR, SWIVEL - B08 - AUTUMN LEAVES
P01178-01-B09	EA COVER-CHAIR, SWIVEL - B09 - WINTER FOREST

**1991 WINNEBAGO
TABLE OF CONTENTS**

INTRODUCTION	A-01 - A-02
ABBREVIATIONS	A-03
ALPHABETICAL INDEX	A-04 - A-06
WCN28RT	A-07 - G-10
WCN32RQ	G-11 - L-20

1991 WCN28RT INDEX

FLOOR PLAN	A-07 - A-08
ACCESSORIES	A-09 - A-24
BATH	B-01 - B-04
BEDROOM	B-05 - B-06
CHASSIS	B-09 - C-06
C C & PAD	C-07 - C-18
DINETTE	C-19 - C-20
DRIVERS	C-21 - C-24
ELECTRICAL	D-01 - D-08
EXTERIOR BODY	D-09 - D-18
GALLEY	D-19 - E-02
HEATING & A/C	E-03 - E-08
INTERIOR FINISH	E-09 - E-13
LABEL	E-14 - E-22
LP	E-23
LOUNGE	E-24 - F-01
SEALANTS & FASTENERS	F-02 - F-04
WATER & SEWAGE	F-05 - F-11
WINDOW, VENT AND EXTERIOR DOOR	F-12 - G-10

KEY PART NUMBER	U/M DESCRIPTION
5 101175-02-B07	EA CUSHION-BACK, COUCH - W/ARMREST - REAR - B07/B22 CAMEO BLUE/STORMY BLUE
5 101175-02-B08	EA CUSHION-BACK, COUCH - W/ARMREST - REAR - B08 - AUTUMN LEAVE
5 101175-02-B09	EA CUSHION-BACK, COUCH - W/ARMREST - REAR - B09 - WINTER FORE
P01175-02-B07	EA COVER-BACK, COUCH - W/ARMREST - REAR - B07/B22 CAMEO BLUE/STORMY BLUE
P01175-02-B08	EA COVER-BACK, COUCH - W/ARMREST - REAR - B08 - AUTUMN LEAVES
P01175-02-B09	EA COVER-BACK, COUCH - W/ARMREST - REAR - B09 - WINTER FOREST
6 101175-03-B07	EA CUSHION-BACK, COUCH - CENTER - B07/B22 CAMEO BLUE/WINTER FOREST
6 101175-03-B08	EA CUSHION-BACK, COUCH - CENTER - B08 - AUTUMN LEAVES
6 101175-03-B09	EA CUSHION-BACK, COUCH - CENTER - B09 - WINTER FOREST
P01175-03-B07	EA COVER-BACK, COUCH - CENTER - B07/B22 CAMEO BLUE/STORMY BLUE
P01175-03-B08	EA COVER-BACK, COUCH - CENTER - B08 - AUTUMN LEAVES
P01175-03-B09	EA COVER-BACK, COUCH - CENTER - B09 - WINTER FOREST
7 101175-01-B07	EA CUSHION-BACK, COUCH - W/ARMREST - FRONT - B07/B22 CAMEO BLUE/STORMY BLUE
7 101175-01-B08	EA CUSHION-BACK, COUCH - W/ARMREST - FRONT - AUTUMN LEAVES - B08
7 101175-01-B09	EA CUSHION-BACK, COUCH - W/ARMREST - FRONT - WINTER FOREST - B09
P01175-01-B07	EA COVER-BACK, COUCH - W/ARMREST - FRONT - B07/B22 CAMEO BLUE/STORMY BLUE
P01175-01-B08	EA COVER-BACK, COUCH - W/ARMREST - FRONT - B08 - AUTUMN LEAVE
P01175-01-B09	EA COVER-BACK, COUCH - W/ARMREST - FRONT - B09 - WINTER FOREST
102872-01-000	EA STRIKE-COUCH, CANADIAN
102874-01-000	EA CATCH-COUCH, CANADIAN
8 089007-05-B07	EA SEAT-COUCH, W/O BACK CUSHIONS - CAMEO BLUE/STORMY BLUE - B07/B22
8 089007-05-B08	EA SEAT-COUCH, W/O BACK CUSHIONS - B08 - AUTUMN LEAVES
8 089007-05-B09	EA SEAT-COUCH, W/O BACK CUSHIONS - B09 - WINTER FOREST
M89007-05-B07	EA COVER-SEAT, COUCH - B07/B22 - CAMEO BLUE/STORMY BLUE
M89007-05-B08	EA COVER-SEAT, COUCH - E38 - AUTUMN LEAVES
M89007-05-B09	EA COVER-SEAT, COUCH - B09 - WINTER FOREST
079386-01-000	EA FRAME-COUCH, CONTINENTAL

CURTAIN, CUSHION & PAD GROUP (CONTINUED)

CURTAIN HARDWARE

KEY PART NUMBER	U/M DESCRIPTION
097919-04-01A	EA TRACK-CURTAIN, WRAPAROUND - DRIVER - OFF WHITE
097919-03-01A	EA TRACK-CURTAIN, WRAPAROUND - PASSENGER - OFF WHITE
046997-01-000	EA GROMMET-BRASS - 7/16" ID X 1" OD
075680-02-000	EA ROD-CURTAIN, SHOWER - 27" TO 38" - ADJUSTABLE
009112-01-000	EA FLANGE-1" ROD, CLOTHES - PLASTIC - OFF WHITE
	FROM: 00-00-00 THRU: 08-01-90
102075-02-01A	EA ROD-CURTAIN, SHOWER - 1" OD X 32.9" - OFF WHITE
	FROM: 08-02-90 THRU: 99-99-99
009136-01-000	EA HANGER-RING, PIN TYPE - CURTAIN - CHROME
	FROM: 00-00-00 THRU: 03-03-91
009136-02-000	EA HANGER-RING, PIN TYPE - CURTAIN - BRASS
	FROM: 03-04-91 THRU: 99-99-99
097825-01-000	EA HOOK-DRAPERY
084432-08-000	FT SLAT-ROLLER SHADE, PLASTIC
087253-01-000	EA PULL-ROLLER SHADE, PLASTIC - CLEAR
096843-01-000	EA SPRING-REWIND, ROLLER SHADE
089522-02-000	EA PANEL-TRIM, WINDOW 31.5
	MUST ORDER 089916-01-000 TO MOUNT THIS PANEL TO THE WALL
097585-01-000	EA BRACKET-MOUNTING, PLEATED BLIND
094996-02-000	EA GROMMET-CORD, PLEATED BLIND - NYLON - GRAY
094907-02-000	EA END CAP-TOP, PLEATED BLIND - PLASTIC - GRAY
094907-03-000	EA END CAP-BOTTOM, PLEATED BLIND - PLASTIC - GRAY
097591-01-000	EA SPRING-EXTENSION, PLEATED BLIND
097592-01-000	EA SPOOL-CORD, ELEVATED BLIND HOLDUP - CLEAR PLASTIC
097593-08-000	FT CORD-BLIND, FLEATED - B07/B22 - CAMEO BLUE/STORMY BLUE
097593-02-000	FT CORD-BLIND, PLEATED - B08 - AUTUMN LEAVES
097593-07-000	FT CORD-BLIND, PLEATED - B09 - WINTER FOREST
084434-01-000	EA BRACKET-MOUNTING, ROLLER SHADE - 1 3/8"
083170-01-000	EA BRACKET-BLIND, FRONT
083170-02-000	EA BRACKET-BLIND, REAR
095591-02-000	EA BRACKET-BLIND, HOLD-DOWN - W/PIN
075943-01-000	EA BRACE-WINDOW VALANCE, BEIGE
068718-01-001	EA BRACE-90 DEGREE ANGLE, 192" - EXTRUDED ALUMINUM
089916-01-000	EA MOUNT-WINDOW LEG, BLACK
093475-01-700	EA WAND-BLIND, W/METAL CLIP - 8" LONG
093475-01-701	EA END CAP-BLIND, W/STUD
102555-01-000	EA CLEAT-CORD, BLIND
078155-01-000	EA STRAP-BACK CUSHION, SNAP
029155-01-000	EA CAP-SNAP, NICKEL
029156-01-000	EA SOCKET-SNAP FASTENER, NICKEL
029130-01-000	EA SCREW-SNAP SOCKET, 8 PH X 5/8
057534-01-000	EA TIEBACK-CURTAIN, 6" - PLASTIC - CLEAR
059797-02-000	EA SHELL-BUTTON, PLASTIC - # 30
069734-01-000	EA BACK-BUTTON, DURASNAP - # 30
048394-02-000	YD VELCRO TAPE-HOOK, ADHESIVE BACK - .75" WIDE - BEIGE
088792-02-000	YD VELCRO TAPE-LOOP, ADHESIVE BACKED - 3/4" - BEIGE
029094-04-000	YD VELCRO TAPE-LOOP, 1" WIDE - BLACK
029096-03-000	YD VELCRO TAPE-HOOK, 1" WIDE - BLACK
086276-01-000	EA TAPE-DOUBLE SIDED, 1/2"

PASSENGER SIDE SWIVEL CHAIR

KEY PART NUMBER	U/M DESCRIPTION
087330-01-000	EA BRACKET-STOP, SLIDING TRACK
089368-04-000	EA FRAME-CABLE, REMOTE SWIVEL
101083-02-000	EA FRAME-CHAIR, SWIVEL - W/RIGHT HAND ARM BRACKET
101083-03-000	EA FRAME-CHAIR, SWIVEL - W/LEFT HAND ARM BRACKET
002755-01-002	EA ANGLE-EXTRUDED, 1.12" X 1.12" X 16"
097683-03-000	EA BRACKET-REMOTE, SIDE MOUNT
101187-01-000	EA ROCKER BOX-CHAIR, SWIVEL
069246-02-000	EA ADJUSTER-SEAT/CHAIR, W/O LOCK - FORWARD & BACK
069246-05-700	EA SPRING-ADJUSTER, FOR REMOTE
069246-05-000	EA ADJUSTER-SEAT/CHAIR, W/REMOTE
069246-05-700	EA SPRING-ADJUSTER, FOR REMOTE
089246-05-701	EA CLIP-CABLE, FOR REMOTE
093481-05-000	EA TOP PLATE-PEDESTAL, SWIVEL CHAIR - W/REMOTE SWIVEL
007221-01-000	EA SPACER-SEAT, ADJUSTER - 4 USED PER SWIVEL CHAIR
093482-01-000	EA SHROUD-PEDESTAL, 13" - PLASTIC - BLACK
093481-01-000	EA BASE-PEDESTAL, SWIVEL CHAIR - W/6" EXTENSION

CURTAIN, CUSHION & PAD GROUP (CONTINUED)

FABRICS & TRIMS

KEY PART NUMBER	U/M DESCRIPTION
062859-01-W30	FT TRIM-EDGE, VINYL - 1.5" WIDE - BEIGE
079680-01-000	YD FABRIC-VINYL, 54" WIDE - BEIGE
078798-03-000	SF VINYL-FOAM/BACK, BEIGE
029012-01-000	BF FOAM-ROLLED, 3/8" THICK - 7/2" WIDE
079680-09-000	YD FABRIC-VINYL, 54" WIDE - OFF WHITE
089351-03-000	YD VINYL-CFILING, DIAMOND DESIGN - 54" WIDE
098008-28-000	YD FABRIC-UPHOLSTERY, PLAIN - 54" - CAMEO BLUE/STORMY BLUE - B07/B22
098008-40-000	YD FABRIC-UPHOLSTERY, PLAIN - 54" - B08 - AUTUMN LEAVES
098008-83-000	YD FABRIC-UPHOLSTERY, PLAIN - 54" - B09 - WINTER FOREST
098008-88-000	YD FABRIC-UPHOLSTERY, PATTERN - 54" - CAMEO BLUE/STORMY BLUE - B07/B22
098008-67-000	YD FABRIC-UPHOLSTERY, PATTERN - 54" - B08 - AUTUMN LEAVES
098008-68-000	YD FABRIC-UPHOLSTERY, PATTERN - 54" - B09 - WINTER FOREST
098008-43-000	YD FABRIC-UPHOLSTERY, DOTTED - 54" - CAMEO BLUE/STORMY BLUE - B07/B22
098008-64-000	YD FABRIC-UPHOLSTERY, DOTTED - 54" - B08 - AUTUMN LEAVES
098008-65-000	YD FABRIC-UPHOLSTERY, SQUARES - 54" - B09 - WINTER FOREST
072333-78-000	YD FABRIC-DRAPERY, DRIFTWOOD
072333-79-000	YD FABRIC-CURTAIN, 54" WIDE - B07 - CAMEO BLUE
	FROM: 10-05-90 THRU: 99-99-99
072333-76-000	YD FABRIC-CURTAIN, 54" WIDE - B09 - WINTER FOREST
087272-01-000	YD FABRIC-LINING, CURTAIN - 48" WIDE - IVORY
079349-01-AA1	YD WELTING-FABRIC, B07/B22 - CAMEO BLUE/STORMY BLUE
079349-01-B03	YD WELTING-FABRIC, B08 - AUTUMN LEAVES
079349-01-B09	YD WELTING-FABRIC, B09 - WINTER FOREST
081928-01-000	YD BACKING-QUILTING, MATTRESS COVER - 59" WIDE - WHITE
088273-58-000	YD FABRIC-BEDSPREAD/CURTAIN, 54" - B07 - CAMEO BLUE
088273-57-000	YD FABRIC-BEDSPREAD/CURTAIN, 54" - B08 - AUTUMN LEAVES
088273-56-000	YD FABRIC-BEDSPREAD/CURTAIN, 54" - B09 - WINTER FOREST
088273-47-000	YD FABRIC-BEDSPREAD/CURTAIN, 54" - B22 - STORMY BLUE
088273-67-000	YD FABRIC-CURTAIN, PLAIN - 54" - B07 - CAMEO BLUE
088273-85-000	YD FABRIC-CURTAIN, PLAIN - 54" - B08 - AUTUMN LEAVES
088273-66-000	YD FABRIC-CURTAIN, PLAIN - 54" - B09 - WINTER FOREST
088273-67-000	YD FABRIC-CURTAIN, PLAIN - 54" - B22 - STORMY BLUE

WALL PADS

KEY PART NUMBER	U/M DESCRIPTION
093195-01-AE6	EA PAD-DOOR, B07/B22 - CAMEO BLUE/STORMY BLUE
093195-01-B08	EA PAD-DOOR, B08 - AUTUMN LEAVES
093195-01-B09	EA PAD-DOOR, B09 - WINTER FOREST

**VINYL FLOORING OPTION L50Y
REPLACE VINYL FLOORING LOCALLY**

KEY PART NUMBER	U/M DESCRIPTION
093486-01-000	SY CARPET-COMPARTMENT, 54" WIDE - DARK GRAY
096060-14-000	SY CARPET-12' ROLL - B07/B22 - CAMEO BLUE/STORMY BLUE
	INCREMENTS OF 4 SY
096060-15-000	SY CARPET-12' ROLL, B08 - AUTUMN LEAVES - INCREMENTS OF 4 SY
	FROM: 00-00-00 THRU: 02-10-91
096060-26-000	SY CARPET-12' ROLL, B08 - AUTUMN LEAVES - INCREMENTS OF 4 SY
	FROM: 02-11-91 THRU: 99-99-99
096060-16-000	SY CARPET-12' ROLL - B09 - WINTER FOREST - INCREMENTS OF 4 SY
047034-02-000	SF PLASTIC-CARPET, 4" WIDE - CLEAR POLY
075233-01-000	SY PAD-CARPET, 3/8" X 6' ROLL
076314-02-000	FT TAPE-CARPET SEAM, HEAT-BOND
100659-01-B03	EA TRIM-FLOOR, 72" X 1" X 1/2" - WOOD
085746-01-000	FT TRIM-J, CARPET - 1.2" X .5" ANGLE - 10' LONG - PVC - BEIGE

**1991 WINNEBAGO
TABLE OF CONTENTS**

INTRODUCTION	A-01 - A-02
ABBREVIATIONS	A-03
ALPHABETICAL INDEX	A-04 - A-08
WCN28RT	A-07 - G-10
WCN32RQ	G-11 - L-20

1991 WCN28RT INDEX

FLOOR PLAN	A-07 - A-08
ACCESSORIES	A-09 - A-24
BATH	B-01 - B-04
BEDROOM	B-05 - B-08
CHASSIS	B-09 - C-08
C & PAD	C-07 - C-18
DINETTE	C-19 - C-20
DRIVERS	C-21 - C-24
ELECTRICAL	D-01 - D-08
EXTERIOR BODY	D-09 - D-18
GALLEY	D-19 - E-02
HEATING & A/C	E-03 - E-08
INTERIOR FINISH	E-09 - E-13
LABEL	E-14 - E-22
LP	E-23
LOUNGE	E-24 - F-01
SEALANTS & FASTENERS	F-02 - F-04
WATER & SEWAGE	F-05 - F-11
WINDOW, VENT AND EXTERIOR DOOR	F-12 - G-10

CURTAIN, CUSHION & PAD GROUP (CONTINUED)

DRIVER & PASSENGER BUCKET SEATS
(B07/B22 CAMEO BLUE/STORMY BLUE) (B08 - AUTUMN LEAVES) (B09 - WINTER FOREST)

KEY PART NUMBER	U/M DESCRIPTION
101171-01-B07	EA SEAT-BUCKET, W/O BASE OR SKIRT - B07 - CAMEO BLUE FROM: 00-00-00 THRU: 02-10-91
101171-01-B08	EA SEAT-BUCKET, W/O BASE OR SKIRT - B08 - AUTUMN LEAVES FROM: 00-00-00 THRU: 02-10-91
101171-01-B09	EA SEAT-BUCKET, W/O BASE OR SKIRT - B09 - WINTER FOREST FROM: 00-00-00 THRU: 02-10-91
101171-01-B10	EA SEAT-BUCKET, W/O BASE OR SKIRT - B22 - STORMY BLUE FROM: 00-00-00 THRU: 02-10-91
101171-04-B07	EA SEAT-BUCKET, W/O BASE OR SKIRT - B07/B22 FROM: 02-11-91 THRU: 99-99-99
101171-04-B08	EA SEAT-BUCKET, W/O BASE OR SKIRT - B08 - AUTUMN LEAVES FROM: 02-11-91 THRU: 99-99-99
101171-04-B09	EA SEAT-BUCKET, W/O BASE OR SKIRT - B09 - WINTER FOREST FROM: 02-11-91 THRU: 99-99-99
M03445-24-B07	EA COVER-BACK, B07/B22 - CAMEO BLUE/STORMY BLUE
M03445-24-B08	EA COVER-BACK, B08 - AUTUMN LEAVES
M03445-24-B09	EA COVER-BACK, B09 - WINTER FOREST
M03445-25-B07	EA COVER-SEAT, B07/B22 - CAMEO BLUE/STORMY BLUE FROM: 00-00-00 THRU: 02-10-91
M03445-25-B08	EA COVER-SEAT, B08 - AUTUMN LEAVES FROM: 00-00-00 THRU: 02-10-91
M03445-25-B09	EA COVER-SEAT, B09 - WINTER FOREST FROM: 00-00-00 THRU: 02-10-91
M03445-36-B07	EA COVER-SEAT, B07/B22 - CAMEO BLUE/STORMY BLUE FROM: 02-11-91 THRU: 99-99-99
M03445-36-B08	EA COVER-SEAT, B08 - AUTUMN LEAVES FROM: 02-11-91 THRU: 99-99-99
M03445-36-B09	EA COVER-SEAT, B09 - WINTER FOREST FROM: 02-11-91 THRU: 99-99-99
M80908-04-000	EA FRAME-SEAT, BACK & SPRING
080731-02-000	EA HINGE-SLAVE, RECLINER, LEFT HAND
081362-01-000	EA BRACKET-ARMREST, RIGHT HAND
081362-02-000	EA BRACKET-ARMREST, LEFT HAND
101125-01-000	EA RECLINER-SEAT BACK, LEFT HAND REMOTE
080243-43-B07	EA ARMREST-BUCKET SEAT, RIGHT HAND - B07/B22
080243-43-B08	EA ARMREST-BUCKET SEAT, RIGHT HAND - B08 - AUTUMN LEAVES
080243-43-B09	EA ARMREST-BUCKET SEAT, RIGHT HAND - B09 - WINTER FOREST
080243-44-B07	EA ARMREST-BUCKET SEAT, LEFT HAND - B07/B22
080243-44-B08	EA ARMREST-BUCKET SEAT, LEFT HAND - B08 - AUTUMN LEAVES
080243-44-B09	EA ARMREST-BUCKET SEAT, LEFT HAND - B09 - WINTER FOREST
M80243-43-B07	EA COVER-ARMREST, BUCKET SEAT - RH - B07/B22
M80243-43-B08	EA COVER-ARMREST, BUCKET SEAT - RH - B08 - AUTUMN LEAVES
M80243-43-B09	EA COVER-ARMREST, BUCKET SEAT - RH - B09 - WINTER FOREST
M80243-44-B07	EA COVER-ARMREST, BUCKET SEAT - LH - B07/B22
M80243-44-B08	EA COVER-ARMREST, BUCKET SEAT - LH - B08 - AUTUMN LEAVES
M80243-44-B09	EA COVER-ARMREST, BUCKET SEAT - LH - B09 - WINTER FOREST
081361-01-000	EA ROD-ARMREST, METAL
089368-05-000	EA FRAME-CABLE, REMOTE RECLINE
089368-08-000	EA FRAME-RECLINER, BUCKET SEAT - W/CABLE SHIELD
089368-04-000	EA FRAME-CABLE, REMOTE SWIVEL
097683-02-000	EA BRACKET-MOUNT, REMOTE FROM: 00-00-00 THRU: 02-10-91
097683-03-000	EA BRACKET-REMOTE, SIDE MOUNT
071126-24-AA1	EA SKIRT-BUCKET SEAT, B07/B22 - CAMEO BLUE/STORMY BLUE
071126-24-B03	EA SKIRT-BUCKET SEAT, B08 - AUTUMN LEAVES
071126-24-B09	EA SKIRT-BUCKET SEAT, B09 - WINTER FOREST
069246-02-000	EA ADJUSTER-BUCKET SEAT W/O LOCK, FORWARD AND BACK
069246-05-700	EA SPRING-ADJUSTER, FOR REMOTE
069246-05-000	EA ADJUSTER-SEAT/CHAIR, W/REMOTE
069246-05-700	EA SPRING-ADJUSTER, FOR REMOTE
069246-05-701	EA CLIP-CABLE, FOR REMOTE
069585-29-000	EA BAR-SEAT BELT, BUCKET SEATS - 20"
093481-04-000	EA TOP PLATE-PEDESTAL, BUCKET SEAT - W/O SEATBELT BAR
069585-08-000	EA BASE-BUCKET SEAT, BOLTS TO FLOOR - VERTICAL 8"
092759-01-000	EA PEDESTAL-TELESCOPING, PASSENGER
092759-01-700	EA HEAD-POWER, TELESCOPING PEDESTAL

CURTAIN, CUSHION & PAD GROUP (CONTINUED)

DRIVERS POWERED SEAT OPTION L63M

KEY PART NUMBER	U/M DESCRIPTION
069585-39-000	EA PLATE-TOP, BUCKET SEAT - POWERED
071126-26-AE6	EA SKIRT-BUCKET SEAT, B07/B22 - CAMEO BLUE/STORMY BLUE
071126-26-B08	EA SKIRT-BUCKET SEAT, B08 - AUTUMN LEAVES
071126-26-B09	EA SKIRT-BUCKET SEAT, B09 - WINTER FOREST
081373-01-000	EA UNIT-POWER, BUCKET SEAT - 6 WAY
081373-01-700	EA SWITCH-CONTROL, W/L BRACKET
069585-37-000	EA PLATE-SUB, VERTICAL - 5"
096808-01-000	EA SPACER-PEDESTAL, DRIVER

SEAT BELTS & HARDWARE

KEY PART NUMBER	U/M DESCRIPTION
007021-01-000	EA BELT-SEAT, 2" X 90" - BLACK

**1991 WINNEBAGO
TABLE OF CONTENTS**

INTRODUCTION	A-01 - A-02
ABBREVIATIONS	A-03
ALPHABETICAL INDEX	A-04 - A-06
WCN28RT	A-07 - G-10
WCN32RQ	G-11 - I-20

1991 WCN28RT INDEX

FLOOR PLAN	A-07 - A-08
ACCESSORIES	A-09 - A-24
BATH	B-01 - B-04
BEDROOM	B-05 - B-08
CHASSIS	B-09 - C-06
C C & PAD	C-07 - C-18
DINETTE	C-19 - C-20
DRIVERS	C-21 - C-24
ELECTRICAL	D-01 - D-08
EXTERIOR BODY	D-09 - D-18
GALLEY	D-19 - E-02
HEATING & A/C	E-03 - E-08
INTERIOR FINISH	E-09 - E-13
LABEL	E-14 - E-22
LP	E-23
LOUNGE	E-24 - F-01
SEALANTS & FASTENERS	F-02 - F-04
WATER & SEWAGE	F-05 - F-11
WINDOW, VENT AND EXTERIOR DOOR	F-12 - G-10

DINETTE GROUP

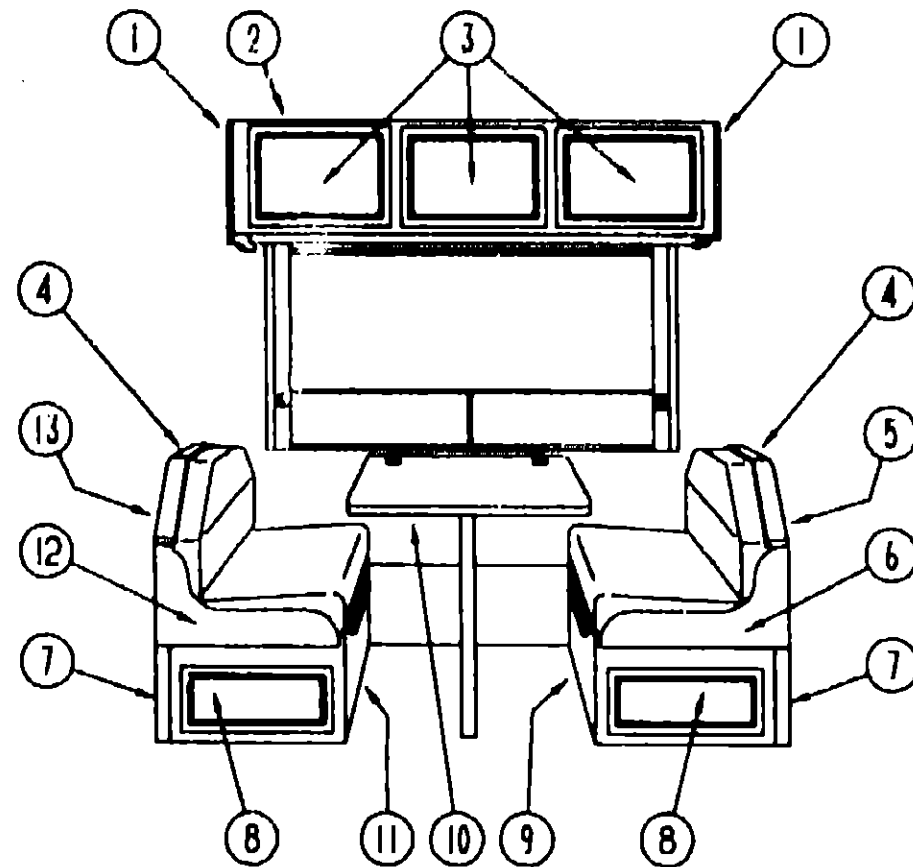

OVERHEAD CABINET W/LIGHT, SPEAKER & RECEPTACLE

KEY PART NUMBER	U/M	DESCRIPTION
1	EA	END CAP-CABINET, OVERHEAD - FRONT OR REAR
2	EA	CABINET-OVERHEAD, DINETTE - W/O DOORS OR HARDWARE
3	EA	DOOR-CABINET, W/O HARDWARE - 14.4" X 21.9"
4	EA	PAD-BACKREST TOP, DINETTE - CAMEO BLUE/STORMY BLUE - B07/B22
4	EA	PAD-BACKREST TOP, DINETTE - B08 - AUTUMN LEAVES
4	EA	PAD-BACKREST TOP, DINETTE - B09 - WINTER FOREST
5	EA	CABINET-BACKREST, FRONT - W/O DOORS OR HARDWARE
6	EA	PAD-SEAT EDGE, DINETTE - FRONT - CAMEO BLUE/STORMY BLUE - B07/B22
6	EA	PAD-SEAT EDGE, DINETTE - FRONT - B08 - AUTUMN LEAVES
6	EA	PAD-SEAT EDGE, DINETTE - FRONT - B09 - WINTER FOREST
7	EA	PAD-SEATBASE EDGE, DINETTE - CAMEO BLUE/STORMY BLUE - B07/B22
7	EA	PAD-SEATBASE EDGE, DINETTE - B08 - AUTUMN LEAVES
7	EA	PAD-SEATBASE EDGE, DINETTE - B09 - WINTER FOREST
8	EA	DOOR-CABINET, W/O HARDWARE - 10" X 19"
8	EA	CABINET-SEATBASE, FRONT - W/O DOORS OR HARDWARE
9	EA	TABLE-DINETTE, W/O HARDWARE
10	EA	CABINET-SEATBASE, REAR - W/O DOORS OR HARDWARE
11	EA	PAD-SEAT EDGE, DINETTE - REAR - CAMEO BLUE/STORMY BLUE - B07/B22
11	EA	PAD-SEAT EDGE, DINETTE - REAR - B08 - AUTUMN LEAVES
11	EA	PAD-SEAT EDGE, DINETTE - REAR - B09 - WINTER FOREST
12	EA	CABINET-BACKREST, REAR - W/O DOORS OR HARDWARE
13	EA	BUTTON-SNAP TOP, #30 - B07 - CAMEO BLUE
13	EA	BUTTON-SNAP TOP, #30 - B08 - AUTUMN LEAVES
13	EA	BUTTON-SNAP TOP, #30 - B09 - WINTER FOREST

SEAT BELTS & HARDWARE

KEY PART NUMBER	U/M	DESCRIPTION
007021-01-000	EA	BELT-SEAT, 2" X 90" - BLACK
000E13-20-008	EA	WASHER-FL-7/16 WIDE ZN
000D44-07-008	EA	NUT-HEX, SER FLG LK - 7/16-20 ZN
057759-01-000	EA	WASHER BRACKET-SEAT BELT, 4" DIAMETER

DINETTE GROUP (CONTINUED)

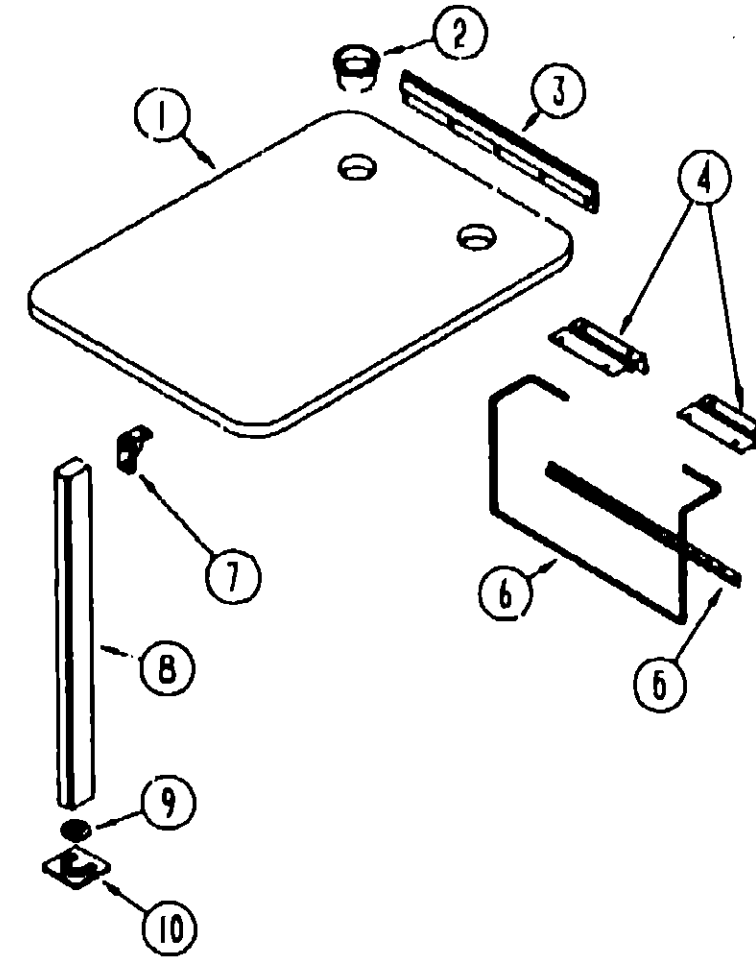

DINETTE TABLE & COMPONENTS

KEY PART NUMBER	U/M	DESCRIPTION
1	EA	TABLE-DINETTE, W/O EDGE BAND OR HARDWARE
2	EA	BUMPER-CABINET DOOR, RUBBER - BROWN
3	EA	HOLDER-CUP, TWO STEP - OFF WHITE
3	EA	BRACKET-TABLE SUPPORT, UPPER WALL MOUNTED - 23.5" - BEIGE
4	EA	BRACKET-LIFT, TABLE MOUNTED - BEIGE
5	EA	BRACKET-LIFT ROD, LOWER WALL MOUNTED - 22.12" - BEIGE
6	EA	ROD-TABLE LIFT, 8" X 18.5" - BEIGE
7	EA	BRACKET-FOLDING LEG
8	EA	LEG-TABLE
9	EA	CATCH-TABLE LEG, BEIGE
10	EA	FLOOR CATCH - TABLE LEG - TAN

COUCH OPTION L83B - US & CANADIAN PEDESTAL TABLES & HARDWARE

KEY PART NUMBER	U/M	DESCRIPTION
009040-04-000	EA	LEG-PEDESTAL TABLE, 27.5" X 2.25" OD - BROWN
041194-01-000	EA	BASE-TABLE, FLUSH - FLOOR MOUNTED
042438-02-000	EA	DOWEL-WOOD, 2" X 2"
009040-03-000	EA	BASE-TABLE, RAISED - TABLE MOUNTED
081298-01-B07	EA	TABLE-PEDESTAL, 17" X 24" TOP - W/O HARDWARE

COUCH OPTION L83B - US & CANADIAN CABINET OVER COUCH

KEY PART NUMBER	U/M	DESCRIPTION
M04154-07-B07	EA	CABINET-OVERHEAD, DINETTE - W/O DOORS OR HARDWARE
092747-01-B07	EA	END CAP-CABINET, OVERHEAD - FRONT OR REAR
P00520-01-B07	EA	DOOR-CABINET, W/O HARDWARE - 14.4" X 21.9"

1991 WINNEBAGO TABLE OF CONTENTS

INTRODUCTION	A-01 - A-02
ABBREVIATIONS	A-03
ALPHABETICAL INDEX	A-04 - A-08
WCN28RT	A-07 - G-10
WCN32RQ	G-11 - L-20

1991 WCN28RT INDEX

FLOOR PLAN	A-07 - A-08
ACCESSORIES	A-09 - A-24
BATH	B-01 - B-04
BEDROOM	B-05 - B-08
CHASSIS	B-09 - C-06
C C & PAD	C-07 - C-18
DINETTE	C-19 - C-20
DRIVERS	C-21 - C-24
ELECTRICAL	D-01 - D-08
EXTERIOR BODY	D-09 - D-18
GALLEY	D-19 - E-02
HEATING & A/C	E-03 - E-08
INTERIOR FINISH	E-09 - E-13
LABEL	E-14 - E-22
LP	E-23
LOUNGE	E-24 - F-01
SEALANTS & FASTENERS	F-02 - F-04
WATER & SEWAGE	F-05 - F-11
WINDOW, VENT AND EXTERIOR DOOR	F-12 - G-10

DRIVERS COMPARTMENT GROUP

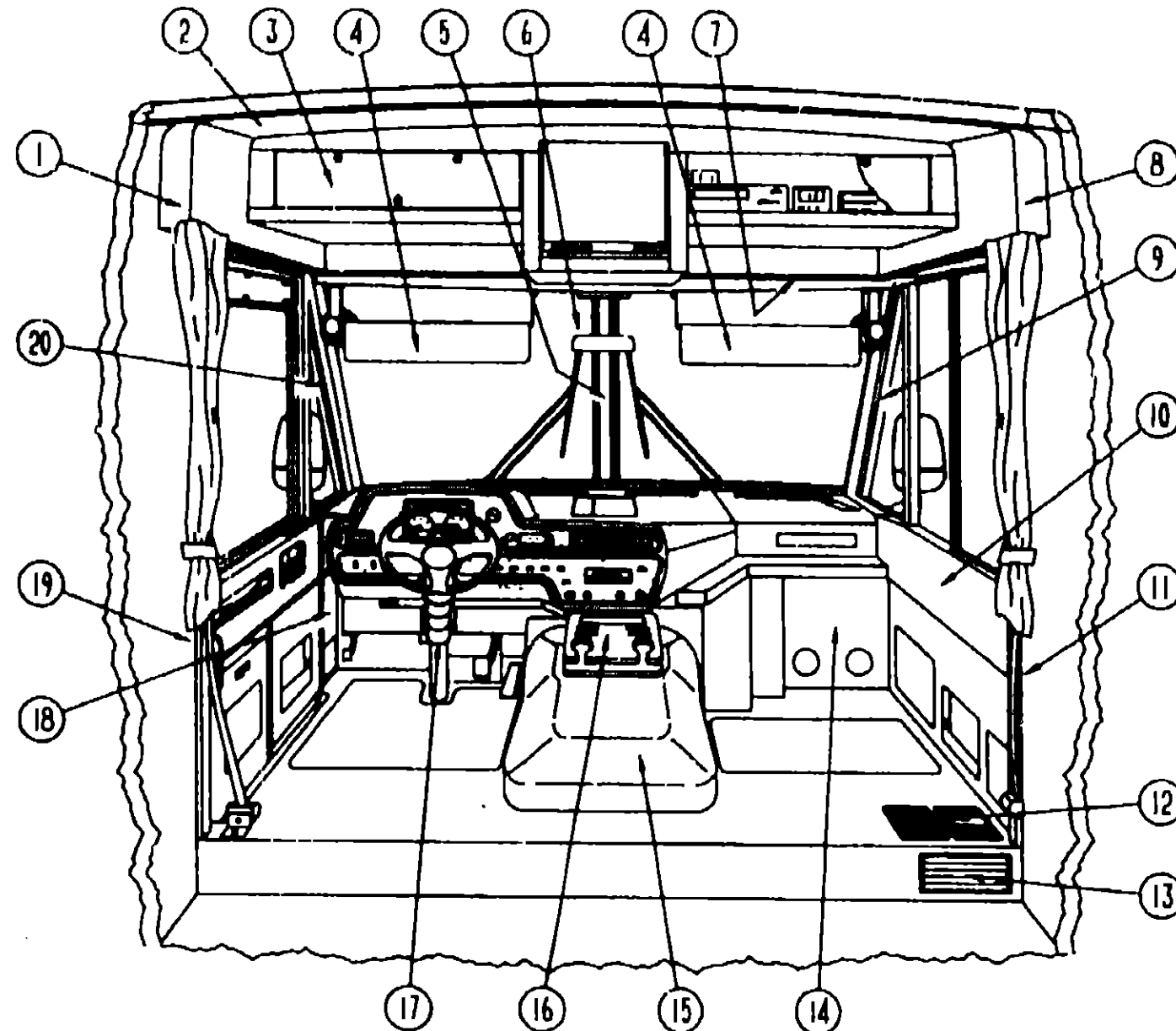

DRIVERS COMPARTMENT

KEY PART NUMBER	U/M	DESCRIPTION
1	EA	TRIM-OVERHEAD, DRIVER SIDE - OFF WHITE
092472-01-01A	EA	TRIM-SIDE, LOWER - DR & PASS - 15.5" LONG - OFF WHITE
092471-01-01A	EA	TRIM-SIDE, UPPER PASSENGER - OFF WHITE - 33 1/4"
092471-02-01A	EA	TRIM-SIDE, UPPER DRIVER - OFF WHITE - 33 1/4"
092472-02-01A	EA	TRIM-SIDE, SIDE - LOWER DR & PASS - 15.5" LONG - OFF WHITE
2	EA	CABINET FACE-OVERHEAD, TV
100622-01-01A	EA	BRACKET-CABINET, TV - OFF WHITE
P00957-01-B07	EA	SHELF-OVERHEAD, FRONT PASSENGER - VINYL COVERED
P00957-02-B07	EA	SHELF-OVERHEAD, FRONT DRIVER - VINYL COVERED
P00958-01-B07	EA	SHELF-OVERHEAD, CENTER - VINYL COVERED
100707-01-000	EA	SPACER
P00520-84-B07	EA	DOOR-CABINET, W/O HARDWARE - 14.4" X 16.1"
3	EA	DOOR-GLASS, TV CABINET - W/O HARDWARE - 6.3" X 27"
100710-01-01A	EA	LOCK-TWIST TYPE
100711-01-01A	EA	HINGE-DOOR, GLASS
101272-01-000	EA	CATCH-GLASS DOOR
101766-01-000	EA	PIN-SUPPORT, GLASS DOOR
4	EA	SUNVISOR-DRIVER OR PASSENGER - OFF WHITE
100423-01-01A	EA	PLATE-MOUNT, SUNVISOR - TRIANGLE SHAPED - PLASTIC
000G39-10-12D	EA	SCREW-SF/DR, 10-16 X 3/4 PPH - BLACK
007211-01-000	EA	HINGE-SUNVISOR
074012-01-000	EA	CLIP-SUNVISOR, SQUARE - PINCH ON
085709-01-000	EA	MOUNT-SUNVISOR, CLIP TYPE - BLACK
102377-01-000	EA	BRACKET-SUNVISOR, 1 PIECE - STEEL
5	EA	COVER-CENTER PILLAR, WINDSHIELD - BEIGE
5	EA	COVER-CENTER PILLAR, WINDSHIELD - BEIGE - UNCUT
6	EA	MIRROR INSIDE REAR VIEW KIT
7	EA	HEADLINER-FRONT, PLASTIC - OFF WHITE

DRIVERS COMPARTMENT GROUP (CONTINUED)

DRIVERS COMPARTMENT CONT

KEY PART NUMBER	U/M	DESCRIPTION
8	EA	TRIM-OVERHEAD, PASSENGER SIDE - OFF WHITE
092472-01-01A	EA	TRIM-SIDE, LOWER - DR & PASS - 15.5" LONG - OFF WHITE
9	EA	COVER-A PILLAR, PASSENGER - BEIGE
10	EA	PANEL-KICK, LOWER PASSENGER SIDE - BEIGE
11	EA	COVER-B PILLAR, PASS - 58" X 2.1" - PLASTIC - OFF WHITE
092585-01-01A	EA	COVER-HINGE PILLAR, PASSENGER - BEIGE
12	EA	GRILLE-FLOOR, HEATING - 9.3" X 5.4" - BROWN
13	EA	GRILLE-RETURN AIR, FURNACE - 15.6" X 7.6" - BROWN
14	EA	COVER-HEATER, W/2 LOUVERED OUTLETS - 10.2" X 17.5" - B07
14	EA	COVER-HEATER, W/2 LOUVERED OUTLETS - 10.2" X 17.5" - B08
14	EA	COVER-HEATER, W/2 LOUVERED OUTLETS - 10.2" X 17.5" - B09
15	EA	COVER-MOTOR W/O CARPET
075584-01-000	EA	BRACKET-MOUNTING, MOTOR COVER
092408-01-000	EA	TRIM-MOTOR COVER, ALUMINUM
039823-01-000	FT	SEAL-MOTOR COVER, RUBBER BULB TYPE - BLACK
16	EA	TRAY-BEVERAGE, WOOD
098911-01-01A	EA	INSERT-BEVERAGE TRAY
M04032-01-AB1	EA	DOWEL-WOOD STAINED
17	EA	BOOT-STEERING COLUMN
17	EA	BOOT-COLUMN, 91 CHEVY, BOTTOM
17	EA	BOOT-COLUMN, 91 CHEVY, TOP
18	EA	PANEL-KICK, LOWER DRIVER SIDE - BEIGE
19	EA	COVER-B PILLAR, DR - 58" X 2.2" - PLASTIC - OFF WHITE
091990-01-01A	EA	SEAT BELT-SHOULDER HARNESS - DRIVERS/PASSENGERS - BLACK
091990-01-700	EA	BOLT COVER
091990-02-01A	EA	BRACKET-SEAT BELT, DRIVERS - FLOOR MOUNT
092585-02-01A	EA	COVER-HINGE PILLAR, DRIVER - BEIGE
093899-02-000	EA	PLATE-STRIKER BOLT
20	EA	COVER-A PILLAR, DRIVER - BEIGE
091990-01-01A	EA	SEAT BELT-SHOULDER HARNESS - DRIVERS/PASSENGERS - BLACK
091990-01-700	EA	COVER-BOLT, SEATBELT - BLACK
081201-01-000	EA	MAT-FLOOR, FRONT - DRIVER
081202-01-000	EA	MAT-FLOOR, FRONT - PASSENGER

KEY PART NUMBER

100602-03-01A

101025-02-01A

101024-03-01A

KEY PART NUMBER

094794-02-000

094796-01-000

094796-03-000

100159-01-000

100159-01-000

U/M DESCRIPTION

EA PANEL-INSTRUMENT, UPPER W/CUTOUTS - "CHIEFTAIN" - BLACK
1991 FORD - MOUNTS CLUSTER

EA PANEL-DASH, LOWER W/CUTOUTS - FORD - 11.9" LONG - BLACK

EA PANEL-DASH, LOWER W/CUTOUTS - FORD - 30.7" LONG - BLACK
DRIVER SIDE - MOUNTS RADIO

CANADIAN OPTION L265 ,L27E - FORD & CHEVY

U/M DESCRIPTION

EA CLUSTER-INSTRUMENT, KILOMETER - FORD CHASSIS-10849-EB
NOT IN THIS OPTION AFTER 11-04-90

EA CLUSTER-INSTRUMENT PANEL, KILOMETERS - GAS - GM# 25088535
FROM: 00-00-00 THRU: 11-04-90

EA CLUSTER-INSTRUMENT PANEL, KILOMETERS - GAS - GM# 16138135
FROM: 00-00-00 THRU: 11-04-90

EA WIRE ASM-DAYTIME RUNNING LIGHTS

EA WIRE ASM-DAYTIME RUNNING LIGHTS, W/FUSE

**1991 WINNEBAGO
TABLE OF CONTENTS**

INTRODUCTION	A-01 - A-02
ABBREVIATIONS	A-03
ALPHABETICAL INDEX	A-04 - A-08
WCN28RT	A-07 - G-10
WCN32RQ	G-11 - L-20

1991 WCN28RT INDEX

FLOOR PLAN	A-07 - A-08
ACCESSORIES	A-09 - A-24
BATH	B-01 - B-04
BEDROOM	B-05 - B-08
CHASSIS	B-09 - C-06
C C & PAD	C-07 - C-18
DINETTE	C-19 - C-20
DRIVERS	C-21 - C-24
ELECTRICAL	D-01 - D-08
EXTERIOR BODY	D-09 - D-18
GALLEY	D-19 - E-02
HEATING & A/C	E-03 - E-08
INTERIOR FINISH	E-09 - E-13
LABEL	E-14 - E-22
LP	E-23
LOUNGE	E-24 - F-01
SEALANTS & FASTENERS	F-02 - F-04
WATER & SEWAGE	F-05 - F-11
WINDOW, VENT AND EXTERIOR DOOR	F-12 - G-10

DRIVERS COMPARTMENT GROUP (CONTINUED)

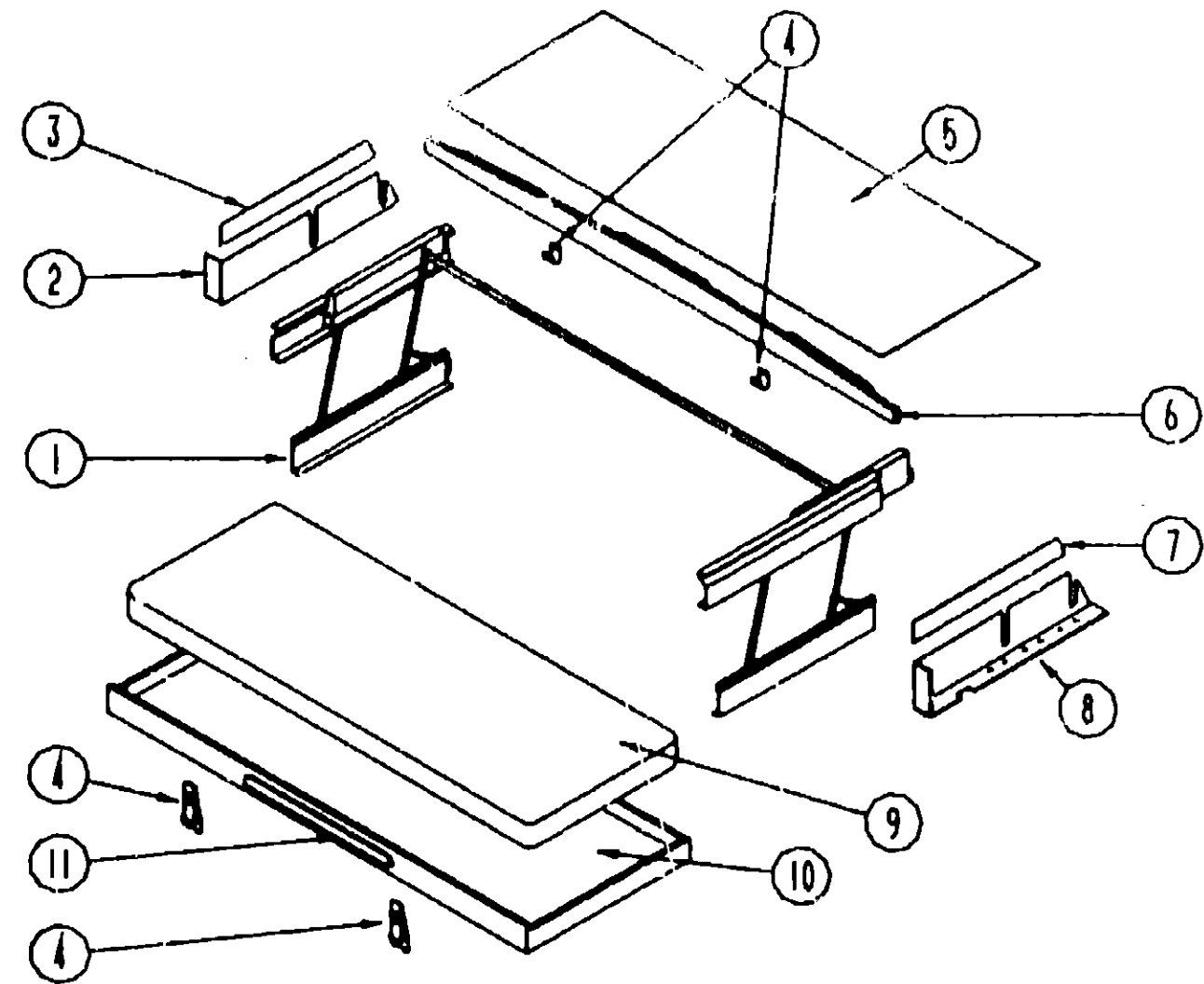

FRONT BUNK-SINGLE (OPT 523)

KEY PART NUMBER	U/M	DESCRIPTION
1 076760-02-000	EA	BUNK HARDWARE
076760-02-700	EA	SPRING-GAS-BUNK HARDWARE
2 092471-02-01A	EA	TRIM-SIDE, UPPER DRIVER - OFF WHITE - 33 1/4"
3 092472-02-01A	EA	TRIM-SIDE, SIDE - LOWER DR & PASS - 15.5" LONG - OFF WHITE
4 042541-04-700	EA	LATCH ASM-W/STRIKE, (2 SETS) - BRASS
092471-04-01A	EA	TRIM-OVERHEAD, DRIVER SIDE - OFF WHITE
042541-05-000	EA	STRIKE-BRASS
049465-04-000	EA	SCREW, 10-16 X 1 PTH W/WASHER - BEIGE
075943-02-000	EA	BRACE-ANGLE, W/HOLES - 1" X 1.5" X 14" - ALUMINUM - BEIGE
5 074497-14-000	SF	PANELING-CEILING, 4' X 8' - INCREMENTS OF 32 SF
093884-01-700	EA	HEADLINER-FRONT, PLASTIC - OFF WHITE
6 M93055-01-Y12	EA	BOARD-BUNK, TRIM - CEILING MOUNTED
016604-05-000	EA	BRACE-L/ANGLED, 2.5" - OFF WHITE
7 092471-01-01A	EA	TRIM-SIDE, UPPER PASSENGER - OFF WHITE - 33 1/4"
8 092472-01-01A	EA	TRIM-SIDE, LOWER - DR & PASS - 15.5" LONG - OFF WHITE
9 079145-04-000	EA	CUSHION-BUNK, OVERHEAD - 4" X 34" X 78" - B03/B04
M79145-04-000	EA	COVER-BUNK CUSHION, OVERHEAD - 4" X 34" X 78" - AA8 & AA9
10 081717-04-Y12	EA	BED-BUNK, FRONT
11 094658-01-Y12	EA	HANDLE-BUNK, OAK

DRIVERS COMPARTMENT GROUP (CONTINUED)

DASH & COMPONENTS

KEY PART NUMBER
076867-01-000
076867-02-000
076972-01-000
077001-01-000
024990-01-000
076783-02-000
076788-02-000
076788-03-000
076788-04-000
076797-02-000
076797-03-000
079364-01-000
077031-01-000
077031-02-000
077069-02-000
077075-01-000
077075-02-000
079382-01-000
081007-01-000
081377-01-700
081914-01-000
085252-02-Y10
086272-02-000
086273-01-000
086273-01-700
086285-01-000
087201-01-000
090979-01-000
091930-02-000
091930-03-000
093921-01-000
097372-01-01A
097372-05-01A
097372-06-01A
097372-07-01A
097372-08-01A
100602-01-01A
100602-04-01A
100602-07-01A
100602-05-01A
100602-08-01A
101024-01-01A
101025-02-01A
101055-01-01A
076788-01-000
088476-01-000
077407-01-000
102087-01-000
076867-01-000
077001-01-000
024460-04-000
078245-01-000
102122-01-B07
076734-05-000
096241-03-000
089294-01-000

U/M	DESCRIPTION
EA	BRACKET-V, LIPPED - 3.5" X 1" - STEEL - W/O SCREW HOLES
EA	BRACKET-V, LIPPED - 8.4" X 1" - STEEL - W/SCREW HOLES
EA	BRACKET-V, LIPPED - 2.7" X 1" - STEEL - W/O SCREW HOLES
EA	ANGLE-MOUNTING, ROOF PANEL - V ANGLE - 3" X 2.4" X 1.5"
EA	OUTLET-DEFROSTER, WITH SWIVEL - 2" - TAN
EA	LOUVER/BEZEL, BLACK, 2 1/2"
EA	CYLINDER-CARDBOARD, LAMP
EA	LAMP PLATE
EA	LAMP PLATE-TURN SIGNAL
EA	PANEL-INSTRUMENT, W/LOUVER CUTOUT 15.5" X 2.5" BLACK-PASSENGER SIDE FROM: 00-00-00 THRU: 08-03-90
EA	PANEL-INSTRUMENT, W/LOUVER CUTOUT - 15.5" X 2.5" - BLACK W/O BORDER - PASSENGER SIDE FROM: 00-04-90 THRU: 90-99-99
EA	SWITCH-ON/OFF ROCKER, BROWN
EA	FILM-BLACK, 1" X 1.75"
EA	FILM-AMBER, 1" X 1.75"
EA	CABLE-ANTENNA, EXTENSION - 96"
EA	GASKET-INSTRUMENT PANEL TO DEFROSTER PLENUM - 6" X 11.3" HOLE SIZE
EA	GASKET-INSTRUMENT PANEL TO DEFROSTER PLENUM - 6" X 10.2" HOLE SIZE
EA	SCREW-SOCKET, 8-18 X 1" - BLACK
EA	LIGHT-INDICATOR, LVS 1498
EA	ADHESIVE-CYANOACRYLATE, 10 GRAM TUBE
EA	BUMPER-RUBBER, ROUND - .43" DIAMETER - BLACK
EA	TOP-PADDED DASH, PASSENGER SIDE - VINYL - BEIGE
EA	SWITCH-ROCKER, 3 POSITION - DPDT
EA	RELAY-BATTERY DISCONNECT
EA	TERMINAL WIRE ASM
EA	SPACER-NYLON, .5" OD X .257" ID
EA	LIGHT-DUMP VALVE
EA	PLUG-INSTRUMENT PANEL, 11.5 MM
EA	DUCT-DEFROSTER, W/O SIDE OUTLET - ARA# 0571020 FROM: 00-00-00 THRU: 07-22-90
EA	DUCT-DEFROSTER, W/O SIDE OUTLET - ARA 0571109 FROM: 07-23-90 THRU: 99-99-99
EA	PLATE-MOUNTING, PEDESTAL
EA	SWITCH-ON/OFF, SPST
EA	SWITCH-ON/OFF/MOMENTARY
EA	SWITCH-BLANK
EA	SWITCH-ON/MOMENTARY (OFF)
EA	SWITCH-ON/ON
EA	PANEL-INSTRUMENT, UPPER W/CUTOUPS - "CHIEFTAIN" - BLACK FROM: 00-00-00 THRU: 02-10-91
EA	PANEL-INSTRUMENT, UPPER W/CUTOUPS - NO LOGO - BLACK FROM: 02-11-91 THRU: 03-17-91
EA	APPLIQUE-INSTRUMENT PANEL, "CHIEFTAIN" - BLACK FROM: 02-11-91 THRU: 03-17-91
EA	PANEL-INSTRUMENT, UPPER W/CUTOUPS - NO LOGO - BLACK FROM: 03-18-91 THRU: 99-99-99
EA	APPLIQUE-INSTRUMENT PANEL, "CHIEFTAIN" - BLACK FROM: 03-18-91 THRU: 99-99-99
EA	PANEL-DASH, LOWER W/CUTOUPS - CHEVY - MOUNTS RADIO - BLACK
EA	PANEL-DASH, LOWER W/CUTOUPS - 11.9" LONG - BLACK
EA	PANEL-DASH, LOWER (DRIVER SIDE) - PLASTIC - BEIGE LOCATED JUST ABOVE STEERING COLUMN
EA	SOCKET-MINI BAYONET LAMP, DASH
EA	SOCKET-CONNECTOR
EA	BRACKET-HOOD RELEASE CABLE
EA	CABLE-HOOD RELEASE
EA	BRACKET-INSTRUMENT PANEL - 3.5"
EA	ANGLE-MOUNTING, ROOF PANEL - V ANGLE - 3" X 2.4" X 1.5"
EA	GAUGE-VACUUM
EA	ROOT-STEERING COLUMN, VINYL - BLACK - CHEVY
EA	TOP-PADDED DASH, DRIVER SIDE - VINYL - BEIGE
EA	TRAY-DASH PANEL, PASSENGER SIDE - PLASTIC - BEIGE
EA	SWITCH-BLANK
EA	LIGHTER ASM-CIGARETTE

**1991 WINNEBAGO
TABLE OF CONTENTS**

INTRODUCTION	A-01 - A-02
ABBREVIATIONS	A-03
ALPHABETICAL INDEX	A-04 - A-06
WCN28RT	A-07 - G-10
WCN32RQ	G-11 - L-20

1991 WCN28RT INDEX

FLOOR PLAN	A-07 - A-08
ACCESSORIES	A-09 - A-21
BATH	B-01 - B-04
BEDROOM	B-05 - B-08
CHASSIS	B-09 - C-08
C C & PAD	C-07 - C-18
DINETTE	C-19 - C-20
DRIVERS	C-21 - C-24
ELECTRICAL	D-01 - D-08
EXTERIOR BODY	D-09 - D-18
GALLEY	D-19 - E-02
HEATING & A/C	E-03 - E-08
INTERIOR FINISH	E-09 - E-13
LABEL	E-14 - E-22
LP	E-23
LOUNGE	E-24 - F-01
SEALANTS & FASTENERS	F-02 - F-04
WATER & SEWAGE	F-05 - F-11
WINDOW, VENT AND EXTERIOR DOOR	F-12 - G-10

ELECTRICAL GROUP

ELECTRICAL CONVERSION OPTION L049 - EXPORT

KEY PART NUMBER	U/M	DESCRIPTION
008054-01-000	EA	CORD-POWER, 10/3 WIRE - 30 AMP - 25'
000G11-08-08B	EA	SCREW, 8-18 X 1/2 PPH ZN
000G11-10-16B	EA	SCREW, 10-16 X 1 - PPH ZN
000G67-10-12B	EA	SCREW, 10-12 X 3/4 - PPH ZN
008026-01-000	FT	WIRE-12/2, ROMEX - W/GROUND
008289-01-000	EA	BOX-ELECTRIC, STEEL - 1/2" AND 3/4" KNOCKOUTS - 4" X 4"
008311-01-000	EA	CONNECTOR-WIRE NUT, INSULATED - RED
008314-01-000	EA	CONNECTOR-WIRE NUT, INSULATED - GRAY
008328-01-000	EA	TERMINAL-RING, 12/10 WIRE - #10 STUD FIT
008331-01-000	EA	TERMINAL-RING-TONGUE - #4 WIRE - 3/8" STUD - COPPER
008355-01-000	EA	CONNECTOR-CABLE CLAMPING, 3/4"
008356-01-000	EA	CONNECTOR-PLASTIC, 3/8" AVG
041953-01-000	FT	CONDUIT-CONVOLUTE SLIT .50ID
073937-03-000	EA	SWITCH-ROTARY SELECTOR, 3 DECK - A/C - CA20-USA892
073937-01-700	EA	KNOB-ROTARY SWITCH-A/C SEL
074890-01-000	EA	BOX-EXTENSION, STEEL - OPEN SIDES - 4" X 4" X 1 1/2"
008294-01-000	EA	COVER-ELECTRICAL BOX, STEEL/BLANK - 4" X 4" - GRAY
091213-01-000	EA	BOX-CIRCUIT BREAKER-W/KNOCKOUTS - 5.3" X 11.5" X 2.5"
092615-01-000	EA	CONVERTER-40 AMP, W/CHARGER - B-W 32400P
094809-01-000	EA	LOAD CENTER-240 VOLT, 125 AMP
094810-01-000	EA	CIRCUIT BREAKER-DOUBLE 30 AMP, GE THOL2130
094811-01-000	EA	CIRCUIT BREAKER-DOUBLE 20 AMP, GE THOL2120

CANADIAN OPTION L285

KEY PART NUMBER	U/M	DESCRIPTION
008089-02-000	EA	LIGHT-PORCH, RECESSED - CANADIAN
008089-01-700	EA	LENS-LIGHT, RECESSED - PORCH

FORD OPTION L16K - US & CANADIAN

KEY PART NUMBER	U/M	DESCRIPTION
063749-02-000	EA	HOUSING-HEADLAMP, 2 BULB
088674-01-000	EA	NUT-HEADLAMP, BLACK
088675-01-000	EA	KNOB-HEADLAMP, W/SHAFT
088476-01-000	EA	SOCKET-CONNECTOR

INTERIOR LIGHTS

KEY PART NUMBER	U/M	DESCRIPTION
067201-01-000	EA	LIGHT-DUMP VALVE
060353-05-000	EA	LIGHT-READING, DOUBLE - BLACK
008103-01-000	EA	BULB-AISLE LIGHT, NUMBER 53 - 12 V - .12 AMP
061424-01-000	EA	LIGHT-AISLE, 12V - RECTANGULAR - BULB P.N. 008103-01-000
068023-02-01A	EA	SHROUD-CEILING LIGHT, DOUBLE, IVORY
068024-03-01A	EA	LIGHT-DOME, 2 BULB - IVORY - BULB # 008218-01-000
068024-01-700	EA	LENS-DOME LIGHT
068024-01-01A	EA	LIGHT-DOME, 1 BULB - US - IVORY
008218-01-000	EA	BULB-DOME LIGHT, 12V - NUMBER 1141
078424-02-000	EA	LIGHT-FLUORESCENT, 12V DC - 18" - ALMOND
078424-02-701	EA	LENS-LIGHT, FLUORESCENT - 18"
091937-04-000	EA	LIGHT-FLUORESCENT, 12 V - RECESSED - THIN-LITE
091937-02-000	EA	LENS-LIGHT FLUORESCENT 12V
091937-03-000	EA	BULB-LIGHT FLUORESCENT 12V
068023-01-01A	EA	SHROUD-CEILING LIGHT, SINGLE - IVORY
067894-01-000	EA	LIGHT-WARDROBE/CLOSET, W/SWITCH
067894-01-700	EA	BULB
062686-07-000	EA	SHADE-LAMP, TABLE
062686-09-000	EA	LAMP-TABLE, W/O SHADE - ACRYLIC
067479-01-000	EA	BULB-12V, NUMBER 1078

ELECTRICAL GROUP (CONTINUED)

EXTERIOR LIGHTS

KEY PART NUMBER	U/M	DESCRIPTION
081250-01-000	EA	LIGHT-FRONT CLEARANCE, AMBER - LENS AND BASE ONLY ORDER 079378-01-000 TERMINAL TO ATTACH BULB TO LIGHT FROM: 00-00-00 THRU: 09-09-90
081250-01-700	EA	LENS-CLEARANCE LIGHT, AMBER
081437-01-000	EA	BRACKET-CLEARANCE LIGHT, L SHAPED METAL FROM: 00-00-00 THRU: 09-09-90
036196-01-000	EA	BULB-12V - #194 - .27AMP
102520-01-000	EA	LIGHT-CLEARANCE, AMBER FROM: 09-10-90 THRU: 99-99-99
102540-01-000	EA	SEAL-SCREW, CLEARANCE LIGHT FROM: 09-10-90 THRU: 99-99-99
102541-01-000	EA	GASKET-CLEARANCE LIGHT FROM: 09-10-90 THRU: 99-99-99
102582-01-000	EA	BRACKET-LIGHT, CLEARANCE FROM: 09-10-90 THRU: 99-99-99
079378-01-000	EA	TERMINAL-WEDGE BASE, 18 AWG NEEDED TO ATTACH BULB TO SIDEMARKER AND CLEARANCE LIGHTS
077955-01-000	EA	J CLIP-VINYL COATED, 3/8" USED IN WIRING TO CLEARANCE LIGHTS
069289-02-000	EA	LIGHT-SIDE MARKER, AMBER - DRIVER OR PASSENGER
069289-02-700	EA	LENS ONLY AMBER - DRIVER OR PASSENGER
036196-01-000	EA	BULB-12V - #194 - .27AMP
069292-01-000	EA	LIGHT-TURN, AMBER
037935-01-000	EA	BULB-LAMP, NUMBER 1157 - 12 V - 2.1 AMP
070907-01-000	EA	HEADLAMP CAPSULE ASM-RECTANGULAR, GM# 5988097
074048-01-000	EA	INSERT-KNURLED, BRASS - #8-32 - FOR HEADLIGHT SCREWS
049359-01-000	EA	SPRING-HEADLAMP RETAINER, GM # 498098
073308-01-000	EA	SCREW-ADJUSTING, HEADLAMP
091838-01-01A	EA	BEZEL-HEADLAMP, PASSENGER - BLACK
091838-02-01A	EA	BEZEL-HEADLAMP, DRIVER - BLACK
063749-02-000	EA	HOUSING-HEADLAMP, 2 BULB

DRIVER SIDE LIGHTS

KEY PART NUMBER	U/M	DESCRIPTION
008089-01-000	EA	LIGHT-PORCH-RECESSED FROM: 00-00-00 THRU: 04-06-90
008089-01-700	EA	LENS-LIGHT, RECESSED - PORCH
091981-01-000	EA	GASKET-PORCH LIGHT FROM: 00-00-00 THRU: 04-06-90
097917-01-02A	EA	LIGHT-PORCH, BEIGE FROM: 04-06-90 THRU: 99-99-99
097917-01-700	EA	LENS-LIGHT, PORCH
042405-03-000	EA	BASE-CLEARANCE/SIDEMARKER LIGHT - RECTANGULAR
042405-02-000	EA	LENS-CLEARANCE/SIDEMARKER LIGHT - FRONT - W/REFLEX - AMBER
036196-01-000	EA	BULB-12V - #194 - .27AMP
091983-01-000	EA	GASKET-SIDE MARKER LIGHT
079378-01-000	EA	TERMINAL-WEDGE BASE, 18 AWG NEEDED TO ATTACH BULB TO SIDEMARKER AND CLEARANCE LIGHTS

PASSENGER SIDE LIGHTS

KEY PART NUMBER	U/M	DESCRIPTION
097917-01-02A	EA	LIGHT-PORCH, BEIGE
097917-01-700	EA	LENS-LIGHT, PORCH
042405-03-000	EA	BASE-CLEARANCE/SIDEMARKER LIGHT - RECTANGULAR
042405-02-000	EA	LENS-CLEARANCE/SIDEMARKER LIGHT - FRONT - W/REFLEX - AMBER
079378-01-000	EA	TERMINAL-WEDGE BASE, 18 AWG NEEDED TO ATTACH BULB TO SIDEMARKER AND CLEARANCE LIGHTS
036196-01-000	EA	BULB-12V - #194 - .27AMP
091983-01-000	EA	GASKET-SIDE MARKER LIGHT
081250-02-000	EA	LIGHT-CLEARANCE, CAB MARKER - W/RED LENS FROM: 00-00-00 THRU: 04-07-91
081250-02-700	EA	LENS ONLY, RED
036196-01-000	EA	BULB-12V - #194 - .27AMP
081437-01-000	EA	BRACKET-CLEARANCE LIGHT, L SHAPED METAL FROM: 00-00-00 THRU: 04-07-91
102520-02-000	EA	LIGHT-CLEARANCE, RED FROM: 04-06-91 THRU: 99-99-99

1991 WINNEBAGO

TABLE OF CONTENTS

INTRODUCTION	A-01 - A-02
ABBREVIATIONS	A-03
ALPHABETICAL INDEX	A-04 - A-06
WCN28RT	A-07 - G-10
WCN32RO	G-11 - L-20

1991 WCN28RT INDEX

FLOOR PLAN	A-07 - A-08
ACCESSORIES	A-09 - A-24
BATH	B-01 - B-04
BEDROOM	B-05 - B-08
CHASSIS	B-09 - C-06
C C & PAD	C-07 - C-18
DINETTE	C-19 - C-20
DRIVERS	C-21 - C-24
ELECTRICAL	D-01 - D-08
EXTERIOR BODY	D-09 - D-16
GALLEY	D-19 - E-02
HEATING & A/C	E-03 - E-08
INTERIOR FINISH	E-09 - E-13
LABEL	E-14 - E-22
LP	E-23
LOUNGE	E-24 - F-01
SEALANTS & FASTENERS	F-02 - F-04
WATER & SEWAGE	F-05 - F-11
WINDOW, VENT AND EXTERIOR DOOR	F-12 - G-10

ELECTRICAL GROUP (CONTINUED)

PASSENGER SIDE LIGHTS CONT

KEY PART NUMBER	U/M	DESCRIPTION
102540-01-000	EA	SEAL-SCREW, CLEARANCE LIGHT FROM: 04-08-91 THRU: 99-99-99
102541-01-000	EA	GASKET-CLEARANCE LIGHT FROM: 04-08-91 THRU: 99-99-99
102582-01-000	EA	BRACKET-LIGHT, CLEARANCE FROM: 04-08-91 THRU: 99-99-99
077955-01-000	EA	J CLIP-VINYL COATED, 3/8" USED IN WIRING TO CLEARANCE LIGHTS
079378-01-000	EA	TERMINAL-WEDGE BASE, 18 AWG NEEDED TO ATTACH BULB TO SIDEMARKER AND CLEARANCE LIGHTS
089289-01-000	EA	LIGHT-CLEARANCE, SIDE - W/RED LENS
089289-01-700	EA	LENS-CLEARANCE LIGHT, RED
036196-01-000	EA	BULB-12V - #194 - .27AMP
089291-01-000	EA	LIGHT-TURN, W/RED LENS
037935-01-000	EA	BULB-LAMP, NUMBER 1157 - 12 V - 2.1 AMP
089290-01-000	EA	LIGHT-BACKUP, W/RED & CLEAR LENS
037934-01-000	EA	BULB-12V NO1156 2.10AMP
067789-02-000	EA	SOCKET-LAMP
076795-01-000	EA	LIGHT-LICENSE PLATE, GM# 912368
036196-01-000	EA	BULB-12V - #194 - .27AMP

FRONT CAP LIGHTS

KEY PART NUMBER	U/M	DESCRIPTION
081250-01-000	EA	LIGHT-FRONT CLEARANCE, AMBER - LENS AND BASE ONLY FROM: 00-00-00 THRU: 00-00-00
081437-01-000	EA	BRACKET-CLEARANCE LIGHT, L SHAPED METAL FROM: 00-00-00 THRU: 00-00-00
102520-01-000	EA	LIGHT-CLEARANCE, AMBER FROM: 09-10-90 THRU: 99-99-99
102540-01-000	EA	SEAL-SCREW, CLEARANCE LIGHT FROM: 08-10-90 THRU: 99-99-99
102541-01-000	EA	GASKET-CLEARANCE LIGHT FROM: 09-10-90 THRU: 99-99-99
102582-01-000	EA	BRACKET-LIGHT, CLEARANCE FROM: 09-10-90 THRU: 99-99-99
036196-01-000	EA	BULB-12V - #194 - .27AMP
077955-01-000	EA	J CLIP-VINYL COATED, 3/8"
079378-01-000	EA	TERMINAL-WEDGE BASE, 18 AWG
067789-02-000	EA	SOCKET-LAMP
088474-09-000	EA	HOUSING-SOCKET, 3 POSITION
088476-01-000	EA	SOCKET-CONNECTOR

FRONT END LIGHTS

KEY PART NUMBER	U/M	DESCRIPTION
070907-01-000	EA	HEADLAMP-RECTANGULAR, GM 5988097
049359-01-000	EA	SPRING-RETAINER, HEADLAMP - GM 498096
073308-01-000	EA	SCREW-ADJUSTING, HEADLAMP
074048-01-000	EA	INSERT-KNURLED, BRASS - #8 - 32 (FOR HEADLAMP SCREWS)
091838-01-01A	EA	BEZEL-HEADLAMP, PASSENGER - BLACK
091838-02-01A	EA	BEZEL-HEADLAMP, DRIVER - BLACK
089289-02-000	EA	LIGHT-SIDE MARKER, AMBER
089289-02-700	EA	LENS-SIDEMARKER, AMBER
037936-01-000	EA	BULB-12V NUMBER 1157A - 2.10 AMP

ELECTRICAL GROUP (CONTINUED)

REAR CAP LIGHTS

KEY PART NUMBER	U/M	DESCRIPTION
081250-02-000	EA	LIGHT-CLEARANCE, CAB MARKER - W/RED LENS FROM: 00-00-00 THRU: 04-07-91
102520-02-000	EA	LIGHT-CLEARANCE, RED FROM: 04-08-91 THRU: 99-99-99
036196-01-000	EA	BULB-12V - #194 - .27AMP
081437-01-000	EA	BRACKET-CLEARANCE LIGHT, L SHAPED METAL FROM: 00-00-00 THRU: 04-07-91
102582-01-000	EA	BRACKET-LIGHT, CLEARANCE FROM: 04-08-91 THRU: 99-99-99
102540-01-000	EA	SEAL-SCREW, CLEARANCE LIGHT FROM: 04-08-91 THRU: 99-99-99
102541-01-000	EA	GASKET-CLEARANCE LIGHT FROM: 04-08-91 THRU: 99-99-99
077955-01-000	EA	J CLIP-VINYL COATED, 3/8" - USED IN WIRING TO LIGHTS
089289-01-000	EA	TAILLIGHT-WRAP AROUND, DRIVER & PASSENGER - W/RED LENS 036196-01-000 BULB
089290-01-000	EA	TAILLIGHT-BACKUP, DRIVER & PASSENGER - W/RED & CLEAR LENS 037934-01-000 BULB
089291-01-000	EA	TAILLIGHT-TURN, DRIVER & PASSENGER - W/RED LENS 037935-01-000 BULB

1991 WINNEBAGO

TABLE OF CONTENTS

INTRODUCTION	A-01 - A-02
ABBREVIATIONS	A-03
ALPHABETICAL INDEX	A-04 - A-08
WCN28RT	A-07 - G-10
WCN32RQ	G-11 - L-20

1991 WCN28RT INDEX

FLOOR PLAN	A-07 - A-08
ACCESSORIES	A-09 - A-24
BATH	B-01 - B-04
BEDROOM	B-05 - B-08
CHASSIS	B-09 - C-06
C C & PAD	C-07 - C-18
DINETTE	C-19 - C-20
DRIVERS	C-21 - C-24
ELECTRICAL	D-01 - D-08
EXTERIOR BODY	D-09 - D-18
GALLEY	D-19 - E-02
HEATING & A/C	E-03 - E-08
INTERIOR FINISH	E-09 - E-13
LABEL	E-14 - E-22
LP	E-23
LOUNGE	E-24 - F-01
SEALANTG & FASTENERS	F-02 - F-04
WATER & SEWAGE	F-05 - F-11
WINDOW, VENT AND EXTERIOR DOOR	F-12 - G-10

ELECTRICAL GROUP (CONTINUED)

CANADA EXPORT OPTION L265
TWIN BED CABINET & TABLE LAMP CHANGE

KEY PART NUMBER	U/M	DESCRIPTION
065201-08-000	EA	SHADE-LAMP, W/GOLD TRIM - PARCHMENT - US
065202-14-000	EA	LAMP-WALL, W/O SHADE - BRASS - US
065202-14-7C0	EA	BRASS FINIAL(NEW STYLE)
067479-01-000	EA	BULB-12V, NUMBER 1076 - WALL LAMP - US
082886-10-000	EA	LAMP-TABLE, BRASS - CANADIAN
SWITCH, PLATES & RECEPTACLES		
098351-02-01A	EA	PLATE-SWITCH, 2 GANG - POLISHED BRASS
079364-01-000	EA	SWITCH-ON/OFF ROCKER, BROWN
079364-03-000	EA	SWITCH-ON/OFF ROCKER, BLACK
084076-01-000	EA	RECEPTACLE-GFI, 15A - 125V - IVORY
		FROM: 00-00-00 THRU: 06-13-90
084076-02-000	EA	RECEPTACLE-GFI, 15A - 125V - BROWN
		FROM: 06-14-90 THRU: 99-99-99
084077-01-000	EA	PLATE-COVER, RECEPTACLE - GFI - IVORY
		FROM: 00-00-00 THRU: 06-13-90
084077-02-000	EA	PLATE-COVER, RECEPTACLE - GFI - BROWN
		FROM: 06-14-90 THRU: 99-99-99
102568-01-B10	EA	SPACER-RECEPTACLE, BETWEEN SIDE WALL & PLATE - WOOD
		NOT USED PRIOR TO 08-02-90
		FROM: 08-02-90 THRU: 99-99-99
058708-02-000	EA	RECEPTACLE-DOUBLE ELECTRIC, IVORY
098351-03-01A	EA	PLATE-SWITCH, 3 GANG - POLISHED BRASS
058707-01-000	EA	RECEPTACLE-ELECTRIC, SINGLE - BROWN
058708-02-000	EA	RECEPTACLE-DOUBLE ELECTRIC, IVORY
098351-01-01A	EA	PLATE-SWITCH, 1 GANG - POLISHED BRASS
084088-01-01A	EA	SWITCH PLATE-SINGLE GANG - BLACK
095188-01-01A	EA	SPACER-SWITCH, DARK BROWN
075738-03-000	EA	COVER-EXTERIOR RECEPTACLE, BEIGE

ELECTRICAL GROUP (CONTINUED)

STANDARD COMPONENTS

KEY PART NUMBER	U/M	DESCRIPTION
098527-01-000	EA	DOOR-CIRCUIT BREAKERS
098196-01-000	EA	LATCH-1/4 TURN, T-BAR
093674-01-000	EA	PLATE-CIRCUIT BREAKER, HOUSE
092547-01-000	EA	LABEL-CIRCUIT BREAKER
067762-01-000	EA	CONVERTER-40 AMP, W/CHARGER - TRIAD TU-740-2
007942-01-000	EA	TAB-WIRE, 18 TO 14 AWG
007949-01-000	EA	TAB-HOUSING, 1 POSITION
041953-09-000	FT	CONDUIT-CONVOLUTED, SLIT .50" ID
007940-01-000	EA	RECEPTACLE-SLIDE, 18 TO 12 AWG
008328-01-000	EA	TERMINAL-RING, 18/14 WIRE - 3/8" STUD
088474-09-000	EA	HOUSING-SOCKET
088476-01-000	EA	SOCKET-CONNECTOR
008037-02-000	FT	CABLE-BATTERY, 1AWG - STRANDED - RED
008343-02-000	EA	TIE-WIRE, 14"
008348-01-000	EA	TERMINAL-RING, 3/8" STUD - #2 WIRE
083610-01-000	EA	CLAMP-WIRE, DUAL - UNEQUAL 5/8" AND 1 1/4" DIAM. PETERS
007940-01-000	EA	RECEPTACLE-SLIDE, 16 TO 12 AWG
007942-01-000	EA	TAB-WIRE, 18 TO 14 AWG
008001-01-000	FT	WIRE-10AWG, STRAND - WHITE
047443-01-000	EA	TERMINAL-.250 RECEPTACLE, FIT, INSULATED - 18/14 AWG
088473-05-000	EA	PIN-HOUSING, 6 POSITION (SINGLE ROW)
088473-08-000	EA	PIN-HOUSING, 6 POSITION (TWO ROWS OF THREE)
088473-08-000	EA	PIN-HOUSING, 4 POSITION
088473-09-000	EA	PIN-HOUSING, 3 POSITION (SINGLE ROW)
088474-02-000	EA	SOCKET-HOUSING, 15 POSITION (3 ROWS OF 5)
088474-08-000	EA	SOCKET-HOUSING, 6 POSITION (2 ROWS OF THREE)
088474-08-000	EA	SOCKET-HOUSING, 4 POSITION (SINGLE ROW)
088476-01-000	EA	SOCKET-CONNECTOR
092549-01-000	EA	PLATE-FUSE BOX
007093-01-000	EA	FLASHER-SIGNAL STAT
008188-01-000	EA	SOLENOID-3 POST, BATTERY CHANGE OVER
008211-01-000	EA	BREAKER-CIRCUIT, 12V - 6AMP
008343-01-000	EA	TIE-WIRE, 6"
008343-02-000	EA	TIE-WIRE, 14"
024459-04-000	EA	GAUGE-VOLTMETER
035416-04-000	EA	TERMINAL-RING #10 STUD FIT, INSULATED BARREL #18/14
062901-02-000	EA	FUSE-5 AMP, AUTOMOTIVE
062901-05-000	EA	FUSE-15 AMPS, AUTOMOTIVE
083912-02-000	EA	RELAY-CANISTER, SPDT W/RESIST
073328-F2-000	EA	CABLE-8 GA, BLACK
008037-01-000	FT	CABLE-BATTERY, 1AWG - STRANDED - BLACK
008348-01-000	EA	TERMINAL-RING, 3/8" STUD - #2 WIRE
082742-01-000	EA	CONNECTOR BODY-3 CNCT FEMALE
085318-01-000	EA	SCREW-8-088X1/2, CRIMP TITE HD
088273-01-000	EA	RELAY-BATTERY DISCONNECT
088273-01-700	EA	TERMINAL WIRE ASM
088298-01-000	EA	WIRE-BATTERY DISCONNECT, RED
088298-02-000	EA	WIRE-BATTERY DISCONNECT, GREEN
008328-01-000	EA	TERMINAL-RING, 18/14 WIRE - 3/8" STUD
092788-01-000	EA	BUSS BAR-2.1" LONG
092788-02-000	EA	BUSS BAR-3.3" LONG
008331-01-000	EA	TERMINAL-RING, TONGUE - #4 WIRE - 3/8" STUD - COPPER
083910-01-000	EA	HOUSING-RELAY
088473-01-000	EA	PIN-HOUSING, 4 ROWS OF 3
088474-08-000	EA	SOCKET-HOUSING, 4 POSITION (SINGLE ROW)
088476-01-000	EA	SOCKET-CONNECTOR
101571-01-000	EA	HOUSING-2 POSITION, MALE
088473-03-000	EA	PIN-HOUSING, 9-POSITION
007942-01-000	EA	TAB-WIRE, 18 TO 14 AWG
007949-01-000	EA	TAB-HOUSING, 1 POSITION
088473-02-000	EA	PIN-HOUSING, 15 POSITION
088476-01-000	EA	SOCKET-CONNECTOR
007940-01-000	EA	RECEPTACLE-SLIDE, 18 TO 12 AWG
008328-01-000	EA	TERMINAL-RING, 18/14 WIRE - 3/8" STUD
093854-01-000	EA	CIRCUIT BREAKER-6 AMP, HOUSE CONTROL PANEL
093854-02-000	EA	CIRCUIT BREAKER-15 AMP
093854-03-000	EA	CIRCUIT BREAKER-20 AMP, HOUSE CONTROL PANEL
093855-01-000	EA	CIRCUIT BREAKER-25 AMP

**1991 WINNEBAGO
TABLE OF CONTENTS**

INTRODUCTION	A-01 - A-02
ABBREVIATIONS	A-03
ALPHABETICAL INDEX	A-04 - A-06
WCN28RT	A-07 - G-10
WCN32RQ	G-11 - L-20

1991 WCN28RT INDEX

FLOOR PLAN	A-07 - A-08
ACCESSORIES	A-09 - A-24
BATH	B-01 - B-04
BEDROOM	B-05 - B-08
CHASSIS	B-09 - C-06
C C & PAD	C-07 - C-18
DNETTE	C-19 - C-20
DRIVERS	C-21 - C-24
ELECTRICAL	D-01 - D-08
EXTERIOR BODY	D-09 - D-18
GALLEY	D-19 - E-02
HEATING & A/C	E-03 - E-08
INTERIOR FINISH	E-09 - E-13
LABEL	E-14 - E-22
LP	E-23
LOUNGE	E-24 - F-01
SEALANTS & FASTENERS	F-02 - F-04
WATER & SEWAGE	F-05 - F-11
WINDOW, VENT AND EXTERIOR DOOR	F-12 - G-10

ELECTRICAL GROUP (CONTINUED)

STANDARD COMPONENTS CONT

KEY PART NUMBER	U/M	DESCRIPTION
093655-02-000	EA	CIRCUIT BREAKER-30 AMP, HOUSE CONTROL PANEL
093655-03-000	EA	CIRCUIT BREAKER-40 AMP
007940-01-000	EA	RECEPTACLE-SLIDE, 16 TO 12 AWG
007942-01-000	EA	TAB-WIRE, 18 TO 14 AWG
007949-01-000	EA	TAB-HOUSING, 1 POSITION
035416-04-000	EA	TERMINAL-RING #10 STUD FIT, INSULATED BARREL #16/14
041953-01-000	FT	CONDUIT-CONVOLUTED SLIT, 1/2" ID
041953-03-000	FT	CONDUIT-CONVOLUTED SLIT, 1" ID (CLOTHES ROD COVER)
041953-07-000	FT	CONDUIT-CONVOLUTED SLIT, .25" ID
058781-01-000	EA	DIODE-6.0A/100 VOLT - MOTOROLA, NO MR751
062036-02-000	EA	TERMINAL-PACK-CON, 18/14 AWG
062037-01-000	EA	HOUSING-AUTO FUSE, NATURAL
062037-02-000	EA	HOUSING-AUTO FUSE, GREEN
062037-03-000	EA	HOUSING-AUTO FUSE, BLACK
062037-04-000	EA	HOUSING-AUTO FUSE, BLUE
062037-05-000	EA	HOUSING-AUTO FUSE, GRAY
062037-08-000	EA	HOUSING-AUTO FUSE, BROWN
082740-01-000	EA	CONNECTOR-PLASTIC BODY, FOR 2 MALE SPADES
088298-01-000	EA	WIRE-BATTERY DISCONNECT, RED
088298-02-000	EA	WIRE-BATTERY DISCONNECT, GREEN
088473-02-000	EA	HOUSING-PIN, 15 POSITION
088473-10-000	EA	PIN-HOUSING, 2 POSITION
088474-03-000	EA	HOUSING-SOCKET, 9-POSITION
088478-01-000	EA	SOCKET-CONNECTOR
088478-02-000	EA	SOCKET-CONNECTOR 12-10 GA
097811-01-000	EA	CIRCUIT BREAKER-6AMP, ATC - BLACK
000C28-04-108	EA	BOLT-HEX, SER FLG - 1/4-20 X 5/8 ZINC
000D39-05-008	EA	NUT-HEX, SER FLG LK - 5/16 - 18 ZN
008343-02-000	EA	TIE-WIRE, 14"
041953-07-000	FT	CONDUIT-CONVOLUTED SLIT, .25" ID
058028-01-000	EA	CONNECTOR-ELECTRICAL PIGTAIL, NYLON - CLEAR
008348-01-000	EA	TERMINAL-RING, 3/8" STUD - #2 WIRE
086233-01-000	EA	STUD-ISOLATED, 3/8" X 7/8" LONG
000D39-04-008	EA	NUT-HEX, SER FLG LK 1/4 - 20 ZN
000D39-05-008	EA	NUT-HEX, SER FLG LK - 5/16 - 18 ZN
008343-01-000	EA	TIE-WIRE, 6"
035416-04-000	EA	TERMINAL-RING #10 STUD FIT, INSULATED BARREL #16/14
008064-02-000	EA	CORD-POWER, 10-3 - 30AMP - 33'
058028-01-000	FT	WIRE-12/2, ROMEX - W/GROUND
008289-01-000	EA	BOX-ELECTRIC, STEEL - 1/2" AND 3/4" KNOCKOUTS - 4" X 4"
008311-01-000	EA	CONNECTOR-WIRE NUT, INSULATED - RED
008314-01-000	EA	CONNECTOR-WIRE NUT, INSULATED - GRAY
008328-01-000	EA	TERMINAL-RING, 12/10 WIRE - #10 STUD FIT
008331-01-000	EA	TERMINAL-RING, TONGUE - #4 WIRE - 3/8" STUD - COPPER
008355-01-000	EA	CONNECTOR-CABLE CLAMPING, 3/4"
008356-01-000	EA	CONNECTOR-PLASTIC, 3/8" AVG
074890-01-000	EA	BOX-EXTENSION, STEEL - OPEN SIDES - 4" X 4" X 1 1/2"
074897-01-000	EA	COVER-ELECTRIC BOX, 1 LARGE & 2 SMALL HOLES - 4" X 4"
008294-01-000	EA	COVER-ELECTRIC BOX, STEEL/BLANK - 4" X 4" - GRAY
083209-02-000	EA	CIRCUIT BREAKER-15/15AMP, 120V
083209-03-000	EA	CIRCUIT BREAKER-15/20AMP, 120V - BW - 0-15/20
083209-05-000	EA	CIRCUIT BREAKER-20A, 120V - BW J-20
083209-08-000	EA	CIRCUIT BREAKER-30/15 AMP, 120V - BW D-30/15
001213-01-000	EA	BOX-CIRCUIT BREAKER- W/KNOCKOUTS - 5.3" X 11.8" X 2.5"
035416-04-000	EA	TERMINAL-RING #10 STUD FIT, INSULATED BARREL #16/14
041953-01-000	FT	CONDUIT-CONVOLUTED SLIT, 1/2" ID
088474-08-000	EA	SOCKET-HOUSING, 8 POSITION (2 ROWS OF THREE)
035416-04-000	EA	TERMINAL-RING #10 STUD FIT, INSULATED BARREL #16/14
088474-07-000	EA	HOUSING-SOCKET
088475-01-000	EA	PIN-CONNECTOR
088475-02-000	EA	PIN-CONNECTOR
008294-01-000	EA	COVER-ELECTRIC BOX, STEEL/BLANK - 4" X 4" - GRAY
008311-01-000	EA	CONNECTOR-WIRE NUT, INSULATED - RED
008001-01-000	FT	WIRE-10AWG, STRAND - WHITE
080015-02-000	EA	RECEPTACLE-FLAG, .185 - 18/14 GA - AMP 3
041953-11-000	FT	CONDUIT-CONVOLUTED, SLIT- 1.06" ID
088474-01-000	EA	HOUSING-SOCKET
077955-01-000	EA	J CLIP-VINYL COATED, 3/8"

ELECTRICAL GROUP (CONTINUED)

STANDARD COMPONENTS CONT

KEY PART NUMBER	U/M	DESCRIPTION
079378-01-000	EA	TERMINAL-WEDGE BASE, 18 AWG
067789-02-000	EA	SOCKET-LAMP
058028-01-000	EA	CONNECTOR-ELECTRICAL PIGTAIL, NYLON - CLEAR
035416-04-000	EA	TERMINAL-RING #10 STUD FIT, INSULATED BARREL #16/14
067789-02-000	EA	SOCKET-LAMP
077955-01-000	EA	J CLIP-VINYL COATED, 3/8"
035416-04-000	EA	TERMINAL-RING #10 STUD FIT, INSULATED BARREL #16/14
084308-01-000	EA	HOUSING-TRAILER, RECEPTACLE
079090-01-000	EA	CONNECTOR-MOLDED, 12/2 LEAD
079378-01-000	EA	TERMINAL-WEDGE BASE, 18 AWG
087744-02-000	EA	HOUSING-TRAILER PIN, 48"
087746-01-000	EA	HOUSING CAP-TRAILER PIN
008028-01-000	FT	WIRE-12/2, ROMEX - W/GROUND
041953-05-000	FT	CONDUIT-CONVOLUTED SOLID, .82" ID
047443-01-000	EA	TERMINAL-.250 RECEPT. FIT, INSULATED - 18/14 AWG
088473-03-000	EA	HOUSING-PIN, 9-POSITION
088474-03-000	EA	HOUSING-SOCKET, 9-POSITION
082740-01-000	EA	CONNECTOR-PLASTIC BODY, FOR 2 MALE SPADES
041953-05-000	FT	CONDUIT-CONVOLUTED SOLID, .62" ID
074017-02-000	EA	HOUSING-5 POSITION, RIGHT ANGLED
041953-05-000	FT	CONDUIT-CONVOLUTED SOLID, .62" ID
088474-08-000	EA	SOCKET-HOUSING, 4 POSITION (SINGLE ROW)
038198-01-000	EA	BULB-12V - #194 - 27AMP
077955-01-000	EA	J CLIP-VINYL COATED, 3/8"
067789-02-000	EA	SOCKET-LAMP
079090-01-000	EA	CONNECTOR-MOLDED, 12/2 LEAD
041953-03-000	FT	CONDUIT-CONVOLUTED SLIT, 1" ID (CLOTHES ROD COVER)
000D39-04-008	EA	NUT-HEX, SER FLG LK 1/4 - 20 ZN
077000-01-000	EA	SOCKET ASM-W/8" PIGTAIL LEADS
090734-02-000	EA	CLIP-WIRE, NYLON
083144-01-000	EA	CONDUIT-WIRE, GM# 15592048
055278-01-001	FT	TUBING-STEEL, .75" X 1.5" X 288"
000G11-08-088	EA	SCREW, 8-18 X 1/2 PPH ZN
008288-01-000	EA	BOX-PLASTIC ELECTRIC, 3" X 3 1/2"
008288-02-000	EA	BOX-ELECTRIC, PLASTIC - 3.94" X 3.13" X 1.81"
008314-01-000	EA	CONNECTOR-WIRE NUT, INSULATED - GRAY
008328-01-000	EA	TERMINAL-RING, 12/10 WIRE - #10 STUD FIT
058028-01-000	EA	CONNECTOR-ELECTRICAL PIGTAIL, NYLON - CLEAR
058049-01-000	EA	BOX-ELECTRIC SWITCH, 2" X 3" X 2.25"
008343-01-000	EA	TIE-WIRE, 6"
058028-01-000	EA	CONNECTOR-ELECTRICAL PIGTAIL, NYLON - CLEAR
090971-01-000	EA	SPLICE-CABLE, 110V
090971-02-000	EA	SPLICE-CABLE, 110V - TAP
092547-01-000	EA	LABEL-CIRCUIT BREAKER
038198-01-000	EA	BULB-12V - #194 - 27AMP
031985-01-000	EA	TAB-HOUSING, 2 POSITION
031988-01-000	EA	PLUG-CONTACT, BRASS
077000-01-000	EA	SOCKET ASM-W/8" PIGTAIL LEADS
077920-02-000	EA	WIRE ASM-BEVERAGE TRAY
077000-01-000	EA	SOCKET ASM-W/8" PIGTAIL LEADS
083739-01-700	EA	BATTERY-12V, DRY - 24TM-WNT-DRY
077479-01-000	EA	BOOT-BATTERY TERM, DBL CABLE
077479-02-000	EA	BOOT-BATTERY TERMINAL, SINGLE CABLE
077510-01-000	EA	LABEL-GENERATOR PREP

**1991 WINNEBAGO
TABLE OF CONTENTS**

INTRODUCTION	A-01 - A-02
ABBREVIATIONS	A-03
ALPHABETICAL INDEX	A-04 - A-08
WCN28RT	A-07 - G-10
WCN32RQ	G-11 - L-20

1991 WCN28RT INDEX

FLOOR PLAN	A-07 - A-08
ACCESSORIES	A-09 - A-24
BATH	B-01 - B-04
BEDROOM	B-05 - B-08
CHASSIS	B-09 - C-06
C C & PAD	C-07 - C-18
DINETTE	C-19 - C-20
DRIVERS	C-21 - C-24
ELECTRICAL	D-01 - D-08
EXTERIOR BODY	D-09 - D-18
GALLEY	D-19 - E-02
HEATING & A/C	E-03 - E-08
INTERIOR FINISH	E-09 - E-13
LABEL	E-14 - E-22
LP	E-23
LOUNGE	E-24 - F-01
SEALANTS & FASTENERS	F-02 - F-04
WATER & SEWAGE	F-05 - F-11
WINDOW, VENT AND EXTERIOR DOOR	F-12 - G-10

EXTERIOR BODY GROUP

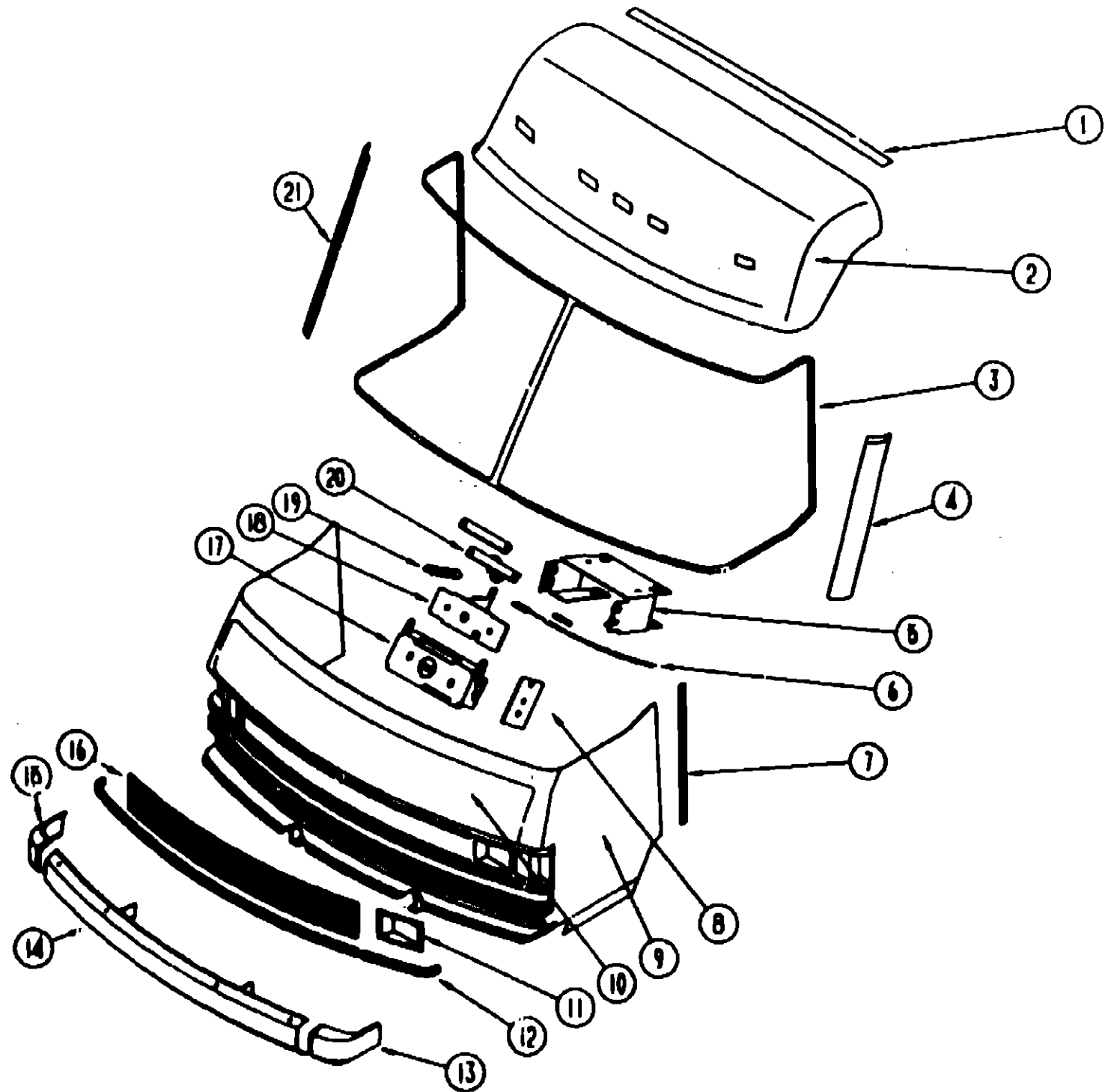

KEY	PART NUMBER
1	083805-14-000
2	M02959-07-AB6
3	091988-01-000
4	091901-02-000
5	073342-01-000
	092693-01-000
6	077064 01 000
6	102087 01 000
	010497-08-000
7	096204-01-01A
8	077407 01 000
8	102515 01 000
9	M01115-20-Y10
10	M92677-01-Y10
	066833-01-000
	082628-01-000
	094060 01 000
	060927-01-000
	078716-02-000
	083851-01-Y12
	093851-02-Y12
	077252-01-000
	058788-01-000
	R77007-51-429
	078772-01-000
	077049-01-000
	093206-02-000
	077048-01-000
	088235-02-000
	095094-01-000
11	091838-02-01A
	091838-01-01A
12	092414-01-000
13	091840-02-01A
14	091994-01-02A
	091994-01-01A
	005200-01-000
	077852-01-000
	093514-01-000
	081107-01-000
15	091840-01-01A
16	092901-01-Y10
17	073338-02-000
18	R77007-51-429
19	R77008-38-499
20	R77007-01-960
	073810-01-000
21	091901-01-000
	083284 01 000
	083895 01 000
	102817 01 000

EXTERIOR BODY GROUP (CONTINUED)

FRONT END COMPONENTS & BUMPER

U/M	DESCRIPTION
EA	TRIM-ROOF TO FRONT CAP
EA	CAP-ROOF, FRONT - W/LIGHTS - BEIGE
EA	MOLDING-REVEAL, WINDSHIELD - SURROUNDS BOTH WINDSHIELDS
EA	TRIM-A-PILLAR, DR - BETWEEN WINDSHIELD & VENT GLASS - BLK
EA	BRACKET ASM-STRIKER,HOOD (MOUNTS TO CROSSMEMBER)
EA	CROSSMEMBER-CENTER, U-CHANNEL STEEL - 2" X 48"
EA	CABLE ASM-HOOD RELEASE
	FROM 00-00-00 THRU 90-07-08
EA	CABLE ASM-HOOD RELEASE
	FROM: 07-09-90 THRU: 99-99-99
EA	CLAMP-CLOSED, .125"
	FROM: 07-09-90 THRU: 99-99-99
EA	TRIM-SEAM, FRONT END TO SIDEWALLS
EA	BRACKET-HOOD RELEASE CABLE
	FROM 000000 THRU 900812
EA	BRACKET-HOOD RELEASE CABLE
	FROM 900813 THRU 999999
EA	FRONT END-FIBERGLASS, BEIGE - W/O HOOD OR HINGES
EA	PANEL-HOOD, W/BRACKETS ONLY - BEIGE
EA	BRACKET-PROP ROD
EA	CLIP-PROP ROD
EA	ROD ASM-PROP,HOOD
EA	GROMMET RUBBER - PROP RED
EA	BRACKET ASM- LATCH - INCLUDED WITH HOOD
EA	HINGE-HOOD, PASSENGER
EA	HINGE-HOOD, DRIVER
EA	PIN-HINGE
EA	BOLT-HOOD ADJUSTING
EA	BRACKET-HOOD RELEASE
EA	CLIP-SPEED, TUBE TYPE
EA	NUT-ACORN, 10-32 ALUMINUM
EA	BRACKET-LATCH, HOOD
EA	SHAFT-ADAPTOR, WINDSHIELD PANTOGRAPH ARM
EA	BEARING-SNAPIN, 3/16" ID X 3/16"
EA	NUT-ACORN, 1/4 - 20 ALUMINUM
EA	BEZEL-HEADLAMP, DRIVER - BLACK
EA	BEZEL-HEADLAMP, PASSENGER - BLACK
FT	TRIM-CHROME, 1.2" WIDE
EA	CAP-BUMPER END, FRONT DRIVER - PLASTIC - BEIGE
EA	BUMPER-FRONT, BEIGE
EA	BUMPER-FRONT, UNFINISHED
EA	BOLT-BUMPER,ROUND HEAD-SQUARE NECK- W/SST CAP 7/16-14 X 1 1/4
EA	BRACKET-BUMPER, FRONT - 2 PER COACH - BENT 2" X 8"
EA	SUPPORT-BUMPER, FRONT - L ANGLE - 4" X 7"
EA	BRACKET-BUMPER PIN, ANGLE 2.8" X 7.8" - METAL - BLACK
EA	CAP-BUMPER END, FRONT PASSENGER - PLASTIC - BEIGE
EA	GRILLE-10 BAR, BRIGHT FINISHED
EA	BRACKET-MOUNTING, LATCH
EA	LATCH ASM-HOOD RELEASE
EA	SPRING-CABLE,HOOD LATCH
EA	STRIKER-LATCH, HOOD
EA	SPRING-STRIKER, LATCH - HOOD
EA	TRIM-A-PILLAR, PASS - BETWEEN WINDSHIELD & VENT GLASS - BL
EA	BRACE-LATCH,HOOD
EA	TRAY ASM-BATTERY
EA	BRACKET-PARK BRAKE VALVE
	FROM 91-04-02 THRU 99-99-99

**1991 WINNEBAGO
TABLE OF CONTENTS**

INTRODUCTION	A-01 - A-02
ABBREVIATIONS	A-03
ALPHABETICAL INDEX	A-04 - A-06
WCN28RT	A-07 - G-10
WCN32RQ	G-11 - L-20

1991 WCN28RT INDEX

FLOOR PLAN	A-07 - A-08
ACCESSORIES	A-09 - A-24
BATH	B-01 - B-04
BEDROOM	B-05 - B-08
CHASSIS	B-09 - C-06
C C & PAD	C-07 - C-18
DINETTE	C-19 - C-20
DRIVERS	C-21 - C-24
ELECTRICAL	D-01 - D-08
EXTERIOR BODY	D-09 - D-18
GALLEY	D-19 - E-02
HEATING & A/C	E-03 - E-08
INTERIOR FINISH	E-09 - E-13
LABEL	E-14 - E-22
LP	E-23
LOUNGE	E-24 - F-01
SEALANTS & FASTENERS	F-02 - F-04
WATER & SEWAGE	F-05 - F-11
WINDOW, VENT AND EXTERIOR DOOR	F-12 - G-10

EXTERIOR BODY GROUP (CONTINUED)

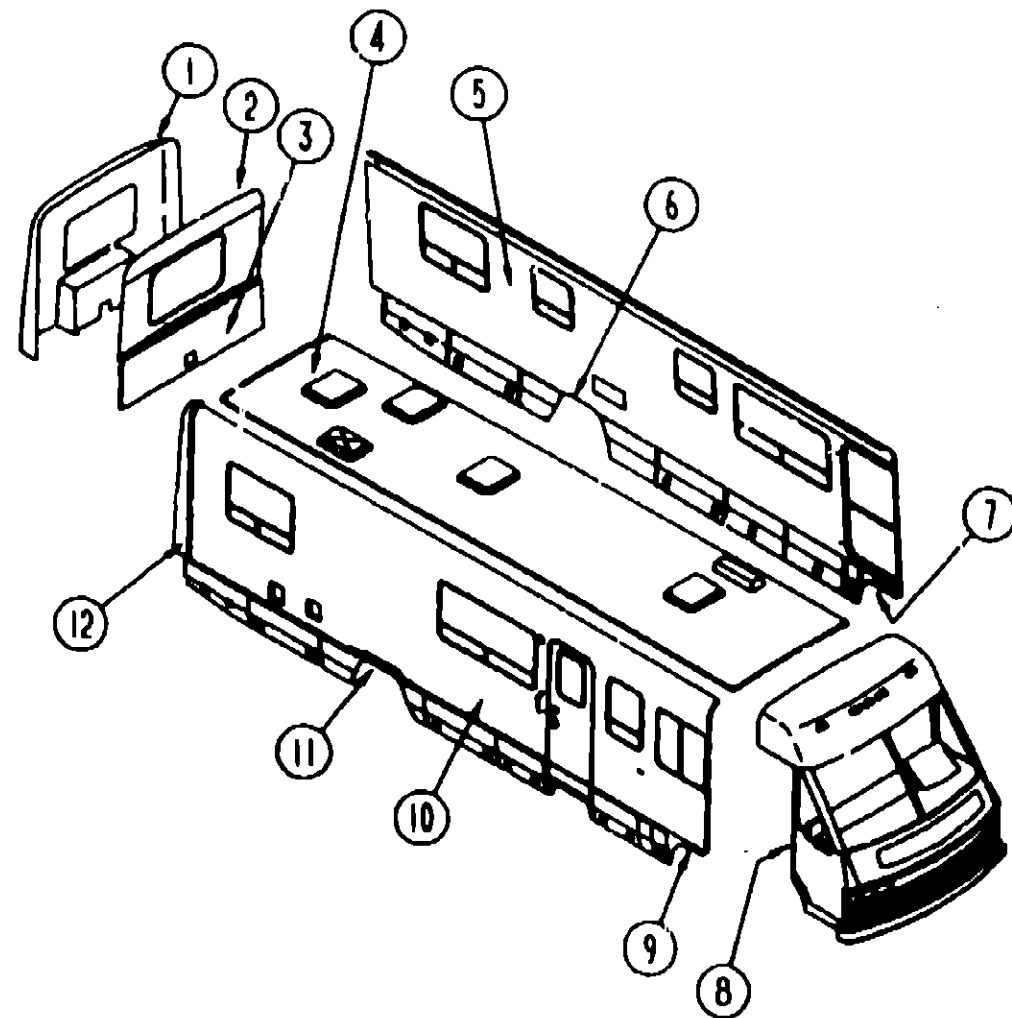

KEY PART NUMBER	U/M	DESCRIPTION
1 M05005-01-B07	EA	CAP-REAR, FIBERGLASS - W/LIGHTS & 2 DOORS IF COACH WAS BUILT BEFORE 04-09-91 YOU MUST ORDER 102681-01-000 WIRING HARNESS ALSO.
2 M05007-02-B07	EA	BACKWALL-UPPER, W/O WINDOWS OR CUTOUTS (SPECIAL ORDER ITEM - DEALER PAYS FREIGHT & IF CANCELED AFTER 7 DAYS DEALER CHARGED 25%-IF SHIPPED NOT RETURNABLE)
2 092732-01-B07	EA	FIBERGLASS/ ALUMINUM & STYROFOAM
3 M05008-01-B07	EA	BACKWALL-UPPER, W/O WINDOWS OR CUTOUTS (SPECIAL ORDER ITEM)
3 M05008-02-B07	EA	BACKWALL ASM-LOWER TWIN BED
4 M97517-01-B07	EA	BACKWALL ASM-LOWER QUEEN BED
4 M97517-01-B07	EA	ROOF-W/O VENTS OR CUTOUTS - (SPECIAL ORDER ITEM) DEALER PAYS FREIGHT. DEALER CHARGED 25% IF CANCELED AFTER 7 DAYS. NOT RETURNABLE IF SHIPPED.
083805-14-000	EA	TRIM-ROOF, FRONT & REAR CAP TO ROOF - 6.4' MILL FINISHED
5 P01089-01-B07	EA	SIDEWALL-DR, W/O WINDOWS, LIGHTS OR DOORS (SPECIAL ORDER ITEM - DEALER PAYS FREIGHT & IF CANCELED AFTER 7 DAYS IS CHARGED 25%-IF SHIPPED NOT RETURNABLE)
6 094345-02-01A	EA	TRIM-WHEELWELL, MILL FINISH - 21.3" LONG
M04019-01-000	EA	BRIDGE-WHEELWELL, E-COATED
6 093244-14-B07	FA	PANEL-WHEEL LIP, REAR - DRIVER SIDE - 51.8" WIDE - BEIGE
7 M04129-02-B07	EA	PANEL-WHEEL LIP, DRIVER SIDE - FRONT - PLASTIC - BEIGE
8 096204-01-01A	EA	TRIM-J, .5" WIDTH EXPOSED - 1" X 29" LONG - ALUMINUM - BEIGE
9 M04129-01-B07	EA	PANEL-WHEEL LIP, PASSENGER SIDE - FRONT - PLASTIC - BEIGE
10 P01088-01-B07	EA	SIDEWALL-PASS, W/O WINDOW, LIGHT, OR DOOR (SPECIAL ORDER ITEM - DEALER PAYS FREIGHT & IF CANCELED AFTER 7 DAYS DEALER CHARGED 25%-IF SHIPPED NOT RETURNABLE)
11 094345-02-01A	EA	TRIM-WHEELWELL, MILL FINISH - 21.3" LONG
M04019-01-000	EA	BRIDGE-WHEELWELL, E-COATED
11 093244-03-B07	EA	PANEL-WHEEL LIP, REAR - PASSENGER SIDE - BEIGE
12 091985-01-02A	FT	INSERT-TRIM, .85" WIDE - VINYL - BEIGE
12 092041-01-01A	EA	TRIM-REAR CAP TO SIDEWALL, 1.8" X 83" - ALUMINUM - BEIGE
001018-01-024	EA	SKIN-ALUMINUM, 4' X 8' - FLAT - BEIGE
100128-01-000	FT	SEAL-PILE, ADHESIVE BACK - GRAY
090340-01-000	FT	SEAL-FOAM, CLOSED CELL - 1/4" X 1/2" X 50'
090886-01-000	EA	HINGE-ALUMINUM, NO HOLES - 1 1/16" X 8" - UNPAINTED
078787-02-000	EA	CABLE-1/16" X 18.5" - STAINLESS STEEL
092250-01-01A	EA	CAP-BUMPER END, REAR PASSENGER - PLASTIC - BEIGE
092250-02-01A	EA	CAP-BUMPER END, REAR DRIVER - PLASTIC - BEIGE
092689-01-01A	EA	END CAP-VALANCE, REAR SIDE - BEIGE
092689-02-01A	EA	END CAP-VALANCE, FRONT SIDE - BEIGE
093021-11-B07	EA	PANEL-VALANCE, 19.4" X 7.8" - BEIGE
094382-02-000	EA	CLIP-CHRISTMAS TREE, FLAT HEAD - 354-220000-01-0078
093021-03-B07	EA	PANEL-VALANCE, 19.4" X 8" - BEIGE
078322-03-000	FT	TAPE-FOAM, DOUBLE COATED ADHESIVE BACKED - .5" X 108'
092785-01-Y12	EA	PANEL-FILLER, BACKWALL - LEFT - RADIUS CORNER - 11.8" X 28
082701-01-000	SF	PANEL-SHEATHING, WAFERBOARD - 4' X 8' - INCREMENTS OF 32 8
092252-01-000	EA	COMPARTMENT-SPARE TIRE
077385-01-000	EA	PIN-PIVOT - FOR 077384-01-000
077399-01-000	EA	RETAINER-SPARE TIRE, 2" X 7.8" - HOLE IN MIDDLE
077941-01-000	FA	SEAL-RUBBER, FLAT - W/SLIT

EXTERIOR BODY GROUP (CONTINUED)

EXTERIOR BODY PANELS AND TRIM

1991 WINNEBAGO

TABLE OF CONTENTS

INTRODUCTION	A-01 - A-02
ABBREVIATIONS	A-03
ALPHABETICAL INDEX	A-04 - A-08
WCN28RT	A-07 - G-10
WCN32RQ	G-11 - L-20

1991 WCN28RT INDEX

FLOOR PLAN	A-07 - A-08
ACCESSORIES	A-09 - A-24
BATH	B-01 - B-04
BEDROOM	B-05 - B-08
CHASSIS	B-09 - C-05
C C & PAD	C-07 - C-18
DINETTE	C-19 - C-20
DRIVERS	C-21 - C-24
ELECTRICAL	D-01 - D-08
EXTERIOR BODY	D-09 - D-18
GALLEY	D-19 - E-02
HEATING & A/C	E-03 - E-08
INTERIOR FINISH	E-09 - E-13
LABEL	E-14 - E-22
LP	E-23
LOUNGE	E-24 - F-01
SEALANTS & FASTENERS	F-02 - F-04
WATER & SEWAGE	F-05 - F-11
WINDOW, VENT AND EXTERIOR DOOR	F-12 - G-10

EXTERIOR BODY GROUP (CONTINUED)

DECALS & PAINT
B07,B08,B09 COLOR CODES
FROM: 00-00-00 THRU: 02-10-81

1991 WINNEBAGO
TABLE OF CONTENTS

INTRODUCTION	A-01 - A-02
ABBREVIATIONS	A-03
ALPHABETICAL INDEX	A-04 - A-06
WCN28RT	A-07 - G-10
WCN32RO	G-11 - L-20

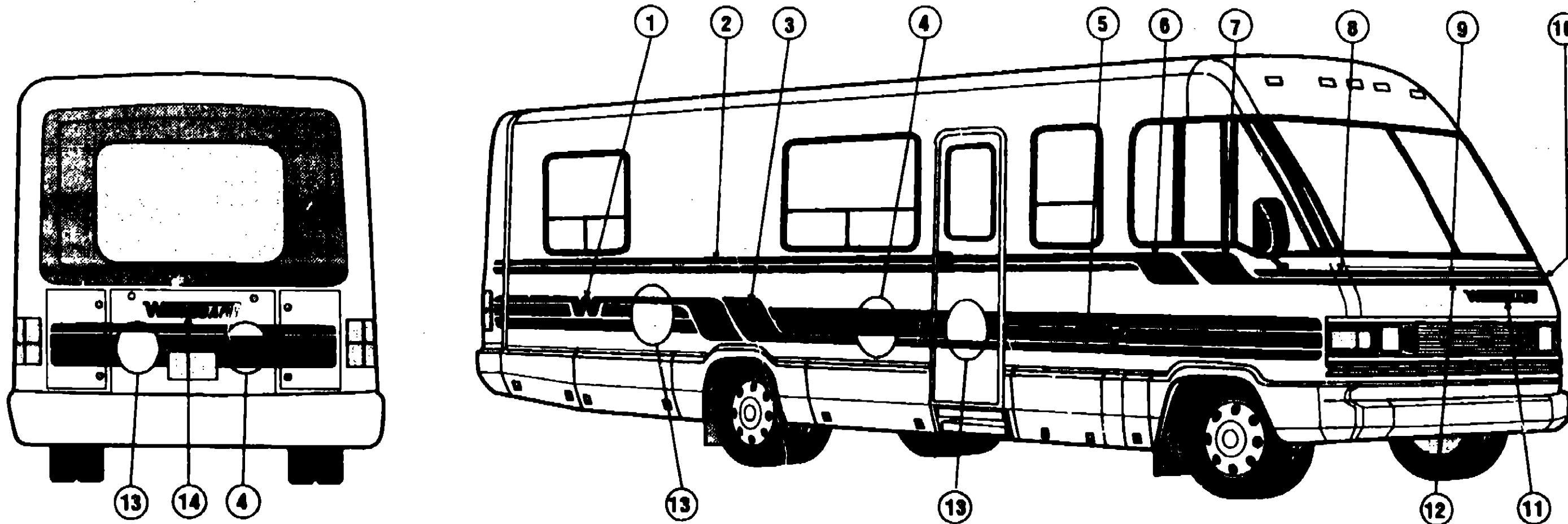

1991 WCN28RT INDEX

FLOOR PLAN	A-07 - A-08
ACCESSORIES	A-09 - A-24
BATH	B-01 - B-04
BEDROOM	B-05 - B-08
CHASSIS	B-09 - C-06
C C & PAD	C-07 - C-18
DINETTE	C-19 - C-20
DRIVERS	C-21 - C-24
ELECTRICAL	D-01 - D-08
EXTERIOR BODY	D-09 - D-18
GALLEY	D-19 - E-02
HEATING & AC	E-03 - E-08
INTERIOR FINISH	E-09 - E-13
LABEL	E-14 - E-22
LP	E-23
LOUNGE	E-24 - F-01
SEALANTS & FASTENERS	F-02 - F-04
WATER & SEWAGE	F-05 - F-11
WINDOW, VENT AND EXTERIOR DOOR	F-12 - G-10

KEY PART NUMBER	U/M	DESCRIPTION
1	EA	DECAL-FLYING W, 6.3" HIGH - REAR SIDEWALL - DARK TEAL DUPONT# K9470
2	FT	MULTISTRIPE-2 LINES, 3.4" WIDE - BELOW SIDEWALL WINDOWS FROM CAB TO REAR CAP - DARK TEAL DUPONT #K9470; LIGHT TEAL DUPONT #K9471
3	EA	DECAL-ANGLE DIAMOND, LARGE - PASS. SIDE - BOTH SECTIONS ABOVE REAR WHEELWELL - DARK TEAL DUPONT # K9470
4	EA	DECAL-ANGLE DIAMOND, LARGE - DRIVER SIDE - BOTH SECTION ABOVE REAR WHEELWELL - DARK TEAL DUPONT #K9470
5	FT	MULTISTRIPE-2 LINES, 7.5" WIDE - LOWER ON REAR CAP & - CENTER ON SIDEWALL BETWEEN CAB DOORS & REAR WHEELWELL - LIGHT TEAL DUPONT #K9471
6	EA	DECAL-LOGO, "CHIEFTAIN" - ON SIDEWALLS - DARK TEAL DUPONT# K9470, BEIGE DUPONT# L0729
7	EA	DECAL-ANGLE DIAMOND, SMALL - DRIVER SIDE - REAR SECTION BELOW CAB DOOR WINDOW - DARK TEAL DUPONT #K9470
8	EA	DECAL-ANGLE DIAMOND, SMALL - PASS. SIDE - BOTH SECTION BELOW CAB WINDOWS - DARK TEAL DUPONT #K9470
9	EA	DECAL-ANGLE DIAMOND, SMALL - DRIVER SIDE - FRONT SECTION BELOW CAB WINDOW - DARK TEAL DUPONT #K9470
10	EA	DECAL-CORNER, PASSENGER SIDE - FRONT - LIGHT TEAL DUPONT #K9471 & DARK TEAL DUPONT #K9470
11	EA	DECAL-CORNER, DRIVER SIDE - FRONT - LIGHT TEAL DUPONT #K9471 & DARK TEAL DUPONT #K9470
12	EA	DECAL-LOGO, "WINNEBAGO" - HOOD - DARK TEAL DUPONT #K9470
13	FT	STRIPE-1 LINE, 1.7" WIDE - ACROSS HOOD PANEL - LIGHT TEAL DUPONT #K9471
14	EA	DECAL-CORNER, DRIVER SIDE - FRONT - LIGHT TEAL DUPONT #K9471 & DARK TEAL DUPONT #K9470
15	EA	DECAL-LOGO, "WINNEBAGO" - 2.8" HIGH - REAR SPARE TIRE DOOR - DARK TEAL DUPONT# K9470

NOTE:
UNIT WITH B22 COLOR CODE ON FOLLOWING PAGE

EXTERIOR BODY GROUP (CONTINUED)

DECALS & PAINT CONT

WB22 COLOR CODE (STORMY BLUE)
 REPLACED B07 - (CAMEO BLUE COACHES)
 FROM: 02-11-91 THRU: 09-09-99

1991 WINNEBAGO
 TABLE OF CONTENTS

INTRODUCTION	A-01 - A-02
ABBREVIATIONS	A-03
ALPHABETICAL INDEX	A-04 - A-06
WCN28RT	A-07 - G-10
WCN32RQ	G-11 - L-20

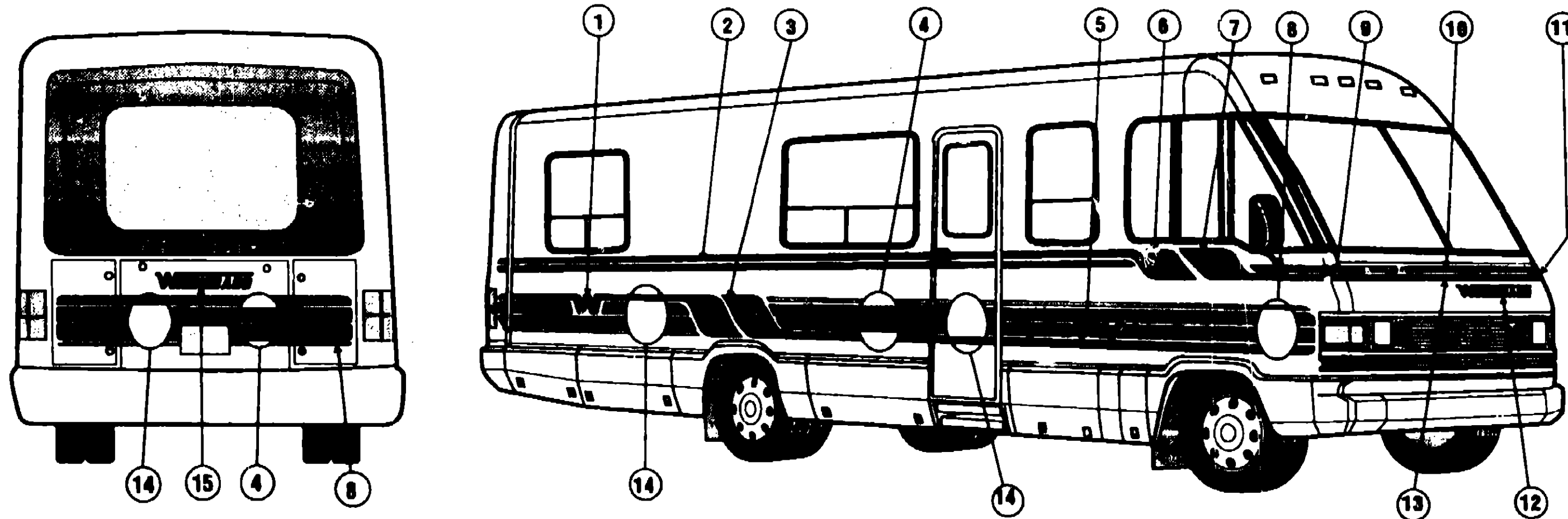

1991 WCN28RT INDEX

FLOOR PLAN	A-07 - A-08
ACCESSORIES	A-09 - A-24
BATH	B-01 - B-04
BEDROOM	B-05 - B-08
CHASSIS	B-09 - C-06
C C & PAD	C-07 - C-18
DINETTE	C-19 - C-20
DRIVERS	C-21 - C-24
ELECTRICAL	D-01 - D-08
EXTERIOR BODY	D-09 - D-18
GALLEY	D-19 - E-02
HEATING & A/C	E-03 - E-08
INTERIOR FINISH	E-09 - E-13
LABEL	E-14 - E-22
LP	E-23
LOUNGE	E-24 - F-01
SEALANTS & FASTENERS	F-02 - F-04
WATER & SEWAGE	F-05 - F-11
WINDOW, VENT AND EXTERIOR DOOR	F-12 - G-10

KEY PART NUMBER

U/M DESCRIPTION

1	093891-02-02A	EA	DECAL-FLYING W, 8.3" HIGH - REAR SIDEWALL - ROYAL BLUE
2	093880-20-03A	FT	MULTISTRIPE-2 LINES, 3.4" WIDE - BELOW SIDEWALL WINDOWS FROM CAB TO REAR CAP - LIGHT BLUE DUPONT # K9473
3	099829-02-02A	EA	DECAL-ANGLE DIAMOND, LARGE - DRIVER SIDE - BOTH SECTIONS ABOVE REAR WHEELWELL - ROYAL BLUE
	099829-01-02A	EA	DECAL-ANGLE DIAMOND, LARGE - PASS. SIDE - BOTH SECTIONS ABOVE REAR WHEELWELL - ROYAL BLUE
14	093881-27-01A	FT	STRIPE-1 LINE, .75" WIDE - LOWER STRIPE ON REAR CAP & UPPER ON SIDEWALL BETWEEN CAB DOOR AND REAR WHEELWELLS - PLUM
4	093880-19-02A	FT	MULTISTRIPE-2 LINES, 7.5" WIDE - LOWER ON REAR CAP & CENTER ON SIDEWALL BETWEEN CAB DOORS & REAR WHEELWELL - LIGHT BLUE DUPONT #K9473
6	058719-05-000	EA	DECAL-LOGO, "CHIEFTAIN" - ON SIDEWALLS - ROYAL BLUE, BEIGE DUPONT# L8729
6	099824-01-02A	EA	DECAL-ANGLE DIAMOND, SMALL - DRIVER SIDE - REAR SECTION BELOW CAB DOOR WINDOW - ROYAL BLUE
7	099826-01-02A	EA	DECAL-DOUBLE DIAMOND, SMALL - PASS. SIDE - BOTH SECTIONS BELOW CAB WINDOWS - ROYAL BLUE
	099827-01-02A	EA	DECAL-ANGLE DIAMOND, SMALL - DRIVER SIDE - FRONT SECTION BELOW CAB WINDOW - ROYAL BLUE
8	099828-01-02A	EA	DECAL-CORNER, PASSENGER SIDE - FRONT - LIGHT BLUE DUPONT# K9473, ROYAL BLUE
9	093881-11-04A	FT	STRIPE-1 LINE, 1.7" WIDE - ACROSS HOOD PANEL - LIGHT BLUE DUPONT# K9473
10	099828-02-02A	EA	DECAL-CORNER, FRONT - DRIVER SIDE - LIGHT BLUE DUPONT# K9473, ROYAL BLUE
11	099825-01-02A	EA	DECAL-LOGO, "WINNEBAGO" - HOOD - ROYAL BLUE
12	093881-11-05A	FT	STRIPE-1 LINE, 1.7" WIDE - ACROSS HOOD PANEL - ROYAL BLUE
13	093881-12-02A	FT	STRIPE-1 LINE, 2.25" WIDE - UPPER STRIPE ON REAR CAP & LOWER ON SIDEWALL BETWEEN CAB DOORS & REAR WHEELWELL - ROYAL BLUE
15	050313-45-030	EA	DECAL-LOGO, WINNEBAGO - 2.8" HIGH - ON REAR CAP

EXTERIOR BODY GROUP (CONTINUED)

EXTERIOR MIRRORS

KEY PART NUMBER	U/M	DESCRIPTION
086260-01-000	EA	MIRROR-W/CONVEX, PASSENGER
086260-02-000	EA	MIRROR-W/CONVEX, DRIVER
086260-03-000	EA	ACCESSORY KIT-MIRROR, EXTENSION
083558-01-000	EA	VENT-PLUMBING PIPE ROOF, W/COVER - BEIGE
083615-01-000	EA	HOLDER-DOOR, PLASTIC - BEIGE
089728-02-000	EA	BUMPER-.88"DIA X .40", BLACK
075736-03-000	EA	COVER-EXTERIOR RECEPTACLE, BEIGE

EXTERIOR MIRRORS, REMOTE - HEAT

KEY PART NUMBER	U/M	DESCRIPTION
086259-04-000	EA	MIRROR-REMOTE HEAT, WARM & MIRRORS - PRE-WIRED - PASSENGER
086259-04-700	EA	GLASS ONLY CONVEX HEATED RH
086259-04-701	EA	GLASS ONLY FLAT HEATED RH
086259-05-000	EA	MIRROR-REMOTE HEAT, WARM & MIRRORS - PRE-WIRED - DRIVER
086259-05-700	EA	GLASS ONLY CONVEX HEATED LH
086259-05-701	EA	GLASS ONLY FLAT HEATED LH
082880-01-000	EA	WIRE-INSTRUMENT PANEL, REMOTE MIRROR

ASSIST HANDLE

KEY PART NUMBER	U/M	DESCRIPTION
009126-02-000	EA	HANDLE-ASSIST, ENTRY DOOR
083886-11-000	EA	HANDLE-ASSIST, DRIVER DOOR, ... AL - BEIGE

WINDSHIELD COMPONENTS

KEY PART NUMBER	U/M	DESCRIPTION
091215-01-000	EA	GLASS-WINDSHIELD, PASSENGER
091215-02-000	EA	GLASS-WINDSHIELD, DRIVER
098788-01-000	EA	CHANNEL-RIGID, WINDSHIELD - .35" - PVC
091988-01-000	EA	MOLDING-REVEAL, WINDSHIELD - SURROUNDS BOTH WINDSHIELDS
091901-01-000	EA	TRIM-A-PILLAR, PASS BETWEEN WINDSHIELD & VENT GLASS - BLACK
091901-02-000	EA	TRIM-A-PILLAR, DR - BETWEEN WINDSHIELD & VENT GLASS - BLACK
002328-02-000	EA	BLOCK-WINDSHIELD, .082" X .5" X .98"
091989-01-000	EA	FRAME-WINDSHIELD, LOWER - INNER - PASSENGER
091989-02-000	EA	FRAME-WINDSHIELD, LOWER - INNER - DRIVER
091953-03-000	EA	GLASS-CORNER VENT, PASSENGER
091953-04-000	EA	GLASS-CORNER VENT, DRIVER
040821-04-000	EA	NUT-SPEED, U TYPE - NO. 8 - .59" LENGTH X .44" WIDTH
040821-05-000	EA	NUT-SPEED, U TYPE - NO. 8 - .67" LENGTH X .44" WIDTH
040821-06-000	EA	NUT-SPEED, U TYPE - NO. 8 - .57" LENGTH X .63" WIDTH

EXTERIOR BODY GROUP (CONTINUED)

SKINS AND PANELS AND STYROFOAM

KEY PART NUMBER	U/M	DESCRIPTION
M03044-02-Y15	EA	PANEL-REPAIR, FIBERGLASS TO STYROFOAM - 4' X 8' - BEIGE
084882-10-000	EA	PANEL-FIBERGLASS TO PARTICLE BOARD, 83.3" X 23.5" - BEIGE FOR SMALL PATCHES YOU MAY WANT TO ORDER M03044-02-Y15 - A 4' X 8' (PANEL GLUE PRESSED TO STYROFOAM) REPAIR SHEET.
077517-51-000	EA	FIBERGLASS-SHEET, 29.7" X 27.9" - BEIGE - FLAT
078054-D5-001	EA	SHEET-FIBERGLASS, 4' X 8' - BEIGE - FILON
001018-01-024	EA	SKIN-ALUMINUM, 4' X 8' - FLAT - BEIGE
044487-01-001	EA	ALUMINUM SHEET - .019" X 96" X 360" - MILL FINISH
001054-01-011	EA	ALUMINUM-SHEET, 4' X 8' - FLAT - OFF WHITE
000868-01-000	SF	STYROFOAM-.75" X 24" X 96" - INCREMENTS OF 16 SF
000870-05-000	SF	STYROFOAM-.5" X 24" X 96" - INCREMENTS OF 16 SF
083574-01-000	SF	STYROFOAM, DOW TYPE SM - 1.5" X 24" X 85.25" - INC OF 14 S
000870-03-000	SF	STYROFOAM-1.34" X 48" X 96" - INCREMENTS OF 32 SF

208" FORD CHASSIS OPTION L51C

KEY PART NUMBER	U/M	DESCRIPTION
074559-01-000	EA	DECAL-LOGO, LPG, ... (CALIF CODE)

1991 WINNEBAGO

TABLE OF CONTENTS

INTRODUCTION	A-01 - A-02
ABBREVIATIONS	A-03
ALPHABETICAL INDEX	A-04 - A-06
WCN28RT	A-07 - G-10
WCN32RQ	G-11 - L-20

1991 WCN28RT INDEX

FLOOR PLAN	A-07 - A-08
ACCESSORIES	A-09 - A-24
BATH	B-01 - B-04
BEDROOM	B-05 - B-08
CHASSIS	B-09 - C-06
C C & PAD	C-07 - C-18
DINETTE	C-19 - C-20
DRIVERS	C-21 - C-24
ELECTRICAL	D-01 - D-08
EXTERIOR BODY	D-09 - D-18
GALLEY	D-19 - E-02
HEATING & A/C	E-03 - E-08
INTERIOR FINISH	E-09 - E-13
LABEL	E-14 - E-22
LP	E-23
LOUNGE	E-24 - F-01
SEALANTS & FASTENERS	F-02 - F-04
WATER & SEWAGE	F-05 - F-11
WINDOW, VENT AND EXTERIOR DOOR	F-12 - G-10

GALLEY GROUP

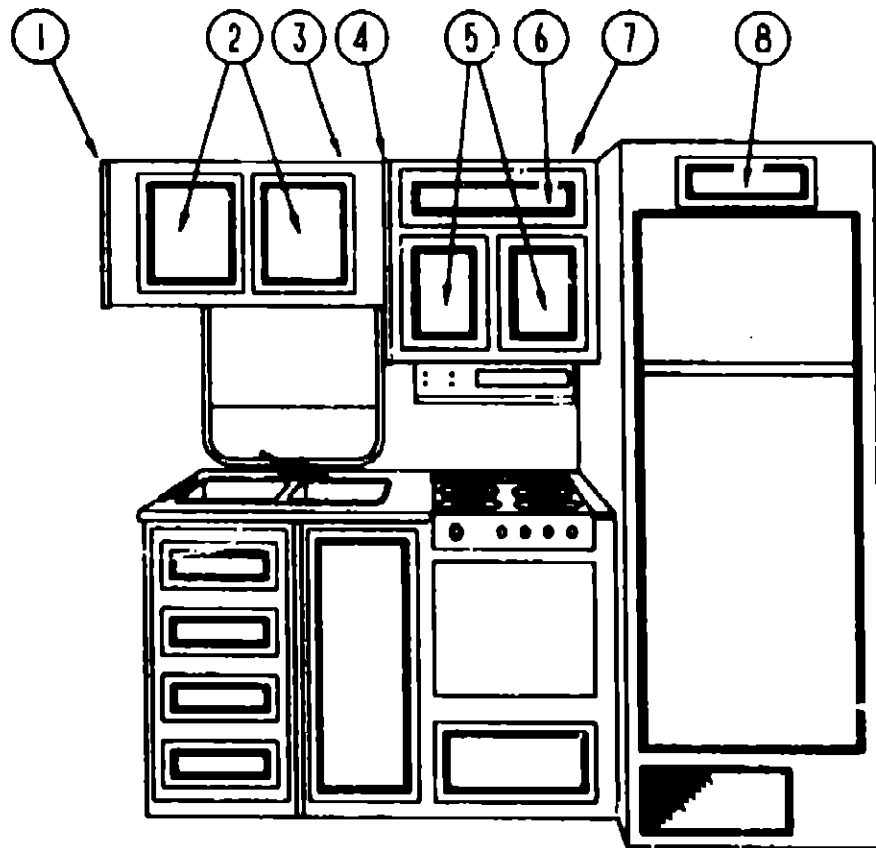

GALLEY CABINETS & COMPONENTS CONT.

GALLEY GROUP (CONTINUED)

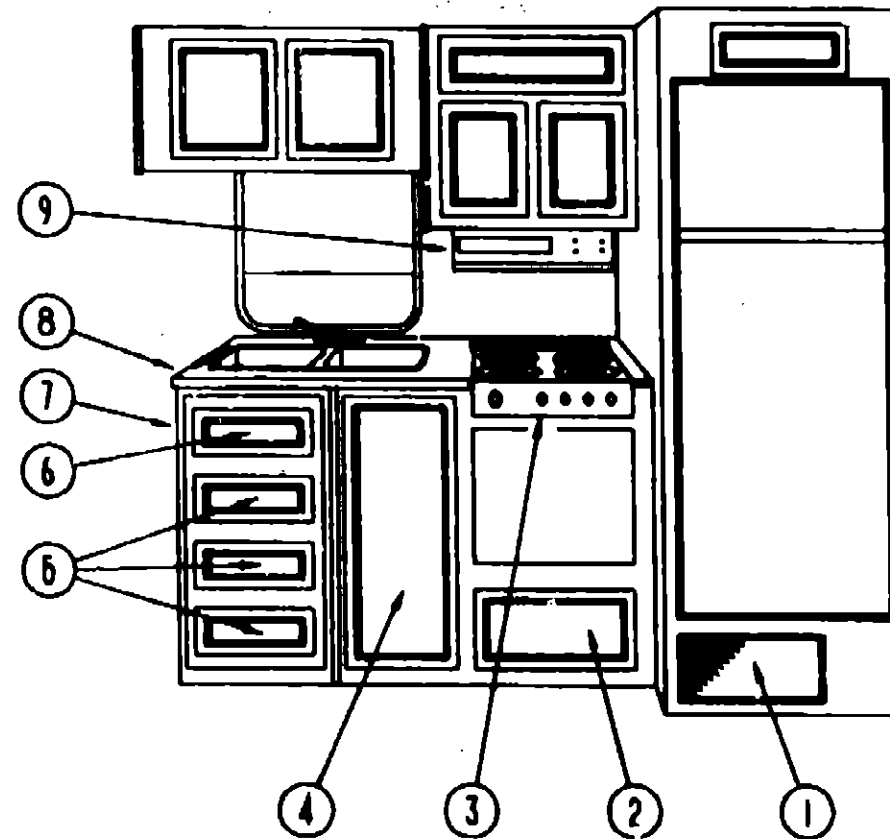

GALLEY CABINETS & COMPONENTS CONT.

**1991 WINNEBAGO
TABLE OF CONTENTS**

INTRODUCTION	A-01 - A-02
ABBREVIATIONS	A-03
ALPHABETICAL INDEX	A-04 - A-06
WCN28FT	A-07 - G-10
WCN32FO	G-11 - L-20

1991 WCN28FT INDEX

FLOOR PLAN	A-07 - A-08
ACCESSORIES	A-09 - A-24
BATH	B-01 - B-04
BEDROOM	B-05 - B-06
CHASSIS	B-09 - C-06
C C & PAD	C-07 - C-16
DINETTE	C-19 - C-20
DRIVERS	C-21 - C-24
ELECTRICAL	D-01 - D-06
EXTERIOR BODY	D-09 - D-16
GALLEY	D-19 - E-02
HEATING & AC	E-03 - E-06
INTERIOR FINISH	E-09 - E-13
LABEL	E-14 - E-22
LP	E-23
LOUNGE	E-24 - F-01
SEALANTS & FASTENERS	F-02 - F-04
WATER & SEWAGE	F-05 - F-11
WINDOW, VENT AND EXTERIOR DOOR	F-12 - G-10

KEY PART NUMBER	U/M DESCRIPTION
1 092747-01-B07	EA END CAP-CABINET, OVERHEAD - FRONT FROM: 00-00-00 THRU: 07-18-90
1 099092-01-B07	EA END CAP-CABINET, OVERHEAD - FRONT FROM: 07-19-90 THRU: 99-99-99
2 P00520-05-B07	EA DOOR-CABINET, W/O HARDWARE - 14.4" X 16"
3 M04152-01-B07	EA CABINET-OVERHEAD, W/O DOORS OR HARDWARE FROM: 00-00-00 THRU: 07-18-90
3 099923-01-B07	EA CABINET-OVERHEAD, SINK - W/O DOORS OR HARDWARE FROM: 07-19-90 THRU: 99-99-99
4 092090-04-B07	EA END CAP-CABINET, OVERHEAD - FRONT
5 P00520-02-B07	EA DOOR-CABINET, W/O HARDWARE - 10.8" X 14.4"
6 P00520-03-B07	EA DOOR-CABINET, W/O HARDWARE - 8.4" X 18"
7 M04092-11-B07	EA CABINET-OVERHEAD, RANGE - W/O DOORS OR HARDWARE
7 M04092-12-B07	EA CABINET-OVERHEAD, MICROWAVE - W/O DOORS OR HARDWARE
8 P00520-03-B07	EA DOOR-CABINET, W/O HARDWARE - 8.4" X 18"

KEY PART NUMBER	U/M DESCRIPTION
1 M02516-56-Y12	EA DOOR-FURNACE, W/MESH INSERT
2 065282-04-000	EA RANGE-4 BURNER, W/OVEN - MAGIC CHEF BT18NA - ALMOND
M82184-28-B07	EA DRAWER-CABINET, W/O HARDWARE - 17.7" X 19.7"
3 P00520-13-B07	EA DOOR-CABINET, W/O HARDWARE - 9.8" X 21.8"
4 P00520-28-B07	EA DOOR-CABINET, W/O HARDWARE - 14.4" X 28.8"
4 P00520-13-B07	EA DOOR-CABINET, W/O HARDWARE-OGEE - 9.8" X 21.8"
5 P00521-01-B07	EA DRAWER ASM-CABINET-OGEE - 13" X 15.2" FROM 00-00-00 THRU 91-01-08
5 P03397-09-B10	EA DRAWER ASM-CABINET,OGEE FROM 91-01-07 THRU 99-99-99
6 P00521-02-B07	EA DRAWER ASM-CABINET-OGEE - 13" X 8.7" FROM 00-00-00 THRU 91-01-08
6 P03397-11-B10	EA DRAWER ASM-CABINET,OGEE FROM 91-01-07 THRU 99-99-99
7 M04103-01-B07	EA CABINET-GALLEY, W/O DOORS OR HARDWARE
7 M04103-03-B07	EA CABINET-GALLEY, W/O DOORS OR HARDWARE - USED W/MICROWAVE
8 099204-12-B07	EA COUNTERTOP-GALLEY
080812-04-B10	EA EXTENSION-COUNTERTOP, GALLEY - W/O HARDWARE
9 100258-04-01A	EA HOOD-RANGE, W/MONITOR PANEL - VENTLINE TCS 4003SAD
M82184-28-B07	EA DRAWER-CABINET, USED W/MICROWAVE - W/O HARDWARE - 17.7" X 19.7"
100081-01-01A	EA TRAY-SILVERWARE, ALMOND - RUBBERMAID
068334-01-000	EA WASTEBASKET-9 3/4" X 7" X 10", WHITE - RUBBERMAID
093805-01-01A	EA RACK-TOWEL, WIRE - ALMOND
065516-03-000	EA BRACKET-REAR TIEDOWN, RANGE W/OVEN
084952-01-000	EA FAUCET-GALLEY
093528-01-000	EA SINK-DOUBLE, STAINLESS STEEL - 19" X 25"
092303-01-000	EA STRAINER-SINK
091208-01-000	EA WASHER-RUBBER, .06" X .75" X .5"
091255-02-000	FT SEAL-ADHESIVE BACKED FOAM, 1.5" X .18"
093653-01-B07	EA COVER-SINK, B07 - CAMEO BLUE
093153-01-000	EA BOARD-CUTTING, MAPLE - 10.8" X 14.5"
093238-01-Y12	EA HOLDER-KNIFE, COUNTERTOP - OAK
093282-01-000	EA BONNET-KNIFE HOLDER, UNDER COUNTER - METAL
098335-02-B03	EA RAIL-GALLEY, .75" X 22.34"

GALLEY GROUP (CONTINUED)

RANGE

KEY PART NUMBER	U/M	DESCRIPTION
085280-03-000	EA	COVER-BIFOLD, RANGE - ALMOND - MAGIC CHEF# KL22A-1 FROM: 00-00-00 THRU: 09-02-90
102021-02-01A	EA	COVER-RANGE, BIFOLD - 22" - ALMOND - MAGIC CHEF KR22A-1 FROM: 09-03-90 THRU: 99-99-99
102020-01-01A	EA	RANGE-4 BURNER ALMOND - 22" - MAGIC CHEF BT22RA-4T-490 FROM: 00-00-00 THRU: 03-10-91
102020-01-701	EA	HANDLE, DOOR
102020-01-702	EA	PANEL, MANIFOLD
102020-01-703	EA	PANEL, DOOR (ALMOND)
102020-01-700	EA	SHELF, OVEN
102020-01-705	EA	TRIM (LEFT)
102020-01-706	EA	TRIM (RIGHT)
102020-01-708	EA	BURNER ASSEMBLY (OVEN)
102020-01-709	EA	BUMPER, GRATE
102020-01-710	EA	FILTER, PILOT
102020-01-711	EA	GRATE, TOP
102020-01-712	EA	KNOB, BURNER VALVE
102020-01-713	EA	KNOB, THERMOSTAT
102020-01-714	EA	PILOT, OVEN
102020-01-715	EA	PIPE, MANIFOLD
102020-01-718	EA	REGULATOR, PRESSURE
102020-01-717	EA	THERMOSTAT
102020-01-718	EA	TOP, MAIN (ALMOND)
102020-01-719	EA	TOP, MAIN (BLACK)
102020-01-720	EA	VALVE, MERCURY CONTROL
102020-01-721	EA	VALVE, SHUT-OFF
102020-01-722	EA	VALVE, TOP BURNER
102020-01-723	EA	PILOT, BURNER
102020-01-724	EA	BUMPER, MAIN TOP
102020-01-03A	EA	RANGE-22" 4 BURNER ALMOND FROM: 03-11-91 THRU: 99-99-99
102020-01-701	EA	HANDLE-DOOR, MAGIC CHEF - 7701P092-80
102020-01-702	EA	PANEL-MANIFOLD, MAGIC CHEF 2618F080-70
102020-01-700	EA	SHELF-OVEN, MAGIC CHEF - 7801-P027-80
102020-3A-700	EA	PANEL-DOOR, W/WINDOW - EBONY - MAGIC CHEF - 2401-F083-70
102020-3A-701	EA	GLASS-OUTER, MAGIC CHEF - 7902-P288-80
102020-01-706	EA	TRIM-LEFT, MAGIC CHEF 3808F018-70
102020-01-708	EA	TRIM-RIGHT, MAGIC CHEF 3808F017-70
102020-01-708	EA	BURNER ASSEMBLY-OVEN, MAGIC CHEF 3403W003-45
102020-01-709	EA	BUMPER-GRATE, MAGIC CHEF 8007P018-80
102020-01-710	EA	FILTER-PILOT, MAGIC CHEF 7507P048-80
102020-01-711	EA	GRATE-TOP, MAGIC CHEF 7518P012-80
102020-01-712	EA	KNOB-BURNER VALVE, MAGIC CHEF 7733P044-80
102020-01-713	EA	KNOB-THERMOSTAT, MAGIC CHEF 7731P042-80
102020-01-714	EA	PILOT-OVEN, MAGIC CHEF 988-143
102020-01-715	EA	PIPE-MANIFOLD, MAGIC CHEF 7513P006-80
102020-01-716	EA	REGULATOR-PRESSURE, MAGIC CHEF 7510P033-80
102020-01-717	EA	THERMOSTAT, MAGIC CHEF 7515P024-80
102020-01-718	EA	TOP-MAIN, ALMOND - MAGIC CHEF 2001F085-84
102020-01-720	EA	VALVE-MERCURY CONTROL, MAGIC CHEF 7501P058-80
102020-01-721	EA	VALVE-SHUT OFF, MAGIC CHEF 7508F008-80
102020-01-722	EA	VALVE-TOP BURNER, MAGIC CHEF 7502P005-80
102020-01-723	EA	PILOT-BURNER, MAGIC CHEF 7505P147-80
102020-01-724	EA	BUMPER-MAIN TOP, MAGIC CHEF 8003P008-80

GALLEY GROUP (CONTINUED)

RANGE TOP

KEY PART NUMBER	U/M	DESCRIPTION
081374-03-000	EA	RANGE-4 BURNER, W/O OVEN - ALMOND - MAGIC CHEF BT85NA-4 FROM: 00-00-00 THRU: 07-29-90
094782-02-715	EA	CLIP-GRATE, MAGIC CHEF 413-00015
081374-03-704	EA	REGULATOR-PRESSURE, MAGIC CHEF 7510P032-80
049045-01-703	EA	VALVE-TOP BURNER, MAGIC CHEF 997-584
081374-03-700	EA	TRIM-CAB, REAR - ALMOND - MAGIC CHEF 3808F018-74 LEFT, DRIVER SIDE REAR - PASSENGER SIDE FRONT
081374-03-704	EA	REGULATOR-PRESSURE, MAGIC CHEF 7510P032-80
081374-03-705	EA	TRIM-BACK, ALMOND - MAGIC CHEF 3808F009-74
084782-02-712	EA	GRATE-TOP BURNER, SQUARE HOLES - MAGIC CHEF 50-25439
081374-03-701	EA	TRIM-CAB, FRONT - ALMOND - MAGIC CHEF 3808F015-74
084782-02-711	EA	TOP-MAIN-ALMOND-4BURNER SQ - MAGIC CHEF 50-27764A
081374-01-000	EA	RANGE-4 BURNER, W/O OVEN - ALMOND - MAGIC CHEF BT85NA-4 FROM: 07-30-90 THRU: 08-05-90
081374-01-700	EA	TRIM-CAB TOP RIGHT, BLACK - MAGIC CHEF 3808F015-70
081374-01-701	EA	TRIM-CAB TOP LEFT, BLACK - MAGIC CHEF 3808F018-70
081374-01-702	EA	PANEL-MANIFOLD WARM, BLACK - MAGIC CHEF 52-20712-5X
081374-01-703	EA	TRIM-TOP REAR, MAGIC CHEF 52-10354-3
055282-03-708	EA	BUMPER-MAIN TOP, PLASTIC PLUG - MAGIC CHEF 744-176
084782-02-715	EA	CLIP-GRATE, MAGIC CHEF 413-00015
081374-02-701	EA	REGULATOR-PRESSURE, MAGIC CHEF 978-27
049045-01-703	EA	VALVE-TOP BURNER, MAGIC CHEF 997-584
081374-03-703	EA	TRIM-CAB, TOP - REAR - MAGIC CHEF 52-10093
084782-02-712	EA	GRATE-TOP BURNER, SQUARE HOLES - MAGIC CHEF 50-25439
084782-02-711	EA	TOP-MAIN-ALMOND-4BURNER SQ - MAGIC CHEF 50-27764A
081374-03-000	EA	RANGE-4 BURNER, W/O OVEN - ALMOND - MAGIC CHEF BT85NA-4 FROM: 08-01-90 THRU: 09-02-90
084782-02-715	EA	CLIP-GRATE, MAGIC CHEF 413-00015
081374-03-704	EA	REGULATOR-PRESSURE, MAGIC CHEF 7510P032-80
049045-01-703	EA	VALVE-TOP BURNER, MAGIC CHEF 997-584
081374-03-700	EA	TRIM-CAB, REAR - ALMOND - MAGIC CHEF 3808F018-74 LEFT, DRIVER SIDE REAR - PASSENGER SIDE FRONT
081374-03-704	EA	REGULATOR-PRESSURE, MAGIC CHEF 7510P032-80
081374-03-705	EA	TRIM-BACK, ALMOND - MAGIC CHEF 3808F009-74
084782-02-712	EA	GRATE-TOP BURNER, SQUARE HOLES - MAGIC CHEF 50-25439
081374-03-701	EA	TRIM-CAB, FRONT - ALMOND - MAGIC CHEF 3808F015-74
084782-02-711	EA	TOP-MAIN-ALMOND-4BURNER SQ - MAGIC CHEF 50-27764A
102019-01-01A	EA	RANGE TOP-4 BURNER, ALMOND - MAGIC CHEF BT85RA-4 FROM: 09-03-90 THRU: 99-99-99
102020-01-709	EA	BUMPER-GRATE, MAGIC CHEF 8007P018-80
102020-01-711	EA	GRATE-TOP, MAGIC CHEF 7518P012-80
062583-04-701	EA	KNOB-TOP BURNER, MAGIC CHEF 7733P039-80
102020-01-718	EA	TOP-MAIN, ALMOND - MAGIC CHEF 2001F085-84
102019-01-700	EA	TRIM-RIGHT, ALMOND - MAGIC CHEF 3808F015-74
102019-01-701	EA	TRIM-LEFT, ALMOND - MAGIC CHEF 3808F018-74
102019-01-702	EA	TRIM-REAR, ALMOND - MAGIC CHEF 3808F009-74
102020-01-724	EA	BUMPER-MAIN TOP, MAGIC CHEF 8003P008-80
102022-01-702	EA	PIPE-MANIFOLD, MAGIC CHEF 7513P006-80
102022-01-703	EA	REGULATOR-PRESSURE, MAGIC CHEF 7510P031-80
102020-01-721	EA	VALVE-SHUT OFF, MAGIC CHEF 7508F008-80
102020-01-722	EA	VALVE-TOP BURNER, MAGIC CHEF 7502P005-80
0813744-03-000	EA	BRACKET-TIEDOWN, STOVE - FRONT
0813744-04-000	EA	BRACKET-TIEDOWN, STOVE - REAR

**1991 WINNEBAGO
TABLE OF CONTENTS**

INTRODUCTION	A-01 - A-02
ABBREVIATIONS	A-03
ALPHABETICAL INDEX	A-04 - A-08
WCN28RT	A-07 - G-10
WCN32RQ	G-11 - L-20

1991 WCN28RT INDEX

FLOOR PLAN	A-07 - A-08
ACCESSORIES	A-09 - A-24
BATH	B-01 - B-04
BEDROOM	B-05 - B-08
CHASSIS	B-09 - C-08
C C & PAD	C-07 - C-18
DINETTE	C-19 - C-20
DRIVERS	C-21 - C-24
ELECTRICAL	D-01 - D-08
EXTERIOR BODY	D-09 - D-18
GALLEY	D-19 - E-02
HEATING & A/C	E-03 - E-08
INTERIOR FINISH	E-09 - E-13
LABEL	E-14 - E-22
LP	E-23
LOUNGE	E-24 - F-01
SEALANTS & FASTENERS	F-02 - F-04
WATER & SEWAGE	F-05 - F-11
WINDOW, VENT AND EXTERIOR DOOR	F-12 - G-10

GALLEY GROUP (CONTINUED)

CANADIAN

KEY PART NUMBER	U/M	DESCRIPTION
100258-05-01A	EA	HOOD-RANGE, W/MONITOR PANEL - VENTLINE TCS 4003SAC
100258-04-701	EA	BEZEL-SWITCH LEVER, CABLE TO VENT - VENTLINE CC116
092696-01-701	EA	KNOB-LEVER, CABLE - PLASTIC - BLACK - VENTLINE CC225
092696-01-702	EA	RESISTER-WIRE, VENTLINE L7314
092696-01-709	EA	BULB-912, VENTLINE VA415
092696-01-710	EA	SOCKET-LIGHT, VENTLINE CB267-2
096983-01-708	EA	LENS-LAMP, VENTLINE CC179
100258-04-702	EA	SWITCH-LEVER, W/CABLE - VENTLINE CB547-1
090973-01-702	EA	BLADE-FAN, LVS VA183-1
096983-01-707	EA	FILTER-GREASE, 8" X 8" - LVS CC246
100258-04-700	EA	CIRCUIT BOARD, VENTLINE 5037
075470-01-702	EA	SWITCH-ON/OFF, LVS CB484
100258-08-701	EA	SWITCH-FAN, 2 SPEED - VENTLINE 122
096983-01-703	EA	SWITCH-ON/ON - JENSEN 115
096983-01-702	EA	SWITCH-TWO WAY MOMENTARY, VENTLINE 112
100258-10-01A	EA	METER-HOUR, VENTLINE 150
090973-01-700	EA	MOTOR - LVS CA508-1

GALLEY GROUP (CONTINUED)

WATER PURIFICATION OPTION L29B

KEY PART NUMBER	U/M	DESCRIPTION
039800-01-000	FT	TUBING-POLYBUTYL, 1/2" OD - INCREMENTS OF 20' - BLACK FROM: 00-00-00 THRU: 11-25-90
039800-02-000	FT	TUBING-POLYBUTYL, 5/8" OD - INCREMENTS OF 20' - BLACK FROM: 11-26-90 THRU: 99-99-99
052952-01-000	EA	NUT-PLASTIC, 1/2" F X 1/2" TUBE - PLASTIC - GRAY FROM: 00-00-00 THRU: 11-25-90
052952-02-000	EA	NUT-PLASTIC, 5/8" FLARE FROM: 11-26-90 THRU: 99-99-99
052957-01-000	EA	ELBOW-PLASTIC, 1/2F X 3/8MPT FROM: 00-00-00 THRU: 11-25-90
052959-02-000	EA	CONNECTOR, 1/2" F X 1/2" MPT - PLASTIC - GRAY FROM: 11-26-90 THRU: 99-99-99
055290-01-000	EA	ELBOW-5/8F X 1/2MPT FROM: 11-26-90 THRU: 99-99-99
065120-01-000	EA	ELBOW-SWIVEL, 1/2" FPT X 1/2" FLARE - PLASTIC - GRAY
08, 200-01-000	EA	FILTER-WATER PURIFICATION, EVERPURE QC2-AC
087200-02-000	EA	CARTRIDGE-WATER FILTER, EVERPURE 9601-11

CUTLERY TRAY & WASTE BASKET

KEY PART NUMBER	U/M	DESCRIPTION
100081-01-01A	EA	TRAY-SILVERWARE, ALMOND - RUBBERMAID
058334-01-000	EA	WASTEBASKET-9 3/4" X 7" X 10", WHITE - RUBBERMAID
093605-01-01A	EA	RACK-TOWEL, WIRE - ALMOND

1991 WINNEBAGO

TABLE OF CONTENTS

INTRODUCTION	A-01 - A-02
ABBREVIATIONS	A-03
ALPHABETICAL INDEX	A-04 - A-06
WCN28RT	A-07 - G-10
WCN32RO	G-11 - L-20

1991 WCN28RT INDEX

FLOOR PLAN	A-07 - A-08
ACCESSORIES	A-09 - A-24
BATH	B-01 - B-04
BEDROOM	B-05 - B-08
CHASSIS	B-09 - C-08
C C & PAD	C-07 - C-16
DINETTE	C-19 - C-20
DRIVERS	C-21 - C-24
ELECTRICAL	D-01 - D-08
EXTERIOR BODY	D-09 - D-18
GALLEY	D-19 - E-02
HEATING & AC	E-03 - E-08
INTERIOR FINISH	E-09 - E-13
LABEL	E-14 - E-22
LP	E-23
LOUNGE	E-24 - F-01
SEALANTS & FASTENERS	F-02 - F-04
WATER & SEWAGE	F-05 - F-11
WINDOW, VENT AND EXTERIOR DOOR	F-12 - G-10

GALLEY GROUP (CONTINUED)

MICROWAVE OVEN OPTION

KEY PART NUMBER	U/M	DESCRIPTION
091299-05-000	EA	OVEN-MICROWAVE, MAGIC CHEF M15E-9PB
094745-01-01A	EA	TRIM-MICROWAVE, LOWER - BLACK
094774-01-01A	EA	TRIM-MICROWAVE, EITHER SIDE - BLACK
		FROM: 00-00-00 THRU: 05-27-90
094774-03-01A	EA	TRIM-MICROWAVE, EITHER SIDE - BLACK
		FROM: 05-28-90 THRU: 99-99-99
094750-01-000	EA	BRACKET-MICROWAVE, 90 DEGREE
099916-01-01A	EA	BRACE-MICROWAVE CABINET, REAR
099916-02-01A	EA	BRACE-MICROWAVE CABINET, FRONT
093744-03-000	EA	BRACKET-TIEDOWN, STOVE - FRONT
093744-04-000	EA	BRACKET-TIEDOWN, STOVE - REAR

BROWNING MICROWAVE OPTION L134 - US & CANADIAN

SAME AS MICROWAVE OPTION EXCEPT FOR THE FOLLOWING ITEMS

KEY PART NUMBER	U/M	DESCRIPTION
091299-03-000	EA	OVEN-MICROWAVE, W/ BROWNING OVEN - M'CHEF M16-10PB
091299-03-701	EA	PLATE-CERAMIC, 9.5" - ROUND - MAGIC CHEF 248-0005
091299-03-702	EA	CLIP-OVEN SHELF, WHITE - MAGIC CHEF 201-0044
091299-03-703	EA	CLIP-OVEN SHELF, BLACK - MAGIC CHEF 201-0031

MICROWAVE W/RANGE TOP OPTION L135 - US & CANADIAN

KEY PART NUMBER	U/M	DESCRIPTION
M04091-02-807	EA	CABINET-GALLEY, W/O DOORS OR HARDWARE
M04091-02-807	EA	CABINET-GALLEY, W/O DOORS OR HARDWARE
098926-11-807	EA	COUNTERTOP-GALLEY
094952-01-000	EA	FAUCET-GALLEY
094952-01-000	EA	FAUCET-GALLEY
091299-01-000	EA	WASHER-RUBBER, .08" X .75" X .5"
091255-02-000	FT	SEAL-ADHESIVE BACKED FOAM, 1.5" X .18"
092303-01-000	EA	STRAINER-SINK
093526-01-000	EA	SINK-DOUBLE, STAINLESS STEEL - 19" X 25"

RANGE HOOD

KEY PART NUMBER	U/M	DESCRIPTION
100258-04-01A	EA	HOOD-RANGE, W/MONITOR PANEL - VENTLINE TCS 4003SAD
100258-04-700	EA	CIRCUIT BOARD - VENTLINE 5037
100258-04-701	EA	BEZEL-SWITCH LEVER, CABLE TO VENT - VENTLINE CC116
100258-04-702	EA	SWITCH-LEVER, W/CABLE - VENTLINE CB547-1
092996-01-701	EA	KNOB-LEVER, CABLE - PLASTIC - BLACK - VENTLINE CC225
092996-01-702	EA	RESISTER-WIRE, VENTLINE L7314
092996-01-709	EA	BULB-912, LVS VA415
092996-01-710	EA	SOCKET-LIGHT, LVS CB267-2
098983-01-708	EA	LENS-LAMP, VENTLINE CC179
100258-04-702	EA	SWITCH-LEVER, W/CABLE - VENTLINE CB547-1
090973-01-702	EA	BLADE-FAN, LVS VA183-1
098983-01-707	EA	FILTER-GREASE, 8" X 8" - LVS CC248
100258-04-700	EA	CIRCUIT BOARD, VENTLINE 5037
078799-01-715	EA	SWITCH-S.P. D.T., VENTLINE 110
100258-08-701	EA	SWITCH-FAN 2-SPEED, VENTLINE CC116
098983-01-703	EA	SWITCH-ON/OFF - JENSEN 115
098983-01-702	EA	SWITCH-TWO WAY MOMENTARY, VENTLINE 112
100258-10-01A	EA	METER-HOUR, VENTLINE 150
C75470-01-703	EA	SWITCH-ON/MOMENTARY, JENSEN RP1016
090973-01-700	EA	MOTOR - LVS CA508-1

GALLEY GROUP (CONTINUED)

REFRIGERATOR & COMPONENTS

KEY PART NUMBER	U/M	DESCRIPTION
094039-04-000	EA	REFRIGERATOR-2-WAY, LARGE DOUBLE DOOR - NORCOLD #882
084880-03-701	EA	COOLING UNIT (HORIZONTAL BURNER) - NORCOLD 81887337
084880-03-700	EA	FLUE(HORIZONTAL) BURNER - NORCOLD 818161
084880-01-735	EA	HINGE BRACKET, TOP LH-BTM RH BROWN - NORCOLD 815809
084880-01-722	EA	CRISPER COVER - NORCOLD 815641
088248-01-709	EA	HEATER-AC, (HORIZONTAL) - NORCOLD# 815627
075217-01-737	EA	CONTROL MODULE, NORCOLD# 81525022
094039-04-701	EA	EYEBROW (SHELL) 2 WAY-NORCOLD 81869822
094039-04-700	EA	PC BOARD (2 WAY) - NORCOLD 81647322
094039-04-702	EA	POWER SUPPLY (2 WAY) - NORCOLD 81647422
094039-01-731	EA	CRISPER (GRAY) SILVER TRIM - NORCOLD 81571360
094039-01-721	EA	CAB ASM.(BLACK FRAME WHITE LINER - NORCOLD 81863238
084880-01-715	EA	VALVE-SHUT OFF, MANUAL - NORCOLD# 81867922
084880-01-713	EA	CONNECTOR-MALE, INLET FITTING - NORCOLD# 815256
084473-01-702	EA	ORIFICE BEG-2, NORCOLD 814521
088248-01-708	EA	BURNER-(HORIZONTAL), NORCOLD# 15881
088248-01-708	EA	ELECTRODE-IGNITION, (HORIZONTAL) - NORCOLD# 815732
084880-01-733	EA	DAIRY KEEPER - NORCOLD 815804
094039-01-723	EA	HINGE BRACKET, TOP RH-BOTTOM LH BLACK - NORCOLD 81580830
094039-01-707	EA	UPPER DOOR HANDLE ASM.(BROWN) - NORCOLD 81850037
094039-01-705	EA	UPPER DOOR LINER (WHITE) BROWN - NORCOLD 81581837-B
094039-01-725	EA	HINGE PIN (BLACK)(MALE) - NORCOLD 81578130
094039-01-730	EA	HINGE PIN SHAFT(BLACK) CENTER HINGE - NORCOLD 81588730
094039-01-728	EA	HINGE BRACKET(BLACK) CENTER HINGE - NORCOLD 81588530
084880-01-749	EA	HINGE BUSHING - NORCOLD 815807
084880-01-746	EA	CABLE, NORCOLD 815715
094039-01-702	EA	GASKET (GRAY) UPPER - NORCOLD 81587830
094039-01-713	EA	DOOR GASKET(LOWER) GRAY - NORCOLD 81588030
094039-01-708	EA	UPPER DOOR LINER (WHITE) BLACK - NORCOLD 81581838-B
094039-01-715	EA	LOWER DOOR LINER (BLACK/WHITE) - NORCOLD 81581738-B
088248-01-707	EA	ELECTRODE-SENSOR, (HORIZONTAL), NORCOLD# 815733
094039-01-717	EA	LOWER DOOR HANDLE ASM. (BLACK) - NORCOLD 81849938
084880-03-705	EA	BRACKET F/INT. REFRIGERATOR LIGHT - NORCOLD 816297
084880-03-706	EA	LAMP (BULB) - NORCOLD 818289
084880-01-718	EA	VALVE-GAS, NORCOLD 815518
084880-01-736	EA	SWITCH-LIGHT, BLACK - NORCOLD# 815810
075217-01-738	EA	SWITCH-HUMIDITY, NORCOLD 815259
084880-01-732	EA	LATCH, NORCOLD 815785
094039-01-732	EA	FRONT COVER(BLACK) BOTTOM TRIM - NORCOLD 81822130
094039-01-712	EA	DOOR BIN(GRAY)SILVER BORDER - NORCOLD 81584080
094039-01-718	EA	MILK BIN (GRAY)W/SILVER TRIM - NORCOLD 81579480
094039-01-740	EA	PLUG-INSTALLATION, BLACK - NORCOLD 81579730
094039-01-722	EA	HOLE PLUG (BLACK) HINGE HOLES - NORCOLD 81582030
094039-01-711	EA	JUICE RACK(GRAY)W/SILVER TRIM - NORCOLD 81580540
084472-01-749	EA	PLUG-1/8", NORCOLD# 814453
075217-01-734	EA	FUSE-3 AMP, NORCOLD# 815388
094039-01-728	EA	SHELF-FREEZER EVAPORATOR, NORCOLD 815236
084880-03-707	EA	COVER F/LAMP OR BULB - NORCOLD 818279
094039-01-733	EA	WIRE SHELF (MIDDLE) - NORCOLD 81563822
094039-01-734	EA	WIRE SHELF (TOP) W/RISER - NORCOLD 81563722
094039-01-704	EA	HINGE PLATE (BLACK) L.H. - NORCOLD 81631430
094039-01-710	EA	HINGE PLATE(BLACK) RIGHT TOP/ LEFT BOTTOM - NORCOLD 81631330
094039-01-741	EA	TRAY-SHELF, PLASTIC - GRAY - NORCOLD 81880922
054450-01-000	EA	LEVEL-REFRIGERATOR
084073-01-000	EA	COVER-ROOF VENT, NORCOLD REFRIGERATOR - BEIGE
084073-04-000	EA	BASE-ROOF VENT, NORCOLD REFRIGERATOR - BLACK

REFRIGERATOR CABINET

KEY PART NUMBER	U/M	DESCRIPTION
090329-01-000	FT	SEAL-REFRIGERATOR CABINET
P00520-03-807	EA	DOOR-CABINET, W/O HARDWARE - 6.4" X 16"
M02516-56-Y12	EA	DOOR-FURNACE, W/MESH INSERT

**1991 WINNEBAGO
TABLE OF CONTENTS**

INTRODUCTION	A-01 - A-02
ABBREVIATIONS	A-03
ALPHABETICAL INDEX	A-04 - A-06
WCN28RT	A-07 - G-10
WCN32RQ	G-11 - L-20

1991 WCN28RT INDEX

FLOOR PLAN	A-07 - A-08
ACCESSORIES	A-09 - A-24
BATH	B-01 - B-04
BEDROOM	B-05 - B-08
CHASSIS	B-09 - C-08
C C & PAD	C-07 - C-18
DINETTE	C-19 - C-20
DRIVERS	C-21 - C-24
ELECTRICAL	D-01 - D-08
EXTERIOR BODY	D-09 - D-18
GALLEY	D-19 - E-02
HEATING & A/C	E-03 - E-08
INTERIOR FINISH	E-09 - E-13
LABEL	E-14 - E-22
LP	E-23
LOUNGE	E-24 - F-01
SEALANTS & FASTENERS	F-02 - F-04
WATER & SEWAGE	F-05 - F-11
WINDOW, VENT AND EXTERIOR DOOR	F-12 - G-10

HEATING & AIR CONDITIONING GROUP
REAR HEATER & WATER HEATER W/MOTOR AID L611

HEATING & AIR CONDITIONING GROUP (CONTINUED)

AUTO A/C COMPONENTS ADDED TO CHEVY CHASSIS

1991 WINNEBAGO

TABLE OF CONTENTS

INTRODUCTION	A-01 - A-02
ABBREVIATIONS	A-03
ALPHABETICAL INDEX	A-04 - A-08
WCN28RT	A-07 - G-10
WCN32RQ	G-11 - L-20

KEY PART NUMBER	U/M	DESCRIPTION
009198-01-000	FT	DUCT-HEAT, FLEXIBLE - 4" ID
009200-01-000	EA	TAPE-FURNACE, 1 1/2"
023148-01-000	EA	CLAMP-SCREW TYPE - 4"
069636-02-000	EA	CONNECTOR-DUCT, 4" ID
000687-10-12B	EA	SCREW, 10-12 X 3/4 PPH. ZN
007108-01-000	FT	HOSE-HEATER, 5/8" ID
008042-01-000	FT	TUBING-VINYL, .85" ID
056464-05-000	EA	REGISTER-PLASTIC W/O DAMPER - 4" DIAMETER - GOLDEN
082401-01-000	EA	CLAMP-HOSE, WORMGEAR .25" - 1"
079059-01-000	EA	HOSE-90 DEGREE, .81"ID X 4" X 36"
079059-02-000	EA	HOSE-90 DEGREE, .81"ID X 4" X 6"
083081-01-000	EA	HOSE-FORMED, 90 DEGREES

EVANS REAR HEATER

KEY PART NUMBER	U/M	DESCRIPTION
084405-01-000	EA	HEATER ASM-REAR, DUCTED - W/MOTOR AID - EVANS
084405-01-700	EA	HEATER CORE-EVANS# FT200229
084405-01-701	EA	FAN BLADES-EVANS# HV029931
084405-01-702	EA	MOTOR ASM-12 V, EVANS# 200148
088753-01-000	FT	TUBE-ALUMINIZED STEEL, 5/8" - 18 GAUGE
007108-02-000	FT	HOSE-HEATER, 3/4"ID
040731-01-000	EA	NIPPLE-INLET MANIFOLD, GM-3838094
081873-01-000	EA	BRACKET-MOTOR AID TUBES, 4" X 1.5" - STEEL
082401-01-000	EA	CLAMP-HOSE, WORMGEAR .25" - 1"
082401-04-000	EA	CLAMP-HOSE, WORMGEAR .69" - 1.25"
071015-13-000	EA	GROMMET-5/8"ID, FITS .09" MATERIAL, RUBBER
073194-02-000	EA	CLAMP-HOSE, WORMGEAR 1.26" - 1.97"
080179-01-000	EA	BRACKET-SUPPORT, HEATER HOSE - IN ENGINE COMPARTMENT
088753-01-000	FT	TUBE-ALUMINIZED STEEL, 5/8" - 18 GAUGE

A/C COMPRESSOR & SYSTEM COMPONENTS

KEY PART NUMBER	U/M	DESCRIPTION
072343-08-000	EA	COMPRESSOR/CLUTCH-460 EFI, TOP DISCHARGE - ARA# 0529039
086814-02-000	EA	MOUNT & DRIVE PACKAGE, A/C COMPRESSOR - 460 EFI
083610-01-000	EA	CLAMP-WIRE, DUAL - UNEQUAL DIAMETERS - .75" & 1.25"
088753-01-000	FT	TUBE-ALUMINIZED STEEL, 5/8" - 18 GAUGE
091930-02-000	EA	DUCT-DEFROSTER, W/O SIDE OUTLET - ARA# 0571020
062401-01-000	EA	CLAMP-HOSE, WORM GEAR .25" - 1"

KEY PART NUMBER	U/M	DESCRIPTION
000G11-08-08B	EA	SCREW, 8-18 X 1/2 PPH - ZN
007076-01-700	FT	HOSE-FLEXIBLE PVC - 2" ID
007108-01-000	FT	HOSE-HEATER, 5/8" ID
007281-01-000	EA	HOSE-FLEXIBLE PVC, 2.5"ID X 50'
007281-01-700	FT	HOSE-FLEXIBLE PVC, 2.5" ID
024990-01-000	EA	OUTLET-DEFROSTER, WITH SWIVEL - 2" - TAN
082401-04-000	EA	CLAMP-HOSE, WORMGEAR .89" - 1.25"

A/C EVAPORATOR

KEY PART NUMBER	U/M	DESCRIPTION
088227-02-000	EA	EVAPORATOR-A/C, ARA 0508213
088227-02-701	EA	BRACKET-BOWDEN CABLE MOUNTING, ARA 0409417
088227-02-702	EA	DOOR ASM., F.A./RECYCLING - ARA 0321330
088227-02-703	EA	SUCTION HOSE #10, ARA 0888712
088227-02-705	EA	HOSE,LIQUID, ARA 0888713
088227-01-700	EA	DOOR ASSEMBLY, ARA 0320518
088227-01-701	EA	CRANK-MIX, ROUND DOOR - ARA 0318225
088227-01-703	EA	EVAPORATOR,CORE, ARA 0500571
088227-01-704	EA	VALVE,EXPANSION BLOCK, ARA 1297022
088227-01-707	EA	RESISTOR,FUSED A/C, ARA 0885515
088227-01-708	EA	MOTOR BLOWER, ARA 1120080
088227-01-709	EA	WHEEL REQUIRED BALANCING, ARA 0252084
088227-01-711	EA	CRANK,MIXING DOOR, ARA 0320480
077052-01-700	EA	COIL,EVAPORATOR, ARA 0560458
072342-03-709	EA	O'RING, #10 - ARA 0050807
072342-03-707	EA	O'RING, #8 - ARA 0050805
072341-01-708	EA	SERVO-VACUUM CONTROL, ARA 1120040
075789-01-718	EA	O'RING-AEROQUIP FITTING, ARA 0543513
088782-02-705	EA	PIN,RETAINER, ARA 1701787
072341-01-707	EA	THERMOSTAT, ARA 1247312
088227-02-705	EA	HOSE,LIQUID, ARA 0888713

CONTROL & PLENUM

KEY PART NUMBER	U/M	DESCRIPTION
091902-03-000	EA	CONTROL/PLENUM ASM-ARA# 0508350

1991 WCN28RT INDEX

FLOOR PLAN	A-07 - A-08
ACCESSORIES	A-09 - A-24
BATH	B-01 - B-04
BEDROOM	B-05 - B-08
CHASSIS	B-09 - C-06
C C & PAD	C-07 - C-18
DINETTE	C-19 - C-20
DRIVERS	C-21 - C-24
ELECTRICAL	D-01 - D-08
EXTERIOR BODY	D-09 - D-18
GALLEY	D-19 - E-02
HEATING & A/C	E-03 - E-08
INTERIOR FINISH	E-09 - E-13
LABEL	E-14 - E-22
LP	E-23
LOUNGE	E-24 - F-01
SEALANTS & FASTENERS	F-02 - F-04
WATER & SEWAGE	F-05 - F-11
WINDOW, VENT AND EXTERIOR DOOR	F-12 - G-10

HEATING & AIR CONDITIONING GROUP (CONTINUED)

SUBURBAN FURNACE & WALL THERMOSTAT

KEY PART NUMBER	U/M	DESCRIPTION
093365-01-060	EA	THERMOSTAT-WALL, FURNACE - SUBURBAN 0160902
092300-03-000	EA	FURNACE-SUBURBAN, 34,000 BTU - NT-348
092300-01-705	EA	ELECTRODE, SUBURBAN 230956
099834-01-733	EA	RELAY, TIME DELAY 20&30 BTU, SUBURBAN 231202
075896-01-700	EA	MOTOR ASM-SUBURBAN# 231208
092300-01-720	EA	WHEEL-ROOM AIR, SUBURBAN 350113
092300-02-702	EA	MICROSWITCH ASM, SUBURBAN# X230509
092300-01-728	EA	WHEEL-COMB AIR, SUBURBAN 350110
075896-02-728	EA	GASKET-CROSSOVER TUBE, SUBURBAN 070385
092300-01-724	EA	GASKET-MOTOR MOUNT, SUBURBAN 070384
092300-01-727	EA	GASKET-COMBUSTION AIR HOUSING, SUBURBAN 070386
092300-01-711	EA	VENT CAP ASSEMBLY, SUBURBAN X280179
099834-01-729	EA	VALVE-GAS, JOHNSON - SUBURBAN 180832
092300-01-701	EA	CABINET FRONT, SUBURBAN 101172
092300-01-708	EA	SWITCH LIMIT, SUBURBAN 231440
099834-01-720	EA	ORIFICE-MAIN BURNER, SUBURBAN# 0180222
092300-01-704	EA	GASKET-ELECTRODE, SUBURBAN 070163
099834-01-708	EA	MODULE BOARD, SUBURBAN# 231427
092300-01-718	EA	ELBOW 90°, SUBURBAN 170374
099834-01-718	EA	VALVE-MANUAL SHUTOFF, SUBURBAN 180740
092300-01-717	EA	WIRE ASSEMBLY (POWER SUPPLY) - SUBURBAN X231428
092300-01-706	EA	DOOR-BURNER ACCESS, SUBURBAN 030523
099834-01-732	EA	GASKET-BURNER ACCESS DOOR, SUBURBAN 070398
075896-02-709	EA	DISC-GLASS, SUBURBAN 310026
092300-01-715	EA	MANIFOLD ASSEMBLY, SUBURBAN 171034
099834-01-712	EA	GASKET-MANIFOLD, SUBURBAN 070408
092300-01-712	EA	BURNER ASM, SUBURBAN X010701
092300-01-721	EA	BLOWER HOUSING ASSEMBLY, SUBURBAN 390283
075896-02-727	EA	BRACKET-MOTOR MOUNT, SUBURBAN# 062136
092300-03-702	EA	HOUSING, COMB AIR ASM NT-34BW - SUBURBAN X390417
092300-01-728	EA	HOUSING, COMB AIR (OUTSIDE) - SUBURBAN 390424
092300-02-700	EA	COMBUSTION CHAMBER ASM. 30&34 BW - SUBURBAN X021015
099834-01-720	EA	ORIFICE-MAIN BURNER, SUBURBAN 180222
092300-03-701	EA	MOTOR ASSEMBLY (NT-34BW)
092300-01-700	EA	CABINET, SUBURBAN X101178
007076-01-700	FT	HOSE-FLEXIBLE PVC - 2" ID
098342-01-000	EA	WYE-CONNECTOR, 2.5" FLEXHOSE
092776-01-000	EA	ADAPTER-DUCT, 2"
099328-01-000	EA	GRILLE-FLOOR, HEATING - 9.3" X 5.4" - BROWN
092321-01-000	FT	INSULATION-FIBERGLASS, W/ALUMINUM FOIL
093814-01-01A	EA	GRILLE-RETURN AIR, FURNACE - 15.6" X 7.6" - BROWN
094800-01-02A	EA	REGISTER-HEAT, FLOOR-W/O DAMPER-3.6" X 10.5" X 1.4" - BROW
094800-02-02A	EA	REGISTER-HEAT, FLOOR - W/DAMPER - 3.6" X 10.5" X 1.4" BROW
024990-01-000	EA	OUTLET-DEFROSTER, WITH SWIVEL - 2" - TAN
024990-03-000	EA	OUTLET-LOUYERED, W/SWIVEL - 2" - GRAY
084077-03-000	EA	COVER-BLANK, ROOF A/C - IVORY

HEATING & AIR CONDITIONING GROUP (CONTINUED)

ROOF A/C-13500 BTU, US & CANADIAN LZ80

KEY PART NUMBER	U/M	DESCRIPTION
098366-01-000	EA	CONNECTOR-PLASTIC, 3/8" AVG
081606-01-708	EA	LIMIT SWITCH (OPEN 180,CLOSE 110), COLEMAN# 6703-3041
ROOF A/C		
093783-01-03A	EA	A/C-ROOF, 13500 BTU - BEIGE - COLEMAN 6759D708/6759-808
093783-03-700	EA	SHROUD(BEIGE/CHARCOAL), COLEMAN# 6759-4581
093308-01-701	EA	DECAL PKG. LEFT&RIGHT, COLEMAN 6706B3561
093783-01-702	EA	OVERLOAD, COLEMAN# 6759-3931
093783-01-712	EA	FAN BLADE-CONDENSER, COLEMAN# 6733-3221
076303-01-712	EA	MOTOR, COLEMAN# 6707A3119
093783-01-703	EA	IMPELLOR-7" DIA X 2.8" WIDE, COLEMAN# 6759-3271
091225-01-709	EA	START RELAY, COLEMAN# 1497-4131
091225-01-710	EA	START CAPACITOR, COLEMAN# 1497-0881
073742-02-704	EA	RUN CAPACITOR (COMPRESSOR), COLEMAN 14994661
093783-01-704	EA	CAPACITOR-FAN, COLEMAN# 1499-3461
042204-01-709	EA	THERMOSTAT IN-64,OUT-58, COLEMAN# 6701-3401
042206-01-702	EA	THERMOSTAT IN-89,OUT-58, COLEMAN# 6703-3401
093783-01-708	EA	HEAT ELEMENT-COLEMAN# 6798-3321
093783-01-708	EA	CONDENSER COIL-COLEMAN# 1452-1251
093783-01-714	EA	COMPRESSOR-TECUMSEH, COLEMAN 6748-3599
093783-01-707	EA	EVAPORATOR COIL-COLEMAN# 1452-1351
073742-01-701	EA	SELECTOR SWITCH (5 TERMINAL), COLEMAN# 6759-3251
073742-01-702	EA	DECAL COOL ONLY, COLEMAN# 6759C3431
073742-01-703	EA	DECAL HEAT&COOL, COLEMAN# 6759-3491
081806-01-708	EA	LIMIT SWITCH (OPEN 180,CLOSE 110), COLEMAN# 6703-3041
091225-01-713	EA	KNOB (2 PER PACKAGE), COLEMAN# 6701-3351
076303-01-707	EA	FILTER-6" X 14 3/4" X 1/2", 12 PER PKG - COLEMAN 6703A3151
093783-01-710	EA	SINGLE PARTS PACKAGE, COLEMAN# 6759-5841
091225-01-717	EA	DECAL (THERMOSTAT) COOL ONLY, COLEMAN# 6799A3441
093783-01-705	EA	DECAL-HEAT/COOL THERMOSTAT, COLEMAN# 6799A3471
081806-01-712	EA	CEILING SHROUD (IVORY), COLEMAN# 6789-5081
093783-01-711	EA	GASKET PACKAGE, COLEMAN 67593281

CEILING ASSEMBLY

KEY PART NUMBER	U/M	DESCRIPTION
093784-01-000	EA	CEILING ASM-A/C COOL ONLY, TSR - COLEMAN 6759D714
102289-01-000	EA	SPRING-SCREW, ROOF A/C GASKET - COLEMAN 6757-150

**1991 WINNEBAGO
TABLE OF CONTENTS**

INTRODUCTION	A-01 - A-02
ABBREVIATIONS	A-03
ALPHABETICAL INDEX	A-04 - A-06
WCN28RT	A-07 - G-10
WCN32RC	G-11 - L-20

1991 WCN28RT INDEX

FLOOR PLAN	A-07 - A-08
ACCESSORIES	A-09 - A-24
BATH	B-01 - B-04
BEDROOM	B-05 - B-08
CHASSIS	B-09 - C-08
C C & PAD	C-07 - C-18
DINETTE	C-19 - C-20
DRIVERS	C-21 - C-24
ELECTRICAL	D-01 - D-08
EXTERIOR BODY	D-09 - D-18
GALLEY	D-19 - E-02
HEATING & A/C	E-03 - E-08
INTERIOR FINISH	E-09 - E-13
LABEL	E-14 - E-22
LP	E-23
LOUNGE	E-24 - F-01
SEALANTS & FASTENERS	F-02 - F-04
WATER & SEWAGE	F-05 - F-11
WINDOW, VENT AND EXTERIOR DOOR	F-12 - G-10

HEATING & AIR CONDITIONING GROUP (CONTINUED)

ROOF A/C-13500 BTU, EUROPEAN L29D

KEY PART NUMBER	U/M	DESCRIPTION
008356-01-000	EA	CONNECTOR-PLASTIC, 3/8" AVG
092440-01-000	EA	A/C-ROOF, 13500 BTU - 220V - 50HZ - COLEMAN# 6713C750 PIECE PARTS N/A WHEN PROCESSED
092441-01-000	EA	CEILING ASM-A/C, 220V - 50HZ - COLEMAN# 6712ET18
102289-01-000	EA	SPRING-SCREW, ROOF A/C GASKET - COLEMAN 6757-150

ROOF A/C-13500 BTU, TWO UNITS - US & CANADIAN L29F

KEY PART NUMBER	U/M	DESCRIPTION
008356-01-000	EA	CONNECTOR-PLASTIC, 3/8" AVG
074983-01-000	EA	LABEL-A/C SELECTOR
093783-01-03A	EA	A/C-ROOF, 13500 BTU - BEIGE - COLEMAN 6759D708/6759-808
093783-03-700	EA	SHROUD(BEIGE/CHARCOAL), COLEMAN# 6759-4581
093306-01-701	EA	DECAL PKG. LEFT&RIGHT, COLEMAN 6798B3591
093783-01-702	EA	OVERLOAD, COLEMAN# 6759-3931
093783-01-712	EA	FAN BLADE-CONDENSER, COLEMAN# 6733-3221
078303-01-712	EA	MOTOR, COLEMAN# 6707A3119
093783-01-703	EA	IMPELLOR-7" DIA X 2.8" WIDE, COLEMAN# 6759-3271
091225-01-709	EA	START RELAY, COLEMAN# 1497-4131
091225-01-710	EA	START CAPACITOR, COLEMAN# 1497-0881
073742-02-704	EA	RUN CAPACITOR (COMPRESSOR), COLEMAN 14994661
093783-01-704	EA	CAPACITOR-FAN, COLEMAN# 1499-3481
042204-01-709	EA	THERMOSTAT IN-64,OUT-58, COLEMAN# 6701-3401
042205-01-702	EA	THERMOSTAT IN-89,OUT-58, COLEMAN# 6703-3401
063783-01-708	EA	HEAT ELEMENT-COLEMAN# 6798-3321
093783-01-708	EA	CONDENSER COIL-COLEMAN# 1452-1251
093783-01-714	EA	COMPRESSOR-TECUMSEH, COLEMAN 6746-3599
093783-01-707	EA	EVAPORATOR COIL-COLEMAN# 1452-1351
073742-01-701	EA	SELECTOR SWITCH (5 TERMINAL), COLEMAN# 6759-3251
073742-01-702	EA	DECAL COOL ONLY, COLEMAN# 6759C3431
073742-01-703	EA	DECAL HEAT&COOL, COLEMAN# 6759-3491
081606-01-708	EA	LIMIT SWITCH (OPEN 160,CLOSE 110), COLEMAN# 6703-3041
091225-01-713	EA	KNOB (2 PER PACKAGE), COLEMAN# 6701-3351
078303-01-707	EA	FILTER-6" X 14 3/4" X 1/2", 12 PER PKG - COLEMAN 6703A3151
093783-01-710	EA	SINGLE PARTS PACKAGE, COLEMAN# 6759-5841
091225-01-717	EA	DECAL (THERMOSTAT) COOL ONLY, COLEMAN# 6799A3441
093783-01-705	EA	DECAL-HEAT/COOL THERMOSTAT, COLEMAN# 6799A3471
081606-01-712	EA	CEILING SHROUD (IVORY), COLEMAN# 6769-5061
093783-01-711	EA	GASKET PACKAGE, COLEMAN 67593281

HEATING & AIR CONDITIONING GROUP (CONTINUED)

CEILING ASSEMBLY

KEY PART NUMBER	U/M	DESCRIPTION
093784-01-000	EA	CEILING ASM-A/C COOL ONLY, TSR - COLEMAN 6759D714
073937-03-000	EA	SWITCH-ROTARY SELECTOR, 3 DECK - A/C - CA20-USA892
073937-01-700	EA	KNOB-ROTARY SWITCH, A/C SELECTOR - 145749
102289-01-000	EA	SPRING-SCREW, ROOF A/C GASKET - COLEMAN 6757-150

ROOF A/C-13500 BTU - TWO UNITS - EUROPEAN L29F

KEY PART NUMBER	U/M	DESCRIPTION
008356-01-000	EA	CONNECTOR-PLASTIC, 3/8" AVG
074983-01-000	EA	LABEL-A/C SELECTOR
092440-01-000	EA	A/C-ROOF, 13500 BTU - 220V - 50HZ - COLEMAN# 6713C750
092441-01-000	EA	CEILING ASM-A/C, 220V - 50HZ - COLEMAN# 6712ET18 PIECE PARTS NOT AVAILABLE WHEN PROCESSED
092441-01-000	EA	CEILING ASM-A/C, 220V - 50HZ - COLEMAN# 6712ET18 PIECE PARTS NOT AVAILABLE WHEN PROCESSED
073937-03-000	EA	SWITCH-ROTARY SELECTOR, 3 DECK - A/C - CA20-USA892
073937-01-700	EA	KNOB-ROTARY SWITCH-A/C SEL
008311-01-000	EA	CONNECTOR-WIRE NUT, INSULATED - RED
008328-01-000	EA	TERMINAL-RING, 12/10 WIRE - #10 STUD FIT
000G67-10-12P	EA	SCREW, 10-12 X .75 PPH - DARK BROWN
009439-07-000	EA	SCREW, 8-32 X 1 1/4 PPH - BLACK
000G67-10-12B	EA	SCREW, 10-12 X 3/4 PPH - ZN
102289-01-000	EA	SPRING-SCREW, ROOF A/C GASKET - COLEMAN 6757-150

1991 WINNEBAGO

TABLE OF CONTENTS

INTRODUCTION	A-01 - A-02
ABBREVIATIONS	A-03
ALPHABETICAL INDEX	A-04 - A-08
WCN28RT	A-07 - G-10
WCN32RC	G-11 - L-20

1991 WCN28RT INDEX

FLOOR PLAN	A-07 - A-08
ACCESSORIES	A-09 - A-24
BATH	B-01 - B-04
BEDROOM	B-05 - B-08
CHASSIS	B-09 - C-08
C C & PAD	C-07 - C-18
DINETTE	C-19 - C-20
DRIVERS	C-21 - C-24
ELECTRICAL	D-01 - D-08
EXTERIOR BODY	D-09 - D-18
GALLEY	D-19 - E-02
HEATING & A/C	E-03 - E-08
INTERIOR FINISH	E-09 - E-13
LABEL	E-14 - E-22
LP	E-23
LOUNGE	E-24 - F-01
SEALANTS & FASTENERS	F-02 - F-04
WATER & SEWAGE	F-05 - F-11
WINDOW, VENT AND EXTERIOR DOOR	F-12 - G-10

INTERIOR FINISH GROUP

ASSIST HANDLE & ENTRY DOOR STRIKE COVER

KEY PART NUMBER	UM	DESCRIPTION
051572-02-AA8	EA	HANDLE-ASSIST, INTERIOR - ENTRY DOOR - VINYL - OFF WHITE
077481-01-000	EA	COVER-STRIKE, ENTRY DOOR - 6.5" X 2.56" - PLASTIC - BEIGE FROM: 00-00-00 THRU: 07-09-90
077481-03-000	EA	COVER-STRIKE, ENTRY DOOR - 6.5" X 2.5" - PLASTIC - OFF WHITE FROM: 07-10-90 THRU: 99-99-99
089178-02-000	EA	BRACKET-MOUNTING, ASSIST HANDLE
000C18-07-16B	EA	BOLT-CARRIAGE, ASSIST HANDLE - 7/16" - 14 X 1" ZN
000D20-07-00B	EA	NUT-ACORN, ASSIST HANDLE - 7/16" X 14 ZN
046887-01-000	EA	GROMMET-BRASS - 7/16" ID X 1" OD

BATH DOOR HARDWARE

KEY PART NUMBER	UM	DESCRIPTION
008059-02-000	EA	HINGE-2" X 2.7", BRASS
094485-01-01A	EA	KNOB-DOOR, POLISHED BRASS
000G57-05-16J	EA	SCREW, 5-20 X 1 PFH - BRASS

PRIVACY DOOR HARDWARE

KEY PART NUMBER	UM	DESCRIPTION
094856-02-01A	EA	TRACK-FOLDING DOOR/CURTAIN, 27.5" - OFF WHITE
008700-04-002	EA	ROD-EXTRUDED, 195.5" - OFF WHITE
008701-01-000	EA	CARRIER-SHOWER CURTAIN
008702-01-000	EA	END STOP-CURTAIN CARRIER, SHOWER
029130-01-000	EA	SCREW-SNAP SOCKET, 8 PH X 5/8
057534-01-000	EA	TIEBACK-CURTAIN, 6" - PLASTIC - CLEAR
029155-01-000	EA	CAP-SNAP, NICKEL
029156-01-000	EA	SOCKET-SNAP FASTENER, NICKEL

BATT STRIPS

KEY PART NUMBER	UM	DESCRIPTION
085284-03-000	FT	BATT STRIP-WOODGRAIN PANELING, ADHESIVE BACK - REGAL OAK
085284-03-700	FT	BATT STRIP-ADHESIVE BACKED, 3" WIDE - WOODGRAIN
088283-56-000	EA	BATT STRIP-BATH PANELING, 8" EA
085284-43-000	FT	BATT STRIP-BATH PANELING, ADHESIVE BACKED
088283-57-000	EA	BATT STRIP-MAIN, DECOR - 8" EA
085284-44-000	FT	BATT STRIP-MAIN, DECOR - ADHESIVE BACK
086229-04-000	EA	BATTEN-CEILING, 1" - IVORY - 8" LONG
086229-01-000	EA	RETAINER-BATTEN, CEILING - .75" WIDE - 7.6" EA
022992-11-000	FT	MOLDING-REVERSE COVE, T-SHAPED - VINYL - IVORY FROM: 00-00-00 THRU: 04-15-90

CANADA EXPORT OPTION L265

KEY PART NUMBER	UM	DESCRIPTION
094499-02-000	EA	EXTINGUISHER-FIRE, DRY - 1A10BC - CANADIAN

FIRE EXTINGUISHER

KEY PART NUMBER	UM	DESCRIPTION
094499-01-000	EA	EXTINGUISHER-FIRE, DRY W/MOUNTING BRACKET - 10 BC
094499-01-700	EA	BRACKET-MOUNTING, W/PLASTIC STRAP - FIRE EXTINGUISHER

INTERIOR FINISH GROUP (CONTINUED)

CABINET AND WALL MOLDINGS AND TRIMS

KEY PART NUMBER	UM	DESCRIPTION
099571-01-01A	EA	TRIM-ROOF COVE, INTERIOR - OFF WHITE - 12'
102239-01-01A	EA	COVER-SPLICE, COVE TRIM - 1.5" X 3" - PLASTIC - OFF WHITE
009787-12-000	FT	MOLDING-SIDEWALL TO CEILING/CABINET - WELTING - OFF WHITE
077840-14-W24	EA	MOLDING-CAP, WALL - WOOD - W/LIP - 1.4" X 80"
009809-24-000	EA	MOLDING-PLASTIC CORNER, OUTSIDE - 1" - PECAN
077840-01-W30	EA	MOLDING-WALL CAP, 8' LONG - L-SHAPED WOOD
042357-17-000	EA	MOLDING-CORNER, RADIUS - 1.5" X 7" EA - PLASTIC - PECAN
076325-28-000	FT	MOLDING-EDGE BAND, 1 5/16" - AB6 - BLUE
092331-H1-830	EA	MOLDING-.7" X 3.5" X 72", VINYL WRAPPED
076325-30-000	FT	MOLDING-EDGE BAND, 1 5/16" FROM: 00-00-00 THRU: 05-27-90
076325-28-000	FT	MOLDING-EDGE BAND, 1 5/16" FROM: 05-28-90 THRU: 99-99-99
083620-01-000	FT	T-MOLDING, END CAP EDGE - 3/4" - BROWN FROM: 00-00-00 THRU: 05-18-90
083620-07-000	FT	T-MOLDING, END CAP EDGE - 3/4" - PECAN FROM: 05-19-90 THRU: 99-99-99
081521-02-007	EA	MOUNT-METAL MOLDING, FOR RADIUS CORNER MOLDING - 12.5'
M03450-03-000	EA	TRIM-OAK, MIRROR
070504-01-000	FT	TRIM-PLASTIC U-CHANNEL, 1/16" - LIGHT BROWN
100359-01-B03	EA	TRIM-FLOOR, 72" X 1" X 1/2" - WOOD
052859-01-W30	FT	TRIM-EDGE, FABRIC - VINYL - BEIGE
100182-10-B07	EA	TRIM-CHAIR RAIL, WALL - 2.5" X 8" - WOOD
070504-20-000	FT	U-CHANNEL, .815" - PLASTIC - PECAN
080178-03-000	EA	CAP-CORNER, RADIUS - TOP - PECAN
074045-01-000	EA	PLUG-OAK, 1/2" DIAMETER
093273-01-Y12	EA	LUMBER-DRILLED, 78.7" - AT BIFOLD DOOR HINGE END
076699-01-C16	EA	LUMBER-.7" X 1.4" X 70.8", W/7 DEGREE BEVEL ON 1 FACE
093281-01-Y12	EA	TRIM-OAK, DOOR - 2" X 74.3"

WALL CLOCK

KEY PART NUMBER	UM	DESCRIPTION
100793-01-01A	EA	CLOCK-WALL, OVAL - 9.5" X 11.1"
101333-01-000	EA	BACKPLATE-CLOCK, IN WALL SHIELD FOR CLOCK

DINETTE TABLE HARDWARE

KEY PART NUMBER	UM	DESCRIPTION
004354-01-000	EA	BUMPER-RUBBER - BROWN
088410-01-000	EA	BRACKET-LIFT, TABLE MOUNTED - BEIGE
092708-01-Y15	EA	LEG-TABLE
092593-01-04A	EA	CATCH-TABLE LEG, BEIGE
093550-01-000	EA	BRACKET-HINGE, MOUNTS TO LEG & TABLE TOP - 1.7" X 2.6"
024275-11-000	EA	ROD-TABLE LIFT, 8" X 18.5" - BEIGE
024281-07-000	EA	BRACKET-LIFT ROD, LOWER WALL MOUNTED - 22.12" - BEIGE
053200-05-000	EA	BRACKET-TABLE SUPPORT, UPPER WALL MOUNTED - 23.5" - BEIGE
064781-06-000	EA	HOLDER-CUP, TWO STEP - OFF WHITE

**1991 WINNEBAGO
TABLE OF CONTENTS**

INTRODUCTION	A-01 - A-02
ABBREVIATIONS	A-03
ALPHABETICAL INDEX	A-04 - A-08
WCN28RT	A-07 - G-10
WCN32RO	G-11 - L-20

1991 WCN28RT INDEX

FLOOR PLAN	A-07 - A-08
ACCESSORIES	A-09 - A-24
BATH	B-01 - B-04
BEDROOM	B-05 - B-08
CHASSIS	B-09 - C-06
C C & PAD	C-07 - C-18
DINETTE	C-19 - C-20
DRIVERS	C-21 - C-24
ELECTRICAL	D-01 - D-08
EXTERIOR BODY	D-09 - D-18
GALLEY	D-19 - E-02
HEATING & A/C	E-03 - E-08
INTERIOR FINISH	E-09 - E-13
LABEL	E-14 - E-22
LP	E-23
LOUNGE	E-24 - F-01
SEALANTS & FASTENERS	F-02 - F-04
WATER & SEWAGE	F-05 - F-11
WINDOW, VENT AND EXTERIOR DOOR	F-12 - G-10

INTERIOR FINISH GROUP (CONTINUED)

WALL TRIMS

KEY PART NUMBER	UM	DESCRIPTION
099571-01-01A	EA	TRIM-ROOF COVE, INTERIOR - OFF WHITE - 12'
102239-01-01A	EA	COVER-SPLICE, COVE TRIM - 1.5' X 3" - PLASTIC - OFF WHITE
FROM: 07-09-90 THRU: 99-99-99		
083820-01-000	FT	T-MOLDING, END CAP EDGE - 3/4" - BROWN
FROM: 00-00-00 THRU: 05-18-90		
083820-07-000	FT	T-MOLDING, END CAP EDGE - 3/4" - PECAN
FROM: 05-19-90 THRU: 99-99-99		
077840-01-W30	EA	MOLDING-WALL CAP, 1.4" X 8" LONG - L-SHAPED WOOD
100182-10-B07	EA	TRIM-CHAIR RAIL, WALL - 2.5" X 8" - WOOD

FABRICS AND TRIMS

KEY PART NUMBER	UM	DESCRIPTION
052859-01-W30	FT	TRIM-EDGE, VINYL - 1.5" WIDE - BEIGE
079880-01-K00	YD	FABRIC-VINYL, 54" WIDE - BEIGE
089351-03-000	YD	VINYL-CEILING, DIAMOND DESIGN - 54" WIDE
086008-28-000	YD	FABRIC-UPHOLSTERY, PLAIN - 54" - CAMEO BLUE/STORMY BLUE - B07/B22
086008-40-000	YD	FABRIC-UPHOLSTERY, PLAIN - 54" - B08 - AUTUMN LEAVES
086008-63-000	YD	FABRIC-UPHOLSTERY, PLAIN - 54" - B09 - WINTER FOREST
086008-68-000	YD	FABRIC-UPHOLSTERY, PATTERN - 54" - CAMEO BLUE/STORMY BLUE - B07/B22
086008-67-000	YD	FABRIC-UPHOLSTERY, PATTERN - 54" - B08 - AUTUMN LEAVES
086008-68-000	YD	FABRIC-UPHOLSTERY, PATTERN - 54" - B09 - WINTER FOREST
086008-43-000	YD	FABRIC-UPHOLSTERY, DOTTED - 54" - CAMEO BLUE/STORMY BLUE - B07/B22
086008-64-000	YD	FABRIC-UPHOLSTERY, DOTTED - 54" - B08 - AUTUMN LEAVES
086008-65-000	YD	FABRIC-UPHOLSTERY, SQUARES - 54" - B09 - WINTER FOREST
072333-78-000	YD	FABRIC-DRAPERY, DRIFTWOOD
072333-79-000	YD	FABRIC-CURTAIN, 54" WIDE - B07 - CAMEO BLUE
FROM: 10-05-90 THRU: 99-99-99		
072333-78-000	YD	FABRIC-CURTAIN, 54" WIDE - B09 - WINTER FOREST
087272-01-000	YD	FABRIC-LINING, CURTAIN - 48" WIDE - IVORY
079349-01-AA1	YD	WELTING-FABRIC, B07/B22 - CAMEO BLUE/STORMY BLUE
079349-01-B03	YD	WELTING-FABRIC, B08 - AUTUMN LEAVES
079349-01-B09	YD	WELTING-FABRIC, B09 - WINTER FOREST
081928-01-000	YD	BACKING-QUILTING, MATTRESS COVER - 50" WIDE - WHITE
088273-58-000	YD	FABRIC-BEDSPREAD/CURTAIN, 54" - B07 - CAMEO BLUE
088273-57-000	YD	FABRIC-BEDSPREAD/CURTAIN, 54" - B08 - AUTUMN LEAVES
088273-56-000	YD	FABRIC-BEDSPREAD/CURTAIN, 54" - B09 - WINTER FOREST
088273-47-000	YD	FABRIC-BEDSPREAD/CURTAIN, 54" - B22 - STORMY BLUE
088273-67-000	YD	FABRIC-CURTAIN, PLAIN - 54" - B07 - CAMEO BLUE
088273-65-000	YD	FABRIC-CURTAIN, PLAIN - 54" - B08 - AUTUMN LEAVES
088273-66-000	YD	FABRIC-CURTAIN, PLAIN - 54" - B09 - WINTER FOREST
088273-67-000	YD	FABRIC-CURTAIN, PLAIN - 54" - B22 - STORMY BLUE

FLOOR COVERINGS & COMPONENTS

KEY PART NUMBER	UM	DESCRIPTION
093486-01-000	SY	CARPET-COMPARTMENT, 54" WIDE - DARK GRAY
096060-14-000	SY	CARPET-12' ROLL - B07/B22 - CAMEO BLUE/STORMY BLUE
INCREMENTS OF 4 SY		
096060-15-000	SY	CARPET-12' ROLL, B08 - AUTUMN LEAVES - INCREMENTS OF 4 SY
FROM: 00-00-00 THRU: 02-10-91		
096060-26-000	SY	CARPET-12' ROLL, B08 - AUTUMN LEAVES - INCREMENTS OF 4 SY
FROM: 02-11-91 THRU: 99-99-99		
096060-16-000	SY	CARPET-12' ROLL - B09 - WINTER FOREST - INCREMENTS OF 4 SY
047034-02-000	SF	PLASTIC-CARPET, 4" WIDE - CLEAR POLY
075233-01-000	SY	PAD-CARPET, 3/8" X 6" ROLL
076314-02-000	FT	TAPE-CARPET SEAM, HEAT-BOND
100659-01-B03	EA	TRIM-FLOOR, 72" X 1" X 1/2" - WOOD
085746-01-000	FT	TRIM-J, CARPET - 1.2" X .5" ANGLE - 10' LONG - PVC - BEIGE

FLOOR MATS

KEY PART NUMBER	UM	DESCRIPTION
081075-01-000	EA	MAT-FLOOR, ENTRANCE
081201-01-000	EA	MAT-FLOOR, FRONT - DRIVER
081202-01-000	EA	MAT-FLOOR, FRONT - PASSENGER

INTERIOR FINISH GROUP (CONTINUED)

CABINET HARDWARE

KEY PART NUMBER	UM	DESCRIPTION
057882-04-000	SF	TAMBOUR-DOOR, 4' X 8' SHEET
M97191-01-000	EA	HANDLE-DOOR, TAMBOUR
097141-01-000	EA	TRACK-SPIRAL, TAMBOUR DOOR - DRIVER SIDE - 24" LONG
097141-02-000	EA	TRACK-SPIRAL, TAMBOUR DOOR, PASSENGER SIDE - 24" LONG
054856-01-000	EA	RAIL-CORNER, BED - METAL - BEIGE
072389-19-000	EA	MESH-EXPANDED, 15.8" X 6.5" - BRONZE
098979-01-000	EA	CLIP-ADJUSTABLE SHELF
098980-02-000	EA	PILASTER-ADJUSTABLE SHELF, 12" LONG
023320-01-000	EA	PAD-FELT, 3/8" DIAMETER - BROWN
059777-02-000	EA	HINGE-CABINET DOOR, BURNISHED BRASS
098845-01-000	EA	PULL-CABINET, BRASS
018804-01-000	EA	BRACE-CABINET, ANGLED METAL - 2.5"
083204-02-000	EA	BUTTON-MIRROR RETAINING
018804-03-000	EA	BRACE-CABINET ANGLE, 2.5" - BEIGE
042356-01-000	EA	PLUG-BUTTON-MAHOGANY 3/8 DIA
074045-01-000	EA	PLUG-OAK, 1/2" DIAMETER
093508-03-000	EA	CATCH-SPRING, ROLLER
093586-04-000	EA	STRIKE-SPRING STEEL
085740-01-000	EA	BRACE-CABINET CORNER, PLASTIC
074493-02-000	EA	SUPPORT-OVERHEAD DOOR, SPRUNG
081295-01-U01	EA	SUPPORT-BASE, DINETTE - 1.5" X 28" - WOOD
085774-01-000	FT	FASTENER-DUAL HOOK, 1" WIDE - ADHESIVE BACK - BLACK
085774-02-000	FT	FASTENER-DUAL LOOP, 1" WIDE - ADHESIVE BACK - BLACK
075943-02-000	EA	BRACE-ANGLE, WHOLES - 1" X 1.5" X 14" - ALUMINUM - BEIGE
088718-01-001	EA	BRACE-90 DEGREE ANGLE, 102" - EXTRUDED ALUMINUM
029094-04-000	YD	VELCRO TAPE-LOOP, 1" WIDE - BLACK
029096-03-000	YD	VELCRO TAPE-HOOK, 1" WIDE - BLACK
009018-01-000	EA	CATCH-SCREEN DOOR ROLLER
079921-01-000	EA	ROLLER-NYLON, W/STEEL SHAFT - BARBED
080738-01-000	EA	PULL-RECESSED, 1.25" X 4" - OAK
098764-02-000	EA	SLIPNOT-ANTISLIP, 1" WIDE (100' ROLLS)
FROM: 02-05-90 THRU: 02-23-90		
091261-01-000	FT	BACKING-NON SKID, 1" WIDE (100' ROLL)
FROM: 02-24-90 THRU: 99-99-99		
084356-03-000	EA	INSERT-TV STAND TAN
084412-01-000	EA	SUPPORT-HINGED
084451-01-000	EA	CATCH-TV SHELF, BRASS
084625-02-000	EA	HINGE-ALUMINUM, W/HOLES - 17.2" - TAN
384413-01-000	EA	HINGE-CONTINUOUS, ALUMINUM - 1" X 72" - W/HOLES
083276-01-000	EA	BRACE-PROP ROD, GAS
089024-01-000	EA	SUPPORT-SPRING, TO FLOOR
089025-01-000	EA	SUPPORT-SPRING, TO BED
088199-02-Y12	EA	HINGE-BED, TOP LIFT - METAL - BEIGE
077252-01-000	EA	PIN-HINGE
086235-02-000	EA	BEARING-SNAPIN, 3/16" ID X 3/16"
057480-02-000	EA	STUD-BALL, GAS SPRING - 10MM - 5/16" - 18
057480-03-000	EA	CLIP-SAFETY, WIREFORM TYPE - GAS SPRING
057480-04-000	EA	SPRING-GAS
057205-04-000	EA	SUPPORT-BED, 20" - METAL - BEIGE
TV STAND HARDWARE		
084356-03-000	EA	INSERT-TV STAND, METAL - TAN
084412-01-000	EA	SUPPORT-HINGED
023320-01-000	EA	PAD-FELT, 3/8" DIAMETER - BROWN
084451-01-000	EA	CATCH-TV SHELF, BRASS
084625-02-000	EA	HINGE-ALUMINUM, W/HOLES - 17.2" - TAN
084413-01-000	EA	HINGE-CONTINUOUS, ALUMINUM - 1" X 72" - W/HOLES
072852-01-000	EA	DETECTOR-SMOKE, W/9 VOLT BATTERY

1991 WINNEBAGO
TABLE OF CONTENTS

INTRODUCTION	A-01 - A-02
ABBREVIATIONS	A-03
ALPHABETICAL INDEX	A-04 - A-08
WCN28RT	A-07 - G-10
WCN32RQ	G-11 - L-20

1991 WCN28RT INDEX

FLOOR PLAN	A-07 - A-08
ACCESSORIES	A-09 - A-24
BATH	B-01 - B-04
BEDROOM	B-05 - B-08
CHASSIS	B-09 - C-06
C C & PAD	C-07 - C-18
DINETTE	C-19 - C-20
DRIVERS	C-21 - C-24
ELECTRICAL	D-01 - D-08
EXTERIOR BODY	D-09 - D-18
GALLEY	D-19 - E-02
HEATING & AC	E-03 - E-08
INTERIOR FINISH	E-09 - E-13
LABEL	E-14 - E-22
LP	E-23
LOUNGE	E-24 - F-01
SEALANTS & FASTENERS	F-02 - F-04
WATER & SEWAGE	F-05 - F-11
WINDOW, VENT AND EXTERIOR DOOR	F-12 - G-10

INTERIOR FINISH GROUP (CONTINUED)

MIRROR

KEY PART NUMBER	U/M	DESCRIPTION
093448-03-Y15	EA	MIRROR-WOOD FRAMED
058331-08-000	EA	MIRROR-GLASS, SAFETY - 24" X 30"
058331-18-000	EA	MIRROR-SAFETY GLASS, 11.25" X 22.4"
058331-22-000	EA	MIRROR-GLASS, SAFETY - 17" X 44.5"
058331-10-000	EA	MIRROR-GLASS, SAFETY - 14" X 17"
009089-01-000	EA	CLIP-MIRROR

PANELING AND LAMINATES

KEY PART NUMBER	U/M	DESCRIPTION
074497-10-000	SF	PANELING-WOODGRAIN, 4' X 8' - INCREMENTS OF 32 SF
088272-72-000	SF	PANELING-SHOWER, 4' X 7' - OFF WHITE - INC. OF 28 SF
088272-77-000	SF	PANELING-BATH, 4' X 7' - INCREMENTS OF 28 SF
088272-78-000	SF	PANELING-MAIN, DECOR - 4' X 7' - INC OF 28 SF
074498-36-000	SF	LAMINATE-PLASTIC, 5' X 8' - INCREMENTS OF 40 SF
093743-01-02A	SF	PLASTIC-ABS, 11.5" WIDE - OFF WHITE
000885-34-000	SF	PARTICLE BOARD-VINYL COVERED, 1 SIDE - WOODGRAIN 3/8" X 48" X 97" - INCREMENTS OF 32 SF
000885-36-000	SF	PARTICLE BOARD-VINYL COVERED, 2 SIDED - .75" X 5' X 8' - WOODGRAIN
089297-01-000	SF	PLYWOOD-LUAN, OVERLAY GRADE-.10" X 4' X 8'-INC. OF 32 SF
089297-01-000	SF	PLYWOOD-LUAN, OVERLAY GRADE - 4' X 8' - INC OF 32 SF

DRAWERS, TOOL BOX & WATER HOSE

KEY PART NUMBER	U/M	DESCRIPTION
077404-02-000	EA	DRAWER-PLASTIC, 20" X 12.7" - BEIGE
094087-01-01A	EA	DIVIDER-DRAWER, PLASTIC - LIGHT OAK
098785-01-000	EA	RAIL-DRAWER
037888-01-000	FT	RAIL-V GUIDE, DRAWER
037888-04-000	EA	BRACKET-RAIL MOUNTING, FRONT
037888-05-000	EA	BRACKET-RAIL MOUNTING, REAR
102827-02-000	EA	BRACKET-ROLLER, DRAWER - REAR
102827-03-000	EA	ROLLER-DRAWER, NYLON - PAIR
102827-04-000	EA	BRACKET-MOUNTING, DRAWER - REAR
102827-05-000	EA	TRACK-DRAWER, 22.6" LONG
084466-02-000	EA	SLIDE-DRAWER, REAR
084466-03-000	EA	SLIDE-DRAWER, FRONT
084466-04-000	EA	SLIDE-CABINET, REAR
084466-05-000	EA	SLIDE-CABINET, FRONT
037688-03-000	EA	GLIDE-CENTER, DRAWER
077404-02-000	EA	DRAWER-PLASTIC, 20" X 12.7" - BEIGE
094087-01-01A	EA	DIVIDER-DRAWER, PLASTIC - LIGHT OAK
098785-01-000	EA	RAIL-DRAWER, 3.1" HIGH X 2.1" WIDE X 20.5 LONG - PLASTIC

FROM: 00-00-00 THRU: 01-06-91
 FROM: 00-00-00 THRU: 01-06-91
 FROM: 00-00-00 THRU: 01-06-91
 FROM: 01-07-91 THRU: 99-99-99
 FROM: 01-07-91 THRU: 99-99-99
 FROM: 01-07-91 THRU: 99-99-99
 FROM: 01-07-91 THRU: 99-99-99

LABEL & TAG GROUP

CALIFORNIA CHASSIS (OPT 37P)

KEY PART NUMBER	U/M	DESCRIPTION
062043-01-000	EA	LABEL-FUEL, UNLEADED
074559-01-000	EA	DECAL-LOGO, LPG - RED - (CALIF CODE)
091243-01-000	EA	LABEL-A/C COVER, CEILING
093238-05-000	EA	LABEL-CIRCUIT BREAKER, MAIN
006195-01-000	EA	LABEL-ELECTRICAL TEST
006196-01-000	EA	LABEL-GAS TEST
006197-01-000	EA	LABEL-WATER TEST
050225-01-000	EA	LABEL-WARNING, STOVE VENT - US
081808-01-000	EA	LABEL-OVERLAY, VEHICLE CERTIFICATION - ADHESIVE BACKED
058259-01-000	EA	LABEL-SAFETY CHECK LIST SUNVISOR
098641-01-000	EA	LABEL-FUEL, UNLEADED - DASH

FROM: 09-11-89 THRU: 01-14-90

CANADIAN EXPORT

KEY PART NUMBER	U/M	DESCRIPTION
008040-02-000	EA	TAG-GAS REFUEL WARNING, CANADIAN
008019-01-000	EA	TAG-RVI APPROVED, PLASTIC
008040-01-000	EA	TAG-GAS REFUELING WARNING
008082-01-000	EA	TAG-ELECTRIC 110V CONNECTION
091243-01-000	EA	LABEL-A/C COVER - CANADIAN EXPORT
091224-02-000	EA	LABEL-TRAILER LIGHTING
090342-01-000	EA	LABEL-VAPOR RELIEF
087207-02-000	EA	LABEL-FUEL CAP REMOVAL
087207-05-000	EA	LABEL-FUEL CAP REMOVAL
077510-01-000	EA	LABEL-GENERATOR PREP
075221-03-000	EA	LABEL-TRAILER HITCH
075220-01-000	EA	LABEL-WARNING, EXTERIOR LOAD
062043-01-000	EA	LABEL-FUEL, UNLEADED
081417-01-000	EA	LABEL-FUEL
054531-01-000	EA	LABEL-LP GAS ONLY
006188-01-000	EA	LABEL-WASTE WATER
006187-01-000	EA	LABEL-SEWAGE
093238-05-000	EA	LABEL-CIRCUIT BREAKER, MAIN
006195-01-000	EA	LABEL-ELECTRICAL TEST
006196-01-000	EA	LABEL-GAS TEST
006197-01-000	EA	LABEL-WATER TEST
050225-01-000	EA	LABEL-WARNING, STOVE VENT - US
058259-01-000	EA	LABEL-SAFETY CHECK LIST
081808-01-000	EA	LABEL-OVERLAY, VEHICLE CERTIFICATION - ADHESIVE BACK
008189-01-000	EA	LABEL-EXT. "ESCAPE WINDOW"
047731-01-000	EA	LABEL-EMERGENCY EXIT

CALIFORNIA CHASSIS OPTION L37P

KEY PART NUMBER	U/M	DESCRIPTION
062043-01-000	EA	LABEL-FUEL, UNLEADED
074559-01-000	EA	DECAL-LOGO, LPG - RED - (CALIF CODE)
098689-01-000	EA	LABEL-WARNING, CANCER/TOXICITY
008040-02-000	EA	TAG-GAS REFUEL WARNING, CANADIAN

AIR RIDE SUSPENSION OPTION L60B

KEY PART NUMBER	U/M	DESCRIPTION
093237-04-000	EA	LABEL-CIRCUIT BREAKER, FRONT - AIR BAG COMP

DRIVER POWER SEAT OPTION L63M

KEY PART NUMBER	U/M	DESCRIPTION
093237-02-000	EA	LABEL-CIRCUIT BREAKER, FRONT - POWER SEAT

**1991 WINNEBAGO
TABLE OF CONTENTS**

INTRODUCTION	A-01 - A-02
ABBREVIATIONS	A-03
ALPHABETICAL INDEX	A-04 - A-06
WCN28RT	A-07 - G-10
WCN32RO	G-11 - L-20

1991 WCN28RT INDEX

FLOOR PLAN	A-07 - A-08
ACCESSORIES	A-09 - A-24
BATH	B-01 - B-04
BEDROOM	B-05 - B-08
CHASSIS	B-09 - C-08
C C & PAD	C-07 - C-18
DINETTE	C-19 - C-20
DRIVERS	C-21 - C-24
ELECTRICAL	D-01 - D-08
EXTERIOR BODY	D-09 - D-18
GALLEY	D-19 - E-02
HEATING & A/C	E-03 - E-08
INTERIOR FINISH	E-09 - E-13
LABEL	E-14 - E-22
LP	E-23
LOUNGE	E-24 - F-01
SEALANTS & FASTENERS	F-02 - F-04
WATER & SEWAGE	F-05 - F-11
WINDOW, VENT AND EXTERIOR DOOR	F-12 - G-10

LABEL & TAG GROUP (CONTINUED)
LABELS & TAGS

KEY PART NUMBER	U/M	DESCRIPTION
093236-01-000	EA	LABEL-CIRCUIT BREAKER, MAIN
093237-01-000	EA	LABEL-CIRCUIT BREAKER, FRONT - BATTERY CONDITION/RADIO
093237-03-000	EA	LABEL-CIRCUIT BREAKER, FRONT - POWER SEAT (LIFT)
093237-06-000	EA	LABEL-CIRCUIT BREAKER, FRONT - REAR PANEL
093237-07-000	EA	LABEL-CIRCUIT BREAKER, FRONT - REAR PNL/CONV
093237-09-000	EA	LABEL-CIRCUIT BREAKER, FRONT - INVERTER
098506-01-000	EA	LABEL-"COMPARTMENT NOT SEALED"
050225-01-000	EA	LABEL-WARNING, STOVE VENT - US
087236-01-000	EA	LABEL-CABLE, INPUT
087236-02-000	EA	LABEL-TV, OUTLET
006031-01-000	EA	LABEL-POTABLE WATER ONLY
061808-01-000	EA	LABEL-OVERLAY, VEHICLE CERTIFICATION - ADHESIVE BACKED
079986-01-000	EA	LABEL-WARNING, STOWED, MOTION
088757-01-000	EA	LABEL-RETAIL, 8 5/8" X 12 7/8"
090342-01-000	EA	LABEL-VAPOR RELIEF
099509-01-000	EA	LABEL-AWNING INSTALLATION
081417-01-000	EA	LABEL-FUEL, ON FUEL FILL DOOR
073998-01-000	EA	LABEL-LPG ODOR WARNING
094675-01-000	EA	LABEL-EXTERIOR LIGHT, SERVICE
098506-01-000	EA	LABEL-"COMPARTMENT NOT SEALED"
050225-01-000	EA	LABEL-WARNING, STOVE VENT - US
008195-01-000	EA	LABEL-ELECTRICAL TEST
008196-01-000	EA	LABEL-GAS TEST
008197-01-000	EA	LABEL-WATER TEST
061808-01-000	EA	LABEL-OVERLAY, VEHICLE CERTIFICATION - ADHESIVE BACKED
098506-01-000	EA	LABEL-"COMPARTMENT NOT SEALED"
008064-01-000	EA	LABEL-SEAT W/O SEATBELT "NOT INTENDED FOR USE WHILE COACH IN MOTION"
008064-01-000	EA	LABEL-SEAT W/O SEATBELT
088757-01-000	EA	LABEL-RETAIL, 8 5/8" X 12 7/8"

FROM: 00-00-00 THRU: 09-14-90

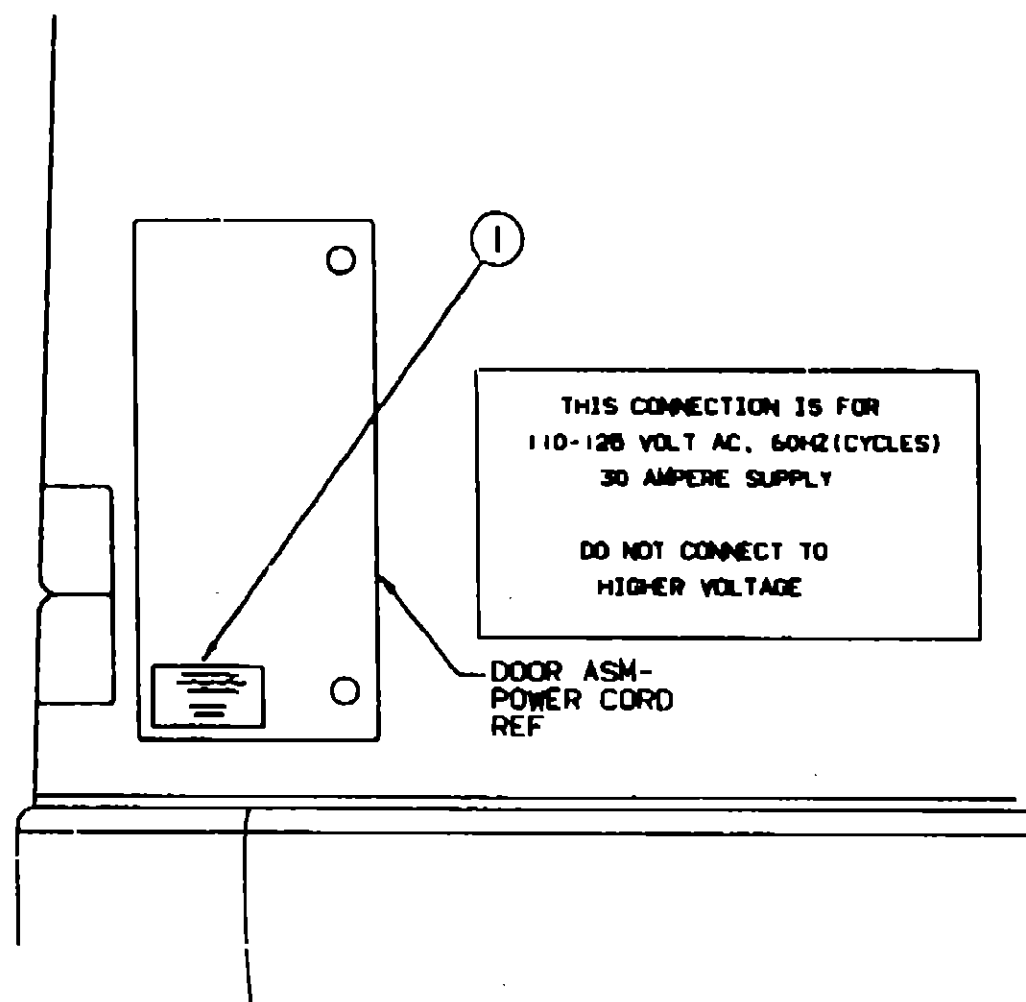

KEY PART NUMBER	U/M	DESCRIPTION
1 006062-01-000	EA	TAG-ELECTRIC, 110V CONNECTION

LABEL & TAG GROUP (CONTINUED)

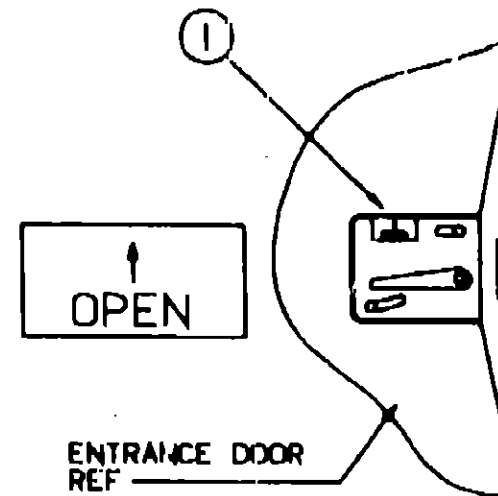

KEY PART NUMBER	U/M	DESCRIPTION
1 040944-01-000	EA	LABEL-ENTRANCE DOOR, "OPEN"

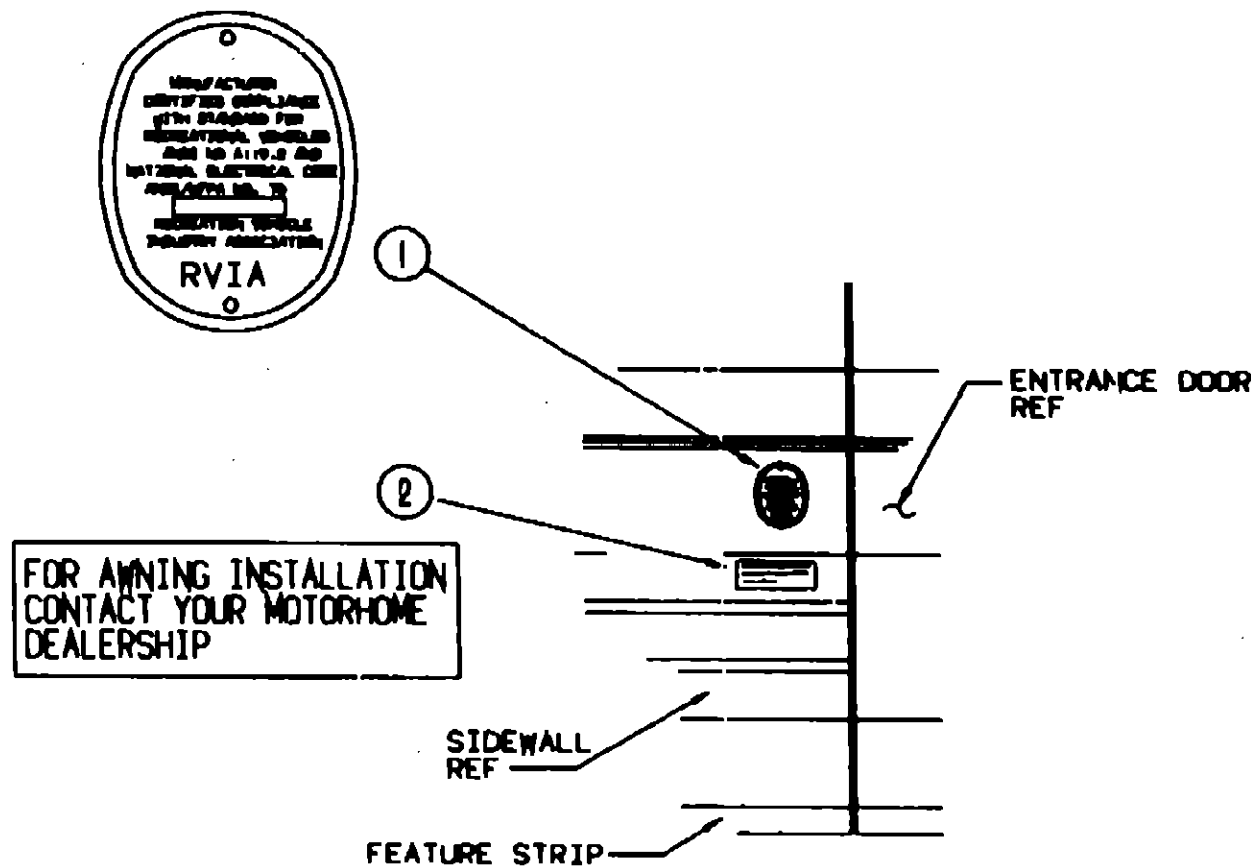

KEY PART NUMBER	U/M	DESCRIPTION
1 006019-01-000	EA	TAG-RVI APPROVED, PLASTIC

1991 WINNEBAGO
TABLE OF CONTENTS

INTRODUCTION	A-01 - A-02
ABBREVIATIONS	A-03
ALPHABETICAL INDEX	A-04 - A-06
WCN28RT	A-07 - G-10
WCN32RQ	G-11 - L-20

1991 WCN28RT INDEX

FLOOR PLAN	A-07 - A-08
ACCESSORIES	A-09 - A-24
BATH	B-01 - B-04
BEDROOM	B-05 - B-08
CHASSIS	B-09 - C-06
C C & PAD	C-07 - C-18
DINETTE	C-19 - C-20
DRIVERS	C-21 - C-24
ELECTRICAL	D-01 - D-06
EXTERIOR BODY	D-09 - D-18
GALLEY	D-19 - E-02
HEATING & AC	E-03 - E-08
INTERIOR FINISH	E-09 - E-13
LABEL	E-14 - E-22
LP	E-23
LOUNGE	E-24 - F-01
SEALANTS & FASTENERS	F-02 - F-04
WATER & SEWAGE	F-05 - F-11
WINDOW, VENT AND EXTERIOR DOOR	F-12 - G-10

LABEL & TAG GROUP (CONTINUED)

LABELS & TAGS

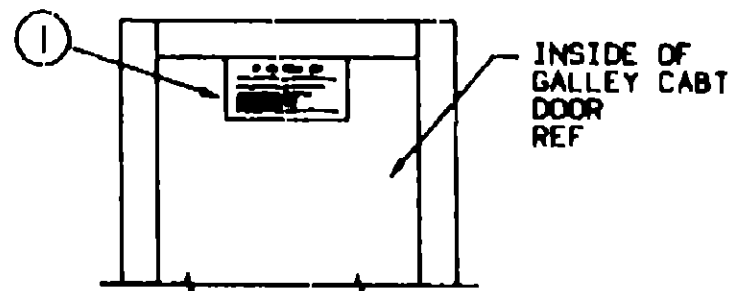

IF YOU SMELL GAS

1. EXTINGUISH ANY OPEN FLAME, PILOT LIGHTS AND ALL SMOKING MATERIALS.
2. SHUT OFF THE GAS SUPPLY AT THE TANK VALVE OR GAS SUPPLY CONNECTION.
3. OPEN DOORS AND OTHER VENTILATING OPENINGS.
4. DO NOT TOUCH ELECTRICAL SWITCHES.
5. LEAVE THE AREA UNTIL ODOR CLEARS.
6. HAVE THE GAS SYSTEM CHECKED AND LEAKAGE SOURCE CORRECTED BEFORE LEAVING AREA.

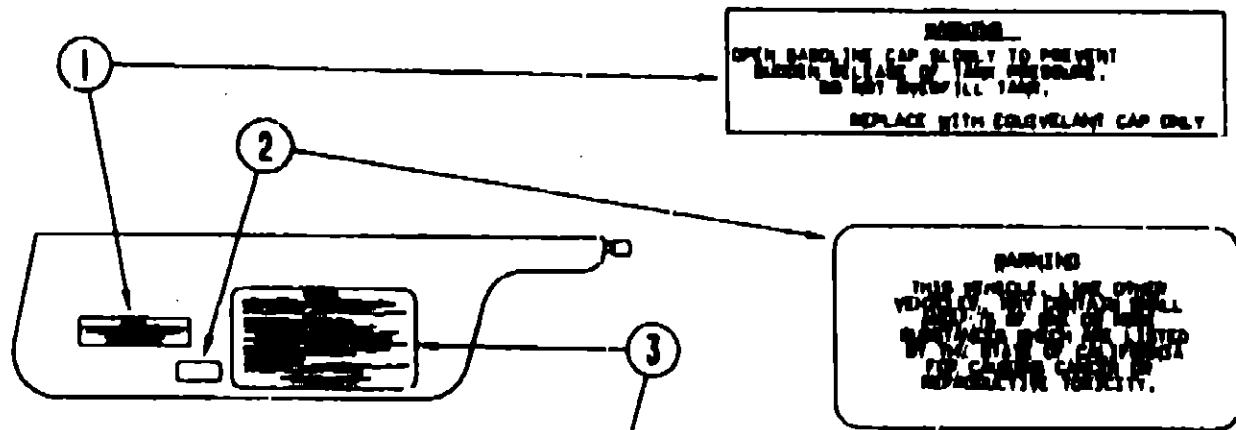

**1991 WINNEBAGO
TABLE OF CONTENTS**

INTRODUCTION	A-01 - A-02
ABBREVIATIONS	A-03
ALPHABETICAL INDEX	A-04 - A-06
WCN28RT	A-07 - G-10
WCN32RQ	G-11 - L-20

CAUTION

THIS MOTOR HOME HAS BEEN DESIGNED, MANUFACTURED AND TESTED WITH CONCERN FOR THE PROTECTION OF IT'S OCCUPANTS. BE RECOMMEND YOU PERFORM THE FOLLOWING INSPECTIONS FOR YOUR SAFETY AND THE SAFETY OF YOUR PASSENGERS BEFORE STARTING YOUR VEHICLE.

1. LP GAS SYSTEM- TURN OFF AT TANK FOR TRAVELING. TEST FOR LEAKS UPON ARRIVAL AT DESTINATION. BEFORE LIGHTING PILOTS.
2. WHEELS- INSPECT FOR DAMAGE AND CHECK LUB RPTS FOR TIGHTNESS.
3. TIRES- INSPECT FOR WEAR AND DAMAGE AND CHECK FOR RECOMMENDED AIR PRESSURE.
4. LIGHTING- TEST FOR PROPER OPERATION OF ALL INTERIOR AND EXTERIOR LIGHTS INCLUDING DASH LIGHTS, HEADLIGHTS, TAIL LIGHTS, BRAKE LIGHTS, CLEARANCE LIGHTS AND TURN SIGNALS.
5. EXITS- INSPECT RELEASE MECHANISM ON EMERGENCY EXIT WINDOW. TEST BOTH LOCKS ON MAIN ENTRANCE DOOR FOR EASE OF OPERATION AND INSTRUCT PASSENGERS HOW TO USE BOTH MEANS OF EXIT.
6. SEAT BELTS- DIRECT PASSENGERS TO DESIGNATED SEATS AND REDUCE USE OF SEAT BELTS.
7. APPLIANCES- TURN OFF AND LATCH OR LOCK DOORS WHERE PROVIDED.
8. LOOSE PARCELS- STORE SECURELY.
9. UTILITY SUPPLY LINES- DISCONNECT ALL ELECTRIC, SEWER AND WATER LINES AND SECURE PROPERLY.
10. ENTRANCE DOOR STEP- PLACE IN RETRACTED POSITION FOR TRAVELING.

READ YOUR MOTOR HOME AND CHASSIS OWNER'S MANUAL FOR FURTHER PRECAUTIONS

KEY PART NUMBER	U/M DESCRIPTION
1 073998-01-000	EA LABEL-LPG ODOR WARNING

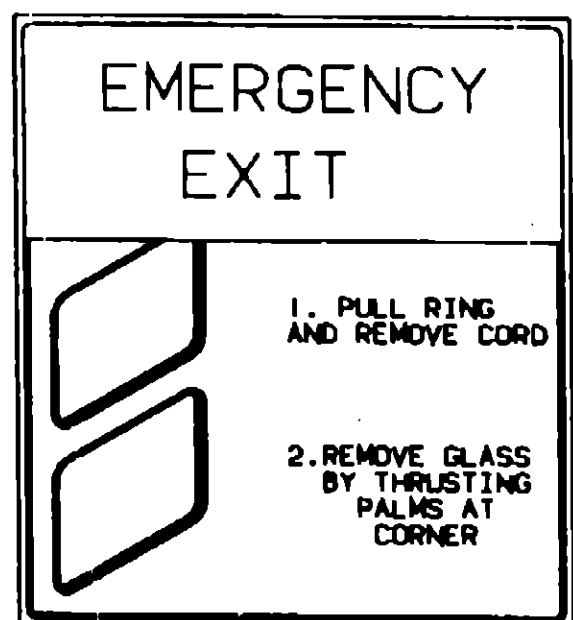

EMERGENCY EXIT
PULL RING
REMOVE CORD
PUSH OUT WINDOW

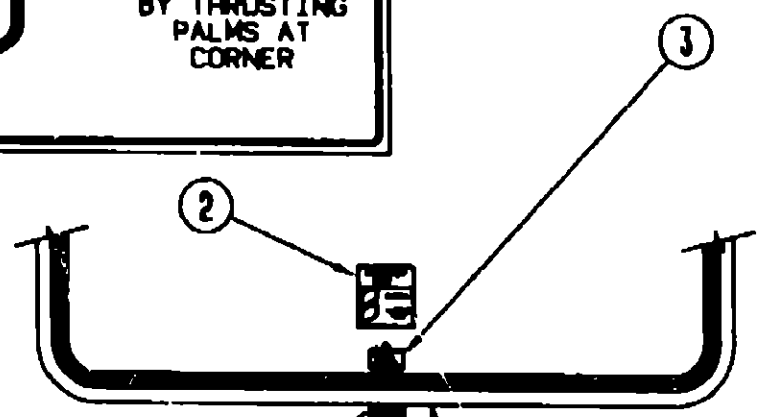

EXIT

KEY PART NUMBER	U/M DESCRIPTION
1 039200 01 000	EA LABEL-WARNING-EXIT
2 047731-01-000	EA LABEL-EMERGENCY EXIT - ESCAPE WINDOW
3 006199 01 000	EA LABEL-EXIT-ESCAPE WINDOW

KEY PART NUMBER	U/M DESCRIPTION
1 087207-05-000	EA LABEL-FUEL CAP REMOVAL
2 099689-01-000	EA LABEL-WARNING, CANCER/TOXICITY
3 056259-01-000	EA LABEL-SAFETY CHECK LIST

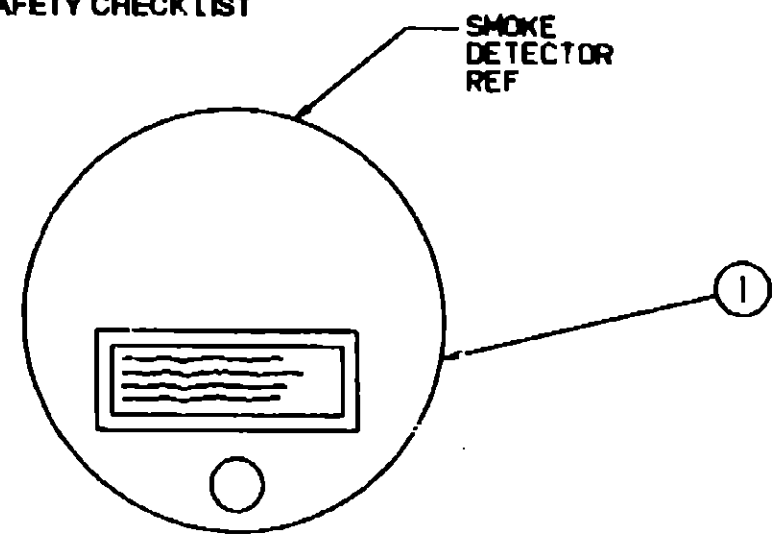

WARNING- TEST SMOKE DETECTOR OPERATION AFTER VEHICLE HAS BEEN IN STORAGE. BEFORE EACH TRIP AND AT LEAST ONCE PER WEEK DURING USE.

KEY PART NUMBER	U/M DESCRIPTION
1 077956-01-000	EA LABEL-WARNING, SMOKE DETECTOR

1991 WCN28RT INDEX

FLOOR PLAN	A-07 - A-08
ACCESSORIES	A-09 - A-24
BATH	B-01 - B-04
BEDROOM	B-05 - B-08
CHASSIS	B-09 - C-06
C C & PAD	C-07 - C-18
DINETTE	C-19 - C-20
DRIVERS	C-21 - C-24
ELECTRICAL	D-01 - D-06
EXTERIOR BODY	D-09 - D-18
GALLEY	D-19 - E-02
HEATING & A/C	E-03 - E-06
INTERIOR FINISH	E-09 - E-13
LABEL	E-14 - E-22
LP	E-23
LOUNGE	E-24 - F-01
SEALANTS & FASTENERS	F-02 - F-04
WATER & SEWAGE	F-05 - F-11
WINDOW, VENT AND EXTERIOR DOOR	F-12 - G-10

LABEL & TAG GROUP CONTINUED

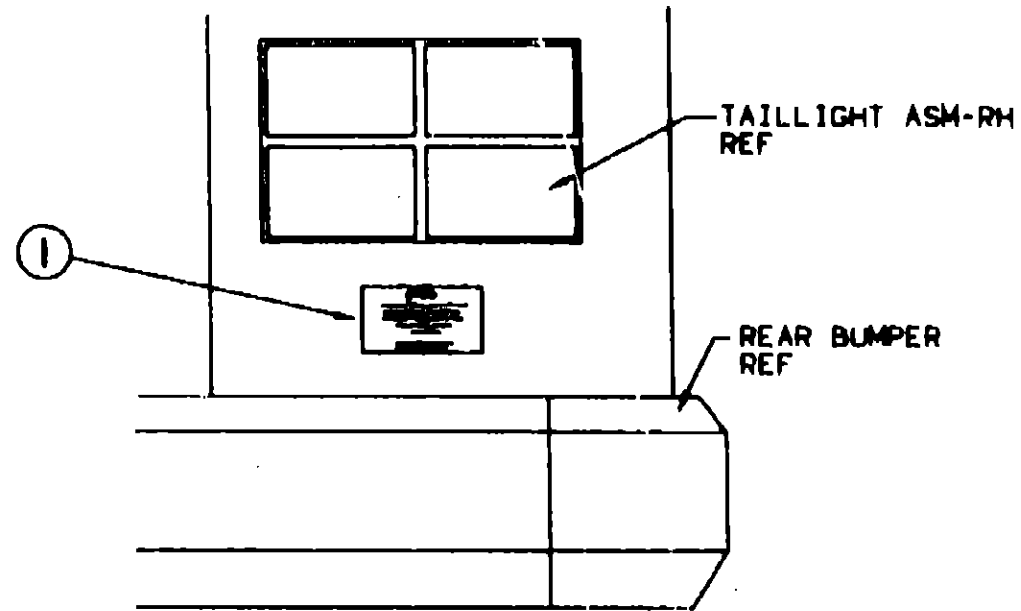

WARNING

DO NOT EXCEED THE VEHICLE WEIGHT RATINGS OR LOADING RECOMMENDATIONS (E.G., GROSS VEHICLE, GROSS AXLE, GROSS COMBINED) OF THE CHASSIS MANUFACTURER OR WINNEBAGO INC.

REFER TO YOUR OWNERS MANUAL, BEFORE LOADING OR TOWING.

KEY PART NUMBER
1 075220-01-000

U/M DESCRIPTION
EA LABEL-WARNING, EXTERIOR LOAD

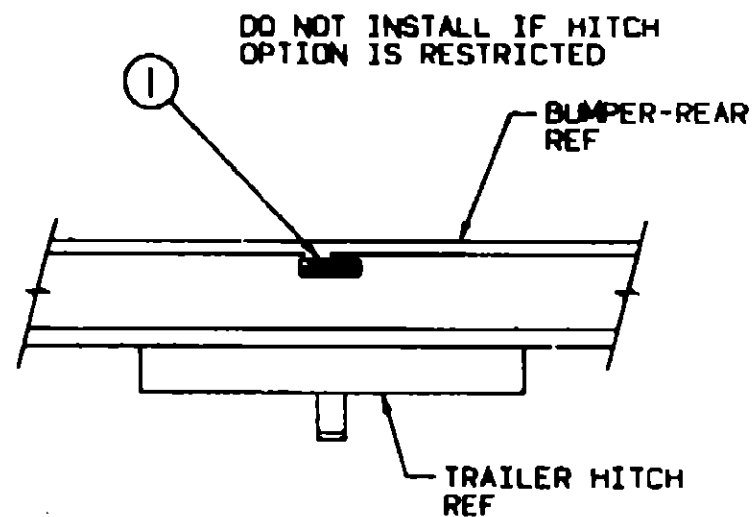

TOWING CAPACITY

TOWED VEHICLE 3500 LB. GROSS MAXIMUM
HITCH BALL 200 LB. MAXIMUM

KEY PART NUMBER
1 075221-03-000

U/M DESCRIPTION
EA LABEL-TRAILER HITCH

LABEL & TAG GROUP CONTINUED

WARNING DISCONNECT BATTERIES BEFORE CONNECTING EXTERNAL CHARGING EQUIPMENT.

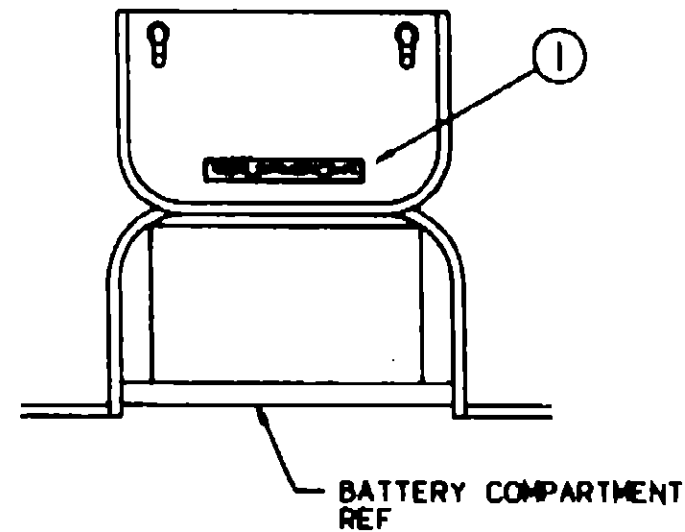

KEY PART NUMBER
1 085748-01-000

U/M DESCRIPTION
EA LABEL-CAUTION, BATTERY CHARGING

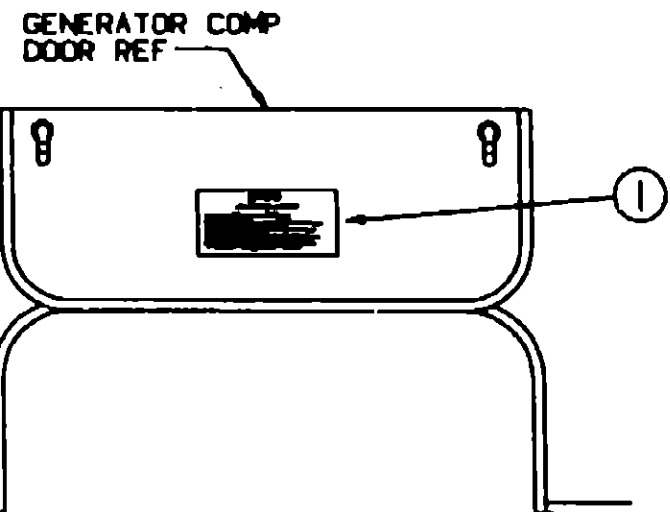

WARNING

WHEN ADDING A GENERATOR SET,

HIGH VOLTAGE-USE EXTREME CAUTION WHEN WORKING ON ELECTRICAL COMPONENTS.
HAVE ALL ELECTRICAL INSTALLATION PERFORMED BY A QUALIFIED LICENSED ELECTRICIAN-FOLLOW ALL STATE AND LOCAL CODES.
ONLY INSTALL GENERATOR SET APPROVED FOR R.V. APPLICATION. HAVE INSTALLED BY QUALIFIED TECHNICIAN.
TO AVOID HEAT BUILD-UP AND TO GUARANTEE AN ADEQUATE AIR SUPPLY TO THE GENERATOR COMPARTMENT, FOLLOW INSTALLATION INSTRUCTIONS.
GENERATOR EXHAUST GASES ARE TOXIC AND MUST NOT TERMINATE UNDER THE VEHICLE-REMOVE EXHAUST AWAY FROM VEHICLE.

KEY PART NUMBER
1 077510-01-000

U/M DESCRIPTION
EA LABEL-GENERATOR PREP

**1991 WINNEBAGO
TABLE OF CONTENTS**

INTRODUCTION	A-01 - A-02
ABBREVIATIONS	A-03
ALPHABETICAL INDEX	A-04 - A-08
WCN28RT	A-07 - G-10
WCN32RQ	G-11 - L-20

1991 WCN28RT INDEX

FLOOR PLAN	A-07 - A-08
ACCESSORIES	A-09 - A-24
BATH	B-01 - B-04
BEDROOM	B-05 - B-08
CHASSIS	B-09 - C-06
C C & PAD	C-07 - C-18
DINETTE	C-19 - C-20
DRIVERS	C-21 - C-24
ELECTRICAL	D-01 - D-08
EXTERIOR BODY	D-09 - D-18
GALLEY	D-19 - E-02
HEATING & AC	E-03 - E-08
INTERIOR FINISH	E-09 - E-13
LABEL	E-14 - E-22
LP	E-23
LOUNGE	E-24 - F-01
SEALANTS & FASTENERS	F-02 - F-04
WATER & SEWAGE	F-05 - F-11
WINDOW, VENT AND EXTERIOR DOOR	F-12 - G-10

LABEL & TAG GROUP (CONTINUED)

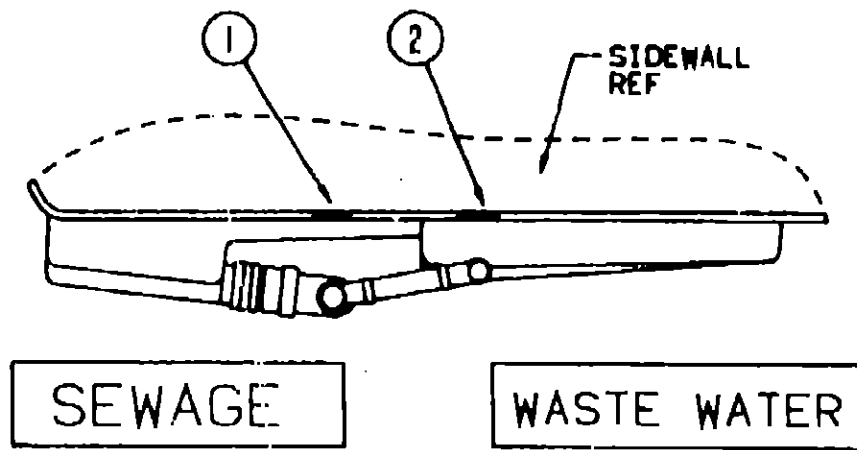

SEWAGE

WASTE WATER

KEY PART NUMBER	U/M	DESCRIPTION
1 006187-01-000	EA	LABEL-SEWAGE
2 006188-01-000	EA	LABEL-WASTE WATER

LPG

WARNING
ALL PILOT LIGHTS AND APPLIANCES SHALL BE TURNED OFF DURING REFUELING OF MOTOR FUEL TANKS AND/OR PERMANENTLY MOUNTED LP-GAS CONTAINERS.

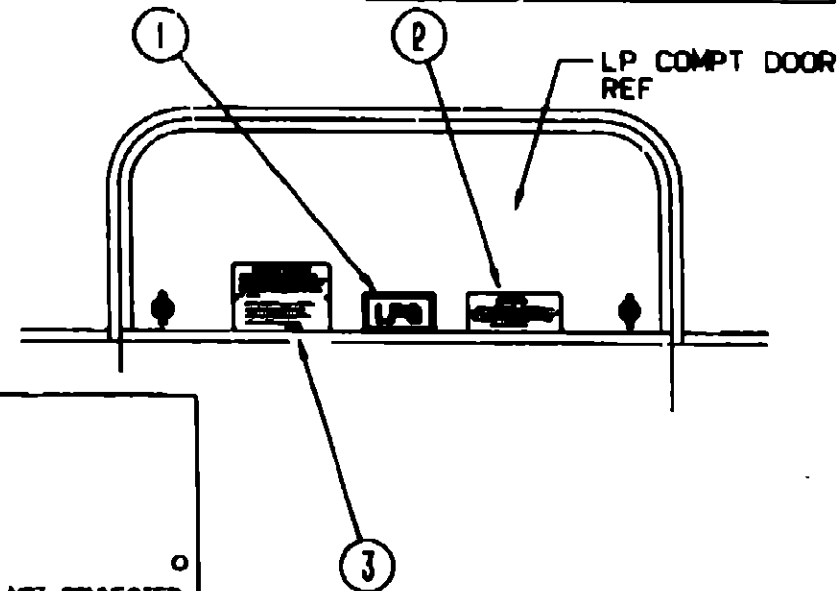

LP-GAS SYSTEM
THIS GAS PIPING SYSTEM IS DESIGNED FOR USE OF UNLEADED PETROLEUM GAS ONLY. DO NOT CONNECT NATURAL GAS TO THIS SYSTEM.

SECURELY CAP INLET(S) WHEN NOT CONNECTED FOR USE. AFTER TURNING ON GAS, EXCEPT AFTER NORMAL CONTAINER REPLACEMENT, TEST GAS PIPING AND CONNECTIONS TO APPLIANCE FOR LEAKAGE WITH SOAPY WATER OR BUBBLE SOLUTION. DO NOT USE PRODUCTS THAT CONTAIN AMMONIA OR CHLORINE.
P.N. 54631

KEY PART NUMBER	U/M	DESCRIPTION
1 074559-01-000	EA	DECAL-LOGO, LPG - RED - (CALIF CODE)
2 006040-01-000	EA	TAG-GAS REFUELING WARNING
2 006040-02-000	EA	TAG-GAS REFUEL WARNING, CANADIAN
3 054531-01-000	EA	LABEL-LP GAS ONLY
3 023769-01-000	EA	LABEL-WARNING, LPG - CANADIAN

LABEL & TAG GROUP CONTINUED

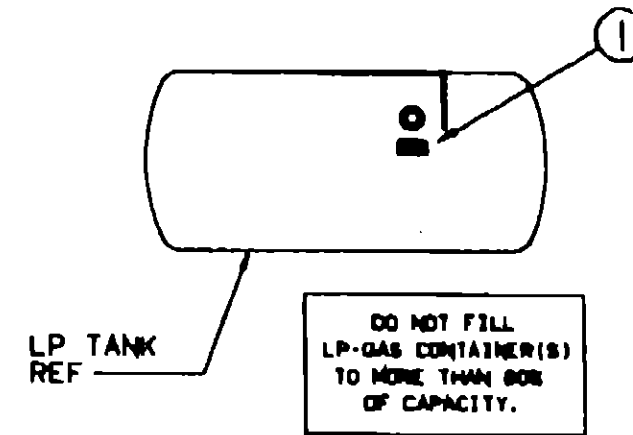

LP TANK REF

DO NOT FILL LP-GAS CONTAINER(S) TO MORE THAN 80% OF CAPACITY.

KEY PART NUMBER	U/M	DESCRIPTION
1 079985-01-000	EA	LABEL-LPG 80 CAPACITY

WARNING
OPEN GASOLINE CAP SLOWLY TO PREVENT SUDDEN RELEASE OF TANK PRESSURE. DO NOT OVERFILL TANK. REPLACE WITH EDOVELANT CAP ONLY

UNLEADED FUEL ONLY

WARNING
ALL PILOT LIGHTS AND APPLIANCES SHALL BE TURNED OFF DURING REFUELING OF MOTOR FUEL TANKS AND/OR PERMANENTLY MOUNTED LP-GAS CONTAINERS.

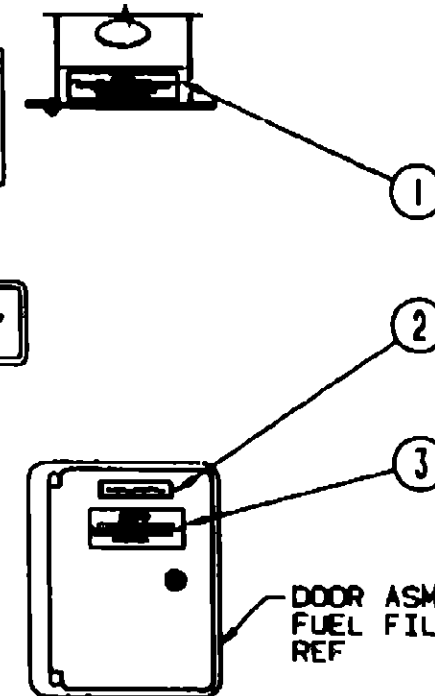

KEY PART NUMBER	U/M	DESCRIPTION
1 087207-05-000	EA	LABEL-FUEL CAP REMOVAL
2 062043-01-000	EA	LABEL-FUEL, UNLEADED
3 006040-01-000	EA	TAG-GAS REFUELING WARNING
3 006040-02-000	EA	TAG-GAS REFUEL WARNING, CANADIAN

1991 WINNEBAGO TABLE OF CONTENTS

INTRODUCTION	A-01 - A-02
ABBREVIATIONS	A-03
ALPHABETICAL INDEX	A-04 - A-09
WCN28RT	A-07 - G-10
WCN32RQ	G-11 - L-20

1991 WCN28RT INDEX

FLOOR PLAN	A-07 - A-08
ACCESSORIES	A-09 - A-24
BATH	B-01 - B-04
BEDROOM	B-05 - B-08
CHASSIS	B-09 - C-08
C C & PAD	C-07 - C-18
DINETTE	C-19 - C-20
DRIVERS	C-21 - C-24
ELECTRICAL	D-01 - D-08
EXTERIOR BODY	D-09 - D-18
GALLEY	D-19 - E-02
HEATING & A/C	E-03 - E-08
INTERIOR FINISH	E-09 - E-13
LABEL	E-14 - E-22
LP	E-23
LOUNGE	E-24 - F-01
SEALANTS & FASTENERS	F-02 - F-04
WATER & SEWAGE	F-05 - F-11
WINDOW, VENT AND EXTERIOR DOOR	F-12 - G-10

LP GROUP

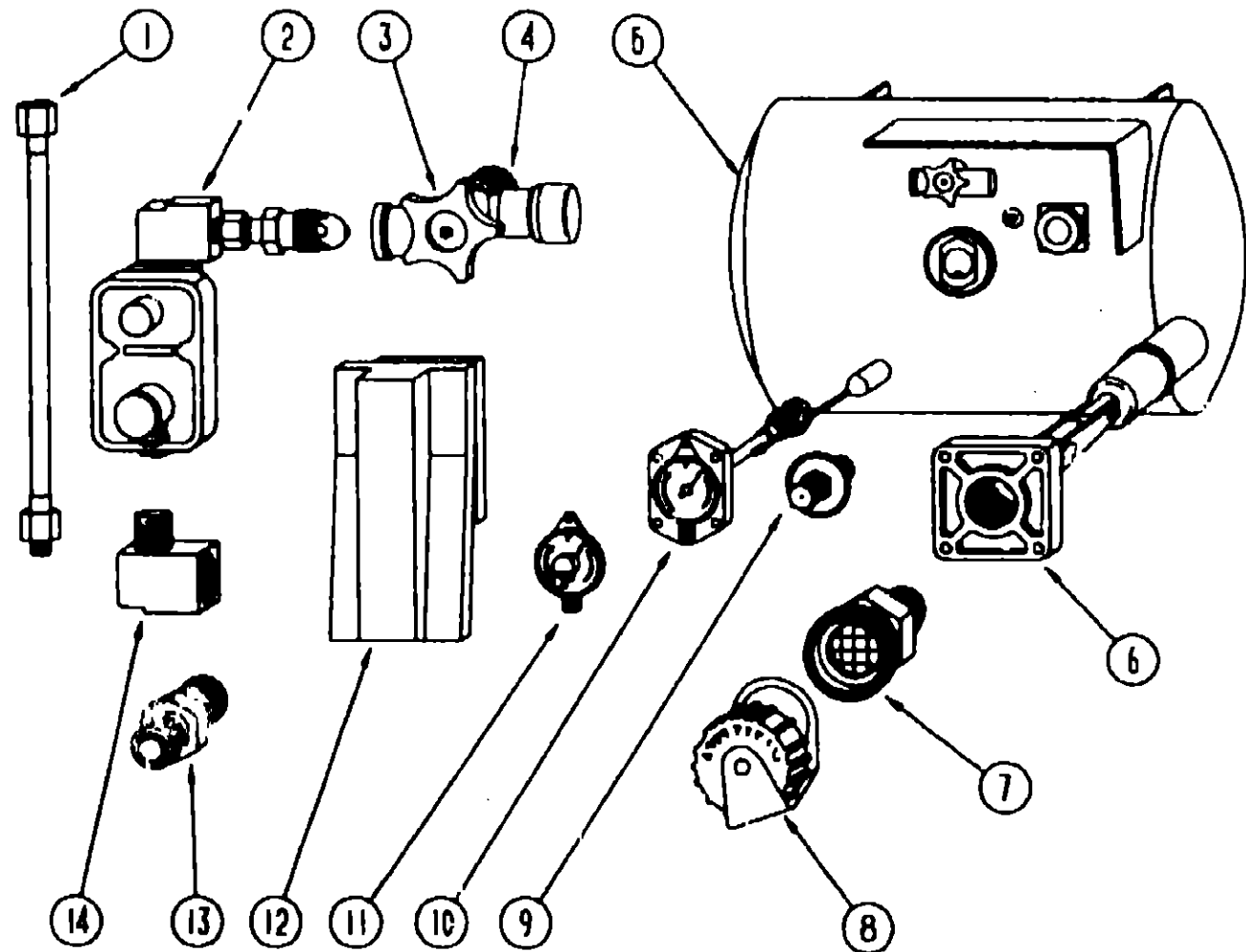

LP TANK & COMPONENTS

KEY PART NUMBER	U/M DESCRIPTION
1	045703-01-000 EA HOSE-LP, 3/8" ID X 24" US - 3/8 MPT X 1/2 F SWIVEL
1	045703-02-000 EA HOSE-LP, 3/8" ID X 24" - 3/8" MPT X 1/2" F SWIVEL - CANADA
2	078301-01-000 EA REGULATOR-LPG, TWO STAGE
3	040421-01-708 EA HANDWHEEL-VAPOR RELIEF VALVE, BRUNNER G-1015-A
4	040421-01-703 EA VALVE-SERVICE W/HANDWHEEL W/VAPOR RELIEF (REG009106CO) BRUNNER G-1015
5	091970-01-000 EA TANK-LP, 80 LBS - 20" X 24"
6	040421-01-711 EA VALVE-80% W/FLOAT, PLATE, BOLTS & GASKET - BRUNNER
7	040421-01-701 EA VALVE-SHORT LP FILLER W/YELLOW CAP - BRUNNER 75478
8	040421-01-702 EA CAP-LP FILLER VALVE, PLASTIC - YELLOW - BRUNNER G-1014-A
9	040421-01-700 EA GAUGE-LIQUID LEVEL, 20% LP - BRUNNER G-1013
10	040421-01-707 EA GAUGE-FLOAT W/VISIBLE DIAL - BRUNNER MA-9 6244-4
11	040440-01-000 EA TRANSMITTER-DIAL, 90 OHM
12	081938-01-000 EA COVER-COMPARTMENT - LP REGULATOR - BLACK
13	010329-01-000 EA ADAPTER-BRASS-1/2" F X 1/2" MPT
14	065318-02-000 EA ELBOW-90 DEGREE, 3/8" MPT TO 3/8" FPT
	010285-01-000 EA CROSS, 3/8" F X 3/8" F X 3/8" F X 1/2" FPT - BRASS
	010377-01-000 EA NUT-3/8" F - BRASS
	010377-02-000 EA NUT-BRASS, 3/8 FEMALE - FORGED
	010380-02-000 EA NUT-BRASS, 1/2" FEMALE - FORGED
	016188-03-000 EA GROMMET-GAS LINE, FLOOR - 3/8" HOLE X 2 1/8" DIAMETER RUBBER
	081642-01-000 EA TEE, 1/2" MPT X 1/2" FL X 3/8" FL - BRASS
	010497-05-000 EA CLAMP-CLOSED, .50" ID
	075148-02-000 EA CLAMP-GROUNDING, BRONZE SCREWS
	000300-01-000 EA GROMMET-RUBBER, 5/8" HOLE X 1 1/2" DIAMETER - BLACK
	010326-01-000 EA ADAPTER-FLARE, W/CONE GASKET 3/8" FEMALE FL X 1/2" MALE F
	065741-01-000 EA GAUGE-DIAPHRAGM PRESSURE - MARSHALLTOWN MFG
	065742-01-000 EA TEE, .38F X .38F X .25FPT - BRASS
	071391-02-000 EA NIPPLE-HEX, .25 PIPE
	008042-01-000 FT TUBING-VINYL, .65" ID
	054531-01-000 EA LABEL-LP GAS ONLY

FROM: 00-00-00 THRU: 04-29-90

FROM: 04-30-90 THRU: 99-99-99

FROM: 04-30-90 THRU: 99-99-99

LOUNGE GROUP

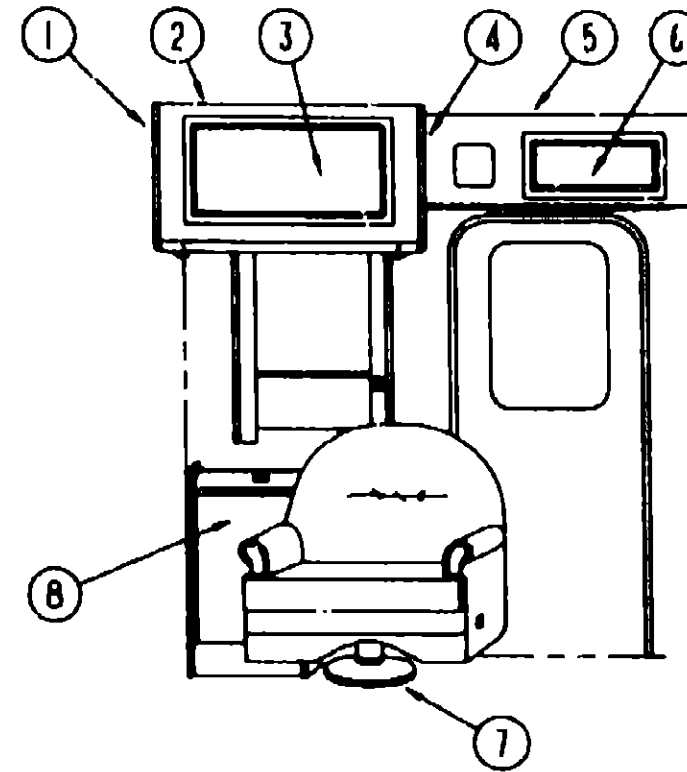

OVERHEAD CABINET & COMPONENTS

KEY PART NUMBER	U/M DESCRIPTION
1	092747-01-B07 EA END CAP-CABINET, OVERHEAD - FRONT
2	M04150-01-B07 EA CABINET-OVERHEAD, SWIVEL CHAIR - W/O DOORS OR HARDWARE
3	P00520-01-B07 EA DOOR-CABINET, W/O HARDWARE - 14.4" X 21.9"
4	092747-01-B07 EA END CAP-CABINET, OVERHEAD - FRONT
5	M04151-01-B07 EA CABINET-OVERHEAD, ENTRY DOOR - W/O DOORS OR HARDWARE
6	P00520-06-B07 EA DOOR-CABINET, W/O HARDWARE - 8.26" X 19.5"
7	093482-01-000 EA SHROUD-PEDESTAL, 13" - PLASTIC - BLACK
	093481-01-000 EA BASE-PEDESTAL, SWIVEL CHAIR - W/6" EXTENSION
8	M96873 02 AB6 EA TABLE ASM-PULLOUT
	096873 11 B05 EA PANEL ASM-PULLOUT TOP
	079921 01 000 EA ROLLER-NYLON, W/SHAFT
	009018 01 000 EA CATCH-ASM-SINGLE ROLLER
	080736 01 000 EA PULL-RECESSED, OAK 1 1/4 X 4

SEAT BELT

KEY PART NUMBER	U/M DESCRIPTION
007021-01-000	EA BELT-SEAT, 2" X 90" - BLACK

**1991 WINNEBAGO
TABLE OF CONTENTS**

INTRODUCTION	A-01 - A-02
ABBREVIATIONS	A-03
ALPHABETICAL INDEX	A-04 - A-06
WC:N28RT	A-07 - G-10
WC:N32RQ	G-11 - L-20

1991 WCN28RT INDEX

FLOOR PLAN	A-07 - A-08
ACCESSORIES	A-09 - A-24
BATH	B-01 - B-04
BEDROOM	B-05 - B-08
CHASSIS	B-09 - C-08
C & PAD	C-07 - C-18
DINETTE	C-19 - C-20
DRIVERS	C-21 - C-24
ELECTRICAL	D-01 - D-08
EXTERIOR BODY	D-09 - D-18
GALLEY	D-19 - E-02
HEATING & A/C	E-03 - E-08
INTERIOR FINISH	E-09 - E-13
LABEL	E-14 - E-22
LP	E-23
LOUNGE	E-24 - F-01
SEALANTS & FASTENERS	F-02 - F-04
WATER & SEWAGE	F-05 - F-11
WINDOW, VENT AND EXTERIOR DOOR	F-12 - G-10

LOUNGE GROUP (CONTINUED)

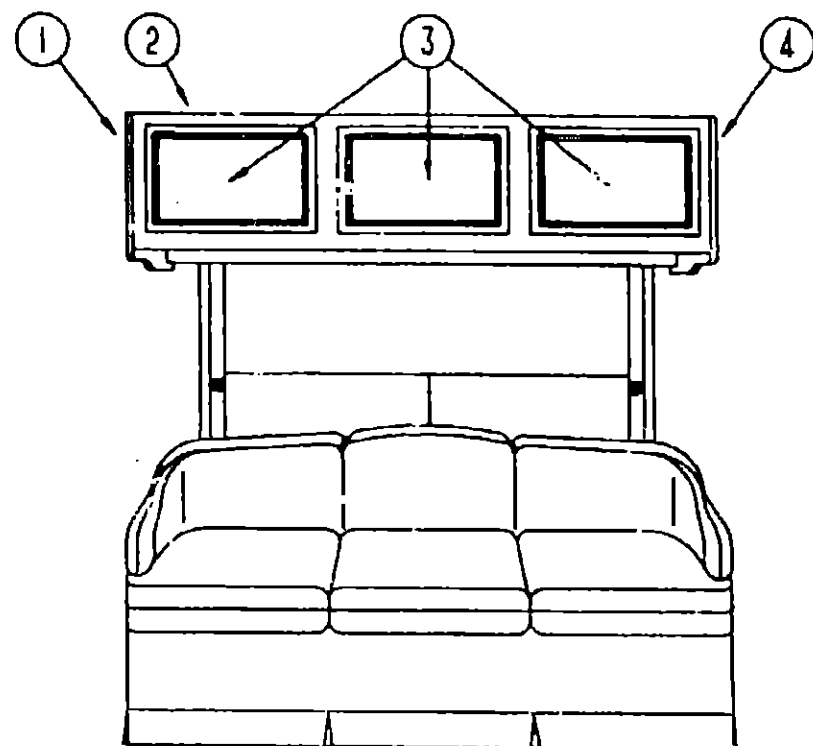

DRIVER SIDE CABINETS

KEY PART NUMBER	U/M	DESCRIPTION
1 092747-01-B07	EA	END CAP-CABINET, OVERHEAD FRONT OR REAR
2 M04154-07-B07	EA	CABINET-OVERHEAD, DINETTE - W/O DOORS OR HARDWARE
3 P00520-01-B07	EA	DOOR-CABINET, W/O HARDWARE - 14.4" X 21.9"
4 092747-01-B07	EA	END CAP-CABINET, OVERHEAD - FRONT OR REAR
079386-01-000	EA	FRAME-COUCH, CONTINENTAL
009040-04-000	EA	LEG-PEDESTAL TABLE, 27.5" X 2.25" OD - BROWN
041194-01-000	EA	BASE-TABLE, FLUSH - FLOOR MOUNTED
042438-02-000	EA	DOWEL-WOOD, 2" X 2"
009040-03-000	EA	BASE-TABLE, RAISED - TABLE MOUNTED
081298-01-B07	EA	TABLE-PEDESTAL, 17" X 24" TOP - W/O HARDWARE

SEAT BELT

KEY PART NUMBER	U/M	DESCRIPTION
056271-02-000	EA	BELT-SEAT, 2" X 72" - BLACK

SEALANTS & FASTENERS GROUP

SEALANTS AND FASTENERS

KEY PART NUMBER	U/M	DESCRIPTION
004020-01-000	QT	ADHESIVE-ABS CEMENT, QUART
081377-01-700	EA	ADHESIVE-CYANOACRYLATE, 10 GRAM TUBE
004006-04-700	EA	ADHESIVE-PIERCE, 1 GAL - J9270-X-1
087211-01-000	GL	ADHESIVE-PROMOTER
004005-02-000	EA	ADHESIVE-SWIFTS, 1 GAL - W1333
099039-01-000	EA	ADHESIVE-WEATHERSTRIP, 8 OZ
053766-02-000	EA	BEDDING COMPOUND-TUBE, WHITE
005200-01-000	EA	BOLT-BUMPER, ROUND HEAD-SQUARE NECK- W/SST CAP 7/16- 14 X 1 1/4
102333-01-01A	EA	BOLT-CARRIAGE, 7/16 - 14 - STAINLESS STEEL CAP- BEIGE
051387-06-000	EA	BOLT-CARRIAGE, W/O HOLE - 5/16-18 X 9.5 ZN
000C12-09-24B	EA	BOLT-HEX, 1/2-13 X 1 1/2 - ZN 5
000C12-05-16B	EA	BOLT-HEX, 5/16-18 X 1 - ZINC 5
000C12-10-24B	EA	BOLT-HEX, 5/8-11 X 1 1/2 ZN - 5
000C12-07-20B	EA	BOLT-HEX, 7/16 - 14 X 1 1/4" - ZN5
000C13-07-48B	EA	BOLT-HEX, 7/16 - 20 X 3 - ZN 5
000C26-04-10B	EA	BOLT-HEX, SER FLG - 1/4-20 X 5/8 ZINC
000C26-05-20B	EA	BOLT-HEX, SER FLG 5/16-18 X 1 1/4" - ZINC
000C12-05-24B	EA	BOLT-HEX-5/16-18X11/2 ZN 5
016604-01-000	EA	BRACE-CABINET, ANGLED METAL - 2.5"
010495-01-000	EA	CLAMP-CABLE, 9/16"
010497-06-000	EA	CLAMP-CLOSED, 11/16" ID
010497-03-000	EA	CLAMP-CLOSED, 1" ID - CUSHIONED
010499-01-000	EA	CLAMP-CLOSED, 3/8" ID
010497-01-000	EA	CLAMP-CLOSED, 5/8" ID
010497-08-000	EA	CLAMP-CLOSED, .125"
075148-02-000	EA	CLAMP-GROUNDING, BRONZE SCREWS
062401-02-000	EA	CLAMP-HOSE, WORMGEAR, 1.56" - 2.5"
062401-10-000	EA	CLAMP-HOSE, WORMGEAR 1.06" - 2"
073194-02-000	EA	CLAMP-HOSE, WORMGEAR 32-50 MM
062401-07-000	EA	CLAMP-HOSE, WORMGEAR 5" - 7"
062401-06-000	EA	CLAMP-HOSE, WORMGEAR .22"-.62"
062401-01-000	EA	CLAMP-HOSE, WORMGEAR .25" - 1"
062401-04-000	EA	CLAMP-HOSE, WORMGEAR .69" - 1.25"
062401-03-000	EA	CLAMP-HOSE WORMGEAR, .22" - 1"
083609-01-000	EA	CLAMP-WIRE, DUAL - EQUAL 5/8" DIAMETER
094362-02-000	EA	CLIP-CHRISTMAS TREE, FLAT HEAD
077953-01-000	EA	GROMMET-EDGE LINER, FITS 1"
023942-01-000	EA	GROMMET-RUBBER, 2" OD
071015-21-000	EA	GROMMET-.50"ID, FITS .19" MATERIAL, RUBBER- SPLIT
009066-01-000	EA	HINGE-ALUMINUM, NO HOLES - 11/16" X 72" - UNPAINTED
056134-02-000	EA	HOLDER-RING, 1.5" ID PIPE SIZE - STEEL
092321-01-000	FT	INSULATION-FIBERGLASS, W/ALUMINUM FOIL
077955-01-000	EA	J CLIP-VINYL COATED, 3/8" USED IN WIRING TO CLEARANCE LIGHTS
072893-01-000	EA	NUTSERT-M5 X 0, 8
077049-01-000	EA	NUT-ACORN, 10-32 ALUMINUM
095094-01-000	EA	NUT-ACORN, 1/4 - 20 ALUMINUM
000D14-05-00B	EA	NUT-HEX, 5/16-18 - ZN 5
000D31-04-00B	EA	NUT-HEX, LK 1/4 - 20 ZN
000D39-04-00B	EA	NUT-HEX, SER FLG LK 1/4 - 20 ZN
000D39-08-00B	EA	NUT-HEX, SER FLG LK - 1/2-13 ZN
000D39-06-00B	EA	NUT-HEX, SER FLG LK - 3/8-16 ZN
000D39-05-00B	EA	NUT-HEX, SER FLG LK - 5/16 - 18 ZN
000D44-07-00B	EA	NUT-HEX, SER FLG LK - 7/16-20 ZN
000D24-10-00B	EA	NUT-HEX, SF/LK - 10-32 ZN
000D34-06-00B	EA	NUT-HEX LK-3/8-16 GRADE C ZN
075467-01-000	EA	NUT-INVERTED FLARE, 1/4"
088497-02-000	EA	NUT-INVERTED FLARE, 1/4"
063253-07-000	EA	NUT-J, #8A .120-.130 PNL THK
044264-02-000	EA	NUT-SPEED, FLAT - ROUND
040921-06-000	EA	NUT-SPEED, U TYPE - NO. 8
040921-04-000	EA	NUT-SPEED, U TYPE - NO. 8
040921-05-000	EA	NUT-SPEED, U TYPE - NO.8
044364-01-000	EA	NUT-SPEED, FLAT
064081-01-000	EA	NUT-WING, 3/8" X 16 THREAD
084884-01-000	EA	PLUG-BRASS, 3/8"
000H16-04-06R	EA	RIVET-POP, AL 1/8 X .313-.375
069592-02-000	EA	RIVET-T (POP) 1/4X.093-.156
063729-04-000	EA	RIVNUT, 10-32 UNF - .010-.080
063729-01-000	EA	RIVNUT, 1/4 X 20 UNC - .030-.125

**1991 WINNEBAGO
TABLE OF CONTENTS**

INTRODUCTION	A-01 - A-02
ABBREVIATIONS	A-03
ALPHABETICAL INDEX	A-04 - A-06
WCN28RT	A-07 - G-10
WCN32RO	G-11 - L-20

1991 WCN28RT INDEX

FLOOR PLAN	A-07 - A-08
ACCESSORIES	A-09 - A-24
BATH	B-01 - B-04
BEDROOM	B-05 - B-08
CHASSIS	B-09 - C-06
C C & PAD	C-07 - C-18
DINETTE	C-19 - C-20
DRIVERS	C-21 - C-24
ELECTRICAL	D-01 - D-08
EXTERIOR BODY	D-09 - D-18
GALLEY	D-19 - E-02
HEATING & A/C	E-03 - E-08
INTERIOR FINISH	E-09 - E-13
LABEL	E-14 - E-22
LP	E-23
LOUNGE	E-24 - F-01
SEALANTS & FASTENERS	F-02 - F-04
WATER & SEWAGE	F-05 - F-11
WINDOW, VENT AND EXTERIOR DOOR	F-12 - G-10

SEALANTS & FASTENERS GROUP (CONTINUED)

SEALANTS AND FASTENERS

KEY PART NUMBER	U/M DESCRIPTION
000G67-10-24B	EA SCREW, 10-12 X 1 1/2 PPH - ZN
000G67-10-16P	EA SCREW, 10-12 X 1 PPH - DARK BROWN
000G67-10-16B	EA SCREW, 10-12 X 1 PPH - ZN
000G67-10-08B	EA SCREW, 10-12 X 1/2 PPH ZN
000G67-10-08R	EA SCREW, 10-12 X 1/2 PPH - BEIGE - TYPE A
000G67-10-12B	EA SCREW, 10-12 X 3/4 - PPH ZN
000G67-10-10B	EA SCREW, 10-12 X 5/8 PPH ZN - TYPE A
000G67-10-10R	EA SCREW, 10-12 X 5/8 PPH - TYPE A - BEIGE
000G67-10-12P	EA SCREW, 10-12 X .75 PPH - DARK BROWN
049465-01-000	EA SCREW, 10-16 W/WASHER PTH - DARK BROWN
049465-04-000	EA SCREW, 10-16 X 1 PTH W/WASHER - BEIGE
000G11-10-16B	EA SCREW, 10-16 X 1 - PPH ZN
000G11-10-12R	EA SCREW, 10-16 X 3/4 PPH - BEIGE
000G11-10-12D	EA SCREW, 10-16 X 3/4 PPH - BLACK
000G68-06-10G	EA SCREW, 6-18 X 5/8 POH - ANTIQUE BRASS
076790-01-000	EA SCREW, 6-20 X 1 1/4 PPH - BLACK
000G13-06-16R	EA SCREW, 6-20 X 1 PFH - BEIGE
000G13-06-08B	EA SCREW, 6-20 X 1/2 PFH ZN
000G13-06-10G	EA SCREW, 6-20 X 5/8 PFH - ANTIQUE BRASS
000G11-06-10B	EA SCREW, 6-20 X 5/8 PPH ZN
000G11-06-10J	EA SCREW, 6-20 X 5/8 PPH - BRASS
000G11-07-08B	EA SCREW, 7-19 X 1/2 PPH - ZN
000G13-07-12B	EA SCREW, 7-19 X 3/4 PFH ZN
000G13-08-16B	EA SCREW, 8-18 X 1 PFH - ZN
000G11-08-08T	EA SCREW, 8-18 X 1/2 PPH
000G11-08-08B	EA SCREW, 8-18 X 1/2 PPH ZN
000G11-08-12B	EA SCREW, 8-18 X 3/4 PPH ZN
000G11-08-12R	EA SCREW, 8-18 X 3/4 PPH - BEIGE
000G11-08-12D	EA SCREW, 8-18 X 3/4 PPH - BLACK
000G11-08-16R	EA SCREW, 8-18X1.00 PPH - BEIGE
000G67-10-32B	EA SCREW, NO. 10 - 12 X 2 PPH ZN
000G55-08-12W	EA SCREW, SF/DR-8-18X.75 PWH
000G67-10-12R	EA SCREW-10-12X.75 PPH BEIGE
000G67-10-120	EA SCREW-10-12X.75 PFH TAN
049465-03-000	EA SCREW-10-16X1.00 W/WASHER
000G11-10-12S	EA SCREW-10-16X.75 PFH OFF WHITE
000G54-04-20B	EA SCREW-1/4-20X1 1/4 PTH TYP 23
000G57-05-16J	EA SCREW-5-20X1.00 PFH BRASS
000G12-06-08T	EA SCREW-6-20 X .50 POH - BLACK
000G13-06-16J	EA SCREW-6-20X1.00 PFH BRASS
000G11-08-12P	EA SCREW-8-18X.75 DARK BROWN
085318-01-000	EA SCREW-8-08B X 1/2 CRIMPTITE HD
000G67-08-32B	EA SCREW-8-15X2 PPH ZN
000G12-08-16S	EA SCREW-8-18 X 1" POH - OFF WHITE
000G11-08-16S	EA SCREW-8-18X1.00 PPH OFF WHITE
009439-07-000	EA SCREW-8-32X1 1/4 POH BLACK
087721-01-000	EA SCREW-FLAT HEAD, TAPPING - 1/4 X 1 1/4 LG ZN
086763-01-000	EA SCREW-MACH, 10 - 32 X 1/4 PTH
000G19-10-08B	EA SCREW-MACH, 10-32 X 1/2 PPH ZN
000G19-10-10B	EA SCREW-MACH, 10-32 X 5/8 - PPH - ZINC
000G50-04-12B	EA SCREW-MACH, 1/4-20 X 3/4 PPH ZN
081908-01-000	EA SCREW-MACH 6-32X.62 W/NYLOCK
089371-01-000	EA SCREW-MACH 8-32X3 5/16 ZN
000G19-10-20B	EA SCREW-MACHINE, 10-32 X 1 1/4 PPH ZINC
000G18-08-16B	EA SCREW-MACHINE, 8 X 32 X 1, PPH ZN
075908-01-000	EA SCREW-MACH-10-32X.56PTH(5EMS
000G53-04-06B	EA SCREW-MACH-1/4-20X3/8 PPH 2N
000G18-08-22B	EA SCREW-MACH-8-32X1 3/8 PPH ZN
000G39-10-20B	EA SCREW-SF/DR, 10-16 X 1 1/4 PPH ZN
000G39-10-12R	EA SCREW-SF/DR, 10-16 X 3/4 PPH - BEIGE
000G39-10-12D	EA SCREW-SF/DR, 10-16 X 3/4 PPH - BLACK
000G39-06-16T	EA SCREW-SF/DR, 6-20 X 1 PPH - BLACK
000G39-06-10T	EA SCREW-SF/DR, 6-20 X 5/8 PPH - BLACK
000G39-08-24B	EA SCREW-SF/DR, 8-18 X 1 1/2 PPH ZN
000G39-08-16E	EA SCREW-SF/DR, 8-18 X 1 PPH CHROME
000G39-08-16B	EA SCREW-SF/DR, 8-18 X 1 PPH ZN
000G39-08-16T	EA SCREW-SF/DR, 8-18 X 1 PPH - BLACK
000G55-08-16Z	EA SCREW-SF/DR, 8-18 X 1.00 - BEIGE

SEALANTS & FASTENERS GROUP (CONTINUED)

SEALANTS AND FASTENERS

KEY PART NUMBER	U/M DESCRIPTION
000G39-08-08B	EA SCREW-SF/DR, 8-18 X 1/2 PPH ZN
000G39-08-32B	EA SCREW-SF/DR, 8-18 X 2 PPH - ZINC
000G39-08-12B	EA SCREW-SF/DR, 8-18 X 3/4 PPH ZN
000G39-08-12T	EA SCREW-SF/DR, 8-18 X 3/4 PPH - BLACK
000G39-08-06B	EA SCREW-SF/DR, 8-18 X 3/8 PPH ZN
000G60-10-28T	EA SCREW-SF/DR, 10-16X1.75
000G39-08-16R	EA SCREW-SF/DR 8-18X1.00 PPH BEIGE
000G39-08-08R	EA SCREW-SF/DR-8-18X1/2 PPH
079382-01-000	EA SCREW-SOCKET, 8-18 X 1" - BLACK
069640-02-000	FT SEALER-RIBBON, 1/2" X 1.8" - INCREMENTS OF 30'
069640-09-000	FT SEALER-RIBBON, 1/32" X 2 1/2"
069640-01-000	FT SEALER-RIBBON, 1/4" DIAMETER - INCREMENTS OF 20'
069640-03-000	FT SEALER-RIBBON, 3/4" X 1/8" - INCREMENTS OF 60'
069640-06-000	FT SEALER-RIBBON, 5/16" DIAMETER - INCREMENTS OF 25'
091255-03-000	FT SEAL-FOAM, 1/4 X 3/16 ROLL
091255-01-000	FT SEAL-FOAM, 3.2MM X 4.8MM
090340-01-000	FT SEAL-FOAM, CLOSED CELL - 1/4" X 1/2" X 50'
053752-01-000	GL SEAM SEALER-5 GAL, ALUMINUM
034552-04-000	EA SILICONE-TUBE, 300 ML - BEIGE
034552-02-000	EA SILICONE-TUBE, 300 ML - CLEAR
008401-01-000	EA STRAP-CONDUIT, 3/4" - 1 HOLE - GALVANIZED STEEL
100028-01-000	FT TAPE-ADHESIVE, .031" X .75" WIDE
004363-01-000	FT TAPE-ADHESIVE FOAM, 1 SIDE - 3/16" X 1/2" - GRAY
093071-01-000	FT TAPE-BONDING, DOUBLE SIDED - 1/64" X 2"
093071-01-000	FT TAPE-BONDING, DOUBLE SIDED - 1/64" X 2"
076322-03-000	FT TAPE-FOAM, DOUBLE COATED - .045" X .5"
088244-01-000	FT TAPE-FOAM, VINYL COATED - 2" WIDE - INCREMENTS OF 108 FT
009200-01-000	EA TAPE-FURNACE, 1 1/2"
087691-01-000	EA TAPE-MASKING, WEATHER RESISTANT
008343-02-000	EA TIE-WIRE, 14"
008343-01-000	EA TIE-WIRE, 6"
077071-01-000	EA WASHER-FENDER, 3/16" ID X 1" OD
000E13-14-00B	EA WASHER-FL, 1/4" WIDE ZN
000E13-11-00B	EA WASHER-FL, 3/16" WIDE ZN
000E13-17-00B	EA WASHER-FL-3/8 AR ZN

**1991 WINNEBAGO
TABLE OF CONTENTS**

INTRODUCTION	A-01 - A-02
ABBREVIATIONS	A-03
ALPHABETICAL INDEX	A-04 - A-06
WCN28RT	A-07 - G-10
WCN32RO	G-11 - L-20

1991 WCN28RT INDEX

FLOOR PLAN	A-07 - A-08
ACCESSORIES	A-09 - A-24
BATH	B-01 - B-04
BEDROOM	B-05 - B-08
CHASSIS	B-09 - C-06
C C & PAD	C-07 - C-18
DINETTE	C-19 - C-20
DRIVERS	C-21 - C-24
ELECTRICAL	D-01 - D-08
EXTERIOR BODY	D-09 - D-18
GALLEY	D-19 - E-02
HEATING & A/C	E-03 - E-08
INTERIOR FINISH	E-09 - E-13
LABEL	E-14 - E-22
LP	E-23
LOUNGE	E-24 - F-01
SEALANTS & FASTENERS	F-02 - F-04
WATER & SEWAGE	F-05 - F-11
WINDOW, VENT AND EXTERIOR DOOR	F-12 - G-10

WATER & SEWAGE GROUP GROUP

WATER SYSTEM

KEY PART NUMBER	U/M	DESCRIPTION
036522-02-000	EA	CAP-BRASS, 1/2" FLARE
039800-01-000	FT	TUBING-POLYBUTYL, 1/2" OD - INCREMENTS OF 20' - BLACK
046128-01-000	EA	VALVE-DRAIN, PLASTIC - 1/2" FPT
052952-01-000	EA	NUT-PLASTIC, 1/2" F X 1/2" TUBE - PLASTIC - GRAY
052953-01-000	EA	NUT-FAUCET, 1/2" TUBE X 1/2" FPT - PLASTIC - GRAY
052956-01-000	EA	TEE-1/2" F X 1/2" MPT X 1/2" F - PLASTIC
052956-02-000	EA	TEE-5/8" F X 1/2" MPT X 5/8" F, PLASTIC
079381-01-000	FT	TUBING-SMOOTH FLEXIBLE, 1 1/4" ID
052957-02-000	EA	ELBOW-MALE, 1/2" F X 1/2" MPT - PLASTIC - GRAY
052959-02-000	EA	CONNECTOR, 1/2" F X 1/2" MPT - PLASTIC - GRAY
052960-03-000	EA	DRAIN VALVE-IN LINE, HEADER - 5/8" F X 5/8" F - PLASTIC
057457-02-000	EA	ELBOW-UNION, 5/8" X 5/8" FL - WATER
065120-01-000	EA	ELBOW-SWIVEL, 1/2" FPT X 1/2" FLARE - PLASTIC - GRAY
070924-01-000	EA	ELBOW-SWIVEL, 1/2" MPT X 1/2" FPT - PLASTIC - GRAY
071015-08-000	EA	GROMMET-1.75"ID, FITS .06" MATERIAL, RUBBER
074462-02-000	FT	TUBING-VINYL, 3/8" ID - CLEAR
087659-04-000	EA	FILL-WATER, CITY - OFF WHITE
091246-02-000	EA	FAUCET-WATER, EXTERNAL - 90 DEGREE
093193-02-000	EA	DRAIN VALVE-IN LINE, HEADER - 1/2" MPT X 1/2" F X 1/2" M
096941-01-000	EA	VACUUM BREAKER-3/4 FPT X 3/4 MPT

DRAINAGE SYSTEM

KEY PART NUMBER	U/M	DESCRIPTION
011066-03-000	EA	P-TRAP, 1 1/2" TRAP X 1 1/4" SOCKET - PLASTIC
079968-01-000	EA	VENT-MECH. TRAP ARM, ANTI-SIPHON - 2" DIA. X 7.3" - PLASTIC
010166-01-000	EA	PLUG-THREADED, 1 1/4" DIAMETER - PLASTIC - BLACK
062422-01-000	EA	ADAPTER-OFFSET REDUCER, 3" X 1 1/2" - PLASTIC - BLACK
011956-01-000	EA	ELBOW-STREET, PLASTIC - 1/4" BD 3 X 90 XLT FROM: 00-00-00 THRU: 09-30-90
031126-01-000	EA	ELBOW-1/4 BEND, 3 X 90 XLT - PLASTIC - BLACK FROM: 10-01-90 THRU: 10-23-90 FROM: 10-24-90 THRU: 99-99-99
089355-01-000	EA	COUPLER-RUBBER, 1 1/2" X 1 1/2"
010122-01-000	EA	BUSHING-REDUCER, 1 1/2"SMOOTH X 1 1/4"THREAD - BLACK PLASTIC
010121-01-000	EA	BUSHING-REDUCER, 1 1/2"SMOOTH 1 1/4"HUB - PLASTIC - BLACK
010115-01-000	EA	COUPLING-1 1/2" HUB X HUB, PLASTIC
010079-01-000	EA	TEE-SANITARY, 1 1/2"H X 1 1/2"H X 1 1/4"H - PLASTIC - BLACK
010073-01-000	EA	WYE-45 DEGREE, 1 1/2" HUB X HUB X HUB - PLASTIC - BLACK
033761-01-000	EA	ELBOW-TURN, 1/4 BEND X 1.5"HUB X 1.5"SPIGOT - BLACK PLASTIC
034250-01-000	EA	ELBOW-90 DEGREE, LONG TURN - 1 1/2" HUB X HUB - ABS
010072-01-000	EA	TEE-SANITARY, 1 1/2" H X 1 1/4" H X 1 1/2" H - PLASTIC
010071-01-000	EA	TEE-SANITARY, 1 1/2" HUB X HUB X HUB - PLASTIC - BLACK
004020-01-000	QT	ADHESIVE-ABS CEMENT
044927-01-000	EA	ADAPTER-HOSE TO PIPE, 1 1/4"MPT X 1 1/4"BARB-BLACK PLASTIC
010006-01-000	EA	ELBOW-45 DEG, 1/8 BEND - 1 1/2" HUB X HUB - BLACK PLASTIC
010008-01-000	EA	ELBOW-90 DEG, 1/4 BEND - 1 1/2" HUB X HUB - BLACK PLASTIC

FRESH WATER TANK - 33 GALLON

KEY PART NUMBER	U/M	DESCRIPTION
077908-03-000	EA	TANK-WATER, W/FITTINGS - 33 GAL. - 36" X 22.6" X 10.5"
077908-01-000	EA	TANK-WATER, W/O FITTINGS - 33 GAL - 36" X 22.6" X 10.5"
042989-05-000	EA	FITTING-WATER TANK, SPINWELD - 1/2" FPT - PLASTIC - WHITE
042989-06-000	EA	FITTING-SPINWELD, PLASTIC - 3/4 FPT
049032-01-000	EA	PATCH-SPINWELD, 3/8" - PLASTIC
039861-01-000	EA	SENDING UNIT W/SCREW, WASHER, WELL NUT AND TERMINAL RING
077954-02-000	EA	FILTER-WATER TANK, SCREEN IN TANK
052957-04-000	EA	ELBOW-5/8" F X 3/4" MPT
052959-02-000	EA	CONNECTOR, 1/2" F X 1/2" MPT - PLASTIC - GRAY
035539-01-000	EA	ELBOW-PLASTIC, 3/8"MPT X 3/8"BARB

WATER & SEWAGE GROUP (CONTINUED)

WATER PURIFICATION OPTION L29B

KEY PART NUMBER	U/M	DESCRIPTION
039800-01-000	FT	TUBING-POLYBUTYL, 1/2" OD - INCREMENTS OF 20' - BLACK FROM: 00-00-00 THRU: 11-25-90
039800-02-000	FT	TUBING-POLYBUTYL, 5/8" OD - INCREMENTS OF 20' - BLACK FROM: 11-26-90 THRU: 99-99-99
052952-01-000	EA	NUT-PLASTIC, 1/2" F X 1/2" TUBE - PLASTIC - GRAY
052957-01-000	EA	ELBOW-PLASTIC, 1/2" F X 3/8" MPT
052959-02-000	EA	CONNECTOR, 1/2" F X 1/2" MPT - PLASTIC - GRAY
065120-01-000	EA	ELBOW-SWIVEL, 1/2" FPT X 1/2" FLARE - PLASTIC - GRAY
087200-01-000	EA	FILTER-WATER PURIFICATION, EVERPURE OC2-AC
087200-02-000	EA	CARTRIDGE-WATER FILTER, EVERPURE 9601-11

WATER HEATER BYPASS VALVE OPTION L53J

KEY PART NUMBER	U/M	DESCRIPTION
039800-01-000	FT	TUBING-POLYBUTYL, 1/2" OD - INCREMENTS OF 20' - BLACK
052952-01-000	EA	NUT-PLASTIC, 1/2" F X 1/2" TUBE - PLASTIC - GRAY
052957-02-000	EA	ELBOW-MALE, 1/2" F X 1/2" MPT - PLASTIC - GRAY
052958-01-000	EA	TEE, 1/2" F X 1/2" F X 1/2" F - PLASTIC - GRAY
099729-01-000	EA	BYPASS KIT-WATER HEATER

EXTERIOR SHOWER STANDARD

KEY PART NUMBER	U/M	DESCRIPTION
079364-06-000	EA	SWITCH-MOMENTARY, OFF/MOM/ON
098351-01-01A	EA	PLATE-SWITCH, 1 GANG - POLISHED BRASS
046128-01-000	EA	VALVE-DRAIN, PLASTIC - 1/2" FPT
052957-02-000	EA	ELBOW-MALE, 1/2" F X 1/2" MPT - PLASTIC - GRAY
076322-02-000	FT	TAPE-FOAM, DOUBLE COATED ADHESIVE BACKED - 1" X 108"
104579-01-000	FT	SEAL-FOAM, CLOSED CELL
103173-01-01A	EA	KIT-SHOWER, EXTERIOR - OFF WHITE WITH EXTERIOR DOOR, FAUCET, HEAD & HOSE FROM: 02-04-91 THRU: 03-24-91
103173-02-01A	EA	KIT-SHOWER, EXTERIOR - OFF WHITE WITH EXTERIOR DOOR, FAUCET, HEAD & HOSE FROM: 03-25-91 THRU: 99-99-99

WATER HEATER W/MOTOR AID & REAR HEATER OPTION L611

KEY PART NUMBER	U/M	DESCRIPTION
051393-01-000	EA	WATER HEATER-W/MOTOR AID, PILOTLESS IGNITION ATWOOD GH6-4E OR GH6-6E
051391-01-700	EA	HINGE KIT-W/CLIP, ATWOOD # 92568 & 92559
051391-01-704	EA	VALVE-RELIEF, 1/2" FITTING - ATWOOD# 91604
051391-01-705	EA	FASTENER-CAMLOC, ATWOOD# 92609
051391-04-703	EA	BURNER-MAIN, 4E AND 6E - ATWOOD #91638
051391-01-710	EA	ORIFICE-MAIN BURNER, ATWOOD# 92742
051391-04-701	EA	THERMOSTAT 12 VDC-120 PRESET, FRONT MOUNT ONLY - ATWOOD# 91470
051391-01-715	EA	DRAIN PLUG, ATWOOD# 91561
051391-04-704	EA	TANK-INNER (FRONT-MT), GH6-4E&6E - ATWOOD# 91642
051391-04-707	EA	KIT-GRILLE, FLUE, & GASKET - ATWOOD# 90960
051393-01-700	EA	TANK-INNER, 3E FRONT MOUNT - ATWOOD# 91023
051393-01-701	EA	SWITCH PACKAGE-ATWOOD# 91959
051393-01-702	EA	SWITCH-ENERGY CUT-OFF, ATWOOD# 91951
051393-01-703	EA	THERMOSTAT-REAR MOUNT, ATWOOD# 91952
051393-01-704	EA	CIRCUIT BOARD-W/BLACK BOX, ATWOOD# 91420
051393-01-705	EA	ORIFICE HOLDER-ATWOOD# 91925
051393-01-716	EA	PROBE & SPARK ASM, ATWOOD# 91606
051391-01-708	EA	BURNER-MAIN, 3E ONLY - ATWOOD# 92615
051393-01-718	EA	VALVE-DUAL SOLENOID, ATWOOD# 91605
051393-01-713	EA	BRACKET-CORNER, PACKAGE OF 4 - ATWOOD# 91838
051393-01-714	EA	TANK-INNER (GH6-3E), REAR MOUNT - ATWOOD# 91408
051393-01-720	EA	KNOB-TEMPERATURE, ATWOOD# 92310
051393-01-721	EA	ECO&THERMOSTAT ASM-FRONT MOUNT, 140 DEGREE - ATWOOD# 91447
062401-01-000	EA	CLAMP-HOSE, WORMGEAR .25" - 1"
079059-02-000	EA	HOSE-90 DEGREE, .61"ID X 4" X 6"
083081-01-000	EA	HOSE-FORMED, 90 DEGREES - 5/8" ID
007108-01-000	FT	HOSE-HEATER, 5/8" ID
008753-01-000	FT	TUBE-ALUMINIZED STEEL, 5/8" - 18 GAUGE
010227-01-000	EA	TEE-PLASTIC, BARB 5/8" ON 3/4" HOSE

**1991 WINNEBAGO
TABLE OF CONTENTS**

INTRODUCTION	A-01 - A-02
ABBREVIATIONS	A-03
ALPHABETICAL INDEX	A-04 - A-06
WCN28RT	A-07 - G-10
WCN32RO	G-11 - L-20

1991 WCN28RT INDEX

FLOOR PLAN	A-07 - A-08
ACCESSORIES	A-09 - A-24
BATH	B-01 - B-04
BEDROOM	B-05 - B-08
CHASSIS	B-09 - C-06
C C & PAD	C-07 - C-18
DINETTE	C-19 - C-20
DRIVERS	C-21 - C-24
ELECTRICAL	D-01 - D-08
EXTERIOR BODY	D-09 - D-18
GALLEY	D-19 - E-02
HEATING & A/C	E-03 - E-08
INTERIOR FINISH	E-09 - E-13
LABEL	E-14 - E-22
LP	E-23
LOUNGE	E-24 - F-01
SEALANTS & FASTENERS	F-02 - F-04
WATER & SEWAGE	F-05 - F-11
WINDOW, VENT AND EXTERIOR DOOR	F-12 - G-10

WATER & SEWAGE GROUP (CONTINUED)

WATER PUMPS

KEY PART NUMBER	U/M DESCRIPTION
045729-01-000	EA PUMP-WATER, W/ 5MPT FITTINGS - FLOW 2.8 GPM - SHURFLOW PUMP HAS BEEN REPLACED BY 098607-01-000 FROM: 00-00-00 THRU: 09-17-90
045729-01-701	EA BASEPLATE-KIT, SHURFLOW# 94-052
045729-01-702	EA DIAPHRAGM-KIT, SHURFLOW# 94-213-00
045729-01-703	EA VALVE ASM-KIT, SHURFLOW# 94-110
045729-01-704	EA UPPER HOUSING-SHURFLOW# 94-025-00
045729-01-705	EA SWITCH CAP KIT W/SWITCH-SHURFLOW# 94-255-01
045729-01-706	EA PUMPHEAD-SHURFLOW# 94-058-11
098607-01-000	EA PUMP-WATER, W/ 5" MPT FITTING - FLOW 2.8 GPM - UL FROM: 09-18-90 THRU: 99-99-99
098607-01-700	EA PUMPHEAD-REPLACEMENT, SHURFLOW# 94-236-08
098607-01-701	EA DRIVE ASM, SHURFLOW# 94-234-03
098607-01-702	EA DIAPHRAGM-KIT, SHURFLOW# 94-233-10
098607-01-703	EA VALVE ASM, SHURFLOW# 94-232-00
098607-01-704	EA HOUSING-UPPER, SHURFLOW# 94-231-01
098607-01-705	EA CHECK VALVE-KIT, SHURFLOW# 94-237-00
098607-01-707	EA MOTOR/BASEPLATE REPLACEMENT, SHURFLOW# 94-234-03

WATER PUMP - CANADIAN

KEY PART NUMBER	U/M DESCRIPTION
045729-02-000	EA PUMP-WATER, W/ 5MPT FITTINGS - FLOW 2.8 GPM - SHURFLOW PUMP HAS BEEN REPLACED BY 098607-02-000 FROM: 00-00-00 THRU: 09-17-90
045729-01-701	EA BASEPLATE-KIT, SHURFLOW# 94-052
045729-01-702	EA DIAPHRAGM-KIT, SHURFLOW# 94-213-00
045729-01-703	EA VALVE ASM-KIT, SHURFLOW# 94-110
045729-01-704	EA UPPER HOUSING-SHURFLOW# 94-025-00
045729-01-705	EA SWITCH CAP KIT W/SWITCH-SHURFLOW# 94-255-01
045729-01-706	EA PUMPHEAD-SHURFLOW# 94-058-11
098607-02-000	EA PUMP-WATER, 2.8 GPM - W/ 1/2" MPT FITTINGS - CANADIAN FROM: 09-18-90 THRU: 99-99-99
098607-01-700	EA PUMPHEAD-REPLACEMENT, SHURFLOW# 94-236-08
098607-01-701	EA DRIVE ASM, SHURFLOW# 94-234-03
098607-01-702	EA DIAPHRAGM-KIT, SHURFLOW# 94-233-10
098607-01-703	EA VALVE ASM, SHURFLOW# 94-232-00
098607-01-704	EA HOUSING-UPPER, SHURFLOW# 94-231-01
098607-01-705	EA CHECK VALVE-KIT, SHURFLOW# 94-237-00
098607-01-706	EA SWITCH ASM-COMPLETE, SHURFLOW# 94-230-00
098607-01-707	EA MOTOR/BASEPLATE REPLACEMENT, SHURFLOW# 94-234-03

WATER HEATER & WATER HEATER DOOR

KEY PART NUMBER	U/M DESCRIPTION
051391-03-000	EA HEATER-WATER, W/ELECTRIC IGNITION - ATWOOD# G6A-3E
051391-01-700	EA HINGE KIT-W/CLIP, ATWOOD# 92568 & 92559
051393-03-700	EA TANK-INNER (G6A-3E), REAR MT - ATWOOD# 91409
051391-01-704	EA VALVE-RELIEF, 1/2" FITTING - ATWOOD# 91604
051391-01-705	EA FASTENER-CAMLOC, ATWOOD# 92609
051391-01-706	EA GRILLE-EXHAUST, 3E ONLY - ATWOOD# 92787
051391-01-708	EA BURNER-MAIN, 3E ONLY - ATWOOD# 92615
051391-01-710	EA ORIFICE-MAIN BURNER, ATWOOD# 92742
051391-04-701	EA THERMOSTAT 12 VDC-120 PRESET, FRCNT MOUNT ONLY ATWOOD# 91470
051391-01-715	EA DRAIN PLUG, ATWOOD# 91561
051391-04-700	EA TANK-INNER (G6A-3E), FRONT MT - ATWOOD# 91608
051393-01-704	EA CIRCUIT BOARD-W/BLACK BOX, ATWOOD# 91420
051393-01-702	EA SWITCH-ENERGY CUT-OFF, ATWOOD# 91951
051393-01-701	EA SWITCH PACKAGE-ATWOOD# 91959
051393-01-703	EA THERMOSTAT-REAR MOUNT, ATWOOD# 91952
051393-01-721	EA ECO&THERMOSTAT ASM-FRONT MOUNT, 140 DEGREE ATWOOD# 91447
051393-C1-716	EA SPARK & PROBE ASM, ATWOOD# 91606
051393-01-718	EA VALVE-DUAL SOLENOID, ATWOOD# 91605
051393-01-705	EA ORIFICE HOLDER-ATWOOD# 91925
052009-02-000	EA DOOR-WATER HEATER, ATWOOD 5576-27 - BEIGE

WATER & SEWAGE GROUP (CONTINUED)

WATER SYSTEM COMPONENTS CONTINUED TO FAUCETS

KEY PART NUMBER	U/M DESCRIPTION
039800-01-000	FT TUBING-POLYBUTYL, 1/2" OD - INCREMENTS OF 20' - BLACK
039800-02-000	FT TUBING-POLYBUTYL, 5/8" OD - INCREMENTS OF 20' - BLACK
052952-01-000	EA NUT-PLASTIC, 1/2" F X 1/2" TUBE - PLASTIC - GRAY
052952-02-000	EA NUT-PLASTIC, 5/8" FLARE
052955-01-000	EA TEE-WATER, 1/2" F X 1/2" F X 1/2" MPT - PLASTIC - GRAY
052957-01-000	EA ELBOW-PLASTIC, 1/2" F X 3/8" MPT
052957-02-000	EA ELBOW-MALE, 1/2" F X 1/2" MPT - PLASTIC - GRAY
052958-01-000	EA TEE, 1/2" F X 1/2" F X 1/2" F - PLASTIC - GRAY
052959-03-000	EA CONNECTOR, 1/2" F X 3/8" MPT - PLASTIC - GRAY
052960-01-000	EA DRAIN VALVE-IN LINE, HEADER - 1/2" F X 1/2" F - GRAY PLASTIC
057457-01-000	EA ELBOW-UNION, 1/2" X 1/2" FLARE
062401-03-000	EA CLAMP-HOSE WORMGEAR, .22" - 1"
065120-01-000	EA ELBOW-SWIVEL, 1/2" FPT X 1/2" FLARE - PLASTIC - GRAY
079317-01-000	EA ADAPTER-SWIVEL, 1/2" TUBE X 1/2" FPT - PLASTIC - GRAY
093217-01-000	EA TEE-SWIVEL, 1/2" - PLASTIC
091208-01-000	EA WASHER-RUBBER, .06" X .75" X .5"
052959-03-000	EA CONNECTOR, 1/2" F X 3/8" MPT - PLASTIC - GRAY
052953-01-000	EA NUT-FAUCET, 1/2" TUBE X 1/2" FPT - PLASTIC - GRAY
075240-05-000	EA FAUCET-LAVATORY, BRASS
091253-01-000	EA GASKET-FAUCET, LAVATORY/GALLEY
064952-01-000	EA FAUCET-GALLEY
075241-04-000	EA FAUCET-SHOWER, BRASS
011048-02-000	EA HEAD-SHOWER, W/60" HOSE

WASTE WATER HOLDING TANK

KEY PART NUMBER	U/M DESCRIPTION
092271-01-000	EA TANK-HOLDING, W/O GROMMETS - 30 GL - 16.6" X 59.9" X 9.7" FROM: 00-00-00 THRU: 10-28-90
101707-01-000	EA TANK-HOLDING, W/O GROMMETS - 42 GL - 24.6" X 59.9" X 8.8" FROM: 10-29-90 THRU: 99-99-99
061607-01-000	EA GROMMET-HOLDING TANK, 1 1/2" NPS
039861-01-000	EA SENDING UNIT W/SCREW, WASHER, WELL NUT AND TERMINAL RING

SEWAGE HOLDING TANK

KEY PART NUMBER	U/M DESCRIPTION
092272-01-000	EA TANK-HOLDING, W/O GROMMETS - 50 GL - 25.8" X 59.9" X 18.6" FROM: 00-00-00 THRU: 10-28-90
101786-01-000	EA TANK-HOLDING, W/O GROMMETS - 38 GL - 21.6" X 59.9" X 8.7" FROM: 10-29-90 THRU: 99-99-99
061607-01-000	EA GROMMET-HOLDING TANK, 1 1/2" NPS
061607-02-000	EA GROMMET-HOLDING TANK, 3" NPS
039861-01-000	EA SENDING UNIT W/SCREW, WASHER, WELL NUT AND TERMINAL RING

DRAINAGE VALVES & HOSE

KEY PART NUMBER	U/M DESCRIPTION
062422-01-000	EA ADAPTER-OFFSET REDUCER, 3" X 1 1/2" - PLASTIC - BLACK
070916-01-000	EA VALVE-DUAL DUMP, W/CAP - 3" X 1 1/2" - PLASTIC - BLACK
070916-01-700	EA VALVE ONLY, 3"
070916-01-701	EA VALVE ONLY, 1 1/2"
062419-02-700	EA HANDLE ONLY - FOR EXTENSION ROD
062415-01-000	EA CAP-SEWER, 3" DIAMETER
078406-01-000	EA COUPLER-RUBBER, W/CLAMPS - 3" X 3"
103354-01-000	EA CONNECTOR-HOSE, SEWER
093592-01-000	EA ADAPTER-PLASTIC, SEWER HOSE - 45 DEGREE
089330-01-000	EA ADAPTER-SEWER HOSE END
010201-02-000	EA HOSE-SEWER, 3 ID X 20 FEET
083558-01-000	EA VENT-PLUMBING PIPE ROOF, W/COVER - BEIGE

**1991 WINNEBAGO
TABLE OF CONTENTS**

INTRODUCTION	A-01 - A-02
ABBREVIATIONS	A-03
ALPHABETICAL INDEX	A-04 - A-06
WCN28RT	A-07 - G-10
WCN32RQ	G-11 - L-20

1991 WCN28RT INDEX

FLOOR PLAN	A-07 - A-08
ACCESSORIES	A-09 - A-24
BATH	B-01 - B-04
BEDROOM	B-05 - B-08
CHASSIS	B-09 - C-06
C C & PAD	C-07 - C-18
DINETTE	C-19 - C-20
DRIVERS	C-21 - C-24
ELECTRICAL	D-01 - D-08
EXTERIOR BODY	D-09 - D-18
GALLEY	D-19 - E-02
HEATING & A/C	E-03 - E-08
INTERIOR FINISH	E-09 - E-13
LABEL	E-14 - E-22
LP	E-23
LOUNGE	E-24 - F-01
SEALANTS & FASTENERS	F-02 - F-04
WATER & SEWAGE	F-05 - F-11
WINDOW, VENT AND EXTERIOR DOOR	F-12 - G-10

WATER & SEWAGE GROUP (CONTINUED)

SINK

KEY PART NUMBER	U/M DESCRIPTION
057671-01-000	EA COVER-SCREW, #8 - PLASTIC - OFF WHITE
093526-01-000	EA SINK-DOUBLE, STAINLESS STEEL - 19" X 25"
096927-01-01A	EA SINK-LAVATORY, RECTANGULAR - PLASTIC - BONE
096927-01-700	EA SINK-STOPPER
092303-01-000	EA STRAINER-SINK
096927-01-701	EA TAILPIECE-SINK

WATER HEATER BYPASS VALVE OPTION L53J - TWIN BED

KEY PART NUMBER	U/M DESCRIPTION
039800-01-000	FT TUBING-POLYBUTYL, 1/2" OD - INCREMENTS OF 20' - BLACK FROM: 00-00-00 THRU: 02-03-91
039800-02-000	FT TUBING-POLYBUTYL, 5/8" OD - INCREMENTS OF 20' - BLACK FROM: 02-04-91 THRU: 99-99-99
052952-01-000	EA NUT-PLASTIC, 1/2" F X 1/2" TUBE - PLASTIC - GRAY FROM: 00-00-00 THRU: 02-03-91
052952-02-000	EA NUT-PLASTIC, 5/8" FLARE FROM: 02-04-91 THRU: 99-99-99
052955-01-000	EA TEE-WATER, 1/2" F X 1/2" F X 1/2" MPT - PLASTIC - GRAY FROM: 00-00-00 THRU: 02-03-91
052955-03-000	EA TEE-5/8" F X 5/8" F X 1/2" MPT - PLASTIC FROM: 02-04-91 THRU: 03-31-91
055291-01-000	EA TEE-PLASTIC, 5/8" F X 5/8" F X 5/8" F FROM: 04-01-91 THRU: 99-99-99
052957-02-000	EA ELBOW-MALE, 1/2" F X 1/2" MPT - PLASTIC - GRAY FROM: 00-00-00 THRU: 02-03-91
052959-02-000	EA CONNECTOR, 1/2" F X 1/2" MPT - PLASTIC - GRAY USED FROM 000000 TO 02-03-91 AND FROM 04-01-91 TO 999999
093217-01-000	EA TEE-SWIVEL, 1/2" - PLASTIC FROM: 00-00-00 THRU: 02-03-91
055290-01-000	EA ELBOW-5/8" F X 1/2" MPT FROM: 02-04-91 THRU: 99-99-99
098417-01-000	EA CONNECTOR-5/8" F X 1/2" MPT, PLASTIC - KEVCO FROM: 02-04-91 THRU: 03-31-91
101814-01-000	EA COUPLING-FEMALE, 1/2" X 1/2" FPT FROM: 02-04-91 THRU: 03-31-91
099729-01-000	EA BYPASS KIT-WATER HEATER

WATER HEATER BYPASS VALVE OPTION L53J- QUEEN BED

KEY PART NUMBER	U/M DESCRIPTION
039800-01-000	FT TUBING-POLYBUTYL, 1/2" OD - INCREMENTS OF 20' - BLACK FROM: 02-04-91 THRU: 99-99-99
039800-02-000	FT TUBING-POLYBUTYL, 5/8" OD - INCREMENTS OF 20' - BLACK FROM: 00-00-00 THRU: 02-03-91
052952-01-000	EA NUT-PLASTIC, 1/2" F X 1/2" TUBE - PLASTIC - GRAY FROM: 00-00-00 THRU: 02-03-91
052952-02-000	EA NUT-PLASTIC, 5/8" FLARE FROM: 02-04-91 THRU: 99-99-99
052955-01-000	EA TEE-WATER, 1/2" F X 1/2" F X 1/2" MPT - PLASTIC - GRAY FROM: 00-00-00 THRU: 07-27-90
052956-01-000	EA TEE-1/2" F X 1/2" MPT X 1/2" F - PLASTIC FROM: 00-00-00 THRU: 02-03-91
055291-01-000	EA TEE-PLASTIC, 5/8" F X 5/8" F X 5/8" F FROM: 02-04-91 THRU: 99-99-99
052959-02-000	EA CONNECTOR, 1/2" F X 1/2" MPT - PLASTIC - GRAY FROM: 00-00-00 THRU: 02-03-91
065120-01-000	EA ELBOW-SWIVEL, 1/2" FPT X 1/2" FLARE - PLASTIC - GRAY FROM: 00-00-00 THRU: 02-03-91
055290-01-000	EA ELBOW-5/8" F X 1/2" MPT FROM: 02-04-91 THRU: 99-99-99
055291-01-000	EA TEE-PLASTIC, 5/8" F X 5/8" F X 5/8" F FROM: 02-04-91 THRU: 99-99-99
098417-01-000	EA CONNECTOR-5/8" F X 1/2" MPT, PLASTIC - KEVCO FROM: 02-04-91 THRU: 03-31-91
099729-01-000	EA BYPASS KIT-WATER HEATER

WATER & SEWAGE GROUP (CONTINUED)

SHOWER PAN

KEY PART NUMBER	U/M DESCRIPTION
M02630-15-B07	EA PAN-SHOWER, W/STRAINER & TAILPIECE
066440-01-000	EA STRAINER W/RUBBER WASHER
069640-06-000	FT SEALER-RIBBON, 5/16" DIAMETER - INCREMENTS OF 25'
069735-01-000	EA WASHER-STRAINER TO TAILPIECE PLASTIC, 1.5"
057671-01-000	EA COVER-SCREW, #8 - PLASTIC - OFF WHITE
011069-02-000	EA TAILPIECE-TUB/SHOWER, 1 1/2" X 1 1/4" X 4" - BRASS
066436-01-000	EA NUT-SLIP, TAILPIECE - 1.5"

TOILET

KEY PART NUMBER	U/M DESCRIPTION
06-1076-01-000	EA TOILET-THETFORD, MODEL 50 - 15.6" X 18.9" X 11.1" - IVORY
039341-02-704	EA SEAT & CVR SET SL & SH NEWSTYLE, THETFORD 08855
700011-14-003	EA BREAKER VACUUM WHITE, THETFORD 8200
039341-02-703	EA PLUG-HOLE IVORY, THETFORD 03895-10
039341-01-700	EA MECH-ASM-SH SL & SH GL & GH, THETFORD 15283
039341-02-705	EA MOUNTING PKG A.M., 08975
064076-01-701	EA MECHANISM STARLIGHT IVORY, THETFORD 14622 AFT 3/85
067487-01-701	EA WATER SAVER PKG., THETFORD 08993
067487-01-702	EA CLAMP, THETFORD 03752
063641-01-000	EA FLANGE-CLOSET, 4" X 3"

**1991 WINNEBAGO
TABLE OF CONTENTS**

INTRODUCTION	A-01 - A-02
ABBREVIATIONS	A-03
ALPHABETICAL INDEX	A-04 - A-06
WCN28RT	A-07 - G-10
WCN32RQ	G-11 - L-20

1991 WCN28RT INDEX

FLOOR PLAN	A-07 - A-08
ACCESSORIES	A-09 - A-24
BATH	B-01 - B-04
BEDROOM	B-05 - B-08
CHASSIS	B-09 - C-06
C C & PAD	C-07 - C-18
DINETTE	C-19 - C-20
DRIVERS	C-21 - C-24
ELECTRICAL	D-01 - D-08
EXTERIOR BODY	D-09 - D-18
GALLEY	D-19 - E-02
HEATING & A/C	E-03 - E-08
INTERIOR FINISH	E-09 - E-13
LABEL	E-14 - E-22
L.P	E-23
LOUNGE	E-24 - F-01
SEALANTS & FASTENERS	F-02 - F-04
WATER & SEWAGE	F-05 - F-11
WINDOW, VENT AND EXTERIOR DOOR	F-12 - G-10

WATER & SEWAGE GROUP (CONTINUED)

FAUCETS & SHOWER HEAD - CANADIAN

KEY PART NUMBER	U/M DESCRIPTION
011048-05-000	EA SHOWER HEAD-W/60" HOSE, W/O VACUUM BREAKER - CANADIAN
075240-06-000	EA FAUCET-LAVATORY, BONE
075241-05-000	EA FAUCET-SHOWER, BONE

PORCELAIN TOILET OPTION L43E - US & CANADIAN

KEY PART NUMBER	U/M DESCRIPTION
010117-01-000	EA COUPLING-PLASTIC, 3" - HXH - U.S.
063641-01-000	EA FLANGE-CLOSET, 4" X 3"
085330-04-000	EA TOILET-CHINA, SHORTY W/SPRAY - TRAVELER 510
085330-04-700	EA BREAKER-VACUUM, FOR HANDSPRAY - SEALAND# 230325
085330-01-700	EA RING & COVER-SEAT, SEALAND# 390340217
085330-04-702	EA LEVER-FLUSH, SEALAND# 340825
085330-01-714	EA SEAL-FLANGE, FLOOR - SEALAND# 390343892
085330-01-709	EA VALVE-WATER, SEALAND# 385314349
085330-01-702	EA TUBE-FLUSH, SEALAND# 385315902
085330-04-703	EA COVER ASM-PEDAL, SEALAND# 310118
085330-01-703	EA RING & HALF CLAMPS ASM-BONE, SEALAND# 385310048
085330-01-704	EA TEFLON & RUBBER SEALS-SEALAND# 385316140
085330-01-705	EA SUPPORT-SEAL, PLASTIC - SEALAND# 390346405
085330-01-706	EA BALL, SHAFT, & CARTRIDGE, SEALAND# 385318162
085330-01-707	EA CARTRIDGE-SPRING, SEALAND# 381236096
085330-01-710	EA PLUG-DRAIN, & CAP - W/SEAL - SEALAND# 385316142
085330-01-716	EA FLANGE-FLOOR, 3" MPT - SEALAND# 390346056
085330-04-705	EA COVER ASM-PEDESTAL, SEALAND# 310109
085330-04-704	EA BASE ASM-BONE, SEALAND# 310124
085330-04-706	EA BREAKER-VACUUM, W/HAND SPRAY - SEALAND# 385319055
085330-01-717	EA BOLT MOUNTING PACKAGE-SEALAND# 385310064
085330-01-718	EA SEAL-BASE & MOUNTING HARDWARE, SEALAND# 385310063

DRAINAGE SYSTEM - CANADIAN

KEY PART NUMBER	U/M DESCRIPTION
004020-01-000	QT ADHESIVE-ABS CEMENT
010006-01-000	EA ELBOW-45 DEG, 1/8" BEND - 1 1/2" HUB X HUB - BLACK PLASTIC
010008-01-000	EA ELBOW-90 DEG, 1/4" BEND - 1 1/2" HUB X HUB - BLACK PLASTIC
010071-01-000	EA TEE-SANITARY, 1 1/2" HUB X HUB X HUB - PLASTIC - BLACK
010072-01-000	EA TEE-SANITARY, 1 1/2" H X 1 1/4" H X 1 1/2" H - PLASTIC
010079-01-000	EA TEE-SANITARY, 1 1/2" H X 1 1/2" H X 1 1/4" H - PLASTIC - BLACK
010115-01-000	EA COUPLING-1 1/2" HUB X HUB, PLASTIC
010121-01-000	EA BUSHING-REDUCER, 1 1/2" SMOOTH 1 1/4" HUB - PLASTIC - BLACK
011066-02-000	EA P TRAP-1 1/4" HUB X SLIP JOINT, W/UNION - ABS - CANADIAN
024676-02-000	EA FLANGE-CLOSET, 4" X 3" - ABS - CANADIAN
034250-01-000	EA ELBOW-90 DEGREE, LONG TURN - 1 1/2" HUB X HUB - ABS
038342-01-000	EA TEE-PLASTIC, 1.5" STREET X 1/2" HUB X 1/2" HUB
053335-01-000	EA P TRAP-1 1/4" HUB X HUB, W/UNION - CANADIAN
070916-01-000	EA VALVE-DUAL DUMP, W/CAP - 3" X 1 1/2" - PLASTIC - BLACK
070916-01-700	EA VALVE ONLY, 3"
070916-01-701	EA VALVE ONLY, 1 1/2"
079968-01-000	EA VENT-MECH. TRAP ARM, ANTI-SIPHON - 2" DIA. X 7.3" - PLASTIC

CONTINUOUS WASTE ASSEMBLY - CANADIAN

KEY PART NUMBER	U/M DESCRIPTION
010071-01-000	EA TEE-SANITARY, 1 1/2" HUB X HUB X HUB - PLASTIC - BLACK
010121-01-000	EA BUSHING-REDUCER, 1 1/2" SMOOTH 1 1/4" HUB - PLASTIC - BLACK
033302-02-000	EA ADAPTER ASM-STRAINER, 1 1/2" - ABS - CANADIAN
037101-02-000	EA ELBOW-PLASTIC, 1/4 BEND VENT 1 1/2" HUB - CANADIAN

WINDOW, VENT & EXTERIOR DOOR GROUP

VENTILATOR FAN OPTION L41M

KEY PART NUMBER	U/M DESCRIPTION
084079-06-000	EA VENT-EXHAUST, POWERED - OFF WHITE - FANTASTIC VENT
084079-01-700	EA VENT COVER - FANTASTIC 1020-19
084079-01-701	EA SCREEN ASM WHITE - FANTASTIC 1030-80
084079-01-702	EA ARM LIFT ASM
084079-01-703	EA CRANK, EXTERIOR
084079-01-704	EA FAN BLADE
084079-01-705	EA MOTOR
084079-01-706	EA 12 VOLT PLUG
084079-01-707	EA SAFETY SWITCH - FANTASTIC 1120.00
084079-01-708	EA REVERSE SWITCH - FANTASTIC 1130-09
084079-01-709	EA SWITCH ON & OFF (MAIN POWER) - FANTASTIC - 1100.00
084079-01-710	EA THERMOSTAT - FANTASTIC 1140.00
084079-01-711	EA H-MOLDING (MOTOR MOUNT)

CANADIAN OPTION L265

KEY PART NUMBER	U/M DESCRIPTION
064469-08-000	EA VENT-ROOF, POWERED - 14" X 14" - 12V - CANADIAN
064469-03-702	EA LID-VENT WHITE
064469-03-706	EA LIFT MECHANISM
048648-01-000	EA MOTOR-ROOF VENT, 1/8 SHAFT - 12V
048649-01-000	EA FAN-ROOF VENT, 6 BLADES - 6"
009439-05-000	EA KNOB-CRANK, WINDOW AND ROOF VENT - BLACK
009439-06-000	EA EXTENSION-CRANK HANDLE, WINDOW/ROOF VENT - .9" - BLACK
009439-07-000	EA SCREW, 8-32 X 1 1/4 POH - BLACK

ENGINE COMPARTMENT

KEY PART NUMBER	U/M DESCRIPTION
098527-01-000	EA DOOR-CIRCUIT BREAKERS, UNDER HOOD - METAL - BLACK
098527-02-000	EA DOOR-FUSES, UNDER HOOD - METAL - BLACK
098196-01-000	EA LATCH-1/4 TURN, T-BAR
093674-01-000	EA PLATE-CIRCUIT BREAKER, HOUSE
087201-01-000	EA LIGHT

SKYLIGHT

KEY PART NUMBER	U/M DESCRIPTION
077902-01-000	EA COLLAR-SKYLITE
080910-01-000	EA COVER-SKYLITE, OUTER - 15.25" X 22.25" - PLASTIC
081171-01-000	EA TRIM-SKYLITE, OUTER - MILL FINISHED

GENERATOR/STORAGE

KEY PART NUMBER	U/M DESCRIPTION
	LAST DOOR ON DRIVER SIDE
092630-02-B07	EA DOOR-STORAGE/GENERATOR, W/LATCHES - 40" TAPERED - BEIGE
092610-01-02A	EA POCKET-LATCH
085730-04-000	EA LATCH-PADDLE, W/O KEY LOCK - PLASTIC - BEIGE
092357-01-01A	EA HINGE-COMPARTMENT DOOR, 76" - BEIGE

FUEL FILL

KEY PART NUMBER	U/M DESCRIPTION
078200-01-000	EA GASKET-DOOR, FUEL FILL - 3.5" OD X 2" ID
072447-04-000	EA SHROUD-FUEL FILL
083578-01-000	EA BOOT-FUEL FILL
084235-01-000	EA SUPPORT-FLANGE, FUEL FILL BOOT
078010-04-000	EA DOOR-FUEL FILL W/JAMB - BEIGE

WATER CENTER

KEY PART NUMBER	U/M DESCRIPTION
096305-02-000	EA COVER-WATER CENTER, 19" X 20.7" - GALVANIZED
009426-01-000	EA HATCH-POWER CORD, WHITE
081113-01-000	EA BUSHING-FLANGE, PLASTIC - WHITE
092481-03-B07	EA DOOR-STORAGE/BATTERY/WATER CENTER, W/LATCHES - 19.4" X 9.5
092357-01-01A	EA HINGE-COMPARTMENT DOOR, 76" - BEIGE
093668-01-02A	EA POCKET-LATCH
085730-01-000	EA PADDLE LATCH-EXTERIOR DOOR, W/KEY LOCK - PLASTIC - BEIGE
	KEY P.N. 082684-01-700

1991 WINNEBAGO TABLE OF CONTENTS

INTRODUCTION	A-01 - A-02
ABBREVIATIONS	A-03
ALPHABETICAL INDEX	A-04 - A-06
WCN28RT	A-07 - G-10
WCN32RQ	G-11 - L-20

1991 WCN28RT INDEX

FLOOR PLAN	A-07 - A-08
ACCESSORIES	A-09 - A-24
BATH	B-01 - B-04
BEDROOM	B-05 - B-08
CHASSIS	B-09 - C-06
C C & PAD	C-07 - C-18
DINETTE	C-19 - C-20
DRIVERS	C-21 - C-24
ELECTRICAL	D-01 - D-08
EXTERIOR BODY	D-09 - D-18
GALLEY	D-19 - E-02
HEATING & A/C	E-03 - E-08
INTERIOR FINISH	E-09 - E-13
LABEL	E-14 - E-22
LP	E-23
LOUNGE	E-24 - F-01
SEALANTS & FASTENERS	F-02 - F-04
WATER & SEWAGE	F-05 - F-11
WINDOW, VENT AND EXTERIOR DOOR	F-12 - G-10

WINDOW, VENT & EXTERIOR DOOR GROUP (CONTINUED)
DRIVER SIDE WINDOWS & DOORS

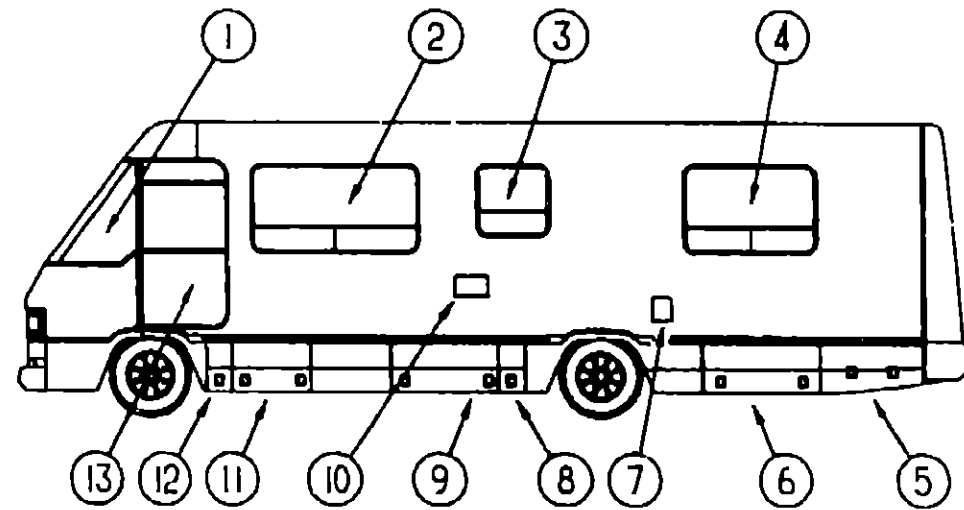

WINDOW, VENT & EXTERIOR DOOR GROUP (CONTINUED)
PASSENGER SIDE WINDOWS & DOORS

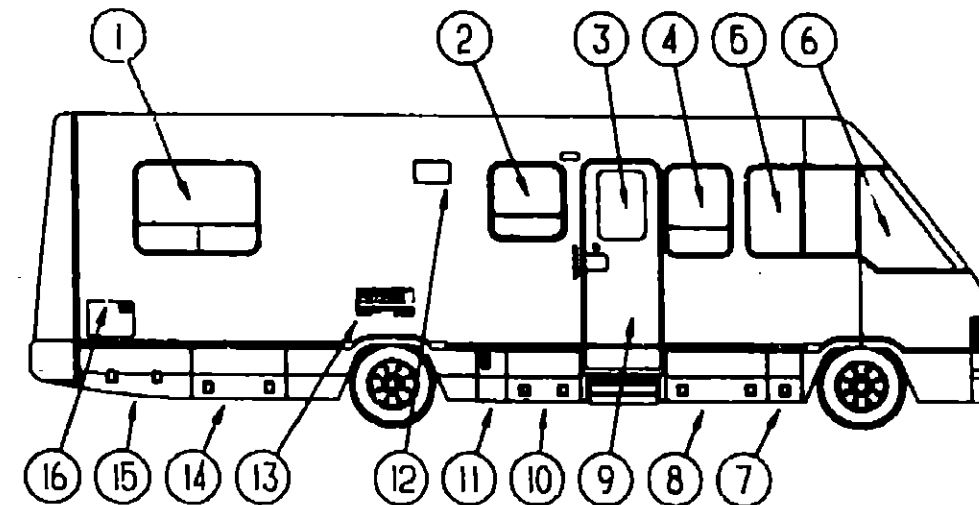

1991 WINNEBAGO
TABLE OF CONTENTS

INTRODUCTION	A-01 - A-02
ABBREVIATIONS	A-03
ALPHABETICAL INDEX	A-04 - A-06
WCN28RT	A-07 - G-10
WCN32RQ	G-11 - L-20

KEY PART NUMBER	U/M	DESCRIPTION
1	EA	GLASS-CORNER VENT, DRIVER
2	EA	WINDOW-TIPOUT, DOUBLE - W/O INSIDE FRAME - 31.5" X 60.9"
3	EA	WINDOW-TIPOUT, W/O INSIDE FRAME - 25.5" X 25.4"
4	EA	WINDOW-TIPOUT, DOUBLE - W/O INSIDE FRAME - 31.5" X 60.9"
5	EA	DOOR-STORAGE/GENERATOR, W/LATCHES - 40" TAPERED - BEIGE
6	EA	DOOR-STORAGE, W/LATCHES - 19.4" X 29.5" - BEIGE
7	EA	DOOR-FUEL FILL W/JAMB - BEIGE
8	EA	DOOR-STORAGE/BATTERY/WATER CENTER, W/LATCHES - 19.4" X 9.5"
9	EA	DOOR-STORAGE/SEWAGE TANK, W/LATCHES - 19.4" X 43.7" - BEIGE
10	EA	DOOR / JAMB - EXTERIOR SHOWER - WASHDOWN
11	EA	DOOR-STORAGE, W/LATCHES - 19.4" X 29.5" - BEIGE
12	EA	DOOR-STORAGE/BATTERY/WATER CENTER, W/LATCHES - 19.4" X 9.5"
13	EA	DOOR-DRIVER
13	EA	DOOR-DRIVER - W/ELECTRIC WINDOW & MIRROR

KEY PART NUMBER	U/M	DESCRIPTION
1	EA	WINDOW-TIPOUT, DOUBLE - W/O INSIDE FRAME - 31.5" X 60.9"
2	EA	WINDOW-TIPOUT, W/O INSIDE FRAME - 25.5" X 25.4"
3	EA	WINDOW-PICTURE, W/O INSIDE FRAME - 17" X 25"
4	EA	WINDOW-TIPOUT, SINGLE - W/O INSIDE FRAME - 31.6" X 22.8"
5	EA	WINDOW-SLIDING, W/O INSIDE FRAME
6	EA	GLASS-CORNER VENT, PASSENGER
7	EA	DOOR-STORAGE/BATTERY/WATER CENTER, W/LATCHES - 19.4" X 9.5"
8	EA	DOOR-STORAGE, W/LATCHES - 19.3" X 23.4" - BEIGE
9	EA	DOOR-ENTRY, W/JAMB AND SCREEN DOOR - B07 - CAMEO BLUE
10	EA	DOOR-STORAGE, W/LATCHES - 19.4" X 29.5" - BEIGE
11	EA	DOOR-FURNACE VENT, 19.4" X 15.8" - BEIGE
12	EA	VENT-RANGE HOOD, W/DOOR - BEIGE
13	EA	DOOR-REFRIGERATOR, VENTED W/O JAMB - BEIGE
	EA	LOCK-MALE, FASTENER - REFRIGERATOR DOOR
	EA	LOCK-FEMALE, FASTENER - REFRIGERATOR DOOR
	EA	JAMB-DOOR, VENTED REFRIGERATOR - BEIGE
14	EA	DOOR-STORAGE/SEWAGE TANK, W/LATCHES - 19.4" X 29.5" - BEIGE
15	EA	DOOR-STORAGE, W/LATCHES - 40" TAPERED - BEIGE
16	EA	DOOR-WATER HEATER, ATWOOD 5576-27 - BEIGE

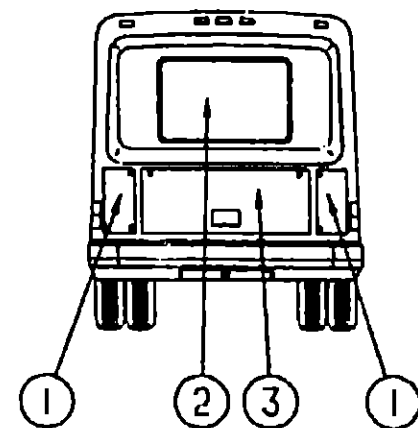

BACKWALL ESCAPE WINDOW AND DOORS

KEY PART NUMBER	U/M	DESCRIPTION
1	EA	DOOR-COMPARTMENT, W/LOCK & KEY - 15.3" X 25.6" - BEIGE
2	EA	WINDOW-ESCAPE, W/O INSIDE FRAME - 30.2" X 46.8"
3	EA	DOOR-SPARE TIRE, W/LOCKS - 26.8" X 41.3" - BEIGE

1991 WCN28RT INDEX

FLOOR PLAN	A-07 - A-08
ACCESSORIES	A-09 - A-24
BATH	B-01 - B-04
BEDROOM	B-05 - B-08
CHASSIS	B-09 - C-06
C C & PAD	C-07 - C-18
DINETTE	C-19 - C-20
DRIVERS	C-21 - C-24
ELECTRICAL	D-01 - D-08
EXTERIOR BODY	D-09 - D-18
GALLEY	D-19 - E-02
HEATING & A/C	E-03 - E-08
INTERIOR FINISH	E-09 - E-13
LABEL	E-14 - E-22
LP	E-23
LOUNGE	E-24 - F-01
SEALANTS & FASTENERS	F-02 - F-04
WATER & SEWAGE	F-05 - F-11
WINDOW, VENT AND EXTERIOR DOOR	F-12 - G-10

WINDOW, VENT & EXTERIOR DOOR GROUP (CONTINUED)

DRIVERS SIDE (LEFT SIDE)

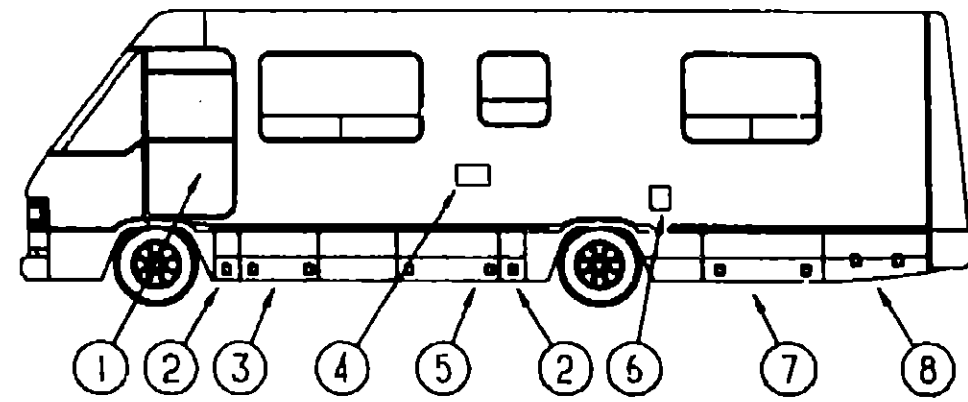

WINDOW, VENT & EXTERIOR DOOR GROUP (CONTINUED)

PASSENGERS SIDE (RIGHT SIDE)

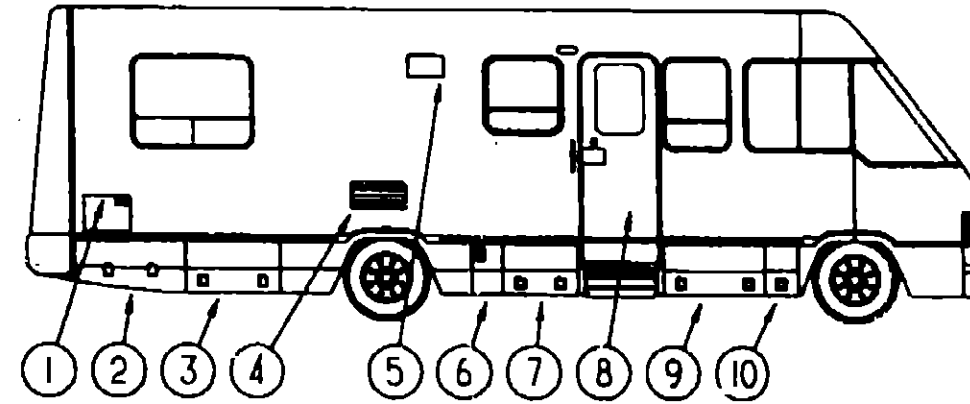

**1991 WINNEBAGO
TABLE OF CONTENTS**

INTRODUCTION	A-01 - A-02
ABBREVIATIONS	A-03
ALPHABETICAL INDEX	A-04 - A-06
WCN28RT	A-07 - G-10
WCN32RQ	G-11 - L-20

KEY PART NUMBER	U/M	DESCRIPTION
1 M97816-04-AB6	EA	DOOR-DRIVER, POWER - STATIONARY WINDOW
1 M97816-03-AB6	EA	DOOR-DRIVER, POWER - TIPOUT WINDOW
2 092481-03-B07	EA	DOOR-STORAGE/BATTERY/WATER CENTER, W/LATCHES - 19.4" X 9.5"
092357-01-01A	EA	HINGE-COMPARTMENT DOOR, 76" - BEIGE
093668-01-02A	EA	POCKET-LATCH
085730-09-000	EA	LATCH-PADDLE, W/KEY LOCK - PLASTIC - KEY# 082684-01-700 - BEIGE
3 092481-04-B07	EA	DOOR-STORAGE, W/LATCHES - 19.4" X 29.5" - BEIGE
092357-01-01A	EA	HINGE-COMPARTMENT DOOR, 76" - BEIGE
093668-01-02A	EA	POCKET-LATCH
085730-01-000	EA	PADDLE LATCH-EXTERIOR DOOR, W/KEY LOCK - PLASTIC - BEIGE KEY P.N. 082684-01-700
4 103173-02-01A	EA	DOOR / JAMB - EXTERIOR SHOWER - WASHDOWN
5 092481-08-B07	EA	DOOR-STORAGE/SEWAGE TANK, W/LATCHES - 19.4" X 43.7" - BEIGE
099008-01-02A	EA	HATCH-COMPARTMENT, SEWER HOSE
009066-01-000	EA	HINGE-ALUMINUM, NO HOLES - 1 1/16" X 6" - UNPAINTED FROM: 00-00-00 THRU: 10-21-91
074470-01-000	EA	PULL-HINGE RELEASE, PIN - RIGHT FROM: 10-22-90 THRU: 99-99-99
074470-01-000	EA	PULL-HINGE RELEASE, PIN - LEFT FROM: 10-22-90 THRU: 99-99-99
088270-01-000	FT	SEAL-BULB, EPDM RUBBER FROM: 10-22-90 THRU: 99-99-99
093668-01-02A	EA	POCKET-LATCH
085730-04-000	EA	LATCH-PADDLE, W/O KEY LOCK - PLASTIC - BEIGE
092357-01-01A	EA	HINGE-COMPARTMENT DOOR, 76" - BEIGE
6 078010-04-000	EA	DOOR-FUEL FILL W/JAMB - BEIGE
078200-01-000	EA	GASKET-DOOR, FUEL FILL - 3.5"OD X 2"ID
072447-04-000	EA	SHROUD-FUEL FILL
093578-01-000	EA	BOOT-FUEL FILL
084235-01-000	EA	SUPPORT-FLANGE, FUEL FILL BOOT
7 092481-04-B07	EA	DOOR-STORAGE, W/LATCHES - 19.4" X 29.5" - BEIGE
092357-01-01A	EA	HINGE-COMPARTMENT DOOR, 76" - BEIGE
093668-01-02A	EA	POCKET-LATCH
085730-01-000	EA	PADDLE LATCH-EXTERIOR DOOR, W/KEY LOCK - PLASTIC - BEIGE KEY P.N. 082684-01-700
8 092630-02-907	EA	DOOR-STORAGE/GENERATOR, W/LATCHES - 40" TAPERED - BEIGE
092610-01-02A	EA	POCKET-LATCH
085730-04-000	EA	LATCH-PADDLE, W/O KEY LOCK - PLASTIC - BEIGE
092357-01-01A	EA	HINGE-COMPARTMENT DOOR, 76" - BEIGE

KEY PART NUMBER	U/M	DESCRIPTION
1 052009-02-000	EA	DOOR-WATER HEATER, ATWOOD 5576-27 - BEIGE
2 092630-01-B07	EA	DOOR-STORAGE, W/LATCHES - 40" TAPERED - BEIGE
092610-01-02A	EA	POCKET-LATCH
092357-01-01A	EA	HINGE-COMPARTMENT DOOR, 76" - BEIGE
085730-01-000	EA	PADDLE LATCH-COMPARTMENT DOOR, W/KEY LOCK - PLASTIC - BEIGE KEY# 082684-01-700
3 092481-04-B07	EA	DOOR-STORAGE, W/LATCHES - 19.4" X 29.5" - BEIGE
092357-01-01A	EA	HINGE-COMPARTMENT DOOR, 76" - BEIGE
093668-01-02A	EA	POCKET-LATCH
085730-09-000	EA	LATCH-PADDLE, W/KEY LOCK - PLASTIC - BEIGE
082684-01-700	EA	KEY-COMPARTMENT DOOR LOCK, BH024
4 084103-01-000	EA	DOOR-REFRIGERATOR, VENTED W/O JAMB - BEIGE
084104-01-700	EA	LOCK-MALE, FASTENER - REFRIGERATOR DOOR
084104-01-701	EA	LOCK-FEMALE, FASTENER - REFRIGERATOR DOOR
084104-01-000	EA	JAMB-DOOR, VENTED REFRIGERATOR - BEIGE
5 092698-02-02A	EA	VENT-RANGE HOOD, W/DOOR - BEIGE
6 093028-05-AB6	EA	DOOR-FURNACE, 19.4" X 15.8" - BEIGE
092263-01-000	EA	PANEL-EXHAUST, FURNACE - 14" X 14.6" - GALVANIZED
092357-01-01A	EA	HINGE-COMPARTMENT DOOR, 76" - BEIGE
7 092481-04-B07	EA	DOOR-STORAGE, W/LATCHES - 19.4" X 29.5" - BEIGE
092357-01-01A	EA	HINGE-COMPARTMENT DOOR, 76" - BEIGE
093668-01-02A	EA	POCKET-LATCH
085730-01-000	EA	PADDLE LATCH-EXTERIOR DOOR, W/KEY LOCK - PLASTIC - BEIGE KEY P.N. 082684-01-700
8 M01870-50-B07	EA	DOOR-ENTRY, W/JAMB AND SCREEN DOOR - B07 - CAMEO BLUE
9 092481-07-B07	EA	DOOR-LP, W/LATCHES - 19.3" X 23.4" - BEIGE
092357-01-01A	EA	HINGE-COMPARTMENT DOOR, 76" - BEIGE
093668-01-02A	EA	POCKET-LATCH
085730-04-000	EA	LATCH-PADDLE, W/O KEY LOCK - PLASTIC - BEIGE
10 092481-03-B07	EA	DOOR-STORAGE/BATTERY/WATER CENTER, W/LATCHES - 19.4" X 9.5"
092357-01-01A	EA	HINGE-COMPARTMENT DOOR, 76" - BEIGE
093668-01-02A	EA	POCKET-LATCH
085730-09-000	EA	LATCH-PADDLE, W/KEY LOCK - PLASTIC - BEIGE KEY# 082684-01-700

1991 WCN28RT INDEX

FLOOR PLAN	A-07 - A-08
ACCESSORIES	A-09 - A-24
BATH	B-01 - B-04
BEDROOM	B-05 - B-08
CHASSIS	B-09 - C-06
C C & PAD	C-07 - C-18
DINETTE	C-19 - C-20
DRIVERS	C-21 - C-24
ELECTRICAL	D-01 - D-08
EXTERIOR BODY	D-09 - D-18
GALLEY	D-19 - E-02
HEATING & A/C	E-03 - E-08
INTERIOR FINISH	E-09 - E-13
LABEL	E-14 - E-22
LP	E-23
LOUNGE	E-24 - F-01
SEALANTS & FASTENERS	F-02 - F-04
WATER & SEWAGE	F-05 - F-11
WINDOW, VENT AND EXTERIOR DOOR	F-12 - G-10

WINDOW, VENT & EXTERIOR DOOR GROUP (CONTINUED)

DRIVER SIDE AND PASS SIDE BEDROOM WINDOWS

KEY PART NUMBER	U/M	DESCRIPTION
090893-07-01A	EA	FRAME-WINDOW, INSIDE - 31.4" X 60.9" - BLACK
092234-01-Y12	EA	WINDOW-TIPOUT, DOUBLE - W/O INSIDE FRAME - 31.5" X 60.9" STATIONARY GLASS IS NOT AVAILABLE - ORDER ENTIRE ASSEMBLY
000G39-06-16T	EA	SCREW-SF/DR, 6-20 X 1 PPH - BLACK
000G39-08-12T	EA	SCREW-SF/DR, 8-18 X 3/4 PPH - BLACK
035302-01-000	EA	OPERATOR-TORQUE, TIPOUT WINDOW - LEFT
035302-02-000	EA	OPERATOR-TORQUE, TIPOUT WINDOW - LEFT
038886-01-000	EA	TAPE-BUTYL, .31" X .31" X 148" LONG
068927-03-000	EA	SEAL-WINDOW, RUBBER - ROUND - .80" DIA. - BLACK
076322-02-000	FT	TAPE-FOAM, DOUBLE COATED - .045" X 1" - INC. OF 108 FT
080218-03-000	SF	SCREEN-FIBERGLASS, 12" WIDE
080914-01-000	EA	KEY-CORNER, TIPOUT WINDOW
081377-01-700	EA	ADHESIVE-CYANOACRYLATE, 10 GRAM TUBE
081649-01-000	EA	RING-SNAP, 7/32 SHAFT DIAMETER
083227-06-000	EA	TUBE-TORQUE, WINDOW - FRONT
080918-01-000	EA	SPRING-TORQUE TUBE, REAR
080918-02-000	EA	SPRING-TORQUE TUBE, FRONT
081427-01-000	EA	ARM-TORQUE TUBE
083228-06-000	EA	TUBE-TORQUE, WINDOW - REAR
080918-01-000	EA	SPRING-TORQUE TUBE, REAR
080918-02-000	EA	SPRING-TORQUE TUBE, FRONT
081427-01-000	EA	ARM-TORQUE TUBE
084067-01-000	FT	SEAL-E SHAPED, SPONGE - TIPOUT WINDOW - .4" X .4" - BLACK
084068-20-000	EA	GLASS-TIPOUT, 9.2" X 20.4"
084453-01-000	EA	WASHER-.060 X .50 X .135 - PLASTIC
084453-02-000	EA	WASHER-.060 X .50 X .250 - PLASTIC
084473-01-000	EA	SEAL-RUBBER, TIPOUT WINDOW
085315-01-000	EA	RIVET-SHOULDER, TIPOUT WINDOW
086762-01-000	EA	T NUT 10-32
086763-01-000	EA	SCREW-MACH, 10 - 32 X 1/4 PTH
087561-01-000	FT	SPLINE-GLASS, EXTERIOR - VINYL - BLACK
089913-01-000	EA	HINGE-TIPOUT WINDOW, BLACK
097578-01-000	EA	LINKAGE-TIPOUT WINDOW
084453-01-000	EA	WASHER-.060 X .50 X .135 - PLASTIC
084473-01-000	EA	SEAL-RUBBER, TIPOUT WINDOW
085315-01-000	EA	RIVET-SHOULDER, TIPOUT WINDOW
100168-01-000	EA	CLIP-SPRING, SCREEN
100240-01-000	FT	SPLINE-SCREEN, T-SHAPED
101290-01-01A	EA	KNOB-OPERATOR, BRASS
101289-01-01A	EA	SCREW-MACH, 8-32 X 4 - POH - BRASS
090025-01-000	EA	EXTENSION-WINDOW CONTROL

WINDOW, VENT & EXTERIOR DOOR GROUP (CONTINUED)

GALLEY WINDOW

KEY PART NUMBER	U/M	DESCRIPTION
090893-02-01A	EA	FRAME-WINDOW, INSIDE - 25.3" X 25.5" - BLACK
092235-09-Y12	EA	WINDOW-TIPOUT, W/O INSIDE FRAME - 25.5" X 25.4" STATIONARY GLASS IS N/A DUE TO MANUFACTURING TECHNIQUE
000G39-06-16T	EA	SCREW-SF/DR, 6-20 X 1 PPH - BLACK
035302-02-000	EA	OPERATOR-TORQUE, TIPOUT WINDOW - LEFT
068927-03-000	EA	SEAL-WINDOW, RUBBER - ROUND - .80" DIA. - BLACK
076322-02-000	FT	TAPE-FOAM, DOUBLE COATED - .045" X 1" - INC. OF 108 FT
080218-03-000	SF	SCREEN-FIBERGLASS, 12" WIDE
080914-01-000	EA	KEY-CORNER, TIPOUT WINDOW
081377-01-700	EA	ADHESIVE-CYANOACRYLATE, 10 GRAM TUBE
081649-01-000	EA	RING-SNAP, 7/32 SHAFT DIAMETER
080918-01-000	EA	SPRING-TORQUE TUBE, REAR
080918-02-000	EA	SPRING-TORQUE TUBE, FRONT
081427-01-000	EA	ARM-TORQUE TUBE
084067-01-000	FT	SEAL-E SHAPED, SPONGE - TIPOUT WINDOW - .4" X .4" - BLACK
084068-15-000	EA	GLASS-TIPOUT, 9.2" X 24.5"
084453-01-000	EA	WASHER-.060 X .50 X .135 - PLASTIC
084453-02-000	EA	WASHER-.060 X .50 X .250 - PLASTIC
084473-01-000	EA	SEAL-RUBBER, TIPOUT WINDOW
085315-01-000	EA	RIVET-SHOULDER, TIPOUT WINDOW
086762-01-000	EA	T NUT 10-32
086763-01-000	EA	SCREW-MACH, 10 - 32 X 1/4 PTH
087561-01-000	FT	SPLINE-GLASS, EXTERIOR - VINYL - BLACK
089913-01-000	EA	HINGE-TIPOUT WINDOW, BLACK
097578-01-000	EA	LINKAGE-TIPOUT WINDOW
084453-01-000	EA	WASHER-.060 X .50 X .135 - PLASTIC
084473-01-000	EA	SEAL-RUBBER, TIPOUT WINDOW
085315-01-000	EA	RIVET-SHOULDER, TIPOUT WINDOW
100168-01-000	EA	CLIP-SPRING, SCREEN
100240-01-000	FT	SPLINE-SCREEN, T-SHAPED
101290-01-01A	EA	KNOB-OPERATOR, BRASS
101289-01-01A	EA	SCREW-MACH, 8-32 X 4 - POH - BRASS
009439-06-000	EA	EXTENSION-CRANK HANDLE, WINDOW/ROOF VENT - .9" - BLACK

**1991 WINNEBAGO
TABLE OF CONTENTS**

INTRODUCTION	A-01 - A-02
ABBREVIATIONS	A-03
ALPHABETICAL INDEX	A-04 - A-06
WCN28RT	A-07 - G-10
WCN32RC	G-11 - L-20

1991 WCN28RT INDEX

FLOOR PLAN	A-07 - A-08
ACCESSORIES	A-09 - A-24
BATH	B-01 - B-04
BEDROOM	B-05 - B-08
CHASSIS	B-09 - C-06
C C & PAD	C-07 - C-18
D'NETTE	C-19 - C-20
DRIVERS	C-21 - C-24
ELECTRICAL	D-01 - D-08
EXTERIOR BODY	D-09 - D-18
GALLEY	D-19 - E-02
HEATING & A/C	E-03 - E-08
INTERIOR FINISH	E-09 - E-13
LABEL	E-14 - E-22
LP	E-23
LOUNGE	E-24 - F-01
SEALANTS & FASTENERS	F-02 - F-04
WATER & SEWAGE	F-05 - F-11
WINDOW, VENT AND EXTERIOR DOOR	F-12 - G-10

WINDOW, VENT & EXTERIOR DOOR GROUP (CONTINUED)

BATH WINDOW

KEY PART NUMBER	U/M	DESCRIPTION
090893-15-01A	EA	FRAME-WINDOW, INSIDE - 25.5" X 15.9" - BLACK
092235-10-Y12	EA	WINDOW-TIPOUT, W/O INSIDE FRAME - 15.8" X 25.5" STATIONARY GLASS IS N/A DUE TO MANUFACTURING TECHNIQUES
000G39-06-16T	EA	SCREW-SF/DR, 6-20 X 1 PPH - BLACK
035302-02-000	EA	OPERATOR-TORQUE, TIPOUT WINDOW - LEFT
068927-03-000	EA	SEAL-WINDOW, RUBBER - ROUND - .80" DIA. - BLACK
080218-03-000	SF	SCREEN-FIBERGLASS, 12" WIDE
080914-01-000	EA	KEY-CORNER, TIPOUT WINDOW
081649-01-000	EA	RING-SNAP, 7/32 SHAFT DIAMETER
080918-01-000	EA	SPRING-TORQUE TUBE, REAR
080918-02-000	EA	SPRING-TORQUE TUBE, FRONT
081427-01-000	EA	ARM-TORQUE TUBE
084067-01-000	FT	SEAL-E SHAPED, SPONGE - TIPOUT WINDOW - .4" X .4" - BLACK
084068-14-000	EA	GLASS-TIPOUT, 9" X 15"
084453-01-000	EA	WASHER-.060 X .50 X .135 - PLASTIC
084453-02-000	EA	WASHER-.060 X .50 X .250 - PLASTIC
084473-01-000	EA	SEAL-RUBBER, TIPOUT WINDOW
085315-01-000	EA	RIVET-SHOULDER, TIPOUT WINDOW
086762-01-000	EA	T NUT 10-32
086763-01-000	EA	SCREW-MACH, 10 - 32 X 1/4 PTH
089913-01-000	EA	HINGE-TIPOUT WINDOW, BLACK
097578-01-000	EA	LINKAGE-TIPOUT WINDOW
084453-01-000	EA	WASHER-.060 X .50 X .135 - PLASTIC
084473-01-000	EA	SEAL-RUBBER, TIPOUT WINDOW
085315-01-000	EA	RIVET-SHOULDER, TIPOUT WINDOW
100168-01-000	EA	CLIP-SPRING, SCREEN
100240-01-000	FT	SPLINE-SCREEN, T-SHAPED
101290-01-01A	EA	KNOB-OPERATOR, BRASS
101289-01-01A	EA	SCREW-MACHINE, 8-32 X 4 - POH - BRASS
090025-01-000	EA	EXTENSION-WINDOW CONTROL

WINDOW, VENT & EXTERIOR DOOR GROUP (CONTINUED)

ENTRY DOOR WINDOW

KEY PART NUMBER	U/M	DESCRIPTION
067609-27-000	EA	FRAME-WINDOW, INSIDE PICTURE - BLACK
079733-07-AA8	EA	WINDOW-ENTRY DOOR, 17" X 25" - FROSTED GLASS
002181-07-000	EA	GLASS-WINDOW, .182" X 16.25" X 24" - FROSTED
050216-02-000	FT	SPLINE-GLASS, EXTERIOR - VINYL - .19" - BLACK FROM: 00-00-00 THRU: 01-07-90
087561-01-000	FT	SEAL-GLASS, EXTERIOR - VINYL - BLACK

CAB PASSENGERS SIDE WINDOW

KEY PART NUMBER	U/M	DESCRIPTION
093703-01-Y10	EA	WINDOW-SLIDING, W/O INSIDE FRAME
000G39-06-16T	EA	SCREW-SF/DR, 6-20 X 1 PPH - BLACK
002328-01-000	EA	BLOCK-WINDOW, 1/8" X 3/16" X 1"
002389-03-209	EA	HOLDER-SEAL, GLASS HOLDER, - 1.16" - BLACK
023320-01-000	EA	PAD-FELT, 3/8" DIAMETER - BROWN
041928-02-000	FT	SEAL-EXTERIOR WINDOW, BLACK
042077-01-000	FT	CHANNEL-WEATHERSTRIP, GLASS RUN - U-SHAPED - 3/16"
047369-01-700	EA	LATCH KIT-WINDOW, W/SCREWS - PLASTIC - BLACK
050216-02-000	FT	SPLINE-GLASS, EXTERIOR - VINYL - .19" - BLACK
057656-12-000	EA	GLASS-STATIONARY, .19" X 30.4" X 15.7"
073740-01-000	FT	SEAL-FIN, .46" PILE HEIGHT - GRAY
079824-01-000	FT	SEAL-WINDOW, WEATHER - C/FOLD - .5"
081377-01-700	EA	ADHESIVE-CYANOACRYLATE, 10 GRAM TUBE
081980-11-000	EA	GLASS-SLIDER, .13" X 30.4" X 16.6"
084170-09-000	EA	MULLION-SLIDER, WINDOW - BLACK -
092665-01-Y10	EA	FRAME-WINDOW, INSIDE - BLACK
078364-01-000	EA	HOLDER-UPPER SCREEN, EXTRUDED PLASTIC - 9.5" - BLACK
078365-01-000	EA	HOLDER-LOWER SCREEN, EXTRUDED PLASTIC - 9.5" - BLACK
092538-01-Y10	EA	FRAME-WINDOW, INSIDE
092664-01-Y10	EA	SCREEN ASSEMBLY
002292-02-000	SF	SCREENING-WINDOW, 20" WIDE - CHARCOAL FROM: 00-00-00 THRU: 03-25-90
002291-02-000	SF	SCREENING-ROOF VENT/WINDOW, 16" - BLACK FROM: 03-25-90 THRU: 99-99-99
002298-02-000	FT	SPLINE-VENT/WINDOW SCREEN, .128 DIAMETER - BLACK
079667-02-000	FT	TAPE-PLASTIC FILM, .375 WIDE
079824-01-000	FT	SEAL-WINDOW, WEATHER - C/FOLD - .5"

**1991 WINNEBAGO
TABLE OF CONTENTS**

INTRODUCTION	A-01 - A-02
ABBREVIATIONS	A-03
ALPHABETICAL INDEX	A-04 - A-06
WCN28RT	A-07 - G-10
WCN32RQ	G-11 - L-20

1991 WCN28RT INDEX

FLOOR PLAN	A-07 - A-08
ACCESSORIES	A-09 - A-24
BATH	B-01 - B-04
BEDROOM	B-05 - B-08
CHASSIS	B-09 - C-06
C C & PAD	C-07 - C-18
DINETTE	C-19 - C-20
DRIVERS	C-21 - C-24
ELECTRICAL	D-01 - D-08
EXTERIOR BODY	D-09 - D-18
GALLEY	D-19 - E-02
HEATING & A/C	E-03 - E-08
INTERIOR FINISH	E-09 - E-13
LABEL	E-14 - E-22
LP	E-23
LOUNGE	E-24 - F-01
SEALANTS & FASTENERS	F-02 - F-04
WATER & SEWAGE	F-05 - F-11
WINDOW, VENT AND EXTERIOR DOOR	F-12 - G-10

WINDOW, VENT & EXTERIOR DOOR GROUP (CONTINUED)

DINETTE WINDOW

KEY PART NUMBER	U/M DESCRIPTION
090893-09-01A	EA FRAME-WINDOW, INSIDE - 31.4" X 60.9" - BLACK
092234-03-Y12	EA WINDOW-TIPOUT, DOUBLE - W/O INSIDE FRAME - 31.5" X 60.9" STATIONARY GLASS IS NOT AVAILABLE - ORDER ENTIRE ASSEMBLY
000G39-06-16T	EA SCREW-SF/DR, 6-20 X 1 PPH - BLACK
000G39-08-12T	EA SCREW-SF/DR, 8-18 X 3/4 PPH - BLACK
035302-01-000	EA OPERATOR-TORQUE, TIPOUT WINDOW - LEFT
035302-02-000	EA OPERATOR-TORQUE, TIPOUT WINDOW - LEFT
038866-01-000	EA TAPE-BUTYL, .31" X .31" X 148" LONG
068927-03-000	EA SEAL-WINDOW, RUBBER - ROUND - .80" DIA. - BLACK
076322-02-000	FT TAPE-FOAM, DOUBLE COATED - .045" X 1" - INC. OF 108 FT
080218-03-000	SF SCREEN-FIBERGLASS, 12" WIDE
080914-01-000	EA KEY-CORNER, TIPOUT WINDOW
081377-01-700	EA ADHESIVE-CYANOACRYLATE, 10 GRAM TUBE
081649-01-000	EA RING-SNAP, 7/32 SHAFT DIAMETER
083227-08-000	EA TUBE-TORQUE, WINDOW - REAR
080918-01-000	EA SPRING-TORQUE TUBE, REAR
080918-02-000	EA SPRING-TORQUE TUBE, FRONT
081427-01-000	EA ARM-TORQUE TUBE
083228-08-000	EA TUBE-TORQUE, WINDOW - FRONT
080918-01-000	EA SPRING-TORQUE TUBE, REAR
080918-02-000	EA SPRING-TORQUE TUBE, FRONT
081427-01-000	EA ARM-TORQUE TUBE
084067-01-000	FT SEAL-E SHAFED, SPONGE - TIPOUT WINDOW - .4" X .4" - BLACK
084068-22-000	EA GLASS-TIPOUT, 9.2" X 29.9"
084453-01-000	EA WASHER-.060 X .50 X .135 - PLASTIC
084453-02-000	EA WASHER-.060 X .50 X .250 - PLASTIC
084473-01-000	EA SEAL-RUBBER, TIPOUT WINDOW
085315-01-000	EA RIVET-SHOULDER, TIPOUT WINDOW
086762-01-000	EA T NUT 10-32
086763-01-000	EA SCREW-MACH, 10 - 32 X 1/4 PTH
087561-01-000	FT SPLINE-GLASS, EXTERIOR - VINYL - BLACK
089913-01-000	EA HINGE-TIPOUT WINDOW, BLACK
097578-01-000	EA LINKAGE-TIPOUT WINDOW
084453-01-000	EA WASHER-.060 X .50 X .135 - PLASTIC
084473-01-000	EA SEAL-RUBBER, TIPOUT WINDOW
085315-01-000	EA RIVET-SHOULDER, TIPOUT WINDOW
100168-01-000	EA CLIP-SPRING, SCREEN
100240-01-000	FT SPLINE-SCREEN, T-SHAPED
101290-01-01A	EA KNOB-OPERATOR, BRASS
101289-01-01A	EA SCREW-MACH, 8-32 X 4 - POH - BRASS
090025-01-000	EA EXTENSION-WINDOW CONTROL

WINDOW, VENT & EXTERIOR DOOR GROUP (CONTINUED)

PASSENGER SIDE LOUNGE WINDOW

KEY PART NUMBER	U/M DESCRIPTION
090893-06-01A	EA FRAME-WINDOW, INSIDE - 31.6" X 22.8" - BLACK
092235-06-Y12	EA WINDOW-TIPOUT, SINGLE - W/O INSIDE FRAME - 31.6" X 22.8" STATIONARY GLASS IS N/A DUE TO MANUFACTURING TECHNIQUE
000G39-06-16T	EA SCREW-SF/DR, 6-20 X 1 PPH - BLACK
080218-03-000	SF SCREEN-FIBERGLASS, 12" WIDE
100240-01-000	FT SPLINE-SCREEN, T-SHAPED
035302-02-000	EA OPERATOR-TORQUE, TIPOUT WINDOW - LEFT
068927-03-000	EA SEAL-WINDOW, RUBBER - ROUND - .80" DIA. - BLACK
076322-02-000	FT TAPE-FOAM, DOUBLE COATED - .045" X 1" - INC. OF 108 FT
080914-01-000	EA KEY-CORNER, TIPOUT WINDOW
081354-01-000	EA SLEEVE-TORQUE TUBE, TIPOUT WINDOW
081377-01-700	EA ADHESIVE-CYANOACRYLATE, 10 GRAM TUBE
081649-01-000	EA RING-SNAP, 7/32 SHAFT DIAMETER
083150-14-000	EA TUBE-TORQUE, WINDOW
080918-01-000	EA SPRING-TORQUE TUBE, FRONT
080918-02-000	EA SPRING-TORQUE TUBE, FRONT
081427-01-000	EA ARM-TORQUE TUBE
084067-01-000	FT SEAL-E SHAPED, SPONGE - TIPOUT WINDOW - .4" X .4" - BLACK
084068-19-000	EA GLASS-TIPOUT, - 9" X 22"
084453-01-000	EA WASHER-.060 X .50 X .135 - PLASTIC
084453-02-000	EA WASHER-.060 X .50 X .250 - PLASTIC
084473-01-000	EA SEAL-RUBBER, TIPOUT WINDOW
085315-01-000	EA RIVET-SHOULDER, TIPOUT WINDOW
086762-01-000	EA T NUT 10-32
086763-01-000	EA SCREW-MACH, 10 - 32 X 1/4 PTH
087561-01-000	FT SPLINE-GLASS, EXTERIOR - VINYL - BLACK
089913-01-000	EA HINGE-TIPOUT WINDOW, BLACK
097578-01-000	EA LINKAGE-TIPOUT WINDOW
084453-01-000	EA WASHER-.060 X .50 X .135 - PLASTIC
084473-01-000	EA SEAL-RUBBER, TIPOUT WINDOW
085315-01-000	EA RIVET-SHOULDER, TIPOUT WINDOW
100168-01-000	EA CLIP-SPRING, SCREEN
101290-01-01A	EA KNOB-OPERATOR, BRASS
101289-01-01A	EA SCREW-MACHINE, 8-32 X 4 - POH - BRASS
090025-01-000	EA EXTENSION-CONTROL, WINDOW - 2"

**1991 WINNEBAGO
TABLE OF CONTENTS**

INTRODUCTION	A-01 - A-02
ABBREVIATIONS	A-03
ALPHABETICAL INDEX	A-04 - A-06
WCN28RT	A-07 - G-10
WCN32RQ	G-11 - L-20

1991 WCN28RT INDEX

FLOOR PLAN	A-07 - A-08
ACCESSORIES	A-09 - A-24
BATH	B-01 - B-04
BEDROOM	B-05 - B-08
CHASSIS	B-09 - C-06
C C & PAD	C-07 - C-18
DINETTE	C-19 - C-20
DRIVERS	C-21 - C-24
ELECTRICAL	D-01 - D-08
EXTERIOR BODY	D-09 - D-18
GALLEY	D-19 - E-02
HEATING & A/C	E-03 - E-08
INTERIOR FINISH	E-09 - E-13
LABEL	E-14 - E-22
LP	E-23
LOUNGE	E-24 - F-01
SEALANTS & FASTENERS	F-02 - F-04
WATER & SEWAGE	F-05 - F-11
WINDOW, VENT AND EXTERIOR DOOR	F-12 - G-10

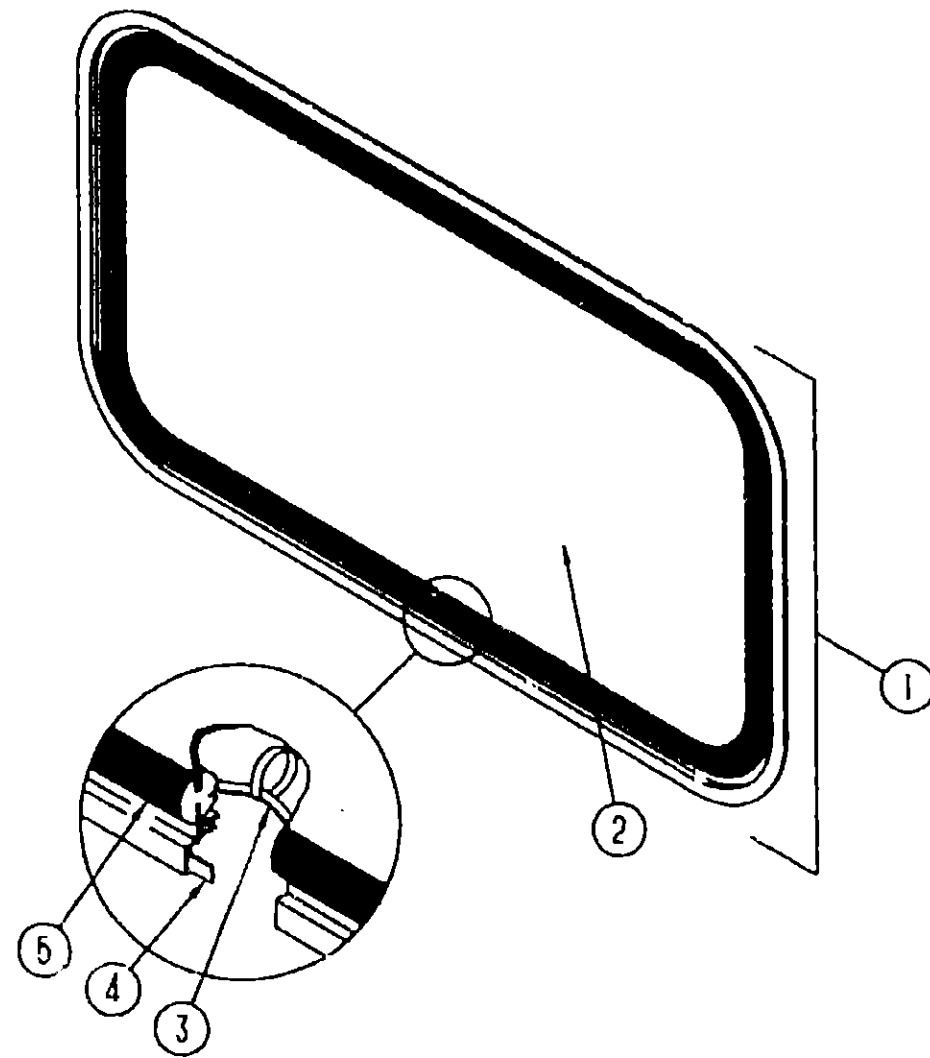

BACKWALL ESCAPE WINDOW

KEY PART NUMBER

U/M DESCRIPTION

076650-04-000	EA	FRAME-WINDOW, INSIDE - BLACK
087985-04-Y12	EA	WINDOW-ESCAPE, W/O INSIDE FRAME - 30.2" X 46.8"
002282-01-000	FT	WEATHER STRIP-WINDOW, RUBBER - .125" - BLACK
002285-01-000	FT	FILLER-WEATHER STRIP, RUBBER - BLACK
069640-07-000	FT	SEALER-RIBBON, 2" X 3/32" - INCREMENTS OF 30"
076337-06-000	EA	GLASS-ESCAPE, - 44.8" X 28"
006199-01-000	EA	LABEL-EXIT, "ESCAPE WINDOW"
047731-01-000	EA	LABEL-EMERGENCY EXIT

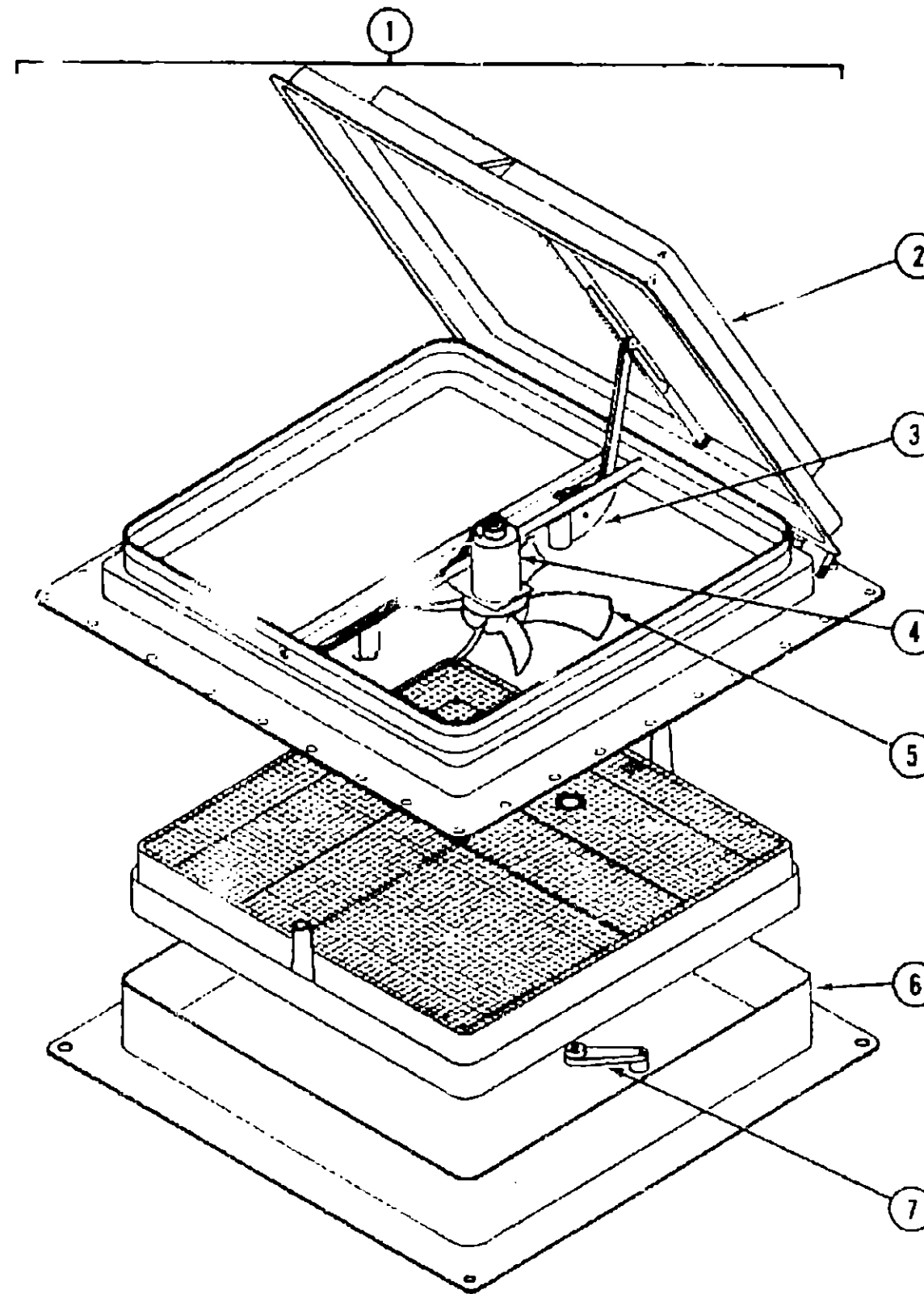

CANADIAN EXPORT

KEY PART NUMBER

U/M DESCRIPTION

1	064469-08-000	EA	VENT-ROOF, POWERED - 14" X 14" - 12V - CANADIAN
2	064469-03-702	EA	LID-VENT WHITE
3	064469-03-706	EA	LIFT MECHANISM
4	048648-01-000	EA	MOTOR-ROOF VENT, 1/8 SHAFT - 12V
5	048649-01-000	EA	FAN-ROOF VENT, 6 BLADE - 6"
6	064469-03-705	EA	GARNISH, VENT 2.5 IN. WIDE
7	009439-01-000	EA	CRANK HANDLE-ROOF VENT

1991 WINNEBAGO
TABLE OF CONTENTS

INTRODUCTION	A-01 - A-02
ABBREVIATIONS	A-03
ALPHABETICAL INDEX	A-04 - A-06
WCN28RT	A-07 - G-10
WCN32RO	G-11 - L-20

1991 WCN28RT INDEX

FLOOR PLAN	A-07 - A-08
ACCESSORIES	A-09 - A-24
BATH	B-01 - B-04
BEDROOM	B-05 - B-08
CHASSIS	B-09 - C-06
C C & PAD	C-07 - C-18
DINETTE	C-19 - C-20
DRIVERS	C-21 - C-24
ELECTRICAL	D-01 - D-08
EXTERIOR BODY	D-09 - D-18
GALLEY	D-19 - E-02
HEATING & A/C	E-03 - E-08
INTERIOR FINISH	E-09 - E-13
LABEL	E-14 - E-22
LP	E-23
LOUNGE	E-24 - F-01
SEALANTS & FASTENERS	F-02 - F-04
WATER & SEWAGE	F-05 - F-11
WINDOW, VENT AND EXTERIOR DOOR	F-12 - G-10

WINDOW, VENT & EXTERIOR DOOR GROUP (CONTINUED)

PASSENGER SLIDING WINDOW

KEY PART NUMBER	U/M	DESCRIPTION
082057-02-U04	EA	WINDOW-DRIVERS, SLANTED SLIDER W/O INSIDE FRAME
082056-02-AB1	EA	FRAME-WINDOW, INSIDE DRIVERS W/SCREEN - BEIGE
082057-01-U04	EA	WINDOW-PASSENGER, SLANTED SLIDER W/O INSIDE FRAME
082056-01-AB1	EA	FRAME-WINDOW, INSIDE PASSENGER W/SCREEN - BLACK
000G39-06-16T	EA	SCREW-SF/DR, 6-20 X 1. PPH - BLACK
002328-01-000	EA	BLOCK-WINDOW, 1/8" X 3/16" X 1"
002389-03-203	EA	HOLDER-GLASS, EXTERIOR VERTICAL - 27.125"
050216-02-000	FT	SPLINE-EXTERIOR GLASS, VINYL - .19" - BLACK
057656-03-000	EA	GLASS-WINDOW, STATIONARY - .19" X 28.11" X 27"
073740-01-000	FT	SEAL-FIN, .46" PILE HEIGHT - GRAY
081980-06-000	EA	GLASS-WINDOW, SLIDER - .19" X 28.11" X 14.88"
082466-01-000	EA	FRAME-WINDOW, PASSENGER SLANTED SLIDER - BLACK
084170-07-000	EA	MULLION-WINDOW, INTERIOR VERTICAL - 27.46" - BLACK
078364-01-000	EA	HOLDER-UPPER SCREEN, EXTRUDED PLASTIC - 9.5" - BLACK
078355-01-000	EA	HOLDER-LOWER SCREEN, EXTRUDED PLASTIC - 9.5" - BLACK
079574-01-T03	EA	SCREEN-WINDOW, PASSENGER SLANTED SLIDER
079667-02-000	FT	TAPE-PLASTIC FILM, .375 WIDE
079824-01-000	FT	SEAL-WINDOW, WEATHER - C/FOLD - .5"

POWERED ROOF VENT

KEY PART NUMBER	U/M	DESCRIPTION
090393-01-Y12	EA	VENT-ROOF, POWERED W/O SCREEN
002825-01-000	EA	WEATHER STRIP-ROOF VENT, GRAY
008195-01-000	EA	SWITCH-ROOF VENT, PUSH BUTTON, 12V
008386-01-000	EA	GROMMET-SNAP, 3/8"
009440-01-000	EA	GEAR/ARM-VENT COVER, LIFT
015911-01-000	EA	TRACK-LIFT ARM, SLIDE - ROOF VENT
048648-01-000	EA	MOTOR-ROOF VENT, 1/8 SHAFT - 12V
048649-01-000	EA	FAN-ROOF VENT, 6 BLADES - 6"
055218-01-000	EA	COVER-ROOF VENT
061603-01-000	EA	GROMMET-SNAP, 3/16 ID - 3/8 HOLE - PLASTIC - BLACK
052639-01-200	EA	HINGE-EXTRUSION, ROOF VENT 7"
052639-01-001	EA	HINGE-VENT COVER, 192"
078785-01-Y12	EA	SCREEN-ROOF VENT, POWERED
002291-02-000	SF	SCREENING-ROOF VENT/WINDOW, 16" - BLACK
002298-02-000	FT	SPLINE-VENT/WINDOW SCREEN, .128 DIAMETER - BLACK
009439-01-000	EA	CRANK HANDLE-ROOF VENT
009439-03-000	EA	EXTENSION-CRANK HANDLE, ROOF VENT - .9"
009439-05-000	EA	KNOB-CRANK, WINDOW AND ROOF VENT - BLACK
009439-07-000	EA	SCREW-8-32X1 1/4 PH, BLACK

WINDOW, VENT & EXTERIOR DOOR GROUP (CONTINUED)

NON POWERED ROOF VENT

KEY PART NUMBER	U/M	DESCRIPTION
090392-01-Y12	EA	VENT-ROOF, NON POWERED
002825-01-000	EA	WEATHER STRIP-ROOF VENT, GRAY
009440-01-000	EA	GEAR/ARM-VENT COVER, LIFT
015911-01-000	EA	TRACK-LIFT ARM, SLIDE - ROOF VENT
055218-01-000	EA	COVER-ROOF VENT
052639-01-001	EA	HINGE-VENT COVER, 192"
009439-01-000	EA	CRANK HANDLE-ROOF VENT
009439-03-000	EA	EXTENSION-CRANK HANDLE, ROOF VENT - .9"
078786-01-Y12	EA	SCREEN-ROOF VENT, NON POWERED
002291-02-000	SF	SCREENING-ROOF VENT/WINDOW, 16" - BLACK
002298-02-000	FT	SPLINE-VENT/WINDOW SCREEN, .128 DIAMETER - BLACK

ROOF VENTS

KEY PART NUMBER	U/M	DESCRIPTION
083558-01-000	EA	VENT-PLUMBING PIPE ROOF, W/COVER - BEIGE
014073-01-000	EA	COVER-ROOF VENT, NORCOLD REFRIGERATOR - BEIGE
004073-04-000	EA	BASE-ROOF VENT, NORCOLD REFRIGERATOR - BLACK

SIDEWALL VENT

KEY PART NUMBER	U/M	DESCRIPTION
092698-02-02A	EA	VENT-RANGE HOOD, W/DOOR - BEIGE

TABLE OF CONTENTS

INTRODUCTION	A-01
ABBREVIATIONS	A-02
ALPHABETICAL INDEX	A-02 - A-04
WCN28RT	A-05 - G-10
WCN32RO	G-11 - L-20

1991 WCN28RT INDEX

FLOOR PLAN	A-07 - A-08
ACCESSORIES	A-09 - A-24
BATH	B-01 - B-04
BEDROOM	B-05 - B-08
CHASSIS	B-09 - C-06
C C & PAD	C-07 - C-18
DINETTE	C-19 - C-20
DRIVERS	C-21 - C-24
ELECTRICAL	D-01 - D-06
EXTERIOR BODY	D-09 - D-18
GALLEY	D-19 - E-02
HEATING & AC	E-03 - E-08
INTERIOR FINISH	E-09 - E-13
LABEL	E-14 - E-22
IP	E-23
LOUNGE	E-24 - F-01
SEALANTS & FASTENERS	F-02 - F-04
WATER & SEWAGE	F-05 - F-11
WINDOW, VENT AND EXTERIOR DOOR	F-12 - G-10

WINDOW, VENT & EXTERIOR DOOR GROUP (CONTINUED)

WINDOW, VENT & EXTERIOR DOOR GROUP (CONTINUED)

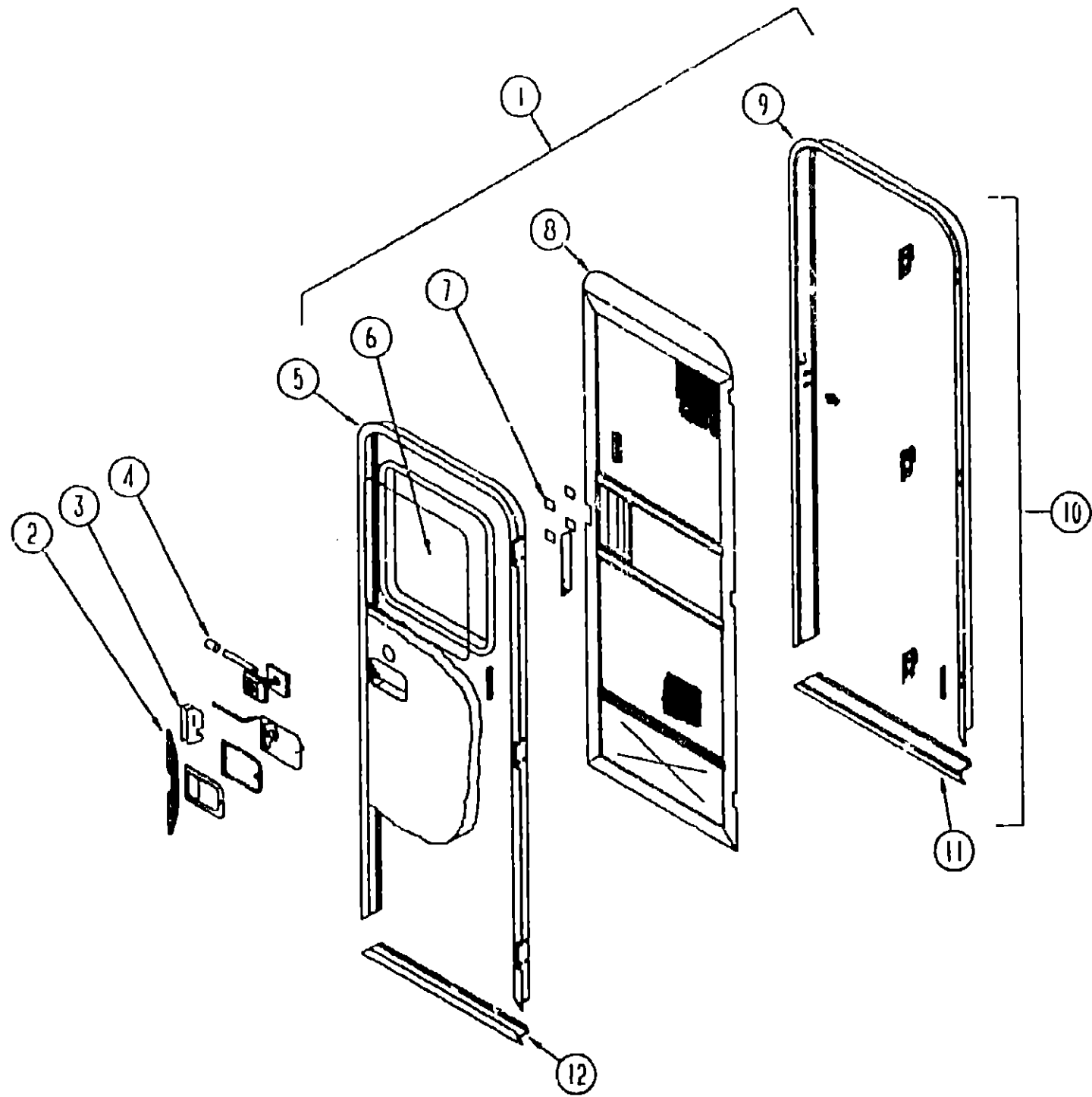

ENTRANCE DOOR

ENTRANCE DOOR

KEY PART NUMBER	U/M	DESCRIPTION
101145-01-01A	EA	DEADBOLT-ENTRY DOOR, BLACK
101145-01-700	EA	KEY ONLY-BLANK
101147-01-000	EA	BOLT-SECURITY, 4.12" BACKSET
039800-03-000	FT	TUBING-POLYBUTYLENE, 3/8" OD
039979-01-000	EA	COVER-INTERIOR LATCH, W/TRIP ARM - RIGHT - BLACK
102524-01-000	EA	BUMPER-RUBBER, FLAT - BLACK
5 095276-01-02A	EA	FRAME-ENTRY DOOR, W/O BOTTOM - BEIGE
6 079733-04-T03	EA	WINDOW-PICTURE, W/O INSIDE FRAME - 17" X 25"
067609-27-000	EA	FRAME-WINDOW, INSIDE PICTURE - BLACK
002181-06-000	EA	GLASS-PICTURE WINDOW, .115" X 16.25" X24"
087561-01-000	FT	SPLINE-GLASS, EXTERIOR - VINYL - BLACK
7 058025-02-000	EA	CLIP-ROLLER LATCH CATCH
053729-04-000	EA	RIVNUT, 10-32 UNF - .010-.080
072893-01-000	EA	NUTSERT-M5 X 0, 8
075671-01-000	FT	SEAL-SPONGE, LAZY T SHAPE - WEATHERSTRIP ON ENTRY DOOR
075673-01-000	FT	SEAL-PILE, ADHESIVE BACK - GRAY
075908-01-000	EA	SCREW-MACH-10-32X.56PTH(SEMS)
7 009018-01-000	EA	CATCH-SCREEN DOOR ROLLER
009016-01-000	EA	CATCH-ELBOW, SPRING LOADED - SCREEN DOOR CATCH
8 079012-01-U01	EA	DOOR-SCREEN
002293-02-000	SF	SCREENING-WINDOW/DOOR, 26" - CHARCOAL
002294-01-000	FT	SPLINE-SCREENING, .135" X .138" - BLACK
002748-01-000	EA	CORNER KEY-DOOR
016454-01-000	EA	INSERT-SCREEN DOOR, CENTER - LEATHER GRAIN ALUMINUM - BEIG
031014-01-013	EA	INSERT-CENTER, .024" X 10.25" X 16.31" - UNPAINTED ALUMINUM
050712-05-000	EA	HANDLE-SCREEN DOOR, UNPAINTED
078552-03-000	EA	KICK PANEL-SCREEN DOOR, LOWER INSERT - UNPAINTED
001014-01-016	EA	ALUMINUM-LEATHER GRAIN, 10.3" X 29.69" - UNFINISHED
078595-01-000	EA	TOP PLATE-SCREEN DOOR, CURVED TOP - 4.7" X 25.35"
078777-01-000	EA	CHANNEL-SLIDE, SCREEN DOOR CENTER SLIDER COVER
079086-02-000	EA	SLIDER-SCREEN DOOR, OFF WHITE
079087-02-000	EA	STRIKE-SLIDER, W/LIP FOR ELBOW CATCH - 1.5" X 8.6"OFF WHITE
100412-01-000	EA	CATCH-SCREEN DOOR
9 095278-01-01A	EA	JAMB-DOOR, ENTRANCE - UNPAINTED
10 095277-02-02A	EA	JAMB-ENTRY DOOR, W/BOTTOM & ROLLER CATCH STRIKER - BEIGE
11 051049-01-000	EA	JAMB BOTTOM-ENTRY DOOR, BEIGE
079207-01-000	EA	STRIKER-ROLLER CATCH, WELDED TO DOOR JAMB - 4" X 1.15"
097724-01-01A	EA	HINGE-ENTRY DOOR, BEIGE
097724-01-04A	EA	HINGE-ENTRY DOOR, UNPAINTED
12 089748-02-000	EA	FRAME-BOTTOM ENTRY DOOR, BEIGE
090340-01-000	FT	SEAL-FOAM, CLOSED CELL - 1/4" X 1/2" X 50'
091968-03-000	FT	TAPE-ADHESIVE, .04" X 1" WIDE
100128-02-000	FT	SEAL-PILE, ADHESIVE BACK - SCREEN DOOR - GRAY
093966-01-01A	EA	CARNISH-RADIUS, ENTRANCE DOOR - ALUMINUM - BEIGE
044582-01-000	EA	CAP-DRIP, ENTRY DOOR, ALUMINUM, BEIGE
100312-01-000	EA	SWITCH-DOOR JAMB, ELECTRIC ENTRY STEP

1991 WINNEBAGO
TABLE OF CONTENTS

INTRODUCTION	A-01 - A-02
ABBREVIATIONS	A-03
ALPHABETICAL INDEX	A-04 - A-06
WCN28RT	A-07 - G-10
WCN32RQ	G-11 - L-20

1991 WCN28RT INDEX

FLOOR PLAN	A-07 - A-08
ACCESSORIES	A-09 - A-24
BATH	B-01 - B-04
BEDROOM	B-05 - B-08
CHASSIS	B-09 - C-06
C C & PAD	C-07 - C-18
DNETTE	C-19 - C-20
DRIVERS	C-21 - C-24
ELECTRICAL	D-01 - D-08
EXTERIOR BODY	D-09 - D-18
GALLEY	D-19 - E-02
HEATING & A/C	E-03 - E-08
INTERIOR FINISH	E-09 - E-13
LABEL	E-14 - E-22
LP	E-23
LOUNGE	E-24 - F-01
SEALANTS & FASTENERS	F-02 - F-04
WATER & SEWAGE	F-05 - F-11
WINDOW, VENT AND EXTERIOR DOOR	F-12 - G-10

KEY PART NUMBER	U/M	DESCRIPTION
1 M01870-50-B07	EA	DOOR-ENTRY, W/JAMB AND SCREEN DOOR - B07 - CAMEO BLUE
076054-D5-001	EA	SHEET-FIBERGLASS, 4' X 8' - BEIGE - FILON
088272-78-000	SF	PANELING-DECORATIVE - 4' X 7' - INCREMENTS OF 28 SF
000G11-08-12R	EA	SCREW, 8-18 X 3/4 PPH - BEIGE
000G39-08-08R	EA	SCREW-SF/DR-8-18X1/2 PPH
000G53-04-06B	EA	SCREW-MACH-1/4-20X3/8 PPH 2N
000G54-04-20B	EA	SCREW-1/4-20X1 1/4 PTH TYP 23
2 098173-01-01A	EA	STIFFENER-ENTRY DOOR, SUPPORTS LATCH/STRIKE AREA - BEIGE
2 098173-01-04A	EA	STIFFENER-ENTRY DOOR, SUPPORTS LATCH/STRIKE AREA - MILL
3 045017-10-000	EA	LATCH-PADDLE, MECHANISM W/LOCK CYLINDER & KEY - BLACK
		FROM: 00-00-00 THRU: 09-02-90
045017-11-700	EA	MASTER KEY, F SERIES
045017-11-701	EA	KEY BLANK, F1 SERIES
039539-01-000	EA	STRIKE-ENTRANCE DOOR LOCK
039540-01-000	EA	LATCH MECHANISM-HOOK, ENTRY DOOR - INTERIOR
039540-01-701	EA	KEY-MASTER-ATWOOD-DOOR-LOCK
039715-01-000	EA	NUT-SERT, 1/4" DIAMETER - 20 THREADS
4 039984-01-000	EA	CAP-ROUND DEADBOLT, VINYL - .28" ID X .62" LONG - BLACK
040944-01-000	EA	LABEL-ENTRANCE DOOR, "OPEN"

WINDOW, VENT & EXTERIOR DOOR GROUP (CONT'NUED)

DRIVERS DOOR & COMPONENTS

KEY PART NUMBER	U/M	DESCRIPTION
M97816-02-AB6	EA	DOOR-DRIVER
M97816-03-AB6	EA	DOOR-DRIVER, POWER - TIPOUT WINDOW
M97816-04-AB6	EA	DOOR-DRIVER, POWER - STATIONARY WINDOW
097278-01-AB6	EA	JAMB-DOOR
077517-51-000	EA	FIBERGLASS-SHEET, 29.7" X 27.9" - BEIGE - FLAT
092753 01 Y10	EA	FRAME ASM-WINDOW, OUTER
089454-02-000	EA	CHANNEL-GLASS RUN, TOP - BLACK
092445-02-000	EA	GLASS-DOOR, ROLL UP - 27.5" X 26.3"
082472 03 000	EA	CHANNEL-GLASS RETAINER
097207-01-02A	EA	HINGE-CONTINUOUS, BEIGE
092752 01 Y10	EA	FRAME ASM-WINDOW, INNER
092970-01-000	EA	GLASS-TIPOUT, 4.5" X 27.9"
092997-01-000	EA	GLASS-STATIONARY, POWER WINDOW - 4.6" X 28"
092632 02 Y10	EA	FRAME ASM-WINDOW, TIPOUT
092752-01-Y10	EA	FRAME-WINDOW, TIPOUT - INNER - 23.6" X 28"
000D39-04-00B	EA	NUT-HEX, SER FLG LK 1/4 - 20 ZN
000E13-11-00B	EA	WASHER-FL, 3/16" WIDE ZN
063729-01-000	EA	RIVNUT, 1/4 X 20 UNC - .030-.125
064219-01-000	EA	RETAINER-CHECK STRAP, DRIVER DOOR
068927-03-000	EA	SEAL-WINDOW, RUBBER - ROUND - .80" DIA. - BLACK
068938-03-000	EA	BEARING-.38"ID, SNAP IN
075671-01-000	FT	SEAL-SPONGE, LAZY T SHAPE - WEATHERSTRIP ON ENTRY DOOR
081908-01-000	EA	SCREW-MACH 6-32X.62 W/NYLOCK
081910-02-000	EA	CHANNEL-WINDOW, SLIDING
081912-01-000	EA	WEATHERSTRIP-RIGID, BLACK
081912-02-000	EA	WEATHERSTRIP-RIGID
084067-01-000	FT	SEAL-E SHAPED, SPONGE - TIPOUT WINDOW - .4" X .4" - BLACK
088473-08-000	EA	HOUSING-PIN, 4 POSITION
090340-01-000	FT	SEAL-FOAM, CLOSED CELL - 1/4" X 1/2" X 50"
091255-02-000	FT	SEAL-ADHESIVE BACKED FOAM, 1.5" X .18"
091968-03-000	FT	TAPE-ADHESIVE, .04" X 1" WIDE
093144-01-000	EA	CONDUIT-WIRE, GM# 15592046
095954-01-Y12	EA	SCREEN-SINGLE TIPOUT, 1 RADIUS CORNER - 6" X 29.2"
096809-01-000	EA	BRACKET-DEADBOLT
097367-01-000	EA	BRACKET-SUPPORT, DOOR LOCK
098030-01-000	EA	STRAP-CHECK, DRIVER DOOR - BLACK
100028-01-000	FT	TAPE-ADHESIVE, FOAM - .75" X 216"
092628 01 01A	EA	MULLION-DOOR/WINDOW BLACK
103413 01 01A	EA	GARNISH-DRIVERS DOOR O/W

FROM 901126 THRU 999999

WINDOW, VENT & EXTERIOR DOOR GROUP (CONTINUED)

DRIVERS DOOR & COMPONENTS CONT

KEY PART NUMBER	U/M	DESCRIPTION
097875-01-01A	EA	THRESHOLD-CAB DOOR - 26.5" - BLACK
092093 02 01A	EA	LINER-STEP BOX, BLACK PLASTIC
103392 02 000	EA	REGULATOR ASM-PWR WDO, 91N
093634-01-000	EA	REGULATOR-WINDOW, DRIVER
092996-01-000	EA	REGULATOR-POWER WINDOW
092996-01-710	EA	MOTOR-POWER WINDOW, DRIVER DOOR
081911-01-000	FT	TAPE-GLASS SETTING, 1/16" X 1.5"
092928-01-000	EA	ROD-LOCK, INSIDE OF DOOR
092928-04-000	EA	ROD-LOCK, INSIDE OF DOOR
092928-03-000	EA	ROD-RELEASE, INSIDE OF DOOR
092927-05-000	EA	CLIP - ROD END RIGHT LATCH-DRIVER'S DOOR
092927-06-000	EA	CLIP - ROD END LEFT LATCH-DRIVER'S DOOR
102235-01-01A	EA	LATCH-OUTSIDE, DRIVER DOOR - BLACK
		FROM: 06-25-90 THRU: 99-99-99
092927 01 000	EA	LATCH-DRIVER'S DOOR, OUTSIDE
		FROM 000000 THRU 900624
092927 04 000	EA	LATCH-DRIVER'S DOOR, LATCH
045017-11-700	EA	MASTER KEY, F SERIES
045017-11-701	EA	KEY BLANK, F1 SERIES
093223-01-700	EA	KEY-BLANK
M97748-01-01A	EA	PANEL-DOOR, INTERIOR - PLASTIC - BEIGE
M97748 01 01A	EA	PANEL-DOOR, INTERIOR, LT FAWN
081903-02-000	EA	SHAFT-MOUNTING, KNOB
081905-02-000	EA	KNOB-SLIDE BOLT, BLACK
081906-02-000	EA	BOLT-SLIDE
092927-02-000	EA	LATCH-DRIVER DOOR, INSIDE
		FROM: 00-00-00 THRU: 06-24-90
092927-04-000	EA	LATCH-DRIVER DOOR, MECHANISM
094575-01-000	EA	CRANK-HAND, GLASS LIFT
088246-01-000	EA	SWITCH-REMOTE, MIRROR
087695-01-000	EA	SWITCH-HEATER, MIRROR
061400-04-000	EA	STRAP-ASSIST, 12" - BLACK W/WOODGRAIN SCREW COVERS
102237-01-01A	EA	LATCH-DRIVER DOOR, INSIDE - BLACK
		FROM: 06-25-90 THRU: 99-99-99
092927 02 000	EA	LATCH-DRIVER'S DOOR, INSIDE
		FROM: 00-00-00 THRU: 90-06-24
093132-01-000	EA	SWITCH-POWER WINDOW
077000-01-000	EA	SOCKET ASM-W/8" PIGTAIL LEADS
077026-01-000	EA	LENS-COURTESY LIGHT, CLEAR
079370-04-000	FT	COVER-SCREW, WINDOW - VINYL - BLACK
080734-02-000	EA	CLIP-WIRE, NYLON
081243-02-000	EA	CLIP-SCREEN, PLASTIC - BLACK
035302 01 000	EA	OPERATOR-SLANT-TORQUE RT
089913 01 000	EA	HINGE-TIPOUT WDO, BLACK
092628 01 01A	EA	MULLION-DOOR/WINDOW BLACK
092632 02 Y10	EA	FRAME ASM-WINDOW, TIPOUT
095889 02 000	EA	BRACKET-TORQUE TUBE/OPER
095954 01 Y12	EA	SCREEN ASM-SINGLE TIPOUT
086259-04-000	EA	MIRROR-REMOTE HEAT, W/ARM & MIRRORS - PRE-WIRED - PASSENGER
086259-04-700	EA	GLASS ONLY CONVEX HEATED RH
086259-04-701	EA	GLASS ONLY FLAT HEATED RH
086259-05-000	EA	MIRROR-REMOTE HEAT, W/ARM & MIRRORS - PRE-WIRED - DRIVER
086259-05-700	EA	GLASS-MIRROR, HEATED CONVEX - DRIVER SIDE
086259-05-701	EA	GLASS-MIRROR, HEATED FLAT - DRIVER SIDE
086284-01-000	EA	SPRING-COMPRESSION, .44" LONG X .36" OD

1991 WINNEBAGO
TABLE OF CONTENTS

INTRODUCTION	A-01 - A-02
ABBREVIATIONS	A-03
ALPHABETICAL INDEX	A-04 - A-06
WCN28RT	A-07 - G-10
WCN32RO	G-11 - L-20

1991 WCN28RT INDEX

FLOOR PLAN	A-07 - A-08
ACCESSORIES	A-09 - A-24
BATH	B-01 - B-04
BEDROOM	B-05 - B-08
CHASSIS	B-09 - C-06
C C & PAD	C-07 - C-18
DINETTE	C-19 - C-20
DRIVERS	C-21 - C-24
ELECTRICAL	D-01 - D-08
EXTERIOR BODY	D-09 - D-18
GALLEY	D-19 - E-02
HEATING & A/C	E-03 - E-08
INTERIOR FINISH	E-09 - E-13
LABEL	E-14 - E-22
LP	E-23
LOUNGE	E-24 - F-01
SEALANTS & FASTENERS	F-02 - F-04
WATER & SEWAGE	F-05 - F-11
WINDOW, VENT AND EXTERIOR DOOR	F-12 - G-10

WINDOW, VENT & EXTERIOR DOOR GROUP (CONTINUED)

DRIVER DOOR W/POWERED WINDOW AND MIRROR OPTION L28P

KEY PART NUMBER	U/M	DESCRIPTION
M97816-03-AB6	EA	DOOR-DRIVER, POWER - TIPOUT WINDOW
M97748-01-01A	EA	PANEL-DOOR, INTERIOR - PLASTIC - BEIGE
000G11-07-08B	EA	SCREW, 7-19 X 1/2 PPH - ZN
097308-01-01A	EA	COVER-MAP POCKET, BEIGE
000D39-04-00B	EA	NUT-HEX, SER FLG LK 1/4 - 20 ZN
000E13-11-00B	EA	WASHER-FL, 3/16" WIDE ZN
000G11-10-12D	EA	SCREW, 10-16 X 3/4 PPH - BLACK
000G19-10-08B	EA	SCREW-MACH, 10-32 X 1/2 PPH ZN
000G39-08-06B	EA	SCREW-SF/DR, 8-18 X 3/8 PPH ZN
000G39-10-12D	EA	SCREW-SF/DR, 10-16 X 3/4 PPH - BLACK
000G50-04-12B	EA	SCREW-MACH, 1/4-20 X 3/4 PPH ZN
000G54-04-20B	EA	SCREW-1/4-20X11/4 PTH TYP 23
061400-04-000	EA	STRAP-ASSIST, 12" - BLACK W/WOODGRAIN SCREW COVERS
063729-01-000	EA	RIVNUT, 1/4 X 20 UNC - .030-.125
064219-01-000	EA	RETAINER-CHECK STRAP, DRIVER DOOR
068927-03-000	EA	SEAL-WINDOW, RUBBER - ROUND - .80" DIA. - BLACK
068938-03-000	EA	BEARING-.38"ID, SNAP IN
075671-01-000	FT	SEAL-SPONGE, LAZY T SHAPE - WEATHERSTRIP ON ENTRY DOOR
100028-01-000	FT	TAPE-ADHESIVE, FOAM - .75" X 216"
077000-01-000	EA	SOCKET ASM-W/8" PIGTAIL LEADS
077026-01-000	EA	LENS-COURTESY LIGHT, CLEAR
079370-04-000	FT	COVER-SCREW, WINDOW - VINYL - BLACK
080734-02-000	EA	CLIP-WIRE, NYLON
081903-02-000	EA	SHAFT-MOUNTING, KNOB
081905-02-000	EA	KNOB-SLIDE BOLT, BLACK
081906-02-000	EA	BOLT-SLIDE
081908-01-000	EA	SCREW-MACH 6-32X.62 W/NYLOCK
081910-02-000	EA	CHANNEL-WINDOW, SLIDING
081911-01-000	FT	TAPE-GLASS SETTING, 1/16" X 1.5"
081912-02-000	EA	WEATHERSTRIP-RIGID
084067-01-000	FT	SEAL-E SHAPED, SPONGE - TIPOUT WINDOW - .4" X .4" - BLACK
086284-01-000	EA	SPRING-COMPRESSION, .44" LONG X .36"OD
087695-01-000	EA	SWITCH-HEATER, MIRROR
088246-01-000	EA	SWITCH-REMOTE, MIRROR
089454-02-000	EA	CHANNEL-GLASS RUN, TOP - BLACK
090340-01-000	FT	SEAL-FOAM, CLOSED CELL - 1/4" X 1/2" X 50"
091255-02-000	FT	SEAL-ADHESIVE BACKED FOAM, 1.5" X .18"
091968-03-000	FT	TAPE-ADHESIVE, .04" X 1" WIDE
092446-02-000	EA	GLASS-DOOR, ROLL UP - 27.5" X 26.3"
092752-01-Y10	EA	FRAME-WINDOW, TIPOUT - INNER - 23.6" X 28"
000G39-08-08B	EA	SCREW-SF/DR, 8-18 X 1/2 PPH ZN
081912-01-000	EA	WEATHERSTRIP-RIGID, BLACK
092845-01-000	EA	WIRE ASSEMBLY-DRIVER DOOR CONTROL PANEL
088473-08-000	EA	HOUSING-PIN, 4 POSITION
093144-01-000	EA	CONDUIT-WIRE, GM# 15592046
092927-01-000	EA	LATCH-DRIVER DOOR, OUTER
FROM: 00-00-00 THRU: 06-24-90		
092927-01-706	EA	LOCK-LEVER, BLACK
092927-01-701	EA	LOCK-LEVER, CHROME
092927-01-702	EA	CYLINDER-KEY, W/KEY
083223-01-700	EA	KEY-BLANK
102235-01-01A	EA	LATCH-OUTSIDE, DRIVER DOOR - BLACK
FROM: 06-25-90 THRU: 99-99-99		
045017-11-700	EA	MASTER KEY, F SERIES
045017-11-701	EA	KEY BLANK, F1 SERIES
092927-02-000	EA	LATCH-DRIVER DOOR, INSIDE
FROM: 00-00-00 THRU: 06-24-90		
102237-01-01A	EA	LATCH-INSIDE, DRIVER DOOR - BLACK
FROM: 06-25-90 THRU: 99-99-99		
092927-04-000	EA	LATCH-DRIVER DOOR, MECHANISM
092927-05-000	EA	LATCH-DRIVER DOOR, ROD END - RH
092927-06-000	EA	LATCH-DRIVER DOOR, ROD END - LEFT
092928-01-000	EA	ROD-LOCK, INSIDE OF DOOR
092928-03-000	EA	ROD-RELEASE, INSIDE OF DOOR
092928-04-000	EA	ROD-LOCK, INSIDE OF DOOR
092970-01-000	EA	GLASS-TIPOUT, 4.5" X 27.9"
092996-01-000	EA	REGULATOR-POWER WINDOW
052996-01-710	EA	MOTOR-POWER WINDOW, DRIVER DOOR

WINDOW, VENT & EXTERIOR DOOR GROUP (CONTINUED)

DRIVER DOOR W/POWERED WINDOW AND MIRROR OPTION L28P

KEY PART NUMBER	U/M	DESCRIPTION
093132-01-000	EA	SWITCH-POWER WINDOW
095954-01-Y12	EA	SCREEN-SINGLE TIPOUT, 1 RADIUS CORNER - 6" X 29.2"
096809-01-000	EA	BRACKET-DEADBOLT
097207-01-02A	EA	HINGE-CONTINUOUS, BEIGE
097278-01-AB6	EA	JAMB-DOOR
055278-01-001	FT	TUBING-STEEL, .75" X 1.5" X 288"
097367-01-000	EA	BRACKET-SUPPORT, DOOR LOCK
077517-51-000	EA	FIBERGLASS-SHEET, 29.7" X 27.9" - BEIGE - FLAT
098030-01-000	EA	STRAP-CHECK, DRIVER DOOR - BLACK
086259-04-000	EA	MIRROR-REMOTE HEAT, W/ARM & MIRRORS - PRE-WIRED - PASSENGER
086259-04-700	EA	GLASS ONLY CONVEX HEATED RH
086259-04-701	EA	GLASS ONLY FLAT HEATED RH
086259-05-000	EA	MIRROR-REMOTE HEAT, W/ARM & MIRRORS - PRE-WIRED - DRIVER
086259-05-700	EA	GLASS ONLY CONVEX HEATED LH

1991 WINNEBAGO
TABLE OF CONTENTS

INTRODUCTION	A-01 - A-02
ABBREVIATIONS	A-03
ALPHABETICAL INDEX	A-04 - A-06
WCN28RT	A-07 - G-10
WCN32RQ	G-11 - L-20

1991 WCN28RT INDEX

FLOOR PLAN	A-07 - A-08
ACCESSORIES	A-09 - A-24
BATH	B-01 - B-04
BEDROOM	B-05 - B-08
CHASSIS	B-09 - C-06
C C & PAD	C-07 - C-18
DINETTE	C-19 - C-20
DRIVERS	C-21 - C-24
ELECTRICAL	D-01 - D-08
EXTERIOR BODY	D-09 - D-18
GALLEY	D-19 - E-02
HEATING & A/C	E-03 - E-06
INTERIOR FINISH	E-09 - E-13
LABEL	E-14 - E-22
LP	E-23
LOUNGE	E-24 - F-01
SEALANTS & FASTENERS	F-02 - F-04
WATER & SEWAGE	F-05 - F-11
WINDOW, VENT AND EXTERIOR DOOR	F-12 - G-10

WINDOW, VENT & EXTERIOR DOOR GROUP (CONTINUED)

WIPER COMPONENTS

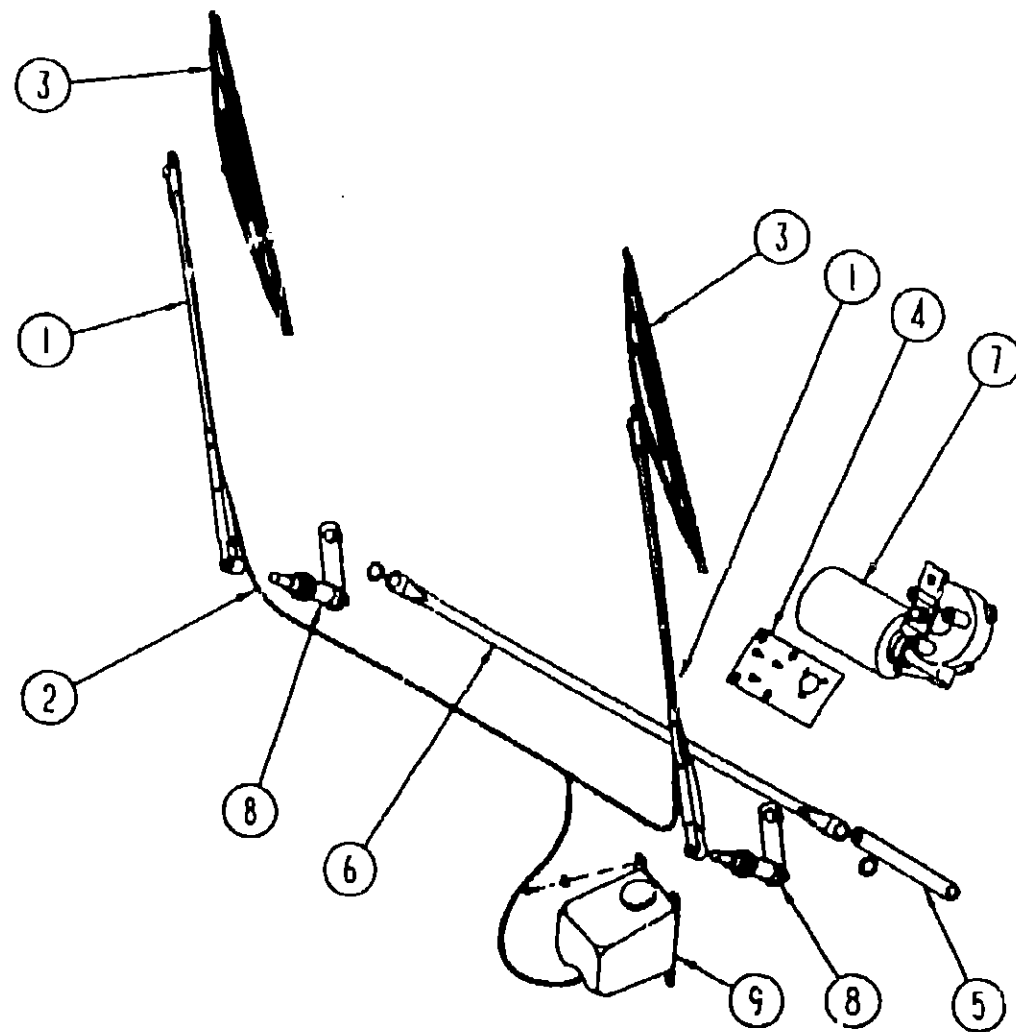

WINDOW, VENT & EXTERIOR DOOR GROUP (CONTINUED)

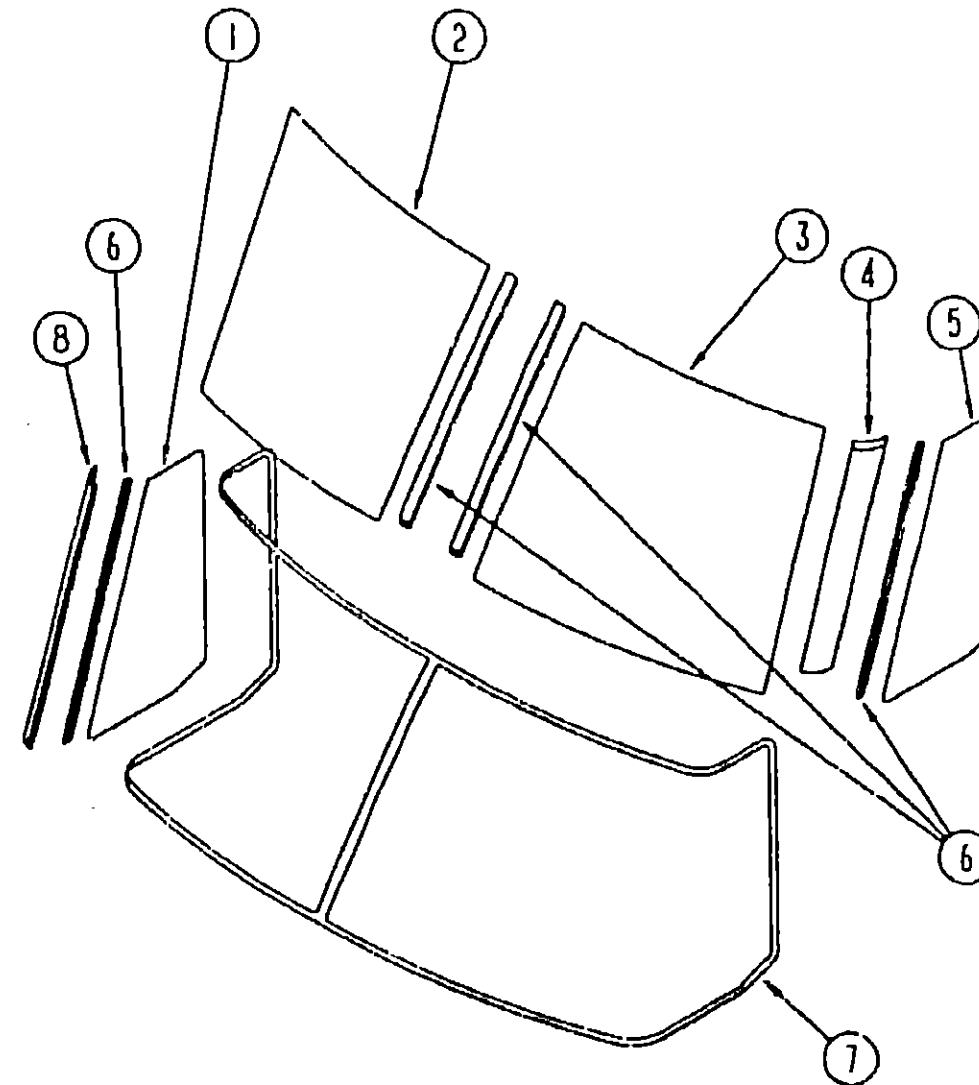

WINDSHIELDS, TRIMS & MOLDINGS

1991 WINNEBAGO
TABLE OF CONTENTS

INTRODUCTION	A-01 - A-02
ABBREVIATIONS	A-03
ALPHABETICAL INDEX	A-04 - A-06
WCN28RT	A-07 - G-10
WCN32RQ	G-11 - L-20

1991 WCN28RT INDEX

FLOOR PLAN	A-07 - A-08
ACCESSORIES	A-09 - A-24
BATH	B-01 - B-04
BEDROOM	B-05 - B-08
CHASSIS	B-09 - C-06
C C & PAD	C-07 - C-18
DINETTE	C-19 - C-20
DRIVERS	C-21 - C-24
ELECTRICAL	D-01 - D-08
EXTERIOR BODY	D-09 - D-18
GALLEY	D-19 - E-02
HEATING & A/C	E-03 - E-08
INTERIOR FINISH	E-09 - E-13
LABEL	E-14 - E-22
LP	E-23
LOUNGE	E-24 - F-01
SEALANTS & FASTENERS	F-02 - F-04
WATER & SEWAGE	F-05 - F-11
WINDOW, VENT AND EXTERIOR DOOR	F-12 - G-10

KEY PART NUMBER	U/M	DESCRIPTION
1 095963-01-000	EA	ARM-WIPER, PANTOGRAPH - 28"
2 045794-01-000	FT	HOSE-WASHER, WINDSHIELD - 5/32" ID - BLACK
3 095964-01-000	EA	BLADE-WIPER, 24"
4 092334 01 000	EA	BRACKET-WIPER,MOTOR
5 067193-02-000	EA	LINK-CONNECTING, PASSENGER - 9.2"
6 067192-01-000	EA	LINK-DRIVER CONNECTING, W/BLACK BUSHING - 37.85"
7 096381-01-000	EA	MOTOR-WIPER, FRONT
8 096505-01-000	EA	PIVOT SHAFT
096526-01-000	EA	SCREW-HEX, 1/4 - 28 UNF
9 056000-02-000	EA	WASHER-WINDSHIELD, BOTTLE & PUMP
056000-01-700	FT	VACUUM HOSE 7/64 - 5/32
041791-01-000	FT	SEAL-VINYL, FLEX U-CHANNEL
061603-01-000	EA	GROMMET-SNAP, 3/16 ID - 3/8 HOLE - PLASTIC - BLACK
071015-21-000	EA	GROMMET-.50"ID, FITS .19" MATERIAL, RUBBER- SPLIT
077049-01-000	EA	NUT-ACORN, 10-32 ALUMINUM
077048-01-000	EA	SHAFT-ADAPTER, WINDSHIELD PANTOGRAPH ARM
091206-02-000	EA	CONTROL-WIPER
067188-01-000	EA	STUD-CRANK,WIPER

KEY PART NUMBER	U/M	DESCRIPTION
1 091953-03-000	EA	GLASS-CORNER VENT, PASSENGER
2 091215-01-000	EA	GLASS-WINDSHIELD, PASSENGER
3 091215-02-000	EA	GLASS-WINDSHIELD, DRIVER
4 091901-02-000	EA	TRIM-A'PILLAR, DR - BETWEEN WINDSHIELD & VENT GLASS - BLK
5 091953-04-000	EA	GLASS-CORNER VENT, DRIVER
6 098788-01-000	EA	CHANNEL-RIGID, WINDSHIELD - .38" - PVC
7 091986-01-000	EA	MOLDING-REVEAL, WINDSHIELD - SURROUNDS BOTH WINDSHIELDS
8 091901-01-000	EA	TRIM-A'PILLER, PASS - BETWEEN WINDSHIELD & VENT GLASS - BLK
002328-02-000	EA	BLOCK-WINDSHIELD, .062" X .5" X .98"
091969-01-000	EA	FRAME-WINDSHIELD, LOWER - INNER - PASSENGER
091969-02-000	EA	FRAME-WINDSHIELD, LOWER - INNER - DRIVER
040921-04-000	EA	NUT-SPEED, U TYPE - NO. 8 - .59" LENGTH X .44" WIDTH
040921-05-000	EA	NUT-SPEED, U TYPE - NO. 8 - .67" LENGTH X .44" WIDTH
040921-06-000	EA	NUT-SPEED, U TYPE - NO. 8 - .57" LENGTH X .63" WIDTH