

PART NUMBER	DESCRIPTION	524D
SS0008-01-000	SEAL SPEC-FIBERGLASS SEAMS	GEN
SS0011-01-000	SEAL SPEC-SELF-LEVEL GUIDELINES	GEN
SS0012-01-000	SEAL SPEC-COVER, VENT PIPE	2
SS0020-01-000	SEAL SPEC-ACRYL SKYLITE INST	1
SS0022-01-000	SEAL SPEC-LADDER, ROOF ACCESS	1
SS0024-01-000	SEAL SPEC-REAR ROOF CAP,PLASTIC	1
SS0030-01-000	SEAL SPEC-JOINT,ROOF-TO-S/W	2
SS0033-01-000	SEAL SPEC-ANTENNA, TELEVISION	1
SS0043-01-000	SEAL SPEC-WINDOWS, CURVED WINDOW	2
SS0047-01-000	SEAL SPEC-FLOOR GUIDELINES	GEN
SS0050-01-000	SEAL SPEC-WINDOWS,4 RAD CRNR	4
SS0052-01-000	SEAL SPEC-FLOOR TO B/W JOINT	GEN
SS0068-01-000	SEAL SPEC-TUBING THRU FLOOR	GEN
SS0075-01-000	SEAL SPEC-S/W TO B/W JOINT	2
SS0078-01-000	SEAL SPEC-GENERATOR COMPT	GEN
SS0079-01-000	SEAL SPEC-COMPT, PLASTIC PNL	GEN
SS0081-01-000	SEAL SPEC-TAIL LIGHT PODS	2
SS0082-01-000	SEAL SPEC-LUGG COMPT, ROTOCAST	GEN
SS0086-01-000	SEAL SPEC-ANTI-WICKING APPLICATION	GEN
SS0087-01-000	SEAL SPEC-TABLE LEG SOCKET	GEN
SS0088-01-000	SEAL SPEC-LUGGAGE COMPARTMENT	GEN
SS0096-01-000	SEAL SPEC-B/W AND S/W GUIDELINES	GEN
SS0101-01-000	SEAL SPEC-STEP BOX	GEN
SS0105-01-000	SEAL SPEC-COMPT DOOR, ENTRAN	1
SS0111-01-000	SEAL SPEC-SEALANT GUIDELINES	GEN
SS0112-01-000	SEAL SPEC-SHOWER GUIDELINES	GEN
SS0113-01-000	SEAL SPEC-COUNTERTOPS	GEN
SS0114-01-000	SEAL SPEC-ENTRANCE DOOR INST	1
SS0116-01-000	SEAL SPEC-BUTYL TAPE GUIDELINES	GEN
SS0135-01-000	SEAL SPEC-FRONT ROOF CAP 500	1
SS0136-01-000	SEAL SPEC-FLOOR RAILS	GEN
SS0141-01-000	SEAL SPEC-SUB-FLOOR PANELS	GEN
SS0142-01-000	SEAL SPEC-HOLE PLUGS, PLASTIC	GEN
SS0143-01-000	SEAL SPEC-ACCESS PANEL	GEN
SS0144-01-000	SEAL SPEC-ACCESS PANEL	GEN
SS0150-01-000	SEAL SPEC-FLOOR TO S/W JOINT	2

PART NUMBER	DESCRIPTION	524D
SS0152-01-000	SEAL SPEC-CAP-SEAL, GUIDELINES	GEN
SS0157-01-000	SEAL SPEC-SLIDE OUT AWNING	1
SS0158-01-000	SEAL SPEC-PATIO AWNING,ELECTRIC	1
SS0198-01-000	SEAL SPEC-INT ACC/CL OUT PNL	GEN
SS0216-01-000	SEAL SPEC-BATH VENT INSTL	1
SS0232-01-000	SEAL SPEC-SLIDE OUT BOX ASSY	1
SS0233-01-000	SEAL SPEC-SLIDE OUT INSTLN	1
SS0238-01-000	SEAL SPEC-ROOF VENT, SCREW IN	1
SS0252-01-000	SEAL SPEC-ROOF ACCESS COVER	1
SS0262-01-000	SEAL SPEC-CLEARANCE LIGHTS, GASKET	5
SS0263-01-000	SEAL SPEC-SATELLITE ANTENNA, CHASSIS SUPPLIED	1
SS0270-01-000	SEAL SPEC-CLEARANCE LIGHTS, W/O GASKET	2
SS0271-01-000	SEAL SPEC-GRAVITY WTR FILL, PUMP BUTYL	1
SS0273-01-000	SEAL SPEC-PORCH LIGHT, W/ GASKET	1
SS0275-01-000	SEAL SPEC-FURNACE DOOR& VENT, PUMP BUTYL	1
SS0276-01-000	SEAL SPEC-COAX OUTLET, PUMP BUTYL	1
SS0290-01-000	SEAL SPEC-WTR HTR PL RING	1
SS0291-01-000	SEAL SPEC-SIDE VENT COVER, PUMP BUTYL	1
SS0292-01-000	SEAL SPEC-S/W TANK FLUSH, PUMP BUTYL	1
SS0293-01-000	SEAL SPEC-ROOF SOLAR PORT W/ FLANGE	1

NOTES: "GEN" REFERS TO GENERAL SEALANT SPECIFICATIONS, NO SPECIFIC LOCATION NOTED.

<b>WINNEBAGO</b> <sup>®</sup>		
COPYRIGHT 2024 WINNEBAGO INDUSTRIES, INC.		
DSNR:	ALL DIMENSIONS ARE IN MILLIMETERS 	
DFTR:		
UNSPECIFIED TOLERANCES:	MATERIAL:	
WHOLE DIM (X) :	3	
ONE-PLACE (X.X) :	1.5	
TWO-PLACE (X.XX) :	0.50	
ANGLE :	1°	
REFER TO ES0018 FOR FASTENER TIGHTENING GUIDELINES	WEIGHT: (LBS)	FIRST USED: (REF)
DESCRIPTION:		
<b>SEALANT SPECIFICATION-524D</b>		
SHEET:	ITEM/PART NO:	REV:
1 OF 2	000041596 / 31980801000	
REF:		1 02-Feb-2026

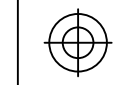
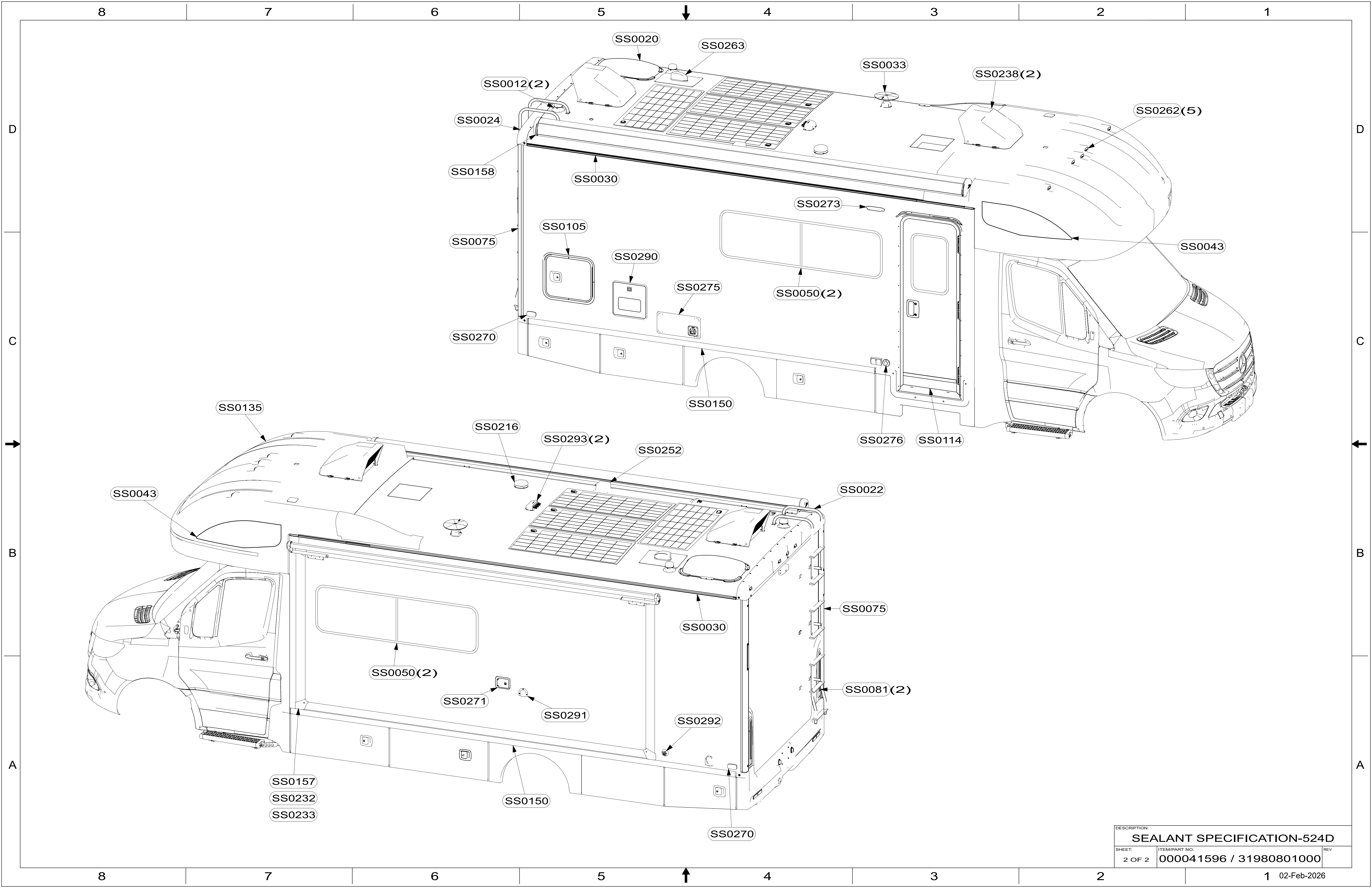

DESCRIPTION:		
SEALANT SPECIFICATION-524D		
SHEET:	ITEM/PART NO.:	REV:
2 OF 2	000041596 / 31980801000	