

FRONT
OF
COACH

BA

- 9. CUT TO LENGTH AS NEEDED TO ENSURE LINES DO NOT EXTEND MORE THAN 2" PAST EDGE OF FLOORING.
- 8. ADD INSULATION 142676-01-000.
- 7. SECURE VALVE HANDLE W/SILICON.
- 6. PARTS TO BE ASSEMBLED AND ABLE TO BE REMOVED AND STORED AS A SINGLE ASM.
- 5. ALL CRIMP FITTINGS TO 1/2" PEX TUBING REQUIRE 1/2" CLAMP 000156249 / 326670-01-000.
- 4. ALL CRIMP FITTINGS TO 5/8" PEX TUBING REQUIRE 5/8" CLAMP 000156248 / 326669-01-000.
- 3. ALL TUBING TO BE SECURED AT 1200 INTERVALS MAXIMUM WITH CLAMP 010495-01-000 AND SCREW 000G67-10-12U OR EQUIVALENT.
- 2. TUBING TO BE INSTALLED WITH SUFFICIENT SLOPE TO PROVIDE DRAINAGE TO NEAREST VALVE.
- 1. PLASTIC FITTINGS TO BE SEALED WITH SEALANT 084456-01-000.

NOTES:

- CC INDICATES A CRITICAL CHARACTERISTIC. ENSURE PROPER PROCEDURES ARE FOLLOWED.
- SC INDICATES A SIGNIFICANT CHARACTERISTIC. ENSURE PROPER PROCEDURES ARE FOLLOWED.
- KC INDICATES A KEY CHARACTERISTIC. ENSURE PROPER PROCEDURES ARE FOLLOWED.



COPYRIGHT 2024 WINNEBAGO INDUSTRIES, INC.

DSNR:		ALL DIMENSIONS ARE IN MILLIMETERS	
DFT:			
UNSPECIFIED TOLERANCES:		MATERIAL:	
WHOLE DIM (X)	3		
ONE-PLACE (X.X)	1.5		
TWO-PLACE (X.XX)	0.50		
ANGLE	1°		
REFER TO ES0018 FOR FASTENER TIGHTENING GUIDELINES		WEIGHT: (LBS)	FIRST USED: (REF)
			26 B44C
DESCRIPTION: WATER SYSTEM INSTL			
SHEET: 1 OF 2	ITEM/PART NO: 000297688 / 36000901000	REV:	

X-X
FOR
WATER
CALLOUTS
SEE DWG NO.
000209446 /
303369-01-000

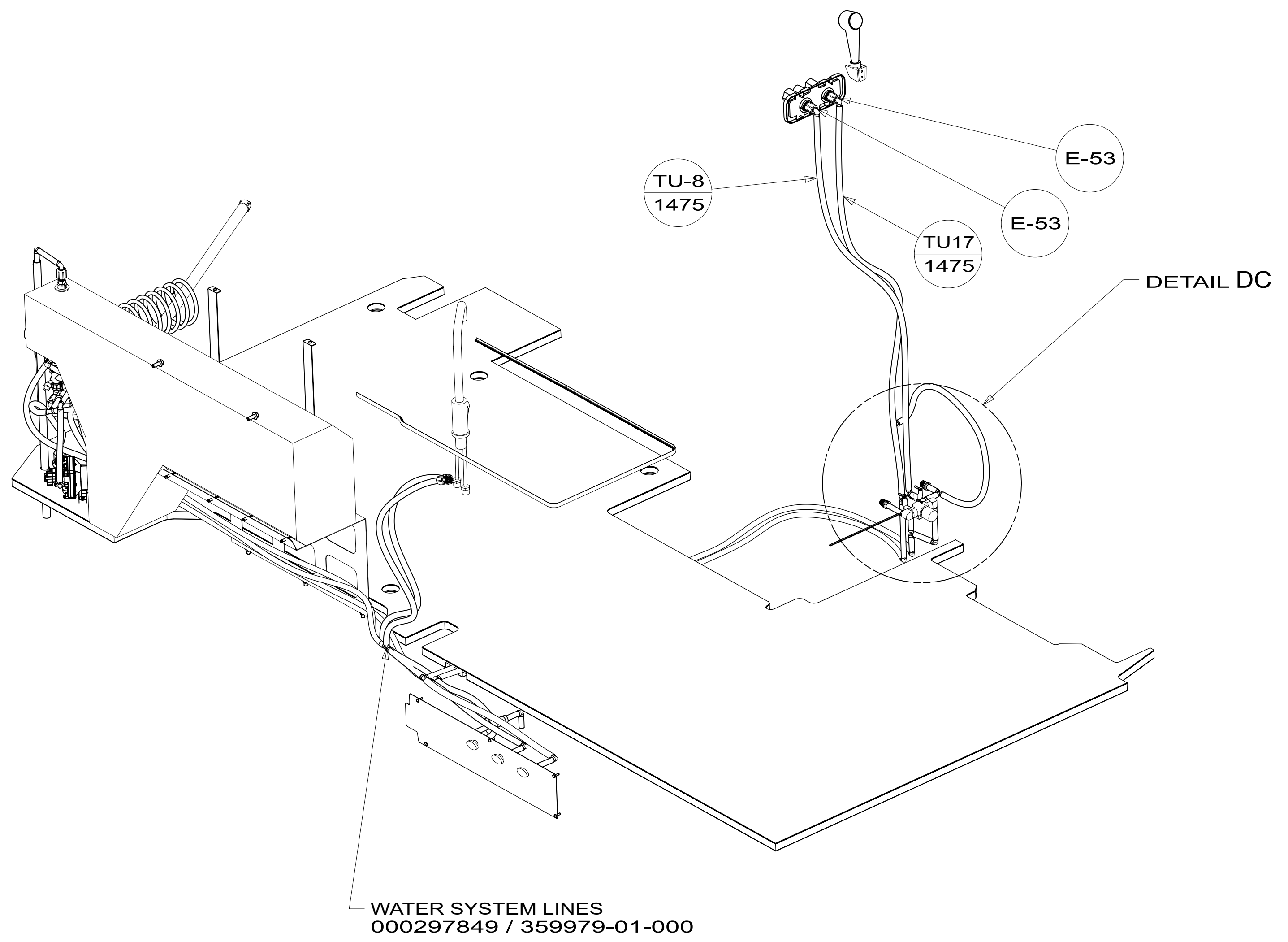

VIEW BA
(SHOWN W/OUT SHOWER
AND W/OUT DINETTE INSTAL)

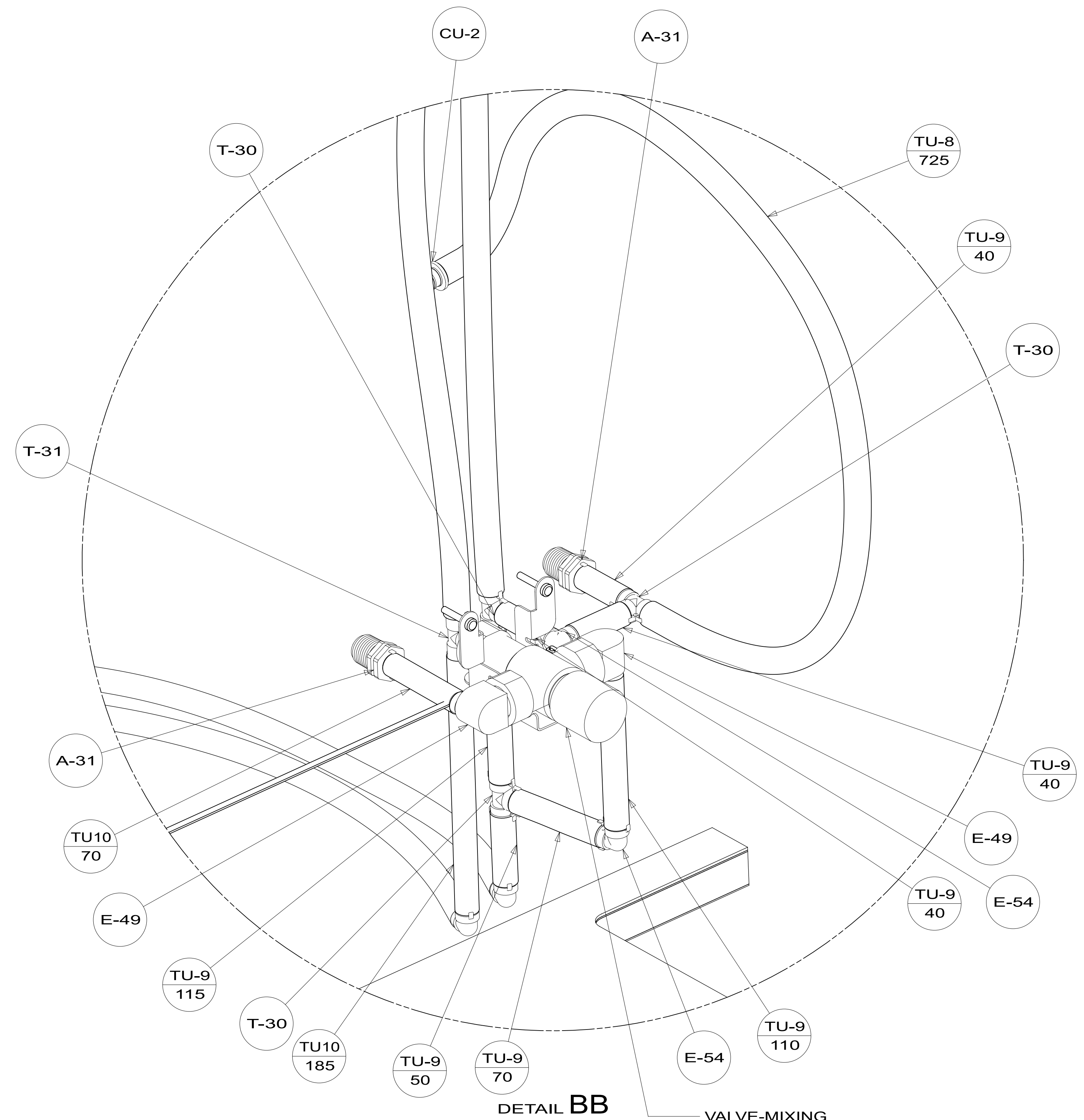

DETAIL BB

DESCRIPTION:		
WATER SYSTEM INSTL		
SHEET:	ITEM/PART NO.:	REV
2 OF 2	000297688 / 36000901000	