

- 12 ROUTE WATER LINES AND WIRES THROUGH CONDUIT-CONVOLUTED BEFORE TAPING TO HOSE-SANITATION, 1" ID.
- 11 PARTS TO BE SUPPLIED WITH FILTER KIT 000038865 / 318913-01-000.
- 10. INSTALL BYPASS PLUG FOR SYSTEM TESTING AND SHIPPING.
- 9 PARTS TO BE ASSEMBLED AND ABLE TO BE REMOVED AND STORED AS A SINGLE ASM.
- 8. ALL CRIMP FITTINGS TO 1/2" PEX TUBING REQUIRE 1/2" CLAMP 000156249 / 326670-01-000.
- 7. ALL CRIMP FITTINGS TO 5/8" PEX TUBING REQUIRE 5/8" CLAMP 000156248 / 326669-01-000.
- 6 LABEL HOT AND COLD SUPPLY TUBES AND TAPE FITTING TO TUBE BEFORE CABINET SET TO PREVENT MOVEMENT.
- 5 ADD PIPE WRAP (LADDER SCRAP 110157-02-000) INSULATION.
- 4 ADD TEFLON TAPE 010405-02-000.
- 3. ALL TUBING TO BE SECURED AT 1200 INTERVALS MAXIMUM WITH CLAMP 010495-01-000 AND SCREW 000G67-10-12U OR EQUIVALENT.
- 2. TUBING TO BE INSTALLED WITH SUFFICIENT SLOPE TO PROVIDE DRAINAGE TO NEAREST VALVE.
- 1. PLASTIC FITTINGS TO BE SEALED WITH SEALANT 084456-01-000.

NOTES:

	INDICATES A CRITICAL CHARACTERISTIC. ENSURE PROPER PROCEDURES ARE FOLLOWED.
	INDICATES A SIGNIFICANT CHARACTERISTIC. ENSURE PROPER PROCEDURES ARE FOLLOWED.
	INDICATES A KEY CHARACTERISTIC. ENSURE PROPER PROCEDURES ARE FOLLOWED.

X-X

FOR WATER CALLOUTS SEE DWG NO. 000209446 / 303369-01-000

9PC TAILGATE PACKAGE



DSNR:		ALL DIMENSIONS ARE IN MILLIMETERS		
DIFTR:		MATERIAL:		
UNSPECIFIED TOLERANCES:	WHOLE DIM (X)	3		
	ONE-PLACE (X.X)	1.5		
	TWO-PLACE (X.XX)	0.50		
	ANGLE	1°		
REFER TO ES0018 FOR FASTENER TIGHTENING GUIDELINES		WEIGHT: (LBS)	FIRST USED: (REF)	
			23 622A	
DESCRIPTION: WATER SYSTEM INSTL				
SHEET:	ITEM/PART NO.:	REF:		REV:
1 OF 4	000255319 / 35010501000			

TANK ASM-WATER  
000209575 / 339778-01-000  
BRACKET-TANK  
000225230 / 343700-01-CHT  
SCREW  
000G39-10-12U (2)

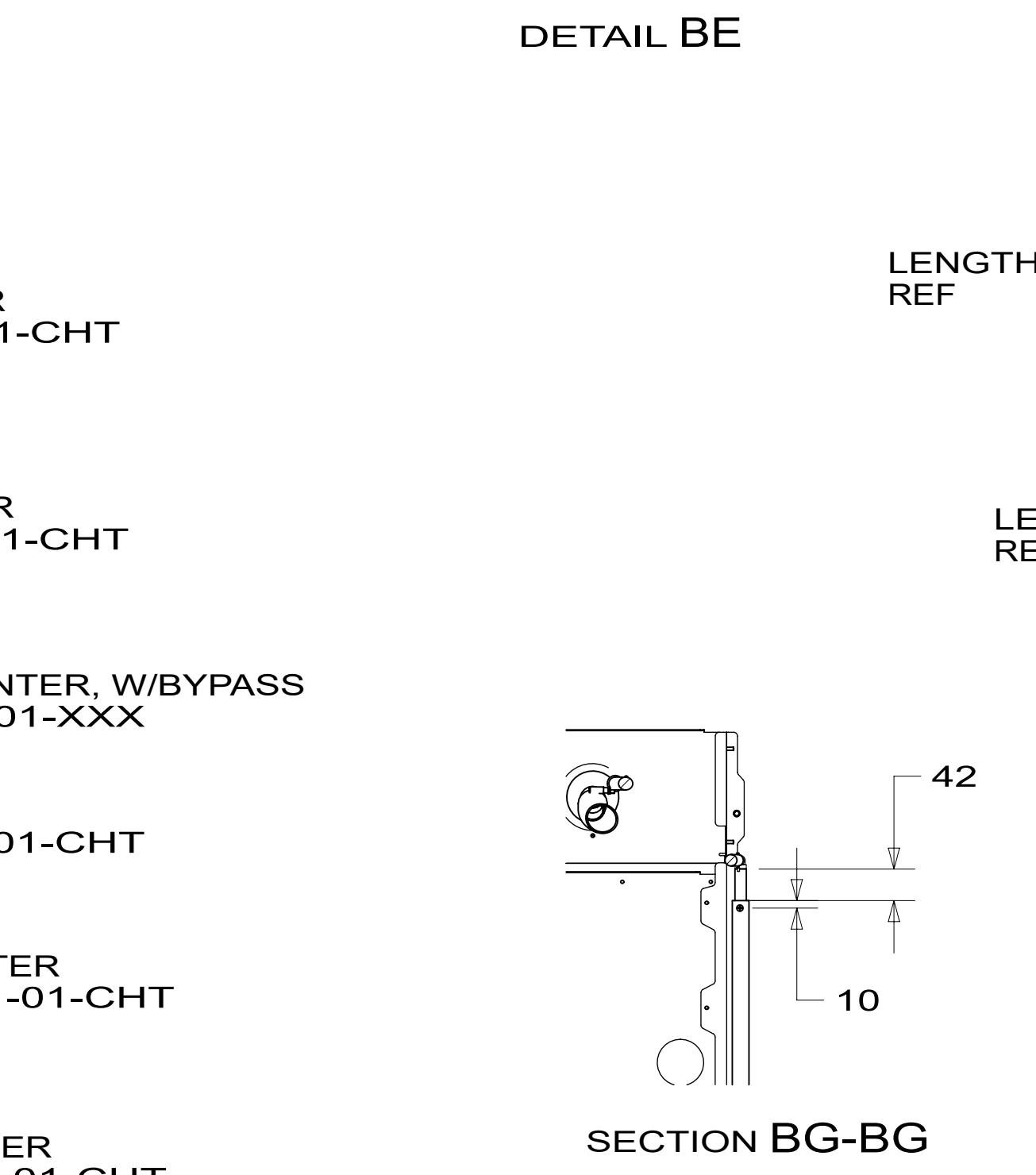
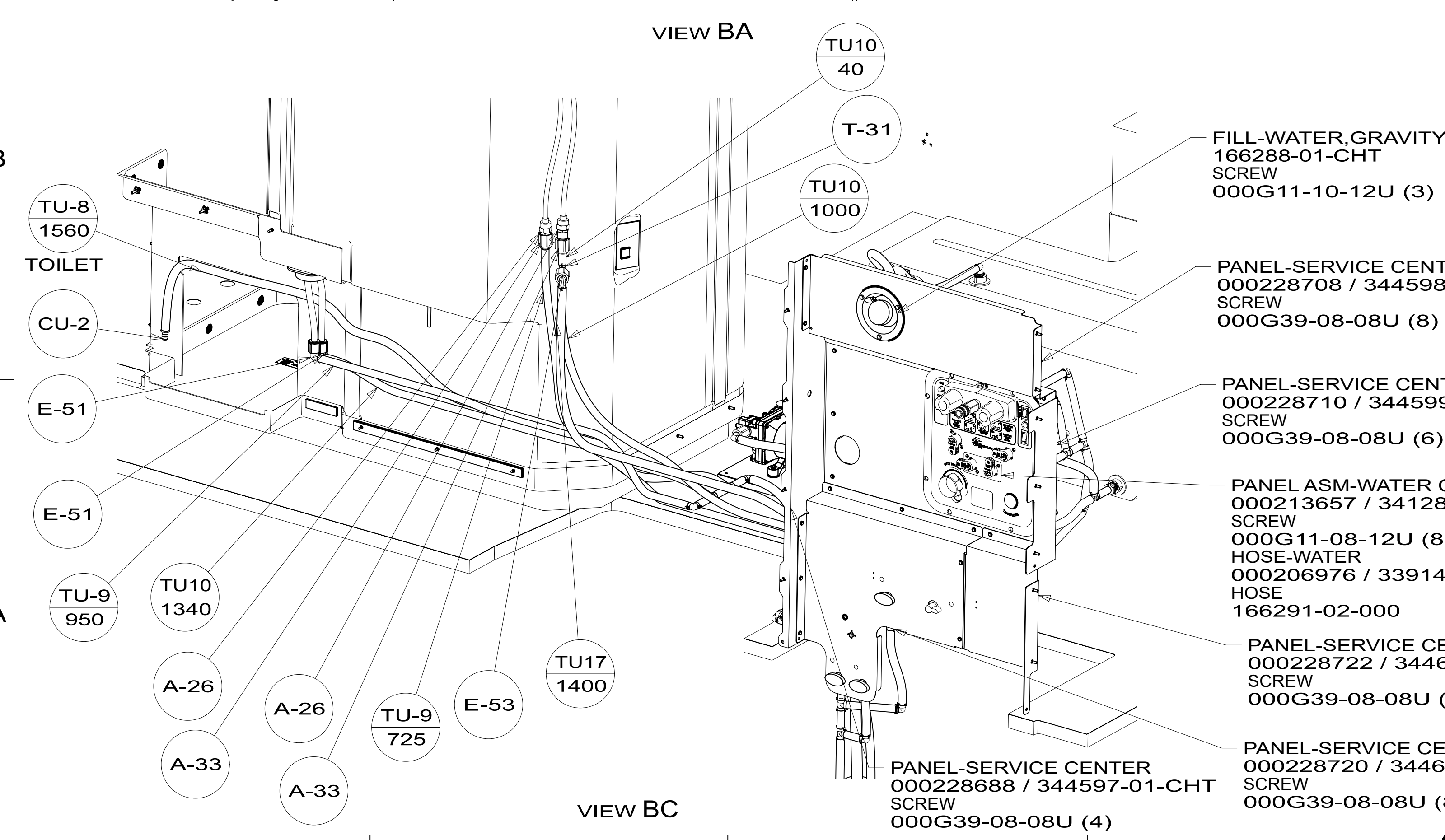
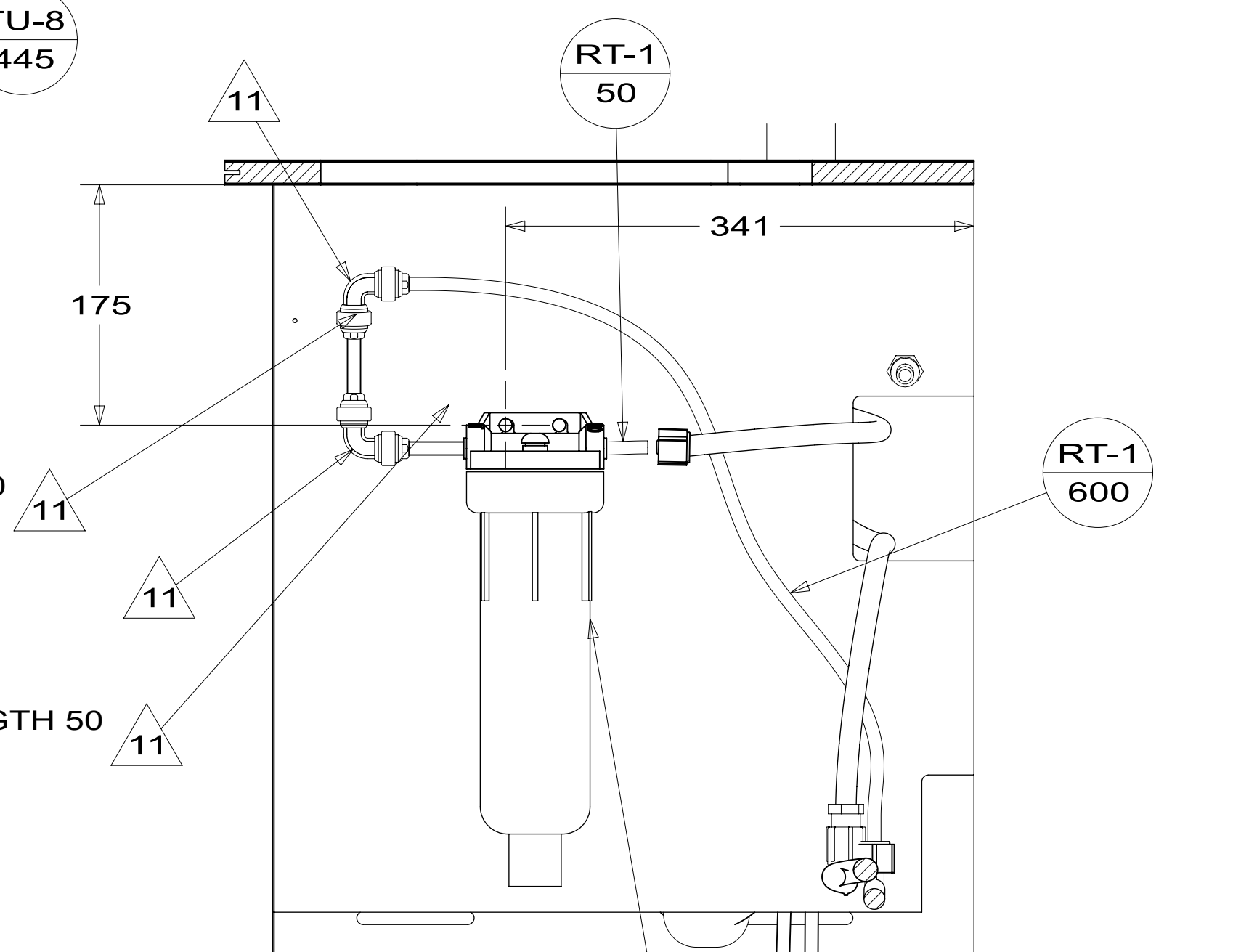
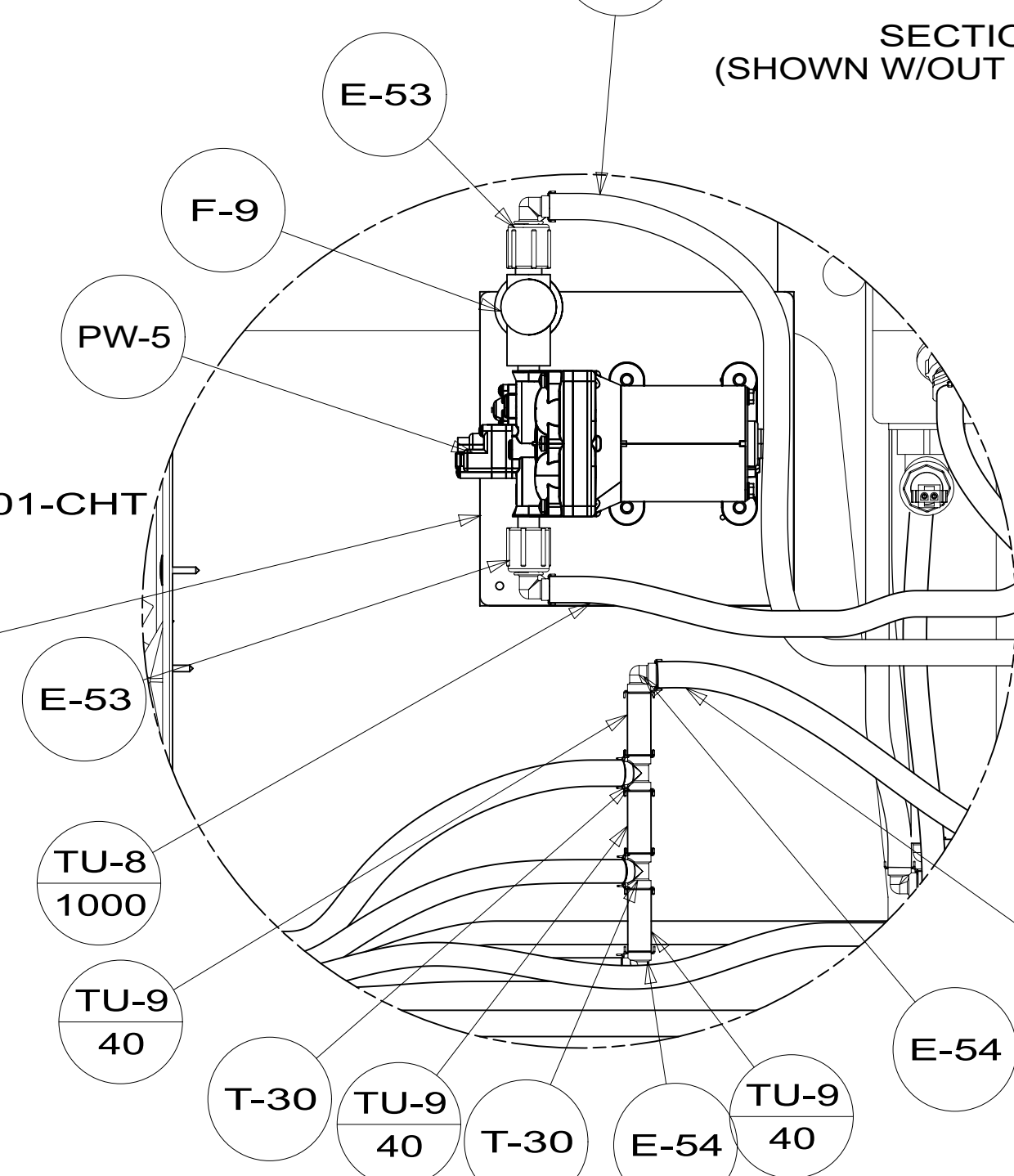
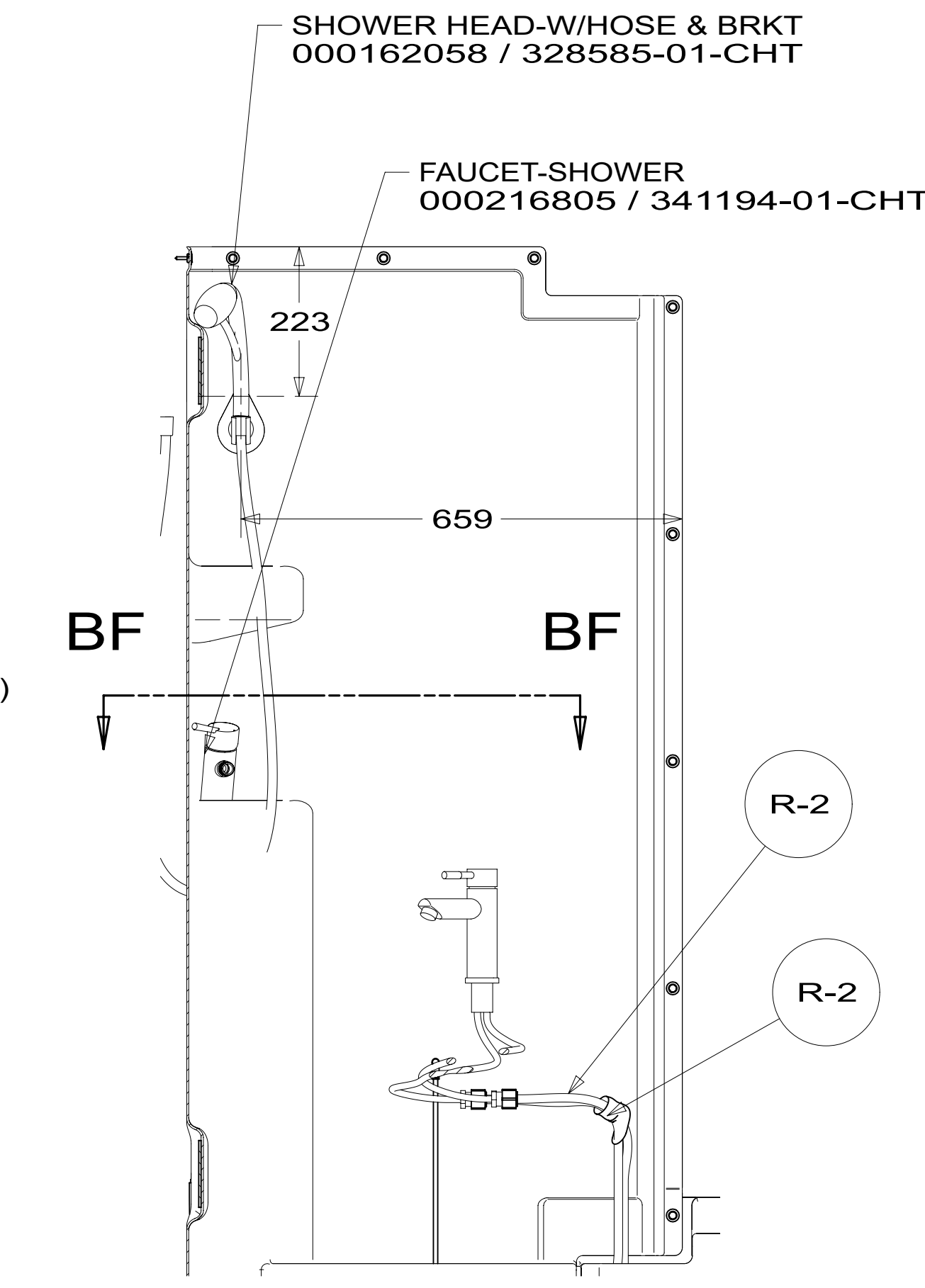
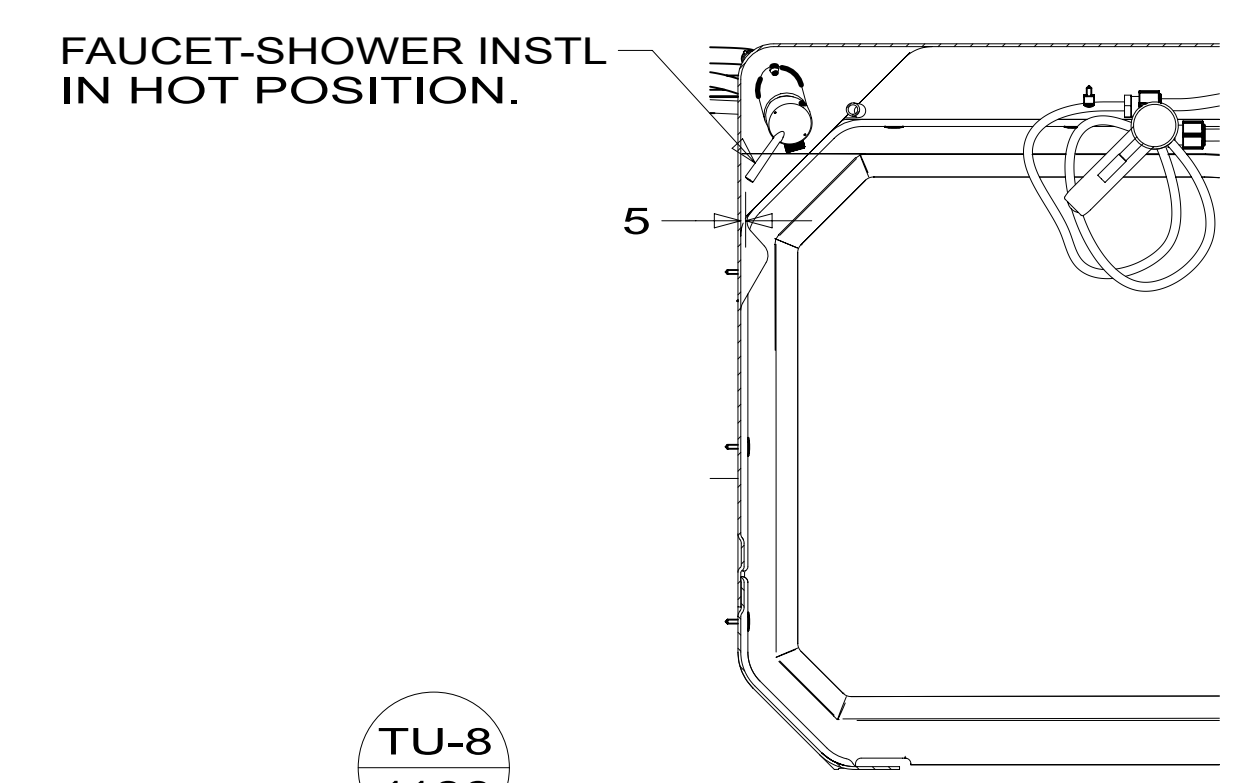
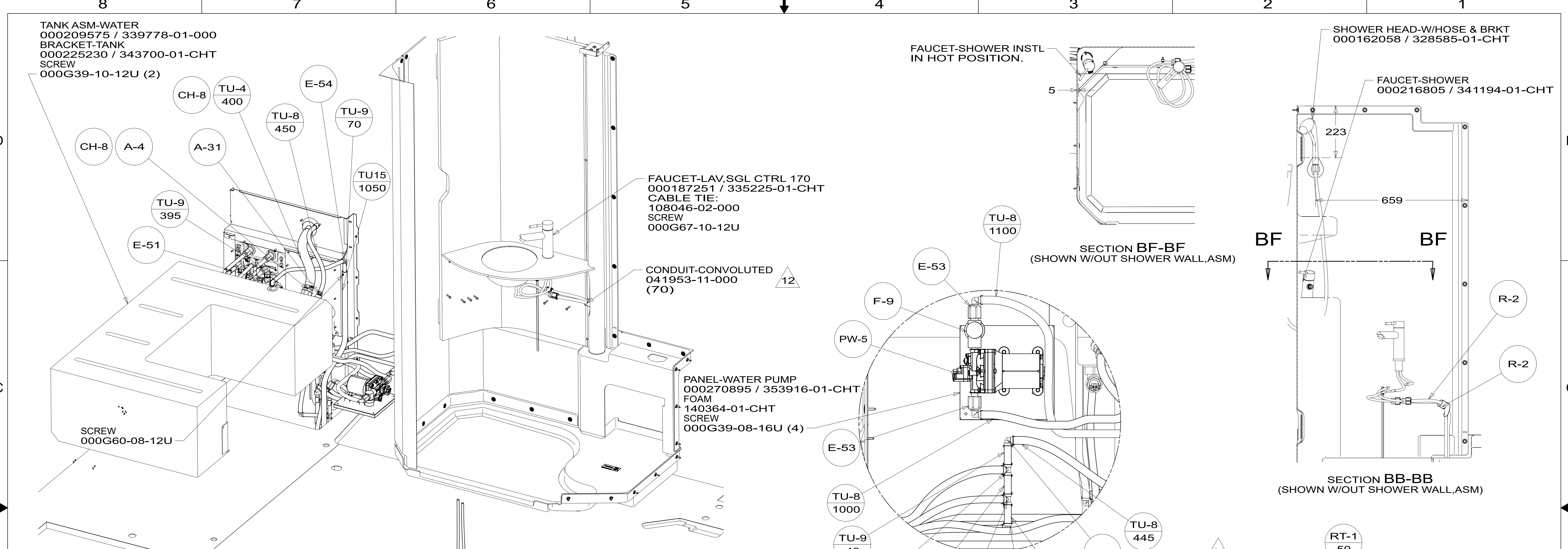

FAUCET-LAV, SGL CTRL 170  
000187251 / 335225-01-CHT  
CABLE TIE:  
108046-02-000  
SCREW  
000G67-10-12U

CONDUIT-CONVOLUTED  
041953-11-000  
(70)

PANEL-WATER PUMP  
000270895 / 353916-01-CHT  
FOAM  
140364-01-CHT  
SCREW  
000G39-08-16U (4)

FILL-WATER, GRAVITY  
166288-01-CHT  
SCREW  
000G11-10-12U (3)

PANEL-SERVICE CENTER  
000228708 / 344598-01-CHT  
SCREW  
000G39-08-08U (8)

PANEL-SERVICE CENTER  
000228710 / 344599-01-CHT  
SCREW  
000G39-08-08U (6)

PANEL ASM-WATER CENTER, W/BYPASS  
000213657 / 341280-01-XXX  
SCREW  
000G11-08-12U (8)  
HOSE-WATER  
000206976 / 339147-01-CHT  
HOSE  
166291-02-000

PANEL-SERVICE CENTER  
000228722 / 344601-01-CHT  
SCREW  
000G39-08-08U (4)

PANEL-SERVICE CENTER  
000228720 / 344600-01-CHT  
SCREW  
000G39-08-08U (8)

PANEL-SERVICE CENTER  
000228688 / 344597-01-CHT  
SCREW  
000G39-08-08U (4)

DESCRIPTION:		
WATER SYSTEM INSTL		
SHEET:	ITEM/PART NO.:	REV
2 OF 4	000255319 / 35010501000	

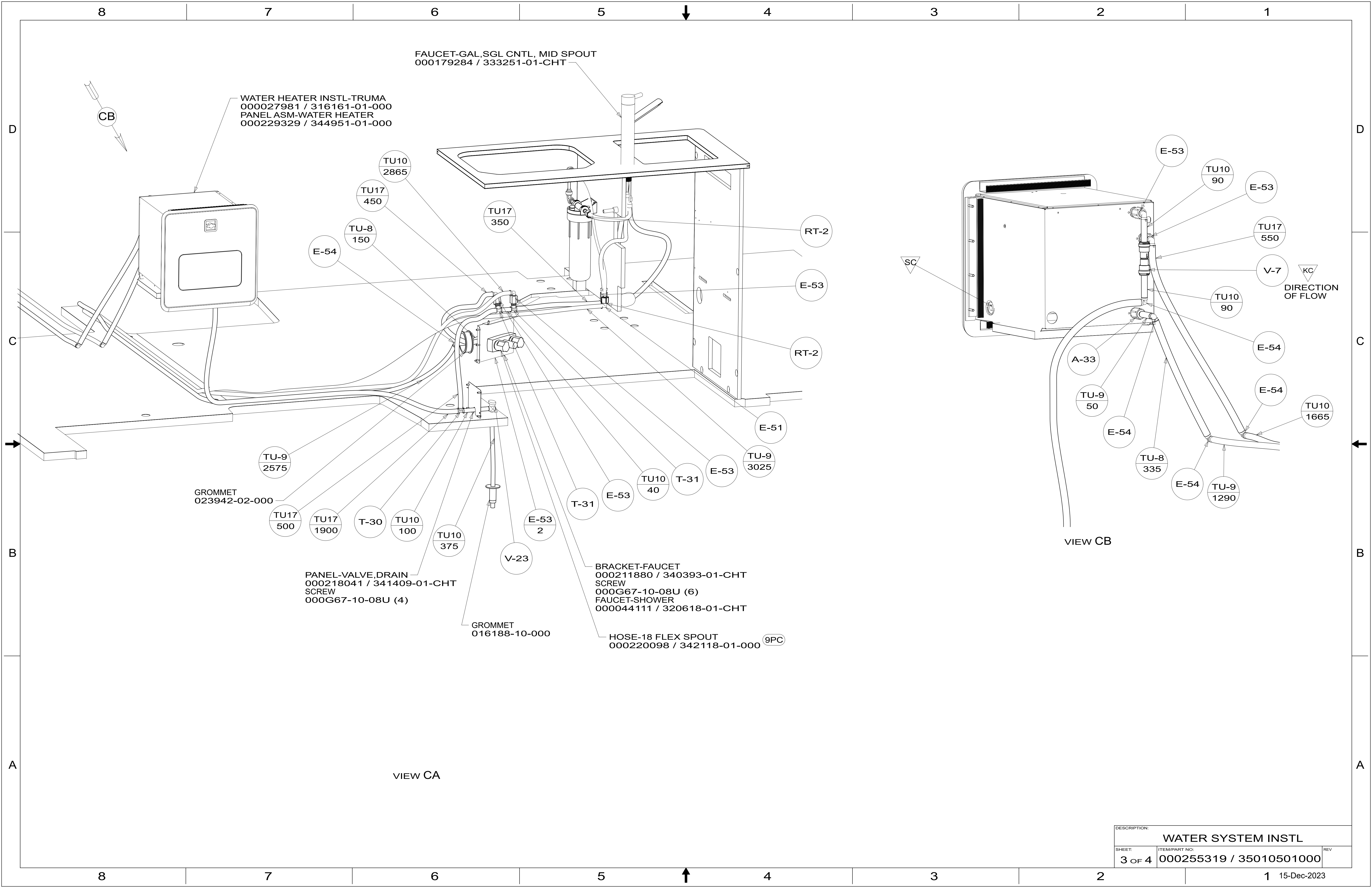

DESCRIPTION:		
WATER SYSTEM INSTL		
SHEET:	ITEM/PART NO.:	REV
3 OF 4	000255319 / 35010501000	

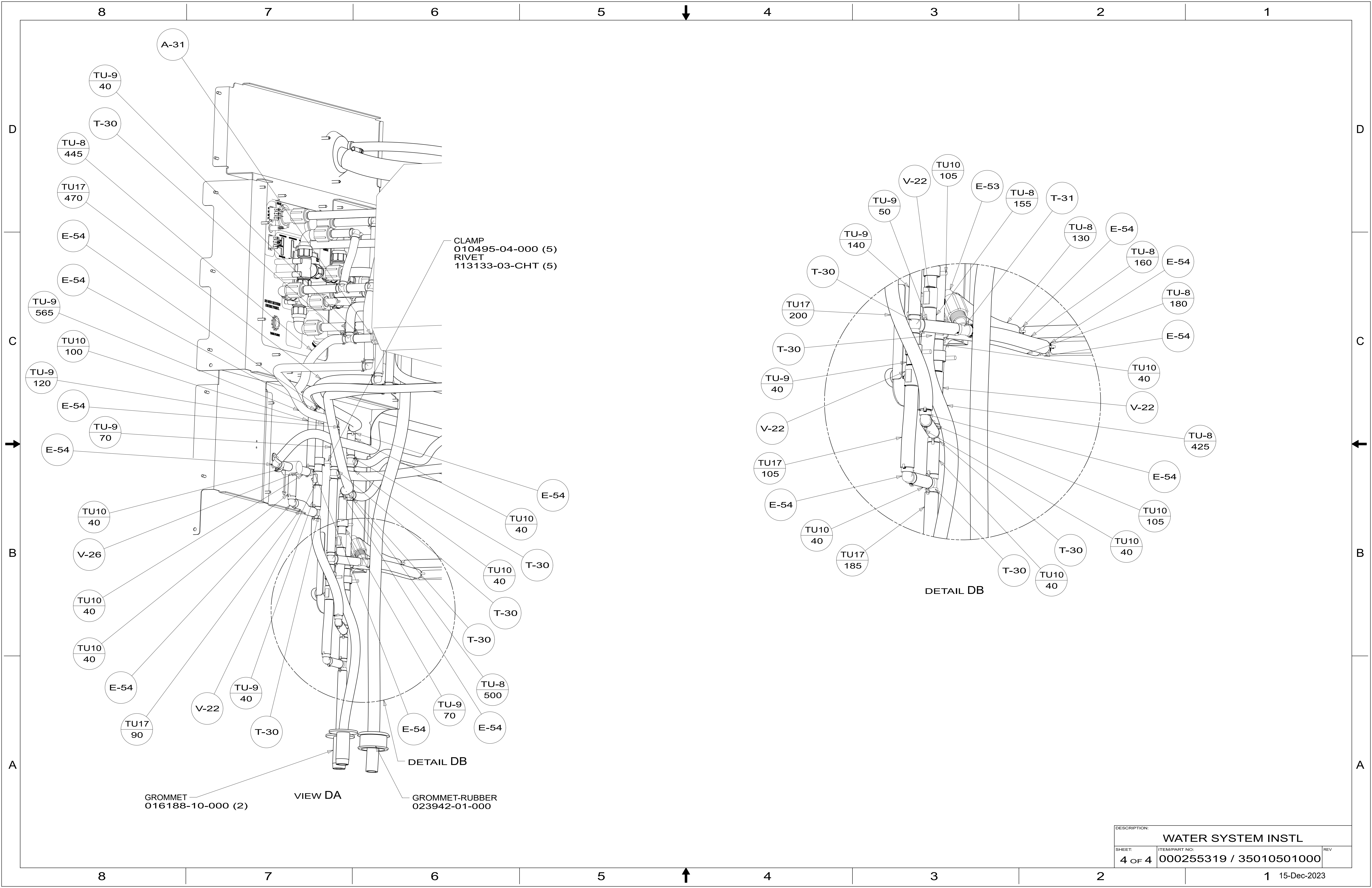

DESCRIPTION:		
WATER SYSTEM INSTL		
SHEET:	ITEM/PART NO.:	REV
4 OF 4	000255319 / 35010501000	