

- 10 USE WITH FAUCET 000221451 / 342498-01-CHT.
- 9. ALL CRIMP FITTINGS TO 3/4" PEX TUBING REQUIRE 3/4" CLAMP 000156247 / 326668-01-000.
- 8. ALL CRIMP FITTINGS TO 1/2" PEX TUBING REQUIRE 1/2" CLAMP 000156249 / 326670-01-000.
- 7. ALL CRIMP FITTINGS TO 5/8" FLEX TUBING REQUIRE 5/8" CLAMP 000156248 / 326669-01-000.
- 6 LABEL HOT AND COLD SUPPLY TUBES AND TAPE FITTING TO TUBE BEFORE CABINET SET TO PREVENT MOVEMENT.
- 5 ADD PIPE WRAP (LADDER SCRAP 110157-02-000) INSULATION.
- 4 ADD TEFLON TAPE 010405-02-000.
- 3. ALL TUBING TO BE SECURED AT 1200 INTERVALS MAXIMUM WITH CLAMP 010495-01-000 AND SCREW 000G67-10-12U OR EQUIVALENT.
- 2. TUBING TO BE INSTALLED WITH SUFFICIENT SLOPE TO PROVIDE DRAINAGE TO NEAREST VALVE.
- 1. PLASTIC FITTINGS TO BE SEALED WITH SEALANT 084456-01-000.

NOTES:

- (21S) WASHER & DRYER-PAIR
- (21M) WASHER/DRYER PREP

WINNEBAGO COPYRIGHT 2024 WINNEBAGO INDUSTRIES, INC.	
DSNR:	ALL DIMENSIONS ARE IN MILLIMETERS
DFTR:	
UNSPECIFIED TOLERANCES:	MATERIAL:
WHOLE DIM (X) : 3	
ONE-PLACE (X.X) : 1.5	
TWO-PLACE (X.XX) : 0.50	
ANGLE : 1°	
REFER TO ES0018 FOR FASTENER TIGHTENING GUIDELINES	WEIGHT: (LBS) FIRST USED: (REF)
	22 F36Z
DESCRIPTION: WATER SYSTEM INSTL	
SHEET: 1 OF 6	ITEM/PART NO: 000241545 / 34679601000
REF:	REV: 1 28-Mar-2024

(X-X)
FOR WATER CALLOUTS SEE DWG NO. 000209446 / 303369-01-000

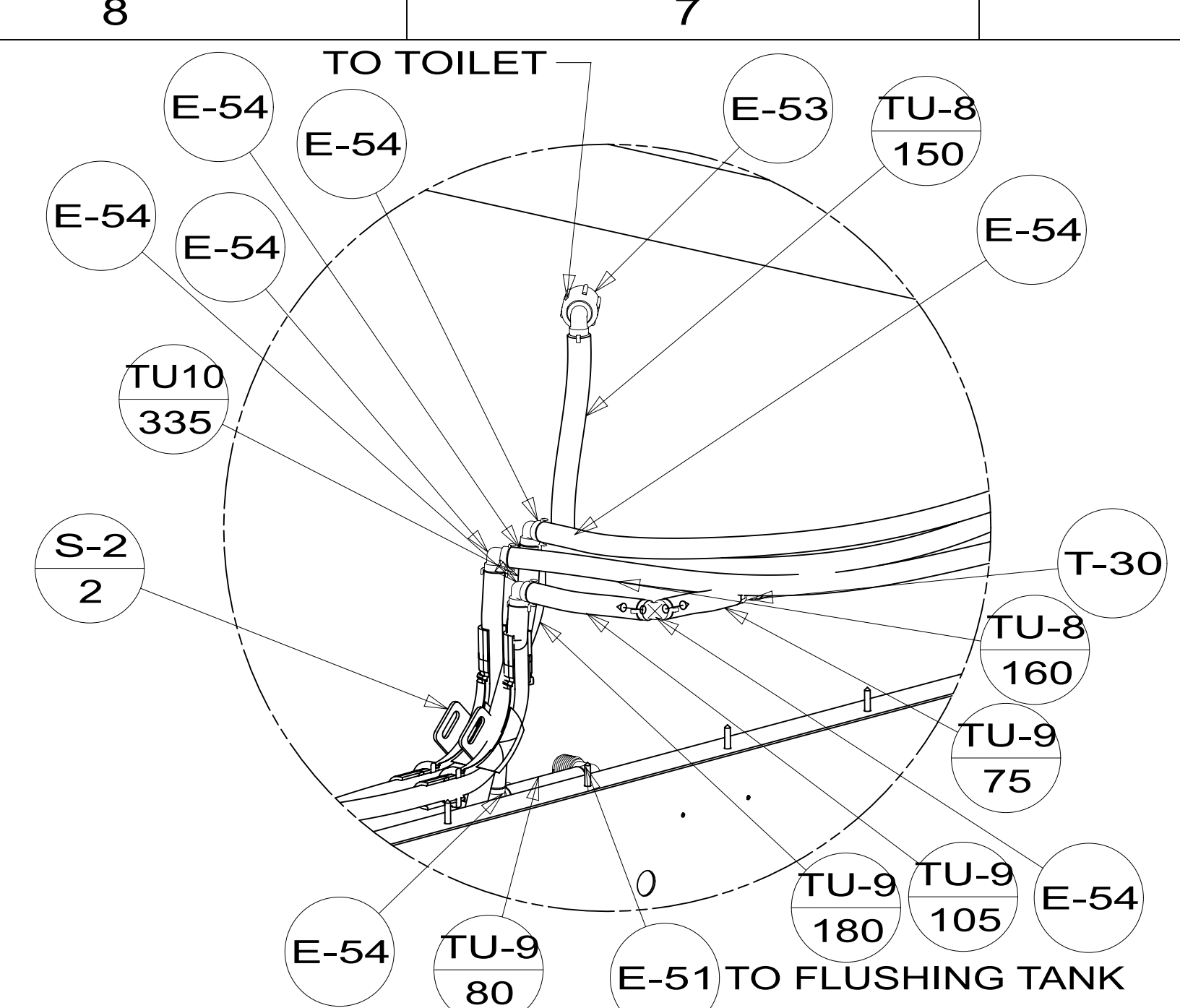

DETAIL BH
(SHOWN W/O FLOOR & CABINETS)

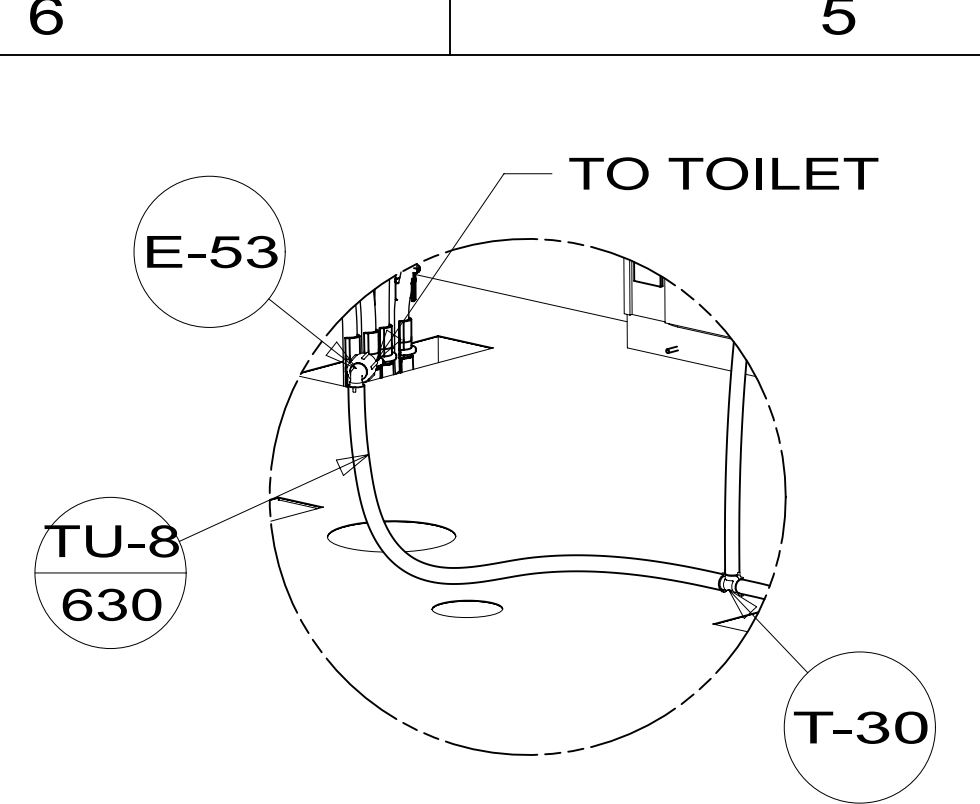

DETAIL BF

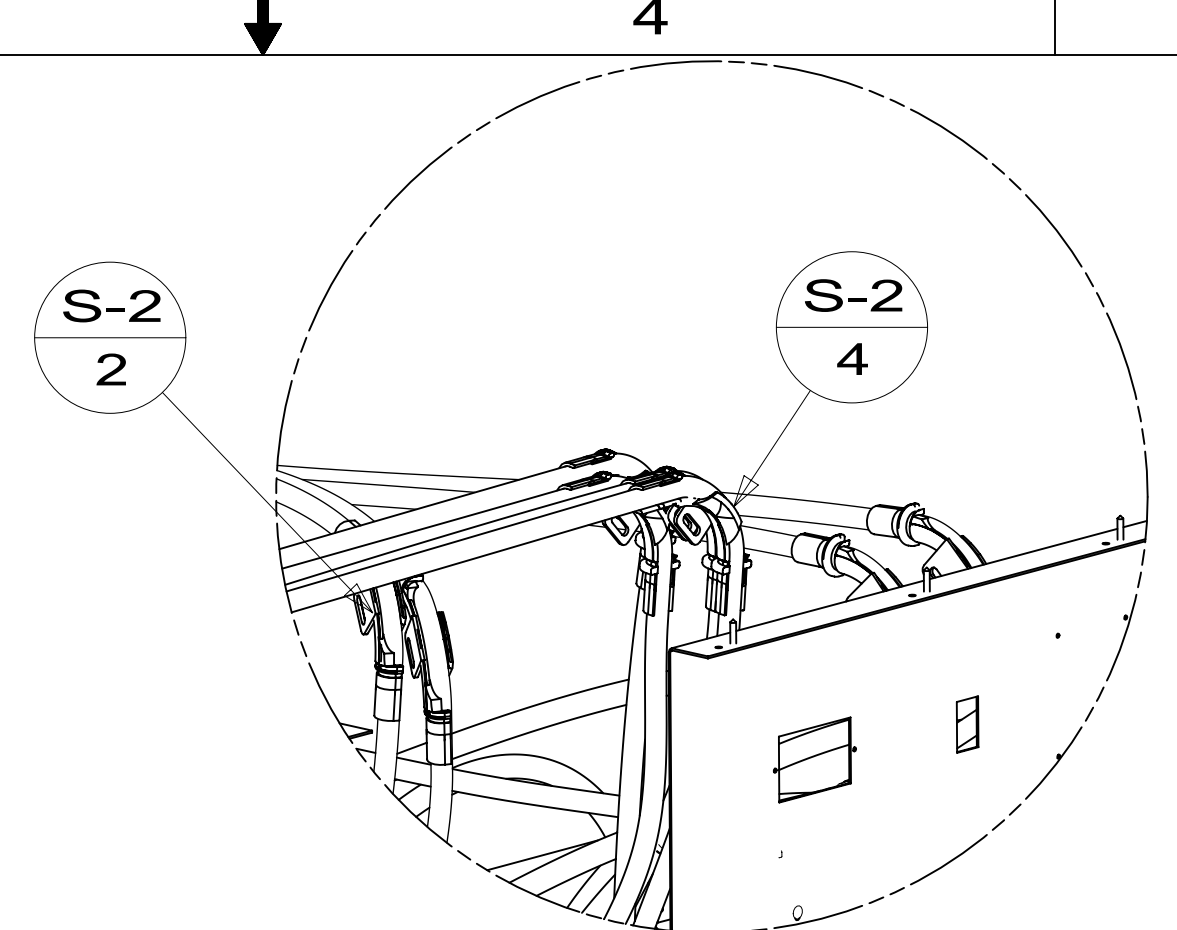

DETAIL BK

PANEL-SHOWER FAUCET
167738-02-CHT
COVER-SCREW,NO 8
166569-01-CHT (4)
SCREW
000G11-08-12U (4)

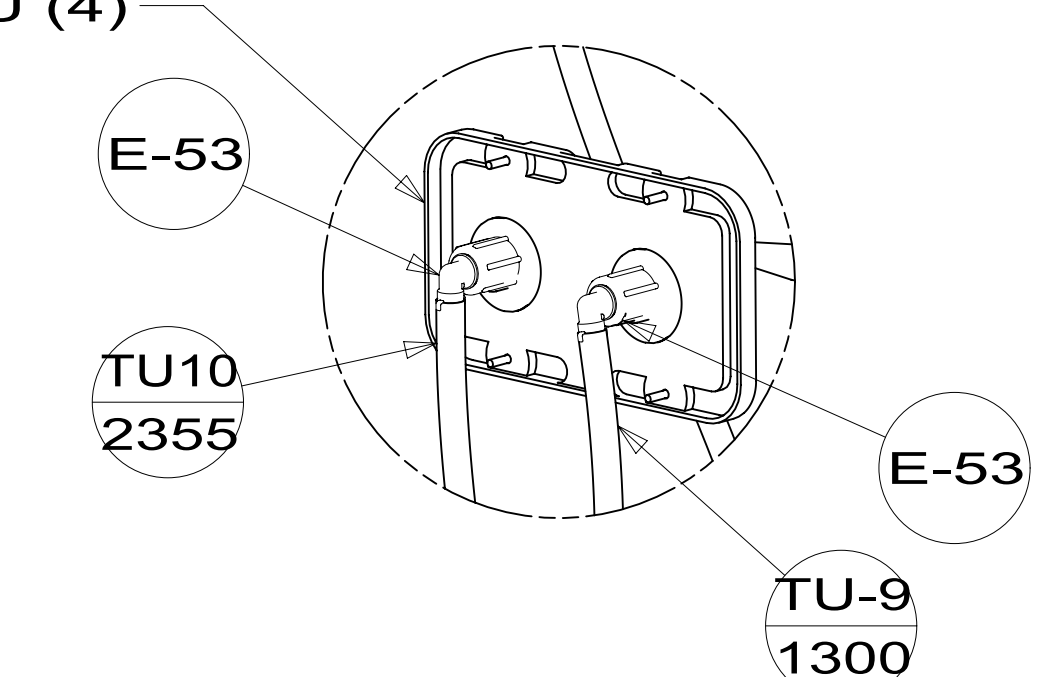

DETAIL BB
(SHOWN W/O SHOWER)

SHOWER-HANDHELD
000236199 / 345608-01-CHT

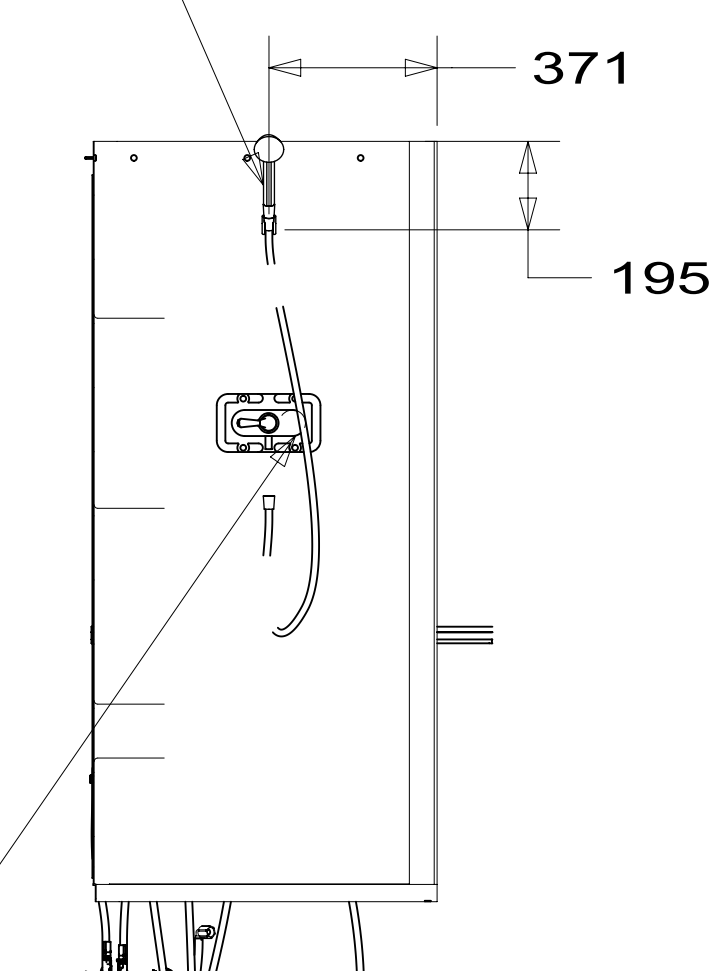

FAUCET-SHOWER, SGL CTRL DIVERTER
000188802 / 335579-01-CHT

SECTION BD-BD

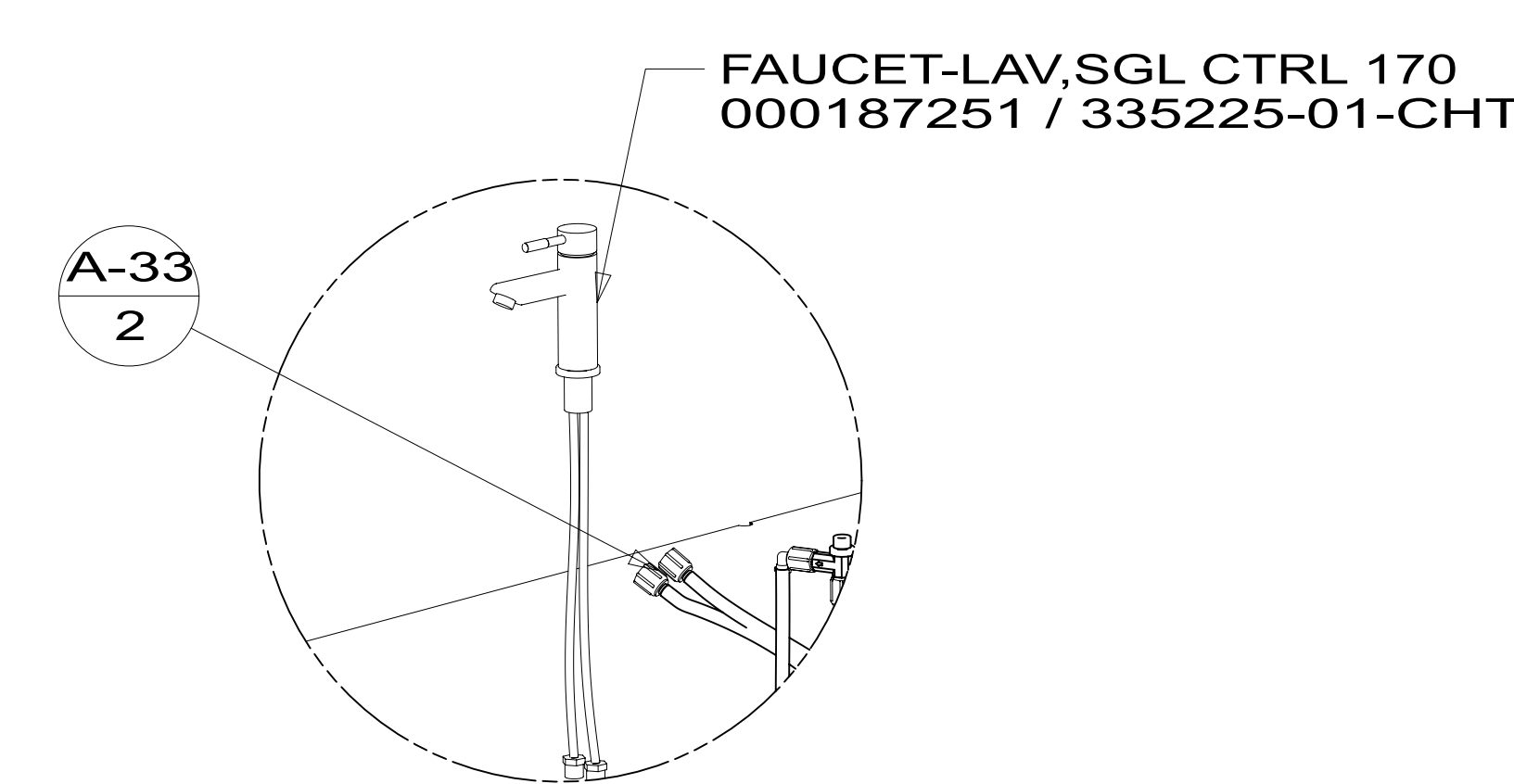

DETAIL BG
(SHOWN W/O CABINETS)

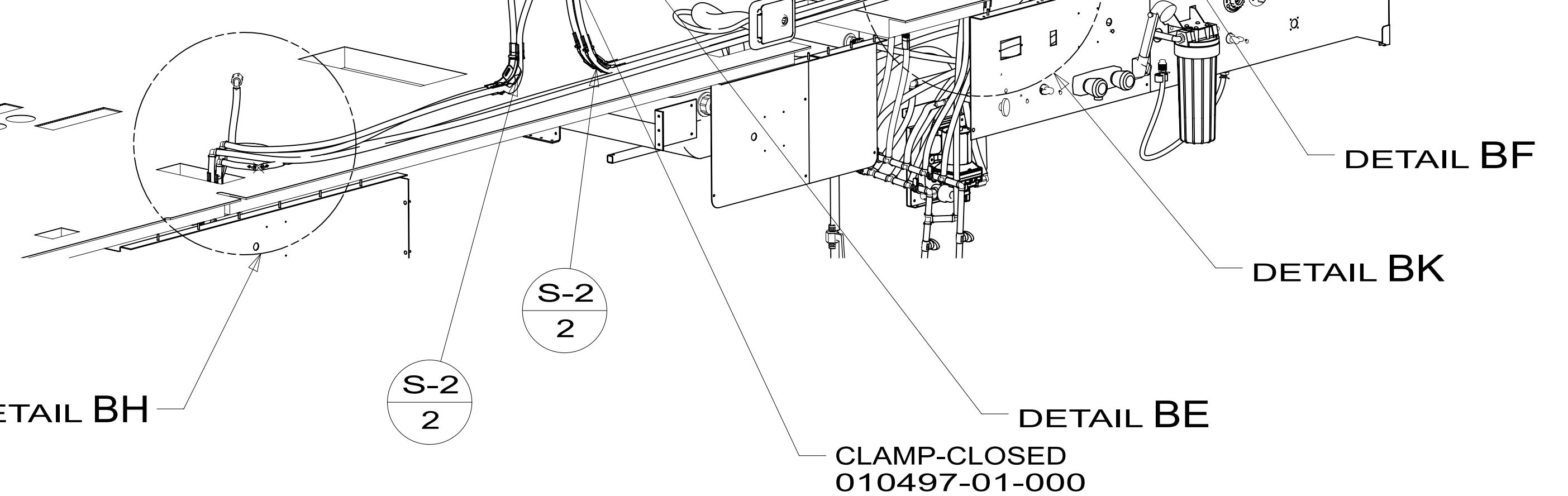
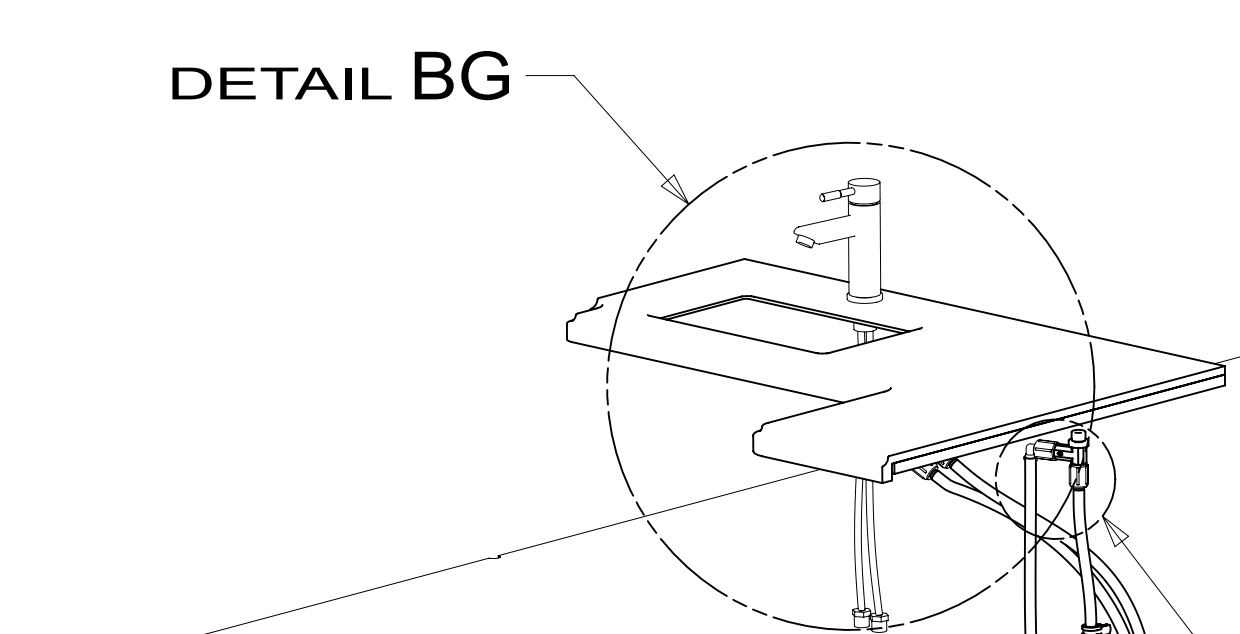

VIEW BA

BREAKER-VACUUM, FLUSHING SYS
000030488 / 316731-01-000

BREAKER-VACUUM, FLUSHING SYS
000030488 / 316731-01-000

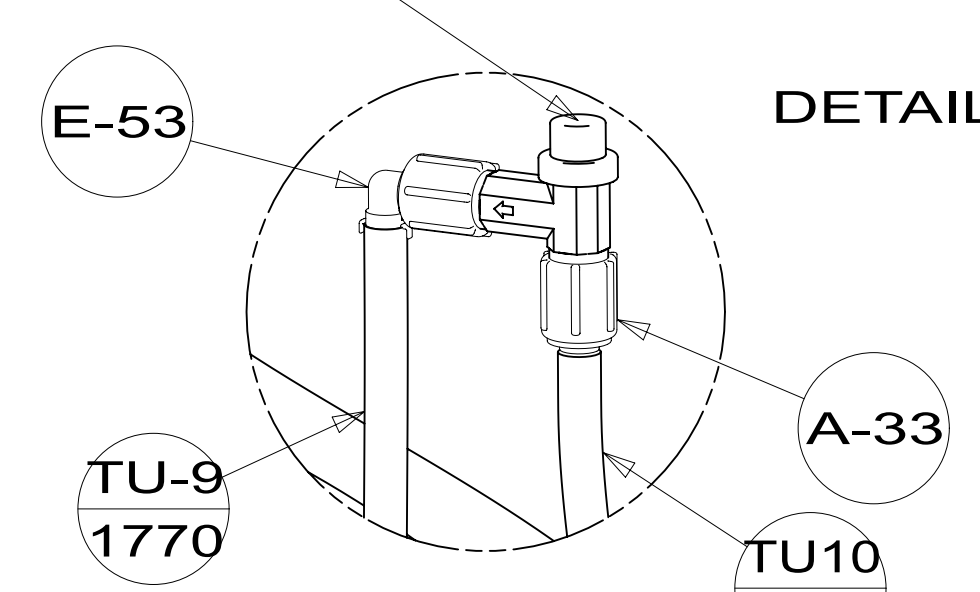

DETAIL BE

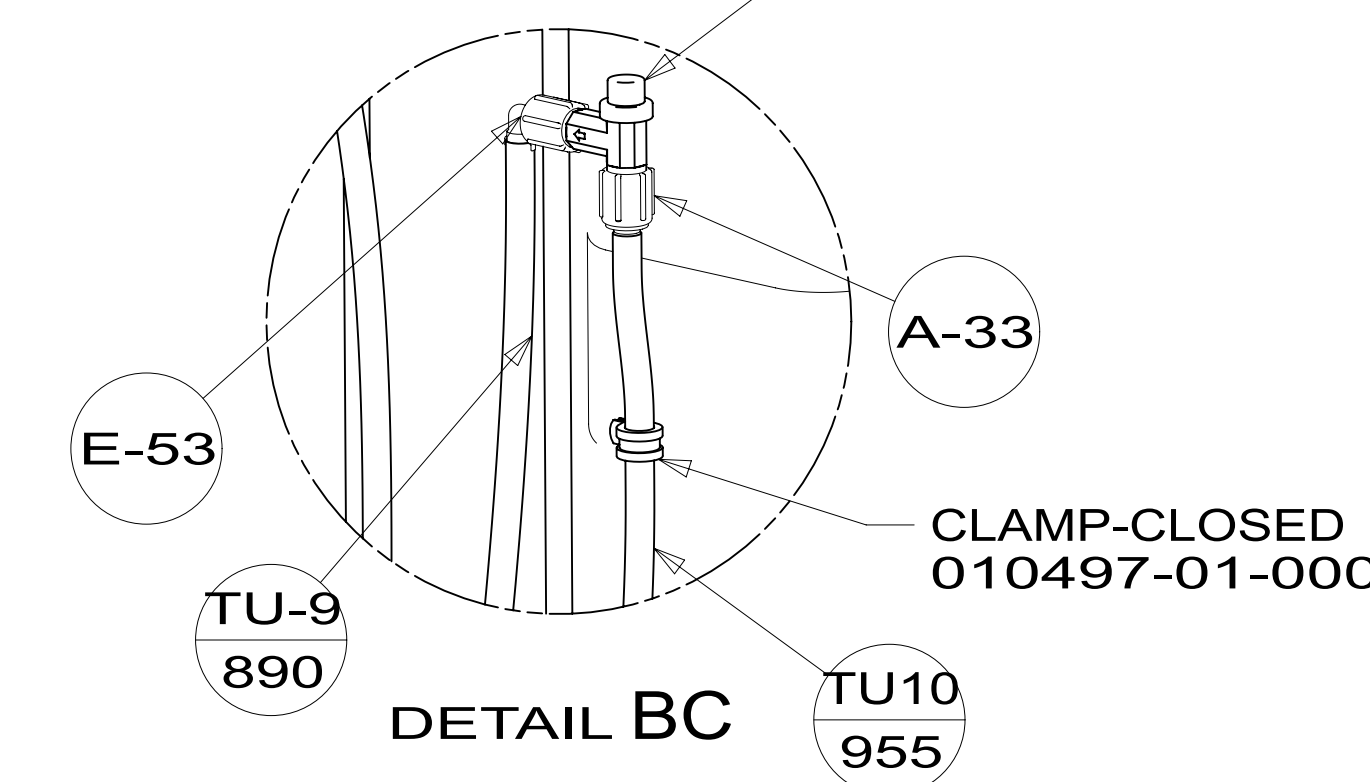

DETAIL BC

DESCRIPTION:		
WATER SYSTEM INSTL		
SHEET:	ITEM/PART NO.:	REV
2 OF 6	000241545 / 34679601000	

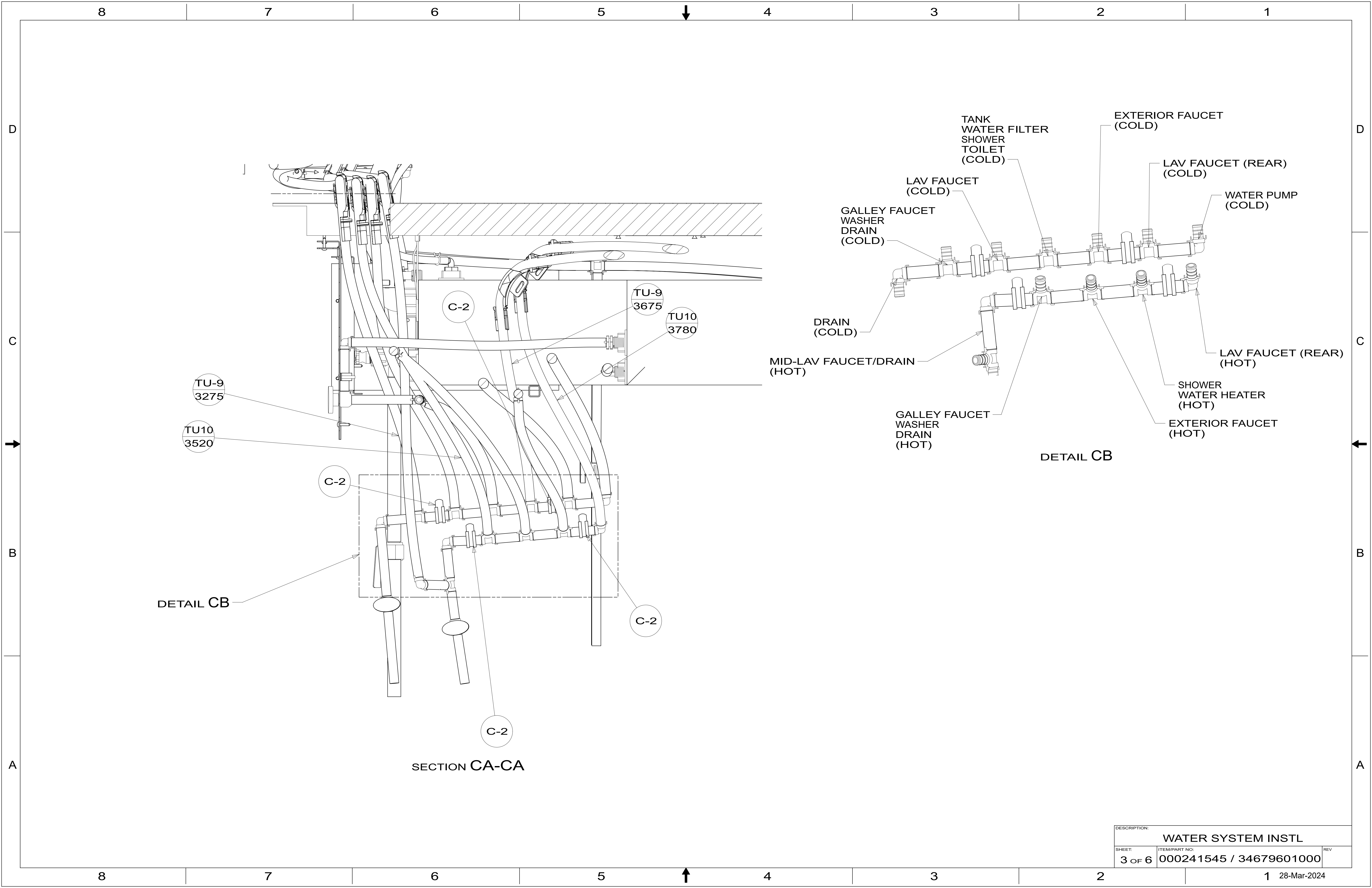

DETAIL CB

SECTION CA-CA

DETAIL CB

DESCRIPTION:		
WATER SYSTEM INSTL		
SHEET:	ITEM/PART NO.:	REV
3 OF 6	000241545 / 34679601000	

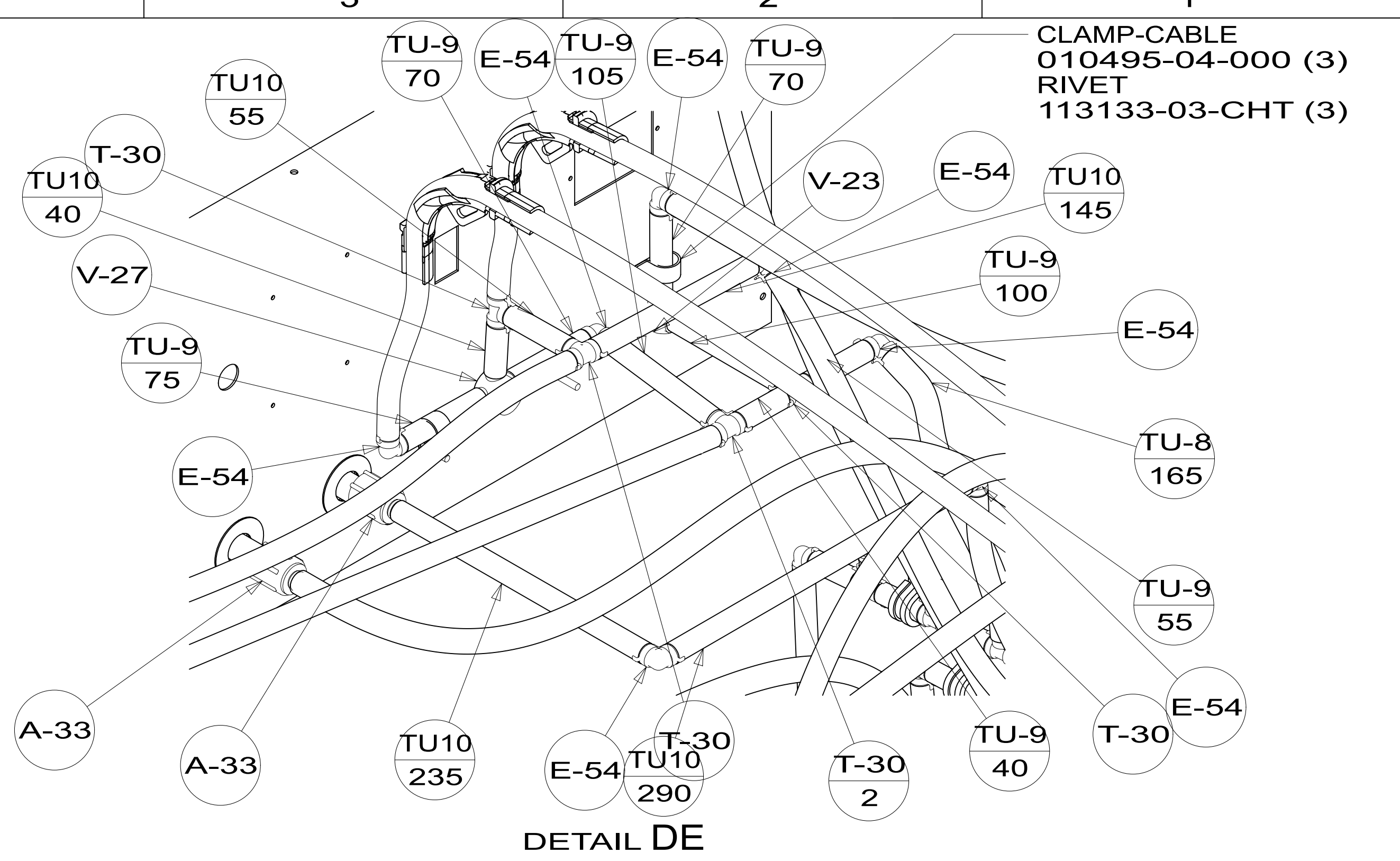
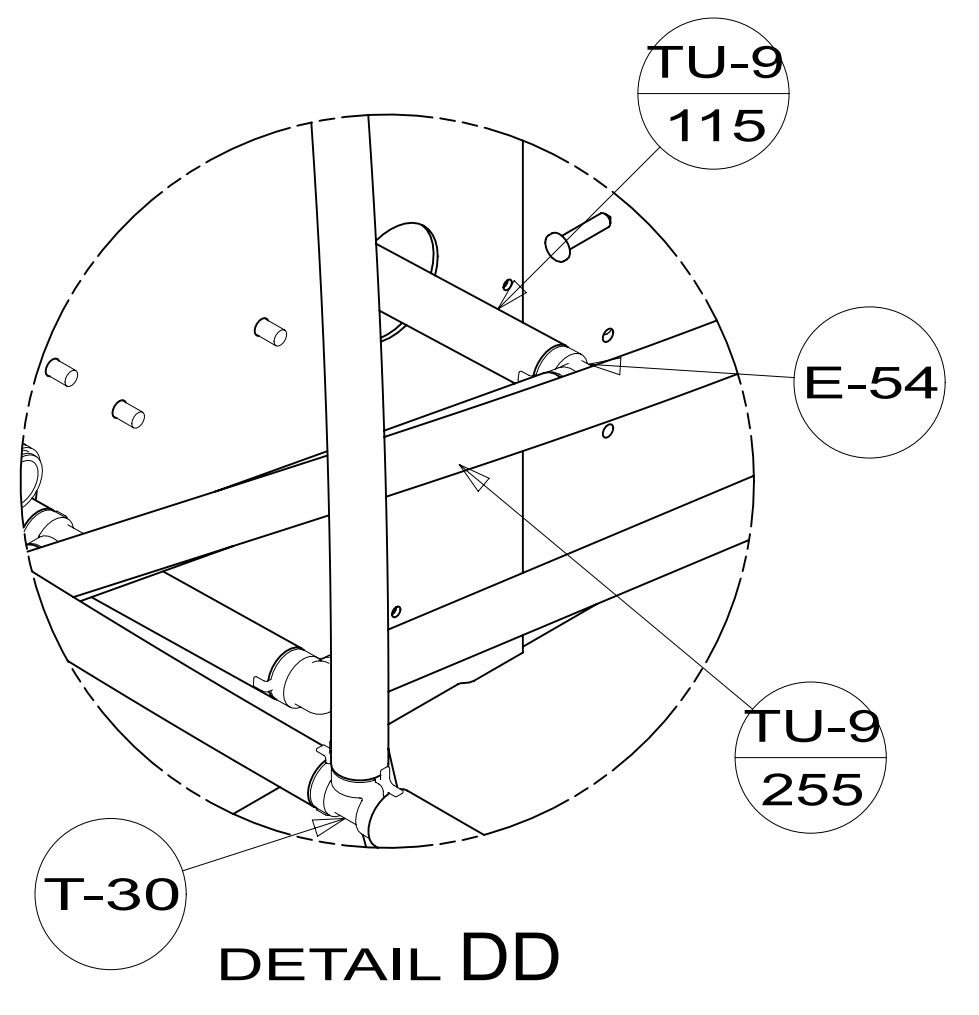
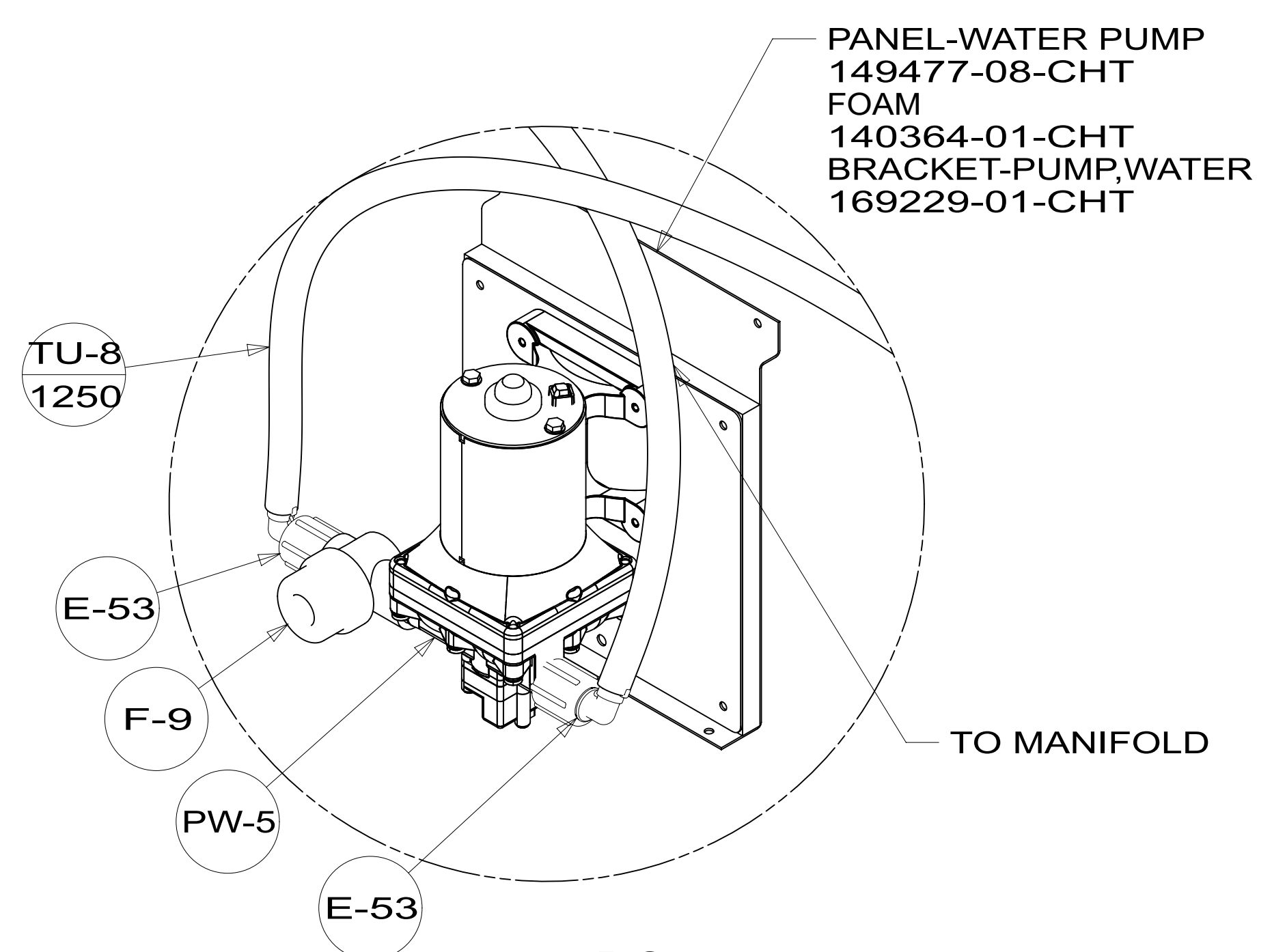

PANEL-SERVICE CENTER
000243497 / 347764-01-CHT
SCREW
000G11-08-12U (6)

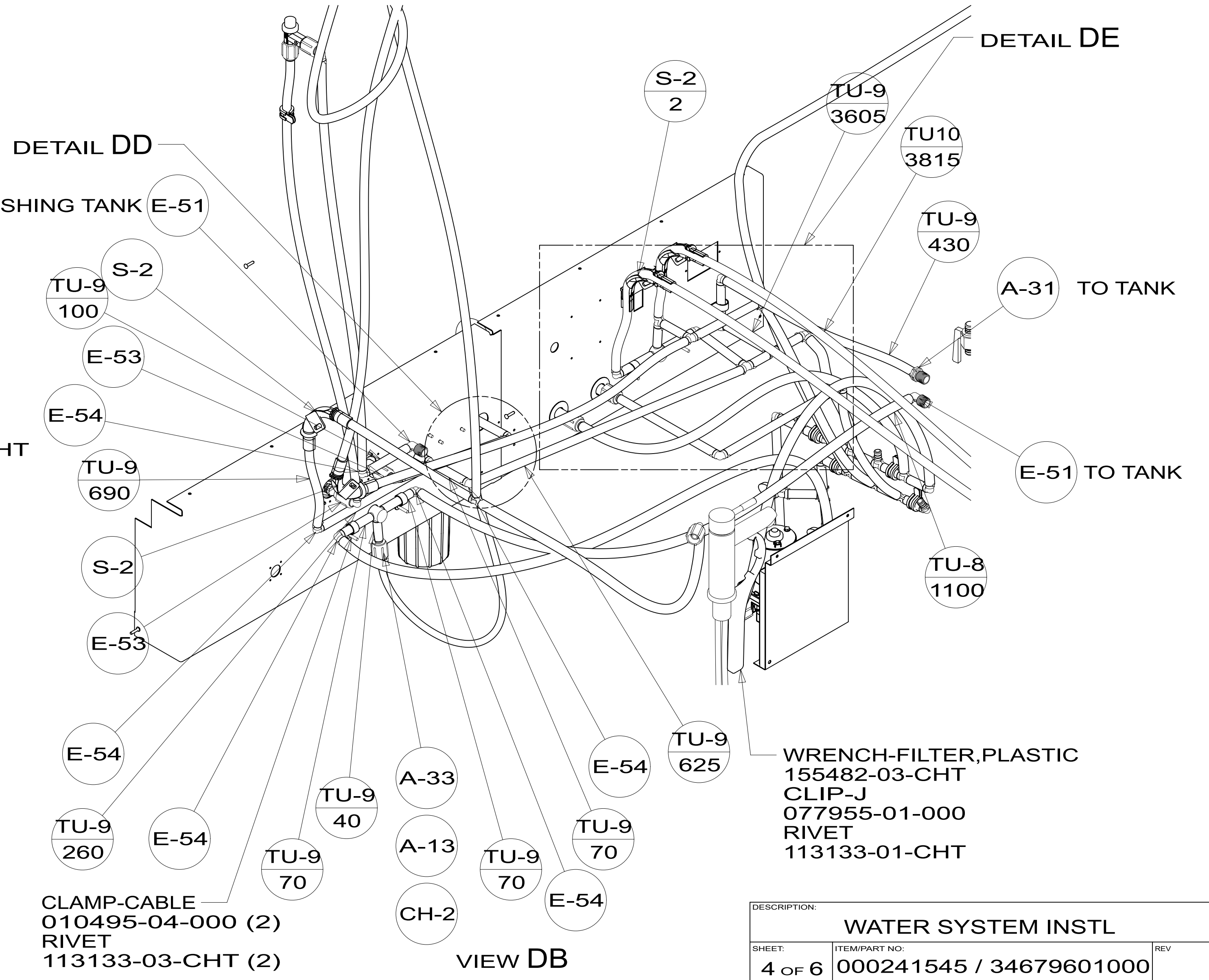
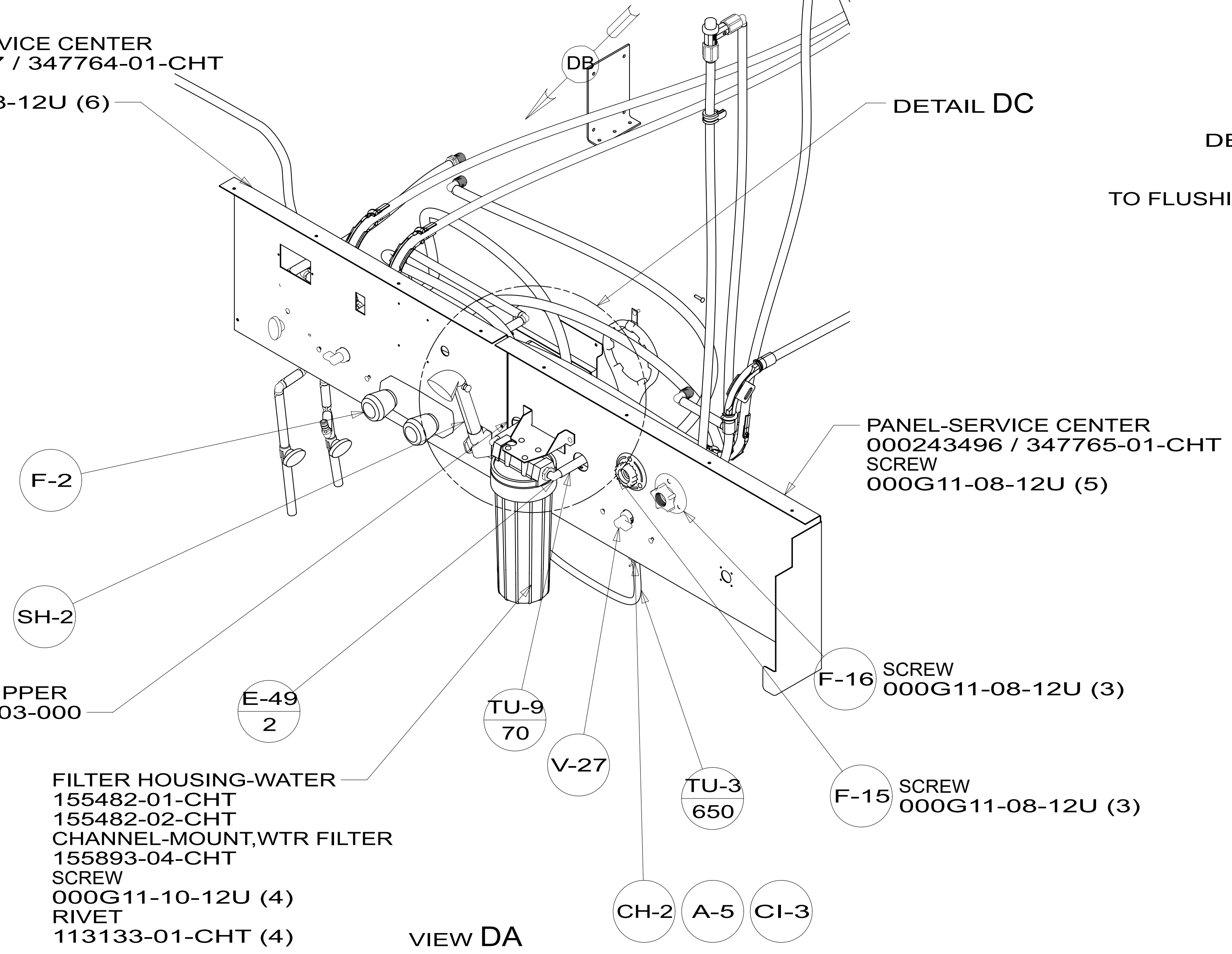

DESCRIPTION:		
WATER SYSTEM INSTL		
SHEET:	ITEM/PART NO:	REV
4 OF 6	000241545 / 34679601000	

VALVE-WASHER BRACKET
 000245189 / 347724-01-CHT (2)
 VALVE-WASHER NOZZLE
 000244523 / 347492-01-CHT (HOT)
 000244951 / 347649-01-CHT (COLD)

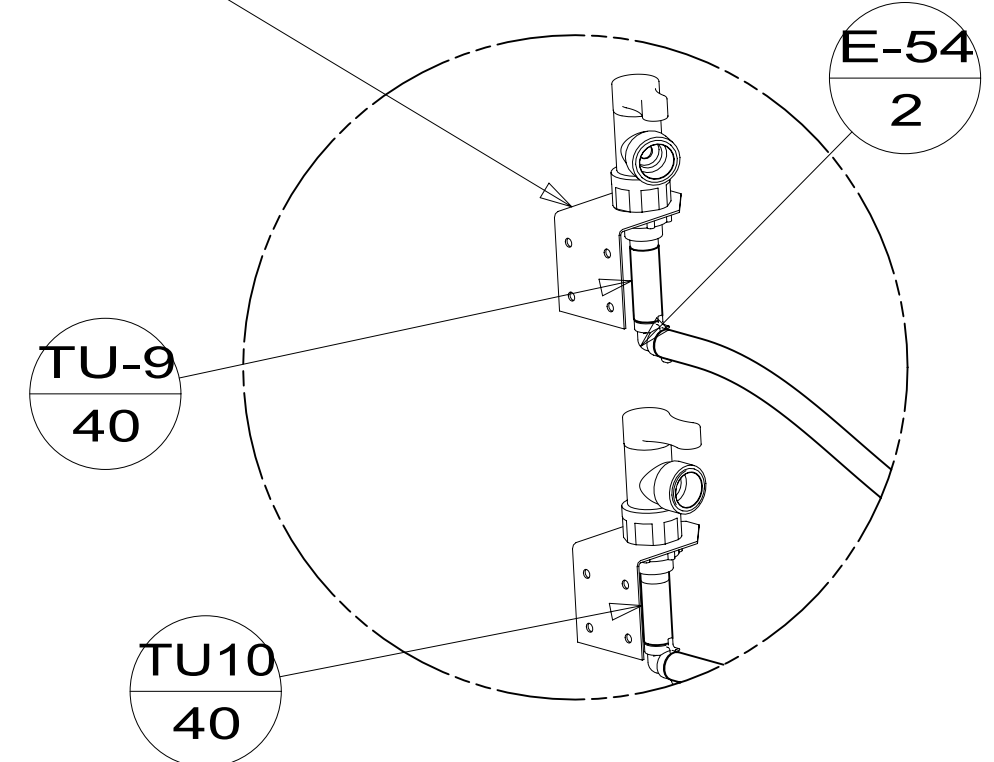

DETAIL ED 21S

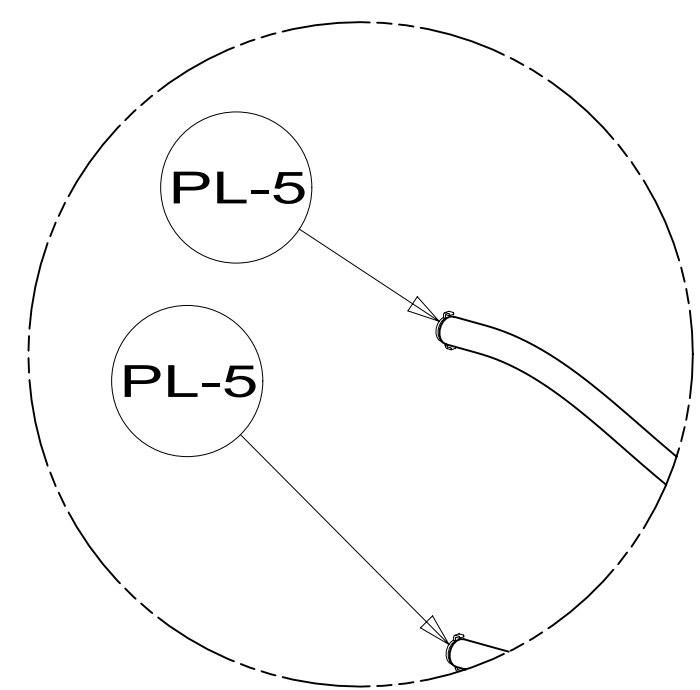

DETAIL ED 21M

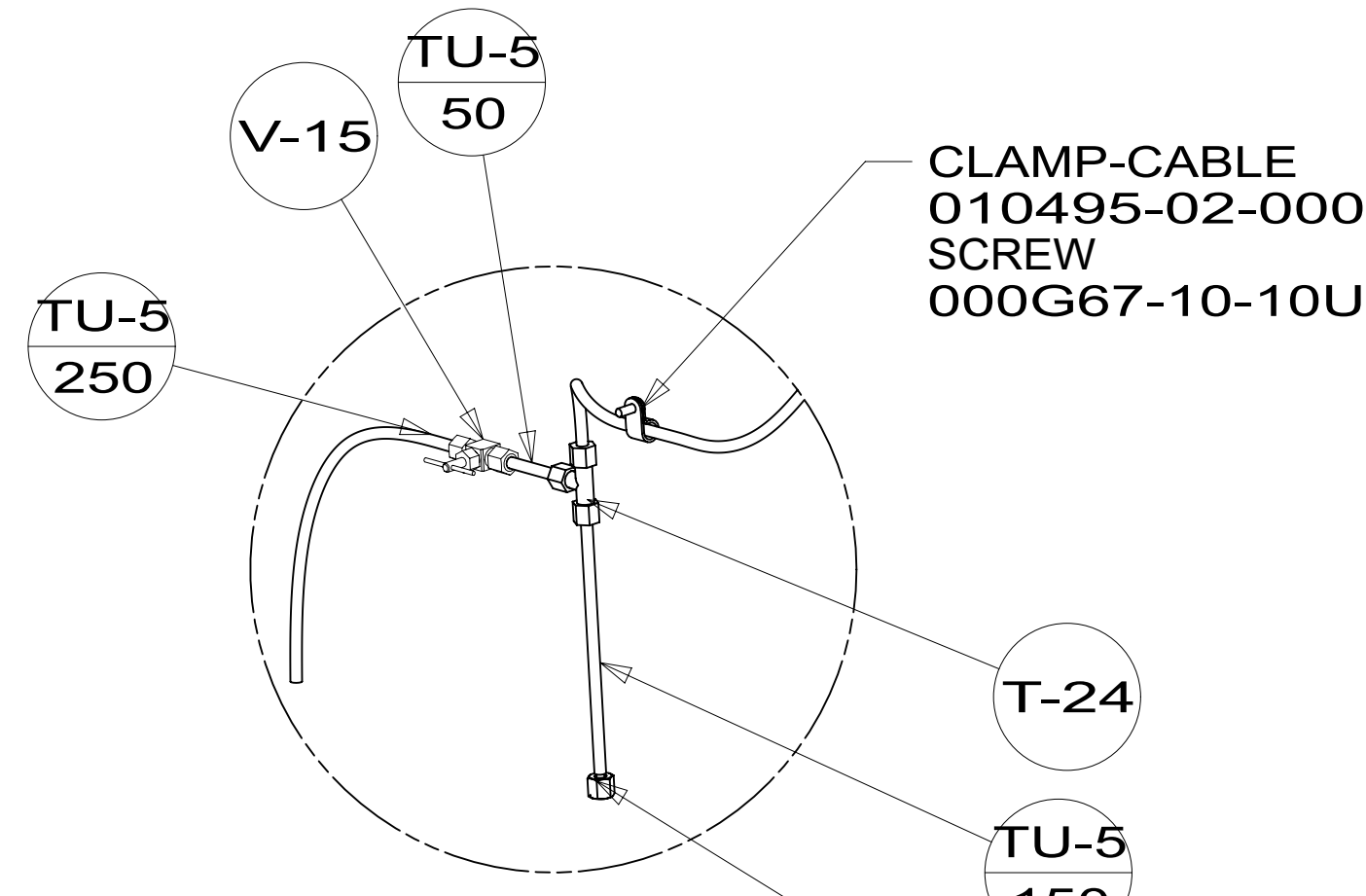

DETAIL EE

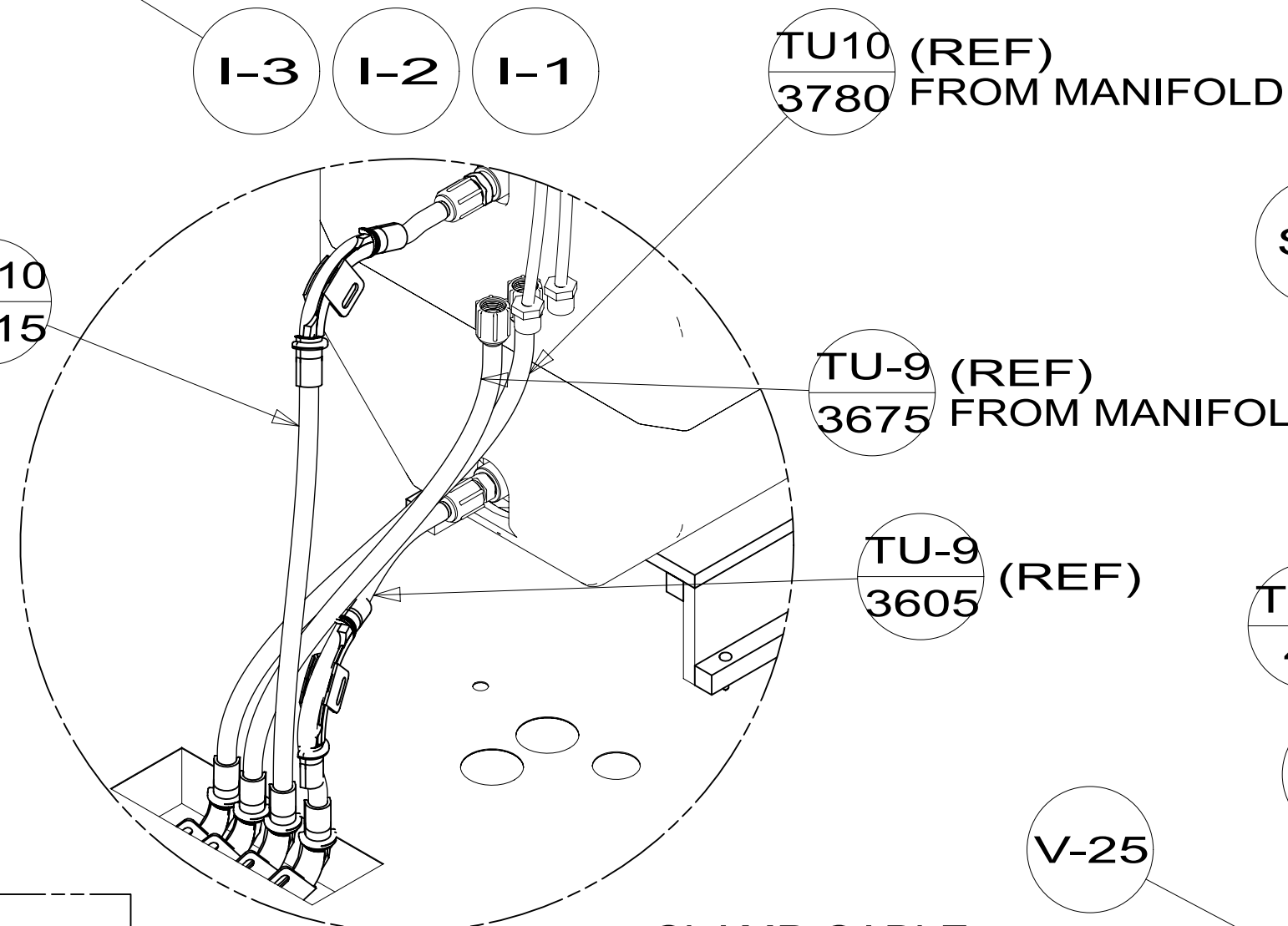

DETAIL EF

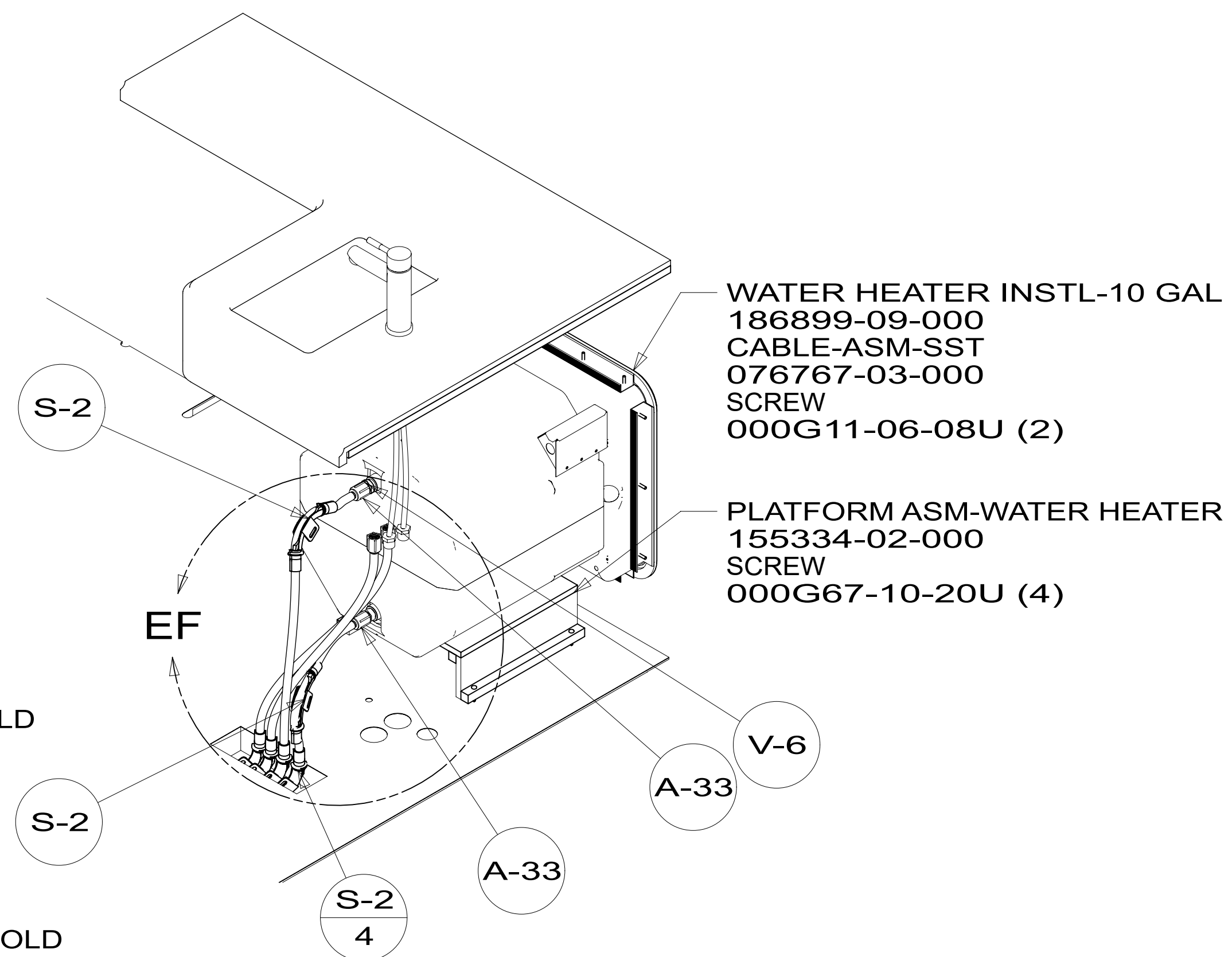

WATER HEATER INSTL-10 GAL
 186899-09-000
 CABLE-ASM-SST
 076767-03-000
 SCREW
 000G11-06-08U (2)

PLATFORM ASM-WATER HEATER
 155334-02-000
 SCREW
 000G67-10-20U (4)

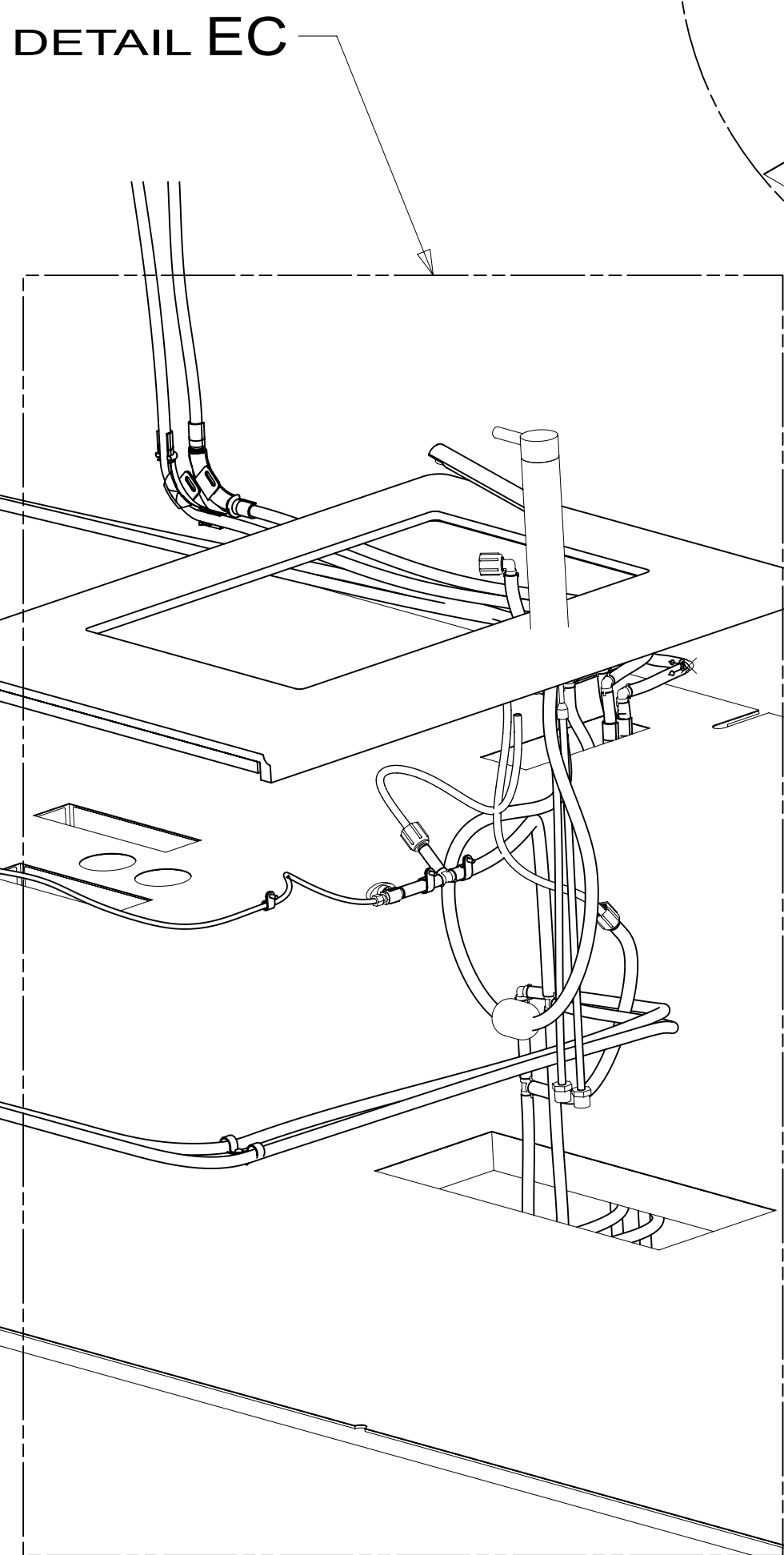

DETAIL EC

CLAMP-CABLE
 010495-02-000
 SCREW
 000G67-10-10U

CLAMP-CABLE
 010495-04-000 (2)
 SCREW
 000G67-10-10U (2)

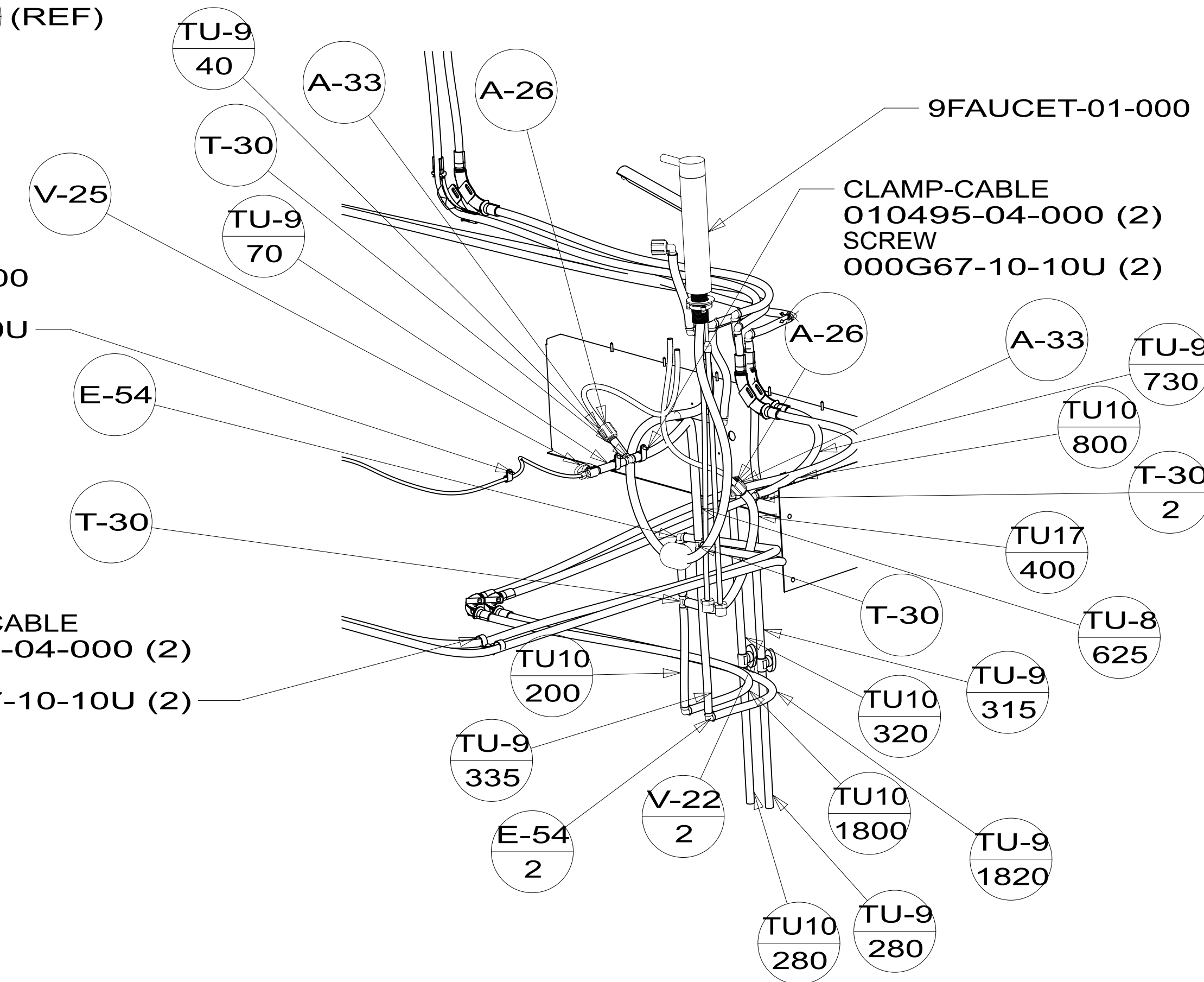

9FAUCET-01-000

CLAMP-CABLE
 010495-04-000 (2)
 SCREW
 000G67-10-10U (2)

DETAIL EC

DETAIL EE

CLAMP-CABLE
 010495-04-000 (2)
 SCREW
 000G67-10-10U (2)

DESCRIPTION: WATER SYSTEM INSTL		
SHEET: 5 OF 6	ITEM/PART NO: 000241545 / 34679601000	REV

8 7 6 5 4 3 2 1

D

D

C

C

B

B

A

A

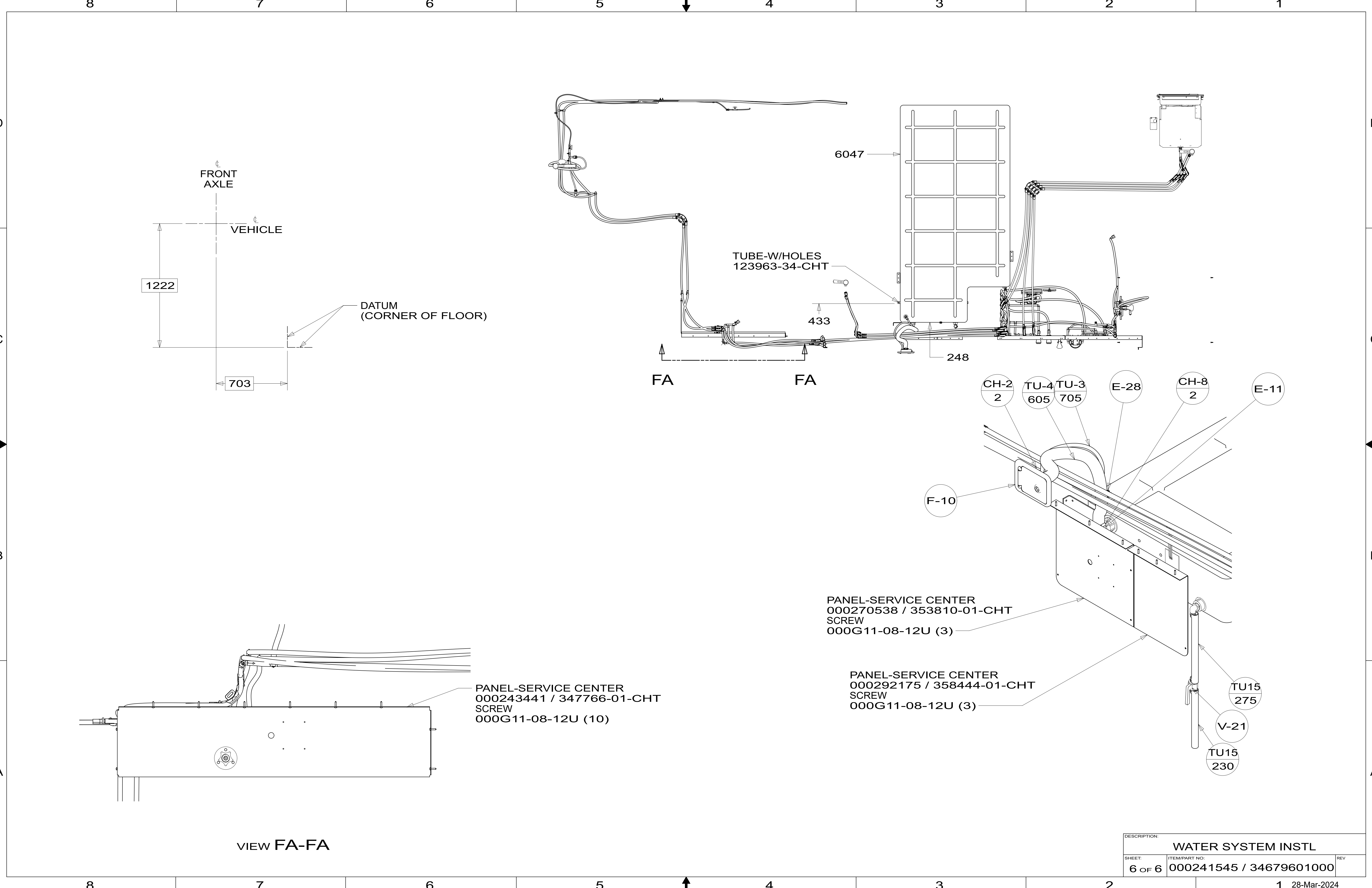

1222

FRONT AXLE
VEHICLE

703

DATUM
(CORNER OF FLOOR)

TUBE-W/HOLES
123963-34-CHT

6047

433

248

FA

FA

CH-2
2

TU-4
605

TU-3
705

E-28

CH-8
2

E-11

F-10

PANEL-SERVICE CENTER
000270538 / 353810-01-CHT
SCREW
000G11-08-12U (3)

PANEL-SERVICE CENTER
000292175 / 358444-01-CHT
SCREW
000G11-08-12U (3)

PANEL-SERVICE CENTER
000243441 / 347766-01-CHT
SCREW
000G11-08-12U (10)

TU15
275

V-21

TU15
230

VIEW FA-FA

8 7 6 5 4 3 2 1

DESCRIPTION:		
WATER SYSTEM INSTL		
SHEET:	ITEM/PART NO.:	REV
6 OF 6	000241545 / 34679601000	