

- 11. TRIM TO FIT
- 10. PREP THE SURFACE PER MANUFACTURERS INSTRUCTIONS BEFORE APPLYING HEAT PAD.
- 9. SEE WIRING INSTL-BODY FOR ELECTRICAL CONNECTIONS.
- 8. USE SMOOTH PLUMBERS PUTTY 167459-01-000 TO SEAL STRAINER (0.2 PER STRAINER).
- 7. REMOVE SWIVEL NUT ON TRAP-WATERLESS 165406-01 AND CONNECT TO A-10.
- 6. VENT PIPE MUST PROJECT 6 TO 15MM FROM SIDEWALL FOR PROPER FIT AND FUNCTION.
- 5. SEAL AROUND SHOWER WITH SILICONE.
- 4. SECURE DRAINAGE PIPES TO CABINET USING WIRE TIE 108046-02-000, AND SCREW 000G67-10-12U AT INTERVALS OF NOT MORE THAN 4 FEET APART.
- 3. ALL PIPE AND FITTINGS TO BE ASSEMBLED WITH SOLVENT 004020-01-000 (USA), 004020-02-000 (CAN)
- 2. SLOPE OF TRAP ARM MUST BE 6 PER 305 mm.
- 1. SLOPE OF HORIZONTAL PIPING TO BE MINIMUM OF 3 PER 305 mm.

NOTES:

X-X  
FOR  
DRAINAGE  
CALLOUTS  
SEE DWG NO.  
000211962 /  
303370-01-000

<b>WINNEBAGO</b> COPYRIGHT 2023 WINNEBAGO INDUSTRIES, INC.		
DSNR:		ALL DIMENSIONS ARE IN MILLIMETERS
DFTR:		
UNSPECIFIED TOLERANCES:		MATERIAL:
WHOLE DIM (X) :	3	
ONE-PLACE (X.X) :	1.5	
TWO-PLACE (X.XX) :	0.50	
ANGLE :	1°	
REFER TO ES0018 FOR FASTENER TIGHTENING GUIDELINES	WEIGHT: (LBS)	FIRST USED: (REF)
		21 U59RA
<b>DRAINAGE SYSTEM INSTL</b>		
SHEET:	ITEM/PART NO:	REV
1 OF 3	000222210 / 34655701000	

SHOWER INSTL  
000225490 / 346491-01-XXX

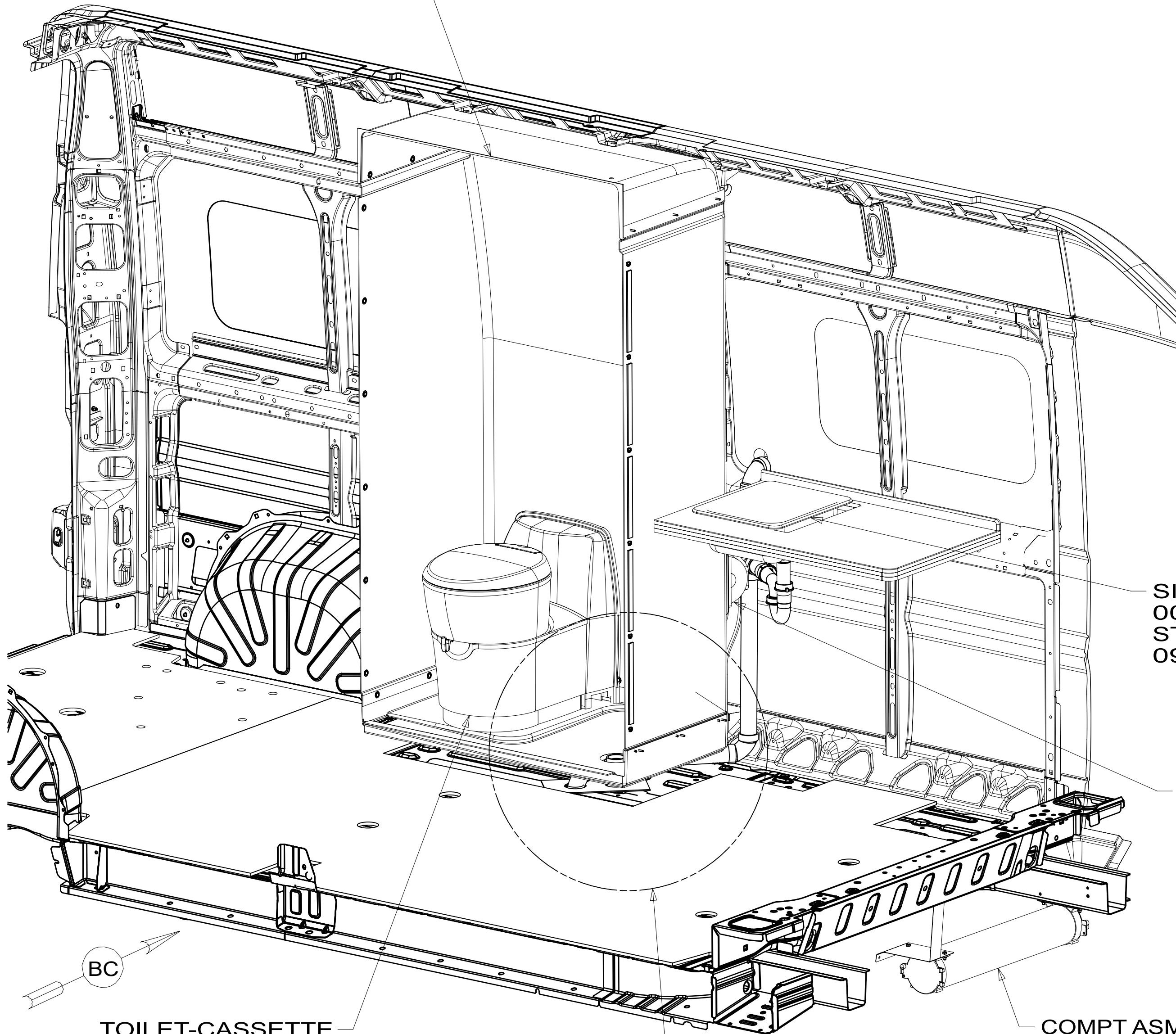

SINK-GALLEY, SGL  
000188453 / 335454-01-CHT  
STRAINER-SINK  
092303-01-000

HOLDER-DRYROLL TISSUE  
190211-01-CHT  
PLATE-BACKING, TOILET PAPER  
000042373 / 320094-01-CHT

COMPT ASM-SEWER HOSE, STORAGE  
000121940 / 323180-01-CHT  
BRACKET-SEWER HOSE COMP  
000253855 / 349756-01-CHT  
BRACKET-COMPT, SEWER  
000253857 / 349710-01-CHT  
BOLT-HEX, 1/4-20X.75, GR5  
000C12-04-12U (4)  
HEX\_NUT  
000D39-04-00U (4)

VIEW BA

STRAINER W/RUBBER WASHER  
066440-01-000

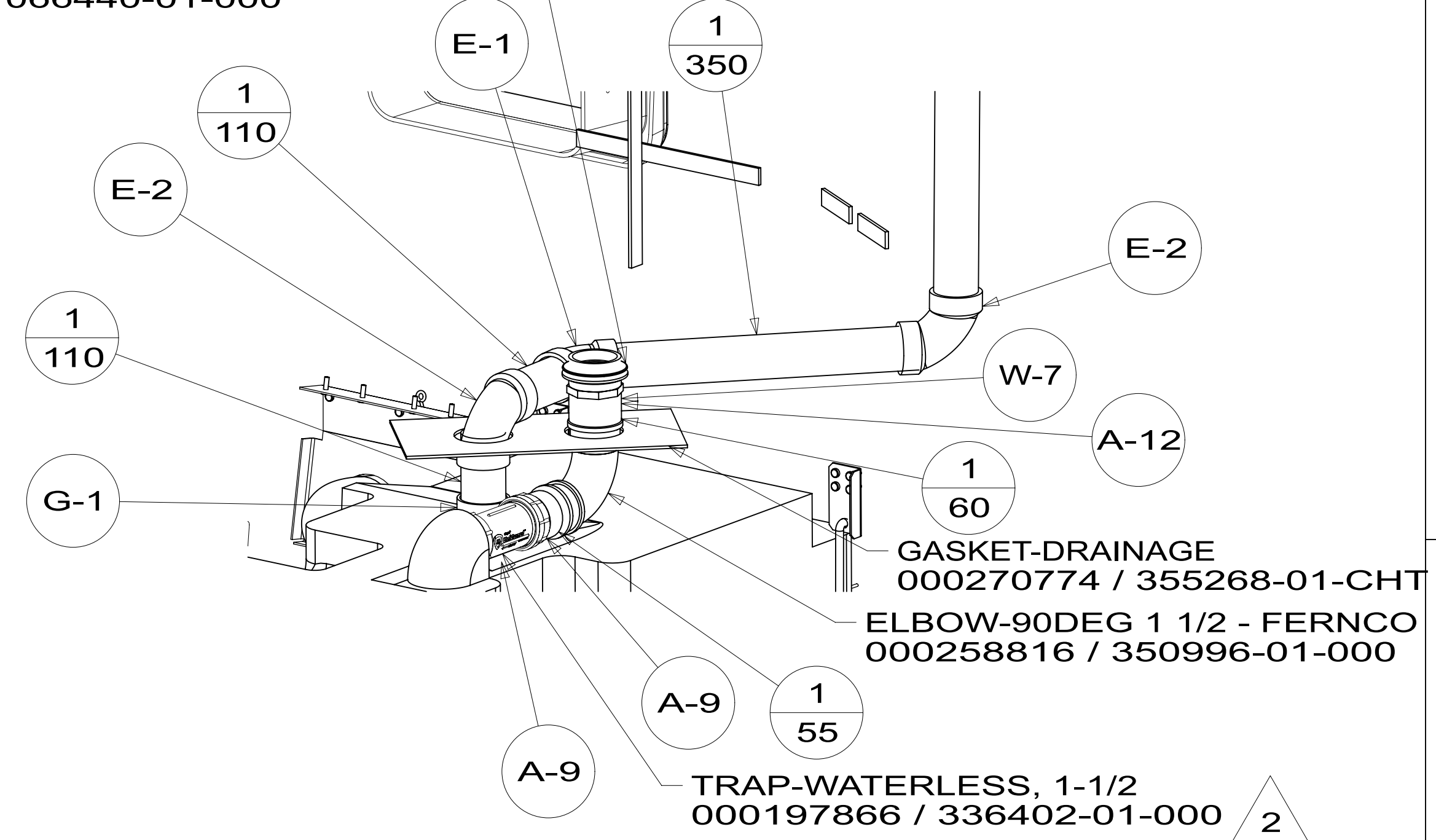

DETAIL BB

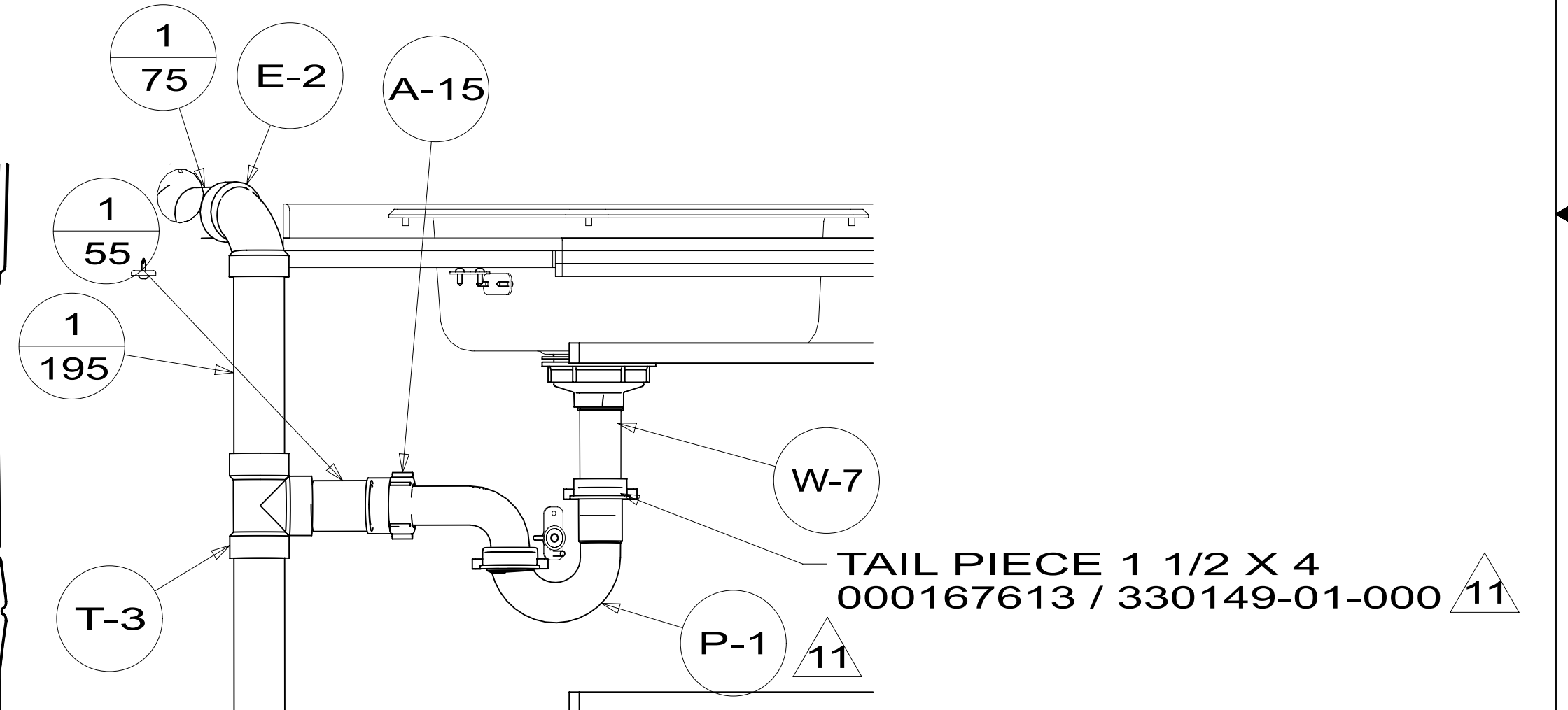

VIEW BC

DESCRIPTION: <b>DRAINAGE SYSTEM INSTL</b>		
SHEET: 2 OF 3	ITEM/PART NO: 000222210 / 34655701000	REV

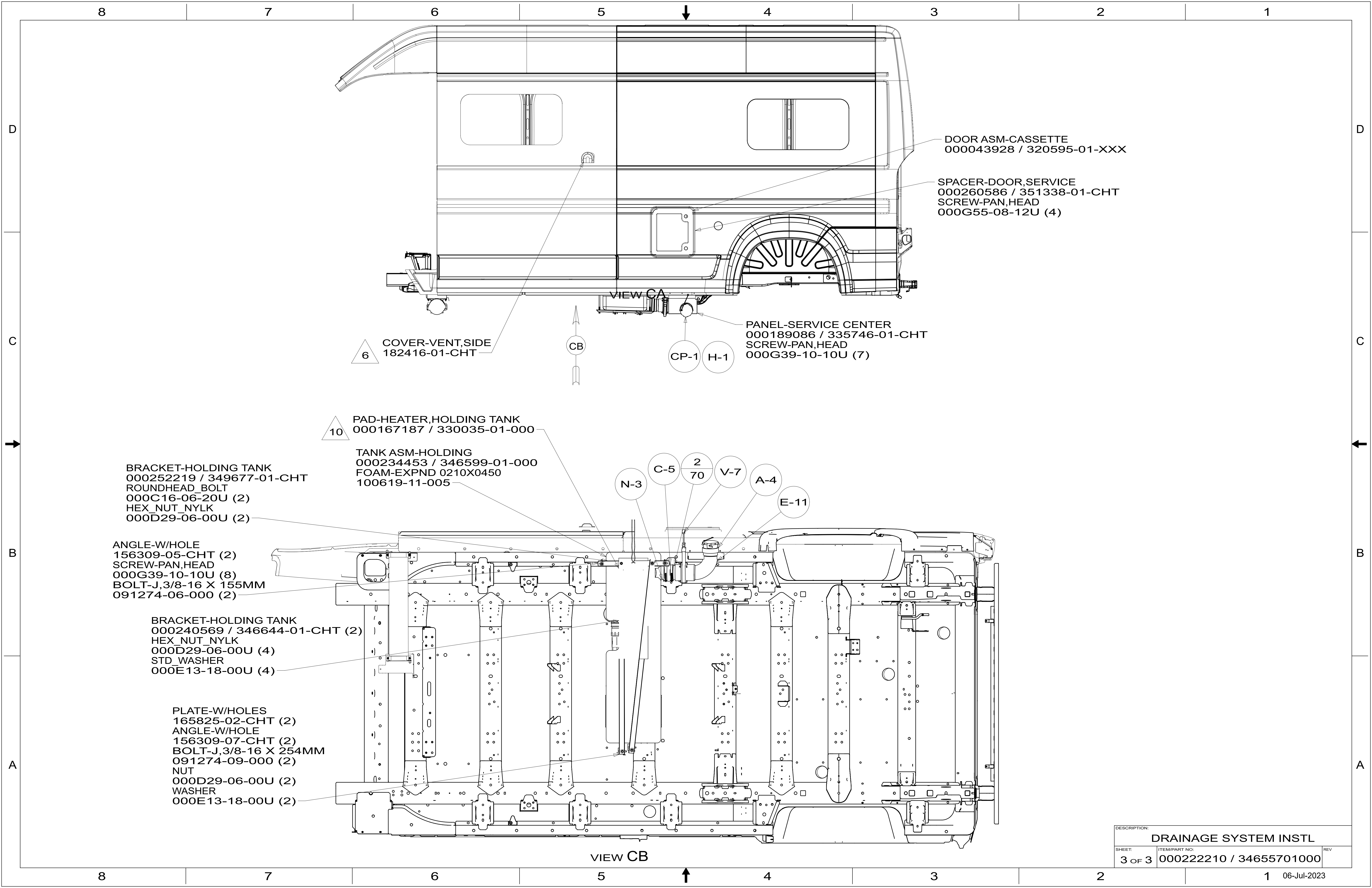

DOOR ASM-CASSETTE  
000043928 / 320595-01-XXX

SPACER-DOOR,SERVICE  
000260586 / 351338-01-CHT  
SCREW-PAN,HEAD  
000G55-08-12U (4)

PANEL-SERVICE CENTER  
000189086 / 335746-01-CHT  
SCREW-PAN,HEAD  
000G39-10-10U (7)

COVER-VENT,SIDE  
182416-01-CHT

PAD-HEATER,HOLDING TANK  
000167187 / 330035-01-000

TANK ASM-HOLDING  
000234453 / 346599-01-000  
FOAM-EXPND 0210X0450  
100619-11-005

BRACKET-HOLDING TANK  
000252219 / 349677-01-CHT  
ROUNDHEAD\_BOLT  
000C16-06-20U (2)  
HEX\_NUT\_NYLK  
000D29-06-00U (2)

ANGLE-W/HOLE  
156309-05-CHT (2)  
SCREW-PAN,HEAD  
000G39-10-10U (8)  
BOLT-J,3/8-16 X 155MM  
091274-06-000 (2)

BRACKET-HOLDING TANK  
000240569 / 346644-01-CHT (2)  
HEX\_NUT\_NYLK  
000D29-06-00U (4)  
STD\_WASHER  
000E13-18-00U (4)

PLATE-W/HOLES  
165825-02-CHT (2)  
ANGLE-W/HOLE  
156309-07-CHT (2)  
BOLT-J,3/8-16 X 254MM  
091274-09-000 (2)  
NUT  
000D29-06-00U (2)  
WASHER  
000E13-18-00U (2)

VIEW CB

DESCRIPTION:		
DRAINAGE SYSTEM INSTL		
SHEET:	ITEM/PART NO.:	REV
3 OF 3	000222210 / 3465701000	