

- 5 MARK WIRES WITH WRAP OF BLU TAPE.
- 4 MARK WIRES WITH WRAP OF ORG TAPE.
- 3 SEE DRAINAGE SYSTEM INSTALLATION FOR ADDITIONAL INFORMATION.
- 2 WIRE ROUTED ALONG DRAINAGE PIPE AND CONNECTED TO PIPE WITH TIE-WIRE 8343-04-000.

1. AT MINIMUM ALL WIRES TO BE SUPPORTED AND SECURED PER CODE REQUIREMENTS. USE CLAMP 10495 OR 10497 OR WIRE TIE 8343 OR 108046 AND SCREW G67-XX-XXX OR G56-XX-XXX AS APPROPRIATE FOR INSTALLATION.

NOTES:

4 WIRE ASM-TANKS, AUX HOLDING 000281136 / 355984-01-000

3 2 WIRE ASM-HEATER, TANKS 183828-02-000

PLATE-WALL, COAX EXTERIOR 183638-01-CHT (COAX-RED) SCREW G39-08-16U (3)

REMOTE PANEL-INVERTER 000037772 / 318694-01-CHT SCREW 000G11-06-08U (2) CABLE-DATA, CSW INVERTER,RJ1 000038250 / 318769-01-000

SWITCH DETAIL CE

SWITCH DETAIL CC

WIRE ASM-LEFT 000044094 / 320613-01-000

ADAPTOR-COAX 82134-01-000

LIGHT-LED, ROUND W/SWITCH, 3.5 PLASTIC 000166892 / 329927-01-CHT (3) SCREW G13-06-10U (9) CONNECTOR 58028-01-000 (6)

THERMOSTAT 135618-06-CHT SCREW G13-07-12U (2)

DETAIL AA THERMOSTAT 000226912 / 344157-01-CHT WIRE ASM-JUMPER 000228132 / 344476-01-000 DETAIL AC

PANEL-MONITOR, W/GEN 000167995 / 330356-01-CHT

RELAY-TANK HEATERS 63912-02-000 SCREW G11-08-12U

RELAY-CLEARANCE LAMPS 063912-02-000 SCREW G11-08-12U

WIRE ASM-TANK, MAIN HOLDING 000281137 / 355983-01-000

FOR ELECTRICAL TORQUE SPECIFICATIONS SEE DWG NO. 128783-01-000

FOR ELECTRICAL CALLOUTS SEE DWG 000228177 344479-01-000

- 290 A/C DEVIATION
- 25Q A/C
- 265 CODES/STANDARDS-CSA/CMVSS
- 1B1 CODES/STANDARDS USA

1B1 265

WINNEBAGO
COPYRIGHT 2023 WINNEBAGO INDUSTRIES, INC.

DSNR:	ALL DIMENSIONS ARE IN MILLIMETERS	
DFT:		
UNSPECIFIED TOLERANCES:	MATERIAL:	
WHOLE DIM (X) :	3	
ONE-PLACE (X.X) :	1.5	
TWO-PLACE (X.XX) :	0.50	
ANGLE :	1°	
REFER TO ES0018 FOR FASTENER TIGHTENING GUIDELINES	WEIGHT: (LBS)	FIRST USED:
		20 325B
DESCRIPTION:		
WIRING INSTL-BODY, 12V		
SHEET:	ITEM/PART NO:	REV:
1 OF 4	000207953 / 33941101000	
REF:		

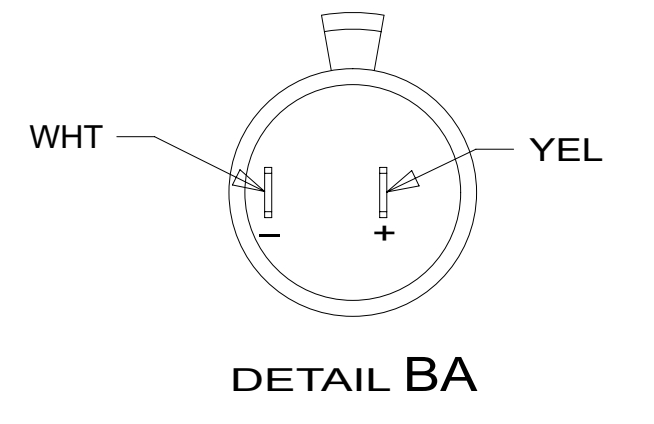
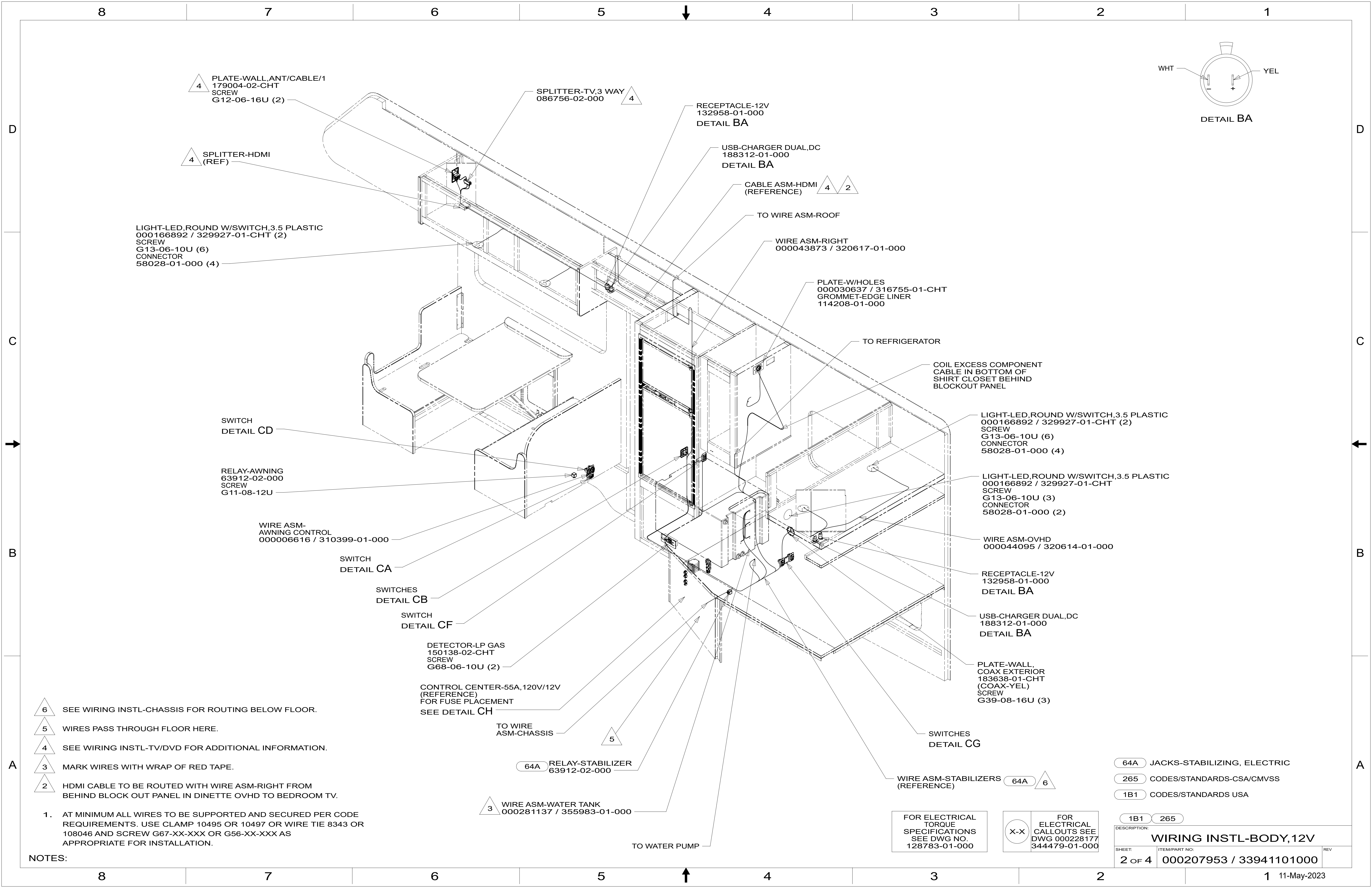

4 PLATE-WALL,ANT/CABLE/1
179004-02-CHT
SCREW
G12-06-16U (2)

SPLITTER-TV,3 WAY
086756-02-000

RECEPTACLE-12V
132958-01-000
DETAIL BA

4 SPLITTER-HDMI
(REF)

USB-CHARGER DUAL,DC
188312-01-000
DETAIL BA

CABLE ASM-HDMI
(REFERENCE)

LIGHT-LED,ROUND W/SWITCH,3.5 PLASTIC
000166892 / 329927-01-CHT (2)
SCREW
G13-06-10U (6)
CONNECTOR
58028-01-000 (4)

TO WIRE ASM-ROOF

PLATE-W/HOLES
000030637 / 316755-01-CHT
GROMMET-EDGE LINER
114208-01-000

TO REFRIGERATOR

COIL EXCESS COMPONENT
CABLE IN BOTTOM OF
SHIRT CLOSET BEHIND
BLOCKOUT PANEL

SWITCH
DETAIL CD

LIGHT-LED,ROUND W/SWITCH,3.5 PLASTIC
000166892 / 329927-01-CHT (2)
SCREW
G13-06-10U (6)
CONNECTOR
58028-01-000 (4)

RELAY-AWNING
63912-02-000
SCREW
G11-08-12U

LIGHT-LED,ROUND W/SWITCH,3.5 PLASTIC
000166892 / 329927-01-CHT
SCREW
G13-06-10U (3)
CONNECTOR
58028-01-000 (2)

WIRE ASM-
AWNING CONTROL
000006616 / 310399-01-000

WIRE ASM-OVHD
000044095 / 320614-01-000

SWITCH
DETAIL CA

RECEPTACLE-12V
132958-01-000
DETAIL BA

SWITCHES
DETAIL CB

USB-CHARGER DUAL,DC
188312-01-000
DETAIL BA

SWITCH
DETAIL CF

DETECTOR-LP GAS
150138-02-CHT
SCREW
G68-06-10U (2)

PLATE-WALL,
COAX EXTERIOR
183638-01-CHT
(COAX-YEL)
SCREW
G39-08-16U (3)

CONTROL CENTER-55A,120V/12V
(REFERENCE)
FOR FUSE PLACEMENT
SEE DETAIL CH

SWITCHES
DETAIL CG

6 SEE WIRING INSTL-CHASSIS FOR ROUTING BELOW FLOOR.

5 WIRES PASS THROUGH FLOOR HERE.

4 SEE WIRING INSTL-TV/DVD FOR ADDITIONAL INFORMATION.

3 MARK WIRES WITH WRAP OF RED TAPE.

2 HDMI CABLE TO BE ROUTED WITH WIRE ASM-RIGHT FROM
BEHIND BLOCK OUT PANEL IN DINETTE OVHD TO BEDROOM TV.

1. AT MINIMUM ALL WIRES TO BE SUPPORTED AND SECURED PER CODE
REQUIREMENTS. USE CLAMP 10495 OR 10497 OR WIRE TIE 8343 OR
108046 AND SCREW G67-XX-XXX OR G56-XX-XXX AS
APPROPRIATE FOR INSTALLATION.

NOTES:

TO WIRE
ASM-CHASSIS

64A RELAY-STABILIZER
63912-02-000

3 WIRE ASM-WATER TANK
000281137 / 355983-01-000

TO WATER PUMP

FOR ELECTRICAL
TORQUE
SPECIFICATIONS
SEE DWG NO.
128783-01-000

FOR ELECTRICAL
CALLOUTS SEE
DWG 000228177
344479-01-000

- 64A JACKS-STABILIZING, ELECTRIC
- 265 CODES/STANDARDS-CSA/CMVSS
- 1B1 CODES/STANDARDS USA

DESCRIPTION: WIRING INSTL-BODY, 12V	
SHEET: 2 OF 4	ITEM/PART NO.: 000207953 / 33941101000
REV 11-May-2023	

SWITCH-BATTERY
108357-18-000
ACTUATOR-SWITCH
108356-19-CHT
CIRCUITS LH,LJ,
LG,JP,JA
WIRE ASM-THERMISTOR
186796-01-000

PLATE-SWITCH
144363-02-CHT
SCREW
G11-06-10U (2)

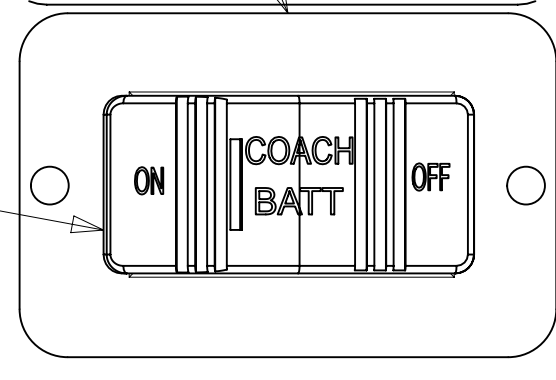

DETAIL CA

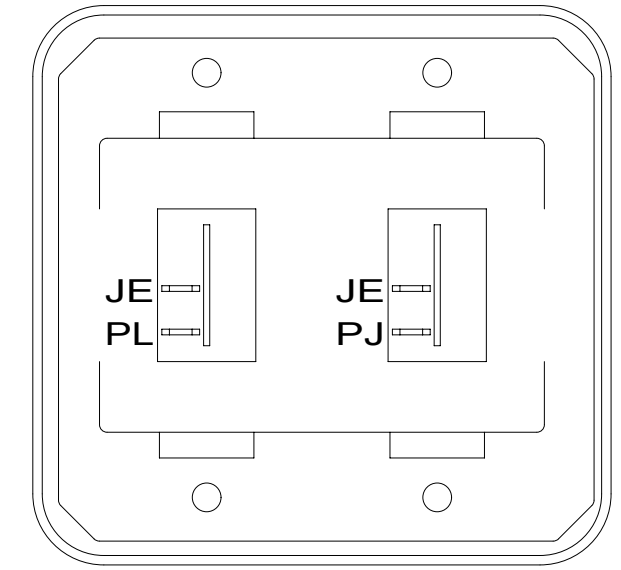

DETAIL CB

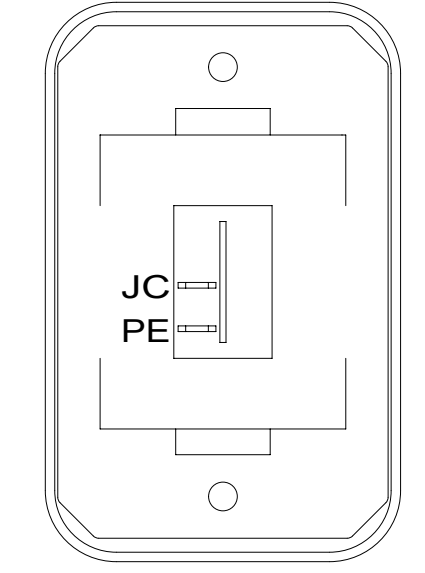

DETAIL CC

SWITCH-ROCKER
135740-01-CHT (2)
SWITCH-BASE
135741-02-CHT
SWITCH-BEZEL
135742-02-CHT
SCREW
G11-08-08U (4)

HOLDING TANK HEATER
TURN OFF When Not In Use
SEE OPERATORS MANUAL

DETAIL CE

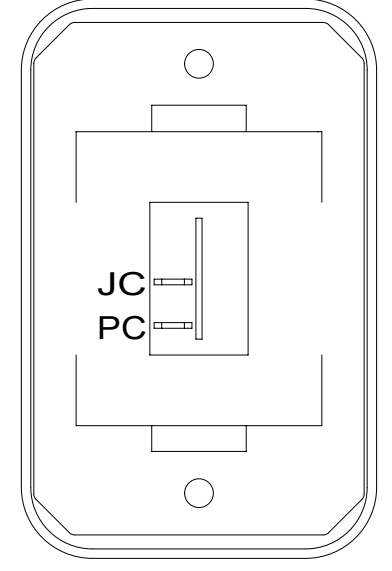

DETAIL CF

SWITCH-ROCKER
135740-06-CHT
SWITCH-BASE
135741-01-CHT
SWITCH-BEZEL
135742-01-CHT
SCREW
G11-08-08U (2)
LABEL-SWITCH
134563-01-CHT

SWITCH-ROCKER
135740-01-CHT
SWITCH-BASE
135741-01-CHT
SWITCH-BEZEL
135742-01-CHT
SCREW
G11-08-08U (2)

CIRCUIT BREAKER-15 AMP
000208380 / 339566-01-000

FUSE-5 AMP
062901-02-000 (2)

J 6 BLK
(BATTERY COMPT)

8 GRN
(GROUND)

FUSE-15 AMP
062901-05-000 (7)

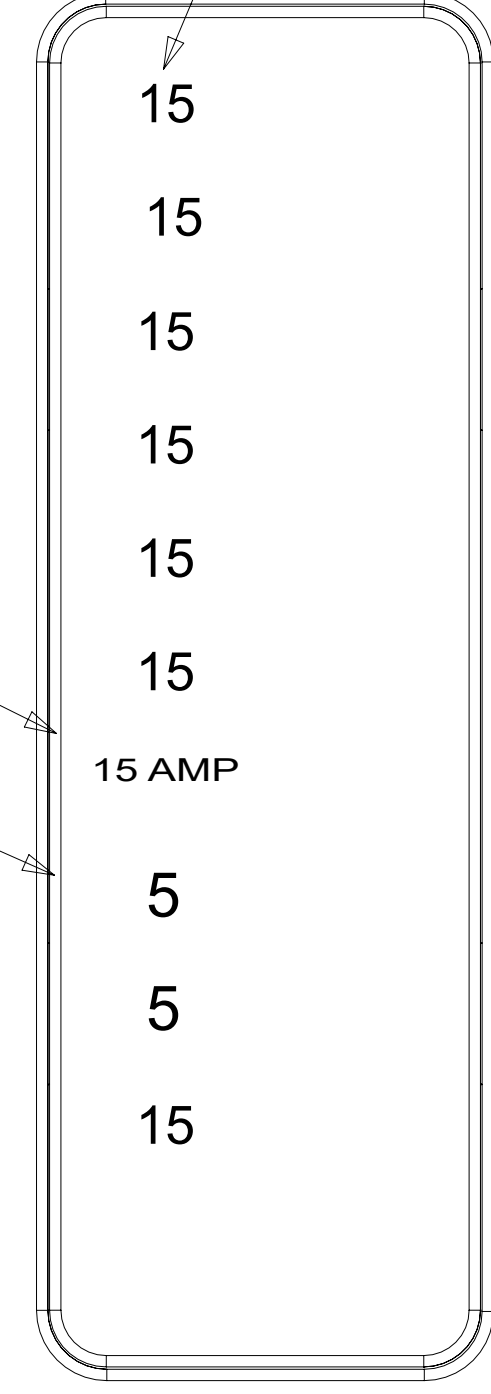

DETAIL CH

- ← JC 14 Y (LAMPS)
- ← JD 14 Y (LAMPS)
- ← JE 14 Y (LAMPS)
- ← NM 12 Y (TANK HEATERS)
- ← JA 14 Y (MONITOR PANEL & PUMP)
- ← JB 14 Y (FURNACE)
- ← FFD 12 Y (AWNING) (STABILIZERS)
- ← WB 16 Y (LP DETECTOR)
- ← ET 16 Y (REFRIGERATOR)
- ← JF 14 Y (TV/RADIO)

SWITCH-ROCKER
108357-06-000
ACTUATOR-SWITCH
108356-12-CHT

PLATE-SWITCH
158431-19-CHT
SCREW
G11-06-10U (4)

SWITCH-ROCKER
108357-14-000
ACTUATOR-SWITCH
108356-28-CHT

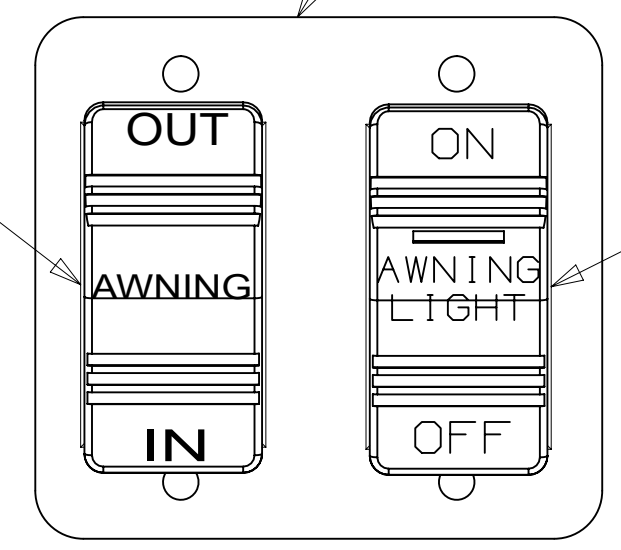

DETAIL CD

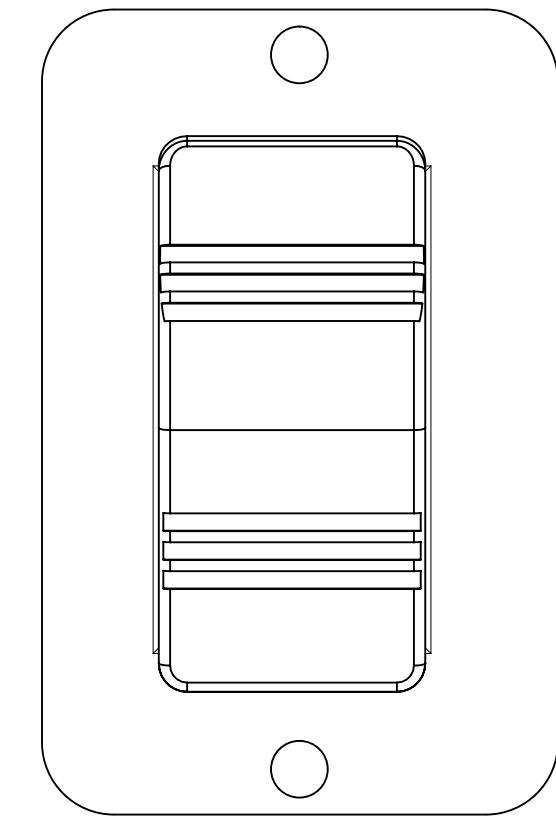

DETAIL CG

LABEL-STABILIZER
000007799 / 310651-01-CHT 64A

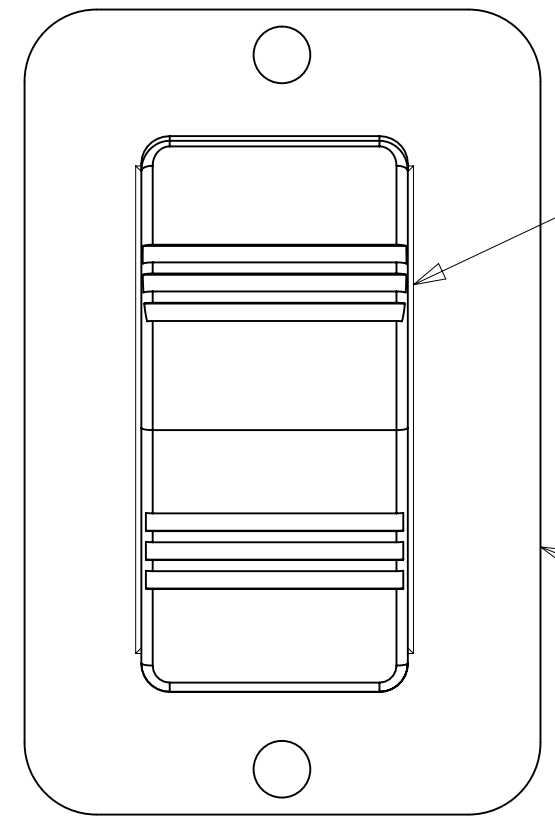
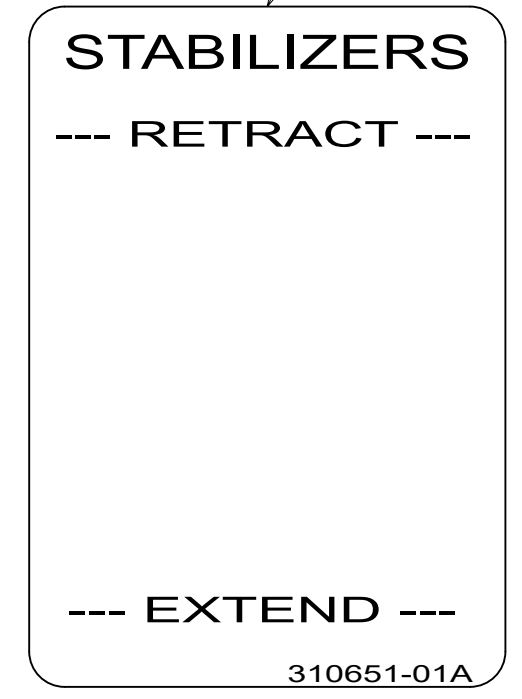

SWITCH-ROCKER
108357-06-000 (2)
ACTUATOR
108356-01-CHT (2)
SWITCH-BLANK
096241-03-000 (2)

PLATE-SWITCH
144363-02-CHT (2)
SCREW
G11-06-10U (4)

- 64A JACKS-STABILIZING, ELECTRIC
- 60T JACKS-STABILIZING,ELECT W/O
- 265 CODES/STANDARDS-CSA/CMVSS
- 1B1 CODES/STANDARDS USA

FOR ELECTRICAL
TORQUE
SPECIFICATIONS
SEE DWG NO.
128783-01-000

FOR ELECTRICAL
CALLOUTS SEE
DWG 000228177
344479-01-000

DESCRIPTION:	1B1 265	
WIRING INSTL-BODY,12V		
SHEET:	ITEM/PART NO:	REV
3 OF 4	000207953 / 33941101000	

8

7

6

5

4

3

2

1



LIGHT-LED,ROUND W/SWITCH,3.5 PLASTIC
 000166892 / 329927-01-CHT
 SCREW
 G13-06-16U (3)
 CONNECTOR
 58028-01-000 (2)

LIGHT-LED,ROUND 4.5 PLASTIC
 000166889 / 329926-01-CHT (6)
 SCREW
 G13-06-16U (18)
 CONNECTOR
 58028-01-000 (12)

ANTENNA-TV, OMNIDIRECTIONAL
 000171487 / 331386-01-CHT
 SCREW
 G67-10-16U (4)

1

1 SEE ANTENNA INSTALLATION MANUAL FOR
 CORRECT INSTALLATION PROCEDURE.

NOTES:

FOR ELECTRICAL
 TORQUE
 SPECIFICATIONS
 SEE DWG NO.
 128783-01-000

X-X

FOR
 ELECTRICAL
 CALLOUTS SEE
 DWG 000228177
 344479-01-000

265 CODES/STANDARDS-CSA/CMVSS

1B1 CODES/STANDARDS USA

1B1 265

DESCRIPTION:
WIRING INSTL-BODY,12V

SHEET: 4 OF 4 ITEM/PART NO: 000207953 / 33941101000 REV

8

7

6

5



4

3

2

1 11-May-2023

D

D

C

C

B

B

A

A

