

STABILIZER DOWN

LABEL-STABILIZER DOWN
000007625 / 310619-01-CHT

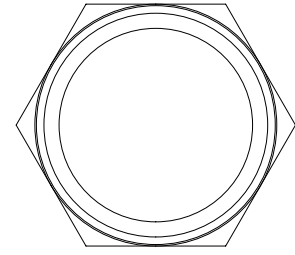

LIGHT ASM-INDICATOR, RED
190682-01-000
DETAIL CC

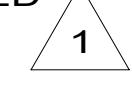

DETAIL CA

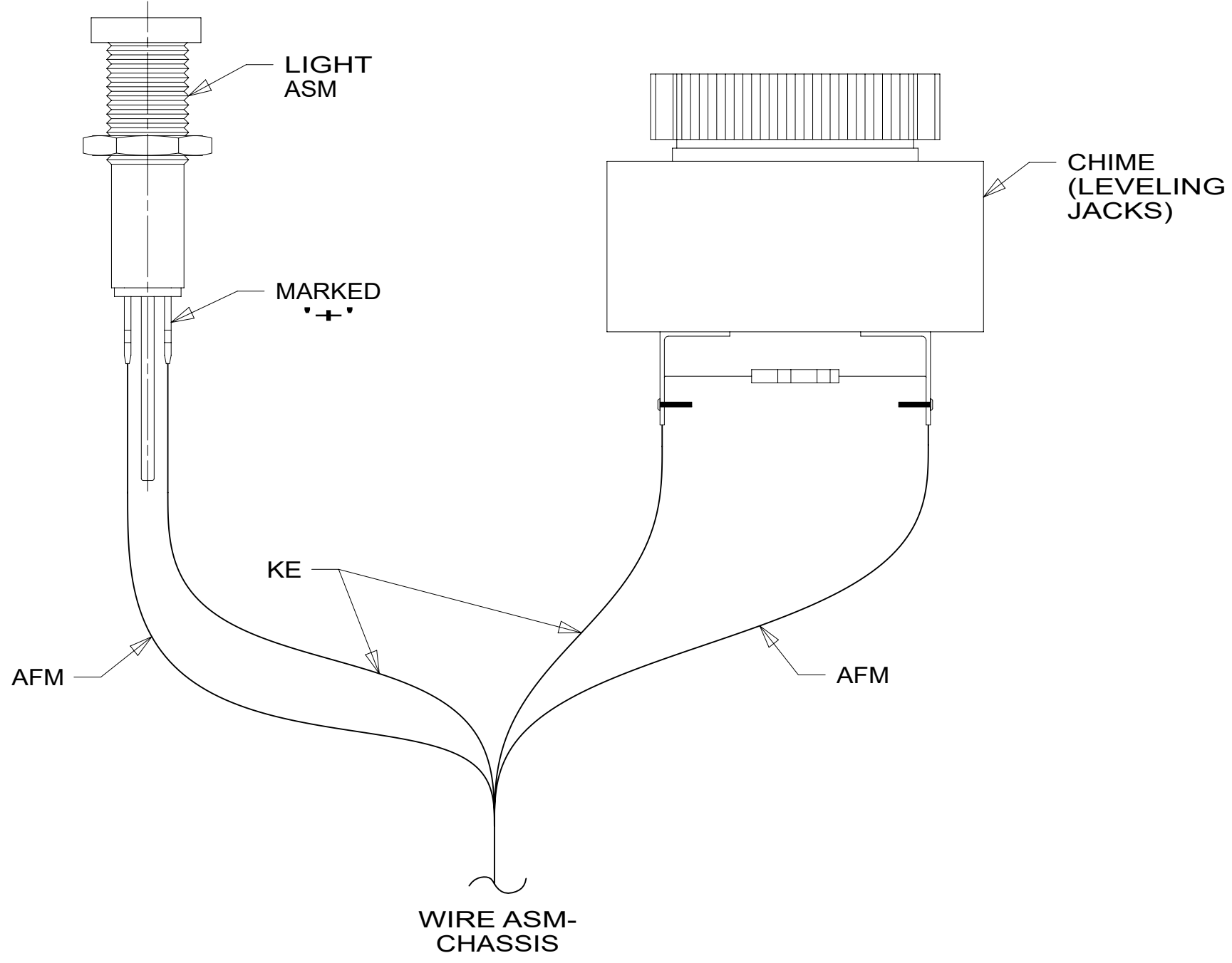

DETAIL CC

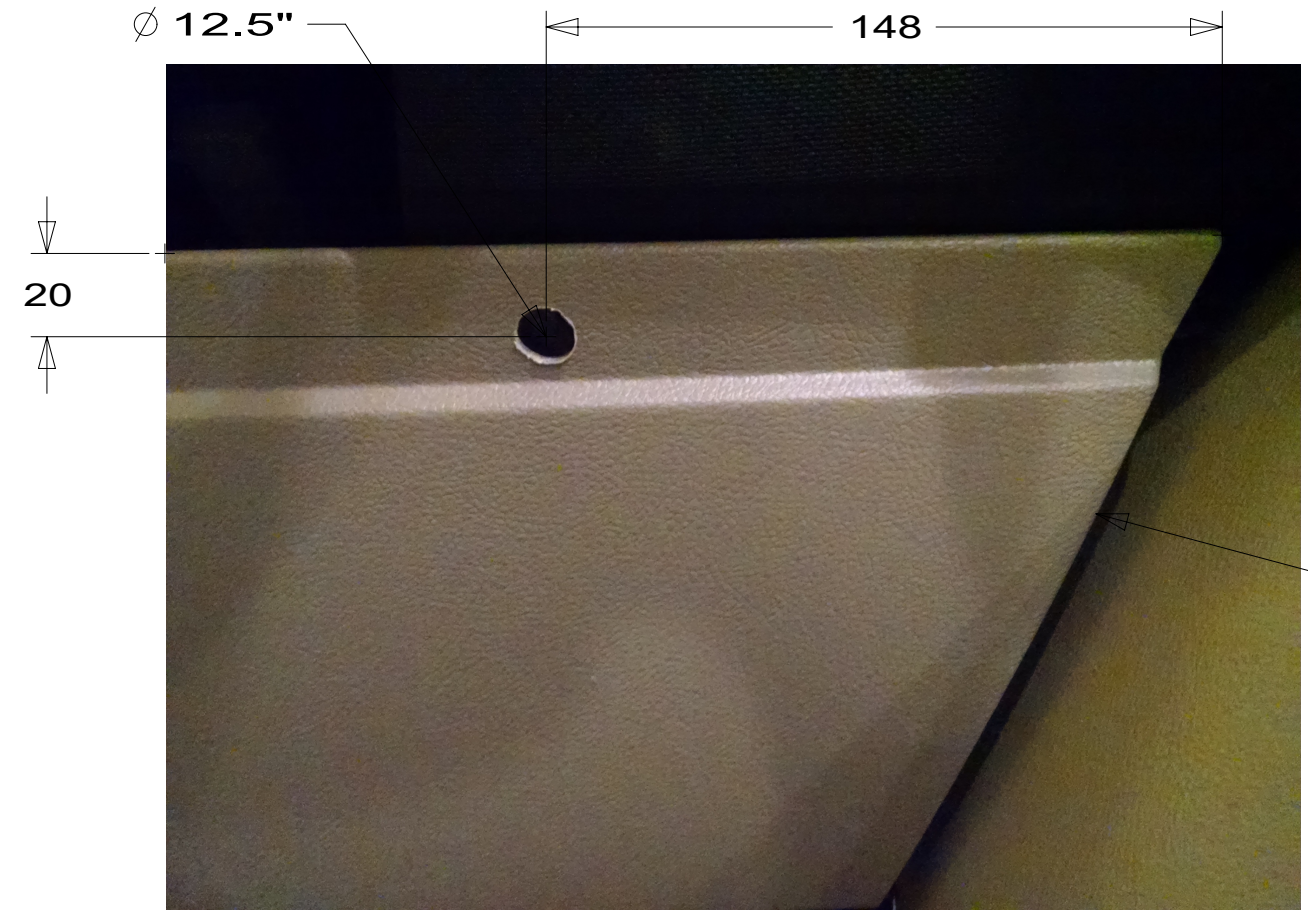

RIGHT SIDE OF STEERING COLUMN

DETAIL CB

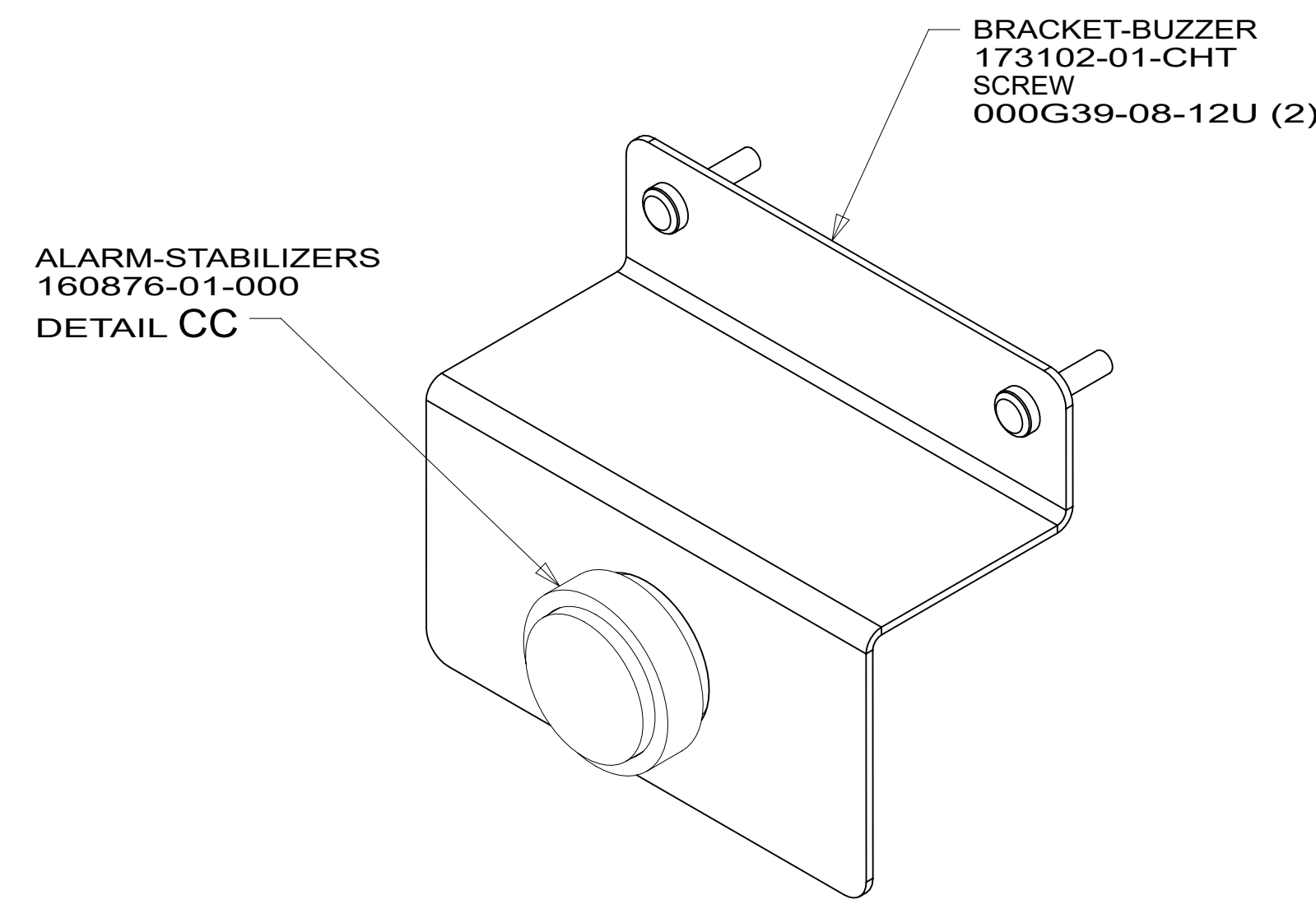

ALARM-STABILIZERS
160876-01-000
DETAIL CC

BRACKET-BUZZER
173102-01-CHT
SCREW
000G39-08-12U (2)

DETAIL CD

NOTES:
1 FOR HOLE SIZE AND LOCATION SEE DETAIL CB.

FOR ELECTRICAL TORQUE SPECIFICATIONS SEE DWG NO. 128783-01-000

FOR ELECTRICAL CALLOUTS SEE DWG 000228177 344479-01-000

- 64A JACKS-STABILIZING, ELECTRIC
- 265 CODES/STANDARDS-CSA/CMVSS
- 1B1 CODES/STANDARDS USA

DESCRIPTION:	1B1 265 64A	
WIRING INSTL-CHASSIS		
SHEET:	ITEM/PART NO:	REV
3 OF 3	000207861 / 33936301000	