

8 7 6 5 4 3 2 1

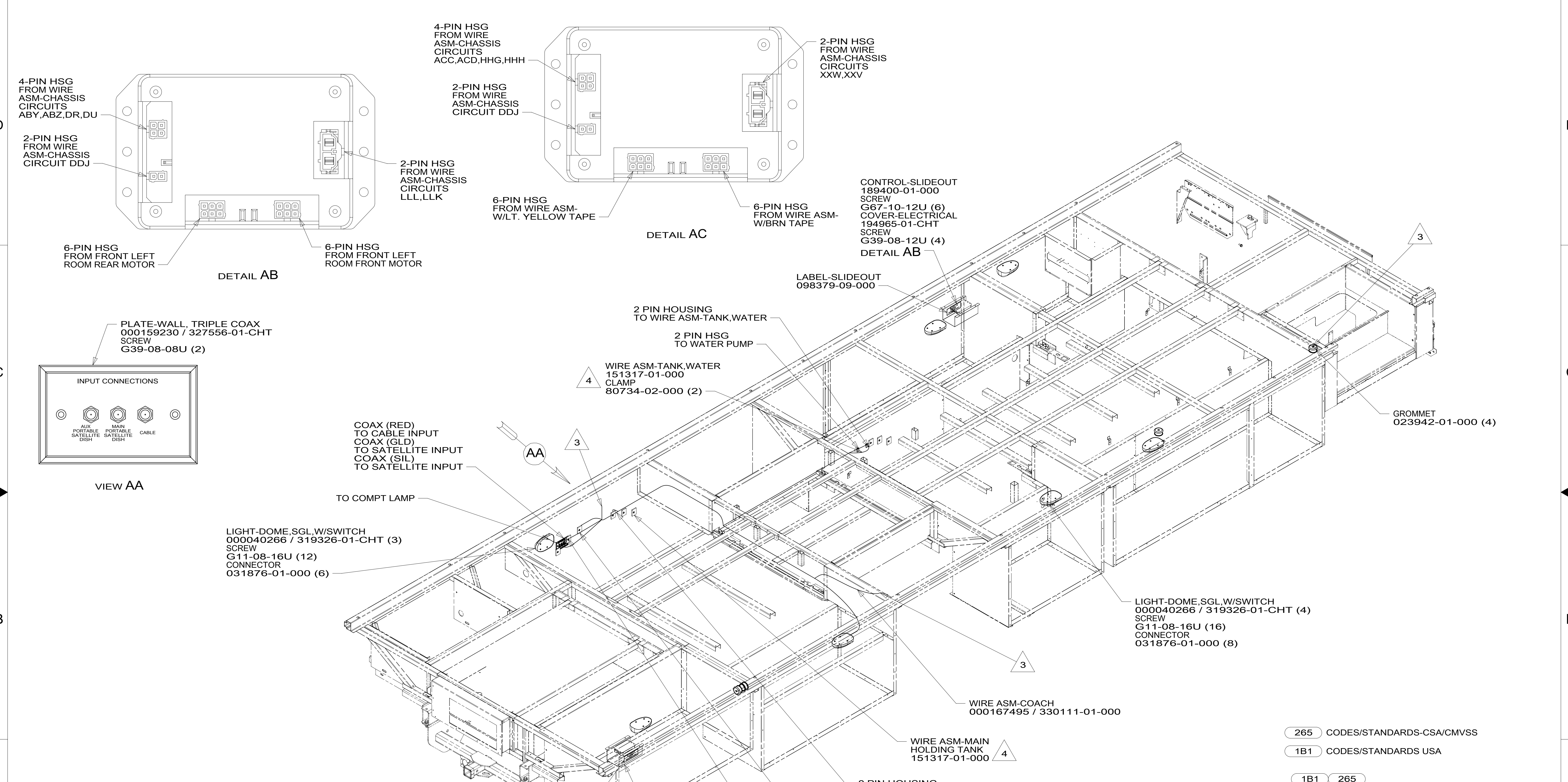

- 4 PLACE CROSS LOCATOR ON SENSORS OVER DIMPLES ON TANK.
- 3 WIRE PASSES THROUGH FLOOR IN THIS AREA.
2. ROUTE TANK SENSOR WIRES SO THEY DO NOT PASS OVER SENSORS. USE WIRE TIE MOUNT 155366-01-000 AND WIRE TIE 8343-01-000 AS NEEDED. TANK SURFACE MUST BE CLEANED USING ISOPROPYL ALCOHOL AND PRIMED WITH PRIMER 94.
1. AT MINIMUM ALL WIRES TO BE SUPPORTED AND SECURED PER CODE REQUIREMENTS. USE CLAMP 10495 OR 10497 OR WIRE TIE 8343 OR 108046 AND SCREW G67-XX-XXX OR G56-XX-XXX AS APPROPRIATE FOR INSTALLATION.

NOTES:

FOR ELECTRICAL TORQUE SPECIFICATIONS SEE DWG NO. 128783-01-000

FOR ELECTRICAL CALLOUTS SEE DWG NO. 121339-01-000

- 265 CODES/STANDARDS-CSA/CMVSS
- 1B1 CODES/STANDARDS USA
- 1B1 265

**WINNEBAGO**  
COPYRIGHT 2016 WINNEBAGO INDUSTRIES, INC.

DSNR:	ALL DIMENSIONS ARE IN MILLIMETERS
DFFR:	MATERIAL:
UNSPECIFIED TOLERANCES:	WEIGHT: (LBS)
WHOLE DIM (X) : 3	FIRST USED: 19 E32YE
ONE-PLACE (X.X) : 1.5	
TWO-PLACE (X.XX) : 0.50	
ANGLE : 1°	
REFER TO ES0018 FOR FASTENER TIGHTENING GUIDELINES	
DESCRIPTION: <b>WIRING INSTL-BODY, 12V</b>	
SHEET: 1 OF 7	ITEM/PART NO: 000167491 / 33010701000
REF:	REV:

8 7 6 5 4 3 2 1

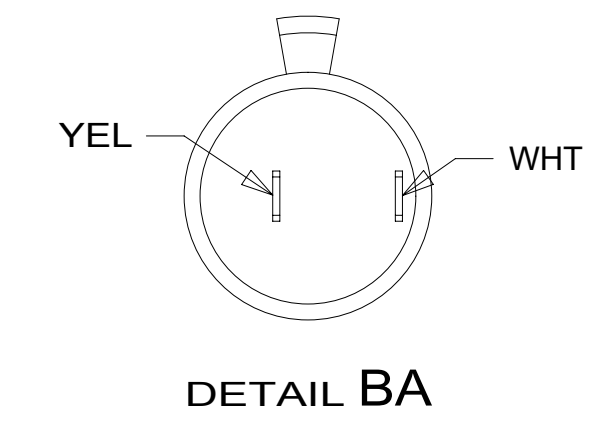
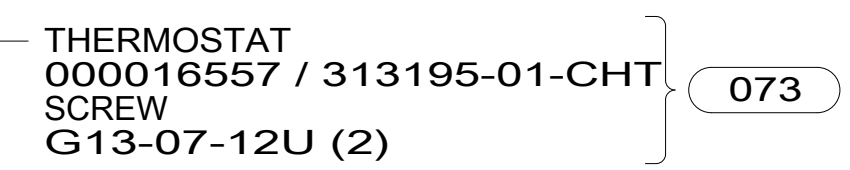
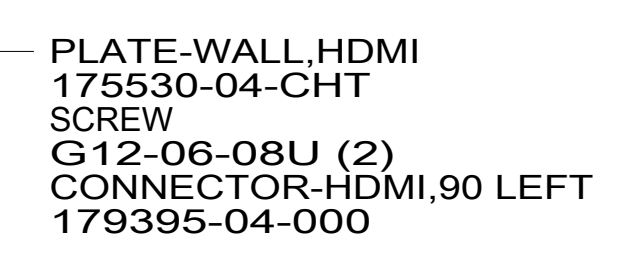
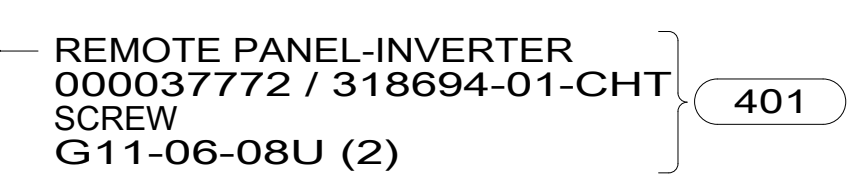
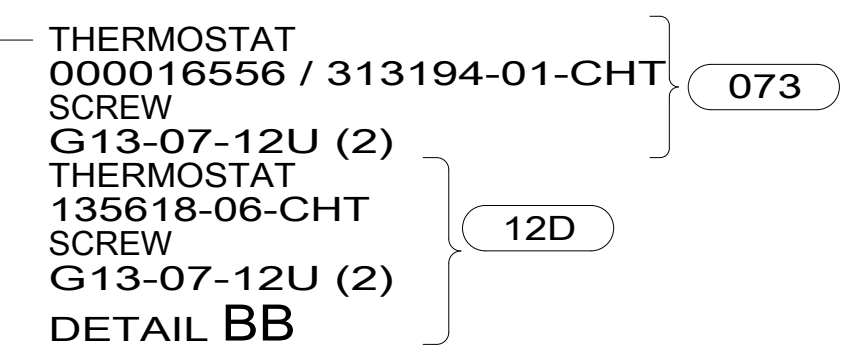
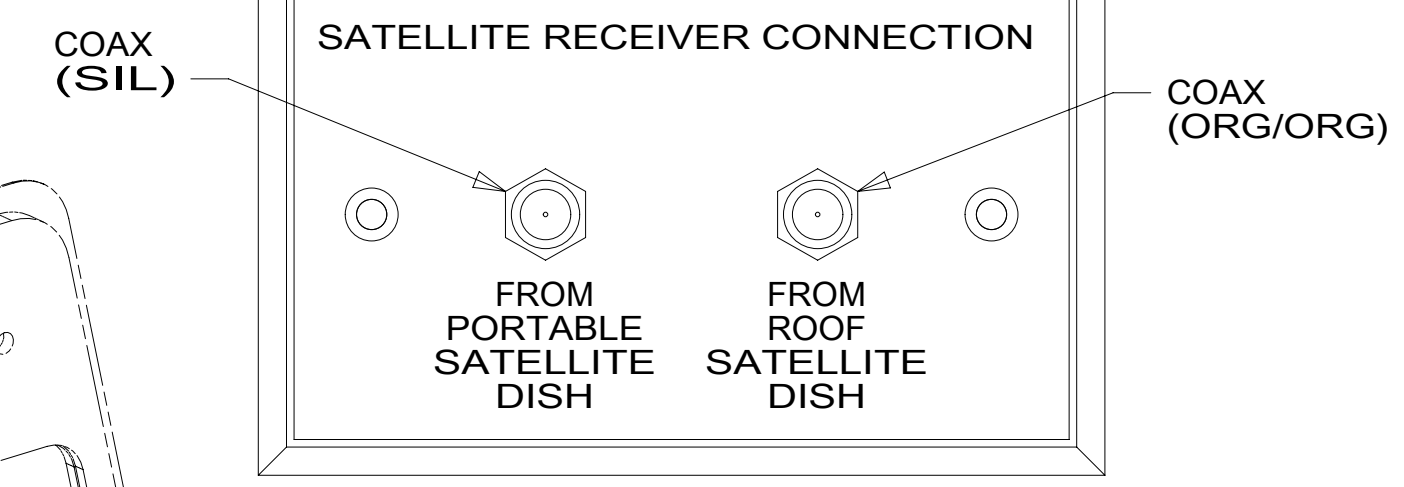
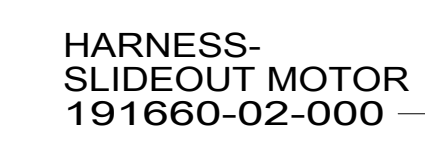
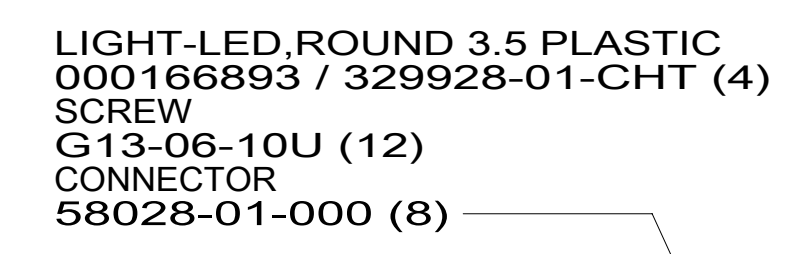
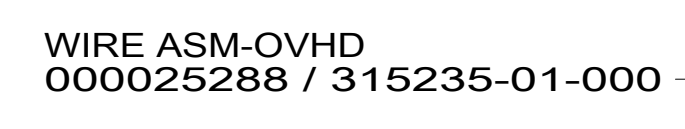
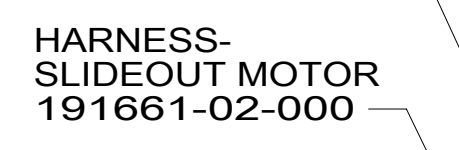
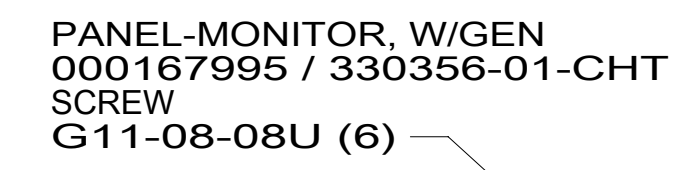
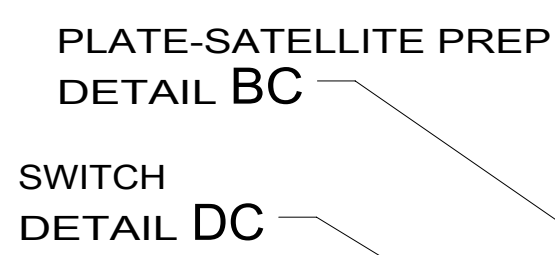
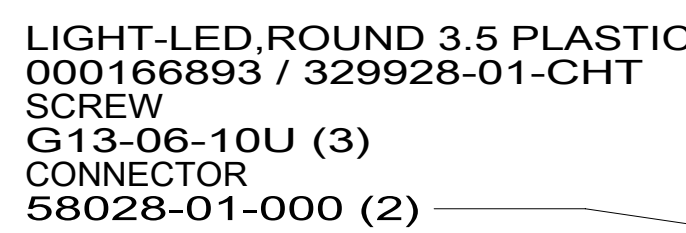
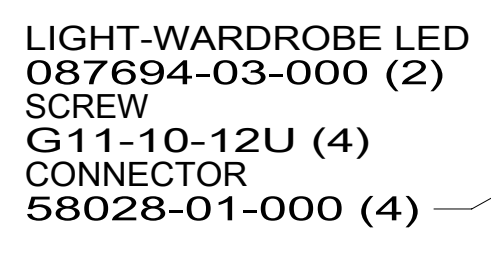
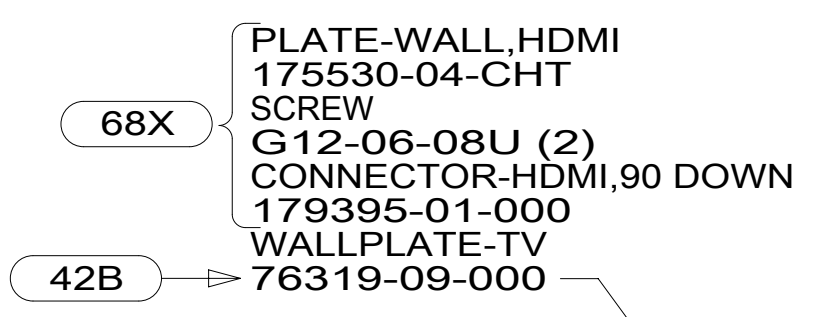
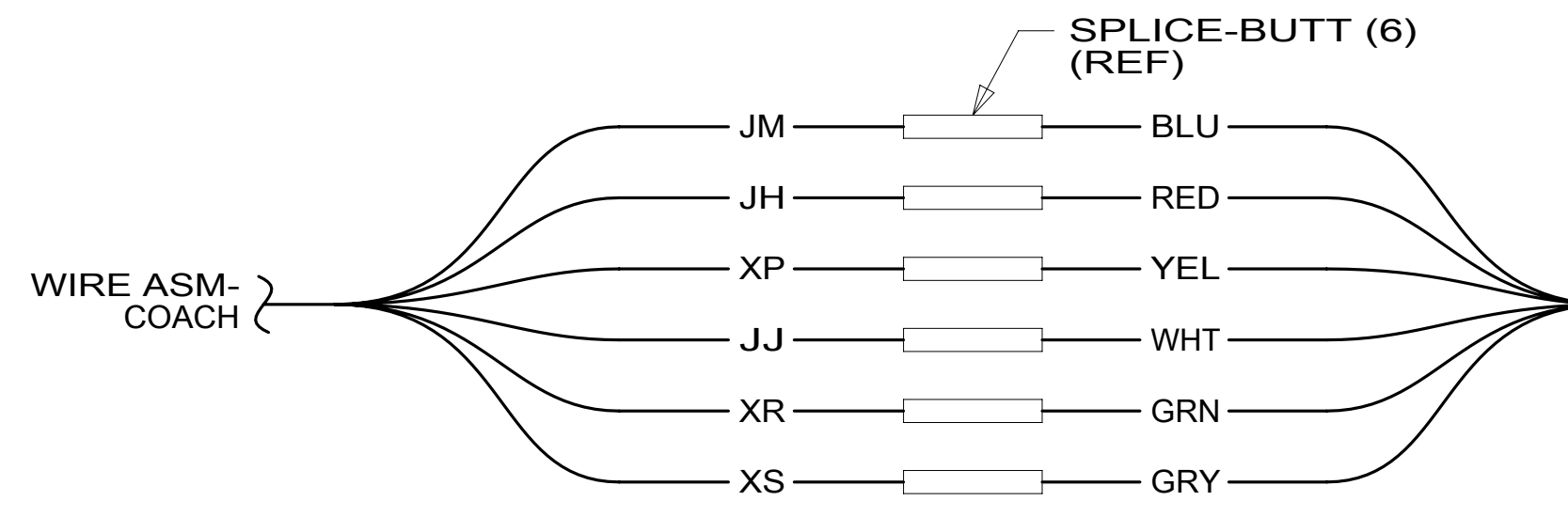
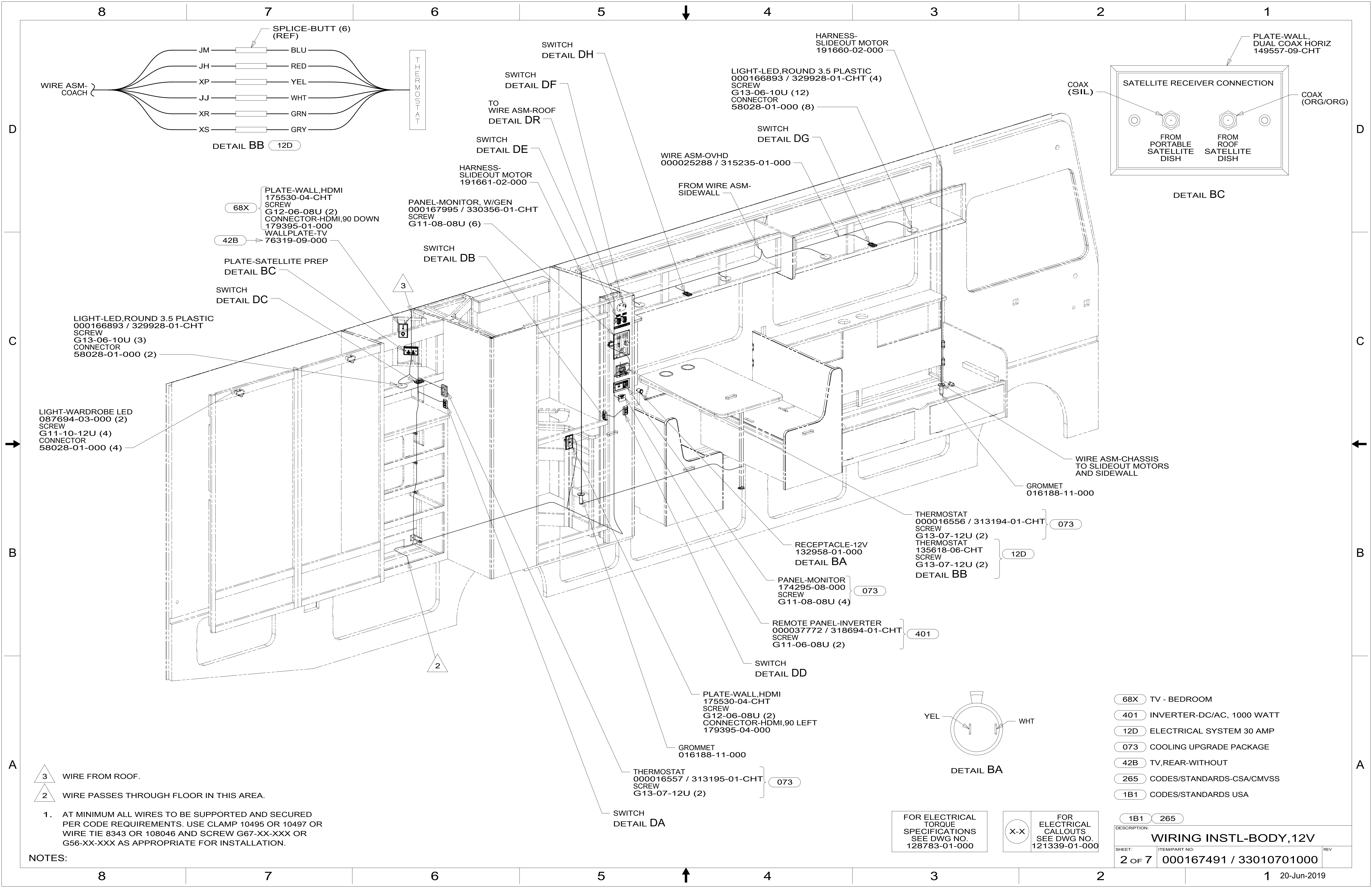

- 68X TV - BEDROOM
- 401 INVERTER-DC/AC, 1000 WATT
- 12D ELECTRICAL SYSTEM 30 AMP
- 073 COOLING UPGRADE PACKAGE
- 42B TV, REAR-WITHOUT
- 265 CODES/STANDARDS-CSA/CMVSS
- 1B1 CODES/STANDARDS USA

- 3 WIRE FROM ROOF.
- 2 WIRE PASSES THROUGH FLOOR IN THIS AREA.

1. AT MINIMUM ALL WIRES TO BE SUPPORTED AND SECURED PER CODE REQUIREMENTS. USE CLAMP 10495 OR 10497 OR WIRE TIE 8343 OR 108046 AND SCREW G67-XX-XXX OR G56-XX-XXX AS APPROPRIATE FOR INSTALLATION.

FOR ELECTRICAL TORQUE SPECIFICATIONS SEE DWG NO. 128783-01-000

FOR ELECTRICAL CALLOUTS SEE DWG NO. 121339-01-000

DESCRIPTION: 1B1 265

**WIRING INSTL-BODY, 12V**

SHEET: 2 OF 7 ITEM/PART NO.: 000167491 / 33010701000 REV:

NEGATIVE BAR  
140031-01-CHT  
BOLT  
C26-06-12U (5)  
NUT  
D39-06-00U (5)  
STUD-ISOLATED  
86233-01-000 (2)  
NUT  
D34-06-00U (2)  
SCREW  
G67-10-12U (4)

DETAIL CC

CONNECT ALL  
GROUNDS TO  
GROUND BAR

SWITCHES  
DETAIL DL

12V BREAKER PANEL  
DETAIL EB

SWITCH  
DETAIL DM

12V FUSES  
DETAIL ED

SWITCHES  
DETAIL DN

CONTROL CENTER-55A  
(REF)

STEP SWITCH  
DETAIL CA

SWITCHES  
DETAIL DK

LED-2

TO HDMI SPLITTER

HARNESS-  
SLIDEOUT MOTOR  
191661-02-000

USB-CHARGER DUAL,DC  
188312-01-000  
DETAIL CD

WIRE ASM-OVHD  
192894-01-000

SWITCH  
DETAIL DJ

LIGHT-LED,ROUND 3.5 PLASTIC  
000166893 / 329928-01-CHT (2)  
SCREW  
G13-06-10U (6)  
CONNECTOR  
58028-01-000 (4)

HARNESS-  
SLIDEOUT MOTOR  
191661-01-000

WIRE ASM-SLIDEOUT  
000167848 / 330195-01-000

USB-CHARGER DUAL,DC  
188312-01-000  
DETAIL CD

AWNING-RELAY  
63912-02-000  
SCREW  
G11-08-08U

JW, JU & JX  
TO WATER  
HEATER  
DETAIL CB

AMPLIFIER-STEREO  
2 CHANNEL  
147139-03-000  
RELAY-RADIO,TV  
SPEAKER SWITCH  
115539-01-000

GROUND BAR  
DETAIL CC

STUD-ISOLATED  
86233-01-000  
NUT  
D34-06-00U  
SCREW  
G67-10-12U (2)  
BOOT  
77479-02-000

CONVERTER-45 AMP  
184353-01-000  
SCREW  
G11-08-12U (3)  
DETAIL EA

GROMMET  
016188-11-000

CLAMP-CABLE  
10495-01-000 (2)  
SCREW  
G67-10-12U (2)

GROMMET  
016188-11-000

SPLICE-BUTT (3)  
(REF)

WIRE ASM-  
COACH

RED

BLU

GRN

HEATER

DETAIL CB

WASHER-LOCK  
000007554 / 310611-01-000 (2)

ROUTE WIRES  
THRU HOLE

GROMMET  
8386-01-000

JAMB-DOOR

SWITCH/MAGNET-  
STEP,ELECTRIC  
116995-03-000  
SCREW  
G11-06-06U (2)

DETAIL CA

YEL

WHT

DETAIL CD

LIGHT-LED,ROUND 3.5 PLASTIC  
000166893 / 329928-01-CHT (2)  
SCREW  
G13-06-10U (6)  
CONNECTOR  
58028-01-000 (4)

HARNESS-  
SLIDEOUT MOTOR  
191661-01-000

WIRE ASM-SLIDEOUT  
000167848 / 330195-01-000

USB-CHARGER DUAL,DC  
188312-01-000  
DETAIL CD

AWNING-RELAY  
63912-02-000  
SCREW  
G11-08-08U

JW, JU & JX  
TO WATER  
HEATER  
DETAIL CB

AMPLIFIER-STEREO  
2 CHANNEL  
147139-03-000  
RELAY-RADIO,TV  
SPEAKER SWITCH  
115539-01-000

GROUND BAR  
DETAIL CC

STUD-ISOLATED  
86233-01-000  
NUT  
D34-06-00U  
SCREW  
G67-10-12U (2)  
BOOT  
77479-02-000

CONVERTER-45 AMP  
184353-01-000  
SCREW  
G11-08-12U (3)  
DETAIL EA

GROMMET  
016188-11-000

CLAMP-CABLE  
10495-01-000 (2)  
SCREW  
G67-10-12U (2)

GROMMET  
016188-11-000

SPLICE-BUTT (3)  
(REF)

WIRE ASM-  
COACH

RED

BLU

GRN

HEATER

DETAIL CB

WASHER-LOCK  
000007554 / 310611-01-000 (2)

ROUTE WIRES  
THRU HOLE

GROMMET  
8386-01-000

JAMB-DOOR

SWITCH/MAGNET-  
STEP,ELECTRIC  
116995-03-000  
SCREW  
G11-06-06U (2)

DETAIL CA

YEL

WHT

DETAIL CD

LIGHT-LED,ROUND 3.5 PLASTIC  
000166893 / 329928-01-CHT (2)  
SCREW  
G13-06-10U (6)  
CONNECTOR  
58028-01-000 (4)

HARNESS-  
SLIDEOUT MOTOR  
191661-01-000

WIRE ASM-SLIDEOUT  
000167848 / 330195-01-000

USB-CHARGER DUAL,DC  
188312-01-000  
DETAIL CD

AWNING-RELAY  
63912-02-000  
SCREW  
G11-08-08U

JW, JU & JX  
TO WATER  
HEATER  
DETAIL CB

AMPLIFIER-STEREO  
2 CHANNEL  
147139-03-000  
RELAY-RADIO,TV  
SPEAKER SWITCH  
115539-01-000

GROUND BAR  
DETAIL CC

STUD-ISOLATED  
86233-01-000  
NUT  
D34-06-00U  
SCREW  
G67-10-12U (2)  
BOOT  
77479-02-000

CONVERTER-45 AMP  
184353-01-000  
SCREW  
G11-08-12U (3)  
DETAIL EA

GROMMET  
016188-11-000

CLAMP-CABLE  
10495-01-000 (2)  
SCREW  
G67-10-12U (2)

GROMMET  
016188-11-000

SPLICE-BUTT (3)  
(REF)

WIRE ASM-  
COACH

RED

BLU

GRN

HEATER

DETAIL CB

WASHER-LOCK  
000007554 / 310611-01-000 (2)

ROUTE WIRES  
THRU HOLE

GROMMET  
8386-01-000

JAMB-DOOR

SWITCH/MAGNET-  
STEP,ELECTRIC  
116995-03-000  
SCREW  
G11-06-06U (2)

DETAIL CA

YEL

WHT

DETAIL CD

LIGHT-LED,ROUND 3.5 PLASTIC  
000166893 / 329928-01-CHT (2)  
SCREW  
G13-06-10U (6)  
CONNECTOR  
58028-01-000 (4)

HARNESS-  
SLIDEOUT MOTOR  
191661-01-000

WIRE ASM-SLIDEOUT  
000167848 / 330195-01-000

USB-CHARGER DUAL,DC  
188312-01-000  
DETAIL CD

AWNING-RELAY  
63912-02-000  
SCREW  
G11-08-08U

JW, JU & JX  
TO WATER  
HEATER  
DETAIL CB

AMPLIFIER-STEREO  
2 CHANNEL  
147139-03-000  
RELAY-RADIO,TV  
SPEAKER SWITCH  
115539-01-000

GROUND BAR  
DETAIL CC

STUD-ISOLATED  
86233-01-000  
NUT  
D34-06-00U  
SCREW  
G67-10-12U (2)  
BOOT  
77479-02-000

CONVERTER-45 AMP  
184353-01-000  
SCREW  
G11-08-12U (3)  
DETAIL EA

GROMMET  
016188-11-000

CLAMP-CABLE  
10495-01-000 (2)  
SCREW  
G67-10-12U (2)

GROMMET  
016188-11-000

SPLICE-BUTT (3)  
(REF)

WIRE ASM-  
COACH

RED

BLU

GRN

HEATER

DETAIL CB

WASHER-LOCK  
000007554 / 310611-01-000 (2)

ROUTE WIRES  
THRU HOLE

GROMMET  
8386-01-000

JAMB-DOOR

SWITCH/MAGNET-  
STEP,ELECTRIC  
116995-03-000  
SCREW  
G11-06-06U (2)

DETAIL CA

YEL

WHT

DETAIL CD

LIGHT-LED,ROUND 3.5 PLASTIC  
000166893 / 329928-01-CHT (2)  
SCREW  
G13-06-10U (6)  
CONNECTOR  
58028-01-000 (4)

HARNESS-  
SLIDEOUT MOTOR  
191661-01-000

WIRE ASM-SLIDEOUT  
000167848 / 330195-01-000

USB-CHARGER DUAL,DC  
188312-01-000  
DETAIL CD

AWNING-RELAY  
63912-02-000  
SCREW  
G11-08-08U

JW, JU & JX  
TO WATER  
HEATER  
DETAIL CB

AMPLIFIER-STEREO  
2 CHANNEL  
147139-03-000  
RELAY-RADIO,TV  
SPEAKER SWITCH  
115539-01-000

GROUND BAR  
DETAIL CC

STUD-ISOLATED  
86233-01-000  
NUT  
D34-06-00U  
SCREW  
G67-10-12U (2)  
BOOT  
77479-02-000

CONVERTER-45 AMP  
184353-01-000  
SCREW  
G11-08-12U (3)  
DETAIL EA

GROMMET  
016188-11-000

CLAMP-CABLE  
10495-01-000 (2)  
SCREW  
G67-10-12U (2)

GROMMET  
016188-11-000

SPLICE-BUTT (3)  
(REF)

WIRE ASM-  
COACH

RED

BLU

GRN

HEATER

DETAIL CB

WASHER-LOCK  
000007554 / 310611-01-000 (2)

ROUTE WIRES  
THRU HOLE

GROMMET  
8386-01-000

JAMB-DOOR

SWITCH/MAGNET-  
STEP,ELECTRIC  
116995-03-000  
SCREW  
G11-06-06U (2)

DETAIL CA

YEL

WHT

DETAIL CD

LIGHT-LED,ROUND 3.5 PLASTIC  
000166893 / 329928-01-CHT (2)  
SCREW  
G13-06-10U (6)  
CONNECTOR  
58028-01-000 (4)

HARNESS-  
SLIDEOUT MOTOR  
191661-01-000

WIRE ASM-SLIDEOUT  
000167848 / 330195-01-000

USB-CHARGER DUAL,DC  
188312-01-000  
DETAIL CD

AWNING-RELAY  
63912-02-000  
SCREW  
G11-08-08U

JW, JU & JX  
TO WATER  
HEATER  
DETAIL CB

AMPLIFIER-STEREO  
2 CHANNEL  
147139-03-000  
RELAY-RADIO,TV  
SPEAKER SWITCH  
115539-01-000

GROUND BAR  
DETAIL CC

STUD-ISOLATED  
86233-01-000  
NUT  
D34-06-00U  
SCREW  
G67-10-12U (2)  
BOOT  
77479-02-000

CONVERTER-45 AMP  
184353-01-000  
SCREW  
G11-08-12U (3)  
DETAIL EA

GROMMET  
016188-11-000

CLAMP-CABLE  
10495-01-000 (2)  
SCREW  
G67-10-12U (2)

GROMMET  
016188-11-000

SPLICE-BUTT (3)  
(REF)

WIRE ASM-  
COACH

RED

BLU

GRN

HEATER

DETAIL CB

WASHER-LOCK  
000007554 / 310611-01-000 (2)

ROUTE WIRES  
THRU HOLE

GROMMET  
8386-01-000

JAMB-DOOR

SWITCH/MAGNET-  
STEP,ELECTRIC  
116995-03-000  
SCREW  
G11-06-06U (2)

DETAIL CA

YEL

WHT

DETAIL CD

LIGHT-LED,ROUND 3.5 PLASTIC  
000166893 / 329928-01-CHT (2)  
SCREW  
G13-06-10U (6)  
CONNECTOR  
58028-01-000 (4)

HARNESS-  
SLIDEOUT MOTOR  
191661-01-000

WIRE ASM-SLIDEOUT  
000167848 / 330195-01-000

USB-CHARGER DUAL,DC  
188312-01-000  
DETAIL CD

AWNING-RELAY  
63912-02-000  
SCREW  
G11-08-08U

JW, JU & JX  
TO WATER  
HEATER  
DETAIL CB

AMPLIFIER-STEREO  
2 CHANNEL  
147139-03-000  
RELAY-RADIO,TV  
SPEAKER SWITCH  
115539-01-000

GROUND BAR  
DETAIL CC

STUD-ISOLATED  
86233-01-000  
NUT  
D34-06-00U  
SCREW  
G67-10-12U (2)  
BOOT  
77479-02-000

CONVERTER-45 AMP  
184353-01-000  
SCREW  
G11-08-12U (3)  
DETAIL EA

GROMMET  
016188-11-000

CLAMP-CABLE  
10495-01-000 (2)  
SCREW  
G67-10-12U (2)

GROMMET  
016188-11-000

SPLICE-BUTT (3)  
(REF)

WIRE ASM-  
COACH

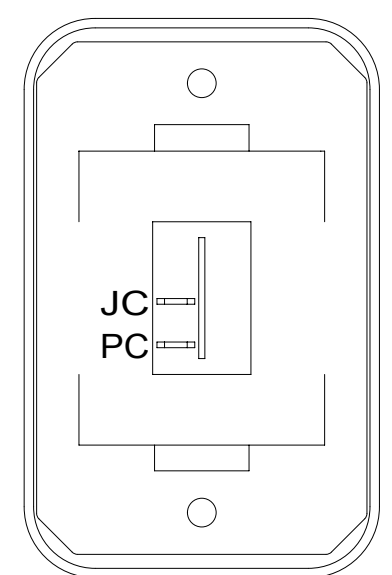

SWITCH-ROCKER  
135740-01-CHT  
SWITCH-BASE  
135741-01-CHT  
SWITCH-BEZEL  
135742-01-CHT  
SCREW  
G11-08-08U (2)

DETAIL DA

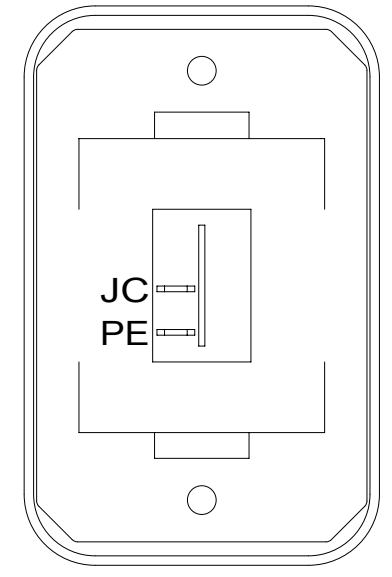

SWITCH-ROCKER  
135740-01-CHT  
SWITCH-BASE  
135741-01-CHT  
SWITCH-BEZEL  
135742-01-CHT  
SCREW  
G11-08-08U (2)

DETAIL DB

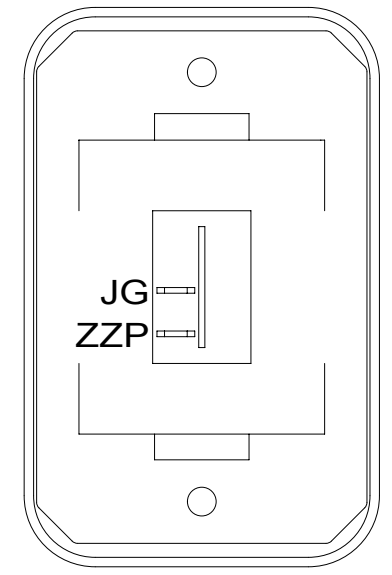

SWITCH-ROCKER  
135740-01-CHT  
SWITCH-BASE  
135741-01-CHT  
SWITCH-BEZEL  
135742-01-CHT  
SCREW  
G11-08-08U (2)

DETAIL DC

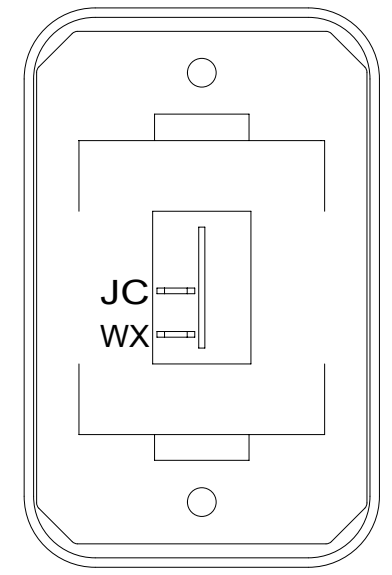

SWITCH-ROCKER  
135740-01-CHT  
SWITCH-BASE  
135741-01-CHT  
SWITCH-BEZEL  
135742-01-CHT  
SCREW  
G11-08-08U (2)

DETAIL DD

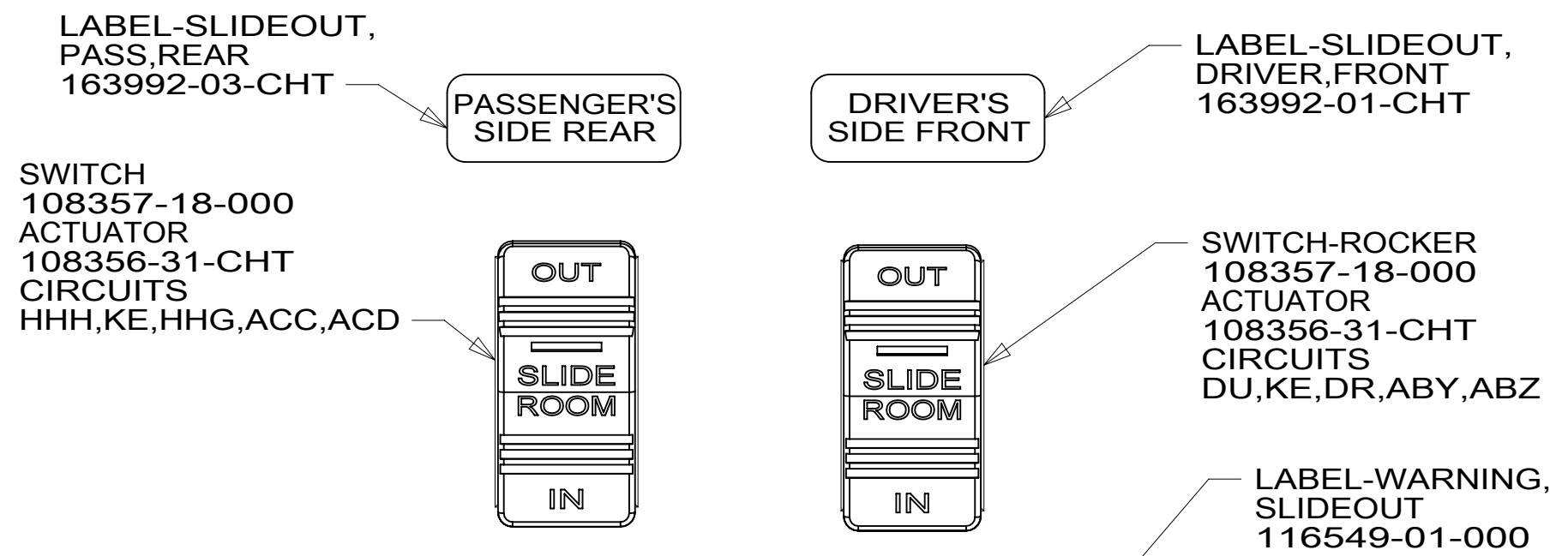

SWITCH  
108357-18-000  
ACTUATOR  
108356-31-CHT  
CIRCUITS  
HHH,KE,HHG,ACC,ACD

SWITCH-ROCKER  
108357-18-000  
ACTUATOR  
108356-31-CHT  
CIRCUITS  
DU,KE,DR,ABY,ABZ

**WARNING** CRUSH HAZARD. Keep people and objects clear of the inside and the outside of the slideout room when operating. Failure to comply could result in death or serious injury.

DETAIL DE

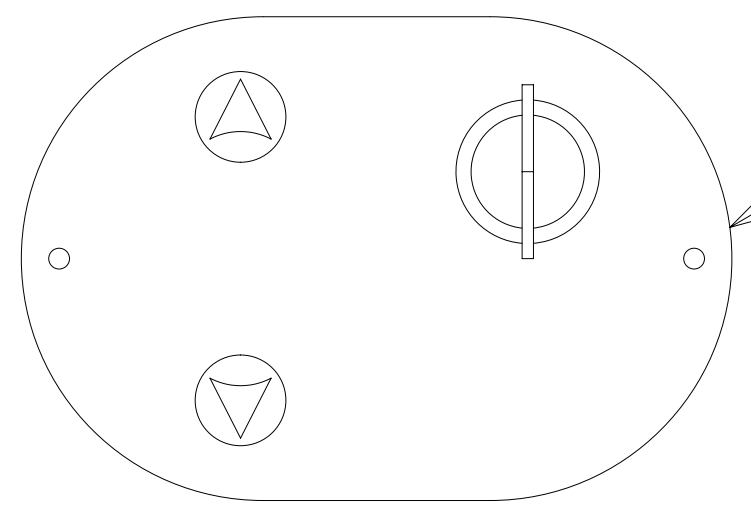

SWITCH-CONTROL,LOFTBED,TOUCH  
189056-01-000  
WIRE ASM-LOFT BED SWITCH  
000122806 / 323456-01-000  
SCREW  
000G11-02-08U (2)

DETAIL DF 45B

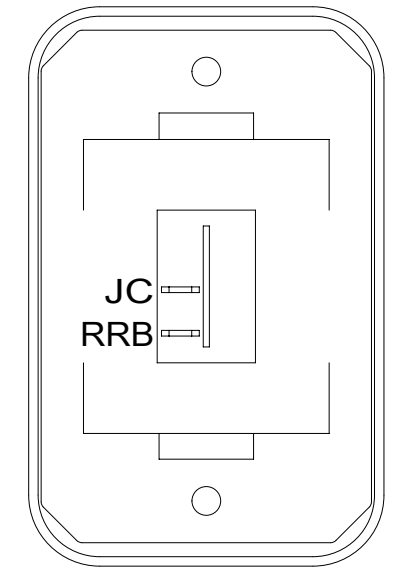

SWITCH-ROCKER  
135740-01-CHT  
SWITCH-BASE  
135741-01-CHT  
SWITCH-BEZEL  
135742-01-CHT  
SCREW  
G11-08-08U (2)

DETAIL DG

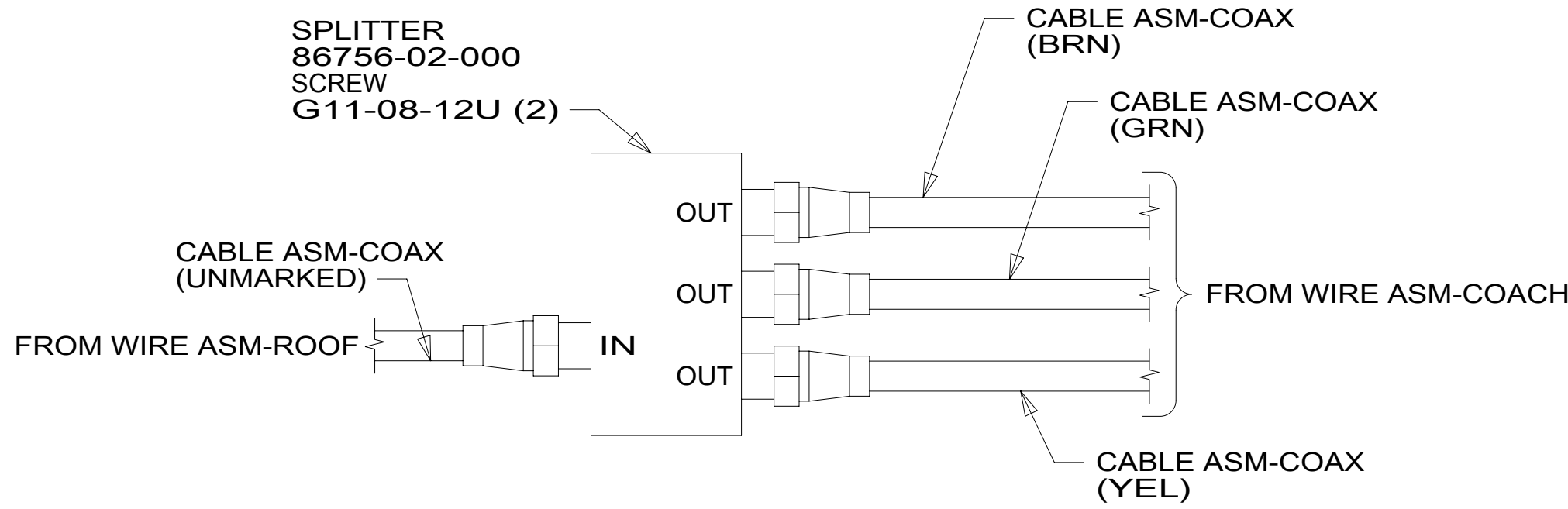

SPLITTER  
86756-02-000  
SCREW  
G11-08-12U (2)

CABLE ASM-COAX (BRN)

CABLE ASM-COAX (GRN)

CABLE ASM-COAX (YEL)

CABLE ASM-COAX (UNMARKED)

CABLE ASM-COAX (RED,GLD)

ADAPTER  
82134-01-000 (2)

CABLE ASM-COAX (RED,GLD)

CABLE ASM-COAX (RED,GLD)

DETAIL DR

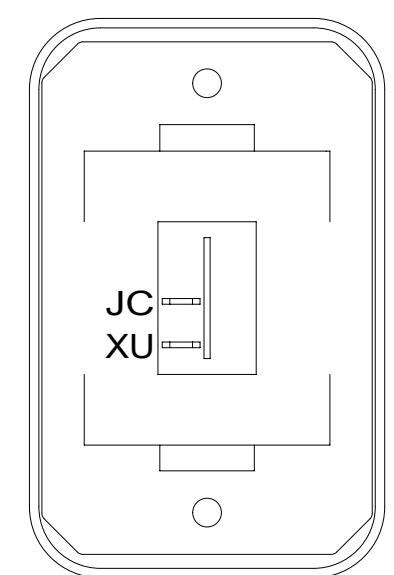

SWITCH-ROCKER  
135740-01-CHT  
SWITCH-BASE  
135741-01-CHT  
SWITCH-BEZEL  
135742-01-CHT  
SCREW  
G11-08-08U (2)

DETAIL DH

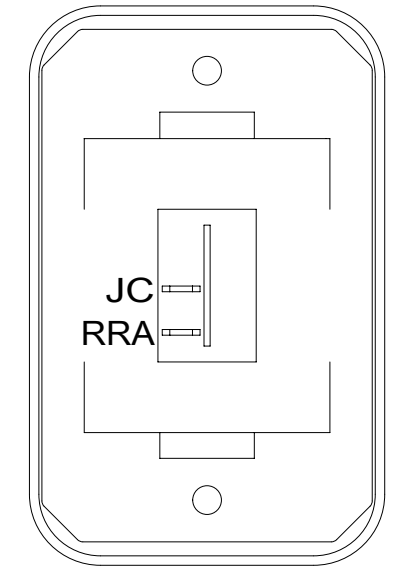

SWITCH-ROCKER  
135740-01-CHT  
SWITCH-BASE  
135741-01-CHT  
SWITCH-BEZEL  
135742-01-CHT  
SCREW  
G11-08-08U (2)

DETAIL DJ

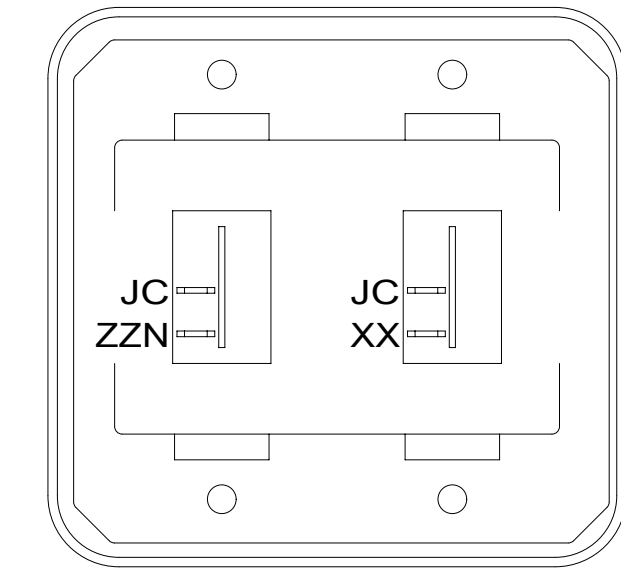

SWITCH-ROCKER  
135740-01-CHT (2)  
SWITCH-BASE  
135741-02-CHT  
SWITCH-BEZEL  
135742-02-CHT  
SCREW  
G11-08-08U (4)

DETAIL DK

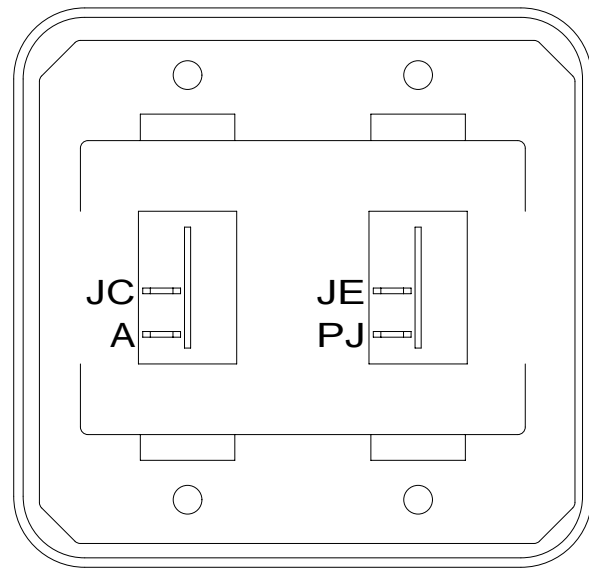

SWITCH-ROCKER  
135740-01-CHT (2)  
SWITCH-BASE  
135741-02-CHT  
SWITCH-BEZEL  
135742-02-CHT  
SCREW  
G11-08-08U (4)

DETAIL DL

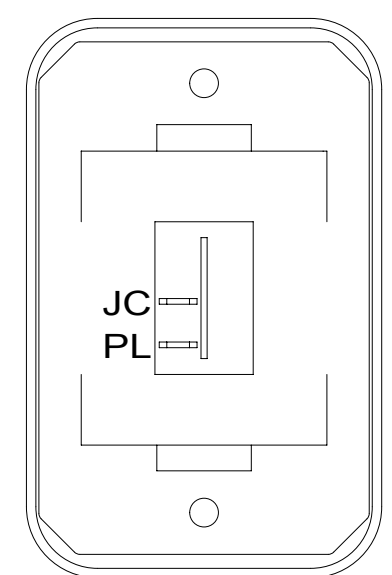

SWITCH-ROCKER  
135740-01-CHT  
SWITCH-BASE  
135741-01-CHT  
SWITCH-BEZEL  
135742-01-CHT  
SCREW  
G11-08-08U (2)

DETAIL DM

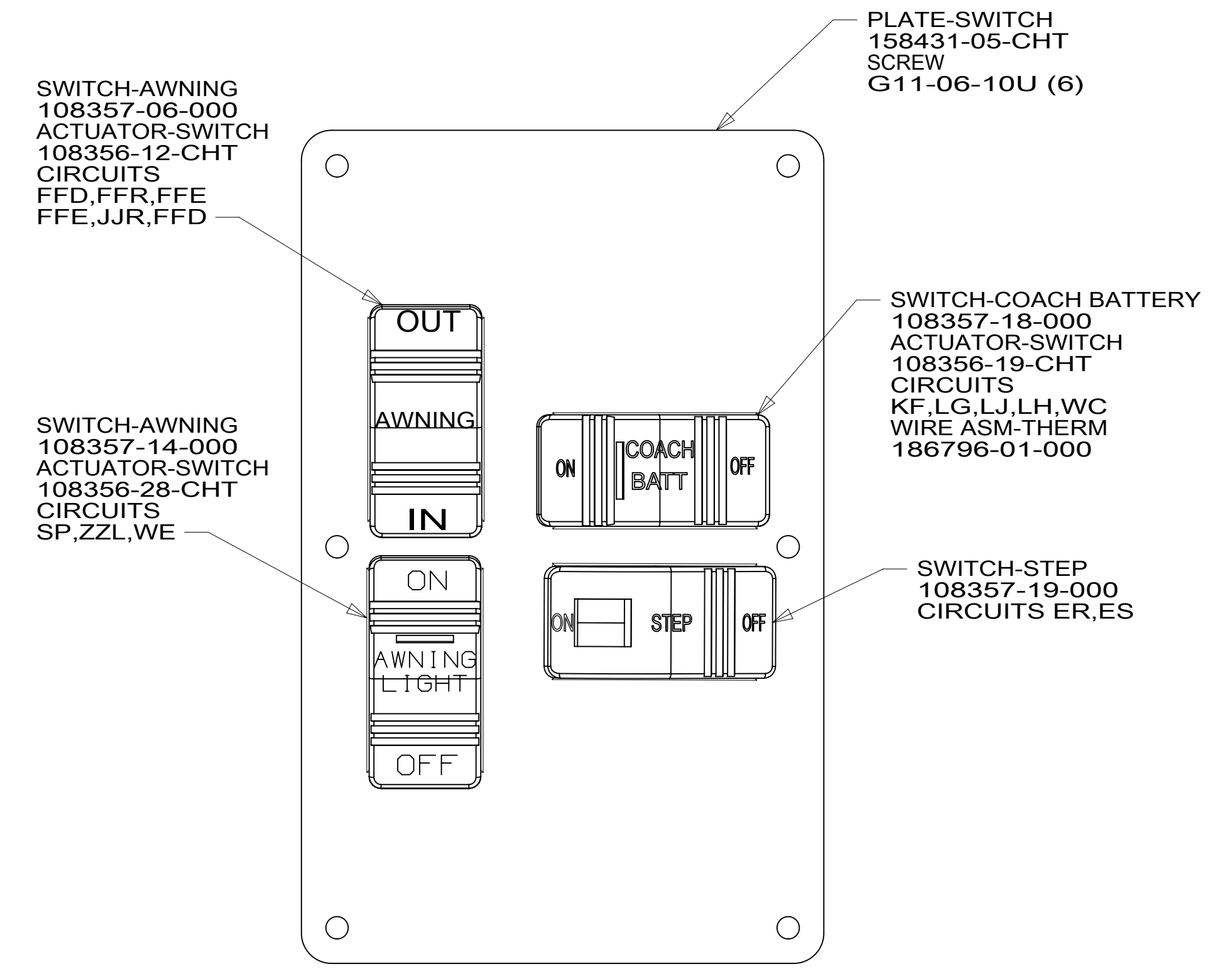

SWITCH-AWNING  
108357-06-000  
ACTUATOR-SWITCH  
108356-12-CHT  
CIRCUITS  
FFD,FFR,FFE  
FFE,JJR,FFD

SWITCH-AWNING  
108357-14-000  
ACTUATOR-SWITCH  
108356-28-CHT  
CIRCUITS  
SP,ZZL,WE

PLATE-SWITCH  
158431-05-CHT  
SCREW  
G11-06-10U (6)

SWITCH-COACH BATTERY  
108357-18-000  
ACTUATOR-SWITCH  
108356-19-CHT  
CIRCUITS  
KF,LG,LJ,LH,WC  
WIRE ASM-THERM  
186796-01-000

SWITCH-STEP  
108357-19-000  
CIRCUITS ER,ES

DETAIL DN 1

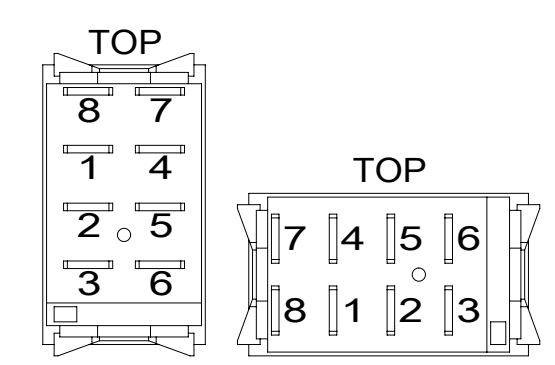

DETAIL DP

- 45B LOFT BED
- 265 CODES/STANDARDS-CSA/CMVSS
- 1B1 CODES/STANDARDS USA

1B1 265

DESCRIPTION: <b>WIRING INSTL-BODY, 12V</b>		
SHEET: 4 OF 7	ITEM/PART NO: 000167491 / 33010701000	REV

FOR ELECTRICAL TORQUE SPECIFICATIONS SEE DWG NO. 128783-01-000

FOR ELECTRICAL CALLOUTS SEE DWG NO. 121339-01-000

NOTES:  
1 FOR SWITCH ORIENTATION SEE DETAIL DP.

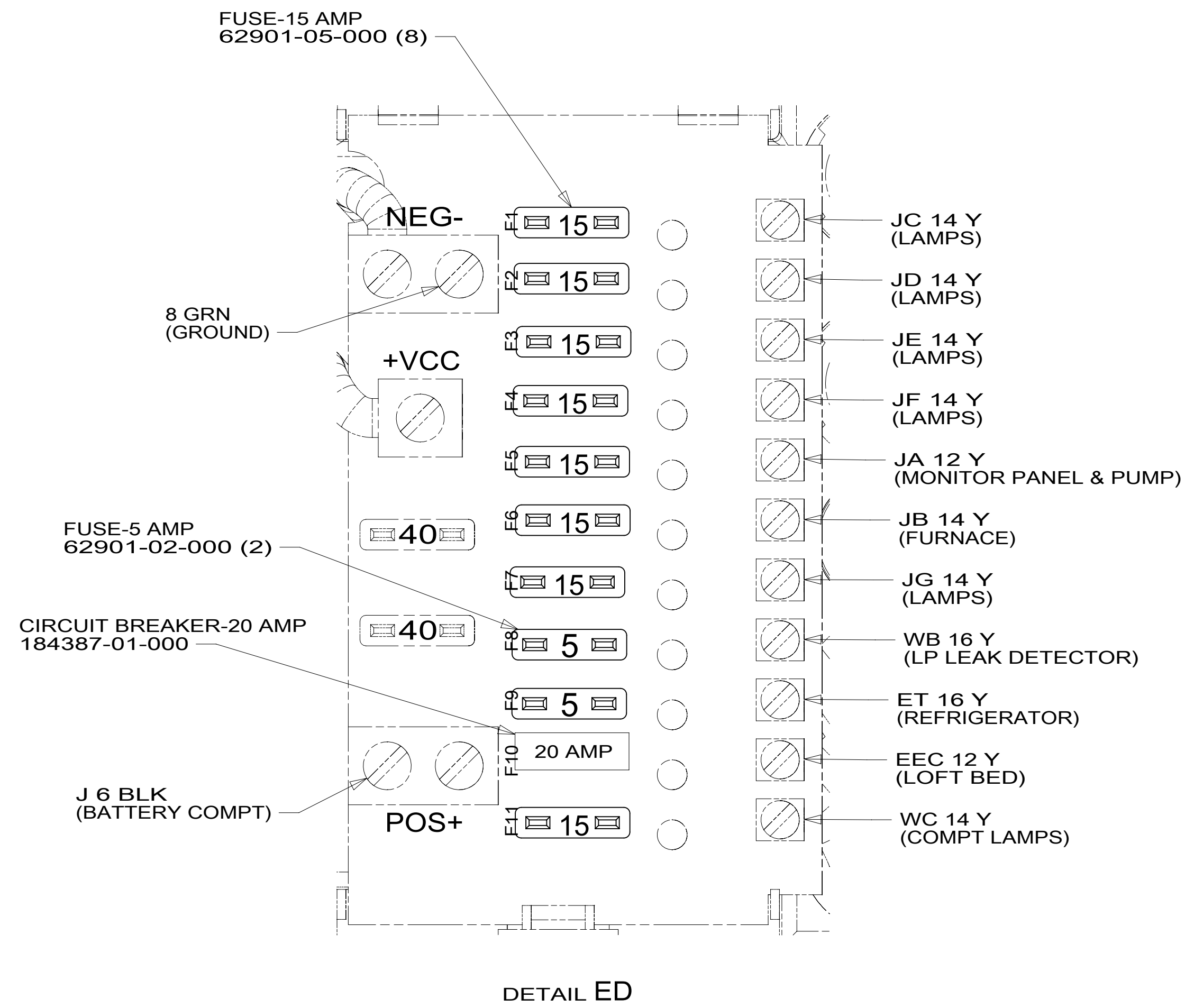
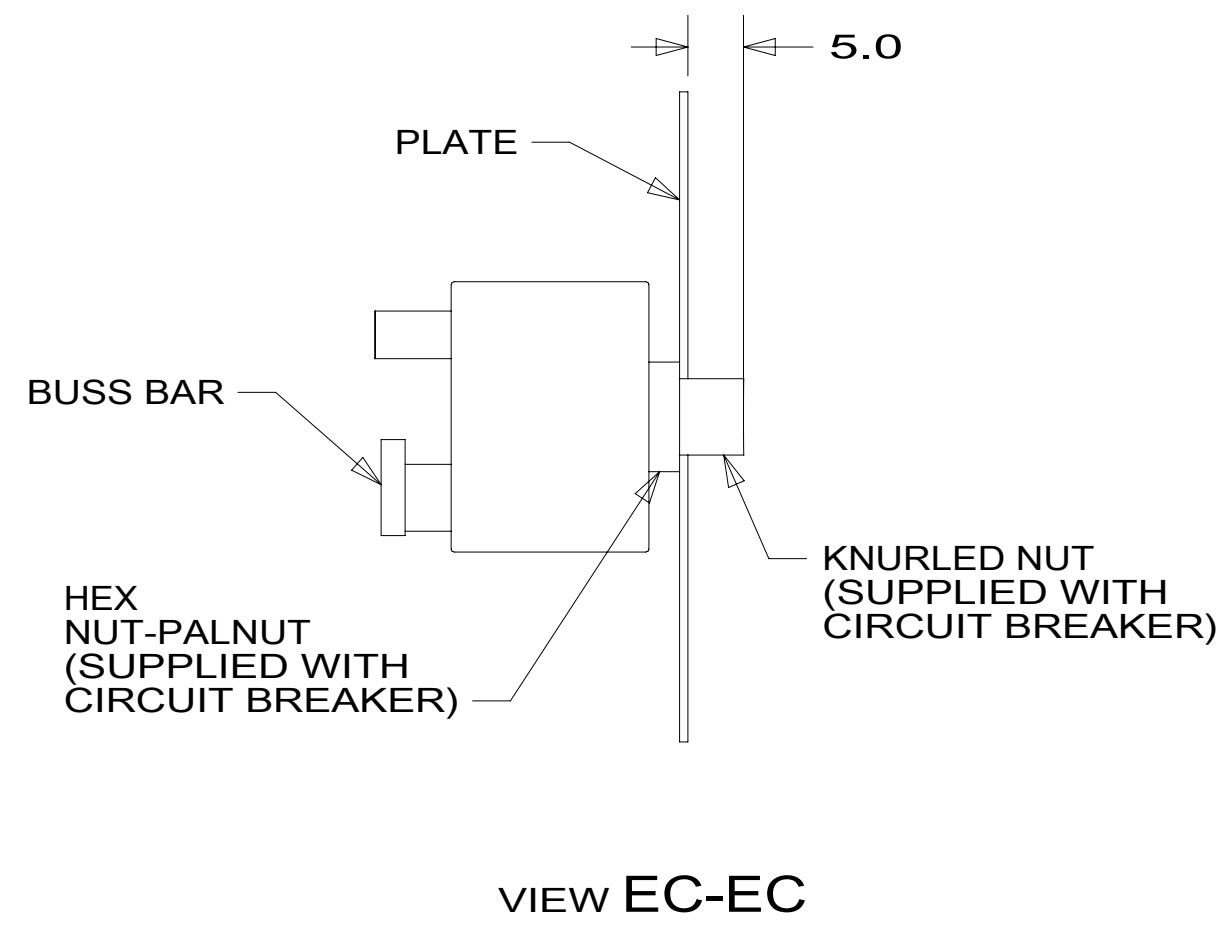
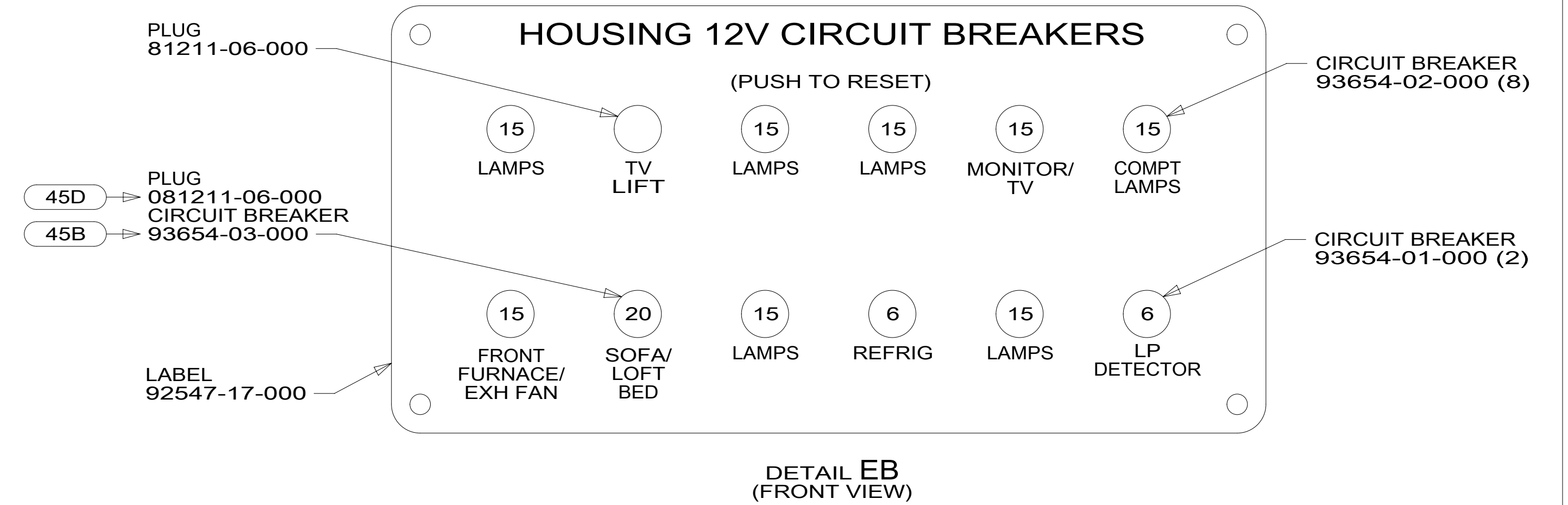
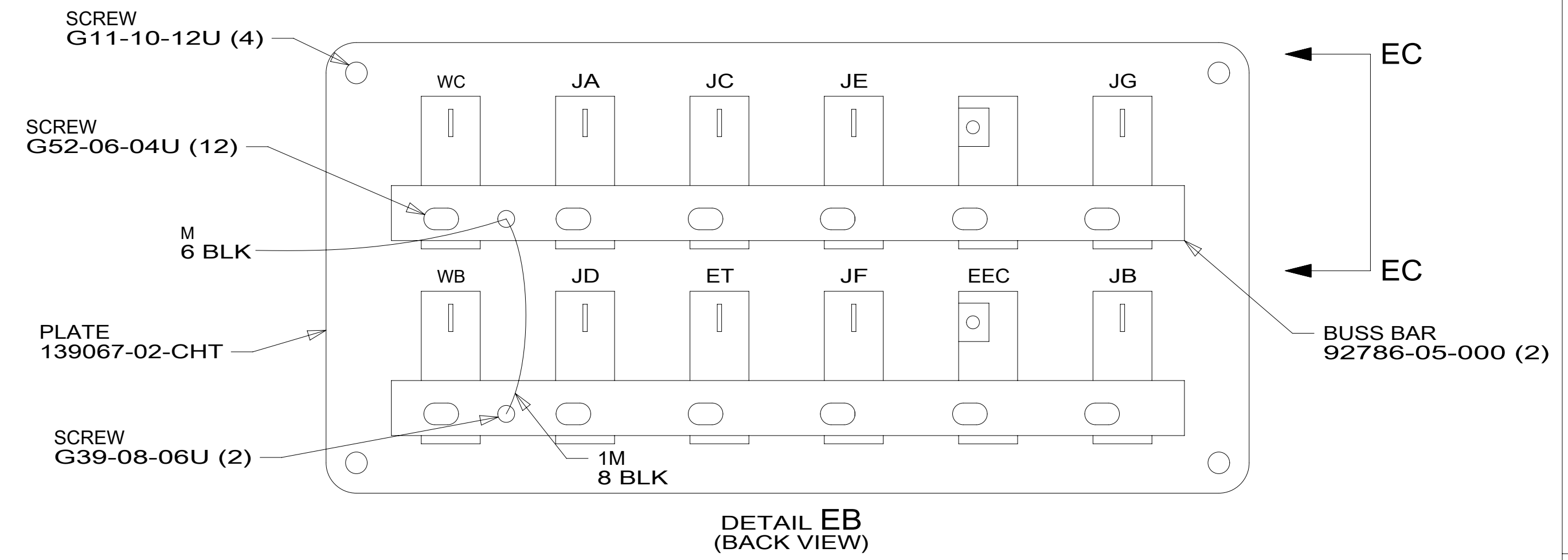
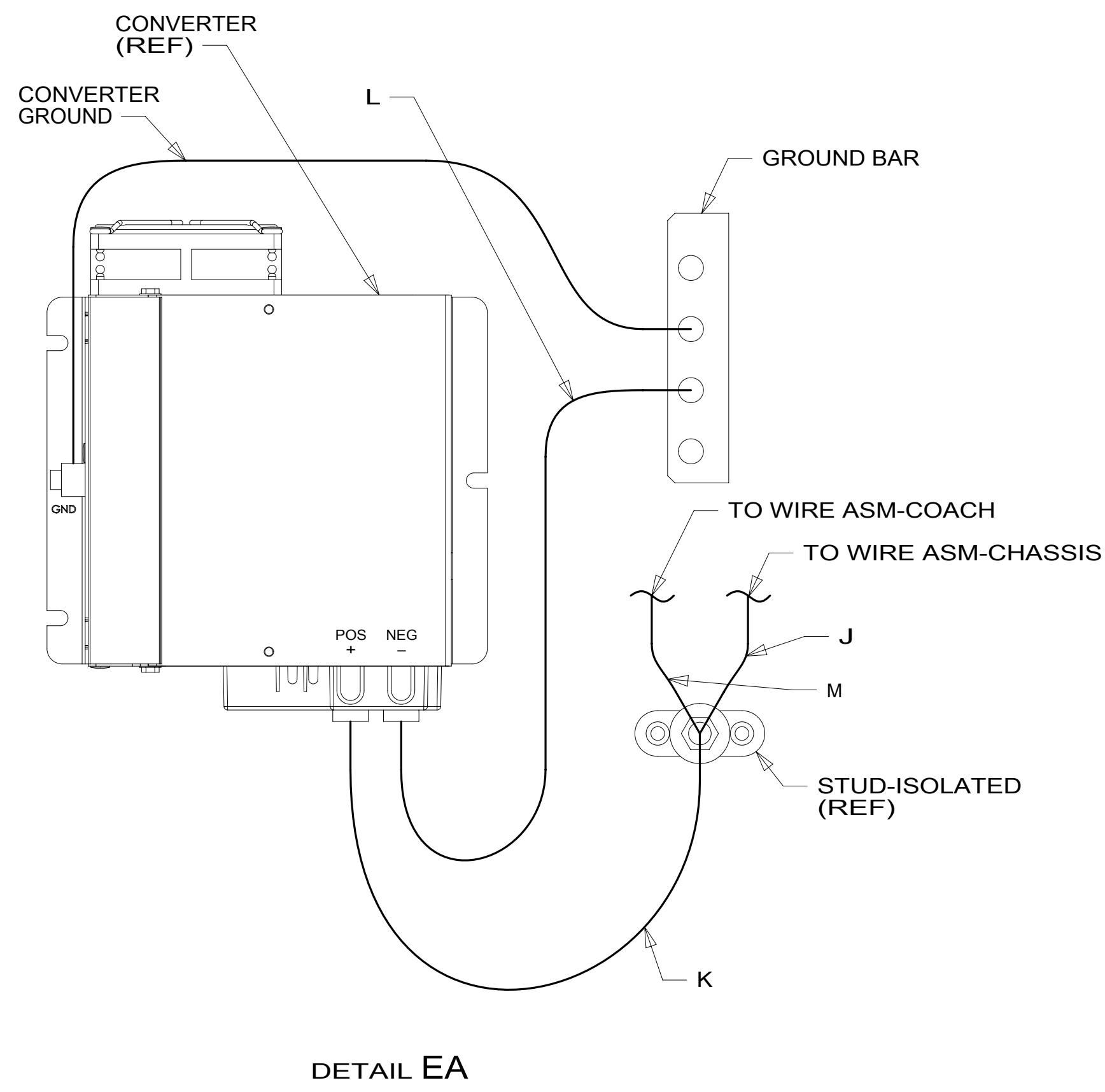

- 45B LOFT BED
- 45D LOFT BED - WITHOUT
- 265 CODES/STANDARDS-CSA/CMVSS
- 1B1 CODES/STANDARDS USA

FOR ELECTRICAL TORQUE SPECIFICATIONS SEE DWG NO. 128783-01-000

FOR ELECTRICAL CALLOUTS SEE DWG NO. 121339-01-000

DESCRIPTION:	1B1 265	
<b>WIRING INSTL-BODY, 12V</b>		
SHEET:	ITEM/PART NO:	REV
5 OF 7	000167491 / 33010701000	

8 7 6 5 4 3 2 1

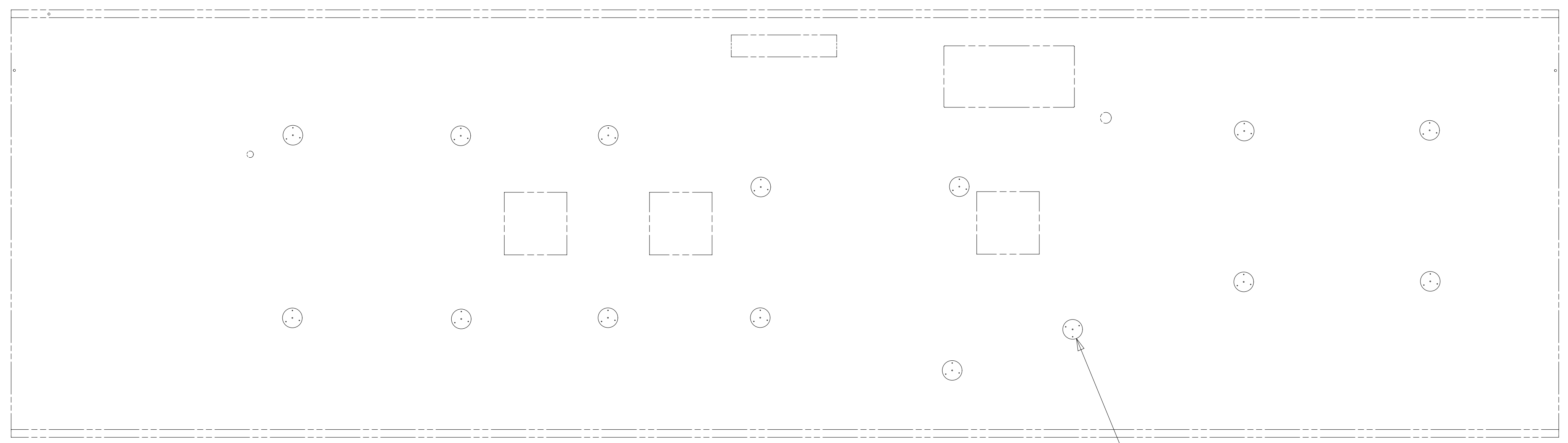

LIGHT-LED, ROUND 4.5 PLASTIC  
000166889 / 329926-01-CHT (15)  
SCREW  
G13-06-16U (45)  
CONNECTOR  
58028-01-000 (30)

D

D

C

C

B

B

A

A



8 7 6 5 4 3 2 1 20-Jun-2019

265 CODES/STANDARDS-CSA/CMVSS  
1B1 CODES/STANDARDS USA

FOR ELECTRICAL  
TORQUE  
SPECIFICATIONS  
SEE DWG NO.  
128783-01-000

FOR  
ELECTRICAL  
CALLOUTS  
SEE DWG NO.  
121339-01-000

1B1 265	
DESCRIPTION: <b>WIRING INSTL-BODY, 12V</b>	
SHEET: 6 OF 7	ITEM/PART NO: 000167491 / 33010701000
REV	

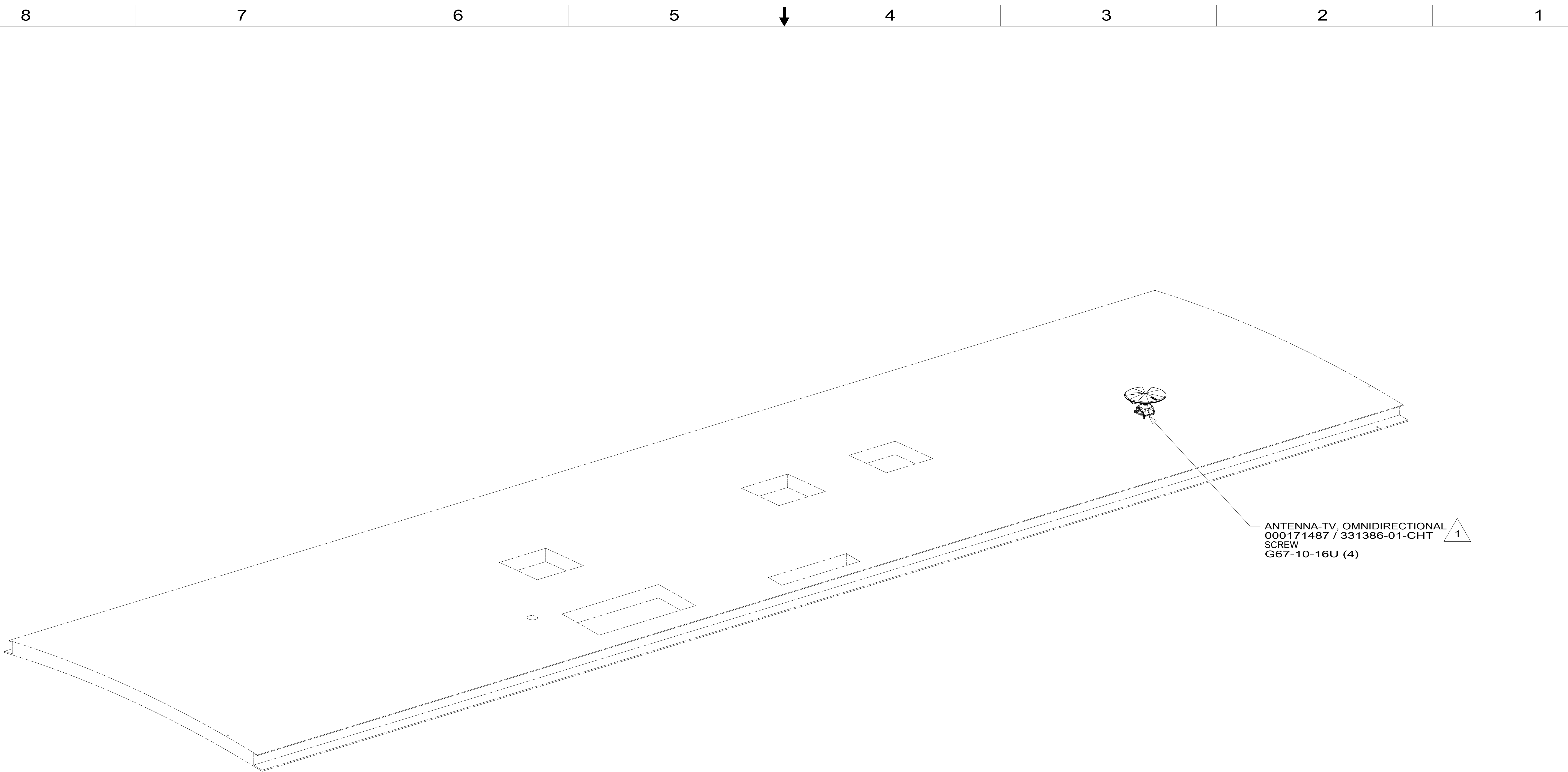

ANTENNA-TV, OMNIDIRECTIONAL  
 000171487 / 331386-01-CHT  
 SCREW  
 G67-10-16U (4) △ 1

△ 1 SEE ANTENNA INSTALLATION MANUAL FOR CORRECT  
 INSTALLATION PROCEDURE.

NOTES:

FOR ELECTRICAL  
 TORQUE  
 SPECIFICATIONS  
 SEE DWG NO.  
 128783-01-000

FOR  
 ELECTRICAL  
 CALLOUTS  
 SEE DWG NO.  
 121339-01-000

265 CODES/STANDARDS-CSA/CMVSS  
 1B1 CODES/STANDARDS USA

DESCRIPTION:		1B1 265	
<b>WIRING INSTL-BODY, 12V</b>			
SHEET:	ITEM/PART NO.:	REV	
7 OF 7	000167491 / 33010701000		