

8 7 6 5 4 3 2 1

SWITCH-DRAIN PUMP  
108357-09-000  
ACTUATOR  
108356-01-CHT

PLATE-WALL, TRIPLE COAX  
000159230 / 327556-01-CHT  
SCREW  
G39-08-08U (2)

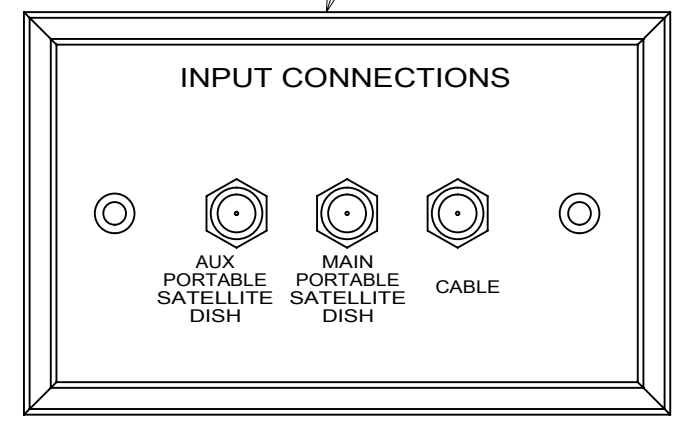

VIEW AA

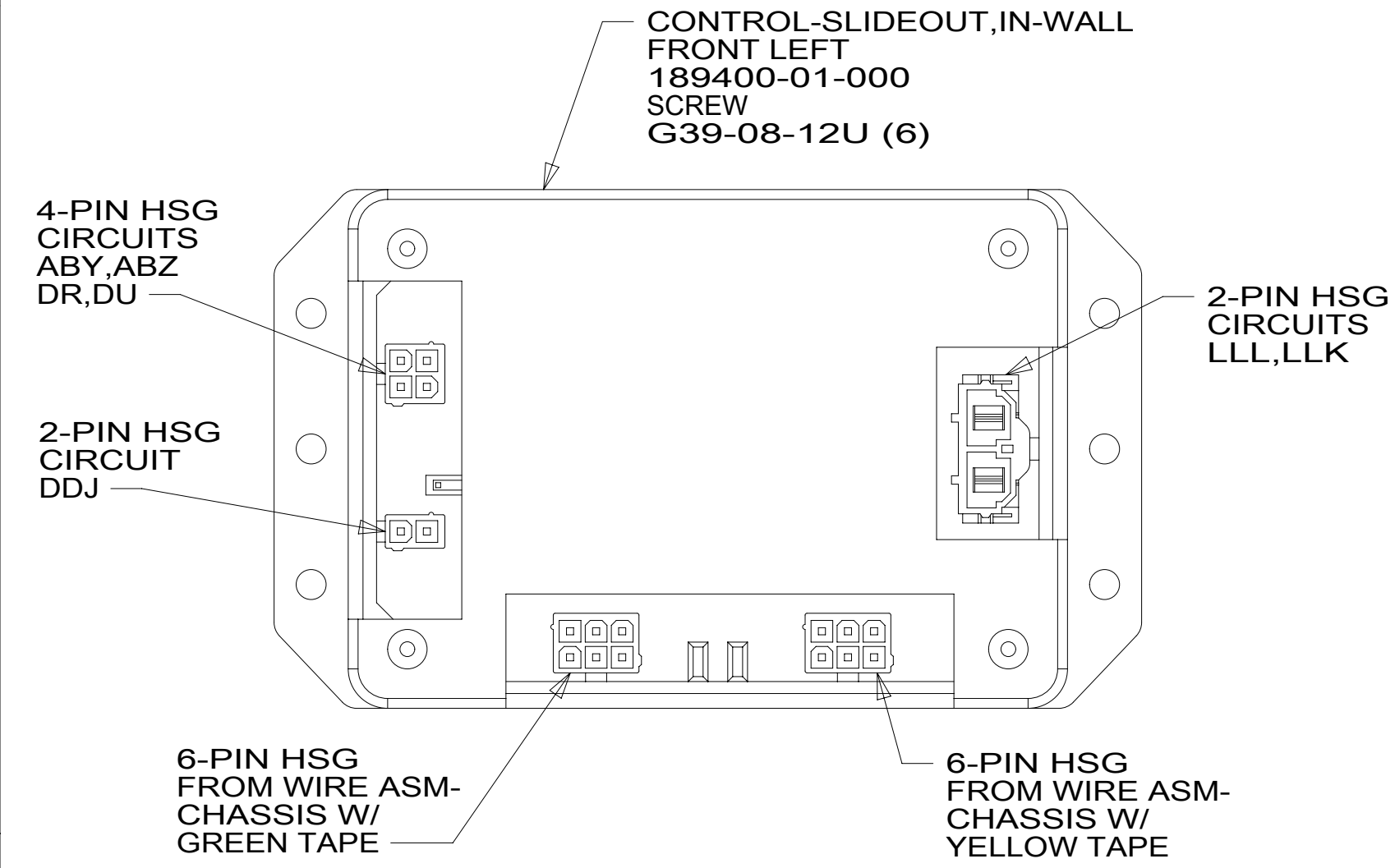

DETAIL AB

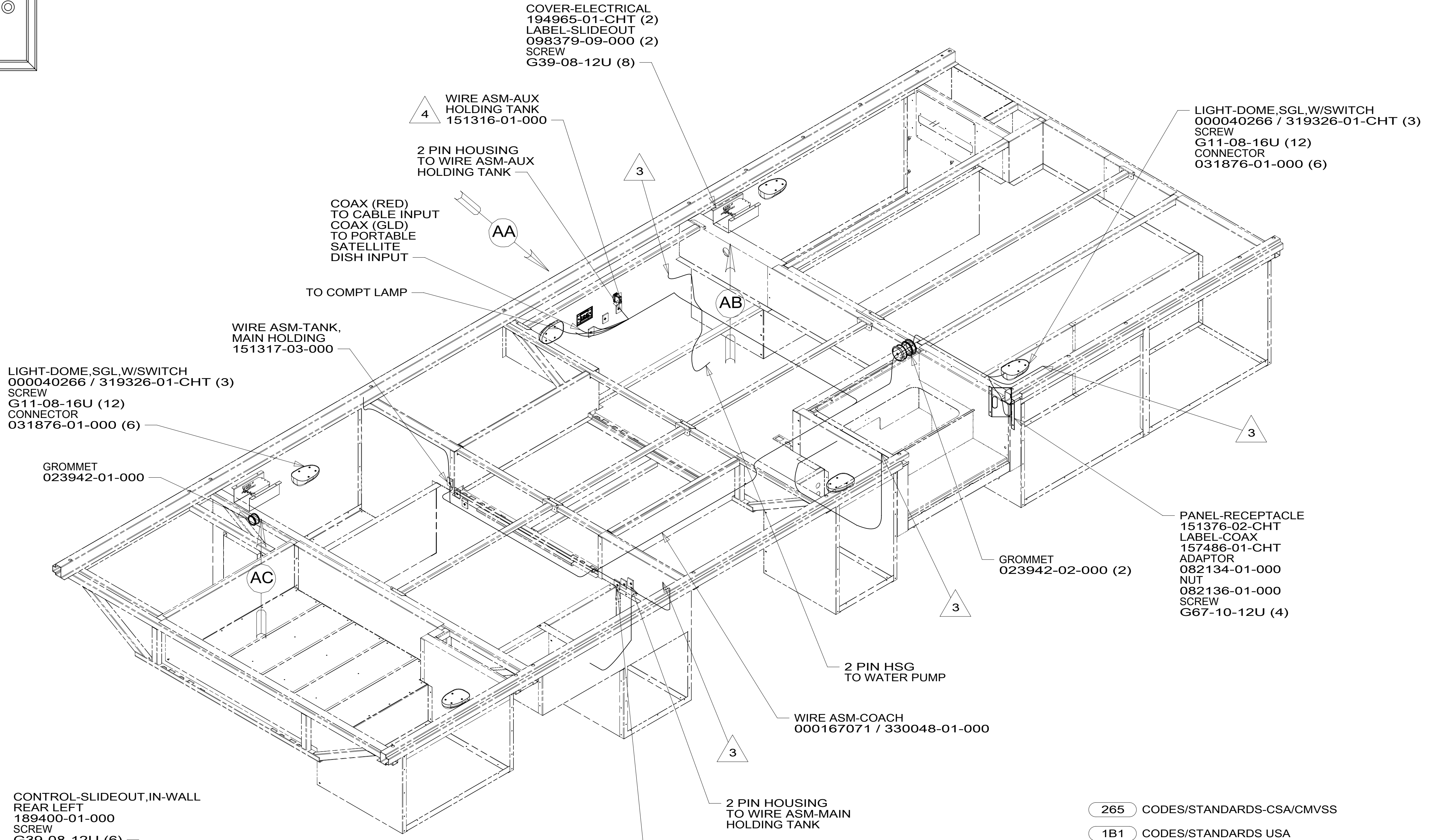

CONTROL-SLIDEOUT, IN-WALL  
REAR LEFT  
189400-01-000  
SCREW  
G39-08-12U (6)

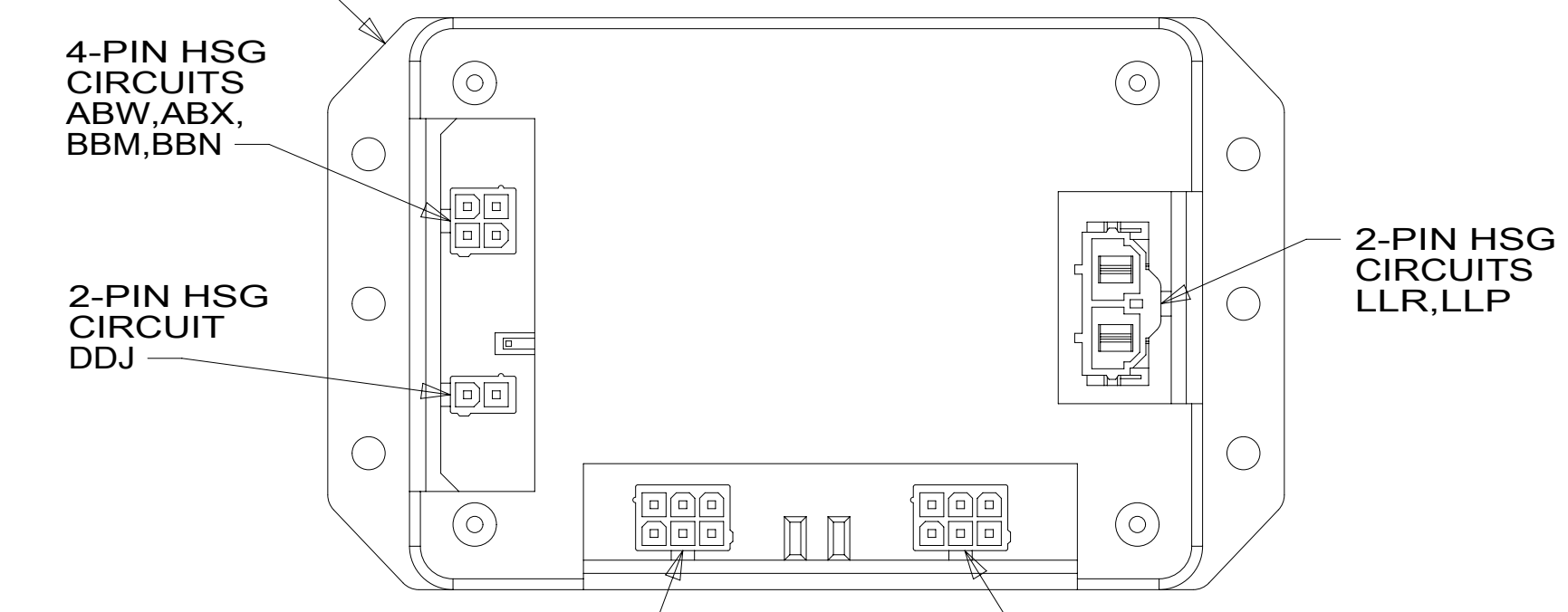

DETAIL AC

- NOTES:
- 1. AT MINIMUM ALL WIRES TO BE SUPPORTED AND SECURED PER CODE REQUIREMENTS. USE CLAMP 10495 OR 10497 OR WIRE TIE 8343 OR 108046 AND SCREW G67-XX-XXX OR G56-XX-XXX AS APPROPRIATE FOR INSTALLATION.
  - 2. ROUTE TANK SENSOR WIRES SO THEY DO NOT PASS OVER SENSORS. USE WIRE TIE MOUNT 155366-01-000 AND WIRE TIE 8343-01-000 AS NEEDED. TANK SURFACE MUST BE CLEANED USING ISOPROPYL ALCOHOL AND PRIMED WITH PRIMER 94.

265 CODES/STANDARDS-CSA/CMVSS  
1B1 CODES/STANDARDS USA

1B1 265



DSNR:	ALL DIMENSIONS ARE IN MILLIMETERS
DFFR:	MATERIAL:
UNSPECIFIED TOLERANCES:	
WHOLE DIM (X) :	3
ONE-PLACE (X.X) :	1.5
TWO-PLACE (X.XX) :	0.50
ANGLE :	1°
REFER TO ES0018 FOR FASTENER TIGHTENING GUIDELINES	WEIGHT: (LBS) FIRST USED: <b>19 E27PE</b>

FOR ELECTRICAL TORQUE SPECIFICATIONS SEE DWG NO. 128783-01-000

FOR ELECTRICAL CALLOUTS SEE DWG NO. 121339-01-000

**WIRING INSTL-BODY, 12V**

SHEET: 1 OF 6 ITEM/PART NO.: 000164478 / 32957101000 REV:

8 7 6 5 4 3 2 1

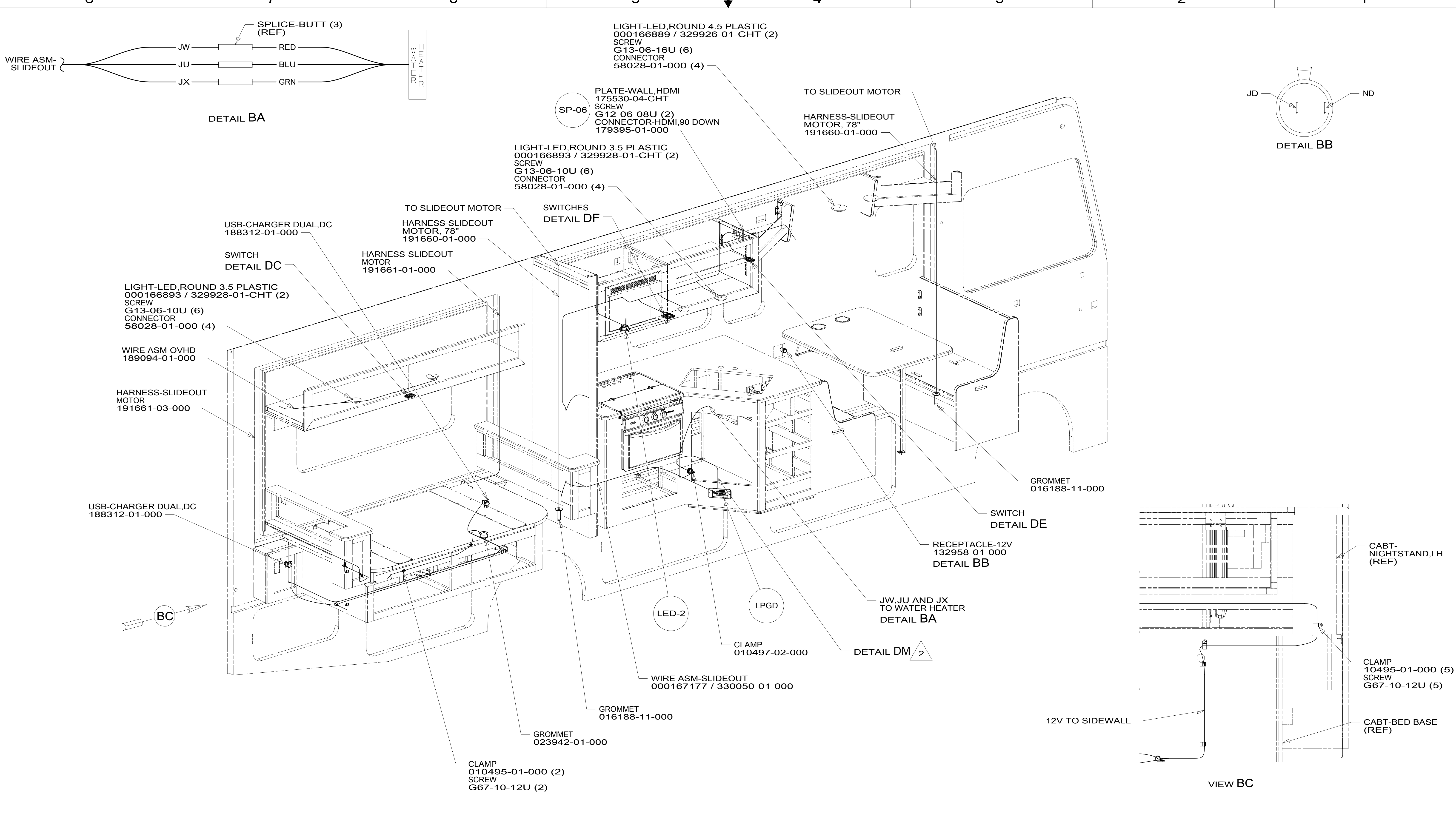

- 2 WIRE PASSES THROUGH FLOOR IN THIS AREA.
1. AT MINIMUM ALL WIRES TO BE SUPPORTED AND SECURED PER CODE REQUIREMENTS. USE CLAMP 10495 OR 10497 OR WIRE TIE 8343 OR 108046 AND SCREW G67-XX-XXX OR G56-XX-XXX AS APPROPRIATE FOR INSTALLATION.

NOTES:

265 CODES/STANDARDS-CSA/CMVSS  
 1B1 CODES/STANDARDS USA

FOR ELECTRICAL TORQUE SPECIFICATIONS SEE DWG NO. 128783-01-000

X-X FOR ELECTRICAL CALLOUTS SEE DWG NO. 121339-01-000

DESCRIPTION:	1B1 265	
<b>WIRING INSTL-BODY, 12V</b>		
SHEET:	ITEM/PART NO.:	REV:
2 OF 6	000164478 / 32957101000	

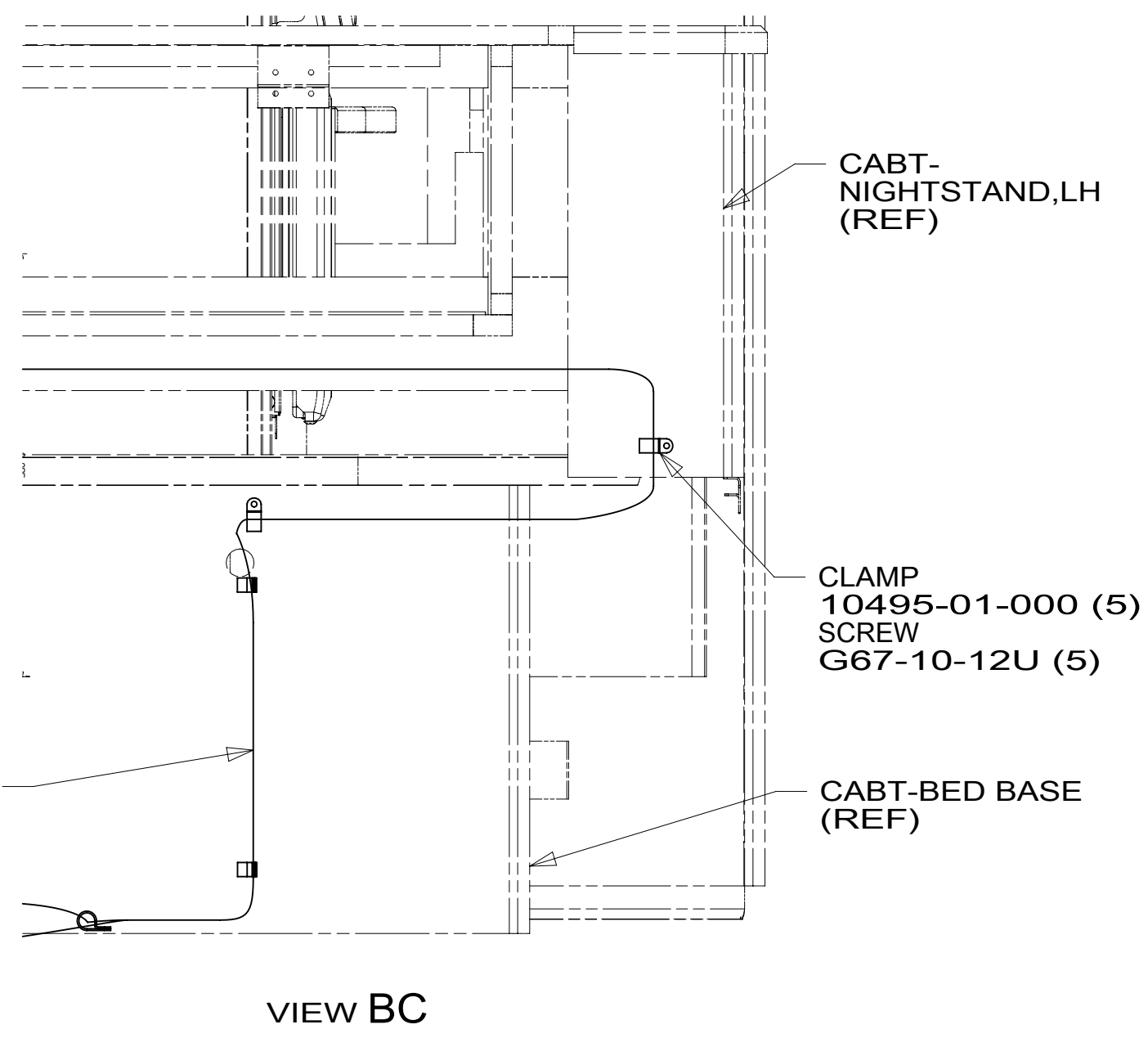

VIEW BC

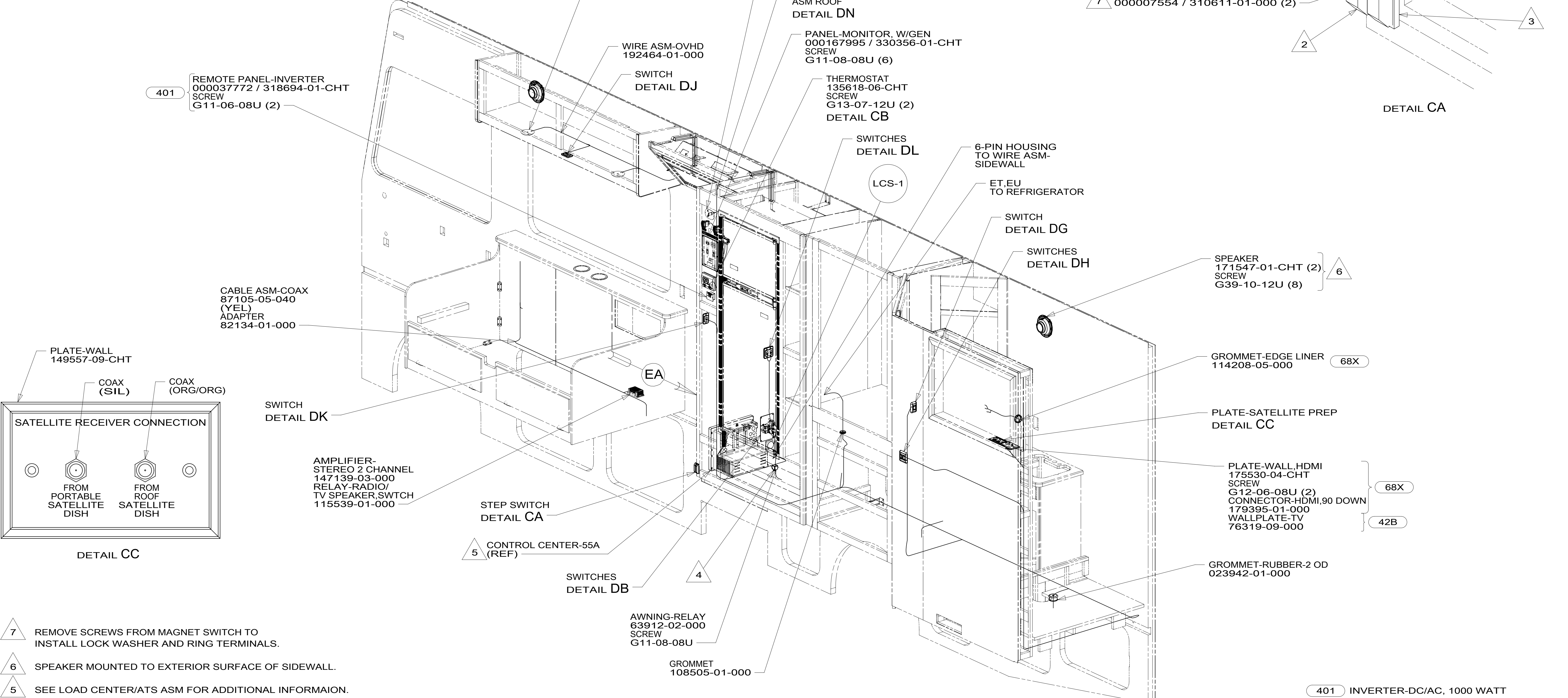
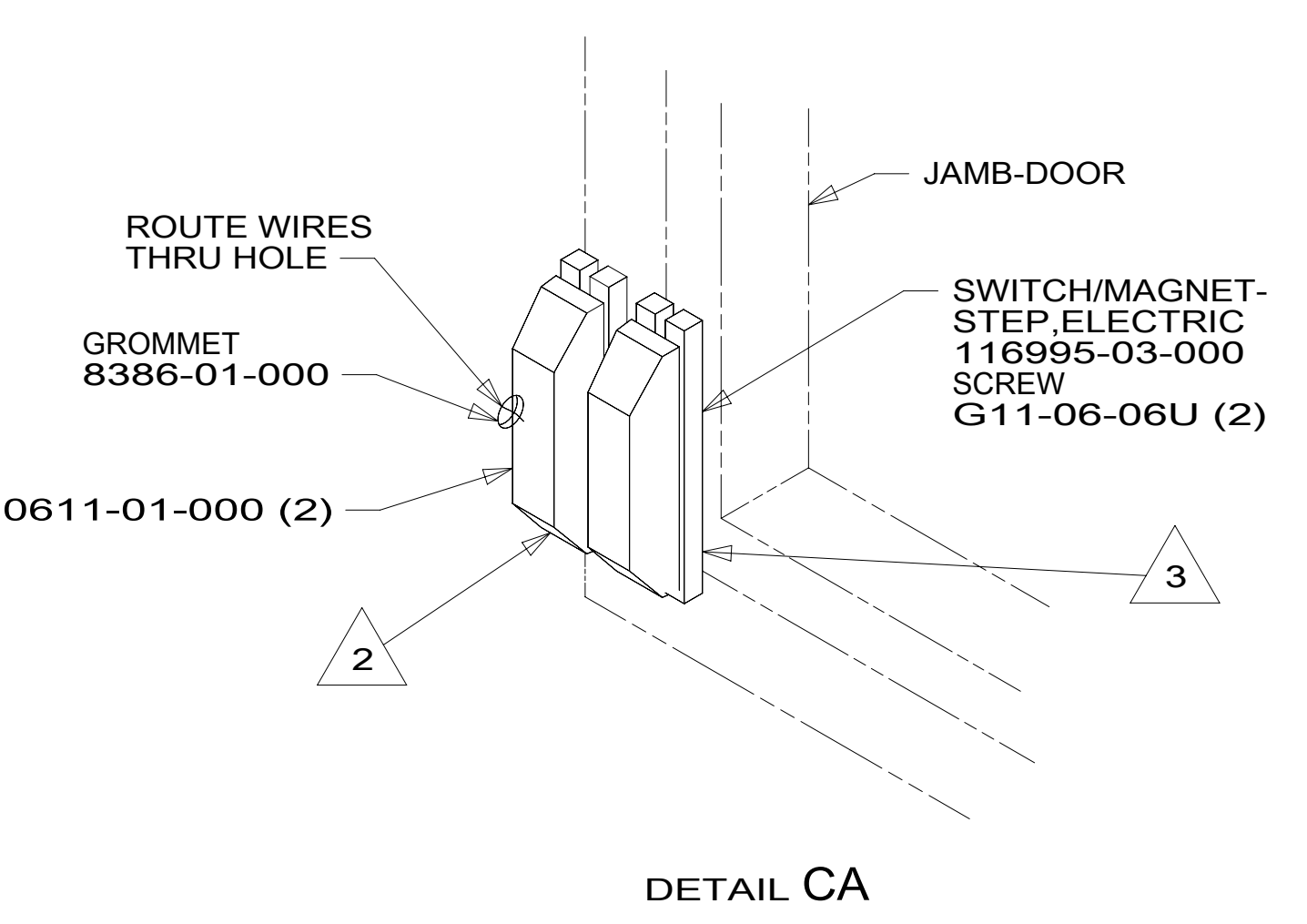
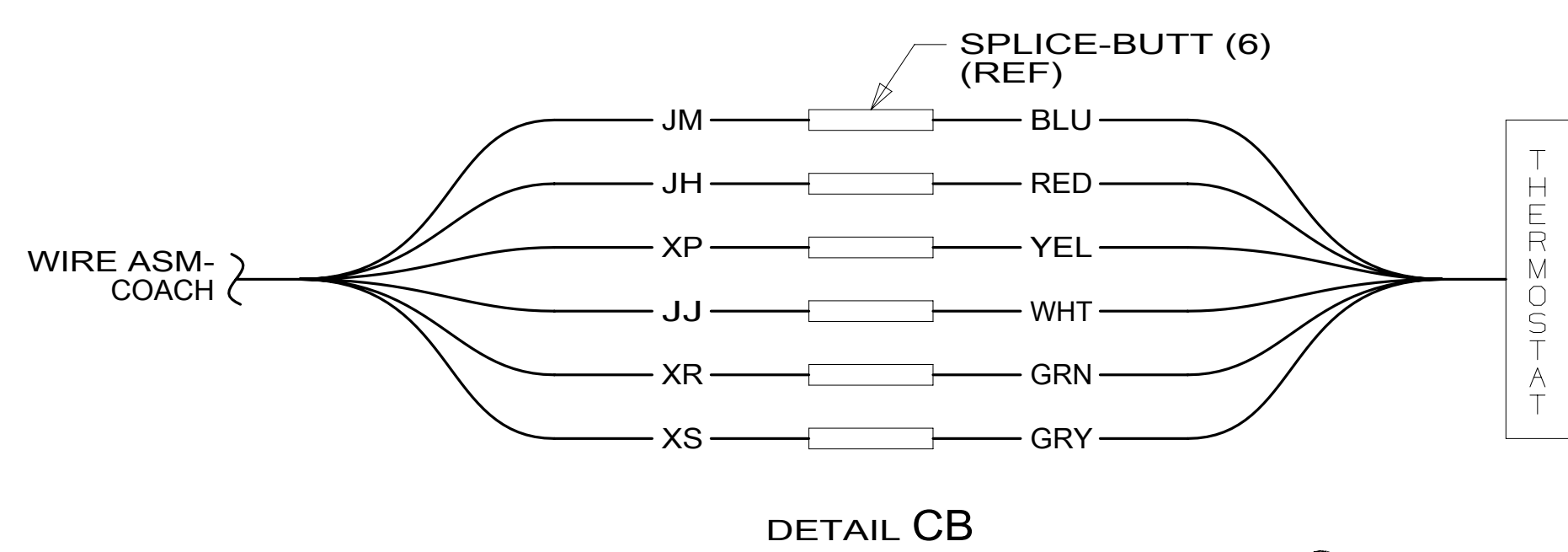

- 7 REMOVE SCREWS FROM MAGNET SWITCH TO INSTALL LOCK WASHER AND RING TERMINALS.
- 6 SPEAKER MOUNTED TO EXTERIOR SURFACE OF SIDEWALL.
- 5 SEE LOAD CENTER/ATS ASM FOR ADDITIONAL INFORMATION.
- 4 WIRE PASSES THROUGH FLOOR IN THIS AREA.
- 3 MOUNT MAGNET TO SCREEN DOOR FRAME, MOUNT WITH MAGNET TOWARD SWITCH.
- 2 MOUNT SWITCH TO DOOR JAMB WITH TAPE 076322-21-000.

1. AT MINIMUM ALL WIRES TO BE SUPPORTED AND SECURED PER CODE REQUIREMENTS. USE CLAMP 10495 OR 10497 OR WIRE TIE 8343 OR 108046 AND SCREW G67-XX-XXX OR G56-XX-XXX AS APPROPRIATE FOR INSTALLATION.

NOTES:

FOR ELECTRICAL TORQUE SPECIFICATIONS SEE DWG NO. 128783-01-000

FOR ELECTRICAL CALLOUTS SEE DWG NO. 121339-01-000

- 401 INVERTER-DC/AC, 1000 WATT
- 42B TV, REAR - WITHOUT
- 68X TV - BEDROOM
- 265 CODES/STANDARDS-CSA/CMVSS
- 1B1 CODES/STANDARDS USA

DESCRIPTION:	1B1 265	
<b>WIRING INSTL-BODY, 12V</b>		
SHEET:	ITEM/PART NO:	REV
3 OF 6	000164478 / 32957101000	

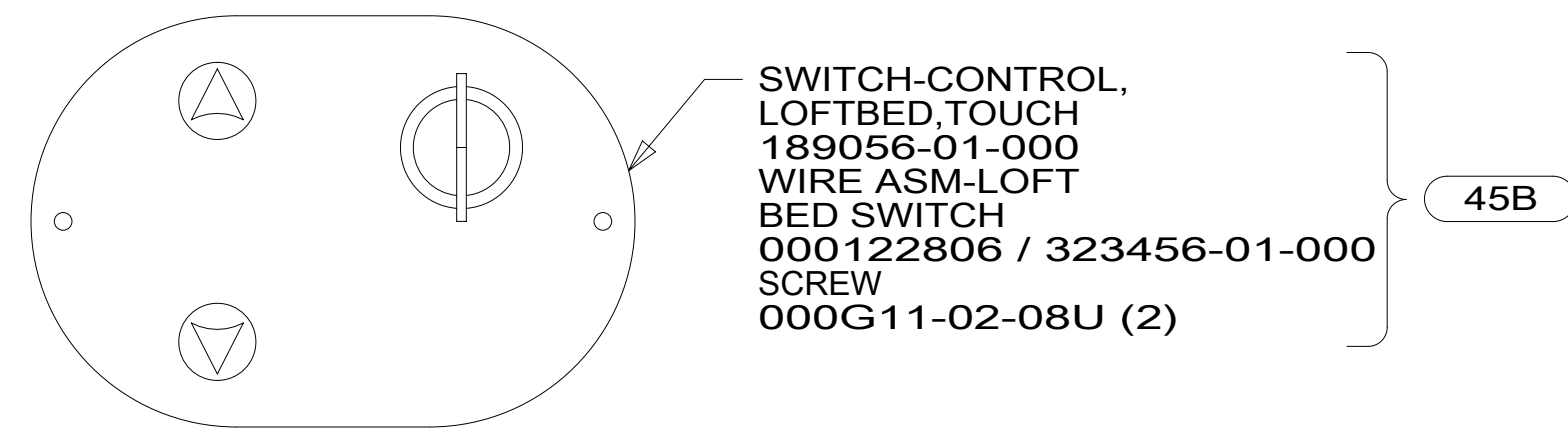

SWITCH-CONTROL,  
LOFTBED, TOUCH  
189056-01-000  
WIRE ASM-LOFT  
BED SWITCH  
000122806 / 323456-01-000  
SCREW  
000G11-02-08U (2)

45B

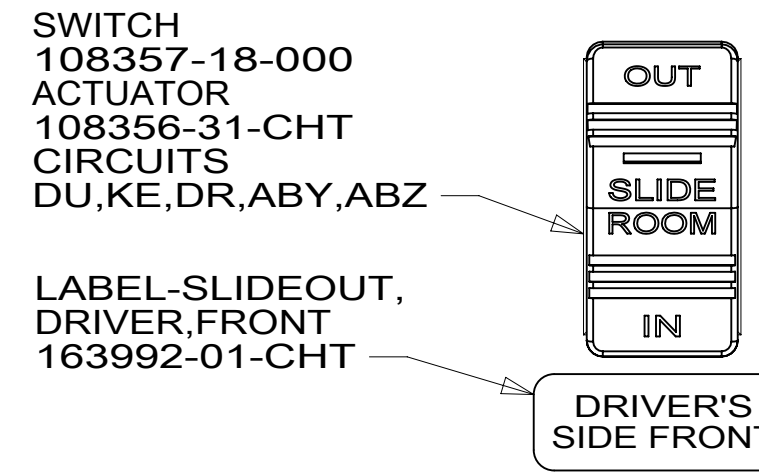

SWITCH  
108357-18-000  
ACTUATOR  
108356-31-CHT  
CIRCUITS  
DU,KE,DR,ABY,ABZ

LABEL-SLIDEOUT,  
DRIVER,FRONT  
163992-01-CHT



SWITCH  
108357-18-000  
ACTUATOR  
108356-31-CHT  
CIRCUITS  
BBM,KE,BBN,ABW,ABX



LABEL-SLIDEOUT,  
DRIVER,REAR  
163992-02-CHT

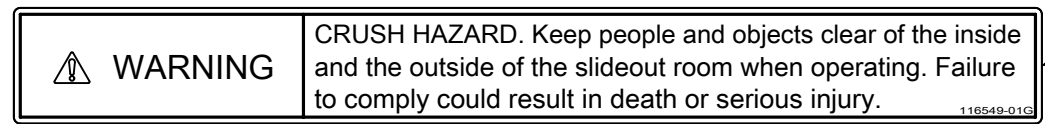

LABEL-WARNING,  
SLIDEOUT  
116549-01-000

DETAIL DA

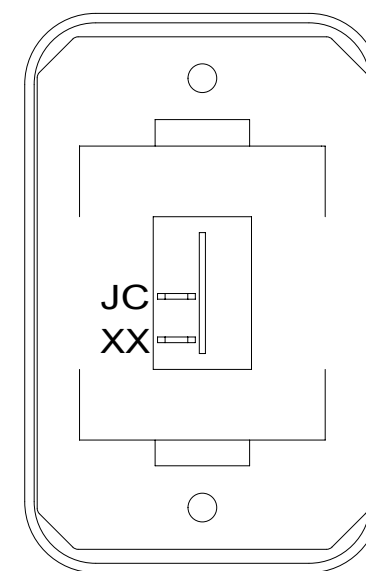

SWITCH-ROCKER  
135740-01-CHT  
SWITCH-BASE  
135741-01-CHT  
SWITCH-BEZEL  
135742-01-CHT  
SCREW  
G11-08-08U (2)

DETAIL DC

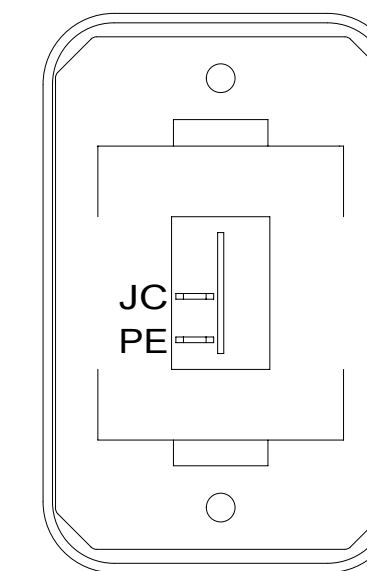

SWITCH-ROCKER  
135740-01-CHT  
SWITCH-BASE  
135741-01-CHT  
SWITCH-BEZEL  
135742-01-CHT  
SCREW  
G11-08-08U (2)

DETAIL DG

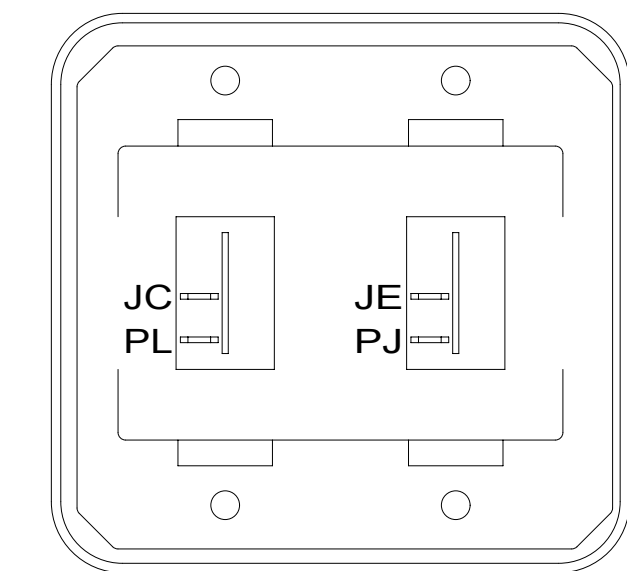

SWITCH-ROCKER  
135740-01-CHT (2)  
SWITCH-BASE  
135741-02-CHT  
SWITCH-BEZEL  
135742-02-CHT  
SCREW  
G11-08-08U (4)

DETAIL DL

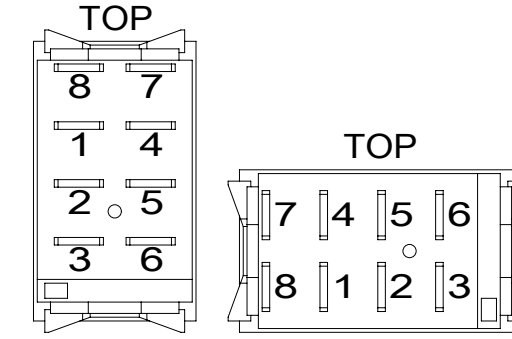

DETAIL DD

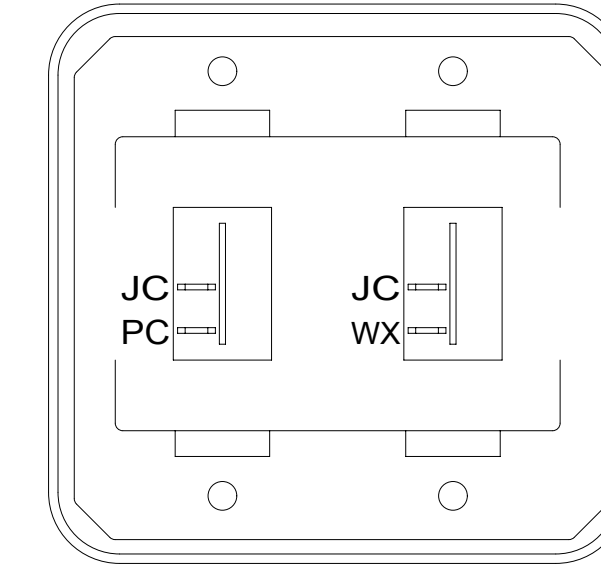

SWITCH-ROCKER  
135740-01-CHT (2)  
SWITCH-BASE  
135741-02-CHT  
SWITCH-BEZEL  
135742-02-CHT  
SCREW  
G11-08-08U (4)

DETAIL DH

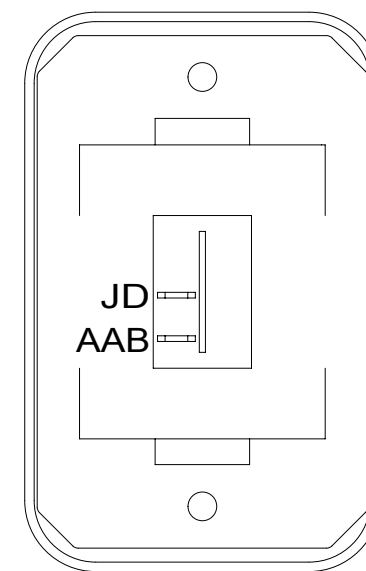

SWITCH-ROCKER  
135740-01-CHT  
SWITCH-BASE  
135741-01-CHT  
SWITCH-BEZEL  
135742-01-CHT  
SCREW  
G11-08-08U (2)

DETAIL DE

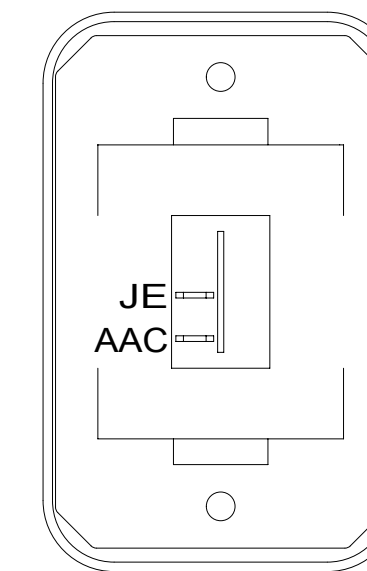

SWITCH-ROCKER  
135740-02-CHT  
SWITCH-BASE  
135741-01-CHT  
SWITCH-BEZEL  
135742-01-CHT  
SCREW  
G11-08-08U (2)

DETAIL DJ

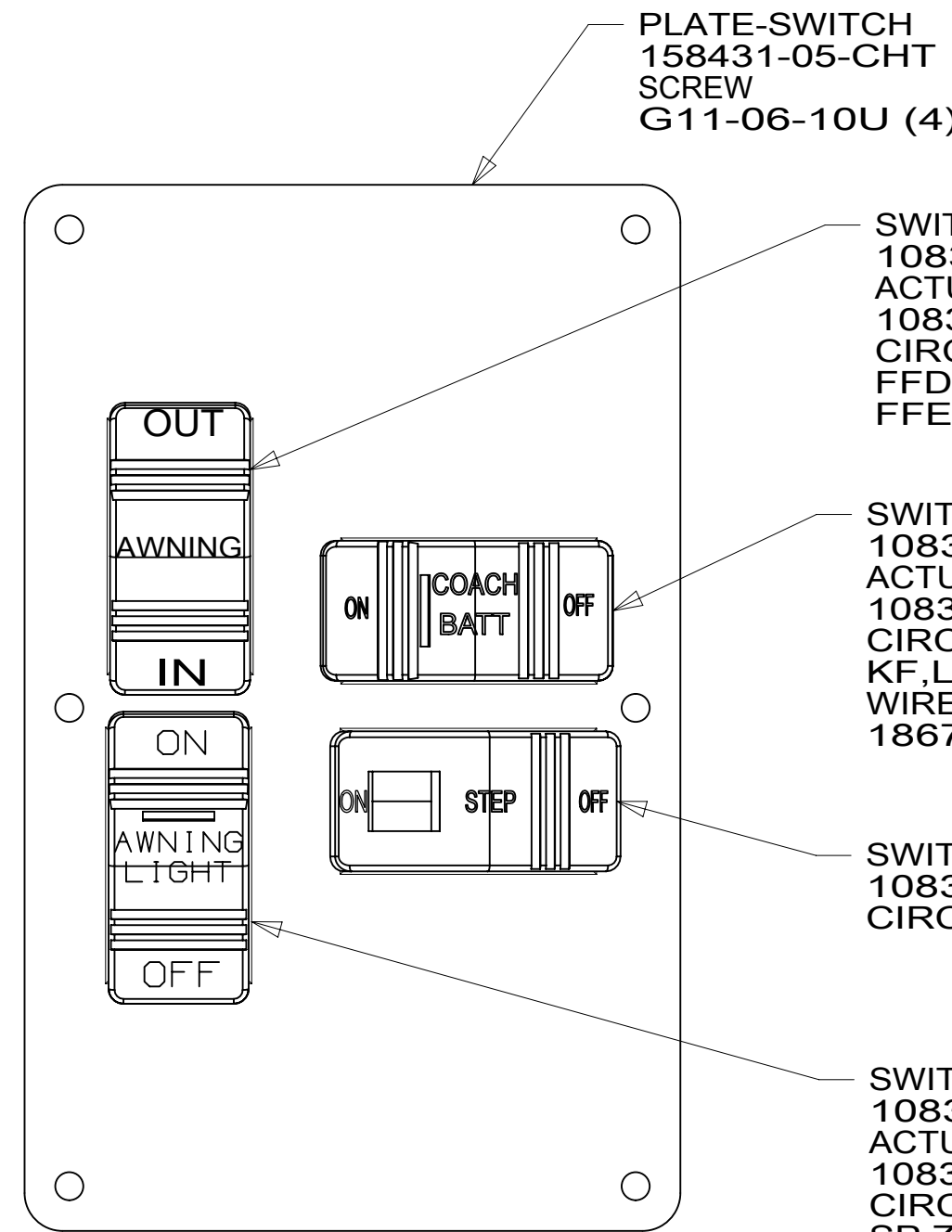

PLATE-SWITCH  
158431-05-CHT  
SCREW  
G11-06-10U (4)

SWITCH-AWNING  
108357-06-000  
ACTUATOR-SWITCH  
108356-12-CHT  
CIRCUITS  
FFD,FFR,FFE  
FFE,JJR,FFD

SWITCH-COACH BATTERY  
108357-18-000  
ACTUATOR-SWITCH  
108356-19-CHT  
CIRCUITS  
KF,LG,LJ,LH,WC  
WIRE ASM-THERM  
186796-01-000

SWITCH-STEP  
108357-19-000  
CIRCUITS ER,ES

SWITCH-AWNING  
108357-14-000  
ACTUATOR-SWITCH  
108356-28-CHT  
CIRCUITS  
SP,ZZL,WE

DETAIL DB 1

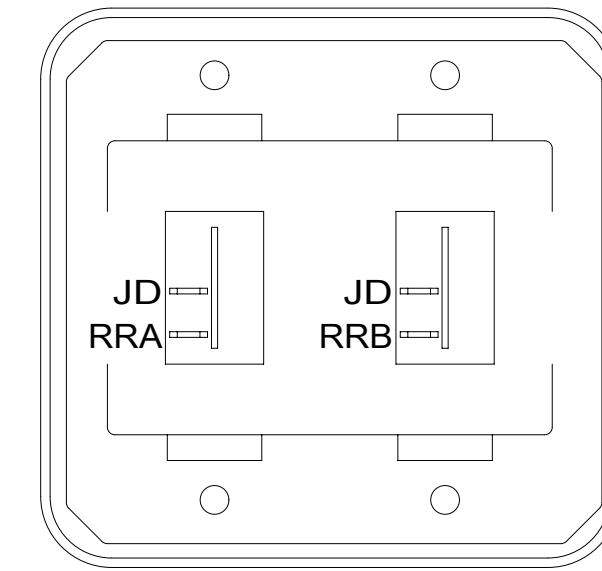

SWITCH-ROCKER  
135740-01-CHT (2)  
SWITCH-BASE  
135741-02-CHT  
SWITCH-BEZEL  
135742-02-CHT  
SCREW  
G11-08-08U (4)

DETAIL DF

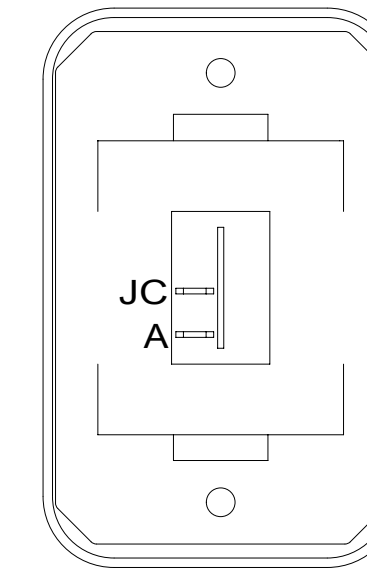

SWITCH-ROCKER  
135740-01-CHT  
SWITCH-BASE  
135741-01-CHT  
SWITCH-BEZEL  
135742-01-CHT  
SCREW  
G11-08-08U (2)

DETAIL DK

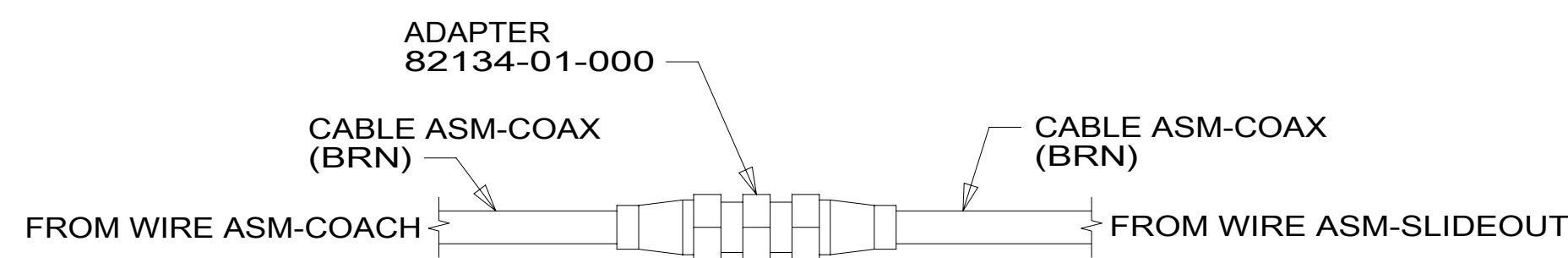

ADAPTER  
82134-01-000

CABLE ASM-COAX  
(BRN)

CABLE ASM-COAX  
(BRN)

DETAIL DM

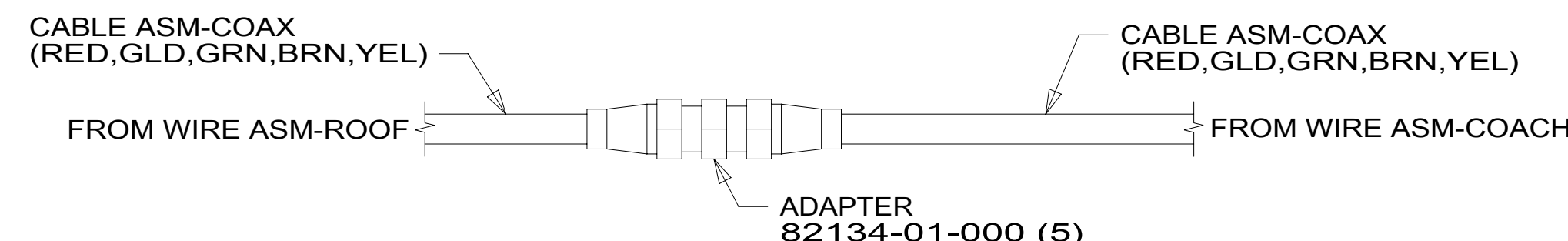

CABLE ASM-COAX  
(RED,GLD,GRN,BRN,YEL)

CABLE ASM-COAX  
(RED,GLD,GRN,BRN,YEL)

ADAPTER  
82134-01-000 (5)

DETAIL DN

1 FOR SWITCH ORIENTATION SEE DETAIL DD.  
NOTES:

FOR ELECTRICAL  
TORQUE  
SPECIFICATIONS  
SEE DWG NO.  
128783-01-000

FOR ELECTRICAL  
CALLOUTS  
SEE DWG NO.  
121339-01-000

- 45B LOFT BED
- 265 CODES/STANDARDS-CSA/CMVSS
- 1B1 CODES/STANDARDS USA

DESCRIPTION: <b>WIRING INSTL-BODY, 12V</b>		
SHEET: 4 OF 6	ITEM/PART NO: 000164478 / 32957101000	REV

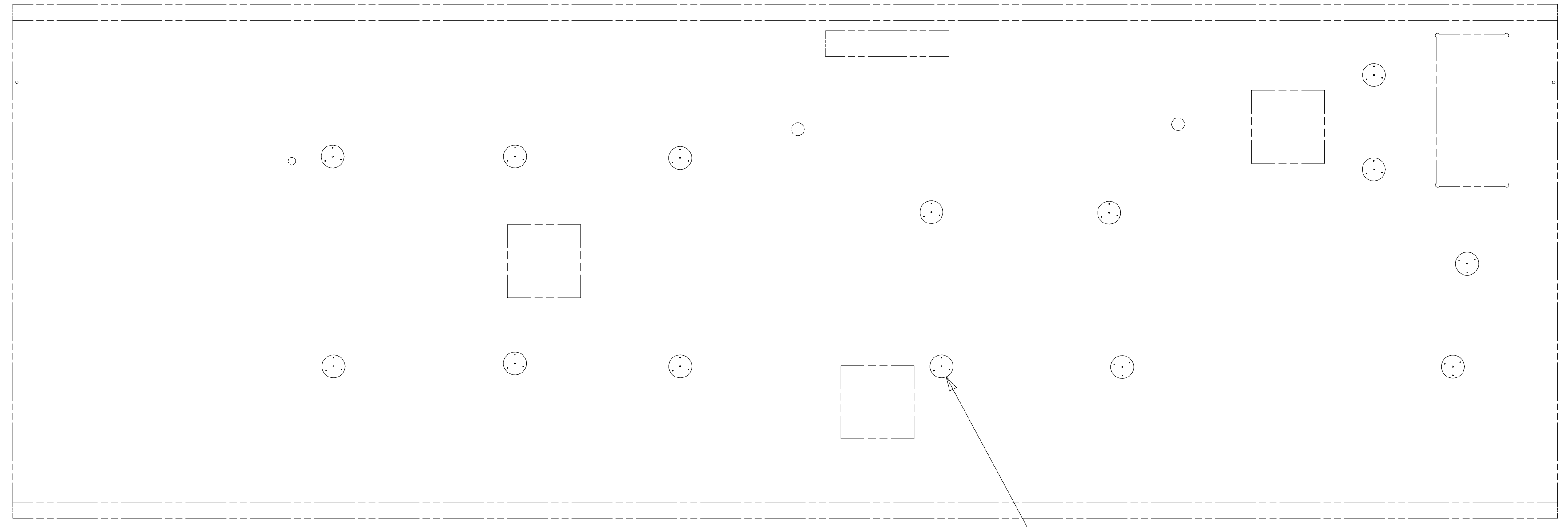

LIGHT-LED,ROUND 4.5 PLASTIC  
 000166889 / 329926-01-CHT (14)  
 SCREW  
 G13-06-16U (42)  
 CONNECTOR  
 58028-01-000 (28)

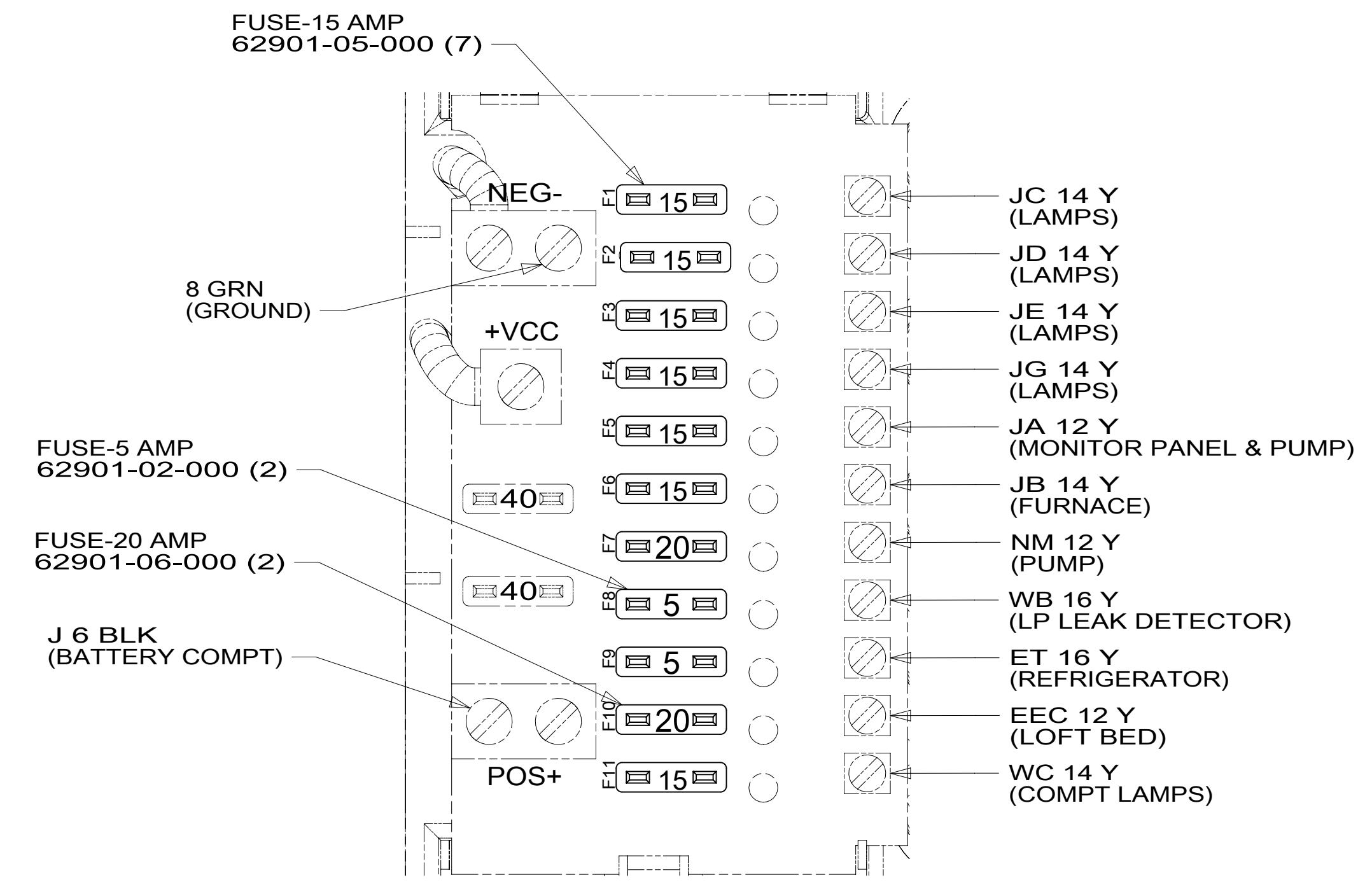

VIEW EA

265 CODES/STANDARDS-CSA/CMVSS  
 1B1 CODES/STANDARDS USA

FOR ELECTRICAL TORQUE SPECIFICATIONS SEE DWG NO. 128783-01-000

FOR ELECTRICAL CALLOUTS SEE DWG NO. 121339-01-000

DESCRIPTION:	
1B1 265	
<b>WIRING INSTL-BODY, 12V</b>	
SHEET:	ITEM/PART NO:
5 OF 6	000164478 / 32957101000
REV	

8

7

6

5

4

3

2

1



D

D

C

C

B

B

A

A

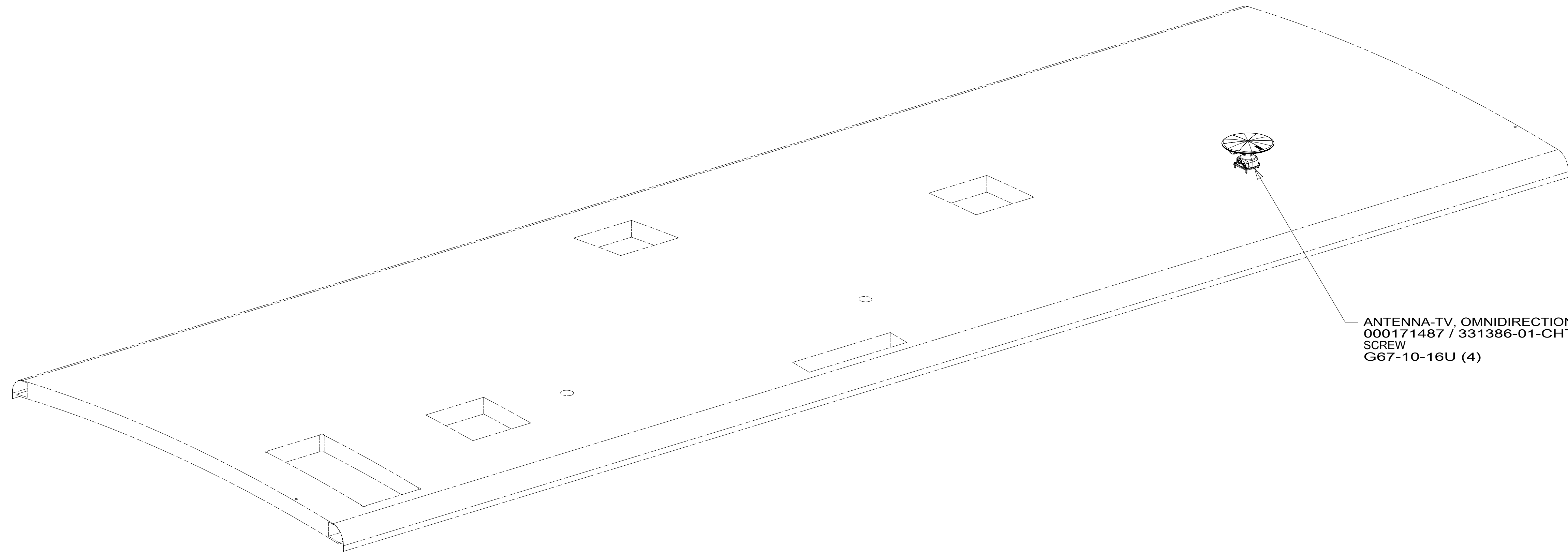

ANTENNA-TV, OMNIDIRECTIONAL  
 000171487 / 331386-01-CHT  
 SCREW  
 G67-10-16U (4) 1

1 SEE ANTENNA INSTALLATION MANUAL FOR CORRECT  
 INSTALLATION PROCEDURE.

NOTES:

FOR ELECTRICAL  
 TORQUE  
 SPECIFICATIONS  
 SEE DWG NO.  
 128783-01-000

FOR  
 ELECTRICAL  
 CALLOUTS  
 SEE DWG NO.  
 121339-01-000

265 CODES/STANDARDS-CSA/CMVSS  
1B1 CODES/STANDARDS USA

1B1 265

DESCRIPTION: <b>WIRING INSTL-BODY, 12V</b>		
SHEET: <b>6 OF 6</b>	ITEM/PART NO: <b>000164478 / 32957101000</b>	REV

8

7

6

5

4

3

2

1



1 20-Jun-2019