

- 9 SUPPLIED WITH CHASSIS
- 8 COVER SHARP EDGES WHERE WIRE CROSSES FRAME RAILS.
- 7 CUT CHASSIS SUPPLIED POSITIVE BATTERY CABLE 150 MM FROM BATTERY TERMINAL END, DISCARD TERMINAL END AND SEPARATE WIRES. ADD TERMINAL 8348-01-000 AND HEAT SHRINK 176567-04-000 TO RED CABLE (CHASSIS STARTER) AND COMBINE YELLOW (CHASSIS POWER DISTRIBUTION) AND BLACK/ORANGE (CHASSIS ALTERNATOR) WIRES TOGETHER AND ADD TERMINAL 8348-01-000 AND HEAT SHRINK 176567-02-000. COIL EXCESS CABLE ALONG FRAME RAIL JUST BEHIND RADIATOR AND TIE UP WITH TIE-WIRE 8343-04-000.
- 6 SEE WIRING INSTL-FRONT END FOR ADDITIONAL INFORMATION.
- 5 CLAMP 83610-01-000, SCREW G11-10-16U.
- 4 SEE BATTERY INSTL FOR ADDITIONAL INFORMATION.

- 3. ALL DIMENSIONS ARE FROM DATUM UNLESS OTHERWISE SPECIFIED.
- 2. SECURE CONDUIT 41953, TAB AS REQUIRED, OVER ALL WIRES IN CONTACT WITH SHARP EDGES.
- 1. WIRE TIE 8343-04-000. FASTEN EVERY 600MM MINIMUM.

NOTES:

- (12D) ELECTRICAL SYSTEM 30 AMP
- (073) COOLING UPGRADE PACKAGE
- (265) CODES/STANDARDS-CSA/CMVSS
- (1B1) CODES/STANDARDS USA

1B1 265

WINNEBAGO
COPYRIGHT 2016 WINNEBAGO INDUSTRIES, INC.

DSNR:	ALL DIMENSIONS ARE IN MILLIMETERS
DFFR:	
UNSPECIFIED TOLERANCES:	MATERIAL:
WHOLE DIM (X) : 3	
ONE-PLACE (X.X) : 1.5	
TWO-PLACE (X.XX) : 0.50	
ANGLE : 1°	
REFER TO ES0018 FOR FASTENER TIGHTENING GUIDELINES	WEIGHT: (LBS) FIRST USED:
	19 E29VE
DESCRIPTION: WIRING INSTL-CHASSIS	
SHEET: 1 OF 2	ITEM/PART NO: 000164055 / 32902001000
REF:	REV:

FOR ELECTRICAL TORQUE SPECIFICATIONS SEE DWG NO. 128783-01-000

FOR ELECTRICAL CALLOUTS SEE DWG NO. 121339-01-000

8 7 6 5 4 3 2 1

D
C
B
A

D
C
B
A

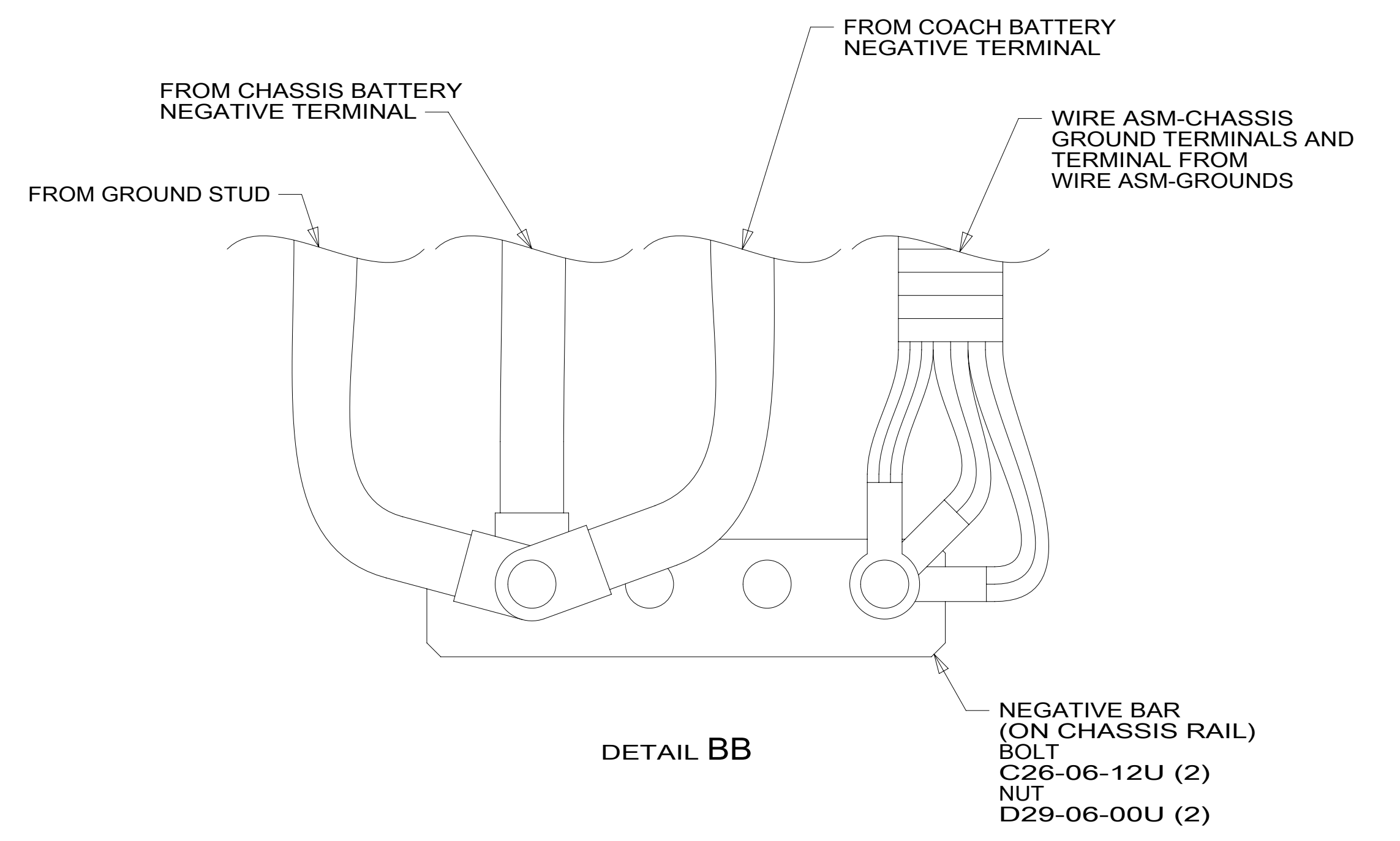
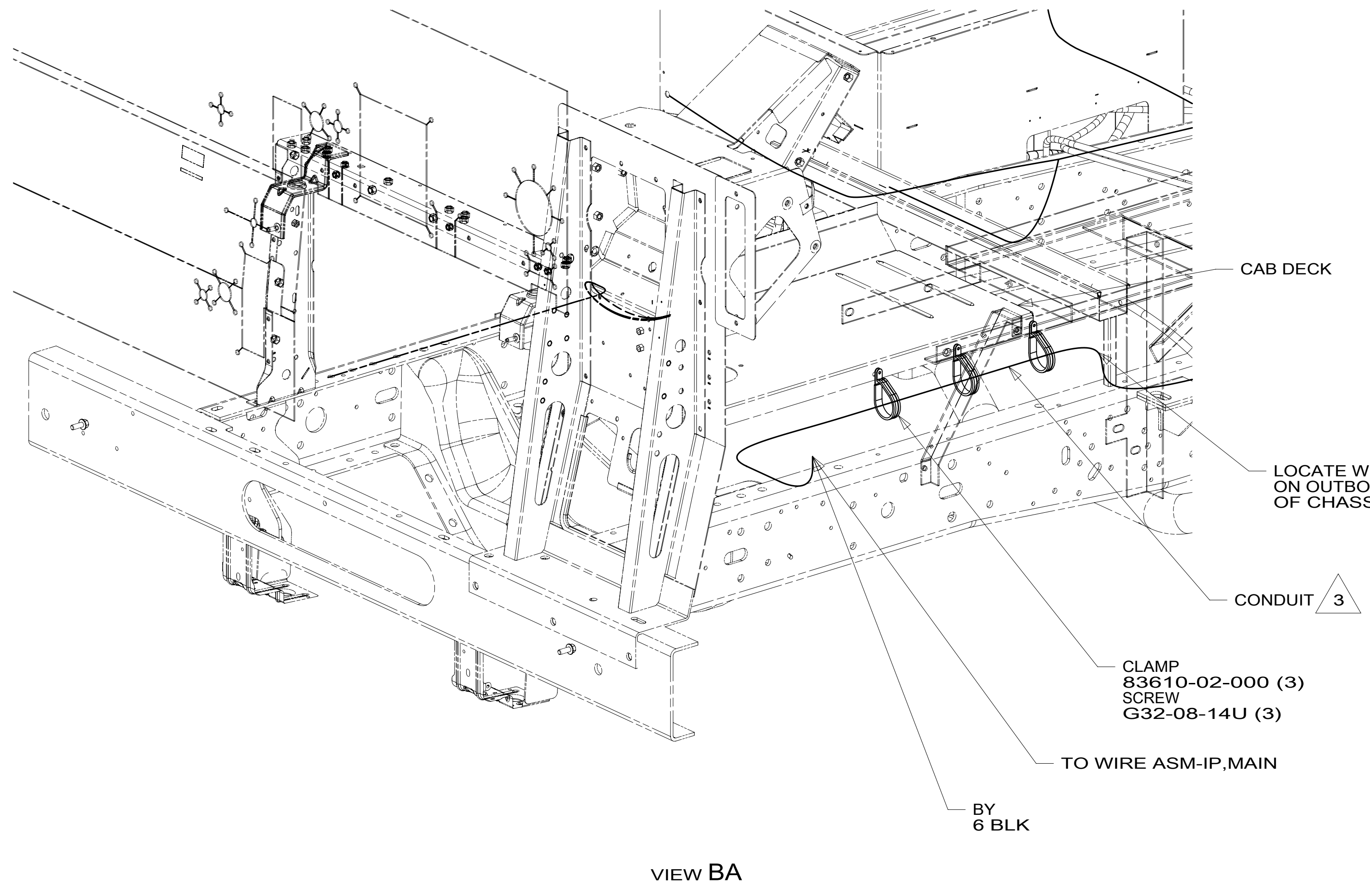

3 COVER WITH CONDUIT 41953-10-000 AND 41953-11-000 AS REQUIRED.

- 2. CONNECT CABLES TO COACH SIDE OF BATTERY DISCONNECT WHEN BATTERY DISCONNECT IS USED.
- 1. CUT OFF EXCESS END OF WIRE TIE.

NOTES:

FOR ELECTRICAL TORQUE SPECIFICATIONS SEE DWG NO. 128783-01-000

FOR ELECTRICAL CALLOUTS SEE DWG NO. 121339-01-000

265 CODES/STANDARDS-CSA/CMVSS
1B1 CODES/STANDARDS USA

DESCRIPTION:		1B1	265
WIRING INSTL-CHASSIS			
SHEET:	ITEM/PART NO.:	REV	
2 OF 2	000164055 / 32902001000		

8 7 6 5 4 3 2 1 20-Jun-2019