

- NOTES:**
- 5 WIRES ARE PART OF WIRE ASM-CHASSIS.
 - 4 PLACE CROSS LOCATOR ON SENSORS OVER DIMPLES ON TANK.
 - 3 WIRE PASSES THROUGH FLOOR IN THIS AREA.
 - 2. ROUTE TANK SENSOR WIRES SO THEY DO NOT PASS OVER SENSORS. USE WIRE TIE MOUNT 155366-01-000 AND WIRE TIE 8343-01-000 AS NEEDED. TANK SURFACE MUST BE CLEANED USING ISOPROPYL ALCOHOL AND PRIMED WITH PRIMER 94.
 - 1. ALL WIRES TO BE SECURED WITH CLAMP 10495 OR 10497 OR WIRE TIE 8343 OR 108046 EVERY 600MM, USE SCREW G67-XX-XXX OR G56-XX-XXX AS APPROPRIATE FOR INSTALLATION.

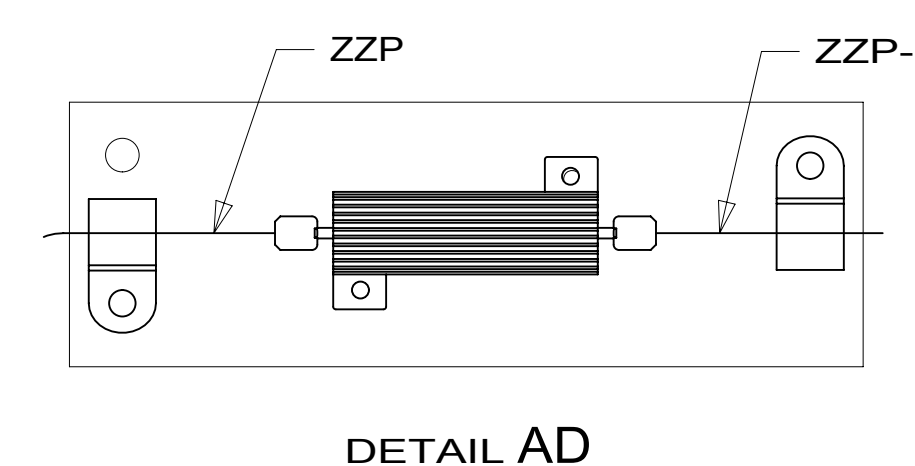

FOR ELECTRICAL TORQUE SPECIFICATIONS SEE DWG NO. 128783-01-000

FOR ELECTRICAL CALLOUTS SEE DWG NO. 121339-01-000

265 CODES/STANDARDS-CSA/CMVSS
 1B1 CODES/STANDARDS USA

1B1 265

COPYRIGHT 2016 WINNEBAGO INDUSTRIES, INC.

DSNR:	ALL DIMENSIONS ARE IN MILLIMETERS	
DFFR:		
UNSPECIFIED TOLERANCES:	MATERIAL:	
WHOLE DIM (X) : 3		
ONE-PLACE (X.X) : 1.5		
TWO-PLACE (X.XX) : 0.50		
ANGLE : 1°		
REFER TO ES0018 FOR FASTENER TIGHTENING GUIDELINES	WEIGHT: (LBS)	FIRST USED:
		19 E31BE
DESCRIPTION: WIRING INSTL-BODY, 12V		
SHEET: 1 OF 6	ITEM/PART NO: 000163931 / 32895701000	REV:
	REF:	1 20-Jun-2019

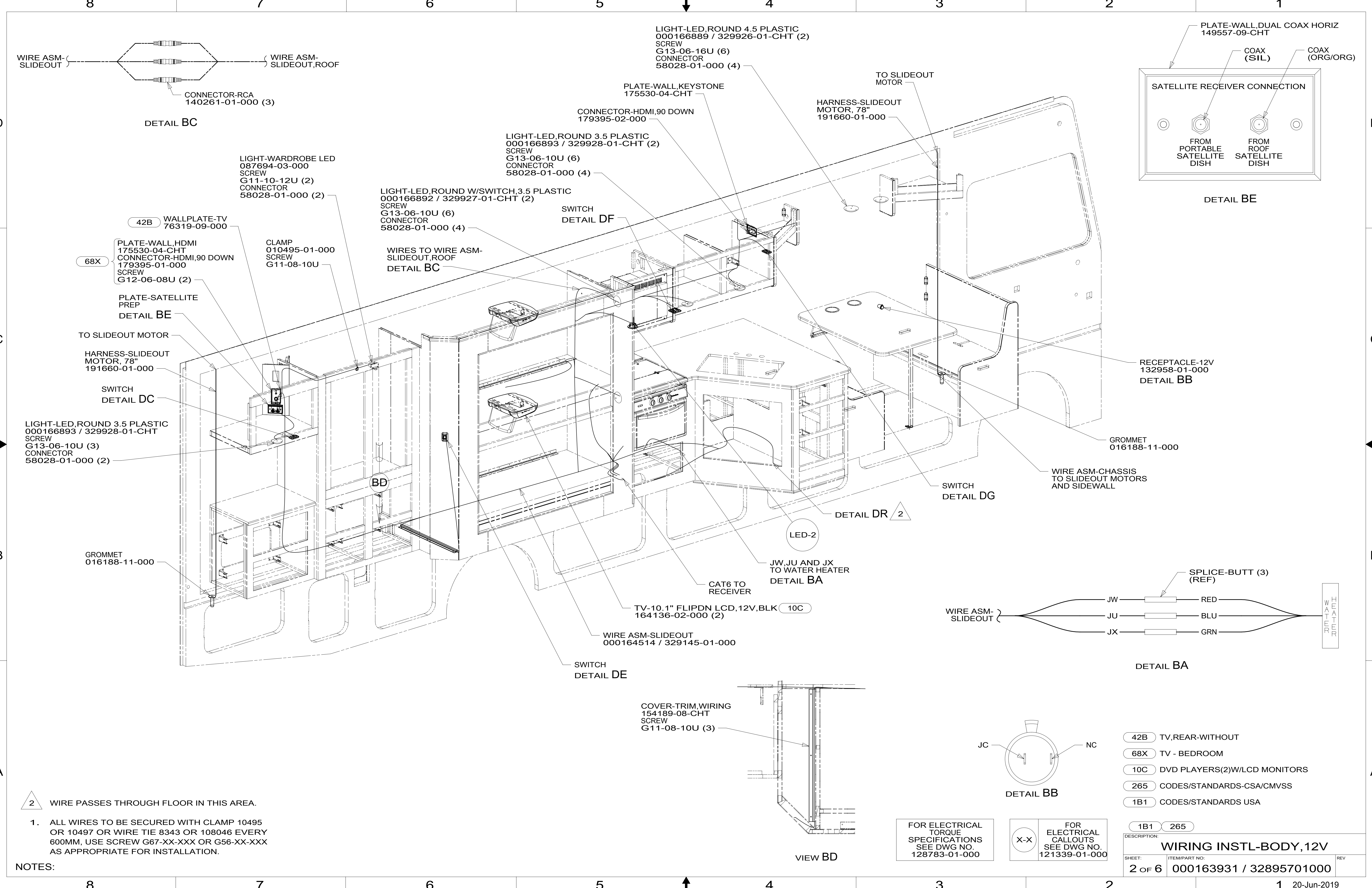

2 WIRE PASSES THROUGH FLOOR IN THIS AREA.

1. ALL WIRES TO BE SECURED WITH CLAMP 10495 OR 10497 OR WIRE TIE 8343 OR 108046 EVERY 600MM, USE SCREW G67-XX-XXX OR G56-XX-XXX AS APPROPRIATE FOR INSTALLATION.

NOTES:

FOR ELECTRICAL TORQUE SPECIFICATIONS SEE DWG NO. 128783-01-000

FOR ELECTRICAL CALLOUTS SEE DWG NO. 121339-01-000

- 42B TV,REAR-WITHOUT
- 68X TV - BEDROOM
- 10C DVD PLAYERS(2)W/LCD MONITORS
- 265 CODES/STANDARDS-CSA/CMVSS
- 1B1 CODES/STANDARDS USA

DESCRIPTION: WIRING INSTL-BODY,12V

SHEET: 2 OF 6

ITEM/PART NO: 000163931 / 32895701000

REV

20-Jun-2019

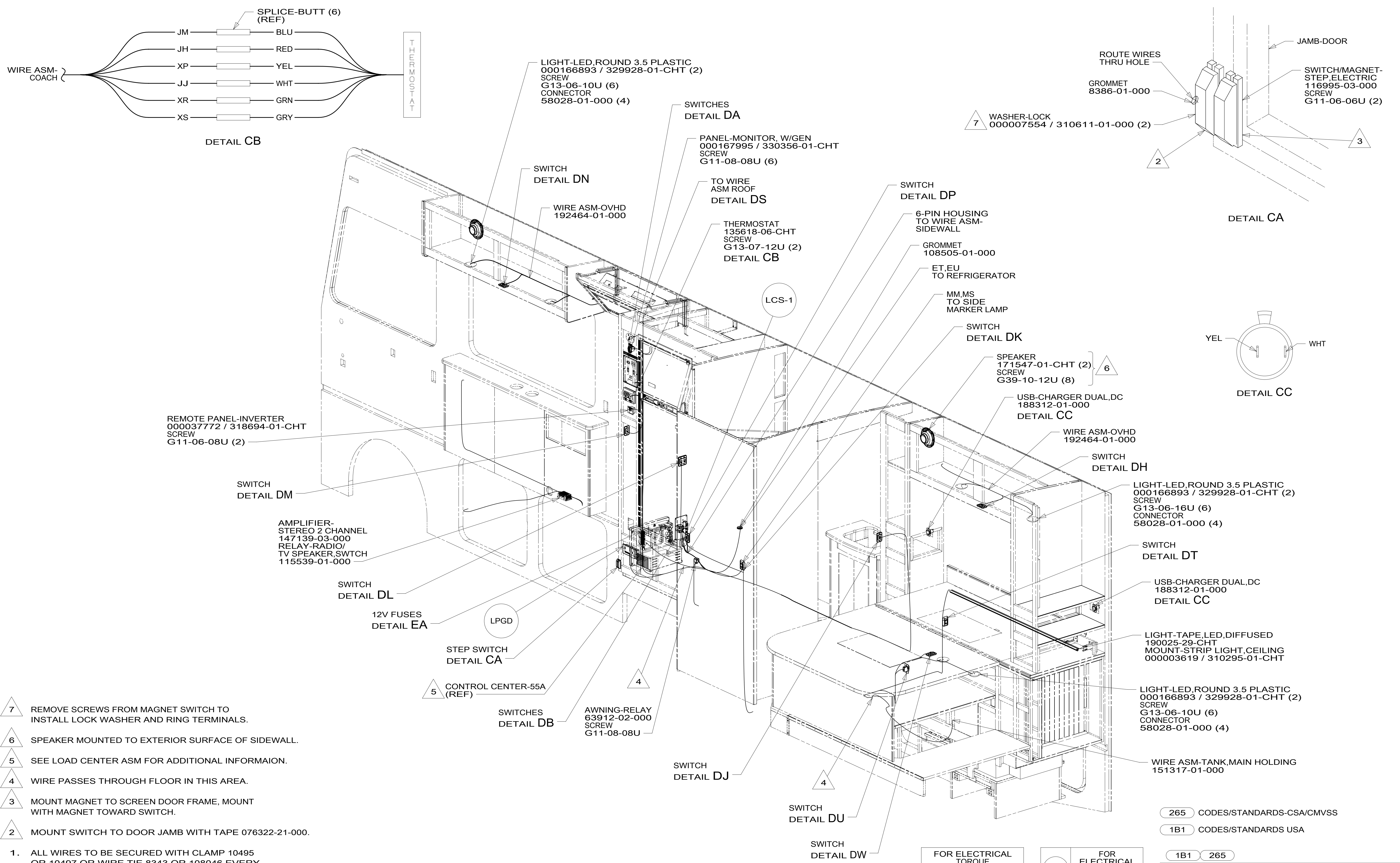

- 7 REMOVE SCREWS FROM MAGNET SWITCH TO INSTALL LOCK WASHER AND RING TERMINALS.
- 6 SPEAKER MOUNTED TO EXTERIOR SURFACE OF SIDEWALL.
- 5 SEE LOAD CENTER ASM FOR ADDITIONAL INFORMATION.
- 4 WIRE PASSES THROUGH FLOOR IN THIS AREA.
- 3 MOUNT MAGNET TO SCREEN DOOR FRAME, MOUNT WITH MAGNET TOWARD SWITCH.
- 2 MOUNT SWITCH TO DOOR JAMB WITH TAPE 076322-21-000.

1. ALL WIRES TO BE SECURED WITH CLAMP 10495 OR 10497 OR WIRE TIE 8343 OR 108046 EVERY 600MM, USE SCREW G67-XX-XXX OR G56-XX-XXX AS APPROPRIATE FOR INSTALLATION.

NOTES:

FOR ELECTRICAL TORQUE SPECIFICATIONS SEE DWG NO. 128783-01-000

FOR ELECTRICAL CALLOUTS SEE DWG NO. 121339-01-000

265 CODES/STANDARDS-CSA/CMVSS
1B1 CODES/STANDARDS USA

DESCRIPTION:		1B1 265	
WIRING INSTL-BODY, 12V			
SHEET:	ITEM/PART NO.:	REV:	
3 OF 6	000163931 / 32895701000		

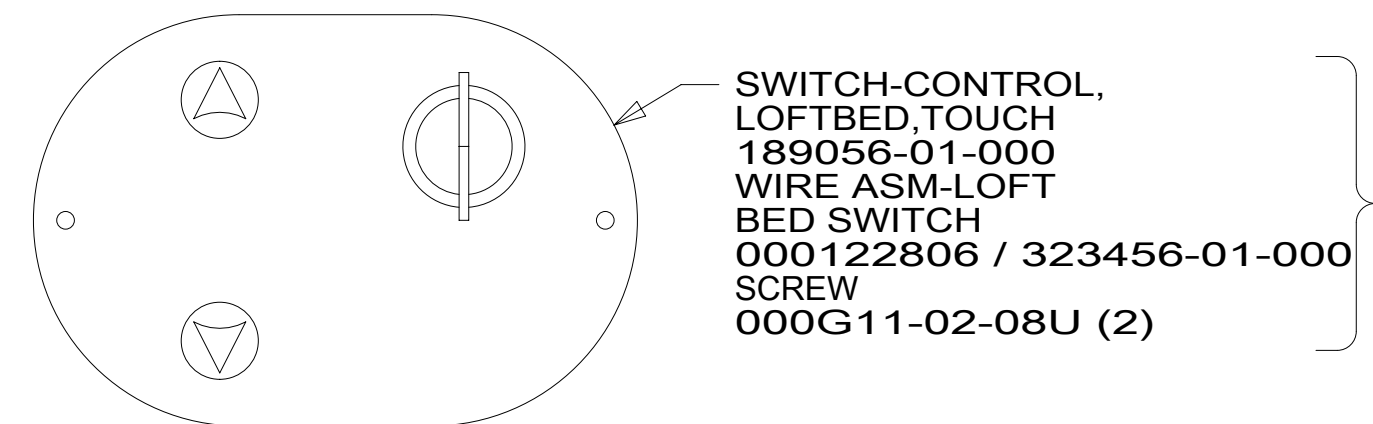

SWITCH-CONTROL, LOFTBED, TOUCH
189056-01-000
WIRE ASM-LOFT BED SWITCH
000122806 / 323456-01-000
SCREW
000G11-02-08U (2)

45B

DRIVER'S SIDE FRONT

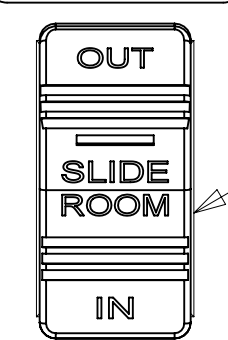

LABEL-SLIDEOUT, DRIVER, FRONT
163992-01-CHT

SWITCH
108357-18-000
ACTUATOR
108356-31-CHT
CIRCUITS
DR, KE, DU
ABY, ABZ

LABEL-WARNING, SLIDEOUT
116549-01-000

WARNING CRUSH HAZARD. Keep people and objects clear of the inside and the outside of the slideout room when operating. Failure to comply could result in death or serious injury.

DETAIL DA

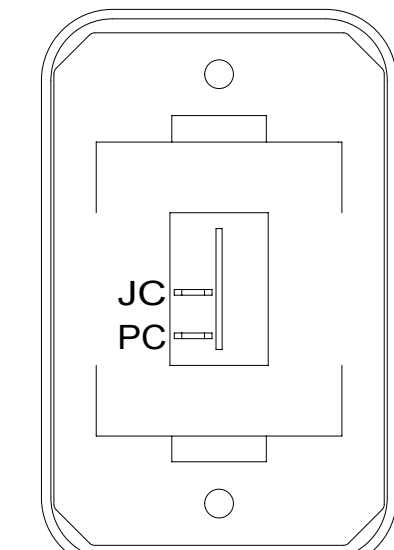

DETAIL DE

SWITCH-ROCKER
135740-01-CHT
SWITCH-BASE
135741-01-CHT
SWITCH-BEZEL
135742-01-CHT
SCREW
G11-08-08U (2)

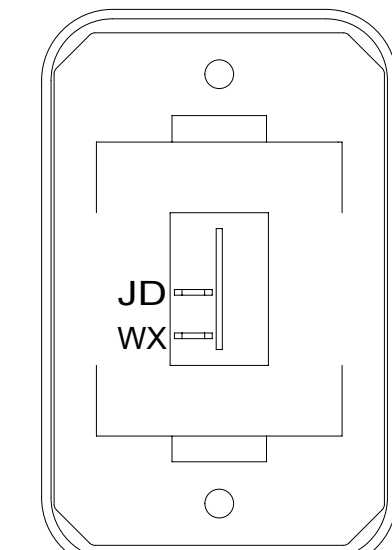

DETAIL DK

SWITCH-ROCKER
135740-01-CHT
SWITCH-BASE
135741-01-CHT
SWITCH-BEZEL
135742-01-CHT
SCREW
G11-08-08U (2)

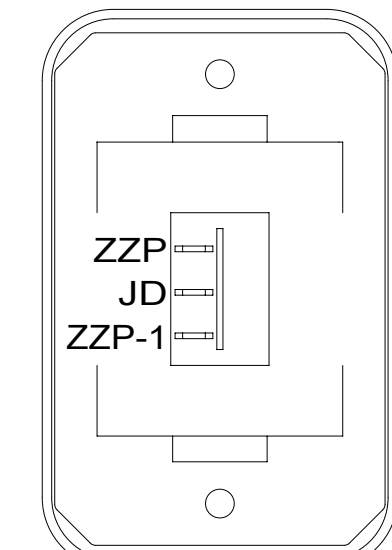

DETAIL DT

SWITCH-ROCKER
135740-04-CHT
SWITCH-BASE
135741-01-CHT
SWITCH-BEZEL
135742-01-CHT
SCREW
G11-08-08U (2)

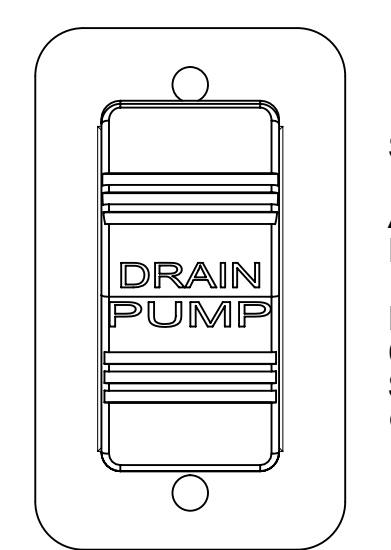

DETAIL DU

SWITCH-ROCKER
108357-09-000
ACTUATOR-SWITCH,
DRAIN PUMP
108356-27-CHT
PLATE-SWITCH, GEN SW
098351-07-CHT
SCREW
G11-06-10U (2)

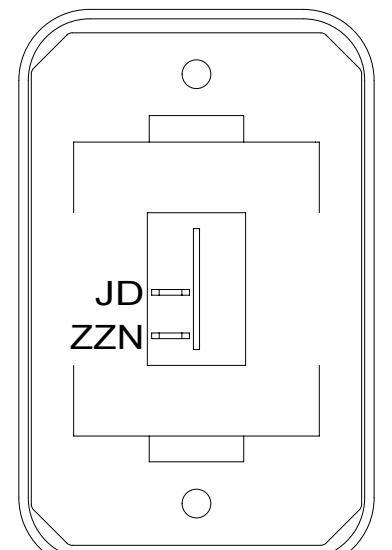

DETAIL DW

SWITCH-ROCKER
135740-01-CHT
SWITCH-BASE
135741-01-CHT
SWITCH-BEZEL
135742-01-CHT
SCREW
G11-08-08U (2)

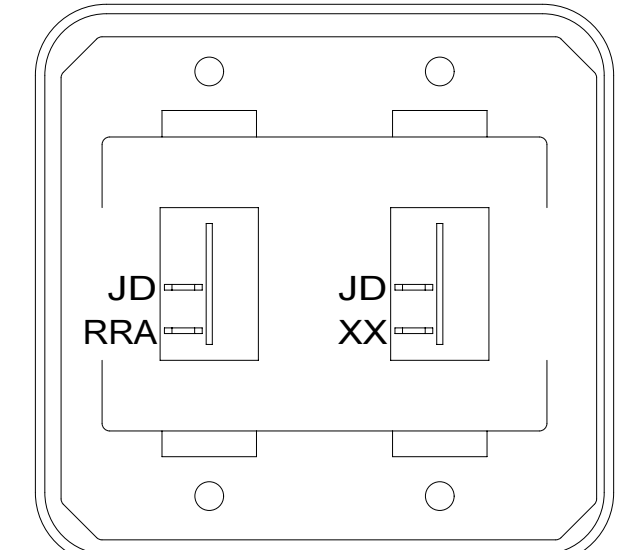

DETAIL DF

SWITCH-ROCKER
135740-01-CHT (2)
SWITCH-BASE
135741-02-CHT
SWITCH-BEZEL
135742-02-CHT
SCREW
G11-08-08U (4)

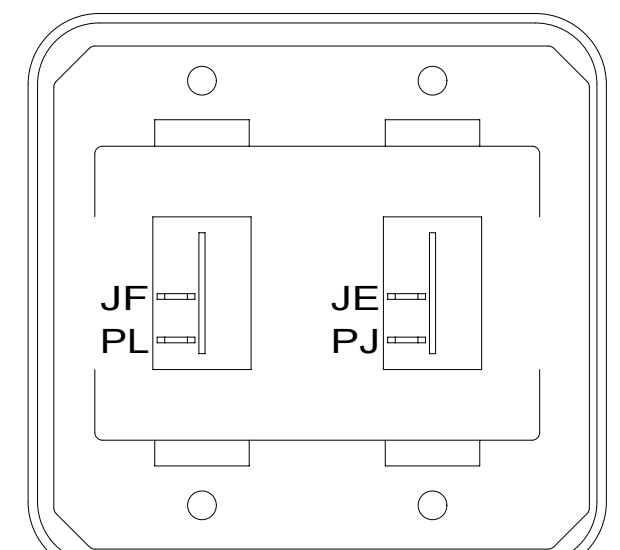

DETAIL DL

SWITCH-ROCKER
135740-01-CHT (2)
SWITCH-BASE
135741-02-CHT
SWITCH-BEZEL
135742-02-CHT
SCREW
G11-08-08U (4)

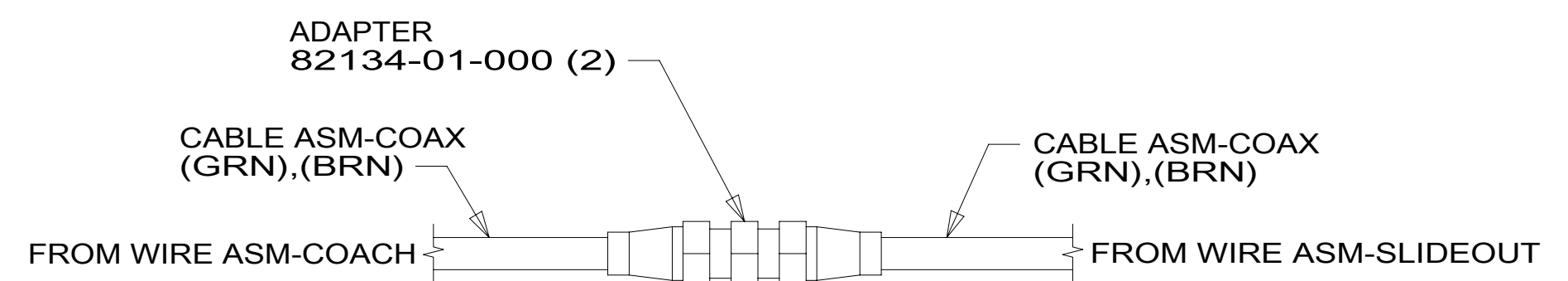

DETAIL DR

ADAPTER
82134-01-000 (2)

CABLE ASM-COAX (GRN),(BRN)

CABLE ASM-COAX (GRN),(BRN)

FROM WIRE ASM-COACH

FROM WIRE ASM-SLIDEOUT

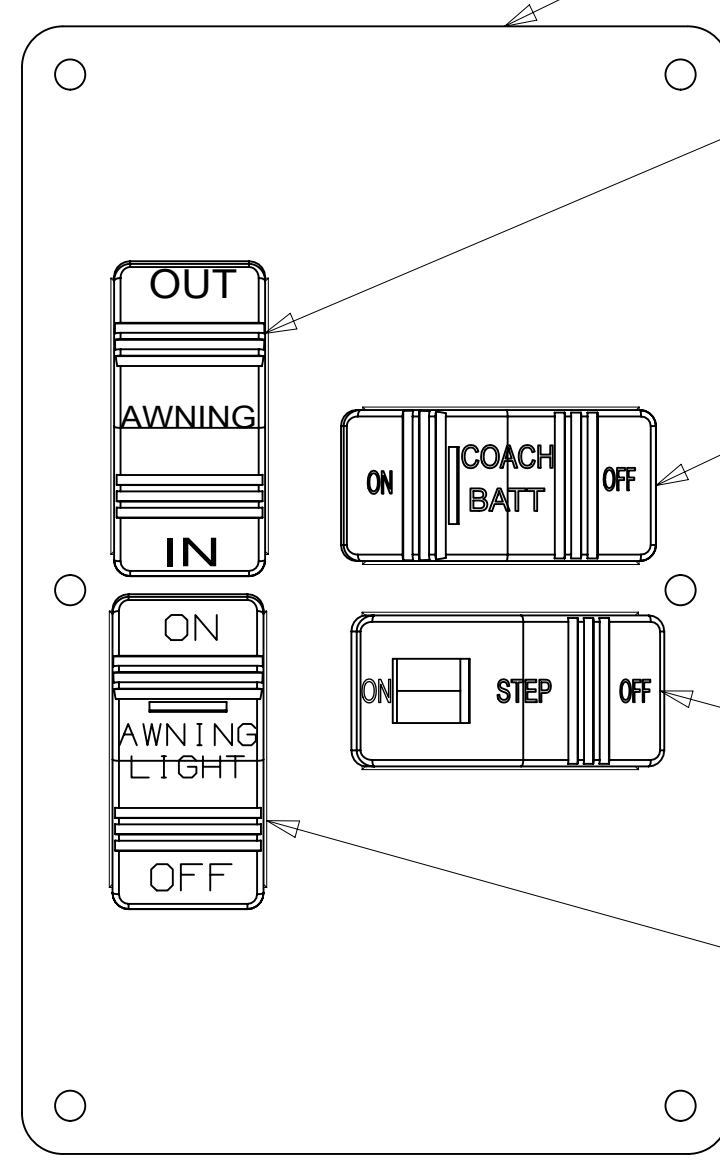

DETAIL DB 1

PLATE-SWITCH
158431-05-CHT
SCREW
G11-06-10U (4)

SWITCH-AWNING
108357-06-000
ACTUATOR-SWITCH
108356-12-CHT
CIRCUITS
FFD, FFR, FFE
FFE, JJR, FFD

SWITCH-COACH BATTERY
108357-18-000
ACTUATOR-SWITCH
108356-19-CHT
CIRCUITS
KF, LG, LJ, LH, WC
WIRE ASM-THERM
186796-01-000

SWITCH-STEP
108357-19-000
CIRCUITS ER, ES

SWITCH-AWNING
108357-14-000
ACTUATOR-SWITCH
108356-28-CHT
CIRCUITS
SP, ZZL, WE

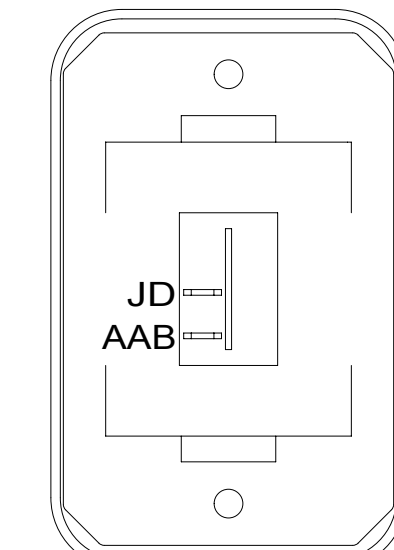

DETAIL DG

SWITCH-ROCKER
135740-01-CHT
SWITCH-BASE
135741-01-CHT
SWITCH-BEZEL
135742-01-CHT
SCREW
G11-08-08U (2)

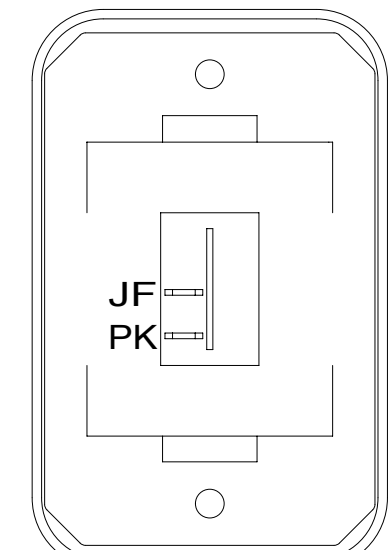

DETAIL DM

SWITCH-ROCKER
135740-01-CHT
SWITCH-BASE
135741-01-CHT
SWITCH-BEZEL
135742-01-CHT
SCREW
G11-08-08U (2)

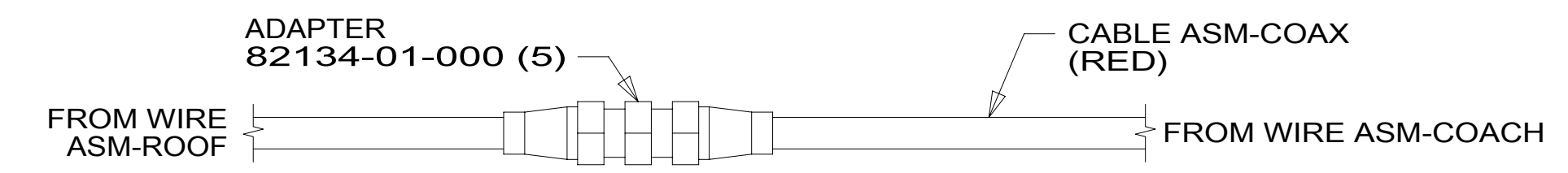

ADAPTER
82134-01-000 (5)

CABLE ASM-COAX (RED)

FROM WIRE ASM-ROOF

FROM WIRE ASM-COACH

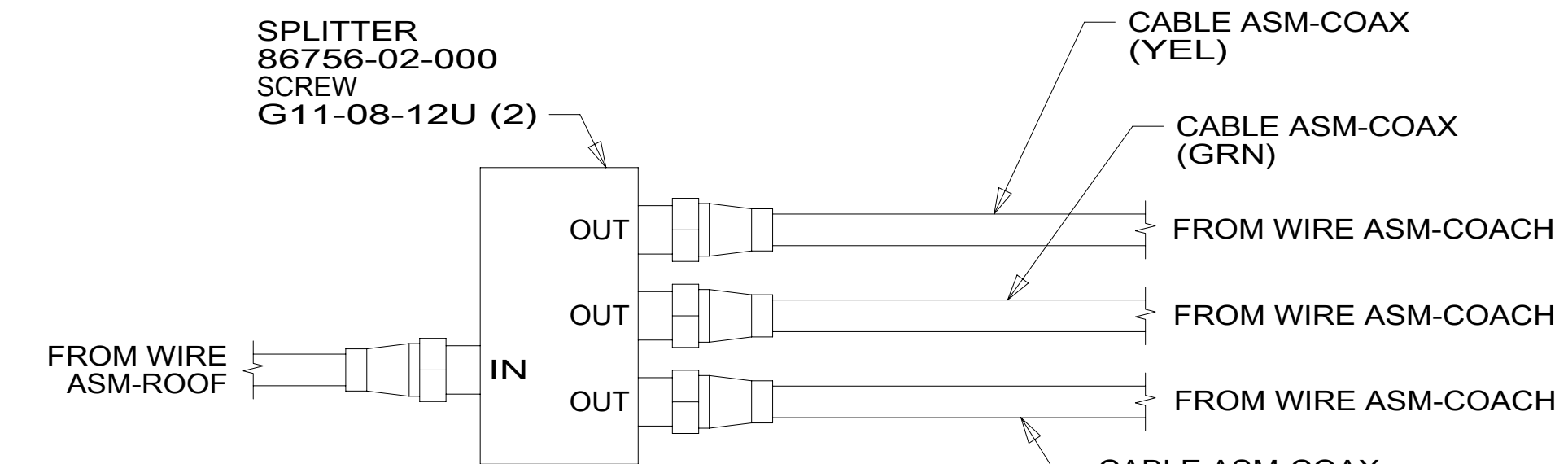

SPLITTER
86756-02-000
SCREW
G11-08-12U (2)

CABLE ASM-COAX (YEL)

CABLE ASM-COAX (GRN)

FROM WIRE ASM-COACH

FROM WIRE ASM-COACH

FROM WIRE ASM-COACH

CABLE ASM-COAX (BRN)

CABLE ASM-COAX (GLD)

FROM WIRE ASM-ROOF

FROM WIRE ASM-COACH

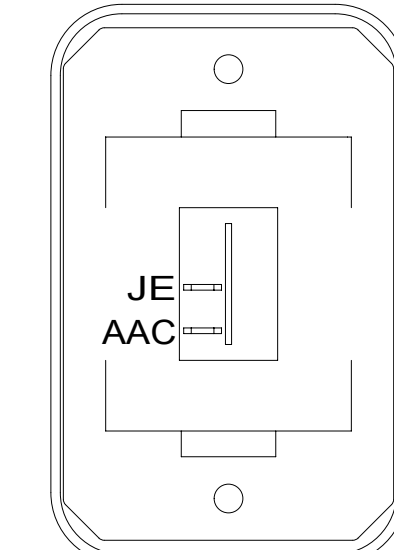

DETAIL DH

SWITCH-ROCKER
135740-01-CHT
SWITCH-BASE
135741-01-CHT
SWITCH-BEZEL
135742-01-CHT
SCREW
G11-08-08U (2)

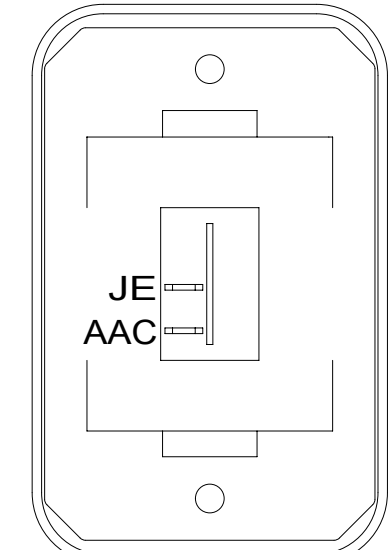

DETAIL DN

SWITCH-ROCKER
135740-01-CHT
SWITCH-BASE
135741-01-CHT
SWITCH-BEZEL
135742-01-CHT
SCREW
G11-08-08U (2)

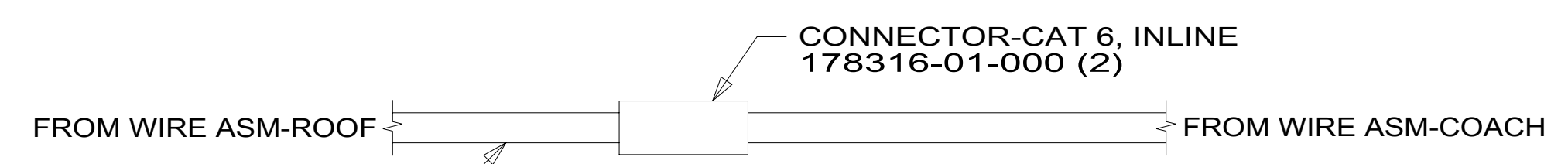

DETAIL DS

CONNECTOR-CAT 6, INLINE
178316-01-000 (2)

FROM WIRE ASM-ROOF

FROM WIRE ASM-COACH

CABLE-CAT6

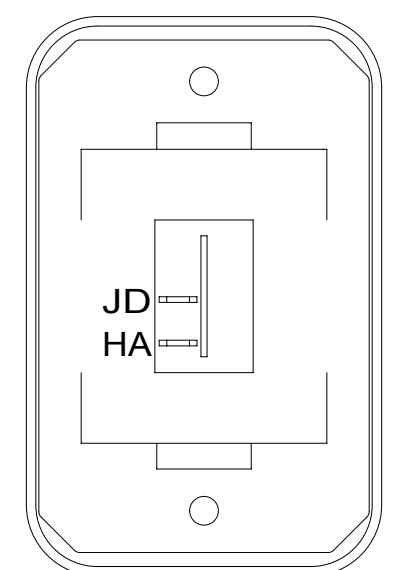

DETAIL DC

SWITCH-ROCKER
135740-01-CHT
SWITCH-BASE
135741-01-CHT
SWITCH-BEZEL
135742-01-CHT
SCREW
G11-08-08U (2)

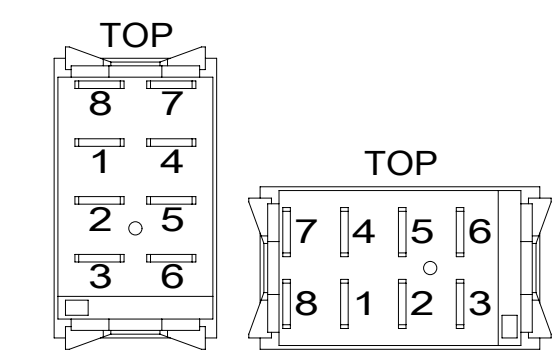

DETAIL DD

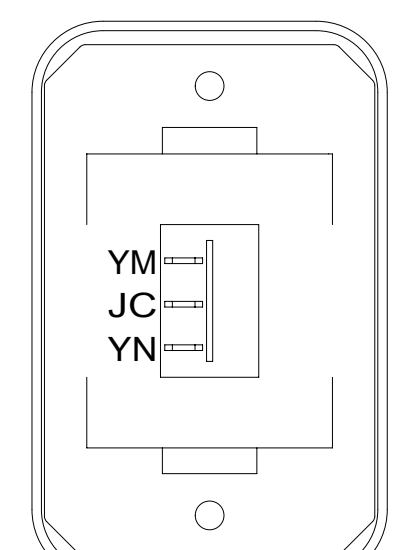

DETAIL DJ

SWITCH-ROCKER
135740-02-CHT
SWITCH-BASE
135741-01-CHT
SWITCH-BEZEL
135742-01-CHT
SCREW
G11-08-08U (2)

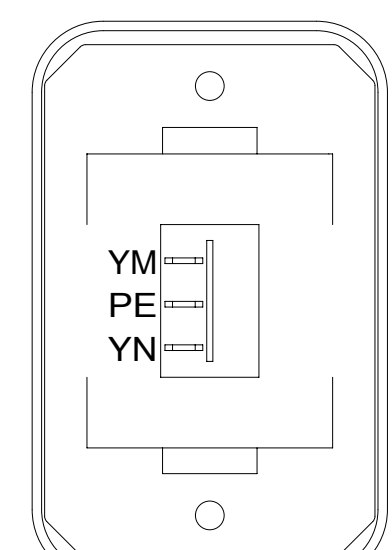

DETAIL DP

SWITCH-ROCKER
135740-02-CHT
SWITCH-BASE
135741-01-CHT
SWITCH-BEZEL
135742-01-CHT
SCREW
G11-08-08U (2)

1 FOR SWITCH ORIENTATION SEE DETAIL DD.

FOR ELECTRICAL TORQUE SPECIFICATIONS SEE DWG NO. 128783-01-000

FOR ELECTRICAL CALLOUTS SEE DWG NO. 121339-01-000

- 45B LOFT BED
- 265 CODES/STANDARDS-CSA/CMVSS
- 1B1 CODES/STANDARDS USA

DESCRIPTION:		1B1 265	
WIRING INSTL-BODY, 12V			
SHEET:	ITEM/PART NO.:	REV:	
4 OF 6	000163931 / 32895701000		

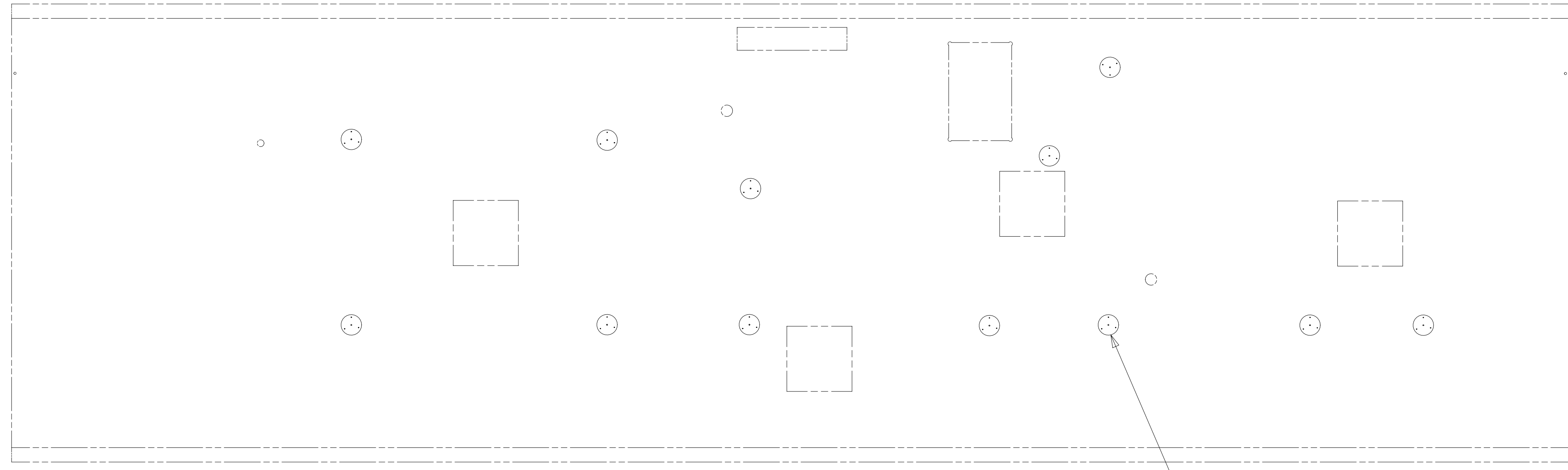

LIGHT-LED,ROUND 4.5 PLASTIC
000166889 / 329926-01-CHT (12)
SCREW
G13-06-16U (36)
CONNECTOR
58028-01-000 (24)

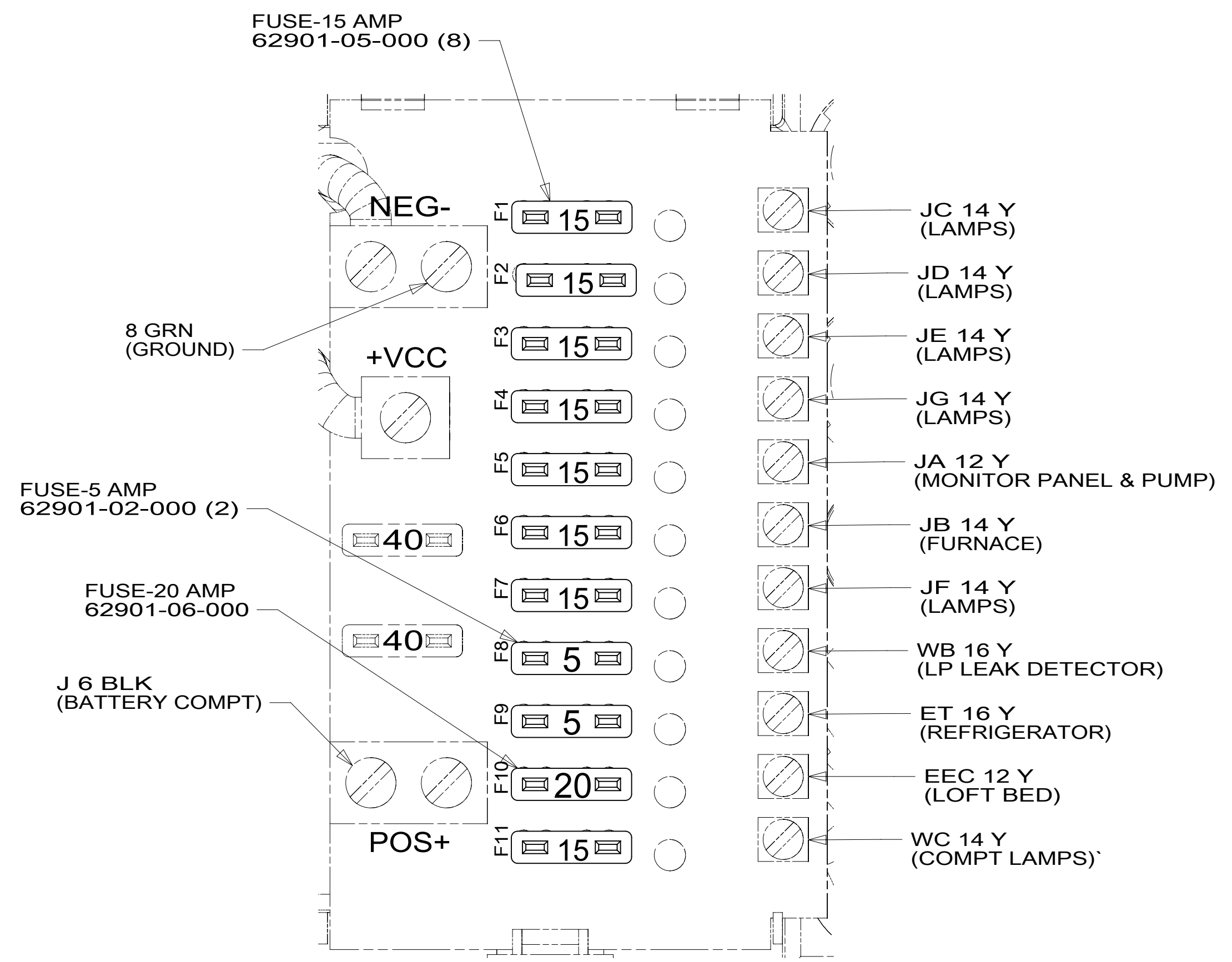

DETAIL EA

265 CODES/STANDARDS-CSA/CMVSS
1B1 CODES/STANDARDS USA

FOR ELECTRICAL TORQUE SPECIFICATIONS SEE DWG NO. 128783-01-000

FOR ELECTRICAL CALLOUTS SEE DWG NO. 121339-01-000

DESCRIPTION:	
1B1 265	
WIRING INSTL-BODY, 12V	
SHEET:	ITEM/PART NO:
5 OF 6	000163931 / 32895701000
REV	

8 7 6 5 4 3 2 1

D

D

C

C

B

B

A

A

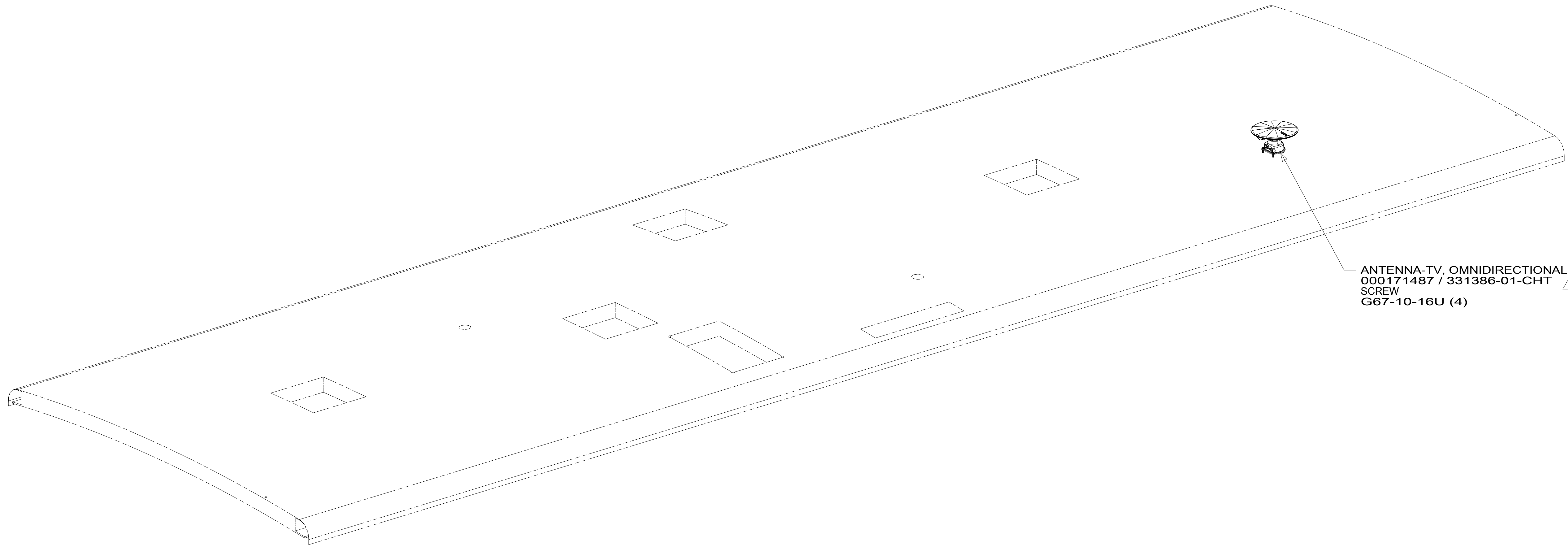

ANTENNA-TV, OMNIDIRECTIONAL
 000171487 / 331386-01-CHT
 SCREW
 G67-10-16U (4) 1

1 SEE ANTENNA INSTALLATION MANUAL FOR CORRECT
 INSTALLATION PROCEDURE.

NOTES:

FOR ELECTRICAL
 TORQUE
 SPECIFICATIONS
 SEE DWG NO.
 128783-01-000

FOR
 ELECTRICAL
 CALLOUTS
 SEE DWG NO.
 121339-01-000

265 CODES/STANDARDS-CSA/CMVSS
1B1 CODES/STANDARDS USA

1B1 265

DESCRIPTION:
WIRING INSTL-BODY, 12V

SHEET: 6 OF 6	ITEM/PART NO.: 000163931 / 32895701000	REV
-------------------------	--	-----

8 7 6 5 4 3 2 1 20-Jun-2019