

WIRE ASM-CHASSIS
000162224 / 328639-01-000

BATTERY INSTL
000162213 / 328632-01-000

WIRING TO SLIDEROOM
& MODULE-110V (BLU)

SEAL-TRIM
113452-02-000 (153 MM)

110V
(BRN-2,BLU,BLK)
MAIN DROP TO
WIRE ASM-COACH
& WIRE ASM-ROOF

TO COMPARTMENT LIGHT

CABLES TO
INVERTER

GROMMET
023942-01-000 (2)

TO FORD SUPPLIED
TAILLAMP CIRCUIT

7 PIN HSG
TO TRAILER
CONNECTOR

TO GROUND BOLT

6 PIN HSG
TO BACKWALL

CABLE ASM-
GENERATOR
GND (BLK)
TO GROUND STUD

8 PIN HOUSING
TO GENERATOR

GROMMET
023942-01-000

2476

2603

902

697

347

80

160

347

10 7

10 9

10 7

FOR ELECTRICAL
TORQUE
SPECIFICATIONS
SEE DWG NO.
128783-01-000

FOR
ELECTRICAL
CALLOUTS
SEE DWG NO.
121339-01-000

- 10 SUPPLIED WITH CHASSIS
- 9 CUT CHASSIS SUPPLIED BATTERY CABLE 700 MM FROM BATTERY TERMINAL AND ADD TERMINAL 8348-01-000 TO CUT END.
- 8 COVER SHARP EDGES WHERE WIRE CROSSES FRAME RAILS.
- 7 CUT CHASSIS SUPPLIED POSITIVE BATTERY CABLE 150 MM FROM BATTERY TERMINAL END, DISCARD TERMINAL END AND SEPARATE WIRES. ADD TERMINAL 8348-01-000 AND HEAT SHRINK 176567-04-000 TO RED CABLE (CHASSIS STARTER) AND COMBINE YELLOW (CHASSIS POWER DISTRIBUTION) AND BLACK/ORANGE (CHASSIS ALTERNATOR) WIRES TOGETHER AND ADD TERMINAL 8348-01-000 AND HEAT SHRINK 176567-02-000. COIL EXCESS CABLE ALONG FRAME RAIL JUST BEHIND RADIATOR AND TIE UP WITH TIE-WIRE 8343-04-000.
- 6 SEE WIRING INSTL-FRONT END FOR ADDITIONAL INFORMATION.
- 5 CLAMP 83610-01-000, SCREW G11-10-16U.
- 4 SEE BATTERY INSTALLATION FOR ADDITIONAL INFORMATION.

3. ALL DIMENSIONS ARE FROM DATUM UNLESS OTHERWISE SPECIFIED.
2. SECURE CONDUIT 41953, TAB AS REQUIRED, OVER ALL WIRES IN CONTACT WITH SHARP EDGES.
1. WIRE TIE 8343-04-000. FASTEN EVERY 600 MM MINIMUM.

NOTES:

265 CODES/STANDARDS-CSA/CMVSS
1B1 CODES/STANDARDS USA

1B1 265

WINNEBAGO
COPYRIGHT 2016 WINNEBAGO INDUSTRIES, INC.

DSNR:	ALL DIMENSIONS ARE IN MILLIMETERS
DFFR:	
UNSPECIFIED TOLERANCES:	MATERIAL:
WHOLE DIM (X) : 3	
ONE-PLACE (X.X) : 1.5	
TWO-PLACE (X.XX) : 0.50	
ANGLE : 1°	
REFER TO ES0018 FOR FASTENER TIGHTENING GUIDELINES	WEIGHT: (LBS) FIRST USED: 19 F30T
WIRING INSTL-CHASSIS	
SHEET: 1 OF 2	ITEM/PART NO: 000162009 / 32852901000
REF:	1 23-Jan-2019

8 7 6 5 4 3 2 1

D
C
B
A

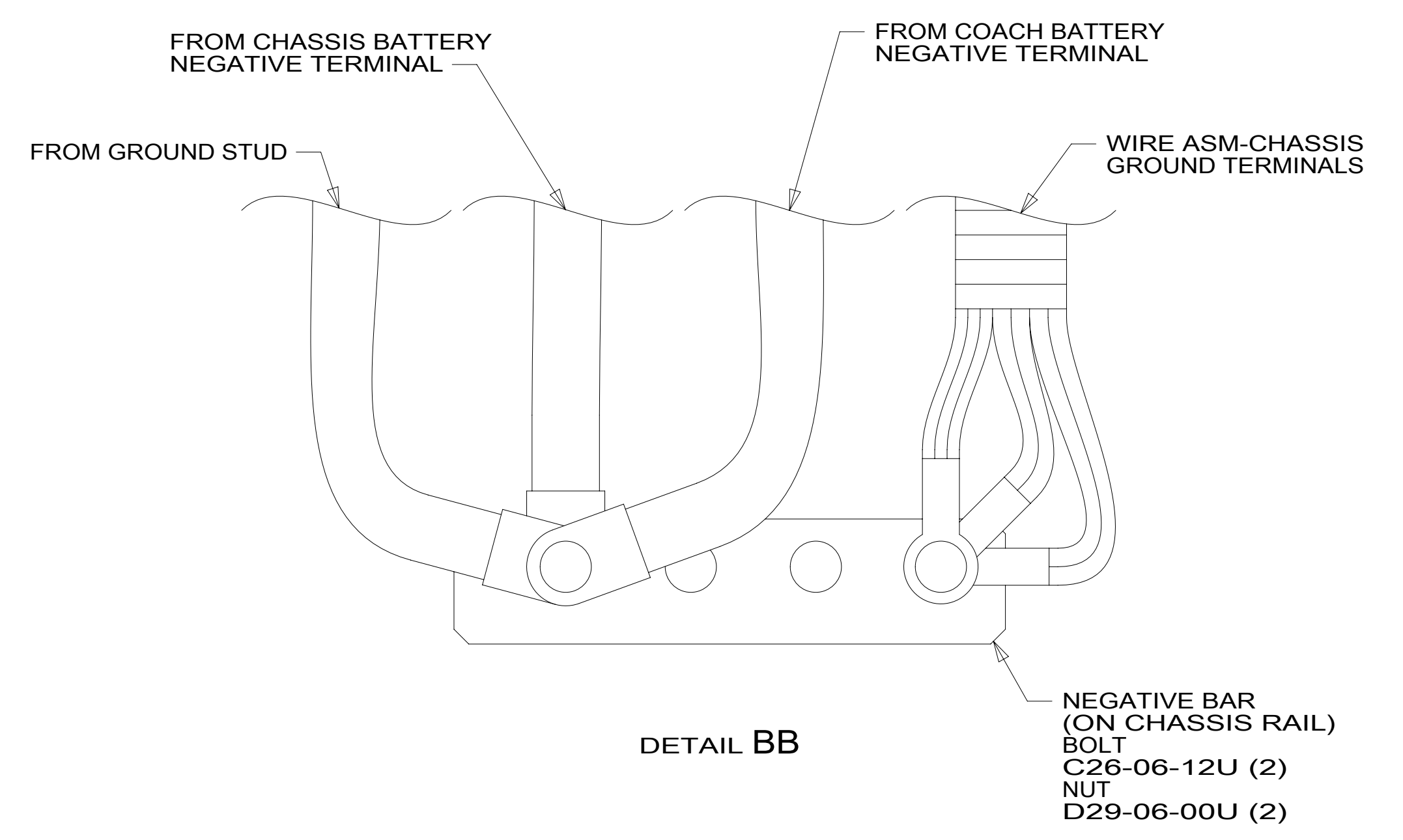
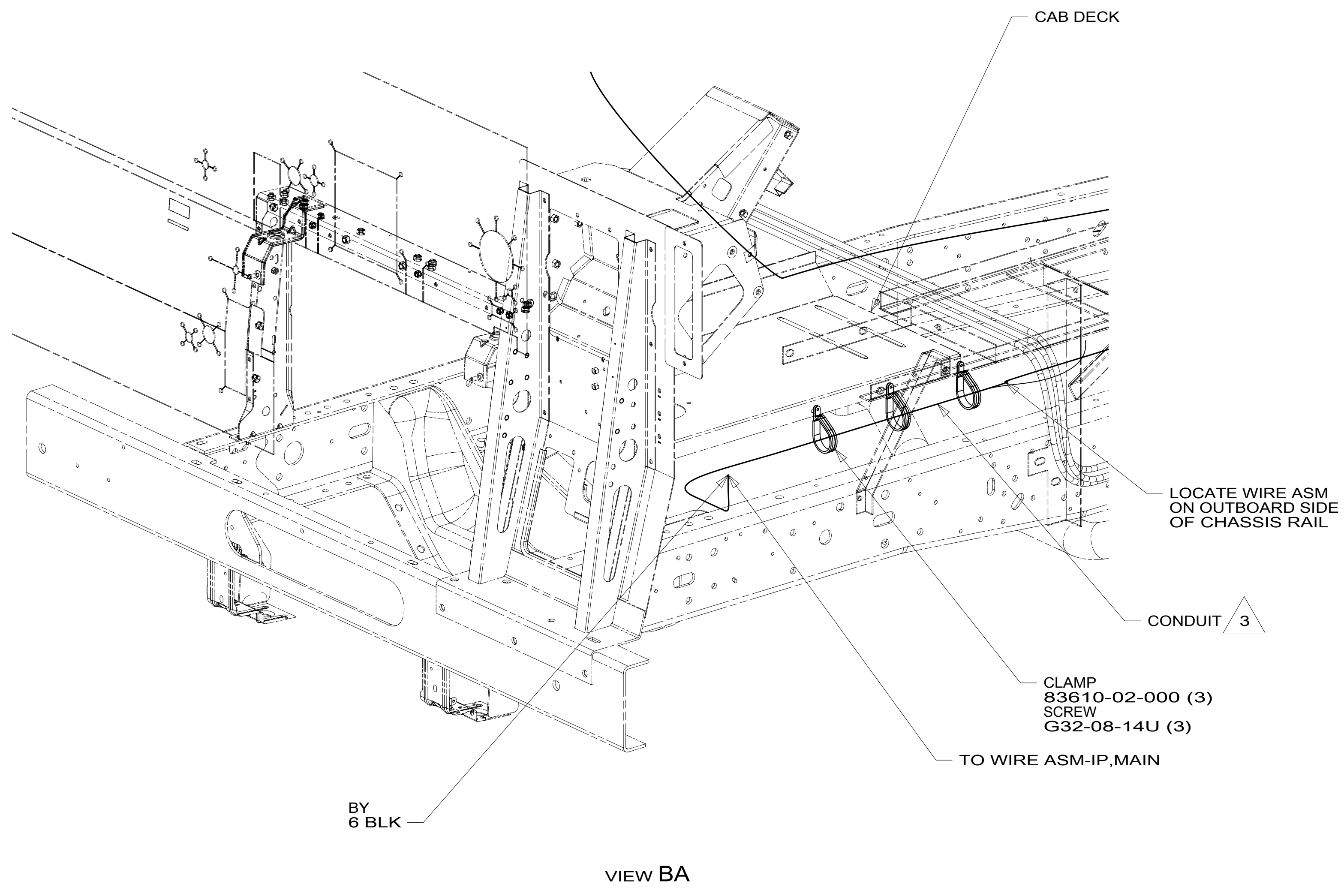

3 COVER WITH CONDUIT 41953-10-000 AND 41953-11-000 AS REQUIRED.

- 2. CONNECT CABLES TO COACH SIDE OF BATTERY DISCONNECT WHEN BATTERY DISCONNECT IS USED.
- 1. CUT OFF EXCESS END OF WIRE TIE.

NOTES:

FOR ELECTRICAL TORQUE SPECIFICATIONS SEE DWG NO. 128783-01-000

FOR ELECTRICAL CALLOUTS SEE DWG NO. 121339-01-000

265 CODES/STANDARDS-CSA/CMVSS
1B1 CODES/STANDARDS USA

DESCRIPTION:		1B1	265
WIRING INSTL-CHASSIS			
SHEET:	ITEM/PART NO.:	REV	
2 OF 2	000162009 / 32852901000		

8 7 6 5 4 3 2 1 23-Jan-2019