

8 7 6 5 4 3 2 1

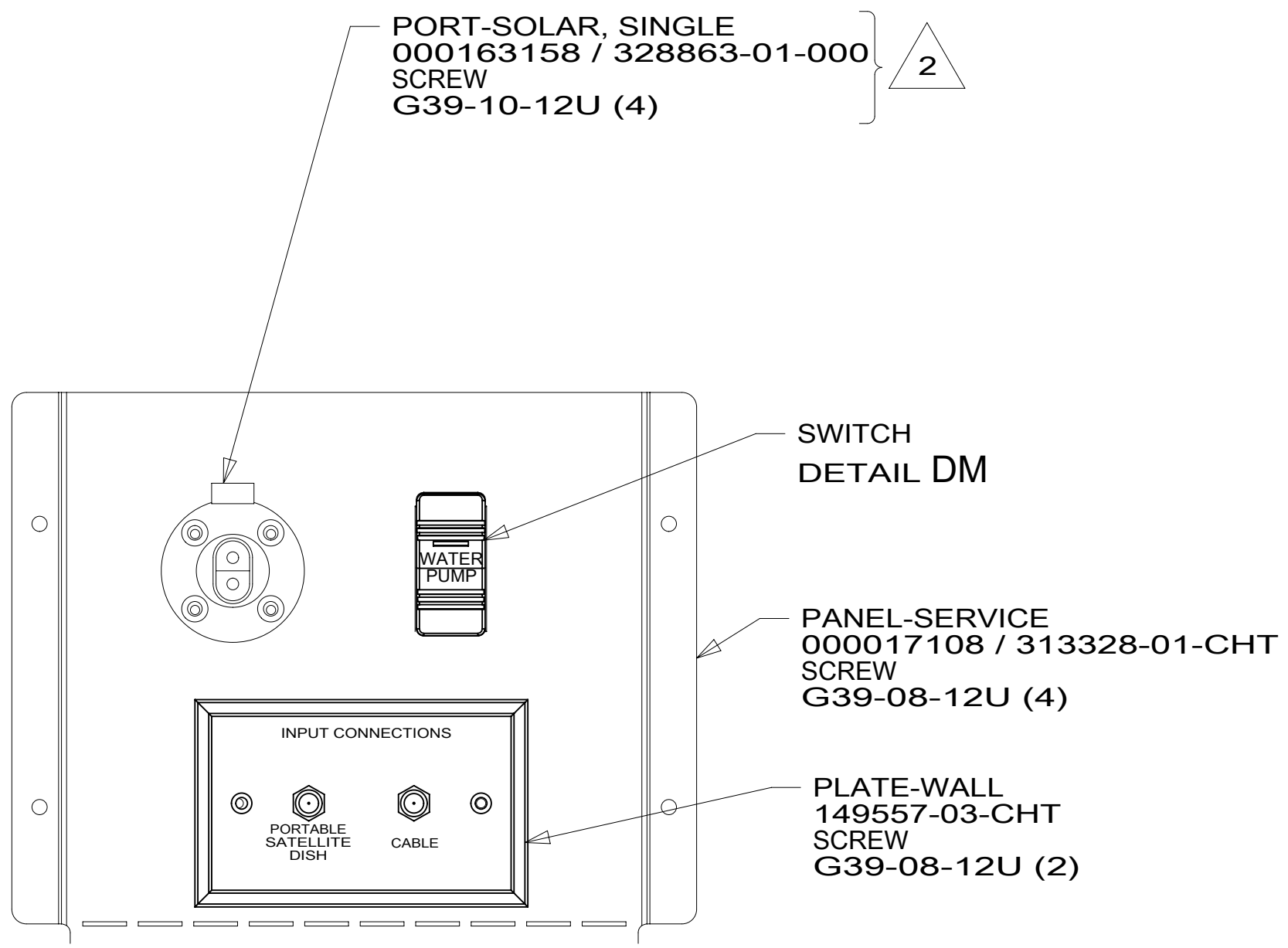

VIEW AA

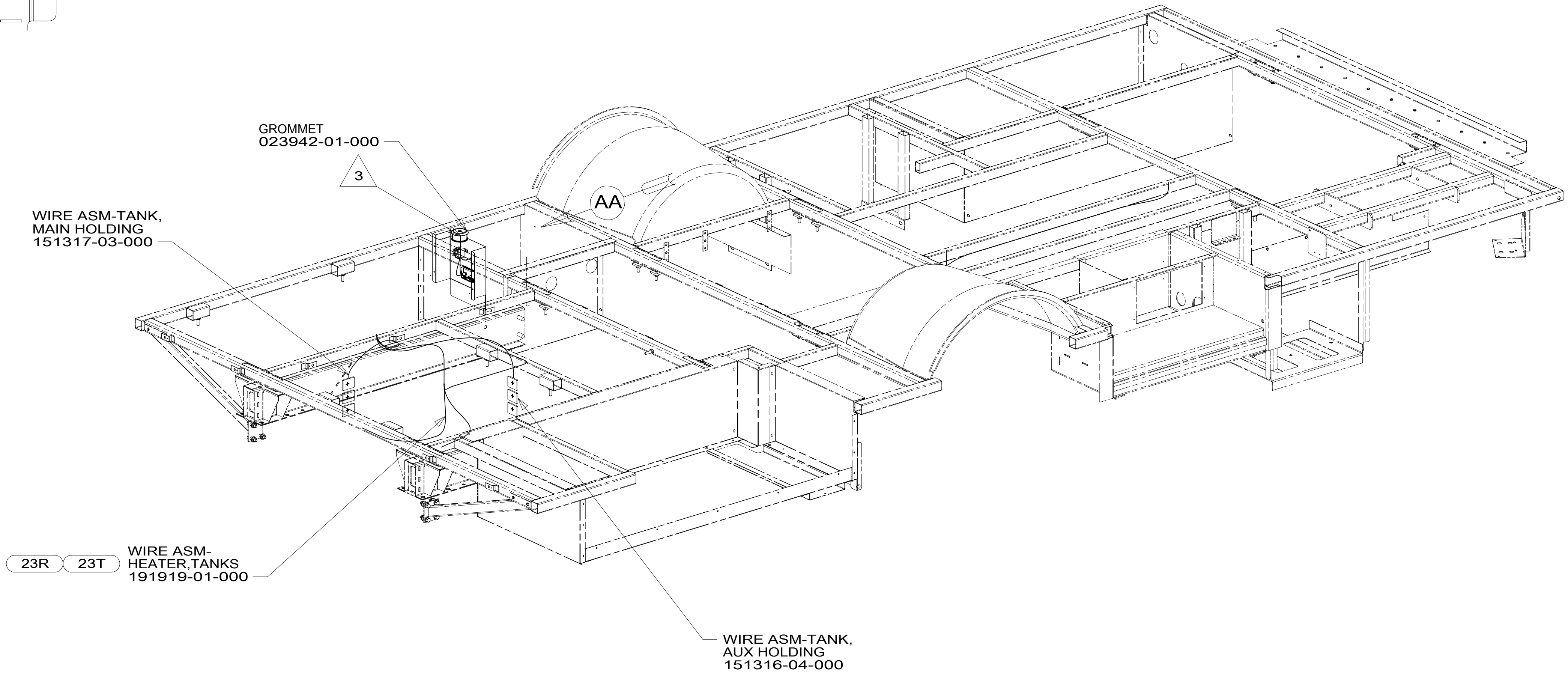

- 3 WIRE PASSES THROUGH FLOOR IN THIS AREA.
- 2 SPLICE YELLOW TO RED AND WHITE TO BLACK.

1. AT MINIMUM ALL WIRES TO BE SUPPORTED AND SECURED PER CODE REQUIREMENTS. USE CLAMP 10495 OR 10497 OR WIRE TIE 8343 OR 108046 AND SCREW G67-XX-XXX OR G56-XX-XXX AS APPROPRIATE FOR INSTALLATION.

NOTES:

- 23T DRAINAGE SYSTEM-HEATED
- 23R DRAINAGE SYSTEM/HEAT-PREWIRED
- 265 CODES/STANDARDS-CSA/CMVSS
- 1B1 CODES/STANDARDS USA

- 1B1 265



DSNR:	ALL DIMENSIONS ARE IN MILLIMETERS	
DIFFR:	MATERIAL:	
UNSPECIFIED TOLERANCES:		
WHOLE DIM (X)	: 3	
ONE-PLACE (X.X)	: 1.5	
TWO-PLACE (X.XX)	: 0.50	
ANGLE	: 1°	

REFER TO ES0018 FOR FASTENER TIGHTENING GUIDELINES

WEIGHT: (LBS) FIRST USED: **19 423T**

**DESCRIPTION:**  
**WIRING INSTL-BODY, 12V**

SHEET:	ITEM/PART NO.:	REV:
<b>1 OF 6</b>	<b>000159976 / 32781101000</b>	

FOR ELECTRICAL TORQUE SPECIFICATIONS SEE DWG NO. 128783-01-000

FOR ELECTRICAL CALLOUTS SEE DWG NO. 121339-01-000

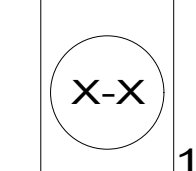

8 7 6 5 4 3 2 1

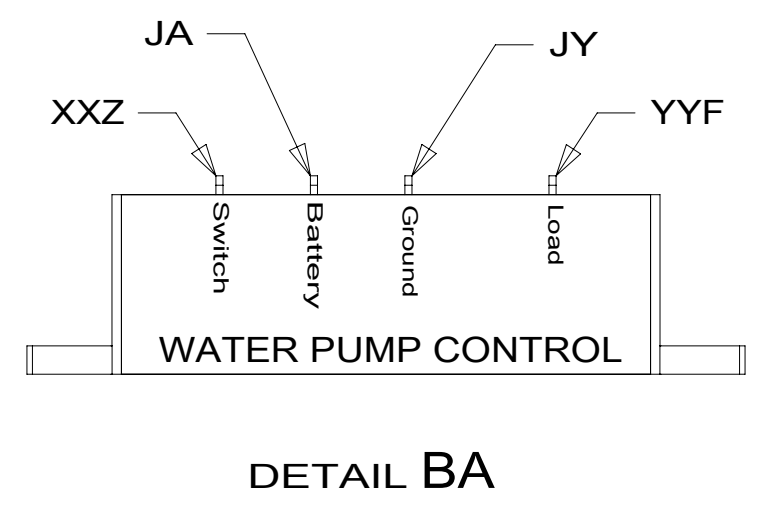
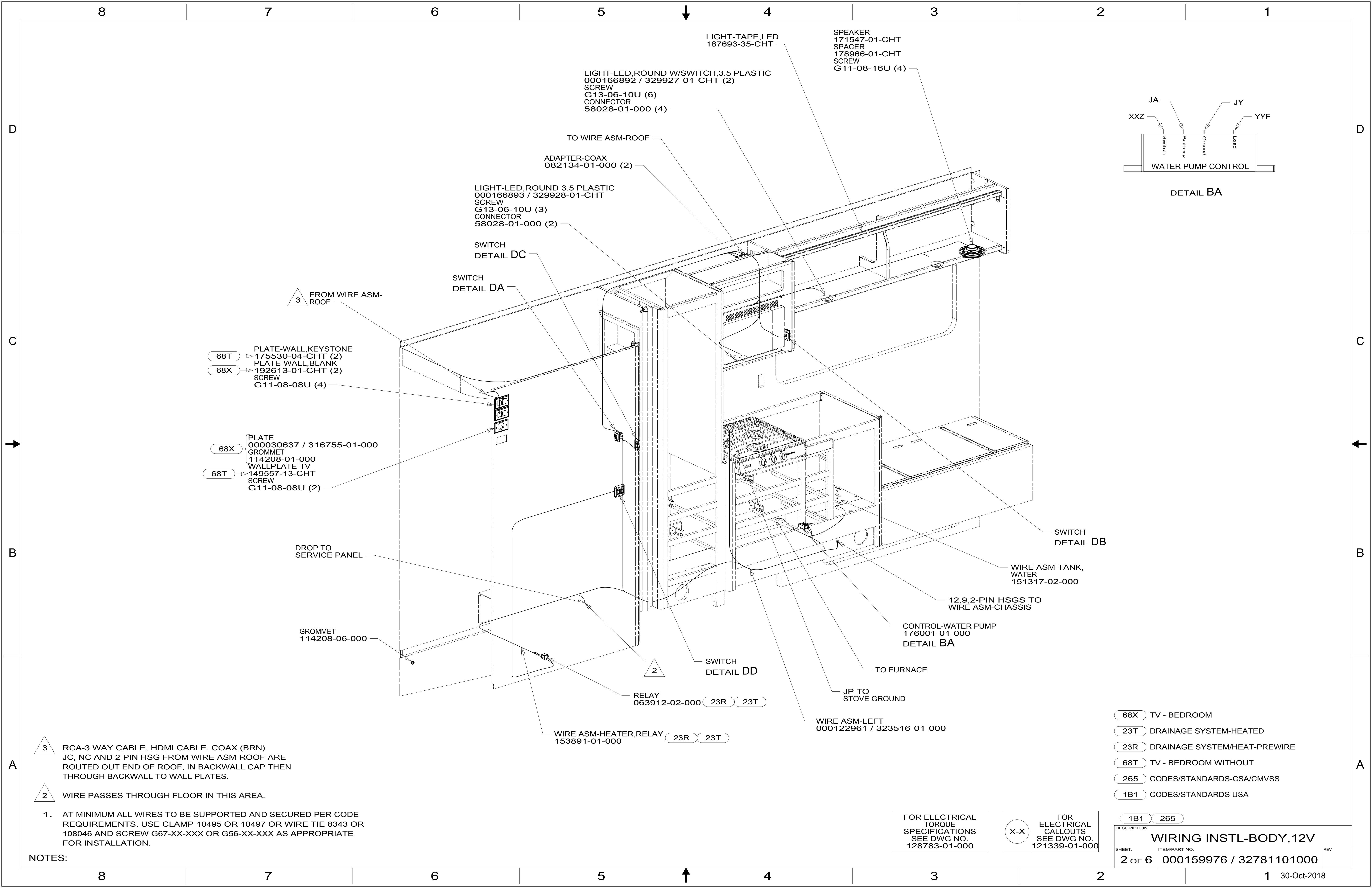

- 68T PLATE-WALL,KEYSTONE  
175530-04-CHT (2)
- 68X PLATE-WALL,BLANK  
192613-01-CHT (2)
- SCREW  
G11-08-08U (4)

- 68X PLATE  
000030637 / 316755-01-000
- GROMMET  
114208-01-000
- 68T WALLPLATE-TV  
149557-13-CHT
- SCREW  
G11-08-08U (2)

3 RCA-3 WAY CABLE, HDMI CABLE, COAX (BRN)  
JC, NC AND 2-PIN HSG FROM WIRE ASM-ROOF ARE  
ROUTED OUT END OF ROOF, IN BACKWALL CAP THEN  
THROUGH BACKWALL TO WALL PLATES.

2 WIRE PASSES THROUGH FLOOR IN THIS AREA.

1. AT MINIMUM ALL WIRES TO BE SUPPORTED AND SECURED PER CODE  
REQUIREMENTS. USE CLAMP 10495 OR 10497 OR WIRE TIE 8343 OR  
108046 AND SCREW G67-XX-XXX OR G56-XX-XXX AS APPROPRIATE  
FOR INSTALLATION.

NOTES:

- 68X TV - BEDROOM
- 23T DRAINAGE SYSTEM-HEATED
- 23R DRAINAGE SYSTEM/HEAT-PREWIRE
- 68T TV - BEDROOM WITHOUT
- 265 CODES/STANDARDS-CSA/CMVSS
- 1B1 CODES/STANDARDS USA

FOR ELECTRICAL  
TORQUE  
SPECIFICATIONS  
SEE DWG NO.  
128783-01-000

FOR  
ELECTRICAL  
CALLOUTS  
SEE DWG NO.  
121339-01-000

DESCRIPTION:	1B1 265	
<b>WIRING INSTL-BODY, 12V</b>		
SHEET:	ITEM/PART NO:	REV
2 OF 6	000159976 / 32781101000	

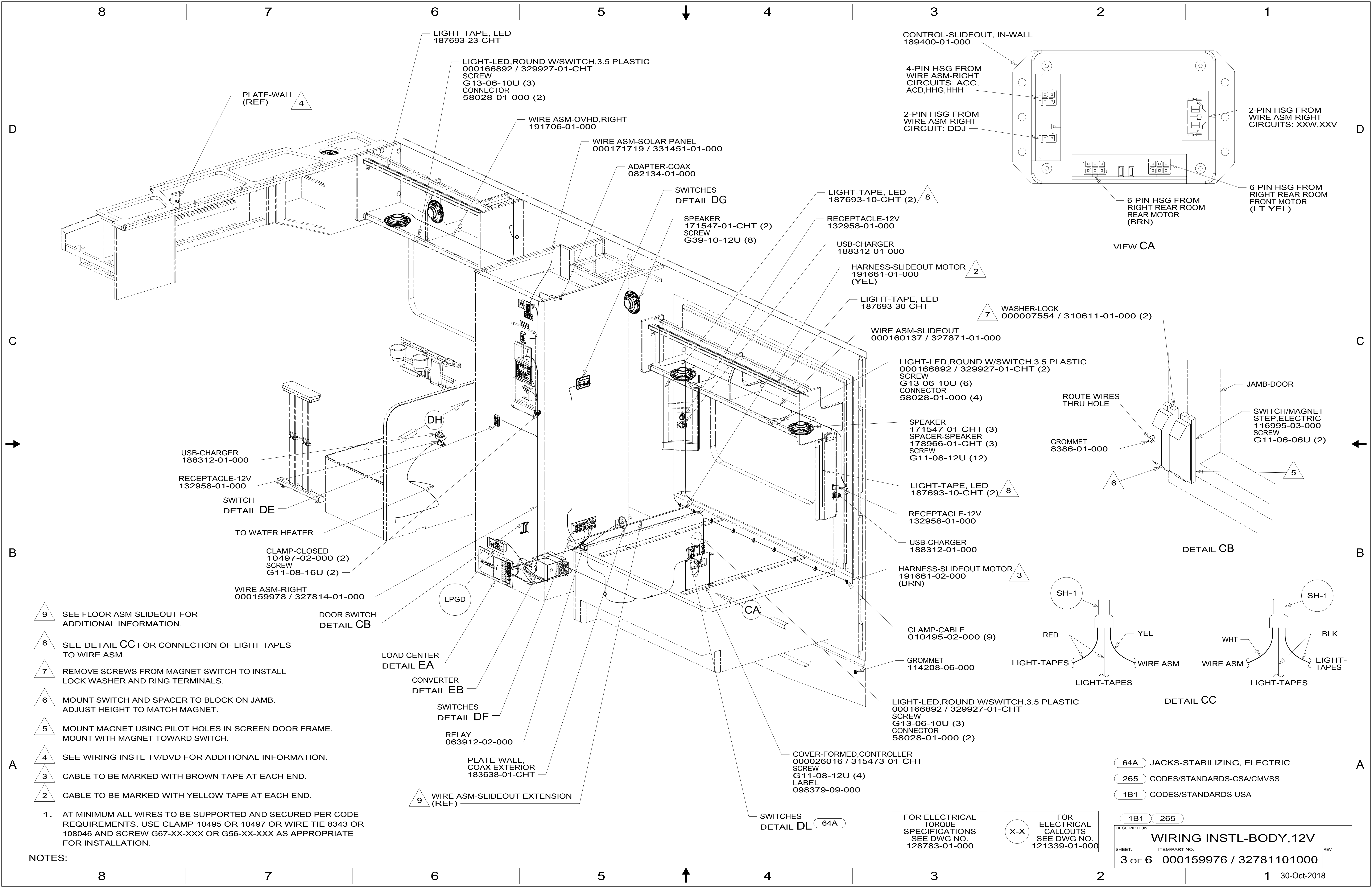

LIGHT-TAPE, LED  
187693-23-CHT

LIGHT-LED, ROUND W/SWITCH, 3.5 PLASTIC  
000166892 / 329927-01-CHT  
SCREW  
G13-06-10U (3)  
CONNECTOR  
58028-01-000 (2)

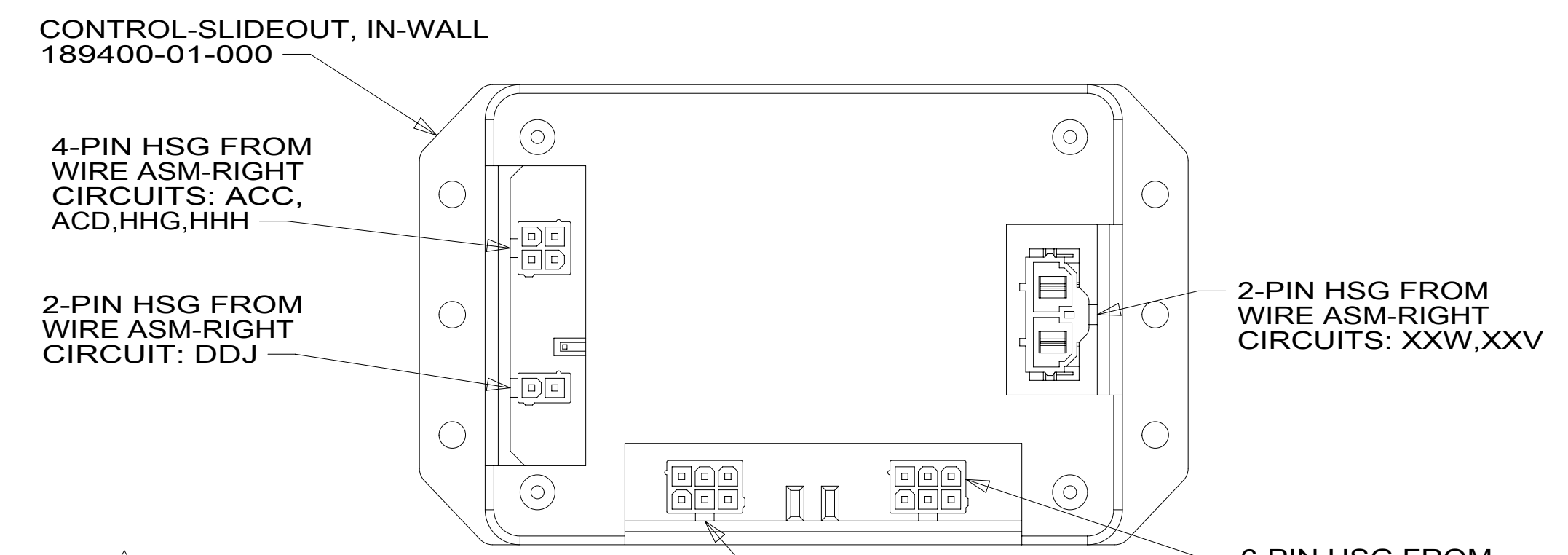

VIEW CA

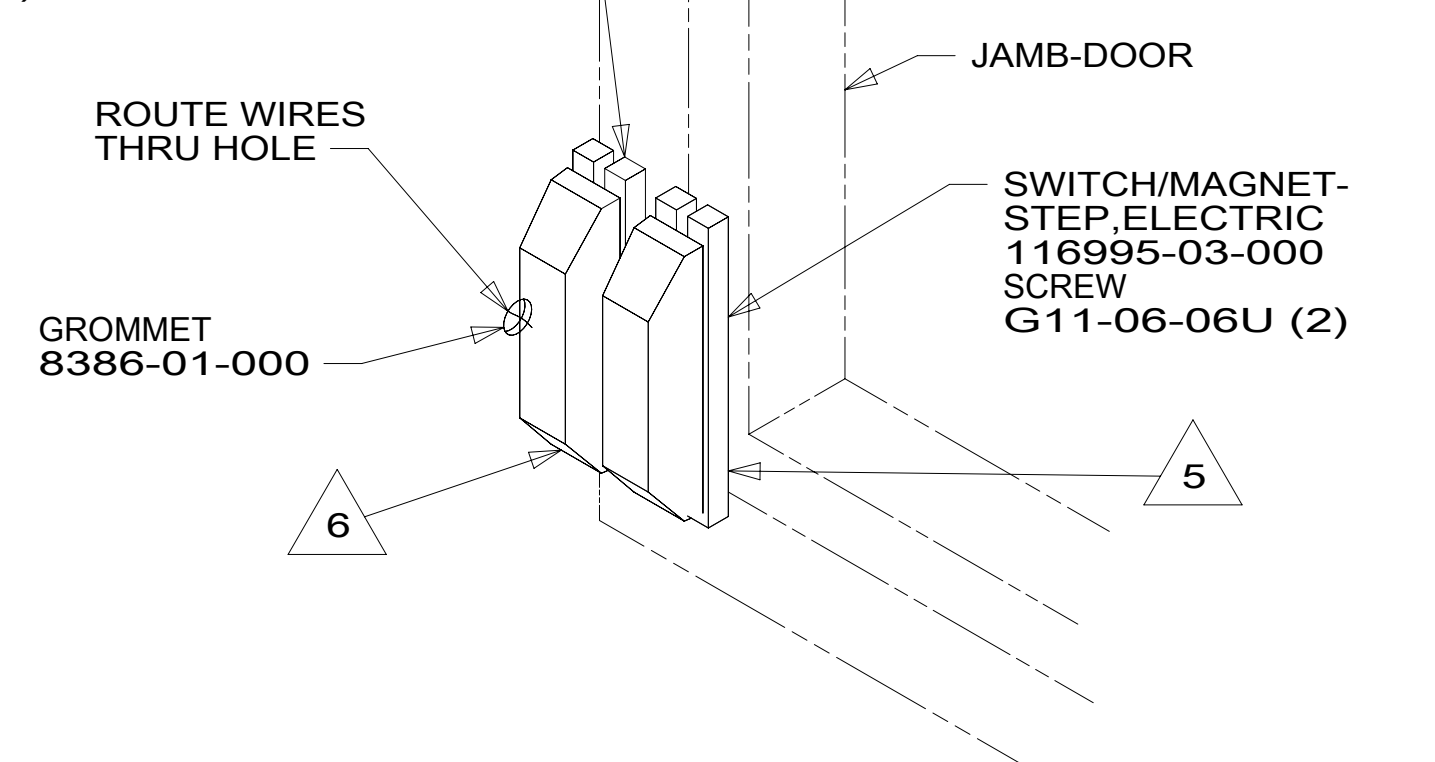

DETAIL CB

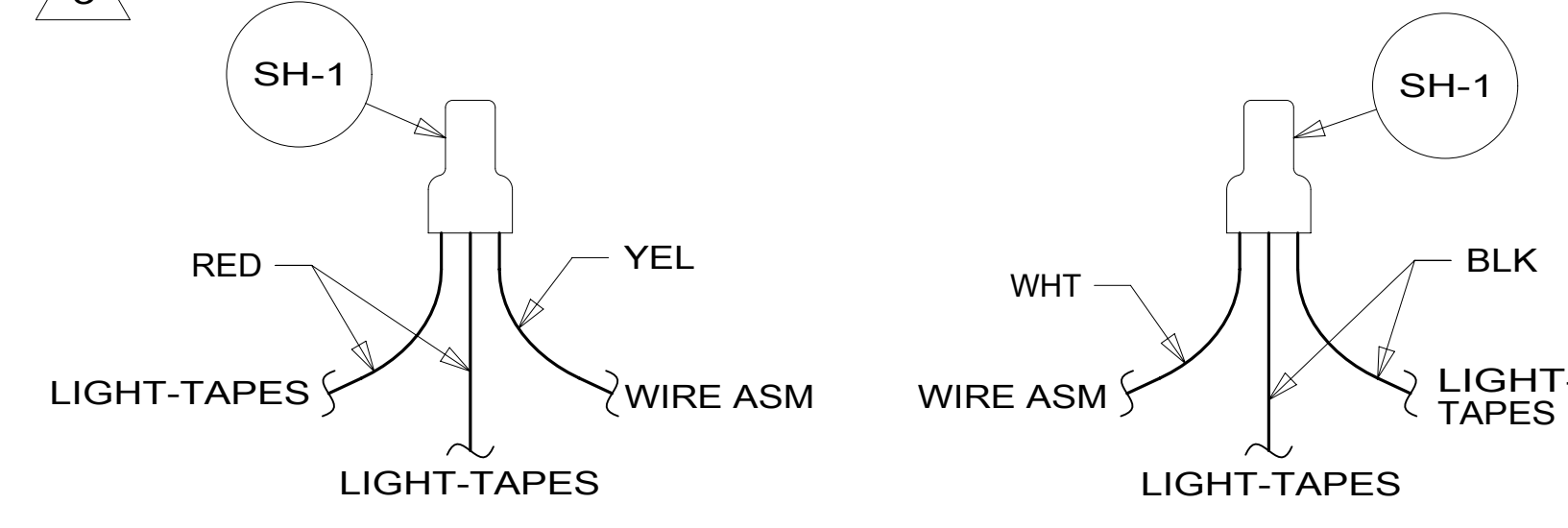

DETAIL CC

- 9 SEE FLOOR ASM-SLIDEOUT FOR ADDITIONAL INFORMATION.
- 8 SEE DETAIL CC FOR CONNECTION OF LIGHT-TAPES TO WIRE ASM.
- 7 REMOVE SCREWS FROM MAGNET SWITCH TO INSTALL LOCK WASHER AND RING TERMINALS.
- 6 MOUNT SWITCH AND SPACER TO BLOCK ON JAMB. ADJUST HEIGHT TO MATCH MAGNET.
- 5 MOUNT MAGNET USING PILOT HOLES IN SCREEN DOOR FRAME. MOUNT WITH MAGNET TOWARD SWITCH.
- 4 SEE WIRING INSTL-TV/DVD FOR ADDITIONAL INFORMATION.
- 3 CABLE TO BE MARKED WITH BROWN TAPE AT EACH END.
- 2 CABLE TO BE MARKED WITH YELLOW TAPE AT EACH END.
1. AT MINIMUM ALL WIRES TO BE SUPPORTED AND SECURED PER CODE REQUIREMENTS. USE CLAMP 10495 OR 10497 OR WIRE TIE 8343 OR 108046 AND SCREW G67-XX-XXX OR G56-XX-XXX AS APPROPRIATE FOR INSTALLATION.

NOTES:

9 WIRE ASM-SLIDEOUT EXTENSION (REF)

FOR ELECTRICAL TORQUE SPECIFICATIONS SEE DWG NO. 128783-01-000

FOR ELECTRICAL CALLOUTS SEE DWG NO. 121339-01-000

- 64A JACKS-STABILIZING, ELECTRIC
- 265 CODES/STANDARDS-CSA/CMVSS
- 1B1 CODES/STANDARDS USA

DESCRIPTION: <b>WIRING INSTL-BODY, 12V</b>		
SHEET: 3 OF 6	ITEM/PART NO.: 000159976 / 32781101000	REV
30-Oct-2018		

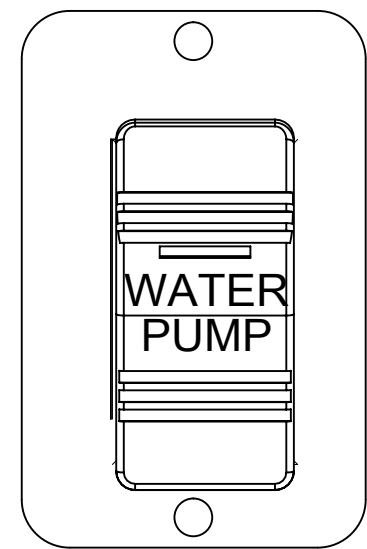

SWITCH-ROCKER  
108357-21-000  
ACTUATOR-SWITCH  
108356-23-CHT  
PLATE-SWITCH  
144363-02-CHT  
SCREW  
G11-06-10U (2)

DETAIL DA

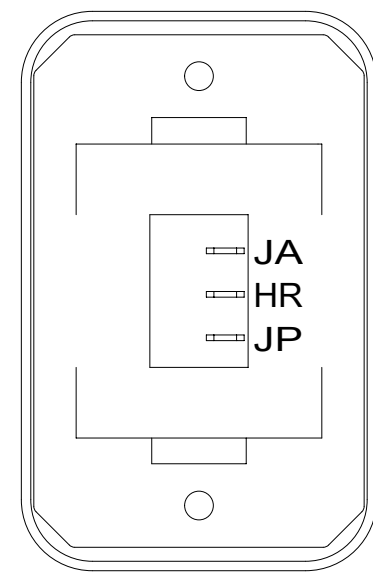

SWITCH-ROCKER  
135740-06-CHT  
SWITCH-BASE  
135741-01-CHT  
SWITCH-BEZEL  
135742-01-CHT  
SCREW  
G11-08-08U (2)

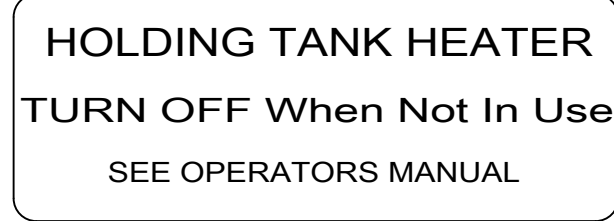

LABEL-SWITCH,  
HTR,HOLDING TK  
134563-01-CHT

DETAIL DJ 23T 23R

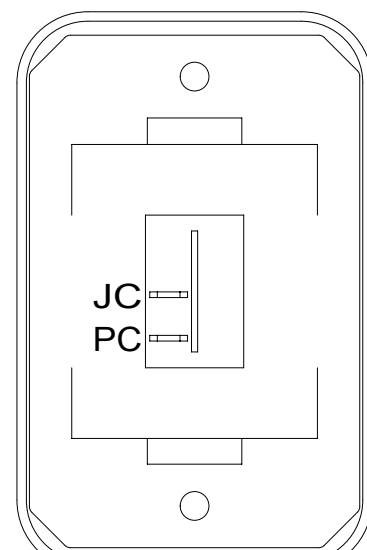

SWITCH-ROCKER  
135740-01-CHT  
SWITCH-BASE  
135741-01-CHT  
SWITCH-BEZEL  
135742-01-CHT  
SCREW  
G11-08-08U (2)

DETAIL DB

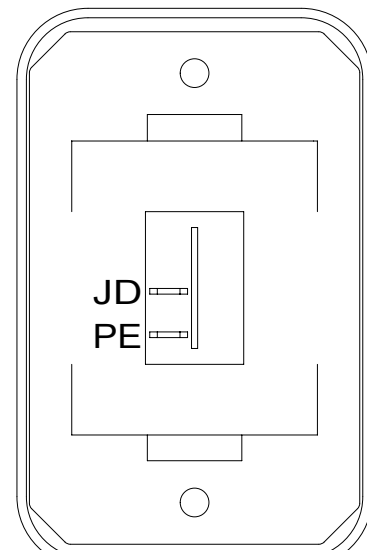

SWITCH-ROCKER  
135740-01-CHT  
SWITCH-BASE  
135741-01-CHT  
SWITCH-BEZEL  
135742-01-CHT  
SCREW  
G11-08-08U (2)

DETAIL DC

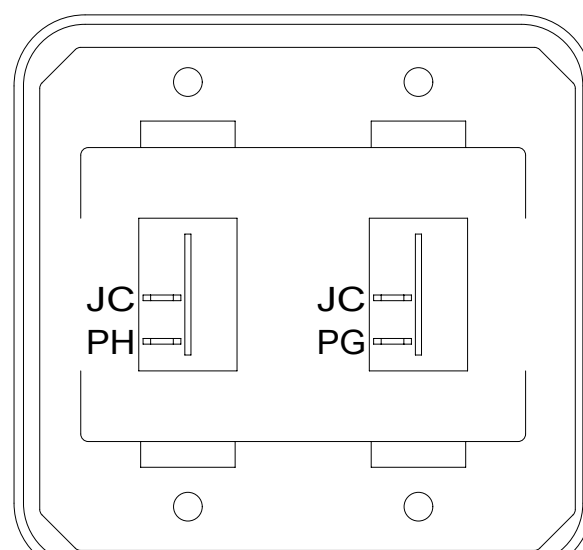

SWITCH-ROCKER  
135740-01-CHT (2)  
SWITCH-BASE  
135741-02-CHT  
SWITCH-BEZEL  
135742-02-CHT  
SCREW  
G11-08-08U (4)

DETAIL DD

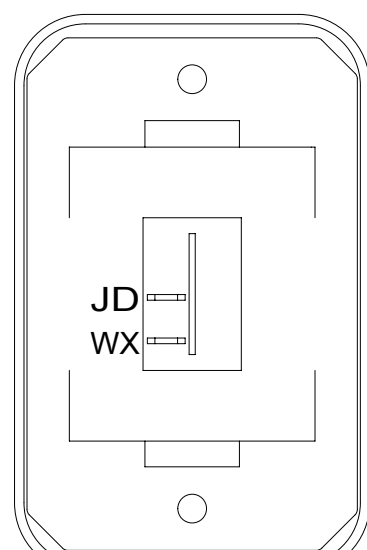

SWITCH-ROCKER  
135740-01-CHT  
SWITCH-BASE  
135741-01-CHT  
SWITCH-BEZEL  
135742-01-CHT  
SCREW  
G11-08-08U (2)

DETAIL DE

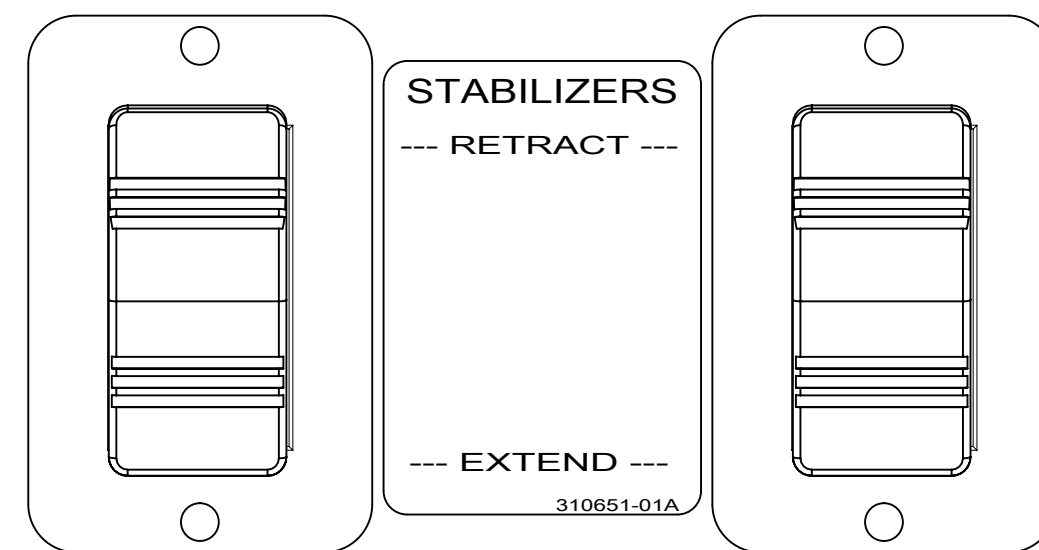

DETAIL DL 64A

SWITCH-ROCKER  
108357-06-000 (2)  
ACTUATOR  
108356-01-000 (2)  
LABEL  
000007799 / 310651-01-CHT  
SWITCH-BLANK  
096241-03-000 (2)  
PLATE-SWITCH  
144363-02-CHT (2)  
SCREW  
G11-08-08U (4)

64A

60T

SWITCH-ROCKER  
108357-18-000  
ACTUATOR-SWITCH  
108356-19-CHT  
CIRCUITS: LH,LG,  
LJ-1,JC,NC  
WIRE ASM-THERMISTOR  
186796-01-000

SWITCH-ROCKER  
108357-01-000  
ACTUATOR-SWITCH  
108356-22-CHT  
CIRCUITS: FFD,FFT

SWITCH-ROCKER  
108357-06-000  
ACTUATOR-SWITCH  
108356-12-CHT  
CIRCUITS: FFN,  
FFP,FFR

SWITCH-ROCKER  
108357-14-000  
ACTUATOR-SWITCH  
108356-28-CHT  
CIRCUITS:  
RS,ZZK,NC

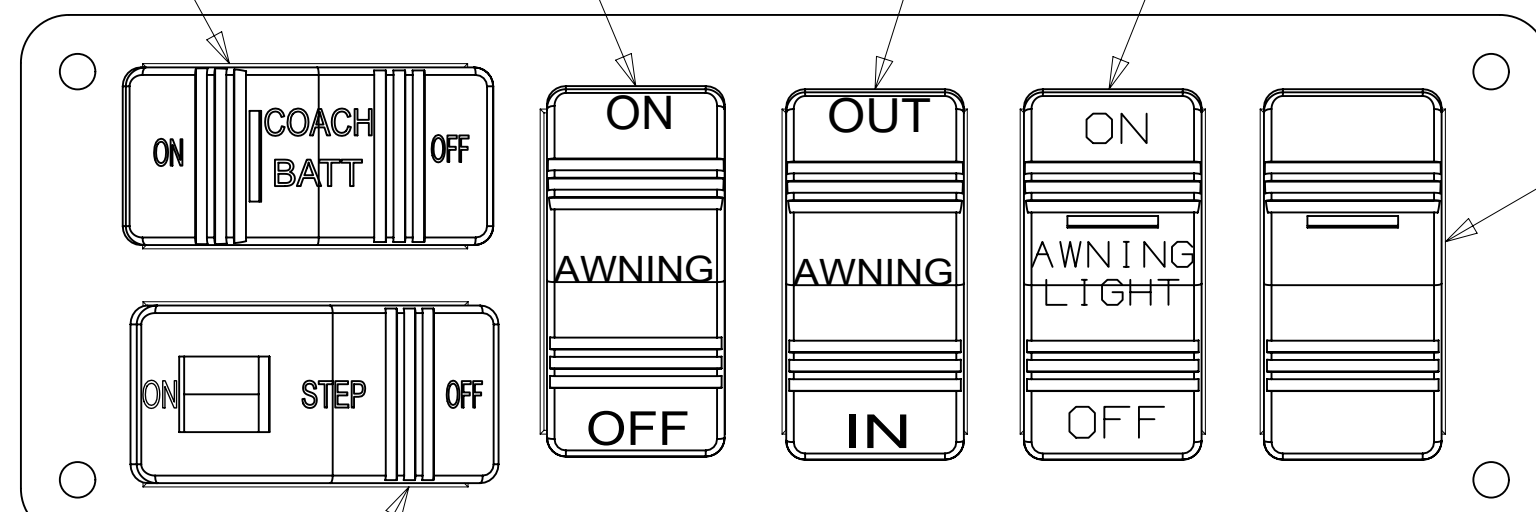

DETAIL DF

SWITCH-ROCKER  
108357-14-000  
ACTUATOR-SWITCH  
108356-03-CHT  
CIRCUITS:  
AES,AET,NC

SWITCH-ROCKER  
108357-19-000  
CIRCUITS: ER,ES

PLATE-SWITCH  
00022055 / 314395-01-CHT  
SCREW  
G11-06-10U (4)

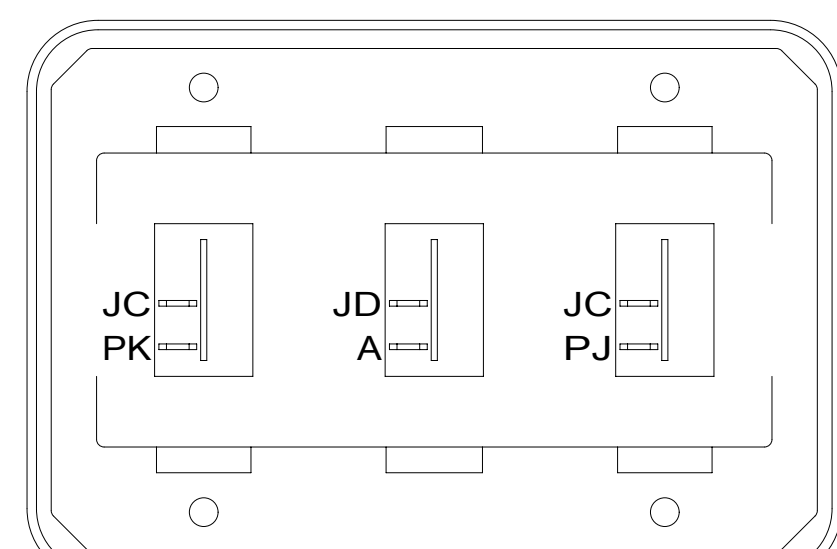

DETAIL DG

SWITCH-ROCKER  
135740-01-CHT (3)  
SWITCH-BASE  
135741-03-CHT  
SWITCH-BEZEL  
135742-03-CHT  
SCREW  
G11-08-08U (4)

REMOTE PANEL-INVERTER  
000037772 / 318694-01-CHT  
SCREW  
G11-06-08U (2)  
CABLE-DATA  
000038250 / 318769-01-000

CONTROL-CHARGE,  
SOLAR 30 AMP  
191278-01-000  
SCREW  
G11-08-08U (2)  
DETAIL DK

PANEL-MONITOR,LCD  
175724-01-000  
SCREW  
G11-08-08U (4)

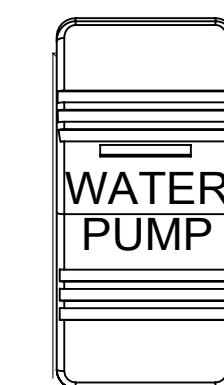

VIEW DM

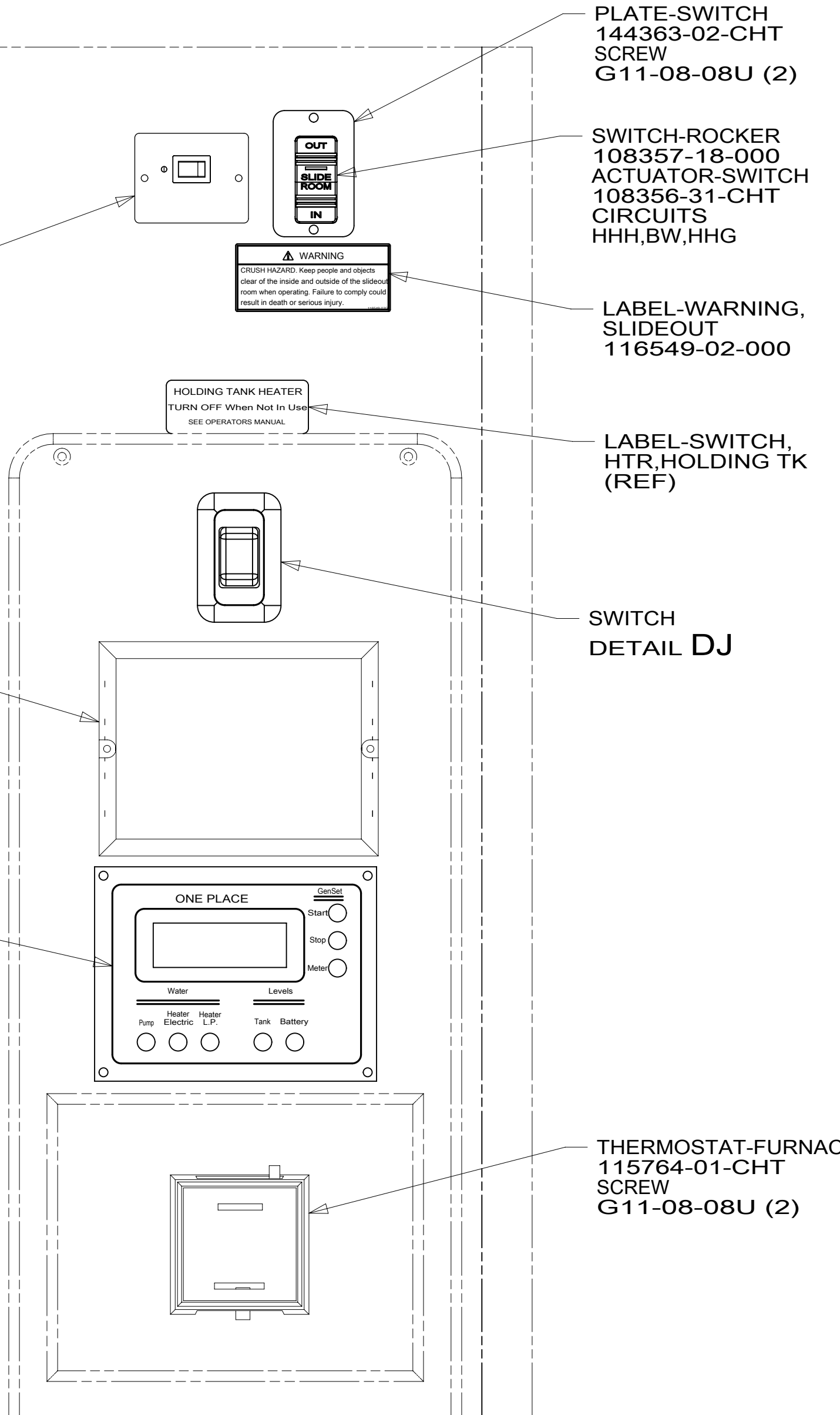

VIEW DH

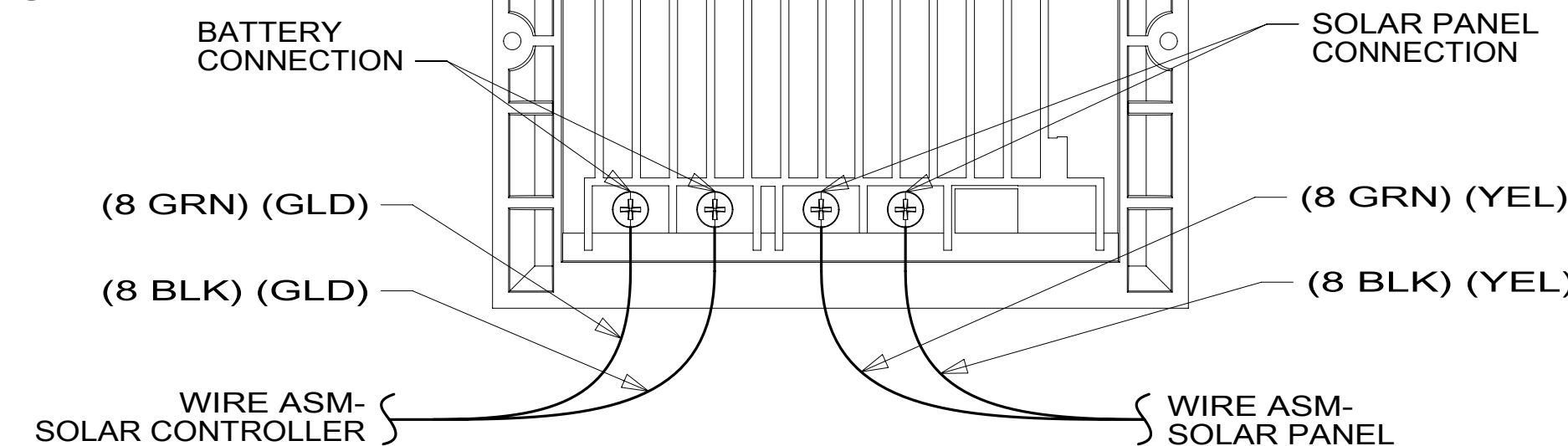

DETAIL DK

- 60T JACKS-STABILIZING,ELECT W/O
- 64A JACKS-STABILIZING, ELECTRIC
- 23R DRAINAGE SYSTEM/HEAT-PREWIRE
- 23T DRAINAGE SYSTEM-HEATED
- 265 CODES/STANDARDS-CSA/CMVSS
- 1B1 CODES/STANDARDS USA

FOR ELECTRICAL  
TORQUE  
SPECIFICATIONS  
SEE DWG NO.  
128783-01-000

FOR ELECTRICAL  
CALLOUTS  
SEE DWG NO.  
121339-01-000

DESCRIPTION:  
**WIRING INSTL-BODY, 12V**  
SHEET: 4 OF 6 ITEM/PART NO: 000159976 / 32781101000 REV

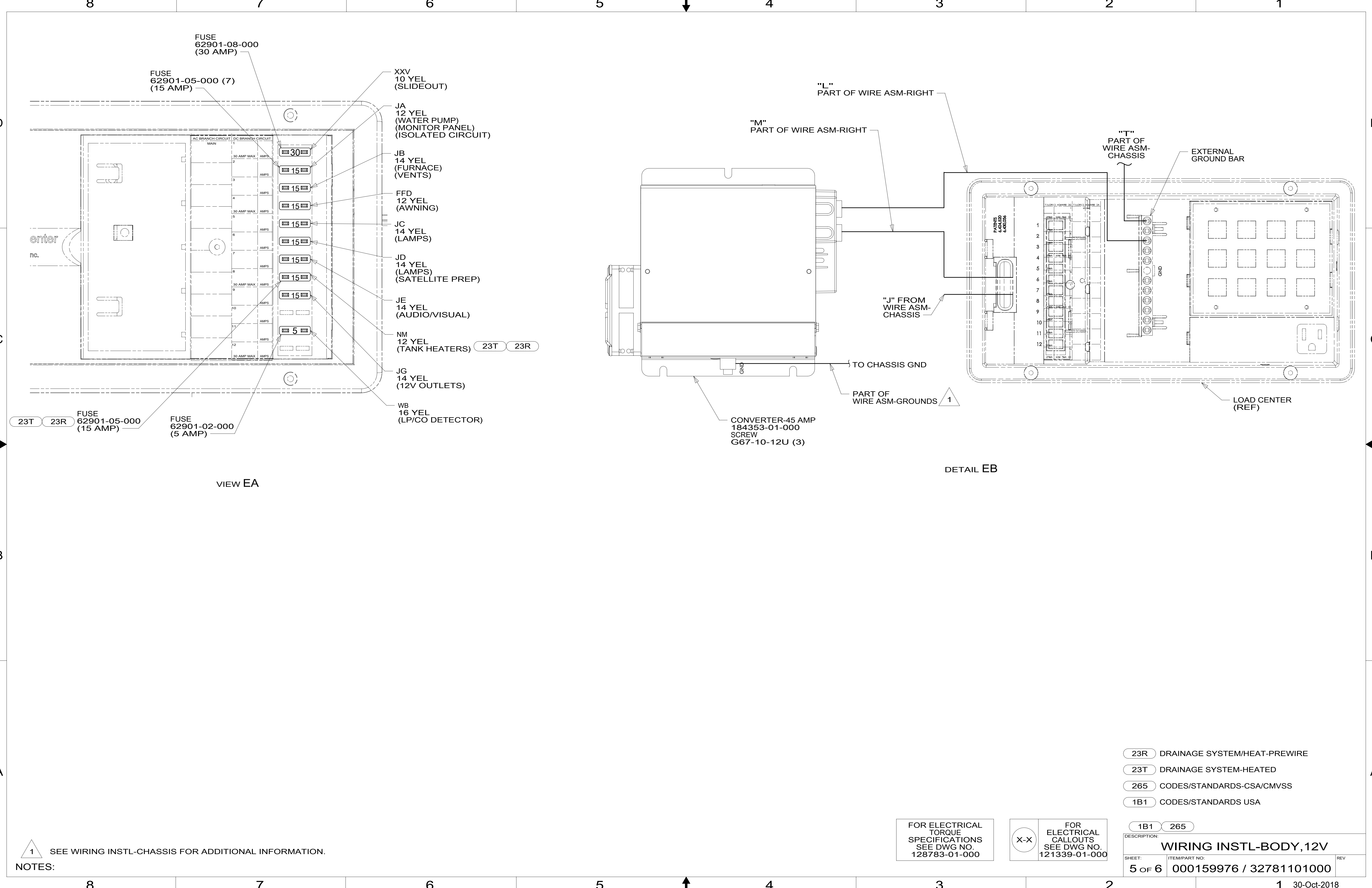

NOTES:

1 SEE WIRING INSTL-CHASSIS FOR ADDITIONAL INFORMATION.

FOR ELECTRICAL TORQUE SPECIFICATIONS SEE DWG NO. 128783-01-000

FOR ELECTRICAL CALLOUTS SEE DWG NO. 121339-01-000

- 23R DRAINAGE SYSTEM/HEAT-PREWIRE
- 23T DRAINAGE SYSTEM-HEATED
- 265 CODES/STANDARDS-CSA/CMVSS
- 1B1 CODES/STANDARDS USA

DESCRIPTION:		
1B1 265		
WIRING INSTL-BODY, 12V		
SHEET:	ITEM/PART NO.:	REV
5 OF 6	000159976 / 32781101000	

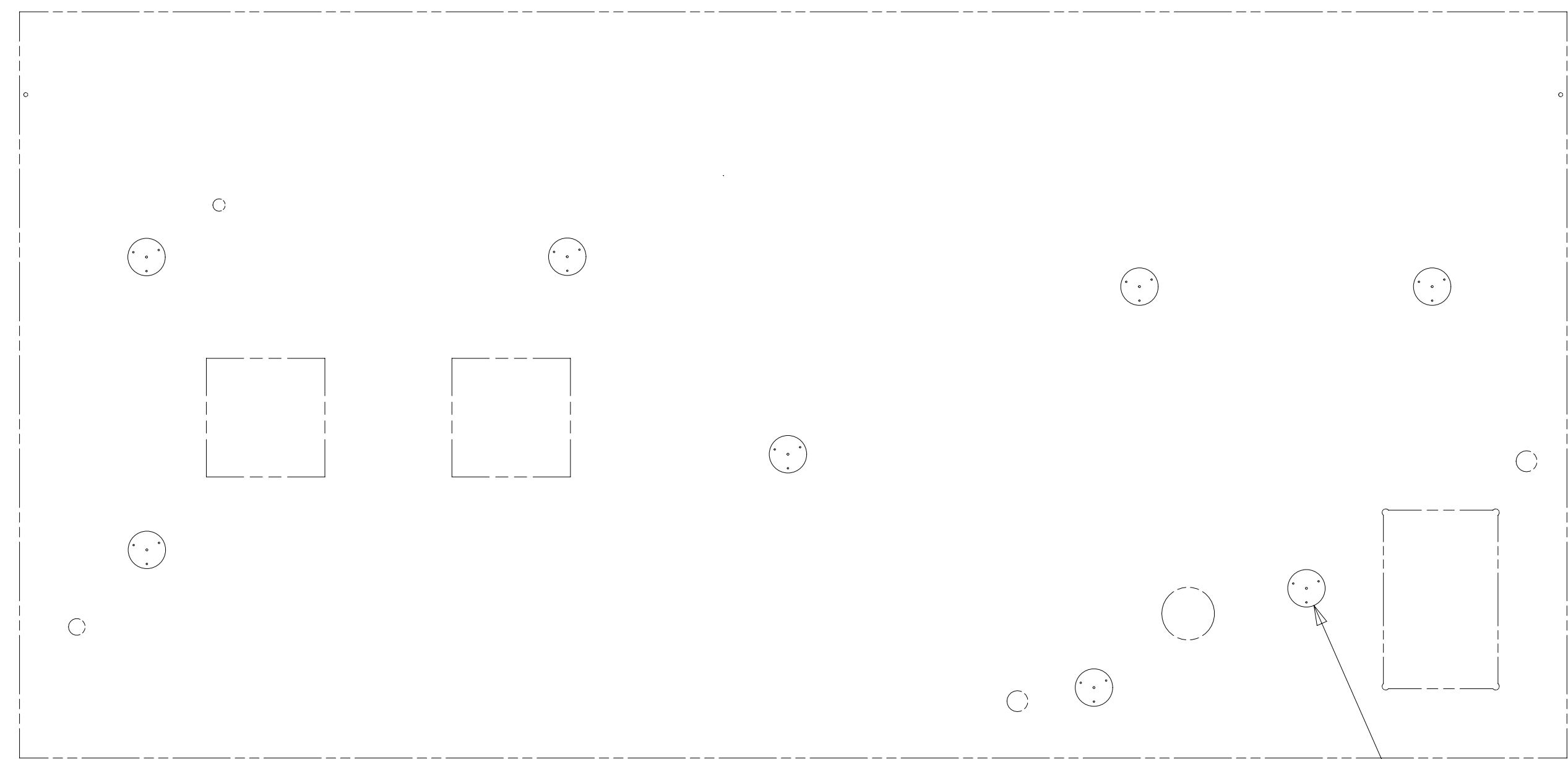

PANEL-SOLAR 100 WATT, FLEXIBLE  
 000131101 / 325665-01-000 (2)  
 WASHER  
 077071-01-000 (12)  
 SCREW  
 000G39-10-16U (12)

LIGHT-LED, ROUND 4.5 PLASTIC  
 000166889 / 329926-01-CHT (8)  
 SCREW  
 G13-06-16U (24)  
 CONNECTOR  
 58028-01-000 (16)

1 ANTENNA-TV, OMNIDIRECTIONAL  
 000171487 / 331386-01-CHT  
 SCREW  
 G67-10-16U (4)

ANTENNA-RADIO, 16 RUBBER  
 090944-01-000  
 BRACKET-ANTENNA GROUND  
 147741-01-CHT  
 VIEW FA

DETAIL FB

PORT-SOLAR, 3 POSITION  
 000170803 / 331218-01-CHT  
 DETAIL FC

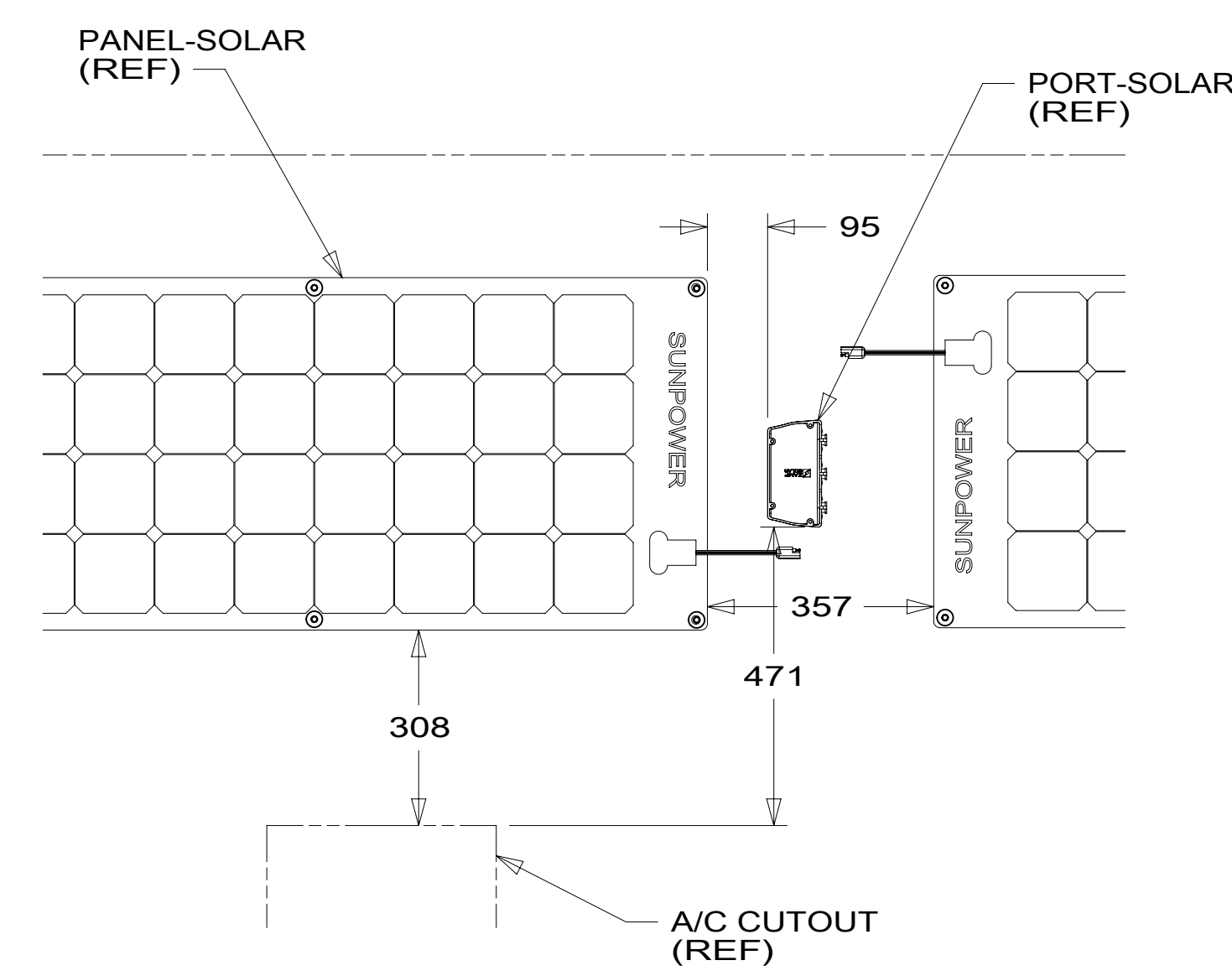
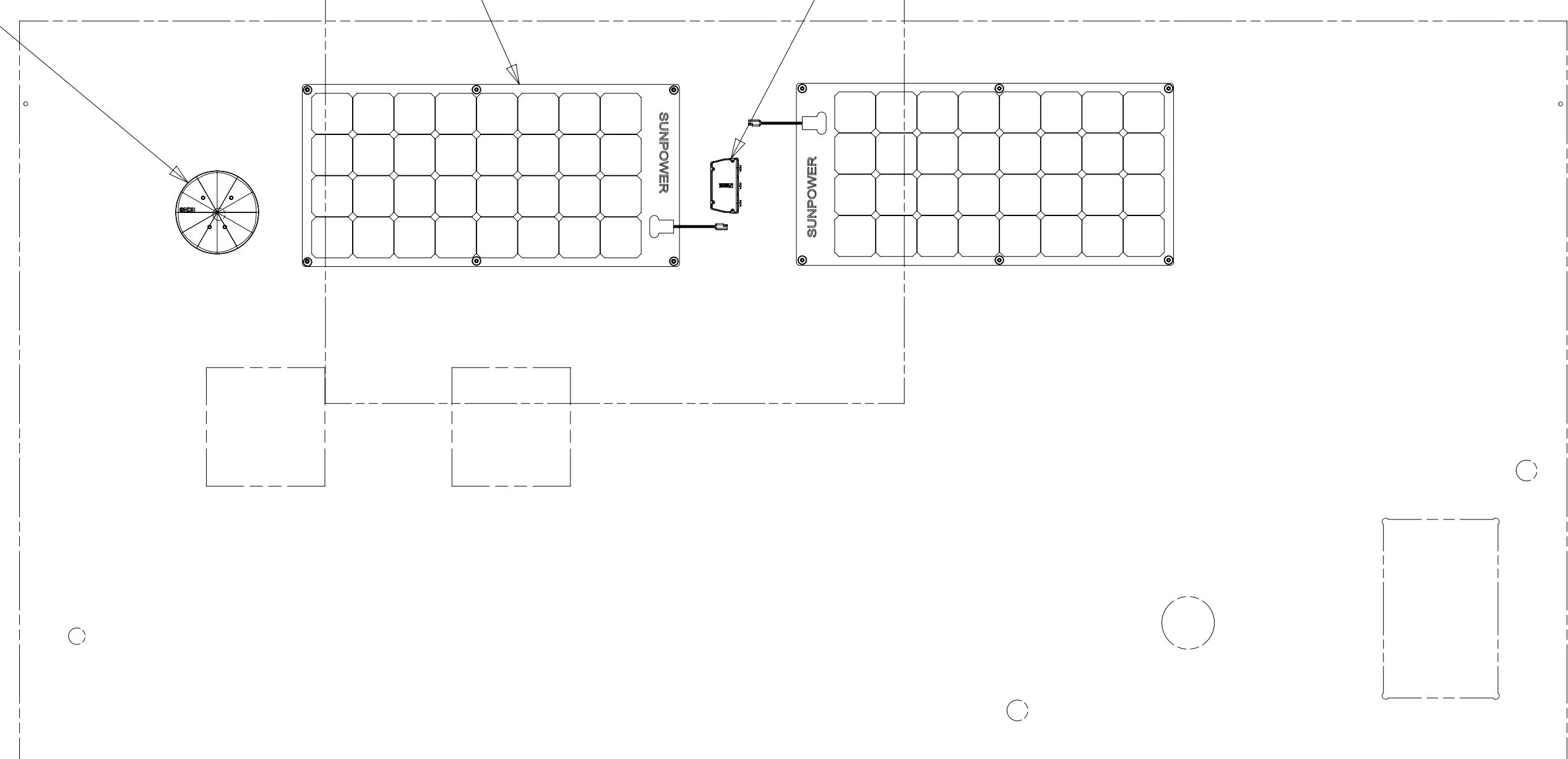

DETAIL FB

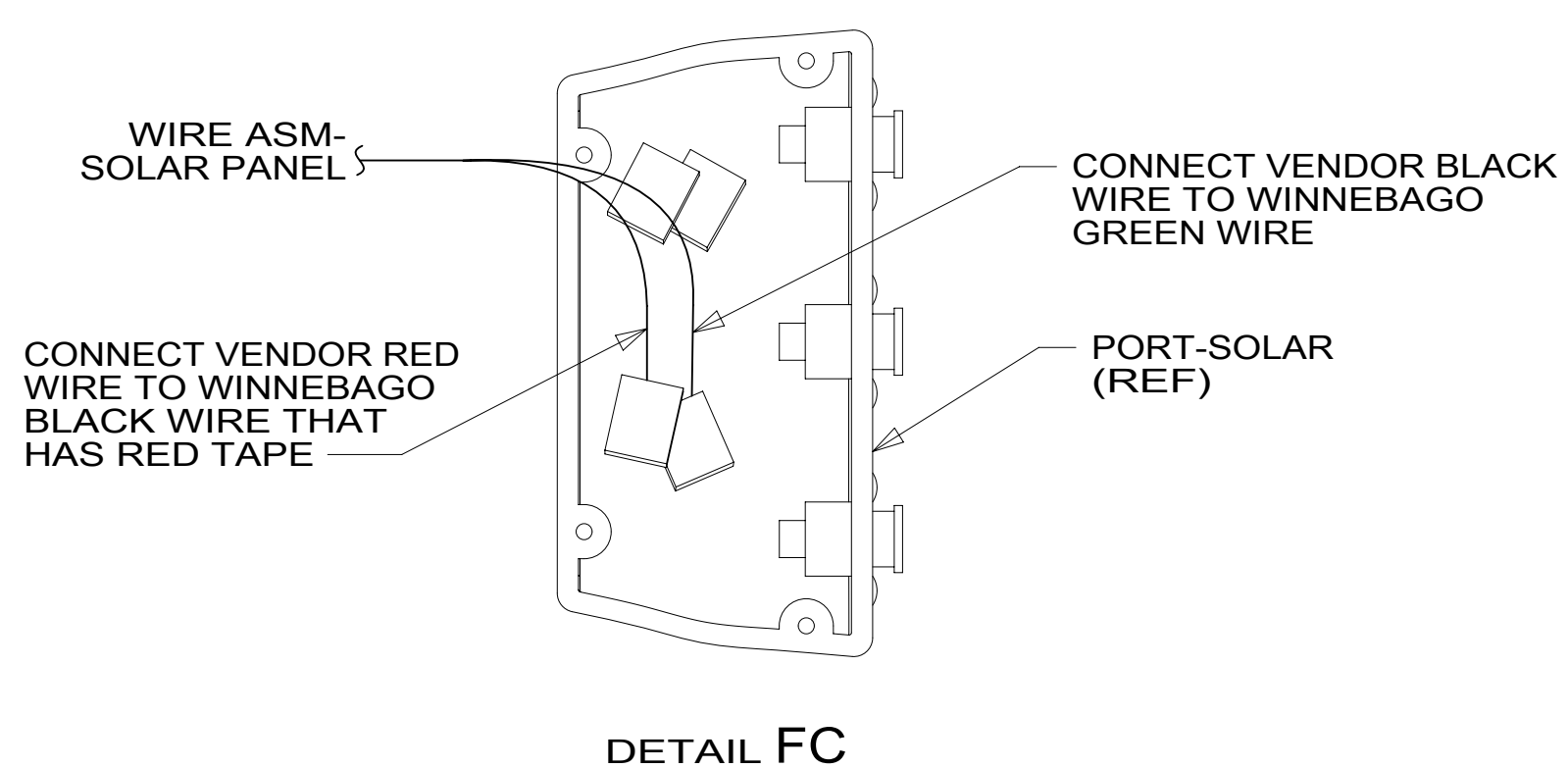

DETAIL FC

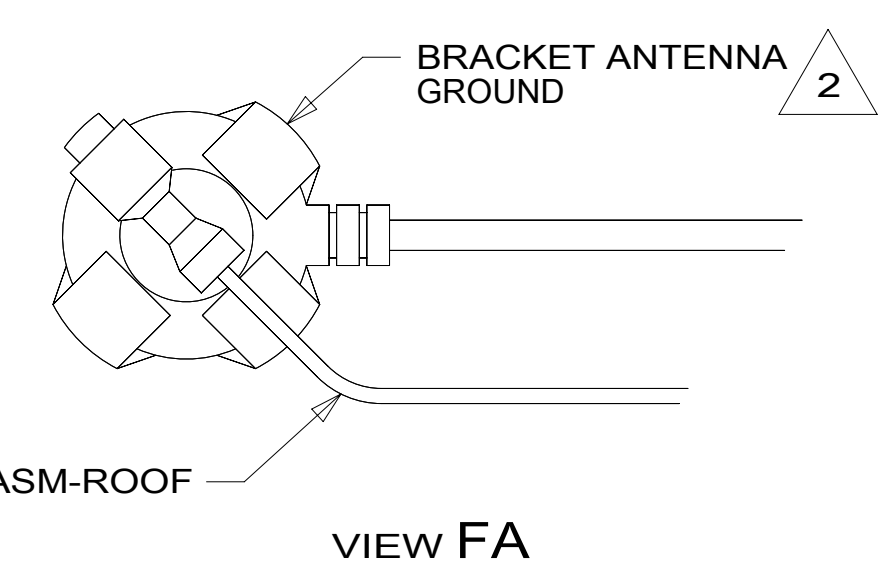

VIEW FA

2 WRAP BRACKET LEGS AROUND ANTENNA BASE.  
 1 SEE ANTENNA INSTALLATION MANUAL FOR CORRECT INSTALLATION PROCEDURE.

NOTES:

FOR ELECTRICAL TORQUE SPECIFICATIONS SEE DWG NO. 128783-01-000

FOR ELECTRICAL CALLOUTS SEE DWG NO. 121339-01-000

265 CODES/STANDARDS-CSA/CMVSS  
 1B1 CODES/STANDARDS USA

DESCRIPTION:	
1B1 265	
<b>WIRING INSTL-BODY, 12V</b>	
SHEET:	ITEM/PART NO. REV
6 OF 6	000159976 / 32781101000