

8 7 6 5 4 3 2 1

D
C
B
A

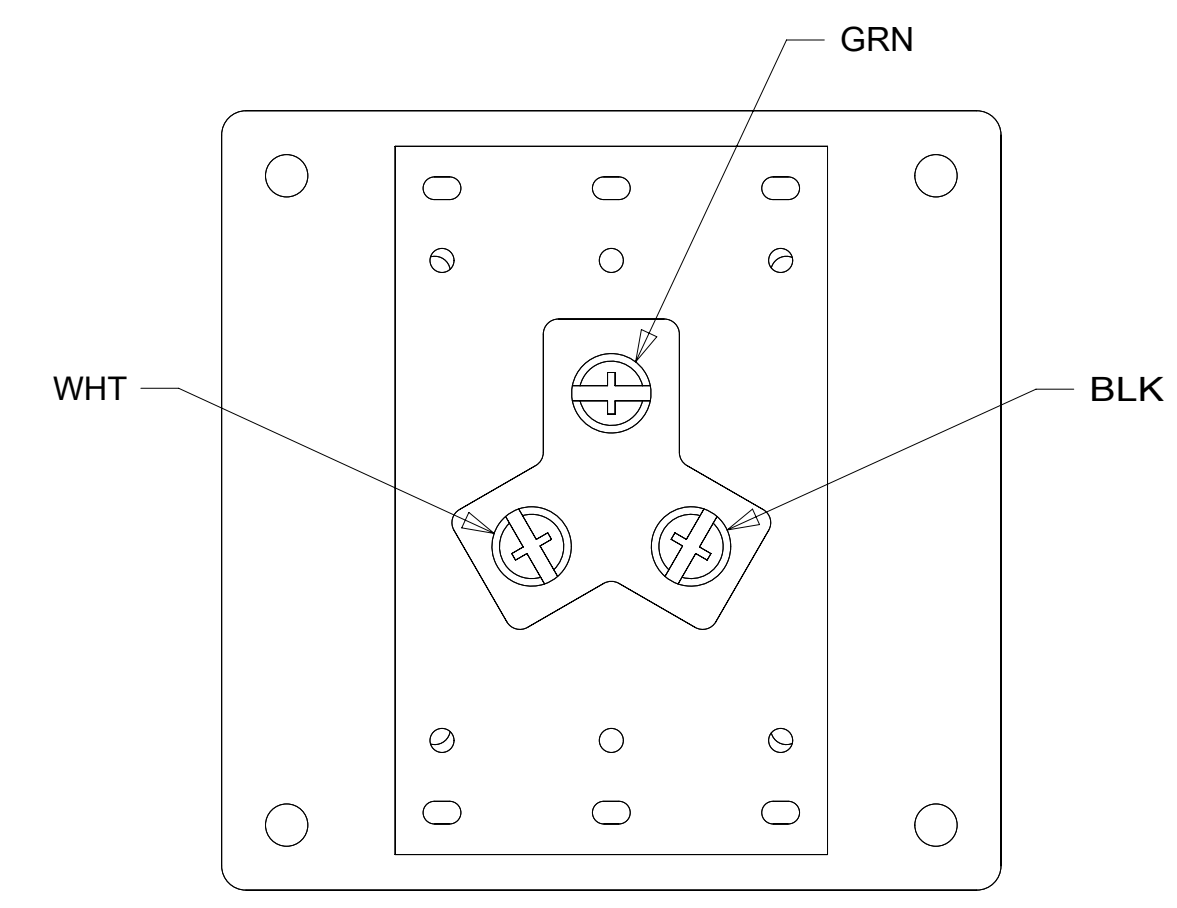
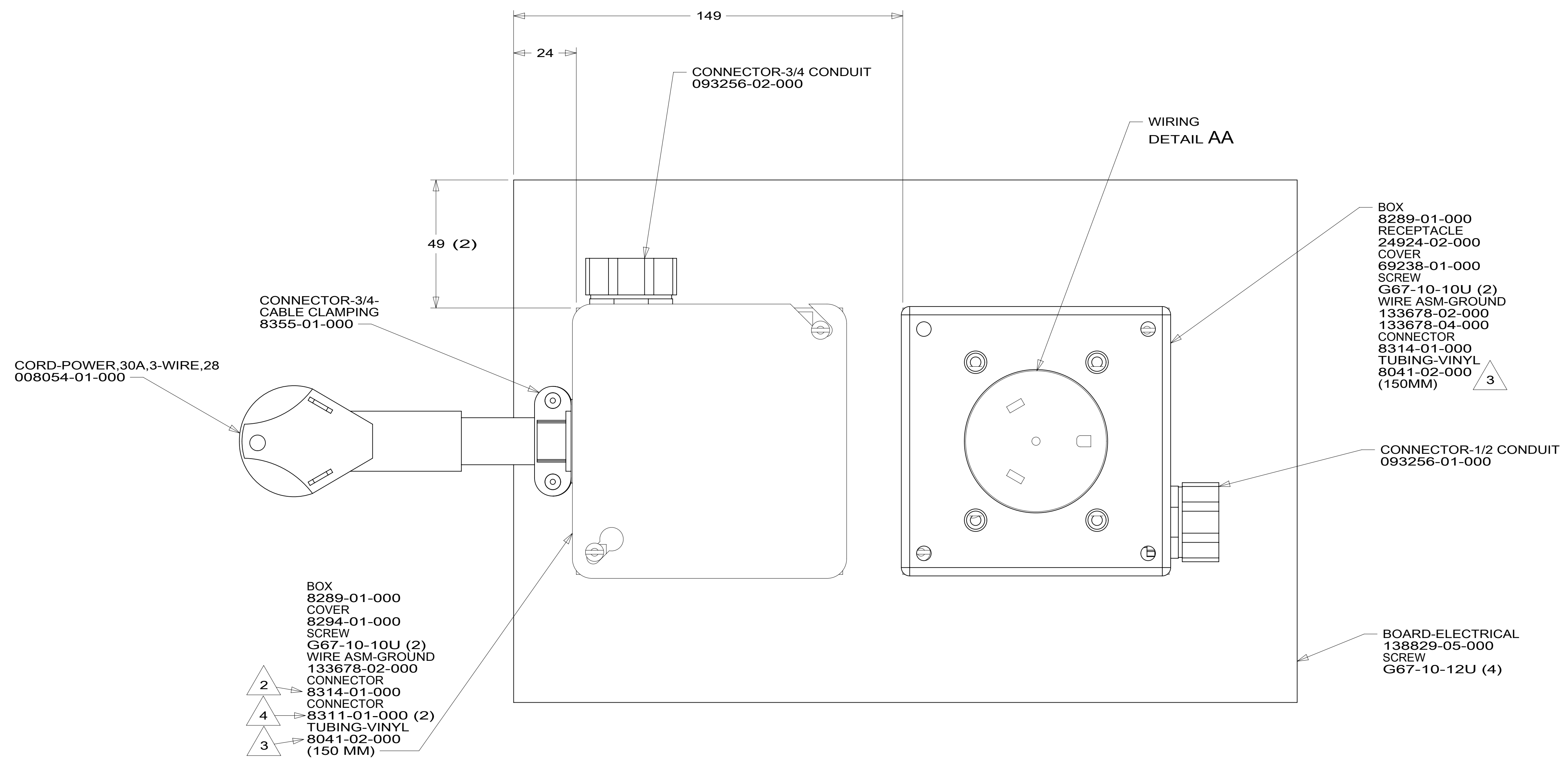

DETAIL AA
(BACK VIEW)

- 4 CONNECT BLK TO BLK, WHT TO WHT.
 - 3 APPLY TUBING TO BARE GROUND WIRES.
 - 2 CONNECT GRNDS TO GRNDS.
1. ALL GROUND WIRES TO BE COVERED WITH TUBING 8041-02-000.

NOTES:

FOR ELECTRICAL
TORQUE
SPECIFICATIONS
SEE DWG NO.
128783-01-000

FOR
ELECTRICAL
CALLOUTS
SEE DWG NO.
121339-01-000

- 265 CODES/STANDARDS-CSA/CMVSS
- 1B1 CODES/STANDARDS USA
- 1B1 265



DSNR:		ALL DIMENSIONS ARE IN MILLIMETERS	
DFFR:		MATERIAL:	
UNSPECIFIED TOLERANCES:			
WHOLE DIM (X)	: 3		
ONE-PLACE (X.X)	: 1.5		
TWO-PLACE (X.XX)	: 0.50		
ANGLE	: 1°		
REFER TO ES0018 FOR FASTENER TIGHTENING GUIDELINES		WEIGHT: (LBS)	FIRST USED:
			18 E-SER
DESCRIPTION: POWER CORD BOX ASM			
SHEET:	ITEM/PART NO.:	REV:	
1 OF 1	000159448 / 32764201000		
REF:		1 20-Jun-2019	

8 7 6 5 4 3 2 1